

PHỤ LỤC

Phụ lục 1 Kết quả kiểm tra

- 1) Bảng kiểm tra thiết bị cơ khí tại trạm xử lý nước thải Kim Liên
- 2) Bảng kiểm tra thiết bị cơ khí tại trạm bơm Kim Liên
- 3) Bảng kiểm tra thiết bị điện/điều khiển tại trạm xử lý nước thải Kim Liên
- 4) Bảng kiểm tra thiết bị cơ khí tại trạm xử lý nước thải Trúc Bạch
- 5) Bảng kiểm tra thiết bị điện/điều khiển tại trạm xử lý nước thải Trúc Bạch
- 6) Bảng kiểm tra thiết bị cơ khí tại trạm xử lý nước thải Bắc Thăng Long
- 7) Bảng kiểm tra thiết bị điện/điều khiển tại trạm xử lý nước thải Bắc Thăng Long

Mechanical Instrument Check Sheet

Facility Name : Kim Lien WWTP

| No | Category | Tag No. | Instrument Name | Placement (P) L Landed S Submerged I Inside O Outside | Physical Check (P/C) W Work O/G Oil & Grease Check S/P Stain & Painting D Damage A Abrasion V/N Vibration & Noise M Motor (with motor only) | Useful Life (L) Number: Year | | | Measurement (M) | | | | | Remark | Result | | | | | |
|----|-------------------------------------|---------|--------------------------------|---|--|---------------------------------|----|---|-----------------|---|---|---|----|--------|--------|---|---|---|--|-------|
| | | | | | | C/R | P | L | C | P | T | V | C | | | P | T | V | | |
| 1 | GRIT AND SCREENING REMOVAL FACILITY | KGC1A | GC Inlet Gate | S | W O/G S/P D A V/N M | B | LO | G | N | N | N | N | 15 | | | | | | | |
| 2 | GRIT AND SCREENING REMOVAL FACILITY | KGC1B | GC Inlet Gate | S | W O/G S/P D A V/N M | B | LO | G | N | N | N | N | 15 | | | | | | | |
| 3 | GRIT AND SCREENING REMOVAL FACILITY | KGC2A | GC Coarse Screen | S | W O/G S/P D A V/N M | B | LO | G | N | N | N | N | 15 | | | | | | | |
| 4 | GRIT AND SCREENING REMOVAL FACILITY | KGC2B | GC Coarse Screen | S | W O/G S/P D A V/N M | B | LO | G | N | N | N | N | 15 | | | | | | | |
| 5 | GRIT AND SCREENING REMOVAL FACILITY | KGC3A | GC Fine Screen | S | W O/G S/P D A V/N M | A | LO | G | N | N | N | G | 15 | | | | | | | 0.4kW |
| 6 | GRIT AND SCREENING REMOVAL FACILITY | KGC3B | GC Fine Screen | S | W O/G S/P D A V/N M | A | LO | G | N | N | N | G | 15 | | | | | | | 0.4kW |
| 7 | GRIT AND SCREENING REMOVAL FACILITY | KGC4A | Grit pump | S | W O/G S/P D A V/N M | A | SO | N | N | N | N | G | 15 | | | | | | | 3.7kW |
| 8 | GRIT AND SCREENING REMOVAL FACILITY | KGC4B | Grit pump | S | W O/G S/P D A V/N M | A | SO | N | N | N | N | G | 15 | | | | | | | 3.7kW |
| 9 | GRIT AND SCREENING REMOVAL FACILITY | KGC5 | Grit Separator | S | W O/G S/P D A V/N M | B | LO | N | N | N | N | G | 15 | | | | | | | 40 |
| 10 | GRIT AND SCREENING REMOVAL FACILITY | KGC6 | GC lifting Equipment for pumps | S | W O/G S/P D A V/N M | C | LO | | | | | | 20 | | | | | | | |
| 11 | GRIT AND SCREENING REMOVAL FACILITY | KGC7A | GC Screenings Bin | S | W O/G S/P D A V/N M | C | LO | | | | | | 15 | | | | | | | |
| 12 | GRIT AND SCREENING REMOVAL FACILITY | KGC7B | GC Screenings Bin | S | W O/G S/P D A V/N M | C | LO | | | | | | 15 | | | | | | | |

Mechanical Instrument Check Sheet

Facility Name : Kim Lien WWTP

| No | Category | Tag No. | Instrument Name | Placement (P) | | Physical Check (P/C) | | | | | | | | | | Useful Life (L) Number: Year | Measurement (M) | | | | Result |
|----|-------------------------------------|---------|-------------------|---------------|-------------|----------------------|---|---|-----|-----|---|---|-----|---|----|---------------------------------|-----------------|---|---|--------------------|--------|
| | | | | L Landed | S Submerged | C/R | P | W | O/G | S/P | D | A | V/N | M | L | | C | P | T | V | |
| | | | | L | I | O | O | W | O/G | S/P | D | A | V/N | M | L | C | P | T | V | Remark | |
| 13 | GRIT AND SCREENING REMOVAL FACILITY | KGC7C | GC Screenings Bin | | | | | C | LO | | G | N | N | | 15 | | | | | | |
| 14 | GRIT AND SCREENING REMOVAL FACILITY | KGC8A | Grit Bin | | | | | C | LO | | N | N | N | | 15 | | | | | rust | |
| 15 | GRIT AND SCREENING REMOVAL FACILITY | KGC8B | Grit Bin | | | | | C | LO | | N | N | N | | 15 | | | | | rust | |
| 16 | EQUALIZATION TANK | KET1A | ET Inlet Gate | | | | | B | LO | G | N | N | N | | 15 | | | | | | |
| 17 | EQUALIZATION TANK | KET1B | ET Inlet Gate | | | | | B | LO | G | N | N | N | | 15 | | | | | | |
| 18 | EQUALIZATION TANK | KET2A | ET Outlet Gate | | | | | B | LO | G | N | N | N | | 15 | | | | | | |
| 19 | EQUALIZATION TANK | KET2B | ET Outlet Gate | | | | | B | LO | G | N | N | N | | 15 | | | | | | |
| 20 | EQUALIZATION TANK | KET3A | ET Agitator | | | | | A | SO | G | | | N | N | 10 | 4.8 | | | | rust chain stopper | |
| 21 | EQUALIZATION TANK | KET3B | ET Agitator | | | | | A | SO | G | | | N | N | 10 | 4.7 | | | | rust chain stopper | |
| 22 | EQUALIZATION TANK | KET4A | ET Transfer pump | | | | | A | SO | G | | | N | N | 15 | 11.2 | 0.17 | | | 7.5kW | |
| 23 | EQUALIZATION TANK | KET4B | ET Transfer pump | | | | | A | SO | G | | | N | N | 15 | | | | | 7.5kW | |
| 24 | EQUALIZATION TANK | KET4C | ET Transfer pump | | | | | A | SO | G | | | N | N | 15 | 11.3 | 0.15 | | | 7.5kW | |

Mechanical Instrument Check Sheet

Facility Name : Kim Lien WWTP

| No | Category | Tag No. | Instrument Name | Placement (P) L Landed S Submerged I Inside O Outside | Physical Check (P/C) W Work O/G Oil & Grease Check S/P Stain & Painting D Damage A Abrasion V/N Vibration & Noise M Motor (with motor only) | Useful Life (L) Number: Year | | | Measurement (M) C Current(A) P Pressure(MPa)(with Press. gauge only) T Temperature(°C) V Vibration (main equipment only) | | | Result G Good N Normal B Bad X Couldn't check | | |
|----|----------------------|---------|-------------------------------|---|--|---------------------------------|---|---|--|-----|-------|---|--------|---------------------------------------|
| | | | | | | L | C | P | T | V | C | | P | T |
| 73 | SLUDGE TREATMENT | KDH9 | Dehydrator room drainage pump | S | A S I | N | N | N | 10 | | | | 0.75kW | |
| 74 | SLUDGE TREATMENT | KDH11 | Booster pump | B | L I G | G | N | N | 15 | 1.6 | 0.38 | | 1.5kW | |
| 75 | SLUDGE TREATMENT | KDH12 | BackWash Valve | C | L I | G | N | N | 15 | | | | 0.1kW | |
| 76 | FILTRATE RETURN PUMP | KFPIA | Filtrate Return pump | B | S O G | N | N | N | | 2.8 | | | 1.5kW | |
| 77 | FILTRATE RETURN PUMP | KFP1B | Filtrate Return pump | B | S O G | N | N | N | | 2.9 | 0.6 | | 1.5kW | |
| 78 | FILTRATE RETURN PUMP | KFP2 | Scum Screen | C | | | | | | | | | | |
| 79 | BLOWER | KBW1A | Aeration Blower | S | L I G | N | N | N | 20 | 35 | 0.092 | 74 | 22kW | Vibration checking: refer other sheet |
| 80 | BLOWER | KBW1B | Aeration Blower | S | L I G | N | N | N | 20 | 43 | 0.068 | 42 | 22kW | Vibration checking: refer other sheet |
| 81 | BLOWER | KBW1C | Aeration Blower | S | L I G | N | N | N | 20 | 40 | 0.083 | 40 | 22kW | Vibration checking: refer other sheet |
| 82 | WATER SUPPLY UNIT | KWS1A | Recyle Water pump | B | S O | | G | N | 15 | | | | 3.7kW | |
| 83 | WATER SUPPLY UNIT | KWS1B | Recyle Water pump | B | S O G | G | N | N | 15 | | 0.23 | | 3.7kW | |
| 84 | WATER SUPPLY UNIT | KWS2A | Recyle Water strainer | B | L O | | N | N | 20 | | | | | |

Mechanical Instrument Check Sheet

Facility Name : Kim Lien WWTP

| No | Category | Tag No. | Instrument Name | C/R | Physical Check (P/C) | | | | | | | | | | | | Useful Life (L) Number: Year | Measurement (M) | | | | Remark | Result | | | | | |
|----|-------------------------------|---------|--|-----|----------------------|---|---|---|-----|-----|---|---|-----|---|---|---|---------------------------------|-----------------|---|---|---|--------|--------|---|---|---|---|-------|
| | | | | | Placement (P) | | | W | O/G | S/P | D | A | V/N | M | L | C | | P | T | V | | | | | | | | |
| | | | | | L | S | O | | | | | | | | | | | | | | C | | | P | T | V | | |
| 85 | WATER SUPPLY UNIT | KWS2B | Recyle Water strainer | B | LO | | | | N | N | N | N | N | N | | | | | | | | | | | | | | |
| 86 | WATER SUPPLY UNIT | KWS3 | Potable Water Supply Unit | B | LI | | | | N | N | N | N | N | N | | | | | | | | | | | | | | |
| 87 | WATER SUPPLY UNIT | KWS3 | Potable Water Supply pump | B | LI | | | | N | N | N | N | N | N | | | | | | | | | | | | | 1.5kW | |
| 88 | WATER SUPPLY UNIT | KWS3 | Potable Water Supply pump | B | LI | | | | N | N | N | N | N | N | | | | | | | | | | | | | 1.5kW | |
| 89 | WATER SUPPLY UNIT | KWS4 | Potable Water Tank | B | LO | | | | N | N | N | N | N | N | | | | | | | | | | | | | | |
| 90 | DEODORIZATION SYSTEM | KDS1 | Deodorizer with activated carbon & accessories | B | LO | | | | N | N | N | N | N | N | | | | | | | | | | | | | manometer malfunction | |
| 91 | DEODORIZATION SYSTEM | KDS2 | Odor Extraction Fan | A | LI | G | N | N | N | N | N | N | G | N | | | | | | | | | | | | | 5.5kW | |
| 92 | DEODORIZATION SYSTEM | KDS3 | Eliminator | C | LI | | | | G | G | G | G | | | | | | | | | | | | | | | routine checking of the inside is necessary | |
| 93 | DEODORIZATION SYSTEM | KDS4 | Lifting Equipment for Deodorizer | C | LO | | | | N | N | N | N | N | N | | | | | | | | | | | | | | |
| 94 | EMERGENCY POWER SUPPLY SYSTEM | KEP1 | Generator | B | LI | | | | G | G | G | G | G | G | | | | | | | | | | | | | | 75kVA |
| 95 | EMERGENCY POWER SUPPLY SYSTEM | KEP2 | Oil Tank | B | LO | | | | N | N | N | N | G | | | | | | | | | | | | | | | 7000 |
| 96 | EMERGENCY POWER SUPPLY SYSTEM | KEP3 | Oil pump | A | | | | | | | | | | | | | | | | | | | | | | | | 0.2kW |

Mechanical Instrument Check Sheet

Facility Name : **Kim Lien Relay Pumping Station**

| Check Rank (C/R) | | Placement (P) | | Physical Check (P/C) | | Useful Life (L) | | Measurement (M) | | | Result | | | | | | | |
|------------------|---|---------------|-----------------------------|----------------------|----|-----------------|-----|-----------------|---|---|--------|----|----|---|----|--------------------------------------|------------------------------------|----------------|
| No | Category | Tag No. | Instrument Name | C/R | P | P/C | | | | | | L | M | | | Remark | Result | |
| | | | | | | W | O/G | S/P | D | A | V/N | | M | C | P | | | T |
| S | Physical Check (all) & Measurement (all) | | | | | | | | | | | | | | | | | |
| A | Physical Check (all) & Measurement (C,P,T only) | | | | | | | | | | | | | | | | | |
| B | Physical Check (all) | | | | | | | | | | | | | | | | | |
| C | Physical Check (S/P,D,A only) | | | | | | | | | | | | | | | | | |
| | | | | | | | | | | | | | | | | | | |
| 1 | PUMPING STATION | KLPIA | Transfer pump | S | LI | G | N | G | N | N | G | 15 | 36 | × | 54 | 22kW discharge pressure gauge broken | N | Normal |
| 2 | PUMPING STATION | KLP1B | Transfer pump | S | LI | | N | G | N | N | G | 15 | | | | 22kW | X | Couldn't check |
| 3 | PUMPING STATION | KLP1C | Transfer pump | S | LI | | N | G | N | N | G | 15 | | | | 22kW | | |
| 4 | PUMPING STATION | KLP2 | Drainage pump | A | SI | | N | N | N | N | | 10 | | | | 0.75kW | | |
| 5 | PUMPING STATION | | Inlet Screen | C | SI | | N | N | N | N | | 15 | | | | | danger to be fallen down | |
| 6 | EMERGENCY POWER SUPPLY SYSTEM | KLP3 | Generator | B | LI | | G | G | G | G | | 15 | | | | 120kVA | Generator maintenance door locked | |
| 7 | EMERGENCY POWER SUPPLY SYSTEM | KLP7 | Deodorizer for pump Station | B | LI | G | N | N | N | N | G | 15 | | | | | manometer maintenance is necessary | |
| 8 | EMERGENCY POWER SUPPLY SYSTEM | KLP8 | Eliminator for pump Station | B | LI | | G | G | G | G | | | | | | | periodic cleaning up is necessary | |

Electric/Control Instrument Check Sheet

Facility Name : **Kim Lien WWTP**

| No | Category | Tag No. | Instrument Name | Placement (P) I Inside O Outside | Physical Check (P/C) S/P Stain & Painting D Damage T Terminal C Cable F Filter I Indicate | Useful Life (L) Number: Year | Measurement (M) | | | Remark | Result | | | | | | | | | | | | | | | |
|-----|---------------------|---------|--------------------------------|--|---|---------------------------------|-----------------|---|---|--------|--------|---|--|--|--|--|--|--|--|-----------------------------------|--|--|--|--|--|--|
| | | | | | | | V | T | L | | | | | | | | | | | | | | | | | |
| | | | | | | | V | T | L | | | | | | | | | | | | | | | | | |
| | | | | | | | P/C | | | | | | | | | | | | | | | | | | | |
| C/R | P | S/P | D | T | C | F | I | L | V | T | L | M | | | | | | | | | | | | | | |
| 1 | Electric instrument | LP-1 | Local Control Panel | | A | O | N | G | G | N | | | | | | | | | | no maintenance space on back side | | | | | | |
| 2 | Electric instrument | LP-2 | Local Control Panel | | A | O | N | G | G | N | | | | | | | | | | | | | | | | |
| 3 | Electric instrument | LP-3 | Local Control Panel | | A | O | N | G | G | N | | | | | | | | | | | | | | | | |
| 4 | Electric instrument | LP-4 | Local Control Panel | | A | I | N | G | G | N | | | | | | | | | | | | | | | | |
| 5 | Electric instrument | LP-5 | Local Control Panel | | A | O | G | G | G | G | | | | | | | | | | | | | | | | |
| 6 | Electric instrument | LP-6 | Local Control Panel | | A | I | G | G | G | N | G | | | | | | | | | | | | | | | |
| 7 | Electric instrument | LP-7 | Local Control Panel | | A | I | G | G | G | N | | | | | | | | | | | | | | | | |
| 8 | Electric instrument | SVP | Supervisory Panel | | S | I | N | G | G | G | G | | | | | | | | | | | | | | | |
| 9 | Electric instrument | | Emergency Generator | | A | I | X | X | X | X | X | | | | | | | | | | | | | | | |
| 10 | Electric instrument | LTDP | L/T Distribution Panel | | S | I | N | G | G | G | G | | | | | | | | | | | | | | | |
| 11 | Electric instrument | LP-KDH1 | DRPP-1500 Control Panel | | A | I | B | G | G | G | | | | | | | | | | | | | | | | |
| 12 | Electric instrument | PS-LTDP | Low Tension Distribution Panel | | A | I | G | G | G | N/B | G | | | | | | | | | | | | | | | |

Electric/Control Instrument Check Sheet Facility Name : Kim Lien WWTP

| No | Category | Tag No. | Instrument Name | Placement (P) I Inside O Outside | Physical Check (P/C) S/P Stain & Painting D Damage T Terminal C Cable F Filter I Indicate | Useful Life (L) Number: Year | Measurement (M) | | | Remark | Result | | | | | |
|----|---------------------|---------|---|--|---|---------------------------------|-----------------|---|---|--------|--------|---|---|---|---|---|
| | | | | | | | V | T | L | | | | | | | |
| | | | | | | | P/C | | | M | | | | | | |
| | | | | | | | S/P | D | T | C | F | I | V | T | L | |
| 13 | Electric instrument | KLP3 | Monitoring Control Panel (Generator) | | A | I | G | G | G | G | G | | | | | |
| 14 | Control Instrument | K-LS1 | Kim Lien PS Level (float level switch) | | A | I | B | B | N | | | | | | | worry of short failure (because of condensation) |
| 15 | Control Instrument | K-LS2 | Equalization Tank Level (float level switch) | | A | O | G | G | G | | | | | | | name plate is unreadable by much painting |
| 16 | Control Instrument | K-LS3 | PST Scum Pit Level (float level switch) | | A | O | N | B | X | N | | | | | | cover is firmly fixed by much painting |
| 17 | Control Instrument | K-LS4A | Reactor Level (float level switch) | | A | O | G | G | G | | | | | | | |
| 18 | Control Instrument | K-LS4B | Reactor Level (float level switch) | | A | O | G | G | G | | | | | | | |
| 19 | Control Instrument | K-LS5 | FST Scum Pit Level (float level switch) | | A | O | N | N | G | G | | | | | | cable cover is broken |
| 20 | Control Instrument | K-LS6 | NaClO Storage Tank Level (electrode level switch) | | A | I | N | N | X | N | | | | | | couldn't open the box connector has rust a little |
| 21 | Control Instrument | K-LS7 | Sludge Reservoir Level (float level switch) | | A | O | N | N | G | N | | | | | | name plate is unreadable by much painting |
| 22 | Control Instrument | K-LS8 | Polymer Tank Level (electrode level switch) | | A | I | N | N | N | N | | | | | | no terminal cover |
| 23 | Control Instrument | K-LS9 | Dehydrator Room Drainage Tank Level(float LS) | | A | I | N | N | X | X | | | | | | couldn't reach the connector box |
| 24 | Control Instrument | K-LS10 | Filtrate Return Pit Level (float level switch) | | A | O | N | N | X | X | | | | | | couldn't open the connector box by much painting |

Electric/Control Instrument Check Sheet

Facility Name : Kim Lien WWTP

| No | Category | Tag No. | Instrument Name | Placement (P) I Inside O Outside | Physical Check (P/C) S/P Stain & Painting D Damage T Terminal C Cable F Filter I Indicate | Useful Life (L) Number: Year | Measurement (M) | | | Remark | Result G Good N Normal B Bad X Couldn't check | | | | | |
|----|--------------------|---------|--|--|---|---------------------------------|-----------------|---|---|--------|---|---|---|---|---|---------------------------------------|
| | | | | | | | V | T | L | | | | | | | |
| | | | | | | | P/C | | | L | | | | | | |
| | | | | | | | S/P | D | T | C | F | I | V | T | L | |
| 25 | Control Instrument | K-LS11 | Recycle Water Pit Level (float level switch) | O | N | N | X | N | | | | | | | | |
| 26 | Control Instrument | K-LS12 | Coagulant Storage Tank Level (electrode LS) | A | N | N | X | N | | | | | | | | couldn't open the connector box |
| 27 | Control Instrument | K-L1A1 | Equalization Tank Level (ultrasonic level sensor) | A | O | G | | G | | | | | | | | |
| 28 | Control Instrument | K-F11 | Grit Chamber Air Flow (manometer) | A | O | B | | B | | | | | | | | almost broken, rust a lot, water leak |
| 29 | Control Instrument | K-F13A | Recirculation Pump Flow (magnetic flow meter) | A | O | G | X | G | | | | | | | | |
| 30 | Control Instrument | K-F13B | Recirculation Pump Flow (magnetic flow meter) | A | O | G | X | G | | | | | | | | |
| 31 | Control Instrument | K-F14 | Effluent Flow (堰式流量計 weir flow meter) | A | O | G | | G | | | | | | | | |
| 32 | Control Instrument | K-F15A | Reactor Air Flow (manometer) | A | O | B | | B | | | | | | | | almost broken, rust a lot |
| 33 | Control Instrument | K-F15B | Reactor Air Flow (manometer) | A | O | B | | B | | | | | | | | almost broken, rust a lot |
| 34 | Control Instrument | K-F1QR4 | ET Transfer Pump Flow (magnetic flow meter) | A | O | N | X | N | | | | | | | | |
| 35 | Control Instrument | K-FIQ1 | PST Sludge Flow (magnetic flow meter) | A | O | N | X | N | | | | | | | | |
| 36 | Control Instrument | K-FIQ2 | WAS Flow (magnetic flow meter) | A | O | N | X | N | | | | | | | | |

Electric/Control Instrument Check Sheet

Facility Name : **Kim Lien WWTP**

| No | Category | Tag No. | Instrument Name | Placement (P) I Inside O Outside | Physical Check (P/C) S/P Stain & Painting D Damage T Terminal C Cable F Filter I Indicate | Useful Life (L) Number: Year | Measurement (M) | | | Result | | | | | | | | |
|----|--------------------|---------|-----------------|--|---|---------------------------------|-----------------------------------|---------------------------------------|---|--------|---|---|---|---|---|---|---|--------|
| | | | | | | | V Voltage (V) (main breaker only) | T Temperature(°C) (main breaker only) | L Leak Current (mA) (main breaker only) | | | | | | | | | |
| | | | | | | | P/C | | | | | | | | | | | |
| | | | | | | | S/P | D | T | C | F | I | L | V | T | L | M | Remark |
| 37 | Control Instrument | K-DO11A | Reactor DO | | | | O | G | X | N | | G | | | | | | |
| 38 | Control Instrument | K-DO11B | Reactor DO | | | | O | G | X | N | | G | | | | | | |

Mechanical Instrument Check Sheet

Facility Name : Truc Bach WWTP

| No | Category | Tag No. | Instrument Name | Placement (P) L Landed S Submerged I Inside O Outside | Physical Check (P/C) W Work O/G Oil & Grease Check S/P Stain & Painting D Damage A Abrasion V/N Vibration & Noise M Motor (with motor only) | Useful Life (L) Number: Year | | | Measurement (M) | | | | | Result | | |
|----|--|---------|-------------------|---|--|---------------------------------|---|---|-----------------|----|-----|---|--------|--------|---|---|
| | | | | | | C | P | M | C | P | T | V | Remark | | | |
| 1 | PUMP STATION | TBP1A | TB Transfer pump | | A SO G | G | N | N | G | 15 | 8.9 | | | | 5.5kW | G |
| 2 | PUMP STATION | TBP1B | TB Transfer pump | | A SO N | G | B | N | N | 15 | 8.8 | × | | | 5.5kW lack of guide rail | N |
| 3 | PUMP STATION | TBP1C | TB Transfer pump | | A SO | G | N | N | N | 15 | | | | | 5.5kW | B |
| 4 | PUMP STATION | TBP2 | Lifting Equipment | | C LO | | | | | 20 | | | | | | X |
| 5 | PUMP STATION | TBP3A | Screenings Bucket | | C LO | | | | | 15 | | | | | | |
| 6 | PUMP STATION | TBP3B | Screenings Bucket | | C LO | | | | | 15 | | | | | | |
| 7 | GRIT AND SCREENING REMOVAL FACILITY | TGC1A | GC Inlet gate | | B | G | N | N | N | 15 | | | | | | |
| 8 | GRIT AND SCREENING REMOVAL FACILITY | TGC1B | GC Inlet gate | | B | G | N | N | N | 15 | | | | | | |
| 9 | GRIT AND SCREENING REMOVAL FACILITY | TGC2A | GC Coarse Screen | | B | G | N | G | N | 15 | | | | | chain grease run down | |
| 10 | GRIT AND SCREENING REMOVAL FACILITY | TGC2B | GC Coarse Screen | | B | G | N | G | N | 15 | | | | | chain grease run down | |
| 11 | GRIT AND SCREENING REMOVAL FACILITY | TGC3A | GC Fine Screen | | A | | N | G | N | 15 | | | | | 0.2kW chain grease run down | |
| 12 | GRIT AND SCREENING REMOVAL FACILITY | TGC3B | GC Fine Screen | | A | G | N | G | N | 15 | 0.7 | | 55 | | 0.2kW rake deformation, chain grease run down | |

Mechanical Instrument Check Sheet

Facility Name : Truc Bach WWTP

| No | Category | Tag No. | Instrument Name | Placement (P) L Landed S Submerged I Inside O Outside | Physical Check (P/C) W Work O/G Oil & Grease Check S/P Stain & Painting D Damage A Abrasion V/N Vibration & Noise M Motor (with motor only) | Useful Life (L) Number: Year | | | Measurement (M) C Current(A) P Pressure(MPa)(with Press. gauge only) T Temperature(°C) V Vibration (main equipment only) | | | Result G Good N Normal B Bad X Couldn't check | | |
|----|---------------------|---------|--------------------------|---|--|---------------------------------|---|---|--|---|----|---|-------------------------------------|----|
| | | | | | | C | P | V | C | P | T | | V | |
| 61 | FINAL SETTLING TANK | TFS2B | Return sludge pump | A | LO | G | G | N | N | G | 15 | 3.7 | 2.2kW | |
| 62 | FINAL SETTLING TANK | TFS2C | Return sludge pump | A | LO | | | | | | | | 2.2kW | |
| 63 | FINAL SETTLING TANK | TFS3 | FST scum pump | A | SO | G | N | N | N | | 15 | | 0.75kW | |
| 64 | FINAL SETTLING TANK | TFS4A | WAS Control Valve | B | LO | G | G | N | N | G | 15 | | 0.2kW | |
| 65 | FINAL SETTLING TANK | TFS4B | WAS Control Valve | B | LO | G | G | N | N | G | 15 | | 0.2kW | |
| 66 | FINAL SETTLING TANK | TFS5 | scum Box | C | | | | | | | | | | |
| 67 | DISINFECTION TANK | TCT1 | NaClO Storage Tank | C | | G | N | N | N | | 10 | | 2.0 m³ | |
| 68 | DISINFECTION TANK | TCT2A | NaClO Dosing pump | B | | G | G | N | N | G | 15 | 0.32 | 0.2kW | 41 |
| 69 | DISINFECTION TANK | TCT2B | NaClO Dosing pump | B | | G | N | N | N | G | 15 | | 0.2kW | |
| 70 | SLUDGE THICKENER | TST1 | Thickened Sludge Scraper | A | LO | N | N | N | N | N | 15 | 0.4 | 0.4kW | 47 |
| 71 | SLUDGE THICKENER | TST2 | Thickened Sludge pump | A | LI | | | N | N | | 15 | | 0.75kW rust around gland packing | |
| 72 | SLUDGE TREATMENT | TDH1 | Dehydrator | A | LI | G | N | N | N | G | 15 | 0.7 | 0.75kW | 35 |

Mechanical Instrument Check Sheet

Facility Name : Truc Bach WWTP

| No | Category | Tag No. | Instrument Name | C/R | P | Physical Check (P/C) | | | | | | | | | | Useful Life (L) Number: Year | Measurement (M) | | | Remark | Result |
|----|----------------------|---------|-------------------------------|-----|----|----------------------|-----|-----|---|---|-----|---|---|----|-----|---------------------------------|-----------------|-------------------|---|--------|--------|
| | | | | | | W | O/G | S/P | D | A | V/N | M | L | C | P | | T | V | C | | |
| 73 | SLUDGE TREATMENT | TDH2 | Coagurator | A | LI | G | N | N | N | N | N | G | G | 15 | 1.1 | 36 | 0.75kW | | | | |
| 74 | SLUDGE TREATMENT | TDH3 | Sludge Cake Hopper | A | LI | | | | | | | | | 15 | | | 1.5kW×2 | 5.2m ³ | | | |
| 75 | SLUDGE TREATMENT | TDH4 | Polymer tank | B | LI | | | | | | | | | 15 | | | | | | | |
| 76 | SLUDGE TREATMENT | TDH5 | Polymer tank agitator | C | LI | | | | | | | | | 15 | | | 1.5kW | | | | |
| 77 | SLUDGE TREATMENT | TDH6 | Polymer feeder | B | LI | | | | | | | | | 15 | | | | | | | |
| 78 | SLUDGE TREATMENT | TDH7 | Polymer dosing pump | B | LI | G | | | | | | | | 15 | 1 | 35 | 0.75kW | | | | |
| 79 | SLUDGE TREATMENT | TDH8 | Sluge feeding pump | A | LI | N | | | | | | | | 15 | 3.1 | 34 | 1.5kW | | | | |
| 80 | SLUDGE TREATMENT | TDH9 | Dehydrator room drainage pump | A | LS | | | | | | | | | 10 | | | 0.2kW | | | | |
| 81 | SLUDGE TREATMENT | TDH11 | Booster pump | B | LI | G | | | | | | | | 15 | 1.9 | | 1.5kW | | | | |
| 82 | SLUDGE TREATMENT | TDH12 | Backwash Valve | B | LI | | | | | | | | | 15 | | | 0.1kW | | | | |
| 83 | FILTRATE RETURN PUMP | TFPIA | Filtrate Return pump | B | SO | | | | | | | | | 15 | | | 0.75kW | | | | |
| 84 | FILTRATE RETURN PUMP | TFPIB | Filtrate Return pump | B | SO | | | | | | | | | 15 | | | 0.75kW | | | | |

Electric/Control Instrument Check Sheet

Facility Name : Truc Bach WWTP

| No | Category | Tag No. | Instrument Name | C/R | P | Physical Check (P/C) | | | | | | | Useful Life (L) Number: Year | Measurement (M) | | | Remark | Result | |
|----|---------------------|---------|--|-----|---|----------------------|-----|---|---|---|---|---|---------------------------------|-----------------|------|---|--|--------|--------|
| | | | | | | S/P | D | T | C | F | I | L | | V | T | L | | | |
| 1 | Electric Instrument | LP-1 | Local Control Panel | A | O | N | G | G | N | | | | | | | | No maintenance space (no stage on back side of the panel) | G | Good |
| 2 | Electric Instrument | LP-2 | Local Control Panel | A | O | N | G | G | N | | | | | | | | lack of maintenance space (planting on back side of the panel) | N | Normal |
| 3 | Electric Instrument | LP-3 | Local Control Panel | A | O | N/B | N | G | N | | | | | | | | bottom of the panel rusts deeply | B | Bad |
| 4 | Electric Instrument | LP-4 | Local Control Panel | A | I | N | N/B | G | N | | | | | | | | | | |
| 5 | Electric Instrument | LP-5 | Local Control Panel | A | O | N/B | N/B | G | N | | | | | | | | side of the panel door rust deeply, panel door and stage are touched | | |
| 6 | Electric Instrument | LP-6 | Local Control Panel | S | I | G | G | G | N | G | | | 392 | 49.4 | 24.2 | | tough location (room temp is very high) | | |
| 7 | Electric Instrument | LP-7 | Local Control Panel | A | I | G | G | G | N | | | | | | | | the breaker is cut when it isn't operated (good point) | | |
| 8 | Electric Instrument | LP-TDH1 | DRPP-1000 Control Panel | A | I | N | N | G | N | | | | | | | | | | |
| 9 | Electric Instrument | LTDP | L/T Distribution Panel | S | I | G | G | G | N | G | | | 392 | 30 | 79.5 | | | | |
| 10 | Electric Instrument | SVP | Supervisory Panel | S | I | G | G | G | N | G | | | 397 | 28.2 | 1.5 | | | | |
| 11 | Electric Instrument | TEP1 | Emergency Generator Monitoring Control Panel | A | I | N | G | G | N | G | | | | | | | | | |
| 12 | Control Instrument | T-LS1 | Truc Bach Influent Pump Pit Level (float SW × 4) | A | O | N | N | G | N | | | | | | | | | | |

Electric/Control Instrument Check Sheet

Facility Name : Truc Bach WWTP

| Check Rank (C/R) | | Physical Check & Measurement | | Physical Check (P/C) | | Useful Life (L) | | Measurement (M) | | | Result | | | | | |
|------------------|--------------------|------------------------------|---|----------------------|-----|-----------------|-----|-----------------|---|---|--------|---|---|----------------|---|--------------------------------------|
| S | Physical Check | I | Inside | S/P | D | T | C | F | I | V | T | L | G | Good | | |
| A | Physical Check | O | Outside | T | N | G | N | N | N | | | | N | Normal | | |
| X | Taking photo only | | | C | N | N | N | N | N | | | | B | Bad | | |
| | | | | F | N/B | G | N | G | N | | | | X | Couldn't check | | |
| | | | | I | | | | | | | | | | | | |
| No | Category | Tag No. | Instrument Name | C/R | P | S/P | D | T | C | F | I | L | V | T | L | Remark |
| 13 | Control Instrument | T-LS2 | Equalization Tank Level (float SW x6) | A | O | N | N | G | N | | | | | | | |
| 14 | Control Instrument | T-LS3 | PST Scum Pit Level (float SW x4) | A | O | N | N | G | N | | | | | | | |
| 15 | Control Instrument | T-LS4A | Reactor Level (float SW x2) | A | O | N | N/B | G | N | | | | | | | tag plate is rust and unreadable |
| 16 | Control Instrument | T-LS4B | Reactor Level (float SW x2) | A | O | N | N/B | G | N | | | | | | | tag plate is rust and unreadable |
| 17 | Control Instrument | T-LS5 | FST Scum Pit Level (float SW x4) | A | O | N | N | G | N | | | | | | | |
| 18 | Control Instrument | T-LS6 | NaClO Storage Tank Level (electrode SW x4) | A | I | G | G | G/B | N | | | | | | | no terminal cover |
| 19 | Control Instrument | T-LS7 | Sludge Reservoir Level (float SW x4) | A | I | N | N | G | N | | | | | | | |
| 20 | Control Instrument | T-LS8 | Polymer Tank Level (electrode SW x4) | A | I | N | N | G | N | | | | | | | connector is rust a little bit |
| 21 | Control Instrument | T-LS9 | Dehydrator Room Drainage Tank Level (float SW x) | A | I | G | G | G | N | | | | | | | blower room is very high temperature |
| 22 | Control Instrument | T-LS10 | Filtrate Return Pit Level (?) | A | O | N | N/B | X | N | | | | | | | couldn't open the terminal box cover |
| 23 | Control Instrument | T-LS11 | Recycle Water Pit Level (float SW x2) | A | O | N | N | G | N | | | | | | | |
| 24 | Control Instrument | T-LS12 | Coagulant Storage Tank Level | A | I | G | G | G | N | | | | | | | |

Electric/Control Instrument Check Sheet

Facility Name : Truc Bach WWTP

| No | Category | Tag No. | Instrument Name | C/R | P | Physical Check (P/C) | | | | | | | Useful Life (L) Number: Year | Measurement (M) | | | Result | | |
|---|--------------------|----------|--|-----------------------|-----|----------------------|-----|---|---|-----|---|---|---------------------------------|-----------------|---------------------------------|-------------------------------------|---------------------------------------|--|-------------------------------------|
| | | | | | | S/P | D | T | C | F | I | L | | V | T | L | | Voltage (V) (main breaker only) | Temperature(°C) (main breaker only) |
| Check Rank (C/R) | | | | Placement (P) | | Physical Check (P/C) | | | | | | | Measurement (M) | | | Result | | | |
| S Physical Check & Measurement A Physical Check X Taking photo only | | | | I Inside O Outside | S/P | D | T | C | F | I | L | V | T | L | Voltage (V) (main breaker only) | Temperature(°C) (main breaker only) | Leak Current (mA) (main breaker only) | G Good N Normal B Bad X Couldn't check | |
| 25 | Control Instrument | T-LS13 | Effluent Pump Pit Level? (?) | A | O | N | X | B | | | | | | | | | | terminal box cover fixed, cable connector almost drops off | |
| 26 | Control Instrument | T-L1A1 | Equalization Tank Level (ultrasonic) | A | O | N | N/B | X | N | N/B | | | | | | | | Error Code E040 | |
| 27 | Control Instrument | T-F11 | Grit Chamber Air Flow (manometer) | A | O | N/B | N/B | | | B | | | | | | | | terminal box is broken | |
| 28 | Control Instrument | T-F13A | Recirculation Pump Flow (magnetic flow meter) | A | O | N | X | N | N | G | | | | | | | | | |
| 29 | Control Instrument | T-F13B | Recirculation Pump Flow (magnetic flow meter) | A | O | N | X | N | N | G | | | | | | | | | |
| 30 | Control Instrument | T-F14 | Effluent Flow (堰式流量計) | A | O | N/B | N | | | G | | | | | | | | rust casing | |
| 31 | Control Instrument | T-F15A | Reactor Air Flow (manometer) | A | O | N | B | | | B | | | | | | | | broken | |
| 32 | Control Instrument | T-F15B | Reactor Air Flow (manometer) | A | O | N | B | | | B | | | | | | | | broken | |
| 33 | Control Instrument | T-F1QR1 | ET Transfer Pump Flow (magnetic flow meter) | A | O | N | X | N | N | G | | | | | | | | | |
| 34 | Control Instrument | T-FIQ1 | PST Sludge Flow (magnetic flow meter) | A | O | N | X | N | N | G | | | | | | | | | |
| 35 | Control Instrument | T-FIQ2 | WAS Flow (magnetic flow meter) | A | O | N | X | N | N | G | | | | | | | | | |
| 36 | Control Instrument | T-DOIR1A | Reactor DO | A | O | N | X | N | N | G | | | | | | | | | |

Electric/Control Instrument Check Sheet

Facility Name : Truc Bach WWTP

| No | Category | Tag No. | Instrument Name | Placement (P) I Inside O Outside | Physical Check (P/C) S/P Stain & Painting D Damage T Terminal C Cable F Filter I Indicate | Useful Life (L) Number: Year | Measurement (M) | | | Result | | | | | | | | | | | |
|----|--------------------|----------|-----------------|--|---|---------------------------------|-----------------------------------|---------------------------------------|---|--------|---|---|---|---|---|--|--|--|--|--|--|
| | | | | | | | V Voltage (V) (main breaker only) | T Temperature(°C) (main breaker only) | L Leak Current (mA) (main breaker only) | | | | | | | | | | | | |
| | | | | P/C | | | M | | | Remark | | | | | | | | | | | |
| | | | | C/R | P | S/P | D | T | C | | F | I | V | T | L | | | | | | |
| 37 | Control Instrument | T-DOIR1B | Reactor DO | | | | | | | | | | | | | | | | | | |

Mechanical Instrument Check Sheet

Facility Name : North Thang Long WWTP

| Check Rank (C/R) | | Placement (P) | | Physical Check (P/C) | | | | | | | | | | Useful Life (L) | | | | Measurement (M) | | | | Result | | | | |
|------------------|-----------------------|---------------|------------------|----------------------|-----|---|-----|-----|---|---|-----|---|----|-----------------|-------|---|---|-----------------|---|---|---|--------|--------|----------------------|----------|-------------|
| No | Category | Tag No. | Instrument Name | C/R | P | W | O/G | S/P | D | A | V/N | M | L | C | P | T | V | C | P | T | V | M | Remark | Result | | |
| | | | | | | | | | | | | | | | | | | | | | | | | | L Landed | S Submerged |
| 1 | Grit Chamber facility | M1-01 | Inflo gate | A | L O | | | G | N | N | | G | 15 | | | | | | | | | | 0.75kW | | G | |
| 2 | Grit Chamber facility | M1-02 | GC Inflo gate | B | L I | G | | G | G | N | | | 15 | | | | | | | | | | | | | |
| 3 | Grit Chamber facility | M1-02 | GC Inflo gate | B | L I | G | | G | G | N | | | 15 | | | | | | | | | | | | | |
| 4 | Grit Chamber facility | M1-02 | GC Inflo gate | B | L I | G | | G | G | N | | | 15 | | | | | | | | | | | | | |
| 5 | Grit Chamber facility | M1-03 | GC Coarse screen | C | L I | | | G | G | G | | | 15 | | | | | | | | | | | screen pitch : 100mm | | |
| 6 | Grit Chamber facility | M1-03 | GC Coarse screen | C | L I | | | | | | | | 15 | | | | | | | | | | | screen pitch : 100mm | | |
| 7 | Grit Chamber facility | M1-03 | GC Coarse screen | C | L I | | | | | | | | 15 | | | | | | | | | | | screen pitch : 100mm | | |
| 8 | Grit Chamber facility | M1-04A | Grit pump | A | S I | G | | G | N | N | G | | 15 | | 0.035 | | | | | | | | | 3.7kW | | |
| 9 | Grit Chamber facility | M1-04B | Grit pump | A | S I | G | | G | N | N | G | | 15 | 7.1 | 0.03 | | | | | | | | | | 3.7kW | |
| 10 | Grit Chamber facility | M1-04C | Grit pump | A | S I | | | | G | N | N | | 15 | | | | | | | | | | | | 3.7kW | |
| 11 | Grit Chamber facility | M1-04D | Grit pump | A | S I | | | | G | N | N | | 15 | | | | | | | | | | | | 3.7kW | |
| 12 | Grit Chamber facility | M1-04E | Grit pump | A | S I | | | | G | N | N | | 15 | | | | | | | | | | | | 3.7kW | |

Mechanical Instrument Check Sheet

Facility Name : North Thang Long WWTP

| No | Category | Tag No. | Instrument Name | C/R | P | Physical Check (P/C) | | | | | | | | | | Useful Life (L) Number: Year | Measurement (M) C Current(A) P Pressure(MPa)(with Press. gauge only) T Temperature(°C) V Vibration (main equipment only) | Result | | | |
|----|-----------------------|---------|--------------------------|-----|-----|----------------------|-----|-----|---|---|-----|---|----|------|---|---------------------------------|--|--------|--------------------------------|---|--------|
| | | | | | | W | O/G | S/P | D | A | V/N | M | L | C | P | | | | T | V | |
| | | | | C | R | P/C | | | | | | | | | | L | M | | | | Remark |
| | | | | | | W | O/G | S/P | D | A | V/N | M | L | C | P | T | V | Remark | | | |
| 13 | Grit Chamber facility | M1-04F | Grit pump | A | S I | | | G | N | N | | | 15 | | | | | 3.7kW | | | |
| 14 | Grit Chamber facility | M1-04G | Grit pump | A | S I | | | G | N | N | | | 15 | | | | | 3.7kW | | | |
| 15 | Grit Chamber facility | M1-04H | Grit pump | A | S I | | | G | N | N | | | 15 | | | | | 3.7kW | | | |
| 16 | Grit Chamber facility | M1-04I | Grit pump | A | S I | | | G | N | N | | | 15 | | | | | 3.7kW | | | |
| 17 | Grit Chamber facility | M1-05 | Grit separator | B | L I | G | | G | N | N | G | G | 15 | 1.27 | | 37 | | 0.25kW | | | |
| 18 | Grit Chamber facility | M1-06 | Grit container | C | L I | | | G | G | G | | | 15 | | | | | | | | |
| 19 | Grit Chamber facility | M1-06 | Grit container | C | L I | | | G | G | G | | | 15 | | | | | | | | |
| 20 | Grit Chamber facility | M1-07A | Fine screen | A | L I | | | G | N | N | | G | 15 | | | | | 0.75kW | | | |
| 21 | Grit Chamber facility | M1-07B | Fine screen | A | L I | | | G | N | N | | G | 15 | | | | | 0.75kW | | | |
| 22 | Grit Chamber facility | M1-07C | Fine screen | A | L I | | | G | N | N | | G | 15 | | | | | 0.75kW | | | |
| 23 | Grit Chamber facility | M1-08 | Fine screenings conveyor | B | L I | | | G | N | N | N | G | 15 | | | | | 2.2kW | Noise (worry of screw damaged) | | |
| 24 | Grit Chamber facility | M1-09 | Screenings container | C | L I | | | G | G | G | | | 15 | | | | | | | | |

Mechanical Instrument Check Sheet

Facility Name : North Thang Long WWTP

| No | Category | Tag No. | Instrument Name | C/R | P | Physical Check (P/C) | | | | | | | Useful Life (L) | | | Measurement (M) | | | | | Remark | Result | | | | | | | | | | | | | | | | | |
|---|-----------------------|---------|----------------------|---------------|-----|----------------------|-----|---------------------------|---|---|-----|-----------------|-----------------|---|---|-----------------|-------|----|---|------------------|--------|--------|---|--|--|--|--|--|--|--|--|--|--|--|--|--|--|--|--|
| | | | | | | W | O/G | S/P | D | A | V/N | M | L | C | P | T | V | C | P | T | | | V | | | | | | | | | | | | | | | | |
| Check Rank (C/R) | | | | Placement (P) | | | | Physical Check (P/C) | | | | Useful Life (L) | | | Measurement (M) | | | | | Result | | | | | | | | | | | | | | | | | | | |
| S Physical Check (all) & Measurement (all) | | | | L Landed | | | | W Work | | | | Number: Year | | | C Current(A) | | | | | G Good | | | | | | | | | | | | | | | | | | | |
| A Physical Check (all) & Measurement (C,P,T only) | | | | S Submerged | | | | O/G Oil & Grease Check | | | | | | | P Pressure(MPa)(with Press. gauge only) | | | | | N Normal | | | | | | | | | | | | | | | | | | | |
| B Physical Check (all) | | | | I Inside | | | | S/P Stain & Painting | | | | | | | T Temperature(°C) | | | | | B Bad | | | | | | | | | | | | | | | | | | | |
| C Physical Check (S/P,D,A only) | | | | O Outside | | | | D Damage | | | | | | | V Vibration (main equipment only) | | | | | X Couldn't check | | | | | | | | | | | | | | | | | | | |
| | | | | | | | | A Abrasion | | | | | | | | | | | | | | | | | | | | | | | | | | | | | | | |
| | | | | | | | | V/N Vibration & Noise | | | | | | | | | | | | | | | | | | | | | | | | | | | | | | | |
| | | | | | | | | M Motor (with motor only) | | | | | | | | | | | | | | | | | | | | | | | | | | | | | | | |
| 25 | Grit Chamber facility | M1-09 | Screenings container | C | L I | | G | G | G | G | G | | | | | | | | | | | | | | | | | | | | | | | | | | | | |
| 26 | Grit Chamber facility | M1-09 | Screenings container | C | L I | | G | G | G | G | G | | | | | | | | | | | | | | | | | | | | | | | | | | | | |
| 27 | Grit Chamber facility | M1-09 | Screenings container | C | L I | | G | G | G | G | G | | | | | | | | | | | | | | | | | | | | | | | | | | | | |
| 31 | Grit Chamber facility | M1-11 | Grit pump hoist | C | L I | | G | G | G | G | G | | | | | | | | | | | | | | | | | | | | | | | | | | | | |
| 32 | Grit Chamber facility | M1-12 | Container hoist | C | L I | | G | G | G | G | G | | | | | | | | | | | | | | | | | | | | | | | | | | | | |
| 33 | Lift pump facility | M2-01A | Lift pump (1) | S | L I | | G | N | N | N | N | | | | | | | | | | | | | | | | | | | | | | | | | | | | |
| 34 | Lift pump facility | M2-01B | Lift pump (1) | S | L I | | G | N | N | N | N | | | | | | | | | | | | | | | | | | | | | | | | | | | | |
| 35 | Lift pump facility | M2-02A | Lift pump (2) | S | L I | G | G | N | N | N | N | G | G | G | G | 53 | 0.046 | 33 | | | | | | | | | | | | | | | | | | | | | |
| 36 | Lift pump facility | M2-02B | Lift pump (2) | S | L I | | G | N | N | N | N | | | | | | | | | | | | | | | | | | | | | | | | | | | | |
| 37 | Lift pump facility | M2-03A | Discharge valve | B | L I | | G | N | N | N | N | | | | | | | | | | | | | | | | | | | | | | | | | | | | |
| 38 | Lift pump facility | M2-03B | Discharge valve | B | L I | | G | N | N | N | N | | | | | | | | | | | | | | | | | | | | | | | | | | | | |
| 39 | Lift pump facility | M2-03C | Discharge valve | B | L I | | G | N | N | N | N | | | | | | | | | | | | | | | | | | | | | | | | | | | | |

Mechanical Instrument Check Sheet

Facility Name : North Thang Long WWTP

| No | Category | Tag No. | Instrument Name | Placement (P) L Landed S Submerged I Inside O Outside | Physical Check (P/C) W Work O/G Oil & Grease Check S/P Stain & Painting D Damage A Abrasion V/N Vibration & Noise M Motor (with motor only) | Useful Life (L) Number: Year | | | Measurement (M) C Current(A) P Pressure(MPa)(with Press. gauge only) T Temperature(°C) V Vibration (main equipment only) | | | Result G Good N Normal B Bad X Couldn't check | | |
|----|--------------------------|---------|--------------------|---|--|---------------------------------|---|-----|--|----|---|---|---------------|---|
| | | | | | | L | A | V/N | M | C | P | | T | V |
| 40 | Lift pump facility | M2-03D | Discharge valve | B | L I | G | N | N | G | 15 | | | 1.5kW | |
| 41 | Lift pump facility | M2-04 | Drainage pump | A | S I | N | N | N | N | 10 | | | 2.2kW | |
| 42 | Lift pump facility | M2-05 | Lift pump hoist | C | L I | G | G | G | G | 20 | | | 2.5kW, 0.75kW | |
| 43 | Water Treatment Facility | M3-01 | PST Inflow gate | B | L O | G | G | N | N | 15 | | | | |
| 44 | Water Treatment Facility | M3-01 | PST Inflow gate | B | L O | G | G | N | N | 15 | | | | |
| 45 | Water Treatment Facility | M3-01 | PST Inflow gate | B | L O | G | G | N | N | 15 | | | | |
| 46 | Water Treatment Facility | M3-01 | PST Inflow gate | B | L O | G | G | N | N | 15 | | | | |
| 47 | Water Treatment Facility | M3-01 | PST Inflow gate | B | L O | G | G | N | N | 15 | | | | |
| 48 | Water Treatment Facility | M3-01 | PST Inflow gate | B | L O | G | G | N | N | 15 | | | | |
| 49 | Water Treatment Facility | M3-02 | PST sludge scraper | A | L O | | N | N | N | 15 | | | 0.25kW | |
| 50 | Water Treatment Facility | M3-02 | PST sludge scraper | A | L O | | N | N | N | 15 | | | 0.25kW | |
| 51 | Water Treatment Facility | M3-02 | PST sludge scraper | A | L O | | N | N | N | 15 | | | 0.25kW | |

Mechanical Instrument Check Sheet

Facility Name : North Thang Long WWTP

| No | Category | Tag No. | Instrument Name | Placement (P) | | Physical Check (P/C) | | | | | | | | | | Useful Life (L) | | | Measurement (M) | | | | Result | | | | |
|----|--------------------------|---------|-----------------|---------------|----|----------------------|-----|-----|---|---|-----|---|---|---|---|-----------------|---|---|-----------------|---|----|--|--------|---|------|---------------------------------------|---|
| | | | | L | S | W | O/G | S/P | D | A | V/N | M | L | C | P | T | V | C | P | T | V | | | | | | |
| 88 | Water Treatment Facility | M3-09A | Surface aerator | S | LO | G | | N | N | N | N | N | N | N | N | N | N | N | N | N | 57 | | 47 | ○ | 37kW | Vibration checking: refer other sheet | N |
| 89 | Water Treatment Facility | M3-09G | Surface aerator | S | LO | G | | N | N | N | N | N | N | N | N | N | N | N | N | N | 55 | | 49 | ○ | 37kW | Vibration checking: refer other sheet | N |
| 90 | Water Treatment Facility | M3-09B | Surface aerator | S | LO | | | N | N | N | N | N | N | N | N | N | N | N | N | N | | | | | 37kW | | X |
| 91 | Water Treatment Facility | M3-09H | Surface aerator | S | LO | | | N | N | N | N | N | N | N | N | N | N | N | N | N | | | | | 37kW | | X |
| 92 | Water Treatment Facility | M3-09C | Surface aerator | S | LO | | | N | N | N | N | N | N | N | N | N | N | N | N | N | | | | | 37kW | | X |
| 93 | Water Treatment Facility | M3-09 I | Surface aerator | S | LO | | | N | N | N | N | N | N | N | N | N | N | N | N | N | | | | | 37kW | | X |
| 94 | Water Treatment Facility | M3-09D | Surface aerator | S | LO | | | N | N | N | N | N | N | N | N | N | N | N | N | N | | | | | 37kW | | X |
| 95 | Water Treatment Facility | M3-09J | Surface aerator | S | LO | | | N | N | N | N | N | N | N | N | N | N | N | N | N | | | | | 37kW | | X |
| 96 | Water Treatment Facility | M3-09E | Surface aerator | S | LO | | | N | N | N | N | N | N | N | N | N | N | N | N | N | | | | | 37kW | | X |
| 97 | Water Treatment Facility | M3-09K | Surface aerator | S | LO | | | N | N | N | N | N | N | N | N | N | N | N | N | N | | | | | 37kW | | X |
| 98 | Water Treatment Facility | M3-09F | Surface aerator | S | LO | | | N | N | N | N | N | N | N | N | N | N | N | N | N | | | | | 37kW | | X |
| 99 | Water Treatment Facility | M3-09L | Surface aerator | S | LO | | | N | N | N | N | N | N | N | N | N | N | N | N | N | | | | | 37kW | | X |

Mechanical Instrument Check Sheet

Facility Name : North Thang Long WWTP

| No | Category | Tag No. | Instrument Name | Placement (P) | | Physical Check (P/C) | | | | | | | | | | Useful Life (L) | | | | Measurement (M) | | | | Remark | Result | | | |
|-----|--------------------------|---------|--------------------|---------------|-------------|----------------------|-----------|--------|-----|-----|---|---|-----|---|---|-----------------|---|---|---|-----------------|---|------|-----|--------|--------------------------------------|-----------------------------|---|---|
| | | | | L Landed | S Submerged | I Inside | O Outside | W Work | O/G | S/P | D | A | V/N | M | L | C | P | T | V | C | P | T | V | | | | | |
| 112 | Water Treatment Facility | M3-13C | FST sludge scraper | A | LO | G | B | N | N | N | N | N | N | N | N | N | N | N | N | N | N | N | 0.4 | 47 | 0.25kW | Gear box grease trickle out | N | |
| 113 | Water Treatment Facility | M3-13D | FST sludge scraper | A | LO | | | | | | | | | | | | | | | | | | | 0.25kW | | | N | |
| 114 | Water Treatment Facility | M3-13E | FST sludge scraper | A | LO | | | | | | | | | | | | | | | | | | | 0.25kW | | | N | |
| 115 | Water Treatment Facility | M3-13F | FST sludge scraper | A | LO | | | | | | | | | | | | | | | | | | | 0.25kW | | | N | |
| 116 | Water Treatment Facility | A | FST scum skimmer | B | LO | | | | | | | | | | | | | | | | | | | 0.12kW | | | N | |
| 117 | Water Treatment Facility | B | FST scum skimmer | B | LO | N | N | N | N | N | N | N | N | N | N | N | N | N | N | N | N | 0.27 | 43 | 0.12kW | | | N | |
| 118 | Water Treatment Facility | C | FST scum skimmer | B | LO | N | N | N | N | N | N | N | N | N | N | N | N | N | N | N | N | 0.27 | 45 | 0.12kW | Gear box grease trickle out | | | N |
| 119 | Water Treatment Facility | D | FST scum skimmer | B | LO | | | | | | | | | | | | | | | | | | | 0.12kW | | | N | |
| 120 | Water Treatment Facility | E | FST scum skimmer | B | LO | | | | | | | | | | | | | | | | | | | 0.12kW | | | N | |
| 121 | Water Treatment Facility | F | FST scum skimmer | B | LO | | | | | | | | | | | | | | | | | | | 0.12kW | | | N | |
| 122 | Water Treatment Facility | M3-14A | RAS pump | A | L I | | | | | | | | | | | | | | | | | | | 18.5kW | | | X | |
| 123 | Water Treatment Facility | M3-14B | RAS pump | A | L I | G | N | N | N | N | N | N | N | N | N | N | N | N | N | N | N | 25 | 40 | 18.5kW | adjusting gland packing is necessary | | | X |

Mechanical Instrument Check Sheet

Facility Name : North Thang Long WWTP

| No | Category | Tag No. | Instrument Name | Placement (P) L Landed S Submerged I Inside O Outside | Physical Check (P/C) W Work O/G Oil & Grease Check S/P Stain & Painting D Damage A Abrasion V/N Vibration & Noise M Motor (with motor only) | Useful Life (L) Number: Year | | | Measurement (M) | | | | | Remark | Result G Good N Normal B Bad X Couldn't check | | | | | | |
|-----|---------------------------|---------|---|---|--|---------------------------------|---|---|-----------------|-----|---|---|-----|--------|---|---|---|---------|-------|---|---|
| | | | | | | C/R | P | W | O/G | S/P | D | A | V/N | | | M | M | | | | |
| | | | | | | | | | | | | | | | | | L | C | P | T | V |
| 155 | Water supply facility | M5-06A | Air compressor for sand filter | S | O/G | B | L | I | G | N | N | G | 15 | | | | | | 7.5kW | | |
| 156 | Water supply facility | M5-06B | Air compressor for sand filter | S | O/G | B | L | I | G | N | N | G | 15 | | | | | | 7.5kW | | |
| 157 | Water supply facility | M5-08 | water supply unit for wastewater treatment facility | S | O/G | B | L | I | G | N | N | G | 15 | | | | | | | | |
| 158 | Water supply facility | M5-09 | water supply unit for wastewater treatment facility | S | O/G | B | L | I | G | N | N | G | 15 | | | | | | | | |
| 159 | Water supply facility | M5-10A | Belt washing pump | S | O/G | B | L | I | G | N | N | G | 15 | | | | | | 3kW | | |
| 160 | Water supply facility | M5-10B | Belt washing pump | S | O/G | B | L | I | G | N | N | G | 15 | | | | | | 3kW | | |
| 161 | Water supply facility | M5-11 | Sand filter supply pump from deep well | S | O/G | B | L | O | N | N | N | | 15 | | | | | 5.5kW | | | |
| 162 | Water supply facility | M5-12 | Sand filter for domestic water | S | O/G | B | L | I | N | N | N | | 15 | | | | | leakage | | | |
| 163 | Water supply facility | M5-13A | Water supply unit for domestic use | S | O/G | B | L | I | G | N | N | G | 15 | | | | | 0.75kW | | | |
| 164 | Water supply facility | M5-14A | Drainage pump | S | O/G | A | S | I | G | N | N | G | 10 | | | | | 2.2kW | | | |
| 165 | Water supply facility | M5-14B | Drainage pump | S | O/G | A | S | I | G | N | N | G | 10 | | | | | 2.2kW | | | |
| 166 | Sludge treatment facility | M6-01 | Mixed sludge mixer | S | O/G | A | S | I | | | | | 10 | | | | | 5.0kW | | | |

Mechanical Instrument Check Sheet

Facility Name : North Thang Long WWTP

| No | Category | Tag No. | Instrument Name | C/R | P | Physical Check (P/C) | | | | | | | | | | Useful Life (L) Number: Year | Measurement (M) | | | | | Result | | | | | | | |
|-----|---------------------------|---------|-----------------------------------|---------------|-----|----------------------|-----|-----|---|---|-----|---|---|---|---|---------------------------------|-----------------|-----------------|---|---|---|--------|--------|---|-------|--------------|-------|--|---|
| | | | | | | W | O/G | S/P | D | A | V/N | M | C | P | T | | V | C | P | T | V | | | | | | | | |
| | | | | Placement (P) | | Physical Check (P/C) | | | | | | | | | | Useful Life (L) | | Measurement (M) | | | | | Result | | | | | | |
| | | | | L | S | W | O/G | S/P | D | A | V/N | M | C | P | T | V | C | P | T | V | G | N | B | X | | | | | |
| 191 | Sludge treatment facility | M6-15B | Drainage pump | A | S I | | | N | N | N | N | | | | | | | | | | | | | | 2.2kW | G | | | |
| 192 | Sludge treatment facility | M6-16A | Sludge dewateret hoist | C | L I | | | G | G | G | G | | | | | | | | | | | | | | | 2.5kW, 0.4kW | N | | |
| 193 | Sludge treatment facility | M6-16B | Sludge dewateret hoist | C | L I | | | G | G | G | G | | | | | | | | | | | | | | | 2.5kW, 0.4kW | N | | |
| 194 | Sludge treatment facility | M6-17 | Maintenance hoist | C | L I | | | G | G | G | G | | | | | | | | | | | | | | | | | | |
| 195 | Sludge treatment facility | M6-18 | FeCl3 storage tank for well water | B | L I | | | N | N | N | N | | | | | | | | | | | | | | | | | | |
| 197 | Sludge treatment facility | M7-02A | Drainage pump | A | S I | | | N | N | N | N | | | | | | | | | | | | | | | | 2.2kW | G | |
| 198 | Sludge treatment facility | M7-02B | Drainage pump | A | S I | | | | | | | | | | | | | | | | | | | | | | 2.2kW | G | |
| 199 | Sludge treatment facility | M7-03 | Maintenance hoist | C | L I | | | | | | | | | | | | | | | | | | | | | | | checking impossible (sludge cake spread) | |
| 201 | Deodorization facility | M8-01 | NaClO storage tank | B | L I | | | G | N | N | N | | | | | | | | | | | | | | | | | | |
| 202 | Deodorization facility | M8-02A | NaClO dosing pump | B | L I | | | G | N | N | N | | | | | | | | | | | | | | | | | 0.022kW | G |
| 203 | Deodorization facility | M8-02B | NaClO dosing pump | B | L I | | | G | N | N | N | | | | | | | | | | | | | | | | | 0.022kW | G |
| 204 | Deodorization facility | M8-03 | NaOH storage tank | B | L I | | | G | N | N | N | | | | | | | | | | | | | | | | | leakage | X |

Mechanical Instrument Check Sheet

Facility Name : North Thang Long WWTP

| Check Rank (C/R) | | Category | Tag No. | Instrument Name | Placement (P) | Physical Check (P/C) | | | | | | | | | | Useful Life (L) Number: Year | Measurement (M) | | | | Result | | | |
|---|-------------------------|-------------|---------------------|-----------------|---------------|-------------------------|---|----------|-----|------------|---|-----------------------|-----|---------------------------|-----|---------------------------------|-----------------|---|---|-------------------|--------|-----------------------------------|---|--------|
| S | A | | | | | B | C | W | O/G | S/P | D | A | V/N | M | L | | C | P | T | V | | C | P | T |
| S Physical Check (all) & Measurement (all) | | L Landed | | W Work | | O/G Oil & Grease Check | | D Damage | | A Abrasion | | V/N Vibration & Noise | | M Motor (with motor only) | | C Current(A) | | P Pressure(MPa)(with Press. gauge only) | | T Temperature(°C) | | V Vibration (main equipment only) | | G Good |
| A Physical Check (all) & Measurement (C,P,T only) | | S Submerged | | I Inside | | O Outside | | C/R | | P | | L | | C | | P | | T | | V | | N Normal | | |
| B Physical Check (all) | | O Outside | | M | | Motor (with motor only) | | B | | L | | I | | 15 | | 0.017kW | | | | | | B Bad | | |
| C Physical Check (S/P,D,A only) | | | | | | | | | | | | | | | | | | | | | | X Couldn't check | | |
| 205 | Deodorization facility | M8-04A | NaOH dosing pump | B | L | I | G | N | N | N | N | N | N | 15 | | | | | | | | 0.017kW | | |
| 206 | Deodorization facility | M8-04B | NaOH dosing pump | B | L | I | G | N | N | N | N | N | N | 15 | | | | | | | | 0.017kW | | |
| 207 | Deodorization facility | M8-05A | Circulating pump | B | L | O | N | N | N | N | N | N | N | 15 | | | | | | | | 1.5kW | | |
| 208 | Deodorization facility | M8-05B | Circulating pump | B | L | O | N | N | N | N | N | N | N | 15 | | | | | | | | 1.5kW | | |
| 209 | Deodorization facility | M8-06 | Mist separator | C | L | O | G | N | N | N | N | N | N | | | | | | | | | | | |
| 210 | Deodorization facility | M8-07 | Deodorization fan | A | L | O | G | N | N | N | N | G | N | 10 | 4.7 | | | | | | | 4kW | | |
| 211 | Deodorization facility | M8-08 | Chemical scrubber | C | L | O | G | N | N | N | N | N | N | 10 | | | | | | | | | | |
| 212 | Generator Room facility | M9-01 | Oil supply pump | A | L | I | G | N | N | N | N | N | N | 15 | | | | | | | | 3.7kW | | |
| 213 | Generator Room facility | M9-02 | Service tank | B | L | I | G | N | N | N | N | G | G | 15 | | | | | | | | | | |
| 214 | Generator Room facility | M9-03 | Emergency Generator | B | L | I | G | N | N | N | N | N | N | 15 | | | | | | | | | | |

Electric/Control Instrument Check Sheet Facility Name : North Thang Long WWTP

| No | Category | Tag No. | Instrument Name | C/R | P | P/C | | | | | | | Useful Life (L) Number: Year | Measurement (M) | | | Remark | Result |
|----|---------------------|---------|--|-----|---|-----|-----|---|---|-----|---|---|---------------------------------|-----------------|------|--|--------|--------|
| | | | | | | S/P | D | T | C | F | I | L | | V | T | L | | |
| 1 | Electric instrument | SVP | Supervisory Panel | S | I | N | N | G | G | N/B | G | | 238 | 30.2 | 54.7 | No fan cover | G | |
| 2 | Electric instrument | LVIP | Low Voltage Incoming Panel | S | I | N | N | G | N | N | G | | X | 29.7 | 60 | Leakage relay is making | N | |
| 3 | Electric instrument | CSP | Changeover Switch Panel | S | I | N | N | N | N | N | N | | X | 30.2 | 770 | | B | |
| 4 | Electric instrument | LVDP | Low Voltage Distribution Panel | S | I | N | N | N | N | N | N | | X | 29.7 | 600 | | X | |
| 5 | Electric instrument | GP | | S | X | X | X | X | X | X | X | | | | | | | |
| 6 | Electric instrument | DB-BP4 | | A | X | X | X | X | X | X | X | | | | | | | |
| 7 | Electric instrument | DB-BP5 | | A | X | X | X | X | X | X | X | | | | | | | |
| 8 | Electric instrument | PSSP | Primary Sludge Scraper Panel | A | O | N/B | N/B | X | X | X | X | | | | | Panel inside is rust, Door is keeping on opening in rainingfalling | N | |
| 9 | Electric instrument | AFSSP | Anaerobic & Final Sludge Scraper Panel | A | O | B | B | X | X | X | X | | | | | inside of the panel is rust | B | |
| 10 | Electric instrument | SAP-1 | Surface Airation Panel-1 | A | O | N/B | N | N | N | N | N | | | | | head of the panel is rust | X | |
| 11 | Electric instrument | SAP-2 | Surface Airation Panel-2 | A | O | N | N | N | N | N | N | | | | | | | |

Electric/Control Instrument Check Sheet Facility Name : North Thang Long WWTP

| No | Category | Tag No. | Instrument Name | C/R | P | Physical Check (P/C) | | | | | | | | Useful Life (L) Number: Year | Measurement (M) | | | Result |
|--------------------------------|--------------------|---------|--------------------------------------|---------------|---|----------------------|---|-----------------|---|-----------------|---------------------------------------|---|--------|---------------------------------|-----------------|---|--|--------|
| | | | | | | S/P | D | T | C | F | I | L | V | | T | L | Voltage (V) (main breaker only) | |
| Check Rank (C/R) | | | | Placement (P) | | Physical Check (P/C) | | Useful Life (L) | | Measurement (M) | | | Result | | | | | |
| S Physical Check & Measurement | | | | I Inside | | S/P Stain & Painting | | Number: Year | | | Voltage (V) (main breaker only) | | | G Good | | | | |
| A Physical Check | | | | O Outside | | D Damage | | | | | Temperature(°C) (main breaker only) | | | N Normal | | | | |
| X Taking photo only | | | | | | T Terminal | | | | | Leak Current (mA) (main breaker only) | | | B Bad | | | | |
| | | | | | | C Cable | | | | | | | | X Couldn't check | | | | |
| | | | | | | F Filter | | | | | | | | | | | | |
| | | | | | | I Indicate | | | | | | | | | | | | |
| 48 | Control Instrument | LCA18 | Chemical Scrubber Level | A | O | X | X | X | X | | | | | | | | Impossible maintenance (a lot of pipes around) | |
| 49 | Control Instrument | DOI-1 | Reactor DO | A | O | N | N | X | N | | | | | | | | Hard to maintain (not enough space) | |
| 50 | Control Instrument | DOI-2 | Reactor DO | A | O | N | N | X | N | | | | | | | | Hard to maintain (not enough space) | |
| 51 | Control Instrument | FIQ1 | Pump Well Flow (magnetic flow meter) | A | I | N | N | X | X | | | | | | | | | |
| 52 | Control Instrument | FIQ2-1 | FST RAS Flow (magnetic) | A | I | N | N | X | X | | | | | | | | | |
| 53 | Control Instrument | FIQ2-2 | FST RAS Flow (magnetic) | A | I | N | N | X | X | | | | | | | | | |
| 54 | Control Instrument | FIQ3 | PST Sludge Flow (magnetic) | A | I | N | N | X | X | | | | | | | | | |
| 55 | Control Instrument | FIQ4 | FST WAS Flow (magnetic) | A | I | N | N | X | X | | | | | | | | Hard to maintain (lack of maintenance stage) | |
| 56 | Control Instrument | FIQ5 | Effluent Flow (堰式) | A | O | N/B | N | X | X | | | | | | | | No Tag plate | |
| 57 | Control Instrument | pHI-1 | NaOH Storage Tank pH | A | | | | | | | | | | | | | | |
| 58 | Control Instrument | RS-1 | No.1 Lifting Pump Rotation Speed | A | X | X | X | X | X | | | | | | | | Door locked | |
| 59 | Control Instrument | RS-2 | No.2 Lifting Pump Rotation Speed | A | X | X | X | X | X | | | | | | | | Door locked | |

Phụ lục 2 Kết quả đo độ dao động/rung

- 1) Kết quả đo độ rung của thiết bị sục khí (KBW1A) tại trạm xử lý nước thải Kim Liên
- 2) Kết quả đo độ rung của thiết bị sục khí (KBW1B) tại trạm xử lý nước thải Kim Liên
- 3) Kết quả đo độ rung của thiết bị sục khí (KBW1C) tại trạm xử lý nước thải Kim Liên
- 4) Kết quả đo độ rung của thiết bị sục khí (TBW1A) tại trạm xử lý nước thải Trúc Bạch
- 5) Kết quả đo độ rung của thiết bị sục khí (TBW1B) tại trạm xử lý nước thải Trúc Bạch
- 6) Kết quả đo độ rung của thiết bị sục khí (TBW1C) tại trạm xử lý nước thải Trúc Bạch
- 7) Kết quả đo độ rung của đường dẫn máy trộn khí (M3-9A) trạm xử lý nước thải Bắc Thăng Long
- 8) Kết quả đo độ rung của đường dẫn máy trộn khí (M3-10A) trạm xử lý nước thải Bắc Thăng Long
- 9) Kết quả đo độ rung của đường dẫn máy trộn khí (M3-11A) trạm xử lý nước thải Bắc Thăng Long

drawing date: 29 May 2010

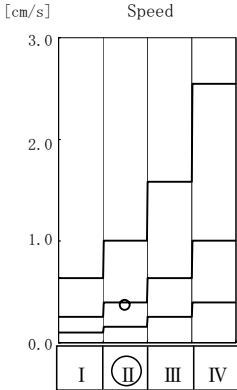
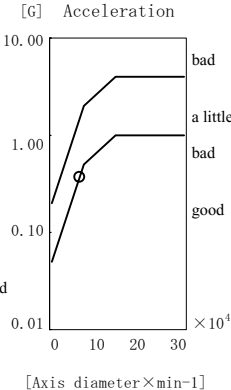
| Simple diagnosis report | | | | | | | | | drawing | | | | | | | | | | | | | | | | | | | | | | | | | | | | | | | | | | | | | | |
|---|----------------------------|--------------------------|------------------------|---------------|-------------|------------------|-----|---------------|---------|--------------|----------|------------|--------|----------------|-----|------|------|-------|------|----------|--------|------|------|-------|-------------|--|-----|------|-------|-------|------|-----|--------|------|------|-------|------|------|------|----|-----|------|------|---|--|--|--|
| equipment name | Kim Lien WWTP | | | | | | | | | | | | | | | | | | | | | | | | | | | | | | | | | | | | | | | | | | | | | | |
| machine name | KBW1A Aeration Blower | | | | | | | | | | | | | | | | | | | | | | | | | | | | | | | | | | | | | | | | | | | | | | |
| measurement part | Motor (Opposite Load Side) | | | | | | | | | | | | | | | | | | | | | | | | | | | | | | | | | | | | | | | | | | | | | | |
| ID code | 111 | Direction of measurement | Vertical | Group No. | 111 | | | | | | | | | | | | | | | | | | | | | | | | | | | | | | | | | | | | | | | | | | |
| Output | 30.0 kW | Rotational speed | 1477 min ⁻¹ | Axis diameter | 50 mm | | | | | | | | | | | | | | | | | | | | | | | | | | | | | | | | | | | | | | | | | | |
| <p>【 Relative value Judgment 】 recorded time: 13 May 2010 12:28</p> <table border="1" style="width:100%; border-collapse: collapse;"> <thead> <tr> <th rowspan="2">Measurement Mode</th> <th rowspan="2">[G]</th> <th colspan="2">Warning Level</th> <th rowspan="2">Measurements</th> <th rowspan="2">Judgment</th> </tr> <tr> <th>Attention</th> <th>Danger</th> </tr> </thead> <tbody> <tr> <td>ACC (THRU, OA)</td> <td>[G]</td> <td>1.00</td> <td>4.00</td> <td>0.731</td> <td>Good</td> </tr> <tr> <td>ACC (OA)</td> <td>[G]</td> <td>1.00</td> <td>4.00</td> <td>0.372</td> <td>Good</td> </tr> <tr> <td>ACC (PEAK)</td> <td>[G]</td> <td>3.00</td> <td>12.00</td> <td>0.986</td> <td>Good</td> </tr> <tr> <td>VEL</td> <td>[cm/s]</td> <td>0.40</td> <td>1.00</td> <td>0.372</td> <td>Good</td> </tr> <tr> <td>DISP</td> <td>[μm]</td> <td>30</td> <td>100</td> <td>20.1</td> <td>Good</td> </tr> </tbody> </table> <p style="text-align: center;">(1G=9.8m/s²)</p> | | | | | | Measurement Mode | [G] | Warning Level | | Measurements | Judgment | Attention | Danger | ACC (THRU, OA) | [G] | 1.00 | 4.00 | 0.731 | Good | ACC (OA) | [G] | 1.00 | 4.00 | 0.372 | Good | ACC (PEAK) | [G] | 3.00 | 12.00 | 0.986 | Good | VEL | [cm/s] | 0.40 | 1.00 | 0.372 | Good | DISP | [μm] | 30 | 100 | 20.1 | Good |  | | | |
| Measurement Mode | [G] | Warning Level | | Measurements | Judgment | | | | | | | | | | | | | | | | | | | | | | | | | | | | | | | | | | | | | | | | | | |
| | | Attention | Danger | | | | | | | | | | | | | | | | | | | | | | | | | | | | | | | | | | | | | | | | | | | | |
| ACC (THRU, OA) | [G] | 1.00 | 4.00 | 0.731 | Good | | | | | | | | | | | | | | | | | | | | | | | | | | | | | | | | | | | | | | | | | | |
| ACC (OA) | [G] | 1.00 | 4.00 | 0.372 | Good | | | | | | | | | | | | | | | | | | | | | | | | | | | | | | | | | | | | | | | | | | |
| ACC (PEAK) | [G] | 3.00 | 12.00 | 0.986 | Good | | | | | | | | | | | | | | | | | | | | | | | | | | | | | | | | | | | | | | | | | | |
| VEL | [cm/s] | 0.40 | 1.00 | 0.372 | Good | | | | | | | | | | | | | | | | | | | | | | | | | | | | | | | | | | | | | | | | | | |
| DISP | [μm] | 30 | 100 | 20.1 | Good | | | | | | | | | | | | | | | | | | | | | | | | | | | | | | | | | | | | | | | | | | |
| <p>【 Absolute value Judgment 】 recorded time: 13 May 2010 12:28</p> <table border="1" style="width:100%; border-collapse: collapse;"> <thead> <tr> <th rowspan="2">Measurement Mode</th> <th rowspan="2">[G]</th> <th colspan="2">Warning Level</th> <th rowspan="2">Measurements</th> <th rowspan="2">Judgment</th> </tr> <tr> <th>little bad</th> <th>Bad</th> </tr> </thead> <tbody> <tr> <td>ACC (OA)</td> <td>[G]</td> <td>0.41</td> <td>1.64</td> <td>0.372</td> <td>Good</td> </tr> <tr> <td>VEL</td> <td>[cm/s]</td> <td>0.40</td> <td>1.00</td> <td>0.372</td> <td>little good</td> </tr> </tbody> </table> <p style="text-align: center;">(1G=9.8m/s²)</p> | | | | | | Measurement Mode | [G] | Warning Level | | Measurements | Judgment | little bad | Bad | ACC (OA) | [G] | 0.41 | 1.64 | 0.372 | Good | VEL | [cm/s] | 0.40 | 1.00 | 0.372 | little good | <p>【 Absolute value Judgment 】 (1G=9.8m/s²)</p> <div style="display: flex; justify-content: space-around;"> <div style="text-align: center;"> <p>[cm/s] Speed</p>  </div> <div style="text-align: center;"> <p>[G] Acceleration</p>  </div> </div> <p style="text-align: center;">[Axis diameter × min⁻¹]</p> | | | | | | | | | | | | | | | | | | | | | |
| Measurement Mode | [G] | Warning Level | | Measurements | Judgment | | | | | | | | | | | | | | | | | | | | | | | | | | | | | | | | | | | | | | | | | | |
| | | little bad | Bad | | | | | | | | | | | | | | | | | | | | | | | | | | | | | | | | | | | | | | | | | | | | |
| ACC (OA) | [G] | 0.41 | 1.64 | 0.372 | Good | | | | | | | | | | | | | | | | | | | | | | | | | | | | | | | | | | | | | | | | | | |
| VEL | [cm/s] | 0.40 | 1.00 | 0.372 | little good | | | | | | | | | | | | | | | | | | | | | | | | | | | | | | | | | | | | | | | | | | |
| 【Comment】 | | | | | | | | | | | | | | | | | | | | | | | | | | | | | | | | | | | | | | | | | | | | | | | |

drawing date: 29 May 2010

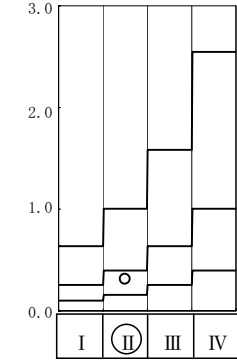
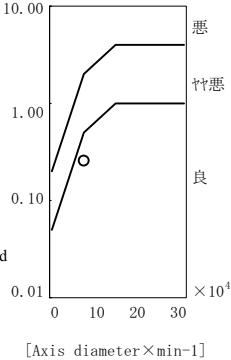
| Simple diagnosis report | | | | | | | | | drawing | | | | | | | | | | | | | | | | | | | | | | | | | | | | | | | | | | | | | | |
|--|-----------------------|--------------------------|------------------------|---------------|-------------|------------------|-----|---------------|---------|--------------|----------|------------|--------|----------------|-----|------|------|-------|------|----------|--------|------|------|-------|-------------|--|-----|------|-------|-------|------|-----|--------|------|------|-------|------|------|------|----|-----|------|-----------|---|--|--|--|
| equipment name | Kim Lien WWTP | | | | | | | | | | | | | | | | | | | | | | | | | | | | | | | | | | | | | | | | | | | | | | |
| machine name | KBW1A Aeration Blower | | | | | | | | | | | | | | | | | | | | | | | | | | | | | | | | | | | | | | | | | | | | | | |
| measurement part | Motor (Load Side) | | | | | | | | | | | | | | | | | | | | | | | | | | | | | | | | | | | | | | | | | | | | | | |
| ID code | 112 | Direction of measurement | Vertical | Group No. | 112 | | | | | | | | | | | | | | | | | | | | | | | | | | | | | | | | | | | | | | | | | | |
| Output | 30.0 kW | Rotational speed | 1477 min ⁻¹ | Axis diameter | 60 mm | | | | | | | | | | | | | | | | | | | | | | | | | | | | | | | | | | | | | | | | | | |
| <p>【 Relative value Judgment 】 recorded time: 13 May 2010 12:29</p> <table border="1" style="width:100%; border-collapse: collapse;"> <thead> <tr> <th rowspan="2">Measurement Mode</th> <th rowspan="2">[G]</th> <th colspan="2">Warning Level</th> <th rowspan="2">Measurements</th> <th rowspan="2">Judgment</th> </tr> <tr> <th>Attention</th> <th>Danger</th> </tr> </thead> <tbody> <tr> <td>ACC (THRU, OA)</td> <td>[G]</td> <td>1.00</td> <td>4.00</td> <td>0.523</td> <td>Good</td> </tr> <tr> <td>ACC (OA)</td> <td>[G]</td> <td>1.00</td> <td>4.00</td> <td>0.256</td> <td>Good</td> </tr> <tr> <td>ACC (PEAK)</td> <td>[G]</td> <td>3.00</td> <td>12.00</td> <td>0.709</td> <td>Good</td> </tr> <tr> <td>VEL</td> <td>[cm/s]</td> <td>0.40</td> <td>1.00</td> <td>0.314</td> <td>Good</td> </tr> <tr> <td>DISP</td> <td>[μm]</td> <td>30</td> <td>100</td> <td>31.3</td> <td>Attention</td> </tr> </tbody> </table> <p style="text-align: center;">(1G=9.8m/s²)</p> | | | | | | Measurement Mode | [G] | Warning Level | | Measurements | Judgment | Attention | Danger | ACC (THRU, OA) | [G] | 1.00 | 4.00 | 0.523 | Good | ACC (OA) | [G] | 1.00 | 4.00 | 0.256 | Good | ACC (PEAK) | [G] | 3.00 | 12.00 | 0.709 | Good | VEL | [cm/s] | 0.40 | 1.00 | 0.314 | Good | DISP | [μm] | 30 | 100 | 31.3 | Attention |  | | | |
| Measurement Mode | [G] | Warning Level | | Measurements | Judgment | | | | | | | | | | | | | | | | | | | | | | | | | | | | | | | | | | | | | | | | | | |
| | | Attention | Danger | | | | | | | | | | | | | | | | | | | | | | | | | | | | | | | | | | | | | | | | | | | | |
| ACC (THRU, OA) | [G] | 1.00 | 4.00 | 0.523 | Good | | | | | | | | | | | | | | | | | | | | | | | | | | | | | | | | | | | | | | | | | | |
| ACC (OA) | [G] | 1.00 | 4.00 | 0.256 | Good | | | | | | | | | | | | | | | | | | | | | | | | | | | | | | | | | | | | | | | | | | |
| ACC (PEAK) | [G] | 3.00 | 12.00 | 0.709 | Good | | | | | | | | | | | | | | | | | | | | | | | | | | | | | | | | | | | | | | | | | | |
| VEL | [cm/s] | 0.40 | 1.00 | 0.314 | Good | | | | | | | | | | | | | | | | | | | | | | | | | | | | | | | | | | | | | | | | | | |
| DISP | [μm] | 30 | 100 | 31.3 | Attention | | | | | | | | | | | | | | | | | | | | | | | | | | | | | | | | | | | | | | | | | | |
| <p>【 Absolute value Judgment 】 recorded time: 13 May 2010 12:29</p> <table border="1" style="width:100%; border-collapse: collapse;"> <thead> <tr> <th rowspan="2">Measurement Mode</th> <th rowspan="2">[G]</th> <th colspan="2">Warning Level</th> <th rowspan="2">Measurements</th> <th rowspan="2">Judgment</th> </tr> <tr> <th>little bad</th> <th>Bad</th> </tr> </thead> <tbody> <tr> <td>ACC (OA)</td> <td>[G]</td> <td>0.54</td> <td>2.16</td> <td>0.256</td> <td>Good</td> </tr> <tr> <td>VEL</td> <td>[cm/s]</td> <td>0.40</td> <td>1.00</td> <td>0.314</td> <td>little good</td> </tr> </tbody> </table> <p style="text-align: center;">(1G=9.8m/s²)</p> | | | | | | Measurement Mode | [G] | Warning Level | | Measurements | Judgment | little bad | Bad | ACC (OA) | [G] | 0.54 | 2.16 | 0.256 | Good | VEL | [cm/s] | 0.40 | 1.00 | 0.314 | little good | <p>【 Absolute value Judgment 】 (1G=9.8m/s²)</p> <div style="display: flex; justify-content: space-around;"> <div style="text-align: center;"> <p>[cm/s] Speed</p>  </div> <div style="text-align: center;"> <p>[G] Acceleration</p>  </div> </div> <p style="text-align: center;">[Axis diameter × min⁻¹]</p> | | | | | | | | | | | | | | | | | | | | | |
| Measurement Mode | [G] | Warning Level | | Measurements | Judgment | | | | | | | | | | | | | | | | | | | | | | | | | | | | | | | | | | | | | | | | | | |
| | | little bad | Bad | | | | | | | | | | | | | | | | | | | | | | | | | | | | | | | | | | | | | | | | | | | | |
| ACC (OA) | [G] | 0.54 | 2.16 | 0.256 | Good | | | | | | | | | | | | | | | | | | | | | | | | | | | | | | | | | | | | | | | | | | |
| VEL | [cm/s] | 0.40 | 1.00 | 0.314 | little good | | | | | | | | | | | | | | | | | | | | | | | | | | | | | | | | | | | | | | | | | | |
| 【Comment】 | | | | | | | | | | | | | | | | | | | | | | | | | | | | | | | | | | | | | | | | | | | | | | | |

| Simple diagnosis report | | | | | | | | | drawing |
|--|---------------------------|--------------------------|------------------------|---------------|------------|---|--------------|--|---------|
| equipment name | Kim Lien WWTP | | | | | | | | |
| machine name | KBW1A Aeration Blower | | | | | | | | |
| measurement part | Blower Inside (Load Side) | | | | | | | | |
| ID code | 113 | Direction of measurement | Vertical | Group No. | 113 | | | | |
| Output | 30.0 kW | Rotational speed | 1244 min ⁻¹ | Axis diameter | 50 mm | | | | |
| 【 Relative value Judgment 】 recorded time: 13 May 2010 12:30 | | | | | |  | | | |
| Measurement Mode | | Warning Level | | Measurements | Judgment | | | | |
| | | Attention | Danger | | | | | | |
| ACC (THRU, OA) | [G] | 1.00 | 4.00 | 1.910 | Attention | | | | |
| ACC (OA) | [G] | 1.00 | 4.00 | 1.065 | Attention | | | | |
| ACC (PEAK) | [G] | 3.00 | 12.00 | 3.596 | Attention | | | | |
| VEL | [cm/s] | 0.40 | 1.00 | 0.684 | Attention | | | | |
| DISP | [μm] | 30 | 100 | 72.2 | Attention | | | | |
| (1G=9.8m/s ²) | | | | | | 【 Absolute value Judgment 】 (1G=9.8m/s ²) | | | |
| Measurement Mode | | Warning Level | | Measurements | Judgment | | | | |
| | | little bad | Bad | | | | | | |
| ACC (OA) | [G] | 0.28 | 1.12 | 1.065 | little bad | | | | |
| VEL | [cm/s] | 0.40 | 1.00 | 0.684 | little bad | | | | |
| (1G=9.8m/s ²) | | | | | | 【 Absolute value Judgment 】 (1G=9.8m/s ²) | | | |
| | | | | | | Speed | Acceleration | | |
| | | | | | | [cm/s] | [G] | | |
| | | | | | | 3.0 | 10.00 | | |
| | | | | | | 2.0 | 1.00 | | |
| | | | | | | 1.0 | 0.10 | | |
| | | | | | | 0.0 | 0.01 | | |
| | | | | | | I | II III IV | | |
| | | | | | | [Axis diameter×min ⁻¹] | | | |
| 【Comment】 | | | | | | | | | |

| Simple diagnosis report | | | | | | | | | drawing |
|--|------------------------------------|--------------------------|------------------------|---------------|------------|---|--------------|--|---------|
| equipment name | Kim Lien WWTP | | | | | | | | |
| machine name | KBW1A Aeration Blower | | | | | | | | |
| measurement part | Blower Inside (Opposite Load Side) | | | | | | | | |
| ID code | 115 | Direction of measurement | Vertical | Group No. | 115 | | | | |
| Output | 30.0 kW | Rotational speed | 1244 min ⁻¹ | Axis diameter | 50 mm | | | | |
| 【 Relative value Judgment 】 recorded time: 13 May 2010 12:31 | | | | | |  | | | |
| Measurement Mode | | Warning Level | | Measurements | Judgment | | | | |
| | | Attention | Danger | | | | | | |
| ACC (THRU, OA) | [G] | 1.00 | 4.00 | 1.391 | Attention | | | | |
| ACC (OA) | [G] | 1.00 | 4.00 | 0.646 | Good | | | | |
| ACC (PEAK) | [G] | 3.00 | 12.00 | 2.775 | Good | | | | |
| VEL | [cm/s] | 0.40 | 1.00 | 0.440 | Attention | | | | |
| DISP | [μm] | 30 | 100 | 34.0 | Attention | | | | |
| (1G=9.8m/s ²) | | | | | | 【 Absolute value Judgment 】 (1G=9.8m/s ²) | | | |
| Measurement Mode | | Warning Level | | Measurements | Judgment | | | | |
| | | little bad | Bad | | | | | | |
| ACC (OA) | [G] | 0.28 | 1.12 | 0.646 | little bad | | | | |
| VEL | [cm/s] | 0.40 | 1.00 | 0.440 | little bad | | | | |
| (1G=9.8m/s ²) | | | | | | 【 Absolute value Judgment 】 (1G=9.8m/s ²) | | | |
| | | | | | | Speed | Acceleration | | |
| | | | | | | [cm/s] | [G] | | |
| | | | | | | 3.0 | 10.00 | | |
| | | | | | | 2.0 | 1.00 | | |
| | | | | | | 1.0 | 0.10 | | |
| | | | | | | 0.0 | 0.01 | | |
| | | | | | | I | II III IV | | |
| | | | | | | [Axis diameter×min ⁻¹] | | | |
| 【Comment】 | | | | | | | | | |

| | | | | | | | | | |
|---|---------|--------------------------|------------------------|---------------|-------|--|--|--|---------|
| Simple diagnosis report | | | | | | | | | drawing |
| equipment name Kim Lien WWTP | | | | | | | | | |
| machine name KBW1A Aeration Blower | | | | | | | | | |
| measurement part Blower Outside (Load Side) | | | | | | | | | |
| ID code | 114 | Direction of measurement | Vertical | Group No. | 114 | | | | |
| Output | 30.0 kW | Rotational speed | 1244 min ⁻¹ | Axis diameter | 50 mm | | | | |



【 Relative value Judgment 】 recorded time: 13 May 2010 12:31

| Measurement Mode | Warning Level | | Measurements | Judgment |
|--------------------|---------------|--------|--------------|-----------|
| | Attention | Danger | | |
| ACC (THRU, OA) [G] | 1.00 | 4.00 | 2.116 | Attention |
| ACC (OA) [G] | 1.00 | 4.00 | 0.850 | Good |
| ACC (PEAK) [G] | 3.00 | 12.00 | 2.970 | Good |
| VEL [cm/s] | 0.40 | 1.00 | 0.714 | Attention |
| DISP [μ m] | 30 | 100 | 66.5 | Attention |

(1G=9.8m/s²)

【 Absolute value Judgment 】 recorded time: 13 May 2010 12:31

| Measurement Mode | Warning Level | | Measurements | Judgment |
|------------------|---------------|------|--------------|------------|
| | little bad | Bad | | |
| ACC (OA) [G] | 0.28 | 1.12 | 0.850 | little bad |
| VEL [cm/s] | 0.40 | 1.00 | 0.714 | little bad |

(1G=9.8m/s²)

【 Absolute value Judgment 】 (1G=9.8m/s²)

Speed [cm/s]

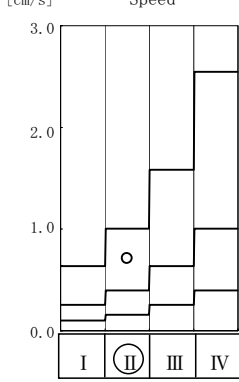

Acceleration [G]

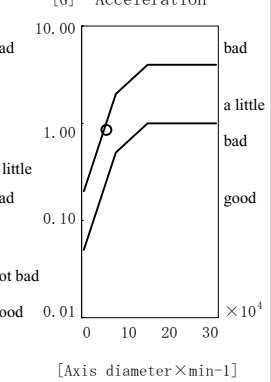

【Comment】

| | | | | | | | | | |
|--|---------|--------------------------|------------------------|---------------|-------|--|--|--|---------|
| Simple diagnosis report | | | | | | | | | drawing |
| equipment name Kim Lien WWTP | | | | | | | | | |
| machine name KBW1A Aeration Blower | | | | | | | | | |
| measurement part Blower Outside (Opposite Load Side) | | | | | | | | | |
| ID code | 116 | Direction of measurement | Vertical | Group No. | 116 | | | | |
| Output | 30.0 kW | Rotational speed | 1244 min ⁻¹ | Axis diameter | 50 mm | | | | |



【 Relative value Judgment 】 recorded time: 13 May 2010 12:32

| Measurement Mode | Warning Level | | Measurements | Judgment |
|--------------------|---------------|--------|--------------|-----------|
| | Attention | Danger | | |
| ACC (THRU, OA) [G] | 1.00 | 4.00 | 1.479 | Attention |
| ACC (OA) [G] | 1.00 | 4.00 | 0.703 | Good |
| ACC (PEAK) [G] | 3.00 | 12.00 | 2.369 | Good |
| VEL [cm/s] | 0.40 | 1.00 | 0.467 | Attention |
| DISP [μ m] | 30 | 100 | 25.1 | Good |

(1G=9.8m/s²)

【 Absolute value Judgment 】 recorded time: 13 May 2010 12:32

| Measurement Mode | Warning Level | | Measurements | Judgment |
|------------------|---------------|------|--------------|------------|
| | little bad | Bad | | |
| ACC (OA) [G] | 0.28 | 1.12 | 0.703 | little bad |
| VEL [cm/s] | 0.40 | 1.00 | 0.467 | little bad |

(1G=9.8m/s²)

【 Absolute value Judgment 】 (1G=9.8m/s²)

Speed [cm/s]

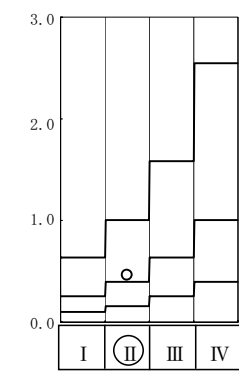

Acceleration [G]

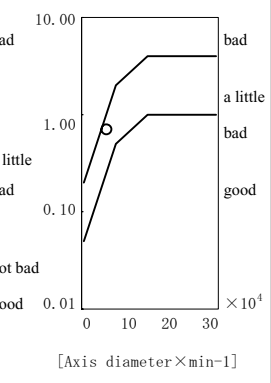

【Comment】

| | | | | | | | | |
|---|---------|--------------------------|------------------------|---------------|-------|--|--|---------|
| Simple diagnosis report | | | | | | | | drawing |
| equipment name Kim Lien WWTP | | | | | | | | |
| machine name KBW1B Aeration Blower | | | | | | | | |
| measurement part Moter (Opposite Load Side) | | | | | | | | |
| ID code | 121 | Direction of measurement | Vertical | Group No. | 111 | | | |
| Output | 30.0 kW | Rotational speed | 1477 min ⁻¹ | Axis diameter | 50 mm | | | |



【 Relative value Judgment 】 recorded time: 13 May 2010 12:45

| Measurement Mode | Warning Level | | Measurements | Judgment |
|--------------------|---------------|--------|--------------|-----------|
| | Attention | Danger | | |
| ACC (THRU, OA) [G] | 1.00 | 4.00 | 0.891 | Good |
| ACC (OA) [G] | 1.00 | 4.00 | 0.538 | Good |
| ACC (PEAK) [G] | 3.00 | 12.00 | 1.535 | Good |
| VEL [cm/s] | 0.40 | 1.00 | 0.425 | Attention |
| DISP [μ m] | 30 | 100 | 20.8 | Good |

(1G=9.8m/s²)

【 Absolute value Judgment 】 recorded time: 13 May 2010 12:45

| Measurement Mode | Warning Level | | Measurements | Judgment |
|------------------|---------------|------|--------------|------------|
| | little bad | Bad | | |
| ACC (OA) [G] | 0.41 | 1.64 | 0.538 | little bad |
| VEL [cm/s] | 0.40 | 1.00 | 0.425 | little bad |

(1G=9.8m/s²)

【 Absolute value Judgment 】 (1G=9.8m/s²)

[cm/s] Speed

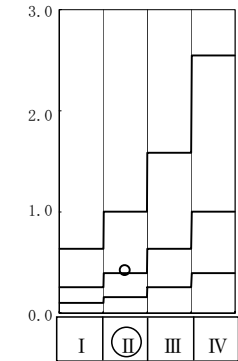

[G] Acceleration

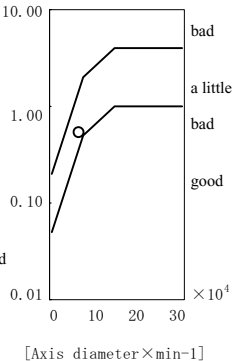

【Comment】

| | | | | | | | | |
|------------------------------------|---------|--------------------------|------------------------|---------------|-------|--|--|---------|
| Simple diagnosis report | | | | | | | | drawing |
| equipment name Kim Lien WWTP | | | | | | | | |
| machine name KBW1B Aeration Blower | | | | | | | | |
| measurement part Moter (Load Side) | | | | | | | | |
| ID code | 122 | Direction of measurement | Vertical | Group No. | 112 | | | |
| Output | 30.0 kW | Rotational speed | 1477 min ⁻¹ | Axis diameter | 60 mm | | | |



【 Relative value Judgment 】 recorded time: 13 May 2010 12:46

| Measurement Mode | Warning Level | | Measurements | Judgment |
|--------------------|---------------|--------|--------------|-----------|
| | Attention | Danger | | |
| ACC (THRU, OA) [G] | 1.00 | 4.00 | 0.625 | Good |
| ACC (OA) [G] | 1.00 | 4.00 | 0.222 | Good |
| ACC (PEAK) [G] | 3.00 | 12.00 | 0.673 | Good |
| VEL [cm/s] | 0.40 | 1.00 | 0.545 | Attention |
| DISP [μ m] | 30 | 100 | 65.1 | Attention |

(1G=9.8m/s²)

【 Absolute value Judgment 】 recorded time: 13 May 2010 12:46

| Measurement Mode | Warning Level | | Measurements | Judgment |
|------------------|---------------|------|--------------|------------|
| | little bad | Bad | | |
| ACC (OA) [G] | 0.54 | 2.16 | 0.222 | Good |
| VEL [cm/s] | 0.40 | 1.00 | 0.545 | little bad |

(1G=9.8m/s²)

【 Absolute value Judgment 】 (1G=9.8m/s²)

[cm/s] Speed

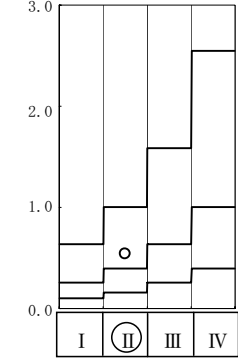

[G] Acceleration

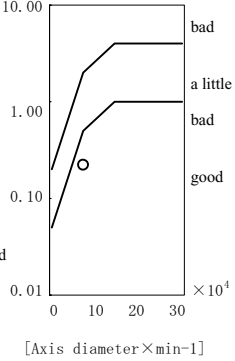

【Comment】

drawing date: 15 May 2010

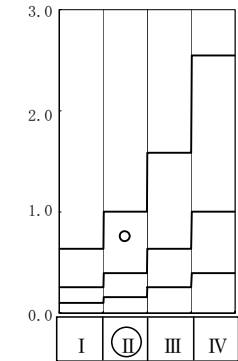
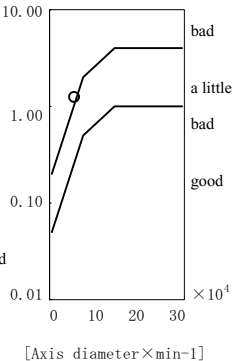
| Simple diagnosis report | | | | | | | | | drawing | | | | | | | | | | | | | | | | | | | | | | | | | | | | | | | | |
|---|---------------|--------------------------|------------------------|---------------|-------|---|---------------|--|--------------|----------|------------|--------|--------------------|------|------|-------|-----------|--------------|------|------|-------|------------|--|------|-------|-------|-----------|------------|------|------|-------|-----------|-----------------|----|-----|------|-----------|--|--|--|--|
| equipment name | | | | | | Kim Lien WWTP | | | | | | | | | | | | | | | | | | | | | | | | | | | | | | | | | | | |
| machine name | | | | | | KBW1B Aeration Blower | | | | | | | | | | | | | | | | | | | | | | | | | | | | | | | | | | | |
| measurement part | | | | | | Blower Inside (Load Side) | | | | | | | | | | | | | | | | | | | | | | | | | | | | | | | | | | | |
| ID code | 123 | Direction of measurement | Vertical | Group No. | 113 |  | | | | | | | | | | | | | | | | | | | | | | | | | | | | | | | | | | | |
| Output | 30.0 kW | Rotational speed | 1240 min ⁻¹ | Axis diameter | 50 mm | | | | | | | | | | | | | | | | | | | | | | | | | | | | | | | | | | | | |
| <p>【 Relative value Judgment 】 recorded time: 13 May 2010 12:48</p> <table border="1" style="width:100%; border-collapse: collapse;"> <thead> <tr> <th rowspan="2">Measurement Mode</th> <th colspan="2">Warning Level</th> <th rowspan="2">Measurements</th> <th rowspan="2">Judgment</th> </tr> <tr> <th>Attention</th> <th>Danger</th> </tr> </thead> <tbody> <tr> <td>ACC (THRU, OA) [G]</td> <td>1.00</td> <td>4.00</td> <td>3.203</td> <td>Attention</td> </tr> <tr> <td>ACC (OA) [G]</td> <td>1.00</td> <td>4.00</td> <td>1.248</td> <td>Attention</td> </tr> <tr> <td>ACC (PEAK) [G]</td> <td>3.00</td> <td>12.00</td> <td>4.811</td> <td>Attention</td> </tr> <tr> <td>VEL [cm/s]</td> <td>0.40</td> <td>1.00</td> <td>0.759</td> <td>Attention</td> </tr> <tr> <td>DISP [μm]</td> <td>30</td> <td>100</td> <td>55.7</td> <td>Attention</td> </tr> </tbody> </table> <p style="text-align: center;">(1G=9.8m/s²)</p> | | | | | | Measurement Mode | Warning Level | | Measurements | Judgment | Attention | Danger | ACC (THRU, OA) [G] | 1.00 | 4.00 | 3.203 | Attention | ACC (OA) [G] | 1.00 | 4.00 | 1.248 | Attention | ACC (PEAK) [G] | 3.00 | 12.00 | 4.811 | Attention | VEL [cm/s] | 0.40 | 1.00 | 0.759 | Attention | DISP [μ m] | 30 | 100 | 55.7 | Attention | | | | |
| Measurement Mode | Warning Level | | Measurements | Judgment | | | | | | | | | | | | | | | | | | | | | | | | | | | | | | | | | | | | | |
| | Attention | Danger | | | | | | | | | | | | | | | | | | | | | | | | | | | | | | | | | | | | | | | |
| ACC (THRU, OA) [G] | 1.00 | 4.00 | 3.203 | Attention | | | | | | | | | | | | | | | | | | | | | | | | | | | | | | | | | | | | | |
| ACC (OA) [G] | 1.00 | 4.00 | 1.248 | Attention | | | | | | | | | | | | | | | | | | | | | | | | | | | | | | | | | | | | | |
| ACC (PEAK) [G] | 3.00 | 12.00 | 4.811 | Attention | | | | | | | | | | | | | | | | | | | | | | | | | | | | | | | | | | | | | |
| VEL [cm/s] | 0.40 | 1.00 | 0.759 | Attention | | | | | | | | | | | | | | | | | | | | | | | | | | | | | | | | | | | | | |
| DISP [μ m] | 30 | 100 | 55.7 | Attention | | | | | | | | | | | | | | | | | | | | | | | | | | | | | | | | | | | | | |
| <p>【 Absolute value Judgment 】 recorded time: 13 May 2010 12:48</p> <table border="1" style="width:100%; border-collapse: collapse;"> <thead> <tr> <th rowspan="2">Measurement Mode</th> <th colspan="2">Warning Level</th> <th rowspan="2">Measurements</th> <th rowspan="2">Judgment</th> </tr> <tr> <th>little bad</th> <th>Bad</th> </tr> </thead> <tbody> <tr> <td>ACC (OA) [G]</td> <td>0.28</td> <td>1.11</td> <td>1.248</td> <td>Bad</td> </tr> <tr> <td>VEL [cm/s]</td> <td>0.40</td> <td>1.00</td> <td>0.759</td> <td>little bad</td> </tr> </tbody> </table> <p style="text-align: center;">(1G=9.8m/s²)</p> | | | | | | Measurement Mode | Warning Level | | Measurements | Judgment | little bad | Bad | ACC (OA) [G] | 0.28 | 1.11 | 1.248 | Bad | VEL [cm/s] | 0.40 | 1.00 | 0.759 | little bad | <p>【 Absolute value Judgment 】 (1G=9.8m/s²)</p> <div style="display: flex; justify-content: space-around;"> <div style="text-align: center;"> <p>[cm/s] Speed</p>  </div> <div style="text-align: center;"> <p>[G] Acceleration</p>  </div> </div> | | | | | | | | | | | | | | | | | | |
| Measurement Mode | Warning Level | | Measurements | Judgment | | | | | | | | | | | | | | | | | | | | | | | | | | | | | | | | | | | | | |
| | little bad | Bad | | | | | | | | | | | | | | | | | | | | | | | | | | | | | | | | | | | | | | | |
| ACC (OA) [G] | 0.28 | 1.11 | 1.248 | Bad | | | | | | | | | | | | | | | | | | | | | | | | | | | | | | | | | | | | | |
| VEL [cm/s] | 0.40 | 1.00 | 0.759 | little bad | | | | | | | | | | | | | | | | | | | | | | | | | | | | | | | | | | | | | |
| 【Comment】 | | | | | | | | | | | | | | | | | | | | | | | | | | | | | | | | | | | | | | | | | |

drawing date: 15 May 2010

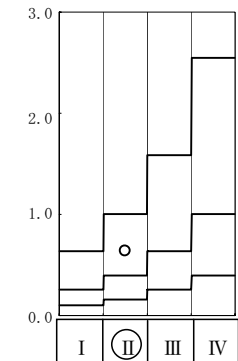
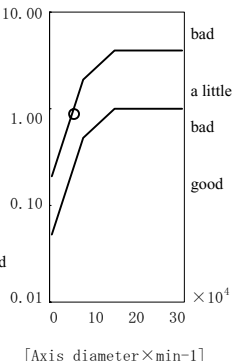
| Simple diagnosis report | | | | | | | | | drawing | | | | | | | | | | | | | | | | | | | | | | | | | | | | | | | | |
|--|---------------|--------------------------|------------------------|---------------|-------|---|---------------|--|--------------|----------|------------|--------|--------------------|------|------|-------|------------|--------------|------|------|-------|------------|--|------|-------|-------|-----------|------------|------|------|-------|-----------|-----------------|----|-----|------|-----------|--|--|--|--|
| equipment name | | | | | | Kim Lien WWTP | | | | | | | | | | | | | | | | | | | | | | | | | | | | | | | | | | | |
| machine name | | | | | | KBW1B Aeration Blower | | | | | | | | | | | | | | | | | | | | | | | | | | | | | | | | | | | |
| measurement part | | | | | | Blower Inside (Opposite Load Side) | | | | | | | | | | | | | | | | | | | | | | | | | | | | | | | | | | | |
| ID code | 125 | Direction of measurement | Vertical | Group No. | 115 |  | | | | | | | | | | | | | | | | | | | | | | | | | | | | | | | | | | | |
| Output | 30.0 kW | Rotational speed | 1240 min ⁻¹ | Axis diameter | 50 mm | | | | | | | | | | | | | | | | | | | | | | | | | | | | | | | | | | | | |
| <p>【 Relative value Judgment 】 recorded time: 13 May 2010 12:49</p> <table border="1" style="width:100%; border-collapse: collapse;"> <thead> <tr> <th rowspan="2">Measurement Mode</th> <th colspan="2">Warning Level</th> <th rowspan="2">Measurements</th> <th rowspan="2">Judgment</th> </tr> <tr> <th>Attention</th> <th>Danger</th> </tr> </thead> <tbody> <tr> <td>ACC (THRU, OA) [G]</td> <td>1.00</td> <td>4.00</td> <td>1.994</td> <td>Attention</td> </tr> <tr> <td>ACC (OA) [G]</td> <td>1.00</td> <td>4.00</td> <td>0.876</td> <td>Good</td> </tr> <tr> <td>ACC (PEAK) [G]</td> <td>3.00</td> <td>12.00</td> <td>3.355</td> <td>Attention</td> </tr> <tr> <td>VEL [cm/s]</td> <td>0.40</td> <td>1.00</td> <td>0.643</td> <td>Attention</td> </tr> <tr> <td>DISP [μm]</td> <td>30</td> <td>100</td> <td>36.4</td> <td>Attention</td> </tr> </tbody> </table> <p style="text-align: center;">(1G=9.8m/s²)</p> | | | | | | Measurement Mode | Warning Level | | Measurements | Judgment | Attention | Danger | ACC (THRU, OA) [G] | 1.00 | 4.00 | 1.994 | Attention | ACC (OA) [G] | 1.00 | 4.00 | 0.876 | Good | ACC (PEAK) [G] | 3.00 | 12.00 | 3.355 | Attention | VEL [cm/s] | 0.40 | 1.00 | 0.643 | Attention | DISP [μ m] | 30 | 100 | 36.4 | Attention | | | | |
| Measurement Mode | Warning Level | | Measurements | Judgment | | | | | | | | | | | | | | | | | | | | | | | | | | | | | | | | | | | | | |
| | Attention | Danger | | | | | | | | | | | | | | | | | | | | | | | | | | | | | | | | | | | | | | | |
| ACC (THRU, OA) [G] | 1.00 | 4.00 | 1.994 | Attention | | | | | | | | | | | | | | | | | | | | | | | | | | | | | | | | | | | | | |
| ACC (OA) [G] | 1.00 | 4.00 | 0.876 | Good | | | | | | | | | | | | | | | | | | | | | | | | | | | | | | | | | | | | | |
| ACC (PEAK) [G] | 3.00 | 12.00 | 3.355 | Attention | | | | | | | | | | | | | | | | | | | | | | | | | | | | | | | | | | | | | |
| VEL [cm/s] | 0.40 | 1.00 | 0.643 | Attention | | | | | | | | | | | | | | | | | | | | | | | | | | | | | | | | | | | | | |
| DISP [μ m] | 30 | 100 | 36.4 | Attention | | | | | | | | | | | | | | | | | | | | | | | | | | | | | | | | | | | | | |
| <p>【 Absolute value Judgment 】 recorded time: 13 May 2010 12:49</p> <table border="1" style="width:100%; border-collapse: collapse;"> <thead> <tr> <th rowspan="2">Measurement Mode</th> <th colspan="2">Warning Level</th> <th rowspan="2">Measurements</th> <th rowspan="2">Judgment</th> </tr> <tr> <th>little bad</th> <th>Bad</th> </tr> </thead> <tbody> <tr> <td>ACC (OA) [G]</td> <td>0.28</td> <td>1.11</td> <td>0.876</td> <td>little bad</td> </tr> <tr> <td>VEL [cm/s]</td> <td>0.40</td> <td>1.00</td> <td>0.643</td> <td>little bad</td> </tr> </tbody> </table> <p style="text-align: center;">(1G=9.8m/s²)</p> | | | | | | Measurement Mode | Warning Level | | Measurements | Judgment | little bad | Bad | ACC (OA) [G] | 0.28 | 1.11 | 0.876 | little bad | VEL [cm/s] | 0.40 | 1.00 | 0.643 | little bad | <p>【 Absolute value Judgment 】 (1G=9.8m/s²)</p> <div style="display: flex; justify-content: space-around;"> <div style="text-align: center;"> <p>[cm/s] Speed</p>  </div> <div style="text-align: center;"> <p>[G] Acceleration</p>  </div> </div> | | | | | | | | | | | | | | | | | | |
| Measurement Mode | Warning Level | | Measurements | Judgment | | | | | | | | | | | | | | | | | | | | | | | | | | | | | | | | | | | | | |
| | little bad | Bad | | | | | | | | | | | | | | | | | | | | | | | | | | | | | | | | | | | | | | | |
| ACC (OA) [G] | 0.28 | 1.11 | 0.876 | little bad | | | | | | | | | | | | | | | | | | | | | | | | | | | | | | | | | | | | | |
| VEL [cm/s] | 0.40 | 1.00 | 0.643 | little bad | | | | | | | | | | | | | | | | | | | | | | | | | | | | | | | | | | | | | |
| 【Comment】 | | | | | | | | | | | | | | | | | | | | | | | | | | | | | | | | | | | | | | | | | |

drawing date: 15 May 2010

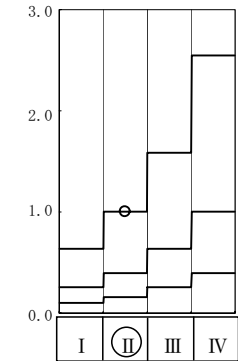
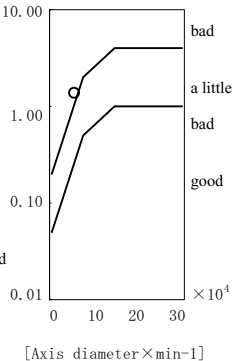
| Simple diagnosis report | | | | | | drawing | | | | | | | | | | | | | | | | | | | | | | | | | | | | | | | | | | | |
|--|---------------|--------------------------|------------------------|---------------|-------|---|---------------|--|--------------|----------|------------|--------|--------------------|------|------|-------|-----------|--------------|------|------|-------|-----------|----------------|------|-------|-------|-----------|------------|------|------|-------|--------|-----------------|----|-----|------|-----------|--|--|--|--|
| equipment name | | | | | | Kim Lien WWTP | | | | | | | | | | | | | | | | | | | | | | | | | | | | | | | | | | | |
| machine name | | | | | | KBW1B Aeration Blower | | | | | | | | | | | | | | | | | | | | | | | | | | | | | | | | | | | |
| measurement part | | | | | | Blower Outside (Load Side) | | | | | | | | | | | | | | | | | | | | | | | | | | | | | | | | | | | |
| ID code | 124 | Direction of measurement | Vertical | Group No. | 114 |  | | | | | | | | | | | | | | | | | | | | | | | | | | | | | | | | | | | |
| Output | 30.0 kW | Rotational speed | 1240 min ⁻¹ | Axis diameter | 50 mm | | | | | | | | | | | | | | | | | | | | | | | | | | | | | | | | | | | | |
| <p>【 Relative value Judgment 】 recorded time: 13 May 2010 12:48</p> <table border="1" style="width:100%; border-collapse: collapse;"> <thead> <tr> <th rowspan="2">Measurement Mode</th> <th colspan="2">Warning Level</th> <th rowspan="2">Measurements</th> <th rowspan="2">Judgment</th> </tr> <tr> <th>Attention</th> <th>Danger</th> </tr> </thead> <tbody> <tr> <td>ACC (THRU, OA) [G]</td> <td>1.00</td> <td>4.00</td> <td>3.698</td> <td>Attention</td> </tr> <tr> <td>ACC (OA) [G]</td> <td>1.00</td> <td>4.00</td> <td>1.374</td> <td>Attention</td> </tr> <tr> <td>ACC (PEAK) [G]</td> <td>3.00</td> <td>12.00</td> <td>4.516</td> <td>Attention</td> </tr> <tr> <td>VEL [cm/s]</td> <td>0.40</td> <td>1.00</td> <td>1.006</td> <td>Danger</td> </tr> <tr> <td>DISP [μm]</td> <td>30</td> <td>100</td> <td>54.7</td> <td>Attention</td> </tr> </tbody> </table> <p style="text-align: center;">(1G=9.8m/s²)</p> | | | | | | Measurement Mode | Warning Level | | Measurements | Judgment | Attention | Danger | ACC (THRU, OA) [G] | 1.00 | 4.00 | 3.698 | Attention | ACC (OA) [G] | 1.00 | 4.00 | 1.374 | Attention | ACC (PEAK) [G] | 3.00 | 12.00 | 4.516 | Attention | VEL [cm/s] | 0.40 | 1.00 | 1.006 | Danger | DISP [μ m] | 30 | 100 | 54.7 | Attention | <p>【 Absolute value Judgment 】 (1G=9.8m/s²)</p> <div style="display: flex; justify-content: space-around;"> <div style="text-align: center;"> <p>Speed [cm/s]</p>  </div> <div style="text-align: center;"> <p>Acceleration [G]</p>  </div> </div> | | | |
| Measurement Mode | Warning Level | | Measurements | Judgment | | | | | | | | | | | | | | | | | | | | | | | | | | | | | | | | | | | | | |
| | Attention | Danger | | | | | | | | | | | | | | | | | | | | | | | | | | | | | | | | | | | | | | | |
| ACC (THRU, OA) [G] | 1.00 | 4.00 | 3.698 | Attention | | | | | | | | | | | | | | | | | | | | | | | | | | | | | | | | | | | | | |
| ACC (OA) [G] | 1.00 | 4.00 | 1.374 | Attention | | | | | | | | | | | | | | | | | | | | | | | | | | | | | | | | | | | | | |
| ACC (PEAK) [G] | 3.00 | 12.00 | 4.516 | Attention | | | | | | | | | | | | | | | | | | | | | | | | | | | | | | | | | | | | | |
| VEL [cm/s] | 0.40 | 1.00 | 1.006 | Danger | | | | | | | | | | | | | | | | | | | | | | | | | | | | | | | | | | | | | |
| DISP [μ m] | 30 | 100 | 54.7 | Attention | | | | | | | | | | | | | | | | | | | | | | | | | | | | | | | | | | | | | |
| <p>【 Absolute value Judgment 】 recorded time: 13 May 2010 12:48</p> <table border="1" style="width:100%; border-collapse: collapse;"> <thead> <tr> <th rowspan="2">Measurement Mode</th> <th colspan="2">Warning Level</th> <th rowspan="2">Measurements</th> <th rowspan="2">Judgment</th> </tr> <tr> <th>little bad</th> <th>Bad</th> </tr> </thead> <tbody> <tr> <td>ACC (OA) [G]</td> <td>0.28</td> <td>1.11</td> <td>1.374</td> <td>Bad</td> </tr> <tr> <td>VEL [cm/s]</td> <td>0.40</td> <td>1.00</td> <td>1.006</td> <td>Bad</td> </tr> </tbody> </table> <p style="text-align: center;">(1G=9.8m/s²)</p> | | | | | | Measurement Mode | Warning Level | | Measurements | Judgment | little bad | Bad | ACC (OA) [G] | 0.28 | 1.11 | 1.374 | Bad | VEL [cm/s] | 0.40 | 1.00 | 1.006 | Bad | | | | | | | | | | | | | | | | | | | |
| Measurement Mode | Warning Level | | Measurements | Judgment | | | | | | | | | | | | | | | | | | | | | | | | | | | | | | | | | | | | | |
| | little bad | Bad | | | | | | | | | | | | | | | | | | | | | | | | | | | | | | | | | | | | | | | |
| ACC (OA) [G] | 0.28 | 1.11 | 1.374 | Bad | | | | | | | | | | | | | | | | | | | | | | | | | | | | | | | | | | | | | |
| VEL [cm/s] | 0.40 | 1.00 | 1.006 | Bad | | | | | | | | | | | | | | | | | | | | | | | | | | | | | | | | | | | | | |
| 【Comment】 | | | | | | | | | | | | | | | | | | | | | | | | | | | | | | | | | | | | | | | | | |

drawing date: 24 May 2010

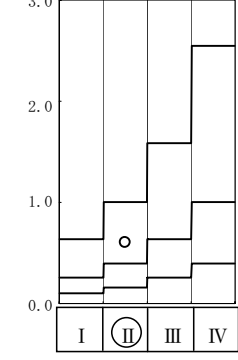
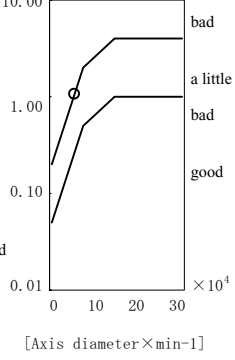
| Simple diagnosis report | | | | | | drawing | | | | | | | | | | | | | | | | | | | | | | | | | | | | | | | | | | | |
|--|---------------|--------------------------|------------------------|---------------|-------|---|---------------|--|--------------|----------|------------|--------|--------------------|------|------|-------|------------|--------------|------|------|-------|------------|----------------|------|-------|-------|-----------|------------|------|------|-------|-----------|-----------------|----|-----|------|------|--|--|--|--|
| equipment name | | | | | | Kim Lien WWTP | | | | | | | | | | | | | | | | | | | | | | | | | | | | | | | | | | | |
| machine name | | | | | | KBW1B Aeration Blower | | | | | | | | | | | | | | | | | | | | | | | | | | | | | | | | | | | |
| measurement part | | | | | | Blower Outside (Opposite Load Side) | | | | | | | | | | | | | | | | | | | | | | | | | | | | | | | | | | | |
| ID code | 126 | Direction of measurement | Vertical | Group No. | 116 |  | | | | | | | | | | | | | | | | | | | | | | | | | | | | | | | | | | | |
| Output | 30.0 kW | Rotational speed | 1240 min ⁻¹ | Axis diameter | 50 mm | | | | | | | | | | | | | | | | | | | | | | | | | | | | | | | | | | | | |
| <p>【 Relative value Judgment 】 recorded time: 13 May 2010 12:50</p> <table border="1" style="width:100%; border-collapse: collapse;"> <thead> <tr> <th rowspan="2">Measurement Mode</th> <th colspan="2">Warning Level</th> <th rowspan="2">Measurements</th> <th rowspan="2">Judgment</th> </tr> <tr> <th>Attention</th> <th>Danger</th> </tr> </thead> <tbody> <tr> <td>ACC (THRU, OA) [G]</td> <td>1.00</td> <td>4.00</td> <td>2.437</td> <td>Attention</td> </tr> <tr> <td>ACC (OA) [G]</td> <td>1.00</td> <td>4.00</td> <td>1.071</td> <td>Attention</td> </tr> <tr> <td>ACC (PEAK) [G]</td> <td>3.00</td> <td>12.00</td> <td>3.485</td> <td>Attention</td> </tr> <tr> <td>VEL [cm/s]</td> <td>0.40</td> <td>1.00</td> <td>0.609</td> <td>Attention</td> </tr> <tr> <td>DISP [μm]</td> <td>30</td> <td>100</td> <td>26.6</td> <td>Good</td> </tr> </tbody> </table> <p style="text-align: center;">(1G=9.8m/s²)</p> | | | | | | Measurement Mode | Warning Level | | Measurements | Judgment | Attention | Danger | ACC (THRU, OA) [G] | 1.00 | 4.00 | 2.437 | Attention | ACC (OA) [G] | 1.00 | 4.00 | 1.071 | Attention | ACC (PEAK) [G] | 3.00 | 12.00 | 3.485 | Attention | VEL [cm/s] | 0.40 | 1.00 | 0.609 | Attention | DISP [μ m] | 30 | 100 | 26.6 | Good | <p>【 Absolute value Judgment 】 (1G=9.8m/s²)</p> <div style="display: flex; justify-content: space-around;"> <div style="text-align: center;"> <p>Speed [cm/s]</p>  </div> <div style="text-align: center;"> <p>Acceleration [G]</p>  </div> </div> | | | |
| Measurement Mode | Warning Level | | Measurements | Judgment | | | | | | | | | | | | | | | | | | | | | | | | | | | | | | | | | | | | | |
| | Attention | Danger | | | | | | | | | | | | | | | | | | | | | | | | | | | | | | | | | | | | | | | |
| ACC (THRU, OA) [G] | 1.00 | 4.00 | 2.437 | Attention | | | | | | | | | | | | | | | | | | | | | | | | | | | | | | | | | | | | | |
| ACC (OA) [G] | 1.00 | 4.00 | 1.071 | Attention | | | | | | | | | | | | | | | | | | | | | | | | | | | | | | | | | | | | | |
| ACC (PEAK) [G] | 3.00 | 12.00 | 3.485 | Attention | | | | | | | | | | | | | | | | | | | | | | | | | | | | | | | | | | | | | |
| VEL [cm/s] | 0.40 | 1.00 | 0.609 | Attention | | | | | | | | | | | | | | | | | | | | | | | | | | | | | | | | | | | | | |
| DISP [μ m] | 30 | 100 | 26.6 | Good | | | | | | | | | | | | | | | | | | | | | | | | | | | | | | | | | | | | | |
| <p>【 Absolute value Judgment 】 recorded time: 13 May 2010 12:50</p> <table border="1" style="width:100%; border-collapse: collapse;"> <thead> <tr> <th rowspan="2">Measurement Mode</th> <th colspan="2">Warning Level</th> <th rowspan="2">Measurements</th> <th rowspan="2">Judgment</th> </tr> <tr> <th>little bad</th> <th>Bad</th> </tr> </thead> <tbody> <tr> <td>ACC (OA) [G]</td> <td>0.28</td> <td>1.11</td> <td>1.071</td> <td>little bad</td> </tr> <tr> <td>VEL [cm/s]</td> <td>0.40</td> <td>1.00</td> <td>0.609</td> <td>little bad</td> </tr> </tbody> </table> <p style="text-align: center;">(1G=9.8m/s²)</p> | | | | | | Measurement Mode | Warning Level | | Measurements | Judgment | little bad | Bad | ACC (OA) [G] | 0.28 | 1.11 | 1.071 | little bad | VEL [cm/s] | 0.40 | 1.00 | 0.609 | little bad | | | | | | | | | | | | | | | | | | | |
| Measurement Mode | Warning Level | | Measurements | Judgment | | | | | | | | | | | | | | | | | | | | | | | | | | | | | | | | | | | | | |
| | little bad | Bad | | | | | | | | | | | | | | | | | | | | | | | | | | | | | | | | | | | | | | | |
| ACC (OA) [G] | 0.28 | 1.11 | 1.071 | little bad | | | | | | | | | | | | | | | | | | | | | | | | | | | | | | | | | | | | | |
| VEL [cm/s] | 0.40 | 1.00 | 0.609 | little bad | | | | | | | | | | | | | | | | | | | | | | | | | | | | | | | | | | | | | |
| 【Comment】 | | | | | | | | | | | | | | | | | | | | | | | | | | | | | | | | | | | | | | | | | |

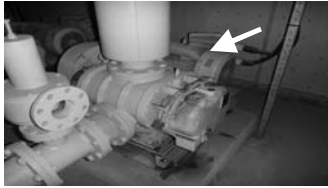
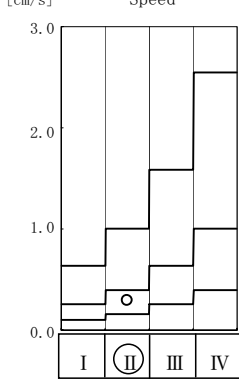
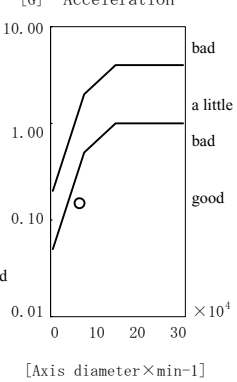
| Simple diagnosis report | | | | | | | | | drawing | | | | | | | | | | | | | | | | | | | | | | | | | | | | | | | | | | | | | | |
|---|---------|--------------------------|------------------------|---------------|-------------|---|-----|---------------|---------|--------------|----------|------------|--------|----------------|-----|------|------|-------|------|----------|--------|------|------|-------|-------------|------------|-----|------|-------|-------|------|-----|--------|------|------|-------|------|------|------|----|-----|------|------|--|--|--|--|
| equipment name | | | | | | Kim Lien WWTP | | | | | | | | | | | | | | | | | | | | | | | | | | | | | | | | | | | | | | | | | |
| machine name | | | | | | KBW1C Aeration Blower | | | | | | | | | | | | | | | | | | | | | | | | | | | | | | | | | | | | | | | | | |
| measurement part | | | | | | Moter (Opposite Load Side) | | | | | | | | | | | | | | | | | | | | | | | | | | | | | | | | | | | | | | | | | |
| ID code | 131 | Direction of measurement | Vertical | Group No. | 111 |  | | | | | | | | | | | | | | | | | | | | | | | | | | | | | | | | | | | | | | | | | |
| Output | 30.0 kW | Rotational speed | 1482 min ⁻¹ | Axis diameter | 50 mm | | | | | | | | | | | | | | | | | | | | | | | | | | | | | | | | | | | | | | | | | | |
| <p>【 Relative value Judgment 】 recorded time: 13 May 2010 12:59</p> <table border="1" style="width:100%; border-collapse: collapse;"> <thead> <tr> <th rowspan="2">Measurement Mode</th> <th rowspan="2">[G]</th> <th colspan="2">Warning Level</th> <th rowspan="2">Measurements</th> <th rowspan="2">Judgment</th> </tr> <tr> <th>Attention</th> <th>Danger</th> </tr> </thead> <tbody> <tr> <td>ACC (THRU, OA)</td> <td>[G]</td> <td>1.00</td> <td>4.00</td> <td>0.298</td> <td>Good</td> </tr> <tr> <td>ACC (OA)</td> <td>[G]</td> <td>1.00</td> <td>4.00</td> <td>0.149</td> <td>Good</td> </tr> <tr> <td>ACC (PEAK)</td> <td>[G]</td> <td>3.00</td> <td>12.00</td> <td>0.364</td> <td>Good</td> </tr> <tr> <td>VEL</td> <td>[cm/s]</td> <td>0.40</td> <td>1.00</td> <td>0.297</td> <td>Good</td> </tr> <tr> <td>DISP</td> <td>[μm]</td> <td>30</td> <td>100</td> <td>18.1</td> <td>Good</td> </tr> </tbody> </table> <p style="text-align: center;">(1G=9.8m/s²)</p> | | | | | | Measurement Mode | [G] | Warning Level | | Measurements | Judgment | Attention | Danger | ACC (THRU, OA) | [G] | 1.00 | 4.00 | 0.298 | Good | ACC (OA) | [G] | 1.00 | 4.00 | 0.149 | Good | ACC (PEAK) | [G] | 3.00 | 12.00 | 0.364 | Good | VEL | [cm/s] | 0.40 | 1.00 | 0.297 | Good | DISP | [μm] | 30 | 100 | 18.1 | Good | <p>【 Absolute value Judgment 】 (1G=9.8m/s²)</p> <div style="display: flex; justify-content: space-around;"> <div style="text-align: center;"> <p>Speed [cm/s]</p>  </div> <div style="text-align: center;"> <p>Acceleration [G]</p>  </div> </div> <p style="text-align: center;">[Axis diameter × min⁻¹]</p> | | | |
| Measurement Mode | [G] | Warning Level | | Measurements | Judgment | | | | | | | | | | | | | | | | | | | | | | | | | | | | | | | | | | | | | | | | | | |
| | | Attention | Danger | | | | | | | | | | | | | | | | | | | | | | | | | | | | | | | | | | | | | | | | | | | | |
| ACC (THRU, OA) | [G] | 1.00 | 4.00 | 0.298 | Good | | | | | | | | | | | | | | | | | | | | | | | | | | | | | | | | | | | | | | | | | | |
| ACC (OA) | [G] | 1.00 | 4.00 | 0.149 | Good | | | | | | | | | | | | | | | | | | | | | | | | | | | | | | | | | | | | | | | | | | |
| ACC (PEAK) | [G] | 3.00 | 12.00 | 0.364 | Good | | | | | | | | | | | | | | | | | | | | | | | | | | | | | | | | | | | | | | | | | | |
| VEL | [cm/s] | 0.40 | 1.00 | 0.297 | Good | | | | | | | | | | | | | | | | | | | | | | | | | | | | | | | | | | | | | | | | | | |
| DISP | [μm] | 30 | 100 | 18.1 | Good | | | | | | | | | | | | | | | | | | | | | | | | | | | | | | | | | | | | | | | | | | |
| <p>【 Absolute value Judgment 】 recorded time: 13 May 2010 12:59</p> <table border="1" style="width:100%; border-collapse: collapse;"> <thead> <tr> <th rowspan="2">Measurement Mode</th> <th rowspan="2">[G]</th> <th colspan="2">Warning Level</th> <th rowspan="2">Measurements</th> <th rowspan="2">Judgment</th> </tr> <tr> <th>little bad</th> <th>Bad</th> </tr> </thead> <tbody> <tr> <td>ACC (OA)</td> <td>[G]</td> <td>0.41</td> <td>1.65</td> <td>0.149</td> <td>Good</td> </tr> <tr> <td>VEL</td> <td>[cm/s]</td> <td>0.40</td> <td>1.00</td> <td>0.297</td> <td>little good</td> </tr> </tbody> </table> <p style="text-align: center;">(1G=9.8m/s²)</p> | | | | | | Measurement Mode | [G] | Warning Level | | Measurements | Judgment | little bad | Bad | ACC (OA) | [G] | 0.41 | 1.65 | 0.149 | Good | VEL | [cm/s] | 0.40 | 1.00 | 0.297 | little good | | | | | | | | | | | | | | | | | | | | | | |
| Measurement Mode | [G] | Warning Level | | Measurements | Judgment | | | | | | | | | | | | | | | | | | | | | | | | | | | | | | | | | | | | | | | | | | |
| | | little bad | Bad | | | | | | | | | | | | | | | | | | | | | | | | | | | | | | | | | | | | | | | | | | | | |
| ACC (OA) | [G] | 0.41 | 1.65 | 0.149 | Good | | | | | | | | | | | | | | | | | | | | | | | | | | | | | | | | | | | | | | | | | | |
| VEL | [cm/s] | 0.40 | 1.00 | 0.297 | little good | | | | | | | | | | | | | | | | | | | | | | | | | | | | | | | | | | | | | | | | | | |
| 【Comment】 | | | | | | | | | | | | | | | | | | | | | | | | | | | | | | | | | | | | | | | | | | | | | | | |

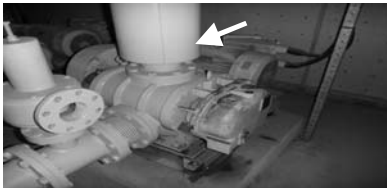
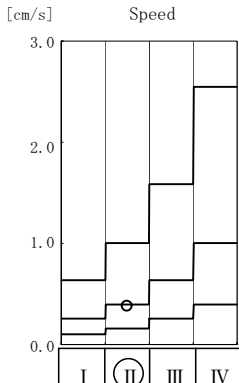
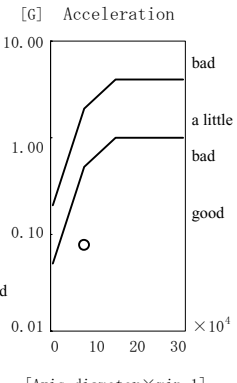
| Simple diagnosis report | | | | | | | | | drawing | | | | | | | | | | | | | | | | | | | | | | | | | | | | | | | | | | | | | | |
|--|---------|--------------------------|------------------------|---------------|-------------|---|-----|---------------|---------|--------------|----------|------------|--------|----------------|-----|------|------|-------|------|----------|--------|------|------|-------|-------------|------------|-----|------|-------|-------|------|-----|--------|------|------|-------|------|------|------|----|-----|------|-----------|--|--|--|--|
| equipment name | | | | | | Kim Lien WWTP | | | | | | | | | | | | | | | | | | | | | | | | | | | | | | | | | | | | | | | | | |
| machine name | | | | | | KBW1C Aeration Blower | | | | | | | | | | | | | | | | | | | | | | | | | | | | | | | | | | | | | | | | | |
| measurement part | | | | | | Moter (Load Side) | | | | | | | | | | | | | | | | | | | | | | | | | | | | | | | | | | | | | | | | | |
| ID code | 132 | Direction of measurement | Vertical | Group No. | 112 |  | | | | | | | | | | | | | | | | | | | | | | | | | | | | | | | | | | | | | | | | | |
| Output | 30.0 kW | Rotational speed | 1482 min ⁻¹ | Axis diameter | 60 mm | | | | | | | | | | | | | | | | | | | | | | | | | | | | | | | | | | | | | | | | | | |
| <p>【 Relative value Judgment 】 recorded time: 13 May 2010 12:59</p> <table border="1" style="width:100%; border-collapse: collapse;"> <thead> <tr> <th rowspan="2">Measurement Mode</th> <th rowspan="2">[G]</th> <th colspan="2">Warning Level</th> <th rowspan="2">Measurements</th> <th rowspan="2">Judgment</th> </tr> <tr> <th>Attention</th> <th>Danger</th> </tr> </thead> <tbody> <tr> <td>ACC (THRU, OA)</td> <td>[G]</td> <td>1.00</td> <td>4.00</td> <td>0.236</td> <td>Good</td> </tr> <tr> <td>ACC (OA)</td> <td>[G]</td> <td>1.00</td> <td>4.00</td> <td>0.078</td> <td>Good</td> </tr> <tr> <td>ACC (PEAK)</td> <td>[G]</td> <td>3.00</td> <td>12.00</td> <td>0.199</td> <td>Good</td> </tr> <tr> <td>VEL</td> <td>[cm/s]</td> <td>0.40</td> <td>1.00</td> <td>0.383</td> <td>Good</td> </tr> <tr> <td>DISP</td> <td>[μm]</td> <td>30</td> <td>100</td> <td>49.9</td> <td>Attention</td> </tr> </tbody> </table> <p style="text-align: center;">(1G=9.8m/s²)</p> | | | | | | Measurement Mode | [G] | Warning Level | | Measurements | Judgment | Attention | Danger | ACC (THRU, OA) | [G] | 1.00 | 4.00 | 0.236 | Good | ACC (OA) | [G] | 1.00 | 4.00 | 0.078 | Good | ACC (PEAK) | [G] | 3.00 | 12.00 | 0.199 | Good | VEL | [cm/s] | 0.40 | 1.00 | 0.383 | Good | DISP | [μm] | 30 | 100 | 49.9 | Attention | <p>【 Absolute value Judgment 】 (1G=9.8m/s²)</p> <div style="display: flex; justify-content: space-around;"> <div style="text-align: center;"> <p>Speed [cm/s]</p>  </div> <div style="text-align: center;"> <p>Acceleration [G]</p>  </div> </div> <p style="text-align: center;">[Axis diameter × min⁻¹]</p> | | | |
| Measurement Mode | [G] | Warning Level | | Measurements | Judgment | | | | | | | | | | | | | | | | | | | | | | | | | | | | | | | | | | | | | | | | | | |
| | | Attention | Danger | | | | | | | | | | | | | | | | | | | | | | | | | | | | | | | | | | | | | | | | | | | | |
| ACC (THRU, OA) | [G] | 1.00 | 4.00 | 0.236 | Good | | | | | | | | | | | | | | | | | | | | | | | | | | | | | | | | | | | | | | | | | | |
| ACC (OA) | [G] | 1.00 | 4.00 | 0.078 | Good | | | | | | | | | | | | | | | | | | | | | | | | | | | | | | | | | | | | | | | | | | |
| ACC (PEAK) | [G] | 3.00 | 12.00 | 0.199 | Good | | | | | | | | | | | | | | | | | | | | | | | | | | | | | | | | | | | | | | | | | | |
| VEL | [cm/s] | 0.40 | 1.00 | 0.383 | Good | | | | | | | | | | | | | | | | | | | | | | | | | | | | | | | | | | | | | | | | | | |
| DISP | [μm] | 30 | 100 | 49.9 | Attention | | | | | | | | | | | | | | | | | | | | | | | | | | | | | | | | | | | | | | | | | | |
| <p>【 Absolute value Judgment 】 recorded time: 13 May 2010 12:59</p> <table border="1" style="width:100%; border-collapse: collapse;"> <thead> <tr> <th rowspan="2">Measurement Mode</th> <th rowspan="2">[G]</th> <th colspan="2">Warning Level</th> <th rowspan="2">Measurements</th> <th rowspan="2">Judgment</th> </tr> <tr> <th>little bad</th> <th>Bad</th> </tr> </thead> <tbody> <tr> <td>ACC (OA)</td> <td>[G]</td> <td>0.54</td> <td>2.17</td> <td>0.078</td> <td>Good</td> </tr> <tr> <td>VEL</td> <td>[cm/s]</td> <td>0.40</td> <td>1.00</td> <td>0.383</td> <td>little good</td> </tr> </tbody> </table> <p style="text-align: center;">(1G=9.8m/s²)</p> | | | | | | Measurement Mode | [G] | Warning Level | | Measurements | Judgment | little bad | Bad | ACC (OA) | [G] | 0.54 | 2.17 | 0.078 | Good | VEL | [cm/s] | 0.40 | 1.00 | 0.383 | little good | | | | | | | | | | | | | | | | | | | | | | |
| Measurement Mode | [G] | Warning Level | | Measurements | Judgment | | | | | | | | | | | | | | | | | | | | | | | | | | | | | | | | | | | | | | | | | | |
| | | little bad | Bad | | | | | | | | | | | | | | | | | | | | | | | | | | | | | | | | | | | | | | | | | | | | |
| ACC (OA) | [G] | 0.54 | 2.17 | 0.078 | Good | | | | | | | | | | | | | | | | | | | | | | | | | | | | | | | | | | | | | | | | | | |
| VEL | [cm/s] | 0.40 | 1.00 | 0.383 | little good | | | | | | | | | | | | | | | | | | | | | | | | | | | | | | | | | | | | | | | | | | |
| 【Comment】 | | | | | | | | | | | | | | | | | | | | | | | | | | | | | | | | | | | | | | | | | | | | | | | |

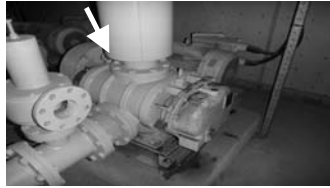
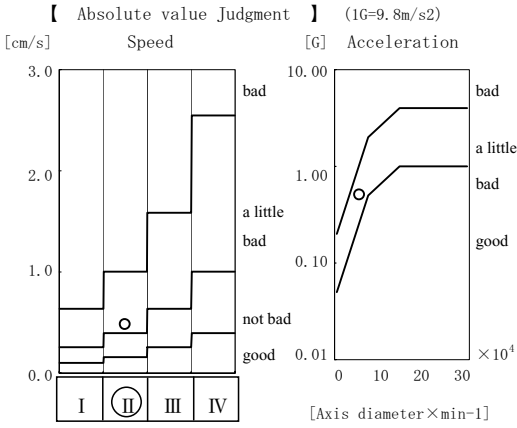
| Simple diagnosis report | | | | | | | | drawing | | | | | | | | | | | | | | | | | | | | | | | | | | | | | | | | |
|--|---------------------------|--------------------------|------------------------|---------------|-------|--|--|---------|------------------|---------------|--|--------------|----------|------------|--------|--------------------|------|------|-------|------------|--------------|------|------|-------|------------|----------------|------|-------|-------|------|------------|------|------|-------|-----------|-----------------|----|-----|------|-----------|
| | | | | | | | | | | | | | | | | | | | | | | | | | | | | | | | | | | | | | | | | |
| equipment name | Kim Lien WWTP | | | | | | | | | | | | | | | | | | | | | | | | | | | | | | | | | | | | | | | |
| machine name | KBW1C Aeration Blower | | | | | | | | | | | | | | | | | | | | | | | | | | | | | | | | | | | | | | | |
| measurement part | Blower Inside (Load Side) | | | | | | | | | | | | | | | | | | | | | | | | | | | | | | | | | | | | | | | |
| ID code | 133 | Direction of measurement | Vertical | Group No. | 113 | | | | | | | | | | | | | | | | | | | | | | | | | | | | | | | | | | | |
| Output | 30.0 kW | Rotational speed | 1247 min ⁻¹ | Axis diameter | 50 mm | | | | | | | | | | | | | | | | | | | | | | | | | | | | | | | | | | | |
|  | | | | | | | | | | | | | | | | | | | | | | | | | | | | | | | | | | | | | | | | |
| <p>【 Relative value Judgment 】 recorded time: 13 May 2010 13:01</p> <table border="1" style="width:100%; border-collapse: collapse;"> <thead> <tr> <th rowspan="2">Measurement Mode</th> <th colspan="2">Warning Level</th> <th rowspan="2">Measurements</th> <th rowspan="2">Judgment</th> </tr> <tr> <th>Attention</th> <th>Danger</th> </tr> </thead> <tbody> <tr> <td>ACC (THRU, OA) [G]</td> <td>1.00</td> <td>4.00</td> <td>0.986</td> <td>Good</td> </tr> <tr> <td>ACC (OA) [G]</td> <td>1.00</td> <td>4.00</td> <td>0.512</td> <td>Good</td> </tr> <tr> <td>ACC (PEAK) [G]</td> <td>3.00</td> <td>12.00</td> <td>1.479</td> <td>Good</td> </tr> <tr> <td>VEL [cm/s]</td> <td>0.40</td> <td>1.00</td> <td>0.484</td> <td>Attention</td> </tr> <tr> <td>DISP [μm]</td> <td>30</td> <td>100</td> <td>62.8</td> <td>Attention</td> </tr> </tbody> </table> <p style="text-align: center;">(1G=9.8m/s²)</p> | | | | | | | | | Measurement Mode | Warning Level | | Measurements | Judgment | Attention | Danger | ACC (THRU, OA) [G] | 1.00 | 4.00 | 0.986 | Good | ACC (OA) [G] | 1.00 | 4.00 | 0.512 | Good | ACC (PEAK) [G] | 3.00 | 12.00 | 1.479 | Good | VEL [cm/s] | 0.40 | 1.00 | 0.484 | Attention | DISP [μ m] | 30 | 100 | 62.8 | Attention |
| Measurement Mode | Warning Level | | Measurements | Judgment | | | | | | | | | | | | | | | | | | | | | | | | | | | | | | | | | | | | |
| | Attention | Danger | | | | | | | | | | | | | | | | | | | | | | | | | | | | | | | | | | | | | | |
| ACC (THRU, OA) [G] | 1.00 | 4.00 | 0.986 | Good | | | | | | | | | | | | | | | | | | | | | | | | | | | | | | | | | | | | |
| ACC (OA) [G] | 1.00 | 4.00 | 0.512 | Good | | | | | | | | | | | | | | | | | | | | | | | | | | | | | | | | | | | | |
| ACC (PEAK) [G] | 3.00 | 12.00 | 1.479 | Good | | | | | | | | | | | | | | | | | | | | | | | | | | | | | | | | | | | | |
| VEL [cm/s] | 0.40 | 1.00 | 0.484 | Attention | | | | | | | | | | | | | | | | | | | | | | | | | | | | | | | | | | | | |
| DISP [μ m] | 30 | 100 | 62.8 | Attention | | | | | | | | | | | | | | | | | | | | | | | | | | | | | | | | | | | | |
| <p>【 Absolute value Judgment 】 recorded time: 13 May 2010 13:01</p> <table border="1" style="width:100%; border-collapse: collapse;"> <thead> <tr> <th rowspan="2">Measurement Mode</th> <th colspan="2">Warning Level</th> <th rowspan="2">Measurements</th> <th rowspan="2">Judgment</th> </tr> <tr> <th>little bad</th> <th>Bad</th> </tr> </thead> <tbody> <tr> <td>ACC (OA) [G]</td> <td>0.28</td> <td>1.12</td> <td>0.512</td> <td>little bad</td> </tr> <tr> <td>VEL [cm/s]</td> <td>0.40</td> <td>1.00</td> <td>0.484</td> <td>little bad</td> </tr> </tbody> </table> <p style="text-align: center;">(1G=9.8m/s²)</p> | | | | | | | | | Measurement Mode | Warning Level | | Measurements | Judgment | little bad | Bad | ACC (OA) [G] | 0.28 | 1.12 | 0.512 | little bad | VEL [cm/s] | 0.40 | 1.00 | 0.484 | little bad | | | | | | | | | | | | | | | |
| Measurement Mode | Warning Level | | Measurements | Judgment | | | | | | | | | | | | | | | | | | | | | | | | | | | | | | | | | | | | |
| | little bad | Bad | | | | | | | | | | | | | | | | | | | | | | | | | | | | | | | | | | | | | | |
| ACC (OA) [G] | 0.28 | 1.12 | 0.512 | little bad | | | | | | | | | | | | | | | | | | | | | | | | | | | | | | | | | | | | |
| VEL [cm/s] | 0.40 | 1.00 | 0.484 | little bad | | | | | | | | | | | | | | | | | | | | | | | | | | | | | | | | | | | | |
|  | | | | | | | | | | | | | | | | | | | | | | | | | | | | | | | | | | | | | | | | |
| 【Comment】 | | | | | | | | | | | | | | | | | | | | | | | | | | | | | | | | | | | | | | | | |

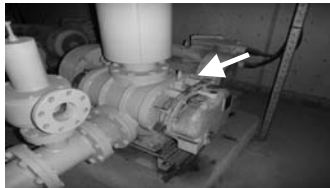
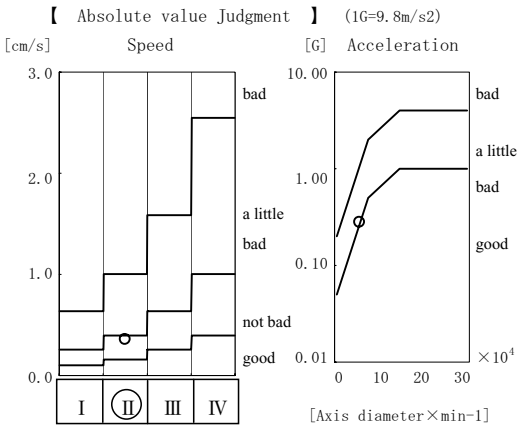
| Simple diagnosis report | | | | | | | | drawing | | | | | | | | | | | | | | | | | | | | | | | | | | | | | | | | |
|--|------------------------------------|--------------------------|------------------------|---------------|-------|--|--|---------|------------------|---------------|--|--------------|----------|------------|--------|--------------------|------|------|-------|------------|--------------|------|------|-------|-------------|----------------|------|-------|-------|------|------------|------|------|-------|------|-----------------|----|-----|------|------|
| | | | | | | | | | | | | | | | | | | | | | | | | | | | | | | | | | | | | | | | | |
| equipment name | Kim Lien WWTP | | | | | | | | | | | | | | | | | | | | | | | | | | | | | | | | | | | | | | | |
| machine name | KBW1C Aeration Blower | | | | | | | | | | | | | | | | | | | | | | | | | | | | | | | | | | | | | | | |
| measurement part | Blower Inside (Opposite Load Side) | | | | | | | | | | | | | | | | | | | | | | | | | | | | | | | | | | | | | | | |
| ID code | 135 | Direction of measurement | Vertical | Group No. | 115 | | | | | | | | | | | | | | | | | | | | | | | | | | | | | | | | | | | |
| Output | 30.0 kW | Rotational speed | 1247 min ⁻¹ | Axis diameter | 50 mm | | | | | | | | | | | | | | | | | | | | | | | | | | | | | | | | | | | |
|  | | | | | | | | | | | | | | | | | | | | | | | | | | | | | | | | | | | | | | | | |
| <p>【 Relative value Judgment 】 recorded time: 13 May 2010 13:01</p> <table border="1" style="width:100%; border-collapse: collapse;"> <thead> <tr> <th rowspan="2">Measurement Mode</th> <th colspan="2">Warning Level</th> <th rowspan="2">Measurements</th> <th rowspan="2">Judgment</th> </tr> <tr> <th>Attention</th> <th>Danger</th> </tr> </thead> <tbody> <tr> <td>ACC (THRU, OA) [G]</td> <td>1.00</td> <td>4.00</td> <td>0.683</td> <td>Good</td> </tr> <tr> <td>ACC (OA) [G]</td> <td>1.00</td> <td>4.00</td> <td>0.282</td> <td>Good</td> </tr> <tr> <td>ACC (PEAK) [G]</td> <td>3.00</td> <td>12.00</td> <td>1.100</td> <td>Good</td> </tr> <tr> <td>VEL [cm/s]</td> <td>0.40</td> <td>1.00</td> <td>0.361</td> <td>Good</td> </tr> <tr> <td>DISP [μm]</td> <td>30</td> <td>100</td> <td>25.0</td> <td>Good</td> </tr> </tbody> </table> <p style="text-align: center;">(1G=9.8m/s²)</p> | | | | | | | | | Measurement Mode | Warning Level | | Measurements | Judgment | Attention | Danger | ACC (THRU, OA) [G] | 1.00 | 4.00 | 0.683 | Good | ACC (OA) [G] | 1.00 | 4.00 | 0.282 | Good | ACC (PEAK) [G] | 3.00 | 12.00 | 1.100 | Good | VEL [cm/s] | 0.40 | 1.00 | 0.361 | Good | DISP [μ m] | 30 | 100 | 25.0 | Good |
| Measurement Mode | Warning Level | | Measurements | Judgment | | | | | | | | | | | | | | | | | | | | | | | | | | | | | | | | | | | | |
| | Attention | Danger | | | | | | | | | | | | | | | | | | | | | | | | | | | | | | | | | | | | | | |
| ACC (THRU, OA) [G] | 1.00 | 4.00 | 0.683 | Good | | | | | | | | | | | | | | | | | | | | | | | | | | | | | | | | | | | | |
| ACC (OA) [G] | 1.00 | 4.00 | 0.282 | Good | | | | | | | | | | | | | | | | | | | | | | | | | | | | | | | | | | | | |
| ACC (PEAK) [G] | 3.00 | 12.00 | 1.100 | Good | | | | | | | | | | | | | | | | | | | | | | | | | | | | | | | | | | | | |
| VEL [cm/s] | 0.40 | 1.00 | 0.361 | Good | | | | | | | | | | | | | | | | | | | | | | | | | | | | | | | | | | | | |
| DISP [μ m] | 30 | 100 | 25.0 | Good | | | | | | | | | | | | | | | | | | | | | | | | | | | | | | | | | | | | |
| <p>【 Absolute value Judgment 】 recorded time: 13 May 2010 13:01</p> <table border="1" style="width:100%; border-collapse: collapse;"> <thead> <tr> <th rowspan="2">Measurement Mode</th> <th colspan="2">Warning Level</th> <th rowspan="2">Measurements</th> <th rowspan="2">Judgment</th> </tr> <tr> <th>little bad</th> <th>Bad</th> </tr> </thead> <tbody> <tr> <td>ACC (OA) [G]</td> <td>0.28</td> <td>1.12</td> <td>0.282</td> <td>little bad</td> </tr> <tr> <td>VEL [cm/s]</td> <td>0.40</td> <td>1.00</td> <td>0.361</td> <td>little good</td> </tr> </tbody> </table> <p style="text-align: center;">(1G=9.8m/s²)</p> | | | | | | | | | Measurement Mode | Warning Level | | Measurements | Judgment | little bad | Bad | ACC (OA) [G] | 0.28 | 1.12 | 0.282 | little bad | VEL [cm/s] | 0.40 | 1.00 | 0.361 | little good | | | | | | | | | | | | | | | |
| Measurement Mode | Warning Level | | Measurements | Judgment | | | | | | | | | | | | | | | | | | | | | | | | | | | | | | | | | | | | |
| | little bad | Bad | | | | | | | | | | | | | | | | | | | | | | | | | | | | | | | | | | | | | | |
| ACC (OA) [G] | 0.28 | 1.12 | 0.282 | little bad | | | | | | | | | | | | | | | | | | | | | | | | | | | | | | | | | | | | |
| VEL [cm/s] | 0.40 | 1.00 | 0.361 | little good | | | | | | | | | | | | | | | | | | | | | | | | | | | | | | | | | | | | |
|  | | | | | | | | | | | | | | | | | | | | | | | | | | | | | | | | | | | | | | | | |
| 【Comment】 | | | | | | | | | | | | | | | | | | | | | | | | | | | | | | | | | | | | | | | | |

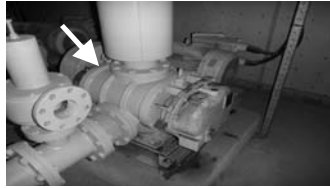
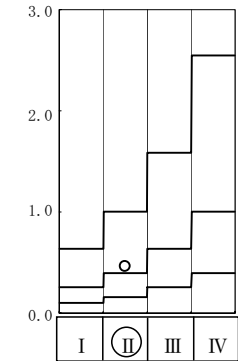
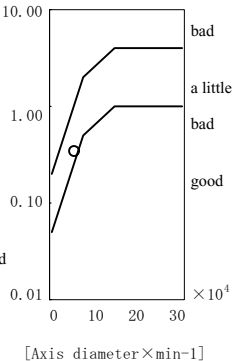
| Simple diagnosis report | | | | | | drawing | | | | | | | | | | | | | | | | | | | | | | | | | | | | | | | | | | | |
|--|---------------|--------------------------|------------------------|---------------|-------|---|---------------|--|--------------|----------|------------|--------|--------------------|------|------|-------|------------|--------------|------|------|-------|------------|----------------|------|-------|-------|------|------------|------|------|-------|-----------|-----------------|----|-----|------|-----------|--|--|--|--|
| equipment name | | | | | | Kim Lien WWTP | | | | | | | | | | | | | | | | | | | | | | | | | | | | | | | | | | | |
| machine name | | | | | | KBW1C Aeration Blower | | | | | | | | | | | | | | | | | | | | | | | | | | | | | | | | | | | |
| measurement part | | | | | | Blower Outside (Load Side) | | | | | | | | | | | | | | | | | | | | | | | | | | | | | | | | | | | |
| ID code | 134 | Direction of measurement | Vertical | Group No. | 114 |  | | | | | | | | | | | | | | | | | | | | | | | | | | | | | | | | | | | |
| Output | 30.0 kW | Rotational speed | 1247 min ⁻¹ | Axis diameter | 50 mm | | | | | | | | | | | | | | | | | | | | | | | | | | | | | | | | | | | | |
| <p>【 Relative value Judgment 】 recorded time: 13 May 2010 13:00</p> <table border="1" style="width:100%; border-collapse: collapse;"> <thead> <tr> <th rowspan="2">Measurement Mode</th> <th colspan="2">Warning Level</th> <th rowspan="2">Measurements</th> <th rowspan="2">Judgment</th> </tr> <tr> <th>Attention</th> <th>Danger</th> </tr> </thead> <tbody> <tr> <td>ACC (THRU, OA) [G]</td> <td>1.00</td> <td>4.00</td> <td>0.880</td> <td>Good</td> </tr> <tr> <td>ACC (OA) [G]</td> <td>1.00</td> <td>4.00</td> <td>0.344</td> <td>Good</td> </tr> <tr> <td>ACC (PEAK) [G]</td> <td>3.00</td> <td>12.00</td> <td>1.094</td> <td>Good</td> </tr> <tr> <td>VEL [cm/s]</td> <td>0.40</td> <td>1.00</td> <td>0.465</td> <td>Attention</td> </tr> <tr> <td>DISP [μm]</td> <td>30</td> <td>100</td> <td>61.0</td> <td>Attention</td> </tr> </tbody> </table> <p style="text-align: center;">(1G=9.8m/s²)</p> | | | | | | Measurement Mode | Warning Level | | Measurements | Judgment | Attention | Danger | ACC (THRU, OA) [G] | 1.00 | 4.00 | 0.880 | Good | ACC (OA) [G] | 1.00 | 4.00 | 0.344 | Good | ACC (PEAK) [G] | 3.00 | 12.00 | 1.094 | Good | VEL [cm/s] | 0.40 | 1.00 | 0.465 | Attention | DISP [μ m] | 30 | 100 | 61.0 | Attention | <p>【 Absolute value Judgment 】 (1G=9.8m/s²)</p> <div style="display: flex; justify-content: space-around;"> <div style="text-align: center;"> <p>Speed [cm/s]</p>  </div> <div style="text-align: center;"> <p>Acceleration [G]</p>  </div> </div> | | | |
| Measurement Mode | Warning Level | | Measurements | Judgment | | | | | | | | | | | | | | | | | | | | | | | | | | | | | | | | | | | | | |
| | Attention | Danger | | | | | | | | | | | | | | | | | | | | | | | | | | | | | | | | | | | | | | | |
| ACC (THRU, OA) [G] | 1.00 | 4.00 | 0.880 | Good | | | | | | | | | | | | | | | | | | | | | | | | | | | | | | | | | | | | | |
| ACC (OA) [G] | 1.00 | 4.00 | 0.344 | Good | | | | | | | | | | | | | | | | | | | | | | | | | | | | | | | | | | | | | |
| ACC (PEAK) [G] | 3.00 | 12.00 | 1.094 | Good | | | | | | | | | | | | | | | | | | | | | | | | | | | | | | | | | | | | | |
| VEL [cm/s] | 0.40 | 1.00 | 0.465 | Attention | | | | | | | | | | | | | | | | | | | | | | | | | | | | | | | | | | | | | |
| DISP [μ m] | 30 | 100 | 61.0 | Attention | | | | | | | | | | | | | | | | | | | | | | | | | | | | | | | | | | | | | |
| <p>【 Absolute value Judgment 】 recorded time: 13 May 2010 13:00</p> <table border="1" style="width:100%; border-collapse: collapse;"> <thead> <tr> <th rowspan="2">Measurement Mode</th> <th colspan="2">Warning Level</th> <th rowspan="2">Measurements</th> <th rowspan="2">Judgment</th> </tr> <tr> <th>little bad</th> <th>Bad</th> </tr> </thead> <tbody> <tr> <td>ACC (OA) [G]</td> <td>0.28</td> <td>1.12</td> <td>0.344</td> <td>little bad</td> </tr> <tr> <td>VEL [cm/s]</td> <td>0.40</td> <td>1.00</td> <td>0.465</td> <td>little bad</td> </tr> </tbody> </table> <p style="text-align: center;">(1G=9.8m/s²)</p> | | | | | | Measurement Mode | Warning Level | | Measurements | Judgment | little bad | Bad | ACC (OA) [G] | 0.28 | 1.12 | 0.344 | little bad | VEL [cm/s] | 0.40 | 1.00 | 0.465 | little bad | | | | | | | | | | | | | | | | | | | |
| Measurement Mode | Warning Level | | Measurements | Judgment | | | | | | | | | | | | | | | | | | | | | | | | | | | | | | | | | | | | | |
| | little bad | Bad | | | | | | | | | | | | | | | | | | | | | | | | | | | | | | | | | | | | | | | |
| ACC (OA) [G] | 0.28 | 1.12 | 0.344 | little bad | | | | | | | | | | | | | | | | | | | | | | | | | | | | | | | | | | | | | |
| VEL [cm/s] | 0.40 | 1.00 | 0.465 | little bad | | | | | | | | | | | | | | | | | | | | | | | | | | | | | | | | | | | | | |
| 【Comment】 | | | | | | | | | | | | | | | | | | | | | | | | | | | | | | | | | | | | | | | | | |

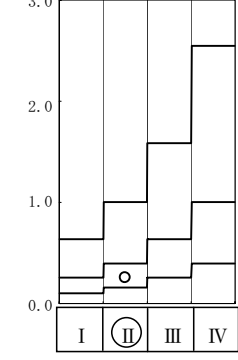
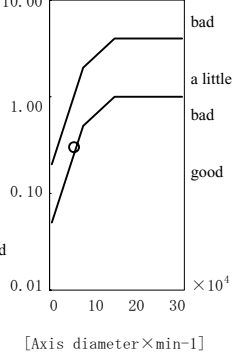
| 簡易診断報告書 | | | | | | drawing | | | | | | | | | | | | | | | | | | | | | | | | | | | | | | | | | | | |
|--|---------------|--------------------------|------------------------|---------------|-------|---|---------------|--|--------------|----------|------------|--------|--------------------|------|------|-------|------------|--------------|------|------|-------|-------------|----------------|------|-------|-------|------|------------|------|------|-------|------|-----------------|----|-----|------|------|--|--|--|--|
| equipment name | | | | | | Kim Lien WWTP | | | | | | | | | | | | | | | | | | | | | | | | | | | | | | | | | | | |
| machine name | | | | | | KBW1C Aeration Blower | | | | | | | | | | | | | | | | | | | | | | | | | | | | | | | | | | | |
| measurement part | | | | | | Blower Outside (Opposite Load Side) | | | | | | | | | | | | | | | | | | | | | | | | | | | | | | | | | | | |
| ID code | 136 | Direction of measurement | Vertical | Group No. | 116 |  | | | | | | | | | | | | | | | | | | | | | | | | | | | | | | | | | | | |
| Output | 30.0 kW | Rotational speed | 1247 min ⁻¹ | Axis diameter | 50 mm | | | | | | | | | | | | | | | | | | | | | | | | | | | | | | | | | | | | |
| <p>【 Relative value Judgment 】 recorded time: 13 May 2010 13:00</p> <table border="1" style="width:100%; border-collapse: collapse;"> <thead> <tr> <th rowspan="2">Measurement Mode</th> <th colspan="2">Warning Level</th> <th rowspan="2">Measurements</th> <th rowspan="2">Judgment</th> </tr> <tr> <th>Attention</th> <th>Danger</th> </tr> </thead> <tbody> <tr> <td>ACC (THRU, OA) [G]</td> <td>1.00</td> <td>4.00</td> <td>0.728</td> <td>Good</td> </tr> <tr> <td>ACC (OA) [G]</td> <td>1.00</td> <td>4.00</td> <td>0.300</td> <td>Good</td> </tr> <tr> <td>ACC (PEAK) [G]</td> <td>3.00</td> <td>12.00</td> <td>0.968</td> <td>Good</td> </tr> <tr> <td>VEL [cm/s]</td> <td>0.40</td> <td>1.00</td> <td>0.259</td> <td>Good</td> </tr> <tr> <td>DISP [μm]</td> <td>30</td> <td>100</td> <td>16.3</td> <td>Good</td> </tr> </tbody> </table> <p style="text-align: center;">(1G=9.8m/s²)</p> | | | | | | Measurement Mode | Warning Level | | Measurements | Judgment | Attention | Danger | ACC (THRU, OA) [G] | 1.00 | 4.00 | 0.728 | Good | ACC (OA) [G] | 1.00 | 4.00 | 0.300 | Good | ACC (PEAK) [G] | 3.00 | 12.00 | 0.968 | Good | VEL [cm/s] | 0.40 | 1.00 | 0.259 | Good | DISP [μ m] | 30 | 100 | 16.3 | Good | <p>【 Absolute value Judgment 】 (1G=9.8m/s²)</p> <div style="display: flex; justify-content: space-around;"> <div style="text-align: center;"> <p>Speed [cm/s]</p>  </div> <div style="text-align: center;"> <p>Acceleration [G]</p>  </div> </div> | | | |
| Measurement Mode | Warning Level | | Measurements | Judgment | | | | | | | | | | | | | | | | | | | | | | | | | | | | | | | | | | | | | |
| | Attention | Danger | | | | | | | | | | | | | | | | | | | | | | | | | | | | | | | | | | | | | | | |
| ACC (THRU, OA) [G] | 1.00 | 4.00 | 0.728 | Good | | | | | | | | | | | | | | | | | | | | | | | | | | | | | | | | | | | | | |
| ACC (OA) [G] | 1.00 | 4.00 | 0.300 | Good | | | | | | | | | | | | | | | | | | | | | | | | | | | | | | | | | | | | | |
| ACC (PEAK) [G] | 3.00 | 12.00 | 0.968 | Good | | | | | | | | | | | | | | | | | | | | | | | | | | | | | | | | | | | | | |
| VEL [cm/s] | 0.40 | 1.00 | 0.259 | Good | | | | | | | | | | | | | | | | | | | | | | | | | | | | | | | | | | | | | |
| DISP [μ m] | 30 | 100 | 16.3 | Good | | | | | | | | | | | | | | | | | | | | | | | | | | | | | | | | | | | | | |
| <p>【 Absolute value Judgment 】 recorded time: 13 May 2010 13:00</p> <table border="1" style="width:100%; border-collapse: collapse;"> <thead> <tr> <th rowspan="2">Measurement Mode</th> <th colspan="2">Warning Level</th> <th rowspan="2">Measurements</th> <th rowspan="2">Judgment</th> </tr> <tr> <th>little bad</th> <th>Bad</th> </tr> </thead> <tbody> <tr> <td>ACC (OA) [G]</td> <td>0.28</td> <td>1.12</td> <td>0.300</td> <td>little bad</td> </tr> <tr> <td>VEL [cm/s]</td> <td>0.40</td> <td>1.00</td> <td>0.259</td> <td>little good</td> </tr> </tbody> </table> <p style="text-align: center;">(1G=9.8m/s²)</p> | | | | | | Measurement Mode | Warning Level | | Measurements | Judgment | little bad | Bad | ACC (OA) [G] | 0.28 | 1.12 | 0.300 | little bad | VEL [cm/s] | 0.40 | 1.00 | 0.259 | little good | | | | | | | | | | | | | | | | | | | |
| Measurement Mode | Warning Level | | Measurements | Judgment | | | | | | | | | | | | | | | | | | | | | | | | | | | | | | | | | | | | | |
| | little bad | Bad | | | | | | | | | | | | | | | | | | | | | | | | | | | | | | | | | | | | | | | |
| ACC (OA) [G] | 0.28 | 1.12 | 0.300 | little bad | | | | | | | | | | | | | | | | | | | | | | | | | | | | | | | | | | | | | |
| VEL [cm/s] | 0.40 | 1.00 | 0.259 | little good | | | | | | | | | | | | | | | | | | | | | | | | | | | | | | | | | | | | | |
| 【Comment】 | | | | | | | | | | | | | | | | | | | | | | | | | | | | | | | | | | | | | | | | | |

drawing date: 24 May 2010

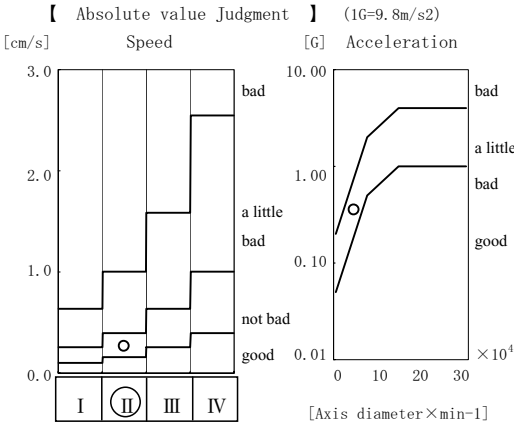
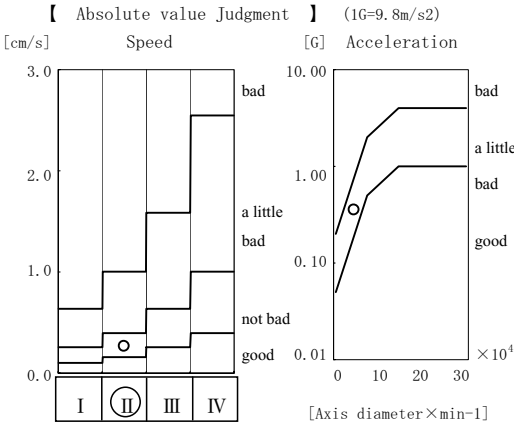
| Simple diagnosis report | | | | | | | | | drawing |
|---|---------|--------------------------|------------------------|---------------|-------------|---|--|--|---------|
| equipment name | | | | | | Truc Bach WWTP | | | |
| machine name | | | | | | TBW1A Aeration Blower | | | |
| measurement part | | | | | | Motor (Opposite Load Side) | | | |
| ID code | 211 | Direction of measurement | Vertical | Group No. | 211 |  | | | |
| Output | 15.0 kW | Rotational speed | 1469 min ⁻¹ | Axis diameter | 40 mm | | | | |
| 【 Relative value Judgment 】 recorded time: 18 May 2010 16:18 | | | | | | 【 Absolute value Judgment 】 (1G=9.8m/s ²) [cm/s] Speed [G] Acceleration  | | | |
| Measurement Mode | | Warning Level | | Measurements | Judgment | | | | |
| | | Attention | Danger | | | | | | |
| ACC (THRU, OA) | [G] | 1.00 | 4.00 | 0.592 | Good | | | | |
| ACC (OA) | [G] | 1.00 | 4.00 | 0.356 | Good | | | | |
| ACC (PEAK) | [G] | 3.00 | 12.00 | 1.084 | Good | | | | |
| VEL | [cm/s] | 0.40 | 1.00 | 0.268 | Good | | | | |
| DISP | [μm] | 30 | 100 | 21.7 | Good | | | | |
| (1G=9.8m/s ²) | | | | | | | | | |
| 【 Absolute value Judgment 】 recorded time: 18 May 2010 16:18 | | | | | | 【 Absolute value Judgment 】 (1G=9.8m/s ²) [cm/s] Speed [G] Acceleration  | | | |
| Measurement Mode | | Warning Level | | Measurements | Judgment | | | | |
| | | little bad | Bad | | | | | | |
| ACC (OA) | [G] | 0.25 | 1.00 | 0.356 | little bad | | | | |
| VEL | [cm/s] | 0.40 | 1.00 | 0.268 | little good | | | | |
| (1G=9.8m/s ²) | | | | | | | | | |
| 【Comment】 | | | | | | | | | |

drawing date: 16 Jul 2010

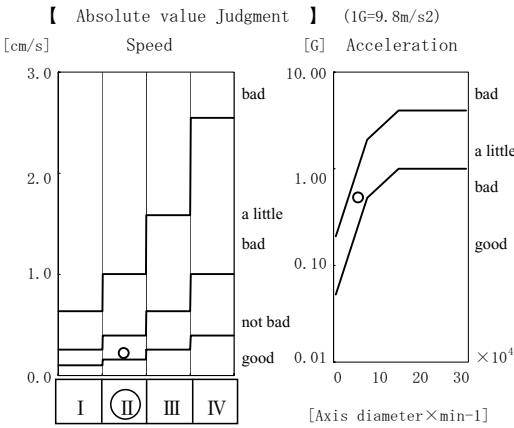
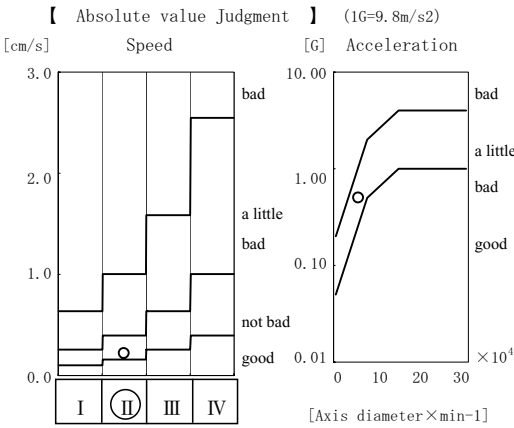
| Simple diagnosis report | | | | | | | | | drawing |
|---|---------|--------------------------|------------------------|---------------|-------------|---|--|--|---------|
| equipment name | | | | | | Truc Bach WWTP | | | |
| machine name | | | | | | TBW1A Aeration Blower | | | |
| measurement part | | | | | | Motor (Opposite Load Side) | | | |
| ID code | 211 | Direction of measurement | Vertical | Group No. | 211 |  | | | |
| Output | 15.0 kW | Rotational speed | 1469 min ⁻¹ | Axis diameter | 40 mm | | | | |
| 【 Relative value Judgment 】 recorded time: 16 Jul 2010 11:34 | | | | | | 【 Absolute value Judgment 】 (1G=9.8m/s ²) [cm/s] Speed [G] Acceleration  | | | |
| Measurement Mode | | Warning Level | | Measurements | Judgment | | | | |
| | | Attention | Danger | | | | | | |
| ACC (THRU, OA) | [G] | 1.00 | 4.00 | 0.655 | Good | | | | |
| ACC (OA) | [G] | 1.00 | 4.00 | 0.491 | Good | | | | |
| ACC (PEAK) | [G] | 3.00 | 12.00 | 1.253 | Good | | | | |
| VEL | [cm/s] | 0.40 | 1.00 | 0.248 | Good | | | | |
| DISP | [μm] | 30 | 100 | 16.9 | Good | | | | |
| (1G=9.8m/s ²) | | | | | | | | | |
| 【 Absolute value Judgment 】 recorded time: 16 Jul 2010 11:34 | | | | | | 【 Absolute value Judgment 】 (1G=9.8m/s ²) [cm/s] Speed [G] Acceleration  | | | |
| Measurement Mode | | Warning Level | | Measurements | Judgment | | | | |
| | | little bad | Bad | | | | | | |
| ACC (OA) | [G] | 0.25 | 1.00 | 0.491 | little bad | | | | |
| VEL | [cm/s] | 0.40 | 1.00 | 0.248 | little good | | | | |
| (1G=9.8m/s ²) | | | | | | | | | |
| 【Comment】 | | | | | | | | | |

drawing date: 24 May 2010

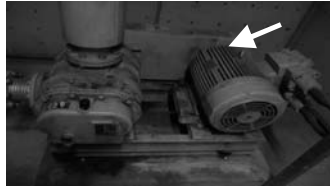
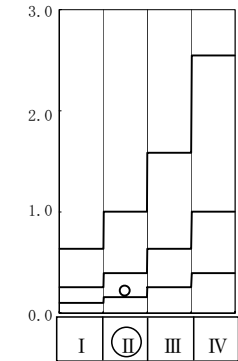
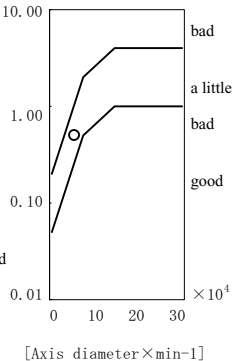
| Simple diagnosis report | | | | | | | | | drawing | | | | | | | | | | | | | | | | | | | | | | | | | | | | | | | | | | | | | | |
|--|---------|--------------------------|------------------------|---------------|-------------|---|-----|---------------|---------|--------------|----------|------------|--------|----------------|-----|------|------|-------|------------|----------|--------|------|------|-------|-------------|------------|-----|------|-------|-------|------|-----|--------|------|------|-------|------|------|------|----|-----|------|------|--|--|--|--|
| equipment name | | | | | | Truc Bach WWTP | | | | | | | | | | | | | | | | | | | | | | | | | | | | | | | | | | | | | | | | | |
| machine name | | | | | | TBW1A Aeration Blower | | | | | | | | | | | | | | | | | | | | | | | | | | | | | | | | | | | | | | | | | |
| measurement part | | | | | | Moter (Load Side) | | | | | | | | | | | | | | | | | | | | | | | | | | | | | | | | | | | | | | | | | |
| ID code | 212 | Direction of measurement | Vertical | Group No. | 212 |  | | | | | | | | | | | | | | | | | | | | | | | | | | | | | | | | | | | | | | | | | |
| Output | 15.0 kW | Rotational speed | 1469 min ⁻¹ | Axis diameter | 45 mm | | | | | | | | | | | | | | | | | | | | | | | | | | | | | | | | | | | | | | | | | | |
| <p>【 Relative value Judgment 】 recorded time: 18 May 2010 16:18</p> <table border="1" style="width:100%; border-collapse: collapse;"> <thead> <tr> <th rowspan="2">Measurement Mode</th> <th rowspan="2">[G]</th> <th colspan="2">Warning Level</th> <th rowspan="2">Measurements</th> <th rowspan="2">Judgment</th> </tr> <tr> <th>Attention</th> <th>Danger</th> </tr> </thead> <tbody> <tr> <td>ACC (THRU, OA)</td> <td>[G]</td> <td>1.00</td> <td>4.00</td> <td>1.069</td> <td>Attention</td> </tr> <tr> <td>ACC (OA)</td> <td>[G]</td> <td>1.00</td> <td>4.00</td> <td>0.503</td> <td>Good</td> </tr> <tr> <td>ACC (PEAK)</td> <td>[G]</td> <td>3.00</td> <td>12.00</td> <td>1.138</td> <td>Good</td> </tr> <tr> <td>VEL</td> <td>[cm/s]</td> <td>0.40</td> <td>1.00</td> <td>0.220</td> <td>Good</td> </tr> <tr> <td>DISP</td> <td>[μm]</td> <td>30</td> <td>100</td> <td>15.6</td> <td>Good</td> </tr> </tbody> </table> <p style="text-align: center;">(1G=9.8m/s²)</p> | | | | | | Measurement Mode | [G] | Warning Level | | Measurements | Judgment | Attention | Danger | ACC (THRU, OA) | [G] | 1.00 | 4.00 | 1.069 | Attention | ACC (OA) | [G] | 1.00 | 4.00 | 0.503 | Good | ACC (PEAK) | [G] | 3.00 | 12.00 | 1.138 | Good | VEL | [cm/s] | 0.40 | 1.00 | 0.220 | Good | DISP | [μm] | 30 | 100 | 15.6 | Good | <p>【 Absolute value Judgment 】 (1G=9.8m/s²)</p> <div style="display: flex; justify-content: space-around;"> <div style="text-align: center;"> <p>Speed [cm/s]</p>  </div> <div style="text-align: center;"> <p>Acceleration [G]</p>  </div> </div> <p style="text-align: center;">[Axis diameter×min⁻¹]</p> | | | |
| Measurement Mode | [G] | Warning Level | | Measurements | Judgment | | | | | | | | | | | | | | | | | | | | | | | | | | | | | | | | | | | | | | | | | | |
| | | Attention | Danger | | | | | | | | | | | | | | | | | | | | | | | | | | | | | | | | | | | | | | | | | | | | |
| ACC (THRU, OA) | [G] | 1.00 | 4.00 | 1.069 | Attention | | | | | | | | | | | | | | | | | | | | | | | | | | | | | | | | | | | | | | | | | | |
| ACC (OA) | [G] | 1.00 | 4.00 | 0.503 | Good | | | | | | | | | | | | | | | | | | | | | | | | | | | | | | | | | | | | | | | | | | |
| ACC (PEAK) | [G] | 3.00 | 12.00 | 1.138 | Good | | | | | | | | | | | | | | | | | | | | | | | | | | | | | | | | | | | | | | | | | | |
| VEL | [cm/s] | 0.40 | 1.00 | 0.220 | Good | | | | | | | | | | | | | | | | | | | | | | | | | | | | | | | | | | | | | | | | | | |
| DISP | [μm] | 30 | 100 | 15.6 | Good | | | | | | | | | | | | | | | | | | | | | | | | | | | | | | | | | | | | | | | | | | |
| <p>【 Absolute value Judgment 】 recorded time: 18 May 2010 16:18</p> <table border="1" style="width:100%; border-collapse: collapse;"> <thead> <tr> <th rowspan="2">Measurement Mode</th> <th rowspan="2">[G]</th> <th colspan="2">Warning Level</th> <th rowspan="2">Measurements</th> <th rowspan="2">Judgment</th> </tr> <tr> <th>little bad</th> <th>Bad</th> </tr> </thead> <tbody> <tr> <td>ACC (OA)</td> <td>[G]</td> <td>0.32</td> <td>1.27</td> <td>0.503</td> <td>little bad</td> </tr> <tr> <td>VEL</td> <td>[cm/s]</td> <td>0.40</td> <td>1.00</td> <td>0.220</td> <td>little good</td> </tr> </tbody> </table> <p style="text-align: center;">(1G=9.8m/s²)</p> | | | | | | Measurement Mode | [G] | Warning Level | | Measurements | Judgment | little bad | Bad | ACC (OA) | [G] | 0.32 | 1.27 | 0.503 | little bad | VEL | [cm/s] | 0.40 | 1.00 | 0.220 | little good | | | | | | | | | | | | | | | | | | | | | | |
| Measurement Mode | [G] | Warning Level | | Measurements | Judgment | | | | | | | | | | | | | | | | | | | | | | | | | | | | | | | | | | | | | | | | | | |
| | | little bad | Bad | | | | | | | | | | | | | | | | | | | | | | | | | | | | | | | | | | | | | | | | | | | | |
| ACC (OA) | [G] | 0.32 | 1.27 | 0.503 | little bad | | | | | | | | | | | | | | | | | | | | | | | | | | | | | | | | | | | | | | | | | | |
| VEL | [cm/s] | 0.40 | 1.00 | 0.220 | little good | | | | | | | | | | | | | | | | | | | | | | | | | | | | | | | | | | | | | | | | | | |
| 【Comment】 | | | | | | | | | | | | | | | | | | | | | | | | | | | | | | | | | | | | | | | | | | | | | | | |

drawing date: 16 Jul 2010

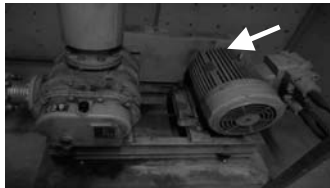
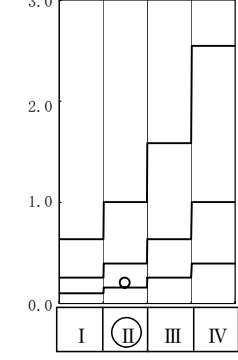
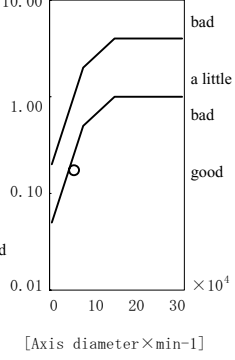
| Simple diagnosis report | | | | | | | | | drawing | | | | | | | | | | | | | | | | | | | | | | | | | | | | | | | | | | | | | | |
|---|---------|--------------------------|------------------------|---------------|-------------|---|-----|---------------|---------|--------------|----------|------------|--------|----------------|-----|------|------|-------|------|----------|--------|------|------|-------|-------------|------------|-----|------|-------|-------|------|-----|--------|------|------|-------|------|------|------|----|-----|------|------|--|--|--|--|
| equipment name | | | | | | Truc Bach WWTP | | | | | | | | | | | | | | | | | | | | | | | | | | | | | | | | | | | | | | | | | |
| machine name | | | | | | TBW1A Aeration Blower | | | | | | | | | | | | | | | | | | | | | | | | | | | | | | | | | | | | | | | | | |
| measurement part | | | | | | Moter (Load Side) | | | | | | | | | | | | | | | | | | | | | | | | | | | | | | | | | | | | | | | | | |
| ID code | 212 | Direction of measurement | Vertical | Group No. | 212 |  | | | | | | | | | | | | | | | | | | | | | | | | | | | | | | | | | | | | | | | | | |
| Output | 15.0 kW | Rotational speed | 1469 min ⁻¹ | Axis diameter | 45 mm | | | | | | | | | | | | | | | | | | | | | | | | | | | | | | | | | | | | | | | | | | |
| <p>【 Relative value Judgment 】 recorded time: 16 Jul 2010 11:34</p> <table border="1" style="width:100%; border-collapse: collapse;"> <thead> <tr> <th rowspan="2">Measurement Mode</th> <th rowspan="2">[G]</th> <th colspan="2">Warning Level</th> <th rowspan="2">Measurements</th> <th rowspan="2">Judgment</th> </tr> <tr> <th>Attention</th> <th>Danger</th> </tr> </thead> <tbody> <tr> <td>ACC (THRU, OA)</td> <td>[G]</td> <td>1.00</td> <td>4.00</td> <td>0.425</td> <td>Good</td> </tr> <tr> <td>ACC (OA)</td> <td>[G]</td> <td>1.00</td> <td>4.00</td> <td>0.173</td> <td>Good</td> </tr> <tr> <td>ACC (PEAK)</td> <td>[G]</td> <td>3.00</td> <td>12.00</td> <td>0.554</td> <td>Good</td> </tr> <tr> <td>VEL</td> <td>[cm/s]</td> <td>0.40</td> <td>1.00</td> <td>0.205</td> <td>Good</td> </tr> <tr> <td>DISP</td> <td>[μm]</td> <td>30</td> <td>100</td> <td>16.4</td> <td>Good</td> </tr> </tbody> </table> <p style="text-align: center;">(1G=9.8m/s²)</p> | | | | | | Measurement Mode | [G] | Warning Level | | Measurements | Judgment | Attention | Danger | ACC (THRU, OA) | [G] | 1.00 | 4.00 | 0.425 | Good | ACC (OA) | [G] | 1.00 | 4.00 | 0.173 | Good | ACC (PEAK) | [G] | 3.00 | 12.00 | 0.554 | Good | VEL | [cm/s] | 0.40 | 1.00 | 0.205 | Good | DISP | [μm] | 30 | 100 | 16.4 | Good | <p>【 Absolute value Judgment 】 (1G=9.8m/s²)</p> <div style="display: flex; justify-content: space-around;"> <div style="text-align: center;"> <p>Speed [cm/s]</p>  </div> <div style="text-align: center;"> <p>Acceleration [G]</p>  </div> </div> <p style="text-align: center;">[Axis diameter×min⁻¹]</p> | | | |
| Measurement Mode | [G] | Warning Level | | Measurements | Judgment | | | | | | | | | | | | | | | | | | | | | | | | | | | | | | | | | | | | | | | | | | |
| | | Attention | Danger | | | | | | | | | | | | | | | | | | | | | | | | | | | | | | | | | | | | | | | | | | | | |
| ACC (THRU, OA) | [G] | 1.00 | 4.00 | 0.425 | Good | | | | | | | | | | | | | | | | | | | | | | | | | | | | | | | | | | | | | | | | | | |
| ACC (OA) | [G] | 1.00 | 4.00 | 0.173 | Good | | | | | | | | | | | | | | | | | | | | | | | | | | | | | | | | | | | | | | | | | | |
| ACC (PEAK) | [G] | 3.00 | 12.00 | 0.554 | Good | | | | | | | | | | | | | | | | | | | | | | | | | | | | | | | | | | | | | | | | | | |
| VEL | [cm/s] | 0.40 | 1.00 | 0.205 | Good | | | | | | | | | | | | | | | | | | | | | | | | | | | | | | | | | | | | | | | | | | |
| DISP | [μm] | 30 | 100 | 16.4 | Good | | | | | | | | | | | | | | | | | | | | | | | | | | | | | | | | | | | | | | | | | | |
| <p>【 Absolute value Judgment 】 recorded time: 16 Jul 2010 11:34</p> <table border="1" style="width:100%; border-collapse: collapse;"> <thead> <tr> <th rowspan="2">Measurement Mode</th> <th rowspan="2">[G]</th> <th colspan="2">Warning Level</th> <th rowspan="2">Measurements</th> <th rowspan="2">Judgment</th> </tr> <tr> <th>little bad</th> <th>Bad</th> </tr> </thead> <tbody> <tr> <td>ACC (OA)</td> <td>[G]</td> <td>0.32</td> <td>1.27</td> <td>0.173</td> <td>Good</td> </tr> <tr> <td>VEL</td> <td>[cm/s]</td> <td>0.40</td> <td>1.00</td> <td>0.205</td> <td>little good</td> </tr> </tbody> </table> <p style="text-align: center;">(1G=9.8m/s²)</p> | | | | | | Measurement Mode | [G] | Warning Level | | Measurements | Judgment | little bad | Bad | ACC (OA) | [G] | 0.32 | 1.27 | 0.173 | Good | VEL | [cm/s] | 0.40 | 1.00 | 0.205 | little good | | | | | | | | | | | | | | | | | | | | | | |
| Measurement Mode | [G] | Warning Level | | Measurements | Judgment | | | | | | | | | | | | | | | | | | | | | | | | | | | | | | | | | | | | | | | | | | |
| | | little bad | Bad | | | | | | | | | | | | | | | | | | | | | | | | | | | | | | | | | | | | | | | | | | | | |
| ACC (OA) | [G] | 0.32 | 1.27 | 0.173 | Good | | | | | | | | | | | | | | | | | | | | | | | | | | | | | | | | | | | | | | | | | | |
| VEL | [cm/s] | 0.40 | 1.00 | 0.205 | little good | | | | | | | | | | | | | | | | | | | | | | | | | | | | | | | | | | | | | | | | | | |
| 【Comment】 | | | | | | | | | | | | | | | | | | | | | | | | | | | | | | | | | | | | | | | | | | | | | | | |

drawing date: 24 May 2010

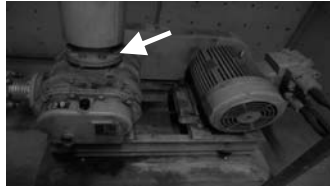
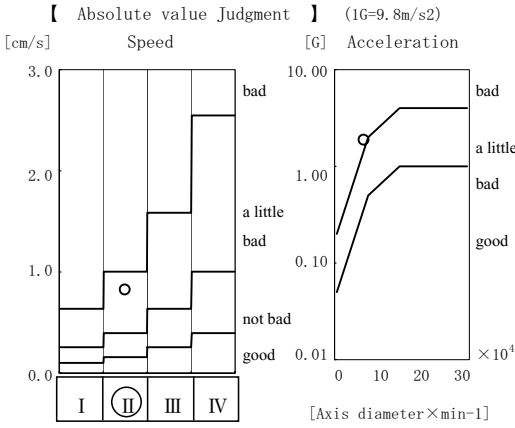
| Simple diagnosis report | | | | | | | | | drawing |
|---|---------|--------------------------|------------------------|---------------|------------|---|--|--|---------|
| equipment name | | | | | | Truc Bach WWTP | | | |
| machine name | | | | | | TBW1A Aeration Blower | | | |
| measurement part | | | | | | Blower Inside (Load Side) | | | |
| ID code | 213 | Direction of measurement | Vertical | Group No. | 213 |  | | | |
| Output | 15.0 kW | Rotational speed | 1518 min ⁻¹ | Axis diameter | 50 mm | | | | |
| 【 Relative value Judgment 】 recorded time: 18 May 2010 16:19 | | | | | | 【 Absolute value Judgment 】 (1G=9.8m/s ²) [cm/s] Speed [G] Acceleration  | | | |
| Measurement Mode | | Warning Level | | Measurements | Judgment | | | | |
| | | Attention | Danger | | | | | | |
| ACC (THRU, OA) | [G] | 1.00 | 4.00 | 3.890 | Attention | | | | |
| ACC (OA) | [G] | 1.00 | 4.00 | 1.885 | Attention | | | | |
| ACC (PEAK) | [G] | 3.00 | 12.00 | 5.622 | Attention | | | | |
| VEL | [cm/s] | 0.40 | 1.00 | 0.827 | Attention | | | | |
| DISP | [μm] | 30 | 100 | 75.8 | Attention | | | | |
| (1G=9.8m/s ²) | | | | | | | | | |
| 【 Absolute value Judgment 】 recorded time: 18 May 2010 16:19 | | | | | | | | | |
| Measurement Mode | | Warning Level | | Measurements | Judgment | | | | |
| | | little bad | Bad | | | | | | |
| ACC (OA) | [G] | 0.44 | 1.75 | 1.885 | Bad | | | | |
| VEL | [cm/s] | 0.40 | 1.00 | 0.827 | little bad | | | | |
| (1G=9.8m/s ²) | | | | | | | | | |
| 【Comment】 | | | | | | | | | |

drawing date: 16 Jul 2010

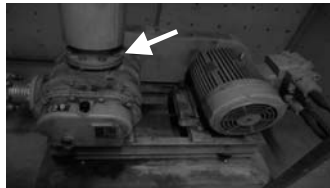
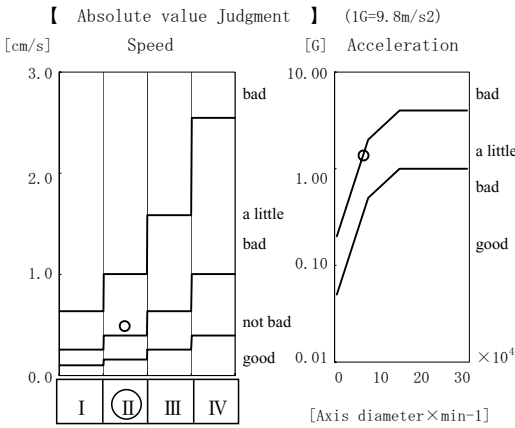
| Simple diagnosis report | | | | | | | | | drawing |
|---|---------|--------------------------|------------------------|---------------|------------|---|--|--|---------|
| equipment name | | | | | | Truc Bach WWTP | | | |
| machine name | | | | | | TBW1A Aeration Blower | | | |
| measurement part | | | | | | Blower Inside (Load Side) | | | |
| ID code | 213 | Direction of measurement | Vertical | Group No. | 213 |  | | | |
| Output | 15.0 kW | Rotational speed | 1518 min ⁻¹ | Axis diameter | 50 mm | | | | |
| 【 Relative value Judgment 】 recorded time: 16 Jul 2010 11:35 | | | | | | 【 Absolute value Judgment 】 (1G=9.8m/s ²) [cm/s] Speed [G] Acceleration  | | | |
| Measurement Mode | | Warning Level | | Measurements | Judgment | | | | |
| | | Attention | Danger | | | | | | |
| ACC (THRU, OA) | [G] | 1.00 | 4.00 | 2.147 | Attention | | | | |
| ACC (OA) | [G] | 1.00 | 4.00 | 1.362 | Attention | | | | |
| ACC (PEAK) | [G] | 3.00 | 12.00 | 3.625 | Attention | | | | |
| VEL | [cm/s] | 0.40 | 1.00 | 0.487 | Attention | | | | |
| DISP | [μm] | 30 | 100 | 38.7 | Attention | | | | |
| (1G=9.8m/s ²) | | | | | | | | | |
| 【 Absolute value Judgment 】 recorded time: 16 Jul 2010 11:35 | | | | | | | | | |
| Measurement Mode | | Warning Level | | Measurements | Judgment | | | | |
| | | little bad | Bad | | | | | | |
| ACC (OA) | [G] | 0.44 | 1.75 | 1.362 | little bad | | | | |
| VEL | [cm/s] | 0.40 | 1.00 | 0.487 | little bad | | | | |
| (1G=9.8m/s ²) | | | | | | | | | |
| 【Comment】 | | | | | | | | | |

drawing date: 24 May 2010

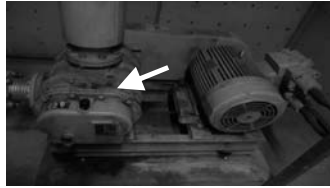
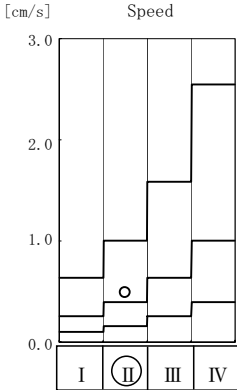
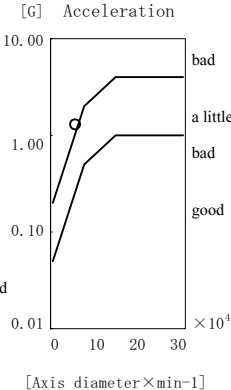
| Simple diagnosis report | | | | | | | | | drawing | | | | | | | | | | | | | | | | | | | | | | | | | | | | | | | | | | | | | | |
|---|--------|--------------------------|--------|---------------|------------|------------------------------------|-----|---------------|---------|--------------|----------|------------|--------|----------------|-----|------|------|-------|------------|----------|--------|------|------|-------|------------|--|-----|------|-------|-------|-----------|-----|--------|------|------|-------|-----------|------|------|----|-----|------|------|---|--|--|--|
| equipment name | | | | | | Truc Bach WWTP | | | | | | | | | | | | | | | | | | | | | | | | | | | | | | | | | | | | | | | | | |
| machine name | | | | | | TBW1A Aeration Blower | | | | | | | | | | | | | | | | | | | | | | | | | | | | | | | | | | | | | | | | | |
| measurement part | | | | | | Blower Inside (Opposite Load Side) | | | | | | | | | | | | | | | | | | | | | | | | | | | | | | | | | | | | | | | | | |
| ID code | | Direction of measurement | | Group No. | | 215 | | | | | | | | | | | | | | | | | | | | | | | | | | | | | | | | | | | | | | | | | |
| Output | | Rotational speed | | Axis diameter | | 45 mm | | | | | | | | | | | | | | | | | | | | | | | | | | | | | | | | | | | | | | | | | |
| <p>【 Relative value Judgment 】 recorded time: 18 May 2010 16:20</p> <table border="1" style="width:100%; border-collapse: collapse;"> <thead> <tr> <th rowspan="2">Measurement Mode</th> <th rowspan="2">[G]</th> <th colspan="2">Warning Level</th> <th rowspan="2">Measurements</th> <th rowspan="2">Judgment</th> </tr> <tr> <th>Attention</th> <th>Danger</th> </tr> </thead> <tbody> <tr> <td>ACC (THRU, OA)</td> <td>[G]</td> <td>1.00</td> <td>4.00</td> <td>2.330</td> <td>Attention</td> </tr> <tr> <td>ACC (OA)</td> <td>[G]</td> <td>1.00</td> <td>4.00</td> <td>1.297</td> <td>Attention</td> </tr> <tr> <td>ACC (PEAK)</td> <td>[G]</td> <td>3.00</td> <td>12.00</td> <td>3.585</td> <td>Attention</td> </tr> <tr> <td>VEL</td> <td>[cm/s]</td> <td>0.40</td> <td>1.00</td> <td>0.495</td> <td>Attention</td> </tr> <tr> <td>DISP</td> <td>[μm]</td> <td>30</td> <td>100</td> <td>29.1</td> <td>Good</td> </tr> </tbody> </table> <p style="text-align: center;">(1G=9.8m/s²)</p> | | | | | | Measurement Mode | [G] | Warning Level | | Measurements | Judgment | Attention | Danger | ACC (THRU, OA) | [G] | 1.00 | 4.00 | 2.330 | Attention | ACC (OA) | [G] | 1.00 | 4.00 | 1.297 | Attention | ACC (PEAK) | [G] | 3.00 | 12.00 | 3.585 | Attention | VEL | [cm/s] | 0.40 | 1.00 | 0.495 | Attention | DISP | [μm] | 30 | 100 | 29.1 | Good |  | | | |
| Measurement Mode | [G] | Warning Level | | Measurements | Judgment | | | | | | | | | | | | | | | | | | | | | | | | | | | | | | | | | | | | | | | | | | |
| | | Attention | Danger | | | | | | | | | | | | | | | | | | | | | | | | | | | | | | | | | | | | | | | | | | | | |
| ACC (THRU, OA) | [G] | 1.00 | 4.00 | 2.330 | Attention | | | | | | | | | | | | | | | | | | | | | | | | | | | | | | | | | | | | | | | | | | |
| ACC (OA) | [G] | 1.00 | 4.00 | 1.297 | Attention | | | | | | | | | | | | | | | | | | | | | | | | | | | | | | | | | | | | | | | | | | |
| ACC (PEAK) | [G] | 3.00 | 12.00 | 3.585 | Attention | | | | | | | | | | | | | | | | | | | | | | | | | | | | | | | | | | | | | | | | | | |
| VEL | [cm/s] | 0.40 | 1.00 | 0.495 | Attention | | | | | | | | | | | | | | | | | | | | | | | | | | | | | | | | | | | | | | | | | | |
| DISP | [μm] | 30 | 100 | 29.1 | Good | | | | | | | | | | | | | | | | | | | | | | | | | | | | | | | | | | | | | | | | | | |
| <p>【 Absolute value Judgment 】 recorded time: 18 May 2010 16:20</p> <table border="1" style="width:100%; border-collapse: collapse;"> <thead> <tr> <th rowspan="2">Measurement Mode</th> <th rowspan="2">[G]</th> <th colspan="2">Warning Level</th> <th rowspan="2">Measurements</th> <th rowspan="2">Judgment</th> </tr> <tr> <th>little bad</th> <th>Bad</th> </tr> </thead> <tbody> <tr> <td>ACC (OA)</td> <td>[G]</td> <td>0.34</td> <td>1.37</td> <td>1.297</td> <td>little bad</td> </tr> <tr> <td>VEL</td> <td>[cm/s]</td> <td>0.40</td> <td>1.00</td> <td>0.495</td> <td>little bad</td> </tr> </tbody> </table> <p style="text-align: center;">(1G=9.8m/s²)</p> | | | | | | Measurement Mode | [G] | Warning Level | | Measurements | Judgment | little bad | Bad | ACC (OA) | [G] | 0.34 | 1.37 | 1.297 | little bad | VEL | [cm/s] | 0.40 | 1.00 | 0.495 | little bad | <p>【 Absolute value Judgment 】 (1G=9.8m/s²)</p> <div style="display: flex; justify-content: space-around;"> <div style="text-align: center;"> <p>Speed [cm/s]</p>  </div> <div style="text-align: center;"> <p>Acceleration [G]</p>  </div> </div> | | | | | | | | | | | | | | | | | | | | | |
| Measurement Mode | [G] | Warning Level | | Measurements | Judgment | | | | | | | | | | | | | | | | | | | | | | | | | | | | | | | | | | | | | | | | | | |
| | | little bad | Bad | | | | | | | | | | | | | | | | | | | | | | | | | | | | | | | | | | | | | | | | | | | | |
| ACC (OA) | [G] | 0.34 | 1.37 | 1.297 | little bad | | | | | | | | | | | | | | | | | | | | | | | | | | | | | | | | | | | | | | | | | | |
| VEL | [cm/s] | 0.40 | 1.00 | 0.495 | little bad | | | | | | | | | | | | | | | | | | | | | | | | | | | | | | | | | | | | | | | | | | |
| 【Comment】 | | | | | | | | | | | | | | | | | | | | | | | | | | | | | | | | | | | | | | | | | | | | | | | |

drawing date: 16 Jul 2010

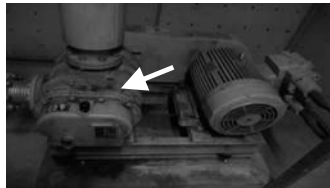
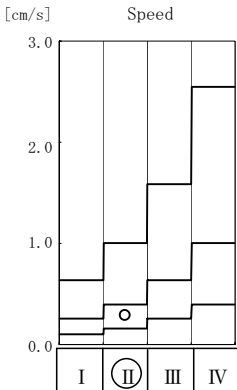
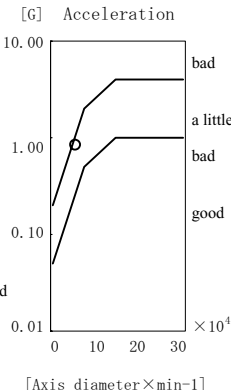
| Simple diagnosis report | | | | | | | | | drawing | | | | | | | | | | | | | | | | | | | | | | | | | | | | | | | | | | | | | | |
|--|--------|--------------------------|--------|---------------|-------------|------------------------------------|-----|---------------|---------|--------------|----------|------------|--------|----------------|-----|------|------|-------|------------|----------|--------|------|------|-------|-------------|--|-----|------|-------|-------|------|-----|--------|------|------|-------|------|------|------|----|-----|------|------|---|--|--|--|
| equipment name | | | | | | Truc Bach WWTP | | | | | | | | | | | | | | | | | | | | | | | | | | | | | | | | | | | | | | | | | |
| machine name | | | | | | TBW1A Aeration Blower | | | | | | | | | | | | | | | | | | | | | | | | | | | | | | | | | | | | | | | | | |
| measurement part | | | | | | Blower Inside (Opposite Load Side) | | | | | | | | | | | | | | | | | | | | | | | | | | | | | | | | | | | | | | | | | |
| ID code | | Direction of measurement | | Group No. | | 215 | | | | | | | | | | | | | | | | | | | | | | | | | | | | | | | | | | | | | | | | | |
| Output | | Rotational speed | | Axis diameter | | 45 mm | | | | | | | | | | | | | | | | | | | | | | | | | | | | | | | | | | | | | | | | | |
| <p>【 Relative value Judgment 】 recorded time: 16 Jul 2010 11:36</p> <table border="1" style="width:100%; border-collapse: collapse;"> <thead> <tr> <th rowspan="2">Measurement Mode</th> <th rowspan="2">[G]</th> <th colspan="2">Warning Level</th> <th rowspan="2">Measurements</th> <th rowspan="2">Judgment</th> </tr> <tr> <th>Attention</th> <th>Danger</th> </tr> </thead> <tbody> <tr> <td>ACC (THRU, OA)</td> <td>[G]</td> <td>1.00</td> <td>4.00</td> <td>1.555</td> <td>Attention</td> </tr> <tr> <td>ACC (OA)</td> <td>[G]</td> <td>1.00</td> <td>4.00</td> <td>0.844</td> <td>Good</td> </tr> <tr> <td>ACC (PEAK)</td> <td>[G]</td> <td>3.00</td> <td>12.00</td> <td>2.869</td> <td>Good</td> </tr> <tr> <td>VEL</td> <td>[cm/s]</td> <td>0.40</td> <td>1.00</td> <td>0.290</td> <td>Good</td> </tr> <tr> <td>DISP</td> <td>[μm]</td> <td>30</td> <td>100</td> <td>22.9</td> <td>Good</td> </tr> </tbody> </table> <p style="text-align: center;">(1G=9.8m/s²)</p> | | | | | | Measurement Mode | [G] | Warning Level | | Measurements | Judgment | Attention | Danger | ACC (THRU, OA) | [G] | 1.00 | 4.00 | 1.555 | Attention | ACC (OA) | [G] | 1.00 | 4.00 | 0.844 | Good | ACC (PEAK) | [G] | 3.00 | 12.00 | 2.869 | Good | VEL | [cm/s] | 0.40 | 1.00 | 0.290 | Good | DISP | [μm] | 30 | 100 | 22.9 | Good |  | | | |
| Measurement Mode | [G] | Warning Level | | Measurements | Judgment | | | | | | | | | | | | | | | | | | | | | | | | | | | | | | | | | | | | | | | | | | |
| | | Attention | Danger | | | | | | | | | | | | | | | | | | | | | | | | | | | | | | | | | | | | | | | | | | | | |
| ACC (THRU, OA) | [G] | 1.00 | 4.00 | 1.555 | Attention | | | | | | | | | | | | | | | | | | | | | | | | | | | | | | | | | | | | | | | | | | |
| ACC (OA) | [G] | 1.00 | 4.00 | 0.844 | Good | | | | | | | | | | | | | | | | | | | | | | | | | | | | | | | | | | | | | | | | | | |
| ACC (PEAK) | [G] | 3.00 | 12.00 | 2.869 | Good | | | | | | | | | | | | | | | | | | | | | | | | | | | | | | | | | | | | | | | | | | |
| VEL | [cm/s] | 0.40 | 1.00 | 0.290 | Good | | | | | | | | | | | | | | | | | | | | | | | | | | | | | | | | | | | | | | | | | | |
| DISP | [μm] | 30 | 100 | 22.9 | Good | | | | | | | | | | | | | | | | | | | | | | | | | | | | | | | | | | | | | | | | | | |
| <p>【 Absolute value Judgment 】 recorded time: 16 Jul 2010 11:36</p> <table border="1" style="width:100%; border-collapse: collapse;"> <thead> <tr> <th rowspan="2">Measurement Mode</th> <th rowspan="2">[G]</th> <th colspan="2">Warning Level</th> <th rowspan="2">Measurements</th> <th rowspan="2">Judgment</th> </tr> <tr> <th>little bad</th> <th>Bad</th> </tr> </thead> <tbody> <tr> <td>ACC (OA)</td> <td>[G]</td> <td>0.34</td> <td>1.37</td> <td>0.844</td> <td>little bad</td> </tr> <tr> <td>VEL</td> <td>[cm/s]</td> <td>0.40</td> <td>1.00</td> <td>0.290</td> <td>little good</td> </tr> </tbody> </table> <p style="text-align: center;">(1G=9.8m/s²)</p> | | | | | | Measurement Mode | [G] | Warning Level | | Measurements | Judgment | little bad | Bad | ACC (OA) | [G] | 0.34 | 1.37 | 0.844 | little bad | VEL | [cm/s] | 0.40 | 1.00 | 0.290 | little good | <p>【 Absolute value Judgment 】 (1G=9.8m/s²)</p> <div style="display: flex; justify-content: space-around;"> <div style="text-align: center;"> <p>Speed [cm/s]</p>  </div> <div style="text-align: center;"> <p>Acceleration [G]</p>  </div> </div> | | | | | | | | | | | | | | | | | | | | | |
| Measurement Mode | [G] | Warning Level | | Measurements | Judgment | | | | | | | | | | | | | | | | | | | | | | | | | | | | | | | | | | | | | | | | | | |
| | | little bad | Bad | | | | | | | | | | | | | | | | | | | | | | | | | | | | | | | | | | | | | | | | | | | | |
| ACC (OA) | [G] | 0.34 | 1.37 | 0.844 | little bad | | | | | | | | | | | | | | | | | | | | | | | | | | | | | | | | | | | | | | | | | | |
| VEL | [cm/s] | 0.40 | 1.00 | 0.290 | little good | | | | | | | | | | | | | | | | | | | | | | | | | | | | | | | | | | | | | | | | | | |
| 【Comment】 | | | | | | | | | | | | | | | | | | | | | | | | | | | | | | | | | | | | | | | | | | | | | | | |

drawing date: 24 May 2010

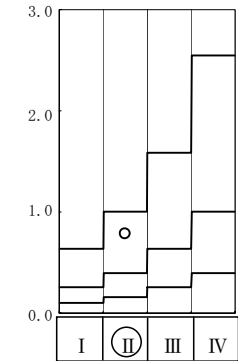
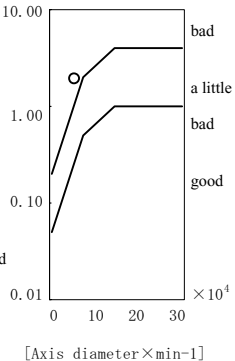
| Simple diagnosis report | | | | | | | | | drawing | | | | | | | | | | | | | | | | | | | | | | | | | | | | | | | | | | | | | | |
|---|---------|--------------------------|------------------------|---------------|------------|---|--|---------------|---------|--------------|----------|------------|--------|----------------|-------|------|------|-------|-----------|----------|--------|------|------|-------|------------|------------|-----|------|-------|-------|-----------|-----|--------|------|------|-------|-----------|------|------|----|-----|------|-----------|--|--|--|--|
| equipment name | | | | | | Truc Bach WWTP | | | | | | | | | | | | | | | | | | | | | | | | | | | | | | | | | | | | | | | | | |
| machine name | | | | | | TBW1A Aeration Blower | | | | | | | | | | | | | | | | | | | | | | | | | | | | | | | | | | | | | | | | | |
| measurement part | | | | | | Blower Outside (Load Side) | | | | | | | | | | | | | | | | | | | | | | | | | | | | | | | | | | | | | | | | | |
| ID code | 214 | Direction of measurement | Vertical | Group No. | 214 |  | | | | | | | | | | | | | | | | | | | | | | | | | | | | | | | | | | | | | | | | | |
| Output | 15.0 kW | Rotational speed | 1518 min ⁻¹ | Axis diameter | 45 mm | | | | | | | | | | | | | | | | | | | | | | | | | | | | | | | | | | | | | | | | | | |
| <p>【 Relative value Judgment 】 recorded time: 18 May 2010 16:20</p> <table border="1" style="width:100%; border-collapse: collapse;"> <thead> <tr> <th rowspan="2">Measurement Mode</th> <th rowspan="2"></th> <th colspan="2">Warning Level</th> <th rowspan="2">Measurements</th> <th rowspan="2">Judgment</th> </tr> <tr> <th>Attention</th> <th>Danger</th> </tr> </thead> <tbody> <tr> <td>ACC (THRU, OA)</td> <td>[G]</td> <td>1.00</td> <td>4.00</td> <td>3.654</td> <td>Attention</td> </tr> <tr> <td>ACC (OA)</td> <td>[G]</td> <td>1.00</td> <td>4.00</td> <td>1.942</td> <td>Attention</td> </tr> <tr> <td>ACC (PEAK)</td> <td>[G]</td> <td>3.00</td> <td>12.00</td> <td>5.055</td> <td>Attention</td> </tr> <tr> <td>VEL</td> <td>[cm/s]</td> <td>0.40</td> <td>1.00</td> <td>0.789</td> <td>Attention</td> </tr> <tr> <td>DISP</td> <td>[μm]</td> <td>30</td> <td>100</td> <td>37.2</td> <td>Attention</td> </tr> </tbody> </table> <p style="text-align: center;">(1G=9.8m/s²)</p> | | | | | | Measurement Mode | | Warning Level | | Measurements | Judgment | Attention | Danger | ACC (THRU, OA) | [G] | 1.00 | 4.00 | 3.654 | Attention | ACC (OA) | [G] | 1.00 | 4.00 | 1.942 | Attention | ACC (PEAK) | [G] | 3.00 | 12.00 | 5.055 | Attention | VEL | [cm/s] | 0.40 | 1.00 | 0.789 | Attention | DISP | [μm] | 30 | 100 | 37.2 | Attention | <p>【 Absolute value Judgment 】 (1G=9.8m/s²)</p> <div style="display: flex; justify-content: space-around;"> <div style="text-align: center;"> <p>Speed [cm/s]</p>  </div> <div style="text-align: center;"> <p>Acceleration [G]</p>  </div> </div> | | | |
| Measurement Mode | | Warning Level | | Measurements | Judgment | | | | | | | | | | | | | | | | | | | | | | | | | | | | | | | | | | | | | | | | | | |
| | | Attention | Danger | | | | | | | | | | | | | | | | | | | | | | | | | | | | | | | | | | | | | | | | | | | | |
| ACC (THRU, OA) | [G] | 1.00 | 4.00 | 3.654 | Attention | | | | | | | | | | | | | | | | | | | | | | | | | | | | | | | | | | | | | | | | | | |
| ACC (OA) | [G] | 1.00 | 4.00 | 1.942 | Attention | | | | | | | | | | | | | | | | | | | | | | | | | | | | | | | | | | | | | | | | | | |
| ACC (PEAK) | [G] | 3.00 | 12.00 | 5.055 | Attention | | | | | | | | | | | | | | | | | | | | | | | | | | | | | | | | | | | | | | | | | | |
| VEL | [cm/s] | 0.40 | 1.00 | 0.789 | Attention | | | | | | | | | | | | | | | | | | | | | | | | | | | | | | | | | | | | | | | | | | |
| DISP | [μm] | 30 | 100 | 37.2 | Attention | | | | | | | | | | | | | | | | | | | | | | | | | | | | | | | | | | | | | | | | | | |
| <p>【 Absolute value Judgment 】 recorded time: 18 May 2010 16:20</p> <table border="1" style="width:100%; border-collapse: collapse;"> <thead> <tr> <th rowspan="2">Measurement Mode</th> <th rowspan="2"></th> <th colspan="2">Warning Level</th> <th rowspan="2">Measurements</th> <th rowspan="2">Judgment</th> </tr> <tr> <th>little bad</th> <th>Bad</th> </tr> </thead> <tbody> <tr> <td>ACC (OA)</td> <td>[G]</td> <td>0.34</td> <td>1.37</td> <td>1.942</td> <td>Bad</td> </tr> <tr> <td>VEL</td> <td>[cm/s]</td> <td>0.40</td> <td>1.00</td> <td>0.789</td> <td>little bad</td> </tr> </tbody> </table> <p style="text-align: center;">(1G=9.8m/s²)</p> | | | | | | Measurement Mode | | Warning Level | | Measurements | Judgment | little bad | Bad | ACC (OA) | [G] | 0.34 | 1.37 | 1.942 | Bad | VEL | [cm/s] | 0.40 | 1.00 | 0.789 | little bad | | | | | | | | | | | | | | | | | | | | | | |
| Measurement Mode | | Warning Level | | Measurements | Judgment | | | | | | | | | | | | | | | | | | | | | | | | | | | | | | | | | | | | | | | | | | |
| | | little bad | Bad | | | | | | | | | | | | | | | | | | | | | | | | | | | | | | | | | | | | | | | | | | | | |
| ACC (OA) | [G] | 0.34 | 1.37 | 1.942 | Bad | | | | | | | | | | | | | | | | | | | | | | | | | | | | | | | | | | | | | | | | | | |
| VEL | [cm/s] | 0.40 | 1.00 | 0.789 | little bad | | | | | | | | | | | | | | | | | | | | | | | | | | | | | | | | | | | | | | | | | | |
| 【Comment】 | | | | | | | | | | | | | | | | | | | | | | | | | | | | | | | | | | | | | | | | | | | | | | | |

drawing date: 16 Jul 2010

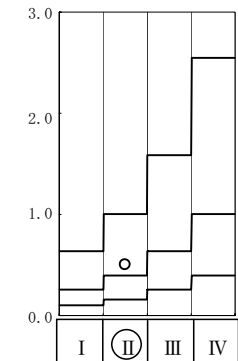
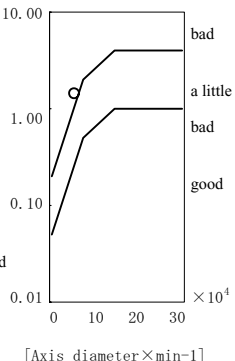
| Simple diagnosis report | | | | | | | | | drawing | | | | | | | | | | | | | | | | | | | | | | | | | | | | | | | | | | | | | | |
|---|---------|--------------------------|------------------------|---------------|------------|---|--|---------------|---------|--------------|----------|------------|--------|----------------|-------|------|------|-------|-----------|----------|--------|------|------|-------|------------|------------|-----|------|-------|-------|-----------|-----|--------|------|------|-------|-----------|------|------|----|-----|------|-----------|--|--|--|--|
| equipment name | | | | | | Truc Bach WWTP | | | | | | | | | | | | | | | | | | | | | | | | | | | | | | | | | | | | | | | | | |
| machine name | | | | | | TBW1A Aeration Blower | | | | | | | | | | | | | | | | | | | | | | | | | | | | | | | | | | | | | | | | | |
| measurement part | | | | | | Blower Outside (Load Side) | | | | | | | | | | | | | | | | | | | | | | | | | | | | | | | | | | | | | | | | | |
| ID code | 214 | Direction of measurement | Vertical | Group No. | 214 |  | | | | | | | | | | | | | | | | | | | | | | | | | | | | | | | | | | | | | | | | | |
| Output | 15.0 kW | Rotational speed | 1518 min ⁻¹ | Axis diameter | 45 mm | | | | | | | | | | | | | | | | | | | | | | | | | | | | | | | | | | | | | | | | | | |
| <p>【 Relative value Judgment 】 recorded time: 16 Jul 2010 11:36</p> <table border="1" style="width:100%; border-collapse: collapse;"> <thead> <tr> <th rowspan="2">Measurement Mode</th> <th rowspan="2"></th> <th colspan="2">Warning Level</th> <th rowspan="2">Measurements</th> <th rowspan="2">Judgment</th> </tr> <tr> <th>Attention</th> <th>Danger</th> </tr> </thead> <tbody> <tr> <td>ACC (THRU, OA)</td> <td>[G]</td> <td>1.00</td> <td>4.00</td> <td>2.741</td> <td>Attention</td> </tr> <tr> <td>ACC (OA)</td> <td>[G]</td> <td>1.00</td> <td>4.00</td> <td>1.438</td> <td>Attention</td> </tr> <tr> <td>ACC (PEAK)</td> <td>[G]</td> <td>3.00</td> <td>12.00</td> <td>4.092</td> <td>Attention</td> </tr> <tr> <td>VEL</td> <td>[cm/s]</td> <td>0.40</td> <td>1.00</td> <td>0.506</td> <td>Attention</td> </tr> <tr> <td>DISP</td> <td>[μm]</td> <td>30</td> <td>100</td> <td>38.4</td> <td>Attention</td> </tr> </tbody> </table> <p style="text-align: center;">(1G=9.8m/s²)</p> | | | | | | Measurement Mode | | Warning Level | | Measurements | Judgment | Attention | Danger | ACC (THRU, OA) | [G] | 1.00 | 4.00 | 2.741 | Attention | ACC (OA) | [G] | 1.00 | 4.00 | 1.438 | Attention | ACC (PEAK) | [G] | 3.00 | 12.00 | 4.092 | Attention | VEL | [cm/s] | 0.40 | 1.00 | 0.506 | Attention | DISP | [μm] | 30 | 100 | 38.4 | Attention | <p>【 Absolute value Judgment 】 (1G=9.8m/s²)</p> <div style="display: flex; justify-content: space-around;"> <div style="text-align: center;"> <p>Speed [cm/s]</p>  </div> <div style="text-align: center;"> <p>Acceleration [G]</p>  </div> </div> | | | |
| Measurement Mode | | Warning Level | | Measurements | Judgment | | | | | | | | | | | | | | | | | | | | | | | | | | | | | | | | | | | | | | | | | | |
| | | Attention | Danger | | | | | | | | | | | | | | | | | | | | | | | | | | | | | | | | | | | | | | | | | | | | |
| ACC (THRU, OA) | [G] | 1.00 | 4.00 | 2.741 | Attention | | | | | | | | | | | | | | | | | | | | | | | | | | | | | | | | | | | | | | | | | | |
| ACC (OA) | [G] | 1.00 | 4.00 | 1.438 | Attention | | | | | | | | | | | | | | | | | | | | | | | | | | | | | | | | | | | | | | | | | | |
| ACC (PEAK) | [G] | 3.00 | 12.00 | 4.092 | Attention | | | | | | | | | | | | | | | | | | | | | | | | | | | | | | | | | | | | | | | | | | |
| VEL | [cm/s] | 0.40 | 1.00 | 0.506 | Attention | | | | | | | | | | | | | | | | | | | | | | | | | | | | | | | | | | | | | | | | | | |
| DISP | [μm] | 30 | 100 | 38.4 | Attention | | | | | | | | | | | | | | | | | | | | | | | | | | | | | | | | | | | | | | | | | | |
| <p>【 Absolute value Judgment 】 recorded time: 16 Jul 2010 11:36</p> <table border="1" style="width:100%; border-collapse: collapse;"> <thead> <tr> <th rowspan="2">Measurement Mode</th> <th rowspan="2"></th> <th colspan="2">Warning Level</th> <th rowspan="2">Measurements</th> <th rowspan="2">Judgment</th> </tr> <tr> <th>little bad</th> <th>Bad</th> </tr> </thead> <tbody> <tr> <td>ACC (OA)</td> <td>[G]</td> <td>0.34</td> <td>1.37</td> <td>1.438</td> <td>Bad</td> </tr> <tr> <td>VEL</td> <td>[cm/s]</td> <td>0.40</td> <td>1.00</td> <td>0.506</td> <td>little bad</td> </tr> </tbody> </table> <p style="text-align: center;">(1G=9.8m/s²)</p> | | | | | | Measurement Mode | | Warning Level | | Measurements | Judgment | little bad | Bad | ACC (OA) | [G] | 0.34 | 1.37 | 1.438 | Bad | VEL | [cm/s] | 0.40 | 1.00 | 0.506 | little bad | | | | | | | | | | | | | | | | | | | | | | |
| Measurement Mode | | Warning Level | | Measurements | Judgment | | | | | | | | | | | | | | | | | | | | | | | | | | | | | | | | | | | | | | | | | | |
| | | little bad | Bad | | | | | | | | | | | | | | | | | | | | | | | | | | | | | | | | | | | | | | | | | | | | |
| ACC (OA) | [G] | 0.34 | 1.37 | 1.438 | Bad | | | | | | | | | | | | | | | | | | | | | | | | | | | | | | | | | | | | | | | | | | |
| VEL | [cm/s] | 0.40 | 1.00 | 0.506 | little bad | | | | | | | | | | | | | | | | | | | | | | | | | | | | | | | | | | | | | | | | | | |
| 【Comment】 | | | | | | | | | | | | | | | | | | | | | | | | | | | | | | | | | | | | | | | | | | | | | | | |

drawing date: 24 May 2010

| | | | | | | | | | |
|--|---------|--------------------------|------------------------|---------------|-------|--|--|--|---------|
| Simple diagnosis report | | | | | | | | | drawing |
| equipment name Truc Bach WWTP | | | | | | | | | |
| machine name TBW1A Aeration Blower | | | | | | | | | |
| measurement part Blower Outside (Opposite Load Side) | | | | | | | | | |
| ID code | 216 | Direction of measurement | Vertical | Group No. | 216 | | | | |
| Output | 15.0 kW | Rotational speed | 1518 min ⁻¹ | Axis diameter | 45 mm | | | | |



【 Relative value Judgment 】 recorded time: 18 May 2010 16:21

| Measurement Mode | Warning Level | | Measurements | Judgment |
|--------------------|---------------|--------|--------------|-----------|
| | Attention | Danger | | |
| ACC (THRU, OA) [G] | 1.00 | 4.00 | 1.741 | Attention |
| ACC (OA) [G] | 1.00 | 4.00 | 0.990 | Good |
| ACC (PEAK) [G] | 3.00 | 12.00 | 2.753 | Good |
| VEL [cm/s] | 0.40 | 1.00 | 0.333 | Good |
| DISP [μ m] | 30 | 100 | 17.1 | Good |

(1G=9.8m/s²)

【 Absolute value Judgment 】 recorded time: 18 May 2010 16:21

| Measurement Mode | Warning Level | | Measurements | Judgment |
|------------------|---------------|------|--------------|-------------|
| | little bad | Bad | | |
| ACC (OA) [G] | 0.34 | 1.37 | 0.990 | little bad |
| VEL [cm/s] | 0.40 | 1.00 | 0.333 | little good |

(1G=9.8m/s²)

【 Absolute value Judgment 】 (1G=9.8m/s²)

[cm/s] Speed

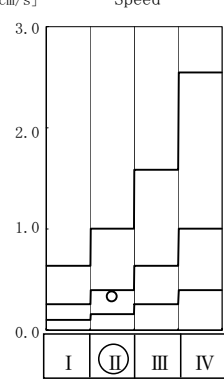

[G] Acceleration

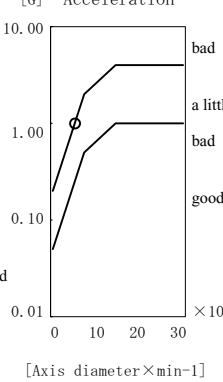

[Axis diameter×min⁻¹]

【Comment】

drawing date: 16 Jul 2010

| | | | | | | | | | |
|--|---------|--------------------------|------------------------|---------------|-------|--|--|--|---------|
| Simple diagnosis report | | | | | | | | | drawing |
| equipment name Truc Bach WWTP | | | | | | | | | |
| machine name TBW1A Aeration Blower | | | | | | | | | |
| measurement part Blower Outside (Opposite Load Side) | | | | | | | | | |
| ID code | 216 | Direction of measurement | Vertical | Group No. | 216 | | | | |
| Output | 15.0 kW | Rotational speed | 1518 min ⁻¹ | Axis diameter | 45 mm | | | | |



【 Relative value Judgment 】 recorded time: 16 Jul 2010 11:37

| Measurement Mode | Warning Level | | Measurements | Judgment |
|--------------------|---------------|--------|--------------|-----------|
| | Attention | Danger | | |
| ACC (THRU, OA) [G] | 1.00 | 4.00 | 1.632 | Attention |
| ACC (OA) [G] | 1.00 | 4.00 | 1.008 | Attention |
| ACC (PEAK) [G] | 3.00 | 12.00 | 3.207 | Attention |
| VEL [cm/s] | 0.40 | 1.00 | 0.299 | Good |
| DISP [μ m] | 30 | 100 | 17.5 | Good |

(1G=9.8m/s²)

【 Absolute value Judgment 】 recorded time: 16 Jul 2010 11:37

| Measurement Mode | Warning Level | | Measurements | Judgment |
|------------------|---------------|------|--------------|-------------|
| | little bad | Bad | | |
| ACC (OA) [G] | 0.34 | 1.37 | 1.008 | little bad |
| VEL [cm/s] | 0.40 | 1.00 | 0.299 | little good |

(1G=9.8m/s²)

【 Absolute value Judgment 】 (1G=9.8m/s²)

[cm/s] Speed

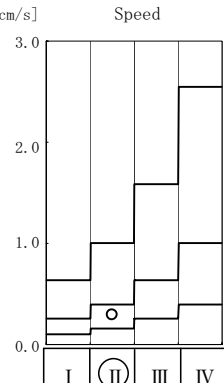

[G] Acceleration

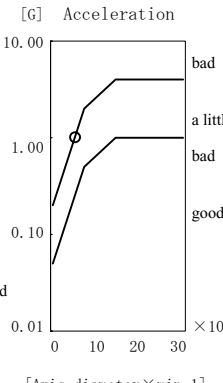

[Axis diameter×min⁻¹]

【Comment】

drawing date: 24 May 2010

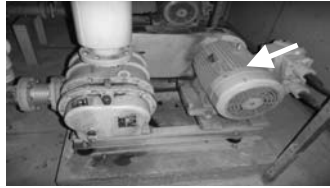
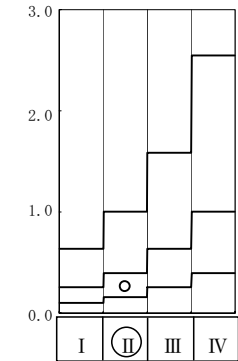
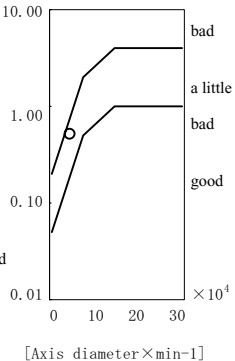
| Simple diagnosis report | | | | | | | | | drawing | | | | | | | | | | | | | | | | | | | | | | | | | | | | | | | | |
|--|---------------|---------|--------------|---|--|----------------------------|---------------|---------------------|--------------|----------|------------|--------|--------------------|------|------|-------|------------|--------------|------|------|-------|-------------|--|------|-------|-------|------|------------|------|------|-------|------|-----------------|----|-----|------|------|---|--|--|--|
| equipment name | | | | | | Truc Bach WWTP | | | | | | | | | | | | | | | | | | | | | | | | | | | | | | | | | | | |
| machine name | | | | | | TBW1B Aeration Blower | | | | | | | | | | | | | | | | | | | | | | | | | | | | | | | | | | | |
| measurement part | | | | | | Moter (Opposite Load Side) | | | | | | | | | | | | | | | | | | | | | | | | | | | | | | | | | | | |
| ID code | | 221 | | <small>Direction of measurement</small> | | Vertical | | Group No. 211 | | | | | | | | | | | | | | | | | | | | | | | | | | | | | | | | | |
| Output | | 15.0 kW | | Rotational speed | | 1459 min ⁻¹ | | Axis diameter 40 mm | | | | | | | | | | | | | | | | | | | | | | | | | | | | | | | | | |
| <p>【 Relative value Judgment 】 recorded time: 18 May 2010 15:57</p> <table border="1" style="width:100%; border-collapse: collapse;"> <thead> <tr> <th rowspan="2">Measurement Mode</th> <th colspan="2">Warning Level</th> <th rowspan="2">Measurements</th> <th rowspan="2">Judgment</th> </tr> <tr> <th>Attention</th> <th>Danger</th> </tr> </thead> <tbody> <tr> <td>ACC (THRU, OA) [G]</td> <td>1.00</td> <td>4.00</td> <td>0.658</td> <td>Good</td> </tr> <tr> <td>ACC (OA) [G]</td> <td>1.00</td> <td>4.00</td> <td>0.520</td> <td>Good</td> </tr> <tr> <td>ACC (PEAK) [G]</td> <td>3.00</td> <td>12.00</td> <td>0.940</td> <td>Good</td> </tr> <tr> <td>VEL [cm/s]</td> <td>0.40</td> <td>1.00</td> <td>0.265</td> <td>Good</td> </tr> <tr> <td>DISP [μm]</td> <td>30</td> <td>100</td> <td>17.1</td> <td>Good</td> </tr> </tbody> </table> <p style="text-align: center;">(1G=9.8m/s²)</p> | | | | | | Measurement Mode | Warning Level | | Measurements | Judgment | Attention | Danger | ACC (THRU, OA) [G] | 1.00 | 4.00 | 0.658 | Good | ACC (OA) [G] | 1.00 | 4.00 | 0.520 | Good | ACC (PEAK) [G] | 3.00 | 12.00 | 0.940 | Good | VEL [cm/s] | 0.40 | 1.00 | 0.265 | Good | DISP [μ m] | 30 | 100 | 17.1 | Good |  | | | |
| Measurement Mode | Warning Level | | Measurements | Judgment | | | | | | | | | | | | | | | | | | | | | | | | | | | | | | | | | | | | | |
| | Attention | Danger | | | | | | | | | | | | | | | | | | | | | | | | | | | | | | | | | | | | | | | |
| ACC (THRU, OA) [G] | 1.00 | 4.00 | 0.658 | Good | | | | | | | | | | | | | | | | | | | | | | | | | | | | | | | | | | | | | |
| ACC (OA) [G] | 1.00 | 4.00 | 0.520 | Good | | | | | | | | | | | | | | | | | | | | | | | | | | | | | | | | | | | | | |
| ACC (PEAK) [G] | 3.00 | 12.00 | 0.940 | Good | | | | | | | | | | | | | | | | | | | | | | | | | | | | | | | | | | | | | |
| VEL [cm/s] | 0.40 | 1.00 | 0.265 | Good | | | | | | | | | | | | | | | | | | | | | | | | | | | | | | | | | | | | | |
| DISP [μ m] | 30 | 100 | 17.1 | Good | | | | | | | | | | | | | | | | | | | | | | | | | | | | | | | | | | | | | |
| <p>【 Absolute value Judgment 】 recorded time: 18 May 2010 15:57</p> <table border="1" style="width:100%; border-collapse: collapse;"> <thead> <tr> <th rowspan="2">Measurement Mode</th> <th colspan="2">Warning Level</th> <th rowspan="2">Measurements</th> <th rowspan="2">Judgment</th> </tr> <tr> <th>little bad</th> <th>Bad</th> </tr> </thead> <tbody> <tr> <td>ACC (OA) [G]</td> <td>0.25</td> <td>0.98</td> <td>0.520</td> <td>little bad</td> </tr> <tr> <td>VEL [cm/s]</td> <td>0.40</td> <td>1.00</td> <td>0.265</td> <td>little good</td> </tr> </tbody> </table> <p style="text-align: center;">(1G=9.8m/s²)</p> | | | | | | Measurement Mode | Warning Level | | Measurements | Judgment | little bad | Bad | ACC (OA) [G] | 0.25 | 0.98 | 0.520 | little bad | VEL [cm/s] | 0.40 | 1.00 | 0.265 | little good | <p>【 Absolute value Judgment 】 (1G=9.8m/s²)</p> <div style="display: flex; justify-content: space-around;"> <div style="text-align: center;"> <p>[cm/s] Speed</p>  </div> <div style="text-align: center;"> <p>[G] Acceleration</p>  </div> </div> <p style="text-align: center;">[Axis diameter×min⁻¹]</p> | | | | | | | | | | | | | | | | | | |
| Measurement Mode | Warning Level | | Measurements | Judgment | | | | | | | | | | | | | | | | | | | | | | | | | | | | | | | | | | | | | |
| | little bad | Bad | | | | | | | | | | | | | | | | | | | | | | | | | | | | | | | | | | | | | | | |
| ACC (OA) [G] | 0.25 | 0.98 | 0.520 | little bad | | | | | | | | | | | | | | | | | | | | | | | | | | | | | | | | | | | | | |
| VEL [cm/s] | 0.40 | 1.00 | 0.265 | little good | | | | | | | | | | | | | | | | | | | | | | | | | | | | | | | | | | | | | |
| 【Comment】 | | | | | | | | | | | | | | | | | | | | | | | | | | | | | | | | | | | | | | | | | |

drawing date: 16 Jul 2010

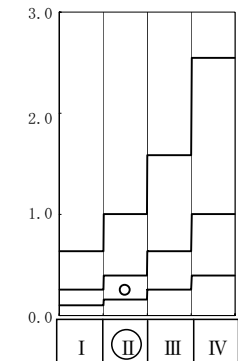
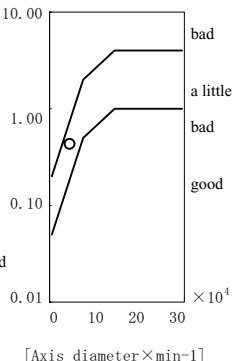
| Simple diagnosis report | | | | | | | | | drawing | | | | | | | | | | | | | | | | | | | | | | | | | | | | | | | | |
|--|---------------|---------|--------------|---|--|----------------------------|---------------|---------------------|--------------|----------|------------|--------|--------------------|------|------|-------|------------|--------------|------|------|-------|-------------|--|------|-------|-------|------|------------|------|------|-------|------|-----------------|----|-----|------|------|---|--|--|--|
| equipment name | | | | | | Truc Bach WWTP | | | | | | | | | | | | | | | | | | | | | | | | | | | | | | | | | | | |
| machine name | | | | | | TBW1B Aeration Blower | | | | | | | | | | | | | | | | | | | | | | | | | | | | | | | | | | | |
| measurement part | | | | | | Moter (Opposite Load Side) | | | | | | | | | | | | | | | | | | | | | | | | | | | | | | | | | | | |
| ID code | | 221 | | <small>Direction of measurement</small> | | Vertical | | Group No. 211 | | | | | | | | | | | | | | | | | | | | | | | | | | | | | | | | | |
| Output | | 15.0 kW | | Rotational speed | | 1459 min ⁻¹ | | Axis diameter 40 mm | | | | | | | | | | | | | | | | | | | | | | | | | | | | | | | | | |
| <p>【 Relative value Judgment 】 recorded time: 16 Jul 2010 11:37</p> <table border="1" style="width:100%; border-collapse: collapse;"> <thead> <tr> <th rowspan="2">Measurement Mode</th> <th colspan="2">Warning Level</th> <th rowspan="2">Measurements</th> <th rowspan="2">Judgment</th> </tr> <tr> <th>Attention</th> <th>Danger</th> </tr> </thead> <tbody> <tr> <td>ACC (THRU, OA) [G]</td> <td>1.00</td> <td>4.00</td> <td>0.662</td> <td>Good</td> </tr> <tr> <td>ACC (OA) [G]</td> <td>1.00</td> <td>4.00</td> <td>0.432</td> <td>Good</td> </tr> <tr> <td>ACC (PEAK) [G]</td> <td>3.00</td> <td>12.00</td> <td>0.910</td> <td>Good</td> </tr> <tr> <td>VEL [cm/s]</td> <td>0.40</td> <td>1.00</td> <td>0.254</td> <td>Good</td> </tr> <tr> <td>DISP [μm]</td> <td>30</td> <td>100</td> <td>19.8</td> <td>Good</td> </tr> </tbody> </table> <p style="text-align: center;">(1G=9.8m/s²)</p> | | | | | | Measurement Mode | Warning Level | | Measurements | Judgment | Attention | Danger | ACC (THRU, OA) [G] | 1.00 | 4.00 | 0.662 | Good | ACC (OA) [G] | 1.00 | 4.00 | 0.432 | Good | ACC (PEAK) [G] | 3.00 | 12.00 | 0.910 | Good | VEL [cm/s] | 0.40 | 1.00 | 0.254 | Good | DISP [μ m] | 30 | 100 | 19.8 | Good |  | | | |
| Measurement Mode | Warning Level | | Measurements | Judgment | | | | | | | | | | | | | | | | | | | | | | | | | | | | | | | | | | | | | |
| | Attention | Danger | | | | | | | | | | | | | | | | | | | | | | | | | | | | | | | | | | | | | | | |
| ACC (THRU, OA) [G] | 1.00 | 4.00 | 0.662 | Good | | | | | | | | | | | | | | | | | | | | | | | | | | | | | | | | | | | | | |
| ACC (OA) [G] | 1.00 | 4.00 | 0.432 | Good | | | | | | | | | | | | | | | | | | | | | | | | | | | | | | | | | | | | | |
| ACC (PEAK) [G] | 3.00 | 12.00 | 0.910 | Good | | | | | | | | | | | | | | | | | | | | | | | | | | | | | | | | | | | | | |
| VEL [cm/s] | 0.40 | 1.00 | 0.254 | Good | | | | | | | | | | | | | | | | | | | | | | | | | | | | | | | | | | | | | |
| DISP [μ m] | 30 | 100 | 19.8 | Good | | | | | | | | | | | | | | | | | | | | | | | | | | | | | | | | | | | | | |
| <p>【 Absolute value Judgment 】 recorded time: 16 Jul 2010 11:37</p> <table border="1" style="width:100%; border-collapse: collapse;"> <thead> <tr> <th rowspan="2">Measurement Mode</th> <th colspan="2">Warning Level</th> <th rowspan="2">Measurements</th> <th rowspan="2">Judgment</th> </tr> <tr> <th>little bad</th> <th>Bad</th> </tr> </thead> <tbody> <tr> <td>ACC (OA) [G]</td> <td>0.25</td> <td>0.98</td> <td>0.432</td> <td>little bad</td> </tr> <tr> <td>VEL [cm/s]</td> <td>0.40</td> <td>1.00</td> <td>0.254</td> <td>little good</td> </tr> </tbody> </table> <p style="text-align: center;">(1G=9.8m/s²)</p> | | | | | | Measurement Mode | Warning Level | | Measurements | Judgment | little bad | Bad | ACC (OA) [G] | 0.25 | 0.98 | 0.432 | little bad | VEL [cm/s] | 0.40 | 1.00 | 0.254 | little good | <p>【 Absolute value Judgment 】 (1G=9.8m/s²)</p> <div style="display: flex; justify-content: space-around;"> <div style="text-align: center;"> <p>[cm/s] Speed</p>  </div> <div style="text-align: center;"> <p>[G] Acceleration</p>  </div> </div> <p style="text-align: center;">[Axis diameter×min⁻¹]</p> | | | | | | | | | | | | | | | | | | |
| Measurement Mode | Warning Level | | Measurements | Judgment | | | | | | | | | | | | | | | | | | | | | | | | | | | | | | | | | | | | | |
| | little bad | Bad | | | | | | | | | | | | | | | | | | | | | | | | | | | | | | | | | | | | | | | |
| ACC (OA) [G] | 0.25 | 0.98 | 0.432 | little bad | | | | | | | | | | | | | | | | | | | | | | | | | | | | | | | | | | | | | |
| VEL [cm/s] | 0.40 | 1.00 | 0.254 | little good | | | | | | | | | | | | | | | | | | | | | | | | | | | | | | | | | | | | | |
| 【Comment】 | | | | | | | | | | | | | | | | | | | | | | | | | | | | | | | | | | | | | | | | | |

drawing date: 24 May 2010

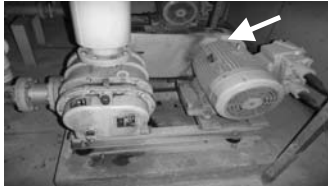
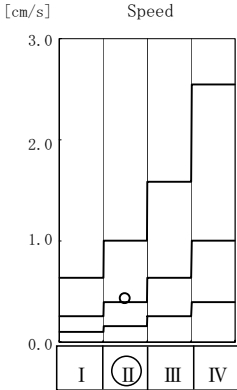
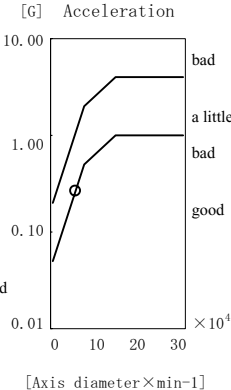
| Simple diagnosis report | | | | | | | | | drawing | | | | | | | | | | | | | | | | | | | | | | | | | | | | | | | | | | | | | | |
|--|---------|--------------------------|------------------------|---------------|------------|---|-----|---------------|---------|--------------|----------|------------|--------|----------------|-----|------|------|-------|------|----------|--------|------|------|-------|------------|------------|-----|------|-------|-------|------|-----|--------|------|------|-------|-----------|------|------|----|-----|------|------|--|--|--|--|
| equipment name | | | | | | Truc Bach WWTP | | | | | | | | | | | | | | | | | | | | | | | | | | | | | | | | | | | | | | | | | |
| machine name | | | | | | TBW1B Aeration Blower | | | | | | | | | | | | | | | | | | | | | | | | | | | | | | | | | | | | | | | | | |
| measurement part | | | | | | Motor (Load Side) | | | | | | | | | | | | | | | | | | | | | | | | | | | | | | | | | | | | | | | | | |
| ID code | 222 | Direction of measurement | Vertical | Group No. | 212 |  | | | | | | | | | | | | | | | | | | | | | | | | | | | | | | | | | | | | | | | | | |
| Output | 15.0 kW | Rotational speed | 1459 min ⁻¹ | Axis diameter | 45 mm | | | | | | | | | | | | | | | | | | | | | | | | | | | | | | | | | | | | | | | | | | |
| <p>【 Relative value Judgment 】 recorded time: 18 May 2010 15:58</p> <table border="1" style="width:100%; border-collapse: collapse;"> <thead> <tr> <th rowspan="2">Measurement Mode</th> <th rowspan="2">[G]</th> <th colspan="2">Warning Level</th> <th rowspan="2">Measurements</th> <th rowspan="2">Judgment</th> </tr> <tr> <th>Attention</th> <th>Danger</th> </tr> </thead> <tbody> <tr> <td>ACC (THRU, OA)</td> <td>[G]</td> <td>1.00</td> <td>4.00</td> <td>0.993</td> <td>Good</td> </tr> <tr> <td>ACC (OA)</td> <td>[G]</td> <td>1.00</td> <td>4.00</td> <td>0.268</td> <td>Good</td> </tr> <tr> <td>ACC (PEAK)</td> <td>[G]</td> <td>3.00</td> <td>12.00</td> <td>0.712</td> <td>Good</td> </tr> <tr> <td>VEL</td> <td>[cm/s]</td> <td>0.40</td> <td>1.00</td> <td>0.435</td> <td>Attention</td> </tr> <tr> <td>DISP</td> <td>[μm]</td> <td>30</td> <td>100</td> <td>20.3</td> <td>Good</td> </tr> </tbody> </table> <p style="text-align: center;">(1G=9.8m/s²)</p> | | | | | | Measurement Mode | [G] | Warning Level | | Measurements | Judgment | Attention | Danger | ACC (THRU, OA) | [G] | 1.00 | 4.00 | 0.993 | Good | ACC (OA) | [G] | 1.00 | 4.00 | 0.268 | Good | ACC (PEAK) | [G] | 3.00 | 12.00 | 0.712 | Good | VEL | [cm/s] | 0.40 | 1.00 | 0.435 | Attention | DISP | [μm] | 30 | 100 | 20.3 | Good | <p>【 Absolute value Judgment 】 (1G=9.8m/s²)</p> <div style="display: flex; justify-content: space-around;"> <div style="text-align: center;"> <p>Speed [cm/s]</p>  </div> <div style="text-align: center;"> <p>Acceleration [G]</p>  </div> </div> | | | |
| Measurement Mode | [G] | Warning Level | | Measurements | Judgment | | | | | | | | | | | | | | | | | | | | | | | | | | | | | | | | | | | | | | | | | | |
| | | Attention | Danger | | | | | | | | | | | | | | | | | | | | | | | | | | | | | | | | | | | | | | | | | | | | |
| ACC (THRU, OA) | [G] | 1.00 | 4.00 | 0.993 | Good | | | | | | | | | | | | | | | | | | | | | | | | | | | | | | | | | | | | | | | | | | |
| ACC (OA) | [G] | 1.00 | 4.00 | 0.268 | Good | | | | | | | | | | | | | | | | | | | | | | | | | | | | | | | | | | | | | | | | | | |
| ACC (PEAK) | [G] | 3.00 | 12.00 | 0.712 | Good | | | | | | | | | | | | | | | | | | | | | | | | | | | | | | | | | | | | | | | | | | |
| VEL | [cm/s] | 0.40 | 1.00 | 0.435 | Attention | | | | | | | | | | | | | | | | | | | | | | | | | | | | | | | | | | | | | | | | | | |
| DISP | [μm] | 30 | 100 | 20.3 | Good | | | | | | | | | | | | | | | | | | | | | | | | | | | | | | | | | | | | | | | | | | |
| <p>【 Absolute value Judgment 】 recorded time: 18 May 2010 15:58</p> <table border="1" style="width:100%; border-collapse: collapse;"> <thead> <tr> <th rowspan="2">Measurement Mode</th> <th rowspan="2">[G]</th> <th colspan="2">Warning Level</th> <th rowspan="2">Measurements</th> <th rowspan="2">Judgment</th> </tr> <tr> <th>little bad</th> <th>Bad</th> </tr> </thead> <tbody> <tr> <td>ACC (OA)</td> <td>[G]</td> <td>0.31</td> <td>1.25</td> <td>0.268</td> <td>Good</td> </tr> <tr> <td>VEL</td> <td>[cm/s]</td> <td>0.40</td> <td>1.00</td> <td>0.435</td> <td>little bad</td> </tr> </tbody> </table> <p style="text-align: center;">(1G=9.8m/s²)</p> | | | | | | Measurement Mode | [G] | Warning Level | | Measurements | Judgment | little bad | Bad | ACC (OA) | [G] | 0.31 | 1.25 | 0.268 | Good | VEL | [cm/s] | 0.40 | 1.00 | 0.435 | little bad | | | | | | | | | | | | | | | | | | | | | | |
| Measurement Mode | [G] | Warning Level | | Measurements | Judgment | | | | | | | | | | | | | | | | | | | | | | | | | | | | | | | | | | | | | | | | | | |
| | | little bad | Bad | | | | | | | | | | | | | | | | | | | | | | | | | | | | | | | | | | | | | | | | | | | | |
| ACC (OA) | [G] | 0.31 | 1.25 | 0.268 | Good | | | | | | | | | | | | | | | | | | | | | | | | | | | | | | | | | | | | | | | | | | |
| VEL | [cm/s] | 0.40 | 1.00 | 0.435 | little bad | | | | | | | | | | | | | | | | | | | | | | | | | | | | | | | | | | | | | | | | | | |
| 【Comment】 | | | | | | | | | | | | | | | | | | | | | | | | | | | | | | | | | | | | | | | | | | | | | | | |

drawing date: 16 Jul 2010

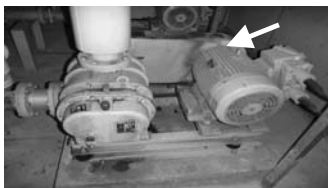
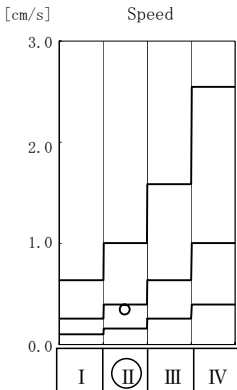
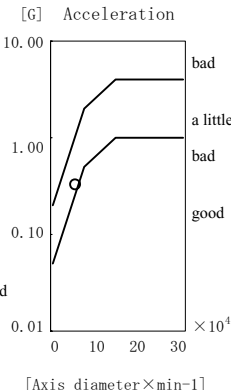
| Simple diagnosis report | | | | | | | | | drawing | | | | | | | | | | | | | | | | | | | | | | | | | | | | | | | | | | | | | | |
|---|---------|--------------------------|------------------------|---------------|-------------|---|-----|---------------|---------|--------------|----------|------------|--------|----------------|-----|------|------|-------|------------|----------|--------|------|------|-------|-------------|------------|-----|------|-------|-------|------|-----|--------|------|------|-------|------|------|------|----|-----|------|------|--|--|--|--|
| equipment name | | | | | | Truc Bach WWTP | | | | | | | | | | | | | | | | | | | | | | | | | | | | | | | | | | | | | | | | | |
| machine name | | | | | | TBW1B Aeration Blower | | | | | | | | | | | | | | | | | | | | | | | | | | | | | | | | | | | | | | | | | |
| measurement part | | | | | | Motor (Load Side) | | | | | | | | | | | | | | | | | | | | | | | | | | | | | | | | | | | | | | | | | |
| ID code | 222 | Direction of measurement | Vertical | Group No. | 212 |  | | | | | | | | | | | | | | | | | | | | | | | | | | | | | | | | | | | | | | | | | |
| Output | 15.0 kW | Rotational speed | 1459 min ⁻¹ | Axis diameter | 45 mm | | | | | | | | | | | | | | | | | | | | | | | | | | | | | | | | | | | | | | | | | | |
| <p>【 Relative value Judgment 】 recorded time: 16 Jul 2010 11:38</p> <table border="1" style="width:100%; border-collapse: collapse;"> <thead> <tr> <th rowspan="2">Measurement Mode</th> <th rowspan="2">[G]</th> <th colspan="2">Warning Level</th> <th rowspan="2">Measurements</th> <th rowspan="2">Judgment</th> </tr> <tr> <th>Attention</th> <th>Danger</th> </tr> </thead> <tbody> <tr> <td>ACC (THRU, OA)</td> <td>[G]</td> <td>1.00</td> <td>4.00</td> <td>0.839</td> <td>Good</td> </tr> <tr> <td>ACC (OA)</td> <td>[G]</td> <td>1.00</td> <td>4.00</td> <td>0.329</td> <td>Good</td> </tr> <tr> <td>ACC (PEAK)</td> <td>[G]</td> <td>3.00</td> <td>12.00</td> <td>0.846</td> <td>Good</td> </tr> <tr> <td>VEL</td> <td>[cm/s]</td> <td>0.40</td> <td>1.00</td> <td>0.344</td> <td>Good</td> </tr> <tr> <td>DISP</td> <td>[μm]</td> <td>30</td> <td>100</td> <td>24.4</td> <td>Good</td> </tr> </tbody> </table> <p style="text-align: center;">(1G=9.8m/s²)</p> | | | | | | Measurement Mode | [G] | Warning Level | | Measurements | Judgment | Attention | Danger | ACC (THRU, OA) | [G] | 1.00 | 4.00 | 0.839 | Good | ACC (OA) | [G] | 1.00 | 4.00 | 0.329 | Good | ACC (PEAK) | [G] | 3.00 | 12.00 | 0.846 | Good | VEL | [cm/s] | 0.40 | 1.00 | 0.344 | Good | DISP | [μm] | 30 | 100 | 24.4 | Good | <p>【 Absolute value Judgment 】 (1G=9.8m/s²)</p> <div style="display: flex; justify-content: space-around;"> <div style="text-align: center;"> <p>Speed [cm/s]</p>  </div> <div style="text-align: center;"> <p>Acceleration [G]</p>  </div> </div> | | | |
| Measurement Mode | [G] | Warning Level | | Measurements | Judgment | | | | | | | | | | | | | | | | | | | | | | | | | | | | | | | | | | | | | | | | | | |
| | | Attention | Danger | | | | | | | | | | | | | | | | | | | | | | | | | | | | | | | | | | | | | | | | | | | | |
| ACC (THRU, OA) | [G] | 1.00 | 4.00 | 0.839 | Good | | | | | | | | | | | | | | | | | | | | | | | | | | | | | | | | | | | | | | | | | | |
| ACC (OA) | [G] | 1.00 | 4.00 | 0.329 | Good | | | | | | | | | | | | | | | | | | | | | | | | | | | | | | | | | | | | | | | | | | |
| ACC (PEAK) | [G] | 3.00 | 12.00 | 0.846 | Good | | | | | | | | | | | | | | | | | | | | | | | | | | | | | | | | | | | | | | | | | | |
| VEL | [cm/s] | 0.40 | 1.00 | 0.344 | Good | | | | | | | | | | | | | | | | | | | | | | | | | | | | | | | | | | | | | | | | | | |
| DISP | [μm] | 30 | 100 | 24.4 | Good | | | | | | | | | | | | | | | | | | | | | | | | | | | | | | | | | | | | | | | | | | |
| <p>【 Absolute value Judgment 】 recorded time: 16 Jul 2010 11:38</p> <table border="1" style="width:100%; border-collapse: collapse;"> <thead> <tr> <th rowspan="2">Measurement Mode</th> <th rowspan="2">[G]</th> <th colspan="2">Warning Level</th> <th rowspan="2">Measurements</th> <th rowspan="2">Judgment</th> </tr> <tr> <th>little bad</th> <th>Bad</th> </tr> </thead> <tbody> <tr> <td>ACC (OA)</td> <td>[G]</td> <td>0.31</td> <td>1.25</td> <td>0.329</td> <td>little bad</td> </tr> <tr> <td>VEL</td> <td>[cm/s]</td> <td>0.40</td> <td>1.00</td> <td>0.344</td> <td>little good</td> </tr> </tbody> </table> <p style="text-align: center;">(1G=9.8m/s²)</p> | | | | | | Measurement Mode | [G] | Warning Level | | Measurements | Judgment | little bad | Bad | ACC (OA) | [G] | 0.31 | 1.25 | 0.329 | little bad | VEL | [cm/s] | 0.40 | 1.00 | 0.344 | little good | | | | | | | | | | | | | | | | | | | | | | |
| Measurement Mode | [G] | Warning Level | | Measurements | Judgment | | | | | | | | | | | | | | | | | | | | | | | | | | | | | | | | | | | | | | | | | | |
| | | little bad | Bad | | | | | | | | | | | | | | | | | | | | | | | | | | | | | | | | | | | | | | | | | | | | |
| ACC (OA) | [G] | 0.31 | 1.25 | 0.329 | little bad | | | | | | | | | | | | | | | | | | | | | | | | | | | | | | | | | | | | | | | | | | |
| VEL | [cm/s] | 0.40 | 1.00 | 0.344 | little good | | | | | | | | | | | | | | | | | | | | | | | | | | | | | | | | | | | | | | | | | | |
| 【Comment】 | | | | | | | | | | | | | | | | | | | | | | | | | | | | | | | | | | | | | | | | | | | | | | | |

drawing date: 24 May 2010

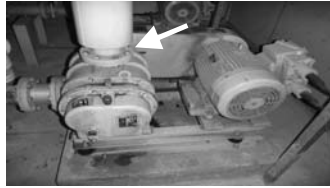
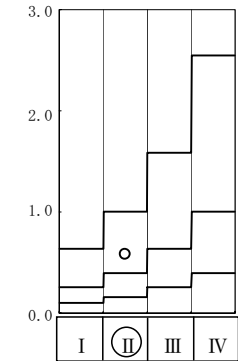
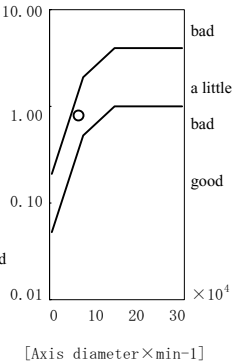
| Simple diagnosis report | | | | | | | | | drawing | | | | | | | | | | | | | | | | | | | | | | | | | | | | | | | | | | | | | | |
|--|--------|--------------------------|--------|------------------------|------------|---------------------------|-----|---------------|---------|--------------|----------|------------|--------|----------------|-----|------|------|-------|------------|----------|--------|------|------|-------|------------|--|-----|------|-------|-------|------|-----|--------|------|------|-------|-----------|------|------|----|-----|------|-----------|---|--|--|--|
| equipment name | | | | | | Truc Bach WWTP | | | | | | | | | | | | | | | | | | | | | | | | | | | | | | | | | | | | | | | | | |
| machine name | | | | | | TBW1B Aeration Blower | | | | | | | | | | | | | | | | | | | | | | | | | | | | | | | | | | | | | | | | | |
| measurement part | | | | | | Blower Inside (Load Side) | | | | | | | | | | | | | | | | | | | | | | | | | | | | | | | | | | | | | | | | | |
| ID code | | Direction of measurement | | Vertical | | Group No. | | 213 | | | | | | | | | | | | | | | | | | | | | | | | | | | | | | | | | | | | | | | |
| Output | | Rotational speed | | 1542 min ⁻¹ | | Axis diameter | | 50 mm | | | | | | | | | | | | | | | | | | | | | | | | | | | | | | | | | | | | | | | |
| <p>【 Relative value Judgment 】 recorded time: 18 May 2010 15:59</p> <table border="1" style="width:100%; border-collapse: collapse;"> <thead> <tr> <th rowspan="2">Measurement Mode</th> <th rowspan="2">[G]</th> <th colspan="2">Warning Level</th> <th rowspan="2">Measurements</th> <th rowspan="2">Judgment</th> </tr> <tr> <th>Attention</th> <th>Danger</th> </tr> </thead> <tbody> <tr> <td>ACC (THRU, OA)</td> <td>[G]</td> <td>1.00</td> <td>4.00</td> <td>1.458</td> <td>Attention</td> </tr> <tr> <td>ACC (OA)</td> <td>[G]</td> <td>1.00</td> <td>4.00</td> <td>0.803</td> <td>Good</td> </tr> <tr> <td>ACC (PEAK)</td> <td>[G]</td> <td>3.00</td> <td>12.00</td> <td>2.513</td> <td>Good</td> </tr> <tr> <td>VEL</td> <td>[cm/s]</td> <td>0.40</td> <td>1.00</td> <td>0.586</td> <td>Attention</td> </tr> <tr> <td>DISP</td> <td>[μm]</td> <td>30</td> <td>100</td> <td>52.3</td> <td>Attention</td> </tr> </tbody> </table> <p style="text-align: center;">(1G=9.8m/s²)</p> | | | | | | Measurement Mode | [G] | Warning Level | | Measurements | Judgment | Attention | Danger | ACC (THRU, OA) | [G] | 1.00 | 4.00 | 1.458 | Attention | ACC (OA) | [G] | 1.00 | 4.00 | 0.803 | Good | ACC (PEAK) | [G] | 3.00 | 12.00 | 2.513 | Good | VEL | [cm/s] | 0.40 | 1.00 | 0.586 | Attention | DISP | [μm] | 30 | 100 | 52.3 | Attention |  | | | |
| Measurement Mode | [G] | Warning Level | | Measurements | Judgment | | | | | | | | | | | | | | | | | | | | | | | | | | | | | | | | | | | | | | | | | | |
| | | Attention | Danger | | | | | | | | | | | | | | | | | | | | | | | | | | | | | | | | | | | | | | | | | | | | |
| ACC (THRU, OA) | [G] | 1.00 | 4.00 | 1.458 | Attention | | | | | | | | | | | | | | | | | | | | | | | | | | | | | | | | | | | | | | | | | | |
| ACC (OA) | [G] | 1.00 | 4.00 | 0.803 | Good | | | | | | | | | | | | | | | | | | | | | | | | | | | | | | | | | | | | | | | | | | |
| ACC (PEAK) | [G] | 3.00 | 12.00 | 2.513 | Good | | | | | | | | | | | | | | | | | | | | | | | | | | | | | | | | | | | | | | | | | | |
| VEL | [cm/s] | 0.40 | 1.00 | 0.586 | Attention | | | | | | | | | | | | | | | | | | | | | | | | | | | | | | | | | | | | | | | | | | |
| DISP | [μm] | 30 | 100 | 52.3 | Attention | | | | | | | | | | | | | | | | | | | | | | | | | | | | | | | | | | | | | | | | | | |
| <p>【 Absolute value Judgment 】 recorded time: 18 May 2010 15:59</p> <table border="1" style="width:100%; border-collapse: collapse;"> <thead> <tr> <th rowspan="2">Measurement Mode</th> <th rowspan="2">[G]</th> <th colspan="2">Warning Level</th> <th rowspan="2">Measurements</th> <th rowspan="2">Judgment</th> </tr> <tr> <th>little bad</th> <th>Bad</th> </tr> </thead> <tbody> <tr> <td>ACC (OA)</td> <td>[G]</td> <td>0.46</td> <td>1.82</td> <td>0.803</td> <td>little bad</td> </tr> <tr> <td>VEL</td> <td>[cm/s]</td> <td>0.40</td> <td>1.00</td> <td>0.586</td> <td>little bad</td> </tr> </tbody> </table> <p style="text-align: center;">(1G=9.8m/s²)</p> | | | | | | Measurement Mode | [G] | Warning Level | | Measurements | Judgment | little bad | Bad | ACC (OA) | [G] | 0.46 | 1.82 | 0.803 | little bad | VEL | [cm/s] | 0.40 | 1.00 | 0.586 | little bad | <p>【 Absolute value Judgment 】 (1G=9.8m/s²)</p> <div style="display: flex; justify-content: space-around;"> <div style="text-align: center;"> <p>[cm/s] Speed</p>  </div> <div style="text-align: center;"> <p>[G] Acceleration</p>  </div> </div> <p style="text-align: center;">[Axis diameter×min⁻¹]</p> | | | | | | | | | | | | | | | | | | | | | |
| Measurement Mode | [G] | Warning Level | | Measurements | Judgment | | | | | | | | | | | | | | | | | | | | | | | | | | | | | | | | | | | | | | | | | | |
| | | little bad | Bad | | | | | | | | | | | | | | | | | | | | | | | | | | | | | | | | | | | | | | | | | | | | |
| ACC (OA) | [G] | 0.46 | 1.82 | 0.803 | little bad | | | | | | | | | | | | | | | | | | | | | | | | | | | | | | | | | | | | | | | | | | |
| VEL | [cm/s] | 0.40 | 1.00 | 0.586 | little bad | | | | | | | | | | | | | | | | | | | | | | | | | | | | | | | | | | | | | | | | | | |
| 【Comment】 | | | | | | | | | | | | | | | | | | | | | | | | | | | | | | | | | | | | | | | | | | | | | | | |

drawing date: 16 Jul 2010

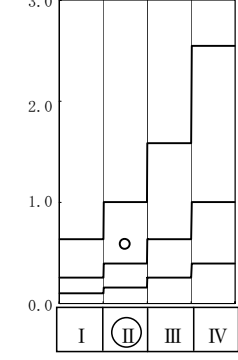
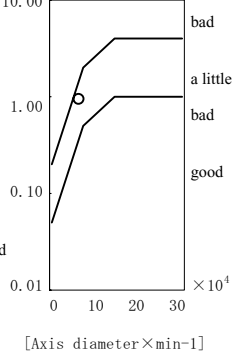
| Simple diagnosis report | | | | | | | | | drawing | | | | | | | | | | | | | | | | | | | | | | | | | | | | | | | | | | | | | | |
|--|--------|--------------------------|--------|------------------------|------------|---------------------------|-----|---------------|---------|--------------|----------|------------|--------|----------------|-----|------|------|-------|------------|----------|--------|------|------|-------|------------|--|-----|------|-------|-------|------|-----|--------|------|------|-------|-----------|------|------|----|-----|------|-----------|---|--|--|--|
| equipment name | | | | | | Truc Bach WWTP | | | | | | | | | | | | | | | | | | | | | | | | | | | | | | | | | | | | | | | | | |
| machine name | | | | | | TBW1B Aeration Blower | | | | | | | | | | | | | | | | | | | | | | | | | | | | | | | | | | | | | | | | | |
| measurement part | | | | | | Blower Inside (Load Side) | | | | | | | | | | | | | | | | | | | | | | | | | | | | | | | | | | | | | | | | | |
| ID code | | Direction of measurement | | Vertical | | Group No. | | 213 | | | | | | | | | | | | | | | | | | | | | | | | | | | | | | | | | | | | | | | |
| Output | | Rotational speed | | 1542 min ⁻¹ | | Axis diameter | | 50 mm | | | | | | | | | | | | | | | | | | | | | | | | | | | | | | | | | | | | | | | |
| <p>【 Relative value Judgment 】 recorded time: 16 Jul 2010 11:38</p> <table border="1" style="width:100%; border-collapse: collapse;"> <thead> <tr> <th rowspan="2">Measurement Mode</th> <th rowspan="2">[G]</th> <th colspan="2">Warning Level</th> <th rowspan="2">Measurements</th> <th rowspan="2">Judgment</th> </tr> <tr> <th>Attention</th> <th>Danger</th> </tr> </thead> <tbody> <tr> <td>ACC (THRU, OA)</td> <td>[G]</td> <td>1.00</td> <td>4.00</td> <td>2.176</td> <td>Attention</td> </tr> <tr> <td>ACC (OA)</td> <td>[G]</td> <td>1.00</td> <td>4.00</td> <td>0.951</td> <td>Good</td> </tr> <tr> <td>ACC (PEAK)</td> <td>[G]</td> <td>3.00</td> <td>12.00</td> <td>2.892</td> <td>Good</td> </tr> <tr> <td>VEL</td> <td>[cm/s]</td> <td>0.40</td> <td>1.00</td> <td>0.588</td> <td>Attention</td> </tr> <tr> <td>DISP</td> <td>[μm]</td> <td>30</td> <td>100</td> <td>47.4</td> <td>Attention</td> </tr> </tbody> </table> <p style="text-align: center;">(1G=9.8m/s²)</p> | | | | | | Measurement Mode | [G] | Warning Level | | Measurements | Judgment | Attention | Danger | ACC (THRU, OA) | [G] | 1.00 | 4.00 | 2.176 | Attention | ACC (OA) | [G] | 1.00 | 4.00 | 0.951 | Good | ACC (PEAK) | [G] | 3.00 | 12.00 | 2.892 | Good | VEL | [cm/s] | 0.40 | 1.00 | 0.588 | Attention | DISP | [μm] | 30 | 100 | 47.4 | Attention |  | | | |
| Measurement Mode | [G] | Warning Level | | Measurements | Judgment | | | | | | | | | | | | | | | | | | | | | | | | | | | | | | | | | | | | | | | | | | |
| | | Attention | Danger | | | | | | | | | | | | | | | | | | | | | | | | | | | | | | | | | | | | | | | | | | | | |
| ACC (THRU, OA) | [G] | 1.00 | 4.00 | 2.176 | Attention | | | | | | | | | | | | | | | | | | | | | | | | | | | | | | | | | | | | | | | | | | |
| ACC (OA) | [G] | 1.00 | 4.00 | 0.951 | Good | | | | | | | | | | | | | | | | | | | | | | | | | | | | | | | | | | | | | | | | | | |
| ACC (PEAK) | [G] | 3.00 | 12.00 | 2.892 | Good | | | | | | | | | | | | | | | | | | | | | | | | | | | | | | | | | | | | | | | | | | |
| VEL | [cm/s] | 0.40 | 1.00 | 0.588 | Attention | | | | | | | | | | | | | | | | | | | | | | | | | | | | | | | | | | | | | | | | | | |
| DISP | [μm] | 30 | 100 | 47.4 | Attention | | | | | | | | | | | | | | | | | | | | | | | | | | | | | | | | | | | | | | | | | | |
| <p>【 Absolute value Judgment 】 recorded time: 16 Jul 2010 11:38</p> <table border="1" style="width:100%; border-collapse: collapse;"> <thead> <tr> <th rowspan="2">Measurement Mode</th> <th rowspan="2">[G]</th> <th colspan="2">Warning Level</th> <th rowspan="2">Measurements</th> <th rowspan="2">Judgment</th> </tr> <tr> <th>little bad</th> <th>Bad</th> </tr> </thead> <tbody> <tr> <td>ACC (OA)</td> <td>[G]</td> <td>0.46</td> <td>1.82</td> <td>0.951</td> <td>little bad</td> </tr> <tr> <td>VEL</td> <td>[cm/s]</td> <td>0.40</td> <td>1.00</td> <td>0.588</td> <td>little bad</td> </tr> </tbody> </table> <p style="text-align: center;">(1G=9.8m/s²)</p> | | | | | | Measurement Mode | [G] | Warning Level | | Measurements | Judgment | little bad | Bad | ACC (OA) | [G] | 0.46 | 1.82 | 0.951 | little bad | VEL | [cm/s] | 0.40 | 1.00 | 0.588 | little bad | <p>【 Absolute value Judgment 】 (1G=9.8m/s²)</p> <div style="display: flex; justify-content: space-around;"> <div style="text-align: center;"> <p>[cm/s] Speed</p>  </div> <div style="text-align: center;"> <p>[G] Acceleration</p>  </div> </div> <p style="text-align: center;">[Axis diameter×min⁻¹]</p> | | | | | | | | | | | | | | | | | | | | | |
| Measurement Mode | [G] | Warning Level | | Measurements | Judgment | | | | | | | | | | | | | | | | | | | | | | | | | | | | | | | | | | | | | | | | | | |
| | | little bad | Bad | | | | | | | | | | | | | | | | | | | | | | | | | | | | | | | | | | | | | | | | | | | | |
| ACC (OA) | [G] | 0.46 | 1.82 | 0.951 | little bad | | | | | | | | | | | | | | | | | | | | | | | | | | | | | | | | | | | | | | | | | | |
| VEL | [cm/s] | 0.40 | 1.00 | 0.588 | little bad | | | | | | | | | | | | | | | | | | | | | | | | | | | | | | | | | | | | | | | | | | |
| 【Comment】 | | | | | | | | | | | | | | | | | | | | | | | | | | | | | | | | | | | | | | | | | | | | | | | |

drawing date: 24 May 2010

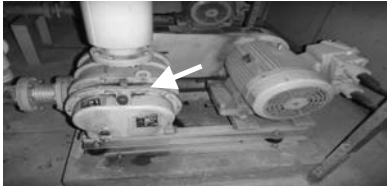
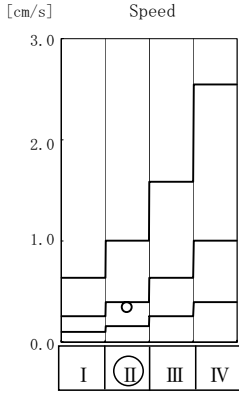
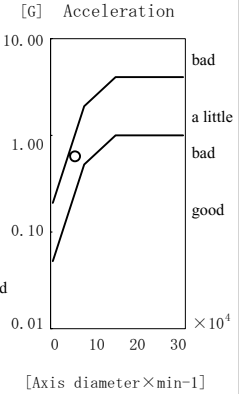
| Simple diagnosis report | | | | | | | | | drawing | | | | | | | | | | | | | | | | | | | | | | | | | | | | | | | | | | | | | | |
|--|--------|--------------------------|--------|---------------|-------------|------------------------------------|-----|---------------|---------|--------------|----------|------------|--------|----------------|-----|------|------|-------|------------|----------|--------|------|------|-------|-------------|--|-----|------|-------|-------|------|-----|--------|------|------|-------|------|------|------|----|-----|------|------|---|--|--|--|
| equipment name | | | | | | Truc Bach WWTP | | | | | | | | | | | | | | | | | | | | | | | | | | | | | | | | | | | | | | | | | |
| machine name | | | | | | TBW1B Aeration Blower | | | | | | | | | | | | | | | | | | | | | | | | | | | | | | | | | | | | | | | | | |
| measurement part | | | | | | Blower Inside (Opposite Load Side) | | | | | | | | | | | | | | | | | | | | | | | | | | | | | | | | | | | | | | | | | |
| ID code | | Direction of measurement | | Group No. | | 215 | | | | | | | | | | | | | | | | | | | | | | | | | | | | | | | | | | | | | | | | | |
| Output | | Rotational speed | | Axis diameter | | 45 mm | | | | | | | | | | | | | | | | | | | | | | | | | | | | | | | | | | | | | | | | | |
| <p>【 Relative value Judgment 】 recorded time: 18 May 2010 16:01</p> <table border="1" style="width:100%; border-collapse: collapse;"> <thead> <tr> <th rowspan="2">Measurement Mode</th> <th rowspan="2">[G]</th> <th colspan="2">Warning Level</th> <th rowspan="2">Measurements</th> <th rowspan="2">Judgment</th> </tr> <tr> <th>Attention</th> <th>Danger</th> </tr> </thead> <tbody> <tr> <td>ACC (THRU, OA)</td> <td>[G]</td> <td>1.00</td> <td>4.00</td> <td>1.018</td> <td>Attention</td> </tr> <tr> <td>ACC (OA)</td> <td>[G]</td> <td>1.00</td> <td>4.00</td> <td>0.603</td> <td>Good</td> </tr> <tr> <td>ACC (PEAK)</td> <td>[G]</td> <td>3.00</td> <td>12.00</td> <td>2.304</td> <td>Good</td> </tr> <tr> <td>VEL</td> <td>[cm/s]</td> <td>0.40</td> <td>1.00</td> <td>0.344</td> <td>Good</td> </tr> <tr> <td>DISP</td> <td>[μm]</td> <td>30</td> <td>100</td> <td>17.2</td> <td>Good</td> </tr> </tbody> </table> <p style="text-align: center;">(1G=9.8m/s²)</p> | | | | | | Measurement Mode | [G] | Warning Level | | Measurements | Judgment | Attention | Danger | ACC (THRU, OA) | [G] | 1.00 | 4.00 | 1.018 | Attention | ACC (OA) | [G] | 1.00 | 4.00 | 0.603 | Good | ACC (PEAK) | [G] | 3.00 | 12.00 | 2.304 | Good | VEL | [cm/s] | 0.40 | 1.00 | 0.344 | Good | DISP | [μm] | 30 | 100 | 17.2 | Good |  | | | |
| Measurement Mode | [G] | Warning Level | | Measurements | Judgment | | | | | | | | | | | | | | | | | | | | | | | | | | | | | | | | | | | | | | | | | | |
| | | Attention | Danger | | | | | | | | | | | | | | | | | | | | | | | | | | | | | | | | | | | | | | | | | | | | |
| ACC (THRU, OA) | [G] | 1.00 | 4.00 | 1.018 | Attention | | | | | | | | | | | | | | | | | | | | | | | | | | | | | | | | | | | | | | | | | | |
| ACC (OA) | [G] | 1.00 | 4.00 | 0.603 | Good | | | | | | | | | | | | | | | | | | | | | | | | | | | | | | | | | | | | | | | | | | |
| ACC (PEAK) | [G] | 3.00 | 12.00 | 2.304 | Good | | | | | | | | | | | | | | | | | | | | | | | | | | | | | | | | | | | | | | | | | | |
| VEL | [cm/s] | 0.40 | 1.00 | 0.344 | Good | | | | | | | | | | | | | | | | | | | | | | | | | | | | | | | | | | | | | | | | | | |
| DISP | [μm] | 30 | 100 | 17.2 | Good | | | | | | | | | | | | | | | | | | | | | | | | | | | | | | | | | | | | | | | | | | |
| <p>【 Absolute value Judgment 】 recorded time: 18 May 2010 16:01</p> <table border="1" style="width:100%; border-collapse: collapse;"> <thead> <tr> <th rowspan="2">Measurement Mode</th> <th rowspan="2">[G]</th> <th colspan="2">Warning Level</th> <th rowspan="2">Measurements</th> <th rowspan="2">Judgment</th> </tr> <tr> <th>little bad</th> <th>Bad</th> </tr> </thead> <tbody> <tr> <td>ACC (OA)</td> <td>[G]</td> <td>0.35</td> <td>1.41</td> <td>0.603</td> <td>little bad</td> </tr> <tr> <td>VEL</td> <td>[cm/s]</td> <td>0.40</td> <td>1.00</td> <td>0.344</td> <td>little good</td> </tr> </tbody> </table> <p style="text-align: center;">(1G=9.8m/s²)</p> | | | | | | Measurement Mode | [G] | Warning Level | | Measurements | Judgment | little bad | Bad | ACC (OA) | [G] | 0.35 | 1.41 | 0.603 | little bad | VEL | [cm/s] | 0.40 | 1.00 | 0.344 | little good | <p>【 Absolute value Judgment 】 (1G=9.8m/s²)</p> <div style="display: flex; justify-content: space-around;"> <div style="text-align: center;"> <p>Speed [cm/s]</p>  </div> <div style="text-align: center;"> <p>Acceleration [G]</p>  </div> </div> | | | | | | | | | | | | | | | | | | | | | |
| Measurement Mode | [G] | Warning Level | | Measurements | Judgment | | | | | | | | | | | | | | | | | | | | | | | | | | | | | | | | | | | | | | | | | | |
| | | little bad | Bad | | | | | | | | | | | | | | | | | | | | | | | | | | | | | | | | | | | | | | | | | | | | |
| ACC (OA) | [G] | 0.35 | 1.41 | 0.603 | little bad | | | | | | | | | | | | | | | | | | | | | | | | | | | | | | | | | | | | | | | | | | |
| VEL | [cm/s] | 0.40 | 1.00 | 0.344 | little good | | | | | | | | | | | | | | | | | | | | | | | | | | | | | | | | | | | | | | | | | | |
| 【Comment】 | | | | | | | | | | | | | | | | | | | | | | | | | | | | | | | | | | | | | | | | | | | | | | | |

drawing date: 16 Jul 2010

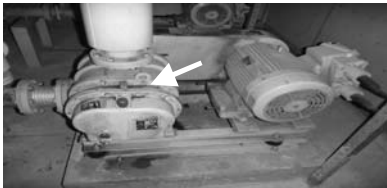
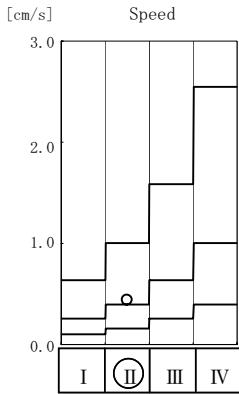
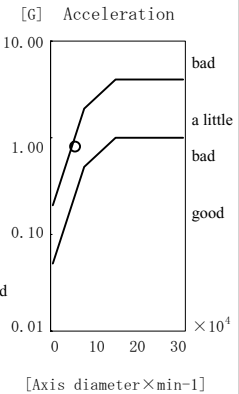
| Simple diagnosis report | | | | | | | | | drawing | | | | | | | | | | | | | | | | | | | | | | | | | | | | | | | | | | | | | | |
|---|--------|--------------------------|--------|---------------|------------|------------------------------------|-----|---------------|---------|--------------|----------|------------|--------|----------------|-----|------|------|-------|------------|----------|--------|------|------|-------|------------|--|-----|------|-------|-------|------|-----|--------|------|------|-------|-----------|------|------|----|-----|------|------|---|--|--|--|
| equipment name | | | | | | Truc Bach WWTP | | | | | | | | | | | | | | | | | | | | | | | | | | | | | | | | | | | | | | | | | |
| machine name | | | | | | TBW1B Aeration Blower | | | | | | | | | | | | | | | | | | | | | | | | | | | | | | | | | | | | | | | | | |
| measurement part | | | | | | Blower Inside (Opposite Load Side) | | | | | | | | | | | | | | | | | | | | | | | | | | | | | | | | | | | | | | | | | |
| ID code | | Direction of measurement | | Group No. | | 215 | | | | | | | | | | | | | | | | | | | | | | | | | | | | | | | | | | | | | | | | | |
| Output | | Rotational speed | | Axis diameter | | 45 mm | | | | | | | | | | | | | | | | | | | | | | | | | | | | | | | | | | | | | | | | | |
| <p>【 Relative value Judgment 】 recorded time: 16 Jul 2010 11:39</p> <table border="1" style="width:100%; border-collapse: collapse;"> <thead> <tr> <th rowspan="2">Measurement Mode</th> <th rowspan="2">[G]</th> <th colspan="2">Warning Level</th> <th rowspan="2">Measurements</th> <th rowspan="2">Judgment</th> </tr> <tr> <th>Attention</th> <th>Danger</th> </tr> </thead> <tbody> <tr> <td>ACC (THRU, OA)</td> <td>[G]</td> <td>1.00</td> <td>4.00</td> <td>1.137</td> <td>Attention</td> </tr> <tr> <td>ACC (OA)</td> <td>[G]</td> <td>1.00</td> <td>4.00</td> <td>0.809</td> <td>Good</td> </tr> <tr> <td>ACC (PEAK)</td> <td>[G]</td> <td>3.00</td> <td>12.00</td> <td>2.151</td> <td>Good</td> </tr> <tr> <td>VEL</td> <td>[cm/s]</td> <td>0.40</td> <td>1.00</td> <td>0.442</td> <td>Attention</td> </tr> <tr> <td>DISP</td> <td>[μm]</td> <td>30</td> <td>100</td> <td>20.0</td> <td>Good</td> </tr> </tbody> </table> <p style="text-align: center;">(1G=9.8m/s²)</p> | | | | | | Measurement Mode | [G] | Warning Level | | Measurements | Judgment | Attention | Danger | ACC (THRU, OA) | [G] | 1.00 | 4.00 | 1.137 | Attention | ACC (OA) | [G] | 1.00 | 4.00 | 0.809 | Good | ACC (PEAK) | [G] | 3.00 | 12.00 | 2.151 | Good | VEL | [cm/s] | 0.40 | 1.00 | 0.442 | Attention | DISP | [μm] | 30 | 100 | 20.0 | Good |  | | | |
| Measurement Mode | [G] | Warning Level | | Measurements | Judgment | | | | | | | | | | | | | | | | | | | | | | | | | | | | | | | | | | | | | | | | | | |
| | | Attention | Danger | | | | | | | | | | | | | | | | | | | | | | | | | | | | | | | | | | | | | | | | | | | | |
| ACC (THRU, OA) | [G] | 1.00 | 4.00 | 1.137 | Attention | | | | | | | | | | | | | | | | | | | | | | | | | | | | | | | | | | | | | | | | | | |
| ACC (OA) | [G] | 1.00 | 4.00 | 0.809 | Good | | | | | | | | | | | | | | | | | | | | | | | | | | | | | | | | | | | | | | | | | | |
| ACC (PEAK) | [G] | 3.00 | 12.00 | 2.151 | Good | | | | | | | | | | | | | | | | | | | | | | | | | | | | | | | | | | | | | | | | | | |
| VEL | [cm/s] | 0.40 | 1.00 | 0.442 | Attention | | | | | | | | | | | | | | | | | | | | | | | | | | | | | | | | | | | | | | | | | | |
| DISP | [μm] | 30 | 100 | 20.0 | Good | | | | | | | | | | | | | | | | | | | | | | | | | | | | | | | | | | | | | | | | | | |
| <p>【 Absolute value Judgment 】 recorded time: 16 Jul 2010 11:39</p> <table border="1" style="width:100%; border-collapse: collapse;"> <thead> <tr> <th rowspan="2">Measurement Mode</th> <th rowspan="2">[G]</th> <th colspan="2">Warning Level</th> <th rowspan="2">Measurements</th> <th rowspan="2">Judgment</th> </tr> <tr> <th>little bad</th> <th>Bad</th> </tr> </thead> <tbody> <tr> <td>ACC (OA)</td> <td>[G]</td> <td>0.35</td> <td>1.41</td> <td>0.809</td> <td>little bad</td> </tr> <tr> <td>VEL</td> <td>[cm/s]</td> <td>0.40</td> <td>1.00</td> <td>0.442</td> <td>little bad</td> </tr> </tbody> </table> <p style="text-align: center;">(1G=9.8m/s²)</p> | | | | | | Measurement Mode | [G] | Warning Level | | Measurements | Judgment | little bad | Bad | ACC (OA) | [G] | 0.35 | 1.41 | 0.809 | little bad | VEL | [cm/s] | 0.40 | 1.00 | 0.442 | little bad | <p>【 Absolute value Judgment 】 (1G=9.8m/s²)</p> <div style="display: flex; justify-content: space-around;"> <div style="text-align: center;"> <p>Speed [cm/s]</p>  </div> <div style="text-align: center;"> <p>Acceleration [G]</p>  </div> </div> | | | | | | | | | | | | | | | | | | | | | |
| Measurement Mode | [G] | Warning Level | | Measurements | Judgment | | | | | | | | | | | | | | | | | | | | | | | | | | | | | | | | | | | | | | | | | | |
| | | little bad | Bad | | | | | | | | | | | | | | | | | | | | | | | | | | | | | | | | | | | | | | | | | | | | |
| ACC (OA) | [G] | 0.35 | 1.41 | 0.809 | little bad | | | | | | | | | | | | | | | | | | | | | | | | | | | | | | | | | | | | | | | | | | |
| VEL | [cm/s] | 0.40 | 1.00 | 0.442 | little bad | | | | | | | | | | | | | | | | | | | | | | | | | | | | | | | | | | | | | | | | | | |
| 【Comment】 | | | | | | | | | | | | | | | | | | | | | | | | | | | | | | | | | | | | | | | | | | | | | | | |

drawing date: 24 May 2010

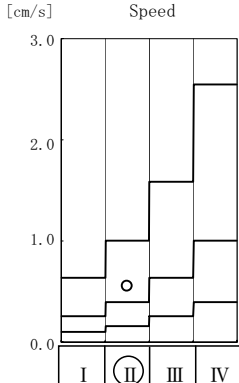
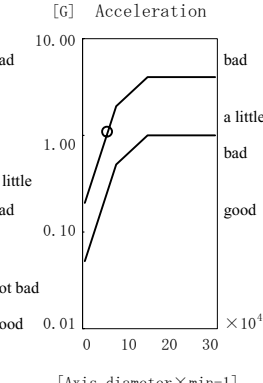
| Simple diagnosis report | | | | | | | | | drawing | | | | | | | | | | | | | | | | | | | | | | | | | | | | | | | | |
|---|---------------|--------------------------|------------------------|---------------|-------|---|---------------|--|--------------|----------|------------|--------|--------------------|------|------|-------|------------|--------------|------|------|-------|------------|----------------|------|-------|-------|-----------|------------|------|------|-------|-----------|-----------------|----|-----|------|-----------|--|--|--|--|
| equipment name | | | | | | Truc Bach WWTP | | | | | | | | | | | | | | | | | | | | | | | | | | | | | | | | | | | |
| machine name | | | | | | TBW1B Aeration Blower | | | | | | | | | | | | | | | | | | | | | | | | | | | | | | | | | | | |
| measurement part | | | | | | Blower Outside (Load Side) | | | | | | | | | | | | | | | | | | | | | | | | | | | | | | | | | | | |
| ID code | 224 | Direction of measurement | Vertical | Group No. | 214 |  | | | | | | | | | | | | | | | | | | | | | | | | | | | | | | | | | | | |
| Output | 15.0 kW | Rotational speed | 1542 min ⁻¹ | Axis diameter | 45 mm | | | | | | | | | | | | | | | | | | | | | | | | | | | | | | | | | | | | |
| <p>【 Relative value Judgment 】 recorded time: 18 May 2010 16:00</p> <table border="1" style="width:100%; border-collapse: collapse;"> <thead> <tr> <th rowspan="2">Measurement Mode</th> <th colspan="2">Warning Level</th> <th rowspan="2">Measurements</th> <th rowspan="2">Judgment</th> </tr> <tr> <th>Attention</th> <th>Danger</th> </tr> </thead> <tbody> <tr> <td>ACC (THRU, OA) [G]</td> <td>1.00</td> <td>4.00</td> <td>1.924</td> <td>Attention</td> </tr> <tr> <td>ACC (OA) [G]</td> <td>1.00</td> <td>4.00</td> <td>1.089</td> <td>Attention</td> </tr> <tr> <td>ACC (PEAK) [G]</td> <td>3.00</td> <td>12.00</td> <td>3.273</td> <td>Attention</td> </tr> <tr> <td>VEL [cm/s]</td> <td>0.40</td> <td>1.00</td> <td>0.558</td> <td>Attention</td> </tr> <tr> <td>DISP [μm]</td> <td>30</td> <td>100</td> <td>52.2</td> <td>Attention</td> </tr> </tbody> </table> <p style="text-align: center;">(1G=9.8m/s²)</p> | | | | | | Measurement Mode | Warning Level | | Measurements | Judgment | Attention | Danger | ACC (THRU, OA) [G] | 1.00 | 4.00 | 1.924 | Attention | ACC (OA) [G] | 1.00 | 4.00 | 1.089 | Attention | ACC (PEAK) [G] | 3.00 | 12.00 | 3.273 | Attention | VEL [cm/s] | 0.40 | 1.00 | 0.558 | Attention | DISP [μ m] | 30 | 100 | 52.2 | Attention | <p>【 Absolute value Judgment 】 (1G=9.8m/s²)</p> <div style="display: flex; justify-content: space-around;"> <div style="text-align: center;"> <p>Speed [cm/s]</p>  </div> <div style="text-align: center;"> <p>Acceleration [G]</p>  </div> </div> | | | |
| Measurement Mode | Warning Level | | Measurements | Judgment | | | | | | | | | | | | | | | | | | | | | | | | | | | | | | | | | | | | | |
| | Attention | Danger | | | | | | | | | | | | | | | | | | | | | | | | | | | | | | | | | | | | | | | |
| ACC (THRU, OA) [G] | 1.00 | 4.00 | 1.924 | Attention | | | | | | | | | | | | | | | | | | | | | | | | | | | | | | | | | | | | | |
| ACC (OA) [G] | 1.00 | 4.00 | 1.089 | Attention | | | | | | | | | | | | | | | | | | | | | | | | | | | | | | | | | | | | | |
| ACC (PEAK) [G] | 3.00 | 12.00 | 3.273 | Attention | | | | | | | | | | | | | | | | | | | | | | | | | | | | | | | | | | | | | |
| VEL [cm/s] | 0.40 | 1.00 | 0.558 | Attention | | | | | | | | | | | | | | | | | | | | | | | | | | | | | | | | | | | | | |
| DISP [μ m] | 30 | 100 | 52.2 | Attention | | | | | | | | | | | | | | | | | | | | | | | | | | | | | | | | | | | | | |
| <p>【 Absolute value Judgment 】 recorded time: 18 May 2010 16:00</p> <table border="1" style="width:100%; border-collapse: collapse;"> <thead> <tr> <th rowspan="2">Measurement Mode</th> <th colspan="2">Warning Level</th> <th rowspan="2">Measurements</th> <th rowspan="2">Judgment</th> </tr> <tr> <th>little bad</th> <th>Bad</th> </tr> </thead> <tbody> <tr> <td>ACC (OA) [G]</td> <td>0.35</td> <td>1.41</td> <td>1.089</td> <td>little bad</td> </tr> <tr> <td>VEL [cm/s]</td> <td>0.40</td> <td>1.00</td> <td>0.558</td> <td>little bad</td> </tr> </tbody> </table> <p style="text-align: center;">(1G=9.8m/s²)</p> | | | | | | Measurement Mode | Warning Level | | Measurements | Judgment | little bad | Bad | ACC (OA) [G] | 0.35 | 1.41 | 1.089 | little bad | VEL [cm/s] | 0.40 | 1.00 | 0.558 | little bad | | | | | | | | | | | | | | | | | | | |
| Measurement Mode | Warning Level | | Measurements | Judgment | | | | | | | | | | | | | | | | | | | | | | | | | | | | | | | | | | | | | |
| | little bad | Bad | | | | | | | | | | | | | | | | | | | | | | | | | | | | | | | | | | | | | | | |
| ACC (OA) [G] | 0.35 | 1.41 | 1.089 | little bad | | | | | | | | | | | | | | | | | | | | | | | | | | | | | | | | | | | | | |
| VEL [cm/s] | 0.40 | 1.00 | 0.558 | little bad | | | | | | | | | | | | | | | | | | | | | | | | | | | | | | | | | | | | | |
| 【Comment】 | | | | | | | | | | | | | | | | | | | | | | | | | | | | | | | | | | | | | | | | | |

drawing date: 16 Jul 2010

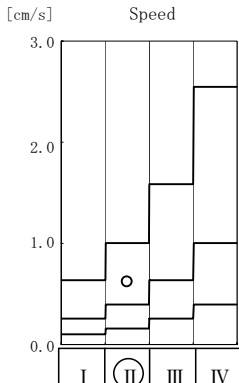
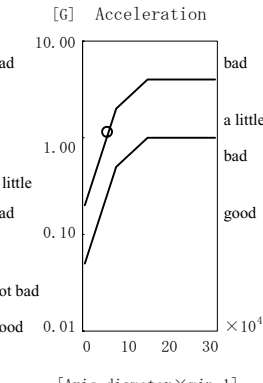
| Simple diagnosis report | | | | | | | | | drawing | | | | | | | | | | | | | | | | | | | | | | | | | | | | | | | | |
|---|---------------|--------------------------|------------------------|---------------|-------|---|---------------|--|--------------|----------|------------|--------|--------------------|------|------|-------|------------|--------------|------|------|-------|------------|----------------|------|-------|-------|-----------|------------|------|------|-------|-----------|-----------------|----|-----|------|-----------|--|--|--|--|
| equipment name | | | | | | Truc Bach WWTP | | | | | | | | | | | | | | | | | | | | | | | | | | | | | | | | | | | |
| machine name | | | | | | TBW1B Aeration Blower | | | | | | | | | | | | | | | | | | | | | | | | | | | | | | | | | | | |
| measurement part | | | | | | Blower Outside (Load Side) | | | | | | | | | | | | | | | | | | | | | | | | | | | | | | | | | | | |
| ID code | 224 | Direction of measurement | Vertical | Group No. | 214 |  | | | | | | | | | | | | | | | | | | | | | | | | | | | | | | | | | | | |
| Output | 15.0 kW | Rotational speed | 1542 min ⁻¹ | Axis diameter | 45 mm | | | | | | | | | | | | | | | | | | | | | | | | | | | | | | | | | | | | |
| <p>【 Relative value Judgment 】 recorded time: 16 Jul 2010 11:39</p> <table border="1" style="width:100%; border-collapse: collapse;"> <thead> <tr> <th rowspan="2">Measurement Mode</th> <th colspan="2">Warning Level</th> <th rowspan="2">Measurements</th> <th rowspan="2">Judgment</th> </tr> <tr> <th>Attention</th> <th>Danger</th> </tr> </thead> <tbody> <tr> <td>ACC (THRU, OA) [G]</td> <td>1.00</td> <td>4.00</td> <td>2.093</td> <td>Attention</td> </tr> <tr> <td>ACC (OA) [G]</td> <td>1.00</td> <td>4.00</td> <td>1.146</td> <td>Attention</td> </tr> <tr> <td>ACC (PEAK) [G]</td> <td>3.00</td> <td>12.00</td> <td>3.055</td> <td>Attention</td> </tr> <tr> <td>VEL [cm/s]</td> <td>0.40</td> <td>1.00</td> <td>0.625</td> <td>Attention</td> </tr> <tr> <td>DISP [μm]</td> <td>30</td> <td>100</td> <td>51.9</td> <td>Attention</td> </tr> </tbody> </table> <p style="text-align: center;">(1G=9.8m/s²)</p> | | | | | | Measurement Mode | Warning Level | | Measurements | Judgment | Attention | Danger | ACC (THRU, OA) [G] | 1.00 | 4.00 | 2.093 | Attention | ACC (OA) [G] | 1.00 | 4.00 | 1.146 | Attention | ACC (PEAK) [G] | 3.00 | 12.00 | 3.055 | Attention | VEL [cm/s] | 0.40 | 1.00 | 0.625 | Attention | DISP [μ m] | 30 | 100 | 51.9 | Attention | <p>【 Absolute value Judgment 】 (1G=9.8m/s²)</p> <div style="display: flex; justify-content: space-around;"> <div style="text-align: center;"> <p>Speed [cm/s]</p>  </div> <div style="text-align: center;"> <p>Acceleration [G]</p>  </div> </div> | | | |
| Measurement Mode | Warning Level | | Measurements | Judgment | | | | | | | | | | | | | | | | | | | | | | | | | | | | | | | | | | | | | |
| | Attention | Danger | | | | | | | | | | | | | | | | | | | | | | | | | | | | | | | | | | | | | | | |
| ACC (THRU, OA) [G] | 1.00 | 4.00 | 2.093 | Attention | | | | | | | | | | | | | | | | | | | | | | | | | | | | | | | | | | | | | |
| ACC (OA) [G] | 1.00 | 4.00 | 1.146 | Attention | | | | | | | | | | | | | | | | | | | | | | | | | | | | | | | | | | | | | |
| ACC (PEAK) [G] | 3.00 | 12.00 | 3.055 | Attention | | | | | | | | | | | | | | | | | | | | | | | | | | | | | | | | | | | | | |
| VEL [cm/s] | 0.40 | 1.00 | 0.625 | Attention | | | | | | | | | | | | | | | | | | | | | | | | | | | | | | | | | | | | | |
| DISP [μ m] | 30 | 100 | 51.9 | Attention | | | | | | | | | | | | | | | | | | | | | | | | | | | | | | | | | | | | | |
| <p>【 Absolute value Judgment 】 recorded time: 16 Jul 2010 11:39</p> <table border="1" style="width:100%; border-collapse: collapse;"> <thead> <tr> <th rowspan="2">Measurement Mode</th> <th colspan="2">Warning Level</th> <th rowspan="2">Measurements</th> <th rowspan="2">Judgment</th> </tr> <tr> <th>little bad</th> <th>Bad</th> </tr> </thead> <tbody> <tr> <td>ACC (OA) [G]</td> <td>0.35</td> <td>1.41</td> <td>1.146</td> <td>little bad</td> </tr> <tr> <td>VEL [cm/s]</td> <td>0.40</td> <td>1.00</td> <td>0.625</td> <td>little bad</td> </tr> </tbody> </table> <p style="text-align: center;">(1G=9.8m/s²)</p> | | | | | | Measurement Mode | Warning Level | | Measurements | Judgment | little bad | Bad | ACC (OA) [G] | 0.35 | 1.41 | 1.146 | little bad | VEL [cm/s] | 0.40 | 1.00 | 0.625 | little bad | | | | | | | | | | | | | | | | | | | |
| Measurement Mode | Warning Level | | Measurements | Judgment | | | | | | | | | | | | | | | | | | | | | | | | | | | | | | | | | | | | | |
| | little bad | Bad | | | | | | | | | | | | | | | | | | | | | | | | | | | | | | | | | | | | | | | |
| ACC (OA) [G] | 0.35 | 1.41 | 1.146 | little bad | | | | | | | | | | | | | | | | | | | | | | | | | | | | | | | | | | | | | |
| VEL [cm/s] | 0.40 | 1.00 | 0.625 | little bad | | | | | | | | | | | | | | | | | | | | | | | | | | | | | | | | | | | | | |
| 【Comment】 | | | | | | | | | | | | | | | | | | | | | | | | | | | | | | | | | | | | | | | | | |

drawing date: 24 May 2010

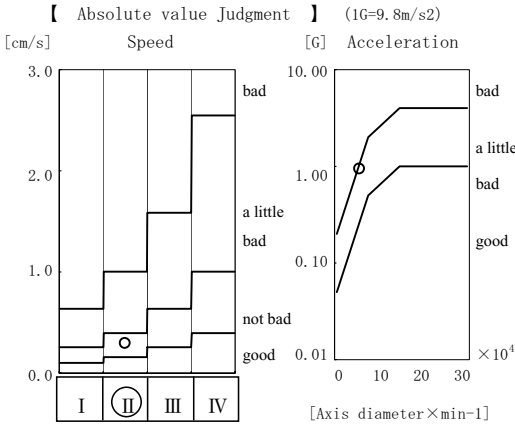
| Simple diagnosis report | | | | | | | | | drawing | | |
|--|--|--------------------------|--------|---------------|--|--|--|--|---------|-------------|--|
| equipment name | | | | | | Truc Bach WWTP | | | | | |
| machine name | | | | | | TBW1B Aeration Blower | | | | | |
| measurement part | | | | | | Blower Outside (Opposite Load Side) | | | | | |
| ID code | | Direction of measurement | | Group No. | | 216 | | | | | |
| Output | | Rotational speed | | Axis diameter | | 45 mm | | | | | |
| 【 Relative value Judgment 】 recorded time: 18 May 2010 16:01 | | | | | |  | | | | | |
| Measurement Mode | | Warning Level | | Measurements | | | | | | Judgment | |
| | | Attention | Danger | | | | | | | | |
| ACC (THRU, OA) [G] | | 1.00 | 4.00 | 1.561 | | | | | | Attention | |
| ACC (OA) [G] | | 1.00 | 4.00 | 0.948 | | | | | | Good | |
| ACC (PEAK) [G] | | 3.00 | 12.00 | 2.673 | | | | | | Good | |
| VEL [cm/s] | | 1.00 | 4.00 | 0.296 | | Good | | | | | |
| DISP [μ m] | | 30 | 100 | 17.6 | | Good | | | | | |
| (1G=9.8m/s ²) | | | | | | 【 Absolute value Judgment 】 (1G=9.8m/s ²) [cm/s] Speed [G] Acceleration  | | | | | |
| Measurement Mode | | Warning Level | | Measurements | | | | | | Judgment | |
| | | little bad | Bad | | | | | | | | |
| ACC (OA) [G] | | 0.35 | 1.41 | 0.948 | | | | | | little bad | |
| VEL [cm/s] | | 0.40 | 1.00 | 0.296 | | | | | | little good | |
| (1G=9.8m/s ²) | | | | | | | | | | | |
| 【 Comment 】 | | | | | | | | | | | |

drawing date: 16 Jul 2010

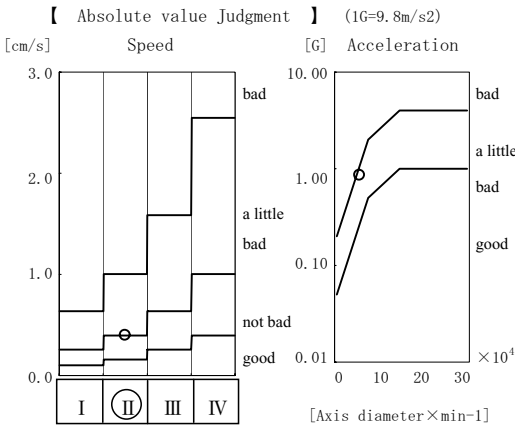
| Simple diagnosis report | | | | | | | | | drawing | | |
|--|--|--------------------------|--------|---------------|--|--|--|--|---------|------------|--|
| equipment name | | | | | | Truc Bach WWTP | | | | | |
| machine name | | | | | | TBW1B Aeration Blower | | | | | |
| measurement part | | | | | | Blower Outside (Opposite Load Side) | | | | | |
| ID code | | Direction of measurement | | Group No. | | 216 | | | | | |
| Output | | Rotational speed | | Axis diameter | | 45 mm | | | | | |
| 【 Relative value Judgment 】 recorded time: 16 Jul 2010 11:39 | | | | | |  | | | | | |
| Measurement Mode | | Warning Level | | Measurements | | | | | | Judgment | |
| | | Attention | Danger | | | | | | | | |
| ACC (THRU, OA) [G] | | 1.00 | 4.00 | 1.661 | | | | | | Attention | |
| ACC (OA) [G] | | 1.00 | 4.00 | 0.868 | | | | | | Good | |
| ACC (PEAK) [G] | | 3.00 | 12.00 | 2.348 | | | | | | Good | |
| VEL [cm/s] | | 1.00 | 4.00 | 0.402 | | Good | | | | | |
| DISP [μ m] | | 30 | 100 | 11.9 | | Good | | | | | |
| (1G=9.8m/s ²) | | | | | | 【 Absolute value Judgment 】 (1G=9.8m/s ²) [cm/s] Speed [G] Acceleration  | | | | | |
| Measurement Mode | | Warning Level | | Measurements | | | | | | Judgment | |
| | | little bad | Bad | | | | | | | | |
| ACC (OA) [G] | | 0.35 | 1.41 | 0.868 | | | | | | little bad | |
| VEL [cm/s] | | 0.40 | 1.00 | 0.402 | | | | | | little bad | |
| (1G=9.8m/s ²) | | | | | | | | | | | |
| 【 Comment 】 | | | | | | | | | | | |

| | | | | | | | | |
|---|---------|---|------------------------|---------------|-------|--|--|---------|
| Simple diagnosis report | | | | | | | | drawing |
| equipment name Truc Bach WWTP | | | | | | | | |
| machine name TBW1C Aeration Blower | | | | | | | | |
| measurement part Moter (Opposite Load Side) | | | | | | | | |
| ID code | 231 | <small>Direction of measurement</small> | Vertical | Group No. | 211 | | | |
| Output | 15.0 kW | Rotational speed | 1473 min ⁻¹ | Axis diameter | 40 mm | | | |



【 Relative value Judgment 】 recorded time: 18 May 2010 16:02

| Measurement Mode | Warning Level | | Measurements | Judgment |
|--------------------|---------------|--------|--------------|----------|
| | Attention | Danger | | |
| ACC (THRU, OA) [G] | 1.00 | 4.00 | 0.902 | Good |
| ACC (OA) [G] | 1.00 | 4.00 | 0.621 | Good |
| ACC (PEAK) [G] | 3.00 | 12.00 | 1.069 | Good |
| VEL [cm/s] | 0.40 | 1.00 | 0.274 | Good |
| DISP [μ m] | 30 | 100 | 10.3 | Good |

(1G=9.8m/s²)

【 Absolute value Judgment 】 recorded time: 18 May 2010 16:02

| Measurement Mode | Warning Level | | Measurements | Judgment |
|------------------|---------------|------|--------------|-------------|
| | little bad | Bad | | |
| ACC (OA) [G] | 0.25 | 1.00 | 0.621 | little bad |
| VEL [cm/s] | 0.40 | 1.00 | 0.274 | little good |

(1G=9.8m/s²)

【 Absolute value Judgment 】 (1G=9.8m/s²)

Speed [cm/s]

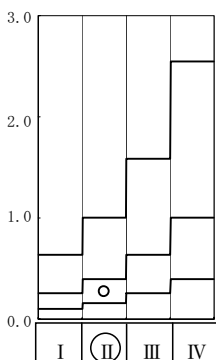

Acceleration [G]

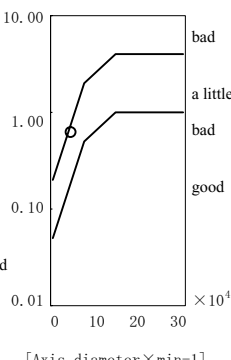

【Comment】

| | | | | | | | | |
|------------------------------------|---------|---|------------------------|---------------|-------|--|--|---------|
| Simple diagnosis report | | | | | | | | drawing |
| equipment name Truc Bach WWTP | | | | | | | | |
| machine name TBW1C Aeration Blower | | | | | | | | |
| measurement part Moter (Load Side) | | | | | | | | |
| ID code | 232 | <small>Direction of measurement</small> | Vertical | Group No. | 212 | | | |
| Output | 15.0 kW | Rotational speed | 1473 min ⁻¹ | Axis diameter | 45 mm | | | |



【 Relative value Judgment 】 recorded time: 18 May 2010 16:02

| Measurement Mode | Warning Level | | Measurements | Judgment |
|--------------------|---------------|--------|--------------|----------|
| | Attention | Danger | | |
| ACC (THRU, OA) [G] | 1.00 | 4.00 | 0.462 | Good |
| ACC (OA) [G] | 1.00 | 4.00 | 0.236 | Good |
| ACC (PEAK) [G] | 3.00 | 12.00 | 0.623 | Good |
| VEL [cm/s] | 0.40 | 1.00 | 0.244 | Good |
| DISP [μ m] | 30 | 100 | 21.0 | Good |

(1G=9.8m/s²)

【 Absolute value Judgment 】 recorded time: 18 May 2010 16:02

| Measurement Mode | Warning Level | | Measurements | Judgment |
|------------------|---------------|------|--------------|-------------|
| | little bad | Bad | | |
| ACC (OA) [G] | 0.32 | 1.28 | 0.236 | Good |
| VEL [cm/s] | 0.40 | 1.00 | 0.244 | little good |

(1G=9.8m/s²)

【 Absolute value Judgment 】 (1G=9.8m/s²)

Speed [cm/s]

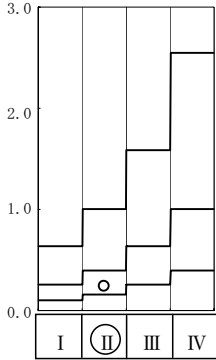

Acceleration [G]

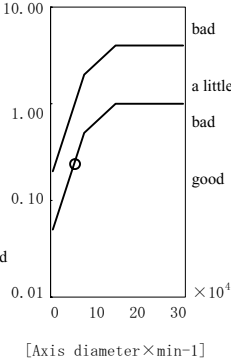

【Comment】

| | | | | | | | | | |
|--------------------------------|---------|--------------------------|------------------------|---------------|-------|--|--|--|---------|
| Simple diagnosis report | | | | | | | | | drawing |
| equipment name | | | | | | | | | |
| Truc Bach WWTP | | | | | | | | | |
| machine name | | | | | | | | | |
| TBW1C Aeration Blower | | | | | | | | | |
| measurement part | | | | | | | | | |
| Blower Inside (Load Side) | | | | | | | | | |
| ID code | 233 | Direction of measurement | Vertical | Group No. | 213 | | | | |
| Output | 15.0 kW | Rotational speed | 1557 min ⁻¹ | Axis diameter | 50 mm | | | | |

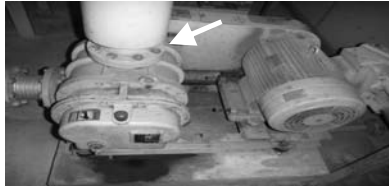

【 Relative value Judgment 】 recorded time: 18 May 2010 16:03

| Measurement Mode | Warning Level | | Measurements | Judgment |
|--------------------|---------------|--------|--------------|-----------|
| | Attention | Danger | | |
| ACC (THRU, OA) [G] | 1.00 | 4.00 | 3.035 | Attention |
| ACC (OA) [G] | 1.00 | 4.00 | 1.633 | Attention |
| ACC (PEAK) [G] | 3.00 | 12.00 | 3.919 | Attention |
| VEL [cm/s] | 0.40 | 1.00 | 0.488 | Attention |
| DISP [μ m] | 30 | 100 | 30.3 | Attention |

(1G=9.8m/s²)

【 Absolute value Judgment 】 recorded time: 18 May 2010 16:03

| Measurement Mode | Warning Level | | Measurements | Judgment |
|------------------|---------------|------|--------------|------------|
| | little bad | Bad | | |
| ACC (OA) [G] | 0.47 | 1.87 | 1.633 | little bad |
| VEL [cm/s] | 0.40 | 1.00 | 0.488 | little bad |

(1G=9.8m/s²)

【 Absolute value Judgment 】 (1G=9.8m/s²)

Speed [cm/s]

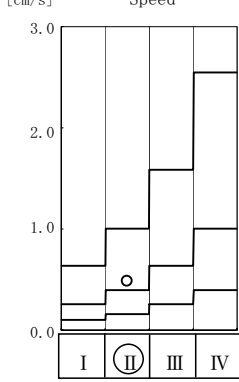

Acceleration [G]

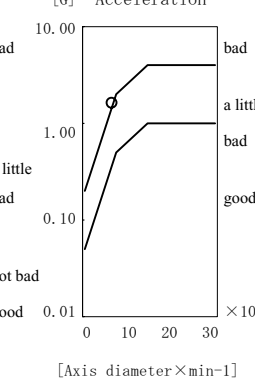

【Comment】

| | | | | | | | | | |
|------------------------------------|---------|--------------------------|------------------------|---------------|-------|--|--|--|---------|
| Simple diagnosis report | | | | | | | | | drawing |
| equipment name | | | | | | | | | |
| Truc Bach WWTP | | | | | | | | | |
| machine name | | | | | | | | | |
| TBW1C Aeration Blower | | | | | | | | | |
| measurement part | | | | | | | | | |
| Blower Inside (Opposite Load Side) | | | | | | | | | |
| ID code | 235 | Direction of measurement | Vertical | Group No. | 215 | | | | |
| Output | 15.0 kW | Rotational speed | 1557 min ⁻¹ | Axis diameter | 45 mm | | | | |



【 Relative value Judgment 】 recorded time: 18 May 2010 16:04

| Measurement Mode | Warning Level | | Measurements | Judgment |
|--------------------|---------------|--------|--------------|-----------|
| | Attention | Danger | | |
| ACC (THRU, OA) [G] | 1.00 | 4.00 | 1.491 | Attention |
| ACC (OA) [G] | 1.00 | 4.00 | 1.090 | Attention |
| ACC (PEAK) [G] | 3.00 | 12.00 | 3.176 | Attention |
| VEL [cm/s] | 0.40 | 1.00 | 0.223 | Good |
| DISP [μ m] | 30 | 100 | 15.5 | Good |

(1G=9.8m/s²)

【 Absolute value Judgment 】 recorded time: 18 May 2010 16:04

| Measurement Mode | Warning Level | | Measurements | Judgment |
|------------------|---------------|------|--------------|-------------|
| | little bad | Bad | | |
| ACC (OA) [G] | 0.36 | 1.45 | 1.090 | little bad |
| VEL [cm/s] | 0.40 | 1.00 | 0.223 | little good |

(1G=9.8m/s²)

【 Absolute value Judgment 】 (1G=9.8m/s²)

Speed [cm/s]

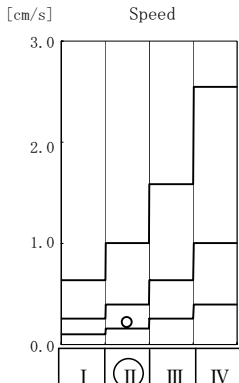

Acceleration [G]

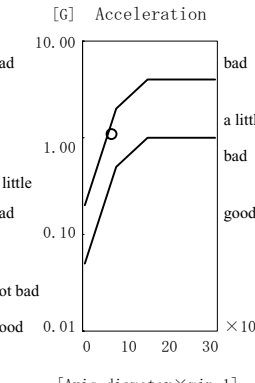

【Comment】

drawing date: 24 May 2010

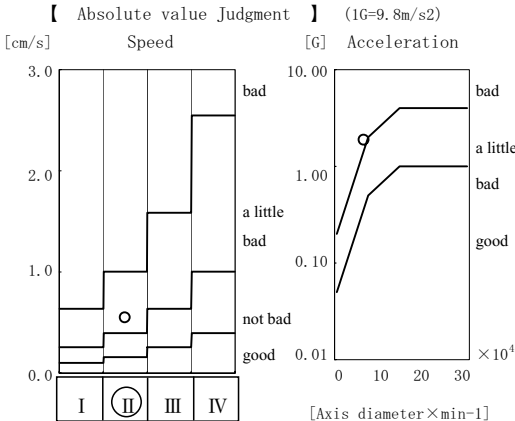
| Simple diagnosis report | | | | | | | | | drawing | | | | | | | | | | | | | | | | | | | | | | | | | | | | | | | | | | | | | | | | | | | | | | | | | | | | | | | | | | |
|--|---------|--------------------------|------------------------|---------------|------------|---|-----|---------------|---------|--------------|----------|-----------|--------|----------------|-----|------|------|-------|-----------|----------|-----|------|------|-------|-----------|------------|-----|------|-------|-------|-----------|-----|--------|------|------|-------|-----------|------|------|----|-----|------|-----------|--|--|--|--|------------------|-----|---------------|--|--------------|----------|------------|-----|----------|-----|------|------|-------|-----|-----|--------|------|------|-------|------------|
| equipment name | | | | | | Truc Bach WWTP | | | | | | | | | | | | | | | | | | | | | | | | | | | | | | | | | | | | | | | | | | | | | | | | | | | | | | | | | | | | | |
| machine name | | | | | | TBW1C Aeration Blower | | | | | | | | | | | | | | | | | | | | | | | | | | | | | | | | | | | | | | | | | | | | | | | | | | | | | | | | | | | | | |
| measurement part | | | | | | Blower Outside (Load Side) | | | | | | | | | | | | | | | | | | | | | | | | | | | | | | | | | | | | | | | | | | | | | | | | | | | | | | | | | | | | | |
| ID code | 234 | Direction of measurement | Vertical | Group No. | 214 |  | | | | | | | | | | | | | | | | | | | | | | | | | | | | | | | | | | | | | | | | | | | | | | | | | | | | | | | | | | | | | |
| Output | 15.0 kW | Rotational speed | 1557 min ⁻¹ | Axis diameter | 45 mm | | | | | | | | | | | | | | | | | | | | | | | | | | | | | | | | | | | | | | | | | | | | | | | | | | | | | | | | | | | | | | |
| <p>【 Relative value Judgment 】 recorded time: 18 May 2010 16:04</p> <table border="1" style="width:100%; border-collapse: collapse;"> <thead> <tr> <th rowspan="2">Measurement Mode</th> <th rowspan="2">[G]</th> <th colspan="2">Warning Level</th> <th rowspan="2">Measurements</th> <th rowspan="2">Judgment</th> </tr> <tr> <th>Attention</th> <th>Danger</th> </tr> </thead> <tbody> <tr> <td>ACC (THRU, OA)</td> <td>[G]</td> <td>1.00</td> <td>4.00</td> <td>3.375</td> <td>Attention</td> </tr> <tr> <td>ACC (OA)</td> <td>[G]</td> <td>1.00</td> <td>4.00</td> <td>1.876</td> <td>Attention</td> </tr> <tr> <td>ACC (PEAK)</td> <td>[G]</td> <td>3.00</td> <td>12.00</td> <td>4.231</td> <td>Attention</td> </tr> <tr> <td>VEL</td> <td>[cm/s]</td> <td>0.40</td> <td>1.00</td> <td>0.552</td> <td>Attention</td> </tr> <tr> <td>DISP</td> <td>[μm]</td> <td>30</td> <td>100</td> <td>42.6</td> <td>Attention</td> </tr> </tbody> </table> <p style="text-align: center;">(1G=9.8m/s²)</p> | | | | | | Measurement Mode | [G] | Warning Level | | Measurements | Judgment | Attention | Danger | ACC (THRU, OA) | [G] | 1.00 | 4.00 | 3.375 | Attention | ACC (OA) | [G] | 1.00 | 4.00 | 1.876 | Attention | ACC (PEAK) | [G] | 3.00 | 12.00 | 4.231 | Attention | VEL | [cm/s] | 0.40 | 1.00 | 0.552 | Attention | DISP | [μm] | 30 | 100 | 42.6 | Attention | <p>【 Absolute value Judgment 】 (1G=9.8m/s²)</p> <table border="1" style="width:100%; border-collapse: collapse;"> <thead> <tr> <th rowspan="2">Measurement Mode</th> <th rowspan="2">[G]</th> <th colspan="2">Warning Level</th> <th rowspan="2">Measurements</th> <th rowspan="2">Judgment</th> </tr> <tr> <th>little bad</th> <th>Bad</th> </tr> </thead> <tbody> <tr> <td>ACC (OA)</td> <td>[G]</td> <td>0.36</td> <td>1.45</td> <td>1.876</td> <td>Bad</td> </tr> <tr> <td>VEL</td> <td>[cm/s]</td> <td>0.40</td> <td>1.00</td> <td>0.552</td> <td>little bad</td> </tr> </tbody> </table> <p style="text-align: center;">(1G=9.8m/s²)</p> | | | | Measurement Mode | [G] | Warning Level | | Measurements | Judgment | little bad | Bad | ACC (OA) | [G] | 0.36 | 1.45 | 1.876 | Bad | VEL | [cm/s] | 0.40 | 1.00 | 0.552 | little bad |
| Measurement Mode | [G] | Warning Level | | Measurements | Judgment | | | | | | | | | | | | | | | | | | | | | | | | | | | | | | | | | | | | | | | | | | | | | | | | | | | | | | | | | | | | | | |
| | | Attention | Danger | | | | | | | | | | | | | | | | | | | | | | | | | | | | | | | | | | | | | | | | | | | | | | | | | | | | | | | | | | | | | | | | |
| ACC (THRU, OA) | [G] | 1.00 | 4.00 | 3.375 | Attention | | | | | | | | | | | | | | | | | | | | | | | | | | | | | | | | | | | | | | | | | | | | | | | | | | | | | | | | | | | | | | |
| ACC (OA) | [G] | 1.00 | 4.00 | 1.876 | Attention | | | | | | | | | | | | | | | | | | | | | | | | | | | | | | | | | | | | | | | | | | | | | | | | | | | | | | | | | | | | | | |
| ACC (PEAK) | [G] | 3.00 | 12.00 | 4.231 | Attention | | | | | | | | | | | | | | | | | | | | | | | | | | | | | | | | | | | | | | | | | | | | | | | | | | | | | | | | | | | | | | |
| VEL | [cm/s] | 0.40 | 1.00 | 0.552 | Attention | | | | | | | | | | | | | | | | | | | | | | | | | | | | | | | | | | | | | | | | | | | | | | | | | | | | | | | | | | | | | | |
| DISP | [μm] | 30 | 100 | 42.6 | Attention | | | | | | | | | | | | | | | | | | | | | | | | | | | | | | | | | | | | | | | | | | | | | | | | | | | | | | | | | | | | | | |
| Measurement Mode | [G] | Warning Level | | Measurements | Judgment | | | | | | | | | | | | | | | | | | | | | | | | | | | | | | | | | | | | | | | | | | | | | | | | | | | | | | | | | | | | | | |
| | | little bad | Bad | | | | | | | | | | | | | | | | | | | | | | | | | | | | | | | | | | | | | | | | | | | | | | | | | | | | | | | | | | | | | | | | |
| ACC (OA) | [G] | 0.36 | 1.45 | 1.876 | Bad | | | | | | | | | | | | | | | | | | | | | | | | | | | | | | | | | | | | | | | | | | | | | | | | | | | | | | | | | | | | | | |
| VEL | [cm/s] | 0.40 | 1.00 | 0.552 | little bad | | | | | | | | | | | | | | | | | | | | | | | | | | | | | | | | | | | | | | | | | | | | | | | | | | | | | | | | | | | | | | |
| <p>【 Comment 】</p> | | | | | |  | | | | | | | | | | | | | | | | | | | | | | | | | | | | | | | | | | | | | | | | | | | | | | | | | | | | | | | | | | | | | |

drawing date: 24 May 2010

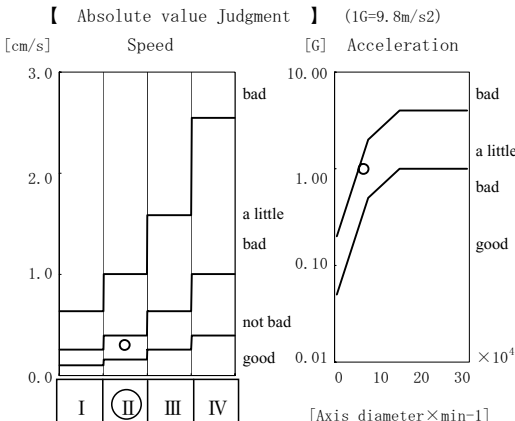
| Simple diagnosis report | | | | | | | | | drawing | | | | | | | | | | | | | | | | | | | | | | | | | | | | | | | | | | | | | | | | | | | | | | | | | | | | | | | | | | |
|---|---------|--------------------------|------------------------|---------------|-------------|---|-----|---------------|---------|--------------|----------|-----------|--------|----------------|-----|------|------|-------|-----------|----------|-----|------|------|-------|------|------------|-----|------|-------|-------|-----------|-----|--------|------|------|-------|------|------|------|----|-----|------|------|--|--|--|--|------------------|-----|---------------|--|--------------|----------|------------|-----|----------|-----|------|------|-------|------------|-----|--------|------|------|-------|-------------|
| equipment name | | | | | | Truc Bach WWTP | | | | | | | | | | | | | | | | | | | | | | | | | | | | | | | | | | | | | | | | | | | | | | | | | | | | | | | | | | | | | |
| machine name | | | | | | TBW1C Aeration Blower | | | | | | | | | | | | | | | | | | | | | | | | | | | | | | | | | | | | | | | | | | | | | | | | | | | | | | | | | | | | | |
| measurement part | | | | | | Blower Outside (Opposite Load Side) | | | | | | | | | | | | | | | | | | | | | | | | | | | | | | | | | | | | | | | | | | | | | | | | | | | | | | | | | | | | | |
| ID code | 236 | Direction of measurement | Vertical | Group No. | 216 |  | | | | | | | | | | | | | | | | | | | | | | | | | | | | | | | | | | | | | | | | | | | | | | | | | | | | | | | | | | | | | |
| Output | 15.0 kW | Rotational speed | 1557 min ⁻¹ | Axis diameter | 45 mm | | | | | | | | | | | | | | | | | | | | | | | | | | | | | | | | | | | | | | | | | | | | | | | | | | | | | | | | | | | | | | |
| <p>【 Relative value Judgment 】 recorded time: 18 May 2010 16:05</p> <table border="1" style="width:100%; border-collapse: collapse;"> <thead> <tr> <th rowspan="2">Measurement Mode</th> <th rowspan="2">[G]</th> <th colspan="2">Warning Level</th> <th rowspan="2">Measurements</th> <th rowspan="2">Judgment</th> </tr> <tr> <th>Attention</th> <th>Danger</th> </tr> </thead> <tbody> <tr> <td>ACC (THRU, OA)</td> <td>[G]</td> <td>1.00</td> <td>4.00</td> <td>1.628</td> <td>Attention</td> </tr> <tr> <td>ACC (OA)</td> <td>[G]</td> <td>1.00</td> <td>4.00</td> <td>0.996</td> <td>Good</td> </tr> <tr> <td>ACC (PEAK)</td> <td>[G]</td> <td>3.00</td> <td>12.00</td> <td>3.319</td> <td>Attention</td> </tr> <tr> <td>VEL</td> <td>[cm/s]</td> <td>0.40</td> <td>1.00</td> <td>0.300</td> <td>Good</td> </tr> <tr> <td>DISP</td> <td>[μm]</td> <td>30</td> <td>100</td> <td>12.8</td> <td>Good</td> </tr> </tbody> </table> <p style="text-align: center;">(1G=9.8m/s²)</p> | | | | | | Measurement Mode | [G] | Warning Level | | Measurements | Judgment | Attention | Danger | ACC (THRU, OA) | [G] | 1.00 | 4.00 | 1.628 | Attention | ACC (OA) | [G] | 1.00 | 4.00 | 0.996 | Good | ACC (PEAK) | [G] | 3.00 | 12.00 | 3.319 | Attention | VEL | [cm/s] | 0.40 | 1.00 | 0.300 | Good | DISP | [μm] | 30 | 100 | 12.8 | Good | <p>【 Absolute value Judgment 】 (1G=9.8m/s²)</p> <table border="1" style="width:100%; border-collapse: collapse;"> <thead> <tr> <th rowspan="2">Measurement Mode</th> <th rowspan="2">[G]</th> <th colspan="2">Warning Level</th> <th rowspan="2">Measurements</th> <th rowspan="2">Judgment</th> </tr> <tr> <th>little bad</th> <th>Bad</th> </tr> </thead> <tbody> <tr> <td>ACC (OA)</td> <td>[G]</td> <td>0.36</td> <td>1.45</td> <td>0.996</td> <td>little bad</td> </tr> <tr> <td>VEL</td> <td>[cm/s]</td> <td>0.40</td> <td>1.00</td> <td>0.300</td> <td>little good</td> </tr> </tbody> </table> <p style="text-align: center;">(1G=9.8m/s²)</p> | | | | Measurement Mode | [G] | Warning Level | | Measurements | Judgment | little bad | Bad | ACC (OA) | [G] | 0.36 | 1.45 | 0.996 | little bad | VEL | [cm/s] | 0.40 | 1.00 | 0.300 | little good |
| Measurement Mode | [G] | Warning Level | | Measurements | Judgment | | | | | | | | | | | | | | | | | | | | | | | | | | | | | | | | | | | | | | | | | | | | | | | | | | | | | | | | | | | | | | |
| | | Attention | Danger | | | | | | | | | | | | | | | | | | | | | | | | | | | | | | | | | | | | | | | | | | | | | | | | | | | | | | | | | | | | | | | | |
| ACC (THRU, OA) | [G] | 1.00 | 4.00 | 1.628 | Attention | | | | | | | | | | | | | | | | | | | | | | | | | | | | | | | | | | | | | | | | | | | | | | | | | | | | | | | | | | | | | | |
| ACC (OA) | [G] | 1.00 | 4.00 | 0.996 | Good | | | | | | | | | | | | | | | | | | | | | | | | | | | | | | | | | | | | | | | | | | | | | | | | | | | | | | | | | | | | | | |
| ACC (PEAK) | [G] | 3.00 | 12.00 | 3.319 | Attention | | | | | | | | | | | | | | | | | | | | | | | | | | | | | | | | | | | | | | | | | | | | | | | | | | | | | | | | | | | | | | |
| VEL | [cm/s] | 0.40 | 1.00 | 0.300 | Good | | | | | | | | | | | | | | | | | | | | | | | | | | | | | | | | | | | | | | | | | | | | | | | | | | | | | | | | | | | | | | |
| DISP | [μm] | 30 | 100 | 12.8 | Good | | | | | | | | | | | | | | | | | | | | | | | | | | | | | | | | | | | | | | | | | | | | | | | | | | | | | | | | | | | | | | |
| Measurement Mode | [G] | Warning Level | | Measurements | Judgment | | | | | | | | | | | | | | | | | | | | | | | | | | | | | | | | | | | | | | | | | | | | | | | | | | | | | | | | | | | | | | |
| | | little bad | Bad | | | | | | | | | | | | | | | | | | | | | | | | | | | | | | | | | | | | | | | | | | | | | | | | | | | | | | | | | | | | | | | | |
| ACC (OA) | [G] | 0.36 | 1.45 | 0.996 | little bad | | | | | | | | | | | | | | | | | | | | | | | | | | | | | | | | | | | | | | | | | | | | | | | | | | | | | | | | | | | | | | |
| VEL | [cm/s] | 0.40 | 1.00 | 0.300 | little good | | | | | | | | | | | | | | | | | | | | | | | | | | | | | | | | | | | | | | | | | | | | | | | | | | | | | | | | | | | | | | |
| <p>【 Comment 】</p> | | | | | |  | | | | | | | | | | | | | | | | | | | | | | | | | | | | | | | | | | | | | | | | | | | | | | | | | | | | | | | | | | | | | |

| | | | | | | | | | |
|--------------------------------------|---------|--------------------------|------------------------|---------------|-------|--|--|--|---------|
| Simple diagnosis report | | | | | | | | | drawing |
| equipment name North Thang Long WWTP | | | | | | | | | |
| machine name M3-9A Surface Aerator | | | | | | | | | |
| measurement part Motor (Load Side) | | | | | | | | | |
| ID code | 352 | Direction of measurement | Horizontal | Group No. | 352 | | | | |
| Output | 37.0 kW | Rotational speed | 1475 min ⁻¹ | Axis diameter | 70 mm | | | | |



【 Relative value Judgment 】 recorded time: 27 May 2010 11:40

| Measurement Mode | Warning Level | | Measurements | Judgment |
|--------------------|---------------|--------|--------------|-----------|
| | Attention | Danger | | |
| ACC (THRU, OA) [G] | 1.00 | 4.00 | 1.310 | Attention |
| ACC (OA) [G] | 1.00 | 4.00 | 0.911 | Good |
| ACC (PEAK) [G] | 3.00 | 12.00 | 2.355 | Good |
| VEL [cm/s] | 0.40 | 1.00 | 0.248 | Good |
| DISP [μ m] | 30 | 100 | 77.1 | Attention |

(1G=9.8m/s²)

【 Absolute value Judgment 】 recorded time: 27 May 2010 11:40

| Measurement Mode | Warning Level | | Measurements | Judgment |
|------------------|---------------|------|--------------|-------------|
| | little bad | Bad | | |
| ACC (OA) [G] | 0.63 | 2.50 | 0.911 | little bad |
| VEL [cm/s] | 0.40 | 1.00 | 0.248 | little good |

(1G=9.8m/s²)

【 Absolute value Judgment 】 (1G=9.8m/s²)

Speed [cm/s]

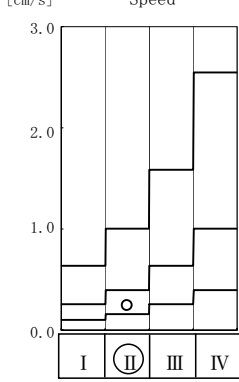

Acceleration [G]

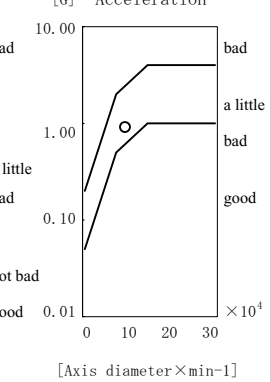

【 Comment 】

| | | | | | | | | | |
|--------------------------------------|---------|--------------------------|------------------------|---------------|-------|--|--|--|---------|
| Simple diagnosis report | | | | | | | | | drawing |
| equipment name North Thang Long WWTP | | | | | | | | | |
| machine name M3-9A Surface Aerator | | | | | | | | | |
| measurement part Motor (Load Side) | | | | | | | | | |
| ID code | 352 | Direction of measurement | Horizontal | Group No. | 352 | | | | |
| Output | 37.0 kW | Rotational speed | 1475 min ⁻¹ | Axis diameter | 70 mm | | | | |



【 Relative value Judgment 】 recorded time: 14 Jul 2010 11:55

| Measurement Mode | Warning Level | | Measurements | Judgment |
|--------------------|---------------|--------|--------------|-----------|
| | Attention | Danger | | |
| ACC (THRU, OA) [G] | 1.00 | 4.00 | 1.217 | Attention |
| ACC (OA) [G] | 1.00 | 4.00 | 0.808 | Good |
| ACC (PEAK) [G] | 3.00 | 12.00 | 2.045 | Good |
| VEL [cm/s] | 0.40 | 1.00 | 0.236 | Good |
| DISP [μ m] | 30 | 100 | 43.5 | Attention |

(1G=9.8m/s²)

【 Absolute value Judgment 】 recorded time: 14 Jul 2010 11:55

| Measurement Mode | Warning Level | | Measurements | Judgment |
|------------------|---------------|------|--------------|-------------|
| | little bad | Bad | | |
| ACC (OA) [G] | 0.63 | 2.50 | 0.808 | little bad |
| VEL [cm/s] | 0.40 | 1.00 | 0.236 | little good |

(1G=9.8m/s²)

【 Absolute value Judgment 】 (1G=9.8m/s²)

Speed [cm/s]

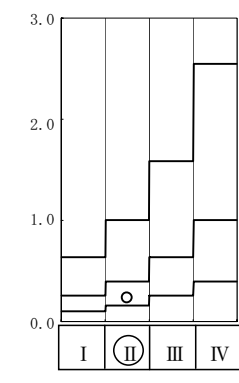

Acceleration [G]

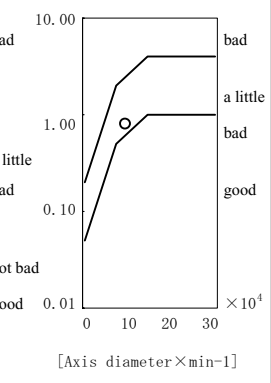

【 Comment 】

drawing date: 27 May 2010

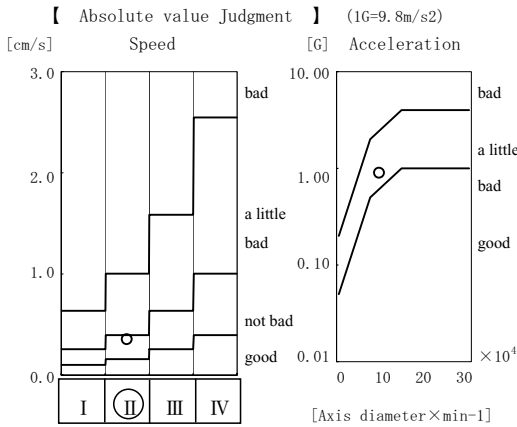
| Simple diagnosis report | | | | | | | | | drawing | | | | | | | | | | | | | | | | | | | | | | | | | | | | | | | | | | | | | | | | | | | | | | |
|--|----------------------------|--------------------------|------------------------|---------------|-------|--|---------------|--|--------------|---------------|-----------|--------------|--------------------|------------|------|--------------|-----------|--------------|------------------|------------|-------|------|-------------------|------|-------|-------|------|------------|------|------|-------|------|-----------------|----|-----|------|-----------|--|--|--|--|---------------|--|--------------|----------|------------|-----|--------------|------|------|------------------|------------|------|------|-------------------|
| equipment name | North Thang Long WWTP | | | | | | | | | | | | | | | | | | | | | | | | | | | | | | | | | | | | | | | | | | | | | | | | | | | | | | |
| machine name | M3-9A Surface Aerator | | | | | | | | | | | | | | | | | | | | | | | | | | | | | | | | | | | | | | | | | | | | | | | | | | | | | | |
| measurement part | Motor (Opposite Load Side) | | | | | | | | | | | | | | | | | | | | | | | | | | | | | | | | | | | | | | | | | | | | | | | | | | | | | | |
| ID code | 351 | Direction of measurement | H | Group No. | 351 | | | | | | | | | | | | | | | | | | | | | | | | | | | | | | | | | | | | | | | | | | | | | | | | | | |
| Output | 37.0 kW | Rotational speed | 1475 min ⁻¹ | Axis diameter | 70 mm | | | | | | | | | | | | | | | | | | | | | | | | | | | | | | | | | | | | | | | | | | | | | | | | | | |
| 【 Relative value Judgment 】 recorded time: 27 May 2010 11:39 | | | | | |  | | | | | | | | | | | | | | | | | | | | | | | | | | | | | | | | | | | | | | | | | | | | | | | | | |
| <table border="1" style="width:100%; border-collapse: collapse;"> <thead> <tr> <th rowspan="2">Measurement Mode</th> <th colspan="2">Warning Level</th> <th rowspan="2">Measurements</th> <th rowspan="2">Judgment</th> </tr> <tr> <th>Attention</th> <th>Danger</th> </tr> </thead> <tbody> <tr> <td>ACC (THRU, OA) [G]</td> <td>1.00</td> <td>4.00</td> <td>1.689</td> <td>Attention</td> </tr> <tr> <td>ACC (OA) [G]</td> <td>1.00</td> <td>4.00</td> <td>0.897</td> <td>Good</td> </tr> <tr> <td>ACC (PEAK) [G]</td> <td>3.00</td> <td>12.00</td> <td>1.964</td> <td>Good</td> </tr> <tr> <td>VEL [cm/s]</td> <td>0.40</td> <td>1.00</td> <td>0.354</td> <td>Good</td> </tr> <tr> <td>DISP [μm]</td> <td>30</td> <td>100</td> <td>67.1</td> <td>Attention</td> </tr> </tbody> </table> <p style="text-align: center;">(1G=9.8m/s²)</p> | | | | | | Measurement Mode | Warning Level | | Measurements | Judgment | Attention | Danger | ACC (THRU, OA) [G] | 1.00 | 4.00 | 1.689 | Attention | ACC (OA) [G] | 1.00 | 4.00 | 0.897 | Good | ACC (PEAK) [G] | 3.00 | 12.00 | 1.964 | Good | VEL [cm/s] | 0.40 | 1.00 | 0.354 | Good | DISP [μ m] | 30 | 100 | 67.1 | Attention | <table border="1" style="width:100%; border-collapse: collapse;"> <thead> <tr> <th colspan="2">Warning Level</th> <th rowspan="2">Measurements</th> <th rowspan="2">Judgment</th> </tr> <tr> <th>little bad</th> <th>Bad</th> </tr> </thead> <tbody> <tr> <td>ACC (OA) [G]</td> <td>0.63</td> <td>2.50</td> <td>0.897 little bad</td> </tr> <tr> <td>VEL [cm/s]</td> <td>0.40</td> <td>1.00</td> <td>0.354 little good</td> </tr> </tbody> </table> <p style="text-align: center;">(1G=9.8m/s²)</p> | | | | Warning Level | | Measurements | Judgment | little bad | Bad | ACC (OA) [G] | 0.63 | 2.50 | 0.897 little bad | VEL [cm/s] | 0.40 | 1.00 | 0.354 little good |
| Measurement Mode | Warning Level | | Measurements | Judgment | | | | | | | | | | | | | | | | | | | | | | | | | | | | | | | | | | | | | | | | | | | | | | | | | | | |
| | Attention | Danger | | | | | | | | | | | | | | | | | | | | | | | | | | | | | | | | | | | | | | | | | | | | | | | | | | | | | |
| ACC (THRU, OA) [G] | 1.00 | 4.00 | 1.689 | Attention | | | | | | | | | | | | | | | | | | | | | | | | | | | | | | | | | | | | | | | | | | | | | | | | | | | |
| ACC (OA) [G] | 1.00 | 4.00 | 0.897 | Good | | | | | | | | | | | | | | | | | | | | | | | | | | | | | | | | | | | | | | | | | | | | | | | | | | | |
| ACC (PEAK) [G] | 3.00 | 12.00 | 1.964 | Good | | | | | | | | | | | | | | | | | | | | | | | | | | | | | | | | | | | | | | | | | | | | | | | | | | | |
| VEL [cm/s] | 0.40 | 1.00 | 0.354 | Good | | | | | | | | | | | | | | | | | | | | | | | | | | | | | | | | | | | | | | | | | | | | | | | | | | | |
| DISP [μ m] | 30 | 100 | 67.1 | Attention | | | | | | | | | | | | | | | | | | | | | | | | | | | | | | | | | | | | | | | | | | | | | | | | | | | |
| Warning Level | | Measurements | Judgment | | | | | | | | | | | | | | | | | | | | | | | | | | | | | | | | | | | | | | | | | | | | | | | | | | | | |
| little bad | Bad | | | | | | | | | | | | | | | | | | | | | | | | | | | | | | | | | | | | | | | | | | | | | | | | | | | | | | |
| ACC (OA) [G] | 0.63 | 2.50 | 0.897 little bad | | | | | | | | | | | | | | | | | | | | | | | | | | | | | | | | | | | | | | | | | | | | | | | | | | | | |
| VEL [cm/s] | 0.40 | 1.00 | 0.354 little good | | | | | | | | | | | | | | | | | | | | | | | | | | | | | | | | | | | | | | | | | | | | | | | | | | | | |
| 【 Absolute value Judgment 】 recorded time: 27 May 2010 11:39 | | | | | | <table border="1" style="width:100%; border-collapse: collapse;"> <thead> <tr> <th colspan="2">Warning Level</th> <th rowspan="2">Measurements</th> <th rowspan="2">Judgment</th> </tr> <tr> <th>little bad</th> <th>Bad</th> </tr> </thead> <tbody> <tr> <td>ACC (OA) [G]</td> <td>0.63</td> <td>2.50</td> <td>0.897 little bad</td> </tr> <tr> <td>VEL [cm/s]</td> <td>0.40</td> <td>1.00</td> <td>0.354 little good</td> </tr> </tbody> </table> <p style="text-align: center;">(1G=9.8m/s²)</p> | | | | Warning Level | | Measurements | Judgment | little bad | Bad | ACC (OA) [G] | 0.63 | 2.50 | 0.897 little bad | VEL [cm/s] | 0.40 | 1.00 | 0.354 little good | | | | | | | | | | | | | | | | | | | | | | | | | | | | | | | | |
| Warning Level | | Measurements | Judgment | | | | | | | | | | | | | | | | | | | | | | | | | | | | | | | | | | | | | | | | | | | | | | | | | | | | |
| little bad | Bad | | | | | | | | | | | | | | | | | | | | | | | | | | | | | | | | | | | | | | | | | | | | | | | | | | | | | | |
| ACC (OA) [G] | 0.63 | 2.50 | 0.897 little bad | | | | | | | | | | | | | | | | | | | | | | | | | | | | | | | | | | | | | | | | | | | | | | | | | | | | |
| VEL [cm/s] | 0.40 | 1.00 | 0.354 little good | | | | | | | | | | | | | | | | | | | | | | | | | | | | | | | | | | | | | | | | | | | | | | | | | | | | |
| 【 Comment 】 | | | | | |  | | | | | | | | | | | | | | | | | | | | | | | | | | | | | | | | | | | | | | | | | | | | | | | | | |

drawing date: 16 Jul 2010

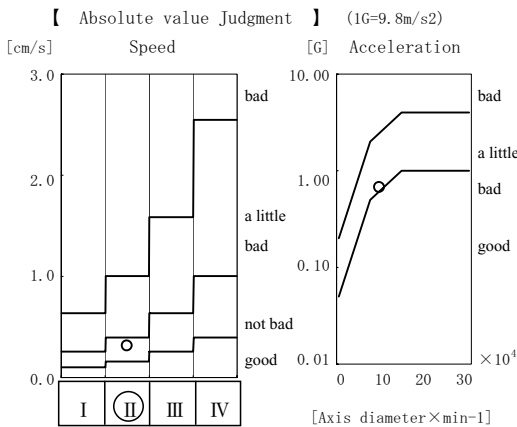
| Simple diagnosis report | | | | | | | | | drawing | | | | | | | | | | | | | | | | | | | | | | | | | | | | | | | | | | | | | | | | | | | | | | |
|--|----------------------------|--------------------------|------------------------|---------------|-------|--|---------------|--|--------------|---------------|-----------|--------------|--------------------|------------|------|--------------|-----------|--------------|------------------|------------|-------|------|-------------------|------|-------|-------|------|------------|------|------|-------|------|-----------------|----|-----|------|-----------|--|--|--|--|---------------|--|--------------|----------|------------|-----|--------------|------|------|------------------|------------|------|------|-------------------|
| equipment name | North Thang Long WWTP | | | | | | | | | | | | | | | | | | | | | | | | | | | | | | | | | | | | | | | | | | | | | | | | | | | | | | |
| machine name | M3-9A Surface Aerator | | | | | | | | | | | | | | | | | | | | | | | | | | | | | | | | | | | | | | | | | | | | | | | | | | | | | | |
| measurement part | Motor (Opposite Load Side) | | | | | | | | | | | | | | | | | | | | | | | | | | | | | | | | | | | | | | | | | | | | | | | | | | | | | | |
| ID code | 351 | Direction of measurement | Horizontal | Group No. | 351 | | | | | | | | | | | | | | | | | | | | | | | | | | | | | | | | | | | | | | | | | | | | | | | | | | |
| Output | 37.0 kW | Rotational speed | 1475 min ⁻¹ | Axis diameter | 70 mm | | | | | | | | | | | | | | | | | | | | | | | | | | | | | | | | | | | | | | | | | | | | | | | | | | |
| 【 Relative value Judgment 】 recorded time: 14 Jul 2010 11:54 | | | | | |  | | | | | | | | | | | | | | | | | | | | | | | | | | | | | | | | | | | | | | | | | | | | | | | | | |
| <table border="1" style="width:100%; border-collapse: collapse;"> <thead> <tr> <th rowspan="2">Measurement Mode</th> <th colspan="2">Warning Level</th> <th rowspan="2">Measurements</th> <th rowspan="2">Judgment</th> </tr> <tr> <th>Attention</th> <th>Danger</th> </tr> </thead> <tbody> <tr> <td>ACC (THRU, OA) [G]</td> <td>1.00</td> <td>4.00</td> <td>1.310</td> <td>Attention</td> </tr> <tr> <td>ACC (OA) [G]</td> <td>1.00</td> <td>4.00</td> <td>0.678</td> <td>Good</td> </tr> <tr> <td>ACC (PEAK) [G]</td> <td>3.00</td> <td>12.00</td> <td>1.583</td> <td>Good</td> </tr> <tr> <td>VEL [cm/s]</td> <td>0.40</td> <td>1.00</td> <td>0.318</td> <td>Good</td> </tr> <tr> <td>DISP [μm]</td> <td>30</td> <td>100</td> <td>61.4</td> <td>Attention</td> </tr> </tbody> </table> <p style="text-align: center;">(1G=9.8m/s²)</p> | | | | | | Measurement Mode | Warning Level | | Measurements | Judgment | Attention | Danger | ACC (THRU, OA) [G] | 1.00 | 4.00 | 1.310 | Attention | ACC (OA) [G] | 1.00 | 4.00 | 0.678 | Good | ACC (PEAK) [G] | 3.00 | 12.00 | 1.583 | Good | VEL [cm/s] | 0.40 | 1.00 | 0.318 | Good | DISP [μ m] | 30 | 100 | 61.4 | Attention | <table border="1" style="width:100%; border-collapse: collapse;"> <thead> <tr> <th colspan="2">Warning Level</th> <th rowspan="2">Measurements</th> <th rowspan="2">Judgment</th> </tr> <tr> <th>little bad</th> <th>Bad</th> </tr> </thead> <tbody> <tr> <td>ACC (OA) [G]</td> <td>0.63</td> <td>2.50</td> <td>0.678 little bad</td> </tr> <tr> <td>VEL [cm/s]</td> <td>0.40</td> <td>1.00</td> <td>0.318 little good</td> </tr> </tbody> </table> <p style="text-align: center;">(1G=9.8m/s²)</p> | | | | Warning Level | | Measurements | Judgment | little bad | Bad | ACC (OA) [G] | 0.63 | 2.50 | 0.678 little bad | VEL [cm/s] | 0.40 | 1.00 | 0.318 little good |
| Measurement Mode | Warning Level | | Measurements | Judgment | | | | | | | | | | | | | | | | | | | | | | | | | | | | | | | | | | | | | | | | | | | | | | | | | | | |
| | Attention | Danger | | | | | | | | | | | | | | | | | | | | | | | | | | | | | | | | | | | | | | | | | | | | | | | | | | | | | |
| ACC (THRU, OA) [G] | 1.00 | 4.00 | 1.310 | Attention | | | | | | | | | | | | | | | | | | | | | | | | | | | | | | | | | | | | | | | | | | | | | | | | | | | |
| ACC (OA) [G] | 1.00 | 4.00 | 0.678 | Good | | | | | | | | | | | | | | | | | | | | | | | | | | | | | | | | | | | | | | | | | | | | | | | | | | | |
| ACC (PEAK) [G] | 3.00 | 12.00 | 1.583 | Good | | | | | | | | | | | | | | | | | | | | | | | | | | | | | | | | | | | | | | | | | | | | | | | | | | | |
| VEL [cm/s] | 0.40 | 1.00 | 0.318 | Good | | | | | | | | | | | | | | | | | | | | | | | | | | | | | | | | | | | | | | | | | | | | | | | | | | | |
| DISP [μ m] | 30 | 100 | 61.4 | Attention | | | | | | | | | | | | | | | | | | | | | | | | | | | | | | | | | | | | | | | | | | | | | | | | | | | |
| Warning Level | | Measurements | Judgment | | | | | | | | | | | | | | | | | | | | | | | | | | | | | | | | | | | | | | | | | | | | | | | | | | | | |
| little bad | Bad | | | | | | | | | | | | | | | | | | | | | | | | | | | | | | | | | | | | | | | | | | | | | | | | | | | | | | |
| ACC (OA) [G] | 0.63 | 2.50 | 0.678 little bad | | | | | | | | | | | | | | | | | | | | | | | | | | | | | | | | | | | | | | | | | | | | | | | | | | | | |
| VEL [cm/s] | 0.40 | 1.00 | 0.318 little good | | | | | | | | | | | | | | | | | | | | | | | | | | | | | | | | | | | | | | | | | | | | | | | | | | | | |
| 【 Absolute value Judgment 】 recorded time: 14 Jul 2010 11:54 | | | | | | <table border="1" style="width:100%; border-collapse: collapse;"> <thead> <tr> <th colspan="2">Warning Level</th> <th rowspan="2">Measurements</th> <th rowspan="2">Judgment</th> </tr> <tr> <th>little bad</th> <th>Bad</th> </tr> </thead> <tbody> <tr> <td>ACC (OA) [G]</td> <td>0.63</td> <td>2.50</td> <td>0.678 little bad</td> </tr> <tr> <td>VEL [cm/s]</td> <td>0.40</td> <td>1.00</td> <td>0.318 little good</td> </tr> </tbody> </table> <p style="text-align: center;">(1G=9.8m/s²)</p> | | | | Warning Level | | Measurements | Judgment | little bad | Bad | ACC (OA) [G] | 0.63 | 2.50 | 0.678 little bad | VEL [cm/s] | 0.40 | 1.00 | 0.318 little good | | | | | | | | | | | | | | | | | | | | | | | | | | | | | | | | |
| Warning Level | | Measurements | Judgment | | | | | | | | | | | | | | | | | | | | | | | | | | | | | | | | | | | | | | | | | | | | | | | | | | | | |
| little bad | Bad | | | | | | | | | | | | | | | | | | | | | | | | | | | | | | | | | | | | | | | | | | | | | | | | | | | | | | |
| ACC (OA) [G] | 0.63 | 2.50 | 0.678 little bad | | | | | | | | | | | | | | | | | | | | | | | | | | | | | | | | | | | | | | | | | | | | | | | | | | | | |
| VEL [cm/s] | 0.40 | 1.00 | 0.318 little good | | | | | | | | | | | | | | | | | | | | | | | | | | | | | | | | | | | | | | | | | | | | | | | | | | | | |
| 【 Comment 】 | | | | | |  | | | | | | | | | | | | | | | | | | | | | | | | | | | | | | | | | | | | | | | | | | | | | | | | | |

drawing date: 28 May 2010

| | | | | | | | | | |
|---|---------|--------------------------|------------------------|---------------|-------|--|--|--|---------|
| Simple diagnosis report | | | | | | | | | drawing |
| equipment name North Thang Long WWTP | | | | | | | | | |
| machine name M3-10A Channei Mixing Blower | | | | | | | | | |
| measurement part Motor (Load Side) | | | | | | | | | |
| ID code | 372 | Direction of measurement | Vertical | Group No. | 372 | | | | |
| Output | 15.0 kW | Rotational speed | 1472 min ⁻¹ | Axis diameter | 45 mm | | | | |

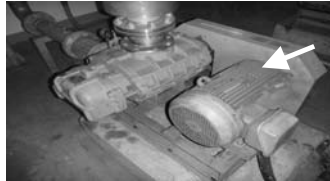

【 Relative value Judgment 】 recorded time: 27 May 2010 16:46

| Measurement Mode | Warning Level | | Measurements | Judgment |
|--------------------|---------------|--------|--------------|----------|
| | Attention | Danger | | |
| ACC (THRU, OA) [G] | 1.00 | 4.00 | 0.422 | Good |
| ACC (OA) [G] | 1.00 | 4.00 | 0.148 | Good |
| ACC (PEAK) [G] | 3.00 | 12.00 | 0.403 | Good |
| VEL [cm/s] | 0.40 | 1.00 | 0.259 | Good |
| DISP [μ m] | 30 | 100 | 19.0 | Good |

(1G=9.8m/s²)

【 Absolute value Judgment 】 recorded time: 27 May 2010 16:46

| Measurement Mode | Warning Level | | Measurements | Judgment |
|------------------|---------------|------|--------------|-------------|
| | little bad | Bad | | |
| ACC (OA) [G] | 0.32 | 1.28 | 0.148 | Good |
| VEL [cm/s] | 0.40 | 1.00 | 0.259 | little good |

(1G=9.8m/s²)

【 Absolute value Judgment 】 (1G=9.8m/s²)

Speed [cm/s]

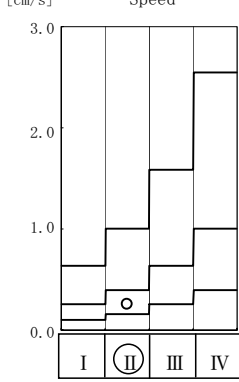

Acceleration [G]

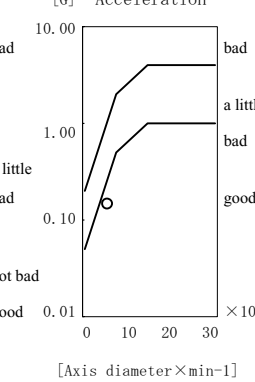

【Comment】

drawing date: 16 Jul 2010

| | | | | | | | | | |
|---|---------|--------------------------|------------------------|---------------|-------|--|--|--|---------|
| Simple diagnosis report | | | | | | | | | drawing |
| equipment name North Thang Long WWTP | | | | | | | | | |
| machine name M3-10A Channei Mixing Blower | | | | | | | | | |
| measurement part Motor (Load Side) | | | | | | | | | |
| ID code | 372 | Direction of measurement | Vertical | Group No. | 372 | | | | |
| Output | 15.0 kW | Rotational speed | 1472 min ⁻¹ | Axis diameter | 45 mm | | | | |



【 Relative value Judgment 】 recorded time: 14 Jul 2010 12:39

| Measurement Mode | Warning Level | | Measurements | Judgment |
|--------------------|---------------|--------|--------------|----------|
| | Attention | Danger | | |
| ACC (THRU, OA) [G] | 1.00 | 4.00 | 0.762 | Good |
| ACC (OA) [G] | 1.00 | 4.00 | 0.568 | Good |
| ACC (PEAK) [G] | 3.00 | 12.00 | 1.092 | Good |
| VEL [cm/s] | 0.40 | 1.00 | 0.270 | Good |
| DISP [μ m] | 30 | 100 | 18.1 | Good |

(1G=9.8m/s²)

【 Absolute value Judgment 】 recorded time: 14 Jul 2010 12:39

| Measurement Mode | Warning Level | | Measurements | Judgment |
|------------------|---------------|------|--------------|-------------|
| | little bad | Bad | | |
| ACC (OA) [G] | 0.32 | 1.28 | 0.568 | little bad |
| VEL [cm/s] | 0.40 | 1.00 | 0.270 | little good |

(1G=9.8m/s²)

【 Absolute value Judgment 】 (1G=9.8m/s²)

Speed [cm/s]

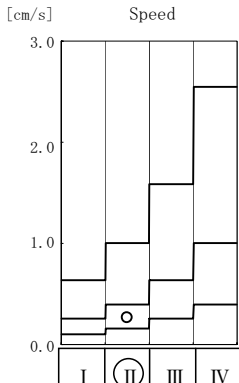

Acceleration [G]

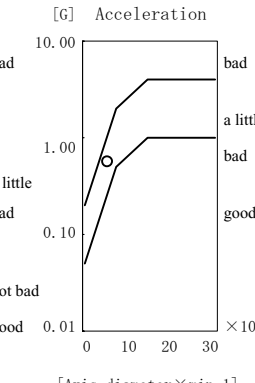

【Comment】

drawing date: 28 May 2010

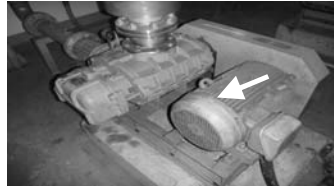
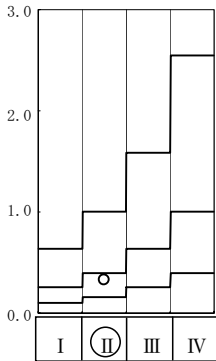
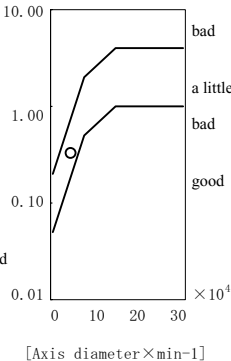
| Simple diagnosis report | | | | | | | | | drawing | | | | | | | | | | | | | | | | | | | | | | | | | | | | | | | | | | | | | | |
|--|------------------------------|---|------------------------|---------------|-------------|------------------|--|---------------|---------|--------------|----------|------------|--------|----------------|-------|------|------|-------|------------|----------|--------|------|------|-------|-------------|--|-----|------|-------|-------|------|-----|--------|------|------|-------|------|------|------|----|-----|------|------|---|--|--|--|
| equipment name | North Thang Long WWTP | | | | | | | | | | | | | | | | | | | | | | | | | | | | | | | | | | | | | | | | | | | | | | |
| machine name | M3-10A Channei Mixing Blower | | | | | | | | | | | | | | | | | | | | | | | | | | | | | | | | | | | | | | | | | | | | | | |
| measurement part | Motor (Opposite Load Side) | | | | | | | | | | | | | | | | | | | | | | | | | | | | | | | | | | | | | | | | | | | | | | |
| ID code | 371 | <small>Direction of measurement</small> | Vertical | Group No. | 371 | | | | | | | | | | | | | | | | | | | | | | | | | | | | | | | | | | | | | | | | | | |
| Output | 15.0 kW | Rotational speed | 1472 min ⁻¹ | Axis diameter | 35 mm | | | | | | | | | | | | | | | | | | | | | | | | | | | | | | | | | | | | | | | | | | |
| <p>【 Relative value Judgment 】 recorded time: 27 May 2010 16:44</p> <table border="1" style="width:100%; border-collapse: collapse;"> <thead> <tr> <th rowspan="2">Measurement Mode</th> <th rowspan="2"></th> <th colspan="2">Warning Level</th> <th rowspan="2">Measurements</th> <th rowspan="2">Judgment</th> </tr> <tr> <th>Attention</th> <th>Danger</th> </tr> </thead> <tbody> <tr> <td>ACC (THRU, OA)</td> <td>[G]</td> <td>1.00</td> <td>4.00</td> <td>0.595</td> <td>Good</td> </tr> <tr> <td>ACC (OA)</td> <td>[G]</td> <td>1.00</td> <td>4.00</td> <td>0.329</td> <td>Good</td> </tr> <tr> <td>ACC (PEAK)</td> <td>[G]</td> <td>3.00</td> <td>12.00</td> <td>0.827</td> <td>Good</td> </tr> <tr> <td>VEL</td> <td>[cm/s]</td> <td>0.40</td> <td>1.00</td> <td>0.332</td> <td>Good</td> </tr> <tr> <td>DISP</td> <td>[μm]</td> <td>30</td> <td>100</td> <td>19.9</td> <td>Good</td> </tr> </tbody> </table> <p style="text-align: center;">(1G=9.8m/s²)</p> | | | | | | Measurement Mode | | Warning Level | | Measurements | Judgment | Attention | Danger | ACC (THRU, OA) | [G] | 1.00 | 4.00 | 0.595 | Good | ACC (OA) | [G] | 1.00 | 4.00 | 0.329 | Good | ACC (PEAK) | [G] | 3.00 | 12.00 | 0.827 | Good | VEL | [cm/s] | 0.40 | 1.00 | 0.332 | Good | DISP | [μm] | 30 | 100 | 19.9 | Good |  | | | |
| Measurement Mode | | Warning Level | | Measurements | Judgment | | | | | | | | | | | | | | | | | | | | | | | | | | | | | | | | | | | | | | | | | | |
| | | Attention | Danger | | | | | | | | | | | | | | | | | | | | | | | | | | | | | | | | | | | | | | | | | | | | |
| ACC (THRU, OA) | [G] | 1.00 | 4.00 | 0.595 | Good | | | | | | | | | | | | | | | | | | | | | | | | | | | | | | | | | | | | | | | | | | |
| ACC (OA) | [G] | 1.00 | 4.00 | 0.329 | Good | | | | | | | | | | | | | | | | | | | | | | | | | | | | | | | | | | | | | | | | | | |
| ACC (PEAK) | [G] | 3.00 | 12.00 | 0.827 | Good | | | | | | | | | | | | | | | | | | | | | | | | | | | | | | | | | | | | | | | | | | |
| VEL | [cm/s] | 0.40 | 1.00 | 0.332 | Good | | | | | | | | | | | | | | | | | | | | | | | | | | | | | | | | | | | | | | | | | | |
| DISP | [μm] | 30 | 100 | 19.9 | Good | | | | | | | | | | | | | | | | | | | | | | | | | | | | | | | | | | | | | | | | | | |
| <p>【 Absolute value Judgment 】 recorded time: 27 May 2010 16:44</p> <table border="1" style="width:100%; border-collapse: collapse;"> <thead> <tr> <th rowspan="2">Measurement Mode</th> <th rowspan="2"></th> <th colspan="2">Warning Level</th> <th rowspan="2">Measurements</th> <th rowspan="2">Judgment</th> </tr> <tr> <th>little bad</th> <th>Bad</th> </tr> </thead> <tbody> <tr> <td>ACC (OA)</td> <td>[G]</td> <td>0.20</td> <td>0.79</td> <td>0.329</td> <td>little bad</td> </tr> <tr> <td>VEL</td> <td>[cm/s]</td> <td>0.40</td> <td>1.00</td> <td>0.332</td> <td>little good</td> </tr> </tbody> </table> <p style="text-align: center;">(1G=9.8m/s²)</p> | | | | | | Measurement Mode | | Warning Level | | Measurements | Judgment | little bad | Bad | ACC (OA) | [G] | 0.20 | 0.79 | 0.329 | little bad | VEL | [cm/s] | 0.40 | 1.00 | 0.332 | little good | <p>【 Absolute value Judgment 】 (1G=9.8m/s²)</p> <div style="display: flex; justify-content: space-around;"> <div style="text-align: center;"> <p>[cm/s] Speed</p>  </div> <div style="text-align: center;"> <p>[G] Acceleration</p>  </div> </div> <p style="text-align: center;">[Axis diameter×min⁻¹]</p> | | | | | | | | | | | | | | | | | | | | | |
| Measurement Mode | | Warning Level | | Measurements | Judgment | | | | | | | | | | | | | | | | | | | | | | | | | | | | | | | | | | | | | | | | | | |
| | | little bad | Bad | | | | | | | | | | | | | | | | | | | | | | | | | | | | | | | | | | | | | | | | | | | | |
| ACC (OA) | [G] | 0.20 | 0.79 | 0.329 | little bad | | | | | | | | | | | | | | | | | | | | | | | | | | | | | | | | | | | | | | | | | | |
| VEL | [cm/s] | 0.40 | 1.00 | 0.332 | little good | | | | | | | | | | | | | | | | | | | | | | | | | | | | | | | | | | | | | | | | | | |
| 【Comment】 | | | | | | | | | | | | | | | | | | | | | | | | | | | | | | | | | | | | | | | | | | | | | | | |

drawing date: 16 Jul 2010

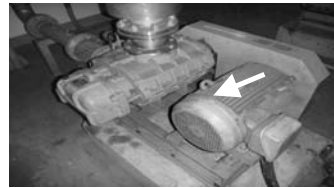
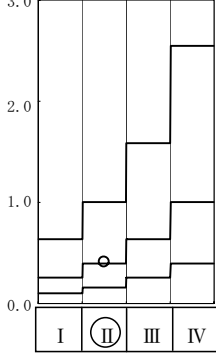
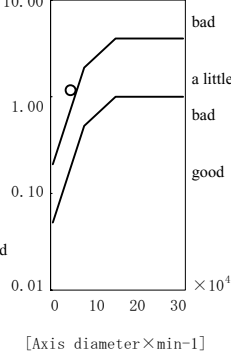
| Simple diagnosis report | | | | | | | | | drawing | | | | | | | | | | | | | | | | | | | | | | | | | | | | | | | | | | | | | | |
|---|------------------------------|---|------------------------|---------------|------------|------------------|--|---------------|---------|--------------|----------|------------|--------|----------------|-------|------|------|-------|-----------|----------|--------|------|------|-------|------------|--|-----|------|-------|-------|------|-----|--------|------|------|-------|-----------|------|------|----|-----|------|------|---|--|--|--|
| equipment name | North Thang Long WWTP | | | | | | | | | | | | | | | | | | | | | | | | | | | | | | | | | | | | | | | | | | | | | | |
| machine name | M3-10A Channei Mixing Blower | | | | | | | | | | | | | | | | | | | | | | | | | | | | | | | | | | | | | | | | | | | | | | |
| measurement part | Motor (Opposite Load Side) | | | | | | | | | | | | | | | | | | | | | | | | | | | | | | | | | | | | | | | | | | | | | | |
| ID code | 371 | <small>Direction of measurement</small> | Vertical | Group No. | 371 | | | | | | | | | | | | | | | | | | | | | | | | | | | | | | | | | | | | | | | | | | |
| Output | 15.0 kW | Rotational speed | 1472 min ⁻¹ | Axis diameter | 35 mm | | | | | | | | | | | | | | | | | | | | | | | | | | | | | | | | | | | | | | | | | | |
| <p>【 Relative value Judgment 】 recorded time: 14 Jul 2010 12:39</p> <table border="1" style="width:100%; border-collapse: collapse;"> <thead> <tr> <th rowspan="2">Measurement Mode</th> <th rowspan="2"></th> <th colspan="2">Warning Level</th> <th rowspan="2">Measurements</th> <th rowspan="2">Judgment</th> </tr> <tr> <th>Attention</th> <th>Danger</th> </tr> </thead> <tbody> <tr> <td>ACC (THRU, OA)</td> <td>[G]</td> <td>1.00</td> <td>4.00</td> <td>1.289</td> <td>Attention</td> </tr> <tr> <td>ACC (OA)</td> <td>[G]</td> <td>1.00</td> <td>4.00</td> <td>1.162</td> <td>Attention</td> </tr> <tr> <td>ACC (PEAK)</td> <td>[G]</td> <td>3.00</td> <td>12.00</td> <td>1.709</td> <td>Good</td> </tr> <tr> <td>VEL</td> <td>[cm/s]</td> <td>0.40</td> <td>1.00</td> <td>0.414</td> <td>Attention</td> </tr> <tr> <td>DISP</td> <td>[μm]</td> <td>30</td> <td>100</td> <td>23.5</td> <td>Good</td> </tr> </tbody> </table> <p style="text-align: center;">(1G=9.8m/s²)</p> | | | | | | Measurement Mode | | Warning Level | | Measurements | Judgment | Attention | Danger | ACC (THRU, OA) | [G] | 1.00 | 4.00 | 1.289 | Attention | ACC (OA) | [G] | 1.00 | 4.00 | 1.162 | Attention | ACC (PEAK) | [G] | 3.00 | 12.00 | 1.709 | Good | VEL | [cm/s] | 0.40 | 1.00 | 0.414 | Attention | DISP | [μm] | 30 | 100 | 23.5 | Good |  | | | |
| Measurement Mode | | Warning Level | | Measurements | Judgment | | | | | | | | | | | | | | | | | | | | | | | | | | | | | | | | | | | | | | | | | | |
| | | Attention | Danger | | | | | | | | | | | | | | | | | | | | | | | | | | | | | | | | | | | | | | | | | | | | |
| ACC (THRU, OA) | [G] | 1.00 | 4.00 | 1.289 | Attention | | | | | | | | | | | | | | | | | | | | | | | | | | | | | | | | | | | | | | | | | | |
| ACC (OA) | [G] | 1.00 | 4.00 | 1.162 | Attention | | | | | | | | | | | | | | | | | | | | | | | | | | | | | | | | | | | | | | | | | | |
| ACC (PEAK) | [G] | 3.00 | 12.00 | 1.709 | Good | | | | | | | | | | | | | | | | | | | | | | | | | | | | | | | | | | | | | | | | | | |
| VEL | [cm/s] | 0.40 | 1.00 | 0.414 | Attention | | | | | | | | | | | | | | | | | | | | | | | | | | | | | | | | | | | | | | | | | | |
| DISP | [μm] | 30 | 100 | 23.5 | Good | | | | | | | | | | | | | | | | | | | | | | | | | | | | | | | | | | | | | | | | | | |
| <p>【 Absolute value Judgment 】 recorded time: 14 Jul 2010 12:39</p> <table border="1" style="width:100%; border-collapse: collapse;"> <thead> <tr> <th rowspan="2">Measurement Mode</th> <th rowspan="2"></th> <th colspan="2">Warning Level</th> <th rowspan="2">Measurements</th> <th rowspan="2">Judgment</th> </tr> <tr> <th>little bad</th> <th>Bad</th> </tr> </thead> <tbody> <tr> <td>ACC (OA)</td> <td>[G]</td> <td>0.20</td> <td>0.79</td> <td>1.162</td> <td>Bad</td> </tr> <tr> <td>VEL</td> <td>[cm/s]</td> <td>0.40</td> <td>1.00</td> <td>0.414</td> <td>little bad</td> </tr> </tbody> </table> <p style="text-align: center;">(1G=9.8m/s²)</p> | | | | | | Measurement Mode | | Warning Level | | Measurements | Judgment | little bad | Bad | ACC (OA) | [G] | 0.20 | 0.79 | 1.162 | Bad | VEL | [cm/s] | 0.40 | 1.00 | 0.414 | little bad | <p>【 Absolute value Judgment 】 (1G=9.8m/s²)</p> <div style="display: flex; justify-content: space-around;"> <div style="text-align: center;"> <p>[cm/s] Speed</p>  </div> <div style="text-align: center;"> <p>[G] Acceleration</p>  </div> </div> <p style="text-align: center;">[Axis diameter×min⁻¹]</p> | | | | | | | | | | | | | | | | | | | | | |
| Measurement Mode | | Warning Level | | Measurements | Judgment | | | | | | | | | | | | | | | | | | | | | | | | | | | | | | | | | | | | | | | | | | |
| | | little bad | Bad | | | | | | | | | | | | | | | | | | | | | | | | | | | | | | | | | | | | | | | | | | | | |
| ACC (OA) | [G] | 0.20 | 0.79 | 1.162 | Bad | | | | | | | | | | | | | | | | | | | | | | | | | | | | | | | | | | | | | | | | | | |
| VEL | [cm/s] | 0.40 | 1.00 | 0.414 | little bad | | | | | | | | | | | | | | | | | | | | | | | | | | | | | | | | | | | | | | | | | | |
| 【Comment】 | | | | | | | | | | | | | | | | | | | | | | | | | | | | | | | | | | | | | | | | | | | | | | | |

drawing date: 28 May 2010

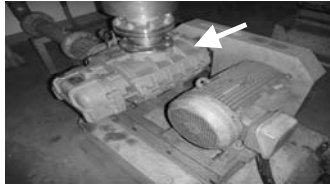
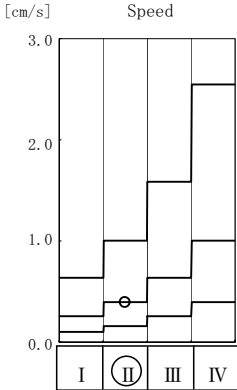
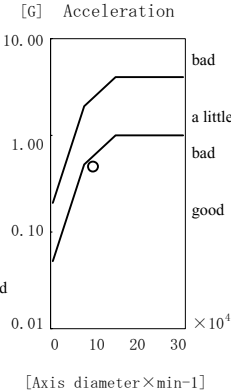
| Simple diagnosis report | | | | | | drawing | | | | | | | | | | | | | | | | | | | | | | | | | | | | | | | | | | | | | | | | | |
|---|---------|--------------------------|------------------------|---------------|------------|---|-----|---------------|--|--------------|----------|------------|--------|----------------|-----|------|------|-------|------|----------|--------|------|------|-------|------------|------------|-----|------|-------|-------|------|-----|--------|------|------|-------|------|------|------|----|-----|------|------|--|--|--|--|
| equipment name | | | | | | North Thang Long WWTP | | | | | | | | | | | | | | | | | | | | | | | | | | | | | | | | | | | | | | | | | |
| machine name | | | | | | M3-10A Channei Mixing Blower | | | | | | | | | | | | | | | | | | | | | | | | | | | | | | | | | | | | | | | | | |
| measurement part | | | | | | Blower Inside (Load Side) | | | | | | | | | | | | | | | | | | | | | | | | | | | | | | | | | | | | | | | | | |
| ID code | 373 | Direction of measurement | Vertical | Group No. | 373 |  | | | | | | | | | | | | | | | | | | | | | | | | | | | | | | | | | | | | | | | | | |
| Output | 15.0 kW | Rotational speed | 1913 min ⁻¹ | Axis diameter | 55 mm | | | | | | | | | | | | | | | | | | | | | | | | | | | | | | | | | | | | | | | | | | |
| <p>【 Relative value Judgment 】 recorded time: 27 May 2010 16:47</p> <table border="1" style="width:100%; border-collapse: collapse;"> <thead> <tr> <th rowspan="2">Measurement Mode</th> <th rowspan="2">[G]</th> <th colspan="2">Warning Level</th> <th rowspan="2">Measurements</th> <th rowspan="2">Judgment</th> </tr> <tr> <th>Attention</th> <th>Danger</th> </tr> </thead> <tbody> <tr> <td>ACC (THRU, OA)</td> <td>[G]</td> <td>1.00</td> <td>4.00</td> <td>0.898</td> <td>Good</td> </tr> <tr> <td>ACC (OA)</td> <td>[G]</td> <td>1.00</td> <td>4.00</td> <td>0.472</td> <td>Good</td> </tr> <tr> <td>ACC (PEAK)</td> <td>[G]</td> <td>3.00</td> <td>12.00</td> <td>1.282</td> <td>Good</td> </tr> <tr> <td>VEL</td> <td>[cm/s]</td> <td>0.40</td> <td>1.00</td> <td>0.397</td> <td>Good</td> </tr> <tr> <td>DISP</td> <td>[μm]</td> <td>30</td> <td>100</td> <td>23.2</td> <td>Good</td> </tr> </tbody> </table> <p style="text-align: center;">(1G=9.8m/s²)</p> | | | | | | Measurement Mode | [G] | Warning Level | | Measurements | Judgment | Attention | Danger | ACC (THRU, OA) | [G] | 1.00 | 4.00 | 0.898 | Good | ACC (OA) | [G] | 1.00 | 4.00 | 0.472 | Good | ACC (PEAK) | [G] | 3.00 | 12.00 | 1.282 | Good | VEL | [cm/s] | 0.40 | 1.00 | 0.397 | Good | DISP | [μm] | 30 | 100 | 23.2 | Good | <p>【 Absolute value Judgment 】 (1G=9.8m/s²)</p> <div style="display: flex; justify-content: space-around;"> <div style="text-align: center;"> <p>Speed [cm/s]</p>  </div> <div style="text-align: center;"> <p>Acceleration [G]</p>  </div> </div> | | | |
| Measurement Mode | [G] | Warning Level | | Measurements | Judgment | | | | | | | | | | | | | | | | | | | | | | | | | | | | | | | | | | | | | | | | | | |
| | | Attention | Danger | | | | | | | | | | | | | | | | | | | | | | | | | | | | | | | | | | | | | | | | | | | | |
| ACC (THRU, OA) | [G] | 1.00 | 4.00 | 0.898 | Good | | | | | | | | | | | | | | | | | | | | | | | | | | | | | | | | | | | | | | | | | | |
| ACC (OA) | [G] | 1.00 | 4.00 | 0.472 | Good | | | | | | | | | | | | | | | | | | | | | | | | | | | | | | | | | | | | | | | | | | |
| ACC (PEAK) | [G] | 3.00 | 12.00 | 1.282 | Good | | | | | | | | | | | | | | | | | | | | | | | | | | | | | | | | | | | | | | | | | | |
| VEL | [cm/s] | 0.40 | 1.00 | 0.397 | Good | | | | | | | | | | | | | | | | | | | | | | | | | | | | | | | | | | | | | | | | | | |
| DISP | [μm] | 30 | 100 | 23.2 | Good | | | | | | | | | | | | | | | | | | | | | | | | | | | | | | | | | | | | | | | | | | |
| <p>【 Absolute value Judgment 】 recorded time: 27 May 2010 16:47</p> <table border="1" style="width:100%; border-collapse: collapse;"> <thead> <tr> <th rowspan="2">Measurement Mode</th> <th rowspan="2">[G]</th> <th colspan="2">Warning Level</th> <th rowspan="2">Measurements</th> <th rowspan="2">Judgment</th> </tr> <tr> <th>little bad</th> <th>Bad</th> </tr> </thead> <tbody> <tr> <td>ACC (OA)</td> <td>[G]</td> <td>0.64</td> <td>2.55</td> <td>0.472</td> <td>Good</td> </tr> <tr> <td>VEL</td> <td>[cm/s]</td> <td>0.40</td> <td>1.00</td> <td>0.397</td> <td>little bad</td> </tr> </tbody> </table> <p style="text-align: center;">(1G=9.8m/s²)</p> | | | | | | Measurement Mode | [G] | Warning Level | | Measurements | Judgment | little bad | Bad | ACC (OA) | [G] | 0.64 | 2.55 | 0.472 | Good | VEL | [cm/s] | 0.40 | 1.00 | 0.397 | little bad | | | | | | | | | | | | | | | | | | | | | | |
| Measurement Mode | [G] | Warning Level | | Measurements | Judgment | | | | | | | | | | | | | | | | | | | | | | | | | | | | | | | | | | | | | | | | | | |
| | | little bad | Bad | | | | | | | | | | | | | | | | | | | | | | | | | | | | | | | | | | | | | | | | | | | | |
| ACC (OA) | [G] | 0.64 | 2.55 | 0.472 | Good | | | | | | | | | | | | | | | | | | | | | | | | | | | | | | | | | | | | | | | | | | |
| VEL | [cm/s] | 0.40 | 1.00 | 0.397 | little bad | | | | | | | | | | | | | | | | | | | | | | | | | | | | | | | | | | | | | | | | | | |
| 【Comment】 | | | | | | | | | | | | | | | | | | | | | | | | | | | | | | | | | | | | | | | | | | | | | | | |

drawing date: 16 Jul 2010

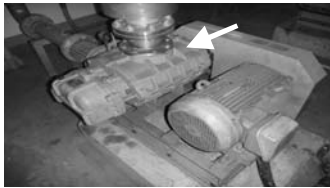
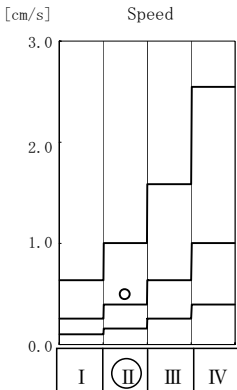
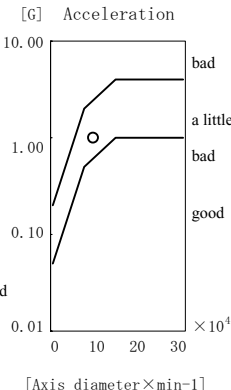
| Simple diagnosis report | | | | | | drawing | | | | | | | | | | | | | | | | | | | | | | | | | | | | | | | | | | | | | | | | | |
|---|---------|--------------------------|------------------------|---------------|------------|---|-----|---------------|--|--------------|----------|------------|--------|----------------|-----|------|------|-------|------------|----------|--------|------|------|-------|------------|------------|-----|------|-------|-------|------|-----|--------|------|------|-------|-----------|------|------|----|-----|------|------|--|--|--|--|
| equipment name | | | | | | North Thang Long WWTP | | | | | | | | | | | | | | | | | | | | | | | | | | | | | | | | | | | | | | | | | |
| machine name | | | | | | M3-10A Channei Mixing Blower | | | | | | | | | | | | | | | | | | | | | | | | | | | | | | | | | | | | | | | | | |
| measurement part | | | | | | Blower Inside (Load Side) | | | | | | | | | | | | | | | | | | | | | | | | | | | | | | | | | | | | | | | | | |
| ID code | 373 | Direction of measurement | Vertical | Group No. | 373 |  | | | | | | | | | | | | | | | | | | | | | | | | | | | | | | | | | | | | | | | | | |
| Output | 15.0 kW | Rotational speed | 1913 min ⁻¹ | Axis diameter | 55 mm | | | | | | | | | | | | | | | | | | | | | | | | | | | | | | | | | | | | | | | | | | |
| <p>【 Relative value Judgment 】 recorded time: 14 Jul 2010 12:40</p> <table border="1" style="width:100%; border-collapse: collapse;"> <thead> <tr> <th rowspan="2">Measurement Mode</th> <th rowspan="2">[G]</th> <th colspan="2">Warning Level</th> <th rowspan="2">Measurements</th> <th rowspan="2">Judgment</th> </tr> <tr> <th>Attention</th> <th>Danger</th> </tr> </thead> <tbody> <tr> <td>ACC (THRU, OA)</td> <td>[G]</td> <td>1.00</td> <td>4.00</td> <td>1.776</td> <td>Attention</td> </tr> <tr> <td>ACC (OA)</td> <td>[G]</td> <td>1.00</td> <td>4.00</td> <td>0.997</td> <td>Good</td> </tr> <tr> <td>ACC (PEAK)</td> <td>[G]</td> <td>3.00</td> <td>12.00</td> <td>2.100</td> <td>Good</td> </tr> <tr> <td>VEL</td> <td>[cm/s]</td> <td>0.40</td> <td>1.00</td> <td>0.497</td> <td>Attention</td> </tr> <tr> <td>DISP</td> <td>[μm]</td> <td>30</td> <td>100</td> <td>28.2</td> <td>Good</td> </tr> </tbody> </table> <p style="text-align: center;">(1G=9.8m/s²)</p> | | | | | | Measurement Mode | [G] | Warning Level | | Measurements | Judgment | Attention | Danger | ACC (THRU, OA) | [G] | 1.00 | 4.00 | 1.776 | Attention | ACC (OA) | [G] | 1.00 | 4.00 | 0.997 | Good | ACC (PEAK) | [G] | 3.00 | 12.00 | 2.100 | Good | VEL | [cm/s] | 0.40 | 1.00 | 0.497 | Attention | DISP | [μm] | 30 | 100 | 28.2 | Good | <p>【 Absolute value Judgment 】 (1G=9.8m/s²)</p> <div style="display: flex; justify-content: space-around;"> <div style="text-align: center;"> <p>Speed [cm/s]</p>  </div> <div style="text-align: center;"> <p>Acceleration [G]</p>  </div> </div> | | | |
| Measurement Mode | [G] | Warning Level | | Measurements | Judgment | | | | | | | | | | | | | | | | | | | | | | | | | | | | | | | | | | | | | | | | | | |
| | | Attention | Danger | | | | | | | | | | | | | | | | | | | | | | | | | | | | | | | | | | | | | | | | | | | | |
| ACC (THRU, OA) | [G] | 1.00 | 4.00 | 1.776 | Attention | | | | | | | | | | | | | | | | | | | | | | | | | | | | | | | | | | | | | | | | | | |
| ACC (OA) | [G] | 1.00 | 4.00 | 0.997 | Good | | | | | | | | | | | | | | | | | | | | | | | | | | | | | | | | | | | | | | | | | | |
| ACC (PEAK) | [G] | 3.00 | 12.00 | 2.100 | Good | | | | | | | | | | | | | | | | | | | | | | | | | | | | | | | | | | | | | | | | | | |
| VEL | [cm/s] | 0.40 | 1.00 | 0.497 | Attention | | | | | | | | | | | | | | | | | | | | | | | | | | | | | | | | | | | | | | | | | | |
| DISP | [μm] | 30 | 100 | 28.2 | Good | | | | | | | | | | | | | | | | | | | | | | | | | | | | | | | | | | | | | | | | | | |
| <p>【 Absolute value Judgment 】 recorded time: 14 Jul 2010 12:40</p> <table border="1" style="width:100%; border-collapse: collapse;"> <thead> <tr> <th rowspan="2">Measurement Mode</th> <th rowspan="2">[G]</th> <th colspan="2">Warning Level</th> <th rowspan="2">Measurements</th> <th rowspan="2">Judgment</th> </tr> <tr> <th>little bad</th> <th>Bad</th> </tr> </thead> <tbody> <tr> <td>ACC (OA)</td> <td>[G]</td> <td>0.64</td> <td>2.55</td> <td>0.997</td> <td>little bad</td> </tr> <tr> <td>VEL</td> <td>[cm/s]</td> <td>0.40</td> <td>1.00</td> <td>0.497</td> <td>little bad</td> </tr> </tbody> </table> <p style="text-align: center;">(1G=9.8m/s²)</p> | | | | | | Measurement Mode | [G] | Warning Level | | Measurements | Judgment | little bad | Bad | ACC (OA) | [G] | 0.64 | 2.55 | 0.997 | little bad | VEL | [cm/s] | 0.40 | 1.00 | 0.497 | little bad | | | | | | | | | | | | | | | | | | | | | | |
| Measurement Mode | [G] | Warning Level | | Measurements | Judgment | | | | | | | | | | | | | | | | | | | | | | | | | | | | | | | | | | | | | | | | | | |
| | | little bad | Bad | | | | | | | | | | | | | | | | | | | | | | | | | | | | | | | | | | | | | | | | | | | | |
| ACC (OA) | [G] | 0.64 | 2.55 | 0.997 | little bad | | | | | | | | | | | | | | | | | | | | | | | | | | | | | | | | | | | | | | | | | | |
| VEL | [cm/s] | 0.40 | 1.00 | 0.497 | little bad | | | | | | | | | | | | | | | | | | | | | | | | | | | | | | | | | | | | | | | | | | |
| 【Comment】 | | | | | | | | | | | | | | | | | | | | | | | | | | | | | | | | | | | | | | | | | | | | | | | |

drawing date: 28 May 2010

| | | | | | | | | |
|---|---------|--------------------------|------------------------|---------------|-------|--|--|---------|
| Simple diagnosis report | | | | | | | | drawing |
| equipment name North Thang Long WWTP | | | | | | | | |
| machine name M3-10A Channei Mixing Blower | | | | | | | | |
| measurement part Blower Inside (Opposite Load Side) | | | | | | | | |
| ID code | 375 | Direction of measurement | Vertical | Group No. | 375 | | | |
| Output | 15.0 kW | Rotational speed | 1913 min ⁻¹ | Axis diameter | 55 mm | | | |

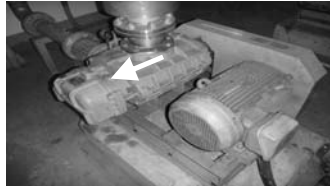

【 Relative value Judgment 】 recorded time: 27 May 2010 16:48

| Measurement Mode | Warning Level | | Measurements | Judgment |
|--------------------|---------------|--------|--------------|----------|
| | Attention | Danger | | |
| ACC (THRU, OA) [G] | 1.00 | 4.00 | 0.460 | Good |
| ACC (OA) [G] | 1.00 | 4.00 | 0.246 | Good |
| ACC (PEAK) [G] | 3.00 | 12.00 | 0.620 | Good |
| VEL [cm/s] | 0.40 | 1.00 | 0.252 | Good |
| DISP [μ m] | 30 | 100 | 18.0 | Good |

(1G=9.8m/s²)

【 Absolute value Judgment 】 recorded time: 27 May 2010 16:48

| Measurement Mode | Warning Level | | Measurements | Judgment |
|------------------|---------------|------|--------------|-------------|
| | little bad | Bad | | |
| ACC (OA) [G] | 0.64 | 2.55 | 0.246 | Good |
| VEL [cm/s] | 0.40 | 1.00 | 0.252 | little good |

(1G=9.8m/s²)

【 Absolute value Judgment 】 (1G=9.8m/s²)

Speed [cm/s]

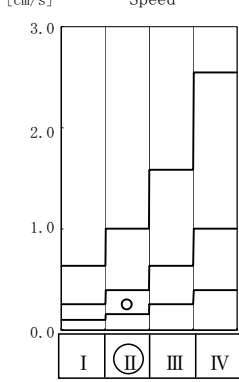

Acceleration [G]

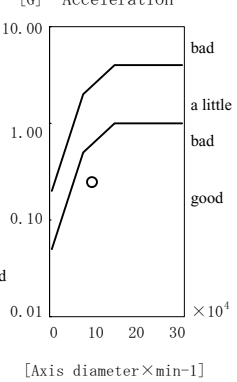

【 Comment 】

drawing date: 16 Jul 2010

| | | | | | | | | |
|---|---------|--------------------------|------------------------|---------------|-------|--|--|---------|
| Simple diagnosis report | | | | | | | | drawing |
| equipment name North Thang Long WWTP | | | | | | | | |
| machine name M3-10A Channei Mixing Blower | | | | | | | | |
| measurement part Blower Inside (Opposite Load Side) | | | | | | | | |
| ID code | 375 | Direction of measurement | Vertical | Group No. | 375 | | | |
| Output | 15.0 kW | Rotational speed | 1913 min ⁻¹ | Axis diameter | 55 mm | | | |

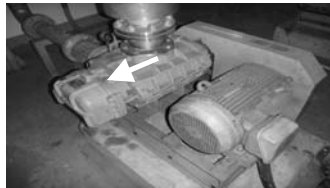

【 Relative value Judgment 】 recorded time: 14 Jul 2010 12:41

| Measurement Mode | Warning Level | | Measurements | Judgment |
|--------------------|---------------|--------|--------------|----------|
| | Attention | Danger | | |
| ACC (THRU, OA) [G] | 1.00 | 4.00 | 0.617 | Good |
| ACC (OA) [G] | 1.00 | 4.00 | 0.398 | Good |
| ACC (PEAK) [G] | 3.00 | 12.00 | 1.119 | Good |
| VEL [cm/s] | 0.40 | 1.00 | 0.273 | Good |
| DISP [μ m] | 30 | 100 | 20.6 | Good |

(1G=9.8m/s²)

【 Absolute value Judgment 】 recorded time: 14 Jul 2010 12:41

| Measurement Mode | Warning Level | | Measurements | Judgment |
|------------------|---------------|------|--------------|-------------|
| | little bad | Bad | | |
| ACC (OA) [G] | 0.64 | 2.55 | 0.398 | Good |
| VEL [cm/s] | 0.40 | 1.00 | 0.273 | little good |

(1G=9.8m/s²)

【 Absolute value Judgment 】 (1G=9.8m/s²)

Speed [cm/s]

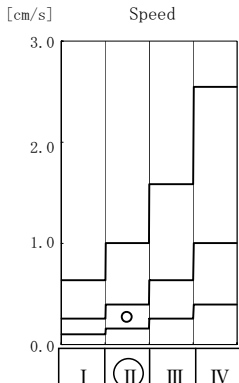

Acceleration [G]

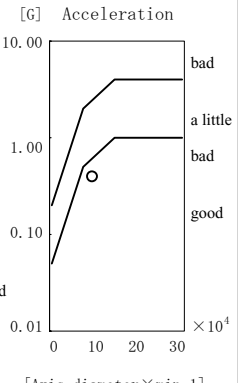

【 Comment 】

drawing date: 28 May 2010

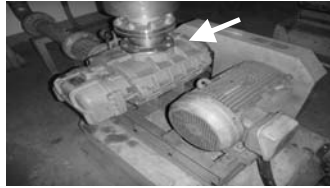
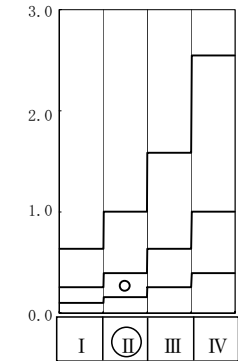
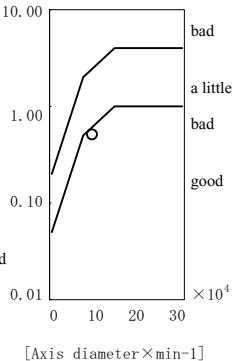
| Simple diagnosis report | | | | | | | | | drawing | | | | | | | | | | | | | | | | | | | | | | | | | | | | | | | | | | | | | | |
|---|---------|--------------------------|------------------------|---------------|-------------|---|-----|---------------|---------|--------------|----------|------------|--------|----------------|-----|------|------|-------|------|----------|--------|------|------|-------|-------------|------------|-----|------|-------|-------|------|-----|--------|------|------|-------|------|------|------|----|-----|------|------|--|--|--|--|
| equipment name | | | | | | North Thang Long WWTP | | | | | | | | | | | | | | | | | | | | | | | | | | | | | | | | | | | | | | | | | |
| machine name | | | | | | M3-10A Channei Mixing Blower | | | | | | | | | | | | | | | | | | | | | | | | | | | | | | | | | | | | | | | | | |
| measurement part | | | | | | Blower Outside (Load Side) | | | | | | | | | | | | | | | | | | | | | | | | | | | | | | | | | | | | | | | | | |
| ID code | 374 | Direction of measurement | Vertical | Group No. | 374 |  | | | | | | | | | | | | | | | | | | | | | | | | | | | | | | | | | | | | | | | | | |
| Output | 15.0 kW | Rotational speed | 1913 min ⁻¹ | Axis diameter | 55 mm | | | | | | | | | | | | | | | | | | | | | | | | | | | | | | | | | | | | | | | | | | |
| <p>【 Relative value Judgment 】 recorded time: 27 May 2010 16:47</p> <table border="1" style="width:100%; border-collapse: collapse;"> <thead> <tr> <th rowspan="2">Measurement Mode</th> <th rowspan="2">[G]</th> <th colspan="2">Warning Level</th> <th rowspan="2">Measurements</th> <th rowspan="2">Judgment</th> </tr> <tr> <th>Attention</th> <th>Danger</th> </tr> </thead> <tbody> <tr> <td>ACC (THRU, OA)</td> <td>[G]</td> <td>1.00</td> <td>4.00</td> <td>0.899</td> <td>Good</td> </tr> <tr> <td>ACC (OA)</td> <td>[G]</td> <td>1.00</td> <td>4.00</td> <td>0.513</td> <td>Good</td> </tr> <tr> <td>ACC (PEAK)</td> <td>[G]</td> <td>3.00</td> <td>12.00</td> <td>1.352</td> <td>Good</td> </tr> <tr> <td>VEL</td> <td>[cm/s]</td> <td>0.40</td> <td>1.00</td> <td>0.269</td> <td>Good</td> </tr> <tr> <td>DISP</td> <td>[μm]</td> <td>30</td> <td>100</td> <td>22.9</td> <td>Good</td> </tr> </tbody> </table> <p style="text-align: center;">(1G=9.8m/s²)</p> | | | | | | Measurement Mode | [G] | Warning Level | | Measurements | Judgment | Attention | Danger | ACC (THRU, OA) | [G] | 1.00 | 4.00 | 0.899 | Good | ACC (OA) | [G] | 1.00 | 4.00 | 0.513 | Good | ACC (PEAK) | [G] | 3.00 | 12.00 | 1.352 | Good | VEL | [cm/s] | 0.40 | 1.00 | 0.269 | Good | DISP | [μm] | 30 | 100 | 22.9 | Good | <p>【 Absolute value Judgment 】 (1G=9.8m/s²)</p> <div style="display: flex; justify-content: space-around;"> <div style="text-align: center;"> <p>Speed [cm/s]</p>  </div> <div style="text-align: center;"> <p>Acceleration [G]</p>  </div> </div> | | | |
| Measurement Mode | [G] | Warning Level | | Measurements | Judgment | | | | | | | | | | | | | | | | | | | | | | | | | | | | | | | | | | | | | | | | | | |
| | | Attention | Danger | | | | | | | | | | | | | | | | | | | | | | | | | | | | | | | | | | | | | | | | | | | | |
| ACC (THRU, OA) | [G] | 1.00 | 4.00 | 0.899 | Good | | | | | | | | | | | | | | | | | | | | | | | | | | | | | | | | | | | | | | | | | | |
| ACC (OA) | [G] | 1.00 | 4.00 | 0.513 | Good | | | | | | | | | | | | | | | | | | | | | | | | | | | | | | | | | | | | | | | | | | |
| ACC (PEAK) | [G] | 3.00 | 12.00 | 1.352 | Good | | | | | | | | | | | | | | | | | | | | | | | | | | | | | | | | | | | | | | | | | | |
| VEL | [cm/s] | 0.40 | 1.00 | 0.269 | Good | | | | | | | | | | | | | | | | | | | | | | | | | | | | | | | | | | | | | | | | | | |
| DISP | [μm] | 30 | 100 | 22.9 | Good | | | | | | | | | | | | | | | | | | | | | | | | | | | | | | | | | | | | | | | | | | |
| <p>【 Absolute value Judgment 】 recorded time: 27 May 2010 16:47</p> <table border="1" style="width:100%; border-collapse: collapse;"> <thead> <tr> <th rowspan="2">Measurement Mode</th> <th rowspan="2">[G]</th> <th colspan="2">Warning Level</th> <th rowspan="2">Measurements</th> <th rowspan="2">Judgment</th> </tr> <tr> <th>little bad</th> <th>Bad</th> </tr> </thead> <tbody> <tr> <td>ACC (OA)</td> <td>[G]</td> <td>0.64</td> <td>2.55</td> <td>0.513</td> <td>Good</td> </tr> <tr> <td>VEL</td> <td>[cm/s]</td> <td>0.40</td> <td>1.00</td> <td>0.269</td> <td>little good</td> </tr> </tbody> </table> <p style="text-align: center;">(1G=9.8m/s²)</p> | | | | | | Measurement Mode | [G] | Warning Level | | Measurements | Judgment | little bad | Bad | ACC (OA) | [G] | 0.64 | 2.55 | 0.513 | Good | VEL | [cm/s] | 0.40 | 1.00 | 0.269 | little good | | | | | | | | | | | | | | | | | | | | | | |
| Measurement Mode | [G] | Warning Level | | Measurements | Judgment | | | | | | | | | | | | | | | | | | | | | | | | | | | | | | | | | | | | | | | | | | |
| | | little bad | Bad | | | | | | | | | | | | | | | | | | | | | | | | | | | | | | | | | | | | | | | | | | | | |
| ACC (OA) | [G] | 0.64 | 2.55 | 0.513 | Good | | | | | | | | | | | | | | | | | | | | | | | | | | | | | | | | | | | | | | | | | | |
| VEL | [cm/s] | 0.40 | 1.00 | 0.269 | little good | | | | | | | | | | | | | | | | | | | | | | | | | | | | | | | | | | | | | | | | | | |
| 【Comment】 | | | | | | | | | | | | | | | | | | | | | | | | | | | | | | | | | | | | | | | | | | | | | | | |

drawing date: 16 Jul 2010

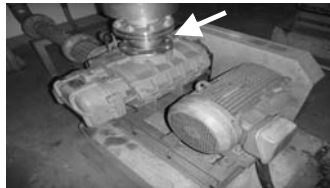
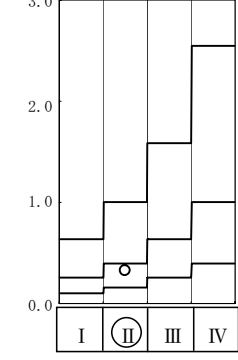
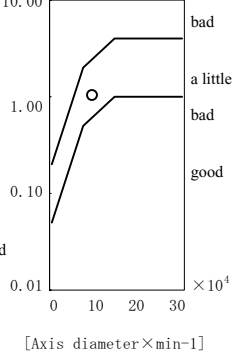
| Simple diagnosis report | | | | | | | | | drawing | | | | | | | | | | | | | | | | | | | | | | | | | | | | | | | | | | | | | | |
|---|---------|--------------------------|------------------------|---------------|-------------|---|-----|---------------|---------|--------------|----------|------------|--------|----------------|-----|------|------|-------|------------|----------|--------|------|------|-------|-------------|------------|-----|------|-------|-------|------|-----|--------|------|------|-------|------|------|------|----|-----|------|------|--|--|--|--|
| equipment name | | | | | | North Thang Long WWTP | | | | | | | | | | | | | | | | | | | | | | | | | | | | | | | | | | | | | | | | | |
| machine name | | | | | | M3-10A Channei Mixing Blower | | | | | | | | | | | | | | | | | | | | | | | | | | | | | | | | | | | | | | | | | |
| measurement part | | | | | | Blower Outside (Load Side) | | | | | | | | | | | | | | | | | | | | | | | | | | | | | | | | | | | | | | | | | |
| ID code | 374 | Direction of measurement | Vertical | Group No. | 374 |  | | | | | | | | | | | | | | | | | | | | | | | | | | | | | | | | | | | | | | | | | |
| Output | 15.0 kW | Rotational speed | 1913 min ⁻¹ | Axis diameter | 55 mm | | | | | | | | | | | | | | | | | | | | | | | | | | | | | | | | | | | | | | | | | | |
| <p>【 Relative value Judgment 】 recorded time: 14 Jul 2010 12:41</p> <table border="1" style="width:100%; border-collapse: collapse;"> <thead> <tr> <th rowspan="2">Measurement Mode</th> <th rowspan="2">[G]</th> <th colspan="2">Warning Level</th> <th rowspan="2">Measurements</th> <th rowspan="2">Judgment</th> </tr> <tr> <th>Attention</th> <th>Danger</th> </tr> </thead> <tbody> <tr> <td>ACC (THRU, OA)</td> <td>[G]</td> <td>1.00</td> <td>4.00</td> <td>1.693</td> <td>Attention</td> </tr> <tr> <td>ACC (OA)</td> <td>[G]</td> <td>1.00</td> <td>4.00</td> <td>1.038</td> <td>Attention</td> </tr> <tr> <td>ACC (PEAK)</td> <td>[G]</td> <td>3.00</td> <td>12.00</td> <td>2.083</td> <td>Good</td> </tr> <tr> <td>VEL</td> <td>[cm/s]</td> <td>0.40</td> <td>1.00</td> <td>0.329</td> <td>Good</td> </tr> <tr> <td>DISP</td> <td>[μm]</td> <td>30</td> <td>100</td> <td>27.5</td> <td>Good</td> </tr> </tbody> </table> <p style="text-align: center;">(1G=9.8m/s²)</p> | | | | | | Measurement Mode | [G] | Warning Level | | Measurements | Judgment | Attention | Danger | ACC (THRU, OA) | [G] | 1.00 | 4.00 | 1.693 | Attention | ACC (OA) | [G] | 1.00 | 4.00 | 1.038 | Attention | ACC (PEAK) | [G] | 3.00 | 12.00 | 2.083 | Good | VEL | [cm/s] | 0.40 | 1.00 | 0.329 | Good | DISP | [μm] | 30 | 100 | 27.5 | Good | <p>【 Absolute value Judgment 】 (1G=9.8m/s²)</p> <div style="display: flex; justify-content: space-around;"> <div style="text-align: center;"> <p>Speed [cm/s]</p>  </div> <div style="text-align: center;"> <p>Acceleration [G]</p>  </div> </div> | | | |
| Measurement Mode | [G] | Warning Level | | Measurements | Judgment | | | | | | | | | | | | | | | | | | | | | | | | | | | | | | | | | | | | | | | | | | |
| | | Attention | Danger | | | | | | | | | | | | | | | | | | | | | | | | | | | | | | | | | | | | | | | | | | | | |
| ACC (THRU, OA) | [G] | 1.00 | 4.00 | 1.693 | Attention | | | | | | | | | | | | | | | | | | | | | | | | | | | | | | | | | | | | | | | | | | |
| ACC (OA) | [G] | 1.00 | 4.00 | 1.038 | Attention | | | | | | | | | | | | | | | | | | | | | | | | | | | | | | | | | | | | | | | | | | |
| ACC (PEAK) | [G] | 3.00 | 12.00 | 2.083 | Good | | | | | | | | | | | | | | | | | | | | | | | | | | | | | | | | | | | | | | | | | | |
| VEL | [cm/s] | 0.40 | 1.00 | 0.329 | Good | | | | | | | | | | | | | | | | | | | | | | | | | | | | | | | | | | | | | | | | | | |
| DISP | [μm] | 30 | 100 | 27.5 | Good | | | | | | | | | | | | | | | | | | | | | | | | | | | | | | | | | | | | | | | | | | |
| <p>【 Absolute value Judgment 】 recorded time: 14 Jul 2010 12:41</p> <table border="1" style="width:100%; border-collapse: collapse;"> <thead> <tr> <th rowspan="2">Measurement Mode</th> <th rowspan="2">[G]</th> <th colspan="2">Warning Level</th> <th rowspan="2">Measurements</th> <th rowspan="2">Judgment</th> </tr> <tr> <th>little bad</th> <th>Bad</th> </tr> </thead> <tbody> <tr> <td>ACC (OA)</td> <td>[G]</td> <td>0.64</td> <td>2.55</td> <td>1.038</td> <td>little bad</td> </tr> <tr> <td>VEL</td> <td>[cm/s]</td> <td>0.40</td> <td>1.00</td> <td>0.329</td> <td>little good</td> </tr> </tbody> </table> <p style="text-align: center;">(1G=9.8m/s²)</p> | | | | | | Measurement Mode | [G] | Warning Level | | Measurements | Judgment | little bad | Bad | ACC (OA) | [G] | 0.64 | 2.55 | 1.038 | little bad | VEL | [cm/s] | 0.40 | 1.00 | 0.329 | little good | | | | | | | | | | | | | | | | | | | | | | |
| Measurement Mode | [G] | Warning Level | | Measurements | Judgment | | | | | | | | | | | | | | | | | | | | | | | | | | | | | | | | | | | | | | | | | | |
| | | little bad | Bad | | | | | | | | | | | | | | | | | | | | | | | | | | | | | | | | | | | | | | | | | | | | |
| ACC (OA) | [G] | 0.64 | 2.55 | 1.038 | little bad | | | | | | | | | | | | | | | | | | | | | | | | | | | | | | | | | | | | | | | | | | |
| VEL | [cm/s] | 0.40 | 1.00 | 0.329 | little good | | | | | | | | | | | | | | | | | | | | | | | | | | | | | | | | | | | | | | | | | | |
| 【Comment】 | | | | | | | | | | | | | | | | | | | | | | | | | | | | | | | | | | | | | | | | | | | | | | | |

drawing date: 28 May 2010

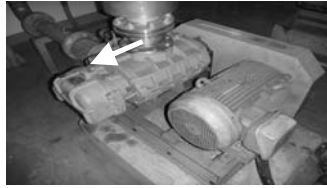
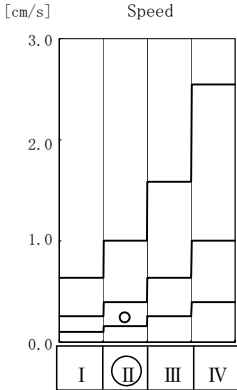
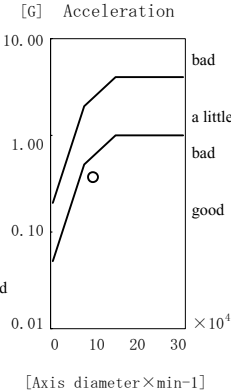
| Simple diagnosis report | | | | | | | | | drawing | | | | | | |
|--|--|--------------------------|--|---------------|----------|--|--|--|---------|--|--|--|--|------|--|
| equipment name | | | | | | North Thang Long WWTP | | | | | | | | | |
| machine name | | | | | | M3-10A Channei Mixing Blower | | | | | | | | | |
| measurement part | | | | | | Blower Outside (Opposite Load Side) | | | | | | | | | |
| ID code | | Direction of measurement | | Group No. | | 376 | | | | | | | | | |
| Output | | Rotational speed | | Axis diameter | | 55 mm | | | | | | | | | |
| 【 Relative value Judgment 】 recorded time: 27 May 2010 16:48 | | | | | |  | | | | | | | | | |
| Measurement Mode | | Warning Level | | Measurements | Judgment | | | | | 【 Absolute value Judgment 】 (1G=9.8m/s ²) [cm/s] Speed [G] Acceleration | | | | | |
| | | Attention Danger | | | | | | | | | | | | | |
| ACC (THRU, OA) [G] | | 1.00 4.00 | | 0.774 | | | | | | | | | | Good | |
| ACC (OA) [G] | | 1.00 4.00 | | 0.367 | | | | | | | | | | Good | |
| ACC (PEAK) [G] | | 3.00 12.00 | | 0.954 | | | | | | | | | | Good | |
| VEL [cm/s] | | 0.40 1.00 | | 0.244 | | Good | | | | | | | | | |
| DISP [μ m] | | 30 100 | | 15.9 | | Good | | | | | | | | | |
| (1G=9.8m/s ²) | | | | | |   | | | | | | | | | |
| 【 Absolute value Judgment 】 recorded time: 27 May 2010 16:48 | | | | | | | | | | | | | | | |
| Measurement Mode | | Warning Level | | Measurements | Judgment | | | | | | | | | | |
| | | little bad Bad | | | | | | | | | | | | | |
| ACC (OA) [G] | | 0.64 2.55 | | 0.367 | | | | | | Good | | | | | |
| VEL [cm/s] | | 0.40 1.00 | | 0.244 | | | | | | little good | | | | | |
| (1G=9.8m/s ²) | | | | | | | | | | | | | | | |
| 【Comment】 | | | | | | | | | | | | | | | |

drawing date: 16 Jul 2010

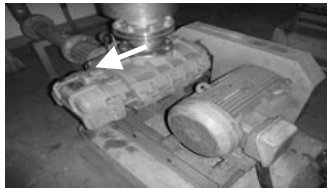
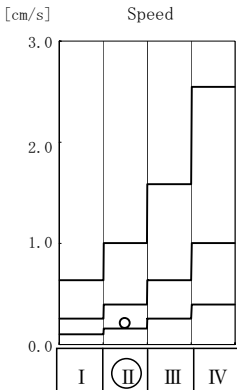
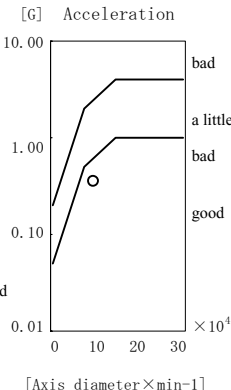
| Simple diagnosis report | | | | | | | | | drawing | | | | | | |
|--|--|--------------------------|--|---------------|----------|--|--|--|---------|--|--|--|--|------|--|
| equipment name | | | | | | North Thang Long WWTP | | | | | | | | | |
| machine name | | | | | | M3-10A Channei Mixing Blower | | | | | | | | | |
| measurement part | | | | | | Blower Outside (Opposite Load Side) | | | | | | | | | |
| ID code | | Direction of measurement | | Group No. | | 376 | | | | | | | | | |
| Output | | Rotational speed | | Axis diameter | | 55 mm | | | | | | | | | |
| 【 Relative value Judgment 】 recorded time: 14 Jul 2010 12:42 | | | | | |  | | | | | | | | | |
| Measurement Mode | | Warning Level | | Measurements | Judgment | | | | | 【 Absolute value Judgment 】 (1G=9.8m/s ²) [cm/s] Speed [G] Acceleration | | | | | |
| | | Attention Danger | | | | | | | | | | | | | |
| ACC (THRU, OA) [G] | | 1.00 4.00 | | 0.568 | | | | | | | | | | Good | |
| ACC (OA) [G] | | 1.00 4.00 | | 0.357 | | | | | | | | | | Good | |
| ACC (PEAK) [G] | | 3.00 12.00 | | 0.993 | | | | | | | | | | Good | |
| VEL [cm/s] | | 0.40 1.00 | | 0.212 | | Good | | | | | | | | | |
| DISP [μ m] | | 30 100 | | 17.9 | | Good | | | | | | | | | |
| (1G=9.8m/s ²) | | | | | |   | | | | | | | | | |
| 【 Absolute value Judgment 】 recorded time: 14 Jul 2010 12:42 | | | | | | | | | | | | | | | |
| Measurement Mode | | Warning Level | | Measurements | Judgment | | | | | | | | | | |
| | | little bad Bad | | | | | | | | | | | | | |
| ACC (OA) [G] | | 0.64 2.55 | | 0.357 | | | | | | Good | | | | | |
| VEL [cm/s] | | 0.40 1.00 | | 0.212 | | | | | | little good | | | | | |
| (1G=9.8m/s ²) | | | | | | | | | | | | | | | |
| 【Comment】 | | | | | | | | | | | | | | | |

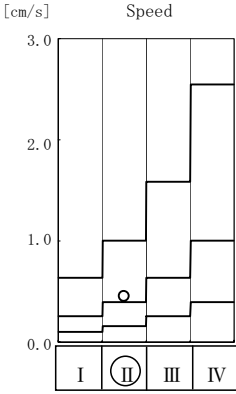
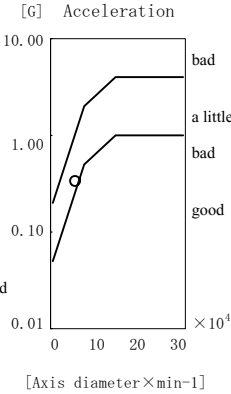
| Simple diagnosis report | | | | | | drawing | | | | | | | | | | | | | | | | | | | | | | | | | | | | | | | | | | | | | | | | | | | | | | | | | | | | | | | | | | | | | |
|---|---------|--------------------------|------------------------|---------------|------------|--|-----|---------------|--|--------------|----------|-----------|--------|----------------|-----|------|------|-------|------|----------|-----|------|------|-------|------|------------|-----|------|-------|-------|------|-----|--------|------|------|-------|-----------|------|------|----|-----|------|-----------|---|--|--|--|------------------|-----|---------------|--|--------------|----------|------------|-----|----------|-----|------|------|-------|------------|-----|--------|------|------|-------|------------|
| equipment name | | | | | | North Thang Long WWTP | | | | | | | | | | | | | | | | | | | | | | | | | | | | | | | | | | | | | | | | | | | | | | | | | | | | | | | | | | | | | |
| machine name | | | | | | M3-10B Channel Mixing Blower | | | | | | | | | | | | | | | | | | | | | | | | | | | | | | | | | | | | | | | | | | | | | | | | | | | | | | | | | | | | | |
| measurement part | | | | | | Moter (Load Side) | | | | | | | | | | | | | | | | | | | | | | | | | | | | | | | | | | | | | | | | | | | | | | | | | | | | | | | | | | | | | |
| ID code | 382 | Direction of measurement | Vertical | Group No. | 372 |  | | | | | | | | | | | | | | | | | | | | | | | | | | | | | | | | | | | | | | | | | | | | | | | | | | | | | | | | | | | | | |
| Output | 15.0 kW | Rotational speed | 1473 min ⁻¹ | Axis diameter | 45 mm | | | | | | | | | | | | | | | | | | | | | | | | | | | | | | | | | | | | | | | | | | | | | | | | | | | | | | | | | | | | | | |
| <p>【 Relative value Judgment 】 recorded time: 27 May 2010 11:35</p> <table border="1" style="width:100%; border-collapse: collapse;"> <thead> <tr> <th rowspan="2">Measurement Mode</th> <th rowspan="2">[G]</th> <th colspan="2">Warning Level</th> <th rowspan="2">Measurements</th> <th rowspan="2">Judgment</th> </tr> <tr> <th>Attention</th> <th>Danger</th> </tr> </thead> <tbody> <tr> <td>ACC (THRU, OA)</td> <td>[G]</td> <td>1.00</td> <td>4.00</td> <td>0.569</td> <td>Good</td> </tr> <tr> <td>ACC (OA)</td> <td>[G]</td> <td>1.00</td> <td>4.00</td> <td>0.335</td> <td>Good</td> </tr> <tr> <td>ACC (PEAK)</td> <td>[G]</td> <td>3.00</td> <td>12.00</td> <td>0.872</td> <td>Good</td> </tr> <tr> <td>VEL</td> <td>[cm/s]</td> <td>0.40</td> <td>1.00</td> <td>0.456</td> <td>Attention</td> </tr> <tr> <td>DISP</td> <td>[μm]</td> <td>30</td> <td>100</td> <td>52.9</td> <td>Attention</td> </tr> </tbody> </table> <p style="text-align: center;">(1G=9.8m/s²)</p> | | | | | | Measurement Mode | [G] | Warning Level | | Measurements | Judgment | Attention | Danger | ACC (THRU, OA) | [G] | 1.00 | 4.00 | 0.569 | Good | ACC (OA) | [G] | 1.00 | 4.00 | 0.335 | Good | ACC (PEAK) | [G] | 3.00 | 12.00 | 0.872 | Good | VEL | [cm/s] | 0.40 | 1.00 | 0.456 | Attention | DISP | [μm] | 30 | 100 | 52.9 | Attention | <p>【 Absolute value Judgment 】 (1G=9.8m/s²)</p> <table border="1" style="width:100%; border-collapse: collapse;"> <thead> <tr> <th rowspan="2">Measurement Mode</th> <th rowspan="2">[G]</th> <th colspan="2">Warning Level</th> <th rowspan="2">Measurements</th> <th rowspan="2">Judgment</th> </tr> <tr> <th>little bad</th> <th>Bad</th> </tr> </thead> <tbody> <tr> <td>ACC (OA)</td> <td>[G]</td> <td>0.32</td> <td>1.28</td> <td>0.335</td> <td>little bad</td> </tr> <tr> <td>VEL</td> <td>[cm/s]</td> <td>0.40</td> <td>1.00</td> <td>0.456</td> <td>little bad</td> </tr> </tbody> </table> <p style="text-align: center;">(1G=9.8m/s²)</p> | | | | Measurement Mode | [G] | Warning Level | | Measurements | Judgment | little bad | Bad | ACC (OA) | [G] | 0.32 | 1.28 | 0.335 | little bad | VEL | [cm/s] | 0.40 | 1.00 | 0.456 | little bad |
| Measurement Mode | [G] | Warning Level | | Measurements | Judgment | | | | | | | | | | | | | | | | | | | | | | | | | | | | | | | | | | | | | | | | | | | | | | | | | | | | | | | | | | | | | | |
| | | Attention | Danger | | | | | | | | | | | | | | | | | | | | | | | | | | | | | | | | | | | | | | | | | | | | | | | | | | | | | | | | | | | | | | | | |
| ACC (THRU, OA) | [G] | 1.00 | 4.00 | 0.569 | Good | | | | | | | | | | | | | | | | | | | | | | | | | | | | | | | | | | | | | | | | | | | | | | | | | | | | | | | | | | | | | | |
| ACC (OA) | [G] | 1.00 | 4.00 | 0.335 | Good | | | | | | | | | | | | | | | | | | | | | | | | | | | | | | | | | | | | | | | | | | | | | | | | | | | | | | | | | | | | | | |
| ACC (PEAK) | [G] | 3.00 | 12.00 | 0.872 | Good | | | | | | | | | | | | | | | | | | | | | | | | | | | | | | | | | | | | | | | | | | | | | | | | | | | | | | | | | | | | | | |
| VEL | [cm/s] | 0.40 | 1.00 | 0.456 | Attention | | | | | | | | | | | | | | | | | | | | | | | | | | | | | | | | | | | | | | | | | | | | | | | | | | | | | | | | | | | | | | |
| DISP | [μm] | 30 | 100 | 52.9 | Attention | | | | | | | | | | | | | | | | | | | | | | | | | | | | | | | | | | | | | | | | | | | | | | | | | | | | | | | | | | | | | | |
| Measurement Mode | [G] | Warning Level | | Measurements | Judgment | | | | | | | | | | | | | | | | | | | | | | | | | | | | | | | | | | | | | | | | | | | | | | | | | | | | | | | | | | | | | | |
| | | little bad | Bad | | | | | | | | | | | | | | | | | | | | | | | | | | | | | | | | | | | | | | | | | | | | | | | | | | | | | | | | | | | | | | | | |
| ACC (OA) | [G] | 0.32 | 1.28 | 0.335 | little bad | | | | | | | | | | | | | | | | | | | | | | | | | | | | | | | | | | | | | | | | | | | | | | | | | | | | | | | | | | | | | | |
| VEL | [cm/s] | 0.40 | 1.00 | 0.456 | little bad | | | | | | | | | | | | | | | | | | | | | | | | | | | | | | | | | | | | | | | | | | | | | | | | | | | | | | | | | | | | | | |
| <p>【 Comment 】</p> | | | | | |   | | | | | | | | | | | | | | | | | | | | | | | | | | | | | | | | | | | | | | | | | | | | | | | | | | | | | | | | | | | | | |

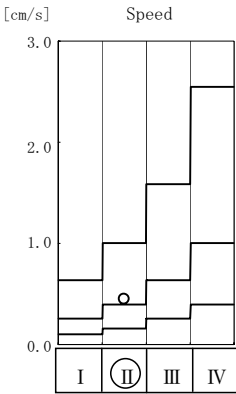
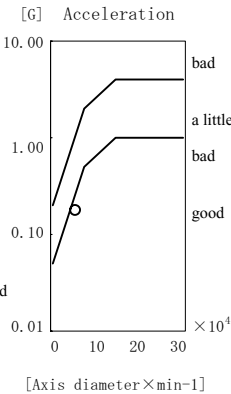
| Simple diagnosis report | | | | | | drawing | | | | | | | | | | | | | | | | | | | | | | | | | | | | | | | | | | | | | | | | | | | | | | | | | | | | | | | | | | | | | |
|---|---------|--------------------------|------------------------|---------------|------------|--|-----|---------------|--|--------------|----------|-----------|--------|----------------|-----|------|------|-------|------|----------|-----|------|------|-------|------|------------|-----|------|-------|-------|------|-----|--------|------|------|-------|-----------|------|------|----|-----|------|-----------|---|--|--|--|------------------|-----|---------------|--|--------------|----------|------------|-----|----------|-----|------|------|-------|------|-----|--------|------|------|-------|------------|
| equipment name | | | | | | North Thang Long WWTP | | | | | | | | | | | | | | | | | | | | | | | | | | | | | | | | | | | | | | | | | | | | | | | | | | | | | | | | | | | | | |
| machine name | | | | | | M3-10B Channel Mixing Blower | | | | | | | | | | | | | | | | | | | | | | | | | | | | | | | | | | | | | | | | | | | | | | | | | | | | | | | | | | | | | |
| measurement part | | | | | | Moter (Load Side) | | | | | | | | | | | | | | | | | | | | | | | | | | | | | | | | | | | | | | | | | | | | | | | | | | | | | | | | | | | | | |
| ID code | 382 | Direction of measurement | Vertical | Group No. | 372 |  | | | | | | | | | | | | | | | | | | | | | | | | | | | | | | | | | | | | | | | | | | | | | | | | | | | | | | | | | | | | | |
| Output | 15.0 kW | Rotational speed | 1473 min ⁻¹ | Axis diameter | 45 mm | | | | | | | | | | | | | | | | | | | | | | | | | | | | | | | | | | | | | | | | | | | | | | | | | | | | | | | | | | | | | | |
| <p>【 Relative value Judgment 】 recorded time: 14 Jul 2010 13:02</p> <table border="1" style="width:100%; border-collapse: collapse;"> <thead> <tr> <th rowspan="2">Measurement Mode</th> <th rowspan="2">[G]</th> <th colspan="2">Warning Level</th> <th rowspan="2">Measurements</th> <th rowspan="2">Judgment</th> </tr> <tr> <th>Attention</th> <th>Danger</th> </tr> </thead> <tbody> <tr> <td>ACC (THRU, OA)</td> <td>[G]</td> <td>1.00</td> <td>4.00</td> <td>0.639</td> <td>Good</td> </tr> <tr> <td>ACC (OA)</td> <td>[G]</td> <td>1.00</td> <td>4.00</td> <td>0.179</td> <td>Good</td> </tr> <tr> <td>ACC (PEAK)</td> <td>[G]</td> <td>3.00</td> <td>12.00</td> <td>0.435</td> <td>Good</td> </tr> <tr> <td>VEL</td> <td>[cm/s]</td> <td>0.40</td> <td>1.00</td> <td>0.453</td> <td>Attention</td> </tr> <tr> <td>DISP</td> <td>[μm]</td> <td>30</td> <td>100</td> <td>40.1</td> <td>Attention</td> </tr> </tbody> </table> <p style="text-align: center;">(1G=9.8m/s²)</p> | | | | | | Measurement Mode | [G] | Warning Level | | Measurements | Judgment | Attention | Danger | ACC (THRU, OA) | [G] | 1.00 | 4.00 | 0.639 | Good | ACC (OA) | [G] | 1.00 | 4.00 | 0.179 | Good | ACC (PEAK) | [G] | 3.00 | 12.00 | 0.435 | Good | VEL | [cm/s] | 0.40 | 1.00 | 0.453 | Attention | DISP | [μm] | 30 | 100 | 40.1 | Attention | <p>【 Absolute value Judgment 】 (1G=9.8m/s²)</p> <table border="1" style="width:100%; border-collapse: collapse;"> <thead> <tr> <th rowspan="2">Measurement Mode</th> <th rowspan="2">[G]</th> <th colspan="2">Warning Level</th> <th rowspan="2">Measurements</th> <th rowspan="2">Judgment</th> </tr> <tr> <th>little bad</th> <th>Bad</th> </tr> </thead> <tbody> <tr> <td>ACC (OA)</td> <td>[G]</td> <td>0.32</td> <td>1.28</td> <td>0.179</td> <td>Good</td> </tr> <tr> <td>VEL</td> <td>[cm/s]</td> <td>0.40</td> <td>1.00</td> <td>0.453</td> <td>little bad</td> </tr> </tbody> </table> <p style="text-align: center;">(1G=9.8m/s²)</p> | | | | Measurement Mode | [G] | Warning Level | | Measurements | Judgment | little bad | Bad | ACC (OA) | [G] | 0.32 | 1.28 | 0.179 | Good | VEL | [cm/s] | 0.40 | 1.00 | 0.453 | little bad |
| Measurement Mode | [G] | Warning Level | | Measurements | Judgment | | | | | | | | | | | | | | | | | | | | | | | | | | | | | | | | | | | | | | | | | | | | | | | | | | | | | | | | | | | | | | |
| | | Attention | Danger | | | | | | | | | | | | | | | | | | | | | | | | | | | | | | | | | | | | | | | | | | | | | | | | | | | | | | | | | | | | | | | | |
| ACC (THRU, OA) | [G] | 1.00 | 4.00 | 0.639 | Good | | | | | | | | | | | | | | | | | | | | | | | | | | | | | | | | | | | | | | | | | | | | | | | | | | | | | | | | | | | | | | |
| ACC (OA) | [G] | 1.00 | 4.00 | 0.179 | Good | | | | | | | | | | | | | | | | | | | | | | | | | | | | | | | | | | | | | | | | | | | | | | | | | | | | | | | | | | | | | | |
| ACC (PEAK) | [G] | 3.00 | 12.00 | 0.435 | Good | | | | | | | | | | | | | | | | | | | | | | | | | | | | | | | | | | | | | | | | | | | | | | | | | | | | | | | | | | | | | | |
| VEL | [cm/s] | 0.40 | 1.00 | 0.453 | Attention | | | | | | | | | | | | | | | | | | | | | | | | | | | | | | | | | | | | | | | | | | | | | | | | | | | | | | | | | | | | | | |
| DISP | [μm] | 30 | 100 | 40.1 | Attention | | | | | | | | | | | | | | | | | | | | | | | | | | | | | | | | | | | | | | | | | | | | | | | | | | | | | | | | | | | | | | |
| Measurement Mode | [G] | Warning Level | | Measurements | Judgment | | | | | | | | | | | | | | | | | | | | | | | | | | | | | | | | | | | | | | | | | | | | | | | | | | | | | | | | | | | | | | |
| | | little bad | Bad | | | | | | | | | | | | | | | | | | | | | | | | | | | | | | | | | | | | | | | | | | | | | | | | | | | | | | | | | | | | | | | | |
| ACC (OA) | [G] | 0.32 | 1.28 | 0.179 | Good | | | | | | | | | | | | | | | | | | | | | | | | | | | | | | | | | | | | | | | | | | | | | | | | | | | | | | | | | | | | | | |
| VEL | [cm/s] | 0.40 | 1.00 | 0.453 | little bad | | | | | | | | | | | | | | | | | | | | | | | | | | | | | | | | | | | | | | | | | | | | | | | | | | | | | | | | | | | | | | |
| <p>【 Comment 】</p> | | | | | |   | | | | | | | | | | | | | | | | | | | | | | | | | | | | | | | | | | | | | | | | | | | | | | | | | | | | | | | | | | | | | |

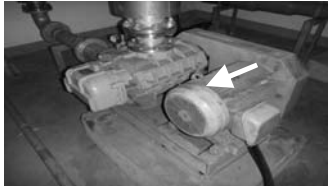
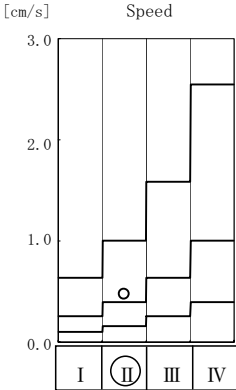
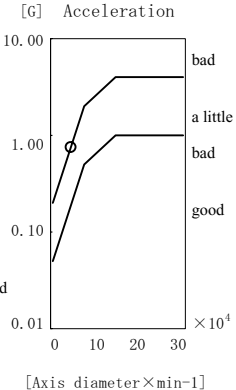
| Simple diagnosis report | | | | | | drawing | | | | | | | | | | | | | | | | | | | | | | | | | | | | | | | | | | | | | | | | | |
|---|---------|--------------------------|------------------------|---------------|------------|---|-----|---------------|--|--------------|----------|------------|--------|----------------|-----|------|------|-------|------------|----------|--------|------|------|-------|------------|------------|-----|------|-------|-------|------|-----|--------|------|------|-------|-----------|------|------|----|-----|------|-----------|--|--|--|--|
| equipment name | | | | | | North Thang Long WWTP | | | | | | | | | | | | | | | | | | | | | | | | | | | | | | | | | | | | | | | | | |
| machine name | | | | | | M3-10B Channel Mixing Blower | | | | | | | | | | | | | | | | | | | | | | | | | | | | | | | | | | | | | | | | | |
| measurement part | | | | | | Moter (Opposite Load Side) | | | | | | | | | | | | | | | | | | | | | | | | | | | | | | | | | | | | | | | | | |
| ID code | 381 | Direction of measurement | Vertical | Group No. | 371 |  | | | | | | | | | | | | | | | | | | | | | | | | | | | | | | | | | | | | | | | | | |
| Output | 15.0 kW | Rotational speed | 1473 min ⁻¹ | Axis diameter | 35 mm | | | | | | | | | | | | | | | | | | | | | | | | | | | | | | | | | | | | | | | | | | |
| <p>【 Relative value Judgment 】 recorded time: 27 May 2010 11:34</p> <table border="1" style="width:100%; border-collapse: collapse;"> <thead> <tr> <th rowspan="2">Measurement Mode</th> <th rowspan="2">[G]</th> <th colspan="2">Warning Level</th> <th rowspan="2">Measurements</th> <th rowspan="2">Judgment</th> </tr> <tr> <th>Attention</th> <th>Danger</th> </tr> </thead> <tbody> <tr> <td>ACC (THRU, OA)</td> <td>[G]</td> <td>1.00</td> <td>4.00</td> <td>0.873</td> <td>Good</td> </tr> <tr> <td>ACC (OA)</td> <td>[G]</td> <td>1.00</td> <td>4.00</td> <td>0.754</td> <td>Good</td> </tr> <tr> <td>ACC (PEAK)</td> <td>[G]</td> <td>3.00</td> <td>12.00</td> <td>1.779</td> <td>Good</td> </tr> <tr> <td>VEL</td> <td>[cm/s]</td> <td>0.40</td> <td>1.00</td> <td>0.479</td> <td>Attention</td> </tr> <tr> <td>DISP</td> <td>[μm]</td> <td>30</td> <td>100</td> <td>47.5</td> <td>Attention</td> </tr> </tbody> </table> <p style="text-align: center;">(1G=9.8m/s²)</p> | | | | | | Measurement Mode | [G] | Warning Level | | Measurements | Judgment | Attention | Danger | ACC (THRU, OA) | [G] | 1.00 | 4.00 | 0.873 | Good | ACC (OA) | [G] | 1.00 | 4.00 | 0.754 | Good | ACC (PEAK) | [G] | 3.00 | 12.00 | 1.779 | Good | VEL | [cm/s] | 0.40 | 1.00 | 0.479 | Attention | DISP | [μm] | 30 | 100 | 47.5 | Attention | <p>【 Absolute value Judgment 】 (1G=9.8m/s²)</p> <div style="display: flex; justify-content: space-around;"> <div style="text-align: center;"> <p>Speed [cm/s]</p>  </div> <div style="text-align: center;"> <p>Acceleration [G]</p>  </div> </div> | | | |
| Measurement Mode | [G] | Warning Level | | Measurements | Judgment | | | | | | | | | | | | | | | | | | | | | | | | | | | | | | | | | | | | | | | | | | |
| | | Attention | Danger | | | | | | | | | | | | | | | | | | | | | | | | | | | | | | | | | | | | | | | | | | | | |
| ACC (THRU, OA) | [G] | 1.00 | 4.00 | 0.873 | Good | | | | | | | | | | | | | | | | | | | | | | | | | | | | | | | | | | | | | | | | | | |
| ACC (OA) | [G] | 1.00 | 4.00 | 0.754 | Good | | | | | | | | | | | | | | | | | | | | | | | | | | | | | | | | | | | | | | | | | | |
| ACC (PEAK) | [G] | 3.00 | 12.00 | 1.779 | Good | | | | | | | | | | | | | | | | | | | | | | | | | | | | | | | | | | | | | | | | | | |
| VEL | [cm/s] | 0.40 | 1.00 | 0.479 | Attention | | | | | | | | | | | | | | | | | | | | | | | | | | | | | | | | | | | | | | | | | | |
| DISP | [μm] | 30 | 100 | 47.5 | Attention | | | | | | | | | | | | | | | | | | | | | | | | | | | | | | | | | | | | | | | | | | |
| <p>【 Absolute value Judgment 】 recorded time: 27 May 2010 11:34</p> <table border="1" style="width:100%; border-collapse: collapse;"> <thead> <tr> <th rowspan="2">Measurement Mode</th> <th rowspan="2">[G]</th> <th colspan="2">Warning Level</th> <th rowspan="2">Measurements</th> <th rowspan="2">Judgment</th> </tr> <tr> <th>little bad</th> <th>Bad</th> </tr> </thead> <tbody> <tr> <td>ACC (OA)</td> <td>[G]</td> <td>0.20</td> <td>0.79</td> <td>0.754</td> <td>little bad</td> </tr> <tr> <td>VEL</td> <td>[cm/s]</td> <td>0.40</td> <td>1.00</td> <td>0.479</td> <td>little bad</td> </tr> </tbody> </table> <p style="text-align: center;">(1G=9.8m/s²)</p> | | | | | | Measurement Mode | [G] | Warning Level | | Measurements | Judgment | little bad | Bad | ACC (OA) | [G] | 0.20 | 0.79 | 0.754 | little bad | VEL | [cm/s] | 0.40 | 1.00 | 0.479 | little bad | | | | | | | | | | | | | | | | | | | | | | |
| Measurement Mode | [G] | Warning Level | | Measurements | Judgment | | | | | | | | | | | | | | | | | | | | | | | | | | | | | | | | | | | | | | | | | | |
| | | little bad | Bad | | | | | | | | | | | | | | | | | | | | | | | | | | | | | | | | | | | | | | | | | | | | |
| ACC (OA) | [G] | 0.20 | 0.79 | 0.754 | little bad | | | | | | | | | | | | | | | | | | | | | | | | | | | | | | | | | | | | | | | | | | |
| VEL | [cm/s] | 0.40 | 1.00 | 0.479 | little bad | | | | | | | | | | | | | | | | | | | | | | | | | | | | | | | | | | | | | | | | | | |
| 【Comment】 | | | | | | | | | | | | | | | | | | | | | | | | | | | | | | | | | | | | | | | | | | | | | | | |

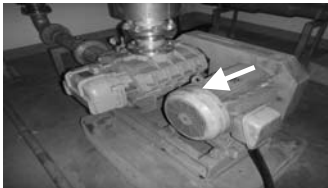
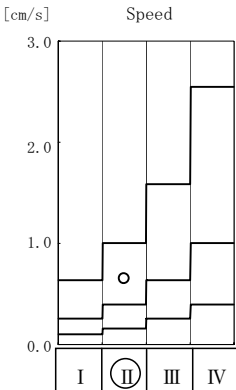
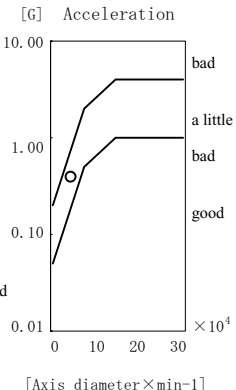
| Simple diagnosis report | | | | | | drawing | | | | | | | | | | | | | | | | | | | | | | | | | | | | | | | | | | | | | | | | | |
|---|---------|--------------------------|------------------------|---------------|-----------|---|-----|---------------|--|--------------|----------|------------|--------|----------------|-----|------|------|-------|------|----------|--------|------|------|-------|------|------------|-----|------|-------|-------|------|-----|--------|------|------|-------|-----------|------|------|----|-----|------|-----------|--|--|--|--|
| equipment name | | | | | | North Thang Long WWTP | | | | | | | | | | | | | | | | | | | | | | | | | | | | | | | | | | | | | | | | | |
| machine name | | | | | | M3-10B Channel Mixing Blower | | | | | | | | | | | | | | | | | | | | | | | | | | | | | | | | | | | | | | | | | |
| measurement part | | | | | | Moter (Opposite Load Side) | | | | | | | | | | | | | | | | | | | | | | | | | | | | | | | | | | | | | | | | | |
| ID code | 381 | Direction of measurement | Vertical | Group No. | 371 |  | | | | | | | | | | | | | | | | | | | | | | | | | | | | | | | | | | | | | | | | | |
| Output | 15.0 kW | Rotational speed | 1473 min ⁻¹ | Axis diameter | 35 mm | | | | | | | | | | | | | | | | | | | | | | | | | | | | | | | | | | | | | | | | | | |
| <p>【 Relative value Judgment 】 recorded time: 14 Jul 2010 13:01</p> <table border="1" style="width:100%; border-collapse: collapse;"> <thead> <tr> <th rowspan="2">Measurement Mode</th> <th rowspan="2">[G]</th> <th colspan="2">Warning Level</th> <th rowspan="2">Measurements</th> <th rowspan="2">Judgment</th> </tr> <tr> <th>Attention</th> <th>Danger</th> </tr> </thead> <tbody> <tr> <td>ACC (THRU, OA)</td> <td>[G]</td> <td>1.00</td> <td>4.00</td> <td>0.629</td> <td>Good</td> </tr> <tr> <td>ACC (OA)</td> <td>[G]</td> <td>1.00</td> <td>4.00</td> <td>0.394</td> <td>Good</td> </tr> <tr> <td>ACC (PEAK)</td> <td>[G]</td> <td>3.00</td> <td>12.00</td> <td>1.002</td> <td>Good</td> </tr> <tr> <td>VEL</td> <td>[cm/s]</td> <td>0.40</td> <td>1.00</td> <td>0.655</td> <td>Attention</td> </tr> <tr> <td>DISP</td> <td>[μm]</td> <td>30</td> <td>100</td> <td>55.9</td> <td>Attention</td> </tr> </tbody> </table> <p style="text-align: center;">(1G=9.8m/s²)</p> | | | | | | Measurement Mode | [G] | Warning Level | | Measurements | Judgment | Attention | Danger | ACC (THRU, OA) | [G] | 1.00 | 4.00 | 0.629 | Good | ACC (OA) | [G] | 1.00 | 4.00 | 0.394 | Good | ACC (PEAK) | [G] | 3.00 | 12.00 | 1.002 | Good | VEL | [cm/s] | 0.40 | 1.00 | 0.655 | Attention | DISP | [μm] | 30 | 100 | 55.9 | Attention | <p>【 Absolute value Judgment 】 (1G=9.8m/s²)</p> <div style="display: flex; justify-content: space-around;"> <div style="text-align: center;"> <p>Speed [cm/s]</p>  </div> <div style="text-align: center;"> <p>Acceleration [G]</p>  </div> </div> | | | |
| Measurement Mode | [G] | Warning Level | | Measurements | Judgment | | | | | | | | | | | | | | | | | | | | | | | | | | | | | | | | | | | | | | | | | | |
| | | Attention | Danger | | | | | | | | | | | | | | | | | | | | | | | | | | | | | | | | | | | | | | | | | | | | |
| ACC (THRU, OA) | [G] | 1.00 | 4.00 | 0.629 | Good | | | | | | | | | | | | | | | | | | | | | | | | | | | | | | | | | | | | | | | | | | |
| ACC (OA) | [G] | 1.00 | 4.00 | 0.394 | Good | | | | | | | | | | | | | | | | | | | | | | | | | | | | | | | | | | | | | | | | | | |
| ACC (PEAK) | [G] | 3.00 | 12.00 | 1.002 | Good | | | | | | | | | | | | | | | | | | | | | | | | | | | | | | | | | | | | | | | | | | |
| VEL | [cm/s] | 0.40 | 1.00 | 0.655 | Attention | | | | | | | | | | | | | | | | | | | | | | | | | | | | | | | | | | | | | | | | | | |
| DISP | [μm] | 30 | 100 | 55.9 | Attention | | | | | | | | | | | | | | | | | | | | | | | | | | | | | | | | | | | | | | | | | | |
| <p>【 Absolute value Judgment 】 recorded time: 14 Jul 2010 13:01</p> <table border="1" style="width:100%; border-collapse: collapse;"> <thead> <tr> <th rowspan="2">Measurement Mode</th> <th rowspan="2">[G]</th> <th colspan="2">Warning Level</th> <th rowspan="2">Measurements</th> <th rowspan="2">Judgment</th> </tr> <tr> <th>little bad</th> <th>Bad</th> </tr> </thead> <tbody> <tr> <td>ACC (OA)</td> <td>[G]</td> <td>0.20</td> <td>0.79</td> <td>0.394</td> <td>ヤヤ悪</td> </tr> <tr> <td>VEL</td> <td>[cm/s]</td> <td>0.40</td> <td>1.00</td> <td>0.655</td> <td>ヤヤ悪</td> </tr> </tbody> </table> <p style="text-align: center;">(1G=9.8m/s²)</p> | | | | | | Measurement Mode | [G] | Warning Level | | Measurements | Judgment | little bad | Bad | ACC (OA) | [G] | 0.20 | 0.79 | 0.394 | ヤヤ悪 | VEL | [cm/s] | 0.40 | 1.00 | 0.655 | ヤヤ悪 | | | | | | | | | | | | | | | | | | | | | | |
| Measurement Mode | [G] | Warning Level | | Measurements | Judgment | | | | | | | | | | | | | | | | | | | | | | | | | | | | | | | | | | | | | | | | | | |
| | | little bad | Bad | | | | | | | | | | | | | | | | | | | | | | | | | | | | | | | | | | | | | | | | | | | | |
| ACC (OA) | [G] | 0.20 | 0.79 | 0.394 | ヤヤ悪 | | | | | | | | | | | | | | | | | | | | | | | | | | | | | | | | | | | | | | | | | | |
| VEL | [cm/s] | 0.40 | 1.00 | 0.655 | ヤヤ悪 | | | | | | | | | | | | | | | | | | | | | | | | | | | | | | | | | | | | | | | | | | |
| 【Comment】 | | | | | | | | | | | | | | | | | | | | | | | | | | | | | | | | | | | | | | | | | | | | | | | |

drawing date: 28 May 2010

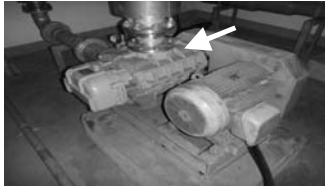
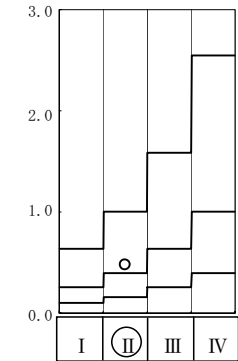
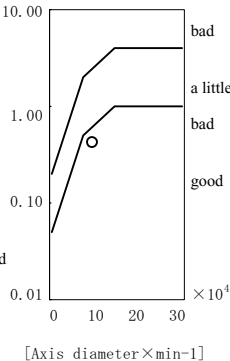
| Simple diagnosis report | | | | | | | | | drawing | | | | | | | | | | | | | | | | | | | | | | | | | | | | | | | | | | | | | | |
|---|---------|--------------------------|------------------------|---------------|------------|---|-----|---------------|---------|--------------|----------|------------|--------|----------------|-----|------|------|-------|------|----------|--------|------|------|-------|------------|------------|-----|------|-------|-------|------|-----|--------|------|------|-------|-----------|------|------|----|-----|------|-----------|--|--|--|--|
| equipment name | | | | | | North Thang Long WWTP | | | | | | | | | | | | | | | | | | | | | | | | | | | | | | | | | | | | | | | | | |
| machine name | | | | | | M3-10B Channel Mixing Blower | | | | | | | | | | | | | | | | | | | | | | | | | | | | | | | | | | | | | | | | | |
| measurement part | | | | | | Blower Inside (Load Side) | | | | | | | | | | | | | | | | | | | | | | | | | | | | | | | | | | | | | | | | | |
| ID code | 383 | Direction of measurement | Vertical | Group No. | 373 |  | | | | | | | | | | | | | | | | | | | | | | | | | | | | | | | | | | | | | | | | | |
| Output | 15.0 kW | Rotational speed | 1920 min ⁻¹ | Axis diameter | 55 mm | | | | | | | | | | | | | | | | | | | | | | | | | | | | | | | | | | | | | | | | | | |
| <p>【 Relative value Judgment 】 recorded time: 27 May 2010 11:36</p> <table border="1" style="width:100%; border-collapse: collapse;"> <thead> <tr> <th rowspan="2">Measurement Mode</th> <th rowspan="2">[G]</th> <th colspan="2">Warning Level</th> <th rowspan="2">Measurements</th> <th rowspan="2">Judgment</th> </tr> <tr> <th>Attention</th> <th>Danger</th> </tr> </thead> <tbody> <tr> <td>ACC (THRU, OA)</td> <td>[G]</td> <td>1.00</td> <td>4.00</td> <td>0.613</td> <td>Good</td> </tr> <tr> <td>ACC (OA)</td> <td>[G]</td> <td>1.00</td> <td>4.00</td> <td>0.425</td> <td>Good</td> </tr> <tr> <td>ACC (PEAK)</td> <td>[G]</td> <td>3.00</td> <td>12.00</td> <td>1.254</td> <td>Good</td> </tr> <tr> <td>VEL</td> <td>[cm/s]</td> <td>0.40</td> <td>1.00</td> <td>0.481</td> <td>Attention</td> </tr> <tr> <td>DISP</td> <td>[μm]</td> <td>30</td> <td>100</td> <td>47.5</td> <td>Attention</td> </tr> </tbody> </table> <p style="text-align: center;">(1G=9.8m/s²)</p> | | | | | | Measurement Mode | [G] | Warning Level | | Measurements | Judgment | Attention | Danger | ACC (THRU, OA) | [G] | 1.00 | 4.00 | 0.613 | Good | ACC (OA) | [G] | 1.00 | 4.00 | 0.425 | Good | ACC (PEAK) | [G] | 3.00 | 12.00 | 1.254 | Good | VEL | [cm/s] | 0.40 | 1.00 | 0.481 | Attention | DISP | [μm] | 30 | 100 | 47.5 | Attention | <p>【 Absolute value Judgment 】 (1G=9.8m/s²)</p> <div style="display: flex; justify-content: space-around;"> <div style="text-align: center;"> <p>Speed [cm/s]</p>  </div> <div style="text-align: center;"> <p>Acceleration [G]</p>  </div> </div> | | | |
| Measurement Mode | [G] | Warning Level | | Measurements | Judgment | | | | | | | | | | | | | | | | | | | | | | | | | | | | | | | | | | | | | | | | | | |
| | | Attention | Danger | | | | | | | | | | | | | | | | | | | | | | | | | | | | | | | | | | | | | | | | | | | | |
| ACC (THRU, OA) | [G] | 1.00 | 4.00 | 0.613 | Good | | | | | | | | | | | | | | | | | | | | | | | | | | | | | | | | | | | | | | | | | | |
| ACC (OA) | [G] | 1.00 | 4.00 | 0.425 | Good | | | | | | | | | | | | | | | | | | | | | | | | | | | | | | | | | | | | | | | | | | |
| ACC (PEAK) | [G] | 3.00 | 12.00 | 1.254 | Good | | | | | | | | | | | | | | | | | | | | | | | | | | | | | | | | | | | | | | | | | | |
| VEL | [cm/s] | 0.40 | 1.00 | 0.481 | Attention | | | | | | | | | | | | | | | | | | | | | | | | | | | | | | | | | | | | | | | | | | |
| DISP | [μm] | 30 | 100 | 47.5 | Attention | | | | | | | | | | | | | | | | | | | | | | | | | | | | | | | | | | | | | | | | | | |
| <p>【 Absolute value Judgment 】 recorded time: 27 May 2010 11:36</p> <table border="1" style="width:100%; border-collapse: collapse;"> <thead> <tr> <th rowspan="2">Measurement Mode</th> <th rowspan="2">[G]</th> <th colspan="2">Warning Level</th> <th rowspan="2">Measurements</th> <th rowspan="2">Judgment</th> </tr> <tr> <th>little bad</th> <th>Bad</th> </tr> </thead> <tbody> <tr> <td>ACC (OA)</td> <td>[G]</td> <td>0.64</td> <td>2.56</td> <td>0.425</td> <td>Good</td> </tr> <tr> <td>VEL</td> <td>[cm/s]</td> <td>0.40</td> <td>1.00</td> <td>0.481</td> <td>little bad</td> </tr> </tbody> </table> <p style="text-align: center;">(1G=9.8m/s²)</p> | | | | | | Measurement Mode | [G] | Warning Level | | Measurements | Judgment | little bad | Bad | ACC (OA) | [G] | 0.64 | 2.56 | 0.425 | Good | VEL | [cm/s] | 0.40 | 1.00 | 0.481 | little bad | | | | | | | | | | | | | | | | | | | | | | |
| Measurement Mode | [G] | Warning Level | | Measurements | Judgment | | | | | | | | | | | | | | | | | | | | | | | | | | | | | | | | | | | | | | | | | | |
| | | little bad | Bad | | | | | | | | | | | | | | | | | | | | | | | | | | | | | | | | | | | | | | | | | | | | |
| ACC (OA) | [G] | 0.64 | 2.56 | 0.425 | Good | | | | | | | | | | | | | | | | | | | | | | | | | | | | | | | | | | | | | | | | | | |
| VEL | [cm/s] | 0.40 | 1.00 | 0.481 | little bad | | | | | | | | | | | | | | | | | | | | | | | | | | | | | | | | | | | | | | | | | | |
| 【Comment】 | | | | | | | | | | | | | | | | | | | | | | | | | | | | | | | | | | | | | | | | | | | | | | | |

drawing date: 16 Jul 2010

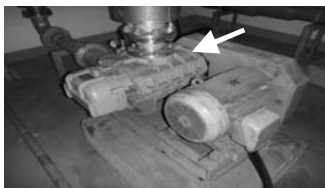
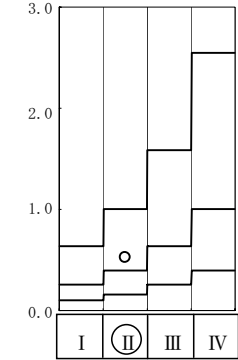
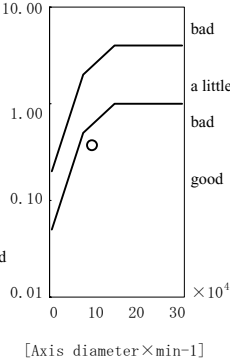
| Simple diagnosis report | | | | | | | | | drawing | | | | | | | | | | | | | | | | | | | | | | | | | | | | | | | | | | | | | | |
|---|---------|--------------------------|------------------------|---------------|------------|---|-----|---------------|---------|--------------|----------|------------|--------|----------------|-----|------|------|-------|------|----------|--------|------|------|-------|------------|------------|-----|------|-------|-------|------|-----|--------|------|------|-------|-----------|------|------|----|-----|------|-----------|--|--|--|--|
| equipment name | | | | | | North Thang Long WWTP | | | | | | | | | | | | | | | | | | | | | | | | | | | | | | | | | | | | | | | | | |
| machine name | | | | | | M3-10B Channel Mixing Blower | | | | | | | | | | | | | | | | | | | | | | | | | | | | | | | | | | | | | | | | | |
| measurement part | | | | | | Blower Inside (Load Side) | | | | | | | | | | | | | | | | | | | | | | | | | | | | | | | | | | | | | | | | | |
| ID code | 383 | Direction of measurement | Vertical | Group No. | 373 |  | | | | | | | | | | | | | | | | | | | | | | | | | | | | | | | | | | | | | | | | | |
| Output | 15.0 kW | Rotational speed | 1920 min ⁻¹ | Axis diameter | 55 mm | | | | | | | | | | | | | | | | | | | | | | | | | | | | | | | | | | | | | | | | | | |
| <p>【 Relative value Judgment 】 recorded time: 14 Jul 2010 13:02</p> <table border="1" style="width:100%; border-collapse: collapse;"> <thead> <tr> <th rowspan="2">Measurement Mode</th> <th rowspan="2">[G]</th> <th colspan="2">Warning Level</th> <th rowspan="2">Measurements</th> <th rowspan="2">Judgment</th> </tr> <tr> <th>Attention</th> <th>Danger</th> </tr> </thead> <tbody> <tr> <td>ACC (THRU, OA)</td> <td>[G]</td> <td>1.00</td> <td>4.00</td> <td>0.584</td> <td>Good</td> </tr> <tr> <td>ACC (OA)</td> <td>[G]</td> <td>1.00</td> <td>4.00</td> <td>0.371</td> <td>Good</td> </tr> <tr> <td>ACC (PEAK)</td> <td>[G]</td> <td>3.00</td> <td>12.00</td> <td>1.173</td> <td>Good</td> </tr> <tr> <td>VEL</td> <td>[cm/s]</td> <td>0.40</td> <td>1.00</td> <td>0.530</td> <td>Attention</td> </tr> <tr> <td>DISP</td> <td>[μm]</td> <td>30</td> <td>100</td> <td>55.4</td> <td>Attention</td> </tr> </tbody> </table> <p style="text-align: center;">(1G=9.8m/s²)</p> | | | | | | Measurement Mode | [G] | Warning Level | | Measurements | Judgment | Attention | Danger | ACC (THRU, OA) | [G] | 1.00 | 4.00 | 0.584 | Good | ACC (OA) | [G] | 1.00 | 4.00 | 0.371 | Good | ACC (PEAK) | [G] | 3.00 | 12.00 | 1.173 | Good | VEL | [cm/s] | 0.40 | 1.00 | 0.530 | Attention | DISP | [μm] | 30 | 100 | 55.4 | Attention | <p>【 Absolute value Judgment 】 (1G=9.8m/s²)</p> <div style="display: flex; justify-content: space-around;"> <div style="text-align: center;"> <p>Speed [cm/s]</p>  </div> <div style="text-align: center;"> <p>Acceleration [G]</p>  </div> </div> | | | |
| Measurement Mode | [G] | Warning Level | | Measurements | Judgment | | | | | | | | | | | | | | | | | | | | | | | | | | | | | | | | | | | | | | | | | | |
| | | Attention | Danger | | | | | | | | | | | | | | | | | | | | | | | | | | | | | | | | | | | | | | | | | | | | |
| ACC (THRU, OA) | [G] | 1.00 | 4.00 | 0.584 | Good | | | | | | | | | | | | | | | | | | | | | | | | | | | | | | | | | | | | | | | | | | |
| ACC (OA) | [G] | 1.00 | 4.00 | 0.371 | Good | | | | | | | | | | | | | | | | | | | | | | | | | | | | | | | | | | | | | | | | | | |
| ACC (PEAK) | [G] | 3.00 | 12.00 | 1.173 | Good | | | | | | | | | | | | | | | | | | | | | | | | | | | | | | | | | | | | | | | | | | |
| VEL | [cm/s] | 0.40 | 1.00 | 0.530 | Attention | | | | | | | | | | | | | | | | | | | | | | | | | | | | | | | | | | | | | | | | | | |
| DISP | [μm] | 30 | 100 | 55.4 | Attention | | | | | | | | | | | | | | | | | | | | | | | | | | | | | | | | | | | | | | | | | | |
| <p>【 Absolute value Judgment 】 recorded time: 14 Jul 2010 13:02</p> <table border="1" style="width:100%; border-collapse: collapse;"> <thead> <tr> <th rowspan="2">Measurement Mode</th> <th rowspan="2">[G]</th> <th colspan="2">Warning Level</th> <th rowspan="2">Measurements</th> <th rowspan="2">Judgment</th> </tr> <tr> <th>little bad</th> <th>Bad</th> </tr> </thead> <tbody> <tr> <td>ACC (OA)</td> <td>[G]</td> <td>0.64</td> <td>2.56</td> <td>0.371</td> <td>Good</td> </tr> <tr> <td>VEL</td> <td>[cm/s]</td> <td>0.40</td> <td>1.00</td> <td>0.530</td> <td>little bad</td> </tr> </tbody> </table> <p style="text-align: center;">(1G=9.8m/s²)</p> | | | | | | Measurement Mode | [G] | Warning Level | | Measurements | Judgment | little bad | Bad | ACC (OA) | [G] | 0.64 | 2.56 | 0.371 | Good | VEL | [cm/s] | 0.40 | 1.00 | 0.530 | little bad | | | | | | | | | | | | | | | | | | | | | | |
| Measurement Mode | [G] | Warning Level | | Measurements | Judgment | | | | | | | | | | | | | | | | | | | | | | | | | | | | | | | | | | | | | | | | | | |
| | | little bad | Bad | | | | | | | | | | | | | | | | | | | | | | | | | | | | | | | | | | | | | | | | | | | | |
| ACC (OA) | [G] | 0.64 | 2.56 | 0.371 | Good | | | | | | | | | | | | | | | | | | | | | | | | | | | | | | | | | | | | | | | | | | |
| VEL | [cm/s] | 0.40 | 1.00 | 0.530 | little bad | | | | | | | | | | | | | | | | | | | | | | | | | | | | | | | | | | | | | | | | | | |
| 【Comment】 | | | | | | | | | | | | | | | | | | | | | | | | | | | | | | | | | | | | | | | | | | | | | | | |

drawing date: 28 May 2010

| | | | | | | |
|---|---------|--------------------------|------------------------|---------------|---------|--|
| Simple diagnosis report | | | | | drawing | |
| equipment name North Thang Long WWTP | | | | | | |
| machine name M3-10B Channel Mixing Blower | | | | | | |
| measurement part Blower Inside (Opposite Load Side) | | | | | | |
| ID code | 385 | Direction of measurement | Vertical | Group No. | 375 | |
| Output | 15.0 kW | Rotational speed | 1920 min ⁻¹ | Axis diameter | 55 mm | |

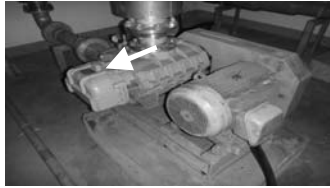

【 Relative value Judgment 】 recorded time: 27 May 2010 11:37

| Measurement Mode | Warning Level | | Measurements | Judgment |
|--------------------|---------------|--------|--------------|-----------|
| | Attention | Danger | | |
| ACC (THRU, OA) [G] | 1.00 | 4.00 | 0.568 | Good |
| ACC (OA) [G] | 1.00 | 4.00 | 0.343 | Good |
| ACC (PEAK) [G] | 3.00 | 12.00 | 1.064 | Good |
| VEL [cm/s] | 0.40 | 1.00 | 0.464 | Attention |
| DISP [μ m] | 30 | 100 | 46.2 | Attention |

(1G=9.8m/s²)

【 Absolute value Judgment 】 recorded time: 27 May 2010 11:37

| Measurement Mode | Warning Level | | Measurements | Judgment |
|------------------|---------------|------|--------------|------------|
| | little bad | Bad | | |
| ACC (OA) [G] | 0.64 | 2.56 | 0.343 | Good |
| VEL [cm/s] | 0.40 | 1.00 | 0.464 | little bad |

(1G=9.8m/s²)

【 Absolute value Judgment 】 (1G=9.8m/s²)

Speed [cm/s]

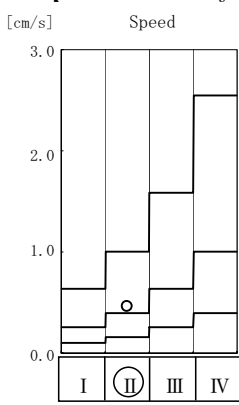

Acceleration [G]

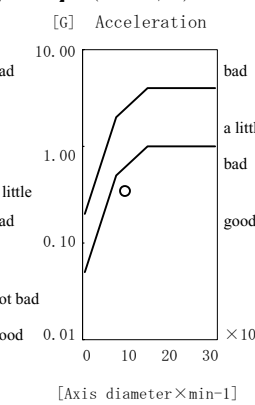

【 Comment 】

drawing date: 16 Jul 2010

| | | | | | | |
|---|---------|--------------------------|------------------------|---------------|---------|--|
| Simple diagnosis report | | | | | drawing | |
| equipment name North Thang Long WWTP | | | | | | |
| machine name M3-10B Channel Mixing Blower | | | | | | |
| measurement part Blower Inside (Opposite Load Side) | | | | | | |
| ID code | 385 | Direction of measurement | Vertical | Group No. | 375 | |
| Output | 15.0 kW | Rotational speed | 1920 min ⁻¹ | Axis diameter | 55 mm | |

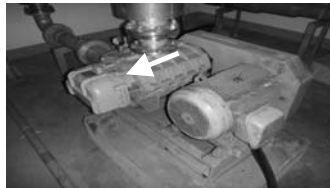

【 Relative value Judgment 】 recorded time: 14 Jul 2010 13:03

| Measurement Mode | Warning Level | | Measurements | Judgment |
|--------------------|---------------|--------|--------------|-----------|
| | Attention | Danger | | |
| ACC (THRU, OA) [G] | 1.00 | 4.00 | 0.546 | Good |
| ACC (OA) [G] | 1.00 | 4.00 | 0.362 | Good |
| ACC (PEAK) [G] | 3.00 | 12.00 | 0.836 | Good |
| VEL [cm/s] | 0.40 | 1.00 | 0.389 | Good |
| DISP [μ m] | 30 | 100 | 37.9 | Attention |

(1G=9.8m/s²)

【 Absolute value Judgment 】 recorded time: 14 Jul 2010 13:03

| Measurement Mode | Warning Level | | Measurements | Judgment |
|------------------|---------------|------|--------------|-------------|
| | little bad | Bad | | |
| ACC (OA) [G] | 0.64 | 2.56 | 0.362 | Good |
| VEL [cm/s] | 0.40 | 1.00 | 0.389 | little good |

(1G=9.8m/s²)

【 Absolute value Judgment 】 (1G=9.8m/s²)

Speed [cm/s]

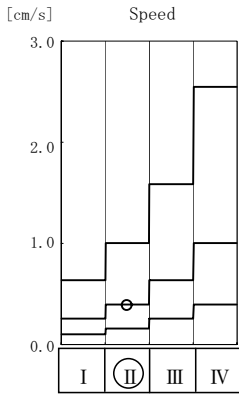

Acceleration [G]

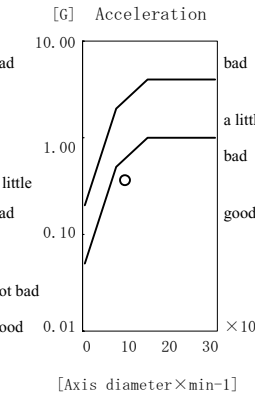

【 Comment 】

drawing date: 28 May 2010

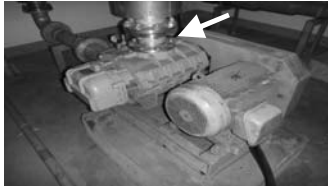
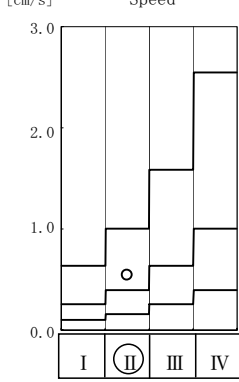
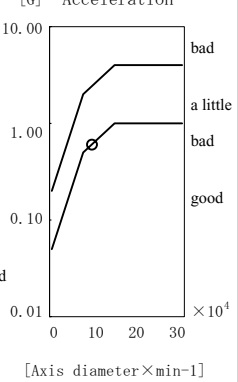
| Simple diagnosis report | | | | | | | | | drawing | | | | | | | | | | | | | | | | | | | | | | | | | | | | | | | | | | | | | | | | | | | | | | | | | | | | | | | | | | | | | | |
|---|---------|--------------------------|------------------------|---------------|------------|---|-----|---------------|---------|--------------|----------|-----------|--------|----------------|-----|------|------|-------|------|----------|-----|------|------|-------|------|------------|-----|------|-------|-------|------|-----|--------|------|------|-------|-----------|------|------|----|-----|------|-----------|---|--|--|--|------------------|-----|---------------|--|--------------|----------|------------|-----|----------|-----|------|------|-------|------|-----|--------|------|------|-------|------------|--|--|--|--|
| equipment name | | | | | | North Thang Long WWTP | | | | | | | | | | | | | | | | | | | | | | | | | | | | | | | | | | | | | | | | | | | | | | | | | | | | | | | | | | | | | | | | | |
| machine name | | | | | | M3-10B Channel Mixing Blower | | | | | | | | | | | | | | | | | | | | | | | | | | | | | | | | | | | | | | | | | | | | | | | | | | | | | | | | | | | | | | | | | |
| measurement part | | | | | | Blower Outside (Load Side) | | | | | | | | | | | | | | | | | | | | | | | | | | | | | | | | | | | | | | | | | | | | | | | | | | | | | | | | | | | | | | | | | |
| ID code | 384 | Direction of measurement | Vertical | Group No. | 374 |  | | | | | | | | | | | | | | | | | | | | | | | | | | | | | | | | | | | | | | | | | | | | | | | | | | | | | | | | | | | | | | | | | |
| Output | 15.0 kW | Rotational speed | 1920 min ⁻¹ | Axis diameter | 55 mm | | | | | | | | | | | | | | | | | | | | | | | | | | | | | | | | | | | | | | | | | | | | | | | | | | | | | | | | | | | | | | | | | | |
| <p>【 Relative value Judgment 】 recorded time: 27 May 2010 11:36</p> <table border="1" style="width:100%; border-collapse: collapse;"> <thead> <tr> <th rowspan="2">Measurement Mode</th> <th rowspan="2">[G]</th> <th colspan="2">Warning Level</th> <th rowspan="2">Measurements</th> <th rowspan="2">Judgment</th> </tr> <tr> <th>Attention</th> <th>Danger</th> </tr> </thead> <tbody> <tr> <td>ACC (THRU, OA)</td> <td>[G]</td> <td>1.00</td> <td>4.00</td> <td>0.932</td> <td>Good</td> </tr> <tr> <td>ACC (OA)</td> <td>[G]</td> <td>1.00</td> <td>4.00</td> <td>0.598</td> <td>Good</td> </tr> <tr> <td>ACC (PEAK)</td> <td>[G]</td> <td>3.00</td> <td>12.00</td> <td>1.661</td> <td>Good</td> </tr> <tr> <td>VEL</td> <td>[cm/s]</td> <td>0.40</td> <td>1.00</td> <td>0.546</td> <td>Attention</td> </tr> <tr> <td>DISP</td> <td>[μm]</td> <td>30</td> <td>100</td> <td>54.1</td> <td>Attention</td> </tr> </tbody> </table> <p style="text-align: center;">(1G=9.8m/s²)</p> | | | | | | Measurement Mode | [G] | Warning Level | | Measurements | Judgment | Attention | Danger | ACC (THRU, OA) | [G] | 1.00 | 4.00 | 0.932 | Good | ACC (OA) | [G] | 1.00 | 4.00 | 0.598 | Good | ACC (PEAK) | [G] | 3.00 | 12.00 | 1.661 | Good | VEL | [cm/s] | 0.40 | 1.00 | 0.546 | Attention | DISP | [μm] | 30 | 100 | 54.1 | Attention | <p>【 Absolute value Judgment 】 (1G=9.8m/s²)</p> <table border="1" style="width:100%; border-collapse: collapse;"> <thead> <tr> <th rowspan="2">Measurement Mode</th> <th rowspan="2">[G]</th> <th colspan="2">Warning Level</th> <th rowspan="2">Measurements</th> <th rowspan="2">Judgment</th> </tr> <tr> <th>little bad</th> <th>Bad</th> </tr> </thead> <tbody> <tr> <td>ACC (OA)</td> <td>[G]</td> <td>0.64</td> <td>2.56</td> <td>0.598</td> <td>Good</td> </tr> <tr> <td>VEL</td> <td>[cm/s]</td> <td>0.40</td> <td>1.00</td> <td>0.546</td> <td>little bad</td> </tr> </tbody> </table> <p style="text-align: center;">(1G=9.8m/s²)</p> | | | | Measurement Mode | [G] | Warning Level | | Measurements | Judgment | little bad | Bad | ACC (OA) | [G] | 0.64 | 2.56 | 0.598 | Good | VEL | [cm/s] | 0.40 | 1.00 | 0.546 | little bad | <p>【 Absolute value Judgment 】 (1G=9.8m/s²)</p> <div style="display: flex; justify-content: space-around;"> <div style="text-align: center;"> <p>Speed [cm/s]</p>  </div> <div style="text-align: center;"> <p>Acceleration [G]</p>  </div> </div> | | | |
| Measurement Mode | [G] | Warning Level | | Measurements | Judgment | | | | | | | | | | | | | | | | | | | | | | | | | | | | | | | | | | | | | | | | | | | | | | | | | | | | | | | | | | | | | | | | | | |
| | | Attention | Danger | | | | | | | | | | | | | | | | | | | | | | | | | | | | | | | | | | | | | | | | | | | | | | | | | | | | | | | | | | | | | | | | | | | | |
| ACC (THRU, OA) | [G] | 1.00 | 4.00 | 0.932 | Good | | | | | | | | | | | | | | | | | | | | | | | | | | | | | | | | | | | | | | | | | | | | | | | | | | | | | | | | | | | | | | | | | | |
| ACC (OA) | [G] | 1.00 | 4.00 | 0.598 | Good | | | | | | | | | | | | | | | | | | | | | | | | | | | | | | | | | | | | | | | | | | | | | | | | | | | | | | | | | | | | | | | | | | |
| ACC (PEAK) | [G] | 3.00 | 12.00 | 1.661 | Good | | | | | | | | | | | | | | | | | | | | | | | | | | | | | | | | | | | | | | | | | | | | | | | | | | | | | | | | | | | | | | | | | | |
| VEL | [cm/s] | 0.40 | 1.00 | 0.546 | Attention | | | | | | | | | | | | | | | | | | | | | | | | | | | | | | | | | | | | | | | | | | | | | | | | | | | | | | | | | | | | | | | | | | |
| DISP | [μm] | 30 | 100 | 54.1 | Attention | | | | | | | | | | | | | | | | | | | | | | | | | | | | | | | | | | | | | | | | | | | | | | | | | | | | | | | | | | | | | | | | | | |
| Measurement Mode | [G] | Warning Level | | Measurements | Judgment | | | | | | | | | | | | | | | | | | | | | | | | | | | | | | | | | | | | | | | | | | | | | | | | | | | | | | | | | | | | | | | | | | |
| | | little bad | Bad | | | | | | | | | | | | | | | | | | | | | | | | | | | | | | | | | | | | | | | | | | | | | | | | | | | | | | | | | | | | | | | | | | | | |
| ACC (OA) | [G] | 0.64 | 2.56 | 0.598 | Good | | | | | | | | | | | | | | | | | | | | | | | | | | | | | | | | | | | | | | | | | | | | | | | | | | | | | | | | | | | | | | | | | | |
| VEL | [cm/s] | 0.40 | 1.00 | 0.546 | little bad | | | | | | | | | | | | | | | | | | | | | | | | | | | | | | | | | | | | | | | | | | | | | | | | | | | | | | | | | | | | | | | | | | |
| 【Comment】 | | | | | | | | | | | | | | | | | | | | | | | | | | | | | | | | | | | | | | | | | | | | | | | | | | | | | | | | | | | | | | | | | | | | | | | |

drawing date: 16 Jul 2010

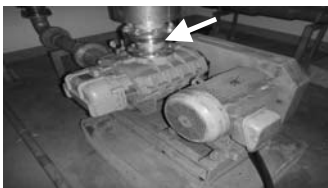
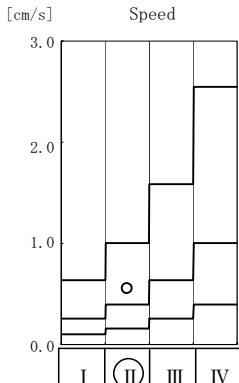
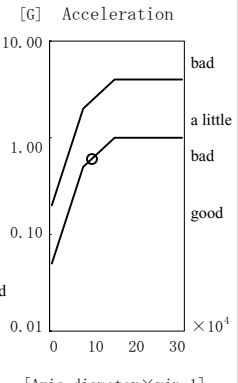
| Simple diagnosis report | | | | | | | | | drawing | | | | | | | | | | | | | | | | | | | | | | | | | | | | | | | | | | | | | | | | | | | | | | | | | | | | | | | | | | | | | | |
|---|---------|--------------------------|------------------------|---------------|------------|---|-----|---------------|---------|--------------|----------|-----------|--------|----------------|-----|------|------|-------|------|----------|-----|------|------|-------|------|------------|-----|------|-------|-------|------|-----|--------|------|------|-------|-----------|------|------|----|-----|------|-----------|---|--|--|--|------------------|-----|---------------|--|--------------|----------|------------|-----|----------|-----|------|------|-------|------|-----|--------|------|------|-------|------------|--|--|--|--|
| equipment name | | | | | | North Thang Long WWTP | | | | | | | | | | | | | | | | | | | | | | | | | | | | | | | | | | | | | | | | | | | | | | | | | | | | | | | | | | | | | | | | | |
| machine name | | | | | | M3-10B Channel Mixing Blower | | | | | | | | | | | | | | | | | | | | | | | | | | | | | | | | | | | | | | | | | | | | | | | | | | | | | | | | | | | | | | | | | |
| measurement part | | | | | | Blower Outside (Load Side) | | | | | | | | | | | | | | | | | | | | | | | | | | | | | | | | | | | | | | | | | | | | | | | | | | | | | | | | | | | | | | | | | |
| ID code | 384 | Direction of measurement | Vertical | Group No. | 374 |  | | | | | | | | | | | | | | | | | | | | | | | | | | | | | | | | | | | | | | | | | | | | | | | | | | | | | | | | | | | | | | | | | |
| Output | 15.0 kW | Rotational speed | 1920 min ⁻¹ | Axis diameter | 55 mm | | | | | | | | | | | | | | | | | | | | | | | | | | | | | | | | | | | | | | | | | | | | | | | | | | | | | | | | | | | | | | | | | | |
| <p>【 Relative value Judgment 】 recorded time: 14 Jul 2010 13:03</p> <table border="1" style="width:100%; border-collapse: collapse;"> <thead> <tr> <th rowspan="2">Measurement Mode</th> <th rowspan="2">[G]</th> <th colspan="2">Warning Level</th> <th rowspan="2">Measurements</th> <th rowspan="2">Judgment</th> </tr> <tr> <th>Attention</th> <th>Danger</th> </tr> </thead> <tbody> <tr> <td>ACC (THRU, OA)</td> <td>[G]</td> <td>1.00</td> <td>4.00</td> <td>0.949</td> <td>Good</td> </tr> <tr> <td>ACC (OA)</td> <td>[G]</td> <td>1.00</td> <td>4.00</td> <td>0.601</td> <td>Good</td> </tr> <tr> <td>ACC (PEAK)</td> <td>[G]</td> <td>3.00</td> <td>12.00</td> <td>1.523</td> <td>Good</td> </tr> <tr> <td>VEL</td> <td>[cm/s]</td> <td>0.40</td> <td>1.00</td> <td>0.556</td> <td>Attention</td> </tr> <tr> <td>DISP</td> <td>[μm]</td> <td>30</td> <td>100</td> <td>54.6</td> <td>Attention</td> </tr> </tbody> </table> <p style="text-align: center;">(1G=9.8m/s²)</p> | | | | | | Measurement Mode | [G] | Warning Level | | Measurements | Judgment | Attention | Danger | ACC (THRU, OA) | [G] | 1.00 | 4.00 | 0.949 | Good | ACC (OA) | [G] | 1.00 | 4.00 | 0.601 | Good | ACC (PEAK) | [G] | 3.00 | 12.00 | 1.523 | Good | VEL | [cm/s] | 0.40 | 1.00 | 0.556 | Attention | DISP | [μm] | 30 | 100 | 54.6 | Attention | <p>【 Absolute value Judgment 】 (1G=9.8m/s²)</p> <table border="1" style="width:100%; border-collapse: collapse;"> <thead> <tr> <th rowspan="2">Measurement Mode</th> <th rowspan="2">[G]</th> <th colspan="2">Warning Level</th> <th rowspan="2">Measurements</th> <th rowspan="2">Judgment</th> </tr> <tr> <th>little bad</th> <th>Bad</th> </tr> </thead> <tbody> <tr> <td>ACC (OA)</td> <td>[G]</td> <td>0.64</td> <td>2.56</td> <td>0.601</td> <td>Good</td> </tr> <tr> <td>VEL</td> <td>[cm/s]</td> <td>0.40</td> <td>1.00</td> <td>0.556</td> <td>little bad</td> </tr> </tbody> </table> <p style="text-align: center;">(1G=9.8m/s²)</p> | | | | Measurement Mode | [G] | Warning Level | | Measurements | Judgment | little bad | Bad | ACC (OA) | [G] | 0.64 | 2.56 | 0.601 | Good | VEL | [cm/s] | 0.40 | 1.00 | 0.556 | little bad | <p>【 Absolute value Judgment 】 (1G=9.8m/s²)</p> <div style="display: flex; justify-content: space-around;"> <div style="text-align: center;"> <p>Speed [cm/s]</p>  </div> <div style="text-align: center;"> <p>Acceleration [G]</p>  </div> </div> | | | |
| Measurement Mode | [G] | Warning Level | | Measurements | Judgment | | | | | | | | | | | | | | | | | | | | | | | | | | | | | | | | | | | | | | | | | | | | | | | | | | | | | | | | | | | | | | | | | | |
| | | Attention | Danger | | | | | | | | | | | | | | | | | | | | | | | | | | | | | | | | | | | | | | | | | | | | | | | | | | | | | | | | | | | | | | | | | | | | |
| ACC (THRU, OA) | [G] | 1.00 | 4.00 | 0.949 | Good | | | | | | | | | | | | | | | | | | | | | | | | | | | | | | | | | | | | | | | | | | | | | | | | | | | | | | | | | | | | | | | | | | |
| ACC (OA) | [G] | 1.00 | 4.00 | 0.601 | Good | | | | | | | | | | | | | | | | | | | | | | | | | | | | | | | | | | | | | | | | | | | | | | | | | | | | | | | | | | | | | | | | | | |
| ACC (PEAK) | [G] | 3.00 | 12.00 | 1.523 | Good | | | | | | | | | | | | | | | | | | | | | | | | | | | | | | | | | | | | | | | | | | | | | | | | | | | | | | | | | | | | | | | | | | |
| VEL | [cm/s] | 0.40 | 1.00 | 0.556 | Attention | | | | | | | | | | | | | | | | | | | | | | | | | | | | | | | | | | | | | | | | | | | | | | | | | | | | | | | | | | | | | | | | | | |
| DISP | [μm] | 30 | 100 | 54.6 | Attention | | | | | | | | | | | | | | | | | | | | | | | | | | | | | | | | | | | | | | | | | | | | | | | | | | | | | | | | | | | | | | | | | | |
| Measurement Mode | [G] | Warning Level | | Measurements | Judgment | | | | | | | | | | | | | | | | | | | | | | | | | | | | | | | | | | | | | | | | | | | | | | | | | | | | | | | | | | | | | | | | | | |
| | | little bad | Bad | | | | | | | | | | | | | | | | | | | | | | | | | | | | | | | | | | | | | | | | | | | | | | | | | | | | | | | | | | | | | | | | | | | | |
| ACC (OA) | [G] | 0.64 | 2.56 | 0.601 | Good | | | | | | | | | | | | | | | | | | | | | | | | | | | | | | | | | | | | | | | | | | | | | | | | | | | | | | | | | | | | | | | | | | |
| VEL | [cm/s] | 0.40 | 1.00 | 0.556 | little bad | | | | | | | | | | | | | | | | | | | | | | | | | | | | | | | | | | | | | | | | | | | | | | | | | | | | | | | | | | | | | | | | | | |
| 【Comment】 | | | | | | | | | | | | | | | | | | | | | | | | | | | | | | | | | | | | | | | | | | | | | | | | | | | | | | | | | | | | | | | | | | | | | | | |

drawing date: 28 May 2010

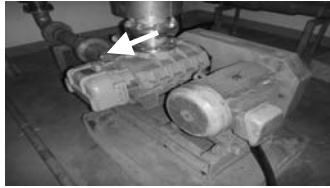
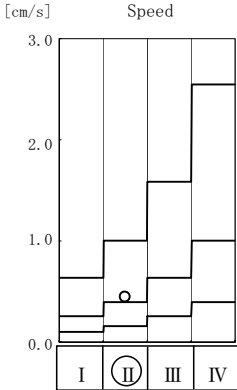
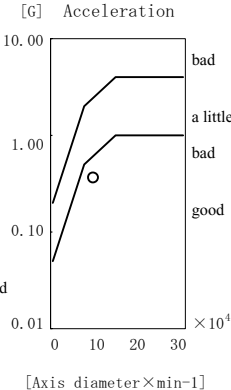
| Simple diagnosis report | | | | | | drawing | | | | | | | | | | | | | | | | | | | | | | | | | | | | | | | | | | | |
|--|---------------|--------------------------|--------------|---------------|--|-------------------------------------|---------------|--|--------------|----------|------------|--------|--------------------|------|------|-------|------|--------------|------|------|-------|------------|----------------|------|-------|-------|------|------------|------|------|-------|-----------|-----------------|----|-----|------|-----------|---|--|--|--|
| equipment name | | | | | | North Thang Long WWTP | | | | | | | | | | | | | | | | | | | | | | | | | | | | | | | | | | | |
| machine name | | | | | | M3-10B Channel Mixing Blower | | | | | | | | | | | | | | | | | | | | | | | | | | | | | | | | | | | |
| measurement part | | | | | | Blower Outside (Opposite Load Side) | | | | | | | | | | | | | | | | | | | | | | | | | | | | | | | | | | | |
| ID code | | Direction of measurement | | Group No. | | 376 | | | | | | | | | | | | | | | | | | | | | | | | | | | | | | | | | | | |
| Output | | Rotational speed | | Axis diameter | | 55 mm | | | | | | | | | | | | | | | | | | | | | | | | | | | | | | | | | | | |
| <p>【 Relative value Judgment 】 recorded time: 27 May 2010 11:37</p> <table border="1" style="width:100%; border-collapse: collapse;"> <thead> <tr> <th rowspan="2">Measurement Mode</th> <th colspan="2">Warning Level</th> <th rowspan="2">Measurements</th> <th rowspan="2">Judgment</th> </tr> <tr> <th>Attention</th> <th>Danger</th> </tr> </thead> <tbody> <tr> <td>ACC (THRU, OA) [G]</td> <td>1.00</td> <td>4.00</td> <td>0.567</td> <td>Good</td> </tr> <tr> <td>ACC (OA) [G]</td> <td>1.00</td> <td>4.00</td> <td>0.365</td> <td>Good</td> </tr> <tr> <td>ACC (PEAK) [G]</td> <td>3.00</td> <td>12.00</td> <td>1.014</td> <td>Good</td> </tr> <tr> <td>VEL [cm/s]</td> <td>0.40</td> <td>1.00</td> <td>0.449</td> <td>Attention</td> </tr> <tr> <td>DISP [μm]</td> <td>30</td> <td>100</td> <td>45.0</td> <td>Attention</td> </tr> </tbody> </table> <p style="text-align: center;">(1G=9.8m/s²)</p> | | | | | | Measurement Mode | Warning Level | | Measurements | Judgment | Attention | Danger | ACC (THRU, OA) [G] | 1.00 | 4.00 | 0.567 | Good | ACC (OA) [G] | 1.00 | 4.00 | 0.365 | Good | ACC (PEAK) [G] | 3.00 | 12.00 | 1.014 | Good | VEL [cm/s] | 0.40 | 1.00 | 0.449 | Attention | DISP [μ m] | 30 | 100 | 45.0 | Attention |  <p>【 Absolute value Judgment 】 (1G=9.8m/s²)</p> <div style="display: flex; justify-content: space-around;"> <div style="text-align: center;"> <p>Speed [cm/s]</p>  </div> <div style="text-align: center;"> <p>Acceleration [G]</p>  </div> </div> <p style="text-align: center;">[Axis diameter × min-1]</p> | | | |
| Measurement Mode | Warning Level | | Measurements | Judgment | | | | | | | | | | | | | | | | | | | | | | | | | | | | | | | | | | | | | |
| | Attention | Danger | | | | | | | | | | | | | | | | | | | | | | | | | | | | | | | | | | | | | | | |
| ACC (THRU, OA) [G] | 1.00 | 4.00 | 0.567 | Good | | | | | | | | | | | | | | | | | | | | | | | | | | | | | | | | | | | | | |
| ACC (OA) [G] | 1.00 | 4.00 | 0.365 | Good | | | | | | | | | | | | | | | | | | | | | | | | | | | | | | | | | | | | | |
| ACC (PEAK) [G] | 3.00 | 12.00 | 1.014 | Good | | | | | | | | | | | | | | | | | | | | | | | | | | | | | | | | | | | | | |
| VEL [cm/s] | 0.40 | 1.00 | 0.449 | Attention | | | | | | | | | | | | | | | | | | | | | | | | | | | | | | | | | | | | | |
| DISP [μ m] | 30 | 100 | 45.0 | Attention | | | | | | | | | | | | | | | | | | | | | | | | | | | | | | | | | | | | | |
| <p>【 Absolute value Judgment 】 recorded time: 27 May 2010 11:37</p> <table border="1" style="width:100%; border-collapse: collapse;"> <thead> <tr> <th rowspan="2">Measurement Mode</th> <th colspan="2">Warning Level</th> <th rowspan="2">Measurements</th> <th rowspan="2">Judgment</th> </tr> <tr> <th>little bad</th> <th>Bad</th> </tr> </thead> <tbody> <tr> <td>ACC (OA) [G]</td> <td>0.64</td> <td>2.56</td> <td>0.365</td> <td>Good</td> </tr> <tr> <td>VEL [cm/s]</td> <td>0.40</td> <td>1.00</td> <td>0.449</td> <td>little bad</td> </tr> </tbody> </table> <p style="text-align: center;">(1G=9.8m/s²)</p> | | | | | | Measurement Mode | Warning Level | | Measurements | Judgment | little bad | Bad | ACC (OA) [G] | 0.64 | 2.56 | 0.365 | Good | VEL [cm/s] | 0.40 | 1.00 | 0.449 | little bad | | | | | | | | | | | | | | | | | | | |
| Measurement Mode | Warning Level | | Measurements | Judgment | | | | | | | | | | | | | | | | | | | | | | | | | | | | | | | | | | | | | |
| | little bad | Bad | | | | | | | | | | | | | | | | | | | | | | | | | | | | | | | | | | | | | | | |
| ACC (OA) [G] | 0.64 | 2.56 | 0.365 | Good | | | | | | | | | | | | | | | | | | | | | | | | | | | | | | | | | | | | | |
| VEL [cm/s] | 0.40 | 1.00 | 0.449 | little bad | | | | | | | | | | | | | | | | | | | | | | | | | | | | | | | | | | | | | |
| 【Comment】 | | | | | | | | | | | | | | | | | | | | | | | | | | | | | | | | | | | | | | | | | |

drawing date: 16 Jul 2010

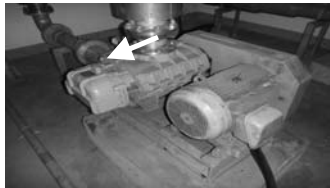
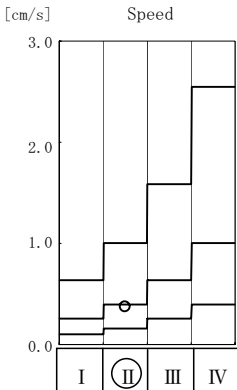
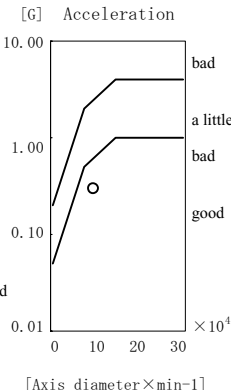
| Simple diagnosis report | | | | | | drawing | | | | | | | | | | | | | | | | | | | | | | | | | | | | | | | | | | | |
|---|---------------|--------------------------|--------------|---------------|--|-------------------------------------|---------------|--|--------------|----------|------------|--------|--------------------|------|------|-------|------|--------------|------|------|-------|-------------|----------------|------|-------|-------|------|------------|------|------|-------|------|-----------------|----|-----|------|-----------|---|--|--|--|
| equipment name | | | | | | North Thang Long WWTP | | | | | | | | | | | | | | | | | | | | | | | | | | | | | | | | | | | |
| machine name | | | | | | M3-10B Channel Mixing Blower | | | | | | | | | | | | | | | | | | | | | | | | | | | | | | | | | | | |
| measurement part | | | | | | Blower Outside (Opposite Load Side) | | | | | | | | | | | | | | | | | | | | | | | | | | | | | | | | | | | |
| ID code | | Direction of measurement | | Group No. | | 376 | | | | | | | | | | | | | | | | | | | | | | | | | | | | | | | | | | | |
| Output | | Rotational speed | | Axis diameter | | 55 mm | | | | | | | | | | | | | | | | | | | | | | | | | | | | | | | | | | | |
| <p>【 Relative value Judgment 】 recorded time: 14 Jul 2010 13:03</p> <table border="1" style="width:100%; border-collapse: collapse;"> <thead> <tr> <th rowspan="2">Measurement Mode</th> <th colspan="2">Warning Level</th> <th rowspan="2">Measurements</th> <th rowspan="2">Judgment</th> </tr> <tr> <th>Attention</th> <th>Danger</th> </tr> </thead> <tbody> <tr> <td>ACC (THRU, OA) [G]</td> <td>1.00</td> <td>4.00</td> <td>0.524</td> <td>Good</td> </tr> <tr> <td>ACC (OA) [G]</td> <td>1.00</td> <td>4.00</td> <td>0.299</td> <td>Good</td> </tr> <tr> <td>ACC (PEAK) [G]</td> <td>3.00</td> <td>12.00</td> <td>0.766</td> <td>Good</td> </tr> <tr> <td>VEL [cm/s]</td> <td>0.40</td> <td>1.00</td> <td>0.376</td> <td>Good</td> </tr> <tr> <td>DISP [μm]</td> <td>30</td> <td>100</td> <td>38.0</td> <td>Attention</td> </tr> </tbody> </table> <p style="text-align: center;">(1G=9.8m/s²)</p> | | | | | | Measurement Mode | Warning Level | | Measurements | Judgment | Attention | Danger | ACC (THRU, OA) [G] | 1.00 | 4.00 | 0.524 | Good | ACC (OA) [G] | 1.00 | 4.00 | 0.299 | Good | ACC (PEAK) [G] | 3.00 | 12.00 | 0.766 | Good | VEL [cm/s] | 0.40 | 1.00 | 0.376 | Good | DISP [μ m] | 30 | 100 | 38.0 | Attention |  <p>【 Absolute value Judgment 】 (1G=9.8m/s²)</p> <div style="display: flex; justify-content: space-around;"> <div style="text-align: center;"> <p>Speed [cm/s]</p>  </div> <div style="text-align: center;"> <p>Acceleration [G]</p>  </div> </div> <p style="text-align: center;">[Axis diameter × min-1]</p> | | | |
| Measurement Mode | Warning Level | | Measurements | Judgment | | | | | | | | | | | | | | | | | | | | | | | | | | | | | | | | | | | | | |
| | Attention | Danger | | | | | | | | | | | | | | | | | | | | | | | | | | | | | | | | | | | | | | | |
| ACC (THRU, OA) [G] | 1.00 | 4.00 | 0.524 | Good | | | | | | | | | | | | | | | | | | | | | | | | | | | | | | | | | | | | | |
| ACC (OA) [G] | 1.00 | 4.00 | 0.299 | Good | | | | | | | | | | | | | | | | | | | | | | | | | | | | | | | | | | | | | |
| ACC (PEAK) [G] | 3.00 | 12.00 | 0.766 | Good | | | | | | | | | | | | | | | | | | | | | | | | | | | | | | | | | | | | | |
| VEL [cm/s] | 0.40 | 1.00 | 0.376 | Good | | | | | | | | | | | | | | | | | | | | | | | | | | | | | | | | | | | | | |
| DISP [μ m] | 30 | 100 | 38.0 | Attention | | | | | | | | | | | | | | | | | | | | | | | | | | | | | | | | | | | | | |
| <p>【 Absolute value Judgment 】 recorded time: 14 Jul 2010 13:03</p> <table border="1" style="width:100%; border-collapse: collapse;"> <thead> <tr> <th rowspan="2">Measurement Mode</th> <th colspan="2">Warning Level</th> <th rowspan="2">Measurements</th> <th rowspan="2">Judgment</th> </tr> <tr> <th>little bad</th> <th>Bad</th> </tr> </thead> <tbody> <tr> <td>ACC (OA) [G]</td> <td>0.64</td> <td>2.56</td> <td>0.299</td> <td>Good</td> </tr> <tr> <td>VEL [cm/s]</td> <td>0.40</td> <td>1.00</td> <td>0.376</td> <td>little good</td> </tr> </tbody> </table> <p style="text-align: center;">(1G=9.8m/s²)</p> | | | | | | Measurement Mode | Warning Level | | Measurements | Judgment | little bad | Bad | ACC (OA) [G] | 0.64 | 2.56 | 0.299 | Good | VEL [cm/s] | 0.40 | 1.00 | 0.376 | little good | | | | | | | | | | | | | | | | | | | |
| Measurement Mode | Warning Level | | Measurements | Judgment | | | | | | | | | | | | | | | | | | | | | | | | | | | | | | | | | | | | | |
| | little bad | Bad | | | | | | | | | | | | | | | | | | | | | | | | | | | | | | | | | | | | | | | |
| ACC (OA) [G] | 0.64 | 2.56 | 0.299 | Good | | | | | | | | | | | | | | | | | | | | | | | | | | | | | | | | | | | | | |
| VEL [cm/s] | 0.40 | 1.00 | 0.376 | little good | | | | | | | | | | | | | | | | | | | | | | | | | | | | | | | | | | | | | |
| 【Comment】 | | | | | | | | | | | | | | | | | | | | | | | | | | | | | | | | | | | | | | | | | |

Phụ lục 3 Bản vẽ thiết kế hệ thống điều khiển tích hợp

- 1) Sơ đồ hệ thống trạm xử lý nước thải Bắc Thăng Long (Bản vẽ số G9607-RGED-01)
- 2) Sơ đồ hệ thống trạm xử lý nước thải Kim Liên (Bản vẽ số G9607-RGED-02)
- 3) Sơ đồ hệ thống và thiết kế hệ thống dây điện tại trạm bơm Kim Liên
(Bản vẽ số G9607-RGED-03)
- 4) Sơ đồ hệ thống trạm xử lý nước thải Trúc Bạch (Bản vẽ số G9607-RGED-04)
- 5) Sơ đồ hệ thống trạm bơm Yên Sở (Bản vẽ số G9607-RGED-05)
- 6) Kế hoạch thiết kế phòng điều khiển trạm XLNT Bắc Thăng Long
(Bản vẽ số G9607-RGED-06)
- 7) Thiết kế hệ thống đi dây điện trạm XLNT Kim Liên (Bản vẽ số G9607-RGED-07)
- 8) Thiết kế hệ thống đi dây điện trạm XLNT Trúc Bạch (Bản vẽ số G9607-RGED-08)
- 9) Kế hoạch thiết kế phòng điều khiển trạm bơm Yên Sở (Bản vẽ số G9607-RGED-09)

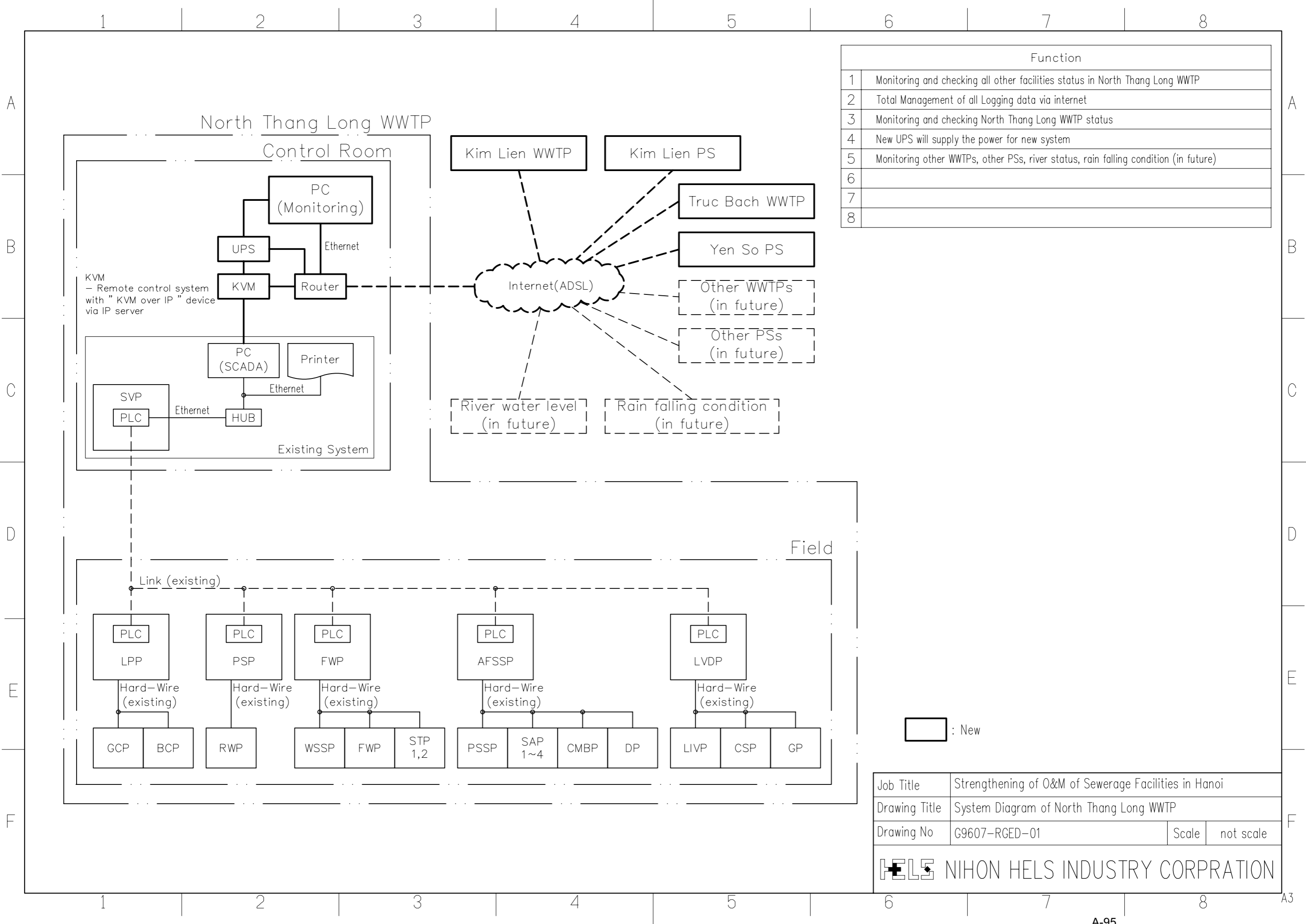

| Function | |
|----------|---|
| 1 | Monitoring and checking all other facilities status in North Thang Long WWTP |
| 2 | Total Management of all Logging data via internet |
| 3 | Monitoring and checking North Thang Long WWTP status |
| 4 | New UPS will supply the power for new system |
| 5 | Monitoring other WWTPs, other PSs, river status, rain falling condition (in future) |
| 6 | |
| 7 | |
| 8 | |

: New

| | | | |
|---------------|--|-------|-----------|
| Job Title | Strengthening of O&M of Sewerage Facilities in Hanoi | | |
| Drawing Title | System Diagram of North Thang Long WWTP | | |
| Drawing No | G9607-RGED-01 | Scale | not scale |

HEL NIHON HELS INDUSTRY CORPRATION

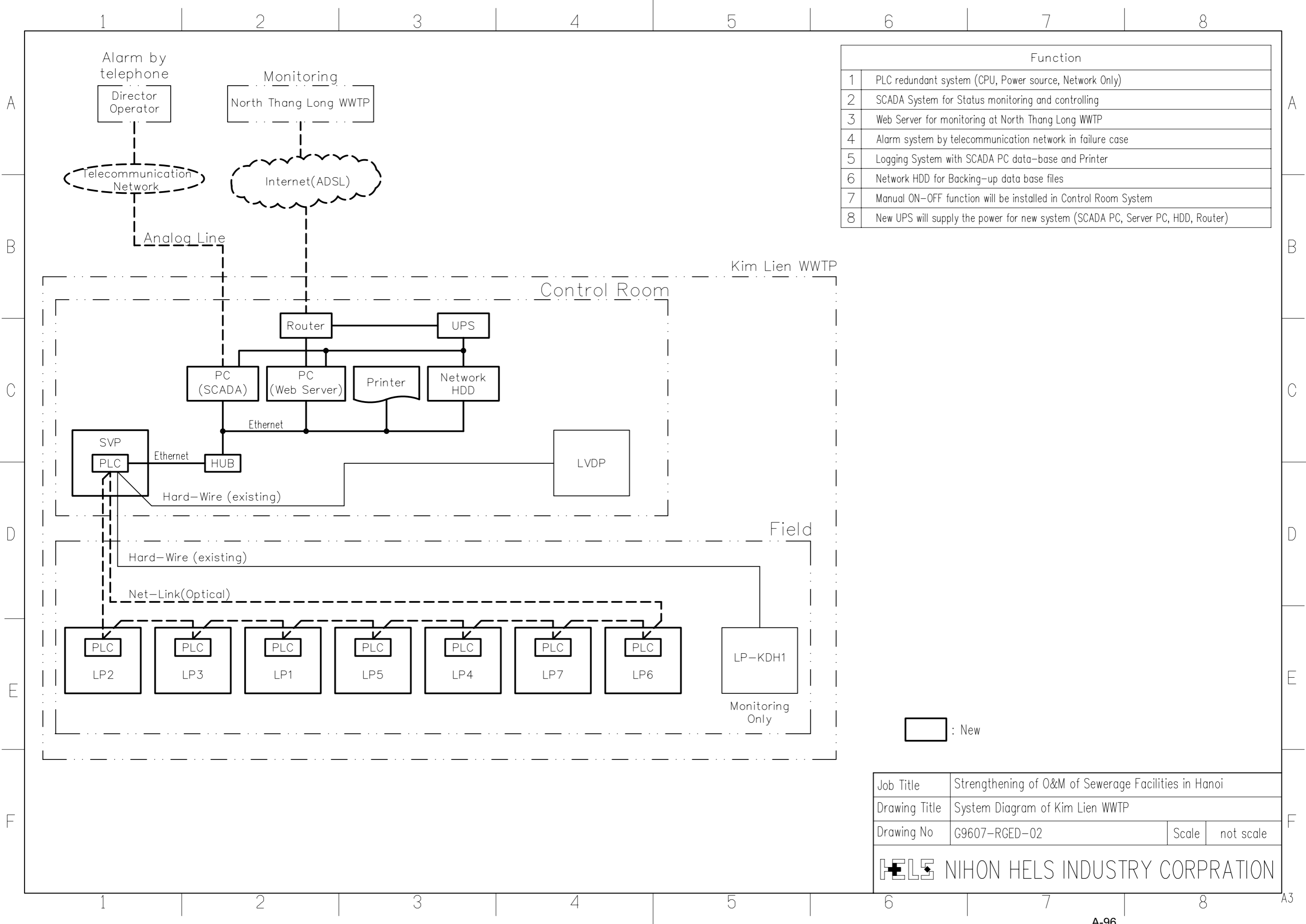

| Function | |
|----------|---|
| 1 | PLC redundant system (CPU, Power source, Network Only) |
| 2 | SCADA System for Status monitoring and controlling |
| 3 | Web Server for monitoring at North Thang Long WWTP |
| 4 | Alarm system by telecommunication network in failure case |
| 5 | Logging System with SCADA PC data-base and Printer |
| 6 | Network HDD for Backing-up data base files |
| 7 | Manual ON-OFF function will be installed in Control Room System |
| 8 | New UPS will supply the power for new system (SCADA PC, Server PC, HDD, Router) |

: New

| | | | |
|---------------|--|-------|-----------|
| Job Title | Strengthening of O&M of Sewerage Facilities in Hanoi | | |
| Drawing Title | System Diagram of Kim Lien WWTP | | |
| Drawing No | G9607-RGED-02 | Scale | not scale |

 HELS NIHON HELS INDUSTRY CORPORATION

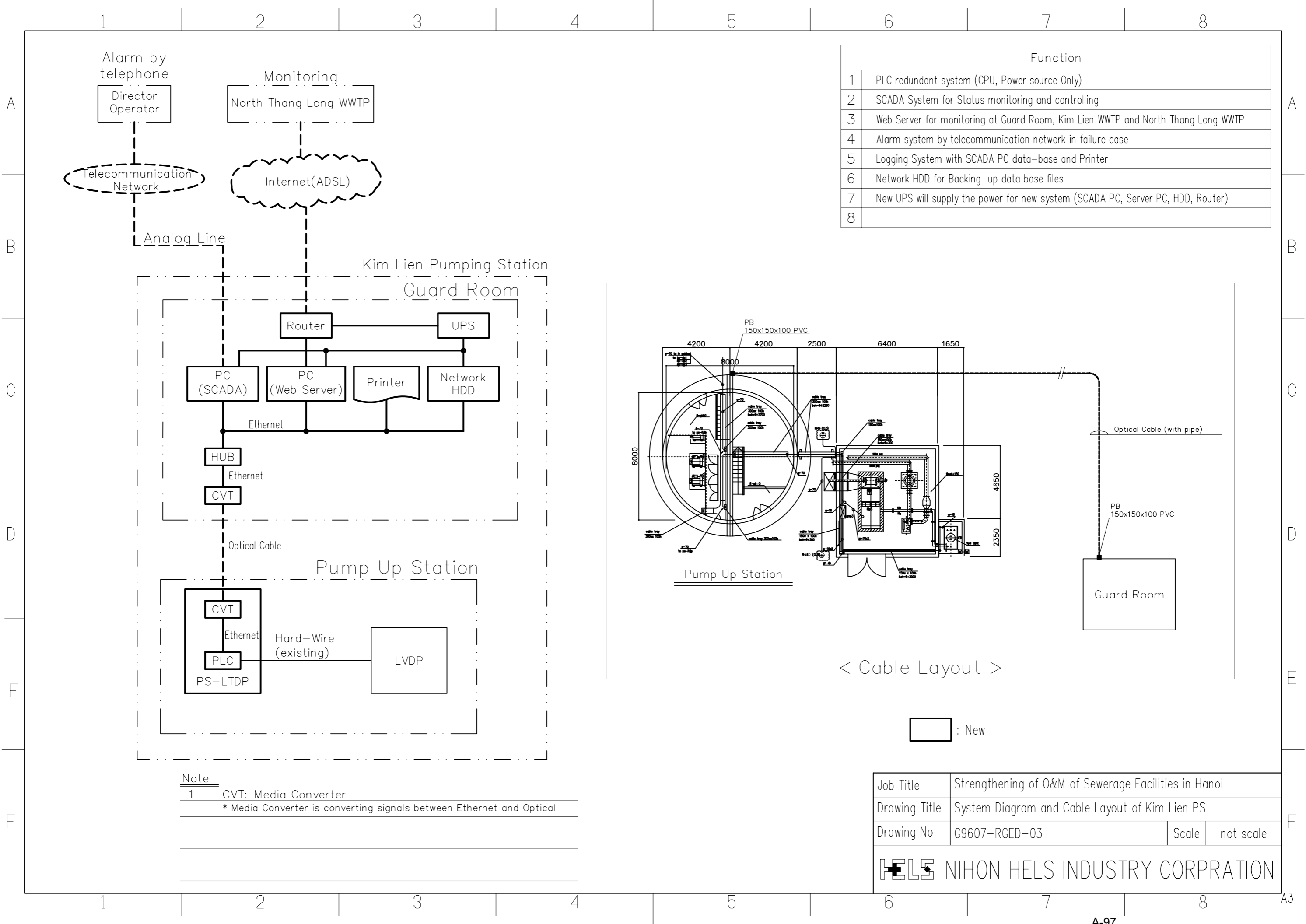

| Function | |
|----------|--|
| 1 | PLC redundant system (CPU, Power source Only) |
| 2 | SCADA System for Status monitoring and controlling |
| 3 | Web Server for monitoring at Guard Room, Kim Lien WWTP and North Thang Long WWTP |
| 4 | Alarm system by telecommunication network in failure case |
| 5 | Logging System with SCADA PC data-base and Printer |
| 6 | Network HDD for Backing-up data base files |
| 7 | New UPS will supply the power for new system (SCADA PC, Server PC, HDD, Router) |
| 8 | |

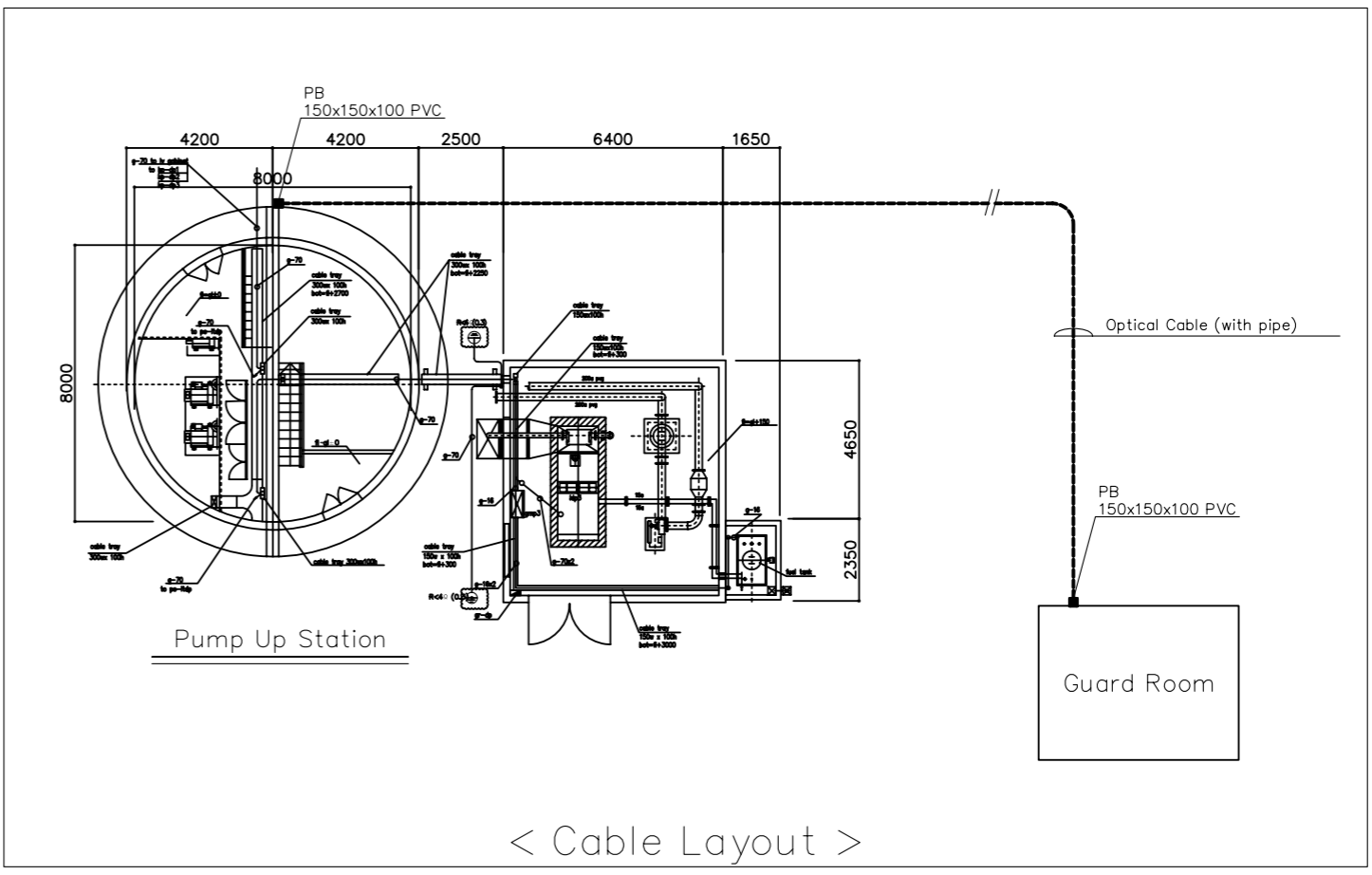

< Cable Layout >

□ : New

Note
 1 CVT: Media Converter
 * Media Converter is converting signals between Ethernet and Optical

| | | | |
|---------------|--|-------|-----------|
| Job Title | Strengthening of O&M of Sewerage Facilities in Hanoi | | |
| Drawing Title | System Diagram and Cable Layout of Kim Lien PS | | |
| Drawing No | G9607-RGED-03 | Scale | not scale |

HEL NIHON HELS INDUSTRY CORPRATION

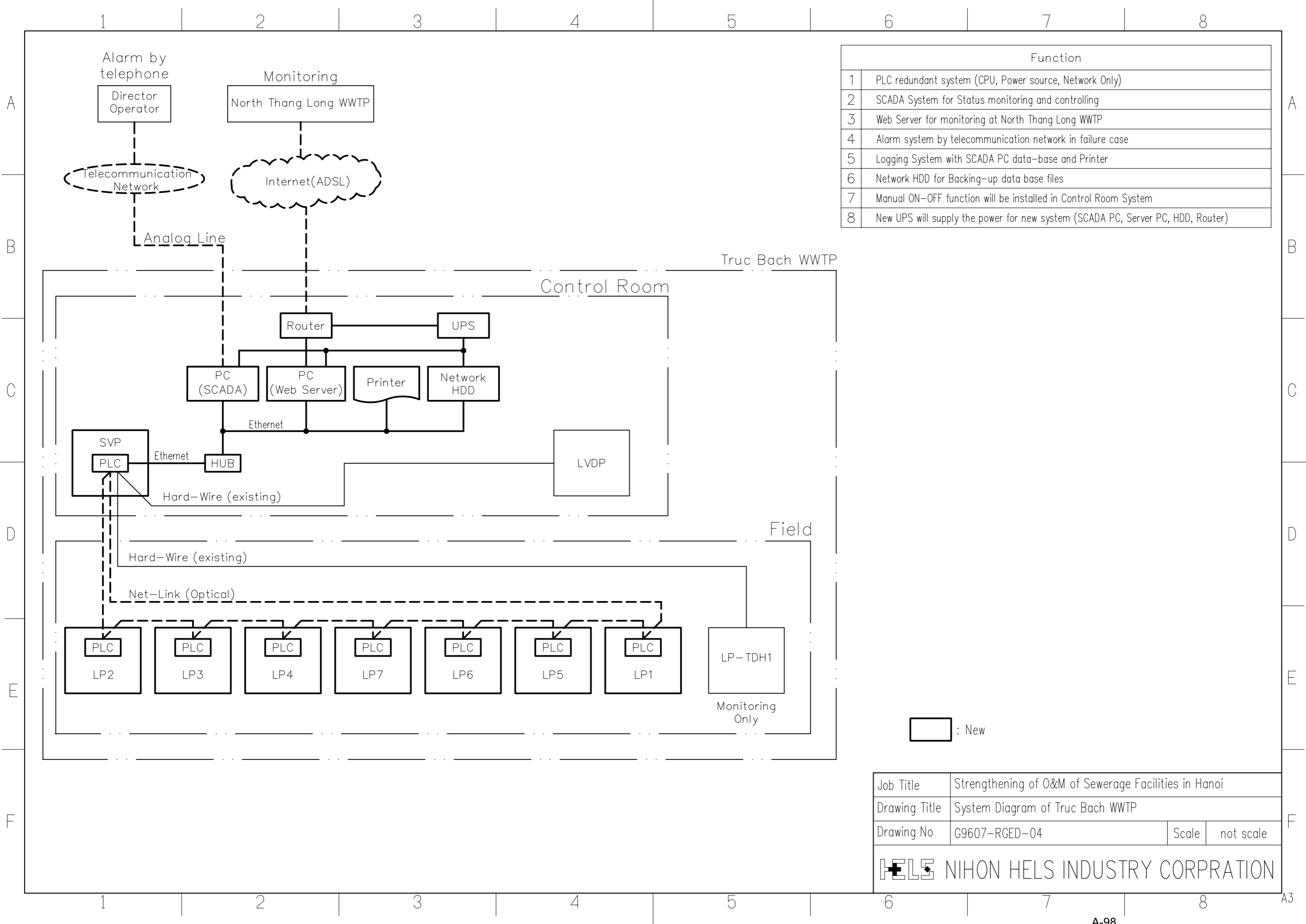

| Function | |
|----------|---|
| 1 | PLC redundant system (CPU, Power source, Network Only) |
| 2 | SCADA System for Status monitoring and controlling |
| 3 | Web Server for monitoring at North Thang Long WWTP |
| 4 | Alarm system by telecommunication network in failure case |
| 5 | Logging System with SCADA PC data-base and Printer |
| 6 | Network HDD for Backing-up data base files |
| 7 | Manual ON-OFF function will be installed in Control Room System |
| 8 | New UPS will supply the power for new system (SCADA PC, Server PC, HDD, Router) |

: New

| | | | |
|---------------|--|-------|-----------|
| Job Title | Strengthening of O&M of Sewerage Facilities in Hanoi | | |
| Drawing Title | System Diagram of Truc Bach WWTP | | |
| Drawing No | G9607-RGED-04 | Scale | not scale |

 HELS NIHON HELS INDUSTRY CORPORATION

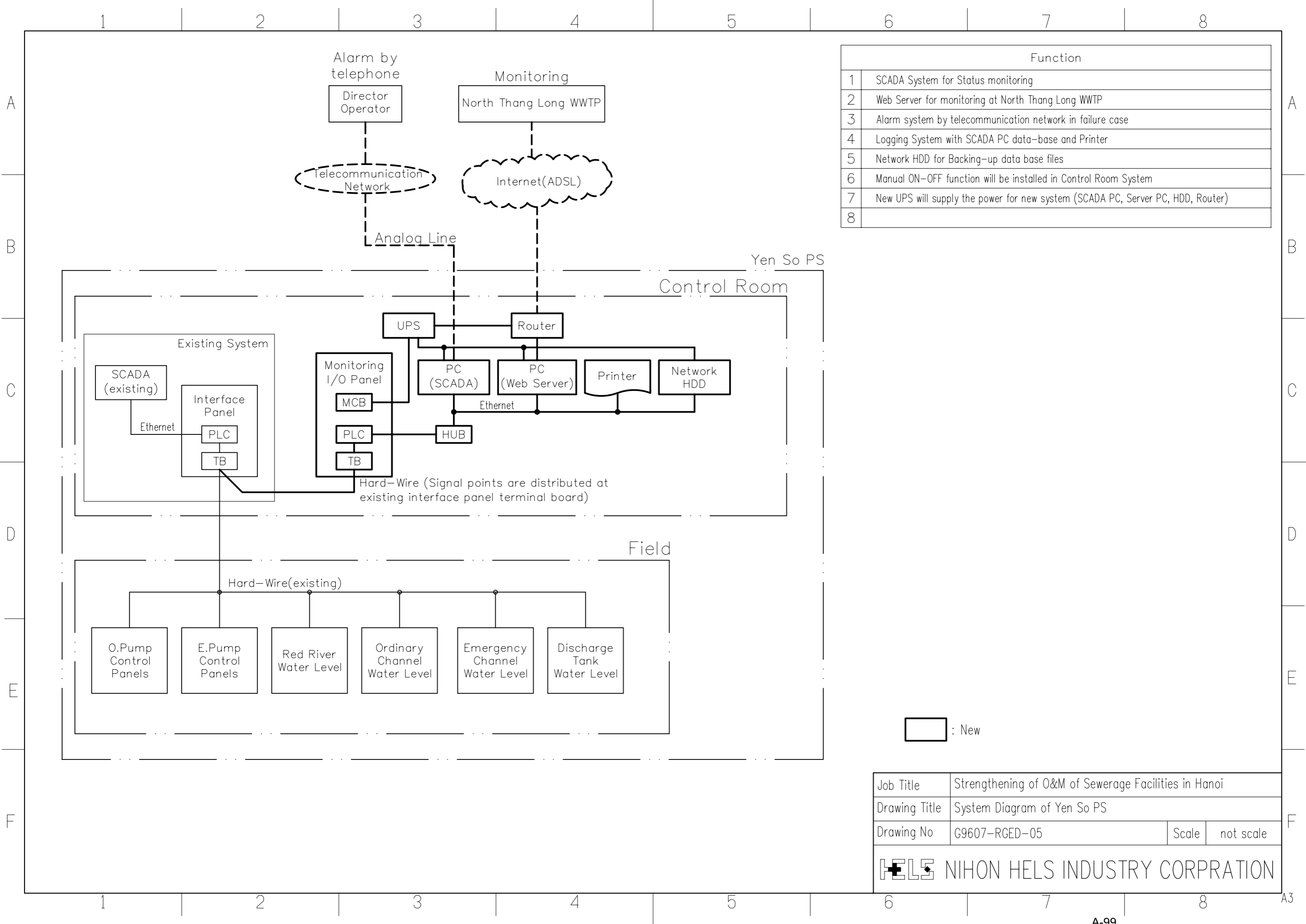

| Function | |
|----------|---|
| 1 | SCADA System for Status monitoring |
| 2 | Web Server for monitoring at North Thang Long WWTP |
| 3 | Alarm system by telecommunication network in failure case |
| 4 | Logging System with SCADA PC data-base and Printer |
| 5 | Network HDD for Backing-up data base files |
| 6 | Manual ON-OFF function will be installed in Control Room System |
| 7 | New UPS will supply the power for new system (SCADA PC, Server PC, HDD, Router) |
| 8 | |

: New

| | | | |
|---------------|--|-------|-----------|
| Job Title | Strengthening of O&M of Sewerage Facilities in Hanoi | | |
| Drawing Title | System Diagram of Yen So PS | | |
| Drawing No | G9607-RGED-05 | Scale | not scale |

HEL NIHON HELS INDUSTRY CORPRATION

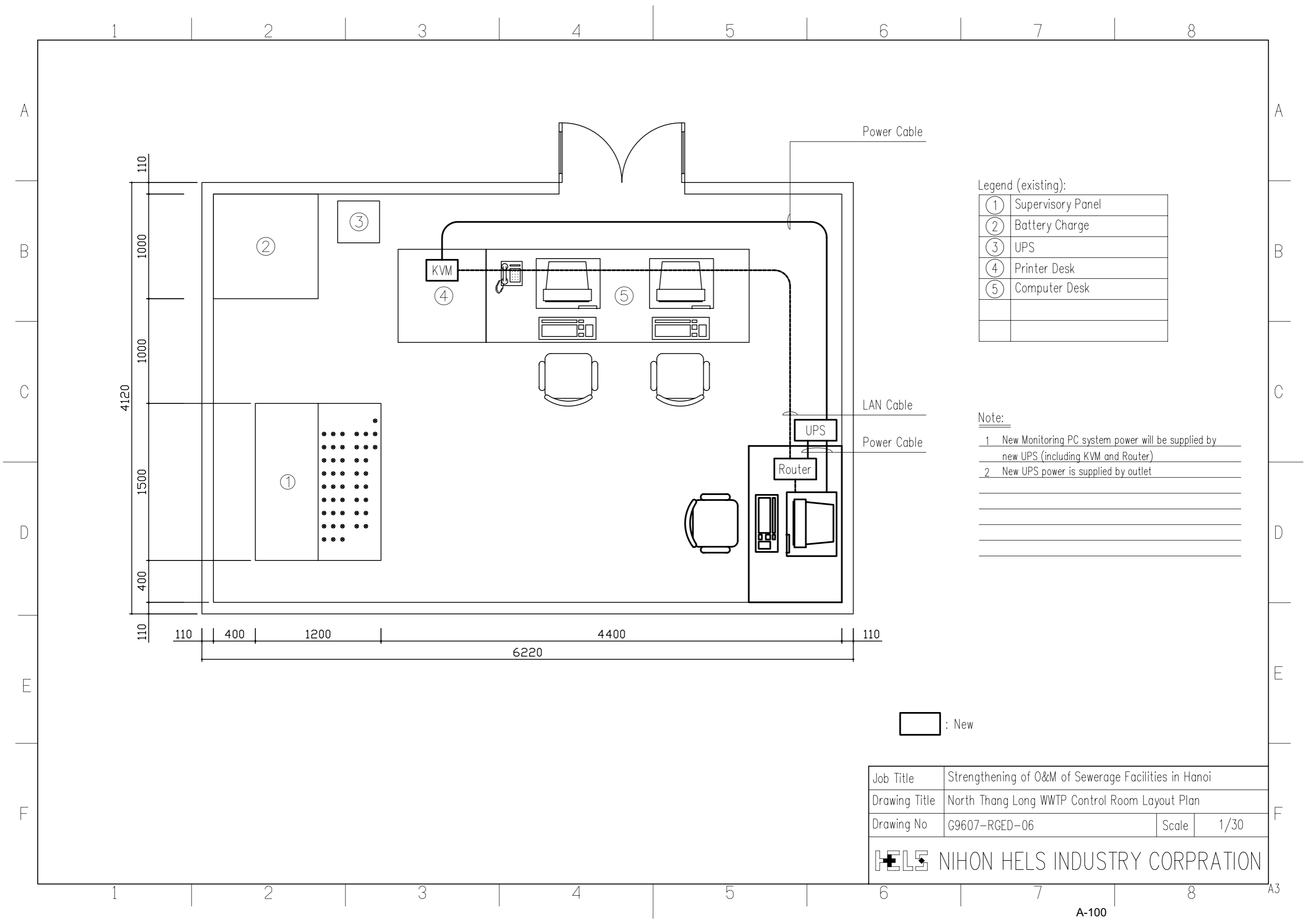

Legend (existing):

| | |
|---|-------------------|
| ① | Supervisory Panel |
| ② | Battery Charge |
| ③ | UPS |
| ④ | Printer Desk |
| ⑤ | Computer Desk |
| | |
| | |

Note:

- 1 New Monitoring PC system power will be supplied by new UPS (including KVM and Router)
- 2 New UPS power is supplied by outlet

□ : New

| | | | |
|---------------|--|-------|------|
| Job Title | Strengthening of O&M of Sewerage Facilities in Hanoi | | |
| Drawing Title | North Thang Long WWTP Control Room Layout Plan | | |
| Drawing No | G9607-RGED-06 | Scale | 1/30 |

HEL NIHON HELS INDUSTRY CORPRATION

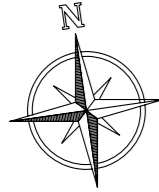

Legend
electrical & instrument equipment

| symbol | description | SYMBOL | DESCRIPTION |
|--------|------------------------------------|--------|---|
| | local panel | | CABLE TRAY |
| | motor | | CABLE TRENCH |
| | submersible motor w/ lead cable | | DUCT BANK |
| | operating switch | | HANDHALL |
| | junction box w/ terminal block 10p | | ABOVEGROUND CABLING |
| | welding outlet ac400v-16a 3p+e | | ABOVEGROUND CABLING |
| | convenience receptacle | | VERTICAL PART OF CABLING |
| | level switch electric type | | CABLING UP |
| | level switch float type | | CABLING DOWN |
| | pressure switch | | LOCAL PANEL |
| | ultrasonic level meter | | GROUNDING ELECTRODE/ GROUND WELLS Cu BAR |
| | magnetic flow meter | | GROUNDING WIRE CONNECTION POINT |
| | dissolved-oxygen converter | | GROUNDING TERMINAL |
| | dissolved-oxygen sensor | | |
| | motor operated valve | | |
| | lighting distribution panel | | |

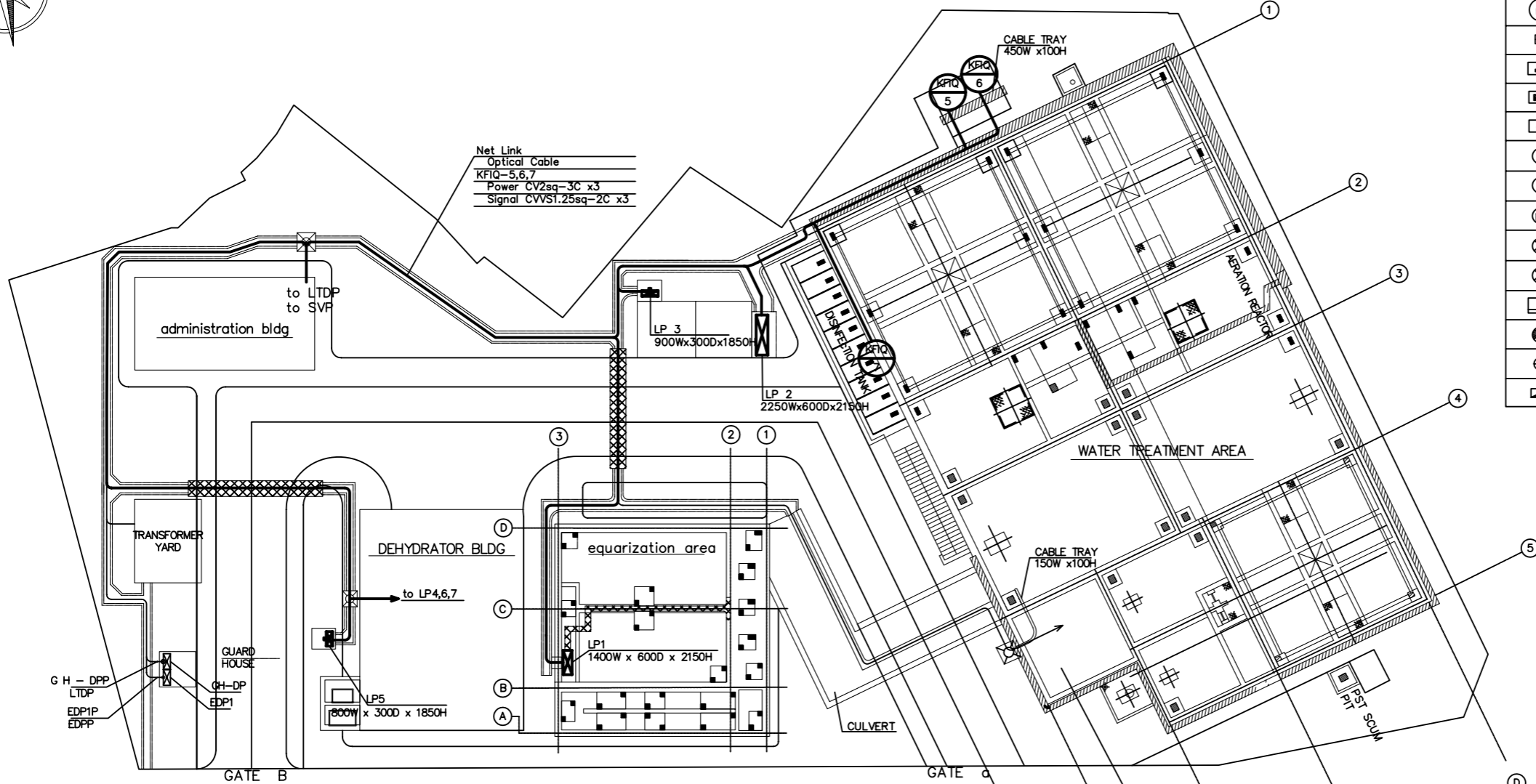

- Note**
- 1 Net Link Optical cable connection is refer to DWG No. G9607-RGED-02
 - 2 SVP and Local Panels (LP1-7) are replaced
 - 3 KFIQ-5,6: Return Sludge Flow Meter (New)
Type Ultrasonic flow meter
Cables from SVP to KFIQ-5,6
Power: CV2sq-3C x2
Signal(4-20mADC): CVVS1.25sq-2C x2
 - 4 KFIQ-7: Effluent Flow Meter (New)
Type Weir type flow meter
Cables from SVP to KFIQ-7
Power: CV2sq-3C
Signal(4-20mADC): CVVS1.25sq-2C

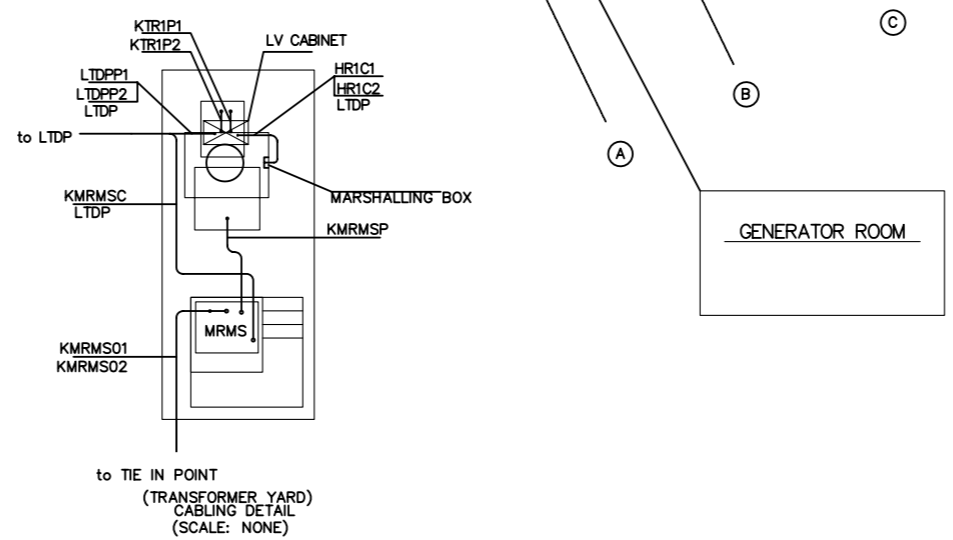

| | | | |
|---------------------------------|--|-------|-------|
| Job Title | Strengthening of O&M of Sewerage Facilities in Hanoi | | |
| Drawing Title | Cable Layout of Kim Lien WWTP | | |
| Drawing No | G9607-RGED-07 | Scale | 1/150 |
| NIHON HELS INDUSTRY CORPORATION | | | |

1 2 3 4 5 6 7 8

A
B
C
D
E
F

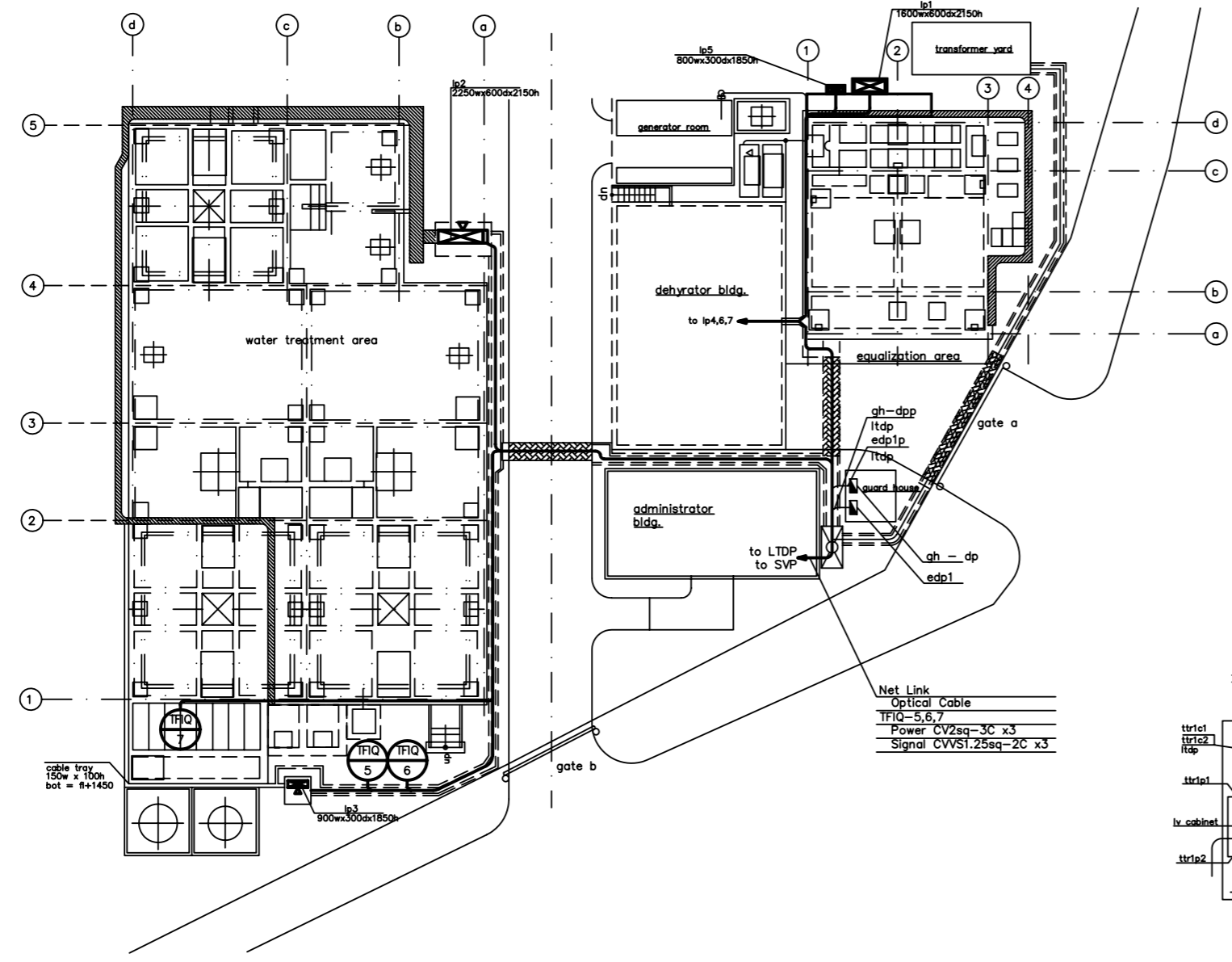

Legend
electrical & instrument equipment

| symbol | description | SYMBOL | DESCRIPTION |
|--------|------------------------------------|--------|--|
| | local panel | | CABLE TRAY |
| | motor | | CABLE TRENCH |
| | submersible motor w/ lead cable | | DUCT BANK |
| | operating switch | | HANDHALL |
| | junction box w/ terminal block 10p | | ABOVEGROUND CABLING |
| | welding outlet ac-400v-16a 3p+e | | ABOVEGROUND CABLING |
| | convenience receptacle | | VERTICAL PART OF CABLING |
| | level switch electric type | | CABLING UP |
| | level switch float type | | CABLING DOWN |
| | pressure switch | | LOCAL PANEL |
| | ultrasonic level meter | | GROUNDING ELECTRODE/ GROUND WELL Cu BAR |
| | magnetic flow meter | | GROUNDING WIRE CONNECTION POINT |
| | dissolved-oxygen converter | | GROUNDING TERMINAL |
| | dissolved-oxygen sensor | | |
| | motor operated valve | | |
| | lighting distribution panel | | |

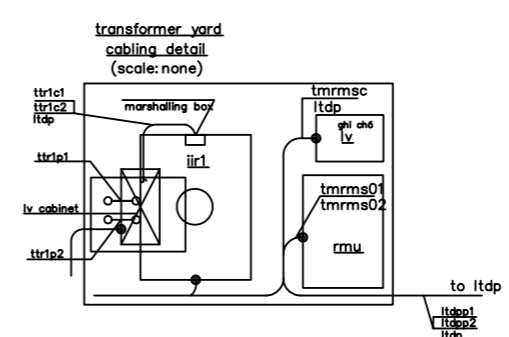

- Note**
- 1 Net Link Optical cable connection is refer to DWG No. G9607-RGED-04
 - 2 SVP and all Local Panels (LP1-7) are replaced
 - 3 TFIQ-5,6: Return Sludge Flow Meter (New)
Type Ultrasonic flow meter
Cables from SVP to TFIQ-5,6
Power: CV2sq-3C x2
Signal(4-20mADC): CVVS1.25sq-2C x2
 - 4 TFIQ-7: Effluent Flow Meter (New)
Type Weir type flow meter
Cables from SVP to TFIQ-7
Power: CV2sq-3C
Signal(4-20mADC): CVVS1.25sq-2C

: New

| | | | |
|---------------|--|-------|-------|
| Job Title | Strengthening of O&M of Sewerage Facilities in Hanoi | | |
| Drawing Title | Cable Layout of Truc Bach WWTP | | |
| Drawing No | G9607-RGED-08 | Scale | 1/150 |

NIHON HELS INDUSTRY CORPORATION

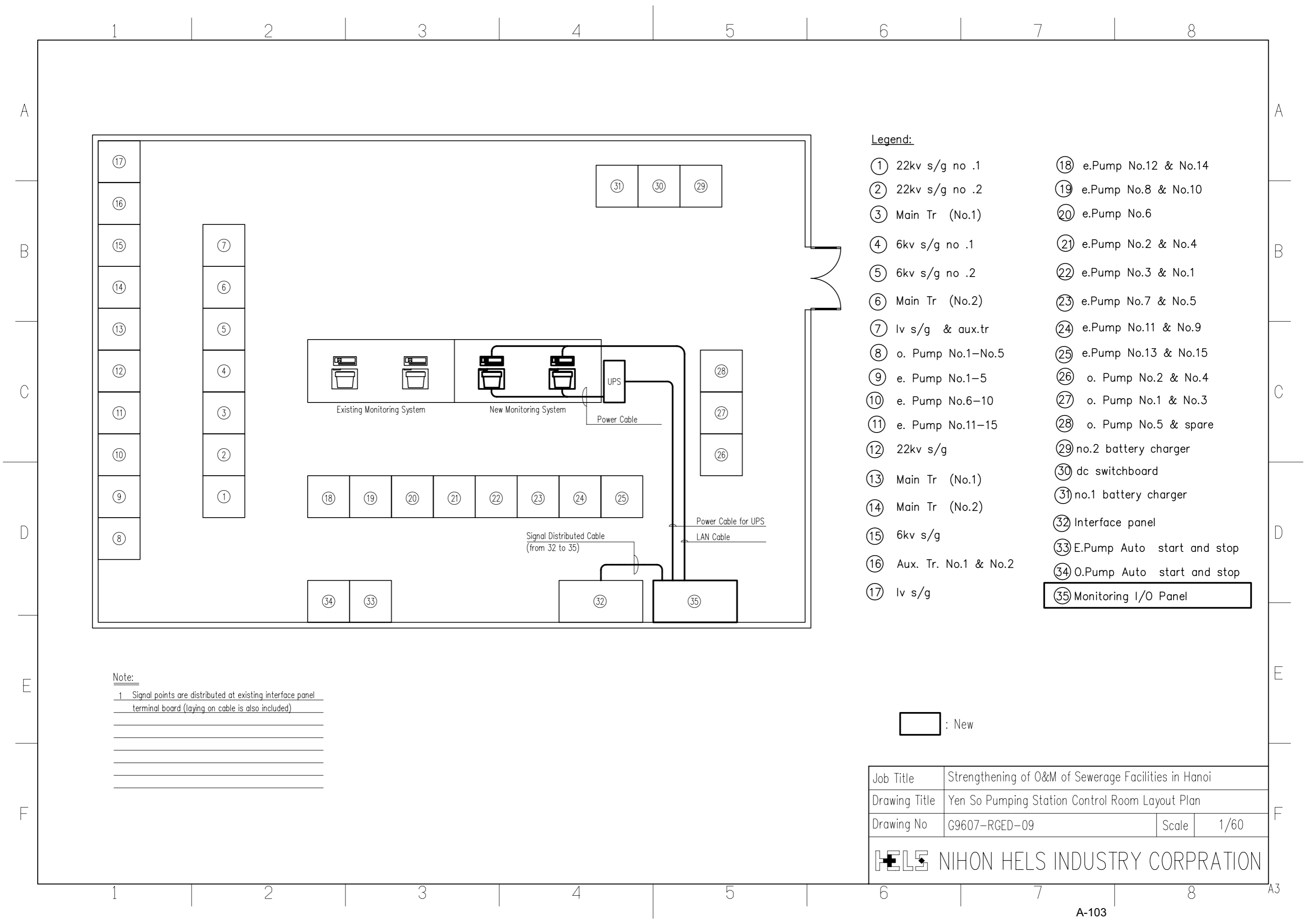

Legend:

- ① 22kv s/g no .1
- ② 22kv s/g no .2
- ③ Main Tr (No.1)
- ④ 6kv s/g no .1
- ⑤ 6kv s/g no .2
- ⑥ Main Tr (No.2)
- ⑦ Iv s/g & aux.tr
- ⑧ o. Pump No.1–No.5
- ⑨ e. Pump No.1–5
- ⑩ e. Pump No.6–10
- ⑪ e. Pump No.11–15
- ⑫ 22kv s/g
- ⑬ Main Tr (No.1)
- ⑭ Main Tr (No.2)
- ⑮ 6kv s/g
- ⑯ Aux. Tr. No.1 & No.2
- ⑰ Iv s/g
- ⑱ e.Pump No.12 & No.14
- ⑲ e.Pump No.8 & No.10
- ⑳ e.Pump No.6
- ㉑ e.Pump No.2 & No.4
- ㉒ e.Pump No.3 & No.1
- ㉓ e.Pump No.7 & No.5
- ㉔ e.Pump No.11 & No.9
- ㉕ e.Pump No.13 & No.15
- ㉖ o. Pump No.2 & No.4
- ㉗ o. Pump No.1 & No.3
- ㉘ o. Pump No.5 & spare
- ㉙ no.2 battery charger
- ㉚ dc switchboard
- ㉛ no.1 battery charger
- ㉜ Interface panel
- ㉝ E.Pump Auto start and stop
- ㉞ O.Pump Auto start and stop
- ㉟ Monitoring I/O Panel

Note:

1 Signal points are distributed at existing interface panel terminal board (laying on cable is also included)

: New

| | | | |
|---------------|--|-------|------|
| Job Title | Strengthening of O&M of Sewerage Facilities in Hanoi | | |
| Drawing Title | Yen So Pumping Station Control Room Layout Plan | | |
| Drawing No | G9607-RGED-09 | Scale | 1/60 |

NIHON HELS INDUSTRY CORPRATION

Phụ lục 4 Danh sách học viên

- 1. Danh sách đợt 1**
- 2. Danh sách đợt 2**
- 3. Danh sách đợt 3**

HANOI PEOPLE'S COMMITTEE
HANOI SEWERAGE & DRAINAGE ONE-MEMBER LIMITED COMPANY

SOCIALIST REPUBLIC OF VIETNAM
Independence – Freedom – Happiness

Hanoi, date month 2010

**TRAINEE LIST ATTENDED THE TRAINING COURSE UNDER THE PROJECT OF
 STRENGTHENING OF OPERATION AND MAINTENANCE FOR SEWERAGE AND DRAINAGE FACILITIES IN HANOI
 THE FIRST TIME FROM JULY 12, 2010 TO JULY 17, 2010**

(Attached to official correspondence no. 763/TNHN dated July 5, 2010 of Hanoi Sewerage & Drainage One-Member Limited Company)

| No | Full Name | Date of Birth | ID No. | Level | Office Address |
|----|------------------|---------------|--|---|---|
| 1 | Tran Phu Quy | June 25, 1975 | 201274195 issued in July 30, 1992 at the Post Office of Quang Nam Da Nang Province | Engineer of Technical Electric | Staff of Technical Department – Danang Drainage and Waste Water Treatment Plant |
| 2 | Nguyen Thi Duc | Nov. 16, 1982 | 201475207 issued in Sep. 07, at the Post Office of Quang Nam Da Nang Province | Bachelor of Environment | Staff of Planning Department – Danang Drainage and Waste Water Treatment Plant |
| 3 | Nguyen Duy Canh | Apr. 10, 1979 | 201400765 issued in Mar. 09, 2010 at the Post Office of Quang Nam Da Nang Province | Graduate from the College of Construction | Deputy Manager of Hoa Cuong Waste Water Treatment Plant - Danang Drainage and Waste Water Treatment Plant |
| 4 | Nguyen Van Hung | Jun. 25, 1981 | 201456565 issued in Mar. 09, 1998 at the Post Office of Quang Nam Da Nang | Electric Worker | Deputy Manager – Son Tra Waste Water Treatment Plant - Danang Drainage and Waste Water Treatment Plant |
| 5 | Nguyen Huu Khoa | Feb. 10, 1969 | 030742051 issued in Mar. 21, 2009 at the Post Office of Hai Phong Province | Engineer of Hydraulic Building | Staff of Technical Department – Haiphong Sewerage & Drainage Company |
| 6 | Nguyen Van Phong | Jan. 10, 1980 | 031015604 issued in May 02, 1995 at the Post Office of Hai Phong Province | Technical Engineer of Infrastructure | Staff of Technical Department – Haiphong Sewerage & Drainage Company |
| 7 | Dang Pham Dung | Feb. 25, 1959 | 173354400 issued in Sep. 27, 2007 at the Post Office of Thanh Hoa Province | Sewerage Engineer | Sewerage & Drainage Team Leader – Thanh Hoa Environmental & Urban Works Company |
| 8 | Vu Ngoc Kien | Jun. 07, 1982 | 171661767 issued in Jun. 23, 1998 at the Post Office of Thanh Hoa Province | Water resource Engineer | Executive - Thanh Hoa Environmental & Urban Works Company |
| 9 | Tran Ngoc Long | Oct. 22, 1965 | 050260088 ngty 6/11/2008 at the Post Office of Son La Province | Bachelor of Construction University | Constructional Team Leader – MTV Son La Urban Environment State-owned Limited Company |
| 10 | Ta Van Tuan | Jan. 10, 1984 | 050459189 issued in Mar. 27, 2002 at the Post Office of Son La Province | Bachelor of Transportation University | Technical staff of Project Management - MTV Son La Urban Environment State-owned Limited Company |

-----***-----

Hanoi, date month 2010

**TRAINEES LIST ATTENDED THE TRAINING UNDER THE PROJECT OF
“STRENGTHENING OF OPERATION AND MAINTENANCE FOR SEWERAGE AND DRAINAGE FACILITIES IN HANOI”
THE SECOND TIME FROM SEP 06, 2010**

| No | Full Name | Date of Birth | ID No. | Level | Office Address |
|----|-------------------|---------------|-----------|------------------------------------|---|
| 1 | Pham Thai Son | 13/9/1979 | 162256119 | Irrigation Engineer | Nam Dinh Urban and Environment Company |
| 2 | Pham Truong Giang | 6/6/1974 | 161976425 | Electrical Engineer | Nam Dinh Urban and Environment Company |
| 3 | Nguyen Xuan Ha | 5/5/1958 | 090595715 | Water Supply and Drainage Engineer | Thai Nguyen Urban and Facility Company |
| 4 | Nguyen Van Tuyen | 12/9/1980 | 090919787 | Technical Worker | Thai Nguyen Urban and Facility Company |
| 5 | Nguyen Thanh Hung | 28/2/1981 | 141982872 | Water Supply and Drainage Engineer | Hai Duong Urban Facility Management Company |
| 6 | Dang Xuan Huong | 28/12/1978 | 141849177 | Electrical Engineer | Hai Duong Urban Facility Management Company |
| 7 | Nguyen Van Thang | 19/12/1977 | 168459605 | Engineer | Ha Nam Urban Facility and Environment Company |
| 8 | Vu Xuan Hoa | 4/5/1986 | 168145406 | Worker | Ha Nam Urban Facility and Environment Company |
| 9 | Nguyen Hong Phong | 24/2/1984 | 081039481 | Engineer | Lang Son Water Supply and Drainage |
| 10 | Phan Thanh Hong | 10/10/1965 | 080916570 | Worker | Lang Son Water Supply and Drainage |

Hanoi, date month 2010

**TRAINEES LIST ATTENDED THE TRAINING UNDER THE PROJECT OF
“STRENGTHENING OF OPERATION AND MAINTENANCE FOR SEWERAGE AND DRAINAGE FACILITIES IN HANOI
THE THIRD TIME FROM SEP 13, 2010**

| No | Full Name | Date of Birth | ID No. | Level | Office Address |
|----|----------------------|---------------|-----------|--------------------------|---|
| 1 | Nguyen Hoang Phuc | 1970 | 191157971 | Civil engineer | Hue Environment & Urban Facilities Limited Company |
| 2 | Nguyen Phuoc Vinh Tu | 1983 | 191479855 | Civil engineer | Hue Environment & Urban Facilities Limited Company |
| 3 | Tran Quoc Vinh | 1983 | 311709791 | Environment Engineer | HCMC Urban Drainage & Sewerage 1 member Limited Company |
| 4 | Tran The Lam | 1983 | 194212067 | Environment Engineer | HCMC Urban Drainage & Sewerage 1 member Limited Company |
| 5 | Pham Thanh Hung | 1980 | 280715802 | Environment Engineer | Binh Duong Environmental Drainage & Sewerage 1 member Limited Company |
| 6 | Phan The Anh | 1983 | 280806038 | Sewerage Engineer | Binh Duong Environmental Drainage & Sewerage 1 member Limited Company |
| 7 | Tran Nam Ninh | 1986 | 280845616 | Sewerage | Binh Duong Environmental Drainage & Sewerage 1 member Limited Company |
| 8 | Bach Van Luan | 1983 | 135181296 | Engineer | Vinh Phuc Environmental Improvement Investment Project Management Board |
| 9 | Nguyen Ba Loc | 1982 | 135064322 | Engineer | Vinh Phuc Environmental Improvement Investment Project Management Board |
| 10 | Nguyen Duy Phu | 10/11/1973 | 112191392 | | Son Tay Urban Facility and Environment Company |
| 11 | Khuat Cao Hien | 21/6/1960 | 112216300 | Civil engineer | Son Tay Urban Facility and Environment Company |
| 12 | Le Dinh Nguyen | 1985 | 121590737 | Environmental Technology | Bac Giang Urban Facilities Management |

| | | | | | |
|----|----------------|------------|-----------|---------------------|---|
| | | | | Engineer | Joint-Stock Company |
| 13 | Chu Viet Trong | 1977 | 121244771 | Electric Engineer | Bac Giang Urban Facilities Management Joint-Stock Company |
| 14 | Pham Văn Công | 1969 | 164051775 | Irrigation Engineer | Ninh Binh Urban Facilities Management Joint-Stock Company |
| 15 | Pham Giang Nam | 13/12/1981 | 164161354 | Sewerage | Ninh Binh Urban Facilities Management Joint-Stock Company |

HSDC