

Q. GREENERY WORKS

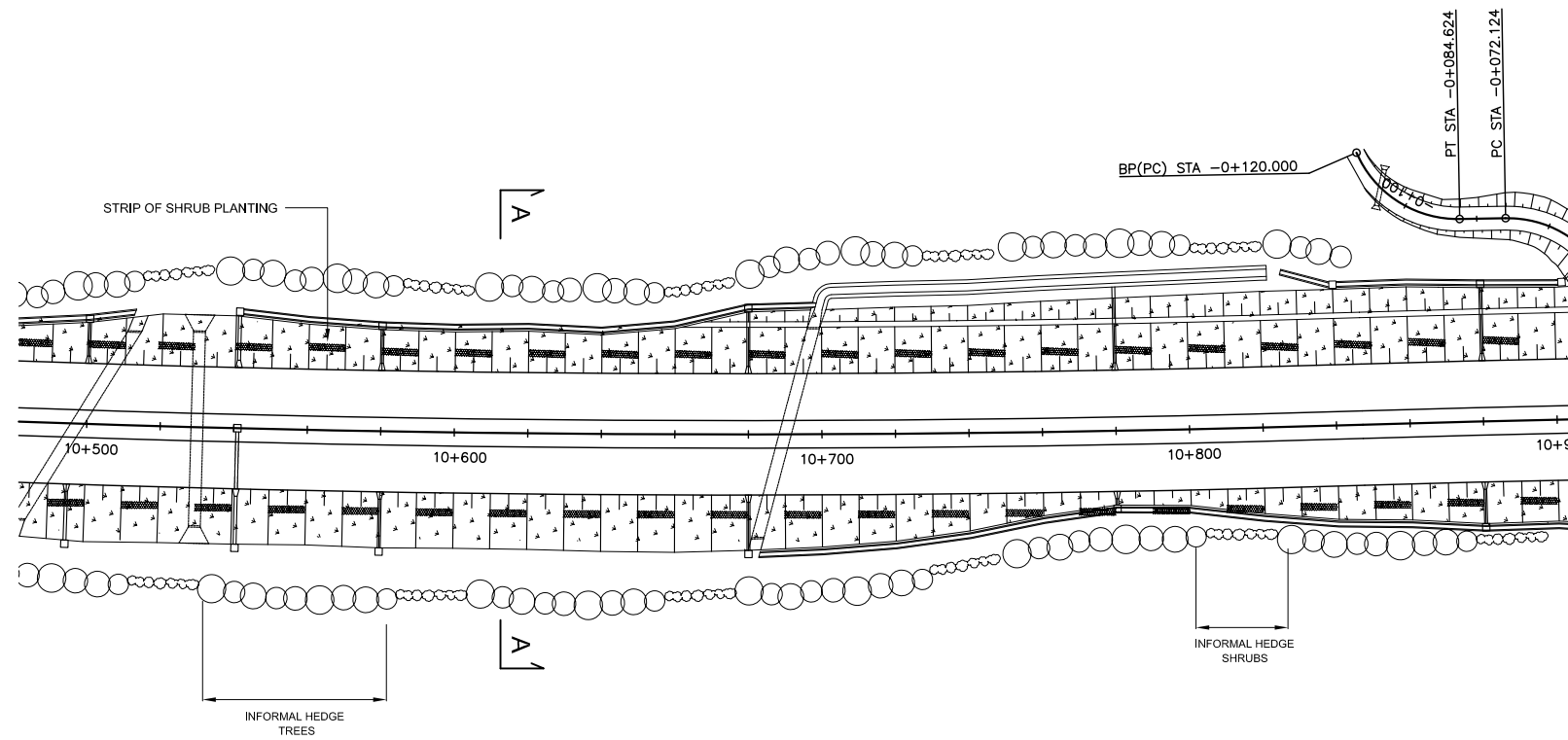

GREENARY PLAN A (FILL AREAS)
SCALE 1:2000

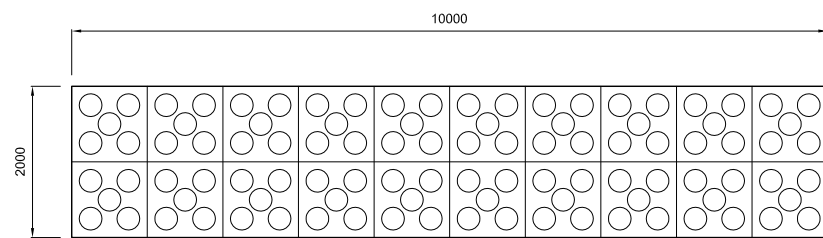

STRIP OF SHRUB PLANTING (5 SHRUBS / 1 sqm)
SCALE 1:100

LEGEND		
SYMBOL	SPECIES	REMARKS
	STRIP OF SHRUB PLANTING	5 shrubs / 1 sqm. ,10,000*2000
	TURF	-
	INFORMAL HEDGE TREES	1 for 1m , 50m lengths
	INFORMAL HEDGE SHRUBS	3 for 1m , 20m lengths

NOTE : NO SHRUB STRIPS, HEDGES AND TREES ALONG THE PADDY, MARSHY AND PLANTATION AREAS. ONLY TURFING (GRASS) FOR THE EMBANKMENTS AS A SOIL PROTECTION MEASURE.

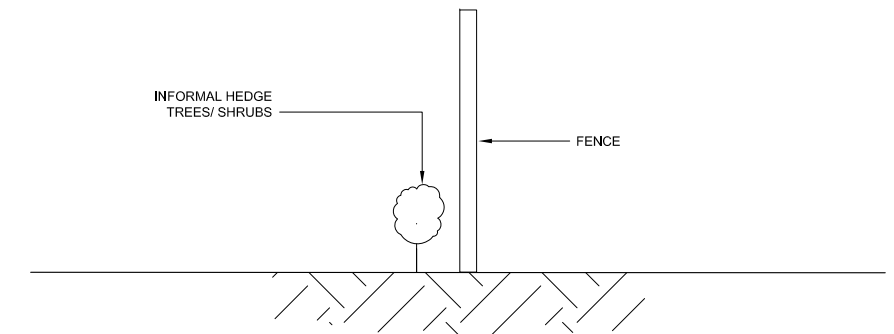

DETAIL 'A'

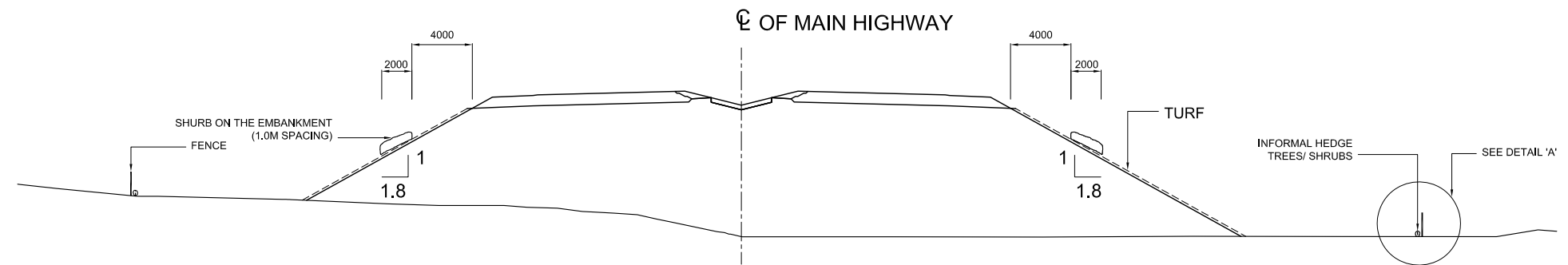

SECTION A - A
SCALE 1:400

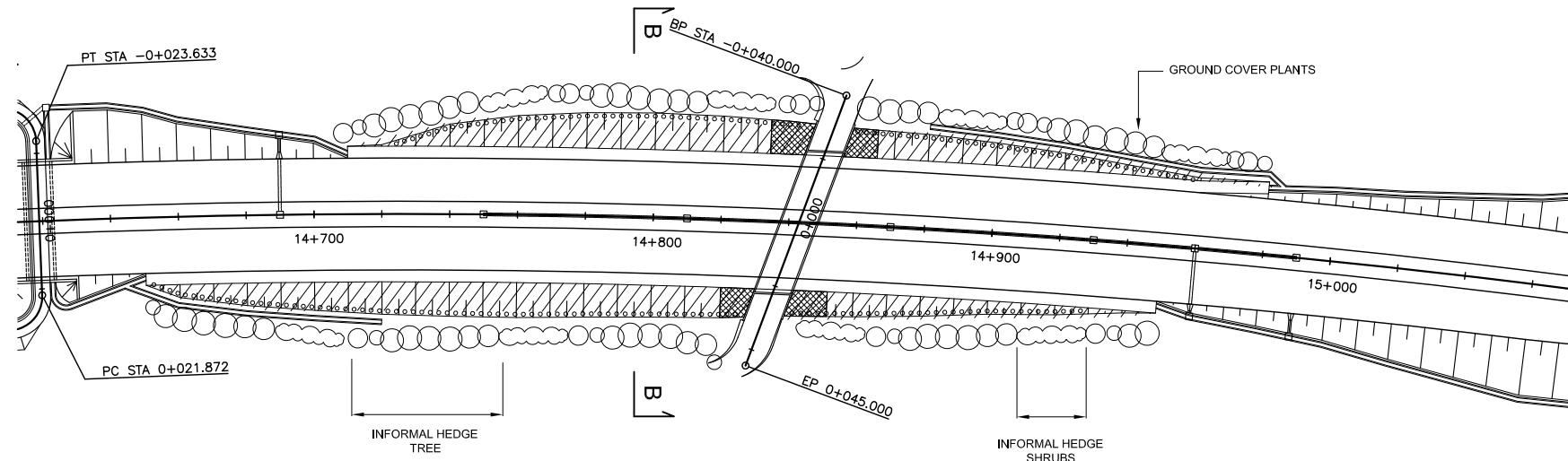

GREENERY PLAN B (CUT AREAS)
SCALE : 1: 2000

LEGEND		
SYMBOL	SPECIES	REMARKS
.....	GROUND COVER PLANTS	3 for 1m
	GRASS PLANTING WITH COIR FIBER	-
	INFORMAL HEDGE TREES	1 for 1m , 50m lengths
	INFORMAL HEDGE SHRUBS	3 for 1m , 20m lengths

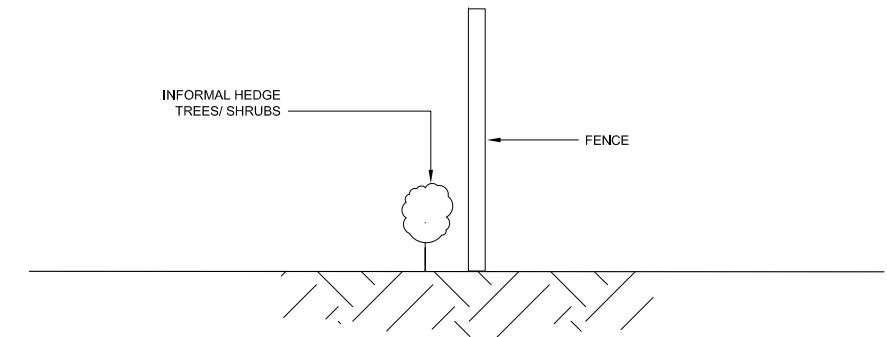

DETAIL 'A'

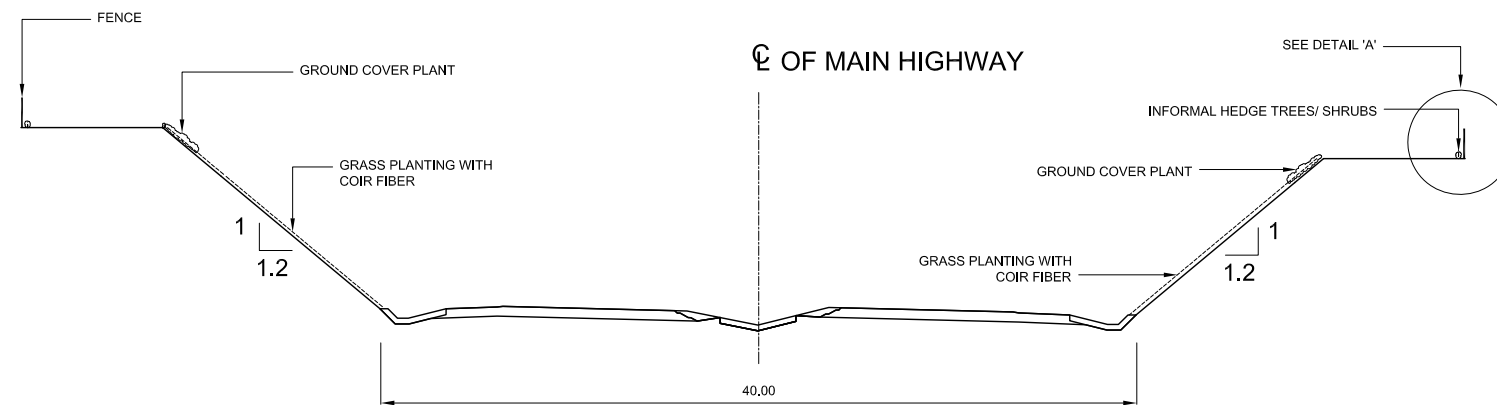

SECTION B - B
SCALE : 1: 400

NOTE : NO SHRUB STRIPS, HEDGES AND TREES ALONG THE PADDY, MARSHY AND PLANTATION AREAS.
ONLY TURFING (GRASS) FOR THE EMBANKMENTS AS A SOIL PROTECTION MEASURE.

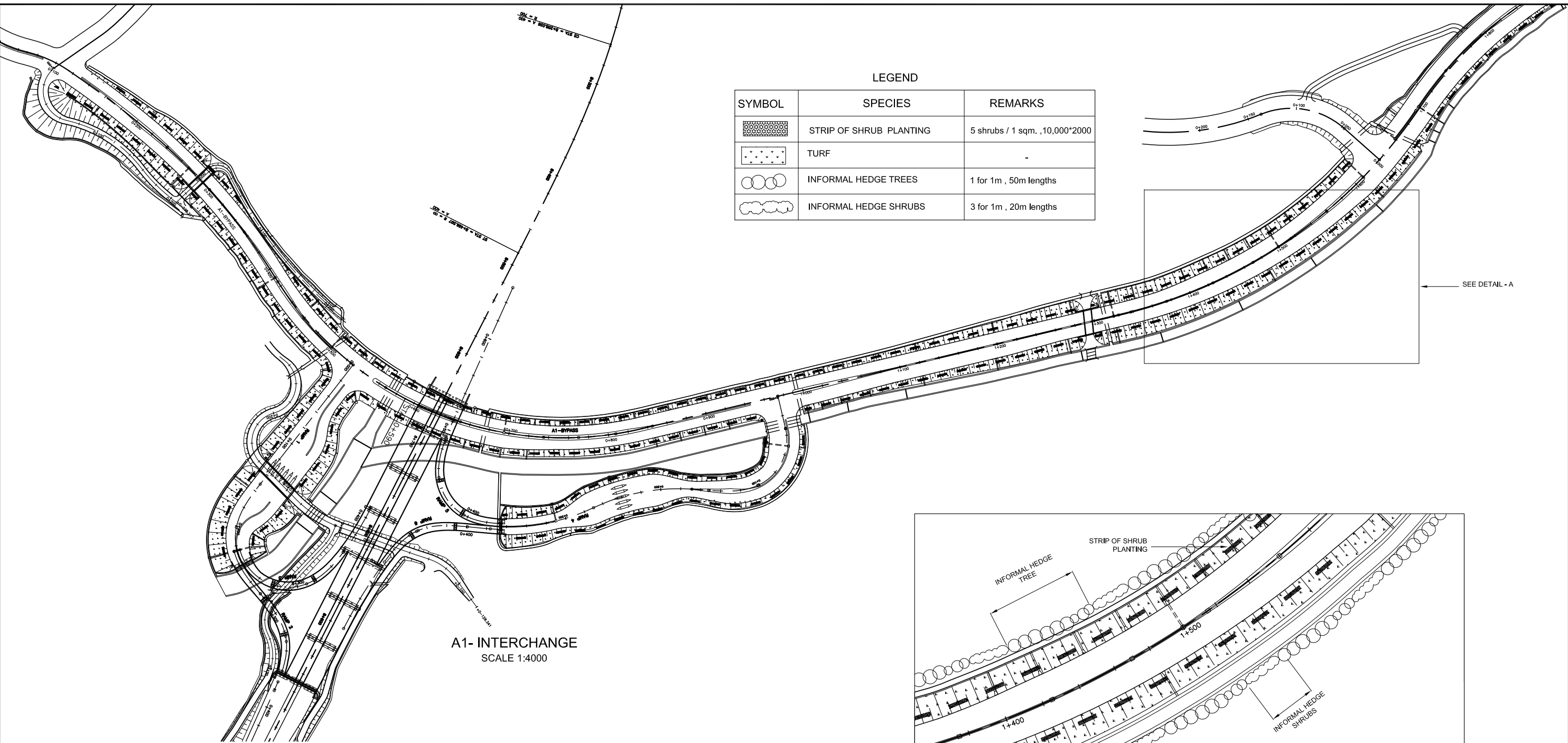

LEGEND		
SYMBOL	SPECIES	REMARKS
	STRIP OF SHRUB PLANTING	5 shrubs / 1 sqm. , 10,000*2000
	TURF	-
	INFORMAL HEDGE TREES	1 for 1m , 50m lengths
	INFORMAL HEDGE SHRUBS	3 for 1m , 20m lengths

A1- INTERCHANGE
SCALE 1:4000

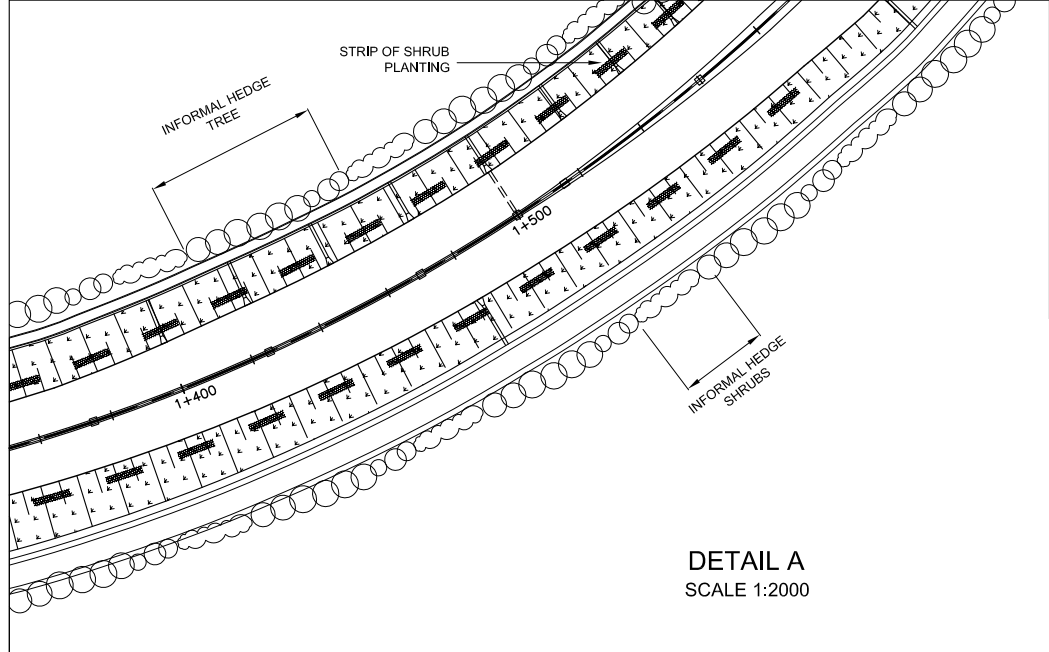

DETAIL A
SCALE 1:2000

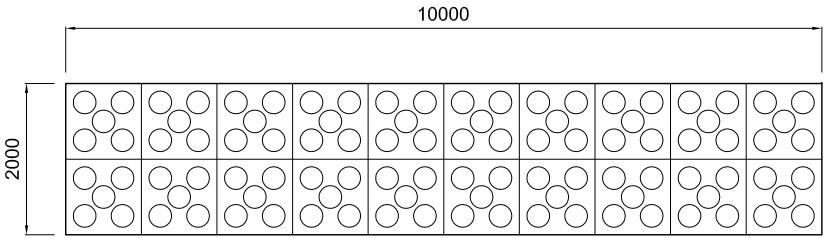

STRIP OF SHRUB PLANTING (5 SHRUBS / 1 sqm)
SCALE 1:100

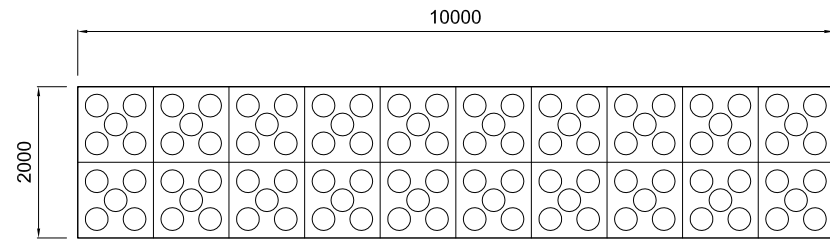

STRIP OF SHRUB PLANTING (5 SHRUBS / 1 sqm)
SCALE 1:100

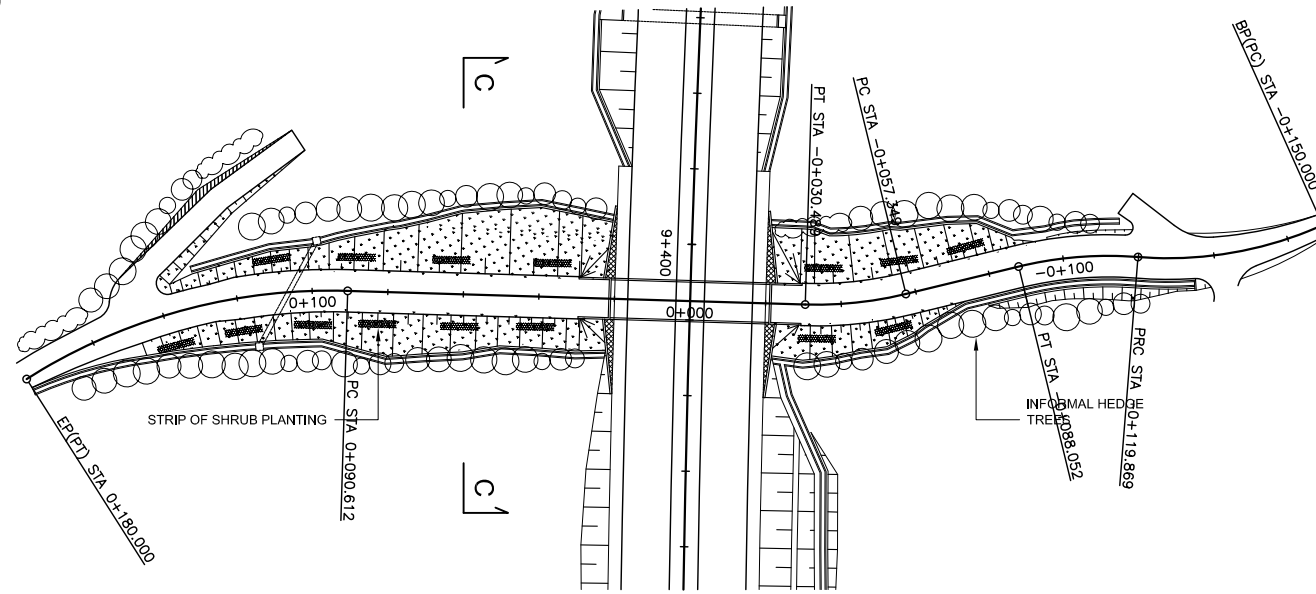

APPROACH ROAD
SCALE 1:2000

LEGEND

SYMBOL	SPECIES	REMARKS
	STRIP OF SHRUB PLANTING	5 shrubs / 1 sqm., 10,000*2000
	TURF	-
	INFORMAL HEDGE TREES	1 for 1m

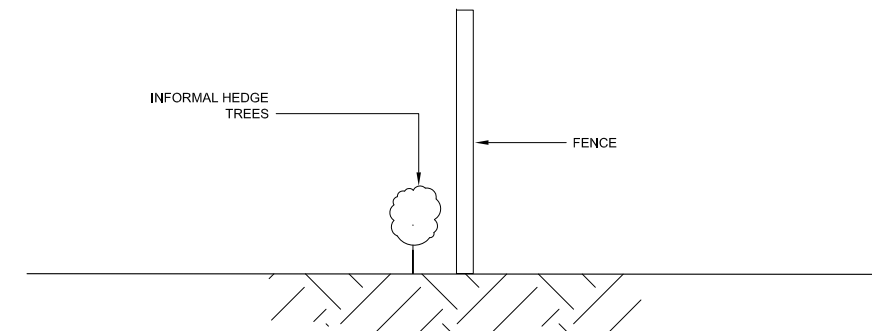

DETAIL 'A'

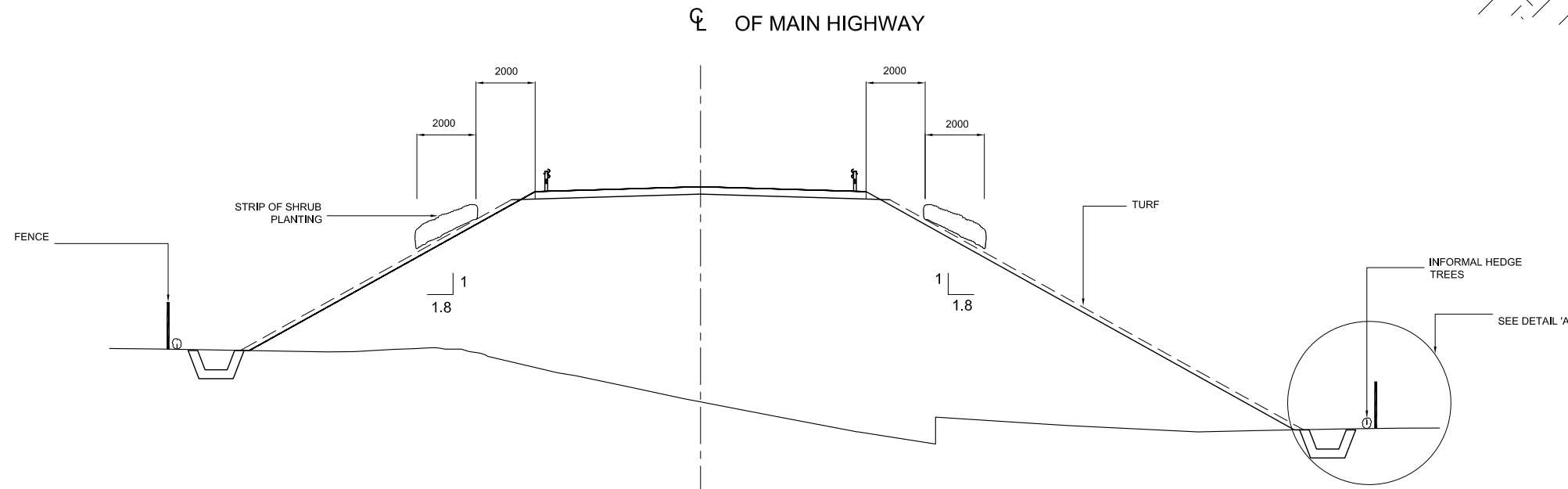

SECTION C-C
SCALE 1:200

No	REVISION	DATE

DESIGNED BY:	
CHECKED BY:	
APPROVED BY:	
DWG. NO.	Q-04

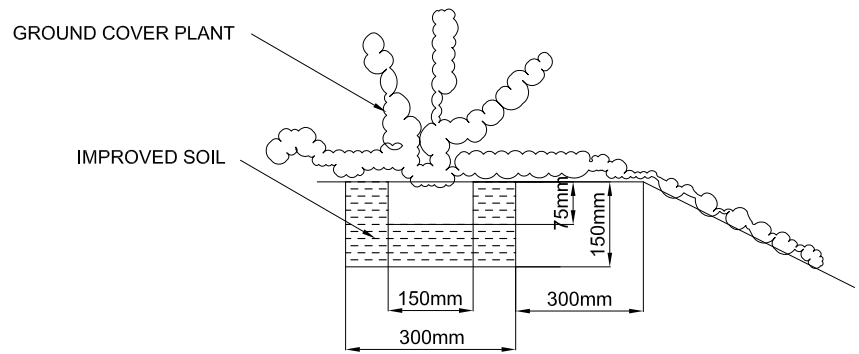

**CUT SLOPE GROUND COVER
(300mm SPACING)**
SCALE 1 :12.5

SOIL IMPROVEMENT FOR GROUND COVER PLANT		
MATERIAL	RATIO	QUANTITY
EXCAVATED SOIL	1	0.0135CUM
MIXED WITH-COIR DUST	0.3	0.0045 CUM
SAND	0.3	0.0045 CUM
COW DUNG/COMPOST	0.3	0.0045 CUM

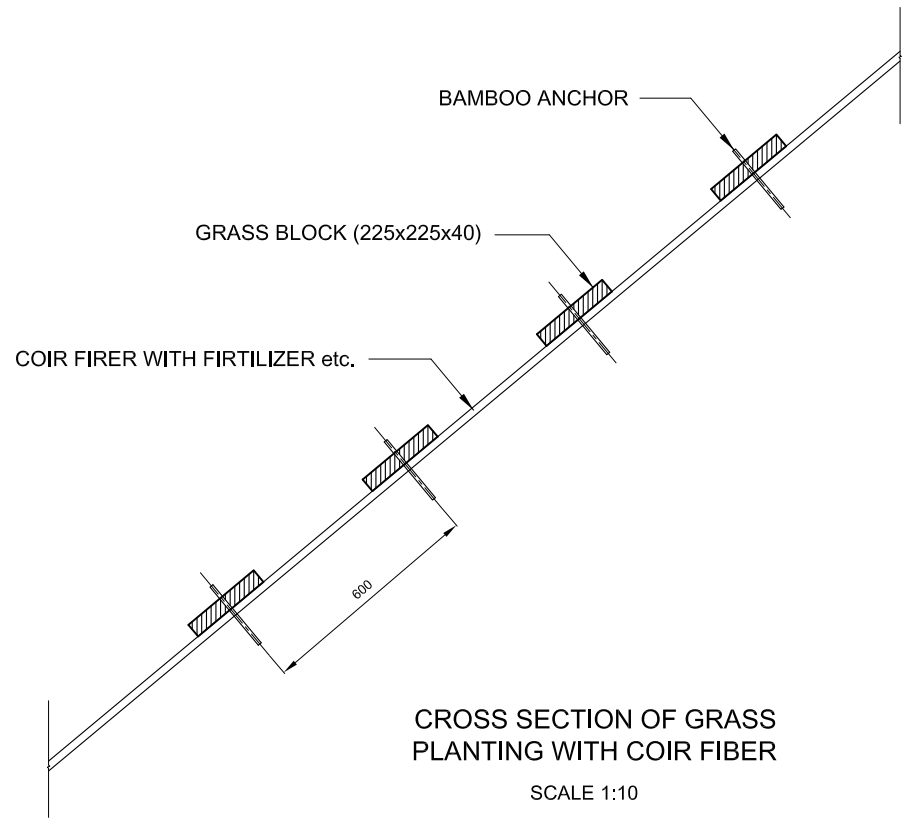

**CROSS SECTION OF GRASS
PLANTING WITH COIR FIBER**
SCALE 1:10

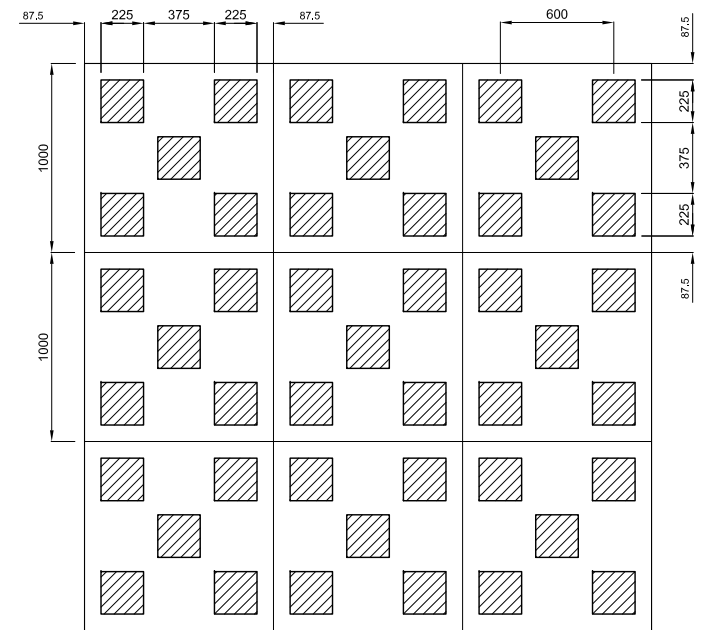

**PLANTING PATTERN FOR
GRASS BLOCKS**
SCALE 1:20

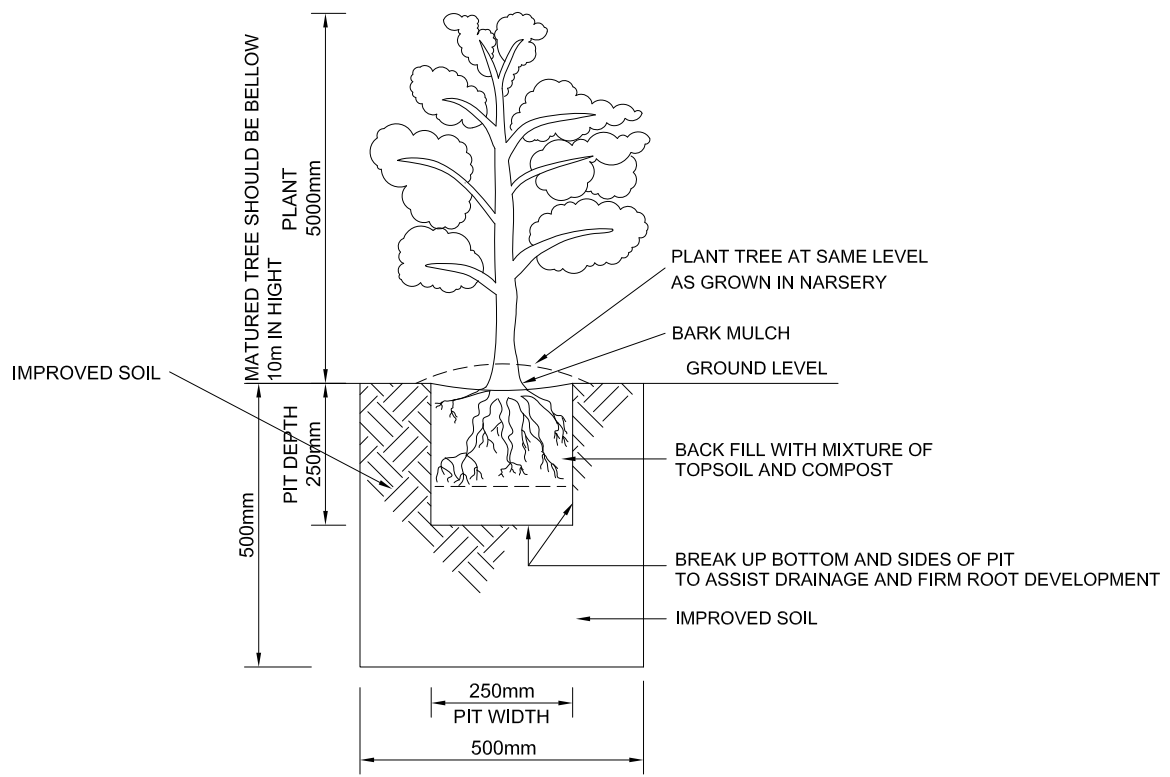

HEDGE - TREE
SCALE 1:12.5

SOIL IMPROVEMENT FOR HEDGE TREE		
MATERIAL	RATIO	QUANTITY
EXCAVATED SOIL	1	0.125 CUM
MIXED WITH-COIR DUST	0.33	0.041 CUM
SAND	0.33	0.041 CUM
COW DUNG/COMPOST	0.33	0.041 CUM

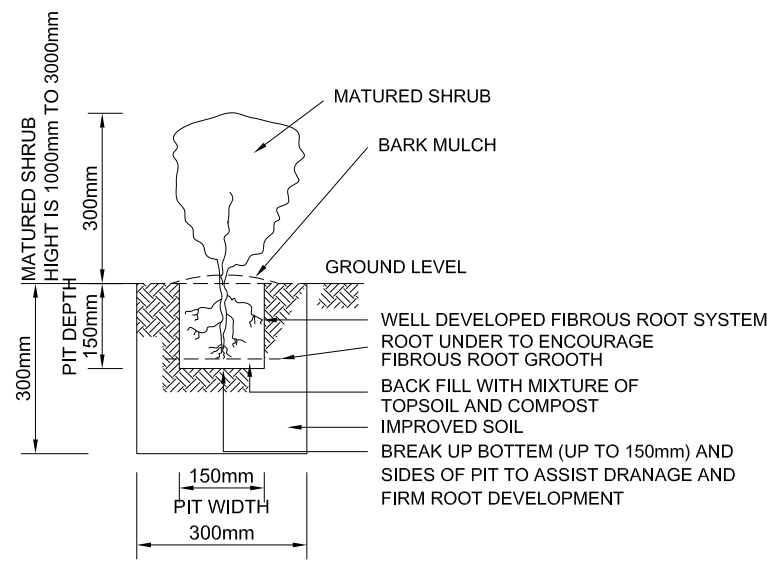

HEDGE - SHRUB
SCALE 1:12.5

SOIL IMPROVEMENT FOR HEDGE SHRUB		
MATERIAL	RATIO	QUANTITY
EXCAVATED SOIL	1	0.027 CUM
MIXED WITH-COIR DUST	0.33	0.009 CUM
SAND	0.33	0.009 CUM
COW DUNG/COMPOST	0.33	0.009 CUM

SOIL IMPROVEMENT FOR TURFING		
MATERIAL	RATIO	QUANTITY
EXCAVATED SOIL	1	0.015CUM
MIXED WITH-COIR DUST	0.33	0.005 CUM
SAND	0.33	0.005 CUM
COW DUNG/COMPOST	0.33	0.005 CUM

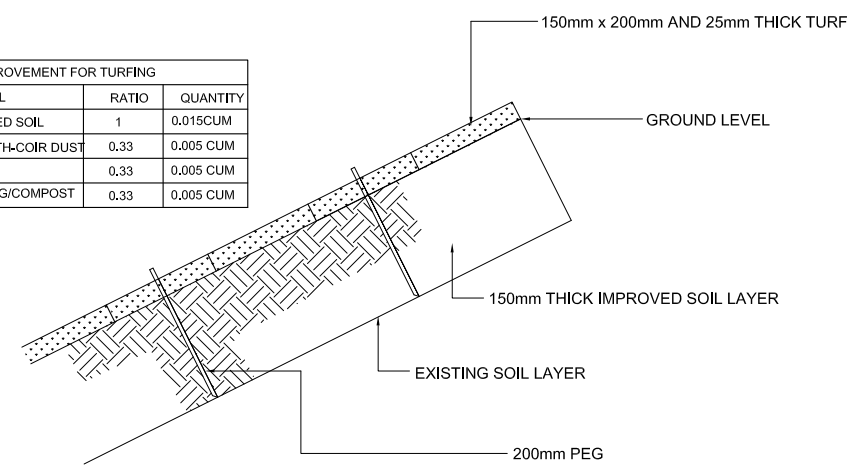

TURF DETAIL
SCALE 1:10

Recommended Species of Shrubs, Trees and Ground Covers

Local Name	Scientific Name
<Shrubs: evergreen, maximum 5m height >	
Bata- Cheena	<i>Bambusa multiplex</i>
Kaha Una	<i>Bambusa vulgaris</i>
Wetakeyiya	<i>Pandanus kaida</i>
Baludan	<i>Ardisa willisii</i>
< Ground Cover Plants: evergreen>	
Maha dupiyaliya	<i>Desmodium</i>
Heen udupiyaliya	<i>Desmodium heterophyllum</i>
Hulantala	<i>Ageratum conyzoides</i>
Monara kukudumbiya	<i>Vernonia cinerea</i>
Habarala	<i>Alocasia macrorrhiza</i>
<Foliage Plants >	
Acalypha	<i>Acalypha marginata</i>
Pseudoeranthemum	<i>Pseudoeranthemum atropurpureum</i>
Durantha	<i>Durantha ripens</i>
<Trees-small size :evergreen, 5 -10m height >	
Agladhara	<i>Justica adhatoda</i>
Ankenda	<i>Acronychia pedunculata</i>
Bowitiya	<i>Osbeckia aspera</i>
Etteriya	<i>Murraya paniculata</i>
Magul Karanda	<i>Pongamia pinnata</i>
Kopi	<i>Coffia Arabica</i>
Bombu	<i>Symplocos cochinchinensis</i>
Divi Kaduru	<i>Paginta dichotoma</i>
Erabadu	<i>Erythrina fusca</i>
Gon Kaduru	<i>Cerbera odollum</i>
Kebella	<i>Aporosa lindlyana</i>
Goraka	<i>Garcinia quaesita</i>
Iriya	<i>Horsfieldia iriya</i>
Kumbuk	<i>Teminalia arjuna</i>
Dan	<i>Syzygium caryophyllatum</i>
<Treesmedium size :evergreen, 10 -20m height >	
Godapara	<i>Dillenia ret usa</i>
Diya Midella	<i>Barringtonoa asiatica</i>
Kaduru	<i>Cinnamomum verum</i>
Belipatta	<i>Hisbicus tiliaceus</i>
Muruta	<i>Lagstroemia speciosa</i>
Diyapara	<i>Dillenia triquetra</i>
<Treeslarge size :evergreen, height >20m >	
Bakmie	<i>Nauclea orientalis</i>
Dawata	<i>Carallia brachiata</i>
Diya Na	<i>Mesua ferra</i>
Wal Ehala	<i>Pterocarpus indicus</i>
Gas Kela	<i>Butea monosperma</i>
Havari Nuga	<i>Alstonia macrophylla</i>
Domba	<i>Calophyllum inophyllum</i>

Quantity for Greenery works (turfing, trees, ground covers and shrubs)

No	Item	Unit	Quantity	Remarks
1	Embankment– Turfing	Sqm.		To be calculated by CAD
2	Slope protection(Cut slope)	Sqm.		To be calculated by CAD
3	Strip of Shrub Planting (5seedlings/m2*2mwidth*10m length) -For main trace facing residential areas -For approach road -For interchange	Nos	58,020	<Main trace facing residential areas> 10m*2m*5sh/sqm=100seedling /plot, Main trace: 4,500m 4500m*2rows/30m/unit= 300plots 300*100= 30,000seedlings <Approach road163m+65=228m> 228 m/30m/unit*100seedlings= 800 seedlings < Interchange area: length of CL=4,803m > 4,083m*2rows/30m/unit*100seedlings= 27,220 seedlings Total: 58,020seedlings
4	Cut Slope Ground Cover	Nos	5,730	Total cut slope length:1,720m(Calculated by CAD) 1,720m/0.3m=5,730seedlings
5	Hedge trees -For main trace facing residential areas -For approach road -For interchange	Nos	13,756	< Main trace facing residential areas> 4500m*2side=9,000m,9000/70m/unit= 129unit, 129unit*50= 6,450seedlings <Approach road:228m*2sides=456m> 456*1seedling/m=456seedlings < Interchange area: length of CL=4,803m > 4,803m*2sides/70m/unit= 137unit 137unit*50= 6,850seedlings Total: 13,756seedlings
6	Hedge– Wild shrubs -For main trace facing residential areas -Interchange	Nos	16,020	< Main trace facing residential areas> 4500m*2side=9,000m, 9000/70m/unit= 129unit 129unit*20*3seedlings/m= 7,740seedlings < Interchange area: length of CL=4,803m > 4,803m*2sides/70m/unit= 137unit 137unit* 20*3seedling/m=8,280seedlings Total: 16,020seedlings

Distance Calculation for Land Use

No.	Chainage	Left	Right	Length(m)
1	9+300-9+700	Residential	Residential	400
2	9+700-9+900	Marsh	Marsh	
3	9+900-10+200	Residential	Residential	300
4	10+200-10+400	Marsh	Residential	200
5	10+400-10+500	Residential	Marsh	100
6	10+500-10+600	Marsh	Residential	100
7	10+600-10+700	Marsh	Marsh	
8	10+700-10+900	Residential	Marsh	200
9	10+900-11+000	Marsh	Marsh	
10	11+000-11+700	Residential	Residential	700
11	11+700-12+100	Residential	Marsh	400
12	12+100-12+200	Residential	Residential	100
13	12+200-12+300	Residential	Marsh	100
14	12+300-12+400	Marsh	Marsh	
15	12+400-12+900	Residential	Residential	500
16	12+900-14+200	Marsh	Marsh	
17	14+200-14+400	Residential	Marsh	200
18	14+400-15+100	Residential	Residential	700
19	15+100-15+600	Marsh	Marsh	
20	15+600-15+800	Residential	Residential	200
21	15+800-16+100	Marsh	Marsh	
22	16+100-16+300	Residential	Residential	200
23	16+400-16+500	Residential	Residential	100
	Total			4500

R. GEOLOGICAL PROFILE

REMARKS

SPT	=	STANDARD PENETRATION TEST
UD	=	UNDISTURBED SAMPLING
WSP	=	WATER STAND PIPE INSTALLATION
WS	=	WATER SAMPLING
SS	=	SOIL SAMPLING

CONTRACT AREA FOR
OCH MAIN ALIGNMENT
START FROM STA No. 8+608

AREA TREATED BY GCP (φ 700, □ 1.2m)

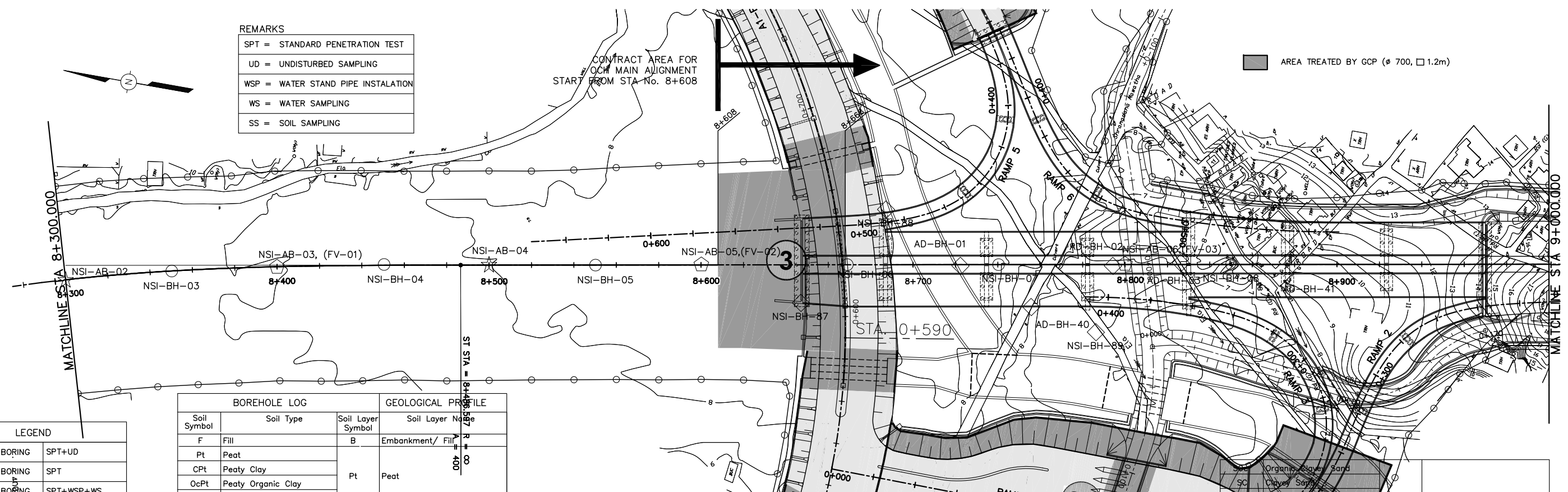

LEGEND

○	ROTARY BORING	SPT+UD
◇	ROTARY BORING	SPT
□	ROTARY BORING	SPT+WSP+WS
△	ROTARY BORING	WSP+WS
☆	AUGER BORING	SS
○	FIELD VANE	VANE SHEAR TEST

BOREHOLE LOG		GEOLOGICAL PROFILE	
Soil Symbol	Soil Type	Soil Layer Symbol	Soil Layer Name
F	Fill	B	Embankment/ Fill
Pt	Peat		
Cpt	Peaty Clay	Pt	Peat
OcPt	Peaty Organic Clay		
CPT-S	Sandy Peaty Clay		
Oc	Organic Clay		
OcM	Silty Organic Clay	Oc	Organic Clay
OcS	Sandy Organic Clay		
CM	Silty Clay		
MOc	Organic Clayey Silt	Ac	Alluvial Clay
MC	Clayey Silt		
CS	Sandy Clay		
CS-M	Silty Sandy Clay	Acs	Alluvial Sandy Clay
MS	Sandy Silt		

SC	Organic Silty Sand		
SC-M	Silty Clayey Sand		
SM	Silty Sand		
SM-C	Clayey Silty Sand	As	Alluvial Sand
SG	Gravelly Sand		
SC-G	Gravelly Clayey Sand		
GM	Silty Gravel	Ag	Alluvial Gravel
Bd	Boulder		
WR	Completely Weathered Rock	Wr	Completely Weathered Rock
R	Rock (Weathered)	Rs	Rock (Weathered)

— Bottom Boundary Line of soft Cohesive Soil
- - - Upper Boundary Line of Bearing Stratum

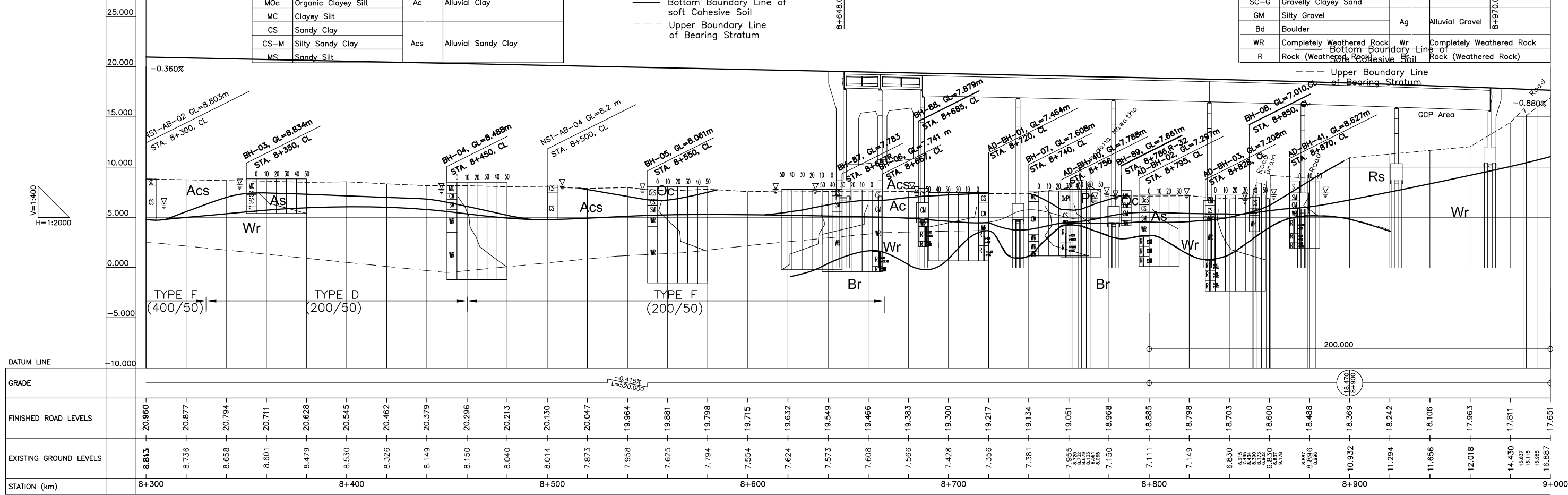

DATUM LINE	GRADE	FINISHED ROAD LEVELS	EXISTING GROUND LEVELS	STATION (km)
		20.960	8.613	8+300
		20.877	8.736	
		20.794	8.658	
		20.711	8.601	
		20.628	8.479	
		20.545	8.530	8+400
		20.462	8.326	
		20.379	8.149	
		20.296	8.150	
		20.213	8.040	
		20.130	8.014	
		20.047	7.873	
		19.964	7.958	
		19.881	7.625	
		19.798	7.794	
		19.715	7.554	
		19.632	7.624	
		19.549	7.573	
		19.466	7.608	
		19.383	7.566	
		19.300	7.428	
		19.217	7.356	
		19.134	7.381	
		19.051	7.955	
		18.968	8.952	
		18.885	8.931	
		18.798	8.905	
		18.703	8.830	
		18.600	8.802	
		18.488	8.830	
		18.369	9.178	
		18.242	8.897	
		18.106	8.896	
		17.963	10.932	
		17.811	11.294	
		17.651	11.656	
			12.018	
			14.430	
			15.885	
			16.887	
			17.651	9+000

NSI-BH-11

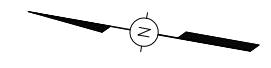

AREA TREATED BY GCP (ø 700, □ 1.2m)

SOc	Organic Clayey Sand		
SC	Clayey Sand		
SC-M	Silty Clayey Sand	As	Alluvial Sand
SM	Silty Sand		
SM-C	Clayey Silty Sand		
S	Sand		
SG	Gravelly Sand		
SC-G	Gravelly Clayey Sand		
GM	Silty Gravel	Ag	Alluvial Gravel
Bd	Boulder		
WR	Completely Weathered Rock	Wr	Completely Weathered Rock
R	Rock (Weathered Rock)	Br	Rock (Weathered Rock)

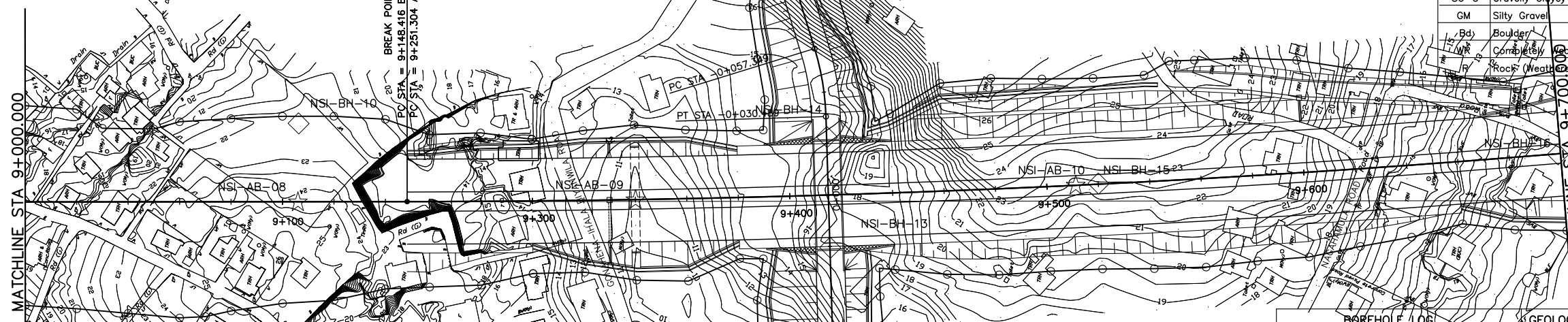

LEGEND	
○	ROTARY BORING SPT+UD
◇	ROTARY BORING SPT
□	ROTARY BORING SPT+WSP+WS
△	ROTARY BORING WSP+WS
☆	AUGER BORING SS
▽	FIELD VANE VANE SHEAR TEST

REMARKS	
SPT	= STANDARD PENETRATION TEST
UD	= UNDISTURBED SAMPLING
WSP	= WATER STAND PIPE INSTALATION
WS	= WATER SAMPLING
SS	= SPIGIL SAMPLING

BOREHOLE LOG		GEOLOGICAL PROFILE	
Soil Symbol	Soil Type	Soil Layer Symbol	Soil Layer Name
F	Fill	B	Embankment/ Fill
Pt	Peat		
CPT	Peaty Clay	Pt	Peat
OcPt	Peaty Organic Clay		
CPT-S	Sandy Peaty Clay		
Oc	Organic Clay		
OcM	Silty Organic Clay	Oc	Organic Clay
OcS	Sandy Organic Clay		
CM	Silty Clay		
MOc	Organic Clayey Silt	Ac	Alluvial Clay
MC	Clayey Silt		
CS	Sandy Clay		
CS-M	Silty Sandy Clay	Acs	Alluvial Sandy Clay
MS	Sandy Silt		

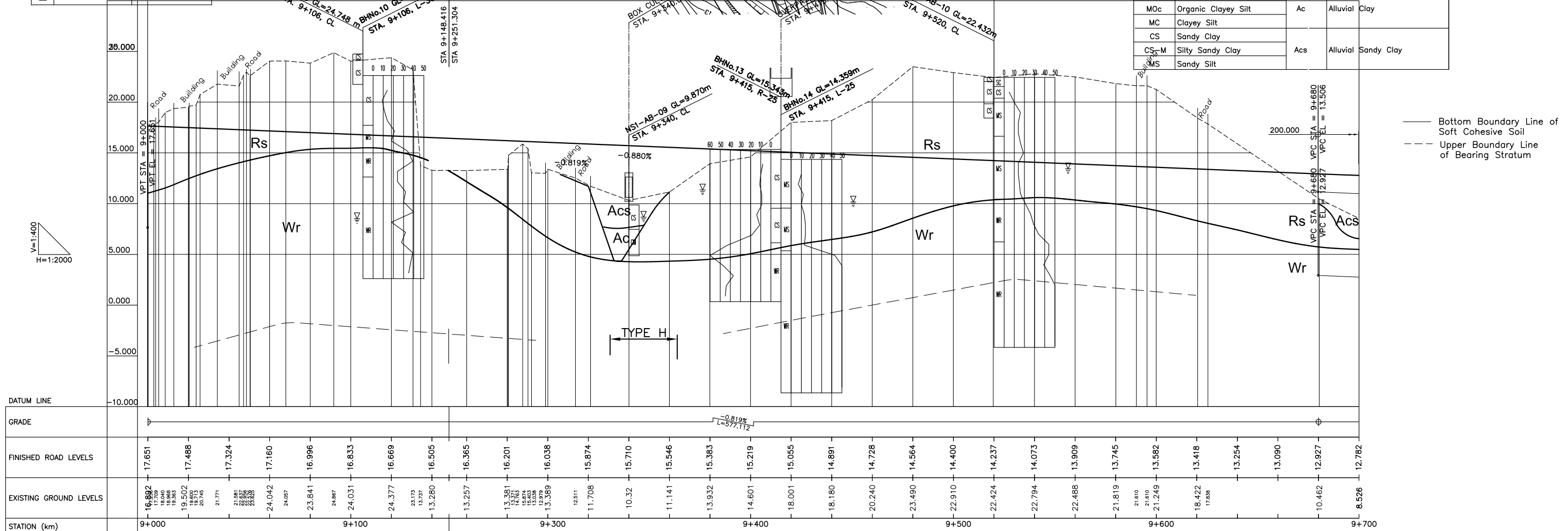

DATUM LINE	GRADE	FINISHED ROAD LEVELS	EXISTING GROUND LEVELS	STATION (km)
		17.651	16.682	9+000
		17.488	19.502	9+100
		17.324	13.257	9+200
		17.160	10.32	9+300
		16.996	11.141	9+400
		16.833	13.932	9+500
		16.669	14.601	9+600
		16.505	18.001	9+700
		16.365	18.180	
		16.201	20.240	
		16.038	23.490	
		15.874	22.910	
		15.710	22.424	
		15.546	22.794	
		15.383	21.819	
		15.219	21.610	
		15.055	21.249	
		14.891	18.422	
		14.728	17.808	
		14.564	10.462	
		14.400	8.526	
		14.237		
		14.073		
		13.909		
		13.745		
		13.582		
		13.418		
		13.254		
		13.090		
		12.927		
		12.782		

SOc	Organic Clayey Sand		
SC	Clayey Sand		
SC-M	Silty Clayey Sand		
SM	Silty Sand		
SM-C	Clayey Silty Sand	As	Alluvial Sand
S	Sand		
SG	Gravelly Sand		
SC-G	Gravelly Clayey Sand		
GM	Silty Gravel	Ag	Alluvial Gravel
Bd	Boulder		
WR	Completely Weathered Rock	Wr	Completely Weathered Rock
R	Rock (Weathered Rock)	Br	Rock (Weathered Rock)

REMARKS

SPT = STANDARD PENETRATION TEST
UD = UNDISTURBED SAMPLING
WSP = WATER STAND PIPE INSTALLATION
WS = WATER SAMPLING
SS = SOIL SAMPLING

LEGEND

○	ROTARY BORING	SPT+UD
◇	ROTARY BORING	SPT
□	ROTARY BORING	SPT+WSP+WS
△	ROTARY BORING	WSP+WS
☆	AUGER BORING	SS
◇	FIELD VANE	VANE SHEAR TEST

BOREHOLE LOG

Soil Symbol	Soil Type	Soil Layer Name	Soil Layer Name
F	Fill		Embankment/ Fill
Pt	Peat		Peat
CPT	Peaty Clay	Pt	Peat
OcPt	Peaty Organic Clay		
CPT-S	Sandy Peaty Clay		
Oc	Organic Clay		
OcM	Silty Organic Clay	Oc	Organic Clay
OcS	Sandy Organic Clay		
CM	Silty Clay		
MOc	Organic Clayey Silt	Ac	Alluvial Clay
MC	Clayey Silty Clay		
CS	Sandy Clay		
CS-M	Silty Sandy Clay	Acs	Alluvial Sandy Clay
MS	Sandy Silt		

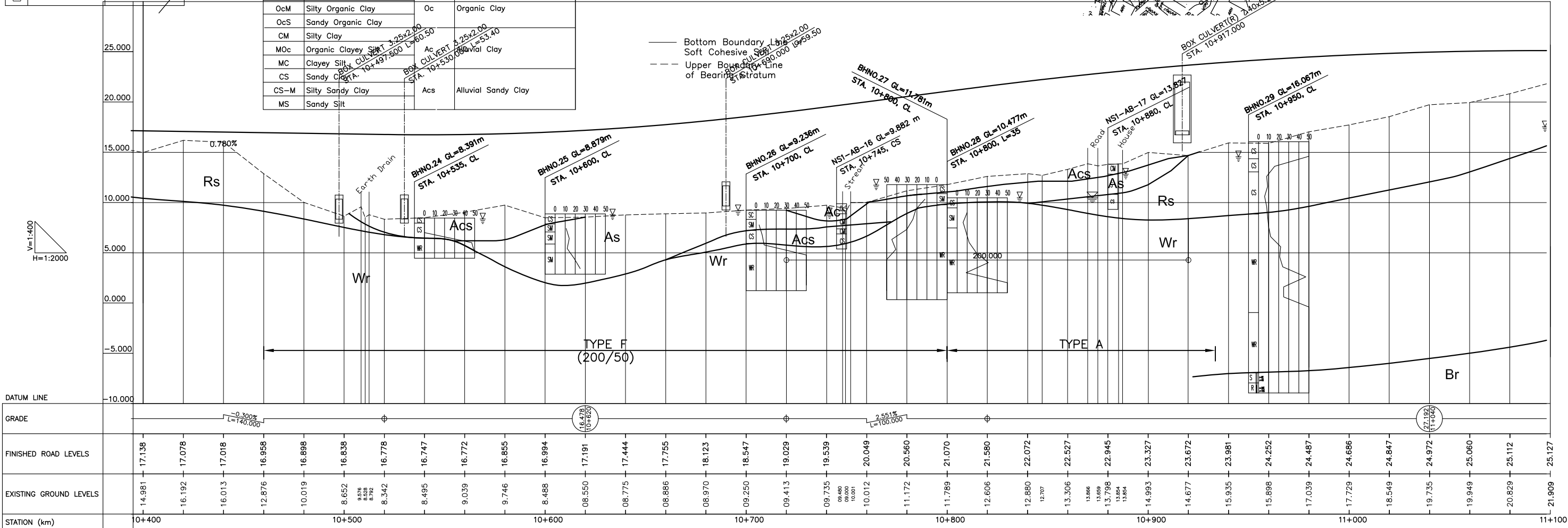

AREA TREATED BY GCP (φ 700, □ 1.2m)

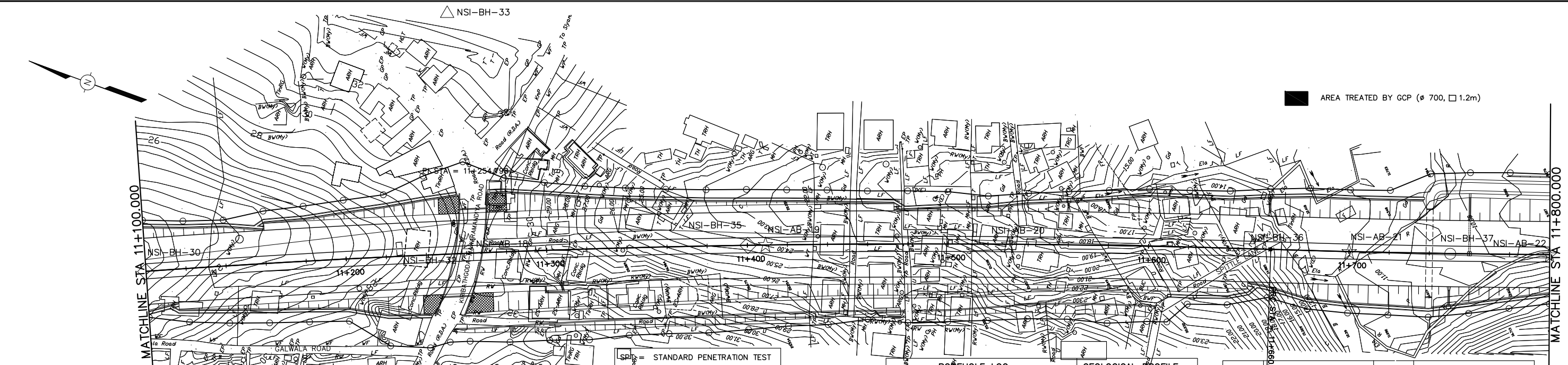

LEGEND

○	ROTARY BORING	SPT+UD
◇	ROTARY BORING	SPT
□	ROTARY BORING	SPT+WSP+WS
△	ROTARY BORING	WSP+WS
☆	AUGER BORING	SS
○	FIELD VANE	VANE SHEAR TEST

REMARKS

SPT	= STANDARD PENETRATION TEST
UD	= UNDISTURBED SAMPLING
WSP	= WATER STAND PIPE INSTALLATION
WS	= WATER SAMPLING
SS	= SOIL SAMPLING

BOREHOLE LOG

Soil Symbol	Soil Type	Soil Layer Symbol	Soil Layer Name
F	Fill	B	Embankment/ Fill
Pt	Peat		
CpT	Peaty Clay	Pt	Peat
OcPt	Peaty Organic Clay		
CpT-S	Sandy Peaty Clay		
Oc	Organic Clay		
OcM	Silty Organic Clay	Oc	Organic Clay
OcS	Sandy Organic Clay		
CM	Silty Clay		
MOc	Organic Clayey Silt	Ac	Alluvial Clay
MC	Clayey Silt		
CS	Sandy Clay		
CS-M	Silty Sandy Clay		
MS	Sandy Silt		

GEOLOGICAL PROFILE

Soil Symbol	Soil Type	Soil Layer Symbol	Soil Layer Name
SOc	Organic Clayey Sand		
SC	Clayey Sand		
SC-M	Silty Clayey Sand		
SM	Silty Sand	As	Alluvial Sand
SM-C	Clayey Silty Sand		
S	Sand		
SG	Gravelly Sand		
SC-G	Gravelly Clayey Sand		
GM	Silty Gravel	Ag	Alluvial Gravel
Bd	Boulder		
WR	Completely Weathered Rock	Wr	Completely Weathered Rock
R	Rock (Weathered Rock)	Br	Rock (Weathered Rock)

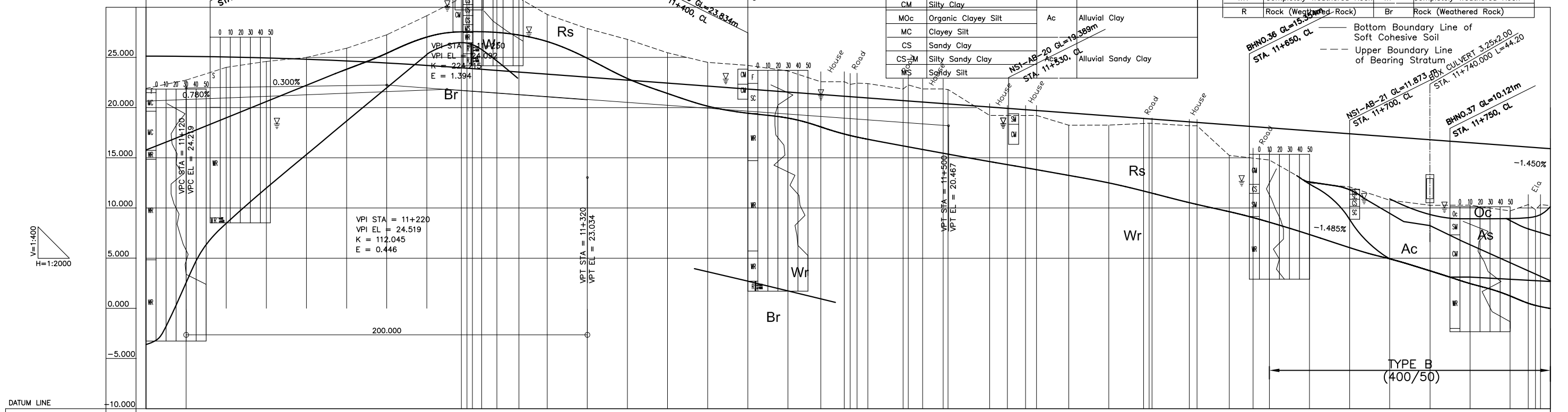

DATUM LINE	
GRADE	
FINISHED ROAD LEVELS	25.127, 25.105, 25.047, 24.951, 24.819, 24.651, 24.446, 24.204, 23.925, 23.628, 23.331, 23.034, 22.737, 22.440, 22.143, 21.846, 21.549, 21.252, 20.955, 20.658, 20.361, 20.064, 19.767, 19.470, 19.173, 18.876, 18.579, 18.282, 17.985, 17.688, 17.391, 17.094, 16.797, 16.500, 16.203, 15.906
EXISTING GROUND LEVELS	21.909, 22.739, 24.010, 24.602, 25.000, 25.918, 27.254, 29.155, 29.206, 31.301, 31.160, 30.908, 29.276, 27.876, 26.794, 25.463, 24.508, 24.207, 23.649, 22.578, 22.576, 22.319, 22.392, 21.853, 22.257, 21.855, 21.853, 21.803, 19.222, 19.222, 19.215, 19.222, 18.246, 18.246, 18.426, 18.426, 18.192, 18.192, 15.237, 14.965, 14.778, 12.504, 12.098, 10.780, 10.270, 10.285, 09.711, 10.337, 10.338, 10.236
STATION (km)	11+100, 11+200, 11+300, 11+400, 11+500, 11+600, 11+700, 11+800

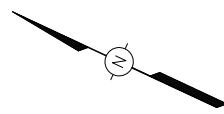

AREA TREATED BY GCP (ø 700, □ 1.2m)

SOc	Organic Clayey Sand		
SC	Clayey Sand		
SC-M	Silty Clayey Sand		
SM	Silty Sand	As	Alluvial Sand
SM-C	Clayey Silty Sand		
S	Sand		
SG	Gravelly Sand		
SC-G	Gravelly Clayey Sand		
GM	Silty Gravel	Ag	Alluvial Gravel
Bd	Boulder		
WR	Completely Weathered Rock	Wr	Completely Weathered Rock
R	Rock (Weathered Rock)	Br	Rock (Weathered Rock)

BOREHOLE LOG		GEOLOGICAL PROFILE	
Soil Symbol	Soil Type	Soil Layer Symbol	Soil Layer Name
F	Fill	B	Embankment/ Fill
Pt	Peat		
CpT	Peaty Clay	Pt	Peat
OcPt	Peaty Organic Clay		
CPT-S	Sandy Peaty Clay		
Oc	Organic Clay		
OcM	Silty Organic Clay	Oc	Organic Clay
OcS	Sandy Organic Clay		
CM	Silty Clay		
MOc	Organic Clayey Silt	Ac	Alluvial Clay
MC	Clayey Silt		
CS	Sandy Clay		
CS-M	Silty Sandy Clay	Acs	Alluvial Sandy Clay
MS	Sandy Silt		

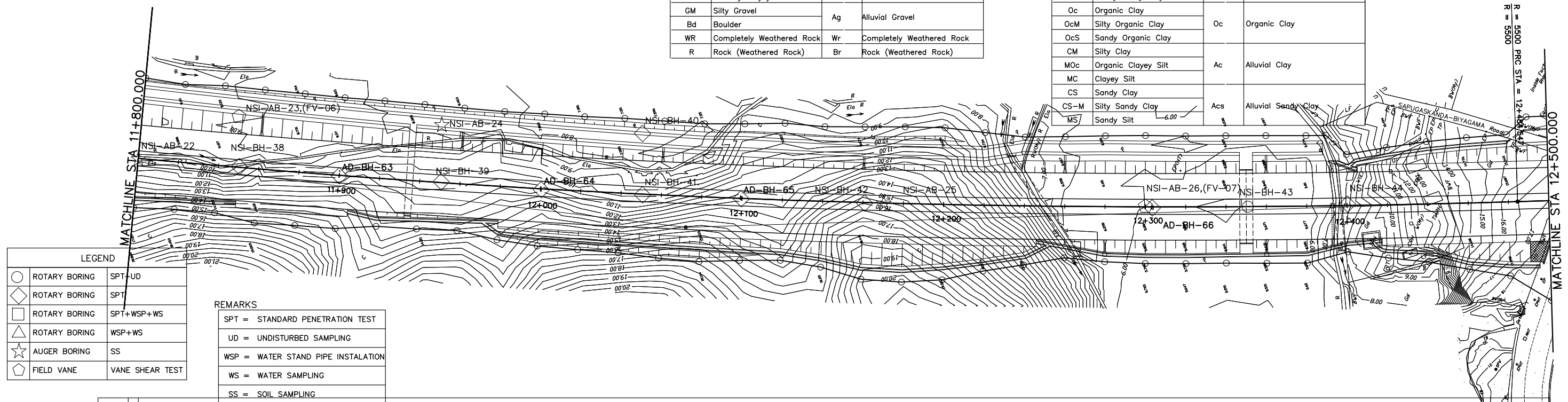

LEGEND	
○	ROTARY BORING SPT-UD
◇	ROTARY BORING SPT
□	ROTARY BORING SPT+WSP+WS
△	ROTARY BORING WSP+WS
☆	AUGER BORING SS
○	FIELD VANE VANE SHEAR TEST

REMARKS	
SPT	= STANDARD PENETRATION TEST
UD	= UNDISTURBED SAMPLING
WSP	= WATER STAND PIPE INSTALLATION
WS	= WATER SAMPLING
SS	= SOIL SAMPLING

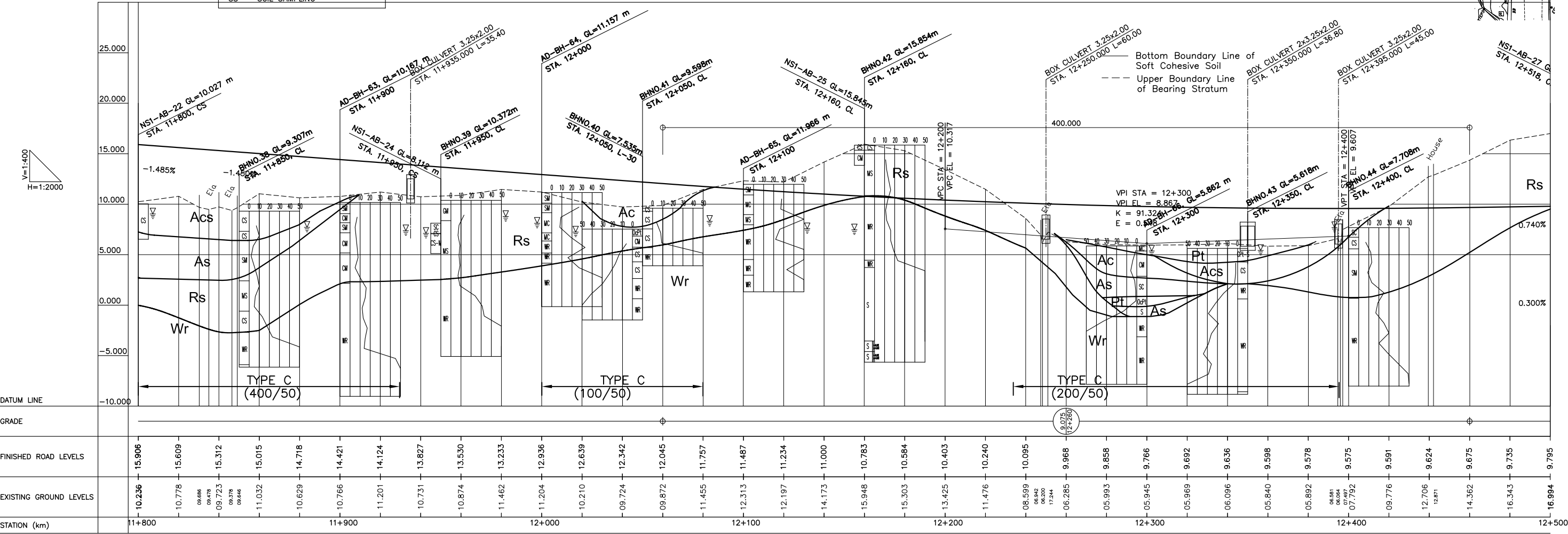

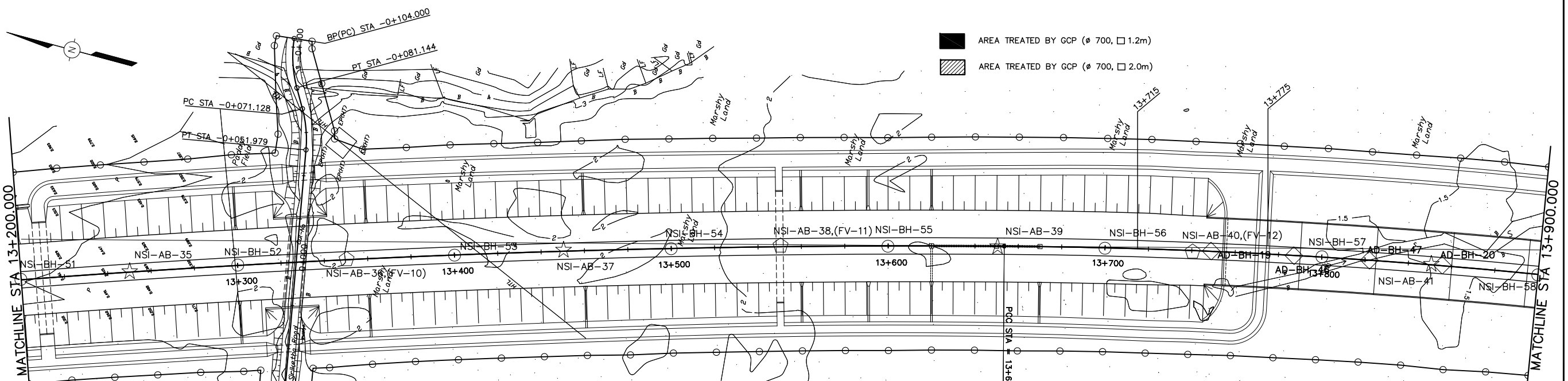

AREA TREATED BY GCP (φ 700, □ 1.2m)
 AREA TREATED BY GCP (φ 700, □ 2.0m)

LEGEND		
	ROTARY BORING	SPT+UD
	ROTARY BORING	SPT
	ROTARY BORING	SPT+WSP+WS
	ROTARY BORING	WSP+WS
	AUGER BORING	SS
	FIELD VANE	VANE SHEAR TEST

REMARKS	
SPT	= STANDARD PENETRATION TEST
UD	= UNDISTURBED SAMPLING
WSP	= WATER STAND PIPE INSTALATION
WS	= WATER SAMPLING
SS	= SOIL SAMPLING

BOREHOLE LOG		GEOLOGICAL PROFILE	
Soil Symbol	Soil Type	Soil Layer Symbol	Soil Layer Name
F	Fill	B	Embankment/ Fill
Pt	Peat	Pt	Peat
CpT	Peaty Clay		
OcPt	Peaty Organic Clay		
CpT-S	Sandy Peaty Clay		
Oc	Organic Clay		
OcM	Silty Organic Clay	Oc	Organic Clay
OcS	Sandy Organic Clay		
CM	Silty Clay		
MOc	Organic Clayey Silt	Ac	Alluvial Clay
MC	Clayey Silt		
CS	Sandy Clay		
CS-M	Silty Sandy Clay		Alluvial Sandy Clay
MS	Sandy Silt		

SOc	Organic Clayey Sand		
SC	Clayey Sand		
SC-M	Silty Clayey Sand		
SM	Silty Sand	As	Alluvial Sand
SM-C	Clayey Silty Sand		
S	Sand		
SG	Gravelly Sand		
SC-G	Gravelly Clayey Sand		
GM	Silty Gravel	Ag	Alluvial Gravel
Bd	Boulder		
WR	Completely Weathered Rock	Wr	Completely Weathered Rock
R	Rock (Weathered Rock)	Br	Rock (Weathered Rock)

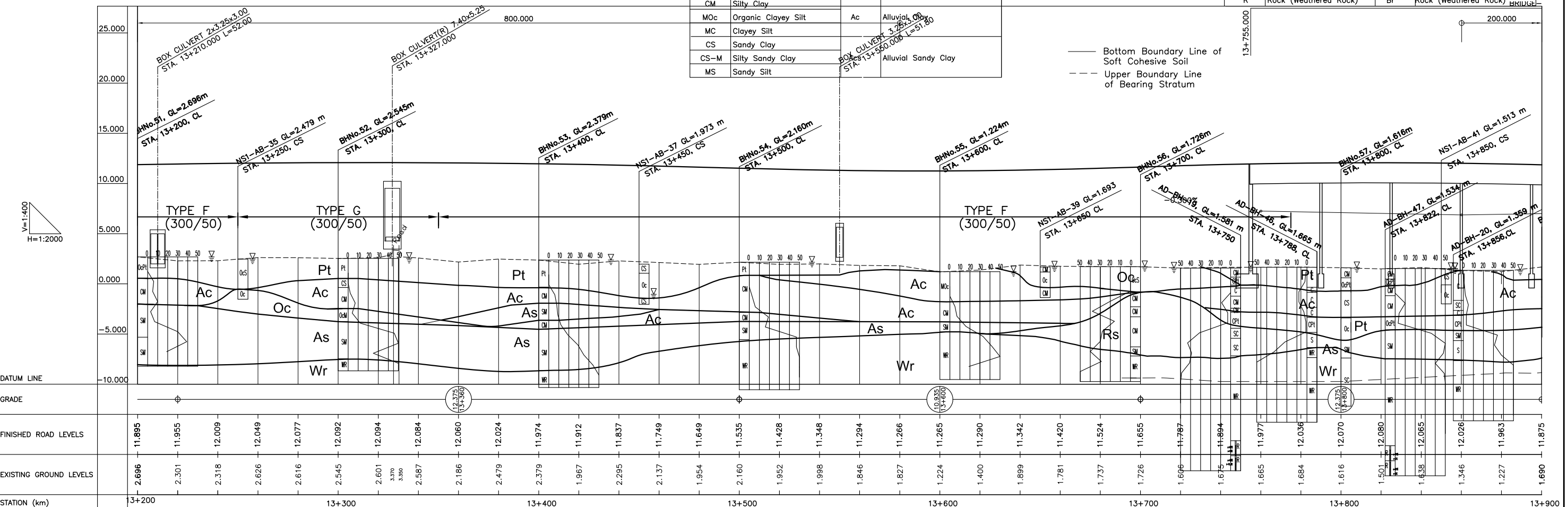

DATUM LINE	GRADE	FINISHED ROAD LEVELS	EXISTING GROUND LEVELS	STATION (km)
		11.895	2.696	13+200
		11.955	2.301	13+210
		12.009	2.318	13+220
		12.049	2.626	13+230
		12.077	2.616	13+240
		12.092	2.545	13+250
		12.094	2.601	13+260
		12.084	2.587	13+270
		12.060	2.186	13+280
		12.024	2.479	13+290
		11.974	2.379	13+300
		11.912	1.967	13+310
		11.837	2.295	13+320
		11.749	2.137	13+330
		11.649	1.954	13+340
		11.535	2.160	13+350
		11.428	1.952	13+360
		11.348	1.998	13+370
		11.294	1.846	13+380
		11.266	1.827	13+390
		11.266	1.224	13+400
		11.290	1.400	13+410
		11.342	1.899	13+420
		11.420	1.781	13+430
		11.524	1.737	13+440
		11.655	1.726	13+450
		11.787	1.606	13+460
		11.894	1.675	13+470
		11.977	1.665	13+480
		12.036	1.684	13+490
		12.070	1.616	13+500
		12.080	1.501	13+510
		12.065	1.438	13+520
		12.026	1.346	13+530
		11.963	1.227	13+540
		11.875	1.690	13+550

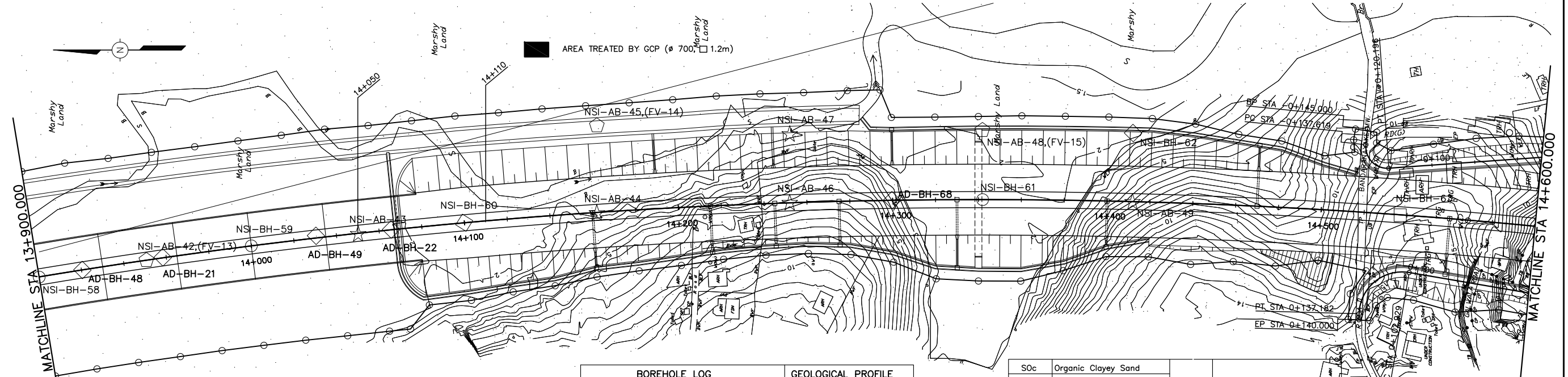

LEGEND	
○	ROTARY BORING SPT+UD
◇	ROTARY BORING SPT
□	ROTARY BORING SPT+WSP+WS
△	ROTARY BORING WSP+WS
☆	AUGER BORING SS
○	FIELD VANE VANE SHEAR TEST

REMARKS	
SPT	= STANDARD PENETRATION TEST
UD	= UNDISTURBED SAMPLING
WSP	= WATER STAND PIPE INSTALLATION
WS	= WATER SAMPLING
SS	= SOIL SAMPLING

BOREHOLE LOG		GEOLOGICAL PROFILE	
Soil Symbol	Soil Type	Soil Layer Symbol	Soil Layer Name
F	Fill	B	Embankment/ Fill
Pt	Peat		
CPt	Peaty Clay	Pt	Peat
OcPt	Peaty Organic Clay		
CPt-S	Sandy Peaty Clay		
Oc	Organic Clay		
OcM	Silty Organic Clay	Oc	Organic Clay
OcS	Sandy Organic Clay		
CM	Silty Clay		
MOc	Organic Clayey Silt	Ac	Alluvial Clay
MC	Clayey Silt		
CS	Sandy Clay		
CS-M	Silty Sandy Clay	Acs	Alluvial Sandy Clay
MS	Sandy Silt		

SOc	Organic Clayey Sand		
SC	Clayey Sand		
SC-M	Silty Clayey Sand		
SM	Silty Sand	As	Alluvial Sand
SM-C	Clayey Silty Sand		
S	Sand		
SG	Gravelly Sand		
SC-G	Gravelly Clayey Sand		
GM	Silty Gravel	Ag	Alluvial Gravel
Bd	Boulder		
WR	Completely Weathered Rock	Wr	Completely Weathered Rock
R	Rock (Weathered Rock)	Br	Rock (Weathered Rock)

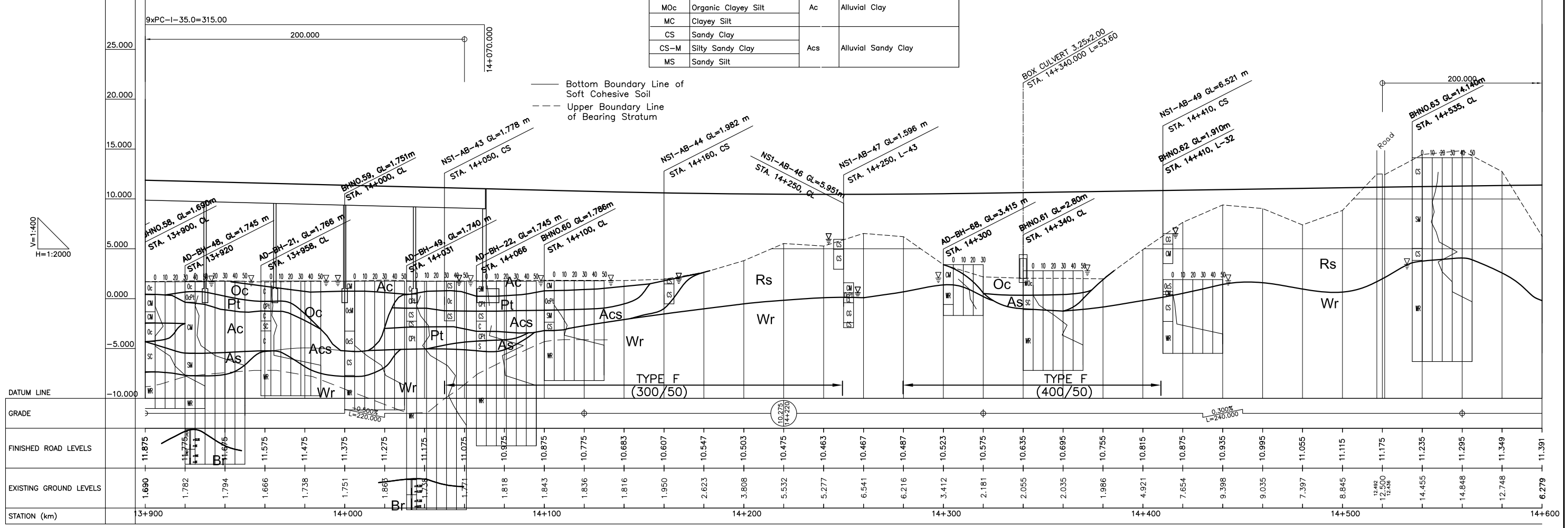

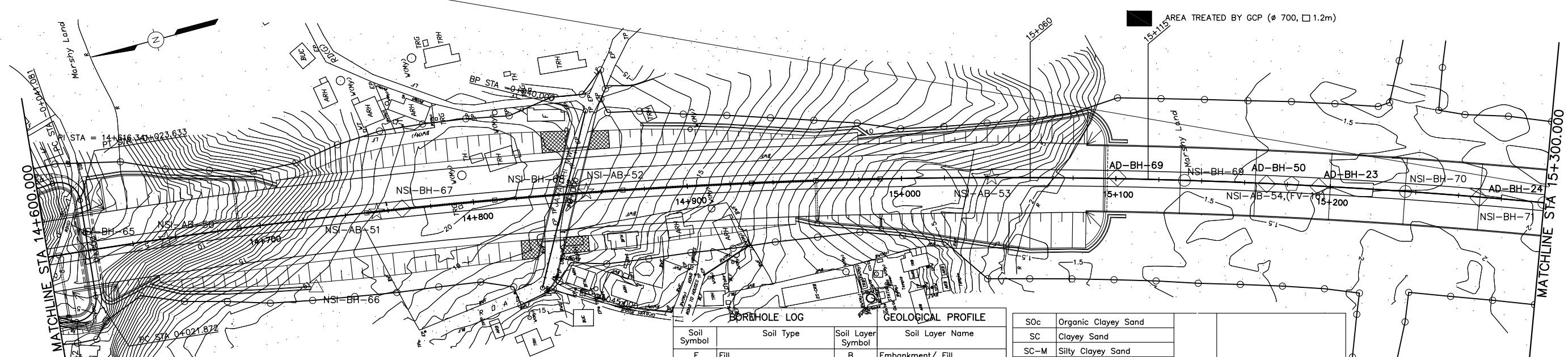

AREA TREATED BY GCP (φ 700, □ 1.2m)

LEGEND	
○	ROTARY BORING SPT+UD
◇	ROTARY BORING SPT
□	ROTARY BORING SPT+WSP+WS
△	ROTARY BORING WSP+WS
☆	AUGER BORING SS
○	FIELD VANE VANE SHEAR TEST

REMARKS	
SPT	= STANDARD PENETRATION TEST
UD	= UNDISTURBED SAMPLING
WSP	= WATER STAND PIPE INSTALLATION
WS	= WATER SAMPLING
SS	= SOIL SAMPLING

Soil Symbol	Soil Type	Soil Layer Symbol	Soil Layer Name
F	Fill	B	Embankment/ Fill
Pt	Peat		
CPT	Peaty Clay	Pt	Peat
OcPt	Peaty Organic Clay		
CPT-S	Sandy Peaty Clay		
Oc	Organic Clay		
OcM	Silty Organic Clay	Oc	Organic Clay
OcS	Sandy Organic Clay		
CM	Silty Clay		
MOc	Organic Clayey Silt	Ac	Alluvial Clay
MC	Clayey Silt		
CS	Sandy Clay		
CS-M	Silty Sandy Clay	Acs	Alluvial Sandy Clay
MS	Sandy Silt		

SOc	Organic Clayey Sand		
SC	Clayey Sand		
SC-M	Silty Clayey Sand	As	Alluvial Sand
SM	Silty Sand		
SM-C	Clayey Silty Sand		
S	Sand		
SG	Gravelly Sand		
SC-G	Gravelly Clayey Sand		
GM	Silty Gravel	Ag	Alluvial Gravel
Bd	Boulder		
WR	Completely Weathered Rock	Wr	Completely Weathered Rock
R	Rock (Weathered Rock)	Br	Rock (Weathered Rock)

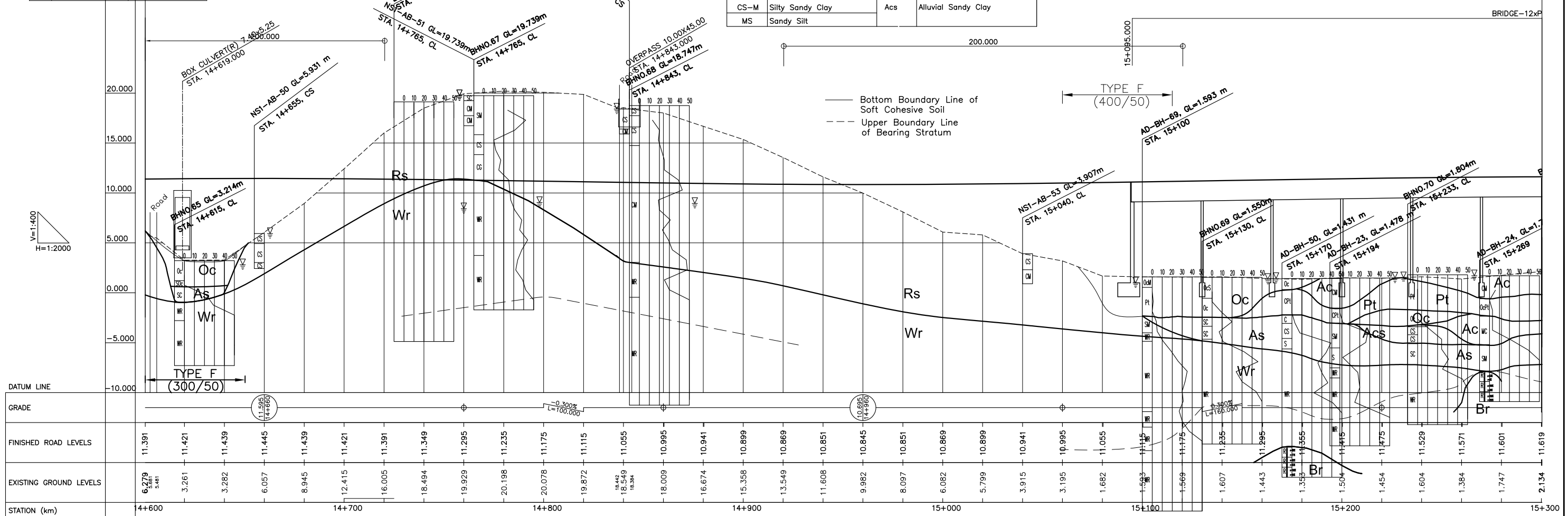

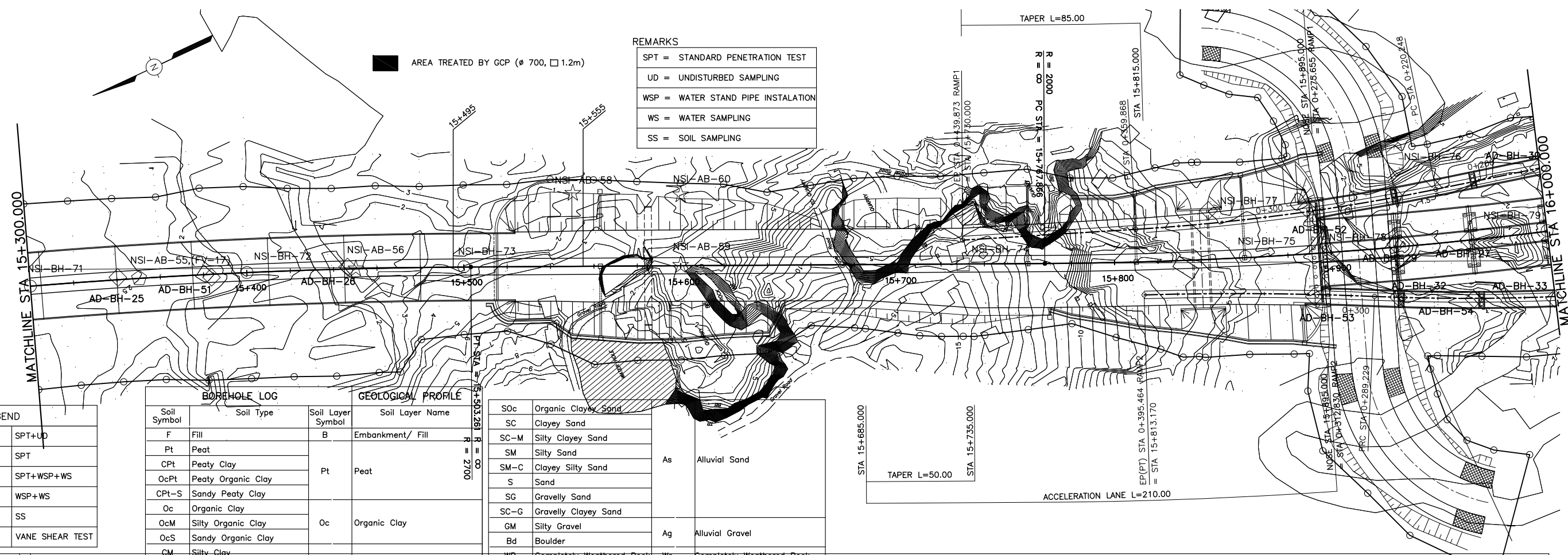

REMARKS

SPT	=	STANDARD PENETRATION TEST
UD	=	UNDISTURBED SAMPLING
WSP	=	WATER STAND PIPE INSTALLATION
WS	=	WATER SAMPLING
SS	=	SOIL SAMPLING

LEGEND

○	ROTARY BORING	SPT+UD
◇	ROTARY BORING	SPT
□	ROTARY BORING	SPT+WSP+WS
△	ROTARY BORING	WSP+WS
☆	AUGER BORING	SS
○	FIELD VANE	VANE SHEAR TEST

BORING LOG

Soil Symbol	Soil Type	Soil Layer Symbol	Soil Layer Name
F	Fill	B	Embankment/ Fill
Pt	Peat		
CPT	Peaty Clay		
OcPt	Peaty Organic Clay	Pt	Peat
CPT-S	Sandy Peaty Clay		
Oc	Organic Clay		
OcM	Silty Organic Clay	Oc	Organic Clay
OcS	Sandy Organic Clay		
CM	Silty Clay		
MOc	Organic Clayey Silt	Ac	Alluvial Clay
MC	Clayey Silt		
CS	Sandy Clay		
CS-M	Silty Sandy Clay	Acs	Alluvial Sandy Clay
MS	Sandy Silt		

GEOLOGICAL PROFILE

Soil Code	Soil Name	Soil Layer Symbol	Soil Layer Name
SOc	Organic Clayey Sand		
SC	Clayey Sand		
SC-M	Silty Clayey Sand		
SM	Silty Sand		
SM-C	Clayey Silty Sand	As	Alluvial Sand
S	Sand		
SG	Gravelly Sand		
SC-G	Gravelly Clayey Sand		
GM	Silty Gravel	Ag	Alluvial Gravel
Bd	Boulder		
WR	Completely Weathered Rock	Wr	Completely Weathered Rock
R	Rock (Weathered Rock)	Br	Rock (Weathered Rock)

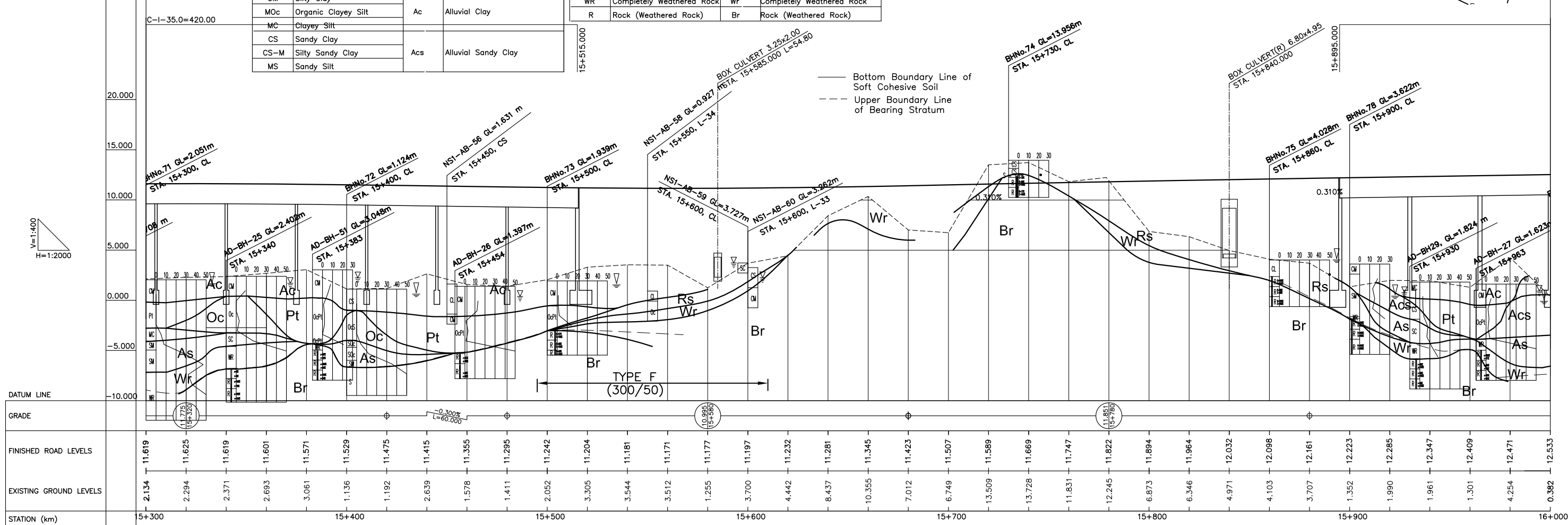

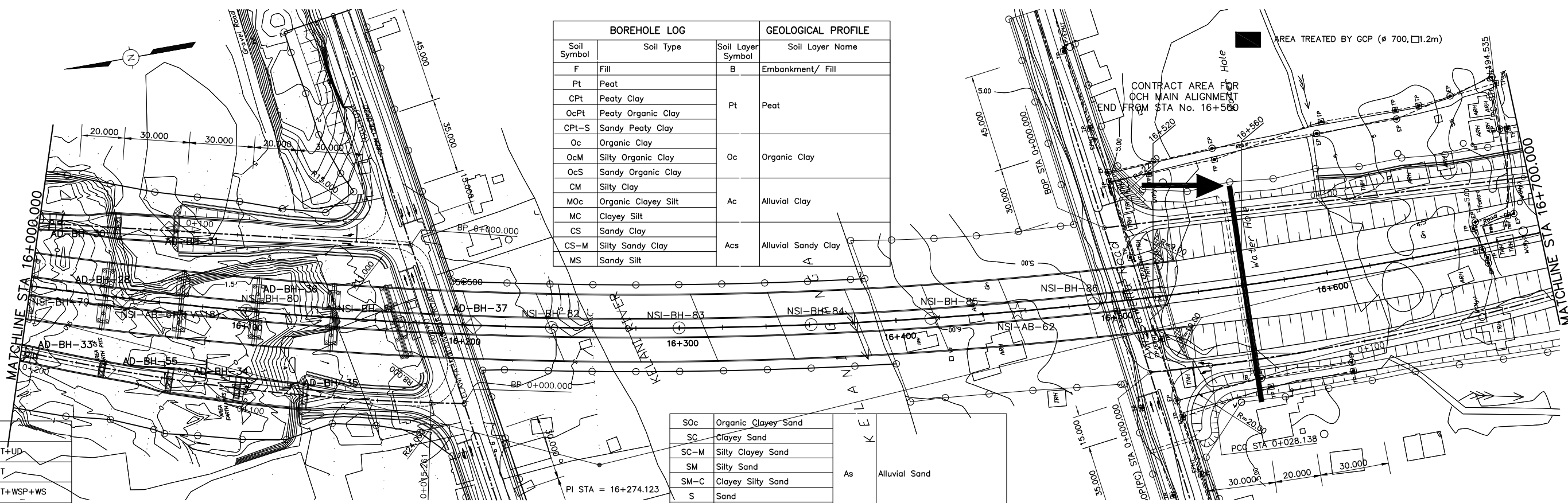

BOREHOLE LOG			GEOLOGICAL PROFILE	
Soil Symbol	Soil Type	Soil Layer Symbol	Soil Layer Name	
F	Fill	B	Embankment/ Fill	
Pt	Peat			
CpT	Peaty Clay	Pt	Peat	
OcPt	Peaty Organic Clay			
CpT-S	Sandy Peaty Clay			
Oc	Organic Clay			
OcM	Silty Organic Clay	Oc	Organic Clay	
OcS	Sandy Organic Clay			
CM	Silty Clay			
MOc	Organic Clayey Silt	Ac	Alluvial Clay	
MC	Clayey Silt			
CS	Sandy Clay			
CS-M	Silty Sandy Clay	Acs	Alluvial Sandy Clay	
MS	Sandy Silt			

SOc	Organic Clayey Sand		
SC	Clayey Sand		
SC-M	Silty Clayey Sand		
SM	Silty Sand	As	Alluvial Sand
SM-C	Clayey Silty Sand		
S	Sand		
SG	Gravelly Sand		
SC-G	Gravelly Clayey Sand		
GM	Silty Gravel		
Bd	Boulder	Ag	Alluvial Gravel
WR	Completely Weathered Rock	Wr	Completely Weathered Rock
R	Rock (Weathered Rock)	Br	Rock (Weathered Rock)

LEGEND	
○	ROTARY BORING SPT+UD
◇	ROTARY BORING SPT
□	ROTARY BORING SPT+WSP+WS
△	ROTARY BORING WSP+WS
☆	AUGER BORING SS
○	FIELD VANE VANE SHEAR TEST

REMARKS	
SPT	= STANDARD PENETRATION TEST
UD	= UNDISTURBED SAMPLING
WSP	= WATER STAND PIPE INSTALLATION
WS	= WATER SAMPLING
SS	= SOIL SAMPLING

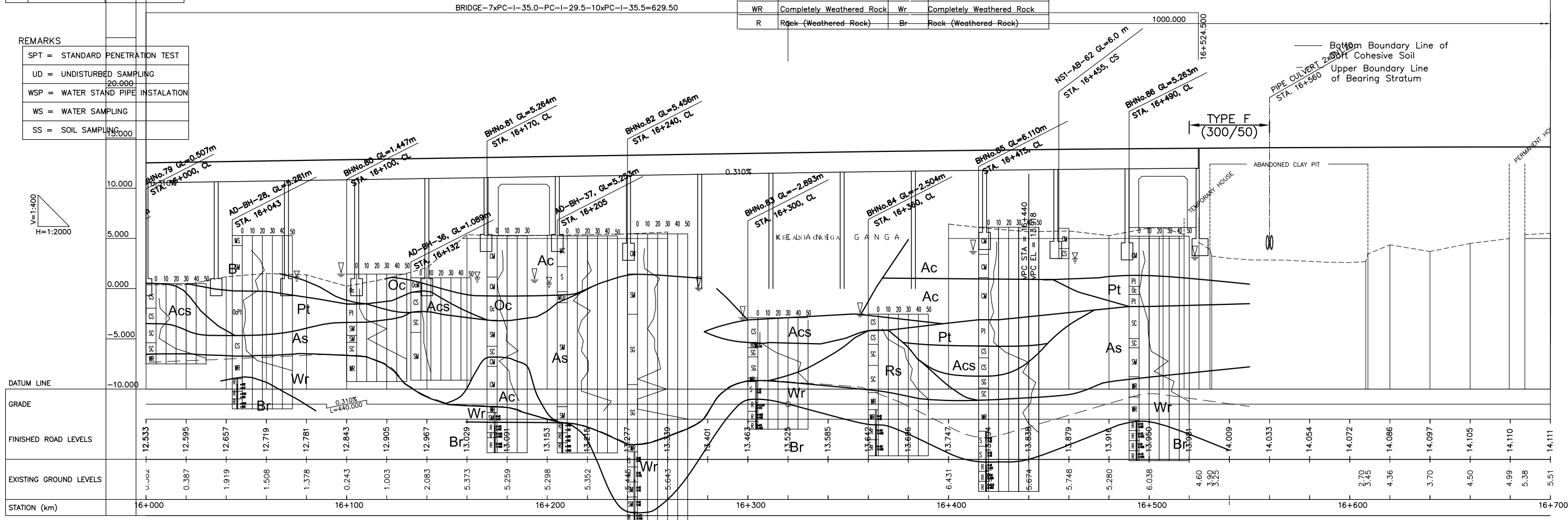

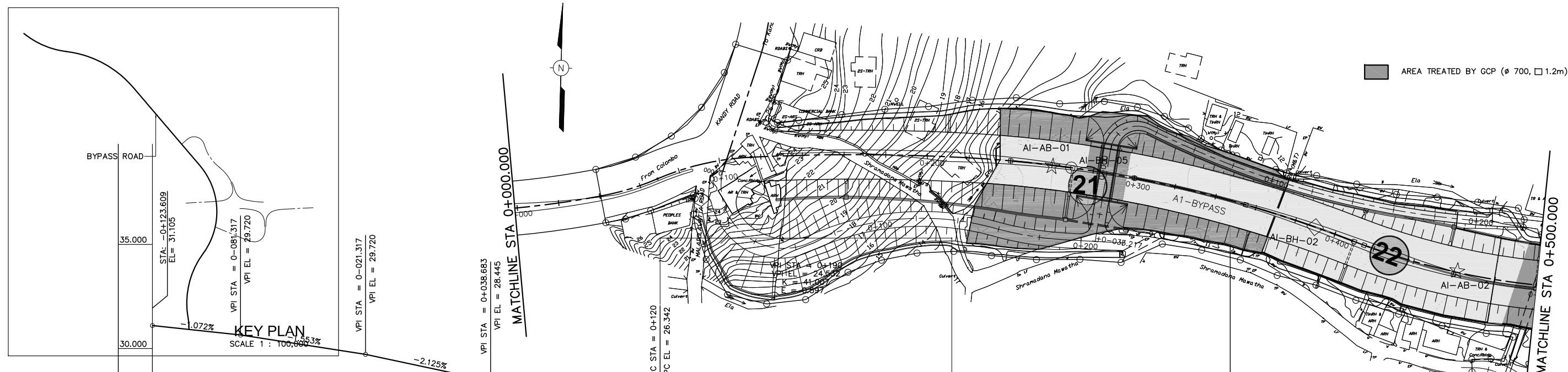

LEGEND

○	ROTARY BORING	SPT+UD
◇	ROTARY BORING	SPT
□	ROTARY BORING	SPT+WSP+WS
△	ROTARY BORING	WSP+WS
☆	AUGER BORING	SS
⬠	FIELD VANE	VANE SHEAR TEST

REMARKS

SPT	= STANDARD PENETRATION TEST
UD	= UNDISTURBED SAMPLING
WSP	= WATER STAND PIPE INSTALLATION
WS	= WATER SAMPLING
SS	= SOIL SAMPLING

BOREHOLE LOG

Soil Symbol	Soil Type	Soil Layer Symbol	Soil Layer Name
F	Fill	B	Embankment/ Fill
Pt	Peat		
CpT	Peaty Clay	Pt	Peat
OcPt	Peaty Organic Clay		
CpT-S	Sandy Peaty Clay		
Oc	Organic Clay		
OcM	Silty Organic Clay	Oc	Organic Clay
OcS	Sandy Organic Clay		
CM	Silty Clay		
MOc	Organic Clayey Silt	Ac	Alluvial Clay
MC	Clayey Silt		
CS	Sandy Clay		
CS-M	Silty Sandy Clay	Acs	Alluvial Sandy Clay
MS	Sandy Silt		

GEOLOGICAL PROFILE

Soil Symbol	Soil Type	Soil Layer Name	
SoC	Organic Clayey Sand		
SC	Clayey Sand		
SC-M	Silty Clayey Sand		
SM	Silty Sand	As	Alluvial Sand
SM-C	Clayey Silty Sand		
S	Sand		
SG	Gravelly Sand		
SC-G	Gravelly Clayey Sand		
GM	Silty Gravel	Ag	Alluvial Gravel
Bd	Boulder		
WR	Completely Weathered Rock	Wr	Completely Weathered Rock
R	Rock (Weathered Rock)	Br	Rock (Weathered Rock)

TYPE F (300/50) TYPE C (300/50) TYPE C (200/50)

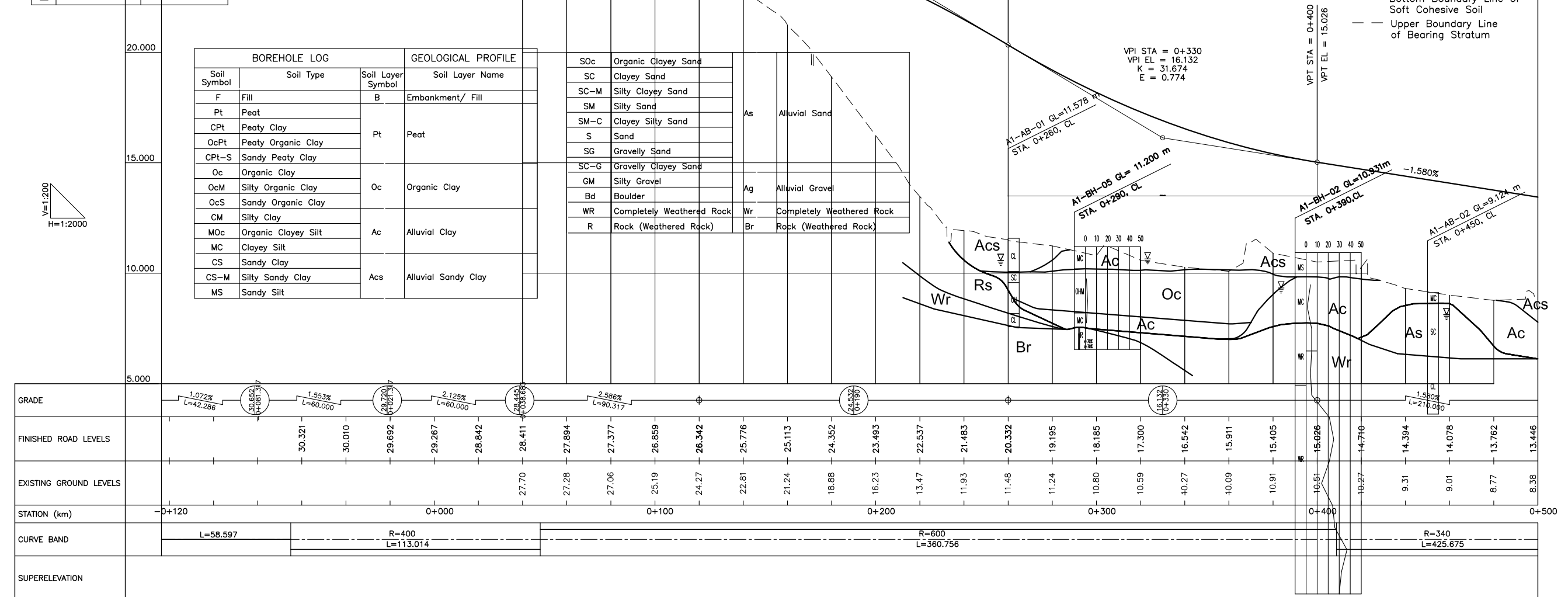

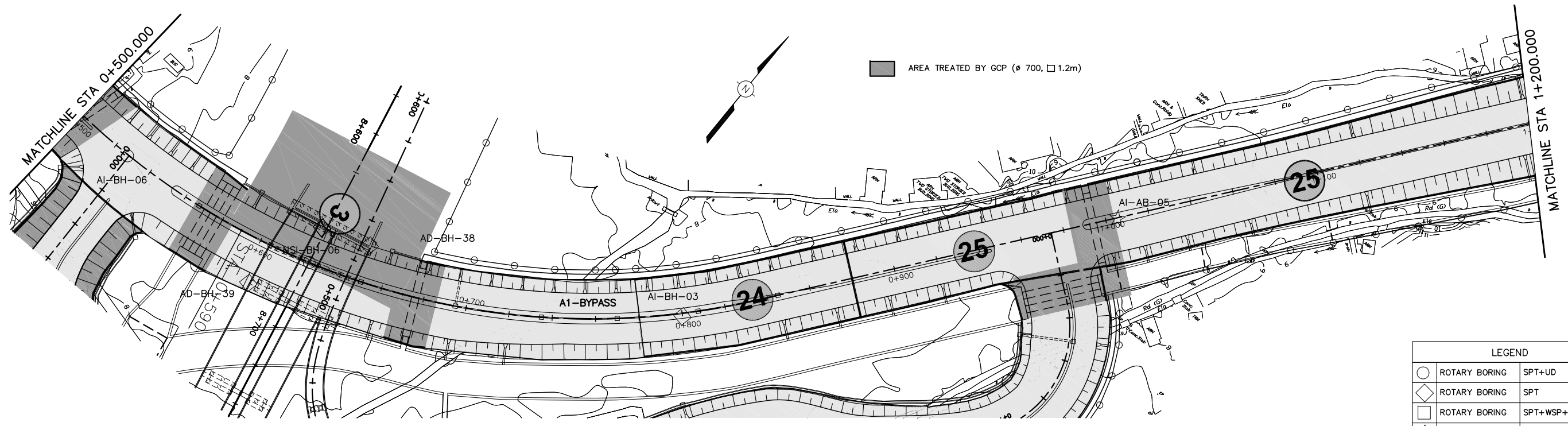

LEGEND	
○	ROTARY BORING SPT+UD
◇	ROTARY BORING SPT
□	ROTARY BORING SPT+WSP+WS
△	ROTARY BORING WSP+WS
☆	AUGER BORING SS
▽	FIELD VANE VANE SHEAR TEST

— Bottom Boundary Line of Soft Cohesive Soil
 - - - Upper Boundary Line of Bearing Stratum

BOREHOLE LOG			GEOLOGICAL PROFILE	
Soil Symbol	Soil Type	Soil Layer Symbol	Soil Layer Name	
F	Fill	B	Embankment/ Fill	
Pt	Peat			
CPt	Peaty Clay	Pt	Peat	
OcPt	Peaty Organic Clay			
CPt-S	Sandy Peaty Clay			
Oc	Organic Clay			
OcM	Silty Organic Clay	Oc	Organic Clay	
OcS	Sandy Organic Clay			
CM	Silty Clay			
MOc	Organic Clayey Silt	Ac	Alluvial Clay	
MC	Clayey Silt			
CS	Sandy Clay			
CS-M	Silty Sandy Clay	Acs	Alluvial Sandy Clay	
MS	Sandy Silt			

S0c	Organic Clayey Sand		
SC	Clayey Sand		
SC-M	Silty Clayey Sand		
SM	Silty Sand	As	Alluvial Sand
SM-C	Clayey Silty Sand		
S	Sand		
SG	Gravelly Sand		
SC-G	Gravelly Clayey Sand		
GM	Silty Gravel	Ag	Alluvial Gravel
Bd	Boulder		
WR	Completely Weathered Rock	Wr	Completely Weathered Rock
R	Rock (Weathered Rock)	Br	Rock (Weathered Rock)

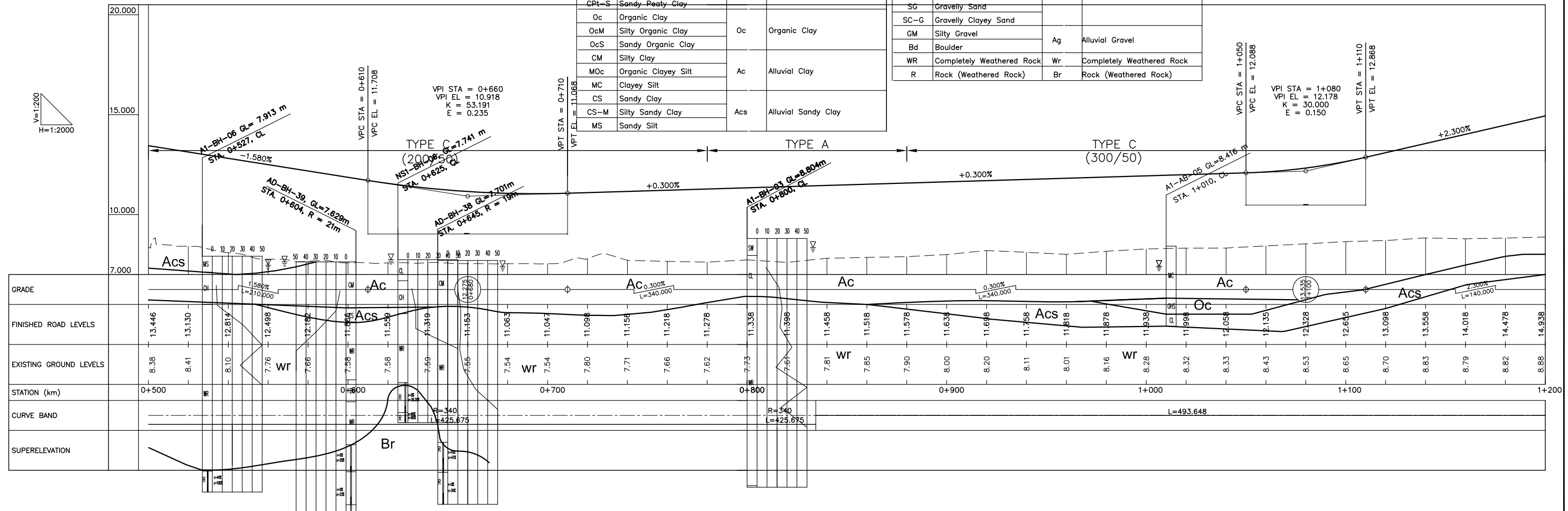

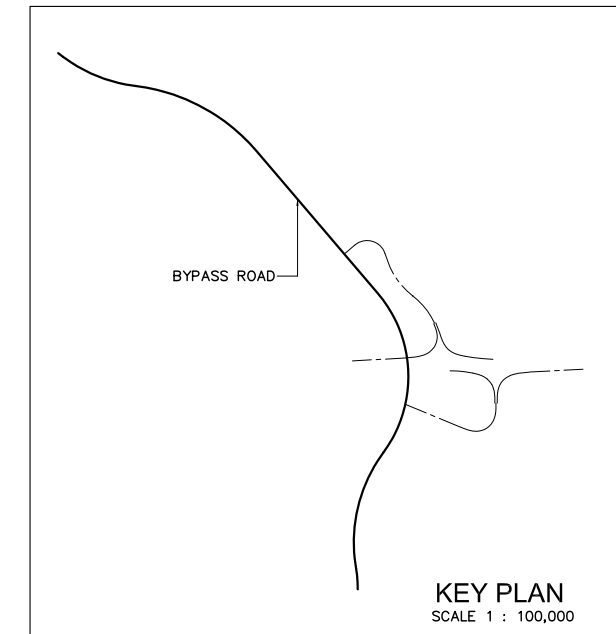
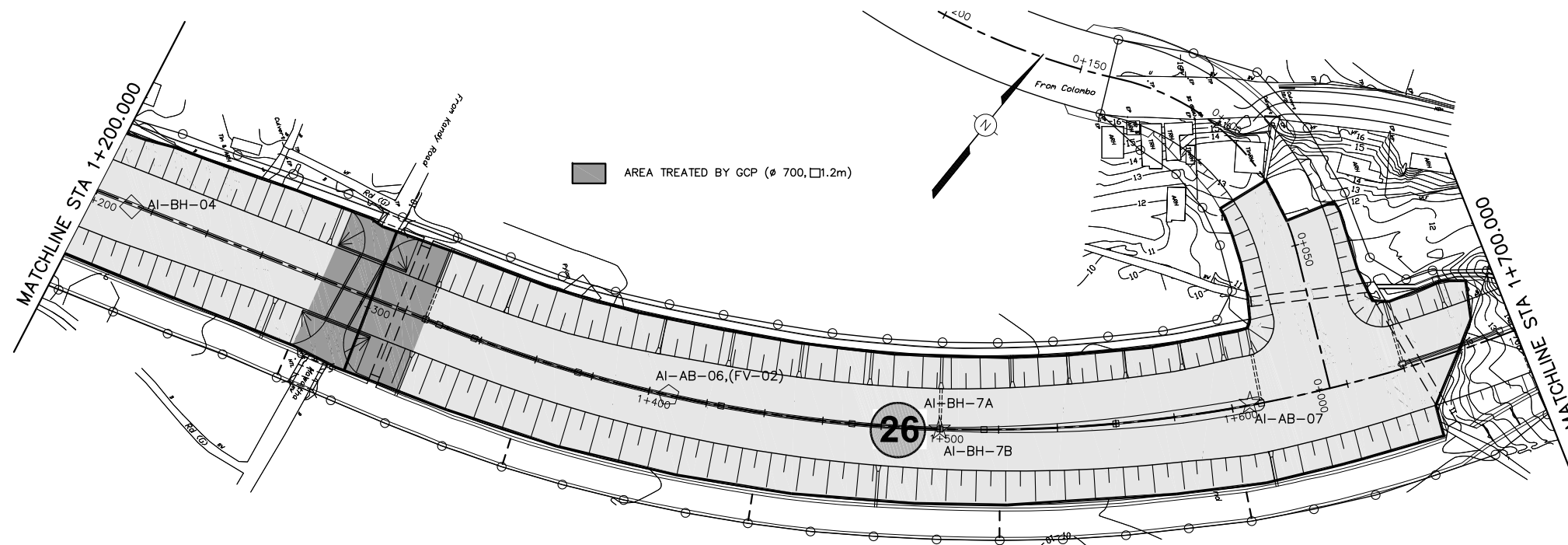

— Bottom Boundary Line of Soft Cohesive Soil
 - - - Upper Boundary Line of Bearing Stratum

BOREHOLE LOG			GEOLOGICAL PROFILE	
Soil Symbol	Soil Type	Soil Layer Symbol	Soil Layer Name	
F	Fill	B	Embankment/ Fill	
Pt	Peat			
Cpt	Peaty Clay	Pt	Peat	
OcPt	Peaty Organic Clay			
Cpt-S	Sandy Peaty Clay			
Oc	Organic Clay	Oc	Organic Clay	
OcM	Silty Organic Clay			
OcS	Sandy Organic Clay			
CM	Silty Clay			
MOc	Organic Clayey Silt	Ac	Alluvial Clay	
MC	Clayey Silt			
CS	Sandy Clay			
CS-M	Silty Sandy Clay	Acs	Alluvial Sandy Clay	
MS	Sandy Silt			

SOc	Organic Clayey Sand		
SC	Clayey Sand		
SC-M	Silty Clayey Sand		
SM	Silty Sand	As	Alluvial Sand
SM-C	Clayey Silty Sand		
S	Sand		
SG	Gravelly Sand		
SC-G	Gravelly Clayey Sand		
GM	Silty Gravel	Ag	Alluvial Gravel
Bd	Boulder		
WR	Completely Weathered Rock	Wr	Completely Weathered Rock
R	Rock (Weathered Rock)	Br	Rock (Weathered Rock)

LEGEND	
○	ROTARY BORING SPT+UD
◇	ROTARY BORING SPT
□	ROTARY BORING SPT+WSP+WS
△	ROTARY BORING WSP+WS
☆	AUGER BORING SS
○	FIELD VANE VANE SHEAR TEST

REMARKS	
SPT	= STANDARD PENETRATION TEST
UD	= UNDISTURBED SAMPLING
WSP	= WATER STAND PIPE INSTALLATION
WS	= WATER SAMPLING
SS	= SOIL SAMPLING

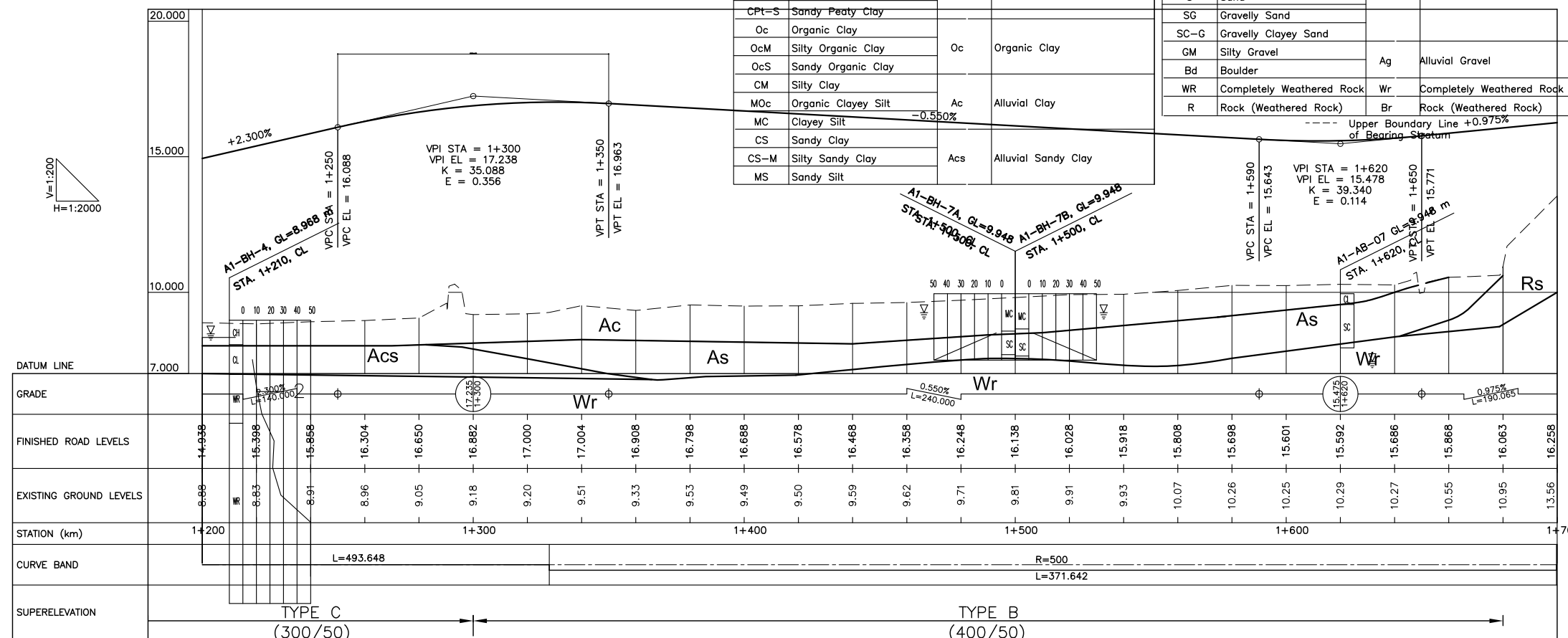

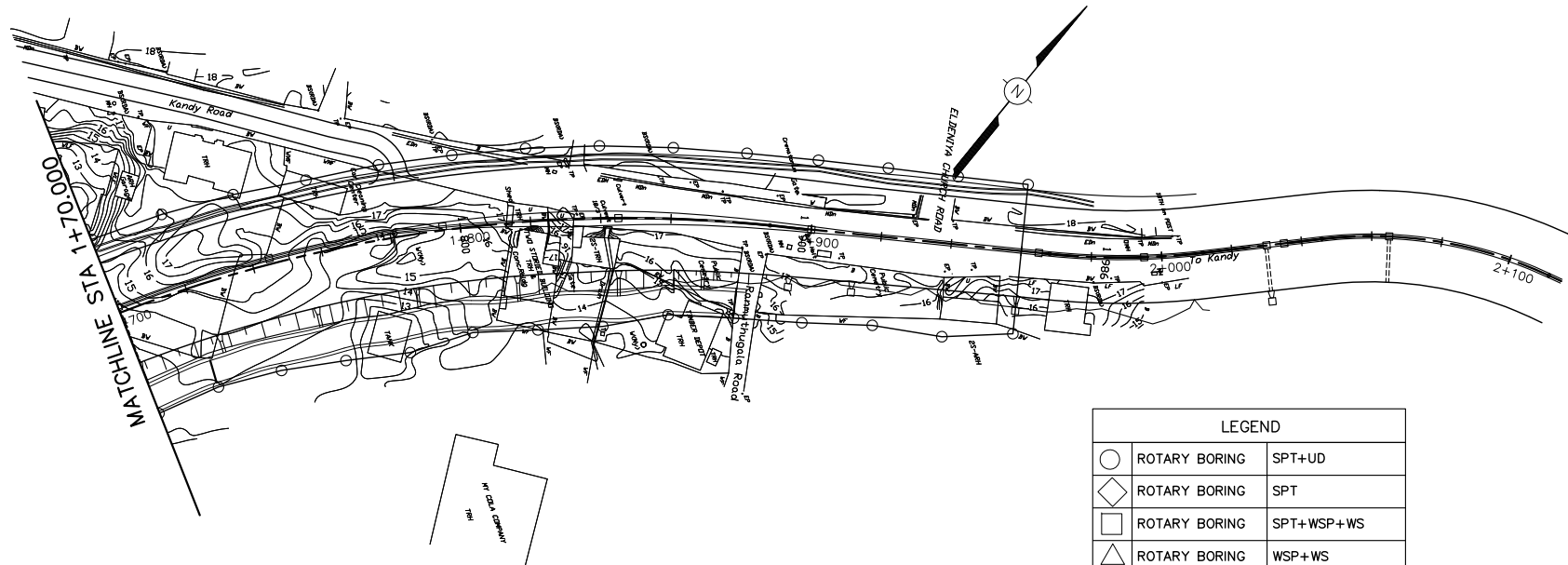

LEGEND	
○	ROTARY BORING SPT+UD
◇	ROTARY BORING SPT
□	ROTARY BORING SPT+WSP+WS
△	ROTARY BORING WSP+WS
☆	AUGER BORING SS
◇	FIELD VANE VANE SHEAR TEST

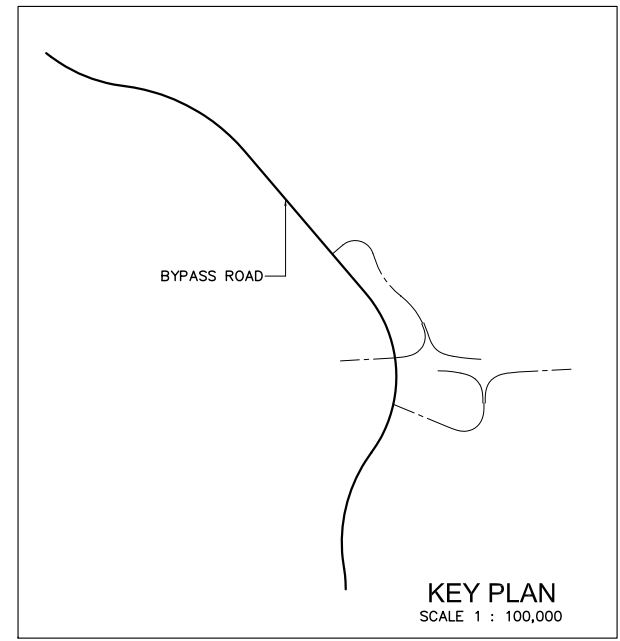

— Bottom Boundary Line of Soft Cohesive Soil
 - - - Upper Boundary Line of Bearing Stratum

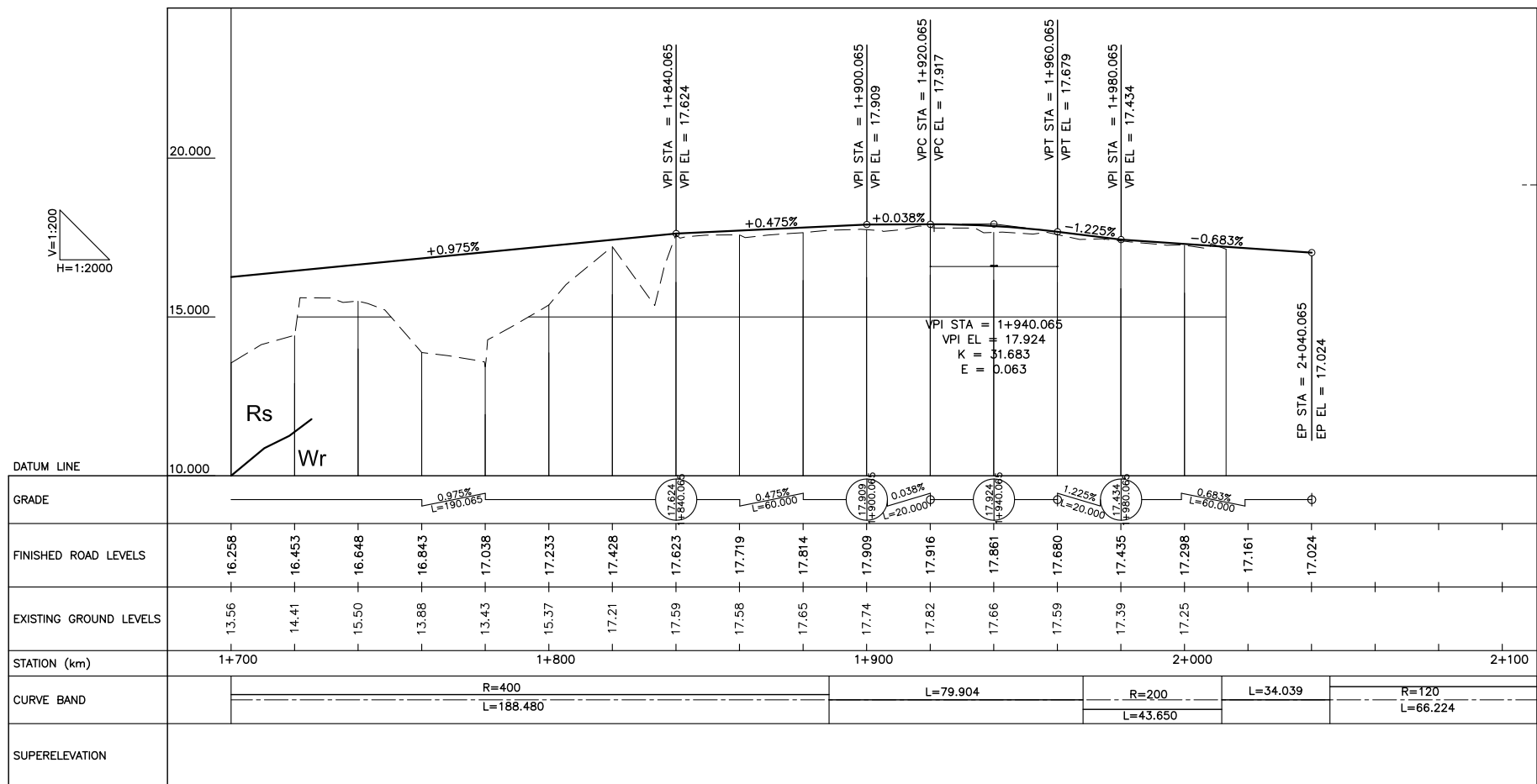

BOREHOLE LOG			GEOLOGICAL PROFILE	
Soil Symbol	Soil Type	Soil Layer Symbol	Soil Layer Name	
F	Fill	B	Embankment/ Fill	
Pt	Peat	Pt	Peat	
CPT	Peaty Clay			
OcPt	Peaty Organic Clay			
CPT-S	Sandy Peaty Clay	Oc	Organic Clay	
Oc	Organic Clay			
OcM	Silty Organic Clay	Oc	Organic Clay	
OcS	Sandy Organic Clay			
CM	Silty Clay	Ac	Alluvial Clay	
MOc	Organic Clayey Silt			
MC	Clayey Silt	Acs	Alluvial Sandy Clay	
CS	Sandy Clay			
CS-M	Silty Sandy Clay			
MS	Sandy Silt			

SoC	Organic Clayey Sand	As	Alluvial Sand
SC	Clayey Sand		
SC-M	Silty Clayey Sand		
SM	Silty Sand		
SM-C	Clayey Silty Sand		
S	Sand		
SG	Gravelly Sand	Ag	Alluvial Gravel
SC-G	Gravelly Clayey Sand		
GM	Silty Gravel		
Bd	Boulder		
WR	Completely Weathered Rock	Wr	Completely Weathered Rock
R	Rock (Weathered Rock)	Br	Rock (Weathered Rock)

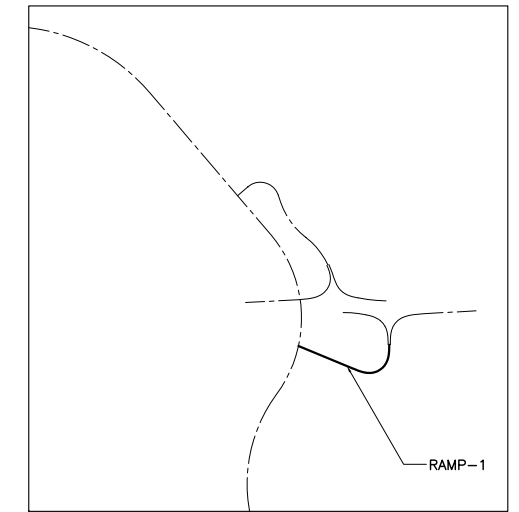
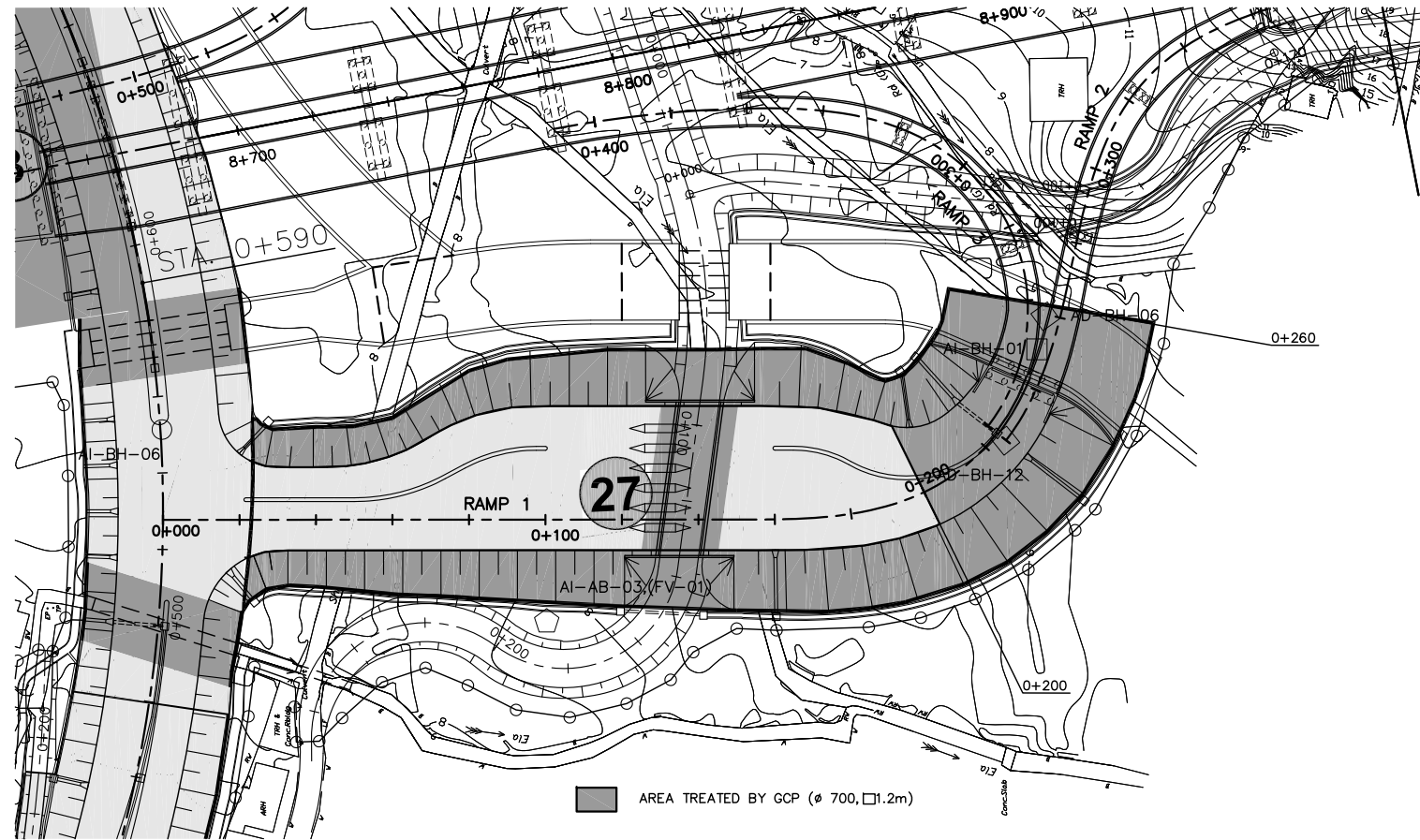
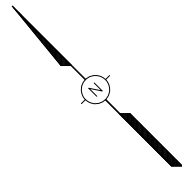

KEY PLAN
SCALE 1 : 100,000

LEGEND	
○	ROTARY BORING SPT+UD
◇	ROTARY BORING SPT
□	ROTARY BORING SPT+WSP+WS
△	ROTARY BORING WSP+WS
☆	AUGER BORING SS
◇	FIELD VANE VANE SHEAR TEST

REMARKS	
SPT =	STANDARD PENETRATION TEST
UD =	UNDISTURBED SAMPLING
WSP =	WATER STAND PIPE INSTALLATION
WS =	WATER SAMPLING
SS =	SOIL SAMPLING

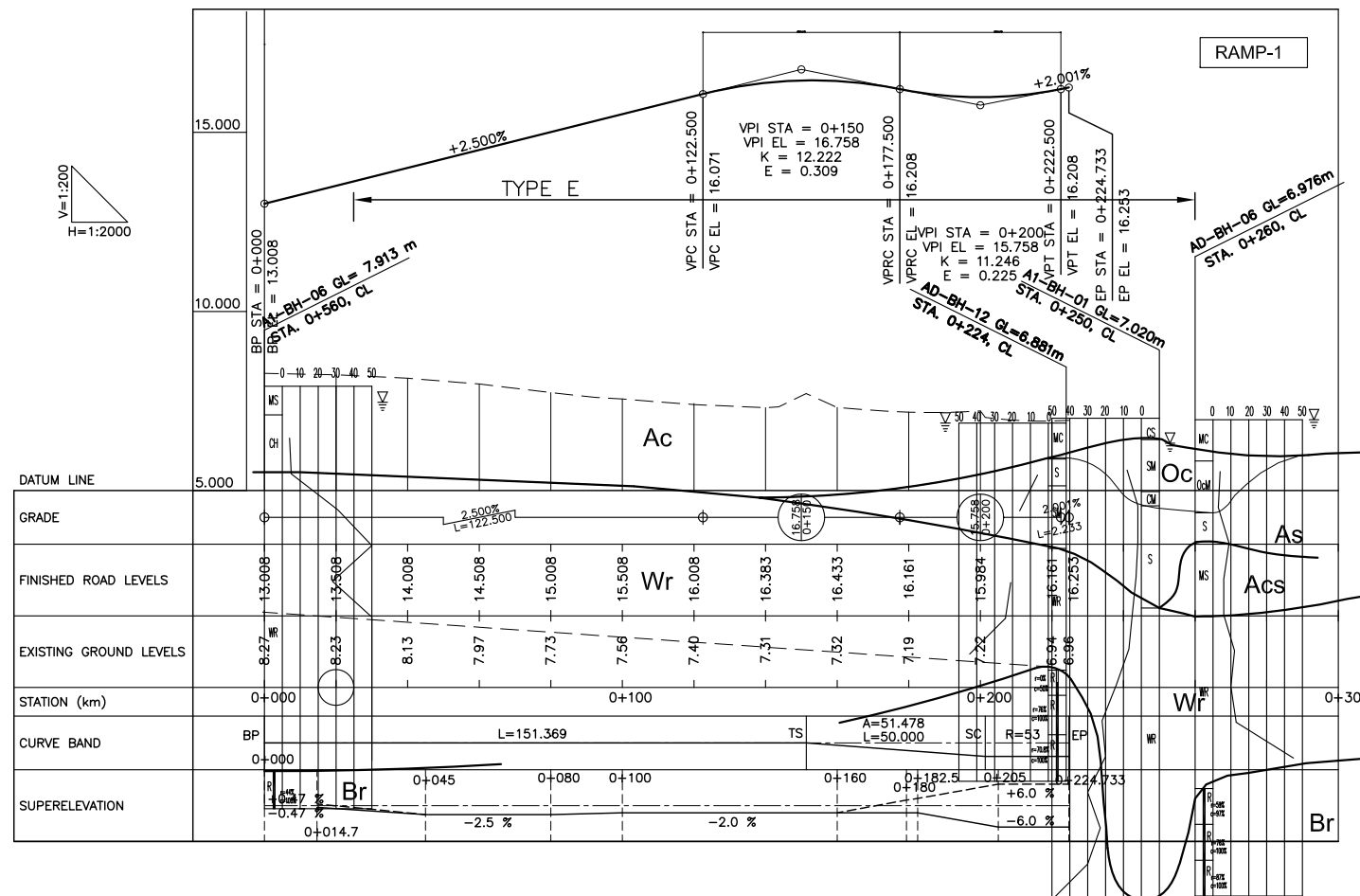

— Bottom Boundary Line of Soft Cohesive Soil
 - - Upper Boundary Line of Bearing Stratum

BOREHOLE LOG			GEOLOGICAL PROFILE
Soil Symbol	Soil Type	Soil Layer Symbol	Soil Layer Name
F	Fill	B	Embankment/ Fill
Pt	Peat		
CPT	Peaty Clay	Pt	Peat
OcPt	Peaty Organic Clay		
CPT-S	Sandy Peaty Clay		
Oc	Organic Clay	Oc	Organic Clay
OcM	Silty Organic Clay		
OcS	Sandy Organic Clay		
CM	Silty Clay		
MOc	Organic Clayey Silt	Ac	Alluvial Clay
MC	Clayey Silt		
CS	Sandy Clay		
CS-M	Silty Sandy Clay	Acs	Alluvial Sandy Clay
MS	Sandy Silt		
SOc	Organic Clayey Sand		
SC	Clayey Sand		
SC-M	Silty Clayey Sand	As	Alluvial Sand
SM	Silty Sand		
SM-C	Clayey Silty Sand		
S	Sand		
SG	Gravelly Sand		
SC-G	Gravelly Clayey Sand		
GM	Silty Gravel	Ag	Alluvial Gravel
Bd	Boulder		
WR	Completely Weathered Rock	Wr	Completely Weathered Rock
R	Rock (Weathered Rock)	Br	Rock (Weathered Rock)

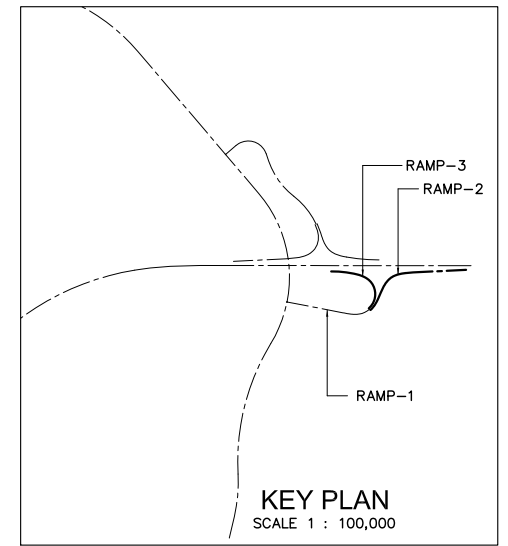
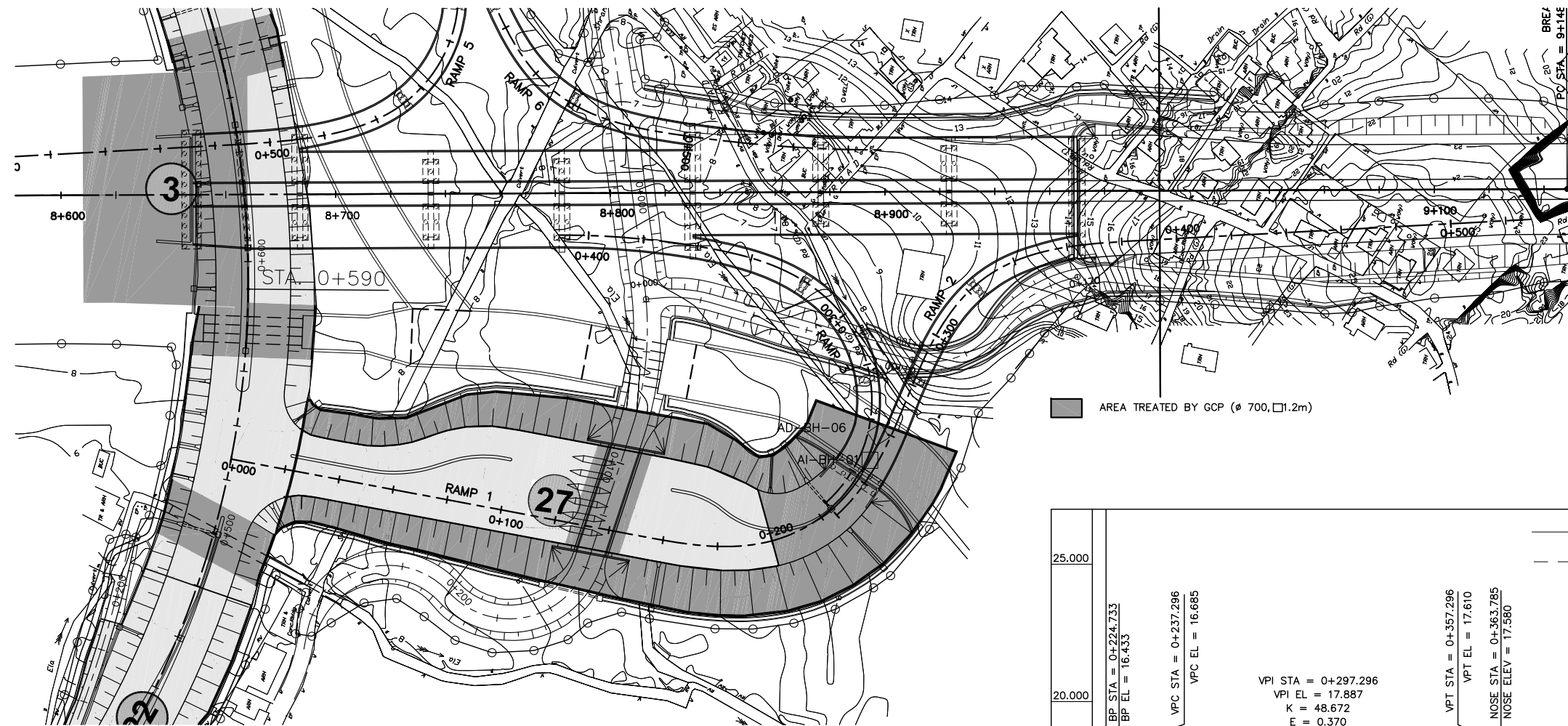

BOREHOLE LOG			GEOLOGICAL PROFILE	
Soil Symbol	Soil Type	Soil Layer Symbol	Soil Layer Name	
F	Fill	B	Embankment/ Fill	
Pt	Peat	Pt	Peat	
CPt	Peaty Clay			
OcPt	Peaty Organic Clay			
CPT-S	Sandy Peaty Clay			
Oc	Organic Clay			
OcM	Silty Organic Clay	Oc	Organic Clay	
OcS	Sandy Organic Clay	Ac	Alluvial Clay	
CM	Silty Clay			
MOc	Organic Clayey Silt			
MC	Clayey Silt			
CS	Sandy Clay			
CS-M	Silty Sandy Clay			
MS	Sandy Silt			
SOc	Organic Clayey Sand			
SC	Clayey Sand			
SC-M	Silty Clayey Sand			
SM	Silty Sand	As	Alluvial Sand	
SM-C	Clayey Silty Sand			
S	Sand	Ag	Alluvial Gravel	
SG	Gravelly Sand			
SC-G	Gravelly Clayey Sand			
GM	Silty Gravel			
Bd	Boulder	Wr	Completely Weathered Rock	
WR	Completely Weathered Rock			
R	Rock (Weathered Rock)	Br	Rock (Weathered Rock)	

LEGEND			
○	ROTARY BORING	SPT+UD	
◇	ROTARY BORING	SPT	
□	ROTARY BORING	SPT+WSP+WS	
△	ROTARY BORING	WSP+WS	
☆	AUGER BORING	SS	
▽	FIELD VANE	VANE SHEAR TEST	

REMARKS

SPT	=	STANDARD PENETRATION TEST
UD	=	UNDISTURBED SAMPLING
WSP	=	WATER STAND PIPE INSTALLATION
WS	=	WATER SAMPLING
SS	=	SOIL SAMPLING

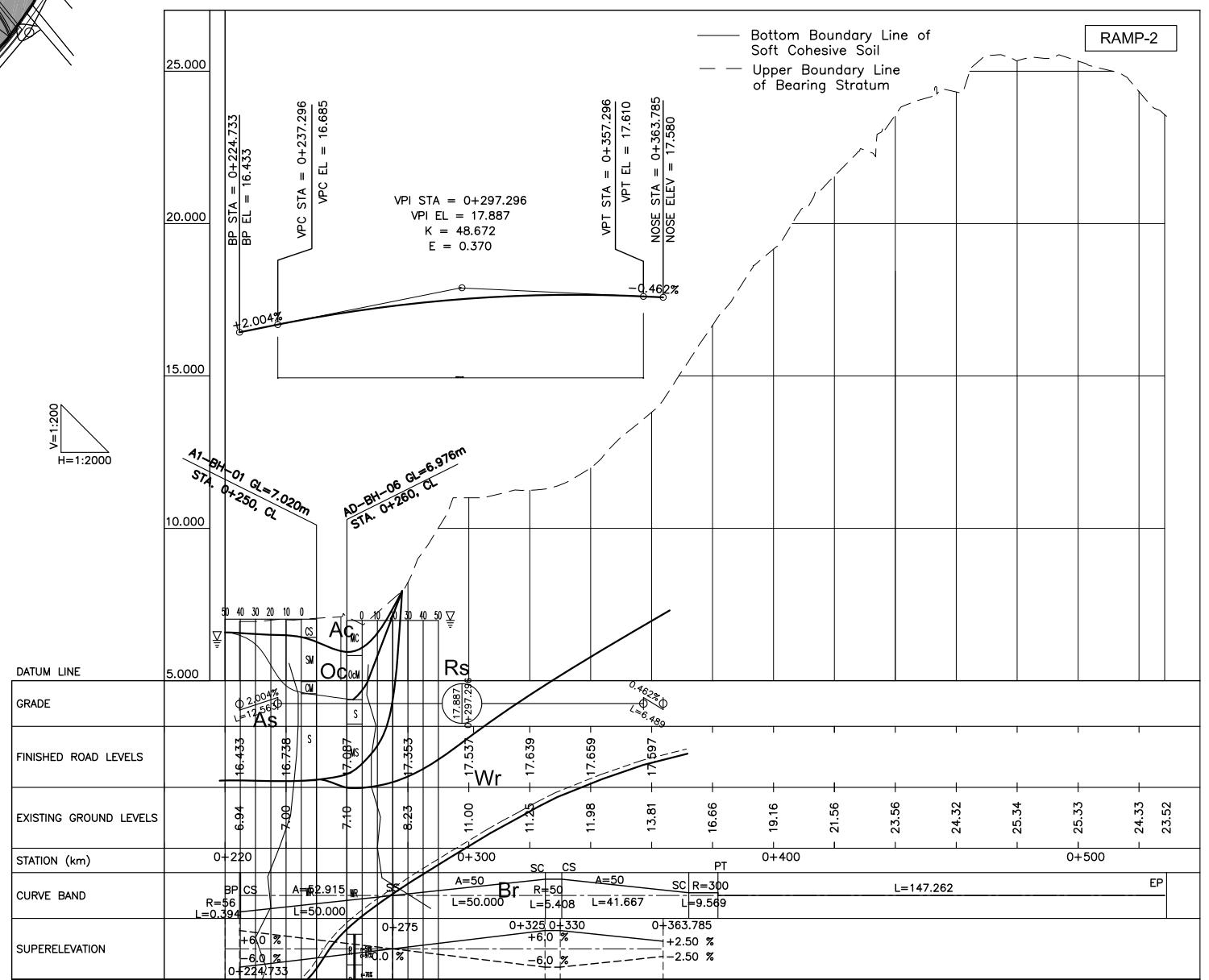

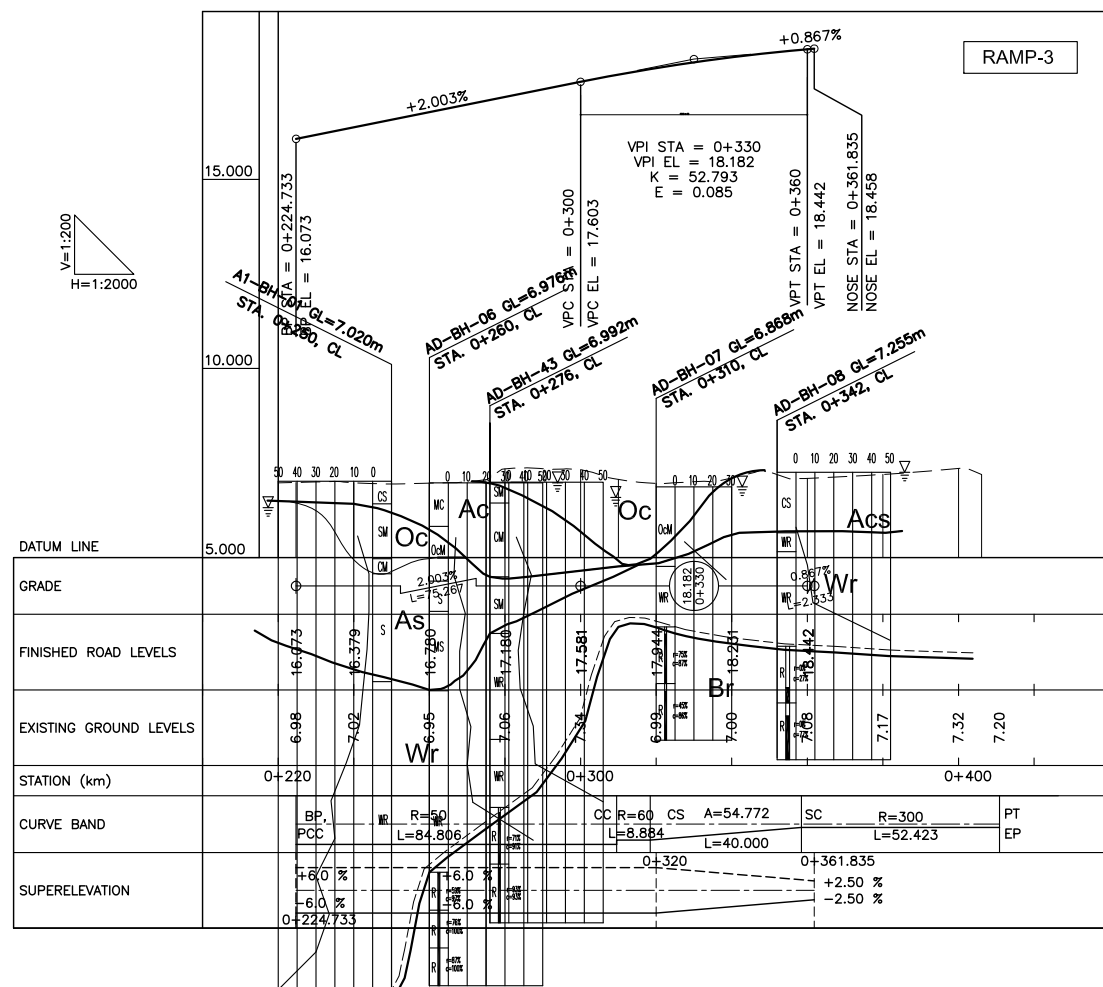
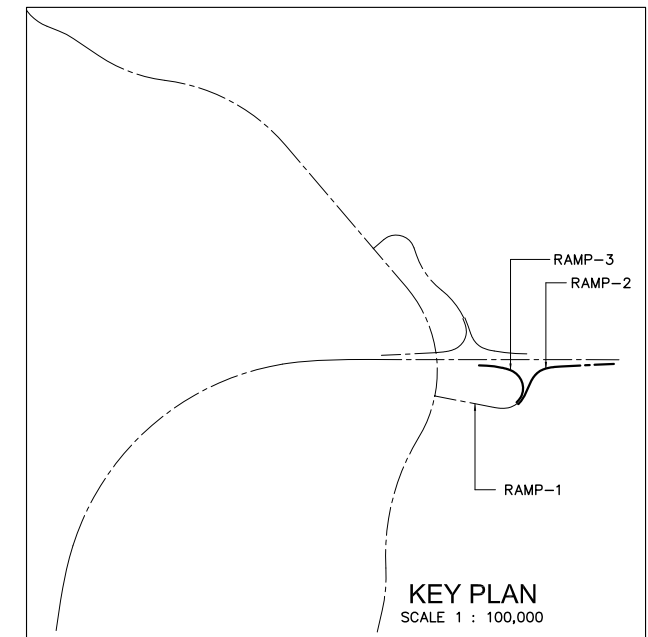
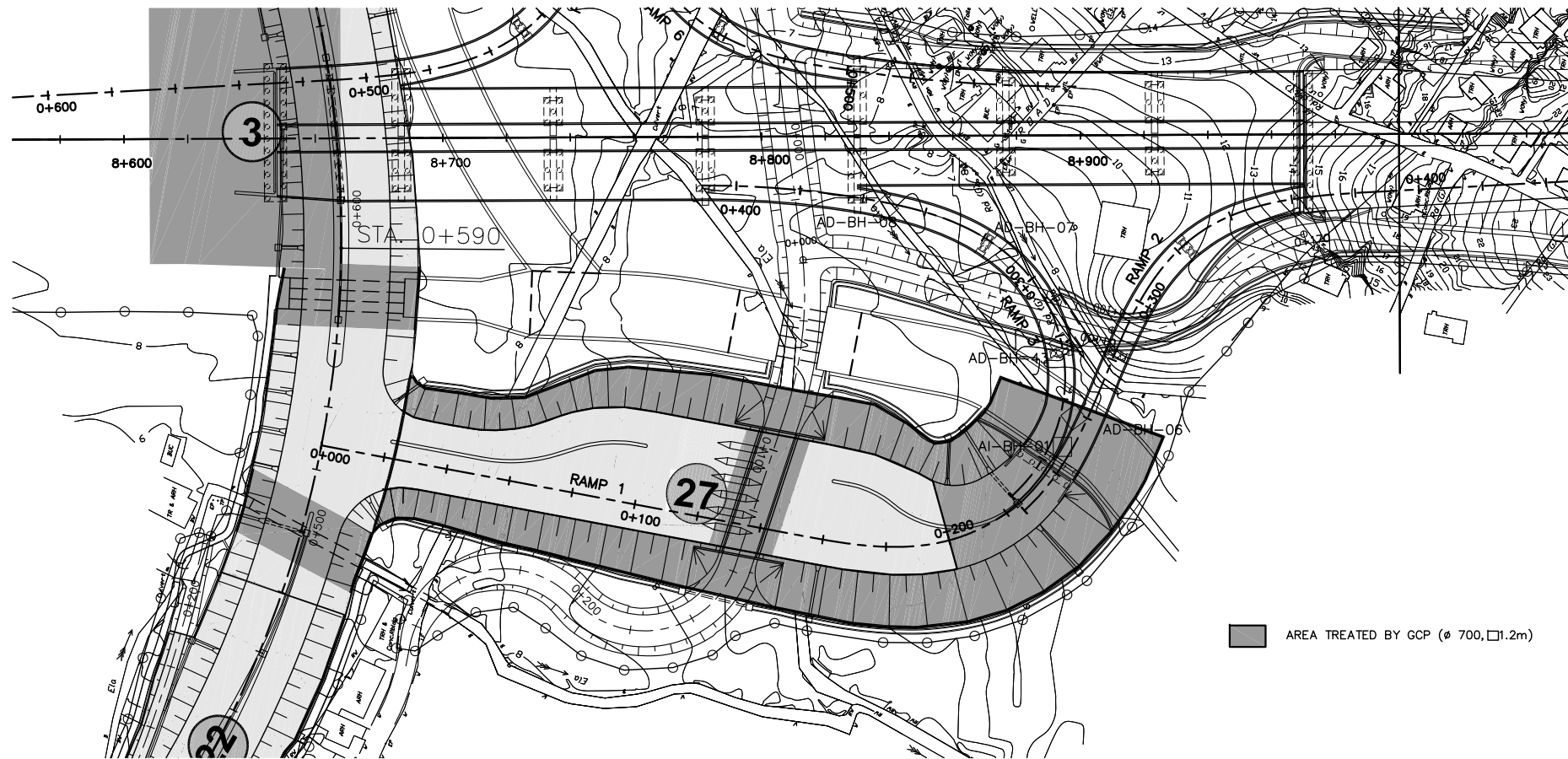

— Bottom Boundary Line of Soft Cohesive Soil
 - - - Upper Boundary Line of Bearing Stratum

LEGEND			
○	ROTARY BORING	SPT+UD	
◇	ROTARY BORING	SPT	
□	ROTARY BORING	SPT+WSP+WS	
△	ROTARY BORING	WSP+WS	
☆	AUGER BORING	SS	
◇	FIELD VANE	VANE SHEAR TEST	

REMARKS

SPT = STANDARD PENETRATION TEST
UD = UNDISTURBED SAMPLING
WSP = WATER STAND PIPE INSTALLATION
WS = WATER SAMPLING
SS = SOIL SAMPLING

BOREHOLE LOG			GEOLOGICAL PROFILE	
Soil Symbol	Soil Type	Soil Layer Symbol	Soil Layer Name	
F	Fill	B	Embankment/ Fill	
Pt	Peat			
CpT	Peaty Clay	Pt	Peat	
OcPt	Peaty Organic Clay			
CPT-S	Sandy Peaty Clay			
Oc	Organic Clay			
OcM	Silty Organic Clay	Oc	Organic Clay	
OcS	Sandy Organic Clay			
CM	Silty Clay			
MOc	Organic Clayey Silt	Ac	Alluvial Clay	
MC	Clayey Silt			
CS	Sandy Clay			
CS-M	Silty Sandy Clay	Acs	Alluvial Sandy Clay	
MS	Sandy Silt			
SOc	Organic Clayey Sand			
SC	Clayey Sand			
SC-M	Silty Clayey Sand			
SM	Silty Sand	As	Alluvial Sand	
SM-C	Clayey Silty Sand			
S	Sand			
SG	Gravelly Sand			
SC-G	Gravelly Clayey Sand			
GM	Silty Gravel	Ag	Alluvial Gravel	
Bd	Boulder			
WR	Completely Weathered Rock	Wr	Completely Weathered Rock	
R	Rock (Weathered Rock)	Br	Rock (Weathered Rock)	

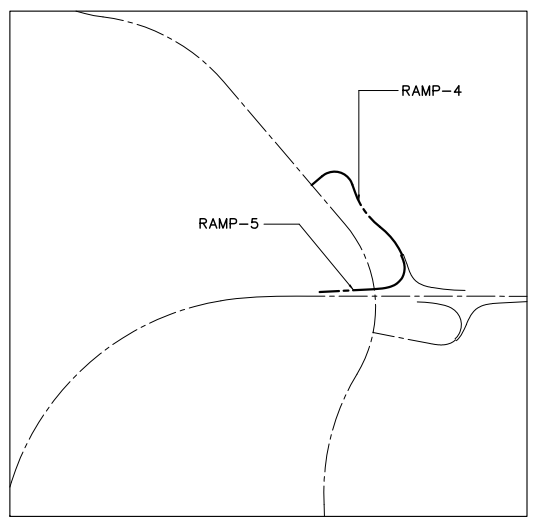
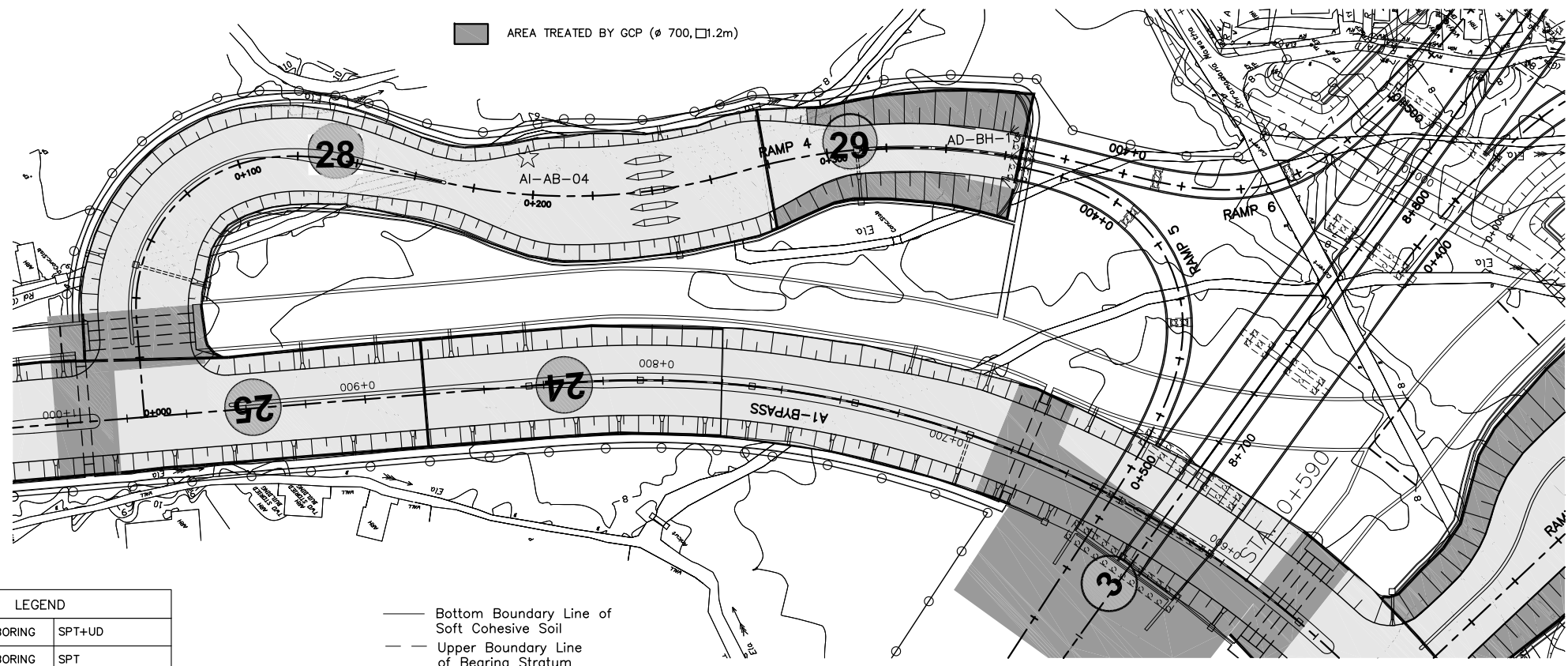

KEY PLAN
SCALE 1 : 100,000

LEGEND

○	ROTARY BORING	SPT+UD
◇	ROTARY BORING	SPT
□	ROTARY BORING	SPT+WSP+WS
△	ROTARY BORING	WSP+WS
☆	AUGER BORING	SS
◇	FIELD VANE	VANE SHEAR TEST

— Bottom Boundary Line of Soft Cohesive Soil
 - - - Upper Boundary Line of Bearing Stratum

REMARKS

SPT = STANDARD PENETRATION TEST
UD = UNDISTURBED SAMPLING
WSP = WATER STAND PIPE INSTALLATION
WS = WATER SAMPLING
SS = SOIL SAMPLING

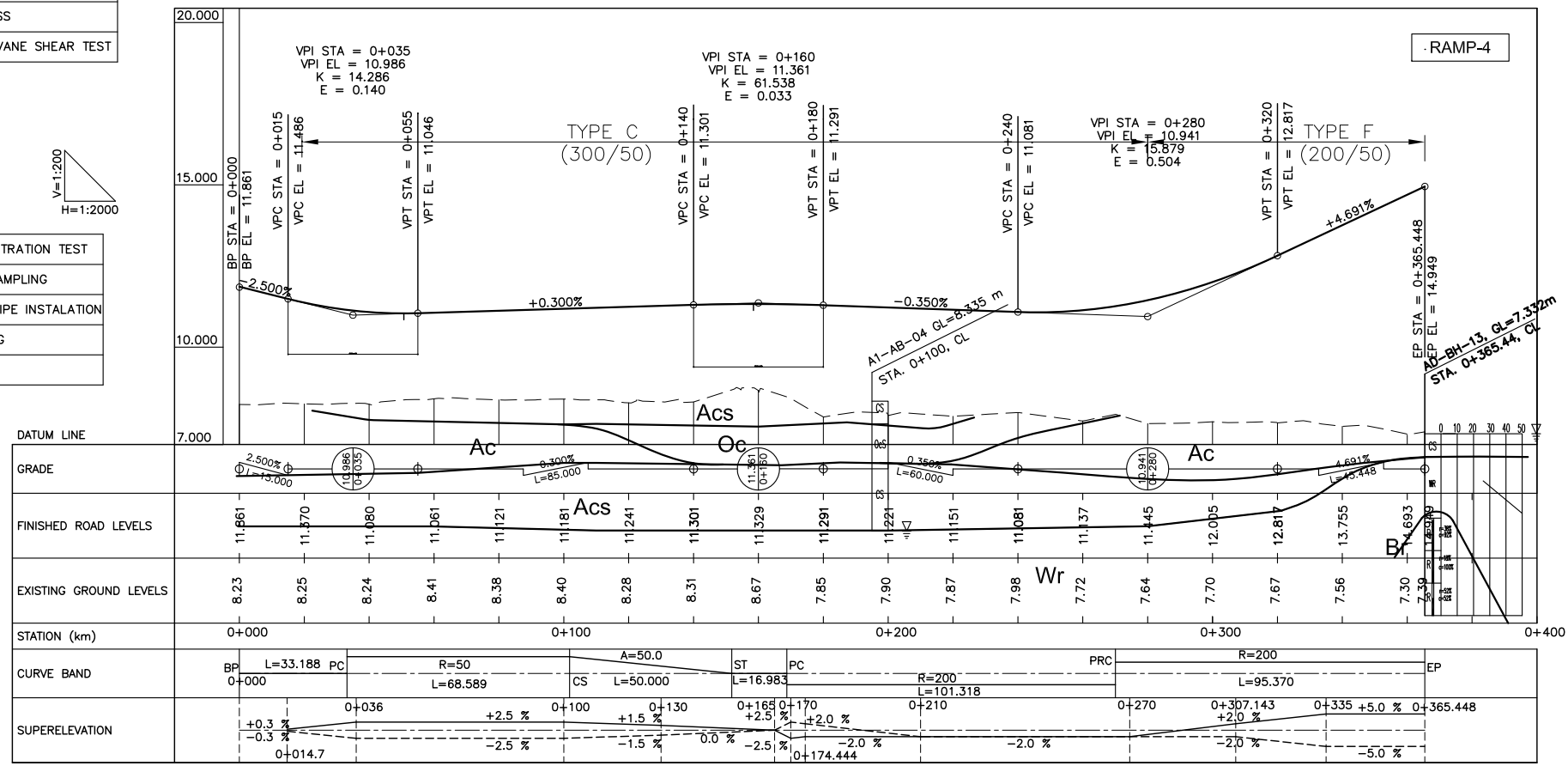

BOREHOLE LOG			GEOLOGICAL PROFILE	
Soil Symbol	Soil Type	Soil Layer Symbol	Soil Layer Name	
F	Fill	B	Embankment/ Fill	
Pt	Peat	Pt	Peat	
CPT	Peaty Clay			
OcPt	Peaty Organic Clay			
CPT-S	Sandy Peaty Clay	Oc	Organic Clay	
Oc	Organic Clay			
OcM	Silty Organic Clay			
OcS	Sandy Organic Clay	Ac	Alluvial Clay	
CM	Silty Clay			
MOc	Organic Clayey Silt			
MC	Clayey Silt	Acs	Alluvial Sandy Clay	
CS	Sandy Clay			
CS-M	Silty Sandy Clay			
MS	Sandy Silt	As	Alluvial Sand	
SOc	Organic Clayey Sand			
SC	Clayey Sand			
SC-M	Silty Clayey Sand	Ag	Alluvial Gravel	
SM	Silty Sand			
SM-C	Clayey Silty Sand			
S	Sand	Wr	Completely Weathered Rock	
SG	Gravelly Sand			
SC-G	Gravelly Clayey Sand			
GM	Silty Gravel	R	Rock (Weathered Rock)	
Bd	Boulder			
WR	Completely Weathered Rock			
R	Rock (Weathered Rock)			

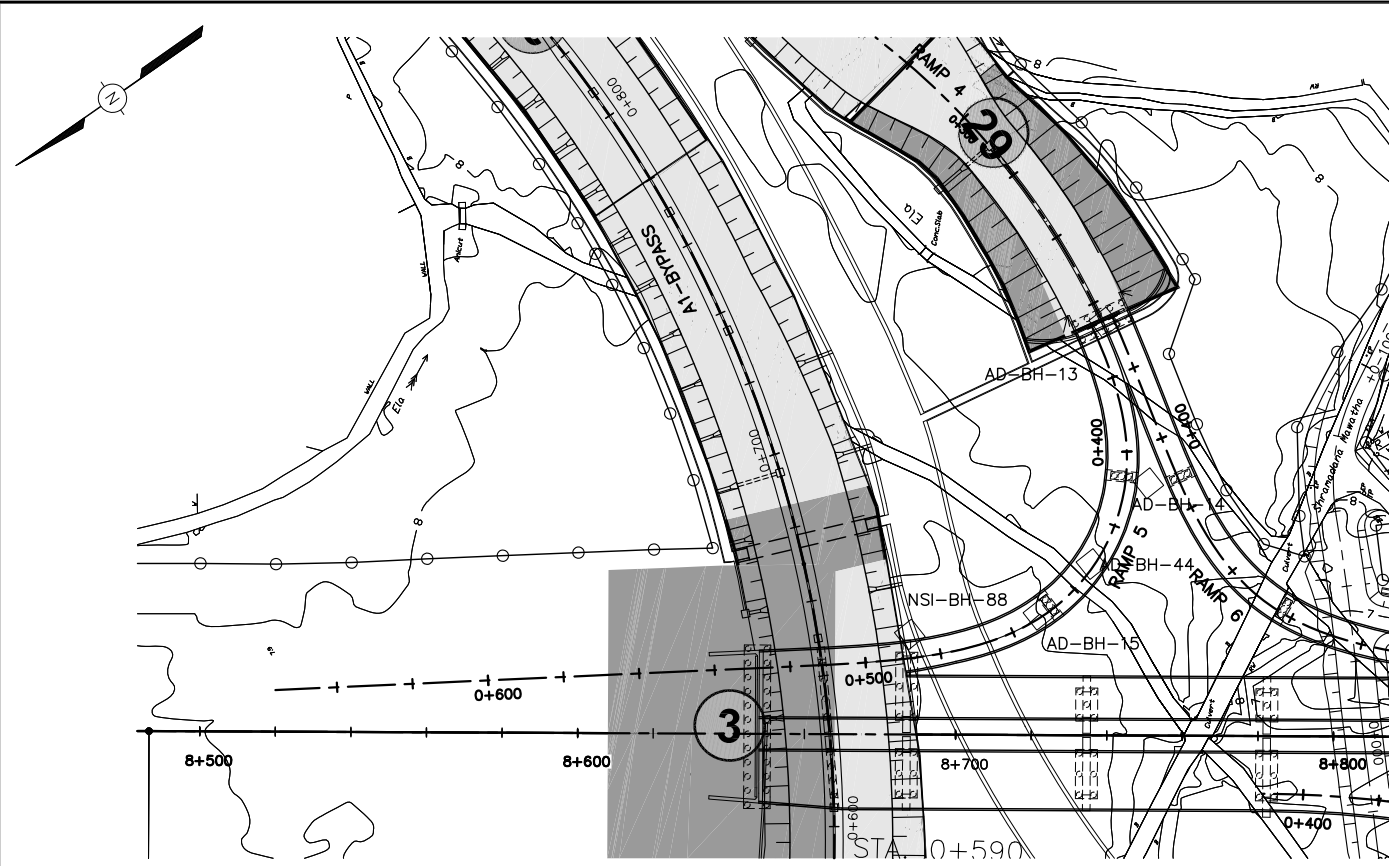

AREA TREATED BY GCP (ø 700, □1.2m)

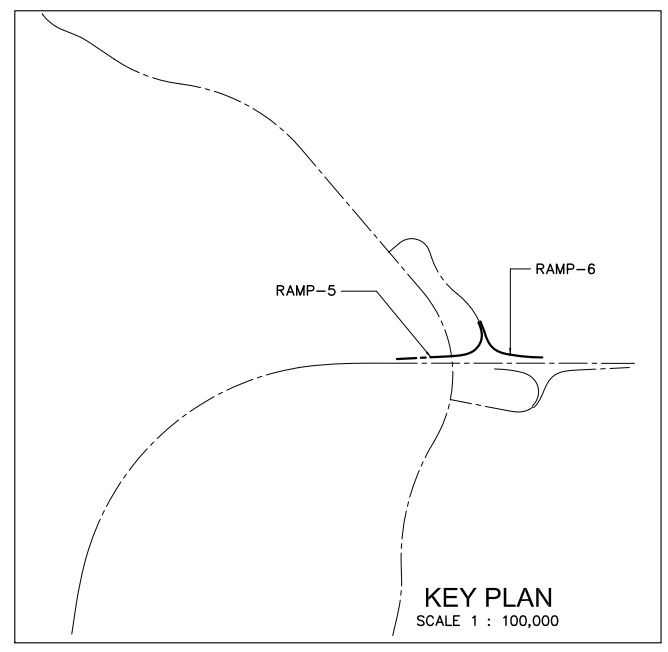

KEY PLAN
SCALE 1 : 100,000

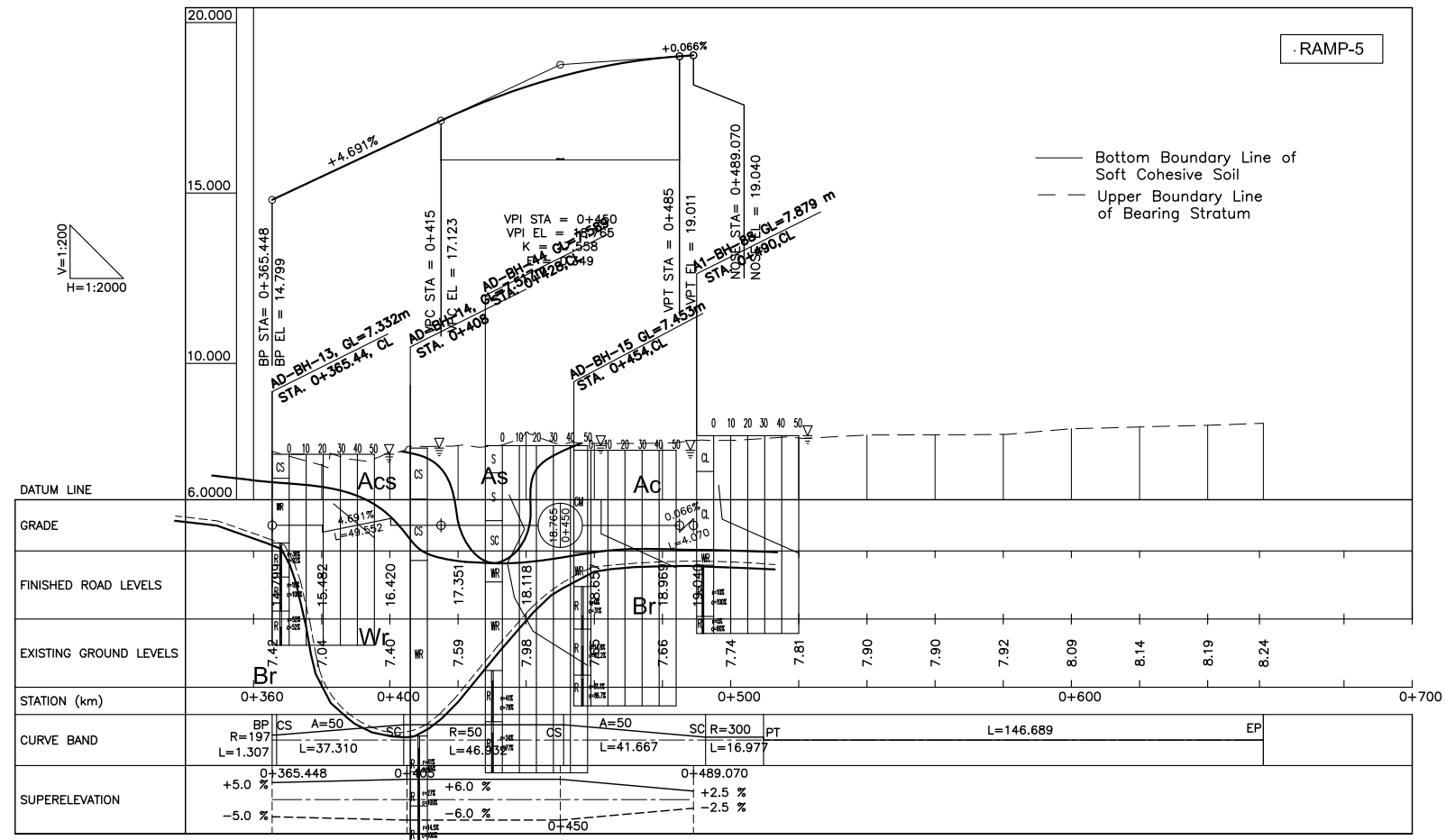

Bottom Boundary Line of Soft Cohesive Soil
Upper Boundary Line of Bearing Stratum

LEGEND	
○	ROTARY BORING SPT+UD
◇	ROTARY BORING SPT
□	ROTARY BORING SPT+WSP+WS
△	ROTARY BORING WSP+WS
☆	AUGER BORING SS
⬠	FIELD VANE VANE SHEAR TEST

REMARKS	
SPT	= STANDARD PENETRATION TEST
UD	= UNDISTURBED SAMPLING
WSP	= WATER STAND PIPE INSTALATION
WS	= WATER SAMPLING
SS	= SOIL SAMPLING

BOREHOLE LOG			GEOLOGICAL PROFILE	
Soil Symbol	Soil Type	Soil Layer Symbol	Soil Layer Name	
F	Fill	B	Embankment/ Fill	
Pt	Peat	Pt	Peat	
CPT	Peaty Clay			
OcPt	Peaty Organic Clay			
CPT-S	Sandy Peaty Clay	Oc	Organic Clay	
Oc	Organic Clay			
OcM	Silty Organic Clay	Oc	Organic Clay	
OcS	Sandy Organic Clay			
CM	Silty Clay	Ac	Alluvial Clay	
MOc	Organic Clayey Silt			
MC	Clayey Silt	Acs	Alluvial Sandy Clay	
CS	Sandy Clay			
CS-M	Silty Sandy Clay	As	Alluvial Sand	
MS	Sandy Silt			
SOc	Organic Clayey Sand	As	Alluvial Sand	
SC	Clayey Sand			
SC-M	Silty Clayey Sand	As	Alluvial Sand	
SM	Silty Sand			
SM-C	Clayey Silty Sand	As	Alluvial Sand	
S	Sand			
SG	Gravelly Sand	Ag	Alluvial Gravel	
SC-G	Gravelly Clayey Sand			
GM	Silty Gravel	Ag	Alluvial Gravel	
Bd	Boulder			
WR	Completely Weathered Rock	Wr	Completely Weathered Rock	
R	Rock (Weathered Rock)	Br	Rock (Weathered Rock)	

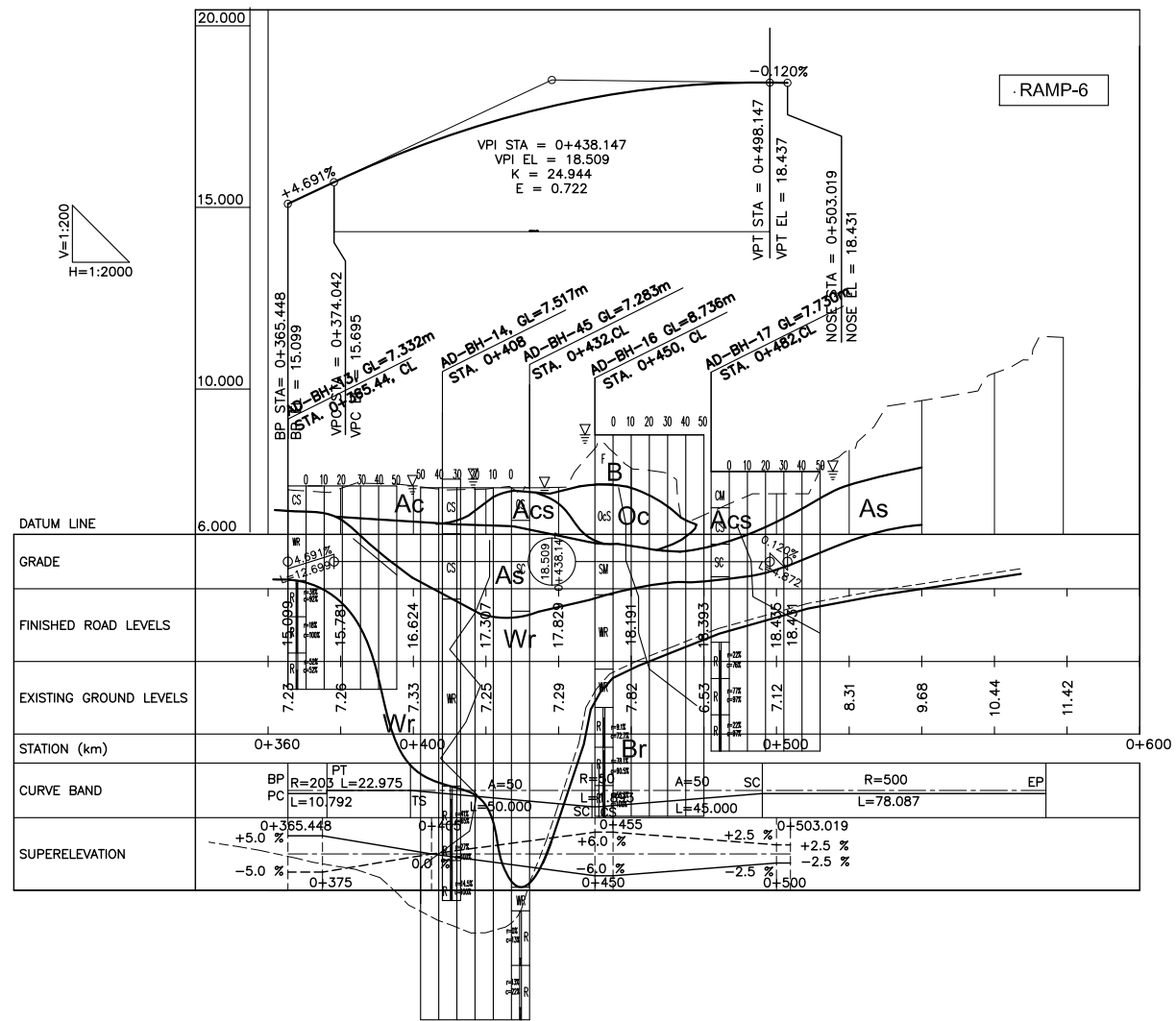
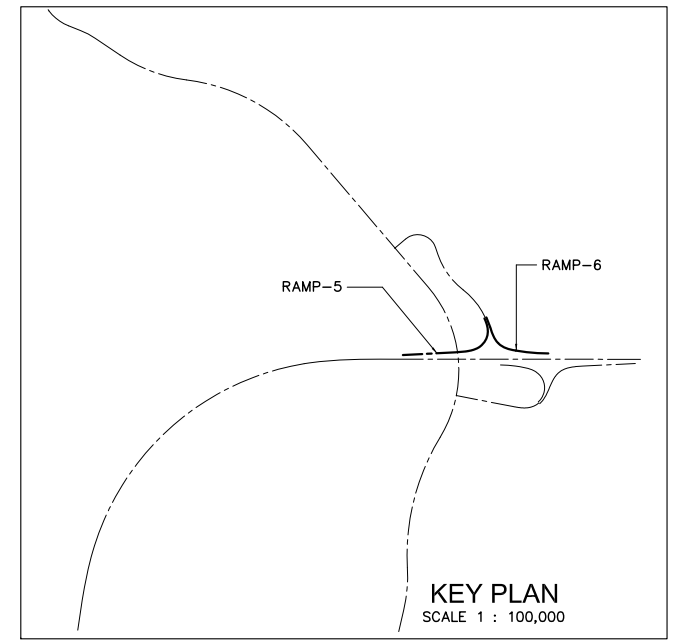
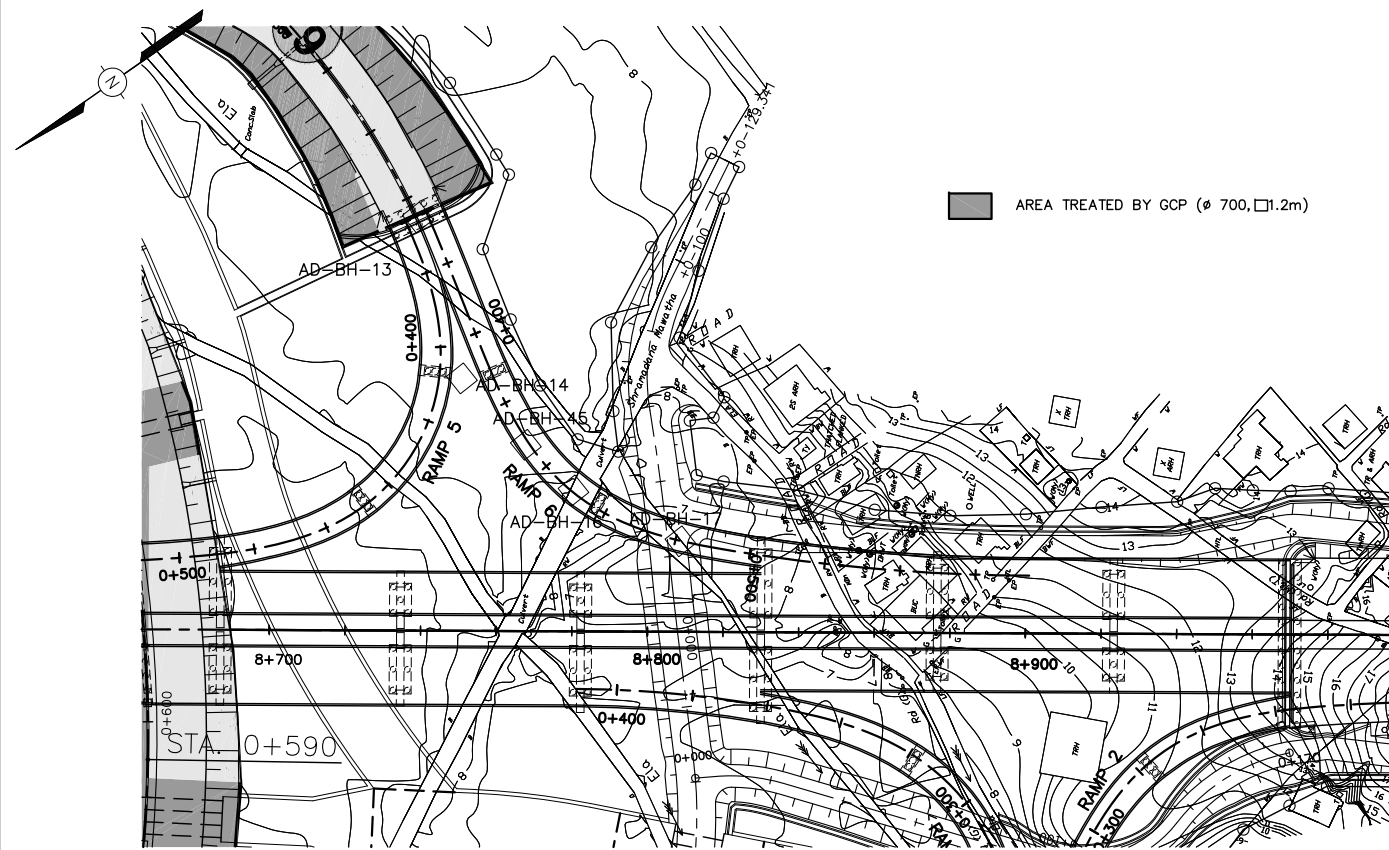

— Bottom Boundary Line of Soft Cohesive Soil
 - - - Upper Boundary Line of Bearing Stratum

LEGEND		
○	ROTARY BORING	SPT+UD
◇	ROTARY BORING	SPT
□	ROTARY BORING	SPT+WSP+WS
△	ROTARY BORING	WSP+WS
☆	AUGER BORING	SS
◇	FIELD VANE	VANE SHEAR TEST

REMARKS	
SPT	= STANDARD PENETRATION TEST
UD	= UNDISTURBED SAMPLING
WSP	= WATER STAND PIPE INSTALLATION
WS	= WATER SAMPLING
SS	= SOIL SAMPLING

BOREHOLE LOG			GEOLOGICAL PROFILE	
Soil Symbol	Soil Type	Soil Layer Symbol	Soil Layer Name	
F	Fill	B	Embankment/ Fill	
Pt	Peat	Pt	Peat	
CpT	Peaty Clay			
OcPt	Peaty Organic Clay			
CpT-S	Sandy Peaty Clay	Oc	Organic Clay	
Oc	Organic Clay			
OcM	Silty Organic Clay	Oc	Organic Clay	
OcS	Sandy Organic Clay			
CM	Silty Clay	Ac	Alluvial Clay	
MOc	Organic Clayey Silt			
MC	Clayey Silt	Acs	Alluvial Sandy Clay	
CS	Sandy Clay			
CS-M	Silty Sandy Clay	As	Alluvial Sand	
MS	Sandy Silt			
SOc	Organic Clayey Sand	As	Alluvial Sand	
SC	Clayey Sand			
SC-M	Silty Clayey Sand	As	Alluvial Sand	
SM	Silty Sand			
SM-C	Clayey Silty Sand	Ag	Alluvial Gravel	
S	Sand			
SG	Gravelly Sand	Ag	Alluvial Gravel	
SC-G	Gravelly Clayey Sand			
GM	Silty Gravel	Ag	Alluvial Gravel	
Bd	Boulder			
WR	Completely Weathered Rock	Wr	Completely Weathered Rock	
R	Rock (Weathered Rock)	Br	Rock (Weathered Rock)	

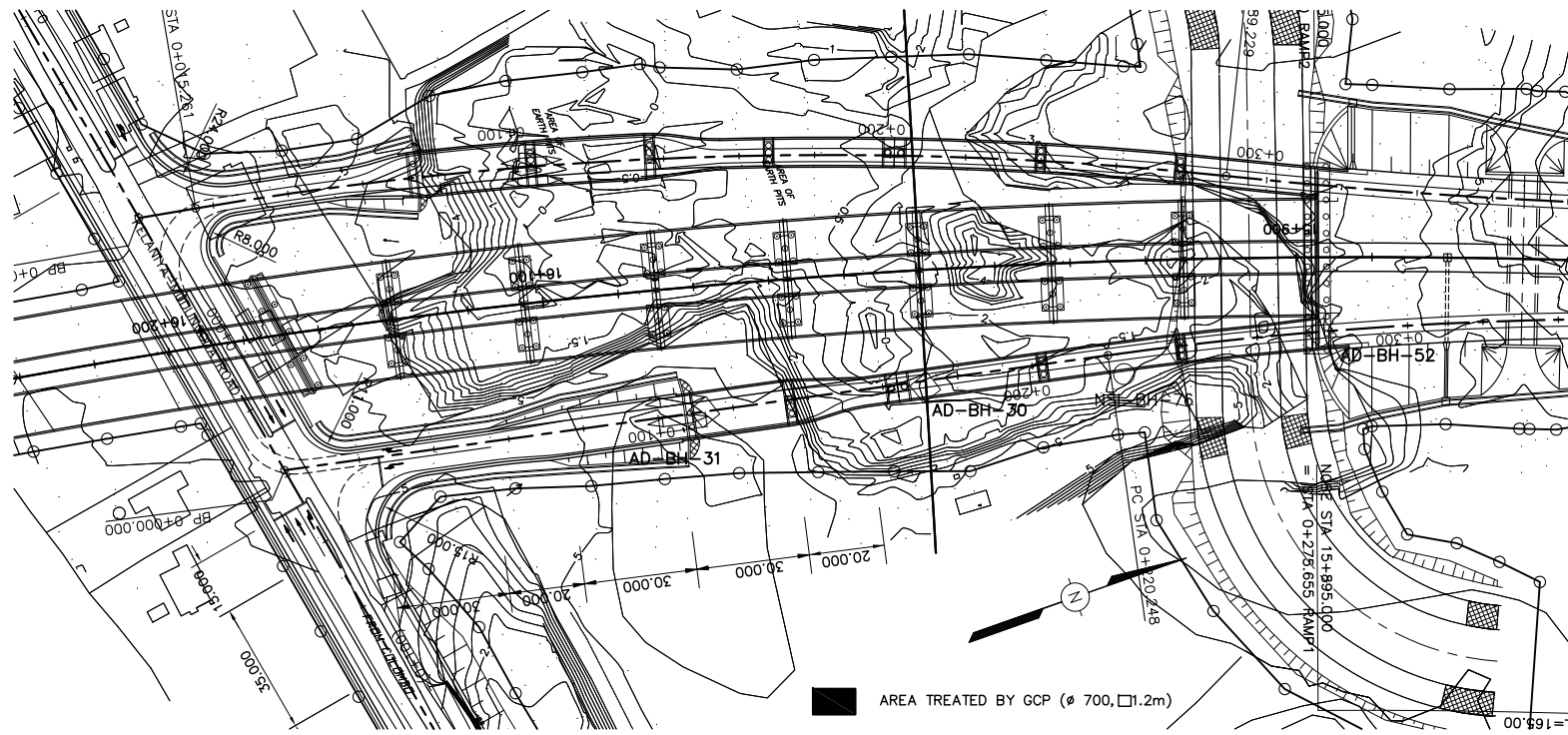

BOREHOLE LOG			GEOLOGICAL PROFILE	
Soil Symbol	Soil Type	Soil Layer Symbol	Soil Layer Name	
F	Fill	B	Embankment/ Fill	
Pt	Peat	Pt	Peat	
CpT	Peaty Clay			
OcPt	Peaty Organic Clay			
CpT-S	Sandy Peaty Clay			
Oc	Organic Clay	Oc	Organic Clay	
OcM	Silty Organic Clay			
OcS	Sandy Organic Clay			
CM	Silty Clay			
MOc	Organic Clayey Silt	Ac	Alluvial Clay	
MC	Clayey Silt			
CS	Sandy Clay	Acs	Alluvial Sandy Clay	
CS-M	Silty Sandy Clay			
MS	Sandy Silt			
SOc	Organic Clayey Sand			
SC	Clayey Sand	As	Alluvial Sand	
SC-M	Silty Clayey Sand			
SM	Silty Sand			
SM-C	Clayey Silty Sand			
S	Sand			
SG	Gravelly Sand			
SC-G	Gravelly Clayey Sand			
GM	Silty Gravel			
Bd	Boulder	Ag	Alluvial Gravel	
WR	Completely Weathered Rock	Wr	Completely Weathered Rock	
R	Rock (Weathered Rock)	Br	Rock (Weathered Rock)	

LEGEND		
○	ROTARY BORING	SPT+UD
◇	ROTARY BORING	SPT
□	ROTARY BORING	SPT+WSP+WS
△	ROTARY BORING	WSP+WS
☆	AUGER BORING	SS
○	FIELD VANE	VANE SHEAR TEST

REMARKS	
SPT	= STANDARD PENETRATION TEST
UD	= UNDISTURBED SAMPLING
WSP	= WATER STAND PIPE INSTALLATION
WS	= WATER SAMPLING
SS	= SOIL SAMPLING

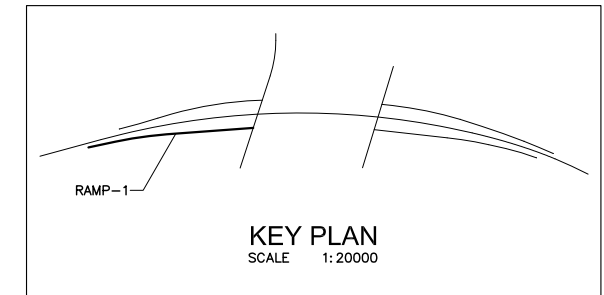
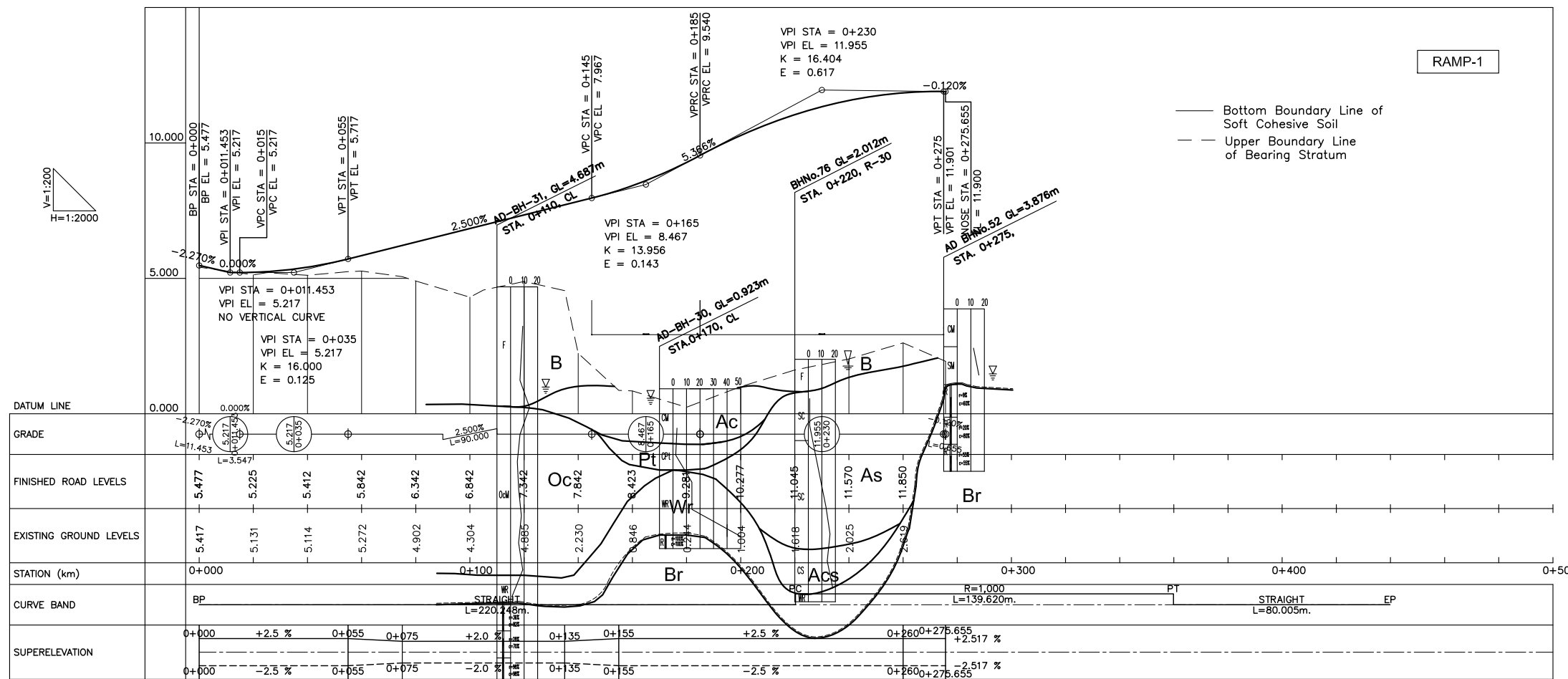

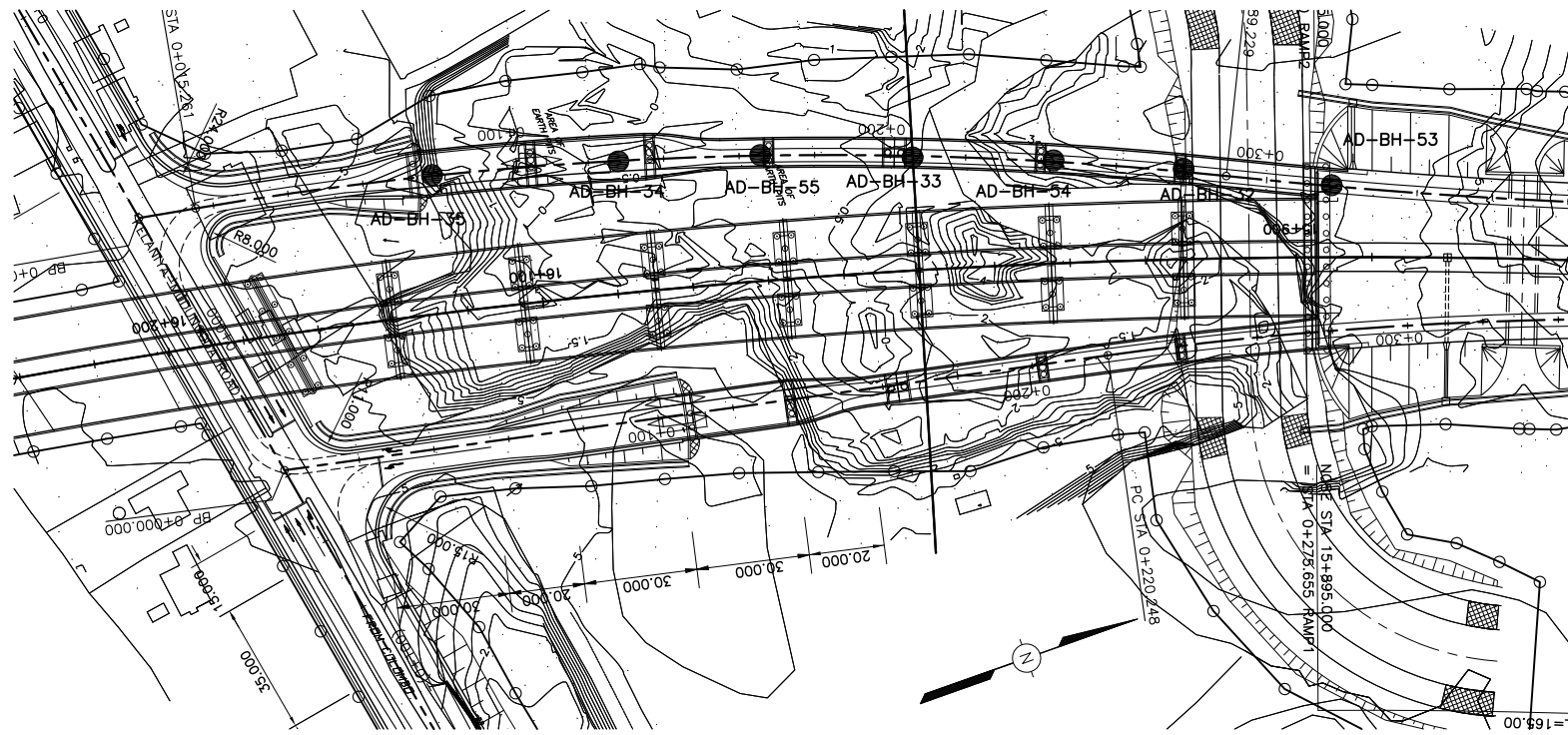

AREA TREATED BY GCP (700, 1.2m)

BOREHOLE LOG			GEOLOGICAL PROFILE	
Soil Symbol	Soil Type	Soil Layer Symbol	Soil Layer Name	
F	Fill	B	Embankment/ Fill	
Pt	Peat	Pt	Peat	
CPT	Peaty Clay			
OcPt	Peaty Organic Clay			
CPT-S	Sandy Peaty Clay			
Oc	Organic Clay	Oc	Organic Clay	
OcM	Silty Organic Clay			
OcS	Sandy Organic Clay			
CM	Silty Clay	Ac	Alluvial Clay	
MOc	Organic Clayey Silt			
MC	Clayey Silt			
CS	Sandy Clay	Acs	Alluvial Sandy Clay	
CS-M	Silty Sandy Clay			
MS	Sandy Silt			

LEGEND			
○	ROTARY BORING	SPT+UD	
◇	ROTARY BORING	SPT	
□	ROTARY BORING	SPT+WSP+WS	
△	ROTARY BORING	WSP+WS	
☆	AUGER BORING	SS	
◇	FIELD VANE	VANE SHEAR TEST	

REMARKS

SPT = STANDARD PENETRATION TEST
UD = UNDISTURBED SAMPLING
WSP = WATER STAND PIPE INSTALLATION
WS = WATER SAMPLING
SS = SOIL SAMPLING

SOc	Organic Clayey Sand	As	Alluvial Sand
SC	Clayey Sand		
SC-M	Silty Clayey Sand		
SM	Silty Sand		
SM-C	Clayey Silty Sand		
S	Sand		
SG	Gravelly Sand		
SC-G	Gravelly Clayey Sand	Ag	Alluvial Gravel
GM	Silty Gravel		
Bd	Boulder	Wr	Completely Weathered Rock
WR	Completely Weathered Rock		
R	Rock (Weathered Rock)	Br	Rock (Weathered Rock)

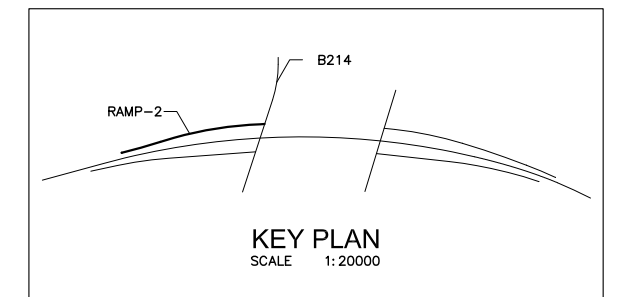
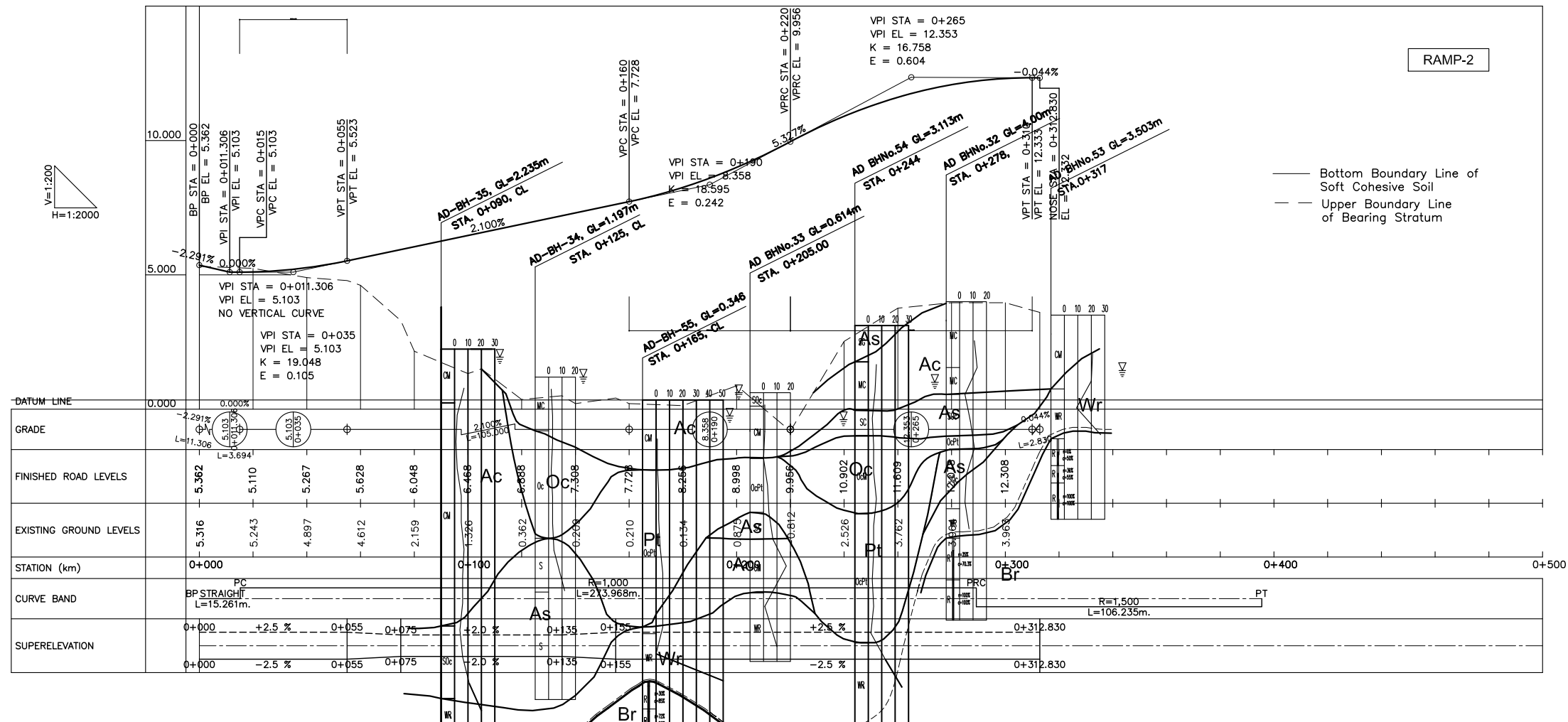

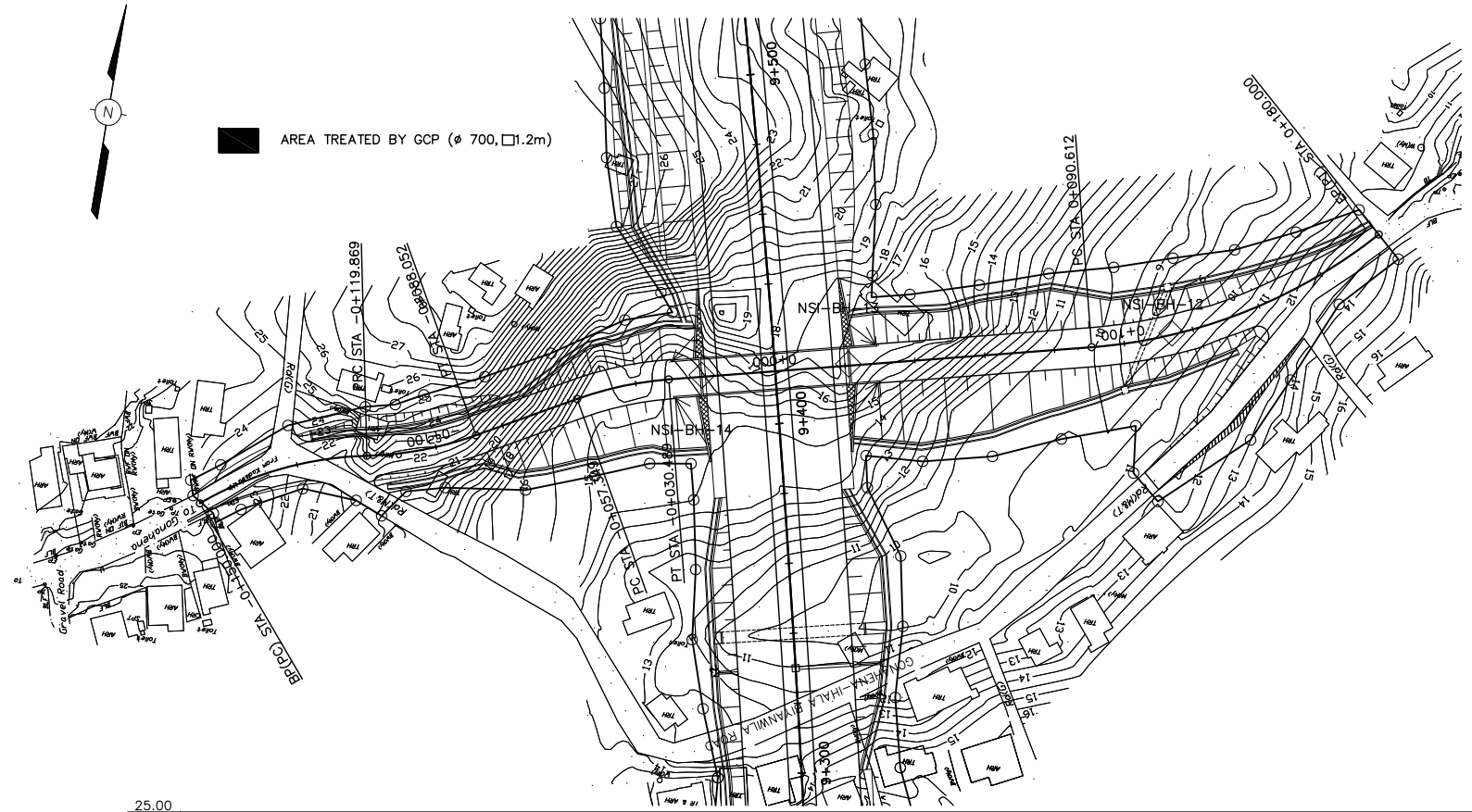

BOREHOLE LOG			GEOLOGICAL PROFILE	
Soil Symbol	Soil Type	Soil Layer Symbol	Soil Layer Name	
F	Fill	B	Embankment/ Fill	
Pt	Peat	Pt	Peat	
CPT	Peaty Clay			
OcPt	Peaty Organic Clay			
CPT-S	Sandy Peaty Clay	Oc	Organic Clay	
Oc	Organic Clay			
OcM	Silty Organic Clay			
OcS	Sandy Organic Clay	Ac	Alluvial Clay	
CM	Silty Clay			
MOc	Organic Clayey Silt			
MC	Clayey Silt	Acs	Alluvial Sandy Clay	
CS	Sandy Clay			
CS-M	Silty Sandy Clay			
MS	Sandy Silt			

SOc	Organic Clayey Sand	As	Alluvial Sand
SC	Clayey Sand		
SC-M	Silty Clayey Sand		
SM	Silty Sand		
SM-C	Clayey Silty Sand		
S	Sand		
SG	Gravelly Sand	Ag	Alluvial Gravel
SC-G	Gravelly Clayey Sand		
GM	Silty Gravel	Wr	Completely Weathered Rock
Bd	Boulder		
WR	Completely Weathered Rock		
R	Rock (Weathered Rock)	Br	Rock (Weathered Rock)

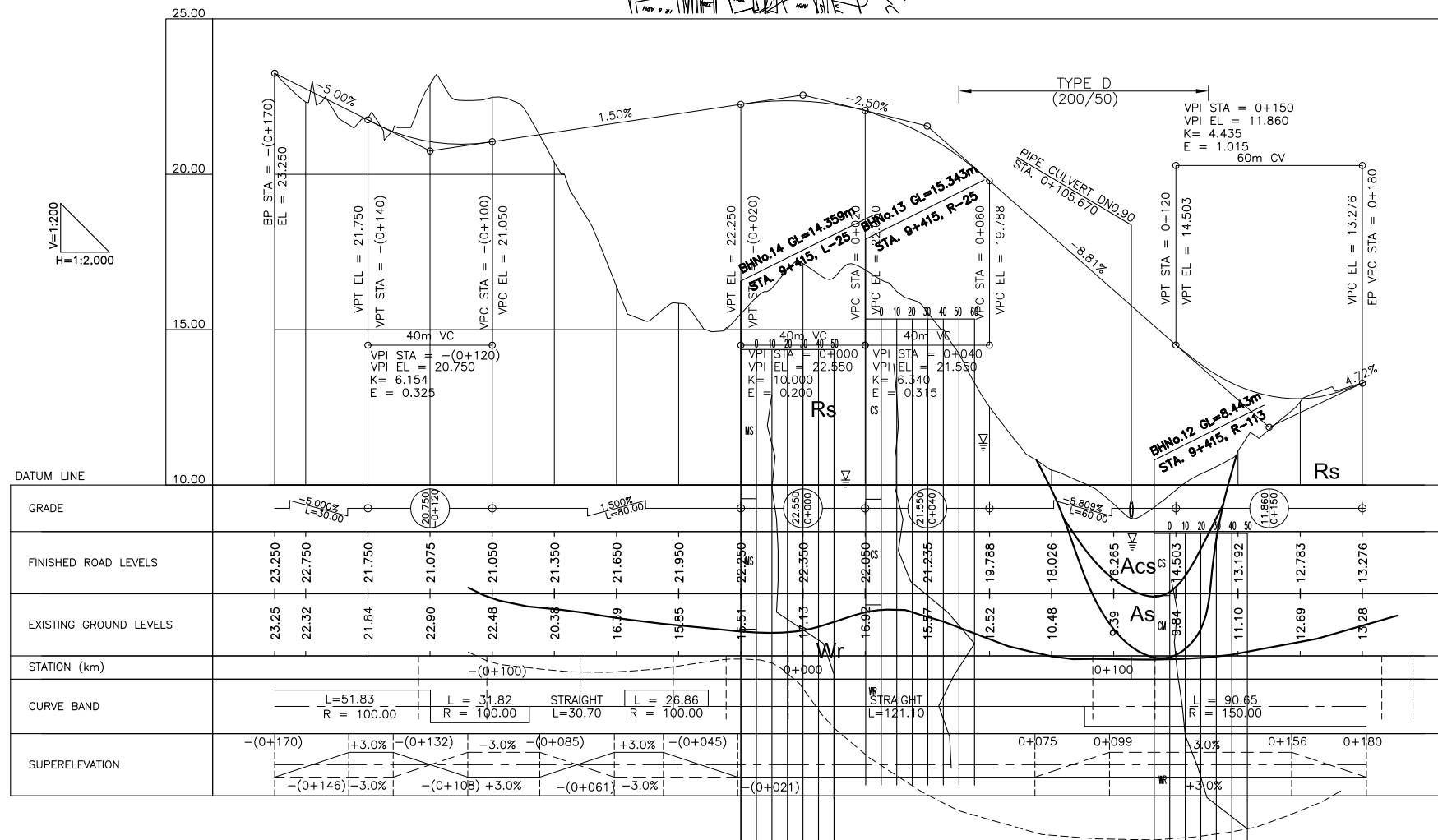

— Bottom Boundary Line of Soft Cohesive Soil
 - - - - Upper Boundary Line of Bearing Stratum

LEGEND		
○	ROTARY BORING	SPT+UD
◇	ROTARY BORING	SPT
□	ROTARY BORING	SPT+WSP+WS
△	ROTARY BORING	WSP+WS
☆	AUGER BORING	SS
○	FIELD VANE	VANE SHEAR TEST

REMARKS	
SPT	= STANDARD PENETRATION TEST
UD	= UNDISTURBED SAMPLING
WSP	= WATER STAND PIPE INSTALLATION
WS	= WATER SAMPLING
SS	= SOIL SAMPLING