

卷末資料 4-3-3 予備的な詳細設計の結果(案)

(図面)

The Project for Capacity Development of Mt. Semeru
Volcanic Disaster Structural Measure Planning
S2 Area

DETAILED DESIGN OF SABO FACILITIES

YACHIYO ENGINEERING CO.,LTD.

**The Project for Capacity Development of Mt. Semeru Volcanic Disaster Structural Measure Planning
S2 Area**

LIST OF DRAWING					
NO	T I T L E	Scale	NO	T I T L E	Scale
1-2	General Layout	1 : 5000 1 : 2000			
3	CD Kobokan5 Layout	1 : 500			
4	Sumbersari , Curah Kobokan Long Plofile	SV=1 : 1000 SH=1 : 5000			
5-6	CD Kobokan 5 Structure (1/2~2/2)	1 : 500			
7	CD Pelintas Curah Lengkong2 Layout	1 : 300			
8	Curah Lengkong Long Plofile	SV=1 : 1000 SH=1 : 5000			
9	CD Pelintas Curah Lengkong2 Structure	1 : 300			
10	Tanggul Curah Lengkong Plan	1 : 1500			
11	Tanggul Curah Lengkong Long Plofile	SV=1 : 200 SH=1 : 2000			
12	Tanggul Curah Lengkong General structure	1 : 50			
13-19	Tanggul Curah Lengkong Cross section (1/7~7/7)	1 : 100			
20	Maintenance road Plan	1 : 1000			
21	Maintenance road Long Plofile	SV=1 : 150 SH=1 : 1500			
22	Maintenance road General structure	1 : 50			
23-31	Maintenance road Cross section (1/9~9/9)	1 : 200			

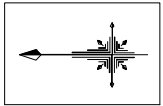

General Layout
1:5000

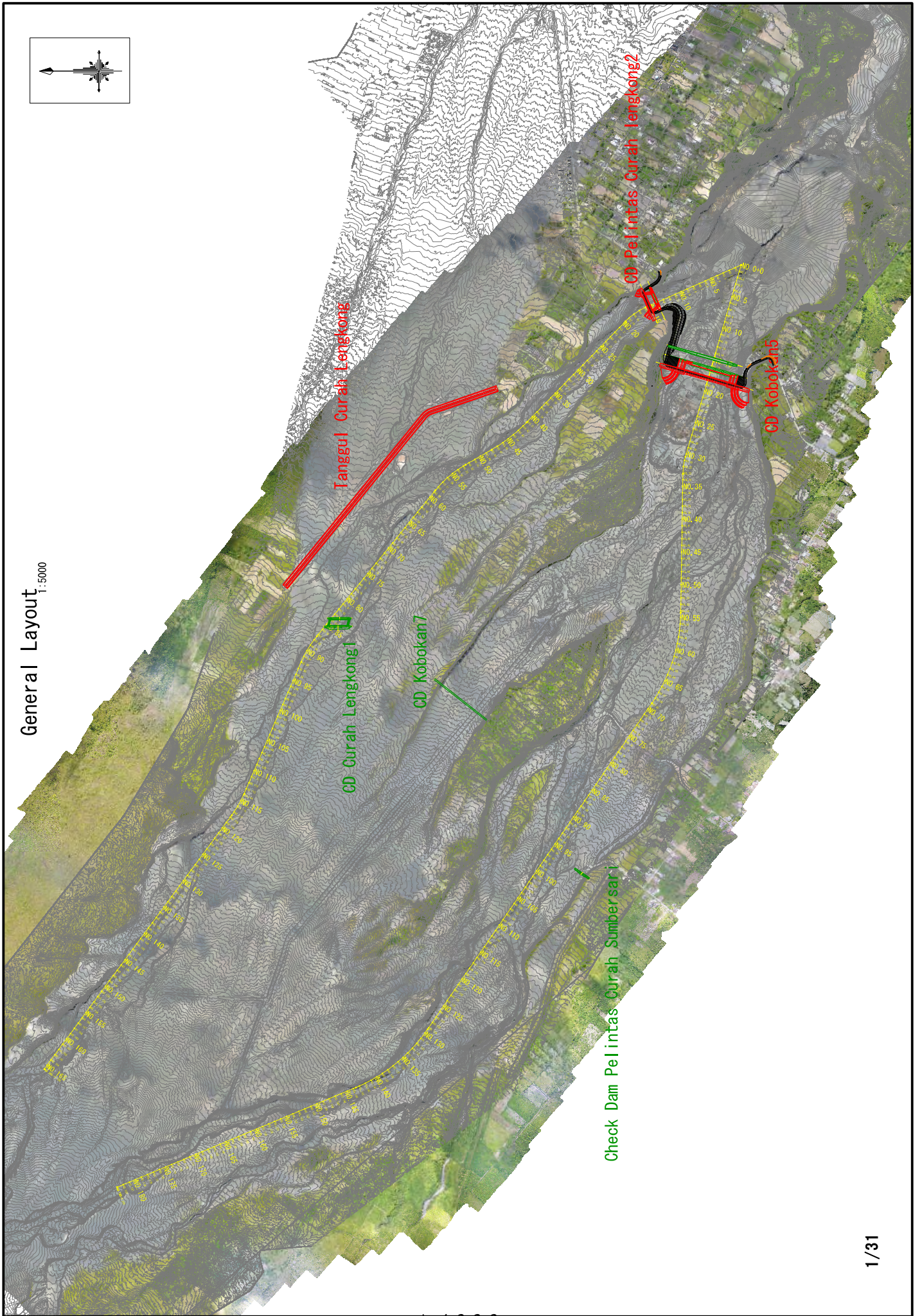

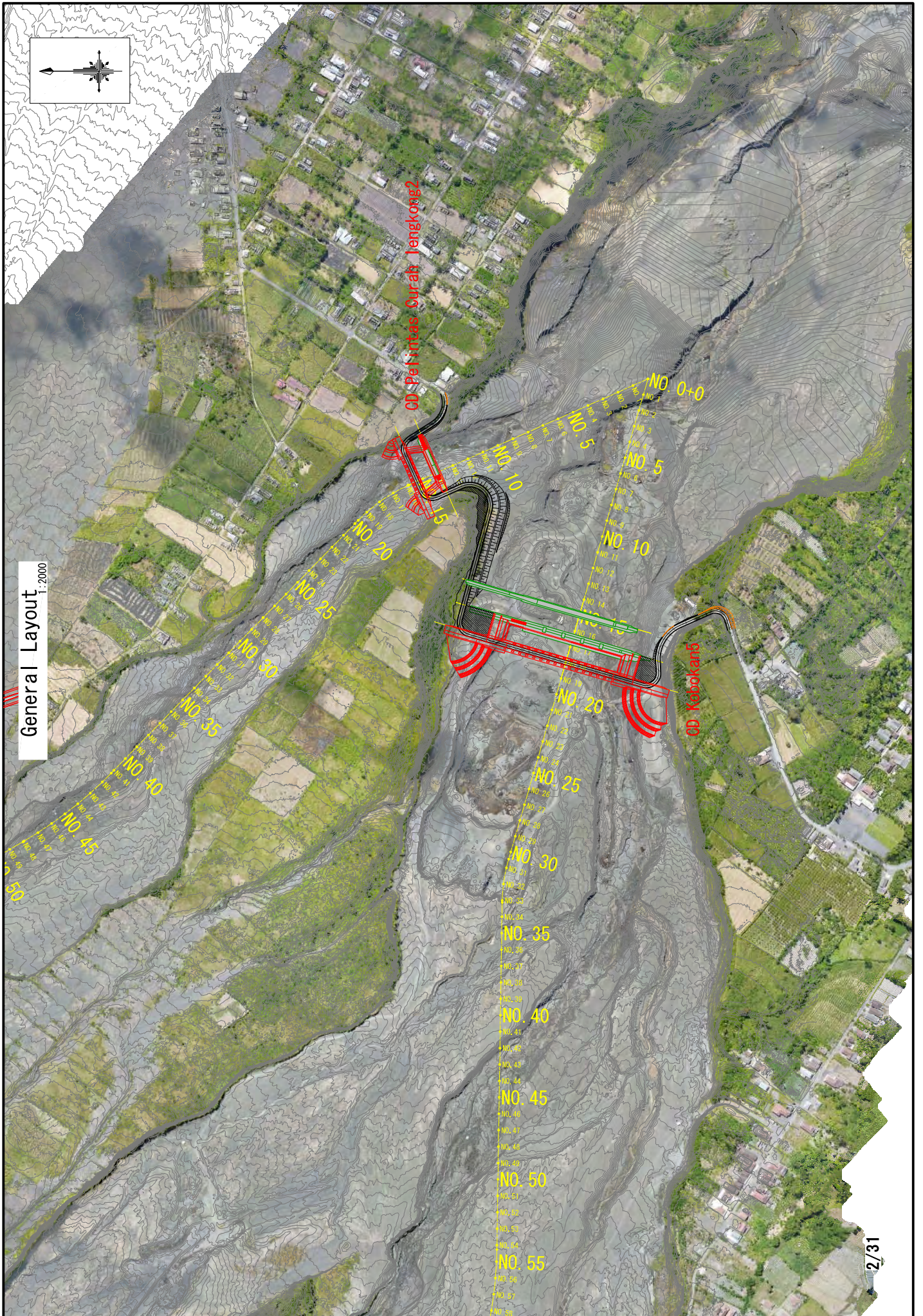

CD Kobokan 5 Layout 1:500



Sumbersari, Curah Kobokan Long Plofile

SKP-11.000
SKP-15.000



Riverbed slope	718.80	793.09	805.04	801.54	792.57	739.00	741.50	742.50	718.80	710.0
Freeboard										
H.W.L										
Design sediment slope										
Cumulative distance	200.00	300.00	400.00	500.00	600.00	700.00	800.00	900.00	1000.00	1100.00
Distance	100.00	100.00	100.00	100.00	100.00	100.00	100.00	100.00	100.00	100.00
No	No. 10	No. 15	No. 20	No. 25	No. 30	No. 35	No. 40	No. 45	No. 50	No. 55
	No. 60	No. 65	No. 70	No. 75	No. 80	No. 85	No. 90	No. 95	No. 100	No. 105
	No. 110	No. 115	No. 120	No. 125	No. 130	No. 135	No. 140	No. 145	No. 150	No. 155
	No. 160	No. 165	No. 170	No. 175	No. 180	No. 185	No. 190	No. 195	No. 200	No. 205
	No. 210	No. 215	No. 220	No. 225	No. 230	No. 235	No. 240	No. 245	No. 250	No. 255
	No. 260	No. 265	No. 270	No. 275	No. 280	No. 285	No. 290	No. 295	No. 300	No. 305
	No. 310	No. 315	No. 320	No. 325	No. 330	No. 335	No. 340	No. 345	No. 350	No. 355
	No. 360	No. 365	No. 370	No. 375	No. 380	No. 385	No. 390	No. 395	No. 400	No. 405

CD Kobokan 5 Structure (1/2)

S=1:500

Front view of Main-dam

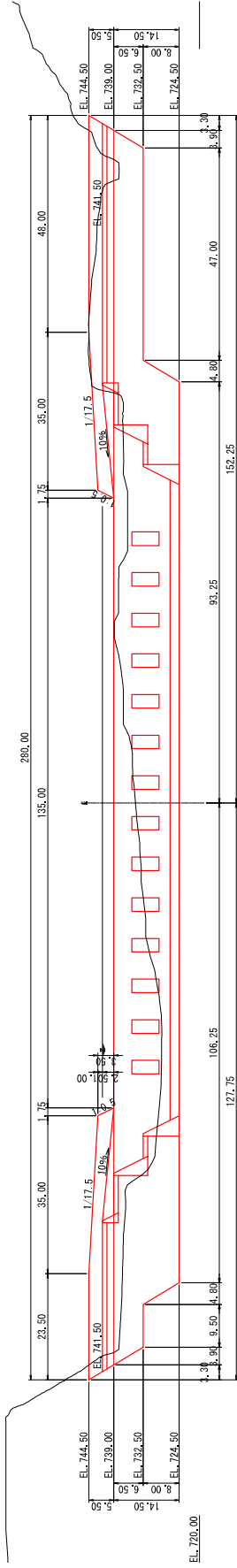

Front view of Sub-dam

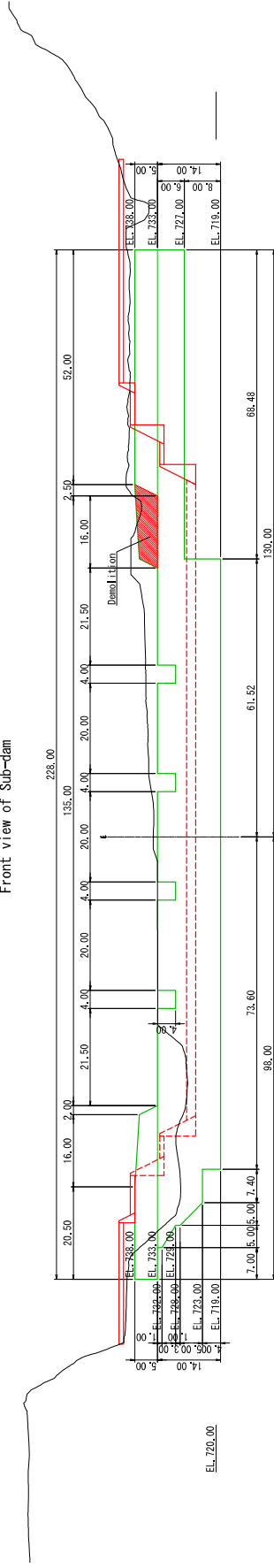

※階段台帳より作図した。

Front view of Sub-dam

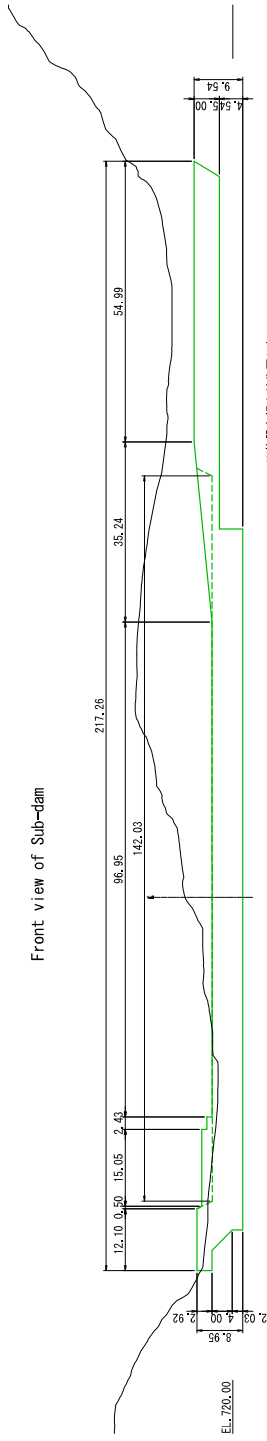

※階段台帳より作図した。

Side View Non-Overflow Section

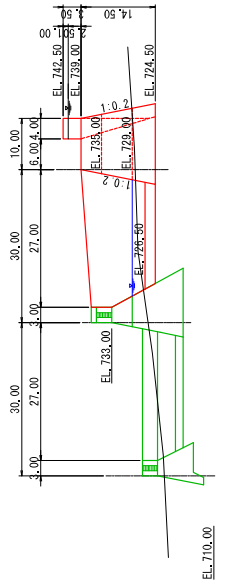

Side View Overflow Section

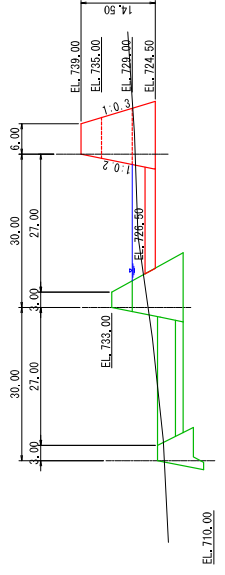

CD Kobokan 5 Structure (2/2)
S=1:500

Plan View

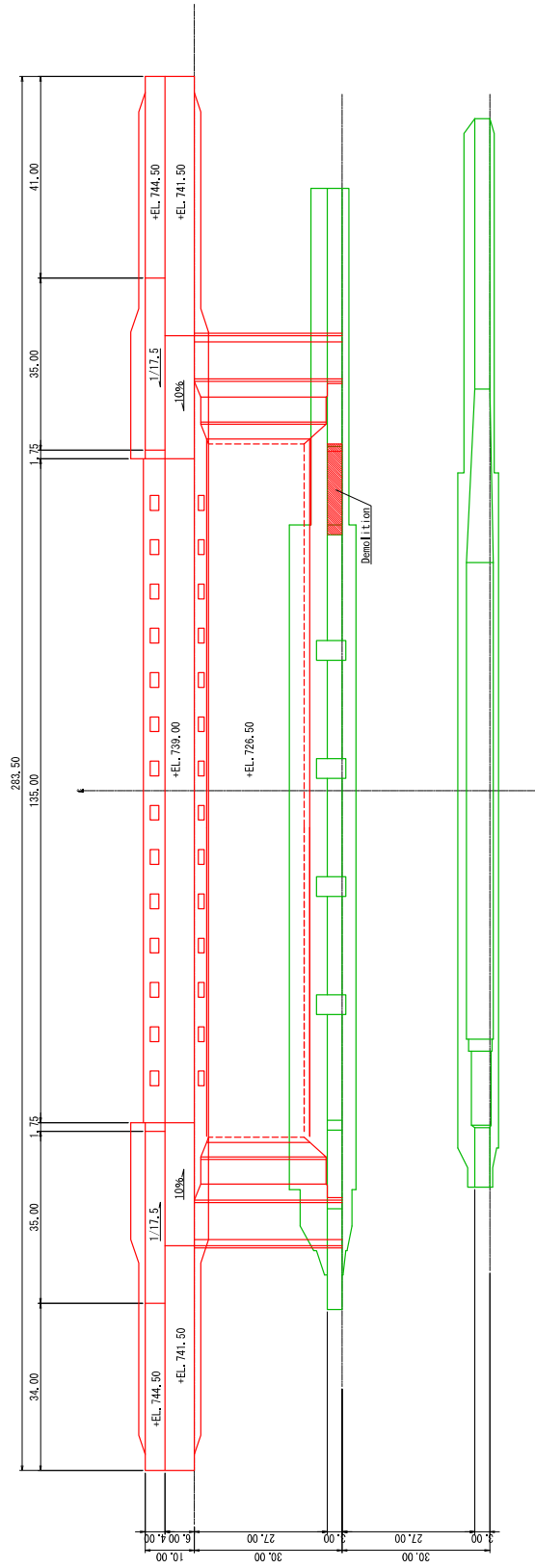

CD Pelintas Curah Lengkong2 Layout

1:300

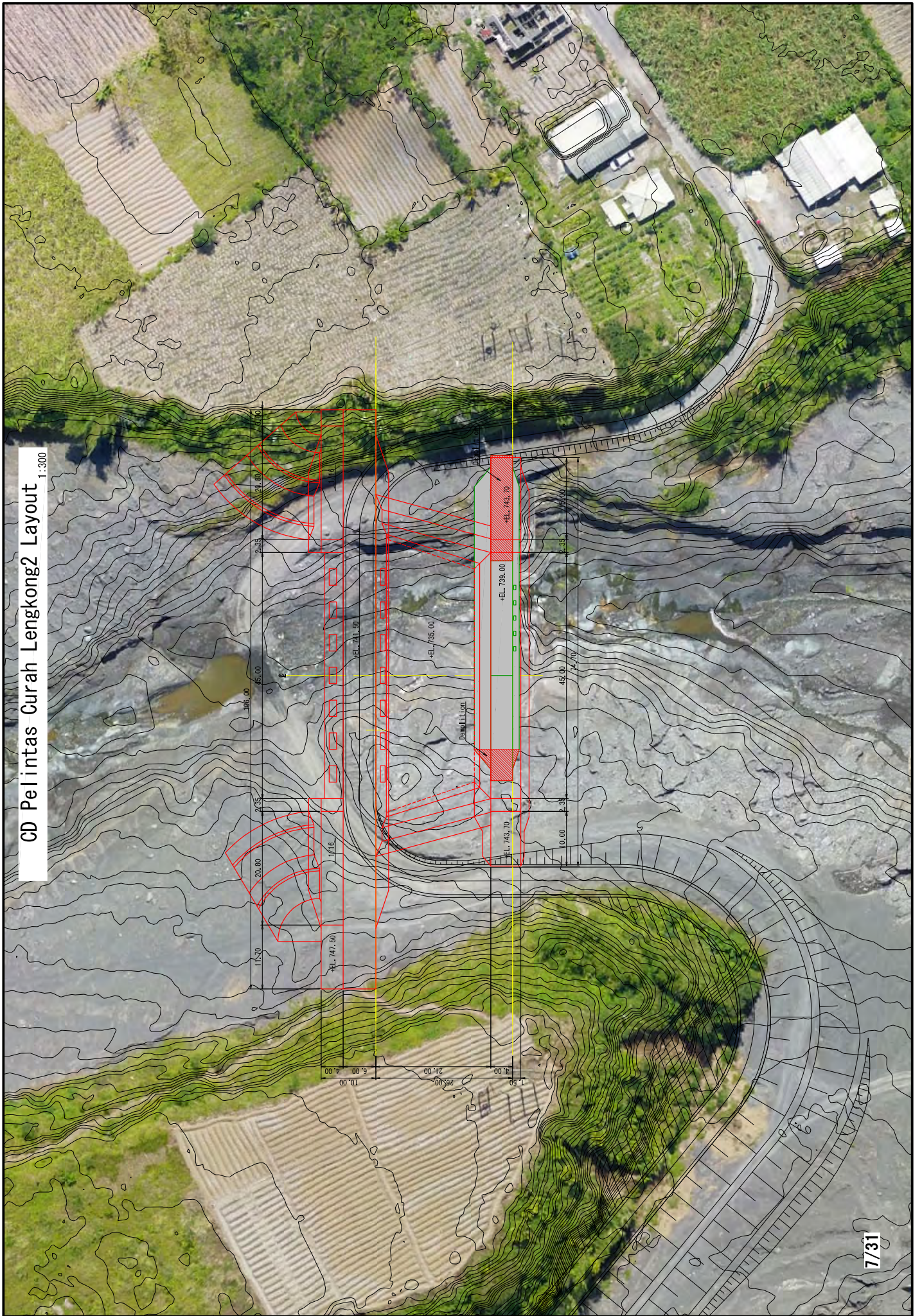

Curah Lengkong Long Profile

REF: 00 - Curah Lengkong

Scale: H=1:1,000
V=1:5,000



No	Distance	Cumulative distance	Design sediment Slope	H.W.L.	Freeboard	Riverbed slope
No. 12	0.00	240.00		741.50	746.20	726.90
No. 15	60.00	300.00		744.80	746.20	726.90
No. 20	100.00	400.00		744.80	746.20	726.90
No. 25	150.00	550.00				
No. 30	200.00	600.00				
No. 35	250.00	700.00	1:1.5/1.30			
No. 40	300.00	800.00	1:1.5/1.30			
No. 45	350.00	900.00	1:1.5/1.30			
No. 50	400.00	1000.00	1:1.5/1.30	780.11		
No. 55	450.00	1100.00				
No. 60	500.00	1200.00				
No. 65	550.00	1300.00				
No. 70	600.00	1400.00				
No. 75	650.00	1500.00				
No. 80	700.00	1600.00				
No. 85	750.00	1700.00				
No. 90	800.00	1800.00				
No. 95	850.00	1900.00				
No. 100	900.00	2000.00				
No. 105	950.00	2100.00				
No. 110	1000.00	2200.00				
No. 115	1050.00	2300.00				
No. 120	1100.00	2400.00				
No. 125	1150.00	2500.00				
No. 130	1200.00	2600.00				
No. 135	1250.00	2700.00				
No. 140	1300.00	2800.00				
No. 145	1350.00	2900.00				
No. 150	1400.00	3000.00				
No. 155	1450.00	3100.00				
No. 160	1500.00	3200.00				
No. 165	1550.00	3300.00				

CD Pelintas Curah Lengkong 2 Structure S=1:300

Front view of Main-dam

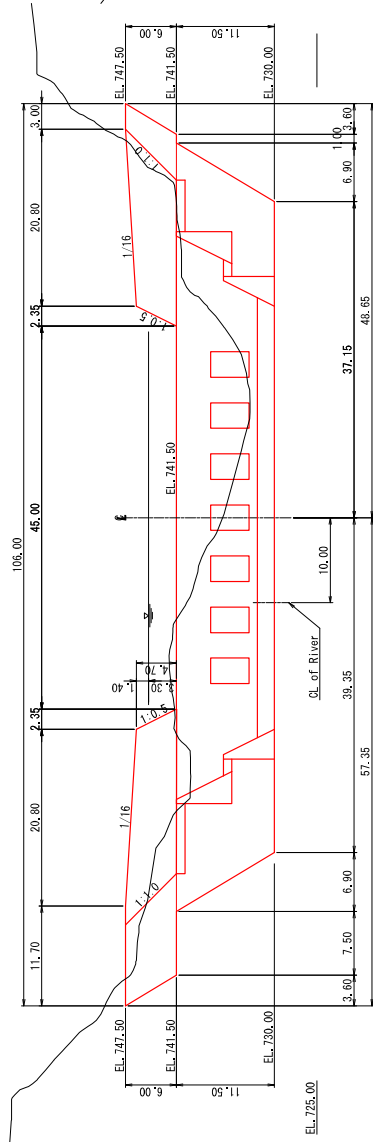

Front view of Sub-dam

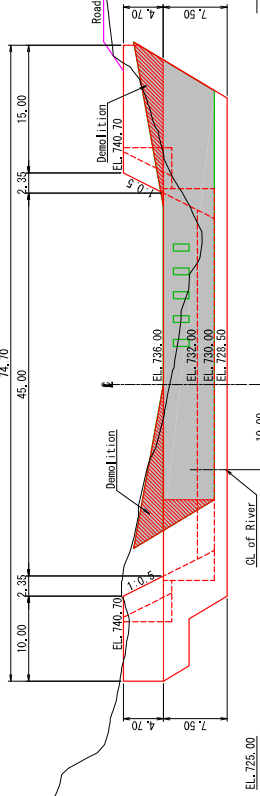

Plan View

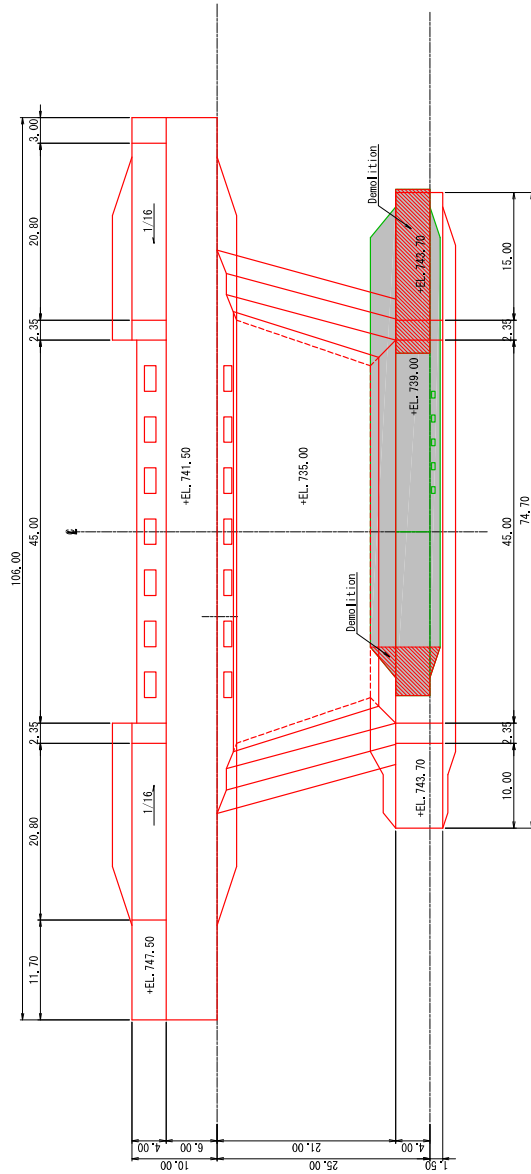

Side View
Overflow Section

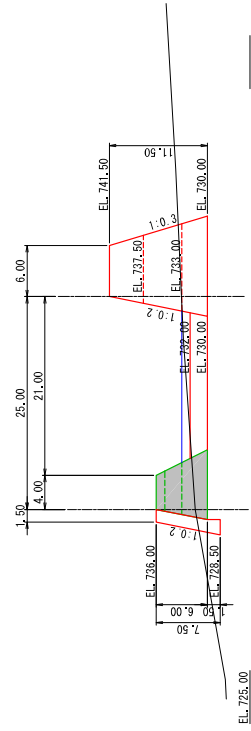

Side View
Non-Overflow Section

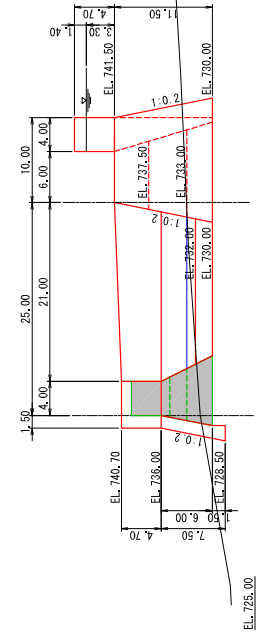

Tanggul Curah Lengkong Plan

1:1500

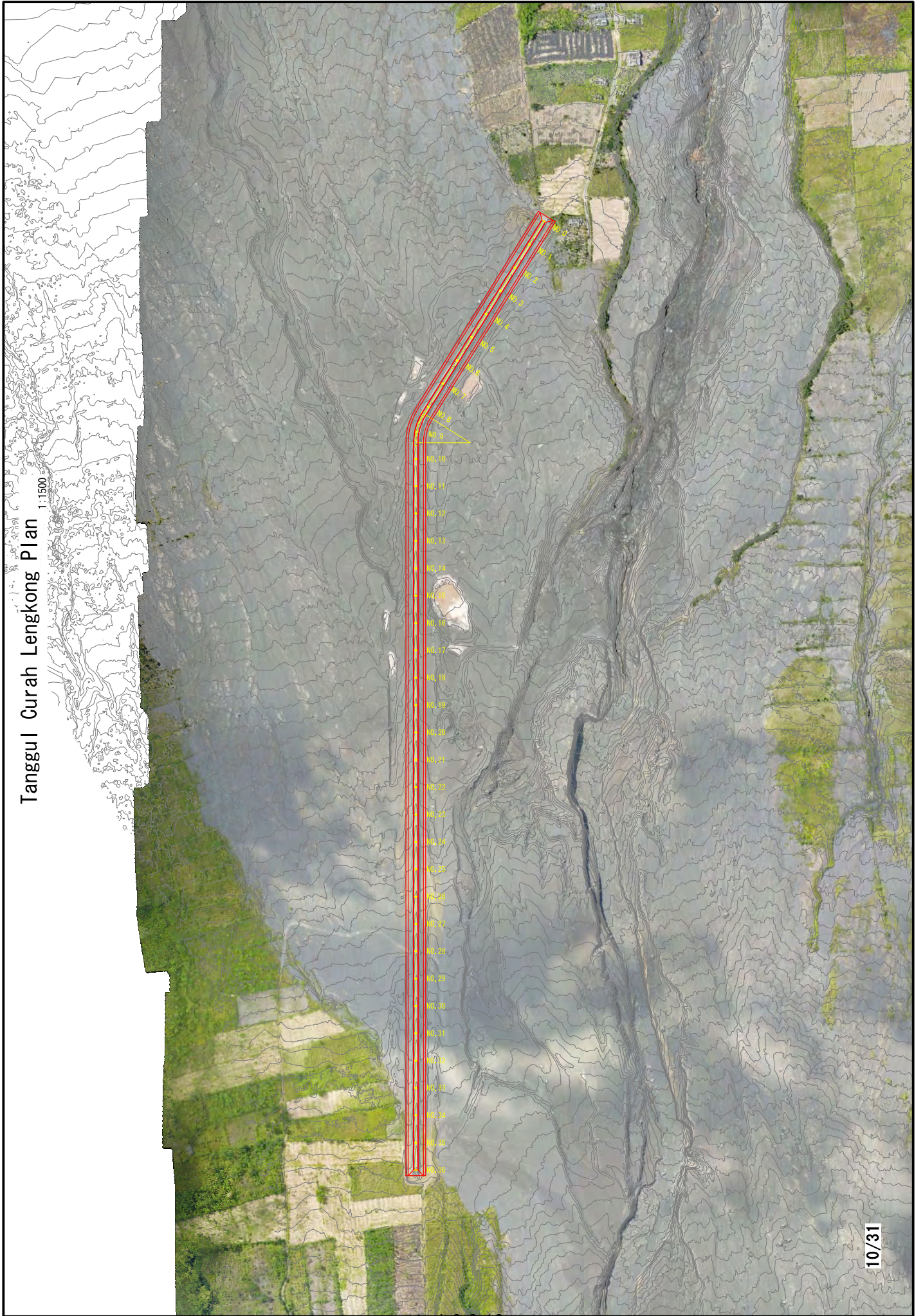

Tanggul Curah Lengkong Long Profile

SV=1 : 200
SH=1 : 2,000

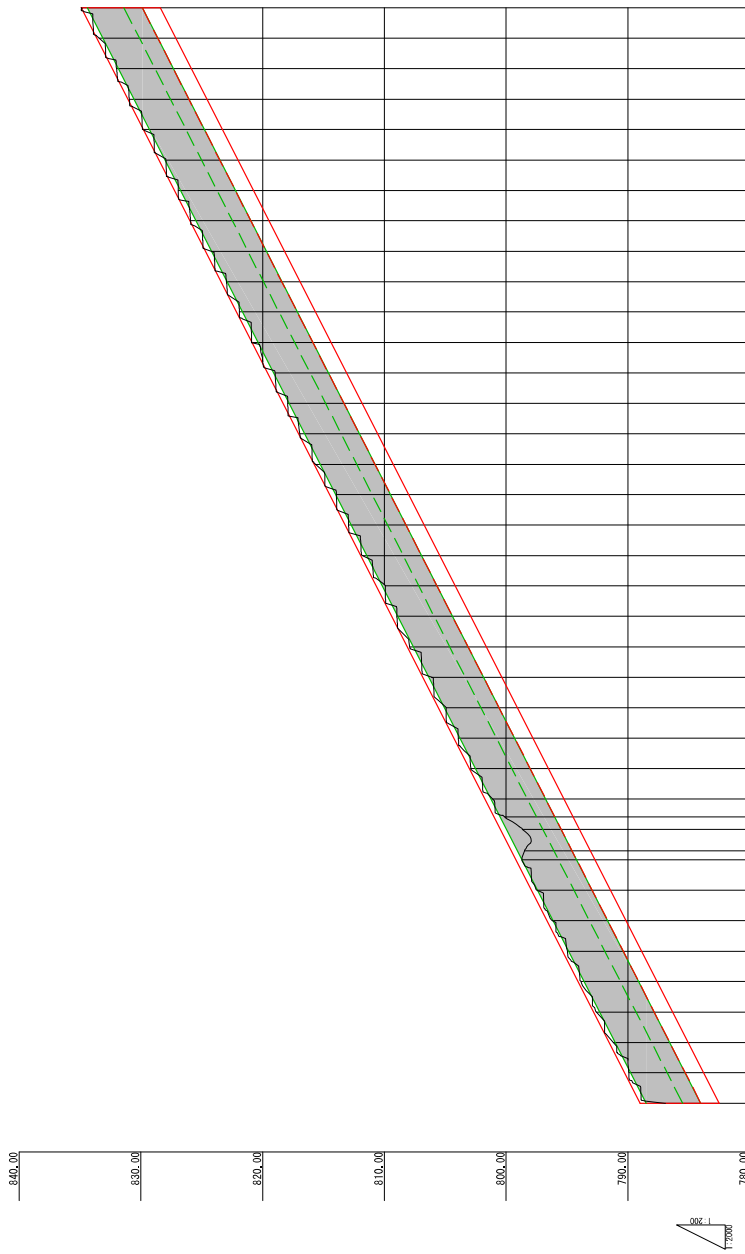

No	Distance	Cumulative distance	Foundation Elevation	Top Elevation
NO.0	0.000	0.000	782.500	782.500
NO.1	25.000	25.000	790.275	790.275
NO.2	25.000	50.000	785.050	791.550
NO.3	25.000	75.000	786.325	792.825
NO.4	25.000	100.000	787.600	794.100
NO.5	25.000	125.000	788.875	795.375
NO.6	25.000	150.000	790.150	796.650
NO.7	25.000	175.000	791.425	797.925
NO.8	25.000	200.000	792.700	799.200
NO.8-1-0	7.413	207.413	793.078	799.578
NO.9	17.587	225.000	793.975	800.475
EC-1-0	10.213	235.213	794.496	800.996
NO.10	14.787	250.000	795.250	801.750
NO.11	25.000	275.000	796.525	803.025
NO.12	25.000	300.000	797.800	804.300
NO.13	25.000	325.000	799.075	805.575
NO.14	25.000	350.000	800.350	806.850
NO.15	25.000	375.000	801.625	808.125
NO.16	25.000	400.000	802.900	809.400
NO.17	25.000	425.000	804.175	810.675
NO.18	25.000	450.000	805.450	811.950
NO.19	25.000	475.000	806.725	813.225
NO.20	25.000	500.000	808.000	814.500
NO.21	25.000	525.000	809.275	815.775
NO.22	25.000	550.000	810.545	817.050
NO.23	25.000	575.000	811.825	818.325
NO.24	25.000	600.000	813.100	819.600
NO.25	25.000	625.000	814.375	820.875
NO.26	25.000	650.000	815.650	822.150
NO.27	25.000	675.000	816.925	823.425
NO.28	25.000	700.000	818.200	824.700
NO.29	25.000	725.000	819.475	825.975
NO.30	25.000	750.000	820.750	827.250
NO.31	25.000	775.000	822.025	828.525
NO.32	25.000	800.000	823.300	829.800
NO.33	25.000	825.000	824.570	831.075
NO.34	25.000	850.000	825.850	832.350
NO.35	25.000	875.000	827.125	833.625
NO.36	25.000	900.000	828.400	834.900

834.900

828.400

789.000

782.500

15.000

15.000

Tanggul Curah Lengkong General structure

S-1:50

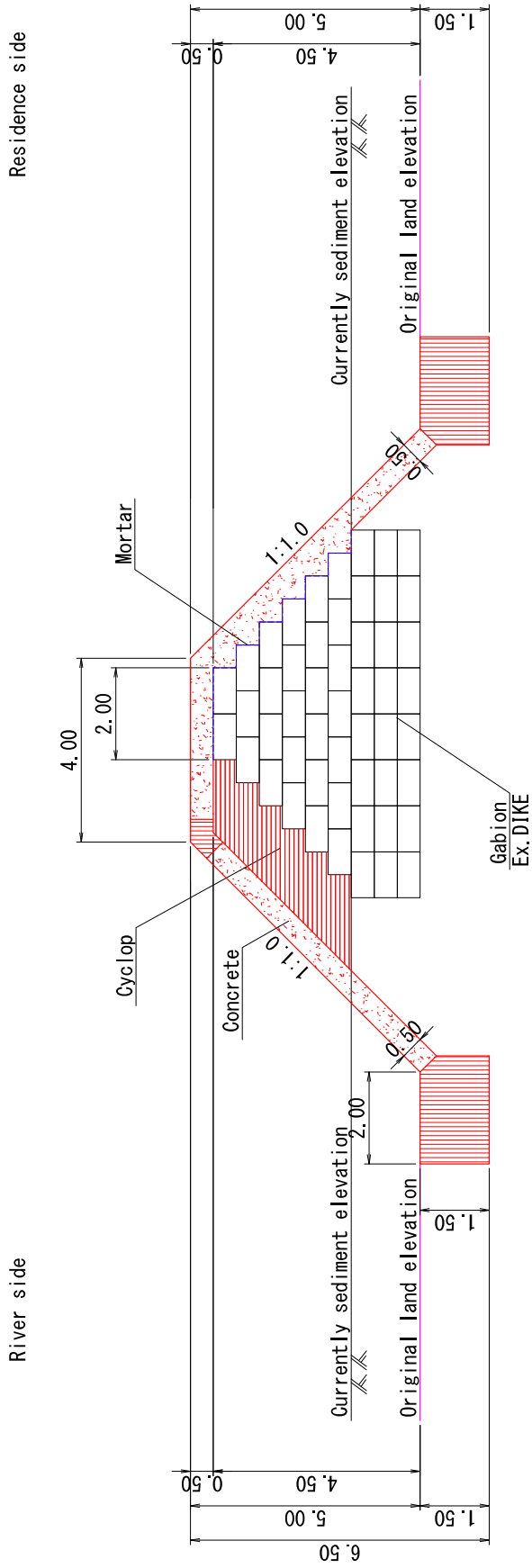

Tanggul Churah Lengkung Cross section (1/7)

S=1:100

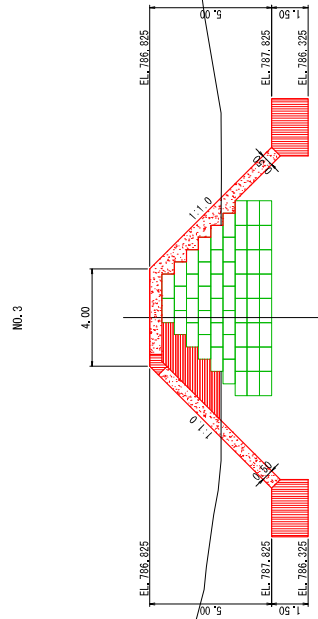
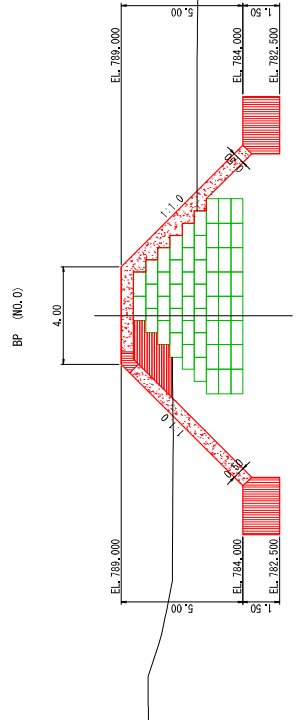
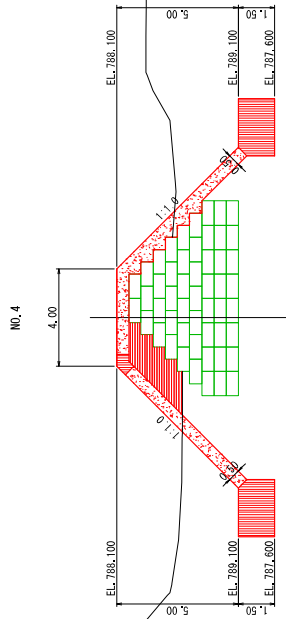
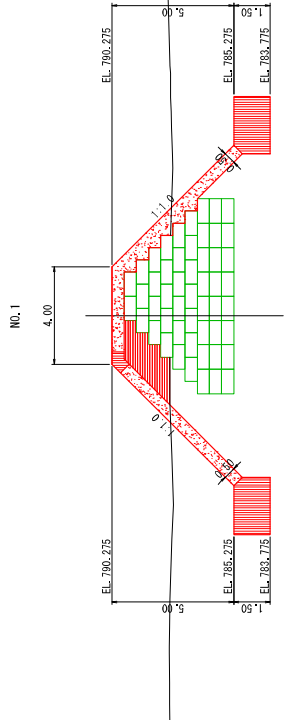
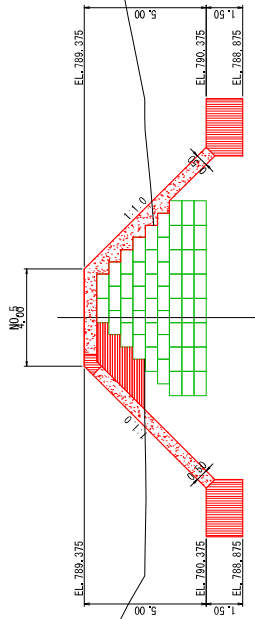
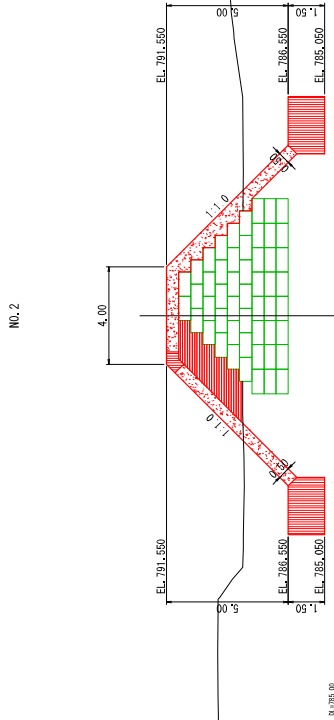

Tanggul Churah Lengkung Cross section (2/7) S=1:100

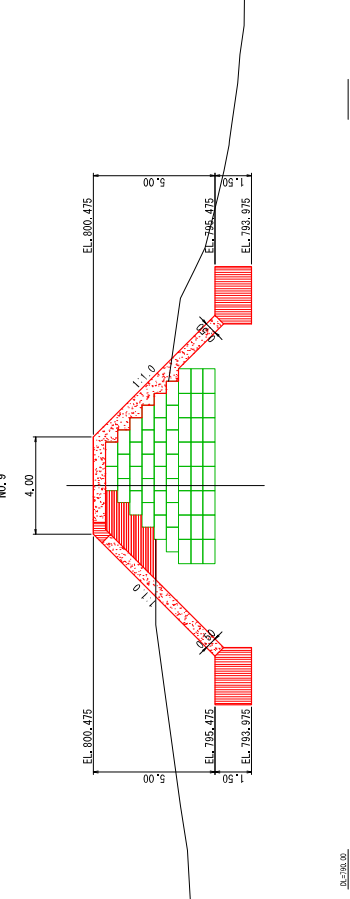
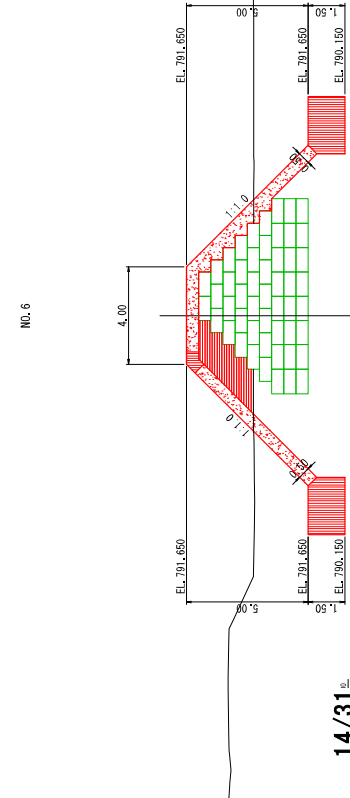
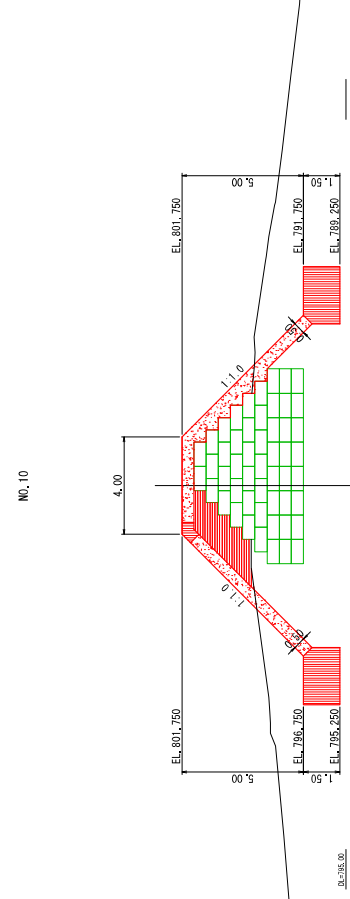
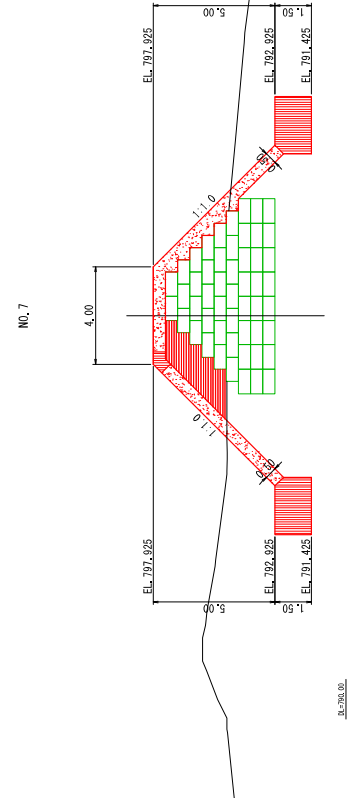
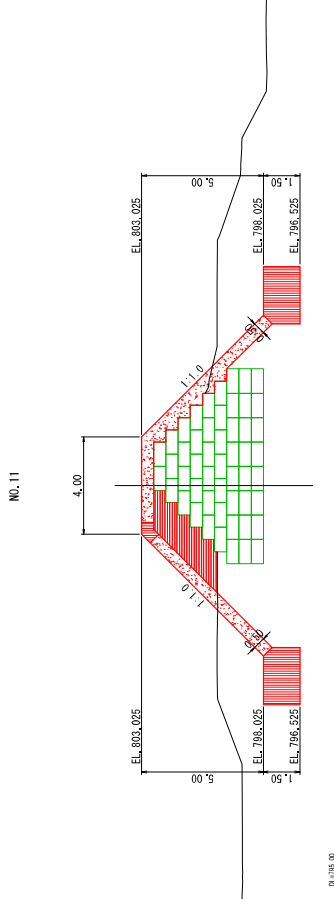
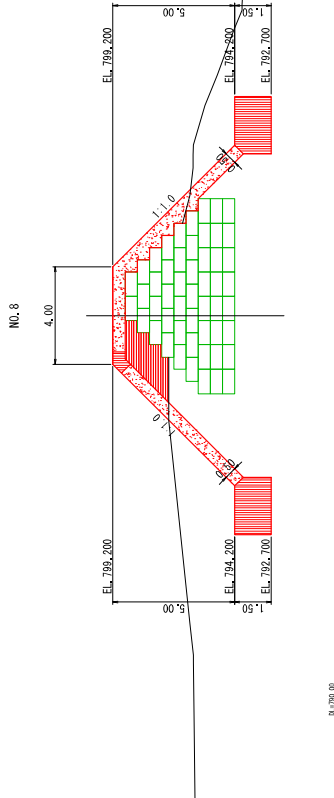

Tanggul Churah Lengkung Cross section (3/7) S=1:100

NO. 14

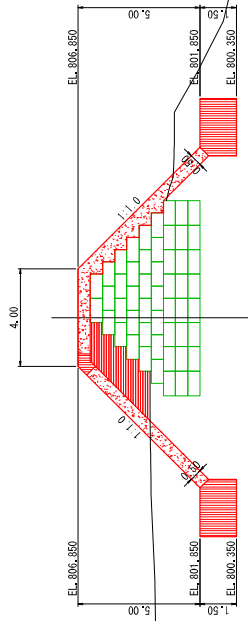

EL. 800.00

NO. 17

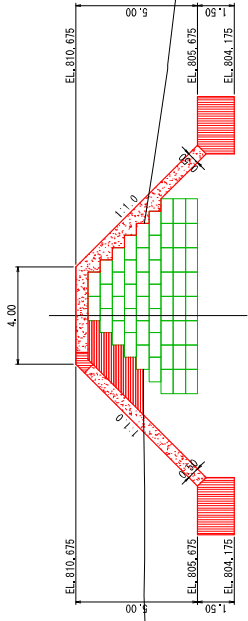

EL. 800.00

NO. 13

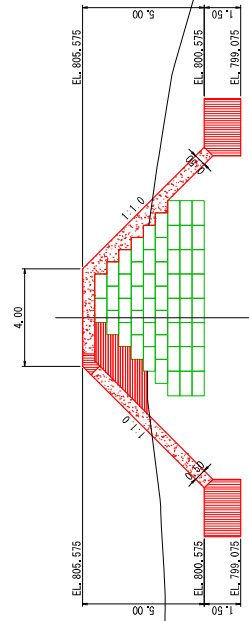

EL. 800.00

NO. 16

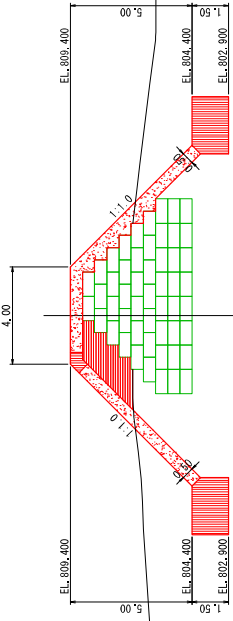

EL. 800.00

NO. 12

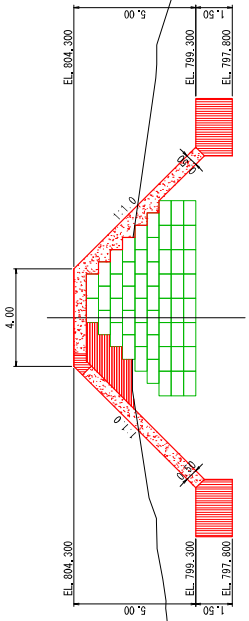

EL. 800.00

NO. 15

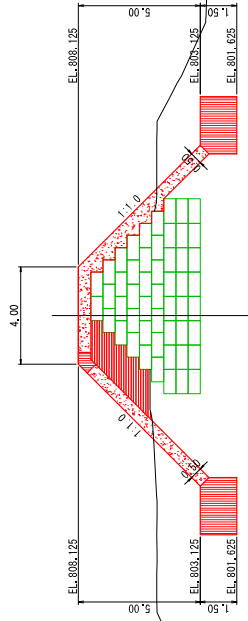

EL. 800.00

Tanggul Churah Lengkong Cross section (4/7) S=1:100

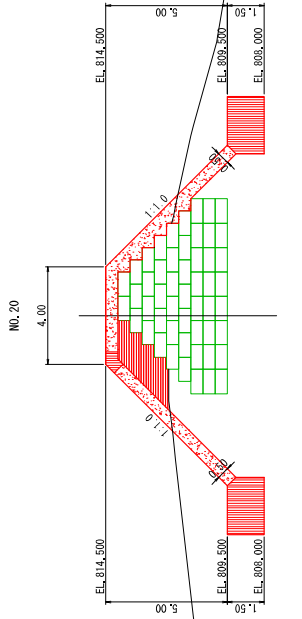

Δ=0.00.00

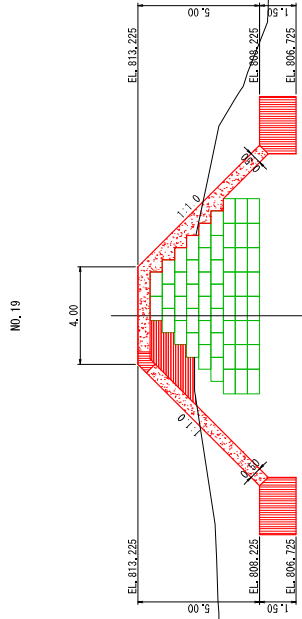

Δ=0.00.00

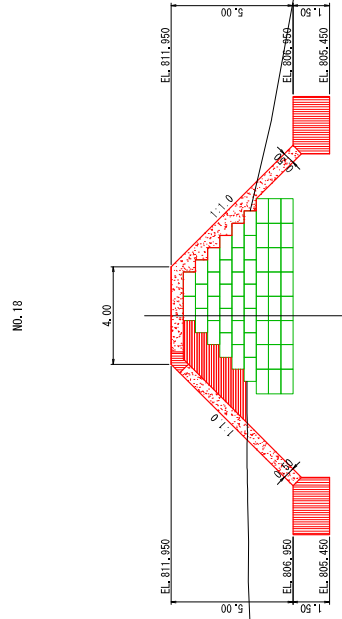

16/31

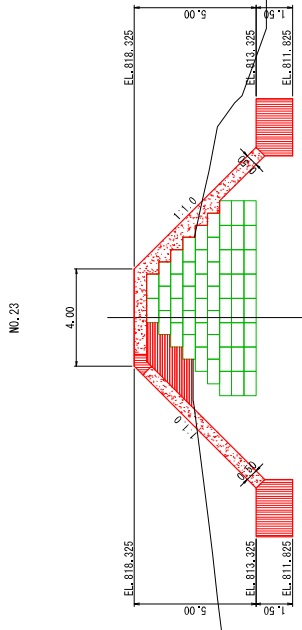

Δ=0.00.00

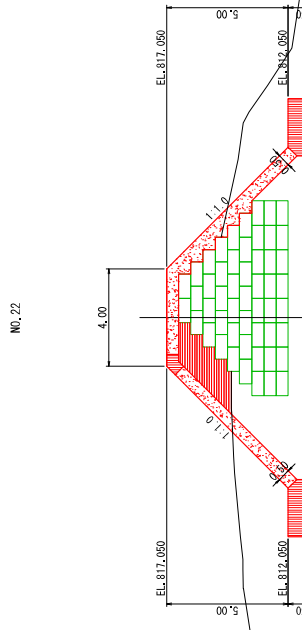

Δ=0.00.00

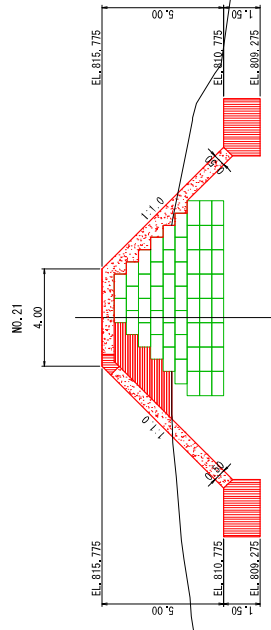

Δ=0.00.00

Tanggul Churah Lengkong Cross section (5/7) S=1:100

NO. 26

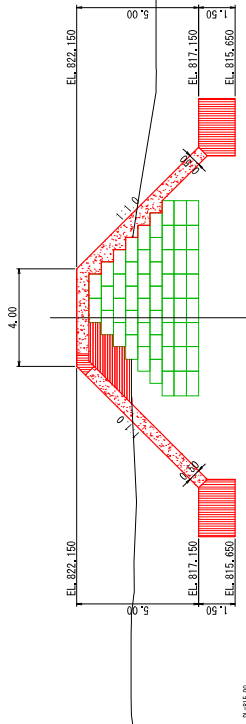

NO. 29

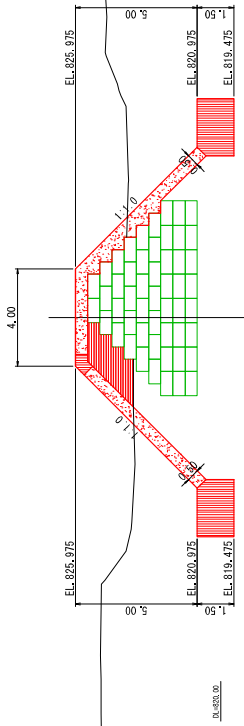

NO. 25

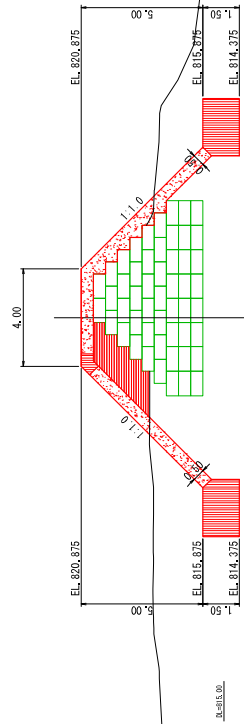

NO. 28

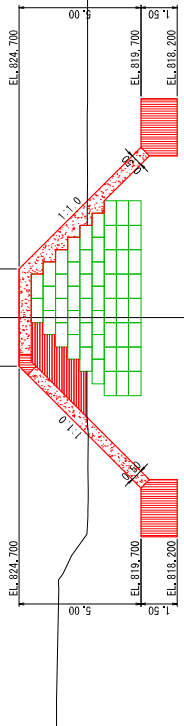

NO. 24

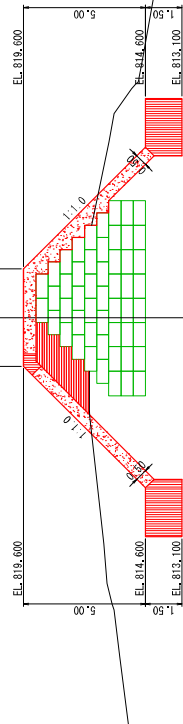

NO. 27

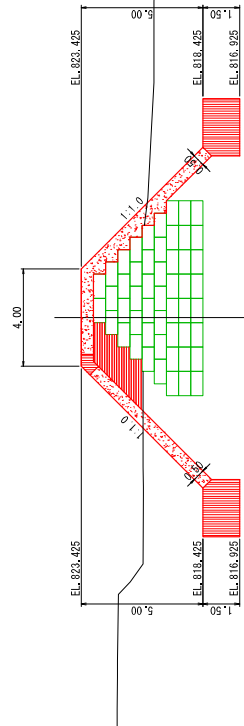

Tanggul Churah Lengkung Cross section (6/7) S=1:100

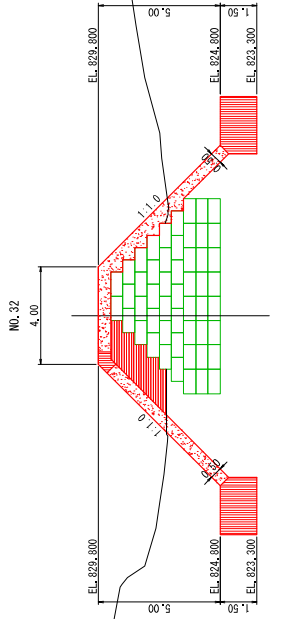

0.0000.00

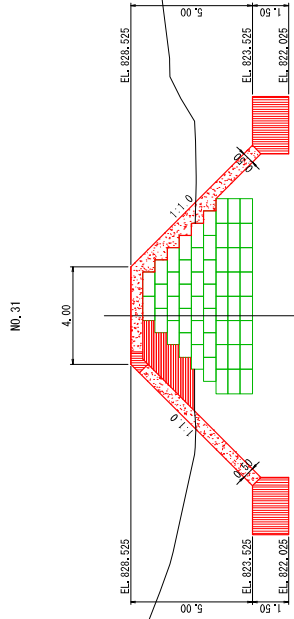

0.0000.00

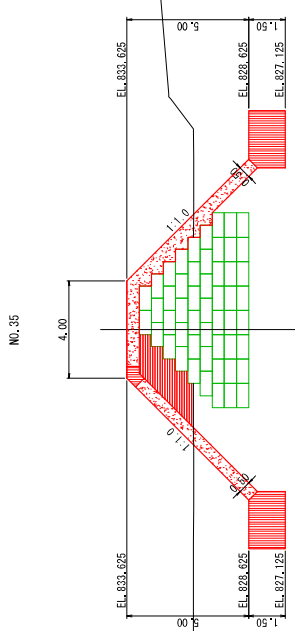
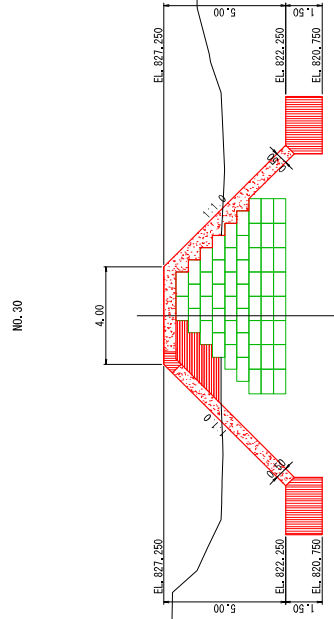

0.0000.00

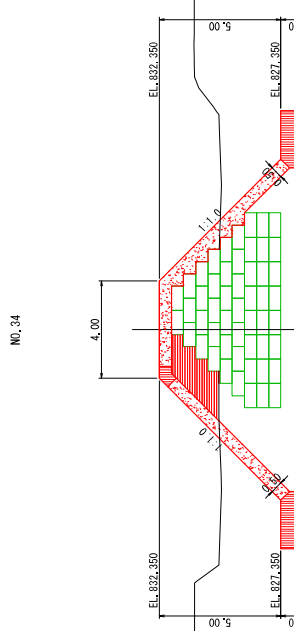

0.0000.00

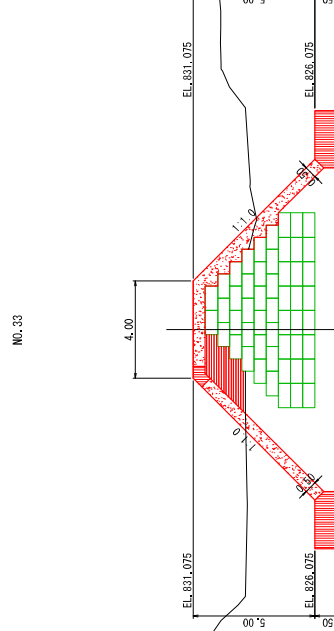

Tanggul Churah Lengkong Cross section (7/7)
 S=1:100

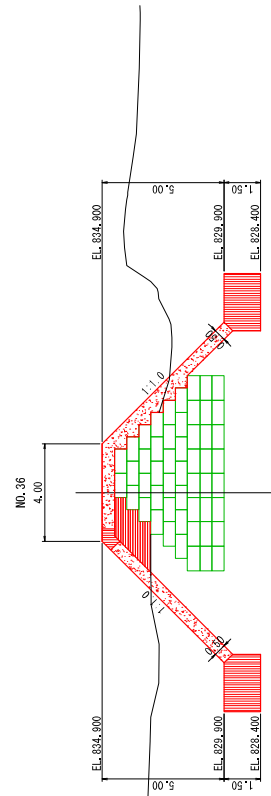



Maintenance road Plan
1:1000

20/31

Maintenance road Long profile

SW=1:150
SH=1:1,500

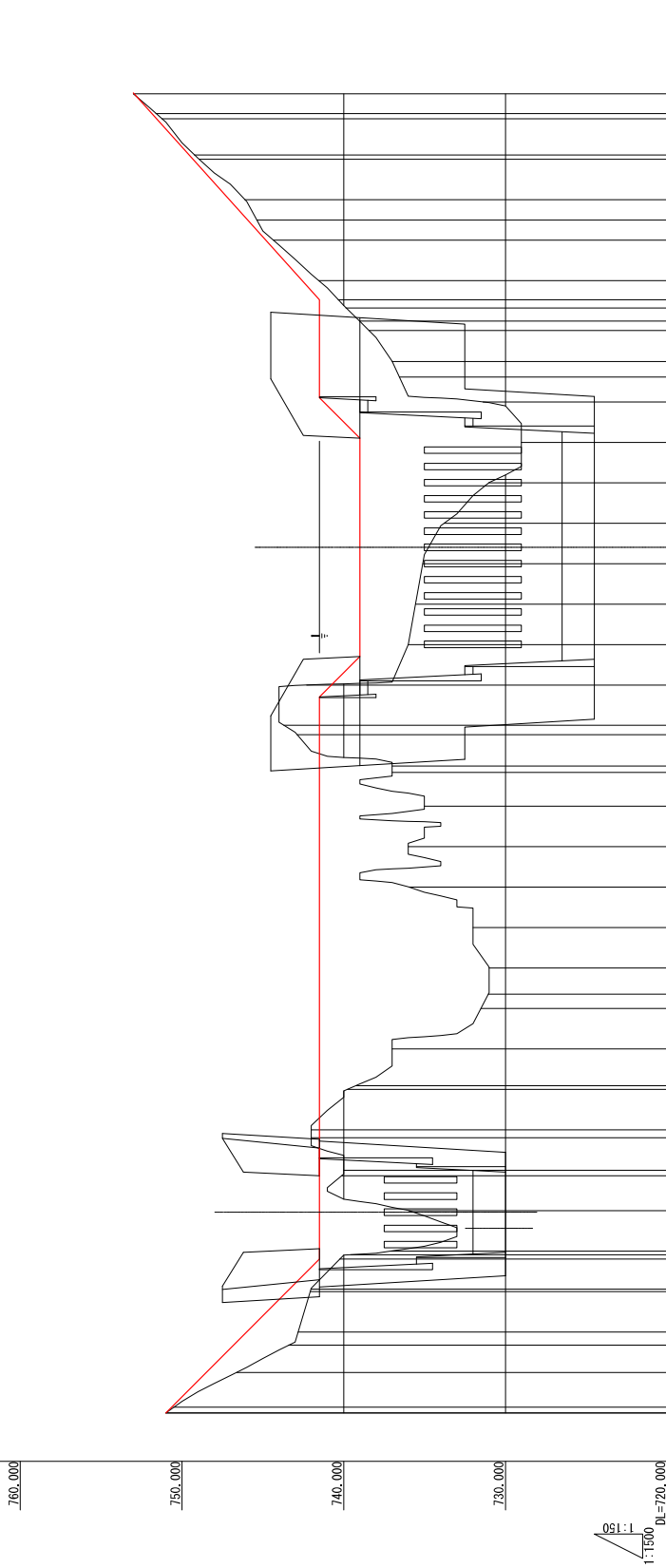

測点	車距	加距離	地面	路面	中面	中心	點
BP	BC 1-0	0.000	751.000	751.000	751.000	751.000	751.000
NO.1	EG 1-0	21.446	750.498	748.500	746.615	746.500	746.500
NO.2	EG 1-0	16.787	743.406	746.821	748.814	746.000	746.000
NO.3	EG 2-0	25.000	75.000	742.061	743.500	743.500	743.500
NO.4	EG 2-0	2.329	100.000	737.087	741.500	741.500	741.500
NO.5	NO.5	25.000	125.000	735.973	741.500	741.500	741.500
NO.6	NO.6	21.636	3.364	146.636	740.134	741.500	741.500
NO.7	NO.7	20.223	170.223	742.000	741.500	741.500	741.500
NO.8	NO.8	25.000	202.357	739.768	741.500	741.500	741.500
NO.9	NO.9	22.643	225.000	737.000	741.500	741.500	741.500
NO.10	NO.10	25.000	250.000	731.515	741.500	741.500	741.500
EG 4-0	EG 4-0	8.767	258.767	731.058	741.500	741.500	741.500
NO.11	NO.11	16.233	275.000	731.000	741.500	741.500	741.500
NO.12	NO.12	25.000	300.000	732.000	741.500	741.500	741.500
NO.13	NO.13	25.000	325.000	735.941	741.500	741.500	741.500
NO.14	NO.14	25.000	350.000	736.000	741.500	741.500	741.500
NO.15	NO.15	25.000	375.000	735.000	741.500	741.500	741.500
NO.16	NO.16	20.931	395.931	737.000	741.500	741.500	741.500
EG 5-0	EG 5-0	4.069	400.000	737.000	741.500	741.500	741.500
NO.17	NO.17	19.228	419.228	742.872	741.500	741.500	741.500
NO.18	NO.18	25.000	450.000	742.284	740.759	741.500	741.500
NO.19	NO.19	25.000	475.000	735.998	739.000	739.000	739.000
NO.20	NO.20	25.000	500.000	735.550	739.000	739.000	739.000
NO.21	NO.21	25.000	525.000	735.101	739.000	739.000	739.000
NO.22	NO.22	25.000	550.000	733.791	739.000	739.000	739.000
NO.23	NO.23	25.000	575.000	731.023	739.000	739.000	739.000
NO.24	NO.24	25.000	600.000	729.000	739.000	739.000	739.000
NO.25	NO.25	25.000	625.000	731.381	741.241	741.500	741.500
NO.26	NO.26	15.491	640.491	736.564	741.500	741.500	741.500
EG 6-0	EG 6-0	9.509	650.000	736.993	741.500	741.500	741.500
NO.27	NO.27	5.892	675.000	739.007	741.500	741.500	741.500
NO.28	NO.28	11.791	700.000	741.529	742.561	742.561	742.561
EG 7-0	EG 7-0	12.992	737.392	745.367	745.927	744.811	744.811
NO.29	NO.29	25.000	725.000	744.345	744.811	744.811	744.811
NO.30	NO.30	12.608	750.000	746.094	747.061	747.061	747.061
NO.31	NO.31	25.000	775.000	748.934	749.311	749.311	749.311
BC 8-0	BC 8-0	2.711	777.711	749.221	749.555	749.555	749.555
NO.32	NO.32	22.289	800.000	751.234	751.561	751.561	751.561
EP	EP	3.301	803.301	751.858	751.858	751.858	751.858
NO.33	NO.33	12.686	815.986	753.000	753.000	753.000	753.000

Maintenance road General structure
S=1:50

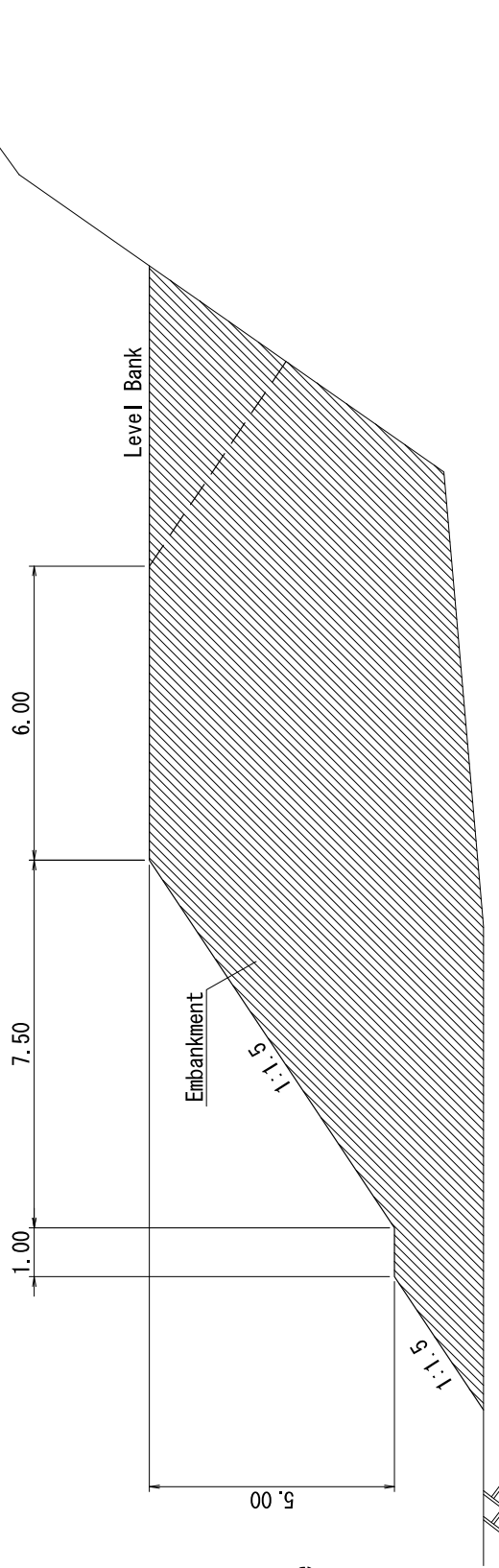

River side

Maintenance road Cross section (1/9) S=1:200

NO. 3

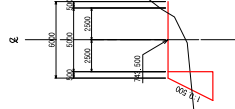

0.5% 0.00

NO. 1

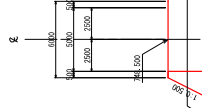

0.5% 0.00

NO. 2

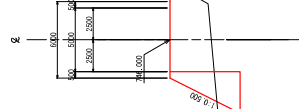

0.5% 0.00

NO. 0

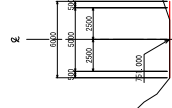

0.5% 0.00

Maintenance road Cross section (2/9) S=1:200

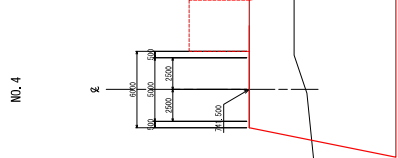
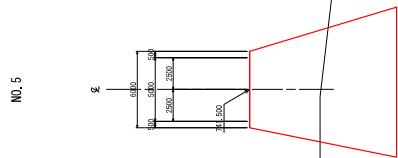
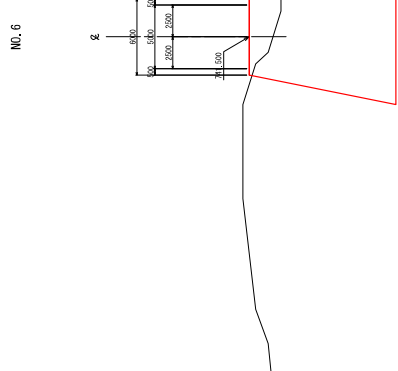
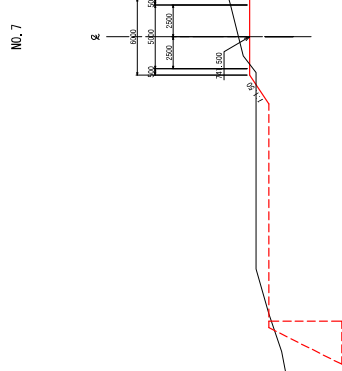

Maintenance road Cross section (3/9) S=1:200

NO. 11

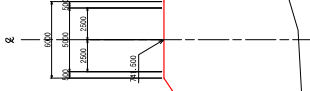

0.6/200.00

NO. 10

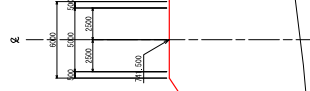

0.6/200.00

NO. 9

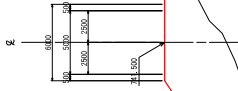

0.6/200.00

NO. 8

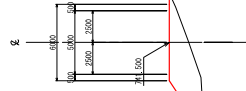

0.6/200.00

Maintenance road Cross section (4/9) S=1:200

NO. 13

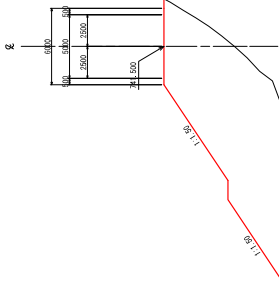

04.720A.00

NO. 12

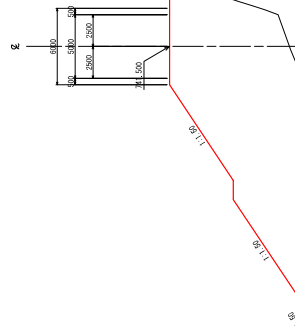

04.720A.00

NO. 15

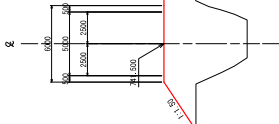

04.720A.00

NO. 14

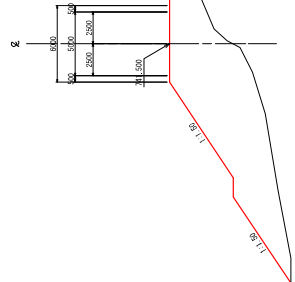

04.720A.00

Maintenance road Cross section (5/9) S=1:200

NO. 19

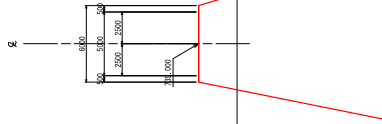

D.L. 120.00

NO. 17

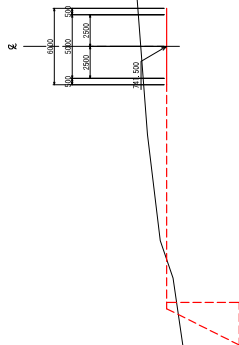

D.L. 120.00

NO. 18

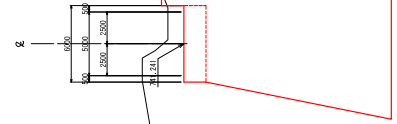

D.L. 120.00

NO. 16

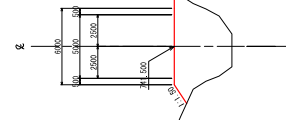

D.L. 120.00

Maintenance road Cross section (6/9) S=1:200

NO. 23

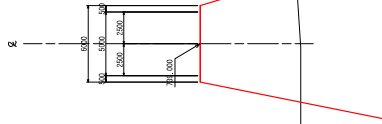

0.01320.00

NO. 21

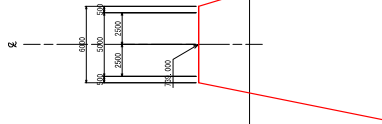

0.01320.00

NO. 22

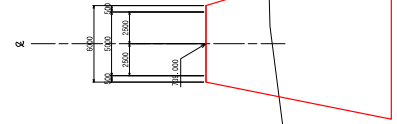

0.01320.00

NO. 20

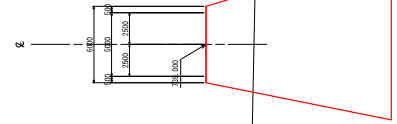

0.01320.00

Maintenance road Cross section (7/9) $S=1:200$

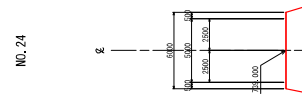
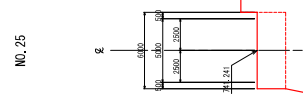
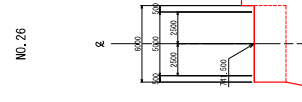
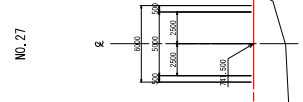

DL 120A.00

DL 120A.00

Maintenance road Cross section (8/9) S=1:200

NO. 29

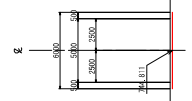

0.1:200.00

NO. 31

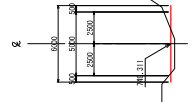

0.1:200.00

NO. 28

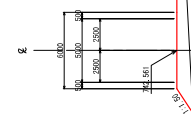

0.1:200.00

NO. 30

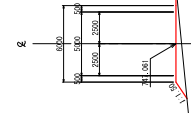

0.1:200.00

Maintenance road Cross section (9/9) S=1:200

EP (NO. 32+15, 9864)

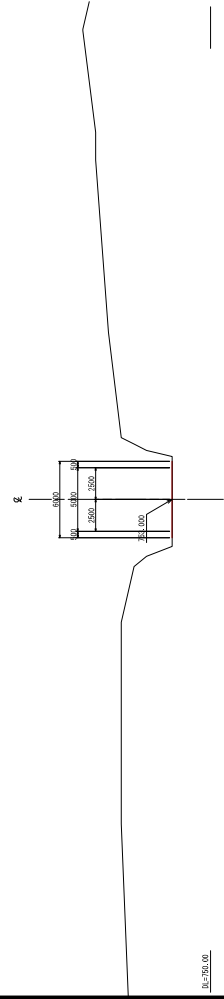

NO. 32

