

## 別添資料 2

# Strategic Environmental Assessment 報告書



# The Western Province Solid Waste Management Master Plan (MP)

## STRATEGIC ENVIRONMENTAL ASSESSMENT (SEA) REPORT

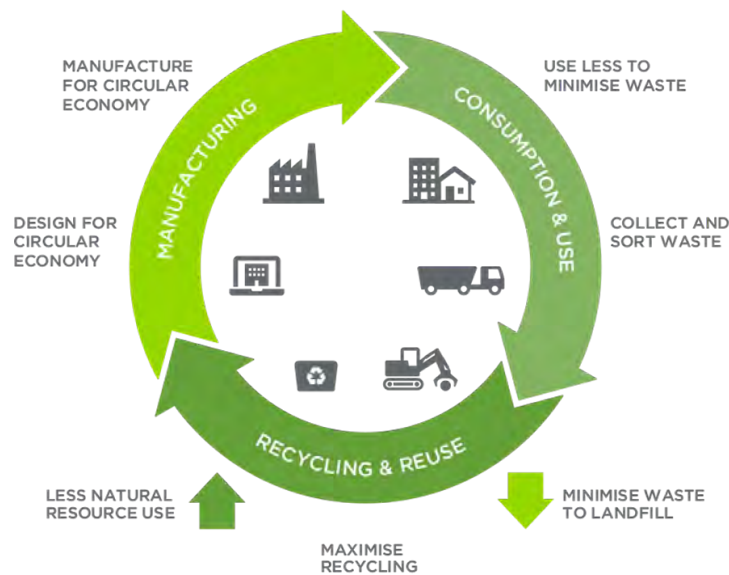

WASTE MANAGEMENT AUTHORITY – WESTERN PROVINCE

MAY 2023



# **The Western Province Solid Waste Management Master Plan (MP)**

## **STRATEGIC ENVIRONMENTAL ASSESSMENT (SEA) REPORT**

**WASTE MANAGEMENT AUTHORITY – WESTERN PROVINCE**

Funded by

**THE PROJECT FOR WESTERN PROVINCE SOLID WASTE MANAGEMENT  
MASTER PLAN IN SRI LANKA**

**Japan International Cooperation Agency**

Prepared by

**WASTE TO ENERGY TECHNOLOGIES LTD**

**MAY 2023**



## Executive Summary

This report sets out the results of a Strategic Environmental Assessment (SEA) for the Western Province Solid Waste Management Master Plan in Sri Lanka (MP). The MP will be a fundamental document outlining the framework for how municipal solid (MSW) waste will be managed in the Western Province up to the year 2042. The MP is proposing strategies to manage solid waste to reduce and eliminate the adverse impacts of waste on human health and the environment, and to support economic development and improved quality of life in the Western Province. This SEA assesses the likely impacts of the proposed strategies of the MP on the natural and socio-economic environment and of the SWM options considered as part of its development.

The Waste Management Authority-Western Province (WMA-WP) executed the current SEA process based on the guideline on SEA provided by the Central Environment Authority (CEA). From the very first stages of MP preparation, the stakeholders have been engaged in the SEA process. In particular, the SEA protocols discussed and agreed at the initial project scoping meetings by the stakeholders have been incorporated, and stakeholders' views have been taken into account in the SEA assessment to the largest extent possible. This SEA aims to facilitate early and systematic consideration of potential impacts of the MP, thereby enabling such impacts are properly addressed at the appropriate stages of planning. Specifically, it seeks to inform the decision-makers of the degree of uncertainty over impacts, the level of consistency in objectives (plan and environmental), the sensitivity of the baseline and the range of plan/program alternatives available to achieve the intended economic, social and environmental goals.

The MP aims at developing the Western Province waste management in harmony with the national waste management policy and the strategic action plan for waste management of the province in 2019. The document contains key strategies and numerous targets and planning solutions that are categorized in promotion of waste reduction and separation, improved waste collection, promotion of 4R concept and circular economy, reduction of disposal, application of zonal concept and simultaneous approach for waste management and waste data and waste management capacities.

During the SEA process, a comprehensive environmental baseline assessment was conducted to identify the environmental, health and socio-economic issues related to waste management in the Western Province. The main areas where problems occur were considered for further analysis. The MP is intended for the whole territory of the Western Province, but it does not indicate specific localities for implementation of individual activities/projects. Therefore, it is difficult to identify the trend of the problems within the specific localities, thus, the analysis provides only general information on the issues and their overall effects on the particular areas. In relation to water, the most problematic areas include riverbanks, inland water bodies and coastal areas where illegal/ unplanned dumping of waste occurs. Surface waters downstream of

big cities are considered to be most polluted with nutrients and heavy metals as well. Groundwater is more prone to pollution in the areas of dumpsites not meeting the standards where pollution percolates down through the groundwater aquifers. In terms of soil, the most contaminated areas include construction sites including waste management facilities. Poor air quality is mostly due to the transportation sector, open burning and energy related activities. Protected areas are also prone to pollution unless the proper waste management plans and infrastructure are on place. Environmental effects on public health and occupational health related issues are identified requiring setting relevant actions for improving existing environmental conditions. Lack of awareness on SWM, lack of institutional capacity and underdeveloped SWM systems are also key issues recognized at the scoping stage.

Guided by the key environmental issues identified above and based on the review of relevant adopted national strategic documents for waste management, an evaluation framework for SEA that defines key relevant environmental objectives, targets, indicators, and evaluation criteria was developed. Analysis of the MP and its alternatives was performed by assessing the likely impacts of the MP and its alternatives against these SEA objectives. These alternative scenarios considered in developing the MP are focused on developing alternative technical systems for integrated SWM that provides practical solutions for solving SWM issues in the Western Province rather than considering more comprehensive planning scenarios that could replace the proposed action in MP. These scenarios have been developed through consideration of the need of the Western Province, relevancy to the national policies and stakeholder consultation. Therefore, the analysis of alternative scenarios in the SEA involves an assessment of these scenarios in comparison to the “Business as usual” (No plan option) scenario in which the SWM systems are maintained at the current level. This assessment suggested that implementing the MP would be preferred to “Business as usual” option and other alternatives. The preferred option “B” will thermally treat 2900 TPD to generate electrical power, produce compost from 1326 TPD and recycle 421 TPD of materials by 2040.

A comprehensive assessment was conducted by evaluating the proposed planning solutions in MP against the SEA objectives for their likely impacts on the environment. Further, the proposed actions of the MP were assessed in terms of their potential compliance or conflict with Sri Lanka’s Nationally Determined Contributions (NDCs) to the United Nations Framework Convention on Climate Change which are a set of waste management targets developed in accordance with the policies and strategies for waste management. This assessment shall further inform MP’s compliance with the policy objectives of the waste management sector.

The overall impact of the MP implementation will have a positive impact for the environment. When potential negative impacts/risks of implementing the MP were revealed, solutions were proposed towards the prevention and mitigation. In place of a mass burning thermal system, Refuse/Residual Derived Fuel can mitigate issues arising from downtime for maintenance and



combine cycle can further reduce coal burning. Moreover, much greater emphasis on shifting from plastics to organic materials in packing will show greater interest in establishing waste to energy plants. Co-composting SW and agricultural wastes will improve the quality of compost and even produce biofertilizers to replace inorganic for sustainable development. Promoting ecofriendly lifestyles will be an added advantage to reduce, reuse, recycle and thermal recovery of waste. Hence, the limitations of the MP can be mitigated to provide best approaches for sustainable development. Notably, the evaluation against the NDCs revealed that the planning solutions of the MP are in formal conformity with the NDCs. However, more details about the MP's planning strategies, such as available opportunities in terms of technologies, techniques, investment locations, infrastructure needs, available funding etc., could have been much useful for a comprehensive SEA assessment.

The SEA formulated several recommendations and conditions intended for further development of the institutional and regulatory framework as well as implementation of key components of the MP. Recommendations and measures revealed during the SEA process will be incorporated in the MP and thus will contribute to its more environmentally and socially conducive delivery. The key recommendations are summarized as follows:

- Development and implementation of adequate mitigation measures as well as of monitoring programs during establishment of treatment facilities, primary transfer stations, waste parks, and during the construction and operation of such facilities is essential.
- Compliance with the national regulatory requirements will ensure adequate precautionary measures to avoid leachate pollution, air pollution, loss of natural ecosystem, and pollution of groundwater resources.
- Waste transportation through large distances from Local Authorities to primary transfer stations may lead to their disposal at the unauthorized locations in contingencies. Such pollution may be local in nature. Mainly non- populated and sparsely populated areas fall under this impact zone, especially in Kalutara District. This can also lead to considerable, indirect negative socio- economic, environmental and health related impact on the neighboring communities. Impact can be long-term in nature.
- Waste collection through modern technologies employing appropriate vehicles will reduce pollution of the neighboring areas. Due to waste recycling, the amount of waste and, hence, surface areas for waste disposal will be reduced. At the same time, the level of pollution of soil (as well as water and air) through various hazardous substances will decrease due to source segregated waste collection and material recycling.
- Mitigation and controlling measures need to be implemented to reduce the risk of unauthorized waste disposal at sources of generation and during waste transportation to transfer stations and treatment facilities. In particular, it is necessary to apply navigation

systems to control the movement of vehicles before and after waste transportation from one area to another to avoid waste disposal into the environment.

As set out in the SEA guidelines, this report focused the monitoring and evaluation plan on the significant effects identified in the assessment that may give rise to irreversible damage, with a view to identifying trends and where appropriate to implement relevant mitigating measures before such damage is caused; and uncertain effects where monitoring would enable preventative or mitigating measures to be undertaken. Therefore, the SEA objectives/topics that suggested having overall positive impacts, namely biodiversity, land use, climatic factors and waste, were excluded from the monitoring and evaluation plan. Further, in the absence of regulatory enforcement of the SEA process in Sri Lanka, the current SEA has

the existing monitoring networks where possible and proposes to take forward the finalized MP indicators and measures when released, as the monitoring framework. This approach will avoid unnecessary duplication and is consistent with the policy goals. Furthermore, it is acknowledged that the planning authority responsible for the implementation of the MP should be responsible for the delivery of the defined monitoring measures while implementing the MP and make the results of its monitoring available to the CEA for compliance and licensing purposes.

## Table of Content

<b>1</b>	<b>Need of a Strategic Environmental Assessment (SEA) for the Western Province Solid Waste Management Master Plan (MP)</b> .....	<b>1</b>
1.1	The Need of a SEA for the MP .....	1
1.2	Purpose of the SEA report .....	2
1.3	Methods and approaches of SEA .....	3
<b>2</b>	<b>Description of the Western Province Solid Waste Management Master Plan (MP)</b> .....	<b>5</b>
2.1	Purpose of the MP for the Western Province.....	5
2.2	Goals and objectives of the MP .....	6
2.2.1	Vision.....	6
2.2.2	Mission.....	7
2.2.3	Key strategies of the MP .....	7
2.3	Quantitative targets of the MP .....	8
2.4	Alternatives considered in the MP.....	9
2.5	Project activities proposed in MP .....	10
2.5.1	Actions promoting waste reduction .....	11
2.5.2	Actions promoting source separation and reduction at the discharge stage.....	12
2.5.3	Actions for waste reduction at the discharge stage .....	13
2.5.4	Improvement of waste collection system.....	13
2.5.5	Improvement of waste transfer system.....	14
2.5.6	Promotion of recycling at intermediate treatment facilities .....	16
2.5.7	Reduction of waste to be disposed.....	19
2.5.8	Establishment of a data management system based on a database .....	20
2.6	Key stakeholders .....	20
<b>3</b>	<b>Policy and legislative framework relevant to waste management</b> .....	<b>23</b>
3.1	Policy framework .....	23
3.2	Legislative framework.....	26
3.3	Strategies and guidelines .....	29
3.4	Provincial policies/strategies applicable to MP .....	32
<b>4</b>	<b>Environmental baseline of the Western Province</b> .....	<b>35</b>
4.1	Topography .....	36
4.2	Geology and soil.....	38
4.2.1	Land use .....	40
4.2.2	Surface and ground water .....	42
4.2.3	Rainfall .....	45
4.2.4	Air and climate .....	46
4.2.5	Hydrology and drainage .....	49
4.3	Ecological resources.....	51
4.3.1	Ecological environment (Flora and fauna) .....	51
4.3.2	Forest cover .....	52

4.3.3	Habitats .....	55
4.3.4	Wetland ecosystems .....	56
4.3.5	Coastal and marine ecosystems.....	57
4.3.6	Environmentally sensitive areas-legally protected and unprotected .....	58
4.4	Socio-economic environment .....	61
4.4.1	Population, density, migration and trends .....	61
4.4.2	Population growth trends .....	62
4.4.3	Rate of urbanization.....	63
4.4.4	Migration trends .....	63
4.4.5	Economic activities and employment.....	65
4.4.6	Public health risks .....	68
4.5	Current state of the pollution in Western Province .....	70
4.5.1	Inland water pollution.....	71
4.5.2	Sustainability of wetland ecosystems.....	73
4.5.3	Marine and coastal environment pollution .....	75
4.5.4	Air pollution .....	76
4.6	Status of solid waste sector .....	77
4.6.1	Global trends in solid waste management .....	77
4.6.2	MSW generation and management in Sri Lanka .....	78
4.6.3	3Rs and resource recovery.....	81
4.7	Current issues in solid waste sector.....	82
4.7.1	Lack of updated data base of waste generation, collection, and disposal in Sri Lanka .....	83
4.7.2	Source separation and waste collection .....	83
4.7.3	Lack of resources for waste collection, transportation, and disposal .....	84
4.7.4	Lack of infrastructure facilities in existing waste management facilities .....	84
4.7.5	Institutional and human resource issues .....	84
4.7.6	Problems in recycling sector .....	85
4.7.7	Issues in biodegradable waste recovery by composting .....	86
4.7.8	Social issues in waste sector .....	86
4.7.9	Environmental issues in waste sector.....	87
4.7.10	Economic and financial issues in waste sector .....	88
4.8	Summary of the characteristics of the environment in areas likely to be significantly affected by MP	88
<b>5</b>	<b>Analysis and evaluation of the MP and its alternatives .....</b>	<b>93</b>
5.1	Selection of sustainable alternatives .....	93
5.2	SEA scenario analysis .....	94
5.3	SEA objectives and indicators .....	95
5.4	Master Plan options.....	98
5.4.1	Business as usual option .....	99
5.4.2	Option A: 750 TPD WtE & 930 TPD composting .....	100
5.4.3	Option B: 2900 TPD WtE & 1326 TPD composting .....	101
5.4.4	Option C: 3300 TPD WtE & 930 TPD composting .....	102

5.5	Evaluation of alternatives/options .....	103
5.6	Summary of alternative comparison .....	110
5.7	Potential environmental and social impacts of the selected planning option in the MP.....	112
5.7.1	Promote waste reduction at generation sources .....	113
5.7.2	Promote waste separation and recycling at discharge state .....	114
5.7.3	Expand the solid waste collection area and waste collection system .....	115
5.7.4	Construction of primary transfer stations .....	116
5.7.5	Increase the capacity of thermal recovery facilities .....	117
5.7.6	Increase capacity of composting and recycling facilities .....	118
5.7.7	Increase the capacity of the sanitary landfill .....	119
5.7.8	Closure of dumping site .....	120
5.7.9	Establishment of data management system .....	120
5.8	Conformity of MP with National Environment Action Plan (NEAP) and Nationally Determined Contributions (NDCs) .....	120
5.8.1	Conformity of MP with National Environment Action Plan (NEAP).....	120
5.8.2	Conformity of MP with Nationally Determined Contributions (NDCs).....	128
5.9	Mitigating Measures .....	131
<b>6</b>	<b>Conclusions and Recommendations .....</b>	<b>135</b>
6.1	General conclusions .....	135
6.1.1	Recommendations towards further development of the legal/regulatory framework ...	135
6.1.2	Recommendations for the institutional arrangements .....	136
6.1.3	Recommendations related to key components of MP .....	137
<b>7</b>	<b>Environmental monitoring and evaluation plan .....</b>	<b>141</b>
7.1	Monitoring framework.....	141
<b>8</b>	<b>ANNEXURES .....</b>	<b>145</b>

## **Annexures**

Annexure 1: TOR

Annexure 2: List of contributors

Annexure 3. Summary of Stakeholder discussions relevant to SEA

Annexure 4. Schedule & workplan of the MP

Annexure 5: Evaluation and selection of the best alternative

Annexure 6. Key stakeholders relevant to SWM sector and the MP

Annexure 7. Detailed assessment of likely effects of planning solutions

Annexure 8: Maps and supplementary information

Annexure 9: References and data sources

## List of Tables

Table 2-1 Quantitative targets of the Master Plan (2022-2042) .....	9
Table 2-2 The key features of four suggested alternatives .....	10
Table 3-1 An outlook of key policies and strategies relevant to solid waste management sector in Sri Lanka .....	24
Table 3-2 An outlook of key regulations relevant to solid waste management sector in Sri Lanka.....	27
Table 3-3 Summary of key strategies and guidelines relevant to solid waste management sector in Sri Lanka .....	29
Table 4-1 Land and water resources of Western Province (Source: Department of Census and Statistics, 2012) .....	35
Table 4-2 List of irrigation tanks in the Western Province.....	43
Table 4-3 Inland fauna and flora found in the Western Province compared to fauna and flora recorded in Sri Lanka .....	51
Table 4-4 Forest cover in the Western Province by district.....	52
Table 4-5 Important Birds areas in the Western Province .....	56
Table 4-6 Wetland ecosystems in the Western Province .....	56
Table 4-7 District- wise total hectare extent of coastal habitats in Western Province .....	57
Table 4-8 Common fish species captured for commercial and/or subsistence fishery from coastal lagoons and estuaries in the Western Province.....	58
Table 4-9 Protected areas in the Western Province.....	59
Table 4-10 Population growth rate of Western Province (1953-2018) .....	63
Table 4-11 Reasons for internal migration in Western Province.....	65
Table 4-12 Poverty Indicators in Western Province 2006-2019 .....	67
Table 4-13 Prominent Health risks associated with SWM in Sri Lanka.....	69
Table 4-14 Status of MSW generation and collection at the provincial level in Sri Lanka in 2020.....	79
Table 4-15 Key environmental and socio-economic issues in the project implementation area .....	89
Table 5-1 SEA objectives and indicators used in evaluation of project alternatives and proposed actions .....	96
Table 5-2 Likely effects of proposed alternatives .....	104
Table 5-3 Key likely effects of MP solutions .....	113
Table 5-4 Conformity of MP with the National Environment Action Plan (NEAP) (2022) .....	121
Table 5-5 Conformity of MP with NDCs .....	129
Table 5-6 Mitigation Measures .....	131
Table 7-1 Proposed monitoring framework for the MP .....	142

## List of Figures

Figure 2-1 Proposed mechanical transfer system for PTS .....	14
Figure 2-2 Location and scale of cluster-based PTS in Western Province .....	15
Figure 2-3 Proposed plan for expansion of Thermal Recovery Facilities.....	17
Figure 2-4 Proposed plan for expansion of organic waste composting and treatment facilities.....	18
Figure 4-1 Three districts in Western province of Sri Lanka .....	35
Figure 4-2 Topographic map of Western Province .....	37
Figure 4-3 Major soil types of western province .....	39
Figure 4-4 The present land use of the Western Province .....	40
Figure 4-5 The land use of Western province a) existing land use pattern and b) future land use (2030) as projected by Megapolis Master Plan and JICA (2018).....	41
Figure 4-6 Water resources and surface water bodies of Western Province.....	42
Figure 4-7 Different types of groundwater aquifers in Sri Lanka (Karunaratne, 2007).....	44
Figure 4-8 The average (2012-2022) Rainfall and Temperature changes in Western Province .....	45
Figure 4-9 Monthly profiles of PM <sub>2.5</sub> from September 2017–July 2021 in Colombo (Adapted from Dhammapala et. al., 2021).....	47
Figure 4-10 Agroecological (climate) zones of Western Province .....	48
Figure 4-11 Major River basins of Western Province .....	50
Figure 4-12 Forest Reserves in Colombo District (Source: Research and Development Unit, CEA, 2017).....	53
Figure 4-13 Forest reserves in Gampaha district (Source: Research and Development Unit, CEA, 2018).....	54
Figure 4-14 Forest reserves and proposed reserves in Kalutara district (Source: Research & Development Unit, CEA, 2014) .....	55
Figure 4-15 Muthurajawela environmental protection area (Source: Research & Development Unit, CEA, 2018).....	61
Figure 4-16 Population and growth trends of Western Province.....	62
Figure 4-17 Migration trend in Western Province (1981-2012) .....	64
Figure 4-18 Annual GDP growth rate from 1962-2021.....	66
Figure 4-19 Provincial contribution to GDP 1999-2021 (CBSL, 2017-2021) .....	67
Figure 4-20 Surface water and wetland pollution due to solid waste disposal in Western Province .....	74
Figure 4-21 An estimation of waste generation in Western Province.....	80
Figure 5-1 Waste material balance and flows of the business-as-usual option .....	99
Figure 5-2 Waste material balance and flows of the option A .....	100
Figure 5-3 Waste material balance and flows of the option B .....	102
Figure 5-4 Waste material balance and flows of the option C .....	103



## Abbreviations

CEA	Central Environmental Authority
CMC	Colombo Municipal Council
CPC	Colombo Port City
DMC	Disaster Management Centre
EIA	Environmental Impact Assessment
EPL	Environmental Protection License
EPR	Extended Producer Responsibility
LA	Local Authority
MCs	Municipal Councils
MoE	Ministry of Environment
MoH	Ministry of Health
MoPCLG	Ministry of Public Administration, Home Affairs, Provincial Councils and Local Government
MoUD	Ministry of Urban Development
MoUD&H	Ministry of Urban Development and Housing
MP	Master Plan
MRFs	Material Recovery Facilities
MSW	Municipal Solid Waste
NBRO	National Building Research Organization
NDCs	Nationally Determined Contributions
NEA	National Environmental Act
NSWMSC	National Solid Waste Management Support Center
PTS	Primary Transfer Stations
RDF	Residual Derived Fuel
SATREPS	Science and Technology Research Partnership for Sustainable Development
SEA	Strategic Environmental Assessment
SEOs	SEA objectives
SWM	Solid Waste Management
TRFs	Thermal Recovery Facilities
TS	Transfer Stations
UDA	Urban Development Authority
WMA-WP	Waste Management Authority of Western Province
WP	Western Province
WPK	Western Power- Kerawalapitiya
WRB	Water Resources Board
WRMP	Western Region Master Plan
WRMSWMP	Western Region Megapolis Solid Waste Management Project
WtE	Waste to Energy
3Rs	Reduce, Reuse and Recycling
4R	Reduce, reuse, and recycle and recovery

# 1 Need of a Strategic Environmental Assessment (SEA) for the Western Province Solid Waste Management Master Plan (MP)

## 1.1 The Need of a SEA for the MP

The role and importance of SEA as a key instrument for implementing sustainable strategies in planning and decision making has been increasingly recognized over time since traditional approaches for environmental assessment, Project Environmental Impact Assessment (EIA) in particular, are being questioned, not because they have not developed sufficient legal mechanisms or methodological tools, or because they did not seek to find solutions for critical environmental degradation, but essentially because they are not efficiently responding to the new challenges of the late 21<sup>st</sup> century, as confirmed and proclaimed by the United Nations Conference on Environment and Development in 1992. Such disillusion with the capacity of project EIA to aid, as a single tool, sound environmental decision-making in a tiering system was the strongest argument that decided the need for SEA in its early days (Lee and Walsh, 1992). The reasons are various and can be summarized as: a) project's EIA takes place at a stage when it is too late to consider the effects of policy and planning critical decisions; these happen in the absence of a systematic impact assessment process, of which the outcome could subsequently influence project planning and design; b) the less concrete and more vague nature of policy and planning decisions, often its incremental nature, through small, sequential and iterative decisions that challenge rational and systematic processes, was seen as a significant constraint to the operation of a pragmatic, technically focused, and rationally oriented tool such as EIA; a new impact assessment tool, inherently adaptable to more strategic, and often incremental, levels of decision-making, was therefore needed; c) the level of information: at the policy and planning level often there are serious limitations in the availability of information, and a reasonable uncertainty regarding action implementation and respective timings; this impeded the satisfaction of project EIA needs, in terms of required detailed levels of information and certainty. SEA has been appearing in this context. It is a process to ensure that significant environmental effects arising from policies, plans and programs are found, assessed, mitigated, communicated to decision-makers, and monitored. Also, the SEA process ensures that opportunities for public involvement are provided. At present, SEA has become an important instrument to help achieve sustainable development in public planning and policy making.

SEA is a generic tool which can be used in a variety of situations. A particular form of SEA is being introduced by the European Union Directive 2001/42/EC<sup>3</sup> which requires national, regional, and local authorities in Member States to carry out SEAs on certain plans and programs that they

promote. The latest European Union Directive identifies that municipal waste strategies, as plans with significant environmental impacts, will require an accompanying SEA to ensure that the environmental and social impacts are thoroughly assessed. Following these protocols, while transposing to some extent in accordance with the national policy framework as needed, member countries, such as Austria, United Kingdom, Ireland, Poland and Belgium, have adopted SEA in strategic planning in various sectors including waste management. Further, an increasing number of international financial institutions, such as the European Commission, World bank, UNDP, UNEP and USAID, have developed instruments and imposed requirement for the implementation of SEA for the purpose of checking and ensuring development initiatives in line with sustainable development. Accordingly, countries in Asia (eg. Thailand) have been adopting SEA as well.

In Sri Lankan context, the Cabinet of Ministers of Sri Lanka in May 2006, approved a Cabinet Memorandum submitted by the Central Environmental Authority (CEA) through the Ministry of Environment and Natural Resources, recommending that in future, all policies, plans and programs should be subjected to a SEA during their development. Although the decision for legalizing the SEA is not yet fully implemented, the CEA recommends and has carried out SEAs for several turnkey projects such as the Integrated Strategic Environmental Assessment of the Northern Province of Sri Lanka (2014), SEA for Trincomalee and Hambantota Development Plans, SEA for the Western Region Megapolis Plan (2016), and SEA for Development of River Basin Level Flood and Drought Mitigation Investment Plans-Kelani River Basin (2018).

The current MP developed by the Japan International Cooperation Agency (JICA) expert team and the Waste Management Authority of Western Province (WMA-WP) will be a fundamental document outlining the framework for how municipal waste will be managed in Western Province up to the year 2042. The MP is the most comprehensive waste management master plan owing to the scale of the project and expected impacts on environmental, socio-economic and finances. Therefore, project planners consider conducting a SEA for the MP project. A detail description of the project is presented in Chapter 2.

## 1.2 Purpose of the SEA report

The purpose of this report is:

- i. to identify, describe and evaluate the likely significant environmental effects of the draft MP including reasonable alternatives;
- ii. to help identify appropriate measures envisaged to prevent, reduce and as fully as possible offset any significant adverse effects on the environment of implementing the MP;

- iii. to provide monitoring measures for the significant effects arising from the implementation of the draft MP and to evaluate if the draft MP has been developed in a manner consistent with the requirements of the SEA guideline and relevant implementing regulations.

The SEA is an assessment of the draft MP only and does not, therefore, consider specific proposals for waste management infrastructure (such proposals are identified and assessed through the waste management planning process). However, when considering the significant effects that could occur as a result of the draft MP, it does, where appropriate, consider the likely activities and potential sources of effects associated with the construction and operation of waste management infrastructure.

### **1.3 Methods and approaches of SEA**

The SEA for the Western Province Solid Waste Management Master Plan (MP) in Sri Lanka was carried out by the Waste Management Authority- Western Province as specified by the Terms of Reference (TOR) for the SEA that was developed by the Central Environmental Authority (CEA). The TOR was also discussed at the project scoping meeting held on 13<sup>th</sup> August 2021. The TOR for the SEA is given in Annexure 1 of this report. The SEA report was prepared by a team of consultants which is shown in Annexure 2.

This SEA consisted of two key phases namely scoping phase and the SEA study. The scoping phase was focused on making a preliminary identification of the key environmental and social concerns in the waste sector, taking into account both the effects of degraded natural resources in key regions for the activities, and the existing and potential impacts on the environment associated with current waste management activities. Based on these findings, elements for the organization of the main SEA study phase were identified, including the key issues that would deserve specific attention and the baseline information required. The key issues are critical to the SEA, as it allows the study to focus efforts and recommendations on these important aspects that need to be solved to achieve a significant improvement in the environmental performance of the SWM planning solutions in the MP.

The preliminary identification of key issues at the scoping stage was based upon a comprehensive examination of all relevant policy and strategic documents and environmental protection objectives related to the waste sector, together with the impacts of the proposed SWM strategy may contribute. The MP provided detailed information on the scope of the MP and scenario analysis for selecting suitable SWM strategies which was determined via stakeholder meetings and thorough assessments. The current SEA was intended to provide supplemental analysis for the environmental and social impacts of the MP. Therefore, for the SEA, the preliminary analysis of the key issues related to environmental and social aspects was conducted by the expert

judgement of the SEA team. These issues were discussed and validated in stakeholders' scoping meetings (see Annexure 3) attended by participants from relevant government institutions.

The SEA Study phase assessed the key issues in detail via a baseline environmental study supported by specific data and trends were available from various government agencies and published literature on the policy and regulatory framework, institutional settings, current environmental trends and socio-economic aspects in the Western Province. From this analysis, the framework for SEA assessment was formulated in terms of defining the SEA environmental objectives and targets against which impacts of the MP would be measured.

It is suggested that SEAs are used to support a choice between different alternatives require more quantitative methods, whereas SEAs used to identify critical aspects and suggest mitigation strategies can suffice with more qualitative methods. The current SEA study focused on informing the likely impacts of the proposed activities in the MP and providing recommendations to improve the MP. Therefore, a qualitative approach based on expert judgment and matrix method was used to assess the proposed strategies of the MP against the SEA objectives. Planning solutions of each SWM option considered in developing the MP was assessed for their likely impacts on the environment. A detailed assessment was performed for the proposed activities of the selected option along with their compatibility with the national waste management targets.

The current SEA suggests overall positive impacts of implementation of the MP in improving the SWM in the Western province. It identified several issues that need attention in further planning as well. Based on the above assessments, this SEA provides recommendations to improve the planned activities and presents a monitoring framework. The SEA informs the decision-makers of the degree of uncertainty over impacts, the level of consistency in objectives (plan and environmental), the sensitivity of the baseline and the range of plan/program alternatives available to achieve the intended economic, social and environmental goals. Thus, the current SEA facilitates early and systematic consideration of potential environmental impacts of the proposed strategies in the WP, thereby enables such impacts are properly addressed at the appropriate stages of planning.

## 2 Description of the Western Province Solid Waste Management Master Plan (MP)

### 2.1 Purpose of the MP for the Western Province

In Sri Lanka, many major cities, and emerging townships, particularly in the Western Province, are faced with the major challenge of improving their inadequate and unsustainable waste management systems, mainly the final disposal. Waste can no longer be deposited in residential areas and uncontrolled landfills, thus ending up on illegal dumpsites and in waterways. It accumulates in the environment causing soil, water and air pollution and deteriorating quality of life of nearby communities. With inadequate SWM, pollution levels associated with waste are rising in most cities and urban centers in Sri Lanka, particularly in the Western Province.

Inadequate allocations and provisions of resources for SWM (Expert Committee on Solid Waste Management, 2021) has been a critical issue in developing a SWM system for the Western Province that aligns with sustainable development based on material and energy recycling options. The conventional waste management approach, collect and dispose, lacks, in particular, the adequate economic instruments to shift the “Collect and dispose management structure” to a “Sustainable material recycling society”. In the absence of value addition for waste resources, incentive to adopt sustainable SWM practices such as reduced waste generation, recycling and proper disposal is low, and consequently the environmental impacts are severe. Thus, the current SWM system is unsuitable and inappropriate for present day context. Public utility service development projects do not sufficiently take account of and analyze technical, organizational, and financial strategies for sustainable waste and resource management and earlier experience with the issue; these factors should feature more prominently in the sectoral discussion at national and international level. Waste management relates to many other areas, including urban development, water, energy, social wellbeing, and food security. This, too, has been overlooked in the past.

The SWM issue became a major topic of discussion in 2017 April when Meethotumulla garbage dump collapsed causing a disaster that took many lives of nearby residents and massive physical damages. In response to the crisis, the Government of Japan (GOJ) supplied emergency relief goods and dispatched the Japan Disaster Relief Expert Team, consisting of relevant technical expert members. Subsequently, in later 2017, former President and Government of Sri Lanka (GOSL) made a request from Government of Japan to formulate a Solid Waste Management Master Plan for Western Province, coordinating with all stakeholders including Central Government Institutes, Provincial Government, and Local Authorities (LAs). In response to the request made by GOSL, Japan International Cooperation Agency (JICA) dispatched the expert

team to carry out a technical cooperation project with the collaboration of Waste management Authority- Western Province since February 2019.

Further, the national policy for waste management has recognized the roles of Provincial and Local Authorities for easing implementation of the national policy. The policy emphasizes the need of developing proper measures to develop strategies and action plans to supply essential resources for implementation of the national policy to local authorities. The Waste Management Authority of Western Province identified the requirements of the waste management sector in the Western Province through a series of stakeholder consultations conducted in parallel to national policy development. The consultation set the vision and mission for the future waste management in the Western Province. The sub-policy and strategies were proposed in line with the adopted vision and mission of waste management in the Western Province in a strategic action plan for waste management of the province in 2019.

The “Western Province Solid Waste Management Master Plan (MP)” is an extension to that strategic action plan; however, the master plan will be the fundamental document outlining the framework for how solid waste will be managed in the Western Province up to the year 2042 (Annexure 4). This MP proposes strategies for developing an integrated system for efficient waste management, specifically intended for municipal solid waste (MSW) in the region. Management of industrial waste, chemical waste, agricultural waste, construction and demolition waste, and any sort of liquid or gaseous waste is beyond the scope of the MP. The MP aims at the development of the Western province SWM to be in harmony with the waste management policies and guidelines in Sri Lanka. The SWM Action Plan will be reviewed every five years taking into account the progress made in waste management. A detail description of the master plan is presented in following sections.

## **2.2 Goals and objectives of the MP**

The Sri Lankan government has recognized the importance of a planned approach to develop the Western Region to become the main economic driver in the country with urban infrastructure facilities to match the highest international standards. Consequently, development initiatives such as the Western Regional Megapolis Plan had been initiated (The Megapolis, 2016) and the plans were reviewed and updated in 2019 with the then national policy “Vistas of Prosperity and Splendor”. Though the national policy on Western Province development changed to a certain extent, the vision and mission for the waste management in the Western Province remained, and the current MP aims to serve this purpose.

### **2.2.1 Vision**

The vision of waste management in Western Province is:

“Make Western Province a Resource /Material efficient province.”

### 2.2.2 Mission

The Mission of waste management in Western Province is:

“To encourage the reduction of waste generation and to inculcate the best waste management practices in the province to convert waste into valuable resources, so that they can be used in the production process, which will finally drive the province toward building a circular economy while protecting public health and the environment.”

### 2.2.3 Key strategies of the MP

The key strategies (also referred to as sub-policies) are intended to provide the foundation for a safe, responsible, and ecologically sound management of solid waste in the Western Province. The proposed strategies are:

- Promotion of 4R concept:  
Reduce, reuse, and recycle and recovery of energy out of non-recyclable and non-reusable waste.
- Facilitation for a circular economy:  
Future development should be based on circular economy principles in all resource consuming enterprises to eliminate waste and encourage recovery of resources.
- Introducing the zonal concept of waste management:  
Introduced by the WMA-WP in 2019, all 49 Local Authorities (LAs) of Western Province are clustered into seven (07) waste management zones with the objective of approaching waste management on a cluster basis. Three Waste Management Zones are identified under Gampaha administrative district namely, Negambo, Gampaha, and Kelaniya. Two waste management zones, Colombo and Dehiwala were identified for Colombo District. The Kalutara and Horana waste management zones come under Kaluthara district.
- Adoption of the seven steps of municipal solid waste management:  
Segregation at Source, Primary Recovery, Primary Collection, Cleaning of Public Places, Secondary Collection /Transportation, Intermediate and Final Recovery and Final disposal. Implementation of polluter pay principal and extended producer responsibility: Recognized in the National Waste Management Policy (2020), Extended Producer Responsibility (EPR) is a policy approach under which producers are given an important financial and/or physical responsibility for the treatment or disposal of post-consumer products. Assigning such responsibility could in principle provide incentives to prevent



waste at source, promote product design for the environment, and support the achievement of public recycling and materials management goals.

→ “Plan-Do-Check-Act” PDCA system:

PDCA is an iterative four-step management method used in business for the control and continual improvement of processes and products. The “Plan” phase involves assessing a current process, or a new process, and figuring out how it can be improved upon. The “Do” phase allows the plan from the previous step to be enacted. Slight changes are usually tested, and data is gathered to see how effective the changes are. During the “Check” phase, the data and results gathered from the “Do” phase are evaluated. Data is compared to the expected outcomes to see whether there are any similarities or differences. If the “Check” phase shows that the “Plan” phase which was implemented in the “Do” phase is an improvement to the prior standard (baseline), then that becomes the new standard (baseline) for how the organization should “Act” in moving forward (new standards are thus said to be enacted). If the “Check” phase shows that the “Plan” phase which was implemented in the “Do” phase is not an improvement, then the existing standard (baseline) will remain in place.

→ Simultaneous approach for waste management:

Mass disposal techniques such as incineration and sanitary landfill are executed simultaneously combined with material recovery techniques such as reuse, recycle, upcycle, etc. for optimal waste management.

→ Introduction of provincial platform for waste management:

Introduction of a provincial platform for waste management in Western Province to facilitate all stakeholders in the achievement of set targets for the provincial waste management plan, both individually and collectively. The Chief Minister of Western Province will chair the provincial waste management platform. There will be representatives from decision-makers in all relevant stakeholder government and affiliated institutes, the private sector, and from the public in the platform. The WMA-WP will be the coordination agency of the said platform.

## 2.3 Quantitative targets of the MP

The MP sets quantitative targets to be achieved by 2042. The quantitative targets are expected to achieve through waste reduction, increase collection coverage, increasing recycling ratio and reducing landfill disposal. The quantitative targets for the entire Western Province and each district are shown in Table 2-1. The actions are to be implemented in phases, short-term (2023-

2025)-, medium-term (2026-2030) and long-term (2031-2042). The MP has identified the milestones that should be achieved in periods, and the MP will be promoted according to these milestones. See Annexure 4 for the milestone plan.

**Table 2-1 Quantitative targets of the Master Plan (2022-2042)**

Western Province					
Target year		Reduction ratio	Collection coverage	Recycling ratio	Disposal ratio
Present	2022	0%	56%	14%	27%
Short term	2025	3%	61%	18%	29%
Medium term	2030	5%	68%	20%	20%
Long term	2042	10%	81%	24%	20%
Colombo District					
Present	2022	0%	70%	14%	27%
Short term	2025	1%	74%	17%	30%
Medium term	2030	3%	80%	18%	18%
Long term	2042	10%	92%	23%	21%
Gampaha District					
Present	2022	0%	43%	16%	26%
Short term	2025	1%	47%	20%	27%
Medium term	2030	3%	54%	23%	29%
Long term	2042	10%	70%	26%	18%
Kalutara District					
Present	2022	0%	41%	13%	28%
Short term	2025	1%	45%	19%	26%
Medium term	2030	3%	51%	20%	12%
Long term	2042	10%	65%	24%	17%

## 2.4 Alternatives considered in the MP

The aim of the alternative suggestion process was to identify potential waste management solutions for the Western Province when achieving the goals and objectives of the MP. The alternative development process was designed in such a way as to be auditable, consistent, and robust, and assist in the identification of a preferred waste management alternative for all municipal wastes arising in the Western Province for the long term. Resource recovery aligned with 3R concepts and appropriate final disposal are the prime objectives of alternatives as national environmental strategy suggested. The requirements of Central, Provincial and Local governments and guidance from relevant key stakeholders had also been considered in suggesting alternatives. The MP compared four alternatives for their technical and financial feasibility to select the most appropriate alternative that was subsequently used to develop the

project activities. The Table 2-2 shows a summary of the alternatives suggested in the screening process.

**Table 2-2 The key features of four suggested alternatives**

Main component of SWM system		Primary transfer stations	Composting facilities		Recycling facilities		Thermal recovery facilities	Disposal site (Aruwakkalu DS through Kelaniya TS)
			LAs & cluster based	Waste Park	LAs	Waste Park		
Without MP	Baseline	Primary transfer stations will be constructed to improve collection efficiency	Current capacity: 324 TPD	n/a	344 TPD	n/a	750 TPD*	2382 TPD
With MP	Alternative A		930 TPD	n/a	421 TPD	n/a	750 TPD*	3157 TPD
	Alternative B		930 TPD	400 TPD	421 TPD	150 TPD	2900 TPD	1206 TPD
	Alternative C		930 TPD	n/a	421 TPD	n/a	3300 TPD	1122 TPD

\* Existing Kerawalapitiya TRF TPD= Tonnes Per Day

In regard to technical evaluation, the MP concluded that the four alternatives are ranked in order of Alternative B > Alternative C > Alternative A > Baseline based on the maximization of organic waste composting and reduction of final disposal. Financial evolution suggested that Alternative B is the inexpensive alternative in terms of total waste management cost and unit cost; thus, alternative B is considered as the optimal SWM system from the viewpoint of minimizing waste management costs. The 20-year average annual treatment cost of alternative B is projected to be 4.3 billion LKR/year, and the cost per ton of collected waste is projected to be 17,100 LKR per ton. Details of the evaluation process of the alternatives are provided in Annexure 5.

## 2.5 Project activities proposed in MP

The MP has identified 6 key priorities in developing actions for implementation under the alternative B. The following section summarizes these strategic priorities of the MP.

- i. Promotion of waste reduction at source
  - a. Take measures to limit the increase in the amount of waste generated caused by population and economic growth
- ii. Promotion of waste separation and reduction at the discharge stage
  - a. Ensure waste separation (organic, recyclable, and other waste) and promote the collection of recyclable waste
  - b. Promote recycling at source and reduce the amount of waste discharged.
- iii. Improved waste collection and transfer system
  - a. Expand the collection area
  - b. Select efficient and hygienic collection vehicles according to the type of waste to be transported

- c. Build Primary Transfer Stations (PTSs) that will be operated and managed jointly by neighboring LAs to improve the collection efficiency of burnable waste (transported to TRFs) and waste to be disposed (transported to Kelaniya TS)
- iv. Promotion of recycling at intermediate treatment facilities
  - a. Aim for zero disposal of collected organic waste
  - b. Recover energy from burnable waste and approximately 20% of collected organic waste.
  - c. Increase the capacity of composting facilities to maximize the production of compost from the organic waste collected
  - d. Promote recycling, increase the capacity of existing LAs' recycling facilities and build MRFs in waste parks
- v. Reduction of waste to be disposed
  - a. Reduce the amount of waste to be disposed by reducing waste generation, and promoting separate collection, recycling and thermal recovery (incineration)
  - b. Close open dump sites
- vi. Establishment of a data management system based on a database
  - a. Collect and enter the data required for waste management using standard forms.
  - b. WMA to manage and operate a database of data entered by LAs and cluster-based facilities
  - c. WMA to analyze the data in the database and support LAs for SWM
  - d. Implement SWM using the database managed by WMA

The following section gives a brief overview of each of six strategies and actions proposed in each strategy. The action includes provincial policy, institutional reforms, regulations, management plans, waste infrastructure development, Information Technology (IT) and human resource development.

### 2.5.1 Actions promoting waste reduction

The key objective of the waste reduction is to achieve 10% waste reduction in Western Province by year 2042. The waste reduction target is to be achieved through policy, regulatory, and awareness tools with the citizens cooperation and participation. The key actions are described below.

- i. **Introduce Extended Producer Responsibility (EPR):** Required legislations will be introduced to reduce the amounts of post-consumer materials (packaging) entering waste stream. Implementation of EPR requires strong collaboration among relevant stakeholders such as regulatory authorities, manufacturers & importers, traders, consumers, and waste handlers.

- ii. **Implement volume/amount-based waste collection fee scheme:** Introduce a mandatory fee levy waste collection system where waste generators are required to use specific types of garbage bag(s) depending on the amount of waste to be discharged. The action requires understanding and cooperation of waste generators, price setting for designated bags, surveillance & guidance to prevent discharge in non- designated bags, establishment of a system for selling designated bags in retail stores and a system for collecting income from the sale of bags.
- iii. **Raise public awareness:** Induce voluntary action for waste minimization by raising awareness through activities of local governments, schools, and other related organizations. The program development, establishing financial mechanisms and establishment of implementation framework are sub-activities to be done.
- iv. **Promote eco-friendly lifestyle:** Encourage consumers and business operators to adopt the habit of consciously reducing their waste by adapting eco-label system, my-bags and other concepts.

### 2.5.2 Actions promoting source separation and reduction at the discharge stage

The key strategic actions are to ensure waste separation (organic, recyclable and other waste), to promote the collection of recyclable waste, and to promote recycling at source and reduce the amount of waste discharged. The waste separation and reduction targets are to be achieved through promoting source segregation, waste reduction through promoting on-site safe disposal, and improving waste collection and transfer system. The key actions are described below.

- i. **Promotion of source separation:** At present, only a few LAs have basic infrastructure to shift from two category separation (biodegradable to non-biodegradable) to three categories (biodegradable, recyclable, and other waste). Also, the introduction of thermal recovery (incineration) demands a new waste category, burnable waste. Ultimately, Western Province aims to achieve seven categories: biodegradable, recyclable, burnable, hazardous, e-waste, bulky waste, and residual waste.
- ii. **Implementation of punctual waste collection schedule:** Punctual and committed waste collection schedule, instruction and training on waste separation, distribution of waste bins/containers, and use of mobile applications are few proposed sub-activities. In order to fully implement the source segregated waste collection, LAs will develop tailor made waste collection programs and sequentially proceed to higher order source segregation system.
- iii. **Awareness on correct separation methods:** Creation and dissemination of correct methods for waste separation and segregation.
- iv. **Distribution of waste containers:** The distribution of waste bins, especially for biodegradable waste, may help encourage citizens to separate waste because an

appropriate container (with a tight lid and sufficient capacity) can store wet waste overnight.

- v. **Mobile phone applications:** Introduction of user-friendly mobile phone applications may help waste generators in waste separation.

### 2.5.3 Actions for waste reduction at the discharge stage

The key strategic actions are to ensure waste reduction at the discharge stage by promoting home composting and encouraging waste resource recovery at the point of generation. The key actions are described below.

- i. **Promotion of home composting:** Support LAs and/or relevant institutions to display/demonstrate home composting technical options in public places; promotion and awareness creation of home composting techniques; facilitation and provision of financial and technical guidance to LAs to promote home composting and support LAs to implement a monitoring and troubleshooting system for home composting are the key sub-activities.
- ii. **Activities for waste reduction at the discharge stage:** Raising awareness of the 3Rs at the community/institutional level; empowering ground-level collectors of recyclable waste; promotion of “PARISARAPOLA”, “PARISARARIYASARA” Programs, etc.; capacity building of recyclers in the Western Province; and formalization of informal recyclers within the province.

### 2.5.4 Improvement of waste collection system

The key strategic actions are to expand the collection area, select efficient and hygienic collection vehicles according to the type of waste to be transported, and to build primary transfer stations. The key actions are described below.

- i. **Increase waste collection coverage area:** The waste collection rates in MCs and UCs in urban areas have already reached 65-70%; however, the waste collection service coverage has to be increased in rural areas, especially in PCs. The MCs and UCs target to achieve 95% collection coverage by 2042 while it is aimed to increase the collection service delivery coverage from 30% at present to 60% in 2042 for PSs.
- ii. **Change collection vehicles from 4WT to garbage collection trucks:** The following vehicles will be progressively put into circulation for each waste category: a) Organic waste: 4-ton compactor trucks; b) Recyclable waste: 4WT & trailers (6-7m<sup>3</sup>); c) other waste: 4-ton compactor trucks.
- iii. **Procurement of collection vehicles:** LAs will procure collection vehicles in accordance with their LA action plans. Additional procurement will be done through the support from the national government or the Western Provincial Council.

### 2.5.5 Improvement of waste transfer system

The key strategic actions are to replace the conventional primary and secondary waste transfer system with an efficient and effective mechanized system. The MP proposes to establish basic civil infrastructure, machinery, and expertise to achieve this target. The key actions are described below.

- i. **Establishment of Primary Transfer Stations (PTS):** The PTSs will be operated within a cluster and jointly managed by neighboring LAs. The PTS will be used to transfer burnable from PTS to Kelaniya main TS. Stationary compactors will be installed in each PTS and waste will be compacted in containers and loaded into transfer trucks (Figure 2-1).

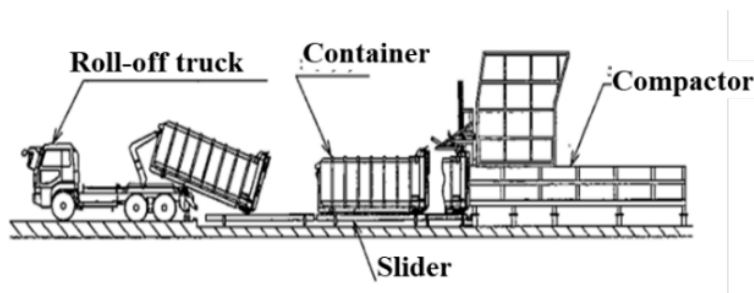

Figure 2-1 Proposed mechanical transfer system for PTS

- ii. **Selection of LAs and location of PTSs:** The LAs located far from Kelaniya TS (> 20km) will be connected to a cluster PTS. The primary transfer clusters are determined according to the geographical conditions of the LAs.

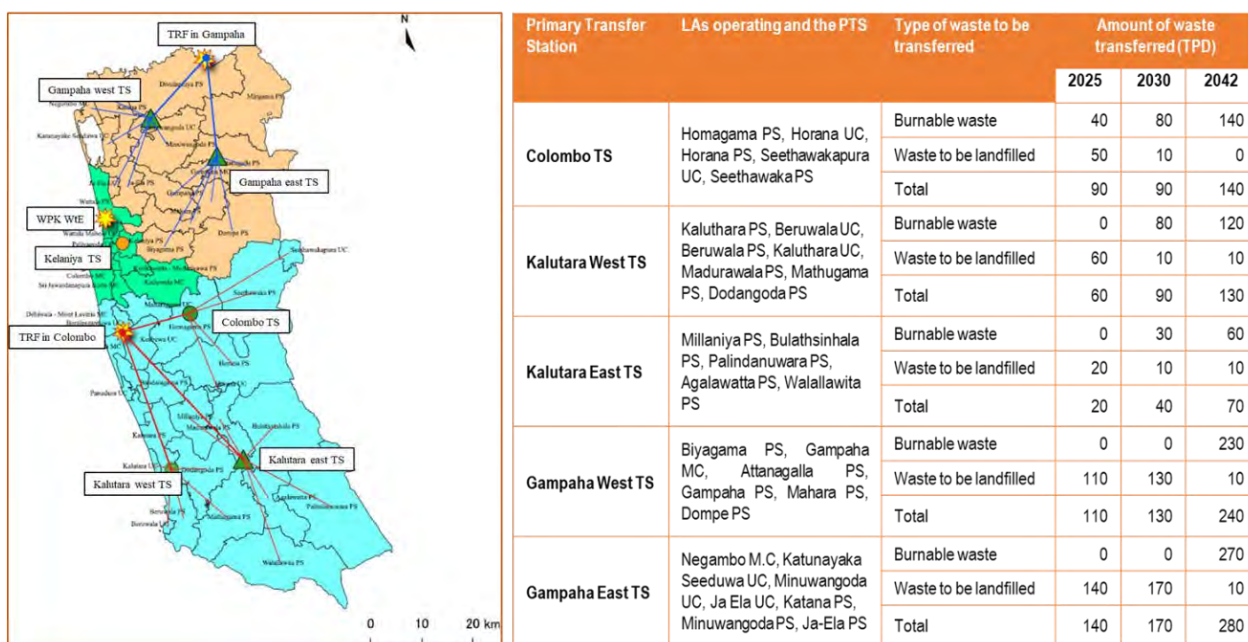

Figure 2-2 Location and scale of cluster-based PTS in Western Province

- iii. **Compact containers and vehicles for PTS:** It has been estimated that 69 garbage containers will be required by year 2025 which will be increased to 143 by year 2042. Further, 12 large Roll-on/roll-off trucks will be used in 2025, and the number of trucks will be increased to 25 in 2042.
- iv. **Kelaniya Transfer Station (Kelaniya TS):** The transfer station has already been established under Western Region Megapolis Solid Waste Management Project (WRMSWMP) in Kelaniya area of the Western Province which is bordered by the Colombo Railway Main Line and the Colombo-Kandy Highway. It adjoins the compost yard and the former dump site of Kelaniya. There are several canals that lead from the West to the East and the North to the South, and the proposed site is a marshy wetland; thus, the transfer station and connecting rail lines are constructed on deep pile foundation. Compacted waste in containers will transfer from primary Roll-on/roll-off trucks to 3 units of static compactors at Kelaniya TS. The static compactor further compact waste to 20-foot transport containers that will be loaded onto rail carriages using cranes. The carriages will transport the waste containers to Aruwakkalu landfill and unloaded into Roll-on/roll-off trucks at the Aruwakkalu transfer station. The trucks will unload the waste in designated areas of the landfill. The rail track from Colombo to Puttalam, and up to Landfill will be used for transportation. It is projected that a single train carrying 100 (220 TPD) containers will operate a single round trip in 2025, and the frequency will increase to 8 trips (1000 TPD) by 2030 and beyond.



### 2.5.6 Promotion of recycling at intermediate treatment facilities

The aim is to achieve zero landfill disposal of collected organic waste. The key strategic actions are to promote thermal recovery of burnable waste and approximately 20% of the collected organic waste; increase capacity of composting facilities to maximize the production of compost from the organic waste; and to improve the existing Sampath Kendraya (SK) increasing treatment of recyclable waste. The MP proposes to establish basic civil infrastructure, machinery, and expertise to achieve this target. The key actions are described below.

- i. **Thermal Recovery Facilities (TRFs):** In addition to the current capacity of 750 tons per day of the Western Power- Kerawalapitiya (WPK) Waste to Energy (WtE) facility, a TRF in Colombo District with a capacity of 400 TPD will be commissioned in 2025. This will be followed by an additional 750 TPD at the WPK WtE facility in 2028, increasing its processing capacity to 1,500 TPD. In 2028, an additional 400 TPD will be added to the TRF in Colombo District to bring the capacity to 800 TPD. In 2036, a TRF in Gampaha with a capacity of 600 TPD will be constructed. The proposed composting capacity improvement program is shown in Figure 2-3. However, the information on future treatment technologies should be continuously gathered to systematically verify their feasibility in terms of waste compatibility, reliability of the technology, amounts of residues generated, and economic efficiency. Upcoming waste to energy plants are more advanced versions than the WtE at WPK including combined cycle recovery and advance flue gas treatment facilities.

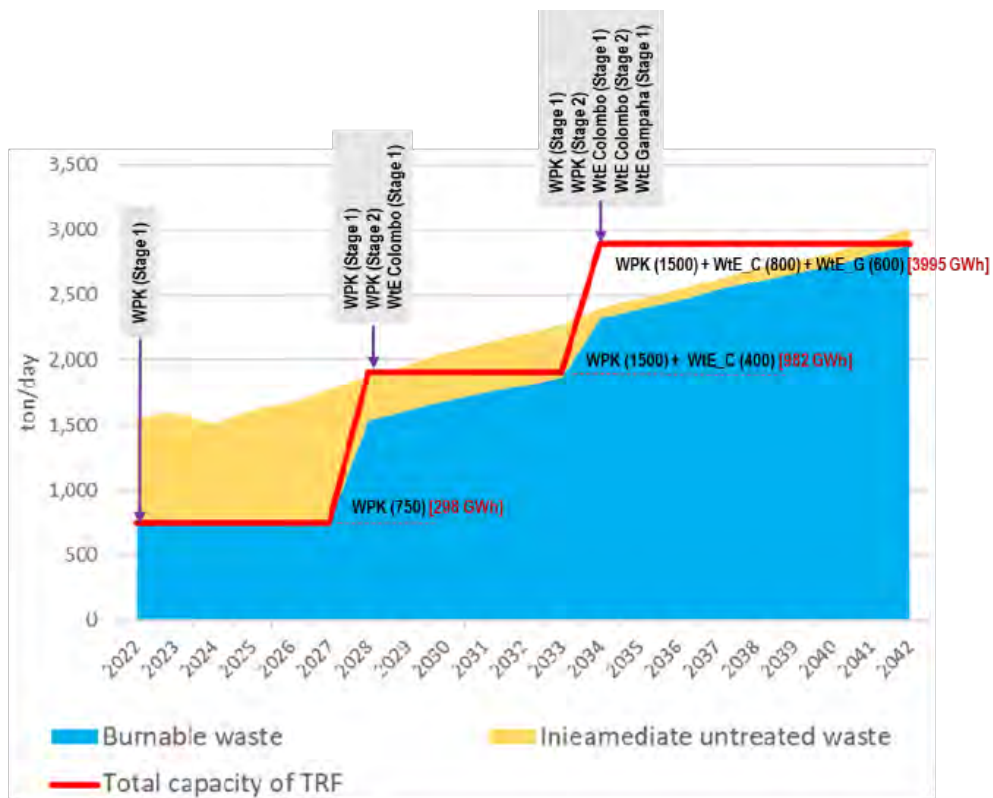

	2021	2022	2023	2024	2025	2026	2027	2028	2029	2030	2031	2032	2033	2034	2035	2036	2037	2038	2039	2040	2041	2042
WPK	750	750	750	750	750	750	750	750	750	750	750	750	750	750	750	750	750	750	750	750	750	750
TRF in Colombo	Proposal, consensus, tender, etc.				Construction			750	750	750	750	750	750	750	750	750	750	750	750	750	750	750
TRF in Gampaha								Proposal, consensus, tender, etc.			Construction			400	400	400	400	400	400	400	400	400
Total capacity	750	750	750	750	750	750	750	1,900	1,900	1,900	1,900	1,900	1,900	2,900	2,900	2,900	2,900	2,900	2,900	2,900	2,900	2,900

Figure 2-3 Proposed plan for expansion of Thermal Recovery Facilities

- ii. **Recycling of biodegradable waste:** The existing organic waste intake capacity of composting facilities own by LAs’ and cluster-based facilities is 324 TPD which will be increased to 930 TPD by 2042. Additionally, the MP proposed to increase the organic waste intake capacity of composting facilities which will be established by Ministry of Urban Development (MoUD) to 400 TPD. The proposed composting capacity improvement program is shown in Figure 2-4.

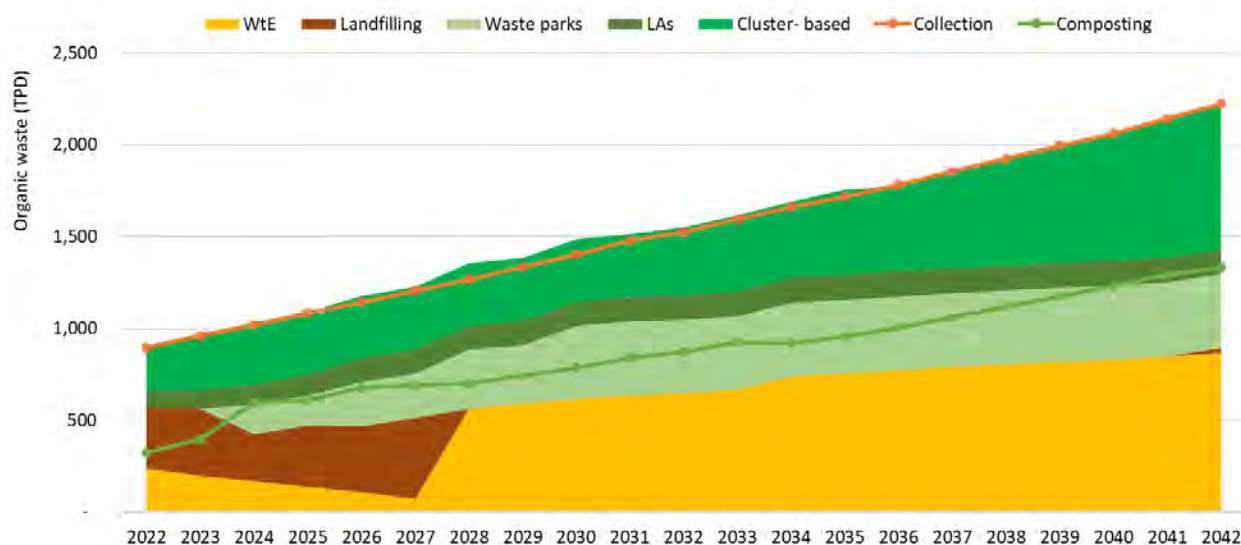

**Figure 2-4 Proposed plan for expansion of organic waste composting and treatment facilities**

- i. **Development and upgrading of Karadiyana Compost Plant:** Karadiyana Compost Plant is being refurbished by expanding the composting capacity and optimizing the waste handling capacity of waste disposal site (site A- organic waste disposal site). The proposed development activities include improvement of the sieving capacity of produced compost, reduction of environmental pollution by inappropriate waste handling at site A and strengthening of the planning and management capacity of the plant’s staff. The refurbished Karadiyana site will be a model for the renovation of other large-scale composting facilities to increase in the treatment capacity of the existing composting process.
- ii. **Development of waste park material recovery and composting facilities:** Waste parks are intermediate treatment zones integrating resource recovery by recyclable material recovery and organic waste composting. The proposed waste park will be an integration of a composting plant, a Material Recovery Facility (MRF), a transfer station, and a leachate treatment system. The MRF will have a recyclable material recovery capacity of 20-30 TPD. The composting plant will have a capacity of 80-100 TPD. The MRF is intended to separate and process metals, plastics, bottles, paper and cardboard as recyclable materials. The composting plant shall be mechanical and is intended to produce compost by aerobic decomposition of kitchen waste and garden waste that have been sorted at source and delivered to waste park by LAs. It is proposed to transfer the residues generated from the MRF and the composting plant to the WtE and landfill disposal facilities.
- iii. **Upgrading and improvement of material recycling system:** Recycling facilities will be upgraded and increased according to the increasing amount of recyclable waste and

improved sorting practices. It is proposed to establish a separate system to discharge and collect recyclable materials from points of generation. The major actions are to strengthen recyclable waste collection program in all LAs, introduce “SAMPATH PIYASA” as pilot project to improve the collection of recyclable waste Promotion of “SAMPATH PIYASA”, upgrading the existing “SAMPATH KENDRA”, or “mini-MRF facilities” in each LA, and improve of the relationship between LAs and informal/ private sector recyclable waste collectors to disperse collected recyclable waste.

- iv. **Establishment of a plastic waste management system:** By 2042, the amount of plastic waste generated is expected to increase to 293,000 tons per year, a 65% increase from the current amount. Thus, MP aims to establish an integrated system to manage plastic waste, from generation to intermediate treatment and final disposal, and to introduce appropriate waste management and environment conservation measures, such as the reduction of plastic waste generation at source, prevention of marine plastic pollution by improving waste collection, and reduction of the amount to be disposed by promoting material and thermal recycling of plastic waste. According to the National Action Plan on Plastic Waste Management (2021-2030) formulated by the Ministry of Environment, Goal 9 sets a target to increase the recycling ratio of plastic waste to 15% by 2025. The estimated ratio of recycled plastics through this MP meets the targets set in the National Action Plan.

### 2.5.7 Reduction of waste to be disposed

The aim is to reduce the amount of waste to be disposed in landfills (dumpsites) and close or rehabilitate existing uncontrolled dumpsites in Western province. The MP proposes to streamline the management of Aruwakkalu sanitary landfill adhering to the actions proposed in the MP. In addition, closure and rehabilitation of existing dumpsites will be done after the technical and financial feasibility analysis. The key actions to reduce the waste to be disposed in landfill are described below.

- i. **Management of Aruwakkalu landfill site:** The Aruwakkalu landfill is in Wanathawilluwa, Pradeshiya Sabha area of Puttalam District. The Aruwakkalu landfill is connected to Kelaniya waste transfer station through the Puttalam railway line. The landfill is designed to dispose non-recyclable, non-compostable residual waste and non-hazardous industrial waste and other inert materials (incinerated ash) generated through waste treatment processes. This would significantly extend the life of the landfill, which has nominal capacity of 5.67 million m<sup>3</sup>. However, it has been estimated that the volume of waste destined for final disposal in the Western Province will exceed the total capacity of Aruwakkalu DS (5.67 million m<sup>3</sup>) of Phase 1 and Phase 2 in 2036. Therefore, it is necessary to increase the total capacity of the final disposal sites by about 3.0 million m<sup>3</sup> by 2042.

The Aruwakkalu landfill development is currently being executed by the Project Management Unit established under the Ministry of Urban Development and Housing (successor to Ministry of Megapolis and Western Development- MM&WD). The landfill is to be open for waste receiving by 2023. It has been proposed to establish a Special Purpose Vehicle (SPV) to operate the landfill.

- ii. **Closure of current dump sites operated by LAs in Western province:** The closure and rehabilitation of existing dumpsites in Western Province will be done after the technical and financial feasibility analysis. First, a manual on the closure of existing dump sites will be developed and presented to LAs for approval. The closure plan will develop the strategies to secure fund for the implementation.

### 2.5.8 Establishment of a data management system based on a database

The aim is to establish an accurate and reliable data and information collection, analysis and retrieval system using Information Technology (IT) and other necessary infrastructure. In order to properly implement, monitor, analyze and improve SWM in the Western Province using a PDCA cycle, it is necessary to collect and integrate data related to SWM from each LA, cluster-based treatment facilities and disposal sites, and to establish a database system for the entire Western Province. The key actions in developing the data management system are described below.

- i. The database system proposed in this MP will be established at the national level as a pilot project of Japan International Cooperation Agency (JICA). MoLGPC (NSWMS), as the main stakeholder, will coordinate as well as operate the database.
- ii. The database will be monitored by WMA, while the LAs will enter the waste-related data gathered within their respective jurisdiction for each stage of the SWM flow, such as collection, transportation, composting, recycling, disposal, etc.

## 2.6 Key stakeholders

The Waste Management Authority of Western Province (WMA) has limited technical and financial capacity to implement actions proposed in the MP. Moreover, some of the proposed project activities such as Aruwakkalu landfill management, management of Kelaniya transfer station, establishment of thermal recovery facilities, etc. require multi-stakeholder coordination. Since the current planning and implementation capacities of WMA are inadequate, there is a prerequisite to establish a strong organization or institutional mechanism (waste management platform) to implement the actions proposed in the plan.

The proposed waste management platform will be chaired by the Chief Minister of the Western Province and will include representatives of decision-makers from all relevant stakeholders,

including governmental institutions, the private sector, and civil society. Details of the key government and government affiliated organizations that have direct or indirect responsibility to involve or cooperate in the proposed MP are provided in Annexure 7.



### 3 Policy and legislative framework relevant to waste management

This chapter provides an overview of policies/strategies, legislations, guidelines, and related projects and programs in the waste sector. The provisions enshrined in these strategic documents are directly linked to the MP. The implementation of the MP (along with the enactment of issues raised in the SEA report) will contribute to achieving objectives and addressing a number of issues raised through these strategic documents towards the development of more conducive waste management system in the Western Province.

#### 3.1 Policy framework

The National Policy on Solid Waste Management introduced by The Ministry of Environment in 2007 is the first policy level mediation in the SWM sector in Sri Lanka. The policy facilitates SWM with more emphasis on municipal waste. Specifically, it recognizes the importance of 3RS in implementing SWM while emphasizing the implementation of “the polluter pays” in order to share the responsibility of solid waste management to waste generators or polluters. However, this policy does not include provisions for many of other allied sectors such as liquid and gaseous waste. Therefore, in 2019, Ministry of Environment presented the National Policy on Waste Management that was approved by Cabinet of Ministers and effective since 01<sup>st</sup> October 2019.

The National Policy on Waste Management-2019 set the goal to provide coherent and comprehensive directions for waste management in the country covering all forms of wastes to meet the acute short-term challenges in line with medium- and long-term sustainable solutions up to 2030 with entrusted accountability. The National Policy on Waste Management – 2019 gives direction to achieve eight objectives through number of policy statement specific to each sub-sector but integrated as a whole. The policy objectives are:

- i. To make all the citizens and institutions legally responsible to engage in waste management activities as generators based on the degree of their involvement.
- ii. To sensitize citizens, institutions, waste mangers and service providers continuously on the need to be accountable and responsible to manage wastes individually and collectively by preventing and minimizing its generation moving beyond compliance.
- iii. To ensure availability of facilities and infrastructure for treatment and final disposal of waste in an environmental sound manner assuring responsible, accountable, and sustainable operation and maintenance.
- iv. To make every effort to minimize final disposal of waste by retaining its resource utilization value throughout the life cycle.



- v. To enhance effectiveness and efficiencies of existing waste management systems/practices and promote new systems for avoidance, prevention and/or minimization of waste with appropriate technology and practices.
- vi. To improve efficiencies and effectiveness of existing appropriate markets, promote new markets with appropriate innovative technologies and partnerships, and facilitate holistic integrated waste management systems/practices.
- vii. To reduce risks to public health, environment, and ecosystems and improve occupational health & safety of waste handlers.
- viii. To enhance effective partnerships to meet international obligations in waste management moving beyond compliance.

In addition to the above a few more policy and strategic plans have been inducted in waste management sector. The key policy and strategic plans are summarized in the Table 3-1.

**Table 3-1 An outlook of key policies and strategies relevant to solid waste management sector in Sri Lanka**

Policy / Strategic plan	Year	Description
National Strategy for Solid Waste Management (NSSWM)	2000	The National Strategy for Solid Waste Management highlights the importance of waste avoidance, reduction, reuse, recycling, and final disposal in an environmentally sound manner and still gives high priority to waste recycling over disposal. And emphasized the importance of waste separation at the source of generation into different components to facilitate subsequent waste management practices, especially recycling.
Solid Waste Management Guideline for Local Authorities	2001	Ministry of Home Affairs, Provincial Councils and Local Government issued guideline for Local Authorities to implement proper waste management systems.
Ten-year Horizon Development Framework	2006	Ten-year Horizon Development Framework identifies the importance of the promotion of the 3Rs and the establishment of an environmentally friendly final disposal site for a sustainable SWM system. It also emphasizes sustainable development.
National Action Plan for Haritha Lanka Programme	2009	The National Action Plan for Haritha Lanka Program focuses on an integrated approaches for waste management, greener cities, and addressing climate change.
National Solid Waste Management Policy	2007	National Solid Waste Management Policy focused on waste reduction, 3R implementation, sanitary landfills, capacity building, use of Best Available Technologies (BAT) and Best Environmental Practices (BEP), research and development.
Sustainable Sri Lanka – Vision & strategic path	2017	Key recommendations relevant to waste management are to introduce environment friendly waste disposal methods, preserve ecosystem services, improve ecosystem health, and minimize adverse impacts on human health (like CKDU and dengue) by reducing water pollution from all sectors, especially industry, agriculture, and waste disposal, through better enforcement of laws, regulation, and pricing policy. Vision envisaged to implement circular economy principles in all resource consuming enterprises to eliminate wastes and encourage recovery of resources.

Policy / Strategic plan	Year	Description
<b>Sustainable Consumption &amp; Production Policy</b>	2018	The overarching principle of this policy is to minimize the natural resources and toxic materials used, and the waste and pollutants generated, throughout the entire production and consumption process in all economic sectors. For the waste sector, this national policy aims for a waste management system that applies the principles of waste hierarchy and sustainable consumption and production via waste generation reduction through prevention, reduction, recycling and reuse, establishing SCP best practices for waste management, strengthening institutional mechanism for SWM, establishment of national data base and integrated monitoring system, improving resource recovery from waste, and implementation of necessary rules, regulations and instruments such as Environmental Protection License (EPL), fees and extended producer responsibility (EPR).
National Waste Management Policy	2019	Goal of the National Solid waste management policy is to provide coherent and comprehensive directions for waste management in the country covering all forms of wastes to meet the acute short-term challenges in line with medium- and long-term sustainable solutions up to 2030 with entrusted accountability. This updated policy was designed to establish an agreed integrated waste management system by providing directions to policy makers and implementers covering vertical and horizontal levels in the administrative and management structures of the country. Several major waste streams such as electrical and electronic waste (E-waste), healthcare waste, construction and demolished waste, and other hazardous waste have been considered in this policy as wastes that need priority attention in addition to the municipal solid waste.
“Vistas of Prosperity and Splendor” policy manifesto of President	2019	This reinforces the National waste management policy (2019) and take necessary action to minimize waste generation as the first step of waste management. Also, policy manifesto ensures proper waste collection systems and designated disposal locations, including sanitary landfills shared by more than one local Authority. Use of modern techniques and improved incinerators in waste management is emphasized. Also, highlight the need of controlling and monitoring of Illegal and irresponsible waste disposers.
Interim Guideline for Management of Solid Waste Generated by Households and Places under Self-Quarantine due to COVID-19 Outbreak	2020	This guideline is the first of such kind that provide guideline for waste management during emergency and disastrous situation. The guidelines were a response to Covid-19 pandemic which set out to guide Local Authorities for waste safe handling and disposal of municipal solid waste and also educate households on the correct ways of segregating waste. The unique feature of the guideline is that health and safety aspects of waste management prioritized over environmental aspects in case of an emergency. Specific yet appropriate provisions have been made in this guideline to accommodate the specific needs of the health emergency prevailed during the Covid-19 outbreak.
National Policy and Strategy on Sustainable Development for a sustainably developed Sri Lanka(Draft)	2020	This policy emphasizes the need of integrated approaches for proper management of municipal solid waste (MSW), giving effect to waste management hierarchy, and to align improved municipal waste management services in developing and managing cities and human settlements.

Policy / Strategic plan	Year	Description
National Environment Policy	2022	This provides guidance and direction for the sustainable use, management and protection of environmental resources. This highlights the need of a robust and integrated solid waste management system for sustainability and green economy, along with a strengthened legal and regulatory framework that enables strategies for a holistic approach, including life cycle principle, circular economy, sustainable production and consumption, 3R and related principles at household, local government, provincial and national levels.
National Policy on Green Procurement (Draft)		Goal of this policy is to develop/direct procurement process within sustainable development framework, and thereby to promote greener production/ consumption. For the waste sector, this particularly highlights the need of minimizing waste generation, toxicity and GHG emissions, maximizing environmental and social responsibility via Polluter Pay principles, Precautionary principles, and Extended Producer Pay principles, and encouraging a lifestyle with green economy concepts.

### 3.2 Legislative framework

The first piece of legislation pertaining to waste management in Sri Lanka was introduced during colonial period in 1862 when the British administrated the country. The first law was implemented through the Nuisances Ordinance (15 of 1862) which was subsequently amended (61 of 1939; 3 of 1946; 57 of 1946). The Ordinance vested power for city government and government sanitary inspectors to inspect, regulate and control public nuisance, particularly inappropriate garbage disposal. Some key functions of the Ordinance still in force where public health inspectors (PHI) enforce the powers. The rest of the legislations were introduced in 1939 and 1947 through Urban Council Act and Municipal Council Act, respectively. However, during the establishment of Provincial Councils in 1987, most of the political administrative legislations were amended and reformed.

At present, the basic legal framework required for MSW management is provided under an umbrella of Central Government, Provincial Council (PC) and Local Authority (LA) regulations and legislations. The 13<sup>th</sup> Amendment to the constitution (1987) and the Provincial Councils Act No. 42 of 1987, the sections 129, 130 and 131 of the Municipal Councils Ordinance (1980), Sections 118, 119 and 120 of the Urban Councils Ordinance, No. 61 of 1989, Sections 41 and 93 to 95 of the Pradeshiya Saba Act, No. 15 of 1987 are the key pieces of legislations pertaining to waste management in local authorities, responsibilities in waste management in particular. For example, the Municipal Council Ordinance, the Urban Council Ordinance and the Pradeshiya Saba Act confer the responsibility to the Local Authorities (LAs) to remove and dispose household waste generated within their boundary without causing any nuisance to the public.

The National Environmental Act, No. 47 of 1980 (NEA) was enforced with aim of establishing regulatory authority for environment monitoring and regulation. The Central Environmental

Authority (CEA) was established under the NEA, and the approval and monitoring and regulation of all environmentally sensitive activities were supposed to be administrated by the CEA. Central Environmental Authority (CEA) along with the Ministry of Environment introduced many regulations that are directly or indirectly relevant to -SWM. Table 3-2 summarizes key regulations related to SWM.

**Table 3-2 An outlook of key regulations relevant to solid waste management sector in Sri Lanka**

Year	Regulations/ citation	Agency/ regulator	Description
1862	Nuisances Ordinance 15 of 1862, and amendments 61 of 1939, 3 of 1946, 57 of 1946.	MoH MoPCLG Sri Lanka Police	Provide for the better preservation of public health and the suppression of nuisances cause by littering. Define offensive activities relevant to waste, wastewater and animal waste and carcasses handling, discharge and disposal.
1939	Urban Council Ordinance No. 61 of 1939	MoPCLG	Specify waste management responsibilities of UCs
1947	Municipal Councils Ordinances No. 16 of 1947	MoPCLG	Sections 129 Duty of council as to conservancy and scavenging Sections 130 All refuse collected to be property of council Sections 131 Places for disposal of refuse and keeping equipment
1980	National Environmental Act No.47 of 1980	MoE	Establishes the Central Environmental Authority (CEA) and defines its powers, functions, and duties. Provides overall environmental protection legislation, including licensing procedures, environmental standards and project approval procedures.
1987	Pradeshiya Sabha Act No.15 of 1987	MoPCLG	Specify waste management responsibilities of PSs
1987	Provincial Councils Act No.42 of 1987	MoPCLG	Specify the role of provincial councils in financing, governing and guiding LAs for proper waste management.
1994	Gazette Notification No. 850/4 of December, 1994	MoE (CEA)	The National Environmental (Ambient Air Quality) Regulations, 1994.
1999	Waste Management Statute No: 9 of 1999	MoPCLG (Western Provincial Council)	Western Province Waste Management Authority was established (WMA-WP).
2005	Sri Lanka Disaster Management Act, No.13	Ministry of Disaster Management	This has provisions for establishing the National Council for disaster management and the Disaster Management Centre, appointing technical advisory committees, preparing disaster management plans at national, provincial and district level, declaring state of disaster and awarding compensation.
2006	Gazette Notification No. 1466/5 dated 10.10.2006	MoE (CEA)	Regulation on Prohibition of Manufacture of Polythene or Any Product of 20 micron or below thickness
2007	Prevention of Mosquitoes	MoH	Prohibition of activities and conditions that are favorable for breeding of mosquitoes. The Director-General of Health Services is the Competent Authority.

Year	Regulations/ citation	Agency/ regulator	Description
	Breeding Act No.11 of 2007		
2008	Gazette Notification No 1533/16 dated 25.01.2008.	MoE (CEA)	Industries and activities which required an EPL are scheduled.
2008	National Environmental (Protection and Quality) Regulations, No. 1 of 2008. Gazette Notification No. 1534/18 dated 01.02.2008	MoE (CEA)	Introduction of Environmental Protection License (EPL) requirement for discharge, deposit or emit waste into the environment or carry on any prescribed activity. Also, the National Environmental (Protection and Quality) Regulation No. 1 of 1990 published in Gazette Extraordinary No. 595/16 of February 1990 as amended from time to time were rescinded.
2008	Gazette Notification No. 1562/22 dated 15-08-2008	MoE (CEA)	Amendment of schedule of the National Environmental (Ambient Air Quality) Regulations, 1994, published in Gazette Extraordinary, No. 850/4 of December 1994.
2009	Gazette Notification No. 1627/19 dated 10.11.2009	MoE (CEA)	National Environmental (Municipal Solid Waste) Regulations, No. 1 of 2009. General Rules on SWM discharge and collection of waste (Prohibition of waste dumping at national highway and at any place other than places designated for such purpose by the LAs.
2017	Gazette Extraordinary No. 2034/33-2034/37 of 2017	MoE (CEA)	Prohibition of manufacture of polythene or any polythene product of twenty (20) microns or below in thickness Prohibition of the sale, offer for sale, offer free of charge, exhibition or use of polythene or any polythene product which is twenty (20) microns or below in thickness.
2017	Gazette Extraordinary No. 2034/34 of 2017	MoE (CEA)	Prohibition of the manufacture of food wrappers from polythene as a raw material. Prohibition of the sale, offer for sale, offer free of charge, exhibition or use of food wrappers manufactured from polythene as a raw material.
2017	Gazette Extraordinary No. 2034/35 of 2017	MoE (CEA)	Prohibition of manufacture of any bag of high-density polyethylene as a raw material. Prohibition of sale, offer for sale, offer free of charge, exhibition or use of any bag manufactured from high density polyethylene as a raw material.
2017	Gazette Extraordinary No. 2034/36 of 2017	MoE (CEA)	National Environmental (Prohibition of open burning of refuse and other combustible matters inclusive of plastics) Regulations No. 1 of 2017.
2017	Gazette Extraordinary No. 2034/37 of 2017	MoE (CEA)	Prohibition of the use of all forms of polyethylene, polypropylene, polyethylene products or polypropylene products as decoration in political, social, religious, national, cultural or any other event or occasion.
2017	Gazette Extraordinary No. 2034/38 of 2017	MoE (CEA)	Prohibition of the manufacture of food containers, plates, cups and spoons from expanded polystyrene. Prohibition of the sale, offer for sale, offer free of charge, exhibition or use of food containers, plates, cups and spoons manufactured from expanded polystyrene within the country.

Year	Regulations/ citation	Agency/ regulator	Description
2019	No. 2126/36 dated 05-06-2019	MoE (CEA)	National Environmental (Stationary Sources Emission Control) Regulations, No. 01 of 2019 which regulate the emission and construction of facilities emanating stack emissions.
2019	No. 2148/20 dated 05-11-2019	MoE (CEA)	National Environmental (Ambient Water Quality) Regulations, No. 01 of 2019 regulating the water quality that shall be maintained in scheduled activities. Also, the regulation empowers CEA to give directives for LAs maintain ambient water quality in its area.
2021	Gazette Extraordinary No. 2264/17 dated 27-01-2022	MoE (CEA)	National Environmental (Plastic Material Identification Standards) Regulations No. 01 of 2021 was implemented to enforce regulations for plastic manufactures to identify resin types in produce goods.
2021	No. 2211/51 dated 21-01-2021	MoE (CEA)	Prohibition of use of Polyethylene terephthalate (PET) or polyvinyl chloride (PVC) material for packing agrochemicals, and restriction of manufacturing and sales of plastic sachets having less than or equal to a net volume of 20ml/ net weight of 20g, Inflatable toys, and cotton buds with plastic stems.
2022	Gazette Extraordinary No. 2264/17 dated 27-01-2022	MoE (CEA)	Amendment of the National Environmental (Protection and Quality) Regulations, No. 1 of 2008 stipulating emission water quality criteria, with special regulation on wastewater from landfill/leachate treatment facilities. Also, empowered CEA and other related organizations for monitoring and licensing requirements.
2022	Gazette Extraordinary No. 2264/18 dated 27-01-2022	MoE (CEA)	Amendment of the Gazette Notification No 1533/16 dated 25.01.2008 defining activities that require EPL.

### 3.3 Strategies and guidelines

In addition to policies and regulations, different government organizations have developed strategies and guidelines to support waste management activities performed by Local Authorities and other stakeholders. Below Table 3-3 is a summary of the key aspects of these strategies and guidelines.

**Table 3-3 Summary of key strategies and guidelines relevant to solid waste management sector in Sri Lanka**

Year	Guideline	Agency/ Organization	Descriptions
2001	Healthcare Waste Management Guideline	MoH	Provide evidence-based recommendation to clinicians to manage hospital generated waste with minimum harm to the environment.
2003	Solid Waste Management Guideline for Local Authorities	MoPCLG	Give guidelines for proper SWM at LA level.
2005	Technical Guidelines on Municipal Solid Waste	CEA	A technical guideline for citing and construction of waste disposal facilities, especially municipal solid waste landfills.

Year	Guideline	Agency/ Organization	Descriptions
	Management in Sri Lanka		
2005	Technical Guidelines on Used Tyre Management in Sri Lanka	CEA	To prevent adverse impacts on health and environment caused by the emission from incomplete burning from used tyres as well as their improper disposal.
2005	Technical Guidelines on Management of Used Lead Acid Batteries	CEA	To introduce safe handling of used lead acid batteries.
2007	Technical Guides on Solid Waste Management in Sri Lanka	CEA	Update version of Technical Guidelines on Municipal Solid Waste Management in Sri Lanka 2005.
2008	Guidelines for the Management of Scheduled Waste in Sri Lanka	CEA	Guideline for effectively managing scheduled waste.
2015	Sendai Framework (2015-2030) for Disaster Risk Reduction Guidelines (SFDRR)		This highlights the need to integrate with the priorities of SFDRR; understanding disaster risk, investing in disaster risk reduction for resilient, enhance disaster preparedness for prevention and reducing disaster risk through cooperation, sharing responsibilities between the central government and national authorities, and empowering of LAs.
2017	Guide for Sustainable Planning, Management, and Pollution Control of Waste Landfills in Sri Lanka, 2011-2016 (SATREPS guide)	Ministry of Higher Education, CEA, NSWMSC	A guideline introducing appropriate techniques for pollution control and environmental restoration of solid waste landfills.
2017	Guideline for the island wide separate waste collection programme	MoPCLG, NSWMSC	As <sup>th</sup> e 1st step of implementation of island wide source separated waste collection programme the ministry introduced the separate collection to all the Municipal Councils on 2016.11.01. The second step scheduled to initiate immediately from 2017.06.01 covering all the Urban Councils and Pradeshiya Sabha in entire country.
2017	National Emergency Operation Plan (NEOP)	Ministry of Defense and Disaster Management	This is national and local disaster response and operation mechanism that addresses the natural, human-induced and technological hazards which have been identified in the Disaster Management Act of Sri Lanka. The Emergency Response process map illustrates the activities performed at three stages of response, just before, during and just after disaster at national and sub national levels. In case of an emergency or a disaster, search and rescue activities are coordinated by Disaster Management Centre according to National Emergency Operational Plan (NEOP). National Disaster Relief Service Center (NDRSC) as well as Disaster Management Center have developed a guideline and SOPs to camp management at a disaster situation.

Year	Guideline	Agency/ Organization	Descriptions
2017	National Disaster Risk Reduction and Management Plan (NDRRMP) (2018-2030)	Ministry of Disaster Management	A long-term national sectoral plan aiming to address four main priority areas as disaster prevention and mitigation, disaster preparedness, disaster response, rehabilitation and recovery.
2019	New Planning & Building Regulations (General) (2019-2030)	UDA	Part IV: Regulation for Planning, Designing and calculation of the Development. No 62: Guidelines for collection and disposal of waste generated within any premises
2020	Interim Guideline for Management of Solid Waste Generated by Households and Places under Self-Quarantine due to COVID-19 Outbreak	MoE, CEA, MoPCLG, NSWMSC, MoH	This guideline is the first of such kind that provide guideline for waste management during emergency and disastrous situation. The guidelines were a response to Covid-19 pandemic which set out to guide Local Authorities for waste safe handling and disposal of municipal solid waste and also educate households on the correct ways of segregating waste. The unique feature of the guideline is that health and safety aspects of waste management prioritized over environmental aspects in case of an emergency. Specific yet appropriate provisions have been made in this guideline to accommodate the specific needs of the health emergency prevailed during the Covid-19 outbreak.
2020	National Action Plan on Plastic Waste Management 2021-2030	MoE	The action plan proposes activities to control plastic waste in the country based on approaches conforming to the National Policy on Waste Management and the Sustainable Consumption and Production Policy.
2021	Guidelines for Safe Closure and Rehabilitation of Municipal Solid Waste Dumpsites in Sri Lanka	MoE	The dumpsite rehabilitation guidelines provide advice on: a) a risk assessment procedure to determine the level of pollution caused by a dump and its rehabilitation potential; b) implementable rehabilitation and closure plans; c) appropriate technical intervention to minimize leachate contamination, uncontrolled gaseous emissions, waste burning, and risk of dumpsite collapse; and d) an appropriate operation and maintenance procedure that ensures sustainability of technical improvement measures.
2022	National Environmental Action Plan 2022-2023: Pathway to Sustainable Development in Sri Lanka.	MoE	This action plan presents 9 strategies and 63 actions as comprehensive solutions based on a Holistic waste management approach within sustainability framework. An Integrated Sustainable Waste Management (ISWM) and Life Cycle (LC) concepts along with the waste management hierarchy have been considered as the guiding principles. The plan specifically aims to ensure sound waste administration and operation for ISWM, prevention and reduction of waste, sustainable management of plastic and recyclables, implementation of biological treatment and energy recovery, proper management of final disposal and hazardous waste, research and development to support holistic approaches, and enhance global participation and collaboration.



### 3.4 Provincial policies/strategies applicable to MP

Various plans and programs that are currently in operation and/or planned to be implemented for spatial transformation of the western urban region, and the structural transformation of the economy in near future in the Western Province may have direct and indirect impacts on implementation of the MP. Among these, plans and programs that address issues related to infrastructure development, transportation, waste management, and environmental management are highly relevant to the MP. The MP has considered these plans and programs, particularly the components of the Metro Colombo Solid Waste Management Project (2017-2020), Port City Development Project (2016-2019), and Western Region MegaPolis Plan (2016-2030), in preparation of strategies for SWM in the Western Province. Below is a summary of such plans and projects.

Metro Colombo Solid Waste Management Project (2017-2020) aimed to design and build waste transfer stations in Kelaniya and Meetotamulla, and sanitary landfill in Aruwakkalu for the municipal solid waste (MSW) generated in the Metro Colombo Region, extend railway lines and build a connection line, and purchase railway equipment, machinery, and other improvements. Further, this project implements 3R concept via setting up of waste collecting centers in school and housing complexes, having provided the training to the selected persons, appointing duty officers for the SWM program. Also, this project promotes waste to energy plants, composting, sanitary landfills, closure of illegal dumpsites and increase community participation in recycling.

Port City Development Project (2016-2019) developed the Colombo Port City (CPC) an extension of Sri Lanka's central business district (CBD). As affected by steady local population growth and a rapid increase in demand for services, CPC has chosen an integrated approach to energy, water, and waste management in order to achieve long-term environmental sustainability and a comfortable environment for its citizens. Waste separation that works properly will reduce the demand for sanitary landfill space as well as the cost of landfill construction and operation. CPC hopes to reduce the environmental impact of waste disposal, reduce greenhouse gas emissions from open dumps, and improve health conditions by implementing waste management best practices. Furthermore, the Special Economic Zone intends to include water, energy, and waste loops ("eco cycles") in order to reduce waste and increase recycling.

Western Region Aero City Development Project (2017-2022), Western Region Tech City Development Project (2017-2020), Western Region Maritime Cities Development Project (2017-2021), and Western Region Administrative Cities Development Project (2017-2023) aimed at infrastructure development, provision of logistics activities, and development of sustainable cities. Townships Development Component of Greater Colombo Urban Transport Development Project (2009-2019), Light Rail Transit Project by JICA (2017-2026), and Western Region Transport

Development Project (2017-2024) are key projects aiming at long-term measures to overcome prolonged traffic congestion, enhancing the capacity of the public transportation system and providing faster, safe, and comfortable public passenger transportation. As of with any development project, implementation of these projects or as a result of implementation of these projects, waste management becomes a crucial issue to address.

Urban Regeneration Project (2012-2019) is a program for the construction of 60,000 housing units for the relocation of underserved settlements in the City of Colombo and its immediate suburbs. This type of land and housing development particularly needs well developed waste management system. The waste management plans for housing projects include source segregation, waste minimization, and collection bins that adhere to national color codes. Waste handling and sorting units are advocated for in underserved, middle-class, and luxurious housing schemes/complexes to facilitate source segregation and temporary storage until collection.

The Metro Colombo Urban Development Project (2012-2020) aims to supplement the Government of Sri Lanka's ongoing urban regeneration programs by reducing the physical and socioeconomic impacts of flooding in the Metro Colombo Region and improving priority local infrastructure and services. Further, it complements investments in physical interventions to help improve the operational efficiency of waste collection in the project area and intercept sewer discharges to Beira Lake. The investment subprojects included acquisition of equipment for solid waste collection (compactor trucks), development of a solid waste management (SWM) strategy, including detailed studies for immediate action plans developing and implementing a public awareness and communication program.

The MP being an overarching strategy for the Western Province, it has considered these projects/plans in plan development. In particular, megaprojects operating in the area as well as newly proposed development plans have been taken into account in assessing the situation of SWM sector in the Western province, identifying gaps in SWM strategies to be addressed in the MP, and calculation and prediction of waste and related data/parameters needed for developing strategies for solving the SWM problem in the Western province.

Future waste generation amounts, and waste composition are key parameters in designing technical systems for SWM, and predicted levels of waste due to future development plans essentially needs to be taken into account. Development plans such as Colombo Port City development plan and the Marine City development plan will have a significant impact on SWM in the Western province, and the MP has considered these development plans when calculating future trash generation quantities, composition, and waste generation rates.

Guided by the situation analysis in the MP, the MP proposes an integrated approach for SWM in the Western province, and the strategies proposed by the MP enable utilizing the existing

facilities that have been developed under other regional plans and improving/constructing facilities in a need-based approach. For example, the MP intends to use and increase capacity of 28 existing compost facilities managed by several institutes, the Western Power Kerawalapitiya (WPK) WtE facility established by The Western Power Company (Pvt.) Ltd need be continued and utilized for energy recovery; Aruwakkalu final disposal site developed by Metro Colombo Urban Development Project (MCUDP) need be utilized for safe disposal; and capacity of material recovery facilities operated by local authorities required be increased.

## 4 Environmental baseline of the Western Province

This chapter aims to outline the current situation and trends regarding the environmental and health aspects related to the waste management in the Western province and to highlight existing environmental and health threats and risks which may be relevant to the MP. This baseline analysis represents a basis for assessing the likely effects of the MP and formulating mitigation measures. The key issues identified through the below baseline analysis are summarized in Section 4.8.

The MP is developed to be implemented in the Western Province of Sri Lanka. Western Province is in the southwest of Sri Lanka. The province is surrounded by the Indian ocean to the west, Northwestern Province to the north, Sabaragamuwa Province to the east and the Southern Province to the south. It has an area of 3,684 km<sup>2</sup> of total land area which consists of 3,593 km<sup>2</sup> land area and 91 km<sup>2</sup> of inland waters. The entire Western Province is occupied only 5.6% of Sri Lankan land area and Colombo district is the smallest district in Sri Lanka owing only 1.1% of total extent of the country. The province consists of three districts: Colombo, Gampaha, and Kalutara. The Western Province is further divided into forty-eight (48) LAs: 6 MCs, 13 UCs, and 29 PSs.

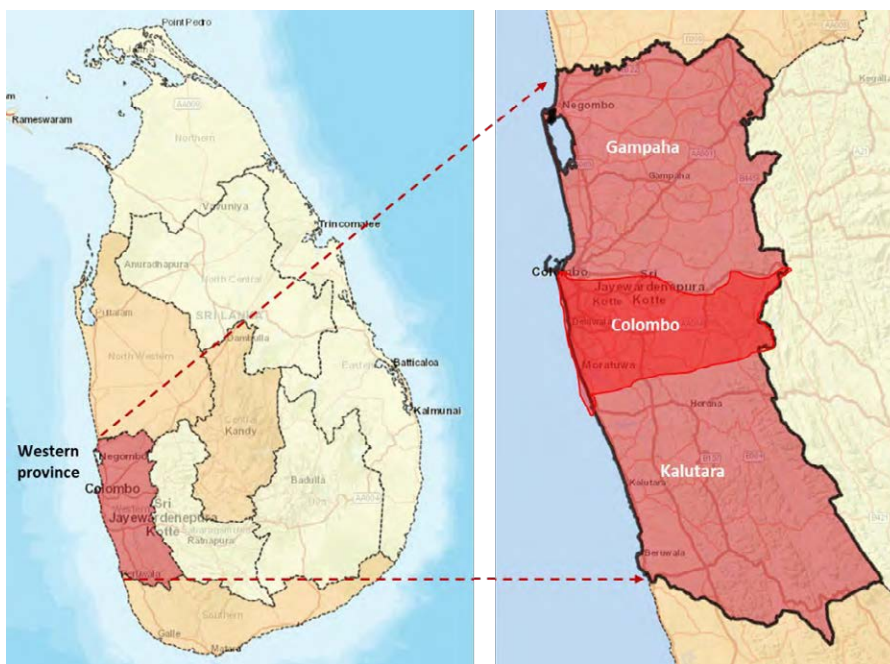

Figure 4-1 Three districts in Western Province of Sri Lanka

Table 4-1 Land and water resources of Western Province (Source: Department of Census and Statistics, 2012)

Total	Land	Inland waters
-------	------	---------------

<b>Sri Lanka</b>	65,610	100%	62,705	100%	2,905	100%
<b>Western Province</b>	3,684	5.6%	3,593	5.7%	91	3.1%
<b>Colombo</b>	699	1.1%	676	1.1%	23	0.8%
<b>Gampaha</b>	1,387	2.1%	1,341	2.1%	46	1.6%
<b>Kalutara</b>	1,598	2.4%	1,576	2.5%	22	0.8%

The Western Province is the most socio-economically developed part in Sri Lanka. It contributes more than fifty percent to the Gross Domestic Product (GDP). The province could also be considered as the heartland of the tourism industry of the island. It is the center of distributional channels of services and administrative center of Sri Lanka. Western Province forms a commercial hub linked with a major airport and the harbor.

The vision of Western Province Council is to pave its way through peace, coexistence, and sustainable development. The following sections describe the physical, demographic, and ecological setting of the Western Province.

#### 4.1 Topography

The topographic features of Sri Lanka are categorized into three distinct zones or peneplains based on elevation and erosion remnants: the coastal belt (0 ~ 30 m MSL), the plains (30 ~ 200 m MSL) and a central mountainous area which is called as the Central Highlands (above 200 m MSL). The proposed project area where the land elevations vary from approximately 0.0 ~ 728.0 m MSL in general falls within the 2<sup>nd</sup> peneplain (Figure 4-2). Detailed land survey maps or 1:10,000 topographic maps of the Western Province are provided in Annexure 8. The region and the study are shown in Figure 4-2 are based on 1:50,000 maps and SRTM/GTOPO30 satellite terrain/digital elevation maps. The major portion of the project area, especially in Colombo and Gampaha districts, is relatively flat with rock knobs and isolated hillocks/low mountain ranges rising to 300 m MSL with slightly to moderately undulating terrain.

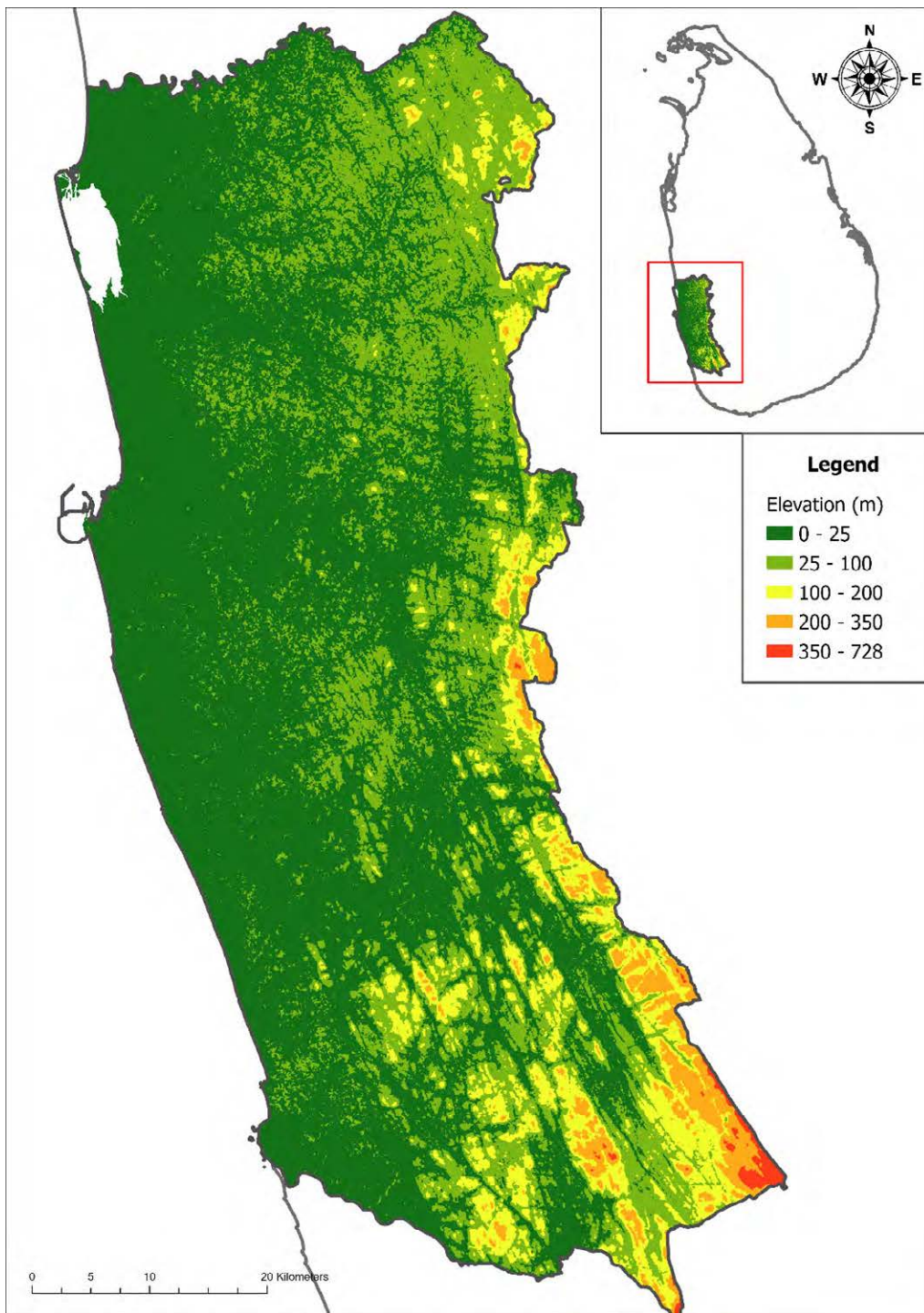

**Figure 4-2 Topographic map of Western Province**

The project area is entirely situated within mid to lower (downstream) part of two major river basins: Kelani River and Kalu river and some of the site localities fall within the floodplain area of the Attanagalu Oya and other associated streams/tributaries. Colombo district is almost entirely fall within the lower Kelani basin which can be divided in to three distinct topographical units of

lower (below 100m MSL), middle (100 to 300m MSL) upper peneplains (above 300m AMSL). The Kelani River Basin landforms vary significantly and includes 11 landforms, namely, mountain, escarpment, hill and ridge, ridge and valley, hill and valley, mantled plain (gently undulating to rolling plains), rock knob plain (rough and broken relief of extensive tracts), erosional remnant (isolated, steeply rising bedrock-controlled hills and ridges), flood plain, coastal plain, and dune and beach (Cooray, 1984). Slope steepness in the Kelani River Basin ranges from steep slopes with 25- 30% slopes in the eastern parts to flat terrain in the lower western portions.

Kalu river basin is the second largest river basin in Sri Lanka covering 2766 km<sup>2</sup> and much of the catchment is located in the highest rainfall area of the country eastern mountains of Kalutara district and Ratnapura district of adjoining Sabaragamuwa province. The Kalu river originates from the central hills of the wet zone at an altitude of 2250 m and garners rainfall on the western slopes and falls out to the sea at Kalutara after traversing about 129 km. The basin has steep gradients in the upper part and mild gradients in the lower part. Due to these hydrological and topographical characteristics of the river Kelani and Kalu river basins, its lower flood plain suffers from frequent floods during the Southwest monsoon season. As the most urbanized province in Sri Lanka, these climate events pose several problems due to the rapid urban growth the province has undergone.

## 4.2 Geology and soil

The geology of the Western Province is dominated by Precambrian strata, some of it dating back 2 billion years. Precambrian rocks of the South- Western group consist of Schists, Gneisses, and granulites of Metasedimentary origin, as well as Migmatite and Granitic Gneisses. Laterite (Cabbok) is a common secondary formation which occurred in Gampaha and Colombo districts. Due to its vesicular structure, it gives significant potential on shallow aquifer system in the lower reach of the river basins. A large stretch of quaternary deposit of unconsolidated sands covers the coastal area of the Western Province. This formation bears the shallow freshwater aquifers. A special type of a lagoonal deposit is the peat swamp at Muthurajawela in between Kelani River and Negombo lagoon north of Colombo. It is composed of debris of several generations of forest, brackish water vegetation and swamp growth, which has been swept into marshes. Alluvial deposits cover a considerable area of the Kelani and Kalu river basin. These deposits bare large quantities of fresh groundwater. Landslides and slope failures are one of the most devastating natural hazards occur in the hilly areas of Colombo and Kalutara districts. Other than influence from build environments; rainfall frequency and geology have significant impact on occurrence of landslides in the basin.

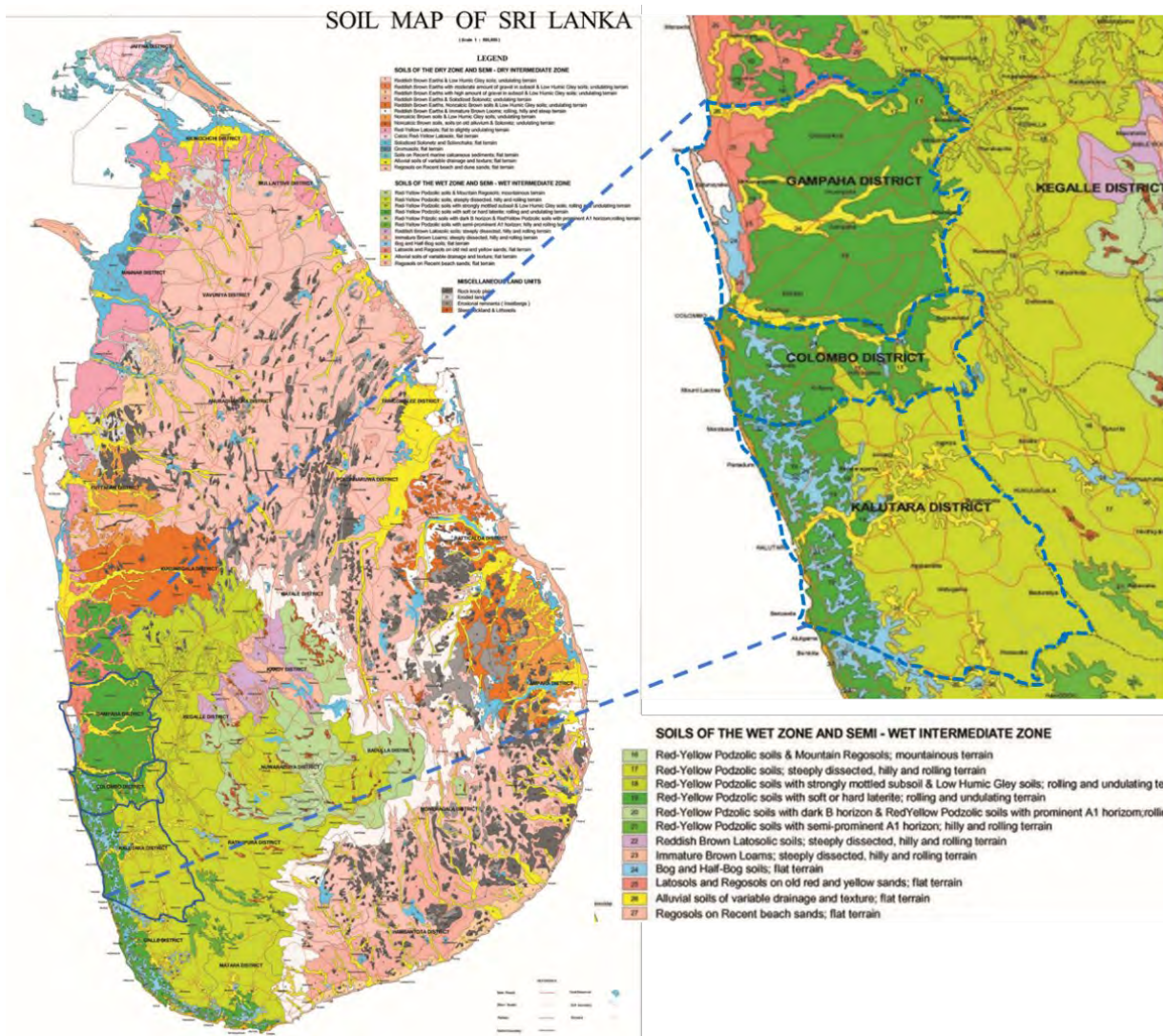

Figure 4-3 Major soil types of western province

General soil map of the study area is given in the Figure 4-3. Red- yellow Podzolic soils are the main soil type in the western region, with sub-groups. Soil in the Colombo and Gampaha districts include the sub-group with soft or hard laterite rolling and undulating terrain, which also occurs to a lesser extent in the Kalutara district. The ill-drained lands in the lower coastal plain of the region include bog and half-bog soils with flat terrain (i.e., in Muthurajawela and Attidiya marshes). The beach areas from Negombo to Mount Lavinia consist of a narrow stretch of Latesols and Regosols on old red and yellow sands. Narrow strips of Alluvial soils occur along the floodplains of Kelani River, Dandugam Oya and Kalu River. Alluvial deposits are dominant along the riverbanks and consist mostly of fine-grained clay soils. Most of the alluvial clay deposits are formed by past flood events. The alluvial deposits of the riverbanks have contrasting layering which demarcates climatic changes during the past.



### 4.2.1 Land use

The land use map developed by the Survey Department was used to obtain the information on land use in Western Province (1:10,000 map numbers 52, 53, 59, 60, 66, 67, 73, 74, 79,80) which covers the three districts of Colombo, Negombo, and Kalutara. Based on these maps, each category of land use such as built-up areas, homesteads, paddy areas, marsh areas, and water bodies were digitized. Since the base topographic map represents land use in 1989, each land use was verified and updated, using the recent satellite image data (Figure 4-4).

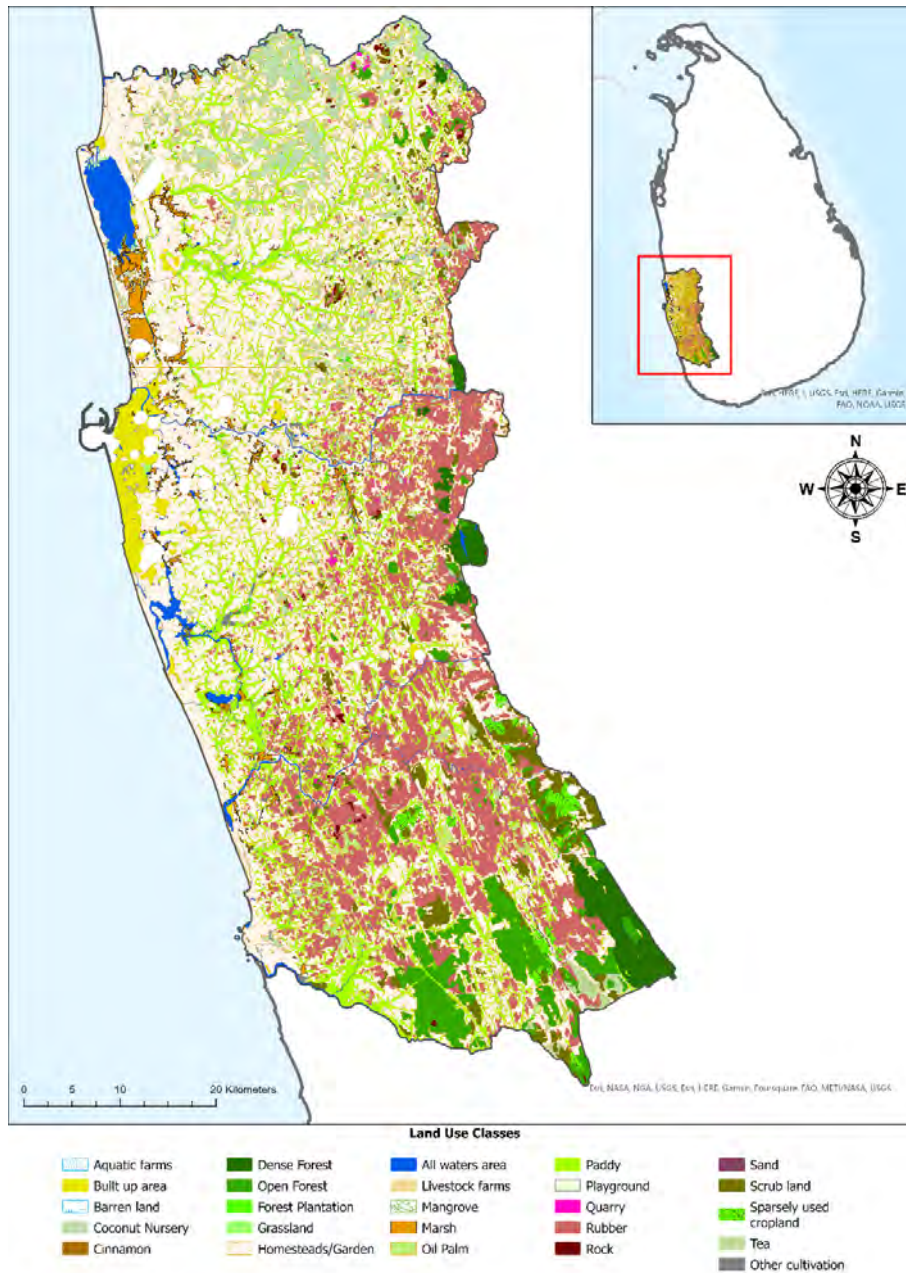
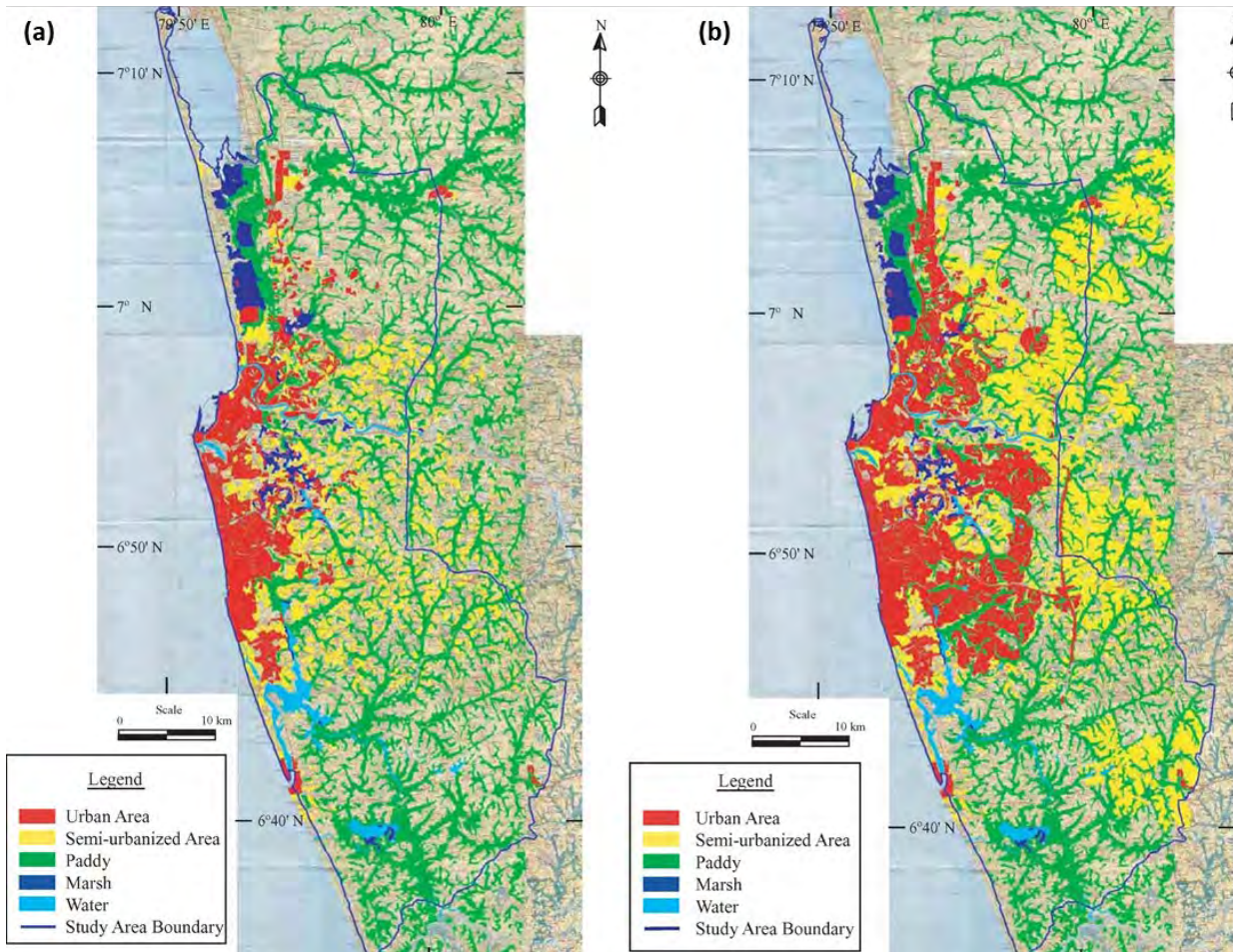

Figure 4-4 The present land use of the Western Province

**Figure 4-4 The present land use of the Western Province**

Within the Western Province, paddy land amounts to 14,229 ha (17.6%), built up area 10,851 ha (13.3%), and marshy area 2,016 ha (2.5%). The Greater Colombo basin indicates the highest share of buildup area (36.9% for the sum of urban and semi-urban area).



**Figure 4-5 The land use of Western province a) existing land use pattern and b) future land use (2030) as projected by Megapolis Master Plan and JICA (2018).**

The land use system of the Western Province is dominated by home gardens followed by rubber plantations, paddy lands, coconut plantations and natural forests, especially in Kalutara and Gampaha districts. In Gampaha district, the dominant form of land use is home gardening followed by coconut plantations, paddy farming and rubber plantations. Gampaha district has the lowest extent of natural forests in a district. In Colombo district, rubber plantations are the dominant form of land use followed by home gardens, paddy farming, built up lands and coconut plantations. In the Kalutara district, the land use pattern is dominated by rubber plantations followed by home gardens, paddy farming and natural forests.

## 4.2.2 Surface and ground water

### 4.2.2.1 Surface water resources

The study area is located along the Kelani and Kalu major river basins in Sri Lanka, which are major sources of water supply, irrigation, hydropower generation, and recreational activities in the Western Province. Furthermore, the Attanagalu Oya basin encompasses a large portion of the Gampaha district. The Bolgoda basin is located south of Colombo district and covers a small area; however, it is an important surface water resource in Western Province.

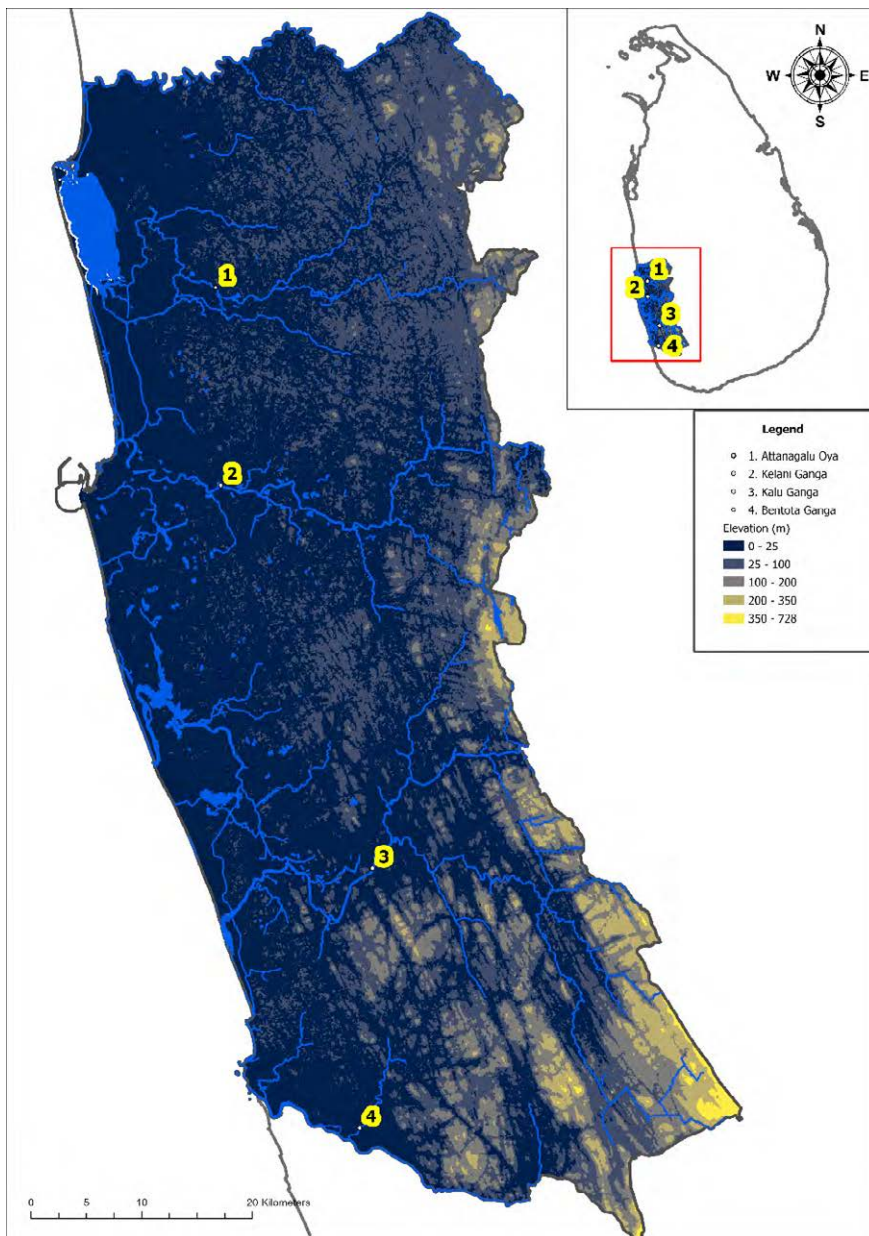

Figure 4-6 Water resources and surface water bodies of Western Province

In addition to natural river water resources, there are a number of tanks/ reservoirs for irrigation, flood control, drinking water, and recreational water reservoirs within Western Province (Table 4-2). A detailed description of river basins and hydrology are shown in section 4.2.5.

**Table 4-2 List of irrigation tanks in the Western Province**

Tanks	District	DS Division
Kopiyawatha wewa; Chamali Pura Wewa;	Kaluthara	Kaluthara
Aluthgama Wewa (Pansal Wewa); Madagama Kuda Wewa; Wawita Wewa; Widagama Wewa (Walgama Wewa); Gammanpila Wewa	Kaluthara	Bandaragama
Remuna Wewa	Kaluthara	Madurawala
Pitadeniya tank; Kudumberiya tank; Ethiliyagala tank; Bogala Agara tank; Siri Ambepura tank; Damwelkatuwa tank; Kalumada tank; Dagonna Dachchagara tank; Hal Ullagara tank; Thota tank; Katukenda tank	Gampaha	Diulapitiya
Mabodale tank	Gampaha	Minuwangoda
Hapittigama Dalugala tank; Heediyawala tank; Detagama Halwatta tank; Thennagama tank; Meegahamadiththa tank; Kuruduwaththa tank	Gampaha	Mirigama
Dadagamuwa tank; Horakale tank; Alubogahadeniya tank; Thalghadeniya tank; Marathagahadeniya tank; Dalupothadeniya tank	Gampaha	Aththanagalla
Lokurudeniya tank	Gampaha	Gampaha
Puwakgahadeniya Yaya tank	Gampaha	Gampaha
Ihalagama tank; Kapuwa tank; Kadurgaha tank (Walpola tank); Peralanda tank	Gampaha	Ja Ela
Nugahenawatta tank; Rajapaksha tank; Dalukanda tank; Sohonabumiya tank; Maharagama tank; Madalanda tank; Horokgaha tank; Thethipanladieniya tank; Nelamagara tank; Rajamahawihara tank; Deniya tank; Gadumuna tank; Saranawatta tank	Gampaha	Mahara
Peenchathudeniya tank; Ariddagahadeniya tank; Panigahawila tank; Herukuburayaya tank; Kibulwila tank; Alubogahadeniya tank; Mawathahena tank; Peerawila Jalasaya tank	Gampaha	Dompe
Yabaraluwa tank; Heladeniya tank	Gampaha	Biyagama
Thalangama tank	Colombo	Homagama
Kesbewa tank	Colombo	Kesbewa

#### 4.2.2.2 Groundwater resources

In Sri Lanka groundwater resources come under the jurisdiction of the Water Resources Board (WRB). The WRB has a database of wells from which certain amounts of groundwater data could be extracted. In addition, the National Water Supply and Drainage Board maintains a database on tube wells. Both of these databases contain information about tube wells and boreholes dug for various projects and investigations. There is however, no coherent or dedicated groundwater study for WRMP area. Some details could be obtained from past studies and investigations conducted for some areas of WRMP (eg. study for the Attanagalu Oya catchment done by WRB,

study by WRB for the coastal areas from Colombo to Negombo). As per the available data, groundwater aquifers in the western province consists mainly of coastal sand aquifer, alluvial aquifer, laterite aquifer and regolith aquifer of hard rock region. Details are presented in Figure 4-7 below.

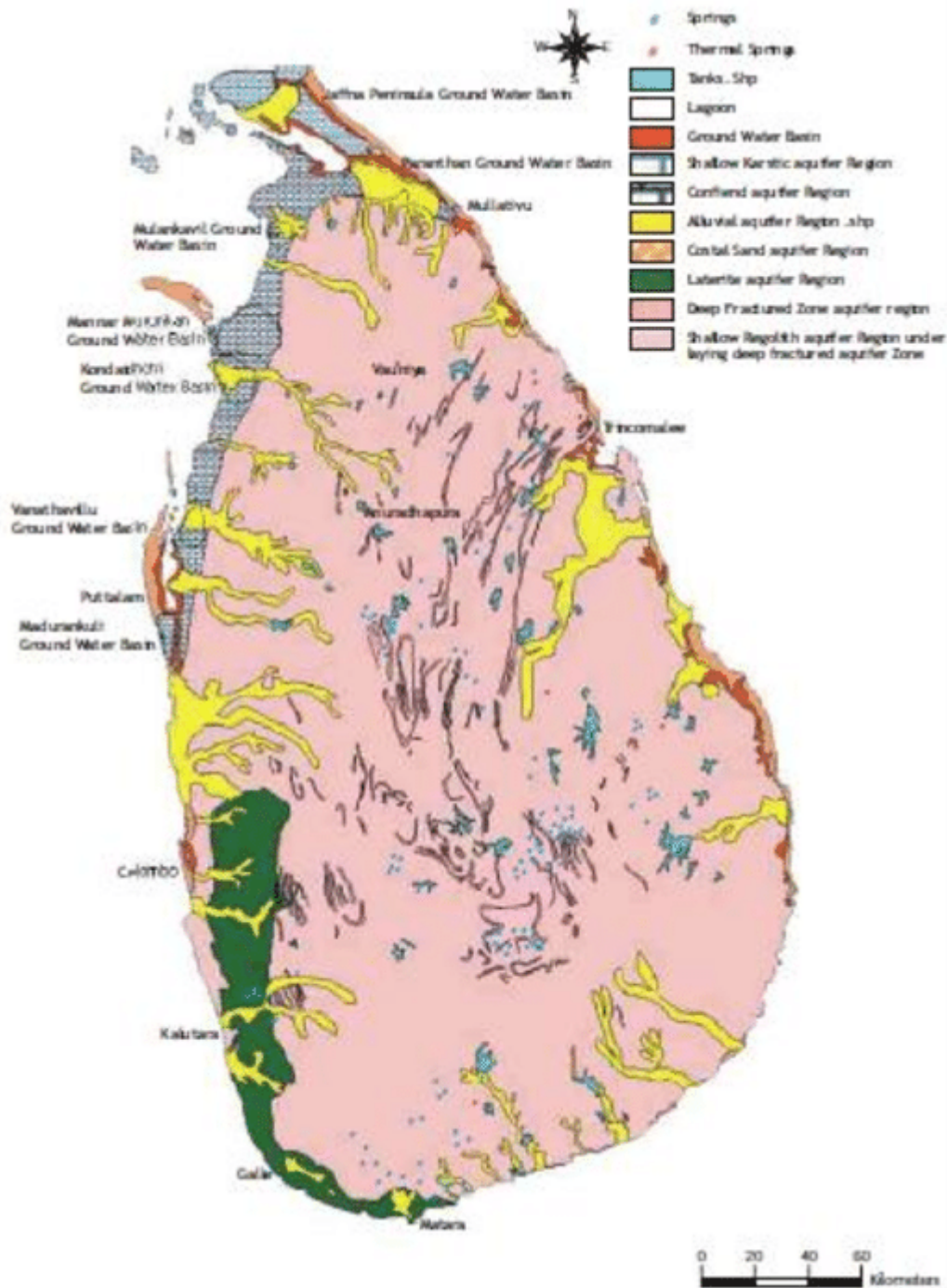

Figure 4-7 Different types of groundwater aquifers in Sri Lanka (Karunaratne, 2007)

### 4.2.3 Rainfall

The mean annual rainfall ranges from 1,500 to over 4,500 mm in various parts of the Western Province depending on the location. As shown in Figure 4-7, the coastal belt of Western Province and Gampaha district receive low rainfall compared to Kalutara and Colombo districts. The Western Province is usually wet and humid, where the mean monthly day time and nighttime relative humidity of the region ranges from 68-77% and 83-91%, respectively.

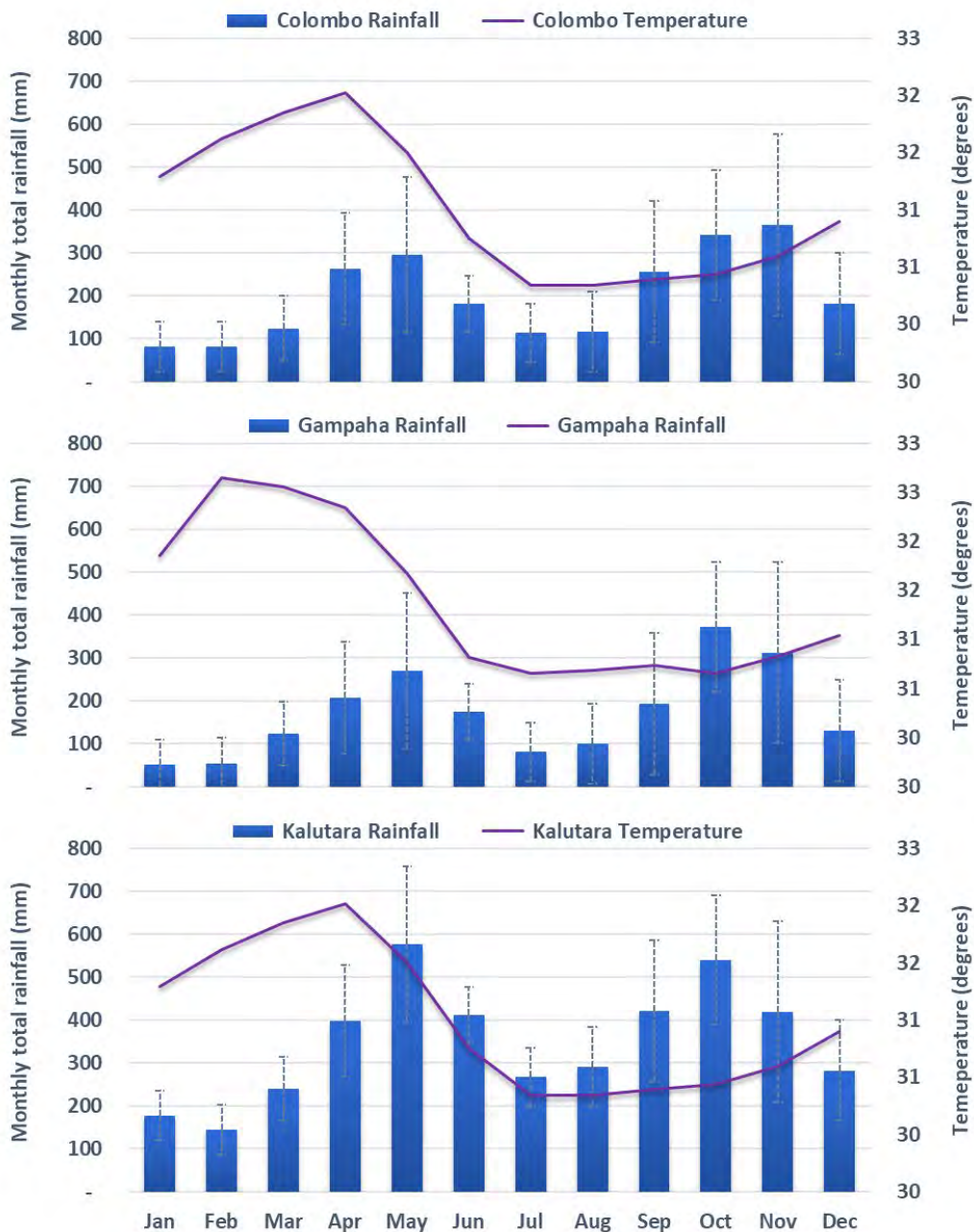

Figure 4-8 The average (2012-2022) Rainfall and Temperature changes in Western Province

There is also a significant variation in rainfall over the year (Figure 4-8) which is a clear bimodal distribution of rainfall pattern. There are two distinct rainy seasons, both significant in terms of monthly rainfall, one associated with the Southwest Monsoon during the period April to June and the other during the period of the Northeast Monsoon in December to February. Most of the major floods have occurred during the Southwest Monsoon period, but some (more than 25% of the total over the last 200 years) have also occurred during the Northeast Monsoon period.

The recent climate data analysis showed that there is an increasing trend of rainfall at both the annual and seasonal level (Alahacoon and Edirisinghe, 2021). The increased rainfall intensity will cause an increased risk of floods in the Western Province in the future.

#### 4.2.4 Air and climate

##### 4.2.4.1 Air quality

According to the United States Air Quality Index (US AQI), Sri Lanka has a “Moderate” figure for air cleanliness in 2019-2021 period, with a US AQI figure of 78. The average annual concentration of the pollutant Particulate Matter (PM) 2.5 was  $25.2 \mu\text{g}/\text{m}^3$  in 2019 and the figure was within the acceptable range suggested by the World Health Organization (WHO). However, it has been recorded that during the winter spell, especially from January to March, the  $\text{PM}_{2.5}$  increases to between  $35.5$  and  $55.4 \mu\text{g}/\text{m}^3$  which is considered “Unhealthy for sensitive groups”. For the remaining months, the figures were “Moderate” with measurements between  $12.1$  and  $35.4 \mu\text{g}/\text{m}^3$ .

A recent study by Dhammapala et. al., (2021) revealed that the annual averages of  $\text{PM}_{2.5}$  in 2018, 2019 and 2020 were  $31.9$ ,  $23.5$  and  $19.5 \mu\text{g}/\text{m}^3$ , respectively, exceeding the Sri Lankan annual  $\text{PM}_{2.5}$  standards of  $25 \mu\text{g}/\text{m}^3$  in 2018. However, all years exceeded the U.S. and WHO annual standards of  $12$  and  $10 \mu\text{g}/\text{m}^3$ , respectively. The Sri Lankan 24-hr  $\text{PM}_{2.5}$  standard was exceeded every year (2018:  $86.1$ , 2019:  $62.3$ , 2020:  $55.0 \mu\text{g}/\text{m}^3$ ).

The monthly variation of Colombo’s  $\text{PM}_{2.5}$  is shown in Figure 4-9. Overall, air quality is “Good” or “Moderate” at least 80% of the time from April to October.

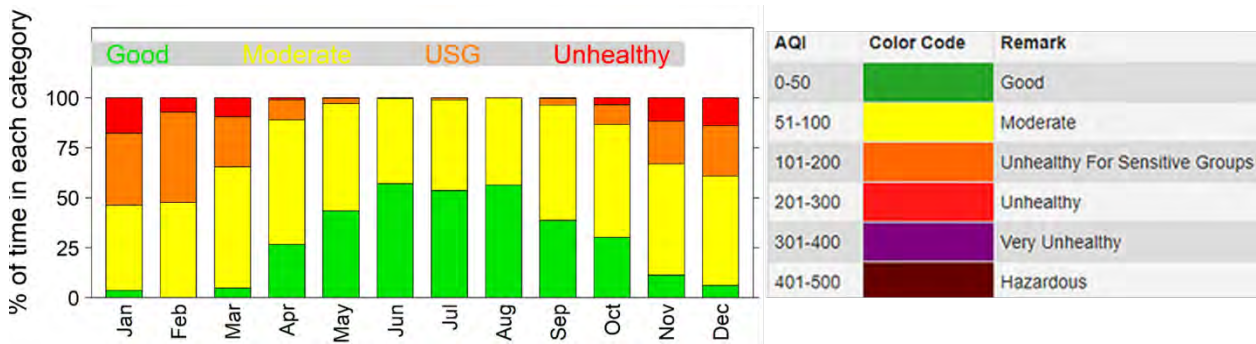

**Figure 4-9 Monthly profiles of PM<sub>2.5</sub> from September 2017–July 2021 in Colombo (Adapted from Dhammapala et. al., 2021)**

However, as well experienced by Sri Lankans on 8<sup>th</sup> December 2022 (NBRO, 2022), the Indian Ocean Brown Cloud or Asian Brown Cloud, a layer of air with considerably higher level of air pollutants, which is recurrently covers parts of South Asia, appears as every year between January and March, possibly also during earlier and later months. The phenomena coined in reports from the UNEP Indian Ocean Experiment – INDOEX (UNEP and C<sup>4</sup>, 2002). It was found that the Asian Brown Cloud is created by a range of airborne particles and pollutants from combustion (e.g., woodfires, cars, and factories), biomass burning and industrial processes with incomplete burning in mainland India (UNEP and C<sup>4</sup>, 2002). The Asian Brown Cloud is associated with the winter monsoon (November/December to April) during which there is no rain to wash pollutants from the air and the winter wind circulate covering southern region of India including Sri Lanka.

The need of air quality improvement had been recognized in the Clean Air 2025- An action plan for Air Quality Management in Sri Lanka which aims to reduce urban, industrial, and indoor air pollution and maintain air quality at desirable levels (Ministry of Mahaweli Development & Environment, (2016). This action plan identified a comprehensive plan to be achieved through an effective stakeholder participatory mechanism and ensuring source identification, quantification, and monitoring of harmful air pollutants along with an appropriate regulatory framework. Further, the action to control the open air burning of refuse or other combustible matters inclusive of plastics in Sri Lanka, has already been implemented under the National Environmental Act, No. 47 of 1980 through the Gazette extraordinary No. 2034/36 - Friday September 01, 2017.

#### 4.2.4.2 Climate

The Western Province belongs to the wet zone except for a small area close to the Northern boundary of Negombo which is a part of the Intermediate Zone (Figure 4-9). The average annual air temperature ranges from 26.2-29.7 °C. The average annual minimum and maximum temperature varies from 22.2-26.7 °C and 29.9-32.7 °C, respectively. The period between



November to January and April to June are considered as the coolest and hottest periods of the Western Province. In the absence of high seasonal variation in temperature, the average pattern of temperature in Western Province is determined mainly by the variations in precipitation.

As shown Figure 4-9, based on the classification of agro-ecological zones of Sri Lanka, the Western Province consists of three main zones of WL 1, WL 3, and WL 4 under the low-country wet zone and few patches of lands fall within WL 2b, IL 1a, WM 1b. The Colombo District spans across WL 2a, WL 1a, and WL 3 agroecological zones. Gampaha District falling within WL 3 with small land masses within WL 1b, WL 1a, WL 2b, and IL 1a agroecological zones. The Kalutara District fall within WL 2a, WL 1b, WL 1a and small landmass in WM 1b.

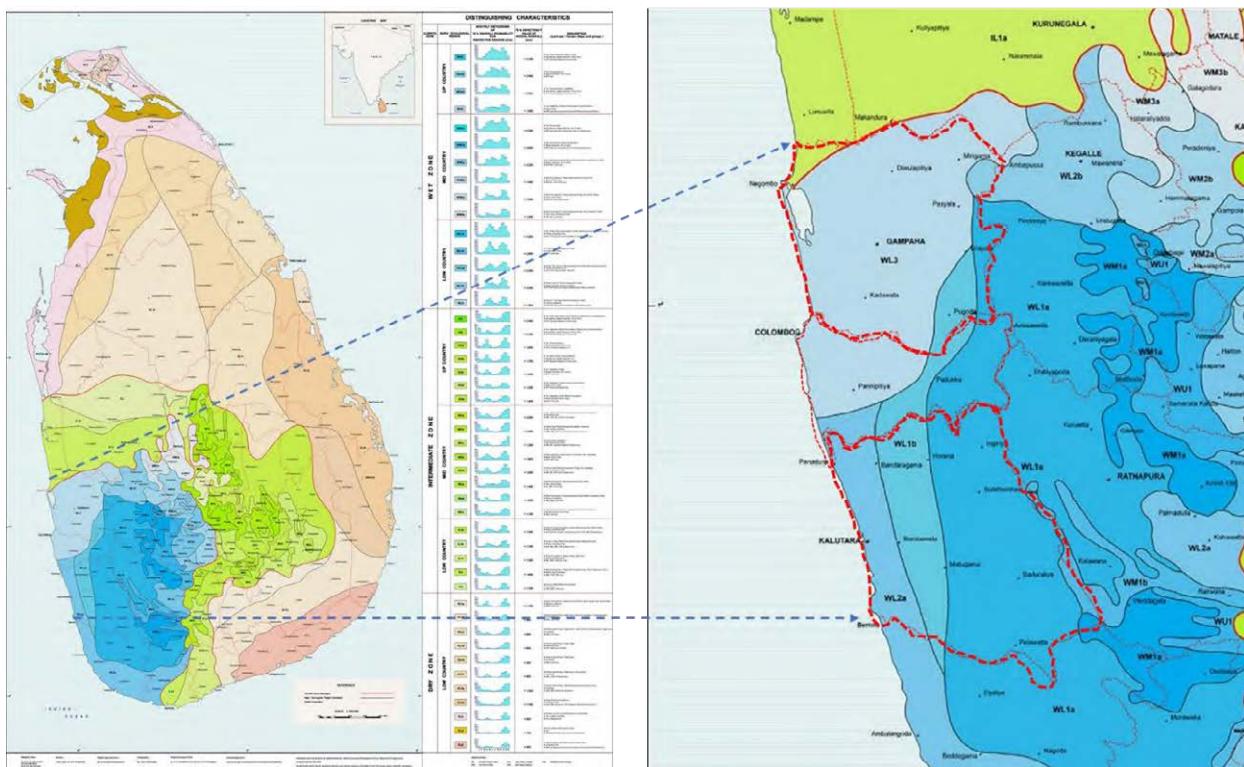

**Figure 4-10 Agroecological (climate) zones of Western Province**

4.2.4.3 Climate change

The Climate Change Secretariat of Sri Lanka (2016) suggests that atmospheric temperature in Sri Lanka is gradually rising everywhere in the country. Further, the report mentions that varied rates of increase in temperature have been reported from various locations and in recent years, the warming trend has become faster. Annual mean air temperature anomalies have shown significant increasing trends in all whether recording stations during the recent decades. It has been reported that mean daytime maximum and mean nighttime minimum air temperatures also have increased. Data indicates that increase in nighttime minimum air temperature

contributes more to average increase in annual temperature than daytime maximum air temperature.

Based on the evidence until 2016, the Climate Change Secretariat of Sri Lanka (2016) suggests that no clear pattern or trend has been observed in precipitation. Though some researchers comparing the mean annual precipitation of recent and earlier periods, suggest that average rainfall is showing a decreasing trend, there is no consensus on this fact among researchers and opposing trends can be observed in different locations (Climate Change Secretariat of Sri Lanka, 2016). Many researchers seem to agree that the variability of rainfall has increased over time, and the number of consecutive dry days has increased, and the consecutive wet periods have decreased. Past studies also indicate that spatial distribution of rainfall appears to be changing although a distinct pattern cannot be recognized yet, suggesting that changes in rainfall distribution can even lead to shifting of agro-ecological boundaries.

The intensity and the frequency of extreme events such as floods and droughts have increased during recent times. Areas of high rainfall intensities and the locations of landslides show a strong correlation (Climate Change Secretariat of Sri Lanka, 2016). The Sea level rise of 1-3 mm/year is observed in the Asian region and is marginally higher than the global averages. An accelerated level of sea level rise has been observed during the period of 1993-2001 (3.1 mm/year) for the Asian region. However, specific levels of sea level rise in areas around Sri Lanka are yet to be assessed.

#### **4.2.5 Hydrology and drainage**

The Kelani River originates from the peaks in south-central highlands at an altitude of 2250 m on the steep slopes and falls out to sea at Colombo after traversing about 145 km. Kelani River has about 2317 km<sup>2</sup> catchment area and receives about 3500 mm average annual rainfall. Generally, the upper reach of the basin is covered with tea plantations and forest lands while the middle and lower reaches have rubber and paddy. The Ambathale water intake at lower Kelani basin is the main water source for major part of Colombo district.

The Kalu River also originates from the south-central highlands and garners rainfall on the western slopes and falls out to the sea at Kalutara after traversing about 129 km. The basin has steep gradients above Rathnapura and mild gradients in lower part of Kalutara district. Since Kalu river catchment receives high rainfall in the upper reaches and has flat river gradient in lower catchment, the Kalutara district experiences regular flooding. It has about 2816 km<sup>2</sup> catchment area and receives about 3680 mm average annual rainfall. Most of the part of the catchment has been developed as rain fed plantation areas of tea, rubber, paddy and some coconut, cinnamon etc.

The Attanagalu Oya originates from Kegalle district and drains into the Negombo Lagoon as Dandugam Oya. The Attanagalu Oya is approximately 76 km with a drainage basin of 727 km<sup>2</sup>. The Attanagalu Oya is often a cause of floods to low-lying areas in the Gampaha district. Bolgoda Lake or Bolgoda River is a freshwater lake in the south of Colombo in Western Province, straddling the border between Colombo District and Kalutara District. It consists of two main bodies of water, a Northern portion and a Southern portion, connected by a waterway called Bolgoda River. The lake drains into the sea at the estuary in Panadura. Bolgoda Lake is part of Bolgoda Environmental Protection Area, gazetted in December 2009.

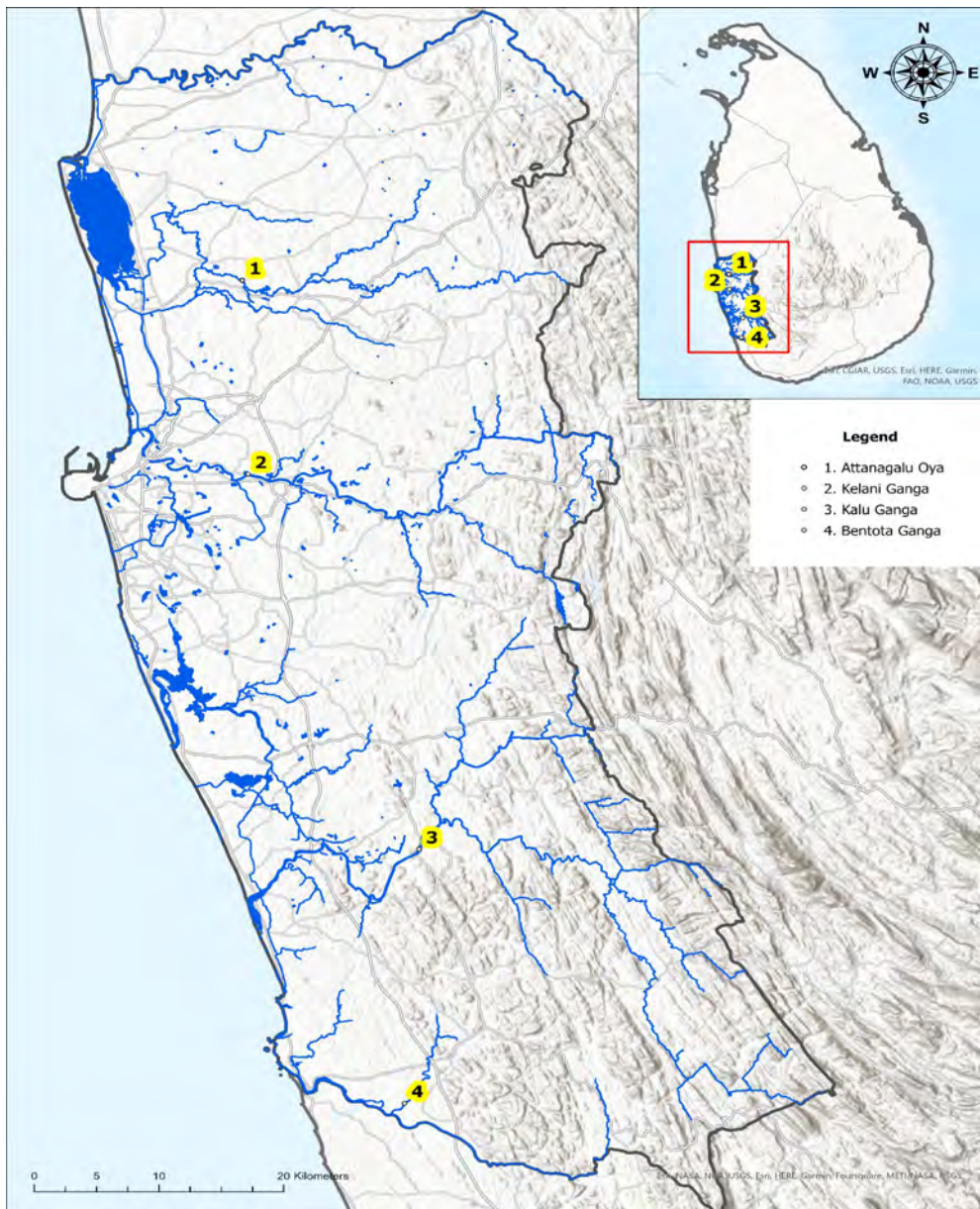

Figure 4-11 Major River basins of Western Province

### 4.3 Ecological resources

Sri Lanka’s high biodiversity can be derived from a wide variety of climatic, topographic and soil conditions that has resulted in a diverse array of aquatic and terrestrial habitats. The physical and climatic features of the Western Province have also contributed to its unique ecological resources described below.

The flora of the Western Province belongs to three main floristic regions from the 15 floristic regions identified in Sri Lanka. The coastal and marine belt (zone I), the northern wet lowlands (zone 5) and southern lowland hills (zone 7) are the three main floristics zones of Sri Lanka (Bambaradeniya, 2008). The inland area of the Western Province belongs to the 4<sup>th</sup> bioregion, while its coastal zone belongs to the 12<sup>th</sup> bioregion out of the total 15 bioregions in Sri Lanka (Bambaradeniya, 2008). It is also reported that the Western Province falls under the south-western ichthyological zone, where 12 species of rare endemic fish are confined to. The wild mammals of the Western Province belong to the wet zone lowlands mammal zone (Bambaradeniya, 2008).

#### 4.3.1 Ecological environment (Flora and fauna)

##### 4.3.1.1 Species richness, endemic species, threatened species

Of the 15 floristic regions identified in Sri Lanka (Gunatilleke and Gunatilleke, 1990), the flora of Western Province belongs to three main floristic regions, the coastal and marine belt (zone 1), the northern wet lowlands (zone 5) and southern lowland hills (zone 7). Of the 3773 flowering plants recorded in Sri Lanka, more than 25% of the species occurs within the Western Province. At least 30% of them are endemic to Sri Lanka, while more than 30% them are nationally threatened. Seventy-three (73) endemic flowering plant species occur in Colombo and Gampaha districts and 174 species occur in the Kalutara district (Bambaradeniya, 2008).

About 35% of the inland indigenous vertebrate species in Sri Lanka occur in the Western Province, which includes about 20% of the endemic vertebrate species in the island (Table 4-3). Approximately 25% of the total indigenous vertebrate species in the Western Province are nationally threatened (Bambaradeniya 2008; IUCN & MOENR, 2007).

**Table 4-3 Inland fauna and flora found in the Western Province compared to fauna and flora recorded in Sri Lanka**

Taxonomic Group	Sri Lanka			Western province			Colombo			Gampaha			Kalutara		
	T	E	TH	T	E	TH	T	E	TH	T	E	TH	T	E	TH
Butterflies	245	26	99	159	14	41	117	7	17	104	5	13	123	12	34
Freshwater Fish	91	50	45	65	29	27	45	18	14	57	25	21	59	26	23

Taxonomic Group	Sri Lanka			Western province			Colombo			Gampaha			Kalutara		
	T	E	TH	T	E	TH	T	E	TH	T	E	TH	T	E	TH
Amphibians	111	95	73	29	19	15	10	3	1	25	15	10	20	14	12
Reptiles	211	124	107	66	28	21	38	10	6	39	10	5	58	26	17
Birds	240	33	67	182	16	26	134	11	5	163	15	12	172	24	18
Mammals	95	21	53	45	6	17	25	4	8	27	3	7	39	6	15
Flowering Plants	3154	894	1385	1,359	381	468	418	48	81	652	111	174	902	338	361

Source: Bambaradeniya, 2008 and IUCN & MOENR, 2007  
 Note: T=Total number of species; E=Endemic species; TH=Threatened species

### 4.3.2 Forest cover

Patches of primary and secondary lowland evergreen forests (tropical rain forests) are scattered across the Western Province. These forest reserves are under the jurisdiction of the Forest Department of Sri Lanka. Colombo district supports 1345.88 ha of lowland rainforests (Table 4-4). Further, 487.59 ha of sparse and open forests and 370.48 ha of plantations forests are also found in the Colombo District. Six secondary lowland forest reserves are located within the Colombo district (Table 4-4). Labugama-Kalatuwawa Strict Forest reserve which is the catchment area of Labugama-Kalatuwawa reservoirs in the Padukka Division is the largest. Kanananpella forest reserve is the second largest (Table 4-4).

**Table 4-4 Forest cover in the Western Province by district**

Forest type	Extent (ha)		
	Colombo District	Gampaha District	Kaluthara District
Lowland rain forest	1346	273	20240
Moist monsoon forests	-	14	-
Sparse and open forests	488	20	126
Plantations	370	20	-
Mangroves	-	122	70
Freshwater	771	-	-
Other	-	-	1140
Total	2975	429	21,576

Research & Development Unit, CEA, 2017

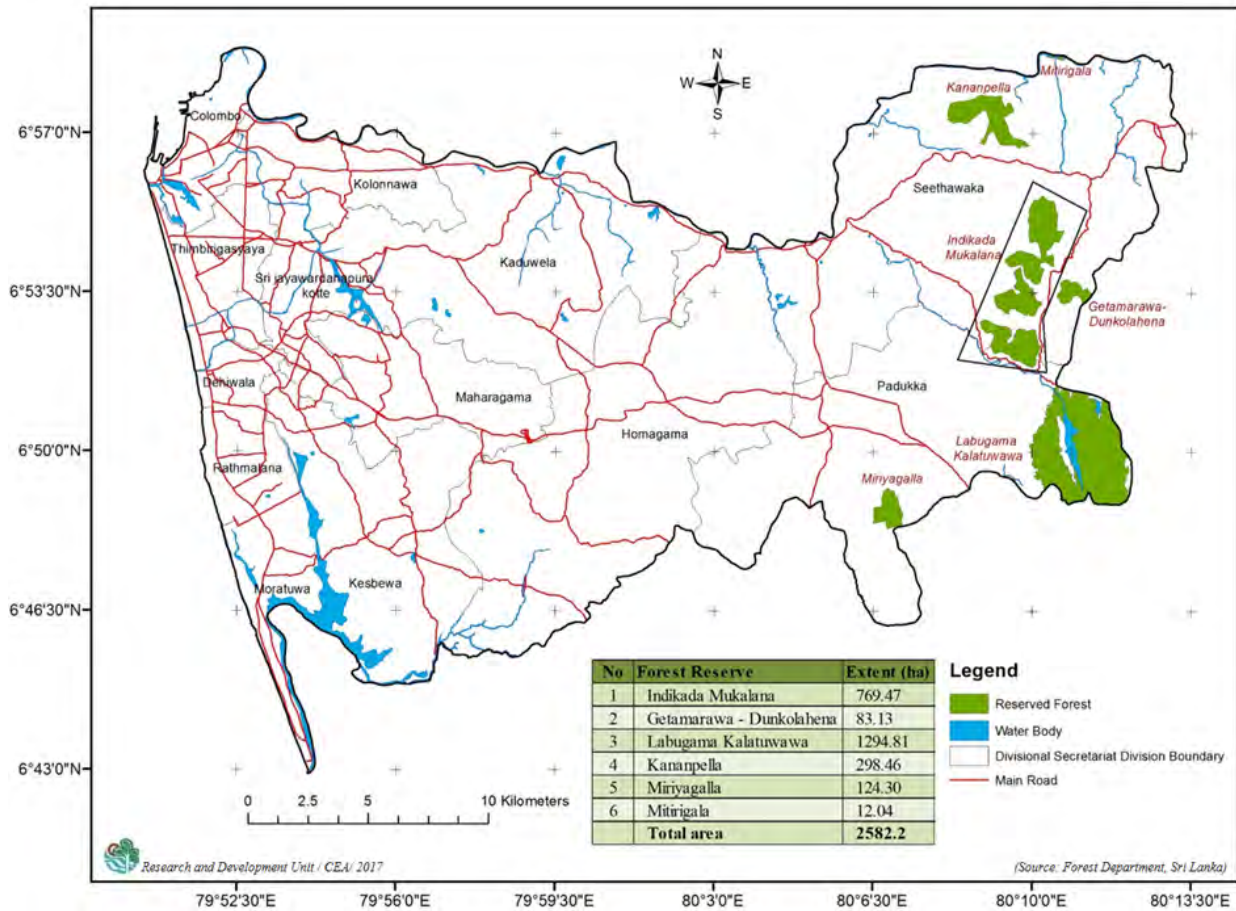

**Figure 4-12 Forest Reserves in Colombo District (Source: Research and Development Unit, CEA, 2017)**

According to estimates made in 1994, the total natural forest cover in Gampaha district was 429 hectares, which is 0.20% of the total forest cover of the island. Gampaha district is located in the low country wet zone of the country and therefore, most of the forests in district are tropical wet evergreen forests (Figure 4-12).

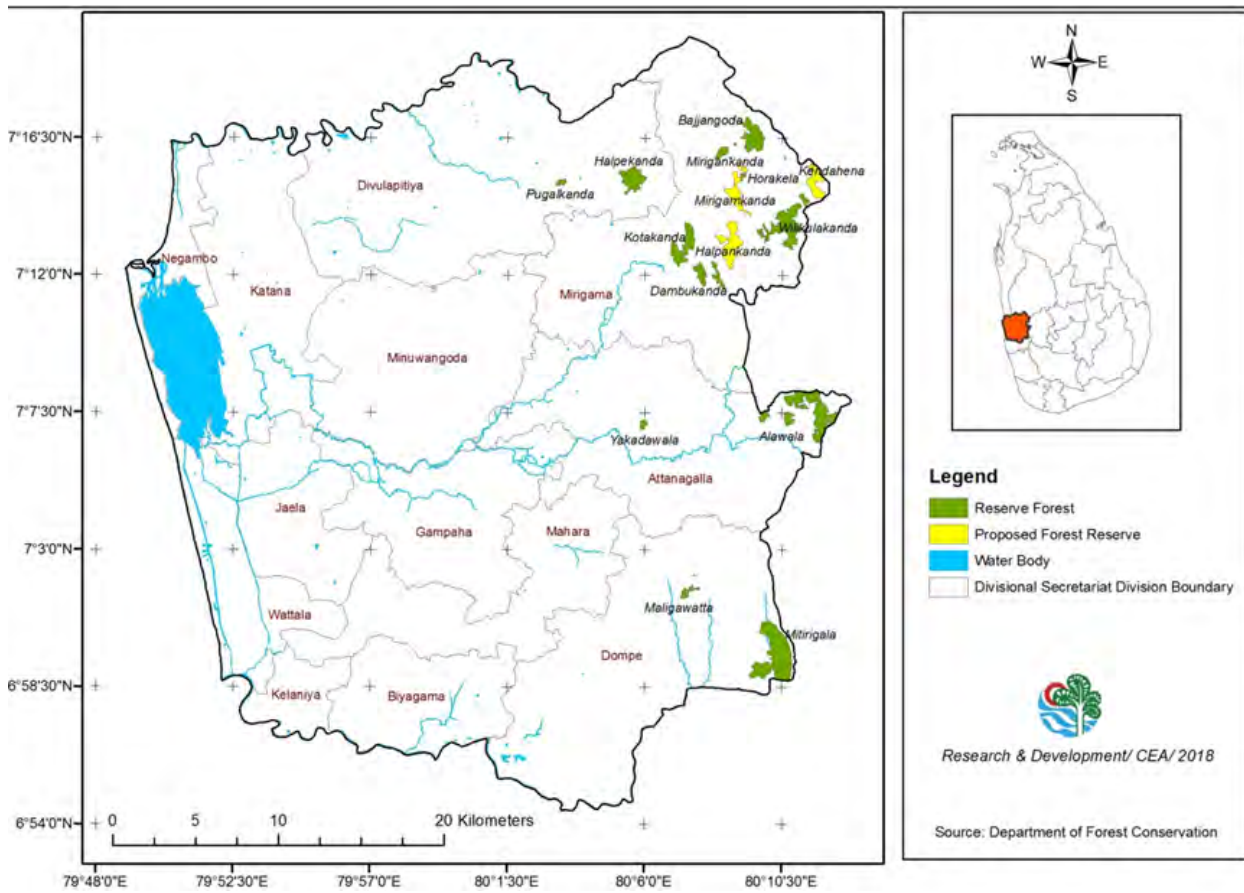

**Figure 4-13 Forest reserves in Gampaha district (Source: Research and Development Unit, CEA, 2018)**

As per the 1994 estimates, the total natural forest cover in the Kalutara district was 21,576 hectares which is 1.0% of the total forest cover of the island (Table 4-4). Remnant patches of tropical lowland rainforests are scattered across the Kalutara district (Figure 4-13). Of the three districts, Kalutara district support the highest number of Proposed Forest Reserves.

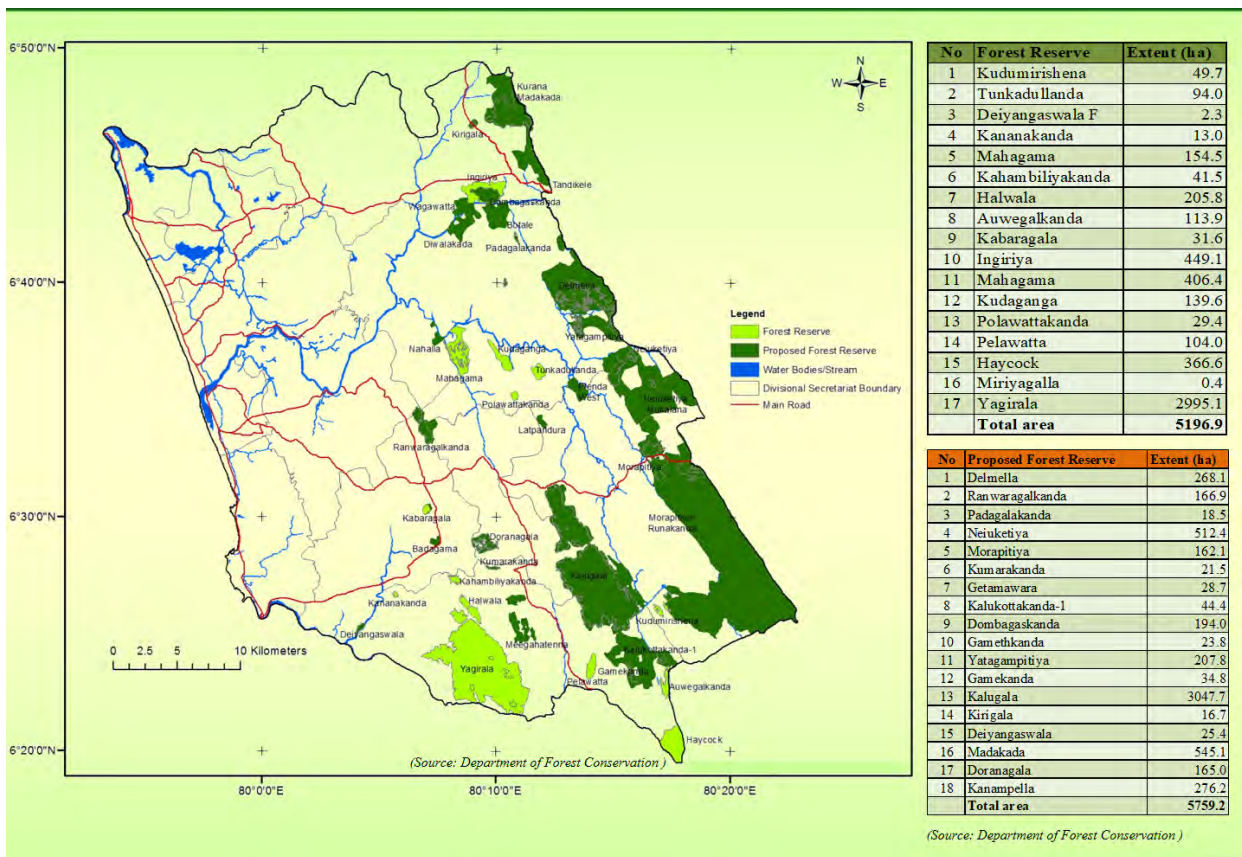

Figure 4-14 Forest reserves and proposed reserves in Kalutara district (Source: Research & Development Unit, CEA, 2014)

### 4.3.3 Habitats

Published information indicates the occurrence of 76 species of fish in the wetland habitats of the Western Province, which include fresh and brackish water forms. Most of the amphibians in the Western Province include species that are adapted to exist in modified landscapes. Of the total reptile species recorded from the Western Province, about 40% are nationally threatened. Nearly half of the native vertebrate species in the Western Province consist of birds. These include several migratory species as well. Of the mammals recorded from the Western Province, five endemic arboreal species namely Toque monkey (*Macaca sinica*), Purple faced leaf monkey (*Trachypithecus vetulus*), Slander Loris (*Loris tardigadis*), Flame-striped jungle squirrel (*Funambulus sublineatus*) and Golden Palm Civet (*Paradoxurus zeylanicus*) are scattered across in three districts. Among the invertebrate fauna in the Western Province, the butterflies are relatively well documented, with about 30% of the total species in Sri Lanka occurring in the three districts (Bambaradeniya, 2008)

Of the 70 'Important Bird Areas' in Sri Lanka identified by the Field Ornithology Group and the Birdlife International, nine are located in the Western Province. These include the Bellanwila-



Attidiya marsh, Muthurajawela marsh, Indikada Mukalana, Morapitiya- Runakanda forest, Haycock Forest, Labugama forest, Bodhinagala forest, Delmella-Yatagampitiya forest, and the Kalugala forest (Table 4-5).

**Table 4-5 Important Birds areas in the Western Province**

Important Bird Area	Geo-coordinates	Area (ha)	Habitat	Threatened Species
Muturajawela	7°02'N 79°52'E	6232	Forest/Wetland	--
Bellanwila-Attidiya	6°50'N 79°53'E	372	Wetland	<i>Pelecanus philippensis</i>
Labugama	6°51'N 80°11'E	2150	Forest	--
Bodhinagala	6°44'N 80°10'E	200	Forest	<i>Columba torringtoni</i>
				<i>Centropus chlororhynchus</i>
Morapitiya-Runakanda	6°29'N 80°18'E	6733	Forest	<i>Urocissa ornata</i>
				<i>Centropus chlororhynchus</i>
Kalugala	6°28'N 80°14'E	4288	Forest	--
Yagirala	6°23'N 80°10'E	2390	Forest	<i>Phaenicophaeus pyrrhocephalus</i>
				<i>Centropus chlororhynchus</i>
				<i>Sturnus albobfrontatus</i>

#### 4.3.4 Wetland ecosystems

A large number of freshwater (inland) and coastal wetland ecosystems are found in the Western Province (Table 4-6). The inland wetland includes freshwater swamps, freshwater marshes, floodplains, rivers and streams, tanks and ponds.

**Table 4-6 Wetland ecosystems in the Western Province**

Wetland Types	Sites
<b>Inland wetlands</b>	
Freshwater Swamps	Walauwatte - Wathurana
Freshwater Marshes	Bellanwila- Attidiya
	Kolonnawa and Bloomendal marsh
	Sri Jayardanapura- Kotte marsh
	Heen marsh
	Muthurajawela marsh
Floodplains	Diyawanna-oya
Rivers and Streams	Kelani River
	Bolgoda river
	Kalu river
	Attanagalu oya (including Dandugam oya)
Tanks and Ponds	Beira lake
	Thalangama tank
	Boralesgamuwa tank

Wetland Types	Sites
	Kesbewa tank
	Gammanpila tank (Bandatagama)
Reservoirs	Labugama and Kalatuwawa
<b>Coastal wetlands</b>	
Mangrove	Negombo (lagoon fringing mangrove)
	Benthota (riverine fringing mangrove)
	Kaduru Duwa (lagoon fringing mangrove)
	Benthota - Ittapana (riverine fringing mangrove)
Lagoons (including sea grass beds)	Lunawa lagoon
	Negombo lagoon
Estuaries	Panadura estuary
	Benthota estuary
	Kelani estuary
Salt marshes	Muthurajawela
Saline peat bogs	Muthurajawela
<b>Marine Wetlands</b>	
Rock and sand-stone reefs (with patches of coral)	Near- shore coastal stretch from Colombo port to Mount Lavinia
	Benthota area
<i>Source: Bambaradeniya, 2008</i>	

### 4.3.5 Coastal and marine ecosystems

Coastal habitats in the Western Province include mangroves, saltmarshes, dunes, beaches, barrier beaches, spits, lagoon and basin estuaries, freshwater marshes and other water bodies (Table 4-7). Comparatively, a higher extent of mangroves, saltmarshes, dunes, beaches, lagoons and basin estuaries and freshwater marshes are reported from the Gampaha district (Table 4-7).

**Table 4-7 District- wise total hectare extent of coastal habitats in Western Province**

District	Mangroves	Salt Marshes	Dunes	Beaches, Barrier beaches, Spits	Lagoons, basin estuaries	Fresh Water Marsh	Other Water Bodies
Colombo	-	-	-	112	-	15	412
Kalutara	70	-	4	77	87	91	476
Gampaha	122	497	-	207	3442	1604	205
Total Extent	135	647	53	157	29	3241	78
<i>Source: Revised Coastal Zone Management Plan, Sri Lanka. 1997</i>							

The commonly caught food fish in coastal wetlands in the Western Province are listed in Table 4-8. The commonly captured crustaceans in saline water wetlands in Western Province include the Giant Freshwater Prawn (*Macrobrachium rosenbergii*), the Mud Lobster (*Thalassina*

*anomala*) the White Prawn (*Penaeus indicus*, *Penaeus monodon*) and the Mud Crab (*Scylla serrata*).

**Table 4-8 Common fish species captured for commercial and/or subsistence fishery from coastal lagoons and estuaries in the Western Province**

Family	Species
Anguillidae	Short-finned Eel – <i>Anguilla bicolor</i>
Carangidae	Big-eye Trevally – <i>Caranx sexfasciatus</i> Black-tipped Trevally – <i>Caranx heberi</i>
Cichlidae	Orange Chromide – <i>Etroplus masculatus</i> Pearl Spot – <i>Etroplus suratensis</i> Tilapia – <i>Oreochromis mossambicus</i>
Channidae	Murrel – <i>Channa striata</i>
Lutjanidae	Red Snapper- <i>Lutjanus argentimaculatus</i>
Chanidae	Milkfish – <i>Chanos chanos</i>
Mullidae	Largescale Mullet – <i>Liza micolepis</i>
Centropomidae	Common Glass fish – <i>Ambassis commersoni</i>

#### 4.3.6 Environmentally sensitive areas-legally protected and unprotected

A considerable number of protected areas exist in the western province. Most of them are forest reserves and proposed forest reserves that come under the authority of the Forest Department (Table 4-9).

In Colombo district, Sri Jayawardanapura sanctuary and the Bellanwila-Attidiya sanctuary are two protected areas managed by the Department of Wildlife Conservation. Bellanwila-Attidiya sanctuary is listed in the directory of Asian wetlands by the IUCN in 1989 and designated as an Important Bird Area by Birdlife International. It was declared a sanctuary under the fauna and flora protection ordinance by gazette extraordinary No.620/9 Of 25<sup>th</sup> July 1990. It is situated within the upper catchments of the Bolgoda river basin.

Two Environmental Protection Areas namely Bolgoda Lake Environmental Protection Area and Talangama Tank Environmental Protection Area, are located in the Colombo District. Bolgoda Lake area is high in biodiversity and is under threat due to discharge of industrial effluents, haphazard development activities, encroachments and spread invasive plants. To control and regulate the development activities in Bolgoda Lake, it was declared as an Environmental Protection Area by the CEA in 2009 (Research & Development Unit, CEA, 2017) Talangama tank is important habitat for water birds, supports about 137 faunal species and 41 plant species and serves as a flood retention area. Considering the unique features, historical value, disturbance due to rapid urbanization such as disposal of garbage, poaching of water birds, and discharge of wastewater imposed on this important wetland, it has been declared as an Environmental Protection Area (Research & Development Unit, CEA, 2017).

The buffer zone identified in the Muthurajawela Master plan prepared by the Grater Colombo Economic Commission in 1991, was declared as an Environmental Protection Area by CEA, considering its major environmental service as a flood retention area, and the need for conservation. This economically important wetland ecosystem consists of marsh, lentic, reed swamp, short grassland, scrubland, stream bank and mangrove harbor 115 floral species and nearly 209 species of fauna, including winter migrant birds (Research & Development Unit, CEA, 2018). However, as shown in Table 4-9 and Figure 4-15, there are various natural formation and anthropogenic activities lies around the Muthurajawela environmental protection area.

Horagolla is the only National Park located in Gampaha district while two wildlife sanctuaries namely Muthurajawela wetland sanctuary (extent 1777 ha) and Manimbilkanda-Nittambuwa sanctuary are also located in Gampaha district. The national park and the sanctuaries have been declared by the Department of Wildlife conservation under the fauna and flora protection act. The Walauwewatte-Waturana swamp forest has been declared as an Environmental Protection area under the National Environmental Act (Research & Development Unit, CEA, 2014).

**Table 4-9 Protected areas in the Western Province**

Site	District	Extent (ha)
<b>Protected Areas under Department of Wildlife Conservation</b>		
Horagolla National Park	Gampaha	13
Bellanwila-Attidiya Sanctuary	Colombo	385
Muthurajawela Sanctuary	Gampaha	1300
Sri Jayawardanapura- Kotte Sanctuary	Colombo	250
<b>Protected Areas under Forest Department</b>		
Alawala- Ataudakanda PR	Gampaha	352
Bajjangoda PR	Gampaha	175
Badagama PR	Kaluthara	40
Dambukanda PR	Gampaha	41
Getamarawa- Dunkolahena PR	Colombo	129
Delmella- Yatagampitiya PR	Kaluthara	1413
Halpankanda PR	Gampaha	158
Haycock FP	Kaluthara	380
Indikada Mukalana PR	Colombo	176
Ingiriya FR	Kaluthara	450
Kaharagala PR	Kaluthara	32
Kalugala PR	Kaluthara	4288
Kananpella FR	Colombo	298
Karaghatenna PR	Gampaha	55
Kebalawita PR	Gampaha	115
Kirigala Mukalana PR	Kaluthara	35

Site	District	Extent (ha)
Kotakanda PR	Gampaha	242
Kudaganga FR	Kaluthara	137
Labugama- Kalatuwana FR	Colombo- Kaluthara-Ratnapura	2150
Latpandura PR	Kaluthara	42
Mahagama FR	Kaluthara	227
Mahakanda PR	Gampaha	103
Meegahatenna PR	Kaluthara	277
Mirigamkanda PR	Gampaha	139
Miriyagalla FR	Colombo	123
Mithirigala FR	Gampaha	500
Morapitiya- Runakanda PR	Kaluthara	7108
Nahalla PR	Kaluthara	35
Neluketiya Mukalana PR	Kaluthara	2384
Pelawatta FR	Kaluthara	110
Plenda West PR	Kaluthara	145
Polawattelanda FR	Kaluthara	29
Ranwaragalakanda PR	Kaluthara	192
Vellihallure OSF	Kaluthara	425
Wagawatte PR	Kaluthara	113
Walbotalekanda PR	Gampaha	42
Wilikulakanda PR	Gampaha	310
Yagirala FR	Kaluthara	3000
Yagirala PR	Kaluthara	34
<b>Protected Areas under Department of Fisheries and Aquatic Resources (Fisheries Management Areas)</b>		
Bolgoda Reservoir	Kaluthara	1200
Negombo Lagoon	Gampaha	3,350
<b>Protected Areas under Sri Lanka Land Reclamation and Development Corporation</b>		
Parliamentary Water Retention Area	Colombo	42
Greater Colombo Flood Retention Area (Heen- ela, Kolonnawa and Kotte marshes)	Colombo	365
<b>Other Protected Areas (Gazetted under National Environmental Act of CEA)</b>		
Wathurana ESR/EPA	Kaluthara	
Thalangama ESR/EPA	Colombo	
Bolgoda Weland ESR/EPA (Panadura ganga, Weasganga, Bolgoda South Lake, Bolgoda North Lake)	Colombo and Kaluthara	
Muthurajawela Buffer Zone	Gampaha	285

Source: Bambaradeniya, 2008

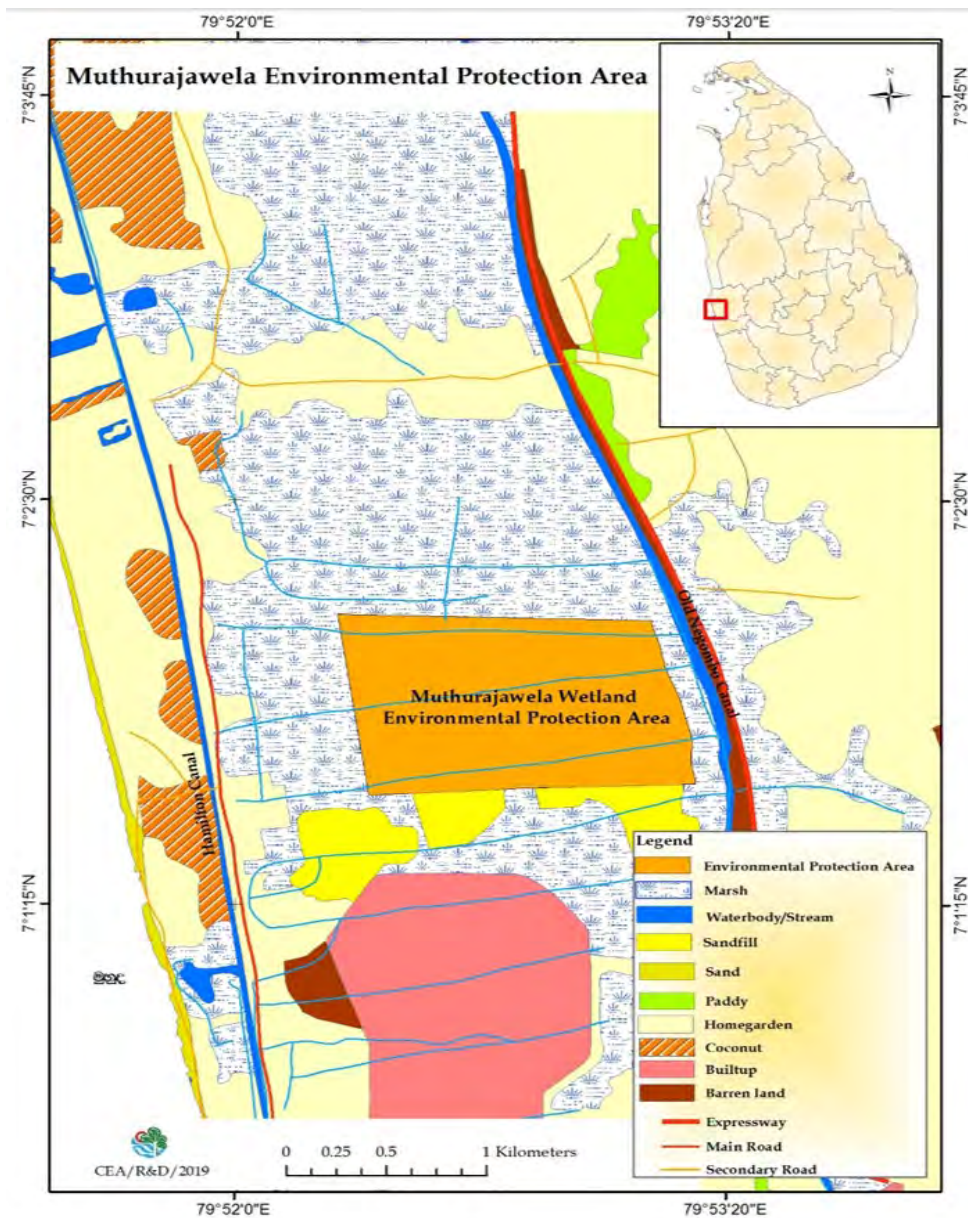

Figure 4-15 Muthurajawela environmental protection area (Source: Research & Development Unit, CEA, 2018)

#### 4.4 Socio-economic environment

This section describes the socio-economic baseline of the Western Province with specific emphasis on its relevance to the SWM sector.

##### 4.4.1 Population, density, migration and trends

The Western Province, located in the southwestern part of Sri Lanka, has an area of 3,684 km<sup>2</sup> and had an estimated population of 6,165,000 in 2020 (Department of Census and Statistics,

2020). The area of the Western Province accounts for 5.6% of the total area of the country and the population of the Western Province accounts for 28.1% of Sri Lanka as a whole. The population density of the Western Province is five times as high as the national average.

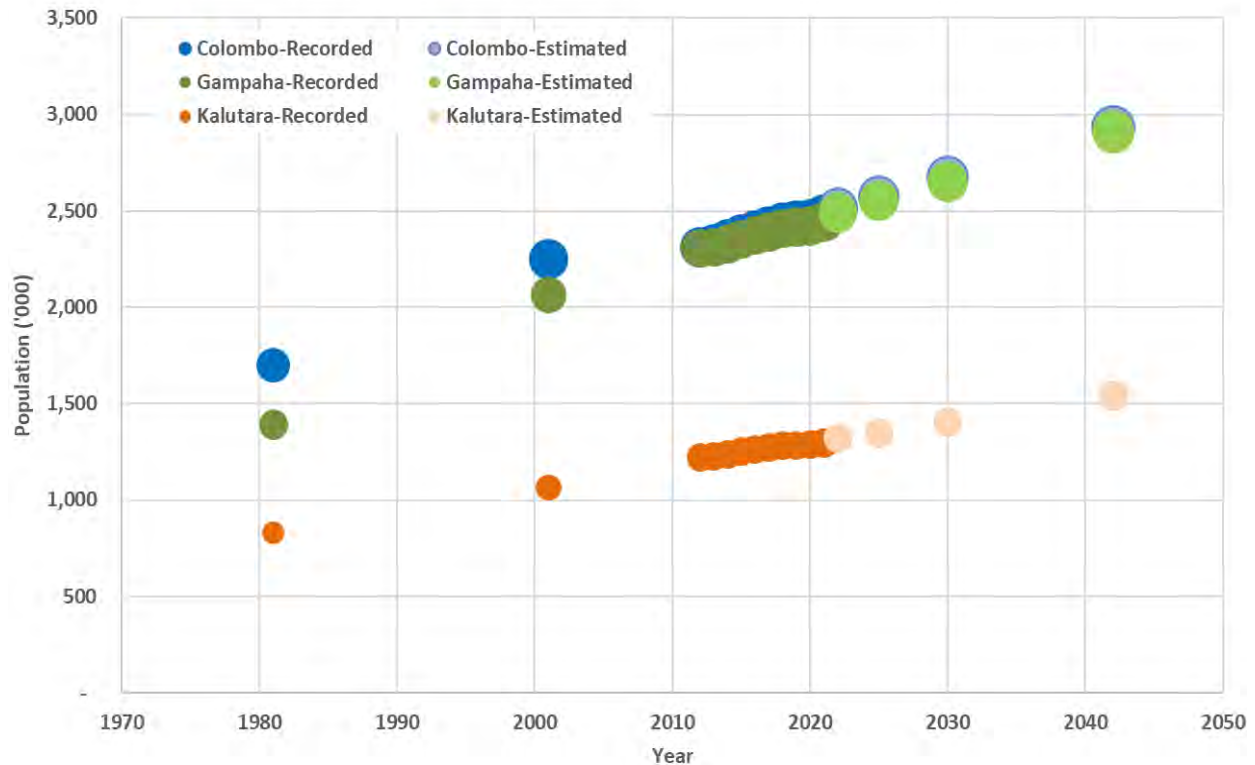

**Figure 4-16 Population and growth trends of Western Province**

The national Census and Statistics survey conducted in 2011 revealed that the total population of Sri Lanka was 20,359,439 in which 5,851,130 people lived in Western Province (Department of Census and Statistics, 2012). The share of the Colombo District population has declined from 43.3 % to 39.8 % from 1981 to 2012; however, the population share of the Gampaha District has increased from 35.4 % to 39.4 %. In Kalutara District the population has increased from 19.9 % to 20.8 % the period of 2001-2012 (Figure 4-16).

Population density is high in Western Province with 1,731 persons per sq. km which is five times higher than the national average (331 person/ km<sup>2</sup>) according to census data in 2020. Kalutara district is the least populated area in the Western Province.

#### 4.4.2 Population growth trends

Annual population growth refers to the change in the population over time, and is affected by factors such as fertility, mortality, and migration. Historically, Annual Average Growth Rate (AAGR) has been slowing down gradually after 1971 in Sri Lanka as well as in Western Province. It was over 2% till 1971 and slowing down gradually. In 2012, AAGR of Sri Lanka was 0.69% and

Western Province was 0.72%. The Western Province's AAGR has progressed at the same rate as the Sri Lanka. The decline was more pronounced in the Colombo and Gampaha Districts during 2001-2012. AAGR of Colombo district is much lower than other two districts in the Western Province in 2012 and increased by 0.4% by 2018 which is progressed at the similar rates with provincial and national average. This was a significant increase in the population growth.

**Table 4-10 Population growth rate of Western Province (1953-2018)**

	1953-1963	1963-1971	1971-1981	1981-2001	2001-2012	2012-2018**
Sri Lanka	2.71%	2.30%	1.70%	1.16%	0.75%	1.05%
Western Province	2.43%	2.29%	1.43%	1.65%	0.72%	0.78%
Colombo	2.59%	2.42%	1.30%	1.43%	0.35%	0.81%
Gampaha*	n/a	n/a	1.80%	2.01%	1.05%	0.74%
Kalutara	1.89%	1.45%	1.40%	1.26%	1.28%	0.79%

*\*Gampaha district was declared as a new administrative district, separated from Colombo District in 1978*  
*\*\* Mid-year population estimates (MP)*  
*Source: Census of Population and Housing 1953-2012, Department of Census and Statistics*

#### 4.4.3 Rate of urbanization

Though population growth and economic growth are the key drivers of urban expansions, rural-urban migration is a significant driver of urban population growth in the provincial capitals of Sri Lanka. Sri Lanka has clearly underestimated the degree and rate of growth of its urban population. Owing to changes in the official definition (which reduced the number of urban settlements from 134 in 1981 to 51 in 2001) and the fact that only eight districts were enumerated at the 2001 Census of Population, Sri Lanka had a low level of urbanization of 14.6%. The number of towns, according to the 2012 Census, was 64. Hence, the degree of urbanization remained low at 18.2%, and the tempo was slow. A "more realistic" degree of urbanization was estimated by the UDA at 30.1% in 2001, which was projected by the UDA to increase to 65% by 2030.

#### 4.4.4 Migration trends

Migration is recognized as a vital component of population change. Internal migration has been playing a key role in redistributing the population in Sri Lanka stemming from the introduction of colonization schemes during the immediate post-independence period. As shown in Figure 4-17, the redistribution occurred because of towns' growth and expansion as commercial and administrative hubs that drew a sizable population to urban areas. The development of Western Province as the primate city and commercial hub has also led to much in-migration from all over the country. Colombo-centric migration and the related suburbanization are distinct patterns



that continue to shape the internal migration flows of Sri Lanka since 1946 (International Organization of Migration, 2005). It was also mentioned that these flows might become more active in the post-conflict situation after 2009.

Western Province is the major industrialized and populated area of Sri Lanka as capital of the country where large- and small-scale industries and services located in all parts of the province. Therefore, most of the migrant workers from other districts are more attracted to the Western Province. And internal migration in Western Province is high due to many commercial and administrative centers that have been in the province. High economic growth of Colombo and Gampaha districts are also attractive to migrants.

Since 1977 Gampaha district of the Western Province has become a popular urban-ward migration destination and a considerable proportion of young people have migrated to engage in employment, especially in Free Trade Zones (FTZs).

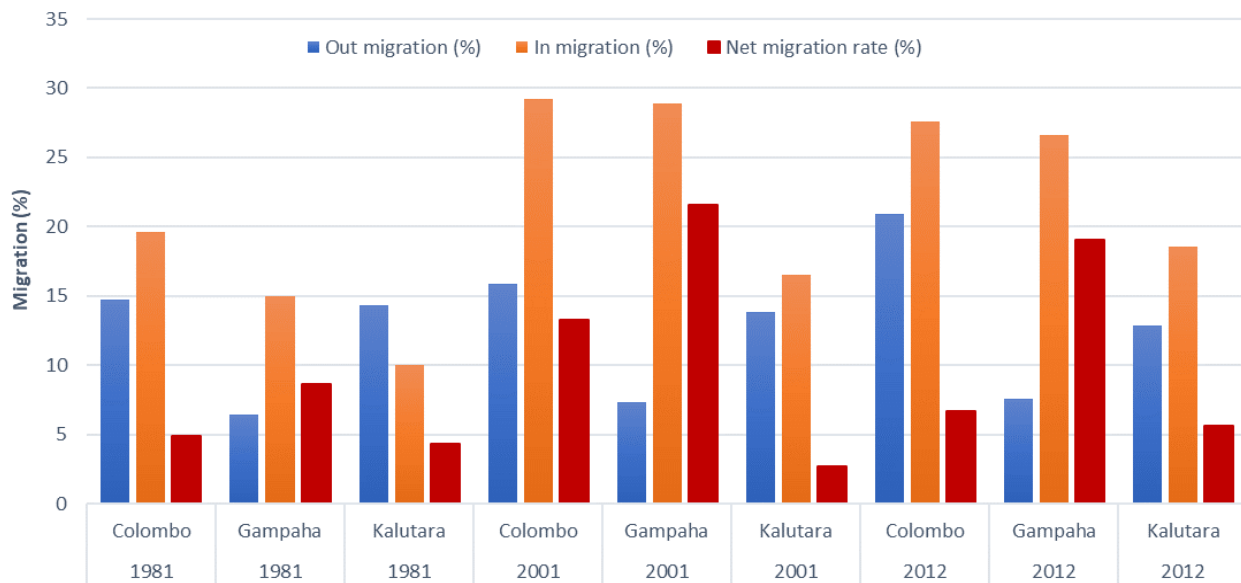

**Figure 4-17 Migration trend in Western Province (1981-2012)**

As shown in Figure 4-17, it is apparent that there is a significant increasing trend in net in-migration in all three districts in Western Province during the period of 1981-2001. The rate of net migration is tripled since 1981-2001 in Colombo district. The rate of net migration for Gampaha district was 8.8% in 1981 and increased to 21.6% by 2001. It also revealed that the migration patterns have changed during the period of 1981-2012. Improved road networks, transport mechanisms, launching urban renewal initiatives and large development projects as Port City in Colombo Metropolitan Region and urban centers outside the western province, and post conflict situation in-migration to Western Province slightly decreased.

**Table 4-11 Reasons for internal migration in Western Province**

	Colombo	Gampaha	Kalutara
<b>Migrant population (Persons)</b>	61,922	613,070	226,289
<b>Reasons for internal migration</b>	<b>(%) of internal migration</b>		
Marriage	31.7	22.8	29.2
Education	42.8	30.6	13.7
Employment	10.5	4.3	3.5
internally displaced	0.9	1.1	1.6
Resettlement	0.2	0.4	1.4
Development Projects	0.1	0.4	0.5
Need of a family member	17.2	21.5	22.4
Other	5.6	12.5	20.1
<i>Source: Census population and Housing 2012</i>			

The Sri Lankan internal migration pattern shown 2012 census publication and recaptured in Table 4-11, shows that the second highest reason for migration is employment (19.4%), and about 32% of all migrants have either moved to Colombo district, where the country’s capital is positioned, or Gampaha district, which is an adjoining district to the former and where the majority of the free-trade zone industries are located. It has also reported that half of the female migrants who moved to the district of Colombo originated from the south-western coastal districts of Kalutara, Galle, and Matara, and the adjacent district of Gampaha. Moreover, migration flows to Colombo from the southwestern coastal belt were already well established by 1946 (International Organization of Migration, 2005).

Even though the internal migration does not negatively impact rural development, in return, it may be a problem that leads to creating several other problems in urban areas as a result of over-expanding of the population density. Further considering the problem of high population density caused due to the heavy rate of migration from rural areas resulted in overcrowding, traffic congestion, pollution, housing shortages (slum and squatter housing), high rents, poor urban living conditions, low infrastructure services, poverty, unemployment, and poor sanitation which have become pervasive and indeed high crime rate.

#### **4.4.5 Economic activities and employment**

##### **4.4.5.1 Economic Growth**

Sri Lanka records a phenomenal socio-economic development after the independence despite few setbacks in 1971 and 1988-89 insurrections, ethnic war, and global economic crisis. During the period 1990-2009, the GDP of Sri Lanka (at constant prices) increased from 962.61 billion rupees to 2,35.7 billion rupees with the increase of per capita GNP from Rs. 59,175.44 to

120,464.53. Sri Lankan economy was able to maintain GDP growth rate above 6% during last six years amidst intensive war and global economic crisis (Central Bank Annual Report, 2009).

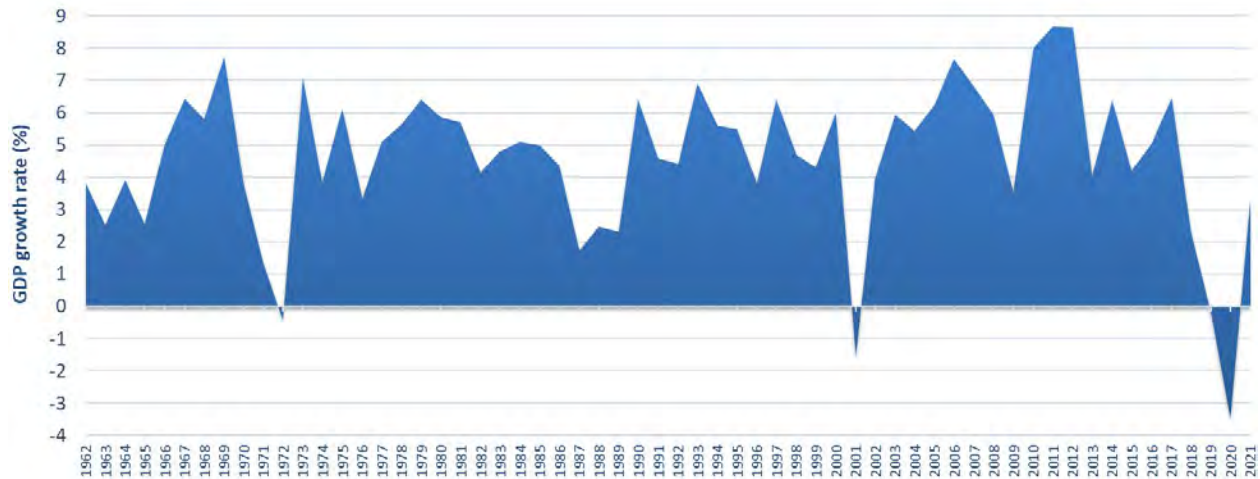

**Figure 4-18 Annual GDP growth rate from 1962-2021**

These regional gaps and regional disparities in Sri Lanka are a chronic issue and have taken a new dimension with excessive concentration of growth in the Western Province, the Colombo Megalopolis while the less developed and disadvantaged other regions are awaiting to shift to a more liberalized economic regime since 1978. The average infrastructure index for the Western Province is 1.77 compared to less than 1.00 for all other provinces.

The records on the provincial contribution of Gross Domestic Product (GDP) clearly show that the contribution of Western Province was 49.6% in 2000 and 42.6% in 2021. The Western Province has benefited from the concentration of infrastructure investment with the Colombo Port, Financial city, Bandaranaike International Airport better road networks than the rest of the country and more reliable power and water supply than the other regions of the country. Western Province continued to account for the largest share of the country’s nominal GDP. However, in line with contemporary trends, its share in the GDP declined in 2016-2017, contributing to narrowing of regional disparity.



Figure 4-19 Provincial contribution to GDP 1999-2021 (CBSL, 2017-2021)

Figure 4-19 Provincial contribution to GDP 1999-2021 (CBSL, 2017-2021)

The composition of economic activities within provinces in 2021 highlights that Services activities played a major role contributing for more than 50% of GDP of the province in recent nine years (Figure 4-19). The largest concentration of Industry activities was observed in Western Province (33.7%,2021). Western Province is most developed and urbanized region in Sri Lanka and its GDP accounts for 45% of the national GDP in the past five years.

#### 4.4.5.2 Employment and poverty

The Poverty level indicated by the Headcount Index (HCI) shows that there has been a significant decline of poverty from 8.2% in 2006 to 1.7% in 2016 in Western Province. According to the survey results, the poverty in terms of HCI in Western Province is the lowest (6.7%) and it is also below the national average. Largest share of poor people recorded from Kalutara district compared to other districts in Western Province. While the Western Province has the lowest poverty rate across provinces, at around 4% in 2019, an increase to 5.7% is expected in 2020.

Table 4-12 Poverty Indicators in Western Province 2006-2019

	Poverty Head Count Index (HCI)			Poverty Gap Index (PGI)		
	2006	2012	2016	2012	2016	2019
<b>Sri Lanka</b>	15.2	6.7	4.1	1.2	0.6	2.8
<b>Western Province</b>	8.2	2.0	1.7	0.4	0.3	1.1
Colombo	5.4	1.4	0.9		0.2	0.4
Gampaha	8.7	2.1	2.0		0.3	1.0
Kalutara	13.0	3.1	2.9		0.4	2.5

*Source: Department of Census and statistics (2016-2019)*

Multidimensional Poverty Index (MPI) is an index that captures the percentage of households in a country deprived along three dimensions of well-being – monetary poverty, education, and basic infrastructure services – to provide a more complete picture of poverty. Approximately one out of every six (16.0%) people in Sri Lanka are multidimensionally poor (MPI, Department of Census and Statistics, 2019). The people living just above the poverty threshold are more vulnerable than the other groups of people. The economic shocks such as loss of the job, severe illnesses, injuries, and loss of livelihood have ghastly impact to cause poverty. In the process of analyzing multidimensional poverty, a person is identified as vulnerable if his/her deprivation score is greater than or equal to 20% and less than 33.3%. It depicts that the lowest number of vulnerable people living in Colombo district (3.4%) where as second lowest vulnerable people living in the Gampaha district (7.3%) (Department of Census and Statistics, 2019b).

#### 4.4.6 Public health risks

The current system of solid waste management is imperfect, it carries many risks, especially regarding the factors affecting human health. The population in all areas of the territory, all age and risk groups (children, the elderly, adults, pregnant women, people with low immunity, patients, etc.) are impacted by the latter throughout the total life span. The following are some of the most serious public health consequences of unsustainable solid waste management.

- iii. Uncollected organic waste from bins, containers, and open dumps is a breeding ground for rodents, insects, and reptiles that can transmit diseases to humans. It also emits odors from organic waste decomposition and leachates, which migrate and contaminate receiving underground and surface waters unsuitable for direct consumption.
- iv. Open dumps and non-engineered landfills release methane from decomposing biodegradable waste under anaerobic conditions. Methane can cause accidental fires and explosions.
- v. Non-biodegradable waste, such as discarded tires, plastics, bottles, and tins, pollutes the ground and collects water, creating breeding grounds for mosquitoes and raising the risk of diseases like malaria, and dengue fever.
- vi. Open burning of MSW releases pollutants into the atmosphere, increasing the likelihood of nose and throat infections and inflammation, inhalation difficulties, bacterial infections, anemia, decreased immunity, allergies, and asthma.
- vii. Uncontrolled incineration causes smog and releases fine particles, which are a major cause of respiratory disease. It also contributes to urban air pollution.
- viii. Moreover, indiscriminate disposal of solid waste can cause infectious diseases such as gastrointestinal, dermatological, respiratory, and genetic diseases, chest pains, diarrhea, cholera, psychological disorders, skin, eyes, and nose irritations, and allergies

Impacts of SWM, such as open burning, and landfill emissions on public health, are abundantly discussed in the literature. However, data is lacking on the rate of occurrence of such impacts in the Western Province. This is mainly due to unavailability of a proper mechanism to record SWM related activities in Sri Lanka.

The Table 4-13 summarizes the prevalence of public health risks in Sri Lanka and its relevance to solid waste management.

**Table 4-13 Prominent Health risks associated with SWM in Sri Lanka**

Disease/ Health risk	Relevance to MSW	Status of Western Province
<b>Respiratory tract diseases</b>	Smoky and dusty conditions, particulates, bio-aerosols, and volatile organic compounds present in solid waste also trigger respiratory illnesses. Open burning of MSW is a major contributor to smog and respiratory illnesses like allergies, asthma, anemia, inflammation of the nose, throat, and chest, difficulty breathing, and low immunity. The health risks associated with methane and ammonia gas emissions from landfills include respiratory illnesses. Uncontrolled incineration causes smog and releases fine particles, which are a major cause of respiratory disease. It also significantly contributes to urban air pollution and GHG emissions (Cointreau., 2006).	In 2018, respiratory diseases, excluding diseases of the upper respiratory tract such as pneumonia and influenza, were the third leading cause of hospital deaths, with pneumonia ranking seventh (MOH, 2019). However, relationship to SWM has not been established.
<b>Dengue Fever (DF)/Dengue Haemorrhagic Fever (DHF)</b>	Studies conducted in India and Sri Lanka confirmed that the discarded containers are the most prominent breeding grounds for Aedes mosquitoes (Arunachalam et al., 2010, MOE, 2019). The presence of solid waste around households, such as cans, car parts, bottles, old and used tyres, plastic materials, broken clay, glass vessels and coconut shells, create outdoor breeding sites for Aedes mosquitoes and represented in our ecosystem (Abeyewickreme et al., 2012).	Western Province reported the highest dengue disease burden in 2019 with 49% of the caseload (this was 37% in 2018). Colombo district had the highest dengue burden, accounting for 45.3% of the cases reported from Western Province and 19.7% of the total (MOH, 2019). Discarded waste and rubbish items are the most common breeding grounds (24%–28%) for dengue vectors (MOH, 2019).
<b>Cancer</b>	Volatile organic compounds in air emissions and inconclusive evidence on altered cancer incidence, birth defects, and infant mortality, as well as psychological stress for those living near solid waste incinerators or inadequately controlled land disposal facilities. Cancer risk could be caused a wide range of constituents being released from solid waste: either into the air, water; or food chain. Volatile organics, heavy metals, and certain inorganic gases each have the potential to induce cancer, if dose levels are high enough over a period that is long enough.	In Sri Lanka, studies have not conducted to establish a relationship between SWM and cancer risk.

#### 4.4.6.1 Occupational Health Risks

Occupational health risks are associated with the Municipal Solid Waste (MSW) management process, specifically during the handling, processing, and disposal stages. Mudalige and Dharmathilake (2000) reported that skin cuts and needle prick injuries are common among municipal waste collectors assigned to Western Province, Sri Lanka. They also stated that health issues such as back pain, traumatic injuries, itchy rash, cough, wounds, and toxicity exposure are quite common among MWCs in the Western Province. A study conducted at the Karadiyana waste management site further confirmed that the most common occupational health problems are respiratory problems such as cough, shortness of breath, chest tightness, and sneezing. Gastritis, Diarrhea, Vomiting, Hemorrhoids, and Fullness are examples of gastrointestinal problems. Musculoskeletal problems such as back pain, knee pain, shoulder pain, headache, vision problems, and fever are also among the occupational health issues experienced by waste workers in Karadiyana waste management, according to the study (Akuressage and Dissanayake, 2017).

Although specific figures were not available, it is well recognized that formal and informal waste collectors, rag pickers, middlemen, and recyclers who handle solid waste are susceptible to solid waste-related health risks. Sri Lanka is handicapped with a trusted data source on occupational hazards, accidents, and diseases due to the lack of a proper recording mechanism and research on this subject, particularly related to waste collectors. Even though waste collection is just a labor-intensive job, it involves a lot of occupational health hazards. Unsafe acts of the employees, the working environment, and management practices are the three main factors that cause occupational accidents.

### 4.5 Current state of the pollution in Western Province

The Western Province is the commercial capital and economic hub of the of Sri Lanka; therefore, the Colombo city and many other suburb cities and townships are highly urbanized and densely populated. The Colombo commercial city and Western part of the Gampaha District accommodate most of the national government establishments and administration centers, commercial and service institutes, industries and industrial zones, residencies, different academic establishments, and major healthcare institutes. Rapid urbanization in Western Province, especially in Colombo and Gampaha Districts, has caused many negative impacts on atmospheric, terrestrial, aquatic and costal environments. The loss of biodiversity, decrease of aquatic habitats including wetlands, land and water pollution due to wastewater and waste disposal, atmospheric emission from vehicular traffic and power generation, noise and light pollution, and reduction of greenery are major environmental issues reported in Western Province (Ministry of Environment, 2019). In addition, it is well evident that floods, atmospheric

pollution, and outbreak of pandemics are frequently reported in many parts of Western Province. However, the level of environmental degradation and pollution in Colombo and other major cities in Western Province is comparatively lower than most of the capital cities of South-Asia and developing countries. In comparison to many other regional cities of Sri Lanka, Colombo and other major cities in the Western province record comparatively higher water pollution, air pollution, land pollution and biosystem degradation.

The unplanned and haphazard conversion of natural environment into built environment are considered the major cause of environmental degradation in Western Province. Until very recent, civic infrastructure development activities were considered isolated project activities; thus, environmental destruction in regional and provincial scale were overlooked. Moreover, insufficient infrastructure to cater to the growing demand for public services from the urban population put a strain on existing infrastructure causing excessive depletion and environmental deterioration. The current global issues such as climate change, Asian brown clouds and ocean pollution are also posing a threat to environmental quality. The key important environmental issues in the Western Province that are relevant to the proposed MP are briefly reviewed in the following sections.

#### **4.5.1 Inland water pollution**

As seen in Figure 4-6, the Western Province contains several inland water bodies, including five major rivers, lakes, lagoons, and irrigation tanks.

Pollution of inland water bodies such as rivers, lakes, lagoons, streams, and tanks in Western Province is an urgent issue to be addressed. Anthropogenic activities are the most prominent factor determining the water quality degradation in waterways. Bentara River, Bolgoda Lake, Lunawa Lagoon, Wellawatta Canal, and Kelani River are some of the water bodies that discharge water into the Indian Ocean influencing the water quality in western coastal areas. On the other hand, major rivers such as the Kelani River and the Kalu Ganga are being used to supply water to Colombo and other major cities in the Western Province. However, many of the other surface water sources in Western Province have already been polluted or in verge of pollution. It is reported that most of the industries in Rathmalana area do not have proper wastewater treatment systems or waste disposal systems, and therefore, waste is directly dumped into Bolgoda Lake. As a result, the lake has been severely subjected to industrial and domestic water pollution. Dumping of waste, exhaust oil, and sawdust from the surrounding timber mills to Bolgoda lake and tributaries has further aggravated the pollution (Hettige et al., 2014).

More than 25% of the Sri Lankan population, especially in the Western Province take benefits from the Kelani River (Edussuriya and Pathirage, 2016); however, it is one of the most polluted rivers in Sri Lanka (Ileperuma, 2010). Further, unplanned anthropogenic activities such as built



areas together with industrial and agricultural activities have been highlighted as major threats. The lower and middle regions of the Kelani River, which consist of flatbed areas, have faced a threat from human activities due to urbanization. The Kelani River is the second largest river and downstream of Kelani River is the most polluted river in Sri Lanka due to the rapid growth of industries along the catchment area. Microbiological contamination and turbidity are major sources of water pollution in the Kelani River (Hettige, et. al., 2014). The variation in turbidity is always associated with the incoming suspension of sediment particles flowing along with the storm water and may be due to anthropogenic activities such as mining activities upstream of the river. Moreover, it is reported that many sub-catchments and tributaries of major rivers in the lower region of Western Province are polluted (Edussuriya and Pathirage, 2016). Many tributaries of Kelani River deliver contaminated industrial wastewater from industrialized areas (e.g., Biyagama Industrial Zone). A monitoring study by CEA (2014) revealed that most water quality parameters exceeded the standard value during the monitoring period, which implies industrial pollution. It has been estimated that 3.8 million cubic meters of wastewater are discharged annually into the Kelani River which adds 766.73 tons of biochemical oxygen demand (BOD) and 42.04 tons of total suspended solids (TSS) to Kelani River (CEA, 2014). Considering this situation, the responsible authorities in Sri Lanka have already proposed many sustainable utilization approaches for the major river basins, especially for the Kelani River (Edussuriya and Pathirage, 2016). Gunawardena et al., (2017) reiterated the fact that industrial parks along the Kelani River basin have a higher water quality impact across all zones of river even though these parks generally comply with existing effluent concentration standards. This provides valuable information on setting priorities for controlling industrial pollution at individual firms versus industrial parks.

At present, the general perception is that water pollution takes place through non-point sources rather than point sources or industries. However, there is significant evidence that point sources have a greater impact on water quality, particularly in smaller water sources. Further, Gomez et al., (2019) has recently revealed that urban and peri-urban canals show much inferior water quality in the wet season, elucidating the impact of catchment laden pollutant runoff. This contrasted with the common local perception that the rainy season would flush out pollutants. Nevertheless, the canal from rural urban fringe was healthier in wet season. Point source pollution was more evident in urban and peri-urban canals, and the input sources were spatially spread yet discontinuous with time. It is also important to stress the fact that population density has a positive correlation with deterioration of water quality in urban areas of Western Province. Based on a study conducted in Kelani River basin, Liyanage and Yamada, (2017) has reported that water quality is worst in highly populated areas, average in medium populated areas and less serious in less populated areas. Further, they identified population density as a major factor that

should be well controlled to overcome the rapid deterioration and degradation of the water ecosystem.

On the other hand, channels close to estuaries have been affected by salinity in coastal areas. In most of the coastal areas, freshwater aquifers have also been contaminated with saltwater, and salinity levels have been higher than the desired levels. Groundwater in unmanaged coastal aquifers is vulnerable to seawater intrusion (SWI), which can result from land use activities. High salinity concentrations can make groundwater unsuitable for public consumption as well as for agricultural activities.

Also, it is well documented that haphazard solid waste disposal in open dumpsites which are often located near surface water bodies poses a great threat to water quality. The level of pollutants in leachate from major open dumpsites located close to surface water resources such as Meethotumulla (Esakku et al., 2007; Chandrasena et al., 2019), Karadiyana (Esakku et al., 2007; Koliyabandara et al., 2020), Blumedhal (Esakku et al., 2007), Negombo (Sewwandi et al., 2010) and many other dumpsites in Western Province have been well demonstrated. Therefore, it is imperative that the present practice of open dumping of solid waste should be discontinued, and all high-risk major dumpsites should be safely closed or rehabilitated (Karunarathna et al., 2020).

Action plan 2018 from the Ministry of Megapolis and Western Development in Sri Lanka has proposed to restore and to protect many surface-water resources in Western Province, especially the Beira Lake rehabilitation and redevelopment project which mainly focused on East Beira Lake rehabilitation and redevelopment by dredging work, bank protection along West bank of East Beira Lake to reduce the pollution loading and Leniar park to improve the surface water quality of the East Beira Lake.

#### **4.5.2 Sustainability of wetland ecosystems**

The historical records revealed that Colombo and suburb area consisted of 'lush green marshes' and cultivated intensively with swamp rice varieties, vegetables and spices (Hettiarachchi et al., 2014). Further there are number of records to show that waterways within the wetland were extensively used for transport at the time the Portuguese arrived in Sri Lanka in 1505 AD, the use of wetlands which continued well into early 20th century. Reclamation and hydrological modification of the wetland has increased steadily with the expansion of the city and especially since late 1970s (Hettiarachchi et al., 2014); however, conversion of wetlands to non-wetland uses became very apparent after 1980, when Sri Lanka adopted market-based economic policies and intensified urban development (CEA, 1994).

With urbanization, the impermeable area (buildings, roads, pavements) in the watershed study area increased from 46% in 1981 to 68% in 2008, highlighting the extensive reductions of wetland extent and watershed permeability (Hettiarachchi et al., 2014). Increased conversion of wetland

to non-wetland areas has consequently caused flood events occur more frequently. From 1980, a number of moderate-major flood incidents occurred 1985, 1989, 1990, 1992, 1994, 2002, 2004, 2005, 2006, 2007, 2008 and 2010, with flood events have becoming more common after 1990. In 2009, 63% of households within the 200 m buffer distance from the wetland were affected by flooding (Hettiarachchi et al., 2014).



Waste disposal site at Meethotumulla wetland



Waste disposal site at Muthurajawela wetland



Waste disposal near Marsh in Kelaniya



Waste disposal near Hamilton channel

**Figure 4-20 Surface water and wetland pollution due to solid waste disposal in Western Province**

Waste disposal made the most significant negative contribution to the sustainability of wetlands in Western Province. All the major wetlands such as Bellanwila- Attidiya, Kolonnawa and Bloomendal marsh, Sri Jayardanapura- Kotte marsh, Heen marsh, and Muthurajawela marshes and most of other wetlands are either used directly for municipal waste disposal by Local Authorities or common illegal waste disposal site for residence and industries (IUCN Sri Lanka and the Central Environmental Authority, 2006; Hettiarachchi et al., 2014; Athukorala et al., 2020; World Bank Sri Lanka, 2022). Moreover, the waste disposal was considered to significantly

negatively affect the wetlands located in heavily built-up areas towards the north-western limit of the Western Province.

The freshwater, brackish water and offshore wetlands are very important ecosystems within the Western Province (World Bank Sri Lanka, 2022). Many of these wetlands are under threat due to rapid urbanization and illegal encroachments, and indiscriminate waste disposal. A significant improvement of the wetlands has been made through the Metro Colombo Urban Development Project (World Bank Sri Lanka, 2022) via multiple strategies within four sub-components: Enhancement of drainage capacity in the Colombo Water Basin, including enhancement of runoff from the southeastern upper section of the basin, creation of lakes/retention areas in the central section of the basin, removal of bottlenecks in the downstream reaches of the canals, improvement of the outflow capacity and improvement/ construction of canal bank protections; rehabilitation and upgrading of the micro-drainage systems in priority flood-prone areas under the jurisdiction of Colombo Municipal Council; development of an integrated flood management system for the Colombo Water basin, including carrying out selected investments to improve public usability of canals and lakes; and rehabilitation and/or construction of embankments and developing a linear/nodal park along the east and southwest shores of Beira Lake and establishing a natural park around the degraded wetland in Beddagana. Further, the Western Region Megapolis Plan has proposed to achieve the objective of a green and livable environment within the Western Province in which protection and restoration of wetland and water environment has been identified as an integral part of the plan (Megapolis, 2016).

#### **4.5.3 Marine and coastal environment pollution**

Deterioration of water quality is one of the main environmental problems in coastal and marine water systems. Sri Lanka is acutely facing this problem, mostly due to an increased human population, rapid urbanization, industrial activities, waste and wastewater disposal, and intensive agricultural practices. Sri Lanka's coastal areas are highly populated, and due to high urbanization, the coastal population density is concentrated in the Western Province. Because the ocean runs through all three districts of the highly urbanized Western Province, there is a high risk of pollution to the marine environment arising through diverse types of discharges into the ocean (Dharmasoma, et al., 2019). Coastal water pollution is caused by land and sea related activities. Agriculture, urbanization, and industrialization are being considered as the mainland-based activities, as well as ship accidents, exploration, and the dumping of oil and garbage/sewage can be considered off-shore/sea-related polluting activities. On the other hand, dissolved and sediment laden discharges from rivers and canals are directly contributing to water pollution of marine environment. Another important aspect is the large-scale accidental spills and wrecks in coastal and marine environments. For example, the X-Press Pearl ship disaster

released considerable amounts of pollutants such as hazardous chemicals and plastic pellets to ocean and west-south beach (Rodrigo, 2022; Pathmalal et al., 2022).

The effluent discharge from industrial and municipal sources (e.g., sewage) to sea and coastal areas is another major environmental issue in the Western Province. Wastewater discharging directly or indirectly affects the biotic and abiotic communities, posing a threat to human well-being in the end. Therefore, coastal habitats are highly vulnerable to degradation, and it is important to minimize inland water pollution in the upper region of the water ways to prevent such contaminations. Weerasekara et al., (2015) reported that 62% of small, medium, and large enterprises in the Western Province are located along the coast and most of effluents are finally discharged into the near shore waters with little or no treatment. Moreover, a comprehensive study conducted in West and Southern coast of Sri Lanka by Manage et al., (2022) concluded that the coastal area between Negombo and Mirissa is highly vulnerable to contamination. Further, incorrect solid waste management, inadequate port practices, land-based waste flowing through canals, untreated industrial effluents, and poor management methods and regulations contribute to coastal pollution.

#### 4.5.4 Air pollution

Air pollutants emitted from industrial, transport, commercial and domestic sectors in the province, power plants, incinerators, waste open burning contribute to air pollution. According to the findings of an air quality study by Premasiri, et al., (2015), the Western Province is the most polluted province in Sri Lanka. The primary sources of emissions in the Western Province are the road transport, residential, industry, power generation, open burning of waste. Emission patterns are influenced by a number of factors, including the traffic controls, modes of transport, inputs to power generation, types of industries permitted, dust control in constructions and extent of environmental enforcement all of which are within the human and institutional control given that the resources and capacity is provided.

The key air pollutants are Carbon Monoxide, Sulphur Dioxide, Ozone, Oxides of Nitrogen Particulate Matter (dust), and Volatile Organic Compounds. Although air pollutants are many, the most important are particulate matter (PM), ground-level ozone (O<sub>3</sub>), carbon monoxide (CO), sulfur oxides (SO<sub>x</sub>), nitrogen oxides (NO<sub>x</sub>), and lead (Pb), which are often found in ambient air (Nandasena et al., 2010). The air pollution issue in the Western Province is aggravated because about 60% of Sri Lanka's vehicle fleet operates in the Western Province, and the vehicle population growth is approximately 12% per year. About 70% of industries, including thermal power plants, iron smelters, petroleum refineries are also located in the Western Province (Premasiri, et al., 2015). Apart from the main pollutants, other harmful wastes include black carbon and volatile organic compounds (VOCs), both of which are formed from the incomplete

combustion of both fossil fuels and organic matter, especially indiscriminate open burning of waste.

Municipal solid waste open burning is a serious air polluting activity in Sri Lanka. An attempt had been made to prohibit the waste open burning in 2018; however, it is evident that open burning of solid waste continues at different scale (Gazette extraordinary No. 2034/36 of 2017). Currently, one municipal waste incinerator is operating in Kerawalapitiya, which ensures modern air pollution control measures are applied to comply with the strict emission limits established by CEA (Gazette extraordinary No. 2034/36 of 2019).

## 4.6 Status of solid waste sector

### 4.6.1 Global trends in solid waste management

Various concepts have been proposed for sustainable development, addressing one or more of its three domains – environmental, social, and economic. Some are formulated as boundary conditions or conditions to be met, such as planetary boundaries, Cradle to Cradle and The Natural Step. Some propose strategies to achieve sustainable resource use, such as circular economy, performance economy, industrial ecology, and prosperity without economic growth. Some concepts are formulated as goals to be reached to achieve sustainable development, such as resource efficiency, the decoupling of resource use from economic growth, dematerialization and zero waste. Several indicators have been proposed to measure progress toward the goals, such as the intensity of material use, material input per unit of service, ecological rucksack and ecological footprint.

**A circular economy** is an industrial system that is restorative or regenerative by design. It replaces the ‘end-of-life’ concept with restoration, shifts towards the use of renewable energy, eliminates the use of toxic chemicals, which impair reuse, and aims for the elimination of waste through the superior design of materials, products, systems, and, within this, business models. In a more limited meaning this concept is widely used in the People’s Republic of China, in accordance with the Circular Economy Promotion Law of 2009. The circular economy is also increasingly prominent in European strategies.

Starting from the premise that ‘design is the first signal of human intention’, **Cradle to Cradle** is a design concept that is based on three fundamental principles that are ‘borrowed’ from natural ecosystems: (1) Waste = Food, (2) Use current solar income (3) Celebrate diversity. In natural ecosystems, processes of individual organisms and species contribute to the health and vitality of the system as a whole. In those ecosystems, waste from one organism serves as nutritious food for another. Living systems thrive on solar energy. Natural systems function and thrive

through diversity and complexity. These principles are translated and applied to the design of materials and products and to production processes.

In a **Sustainable society**, nature is not subject to systematically increasing: (1) concentrations of substances extracted from the Earth's crust; (2) concentrations of substances produced by society; (3) degradation by physical means; and in that society (4) people are not subject to conditions that systematically undermine their capacity to meet their needs. These conditions are incorporated in a strategic planning approach for companies or communities, with back-casting as the central approach – a successful outcome is imagined in the future, then the actions are identified that are needed to reach that vision of success.

**Performance economy** is an economy in which consumers purchase certain performances (services) rather than physical products. Ownership of the goods (in this case, the light bulbs, electricity and so on) is retained by the producer rather than the consumer and therefore encourages the producer to reduce waste, minimize resource consumption and lengthen product life. 'Product-service systems' is the term used to denote the performance-based business models in which the manufacturer retains ownership of the items and equipment involved, which is a fundamental change from the current practices.

A detail analysis on solid waste sector is presented in the MP. This section provides an overview of the municipal solid waste (MSW) sector in Sri Lanka.

#### 4.6.2 MSW generation and management in Sri Lanka

According to the updated database of MSW management in Sri Lanka in September 2020 by the National Steering/Advisory Committee of Solid Waste Management and modified for the Guidelines for Safe Closure and Rehabilitation of Municipal Solid Waste Dumpsites in Sri Lanka (2021), approximate MSW generation in Sri Lanka was estimated to be around 8,141 TPD in 2020 as given in Table 4-14. The Western Province, the biggest waste generator, accounts for 41 % of the country's waste. In 2020, the rate of waste collection by local authorities (LAs) in Sri Lanka was estimated to be about 3,854 TPD. Around 58 % of the waste is being collected from cities and towns in the Western Province, which are highly populated, urbanized, and developed. Lowest MSW collection rate reported in North Central Province which amounted to 25%.

However, it is important to note that accurate statistics on waste generation, collection, resource recovery and final disposal are not available in Sri Lanka. Accurate and continuous waste quantity data are available only in very few disposal and resource recovery facilities; thus, different reports or publications present their own measures and estimates. Therefore, the discrepancies on waste statistics should be taken into consideration in data analysis, and decision making.

**Table 4-14 Status of MSW generation and collection at the provincial level in Sri Lanka in 2020**

Province	Generation (TPD)	Collection (TPD)	Collection rate	Number of dumpsites	Reference
<b>Western</b>	3,368	1,952	58%	51	Karunarithna et al., 2021*
Colombo	1,914	1,222	64%	5	MP**
Gampaha	1,227	450	37%	9	MP**
Kalutara	594	230	38%	8	MP**
Western	3,732	1,902		21	MP**
<b>Northern</b>	374	195	52%	16	Karunarithna et al., 2021*
<b>Eastern</b>	838	431	52%	38	Karunarithna et al., 2021*
<b>Central</b>	871	362	41%	43	Karunarithna et al., 2021*
<b>Northwestern</b>	596	235	39%	45	Karunarithna et al., 2021*
<b>Uva</b>	323	123	38%	22	Karunarithna et al., 2021*
<b>Sabaragamuwa</b>	525	182	35%	29	Karunarithna et al., 2021*
<b>Southern</b>	838	272	33%	60	Karunarithna et al., 2021*
<b>North Central</b>	409	103	25%	35	Karunarithna et al., 2021*
<b>Total</b>	<b>8,141</b>	<b>3,854</b>		<b>339</b>	Karunarithna et al., 2021*

\* Karunarithna, A., Rajapaksha, T., Singh, R. K., Premakumara, D. G. J., & Onogawa, K. (2021). Guidelines for Safe Closure and Rehabilitation of Municipal Solid Waste Dumpsites in Sri Lanka. Ministry of Environment, Battaramulla, Sri Lanka. ISBN: 978-955-8395-53-0.  
 \*\* Western Province Solid Waste Management Master Plan in Sri Lanka (MP), 2023

The total amount of MSW generated in the Western Province is between 3,368 (National expert committee, 2020) and 3,732 TPD (Master Plan 2023), of which 48% is household waste and 52% is non-household waste. The MP has estimated that 1% of the total waste generated in Western Province is recycled at the generation source mainly through home composting and Parisara Pola. In Western Province, 51% of the collected waste is transferred to intermediate treatment facilities and 49% is either self-disposed or improperly discharged.

As shown in Figure 4-21, among the 49 LAs in Western province, Colombo Municipal Council generate about 800 MTD and is the largest waste generator in the country as well. Further, most of LAs in Colombo District generate and collect larger amounts of waste than LAs in Gampaha and Kalutara Districts. Kalutara District generates the lowest waste amounts.



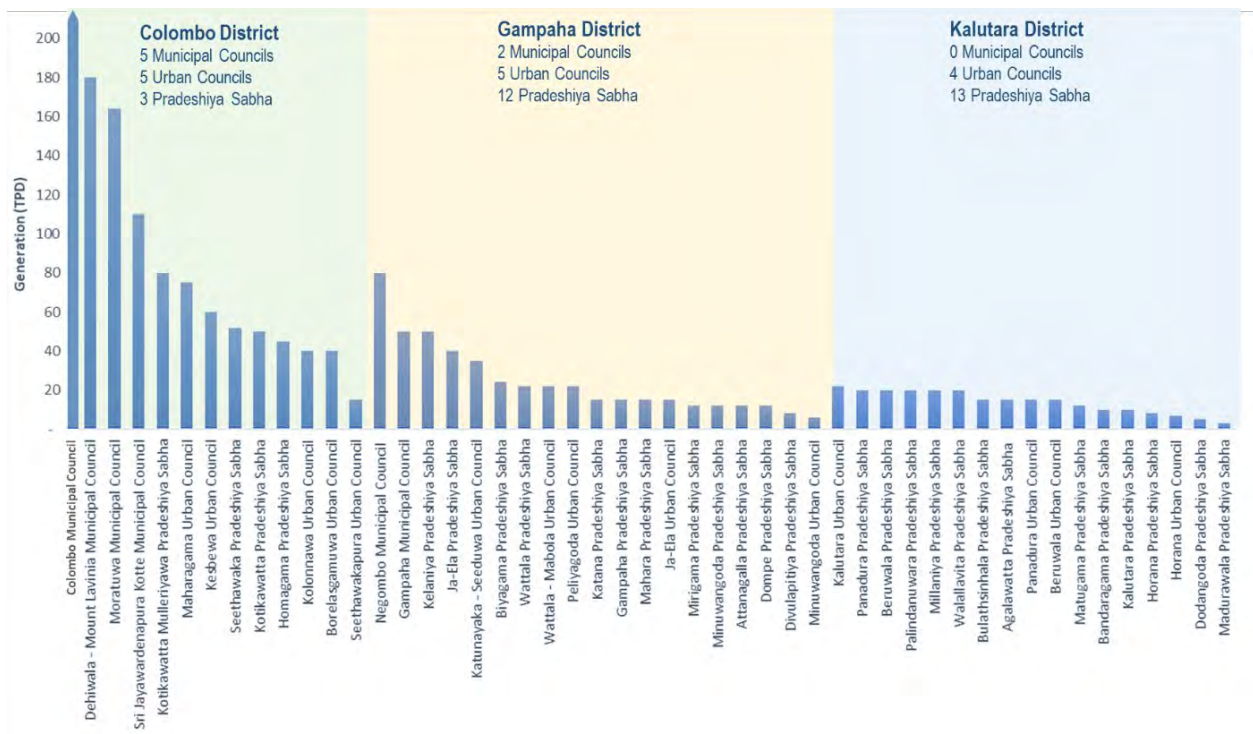

**Figure 4-21 An estimation of waste generation in Western Province**

However, integrated MSW planning requires a deeper understanding of the waste generation and waste streams to configure infrastructure for upgrading. Though the waste generation in a territory is primarily determined by its population, many factors that contribute to the overall quantity of waste generation. Level of urbanization, type of major economic activities in LA, population density, geography, road infrastructure, and proximity to major cities are a few prominent factors that influence the waste generation rate. Accordingly, the following few observations were drawn from the analysis of existing MSW datasets.

- ✓ The contribution of residential waste to the existing waste collection varies from 90% in rural LAs to 10% in congested major cities.
- ✓ The contribution of residential waste to the waste generation stream is 30 to 50% in MCs. The remaining 50–70% is generated by institutions, commercial establishments, industries, and other activities in the city.
- ✓ The contribution of residential waste to the waste generation stream is 40 to 50% in UCs. The remaining 50–60% is generated by institutions, commercial establishments, industries, and other activities in the city.
- ✓ The contribution of residential waste to the waste generation stream is 70 to 98 % in PSs. Only 2% to a maximum of 30% is generated by institutions, commercial establishments, industries, and other activities in small cities and towns.

- ✓ The MP assumes waste generation rate of MCs is equal to 0.97 kg/person/day. However, it can be varied from 0.5 to 1.8, depending on urbanization.
- ✓ The MP assumes waste generation rate of UCs is equal to 0.63 kg/person/day. However, it can be varied from 0.4 to 1.2, depending on urbanization.
- ✓ The MP assumes waste generation rate of PSs is equal to 0.44 kg/person/day. However, it can be varied from 0.05 to 0.8, depending on urbanization.
- ✓ For MCs, 0.8 kg/person/day is a reasonable estimate for the waste generation rate based on the residential population of the city in Sri Lanka (Basnayake et al., 2020; Karunaratna et al., 2021). However, highly urbanized and populated cities in the Metro Colombo area, Kandy, and Kurunegala municipalities have exceptionally high generation rates (1.2 to 1.8 kg/person/day). The increase is mainly attributed to intense commercial, industrial, and service activities in these cities. Therefore, the estimate made for MCs (0.97 kg/person/day) in the Master Plan is reasonable.
- ✓ There are several LAs in Kalutara and Gampaha District which do not provide area-based waste collection services, or the waste collection service is limited to a few small townships.
- ✓ More than half of LAs, especially PSs, collect only a small amount of waste (1–10 MT/day) that is also from small townships. Generally, LAs that collect less than 5 MT/day does not provide regular waste collection service to residents, but limited service is provided to townships and public places such as Sunday Pola, and bus stand.

### 4.6.3 3Rs and resource recovery

At present, resource recovery from waste is growing because of various programs launched by the government, non-governmental organizations and through and self-initiatives of LAs. The resource recovery route starts from point of generation where most of readily marketable waste such as metal, cardboard, clean papers, and solid plastics are recovered by generators and channel through formal (municipal) or informal recycling streams. However, on-site composting is limited to rural and semi-urban households and institutes, thus diversion remains low. Most of the low value recyclables are recovered after discharge either as source segregated collection by the LA or waste pickers, collection workers. Once collected separately or as mixed waste, much of the degradable organic waste divert to centralized composting facilities found in many LAs. The waste disposed at dumpsites are mainly low value recyclables, non-recyclable plastics and mix waste that are difficult to be sorted for organic or inorganic resource recovery (Basnayake et al., 2020).

In global context, the term recycling is used to describe a wide array of resource and energy recovery activities. Mechanical recycling, chemical recycling, and thermal recycling are commonly practiced recycling technologies around the world. Mechanical recycling evolves in

shredding plastic waste in to recyclate or regranualte without changing its chemical structure. In chemical recycling of plastic waste, the waste material is subject to degradation, and it provides low-molecular compounds as a result. The thermal process of plastic recycling is conducted through combustion, pyrolysis, gasification, and hydrocracking. The thermal process of plastic recycling is significantly important due to the potential of recovering fuel or thermal energy as a result.

Plastic recycling and incineration rates vary considerably by region. For example, based on the available data, 2014 recycling rate estimates are 30% for Europe, 25% in China, and 9% for the United States, while the 2014 incineration rate estimates are 39% for Europe, 30% for China, and 16% for the United States. The US plastic recycling rate appears to have been stagnant since 2012, while its incineration rate actually declined from 21% in 1995. Additional waste management data are used to generate 2014 recycling and incineration rate estimates for the rest of the world, which are 11% for recycling and 15% for incineration (Gayer, 2020).

The objectives and targets in waste management and alike policies, strategies and action plans of Sri Lanka priority focused on material recycling, and chemical and thermal recycling are considered secondary options, particularly for the plastic waste resource recovery. Although material recovery is often favored over other recycling options, it is imperative that a major portion of post-consumer plastic waste in the world as well as in Sri Lanka cannot be effectively recycled to materials (Gayer, 2020). The unique chemical characteristics of different types of plastic resins, demand for recycled materials from manufacturing sector, competition from virgin materials, level of technology in the country or region, economic feasibility are some of the key factors that determine the success of material recycling industry. Though chemical and thermal recovery techniques have not identified as recycling alternatives in Sri Lanka; plans often set targets to achieve higher recycling rates through material recycling. However, the SEA uses the broader definition of recycling that identifies material, chemical and thermal material conversion and recovery techniques as recycling methods.

#### **4.7 Current issues in solid waste sector**

The waste management policy document states that the mandatory community involvement in managing waste is recognized as a significant input to ensure that waste managers perform their duties with the highest degree of responsibility and accountability throughout the country. So far, individuals and communities are yet to be fully delegated to ensure productive participation with commitment and responsibility. Although the degree and quantity of waste separations are increasing, but the behavior of the public towards waste disposals is still astonishing with the practice of burning wastes and throw away habits. Inadequate facilities for collections and disposal of wastes are the primary reasons for such indifference towards the wellbeing of the

neighbors and communities. On the other hand, officials are yet to implement sound disposal technologies, thus improving collections. Management and accountability were never issued at the beginning of establishing and operating the facilities, because at least a few LA officials are keen and eager to function the system efficiently. As soon as those persons are transferred or resigned from the post, negligence, and indifference shown by persons responsible to reduce workload and revert to disposals in the dumpsite (Japan International Cooperation Agency and (JICA) Kokusai Kogyo Co., Ltd. 2016; Basnayake et al., 2020; Karunaratna et al., 2021). According to comprehensive integrated solid waste management plan for target provinces in Sri Lanka, developed by the Ministry of Mahaweli Development and Environment (MoMD&E) (2016) with technical assistance from the United Nations Human Settlements Programme following issues in the MSW management in Sri Lanka were identified.

Current issues and problems in MSW sector in general and specific problems in the Western Province are summarized below.

#### **4.7.1 Lack of updated data base of waste generation, collection, and disposal in Sri Lanka**

- a) Not maintaining an updated database on waste generation, collection, disposal facilities of each local authority.
- b) Access to information at LA level is limited.
- c) Although there is a centralized database at WMA-WP, it is not available online or in any other published form thus is not easily accessible for the public.

#### **4.7.2 Source separation and waste collection**

- a) In most of the urban centers, waste is collected, but partially mixed, or without any segregation. Unsorted waste makes recycling nearly impossible.
- b) Garbage collection, public cleaning/ sweeping are irregular and waste collection without proper time schedule.
- c) Garbage collection, public cleaning/ sweeping frequencies are low.
- d) In many LAs, there is no proper mechanism to collect waste after source separation.
- e) Efficiency is hampered with the involvement of the collection crew in sorting and separating recyclable wastes.
- f) In rural areas, problems of poor collections and waste management still exist.
- g) Inappropriate waste transfer from handcarts to tractor-trailers is still practice in some places.
- h) Very high collection costs and poor services.
- i) Lack of home composting bins and on-site organic waste safe disposal facilities and techniques.

#### **4.7.3 Lack of resources for waste collection, transportation, and disposal**

- a) Shortages of waste collectors, waste transporting vehicles, equipment etc. waste collection bins, composting bins.
- b) Failure to optimize vehicle productivity by selecting the appropriate crew size.
- c) Frequent breakdown of waste transporting vehicles. Long vehicle down-times from poor equipment maintenance/repair.
- d) Inappropriate type and size of collection vehicles.
- e) During the rainy season, waste collection is irregular due to lack of protective gears for waste collectors such as gloves, raincoats, and boots.
- f) In several LAs, there is a requirement for waste transporting vehicles that can be used to collect source separated waste.
- g) Long haulage times to disposal sites coupled with lack of transfer stations, harsh driving conditions at disposal sites.

#### **4.7.4 Lack of infrastructure facilities in existing waste management facilities**

- a) Shortage of tools and machinery such as shredders, huller/ screening machine loaders etc. for existing composting and waste treatment facilities.
- b) Frequent breakdown of waste processing machinery and absence of proper replacement, operation & maintenance plan.
- c) Lack of storage facilities for waste, material recovery facilities, and sanitary/resting facilities for workforce.
- d) Lack of utility services such as water, electricity supply, and telecommunication in some waste processing facilities.
- e) Delapidated status of access road and need of service roads to waste treatment facilities.
- f) Requirement for fencing and security in waste handling, treatment and disposal facilities. The entry of wild animals and stray dogs into waste management facilities is a recurrent issue.
- g) The need to improve drainage and flood control measures in waste handling, treatment, and disposal facilities.

#### **4.7.5 Institutional and human resource issues**

- a) Inadequate institutional facilities such as office space, training centers, and storage facilities for waste management section.
- b) Inadequate financial resource allocation for waste treatment and disposal site management by LAs.

- c) Shortage of healthy, young, and skillful workers in the waste management division of LAs. There is frequent absenteeism of the health workers since they are working in other places as laborers for higher daily wages.
- d) Poor labor management and supervision often occur due to allocation of health/waste management workers to other services.
- e) When the absence of political leadership and strong policy, officers and workforce are demotivated.
- f) Lack of adequate number of technically competent human resources in waste management. Although there are some vacancies and cadre positions for engineers, technical officers and supervisors, it takes considerable time to fill these vacancies.
- g) Ordinary workers have little knowledge/expertise in waste management and opportunities for career development are limited.
- h) There is no proper mechanism to develop cooperation between the local authorities and external parties involved in waste management.
- i) The policy and regulations are not properly implemented by LAs. For example, a little attention is paid to transferring the responsibility of waste management at industries and hotels to themselves.
- j) Inadequate or outdated laws, by-laws and regulations to control the waste generators who dispose of waste in an irregular and improper manner.
- k) Lack of suitable lands for establishing waste handling, treatment, and waste disposal facilities. Some local authorities are unable to find land or not being able to make legal clearance to establish waste management facilities.

#### **4.7.6 Problems in recycling sector**

- a) Recycling of high valuable waste such as metal, sorted and clean cardboards, hard plastics are well established industry that is mainly managed by informal sector. However, in absence of advanced recycling options and poor demand from manufacturing sector for recycled materials often hinder the recycling of low-value recyclable resource recovery (glass, paper, plastics etc.). The issue is aggravated due to narrow focus on conventional material recovery which requires substantial integration with the manufacturing sector. Lack of solid sustainable manufacturing and industrial policies, legislations and actions often bring indirect negative influence on material resource recovery because the demand for recycled/ recovered materials are not steady and consistent. Informal recycling businesses are extremely sensitive to socio-economic changes in the country; thus, expansion of informal recycling industry in Sri Lanka is questionable.

- b) In the rural areas where the waste collection is not being practiced, unfortunately, the communities are facing difficulties in handling non-biodegradable waste such as polythene. All through the villages are collecting non-biodegradable waste separately, in the absence of collection and proper disposal methods, simply, they burn polythene in their homes to get rid of it which causes environmental pollution. Thus, it is imperative that there should be a mechanism to collect non-biodegradables in rural areas.
- c) There is no well-organized network for recyclable collection and buying. Consequently, in some LA areas, recyclables are being collected, and are stored without a proper plan for recycling or disposal.
- d) Recyclable buyers and vendors are facing challenges because of inadequate infrastructure facilities, lack of encouragement from LAs, lack of loan facilities to improve the business, and insecure/ unstable market for recyclables.
- e) There are no programs to encourage middlemen and informal recyclers.

#### **4.7.7 Issues in biodegradable waste recovery by composting**

- a) Most of MSW composting facilities were started as a means of diverting organic waste from dumpsite to resource recovery or pre-treatment prior to disposal. However, in present day context, MSW composting facilities aim to produce compost for agricultural use. However, some of the MSW composting systems have not upgraded its infrastructure, technology, and human resource training to achieve the quality compost manufacturing objective.
- b) The limited success of some centralized composting systems was due to their unsuitable location, design failures, inefficient operation, and lack of facilities for residual waste disposal.
- c) Inferior quality of produced compost due to high sand and inert content is a common issue in Western province.
- d) Unstable and inadequate market for produce compost is another challenge face by LAs.
- e) The LAs has limited in-house knowledge and infrastructure to improve the composting system.

#### **4.7.8 Social issues in waste sector**

- a) Lack of social recognition for the waste sector workforce, especially in middle and low-grade workforce is a serious social stigma that hinders new recruitment and job satisfaction of employers.

- b) Living condition and quality of life of the waste collectors is not up to expectation of the workers. The issue is serious in line-houses in major cities.
- c) Lack of public awareness and environmental ethics have led to uncontrolled waste disposal.
- d) Health problems, nuisance, and air pollution due to uncontrolled waste dumpsites and open burning of waste.
- e) One important aspect of solid waste issue is the negative attitudes of communities on establishing new waste management infrastructures or physical improvement/ expansion of existing waste management sites. In general, public and nearby community do not accept waste from elsewhere to their residential areas. There are numerous examples that unsatisfied communities/ groups went to the extent of seeking legal remedies to stop upgrading/ establishment of waste management facilities. The issue is well documented as NIMBY (Not In My Back Yard) syndrome in social sciences.
- f) After Meethotumulla dumpsite disaster in 2017, most communities living close to dumpsites expressed their displeasure and fear about dump sites. The public displeasure towards waste dumpsites and other management facilities has aggravated due to Meethotumulla incidence.
- g) LAs are not providing relief and assistance to the communities living near waste management and disposal sites.
- h) Inefficient involvement of stakeholders, especially the lack of community participation in decision making and management is an issue.

#### **4.7.9 Environmental issues in waste sector**

- a) Open dumping of waste in vacant lands, marshy areas, water courses, open quarries and other low-lying areas is a well-recognized issue. In Western Province, except the Dompe landfill, none of the open dumpsites are engineered to minimize or control pollutants released from the dump. The high moisture content in the MSW leads to excessive leachate generation from these dumpsites, causing numerous problems to the surrounding soil and water environments.
- b) The carrying capacity and stability of dumpsite in many parts of Western province have reached to their maximum level. The failure of Meethotumulla dumpsite in 2017 is one of the best examples to validate the issue.
- c) Inadequacy of application of appropriate technologies for waste treatment, resource recovery and final disposal is well correlated with environment pollution. Though many LAs operate centralized composting facilities, leachate and gaseous emission control measures are inadequate or neglected. Thus, composting facilities continue



to cause environmental pollution and public nuisance. The waste resource recovery facilities and recycling facilities are not designed with adequate measures to control emissions; therefore, pollution control aspects are remained to be addressed.

- d) Though the regulation to ban open burning of refuse was implemented in 2017 (Gazette Extraordinary No. 2034/36 - Friday September 01, 2017), waste open burning at point of generations (residential, commercial, industrial, institutional, and public places) and final disposal sites is continuing (Basnayake et al., 2000; Karunarathna et al., 2021). The emissions such as particulate matter, combustion products, volatile organic compounds and other problematic tracer gases from waste burning at point source and non-point sources are recognized as one of the major air pollution sources in Sri Lanka (NBRO, 2022).

#### **4.7.10 Economic and financial issues in waste sector**

- a) LAs expend 10-40% of their budgetary allocation for MSW management; thus, waste collection service is one of the major public services of LAs. However, though the legislation allows LAs to impose waste collection fees for large waste generators and commercial sectors, most of LAs do not attempt to collect revenues and merely 10% of the potential revenue is collected.
- b) One of the top priorities in the SWM sector is to improve the SWM financial system of LAs, Provincial Councils and Central Government. Recent studies revealed that approximately 70-80% of the LA budget allocated for MSW management is spent for waste collection and transportation, especially to cover labor and fuel costs, and a much lesser amount spent on resource recovery, final disposal site management and human resource training and development (Basnayake and Visvanathan, 2014; Japan International Cooperation Agency and Kokusai Kogyo Co., Ltd. 2016). Serious drawbacks are visible in some important sectors such as resource recovery and final disposal site management in MSW management system of LAs.
- c) Most of small and medium LAs make insignificant budgetary allocation for capital investment in MSW sector; thus, LAs often rely on external financials resources from Provincial Council, Central Government, or donor agencies to secure funds for capital investment.

### **4.8 Summary of the characteristics of the environment in areas likely to be significantly affected by MP**

The Table 4-15 below summarizes key environmental and socio-economic issues identified above and provides description of those areas where the main environmental and socio-economic issues are detected and identified. To the extent possible, the table determines the geographical

scope of the problems. However, since the MP is supposed to be applied on the whole territory of the western province, and at the same time it does not indicate specific localities for implementation of individual activities/projects, it is difficult to identify the trend of the problems within the specific localities. Thus, the analysis provides only general information on the issues and their overall effects on the particular areas. These key environmental issues were used in the SEA as a guide to develop a framework for SEA objective and evaluation of the MP compliance with the relevant environmental objectives in the Chapter 5.

In relation to water, the most problematic areas include riverbanks, inland water bodies and coastal areas where illegal/ unplanned dumping of waste occurs. Surface waters downstream of big cities are considered to be most polluted with nutrients and heavy metals as well. Ground water is more prone to pollution in the areas of dumpsites not meeting the standards where pollution percolates down through the groundwater aquifers. In terms of soil, the most contaminated areas include construction sites including waste management facilities. Poor air quality is mostly due to transportation sector, open burning and energy related activities. Protected areas are also prone to pollution unless the proper waste management plans and infrastructure are on place. SWM imposes significant impact on the environmental quality in the western province, therefore, setting relevant management and regulatory activities for further prevention of solid waste is essential. It is also very important to consider environmental impact on health and occupational health related issues to set relevant actions for improving existing environmental conditions. Local Authorities should be prepared to develop and ensure proper implementation of cost-effective well-coordinated mechanisms for municipal waste management.

**Table 4-15 Key environmental and socio-economic issues in the project implementation area**

Environmental receptor	Baseline issues	Affected geographic area
<p><b>Surface and ground water</b></p>	<ul style="list-style-type: none"> <li>● Leakages from landfills</li> <li>● Pollution of surface water with organic matter, nutrients, heavy metals and pesticides</li> <li>● Industrial wastewater discharges</li> <li>● Municipal wastewater discharges</li> <li>● Storm water runoffs</li> <li>● Agricultural runoffs</li> </ul>	<ul style="list-style-type: none"> <li>● Illegal dumpsites, such as Meethotumulla, Karadiyana Koliyabandara, Blumedhal, and Negombo, mainly located near the rivers and other inland water bodies.</li> <li>● Attanagalu Oya, Muthurajawela wetland, Bolgoda Lake, Kelani River and its tributaries, most of the urban and peri-urban canals has been severely subjected to industrial and domestic water pollution.</li> </ul>

Environmental receptor	Baseline issues	Affected geographic area
<p><b>Air / Climate/ Climatic factors</b></p>	<ul style="list-style-type: none"> <li>● Self-burning of waste- open air burning of refuse or other combustible matters such as plastics</li> <li>● Poor data collection and processing of dumpsite/ landfill emissions</li> <li>● Adopt and implement necessary laws related to air quality protection.</li> <li>● Landfill gas emissions are not collected and treated.</li> <li>● No use of waste as energy source</li> </ul>	<ul style="list-style-type: none"> <li>● Major sources of air pollution in the western province is transport, energy (power plants and incinerators), and industrial sectors.</li> <li>● Most of the existing dumpsites do not have a system of collection and removal of combustible landfill gasses.</li> <li>● The existing sanitary landfill and proposed new landfill do not have sufficient measures to safely dispose and lessen GHG emissions.</li> </ul>
<p><b>Soil and land</b></p>	<ul style="list-style-type: none"> <li>● Unplanned land use and haphazard conversion of natural environment into built environment cause environmental degradation.</li> <li>● Contamination of soil by organic, inorganic, microbiological pollutants, chemical waste from industry, organic and inorganic fertilizers from agriculture, leakages from landfills, construction waste and mining waste</li> </ul>	<ul style="list-style-type: none"> <li>● Illegal dumpsites and improperly managed landfills are also responsible for soil contamination.</li> <li>● Areas where industrial and municipal waste are stored, transfer or disposed.</li> <li>● Areas where inferior quality residuals and by-products of waste treatment systems (MSW compost, sludge) are used as soil amendment, fertilizer or filling materials.</li> </ul>
<p><b>Biodiversity and nature conservation</b></p>	<ul style="list-style-type: none"> <li>● Conversion of wetlands to non-wetland uses due to urbanization</li> <li>● Disposal of waste and effluents in terrestrial protected areas</li> <li>● Degradation of biodiversity due to pollution</li> <li>● Lack of capacity of LAS to meet waste management obligation in terms of protected areas</li> <li>● Absence of legal landfills or areas for waste collection near protected areas</li> <li>● Lack of specific waste management plans for PAs</li> <li>● Lack of segregation of toxic substances from normal waste</li> </ul>	<ul style="list-style-type: none"> <li>● All the major wetlands such as Bellanwila- Attidiya, Kolonnawa and Bloomendal marsh, Sri Jayardanapura- Kotte marsh, Heen marsh, Muthurajawela marshes, and other sensitive areas are either used directly for municipal waste disposal by Local Authorities or common illegal waste disposal site for residence and industries.</li> <li>● Protected forest and wildlife reserved in Western Province, especially forests in rural areas of Kalutara District</li> </ul>
<p><b>Public Health</b></p>	<ul style="list-style-type: none"> <li>● Public health is affected by lower air quality and water quality across the western province.</li> <li>● Risk of vector borne diseases spread due to inappropriate waste management.</li> <li>● Risk of diseases and emissions due to improper solid waste management</li> </ul>	<ul style="list-style-type: none"> <li>● These problems are relevant to all regions of the western province.</li> <li>● Diseases such as dengue are spreading in the urban and suburban areas near waste disposal and storing sites</li> </ul>

Environmental receptor	Baseline issues	Affected geographic area
	<ul style="list-style-type: none"> <li>● Occupational health risk in collecting, sorting, handling, processing and disposal of municipal, hazardous waste, construction waste, and healthcare waste</li> </ul>	<ul style="list-style-type: none"> <li>● Persons involved in all segments of waste management service are at a risk of occupational health risk.</li> </ul>
<p><b>Socio-economic</b></p>	<ul style="list-style-type: none"> <li>● Lack of public awareness of SWM</li> <li>● Lack of proper data collection and monitoring system for SWM</li> <li>● Lack of institutional capacity for SWM</li> <li>● Lack of an integrated system for SWM</li> <li>● Lack of opportunities for resource recovery and employment generation</li> <li>● Insufficient political and legal environment for SWM</li> <li>● Lack of social acceptance for waste management occupation and inadequate sanitary and welfare facilities for SWM workforce</li> <li>● Lack of economic and financial support for self-employed MSW service personals and small &amp; medium scale businesses</li> <li>● Social unrest and dissatisfaction due to establishment and continuous operation of inappropriate waste storing, processing, and disposal facilities.</li> </ul>	<ul style="list-style-type: none"> <li>● These problems are relevant to all municipalities of the western province</li> <li>● These problems are relevant to all regions of the western province</li> <li>● Social unrest and dissatisfaction are often seen in areas where large scale waste management facilities are located.</li> </ul>



## 5 Analysis and evaluation of the MP and its alternatives

### 5.1 Selection of sustainable alternatives

Effective integrated solid waste management (ISWM) requires the informed participation of key stakeholders of MSW sector: waste generators, waste management service providers (e.g., local governments, private sector), governing institutes (Provincial Councils and Central Government), regulatory institutes (e.g., Ministries, Authorities etc.), and citizens (individuals and formal-informal community organizations). In Sri Lanka, SWM policies, strategies, and action plans exist from the community level to the national level, but SWM decisions are often made locally at Local Authority level. These decisions impact how stakeholders' interface with the SWM system, and the cost and environmental performance of SWM. Thus, decision makers must balance competing factors when selecting an SWM strategical alternatives to minimize, collect, process, recover materials or energy, and eventually dispose of municipal solid waste (MSW).

MSW alternative analysis can be done using a wide range of methodologies. SWM system-wide cost and/or environmental impacts can be studied using life-cycle assessment (LCA) to compare alternative scenarios and to identify optimal strategies. Some studies use other methods, including carbon and energy flow analysis, life-cycle carbon accounting and carbon emission pinch analysis, economic, energetic & environmental analysis, eco-efficiency analysis and waste flow analysis. Life-cycle modelling tools provide a systematic approach to analyze SWM systems and to compare alternative solutions in consideration of multiple, frequently conflicting, goals. While LCA-based models can identify efficient SWM strategies that optimize key objectives, mathematically optimal strategies may not be implementable when considering the many secondary objectives (e.g., practical limitations due to technical and economic reasons, social preferences, and political and management challenges). Consequently, solutions with similar cost and environmental performance metrics may perform differently with respect to other objectives. Uncertainties are inherent in SWM LCAs, and any particular optimal solution is unlikely to capture all aspects of stakeholders. Making SWM decisions with long-term implications becomes challenging when systematically considering other aspects, including policies that ban disposal of mix waste in landfills, practical challenges such as reliably ensuring the economic feasibility of a material recovery facility (MRF), and social considerations shaped by public opinion that may not, for example, favor waste incineration.

The use of LCA or any other advance methos in alternative scenario development and comparison requires substantial amount of quantitative and qualitative information on existing MSW systems as well as the environmental setting. However, it should be noted that there are a number of areas where data was not readily available which include: lack of reliable statistics on waste

quality (e.g., composition, recyclability, time dependent changes), economics of informal sector resource recovery activities, uncertain and frequent policy changes in MSW sector, and lack of feedback and monitoring data on existing MSW system. Therefore, this analysis presents a waste material flow optimization approach that systematically explores and identifies alternative SWM strategies that are reasonably different from each other. These strategies achieve improvements in terms of cost, waste resource recovery and landfill diversion using diverse waste item–treatment process combinations.

This SEA process was initiated after the stakeholder consultation on the draft Master plan and the process continued until the draft final master plan was developed. The different planning alternatives presented in the Master Plan were developed through the stakeholder consultation process; thus, a separate set of hypothetical alternatives were not developed at the final SEA report. The technical and economic feasibilities of the baseline (existing MSW system) and proposed alternatives are presented in the Master Plan. The SEA final report presents an analysis of selected alternative in policy, regulation and environmental point of view.

The process of SEA is led by the description of the existing environmental baseline and from this information the likely effects of implementing the Master Plan can be identified and evaluated. Information is therefore provided on existing environmental problems which are relevant to the Masterplan, thus helping to ensure that the Masterplan does not result in any existing environmental problems to worsen.

The SEA TOR requires that information on the baseline environment be focused upon the relevant aspects of the environmental characteristics of areas likely to be significantly affected and the likely evolution of the current environment in the absence of the strategic action i.e. the masterplan. Any information that does not focus upon this is surplus to requirements; therefore, the SEA of the masterplan focuses on the significant issues, disregarding the less significant ones.

## 5.2 SEA scenario analysis

Assessment of likely impacts of the strategic actions against the SEA objectives provides the basis for the evaluation of the planning scenarios and planning solutions considered and/or proposed in the MP. Section 5.1 of this chapter describes the SEA objectives used for these analyzes.

At plan development, several alternative scenarios of SWM for the Western Province have been considered. These alternative scenarios are more or less focused on developing alternative technical options for an integrated SWM system that would be viable in the current setting in the waste sector than focusing on more comprehensive planning scenarios. These alternatives have been developed, with consultation of the stakeholders, to align with the need of the Western Province for an efficient SWM system and the waste management policies.

In the SEA, these alternative scenarios were assessed for their potential environmental impacts in comparison to the Business as usual (No plan option) scenario in which the SWM systems are maintained at the current level. Other alternative scenarios were not considered as such alternatives that could replace the proposed action of the MP were not available and/or such alternatives could not be developed because there was no sufficient background/ input data to make assumptions of potentially feasible and environmentally friendly alternatives. Section 5.2 describes the alternative scenarios and sections 5.3 and 5.4 present the assessment and comparison of these scenarios.

Of the alternatives considered in planning stage of the MP, alternative B has been selected as the preferred alternative based on its technical efficiency and financial feasibility in addressing the SWM problem in the Western Province. Section 5.4 of this chapter analyses the likely effects of this preferred alternative on the natural and socio-economic environment in relation to the SEA objectives in detail. A further evaluation on the compliance of the proposed activities to existing programs, policies and sustainable development goals in the sector is given in section 5.5.

### **5.3 SEA objectives and indicators**

The SEA objectives are defined as desirable future outcomes in relation to each environmental receptor leading to sustainable development. Specific SEA objectives further describe a SEA objective as targets/thresholds to be used for measuring progress in achieving SEA objectives and each target can be measured using indicators. An environmental indicator is a gauge that measures the level of accomplishment of specific objective. For each SEA objective, one or more indicators are defined. These and include the cause indicators representing human activities and processes influencing the environment, consequence indicators representing the state of the environment; the response indicators representing political and institutional actions aimed at changing the consequences to the environment (Josimovic et al., 2015).

The SEA objectives help assessing if a proposed strategic action of the MP benefits the environment, comparing possible effects of proposed alternatives, and suggesting improvements to the proposed action. General and specific SEA objectives and indicators for our SEA were set in accordance with the national regulations and standards for SWM and requirements and purposes of environmental protection, as stated in national policies, plans and programs for SWM in Sri Lanka. Specifically, these objectives are based on the policy and strategies described in Chapter 3.



**Table 5-1 SEA objectives and indicators used in evaluation of project alternatives and proposed actions**

Environmental receptors	General SEA objectives	Specific SEA objectives	Indicators
<b>Water</b>	Reduce surface water and ground water pollution to the level that will not affect their quality	Discharge of polluting matters derived from activities related to waste in water should be aligned with national policy and regulations.	National Environmental (Protection and Quality) Regulations stipulated by Gazette Extraordinary No. 2264/17 dated 27-01-2022 (list V).
		Ensure that water quality downstream of waste facilities is not deteriorating	Water quality downstream from the waste disposal location as specified in National Environmental (Ambient Water Quality) Regulations, No. 01 of 2019.
		Mitigate negative impacts of waste on surface water and quality of ground water	Reused and recycled water as a result of waste management activities.
<b>Air and climate change</b>	Limit air pollutant emissions to the level that will not affect air quality	Air pollutant emissions from activities related to waste must be aligned with national policy	National standards stipulated by National Environmental (Stationary Sources Emission Control) Regulations No. 2126/36 dated 05-06-2019.
		Reduce open burning of solid waste and refuse	% Reduction in open burning
		Reduce uncontrolled disposal of waste	% Reduction in uncontrolled waste disposal
		Maximize waste-to-energy potential	% Waste incinerated and compliance with National Environmental (Stationary Sources Emission Control) Regulations No. 2126/36 dated 05-06-2019.
	Reduce greenhouse gas emissions	Reduce emissions of CH <sub>4</sub> , NO <sub>x</sub> , SO <sub>x</sub> and other GHGs from waste facilities	National Environmental (Ambient Air Quality) Regulations, 1994 amended in 2008.
		Meet national goals for waste management including the use of landfill gas	National Waste Management Policy 2019
		Use of renewable sources of energy	% Increase in Renewable Energy Sources (RES) share in energy balance
<b>Land/Soil</b>	Minimize soil contamination by	Surface area and quality of land used for activities related to waste should be in accordance with best practices	National standards: National Land Use Policy of Sri Lanka.

Environmental receptors	General SEA objectives	Specific SEA objectives	Indicators
	establishing an effective and environmentally friendly waste collection, transportation and disposal/storage/treatment system	Minimize the area that becomes polluted with waste related activities	% Share of degraded areas as a result of waste management activities
<b>Biodiversity and nature conservation</b>	Reduce harmful effects on biodiversity	Build new waste facilities on environmentally insensitive sites	Number of endangered flora and fauna that may be affected as describe by NEA and subsequent regulation.
		Provide measures for the compensation for damages caused to habitats	Area of all protected natural areas that may be affected
<b>Landscape</b>	Protection of landscape and natural resources	Protect landscape by carefully selecting sites for new waste facilities	Number of places/valuable vistas threatened by inadequate waste disposal
		Maximize the remediation of closed landfills to preserve landscapes	% Share of re-cultivated areas in the overall area of degraded regions
		Minimize inadequate waste management	Increased level of waste management in accordance with best practices
<b>Cultural and historical heritage</b>	Protect cultural heritage	Safeguard unprotected important cultural properties	Number of cultural properties protected
<b>Transportation</b>	Minimize environmental impacts of transportation of waste	Reduce waste vehicle traffic by building the transfer stations for waste reloading and long-distance waste transport	Number of transfer stations build/improved
		Use waste treatment site in proximity as much as possible	Number of transfer stations build in close proximity to waste collecting area
		Minimize generation of waste to reduce waste transportation	% Waste generated
<b>Human health</b>	Human health protection	Minimize the risk and impact of waste-related accidental emissions	Frequency of respiratory diseases (%) close to SWM facilities
		Minimize the level of environmental problems due to waste-related activities	Frequency of diseases that can be associated with SWM
			Number of people affected by SWM activities
			Number of households displaced as a result of SWM activities

Environmental receptors	General SEA objectives	Specific SEA objectives	Indicators
		Establish criteria for landscape protection in selecting sites for waste facilities	Waste facilities are established in areas that does not affect human health and economic activities
<b>Socio-economic development</b>	Stimulate economic growth and employment in the region	Stimulate job creation in waste management sector	Number of new employment opportunities created as a result of SWM activities (collection, sorting, private vendors for recycled waste, income earned by private landowners of dumping sites)
		Meet national goals for recycling and reuse of packaging waste	National goals set out in National Action Plan on Plastic Waste Management 2021-2030
	Improve knowledge, increase investment in human capital, equipment and infrastructure	Enable acquisition of new knowledge at local institutional level	Number of employees trained/have access to new knowledge in waste management
		Increase investment in developing the waste management system	Increase in funding, human capital, equipment and infrastructure for waste management
	Improve waste management and monitoring services	Improve waste management system	Establishment of integrated waste management system
			Enhanced methods for charging for waste collection
		Improve monitoring of the environment and waste management	Designing an improved monitoring plan
	Increase awareness and provision of information to the public	Establish information systems for waste management	Establishment of a data base for waste management
		Create educational programs	Number of educations programs established

## 5.4 Master Plan options

Below is the description of the alternative scenarios assessed in the SEA. These include the 3 SWM systems considered in the MP as alternative means for the western province and the “Business as usual (No plan option)”. The “Business as usual” option is the continuation of the existing SWM scenario in the Western province as an alternative to preparing a new plan. The 3 alternatives have been developed as improvements to SWM from baseline. The SWM strategies or the degree to which these strategies are implemented may differ across the scenarios, and their technical features are briefly described below in the following sections.

### 5.4.1 Business as usual option

The current waste management system continues will be continued without major changes. The key features of the business-as-usual option are;

- Total capacity of LAs & cluster-based composting facilities is 324 TPD. Collected organic waste that exceeds the total capacity of composting facilities will be transported and disposed of at Aruwakkalu landfill. The total capacity of composting facilities (324 TPD) will remain the same in the future.
- Capacity of Western Power at Kerawalapitiya (Western Power Company) WtE facility is 750 ton/day which will mainly treat mixed waste including other waste and organic waste from Colombo Municipal Council (CMC), but burnable waste collected from facilities of surrounding LAs is also be incinerated. The thermal recovery capacity will not increase compared to the current level (750 TPD).
- Waste reduction and improved collection are not envisaged.
- Recyclables will mainly be sorted in the recycling facilities of each LA. The capacity of these facilities will increase in line with the amounts of recyclables separated and collected.
- Non-burnable waste, residues from intermediate treatment facilities, and untreated waste will be transported to Aruwakkalu Sanitary Landfill in Puttalam.

The Figure 5-1 shows the waste material balance and flows of the business-as-usual option which will be achieved by year 2042.

Baseline (Without MP) as of 2042

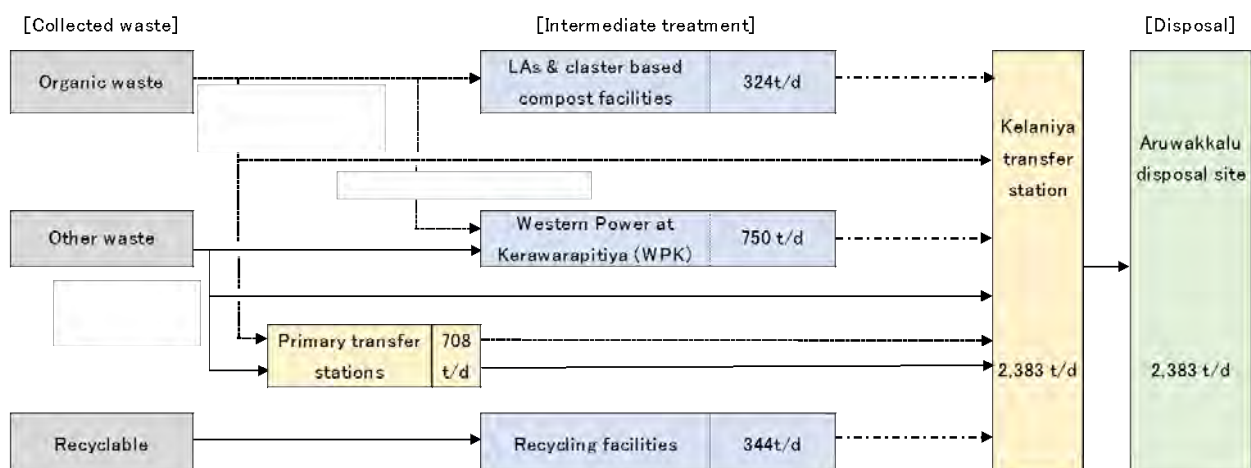

Figure 5-1 Waste material balance and flows of the business-as-usual option

### 5.4.2 Option A: 750 TPD WtE & 930 TPD composting

Alternative A aims for implementation of waste reduction and improved collection. The key features of the option A are;

- Waste reduction and improved collection are considered.
- The Kerawalapitiya WtE facility (750 TPD) will continue to treat mixed waste including other waste and organic waste from CMC, but burnable waste collected from facilities of surrounding LAs are also be incinerated. The thermal recovery capacity will not increase compared to the current level (750 TPD).
- The total capacity of LAs and cluster-based composting facilities will be increased to 930 TPD. Collected organic waste that exceeds the total capacity of composting facilities will be transported and disposed of at Aruwakkalu Sanitary Landfill in Puttalam.
- Recyclables will mainly be sorted in the recycling facilities of each LA. The capacity of these facilities will be increased in line with the amounts of recyclables separated and collected.
- Non-burnable waste, residues from intermediate treatment facilities, and untreated waste will be transported to Aruwakkalu Sanitary Landfill in Puttalam.

The Figure 5-2 shows the waste material balance and flows of the option A which will be achieved by year 2042.

Alternative A as of 2042

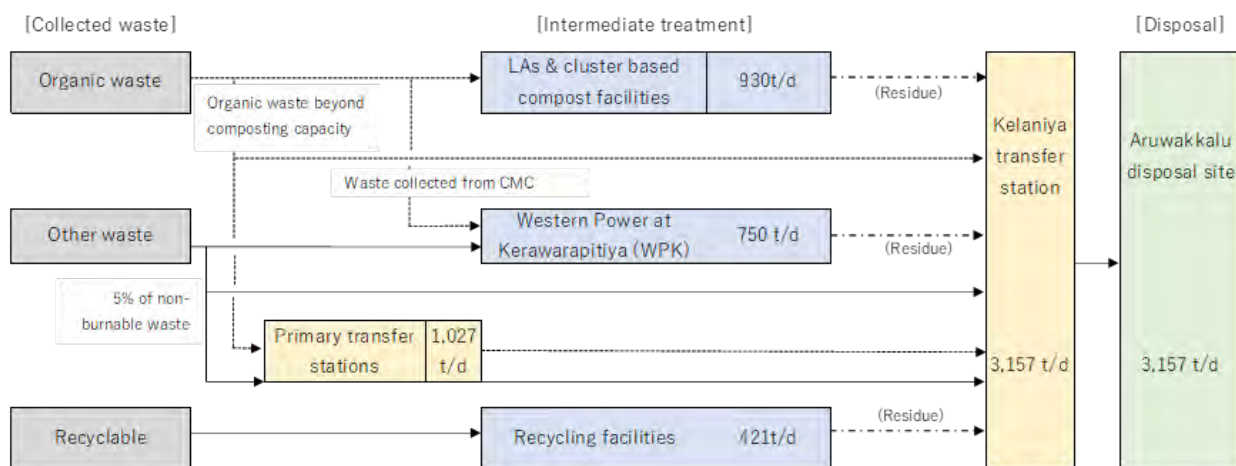

Figure 5-2 Waste material balance and flows of the option A

### 5.4.3 Option B: 2900 TPD WtE & 1326 TPD composting

Alternative B aims for implementation of waste reduction and improved collection. The key features of the option B are;

- Waste reduction and improved collection are considered.
- Mixed waste collected in CMC, as well as burnable and 20% of organic waste collected in LAs (excluding CMC) will be treated in Thermal Recovery Facility (TRFs), and the thermal recovery capacity will be increased.
- At the end of year 2042, the total capacity of thermal recovery facilities will be increased to 2,900 TPD.
- The total capacity of composting facilities will be increased to 1,326 TPD that includes 930 TPD of composting by LAs and 400 TPD of composting by cluster-based composting facilities, and 400 TPD at the waste parks' composting facilities. The amount of organic waste generated does not exceed the capacity of the composting facilities and therefore no organic waste is disposed of at the final disposal site.
- Recyclables will be sorted in the recycling facilities of each LA and in MRFs located in waste parks. Waste parks' MRFs will be constructed with a capacity of 30 TPD in each location. In addition, the capacity of LAs' recycling facilities will increase in line with the amounts of recyclables separated and collected.
- Non-burnable waste and residues from intermediate treatment facilities will be transported to Aruwakkalu Sanitary Landfill in Puttalam.
- Figure 5-3 shows the waste material balance and flows of the option B which will be achieved by year 2042.

Alternative B as of 2042

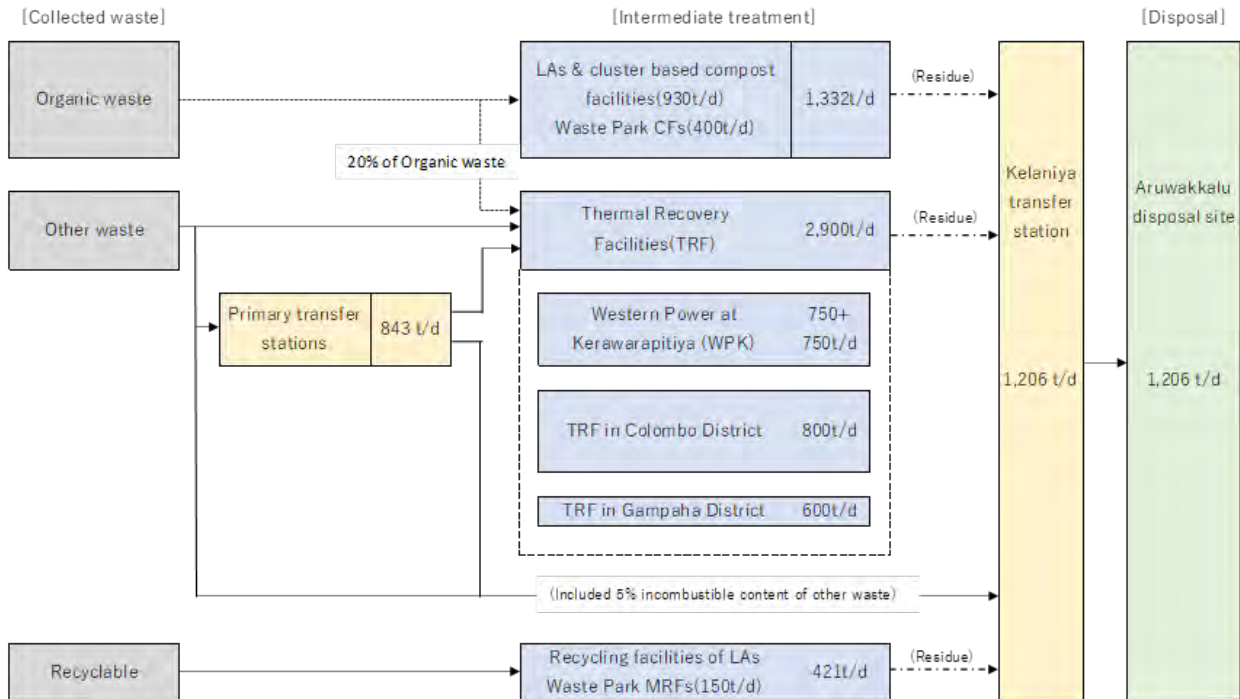

Figure 5-3 Waste material balance and flows of the option B

5.4.4 Option C: 3300 TPD WtE & 930 TPD composting

The alternative C aims for implementation of waste reduction and improved collection. The key features of the baseline alternative are;

- Waste reduction and improved collection are considered.
- Mixed waste collected within CMC and the burnable waste collected in other LAs, and organic waste that exceeds the capacity of the composting facilities will be treated in TRFs, and the thermal recovery capacity will be increased to 3300 TPD.
- The total capacity of LAs and cluster-based composting facilities will be increased to 930 TPD. Collected organic waste that exceeds the total capacity of the composting facilities is transported to be treated at TRFs.
- Recyclables will mainly be sorted in the recycling facilities of each LA. The capacity of these facilities will increase in line with the amounts of recyclables separated and collected.
- Non-burnable waste and residues from intermediate treatment facilities will be transported to Aruwakkalu Sanitary Landfill in Puttalam.

The Figure 4-5 shows the waste material balance and flows of the option C which will be achieved by year 2042.

Alternative C as of 2042

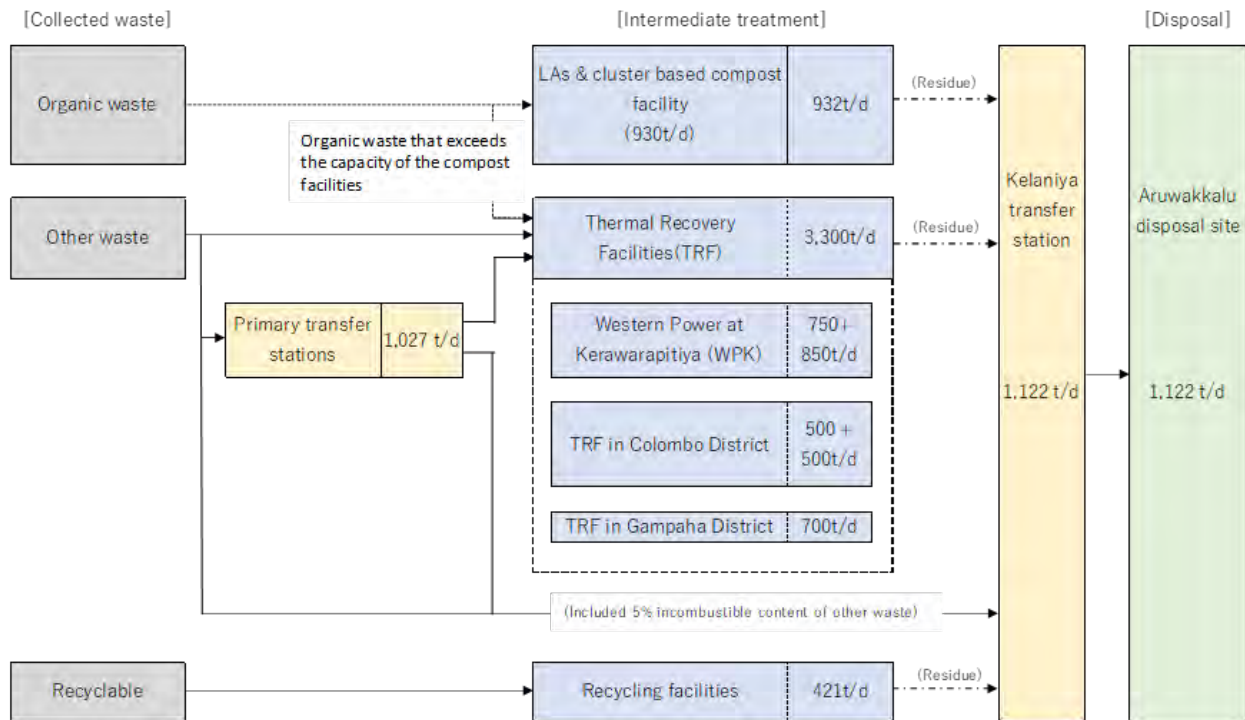

Figure 5-4 Waste material balance and flows of the option C

### 5.5 Evaluation of alternatives/options

As mentioned in Section 5.4, the baseline scenario (business as usual) and three options were considered during the MP planning stage. In the SEA evaluation section, the term options here is used for different alternatives. In the MP, the options summarized above are evaluated based on technical and financial feasibilities. National policies intended for SWM in Sri Lanka, such as the National Environmental Policy (2022), National Waste Management Policy (2019), Sustainable production and consumption policy (2018), National action plan on plastic waste (2020), emphasize the need of adopting holistic approaches that focus on the lifecycle of products and waste hierarchy in developing SWM systems and the importance of integrated SWM systems that promote sustainable use, management and protection of environmental resources. Key strategies of the MP (pp 18) are intended for developing an efficient waste management system that is in line with the above policy guidelines. Each of the technical alternatives considered in



the MP therefore include strategies based on lifecycle of products, circular economy, waste hierarchy, integrated system for SWM, and simultaneous approach for SWM.

As per the national policies, sustainable SWM systems need to promote maximum conservation of resources. In particular, SWM systems can adopt the most suitable strategies focusing on waste hierarchy. In this context, sustainable use of resources implies that minimizing waste generation followed by 3R concepts are preferred to waste disposal and energy recovery. All the alternative scenarios in the MP include strategies based on the waste hierarchy-waste reduction, 3R approaches, energy recovery and disposal. However, Option B adopts strategies that enable most sustainable management of waste. Compared to other alternatives, Option B promotes greater waste reduction, greater recycling, optimum energy recovery and less disposal.

In the SEA, each of the SWM alternatives were assessed against the SEA objectives. Both positive and negative impacts were considered along with the significance and uncertainties of the environmental impacts. The results are summarized in the Table 5-2, and the six-color coding system below depicts the results.

	<b>Likely to improve the status of SEOs</b>	Implies that the proposed action is likely to improve the status of an indicator
	<b>Likely to adversely affect the status of the SEOs and unlikely to mitigate</b>	Implies that the proposed action is intrinsically likely to adversely affect status of an indicator
	<b>Likely to adversely affect the status of the SEOs but likely to mitigate</b>	Implies that the proposed type of action envisaged has a definite potential to give rise to adverse environmental effects; however, proposed action can be sustainably accommodated.
	<b>Not likely to affect the status of the SEOs</b>	Implies that there is no significant pathway by which this type of action is likely to significantly affect any of the indicators.
	<b>Not considered in the development scenario</b>	Implies that the proposed type of action has not been included or considered in the development scenario.

**Table 5-2 Likely effects of proposed alternatives**

Planning strategies	Business as usual alternative					Alternative A				
	Water	Air/ climate change	Soil/ biodiversity/ landscape	Human health	Socio-economic	Water	Air/ climate change	Soil/ biodiversity /landscape	Human health	Socio-economic
Promote waste reduction at generation sources										
Promote waste separation and reduction at the discharge stage										
Improve waste collection and transfer system										

Planning strategies	Business as usual alternative					Alternative A				
	Water	Air/ climate change	Soil/ biodiversity/ landscape	Human health	Socio-economic	Water	Air/ climate change	Soil/ biodiversity/ landscape	Human health	Socio-economic
Promote recycling at intermediate treatment facilities	Yellow	Yellow	Yellow	Yellow	Yellow	Yellow	Orange	Orange	Yellow	Green
Reduce waste to be disposed	Yellow	Red	Red	Red	Yellow	Yellow	Orange	Orange	Orange	Yellow

Planning strategies	Alternative B					Alternative C				
	Water	Air and climate change	Soil/ biodiversity /landscape	Human health	Socio-economic	Water	Air and climate change	Soil/ biodiversity/ landscape	Human health	Socio-economic
Promote waste reduction at generation sources	Green	Green	Green	Yellow	Green	Green	Green	Green	Yellow	Green
Promote waste separation and reduction at the discharge stage	Yellow	Yellow	Yellow	Yellow	Green	Yellow	Yellow	Yellow	Yellow	Green
Improve waste collection and transfer system	Green	Green	Green	Green	Green	Green	Green	Green	Green	Green
Promote recycling at intermediate treatment facilities	Yellow	Orange	Orange	Yellow	Green	Yellow	Yellow	Yellow	Yellow	Green
Reduce waste to be disposed	Yellow	Orange	Orange	Orange	Yellow	Yellow	Orange	Red	Yellow	Yellow

It is noted that the alternative scenarios considered during the MP preparation may have different environmental impacts. However, continuation of the base case scenario of the “Business as usual” without implementing any SWM strategy will aggravate the existing environmental issues in the Western Province. Therefore, implementing the MP will be preferred to “No action”.

Three strategic alternatives outlined in the MP are compared in terms of their potential environmental and health effects and against the business-as-usual alternative (this includes the trends identified via the baseline analysis at the scoping stage). The following scale and symbols have been used to denote the change that could be expected from the realization of the alternatives against the business-as-usual one.

- ❖ “ 0 ” the same state

- ❖ “ - ” a change to a worse state
- ❖ “ + ” a change to a better state
- ❖ “ ? ” uncertain

Effect/risk	Business as usual	Alternative A	Alternative B	Alternative C
<b>General</b>	Without the MP implementation, waste generation, improper disposal, insufficient treatment, and insufficient material recovery will continue to increase, and pollution impacts intensify. All components of the environment will be negatively affected.	This alternative aims for waste reduction and improved collection, thus will be beneficial compared to the baseline. It does consider increasing composting capacity to some extent but not thermal recovery capacity. Increased collection with insufficient amount of waste treatment, specifically of untreated organic waste, shall lead to more final disposal, less material recovery, and health risks, thus causes considerable negative impact on environment.	Preferred to the baseline and other alternatives. These alternative aims to reduce waste generation, increased collection, recycling, intermediate treatment, thermal recovery, and material recovery and reduce final disposal. These planning solutions will encourage proper SWM, thus causes lower environmental impacts.	Preferred to the baseline; Increased waste collection and treatment leads to lower disposal, but increased waste treatment via thermal recovery may cause relatively more damage to the environment unless precautionary actions are not taken. Further, low impact actions such as composting, and material recovery are lower compared to Alternative B.
<b>Water</b>	-	+	+	+
	Pollution of surface and groundwater will continue due to illegal dumping and improper management at waste facilities and landfills.	Pollution of surface and ground water due to leachate from the open dumpsites will reduce to a substantial level; however, considerable surface and ground water pollution may occur due to landfilling of organic and residual waste.	As a result of increased waste collection, treatment and control of inappropriate disposal, pollution of surface and ground water will reduce significantly. However, surface and ground water pollution may occur due to landfilling of residual waste.	Pollution of surface and ground water shall reduce considerably with improved waste collection and recycling systems. However, unless properly managed, impact on water will occur through water abstraction for cooling etc.
<b>Air and Climate change</b>	-	-	+ / 0	-
	Air pollution and GHG emissions will continue due to Improper disposal and uncontrolled emissions	Increased final disposal demands more waste transported to sanitary landfill, and	Improved waste collection, transportation and treatment system shall lead to reduced	As in Alternative B, improved collection, treatment and proper disposal of waste will have

Effect/risk	Business as usual	Alternative A	Alternative B	Alternative C
	from decomposing waste.	emissions from transported waste may cause local air pollution along transportation routes. Also, air pollution shall occur due to emissions from the landfill.	generation and proper disposal. Further, sufficient treatment of solid waste reduces atmospheric emissions and the hazardous materials available in the landfills. Therefore, implementing this alternative shall have positive impact on GHG yet the emissions from incineration projected to be greater than baseline and Alternative A.	positive impacts on air quality. However, Waste-to-energy incineration will, to a certain extent, lighten the burden of sources of energy, yet it will not have significant impact on GHG balance. Increased thermal recovery elevate the emissions than all other Alternatives.
<b>Soil/ land/ Biodiversity and nature conservation</b>	-	-	+	-
	Inefficient and uncoordinated waste management practices will continue, and because of these large areas of land will continue being polluted. Pollution in vicinity of landfills and waste transportation roadside areas will persist. Further increase of uncontrolled dumping has negative impacts on biodiversity.	Increased final disposal demands more waste transported to the landfill, and thus may increase pollution in lands along transportation routes. Increased capacity of the landfill to accommodate increasing disposed waste shall cause more land area being polluted and negative impacts on biodiversity if the facility expands into sensitive areas such as wetlands.	Increased collection and treatment and reduced disposal will have overall positive impacts on soil, land, and biodiversity. Material recovery shall add additional benefits. However, increased construction and/or expansion of TRFs shall cause negative impacts on environment. Remaining ashes needs to be disposed in environmentally sound manner at Aruwakkalu or elsewhere.	Implementation of this alternative shall result in increased level of thermal treatment compared to other alternatives, therefore, reduce the amount of waste to be disposed, thus, land utilization areas will significantly decrease. However, there is a substantial risk of the soil and land being polluted from the waste by-products from the thermal recovery. New secure disposal or processing facilities may need to manage huge quantities of incineration ash in environmentally sound manner which requires new land acquisition.
<b>Human</b>	-	-	+	0/-

Effect/risk	Business as usual	Alternative A	Alternative B	Alternative C
<b>health</b>	Sufficient number of precautionary actions to reduce health risk and occupational hazards will not take place, therefore, community health and life quality will continue to deteriorate.	Improved waste collection will be beneficial for reduced health risks to the general population in the western province. However, the substantial amount of untreated organic waste to be dumped in the landfill may pose high health risks (diseases, hazard material) to communities in the vicinity and employees of landfill.	Improved waste collection, recycling and proper management at waste facilities shall reduce health risk to communities in general. However, local negative impacts may occur unless emissions from treatment facilities and the landfill are properly controlled.	Improved waste collection, recycling and proper management at waste facilities shall reduce health risk to communities in general. In particular, reduced amounts of untreated organic waste dumped at the landfill shall lead to lowering health hazards. However, local negative impacts, especially in a major part of Western province, may occur unless emissions and ash from thermal recovery are properly controlled.
<b>Socio-economic</b>	-	+/0	+	-
	In the absence of comprehensive and regulated waste collection, the environmental/health costs in the long run would be enormous, and eventually this affects the economic and social well-being. 1. Large areas and community dwellers will be under the negative impact of unsorted and uncontrolled waste. 2. Economic opportunities to get the best use of waste as a resource will be lost.	<u>Advantages:</u> 1. Ensured improvement in waste generation reduction, collection, and management 2. Improved impact on environment and health of the nearby communities 3. Employment opportunities and legalization of waste sorting, recycling, etc. <u>Deficiencies:</u> 1. Relatively lower composting, lower recycling, lower thermal recovery and zero mineral recovery is a missed opportunity for optimal resource use and economic gains.	<u>Advantages:</u> Overall improvement from the baseline in health and environment compared to other alternatives. <u>Deficiencies:</u> Negative impacts from this alternative may occur unless proper measures are taken to address institutional and legal issues and environmental impacts of proposed constructions and waste management practices that may hinder implementation of the MP.	<u>Advantages:</u> Improved impact on human health – air, water and soil, compared to the base line and alternative A. <u>Deficiencies:</u> This alternative delivers certain environmental benefits but with risks of; 1. Diverging resources from more fundamental waste management components (composting, material recovery) 2. Increased pollution due to thermal treatment which may and has an impact on

Effect/risk	Business as usual	Alternative A	Alternative B	Alternative C
		<p>2. Implementing this alternative involves more waste transportation and disposal, thus demands more investment on waste transportation and disposal systems over other strategies.</p> <p>3. Waste sector in the western province suffers from lack of public awareness, institutional and legal arrangements for reduced generation and restricted budgets. Successful implementation of this alternative may be affected unless measures are taken to ensure greater awareness of the public about fundamental waste management components at generation sources, sufficient economic approaches to discourage waste generation and proper disposal, and sufficient investments are made to improve waste collection and transportation systems.</p>		<p>community and waste workers, worsening the attractiveness of life and environment for dwellers.</p>

As for the differences among the proposed technological options, the Business as usual (no plan implemented) is clearly the least desirable. Continuation of the base case scenario of the “Business as usual” without implementing any improved SWM strategy will aggravate the existing environmental issues in the western province. In contrast, the 3 Alternatives consider different planning solutions promoting 4R concepts and integrating simultaneous approaches to SWM which are improvements from “Business as usual” scenario, therefore would contribute to

improve the environmental and socio-economic aspects compared to the “Business as usual” scenario”. In general, planning solutions considered in these options shall lead to cleaner environment, less pollution, lower health risks, increased revenues for SWM via fees, increased employment opportunities, increased resource use, and improved waste management systems. Environmental risks that may be associated with implementation of any planning solutions will almost certainly be significantly smaller than in case of continuation of existing practices and/or are likely to be minimized/mitigated if proper measures are taken. Therefore, implementing any of the three options is preferred to “Business as usual” scenario.

## 5.6 Summary of alternative comparison

From the discussion of proposed alternatives, it appears that the continuation of business-as-usual alternative which is a centralized system based on Aruwakkalu landfill served by the rail transport is not considered to be efficient, or even practically feasible in Western Province, taking into consideration of the huge quantities of waste to be transported to the landfill and absence of appropriate measures to recover resources from organic, recyclable and burnable waste in the foreseeable future. In terms of GHG emission reduction, water pollution and biodiversity preservation, the use of Aruwakkalu landfill makes it possible to avoid environmental issues in other locations. Moreover, in all alternatives, the most important explicit environmental benefit is associated with the commitment to close and clean-up existing uncontrolled dump sites.

All the alternatives are vulnerable to factors like climate, economic downfall of the country, and level of implementation of other key development activities in the Western province. Decentralized regional waste transfer system and centralized waste transfer to Aruwakkalu via Kelaniya transfer station can constitute acceptable options for organizing waste management system in Western Province. However, any failure or non-functionality of railroad network between Kelaniya and Aruwakkalu will hinder the smooth functioning of entire waste collection and disposal system.

In terms of environmental impacts, either alternative is better than continuation of the business-as-usual alternative. Centralized systems with one landfill can in theory be better supervised for the implementation of sound environmental management, whereas it will probably be more prone to risks associated with transportation of waste on longer distances. It is expected that there will be an increased number of vehicles and longer transportation distances to regional transfer stations and centralized transfer station which will increase environmental pressure on Western Province. Collection vehicle emissions will eventually pollute the environment, soil, air, increase emissions, water resources. From the holistic environmental perspective, in all alternatives, there are considerable environmental benefits in increasing the organic waste recovery through composting from present status to several fold increase, increasing the waste

collection coverage, increasing resource recovery by recycling, and increasing the thermal resource recovery by waste to energy. The alternative B has better environmental benefits over other alternatives because it has proposed a system with well-adjusted integrated waste treatment solutions in which the system is not heavily depended on one solution (composting, thermal recovery, or landfilling) but realistically divert waste to three treatment solutions.

From the perspective of soil contamination, water pollution, and public nuisance, disposing waste to a modern sanitary landfill will significantly reduce the level of pollution in dumpsites and adjacent areas. At the same time, waste transportation through railroad will also allow avoiding the danger of pollution of roadside lands and illegal waste disposal as currently waste collection especially in remote rural areas is not being controlled and it is not excluded that dishonest waste generators/collectors dispose of waste directly into the nearest dumps/ vacant land/ water source. The alternatives B and C has greater advantage over business-as-usual and alternative A because former alternatives have less amount of waste to be landfilled in Aruwakkalu sanitary landfill. The comparison between alternative B and C showed that alternative B has an advantage in term of type of waste which is incineration ash to be landfilled. However, inappropriate disposal of residual ash from incineration facilities will cause severe land, soil and water contamination; thus, all alternatives are posing a risk of contamination if not properly managed.

Socio-economic perspective suggests that a de-centralized waste collection and treatment option is more beneficial since it provides Local Authorities with the opportunity to develop their waste management capacities, improve infrastructure, etc. The Aruwakkalu landfill and transport infrastructure between Kelaniya Transfer Station and Aruwakkalu landfill, which are still under construction, would require allocation of substantial resources to address this issue first, at the expense of other priorities.

Environmental risks that may be associated with poor leachate management on the landfill causing pollution will almost certainly be significantly smaller than in case of continuation of existing practices. Technological alternative consisting of pre-treatment like composting reduces the amount of biodegradable waste, thereby reducing the leachate. Increase of source segregated waste collection prevents potentially hazardous waste contaminants such as batteries, solvents, paints, light bulbs etc. to reach the landfill sites. Biological treatment by composting could also assist in the reduction of the amount of waste and emission of filtrate, methane and greenhouse gases into the air. Therefore, it is apparent that the alternative with maximum organic waste recovery solution, alternative B, is considered as useful and environmentally beneficial than other two alternatives.

As for the Waste-to-energy solutions, the incineration of waste might to a certain extent, offset other sources of energy (with small positive effect in terms of GHG emission balance), and it can also reduce the volume of waste to be deposited to landfills (thus saving landfill capacity).



However, there are significant risks associated with operating waste incineration technologies without context provided by functioning sound waste management system. This risk might include toxic air emissions (namely when technology is not properly operated), lack of capacity for the final disposal of incineration toxic residual ash (which needs to be treated as hazardous waste), and social and economic impacts on local communities (risks to public health, property prices decrease). Another important risk is that operation of large incinerator might undermine implementation of the separate waste collection and recycling initiatives as the economy of the incinerator project requires constant supply of waste with preference towards energy-rich components (e.g., paper, plastic). The alternative C is proposed to combust a sizable portion of biodegradable waste that can be effectively treated by composting. Therefore, in agreement with economic reasoning provided by the MP, the SEA regards incineration shall only be used to treat non-compostable, non-recyclable yet burnable waste as proposed in alternative B. Therefore, alternative analysis suggest that the alternative B has comparative advantages over business-as-usual and alternatives A and C.

### 5.7 Potential environmental and social impacts of the selected planning option in the MP

This is a strategic level assessment of the potential impacts as is usually done in SEA, but not an in-depth analysis done in an EIA. This stage includes tracking the environmental trends which could be a negative trend (consequence) or a positive trend (result) of implementing the planning solutions. A qualitative assessment was carried out in SEA to evaluate the overall environmental impacts of the proposed actions of the selected option B in the MP in comparison to “No action” option (the status quo). Likely positive and negative impacts were identified using the matrix method, in which the planning solutions of the MP were intersected with the SEA objectives. The detailed matrix is presented in Appendix 5. Table 5-3 below is the summary of the key likely effects of the planning solutions, depicted by the four-colour coding system mentioned below.

	Likely to improve the status of SEOs
	Likely to adversely affect the status of the SEOs and unlikely to mitigate
	Likely to adversely affect the status of the SEOs but likely to mitigate
	Not likely to affect the status of the SEOs

**Table 5-3 Key likely effects of MP solutions**

Key strategy	Planned solutions	Water	Air and climate change	Soil/ biodiversity / landscape	Human health	Socio-economic
Promote waste reduction, separation and recycling at generation sources	Promote waste reduction at generation sources	Green	Green	Green	Green	Green
	Promote waste separation and recycling at discharge state	Green	Green	Green	Green	Green
Improved waste collection and transfer system	Expand the solid waste collection area and waste collection system	Green	Green	Green	Green	Green
	Construction of primary transfer stations	Yellow	Yellow	Yellow	Yellow	Green
Promotion of recycling at intermediate treatment facilities	Increase the capacity of Thermal Recovery Facilities	Orange	Red	Yellow	Green	Orange
	Increase capacity of composting and recycling facilities	Orange	Orange	Yellow	Orange	Yellow
Minimize final waste disposal	Increase the capacity of the sanitary landfill	Orange	Orange	Yellow	Orange	Orange
	Closure of dumping sites	Green	Green	Green	Green	Green
Establishment of data management system	Establishment of data management system	Yellow	Yellow	Yellow	Yellow	Green

The key likely impacts of the selected planning option (Option B: 2900 TPD WtE & 1326 TPD composting) is described below (Table 5-3).

**5.7.1 Promote waste reduction at generation sources**

- a) Reducing the overall production of waste at source of generation will reduce the impact of collections and waste treatment capacity required. Waste minimization will reduce the requirement for waste management and increased recycling at sources of generation should reduce residual waste and problems associated with illegal dumping, littering and incidence of mini-dump yards. Reducing waste to landfill will have a positive impact upon overall GHG emissions thereby improving residents’ quality of environment.
- b) The likely impacts of the components are uncertain as institutional changes in tariff collection (EPR and volume-based tariff) may either improve or worsen the collection rates. The system of tariffs may have positive impact of improved waste collection practice; however, it can also have negative impact on vulnerable groups of population which will be unable to pay higher tariffs, therefore it is important to apply an approach which would differentiate between the groups in the society. It is also, important that a

chosen mechanism allows directing certain part of collected payments to the improvement of the waste management sector.

- c) The technical assistance, promotion of institutional and legal regulation as well as public-private partnerships and public awareness-raising is expected to contribute to more efficient waste management system and thus lead to the likely positive effects on biodiversity, air and water quality, and land resources. It also represents an opportunity to implement the public healthcare program aimed at public awareness raising on the health aspects related to waste management.
- d) There are challenges in conceptualizing and implementing eco-friendly lifestyles to minimize waste generation in developing economies. Although there are many promising policies and practices in the world, eco-friendly lifestyles are not currently always considered from a holistic perspective and frequently emphasize one method or approach. Aspirations of ever-expanding urban middle class lifestyles remain dominant, rather expanding and thinking is generally focused on typical consumption domains such as buildings, consumer goods, food, mobility, healthcare, and leisure. Moreover, there are considerable challenges in implementing eco-friendly lifestyles policies and practices both in evaluation and scaling. There are several means of evaluating eco-friendly lifestyles policies and practices; however, the adoption of such methods is not widespread and are frequently complex and labor intensive. Thus, promotion of eco-friendly lifestyles needs to have a broad shared understanding of the need to combine wellbeing with respect for ecological limits. However, any attempt to promote eco-friendly lifestyles will have a positive impact on waste reduction, recycling, and all aspects of environmental pollution control.
- e) No risks regarding the key environmental, health or socio-economic issues were identified with respect to the waste reduction strategy. In particular, plastic waste account for much greater impacts than beneficial use of it, thus the industries as well as exporters are expected to abide by EPR to replace plastic as much to give needed employment opportunities while moving towards sustainable development. Such concerned effort in planning is beyond eco-friendly lifestyle that require research and development in all aspects of waste management, notably socioeconomics and technical advances. It should also include reduction of food waste and complete elimination of e-wastes from the waste stream.

### **5.7.2 Promote waste separation and recycling at discharge state**

- a) Likely positive environmental effects can be expected from waste separation and recycling at the generation sources. This promotes proper disposal and reduced disposal

of waste, thereby reducing water, air and land pollution leading to cleaner environment and better health in communities. Inadequate knowledge about waste selection, sorting and recycling, and inadequate supply of waste bins may reduce the efficacy of this planning solution.

- b) By reducing waste production and increasing recycling there will be less waste sent to landfills as even the best managed waste treatment facilities such as centralized composting, centralized material recycling, incineration and sanitary landfilling activities pose a threat to atmosphere, surface water, groundwater, soil and biota. In terms of waste as a resource, run off produced from composting will contain leachate and may require managing, however the application of compost to land will also increase the fertility, soil health, and water retention capabilities of the soil, thus positive environmental effects are envisaged.

### **5.7.3 Expand the solid waste collection area and waste collection system**

- a) Likely positive effects can be expected as the enhanced waste collection system should lead to reduced improper disposal of waste. Therefore, it should result in reduced risks related to air quality, water and soil contamination, and also reduce the pressures on ecosystems. An improved waste collection system will reduce the amount of solid waste to be disposed by on-site burning, dispose in adjacent water bodies, thus it shall lead to better water and air quality. Further, improved waste collection helps reduce health pressures through enhancing the quality of environment, and by eliminating the source of infectious diseases (rodents, insects).
- b) The transport associated with the expanded waste collection may negatively affect the air quality and will also become an additional source of GHGs emissions. It can also contribute to increased traffic congestion and noise levels in populated areas. However, these likely adverse effects will be mainly of a local nature.
- c) Increased traffic on the local road and the access road leading to the transfer station poses a threat to the environment in case of an accident or disaster. However, this likely adverse effect will be mainly of a local nature.
- d) There are certain economic and operational risks which need to be carefully considered in further planning: In rainy season, the waste transport vehicles can be hindered due to closure in inaccessibility of local roads because of a bad weather condition. In such a case, the waste will not be collected for several days, even for weeks. Also, due to the highland location of some rural areas (e.g., Kalutara district), the fuel costs may increase which adds to the overall costs of the waste collection.

#### 5.7.4 Construction of primary transfer stations

- a) Likely positive impacts on air, water, and soil can be expected since new transfer stations together with the entire waste collection and recycling system should reduce waste disposal negatively affecting environmental components. Improving the quality of environment also leads to positive health effects. Establishing the transfer stations can also provide additional jobs for the local communities.
- b) Transfer stations may become additional sources of land, surface and groundwater pollution and biodiversity loss in case they are located in sensitive ecosystems, populated urban centers, protected water bodies, ecotones and coastal zones.
- e) The transfer stations may have local adverse impacts on the air quality due to dust, odor, and emissions from decomposing waste. The transport associated with the waste collection may negatively affect the air quality and will also become an additional source of GHGs emissions. It can also contribute to increased noise levels in populated areas. Together with increased noise and odors, and the possibility of becoming a source of infectious diseases, it may negatively affect the health of the population in surrounding areas. However, this likely adverse effect will be mainly of a local nature which can be effectively mitigated by adhering to standard point source pollution control guidelines and standards.
- c) There is also a risk of an increased level of infectious and non-infectious diseases among the employees of the station, if the transfer stations are not properly built, operate and monitor. However, these likely adverse effects will mainly be of a local nature.
- d) Having considered all the circumstances relating to waste transportation and transfer, the proposed cluster-based PTS model is a better and less risky short- and medium-term solution than the transportation of waste for a long distance to the Kelaniya main transfer station for landfilling. Moreover, the proposed waste collection schedule that gradually reduced the waste amounts to be landfilled at Aruwakkalu and increasing the amounts to be incinerated in TRFs will reduce the overall negative impacts from transportation. Therefore, this is a more acceptable solution for the Local Authorities in Kalutara and Gampaha districts. Transportation of waste within the 5-regions concept mainly involves transport over a short distance and therefore smaller volumes of waste to be transported to primary transfer stations. This type of transport is not a significant risk to the environment, except for the fact that there will be some increase in traffic around the location of the waste management system.

### 5.7.5 Increase the capacity of thermal recovery facilities

- a) The likely positive effects are mainly linked to the assumption that waste incineration will result in less waste to be land filled. In this case, it will reduce soil and water pollution as well as health risks (infectious diseases). Incineration may also be considered as an additional energy source.
- b) There are several likely adverse impacts:
  - i. direct adverse impacts on the air quality,
  - ii. soil and water pollution in adjacent and neighboring areas by atmospheric deposition,
  - iii. increased demand of water for cooling processes in the process of incineration may negatively affect the quantity of water resources,
  - iv. need of robust contingency and alternative waste diversion mechanism allowing waste to be diverted during regular maintenance and accidental breakdowns, and
  - v. need of secure landfilling or advance processing systems for final disposal of incineration ashes. At the MP development stage, the MP notes that the residual product from thermal recovery (ash) must be disposed of e.g. in special hazardous waste landfills. It would be useful to provide more details regarding the referred special hazardous waste landfills and how. Alternatively, ash can be further processed to use as construction material (e.g., bricks, concrete); however, it should be validated through a systematic study that ensure the products are safe and stable.
- c) Application of old technologies as well as violations of technological processes may lead to significant air pollution causing health problems (carcinogenic, embryo, genetic mutations).
- d) Incineration facilities require less land footprint than many other waste treatment (composting, recycling) and final disposal solutions (landfilling); thus, the cumulative negative impact on biodiversity and landscape will be lower. Also, the proposed TRFs are to be located in areas where substantial disturbances to natural ecosystem had been occurred due to urbanization; thus, anticipated negative effect on biodiversity is minimum.
- e) However, most of these technology related issues can be effectively managed by proper planning, design and implementing a robust operational and monitoring procedure. Moreover, except for the air pollution risk, most of these likely adverse effects will mainly

be of a local nature. For example, Refuse/residual Derived Fuel (RDF) can overcome downtime maintenance since replenishing buffer stocks takes place during such periods. Thermal power generation in the cities or proximity to them can reduce power transmission losses of the National Electricity Grid, inevitably reducing total pollution loads. Latest WTE options like combined cycle should be considered to reduce thermal pollution while increasing electrical output. Moreover, such TRFs offset coal requirements for electricity generation. TRFs will become renewable sources of energy productions with more and more organic materials replace plastics in packaging while increasing the collections of garden wastes.

### 5.7.6 Increase capacity of composting and recycling facilities

- f) Likely positive environmental effects can be expected from reduction of disposed waste via composting and recycling. Further it helps create opportunities for material recycling and local jobs.
- g) However, improper management of composting and recycling facilities shall emit leachate and emissions to water, air and land, and cause transmission of diseases to the community.
- h) The MP recognizes the need of strengthening the composting at waste parks that are to be constructed by MoUD and planned to be operated by WMA-WP. However, the locations of waste parks and specific construction/operation procedure are not visible in the MP. Therefore, the extent of environmental effects that can be caused by waste park composting facilities are uncertain.
- i) The recent abrupt agricultural policy change created a sudden boost in demand for compost consequently the market was flooded with adulterated and low-quality compost-like products to cater the demand. However, the reversing of organic agriculture policy and re-introduction of chemical fertilizer importation has created chaos in compost market. The short-term recessions are evident; however, the long-term effects are yet to be understood. The long-term economic sustainability of MSW composting systems heavily depends on marketing potential in future; therefore, the feasibility of composting as a mean of revenue generating activity is uncertain.
- j) The use of MSW compost in agriculture entirely depends on compost quality in term of nutrient status, absence of pollutants and competitive price.
- k) Waste resource recovery by private sector depends on profitability of business; thus, most of low-quality and low-value recyclable resources are not integrated into the private

resource recovery and recycling systems. Thus, the effectiveness of recycling as a mean of resource recovery is unclear.

- l) Lack of proper legal and economic payment systems to facilitate recycling may discourage composting and recycling by the private sector.
- m) Therefore, a much-desired planned approach is needed to ensure sustainable production of compost. It is best to incorporate additives and implement improved processing techniques to convert waste directly to fertilizer. In effect, inorganic fertilizer requirements can be reduced by mixing with MSW compost and biochar. Biochar biofertilizers can be produced to give much higher yields than inorganic fertilizers. Moreover, co-composting in fertilizer productions with agriculture wastes is the way forward to improve quality and reduce toxicities. Unfortunately, inorganic fertilizer subsidy has been the major drawback for sustainable agriculture productions.

#### **5.7.7 Increase the capacity of the sanitary landfill**

- a) Construction of modern sanitary landfills will have long term positive effect on the environment and public health. However, proper operational plan is needed before opening the landfill. The potential negative impacts would be related to land take, usual impacts of any construction projects, occupational and safety risks, community health and security risks, increased transportation on the roads and the associated noise, air emissions, mud and dust impacts, and further operational impacts.
- b) Generally, positive effects can be expected as the waste will not be accumulated in the vicinity of small and medium sized dumpsites and the environment shall be cleaner from waste. In particular, likely positive impacts on the water quality can be expected as properly organized sanitary landfills will reduce the amount of waste dumped to the riverbanks in the communities where landfills do not exist, and waste collection is not organized properly. Improving the quality of the environment shall lead to positive health effects. Establishing sanitary landfills can also provide additional jobs for the local communities.
- c) There is a risk of leachate leakages, therefore sanitary landfills may become as additional sources of surface and groundwater pollution in case they are located in the sanitary zones of aquatic ecosystems, flow formation zones, water protection zones, ecotones and inalienable areas. It may also result in soil contamination and in reducing land available for adjacent communities. Sanitary landfills may have local adverse impacts on the air quality. Together with increased noise and odors, and the possibility of becoming a source of infectious diseases, it may negatively affect the health of the population in surrounding areas. There is also a risk of an increased level of infectious and noninfectious diseases



among the employees of the landfills (to be operated by the communal services). However, these likely adverse effects will mainly be of a local nature.

#### **5.7.8 Closure of dumping site**

- a) This measure will have a positive impact on environment – expected reduction of the amount of the waste should result in reduced emissions to the air and water, as well as GHG emissions. It should also lead to a considerable decrease of polluted land surfaces.
- b) Implementation of GHG recovery and resource recovery through mining (e.g. Residue Derive Fuel- RDF, recyclables) from major dumpsites will have a positive impact on environment and resource circulation.
- c) The risks can be seen in relation to improper organization of dumpsite closure and reclamation activities. Thus, proper planning and feasibility study are needed before closing or rehabilitating dumpsites.

#### **5.7.9 Establishment of data management system**

- a) Development of waste data and information management system is essential for having relevant and verified information and data on produced, transported, collected, disposed, recycled etc. waste. It also will make easy transfer of information between private and public entities including Local Authorities and the Ministry of Environment resulting in reduced operational and business costs for private companies and improved data exchange with relevant public entities.

### **5.8 Conformity of MP with National Environment Action Plan (NEAP) and Nationally Determined Contributions (NDCs)**

As a part of the SEA, the compliance of the MP with the SWM objectives/targets established at the national and regional level was assessed. In particular, this assessment was performed by evaluating the planned activities in the MP as to whether they are in compliance or in potential conflict with the strategies for Holistic Waste Management in the Environment Action Plan (NEAP) (2022) and the set of waste management targets as defined in the Nationally Determined Contributions - 2021 (NDCs).

#### **5.8.1 Conformity of MP with National Environment Action Plan (NEAP)**

The NEAP presents a set of guiding principles that are aligned with the 2030 Agenda for Sustainable Development and SDGs, the National Policy on Waste Management, the National Policy on Sustainable Consumption and Production for Sri Lanka and the draft National Environment Policy. These strategies and activities are intended for holistic management of waste enabled via an integrated SWM and adoption of life cycle concepts to accommodate

resource management to achieve sustainable development. The NEAP identifies the need of supportive policy and institutional frameworks, active engagement of stakeholders, knowledge and capacity to develop plans/systems, proper use of environmentally sound technologies with technology transfer, and sustainable financial instruments to support the implementation of proposed plans for SWM. Assessing the MP against the SWM strategies of the NEAP shall inform the overall compliance of the MP with the policy objectives of the waste management sector. Results of this assessment are given in Table 5-4 below.

**Table 5-4 Conformity of MP with the National Environment Action Plan (NEAP) (2022)**

Strategy #	Action	Conformity actions of MP with Holistic Waste Management theme in National Environment Action Plan.	Relevant SDG Target/s
<b>Strategy 1</b>	<b>Ensure a sound waste administration and operation for Integrated Sustainable Waste Management, while fostering governance, information, advocacy, compliance and stakeholder engagement.</b>		
1.1	Establish a high-level national entity with effective coordination mechanism and functional arrangement for (i) waste management authorities at all levels of governance, and (ii) effective mobilization of all other stakeholders including private sector, academics and the civil society organizations (CSOs).	The MP proposed to establish a consortium consisting of all relevant stakeholders to implement the MP in which fostering governance and involvement of all stakeholders will be an integral part of activities.	16.6
1.2	Develop and implement operational roadmap for Integrated Sustainable Waste Management considering the local circumstances, in consultation with all stakeholders, with particular emphasis on effective communication of information and advocacy at all governance levels and sectors	MP proposes an integrated system which is intended to operate for 20 years and addresses and accommodates local conditions for a sustainable SWM.	11.6 12.3 to 12.5

1.3	Establish and operationalize a sound information management system (IMS), with the engagement of all PCs and LAs and sectors for waste related data and indicators, with a data tier system based on importance and availability of data.	The MP proposes to collect and integrate data related to SWM from each LA, cluster-based treatment facilities and disposal sites, and to establish a database system for the entire Western Province.	16.10 17.18
1.4	Establish and implement monitoring, reporting and verification (MRV) schemes covering all sectors and Waste streams, to ensure compliance with standards and regulations, while generating different strata of data to diagnose the ground realities.	The MP proposes to collect and integrate data related to SWM from each LA, cluster-based treatment facilities and disposal sites, and to establish a database system for the entire Western Province.	2.4 3.9 12.2
1.5	Develop and implement capacity building programs on data management for effective and sustainable operations of the IMS and MRV schemes for all stakeholder institutions at all levels of governance.	The MP proposes to collect and integrate data related to SWM from each LA, cluster-based treatment facilities and disposal sites, and to establish a database system for the entire Western Province.	16.6
1.6	Promote dissemination of information covering both formal regular communications including advocacy and informal/non-formal communications for knowledge management, with an interactive platform for information sharing among interested parties.	The MP proposes to establish a database system for the entire Western Province. As sub-activities, it proposes program development to raise awareness through activities of local governments, schools, and other related organizations.	16.6 16.10
1.7	Develop and pilot a holistic waste management (HWM) plan for local governments covering all waste streams, including domestic hazardous waste with the emphasis on localization and ground level implementation.	MP proposes an integrated system to include all the LAs in the Western province and adopts a holistic approach that promotes life cycle and 3R concepts to be implemented at all levels for sustainable SWM. Hazardous waste is beyond the scope of the MP.	3.9 6.3 11.6 12.3 to 12.5
<b>Strategy 2</b>	<b>Effect maximum conservation of resources in waste management through prevention and reduction.</b>		
2.1	Formulate and operationalize a comprehensive behavior	The MP proposes to increase awareness and strategies for waste prevention and reduction at generation sources. As sub-activities, it proposes	11.6 12.3 12.5

	change communication (BCC) strategy, together with a program of actions for awareness creation across different strata of the society and other stakeholders to effectuate waste prevention and reduction, particularly through promoting sustainable, resource efficient lifestyles.	program development to raise awareness and promote adopting eco-friendly life styles such as eco-labeling and my-bags concepts.	
<b>2.2</b>	Develop and implement a comprehensive education strategy, together with a program of actions for knowledge management across all levels of formal education incorporating necessary curriculum changes (with particular emphasis on early childhood education).	The MP proposes to increase awareness and strategies for waste prevention and reduction at generation sources. As sub-activities, it proposes program development to raise awareness through activities of local governments, schools, and other related organizations. Detailed plans are not provided in the MP.	11.6 12.3 12.5
<b>2.3</b>	Conduct communication campaigns, with particular emphasis on social responsibility, ethical behavior, human rights and respect to laws, for mainstreaming prevention and reduction of waste (link, but further, to Activity 2.1 above), with the use of effective communication tools for different target groups including effective use of social media /ICT.	The MP proposes to increase awareness and strategies for waste prevention and reduction at generation sources. As sub-activities, it proposes program development to raise awareness through activities of local governments, schools, and other related organizations. Detailed plans are not provided in the MP.	11.6 12.3 12.5
<b>2.4</b>	Strengthen the regulatory framework effectively to guide society towards more sustainable, resource efficient lifestyles (sustainable consumption) and to drive industries towards cleaner production (sustainable production) (link, but further, to Activity 2.1 above).	The MP does not specifically explain plans to strengthen the regulatory framework, but it intends to adopt exiting regulations and proposes strategies for waste prevention and reduction at generation sources specifically via implementation of Extended PPP policies.	11.6 12.3 12.5
<b>2.5</b>	Introduce economic instruments to promote sustainable consumption	The MP proposes to implement instruments such as volume-based waste collection fees to promote sustainable consumption and production.	11.6 12.3 12.5

	and production, such as 'Polluter Pays Principle (PPP)', 'User Pays Principle (UPP)' and 'Precautionary Principle' (Link to Activity 3.4).		
2.6	Facilitate the introduction of alternative products and regulatory options that guide less use and generation of waste materials.	The MP does not specifically explain plans to introduce alternative products.	11.6 12.3 12.5
2.7	Implement Road Map and National Action Plan on Prevention and Reduction of Food Waste (Link and further to Activities 2.1 to 2.4 above).	The MP intends to prevent and reduce all solid waste but does not provide plans specifically for food waste.	11.6 12.3 12.5
<b>Strategy 3</b>	<b>Ensure sustainable management of plastics and other recyclables.</b>		
3.1	Implement National Action Plan on Plastic Waste Management 2021-2030.	The National Action Plan on Plastic Waste Management (2021-2030) formulated by the Ministry of Environment, Goal 9 sets a target to increase the recycling ratio of plastic waste to 15% by 2025. The MP aims to increase informal recycling to 5% by 2030 and 6.8% by 2042, and to increase formal recycling to 4% by 2030 and 5% by 2042. This helps meet the targets set in the National Action Plan for plastics waste.	11.6 12.3 12.5
3.2	Develop and implement nation-wide awareness programs and media campaigns to motivate and facilitate segregation and recycling of plastics and other waste (link, but further, to Activity 3.1 above).	The MP proposes to increase awareness and strategies for waste prevention and reduction at generation sources in the Western Province. Not detailed plans are given in the MP.	11.6 12.3 12.5
3.3	Enhance the resources (human, technical and financial)/ land resources and infrastructure of local governments for plastic management (link, but further to Activity 3.1 above).	The MP intends to increase capacity at intermediate treatment facilities to promote recycling of plastic waste and energy recovery from non-recyclable plastics.	11.6 12.3 12.5
3.4	Manage recycling and up-cycling of plastics through Regulatory interventions (enforcement of more stringent regulation and	The MP proposes to implement technical strategies for management of plastic waste while accommodating existing regulations, but no details on specific plans for regulatory interventions are presented.	11.6 12.3 12.5

	control mechanisms) (link, but further to Activity 3.1 above)		
3.5	Promote recycling and up-cycling of other recyclable components of waste categories (such as glass, metal, paper) through regulatory and other interventions.	The MP proposes to implement technical strategies for management of plastic waste while accommodating existing regulations, but no details on specific plans for regulatory interventions are presented.	11.6 12.3 12.5
3.6	Introduce, facilitate and regularize/mandate of Extended Producer Responsibility (EPR) as an effective instrument to meet concepts such as 'Polluter Pays Principle (PPP)', 'User Pays Principle (UPP)' and 'Precautionary Principle'. (Link to Activity 2.5. and Activity 3.1 above).	MP proposed to establish volume-based waste collection fee structure which will follow the "polluter Pays Principle".	
3.7	Promote and facilitate control of environmental pollutions in other solid waste streams(e.g. packaging waste, construction and demolition waste, marine waste, food, agriculture and livestock waste, slaughterhouse waste) (link to Activity 8.8).	The MP proposes strategies for managing packaging waste. Other waste categories are beyond the scope of the MP.	11.6 12.3 12.5
<b>Strategy 4</b>	<b>Manage the biodegradable waste component through biological treatments.</b>		
4.1	Promote composting at local governments, institutions and households, as a priority treatment for the management of biodegradable wastes, with particular emphasis on integrating with value-added composting, agro-ecological farming schemes through; (i) Introduction of regulations, guidelines and procedures, GMP (ii) Certifications (SLS), (iii) Technology assessment on composting, (iv) Effective business models and	The MP proposes strategies for composting at all levels.	2.3 2.4 12.4

	(v) Decentralized systems for optimum utilization.		
4.2	Introduce suitable treatment and disposal facilities for liquid waste, sewage, and night soil, incorporating appropriate commercial technologies including central / networked facilities	The MP proposes strategies for managing solid waste. Other waste categories are beyond the scope of the MP.	6.3 6.a
4.3	Promote proper treatment and disposal of industrial wastewater in Board of Investment (BOI) zones, in non BOI industrial parks and standalone industries (link to Theme 9: Greening of Industries).	The MP proposes strategies for managing solid waste. Other waste categories are beyond the scope of the MP.	6.3 6.a
4.4	Promote and introduce biogas technology for the management and treatment of biodegradable waste, particularly where composting is not practical, with an emphasis of harnessing triple benefits.	The MP does not specifically explain plans for gas recovery system.	7.2 7.4
4.5	Explore the option of anaerobic digestion for production of biogas (methane) for (i) transport applications, and (ii) integrated to propose Natural Gas in the energy sector.	The MP does not specifically explain plans for gas recovery system.	7.2 7.4
4.6	Promote and facilitate control of environmental pollutions in other liquid waste.	The MP proposes strategies for managing solid waste. Other waste categories are beyond the scope of the MP.	11.6 12.3 12.5
<b>Strategy 5</b>	<b>Exploit treatment with an energy recovery option for management of non-recyclable and non-usable waste.</b>		
5.1	Establish a technology compendium in characterizing waste treatment technologies with energy recovery Options to appraise the role of energy recovery, under local circumstances within HWM framework.	The MP proposes energy recovery from non-recyclable and non-usable waste as a strategy for SWM within the HWM framework and in line with the need in the Western Province.	7.2 7.a 11.6 12.5
5.2	Ensure proper operation and optimum utilization of the WtE plant already	The MP proposes to improve the existing facility and increase its capacity as needed in future.	7.2 7.a 11.6

	commissioned through monitoring and regulatory compliance. (Link to Theme 1 Activity 3.2.).		12.5
5.3	Ensure the other committed WtE and incineration plant/s complies with regulatory requirements during installation, commissioning, and operation, while embracing environmental best practices and best available technologies for pollution control (link to Theme 1 Activity 3.2).	The MP proposes constructing new facilities as needed in future.	7.2 7.a 11.6 12.5
5.4	Ensure the safe disposal of residues generated in WtE plants.	The MP proposes plans to properly disposal of residues from WtE plants.	7.2 7.a 11.6 12.5
<b>Strategy 6</b>	<b>Manage final disposal sites.</b>		
6.1	Characterize the performance of present SWDS/waste disposal sites and, in line with the Guideline for Safe Closure of MSW dumpsite in SL and develop a plan/ roadmap for sustainable management.	The MP proposes the closure of existing open disposal sites and discourage open dumping, and reduce final disposal via alternative SWM technics.	6.3 11.6 12.3 12.4
6.2	Rehabilitate existing SWDS, with proper monitoring mechanisms and safe closure of high-risk sites.	The MP proposes to improve Aruwakkalu as the final disposal site and to closure of open disposal sites.	6.3 11.6 12.3
6.3	Promote sanitary landfilling, while improving the performance of existing sites with optimum supply chain utilization, methane recovery and clustering of Las.	The MP proposes to improve the Aruwakkalu disposal site ad sanitary landfill.	6.3 11.6 12.3
6.4	Support establishment of MSW Transfer stations (feasibility /implementation).	The MP proposes to establish new transfer stations.	6.3 11.6 12.3
6.5	Enforce the relevant regulations to prevent open burning in SWDS through sound technological and operational procedures (link to Activity 5.2).	The MP proposes better strategies for SWM that comply with regulation.	6.3 11.6 12.3



6.6	Monitoring of the environment performance of disposal sites, particularly air pollution (GHG) (link to Theme 1 AQM).	The MP intends to develop and implement monitoring plans that comply with regulation and aligned with best practices for SWM.	6.3 11.6 12.3
6.7	Facilitate LAs to minimize open dumping through identification of lands for proper disposal and awareness/training.	The MP proposes plans for centralized disposal to minimize improper dumping.	6.3 11.6 12.3
6.8	Ensure no open dumping in LAs through enforcement (link to Activity 5.5).	MP proposed to establish a consortium consisted of all relevant stakeholders to implement the MP in which regulatory reforms will be an integral part of activities.	6.3 11.6 12.3
6.9	Promote prevention of open dumping and open burning of waste by individual generators through awareness and regulatory interventions.	The MP aims to increase awareness as a strategy to control open burning. Further, the MP proposed to establish a consortium consisted of all relevant stakeholders to implement the MP in which regulatory reforms will be an integral part of activities.	6.3 11.6 12.3

### 5.8.2 Conformity of MP with Nationally Determined Contributions (NDCs)

Nationally Determined Contributions (NDCs) presents the planned contributions of Sri Lanka to the United Nations Framework Convention on Climate Change (UNFCCC) and reflect progressive and the highest possible ambition for climate action. The NDCs for the waste sector have been developed, as climate change mitigation strategies, in accordance with the Sri Lanka’s policies and strategies for waste sector such as the National Environment Policy, National Climate Change Policy, National Policy for Sustainable Development (draft) and National Policy for Sustainable Consumption & Production. Therefore, evaluating the planning solutions of the MP against the NDCs shall further informs MP’s compliance with the national targets of the waste management sector. Results of this assessment are given in Table 5-5 below.

However, the level of actual contribution of the MP to the fulfilment of the country’s SWM targets remains questionable. The low level of detail about how the MP’s planning strategies are elaborated and the lack of information on how the stated objectives will be achieved are the limiting factors of this analysis. The information base concerning available opportunities in terms of technologies, techniques, investment locations, infrastructure needs, available funding etc. should be developed in order to ensure rational decision making while preparing subsequent strategic decisions envisaged by the MP. Without this, the risk of negative side-effects of the MP implementation on individual environmental components, localities, or population groups cannot be fully ruled out, despite the formal compliance of the MP with the NEAP and the NDCs. Concerns identified in this analysis are incorporated in recommendations in Chapter 6.

Table 5-5 Conformity of MP with NDCs

NDC #	NDC and Action	Effect of implementing proposed actions of the MP
<b>NDC 1</b>	<b>Improve “Circular economy” practices in all MSW generation sources</b>	
1.1	Prevent, avoid, or reduce MSW generation by reducing the growth by 10 % and also by reducing generation growth of industry solid waste and effluent	This target is achieved not by 2030, but by 2042. In 2030, the MP targets to achieve only 5% reduction rate.
1.2	Improve the segregation of MSW at source and increase number of segregation categories	MP aims to eventually increase waste segregation categories to 7: biodegradable, recyclable, burnable, hazardous, e-waste, bulky waste, and residual waste.
1.3	Improve MSW collection and transportation system (Up to 75% on generation basis in Western Province and 60% in other provinces)	MP proposes as its medium target to achieve 68% collection ratio on average for the western province by 2030 which is below the NDC target. However, the MP targets for 81% average collection rate by 2042. Of this, a significant improvement could occur in MC and UC (where the MP targets to achieve 95% collection coverage respectively), but improvement targeted for PC is lower (with 60% coverage) than the NDC target. MP proposes strategies for an integrated and efficient waste collection and transportation system.
1.4	Improve waste recycling to 7% on collection basis in Western Province (WP) and 5.0% in other provinces.	The MP aims to increase informal recycling to 5% by 2030 and 6.8% by 2042. Formal recycling shall increase to 4% by 2030 and 5% by 2042. In addition to the NDC, the National Action Plan on Plastic Waste Management (2021-2030) formulated by the Ministry of Environment, Goal 9 sets a target to increase the recycling ratio of plastic waste to 15% by 2025. Above mentioned targets of the MP help meet the targets set in the National Action Plan for plastics waste.
1.5	Implement regulatory framework to control high waste generating products	Extended Producer Responsibility (EPR) is proposed to reduce the amounts of post-consumer materials (packaging); a mandatory fee levy waste collection system is implemented to promote waste reduction.
<b>NDC 2</b>	<b>Manage biodegradable waste component through biological treatments</b>	
2.1	Increase the present level of composting to 30% of compostable waste collected in Western Province and other Provinces	The current level of composting in the western province is 21% which is below the NDC target. Any strategy to improve composting by the MP shall contribute to positive impacts. The MP intends to increase the capacity of compost facilities so that the level of composting at these facilities will increase from 8% to 15% by 2030. Further 20% of waste generated will be composted at these facilities by 2042.
2.3	Adopt biogas technology where composting is not practically applicable	The MP does not specifically explain plans for adopting biogas technology.
<b>NDC 3</b>	<b>Introduce energy recovery using non-recyclables and waste which cannot be managed by other means</b>	

NDC #	NDC and Action	Effect of implementing proposed actions of the MP
3.1	Establish already committed two waste-to-energy generation facilities	The MP proposes to increase capacity of Kerawalapitiya WtE facility and establish two more facilities in Gampaha and Colombo increasing the thermal recovery capacity to 2,874 TPD by 2042.
3.2	Make policy enhancement to clearly define the purpose of waste-to-energy and plan the phasing out of preferential feed-in-tariffs	The MP proposes using WtE technology to promote intermediate treatment of waste via thermal recovery. The MP does not specifically explain plans for phasing out of tariffs in this regard.
3.3	Regulate the establishment of new waste-to-energy facilities	The MP proposes to establish two new WtE facilities in Colombo and Gampaha districts.
3.4	Introduce other thermal treatment technologies	The MP does not specifically explain plans for other thermal treatment technologies.
<b>NDC 4</b>	<b>The use of sanitary landfills for the disposal of residual waste</b>	
	The use of sanitary landfills for the disposal of residual waste will be increased from the current level of 5% to 100% on weight basis	The MP proposes to dispose all the residual waste from intermediate treatment in sanitary landfills. A small amount of untreated waste (2% of total waste generated) will also be disposed at landfills. Altogether, 20% of the total generation waste will be disposed.
4.1	4.1 Operationalize policy and regulation for siting and implementation of sanitary landfills	The MP proposes to close open landfills and to use a centralized sanitary landfill for final disposal. Capacity of the landfill will be increased to accommodate incoming waste.
4.2	Rehabilitate existing waste dump sites	The MP proposes to close open landfills and rehabilitate the closed dump site. The MP does not provide detailed information of this planning solution.
4.3	Introduce Land-fill Gas recovery systems	The MP does not specifically explain plans for gas recovery system.
<b>NDC 5</b>	<b>Generic enabling activities</b>	
5.1	Update or introduce the required legislation to facilitate and enforce the implementation of NDCs	MP proposed to establish a consortium consisted of all relevant stakeholders to implement the MP in which regulatory reforms will be an integral part of activities.
5.2	Introduce a mechanism for waste generation forecasting with a tracking system to monitor the generation	The MP proposes to collect and integrate data related to SWM from each LA, cluster-based treatment facilities and disposal sites, and to establish a database system for the entire Western Province database.
5.3	Introduce legislation to make segregation of waste at household level mandatory	MP proposed to establish a consortium consisted of all relevant stakeholders to implement the MP in which regulatory reforms will be an integral part of activities.
5.4	Introduce or amend necessary legal framework and instruments to initiate Market-Based Instruments (MBIs) and non-market-based instruments to incentivize and promote sustainable consumption patterns	MP proposed to establish a consortium consisted of all relevant stakeholders to implement the MP in which regulatory reforms will be an integral part of activities.

NDC #	NDC and Action	Effect of implementing proposed actions of the MP
5.5	Implement “Polluter Pays Principle” for mixed waste generators	MP proposed to establish volume-based waste collection fee structure which will follow the “polluter Pays Principle”.
5.6	Conduct awareness and capacity building programmes for behavioral changes of waste consumption patterns	MP proposed to conduct awareness raising programs targeting public, and other key stakeholders in SWM sector.
5.7	Facilitate public-private-partnerships to finance waste sector NDCs	The MP does not specifically explain plans public-private partnership; however, recognize the vital role of private sector in resource recycling and development of waste-to-energy facilities.

## 5.9 Mitigating Measures

Based on the assessment of the draft MP presented in Section 5.5 above, a range of mitigation measures have been identified. These measures are principally project/service-level mitigation identified which could address the potential adverse environmental effects associated with the construction and operation of waste management facilities and waste collection services, as opposed to revisions to the plan itself. The mitigating measures are summarized in Table 5-6.

**Table 5-6 Mitigation Measures**

SEA Objective	Mitigating Measures
Water	<ul style="list-style-type: none"> <li>✓ Any new infrastructure proposed should be considered against the policies and requirements of the relevant regulation, or National Policy.</li> <li>✓ The full impact of any new infrastructure should be thoroughly assessed. This should include an assessment of the proposed plant’s water resource demand, and whether there are any water availability restrictions which need to be identified and resolved.</li> <li>✓ Plants should be required to have emergency preparedness plans to provide operational flexibility during periods of low water availability.</li> <li>✓ Strong awareness campaigns could be implemented to encourage participation in any collection services to minimize the water footprint of wastes.</li> </ul>
Climatic Factors/ GHG emission	<ul style="list-style-type: none"> <li>✓ Any new infrastructure proposed should be considered against the policies and requirements of the relevant regulation, or National Policy.</li> <li>✓ Renewable energy generation could be included at sites of new waste infrastructure.</li> <li>✓ Adaptation measures to enhance resilience to climate change could be included for new waste infrastructure.</li> </ul>

SEA Objective	Mitigating Measures
	<ul style="list-style-type: none"> <li>✓ Heat recovery from TRFs should be optimized by increasing generating efficiencies.</li> </ul>
Air Quality	<ul style="list-style-type: none"> <li>✓ Any new infrastructure proposed should be considered against the policies and requirements of the relevant regulation, or National Policy.</li> <li>✓ Uptake of use of electric vehicles wherever possible for waste collection and transportation, subject to feasibility, applicability and cost.</li> <li>✓ Uptake of renewable energy sources to power waste management sites wherever possible. This could include on-site electricity generation.</li> <li>✓ Monitoring of odor and emissions from waste management sites including the delivery and disembarking activities, as appropriate under environmental permitting requirements.</li> <li>✓ Avoiding residential areas wherever possible for transfer and waste treatment sites and ensuring monitoring is in place where no more preferable alternative is possible, as appropriate under environmental permitting/ licensing requirements.</li> <li>✓ Longitudinal litter audits could be undertaken regularly to track the impact of new services upon litter and fly-tipping on both terrestrial and marine environments.</li> </ul>
Geology and Soils	<ul style="list-style-type: none"> <li>✓ Any new infrastructure proposed should be considered against the policies and requirements of the relevant regulation, or National Policy.</li> <li>✓ Investigative excavation works could be undertaken at proposed sites to ensure soils and geological materials are identified, analyzed and implications for development proposals understood and that any designated sites of geological importance identified.</li> <li>✓ Any excavated material arising from the construction of new infrastructure could be reused in other local developments, nearby communities such as local parks or to construction sites.</li> <li>✓ Remediation of dumping sites could produce opportunities to improve local soil conditions subject to adequate capping of dumpsite, extraction of leachates and ongoing monitoring of the site.</li> </ul>
Landscape and Townscape	<ul style="list-style-type: none"> <li>✓ Any new infrastructure proposed should be considered against the policies and requirements of the relevant regulation, or National Policy.</li> <li>✓ Any new infrastructure should seek to be compatible with the surrounding landscape and land uses, and consistent with the requirements of the National Planning/UDA planning, seek to protect and enhance landscape quality. Consideration should be given where appropriate to make such sites interesting and innovative in design through form, function and materials.</li> </ul>

SEA Objective	Mitigating Measures
Biodiversity and nature conservation	<ul style="list-style-type: none"> <li>✓ Any new infrastructure proposed should be considered against the policies and requirements of the relevant regulation, or National Policy.</li> <li>✓ Biodiversity enhancement measures such as prevention of wildlife entry should be included for new infrastructure.</li> <li>✓ New infrastructure should be appropriately sited to avoid impacts on sensitive habitats and species, and to avoid habitat fragmentation.</li> <li>✓ Restoration of dumpsite sites could provide nature reserves for wildlife.</li> </ul>
Human health protection & employment	<ul style="list-style-type: none"> <li>✓ Any new infrastructure proposed should be considered against the policies and requirements of the relevant regulation, or National Policy.</li> <li>✓ Uptake of use of electric vehicles wherever possible for waste collection and transportation, subject to feasibility, applicability and cost.</li> <li>✓ Uptake of renewable energy sources to power waste management sites wherever possible. This could include on site electricity generation.</li> <li>✓ Monitoring of effects from waste management sites including the delivery and disembarking activities, consistent with permitting and licensing conditions.</li> <li>✓ Avoiding residential areas wherever possible for transfer and waste treatment sites and ensuring monitoring is in place where not possible.</li> <li>✓ Restoration of dumping sites to provide recreational sites and green space for local communities.</li> <li>✓ In new developments, opportunities could be created for those who have obtained required competencies and are traditionally found it difficult to access employment.</li> <li>✓ Employment opportunities at an appropriate skill level could be created in areas of high unemployment.</li> <li>✓ Restoration of landfill sites could produce recreational site for local populations, thus employment opportunities for nearby communities.</li> </ul>
Flood Risk and Coastal Change	<ul style="list-style-type: none"> <li>✓ Any new infrastructure proposed should be considered against the policies and requirements of the relevant regulation, or National Policy.</li> <li>✓ A site-specific flood risk assessment should be provided for all waste infrastructure development proposals in flood zones.</li> <li>✓ For specific waste infrastructure proposals, consider the risk of all forms of flooding arising from the development, in addition to the risk of flooding to the project, and demonstrate how these risks will be managed and, where relevant, mitigated, so that the development remains safe throughout its lifetime.</li> </ul>

SEA Objective	Mitigating Measures
	<ul style="list-style-type: none"> <li>✓ Sustainable drainage systems should be used within the design of new facilities unless there is clear evidence that this would be inappropriate.</li> </ul>
Resources Recovery	<ul style="list-style-type: none"> <li>✓ Any new infrastructure proposed should be considered against the policies and requirements of the relevant regulation, or National Policy.</li> <li>✓ Services should be designed to maximize recycling and recovery rates and should take into account the convenience to consumers by, for example, optimizing the number and siting of collection points for any recyclables.</li> <li>✓ Strong awareness campaigns could be implemented to encourage participation in any collection services.</li> <li>✓ Partnership opportunities should be explored between local authorities or private contractors to explore asset-sharing opportunities.</li> </ul>
Traffic and Transport	<ul style="list-style-type: none"> <li>✓ Any new infrastructure proposed should be considered against the policies and requirements of the relevant regulation, or National Policy.</li> <li>✓ Any new waste infrastructure should include a Traffic Assessment to determine the impacts of, and any remedial efforts, around traffic movements. The assessment should distinguish between the construction and operation stages if appropriate.</li> <li>✓ Any new infrastructure should be sustainably located to minimize vehicle movements. Where regular traffic will be affected, consideration should be given to the number, frequency, scheduling and route selections when seeking to understand the effects on the existing road network and those communities living close to the proposed waste management site and/or route.</li> <li>✓ Alternative modes of transport should be explored in the design, and delivery, of future infrastructure or services – such as rail freight, wherever applicable.</li> <li>✓ Uptake of use of electric vehicles wherever possible for waste collection and transportation, subject to feasibility, applicability and cost.</li> <li>✓ Backhauling opportunities should be explored within, and between, local authorities and waste management contractors to minimize vehicle movements.</li> <li>✓ Traffic movements should be monitored throughout construction and operation to ensure compliance with operating permits and planning approvals.</li> </ul>

## 6 Conclusions and Recommendations

### 6.1 General conclusions

The MP is by nature a strategy with a potential for a positive impact on various aspects of the environment and public health. This is largely due to the fact that the MP is laying grounds for a comprehensive waste management system for Western Province based on the principles set in the waste management policies and regulations. That represents substantial qualitative change and departure from existing waste management practices, characterized by lack of strategic approach, unsystematic or non-existing record keeping, relying on low-tech and makeshift local solutions with substantial negative environmental side-effects.

Despite its unquestionable net positive environmental effect, the implementation of individual MP components is not a risk-free and it is important to ensure that is accompanied with measures further enhancing the positive and mitigating any potentially negative impacts. The SEA formulated several recommendations related to the further development of the institutional and regulatory framework as well as proposed number of recommendations and conditions for implementation of key components of the MP. These are listed below:

#### 6.1.1 Recommendations towards further development of the legal/regulatory framework

For MP to be implemented effectively it is necessary that envisaged and already approved waste management-related legislation is implemented and enforced. Following conditions need to be ensured:

- i. Establish legislative targets enabling gradual decrease of mix waste disposal and collection while increase separation, recycling and re-use.
- ii. Establish legislation enabling the control and monitor waste flows from the generation to the final recycling and/or disposal in order to achieve long term waste reduction targets.
- iii. Setting targets for closure of existing dumpsites (not meeting any standards) and for diversion of waste (recycling of dry materials and reduction of landfill of biodegradable waste to reduce need for using the landfills not complying with sound waste management principles).
- iv. It is necessary to introduce regulations to implement real-time flue gas monitoring system in all waste incineration facilities which will enforce the monitoring and environmental accountability.



- v. It is necessary to introduce national regulations, in particular with the manual for design and maintenance of landfills, transfer stations, treatment facilities and axillary activities that possibly effect on environment and public health.
- vi. Develop transparent and fair pricing for waste tariffs. The legal ceiling on waste tariffs should be developed considering affordability and willingness-to-pay on individual basis. In addition, economic instruments should be introduced to support the recycling private sector businesses.
- vii. Legislation or regulations should be made to integrate the MP with the SWM related activities to be implemented under other major development projects such as Port City, Megapolis etc., in Western Province.
- viii. WMA-WP should be reinforced with necessary legislative and regulatory powers and facilitated with physical infrastructure and competent human resources to execute and implement the MP activities under the recommendation and guidance of coordinating platform. In absence of a strong leading organization, it is unlikely that the proposed inter-governmental and key stakeholder coordination platform would be effective.

#### **6.1.2 Recommendations for the institutional arrangements**

- i. Western Provincial Council (WMA-WP) and coordination platform should empower to coordinate and exchange data and information with relevant monitoring agencies, as well as the government and private sector organizations involved in waste management.
- ii. The Central Environmental Authority would retain its independent authority with respect to setting environmental standards, environmental expertise and permitting along with enforcement. Its capacities should be strengthened to provide independent, comprehensive and regular inspections of all waste handling facilities, TRFc, and Aruwakkalu landfill.
- iii. Precisely define the competences within the waste management system, including planning, implementation (operation), coordination, and enforcement, and ensure impartiality and transparency of institutions.
- iv. The collection of municipal waste collection fee (tariffs from commercial and institutional sector and households as proposed in the MP), currently a responsibility of the Local Authorities, might be transferred to higher administrative level with the power to extract the tariff from municipalities regardless of whether they actually collect the full prescribed amount from the population (and thus allow the local authorities to structure payments according to local conditions, e.g. with respect to situation of disadvantaged groups). In the absence of such financing mechanism, implementation and sustaining of

common facilities such as transfer stations, resource recovery facilities and landfill will not be financially sustainable. Local Authorities may continue collecting the waste fees, but it is necessary to fix the collection and control mechanisms: for example, through electronic payment system/ which will enable public administration bodies regularly carry out control/audit.

- v. It is advised to propose targeted social assistance, including monetary assistance, as well as comprehensive social services packages, to the socially vulnerable and groups of population who may adversely affect due to project implementation and public nuisance.

### **6.1.3 Recommendations related to key components of MP**

#### **6.1.3.1 Promote waste reduction at generation sources**

- i. SEA foresee potential barriers for certain sectors of the stakeholder/ community to participating in Extended Producer Responsibility – EPR and Polluter Pays – PP (volume-based tariff) schemes either through physical, psychological, financial, or cultural barriers or issues. Thus, SEA recommends conducting a comprehensive study and analysis to identify the gaps in existing programs and design innovative approach which ensures all sectors are willingly contribute to the programs. These programs should be supported and reinforced by appropriate regulations.
- ii. The sustainability of TRFs largely depends on thermal properties (calorific value) of waste which is mainly governed by the percentage of plastics and paper wastes. Accordingly, any plan to reduce plastic in waste stream may negatively effect on the feasibility of proposed TRFs. Thus, SEA recommends conducting a sensitivity analysis considering not only waste quantities but also potential qualitative changes in waste composition prior to designing TRFs.
- iii. The likelihood of embracing EPR by industries is remote, but the economic benefits could be overwhelming to create incentives and moral righteousness for using alternate materials than plastic. Inevitably, fuel shortages will not occur to prepare combustible waste free of hazardous materials even from domestic wastes.

#### **6.1.3.2 Actions promoting source separation and reduction at the discharge stage**

- i. The MP envisages implementing a new source segregated waste discharge and collection system which comprises of seven categories of waste such as biodegradable, recyclable, burnable, hazardous, e-waste, bulky waste, and residual waste. In present legal context, Local Authorities are not compelled to collect hazardous and e-waste; thus, an appropriate mechanism for collection and management of these waste should be proposed in the MP. Moreover, bulky waste management often requires a special

purpose collection scheme which may not be readily integrated to general waste collection scheme. Therefore, MP should give suggestions/ directions to divert such waste (household hazardous, E-waste and bulky waste) through appropriate management channels.

- ii. The proposed digital platform (e.g., Mobile App) can be customized as a monitoring tool in addition to the major utility function of awareness creation and information sharing.

#### 6.1.3.3 Actions for waste reduction at the discharge stage

- i. The success of conventional home composting systems is often questioned owing to technical issues with home composting bins and sustainability. Therefore, home composting should only be promoted after thorough technical and user assessment which will help to identify the technical and operation issues in existing home composting systems.
- ii. In addition to on-site composting, SEA should promote all other proven on-site organic waste management techniques such as biogas (anaerobic digestion), animal feed processing and thermal processes (biochar from garden waste etc.) which are having similar or greater environmental benefits.
- iii. The concept of flea market and junk shops should be promoted, especially encouraging private entrepreneurs with necessary legislative, administrative and promotional support schemes.

#### 6.1.3.4 Improvement of waste collection system

- i. Ensure adequate technical standards and maintenance of the collection trucks to minimize emissions.
- ii. The increase of waste collection coverage in rural areas should be initially limited to residual waste collection; thereafter gradually increase to other waste types because collection of entire waste quantity may cause excessive strain on the collection infrastructure. Also, introduction of full-scale waste collection system in rural areas may hinder environmentally friendly organic waste management practices such as composting and on-site safe disposal in rural areas.
- iii. It is recommended to establish a real time vehicle movement / navigation tracker which will enable the effective monitoring and management of waste flow in the system.

#### 6.1.3.5 Improvement of waste transfer system

- i. New primary transfer facilities shall be set up at a respective distance from specially protected natural areas.

- ii. Installation of primary transfer stations in the degraded, e.g. already contaminated areas shall be preferred to placing the facilities on virgin land.
- iii. It is recommended to assess the feasibility of integrating resource recovery/ material recovery facilities (MRFs) within primary transfer stations in order to maximize resource recovery and minimize energy footprint that may likely to occur when such facilities are located elsewhere. A feasible avenue is to integrate waste park and primary transfer stations in the same physical location.
- iv. Taking into consideration wet zone climate of the Western province, especially in Kalutara District, obstruction on roads in some areas during rainy season, bad condition of roads etc. might require different seasonal regimes of operation in regional/ local waste management planning.
- v. A robust operating and management plan for each primary transfer station should be proposed. The proposed plan should include a) conduct audit and monitoring of transfer stations on a regular basis, b) climatic (wind, precipitation) and erosion conditions should be considered while designing the transfer stations, c) minimize risks to public health through installation of transfer stations in non-residential zones and maintaining a buffer zone, and occupational morbidity study among employees of communal services, and d) Improved sanitary and hygienic conditions of the workplaces of employees of transfer stations engaged in the processes of waste collection, transportation and recycling: availability of bathing facility, individual protective measures, etc.

#### 6.1.3.6 Promotion of recycling at intermediate treatment facilities

- i. At the inception of TRFs, it is necessary to develop cost and technical feasibility study for the purpose of selecting the best possible thermal treatment technology ensuring that the study adequately analyses key issues related to environmental protection (emission control, systemic implications of the entire waste management system, risks).
- ii. Considering the incineration technology, the MP notes that the residual product from flue gas cleaning is heavily contaminated with heavy metals and must be disposed of in special hazardous waste landfill. Moreover, it is yet to be decided the potential methods for safe application/ disposal of bottom ash. Therefore, it is highly recommended to incorporate a feasible mechanism for management of fly and bottom ash from existing and proposed TRFs. The straightforward solution is to establish a specially designed separate cell or demarcated area in Aruwakkalu landfill for disposal of incinerator residues. The modification should consider the hazardous nature of ash and appropriate leachate management techniques.

- iii. A technical and cost feasibility should be conducted prior to establishment of major composting facilities in order to avoid possible issues that may arise due to compost appropriateness of manufacturing technologies, compost marketing, environmental sanitation and location specific public nuisances. A standard composting site selection and designing guideline should be established by regulatory authorities (CEA, WMA-WP) ensuring environment pollution control, health and safety of workforce, and resolving public nuisances.

#### 6.1.3.7 Reduction of waste to be disposed

- i. All possible measures should be taken to minimize the amount of waste to be disposed of at Aruwakkalu sanitary landfill. Aruwakkalu landfill construction is to be completed in the near future; however, a proper operation and management plan has not mentioned in the MP. The selected option B and all other alternatives are to be heavily depended on the Aruwakkalu landfill and any notable change in Aruwakkalu management modality would have an impact on MP; therefore, it is necessary to integrate a rational management plan for Aruwakkalu landfill in the Master Plan. The operation and landfill management plan should be mentioned as a mandatory sub-activity in the MP.
- ii. A robust monitoring and pollution control compliance plan should be developed for landfill management. The plan should be mentioned as a mandatory sub-activity in the MP.
- iii. Capacity development will be necessary for sanitary landfill operators and their staff to ensure sound waste management practices and minimization of risks of accidental pollution and proper operation of environmental mitigation measures (e.g. leachate collection, greenhouse gases utilization) and monitoring systems, as well as proper record keeping and reporting.

## 7 Environmental monitoring and evaluation plan

It is a requirement of the SEA process to establish how the significant effects of implementing the MP will be monitored. As set out SEA guidelines, it is not necessary to monitor everything or monitor an effect indefinitely. Instead, monitoring needs to be focused on significant sustainability effects. Monitoring should therefore be focused on:

- a) the significant effects identified in the assessment that may give rise to irreversible damage, with a view to identifying trends and where appropriate to implement relevant mitigating measures before such damage is caused; and
- b) uncertain effects where monitoring would enable preventative or mitigating measures to be undertaken.

As set out in Section 5.3, the assessment contained in this SEA has found that the implementation of the draft MP is likely to have positive effects across all of the SEA objectives and in the case of biodiversity, land use, climatic factors and waste (when in-combination effects are considered), significant positive effects have been identified; no significant negative effects have been identified. Therefore, it is therefore not deemed necessary to develop indicators for each SEA objective/topic.

Also, in absence of regulatory enforcement of SEA process in Sri Lanka, where appropriate, existing monitoring arrangements may be used to assess the success of the appropriate plan in achieving its objectives; it does not require that targets be developed for the SEA itself. In this context, the monitoring plan includes an Indicator Framework for monitoring progress against waste management policy, regulations and commitments that consists of a number of measures, and which reflect progress against the following six policy priorities in Section 2.3.1 of this report.

### 7.1 Monitoring framework

Taking into account the findings of the assessment presented in this report (that the draft MP is unlikely to have significant negative environmental effects) and the SEA guidance (that existing monitoring arrangements may be used), the finalized MP indicators and measures when released, are proposed to be taken forward as the monitoring framework for the purposes of the SEA. This approach will avoid unnecessary duplication and is consistent with the policy goals.

It is recognized that waste management, including the construction and operation of waste management facilities, can have a range of socio-economic and environmental effects that may be significant at a local level. However, these effects are considered and monitored by waste

planning authorities. Given the context, the following monitoring framework is proposed for the MP.

**Table 7-1 Proposed monitoring framework for the MP**

Medium	Locations	Indicators	Responsible Agency of Monitoring	Monitoring Frequency
<b>Air</b> Stack emission Ambient Air Quality	Incineration facilities	Flue gas Analysis (PM, NO <sub>x</sub> , CO, CO <sub>2</sub>  Dioxin, Furan and Halagens)	Facility operators	24-hour continuous stack monitoring and daily monitoring at sensitive locations around the site
<b>Ambient Water Quality</b> Inland water bodies Coastal waters	Incineration facilities Transfer stations Waste parks Landfill (wastewater outfall)	BOD, COD, pH, DO, TSS, Heavy Metals, pathogen, and indicative emergency organic pollutants	Facility operators	Daily monitoring (weekly monitoring of heavy metals and emerging pollutants)
<b>Land and soil</b>	Monitoring locations within 100m radius of Incineration facilities Transfer stations Waste parks Landfill	Soil contaminants (Oil & grease, Heavy metals, organic pollutants)	Facility operators	Annually
<b>Noise &amp; vibration</b>	Incineration facilities Transfer stations Waste parks Landfill (wastewater outfall)	Noise and vibration levels as prescribed by regulations	Facility operators	Weekly monitoring or on complaint basis

<b>Air Quality Impacts from Vehicular Emissions</b>	Exhaust Emission Monitoring	SO <sub>2</sub> , NO <sub>x</sub> , CO	Vehicle owner	Annually
<b>Wetlands</b>	Any wetland within 500m radius of major facility	Water quality Water quantity Biodiversity	Facility operator	Annually
<b>Hazardous Waste in waste stream</b>	Received at transfer station, treatment facilities	Household hazardous waste, E-waste through composition study	Facility operators	Monthly

It is recommended to conduct annual comprehensive Air, water (surface & groundwater), land & soil, and ecological surveys in (or around) major waste management facilities such as transfer stations, treatment facilities and Aruwakkalu landfill. The monitoring reporting should be submitted to CEA for complacence and licensing purposes.





## **8 ANNEXURES**

## **Annexure 1:**

### **TOR**

**මධ්‍යම පරිසර අධිකාරිය**  
**மத்திய சுற்றாடல் அதிகாரசபை**  
**Central Environmental Authority**



පරිසර පියස, 104, ඩෙන්සිල් කොබ්බෑකඩුව මාවත, බත්තරමුල්ල, ශ්‍රී ලංකාව  
 "Parisara Piyasa", 104, ධෙණ්සිල් කොබ්බෑකඩුව මාවත, බත්තරමුල්ල, ශ්‍රී ලංකාව.  
 "Parisara Piyasa", 104, Denzil Kobbekaduwa Mawatha, Battaramulla, Sri Lanka. Web : www.cea.lk

අපේ ලොඹුව  
 எமது தொடர்பு } 08/SEA/SEA/03/2020  
 Our Ref. }  
 ඔබේ ලොඹුව  
 உமது தொடர்பு }  
 Your Ref. }  
 දිනය  
 திகதி } 14<sup>th</sup> September 2021  
 Date }

Director,  
 Waste Management Authority (Western Province)

**Strategic Environmental Assessment (SEA) for Solid Waste Management Master Plan  
 for the Western Province**

This has reference to your letter No WP/WMA/IC (Dir)/2021 dated 07.07.2021 and to the online scoping committee meeting held on 13<sup>th</sup> August 2021 regarding the SEA of the above Master plan

Please find attached herewith the Terms of Reference (ToR) for the Strategic Environmental Assessment of the above Master Plan. Please note that this ToR is only a guidance document.

You are kindly requested to carry out the SEA study in consultation with the relevant stakeholders and submit the SEA report with the Draft Master Plan to this Authority for review.

  
 N S Gamage  
 Deputy Director General  
 Environmental Management & Assessment Division

Copy::

1. Dr. Naofumi Sato, Chief Consultant, WP-SWM Master Plan project - for your information
2. Dr. M M S S B Yalagama, Additional Secretary (Policy & Admin.) Ministry of Urban Dev. & Housing
3. Dr. W.L.G. Samarasinghe, Additional Secretary (Agric. Development) Ministry of Agriculture
4. Eng. Mr. S.M. Madawalagama Director General (Technical), State Ministry of Urban Development, Waste Disposal and Community Cleanliness
5. Mr. Gamini Hewage, Director General, NPPD
6. Mrs. M Gangadaran, Additional Director General, National Planning Department
7. Mr. Mahinda Werahera, Director (EPC & CM), Ministry of Environment
8. Mr. Sunil Jayaweera, Director (Preparedness), DMC
9. Ms. Sakunthala H K Semasinghe, Assistant Director, UDA

Chairman	Tel : 2872361, 2872348 Fax : 2872347	Director General	Tel : 2872359 Fax : 2872608	General Office	Tel : 2872278, 2873447, 2873448 7877277-280	Complaint : 2888999
D. D. G	HRD. Admin. & Finance Tel : 2865296 Fax : 2877515	Envt. Pollution Control	Envt. Mgt. & Assess. Tel : 2873453 Fax : 2872605	Envt. Edu. & Awareness	Waste Mgt. Tel : 2872297 Fax : 2872609	Regional Oper. Tel : 2872409 Fax : 2882152 Tel : 2872370

පරිසර හා වනජීවී සම්පත් අමාත්‍යාංශය | சுற்றாடல் மற்றும் வனஜீவராசி வளங்கள் அமைச்சு | Ministry of Environment and Wild Life Resources



**TERMS OF REFERENCE FOR THE STRATEGIC ENVIRONMENTAL ASSESSMENT (SEA)  
Western Province Solid Waste Management Master Plan**

**Proponent Agency: Waste Management Authority-Western Province (WMA-WP)**

SEA should be carried out parallel to the preparation of the plan (Scheduling should be done accordingly.)

**1. BACKGROUND**

**1.1. Scope and the objectives of the Master Plan:**

A. Minimize the waste amount finally disposed of, through

- ① reduction of waste generation
- ② encourage recycling (incl. source separation for composting)
- ③ waste treatment by Waste to Energy (WTE) and composting

B. In a manner that is

- ① Physically feasible
- ② Environmentally and socially acceptable
- ③ Economically rational/acceptable

C. And to clarify the roles and responsibilities of related organizations, incorporate development plans and waste management facility plans of related organizations, and make it the most rational and efficient waste management in Western Province

**1.2. Objectives of the SEA study:**

- To select the most appropriate and acceptable alternative, further improve it and suggest actions to avoid or mitigate any negative environmental effects/impacts
- To incorporate environmental concerns and sustainability aspects into the Master Plan, and
- To incorporate stakeholder contributions and to address concerns of the stakeholders wherever possible in the Master Plan

**1.3. The responsible Agency/agencies for the Master Plan:**

- Provincial Government (WMA-WP and Local Authorities of the Western Province)
- Central Government (Ministry of Provincial Councils and Local Governments, and National Solid Waste Management Support Centre)

**1.4. The key stakeholders :**

- Ministry of Environment
- Ministry of Urban Development and Housing
- Ministry of Health
- Ministry of Agriculture
- State ministry of Urban Development, Waste Disposal and Community Cleanliness
- National Planning Department
- National Physical Planning Department
- Land Use Policy Planning Department
- Urban Development Authority
- Disaster Management Center
- Sri Lanka Land Development Corporation
- Natural resource conservation agencies (if applicable)
- Relevant District Secretaries / Divisional Secretaries



- Relevant Local Authorities
- Central Environmental Authority
- Any other agency as appropriate

**(It is the responsibility of the WMA-WP / SEA consultants to get the participation of key stakeholders throughout the SEA study.)**

#### 1.5. Expected Composition of the SEA Study Team

The SEA study team should have expertise and experience in the following fields

- Waste Management
- Urban Planning
- Sociology
- Economics

## 2. SEA Study

The scope of the SEA study should be in accordance with this Terms of Reference (ToR) and findings of the SEA study carried out by WMA-WP/SEA Consultants. The SEA study should include a description of the Master Plan, an environmental baseline study, identification of environmental constraints and opportunities, identification and assessment of the potential environmental effects/impacts with an analysis of performance indicators proposed in the Master Plan, an assessment of the institutional capacities to implement the Master Plan addressing environmental challenges and conclusions and recommendations.

### 2.1. Proposed Master Plan

- Necessity and legal ground for planning
- Key Agencies for implementing the Master Plan
- The Master Plan should be clearly identified with its exact spatial and temporal boundaries.
- Salient features of the Master Plan and its limitations should be clearly identified.
- A description of all components of the Master Plan including the associated projects which are already in operation / approved projects which are yet to be commissioned, any expansions/modifications proposed to already implemented projects, proposed new projects and proposed abandonment of any existing project.
- Possible alternatives already suggested for consideration during the SEA study. Present legal framework and institutional arrangement for implementation of the Master Plan and any gaps identified thereof.
- A brief description of the relevant National/sectoral or Provincial policies/strategies applicable
- Relevant stakeholders

### 2.2. Environmental baseline study

A description and an appraisal should be made of the current state of relevant environmental aspects and their existing trends in relation to the proposed Master Plan and to the Affected area. Environmental and associated social issues already exist in the sector and in the study area. Projections should be made of the state of the environment on the short-medium and long term without implementation of the proposed plan.

### 2.3. Analysis and evaluation of the Master Plan and its alternatives

Components and alternatives of the proposed Master Plan should be analyzed against the following criteria to identify most appropriate alternative and improvements to the same, if any.

- Conformity of the Master Plan with the National Environmental Policy, National Waste Management Policy, strategies of the Western Province and other related/applicable policies related to sustainable development, disaster management etc.



- Compatibility of the proposed plan/alternatives with the existing or proposed plans of the sector and proposed for the project affected area.
- Compliance with environmental regulations and standards
- Consistency with the policies /objectives goals related to environmental management and sustainable development (Sustainable Development Goals (SDGs) of the country;
- Prevailing environmental and socio-economic issues (in the sector and in the planning area) and their implications on sustainable development. (potential of the plan to address the issues in the sector and in the area )
- Social acceptances and the views and concerns of stakeholders
- Costs of collecting, processing and final disposal of solid waste and related economic aspects
- Natural Resources that may be affected due to implementation of the Master Plan
- The potential environmental effects/ impacts and risks due to implementation of the proposed Master Plan should be identified and described, including possible impacts in terms of vulnerability to climate risks. Special attention should be paid to views and concerns of stakeholders. The significance of the impacts (positive and negative) should be determined according to their characteristics such as duration, probability, magnitude, mitigability, reversibility and the sensitivity of the environment. Impacts which are significant should be assessed and suitable methods/alternatives for avoiding negative impacts and possible mitigation measures for remaining impacts proposed.

#### 2.4. Analysis of performance indicators

**Performance indicators proposed by the Master Plan should be assessed from an environmental perspective**, i.e. with regard to their usefulness to identify the environmental impacts (positive and negative) of development plan implementation. Based on this analysis, proposals should be made as appropriate for the improvement of the existing performance assessment framework. The set of indicators that are proposed should be practical and SMART (Specific, Measurable, Achievable, Realistic and Time-bound). A baseline will have to be defined for them.

The Consultants should give an indication of how recommended indicators may be applied, including: information / data need for applying the indicators, the sources where it may be obtained, and any other resources need for applying the indicator. An indication of possible costs associated in this respect should also be included under this.

#### 2.5. Assessment of the institutional framework to address environmental challenges

Existing legal and institutional framework for implementation of the Master Plan and carrying out identified environmental interventions, both in terms of adaptation and mitigation, should be assessed and recommendations should be made.

#### 2.6. Stakeholder engagement

Key stakeholders, relevant authorities and their concerns, consultations carried out, outcomes of such consultations and improvements made to the Master Plan based on such outcomes.

Stakeholders should be engaged throughout the SEA study (Stakeholder engagement could include a mix of different mechanisms, such as questionnaires, focused semi-structure interviews and workshops with key stakeholders etc.),

#### 2.7. Conclusions and Recommendations

This SEA study should summarize the key environmental issues of the area affected by the Master Plan, including policy and institutional constraints, challenges and main recommendations. Recommendations should be made on how to optimize positive impacts and make the best out of environment and natural resource related opportunities, as well as on how to avoid or mitigate negative impacts, adapt to environmental constraints and manage risks. It should suggest the most



appropriate alternative(s), and potential improvements to the design, implementation and monitoring modalities of the proposed Master Plan.

The Consultants should pay specific attention to provide realistic and workable recommendations. The limitations of the SEA and assumptions made should be presented. The recommendations should take into account the views presented by the stakeholders and explain how these were integrated. In the case of concerns that were not integrated in the final recommendations, the reasons thereof should be given.

### 3. Structure of the Report :

SEA report for the Master Plan should include but may not be limited to, the following;

1. Executive summary
2. Background of the sector plan
  - 2.1. Description of the sector plan
  - 2.2. Justification and purpose of the plan
  - 2.3. Alternatives considered
3. Scope and objectives of the SEA
4. Environmental baseline study
5. Approach and methodology used in the SEA
6. Results/outcomes of the analysis and evaluation of components of the Master Plan and its alternatives
7. Description of adaptation, mitigation and optimizing measures proposed
8. Performance indicators
9. Legal framework, institutional arrangement and capacities of the institutions
10. Conclusions and recommendations
  - 10.1. General conclusions
  - 10.2. Specific Recommendations
11. Appendices
  - 11.1. Terms of Reference for the SEA
  - 11.2. Consultants involved in the SEA study
  - 11.3. List of references and data sources
  - 11.4. Details of consultations with stakeholders, the results of discussion/consultation etc. and how the outcomes of these consultations were integrated into the Master Plan. (the mitigation measures, recommendation and comments should be reflected in the Master Plan)
  - 11.5. Maps and other illustrative information not incorporated to the main report
  - 11.6. A summary of technical data and information used in the study which are not included in the report



## Annexure 2: List of contributors

	Consultant	Position/ Assignment	Designation/Affiliation
1.0	Dr. Anurudda Karunaratna	Principle investigator and Team leader	Senior Lecturer University of Peradeniya
2.0	Prof. B F A Basnayake	Waste management policy and strategy analysis	Emirates Professor University of Peradeniya
3.0	Prof. Sarath Ranawana	Analysis of ecological aspects	Professor University of Peradeniya
4.0	Prof. Mallika Pinnawala	Social aspects	Professor University of Peradeniya
5.0	Ms. Thilini Rajapaksha	Management and socio-technical assessment	Freelance consultant affiliated to WtoE Ltd
6.0	Dr. Renuka Ariyawansa	Waste management system analysis	Senior Lecturer, SLTC Campus, Sri Lanka
7.0	Dr. Shaymani Siriwardena	Policy and economic aspects	Freelance consultant affiliated to WtoE Ltd
8.0	Ms. Poornima Dissanayake	Project assistant	Research assistant affiliated to WtoE Ltd

## Annexure 3.

### Summary of Stakeholder discussions relevant to SEA

The key stakeholders consulted for scoping are:

- Ministry of Environment
- Ministry of Urban Development and Housing
- Ministry of Health
- Ministry of Agriculture
- State Ministry of Urban Development, Waste Disposal and Community Cleanliness
- National Planning Department
- National Physical Planning Department
- Land Use Policy Planning Department
- Urban Development Authority
- Disaster Management Center
- Sri Lanka Land Development Cooperation
- Natural Resource Conservation Agencies
- Relevant District Secretaries/ Divisional Secretariats
- Relevant Local Authorities
- Central Environmental Authority

#### General comments on SEA

- TOR for the SEA was discussed at the project scoping meeting held on 13th August, 2021.
- The SEA report is expected to discuss and inform the likely effects of implementing the MP on the environment and socio-economic aspects in the Western province.

#### Aspects related to scope of study

- The MP provides detailed plans and options for SWM. Therefore, the SEA shall follow an approach that focuses on assessing planning solutions rather than conducting a policy-led assessment.
- New studies are not feasible due to time and data restrictions. Therefore, the baseline assessment shall perform using secondary data.
- The MP does not provide project alternatives to the MP. Therefore, proposed strategy shall be evaluated against the "business as usual plan

#### Aspects to be considered and discussed in assessment

- In the western province lands are limited for development projects; most development projects are close to residential areas, water bodies, wetlands and protected areas. SEA shall consider these issues in impact evaluation.
- Project sites are not yet identified for certain project activities; therefore, the likely impacts shall be considered for the overall region in such cases: Compost facilities, transfer stations
- Waste management practices, particularly waste transportation, are affected by traffic, bad weather conditions (floods), topography (highlands in Kaluthara district) and infrastructure.
- Insufficient and less efficient policy and regulatory framework may hinder benefits of proposed strategies: economic instruments.
- Ineffective and less efficient SWM practices may hinder benefits of proposed strategies: Incineration of organic waste, lack of monitoring plan, lack of data collection, less coordinated SWM activities across the region.
- Proposed activities must be aligned with other existing developing plans and programs; Railroad will be prioritized as the mode of waste transportation in accordance with the Mega polis plan over other options.
- Lack of knowledge/interest/acceptance of people for SWM; Discussed the present issues with existing SWM facilities and expressed that MP will bring solutions to environmental issues reported by the surrounding communities.

## Annexure 4.

### Schedule & workplan of the MP

#### Milestones for achieving MP targets

	Short term				Medium term					Long term												
	2022	2023	2024	2025	2026	2027	2028	2029	2030	2031	2032	2033	2034	2035	2036	2037	2038	2039	2040	2041	2042	
<b>Reduction of generation waste</b>	→ 1%				→ 3%					→ 10%												
<b>Separation of discharge waste</b>	→																					
Improvement of collection rate	MC	65%				→					→ 95%											
	UC	72%				→					→ 95%											
	PS	32%				→					→ 60%											
<b>Thermal Recovery Facilities (TRF)(ton/day)</b>																						
WPK WtE facility	→				→					→												
TRF in Colombo District	→				→					→												
TRF in Gampaha District	→				→					→												
<b>Compost facilities(CF)(ton/day)</b>																						
LAs CFs	92	→ 117			→ 131					→ 136												
Custer-bases CFs	232	→ 333			→ 383					→ 794												
Waste Park CFs	0	→ 160			→ 400					→ 400												
<b>Recycling facilities(MRF)(ton/day)</b>																						
LAs recycling facilities	116	→ 116			→ 116					→ 270												
Waste Park MRFs	0	→ 60			→ 150					→ 150												
<b>Transfer station (TS)(ton/day)</b>																						
Primary TS	→			400	→				490	→ 850												
Secondary TS (Kelaniya transfer station)	1,065	→ 1,242			→				997	→ 1,206												
<b>Final disposal (Aruwakkalu DS) (accumulated disposal volume for 20 years (million m<sup>3</sup>))</b>																						
	→			1.5	→				4.0	→ 9.5												
<b>By Product</b>																						
Amount of electric power (GWh/year)	→			74	→				179	→ 279												
Compost product (ton/year)	→			6,700	→				8,700	→ 14,600												
GHG emission reductions from composting*(mill. t CO <sub>2</sub> /year)	71	→ 156			→				322	→ 1,273												
* The emission reduction from the project activity is determined as the differences between the GHG emissions of baseline scenario (methane are emitted to atmosphere without recovery) and project scenario (composting organic wastes).																						

## Annexure 5:

### Evaluation and selection of the best alternative

#### A. 5.1 Technical evaluation

The baseline and the three alternative scenarios have been evaluated for the following technical criteria that are relevant to SWM in the Western Province.

- i. Reduction of improper waste discharge through increased collection coverage and reduction of the amount of waste to be disposed through the promotion of intermediate treatment
- ii. Optimization of final disposal
- iii. Maximization of organic waste composting and reduction of final disposal

The reduction of improper waste discharge should be achieved by increasing the waste collection amounts and promoting resources recovery and appropriate waste treatment and recycling programs. The Table A compares the quantitative achievements of four alternatives which can be forecasted for four alternatives.

**Table A Comparison of waste flow forecast by four alternatives**

Waste Flow	Baseline		Alternative A		Alternative B		Alternative C	
	(TPD)	(%)	(TPD)	(%)	(TPD)	(%)	(TPD)	(%)
Generation	6,827	100%	6,181	100%	6,181	100%	6,181	100%
Improper discharge	1,913	28%	515	8%	515	8%	515	8%
Discharge for collection	3,805	56%	4,985	81%	4,985	81%	4,985	81%
Informal recycling	290	4%	229	4%	229	7%	229	4%
Compost	325	5%	932	15%	1,332	22%	932	15%
Formal recycling	344	5%	421	7%	421	5%	421	7%
Thermal recovery	750	11%	750	12%	2,874	47%	3,300	53%
Untreated waste	2,096	31%	2,653	43%	129	2%	103	2%
Final disposal in landfills	2,383	35%	3,157	51%	1,206	20%	1,122	18%

Based on the waste flow forecast for optimum resources recovery and treatment, the MP identifies that the alternatives B and C are technically advantageous than the alternative A and the baseline scenario.

The alternative comparison based on the final disposal amount and requirement for future expansion of landfill capacity beyond the capacity of Aruwakkalu landfill in the MP identifies that alternative B and C will require 3.6 and 3.9 million m<sup>3</sup> additional capacity by 2042. Moreover, the baseline scenario and alternative A will require 9.8 and 14 million m<sup>3</sup> of additional landfilling capacities. Thus, the MP recognizes that alternative B and C have similar advantages in term of optimization of final disposal compared to the baseline and alternative A. Also, alternative C is considered as the optimal SWM system from the viewpoint of minimizing the amount of final disposal. Further, the alternative B is recognized as the ideal SWM system for optimizing organic waste treatment and recovery through composting.

In conclusion, the MP concludes that the four alternatives are ranked in order of Alternative B > Alternative C > Alternative A > Baseline based on the maximization of organic waste composting and reduction of final disposal.

### A. 5.2 Financial evaluation

The waste management costs of the baseline and each alternative for the period of 20 years (2022-2041) have been compared in the MP project report. Following components were considered in the cost calculation.

- **Costs for waste collection and transportation** including fuel costs, vehicle maintenance costs, and labor costs related to the collection of organic waste, recyclable waste, and other waste.
- **Costs for waste transfer and transportation** including fuel costs, vehicle maintenance costs, and labor costs related to the transportation of the following waste to Kelaniya Transfer Station (TS), costs and maintenance costs related to rail transport from Kelaniya TS to Aruwakkaru landfill and Operating costs of Kelaniya TS
- **Costs for intermediate treatment** which includes construction and running costs of composting facilities, construction and running costs of recycling facilities, and construction and running costs of thermal recovery facilities
- **Costs for final disposal** which includes operating costs of the final disposal sites and costs for the expansion of Aruwakkalu landfill to dispose of waste that exceeds the initially planned landfill capacity.

Currently, CMC and few major cities use garbage compactor trucks for waste collection and transport; however, most of semi-urban and rural LAs still continue to use four-wheel tractors for waste collection and transport. The baseline scenario assumes that the current vehicle types will continue to be used in the future, whereas the other alternatives assume that the inappropriate collection vehicles will be replaced by garbage compactor trucks. Therefore, to

transport waste to be disposed to the Aruwakkula landfill in the future, each municipality will need to transport collected waste to the Kelaniya TS. In overall transport cost assessment, the MP recognized that the costs are higher in the baseline scenario and alternative A.

Table B shows a comparison of comprehensive cost forecast for different segments of the MSW system.

**Table B Comparison of cumulative and unit costs of SWM for 2023-2042**

Cost item	Unit	Baseline	Alternative A	Alternative B	Alternative C
Collection	million	186,076	109,037	102,935	106,487
Transfer	LKR	99,596	145,227	75,899	82,166
Composting facilities	for	7,100	13,010	20,303	12,997
Recycling facilities	2023-	3,452	4,164	6,164	4,164
Thermal recovery facilities	2042	41,649	42,238	153,185	174,820
Final disposal		140,424	190,709	69,368	72,041
Total		478,297	504,385	427,853	452,675
Unit cost for SWM	LKR/ton	26,197	20,279	17,121	18,198

The MP recognizes that intermediate treatment costs are higher in alternatives B and C due to the high construction and maintenance costs associated with the large scale of the thermal recovery facilities. Final disposal costs are higher in the baseline scenario and alternative A due to the large amount waste to be transported to the final disposal site without sufficient intermediate treatment.

Alternative B is the inexpensive alternative in terms of total waste management cost and unit cost; thus, alternative B is considered as the optimal SWM system from the viewpoint of minimizing waste management costs. The 20-year average annual treatment cost of alternative B is projected to be 4.3 billion LKR/year, and the cost per ton of collected waste is projected to be 17,100 LKR per ton.

### A. 5.3 The optimum MSW management system for the master plan

The selection of the best alternative from the four alternatives has been done based on an objective comparison shown in previous section.

It has recognized that waste to energy as a technically feasible and appropriate method to treat residual organic and other type of burnable waste. The alternatives B and C promote the recovery of energy through incineration and reduce the volume of waste to be disposed of in final disposal sites. Incineration is particularly suitable as treatment method in the Western Province as land

for disposal sites must be sought out of the province and it is therefore essential to minimize the volume of waste to be transported and disposed in Aruwakkalu landfill.

Alternatives A, B and C all actively promote organic waste composting, but the proposed system in alternative B allows all the collected organic waste to be composted, except for the 20% that is to be incinerated, while maximizing the recycling of recyclable materials.

Economically, alternative B is recognized as the most cost-effective system compared to the other options. Based on the technical and financial analysis, the MP recommends following project activities which are aligned with the proposed alternative B: 2900 TPD WtE & 1326 TPD composting by year 2042.



## Annexure 6.

### Key stakeholders relevant to SWM sector and the MP

Stakeholder	Role of the Stakeholder in Western Province Waste Management Master Plan	Relevance Direct/ Indirect
	<b>MINISTRIES</b>	
Ministry of Public Administration, Home Affairs, Provincial Councils and Local Government (MoPCLG)	<ul style="list-style-type: none"> <li>● Compilation of laws and provision of consulting services to introduce methodological and proper solid waste management activities for the local authorities.</li> <li>● Provision of adequate technical assistance in solid waste management to local government institutions (e.g., National Solid Waste Management Support Center- NSWMSC).</li> <li>● Promoting the local authorities to obtain local and foreign technical cooperation in solid waste management.</li> <li>● Supporting the local authorities to obtain technical and financial assistance from non-government organizations and financial institutions.</li> <li>● Construction and development of environmental conservation centers (e.g., composting facilities, recycling facilities etc.) for local authorities and state institutes.</li> <li>● Promoting 3R.</li> <li>● Technical and financial assistance for Local Authorities to prepare waste management plans for provinces and Local Authorities.</li> <li>● Implementation of a national waste management special programs to improve waste management in local governments.</li> <li>● Implementation of nationwide awareness campaign by facilitating local authorities and government institutes.</li> <li>● Provide policy directives for all organizations under the MoPCLG.</li> </ul>	Direct
Ministry of Urban Development and Housing (MoUD&H)	<ul style="list-style-type: none"> <li>● Formulating and implementing national policy on housing and construction and other subjects that comes under its purview.</li> <li>● Policy on solid waste management and national urban sanitation.</li> <li>● Bring systematic changes and development processes into the urban community in Sri Lanka, which will ensure that the inhabitants of urban areas become a part of the socioeconomic development of the country while maintaining high levels of quality of life.</li> <li>● Discover solutions to resolve distinctive issues related to urbanization, such as garbage, slums, energy, traffic, the environment, and livelihoods.</li> <li>● Provide policy directives for all organizations under the MoUD&amp;H.</li> </ul>	Indirect (Direct)
Ministry of Environment (MoE)	<ul style="list-style-type: none"> <li>● Development of national policies, strategies, and guidelines on solid waste management and affiliated subjects.</li> <li>● Implement programs to manage waste and to control pollution.</li> <li>● Implement programs to strengthen institutional capacity in waste management.</li> <li>● Implement programs to educate and train human resources in government and private sector organizations.</li> <li>● Coordinate and monitor activities relevant to waste management and environmental conservation.</li> </ul>	Direct (Indirect)

Stakeholder	Role of the Stakeholder in Western Province Waste Management Master Plan	Relevance Direct/ Indirect
	<ul style="list-style-type: none"> <li>● Fulfill the obligatory requirement of international convention relevant to waste management and pollution.</li> <li>● Provide policy directives for all organizations under the MoE.</li> </ul>	
Ministry of Health (MoH)	<ul style="list-style-type: none"> <li>● Provide guidelines and directions for healthcare institutes and affiliated sectors for healthcare waste management.</li> <li>● Develop strategic plans to achieve the strategic objectives of the programs under environmental health.</li> <li>● Advocate with the policy makers and stakeholders at the central and provincial levels on the importance of improving environmental health.</li> <li>● Intra- and inter-sectorial coordination on multidisciplinary issues related to environmental health.</li> <li>● Conduct operational research on environmental health issues.</li> <li>● Provide technical expertise on environmental health in matters related to intra- and inter-sectorial planning, implementation, monitoring, and evaluation of various programs and activities at various levels.</li> <li>● Provide policy directives for all organizations under the MoH.</li> </ul>	Indirect (direct)
Ministry of Agriculture (MoA)	<ul style="list-style-type: none"> <li>● Formulating policies and regulations relevant to soil and water resource conservation.</li> <li>● Management of agricultural and arable lands.</li> <li>● Policy and legislation pertaining to postharvest produce management relevance to postharvest waste control.</li> <li>● Regulation of pollution that may cause due to agricultural activities.</li> <li>● Provide policy directives for all organizations under the MoA.</li> </ul>	Indirect
Ministry of Power and Energy (MoP&E)	<ul style="list-style-type: none"> <li>● Formulate policies, strategies and master plan for management of energy sector including waste to energy.</li> </ul>	Indirect
Ministry of Investment Promotion (MoIP)	<ul style="list-style-type: none"> <li>● Formulate policies, strategies and investment plan for local and foreign investment, especially for waste management infrastructure and service supply.</li> </ul>	Indirect
Ministry of Wildlife and Forest Resources Conservation (MoWF)	<ul style="list-style-type: none"> <li>● Formulate policies, strategies and master plan for conservation and management of forest and wildlife resources including the protected areas affected by waste management.</li> </ul>	Indirect
<b>AUTHORITIES AND GOVERNMENT DEPARMENTS</b>		
National Solid Waste Management Support Centre (NSWMSC)	<ul style="list-style-type: none"> <li>● Assist LAs to improve the solid waste management capacity.</li> <li>● Develop a variety of manuals and guidelines to facilitate LAs' implementation of proper SWM.</li> <li>● Provide a range of solid waste management technical assistance to LAs, government institutes and other stakeholders.</li> <li>● Collect and disseminate information on the current SWM practices and the practices in LAs, as well as those in foreign countries.</li> <li>● Facilitate LAs getting technical and financial assistance from NGOs and donors.</li> </ul>	Direct

Stakeholder	Role of the Stakeholder in Western Province Waste Management Master Plan	Relevance Direct/ Indirect
	<ul style="list-style-type: none"> <li>Promote, evaluate, and make recommendations to the SWM plan develop by state organizations.</li> </ul>	
Central Environmental Authority (CEA)	<ul style="list-style-type: none"> <li>Formulate regulations, guidelines and strategies relevance to waste management and pollution control.</li> <li>Grant approval for implementation of large-scale and schedule projects through EIA process.</li> <li>Responsible for the monitoring, supervision, and directing all the activities that may pose risk to environment.</li> <li>Assist formulation of national/ sub-national policies, programs, and projects relevant to waste management and pollution control.</li> </ul>	Direct (Indirect)
National Planning Department (NPD)	<ul style="list-style-type: none"> <li>Assist formulation of national policies, programs, and projects; and assist in development of sub-national, and sectoral policies.</li> <li>Policy development, planning and implementation, to accelerate economic growth and social progress.</li> </ul>	Indirect
Marine Environment Protection Authority (MEPA)	<ul style="list-style-type: none"> <li>Responsible for the planning and operation of all technical activities including formulation of policies to reduce, control, manage and prevent the marine pollution.</li> <li>Prevent, minimize or control the dispose of ship generated waste into the marine environment.</li> <li>Fulfill the obligatory requirement of international convention relevant to marine pollution.</li> </ul>	Indirect (Direct)
National Planning Department (NPD)	<ul style="list-style-type: none"> <li>Assist formulation of national policies, programs, and projects; and assist in development of sub-national, and sectoral policies.</li> <li>Policy development, planning and implementation, to accelerate economic growth and social progress.</li> </ul>	Indirect
Urban Development Authority (UDA)	<ul style="list-style-type: none"> <li>Possess and develop land resources to effectively improve utilization for public services and revenue generation.</li> <li>Develop city/ township and urban development plans.</li> <li>Plan, develop and implement waste management facilities and infrastructure.</li> <li>Authorize to create environmental standards and plan environmental improvements in UDA decayed areas.</li> </ul>	Indirect (Direct)
Sri Lanka Land Reclamation and Development Corporation (SLRDC)	<ul style="list-style-type: none"> <li>Regulates construction work and consulting assignments in the field of engineering and matters connected therewith or incidental thereto.</li> <li>Possess and develop land resources to effectively improve utilization for public services and revenue generation.</li> <li>Plan, develop and implement waste management facilities and infrastructure.</li> </ul>	Indirect (Direct)
National Physical Planning Department (NPPD)	<ul style="list-style-type: none"> <li>Guidance for the sustainable development within the territory of Sri Lanka, including land and ocean, is provided through the National Physical Planning Policy and the Plan.</li> <li>Promote and regulate a balanced development at the regional level through optimal utilization of existing resources and conservation.</li> <li>Achieve optimal development at the local level through concise plans prepared according to the National Physical Plan and Regional Physical Plans.</li> <li>Declaration and preparation of a development plan for sacred areas that are nationally, regionally, and locally significant.</li> </ul>	Indirect (Direct)

Stakeholder	Role of the Stakeholder in Western Province Waste Management Master Plan	Relevance Direct/ Indirect
	<ul style="list-style-type: none"> <li>● Implementation of identified projects as the national, regional, and local physical plans by liaising with relevant institutions and stakeholders.</li> </ul>	
Board of Investment (BOI)	<ul style="list-style-type: none"> <li>● Responsible for attracting foreign investors and investments for waste management.</li> <li>● Facilitate foreign and local investment for manufacturing and service industries relevance to waste management.</li> </ul>	Indirect
Disaster Management Centre (DMC)	<ul style="list-style-type: none"> <li>● Provide advisory services for implementing regulations relevant to disaster management.</li> <li>● Protect human health, comply with regulations, conserve disposal capacity, reduce injuries, and minimize or prevent environmental impacts.</li> </ul>	Indirect
National Building Research Organization (NBRO)	<ul style="list-style-type: none"> <li>● Provide advisory services for implementing regulations relevant to construction and built-environment management.</li> <li>● Provide technical services for scientific analysis.</li> </ul>	Indirect
District/ Divisional Secretariat (DS)	<ul style="list-style-type: none"> <li>● Directing and coordinating all the development activities taking place in the division or district.</li> <li>● Allocation of land and other state resources for development purposes.</li> </ul>	Indirect

## Annexure 7.

### Detailed assessment of likely effects of planning solutions

Following scale was used for evaluation of likely impacts:

- +2 Very significant positive likely impacts
- +1 Significant positive likely impacts
- 0 No impacts
- 1 Significant negative likely impacts
- 2 Very significant negative likely impacts
- ? Likely impacts uncertain

Planning solution	Environmental receptor	Evaluation	Environmental risks	Environmental benefits	Mitigation measures
Promote waste reduction at generation sources	Water	+1	No risk identified	Reduced amounts of waste leads to less pollution of water bodies	
	Air and climate change	+1	No risk identified	Reduced amounts of waste leads to less air pollution	
	Soil/land/biodiversity	+1	No risk identified	Reduced amounts of waste leads to less pollution of soil and lower illegal dumping in environmentally sensitive areas	
	Human health	+1	No risk identified	Overall positive effect of waste reduction on the environment leads to improved	

Planning solution	Environmental receptor	Evaluation	Environmental risks	Environmental benefits	Mitigation measures
				health in the community	
	Socio-economic	?	The system of tariffs may have positive impact of improved waste collection practice, however, it can also have negative impact on vulnerable groups of population which will be unable to pay for higher tariffs.	Overall positive effect of waste reduction on the environment leads to improved quality of life  Effective solutions in terms of adequate tariffs on waste collection	While introducing waste tariff and waste fee collection system may positively change the behaviors of population, private or public entities in waste management, a proper planning and analysis is essential (including economic and social aspects). Mitigations • Before setting waste tariff and waste collection fee systems affordability study should be conducted to define reasonability of any tariff and waste collection fee. Waste tariffs and collection fees shall differ for different regions based on the social, economic, geographical and other conditions of the population and the region itself.

Planning solution	Environmental receptor	Evaluation	Environmental risks	Environmental benefits	Mitigation measures
					<ul style="list-style-type: none"> <li>• Developing a standard methodology for calculating the service delivery fee.</li> <li>• Landfill gate fees should be set very carefully, which should be affordable for waste collection and transportation companies otherwise, this will create incentive for illegal dumping.</li> <li>• Municipalities should be given assistance (relevant infrastructure, software and training) to enable them for charging and collecting waste fees electronically and improving their administrative skills in fee collection.</li> </ul> <p>Introduction of Extended Producers Responsibility is an effective tool to change the behaviour of the producer in waste management and</p>

Planning solution	Environmental receptor	Evaluation	Environmental risks	Environmental benefits	Mitigation measures
					reduce the dumping of the waste in the environment. Mitigation <ul style="list-style-type: none"> <li>• Ensure preparation and implementation of broad awareness raising and educational campaigns or pilot projects for Extended Producers Responsibility</li> <li>• Develop and implement relevant economic incentives to promote EPR</li> </ul>
<b>Promote waste separation and reduction at discharge stage</b>	Water	+1	No risk identified	Waste separation and recycling via composting helps proper disposal and reduced disposal, thereby reduce water pollution from waste	



Planning solution	Environmental receptor	Evaluation	Environmental risks	Environmental benefits	Mitigation measures
	Air and climate change	+1	No risk identified	Waste separation and recycling via composting helps proper disposal and reduced disposal, thereby reduce air pollution from waste	
	Soil/land/biodiversity	+1	No risk identified	Waste separation and recycling via composting helps proper disposal and reduced disposal, thereby reduce land pollution from waste and reduce threats to biodiversity	
	Human health	-1	Inadequate knowledge on waste categories, specifically chemical and biological waste, may incur health hazards and diseases	Waste separation and composting helps proper disposal and reduced disposal, thereby avoid infectious diseases	Capacity-building, awareness and education of waste collectors and community dwellers on waste management practice, standards (environmental, health and safety)
	Socio-economic	+	Inadequate knowledge of different types of waste	Waste separation and composting	Disseminate sufficient information on

Planning solution	Environmental receptor	Evaluation	Environmental risks	Environmental benefits	Mitigation measures
			<p>may hinder proper waste separation and proper use of the mobile app</p> <p>Inadequate supply of waste bins, especially for biodegradable waste, may discourage citizens to separate waste</p> <p>Inadequate knowledge on home composting and recycling hinder sufficient amount of waste reduction at discharge</p>	<p>helps provide raw materials for recycling at intermediate facilities and additional job opportunities</p>	<p>waste separation and segregation</p>
<b>Expand the solid waste collection area and improve waste collection system</b>	Water	+	<p>Increased number of waste collection vehicles will have negative impact on surface water resources due to increased car emissions and dust</p>	<p>Improved waste collection system and establishment of waste collection points with containers will reduce the amount of solid waste entering in adjacent</p>	<p>Ensure adequate service of the collection trucks to minimize emissions</p>

Planning solution	Environmental receptor	Evaluation	Environmental risks	Environmental benefits	Mitigation measures
				water bodies, thus improving the water quality	
	Air and climate change		Increased number of waste collection vehicles will have negative impact on air quality due to increased GHG emissions	Increased waste collection reduces illegal/improper waste disposal, thereby reduce odor from waste	
	Soil/land/biodiversity	+1	Unlicensed waste disposal by transporting vehicles	Cleaning of littered areas Increased use of areas for other purposes Improved waste collection system will reduce the illegal dumping on waste in sensitive areas eg. wetlands	Application of SWM control system
	Human health		Pollution of lands (soil and air) throughout the waste collection process	Decrease / elimination of disseminators of infectious diseases (rodents, insects) in residential areas and buildings	Research of infectious and noninfectious diseases among employees of communal services  Proper decontamination of waste

Planning solution	Environmental receptor	Evaluation	Environmental risks	Environmental benefits	Mitigation measures
				Decrease of health risk in waste collection process by using efficient and hygienic waste collection vehicles	transportation means  Improved sanitary – hygienic conditions of the workplaces of employees of communal services engaged in the processes of waste collection and recycling
	Socio-economic	+1		Clean area, clean environment Reduction of stench, increase of waste-free areas Regular waste collection and proper management Improved environmental and sanitary situation	Capacity-building, awareness and education of waste collectors and community dwellers on waste management practice, standards (environmental, health and safety)
<b>Construction of primary transfer stations and waste transportation</b>	Water	-1/?	Transfer stations may become as additional sources of surface and groundwater pollution if not located in suitable areas, avoiding the sanitary zones of aquatic ecosystems		Refer to the Government Resolution No 64-N “On Criteria for Definition of Areas for Sanitary Conservation of Aquatic Ecosystems, Flow Formation, Conservation of Groundwater, and Identification of Water Protection

Planning solution	Environmental receptor	Evaluation	Environmental risks	Environmental benefits	Mitigation measures
					Zones, Ecotones, and Inalienable Areas” (the details are in the Scoping Report). Climatic (wind, precipitation) and erosion conditions should also be considered while designing the transfer stations
	Air and climate change		Odor and emissions from waste can affect local air quality in the vicinity of transfer stations and along transportation routes		
	Soil/land/biodiversity	-1	Alienation of lands and pollution	Reduction of polluted areas  Positive impact can be expected since transfer stations can accumulate waste placed in the vicinity freeing lands that can be used for development	Conduct of audit and monitoring Installation of the transfer stations in the degraded, dirty areas Establish facilities at a respective distance from specially protected natural areas
	Human health	+1	1.Pollution of transportation routes and dissemination	Exploitation of modernized waste collection	1. Installation of transfer stations in nonresidential zones

Planning solution	Environmental receptor	Evaluation	Environmental risks	Environmental benefits	Mitigation measures
			<p>of possible diseases during the waste transportation process</p> <p>2. Pollution of new areas where new transfer stations are located through organic, chemical pollutants and viruses of infectious diseases</p> <p>3. Increase of infectious and noninfectious diseases among employees of communal services</p>	<p>vehicles for efficient transfer of waste</p> <p>2. Quick removal of waste from residential buildings</p>	<p>2. Occupational morbidity study among employees of communal services</p> <p>3. Improved sanitary – hygienic conditions of the workplaces of employees of transfer stations engaged in the processes of waste collection, transportation and recycling: bath conditions, individual protective measures, etc.</p>
	Socio-economic	+1	Community impact with long-term negative effects on environment and health.	Local job creation at transfer stations and waste transportation	Selection of the location of the transfer stations, maintaining the buffer zones, secure environment and sanitary conditions for the nearby communities and waste workers
<b>Increase capacity of composting and</b>	Water	+1	Poor management of leachate during the	Recycling helps reduce disposal of plastic and	The MP proposes a leachate treatment facility at waste parks.

Planning solution	Environmental receptor	Evaluation	Environmental risks	Environmental benefits	Mitigation measures
<b>recycling facilities</b>			mechanical biological treatment is a risk	hazardous waste in water bodies  Composting reduces the amount of biodegradable waste, thereby reducing the leachate.	Proper management of leachate (lining, collection etc.) during mechanical composting will lead to overall environmental benefits and reduced pollution of surface and groundwater.
	Air and climate change	+1		Waste Park reduces the mass of the input waste through composting processes and makes an input for reduction of GHG and other emissions  Can help generate energy from waste (although additional planning and costs are needed)	
	Soil/land/biodiversity	+2		Considerable decrease of the amount of waste accumulated  Reduction in the amount of	

Planning solution	Environmental receptor	Evaluation	Environmental risks	Environmental benefits	Mitigation measures
				biologically degradable waste	
	Human health	-1	During the mechanical destruction of non-decontaminated waste, pathogenic microorganisms and aerosols will be emitted to the environment creating a threat to the employees and the environment	Prevention of the transfer of specific household waste (batteries, lamps containing mercury, etc.) to the landfill and their neutralization	Air disinfection during the mechanical process and after it, before being emitted to the environment  Regular disinfection of grinding and mixing devices  Capacity-building, awareness and education of waste management practice, standards (environmental, health and safety)
	Socio-economic	+2	Change of the landscape  Absence or insufficient payment systems will discourage recycling and composting Absence of legal basis regulating the economic mechanisms to support the recycling businesses	Reliable waste conservation Increased material recovery Increased job creation	Proper selection of areas and landscape  Legalization of waste /recycling market/employment opportunities for waste pickers and nearby community dwellers in accordance with environmental, health and safety regulations and standards



Planning solution	Environmental receptor	Evaluation	Environmental risks	Environmental benefits	Mitigation measures
<b>Increase the incineration capacity at WtE facility</b>	Water	-1	Water abstraction for gas cooling processes in the process of incineration. Risk of pollution of water resources due to incineration gas emissions.	Reduced amount of waste will need less area for landfills and, subsequently, less pollution risks. Thermal recovery of plastic waste helps reduce marine plastic pollution	The WMP notes that the residual product from thermal recovery (ash) must be disposed of e.g., in special hazardous waste landfills. It would be useful to provide more details regarding the referred special hazardous waste landfills and how
	Air and climate change	+1	Pollution of environment and damage to biodiversity, additional air pollution with unwanted gases. Negative health impact Not effective for landfill facilities with weak air pollution control	Waste separation/ recycling (Glass, paper, metal) Waste to energy generation Thermal processes Incineration, industrial combustion, advanced waste-to - energy technologies reducing GHG emissions, costly but effective mitigation potential in waste sector (short term effect)	Secure technologies for waste burning /incineration with reduced or no damage to environment and human health Required control over toxic emissions and preventive measures (dioxin, acids, heavy metals, etc.)

Planning solution	Environmental receptor	Evaluation	Environmental risks	Environmental benefits	Mitigation measures
	Soil/land/biodiversity	+2	Pollution of adjacent and neighboring lands due to the dispositioning of compounds emitted to the atmosphere	Considerable decrease of the amount of waste accumulated	Composting is not a final option towards waste elimination; it solves the issues of reduction in the amount of waste as well as utilization of dangerous waste. Best practices envisage either composting or incineration.
	Human health	-2	<ol style="list-style-type: none"> <li>1. Pollution of the atmospheric air</li> <li>2. Application of old technologies as well as violations of technological processes lead to mass pollution of the atmospheric air causing carcinogenic and embryo, genetic mutations through stable organic pollutants</li> <li>3. Health hazards to people working in the field</li> </ol>	<ol style="list-style-type: none"> <li>1. Reduction of the amount of waste as well as areas designated for landfills</li> <li>2. Destruction of agents and transmitters of infectious diseases</li> </ol>	<ol style="list-style-type: none"> <li>1. Occupational morbidity study among employees of communal services</li> <li>2. Conduct of monitoring of air pollutants</li> <li>3. Application of new furnaces in line with the guidelines of Stockholm Convention</li> </ol>
	Socio-economic	+1	Air pollution, emission of undesirable	Energy generation,	Application of mechanical and other

Planning solution	Environmental receptor	Evaluation	Environmental risks	Environmental benefits	Mitigation measures
			gases into the environment	neutralization of waste	filters
<b>Increase the capacity of landfill</b>	Water	-2	Sanitary landfills may become as additional sources of surface and groundwater pollution if not located in suitable areas, avoiding the sanitary zones of aquatic ecosystems, flow formation zones, water protection zones, ecotones and inalienable areas. Risk of leachate leakages	Properly organized sanitary landfills will reduce the amount of waste dumped to the water bodies in the communities where landfills do not exist, and waste collection is not organized properly.	Considering geological assessment of territory in feasibility study of expansion of the landfill  Proper lining to prevent groundwater pollution due to leachate leakages. Avoid flood-prone zones when defining landfill location. Ensure compliance with the Gov. Resolution No 64-N "On Criteria for Definition of Areas for Sanitary Conservation of Aquatic Ecosystems, Flow Formation, Conservation of Groundwater, and Identification of Water Protection Zones, Ecotones, and Inalienable Areas".
	Air and climate change	+1	Sanitary landfills will have negative impact on environment should they		Control over areas of potential landfills, setting fines and public awareness-raising

Planning solution	Environmental receptor	Evaluation	Environmental risks	Environmental benefits	Mitigation measures
			be placed close to communities		
	Soil/land/biodiversity	+1	Contamination of the specially protected areas, residential areas, fertile layer of the land	Creation of manageable waste dumps Enforcement of coordinated control	<ul style="list-style-type: none"> <li>Considering vicinity of protection areas, residential areas, agricultural areas in the feasibility study of expansion of the landfill</li> </ul>
	Human health	+1	<p>Pollution of new areas, soil, underground and surface waters and atmospheric air</p> <p>Certain segments of population will undergo certain level of impact which will imply emergence of new issues in target areas</p>	<p>1. Limited pollution of air, soil, underground and surface waters in areas adjacent to the landfills due to setting the sanitary zone</p> <p>2. Limited access of residents and animals</p>	<ul style="list-style-type: none"> <li>Ensure enforcement of Environmental Health monitoring procedures and risk assessment during the operation of landfills</li> </ul> <p>1. Occupational morbidity study among employees of communal services</p> <p>2. Conduct of proper laboratory monitoring of air, soil, underground and surface waters in areas outside the landfills</p>
	Socio-economic	+1	Being very close to the residential areas	Availability of waste-free areas, lack of garbage scattered around residential areas	Conduct surveys towards proper and rational selection of the location of landfills

Planning solution	Environmental receptor	Evaluation	Environmental risks	Environmental benefits	Mitigation measures
<b>Closure or rehabilitation of existing uncontrolled dumpsites</b>	Water	+1	No negative impact on water	Reduced contamination of surface and ground water in vicinity	The MP proposes to have technical and financial feasibility analysis before closure and rehabilitation of existing dumpsites.
	Air and climate change	+1	There are no observable risks	Reduced emissions of air pollutants from landfills	Recultivation of areas
	Soil/land/biodiversity	+1	There are no observable risks	Elimination of irregular landfills, considerable decrease of polluted land surfaces and circulation of recultivated lands.	Monitoring of proper organization of recultivating activities
	Human health	+2	No negative impact on health	Landfills with highly insufficient sanitary hygienic conditions are conserved and closed.	<ul style="list-style-type: none"> <li>• Ensure consideration of Public Health aspects on closure preparation stage of high-risk existing landfills</li> <li>• Ensure enforcement of health impact assessment and environmental impact monitoring for closed landfills (especially for high-risk landfills)</li> <li>• Ensure enforcement of health impact</li> </ul>

Planning solution	Environmental receptor	Evaluation	Environmental risks	Environmental benefits	Mitigation measures
					assessment and environmental impact monitoring for closed dumpsites
	Socio-economic	+1	Improper organization of landfill closure and reclamation activities	Waste will not be accumulated in the vicinity of uncontrolled landfills and the environment will be clean from waste.	Ensure coordination with Public Health authorities for considering all environmental health aspects during the preparation of plans for closure of existing dumpsites and implementation of the plans  Capital formation to implement the planned activities
<b>Development of data base for SWM</b>	Water	+1		Overall positive impact on water resources improved waste management	
	Air and climate change	+1		Overall positive impact on air and climate via	
	Soil/land/biodiversity	+1		Proper organization of the envisaged activities will considerably reduce surfaces of	

Planning solution	Environmental receptor	Evaluation	Environmental risks	Environmental benefits	Mitigation measures
				distorted lands and will allow for their conservation and circulation	
	Human health	+1		Overall positive impact on health via improved waste management aligned with minimizing health hazards in SWM	Ensure collection of environmental health monitoring, data for waste analysis and management
	Socio-economic	+2		Database will provide useful information for further decision-making and improved waste management. It also will make easy transfer of information between stakeholders, thereby promotes integrated SWM and helps reduce operational costs.	Detailed research, mapping

## **Annexure 8:**

### **Maps and supplementary information**



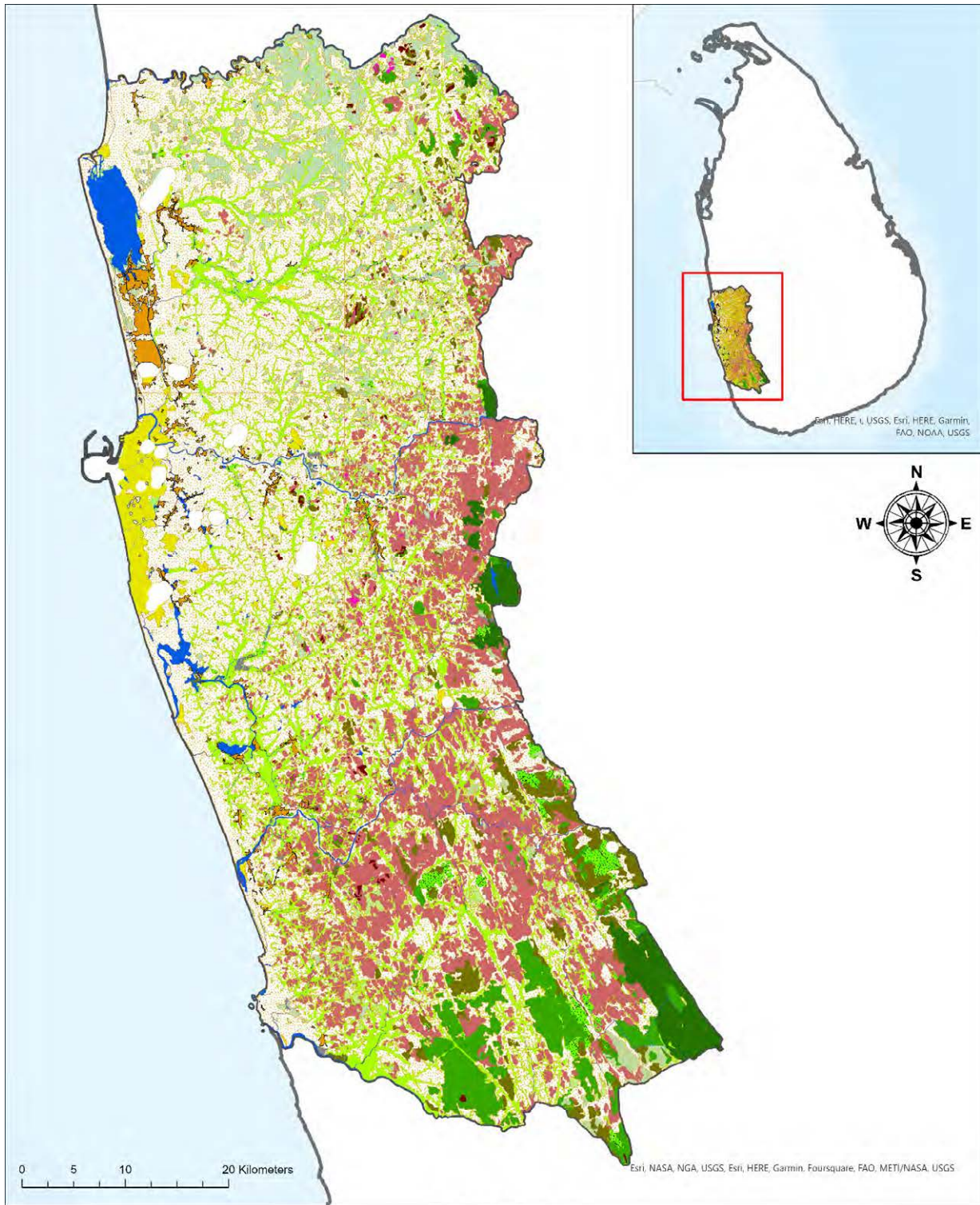

**Land Use Classes**

- |                 |                   |                 |            |                        |
|-----------------|-------------------|-----------------|------------|------------------------|
| Aquatic farms   | Dense Forest      | All waters area | Paddy      | Sand                   |
| Built up area   | Open Forest       | Livestock farms | Playground | Scrub land             |
| Barren land     | Forest Plantation | Mangrove        | Quarry     | Sparsely used cropland |
| Coconut Nursery | Grassland         | Marsh           | Rubber     | Tea                    |
| Cinnamon        | Homesteads/Garden | Oil Palm        | Rock       | Other cultivation      |

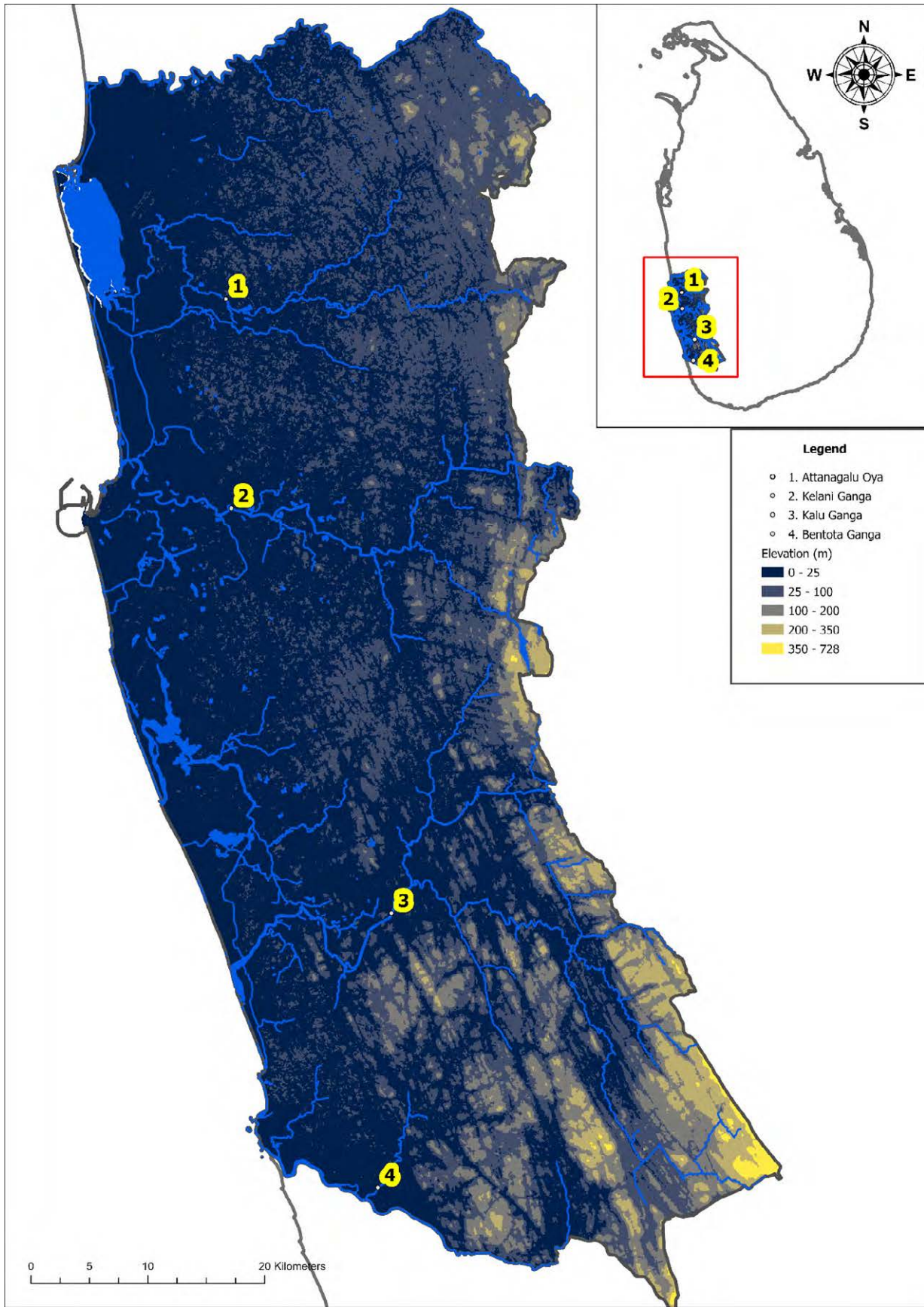

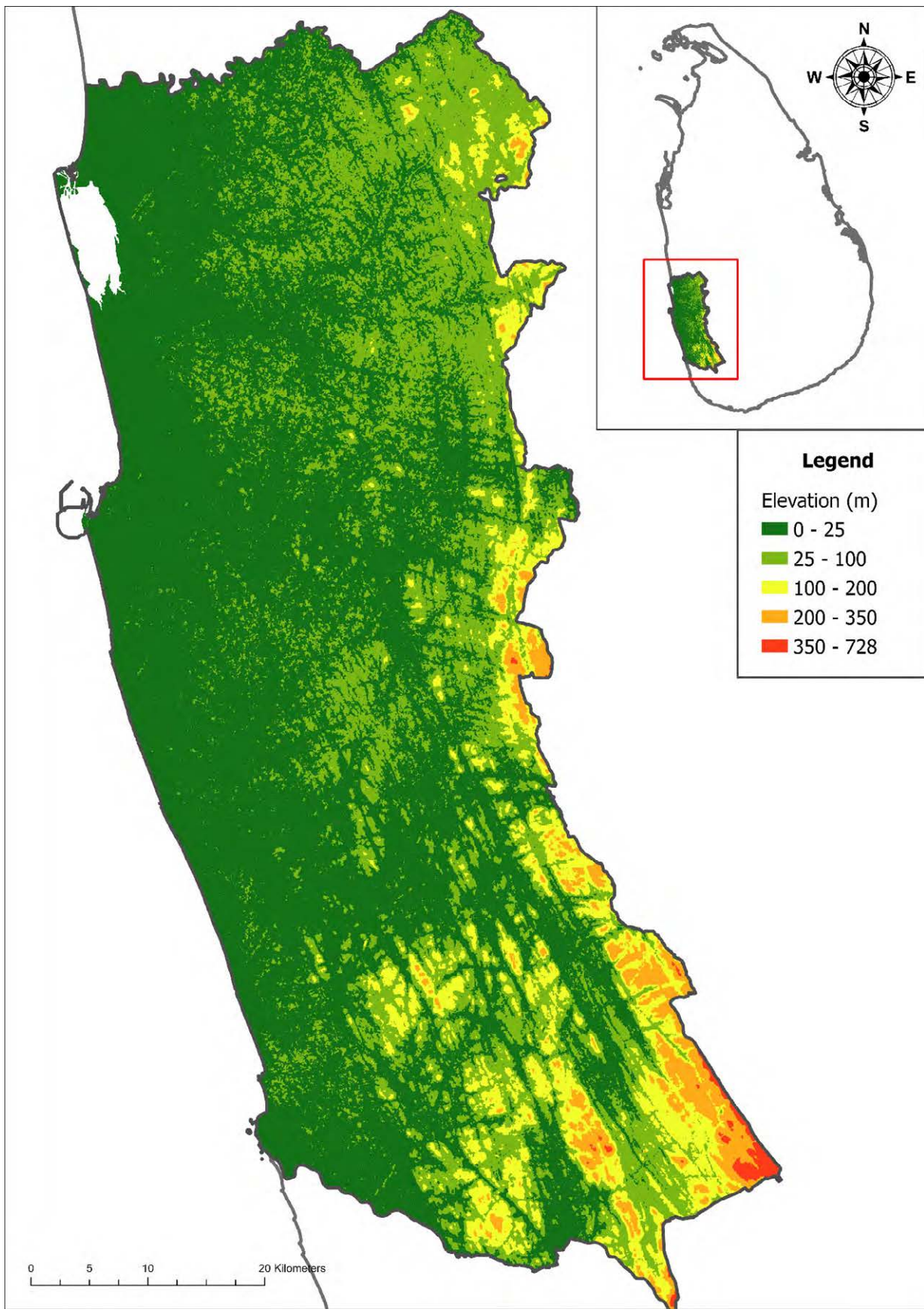

## Annexure 9:

### References and data sources

1. Abeyewickreme, W., Wickremasinghe, A. R., Karunatilake, K., Sommerfeld, J., & Axel, K. (2012). Community mobilization and household level waste management for dengue vector control in Gampaha District of Sri Lanka; an intervention study. *Pathogens and Global Health*, 106(8), 479-487. doi:10.1179/2047773212y.0000000060.
2. Alahacoon, N. and Edirisinghe, M. (2021). Spatial Variability of Rainfall Trends in Sri Lanka from 1989 to 2019 as an Indication of Climate Change. *ISPRS Int. J. Geo-Inf.* 2021, 10, 84. <https://doi.org/10.3390/ijgi10020084>.
3. Athukorala, D.; Estoque, R.C.; Murayama, Y.; Matsushita, B. (2020). Impacts of Urbanization on the Muthurajawela Marsh and Negombo Lagoon, Sri Lanka: Implications for Landscape Planning towards a Sustainable Urban Wetland Ecosystem. *Remote Sens.* 2021, 13, 316. <https://doi.org/10.3390/rs13020316>.
4. Bambaradeniya, C. (2008). Western Province Biodiversity Profile and Conservation Action Plan. Biodiversity Secretariat Ministry of Environment and Natural Resource Sri Lanka.
5. Bambaradeniya, C.N.B.; Ekanayake, S.P.; Kekulandala, L.D.C.B.; Samarawickrama, V.A.P.; Ratnayake, N.D.; Fernando, R.H.S.S. (2002). An Assessment of the Status of Biodiversity in the Muthurajawela Wetland Sanctuary; IUCN: Colombo, Sri Lanka: ISBN 9558177172.
6. CEA (1994). Wetland site report and conservation management plan – Colombo FloodDetention Areas. Colombo: Central Environmental Authority of Sri Lanka.
7. Central Bank of Sri Lanka, Annual Report 2008, 2009, 2021. Central Bank of Sri Lanka, No. 30, Janadhipathi Mawatha, Sri Lanka. ISBN: 978-955-575-288-6
8. Central Bank of Sri Lanka, Economics and Social Statistics of Sri Lanka 2010, 2012, 2021. Central Bank of Sri Lanka, No. 30, Janadhipathi Mawatha, Sri Lanka. ISBN 978 - 955 - 575 - 198 - 8
9. Chandrasena W. K. N., Premasiri H. D. S. and Karunarathna A. K. (2019) Design challenges in landfill gas and leachate management in the development of Meethotamulla Dump Site to an urban park in Sri Lanka. In: Proceedings of the 10th annual research symposium. Equitable Resilience, Colombo, Sri Lanka. Vol. 2019. p. 269-79.

10. Channa Bambaradeniya, 2008. Western Province Biodiversity Profile and Conservation Action Plan. Biodiversity Secretariat Ministry of Environment and Natural Resource Sri Lanka.
11. Climate Change Secretariat of Sri Lanka, (2016). National Adaptation Plan for Climate Change Impacts in Sri Lanka: 2016-2025. Ministry of Mahaweli Development and Environment, Battaramulla, Sri Lanka.
12. Cointreau, S. (2006). Sustainable solid waste management systems in developing countries [Online]. [Accessed on 7th June 2014]. Available at [http://siteresources.worldbank.org/INTUSWM/Resources/English\\_e-Sessions.pdf](http://siteresources.worldbank.org/INTUSWM/Resources/English_e-Sessions.pdf)
13. Cooray, P. G. (1984). An Introduction to the Geology of Sri Lanka (Ceylon), 2nd revised edition. National Museums of Sri Lanka, Colombo, Sri Lanka.
14. Department of Census and Statistics (2001), Census of population and Housing. Ministry of Economic policies and plan implementation, Sri Lanka.
15. Department of Census and Statistics (2007, 2017, 2021) Labor Force Survey Final Report, Ministry of Finance and planning, Sri Lanka.
16. Department of Census and Statistics (2012) Census of population and Housing Final Report, Statistics Ministry of Policy Planning Economic Affairs, Child Youth and Cultural Affairs. ISBN: 978 – 955 – 577 – 940-1.
17. Department of Census and Statistics (2012), Census of population and Housing. Ministry of Economic policies and plan implementation, Sri Lanka.
18. Department of Census and Statistics (2018), Household Income and Expenditure Survey - 2016/17, Ministry of Finance and planning, Sri Lanka.
19. Department of Census and Statistics (2020), Poverty indicators-2019, Ministry of Economic Policies and Plan Implementation Sri Lanka.
20. Department of Census and Statistics (2021), Statistical pocketbook, Ministry of Economic policies and plan implementation, Sri Lanka. ISBN 978-624-5919-86-4 <http://www.statistics.gov.lk/Publication/PocketBook>
21. Department of Census and Statistics, Global Multidimensional Poverty for Sri Lanka (2019), Ministry of Economic Reforms and Public Distribution, ISSN 2630-7480.
22. Department of Census and Statistics, Multidimensional Poverty in Sri Lanka (2019), Ministry of Economic Policies and Plan Implementation.

23. Dhammapala, R., Basnayake, A., Premasiri, S., Chathuranga, L., and Mera, K., (2021). PM2.5 in Sri Lanka: Trend Analysis, Low-cost Sensor Correlations and Spatial Distribution, *Aerosol and Air Quality Research*, Vol. 22(5): 210266. <https://doi.org/10.4209/aaqr.210266>.
24. Dharmasoma, I., Wijayarathna, N.S. and Munaweera, K. (2019) Application of Water Quality Index to Monitor Ground Water Quality: A Case Study in Colombo Catchment of Sri Lanka, 24th International Forestry and Environment Symposium 2019. Available at: <https://doi.org/10.31357/fesympo.v24i0.4344>.
25. Edussuriya, C.H.; Pathirag, S. (2016). Natural Resource Management and Monitoring Unit Published Final Report of Medium to Long-Term Multi-Stakeholder Strategy and Action Plan for Management and Conservation of the Kelanni River Basin; Central Environment Authority: Battaramulla, Sri Lanka.
26. Esakku, S., Karthikeyan, O.P., Joseph, K., Nagendran, R., Palanivelu, K., Pathirana, K.P.M.N., Karunarathna, A.K., & Basnayake, B.F.A. (2007). Seasonal variations in leachate characteristics from municipal solid waste dumpsites in India and Sri Lanka. In *Proceedings of the international conference on sustainable solid waste management* (pp. 2–8).
27. Gomes, P. I. A., Fernando B. A. V. W., and Dehini, G. K. (2019). Assessment of Pollution Sources, Fate of Pollutants, and Potential Instream Interventions to Mitigate Pollution of Earthen Canals of Urban to Rural-Urban Fringe. *Water Air Soil Pollut* (2019) 230: 262.
28. Gunatilleke, I. A. U. N. and Gunatilleke, C. V. S. 1990. Distribution of Floristic Richness and Its Conservation in Sri Lanka. *Conservation Biology*, 4(1), 21–31. <http://www.jstor.org/stable/2385959>.
29. Gunatilleke, I. A. U. N. and Gunatilleke, C. V. S. (1990). Distribution of Floristic Richness and Its Conservation in Sri Lanka. *Conservation Biology*, 4(1), 21–31. <http://www.jstor.org/stable/2385959>
30. Gunawardena, A., Wijeratne, E. M. S., White, B., Hailu, A. and Pandit, R. (2017). Industrial pollution and the management of river water quality: a model of Kelani River, Sri Lanka. *Environ Monit Assess*, 189: 457. DOI 10.1007/s10661-017-6172-3.
31. Hettiarachchi, H., Morrison, T.H., Wickramasinghe, D., Mapa, R., Alwis, A. De, McAlpine, C.A. (2014). The eco-social transformation of urban wetlands: A case study of Colombo, Sri Lanka. *Landscape and Urban Planning*, 132:55-68.
32. Hettige, N.D. et al. (2014) “Water pollution in selected coastal areas in Western Province, Sri Lanka: A baseline survey,” *Journal of Environmental Professionals Sri Lanka*, 3(2), p. 12. Available at: <https://doi.org/10.4038/jepsl.v3i2.7843>.

33. Ileperuma, O.A. (2010). Environmental pollution in Sri Lanka: A review. *J. Natl. Sci. Found. Sri Lanka*, 28, 301–325.
34. ILO. (2009). International labour organization: Colombo; safety and health at work [Online]. [Accessed on 04th April 2014]. Available at <http://www.ilo.org/colombo/areasofwork/safety-and-health-at-work/lang--en/index.htm>
35. IUCN Sri Lanka and the Central Environmental Authority (2006). *National Wetland Directory of Sri Lanka*, Colombo, Sri Lanka. ISBN: 955-8177-54-7.
36. IUCN Sri Lanka and the Ministry of Environment and Natural Resources (2007). *The 2007 Red List of Threatened Fauna and Flora of Sri Lanka*, Colombo, Sri Lanka. Xiii+148pp.
37. Japan International Cooperation Agency and (JICA) Kokusai Kogyo Co., Ltd. (2016). *Data Collection Survey on Solid Waste Management in Democratic Socialist Republic of Sri Lanka*. Report No. JR-16-029.
38. Josimović, B. Igor Marić, I. & Milijić, S. (2015). Multi-criteria evaluation in strategic environmental assessment for waste management plan, a case study: The city of Belgrade, *Waste Management*, 36, 331-342; doi.org/10.1016/j.wasman.2014.11.003.
39. Karunarathna, A., Rajapaksha, T., Singh, R. K., Premakumara, D. G. J., & Onogawa, K. (2021). *Guidelines for Safe Closure and Rehabilitation of Municipal Solid Waste Dumpsites in Sri Lanka*. Ministry of Environment, Battaramulla, Sri Lanka. ISBN: 978-955-8395-53-0. Available on <https://env.gov.lk/web/index.php/en/divisions/environment-pollution-control-and-chemical-management-division/publications>.
40. Koliyabandara, S.M.P.A., Asitha, T.C., Sudantha L., and Siriwardana C. (2020). Assessment of the impact of an open dumpsite on the surface water quality deterioration in Karadiyana Sri Lanka. *Environ. Nanotechnology, Monit. Manag.*, 14.
41. Lee, N. and F. Walsh (1992) "Strategic Environmental Assessment: an overview", *Project Appraisal*, 7 (3): 126-136.
42. Liyanage, C. P. and Yamada, K. (2017). Impact of Population Growth on the Water Quality of Natural Water Bodies. *Sustainability* 2017, 9, 1405; doi:10.3390/su9081405.
43. Manage P. M., Liyanage G.Y., Abinaiyan I., Madusanka D.A.T., Bandara K.R.V. (2022). Pollution levels in Sri Lanka's west-south coastal waters: Making progress toward a cleaner environment *Reg. Stud. Mar. Sci.*, 51, Article 102193.
44. Metro Colombo Urban Development Project - MCUDP (2016). *Technical Report 04. Wetland Management Strategy*.

45. Ministry of Health (2019). Annual Health Statistics 2019 Sri Lanka. Colombo: Medical Statistics Unit, Ministry of Health.
46. Ministry of Mahaweli Development & Environment, (2016). Clean Air 2025- An action plan for Air Quality Management. Air Resource Management Centre, Ministry of Mahaweli Development & Environment, Battaramulla, Sri Lanka.
47. Ministry of Megapolis and Urban Development (2016) “Strategic Environmental Assessment Western Region Megapolis Plan”.
48. Mudalige, O.M.D.C.S. & Dharmathilake, A.D. (2000). Health Problems Among Colombo Municipal Council Workers. Colombo, University of Colombo.
49. National Policy on Waste Management (2020). Ministry of Environment, ‘Sobadam Piyasa’, Robert Gunawardena Mawatha, Battaramulla. CM 33114 (T - 03) (7th Reading).
50. NBRO, 2022. Ambient Air Quality Status in Major Urban Areas in Sri Lanka, 24-Hour Average of Particulate Matter (Dust) level on 08th December 2022. Environmental Studies & Services Division, National Building Research Organization, 99/1, Jawatte Road, Colombo 05.
51. Pathmalal M.M., Hemantha R.S.K.W.D., Dilena P.K., Liyanage G.Y., Chalani H.T.R., Bandara K.R.V., Wijerathna P.A.K.C., Abeysiri H.A.S.N. (2022). Impact of the MV X-Press Pearl ship disaster on the coastal environment from Negambo to Bentota in Sri Lanka. Regional Studies in Marine Science 51, Article 102193.
52. Ranasinghe, T K G P and Piyadasa R U K. (2019). Visualizing the spatial water quality of Bentota, Sri Lanka in the presence of seawater intrusion[J]. Journal of Groundwater Science and Engineering, 7(4): 340-353. doi: 10.19637/j.cnki.2305-7068.2019.04.005.
53. Research and Development Unit/CEA/2014. Environmental Resources Information System – Kalutara District.
54. Research and Development Unit/CEA/2017. Environmental Resources Information System – Colombo District.
55. Research and Development Unit/CEA/2018. Environmental Resources Information System – Gampaha District.
56. Revised Coastal Zone Management Plan of Sri Lanka. 1997. Coast Conservation Department of the Ministry of Fisheries and Aquatic Resources, Sri Lanka.



57. Sewwandi, BGN., Takahiro, K., Kawamoto, K., Hamamoto, S., Asamoto, S. and Sato, H. (2010). Characterization of landfill leachate from municipal solid waste landfills in Sri Lanka, in The International Conference for Sustainably Built Environments. Kandy, Sri Lanka, 2010.
58. Surface Water Quality Monitoring by The Laboratory of Central Environmental Authority (2014) Water quality monitoring. Central Environmental Authority (CEA). Available at: <https://www.cea.lk/web/en/water>.
59. The Megapolis (2016). Western Region Master Plan 2030 - Sri Lanka. Western province Megapolis Planning Project, Ministry of Megapolis and Western Development, Battaramulla, Sri Lanka.
60. UNECE Protocol on Strategic Environmental Assessment to the Convention on Environmental Impact Assessment in a Transboundary Context (2017). (ECE/MP.EIA/SEA/8), United Nations Economic Commission for Europe, Geneva, Switzerland.
61. UNEP and C (2002). The Asian Brown Cloud: Climate and Other Environmental Impacts UNEP, Nairobi. ISBN: 92-807-2240-9.
62. Wickramatillake, H. (2011). Occupational Health in South [Online]. [Accessed on 02nd February 2013]. Available at <http://www.collegiumramazzini.org/download/WICKRAMATILLAKE11.pdf>
63. World Bank Sri Lanka (2022). Metro Colombo Urban Development Project (English). Washington, D. C.: World Bank Group. <http://documents.worldbank.org/curated/en/099445012152224197/BOSIB07d79fdf10e7085aa020fe1a35cff1>.



## 別添資料 3

# Mahara Pradeshiyan Sabha の廃棄物事業継続計画



**Business Continuity Plan for Waste  
Management  
in Mahara Pradeshiya Sabha**

**Contents**

What is Business Continuity Plan.....	3
Basic Policy .....	3
Scope of this BCP .....	3
1. Precondition for BCP.....	4
1.1 Evidence of damage assumption.....	4
1.2 Stage of pandemic.....	4
1.3 Damage assumption in BCP .....	6
2. Structure of BCP .....	6
3. System establishment.....	8
3.1 Crisis management system.....	8
3.2 Communication system.....	9
3.3 Information management system.....	12
4. Infection control measures.....	13
4.1 Basic items.....	13
4.2 Infection risk assessment .....	14
4.3 Concrete infection control measurement (Preparation and Execution).....	15
5. Secure the essential resources for business continuity.....	18
5.1 Secure the personnel.....	18
5.2 Secure supplies .....	21
6. Measures in case of shortage of resources for business continuity.....	22
6.1 The countermeasures in case of staff shortage.....	22
6.2 The countermeasures in case lack of necessary items.....	23
6.3 Business Impact analysis (prioritization of operations).....	24
7. The way of dealing after outbreak .....	27
7.1 What to do if an employee is infected.....	27
8. Training.....	28
9. Check and revise.....	28

## SUMMARY

### What is Business Continuity Plan

A Business Continuity Plan (BCP) is a document that outlines how a business will continue operating during an unpredicted disruption in service. BCP creates a system of prevention and recovery from potential threats to an organization. typically contains a checklist that includes supplies and equipment, data backups and backup site locations. BCP can also identify plan administrators and include contact information for emergency responders, key personnel, and backup site providers. BCP may provide detailed strategies on how business operations can be maintained for both short-term and long-term outages.

### Basic Policy

- Since waste management is an essential service to sustain the citizen's life, Mahara Pradeshiya Sabha is going to continue the waste management service even under the emergency period. (Covid-19 period)
- While keeping the life and health of staff and their families safe, necessary measures for business continuity are speculated in BCP.

<<Key Point>>

Since waste management is an essential service for citizen's life, it shall be clearly stated as a basic policy that is BCP based on business continuity.

### Scope of this BCP

This BCP is limited to the Mahara Pradeshiya Sabha with a total area of 98.8 Km<sup>2</sup>. The total population covered is 215,560 people. The BCP mainly engaged in a waste management continuity plan especially during times of infections and pandemics. This BCP targets activities related to waste collection and disposal in Mahara PS and will enable safe and sound service of waste management for residents and safe working environment for workers. Given below are the basic details related to waste management in Mahara PS:

Amount of waste generated:	102 t/day.
Waste Collection Operation:	door to door (Local government + private company).
Collection rate:	20%
Final disposal site:	Kerawalapitiya Waste Disposal Site.
Staff in charge of waste management:	Environment and community development division.
Number of staff	Works officer:1

	Clerk: 1 Health administrator: 1 Drivers: 6 Health workers: 12
--	---

## **1. Precondition for BCP**

### **1.1 Evidence of damage assumption**

BCP will be based on the damage assumptions shown in the guideline for measures against the pandemic at businesses and workplaces established by the relevant ministries and agencies' countermeasure meeting regarding pandemic. Table1 shows the damage assumption of the pandemic.

Table1 : Damage assumption

Number of onset		---
Number of patients		---
Number of hospital inpatients	Moderate	---
	Severe	---
Death toll	Moderate	---
	Severe	---
Absence rate		40%
Absence period		Around 10 days
Rampant frequency		Around 2 months

#### <<Key Point>>

If plans are established for the entire municipality, the figures of damage assumptions in plans are transcribed to BCP. If no action plan has been formulated (or if no damage assumptions have been shown), the figures of damage assumptions indicated in the guidelines, plans, established by the national government, or local authorities would be transcribed to BCP.

### **1.2 Stage of pandemic**

BCP shall be following the stage of pandemic indicated in the guideline for pandemic at businesses and agencies' countermeasure meetings regarding the pandemic. Table2 shows the stage of pandemic and chart1 indicates the number of patients following the stage.



Table2: Stage of pandemic

Phase		Status	
Pre-outbreak stage	Pre-Outbreak Stage	Pandemic has not occurred yet.	
Phase 1	Overseas outbreak	Overseas outbreak occurred.	
Phase 2	Early Domestic outbreak	Domestic outbreak has occurred.	
Phase 3		Contact history of the patients cannot be tracked by an epidemiological survey in domestic.	
		Spread of infection	The spread of infection is expected to be prevented by the care in hospital.
		Epidemic	The effect of preventing the spread of infection due to the care in hospital is no longer sufficiently function.
		Recovery period	It can be judged that the peak of outbreak has ended.
Phase 4	Calm period	The number of new patients decreased and remains at a low level	

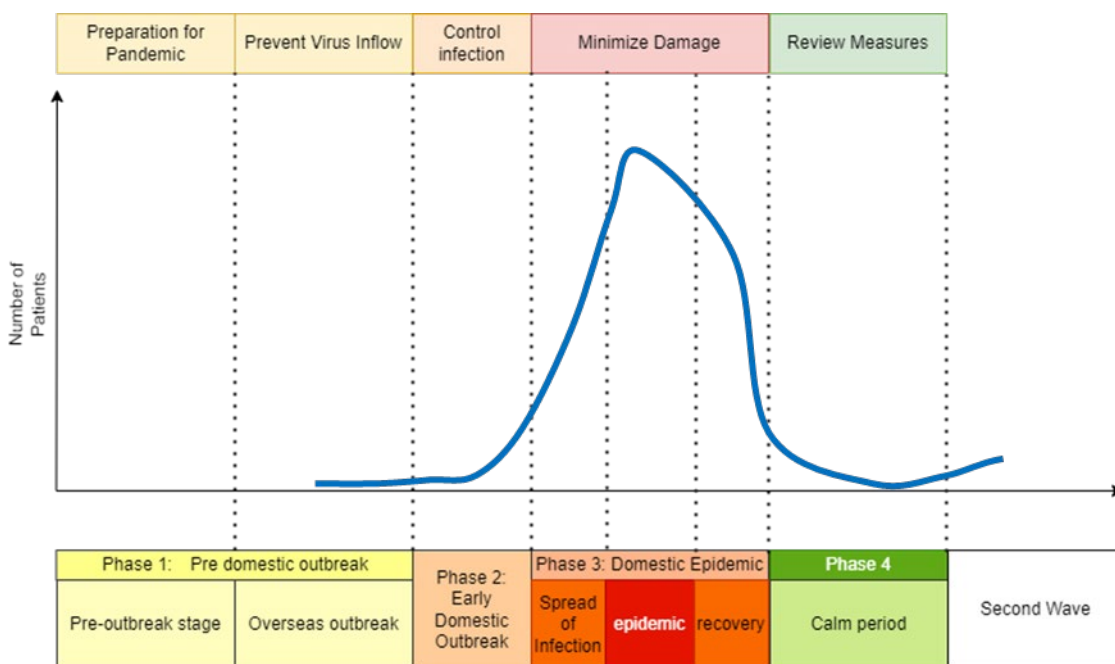

Chart 1: Phases of pandemic and their correspondent BCP phases

<<Key Point>>

The tables and figures regarding the pandemic phases in Japan's national or district guidelines, plans, are transcribed to the above chart.

### **1.3 Damage assumption in BCP**

Based on the above table, BCP is formulated with the assumption that a maximum of about 40% of the staff will be absent from work for several weeks in about two months from the outbreak of the pandemic to its termination.

## **2. Structure of BCP**

BCP has a structure shown in the chart below.

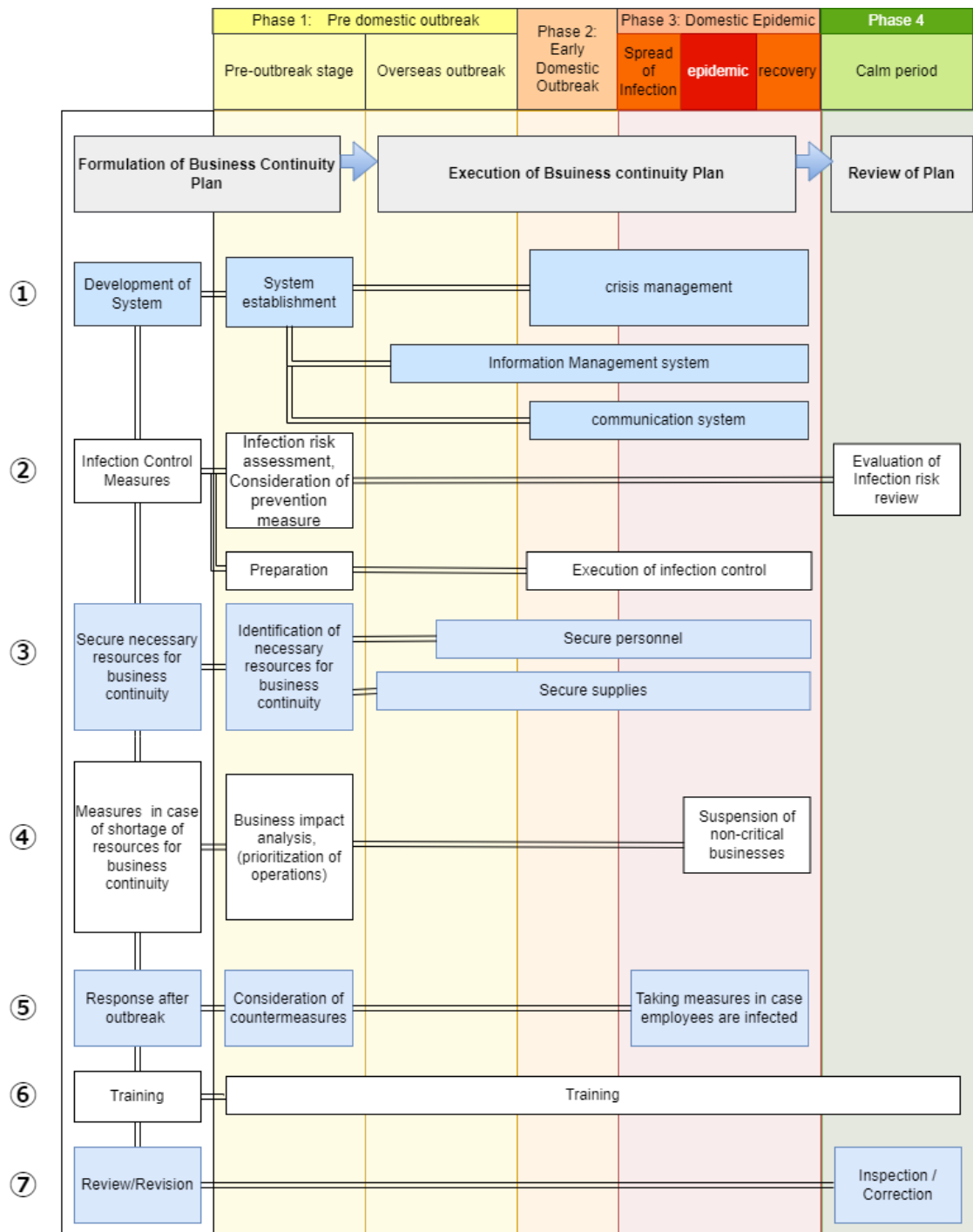

Chart 2 : Structure of BCP

- When a BCP is made by adding or modifying the above structure, the system of BCP or figure is specified in the boxes.

### **3. System establishment**

#### **3.1 Crisis management system**

- i. Pandemic occurs (Emergency)

In the case pandemic occurs, a crisis management organization is established to deal with the imminent crises.

<Crisis management organization – emergency period>

Organization member		Name and designation	Role in the organization
Responsible person			Decision making
Sub-leader			
Member			Communication
Member			
Member			
Member			
Member			

The establishment period of crisis management organization is from the Phase 1 to Phase 4.

<<Key Point>>

- Since the crisis management organization is required to make critical decisions, such as continuation, suspension of business, it is necessary for the person who is responsible to make such decisions to be involved.
- If the entire municipality has already established a countermeasures headquarters for medical and social response in the event of a pandemic outbreak, the organization can also consider waste treatment within the relevant organization. However, if no countermeasures headquarter is set up, it is desirable to set up a crisis management organization within the Environment Department to consider the continuation of the waste management services.

Consideration of the crisis management organization is shown as follows.

Consideration
<ul style="list-style-type: none"> <li>• Establish the organization system for business continuity and clarify the roles and command system of each person</li> <li>• Establish emergency decision-making methods</li> </ul>

## ii. Normal period

The examination and preparations for measures against pandemic during the normal period will be handled by the following system within the Environment Department.

<Crisis management organization – normal period>

Organization member	Name and designation	Role in the organization
Responsible person	Chief	Decision making
Sub-leader	Deputy chief	
Member		Waste collection & transportation
Member		Human resource
Member		Information
Member		Communication to citizen
General affairs		

<<Key Point>>

It is desirable to establish a system within the environment bureau that allows examination of pandemic measures in waste management even in the normal period, apart from the headquarters of municipalities.

### 3.2 Communication system

It is important to have contact details of important personnel inside the department, business partner/contractor and other relevant organizations to coordinate activities during the pandemic

a. Inside Mahara PS

Mahara PS establishes the following emergency communication system

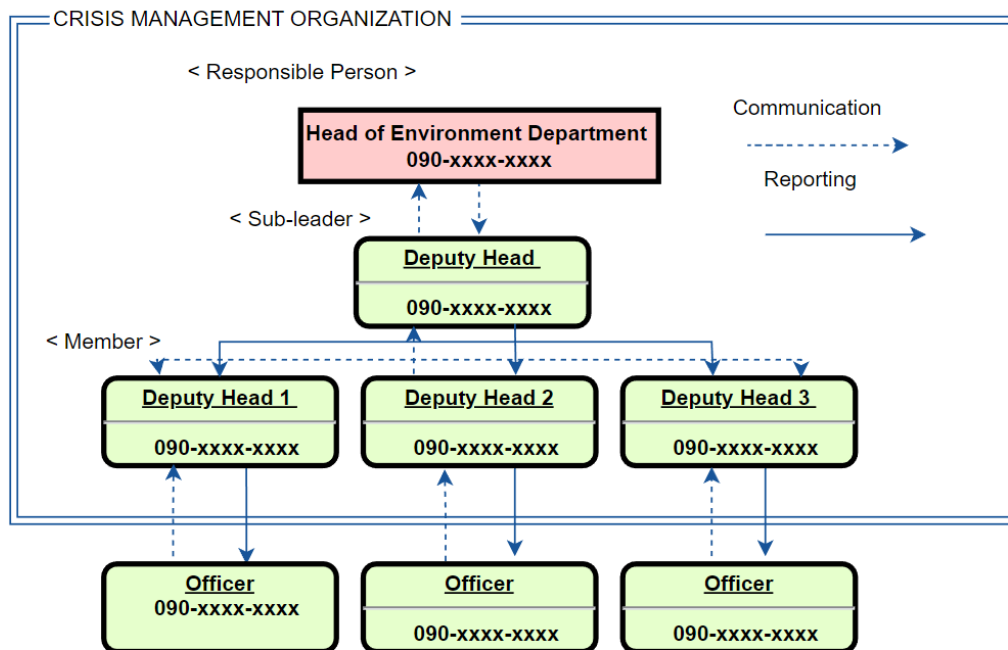

Figure 1: Structure of the emergency communication system

<List of contact information in emergency period>

Name	Designation	Contact number	Mail Address	Remarks
	Head of department	090-xxx-xxxx	xxxx@xxx.jp	
	Deputy Head			
	Section Head			
	Section Head			
	Section Head			

Regarding the matters to be decided by the crisis management organization and other matters to be contacted in case of emergency, the staff will contact in the system shown above.

- When a staff member or their family is infected new type of influenza, the status is reported to the section head, and the section head reports the status such as the staff member's sickness to the crisis management organization within theMahara PS.

## &lt;&lt;Key Point&gt;&gt;

In addition to the system for contacting staff, it is necessary to clarify the system for collecting information such as sickness of the pandemic from staff.

## b. Business partner/ Contractor

Organization name	Address	Contact number	Mail address
Waste collection company			
Waste recycle company			
Waste disposal company			

## c. Other related organization

Organization name		
Waste Management Authority		
Public Health Inspector		
Hospital		
Environment police		

- It is necessary not only to share information with other prefectures and relevant organizations but also to establish a cooperation system for the waste management of municipal solid waste and industrial waste in the region through consultations and other means.
- It is necessary to set in advance the information to be collected and transmitted from the Contractor and Other relevant organizations.
- Among the relevant organizations, the manufacturers and distributors of necessary goods are arranged in Securing supplies in securing important elements for business continuity.
- Other relevant organizations are selected with referring to information on the pandemic in each prefecture and municipality.

## d. Citizen

<Publicizing and providing the information to citizen>

Communicating on time with citizens to inform about changes in waste collection schedule/system is crucial to smooth operations.

*[need to add more points]*

### 3.3 Information management system

Information collection is necessary to ensure smooth functioning of crisis management.

## a. System

The information collection system regarding pandemic is established as shown below.

<Information collection system>

- [~] section oversees information collection.
- Information collection starts before the pandemic outbreak occurs and after the outbreak occurs overseas, the information collection system is strengthened.
- The collected information is transmitted to crisis management organizations and business partners promptly.
- The decisions made by the Ministry of Health and urgent information are transmitted to the staff through an emergency contact network described in 3.2

## b. Source of information to be collected

The source of information to be collected is shown below.

Information source	Information to be collected	Information collection period
Ministry of Environment		Normal period, After overseas outbreak
Ministry of Health		After overseas outbreak
Local Authority		After overseas outbreak
Local Lifeline business	Necessary lifeline for waste management (Electricity, Water supply, Oil and so on)	After overseas outbreak
Waste related organization	Other, Items related to waste management	Normal period, After overseas outbreak



## &lt;&lt;Key Point&gt;&gt;

- When collecting other information than the above, information to be collected, the source of the information, and the period of information collection should be specified.
- It is necessary to include the way of collecting information during normal period other than the way during the emergency period.

**4. Infection control measures****4.1 Basic items**

Once the pandemic outbreaks, the following infection prevention measures are the basic rule.

Infection prevention measurements	Method
Keeping the social distance	<ul style="list-style-type: none"> <li>• Stay within 2 meters of the infected person</li> <li>• Not going to places where a large number of unspecified people gather and avoiding unnecessarily going out</li> <li>• Try to keep the social distance as much as possible in the workplace.</li> </ul>
Wash hands	<ul style="list-style-type: none"> <li>• After returning to the office from home, after touching a place where an unspecified number of people touch it, after smoking or before eating, wash your hands frequently.</li> <li>• Frequently use hand sanitizer.</li> </ul>
Cough etiquette	<ul style="list-style-type: none"> <li>• When you cough or sneeze, cover your mouth and nose with a tissue and face away and keep at least 1 to 2 meters away.</li> </ul>
Clean and sanitize the workplace	<ul style="list-style-type: none"> <li>• Clean the area that may have been touched by the infected person and the area where the infected person may have sneezed at least once a day.</li> </ul>
Regular vaccination	<ul style="list-style-type: none"> <li>• All employees receive regular influenza vaccinations at medical institutions each year.</li> </ul>
Use the personal infection prevention items	<ul style="list-style-type: none"> <li>• Use mask, gloves, goggles, etc...</li> </ul>

## &lt;&lt;Key Point&gt;&gt;

- When carrying out other measures than the above, specify them in the blank of the table.

## 4.2 Infection risk assessment

### i. Collection and transportation

Work	Frequency	Infection risk	Remarks
Driving waste collection vehicle	1	III	Infected by passengers
Loading waste to waste collection vehicle	30	II	Infected by pedestrians around the waste collection point.

### ii. Final disposal

Work	Frequency	Infection risk	Remarks
Operating the facility	1	II	Infected by other coworkers
Sorting waste by hand	1	III	Infected by other coworkers in other lines

### iii. Office work

Work	Frequency	Infection risk	Remarks
Coordination of communication with business operators	5	I	
Contact service, reception	5	III	Infected by visitors
Internal meeting	1	III	Infected by other coworkers

### iv. After work hours

Work	Frequency	Infection risk	Remarks
Commuting with public transportation	2	III	Infected by a passenger
Daily life	-	III	Infected by family members, Infected by others when going out

## &lt;&lt;Key Point&gt;&gt;

- The level of infection risk refers to the following table.

Risk of infection	Evaluation standard
IV High	It is difficult to keep social distance (2m or more) because there is an opportunity to contact the patient or suspected patient in the hospital
III Normal	There is an opportunity to contact other people (staff, visitors, etc)
II Low	It is possible to keep social distance from others.
I Little	There is no opportunity to contact other people.

- In assessing the risk of infection, it is desirable to consult with a person with medical knowledge in cooperation with the health department.
- The risk of infection should be evaluated in advance before the outbreak of the pandemic, and it will be reviewed again as necessary when information such as the pathogenicity of the pandemic has been revealed and the information on the pathogenicity has been revealed.

### 4.3 Concrete infection control measurement (Preparation and Execution)

- i. Waste collection and transportation
  - The following infection prevention measurements are carried out in the operations related to waste collection and transportation.
  - The measurements are carried out from the early stage of the domestic outbreak to the tranquility period.

Work	Infection risk	Infection prevention measurements
Driving waste collection vehicle	III	<ul style="list-style-type: none"> <li>• Use mask and gloves</li> <li>• Wash and sanitize hands when returning to the office</li> <li>• Regularly clean and sanitize the waste collection vehicle</li> </ul>
Loading waste to waste collection vehicle	II	<ul style="list-style-type: none"> <li>• Wearing work clothes (long-sleeved/long pants) with minimal skin exposure</li> <li>• Hand sanitization after loading and unloading waste</li> <li>• Hand washing, hand sanitization and gargling when returning to the office</li> </ul>

ii. Final disposal

- The following infection prevention measurements are carried out in the operations related to the final disposal.
- The measurements are carried out from the early stage of the domestic outbreak to the tranquility period.

Work	Infection risk	Infection prevention measurements
Operation and management of waste management facility	II	<ul style="list-style-type: none"> <li>• Use mask and gloves</li> <li>• Wash and sanitize hands after finishing work</li> <li>• Regularly clean and sanitize the facility</li> </ul>
Sorting waste by hand	III	<ul style="list-style-type: none"> <li>• Use mask and gloves</li> <li>• Wearing work clothes(long-sleeved/long pants) with minimal skin exposure</li> <li>• Wash and sanitize hands after finishing work</li> <li>• Regularly clean and sanitize the facility</li> </ul>

iii. Office work

- The following infection prevention measurements are carried out in the office work.
- The measurements are carried out from the early stage of the domestic outbreak to the tranquility period.

Work	Infection risk	Infection prevention measurements
Contact service, reception	III	<ul style="list-style-type: none"> <li>• Keep social distance at service counter</li> <li>• Use mask</li> <li>• Wash and sanitize hands</li> <li>• Limit the entrance and exit of visitors and measuring body temperature before entering the office</li> <li>• Restrict visitor access (place, number of people, etc)</li> <li>• Write down the name and address of the visitor</li> <li>• Set the place for visitors to sanitize hands</li> <li>• Set the partition at service counter</li> <li>• Regularly clean and sanitize the office</li> </ul>
Internal meeting	III	<ul style="list-style-type: none"> <li>• Use mask</li> <li>• Reduce the frequency of meeting (Avoid the face-to-face meeting and utilize telephone meeting or online video meeting)</li> <li>• Regularly clean and sanitize the office</li> </ul>

- iv. After work hours
- The following infection prevention measurements are carried out in the office work.
  - The measurements are carried out from the early stage of the domestic outbreak to the tranquility period.

Work	Infection risk	Infection prevention measurements
Commuting with public transportation	III	<ul style="list-style-type: none"> <li>• Measure the body temperature before going to workplace</li> <li>• Avoid commuting by public transportation in rush hour</li> <li>• Use mask while commuting</li> <li>• Limit the entrance and exit for employees and measure their body temperature before entering the workplace</li> <li>• Wash hands and gargle when getting home</li> </ul>
Daily life	III	<ul style="list-style-type: none"> <li>• Refrain from unnecessary and urgent outings to the crowded areas and downtown</li> <li>• Health management</li> </ul>

<<Key Point>>

- ◇ Assess infection risk in all work
- ◇ The concrete measurements to works with II and III should be specified
- ◇ It is possible to reduce the infection risk by taking appropriate measures such as keeping social distance and using a mask and so on

## **5. Secure the essential resources for business continuity**

### **5.1 Secure the personnel**

The current personnel in the waste management business, the minimum number of personnel required to continue the work, and BCP regarding the supplementary organization in the event of a shortage (personnel planning) shall be carried out in the following way.

## i. Waste collection and transportation

Work	Department in charge	Number of personnel	Minimum number of personnel	Supplementary organization
Burnable waste collection	●● section	30	20	Environmental division
Non-burnable waste collection	●● section	10 (5)	5	Retiree
Recyclable waste collection				
Bulky waste collection				

## ii. Final disposal

Work	Department in charge	Number of personnel	Minimum number of personnel	Personnel supplement organization
Operation and management of incineration	●● section	10	5	Supplement from contractor
Waste intake	●● section	5	2	Temporary employment
Operation and management of processing bulky waste				
Operation and management of processing recyclable waste				

## iii. Office work

Work	Department in charge	Number of personnel	Minimum number of personnel	Personnel supplement organization
Information collection	●● section	0	1	Supplement from contractor
Procurement of supplies, inventory management	●● section	0	1	Temporary employment
Securing and managing storage places for waste that cannot be processed	●● section	0	1	
Formulation of BCP	●● section	0	2	
Coordination with contractors and response to residents	●● section	5	3	Environment division
Service counter	●● section	3	1	Unnecessary to supplement

## &lt;&lt;Key Point&gt;&gt;

- Consider the required minimum number of personnel and a personnel plan regarding the supplement source when there is a shortage for all work.
- In the personnel plan, the business operation system including the business operators and auxiliary personnel will be examined and measures will be taken.
- Consider a personnel plan that allows substitute personnel to continue important work even if the staff in charge of important work is infected.
- Priority is given to securing the personnel who are involved in the actual operation of waste processing rather than the office work.
- If necessary, consider hiring retirees, people who have moved to another department, etc, and temporary employees.
- For work that requires qualification, take measures such as increasing the number of qualified people in advance so that the work can be continued by the substitutes.



## 5.2 Secure supplies

The necessary materials for the continuation of waste management are secured in the following way.

i. Necessary supplies for actual waste management works

Items	Necessary amount / month	stockpile	source	Preliminary source (i)	Preliminary source (ii)
Kerosene	m <sup>3</sup>	m <sup>3</sup> (30)	●Ltd.	●Ltd.	●Ltd.
Slaked lime	m <sup>3</sup>	m <sup>3</sup> (30)	●Ltd.	●Ltd.	●Ltd.
Activated carbon	m <sup>3</sup>	m <sup>3</sup> (30)	●Ltd.	●Ltd.	●Ltd.
Sulfuric acid band	m <sup>3</sup>	m <sup>3</sup> (30)	●Ltd.	●Ltd.	●Ltd.
Ammonia	m <sup>3</sup>	m <sup>3</sup> (30)	●Ltd.	●Ltd.	●Ltd.
Calcium chloride	m <sup>3</sup>	m <sup>3</sup> (30)	●Ltd.	●Ltd.	●Ltd.
Hydrochloric acid	m <sup>3</sup>	m <sup>3</sup> (30)	●Ltd.	●Ltd.	●Ltd.
Caustic soda	m <sup>3</sup>	m <sup>3</sup> (30)	●Ltd.	●Ltd.	●Ltd.
Gasoline	kl	kl(0)	●Ltd.	●Ltd.	●Ltd.
Engine oil			●Ltd.	●Ltd.	●Ltd.
Battery			●Ltd.	●Ltd.	●Ltd.

*Necessary supplies for infection prevention measures*

Items	Necessary amount / month	stockpile	source	Preliminary source (i)	Preliminary source (ii)
Surgical mask	1	(0)	Company name		
Gloves	5	(30)			
Goggle	3	(30)			
Protective clothing	5	(30)			
Hand sanitizer		ml			
Hand soap		ml			
Medical kit					
thermometer					

*Others*

Items	Necessary amount / month	stockpile	source	Preliminary source (i)	Preliminary source (ii)
PC for working at home					
Preserved food					

**6. Measures in case of shortage of resources for business continuity****6.1 The countermeasures in case of staff shortage**

- i. Staff management
 

In case there is a shortage of personnel, adjust the personnel in the following methods and deal with the issue.

< The countermeasures in case of staff shortage >

  - a. Pre-occurrence period, tranquility period (below 40% absent)
    - Waste management is continued as in the normal period.
  - b. Early outbreak, domestic outbreak and recovery period (40 ~ 60% absent)
    - The waste disposal is continued as usual due to overtime work by attendants, work on public holidays, overnight stays at the office, etc.
  - c. Prevalence period (60 ~ 80% absent)

- According to “6(1) Securing personnel”, waste management is continued as usual by supplementing personnel from other departments, contractors, etc.
- d. Prevalence period (over 80% absent)
- Prioritize important businesses (businesses with a high priority) and continue the business, while reducing, canceling, or suspending businesses other than important businesses (businesses with a low priority) as necessary. (By”7(3) identification of important work (determination of work priority)”)
  - Store waste that cannot be processed in a storage location secured in advance.
  - Inform the residents to reduce waste and store it at home.

<<Key Point>>

Develop a staffing plan according to the stage of the outbreak of pandemic or the absence rate of staff.

ii. Waste storage

If a waste that cannot be processed generates due to lack of personnel, store the waste in the following way.

<Waste storage>

- In the prevalence period of the pandemic, carrying out high-priority work and limiting low-priority work, waste that cannot be treated will be stored and handled after being received at the facility.
- Before the outbreak of the pandemic, prepare an emergency waste storage location and take necessary measures to meet the storage standards specified by the waste management law.

## 6.2 The countermeasures in case lack of necessary items

In case of lack of supplies, the issue is dealt with the following way.

<The countermeasures in case important items are lacking >

- Stock supplies necessary to continue the waste management in advance. (By “6(2) Securing supplies”)
- Increase the stockpile of supplies that are expected to be in short supply during the pandemic flu. (By “6(2) Securing supplies”)
- In case of shortage of supplies, the issue is dealt with by securing multiple places where the supplies can be purchased in addition to the place of purchase the supplies in normal period.

### 6.3 Business Impact analysis (prioritization of operations)

- i. Arrangement by work priority  
 a. New work (measures against pandemic)

Work	Section in charge	Start period	remarks
Information collection		Pre-occurrence period	
Procurement of stockpile, management of inventory		Pre-occurrence period	
Securing and managing the storage place for the waste that cannot be processed		Pre-occurrence period	
Formulation of BCP		Pre-occurrence period	

- b. The work continued as usual

Work	Section in charge	Period	remarks
Collection and transportation of burnable waste		All period	

- c. The work continued with reduction

Work	Section in charge	Reduction period	remarks
Collection and transportation of non-burnable waste		Spread outbreak ~ Prevalence period	Once or twice a month
Incinerate the burnable waste		Spread outbreak ~ Prevalence period	Change driving from 24 hours to 8 hours
Coordinate with citizen and contractors		Spread outbreak ~ Prevalence period	If necessary, some staff support the processing work After the postponement, citizen are requested to reduce their emissions and store them at home.

## d. Operation to be suspended or stopped

Work	Section in charge	Start period	remarks
Collection of non-perishable and burnable waste		Prevalence stage	Request citizen to generate and store the waste at home.
Disposal of non-perishable		Prevalence stage	Request citizen to generate and store the waste at home. Directly bring is same



## &lt;&lt;Key Point&gt;&gt;

- Consider all work priorities.
- Consider the following items when identifying important operations (determining the priority of operations).
- Prioritize the treatment of combustible waste that is prone to perish over the treatment of non-burnable waste, bulky waste, and recyclable waste.
- Prioritize the practical works over office work and on-site guidance.
- Prioritize the normal waste collection work over unique works.
- Regarding determining the timing of work reduction, suspension, or interruption, it is possible to use the outbreak stage of pandemic and the absentee rate of employees as criteria.

## **7. The way of dealing after outbreak**

After the outbreak of the pandemic, in addition to taking measures according to BCP set out above, if the staff suffers from the pandemic, the following measures will be taken.

### **7.1 What to do if an employee is infected**

- When a staff member has a symptom at the office, he/ she should be isolated from other staff at the office, secure the waiting place for transportation to a medical institute, and then contact the hospital.
- Regarding the infected person's cohabitants and staff who have come into contact with the infected person without wearing personal protective equipment, check the health status such as measuring the body temperature, and immediately if any abnormal health condition occurs, promptly contact the hospital and take appropriate measures.
- If an employee is infected during off-hours, take the same steps as above and report the situation to the department manager.

## &lt;&lt;Key Point&gt;&gt;

- Decide on specific procedures for dealing with infected persons in staff or their families during business hours and after hours.
- Clarify the number of days of leave and how to handle the leave in advance.

**8. Training**

Regularly hold education and training to ensure correct knowledge of pandemic and smooth implementation of BCP.

<Record of education/training>

Day/Month/Year		Target Group	Contents
		All staff	
		All staff	
		Environment division	

**9. Check and revise**

If necessary BCP is checked, corrected and appropriate measures will be taken.

<<Record of amendment>>

Day/Month/Year	Contents of amendment

<<Key Point>>

Examples of cases where inspections and corrections are necessary are as follows.

- Consultation results with regulatory agencies and public health centers, and consultation results with business partners
- When a problem is identified due to training or operation.
- When new knowledge is obtained regarding infection control measures.
- When the national and local governments review plans for pandemic and formulate new guidelines, etc



## 別添資料 4

### 廃棄物管理に関わる組織の役割と課題



## **Roles and Responsibilities of Relevant Government Organizations for Municipal Solid Waste Management**

This paper explains and discusses the roles and responsibilities assigned to relevant government organisations for municipal solid waste management. The article consists of the following sections;

1. Summary
2. Details of organizational roles and responsibilities with obligations with legal provisions
3. Details of organizational roles and responsibilities assigned through policy and budget of the government

### **1. Summary**

The roles and responsibilities of relevant organizations – such as those with regulatory and enforcement functions, those responsible for the collection and disposal of solid waste, and for provision of services such as waste collection, transportation and disposal – were clarified for each type of waste by examining legal and policy documents. The summary of roles and responsibilities of relevant organizations concerning Western Province's municipal solid waste is shown in the attached table.

Local authorities (Municipal Council, Urban Council, Pradeshya Sabha) are responsible for managing (collecting, transporting and disposing of) municipal solid waste under Municipal Councils Ordinance, Urban Councils Ordinance and Pradeshya Sabha Act. Central Environmental Authority (CEA) regulates waste management under the National Environmental Act (NEA).

The Waste Management Authority (WMA) of the Western Province plays two major roles promoting appropriate waste management methods and supporting local authorities' waste management activities. With regard to the waste management planning of WMA and local authorities, it is worth noting that there is a possibility of inconsistency between WMA's Western Province waste management plan and local authorities' waste management plans if each local authority makes its plan based on optimizing its own needs and circumstances. Partial optimizations do not guarantee total optimization. Therefore, it is necessary to coordinate the planning processes at provincial and local authority levels by first optimizing provincial planning and then optimizing local authorities' plans in line with the provincial program.

There are three districts (Colombo, Gampaha and Kalutara districts) in Western Province, and each district has a District Coordinating Committee, for which the Chairperson is appointed by Members of Parliament and the Vice-Chairperson is appointed by Members of the Provincial Council. Members of the Committee are appointed from relevant organizations at national, provincial and local authority levels). The committees are in charge of coordination and supervision of all development projects implemented within the respective area.

In the past, the ministry in charge of urban development, including UDA and SLLDC, has been implementing large-scale waste management projects, and the Ministry of Provincial Councils and Local Government (NSWMSC) and the Ministry of Environment (CEA) have been implementing pilot projects and demonstration projects. Though these activities (implementation of waste management projects by

these ministries) are not explicitly stipulated in relevant acts, their initiatives and involvements are required if considered the limited technical and financial capabilities at the provincial and local authority levels. In addition to general functional demarcation among relevant government organizations in municipal solid waste management, when projects are planned and proposed, especially in the Master Plan, not only must the responsibilities of the project proponent be clearly stated and agreed upon among stakeholders and those of other relevant organizations.

Concerning industrial waste, healthcare waste and construction and demolition waste, It is the responsibility of the parties who discharge such wastes, and CEA regulates it in terms of NEA. The line ministries in charge of such industry and services (e.g. Ministry of Industry for industrial waste, Ministry of Health for healthcare waste, Ministry of Urban Development and Housing for construction and demolition waste) support and facilitate the implementation of relevant waste management. The private sector is undertaking some part of waste management, where commercially viable, on a fee basis. During this Project period, it is planned to identify issues related to non-municipal solid wastes in terms of regulations, guidelines, and involved organizations.

Table The summary of roles and responsibilities of relevant organizations

Organizational	Roles and Responsibility for SWM <sup>1</sup>	Reference (Act, Statute, Gazette, etc.)	Facility Development & Operation (examples)
MoPAHAP CLG	<ul style="list-style-type: none"> <li>● Policy, strategy development for MSWM</li> <li>● Facilitation of implementation</li> </ul>	<ul style="list-style-type: none"> <li>● Sectoral oversight functions<sup>2</sup> in Gazette Notification for Ministry's Powers, Duties, Functions, 2015.9.21</li> </ul>	<ul style="list-style-type: none"> <li>● Development of compost plants</li> </ul>
NSWMS	<ul style="list-style-type: none"> <li>● Technical support, financial assistance to LAs</li> <li>● Provision of machinery and infrastructure</li> </ul>		
MoE	<ul style="list-style-type: none"> <li>● Development of national policy for SWM</li> <li>● Coordination, facilitation of implementation</li> </ul>	<ul style="list-style-type: none"> <li>● National Environmental Act, No. 47, 1980 &amp; subsequent Amendments, Regulations</li> </ul>	<ul style="list-style-type: none"> <li>● Development of compost plants under Pirisaru, (to be operations by LAs)</li> </ul>
CEA	<ul style="list-style-type: none"> <li>● Implementing technical guidelines (municipal waste, scheduled waste)</li> </ul>		
WPC	<ul style="list-style-type: none"> <li>● Publishing technical guidelines (municipal waste, scheduled waste)</li> <li>● Development of strategies, action plans</li> <li>● Provision of essential resources to LAs</li> </ul>		
WMA	<ul style="list-style-type: none"> <li>● Management of collection, segregation, transportation, transfer, treatment, disposal of waste in WP</li> <li>● Municipal solid waste management</li> </ul>	<ul style="list-style-type: none"> <li>● Western Province Waste Management Statute, No. 1, 2007</li> </ul>	<ul style="list-style-type: none"> <li>● Development &amp; operation of Karadiyana SWM Centre, including WtE by private party</li> </ul>
Local authority		<ul style="list-style-type: none"> <li>● Municipal Council Ordinance, Urban Council Ordinance, Pradeshiya Sabha Act</li> </ul>	<ul style="list-style-type: none"> <li>● Development, operation of municipal solid waste management facilities</li> <li>● Collection and disposal contract with private</li> </ul>
MoUD&H UDA/ SLLRDC	<ul style="list-style-type: none"> <li>● Urban solid waste management</li> <li>● Provision of infrastructure facilities</li> <li>● Provision of infrastructure facilities</li> </ul>	<ul style="list-style-type: none"> <li>● "Urban solid waste management", Gazette Notification for Ministry's Powers, Duties, Functions, 2015.9.21</li> </ul>	<ul style="list-style-type: none"> <li>● Large scale infrastructure development, Aruwakkalu</li> <li>● Infrastructure development, operation of facilities</li> </ul>
MoI	<ul style="list-style-type: none"> <li>● Development of sectoral policies, R&amp;D, facilitation of implementation</li> </ul>	<ul style="list-style-type: none"> <li>● Sectoral oversight functions of ministries in Gazette Notification for Ministry's Powers, Duties, Functions, 2015.9.21</li> </ul>	
BOI/IDB/ Processing Zone	<ul style="list-style-type: none"> <li>● Facilitation of infrastructure development in Export Processing Zone</li> </ul>	<ul style="list-style-type: none"> <li>● Scheduled waste management in terms of Regulations under National Environmental Act</li> </ul>	<ul style="list-style-type: none"> <li>● Solid waste treatment (incineration) plant in Seethawaka EPZ by private party (procurement stage)</li> </ul>
MoH	<ul style="list-style-type: none"> <li>● Development of sectoral policies,</li> </ul>	<ul style="list-style-type: none"> <li>● National Environmental Act</li> </ul>	<ul style="list-style-type: none"> <li>● Healthcare waste management</li> </ul>

<sup>1</sup> Extracted from National Waste Management Policy, Ministry of Environment 2019, and from various documents such as annual reports of relevant organizations.

<sup>2</sup> Formulation of policies, programmes and projects, monitoring and evaluation in regard to the subjects.

development of guidelines, facilitation of  
implementation

- Development of sectoral policies,  
development of guidelines, facilitation of  
implementation

CIDA

facilities developed by MoH,  
operated by private

## 2. Details of organizational roles and responsibilities with obligations with legal provisions

### 2.1 Responsibility of Waste Management Vested to Local Authorities

The establishment of and duties and functions for the local authorities (Municipal Councils, Urban Councils, Pradeshiya Sabhas) are stipulated in Municipal Councils Ordinance No. 29 of 1947, Urban Councils Ordinance No. 61. Of 1939 and Pradeshiya Sabha Act No. 15 of 1987.

#### Urban Councils Ordinance

Section 118 Duty of Council as to conservancy and scavenging: It shall be the duty of the Urban Council of each town, so far as is reasonably practicable, to take all necessary measures in every part of the town

a) for properly sweeping and cleansing the streets, including the footways, and for collecting and removing all street refuse ;

b) for securing the due removal at proper periods of all house refuse, and the due cleansing and emptying at proper periods of all latrines and cesspits; and

c) for the proper disposal of all street refuse, house refuse, and night-soil

Section 119 All refuse collected to be the of Council: All street refuse, house refuse, night-soil, or other similar matter collected by any Urban Council under the provisions of this Part shall be the property of the Council, and the Council shall have full power to sell or dispose of all such matter.

Section 120 Place for disposal of refuse and keeping equipment: Every Urban Council shall, from time to time, provide places convenient for the proper disposal of all street refuse, house refuse, night-soil, and similar matter removed in accordance with the provisions of this Part,

and for keeping all vehicles, animals, implements, and other things required for that purpose or for any of the other purposes of this Ordinance, and shall take all such measures and precautions as may be necessary to ensure that no such refuse, night-soil, or similar matter removed in accordance with the provisions of this Part is disposed of in such a way as to cause a nuisance.

Section 157 Subjects of by-laws: The power of any Urban Council to make by-laws under this Part shall, without prejudice to the generality of the powers thereby conferred, include power to make by-laws for or with respect to all or any of the following purposes, namely:-

(6) Land and property, including- (b)the care of waste or public land ;

(7) Thoroughfares, including- (b)the cleaning, watering, and lighting of the streets

There are the same or similar provisions for waste management by the local authority in Municipal Councils Ordinance (Sections 129, 130, 131 and 272) and Pradeshiya Sabha Act (Sections 93, 94, 95 and 101) as in the Urban Councils Ordinance referred to the above.

National Policy on Waste Management 2020 Annex I provides information related to the stakeholders who have been assigned to take responsibilities and be accountable for those responsibilities in the implementation of the National Policy;

Local Authority's Responsibilities: Development of strategies and action plans for the management of Municipal waste, including night soil and wastewater, in line with the national policy and facilitate

implementation of other waste management activities at the local level to fulfil the objectives of the national policy in collaboration with respective institutions at local, provincial and national level; Provide infrastructure facilities for storage, treatment and disposal of waste; Maintain cleanliness of the area in collaboration with the general public; Ensure no waste is haphazardly disposed causing environmental and health problems and public nuisance; Introduce incentive schemes in order to maximization of citizen's participation and minimization of waste generation in their respective areas Monitor and evaluate performance and report progress periodically to the national authorities and to the general public with access to feedback.

## **2.2 Roles of Provincial Council Stipulated in the Constitution of Sri Lanka**

In the Thirteenth (13<sup>th</sup>) Amendment of the Constitution, provisions for protecting the environment and waste management-related responsibilities are defined at different government levels, i.e. national, provincial and local.

The Thirteenth Amendment to the Constitution of Sri Lanka introduced a conception of a unitary decentralized State based on a system of Provincial Governments at a sub-national level.

Mainly, the 13th Amendment to the Constitution provides for establishing Provincial Councils. Article 154G Statute of Provincial Councils (1) introduced by the Amendment vests legislative power regarding the matters set out in List I of the Ninth Schedule (the Provincial Council List) in Provincial Councils.

Article 154C Exercise of executive powers by the Governor vests the executive power within a Province extending to the matters in List I to the Governor to be exercised in terms of Article 154F Board of Ministers (1) on the advice of the Board of Ministers. In terms of Article 154F Board of Ministers (6), the Board of Ministers are collectively responsible and answerable to the Provincial Council.

The three lists in the Ninth Schedule of the Constitution are the Provincial Council List, the Reserved List and the Concurrent List. The Provincial Council List contains the subject matters over which the provincial council has exclusive rights. Under the Provincial list, the subject of Local Government is devolved to the Provincial Councils. In contrast, the subject of environmental protection is listed in both the Provincial Council list and the concurrent list to be handled at the national and provincial levels.

Based on the above provisions, the Provincial Councils are also involved in waste management which is under the responsibility of the local authorities.

National Policy on Waste Management 2020 Annex I provides Provincial Council's responsibilities as follows;

Provincial Councils: Develop strategies and action plans to facilitate implementation of the national policy covering all forms of waste including solid, liquid and gaseous waste as appropriate with the provincial line ministries; Performance monitoring, recording evaluation and annual reporting with feedback mechanisms; Develop strategies and action plans to provide essential resources to local authorities for implementation of the national policy such as required Cadre, Vehicles, Machinery & Equipment etc. and build the capacity of relevant staff periodically including administrative, managerial and skills development based on the capacity of local authorities; Provide infrastructure facilities such as lands for waste storage, treatment and



disposal; Public education and awareness creation in continuous basis; Performance monitoring and evaluation of the local authorities and reporting performance annually for the information of the general public; Introduction of performance appraisal schemes to recognize and disseminate best practices. Designate cleanest areas in the province to recognize the cleanest areas and its sustainability; Ensure sufficient budgetary provisions annually for the local authorities linking with strict monitoring and evaluation of the performance of accountability in delivering the services.

### **2.3 Creation of Waste Management Authority of Western Province (WMA)**

The Western Province enacted the Waste Management Authority Statute No 09 of 1999 of the Western Province. This Statute was repealed in 2007 and introduced new Statute No 01 of 2007. In this Statute, provisions are available for ensuring proper solid waste management process by providing financial and technical support to local authorities through other similar organizations engaged in waste management.

Section 7 of the Statutes: Objectives of the Authority include the followings;

(2) to prevent the accumulation of waste in the environment and make provision for maintaining a clean atmosphere for the well-being of the public and the fauna and flora within the Province.

(3) to plan, advise, organize and supervise the regulation of the functions of disposal, transportation and storage of waste generated within the areas of Western Province in a manner not to cause any hazard to the environment and health, for the purpose of subsection (3), in coordination with local authorities and other institutions with similar interest and determine and evaluate the hazardousness, if any, that may be caused, with a view to adopting a necessary procedure for the prevention thereof.

(4) to conduct research in the recycling and re-use of waste

(5) to issue direction with a view to redeeming the places, areas and zones that have been polluted due to injudicious disposal of waste and to implement measures and supervise activities connected therewith

(6) to coordinate with local authorities or any other institution or person and supervise all the projects concerning waste management carried out within the Province, with local or foreign assistance

(7) to publish papers, reports, books, information and notices jointly with other institutions in the Province or independently, and create awareness among the public on waste management (8) to work in conjunction with other organizations within Sri Lanka and abroad that have similar objects to those of the authority

(9) to conduct research to find ways and means to arrest the proliferation of waste, to create public awareness and to specify certain measures in relation to them.

National Policy on Waste Management 2020 Annex I provides Waste Management Authority (WMA)'s responsibilities as follows;

Waste Management Authority of Western Province: Waste management in the Western Province in accordance with the WPWM Act and the Constitution of Sri Lanka.

### **2.4 Regulatory Powers in Central Environmental Authority (CEA) at National Level**

National Environment Act No 47 of 1980, as amended from time to time;

Section 12 Power to give directions to local authorities:

(1) The Authority may with the concurrence of the Minister, from time to time, give to any local authority in writing such directions whether special or general to do or cause to be done any act or thing which the Authority deems necessary for safeguarding and protecting the environment within the local limits of such local authority.

(2) Every local authority to which a direction has been given under subsection (1) shall comply with such direction.

Section 23A Minister to determine activities respect of which a licence is required:

(1) The Minister shall determine by Order published in the Gazette the activities in respect of which a licence is required to be obtained under this Act (hereinafter referred to as ‘prescribed activities’) being activities which involve or result in discharging, depositing or emitting waste into the environment causing pollution.

(2) No person shall carry on any prescribed activity except- (a) under the authority of a licence issued by the Authority; and (b) in accordance with such standards and other criteria as may be prescribed under this Act.

The Regulations cited as the National Environmental (Protection and Quality) Regulations, No. 1 of 2008, were issued in January 2008, in terms of Section 23A of the National Environmental Act No. 47 of 1980.

Central Environmental Authority (CEA), not in a regulatory role by the Act but with the policy and government budget, has been implementing several waste management projects in the past. The National ‘Pilisaruru (re-resource in Sinhala)’ Waste Management Programme is one such project. The concept of this programme is to maximize the reutilization of resources discarded as wastes & to dispose of the non-utilizable residue in an environmentally acceptable manner.

The Pilisaruru National Solid Waste Management Project was established in the CEA in January 2008 with approval given by the Cabinet. The overall guidance for the implementation of the Pilisaruru program was provided by a high-level National Committee on SWM (called as „National Pilisaruru Platform) co-chaired by the Secretaries of the Ministries of Environment & Natural Resources and the Local Government & Provincial Councils (MLGPC). This program includes inter alia the following activities;

- Preparation of a National Waste Management Policy.
- Capacity building and awareness creation for those involved with waste management.
- Provision of technical assistance and resources to Local Authorities to improve ongoing waste management programs and to embark on new initiatives.
- Facilitation of waste management programs through mobilization and optimal utilization of resources.
- Monitoring of waste management program.
- Legal actions as a long-term approach to address non-compliance by responsible parties.

National Policy on Waste Management 2020 Annex I provides Central Environmental Authority (CEA)’s responsibilities as follows;

Central Environmental Authority (CEA): Overall enforcement of law at the national level covering all forms of waste

### **3. Details of organizational roles and responsibilities assigned through policy and budget of the government**

#### **3.1 Ministry of Provincial Councils and Local Government (MOPC&LG) and National Solid Waste Management Support Center (NSWMSC)**

Minister of Public Administration, Home Affairs, Provincial Councils and Local Government (MOPAHAPCLG)

Gazette Notification of the assignment of subjects and functions of the Ministers dated ib May 27th, 2022:

Formulation and implementation of special projects to provide facilities for identified fields/divisions with less facilities in Provincial Councils and Local Government Institutions.

National Policy on Waste Management 2020 Annex I provides Ministry in charge of the subject of Provincial Councils and Local Government (MPC&LG)'s responsibilities as follows;

Ministry in charge of the subject of Provincial Councils and Local Government (MPC&LG): Development of sectoral/sub-sectoral policies in line with the national policy, Facilitation of implementation of the national policies at national, provincial and local authority level, Development of strategies for human, financial and technical resource mobilization covering all provincial councils and local authorities avoiding duplication, Conducting research on human resource and financial resource management and good governance practices in waste management periodically on MSW waste management, development of time-bound master plans for MSW management, Performance monitoring, evaluation and reporting, transmission of information on the performance of municipal waste management with feedback mechanisms.

The National Solid Waste Management Support Center (NSWMSC) was established under the Ministry of Provincial Councils and Local Government in 2007, which assists local authorities in improving solid waste management problems.

The roles expected to be played by NSWMSC, as shown on its web page, are as follows;

- Compilation of laws and provision of consultancy to introduce methodological and proper solid waste management activities for the Local authorities.
- Provision of proper technical support on solid waste management for the Local government institutions.
- Promoting the local authorities for the creating of local and foreign experience of solid waste management.
- Supporting to the Local authorities to obtain technical and financial assistance from the non - government organizations and financial institutions.
- Construction and development of environmental conservation centers (compost projects) in local authorities.
- Improvement of 3R methodology
- Providing of compost barrels for the domestic waste management.

- Providing of compost barrels for the waste management in schools.
- Implementation of national program of collecting of waste separately to improve the waste management in local authorities.
- Printing and distributing of waste separation awareness posters and hand bills for the local authorities and school children.
- Making aware the community about waste management using the electronic media
- Preparation of advertisements.

### **3.2. Ministry of Urban Development and Housing**

Gazette Notification of the assignment of subjects and functions of the Ministers:

“Urban Solid Waste Management” was one of the Duties and Functions of the Ministry of Megaloiis and Western Development in the Gazette Notification of the assignment of subjects and functions of the Ministers dated September 21<sup>st</sup>, 2015. The same duty is assigned in the Gazette after the change of the government dated December 10<sup>th</sup>, 2019, under the Ministry of Urban Development, Water Supply and Housing Facilities; Same in another Gazette Notification dated May 27<sup>th</sup> under the Minister of Urban Development and Housing.

National Policy on Waste Management 2020 Section 8.3.4 (d) A dedicated and sustainable institutional mechanism shall be developed to provide infrastructure facilities for municipal waste management securing ownership with the highest degree of responsibility and accountability for operation, maintenance and management with private and ‘public-private’ partnerships as appropriate.

Section 8.3.4 (b): Infrastructure development for industrial and healthcare waste management shall be the responsibility of the line ministries; special precautions shall be taken for hazardous waste in line with the regulations and guidelines developed by CEA.

Section 8.3.4 (c): CEA shall guide and facilitate e-waste management infrastructure facilities by developing and incorporating appropriate tools to apply Polluter Pays Principle and Extended Producer Responsibility (EPR) principle.

National Policy on Waste Management 2020 Annex I provides Ministry in charge of the subject of Urban Planning and Development’s responsibilities as follows;

Ministry of Urban Planning and Development: Provision of infrastructure facilities in urban planning, facilitation of implementation of the national policies on waste management, periodical evaluation of the challenges related to haphazard waste disposal practices and take necessary action to prevent such incidences in collaboration with relevant stakeholders with feedback mechanisms, Publication of cleanliness and esthetic appearances.

National Policy on Waste Management 2020 Annex I provides the Urban Development Authority (UDA)’s responsibilities as follows;

Urban Development Authority (UDA): Provision of infrastructure facilities in urban planning, Facilitation

of implementation of the national policies on waste management, periodical evaluation of the challenges related to haphazard waste disposal practices and take necessary action to prevent such incidences in collaboration with relevant stakeholders with feedback mechanisms, Publication of cleanliness and esthetic appearances.

Sri Lanka Land Development Corporation (SLLDC) has been involved in developing and operating large-scale compost plants and disposal facilities in Muthurajawela. However, there is no such specific description for waste management for the Sri Lanka Land Development Corporation (SLLDC) in policy documents as is seen in the case of the Urban Development Authority (UDA).

[END]



## 別添資料 5

小規模の廃棄物積み替え中継基地

オペレーションマニュアル





**General Guidelines for the Operation  
and Maintenance of Kalutara Transfer  
Station**

## *Table of Contents*

Photo Album .....	3
1 Background on the current situation of Waste Management in the Western Province.....	5
1.1 Issues related to solid waste management in Western Province.....	5
1.2 Necessity of a transfer station .....	5
2 Purpose and objectives of the pilot project .....	6
2.1 Objectives .....	6
2.2 Pilot project site selection .....	6
2.3 Consistence of the pilot project.....	8
2.4 Equipment used at the Transfer Station .....	9
3 Current situation and design specifications of the Transfer Station.....	10
3.1 Analysis of the waste collection system before the Transfer Station .....	10
3.2 Daily operations of the transfer station .....	11
3.3 Design and specifications of the transfer station.....	13
3.4 Environmental and social considerations for development of the Solid Waste Transfer Station14	
3.5 Guidelines for the operation and maintenance.....	18
4 Benefits and economic justification analysis of the transfer station .....	26
4.1 Advantage of transfer station (comparison with/without).....	26
4.2 Economic justification of the TS: transportation cost reduction .....	26
Conclusion .....	32







## LIST OF FIGURES

FIGURE 1 SCHEMATIC EXPLANATION OF TRANSFER STATIONS WASTE TRANSPORTATION.....	6
FIGURE 2 LAND PLOT WHERE WASTE IS CURRENTLY DROPPED AND WHICH WILL BE SOLVED BY THE TS .....	7
FIGURE 3 RAMP AND A ROOFED AREA FOR KALUTARA TRANSFER STATION .....	7
FIGURE 4 SCHEMATIC DESIGN OF STATIC COMPACTOR WITH INPUT HOPPER .....	10
FIGURE 5 EQUIPMENT OPERATED AT KALUTARA TRANSFER STATION: TRUCK SCALE AND BOBCAT .....	10
FIGURE 6 EQUIPMENT TO BE USED AT THE TRANSFER STATION (WASTE CONTAINER+ CONTAINER HAULER VEHICLE WITH HOOK SYSTEM + STATIC COMPACTOR WITH INPUT HOPPER) .....	11
FIGURE 7 WASTE CONTAINER AND HOPPER.....	20
FIGURE 8 WASTE HYDRAULIC COMPACTOR AND CONTAINER.....	21

## LIST OF TABLES

TABLE 1 DETAILS OF FACILITY AND EQUIPMENT OF THE SMALL-SCALE SOLID WASTE TRANSFER STATION	9
TABLE 2 ENVIRONMENTAL AND SOCIAL CONSIDERATION FOR THE TRANSFER STATION	15
TABLE 3 EMERGENCY TYPES AND MEASURE TO BE UNDERTAKEN FOR THE TRANSFER STATION	25
TABLE 4 USUAL TECHNOLOGIES USED FOR WASTE TRANSFER STATIONS	30

Photo Album

	
<p>Mihisaru waste management center</p>	<p>Weight bridge</p>
	
<p>Waste compacting hydraulic cylinder</p>	<p>Container hauler trailer vehicle with hook system</p>
	
<p>Waste hopper and Bobcat</p>	<p>Waste container and vehicle with hook system unloading</p>



Solid waste container



Compactor door lifting hydraulic cylinder



Container hauler trailer vehicle with hook system



Bobcat used to feed hopped with waste



Transfer station entrance ramp



Control panel

## 1 Background on the current situation of Waste Management in the Western Province

### 1.1 Issues related to solid waste management in Western Province

Due to population increase and economic development the waste volume generated in Sri Lanka has been rapidly increasing to about 10,800t/day. Resulting in difficulties related to its management from collection to treatment and disposal.

In the course of its efforts to solve these issues, and as a response to GOSL's request, JICA is conducting a project in Sri Lanka's Western province. The Project is designed to assist Western Province in improving its solid waste management through the formulation of a Master plan that takes into account medium to long-term forecasts and a range of proposed solutions to the waste problems.

As part of this Project several pilot projects have been planned and Kalutara Transfer Station Pilot Project is one of them.

### 1.2 Necessity of a transfer station

As more and more waste is generated in Sri Lanka, the life span of available landfills grows gradually shorter and the necessity to find alternative solutions becomes more pressing. And given the fact that final disposal sites are hard to find in areas close to the waste generation points, the transportation distance, and thus the cost of transportation increases. Especially since one of the final disposal options in the future might be the regional landfill at Aruwakkalu located in the Northwestern Province. In these situations where the final disposal site is rather far from the generation point of waste, transfer station become an efficient technical solution for the transportation of waste.

Especially in a context of energy crisis, transfer stations also contribute to reducing fuel consumption and vehicle maintenance cost while also improving traffic conditions and producing less overall air emissions.

As a result, this small-scale solid waste transfer station pilot project draws its necessity from its contribution to the following aspects:

- Cost reduction for waste collection operations
- Efficient management of waste collection
- Transfer of technical knowledge from the Expert Team to C/P and contribution to potential future TS design and implementation in other sites through capacity building
- Establishment of the Operation and Maintenance activities of the TS.

At the current situation, some waste that cannot composted is disposed of at a site adjacent to the composting plant. Therefore, after the establishment of the Transfer Station Pilot Project, it will become possible to close the open waste disposal site with a proper plan and thereby avoid the environmental damage caused by the open dump.

As a result, the objections and complaints from the surrounding community about issues such as odors and leachate could be curbed with the commencement of the transfer station due to

reduction of pollutants such as rodents, flies, odors and leachate and improved aesthetic appearance.

In addition, a lot of issues in the composting plant are related to the residue from composting operations (after sieving). The transfer station pilot project can help to divert the residue from composting facility with less transportation cost.

## 2 Purpose and objectives of the pilot project

### 2.1 Objectives

The main objectives from the Transfer Station (TS) are to improve the efficiency of solid waste transportation and reduce the negative environmental issues in the vicinity.

by utilization of the transfer station, the long-distance haul of waste can be done more efficiently (figure)

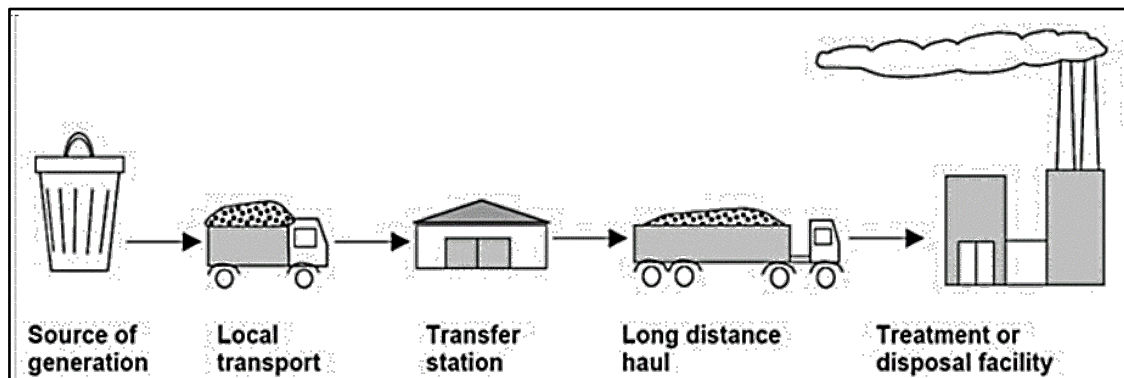

Figure 1 Schematic explanation of Transfer Stations waste transportation

### 2.2 Pilot project site selection

The selection of a suitable site for the waste transfer station is a rather challenging process. Site suitability depends on many technical, environmental, economic, social, and political factors. When selecting a site, a balance needs to be achieved among these multiple criteria.

Such tradeoffs need to be taken into account when deciding on a TS candidate site. For example, a site large enough to accommodate all required functions and possibly future expansion, might not be centrally located in the area where waste is generated. Similarly, in urban areas, ideal sites that fill all the requirements are very difficult to come across.

Also, in many cases, the public concern is a main discussion topic for the choice of the transfer station location, particularly from people living or working near the proposed site.

In the case of Kalutara composting plant, the selection of the site was done jointly with the WMA representatives and it took into account several factors such as:

- The current practices and situation at the selected site: currently Kalutara Municipal Council and Kalutara PS dispose of non-biodegradable waste in a land plot adjacent to the

compost facility and periodically cover the dumped material with a layer of soil (Figure 2). The dumping site is a marshy land and therefore it principally contaminates the surface and ground water sources. Apart from this the non-biodegradable components contaminated with biodegradable waste materials make malodorous emissions which are less tolerant to the neighborhood. Therefore, there is a need to stop open dumping of waste on the premises and introduce efficient and environmentally friendly management practices that are acceptable to the residents or working public in the vicinity.



Figure 2 Land plot where waste is currently dropped and which will be solved by the TS

- The current and future waste generation amount: the design and planning of the facility has to be determined and planned based on the current generation volume in the service areas and forecasts of the future generation volume. Therefore, it was decided that a medium-scale transfer station with necessary mitigation measures for environmental hazards would be more appropriate for the Kalutara pohorawatta. To be sustainable, economic affordability, environmental efficiency and social acceptability had been considered to avoid short-term and long-term harmful effects on the environment and human health.
- Proximity to the composting plant: the selected site is located next to the composting facility. It consists of a ramp and a roofed area (Figure 3) which could be used with slight modifications for accommodate the mechanical components of the facility. This has reduced the initial investment as well as facilitates the efficient use of the underutilized existing building. With the existing resources the development didn't require to incorporate special engineering design and construction techniques.



Figure 3 ramp and a roofed area for Kalutara Transfer Station



- All waste collection vehicles that collect waste from specific collection routes of local authorities selected to provide the service can arrive at the transfer station and deposit it in one operational shift. This maximizes the efficiency of waste collection.
- The transfer station has direct and convenient access to transportation route. The accessible routes are not highly utilized or congested. It avoids routing traffic through residential areas because traffic generated by transfer stations contributes to congestion; increased risk to pedestrians; increased air emissions, noise, and wear on roads; and might contribute to litter problems.
- Expansion possibility: the selected site is still enough to accommodate buffer with an expansion.
- Environmental considerations: Additional pollutants added to the environment through leachate generation and runoff processes can be mitigated. Safety measures are able to accommodate in place to prevent contamination of surface and groundwater resources.
- Technical input from the project team and community input from neighbors, community advisory groups and community surveys helped to choose and evaluate the site during the environmental review process
- Flooding possibility: The site is located outside the 100-year floodplain, has no known historic, archaeological, or cultural designations, is not designated for any type of preservation, is not adjacent to an urban growth area, and is not adjacent to sensitive receptive land uses.

As a result of these considerations, the current composting plant is situated in the following site:

- Address: Premises of Kalutara compost plant owned by Kalutara UC within Kalutara PS boundary.
- Owner of Compost Plant: Kalutara UC
- Execution body of Kalutara compost plant: Waste Management Authority (WMA)

### **2.3 Consistence of the pilot project**

The pilot project consists of the construction of a waste transfer station at the composting plant site, where non-organic waste (excluding recycled waste) and residues generated from the composting plant treatment process are also transferred into shipping containers and transported to the WtE treatment facility under consideration in the southern region of the Western Province or, if necessary, to the Aruwakkaruwa Regional Landfill located in the Northwestern Province.

The use of shipping containers will help prevent odor, scattering, collection of sewage, and deterioration of the landscape during transportation of the waste. The existing open dumping site will be closed with the technical support of JICA expert team and the budget of the counterpart.

The details of the pilot project are as follows.

- Basic plan and detailed design of the small-scale solid waste transfer station
- Construction of facility and procurement of equipment
- Operation of small-scale solid waste transfer station
- Closing current open dumping site
- Monitoring

## 2.4 Equipment used at the Transfer Station

The details of the facilities and equipment of the small-scale solid waste transfer station is shown as below. The required number of waste containers is two because one of the containers should continuously stay at the transfer station, while the other one is transported to the final destination.

Table 1 Details of facility and equipment of the small-scale solid waste transfer station

No.	Item	Specification	Qty.	Detail
1	Truck scale	-	1 unit	Measure the weight of vehicle upon arrival at the TS and when leaving the TS. (Figure 4)
2	Bobcat	-	1 unit	Recently repaired for future operations (Figure 4)
3	Static compactor with input hopper	Loading capacity 30 ton/day	1 unit	It consists of the static compactor loading the waste from hopper to container, driving system and hopper. (Figure 5)
4	Waste container	Capacity 26m <sup>3</sup>	2 units	It stores the residue for transportation to Karadiyana or Aruwakkalu final disposal site. (Figure 5)
5	Container hauler trailer vehicle with hook system	More than GVW 15 ton	1 unit	Its purpose is to haul the waste containers. (Figure 5)

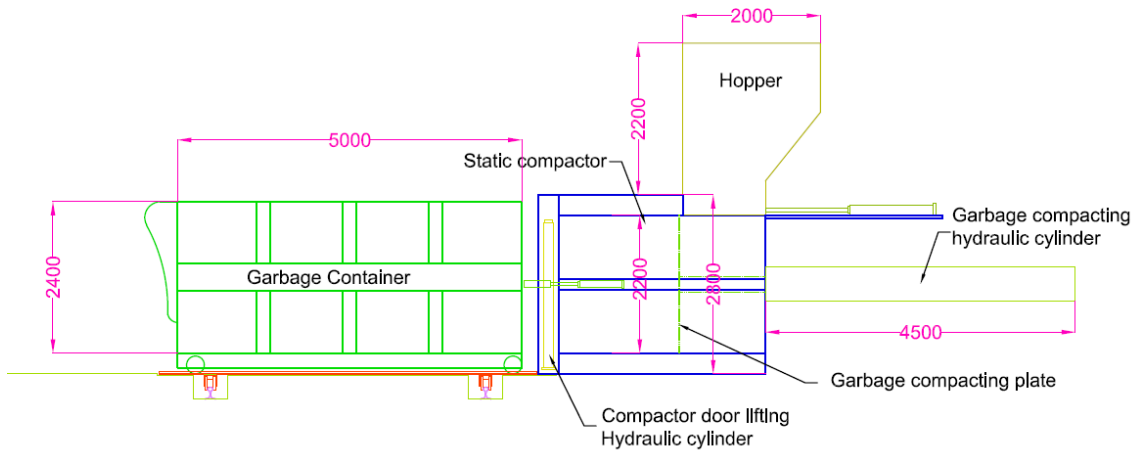

Figure 4 schematic design of static compactor with input hopper

### 3 Current situation and design specifications of the Transfer Station

#### 3.1 Analysis of the waste collection system before the Transfer Station

Before the establishment of the Transfer Station



Figure 5 Equipment operated at Kalutara Transfer Station: Truck scale and Bobcat



Figure 6 Equipment to be used at the Transfer Station (Waste container+ Container hauler vehicle with hook system + static compactor with input hopper)

### 3.2 Daily operations of the transfer station

Total collection amount of waste of Kalutara UC and Kalutara PS is approximately 34 ton/day and the segregated biodegradable waste is approximately 27 ton/day out of total collection amount of waste. The segregated biodegradable waste is treated at Kalutara compost plant operated by WMA. The sum of waste collected and the screened residue during the biodegradable waste treatment process is approximately 16 ton/day, and all the residue has been improperly discharged to the open dumping site behind the Kalutara compost plant for many years.

Environmental issues, such as offensive odors, stray dogs, pests, leachate generated from the open dumping site has negatively impacted the surrounding area of the Kalutara composting facility even though Kalutara UC covers the open dumping site with soil several times a year.

### **3.2.1 Accepted waste at the TS and loading operations**

The Transfer station will accept initially the non-biodegradable waste collected from Kalutara UC and Kalutara PS. On the other hand, Hazardous waste, medical waste and recyclables will not be accepted, (including e-waste and plastics).

### **3.2.2 Maintenance and cleaning**

#### **3.2.2.1 Management and maintenance of the compaction unit at the TS**

It is important to manage the compaction unit well and perform periodical maintenance.

The compaction unit is a hydraulic mechanical system, its unexpected downtime is time consuming as well as costly given that the operation of the whole TS depends on it.

Simply performing the regular maintenance tasks and attending to the early warning signs of poor compactor performance can typically avoid compactor down time. Operation of the compactor has to be done within the rated capacity and follow a maintenance and lubrication program. A qualified service technician should always perform preventative maintenance. A regular preventative maintenance plan is the best way to keep the compactor running efficiently and protect against premature failure and/or wearing down of hydraulic and mechanical components.

As a result, scheduling regular maintenance can significantly extend the compactor's life cycle and avoid unexpected issues.

#### **3.2.2.2 Recommended Weekly Maintenance at the TS**

Some maintenance tasks need to be performed on weekly basis such as:

- Checking fluid levels in the hydraulic fluid tank and adjusting the fluid as necessary.
- Checking the hydraulic hoses and fittings for leakages.
- Removing dust and dirt on the complete compaction unit and control unit.
- Wiping off or removing any grease, oil or moisture on the complete compaction unit
- Keeping close observation at the initial cycles of compaction at the start of the process for smooth operation.

#### **3.2.2.3 Recommended Monthly Maintenance at the TS**

Other tasks for maintenance need to be performed at least once every month or whenever necessary:

- Visually inspecting the condition of the static compactor for potential problems.
- Clean refuse from the ram.
- Ensuring the compactor is securely anchored.
- Applying grease to all grease fittings as applicable.
- Lubricating ram contact surfaces.

- Checking the condition of hydraulic oil and changing in case it is discolored (milky or dark) or dirty, or if it contains water, smells burnt, or lacks lubricity when rubbed between the fingers.
- Checking cylinder pins and retaining bolts.

#### **3.2.2.4 Recommended Yearly Maintenance at the TS**

In addition, some maintenance tasks need to be performed at least once a year or whenever necessary at the transfer station to avoid unexpected down time:

- Drain, flush and refill hydraulic oil tank.
- Replace oil filter.
- Check all fasteners and tighten as required.
- Replace air breather.
- Check structure of compactor for potential trouble areas.
- Check anchor bolts and tighten as necessary.

#### **3.2.3 Environmental monitoring**

The monitoring of the environment around is important for many reasons, one is to check for the safety of all nearby residents, and another one is to measure the impact of the transfer station, be it a positive impact (reduction of odors and leachate) or potential negative impact to find mitigating solutions.

Consequently, it is important to monitor odors and sounds emanating from the TS periodically.

In addition, since leachate is produced with the handling and compaction of the waste materials, this leachate needs to be handled with care and not disposed in natural environments without treatment.

The generation of leachate will be higher in wet weather. Therefore, leachate treatment is important to alleviate the possible environmental damage through surface water, ground water contamination and air contamination as a result of odorous emissions.

At the TS, the leachate could be collected in the collection pit constructed next to the compactor housing and could be diverted to the central leachate collection tank through gravity or pumped with the intention of use for the composting process for the moisture balance.

### **3.3 Design and specifications of the transfer station**

Design specifications of the transfer station are described below:

- Processing capacity: 30 ton/day
- Waste density before compaction: 0.3-0.4 ton/m<sup>3</sup>
- Waste density after compaction: 0.4 ton/m<sup>3</sup>

- Capacity of container:  $26\text{m}^3 \times 0.4\text{ton}/\text{m}^3 = 10.4 \text{ t}$
- Required trips:  $20\text{t} \div 10.4\text{t} = 2 \text{ round trip}/\text{day}$
- Transportation distance: 60km
- Velocity: 30km/hour
- Required time of round trip:  $(60\text{km}/30\text{km}/\text{hour}) \times 1 \text{ round trip} = 4.0 \text{ hour}/\text{round trip}$
- Working hours: 10 hours/day.
- Number of round trips per day:  $10 \text{ hours}/\text{day} \div 4.0 \text{ hours}/\text{round trip} = 2.5 \text{ round trips}$   
→2.0 round trips

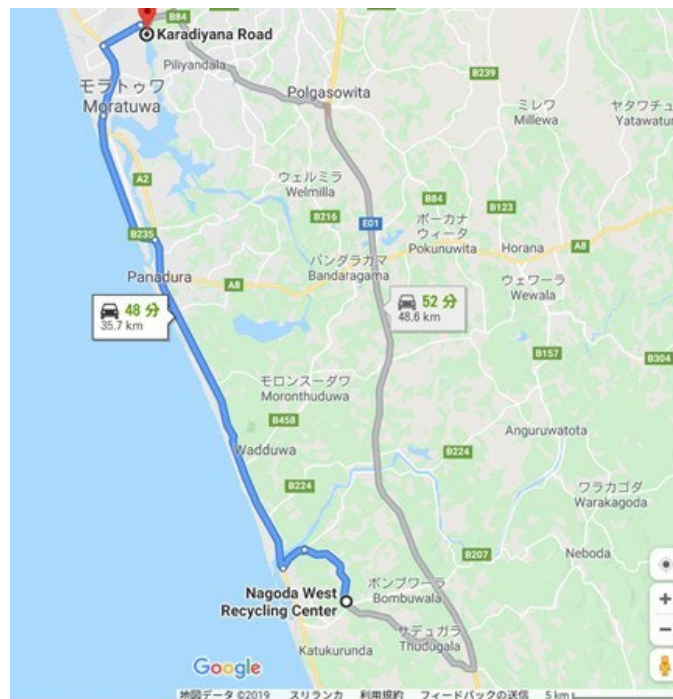

m

### 3.4 Environmental and social considerations for development of the Solid Waste Transfer Station

The development of transfer stations needs to take into account environmental and social considerations, given the fact that its establishment will result in impacts to the traffic volume due to the arrival and departure of vehicles transporting refilled waste.

In addition to the traffic volume, noise, dust and odor from non-organic waste are expected to be generated.

In order to put careful attention into these issues, it is necessary to carefully analyze and consider potential nuisances from traffic to noises and odors as shown in the following table.

Table 2 Environmental and social consideration for the Transfer Station

Environmental issues	Considerations
Traffic	<p>The TS opted for a frequency of two roundtrips per day for the transportation of waste, which is a rather low frequency. However, especially for TSs situated in urban and suburban areas where traffic congestion is often already a significant problem for the local community, these traffic considerations are important.</p> <p>It necessary to note whether the routes leading to the TS have any limitations on gross vehicle weight or size for certain roads or bridges.</p> <p>A special attention should be put into evaluating travel routes and the resulting traffic impacts during the selection of the TS site to minimize the traffic’s offsite environmental impacts.</p> <p>Through scheduling, transfer stations can indirectly control the flow of traffic arriving at the facility. And in case of traffic issues, on potential measure by the operator might be to designate traffic routes to the facility. In some case a traffic sign like “Left turn only” at the exit can relieve some traffic conflicts. If offsite routes are designated, clear authority for enforcement needs to be established (e.g., by local police or by the station operator refusing access to violators).</p> <p>Some design or operation features might help to reduce the environmental impacts of transfer station such as:</p> <ul style="list-style-type: none"> <li>• Designating haul routes to and from the transfer station that avoid congested areas, residential areas, and other sensitive areas.</li> <li>• Adding offsite directional signs, pavement markings, and intersection signals.</li> <li>• Providing acceleration and deceleration lanes that allow vehicles to enter and leave the flow of offsite traffic smoothly, reducing congestion and the likelihood of accidents.</li> <li>• Using right turns to enter and leave the station site and minimizing left turns to reduce congestion and the likelihood of accidents off site.</li> <li>• Providing adequate onsite queuing space so lines of customers and transfer vehicles waiting to enter the facility do not interfere with offsite traffic.</li> <li>• Installing and using compaction equipment to maximize the amount of waste hauled in each transfer trailer, thus reducing the number of loads leaving the site.</li> <li>• Establishing operating hours, including restrictions, that encourage</li> </ul>



	<p>facility use during nonpeak traffic times on area roads.</p> <ul style="list-style-type: none"> <li>• Schedule commercial waste deliveries to avoid rush-hour traffic.</li> </ul>
<p>Noise and vibrations</p>	<p>The current transfer station is located close to the composting plant, which can be a significant source of noise, and thus cause nuisances to neighbors.</p> <p>The operation of the stationary solid waste compactor and trailer vehicle as well as the heavy-duty facility equipment are the primary sources of noise from the transfer station. The unloading of waste onto a tipping floor, pit, steel drop box, or trailer can also create substantial noise, depending on the type of waste, fall distance, and surface.</p> <p>Noise can be reduced through some measures related to facility design and operations of from the transfer station. This includes:</p> <ul style="list-style-type: none"> <li>• Designing the TS so as to increase the distance between the noise source and the receiver or providing natural or man-made barriers to reduce noise in cases when the sound generation level cannot be reduced.</li> <li>• Providing sound-absorbent materials on building walls and ceilings if possible.</li> <li>• Shutting off equipment when not in use.</li> <li>• Avoiding traffic flows adjacent to noise sensitive property.</li> <li>• Arranging the facility layout to eliminate steep uphill grades for waste-hauling trucks, as driving uphill can significantly increase noise levels.</li> <li>• Facing building openings such as entrances away from noise-sensitive adjoining property.</li> <li>• Opt for quieter equipment during design or in case of operation, confine noisy activities within specified buildings or other enclosures. (Particularly, enclose the compactor in a confined area)</li> <li>• Properly maintaining mufflers and engine enclosures on mobile equipment operating within the transfer station.</li> <li>• Designate hours for conducting activities that generate the loudest noise, such as late morning or afternoon commute hours, and avoid early morning or late night.</li> </ul>
<p>Odors</p>	<p>The hot/humid climate and the type of waste that arrives at the transfer station make for a high potential for odor generation in Sri Lanka. As a result, the transfer station needs to address odor management so as not to disturb the neighboring areas.</p> <p>In this transfer station the design was done with the consideration of odors mitigation in mind and sealed type containers were chosen. But odors can</p>

	<p>further be managed by:</p> <ul style="list-style-type: none"> <li>• Similarly to the noise mitigation measures, increasing the distance between the source of the odor and the receiver effectively reduces its impact.</li> <li>• Evaluating the prevailing wind direction to determine building orientation and impact on adjacent properties.</li> <li>• Designing floors for easy cleanup, including a slope to drainage systems. Eliminating crevices, corners, and flat surfaces, which are hard to keep clean and where waste residue can accumulate.</li> <li>• Minimizing onsite waste storage, both in the facility and in the loaded trailers, by immediately loading odorous or potentially odorous wastes into transfer trailers and quickly transferring them to the disposal site.</li> <li>• Removing all waste from the tipping floor or pit at the end of each operating day, then cleaning those areas to remove remaining residues.</li> <li>• Using enclosed trailers whenever possible when loaded trailers must sit on site temporarily before transfer.</li> <li>• FIFO: Practicing “first-in, first-out” waste handling practices so wastes are not allowed to sit on site for long periods of time.</li> <li>• Keeping building catch basins, floor drains and drainage systems clean so odor-causing residues do not build up.</li> <li>• Treating drainage systems periodically with odor-neutralizing and bacteria-inhibiting solutions.</li> <li>• if necessary: divert very odorous waste loads to facilities with less sensitive surroundings during adverse weather conditions.</li> <li>• Refusing to accept certain highly odorous wastes.</li> <li>• Practicing other “good housekeeping” measures, including regularly cleaning and disinfecting containers, equipment, and other surfaces that come into contact with waste.</li> </ul>
Air quality	<p>Air emissions at the transfer station result from dusty wastes and exhaust (particularly diesel) from mobile equipment such as trucks and loaders, driving on unpaved or dusty surfaces, and cleanup operations such as street sweeping. The following measures can help to mitigate them:</p> <ul style="list-style-type: none"> <li>• Paving as much as possible the traffic carrying roads.</li> <li>• Keeping roads and tipping floors clean and ensuring any street sweeping operations use sufficient water to avoid stirring up dust.</li> </ul>

	<ul style="list-style-type: none"> <li>• Restricting vehicles from using residential streets.</li> <li>• Selecting alternative fuel or low-emission equipment or retrofitting facility equipment with oxidation catalysts and particulate traps.</li> <li>• Maintain vehicles and equipment engines in proper operating condition by performing routine checks to reduce exhaust emissions.</li> <li>• Using a hose to spray dusty wastes as they are unloaded and moved to the receiving vehicles.</li> <li>• Turning off engines when not in use.</li> <li>• Cleaning truck bodies and tires to reduce tracking of dirt onto streets.</li> </ul>
Water quality	<p>Waster from collection vehicle washing or wash-down water flow from tipping floors, roads or parking lots can be contaminated with leachate from waste. Consequently, keeping surface water and groundwater free of runoff contamination from waste, fuel and oil that drips from vehicles is important to maintaining the quality of both the surface and ground water.</p> <p>Contaminated water should be collected separately, then properly managed on site or discharged to the sewer. Many transfer stations send some amount of wastewater to sewer systems. To minimize impacts on sewer systems, transfer stations should consider:</p> <ul style="list-style-type: none"> <li>● Removing as much waste and debris from the tipping floor as possible by scraping or sweeping and then hosing the floor down.</li> <li>● Installing drain covers on floor drains. During normal operations, floor drains should be covered to prevent spilled liquid wastes from entering the sewer system. Covers can be opened or removed during floor cleaning.</li> <li>● Providing appropriate pretreatment of leachate before its disposal. Pretreatment systems depend on the local situation (requirement of receiving sewer system / treatment plant but could be primary sedimentation and use of oil/water separators etc.)</li> </ul>

### 3.5 Guidelines for the operation and maintenance

#### 3.5.1 Operation and maintenance plan

The operation of a transfer station might seem like a simple task given its function of waste reception and transportation, but it actually involves the proper execution of many different tasks that need to be defined and executed in a clear and timely manner.

Some of the required tasks are repetitive and rather simple to perform but other irregular tasks require more detailed directions and a certain know-how. As a result, all tasks should be included in an “operation and maintenance plans” document. This document should be specifically written

for the Transfer station in question and not a general one as the situations differ on the technologies used and the local circumstances of the transfer station.

The operation and maintenance plan should include as many of the following elements as possible:

1. The schedule of operation of the facility: days of the week, hours each day, and holidays.
2. Work schedule: including the lists of staff on duty by job title, minimum staffing on-site.
3. Description of acceptable and unacceptable wastes, and procedures for diverting restricted waste before and after unloading.
4. Operating methods for each component of the facility, including waste-screening methods, truck-weighing procedures, tipping floor operations, transfer vehicle loading, onsite and offsite litter cleanup, and wastewater collection system operations.
5. Description of maintenance procedures for each component, including the building, mobile equipment, utilities, and landscaping.
6. Employee training content and schedule.
7. Safety rules and regulations (including for the heavy equipment used at the TS).
8. Recordkeeping procedures.
9. Contingency plans in the event of transfer vehicle or equipment failure, or if the disposal site is unavailable.

### **3.5.2 Compactor operation method**

#### **3.5.2.1 Feeding and compacting operation**

- Loading of the Waste to the hopper:
  - 1 0.6 ton - 1 ton Waste shall be loaded into the Hopper
  - 2 It shall be weighed in the hopper
  - 3 After loading 1 ton/0.6ton of waste to the hopper, it will be automatically dropped into the compactor chamber.
- Specification of the bale:
  - 1 Full bale size (In the container) will be prepared L W H 4.2m X 2.1m X 2.2 m
  - 2 Total Baled weight to be loaded in the container will be 11 tons (3.5 -3.6 ton / per bale X 3 Bales)
  - 3 Single bale weight: 3.5 Ton/3.6 Ton
  - 4 Total tonnage will be prepared in 3 cycles,
  - 5 First 3.5 Ton/3.6 Ton bale will be prepared and similar another 2 bales shall be prepared and inserted to the container



Figure 7 Waste container and hopper

### 3.5.2.2 Container Handling Method

The following steps should be followed for a good operation of the container and the compactor:

1. Placing the container on the sliding frame from the truck.
2. Opening the Container door while container is on the sliding frame.
3. Aligning the container to the compactor door engaged with two hydraulic locks.  
(Three compacted bales will be inserted into the container.)
4. After releasing the locks, the container will be slid to a side along the guide rails and close doors.
5. The closed container is slid back to the loading bay for transportation
6. The other empty container shall be placed on the transfer system rail deck
7. After the unloading the empty container truck shall be moved and aligned with the container with the compactor waste.
8. Pull the container by the truck on the transfer system rail bed. (It should be carefully pull on the deck and maximum pulling length shall 1.5 M distance.)
9. Manually push the controlling button of transfer system rail deck and shift the container perpendicular to the compactor axis.
10. At the same time, empty container shall be automatically aligned with the compactor system.
11. Close and lock the container door.

12. Lift the container utilizing the hook and place it on the truck



Figure 8 waste hydraulic compactor and container

### 3.5.3 Operating Hours of the Transfer station (Peak Time Management)

The operation hours of the transfer station must be designed so that the collection schedules of the vehicles delivering waste are included.

Operating hours need to consider the local situation of the TS, such as neighboring land uses (in this case the composting plant), as well as the operating hours of the final disposal site receiving waste from the transfer station.

In Kaultara TS, the operating schedule is planned to be from:08:00 to 17:00 (9 hours/day).

In many cases, the last trailer must be loaded with sufficient time to reach the disposal site before it closes.

Peak Time management is one of the important aspects to consider when deciding the operating schedule. To avoid any traffic issue, any queuing of vehicles should occur on the transfer station site so as not to inhibit the traffic flow on public streets. Queuing on streets creates public safety concerns, blocks traffic and access to adjacent properties, and in some cases, causes damage to streets not designed for heavy vehicles. Exhaust from idling truck engines queuing on public streets can also create air quality and health concerns.

If space on the site is insufficient, alternatives should be considered. These could include providing a separate tipping area for certain types of customers (such as self-haulers, who generate a lot of traffic, but not much waste) or establishing a remote holding lot for inbound vehicles to use before joining the onsite queue. Regulatory agencies sometimes can address and control queuing problems through the permitting process. Permitting agencies can incorporate provisions

that require transfer stations to provide adequate queuing space on site or off site or that prohibit queuing on public streets.

In Kalutara TS a tipping area is designated, and waste will be checked at the tipping area before it is loaded into the compactor.

### **3.5.4 Safety instruction / emergency situations**

#### **3.5.4.1 Safety instruction**

Safety measures are one of the most important aspects of the operation of the TS. Its design and operation should be done with the safety of employees and potential visitors in mind.

In order to avoid accidents, signs should be posted around the perimeter, with warnings about potential risks due to falls or contact with waste. And the staff in charge of the TS must take action to eliminate or at least reduce the risk of injury related to the following:

##### **■ Exposure to hazard**

The employees of the transfer station work in close proximity to a variety of hazards, including equipment with moving parts, such as the compactor in Kalutara TS (or in some cases conveyor belts, push blades, balers, and heavy vehicles).

Facility operators should develop an equipment orientation program and establish safety programs to minimize the risk of injury from equipment.

Utilizing locks for equipment such as the compactor for example, can effectively minimize hazards associated with transfer station equipment.

The TS operators must implement and strictly enforce rules about visitors. Posting signs and applying brightly colored paint or tape to hazards can alert customers to potential dangers.

##### **■ Personal Protective Equipment (PPE)**

Transfer station employees coming in close contact with waste and heavy machinery should wear appropriate Personal Protective Equipment. Common pieces of protective gear include hard hats, protective eye goggles, dust masks, steel tipped boots, and protective gloves.

Ensure that all facility employees are using the appropriate equipment and are properly maintaining it.

##### **■ Traffic accidents due to operated vehicles and machinery**

The traffic accident at the TS depends on many factors such the frequency of vehicle arrival at the TS but they can be minimized through some measures.

Controlled, safe traffic flows in and around the facility are critical to ensuring employee and customer safety. The operators of the TS should consider the following measures:

- One-way Traffic Flow: directing traffic flow in a one-way loop through the main transfer building and around the entire site. Facilities with one-way traffic flow have buildings (and sometimes entire sites) with separate entrances and exits. The transfer trailers, in particular, are difficult to maneuver and require gentle slopes and sufficient turning radius. Ideally, these

trailers should not have to back up.

- Minimizing intersections: Arranging buildings and roads on the site to eliminate or minimize intersections, the need to back up vehicles, and sharp turns.
- Providing space for vehicles to queue when the incoming traffic flow is greater than the facility's tipping area can accommodate.
- Queueing area: Sufficient queuing areas should be located
- Signs: Providing easily understood and highly visible signs, pavement markings, and directions from transfer station staff to indicate proper traffic flow.
- Lighting: Providing bright lighting, both artificial and natural, inside buildings. Using light-colored interior finishes that are easy to keep clean is also very helpful. When entering a building on a bright day, drivers' eyes need time to adjust to the building's darker interior. This adjustment period can be dangerous. Good interior lighting and light-colored surfaces can reduce the contrast and shorten adjustment time.
- Clothing: Requiring facility staff to wear bright or conspicuous clothing. Personnel working in the tipping area especially must wear high visibility clothing at all times.
- Alarms: Installing backup alarms on all moving facility equipment and training all vehicle operators in proper equipment operations safety. Backup alarms must be maintained in proper working condition at all times.
- Cameras and monitors can also be installed.

■ Exposure to extreme temperatures:

Facilities located in areas of extreme weather must account for potential impacts to employees from prolonged exposure to heat. The following measures can help reduce those impacts:

- Proper ventilation: can significantly reduce the effect of heat exhaustion and heat strokes
  - Access to water and shade: hydration plays an important role undeniably.
  - Periodic work breaks.
  - In addition, depending on the local area extreme temperature can mean cold weather. And it is addressed by proper clothing, protection from wind and precipitation, and access to warming areas.
- Falls: In many situations we might hear about accidental falls in transfer stations. Employees (and even customers/ visitors in some cases), Especially in facilities with pits or direct dump designs where the drop at the edge of the tipping area might be 1.5m to 4m deep.

Facilities with flat tipping areas offer greater safety in terms of reducing the height of falls, but they present their own hazards. These include standing and walking on floor surfaces that could be slick from recent waste material and being close to station operating equipment that removes waste after each load is dumped.



Depending on the station design (pit or flat floor), a number of safety measures should be considered to reduce the risk of falls:

- Safety barriers/nets, such as chains or ropes, can be placed around the pit edges at the end of the day or during cleaning periods to prevent falls. These barriers, however, should be removed during normal operating hours as they can interfere with the unloading of waste.
- Wheel stops can be installed on the facility floor to prevent vehicles from backing into a pit or bin. Some curbs are removable to facilitate cleaning.
- Locating wheel stops a good distance from the edge of the unloading zone ensures that collection vehicles will not find themselves dangerously close to a ledge or the operating zone for station equipment.
- To prevent falls due to slipping, the floor should be cleaned regularly and designed with a skid-resistant surface. Designers need to provide sufficient slope in floors and pavements so that they drain readily and eliminate standing water. This is especially crucial in cold climate areas where icing can cause an additional fall hazard.

Because of transfer stations' large size and volume and the constant flow of vehicles, it is impractical to design and operate them as heated facilities.

- Use of colored floor coatings (such as bright red or yellow) in special hazard zones (including the area immediately next to a pit) can give customers a strong visual cue.
- If backing movements are required, design the facility so vehicles back in from the driver's side (i.e., left to right) to increase visibility.

- Leachate: leachate generated from washing vehicles and compacting waste will be stored in

#### **3.5.4.2 Emergency situation**

Transfer station operators should prepare for emergencies, and safety instructions in case of emergencies, the following emergencies could be taken into account when preparing an

emergency plan for the Transfer Station.

Table 3 Emergency types and measure to be undertaken for the Transfer Station

Emergency Type	Measures to be undertaken
Power failure	In the current context, power failure may happen occasionally, it is necessary to foresee a method record customer information, collect fees, and load transfer trailers during a power outage. Many larger transfer stations have backup power generators so at least some operations can continue during a power failure.
Unavailability of transfer vehicles	The plan should address what to do if poor weather, road closures, or strikes prevent empty transfer vehicles from arriving at the transfer station. The plan should also address when the transfer station should stop accepting waste deliveries if the waste cannot be hauled out in a timely manner.
Unavailability of scales	In cases where the scale is not operable, it is necessary to describe recordkeeping and fee assessment alternative (such as recording the volume of the truck and an estimation of waste density etc.)  Some facilities have an inbound and outbound scales, one scale can temporarily serve both purposes.
Fire	Fire remains a possibility at the transfer station and should be taken into account. The response procedures should consider fires found in incoming waste, temporary storage at the transfer station, compaction equipment, and also transfer vehicles.  Fire procedures prioritize protecting workers health and contacting professional fire departments as soon as possible. Ceiling sprinkler systems by themselves might not be completely effective in preventing small fires from spreading. Due to the high ceilings common in transfer stations, a fire could spread substantially before it gets hot enough at the ceiling level to activate sprinkler systems. Consequently, facilities should have fire hoses or other firefighting equipment in the area, in addition to ceiling mounted sprinklers.
Spill of containment	Spills can occur from waste materials or from vehicles delivering waste. For example, hydraulic compaction system hoses on garbage trucks can break. In case of spill, the containment plans should address spill identification, location of spills, deployment of absorbent materials, and cleanup procedures. For large spills, the plan should also address preventing the spill from entering storm drains or sewers.
Discovery of hazardous materials	Hazardous materials plans should include methods to identify and isolate hazardous materials, temporary storage locations and methods, and emergency phone numbers.

Injuries	The plan should include first aid procedures, emergency phone numbers of workers and visitors, and routes to nearby hospitals.
Natural Disaster/ Pandemic	A Business Continuity Plan for waste management should be developed

#### 4 Benefits and economic justification analysis of the transfer station

##### 4.1 Advantage of transfer station (comparison with/without)

The Transfer Station brings many benefits related to logistical, environmental, and social aspects. Some of the most significant benefits of solid waste transfer stations may include:

Increased fuel savings

- Minimized traffic congestion
- Improved safety at landfills and waste-to-energy facilities
- Encourages adequate screening of waste items before disposal
- Potential drop-off location open to the public
- Reduced air, water pollution
- The adjacent composting plant will also benefit greatly from the operation of the TS through reduction of waste accumulated at the adjacent waste disposal site and thus the reduction of odors through transportation of the waste from the site. Some residues from composting can easily be disposed of through the TS.

##### 4.2 Economic justification of the TS: transportation cost reduction

Despite the initial capital costs, the transfer station can be justified due to the long-term benefits it offers, particularly when considering the haul cost. While establishing a waste transfer station incurs expenses related to construction, equipment, and operational maintenance, it ultimately proves cost-effective in comparison to the alternative of directly transporting waste to disposal sites.

The capital cost for the establishment of the transfer station including civil works, purchase of the compactor and containers, and also a truck with bin lifting and hook system was initially estimated at 210,930USD. The estimated construction cost of the small-scale waste transfer station at Kalutara pilot project development in 2022 was found to exceed the initial budget prepared in 2019.

A breakdown of the original budget and final estimate is given below.

- Estimate December 2019      LKR 37,790,000 (¥23,094,225, USD 210,935)
- Final estimate January 2022      LKR 87,689,800 (¥48,115,518, USD440,835)

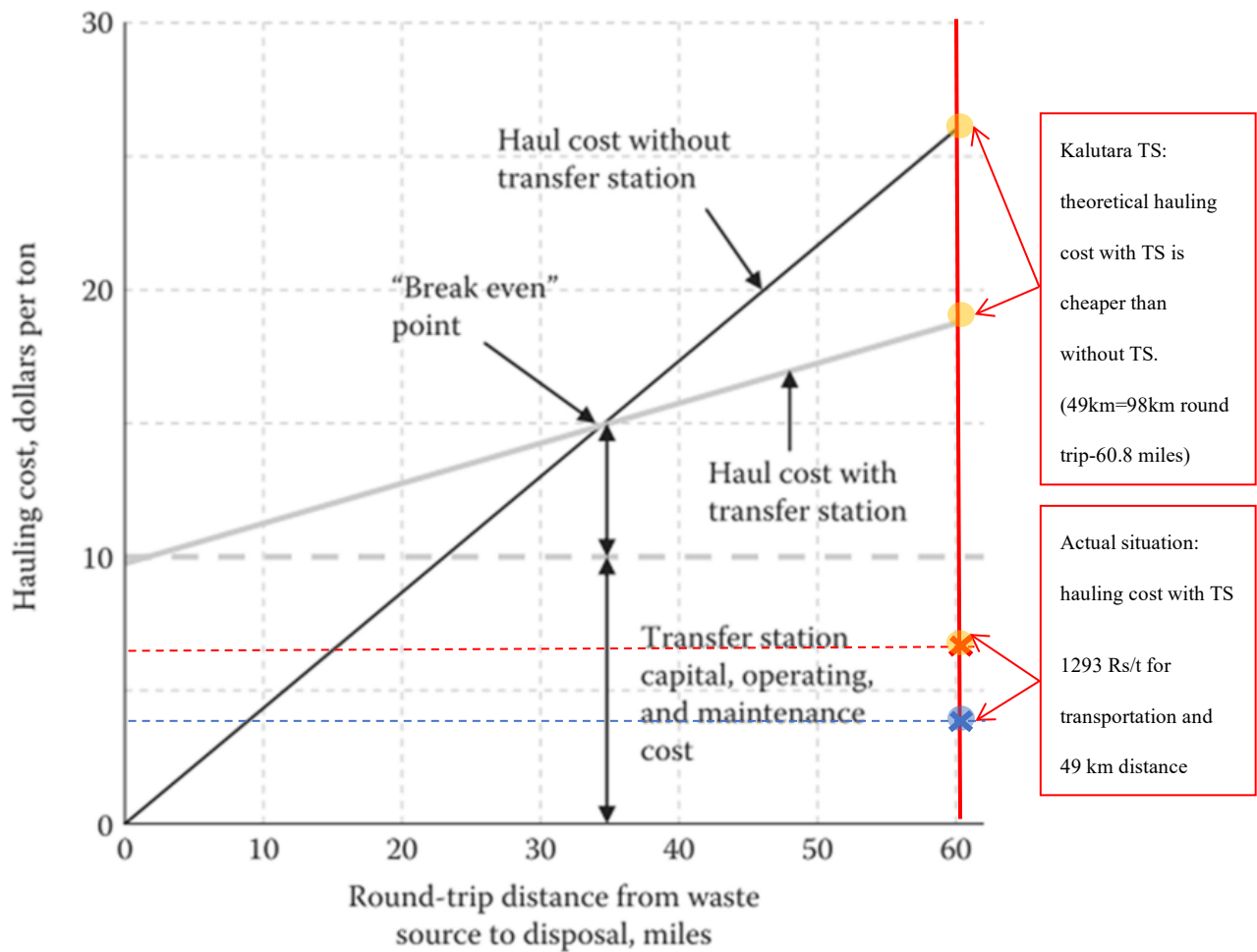

Source ([Waste Transportation and Transfer Station | SpringerLink](#))

By consolidating and compacting waste at the transfer station, larger volumes can be transported at once, optimizing the efficiency of each trip. This leads to significant savings in fuel, labor, and vehicle maintenance expenses. This ongoing cost advantage, coupled with improved waste management efficiency, makes the construction and operation of a waste transfer station a justified expenditure in the long run. The figure below shows the hauling cost with and without a TS and the specific case of Kaluthara TS.

As for the average cost of hauling 1 ton of waste it is as shown in the table below:

Unit	Sri Lankan Rupees	US Dollars*
Without transfer station	2,422	7.8
With transfer station	1,392	4.5

\* Rate as of May 2023 (1USD ~304 LKR)

For each ton of waste transported through the TS, 3.2 USD\* (1,000 LKR) is saved on average transportation cost. Which means an average of 25,337 USD\* (7,800,000 LKR) per year saved on transportation (assuming a capacity of 30t/day and 260 working days per year).

### **4.3 Main lessons learned for future Transfer stations**

#### **4.3.1 Types of waste not to accept at the TS**

Certain types of waste should not be accepted in the transfer station for a variety of reasons, including:

- PCBs, lead acid batteries or radioactive materials.
- Wastes that are difficult or costly to process (e.g., tires).
- Wastes that might pose a health or fire hazard.
- Wastes that might be prohibited at the disposal facility to which the transfer station delivers.
- Wastes that might be prohibited (within a mixed waste load destined for disposal) because local regulations require they be recycled.
- Large size waste that might damage trucks or equipment during waste loading operations.
- Large bulky objects such as tree stumps, mattresses, or furniture;
- infectious medical waste; hazardous waste; explosives; radioactive materials; fuel tanks (even if empty); appliances; dead animals; asbestos; liquids and sludges; and dust prone materials.

This is a general list; some transfer stations might be set up to process these wastes, while others might have a longer list of unacceptable materials.

While these and other unacceptable wastes represent a small fraction of the solid waste stream, properly managing them can require significant effort by the transfer station operator and the local solid waste management authority. The section on waste screening in the Transfer Station Design and Operation chapter further discusses how to properly manage and reduce the frequency of unacceptable waste at a transfer station.

#### **4.3.2 Site selection**

One of the most challenging aspects of design solid waste management facilities is to identify a suitable site. The suitability of a site depends on many factors (technical, environmental, economic, social, and political).

The analysis of all tradeoffs and an analysis of the local situation is necessary to achieve a certain balance among these different aspects. For example, a site that has the right size and is suitable for potential future expansion might be positioned in a sub-optimal location (far from waste generation source). Likewise, in densely developed urban areas, ideal sites might not be available. Less than ideal sites may still present the best option due to transportation, environmental, and economic considerations.

A suitable site for the transfer station should answer not only the technical and practical

requirements but also the social requirements related to public concern or opposition, particularly from people living or working near the proposed site.

#### **4.3.3 Public involvement and information sharing with community**

Involving the community in the decision-making process is important for all stages from site selection to the design and operation of the TS.

Such involvement in the process allows to establish credibility and build trust with the community and thus avoid complaints from residents after the construction of the TS. The communication can either be done directly with the community or by identifying key members of the community. Good communication can make individual proponents of the proposed TS rather than opposing it and leading to conflicts.

#### **4.3.4 Design of the transfer station**

Once a site is identified for the transfer station, it is necessary to develop a site plan for the proposed facility.

A site plan shows the layout of the transfer station site including its major features, such as access road entrances and exits, buildings, parking lots, utilities, surface water drainage features, fences, adjacent land uses, and landscaping.

During site selection many factors related to the impact of the TS should be considered like the TS Impact on air quality, on local infrastructure, adjacent land uses, proximity to schools, recreation sites, and residences, Prevailing winds, Number of residences impacted, Expansion possibilities, Traffic compatibility and potential impact on historic or cultural features.

### 4.3.5 Technology selection

The method used to handle waste at the transfer station from the time it is unloaded by collection vehicles until it leaves the site is central to any transfer station’s design. In the simplest cases, waste from collection vehicles is unloaded directly into the transfer container or vehicle. As this eliminates opportunities to inspect or sort the material, other floor tipping methods are more common. Each technology has its advantages and disadvantages, and it is necessary to analyze the local situation to choose which methods are most appropriate.

Table 4 Usual technologies used for Waste Transfer stations

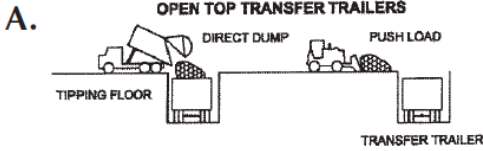
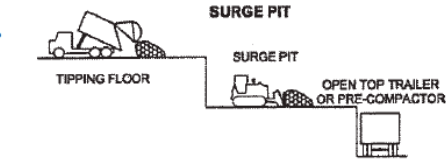
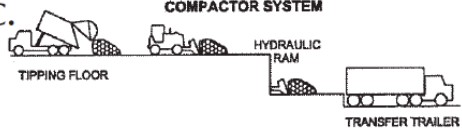
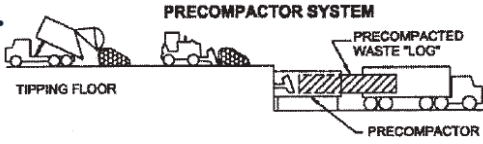
Technology	Drawing	Specifications
<p>A. Open top transfer Trailers</p>	 <p><b>A. OPEN TOP TRANSFER TRAILERS</b></p> <p>TIPPING FLOOR, DIRECT DUMP, PUSH LOAD, TRANSFER TRAILER</p>	<p>Waste can be unloaded directly into the “open top” of the trailer but is most often unloaded on the tipping floor to allow for materials recovery and waste inspection before being pushed into the trailer. Large trailers are necessary to get a good payload because the waste is not compacted. This is a simple technology that does not rely on sophisticated equipment (e.g., compactor or baler). Its flexibility makes it the preferred option for low-volume operations.</p>
<p>B. Surge pit</p>	 <p><b>B. SURGE PIT</b></p> <p>TIPPING FLOOR, SURGE PIT, OPEN TOP TRAILER OR PRE-COMPACTOR</p>	<p>The pit can store peak waste flow, thus reducing the number of transfer trailers needed. A tracked loader or bulldozer is used to compact the waste before loading, increasing payload. Because waste is often unloaded directly into the surge pit, this technology might deter materials recovery and waste screening efforts.</p>
<p>C. Compactor system</p>	 <p><b>C. COMPACTOR SYSTEM</b></p> <p>TIPPING FLOOR, HYDRAULIC RAM, TRANSFER TRAILER</p>	<p>Stationary compactors use a hydraulic ram to compact waste into the transfer trailer. Because the trailer must be designed to resist the compaction force, it is usually made of reinforced steel. The heavy trailer and the weight of the onboard unloading ram reduce the payload available for waste. This technology is declining in popularity.</p>
<p>D. Pre-compactor system</p>	 <p><b>D. PRECOMPACTOR SYSTEM</b></p> <p>TIPPING FLOOR, PRECOMPACTED WASTE "LOG", PRECOMPACTOR</p>	<p>Pre-compactor systems use a hydraulic ram inside a cylinder to create a dense “log” of waste. The log is pushed into a trailer that uses “walking floor” technology to unload or relies on a tipper at the landfill to unload by gravity. Most pre-compactor installations have two units in case one unit requires repair.</p>

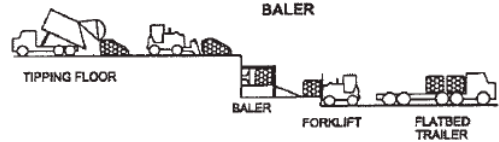
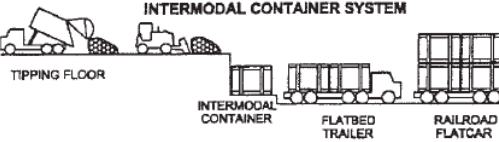
		<p>The capital cost is relatively high, but the superior payload can offset these initial costs.</p>
<p>E. Baler</p>	<p><b>E.</b></p>  <p>The diagram illustrates the baler process. It starts with a 'TIPPING FLOOR' where a truck dumps waste. A 'BALER' machine then compresses the waste into rectangular bales. A 'FORKLIFT' is used to move these bales from the baler onto a 'FLATBED TRAILER' for transport.</p>	<p>Balers are units that compress waste into dense, self-contained bales. Wire straps may be used to hold the bales intact. They are usually moved by forklifts and transported by flatbed trailers. The baler units can also be used for recyclables such as paper and metal. Payloads are very high, but so are capital costs. Most baling stations have at least two units in case one is down, and they cost more than \$500,000 apiece. This high-technology option is normally used only in high-volume operations, and special equipment or accommodations might be required at the landfill.</p>
<p>F. Intermodal container system</p>	<p><b>F.</b></p>  <p>The diagram illustrates the intermodal container system. It starts with a 'TIPPING FLOOR' where a truck dumps waste. The waste is then loaded into an 'INTERMODAL CONTAINER'. This container can be transported on a 'FLATBED TRAILER' or a 'RAILROAD FLATCAR'.</p>	<p>In this alternative, waste is tipped at a transfer station, then loaded into intermodal containers. These containers typically have moisture- and odor-control features and are designed to fit on both flatbed trailers and railroad flatcars. The containers may be loaded directly onto railcars or transferred by truck to a train terminal.</p> <p>The sealed containers can be stored on site for more than 24 hours until enough containers are filled to permit economic transport to the landfill. At the landfill, these containers are usually unloaded by tippers. This option allows for reduction of total truck traffic on local roads and can make distant disposal sites economically viable.</p>

(Source: adapted from US EPA,2002: Waste Transfer Stations: A Manual for Decision-Making)



## Conclusion

A waste transfer station is a facility where waste is collected and then transferred to a larger collection vehicle or another processing facility for further handling. There are several key factors to consider when operating a waste transfer station effectively:

- **Safety:** Ensuring the safety of workers and the general public should be the top priority when operating a waste transfer station. This includes implementing safety procedures, providing personal protective equipment (PPE) for workers, and maintaining a clean and orderly facility.
- **Compliance:** Waste transfer stations must follow all applicable laws and regulations, including those related to environmental protection, waste handling, and occupational safety.
- **Efficiency:** It is important to operate the transfer station in a way that maximizes efficiency and minimizes downtime. This may include investing in equipment and technology to streamline the waste handling process, as well as training workers to work efficiently and effectively.
- **Sustainability:** Many waste transfer stations are now focused on finding ways to reduce waste and increase recycling and composting efforts. This may include implementing programs to separate and process different types of waste, such as organic material and recyclables.
- **Community engagement:** It is important for a waste transfer station to be a good neighbor and to engage with the local community. This may include hosting tours and educational events, as well as communicating openly about the facility's operations and any potential impacts on the community.



## 別添資料 6

### ごみアプリの導入ガイドライン



# “Smart Citizen” Mobile Application for Waste Separation

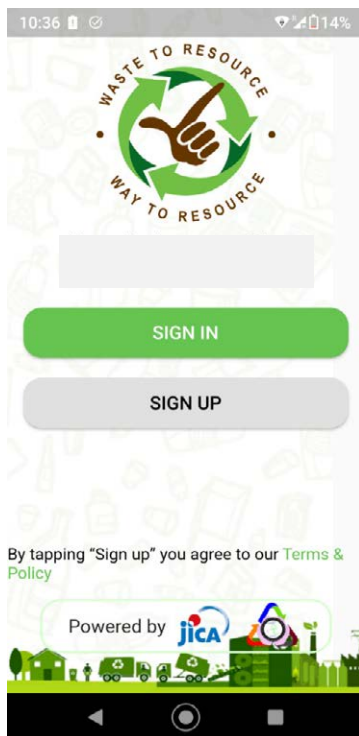

May, 2023

Western Province - Waste Management Authority (WMA)  
Project for Formulation of Western Province  
Solid Waste Management Master Plan

## Contents

1. Overall Objectives of the Application
2. Purpose of the Application
3. Benefits of the Application
4. Functions of the Application Development
  - 1) Development of Waste Dictionary by WMA
  - 2) Development of Collection Route Map in Respective LAs
5. Responsibility of Local Authorities and WMA
  - 1) Local Authorities
  - 2) WMA
6. How to create GPS-based “collection routes maps”
7. Data Entries from Backend by Local Authorities



# 1. Overall Objectives of the Application

- By encouraging and ensuring the separation at the discharge source,
  - it will help increasing the recycling rate in the Western Province.
  - It will decrease non-biodegradable to be mixed in the “degradable” waste and will increase efficiency of composting.

## As secondary effects...

- WMA and Local Authorities will know:
  - what “recyclable” items currently require a new domestic market to be recycled properly
  - more accurate amount of recyclable waste to be collected, which helps planning for efficient vehicle allocation for collection, and considering reduction targets.



# 2. Purpose of the Application

- Application would help **citizens** to do the following:
  1. Waste Dictionary (to be able to look up the waste category of each item);
  2. Waste collection schedule of respective local authorities (to be able to know which waste category would be collected on what day of the week);
  3. Notice board for information from WMA and local authorities (to inform citizens about sudden changes of collection schedule, or schedule of special collections and events in advance).
  4. Will be able to track the progress of On-demand service requests (for gully bowser request, bulk waste collection, etc.)
  5. Will be able to identify the relevant recyclers if they want to bring in on their own.

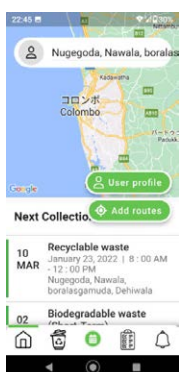

Schedule by route



Waste Category

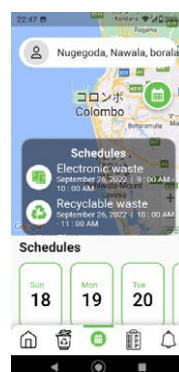

Schedule by category

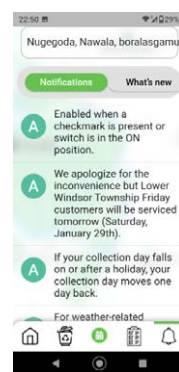

Push Notification

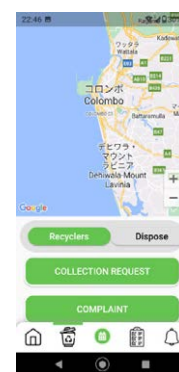

On-demand request



### 3. Benefits of the Application

- For Citizens
  - No confusion about discharging days
  - No confusion about waste categories – no hustles when giving their waste to collection vehicles.
- For Local Authorities
  - No time will be wasted on picking out recyclables from mixed waste upon collection, thus, more efficient allocation of vehicles will become possible. (One vehicle can cover longer distance.)
  - Clearly separated burnable waste for WtE (incineration) means less unburnable waste mixed in in the portion transported to WtE, thus more actually burnable portion can be transported to WtE. As a result, more portion (which used to have gone to WtE wrongly) can be given for recyclable.
  - The app will also help citizens to be connected to recyclers directly as well, thus less loads of recyclable may be discharged for collection. This will allow larger coverage of waste collection services.



### 4. Functions of the Application Development

#### 1) Waste Dictionary developed by WMA

- listing up waste items from their daily life in alphabetical order, and sorting them to 7 categories:
  1. bio-degradable,
  2. recyclable,
  3. burnable,
  4. E-waste,
  5. bulky,
  6. hazardous (buttery, florescent light, medicine, injection needles, etc),
  7. residual wastes
- For those local authorities that cannot introduce separate collection with 7 waste categories,

##### 5 categories

1. Bio-degradable,
2. Recyclable,
3. Burnable, and
4. Residual wastes
5. Special Waste (E & Hz)

##### 4 categories

1. bio-degradable,
2. recyclable, and
3. residual wastes
4. Special waste (E & Hz)



Example of the Waste Dictionary (data sheet)

Alp	Items	Discharge Category (4 streams)	How to Discharge	Treatment after Collection
D	Dairy Products	bio-degradable waste	Remove its container and mix with other organic waste. Drain any liquid contents.	composting
	Dash board (vehicle)	recyclable waste		sold to recyclers (factory, middleman)
	Debris	residual waste		Landfill
	Decanter (guruleththuwa; clay)	residual waste		Landfill
	Decanter (guruleththuwa; glass)	recyclable waste		sold to recyclers (factory, middleman)
	Decanter (guruleththuwa; metal)	recyclable waste		sold to recyclers (factory, middleman)
	Decanter (guruleththuwa; plastic)	recyclable waste		sold to recyclers (factory, middleman)
	Demy paper	recyclable waste		sold to recyclers (factory, middleman)
	Denture	residual waste		landfill
	Deodorizer container	recyclable waste		sold to recyclers (factory, middleman)
	Desk (metal)	recyclable waste		sold to recyclers (factory, middleman)
	Desk (plastic)	recyclable waste		sold to recyclers (factory, middleman)
	Desk (wooden)	burnable waste		incineration
	Desk lamp	special waste	Bring in on the day of E-waste collection or Parisara Pola.	available dealers to be connected
	Desk telephone	special waste	Bring in on the day of E-waste collection or Parisara Pola.	available dealers to be connected
	Dessertspoon	recyclable waste		sold to recyclers (factory, middleman)
	Detergent containers (hard plastic)	recyclable waste		sold to recyclers (factory, middleman)
	Diapers	special waste	Discharge in a separate bag and mark it as hazardous. Discharge when your local authority provide "hazardous waste" collection.	available dealers to be connected



## 4. Functions of the Application Development

### 1) Waste Dictionary developed by WMA (Cont'd)

- In addition to the default categories mentioned above, LA-specific category can be displayed.

If the LA categorize the waste item differently from the given categories, the LA – after selecting the most applicable set of categories (7, 5, or 4 streams) - can indicate their own category on the website that will be directed from the link to be indicated to the relevant item.







## 4. Functions of the Application Development

### 2) Development of Collection Route Map in Respective LAs

- a resident can select (a) collection route(s) by selecting his/her own location of resident. (also by a provided QR code).
  - The number of routes that one user can register is XX. (Ex. Parents' house, office, etc.)
- To inform “Waste collection schedule of respective local authorities” to citizens requires the application to have the data that allows **to indicate each house's location on the relevant collection route and the collection schedule of the applicable collection route.**
- In order for this function to be effective, **the collection route and the collection schedule need to be stable.**

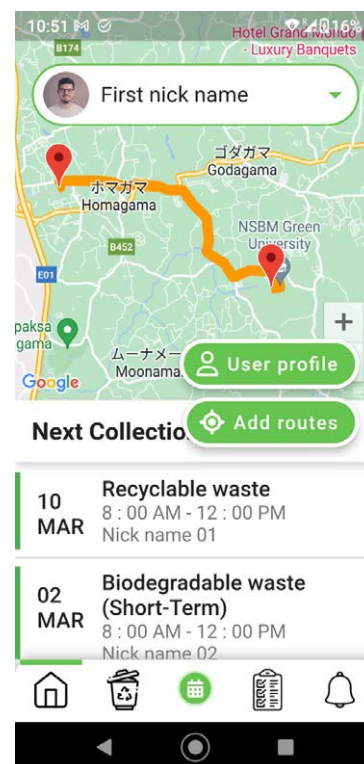

## 4. Functions of the Application Development

### 3) Development of Collection Route Map in Respective LAs (Continued...)

- The existing collection vehicles' route map for each collection vehicle may only indicate their routes on major roads, but not include by-roads. This map would be insufficient to allow residents to identify their relevant collection route.
- In order to develop the route maps sufficient for the purpose, following each collection vehicle with GPS to draw a complete route map for each route is necessary.
- WMA Zonal Manager will support route map development by renting a GPS logger and technical assistant. (JET will support, if further assistant is necessary.)





## 5. Responsibility of WMA and Local Authorities

### 1) Local Authorities

- Feeding route maps and collection schedule
- Selection of “Category” set (either 7, 4, or 3-categories)
- Prompt input about their collection service (about any interruptions, changes, special collection, etc...)
- Prompt responses to the requests given through the App.
- Maintenance of Google Store and App Store (annual charge) and Google Map download charge
- Dissemination throughout the responsible communities
- Accumulate the items that are questioned by citizen and report to WMA for updates.



## 5. Responsibility of Local Authorities and WMA

### 2) WMA

- Updating waste dictionary periodically (adding new words, changing the applicable categories according to availabilities of recyclers in the province.)
- Provision of technical support for preparing collection route maps with GPS.
- Liaising the LA and the App developer for uploading the route maps
- Technical support upon installation in respective LAs
- Setting up Google Store and App Store account
- Creating notifications about WMA-organized services and events such as E-waste collection, Parisara Pola, etc.
- Informing about the App throughout the Western Province
- Liaising E-waste collectors to LAs when introducing the App.
- Supporting LAs to prepare for separate “hazardous waste” collection and liaise with final disposal service providers of such kind of waste.



## 6. How to create GPS-based “collection routes maps”

- **Necessary Tools and Equipment**

- GPS device (This can be rented from WMA)
- LAs usual collection vehicles

### 1. Pre-condition

1. The LA that plans to use the App within its territory should have a stable set of waste collection routes and a set of waste collection schedule by waste categories.
2. The LA should know either 1) 7 categories, 2) 4+1 categories, or 3) 3+1 categories would be applied in their LA area’s waste collection.

### 2. Preparation

1. Using the current route map, decided on the schedule for mapping. “1 route” means a route covered by one trip by one collection vehicle. If the same route will be repeatedly visited within the same week, it will be considered as “one route.”
  2. Inform the LA’s collection workers and drivers the planned schedule.
  3. The responsible staffs for each route should be trained how to record the respective route with a GPS device. (WMA will be able to support on this.)
-

# 7. Data Entries from Backend by LAs

## 0. Log in.

After your LA's collection routes are set up in the App's system by Ceytech, the LA needs to set up the collection schedule applicable to each collection route in the LA.

**1.** Before starting, you will need to provide an e-mail address as your LA's user address to Ceytech (the developer of the App) to give you the credential. Ceytech will then provide you a password.

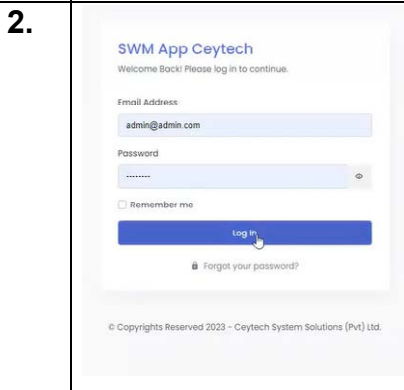

- 1) Go to <https://swm.ceytech.lk/login>
- 2) Type in user's e-mail address
- 3) Type in your password that is provided by Ceytech.

## I. Entering Collection Schedule for Each Collection Route by Local Authority

After login in,

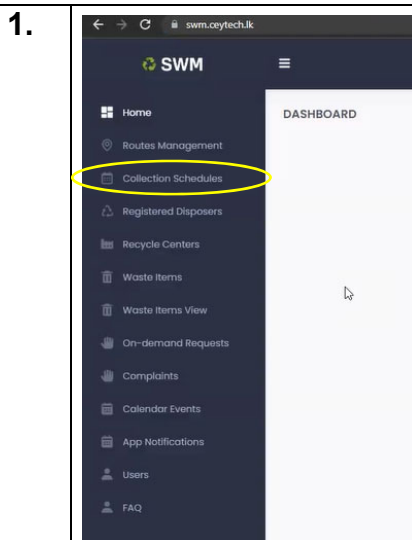

- On the right side panel,
- 1) On the side panel, click on "Collection Schedules"

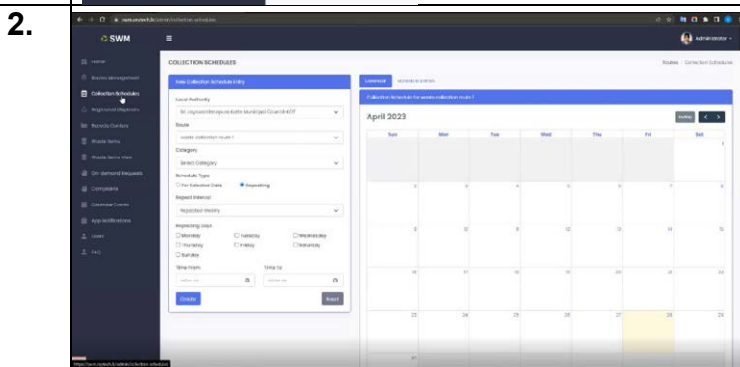

A screen with a blank calendar will appear.

## 7. Data Entries from Backend by LAs

<p>3.</p>		<p>Under “Local Authority”, select your own local authority’s name from the drop-down list.</p>
<p>4.</p>		<p>Under “Route”, you will see the names of the routes that you have requested Ceytech to set up.</p> <p>Select a route for which you are going to register the collection schedule now.</p>
<p>5.</p>		<p>Under “Category”, select a category of waste collection route for which the collection schedule you are going to register.</p> <p>(Ex. If you are going to register the collection schedule of “Bio-degradable waste” for the selected route, select “Bio-degradable”.)</p>
<p>6.</p>		<p>If this collection is done on a specific day:</p> <ol style="list-style-type: none"> <li>1) “Under Schedule Type”, select “For Selected Date”.</li> <li>2) Enter the specific day in the box under “Schedule Date”, or select the specific day from the calendar appears below.</li> </ol> <p>(Ex. 30/04/2023)</p>

## 7. Data Entries from Backend by LAs

3) Enter also times that the collection route is expected to be operated. Enter the starting time in the left box and the ending time in the right box. (Ex. From 01:22AM to 02:22AM)

4) After entering the times, click on "Create".

Then, in the Calendar on the left, the date that you specified should be indicated with the collection of the waste category and times. (In the above example, "1:22am Biodegradable Waste" is indicated on 30 April.)

## 7. Data Entries from Backend by LAs

7.

**If the collection is done weekly (or on certain days of a week);**

1) Under “Schedule Type”, select “Repeating”.

2) If the collection schedule for the route that you are going to register is weekly (conducted on certain days of a week), under “Repeated interval”, select “Repeated Weekly”.

3) Under “Repeating Days”, select days when the collection of the registering route is conducted. (Ex. Monday, Tuesday, and Friday.)

4) Under “Time From” and “Time To”, enter the expected starting and ending times of the collection on selected days. (Ex. 05:30PM to 6:30PM).

5) Click on “Create”.

Then, on the calendar on the right, the days of collection of the selected waste category for the registering route will be indicated. (In the above example, on every Monday, Tuesday, and Friday, “the bio-degradable waste collection starting from 5:30pm” are indicated.

If the registering collection is conducted every day, in the process 3), under “Repeating Days”, select all days.

## 7. Data Entries from Backend by LAs

<p><b>8.</b></p>		<p><b>If the collection is done monthly ;</b>          1) Under “Repeat Interval”, select “Repeated Monthly”.</p>
<p><b>9 a.</b></p>		<p>If the collection day(s) is decided on a date(s) of a month (Ex. 30<sup>th</sup> of every month),          2) Under “Monthly Repeat Type”, select “Date of Month”.          3) Under “Monthly Repeating Dates”, enter the date(s). You may enter several days here.          4) Enter the expected starting and ending times of the collection, and click on “Create”.</p>
<p><b>9 b.</b></p>		<p>If the collection day(s) is on a certain date(s) of a week (Ex. Every first Monday of a month),          2) Under “Monthly Repeat Type”, select “Day of Week”.          3) Under “Monthly Repeating Week”, select the applicable week(s). You may select multiple weeks here.          4) Under “Repeating Days”, select the applicable day(s) of a week. You may select multiple days here.          5) Enter the expected starting and ending times of the collection, and click on “Create”.</p>



**If you need to change the registered schedule:**

1. Above the right side calendar, select **“Schedule Entries”**.

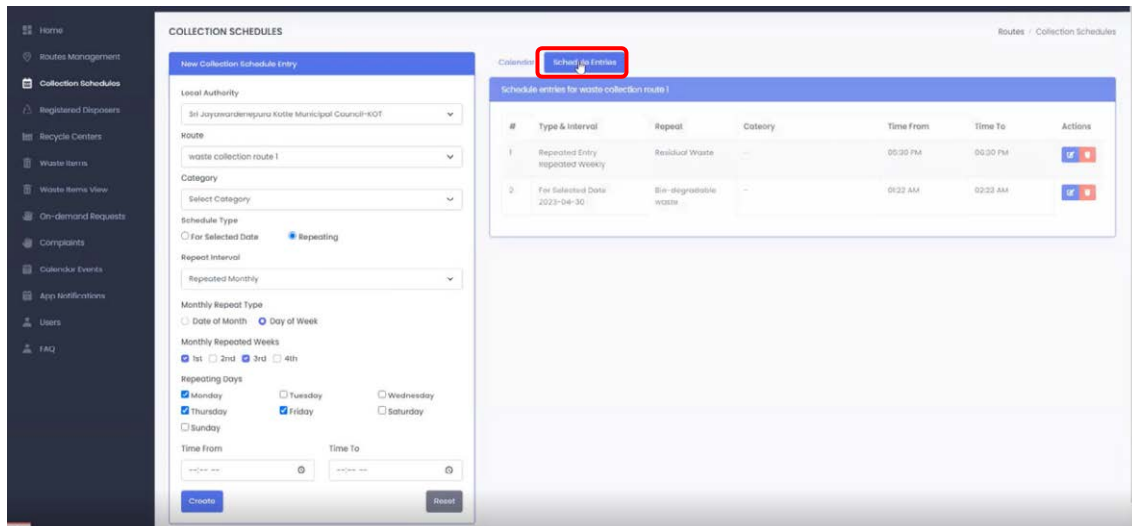
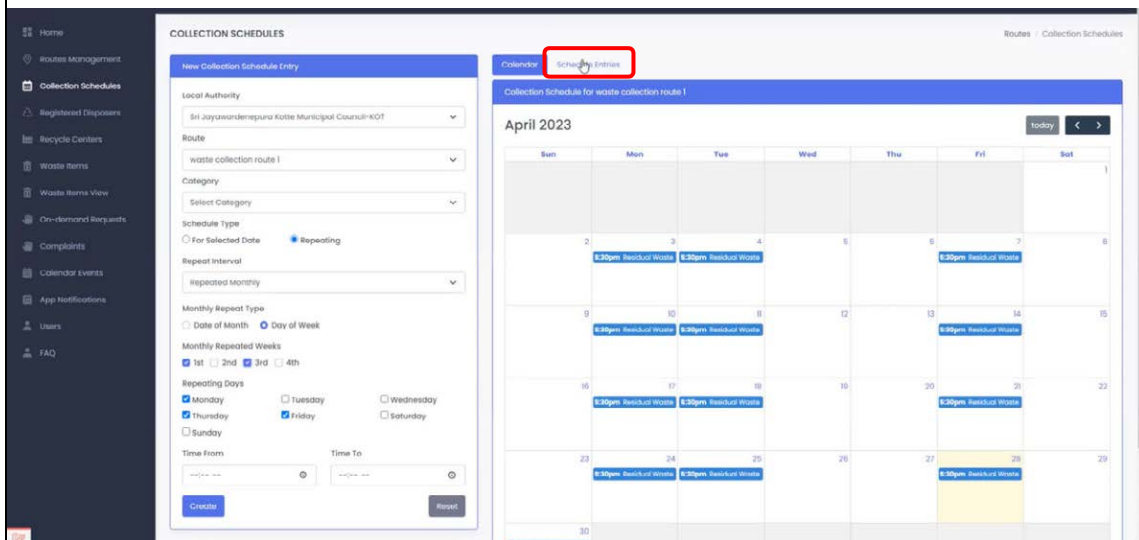

2.

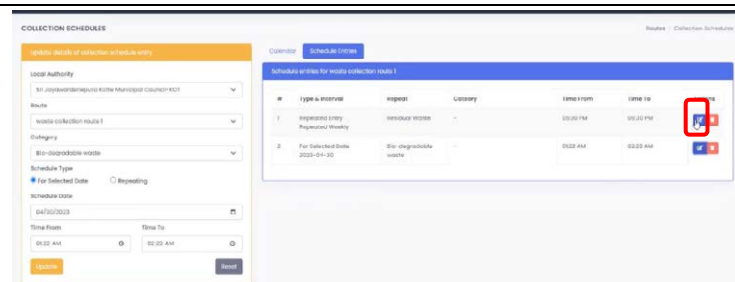

Click on the blue icon next to the schedule which you wish to change. (The red icon is to delete the schedule completely.)

# 7. Data Entries from Backend by LAs

## II. Entering Information of Registered Recyclable/ Hazardous Waste Dealers

- For entering information of local recyclable or hazardous waste dealers that are registered with your Local Authority (or with WMA),  
Click on “Registered Dealers” on the left panel.

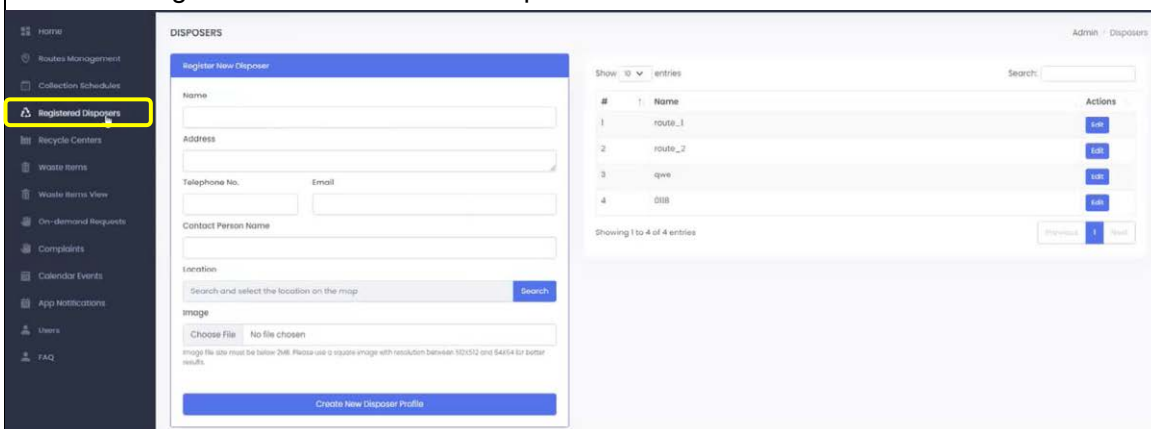

- Enter “Name” of the dealer, “Address”, “Telephone No.”, “Email” address, and “Contact Person Name” accordingly.
  - Click on Search to enter the location on a map.

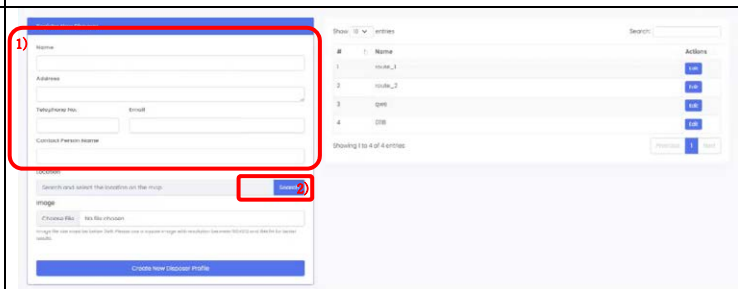

- Google map window will pop up.
- Enter the same address that you entered in 1) in Search window.
- Save by “Chose marked location.”

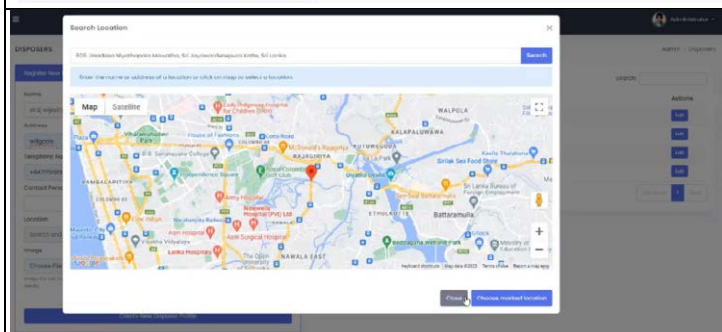

# 7. Data Entries from Backend by LAs

## III. Checking Complaints Received from Citizen Users

<p>1.</p>		<p>1) Click on “Complaints” on the left panel, to show the list of complaints sent to your LA.</p> <p>2) Click on “View” to see the contents of the complaint.</p>
<p>2.</p>		<p>The content includes:</p> <ul style="list-style-type: none"> <li>- name of the person who sent the complaint,</li> <li>- phone number, and</li> <li>- time &amp; date when the entry was made,</li> </ul> <p>indicated at the top.</p> <p>On the right window, photos will appear if provided by the citizen user.</p>
<p>3.</p>		<p>After checking the contents of the complaints, change the status of LA’s action under “Update Request Status” according to the action taken by your LA.</p> <p>When the status is update, SMS will be sent to the person who filed the complaint.</p>

## IV. Checking “On Demand Request” Received from Citizen Users

<p>1.</p>		<p>1) Click on “On-demand Request” on the left panel, to show the list of requests sent to your LA.</p> <p>2) Click on “View” to see the contents of the request.</p>
<p>2.</p>		<p>The content includes: Name of the person who sent the request, phone number, and time &amp; date when the entry was made, indicated at the top. On the right windows, photos will appear if provide.</p>
<p>3.</p>		<p>After checking the contents of the request, change the status of LA’s action under “Update Request Status” according to the action taken by your LA. When the status is update, SMS will be sent to the person who filed the request.</p>

# 7. Data Entries from Backend by LAs

## V. Entering Event by LA on Calendar

1. If you plan a special collection or event such as “parisala pola” or “bulky waste collection”, post it on the calendar.

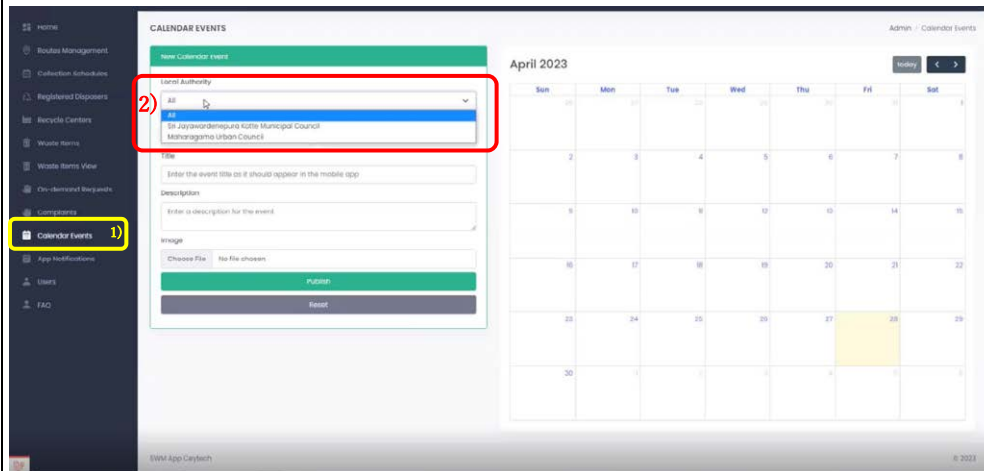

- 1) Select “Calendar Events” on the left panel.
- 2) Select your LA under “Local Authority”.

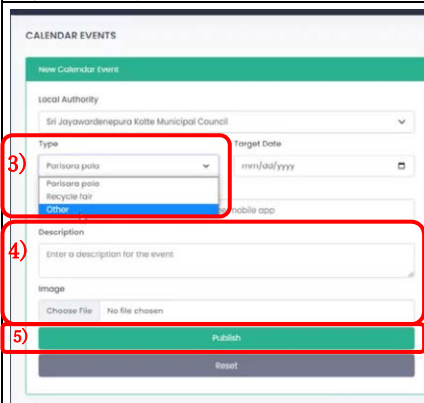

- 3) Under “Type”, select your event. If the event is neither Parisala Pola or Recycle fair, select “Other” and type in “Title” of the event.
- 4) Enter the date of the event under “Target Date”, “Description” and add any image (jpg files).
- 5) Click “Publish”. It can be seen by the citizen users in your LA only.

## VI. Sending Notifications to Citizen Users through “Smart Citizen” App.

<p>1.</p>		
<p>2.</p>		<p>1) Select your LA under “Local Authority”.</p> <p>2) Enter “Title”, “Description” (contents of the message), and (if you wish) add a photo (jpg.)</p> <p>3) Click on “Create New Notification” to save.</p>
<p></p>		<p>4) You can publish the notification just created, to the citizen users, by clicking on “Publish this notification”.</p>
<p>3.</p>		<p>5) Click on the green icon to send a push notification.</p>

## 7. Data Entries from Backend by LAs

### VII. Adding a “FAQ”.

When you receive similar questions often, create a “FAQ” to share the answer with everyone.

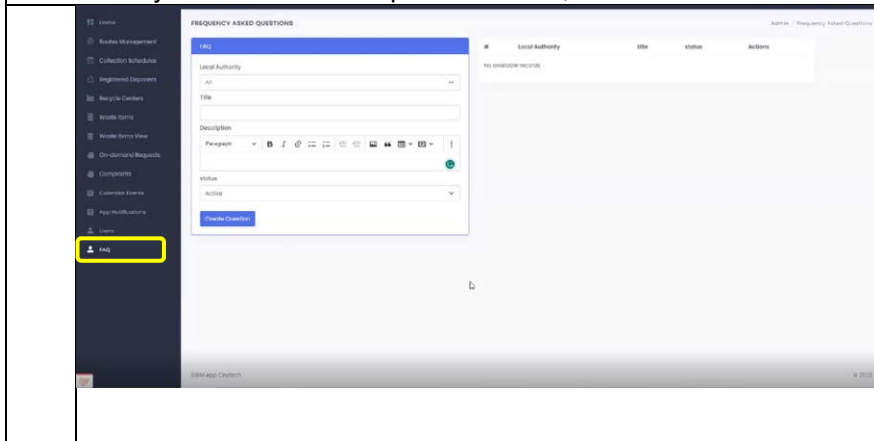

- 1) Select “FAQ” on the left panel.
- 2) Select your own LA’s name under “Local Authority”.
- 3) Create a “Title” of the FAQ to be added.
- 4) Write the contents under “Description”.
- 5) Under “status”, select “Active” to publish.
- 6) Click on “Create Question” to save and publish.

### VIII. If you want to add a user...

1.

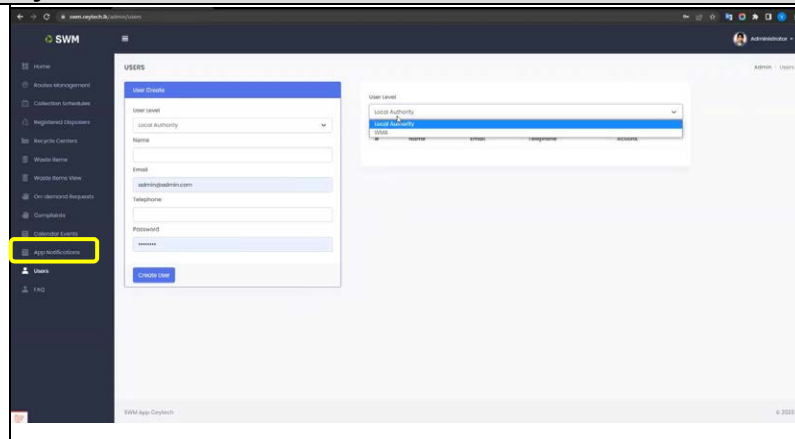

- After being registered by Ceytech,
- 1) Go to <https://swm.ceytech.lk/login>
  - 2) Select “Users” on the left panel.
  - 3) Register the person that will be responsible for the LA’s account by entering your “Name”, “Email”, “Telephone” and “Password”.
    - 3) Your “User Level” should be “Local Authority”.
- ※ Do note down the password you have created.





Flow of Implementing the Smart Citizen App by LA and Responsibilities of WMA, LAs, and Ceytech

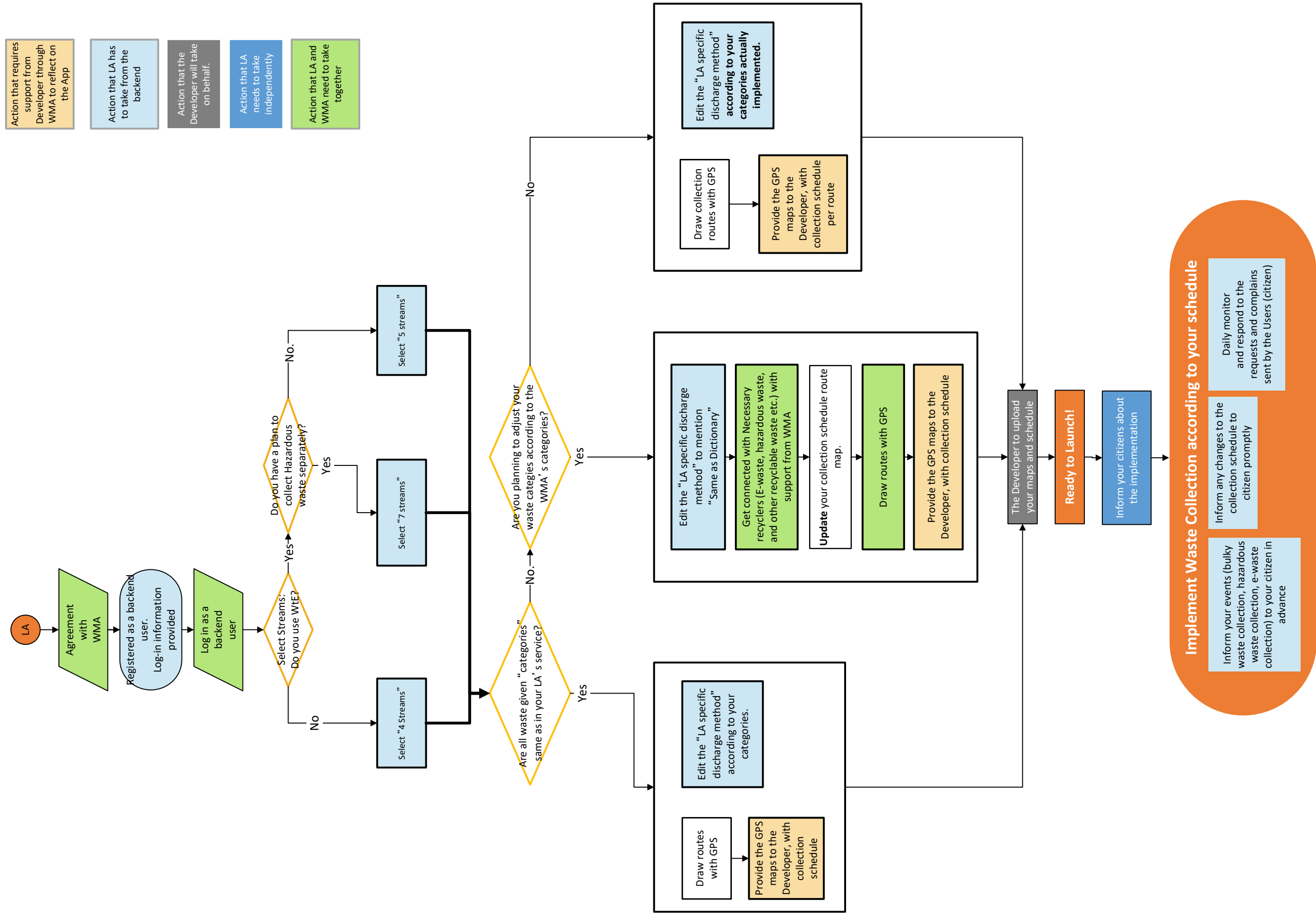

Flow of Using the Smart Citizen App by a Citizen User

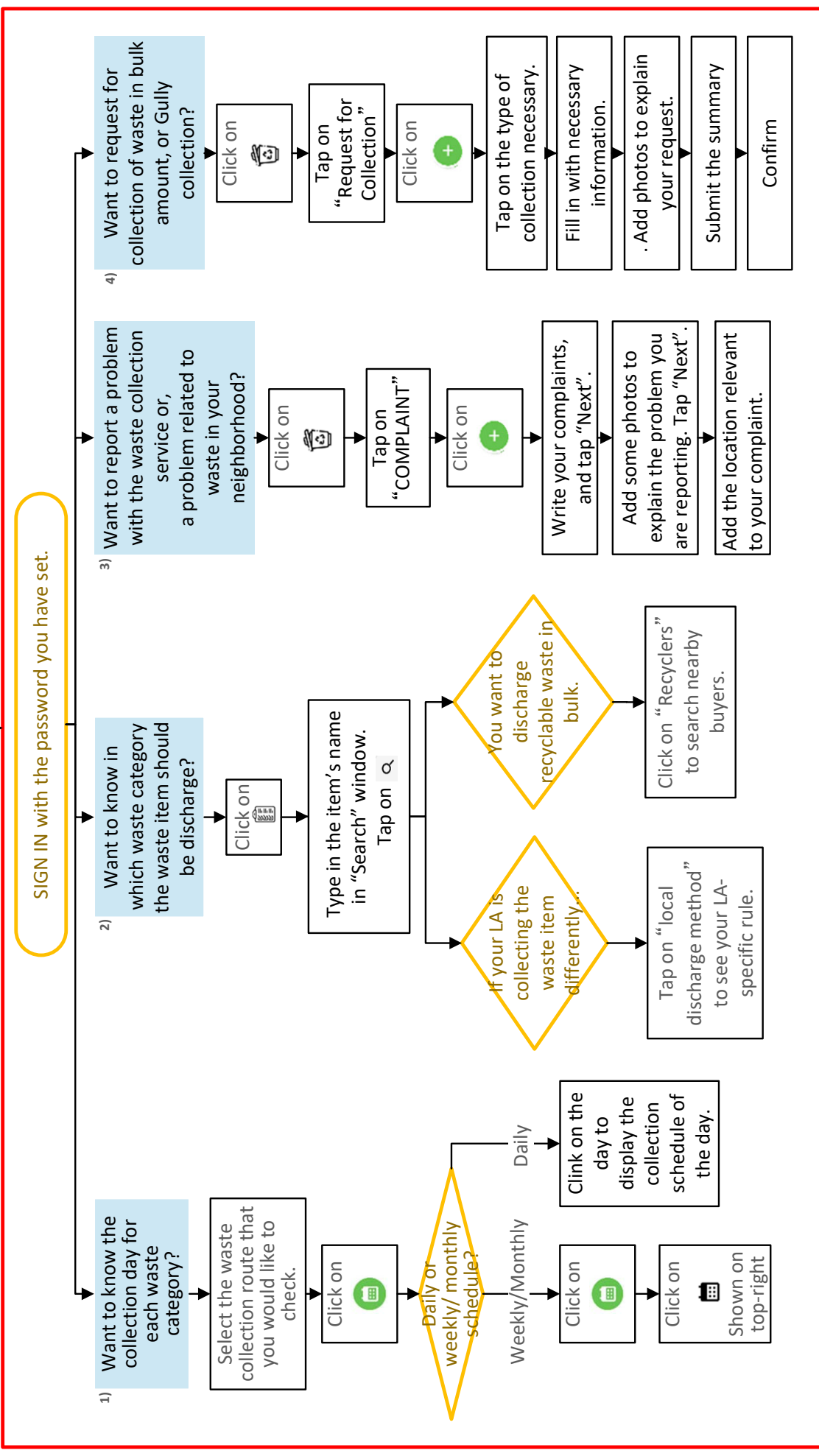
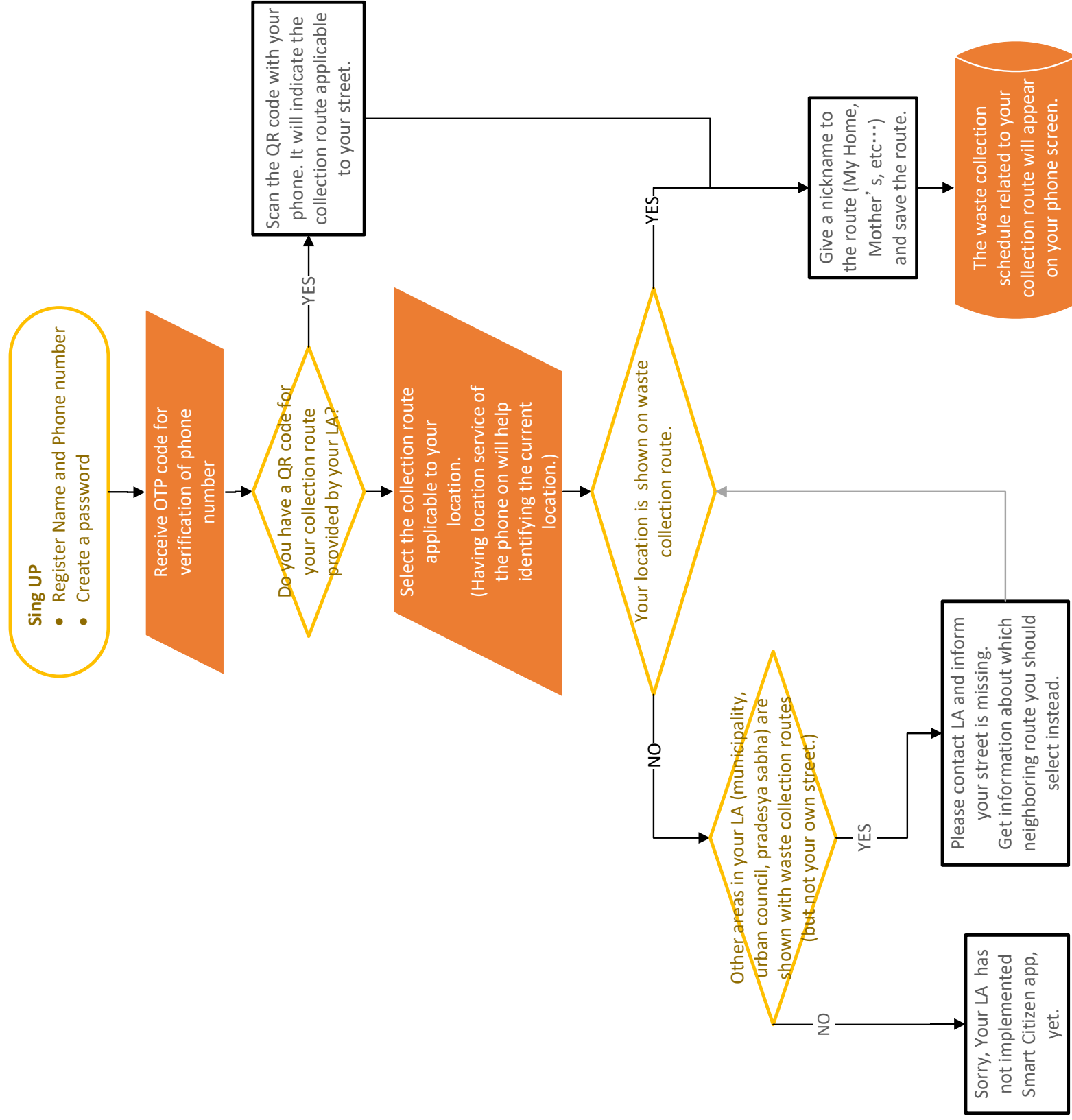



## 0. Log in.

After your LA's collection routes are set up in the App's system by Ceytech, the LA needs to set up the collection schedule applicable to each collection route in the LA.

**1. Before starting, you will need to provide an e-mail address as your LA's user address to Ceytech (the developer of the App) to give you the credential. Ceytech will then provide you a password.**

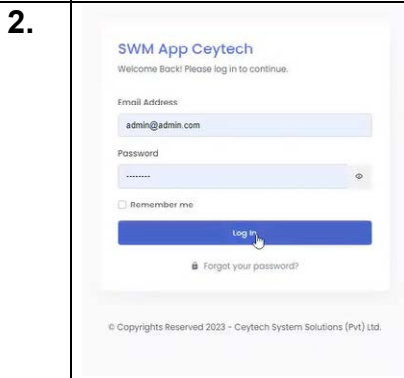

- 1) Go to <https://swm.ceytech.lk/login>
- 2) Type in user's e-mail address
- 3) Type in your password that is provided by Ceytech.

## I. Entering Collection Schedule for Each Collection Route by Local Authority

After login in,

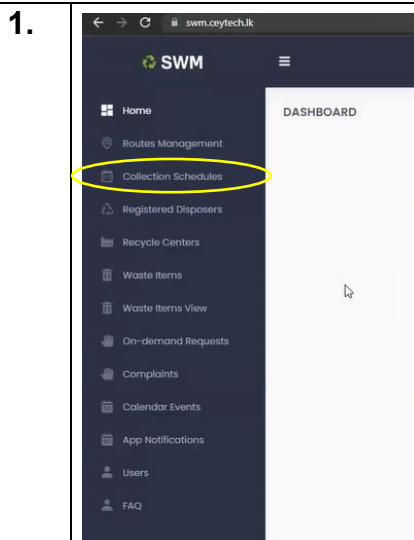

- On the right side panel,
- 1) On the side panel, click on "Collection Schedules"

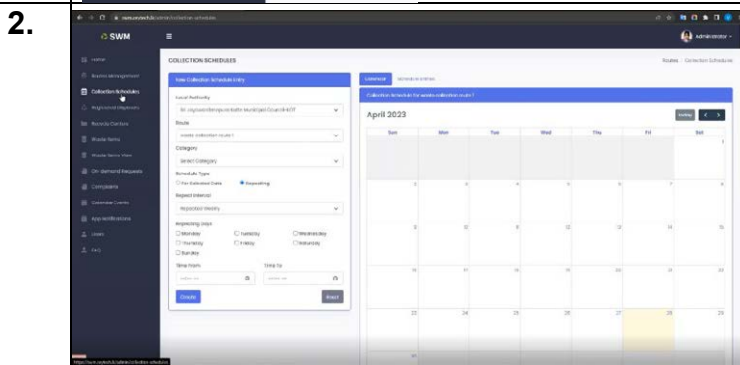

A screen with a blank calendar will appear.

<p>3.</p>		<p>Under “Local Authority”, select your own local authority’s name from the drop-down list.</p>
<p>4.</p>		<p>Under “Route”, you will see the names of the routes that you have requested Ceytech to set up.</p> <p>Select a route for which you are going to register the collection schedule now.</p>
<p>5.</p>		<p>Under “Category”, select a category of waste collection route for which the collection schedule you are going to register.</p> <p>(Ex. If you are going to register the collection schedule of “Bio-degradable waste” for the selected route, select “Bio-degradable”.)</p>
<p>6.</p>		<p><b>If this collection is done on a specific day:</b></p> <ol style="list-style-type: none"> <li>1) “Under Schedule Type”, select “For Selected Date”.</li> <li>2) Enter the specific day in the box under “Schedule Date”, or select the specific day from the calendar appears below.</li> </ol> <p>(Ex. 30/04/2023)</p>

3) Enter also times that the collection route is expected to be operated. Enter the starting time in the left box and the ending time in the right box. (Ex. From 01:22AM to 02:22AM)

4) After entering the times, click on "Create".

Then, in the Calendar on the left, the date that you specified should be indicated with the collection of the waste category and times. (In the above example, "1:22am Biodegradable Waste" is indicated on 30 April.)

7.

**If the collection is done weekly (or on certain days of a week);**

1) Under “Schedule Type”, select “Repeating”.

2) If the collection schedule for the route that you are going to register is weekly (conducted on certain days of a week), under “Repeated interval”, select “Repeated Weekly”.

3) Under “Repeating Days”, select days when the collection of the registering route is conducted. (Ex. Monday, Tuesday, and Friday.)

4) Under “Time From” and “Time To”, enter the expected starting and ending times of the collection on selected days. (Ex. 05:30PM to 6:30PM).

5) Click on “Create”.

Then, on the calendar on the right, the days of collection of the selected waste category for the registering route will be indicated. (In the above example, on every Monday, Tuesday, and Friday, “the bio-degradable waste collection starting from 5:30pm” are indicated.

If the registering collection is conducted every day, in the process 3), under “Repeating Days”, select all days.

<p><b>8.</b></p>		<p><b>If the collection is done monthly ;</b></p> <p>1) Under “Repeat Interval”, select “Repeated Monthly”.</p>
<p><b>9 a.</b></p>		<p>If the collection day(s) is decided on a date(s) of a month (Ex. 30<sup>th</sup> of every month),</p> <p>2) Under “Monthly Repeat Type”, select “Date of Month”.</p> <p>3) Under “Monthly Repeating Dates”, enter the date(s). You may enter several days here.</p> <p>4) Enter the expected starting and ending times of the collection, and click on “Create”.</p>
<p><b>9 b.</b></p>		<p>If the collection day(s) is on a certain date(s) of a week (Ex. Every first Monday of a month),</p> <p>2) Under “Monthly Repeat Type”, select “Day of Week”.</p> <p>3) Under “Monthly Repeating Week”, select the applicable week(s). You may select multiple weeks here.</p> <p>4) Under “Repeating Days”, select the applicable day(s) of a week. You may select multiple days here.</p> <p>5) Enter the expected starting and ending times of the collection, and click on “Create”.</p>



**If you need to change the registered schedule:**

**1.** Above the right side calendar, select **“Schedule Entries”**.

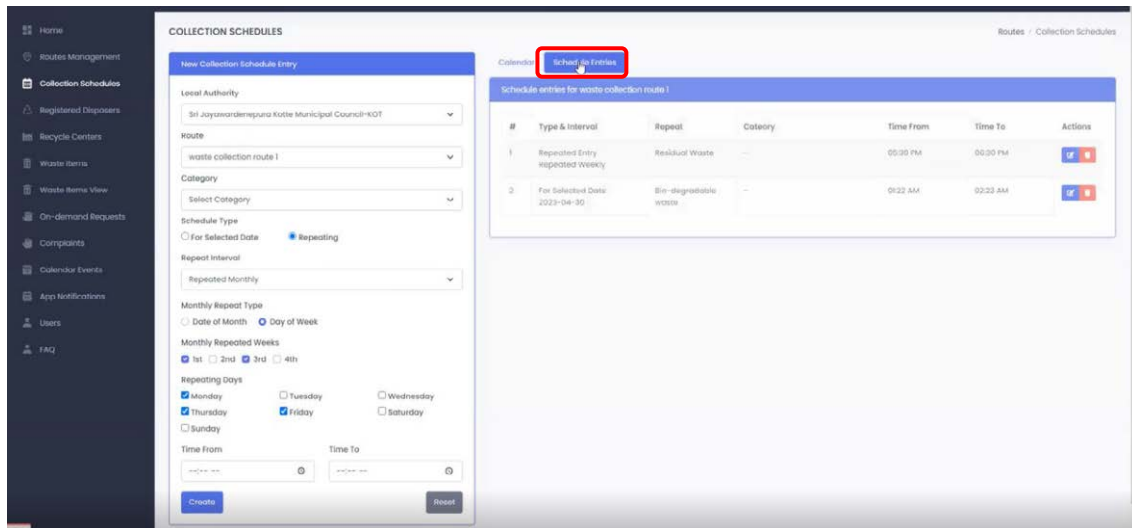
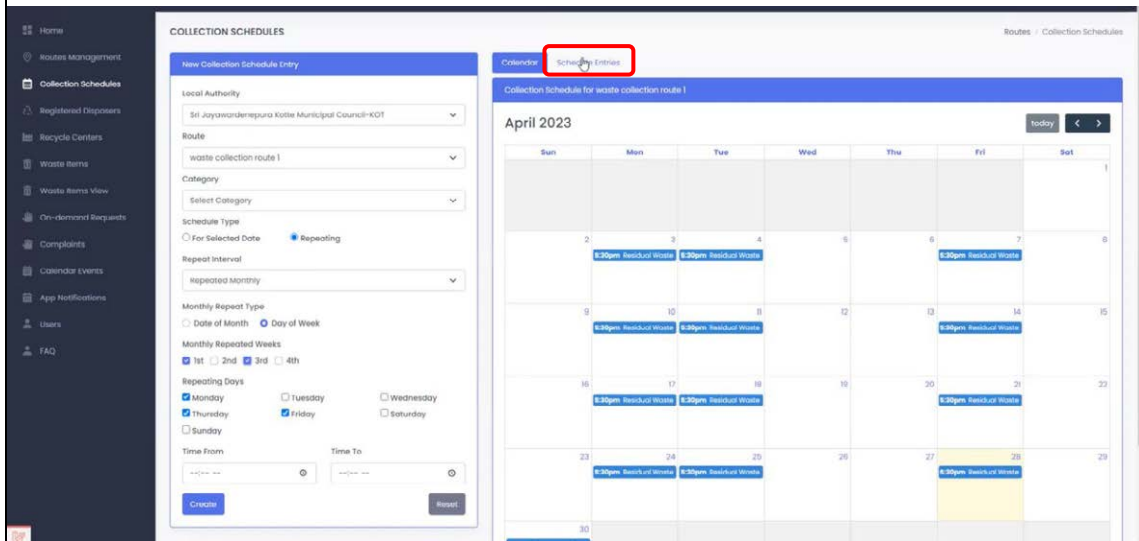

**2.**

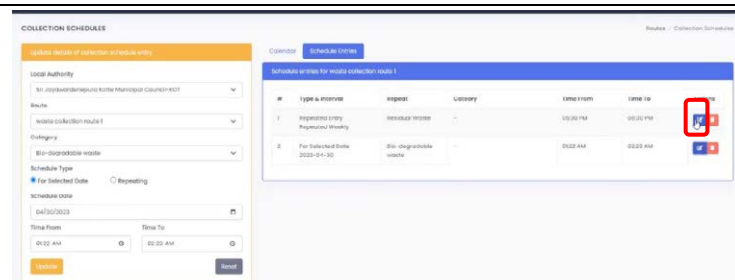

Click on the blue icon next to the schedule which you wish to change. (The red icon is to delete the schedule completely.)

## II. Entering Information of Registered Recyclable/ Hazardous Waste Dealers

- For entering information of local recyclable or hazardous waste dealers that are registered with your Local Authority (or with WMA),  
Click on “Registered Dealers” on the left panel.

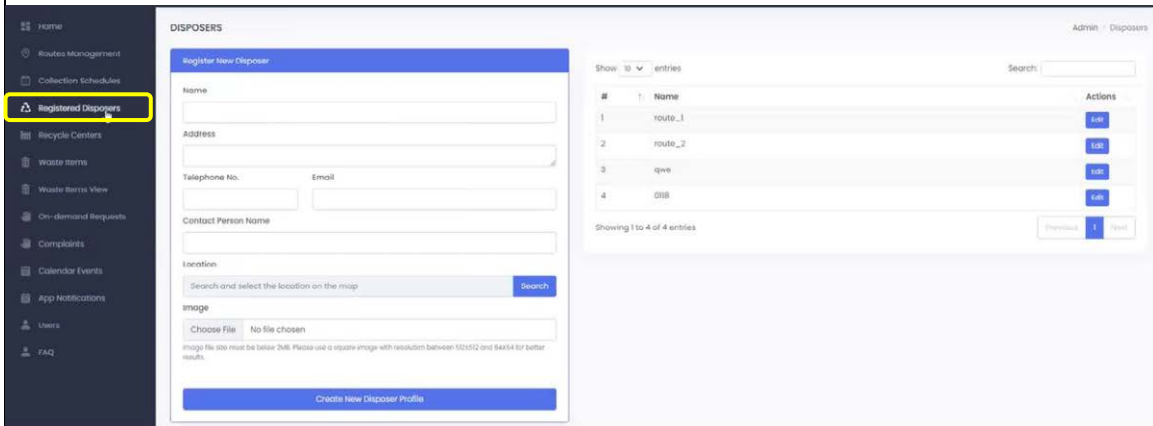

- Enter “Name” of the dealer, “Address”, “Telephone No.”, “Email” address, and “Contact Person Name” accordingly.
  - Click on Search to enter the location on a map.

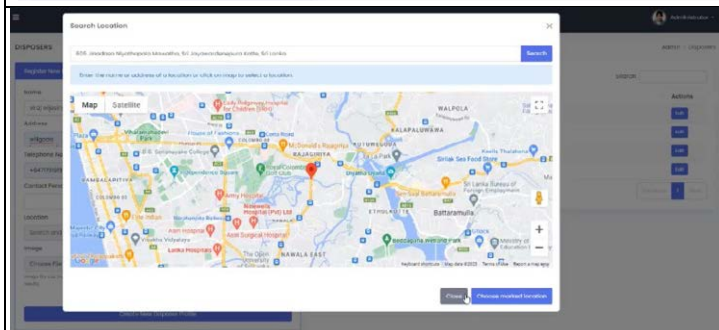

- Google map window will pop up.
- Enter the same address that you entered in 1) in Search window.
- Save by “Chose marked location.”

## III. Checking Complaints Received from Citizen Users

<p>1.</p>		<p>1) Click on “Complaints” on the left panel, to show the list of complaints sent to your LA.</p> <p>2) Click on “View” to see the contents of the complaint.</p>
<p>2.</p>		<p>The content includes:</p> <ul style="list-style-type: none"> <li>- name of the person who sent the complaint,</li> <li>- phone number, and</li> <li>- time &amp; date when the entry was made,</li> </ul> <p>indicated at the top.</p> <p>On the right window, photos will appear if provided by the citizen user.</p>
<p>3.</p>		<p>After checking the contents of the complaints, change the status of LA's action under “Update Request Status” according to the action taken by your LA.</p> <p>When the status is update, SMS will be sent to the person who filed the complaint.</p>

## IV. Checking “On Demand Request” Received from Citizen Users

<p>1.</p>		<p>1) Click on “On-demand Request” on the left panel, to show the list of requests sent to your LA.</p> <p>2) Click on “View” to see the contents of the request.</p>
<p>2.</p>		<p>The content includes: Name of the person who sent the request, phone number, and time &amp; date when the entry was made, indicated at the top. On the right windows, photos will appear if provide.</p>
<p>3.</p>		<p>After checking the contents of the request, change the status of LA’s action under “Update Request Status” according to the action taken by your LA. When the status is update, SMS will be sent to the person who filed the request.</p>

## V. Entering Event by LA on Calendar

1. If you plan a special collection or event such as “parisala pola” or “bulky waste collection”, post it on the calendar.

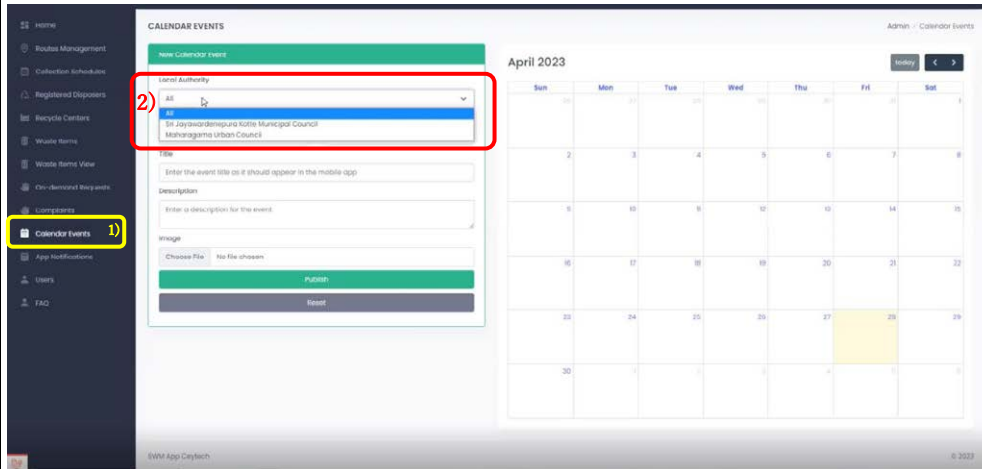

- 1) Select “Calendar Events” on the left panel.
- 2) Select your LA under “Local Authority”.

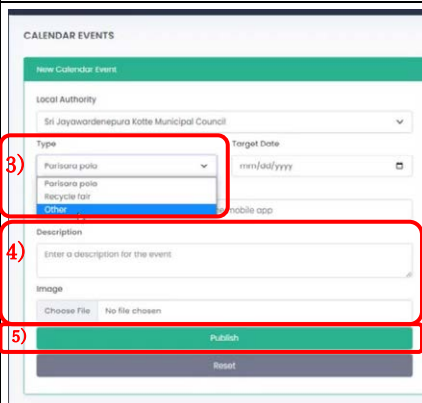

- 3) Under “Type”, select your event. If the event is neither Parisala Pola or Recycle fair, select “Other” and type in “Title” of the event.
- 4) Enter the date of the event under “Target Date”, “Description” and add any image (jpg files).
- 5) Click “Publish”. It can be seen by the citizen users in your LA only.

## VI. Sending Notifications to Citizen Users through “Smart Citizen” App.

<p>1.</p>	
<p>2.</p>	<p>1) Select your LA under “Local Authority”.</p> <p>2) Enter “Title”, “Description” (contents of the message), and (if you wish) add a photo (jpg.)</p> <p>3) Click on “Create New Notification” to save.</p>
<p></p>	<p>4) You can publish the notification just created, to the citizen users, by clicking on “Publish this notification”.</p>
<p>3.</p>	<p>5) Click on the green icon to send a push notification.</p>

## VII. Adding a “FAQ”.

When you receive similar questions often, create a “FAQ” to share the answer with everyone.

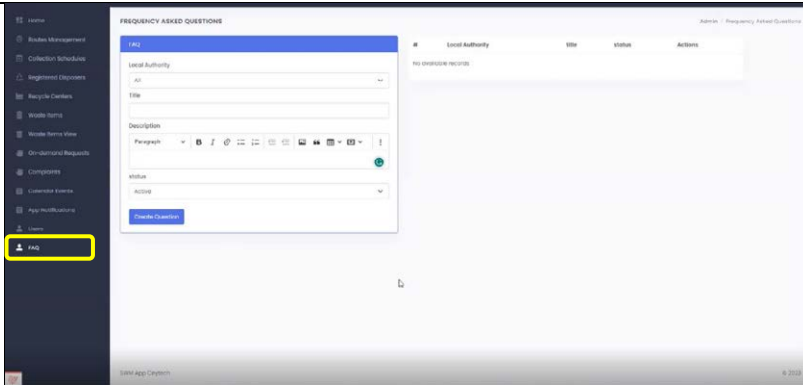

- 1) Select “FAQ” on the left panel.
- 2) Select your own LA’s name under “Local Authority”.
- 3) Create a “Title” of the FAQ to be added.
- 4) Write the contents under “Description”.
- 5) Under “status”, select “Active” to publish.
- 6) Click on “Create Question” to save and publish.

## VIII. If you want to add a user...

1.

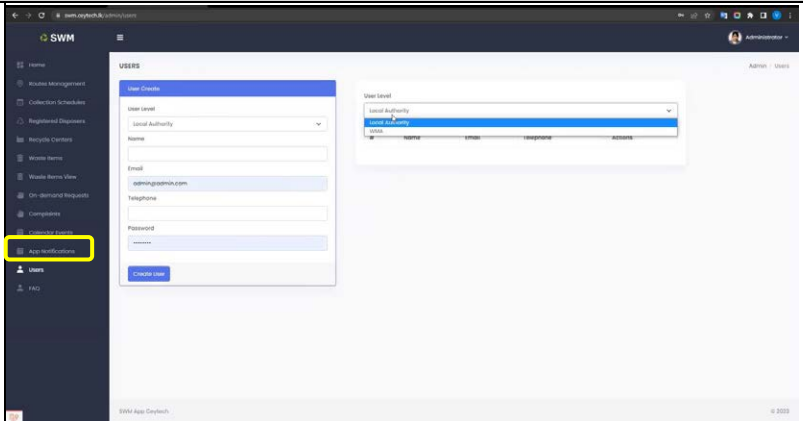

- After being registered by Ceytech,
- 1) Go to <https://swm.ceytech.lk/login>
  - 2) Select “Users” on the left panel.
  - 3) Register the person that will be responsible for the LA’s account by entering your “Name”, “Email”, “Telephone” and “Password”.
    - 3) Your “User Level” should be “Local Authority”.
- ※ Do note down the password you have created.





## 別添資料 7

西部州における廃棄物管理グッドプラクティス





別添資料7



# Good Practice for SWM

March 2023

## 1. Purpose of selecting good practices of SWM

---

- Good practice is defined as cases that contribute to improved waste management in terms of environmental, economic, efficiency, safety and hygiene. The good practices cover activities related to municipal waste management.
- The aim is to spread activities to improve municipal waste management by selecting good practices and introducing them widely to relevant organizations.

## 2. Procedure for collecting and compiling good practices

---

- The procedure for collecting and compiling good practices are as follows.
  - a. Preparation of compiling form
  - b. Collection of good practices by WMA staff
  - c. scrutinizing the content of the collected good practices
  - d. Carrying out additional investigations if necessary
  - e. Compiling of the good practices according to the categories
  - f. Selection of good practices
  - g. Compilation and distribution of good practice for SWM

### 3. Good practice completion form

---

<b>Category of good practice for SWM:</b>
<b>Title of good practice:</b>
<b>Name of Local Authority:</b>
<b>1. Outline of SWM</b>
<b>2. Feature of GP</b>
<b>3. Local Authority that can refer to this GP</b>
<b>4. Expected effects to local authority by sharing this good practice</b>
<b>5. Photos and/or references, etc.</b>

## 4. Selected good practices and summarized feature of them

No.	Title of GP	Summarized feature of GP
GP 1	Eco Bricks concept for polithene waste management (Homagama PS)	Recycle a single waste material "polithene" at source. Eco Bricks are made by filling plastic bottles with polithene, and the Eco Bricks are exchanged for flowerpots recycled from the Eco Bricks at various events and programs. This is a good practice that is easy to participate in and contributes significantly to raising recycling awareness and reducing waste at the source.
GP 2	Promotion of waste segregation through awareness and instruction of collection workers. (Moratuwa MC etc.)	Organic waste segregation is encouraged due to the instruction and awareness-raising of residents by collection workers. Selected areas where organic waste is not being separated based on Weigh bridge data and focused awareness-raising activities. This is a good practice of promoting waste segregation at the source.
GP 3	Management of collection & transportation vehicles by utilizing GPS (Colombo MC)	All collection vehicles are installed with GPS to control the collection route and collection time. If a collection vehicle breaks down, another vehicle takes over the collection using GPS. This is a good practice of providing reliable waste collection and transportation.
GP 4	Management of small-scale compost plant (Seethawaka PS etc.)	The board that the date of intake, turning and the times of turning is recorded on are set above each compost piles. This is a good practice of how careful management produces good quality compost.

## 4. Selected good practices and summarized feature of them

No.	Title of GP	Summarized feature of GP
GP 5	Management of medium-scale compost plant (Ja-Ela Pradeshya Sabha etc.)	The good degree of segregation of organic waste is due to the awareness of residents and the guidance and instruction provided by the collection crews during collection. Compost plant is large enough to manage and mature the composting by taking enough time. This is a good practice of the production of good-quality compost.
GP 6	Segregation of recyclable during collection work and at recycling facility (Seethawakapure UC etc.)	Five categories are segregated at the source. Further separation is carried out in the collection process, and the final 17 categories of recyclables are sorted at the recycling center. This is a good practice of the comprehensive promotion of recycling at the stages of generation, collection and treatment.
GP 7	Animal Feeding (Seethawakapure UC etc.)	This is a good practice of how fresh organic waste can be separated and recycled as animal feed. Sorting animal feed from organic waste takes the role of removing contamination from organic waste as pre-sorting and it improves the quality of compost production.
GP 8	Thermal recycle of Organic waste by Biogas (Kaduwela MC)	This LA has its own biogas plant and its intake is 7t/d. Generated electricity used for the compost plant activity. The LA is giving priority to manage their waste by using the waste as a resource.



# Good Practices



<p>Good practice No.: (GP-1)</p>	<p>[Name of LA] Homagama PS</p>	
<p>[Category] Recycling</p>	<p>[Title of GP] Eco Bricks concept for polithene waste management</p>	
<p>[Feature of GP]</p> <ul style="list-style-type: none"> <li>• People who are very sensitive to the environment in Homagama PS area make Eco Bricks using the polithene waste generated in their homes and hand over to the several locations, events and programs.</li> <li>• This will provide free flowerpots made from recycled Eco Bricks and plants to those who deliver bottles to “Parisara Pola” programs and rusiru “mal pala thawana” Polgasowita.</li> <li>• Average 185kg of eco bricks are collected daily and transported to the processing center located at Padukka where they are washed and separated into polithene and - PET and transported to the Yatiyanthota flowerpots manufacturing company to make recycled pots.</li> <li>• The uniqueness of this program is that all of the polithene that comes out of it can be cleaned and the problem of mixing with other waste can be avoided. And this process helps to recycle 91% of collected polythenes.</li> <li>• Eco brick is a plastic bottle which is contained with all the polythene materials (Recyclables and non-recyclables) compacted inside the bottle. It is hard that can be used to recycle.</li> </ul>	 <p>Eco Bricks making</p>	 <p>Eco Bricks collection through “Parisara Pola” program</p>
<p>Recycle pots made from eco bricks</p>		 <p>Polithene crushing</p>





<p>Good practice No.: (GP-2)</p>	<p>[Name of LA] Moratuwa MC</p>
<p>[Category] Waste segregation at sources</p>	<p>[Title of GP] Promotion of waste segregation through awareness and instruction of collection workers.</p>
<p>[Feature of GP]</p> <ul style="list-style-type: none"> <li>• Training of collection cure Waste collectors are well trained to teach the public on segregation check the degree of sorting of the waste discharged at the time of collection, and if there are impurities mixed within that , they return the waste to the residents and instruct them not to mix the waste next time. Awareness-raising tools are brochures and verbal instructions at the time of collection.</li> <li>• Estimation of waste segregation rate by region The percentage of organic and inorganic waste as a percentage of total collected ('in-coming') waste is calculated for each region using Weigh Bridge data, and areas with a relatively low percentage of organic waste are identified as priority areas for awareness-raising!</li> <li>• Focus on awareness program regarding waste segregation to the region that waste segregation rate is low. The instruction given by the collector is shared with the SUPERVISOR in the area and is strictly do awareness at the time of collection.</li> </ul>	
	
<p>Recyclables are sorted from non-biodegradable waste at Sampath Kendraya.</p>	
<p>9</p>	

<p>Good practice No.: (GP-3)</p>	<p>[Name of LA] Colombo Municipal Council</p>
<p>[Category] Collection/ Transportation</p>	<p>[Title of GP] Management of collection &amp; transportation vehicles by utilizing GPS</p>
<p>[Feature of GP]</p>	
<ul style="list-style-type: none"> <li>• GPS has been installed to all waste collection vehicle and the route of waste collection &amp; transportation has made. Utilizing the GPS data, waste collection and transportation of each collection vehicle has been managed.             <ul style="list-style-type: none"> <li>- Vehicle movement has displayed with maps.</li> <li>- The purpose of installing GPS on the collection vehicles is to manage performance of collection work such as proper collection routes and collection times, etc. Also this helps to monitor the performance of the vehicle and its efficiency.</li> </ul> </li> <li>• In case that waste collection vehicle is out of order and waste collection can be done by schedule, other waste collection vehicles are instructed based on GPS data. The conformation vehicle breakdown is done by the GPS locations and vehicle movement observed through GPS.</li> </ul>	 <p>Waste collection App – “Clean up” (Google Map...)</p>
<p>10</p>	



<p><b>Good practice No.: (GP-4)</b></p>	<p><b>[Name of LA] Seethawaka PS</b></p>	
<p><b>[Category] Compost plant</b></p>	<p><b>[Title of GP] Management of small-scale compost plant</b></p>	
<p><b>[Feature of GP]</b></p> <ul style="list-style-type: none"> <li>Local Authority has its own compost plant the intake of which is 2.1 t/d (100%). Production &amp; Sales amount are both 0.12 t/d (6%) and the residue generated from composting is 0.05t/d (2%). Approximately, the revenue is 80,000 LKR/month.</li> <li>Since the residents handover organic waste with bucket, the collected organic waste is not contaminated with plastic bags. A community-based awareness activities on the separation of organic waste are frequent.</li> <li>The board that the date of intake, turning and the times of turning is recorded on are set above the each compost piles in the compost plant. The moisture level of the compost piles are managed and matured based on the records.</li> <li>Before removing the residues of compost by Sieving Machine, compost quality is improved by handy sieving.</li> </ul>		
<div style="display: flex; justify-content: space-between;"> <div data-bbox="395 156 778 981">  </div> <div data-bbox="778 156 893 981"> <p>Moisture level of compost piles is well-managed. Intake date and turning frequency are recorded on the board set above the compost piles.</p> </div> <div data-bbox="893 156 1273 981">  </div> </div> <div data-bbox="1273 156 1364 981" style="text-align: right; padding-right: 20px;"> <p>Handy sieving makes compost products good quality with removing the contamination.</p> </div>		

<p>Good practice No.: (GP-5)</p>	<p>[Name of LA] Ja-Ela PS</p>		
<p>[Category] Compost plant</p>	<p>[Title of GP] Management of medium-scale compost plant</p>	<ul style="list-style-type: none"> <li>Local Authority has its own compost plant the intake of which is 10 t/d (55.5 %). Production &amp; Sales amount are both 29 and 23 t/month and 79 % of compost is sold. The residue generated from composting is 7 t/d (15 % of product). The revenue is 274,728.00 LKR/month.</li> <li>Leaflet and poster for informing the waste collection schedule and awareness to the public is made and distributed to the residents.</li> <li>The good degree of segregation of organic waste is due to the awareness of residents and the guidance and instruction provided by the collection crews during collection.</li> <li>Compost plant is large enough to manage and mature the composting by taking enough time.             <ul style="list-style-type: none"> <li>- Size of compost yard: 845 m<sup>2</sup></li> <li>- Size of yard / amount of organic waste carried in = 84.5 m<sup>2</sup> / ton</li> </ul> </li> </ul>	<div style="display: flex; justify-content: space-around;"> <div data-bbox="427 660 805 1131">  <p>Since organic waste is segregated at source, the contamination of compost is quite few.</p> </div> <div data-bbox="427 145 805 638">  <p>All space of compost plant is used for composting activity.</p> </div> </div> <div style="display: flex; justify-content: space-around; margin-top: 10px;"> <div data-bbox="917 660 1268 1131">  <p>Leaflet regarding waste segregation for the residents</p> </div> <div data-bbox="917 145 1268 638">  <p>The half space of compost plant is used for recycling activity.</p> </div> </div>

<p>Good practice No.: (GP-6)</p>	<p>[Name of LA] Seethawakapure UC</p>	
<p>[Category] Recycling</p>	<p>[Title of GP] Segregation of recyclable during collection work and at recycling facility</p>	
<ul style="list-style-type: none"> <li>Waste collection vehicles are mainly 4W tractor-trailers (9 vehicles). Collected waste is sorted using containers loaded on the vehicles and by dividing spaces in the trailers.</li> <li>Waste is sorted at source in order to categorize the waste easily.</li> <li>Recyclable waste is categorized into 17 items and weighed the category wise. 17 items are bought by recycle collectors regularly.</li> </ul>		
	<p>Containers for waste segregation are set on the trailer of tractor</p>	<p>17 categories of waste sorted at source and waste collection point are stored.</p>

<p>Good practice No.: (GP-7)</p>	<p>[Name of LA] Seethawakapure UC</p>	
<p>[Category] Recycling</p>	<p>[Title of GP] Animal Feeding</p>	
<p>• Fresh organic waste are sorted as feeding for animal from collected organic waste, stored in small containers and carried 1t/d to nearby pig farm. Fresh organic waste is bought for 4,100R/t. Organic waste other than animal feed are used for composting and sold for 25R/2kg. Sorting animal feed from organic waste takes the role of removing contamination from organic waste as pre-contamination and it improves the quality of compost production.</p>		
		<p>Fresh organic waste sorted as animal feedings</p>
		<p>Compost less mixed with contamination</p>
<p>Storing the animal feedings 1ton/day)</p>	<p>Compost less mixed with contamination</p>	



<p>Good practice No.: (GP -8)</p>	<p>[Name of LA] Kaduwela MC</p>
<p>[Category] Thermal Recycling</p>	<p>[Title of GP] Thermal recycle of Organic waste by Biogas</p>
<p>Local Authority has its own biogas plant and its intake is 7t/d. Generated electricity used for the compost plant activity. Other generated electricity is hope to connect to National grid. This local authority is giving priority to manage their waste by using the waste as a resource. They have all the waste management/treatment methods as follows</p> <ol style="list-style-type: none"> <li>1. In order to promote home composting, they distribute compost bins among community in nominal cost</li> <li>2. The degradable waste they collect is sent to compost plant and produce compost.</li> <li>3. They have another Biogas plant in the same premises and its intake is 7tons/day and plan to supply electricity to the National grid. For the moment they use the output for the canteen process and plant lighting</li> <li>4. They have a separate recycling facility and store their recyclables in it. It has crushing and bailing facilities.</li> <li>5. Send residue to Waste to power plants.</li> <li>6. In addition to the waste collection vehicles, they Collect recyclable waste from “Parisara Pola” which are held in each weekends in different GN divisions.</li> </ol>	<div style="display: flex; justify-content: space-around;">   </div> <p>They give power to National grid –Rs. 30.75/unit.  <b>They are having test runs in these days</b></p> <p>Generator capacity – 40KW</p> <p>In addition to that,</p> <ol style="list-style-type: none"> <li>01. Preparing labors meals-Gas cooker</li> <li>02. Electricity for machines operation (bailing / sieving / weigh bridge/crushing machine</li> <li>03. Bulbs.</li> <li>04. Liquid fertilizer (planned 5000litrs/day) Plan to earn Rs.250,000.00</li> </ol>



## 別添資料 8

エアレーションシステムのオペレーションマニュアル



**Manual on the Introduction of a  
Forced Aeration System at Kaluthara  
Composting Plant**

## Table of Contents

Photo Album .....	3
1 Background and Introduction.....	5
1.1 Purpose of the pilot project.....	5
1.2 Necessity of the Forced Aeration System pilot project .....	6
2 Advantages of the introduction of forces aeration .....	7
2.1 Forced aeration system.....	7
2.2 Impact on the Composting Speed.....	8
2.3 Odor control .....	8
2.4 Leachate control.....	8
2.5 Temperature control and compost quality .....	8
3 Forced Aeration System Components and Layout of the Aeration System .....	9
3.1 Components .....	9
3.2 Layout of the aeration system .....	12
4 Installation and testing .....	14
4.1 Installation of test run.....	14
4.2 Lessons learned from testing the aeration system in Kaluthara .....	15
5 Installation and operation of the aeration system.....	16
5.1 Site Preparation.....	16
5.2 Blower Installation .....	17
5.3 Perforated pipes Installation.....	18
6 Monitoring of the Forced Aeration Windrow Composting System.....	20
7 Cost assessment of forced aeration system .....	25
8 Safety Procedures Operation Manual.....	27
8.1 Personal Protective Equipment (PPE).....	27
8.2 Lockout/Tagout Procedures.....	27
8.3 Emergency Response .....	28
9 Operation, Monitoring and Maintenance Procedures for the aeration system .....	30
9.1 Operation and Monitoring of the Aeration System .....	30
9.2 Maintenance of the Aeration System .....	31
10 Conclusions and recommendations.....	32

### List of figures

Figure 1 conceptual image of an aeration system in a compost windrow .....	7
Figure 2 Power control switch and timer.....	9
Figure 3 Blower specifications .....	9
Figure 4 Blower and power supply.....	10
Figure 5 Manifold and air flow control valves .....	10
Figure 6 perforated pipe for air supply .....	11
Figure 7 Schematic section of aeration trench and pipe layout.....	11
Figure 8 layout of the aeration system.....	12
Figure 9 layout of the pipes, trenches, and blowers .....	13
Figure 10 photos taken during the test run .....	14
Figure 11 Construction of static piles for the above ground forced aerated pipes .....	15
Figure 12 Construction of below ground forced aeration system.....	16
Figure 13 Laying of PE aeration pipe on the concrete ditch .....	18
Figure 14 Monitoring of conventional windrow and forced aeration system .....	20
Figure 15 Effectiveness of forced aeration on oxygen supply and carbon dioxide emission in composting piles.....	21
Figure 16 Comparison of leachate generation between conventional windrow and forced aeration system.....	23

### List of Tables

Table 1 Change in gas composition inside the composting piles during the monitoring period .....	22
Table 2 Unit cost for loader operation.....	25
Table 3 A simple cost comparison between conventional and forced aerated composting system .....	26

Photo Album

	
<p>Mihisaru Waste Management Center</p>	<p>Truck scale for waste collection vehicles</p>
	
<p>Waste collection vehicle</p>	<p>Vehicle collection vehicle on truck scale</p>
	
<p>Aeration pipe installation for first trial (Above the ground system)</p>	





Aerated compost pile (1<sup>st</sup> trial)



Monitoring of compost piles during the aerated composting trial



Monitoring of compost pile



Perforated pipe laying in trench for below the ground aeration system

## 1 Background and Introduction

The rapid increase in population and economic development in Sri Lanka has led to a significant rise in the volume of waste generated, reaching approximately 10,800t per day. Consequently, managing this waste, from collection to treatment and disposal, has become increasingly challenging.

In response to the Sri Lankan government's request, JICA is currently undertaking a project in the Western province of Sri Lanka in order to formulate a master plan. The objective of this project is to assist the Western Province in enhancing its solid waste management practices by formulating a comprehensive Master plan that encompasses medium to long-term forecasts and proposes a variety of solutions to tackle the waste-related problems.

Among the several pilot projects initiated under this master plan project, a pilot project for the improvement of Kaluthara composting plant was planned and implemented. This manual explains the purpose and scope of the improvements made to the composting plant.

Through these pilot projects and the solid waste management master plan, efforts are being made to address the challenges associated with waste management in the Western province, striving for more sustainable and effective waste management practices

### 1.1 Purpose of the pilot project

The Western province faces several challenges in solid waste management, stemming from various factors. Firstly, the population increase and economic development in the region have contributed to a significant rise in waste volume. Additionally, changing consumer habits have further compounded the issue. As a result, the collection, transportation, treatment, and disposal of waste have become increasingly difficult.

The current situation at Kaluthara composting plant is that there are complaints from local residents about the offensive odors. The pilot project thus focuses on enhancing the efficiency of the composting facility with the objective of reducing offensive odors and improving waste management practices overall.

Consequently, the objectives of this pilot project were:

- To modify the existing physical infrastructure to install forced aeration composting in three replicates.
- To monitor the performance of the forced aeration composting system by evaluating feedstock degradation, aeration performances, odor and fly control.
- To select the most appropriate aeration method facilitating easy and convenient operation of the facility.

Following section describe the pilot project design, system performances and a brief financial analysis of the force aerated composting system.

## 1.2 Necessity of the Forced Aeration System pilot project

Making improvements to the operation of the current large-scale composting plant is essential. The necessity arises from the need to mitigate the negative impact of the odors on the surrounding environment and nearby communities. Offensive odors generated during the composting process can lead to complaints, health concerns, and the impact that has on the quality of life for residents in the vicinity.

The Mihisaru integrated MSW management facility is one of the largest MSW composting facility in the country, which is located in Pohorawatta, Kalutara District of Sri Lanka. The facility daily receives approximately 50 metric tons of source segregated organic municipal waste from several Local Authorities namely: Pandura Urban Council, Kalutara Pradeshya Sabha and Kalutara Urban Council. The waste composition showed that the partially segregated waste contained approximately 85% organic matter with 75% water which exerts a higher oxygen requirement during the early decomposition stage.

The normal windrow composting procedure at Mihisaru facility is to heap up the material into rectangular piles on the concreted floor under the shed with the use of loader. The composting facility management construct one single pile of waste from the daily feedstock. The average height of the composting pile was 1.5 m with 3.0m width that often make into 15 m long windrow pile. The aeration is generally through passive venting due to convective flows induced by feedstock heating. The facility management increases the aeration efficiency by turning the waste piles at different frequencies. Windrow pile is turned 2 times during the first month (day 15 and day 30), and at two-weeks interval for another 6 weeks. After 10-12 weeks of composting, the piles are set for maturing which requires minimum one turning. Consequently, the conventional windrowing requires minimum 6 turning of each pile before the completion of the process.

Although conventional windrow composting practice is often practiced in Sri Lanka, it is well known that the turning frequencies are not adequate to supply the oxygen demand in large scale windrow composting systems. The problem is aggravated when the facility receives well-sorted organic waste rich in perishables that increase oxygen demand, decrease porosity, and contain excessive moisture. Consequently, most of the windrow piles undergo anaerobic decomposition emitting odorous gases ( $H_2S$ , mercaptans etc.) and delaying decomposition rate. Also, inadequate aeration tends to generate more leachate and facilitate fly breeding.

One way to decrease these negative impacts is through the introduction of an aeration system to the composting plant. By implementing an aeration system, the composting plant can enhance the management of odor emissions, ensuring a more pleasant environment for both employees and the community. This improvement not only contributes to the plant's compliance with environmental regulations but also demonstrates a commitment to sustainable and responsible waste management practices. By addressing the odor issue, the composting plant can operate more efficiently and effectively, fostering positive community relations and supporting the overall goals of a cleaner and healthier environment.

Therefore, this pilot scale project was conducted to assess the efficiency of introducing forced aeration composting system to solve some of the issues of the conventional windrow composting system.

## 2 Advantages of the introduction of forced aeration

### 2.1 Forced aeration system

The combination of forced aeration and turning of compost windrow piles can be an effective way to enhance the efficiency of the composting process. Forced aeration systems bring forth numerous advantages to the composting process.

Firstly, forced aeration significantly speeds up the composting process. By supplying controlled amounts of oxygen to the compost piles, microbial activity is enhanced, leading to faster decomposition of organic materials. Accelerated decomposition not only reduces the overall composting time but also increases the plant's capacity to handle larger volumes of waste.

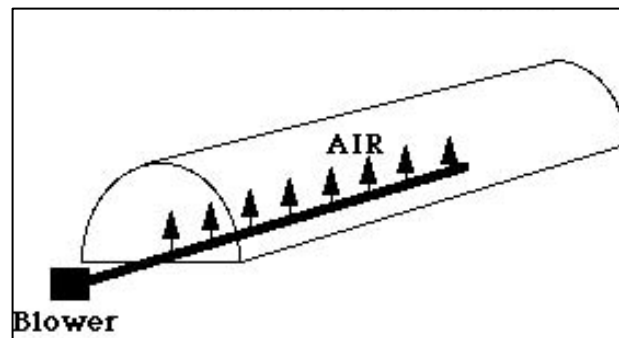

Figure 1 conceptual image of an aeration system in a compost windrow

Another significant benefit of forced aeration is its ability to control and mitigate odors. By maintaining proper aeration levels, the system minimizes anaerobic conditions that contribute to bad odors. This odor control is crucial for maintaining a positive relationship with the surrounding community and ensuring a more pleasant working environment for employees.

Additionally, forced aeration helps in managing leachate, the liquid byproduct of the composting process. Proper aeration prevents the accumulation of excessive moisture within the compost piles, reducing the leachate production and potential contamination of surrounding soils and water sources.

Temperature control is another advantage offered by forced aeration systems. By facilitating optimal air circulation, the composting process can be maintained within the desired temperature range. This control promotes the growth of thermophilic microorganisms, which are responsible for rapid decomposition and pathogen reduction.

Finally, the introduction of forced aeration improves the quality of the compost produced. Adequate oxygen supply promotes the development of beneficial microorganisms, resulting in a more homogeneous and nutrient-rich end product. The enhanced compost quality opens up opportunities for various applications, such as soil amendment in agriculture and landscaping.

## **2.2 Impact on the Composting Speed**

The use of forced aeration can increase the rate of composting by providing a constant supply of oxygen to the microorganisms that break down the organic matter in the compost pile. This can result in a shorter composting time, which means you can produce compost more quickly, and consequently treat more waste.

## **2.3 Odor control**

By providing a constant supply of oxygen to the compost pile, forced aeration can help to reduce unpleasant odors that result from anaerobic conditions in the pile.

This is particularly important in the context of climate with high humidity and high temperature (which is the case in Sri Lanka) and also where composting is in an area where there is a possibility of complaints from neighboring residents.

The aeration system can thus contribute to the reduction of the odors from composting

## **2.4 Leachate control**

Forced aeration in composting can contribute to the reduction of leachate.

Through a constant supply of oxygen to the composting windrow pile, breakdown of organic matter in the compost pile is improved. This results in a more efficient composting process, with fewer organic materials remaining in the compost pile. As a result, there is less organic matter available to create leachate.

Forced aeration can help maintain a consistent level of moisture in the compost pile, which can also contribute to reducing leachate production because excess moisture is prevented from accumulating.

## **2.5 Temperature control and compost quality**

### **2.5.1 More consistent temperature**

Forced aeration can also help to maintain more consistent temperatures within the compost pile, which is important for the growth and activity of the microorganisms involved in the composting process. This can result in more efficient composting and better-quality compost.

### **2.5.2 Higher quality compost**

Overall, the use of forced aeration can result in higher quality compost with a more consistent texture and nutrient content. This can be particularly important if you are using the compost for agricultural or horticultural purposes. (It can contribute to increase the value of the compost)

### 3 Forced Aeration System Components and Layout of the Aeration System

#### 3.1 Components

##### 3.1.1 Power supply

- A 3-phased electric power connection is supplying each blower through a power control unit (Figure below).
- Each power control consists of a breaker switch, analog timer, control switches and indicator lights (Figure below ).

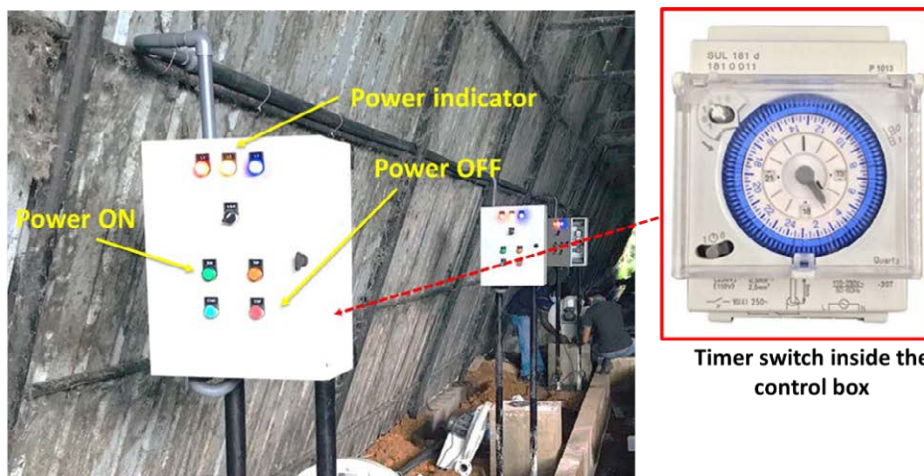

Figure 2 Power control switch and timer

##### 3.1.2 Air Blower

A blower is used to inject air into the compost pile through a network of perforated pipes.

In this case, the blower is a simple bounce house blower and an analog cycle timer with simple dials to allow you to control the on/off cycle to your requirement.



##### Specifications

1. **Fans:** Single inlet, high pressure centrifugal fans with cast aluminum casing and impeller
2. **Motor:** High efficiency motor 0.75kW
3. **Power Supply:** Three-phase 230/400 V 50 Hz
4. **Operating Temperature:** -20 °C +120 °C
5. **Finishing:** Anti-corrosive finish in polyester resin

Figure 3 Blower specifications

The blower plays a crucial role as it is responsible for providing the necessary airflow and oxygen supply to facilitate the aerobic decomposition process within the composting system. It functions by generating a continuous flow of air, which is then directed into the compost windrows through a network of distribution pipes or channels.

The blower creates a controlled and consistent stream of air that is essential for maintaining optimal oxygen levels within the compost pile. Adequate oxygen supply is vital for the growth and activity of aerobic microorganisms, such as bacteria and fungi, which are responsible for breaking down organic matter into stable compost. These microorganisms require oxygen to carry out their metabolic processes effectively, ensuring efficient decomposition and the production of high-quality compost.

The blower is installed on a concrete supporting structure and is supplied with electric energy through the power supply.



Figure 4 Blower and power supply

### 3.1.3 Manifold and Flow Control Valves

Each blower supplies air to two PVC distribution (10 cm) pipelines through flow control valves. Valves can be fully closed, partially closed, or fully opened. Each pipeline is connected to HDPE perforated pipe buried in the aeration ditch.

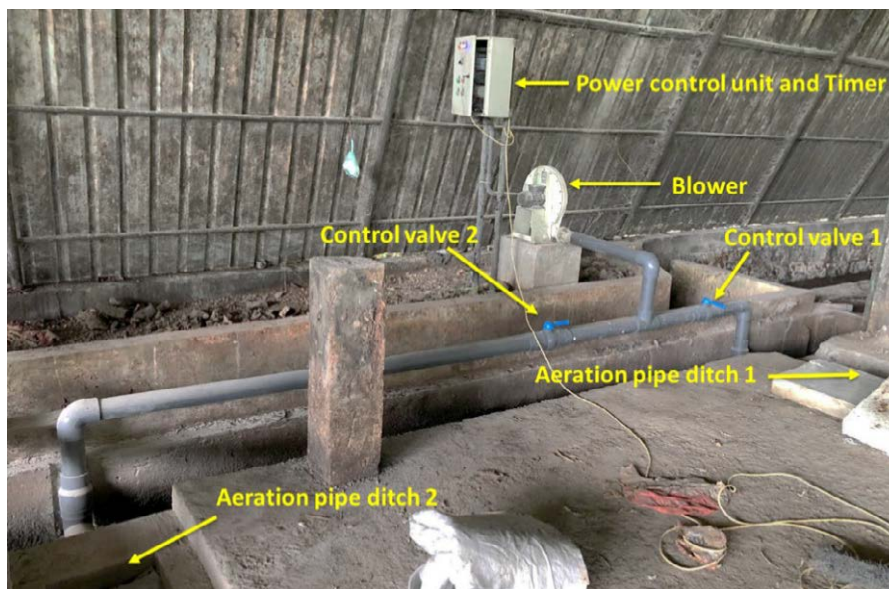

Figure 5 Manifold and air flow control valves

### 3.1.4 Perforated pipes- and air distribution trenches

The blower injects air into the compost pile through a network of PVC perforated pipes. These pipes are strategically placed within the compost pile to facilitate the even distribution of airflow and maximize oxygen transfer throughout the pile.

Each pile is laid on top of two PVC perforated pipes which act as conduits for the air generated by the blower, allowing it to reach the core of the compost pile efficiently. The pipes are installed across the whole windrow with an inter-pipe distance that ensures uniform coverage of air flow. The perforations or small holes along the pipes enable the controlled release of air into the compost, promoting aeration and oxygenation of the organic matter.

The pipes are placed inside trenches built on the concreted floor. There are three trenches for the three



Figure 6 perforated pipe for air supply

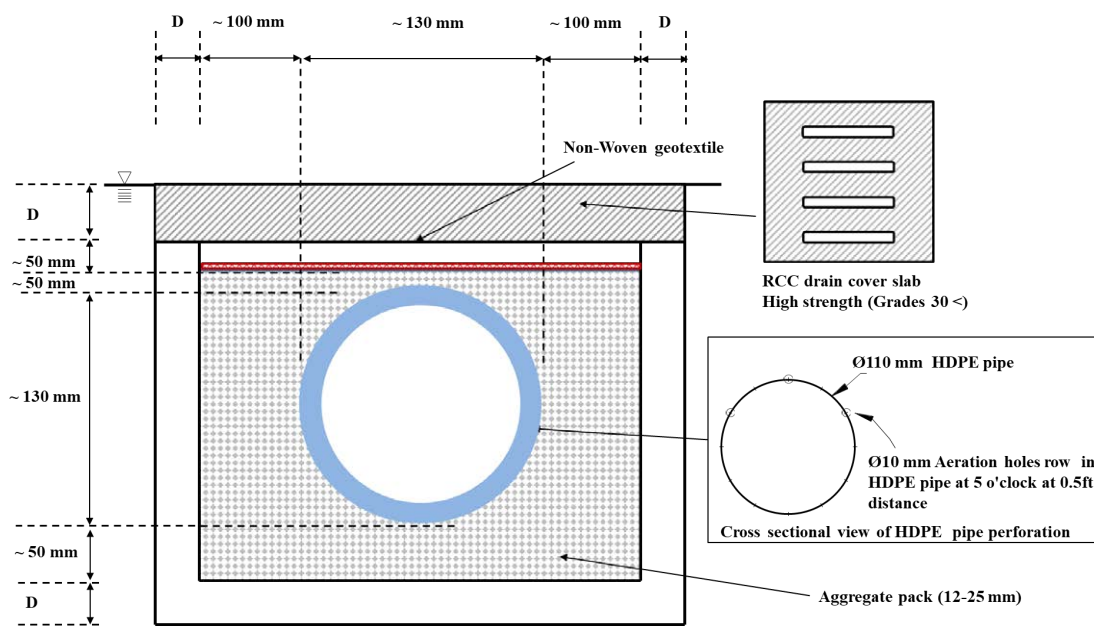

Figure 7 Schematic section of aeration trench and pipe layout forced aerated compost piles.



### 3.1.5 Other potential components: Diffusers

In a forced aeration system, diffusers can be used to distribute the airflow generated by the blower into the compost pile.

Diffusers are designed to disperse the air evenly and efficiently throughout the composting material, ensuring optimal oxygen transfer and promoting effective decomposition. The design, placement, and maintenance of diffusers are crucial for the overall performance of the forced aeration system.

Diffusers are strategically placed within the compost pile to achieve uniform airflow distribution. They are typically installed at regular intervals throughout the composting material, either horizontally or vertically. Horizontal diffuser placement involves burying or embedding the diffusers within the compost pile, while vertical placement positions the diffusers on the sides or in the center of the pile. The selection of placement depends on factors such as compost pile dimensions, composition, and desired aeration pattern.

### 3.2 Layout of the aeration system

The layout consists of a series of horizontal pipes strategically positioned within the composting area. These pipes are responsible for distributing the airflow generated by the blowers throughout the compost pile. Considering a processing capacity of 20 tons per day and a waste density before compaction of 0.3-0.4 ton/m<sup>3</sup>, the number and length of the pipes can be determined to ensure adequate air supply to the entire composting area.

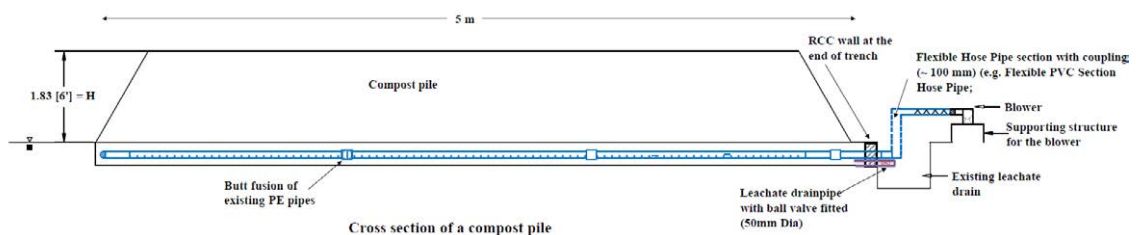

Figure 8 layout of the aeration system

To achieve a proper distribution of airflow, the horizontal pipes are placed at regular intervals along the length and width of the composting area. The spacing between the pipes depends on factors such as the compost pile dimensions and desired aeration pattern. The pipes are typically positioned slightly above the ground to allow for uniform air dispersion across the compost pile.

The perforated pipes used in this layout have small holes or perforations along their length to release the airflow into the composting material. These perforations ensure even distribution of the supplied air throughout the pile, facilitating optimal oxygen transfer and promoting efficient decomposition.

Considering the maximum air flow of 40m<sup>3</sup>/min and a static pressure requirement of more than 3.0kPa, the blowers are sized accordingly to meet these specifications. The blower(s) are connected to the horizontal pipes via a distribution system, allowing the generated airflow to be evenly distributed throughout the perforated pipes.

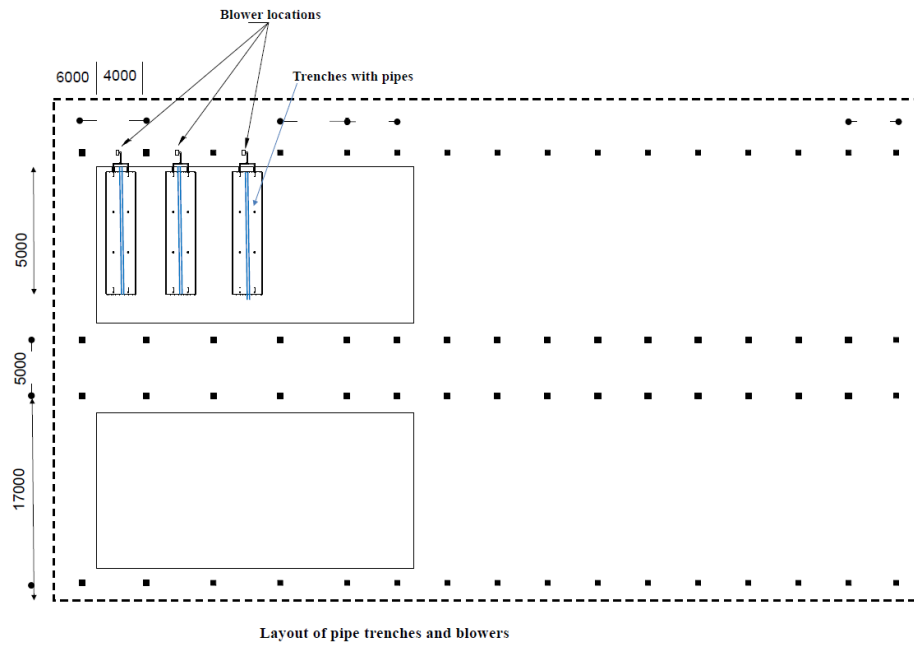

Figure 9 layout of the pipes, trenches, and blowers

## 4 Installation and testing

### 4.1 Installation of test run

On December 24, 2021, the air blower and perforated pipe were installed into the windrow pile and the performance was measured.

- Two perforated pipes for air blowing were inserted into each of the three rows of windrows.
- Each blower is connected to 2 underlying perforated pipes supplying air to the windrows (~40 tons)
- Gas composition+ pile temperature +waste decomposition rate +leachate generation were measured.



Figure 10 photos taken during the test run

The forced aeration system was designed based on the requirements of the composting facility operators and also considering the existing physical infrastructure (Ground, building etc.). At the beginning, the construction designs or detail on ground condition were not available with WMA-WP; thus, designers were reluctant to implement ditch excavation on the existing floor due to the fact that excavation may weaken the building floor and structure. Therefore, the first aeration system was designed as above ground perforated pipe system.

The above ground forced aeration system was constructed by installing a series of parallel 110mm diameter HDPE perforated pipe networks into the windrow compost piles. The HDPE pipe network was placed on the 600mm height windrow compost pile and the pipes are connected to each other using 110mm diameter HDPE STUB Flange neck with a steel flange including a rubber gasket. After laying pipe networks further compost pile (1200 mm) was stacked on the perforated pipe network leaving the manifold pipe area.

The pattern of the aeration holes in the pipe is 10mm diameter and two holes in a row, each hole in HDPE pipe at 4 O'clock & 8 O'clock and are repeated along at 1/2 ft distance intervals. The pattern of the Leachate holes in the pipe is 10mm diameter at the bottom of the pipe at the 1m distance intervals. The air escapes from the holes of HDPE pipes and enters the compost pile through the holes. One compost pile has two parallel rows of pipes at a 1.83m distance and the end of each pipe is closed by an end cap to prevent air from escaping. The end of the manifold HDPE pipe is connected to Centrifugal Blower. The pipe networks are aerated by coupling a

Centrifugal Blower to the manifold pipe end. The system was installed in three piles. The forced aeration system was designed to aerate large trapezoidal piles with approximate dimensions of 15m length, 2m height, and 4m width at bottom.



Figure 11 Construction of static piles for the above ground forced aerated pipes

#### 4.2 Lessons learned from testing the aeration system in Kaluthara

With the setting explained above, the aerated windrow piles were supplied with sufficient oxygen concentration (19%) resulting in optimum temperature (58°C) for aerobic decomposition by forced aeration. The results of the first test run were as follows:

- The conventional windrow pile had a very low oxygen concentration (less than 1%) and anaerobic conditions (high hydrogen gas production). The accumulated carbon oxides produce bad odors (Mercaptan, H<sub>2</sub>S, NH<sub>4</sub>, etc.).
- In conventional windrow piles, it is assumed that low aeration causes water vapor accumulation and increased leachate.
- The aerated windrow pile in the aeration system was determined to be ready for sieving after an additional 4-6 weeks of aging.
- The Conventional windrow piles need to be laid down and aged for an additional 10-12 weeks.
- Odor mitigation: the aeration system significantly contributes to the mitigation of the odors in two different ways: through establishing aerobic condition (H<sub>2</sub>S, NH<sub>4</sub> are avoided) and through reduction of leachate from the process of composting.
- Operational Issues (turning): While the above ground forced aeration was in operation, facility operators found that the concreted floor of the building was stable exploring the construction of ditch on the floor. Thereafter, consultants agreed to modify the aeration system to a below ground ditch aeration system enabling smooth and easy operation.

→ Necessity to embed the perforated pipes in trenches in the concrete floor to avoid damage during the turning operations.

## 5 Installation and operation of the aeration system

Taking into account results of the first test, the below ground aerated system was constructed as a perforated pipelines embedded in a gravel pack on a ditch below the ground level. The ditch was excavated and finished with high strength reinforced concrete which was then covered by removable high-strength concrete cover slabs.



Figure 12 Construction of below ground forced aeration system

### 5.1 Site Preparation

Site preparation for installing the forced aeration system involves several key considerations, including grading, drainage, and access.

- **Grading:** Proper grading of the site is essential for the installation of a forced aeration system. The site should be leveled or graded to ensure a uniform and flat surface where the composting area will be located. Grading helps to prevent water pooling and uneven distribution of compost during the composting process. It also facilitates the efficient movement of equipment and personnel within the site. In case previous composting piles are already in place, they should be momentarily removed from the area.
- **Drainage:** Adequate drainage is crucial to manage water runoff and prevent waterlogging in the composting area. The site should be designed or modified to have proper drainage systems in place. This can include features such as sloping the ground away from the composting area, installing drainage ditches or swales, or utilizing drainage pipes or gravel trenches. Ensuring effective drainage helps to maintain optimal moisture levels within the compost pile and prevents potential issues associated with excessive moisture accumulation.
- **Access:** Easy and convenient access to the composting area is important for operational efficiency and maintenance activities. Access roads or pathways should be constructed to allow vehicles and equipment to enter and exit the site smoothly. Sufficient space should be allocated for turning and maneuvering larger vehicles, such as delivery trucks or maintenance vehicles. Additionally, pedestrian access should be considered to ensure the safety and accessibility of personnel during routine operations and maintenance tasks.

It's also worth noting that site preparation may involve other factors depending on specific requirements and depending on the local situation. This can include considerations such as setback distances from neighboring properties, compliance with zoning regulations, and environmental impact assessments.

## 5.2 Blower Installation

Installing the blower involves several steps, including mounting the blower, connecting it to power, and performing a startup test.

### 5.2.1 Mounting the Blower

It is important to select a suitable location for the blower installation and to ensure that it is positioned securely and allows for proper ventilation.

Also, the blower should be placed on a stable surface or use mounting brackets to attach it to a support structure while ensuring that it is level and securely fixed in place.



Figure 13 Air blower

### 5.2.2 Connecting the Blower to Power

- Identify the power source for the blower. It should be compatible with the voltage and electrical requirements specified by the blower manufacturer.
- Install an appropriate disconnect switch near the blower for easy access to power control.
- Connect the blower to the power source using appropriate electrical wiring and connectors. Follow the manufacturer's instructions and local electrical codes for safe and proper wiring practices.

### 5.2.3 Startup Test

- Ensure that all connections are secure and power to the blower is switched off.
- Perform a visual inspection of the blower, checking for any signs of damage or loose components. Address any issues before proceeding.
- Double-check that the blower is correctly mounted and positioned.
- Turn on the power to the blower using the power supply switch.
- Gradually increase the blower speed to the desired operating level, following the manufacturer's recommendations.
- Observe the blower operation for any unusual noises, vibrations, or irregularities. Address any concerns promptly.
- Verify that the blower is generating the intended airflow and that it is being properly distributed to the compost pile through the diffusers or distribution pipes.
- Monitor the blower performance and operational parameters to ensure they align with

the specifications provided by the manufacturer.

It is crucial to follow the manufacturer's instructions and guidelines specific to the blower model being installed. Additionally, it is advisable to consult with a qualified professional or an electrician for any electrical wiring or power connection requirements to ensure compliance with local regulations and safety standards.

It is important to note that working with electrical components can be hazardous, and it is essential to take appropriate safety precautions and seek professional assistance if needed.

### 5.3 Perforated pipes Installation

After the initial trial tests and the operation issues that were discovered for turning, trenches were dug in the concrete floor to protect the perforated pipes from similar issues during the turning operations.

As shown in the pictures below, pipes were then laid in the trenches and a cover was applied to prevent waste from filling the trenches. The picture below shows a step-by-step explanation of the operations of laying the pipes in the trenches:

- 1) Perforated PE pipe is laid on the trench,
- 2) Covered with layer of aggregates (12-25mm),
- 3) Place a geotextile on the aggregate layer,
- 4) Cover the ditch with movable concrete slabs.
- 5) A leachate drainage pipe (5 cm) is placed at the beginning of each ditch to remove leachate and prevent its accumulation in the ditch and aeration pipe.



Figure 14 Laying of PE aeration pipe on the concrete ditch

Installing the piping in a forced aeration system involves several steps, including routing the pipes, connecting them to the blower and diffusers, and performing pressure tests.

#### 5.3.1 Planning and Routing:

- Determine the layout of the piping system based on the composting area and the desired airflow distribution pattern. Consider factors such as the compost pile dimensions, access points, and perforation placement on the pipes.

- Calculate the required length of pipes and plan the routing, ensuring that the pipes reach all desired locations within the compost pile.
- Select the appropriate pipe material (such as PVC or HDPE), based on the system requirements and environmental conditions.

### **5.3.2 Mounting and Connecting the Pipes:**

- Install the mounting brackets or supports for the pipes along the designated route. Ensure that they are securely attached and provide adequate support for the piping.
- In case the provided pipes are not cut in advance, cut the piping to the required lengths using appropriate tools and techniques.
- Connect the piping to the blower outlet using suitable connectors or adapters, following the manufacturer's instructions. Ensure a secure and airtight connection.
- Install any necessary fittings, valves, or connectors along the piping route to accommodate changes in direction, branches, or connections to diffusers.
- Connect the piping to the diffusers or distribution pipes using appropriate connectors or fittings. Ensure proper alignment and a secure connection at each diffuser location.

### **5.3.3 Performing Pressure Tests:**

- Close all valves and ensure that the piping system is sealed.
- Attach a pressure gauge to the blower outlet or a suitable point in the piping system.
- Gradually increase the blower speed to generate the desired airflow while monitoring the pressure gauge.
- Verify that the system maintains the required static pressure and that there are no significant pressure drops or leaks (Air pressure should be more than 500 Pa (10 millibar) at the far end of the compost pile).
- Inspect the entire piping system, including connections, joints, and fittings, for any signs of leakage or air loss. Address any issues promptly by tightening connections or replacing faulty components.
- Repeat the pressure test if necessary to ensure the integrity of the system.



## 6 Monitoring of the Forced Aeration Windrow Composting System

The variations of flow volumes, air pressure, and temperature were daily monitored while the moisture content, volatile solids changes and compositions of air in-side the waste piles were monitored every other week for 3 months during the first modification. The same parameters were evaluated for the below ground forced aeration system since 26<sup>th</sup> April and the monitoring continues. The Odor emission and fly abundance were qualitatively assessed using the Citizen science (CS) protocol (Brax et al., 2020) by scaling the odor levels and abundance of flies adjacent to the composting site by walking along a path 50m away from the site boarder. The same assessment was done 30 days after the installation of aeration system.

### 6.1 Monitoring of forced aeration system

Concentrations of oxygen (O<sub>2</sub>), carbon dioxide (CO<sub>2</sub>), carbon monoxide (CO), methane (CH<sub>4</sub>) and hydrocarbon (C<sub>n</sub>H<sub>m</sub>) were measured in the interstitial gas of the compost pile at different time periods and at increasing depths to reflect the differing decomposition regions within the piles. The following figure shows the process of aeration monitoring.



- ✓ Measuring of gas composition and temperature of conventional windrow& forced aerated composting system
- ✓ Measurement and recording of waste decomposition and leachate generation

- ✓ Installation of forced aeration pipes while the fresh waste is heaped up on the floor
- ✓ Pile was 15m long, 4m wide and 2m high (approximately 40 MT)

- ✓ Measuring of gas composition and temperature of force aerated compost piles
- ✓ Measurement of temperature, air pressure and leachate generation by facility operators (daily records)

Figure 15 Monitoring of conventional windrow and forced aeration system

The optimum O<sub>2</sub> concentration in interstitial gas for optimal composting is 10 %. Any level below the optimum can cause anaerobic condition which can be estimated by measuring the Methane emission from composting piles. Low oxygen levels below 5% is detrimental for aerobic microorganisms and this is considered the lower limit of oxygen for composting systems.

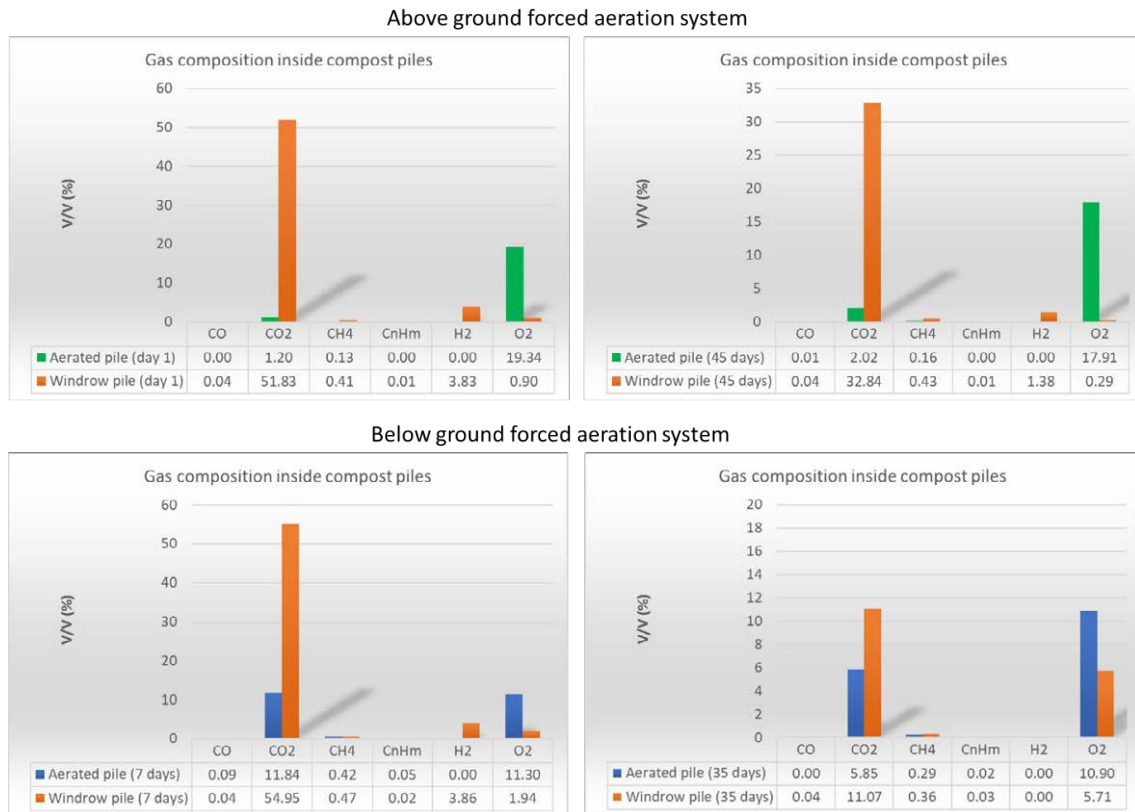

Figure 16 Effectiveness of forced aeration on oxygen supply and carbon dioxide emission in composting piles

### 6.2 First Trial Tests: Above Ground Forced Aeration System

There are four differences in gas emissions over the period of monitoring.

Firstly, in the forced aerated pile, CO<sub>2</sub> emission was stable at a lower level from 1.20 to 4.51% while, in the normal windrow pile, CO<sub>2</sub> started at 51.83%, decreased to around 30% on the 15<sup>th</sup> and 20<sup>th</sup> day, increased to 46.15% on the 30<sup>th</sup> day then sharply decreased to 11.84% on the 60<sup>th</sup> day.

Secondly, CH<sub>4</sub> was almost stable in the range of 0.13 to 0.73% in the forced aerated pile while it fluctuated at the timing of turning the normal windrow pile on the 15<sup>th</sup> day.

Thirdly, H<sub>2</sub> was not seen in the forced aerated pile but it was seen in conventional windrow piles at a rate of 3.83% on the 1<sup>st</sup> day and de-creased to 0.00% on the 60<sup>th</sup> day. Fourthly, O<sub>2</sub> was stable at a higher level of 17.19 to 19.34% in the forced aerated pile whereas it began at 0.90% on the 1<sup>st</sup> day and in-creased to 4.73% on the 30<sup>th</sup> day in the normal windrow pile. CO and C<sub>n</sub>H<sub>m</sub> were stable at a lower level over the period both in the forced aerated pile and normal windrow pile.

The mean O<sub>2</sub> values measured during the gaseous investigation were in the range: 17-19 %, which indicated that the process of waste biodegradation in the compost piles was aerobic. There was slight variation in mean compost O<sub>2</sub> concentrations between the 30 and 60 cm sample depths. However, a marginal decline in O<sub>2</sub> was observed with depth and the lowest concentration (15 %) was recorded at 60 cm. Nevertheless, in all cases, the mean O<sub>2</sub> concentration was significantly higher than the suggested minimum (5 %) and optimum (10%) necessary for supporting aerobic composting activity.

There was also slight variation between sampling periods, which suggested that gaseous evolution from the aerobic decomposition of materials was unrelated to climatic seasonal variability.

During later part of conventional windrowing, mixing the compost had a significantly increased O<sub>2</sub> concentration by approximately 4 % compared to the first 30 days.

Table 1 Change in gas composition inside the composting piles during the monitoring period

Forced aerated pile (Above Ground Pipes)								Normal windrow pile									
Days		CO	CO <sub>2</sub>	CH <sub>4</sub>	C <sub>n</sub> H <sub>m</sub>	H <sub>2</sub>	O <sub>2</sub>	Temperature (°C)	Days		CO	CO <sub>2</sub>	CH <sub>4</sub>	C <sub>n</sub> H <sub>m</sub>	H <sub>2</sub>	O <sub>2</sub>	Temperature (°C)
1	Average (n=3)	0.00	1.20	0.13	0.00	0.00	19.34	53.28	1	Average (n=3)	0.04	51.83	0.41	0.01	3.83	0.90	68.22
	Standard deviation	0.00	0.12	0.01	0.00	0.00	0.22	0.04		Standard deviation	0.00	1.64	0.01	0.00	0.47	0.18	0.68
									<i>Pile mixing and reconstruction</i>								
15	Average (n=3)	0.03	4.51	0.28	0.02	0.00	17.19	57.09	15	Average (n=3)	0.04	32.84	0.43	0.01	1.38	0.29	69.68
	Standard deviation	0.01	1.51	0.02	0.00	0.00	0.98	0.02		Standard deviation	0.01	0.69	0.01	0.01	0.08	0.10	0.05
									<i>Pile mixing and reconstruction</i>								
20	Average (n=3)	0.04	3.04	0.42	0.04	0.00	19.11	58.57	20	Average (n=3)	0.03	34.52	9.97	0.03	0.04	0.62	57.44
	Standard deviation	0.01	0.63	0.04	0.01	0.00	0.20	0.09		Standard deviation	0.01	5.79	2.28	0.01	0.07	0.40	0.10
									<i>Pile mixing and reconstruction</i>								
30	Average (n=4)	0.01	3.44	0.73	0.06	0.00	17.68	61.81	30	Average (n=4)	0.02	46.15	7.98	0.05	0.61	4.73	63.79
	Standard deviation	0.00	0.02	0.02	0.00	0.00	0.01	0.15		Standard deviation	0.01	2.00	0.67	0.01	0.03	0.55	0.06
									<i>Pile mixing and reconstruction</i>								
45	Average (n=3)	0.01	2.02	0.16	0.00	0.00	17.91	64.60	45	Average (n=3)	0.03	43.26	6.34	0.04	0.50	4.14	66.20
	Standard deviation	0.01	1.30	0.06	0.00	0.00	1.80	4.71		Standard deviation	0.01	0.20	0.07	0.01	0.02	0.04	1.66
									<i>Pile mixing and reconstruction</i>								
60	Average (n=3)	0.00	1.52	0.14	0.00	0.00	18.78	61.50	60	Average (n=3)	0.09	11.84	0.60	0.05	0.00	5.64	69.61
	Standard deviation	0.00	0.02	0.01	0.00	0.00	0.04	0.66		Standard deviation	0.01	0.86	0.01	0.00	0.00	0.08	0.11

Forced aerated pile (Below Ground Pipes)								Normal windrow pile									
Days		CO	CO <sub>2</sub>	CH <sub>4</sub>	C <sub>n</sub> H <sub>m</sub>	H <sub>2</sub>	O <sub>2</sub>	Temperature (°C)	Days		CO	CO <sub>2</sub>	CH <sub>4</sub>	C <sub>n</sub> H <sub>m</sub>	H <sub>2</sub>	O <sub>2</sub>	Temperature (°C)
7	Average (n=3)	0.09	11.84	0.42	0.05	0.00	11.30	49.09	1	Average (n=3)	0.04	54.95	0.47	0.02	3.86	1.94	46.50
	Standard deviation	0.01	0.86	0.31	0.00	0.00	0.88	4.75		Standard deviation	0.01	5.53	0.12	0.01	0.33	1.80	0.80
									<i>Pile mixing and reconstruction</i>								
35	Average (n=3)	0.00	5.85	0.29	0.02	0.00	10.90	59.85	15	Average (n=3)	0.04	11.07	0.36	0.03	0.00	5.71	56.43
	Standard deviation	0.00	0.03	0.01	0.01	0.00	0.00	1.55		Standard deviation	0.00	0.01	0.00	0.00	0.00	0.01	6.69

The temperature of the forced aeration pile went up slightly from 53.28 to 64.60°C during the monitoring period while there was a drop in the temperature of the normal windrow pile during the turning period around the 15<sup>th</sup> day.

### 6.3 Below ground forced aeration system

The gaseous composition within the compost piles constructed above the below ground forced aerated system has oxygen concentration above the optimum level, both at the 7<sup>th</sup> day (11.3% and 35<sup>th</sup> day (60%) indicating that pile consistently receive sufficient level of oxygen through aeration. On the other hand, the conventional windrow piles showed lower oxygen levels (2-6%) and higher CO<sub>2</sub> concentrations compared to aerated system.

The level of aeration in below ground forced aeration system was lower than the above

ground system that send air through two perforated pipes. The below ground forced aeration system supply through a single air passage placed at the bottom of the pile. However, the monitoring showed that below ground aeration system was also very effective maintaining oxygen levels at the optimum level. Slightly higher CO<sub>2</sub> concentrations in below ground aeration system also support the observation that aeration through a single trench was inferior to double pipe aeration but does not create unfavorable condition for aerobic decomposition.

The temperature of the below ground forced aeration system steadily maintained temperatures between 49.09 and 59.85°C during the monitoring period while there were slightly lower temperatures in normal windrow pile (46.5 – 56.4°C) during the monitoring period. This indicate that the lower temperature observed during the second monitoring period was probably due to lower environment temperatures during rain

#### 6.4 Impact on leachate, odor and fly control

It has been estimated that each metric ton of organic waste in conventional windrow composting system generates about 150L of leachate during first four weeks. If not properly control, leachate flows on the surface, generates malodors and creates a favorable breeding environment for flies. As shown in below figure, excessive leachate generation is the main cause for fly breeding and unpleasant odor emission.

However, leachate generation was minimum after the improvement of the aeration system with below ground forced aerated system. Moreover, the leachate flow from adjacent piles and excess water from odor control spraying was easily drained to trenches without flowing on ground.



Figure 17 Comparison of leachate generation between conventional windrow and forced aeration system

The odor intensity felt by some citizens prior to aeration survey was significantly higher than condition felt after installation of aeration system. Further observation proved that the forced aerated piles did not generate a strong odor but there was a butyric odor emission throughout the process which is typical of any well-managed organic waste composting system. The conventional windrow compost is likely to generate an offensive odor. Although the conventional

windrow compost is an aerobic system by turning, anaerobic space can be produced inside the pile and anaerobic respiratory substances mainly methane is likely to emit into the atmosphere. This phenomenon is marked in static piles where the offensive odor comes out.

Flies were attracted to the aerated piles only during the first 2-3 days, and fly breeding sharply reduced. Flies and maggots observed in first few days were due to the infection of waste during discharge and collection. However, after the aeration to accelerate the decomposition, the fly infestation was not observed. On the other hand, in conventional windrow piles, fly breeding declined only after second turning that usually done after 15-20 days.

## 7 Cost assessment of forced aeration system

A general cost assessment was conducted to compare the overall operation and maintenance cost of the improved system. The cost comparison was done based on the available data and information at the Mihisaru waste management facility. It should be noted that the capital and replacement costs are not considered in the analysis, but only the general operation and maintenance cost of major items. The cost comparison should only be used for comparison purpose but not as actual estimate of actual cost.

The major operation cost is the fuel and maintenance cost of the loader. The unit operation cost of the loader was calculated based on fuel cost and general maintenance cost. As shown in following table, it is estimated that the loader operation cost a minimum Rs 4, 253/ hour.

Table 2 Unit cost for loader operation

Item	Quantity	Unit	Rate (Rs)	Amount (Rs)
Diesel cost	7	Liters/ Hour	310	2,170
Maintenance cost	1	Hour	2,083	2,083
Unit cost				4,253

The cost comparison between conventional windrow and forced aerated composting systems were done based on cost on machine use, fuel, chemical, electricity, and labor.

Table 3 A simple cost comparison between conventional and forced aerated composting system

Windrow composting system (Operation & maintenance cost for one 50 MT pile)					
Activity	Description	Quantity	Units	Rate (Rs)	Amount (Rs)
Pile making	Construction of Windrow/ Static pile by waste unloading on floor and piling up by loader (~ 50MT)	1.5	Loader Hrs	4,253.33	6,380.00
Pile Turning	Turning of windrow piles during first month (1.5 hr, 2-turning)	3	Loader Hrs	4,253.33	12,760.00
Pile Turning	Turning of windrow piles during next two months (1.0 hr, 4-turning)	4	Loader Hrs	4,253.33	17,013.33
Pile Turning	Labour charges for pile turning (6+1 occurrence)	7	Labour days	2,000.00	14,000.00
Odor control	Spaying of EM & odour control chemicals (3 times during 1st month)	3	Application	2,343.75	7,031.25
<i>Approximate cost of windrowing (Single pile until maturing)</i>					57,184.58
Forced aerated composting system (Operation & maintenance cost for one 50MT pile)					
Activity	Description	Quantity	Units	Rate (Rs)	Amount (Rs)
Pile making	Construction of Windrow/ Static pile by waste unloading on floor and piling up by loader (~ 50MT)	1.5	Loader Hrs.	4,253.33	6,380.00
Pile Turning	Turning of windrow pile after 6th week for maturing (1.0 hr., 1-turning)	1	Loader Hrs.	4,253.33	4,253.33
Electricity	Electricity consumption for blowers (0.75kW @ 12 hrs./ day for 50 days)	270	kWh	75.00	20,250.00
Pile Turning	Labour charges for pile turning (1 occurrence)	1	Labour days	2,000.00	2,000.00
Odor control	Spaying of EM & odour control chemicals (1 time during 1st month)	1	Application	2,343.75	2,343.75
<i>Approximate cost of forced aeration (Single pile until maturing)</i>					35,227.08

As shown above, the minimum cost for making compost (up to maturity) by forced aeration system is only about 60% compared to the conventional windrow composting. However, the actual cost for both systems is higher than this simple estimate.

## **8 Safety Procedures Operation Manual**

### **8.1 Personal Protective Equipment (PPE)**

Composting procedures within the plant involve various activities that require specific personal protective equipment (PPE) to ensure the safety of workers. During the initial stages of waste handling and sorting, workers should wear sturdy gloves to protect against cuts, abrasions, and potential contact with sharp objects. Eye protection, such as safety goggles, should be worn to shield against flying debris or particles generated during waste handling. Additionally, respiratory protection in the form of dust masks or respirators may be necessary, especially when dealing with fine particles or organic dust that could pose a respiratory hazard. Workers should also be equipped with appropriate footwear and clothing that can withstand the demands of the composting environment, including sturdy boots, coveralls, and high-visibility vests for enhanced visibility and protection.

When working with the forced aeration system in the composting plant, no specific PPE additional requirements are necessary, but it is advised to wear the usual safety goggles, face masks, protective gloves and boots.

By adhering to the appropriate PPE requirements for both composting procedures and the forced aeration system, workers can significantly reduce the risk of injuries, respiratory issues, and other potential hazards associated with the composting process. It is important for management to conduct regular assessments, provide necessary training, and ensure that workers have access to the required PPE. Continuous monitoring and reinforcement of PPE usage will create a safer working environment and protect the well-being of all personnel involved in composting and aeration operations.

### **8.2 Lockout/Tagout Procedures**

Lockout/Tagout procedures are crucial safety measures that must be followed during maintenance and repair work of the equipment used in the composting plant. These procedures involve isolating energy sources and ensuring that equipment is in a safe state before any maintenance tasks are performed. To effectively implement lockout/tagout procedures, the following steps should be taken:

- **Equipment Identification:** Each piece of equipment that requires maintenance or repair should be clearly identified with a lockout/tagout device. This device serves as a visual indication that the equipment is undergoing maintenance and should not be operated.
- **Energy Source Isolation:** Before starting any maintenance work, all energy sources, including electrical, hydraulic, and mechanical, must be isolated. This involves shutting off power supply, closing valves, and disconnecting energy sources to prevent unexpected startup or release of stored energy.
- **Verification of Equipment Status:** Once energy sources are isolated, it is essential to verify that the equipment is in a safe state to work on. This includes ensuring that all moving parts have come to a complete stop, residual energy has dissipated, and any potential hazards, such as high temperatures or pressure, have been eliminated.
- **Lockout/Tagout Application:** After confirming the safety status, lockout/tagout devices should be applied to the energy isolation points. Lockout devices, such as padlocks,



should be securely attached to energy control devices, and tagout warnings should be affixed to clearly indicate that maintenance work is in progress.

- **Communication and Coordination:** Effective communication and coordination among maintenance personnel are essential during lockout/tagout procedures. Clear communication channels should be established to inform other workers about the ongoing maintenance activities and the importance of not removing or tampering with lockout/tagout devices.

For the forced aeration system specifically, the following additional considerations apply:

- **System Shutdown:** Before performing any maintenance or repair tasks, shut down the forced aeration system and follow the general lockout/tagout procedures outlined above.
- **Secure Energy Isolation:** Once the system is shut down, secure the energy isolation points using lockout/tagout devices. Apply locks to control switches or valves and attach tagout warnings to indicate that the forced aeration system is under maintenance.
- **Verification and Testing:** After the lockout/tagout devices are in place, verify that the system is de-energized by attempting to start or operate it. This step ensures that all energy sources have been effectively isolated, and that the system is safe to work on.

By strictly adhering to these lockout/tagout procedures for both the composting plant and the forced aeration system, potential accidents, injuries, or incidents caused by unexpected energy releases can be prevented. Regular training, awareness programs, and periodic evaluations are essential to ensure compliance and maintain a safe working environment for all personnel involved in maintenance and repair activities.

### **8.3 Emergency Response**

Effective emergency response procedures are crucial to ensuring the safety and well-being of personnel in the event of an accident or emergency situation within the composting plant. The following points outline the key steps to be followed:

- **Emergency Preparedness:** Establish an emergency response plan that includes identifying potential hazards, defining evacuation routes, and designating assembly points for personnel. Conduct regular drills and training sessions to familiarize employees with emergency procedures and ensure a prompt and effective response.
- **Evacuation Procedures:** In the event of an emergency, it is essential to evacuate the area quickly and safely. Clearly mark evacuation routes with illuminated signs and ensure they are free from obstructions. Designate assembly points at a safe distance from the facility to account for all personnel and facilitate communication.
- **Emergency Communication:** Establish a reliable communication system to quickly alert and inform all employees during emergencies. This may include using alarm systems, public address systems, or other communication devices. Ensure that emergency contact information for local emergency services, including fire department, medical assistance, and hazardous materials response teams, is readily available.
- **Emergency Equipment and Supplies:** Maintain well-stocked emergency response

equipment and supplies in easily accessible locations throughout the composting plant. This may include fire extinguishers, first aid kits, emergency eyewash stations, and spill response materials. Regularly inspect and maintain emergency equipment to ensure functionality.

- **Training and Responsibilities:** Train employees on their specific roles and responsibilities during emergencies. Assign designated individuals or teams to perform critical tasks such as operating emergency equipment, assisting with evacuation, or contacting emergency services. Regularly update and review emergency response procedures to reflect any changes in the plant layout or operations.
- **Preparation of a Business Continuity Plan (BCP)** in case of a major event (such as a pandemic or a natural disaster) is recommended.

In addition to the general emergency response procedures for the composting plant, specific measures must be taken for the forced aeration system. Such as:

- **System Shutdown:** In the event of an emergency, immediately shut down the forced aeration system to prevent further escalation of the situation. Follow established shutdown procedures and secure energy isolation points using lockout/tagout devices.
- **Isolation of Hazardous Areas:** Identify and isolate any hazardous areas associated with the forced aeration system. This may include hot surfaces, electrical panels, or confined spaces. Ensure these areas are clearly marked and access is restricted to authorized personnel only.
- **Reporting and Communication:** Promptly report the emergency to the appropriate personnel and communicate the nature of the incident. Provide accurate and detailed information to emergency responders to facilitate their response and ensure they are aware of any specific hazards related to the forced aeration system.

By implementing comprehensive emergency response procedures and regularly training personnel on their roles and responsibilities, the composting plant equipped with a forced aeration system can minimize the potential impact of accidents or emergencies. Conduct regular reviews and drills to ensure the effectiveness of the emergency response plan and maintain a culture of safety throughout the facility.

## **9 Operation, Monitoring and Maintenance Procedures for the aeration system**

### **9.1 Operation and Monitoring of the Aeration System**

#### **9.1.1 Waste discharging and compost pile making**

- ① Waste can be directly unloaded on the floor, starting from the edge of the aeration ditch leaving a minimum 50 cm gap between the leachate drainage canal and base of the waste pile.
- ② Operator must make sure that the aeration ditch is at the center of the pile.
- ③ Waste pile can make in trapezoidal shape with 5.0 m base width and 1.5 m height.
- ④ Loader or skid-steer loader can be used to pile up the waste and keep the shape of the waste pile. However, waste should not be compacted.
- ⑤ The waste pile can be extended up to 15 m length.

#### **9.1.2 Operation of aeration system**

- ① Switch on the aeration blower (or open the air pipe valve if the blower is pumping air to an adjacent pile).
- ② Blower time controller is set to blow air for 15 minutes, automatically switched off and rest for 15 minutes, and then witch on for another 15 minutes. The process moves on continuous cycle.
- ③ Do not switch off the blower until active composting phase ends on 8th week.
- ④ If blower does not automatically switch on after power failure, manually witch on the blower by pressing the green switch on the control panel.
- ⑤ Do not open the power control box without supervision of technician or electrician.

#### **9.1.3 Operation and maintenance of leachate collection and drainage system**

- ① The leachate drainage valve in each ditch should be kept closed during the normal operation.
- ② However, the valve should be opened and allow to drain all leachate once in every day.
- ③ Make sure to close the leachate drain valve after draining all leachate.

#### **9.1.4 Monitoring of aeration system**

- ① Aeration system was designed to supply enough air for each pile. Therefore, specific monitoring is not required.
- ② If the operator observes obstruction of air flow or suspicious of insufficient aeration, insert the pressure gauge tube to a minimum depth of 1.5 m in the pile and measure the air pressure. Air pressure should be more than 500 Pa (10 millibar) at the far end of the compost pile.

### 9.1.5 Monitoring of temperature

- ① Measure the temperature of each forced aerated pile in three locations at 30 cm depth.
- ② Temperature should be measured and recorded every day.
- ③ If an unusual drop of temperature below 40 °C is observed, measure the pile temperature twice a day. If low temperature is continuously observed (more than 2 consecutive days) during the active composting period (1-8th weeks), compost pile should be mixed by the loader and re-established.

### 9.1.6 Turning of forced aerated piles

- ① Forced aeration system supplies sufficient quantity of air to each pile. Therefore, windrowing (Turning) is not necessary during the first eight weeks (8).
- ② However, turning the compost pile on 4th week after establishment will help to uniformly mix waste and increase decomposition.

### 9.1.7 Sending composted feedstock for maturing

- ① After eight weeks of forced aeration, composted feedstock can be placed in the maturing area for maturation.
- ② It is recommended to keep the feedstock for another 6 weeks or more for maturation.
- ③ Compost can be extracted by sieving after maturation.

### 9.1.8 Health and safety measures

- ① There are no extra health and safety risk due to forced aerated composting system.
- ② However, operator should not try to change or test the power control unit of the blower without the supervision or instruction of an electrician.

## 9.2 Maintenance of the Aeration System

Maintenance of the compost plant's aeration system, encompassing components such as the blower, piping, and power supply, is of paramount importance to ensure its efficient and effective operation. Regular maintenance activities play a crucial role in preserving the system's functionality, maximizing its lifespan, and minimizing the risk of unexpected breakdowns or malfunctions. The blower, a critical component responsible for supplying the necessary air flow, should be inspected and serviced periodically to maintain its performance and prevent potential issues such as motor failures or air leaks. Piping and diffusers, which distribute the airflow throughout the composting area, should be inspected for clogs, leaks, or blockages that could hinder proper aeration.

Regular cleaning, repair, or replacement of these components as needed is essential to optimize oxygen transfer, maintain appropriate temperature levels, and ensure uniform decomposition of organic matter. Adhering to a comprehensive maintenance schedule not only

guarantees the smooth operation of the aeration system but also enhances compost quality, odor control, and overall plant efficiency.

## 10 Conclusions and recommendations

The introduction of the aeration system can help **to increase the speed of the composting process** and **mitigate the odor issues** at the composting plant, it will allow to treat more waste with less impact on the environment and on the neighboring residents.

There are several key operation and maintenance practices that should be considered when using the forced aeration system for composting. Such as:

- **Monitoring temperature and moisture:** Temperature should be maintained between 55-65°C for efficient composting, while moisture levels should be kept between 40-60%.
- **Maintaining oxygen supply:** The air supply should be monitored regularly and adjusted as needed to maintain optimal oxygen levels.
- **Turning the compost:** Regular turning of the compost pile is necessary to ensure even distribution of oxygen and nutrients throughout the pile. With the aeration system, the frequency of turning is significantly reduced.
- **Regular maintenance of equipment:** Regular maintenance and cleaning of the forced aeration system equipment is important to ensure optimal performance and prevent breakdowns or malfunctions. This may involve regular inspections, cleaning, and replacement of parts as needed.

In addition, the effectiveness of forced aerated composting system can be increased by:

- Using decomposing agents (EM). The usual application procedure can be applied.
- Covering the compost pile by a layer of sieving rejects. A minimum 15 cm thick layer of rejects must cover the entire compost pile.
- Adding a layer of matured compost or sieving rejects as the base layer of the composting pile. A 20-30 cm layer of sieving rejects can be used



## 別添資料 9

### 住民との合意形成に関するガイドライン







別添資料9



THE PROJECT FOR FORMULATION OF  
WESTERN PROVINCE SOLID WASTE  
MANAGEMENT MASTER PLAN SRI LANKA

General guidelines on Consent-  
building for the Improvement of  
Operations

March 2023

# Contents

別添資料9

1. Background
  2. Purpose and Objectives
  3. Brief Overview of the MP
- Approach and Methodology**
1. Approach and Methodology
  2. Approach and Methodology in the MP

## **APPROACH 1: hearing opinions**

- 1.1 Focus Group Discussion
- 1.2 Focus Group Discussion in the MP
- 1.3 Focus Group Discussion Results
- 2.1 Public Opinion Survey
- 2.2 Public Opinion Survey in the MP
- 2.3 Public Opinion Survey Results

## **APPROACH 2 & 3: Training and Raising Awareness**

- 1.1 Training of Trainer's
- 1.2 Trainer's Training in the MP
- 2.1 Social Awareness
- 2.2 Social awareness in the MP

## **APPROACH 4: Monitoring**

- 1.1 Monitoring Committee
- 1.1 Monitoring Committee in the MP

## **TIMELINE**

References, Useful Resources  
Appendix

# 1. Background

## Solid Waste Management Problems:

- Caused by increase in waste amount and unregulated informal sector expansion due to urbanization and economic growth.

## In the case of Sri Lanka:

- Public and Political Unrest:
  - collapse of the Meethotamulla landfill April 2017 led to protests
  - Protests spread to far-flung areas where waste treatment facilities are planned to be built
- Underlying cause of conflicts:
  - Failure to consider social dimensions
  - Lack of community perspective in solutions

There is a need to give due attention to the social aspects.



Fig. 1 Meethotamulla Garbage Dump Collapse  
Source: Disaster Services ([Meethotamulla - Disaster Services](#))

## 2. Purpose and Objectives

### Purpose of this manual

1. Impart methods to understand community concerns, and impact of the proposed Project on social organization and the physical environment
2. Impart methods to build consensus

### Specific objectives

1. To collect background Socio-economic data necessary for project planning, monitoring and evaluation.
2. To identify impacts, both benefits and adverse impacts, concerns and potential obstacle in proposed project
3. Recommend mitigatory measures considering the community concern

In this manual, we will **explore how to achieve the objectives** through examples from "The Project for Formulation of Western Province Solid Waste Management Master Plan" (MP from here on).

**Each explanation will be followed by examples from the MP**

## 3. Brief Overview of the MP

**Objective:** To assist Western Province in filling the gaps in its management of solid waste by formulating an evidence-based solid waste management Master Plan (MP) that encompasses medium to long-term forecasts and a range of proposed solutions to the waste problems.

- Output 1. Roles and responsibilities of organizations are clarified
- Output 2. Current situations and challenges are clarified.
- Output 3. Knowledge and experience are acquired through pilot projects on appropriate waste management and 3Rs. (Target areas: Colombo Municipality and other LAs).
- Output 4. Knowledge and experience are acquired through pilot projects for improving planning/ operation of waste management facilities.
- Output 5. Collaboration and coordination among relevant organizations are strengthened.

# 3. Brief Overview of the MP

別添資料9

**Objective:** To assist Western Province in filling the gaps in its management of solid waste by formulating an evidence-based solid waste management Master Plan (MP) that encompasses medium to long-term forecasts and a range of proposed solutions to the waste problems.

- Output 1. Roles and responsibilities of organizations are clarified
- Output 2. Current situations and challenges are clarified.
- Output 3. Knowledge and experience are acquired through pilot projects on appropriate waste management and 3Rs. (Target areas: Colombo Municipality and other LAs).
- Output 4. Knowledge and experience are acquired through pilot projects for improving planning/ operation of waste management facilities.
- Output 5. Collaboration and coordination among relevant organizations are strengthened.

Need to build consensus with the community

At the pilot project site, there are two waste management facilities: **compost plant** and **open dumping site**.

The MP aims to establish:

- Small scale solid waste transfer station at Kalutara composting facility
- Forced aeration system in existing Kalutara composting facility

# Approach and Methodology

# 1. Approach and Methodology

## Problem-solving Process

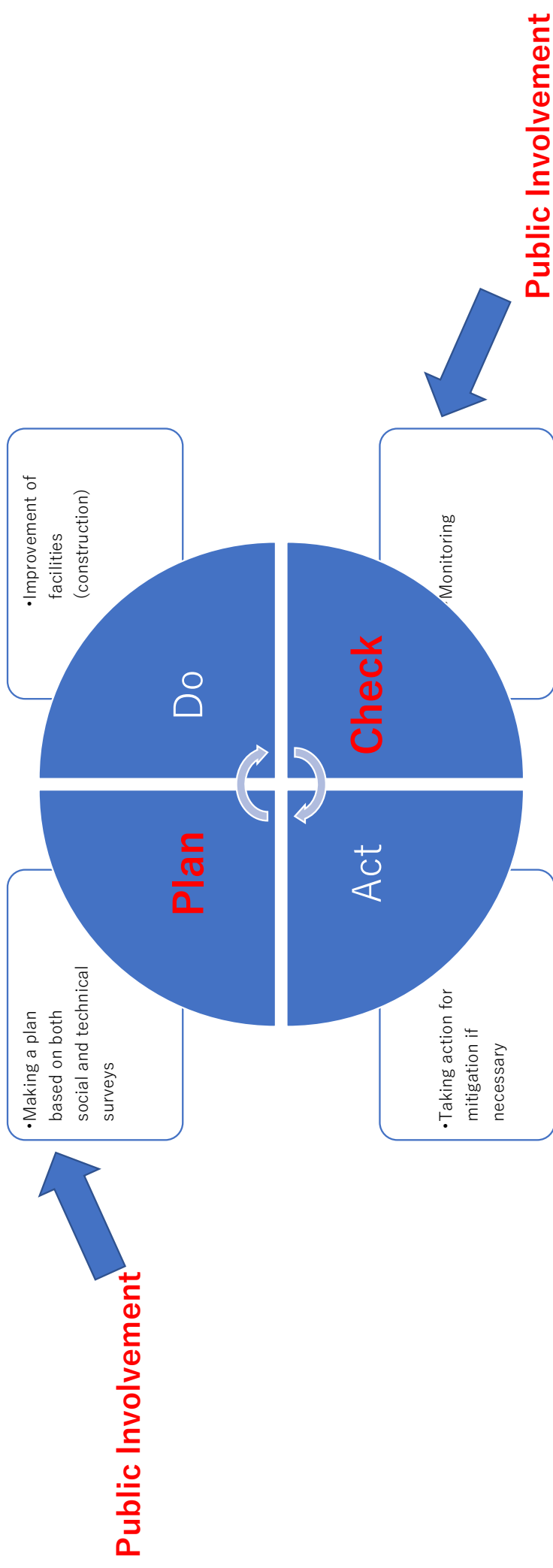



# 1. Approach and Methodology



## **APPROACH 1:** Hearing opinions and perspectives

1. Grasp complaints and requests received from community in the neighboring area of the project site before planning, during planning and during implementation.
2. Understand social problems identified at the project site



## **APPROACH 2:** Training

Conduct training of trainers so as to ensure smooth communication and raising awareness

## **APPROACH 3:** Raising Awareness

Based on the results of the survey and interviews, conduct social awareness sessions and campaigns for the community regarding project



## **APPROACH 3:** Monitoring

Before, during and after implementation of project, conduct monitoring of environmental issues and make the results available to public

# 2. Approach and Methodology in the MP

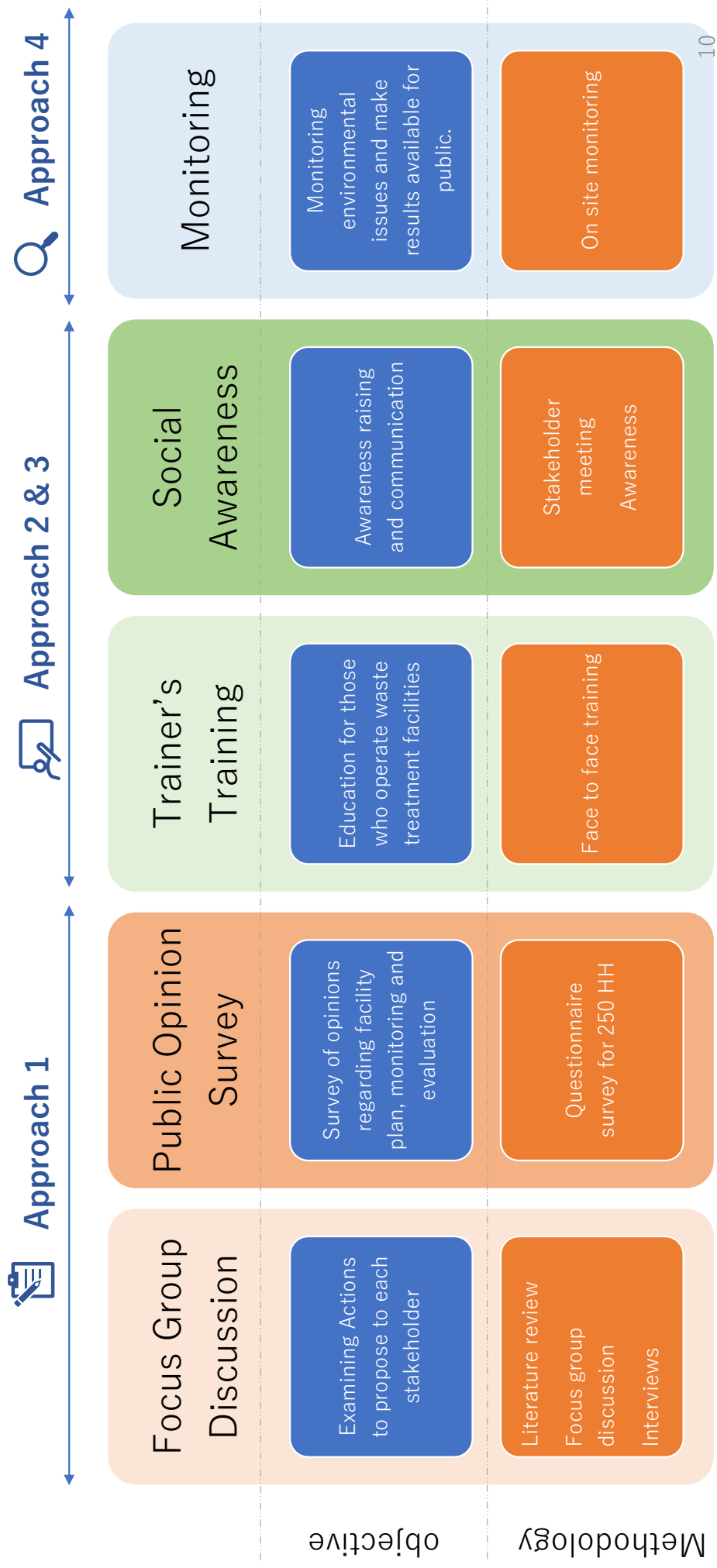

# APPROACH 1: Hearing Opinions

# 1.1 Focus Group Discussions

## Specific Objectives

1. To be familiar with the area and build a good rapport with the community
2. Obtain in depth information about the problems at the community level both to prepare the questionnaire for baseline survey and to use in the formulation of Mater Plan Strategies

## **STEP 1** - Selected the study Participants

- representing different segments of the community

## **STEP 2** – Prepared question set based on main areas of concern

**STEP 3** – conducted interviews and recorded it (ensured participants were aware of being recorded)

## **STEP 4** – Transcribed interviews and analyzed the data.

### **Key Point:**

Can consult with professionals/ previous research to design the questionnaire.

# 1.2 Focus Group Discussion in the MP

別添資料9

## Focus Groups:

### Group 1:

Officials directly connected with Mihisaru Compost

### Group 2:

Office Staff and Field Staff of Mihisaru Compost

### Group 3:

Community leaders and members

### Group 4:

Employees of 2 nearby institutions

### Group 5:

6 villagers

### Group 6:

5 Business Owners

### Group 7:

15 school children

### Group 8:

Five high level administrative officers and holders of political office

## Main areas of Discussion

1. Understand the community perspective of the Composting Plant Complex/Yard and the Open Dump including, history, operations and other connected issues
2. Understand both negative and positive impacts of the Compost Yard and the Open Dump in the community.
3. Understand the reasons behind the negative impacts/problem of the Compost Yard and the Open Dump
4. Understand the community views on the potential solutions to negative impact of both facilities.
5. To find out whether there may be obstacles from the community to in the form of conflicts, attitudes etc. in future implementation of the Master Plan in the are of community participation
6. Obtain views on the establishment of a “transfer station” instead of Open Dump
7. Understand the waste collection practices in the area, and review their pros and cons and make suggestions

# 1.3 Focus Group Discussion Results

別添資料9

- Discussion about compost plant and open dumping site at Kalutara Compost Plant

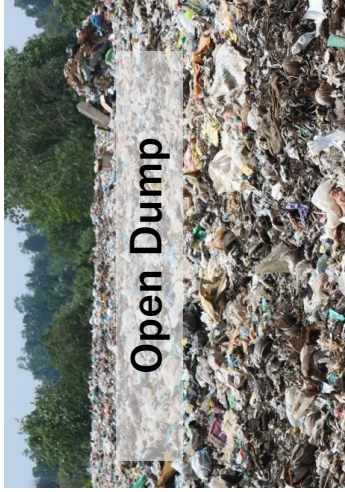

- Waste is dumped in open space with mixed waste
- Animals are attracted to open dumped waste.
- High degree of environmental pollution
- Strong and unpleasant odor
- Waste accumulation is a potential hazard
- Open dumping site is in a wetland area, which is unsuitable for environmentally sensitive waste dumping.
- There are no environmental protection measures other than covering the waste with earth at irregular intervals by court order.

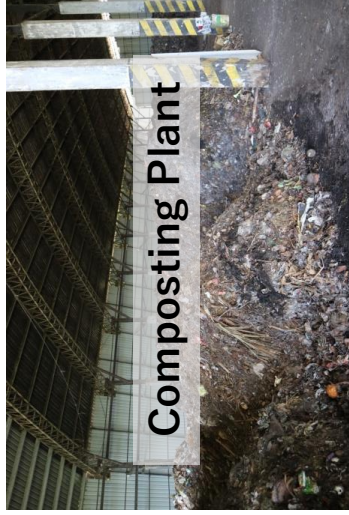

- Separated waste is deposited
- Waste is not exposed to natural elements. No attraction to scavenging animals.
- Minimum levels of environmental pollution due to the type of waste that is brought in separated and processed quickly
- Unpleasant odor, particularly when the waste is rolled or mixed, but not as unpleasant or offensive as that coming from the open dumping.
- No hazards as waste is recycled as compost. However, there have been complaints that Kalutara UC brings in waste that is not suitable for treatment (including non-biodegradable materials) and calls it degradable waste.
- Composting Yard and Plant Complex is a planned operation incorporating environmental safeguards

# 1.3 Focus Group Discussion Results

別添資料9

## Proposal of community:

- **Open dump: Closure**
- **Composting plant: Rehabilitation**
  - Establishment of buffer zone (from Road to Composting Plant)
  - Relocation of the composting plant to back yard
  - Environmental improvements to the facilities (e.g., construction of flower beds, artificial waterfalls, water fencing, green fencing with weeping willow and other tall trees)
- Installation of separate entrances or gates (if transfer station is to be developed).
- Introduce new technology to control odors.
- Improvement of compost quality by sorting waste
- Provision of free or subsidized household composting to nearby residents.
- Involvement community representatives as members of 'management committees' and 'monitoring committees'.
- Use environmental police and environmental committees.



Fig 2: Focus Group meeting (Group 1)



Fig 3: Focus Group meeting (school) (Group 4)



Fig 4: Focus Group meeting (Group 7)

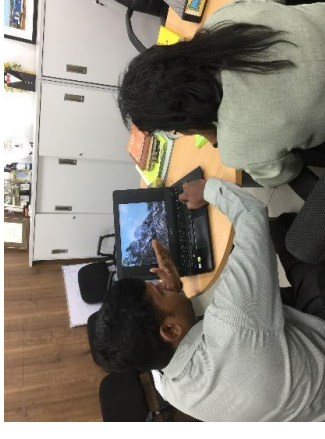

Fig 5: Focus Group meeting (Group 1)

# 2.1 Public Opinion Survey

別添資料9

## **Objective:**

1. understand the potential social obstacles arising in the community when implementing the proposed project
2. identify the environmental and socio-economic consequences of the existing solid waste management, as well as to understand community concerns and impact of the Project.

**STEP 1** – Chose target area and target number of respondents.

**STEP 2** – Created the survey

**STEP 3** – Distributed survey using trained interviewers

**STEP 4** - Analyzed the results

## **Key Point:**

Can consult with professionals/ previous research to design the questionnaire.





## 2.3 Public Opinion Survey Results

Impact of open dumpsite and composting plant are divided into

1. Environmental Impacts
2. Social and Economic Impacts
3. Future Development Activities



Fig 7. Training for interviewers before conducting the survey



Fig 8. Socio-economic survey to residents



Fig 9. Resident took the surveyors to the landfill at backyard of his house



Fig 10. Interview survey to temple in front of the compost plant

# 2.3.1 Environmental Impact

別添資料9

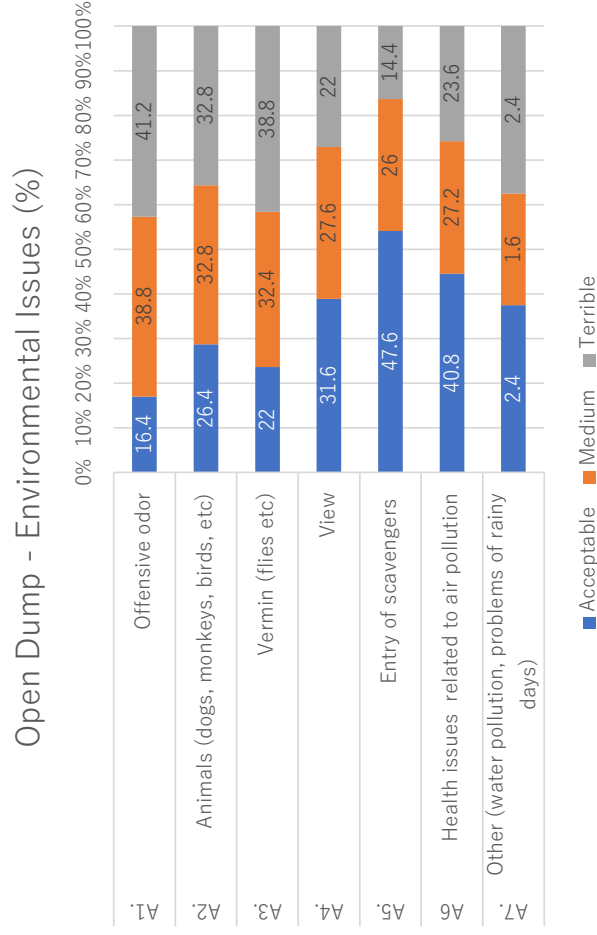

Figure 11. Open Dump Environmental Effect

- Offensive odor is the major problem caused by the two facilities as increasing of waste volume.

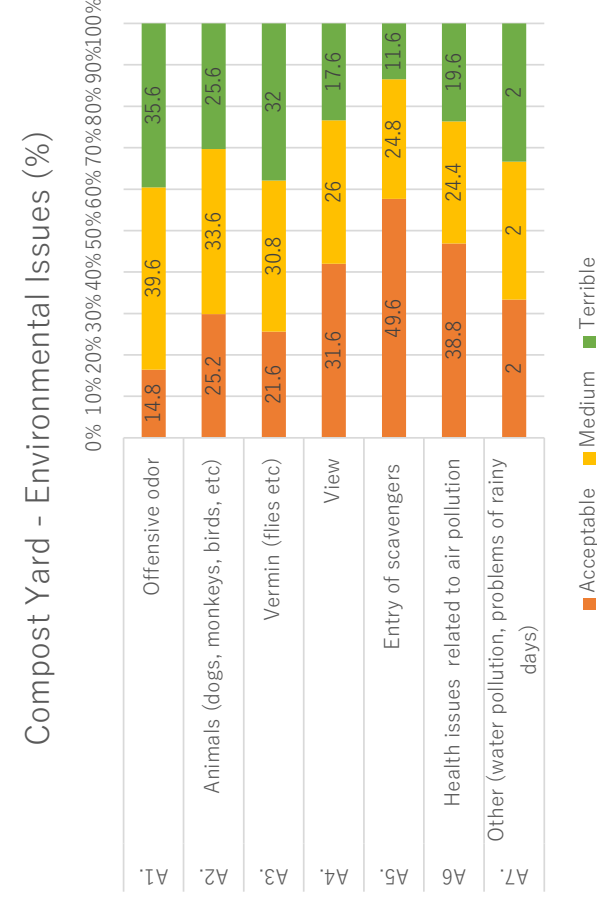

Figure 12. Composting Yard Environmental Effect

- Offensive odor is the major problem caused by the two facilities as increasing of waste volume.
- Other critical environmental issues caused by the two facilities are increasing number of animals scavenging at landfill site and vermin.

# 2.3.1 Environmental Impact – Local Authority

別添資料9

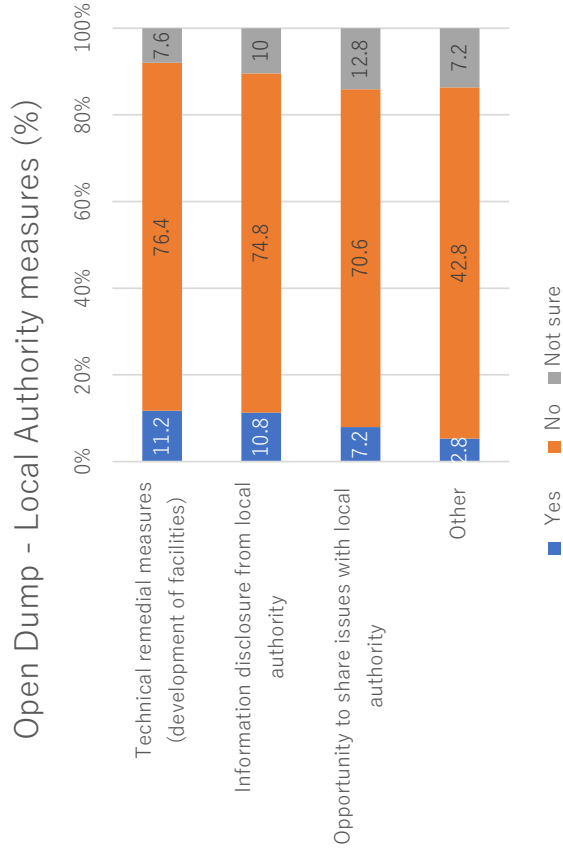

Figure 13. Open Dump – remedial measures by Local Authority

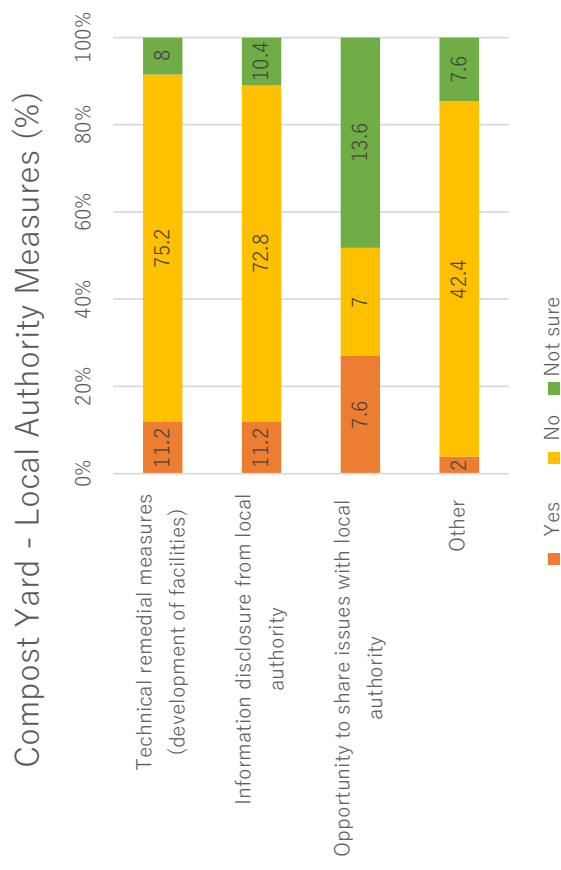

Figure 14. Composting Yard remedial measures by Local Authority

- Residents understand that no practical measures have not been taken by local authority to solve the above-mentioned environmental issues.

## 2.3.1 Environmental Impact – Local Authority

別添資料9

### **Possible Reasons according to the community**

- regulatory deficiencies
- nonadherence to court directives in terms of mitigating public harassments
- insufficient workforce and other resources.
- lack of coordination
- lackadaisical attitude towards the community issues by the responsible heads of the authorities.

## 2.3.1 Environmental Impact – Local Authority

別添資料9

### **Possible solutions according to the community**

- proper monitoring system and supervision to manage activities of both compost yard and open dump.
- compliance to relevant Acts, Court directives and other regulatory requirements
- respecting the public in all concerns
- informed decision making should be taken place rather than taking decisions on various interests and influences.

## 2.3.1 Environmental Impact – Project Acceptance

別添資料9

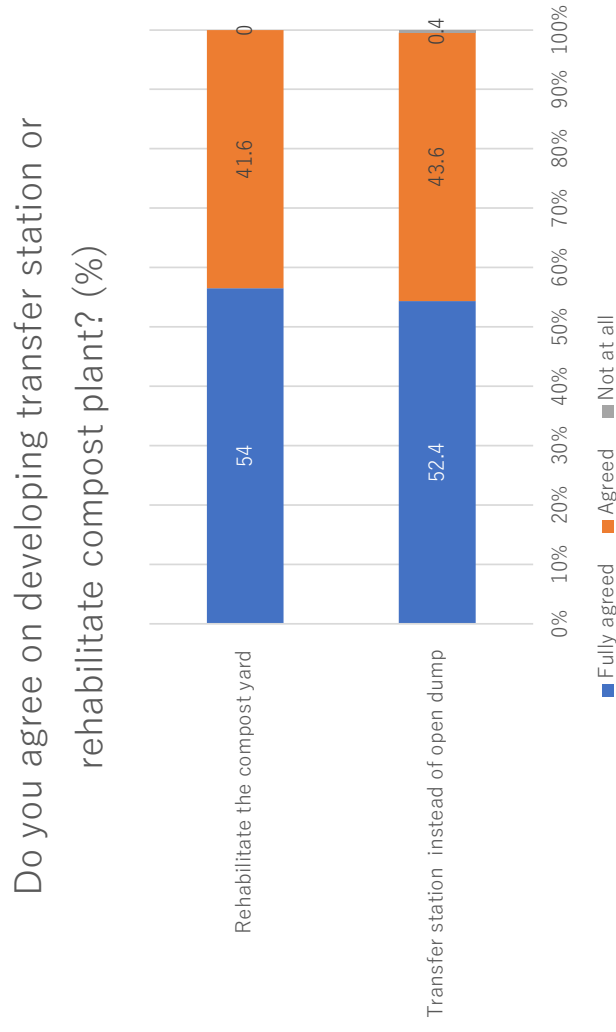

Figure 15. Agreement to project developments

- residents fully agree/agree to developing transfer station and rehabilitation of compost plant

## 2.3.1 Environmental Impact – Project Acceptance

別添資料9

### Regarding Transfer Station

- Before establishing the transfer station organize a demonstration to show its operations
- Create awareness about its potential positive impact.
- Do not bring waste from other Local Authorities
- Do not leave waste on the site for a period more than necessary.
- Waste brought to the Dump should be transferred on regular basis (preferably daily) so that there is no accumulation of waste on the site.
- Need to establish a “management committee” as well as “monitoring committee” with community representatives
- Adopt suitable treatment methods to control odor (bad smell)



## 2.3.1 Environmental Impact – Project Acceptance

別添資料9

### Regarding Compost Yard Rehabilitation

- Establish a buffer zone( from Road to Compost Plant )
- Move the compost yard to the back of the complex and bring the control office to the front
- Beautification of the compost yard (flower beds, water fence, green fence, artificial waterfalls)  
Construct a separate entrance/gate
- Adopt new technology to control the stench generated by the composting complex
- Reactivate the system of segregation of waste to improve quality of compost
- Need to add community representatives as members of a “management committee” as well as “monitoring committee “
- Get the service of environment police and environment committee
- Give more job opportunities to villagers in the compost yard

# 2.3.1 Environmental Impact - Activities

別添資料9

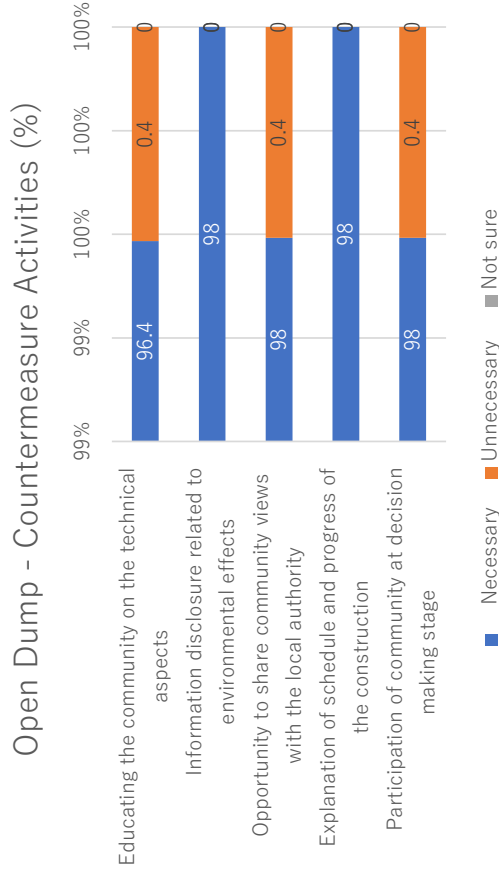

Figure 16. Open Dump Counter Measure Activities

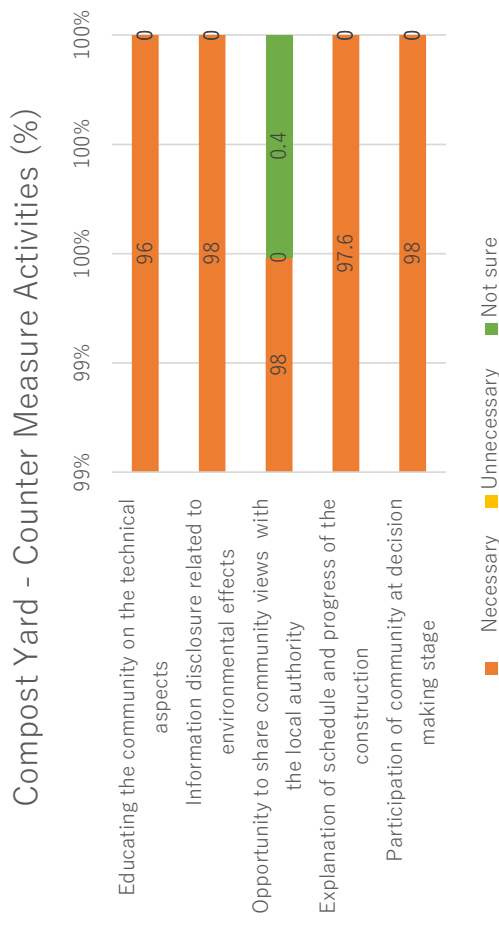

Figure 17. Compost Yard Counter Measure Activities

- Residents expect local authority to **educate community** on technical aspects, information disclosure related to environmental effects, opportunity to share community views with local authority, explanation of schedule and progress of the construction and participation of community at decision making.

# 2.3.3 Future Development Activities

別添資料9

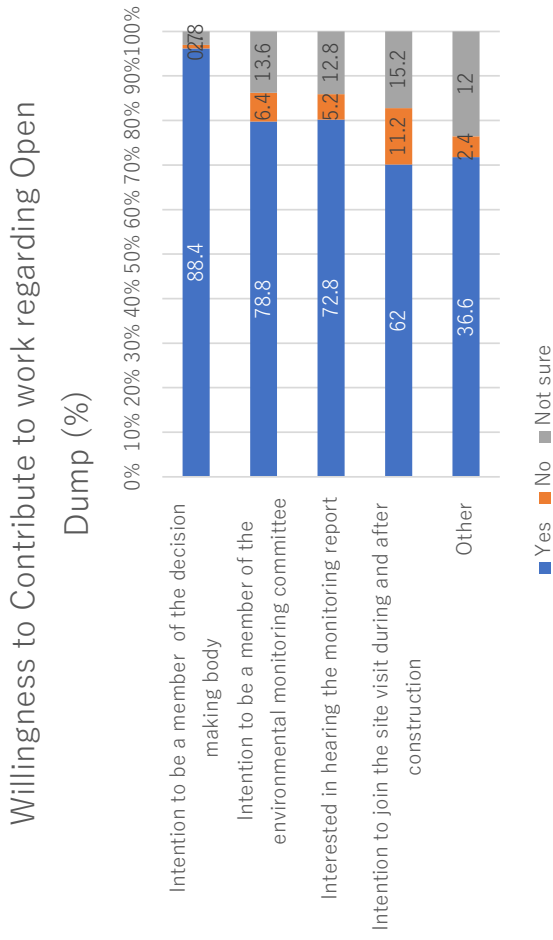

Figure 18. Open Dump Future Development Activities

Large majority prefer to be a member of decision-making body of both the open dump and the compost yard (approximately 88.4% and 82.0% respectively).

Similar majority is interested in being a member of the **Monitoring Committee** as well.

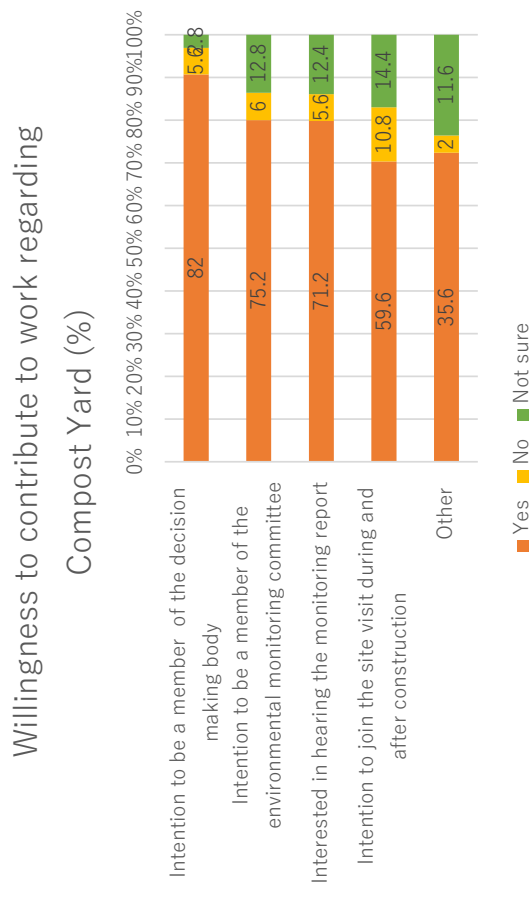

Figure 19. Compost Yard Future Development Activities

# APPROACH 2 & 3: Training and Raising Awareness

# 1.1 Training of Trainers

**Objective:**

1. To coach new trainers that are less experienced with consensus building, or with training
2. Build a pool of competent instructors who can conduct social awareness

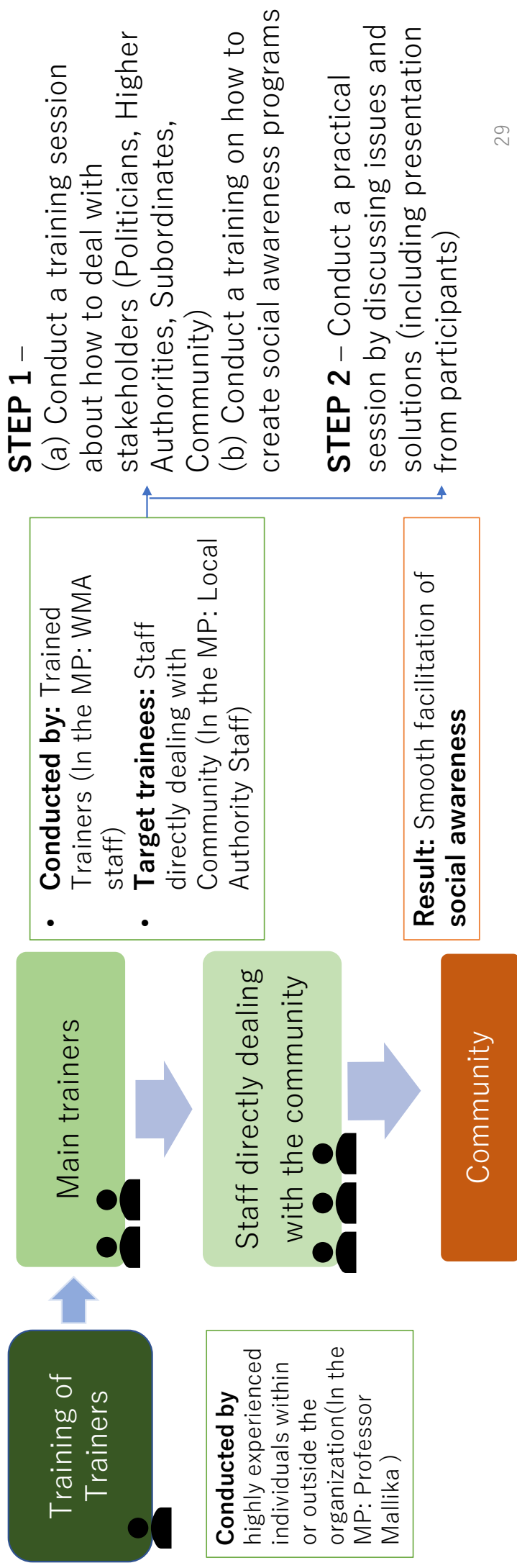

# 1.1 Training of Trainers

## Conducting ToT using Experiential Model

**Model:** ‘Involving’ participants in a training workshop in an active way that incorporates their own experience

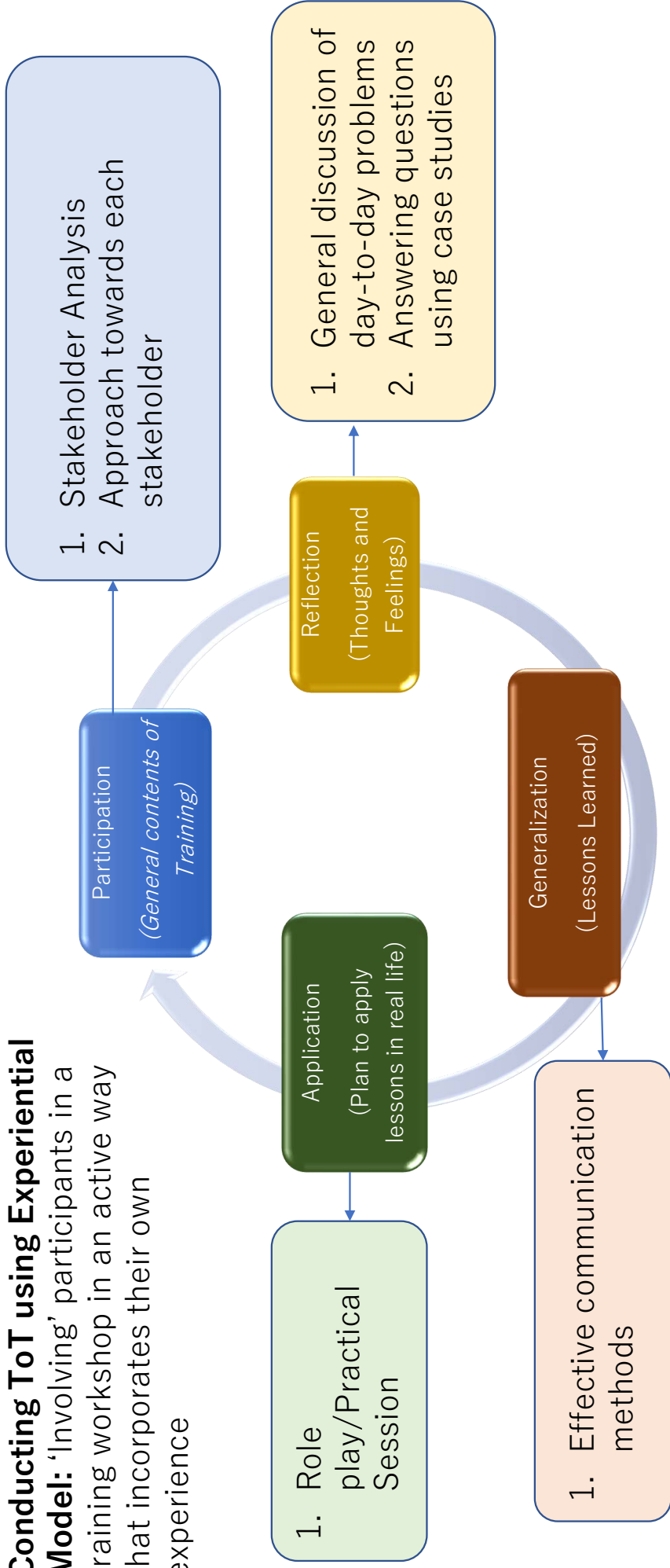

Figure 20: Experiential Model  
Source: United Nations Population Fund and Youth Peer Education Network (2005)

# 1.1 Training of Trainers

別添資料9

Participation  
*(General contents  
of Training)*

## 1. Stakeholder Analysis:

Stakeholder analysis: identifying and describing role of stakeholders based on their characteristics, relationships, and interests towards the issue of concern (Ramirez, 1999).

Steps to conduct:

1. Identify principal stakeholders;
2. Investigate stakeholder interests, characteristics, and circumstances;
3. Identify patterns and contexts of interaction between stakeholders; and
4. Discuss appropriate approach towards each stakeholder (Grimble et al., 1995, p. 7)

# 1.1 Training of Trainers

Reflection  
(Thoughts and  
Feelings)

## 1. General Discussion of Day-to-day Problems:

Free space for participants to express their everyday problems  
Discussion among participants regarding problems and possible solutions

## 2. Answering Questions Through Case Studies:

Facilitators mention case studies (from either personal experience or from case studies) to address the problems.

Generalization  
(Lessons Learned)

## 1. Effective Communication Methods:

Remember the names of person  
Find Common background  
Listen carefully and sincerely  
Question respectfully  
Body language should be friendly and positive



# 1.1 Training of Trainers

Application  
(Plan to apply  
lessons in real  
life)

## 1. **Role Plays/Drama** (United Nations Population Fund and Youth Peer Education Network (2005))

- Create a scene of a difficult situation with the community
- Assign roles to participants (1 or 2 per scene)
- Enact the scene
- Discuss the scene with all participants
- Offer comments and recommendations

## 2. **Practical Session**

- Grouping of participants
- Discuss an issue that group has to face and how to solve it using skills learned (involves field observation)
- Presentation by participant

# 1.2 Training of Trainers in the MP

別添資料9

<b>Date</b>	17 <sup>th</sup> January, 2023
<b>Venue</b>	Western Provincial Council
<b>Number of Participants</b>	14 (including WMA staff, CEA staff, NSWMSC staff)
<b>Purpose</b>	<p>To understand how to deal with various stakeholders</p> <p>To have basic knowledge in order to conduct a training program</p>
<b>Agenda</b>	<ul style="list-style-type: none"> <li>Lecture by Professor Mallika on what is ToT, how to deal with stakeholders,</li> </ul>
<b>Key Takeaway</b>	<ul style="list-style-type: none"> <li>2.5 hours of training was conducted</li> <li>Upcoming timeline of activities was confirmed</li> <li>Trainers' communication group (on WhatsApp) was established</li> </ul>



Fig. 21 Training by Professor Mallika



Fig. 22 Hearing issues by WMA staff

## 2.1 Social Awareness

**Objective:**

1. To establish mutual understanding between stakeholders
2. To pass on relevant information
3. To discuss future steps
4. To get community opinion and ideas

**STEP 1:** Explain the project in detail (technical aspect)

**STEP 2:** Discuss the results of the survey (social aspect)

**STEP 3:** Question and Answer session; Open discussion about future plans and consensus building

## 2.1 Social Awareness

### **STEP 1:** Explain the project in detail (technical aspect)

- ◆ Giving kind explanation on technical improvement by using pictures, graphs, tables, but to avoid being over-specialised
- ◆ Clarifying what is to be improved and why it is needed
- ◆ Giving a detailed timetable
- ◆ Informing of any anticipated impacts (noise, dust, and etc) during construction, if any
- ◆ Giving a clear image of the improvements, before and after construction
- ◆ Addressing residents' concerns and seeking their cooperation and understanding

## 2.1 Social Awareness

### **STEP 2:** Discuss the results of the survey (social aspect)

- ◆ Giving kind explanation on the result of the social survey by using pictures, graphs, tables, but to avoid being over-specialised
- ◆ Giving kind explanation on the improvement plan according to the result of the survey, reflection of residents' voice and concerns
- ◆ Giving a kind explanation on remaining concerns if any and mitigation plan
- ◆ Addressing residents' concerns and seeking their cooperation and understanding

## 2.1 Social Awareness

**STEP 3:** Question and Answer session; Open discussion about future plans and consensus building

- ◆ Encouraging the participation of people from as many different positions and genders as possible
- ◆ Listening to each person until the end and do not disturb when they are giving their opinions
- ◆ Focusing on listening to opinions and do not force solutions or dismiss opinions
- ◆ Addressing residents' concerns and seeking their cooperation and understanding

## 2.2 Social Awareness in the MP

別添資料9

<b>Date</b>	6th November 2022
<b>Venue</b>	Nagoda MahaVidyalaya (school)
<b>Number of Participants</b>	10 (monks and community leader)
<b>Purpose</b>	Mutual understanding of current situation and future requirements
<b>Agenda</b>	<ul style="list-style-type: none"> <li>Findings of the Survey: Prof. Mallika Pinnawala, University of Peradeniya</li> <li>Details of 2 Pilot Projects (Forced Aeration Composting PP and Transfer Station): Dr. Naofumi Sato, Leader of JICA Project</li> <li>Q &amp; A</li> </ul>
<b>Key Takeaway</b>	<ul style="list-style-type: none"> <li>Understood and confirmed the current situation.</li> <li>Agreed to establish a <b>monitoring committee</b> to monitor the facilities frequently and continuously.</li> </ul>



Fig 23. Welcome speech given by WMA staff Ms. Niranja



Fig 24. Sharing the findings of the survey by Prof. Mallika

# APPROACH 4: Monitoring



# 1.1 Monitoring Committee

## **Objective:**

1. To involve stakeholders in project process
2. Evaluating status of the project site
3. To establish a system to deliver information/updates
4. To enable constant feedback checking

**STEP 1:** Select willing members for the monitoring committee (across all stakeholders)

**STEP 2:** Decide the contents of the project site evaluation sheet and frequency of monitoring committee

**STEP 3:** Conduct session for information sharing, and evaluation of project site by committee members (before, during and after project implementation)

**STEP 4:** Make the data of the evaluation public and consider mitigation measures

# 1.1 Monitoring Committee

別添資料9

**STEP 1:** Select willing members for the monitoring committee (across all stakeholders)

Position	Kalutara
Chairman	Chairman of UC/PS
Member 1	Assistant commissioner Local Government
Member 2	Director of WMA
Member 3	District manager, WMA
Member 4	Manager of the facility, WMA
Member 5	Deputy Director of CEA (Kalutara)
Member 6	MOH (Kalutara)
Member 7	OIC (Kalutara Police Environment)
Member 8	From Divisional Secretary
Member 9	Community Leader 1
Member 10	Community Leader 2
Member 11	Community Leader 3

The committee should preferably be chaired by UC/PS chairman, the facility owner, however, depending on the circumstances, WMA director can also be conducted it.

# 1.1 Monitoring Committee

**STEP 2:** Decide the contents of the project site evaluation sheet and frequency of monitoring committee

- ◆ Preparing monitoring / evaluation sheet for each target facility
- ◆ Evaluating on environmental and social effect, and function of facilities after completion of construction
- ◆ Evaluation items should be considered based on the results of the survey (neighbourhood concerns).
- ◆ Considering evaluation scores and criteria

Checklist done by Monitoring committee for compost		Date/Time:	
කොමිටියේ අංශය අගයන කමිටුව සඳහා පිරික්සුම් ලැයිස්තුව		Time/වේලාව:	
Category A / A බැඳවිය: Environmental and social effect / සාමාජික සහ සාමාජික බලපෑම (Before, during and after construction) ඉදිකිරීමට පෙර, ඉදිකිරීම අතරතුර සහ ඉදිකිරීමෙන් පසු			
No/අංශ	Item / අයිතමය	Score*/ ලකුණ	Notes/ සටහන්
A1.	Offensive odour දුර්ගන්ධය (Animals (dogs, monkeys, birds, etc) සතුන් (බල්ලන්, චිත්තුන්, කුරුල්ලන් ආදී))		
A2.			
A3.	Vermun(flies etc) කෘමීන් (මැස්සන් ආදී)		
A4.	Dust දුර්ලි		
A5.	Leachate අප ජලය		
A6.	Overall Cleanmess of the site ක්ෂේත්‍රයේ පිරිසිදු බව		
A7.	Image/ Discrimination/නිරෝධය / ප්‍රතිචාර		
A8.	Information disclosure තොරතුරු නිරූපණය		
A9.	Opportunity to share issue ගැටළු ඉදිරිපත් කිරීමට ඇති ඉඩප්‍රස්ථා		
		*0-33%: Acceptable, 33-66%: Medium, 67-100%: Terrible	
		Total of Category A/A වැරදවිය සඳහා මුළු ගණන	

# 1.1 Monitoring Committee

**STEP 3:** Conduct session for information sharing, and evaluation of project site by committee members (before, during and after project implementation)

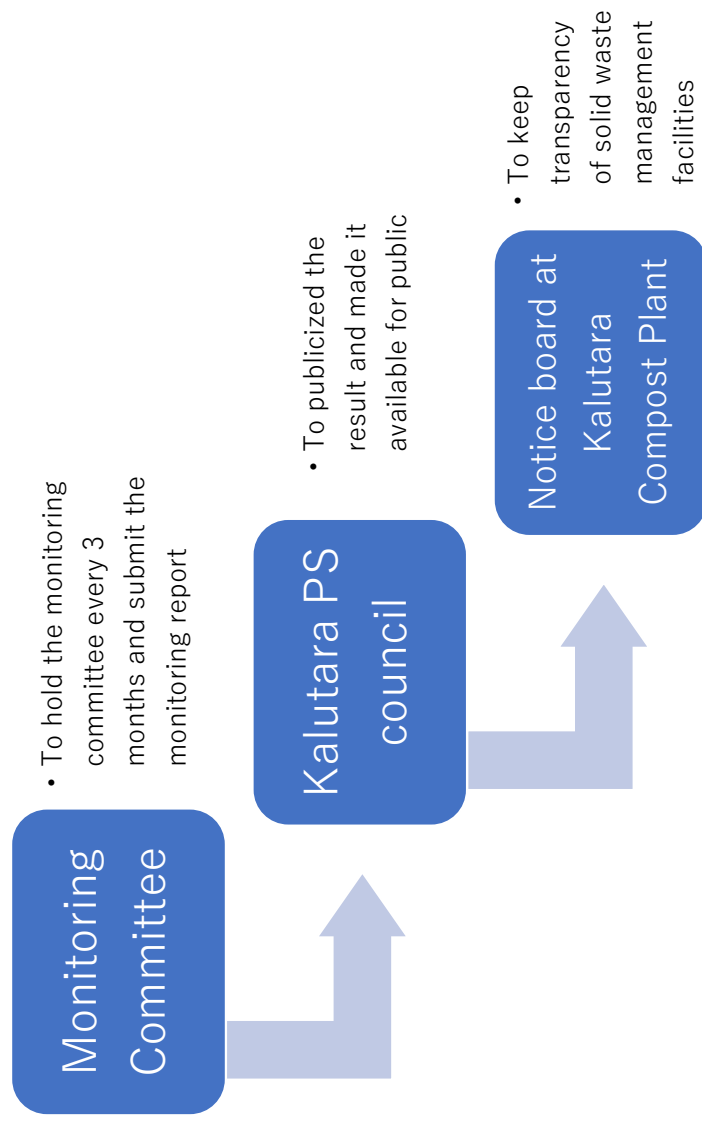

**STEP 4:** Make the data of the evaluation public and consider mitigation measures

# 1.2 Monitoring Committee in the MP

別添資料9

<b>Date</b>	18 <sup>th</sup> January 2023
<b>Venue</b>	Mihisaru Compost Plant, Kalutara
<b>Number of Participants</b>	19 participants
<b>Purpose</b>	Report the progress of Compost Plant improvement to the monitoring committee and have them evaluate the baseline condition before improvement.
<b>Agenda</b>	<ul style="list-style-type: none"> <li>• Presentation of current project (Mr. Nalin Mannapperuma, Director of WMA)</li> <li>• Discussion with the committee members</li> <li>• Evaluation of compost plant, open dump and transfer station</li> </ul>
<b>Key Takeaway</b>	<ul style="list-style-type: none"> <li>• Conducted first project site evaluation at the before implementation stage (baseline data)</li> <li>• Updated committee members about progress</li> </ul>



Fig 25. Project Explanation by Mr. Nalin



Fig 26. Evaluation of transfer station (currently under construction)

# Timeline

別添資料9

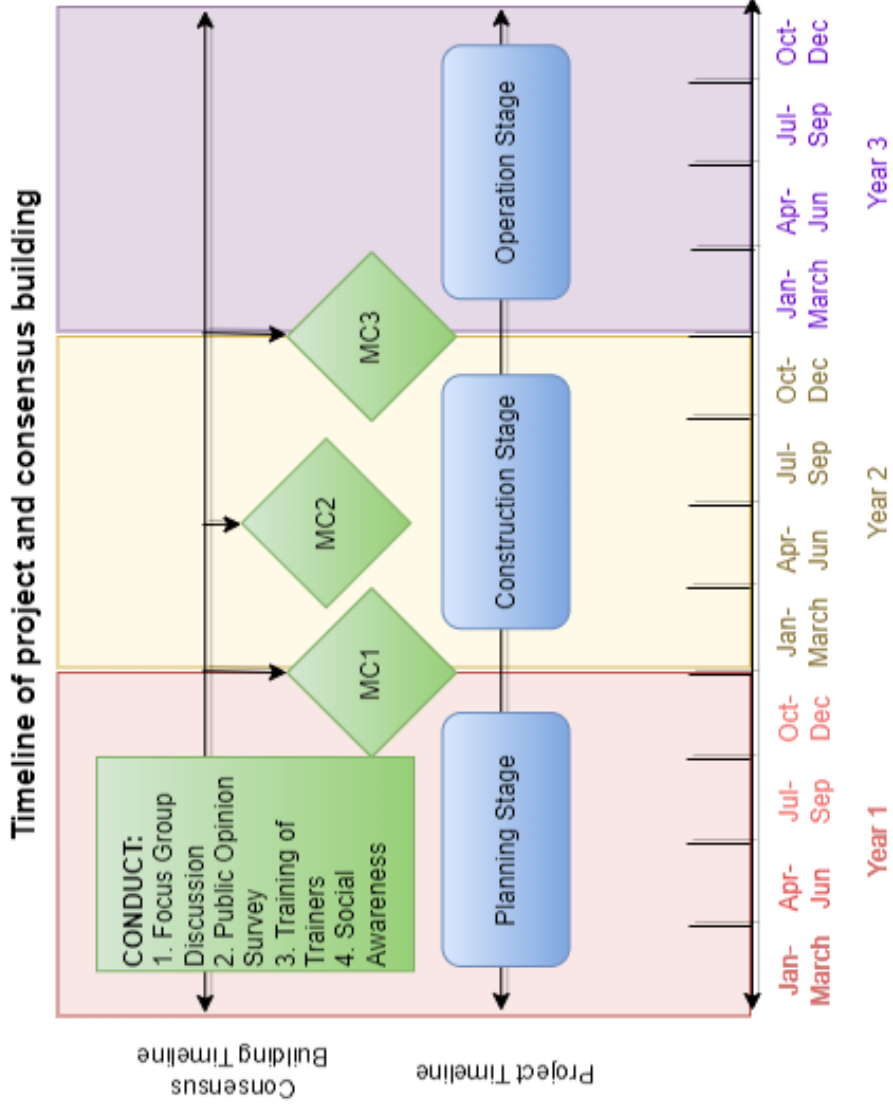

## 別添資料 10

西部州における廃棄物管理計画（マスタープラン）  
（英文）







# WESTERN PROVINCE SOLID WASTE MANAGEMENT MASTER PLAN IN SRI LANKA - 2023 - 2042



DEMOCRATIC SOCIALIST REPUBLIC OF SRI LANKA  
JAPAN INTERNATIONAL COOPERATION AGENCY

**WESTERN PROVINCE SOLID WASTE  
MANAGEMENT MASTER PLAN in Sri Lanka**

June 2023



Source: United Nation

Location Map of the Western Province and its 3 Districts in Sri Lanka



## Forward

Solid waste management is an undeniably crucial issue that the western province has been facing for a while. Despite the efforts being made to solve these solid waste issues, a lot of them persist to this day resulting in environmental and social problems or even potential disastrous events such as the collapse at Meethotamulla Waste Disposal Site in April 2017.



The Western Province Solid Waste Management Master Plan was thus designed to assist the improvement of solid waste management in the western province by formulating a comprehensive set of medium (2030) to long term (2042) solutions promoting a 3R while protecting public health and the environment. The Master Plan sets out its mission to “encourage the reduction of waste generation and to inculcate the best waste management practices in the province to convert waste into valuable resources”.

I am delighted to share this message upon the completion of the formulation of Master Plan, and I would like to express my gratitude to all the individuals and organizations who contributed to the formulation of the Master plan from the Japanese and the Sri Lanka side. I take this opportunity to extend my greatest respect and appreciation from the Japanese side to the Japan International Cooperation Agency (JICA), and from the Sri Lankan side to the Ministry of Public Administration, Home Affairs, Provincial Councils and Local Government, Ministry of Environment, Ministry of Urban Development and Housing, Central Environmental Authority, National Solid Waste Management Support Center (NSWMS), Waste Management Authority (WMA), and all other relevant authorities. It is through their collective efforts that the team was able to develop a comprehensive and actionable plan that will pave the way for a sustainable and effective waste management system in the Western Province.

**K.D.N. Ranjith Asoka**

**Secretary**

**Ministry of Public Administration, Home Affairs,  
Provincial Councils and Local Government**

## Message

In Sri Lanka the waste management is Local government subject. According to the 13th amendment made to the constitution of the country in 1987; the local Government subject has fully devolved to the provincial level. Meanwhile, the daily collection of municipal solid waste in the Western Province has estimated to be sixty present (60%) of the total collection of the country. As such, the Western Provincial council has paid their due attention on the provincial waste management subject in order to offer healthy environment to the general public and also to protect the natural environment gifted. In order to that the provincial council has passed the waste management statute and the Waste Management Authority has been established to look in this matter with greater attention. Further, forty-nine (49) local authorities have been empowered to work with their limited available resource to keep the province cleaner.



However, considering the present complexity of waste problem in the province it has become a subject that should be done jointly by the three tiers of local government, provincial councils and the central government. Considering the catastrophic that happened in Meethotamulla dumpsite in 2017, it was realised that need for long term master plan for waste management with inter coordination and sharing of responsibilities among local authorities, provincial council and the government. Accordingly, I personally believe that the said gap has been accomplished by compiling this twenty years master plan in relation to the municipal solid waste management in the province, and this plan would guide us to take forward the western province into another turning point of the waste management history.

The master plan that has been presented, has well identified direction of municipal solid waste management in the Western Province in the coming twenty years. Also, it appears that through this project proposal, the waste management strategies have been proposed based on blending the experience gained in the past and available limited resource with the state-of-Art technology in waste management. Moreover, the JICA expert team has tried to fully adapt the waste management policy of the country into this master plan too. Furthermore, the proposal is also in line with the SDGs and NDCs of the country. By doing Strategic Environmental Assessment (SEA) for the Master Plan, environmental compliance has been shown and thereby it added additional value to the Master Plan. Finally, I feel that we can make use this master plan as a strength in waste management in the western province.

Therefore, I would like to express my primary thanks to the government of Japan for their generous financial and technical assistance extend through JICA for preparing this timely required master plan on the request of the government of Sri Lanka. Also, I appreciate the contributions extended by the JICA -Sri Lanka office, all member of the project team of the EX-Research institute led by Dr Naofumi Sato, the Waste Management Authority of the Western Province and all other stakeholder institutions toward the success of this project.

**Pradeep Yasarathne**  
Chief Secretary  
Western Province

## Message

It's my great honor to celebrate the completion of the "Western Province Solid Waste Management Master Plan in Sri Lanka." It has been around 6 years since the tragic collapse of Meethotamulla waste disposal site. Following the emergency assistance by Japan Disaster Relief Team, JICA has continued the supports through "Project for Formulation of Western Province Solid Waste Management Master Plan" even during COVID-19 pandemic period.



I would like to extend my greatest respect and appreciation to the Government of Sri Lanka, Ministry of Public Administration, Home Affairs, Provincial Councils and Local Government, Ministry of Environment, Ministry of Urban Development and Housing, Central Environmental Authority, National Solid Waste Management Support Center (NSWMSC), Waste Management Authority (W.P), and other relevant authorities to develop the Master Plan (MP). I would also like to appreciate the strong leadership of NSWMSC and WMA to complete the MP collaboratively together with many stakeholders.

The MP proposes the improvement of Solid Waste Management (SWM) system comprehensively from long-term and economical perspectives. All the stakeholders can use the MP as the guide to seek appropriate SWM practices. The pilot projects conducted under the project have provided good lessons to plan and conduct various activities laid out in the MP.

Through the project, coordination structures such as Coordination Committee on Waste Management in Western Province as specified in the MP has been built. Also, coordination capacity for the development and implementation of the MP has been enhanced.

I cordially expect that such coordination structures capacity of the related institutions build through this MP project will continue to play a central role in facilitating further cooperation and coordination to achieve appropriate solid waste management in the Western Province.

Tetsuya Yamada  
Chief Representative  
JICA Sri Lanka Office

# Executive Summary

## 1 Introduction & background of the project

As in many developing countries, the current situation of solid waste management in Sri Lanka faces many challenges and difficulties. In a context of rapidly growing population and increased urbanization, the amount of waste generated in the country is increasing at an alarming rate and its management is not done in a proper manner. In order to address this issue effectively, a solid waste management master plan is essential to ensure that the waste generated is collected, treated, and disposed of in a manner that is safe, sustainable, and environmentally friendly.

It is from this perspective that the Government of Sri Lanka made a request to Government of Japan to formulate a solid waste management MP for Western Province, coordinating with the Central Government, Provincial Government and Local Authorities. In response to the request made by GOSL, Japan International Cooperation Agency (JICA) conducted a detailed planning survey in May 2018 to formulate a technical cooperation project and agreed on the framework and contents of the Project with GOSL.

The Project is designed to assist Western Province in filling the gaps in its management of solid waste by formulating an evidence-based solid waste management MP that encompasses medium- to long-term forecasts and a range of proposed solutions to the waste problems.

## 2 Target area and current status

### 2.1 Target area and population

The target area for the Master Plan is the Western Province, which is one of the nine provinces of Sri Lanka. The Western Province, located in the southwestern part of Sri Lanka, has an area of 3,684 km<sup>2</sup> and had an estimated population of 6,165,000 in 2020 (Department of Census and Statistics). The area of the Western Province accounts for 5.6% of the total area of the country and the population of the Western Province accounts for 28.1% of Sri Lanka as a whole. The population density of the Western Province is five times as high as the national average.

### 2.2 Natural condition and socio-economic status

The Western Province has a rectangular shape measuring 90 km from north to south, and 40 km from east to west. There are flatlands along the coast, hills with an altitude of several tens of meters inland, mountains at the eastern end, and there is a flat terrain that is almost 100 meter above sea level. The province has a tropical rainforest climate, with annual rainfall of 2,516 mm, and rainy seasons in April-June, and September-November. The average temperature is 28.2°C. The Western Province produces about 40% of national GDP, but this share is declining, and it is unclear whether high growth can be maintained.

## 3 Planning conditions for the establishment of the Master Plan

### 3.1 Overview of the situation of SWM in the Western Province

Local authorities are responsible for the management of waste generated within their respective boundaries in Sri Lanka. Waste generated in the Western Province accounts for more than 60% of the total amount of waste generated in Sri Lanka, and its final disposal remains one of the main difficulties to be tackled in order to reduce the environmental and social impact of



solid waste management in the western province. Consequently, solving this issue can be very beneficial from a sanitary and environmental standpoint.

### 3.2 Waste amount and composition

The total amount of MSW generated in the Western Province is 3,732 tons per day, of which 48% is household waste and 52% is non-household waste, 1% of the total waste generated is recycled at the generation source, mainly through home composting and Parisara Pola, and it is assumed that 5% of the total waste generated consists of recyclables collected by collection workers, 51% of the collected waste is transferred to intermediate treatment facilities, and 49% is either self-disposed or improperly discharged.

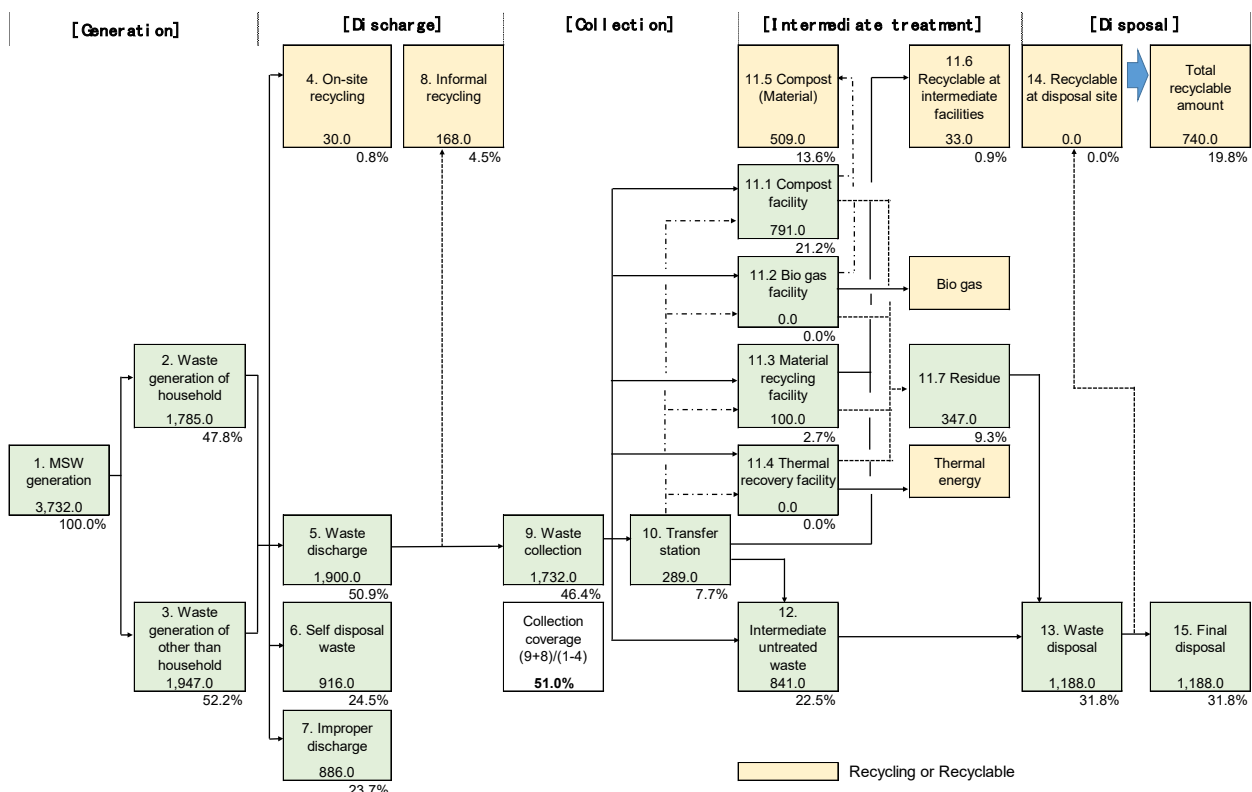

Figure 1 Waste flow for Western Province in 2020 (ton/day)

### 3.3 Waste collection, transportation, treatment and final disposal

Almost all LAs directly operate waste collection, except CMC, Negombo MC, Kotte MC, Maharagama UC which contracted with private companies. The vehicles used for collection are mainly tractor-trailers given road conditions and accessibility to disposal sites. However, these vehicles are not suited for long-distance transport.

As for transportation, 15 LAs have transfer stations in the Western Province. These transfer stations do not have any facilities, and in most cases, the collected biodegradable and non-biodegradable waste is separately unloaded onto the ground. It is then transferred to large-capacity dump trucks using heavy machinery such as shovel loaders and excavators and transported to treatment facilities or disposal sites. In some LAs, such as Kolonnawa UC, Gampaha MC, Panadura UC, and Homagama PS, transfer stations are located in urban areas due

to their density making it difficult to secure land for treatment and disposal facilities. This results in a negative impact on the surrounding environment, such as foul odors and waste scattering by animals.

In the entire Western Province, 16% of the waste collected is carried to composting facilities, 6% to recycling-related facilities, 38% to TRF and 40% to disposal sites as of base year 2022. Treatment Composting is rather popular, There are 28 composting facilities in the Western Province. Of these, 23 facilities are managed by LAs and three, namely Karadiyana, Dikkowita, and Kalutara, are managed by WMA. One composting facility located at the Dompe Disposal Site is managed by CEA and the Kerawalapitiya Composting Plant is managed by SLLRDC.

As for final disposal sites, 22 LAs operate their own disposal sites and 10 LAs have outsourced disposal to the private sector because they were not able to secure land for final disposal sites.

#### **4 Formulation of alternative scenarios for the SWM system**

In order to assess the analyze the future possibilities and compare them effectively, A baseline scenario (continuing the current SWM system without introducing measures to reduce the amount of waste or improve collection) and three alternatives scenario (A, B and C) were formulated.

An in-depth multi-criteria analysis of each scenario was done and the optimal SWM system was chosen (alternative B). The analysis took into account technical, institutional, economic and social considerations and factors such as the amount of waste reaching the final disposal site, the improvement of recyclables recovery by promoting sorting, and minimizing residues and also the financial aspect (the unit cost per ton of waste).

The chosen scenario (Alternative B) aims to reduce generated waste, and improve collection rates by targeting a situation where:

- 8% of the waste generated is improperly discharged and 73% is collected.
- Some of the waste collected is recovered as recyclables by collection workers at the collection stage, and the rest is transported to a composting facility, recycling facility, and/or TRF.
- The final disposal amount represents 18% of the waste generation amount, including residues generated in intermediate treatment facilities.

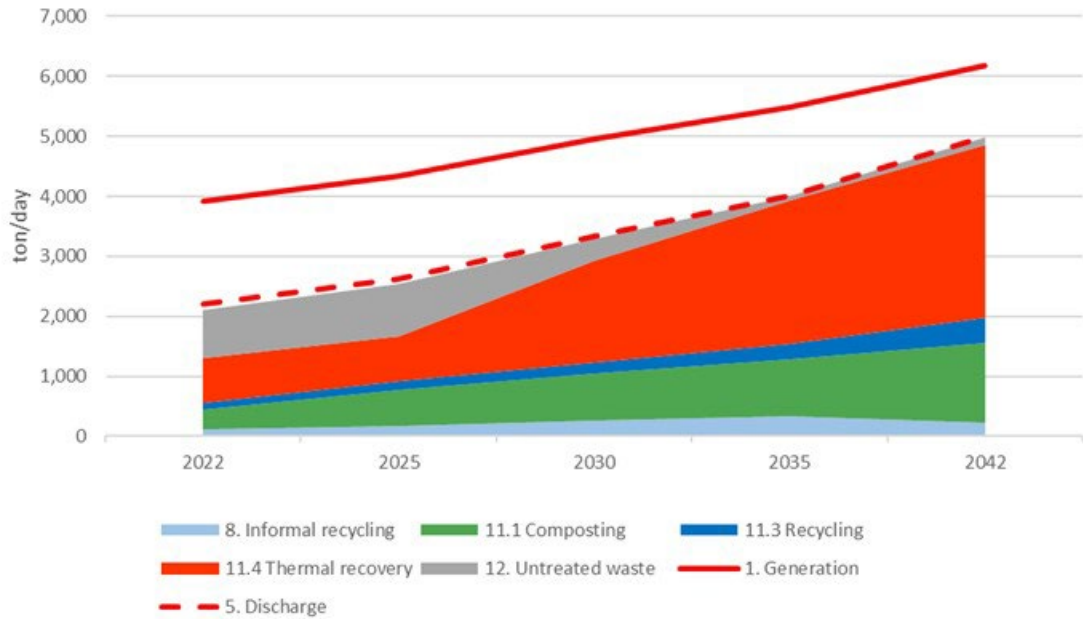

**Figure 2 Breakdown of waste generation amount and discharge amount in the chosen scenario**

## 5 Plan of Operations for the MP implementation

### 5.1 MP authorization and formulation of LAs' SWM Action Plan

The Solid Waste Management Master Plan for the Western Province establishes a comprehensive waste management system with a long-term perspective in the Western Province. The central organization is the Western Provincial Council, represented by WMA. Once approved, the MP will be owned and operated by the Provincial Council and WMA. The MP will serve as a guideline to the LAs for their SMW Action Plan and Annual Work Programs.

#### (i) Authorization of the Provincial MP

- For the recognition as a sectoral plan, the SWM MP must comply with the National Policy on Waste Management.
- Once developed by WMA through a consultation process with all stakeholders, the WMA Board submits the MP to the Minister for concurrence by the Board of Ministers of Western Province.
- Once concurred by the Board of Ministers, the Minister submits the SWM MP to the Western Provincial Council for approval.
- The Provincial Council, through the (national level) Minister in charge of Local Governments, forwards the MP to the Cabinet of Minister for approval. This process is necessary as the MP contains sectoral strategies and plans and requires technical and financial support from the national government for its implementation.

#### (ii) LAs' Action Plan in line with the MP

- Every LA prepares its Action Plan on waste management in accordance with the Provincial MP. Once the Council has approved the Action Plan, LAs submit it to WMA for WMA's

review and concurrence. When LAs request a capital budget for development, WMA's concurrence provides evidence to justify such development.

- Every LA shall submit a progress report and Annual Work Program on the Action Plan to WMA for progress monitoring.

## 5.2 Organizational development for MP implementation

WMA is expected to play a central role in the implementation of the MP. However, this organization was created to meet the needs that existed 15 years ago. Since all projects and programs derived from the MP require technical and financial analysis and a consultation process with all relevant stakeholders, the current planning and implementation capacities of WMA are inadequate and need to be strengthened urgently as a prerequisite for effective implementation of the MP.

The most critical ones, not visible now, are the planning and monitoring functions. Without an effective division for planning and monitoring, the organization will not be able to implement programs systematically. Planning is essential for evaluating project proposals, improving cost-effectiveness, and finally for proper decision-making. Currently, the functions are performed by several senior managers, but this system does not work well as all are busy with other duties. Proper monitoring and evaluation will guide the organization towards the targeted goals and outcomes. Although each division manager monitors the work of his/her team, review by a centralized team of professionals is essential for feedback and future planning.

For WMA to play an effective driving role in the implementation of the MP, it is recommended to create a new division dedicated to Planning and Monitoring with two subdivisions, namely (a) Planning/R&D and (b) Monitoring and Evaluation. The Planning/R&D subdivision would primarily deal with strategic and long-term planning as well as project development, including implementation arrangement, while the Monitoring and Evaluation subdivision would be in charge of monitoring, performance review and feedback. The new division should be headed by a senior executive officer who would directly report to the Director/CEO.

### 5.3 Implementation of the SWM MP (short- and medium- term)

The solid waste management projects (SWM projects) that need to be prepared and implemented within eight years to achieve the MP targets have been selected and planned.

The short- and medium- (eight years) term SWM projects mainly consist of the following eight projects:

- Project 1: Development of five Primary Transfer Stations (PTS)
- Project 2: Implementation of Kelaniya Transfer Station (Kelaniya TS)
- Project 3: Development of Cluster-based Waste Treatment Facilities (CWTF)
- Project 4: Improvement of composting facilities
- Project 5: Improvement of recycling facilities for recyclables collected by the formal collection service
- Project 6: Procurement of collection and transfer vehicles
- Project 7: Closure of current dump sites managed by LAs
- Project 8: Encouragement of waste separation

### 5.4 Objectives of the SWM Action Plan

The SWM Action Plan for LAs will be formulated in line with the SWM MP for the Western Province. Quantitative targets and feasible SWM activities will be set in the Action Plan. In addition, an Annual Work Program (AWP) will be prepared for each year of the SWM Action Plan period, including yearly activities, implementation schedules, and budgets in order to achieve the SWM Action Plan. The AWP is not only an annual implementation plan, but also an important monitoring instrument for the SWM Action Plan. The SWM Action Plan will be reviewed every five years taking into account the progress made in waste management.

## 6 Recommendations for a successful implementation of the MP

### 6.1 MP authorization

The MP establishes a comprehensive waste management system with a long-term perspective in the Western Province. The central organization is the Western Provincial Council, represented by WMA. Once approved, the MP will be owned and operated by the Provincial Council and WMA. The MP will serve as a guideline for the LAs for their SWM Action Plan and Annual Work Programs. Once developed by WMA through a consultation process with all stakeholders, the WMA Board will submit the MP to the Minister in charge of local authorities for concurrence by the Board of Ministers of Western Province. The Provincial Council, through the (national level) Minister in charge of Local Governments, will forward the MP to the Cabinet of Minister for approval. This process is necessary as the MP contains sectoral strategies and plans and requires technical and financial support from the national government for its implementation.

### 6.2 Implementation of MP for optimal SWM system

It is recommended that the Sri Lankan side should implement the detailed project activities according to alternative B of the MP immediately after the MP and the inter-organizational coordination body structure have been authorized.

The amount of waste generated in the Western Province is estimated at 3,730 ton per day. This amount is expected to increase in line with future population and economic growth. At present, about 50% of the waste generated is discharged to the LA's collection service, but it is expected that this amount will increase in the future as collection coverage improves. Therefore, in the Western Province, where there are waste disposal problems, it is necessary to enhance waste separation by conducting awareness-raising activities for residents and by increasing the capacity of intermediate treatment facilities in order to reduce amount of waste to be disposed of as much as possible. In the entire Western Province, 16% of the waste collected is carried to composting facilities, 6% to recycling-related facilities, 38% to TRFs and 40% to disposal sites, as of base year 2022. In order to collect and transport this waste efficiently and hygienically, it is necessary to select and procure appropriate collection vehicles and to set up in the future a transfer system in accordance with the separated waste and the distance to intermediate treatment facilities and/or disposal sites.

Recycling in the Western Province is carried out at the source of generation, at the collection stage and in intermediate treatment facilities such as composting and recycling facilities. The total amount of recyclables accounts for about 20% of the total waste generated, which is a relatively high rate compared to other developing countries. In the future, it is necessary to reduce the amount of waste disposed by promoting the separate collection of recyclables and expanding the capacity of composting facilities. The amount of waste disposed represents 32% of all waste generated. Approximately 70% of the total waste disposed is waste directly landfilled and the remaining 30% is residue generated from composting and recycling facilities. To reduce this amount despite the expected increase resulting from improved collection coverage, it is critical to develop intermediate treatment such as WtE. It is also necessary to gradually shift from disposal sites operated independently by LAs to cluster-based disposal sites, and to close the open dump sites currently used by LAs. In order to implement proper SWM, it is also necessary to collect and consolidate data related to SWM from each LA, cluster-based treatment facilities and disposal sites, and establish a database for the entire Western Province.

Waste management in urban areas requires cooperation and coordination between neighboring LAs and higher authorities. However, collaboration between relevant authorities is currently inadequate. In the recent past, some new, state-of-the-art, large-scale waste management technologies have been introduced in the Western Province, but they are not yet fully deployed. The amount of waste in urban areas is increasing at a higher pace than the population, and even than economic growth. This implies that costs for waste management are growing at a faster rate than the allocation of the government's budget.

Economically, alternative B was evaluated as the cheapest system compared to the other options. Based on the above, alternative B is recommended as the MP for optimal SWM in the Western Province.

### 6.3 Economic financial aspects

A comparison of the waste management costs incurred during the MP period (20 years from 2022 to 2041) by management process, separated for capital investment costs and operating costs, shows that collection costs account for 29% and transportation costs for 23%, which means that transportation-related costs represent more than half. This is followed by thermal recovery (incineration with power generation), final disposal, and composting.

In 2020 in the Western Province, LAs' own revenue covered only one quarter of their total expenditure. The remaining three quarters have been taken over by the national government. In that context, LAs' room for maneuver to allocate a budget to their priority areas is limited. Waste management currently receives 20% of the total recurrent expenditure, the highest among expenditure heads. It is unlikely that the percentage allocated to waste management will increase significantly. The share of waste management in LAs' budget is within a reasonable range of financial affordability, except for the first five years (from 2023 to 2027). The proportion of 33% in 2023 and peak of 34% in 2027 are 1.7 times the current level (20%). The sharp increase during this period is caused by the large volume of untreated waste transported to and disposed of in Aruwakkalu DS due to the lack of intermediate treatment facilities. The percentage then gradually lowers as intermediate treatment facilities develop and the amount of waste disposed of without treatment decreases.

The above scenario is based on the assumption that capital expenditure is borne by the government. Removing the capital component from LAs' burden can be done either by financing the capital cost, e.g. through viability gap funding (VGF) by the national government at the initial stage, or by subsidizing the capital portion through annual fund transfers from the Treasury to the concessionaire. It is essential that the national government, Provincial Council and LAs discuss and agree on this matter when formulating the project.





## Table of Contents

1	Overview of the Master Plan .....	1
1.1	Target area and population.....	1
1.2	Natural conditions and socio-economic status.....	3
2	Situation analysis of SWM .....	4
2.1	Overview of SWM situation.....	4
2.2	Waste amount and composition .....	4
2.2.1	Waste amount and composition survey by SATREPS .....	4
2.3	Waste flow analysis .....	5
2.3.1	Objectives of the waste flow analysis.....	5
2.3.2	Concept of waste flow .....	6
2.3.3	Data used for the waste flow analysis and calculation method.....	7
2.3.4	Result of waste flow analysis .....	9
2.4	Waste collection & transportation, intermediate treatment and final disposal.....	12
2.4.1	Waste collection & transportation.....	12
2.4.2	Waste transfer .....	14
2.4.3	Intermediate treatment and final disposal of waste .....	15
2.5	Recycling.....	24
2.5.1	Overview of the recycling situation in the Western Province.....	24
2.5.2	Current Status of Plastic Waste Recycling in the Western Province.....	27
2.6	Activity status at citizen level.....	28
2.6.1	Legal Basis for Waste Separation in the Western Province .....	28
2.6.2	Practical implementation by local authorities.....	28
2.6.3	Daily separation practice by residents in high-rise apartments.....	29
2.6.4	Issues and solutions .....	36
2.7	Administrative regulatory framework and financial status .....	38
2.7.1	Legal framework and institutions involved .....	38
2.7.2	Financial situation.....	39
2.8	SWM issues .....	41
2.8.1	Technical issues .....	41
2.8.2	Operational issues.....	44
3	Selection of optimal SWM system for the proposed 20-year Master Plan.....	45
3.1	Pre-conditions for formulating a MP .....	45
3.1.1	Planning period.....	45
3.1.2	Estimation of future population.....	45
3.1.3	Estimation of future waste amount .....	46
3.2	Time dependency on the establishment of ISWM systems .....	57

3.3	Formulation of alternatives scenarios for the SWM system.....	59
3.3.1	Formulation of alternatives.....	59
3.4	Evaluation of the alternative scenarios for the SWM system.....	68
3.4.1	Technical evaluation.....	68
3.4.2	Cost evaluation for SWM system.....	72
3.4.3	Environmental and social considerations.....	102
3.5	Selection of the optimal SWM alternative plan.....	103
4	SWM Master Plan.....	104
4.1	Principles of waste management in the Western Province.....	104
4.1.1	Vision.....	104
4.1.2	Mission.....	104
4.1.3	National Policy Statements, Strategies, and Actions on Solid Waste Management..	104
4.1.4	Sub-policy/strategy.....	114
4.2	Details of the sub-policy/strategy.....	115
4.2.1	Promotion of the 4R concept.....	115
4.2.2	Facilitation of circular economy.....	115
4.2.3	Introduction of the “Zonal Concept of Waste Management”.....	115
4.2.4	Adoption of the seven steps of municipal solid waste management.....	115
4.2.5	Implementation of the polluter pays principle and extended producer responsibility	116
4.2.6	PDCA cycle.....	116
4.2.7	Simultaneous approach in waste management.....	118
4.2.8	Introduction of a provincial platform for waste management.....	118
4.2.9	Interpersonal Communication and Education.....	119
4.3	Targets.....	119
4.3.1	Narrative summary of the targets of the MP.....	119
4.3.2	Numerical targets.....	120
4.3.3	Milestones for the MP.....	121
4.4	Actions.....	122
4.4.1	Outline of the SWM system.....	122
4.4.2	Forecasted waste flow.....	126
4.4.3	Key strategic actions for the SWM system.....	128
4.4.4	Details of key strategic actions for the SWM system.....	129
4.5	Economic and financial analysis of the MP.....	157
4.5.1	Framework of economic and financial analysis.....	157
4.5.2	Cost-effectiveness analysis (CEA).....	158
4.5.3	Financial sustainability analysis (FSA).....	160
4.6	Operation of the MP.....	164
4.6.1	Roles of the relevant organizations for M P implementation.....	164
4.6.2	Master Plan authorization.....	165

4.6.3	Organizational development for MP implementation .....	166
5	Implementation of the SWM MP (short- and medium- term) .....	167
5.1	Short- and medium-term implementation projects based on MP .....	167
5.1.1	SWM projects and implementation schedule .....	167
5.1.2	Implementation of the projects .....	169
5.2	SWM Action Plan for LAs .....	188
5.2.1	Objectives of the SWM Action Plan.....	188
5.2.2	Preparing a template for the SWM Action Plan .....	188
5.2.3	Formulation of the SWM Action Plan .....	189
6	Recommendations .....	191
6.1	Master plan for optimal SWM system.....	191
6.2	Economic financial aspects.....	192
6.3	Master Plan authorization.....	192
6.4	Monitoring of the Master Plan implementation.....	193

## Tables

Table 1-1 Basic information of Sri Lanka and the Western Province.....	1
Table 1-2 Population estimates in 2020.....	2
Table 1-3 Administrative divisions of the Western Province of Sri Lanka.....	2
Table 2-1 WACS implemented in the Central and Southern provinces of Sri Lanka by SATREPS (2012-2014).....	5
Table 2-2 Waste Composition Data for Household Waste (% wet base).....	5
Table 2-3 Summary of calculation method for waste flow analysis.....	8
Table 2-4 Waste data by district and zone (ton/day).....	10
Table 2-5 Waste data by type of LA (ton/day).....	12
Table 2-6 Amount of collected waste transported to intermediate treatment facilities and disposal sites.....	15
Table 2-7 Composting plants/facilities located in the Western Province in 2019.....	19
Table 2-8 Disposal sites used by LAs in the Western Provinces as of 2020.....	20
Table 2-9 Amount of waste brought to Karadiyana DS from June 2018 to May 2019 (ton/day).....	21
Table 2-10 Recycling amount in the Western Province (ton/day).....	26
Table 2-11 Case 1: Low-income long-standing settlement in Colombo Municipal Council.....	29
Table 2-12 Case 2: Low-income new high-rise apartment settlements, Kolonnawa Urban Council.....	32
Table 2-13- Case 3: High-income settlement, Maharagama Urban Council.....	33
Table 2-14 Recurrent budget of the Government, Provincial Council, and LAs (2020).....	40
Table 2-15 Share of the recurrent budget of LAs allocated to waste management in 2021.....	40
Table 2-16 Central government capital budget for solid waste management.....	41
Table 3-1 Estimated population growth rate and population projection.....	46
Table 3-2 Generation rates of household waste and MSW.....	47
Table 3-3 Actual GDP growth rate and GDP growth rate projections (%).....	48
Table 3-4 Future waste generation rates without MP (g/person/day).....	48
Table 3-5 Waste reduction rates.....	49
Table 3-6 Comparison of future waste generation rates (g/person/day).....	50
Table 3-7 Waste collection targets by category of LA.....	50
Table 3-8 Targets for the waste discharged separately by type of LA in 2042.....	51
Table 3-9 Population projections based on CPC development project.....	52
Table 3-10 Generation rate of MSW.....	53
Table 3-11 Composition of MSW.....	53
Table 3-12 Forecasts of generated waste based on CPC development.....	53
Table 3-13 Composition of solid waste.....	54
Table 3-14 Forecasts of generated solid waste in MC.....	55
Table 3-15 Future waste generation in CMC in 2042.....	55
Table 3-16 Future amount of waste generated (ton/day).....	56
Table 3-17 Future amount of waste generated and collected based on the MP (ton/day).....	56

Table 3-18 Main components of the alternatives for the SWM system.....	59
Table 3-19 Breakdown of waste generation amount and discharge amount (Baseline) .....	64
Table 3-20 Breakdown of waste generation amount and discharge amount (Alternative A).....	65
Table 3-21 Breakdown of waste generation amount and discharge amount (Alternative B).....	66
Table 3-22 Breakdown of waste generation and discharge amount (Alternative C) .....	67
Table 3-23 Comparison of breakdown of MSW generated in 2042 .....	68
Table 3-24 Cumulative amount of final disposal including soil cover (million m <sup>3</sup> ).....	70
Table 3-25 Breakdown of biodegradable waste treated / disposed (ton/day) .....	71
Table 3-26 Cumulative costs and unit costs for SWM for 2023-2042.....	73
Table 3-27 Summary table of detail cost estimates for the SWM systems.....	75
Table 3-28 Procurement costs of collection vehicles (Baseline) .....	76
Table 3-29 Procurement costs of collection vehicles (Alternative A) .....	76
Table 3-30 Procurement costs of collection vehicles (Alternative B) .....	76
Table 3-31 Procurement costs of collection vehicles (Alternative C) .....	76
Table 3-32 Considered factors and calculation of fuel and maintenance costs for collection ....	77
Table 3-33 Fuel and Maintenance cost for collection (Baseline).....	78
Table 3-34 Fuel and Maintenance cost for collection (Alternative A).....	79
Table 3-35 Fuel and Maintenance cost for collection (Alternative B).....	80
Table 3-36 Fuel and Maintenance cost for collection (Alternative C).....	81
Table 3-37 Considered factors and calculation of labor costs for waste collection .....	81
Table 3-38 Details of total number of waste collection vehicles and estimated labor costs .....	82
Table 3-39 Procurement costs of waste transfer vehicles (Baseline).....	83
Table 3-40 Procurement costs of transfer vehicles (Alternative A).....	83
Table 3-41 Procurement costs of transfer vehicles (Alternative B).....	84
Table 3-42 Procurement costs of transfer vehicles (Alternative C).....	84
Table 3-43 Considered factors and calculation of fuel and maintenance costs for waste transfer .....	85
Table 3-44 Fuel and maintenance costs for waste transfer (Baseline).....	86
Table 3-45 Fuel and maintenance costs for waste transfer (Alternative A).....	87
Table 3-46 Fuel and maintenance costs for waste transfer (Alternative B).....	88
Table 3-47 Fuel and maintenance costs for waste transfer (Alternative C).....	89
Table 3-48 Considered factors and calculation of labor costs for waste transfer.....	89
Table 3-49 Total number of transfer vehicles and labor costs for waste transfer.....	90
Table 3-50 Amount of transferred Waste, O&M and Construction Costs of transfer station (Baseline).....	91
Table 3-51 Amount of transferred Waste, O&M and Construction Costs of transfer station (Alternative A).....	92
Table 3-52 Amount of transferred Waste, O&M and Construction Costs of transfer station (Alternative B).....	93
Table 3-53 Amount of transferred Waste, O&M and Construction Costs of transfer station	

(Alternative C).....	94
Table 3-54 Waste treated and O&M and construction costs of thermal recovery facility .....	95
Table 3-55 Capacity and construction cost of thermal recovery facility (Alternative B).....	96
Table 3-56 Capacity and construction cost of thermal recovery facility (Alternative C).....	97
Table 3-57 Waste treated and O&M cost of composting facilities .....	98
Table 3-58 capacity and construction costs of composting facilities.....	99
Table 3-59 Treated waste amount and O&M cost of material recovery facilities .....	100
Table 3-60 Waste disposal volume and O&M costs .....	101
Table 3-61 Cumulative volume of waste to be disposed and construction cost of disposal site .....	102
Table 4-1 Numerical targets for the Western Province .....	120
Table 4-2 Numerical targets for Colombo District .....	120
Table 4-3 Numerical targets for Gampaha District.....	120
Table 4-4 Numerical targets for Kalutara District .....	120
Table 4-5 Milestones for achieving the MP.....	122
Table 4-6 Outline of the SWM system .....	124
Table 4-7 Future waste amounts .....	126
Table 4-8 Targets for waste generation reduction rates .....	129
Table 4-9 Examples of approaches and technologies to reduce waste generation.....	131
Table 4-10 Target rates for the separate collection of discharged waste by type of LA .....	132
Table 4-11 Target of collection coverage in percentage by type of LA .....	136
Table 4-12 Required number of collection vehicles .....	137
Table 4-13 Selection of LAs requiring a PTS.....	140
Table 4-14 PTSs, associated LAs and waste to be transferred .....	141
Table 4-15 Required number of containers.....	142
Table 4-16 Distance to TRFs/Kelaniya TS and number of trips.....	143
Table 4-17 Number of transfer vehicles required.....	143
Table 4-18 Required number of containers and number of trips per day in Kelaniya TS .....	145
Table 4-19 Development plans for TRFs (ton/day).....	146
Table 4-20 Electric power expected to be generated by TRF .....	147
Table 4-21 Biodegradable waste treated and capacity of composting facilities (ton/day).....	148
Table 4-22 Recyclable waste collected (ton/day) .....	152
Table 4-23 Plastic waste recycling ratio .....	153
Table 4-24 Equipment list of Aruwakkalu DS.....	154
Table 4-25 Progression of the volume to be landfilled (million m <sup>3</sup> ) .....	155
Table 4-26 Specific Conditions of the Alternatives Considered: Intermediate Treatment and Final Disposal.....	159
Table 4-27 Levelized costs of waste treatment and disposal per ton .....	160
Table 4-28 Cost for the Master Plan (Total of 20 years).....	161
Table 4-29 Recurrent budget of the national government, WPC, and LAs (2020).....	161

Table 4-30 Share of Budget Allocation for Waste Management in Las (2021) .....	162
Table 4-31 Projection of total recurrent budget in the 49 LAs in the Western Province (2022-2041).....	163
Table 4-32 Estimated operation cost of waste management (2022-2041) - Case 1 .....	163
Table 4-33 Estimated Operation Cost of Waste Management (Case 2).....	164
Table 5-1 Schedule of short- and medium-term implementation plans .....	168
Table 5-2 PTSs, related LAs and amount of waste to be transferred.....	169
Table 5-3 Distance to TRF/Kelaniya TS and number of trips .....	171
Table 5-4 Required number of containers and transfer vehicles by 2030.....	171
Table 5-5 Implementation schedule.....	171
Table 5-6 Responsible organizations .....	172
Table 5-7 Project costs for the development of five PTSs (million LKR).....	172
Table 5-8 Required number of containers and number of trips per day in Kelaniya TS.....	173
Table 5-9 Implementation schedule of Kelaniya TS.....	173
Table 5-10 Responsible organizations of Kelaniya TS.....	173
Table 5-11 Project costs for the improvement of Kelaniya TS (million LKR).....	174
Table 5-12 Implementation schedule of thermal Recovery Facility in Colombo .....	174
Table 5-13 Responsible organizations of thermal recovery facility in Colombo.....	175
Table 5-14 Project costs for the development of a TRF in Colombo District (million LKR) ..	175
Table 5-15 TRF Implementation schedule of TRF next to Western Power at Kerawalapitiya .	176
Table 5-16 Responsible organizations of TRF next to Western Power at Kerawalapitiya .....	176
Table 5-17 Project costs for the development of a new TRF next to WPK (million LKR).....	177
Table 5-18 Biodegradable waste treatment and capacity of composting facilities (ton/day)....	178
Table 5-19 Implementation schedule for waste park composting facilities .....	178
Table 5-20 Implementation schedule for Karadiyana Compost Plant .....	179
Table 5-21 Responsible organizations of composting facilities in waste parks.....	179
Table 5-22 Responsible Organizations of composting facility of WMA in Karadiyana.....	179
Table 5-23 Responsible Organizations of composting facility of SLLDC in Muthurajawela ..	179
Table 5-24 Project costs for scheduled implementation of composting facilities in waste parks (million LKR).....	180
Table 5-25 Project costs for implementation of the Karadiyana Compost Plant (million LKR) .....	180
Table 5-26 Recyclables to be collected (ton/day).....	181
Table 5-27 Implementation schedule for LAs' recycling facilities.....	181
Table 5-28 Implementation schedule for MRFs in waste parks.....	181
Table 5-29 Responsible organizations of Improved existing recycling facilities .....	181
Table 5-30 Responsible organizations of recycling facilities in waste parks.....	182
Table 5-31 Project costs for the improvement of recycling facilities (million LKR) .....	182
Table 5-32 Required number of compactor trucks for biodegradable waste (unit) .....	182
Table 5-33 Required number of compactor trucks for other waste (unit).....	183

Table 5-34 Required number of trailer tractors for recyclables (unit) .....	183
Table 5-35 Implementation schedule for waste collection and transportation.....	183
Table 5-36 Responsible organizations of waste collection and transportation .....	183
Table 5-37 Project costs for the procurement of collection and transfer vehicles (million LKR) .....	185
Table 5-38 Implementation schedule of closure of dump sites.....	186
Table 5-39 Responsible organizations of closure of dump sites .....	186
Table 5-40 Project costs for the closure of current LAs' dump sites (million LKR) .....	186
Table 5-41 Implementation schedule of waste separation .....	187
Table 5-42 Responsible organizations for waste separation .....	187
Table 5-43 Project costs to encourage waste separation (million LKR).....	187
Table 5-44 Monitoring the implementation status of the SWM Action Plan.....	189

## Figures

Figure 2-1 Conceptual diagram of the waste flow.....	6
Figure 2-2 Waste flow for Western Province in 2020 (ton/day) .....	9
Figure 2-3 Comparison of collection coverage, etc. by district and zone.....	11
Figure 2-4 Comparison of collection coverage by type of LA .....	12
Figure 2-5 Examples of collection vehicles used by LAs .....	13
Figure 2-6 Examples of transfer stations in LAs .....	15
Figure 2-7 Ratio of collected waste transported to intermediate treatment facilities .....	16
Figure 2-8 Western Power Kerawalapitiya (WPK) WtE facility .....	18
Figure 2-9 Photos related to composting, such as composting facilities .....	20
Figure 2-10 Location map of the open dump sites in the Western Province (Strategic Action Plan WMA 2019-2023).....	23
Figure 2-11 Examples of disposal sites .....	24
Figure 2-12 Ratio of recycling amount by district and zone .....	26
Figure 2-13 Examples of Recycling in the Western Province .....	27
Figure 2-14 Waste segregation and awareness tool .....	30
Figure 2-15 Waste composition (weight base) in low-income old high-rise apartments in CMC .....	30
Figure 2-16 POS result in low-income old high-rise apartments in CMC (as of February 2020) .....	31
Figure 2-17 Waste composition (weight base) in low-income new high-rise apartments in Kolonnawa UC (as of February 2020).....	33
Figure 2-18 POS result in low-income new high-rise apartments in Kolonnawa UC (as of February 2020) .....	33
Figure 2-19 Waste composition (weight base) in high-income high-rise apartments in Maharagama UC (as of February 2020) .....	34
Figure 2-20 POS result in high-income high-rise apartments in Maharagama UC (as of	



February 2020) .....	35
Figure 2-21 Waste Composition Survey .....	36
Figure 3-1 Population projections in the CPC development project .....	52
Figure 3-2 Future waste generation amount in CMC .....	55
Figure 3-3 Comparison of the future amount of waste generated with and without the MP .....	56
Figure 3-4 Future amount of waste generated and collected with the MP .....	57
Figure 3-5 Waste flow baseline (without MP) as of 2042 .....	60
Figure 3-6 Waste flow of alternative A as of 2042 .....	61
Figure 3-7 Waste flow of alternative B as of 2042 .....	62
Figure 3-8 Waste flow of alternative C as of 2042 .....	63
Figure 3-9 Breakdown of waste generation amount and discharge amount (Baseline).....	64
Figure 3-10 Breakdown of waste generation amount and discharge amount (Alternative A)....	65
Figure 3-11 Breakdown of waste generation amount and discharge amount (Alternative B)...	66
Figure 3-12 Breakdown of waste generation and discharge amount (Alternative C).....	67
Figure 3-13 Breakdown of MSW generated.....	69
Figure 3-14 Cumulative amount of final disposal (2023-2042) and planned disposal capacity of the Aruwakkalu DS.....	70
Figure 3-15 Breakdown of biodegradable waste treated and disposed.....	72
Figure 3-16 Cumulative costs and unit costs for SWM for 2023-2042 .....	74
Figure 4-1 PDCA cycle.....	117
Figure 4-2 Continuous monitoring with the PDCA cycle.....	117
Figure 4-3 Simultaneous approach for waste management.....	118
Figure 4-4 Future waste flow by 2025 (Short-term).....	127
Figure 4-5 Future waste flow by 2030 (Medium-term).....	127
Figure 4-6 Future waste flow by 2042 (Long-term).....	128
Figure 4-7 Examples of measures to reduce waste generation .....	130
Figure 4-8 Progressive development of waste separation .....	133
Figure 4-9 Collection schedule tools .....	134
Figure 4-10 Separation awareness material.....	134
Figure 4-11 Distribution of waste containers.....	134
Figure 4-12 Example of a mobile phone application (Nerima city in Tokyo, Japan).....	135
Figure 4-13 Types of collection vehicles.....	137
Figure 4-14 Mechanical transfer system.....	138
Figure 4-15 Location of TRFs and PTSs .....	142
Figure 4-16 Burnable waste vs TRFs' capacity .....	146
Figure 4-17 Biodegradable waste collected and treated/disposed .....	148
Figure 4-18 Proposed development plan of Karadiyana Compost Plant.....	149
Figure 4-19 Proposed layout for waste parks .....	150
Figure 4-20 Proposed concept for intermediate treatment in waste parks.....	151
Figure 4-21 Current situation of LAs' recycling facilities.....	152

Figure 4-22 Evolution of the volume to be landfilled (million m <sup>3</sup> ).....	155
Figure 4-23 Current dump sites operated by LAs.....	156
Figure 4-24 Comparison of recurrent budget per person (2020).....	162
Figure 4-25 LAs' allocation to waste management in recurrent budget.....	162
Figure 5-1 Location of the transfer stations.....	170
Figure 5-2 Mechanical compaction system .....	170
Figure 5-3 Relationship between the SWM MP for the Western Province, SWM Action Plans and Annual Work Programs.....	188
Figure 6-1 Structure of Coordination Committee on Waste Management in Western Province .....	193

## Abbreviations

---

AP	Action Plan
BOI	Board of Investment
CEA	Central Environmental Authority
C&D Waste	Construction and Demolition Waste
CIDA	Construction Industry Development Authority
CMC	Colombo Municipal Council
C/P	Counterpart
ERD	External Resource Department
IDB	Industrial Development Board
JCC	Joint Coordinating Committee
JICA	Japan International Cooperation Agency
JOCVs	Japan Overseas Cooperation Volunteers
LA	Local Authority
MEPA	Marine Environmental Protection Authority
MoE	Ministry of Environment
MoFESNP	Ministry of Finance, Economic Stabilization and National Policies
MoPAHAPCLG	Ministry of Public Administration, Home Affairs, Provincial Councils and Local Government
MoUD&H	Ministry of Urban Development and Housing
MP	Master Plan
NGO	Non-Governmental Organization
NPD	Department of National Planning
NSWMSC	National Solid Waste Management Support Centre
OJT	On-the-Job Training
PDM	Project Design Matrix
PO	Plan of Operation
POS	Public Opinion Survey
PP	Pilot Project
PTS	Primary Transfer Stations
R/D	Record of Discussion
SATREPS	Science and Technology Research Partnership for Sustainable Development
SEA	Strategic Environmental Assessment
SK	Sampath kendra
SLLDC	Sri Lanka Land Development Corporation
SME	Small and Medium Enterprise
SWM	Solid Waste Management
SWML	Scheduled Waste Management License
SWOT	Strengths, Weaknesses, Opportunities, and Threats
TOR	Terms of Reference
UDA	Urban Development Authority
WG	Working Group
WMA	Waste Management Authority
WPC	Western Provincial Council
3Rs	Reduce, Reuse and Recycle

---

# 1 Overview of the Master Plan

## 1.1 Target area and population

The target area for the Master Plan (hereinafter referred to as “MP”) is the Western Province, which is one of the nine provinces of Sri Lanka.

The provincial council system of Sri Lanka was established as an institution between the central and local governments by the 13th constitutional amendment in 1987. The purpose of the establishment of these provinces was to strengthen and promote decentralization.

The Western Province, located in the southwestern part of Sri Lanka, has an area of 3,684 km<sup>2</sup> and had an estimated population of 6,165,000 in 2020 (Department of Census and Statistics). The area of the Western Province accounts for 5.6 % of the total area of the country and the population of the Western Province accounts for 28.1 % of Sri Lanka as a whole. The population density of the Western Province is five times as high as the national average.

The GPP (Gross Provincial Product) of the Western Province accounts for 38% of the national GDP, which far exceeds the area and population ratios. The industry and construction sectors account for a relatively high proportion of the economy, with agriculture accounting for 10 %, manufacturing (including construction) 47 %, and the service sector 38 %.

Table 1-1 Basic information of Sri Lanka and the Western Province

	Sri Lanka	Western Prov.	WP/SL
Area (km <sup>2</sup> )	65,610	3,684	5.6%
Population 2020 (1,000 people)	21,919	6,165	28.1%
Population Density (people/km <sup>2</sup> )	334	1,673	501%
GDP 2018 (LKR bn) *	14,366	5,526	38%
- Agriculture (LKR bn)	1,138	112	10%
- Industry (LKR bn)	3,820	1,786	47%
- Services (LKR bn)	8,207	3,159	38%

Note: \* GDP is not equal to the sum of the three sectors due to omission of taxes

Source: Department of Census and Statistics, Central Bank of Sri Lanka

During the eight years since the 2012 census, the national population has increased at an annual rate of 0.93 %, an augmentation of 0.2 % compared to the previous year census of 2001-2012 period during which the population grew at an annual rate of 0.73 %. The Western Province has had an average annual growth rate of 0.66 % over the last eight years, which is an increase of 0.13 % from 0.79 % during the previous census. The population growth rate of the Western Province is 0.27 % lower than the national average. The population growth rate is declining in the long run both nationally and in the Western Province.

Table 1-2 Population estimates in 2020

Population Data	1981 Census		2001 Census		2012 Census		2020 Estimate
	Annual Inc. (%)	Annual Inc. (%)	Annual Inc. (%)	Annual Inc. (%)	Annual Inc. (%)	Annual Inc. (%)	
Sri Lanka	14,846,274	1.19%	18,797,257	0.73%	20,359,439	0.93%	21,919,000
<b>Western Province</b>	<b>3,867,624</b>	<b>1.65%</b>	<b>5,365,801</b>	<b>0.79%</b>	<b>5,851,130</b>	<b>0.66%</b>	<b>6,165,000</b>
Colombo District	1,675,847	1.46%	2,239,696	0.34%	2,324,349	0.69%	2,455,000
Gampaha District	1,367,813	2.07%	2,060,470	1.02%	2,304,833	0.63%	2,423,000
Kalutara District	823,964	1.29%	1,065,635	1.25%	1,221,948	0.65%	1,287,000

Source: 2012 Census Report; Mid-year Population Estimates by District, DCS

The population density is of 1,672 people per km<sup>2</sup> in average in the Western Province. The highest is CMC (14,000 people per km<sup>2</sup>), which is almost the same as the 23 wards of Tokyo. The smallest is 200 people per km<sup>2</sup>.

There are two levels of administrative division in Sri Lanka: the central government administration and the local government administration.

The central government administration is in charge of civil administration, facilitation and coordination. It has four layers: National (Ministry of Home Affairs) > District > Division > Village (Grama Niladhari).

The decentralized local administration consists of three layers: National Government (Ministry of Public Administration, Home Affairs, Provincial Councils and Local Government) > Provincial Council > Local Authorities (Municipal Council, Urban Council, Pradeshiya Sabha). The subjects devolved to the Provincial Councils and Local Authorities are listed in the Ninth Schedule of the Constitution. Provincial Councils and Local Authorities are autonomous bodies and each institution has its own council and head of the institution. The heads of the Local Governments are elected chiefs.

Table 1-3 Administrative divisions of the Western Province of Sri Lanka

Central Government Hierarchy Local Authority (LA)						
	District	No. of Divisions	No. of Grama Niladhari	Kind of LA	Number	Total
Western Province	Colombo	13	557	MC	5	13
				UC	5	
				PS	3	
	Gampaha	13	1,177	MC	2	19
				UC	5	
				PS	12	
	Kalutara	14	762	MC	0	17
				UC	4	
				PS	13	
1	3	40	2,496		49	49

Note: MC: Municipal Council; UC: Urban Council; PS: Pradeshiya Sabha

Source: District Statistical Handbook 2020, DCS

## 1.2 Natural conditions and socio-economic status

The Western Province has a rectangular shape measuring 90 km from north to south, and 40 km from east to west. There are flatlands along the coast, hills with an altitude of several tens of meters inland, mountains at the eastern end, and there is a flat terrain that is almost 100 meter above sea level.

The province has a tropical rainforest climate, with annual rainfall of 2,516 mm,<sup>1</sup> and rainy seasons in April-June, and September-November. The average temperature is 28.2 °C.<sup>2</sup>

Cultivated land is decreasing and built-up land is increasing. The road network has developed radially from Colombo, such as National Highway No.1 heading northeast to Kandy, National Highway No.3 towards Puttalam via Negombo northeast, National Highway No.4 towards Nuwara Eliya in the east and Kalutara in the south, and National Highway No.2 towards Galle. The highway network consists of Highway No.3 to the North Airport, Highway No.2 (Outer Circular Highway), and Highway No.1 in the direction of the south of Galle. There is a Central Expressway under construction.

Railroads have developed radially from Colombo to the north (Negombo, etc.) and northeast (Kandy, etc.) respectively, just like the road network. There is a railroad to the east of Avissawella parallel to Route 4 along the south coast.

As mentioned earlier, the Western Province produces about 40 % of national GDP, but this share is declining and it is unclear whether high growth can be maintained. The scenario for the MP period assumes that the current level will be sustained, but follow-up is required. Industry (manufacturing) has declined from 33 % in 2016 to 30 % in 2020 in the Western Province.<sup>3</sup> In the service industry, which accounts for two-thirds of the Provincial GDP of Western Province, communications and tourism are the driving forces. According to household statistics, consumption trends in the Western Province are on the rise.

---

<sup>1</sup> Annual average rainfall, Colombo 2015-2020; Source: Statistical Abstract Sri Lanka 2021

<sup>2</sup> Annual average air temperature, Colombo 2020; Source: Statistical Abstract Sri Lanka 2021

<sup>3</sup> Source: Annual Report, Central Bank of Sri Lanka, 2021

## 2 Situation analysis of SWM

### 2.1 Overview of SWM situation

Local authorities (LAs) are statutorily responsible for the management of waste generated within their respective boundaries in Sri Lanka. Population and economic growth as well as rapid urbanization have aggravated the burden of management of municipal solid waste (MSW) in developing countries, and Sri Lanka is no exception. Most of the LAs have already reached a satisfactory level of sanitation, especially the LAs of the Western Province, but are still struggling with the environmental consequences and health hazards of solid waste management (SWM) particularly final disposal. Increasing amount of MSW and poor SWM, such as lack of waste reduction efforts, no or little effort to control illegal dumping, widespread practice of unsafe open dumping, etc. have intensified the adverse impacts on the environment and humans, as evidenced by the collapse of Meethotamulla open dump which resulted in the loss of many lives and major physical damage in 2017. Open dumping also implies very high opportunity cost as it deprives large tracts of valuable municipal land unavailable for more productive use. Problems related to SWM in the Western Province, which accounts for more than 60 % of the total amount of waste generated in Sri Lanka, are serious and require urgent corrective actions.

### 2.2 Waste amount and composition

#### 2.2.1 Waste amount and composition survey by SATREPS

SATREPS (Science and Technology Research Partnership for Sustainable Development) is a program of the Japanese government to promote international collaborative research on global issues. Under this program, a waste amount and composition survey (WACS) was conducted in the Central and Southern Provinces of Sri Lanka from 2012 to 2014. In this study, a total of five Local Authorities (LA), including three Municipal Councils (MC), one Urban Council (UC) and one Pradeshiya Sabha (PS), were surveyed for determining the waste generation amount per unit and waste composition.

The current waste amount generated per unit person and waste composition used in this MP are based on this survey as the survey method and calculation method are scientific and credible, i.e. i) the survey was conducted by type of LA, and ii) the total waste amount was estimated based on the individual waste amount per unit and the total number of the unit.

The amount per person of waste generated in households and of MSW per person, which includes both household waste and waste from business entities, by LA type are shown in Table 2-1. According to this table, the waste amount generated per person in households is at its highest in MC at 0.35 kg per person per day, while UC and PS are at 0.33 and 0.25 kg per person per day, respectively. The waste amount generated per person by business entities is also the highest in MC at 0.97 kg per person per day, while UC and PS are at 0.63 and 0.44 kg per person per day, respectively. The results show that the amount of waste generated tends to increase along with the progress of urbanization.

Table 2-1 WACS implemented in the Central and Southern provinces of Sri Lanka by SATREPS (2012-2014)

LA	LA Type	Population	Amount of waste generated	Amount of MSW generated
			per person in households	per person
			kg/person/day	kg/person/day
Kandy MC	MC	133,490	0.35	1.32
Galle MC	MC	91,204	0.28	0.56
Hambantota MC	MC	22,691	0.42	1.02
Average of MC	-	-	0.35	0.97
Gampola UC	UC	41,179	0.33	0.63
Udawalpala PS	PS	97,567	0.25	0.44

The waste composition by LA type is given in Table 2-2. It shows that kitchen waste accounts for 60-70 % of total waste, and total biodegradable waste, including garden waste, accounts for 80 %. In addition, recyclable waste such as paper, plastics, and metals make up around 10 % of the total.

Table 2-2 Waste Composition Data for Household Waste (% wet base)

	Kandy MC	Galle MC	Hambantota MC	Gampola UC	Udawalpala PS
Kitchen	74.6	68.1	54.3	73.2	69.2
Garden	4.8	11.6	32.4	10.4	13.2
Paper & Cardboard	7.8	6.2	2.7	4.1	4.0
Soft Plastic	4.2	4.6	1.6	3.8	4.0
Hard Plastic	0.9	1.7	1.0	0.6	1.2
Textiles	1.0	1.0	2.4	0.8	0.7
Rubber & Leather	0.4	0.6	0.4	0.4	0.2
Metal	0.9	0.9	0.2	0.8	1.0
Glass	1.7	1.8	1.3	1.2	2.9
Ceramics	0.5	0.6	0.2	0.1	1.2
Hazardous	0.4	0.2	0.0	0.4	0.4
E-Waste	0.2	0.1	0.4	3.8	0.3
Misc.	2.7	2.7	3.2	0.4	1.7

## 2.3 Waste flow analysis

### 2.3.1 Objectives of the waste flow analysis

The objectives of a waste flow analysis are as follows:

- Quantitatively understand the current situation of SWM in the Western Province,
- Set one or more quantitative goal(s) for the SWM Master Plan in the Western Province, and
- Quantitatively monitor progress toward the goal(s)

Based on data collected from LAs, a waste flow analysis was conducted for each LA, each zone, each district, and the entire Western Province.



**2.3.2 Concept of waste flow**

A conceptual diagram of the waste flow is shown in the following figure.

The total amount of municipal solid waste (MSW generation) (No.1) generated by households (No.2) and at places other than households such as business entities (No.3) is discharged (No.5) to collection services within a collection area. Waste generated in areas that are not covered by collection services is self-disposed at the source of generation (No.6). A part of the MSW generated (No.1) is discharged improperly by littering or illegal dumping (No.7).

Waste discharged in collection areas is collected (No.9) and transported to an intermediate treatment facility (No.11-1, 2, 3, 4) or directly to a disposal site without intermediate treatment (No.12). To improve transport efficiency, some LAs have transfer stations (No.10), where the collected waste is transferred to large-capacity vehicles and transported to intermediate treatment facilities and/or disposal sites.

Waste recycling occurs at each stage, i.e. generation (No.4), discharge/collection (No.8), at intermediate facilities (No.11-5, No.11-6), and during final disposal (No.14).

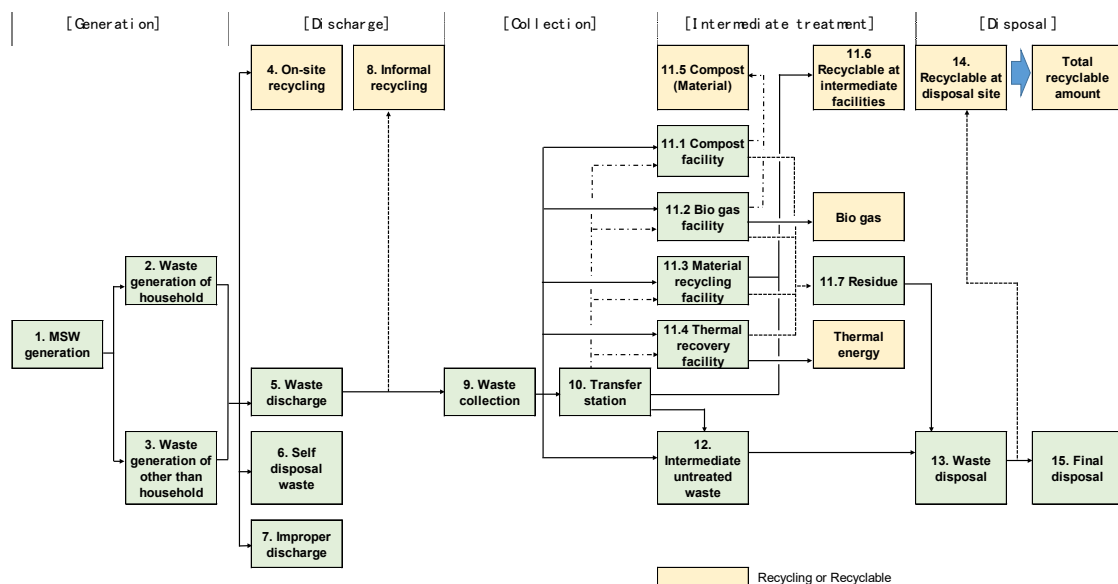

Figure 2-1 Conceptual diagram of the waste flow

Based on the above-mentioned definition of MSW, the terms used in the waste flow analysis are defined below.

- MSW generation (No.1) is the total amount of waste generated by households (No.2) and other than households (No.3).
- On-site recycling (No.4) mainly refers to home composting of biodegradable waste and recycling activities such as Parisara Pola.<sup>4</sup>
- Waste discharge (No.5) refers to the discharge of waste to regular collection services

<sup>4</sup> Parisara Pola – LA associate with recyclers and gather to a common place where residence of the selected area can sell or exchange their recyclables.

- provided directly by an LA and/or private sector companies under contract with the LA.
- Self-disposal waste (No.6) refers to the disposal of waste generated in areas not covered by collection services and eliminated at source, mainly by burying, burning, and stockpiling.
  - Improper discharge (No.7) refers to littering or illegal dumping.
  - Informal recycling (No.8) refers to the recycling of recyclable materials collected mainly by collection workers.
  - Waste collection (No.9) refers to the collection of waste by regular collection services.
  - Transfer stations (No.10) refers to stations where the waste collected by small-capacity collection vehicles is transferred to larger collection vehicles to improve transport efficiency and reduce collection costs.
  - Intermediate treatment facilities (No.11-1, 2, 3, 4) refers to composting facilities, biogas facilities, recycling facilities including Sampath Kendra and thermal recovery facilities, where waste is transported to be treated.
  - Compost material (No.11-5) refers to the use of biodegradable waste to produce compost.
  - Material recycling facilities (No.11-6) refers to the recycling of waste (through composting, biogas production, material recycling, or thermal recovery) at intermediate facilities (No.11-1, 2, 3, 4).
  - Residues (No.11-7) refers to the waste remaining after recycling, composting, and treatment at intermediate facilities (No.11-1, 2, 3, 4).
  - Intermediate untreated waste (No.12) refers to waste collected and transported either directly or via a transfer station facility to a disposal site.
  - Waste disposal (No.13) refers to the elimination of waste, including residues generated at intermediate treatment facilities, in final disposal sites (landfills).
  - Recyclable at disposal sites (No.14) refers to the recycling of recyclable materials recovered at disposal sites, mainly by waste pickers.
  - Final disposal (No.15) refers to the elimination of all the waste, except recyclables recovered at disposal sites (No.14), in final disposal sites (landfills).

### 2.3.3 Data used for the waste flow analysis and calculation method

The following data has been used for the waste flow analysis:

- Data on waste generation rates (gram/person/day) obtained from the waste amount and composition survey conducted by SATREP in 2014.
- Waste amount data measured by weighbridges installed at waste management facilities. The facilities where weighbridges were installed include the Karadiyana Disposal Site, the Kerawalapitiya Disposal Site, the Kalutara Composting Plant, and the Dikkowita Composting Plant.
- Waste Management Authority (WMA) monthly reports that are compiled as part of SWM

data of LAs.

The calculation method for each waste that constitutes the waste flow is summarized in the table below.

**Table 2-3 Summary of calculation method for waste flow analysis**

			Generation rates have been calculated for each LA category (namely MC, UC and PS) based on the results of SATREP, 2014.		
			Type of LA	Household waste	MSW
			g/person/day		g/person/day
1	MSW generation	a	MC	350	930
			UC	330	630
			PS	250	440
2	Amount of waste generated by households	a	(Generation rates of households based on the result of SATREP) x (Population)		
3	Amount of waste generate by other than households	a	(Generation rates of non-households based on the result of SATREP) x (Population)		
4	On-site recycling (home composting)	c	(Number of composting bins distributed) x (Average number of family members: 5 person/family) x (Average amount of biodegradable waste put into the bin: 50 g/person/day) Recycling data of Parisara Pola		
5	Waste discharge	-	(9. Amount collected) + (8. Informal recycling by collection workers)		
6	Self-disposal	c	[(Waste amount per person generated at households) + (Waste amount per person generated at non-households)] x (Population in areas not covered by collection services)		
7	Improper discharge	-	(1. MSW generation) - [(4. On-site recycling) + (5. Waste discharge) + (6. Self-disposal)]		
8	Informal recycling	c	(Amount of recyclables collected by waste collectors): 38.8 kg/collector/day (Kotikawaththa PS) x (Number of waste collectors)		
9	Waste collection	b or c	Weighbridge data or calculation based on vehicle operation information		
10	Transfer station	b or c	Weighbridge data or calculation based on vehicle operation information		
11.1	Composting facility	b or c	Weighbridge data or calculation based on vehicle operation information		
11.2	Biogas facility	b or c	Weighbridge data or calculation based on vehicle operation information		
11.3	Material recycling facility	b or c	Weighbridge data or calculation based on the vehicle operation information		
11.4	Thermal recovery facility	b or c	Weighbridge data or calculation based on vehicle operation information		
11.5	Composting	b or c	Weighbridge data or calculation based on vehicle operation information		
11.6	Recycling at TRF&TS Residues	c	Amount of recyclable materials recovered at Sampath Kendra + (Transfer station + Thermal recovery facility)		
11.7		c	(Ratio of residue generated during sieving process of compost: 35% (Karadiyana)) x (Amount of biodegradable waste treated in the composting facilities) + (Amount of waste treated at the recycling facilities – Amount of recyclable materials recovered)		
12	Untreated waste	b or c	Weighbridge data or calculation based on vehicle operation information		
13	Waste disposal	-	(12. Intermediate untreated waste) + (11.7 Residues)		
14	Recycling at disposal sites	c	Based on the information of LAs		
15	Final disposal	-	(13. Waste disposal) - (14. Recycling at disposal sites)		

A: Previous survey results, b: Weighbridge data, c: Waste management data of LAs

### 2.3.4 Result of waste flow analysis

The waste flow in the Western Province for 2020 is represented in the following figure:

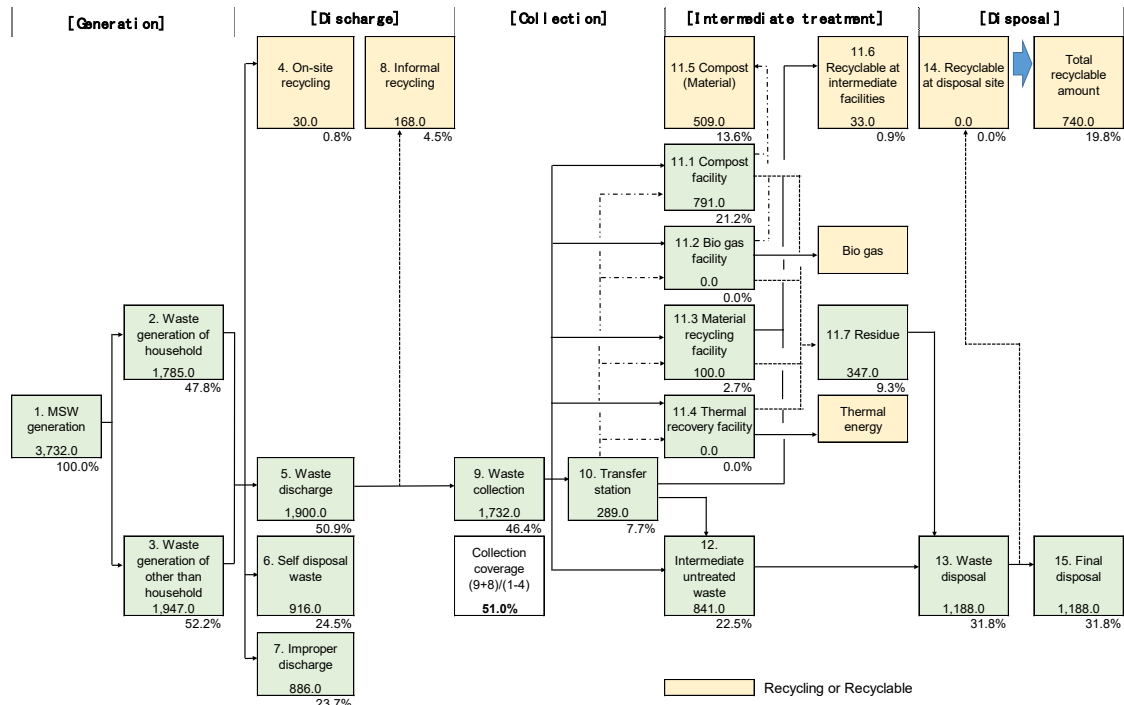

Figure 2-2 Waste flow for Western Province in 2020 (ton/day)

The total amount of MSW generated in the Western Province is 3,732 tons per day, of which 48% is household waste (No.2) and 52 % is non-household waste (No.3), 1 % of the total waste generated is recycled at the generation source (No.4), mainly through home composting and Parisara Pola, and it is assumed that 5 % of the total waste generated consists of recyclables collected by collection workers (No.8), 51 % of the collected waste is transferred to intermediate treatment facilities (No.9), and 49 % is either self-disposed (No.6) or improperly discharged (No.7).

The amount of waste generated, recyclables recovered at source by collection workers, waste (including recyclables) collected by regular collection services, self-disposed waste in areas not covered by collection services and waste improperly discharged waste in each district and zone, are summarized in the following table and figures.

Based on data the collection coverage, i.e., the ratio of waste collected to waste generated, was compared for three districts. The collection coverage in the Colombo district is 64 %, and lower in the Gampaha and Kalutara districts, respectively at 37 % and 39 %. Also, Kotte and Dehiwala zones in the Colombo district tend to have a higher collection coverage than zones in other districts. As a result, amount of waste collected in Colombo District, where is high population concentration and even higher waste collection coverage, accounts for 65 % of the total waste collection in the Western Province.

Table 2-4 Waste data by district and zone (ton/day)

District/Zone	Generation	Recycling <sup>5</sup> at generation stage	Collection*	Non-collection/Improper discharge
Western Province	3,732	31	1,902	1,801
Colombo District	1,914	12	1,222	680
Gampaha District	1,227	12	450	765
Kalutara District	594	7	230	357
Kotte Zone	1,184	7	801	376
Dehiwala Zone	730	5	421	303
Negambo Zone	423	4	149	271
Gampaha Zone	486	5	168	313
Kelaniya Zone	318	4	133	181
Horana Zone	323	4	115	205
Kalutara Zone	271	3	116	152

\*: "Collection" includes recyclables collected informally by regular collection workers.

Source: JICA team estimation

<sup>5</sup> Recycling at source includes both home composting and recyclables collected by waste pickers.

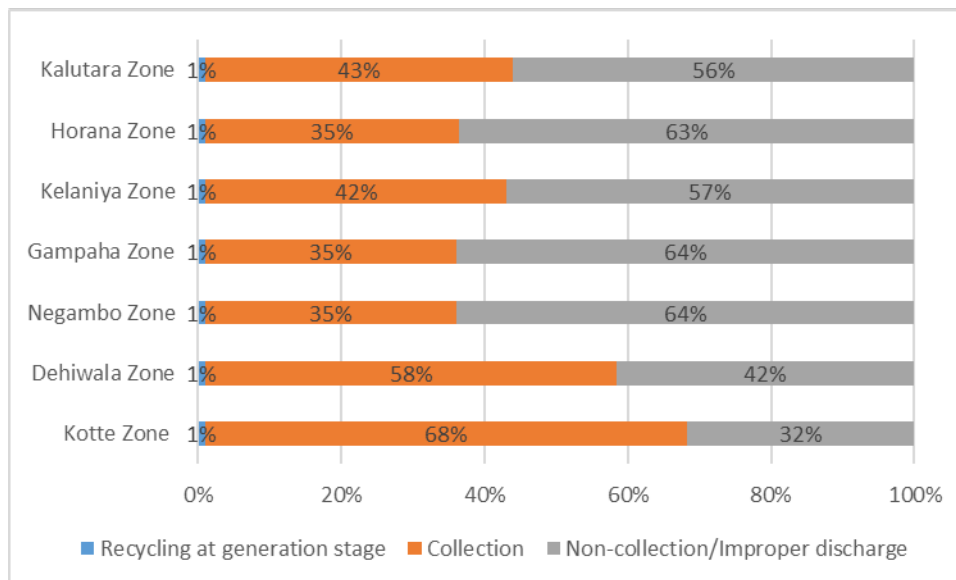
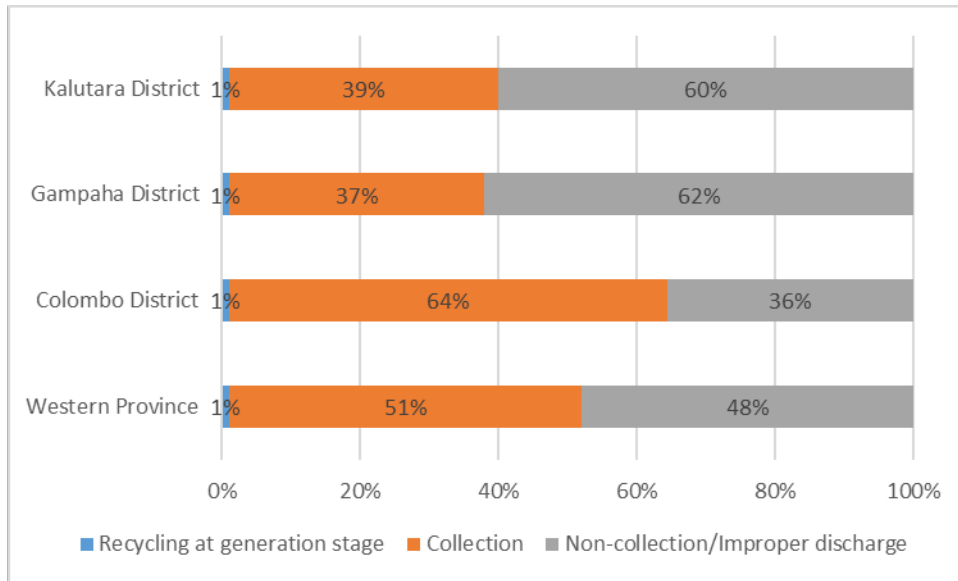

Figure 2-3 Comparison of collection coverage, etc. by district and zone

In the same way, collection coverage was compared by type of LA, namely MC, UC, and PS. As a result, the collection coverage of UC is the highest at 72 %, followed by MC at 65 % and PS at 32 %. This shows that UC is the type of LA with the highest population density and the highest need for waste collection. The following table shows a comparison of the generation amount and collection amount by type of LA, and the following figure compares the collection coverage by type of LA.

Table 2-5 Waste data by type of LA (ton/day)

Type of LA	Population (person)	Generation	Recycling at generation stage	Collection*	Non-collection / Improper discharge
MC	1,574,000	1,526.8	7.9	988.4	530.5
UC	849,000	535.0	4.4	382.8	147.8
PS	3,807,000	1,675.2	19.0	530.7	1,125.5
Total	6,230,000	3,732.0	31.3	1,901.9	1,803.8

\*: Collection amounts include recyclables collected by waste collectors.

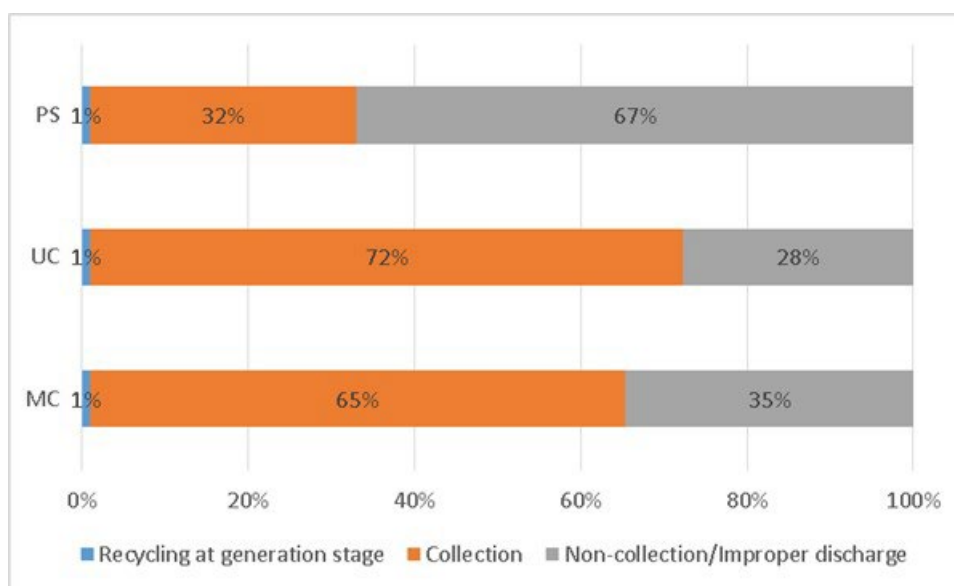

Figure 2-4 Comparison of collection coverage by type of LA

## 2.4 Waste collection & transportation, intermediate treatment and final disposal

### 2.4.1 Waste collection & transportation

Almost all LAs directly operate waste collection, except CMC, Negombo MC, Kotte MC, Maharagama UC which contracted with private companies.

The vehicles used for collection are mainly tractor-trailers given road conditions and accessibility to disposal sites. However, these vehicles are not suited for long-distance transport. On the other hand, one LA has been provided with a 4-ton compactor truck by WMA and some LA have received 6-ton compactor trucks by the Ministry of Public Administration, Home Affairs and Provincial Councils and Local Government (MoPAHAPCLG). However, these vehicles are not used efficiently due to the road conditions and accessibility issues mentioned above.

Most LAs collect waste separately in two categories: biodegradable and other (non-biodegradable) waste. In addition, some LAs set a collection date for recyclables and collect three categories of waste: biodegradable, recyclable, and other waste. Some LAs separately collect recyclables and distribute leaflets and other educational materials to inform and educate residents about the importance of properly separating their waste. In such LAs, the incoming biodegradable

waste at composting facilities is less contaminated with other waste, thus enabling the production of high-quality compost (such as in Ja Ela PS, Horana UC, Bulathsinhara PS, and Agalawatta PS).



**Horana PS**  
This type of tractor-trailer with a loading capacity of 6.6 m<sup>3</sup> is a typical collection vehicle in the Western Province



**Gampaha MC**  
Compactor truck with 6-ton loading capacity donated by MoPAHAPCLG



**Seethawaka PS**  
Compactor truck with 4-ton capacity donated by WMA. Biodegradable waste is collected by the compactor and transported to a composting facility.



**Seethawakapure UC**  
Three-wheeled vehicles are also used for waste collection.



**Bandaragama PS**  
Half cylindrical collection trailer with slide-type lid (6 m<sup>3</sup>).



**Kotikawattha PS**  
Container type collection trailer.

Figure 2-5 Examples of collection vehicles used by LAs



### 2.4.2 Waste transfer

15 LAs have transfer stations in the Western Province. These transfer stations do not have any facilities, and in most cases, the collected biodegradable and non-biodegradable waste is separately unloaded onto the ground. It is then transferred to large- capacity dump trucks using heavy machinery such as shovel loaders and excavators, and transported to treatment facilities or disposal sites.

In some LAs, such as Kolonnawa UC, Gampaha MC, Panadura UC, and Homagama PS, transfer stations are located in urban areas due to their density making it difficult to secure land for treatment and disposal facilities. This results in a negative impact on the surrounding environment, such as foul odors and waste scattering by animals.

Several LAs in Gampaha District, including Gampaha MC, Gampaha PS, and Attanagalla PS, have stopped transporting collected waste to the Kerawalapitiya Disposal Site, and outsourced the transportation and disposal of waste to private companies. The collected waste is transferred on to large-capacity dump trucks to be transported from transfer stations to disposal sites on private land. Transportation and disposal costs are high, ranging from LKR 27,000 to 30,000 per trip.

In addition, as CMC has also suspended the disposal of collected waste at the Aruwakkalu Disposal Site, CMC has been temporarily storing collected waste at former disposal sites in Kerawalapitiya and Madampitiya. This amount of waste is treated as transfer waste in the current waste flow.



**Panadura UC**  
Collected waste is unloaded separately into two piles (biodegradable and other waste) at the transfer station. However, these piles are then mixed when transported to the disposal site.



**Biyagama PS**  
Transfer station of Biyagama PS. On the right side is the biodegradable waste and on the left side is the other waste.



**Gampaha MC**  
Waste transfer is entrusted to a private company. Waste is transferred three times a day by 20 m<sup>3</sup> dump trucks.



**Kolonnawa UC**  
Collected waste is generally unloaded separately into two piles (biodegradable and other waste) at the transfer station. Collection vehicles, transfer equipment and vehicles operate in a very narrow transfer space.

Figure 2-6 Examples of transfer stations in Las

### 2.4.3 Intermediate treatment and final disposal of waste

The amount of waste treated in composting facilities, recycling facilities, and disposal sites are shown in the table below. The figure that follows shows the ratio of composting, recycling and disposal to the total amount of waste collected.

In the entire Western Province, 16 % of the waste collected is carried to composting facilities, 6 % to recycling-related facilities, 38 % to TRF and 40 % to disposal sites as of base year 2022.

The amount of waste disposed does not include residue generated at intermediate treatment facilities. In some cases, the recovery of recyclable materials from other waste is executed not only in recycling facilities but also in composting facilities, hence the recyclable materials recovered in the intermediate treatment facilities were also counted in the recycling amounts.

Table 2-6 Amount of collected waste transported to intermediate treatment facilities and disposal sites

District/Zone	Collection*	Composting facilities	Recycling facilities	Disposal sites
Western Province	1,738	791	105	843
Colombo District	1,128	568	31	529
Gampaha District	403	138	57	208
Kalutara District	207	85	17	105
Kotte Zone	752	401	23	328
Dehiwala Zone	376	167	8	201
Negambo Zone	126	24	5	97
Gampaha Zone	157	51	44	62
Kelaniya Zone	120	63	8	49
Horana Zone	105	36	9	60
Kalutara Zone	102	50	7	45

\*The waste amount in "Collection" excludes the recyclable materials collected informally by waste collectors at the collection stage.

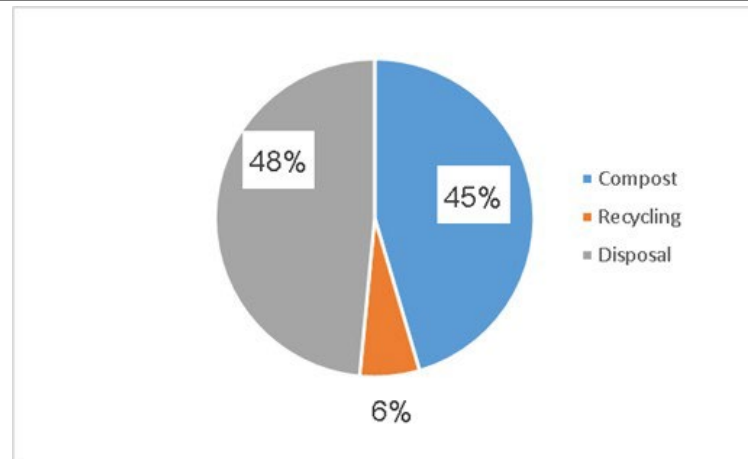

Figure 2-7 Ratio of collected waste transported to intermediate treatment facilities

### (1) Thermal recovery facility (TRF)

Energy recovery from waste is the conversion of MSW materials into usable heat, electricity, or fuel through a variety of processes, including combustion, gasification, pyrolyzation, anaerobic digestion and landfill gas recovery. This process is often called waste to energy. Energy recovery from municipal solid waste is a key part of the waste management hierarchy, which ranks various management strategies from most to least environmentally preferred. Energy recovery ranks below source reduction and recycling/reuse but above treatment and disposal. It's not only decreased the volume of solid waste destined for landfills where the land scarcity is a burden, but can also recover energy from the waste burning process. This generates a renewable energy source and reduces carbon emissions by offsetting the need for energy from fossil sources and reduces methane generation from landfills. A Thermal Recovery Facility (TRF) is an advancement of existing waste to energy (WtE) technology. The TRF system converts municipal solid waste (MSW) into either electricity or steam for industrial customers. The combustion bottom ash and the combustion fly ash along with the air pollution control system treated to produce products that can be beneficially reused. Fly ash typically amounts to 10-20 percent by weight of the total ash. The rest of the MSW combustion ash is called bottom ash (80-90 percent by weight).

Due to the high soluble salts content, leachable heavy metals content and organic pollutants content of the fly ash are relatively high, fly ash's resource utilization rate is rather low and resource utilization approaches should be prudently evaluated while selecting. The major considering factors are suitability of the treatment approach, feasibility of the treatment approach, economy of the treatment approach and environmental effect evaluation of the treatment approach. In view of the above factors, fly ash's resource utilization can be classified into four categories:

- construction class, including cement products, concrete products, pottery and glasswork or glass-ceramic products;
- geology class, including road-paving materials and embankment materials
- agriculture class, mainly referring to soil conditioner
- adsorbent and sludge conditioner

The main chemical components of bottom ash are silica (sand and quartz), calcium, iron oxide, and aluminium oxide. Bottom ash usually has a moisture content of 22-62 percent by dry weight. The chemical composition of the ash varies depending on the original MSW feedstock and the combustion technology, and the operational conditions. Bottom ash has the potential for the recovery of metals and minerals, contributing to decreasing the exploitation of natural resources and it has been largely recycled in different countries especially in various construction and soil improvement projects by compensating the primary aggregates. The presence of certain chemical compounds in bottom ash is leading to advanced industrial-based applications as well.

Necessity of technical specifications for ash management in Sri Lanka is vital.

Given below are the options for ash management.

- Dispose at designated secure cell at Aruwakkalu sanitary landfill
- Cement kiln co-disposal
- Use of secondary aggregate in construction (commonly used as bulk fill (areas that simply need filling with something), asphalt, cement bound materials, lightweight blocks (breeze blocks)).

An overview of the Western Power Kerawalapitiya (WPK) WtE facility operating currently is given below.

- Plant Name: 10 MW Colombo Waste to Energy Power Plant
- Capacity: 700-800 t/day
- Electrical Power: 10 MW net
- Type of incinerator: Moving Grate Incinerator
- Owner / Operations & Maintenance: Western Power Company Pvt. Ltd. (A subsidiary of Aitken Spence PLC)
- Construction Cost: LKR 13 billion
- Commercial Operation: 2021 January



Source: Daily News Feb. 28, 2021



Figure 2-8 Western Power Kerawalapitiya (WPK) WtE facility

## (2) Composting facilities

There are 28 composting facilities in the Western Province. Of these, 23 facilities are managed by LAs and three, namely Karadiyana, Dikkowita, and Kalutara, are managed by WMA. One composting facility located at the Dompe Disposal Site is managed by CEA and the Kerawalapitiya Composting Plant is managed by SLLRDC.

The following situations were observed at some composting facilities:

- There is not enough space in the yard to turn, mature and stabilize biodegradable materials at appropriate intervals and durations. Therefore, good-quality compost is not being produced.
- Matured compost remains in the yard because of an insufficient market for selling compost.
- Separately collected biodegradable waste is not composted but disposed of at disposal sites due to the above -mentioned reasons.

On the other hand, the following features were observed at facilities and LAs that manufacture good-quality compost:

- The area of the yard for composting processes, such as turning decomposing materials, is spacious.
- There is a sufficient number of workers at the composting facilities.
- Separation rules at the discharge stage are followed by residents, and the biodegradable waste contains few contaminants.
- The LA, including the political leaders as well as the management, is highly conscious of the environment and waste management.

It is necessary to clarify the role of composting facilities and the purpose of compost

production to promote appropriate waste management in the Western Province.

Table 2-7 Composting plants/facilities located in the Western Province in 2019

LA	Management sector	Number of facilities	Number of LAs carrying waste	Remarks
		23	23	
WMA	Karadiyana Composting Plant	1	7	Some LAs that carry biodegradables into Karadiyana Composting Plant also have their own composting facilities.
	Dikkowita Composting Plant	1	1	
	Kalutara Composting Plant	1	4	
	Sub-total	3	12	
CEA	Dompe Disposal Site	1	1	Composting facility is located at the disposal site.
MoUD&H	Muthurajawela Composting Plant	1	5	Some LAs that carry biodegradables into the Muthurajawela Composting Plant also have their own composting facilities.
Total		28	41	



Seethawakapure UC  
Waste is collected by trailer with containers or spaces for each type of waste.



Seethawakapure UC  
Contaminants are separated from biodegradable waste for animal feed



Ja Ela PS  
Ja Ela PS composting facility.



Kelaniya PS  
Packaged compost is sold on the side of the main road.



Ja Ela PS  
Brochures used for public awareness on source segregation.



Kotikawattha PS  
Leaflet used for public education on waste segregation

Figure 2-9 Photos related to composting, such as composting facilities

**(3) Final disposal**

The final disposal sites currently operated in the Western Province and the number of LAs using them are shown in the following table. 22 LAs operate their own disposal sites and 10 LAs have outsourced disposal to the private sector because they were not able to secure land for final disposal sites.

Table 2-8 Disposal sites used by LAs in the Western Provinces as of 2020

Classification	Name of disposal site	Number of LAs using the disposal site
Common disposal site (managed by Central Government or Western Province)	Aruwakkalu Disposal Site	0
	Karadiyana Disposal Site	7
	Muthurajawela Disposal Site	5
	Dompe Disposal Site	1
Local authority		22 (including Kalutara PS)
Private		10

Disposal sites for Bandaragama PS, Madurawala PS and Wallalawita PS could not be confirmed.

**i. Aruwakkalu Disposal Site**

Aruwakkalu Disposal Site is located about 150 km north of the capital Colombo and was constructed to dispose of waste from the Northwestern Province and Western Province and started its operation in 2020. Waste from the Western Province is planned to be transported by rail via Kelaniya Transfer Station (Kelaniya TS) to this disposal site.

The outline of the Aruwakkalu disposal site is described below.

- Operation management entity: MoUD&H
- Landfill capacity: 5,668,000 m<sup>3</sup>
- Starting year of operation: Rescheduled to start in January 2024
- Equipment: 3 stationary compactors, 4 transfer cranes, 3 special duty shovels, 8 trailers for loading transferred waste at Kelaniya TS, 8 trailers for unloading transferred waste at Aruwakkalu TS, 8 prime movers at KTS, 8 prime movers at ATS,

68 containers, 2 weighbridges (2)

- Environmental measures: design and build contract including wastewater treatment plant, deodorizer, effluent treatment plant to fulfill the environmental requirements stipulated in the National Environmental Act and relevant Regulations under the Act.
- Operation management system: PMU/Contractor operate and manage the facilities until a Special Purpose Vehicle (SPV) is formed.

## ii. Karadiyana Disposal Site

The overview of the Karadiyana Disposal Site (Karadiyana DS) has been summarized as follows based on incoming waste data collected for one year period from April 2018 to May 2019.

- The total amount of incoming waste was 543 tons per day, of which 492 tons per day were collected and disposed of by LAs, accounting for 90% of the total incoming waste.
- Incoming waste was managed under 13 categories. Waste brought to Karadiyana DS by the LAs was sorted into biodegradable waste and mixed waste.
- 36% of the total incoming waste (196 tons per day) were sorted biodegradable waste. First temporarily dumped on site A, it was then matured at a composting plant located in/ the Karadiyana DS.
- Mixed waste, which totaled 295 tons per day and accounted for 54% of the total incoming waste, was disposed of at site B.
- Seven LAs were bringing waste to the Karadiyana DS.

Table 2-9 Amount of waste brought to Karadiyana DS from June 2018 to May 2019 (ton/day)

MSW				
LA	Mixed waste	Sorted biodegradable waste	Other waste	Total
Moratuwa MC	26.0	43.2	15.0	84.2
Boralegamuwa UC	19.0	10.9	0.3	30.2
Kesbewa UC	36.2	30.1	1.9	68.2
Dehiwala-Mt, Lavina MC	83.3	63.1	28.6	175.0
Kotte MC	24.1	20.3	3.9	48.3
Maharagama UC	84.6	16.0	1.4	102.0
Homagama PS	22.0	12.8	0.8	35.6
<b>Total</b>	<b>295.1</b>	<b>196.4</b>	<b>51.9</b>	<b>543.4</b>
<b>%</b>	<b>54.3%</b>	<b>36.1%</b>	<b>9.6%</b>	<b>100.0%</b>

\* Other waste: bulky waste, soil with waste, wood trunks, slaughterhouse waste, general waste discharged from industries, treated sanitary waste, polythene & regiform, soil, sawdust, and construction & demolition waste.

## iii. Muthurajawela Disposal Site

Muthurajawela Disposal Site (Muthurajawela DS) is managed by MoUD&H. Muthurajawela DS has now stopped receiving other waste and only accepts biodegradable waste, which is composted in the adjacent composting plant.



According to data on incoming waste in 2018, the total amount of incoming waste was approximately 700 tons per day in average, of which 470 tons per day (67%) was separated biodegradable waste. In addition, 14 LAs of the Colombo and Gampaha districts disposed of their waste in the Muthurajawela DS.

#### **iv. Dompe Disposal Site**

Dompe Disposal Site was constructed under a grant project from KOICA and is managed by CEA.

It was planned as a regional disposal site, but due to opposition from local residents, only waste from Dompe PS is brought in. The average daily amount of mixed waste is about 2.5 tons per day, and the average daily amount of biodegradable waste is about 1.5 tons per day.

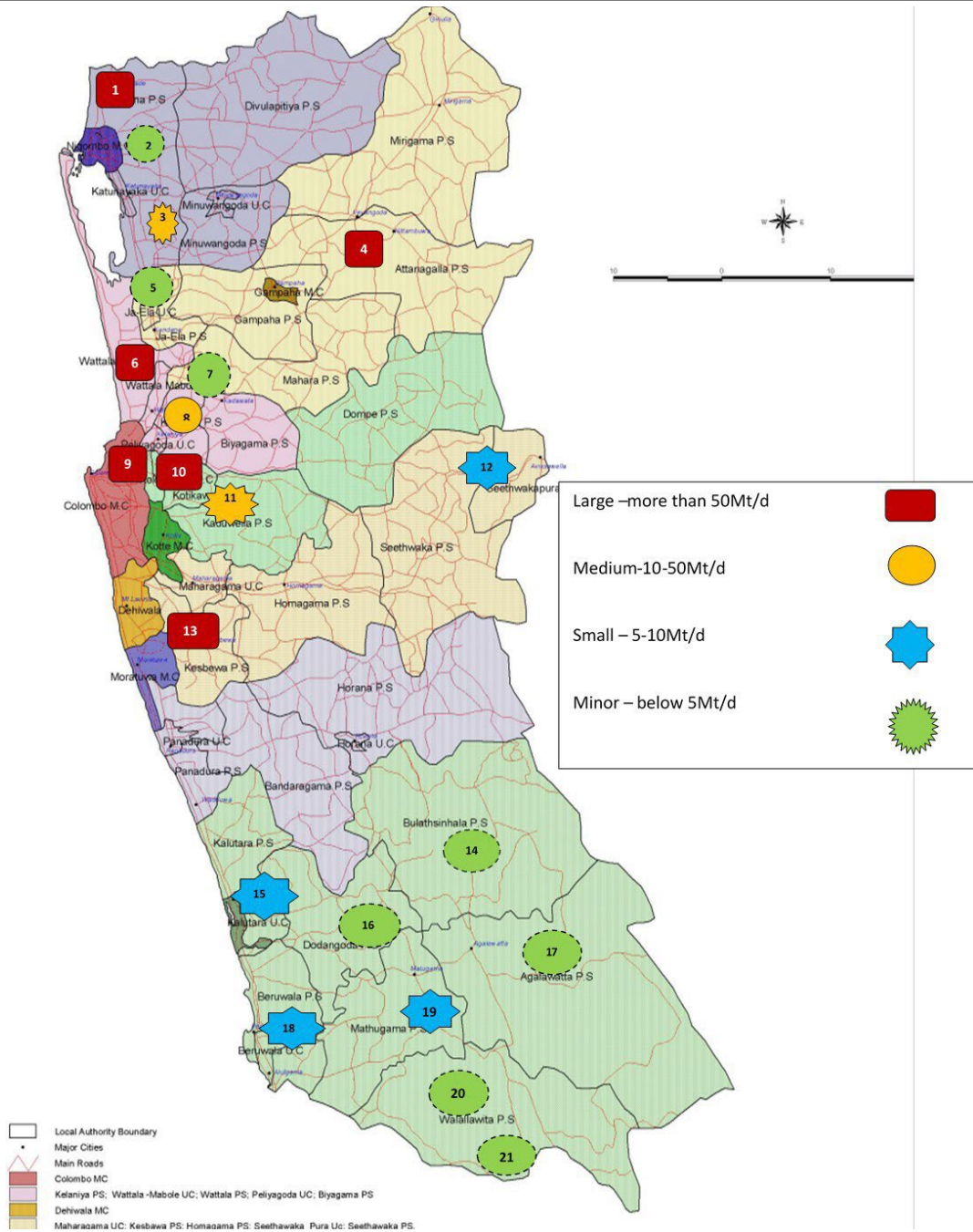

Figure 2-10 Location map of the open dump sites in the Western Province (Strategic Action Plan WMA 2019-2023)

When formulating the Waste Management Master Plan for the Western Province, it is necessary to comprehensively consider the following points related to the disposal sites.

- All the waste required to dispose in the Western Province shall be transported to Aruwakkalu DS.
- Primary transfer stations (PTS) shall be constructed at appropriate locations throughout the Western Province to transport waste to Kelaniya TS.
- Open dump sites shall be properly closed.



**Beruwala UC**  
Disposal site in Beruwala UC. The disposal site is located in a part of the city where low-income people live.



**Bulathsinhala PS**  
Residue generated from the composting facility is openly dumped in an adjacent valley.



**Minuwangoda PS**  
Biodegradable waste is buried at a coconut plantation field. A composting facility is in operation since December 2019.



**Katunayake Seeduwa UC**  
The disposal site maintenance by heavy equipment twice a month. However, as access roads for collection vehicles are not properly maintained, only tractors are able to enter the site.



**Kotikawathatha PS**  
The disposal site is managed by the LA. The site is adjacent to the town area. Waste disposed at site is managed by pushing and pressing by bulldozer.



**Agalawatta PS**  
Residual materials remaining after sorting recyclables from other waste are packed in bags and used as earth retaining walls for disposal sites.

Figure 2-11 Examples of disposal sites

## 2.5 Recycling

### 2.5.1 Overview of the recycling situation in the Western Province

The recycling of organic and inorganic waste in the Western Province is carried out as

follows.

- Recycling of biodegradable waste
  - Recycling of biodegradable waste by home composting
  - Recycling of biodegradable waste at composting facilities
  
- Recycling of inorganic waste
  - Recycling through Parisara Pola occurs at the source of waste generation by private collectors (recovery at source)
  - Informal recycling by waste collectors during regular waste collection at the discharge and collection stages
  - Recycling of recyclables at recycling facilities
  - Recycling of recyclables at final disposal sites

The table and figure below show the amount of waste recycled at the above-mentioned stages, and the total recycling rate in relation to amount of waste generated. The ratio between the total amount of waste recycled and waste generated in the Western Province is 20%, which is a relatively high percentage compared to other developing countries. This is mainly due to the amount of biodegradable waste brought to composting facilities and the informal recycling by collectors during collection work.

The amount recycled at composting facilities shown in the waste flow is not the amount of compost produced, but the amount of biodegradable waste (wet weight) transported to the facilities as raw material for composting.

Table 2-10 Recycling amount in the Western Province (ton/day)

Area	Biodegradable waste		Inorganic waste			Total recyclable amount	Total recyclable rate (%)
	On-site Recycling	Composting facilities	Informal Recycling	Recycling facilities	Recycling at disposal site		
Western Province	31	514	167	37	0	748.9	20%
Colombo District	12	369	94	29	0	504	26%
Gampaha District	12	89	50	3	0	154.6	13%
Kalutara District	7	55	23	5	0	90.3	15%
Kotte Zone	7	261	49	23	0	339.1	29%
Dehiwala Zone	5	109	45	6	0	164.9	23%
Negambo Zone	4	15	23	2	0	43.3	10%
Gampaha Zone	5	33	14	1	0	53.4	11%
Kelaniya Zone	4	41	13	1	0	57.9	18%
Horana Zone	4	23	10	5	0	41.4	13%
Kalutara Zone	3	32	13	0	0	48.9	18%

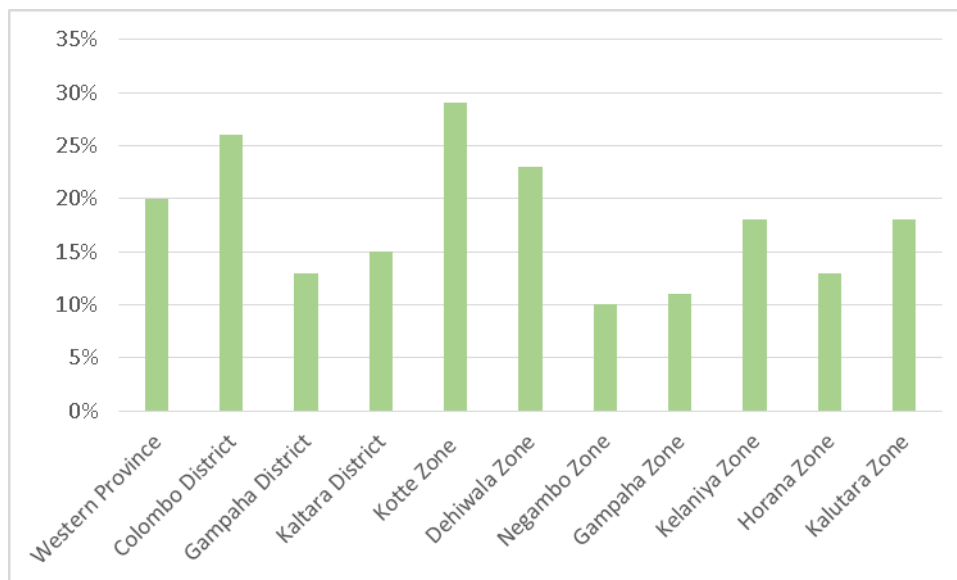

Figure 2-12 Ratio of recycling amount by district and zone



Peliyagoda UC  
Door-to-Door recyclable collection.



Horana UC  
Waste collectors collect recyclables during collection work and sell it to buyers.



Moratuwa MC  
Recyclables are sorted from non-biodegradable waste at Sampath Kendraya.



Moratuwa MC  
Non recyclables such as polythene sorted from non-biodegradable waste are baled and transported to a cement factory, INSEE, as fuel substitute.



Biyagama PS  
PET bottles are sorted at the transfer station. They are stored and baled at a Sampath Kendraya built on the same site as the transfer station. ECO SPINDLES comes to buy them regularly.



“Karadiyana disposal site”  
Recyclables are recovered from the dump site

Figure 2-13 Examples of Recycling in the Western Province

## 2.5.2 Current Status of Plastic Waste Recycling in the Western Province

### (1) Amount of generated plastic waste

The amount of plastic waste generated in the Western Province is estimated to be about 177,197 tons per year, which is based on a waste generation amount of 3,734 tons per day obtained from the waste flow, and a plastic ratio of 13% according to the waste composition survey result (Katunayake Seeduwa UC).

The amount of plastic waste generated in the Western Province is calculated as follows:  
3,734 tons per day × 365 days × 13% which equals approximately 177,197 tons per year.

**(2) Amount of recycled plastic waste**

In addition, plastic is mainly recycled at the collection stage by waste collection workers and at the resource recovery facilities of LAs. It is estimated that the amount of plastic recycled by collection workers is 11,283 tons per year and the amount of plastic recycled at LAs' resource recovery facilities is 2,216 tons per year, for a total of 13,499 tons per year.

(Amount of plastic waste recycled by collection workers:  $168 \text{ tons per day} \times 365 \text{ days} \times 18.4\% = 11,283 \text{ tons per year}$ )

(Amount of plastic waste recycled at LA's resource recovery facilities:  $33 \text{ tons per day} \times 365 \text{ days} \times 18.4\% = 2,216 \text{ tons per year}$ )

**(3) Plastic waste recycling**

Although not all plastic waste can be recycled, it is estimated that the percentage of recyclable plastic waste generated in the Western Province is about 7.6%.

(Recycling rate of plastic waste:  $(13,499 \text{ tons per year} \div 177,197 \text{ tons per year}) \times 100 = 7.6\%$ )

**2.6 Activity status at citizen level****2.6.1 Legal Basis for Waste Separation in the Western Province**

The official categories for waste separation effective as of April 2022 are biodegradable waste and non-biodegradable waste, according to Gazette No. 1560/6-2008, and there exists no newer legal document to set the required categories in the Western Province.

Meanwhile, the Central Environmental Authority (CEA) has recommended in the "Technical Guideline for Solid Waste Management" issued in 2007 waste bag colours for sorting the following five categories, respectively Biodegradable waste - Green; Paper - Blue; Glass Bottles - Red; Metals / Coconut shells - Brown; and Plastic & Polythene - Orange.

Furthermore, the National Policy for Waste Management issued in 2020 (hereinafter referred to as "the National Policy") states that bulky waste from households should be collected on demand, and not during the regular collection of municipal waste. This implies that separate discharge of bulky waste<sup>6</sup> shall also be implemented. It also states that e-waste, construction & demolition (C&D) waste, and healthcare waste<sup>7</sup> need to be treated separately (C&D waste and healthcare waste are not defined as municipal waste).

**2.6.2 Practical implementation by local authorities**

Several different manners of waste separation have been introduced or recommended by various authorities. Each local authority also implements yet different separation categories, - in many cases with less categories - according to their available facilities and equipment for

<sup>6</sup> Bulky waste means large items of solid waste such as household appliances, furniture, large auto parts, trees, branches, stumps, and other oversize wastes whose large size precludes or complicates their handling by normal solid wastes collection, processing, or disposal methods.

<sup>7</sup> Healthcare waste: The National Policy for Waste Management (2020) uses the term "clinical waste."

transportation and treatment. In addition to the regular collection implemented by respective LAs, Parisala Pola, where recyclable waste can be dropped off, and e-waste collection have also been organized by WMA.

Colombo Municipal Council (CMC) and Maharagama Urban Council (UC), for example among many others, implemented three categories including biodegradable (or kitchen waste), recyclable, and residual waste (as of February 2020), while Kolonnawa UC implements a two-category separation, namely biodegradable and non-biodegradable waste. CMC, in addition to the regular collection, has installed several “Sampath Keandra” (Eco-Kiosks) and drop-off stations for recyclable waste within the city.

After CMC started using Kerawalapitiya TRF in late 2020 in collaboration with other LAs of the Western Province, they added the category “burnable waste”, resulting in a change of the contents of the other categories. Following the change, the collection workers and Public Health Inspectors of the relevant LAs have been asked to provide instruction to the citizens on what to discharge into which category directly during collection.

### 2.6.3 Daily separation practice by residents in high-rise apartments

The Western Province has several high-rise apartment complexes to house the largest population of the province. Residents living in individual houses are relatively approachable when it comes to providing them with SWM information and instructions, while it is assumed to be more difficult to approach residents living in high-rise apartment buildings and ensure the proper delivery of information and instruction due to lack of daily direct contact with collection workers.

In order to understand the actual status of waste management in such buildings, waste composition surveys (WCS) have been conducted in three high-rise apartment complexes in the Western Province in January and February 2020 as case studies. The results indicate degree of “separation” of the household waste according to respective local authorities’ methods of waste collection. In the same settlements, Public Opinion Surveys (POS) were also conducted to evaluate the residents’ awareness and challenges they face in terms of waste management in their respective condominium.

The survey results reveal that the citizens are aware that the local authorities require them to discharge their waste separately, but they do not have an exact knowledge about which waste to sort into which category and when each category should be discharged.

**Table 2-11 Case 1: Low-income long-standing settlement in Colombo Municipal Council**

Survey period	2020/02/03 to 02/10
Number of housing units	244 in the condominium
Number of samples	39
Waste categories of the LA's collection service	2 categories: biodegradable and other waste.
Remarks	3 units each from Buildings A, B, C, D, 12 from Building E, and 9 from Building F were selected. The number of samples vary according to the number of housing units of each building.

At the time of the survey in February 2020, had not started using the Kerawalapitiya TRF,



and proceeded to a separate collection of waste in three categories, namely degradable waste, recyclable waste, and non-recyclable waste, in principle. CMC had developed leaflets with a waste collection schedule for each waste management zone serviced by the municipality and distributed them to the residents. However, in the surveyed settlement, the collection was carried out in two categories (biodegradable and other waste).

CMC had distributed green-colored bins to households within the city before 2022 and many households in the surveyed settlements were using

them for storing and discharging their biodegradable waste. As the municipality’s instruction, collection workers recently became stricter about waste separation and giving instructions when inappropriate waste is found in the discharged biodegradable waste bags, sometimes even refusing to take them. If a resident brings a bag of “other waste” on a biodegradable waste collection day, the worker refuse to accept it and the resident has to bring it back home. As a result of this strict practice, “biodegradable waste” contained just a little more than 10% of non-biodegradable waste, while biodegradable waste was hardly found in the “other waste” bags on the “other waste” collection days.



Residents keep biodegradable waste (left) from other waste at home



Example of leaflet developed by CMC

Figure 2-14 Waste segregation and awareness tool

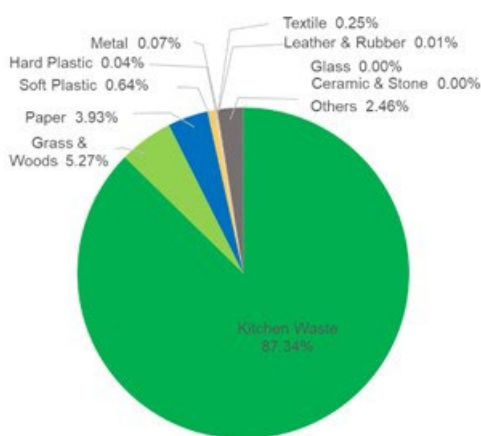

Biodegradable Waste Collection

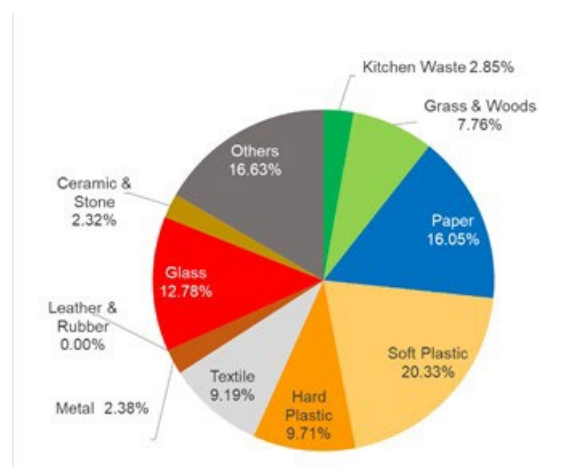

Other Waste Collection

Figure 2-15 Waste composition (weight base) in low-income old high-rise apartments in CMC

However, it was observed that garden waste, which should be considered as “biodegradable waste”, was mistakenly identified as “other waste”. In Sinhalese, “biodegradable waste” is often referred to as “Indul”, which literally means kitchen waste and does not include fallen tree leaves or grasses. “Indul” is often used among the collection workers, who would call out “Indul, indul!” to inform the residents of their arrival at the time of collection, and consequently the general understanding of the residents follows this definition.

Some parts of the recyclable waste such as cardboard and PET bottles were separated manually by the collection workers at the time of collection when such waste were visibly discharged by the residents, and loaded separately on the collection vehicle. According to the POS, many residents (62%) separated and discharged such recyclable waste.

In the surveyed settlement, the residents had a good knowledge about the collection schedule. However, the majority of the residents (100% for biodegradable waste collection; 94% for other waste collection) claimed that the actual time of the collection varies every day.

In terms of reduction, many residents claim to be making conscious choices in their actions of daily life, such as bringing their own bags for shopping, reusing bottles when buying oil, as shown in the figure below.

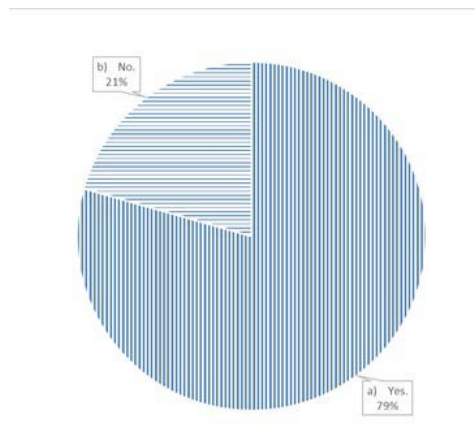

Q. Are you making any efforts to reduce the amount of waste generated in your house?

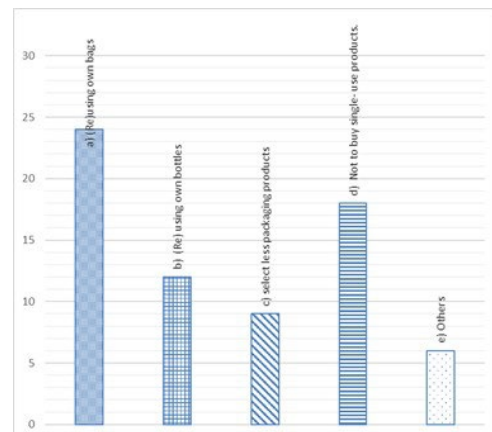

Q. What kind of actions are you taking to reduce waste amount? Select all applicable.

Figure 2-16 POS result in low-income old high-rise apartments in CMC (as of February 2020)

Table 2-12 Case 2: Low-income new high-rise apartment settlements, Kolonnawa Urban Council

Survey period	2020/02/12 to 02/19
Number of housing units	374 in the target building
Number of samples	37
Waste categories of the LA's collection service	2 categories: biodegradable and other waste.
Remarks	In the target "Building C", 3 or 4 housing units on each floor were first randomly designated on paper. If the selected housing unit was not available at the time of the visit, the neighboring unit was chosen.

Kolonnawa Urban Council (UC) was generally collecting waste in two categories, namely biodegradable waste and other waste, and transported it to Karadiyana for disposal. The collection of biodegradable waste and other waste was carried out every day alternately, and as no printed schedule was provided, residents seem to rely on their memory ("Yesterday's collection was for biodegradable waste, so today's should be for other waste.").

The WCS revealed that the contents of the bags discharged on the day of biodegradable waste and that on the day of other waste both showed similar composition. Contrary to the result of the WCS, 82% of the respondents of the POS said they separate biodegradable waste. This may suggest the lack of awareness of what shall be separated.

Another reason for insufficient separation, or discharge of mixed waste, might be that 32% were wrong about the collection dates for each waste category.

Those who responded that they do not separate biodegradable waste selected reasons such as "I don't know what should be separated"; "I don't have time for separating them"; "I don't have space for keeping kitchen waste separately"; "The collection for kitchen waste does not come regularly even if I would separate"; and "I do not trust that the separated kitchen waste is treated separately until the end".

"Lack of time" for separation was also evidenced by the residents' practice of outsourcing waste separation within the settlement. There were people paid to sort waste and some residents (11%) answered that they used their service.

There seems to be issues that need to be solved in terms of general solid waste management as well. The survey result reveals that 82% of the respondents answered that collection times varies every day. In order not to miss the collection, they need to pay attention to the bell installed in one of the buildings of the condominium that the collection workers ring when they arrive for collection. Another issue described by some respondents is that they have to discharge their waste in containers located off-site and nearby their workplaces.

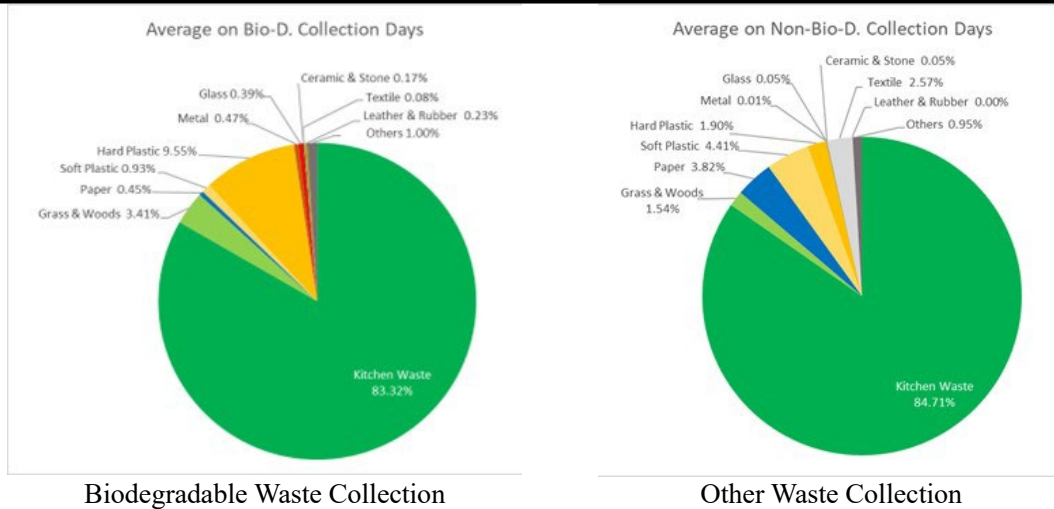

Figure 2-17 Waste composition (weight base) in low-income new high-rise apartments in Kolonnawa UC (as of February 2020)

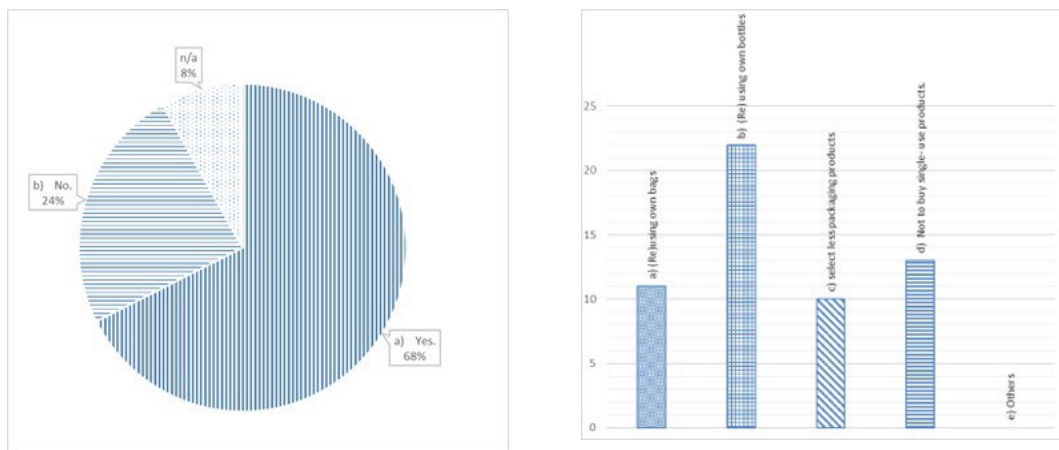

Figure 2-18 POS result in low-income new high-rise apartments in Kolonnawa UC (as of February 2020)

Table 2-13- Case 3: High-income settlement, Maharagama Urban Council

Survey period	2020/02/20 to 02/27
Number of housing units	64 occupied (137 in total)
Number of samples	22
Waste categories of the LA's collection service	LA's categories: 2 categories, namely biodegradable waste and other waste.  Condominium's original categories: 4 categories, namely kitchen waste, paper/cardboard, glass/metal, and polythene/plastic.
Remarks	Sample households were selected by the condominium management due to their privacy policy. The Project team requested that samples be selected at each floor as evenly as possible.

Maharagama UC has implemented separate collection for two types of waste, namely biodegradable waste and other waste, but the condominium has introduced its own four categories. Four colored trash bins, assigned for each waste category, have been placed on each floor. Among the recyclable waste discharged by the residents, the workers of the condominium’s management company recovered valuable materials such as metals, PET, and cardboard, and sold them to dealers.

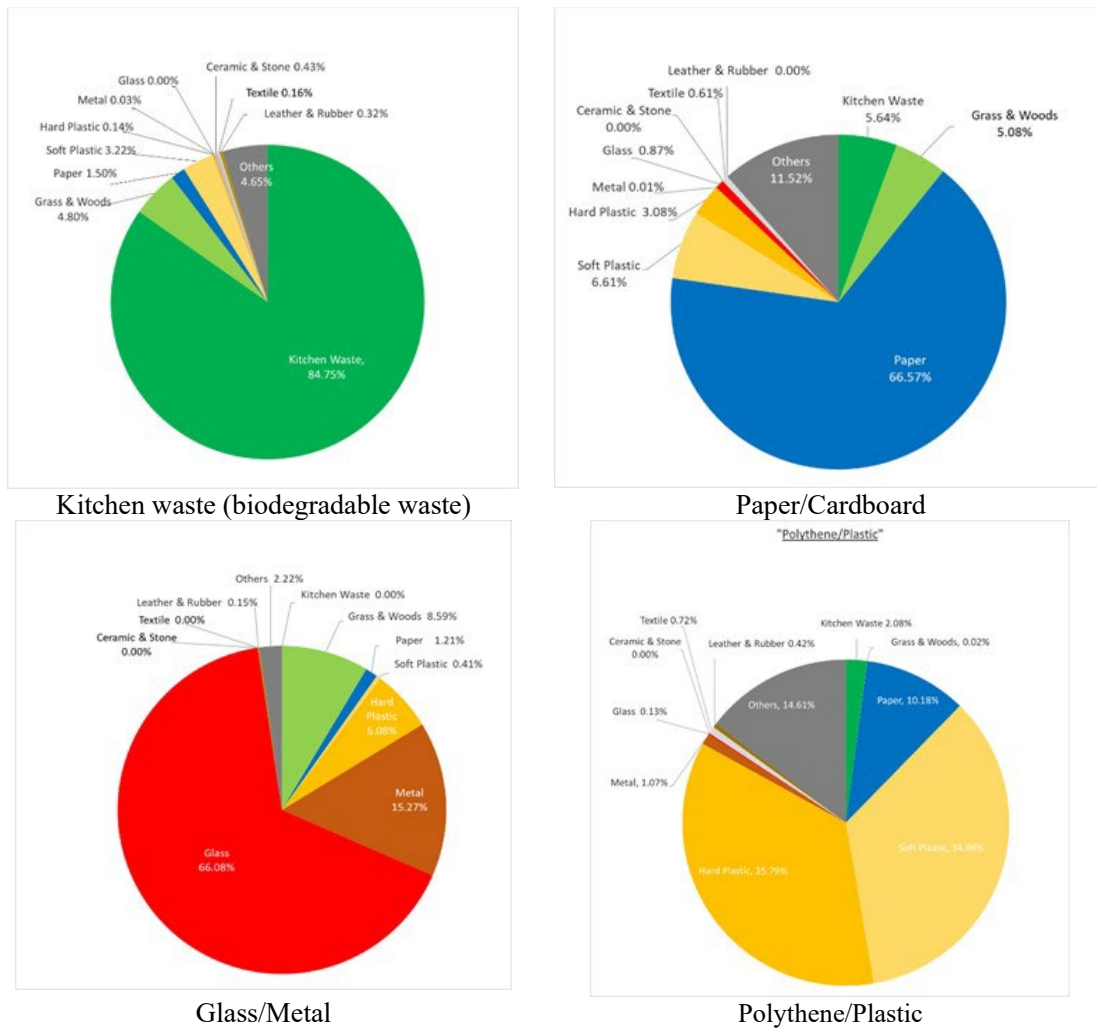

Figure 2-19 Waste composition (weight base) in high-income high-rise apartments in Maharagama UC (as of February 2020)

As shown in the figure above, some inappropriate waste was found mixed in every waste category although categories such as “Glass/Metal” and “Paper/Cardboard” seem to be very simple. The main problem of this condominium’s system is that it does not provide a bin where “other waste” can be discharged. It was observed that many residents placed waste that did not have designated bins on the floor of the waste room.

The survey team also noticed that many paper/cardboard waste stained with leftover food and oil were discarded in the “paper/cardboard” bin. In this case, the sorting is correct, but such dirty items cannot be accepted by recyclable dealers and will end up discharged with other waste.

Thus, the actual conditions for recycling should also be taken into account when giving residents instructions on waste separation so that their sorting efforts are not in vain.

Although most of the respondents to the POS (82%) answered that they were separating their waste, the others were not due to “No space for keeping recyclables separately.” Several categories of waste require the residents to store several waste containers. Even among those who were separating, the limited space was often mentioned as a problem when separating waste. Some residents have developed good ideas to save space and separate waste according to the required categories. Awareness-raising activities could include idea sharing to make waste separation easy.

In terms of waste reduction, a majority of residents claim to take some actions in their daily life. Compared to the other two low-income apartment complex, “Select products with less packaging” or “Do not select single-use products” appeared to be less popular in high-income apartment complex. Their high economic status may allow them to pick up products as they please, which indicates needs for changes in production (of more attractive less-waste products) to induce waste reduction among high-income residents.

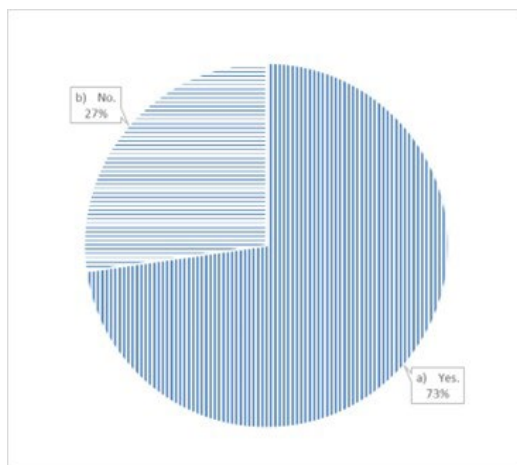

Q. Are you making any efforts to reduce the amount of waste generated in your house?

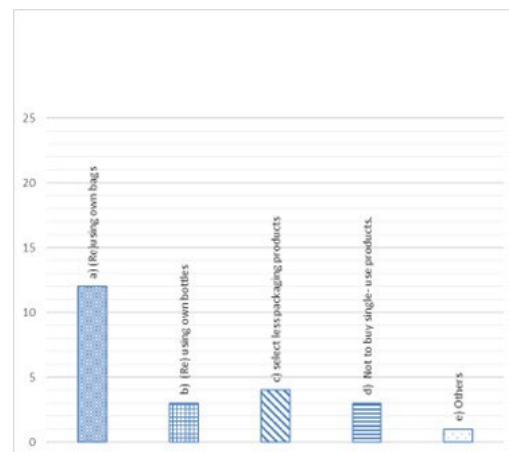

Q. What kind of actions are you taking to reduce waste amount? Select all applicable.

Figure 2-20 POS result in high-income high-rise apartments in Maharagama UC (as of February 2020)

## &lt; Method of Waste Composition Survey &gt;

- 1) A colored plastic bag for each waste category was provided to each household a day before the collection of the designated waste.
- 2) Each sample household separated its waste and handed it over to the survey team. The sample households were not explained about the content of each waste category but were expected to separate according to their understanding.
- 3) The sample households handed over the separated waste in a colored bag according to the respective local government's waste collection schedule.
- 4) The Survey team weighed and recorded each bag received.
- 5) In an open space within each survey site, with the help of the respective local government's collection workers, the collected bags were emptied on a blue sheet by category.
- 6) The waste discharged as "biodegradable" was sorted manually by the workers in order to remove non-biodegradable materials mixed in the waste. The removed non-biodegradable waste was sorted into 10 categories, namely paper, textile, soft plastic, hard plastic, grass & wood, leather & rubber, metal, glass, ceramic & stone, and others, and weighed by category.
- 7) The waste collected as "recyclable" and "non-biodegradable" were separated manually by the workers into 11 categories, including the above 10 categories and kitchen waste. Each waste category was then weighed.
- 8) The composition of each collection category was analyzed for each site. (The results are indicated in percentage on weight basis.)



Waste segregated by category



Collection workers conducting composition survey

Figure 2-21 Waste Composition Survey

#### 2.6.4 Issues and solutions

The general population is aware that their respective LAs are conducting separate collection of waste and that citizens need to discharge waste separately. However, it seems that they do not have a very clear understanding of which waste should be separated into which category. Those who know the practices of other countries may follow these practices and separate the "recyclables", but in view of the existing facilities and resources currently available in Sri Lanka, many of such "recyclables" are not actually traded by dealers and therefore end up in landfills. Or, as mentioned earlier about garden waste, there is a misunderstanding about what is considered biodegradable and what is not. Another example of missorted "biodegradable waste" is paper, which is theoretically biodegradable, but since it takes much longer to decompose than food waste,

LAs do not accept this material in their composting facilities.

Another issue that many LAs in Sri Lanka have faced is the sudden change in operation that they were required to make due to changes in system in higher hierarchy. The introduction of waste incineration as mentioned earlier is one example that required many LAs to adjust without prior notification or preparation. Without any leading time to implement the new system, residents could not be informed about the necessary changes they should make to their daily waste discharging practices and were required to “correct” on the spot. Such sudden changes in practices make citizens confused, or frustrated, and may eventually lead to mistrust or non-compliance to the rules.

The key solution is to share clear and detailed information with the citizens in a timely manner. Leaflets have been developed by several LAs to explain the meaning of each waste category and provide concrete examples of waste items. This method is still appreciated, while some citizens are still left uncertain about what to do with items which are difficult to clearly categorize.

A few other LAs in the Western Province have attempted to share their waste collection schedule using mobile phone applications. These applications were supposed to notify the residents when the waste collection was approaching. Although the reasons for their necessity are understandable, the applications could not keep up with the daily changes in collection vehicle placement. The vehicle may start the service in the morning as planned, but due to mechanical problems, or an ad hoc request for collection, it will not reach the service areas at the expected time. Lack of continuous funding to sustain the access to the application’s database also prevented them to be sustainable/feasible. Such applications require, before information sharing, to have a reliable collection system in which citizens can be sure that waste will be collected on the scheduled days at the scheduled time.

The Western Province plans to develop a new mobile application that focuses on waste separation with the aim to clarify waste separation rules and improve recycling rate. The application will mainly consist of an extensive list of waste items stipulating for each the applicable waste category, allowing users to look for an item and confirm the correct sorting rule. The category assigned to each item will reflect the actual treatment after collection implemented in the disposal sites and by available (registered) recyclable dealers in the Western Province, and LAs’ collection workers and the workers at the disposal sites should follow the same categorization uniformly. The application will also show the waste collection schedule and collection routes of each LA on a map, and users will be able to locate their residence and identify the applicable collection schedule. This feature will require the development of a stable collection system by LAs, for which the Western Province will provide guidance.



## 2.7 Administrative regulatory framework and financial status

### 2.7.1 Legal framework and institutions involved

#### (1) Stakeholders responsible for municipal solid waste management

In Sri Lanka, LAs are responsible for the collection and disposal of waste generated by residents who live within the authority's area, as stipulated in the Municipal Councils Ordinances, Urban Council Ordinance, and the Pradeshiya Sabha Act. Each LA is empowered to define the necessary implementation rules and regulations and can impose penalties. At the provincial level, the supervision rights over LAs have been handed over from the central government to Provincial Councils by the 13th Amendment of the Constitution of 1987, and rights pertaining to waste management have accordingly been transferred to Provincial Councils in the Provincial Council Act No. 42 of 1987.

The relevant ministries of the central government that have functions related to municipal solid waste management are as follows:

1. Ministry of Public Administration, Home Affairs, Provincial Councils and Local Government:
  - Assists in the formulation of policies in relation to the subject of Provincial Councils and local governments for the creation of a "Work Culture for the Country" under the direction and guidance of the Minister of Public Services, Provincial Councils and Local Government in conformity with prescribed laws, acts and ordinances.
  - Implements projects under the national budget, state investment, and national development programs.
2. Ministry of Environment and Central Environmental Authority:
  - Provides policy guidance and formulates policies related to the environment.
3. Ministry of Urban Development and Housing:
  - Formulates policies in relation to urban development, coast conservation, waste disposal, and community cleanliness for the creation of "Modern Cities and Clean Country." It is introducing efficient mechanisms for the management of urban waste and sewerage and is establishing a methodology for recycling water.
  - Adopts measures to prevent the uncontrolled disposal of waste by installing waste disposal yards and sanitary waste holdings in collaboration with local government bodies. Adopts measures to prevent the disposal of waste in an irresponsible manner.
4. Waste Management Authority of Western Province:

The Waste Management Authority (WMA) Statute No. 9 of 1999 was adopted by the Western Provincial Council (WPC), and WMA was formally established in 2004. WMA defined an

important strategy known as the Seven Steps of Waste Management to streamline the existing practices of waste management in the province and these steps came into effect through the Municipal Solid Waste Management Rules enforced in the Western Province in 2008. The seven steps are (i) segregation at source by waste generators, (ii) primary recovery by waste generators, (iii) primary collection by LAs, (iv) cleaning of public places by LAs, (v) secondary collection (transportation) by LAs and WMA, (vi) intermediate and final recovery by LAs and WMA, and (vii) final disposal by relevant authority. WMA, in coordination with LAs, manages the collection, segregation, transportation, transfer, treatment, and disposal of waste in certain areas of the Western Province.

## **(2) Legal framework of municipal solid waste management**

In 1980, the National Environmental Act (NEA) No. 47 of 1980 was enacted to preserve the environment, maintain environmental quality, and prevent pollution. Consequently, the Central Environmental Authority (CEA) was established, and its jurisdiction, functions, and responsibilities were defined in the NEA. Furthermore, an Amendment to the NEA in 1993 requires an Environmental Impact Assessment (EIA) or Initial Environmental Examination (IEE) for the establishment of facilities such as intermediate treatment and final disposal sites with a capacity exceeding 100 tons per day.

The Environmental Protection License (EPL) is another regulatory program for industrial pollution control. The EPL is operated under the provisions of the National Environmental Act No. 47 of 1980 amended by Acts No. 56 of 1988 and No. 53 of 2000. Industries and activities which require an EPL are listed in Gazette Notification No. 1533/16 dated 25.01.2008, and include pollution discharged by waste management. Composting plants, waste recovery/recycling facilities, and waste disposal facilities are required to obtain an EPL from the CEA regardless of their capacity. WMA also set waste management rules in accordance with the regulations of the CEA. WMA is empowered to issue licenses for waste collection, cleaning of roads and public places, mass transportation, and waste recycling or reusing facility.

### **2.7.2 Financial situation**

In principle, waste management services are provided by the LAs. Thus, the level of service is limited by the available budget of the LAs, especially the recurrent budget.

Table 2-14 Recurrent budget of the Government, Provincial Council, and LAs (2020)

	Unit	Sri Lanka Central Gov.	Western Provincial Council	LAs in Western Province		
				Total (49 LAs)	CMC	48 LAs
Recurrent Budget	(Rs. Mil)	2,806,427	73,774	22,533	10,895	11,638
Of which, Personal Emoluments	(Rs. Mil)	591,583	449,992	10,823	3,590	7,133
Population	('000)	21,919	6,226	6,226	597	5,629
Recurrent /person	(Rs. / person)	128,036	11,849	3,619	18,250	2,068

Source: Budget Estimates 2020, Western Provincial Council Financial Statement 2020, Finance Commission

- As shown in the table above, when comparing the per capita recurrent budget, the Provincial Council recurrent budget is 1/11th of the central government budget, while the LAs recurrent budget is 1/35th of the central government. The Colombo Municipal Council (CMC)'s recurrent budget is 1.6 times that of the Western Provincial Council.
- 61% of the recurrent budget of the Western Provincial Council is allocated to personal emoluments, while the personal emoluments in the LAs account for 48 % of the total recurrent budget. This means that the room for expenditure on new services or better services is rather limited, unless new sources can be found for financing such expenditures.
- The budgets of the Provincial Council and of the LAs are very much dependent on government allocations. For the Western Province, 62 % of the total budget comes from government grants, while 69 % of the budget of LAs originates from sources other than revenue.

The share allocated to waste management in the 2021 recurrent budget of LAs was as follows:

These data are taken from the available 2021 budget books for 42 LAs. The share allocated to waste management is 20 % in average. Two- thirds of the LAs allocate a share hat ranges between 10 % to 30 %.

Table 2-15 Share of the recurrent budget of LAs allocated to waste management in 2021

	0%- 10%	10% - 20%	20% - 30%	30% - 40%	40% - 50%
No. of LA	9	12	15	5	1

Source: Local Authority's Budget 2021 Books

The capital expenditure for waste management depends completely on the central government budget. The majority of these capital investment projects is for projects planned and implemented by government ministries, such as the State Ministry of Provincial Councils and Local Government, the Ministry of Environment, and the State Ministry of Urban Development, Waste Disposal, and Community Cleanliness.

The 2022 Budget Estimate (draft) shows a significant decrease in capital expenditure in general, and for waste management in particular, due to economic and fiscal deterioration caused by the COVID-19 pandemic.

Table 2-16 Central government capital budget for solid waste management  
(LKR million)

	2016	2017	2018	2019	2020
(1) Ministry of Megapolis and Western Development					
Metro Colombo Solid Waste Management Project		500	2,500	8,000	6,400
Townships Development & Urban Solid Waste Management	3,331	10,121			
(2) Ministry of Mahaweli Development and Environment					
Construction of Solid Waste Disposal Facilities - 4 locations	86	1,523	1,200	1,000	
Environmentally Sound Management and Disposal of Polychlorinated Biphenyls Waste	2	22	27	22	50
(3) Ministry of Provincial Councils and Local Government					
Solid Waste Management Project	218	2,300	750	1,500	1,000
Waste Management of Local Government Authorities		500			

## 2.8 SWM issues

### 2.8.1 Technical issues

#### (1) Waste generation

The amount of waste generated in the Western Province was estimated at 3,730 tons per day in 2019. This amount is expected to increase in line with future population and economic growth. Furthermore, future infrastructure development and improved collection coverage are expected to increase the amount of waste collected, as well as significantly increase the load on treatment and disposal facilities. In this context, it is necessary to take measures to reduce the generation of waste through awareness-raising activities to obtain the cooperation of residents, and in collaboration with the relevant authorities.

#### (2) Waste discharge

The separation of biodegradable, non-biodegradable and recyclable waste at source was enhanced by the Western Province MSW Management Rules (2008). Many LAs have implemented separate collection for biodegradable and non-biodegradable waste, but few sort recyclables. At present, about 50% of generated waste is discharged to the LA's collection service, but it is expected that this amount will increase in the future as collection coverage improves. Therefore, in the Western Province, where there are waste disposal problems, it is necessary to enhance waste separation by conducting awareness-raising activities for residents and by increasing the capacity of intermediate treatment facilities in order to reduce the amount of waste to be disposed of as much as possible.

### **(3) Waste collection and transportation**

The collection vehicles used in the Western Province are generally tractor-trailers, mainly due to lack of resources of the LAs, which results in poor collection efficiency, offensive odor, waste scattering caused by overloading and absence of cover, as well as traffic congestion. Furthermore, old vehicles, frequent breakdowns, poor maintenance, high absenteeism rate, inadequate human and physical resources, long procurement procedures adversely impact the efficiency of collection and transportation, which subsequently deteriorate the service quality. In order to improve collection efficiency, Ministry of Public Administration, Home Affairs Provincial Councils and Local Government provided compactor trucks to several LAs. Some LAs use these compactors for the collection of biodegradable waste to prevent malodor, waste scattering and leaking of leachate. Presently (2020) 46% of the collected waste is transported to composting facilities, 6% to recycling-related facilities and 48% to disposal sites. It is essential to select and procure collection vehicles in accordance with the requirement, source separation, treatment system, transportation distance, etc. for the provision of an effective, efficient and hygienical waste collection and transportation service.

### **(4) Waste transfer**

To improve the transportation efficiency of the total amount of waste collected, 17% is transferred. In particular, some LAs, such as MC and UC, which have densely populated areas and difficulties in securing land for intermediate treatment facilities and disposal sites, often have transfer stations (TS) in urban areas for transporting waste to cluster-based disposal sites or private land.

Few of these TS have facilities, and the waste collected is dumped directly on the ground and transferred to large capacity dump trucks with heavy machinery such as shovel loaders and excavators for transportation to intermediate treatment facilities or disposal sites.

To improve transportation efficiency, multiple primary transfer stations (PTS) should be installed and jointly operated and managed by neighboring LAs.

The location and number of PTSs should be decided in consideration of the transportation distance from LAs to intermediate treatment facilities or Aruwakkalu TS. In addition, the size and equipment of the facilities of the PTSs should be considered according to the type and amount of waste to be relayed.

### **(5) Waste intermediate treatment**

#### **i. Composting**

The treatment of biodegradable waste is very important for waste management in the Western Province as about 46% of the collected waste is carried to composting facilities. To produce good quality compost from biodegradable waste, it is essential to prevent impurities from entering the waste stream, secure sufficient space for facilities, regularly turn compost heaps, allow enough time for the maturation process, etc. However, many LAs do not take enough

measures to produce good quality compost. In addition, sewage and odors from composting facilities can negatively impact the surrounding environment.

As the use of organic fertilizers is an important measure of the national government policy and the amount of biodegradable waste is expected to increase in the future, it is necessary to thoroughly separate waste and expand the processing capacity of existing composting facilities, for example by installing forced aeration equipment and improved compost production technology, and/or by introducing mechanical composting facilities.

## ii. Material recycling

Material recycling at intermediate facilities is mainly carried out at Sampath Kendra. Collected materials are sorted manually instead of mechanically, which is inefficient. In addition, the space for sorting and storage is limited. The large amount of non-recyclable waste mixed with the collected recyclables further hinders the efficiency of the operation. The total amount of recyclables, including biodegradable waste, accounts for about 20% of the total waste generated, which is a relatively high rate compared to other developing countries.

In the future, it is necessary to reduce the amount of waste disposed of by promoting the separate collection of recyclables and expanding the capacity of composting facilities.

## (6) Waste disposal

The amount of waste disposed represents 32% of all waste generated. Approximately 70% of the total waste disposed is directly landfilled and the remaining 30% is residue generated from composting and recycling facilities.

To reduce the disposal quantities despite the expected increase resulting from improved collection coverage, it is critical to develop intermediate treatment such as composting, WtE etc. It is also necessary to shift gradually from disposal sites operated independently by LAs to cluster-based disposal sites, and to close open dump sites used by LAs.

## (7) Data for solid waste management

Since data related to SWM has not been gathered and managed in each LA, it is impossible to understand the problems quantitatively and to formulate concrete proposals for improvement. It is necessary to collect and consolidate data related to SWM in each LA, as well as cluster-based treatment facilities and disposal sites, and establish a database for the entire Western Province to formulate/define appropriate SWM plan/strategy based on the analysis results of this data. It is expected that WMA will develop such a database in the future and manage MSW in the Western Province based on data analysis.

### **2.8.2 Operational issues**

#### **(1) Lack of coordination among relevant authorities**

As Sri Lanka enters an era of development with intensive urbanization, LAs alone cannot plan, nor implement such plans, for the growing amount of solid waste. They face great difficulties in finding space for intermediate treatment facilities such as composting plants and TRFs, and even more for final disposal sites. Thus, waste management in urban areas requires cooperation and coordination among neighboring LAs together with higher authorities. However, such coordination among relevant authorities is lacking.

#### **(2) Weak management capacity of relevant authorities**

In the recent past, some new, large-scale waste management technologies have been introduced in the Western Province but are not yet fully deployed.

#### **(3) Insufficient financial resources**

The volume of waste in urban areas is increasing at a higher pace than the population, and even than the economic growth. This implies that costs for waste management are growing at a faster rate than the growth of the government's budget.

### **3 Selection of optimal SWM system for the proposed 20-year Master Plan**

In this chapter, the future waste amount is estimated, and the optimal solid waste management (SWM) system is selected to present the Master Plan (MP)'s strategy and target in quantitative terms. The MP's Vision, Mission, Strategy, Targets, etc. are detailed in Chapter 4.

This chapter describes:

- Estimation of the future population and future waste amount which are prerequisites for the formulation of a MP.
- Formulation of alternative scenarios for SWM based on a combination of individual and collective systems.
- Evaluation of alternatives from a technical, institutional, economical, and environmental point of view.
- Selection of the optimal SWM system for the MP.
- Setting of short-term, medium-term, and long-term numerical targets for the MP.

#### **3.1 Pre-conditions for formulating a MP**

##### **3.1.1 Planning period**

The planning period for the MP is set as follows:

2022: Base year of this MP (2022, the year the MP was developed, is considered as the MP base year. However, the waste amount data for 2022 is based on the baseline survey conducted in 2019, and has been projected taking into account the increase in population, the increase in waste amount per person per day, etc.)

2023-2025 (3 years): Short-term

2026-2030 (5 years): Medium-term

2031-2042 (12 years): Long-term

##### **3.1.2 Estimation of future population**

The future population of each LA (49 in total) during the target period of the MP has been estimated based on the Census of 2012 and the annual average growth rate of the Western Province during the period 2012-2018 (0.78% per year) has been evenly applied for the period of the MP. The results are shown in the table below.



Table 3-1 Estimated population growth rate and population projection

Item	Annual Average Growth Rate (%)				Population Projection (1'000)			
	Actual		Projection		2022	2025	2030	2042
	1981 - 2001*	2001 - 2012*	2012 - 2018**	2020 - 2042				
Sri Lanka	1.19%	0.73%	1.05%	-				
Western Province	1.65%	0.79%	0.78%		6,324	6,474	6,729	7,386
Colombo District	1.46%	0.34%	0.81%	0.78%	2,511	2,574	2,673	2,934
Gampaha District	2.07%	1.02%	0.74%		2,491	2,551	2,651	2,912
Kalutara District	1.29%	1.25%	0.79%		1,322	1,349	1,405	1,540

Source: \* Census 1981, 2001, 2012

Source: JICA Team

\*\* Mid-year Population Estimates

### 3.1.3 Estimation of future waste amount

The future waste amount is estimated following the steps described below:

- Step 1: The future waste amount (without MP) is estimated based on the projected future population and future waste generation rates per person per day.

(Amount of waste generated [Without MP]) = (Future population) × (Future waste generation rate per person per day)

- Step 2: The amount of waste that is expected to be generated after implementation of the MP is estimated by taking into consideration the target rate for waste reduction to reduce the amount of waste generated calculated in step 1.

(Amount of waste generated [With MP]) = (Future population) × [(Future waste generation rate per person per day) × (100 - (Targeted waste reduction rate) / 100)]

- Step 3: The amount of waste that is expected to be collected is estimated by taking into consideration the target rate for waste collection applied to the amount of waste generated calculated in step 2.

(Future amount of waste collected) = (Amount of waste generated [With MP]) × (Targeted waste collection rate)

#### (1) Step 1

The estimate of the amount of waste is based on the future population and future waste generation rate per person per day.

**i. Waste generation rates per person per day**  
**a. Current (2020) waste generation rates**

In the Western Province, there is no publicly available data on waste amount and composition that can be shared reliably by municipalities. The following waste generation rates by type of LA, namely Municipal Council (MC), Urban Council (UC), and Pradeshya Sabha (PS) are based on the results of a study conducted by SATREPS, This study has been used for the estimation since it is the most recent and reliable study on waste generation rates for both household waste and MSW in Sri Lanka.

**Table 3-2 Generation rates of household waste and MSW**

	Generation rate of household waste	Generation rate of MSW
	g/person/day	g/person/day
MC	350	970
UC	330	630
PS	250	440

**b. Future waste generation rates**

The waste generation rates are closely related to economic growth. Therefore, the future waste generation rates are estimated using the following formula:

$$(\text{Future waste generation rates}) = (\text{Present waste generation rates}) \times [1 + (\text{GDP growth rate per person}^*) \times (\text{Correlation coefficient between waste generation amount and GDP}^{**})]^n$$

- GDP growth rate per person \* = (GDP growth rate) – [Population growth rate (0.78 ≈ 0.8)]
- Correlation coefficient between waste generation amount and GDP growth rate per person \*\*: 0.4
- n: Elapsed years with 2020 as the base year

\*The latest edition of the Central Bank of Sri Lanka Annual Report predicts that the GDP growth rate from 2020 to 2024 will be, for each year respectively, 1.5%, 4.5%, 6.0%, 6.2%, and 6.5%. The subsequent GDP growth rate assumes that an average GDP growth rate of 4.9% for five years will continue until 2042, the final year of the MP.

The GDP growth rate per person is the value obtained by subtracting the population growth rate (0.8%) from the GDP growth rate for each year.

Table 3-3 Actual GDP growth rate and GDP growth rate projections (%)

Year	2003	2004	2005	2006	2007	2008	2009	2010	2011	2012	2013
Actual GDP growth rate	5.9	5.4	6.2	7.7	6.8	6.0	3.5	8.0	8.4	9.1	3.4
Year	2014	2015	2016	2017	2018	2019	2020	2021	2022	2023	2024
Actual GDP growth rate	5.0	5.0	4.5	3.6	3.3	2.3					
GDP growth rate projections							1.5	4.5	6.0	6.2	6.5
							Average GDP growth rate 4.9% per year				

Source: Central Bank of Sri Lanka Annual Report

\*\* Correlation coefficient between waste generation rates and GDP growth rate per person: Elasticity from the viewpoint of correlation between GDP growth rate per person and fluctuation of MSW generation rate.

Since Sri Lanka’s GDP per capita in 2020 is about USD 4,000 and the waste generation rate of MSW is approximately 600 g per person per day, the elastic modulus was calculated by applying the forecast formula:

$$y = 134.41 x^{0.3805}, R^2 = 0.9868$$

- $y$  = MSW generated waste per person (kg/person/year)
- $x$  = GDP growth per person (‘000 US\$ /person /year)

Reference: “Estimation of waste generation amount in the world and future forecast, 2020 revised edition” (Waste Engineering Research Institute Co., Ltd.; Representative Masaru Tanaka)

Table 3-4 Future waste generation rates without MP (g/person/day)

Classification		2022	2025	2030	2042
Household	MC	362	384	416	506
	UC	342	363	393	478
	PS	259	275	300	364
MSW	MC	1,004	1,066	1,150	1,406
	UC	652	692	751	913
	PS	456	485	525	683

## (2) Step 2

The future amount of waste generated is estimated by taking into consideration the target rate for waste reduction to reduce the amount of waste generated calculated in step 1.

### ii. Waste reduction rate

The amount of waste generated is expected to increase in line with the waste generation rates, population growth and economic growth. Since the financial burden for waste collection, transportation, treatment, and disposal is expected to increase for all LAs, the amount of waste

generated needs to be reduced in accordance with the following targets for each source of waste generation in order to lessen this burden.

Table 3-5 Waste reduction rates

Target year	2022	2025	2030	2042
Waste reduction rate	0%	1%	3%	10%

### iii. Future waste generation rate

The future waste generation rate (with MP) is estimated by taking into consideration the waste reduction rates and the amount of waste generated calculated in step 1 (without MP).

By comparing the waste generation amount in 2042 with and without waste reduction, the waste reduction amount has been estimated to be approximately 50g per person per day.

**Table 3-6 Comparison of future waste generation rates (g/person/day)**

Classification		Without MP				With MP			
		2022	2025	2030	2042	2022	2025	2030	2042
Household	MC	362	384	416	506	362	380	404	455
	UC	342	363	393	478	342	359	381	430
	PS	259	275	300	364	259	272	291	328
MSW	MC	1,004	1,066	1,150	1,406	1,004	1,055	1,121	1,265
	UC	652	692	751	913	652	685	728	822
	PS	456	485	525	683	456	480	509	574

**(3) Step 3**

The future amount of waste collected is estimated using the waste collection rates and the amount of waste generated calculated in step 2.

**i. Waste collection rate**

As urbanization progresses, waste collection rates in MC and UC, where the population density is high, have already reached 65-70%. On the other hand, the waste collection rate in PS, where the population density is low, the collection rate is below 30%. In this MP targets a waste collection rate of 95% is for MC and UC. On the other hand, considering the financial burden on the LAs for waste collection, a 60% waste collection rate is aimed for PSs. LAs that already exceed the 60% waste collection rate will maintain their waste collection rates at the current level. Collection coverage has been calculated using the following formula:

$$[(\text{Amount collected}) + (\text{Amount of recyclables at discharge and collection stage})] \div [(\text{Amount generated}) + (\text{Amount of recyclables at generation stage})]$$

**Table 3-7 Waste collection targets by category of LA**

	2022	2042
MC	65%	95%
UC	72%	95%
PS	32%	60%

**ii. Percentage of separately discharged waste**

The percentage of waste discharged is strongly related to the development of urbanization. As urbanization progresses, the proportion of biodegradable waste tends to decrease, and that of recyclable materials tends to increase.

The targets for the discharged waste have been set as follows:

**Table 3-8 Targets for the waste discharged separately by type of LA in 2042**

Type of LA	Biodegradable waste	Recyclables			Other waste
		Recycling at discharge/collection	Recycling at recycling facilities /SK	Total	
MC	40%	5%	10%	15%	45%
UC	45%	5%	7%	12%	43%
PS	50%	5%	5%	10%	40%

\* The percentage is the ratio between the amount of discharged waste and the amount of waste collected.

#### **(4) Waste generation based on the development plan**

##### **i. Colombo Port City (CPC)**

Colombo Port City is a new city development built as an extension of the Central Business District on 269 hectares of reclaimed land adjacent to the Galle Face Green. This will be the largest single foreign direct investment of around USD 1.5 billion for the land development that has potential to attract around USD 5 billion from all over the world. The development will comprise of 5 different areas including the Financial District, Central Park Living, Island Living, The Marina and the International Island, and will include sport complexes, mini golf ground, housing and office complexes, luxury hotels and many other modern facilities.

Constructions of the port city is carried out by China Harbour Engineering Company under an MOU signed by Sri Lanka Ports Authority with China Communications Construction Company. The project is due for completion by 2022.

##### **a. Outline of CPC development project**

- Implementing authority: Ministry of Urban Development & Housing
- Development period: 2023-2041 (delay)
- Population: The resident population and total increased population, including shops and businesses, are assumed to be 70,000 and 250,000 respectively.

Table 3-9 Population projections based on CPC development project

Year	Residential	Commercial	Office	Hotel	Others	Yearly total	Accumulation
2023	800	1,551	9,083	322	19,077	30,833	30,833
2024	900	1,745	10,218	362	10,867	24,092	54,925
2025	2,255	2,615	12,839	403	0	18,112	73,037
2026	3,296	3,315	15,088	443	0	22,142	95,179
2027	3,710	3,678	16,595	483	0	24,466	119,645
2028	5,410	2,653	4,700	1,407	0	14,170	133,815
2029	6,691	2,522	5,648	895	7,848	23,604	157,419
2030	7,344	2,254	5,854	650	4,709	20,811	178,230
2031	6,717	1,516	5,111	115	3,139	16,598	194,828
2032	5,802	603	3,460	138	0	10,003	204,831
2033	4,835	502	2,883	115	0	8,335	213,166
2034	4,351	452	2,595	104	0	7,502	220,668
2035	3,868	402	2,306	92	0	6,668	227,336
2036	3,384	352	2,018	81	0	5,835	233,171
2037	2,901	301	1,730	69	0	5,001	238,172
2038	2,417	251	1,441	58	0	4,167	242,339
2039	1,934	201	1,153	46	0	3,334	245,673
2040	1,450	151	865	35	0	2,501	248,174
2041	967	100	577	23	0	1,667	<b>249,841</b>
2042	0	0	0	0	0	0	249,841
<b>Total</b>	<b>69,032</b>	<b>25,164</b>	<b>104,164</b>	<b>5,841</b>	<b>45,640</b>	<b>249,841</b>	-

Source: Proposed Colombo Port City Development Project December 2015

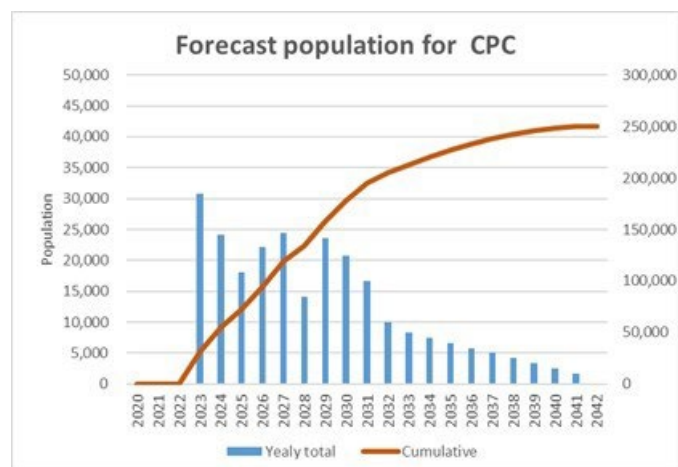

Figure 3-1 Population projections in the CPC development project

**b. Waste generation in CPC development**

➤ Generation rate

Table 3-10 Generation rate of MSW

Total generated MSW	1.5	kg/person/day
Household waste	0.6	kg/person/day

➤ Composition

Table 3-11 Composition of MSW

Category	Rate	Remarks
Food waste	45.3%	
Recyclable	15.1%	paper, plastic, glass, metal
Others	39.6%	

Source: CPC Master Plan Implementation, June 2017

Table 3-12 Forecasts of generated waste based on CPC development

Year	Generated MSW (ton/day)								
	Total			HH			Other than HH		
	Bio-degradable	Recyclables	Others	Bio-degradable	Recyclables	Others	Bio-degradable	Recyclables	Others
2023	21	7	18	8	3	7	13	4	11
2024	37	12	33	15	5	13	22	7	20
2025	50	17	43	20	7	17	30	10	26
2026	65	22	56	26	9	22	39	13	34
2027	81	27	71	33	11	28	48	16	43
2028	91	30	80	36	12	32	55	18	48
2029	107	35	94	43	14	37	64	21	57
2030	120	40	107	48	16	43	72	24	64
2031	132	44	116	53	18	46	79	26	70
2032	139	47	121	56	19	48	83	28	73
2033	145	48	127	58	19	51	87	29	76
2034	150	50	131	60	20	52	90	30	79
2035	155	52	134	62	21	53	93	31	81
2036	158	53	139	63	21	56	95	32	83
2037	162	54	141	65	22	56	97	32	85
2038	165	55	144	66	22	57	99	33	87
2039	168	56	145	67	22	58	101	34	87
2040	168	56	148	67	22	58	101	34	88
2041	170	57	148	68	23	59	102	34	89
2042	170	57	148	68	23	59	102	34	89

**ii. Marine City (MC)**

Marine City, which was conceptualized at the same time as the CPC, is 121.6 ha beach reclamation from Kollupitiya to Dehiwala and was initially valued at around USD 155 million. The project will be advertised for investment as a joint venture with the Government under the public-private partnership (PPP) model. The National Aquatic Resources Agency carried out the EIA and evaluated the first phase that covers reclamation, dredging (from a borrow pit in the sea)



and construction of several breakwaters. The Marine City aims to reclaim land from the sea and create open spaces to ease the strain on Galle Face. Around 8.93 ha will be allocated to a transport corridor, 30.72 ha to common utilities such as sewage facilities, CEB grid stations and a wastewater treatment plant from which water will be taken to water green areas, and 43.07 ha for recreation and as open space for public use. 20 ha, subdivided into three hubs in the vicinity of the railway stations, will be leased for 99 years to the developer, while recreational areas will belong to the State.

The second phase of the project will consist in the construction of buildings and infrastructure on the reclaimed land and investors will be expected to finance, design, build, operate and transfer the development. There will be five zones: transport corridor, special seafront zone, special seafront recreational zone, infrastructure amenities and parking areas, and sandy beach. Permitted activities in the recreational zone include nature parks and playground, fair and exhibition ground, amphitheaters, recreational clubs, gyms and swimming pools, water-related eco-tourism activities, camping, picnicking, bird watching and nature-based entertainment activities, nature trails, observation towers, canopy walkways, cycle paths, etc.

**a. Outline of MC development plan**

- Chief Ministry/Authority for MC development: Ministry of Urban Development & Housing
- Development period: 2025-2034

**b. Waste generation in MC development**

- Composition

Category	Rate	Remarks
Food waste	60.0%	
Recyclables	30.0%	paper, plastic
Others	10.0%	

**Table 3-14 Forecasts of generated solid waste in MC**

Year	Generated SW (ton/day)			
	Total	Bio-degradable	Recyclables	Others
2025	0.5	0	0	0.5
2026	2.5	1	1	0.5
2027	6	3	2	1
2028	11	6	4	1
2029	17.5	10	6	1.5
2030	22	13	7	2
2031	25.5	15	8	2.5
2032	27.5	16	9	2.5
2033	29	17	9	3
2034	30	18	9	3

**iii. Future waste generation in Colombo Municipal Council (CMC) based on development plans**

**Table 3-15 Future waste generation in CMC in 2042**

Forecasted waste generation amount based on future population	Forecasted waste generation amount based on development plan			Total
	CPC	MC	Sub-total	
896	375	30	405	1,301

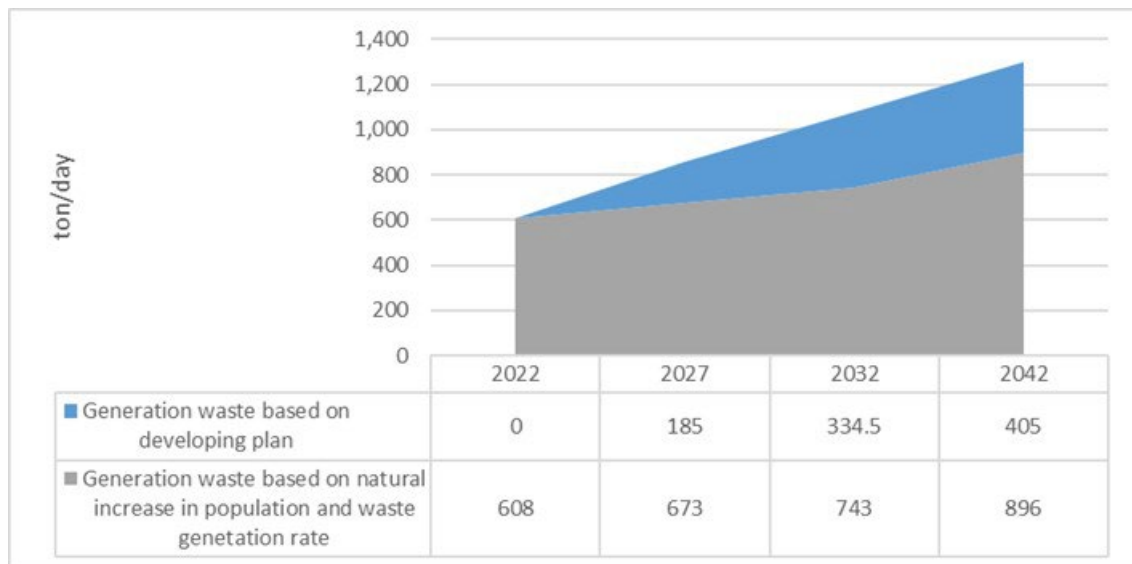

**Figure 3-2 Future waste generation amount in CMC**

**(5) Waste generation**

The predicted amount of waste that will be generated with and without the MP, taking into account the target rates for waste reduction, are shown below. The amount of waste expected to be generated with the MP in the Western Province in 2042 is approximately 6,181 tons per day which corresponds to 1.6 times the amount of 2022.

**Table 3-16 Future amount of waste generated (ton/day)**

	Without the MP				With the MP			
	2022	2025	2030	2042	2022	2025	2030	2042
Western Province	3,926	4,272	4,811	6,422	3,926	4,342	4,952	6,181
Colombo District	2,010	2,188	2,465	3,290	2,010	2,278	2,679	3,365
Gampaha District	1,290	1,405	1,580	2,112	1,290	1,390	1,532	1,898
Kalutara District	626	678	766	1,020	626	674	741	918

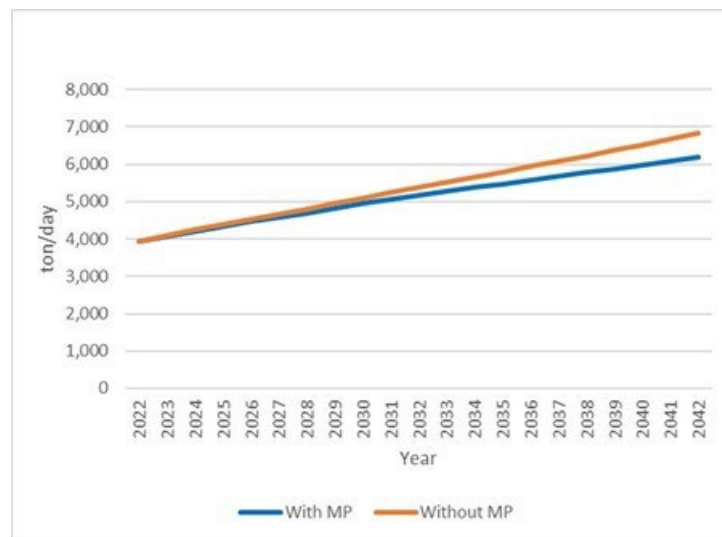

Figure 3-3 Comparison of the future amount of waste generated with and without the MP

**(6) Waste collection**

The predicted amount of waste collected, taking into account the target rates for waste collection, are shown below.

**Table 3-17 Future amount of waste generated and collected based on the MP (ton/day)**

Province/District	Amount of waste generated				Amount of waste collected			
	2022	2025	2030	2042	2022	2025	2030	2042
Western Province	3,926	4,342	4,952	6,181	1,994	2,396	3,093	4,756
Colombo District	2,010	2,278	2,679	3,365	1,274	1,548	2,005	2,937
Gampaha District	1,290	1,326	1,532	1,898	486	577	745	1,258
Kalutara District	626	641	741	918	234	271	343	561

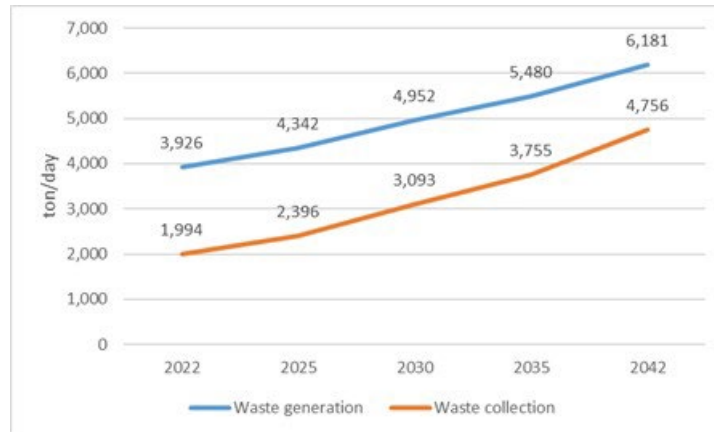

Figure 3-4 Future amount of waste generated and collected with the MP

### 3.2 Time dependency on the establishment of ISWM systems

The formulations of alternative management systems will depend on the technological options available for an Integrated Solid Waste Management (ISWM) approach and the enactment of the national policy on waste management. Out of the policy statements, EPR is the key factor in determining the resource recovery rate. Hence the national agencies are responsible for bringing about cohesive understanding among the producers to reduce harmful chemical elements and agents in their products and packaging. The selection of materials for production and importation of goods should also be considered to enable reuse and recycle of waste resources at the end of the product life. Importation of finished products may cause concern for the local producers as well as government agencies. Government agencies may not have the capacities to regularize imported goods to comply with 3R requirements set out in the obligations of EPR in the country. Inevitably, a greater understanding among producers, government agencies and importers as well as consumers is needed to reach a very high percentage of resource recovery and reduction. It may be an activity based 4R concept of “Rethinking”.

Rethinking is imbedded in the activities of inventions and innovations in society without undue restrictions on time dependency, thus provisions should be made to allow effective transformations. Such changes are taking place to replace plastics with biodegradable ones originating from organic materials. Both biodegradable plastics from organic and petrochemicals have inherent issues of micro and nano particles in the food chain, in aquatic systems, on ground and in the atmosphere. Nondegradable plastics are preferred for food packaging and replacement of them would not be practical. However, the reduction of the quantity should be addressed while quality needs to be improved to enable recycling, like printing on plastics and use of non-recyclable plastics should be avoided. The replacement of plastic bags, rice packet plastics and the like with organic materials will no doubt increase organic waste as discarded packaging materials. Such replacement materials of plastics are not suitable for composting but could be recycled. Even direct recycling becomes an issue viewing from the Life Cycle Assessment (LCA) perspective and employment. In fact, effluent management and other environmental issues arising from direct recycling could be less attractive than combusting to generate electrical power needed

in a transformation economy from fossil fuel to renewable energy.

The Refuse Derive Fuel (RDF) manufacture from compost could become a reality because of the farmer (consumer) resistance to using compost due to confused market forces induced by government policy changes to promote inorganic fertilizers. Moreover, the quality of MSW compost is questionable because of poor methods and operational parameters in making compost. Most importantly, pesticide fortified organic and healthcare waste and urban pathogen loads in the payloads are causing concerns for many agronomists, thus they are against the use of MSW compost. The quality of MSW compost could be improved if selected agricultural waste and bio char are mixed with incoming raw waste to make thermophilic compost. Alternatively, compost can be used to establish and support the establishment of fuelwood forests. If there are many issues in finding different markets for compost, in roads should be made to promote bio-drying as a means of processing the waste to produce RDF rather than laboring with making compost.

For example, stakeholders in Gampaha District is appealing for RDF productions from MSW waste to cater to the energy demands of the industry since biomass fuel resources are becoming fewer. It is one of the best alternatives, but RDF should not have plastics because the industries are not geared to control dioxins and furans in their combustion systems. Hence, the technological path could be sorting, size reduction, bio-drying, RDF manufacture and storage. Storage is an important component in RDF productions since seasonal requirements can be met besides manufacture of RDF during downtime of thermal recovery facilities (TRF). Therefore, it is recommended to install RDF power plants instead of mass burning systems.

Thermal recovery of waste is the best solution because availability of land for landfilling is a constraint within the Western Province. The only option is the far distant landfill at Arruwakkaru. Although it is newly developed, it has physical limitations of filling over the design capacity and period. There should be a buffer capacity in the Arruwakkaru landfill to enable disaster waste management. It is prudent to divert as much waste from the landfill. Otherwise, the Western Province will have to face major or even minor disasters once again. It is evident that the burial of money in operating the landfill and the cost of transportation will increase exponentially over time. It is necessary, therefore, to comply with the national policy, which states that land filling shall be limited to non-recyclable, non-compostable and inert material generated through waste treatment processes.

Energy recovery is essentially a recycling activity if the waste is organic. There are two distinct technologies to extract energy from organic waste. One is anaerobic digestion of very moist materials like market or food waste and the other is thermal treatment. In most countries, agricultural waste like cow dung is used to mix with selected MSW to function efficiently the digesters. Both energy recovery technologies are complimentary in an integrated system. However, thermal treatment can cope with wet waste if bio-drying is carried out as pretreatment to RDF manufacture. It is recommended to upgrade the Kerewalapitiya power plant to combust with RDF so that downtime is not an issue while improving the thermal efficiency of the plant. It will allow a greater amount of recycling to take place. It could also be modified to use waste steam in a combined cycle. Hence, the establishment of electrical generation from thermal

systems should support combustion of RDF with a combined cycle to make best use of residual plastic combustible resources and organic wastes. The new gasification technology should be considered to cope with large variations in the quality of waste combustibles. The ash derived from the combustion of unrecyclable residual plastics without heavy metal concentrations can be used for the construction industry. Converting it to fertilizer can also serve the agriculture sector since ash has a high percentage of potassium. The key factor is the use of high quality non-degradable plastics so that some energy for manufacturing the plastics could be finally extracted to produce useful energy and quality ash.

In a planning process time factor must be considered in establishing ISWM systems in the province as well as assurances should be made to prevent disasters by maximum diversion of wastes from landfills. On the other hand, minimum direct recycling to be considered to avoid failures. Those are the extreme criteria to be considered to develop a sound ISWM system for the Western Province with the national requirements in managing the waste. TRFs should be established to overcome the lack of direct recycling while minimizing landfilling. When direct recycling efforts of plastics are successful, organic waste materials can be made to RDF rather than compost to replace the plastics. Since RDF is a stable fuel, it can be made to supply many of the increasing demands for renewable energy sources. The best baseline option among alternatives of ISWM systems should be selected to enable incorporation of RDF manufacture, establishment of anaerobic digesters and other recycling technologies.

### 3.3 Formulation of alternatives scenarios for the SWM system

#### 3.3.1 Formulation of alternatives

Alternatives for the SWM system are proposed as follows:

Continuing the current SWM system without introducing measures to reduce the amount of waste or improve collection has been established as the baseline (Without MP scenario).

In turn, three alternatives (A, B, and C), have been formulated to improve the current SWM system, including waste reduction and improved collection. The main components of each alternative are described in the table below:

Table 3-18 Main components of the alternatives for the SWM system

Main component of SWM system		Primary transfer stations	Composting facilities		Recycling facilities (MRF)		Thermal recovery facilities	Disposal site (Aruwakkalu DS through Kelaniya TS)
			LAs & cluster based	Waste Park	LAs	Waste Park		
Without MP	Baseline	Primary transfer stations will be constructed to improve collection efficiency	Current capacity: 324 ton/day	-	344 ton/day	-	750 ton/day (WPK*)	2,382 ton/day
	Alternative A		930 ton/day	-	421 ton/day	-	750 ton/day (WPK)	3,157 ton/day
With MP	Alternative B		930 ton/day	400 ton/day	421 ton/day	150 ton/day	2,900 ton/day	1,206 ton/day
	Alternative C		930 ton/day	-	421 ton/day	-	3,300 ton/day	1,122 ton/day

\*WPK: Western Power at Kerawalapitiya

**i. Overview of the alternative scenarios for the SWM system**

■ **Baseline**

*The current waste management system continues as is. Total capacity of LAs & cluster-based composting facilities: 324 ton/day. Capacity of Western Power at Kerawalapitiya (WPK) WtE facility: 750 ton/day.*

- Waste reduction and improved collection are not considered.
- The total capacity of LAs and cluster-based composting facilities is currently 324 tons per day. Collected biodegradable waste that exceeds the total capacity of composting facilities is transported and disposed at Aruwakkalu Puttalam DS. The total capacity of composting facilities (324 tons per day) will remain the same in the future.
- Recyclables will mainly be sorted in the recycling facilities of each LA. The capacity of these facilities will increase in line with the amount of recyclables separated and collected.
- The WPK WtE facility (750 tons per day) mainly treats mixed waste including other waste and biodegradable waste from CMC, but burnable waste collected from facilities of surrounding LAs is also incinerated. The thermal recovery capacity will not increase compared to the current level (750 tons per day).
- The following waste categories will be transported to Aruwakkalu Puttalam DS:
  - ✓ Non-burnable waste
  - ✓ Residues from intermediate treatment facilities
  - ✓ Untreated waste

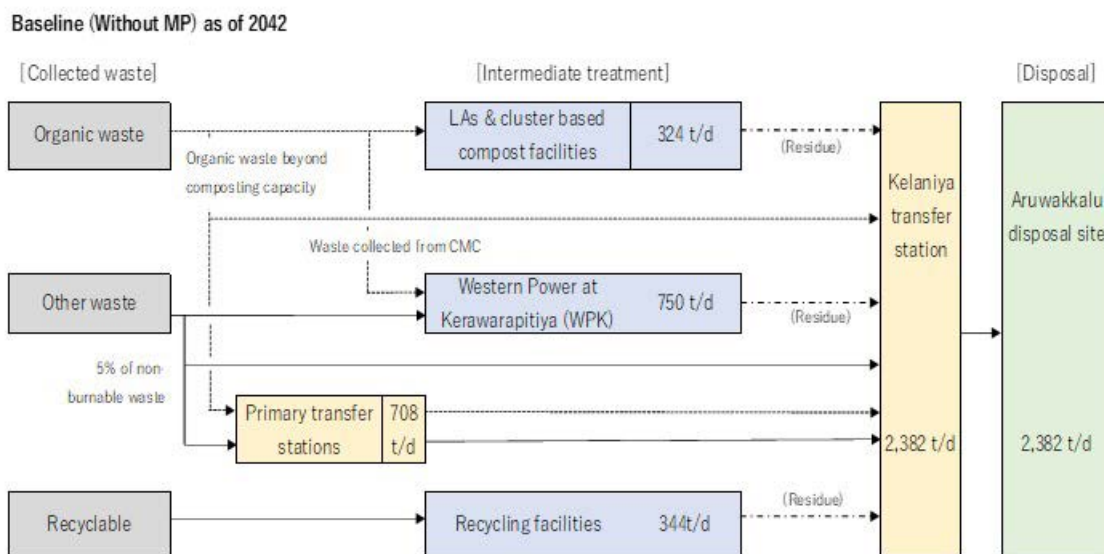

Figure 3-5 Waste flow baseline (without MP) as of 2042

■ **Alternative A**

*Waste reduction and collection improvement. Capacity of the WPK WtE facility: 750 ton/day. Total capacity of LAs & cluster-based composting facilities: 930 ton/day.*

- Waste reduction and improved collection measures are introduced.
- The WPK WtE facility (750 tons per day) mainly treats mixed waste including other waste and biodegradable waste from CMC, but burnable waste collected from facilities of surrounding LAs are also incinerated. The thermal recovery capacity will not increase compared to the current level (750 tons per day).
- The total capacity of LAs and cluster-based composting facilities will increase to 930 tons per day. Collected biodegradable waste that exceeds the total capacity of composting facilities is transported and disposed at Aruwakkalu Puttalam DS.
- Recyclables will mainly be sorted in the recycling facilities of each LA. The capacity of these facilities will increase in line with the amount of recyclables separated and collected.
- The following waste categories will be transported to Aruwakkalu Puttalam DS:
  - ✓ Non-burnable waste
  - ✓ Residues from intermediate treatment facilities
  - ✓ Untreated waste

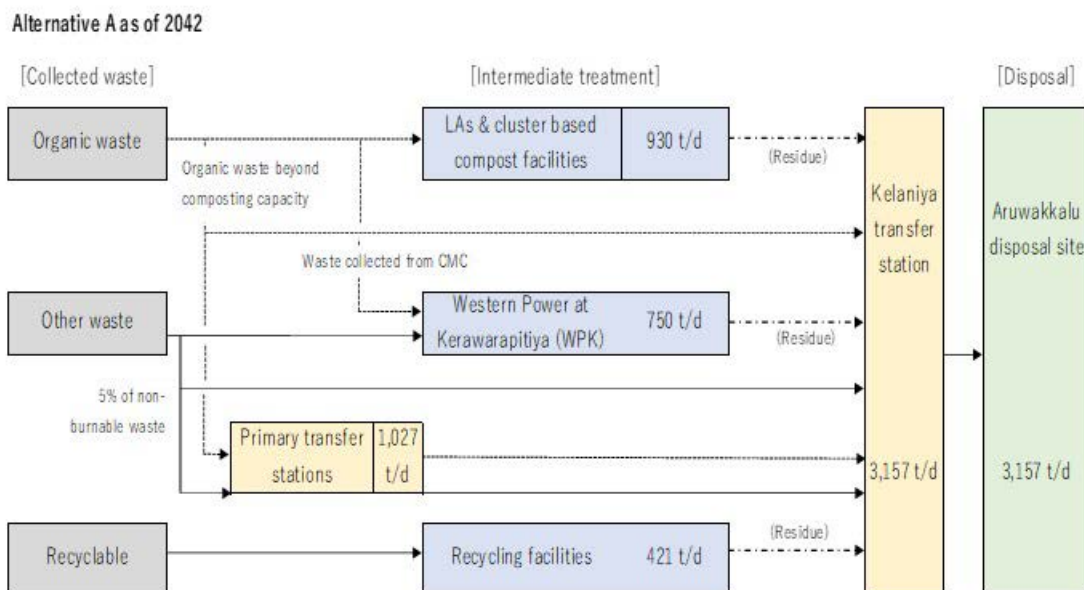

Figure 3-6 Waste flow of alternative A as of 2042



■ **Alternative B**

*Waste reduction and improved collection. Total capacity of thermal recovery facilities: 2,900 ton/day. Total capacity of composting facilities: 1,332 ton/day, including 932 ton/day at the LAs' and cluster-based composting facilities and 400 ton/day at the waste parks' composting facilities.*

- Waste reduction and improved collection are considered.
- Mixed waste collected in CMC, as well as burnable and 20% of biodegradable waste collected in LAs (excluding CMC) will be treated in TRFs, and the thermal recovery capacity will increase.
- The total capacity of composting facilities will increase to 1,332 tons per day. This includes 932 tons per day treated in LAs' and cluster-based composting facilities and 400 tons per day in waste parks' composting facilities (operated and managed by MoUD&H). The amount of biodegradable waste generated does not exceed the capacity of the composting facilities and therefore no biodegradable waste is disposed of at the final disposal site.
- Recyclables will be sorted in the recycling facilities of each LA and in MRFs located in waste parks. Waste parks' MRFs will be constructed with a capacity of 30 tons per day per location. In addition, the capacity of LAs' recycling facilities will increase in line with the amount of recyclables separated and collected.
- The following waste categories will be transported to Aruwakkalu Puttalam DS:
  - ✓ Non-burnable waste
  - ✓ Residues from intermediate treatment facilities

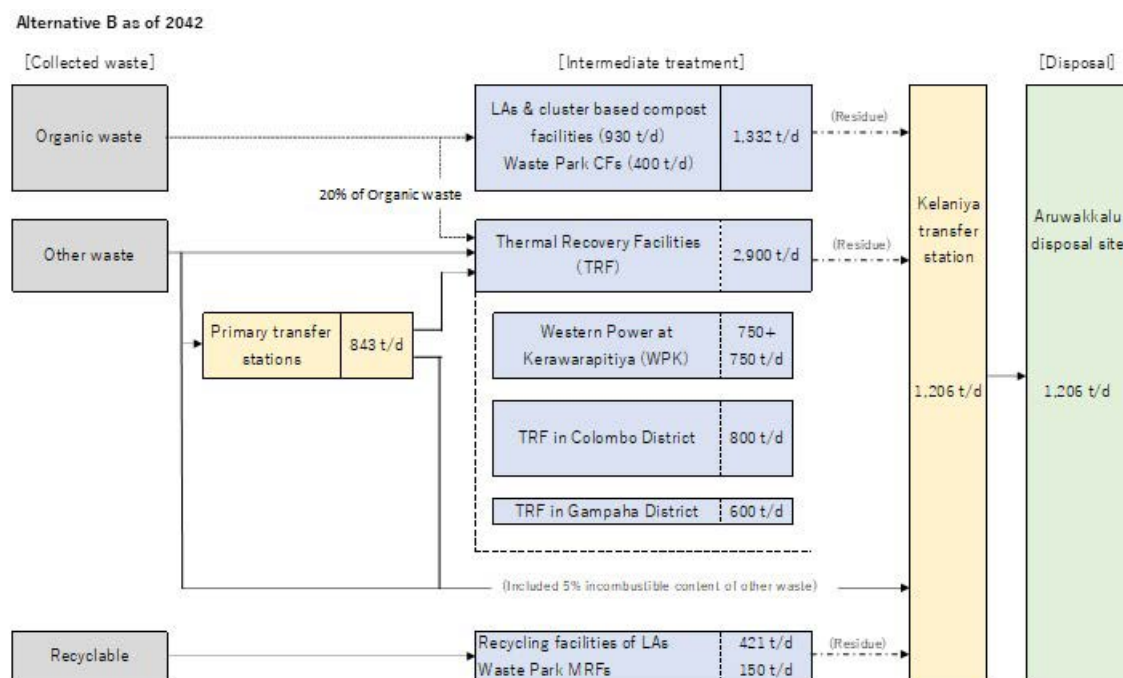

Figure 3-7 Waste flow of alternative B as of 2042

■ **Alternative C**

*Waste reduction and collection improvement. Total capacity of thermal recovery facilities: 3,300 ton/day. Total capacity of LAs & cluster-based composting facilities: 932 ton/day.*

- Waste reduction and improved collection are considered.
- Mixed waste collected in CMC, burnable waste collected in LAs (excluding CMC), and biodegradable waste that exceeds the capacity of the composting facilities will be treated in TRFs, and the thermal recovery capacity will increase.
- The total capacity of LAs and cluster-based composting facilities will increase to 932 tons per day. Collected biodegradable waste that exceeds the total capacity of the composting facilities is transported to be treated at TRFs.
- Recyclables will mainly be sorted in the recycling facilities of each LA. The capacity of these facilities will increase in line with the amount of recyclables separated and collected.
- The following waste categories will be transported to Aruwakkalu Puttalam DS:
  - ✓ Non-burnable waste
  - ✓ Residues from intermediate treatment facilities
  - ✓ Untreated waste

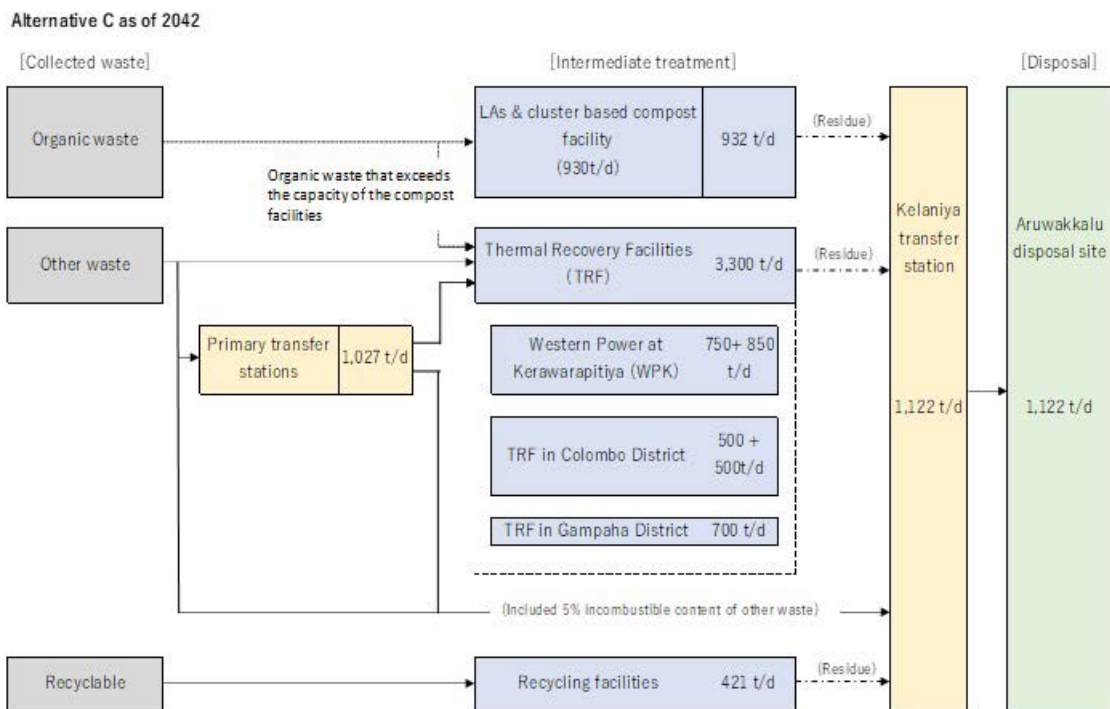

Figure 3-8 Waste flow of alternative C as of 2042

**ii. Breakdown of waste generation and waste discharge**

■ **Baseline**

*Waste reduction and improved collection are not considered.*

- 28% of the waste generated is improperly discharged and 56% is discharged for collection.
- Some of the waste collected is recovered as recyclables by collection workers at the collection stage, and the rest is transported to a composting facility, recycling facility, and/or TRF.
- The final disposal amount represents 35% of the waste generation amount, including residues generated in intermediate treatment facilities.

Table 3-19 Breakdown of waste generation amount and discharge amount (Baseline)

Waste Flow	2021		2025		2030		2041	
	Vol. (tpd)	(%)	Vol. (tpd)	(%)	Vol. (tpd)	(%)	Vol. (tpd)	(%)
1. Generation	3,926	100%	4,382	100%	5,100	100%	6,827	100%
7. Improper discharge	1,179	30%	1,275	29.10%	1,432	28.08%	1,913	28.02%
5. Discharge	2,072	52.78%	2,372	54.13%	2,839	55.67%	3,805	55.73%
8. Informal recycling	171	4.36%	192	4.38%	217	4.25%	290	4.25%
11.1 Composting	325	8.28%	327	7.46%	325	6.37%	325	4.76%
11.3 Recycling	112	2.85%	149	3.40%	213	4.18%	344	5.04%
11.4 Thermal recovery	750	19.10%	749	17.09%	750	14.71%	750	10.99%
12. Untreated waste	714	18.19%	955	21.79%	1,334	26.16%	2,096	30.70%
15. Final Disposal	981	24.99%	1,229	28.05%	1,621	31.78%	2,383	34.91%

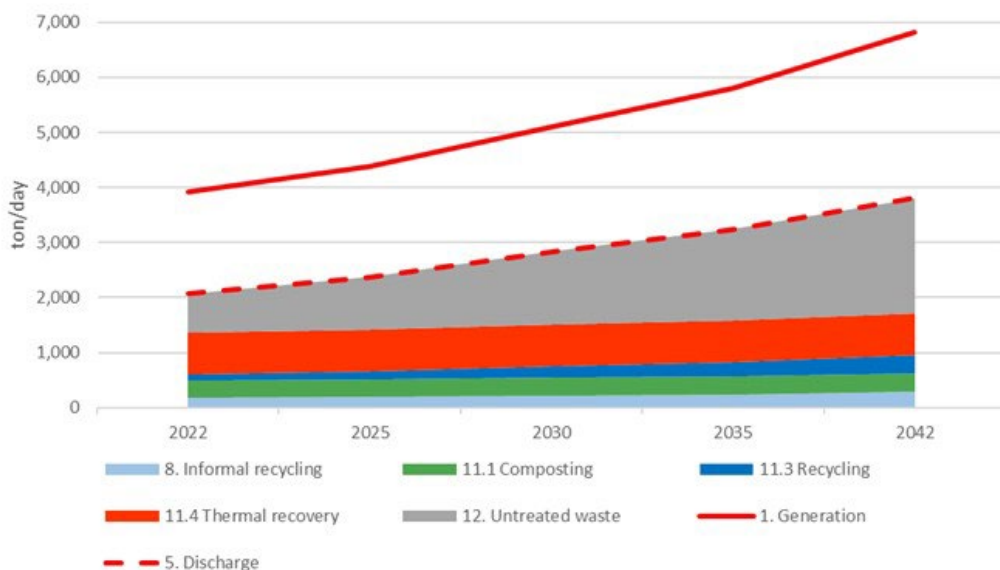

Figure 3-9 Breakdown of waste generation amount and discharge amount (Baseline)

■ **Alternative A**

*Waste reduction and improved collection are considered.*

- 8% of the waste generated is improperly discharged and 73% is collected.
- Some of the waste collected is recovered as recyclables by collection workers at the collection stage, and the rest is transported to a composting facility, recycling facility, and/or TRF.
- The final disposal amount represents 46% of the waste generation amount, including residues generated in intermediate treatment facilities.

Table 3-20 Breakdown of waste generation amount and discharge amount  
(Alternative A)

Waste Flow	2021		2025		2030		2041	
	Vol. (tpd)	(%)	Vol. (tpd)	(%)	Vol. (tpd)	(%)	Vol. (tpd)	(%)
1. Generation	3,926	100%	4,342	100%	4,952	100%	6,181	100%
7. Improper discharge	821	21%	815	18.60%	748	14.67%	515	7.54%
5. Discharge	2,198	55.99%	2,620	59.79%	3,337	65.43%	4,985	73.02%
8. Informal recycling	204	5.20%	224	5.11%	244	4.78%	229	3.35%
11.1 Composting	325	8.28%	451	10.29%	448	8.78%	932	13.65%
11.3 Recycling	118	3.01%	169	3.86%	255	5.00%	421	6.17%
11.4 Thermal recovery	752	19.15%	751	17.14%	750	14.71%	750	10.99%
12. Untreated waste	799	20.35%	1,025	23.39%	1,640	32.16%	2,653	38.86%
15. Final Disposal	1,065	27.13%	1,342	30.63%	1,972	38.67%	3,157	46.24%

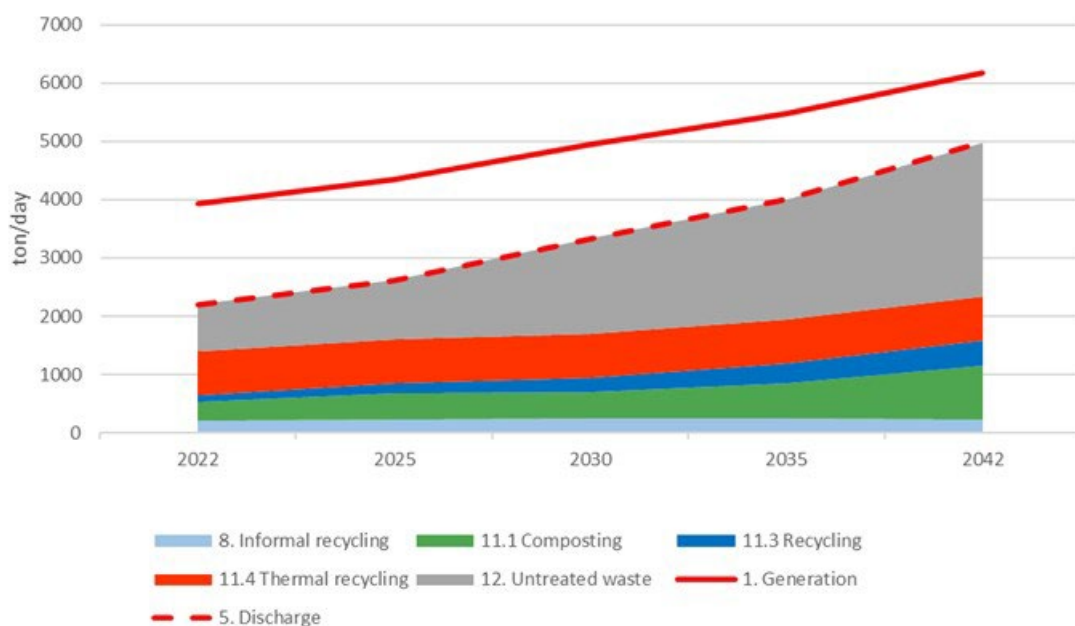

Figure 3-10 Breakdown of waste generation amount and discharge amount  
(Alternative A)

■ **Alternative B**

*Waste reduction and improved collection are considered.*

- 8% of the waste generated is improperly discharged and 73% is collected.
- Some of the waste collected is recovered as recyclables by collection workers at the collection stage, and the rest is transported to a composting facility, recycling facility, and/or TRF.
- The final disposal amount represents 18% of the waste generation amount, including residues generated in intermediate treatment facilities.

Table 3-21 Breakdown of waste generation amount and discharge amount  
(Alternative B)

Waste Flow	2021		2025		2030		2041	
	Vol. (tpd)	(%)	Vol. (tpd)	(%)	Vol. (tpd)	(%)	Vol. (tpd)	(%)
1. Generation	3,926	100%	4,342	100%	4,952	100%	6,181	100%
7. Improper discharge	821	21%	815	18.60%	748	14.67%	515	7.54%
5. Discharge	2,198	55.99%	2,620	59.79%	3,337	65.43%	4,985	73.02%
8. Informal recycling	118	3.01%	169	3.86%	255	5.00%	229	6.17%
11.1 Composting	325	8.28%	611	13.94%	786	15.41%	1,332	19.51%
11.3 Recycling	110	2.80%	143	3.26%	194	3.80%	421	4.85%
11.4 Thermal recovery	752	19.15%	751	17.14%	1,687	33.08%	2,874	42.10%
12. Untreated waste	799	20.35%	865	19.74%	365	7.16%	129	1.89%
15. Final Disposal	1,065	27.13%	1,241	28.32%	997	19.55%	1,206	17.67%

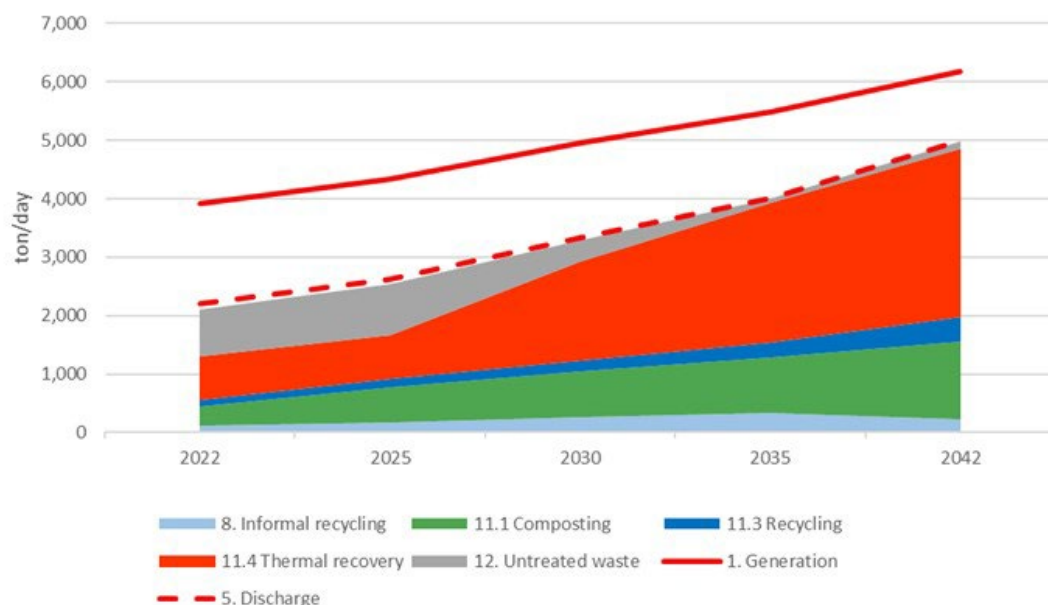

Figure 3-11 Breakdown of waste generation amount and discharge amount  
(Alternative B)

■ **Alternative C**

*Waste reduction and improved collection are considered.*

- 8% of the waste generated is improperly discharged and 73% is collected.
- Some of the waste collected is recovered as recyclables by collection workers at the collection stage, and the rest is transported to a composting facility, recycling facility, and/or TRF.
- The final disposal amount represents 16% of the waste generation amount, including residues generated in intermediate treatment facilities.

Table 3-22 Breakdown of waste generation and discharge amount (Alternative C)

Waste Flow	2021		2025		2030		2041	
	Vol. (tpd)	(%)	Vol. (tpd)	(%)	Vol. (tpd)	(%)	Vol. (tpd)	(%)
1. Generation	3,926	100%	4,342	100%	4,952	100%	6,181	100%
7. Improper discharge	821	21%	815	18.60%	748	14.67%	515	7.54%
5. Discharge	2,198	55.99%	2,620	59.79%	3,337	65.43%	4,985	73.02%
8. Informal recycling	204	5.20%	224	5.11%	244	4.78%	229	3.35%
11.1 Composting	329	8.38%	451	10.29%	448	8.78%	932	13.65%
11.3 Recycling	118	3.01%	169	3.86%	255	5.00%	421	6.17%
11.4 Thermal recovery	749	19.08%	753	17.18%	1,906	37.37%	3,300	48.34%
12. Untreated waste	798	20.33%	1,023	23.35%	484	9.49%	103	1.51%
15. Final Disposal	1,084	27.61%	1,392	31.77%	1,044	20.47%	1,122	16.43%

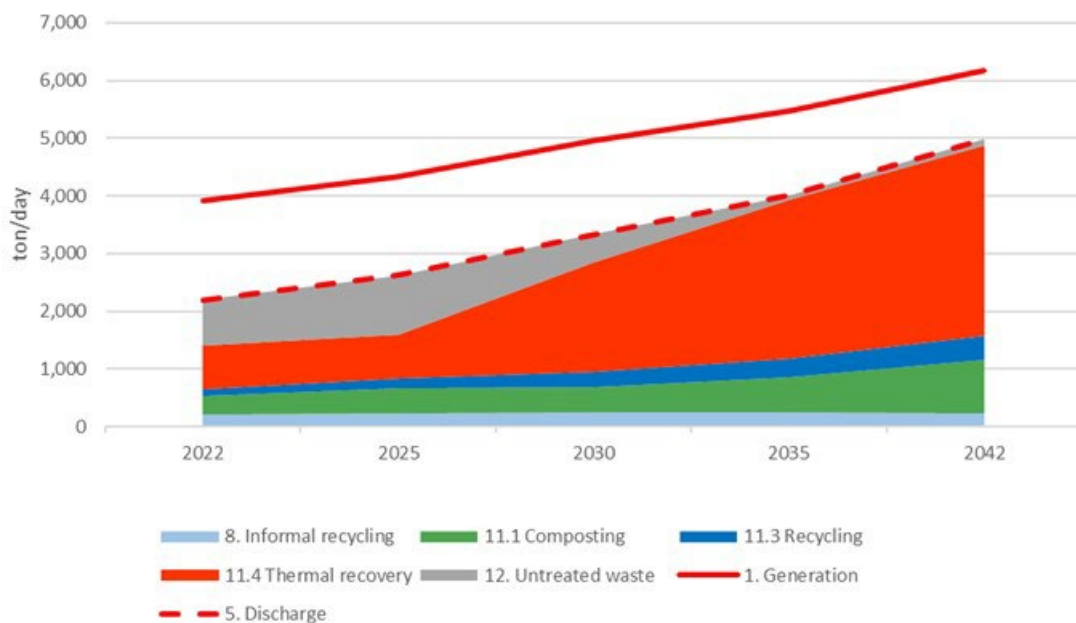

Figure 3-12 Breakdown of waste generation and discharge amount (Alternative C)

### 3.4 Evaluation of the alternative scenarios for the SWM system

The baseline and alternative scenarios have been evaluated based on technical, institutional, economic and social considerations, in order to select the optimal plan.

#### 3.4.1 Technical evaluation

The baseline and the three alternative scenarios have been evaluated for the following technical items that are relevant to SWM in the Western Province.

- Reduction of improper waste discharge through increased collection coverage and reduction of the amount of waste to be disposed through the promotion of intermediate treatment.
- Optimization of final disposal.
- Maximization of biodegradable waste composting and reduction of final disposal.

#### (1) Reduction of improper waste discharge by increasing collection coverage and promoting intermediate treatment

In the baseline scenario, 28% of the waste generated is improperly discharged and 56% is discharged for collection. On the other hand, in alternatives A, B, and C, improved collection results in a significant reduction in the amount of waste improperly discharged, with only 8% of the waste generated that is discharged improperly and 81% that is discharged for collection.

As for the final disposal amount, it represents 35% of the waste generation amount, including residues generated from composting facilities, recycling facilities and TRFs, in the baseline scenario. In contrast, it is 51%, 20%, and 18%, for alternatives A, B, and C respectively.

Evaluation of the technical item “Reduction of improperly discharged waste and waste to be disposed”: Alternative B = Alternative C > Alternative A = Baseline

Table 3-23 Comparison of breakdown of MSW generated in 2042

Waste Flow	Without MP				With MP			
	Baseline		Alternative A		Alternative B		Alternative C	
	Vol. (tpd)	(%)	Vol. (tpd)	(%)	Vol. (tpd)	(%)	Vol. (tpd)	(%)
1. Generation	6,827	100.0%	6,181	100.0%	6,181	100.0%	6,181	100.0%
7. Improper discharge	1,913	28.0%	515	8.3%	515	8.3%	515	8.3%
5. Discharge for collection	3,805	55.7%	4,985	80.7%	4,985	80.7%	4,985	80.7%
8. Informal recycling	290	4.2%	229	3.7%	229	6.8%	229	3.7%
11.1 Compost	325	4.8%	932	15.1%	1,332	21.5%	932	15.1%
11.3 Recycling	344	5.0%	421	6.8%	421	5.4%	421	6.8%
11.4 Thermal recovery	750	11.0%	750	12.1%	2,874	46.5%	3,300	53.4%
12. Untreated waste	2,096	30.7%	2,653	42.9%	129	2.1%	103	1.7%
15. Final Disposal	2,383	34.9%	3,157	51.1%	1,206	19.5%	1,122	18.2%

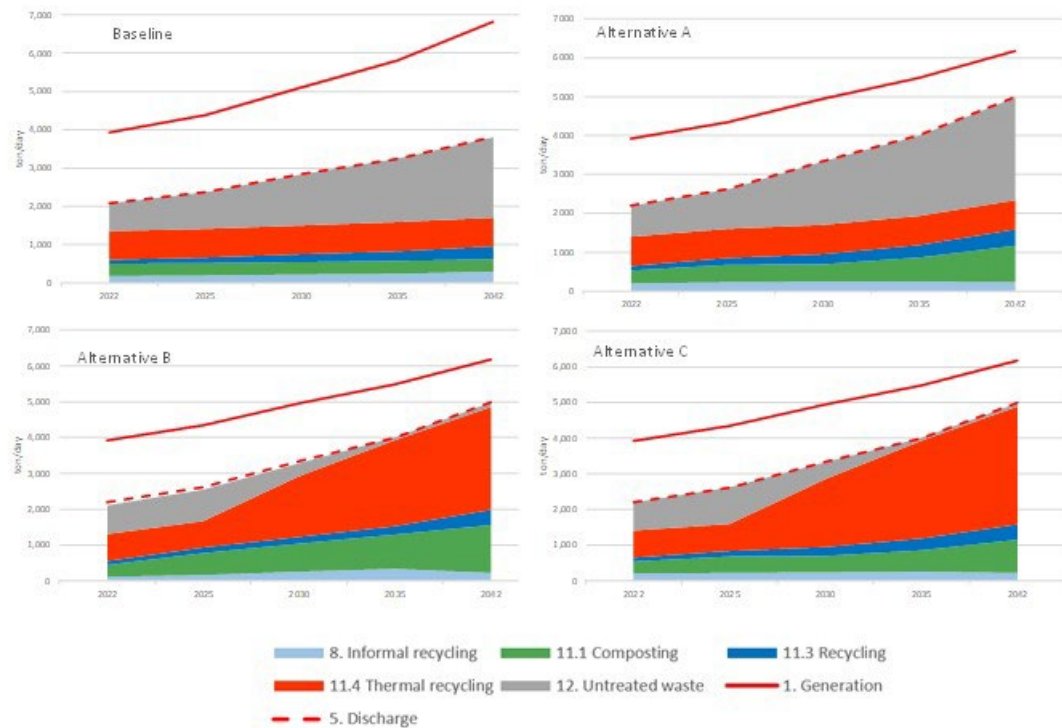

Figure 3-13 Breakdown of MSW generated

## (2) Optimization of final disposal

A comparison of the cumulative amount of waste disposed of in final disposal sites (including 20% soil cover) across the entire Western Province over the 20 years covered by the MP (2022-2041) is shown in the table and figure below.

As a result, the cumulative amount of final disposal is the highest in alternative A. Under this scenario, a large amount of the waste collected is transported to the final disposal site as is, without being reduced or recycled. Although waste collection is improved and the capacity of some composting facilities is increased, the improvement of intermediate treatment facilities as a whole is not sufficient.

In addition, although the baseline scenario does not include collection improvements as in alternative A, a large amount of collected waste is transported to the final disposal site as is because there is no sufficient improvement of intermediate treatment facilities, which increases the amount to be disposed of in final disposal sites.

On the other hand, in alternatives B and C, the capacity of TRFs and composting facilities are increased to manage the increased collected waste due to improved collection. As a result of the amount of waste to be disposed of in final disposal sites significantly decreases.

While the cumulative amount of final disposal of the baseline scenario is expected to be 15.4 million m<sup>3</sup>, with alternatives A, B, and C this amount is projected to be, respectively, 127%, 62%, and 60% of that of the baseline.

It is planned that in the future, all waste from the Western Province that needs to be disposed of at a final disposal site will be transported by rail via the Kelaniya TS to the Aruwakkalu DS,



located approximately 150 km north of Colombo City. Since the initially planned capacity of the Aruwakkalu DS is 5.6 million m<sup>3</sup>, it would need to be increased. The required additional capacity would be the highest with alternative A (up to 14.0 million m<sup>3</sup>), while only 3.6 million m<sup>3</sup> would be necessary for alternative C.

Therefore, alternative C is considered as the optimal SWM system from the viewpoint of minimizing the amount of final disposal.

Evaluation of the technical item “Optimization of final disposal”: Alternative C = Alternative B > Baseline > Alternative A

**Table 3-24 Cumulative amount of final disposal including soil cover (million m<sup>3</sup>)**

	Baseline	Alternative A	Alternative B	Alternative C
Cumulative amount of final disposal (2023-2042)	15.4	19.6	9.5	9.2
Planned amount of final disposal at Aruwakkalu DS	5.6	5.6	5.6	5.6
Additional capacity required for final disposal	9.8	14.0	3.9	3.6

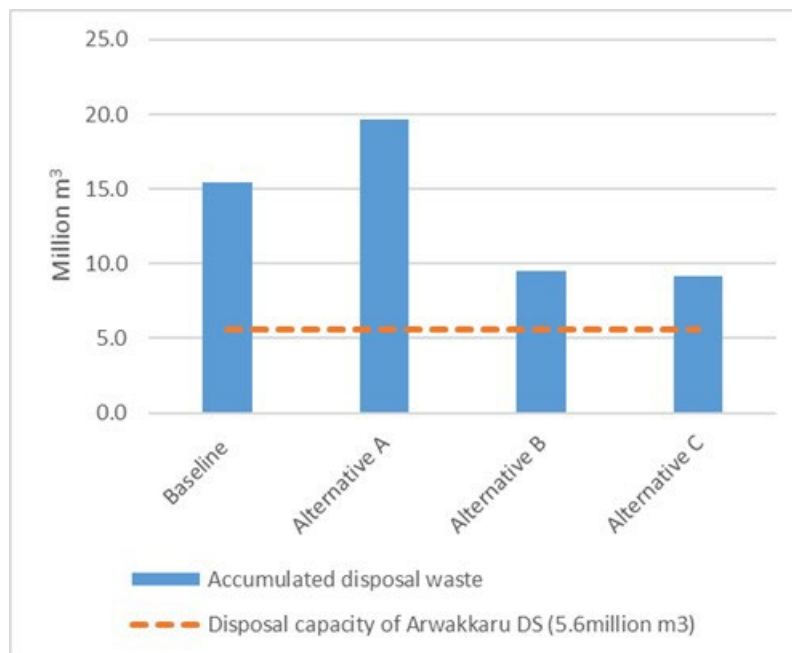

Figure 3-14 Cumulative amount of final disposal (2023-2042) and planned disposal capacity of the Aruwakkalu DS

**(3) Maximization of biodegradable waste composting and reduction of final disposal**

The amount of biodegradable waste collected and the breakdown of its treatment and disposal are shown in the table and figure below.

Since the capacity of the composting facilities and the amount of biodegradable waste treated in TRF is limited in the baseline scenario, the amount of biodegradable waste that would be disposed of in 2042 (final year of the MP) would exceed 1,000 tons per day. The capacity of the composting facilities increases in alternative A, but as with the baseline, a large amount of biodegradable waste is finally disposed of without being reduced in volume nor recycled.

On the other hand, thermal recovery is actively promoted in alternatives B and C, reducing the amount of biodegradable waste that is disposed of at the final disposal site as both other waste and biodegradable waste would be incinerated, in line with the National Policy as well as the Government mandate on Waste Management 2019 that regulates the final disposal of biodegradable waste. Furthermore, alternative B not only enhances the capacity of the cluster-based composting facilities in LAs but also connects with the Waste Park concept promoted by MoUD&H to maximize the use of biodegradable waste to produce compost.

Therefore, alternative B is considered as the optimal SWM system from the viewpoint of optimizing the treatment of biodegradable waste.

Evaluation of the technical item “Maximization of biodegradable waste composting and reduction of final disposal”: Alternative B > Alternative C > Alternative A > Baseline

Table 3-25 Breakdown of biodegradable waste treated / disposed (ton/day)

		2022	2025	2030	2042
Baseline	Biodegradable waste collected	874	1,043	1,327	2,015
	Composting facilities	325	325	325	325
	- LAs’ composting facilities	92	92	92	92
	- cluster-based composting facilities	232	232	232	232
	- waste park composting facilities	0	0	0	0
	Thermal recovery facilities	324	394	448	317
	Disposal site	225	322	554	1,373
Alternative A	Biodegradable waste collected	896	1,084	1,402	2,226
	Composting facilities	325	451	514	932
	- LAs’ composting facilities	92	117	131	136
	- cluster-based composting facilities	232	333	383	794
	- waste park composting facilities	0	0	0	0
	Thermal recovery facilities	317	349	417	245
	Disposal site	254	284	473	1,049
Alternative B	Biodegradable waste collected	896	1,084	1,402	2,226
	Composting facilities	325	611	850	1,332
	- LAs’ composting facilities	92	117	131	136
	- cluster-based composting facilities	232	333	383	749
	- waste park composting facilities	0	160	400	400
	Thermal recovery facilities	237	136	552	868
	Disposal site	334	337	0	0
Alternative C	Biodegradable waste collected	896	1,084	1,402	2,226
	Composting facilities	325	451	448	932
	- LAs’ composting facilities	92	117	131	136
	- cluster-based composting facilities	232	333	383	749
	- waste Park composting facilities	0	0	0	0
	Thermal recovery facilities	325	383	835	1,294
	Disposal site	242	250	55	0

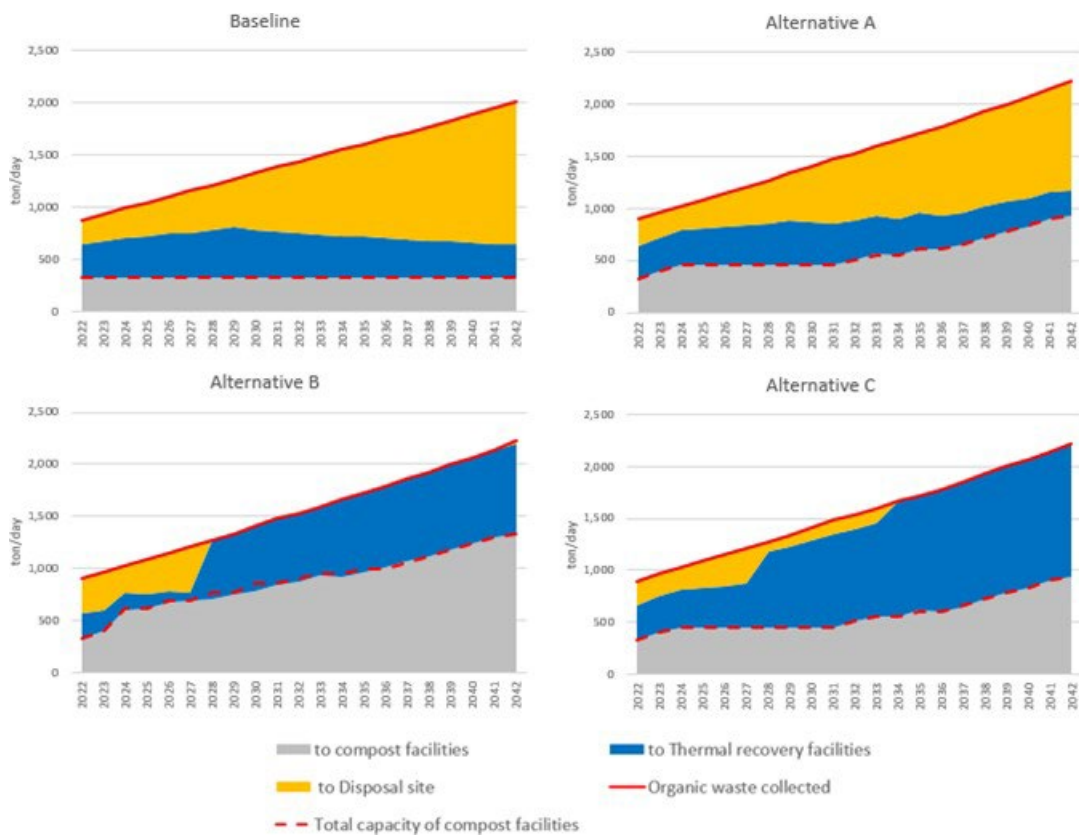

Figure 3-15 Breakdown of biodegradable waste treated and disposed

### 3.4.2 Cost evaluation for SWM system

#### (1) Component of cost evaluation

The waste management costs of the baseline and each alternative for the MP period of 20 years (2023-2042) have been compared. Following components were considered in the cost calculation.

- Costs for waste collection and transportation:
  - Include procurement of collection vehicles, fuel & maintenance costs, and labor costs related to the collection of biodegradable waste, recyclable waste, and other waste.
- Costs for waste transfer and transportation:
  - Include procurement of vehicles, fuel & maintenance costs, and labor costs related to the transportation of the following waste to Kelaniya TS.
  - Operation and maintenance cost for primary TS s and Kelaniya TS.
  - Construction cost for primary TSs.
- Costs for intermediate treatment:
  - Construction and operating costs of composting facilities
  - Construction and operating costs of recycling facilities
  - Construction and operating costs of thermal recovery facilities

- Costs for final disposal
  - Operating costs of the final disposal site
  - Construction costs for the expansion of Aruwakkalu DS to dispose of waste that exceeds the initially planned landfill capacity.

**i. Cost evaluation**

Currently, collection vehicles are mainly compactor trucks in Colombo City and 4W tractors in other LAs. The baseline scenario assumes that the current vehicle types will continue to be used in the future, whereas the other alternatives assume that the collection vehicles will be switched to compactor trucks. Therefore, in order to transport waste to be disposed to the Aruwakkula DS in the future, each municipality will need to transport collected waste to the Kelaniya TS. In that context, since the baseline operation using 4W tractors is less efficient in terms of collection and transportation than the other alternatives that assume a switch to compactor trucks, collection costs are higher.

Transportation costs are higher in the baseline scenario and alternative A, in which a large amount of waste is transported from the Kelaniya TS to the Aruwakkalu DS.

Intermediate treatment costs are higher in alternatives B and C due to the high construction and maintenance costs associated with the large scale of the thermal recovery facilities.

Final disposal costs are higher in the baseline scenario and alternative A due to the large amount of collected waste that is directly transported to the final disposal site without sufficient intermediate treatment.

Alternative B is the cheapest in the following order in terms of total waste management cost and cost per unit of waste collected, and alternative B is considered as the optimal SWM system from the viewpoint of minimizing waste management costs.

Waste management Cost: Alternative B < Alternative C < Baseline < Alternative A

The 20-year average annual treatment cost of alternative B is projected to be 4.3 billion LKR/year, and the cost per ton of collected waste is projected to be 17,100 LKR per ton.

**Table 3-26 Cumulative costs and unit costs for SWM for 2023-2042**

	Unit	Baseline	Alternative A	Alternative B	Alternative C
Collection		167,770	97,213	102,943	106,487
Transfer		100,564	145,975	80,083	87,359
Composting facilities		7,100	13,010	20,303	12,997
Recycling facilities	million LKR for 2023-2042	3,452	4,164	6,164	4,164
Thermal recovery facilities		38,320	38,320	149,229	171,643
Final disposal		140,424	190,709	69,337	72,041
<b>Total</b>		<b>457,630</b>	<b>489,391</b>	<b>428,058</b>	<b>454,691</b>

Unit cost for SWM	LKR/ton	25,065	19,676	17,210	18,279
-------------------	---------	--------	--------	--------	--------

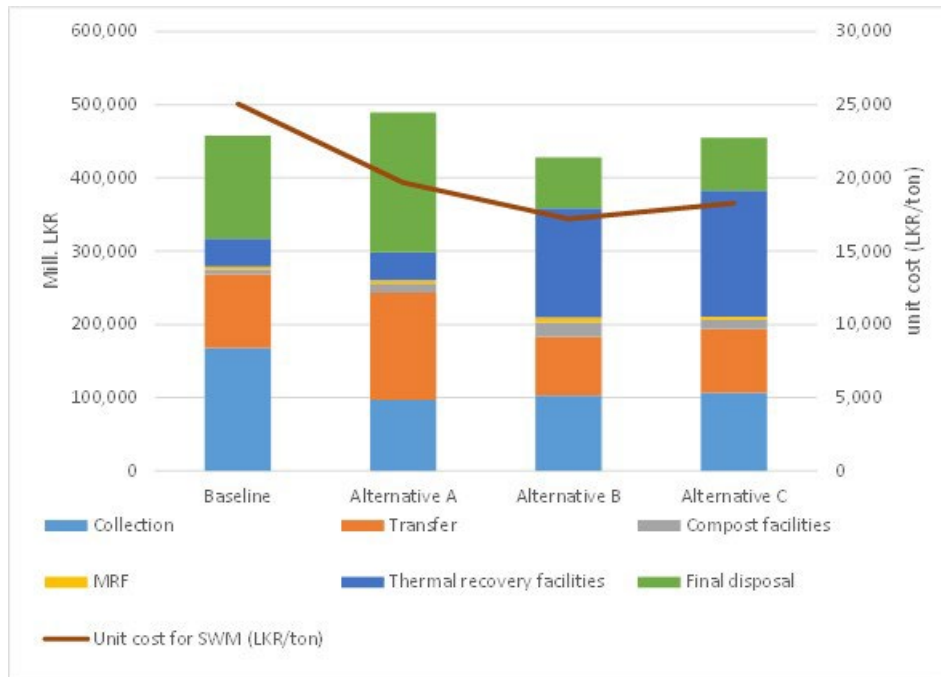

Figure 3-16 Cumulative costs and unit costs for SWM for 2023-2042

**(2) Basis of cost estimates for the SWM system**

A summary table of the detail costs estimations for the baseline and alternatives is shown below. And more, the basis for the estimation of each cost is also described.

Table 3-27 Summary table of detail cost estimates for the SWM systems

		Baseline	Alternative A	Alternative B	Alternative C
Collection	Procurement cost of vehicles	5,986	4,903	7,189	7,333
	Fuel & maintenance cost	99,263	67,623	69,778	72,567
	Labor cost	62,521	24,687	25,976	26,587
	sub-total	167,770	97,213	102,943	106,487
Transfer	Procurement cost of vehicles	447	1,931	2,050	2,487
	Fuel & maintenance cost	59,659	90,758	44,556	46,742
	Labor cost	393	1,248	1,507	1,765
	OM cost	32,985	41,768	23,540	26,095
	Initial cost	7,080	10,270	8,430	10,270
	sub-total	100,564	145,975	80,083	87,359
Compost facility	OM cost	7,100	12,707	19,638	12,694
	Initial cost	0	303	665	303
	sub-total	7,100	13,010	20,303	12,997
MRF	OM cost	3,452	4,164	4,164	4,164
	Construction cost	0	0	2,000	0
	sub-total	3,452	4,164	6,164	4,164
WtE facility	OM cost	38,320	38,320	95,481	107,893
	Construction cost	0	0	53,748	63,750
	sub-total	38,320	38,320	149,229	171,643
Final disposal	OM cost	61,741	78,503	38,046	38,947
	Construction cost	78,683	112,206	31,291	33,094
	sub-total	140,424	190,709	69,337	72,041
Total		457,630	489,391	428,058	454,691

**i. Collection and transportation**

■ Procurement costs of collection vehicles

**Table 3-28 Procurement costs of collection vehicles (Baseline)**

Type of collection vehicle	Biodegradable waste		Other waste		Recyclables		Total
	Trailer	Tractor	Trailer	Tractor	Trailer	Tractor	
Required number of vehicles (unit)		707		819		184	1,710
Unit cost (million LKR)		3.5		3.5		3.5	-
<b>Total cost (million LKR)</b>		<b>2,475</b>		<b>2,867</b>		<b>644</b>	<b>5,986</b>

**Table 3-29 Procurement costs of collection vehicles (Alternative A)**

Type of collection vehicle	Biodegradable waste		Other waste		Recyclables		Total
	4t compactor	4t compactor	4t compactor	4t compactor	Trailer	Tractor	
Required number of vehicles (unit)		130		328		223	681
Unit cost (million LKR)		9		9		3.5	-
<b>Total cost (million LKR)</b>		<b>1,170</b>		<b>2,952</b>		<b>781</b>	<b>4,903</b>

**Table 3-30 Procurement costs of collection vehicles (Alternative B)**

Type of collection vehicle	Biodegradable waste		Other waste		Recyclables		Total
	4t compactor	4t compactor	4t compactor	4t compactor	Trailer	Tractor	
Required number of vehicles (unit)		188		524		223	935
Unit cost (million LKR)		9		9		3.5	-
<b>Total cost (million LKR)</b>		<b>1,692</b>		<b>4,716</b>		<b>781</b>	<b>7,189</b>

**Table 3-31 Procurement costs of collection vehicles (Alternative C)**

Type of collection vehicle	Biodegradable waste		Other waste		Recyclables		Total
	4t compactor	4t compactor	4t compactor	4t compactor	Trailer	Tractor	
Required number of vehicles (unit)		130		598		223	951
Unit cost (million LKR)		9		9		3.5	-
<b>Total cost (million LKR)</b>		<b>1,170</b>		<b>5,382</b>		<b>781</b>	<b>7,333</b>

■ Fuel & maintenance costs

Table 3-32 Considered factors and calculation of fuel and maintenance costs for collection

Item	Biodegradable waste	Other waste			Recyclables
		to TRF	to Kelaniya TS	to Primary TSs	
Factors considered for cost calculation					
(1) Apparent specific gravity (ton/m <sup>3</sup> )	0.3	0.2	0.2	0.2	0.15
(2) Type of collection vehicle	4t compactor (8 m <sup>3</sup> )	4t compactor (8 m <sup>3</sup> )	4t compactor (8 m <sup>3</sup> )	4t compactor (8 m <sup>3</sup> )	Trailer 4W (6.6 m <sup>3</sup> )
(3) Loading capacity (ton)	4.3	2.9	2.9	2.9	1.0
(4) Number of trips per day (trip)	2	2	2	2	1
(5) Average distance from the collection area and transportation (km)	- 25 km to cluster CF - 15 km to individual CF	25 km	- 25 km Colombo and Gampaha districts - 50 km Kalutara district	25 km	15 km
(6) Fuel consumption (km/liter)	1.5	1.5	1.5	1.5	1.5
(7) Unit price of fuel (LKR/liter) *2021	220	220	220	220	220
(8) Maintenance costs per vehicle	10% of fuel costs	10% of fuel costs	10% of fuel costs	10% of fuel costs	10% of fuel costs
Calculation of fuel and maintenance costs	- (Total number of trips per day) = (Waste amount per day) / (3) - (Total mileage (km/day)) = [(5) x 2] x (Total number of trips per day) - (Fuel costs (LKR/day)) = [(Total mileage per day)/(6)] x (7) - (Total fuel and maintenance costs (LKR/day)) = (Fuel costs) + (8)				



Table 3-33 Fuel and Maintenance cost for collection (Baseline)

Year	Biodegradable waste (LKR/day)	Other waste (LKR/day)			Recyclables (LKR/day)	Total (LKR/day)
		to TRF	to Kelaniya TS	to Primary TSs		
2023	1,890,826	3,992,998	3,492,866	0	595,320	9,972,010
2024	2,002,146	4,138,198	3,581,602	0	653,400	10,375,346
2025	2,102,170	4,251,134	1,451,996	2,516,800	721,160	11,043,260
2026	2,203,810	4,364,066	1,500,394	2,597,468	779,240	11,444,978
2027	2,300,616	4,517,334	1,451,996	2,791,066	842,160	11,903,172
2028	2,670,066	2,000,534	3,412,202	2,952,396	905,080	11,940,278
2029	2,818,492	2,129,600	3,420,268	3,057,264	958,320	12,383,944
2030	2,916,908	2,089,266	3,557,398	3,129,860	1,030,920	12,724,352
2031	3,052,428	2,089,266	3,613,866	3,218,594	1,089,000	13,063,154
2032	3,204,082	2,089,266	3,662,264	3,315,398	1,137,400	13,408,410
2033	3,328,308	2,089,266	3,718,732	3,436,398	1,190,640	13,763,344
2034	3,502,548	2,089,266	3,783,264	3,508,998	1,239,040	14,123,116
2035	3,625,160	2,089,266	3,823,598	3,638,066	1,277,760	14,453,850
2036	3,783,266	2,089,266	3,855,866	3,742,940	1,350,360	14,821,698
2037	3,936,534	2,089,266	3,863,932	3,888,136	1,393,920	15,171,788
2038	4,102,708	2,089,266	3,896,198	4,041,400	1,427,800	15,557,372
2039	4,268,880	2,089,266	3,888,132	4,138,204	1,471,360	15,855,842
2040	4,446,348	2,089,266	3,920,402	4,243,070	1,539,120	16,238,206
2041	4,638,332	2,089,266	3,920,400	4,428,598	1,602,040	16,678,636
2042	4,848,066	2,089,266	3,912,334	4,517,332	1,664,960	17,031,958
Total cost for 2023-2042 (million LKR)	23,959	19,182	24,721	23,054	8,347	<b>99,263</b>

Table 3-34 Fuel and Maintenance cost for collection (Alternative A)

Year	Biodegradable waste (LKR/day)	Other waste (LKR/day)			Recyclables (LKR/day)	Total (LKR/day)
		to TRF	to Kelaniya TS	to Primary TSs		
2023	808,278	2,718,468	1,976,336	0	638,880	6,141,962
2024	864,744	2,839,468	2,008,602	0	730,840	6,443,654
2025	859,904	2,992,734	830,866	1,371,330	817,960	6,872,794
2026	858,290	3,146,002	879,268	1,460,064	900,240	7,243,864
2027	861,518	3,299,266	895,400	1,564,932	977,680	7,598,796
2028	858,294	2,008,600	1,992,472	1,774,668	1,059,960	7,693,994
2029	863,134	2,129,600	2,040,868	1,855,334	1,166,440	8,055,376
2030	855,068	2,089,266	2,266,736	1,976,338	1,234,200	8,421,608
2031	851,842	2,089,266	2,411,938	2,097,342	1,321,320	8,771,708
2032	929,278	2,089,266	2,532,934	2,169,938	1,379,400	9,100,816
2033	1,022,848	2,089,266	2,670,068	2,202,202	1,422,960	9,407,344
2034	1,009,942	2,089,266	2,766,868	2,355,466	1,490,720	9,712,262
2035	1,088,998	2,089,266	2,895,934	2,387,736	1,582,680	10,044,614
2036	1,093,838	2,089,266	3,000,798	2,540,998	1,650,440	10,375,340
2037	1,158,372	2,089,266	3,113,734	2,670,064	1,713,360	10,744,796
2038	1,264,852	2,089,266	3,218,600	2,726,532	1,756,920	11,056,170
2039	1,358,424	2,089,266	3,299,268	2,791,070	1,839,200	11,377,228
2040	1,422,960	2,089,266	3,396,068	2,895,934	1,916,640	11,720,868
2041	1,513,308	2,089,266	3,517,068	2,992,732	1,979,560	12,091,934
2042	1,560,098	2,089,266	3,613,870	3,089,534	2,037,640	12,390,408
Total cost for 2023-2042 (million LKR)	7,703	16,898	18,005	14,937	10,080	<b>67,623</b>

Table 3-35 Fuel and Maintenance cost for collection (Alternative B)

Year	Biodegradable waste (LKR/day)	Other waste (LKR/day)			Recyclables (LKR/day)	Total (LKR/day)
		to TRF	to Kelaniya TS	to Primary TSs		
2023	1,047,048	2,137,664	3,073,404	0	638,880	6,896,996
2024	1,100,288	2,145,732	2,710,406	0	730,840	6,687,266
2025	1,168,052	2,137,666	1,661,736	1,097,070	817,960	6,882,484
2026	1,198,706	2,137,666	1,790,804	1,129,338	900,240	7,156,754
2027	1,274,532	2,129,600	1,992,470	1,234,200	977,680	7,608,482
2028	1,258,398	3,872,000	282,332	1,371,332	1,059,960	7,844,022
2029	1,310,024	4,065,600	290,400	1,403,598	1,166,440	8,236,062
2030	1,364,876	4,251,130	298,468	1,460,066	1,234,200	8,608,740
2031	1,466,518	4,396,332	322,670	1,540,730	1,321,320	9,047,570
2032	1,513,308	4,517,334	330,736	1,589,134	1,379,400	9,329,912
2033	1,576,226	4,670,600	338,802	1,621,402	1,422,960	9,629,990
2034	1,600,424	4,896,466	274,268	1,831,136	1,490,720	10,093,014
2035	1,653,666	5,001,334	282,334	1,903,736	1,582,680	10,423,750
2036	1,755,308	5,114,264	282,334	1,968,272	1,650,440	10,770,618
2037	1,819,840	5,267,530	282,334	2,016,670	1,713,360	11,099,734
2038	1,897,280	5,396,598	298,466	2,105,406	1,756,920	11,454,670
2039	1,981,174	5,493,398	290,400	2,178,008	1,839,200	11,782,180
2040	2,058,610	5,590,202	290,400	2,290,934	1,916,640	12,146,786
2041	2,134,436	5,727,330	298,466	2,363,532	1,979,560	12,503,324
2042	2,269,960	5,856,400	338,798	2,468,396	2,037,640	12,971,194
Total cost for 2023-2042 (million LKR)	11,479	30,954	5,741	11,524	10,080	<b>69,778</b>

Table 3-36 Fuel and Maintenance cost for collection (Alternative C)

Year	Biodegradable waste (LKR/day)	Other waste (LKR/day)			Recyclables (LKR/day)	Total (LKR/day)
		to TRF	to Kelaniya TS	to Primary TSs		
2023	793,760	2,145,734	3,089,540	0	638,880	6,667,914
2024	879,266	2,145,732	3,283,134	0	730,840	7,038,972
2025	871,196	2,145,734	1,903,734	1,347,132	817,960	7,085,756
2026	858,292	2,145,734	2,137,670	1,468,134	900,240	7,510,070
2027	879,268	2,121,534	2,379,662	1,581,068	977,680	7,939,212
2028	858,294	4,218,866	314,600	1,702,068	1,059,960	8,153,788
2029	863,134	4,452,800	330,734	1,782,734	1,166,440	8,595,842
2030	855,068	4,694,798	346,868	1,895,672	1,234,200	9,026,606
2031	851,842	4,904,534	371,070	2,016,676	1,321,320	9,465,442
2032	929,278	5,001,336	379,136	2,089,272	1,379,400	9,778,422
2033	1,022,848	5,138,466	387,202	2,113,468	1,422,960	10,084,944
2034	1,009,942	5,477,270	274,268	2,258,666	1,490,720	10,510,866
2035	1,088,998	5,574,068	282,334	2,290,936	1,582,680	10,819,016
2036	1,093,838	5,759,594	282,334	2,444,198	1,650,440	11,230,404
2037	1,158,372	5,912,868	282,334	2,565,198	1,713,360	11,632,132
2038	1,264,852	6,017,734	298,466	2,621,666	1,756,920	11,959,638
2039	1,358,424	6,114,530	290,400	2,694,272	1,839,200	12,296,826
2040	1,422,960	6,211,332	290,400	2,791,068	1,916,640	12,632,400
2041	1,513,308	6,324,262	298,466	2,879,798	1,979,560	12,995,394
2042	1,560,098	6,485,600	330,730	2,976,600	2,037,640	13,390,668
Total cost for 2023-2042 (million LKR)	7,714	33,942	6407	14,424	10,080	<b>72,567</b>

■ Labor costs

Table 3-37 Considered factors and calculation of labor costs for waste collection

Composition of the collection team and salary of the members		
	Number (person)	Monthly salary (LKR)
Driver	1	85,000
Worker	2	34,000
Calculation of labor costs (LKR/mon.)	(Labor costs) = [(85,000 x 1) + (34,000 x 2)] x (Number of collection vehicles)	

**Table 3-38 Details of total number of waste collection vehicles and estimated labor costs**

Year	Total number of collection vehicles (unit/day)				Estimated labor costs (million LKR/year)			
	Baseline	Alternative A	Alternative B	Alternative C	Baseline	Alternative A	Alternative B	Alternative C
2023	1,183	436	472	454	2,172	800	867	834
2024	1,226	454	472	483	2,251	834	867	887
2025	1,366	500	499	514	2,508	918	916	944
2026	1,416	528	522	545	2,600	969	958	1,001
2027	1,479	554	558	574	2,715	1,017	1,024	1,054
2028	1,486	560	591	602	2,728	1,028	1,085	1,105
2029	1,544	587	619	634	2,835	1,078	1,136	1,164
2030	1,588	612	647	665	2,916	1,124	1,188	1,221
2031	1,635	638	678	695	3,002	1,171	1,245	1,276
2032	1,680	666	698	722	3,084	1,223	1,282	1,326
2033	1,728	685	717	740	3,173	1,258	1,316	1,359
2034	1,777	706	748	770	3,263	1,296	1,373	1,414
2035	1,823	731	773	795	3,347	1,342	1,419	1,460
2036	1,868	752	800	821	3,430	1,381	1,469	1,507
2037	1,915	780	824	849	3,516	1,432	1,513	1,559
2038	1,969	800	848	871	3,615	1,469	1,557	1,599
2039	2,014	826	879	897	3,698	1,517	1,614	1,647
2040	2,063	850	908	922	3,788	1,561	1,667	1,693
2041	2,123	880	933	951	3,898	1,616	1,713	1,746
2042	2,170	901	962	977	3,984	1,654	1,766	1,794
<b>Total cost for 2023-2042 (million LKR)</b>					<b>62,521</b>	<b>24,687</b>	<b>25,976</b>	<b>26,587</b>

ii. **Transfer**

■ Procurement costs of transfer vehicles (million LKR)

**Table 3-39 Procurement costs of waste transfer vehicles (Baseline)**

	Primary TSs to TRF	TRF to Kelaniya TS	Primary TSs to Kelaniya TS	Total
<b>Vehicles</b>				
Type of collection vehicle	Roll-on/roll-off truck	Dump truck	Roll-on/roll-off truck	
Required number	0	4	12	
Unit cost	25	25	25	-
Cost	0	100	300	400
<b>Containers</b>				
Required number	0	0	67	
Unit cost	0.7	0	0.7	
Cost	0	0	47	47
<b>Total cost</b>	<b>0</b>	<b>100</b>	<b>347</b>	<b>447</b>

**Table 3-40 Procurement costs of transfer vehicles (Alternative A)**

	Primary TSs to TRF	TRF to Kelaniya TS	Primary TSs to Kelaniya TS	Total
<b>Vehicle</b>				
Type of collection vehicle	Roll on roll off truck	Dump truck	Roll on roll off truck	-
Required number	0	4	66	-
Unit cost	25	25	25	-
Cost	0	100	1,650	1,750
<b>Container</b>				
Required number	0	0	258	-
Unit cost	1	0	1	-
Cost	0	0	181	181
<b>Total cost</b>	<b>0</b>	<b>100</b>	<b>1,831</b>	<b>1,931</b>

**Table 3-41 Procurement costs of transfer vehicles (Alternative B)**

	Primary TSs to TRF	TRF to Kelaniya TS	Primary TSs to Kelaniya TS	Total
Vehicle				
Type of collection vehicle	Roll on roll off truck	Dump truck	Roll on roll off truck	-
Required number	55	15	5	-
Unit cost	25	25	25	-
Cost	1,375	375	125	1,875
Container				
Required number	237	0	13	-
Unit cost	1	0	1	-
Cost	166	0	9	175
<b>Total cost</b>	<b>1,541</b>	<b>375</b>	<b>134</b>	<b>2,050</b>

**Table 3-42 Procurement costs of transfer vehicles (Alternative C)**

	Primary TSs to TRF	TRF to Kelaniya TS	Primary TSs to Kelaniya TS	Total
Vehicle				
Type of collection vehicle	Roll on roll off truck	Dump truck	Roll on roll off truck	-
Required number	68	18	5	-
Unit cost	25	25	25	-
Cost	1,700	450	125	2,275
Container				
Required number	291	0	11	-
Unit cost	1	0	1	-
Cost	204	0	8	212
<b>Total cost</b>	<b>1,904</b>	<b>450</b>	<b>133</b>	<b>2,487</b>

■ Fuel & maintenance costs

Table 3-43 Considered factors and calculation of fuel and maintenance costs for waste transfer

Item	Primary TSs to TRF	TRF to Kelaniya TS	Primary TSs to Kelaniya TS	Kelaniya TS to Aruwakkalu DS
Factors considered for cost calculation				
(1) Type of waste	Other waste (Burnable waste)	Incinerated residue (Ash)	Other waste (untreated waste, residues from intermediate treatment facilities)	- Other waste - Ash
(2) Apparent specific gravity (ton/m <sup>3</sup> )	0.2	1.0	0.2	- Other waste: 0.2 - Ash: 1.0
(3) Type of collection vehicle	Roll-on/roll-off truck (Container: 10 m <sup>3</sup> , compaction ratio for loading:1.8)	Dump truck	Roll-on/roll-off truck (Container: 10 m <sup>3</sup> , compaction ratio for loading:1.8)	Railway transfer system (Container: 27.3 m <sup>3</sup> )
(4) Loading capacity (ton)	3.6	10.0	3.6	- Other waste: 2 - Ash: 10
(5) Number of trips per day	5	4	- Colombo TS: 8 - Kalutara West TS: 4 - Kalutara East TS: 3 - Gampaha West TS: 8 - Gampaha East TS: 8 - Colombo TS: 20	Number of containers that can be transported per trip: 30 container/trip
(6) Average transport distance (km)	25	- WPK: 10 - TRF in Colombo: 20 - TRF in Gampaha: 20	- Kalutara West TS: 40 - Kalutara East TS: 45 - Gampaha West TS: 25 - Gampaha East TS: 25	-
(7) Fuel consumption (km/liter)	3.0	3.0	3.0	-
(8) Unit price of fuel (LKR/liter) *2021	220	220	220	Transportation costs per trip: 500,000 LKR/trip
(9) Maintenance costs per vehicle	10% of fuel costs	10% of fuel costs	10% of fuel costs	10% of transportation costs
Calculation for fuel and maintenance costs	- (Total number of trips per day) = (Waste amount per day) / (4) - (Total mileage (km/day)) = [(6) x 2] x (Total number of trips per day) - (Fuel costs (LKR/day)) = [(Total mileage) / (7)] x (8) - (Total fuel and maintenance costs (LKR/day)) = (Fuel costs) + (9)			- (Total number of containers required per day) = (Waste amount) / (2) / (3) - (Number of trips per day) = (Total number of containers required per day) / (5) - (Transportation cost per day) = (Number of trips per day) x (8) - (Total transportation cost) = (Transportation cost) + (9)



Table 3-44 Fuel and maintenance costs for waste transfer (Baseline)

Year	Primary TSs to TRF	TRF to Kelaniya TS	Primary TSs to Kelaniya TS	Kelaniya TS to Aruwakkalu DS	Total
2023	0	193,600	0	209,000	402,600
2024	0	206,506	0	214,500	421,006
2025	0	206,506	0	225,500	432,006
2026	0	274,266	0	231,000	505,266
2027	0	290,400	0	242,000	532,400
2028	0	193,600	279,914	7,700,000	8,173,514
2029	0	206,506	289,594	8,250,000	8,746,100
2030	0	193,600	283,140	8,250,000	8,726,740
2031	0	193,600	289,594	8,800,000	9,283,194
2032	0	193,600	286,366	9,350,000	9,829,966
2033	0	193,600	286,366	9,350,000	9,829,966
2034	0	193,600	283,140	9,900,000	10,376,740
2035	0	193,600	286,366	10,450,000	10,929,966
2036	0	193,600	289,594	10,450,000	10,933,194
2037	0	193,600	283,140	11,000,000	11,476,740
2038	0	193,600	290,400	11,550,000	12,034,000
2039	0	193,600	283,140	11,550,000	12,026,740
2040	0	193,600	276,686	12,100,000	12,570,286
2041	0	193,600	267,006	12,650,000	13,110,606
2042	0	193,600	263,780	12,650,000	13,107,380
Total cost for 2023-2042 (million LKR)	0	1,492	1,547	56,620	<b>59,659</b>

Table 3-45 Fuel and maintenance costs for waste transfer (Alternative A)

Year	Primary TSs to TRF	TRF to Kelaniya TS	Primary TSs to Kelaniya TS	Kelaniya TS to Aruwakkalu DS	Total
2023	0	193,600	0	5,500,000	5,693,600
2024	0	206,506	0	6,050,000	6,256,506
2025	0	274,266	423,500	6,600,000	7,297,766
2026	0	290,400	469,480	7,150,000	7,909,880
2027	0	306,534	495,294	8,250,000	9,051,828
2028	0	193,600	557,406	9,350,000	10,101,006
2029	0	206,506	593,706	9,350,000	10,150,212
2030	0	193,600	642,914	10,450,000	11,286,514
2031	0	193,600	692,120	11,000,000	11,885,720
2032	0	193,600	712,286	11,550,000	12,455,886
2033	0	193,600	721,966	12,100,000	13,015,566
2034	0	193,600	780,854	12,650,000	13,624,454
2035	0	193,600	790,534	13,200,000	14,184,134
2036	0	193,600	853,454	13,750,000	14,797,054
2037	0	193,600	879,266	14,300,000	15,372,866
2038	0	193,600	901,854	14,850,000	15,945,454
2039	0	193,600	938,960	15,400,000	16,532,560
2040	0	193,600	972,034	15,950,000	17,115,634
2041	0	193,600	1,001,880	16,500,000	17,695,480
2042	0	193,600	1,034,146	17,050,000	18,277,746
Total cost for 2023-2042 (million LKR)	0	1,529	4,914	84,315	<b>90,758</b>

Table 3-46 Fuel and maintenance costs for waste transfer (Alternative B)

Year	Primary TSs to TRF	TRF to Kelaniya TS	Primary TSs to Kelaniya TS	Kelaniya TS to Aruwakkalu DS	Total
2023	0	200,054	0	6,050,000	6,250,054
2024	0	200,054	0	6,050,000	6,250,054
2025	0	193,600	354,934	6,600,000	7,148,534
2026	0	206,506	364,614	6,600,000	7,171,120
2027	0	200,054	393,654	7,700,000	8,293,708
2028	213,766	619,520	232,320	3,850,000	4,915,606
2029	221,834	780,854	238,774	3,850,000	5,091,462
2030	242,002	926,052	248,454	4,400,000	5,816,508
2031	246,036	948,640	258,134	4,400,000	5,852,810
2032	270,234	974,454	264,586	4,400,000	5,909,274
2033	278,298	997,040	271,040	4,950,000	6,496,378
2034	717,936	1,026,080	22,586	3,300,000	5,066,602
2035	754,236	1,335,840	22,586	3,300,000	5,412,662
2036	778,436	1,335,840	22,586	3,300,000	5,436,862
2037	790,538	1,381,014	25,814	3,300,000	5,497,366
2038	822,804	1,329,388	35,494	3,850,000	6,037,686
2039	871,202	1,361,654	38,720	3,850,000	6,121,576
2040	899,432	1,384,240	38,720	3,850,000	6,172,392
2041	931,702	1,435,866	45,980	3,850,000	6,263,548
2042	955,898	1,458,452	52,434	4,400,000	6,866,784
Total cost for 2023-2042 (million LKR)	3,283	6,678	1,070	33,525	<b>44,556</b>

Table 3-47 Fuel and maintenance costs for waste transfer (Alternative C)

Year	Primary TSs to TRF	TRF to Kelaniya TS	Primary TSs to Kelaniya TS	Kelaniya TS to Aruwakkalu DS	Total
2023	0	200,054	0	6,050,000	6,250,054
2024	0	200,054	0	6,600,000	6,800,054
2025	0	193,600	443,666	7,150,000	7,787,266
2026	0	206,506	486,420	7,700,000	8,392,926
2027	0	200,054	525,140	8,250,000	8,975,194
2028	254,100	677,600	293,626	3,850,000	5,075,326
2029	274,266	977,680	309,760	4,400,000	5,961,706
2030	302,498	1,135,788	329,120	4,400,000	6,167,406
2031	334,768	1,180,960	354,934	4,400,000	6,270,662
2032	334,768	1,213,226	361,386	4,950,000	6,859,380
2033	338,800	1,329,386	371,066	4,950,000	6,989,252
2034	895,398	1,426,186	22,586	2,750,000	5,094,170
2035	923,632	1,658,508	22,586	2,750,000	5,354,726
2036	976,066	1,684,320	22,586	2,750,000	5,432,972
2037	1,004,302	2,003,760	25,814	2,750,000	5,783,876
2038	1,032,536	1,694,000	35,494	2,750,000	5,512,030
2039	1,068,832	1,677,866	38,720	3,300,000	6,085,418
2040	1,101,098	1,819,840	38,720	3,300,000	6,259,658
2041	1,129,332	1,974,720	45,980	3,300,000	6,450,032
2042	1,173,702	2,039,252	45,980	3,300,000	6,558,934
Total cost for 2023-2042 (million LKR)	4,068	8,575	1,377	32,722	<b>46,742</b>

■ Labor costs for waste transportation

Table 3-48 Considered factors and calculation of labor costs for waste transfer

Composition of the collection team and salary of the members		
	Number (person)	Monthly salary (LKR)
- Driver	1	85,000
- Worker	1	34,000
Calculation of labor costs (LKR/mon.)	- (Labor costs) = [(85,000 x 1) + (34,000 x 1)] x (Number of collection vehicles)	

Table 3-49 Total number of transfer vehicles and labor costs for waste transfer

Year	Total number of collection vehicles (unit/day)				Labor costs (million LKR/year)			
	Baseline	Alternative A	Alternative B	Alternative C	Baseline	Alternative A	Alternative B	Alternative C
2023	4	4	5	5	6	0	7	7
2024	4	4	5	5	6	0	7	7
2025	4	34	29	35	6	41	41	50
2026	5	36	30	37	7	44	43	53
2027	5	38	32	40	7	47	46	57
2028	17	41	49	55	24	53	70	79
2029	17	43	50	58	24	56	71	83
2030	17	46	52	61	24	60	74	87
2031	17	49	53	65	24	64	76	93
2032	17	51	54	66	24	67	77	94
2033	17	52	55	68	24	69	79	97
2034	17	54	64	73	24	71	91	104
2035	17	54	69	77	24	71	99	110
2036	17	59	70	79	24	79	100	113
2037	17	61	70	81	24	81	100	116
2038	18	62	71	82	26	83	101	117
2039	17	64	73	83	24	86	104	119
2040	16	66	74	85	23	89	106	121
2041	16	69	75	90	23	93	107	129
2042	16	70	75	91	23	94	107	130
Total cost for 2023-2042 (million LKR)					<b>393</b>	<b>1,248</b>	<b>1,507</b>	<b>1,765</b>

- Operation and Maintenance Costs (O&M costs) and Construction cost of transfer stations
  - O&M costs
    - O&M unit cost of transfer station: 2,000 LKR/ton
    - O&M costs of transfer stations (LKR/year) = [(Amount of waste transferred /day) x 2,000 LKR/ton] x 365 days
  - Construction cost/Capital cost
    - Unit construction cost of primary transfer station: 10.0 million LKR/ton
    - Initial cost of Primary TSs (million LKR) = (Expected amount of waste transferred per day in 2030) x 10,000 LKR/ton = 4,790 million LKR
    - Secondary construction cost of transfer stations (million LKR) = (Additional amount of waste transferred waste per day during the period 2031-2042) x 10,000 LKR/ton = 3,640 million LKR

Table 3-50 Amount of transferred Waste, O&M and Construction Costs of transfer station (Baseline)

Year	Amount of waste transferred (ton/day)			Costs (million/year)		
	Primary TSs	Kelaniya TS	Total	O&M costs	Construction cost	Total cost
2023	0	1,075	1,075	785	0	785
2024	0	1,165	1,165	850	4,820	5,670
2025	425	1,229	1,654	1,207	0	1,207
2026	437	1,302	1,739	1,269	0	1,269
2027	464	1,395	1,859	1,357	0	1,357
2028	456	1,476	1,932	1,410	0	1,410
2029	471	1,525	1,996	1,457	0	1,457
2030	482	1,612	2,094	1,529	2,260	3,789
2031	499	1,687	2,186	1,596	0	1,596
2032	517	1,752	2,269	1,656	0	1,656
2033	537	1,817	2,354	1,718	0	1,718
2034	551	1,881	2,432	1,775	0	1,775
2035	568	1,945	2,513	1,834	0	1,834
2036	588	2,006	2,594	1,894	0	1,894
2037	608	2,068	2,676	1,953	0	1,953
2038	631	2,139	2,770	2,022	0	2,022
2039	647	2,197	2,844	2,076	0	2,076
2040	665	2,259	2,924	2,135	0	2,135
2041	693	2,329	3,022	2,206	0	2,206
2042	708	2,383	3,091	2,256	0	2,256
Total cost for 2023-2042 (million LKR)				<b>32,985</b>	<b>7,080</b>	<b>40,065</b>

Table 3-51 Amount of transferred Waste, O&M and Construction Costs of transfer station (Alternative A)

Year	Amount of waste transferred (ton/day)			Costs (million/year)		
	Primary TSs	Kelaniya TS	Total	O&M costs	Construction cost	Total cost
2023	0	1,145	1,145	836	0	836
2024	0	1,224	1,224	894	6,380	7,274
2025	464	1,342	1,806	1,318	0	1,318
2026	503	1,467	1,970	1,438	0	1,438
2027	538	1,591	2,129	1,554	0	1,554
2028	561	1,732	2,293	1,674	0	1,674
2029	591	1,821	2,412	1,760	0	1,760
2030	638	1,972	2,610	1,905	3,890	5,795
2031	686	2,104	2,790	2,037	0	2,037
2032	704	2,175	2,879	2,102	0	2,102
2033	720	2,262	2,982	2,177	0	2,177
2034	772	2,391	3,163	2,309	0	2,309
2035	785	2,459	3,244	2,368	0	2,368
2036	840	2,585	3,425	2,500	0	2,500
2037	877	2,686	3,563	2,601	0	2,601
2038	897	2,778	3,675	2,683	0	2,683
2039	925	2,860	3,785	2,763	0	2,763
2040	959	2,948	3,907	2,852	0	2,852
2041	987	3,045	4,032	2,943	0	2,943
2042	1,027	3,157	4,184	3,054	0	3,054
Total cost for 2023-2042 (million LKR)				<b>41,768</b>	<b>10,270</b>	<b>52,038</b>

Table 3-52 Amount of transferred Waste, O&M and Construction Costs of transfer station (Alternative B)

Year	Amount of waste transferred (ton/day)			Costs (million/year)		
	Primary TSs	Kelaniya TS	Total	O&M costs	Construction cost	Total cost
2023	0	1,065	1,065	777	0	777
2024	0	1,144	1,144	835	4,790	5,625
2025	396	1,133	1,529	1,116	0	1,116
2026	409	1,241	1,650	1,204	0	1,204
2027	436	1,314	1,750	1,277	0	1,277
2028	445	1,434	1,879	1,372	0	1,372
2029	458	915	1,373	1,002	0	1,002
2030	479	954	1,433	1,046	3,640	4,686
2031	499	997	1,496	1,092	0	1,092
2032	521	1,048	1,569	1,145	0	1,145
2033	541	1,082	1,623	1,184	0	1,184
2034	612	1,127	1,739	1,269	0	1,269
2035	636	889	1,525	1,113	0	1,113
2036	662	921	1,583	1,156	0	1,156
2037	692	957	1,649	1,204	0	1,204
2038	717	999	1,716	1,253	0	1,253
2039	745	1,037	1,782	1,301	0	1,301
2040	775	1,070	1,845	1,347	0	1,347
2041	806	1,103	1,909	1,394	0	1,394
2042	843	1,147	1,990	1,453	0	1,453
Total cost for 2023-2042 (million LKR)				<b>23,540</b>	<b>8,430</b>	<b>31,970</b>



Table 3-53 Amount of transferred Waste, O&M and Construction Costs of transfer station (Alternative C)

Year	Amount of waste transferred (ton/day)			Costs (million/year)		
	Primary TSs	Kelaniya TS	Total	O&M costs	Construction cost	Total cost
2023	0	1,176	1,176	858	6,380	858
2024	0	1,265	1,265	923	0	923
2025	474	1,392	1,866	1,362	0	1,362
2026	517	1,530	2,047	1,494	0	1,494
2027	551	1,664	2,215	1,617	0	1,617
2028	561	948	1,509	1,102	0	1,102
2029	591	994	1,585	1,157	0	1,157
2030	638	1,044	1,682	1,228	3,890	1,228
2031	686	1,104	1,790	1,307	0	1,307
2032	704	1,141	1,845	1,347	0	1,347
2033	721	1,191	1,912	1,396	0	1,396
2034	772	834	1,606	1,172	0	1,172
2035	785	870	1,655	1,208	0	1,208
2036	840	898	1,738	1,269	0	1,269
2037	878	928	1,806	1,318	0	1,318
2038	897	980	1,877	1,370	0	1,370
2039	926	1,014	1,940	1,416	0	1,416
2040	963	1,047	2,010	1,467	0	1,467
2041	988	1,088	2,076	1,515	0	1,515
2042	1,027	1,122	2,149	1,569	0	1,569
Total cost for 2023-2042 (million LKR)				<b>26,095</b>	<b>10,270</b>	<b>36,365</b>

iii. **Thermal recovery facilities (TRFs)**

■ O&M and Construction costs of TRFs

➤ O&M costs

- O&M unit cost of TRFs: 7,000 LKR/ton

- O&M costs of TRFs (LKR/year) = [(Waste treated in TRFs/day) x 7,000 LKR/ton] x 365 days

Table 3-54 Waste treated and O&M and construction costs of thermal recovery facility

Year	Waste treated in TRFs (ton/day)				Costs (million LKR/year)			
	Baseline	Alternative A	Alternative B	Alternative C	Baseline	Alternative A	Alternative B	Alternative C
2023	750	750	750	750	1,916	1,916	1,916	1,916
2024	750	750	750	750	1,916	1,916	1,916	1,916
2025	750	750	750	750	1,916	1,916	1,916	1,916
2026	750	750	750	750	1,916	1,916	1,916	1,916
2027	750	750	750	750	1,916	1,916	1,916	1,916
2028	750	750	1,541	1,702	1,916	1,916	1,916	4,349
2029	750	750	1,607	1,795	1,916	1,916	1,916	4,586
2030	750	750	1,687	1,906	1,916	1,916	3,937	4,870
2031	750	750	1,746	1,998	1,916	1,916	4,106	5,105
2032	750	750	1,804	2,040	1,916	1,916	4,310	5,212
2033	750	750	1,864	2,091	1,916	1,916	4,461	5,343
2034	750	750	2,321	2,694	1,916	1,916	4,609	6,883
2035	750	750	2,387	2,737	1,916	1,916	4,763	6,993
2036	750	750	2,453	2,863	1,916	1,916	5,930	7,315
2037	750	750	2,536	2,949	1,916	1,916	6,099	7,535
2038	750	750	2,601	3,003	1,916	1,916	6,267	7,673
2039	750	750	2,664	3,060	1,916	1,916	6,479	7,818
2040	750	750	2,727	3,137	1,916	1,916	6,646	8,015
2041	750	750	2,809	3,203	1,916	1,916	6,807	8,184
2042	750	750	2,874	3,300	1,916	1,916	6,967	8,432
Total cost for 2023-2042 (million LKR)					<b>38,320</b>	<b>38,320</b>	<b>95,481</b>	<b>107,893</b>

- Construction cost
- Construction unit cost of TRF: 25.0 million LKR/ton
- Construction period: 3 years
- Construction cost of TRF (million LKR/year) = [(Waste treated in TRFs/day) x 25 million LKR /ton] / 3 years

**Table 3-55 Capacity and construction cost of thermal recovery facility (Alternative B)**

Year	Construction year and capacity of TRF (ton/day)				Construction cost (million LKR)			
	WPK	TRF in Colombo	TRF in Gampaha	Total	WPK	TRF in Colombo	TRF in Gampaha	Total
2023								
2024								
2025					6,250	3,333		9,583
2026	750,	400		1,150	6,250	3,333		9,583
2027					6,250	3,333		9,583
2028								
2029								
2030								
2031						3,333	5,000	8,333
2032		400	600	1,000		3,333	5,000	8,333
2033						3,333	5,000	8,333
2034								
2035								
2036								
2037								
2038								
2039								
2040								
2041								
2042								
Total cost for 2023-2042 (million LKR)					18,750	19,998	15,000	<b>53,748</b>

**Table 3-56 Capacity and construction cost of thermal recovery facility (Alternative C)**

Year	Construction year and capacity of TRF (ton/day)				Construction cost (million LKR)			
	WPK	TRF in Colombo	TRF in Gampaha	Total	WPK	TRF in Colombo	TRF in Gampaha	Total
2023								
2024								
2025					7,083	4,167	0	11,250
2026	850	500		1,350	7,083	4,167	0	11,250
2027					7,083	4,167	0	11,250
2028								
2029								
2030								
2031						4,167	5,833	10,000
2032		500	700	1,200		4,167	5,833	10,000
2033						4,167	5,833	10,000
2034								
2035								
2036								
2037								
2038								
2039								
2040								
2041								
2042								
Total cost for 2023-2042 (million LKR)-					21,249	25,002	17,499	<b>63,750</b>

**iv. Composting facilities**

- O&M and Construction costs of composting facilities
  - O&M costs
    - O&M unit cost of composting facilities: 3,000 LKR/ton
    - O&M costs of composting facilities (LKR/year) = [(Waste treated in composting facilities/day) x 3,000 LKR/ton] x 365 days

**Table 3-57 Waste treated and O&M cost of composting facilities**

Year	Waste treated in composting facilities (ton/day)				Costs (million LKR/year)			
	Baseline	Alternative A	Alternative B	Alternative C	Baseline	Alternative A	Alternative B	Alternative C
2023	324	400	400	400	355	437	437	437
2024	324	450	610	450	355	493	653	493
2025	324	450	610	450	355	493	668	493
2026	324	450	690	450	355	493	741	493
2027	324	450	690	450	355	493	756	493
2028	324	450	770	450	355	493	767	493
2029	324	450	770	450	355	493	815	493
2030	324	448	850	448	355	491	861	491
2031	324	450	850	450	355	493	921	493
2032	324	500	900	500	355	548	958	548
2033	324	550	950	550	355	602	1,014	602
2034	324	548	950	548	355	600	1,008	600
2035	324	600	1,000	600	355	657	1,051	657
2036	324	600	1,000	600	355	657	1,095	657
2037	324	651	1,060	651	355	713	1,161	713
2038	324	719	1,120	719	355	787	1,226	787
2039	324	780	1,180	780	355	854	1,287	854
2040	324	827	1,230	827	355	906	1,347	906
2041	324	900	1,300	900	355	986	1,416	986
2042	324	930	1,330	930	355	1,018	1,456	1,018
Total cost for 2023-2042 (million LKR)					<b>7,100</b>	<b>12,707</b>	<b>19,638</b>	<b>12,707</b>

- Construction cost
  - Construction unit cost of LAs & cluster-based composting facilities: 0.5 million LKR/ton
  - Construction unit cost of composting facilities in waste parks: 1.0 million LKR/ton
  - Construction cost of LAs & cluster-based composting facilities (million LKR/year) = [(Increased amount of biodegradable waste/day during the period 2023-2042) / day] x 0.5 (million LKR/ton)
  - Construction cost of composting facilities in waste parks (million LKR/year) = [(Waste treated in composting facilities/day) x 1.0 (million LKR/ton)]

Table 3-58 capacity and construction costs of composting facilities

Year	Capacity of composting facilities (ton/day)					Costs (million LKR/year)				
	Baseline	Alternative A	Alternative B		Alternative C	Baseline	Alternative A	Alternative B		Alternative C
			Waste parks	LAs & cluster-based composting facilities				Waste parks	LAs & cluster-based composting facilities	
2023	324	400		400	400					
2024	324	450	160	450	450			160		
2025	324	450		450	450					
2026	324	450	80	450	450			80		
2027	324	450		450	450					
2028	324	450	80	450	450			80		
2029	324	450		450	450					
2030	324	450	80	450	450			80		
2031	324	450		450	450					
2032	324	500		500	500	0	265		265	265
2033	324	550		550	550					
2034	324	550		550	550					
2035	324	600		600	600					
2036	324	600		600	600					
2037	324	660		660	660					
2038	324	720		720	720					
2039	324	780		780	780					
2040	324	830		830	830					
2041	324	900		900	900					
2042	324	930		930	930					
Total cost for 2023-2042 (million LKR)						0	303	400	303	303

**v. Material recovery facilities (MRFs)**

■ O&M and Construction costs of MRFs

➤ O&M costs

- O&M unit cost of MRFs: 2,000 LKR/ton

- O&M costs of MRFs (LKR/year) = [(Waste treated in MRFs/day) x 2,000 LKR/ton] x 365 days

**Table 3-59 Treated waste amount and O&M cost of material recovery facilities**

Year	Waste amount treated in MRFs (ton/day)				Costs (million LKR/year)			
	Baseline	Alternative A	Alternative B	Alternative C	Baseline	Alternative A	Alternative B	Alternative C
2023	123	132	132	132	90	96	96	96
2024	135	151	151	151	99	110	110	110
2025	149	169	169	169	109	123	123	123
2026	161	186	186	186	118	136	136	136
2027	174	202	202	202	127	147	147	147
2028	187	219	219	219	137	160	160	160
2029	198	241	241	241	145	176	176	176
2030	213	255	255	255	155	186	186	186
2031	225	273	273	273	164	199	199	199
2032	235	285	285	285	172	208	208	208
2033	246	294	294	294	180	215	215	215
2034	256	308	308	308	187	225	225	225
2035	264	327	327	327	193	239	239	239
2036	279	341	341	341	204	249	249	249
2037	288	354	354	354	210	258	258	258
2038	295	363	363	363	215	265	265	265
2039	304	380	380	380	222	277	277	277
2040	318	396	396	396	232	289	289	289
2041	331	409	409	409	242	299	299	299
2042	344	421	421	421	251	307	307	307
Total cost for 2023-2042 (million LKR)					3,452	4,164	4,164	4,164

- Construction cost
  - Construction unit cost of MRFs in waste parks: 400 million LKR / facility with capacity 30 tons
  - [Alternative B] MRFs in waste parks: 400 million LKR x 5 facilities = 2,000 million LKR

**vi. Disposal**

- O&M costs of disposal sites (DS)
  - O&M costs
    - O&M unit cost of DS: 4,000 LKR/m<sup>3</sup>
    - O&M costs of DS (LKR/year) = [(Amount of waste disposed/day) x 4,000 LKR/ton] x 365 days

Table 3-60 Waste disposal volume and O&M costs

Year	Volume disposed(m <sup>3</sup> /year)				Costs (million LKR/year)			
	Baseline	Alternative A	Alternative B	Alternative C	Baseline	Alternative A	Alternative B	Alternative C
2023	470,850	501,510	501,072	515,088	1,883	2,006	2,004	2,060
2024	510,270	536,112	496,254	554,070	2,041	2,144	1,985	2,216
2025	538,084	587,578	543,340	609,696	2,152	2,350	2,173	2,439
2026	570,058	642,328	575,314	670,140	2,280	2,569	2,301	2,681
2027	611,010	696,858	628,092	728,832	2,444	2,787	2,512	2,915
2028	646,488	758,616	400,770	415,224	2,586	3,034	1,603	1,661
2029	667,732	797,380	417,634	435,372	2,671	3,190	1,671	1,741
2030	706,056	863,736	436,686	457,272	2,824	3,455	1,747	1,829
2031	738,906	921,552	458,806	483,552	2,956	3,686	1,835	1,934
2032	767,376	952,650	473,698	499,758	3,070	3,811	1,895	1,999
2033	795,846	990,756	493,626	521,658	3,183	3,963	1,975	2,087
2034	823,878	1,047,258	389,382	365,292	3,296	4,189	1,558	1,461
2035	851,910	1,077,042	403,398	381,060	3,408	4,308	1,614	1,524
2036	878,628	1,132,230	419,166	393,324	3,515	4,529	1,677	1,573
2037	905,784	1,176,468	437,562	406,464	3,623	4,706	1,750	1,626
2038	936,882	1,216,764	454,206	429,240	3,748	4,867	1,817	1,717
2039	962,286	1,252,680	468,660	444,132	3,849	5,011	1,875	1,777
2040	989,442	1,291,224	483,114	458,586	3,958	5,165	1,932	1,834
2041	1,020,102	1,333,710	502,386	476,544	4,080	5,335	2,010	1,906
2042	1,043,754	1,382,766	528,228	491,436	4,175	5,531	2,113	1,966
Total cost for 2023-2042 (million LKR)					<b>61,741</b>	<b>78,503</b>	<b>38,047</b>	<b>38,947</b>

➤ Construction cost

- Construction unit cost of DS: 8,000 LKR/m<sup>3</sup>
- Total Construction cost of DS = 8,000 LKR/m<sup>3</sup> x (Waste to be disposed that exceeds the total landfill capacity of 5.6 million m<sup>3</sup>)



Table 3-61 Cumulative volume of waste to be disposed and construction cost of disposal site

Year	Cumulative volume of waste to be disposed(m <sup>3</sup> )				Cumulative excess volume (m <sup>3</sup> )			
	Baseline	Alternative A	Alternative B	Alternative C	Baseline	Alternative A	Alternative B	Alternative C
2023	470,850	967,980	501,072	515,088	0	0	0	0
2024	981,120	1,504,092	997,326	1,069,158	0	0	0	0
2025	1,519,204	2,091,670	1,540,666	1,678,854	0	0	0	0
2026	2,089,262	2,733,998	2,115,980	2,348,994	0	0	0	0
2027	2,700,272	3,430,856	2,744,072	3,077,826	0	0	0	0
2028	3,346,760	4,189,472	3,144,842	3,493,050	0	0	0	0
2029	4,014,492	4,986,852	3,562,476	3,928,422	0	0	0	0
2030	4,720,548	5,850,588	3,999,162	4,385,694	0	250,588	0	0
2031	5,459,454	6,772,140	4,457,968	4,869,246	0	1,172,140	0	0
2032	6,226,830	7,724,790	4,931,666	5,369,004	626,830	2,124,790	0	0
2033	7,022,676	8,715,546	5,425,292	5,890,662	1,422,676	3,115,546	0	290,662
2034	7,846,554	9,762,804	5,814,674	6,255,954	2,246,554	4,162,804	214,674	655,954
2035	8,698,464	10,839,846	6,218,072	6,637,014	3,098,464	5,239,846	618,072	1,037,014
2036	9,577,092	11,972,076	6,637,238	7,030,338	3,977,092	6,372,076	1,037,238	1,430,338
2037	10,482,876	13,148,544	7,074,800	7,436,802	4,882,876	7,548,544	1,474,800	1,836,802
2038	11,419,758	14,365,308	7,529,006	7,866,042	5,819,758	8,765,308	1,929,006	2,266,042
2039	12,382,044	15,617,988	7,997,666	8,310,174	6,782,044	10,017,988	2,397,666	2,710,174
2040	13,371,486	16,909,212	8,480,780	8,768,760	7,771,486	11,309,212	2,880,780	3,168,760
2041	14,391,588	18,242,922	8,983,166	9,245,304	8,791,588	12,642,922	3,383,166	3,645,304
2042	15,435,342	19,625,688	9,511,394	9,736,740	9,835,342	14,025,688	3,911,394	4,136,740
Total cost for 2023-2042 (million LKR)					<b>78,683</b>	<b>112,206</b>	<b>31,291</b>	<b>33,094</b>

### 3.4.3 Environmental and social considerations

The MP includes existing infrastructure/facility construction and development plans such as Port City to design the optimal system for managing MSW in the Western Province. Several alternative scenarios or options concerning facilities and equipment to be included in the MP have been evaluated during the formulation of the MP in accordance with strategic environmental assessment (SEA). The official SEA procedure of is not yet fully implemented in Sri Lanka, awaiting cabinet approval. The SEA for the MP was conducted on a pilot basis by CEA the competent authority.

In particular, the essential environmental and social impact items and evaluation methods (scoping) have been studied at the decision-making stage of the plans and programs. A comparative review of environmental and social considerations for several alternatives has been carried out in the SEA study. A plan for monitoring the environmental and social impacts during the implementation of the MP has also been formulated as a result of SEA by CEA. The results of the study are summarized in the SEA report.

### **3.5 Selection of the optimal SWM alternative plan**

As a result of the evaluation the baseline scenario and the three alternatives for the SWM system, alternatives B and C, which assume the recovery of energy associated with incineration and reduce the volume of waste to be disposed of in final disposal sites by actively promoting incineration, are preferred to the other options. Incineration is particularly suitable as treatment method in the Western Province as land for disposal sites must be sought out of the province and it is therefore essential to minimize the volume of waste to be disposed.

Alternatives A, B and C all actively promote the recycling of biodegradable waste through composting, but the system in alternative B allows all the collected biodegradable waste to be composted, except for the 20% that is incinerated, while maximizing the recycling of recyclable materials.

Economically, alternative B was evaluated as the cheapest system compared to the other options.

The recognition that the most significant problem facing the Western Province with regard to waste management is the issue of waste disposal and the (inability?) to build a disposal site in the Western Province. The assessment is based on the policy or the social and environmental context in which the Western Province is situated.

As a result, it has been assessed that Alternative B is the best alternative for the Western Province, as it reduces the amount of waste disposed of as much as possible by introducing intermediate treatment, such as maximizing the use of biodegradable waste as compost, improving the recovery of recyclable waste by promoting sorting, and minimizing residues by using combustible waste as heat in a heat recovery facility. The Western Province has just evaluated Alternative B as the most suitable alternative for the Western Province. Also, financially, although the active introduction of intermediate treatment would increase construction and operation and maintenance costs, the reduced disposal volume would result in Alternative B having the lowest unit cost per tonne of waste compared to the other alternatives.

Based on the above, alternative B has been selected as the optimal SWM system for the Western Province.

## 4 SWM Master Plan

### 4.1 Principles of waste management in the Western Province

The Ministry of Environment has introduced a national policy for waste management on the island. In line with this national policy, each province introduced a sub-policy/strategy based on its specific needs and characteristics. The Western Province identified the needs of the waste management sector through a series of stakeholder consultations during which a vision and mission were formulated. The sub-policy and strategy have been developed in line with the adopted vision and mission and implemented in the strategic action plan for waste management in the Western Province drafted in 2019.

#### 4.1.1 Vision

The Vision of waste management in the Western Province is as follows:

“Make the Western Province a resource and material efficient province.”

#### 4.1.2 Mission

The Mission of waste management in the Western Province is as follows:

“To encourage reduction of waste generation and to inculcate the best waste management practices in the province to convert waste into valuable resources, so that it can be used in the production process, which will finally drive us towards building a circular economy while protecting public health and the environment.”

#### 4.1.3 National Policy Statements, Strategies, and Actions on Solid Waste Management

In the planning process, all the Local Authorities should consider the National Policy and develop appropriate strategies and actions to cater the needs of the population in each local area. There are some obligatory strategies, and actions for each of the National Policy Statements. It also embraces the sub-policy and strategies of the Waste Management Authority of the Western Province.

##### Policy statement (a)

Active involvement of all the households, institutions and other commercial entities shall be secured by the Local Authorities for proper collection of municipal waste effectively and efficiently with feedback mechanisms.

##### **Strategy**

Establishment of communication channels between Local Authorities and Stakeholders

##### **Actions**

- Approval of activities, including budgets and expenditure through SWM committee
- Establishment of Evidence Based Informative and Interactive Data sites (EBIIDs) (a feedback mechanism)
- Appointment of community leaders for improving participatory approach in SWM

##### Policy statement (b)

Waste collection timetables shall be developed by the Local Authorities with community involvement and any time difference or delay shall be informed in advance to the community using digital technology or any other user-friendly methodology to prevent scattering and haphazard disposal of waste.

### **Strategy**

Critical evaluation of the present collection system and increasing collection efficacy and efficiency

### **Actions**

- Determination of generation rate and obtain the collection efficacy.
- Approval of timetables from SWM committee for collections.
- Implementation of a feedback system, preferable EBIIDs
- Optimize fuel efficiency of collection vehicles.

### **Policy statement (c)**

Strategies shall be developed by the Local Authorities to promote prevention of generation and reduction at source followed by source separation and further segregation as appropriate to facilitate regaining the utility value of household refuse as much as possible.

### **Strategy**

Increase social awareness among all stakeholders: households, commercial & industrial and government agencies of 3R concept and application with emphasis of recycling organic waste materials and extended producer responsibility.

### **Actions**

- Conduct awareness programs on 3R concept and applications and any other waste minimization efforts.
- Conduct awareness programs on EPR to producers, wholesalers, and retailers (National Agencies through respective Ministries should provide information such as guidelines on agreements reached with stakeholders).
- Arrange and conduct training programs for recyclers.

### **Policy statement (d)**

A market mechanism shall be developed by the Ministry of Public Administration, Home Affair, Provincial Councils and Local Government and Ministry of Environment to promote use of compost produced from municipal waste with proper quality control systems and guidelines in collaboration with the Ministry of Agriculture and other stakeholders.

### **Strategy**

- Improve separation of waste streams to have safe biodegradable component for composting and improve the methods of composting to produce quality fertilizer.
- Promote co-composting of biodegradable SW and agricultural wastes.
- Improve the quality to increase the demand for composting.

### **Actions**

- M/PC&LG and M/Environment should take the initiative to formulate a market mechanism with the directives of the Department of Agriculture, Tea Board/Tea Research

Institute (TRI), Rubber Research Institute (RRI), Coconut Research Institute (CRI), Cashew Development Corporation and Palmarah .....

- Introduce systematically separation categories for biodegradable and non-biodegradable.
- Introduce advanced practices of moisture control with recycled lignified materials, high temperature and adding rock phosphate, biochar, neem products etc.
- Undertake if possible, co-composting with a larger portion of agricultural wastes, especially when covered roofs are not available.
- Introduce a marketing strategy for offseason sale of made fertilizer or increase keeping quality of it for long term storage.
- A financial mechanism should be introduced to lessen the burden of storage.

#### **Policy statement (e)**

Organizers of festivals and other special events shall be held responsible to manage refuse arising from such events in collaboration with the Local Authorities and appropriate agreements shall be signed with the Local Authorities before the event with provisions to bear additional financial requirements.

#### **Strategies**

It is imperative that both Local Authority and festival organizers agree on the type of materials to be used for the event and eventual management of the wastes efficiently.

#### **Actions**

- Local Authorities should undertake historical record of events and possible costs for managing the wastes.
- From the lessons learnt, best management practices and suppliers shall be made available to festival organiser such as biodegradable organic materials replacing plastic and the like.
- A gross waste management fee to be determined and it should be made available to the public.
- A template agreement should be made available to accelerate the process of approval.
- Local Authority should enter into a binding agreement to manage the wastes and this agreement shall contain a clause for additional costs incurred in managing the wastes.

#### **Policy statement (f)**

Land filling shall be limited to non-recyclable, non-compostable and inert material generated through waste treatment processes.

#### **Strategies**

- Infrastructure and waste processing systems should be developed to dispose only non-recyclable, non-compostable and inert material.
- Establishment of sanitary and engineered landfills should be undertaken to manage even waste arising from disasters.

#### **Actions**

- Allocation of designated cells for different types of wastes within the landfill, thus facilitating and permitting mining of wastes.

- Every effort should be made to recycle, sell or give free residual wastes arising from compost and fertilizer productions.

#### **Policy statement (g)**

Development and Maintenance of databases on (1) Amounts and composition of waste collected by Local Authorities and the residences covered (2) Periodical reduction of waste, and (3) Waste to be disposed in landfill sites shall be made mandatory to all the Local Authorities.

#### **Strategies**

- Establishment of databases on generation, collection, recycling, and disposal in each Local Authority, District and Province.
- Frequently reporting such data to determine trends and changes in composition and effective reduction while minimizing waste disposal to the WMA.

#### **Actions**

- A sound communication link to be established between the Local Authority and government agencies based on reporting.
- At the time of issuing EPL to the Local Authority each year, data and information on generation rate, composition of wastes, collection rate, collection efficacy, extent of collections, recycling amount and final disposal should be made available to the WMA, CEA, and the Public.
- If the Local Authority workforce is inadequate to undertake the tasks, assistance should be sort from the closest university or technical college.
- Introduce best management practices like creating an Evidence Based Informative and Interactive Data site (EBIIDs)

#### **Policy Statement (h)**

Local Authorities shall be made responsible to provide places convenient for storage and treatment facilities time to time, maintain their vehicle fleet and take all other measures and precautions to ensure that no refuse, night soil or similar matter is disposed of in such a way to cause environmental pollution and nuisance.

#### **Strategy**

- Evaluate the present status of effluent treatment facilities and effluent storage requirements.
- Improve or introduce new effluent treatment facilities.

#### **Actions**

- Obtain approval for vehicle washing system from WMA and CEA.
- Disclosure of daily vehicle cleaning logs. In the absence such logs to commence good management practice.
- Introduction or improvement of effluent treatment plant for vehicle cleaning system.

#### **Policy Statement (i)**

Provincial Councils shall identify and provide suitable locations to assist Local Authorities for disposal of waste by clustering of Local Authorities and ensure disposal of waste in an

environmental sound manner.

### **Strategies**

- Formulation of this MP for the Province which include the reporting on the present status of waste disposal and identify issues arising in view of several options.
- Continue with the present system if compliance of policy is effective.
- Improve the present system for complying with all policy framework outlined.
- Introduce clustering for environmental compliance and economic appraisals.

### **Actions:**

- A survey of the existing resources and issues have been recorded in this MP.
- The MP has selected the best option for waste management based on technical and financial feasibilities of recycling giving due consideration to non-degradable plastics, composting, thermal recovery, and landfilling.

### **Policy Statement (j)**

Local Authorities and Provincial Councils shall be guided, assisted, and facilitated at National Level to ensure availability of infrastructure facilities for waste treatment and disposal in an environmentally sound manner.

### **Strategy**

Establish integrated solid waste management practices in Local Authorities with the coordination of the WMA.

### **Actions**

- Identify and evaluate infrastructure requirements for sorting & separation of wastes, recycling, and final disposal.

### **Policy Statement (k)**

Appropriate tools and strategies shall be identified to apply polluter pays principal and extended producer responsibility principle to maximize resource recovery and prevent scattering and haphazard disposal of waste.

### **Strategy**

- Determine polluter pay component by identification of capital and operational expenditures, income generations from waste recycling and allocation of local government taxes for waste management.
- Alternatively, determine the costs for collections and landfilling all the wastes, including environmental costs and allocation of local government taxes for waste management.
- Introduce a taxation scheme for environmental degradation for enforcing Extended Producer Responsibility.

### **Actions**

- Determine all expenditure, collection, recycling, new infrastructure.
- Determine all revenues from recycling and local government allocations.
- Conduct feasibility studies to determine polluter pay.

- Conduct economic appraisal for reducing landfilling.
- Awareness programs for producers of consumer goods on EPR or pay additional environmental tax based on complexities in the effective application of 3R.

#### **Policy Statement (l)**

Slaughterhouse waste shall not be mixed with general municipal waste and the generators shall be held responsible to proper management and disposal waste without causing health and environmental problems in consultation with the relevant Local Authorities.

#### **Strategy**

The fate of slaughterhouse waste to be determined and make recommendations for implementing best practices.

#### **Actions**

- Conduct a comprehensive study of slaughterhouses; cattle, pigs, chicken and make it available for public scrutiny and report the findings to the Solid Waste Management Committee of the Local Authority.
- Recommendations for improving the management of slaughterhouses and wastes, including wastewater arising from washing, recycling of nutrients like phosphorus to be undertaken etc.

#### **Policy Statement (m)**

Local Authorities shall develop mechanisms for safe disposal of household sanitary related wastes in collaboration with the Provincial Council Ministries of Health and the Ministry of Health.

#### **Strategy**

Establishment of incinerator facilities in the Local Authority or elsewhere for disposing healthcare wastes arising from households.

#### **Actions**

- Purchase or fabricate incinerator or transport waste for combusting healthcare wastes (clinical waste) at 1100-1200 °C
- Conduct awareness programs on disposal of sanitary waste, pharmaceutical waste, and other healthcare related household wastes in consultation with the Provincial Council and the Ministry of Health.
- Monitoring and reporting of compliance and feedback from waste generators.

#### **Policy Statement (n)**

Mechanisms shall be developed by Local Authorities to collect bulk waste on demand from households and safely disposed in an environmentally sound manner in accordance with the guidelines stipulated by CEA.

#### **Strategy**

Introduce bulk waste handling mechanisms for serviceable communities within the Local Authority with the consultation of WMA.



**Actions**

- Establishment of waste exchange platform with websites to assist communities, recyclers, and local authorities to communicate effectively for managing bulk wastes.
- Establishment of bulk waste handing centres when needed.

**Policy Statement (o)**

Waste tracking systems shall be developed to ensure that no waste is haphazardly disposed by households, institutions, commercial entities and also by the waste management institutions and service providers.

**Strategy**

Introduction of Volume-based Waste Fee (VWF) coupled to barcoding system.

**Actions**

- Identify potential locations for introducing VWF in the Local Authority.
- Select a plastic recycling company to supply and recycle bags with barcodes.
- All healthcare wastes including households must use barcoded VWF.

**Policy Statement (p)**

Local Authorities shall develop user-friendly communication models to receive feedback on the service provided by them from households, institutions, commercial entities, other waste managers and service providers, and action shall be taken to encourage best practices while addressing the challenges in collaboration with each other.

**Strategy**

Establishment of effective communication network among stakeholders: households, industrial and commercial, government agencies.

**Actions:** Development of software for establishing solid waste management database.

Alternatively, each Local Authority have a website which include solid waste information and feedback cloud for interactive communications or only for waste management.

Clustering of websites at District, Provincial and National levels.

Incorporate VWF and barcoding to the websites.

Installation of GPS tracking system traced and recoded on Local Authority website and other liked websites of collection and disposal vehicles.

**Policy Statement (q)**

Local Authorities shall develop time bound (short, medium, and long term) action plans with performance indicators in collaboration with the Provincial Councils in line with the national policy and submit the plans to the Provincial Councils and to the Ministry in charge of the subject of Provincial Councils and Local Government.

**Strategy**

Establishment of an administrative network for undertaking SWM planning study approach to reduce waste and maximize reuse and recycling of waste and obtain time bound approvals of developed plans at Local Authority, District and Provincial levels.

**Actions**

- Establishment of data acquisition and information gathering system in each Local Authority. An ongoing questionnaire is preferred to complete the tasks to update the comprehensive ISWM plans under the purview of WMA.
- Formulate ISWM plans in accordance with this MP.
- Incorporation of Performance Indicators in the comprehensive plans which will change with time while well-defined action plans approved by the WMA are implemented.

**Policy Statement (r)**

Provincial Councils shall develop master plans in collaboration with the local authorities based on the local level requirements in line with this policy and a robust system shall be established to ensure sustainable implementation of these master plans to achieve end results.

**Strategy**

Evaluate and synergize individual comprehensive ISWM and action plans of Local Authorities to develop Strategic Action Plans for the Provincial Council, considering mechanisms for initiating activities, monitoring the progress, and reporting the outcomes and shortcomings.

**Actions**

- In the absence of individual master plans, a top bottom approach is undertaken in formulating the WMA strategic MP.
- WMA shall evaluate individual master plans in view of clustering activities to enhance 3R applications.
- Undertake Cost Benefit Analysis (CBA) of the Local Authorities to establish polluter pays, targeting the requirements of the province on a rotational basis for investments.
- Synergize social and technical aspects of the plans considering local level requirements and needs to establish economically feasible options for the District and Province based on this MP.

**Policy Statement (s)**

Local Authorities shall report their performance annually to the ministry in charge of the subject of Provincial Councils and Local Government and the Ministry shall evaluate the performance and rank the Local Authorities based on the performance reflecting accountability at all levels and publicize to make all the citizens and other stakeholders aware on the status of municipal waste management in the country.

**Strategy**

Establish an institutional review process through performance indexes of waste collection efficacy, maximum waste reductions and maximum resource extraction and recycling to reduce subjectivity in evaluating Local Authorities by Provincial Councils and the Ministry to establish expert committee to evaluate both individual Local Authorities and Provincial Councils.

**Actions**

- Report and publicize the routine collection services accessible to the public and update the efficacy of collections.
- Bench mark the quantity, quality and composition of waste generations and collections.
- Make agreements between stakeholders, including the Ministry to increase efficacy of collections, including recyclables.
- Introduce best management practices like creating an Evidence Based Informative and Interactive Data site (EBIIDs). It should also have operational information like VWF and barcoding to get the fullest support from all stakeholders.
- Any shortcomings to be rectified within a defined timeframe agreed by all stakeholders.
- Appointment of Expert Committee to evaluate the performance of Local Authorities

**Policy statement (t)**

Recognition and rewarding systems shall be applied to promote best practices with attractive incentives.

**Strategy**

Introduction of a comprehensive grading system which involves professional development for continuous appreciation through merit rather than purely relying on yearly awards.

**Actions**

- Prepare guidelines for establishing Local Authority Merit schemes by the MoPAHAPCLG with the consultation of the Salaries and Cadre Commission.
- Local Authorities to report on successful implementation of Provincial Council Strategic Action Plans based on Comprehensive and Action Plans of the Local authorities.
- Appointment of Expert Committee to evaluate the performance of Local Authorities.

**Policy Statement (u)**

Local Authorities shall maintain a healthy labour force throughout by adhering to occupational health and safety practices to ensure effective and efficient service to the communities without disturbances.

**Strategy**

Evaluate health status and safe working conditions of the labour force.

**Actions**

- Arrange basic and advanced training programs on occupational health and safety with special training for collection crews.
- Background health related information of workers to be established, including number of children and their ages.
- Quarterly health checks for collection crew, recycling centre workers and landfill operators. Immediate action to be taken if health is deteriorating.
- Annual report shall contain a chapter on health of the MSW management staff with special reference to the labour force and their families.

**Policy Statement (v)**

Periodical skill development and training shall be made mandatory by the Ministry of Public Administration, Home Affairs, Provincial Councils and Local Government, and Provincial Councils for all the waste managers and service providers including the labour force.

**Strategy**

Institutional evaluation shall include human resource development with special reference to skill development with advancement of sustainable technologies.

**Actions**

- Identify, assess, and evaluate knowledge gaps and skill requirements in view of providing specific training programs to address the deficiencies.
- Development and conduct education and training courses, modules and programs on resource circular economy for sustainable development with greater emphasis on social development.
- Guidelines to be provided when necessary.

**Policy statement (x)**

Overall independent annual reviews of municipal waste management shall be organized at National, Provincial and Local Authority levels via citizens' platforms.

**Strategy**

Establishment of SWM committee in each of the local authority for approval of local authority activities on SWM and evaluation of technological options with due consideration of social implications.

**Actions**

Establishment of SWM committees at National and Provincial levels to conduct institutional reviews and evaluate the reports from local authority level SWM committees.  
Organize and attend conferences, seminars, and symposia on SWM.

**Policy Statement (y)**

Rehabilitation or Restoration plans as appropriate shall be developed by all the Local Authorities for existing uncontrolled dump sites with time targets under the guidance and technical assistance of CEA.

**Strategy**

Formulate feasible options for restoration or rehabilitating dumpsites including dumpsite mining.

**Actions**

- Assess the base level emissions with well-defined pollution loads.
- Identify all deposition points and the transport distances to clean the locations.
- Formulate technical options with defined timelines.
- Assess the emissions loads after restoration or rehabilitation of dumpsites.

#### **4.1.4 Sub-policy/strategy**

The sub-policy/strategy for solid waste management is intended to provide a foundation for a safe, responsible, and ecologically sound management of solid waste in the province. The proposed sub-policies/strategies and details are listed below.

- Promotion of the 4R (reduction, reuse, recycling, and recovery) concept
- Promotion of a circular economy
- Introduction of the “Zonal Concept of Waste Management”
- Adoption of the seven steps of municipal solid waste management
- Implementation of the polluter pays principle and extended producer responsibility
- Adoption of the PDCA cycle
- Simultaneous approach for waste management
- Introduction of a provincial platform for waste management
- Interpersonal Communication and Education

## **4.2 Details of the sub-policy/strategy**

### **4.2.1 Promotion of the 4R concept**

Several waste prevention techniques exist and are commonly referred to as the 4Rs: reduction, reuse, recycling, and recovery. The concepts of reduce, reuse, and recycle, known as the 3Rs, are common and constitute the principles of the government's waste management policy. In addition, the Western Province, which is one of the most advanced provinces in terms of waste management, also promotes energy recovery from non-recyclable and non-reusable waste. Hence the additional "R", that stands for "recovery", has been adopted and the 4Rs have emerged as a key concept in waste management in the province.

### **4.2.2 Facilitation of circular economy**

To ensure that there will be enough raw materials for food, housing, heating, and other necessities in the future, the economy must become circular. This involves preventing waste generation by manufacturing products and materials more efficiently and reusing them. If new raw materials are needed, they must be obtained sustainably so that the natural and human environment is not damaged. In a circular economy, manufacturers design products to be reusable. Electrical devices are designed in such a way that they are easy to repair. Products and raw materials are also reused as much as possible.

### **4.2.3 Introduction of the "Zonal Concept of Waste Management"**

The zonal concept has been introduced in the Western Province by the Waste Management Authority (WMA). Under this concept, all 49 LAs in the Western Province are divided into seven waste management zones with the objective of addressing waste management in a collective way. The boundaries of the administrative districts, the geographical distribution of LAs, the available resources for waste management, and the willingness to collaborate were key factors that were taken into consideration when clustering LAs into waste management zones.

Three waste management zones have been established in Gampaha administrative district (Negambo, Gampaha, and Kelaniya), two in Colombo District (Colombo and Dehiwala), and two in Kaluthara administrative district (Kalutara and Horana).

### **4.2.4 Adoption of the seven steps of municipal solid waste management**

The objective of the seven steps strategy is to introduce a unique waste management system for municipal solid waste (MSW) management throughout the Western Province. All the activities pertaining to MSW management are divided into seven steps, starting from waste separation at source to final disposal.

STEP I : Waste Reduction and Segregation at Source

STEP II : Primary Recovery

STEP III : Primary Collection

STEP IV : Cleaning of Public Places

STEP V : Secondary Collection /Transportation

STEP VI : Intermediate Treatment and Final Recovery

STEP VII: Final disposal

#### 4.2.5 Implementation of the polluter pays principle and extended producer responsibility

The **polluter pays** principle is an environmental policy principle that requires that the costs of pollution must be borne by those who cause it. This principle is usually implemented through two different policy approaches: command-and-control and market-based. Command-and-control approaches include performance and technology standards, such as environmental regulations in the production of a given polluting technology. Market-based instruments include pollution or eco-taxes, tradable pollution permits, and product labeling. The polluter pays principle is part of a set of broader principles to guide sustainable development worldwide.

Faced with increasing amounts of waste, many governments have reviewed available policy options and came to the conclusion that placing the responsibility for the post-consumer phase of certain goods on producers could be an option. **Extended Producer Responsibility (EPR)** is a policy approach under which producers are given a significant responsibility – financial and/or physical – for the treatment or disposal of post-consumer products. Assigning such responsibility could in principle provide incentives to prevent waste at source, promote product design for the environment, and support the achievement of public recycling and materials management goals.

#### 4.2.6 PDCA cycle

PDCA (Plan, Do, Check, Act) is an iterative four-step management method used in business for the control and continual improvement of processes and products. The PDCA cycle is also known as the Deming circle/cycle/wheel.

##### ■ Plan

The “Plan” phase involves assessing an existing or new process and finding out how it can be improved. Knowing what types of outcomes desired enables are to develop a plan to fix the problems. It is often easier to plan small changes as they can be easily monitored, and the outputs are more predictable.

##### ■ Do

The “Do” phase is the implementation of the plan from the previous step. Small changes are usually tested, and data is gathered to evaluate the effectiveness of the changes.

##### ■ Check

During the “Check” phase, the data and results gathered from the “Do” phase are evaluated. Data is compared to the expected outcomes to identify any similarities or differences. The

testing process is also evaluated to see if there were any changes from the original test created during the planning phase. If the data is placed in a chart and the PDCA cycle is conducted multiple times, trends can be observed. This helps to determine what changes work better than others, and if said changes can be improved as well. The SWOT analysis may be useful planning tool of process improvement based on PDCA cycle that is an interactive, four- stage approach for continually improving.

■ **Act**

If the “**Check**” phase shows that the “**Plan**” which was implemented in the “**Do**” phase results in an improvement compared to the prior standard (baseline), then it becomes the new standard (baseline) for how the organization should “**Act**” in the future (new standards are thus said to be enacted). If the “**Check**” phase shows that the “**Plan**” which was implemented in the “**Do**” phase is not an improvement, then the existing standard (baseline) will remain in place. In either case, if the “**Check**” phase showed an outcome different than expected (whether better or worse), then additional investigation must be conducted and further PDCA cycles might be required in the future. It is worth noting that some PDCA instructors claim that the “**Act**” phase involves making adjustments or taking corrective actions, but it would be contrary to the PDCA thinking to propose and decide on other changes without going through a proper “**Plan**” phase, or to make them the new standard (baseline) without carrying out the “**Do**” and “**Check**” steps.

The figure below is an illustration of the PDCA cycle.

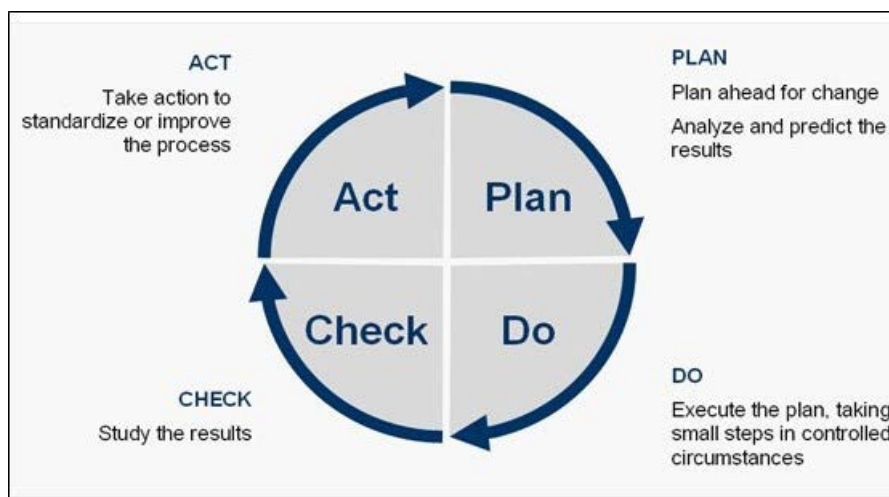

Figure 4-1 PDCA cycle



Figure 4-2 Continuous monitoring with the PDCA cycle



#### 4.2.7 Simultaneous approach in waste management

The simultaneous approach for waste management is another strategy that has been implemented for SWM in the Western Province. As illustrated in the figure below, in this system, mass disposal technologies such as incineration and disposal in sanitary landfills, are used in combination with material recovery technologies such as reuse, recycle, upcycle, etc. The global trend in waste management is to move from mass disposal to material recovery, based on sustainable development objectives. However, material recovery is a slow process since it is strongly linked to the discipline of the residents. Inculcating “material recovery discipline” to the population is a challenge all over the world, and continuous efforts are required to achieve goals and maintain progress. Meanwhile, mass disposal technologies can be implemented independently of public cooperation in waste sorting, and it is a faster solution to the open dumping practices currently taking place across the Western Province. Hence, mass disposal technologies enable to prevent negative consequences for the environment and public health caused by open dumping. When considering waste management approaches, quick actions for optimizing final disposal and material recovery are essential. In that context, a simultaneous approach for waste management has been introduced in the province. To implement the above strategy, WMA has estimated the minimum number of mass disposal facilities to be developed, while taking all possible steps to recover waste throughout the waste flow.

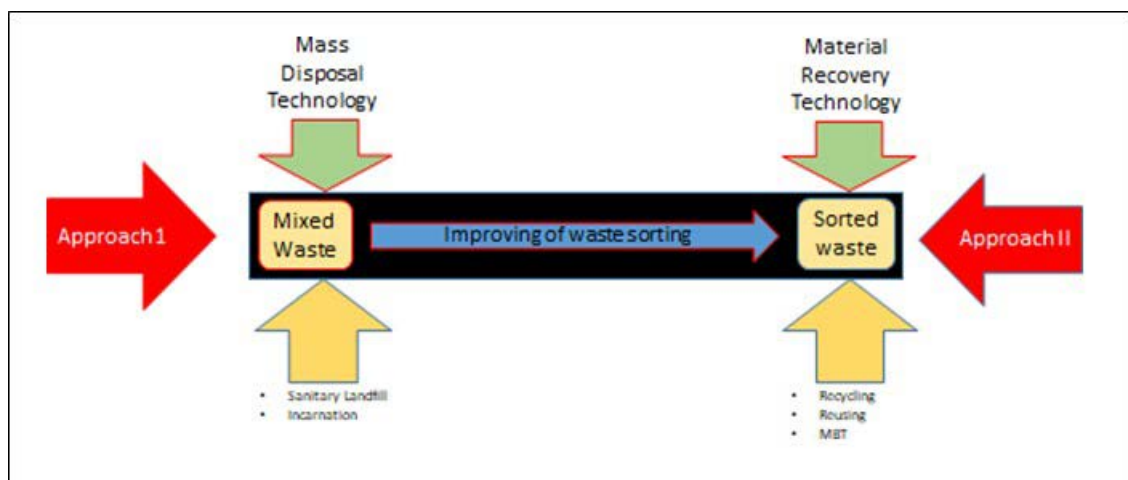

Figure 4-3 Simultaneous approach for waste management

#### 4.2.8 Introduction of a provincial platform for waste management

The implementation of a waste management master plan requires:

- Coordinated efforts by international agencies, governments, provincial councils, LAs, civil society, and the private sector.
- Coherent policy development and implementation, financing, technology, infrastructure, as well as clear roles and responsibilities for stakeholders.

- At the local level, the focus is on the implementation of a waste management system, while at the national level efforts are directed towards policy development and support to local governments. At the international level, the priority is to provide technical and financial support to developing countries.

Therefore, there should be a platform that all stakeholders can use for the effective implementation of the master plan. Hence, WMA is considering introducing a provincial platform for waste management in the Western Province. This platform aims to help stakeholders achieve the targets set in the provincial waste management plan, both individually and collectively.

The provincial waste management platform will be chaired by the Chief Minister of the Western Province and will include representatives of decision-makers from all relevant stakeholders, including governmental institutions, the private sector, and civil society. WMA will be the coordination agency of the platform.

#### **4.2.9 Interpersonal Communication and Education**

The interpersonal communication and education approach, based on personal communication sources and channels, can disseminate, improve, and reinforce acquired knowledge, skills, attitude, and behavior. It is recognized as an effective two-way communication method that encourages interactive dialogue between individuals or among group members. WMA will use this approach to change the behavior of residents towards waste management in the province.

### **4.3 Targets**

#### **4.3.1 Narrative summary of the targets of the MP**

- i. Minimize the final amount of waste to be disposed through**
  - (1) Reduction of waste generation
  - (2) Promotion of recycling (incl. source separation for composting)
  - (3) Waste treatment by thermal recovery and composting
  
- ii. Achievable**
  - (1) Physically feasible
  - (2) Environmentally and socially acceptable
  - (3) Economically rational/acceptable
  
- iii. Optimization and clarification**
  - (1) Define the roles and responsibilities of related organizations
  - (2) Incorporate development plans and waste management facility plans of related organizations
  - (3) formulate the most rational and efficient waste management system for the Western Province.

### 4.3.2 Numerical targets

The tables below show the numerical targets for the Western Province and each district. The waste reduction ratio is a future target value determined in consultation with the relevant authorities, while other targets were established based on the future projections of each local authority.

Table 4-1 Numerical targets for the Western Province

Target year		Waste reduction ratio	Collection coverage	Recycling ratio	Disposal ratio
Present	2022	0%	56%	14%	27%
Short-term	2025	3%	61%	18%	29%
Medium-term	2030	5%	68%	20%	20%
Long-term	2042	10%	81%	24%	20%

Table 4-2 Numerical targets for Colombo District

Target year		Waste reduction ratio	Collection coverage	Recycling ratio	Disposal ratio
Present	2022	0%	70%	14%	27%
Short-term	2025	1%	74%	17%	30%
Medium-term	2030	3%	80%	18%	18%
Long-term	2042	10%	92%	23%	21%

Table 4-3 Numerical targets for Gampaha District

Target year		Waste reduction ratio	Collection coverage	Recycling ratio	Disposal ratio
Present	2022	0%	43%	16%	26%
Short-term	2025	1%	47%	20%	27%
Medium-term	2030	3%	54%	23%	29%
Long-term	2042	10%	70%	26%	18%

Table 4-4 Numerical targets for Kalutara District

Target year		Waste reduction ratio	Collection coverage	Recycling ratio	Disposal ratio
Present	2022	0%	41%	13%	28%
Short-term	2025	1%	45%	19%	26%
Medium-term	2030	3%	51%	20%	12%
Long-term	2042	10%	65%	24%	17%

### 4.3.3 Milestones for the MP

The table below shows the milestones for achieving the targets during the MP period, i.e. 1) Short-term: 2023-2025, 2) Medium-term: 2026-2030 and 3) Long-term: 2031-2042. The MP will be implemented according to these milestones.

Waste generated will be reduced 10 % by 2042 compared to the status quo. In addition, collection is to be improved, with 95 % of the volume to be collected at MC and UC and 65 % at PS.

To reduce the volume of final disposal, the construction of intermediate treatment facilities will be promoted: the Thermal Recovery Facilities (TRF) plans to expand the currently operating 750 ton/day WPK WtE facility, as well as to construct TRF in Colombo District and TRF in Gampaha. Composting facilities include LAs' composting facilities, cluster-based composting facilities and Waste Parks' composting facilities, with a total planned capacity of 1,285 ton/day. A total of 430 ton/day of recycling facilities are planned for LAs' recycling facilities and Waste parks' MRFs.

In order to reduce transport costs of waste, five primary transfer stations are to be constructed in the Western Province. The volume of transferred waste in 2042 is 850 ton/day. In addition, Kelaniya Transfer Station will be positioned as a secondary transfer station and will transfer waste for final disposal to be transported to Aruwakkalu DS. The volume of transferred waste in 2042 is 1,200 ton/day. Cumulative volume disposed from 2023 to Aruwakkalu DS was estimated at approximately 9.5 mill. m<sup>3</sup>, including cover soil.

Other are expected to generate 279 GWh/year in the TRF in 2042. In addition, 14,600 tons/year of compost is expected to be produced. And more, compost production can reduce GHG emissions by 1,273 million-tons CO<sub>2</sub>/year.

Table 4-5 Milestones for achieving the MP

		Short term				Medium term					Long term											
		2022	2023	2024	2025	2026	2027	2028	2029	2030	2031	2032	2033	2034	2035	2036	2037	2038	2039	2040	2041	2042
<b>Reduction of waste generated</b>		→ 1%				→ 3%					→ 10%											
<b>Waste separation at source</b>		→																				
Improvement of collection rate	MC	65%	→																			95%
	UC	72%	→																			95%
	PS	32%	→																			60%
<b>Thermal Recovery Facilities (TRF)(ton/day)</b>																						
WPK WtE facility		750	→				1,500 (750+750)					→										
TRF in Colombo District						400					800(400+400)											
TRF in Gampaha District																600						
<b>Compost facilities (CF) (ton/day)</b>																						
LAs CFs		92	→ 117				→ 131					→ 136										
Cluster-bases* CFs		232	→ 333				→ 340					→ 794										
Waste Park CFs		0	→ 160				→ 400					→ 400										
<b>Material Recovery facilities (MRF) (ton/day)</b>																						
LAs recycling facilities		110	→ 169				→ 255					→ 421										
Waste Park MRFs		0	→ 60				→ 150					→ 150										
<b>Transfer station (TS) (ton/day)</b>																						
Primary TS						400					490										850	
Secondary TS (Kelaniya transfer station)		1,065	→ 1,242				→ 997					→ 1,206										
<b>Final disposal (Aruwakkalu DS)</b>																						
(Accumulated volume of waste disposed for 20 years (million m <sup>3</sup> ))		→ 1.5				→ 4.0					→ 9.5											
<b>By-Product</b>																						
Amount of electric power (GWh/year)		→ 74				→ 179					→ 279											
Compost (ton/year)		→ 6,700				→ 8,700					→ 14,600											
GHG emission reductions from composting of biodegradable waste**(mill.-t CO <sub>2</sub> /year)		71	→ 156				→ 322					→ 1,273										

\* Common compost facilities managed by Central Government or Western Province.

\*\* The emission reduction from the project activity is determined as the differences between the GHG emissions of baseline scenario (methane are emitted to atmosphere without recovery) and project scenario (composting biodegradable wastes).

## 4.4 Actions

### 4.4.1 Outline of the SWM system

Waste reduction at present is considered as 0% and it is expected to active 1%, 3% and 10% by 2025, 2030 and 2042 respectively. Recycling targets are set as 15% for MCs, 12% for UCs and 10% for PSs and the collection service coverage which accounts for 65% for MC and 72% for UC and 32% for PS currently targeted to expanded up to 95%, 95% and 60% respectively by 2042. The daily MSW collection at present is 1,994 Ton (collection amount including recyclables collected by workers 2,198 Ton) and estimated collection amount in 2025 is 2,396 Ton (collection amount including recyclables collected by workers 2,620) and it is estimated that 3,093 Tons of waste is collected in 2030 (collection amount including recyclables collected by workers 3,337) and in 4,985 Tons (collection amount including recyclables collected by workers 4,985) in 2042.

Compactor trucks with the capacity of 4 tons will be used for biodegradable waste as well as other waste collection while 6-7 m<sup>3</sup> tractor trailers for recyclables collection. Accordingly estimated total vehicle requirement based on the collection quantities in the province in 2025 is 561, 2030 is 649 and 2042 its 980 vehicles. The requirement of the primary transfer station for waste transportation in the province is 5 and the estimated handling quantities are 400 Ton/490

Ton/850 Ton in 2025, 2030 and 2042 respectively. Kelaniya transfer station act as the secondary waste transfer station which carries waste to Aruwakkalu sanitary landfill site and the according to the estimation the amount of waste transfer through Kelaniya TS is 2025 is 1,242 Ton/day, 2030 is 997 Tons and 1,296 Tons/day in 2042.

Intermediate treatment facilities are the core facilities of the master plan and the requirement of the total capacity of TRF facilities for the Western province is 2900Ton/day whereas Colombo district requirement is 2,300 Ton/day and Gampaha district is 600 Tons/day. Present composting capacity of the province is 324 Tons/day and the treatment capacity will be increased to 610 Ton/day by 2025 and 850 Ton/day by 2030 and 1,285 Ton/day by 2042. To achieve the target composting rates individual composting capacity will be increased to 136 Ton/day and cluster-based facilities to 749 Ton/day and the compost facilities at waste park to 400 Ton/day. Capacity of the LA recycling facilities will be increased from current 116 Ton/day to 270 Ton/day by 2042 while MRF of waste park is targeted from 0 to 150 by 2042. Estimated waste disposal volumes in the western province in 2025 is 453,000 m<sup>3</sup> and 364,000 m<sup>3</sup> in 2030 and 440,000 m<sup>3</sup> in 2042.

The total estimated cost for the implementation of the WP master plan is 432,014 million LKR. The share of the collection cost is 102,943 million LKR, while transfer cost 80,083 million LKR, composting 20,303 million LKR, MRF 6,164 million LKR, TRF 153,185 million LKR and final disposal accounts for 69,337 million LKR.

Table 4-6 Outline of the SWM system

SWM system	Contents					
Waste reduction at generation source	➤	Waste reduction is to be promoted according to the following targets.				
		Targets of waste reduction rate and waste generated				
		Year	2022	2025	2030	2042
		Targets for waste reduction rates (%)	0%	1%	3%	10%
		Waste generated (ton/day)	3,926	4,342	4,952	6,181
Separation of waste discharged	➤	Separation of discharged waste, e.g. organic waste, recyclable and other waste is to be promoted.				
		Target ratio of discharged waste separation by type of LA				
	Type of LA	Organic waste	Recyclable			Other waste
			Recycling at discharge/collecti on	Recycling at Recycling yard/SK	Total	
MC	40%	5%	10%	15%	45%	
UC	45%	5%	7%	12%	43%	
PS	50%	5%	5%	10%	40%	
Collection system	➤	Expansion of collection area will be improved based on the target of collection coverage by type of LA.				
		Target of collection coverage by type of LAs				
			2022	2042		
		MC	65%	95%		
		UC	72%	95%		
		PS	32%	60%		
	➤	Collected Waste				
		Year	2022	2025	2030	2042
		Collected Waste (ton/day) (* Including recyclables collected by waste collection crews)	1,994 (2,198)	2,396 (2,620)	3,093 (3,337)	4,756 (4,985)
	➤	Type of collection vehicles				
	<ul style="list-style-type: none"> <li>■ Organic waste: 4-ton compactor truck</li> <li>■ Recyclable: Tractor-trailer (6-7 m<sup>3</sup>)</li> <li>■ Other waste: 4-ton compactor truck</li> </ul>					
➤	Required number of collection vehicles					
		2025	2030	2042		
	Organic waste	99	114	188		
	Recyclable	94	144	223		
	Other waste	358	391	569		
	Total	551	649	980		

Transfer system ➤ Primary transfer stations to be constructed, operated and managed jointly with neighboring LAs.

Primary Transfer Station	Transfer waste amount (t/day)		
	2025	2030	2042
Colombo TS	90	90	140
Kalutara west TS	60	90	130
Kalutara east TS	10	40	760
Gampaha west TS	100	130	240
Gampaha east TS	140	170	280
Total	400	490	850

➤ Secondary transfer station, namely Kelaniya Transfer Station

■ Transportation to Aruwakkalu DS by train

	2025	2030	2042
Amount of waste transferred (t/d)	1,242	997	1,206

Intermediate treatment system

➤ Capacity of Thermal Recovery Facilities (TRF)

	2022	2025	2030	2042
Western Power at Kerawalapitiya (WPK) TRF facility (t/d)	750	750	1,500	1,500
TRF in Colombo District (t/d)	-	-	400	800
TRF in Gampaha District (t/d)	-	-	-	600
Total (t/d)	750	750	1,900	2,900
Accumulated amount of electric power for 2023-2042 (GWh)	372	372	1,056	4,070

➤ Required capacity of compost facilities (ton/day)

	2022	2025	2030	2042
LAs compost facilities	92	117	131	136
Cluster-based compost facilities	232	333	340	794
Waste Park compost facilities	0	160	400	400
Total	324	610	871	1,330
Accumulated compost products for 2021-2041 (t/d)	3,600	35,200	76,400	194,600

➤ Required capacity of recycling facilities (ton/day)

Year	2022	2025	2030	2042
LAs recycling facilities	116	116	116	270
Waste Park MRF	0	60	150	150

Final disposal system

➤ Disposal waste generated in Western Province is disposed at Aruwakkalu DS.

➤ Disposal volume (1,000 m<sup>3</sup>)

Year	2025	2030	2042
✓ Disposal waste volume	453	364	440
✓ Covering soil	91	73	88
Total disposal volume	544	437	528
Accumulated total disposal volume (mill. m <sup>3</sup> ) from 2023	1.54	4.00	9.51



Cost	Total cost for SWM (million LKR for 2023-2042)		
	Item	Sub-item	Cost
Collection		Procurement cost of vehicles	7,189
		Fuel & maintenance cost	69,778
		Labor cost	25,976
		sub-total	102,943
Transfer		Procurement cost of vehicles	2,050
		Fuel & maintenance cost	44,556
		Labor cost	1,507
		OM cost	23,540
		Initial cost	8,430
		sub-total	80,083
Compost facility		OM cost	19,638
		Indicial cost	665
		sub-total	20,303
MRF		OM cost	4,164
		Initial cost	2,000
		sub-total	6,164
TRF		OM cost	99,437
		Initial cost	53,748
		sub-total	153,185
Final disposal		OM cost	38,046
		Initial cost	31,291
		sub-total	69,337
	<b>Total</b>		<b>432,014</b>

#### 4.4.2 Forcasted waste flow

Table 4-7 Future waste amounts

Waste Flow	2022		2025		2030		2042	
	Amount (ton/day)	(%)	Amount (ton/day)	(%)	Amount (ton/day)	(%)	Amount (ton/day)	(%)
1. Generation	3,926	100%	4,342	100%	4,952	100%	6,181	100%
7. Improper discharge	821	21%	815	18.60%	748	14.67%	515	7.54%
5. Discharge	2,198	55.99%	2,620	59.79%	3,337	65.43%	4,985	73.02%
8. Informal recycling	118	3.01%	169	3.86%	255	5.00%	229	3.35%
11.1 Composting	325	8.28%	611	13.94%	786	15.41%	1,332	19.51%
11.3 Recycling	110	2.80%	143	3.26%	194	3.80%	421	6.17%
11.4 Thermal recovery	752	19.15%	751	17.14%	1,687	33.08%	2,874	42.10%
12. Untreated waste	799	20.35%	865	19.74%	365	7.16%	129	1.89%

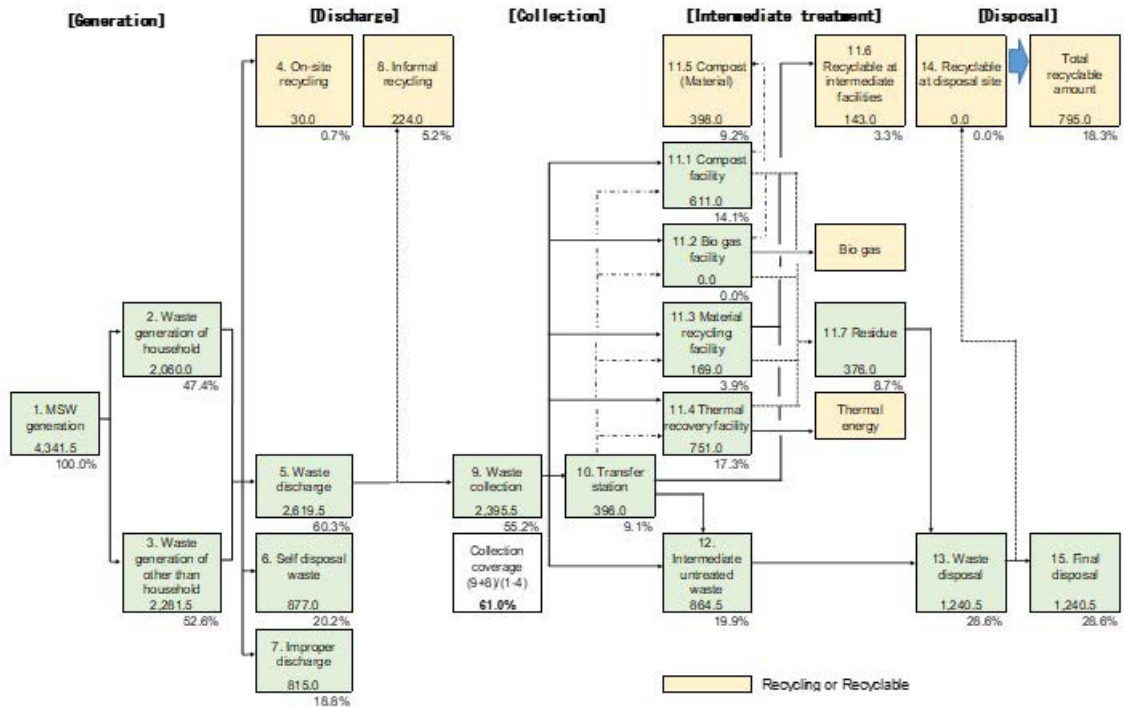

Figure 4-4 Future waste flow by 2025 (Short-term)

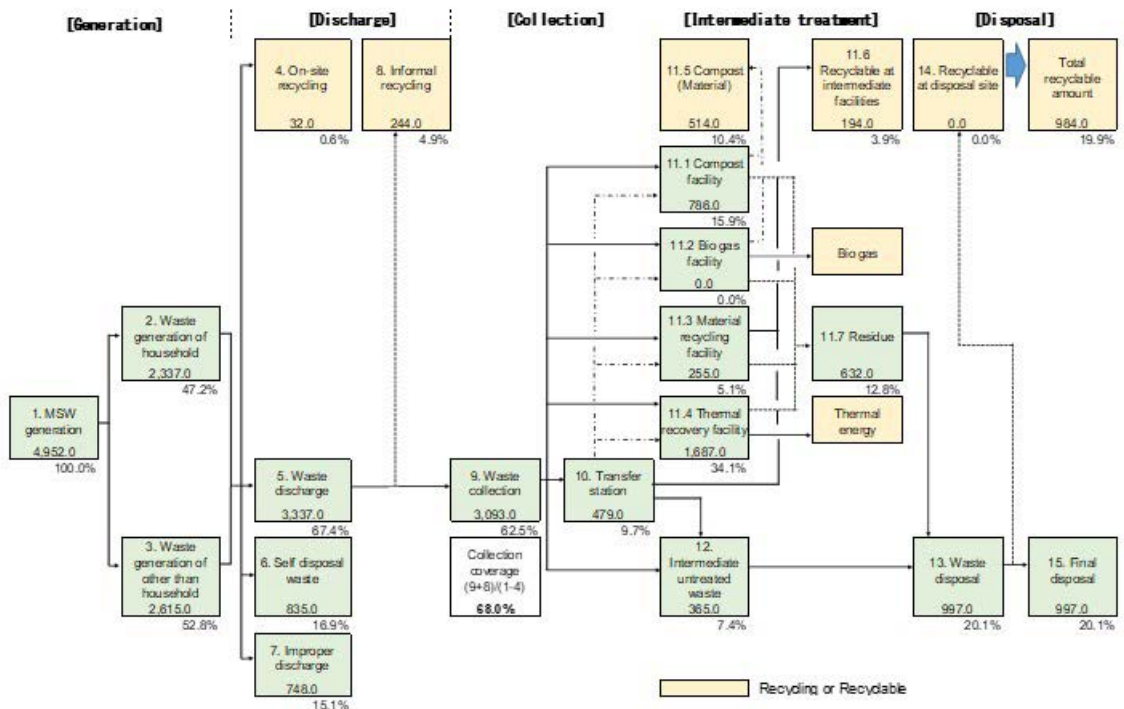

Figure 4-5 Future waste flow by 2030 (Medium-term)

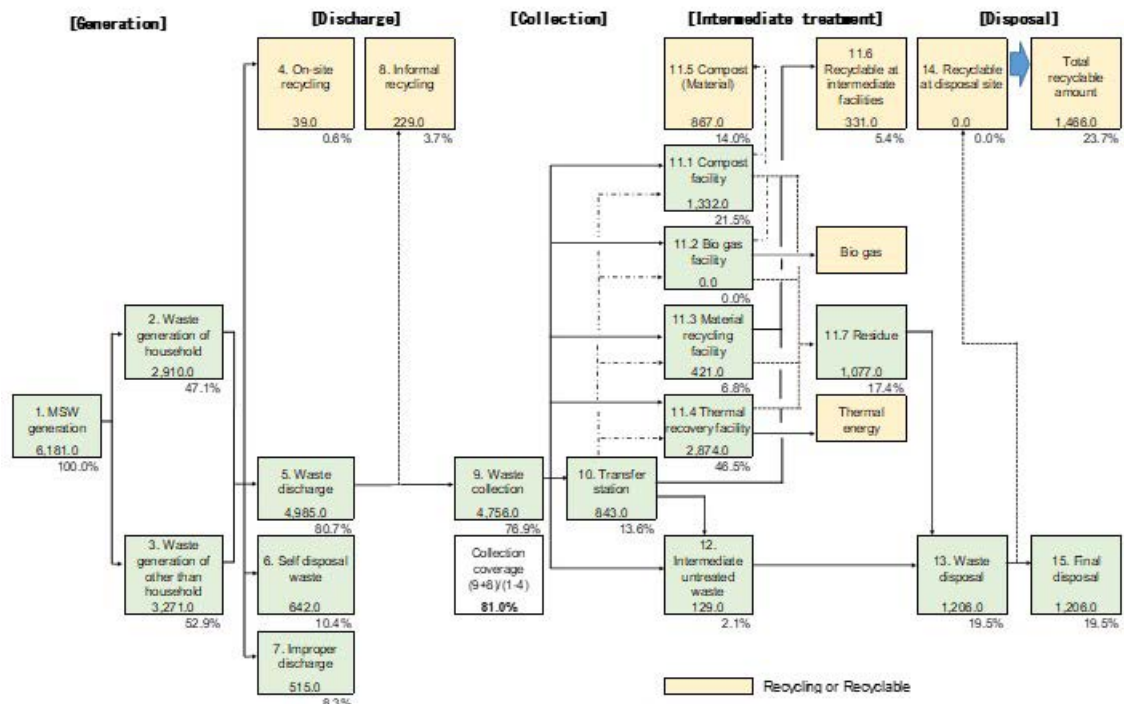

Figure 4-6 Future waste flow by 2042 (Long-term)

#### 4.4.3 Key strategic actions for the SWM system

The following six items have been identified as the strategic priorities of the MP.

##### (1) Promotion of waste reduction at source

- Take measures to limit the increase in the amount of waste generated caused by population and economic growth.

##### (2) Promotion of waste separation and reduction at the discharge stage

- Ensure waste separation (organic, recyclable, and other waste) and promote the collection of recyclable waste.
- Promote on site recycling at source and reduce the amount of waste discharged.

##### (3) Improved waste collection and transfer system

- Expand the collection area.
- Select efficient and hygienic collection vehicles according to the type of waste to be transported.
- Build primary transfer stations (PTSs) that will be operated and managed jointly by neighboring LAs to improve the collection efficiency of burnable waste (transported to TRFs) and waste to be disposed (transported to Kelaniya TS).

##### (4) Promotion of recycling at intermediate treatment facilities

- Aim for zero disposal of collected biodegradable waste.
- Recover energy from burnable waste and approximately 20% of collected

biodegradable waste.

- Increase the capacity of composting facilities to maximize the production of compost from the biodegradable waste collected.
- Promote recycling, increase the capacity of existing LAs’ recycling facilities and build MRFs in waste parks.

**(5) Reduction of waste to be disposed**

- Reduce the amount of waste to be disposed by reducing waste generation, and promoting separate collection, recycling and thermal recovery (incineration).
- Close open dump sites.

**(6) Establishment of a data management system based on a database**

- Collect and enter the data required for waste management using standard formats
- WMA to manage and operate a database of data entered by LAs and cluster-based facilities.
- WMA to analyze the data in the database and support LAs for SWM.
- Implement SWM using the database managed by WMA.

**4.4.4 Details of key strategic actions for the SWM system**

**(1) Promotion of waste reduction at source**

[Key strategic action]

- Measures to limit the augmentation of waste generation due to population and economic growth.

**a. Targets for waste generation reduction rates**

To reduce the financial burden of collecting, transporting, treating and disposing of waste, the generation of waste at source shall be reduced according to the following targets.

Target year	2022	2025	2030	2042
Waste reduction rate	0 %	1 %	3 %	10%

**b. Measures to reduce waste generation**

The following are some examples of measures adopted in other countries to reduce the amount of waste generated at the national, regional, and local levels, as well as at the level of citizens and business operators. Measures to reduce waste generation in the Western Province will be considered by WMA in collaboration with the relevant authorities, depending on the state of economic development, the needs of society, and the level of public awareness.

Among the measures presented in the chart below, those indicated in blue are the measures to be taken at the level of citizens, and which LAs should promote as part of waste management action plan. On the other hand, the measures indicated in yellow require efforts from industries. “Purchasing eco-friendly products” cannot be realized with the efforts of citizens alone but requires such products to be readily available, and this can only be achieved if the waste management policies and industrial policies are in line with each other.

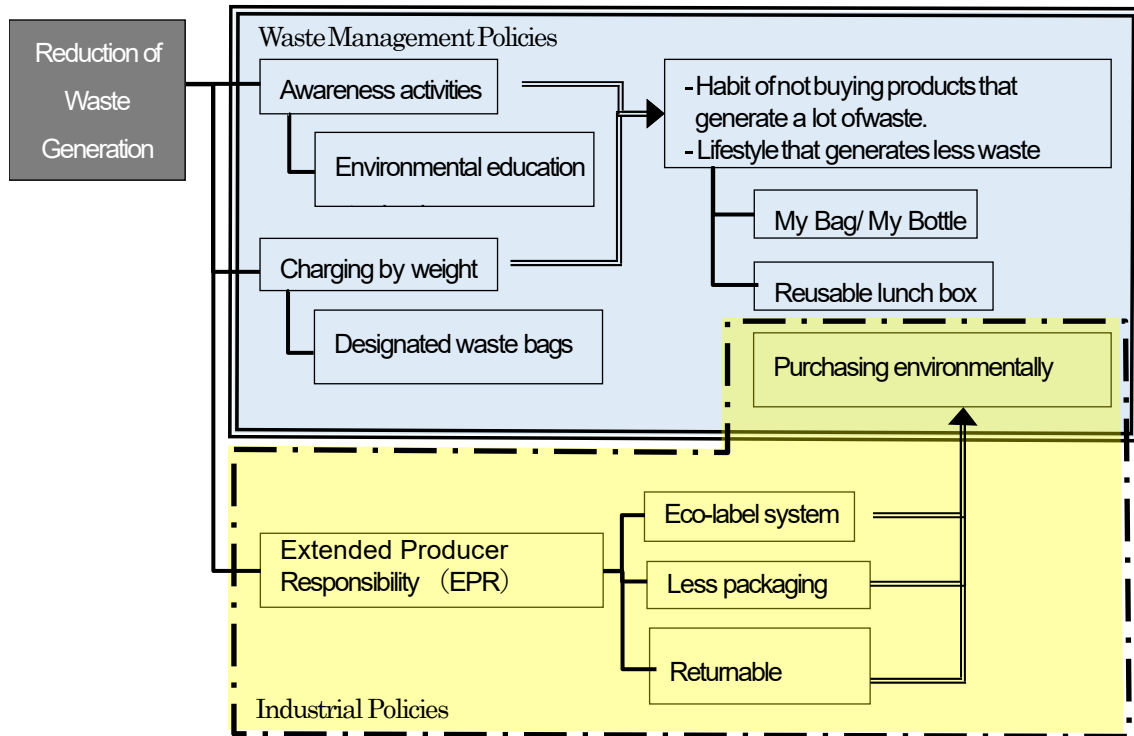

Figure 4-7 Examples of measures to reduce waste generation

Table 4-9 Examples of approaches and technologies to reduce waste generation

Approach/Technology	General description	Points to be considered
Extended Producer Responsibility (EPR)	Method recommended by the OECD (Organization for Economic Co-operation and Development). It is a policy approach where producers' responsibilities are extended to treatment or final disposal of used products financially or physically. In Japan, as a general principle law, the Act for Establishing a Recycling-Oriented Society prescribes the responsibilities of producers as follows:  Improvement of products/containers durability and enhancement of repair systems. Revised design for products/containers, material labeling, and prevention of complications that could hinder proper disposal. Acceptance of recyclables from products/containers and reuse.  In Germany, container and packaging manufacturers may join a so-called "dual system" to collect and manage waste resulting from their own products. In addition, companies can use the Green Dot trademark to help consumers to identify the products that are fed into the package recycling system. Consumers can discharge packaging waste into designated yellow sacks or bins, which are then transported to recycling facilities. This system has been implemented in accordance with Germany's Packaging Ordinance for the collection and subsequent recycling of packaging waste.	Institutional design (deciding targeted waste, financing method) Legislation Collaboration with related industries
Charging for waste service based on amount discharged (Prepaid bag according to system)	Obligation to discharge waste in designated bags. Waste generators (households) pay a service fee according to the amount of waste generated through the purchase of a designated bag which includes the waste service cost. This can provide incentives for waste generators to minimize waste generation.	Requires understanding and cooperation of waste generators. Price setting of designated bag. Surveillance and guidance to prevent discharge in non-designated bags. Establishment of a system for selling designated bags in retail stores and a system for collecting income from the sale of bags. Shift from current tariff collection system.
Public awareness-raising activities Education in schools	Induce voluntary action for waste minimization by raising awareness on current waste situation/importance of waste minimization and environmental consciousness through public awareness campaigns by local governments, education in schools, and supporting activities of related organizations.	Development of programs Financing Establishment of implementation framework Collaboration with related organizations and activities
Daily habit of not buying products that tend to generate waste, and adopt a lifestyle that does not generate waste	Encourage consumers and business operators to adopt the habit of consciously select products which will generate less waste.	Selection of target group of people and implementation of awareness-raising activities Evaluation of materials and methods of awareness raising.
Selection of environmentally friendly products	Introduction of the eco-label system. (See "Eco-label system" below.)	
"My-bag" (reusable shopping bag) movement	Control the amount of waste generated by encouraging environmental awareness among consumers and giving them economic incentives.	
Approach/Technology	General description	Points to be considered
Simple packaging	Reduce the amount of waste generated through the environmental consciousness of producers/manufacturers, and the understanding of consumers.	
Eco label system	Various labeling systems exist, such as the EU Ecolabel (EU), Eco Mark (Japan), and Blue Angel (Germany). The EU Ecolabel certifies products that satisfy environmental conditions. This system supports both demand and supply by promoting companies' contribution to environmental conservation, while guaranteeing consumers that the product is environmentally friendly. Application review and certification are carried out by the national Ecolabel certification body of the EU country where the products are manufactured or sold.	Labeling is voluntary and up to each business entity, although it can help differentiate products Need to raise consumers' recognition

**(2) Promotion of waste separation and reduction at the discharge stage**

[Kat strategic actions]

- Ensure waste separation (biodegradable, recyclable and other waste) and promote the collection of recyclable waste.
- Promote recycling at source and reduce the amount of waste discharged.

**a. Target rate for the separate collection of discharged waste**

The first step is to promote the separation of waste into three categories in all LAs.

In order to promote recycling, the target rate for the separate collection of discharged waste should be carried out according to the type of LA.

Table 4-10 Target rates for the separate collection of discharged waste by type of LA

Type of LA	Biodegradable waste	Recovered at discharge/collection stage	Recyclable	Total	Other waste
			Separated at source and transported to recycling facilities/SK		
MC	40%	5%	10%	15%	45%
UC	45%	5%	7%	12%	43%
PS	50%	5%	5%	10%	40%

**b. Waste separation**

In many small LAs in the Western Province, separation of biodegradable and non-biodegradable waste at the discharger level has just started and only a few LAs with the necessary capacity have implemented three categories, i.e. biodegradable, recyclable, and other waste. The introduction of thermal recovery has created the need to add another category, burnable waste, in several LAs. The Western Province aims to achieve seven categories, namely biodegradable, recyclable, burnable, hazardous, e-waste, bulky waste, and residual waste. In order to promote waste separation, the progressive introduction of additional categories will be easier to implement than the introduction of all categories at once.

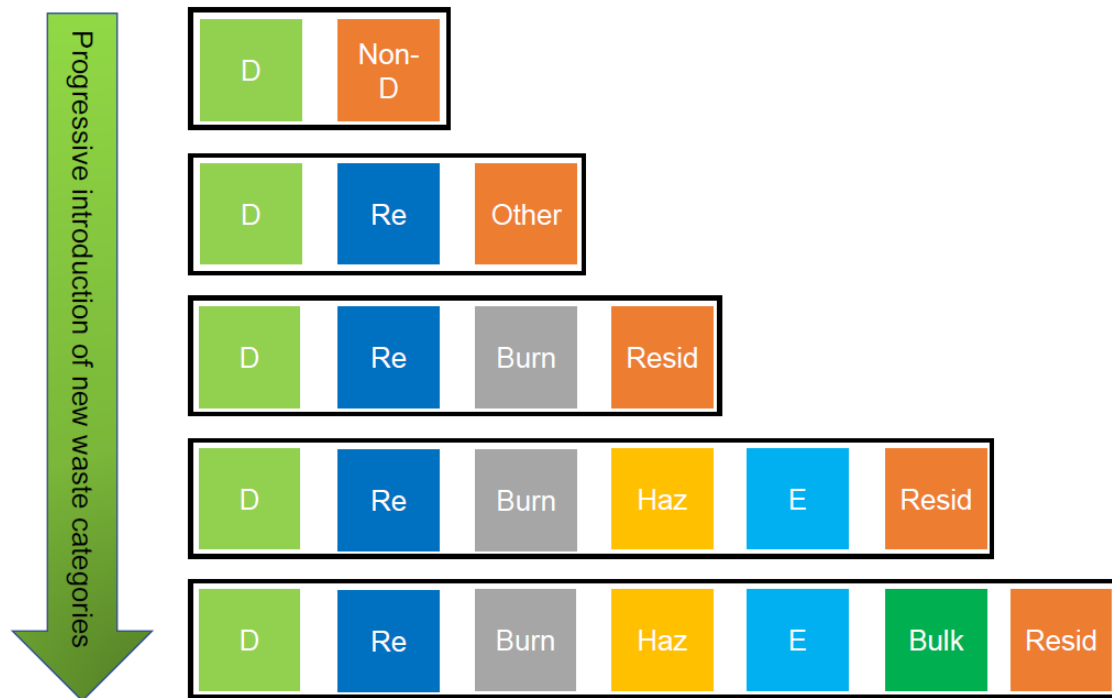

D: Degradable, Non-D: Non-Degradable, Re: Recyclable, Burn: Burnable, Resid: Residual, Haz: Hazardous, E: Electronic, Bulk: Bulky

Figure 4-8 Progressive development of waste separation

When introducing a new category, LAs should carefully plan the collection route and collection schedule according to their available capacity. In addition, the collection schedule for each category and sufficient explanations on the expected separation should be fully communicated to the waste generators, so that there is no confusion at the discharge stage.

The following are some examples that have been put in place to help citizens separate their waste easily.

**c. Collection schedule**

Taking into account the available vehicles and human resources of each LA, a collection schedule should be established, and the collection service should be punctual. To be able to cooperate with this effort of the LAs, citizens will need to have a clear knowledge of the schedule. This can be achieved through leaflets and/or notice boards.

In the event that the schedule needs to be modified for any reason, the LA should notify citizens in advance through leaflets, loudspeaker announcements, collection workers, etc.



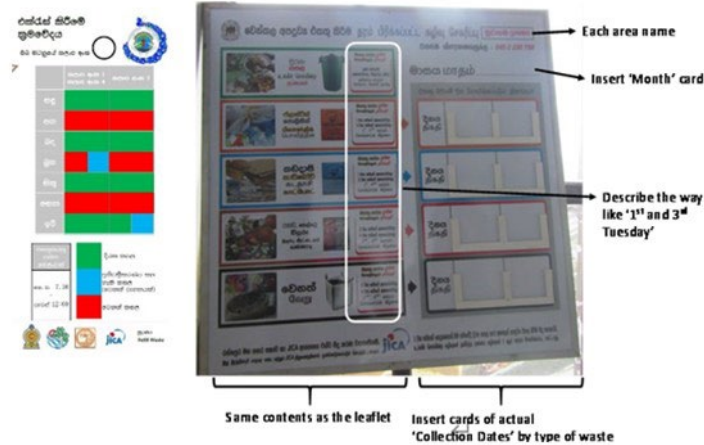

Figure 4-9 Collection schedule tools

**d. Separation method**

It is essential that citizens understand which waste falls into which category. Citizens may judge using common sense and categorize certain items as “recyclable”, but that particular item may not be recyclable. Awareness material should help avoid such confusion.



Figure 4-10 Separation awareness material

**e. Distribution of waste containers**

The distribution of waste bins, especially for biodegradable waste, may help encourage citizens to separate waste because an appropriate container (with a tight lid and sufficient capacity) can store wet waste overnight. However, it should always be implemented in combination with other awareness tools about waste separation.

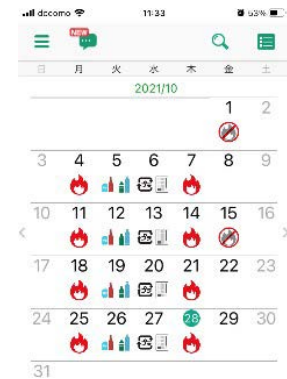

Figure 4-11 Distribution of waste containers

**f. Mobile phone application**

Separating waste into multiple categories can be very confusing, and not being able to know the correct category immediately can discourage citizens. Mobile phone applications may help by having the details of each waste category at hand.

The Western Province will promote the development of such applications throughout the province gradually, in order to implement a uniform 7-category separation system in the province.

**g. Measures for waste reduction at the discharge stage**

Examples of measures to reduce the waste amount at the discharge stage are described below.

Figure 4-12 Example of a mobile phone application (Nerima city in Tokyo, Japan)

**h. Promotion of home composters**

WMA has set out the following activities to promote home composting.

- Support to LAs and/or relevant institutions to display/demonstrate home composting technical options in public places (LA offices/sub-offices, libraries, public places, etc.) with the assistance of other stakeholders.
- Promotion and awareness creation of home composting techniques
- Facilitation and provision of financial and technical guidance to LAs to promote home composting.
- Support to LAs to implement a monitoring and troubleshooting system for home composting.

**i. Other activities for waste reduction at the discharge stage**

WMA has set out the following activities to promote waste reduction:

- Raising awareness of the 3Rs at the community/institutional level
- Empowerment of ground-level collectors of recyclable waste
- Continuous promotion of “PARISARAPOLA”, “PARISARARIYASARA” Programs, etc., at LA level
- Capacity building of recyclers in the Western Province
- Identification and registration of existing & potential recyclers within the province

### (3) Improved waste collection and transfer system

[Key strategic actions]

- Expand the collection area.
- Select efficient and hygienic collection vehicles according to the type of waste to be transported.
- Build primary transfer stations that will be operated and managed jointly by neighboring LAs to improve the collection efficiency of burnable waste (transported to TRFs) and waste to be disposed (transported to Kelaniya TS).

#### a. Collection coverage targets

As urbanization progresses, the waste collection rates in MCs and UCs which have high population densities has already reached 65-70%. On the other hand, in PSs, where collection areas are widely dispersed, the collection rate is still only around 30%. The aim for MCs and UCs is to achieve a collection rate of 95%. On the other hand, considering the financial burden on LAs, the aim for is a 60% waste collection rate.

Table 4-11 Target of collection coverage in percentage by type of LA

	2022	2042
MC	65%	95%
UC	72%	95%
PS	32%	60%

#### b. Collection vehicles

##### ■ Types of collection vehicles

As compactor trucks are more efficient than the tractor-trailers used by many LAs, and they also prevent wastewater leaks and the spread of odors, they will be used for the collection of organic and other waste and will gradually replace the current vehicles.

On the other hand, tractor-trailers will be used for the collection of recyclables as before, because it is possible to load the collected materials by type, and as the recycling facilities are located within the LAs, the transport distance is relatively short.

The following vehicles will be progressively put into circulation for each waste category:

- Biodegradable waste: 4-ton compactor trucks
- Recyclable: Tractor-trailers (6-7 m<sup>3</sup>)
- Other waste: 4-ton compactor trucks



Compactor trucks are suitable as collection vehicles for organic and other waste due to their high collection efficiency.



Compactor trucks are suitable for the collection of biodegradable waste as they can prevent wastewater leaks and offensive odors.



Tractor-trailers are suitable for transport over short distances. They are also suitable for the collection of recyclables as waste can be loaded separately by type.



Figure 4-13 Types of collection vehicles

■ Procurement of collection vehicles

LAs will procure collection vehicles in accordance with their action plans. Some of the collection vehicles that need to be procured will be requested as support from the national government or the Western Provincial Council, such as NSWMSC and WMA.

Table 4-12 Required number of collection vehicles

	Short-term (2025)	Medium-term (2030)	Long-term (2042)
<b>WP</b>			
Biodegradable waste	99	114	188
Recyclable	94	144	223
Other waste	358	391	569
<b>Total</b>	<b>551</b>	<b>649</b>	<b>980</b>
<b>Colombo District</b>			
Biodegradable waste	40	47	80
Recyclable	46	80	150
Other waste	257	268	362
<b>Total</b>	<b>343</b>	<b>395</b>	<b>598</b>
<b>Gampaha District</b>			
Biodegradable waste	35	44	70
Recyclable	37	46	45
Other waste	68	78	140
<b>Total</b>	<b>140</b>	<b>168</b>	<b>255</b>
<b>Kalutara District</b>			
Biodegradable waste	24	23	38

Recyclable	11	18	22
Other waste	33	45	67
Total	68	86	127

\* The number of vehicles for biodegradable waste are calculated based on the amount of biodegradable waste to be transported to the composting facilities.

\*\* The calculation for the number of vehicles for other waste includes the amount of biodegradable waste to be transported to TRFs.

**c. Transfer system**

Burnable waste will be transported to TRFs and waste to be disposed to Kelaniya TS. If the distance between the discharge point and these facilities (TRF/TS) exceeds 20 km, a primary transfer station (PTS) will be constructed, operated, and managed jointly by neighboring LAs.

Kelaniya TS, which is used for the transfer of waste to be disposed of in Aruwakkalu DS, is defined as a secondary transfer station.

■ Primary transfer stations (PTS)

➤ Transfer system

The system of unloading to the ground and reloading into dump trucks using heavy equipment such as shovel loaders, which is practiced by many LAs, will be terminated and some of them proposed to upgrade because of its negative impact on the surrounding environment (bad smells, pest infestations, and scattering of garbage) and low transfer efficiency. The PTSs will be operated within a cluster and jointly managed by neighboring LAs.

An overview of the PTS system is shown below:

- Waste to be transferred:
  - Burnable waste (transported to TRFs)
  - Waste to be disposed (transported to Kelaniya TS)
  
- Transfer system:
  - Waste is compressed by a stationary compactor and transferred into containers
  - Containers are loaded onto trucks

The waste collected by various types of collection vehicles is highly compressed by compactors and stored in large containers that are transported by arm-roll vehicles. The system is characterized by its ability to transport large volumes of waste efficiently, is environmentally friendly and can be installed with a relatively low Construction investment.

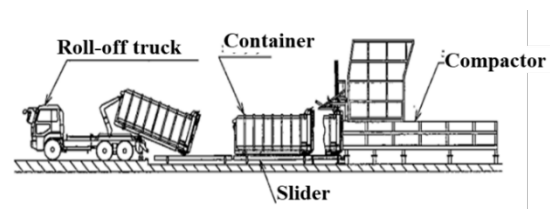

Figure 4-14 Mechanical transfer system

➤ Selection of LAs and location of PTSs

LAs where the approximate transport distance between their center and the relevant TRF

and/or Kelaniya TS exceeds 20 km were identified. Based on this selection, groups of LAs have been formed to jointly operate and manage the PTSs. The approximate location of the PTSs was determined according to the geographical conditions of the LAs belonging to the same cluster. The results of the selection of LAs in need of a PTS are shown in the table below.

The name of the PTS, the LAs that operate and manage them, and the amount of waste transferred are shown in the table following the one below.

The location of the TRFs and PTSs are shown in the figure below.

Table 4-13 Selection of LAs requiring a PTS

LA	District	Zone	Relevant TRF	Distance between LA and TRF (km)	Need for a PTS
Colombo MC	Colombo	Kotte	WPK	13.8	
Kaduwela MC	Colombo	Kotte	WPK	19	
Kolonnawa UC	Colombo	Kotte	WPK	14.8	
Kotikawaththa Mulleriyawa PS	Colombo	Kotte	WPK	16.5	
Wattala UC	Gampaha	Kelaniya	WPK	10.2	
Paliyagoda UC	Gampaha	Kelaniya	WPK	9	
Wattala PS	Gampaha	Kelaniya	WPK	11.1	
Kelaniya PS	Gampaha	Kelaniya	WPK	12.7	
Sri Jayawardanapura kotte MC	Colombo	Kotte	WPK	15.9	
Maharagama UC	Colombo	Kotte	Colombo district	6.5	
Dehiwala Mount-lavana MC	Colombo	Dehiwala	Colombo district	6	
Moratuwa MC	Colombo	Dehiwala	Colombo district	6.5	
Kesbewa UC	Colombo	Dehiwala	Colombo district	5.6	
Boralesgamuwa UC	Colombo	Dehiwala	Colombo district	3.7	
Homagama PS	Colombo	Dehiwala	Colombo district	20	Yes
Panadura UC	Kalutara	Horana	Colombo district	14.5	
Horana UC	Kalutara	Horana	Colombo district	28.5	Yes
Panadura PS	Kalutara	Horana	Colombo district	15	
Horana PS	Kalutara	Horana	Colombo district	24.3	Yes
Kaluthara PS	Kalutara	Horana	Colombo district	25.7	Yes
Beruwala UC	Kalutara	Kalutara	Colombo district	43.3	Yes
Beruwala PS	Kalutara	Kalutara	Colombo district	54.3	Yes
Bandaragama PS	Kalutara	Horana	Colombo district	19.9	
Kaluthara UC	Kalutara	Kalutara	Colombo district	30.4	Yes
Seethawakapura UC	Colombo	Dehiwala	Colombo district	47.8	Yes
Seethawaka PS	Colombo	Dehiwala	Colombo district	28.4	Yes
Madurawala PS	Kalutara	Horana	Colombo district	43.8	Yes
Millaniya PS	Kalutara	Horana	Colombo district	27.6	Yes
Bulathsinhala PS	Kalutara	Kalutara	Colombo district	50	Yes
Mathugama PS	Kalutara	Kalutara	Colombo district	51.3	Yes
Dodangoda PS	Kalutara	Kalutara	Colombo district	41.9	Yes
Palindanuwara PS	Kalutara	Kalutara	Colombo district	66.6	Yes
Agalawatta PS	Kalutara	Kalutara	Colombo district	56.6	Yes
Walallawita PS	Kalutara	Kalutara	Colombo district	69.4	Yes
Negambo M.C	Gampaha	Negambo	Gampaha district	28.4	Yes
Katunayaka Seeduwa UC	Gampaha	Negambo	Gampaha district	32.3	Yes
Minuwangoda UC	Gampaha	Negambo	Gampaha district	21	Yes
Ja Ela UC	Gampaha	Gampaha	Gampaha district	34.1	Yes
Biyagama PS	Gampaha	Kelaniya	Gampaha district	44.2	Yes
Katana PS	Gampaha	Negambo	Gampaha district	24.3	Yes
Mimuwangoda PS	Gampaha	Negambo	Gampaha district	24.1	Yes
Gampaha MC	Gampaha	Gampaha	Gampaha district	29.5	Yes
Attanagalla PS	Gampaha	Gampaha	Gampaha district	26.1	Yes
Gampaha PS	Gampaha	Gampaha	Gampaha district	29.5	Yes
Ja-Ela PS	Gampaha	Gampaha	Gampaha district	34.2	Yes
Mahara PS	Gampaha	Gampaha	Gampaha district	38.8	Yes
Divulapitiya PS	Gampaha	Negambo	Gampaha district	10.9	
Mirigama PS	Gampaha	Gampaha	Gampaha district	16.7	
Dompe PS	Gampaha	Kelaniya	Gampaha district	39.6	Yes

WPK: Western Power at Kerawalapitiya, TRF: Thermal recovery facility

Table 4-14 PTSs, associated LAs and waste to be transferred

Primary Transfer Station	LAs operating and the PTS	Type of waste to be transferred	Amount of waste transferred (ton/day)		
			2025	2030	2042
Colombo TS	Homagama PS, Horana UC, Horana PS, Seethawakapura UC, Seethawaka PS	Burnable waste	40	80	140
		Waste to be disposed	50	10	0
		Total	90	90	140
Kalutara West TS	Kaluthara PS, Beruwala UC, Beruwala PS, Kaluthara UC, Madurawala PS, Mathugama PS, Dodangoda PS	Burnable waste	0	80	120
		Waste to be disposed	60	10	10
		Total	60	90	130
Kalutara East TS	Millaniya PS, Bulathsinhala PS, Palindanuwara PS, Agalawatta PS, Walallawita PS	Burnable waste	0	30	60
		Waste to be disposed	20	10	10
		Total	20	40	70
Gampaha West TS	Biyagama PS, Gampaha MC, Attanagalla PS, Gampaha PS, Mahara PS, Dompe PS	Burnable waste	0	0	230
		Waste to be disposed	110	130	10
		Total	110	130	240
Gampaha East TS	Negambo M.C, Katunayaka Seeduwa UC, Minuwangoda UC, Ja Ela UC, Katana PS, Minuwangoda PS, Ja-Ela PS	Burnable waste	0	0	270
		Waste to be disposed	140	170	10
		Total	140	170	280



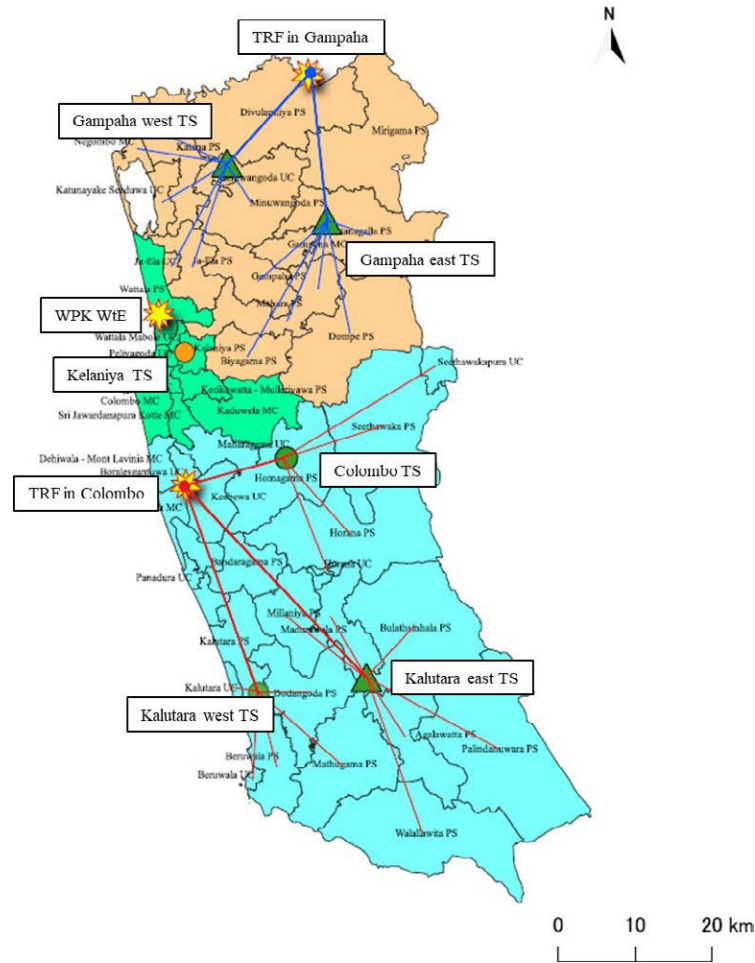

Figure 4-15 Location of TRFs and PTSs

■ Required number of containers and vehicles for PTSs

➤ Required number of containers

The number of containers required by the PTSs is calculated according to the following conditions:

- Capacity of the containers: 15 m<sup>3</sup>/unit (9 ton/unit)
- Apparent specific gravity of waste: 0.2 ton/m<sup>3</sup>
- Compaction ratio for loading: 1: 3

Table 4-15 Required number of containers

	2025	2030	2042
Colombo TS	15	14	24
Kalutara West TS	10	14	22
Kalutara East TS	3	5	10
Gampaha West TS	17	22	41
Gampaha East TS	24	28	46

➤ Required number of vehicles

The number of transfer vehicles required by the PTSs is calculated according to the following conditions:

- Distance to TRFs/Kelaniya TS and number of trips:

**Table 4-16 Distance to TRFs/Kelaniya TS and number of trips**

	Average distance to TRFs / Kelaniya TS (km)	Number of trips (Trips/day)
Colombo TS	20	8
Kalutara West TS	40	4
Kalutara East TS	45	3
Gampaha West TS	20	8
Gampaha East TS	20	8

- Type of transfer vehicles: Roll-on/roll-off trucks
- Speed per hour: 40 km/h
- Working hours per day: 8 h/day

**Table 4-17 Number of transfer vehicles required**

	2025	2030	2042
Colombo TS	2	2	3
Kalutara West TS	3	4	6
Kalutara East TS	1	2	4
Gampaha West TS	3	3	6
Gampaha East TS	3	4	6

■ Kelaniya Transfer Station (Kelaniya TS)

The Government of Sri Lanka (GOSL) and Western Region Megapolis Solid Waste Management Project (WRMSWMP) have concurred that a sanitary landfill was the most appropriate long-term solution for the management of MSW generated in the Metro Colombo Region and selected the abandoned limestone quarries in Aruwakkalu, Puttalam as final disposal site to meet city-wide needs for at least 20 years with waste transfer using rail transport from Colombo to the sanitary landfill under a Design & Build Contract. Transfer stations are places where MSW is loaded into trains for transportation and unloaded from the trains. In addition to mere loading and unloading, some other activities such as compacting, weighing, etc. are carried out in the transfer stations. Two transfer stations, namely Loading Transfer Station at Kelaniya and Unloading Transfer Station at Aruwakkalu, have been constructed.

The Loading Transfer Station located in the Kelaniya area of the Western Province is bordered by the Colombo Railway Main Line and the Colombo-Kandy Highway. It adjoins the compost yard and the former dump site of Kelaniya. There are several canals that lead from the west to the east and the north to the south, and the proposed site is a marshy, wetland.

The activities intended to be performed at the Kelaniya TS, where the collected MSW is

transferred for rail transportation are:

- 1) Reception of MSW
- 2) Weighing and accounting
- 3) Compaction and loading into containers
- 4) Unloading of the empty containers from the train
- 5) Transfer of the loaded containers to the rail wagons and dispatch to Aruwakkalu
- 6) General administration and maintenance of the transfer station

It is necessary to compact the MSW before rail transport to minimize the transportation costs. The “Compactor cum Loader” shall press the compacted MSW into transfer containers placed on tractor trailers. The capacity of a compactor shall be 80 tons per hour or 4 containers per hour. Compactors shall be able to compact 600 tons of MSW in less than 5 hours. Accordingly, the required compaction rate is approximately 120 tons per hour and one container should carry 20 to 24 tons of compacted MSW. The capacity of the Loading Transfer Station should be sufficient to handle 1,200 ton/day compaction capacity to compact and load into containers for 2 trains in a day each with 26 containers carrying capacity as a train has to carry nearly 600 tons of MSW.

An overview of Kelaniya TS is shown below.

- Types of waste to be transported:
  - Untreated waste
  - Residue generated at composting, recycling and thermal recovery facilities
- Transfer system:
 

The main transfer system will be as follows:

  - Waste collected from LAs whose distance with Kelaniya TS exceeds 20 km will be first transferred at a PTS before being transported to a TRF/Kelaniya TS.
  - The MSW will be compacted at the Kelaniya transfer station using 3 units of static compactors. The capacity of each compactor is 80 tons per hour.
  - The compacted MSW known as bales will be transferred into 20- foot transport containers that will be loaded onto trucks.
  - The total weight of a container including compacted MSW is limited to 20 tons.
  - The truck loaded with the container will drive to the railway loading point.
  - The MSW containers will be loaded onto trains using cranes. These cranes have a safe lifting load of 20 tons.
  - The train will proceed to the final railway station.
  - The MSW loaded containers will be removed and loaded onto 6x6 flatbed tipper trucks.
  - The tipper trucks will then proceed to the landfill area and unload the MSW by tipping their beds.
  - After unloading the MSW, the trucks will bring back the empty containers and load them onto a train.
  - The train will proceed back to Kelaniya with the empty containers and unload them at an

assigned area.

- The existing rail track from Colombo to Wanathawilluwa via Puttalam will be used for transportation.
- The transportation network from Kelaniya TS to the main railway track will be extended from Wanathawilluwa railway station to the nearest point to the landfill.

➤ Amount of waste to be transferred, required number of containers and number of trips per day

The required number of containers and number of trips per day have been calculated based on the following conditions:

- Distance: 150 km (from Kelaniya TS to Aruwakkalu DS)
- Capacity of containers: 10 m<sup>3</sup>
- Number of containers that can be transported per trip: 100 containers/trip

**Table 4-18 Required number of containers and number of trips per day in Kelaniya TS**

	2025	2030	2042
Amount of waste to be transferred (ton/day)	220	1,000	1,210
Required number of containers (container/day)	50	730	750
Number of trips per day (trip/day)	1	8	8

**(4) Promotion of recycling at intermediate treatment facilities**

[Key strategic actions]

- The aim is to achieve zero disposal of collected biodegradable waste.
- Promotion of thermal recovery for burnable waste and approximately 20% of the collected biodegradable waste.
- Increased capacity of composting facilities to maximize the production of compost from the biodegradable waste collected.
- Improvement of the existing Sampath Kendraya (SK), incl. increased treatment capacity, in order to promote recycling.

**d. Thermal Recovery Facilities (TRFs)**

■ Development plans for TRFs

In this MP, considering the strained final disposal sites in the Western Province, thermal recovery was identified as the most effective intermediate treatment technology as it reduces the volume of waste to be disposed. Furthermore, land scarcity, treating large quantity of waste in small land area, social pressure etc. are the reasons for the selection of TRFs. The policy to develop TRF is as follows.

In addition to the current capacity of 750 tons per day of the WPK WtE facility, a TRF in Colombo District with a capacity of 400 tons per day will be commissioned in 2025. This will be

followed by an additional 750 tons per day at the WPK WtE facility in 2028, taking its processing capacity to 1,500 tons per day. In 2028, an additional 400 tons per day will be added to the TRF in Colombo District to bring the capacity to 800 tons per day. In 2036, a TRF in Gampaha with a capacity of 600 tons per day will be constructed.

Table 4-19 Development plans for TRFs (ton/day)

	2021	2022	2023	2024	2025	2026	2027	2028	2029	2030	2031	2032	2033	2034	2035	2036	2037	2038	2039	2040	2041	2042
WPK	750	750	750	750	750	750	750	750	750	750	750	750	750	750	750	750	750	750	750	750	750	750
TRF in Colombo								Construction		400	400	400	400	400	400	400	400	400	400	400	400	400
TRF in Gampaha								Proposal, consensus, tender, etc.		Construction		600	600	600	600	600	600	600	600	600	600	600
Total capacity	750	750	750	750	750	750	750	1,900	1,900	1,900	1,900	1,900	1,900	2,900	2,900	2,900	2,900	2,900	2,900	2,900	2,900	2,900

The figure below shows the variations in the amount of burnable waste and the capacity of the TRFs. Depending on the requirements and capacity of the developers, the construction schedule of the facilities may be modified to meet the final thermal recovery targets.

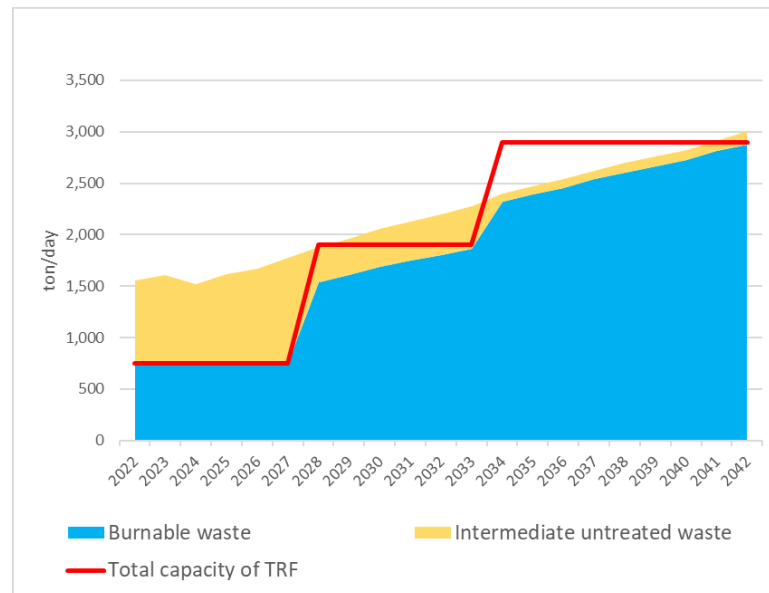

Figure 4-16 Burnable waste vs TRFs' capacity

Information on future treatment technologies should be continuously gathered to systematically verify their feasibility in terms of waste compatibility, reliability of the technology, amount of residues generated, and economic efficiency.

■ Forecasted amount of electricity generated from the proposed TRFs

The table below shows the capacity of the TRFs to be developed in the Western Province in the short-, medium-, and long-term, the electric power associated with waste generation, and the cumulative electricity power generation.

Table 4-20 Electric power expected to be generated by TRF

	2025	2030	2042
Capacity of TRF (ton/day)	750	1,800	2,900
Electric power (kW)	10,000	24,000	37,000
Amount of electric power (MWh)*	74,400	178,560	275,280
Cumulative amount of electric power generated (GWh)	298	982	3,995

\* Number of days of operation: 310 days/year

#### ■ Recycling of biodegradable waste

##### ➤ Collection and intermediate treatment of biodegradable waste

The processing capacity of the LAs' and cluster-based composting facilities is 324 tons per day in 2022 and will increase to 930 tons per day in the long-term. In addition, composting facilities capable of processing a total of 400 tons per day of biodegradable waste will be developed in several waste parks planned by MoUD&H.

Table 4-21 Biodegradable waste treated and capacity of composting facilities (ton/day)

Year	Biodegradable waste			Capacity of composting facilities			Total capacity	Directly transported to final disposal site
	Collected	Treated in TRF*	Treated in composting facilities	Waste parks	LAs' composting facilities	Cluster- based composting facilities		
2022	896	237	325	0	92	232	324	334
2023	962	199	399	0	103	297	400	364
2024	1,021	171	596	160	110	340	610	254
2025	1,084	136	611	160	117	340	610	337
2026	1,146	108	677	240	130	340	710	361
2027	1,207	72	692	240	131	340	710	443
2028	1,266	566	700	320	131	340	790	0
2029	1,335	591	744	320	131	340	790	0
2030	1,402	616	786	400	131	340	870	0
2031	1,479	638	841	400	136	340	870	0
2032	1,525	650	875	400	136	364	900	0
2033	1,594	668	926	400	136	414	950	0
2034	1,662	741	921	400	136	414	950	0
2035	1,717	757	960	400	136	464	1,000	0
2036	1,782	772	1,006	400	136	464	1,000	4
2037	1,856	793	1,063	400	136	524	1,060	0
2038	1,926	806	1,120	400	136	584	1,120	0
2039	1,997	822	1,175	400	136	644	1,180	0
2040	2,063	832	1,231	400	136	694	1,230	0
2041	2,143	850	1,293	400	136	764	1,300	0
2042	2,226	868	1,332	400	136	794	1,330	26

\*Percentage of residues generated from biodegradable waste: 35%, Water content+ degradable: 62%, Compost (product): 3%

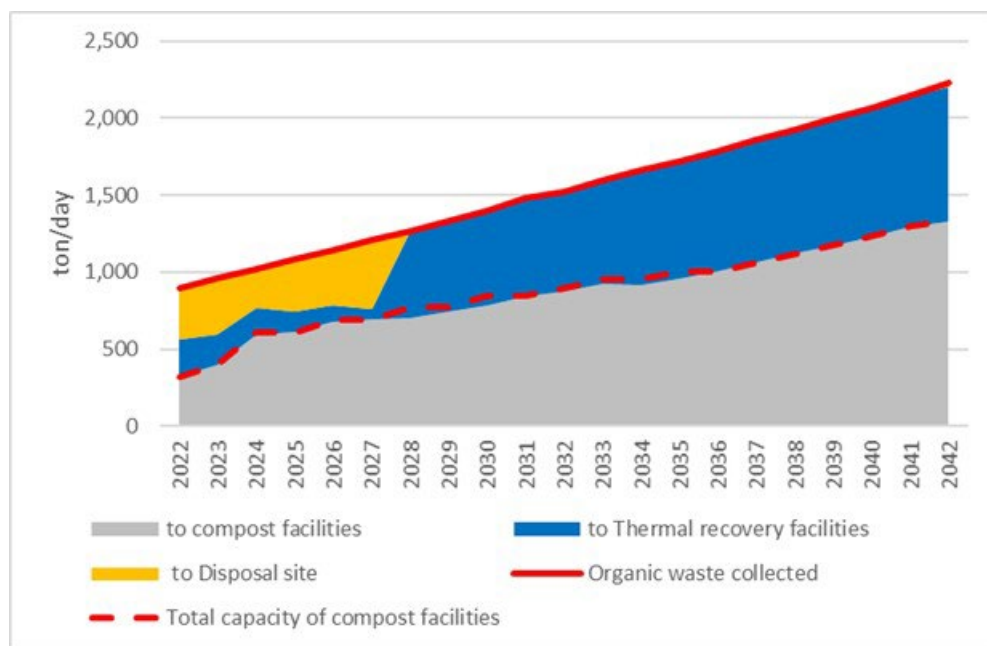

Figure 4-17 Biodegradable waste collected and treated/disposed

➤ Development policy for the Karadiyana Compost Plant

Karadiyana Compost Plant is being refurbished, in particular to rehabilitate the dump yard for biodegradable waste and upgrade the treatment facility which is an essential component of the MP, and it is planned to use the refurbishment plan as a model for the renovation of other large-scale composting facilities.

- The main refurbishments being implemented at the Karadiyana Compost Plant are as follows:
- Increase in the treatment capacity of the existing composting process.
- Improvement of the compost sieving capacity.
- Reduction of environmental pollution such as offensive odors and leachate caused by inappropriate waste handling at site A.
- Strengthening of the planning and management capacity of the plant's staff

➤ Refurbishment phases:

Phase 1: Trommel installation and sieving

Phase 2: Landfill mining and composting

Phase 3: Windrow composting over the entire area of site A

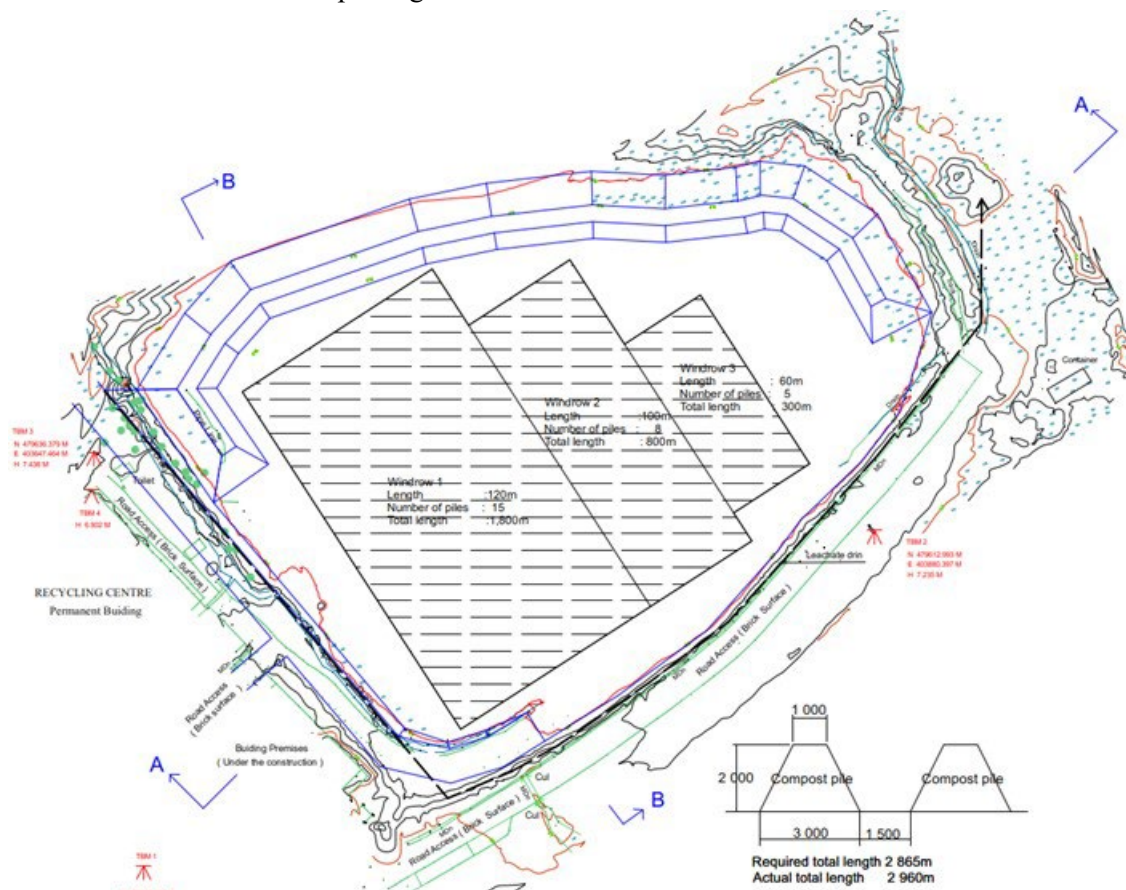

Figure 4-18 Proposed development plan of Karadiyana Compost Plant



■ Development policy of waste park composting facilities

Waste parks are intermediate treatment zones aimed at facilitating recycling, and consisting of a composting plant, a material recovery facility (MRF), a transfer station, etc. It is planned that MRF with a treatment capacity of 20-30 ton/day and the composting plant with a capacity of 80-100 ton/day. The proposed layout of a waste park is shown below.

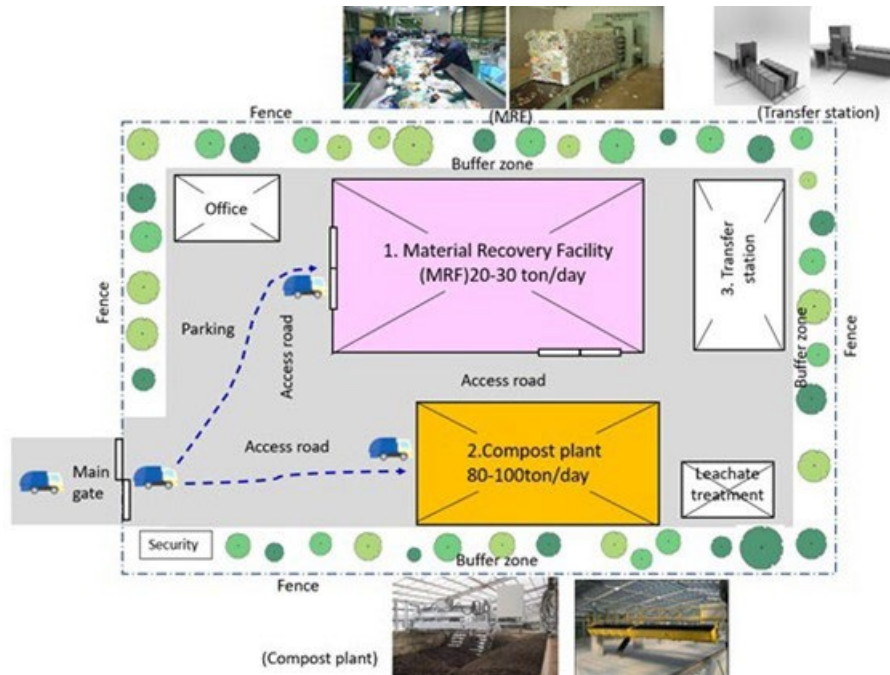

Figure 4-19 Proposed layout for waste parks

The MRF is intended to separate and process metals, plastics, bottles, paper and cardboard as recyclable materials. The composting plant shall be mechanical and is intended to produce compost by aerobic decomposition of kitchen waste and garden waste that have been sorted at source and brought to the waste park. The TS is intended to transfer the residues generated from the MRF and the composting plant into containers for transport to the final disposal facility.

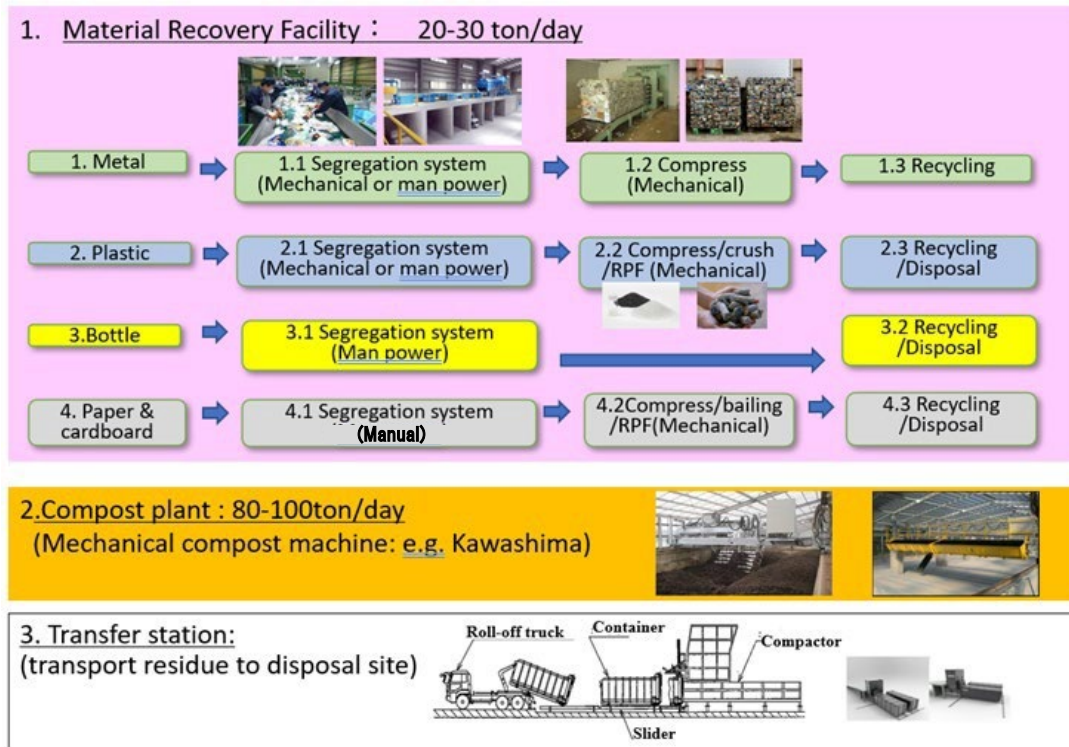

Figure 4-20 Proposed concept for intermediate treatment in waste parks

■ Material recycling

Recycling facilities will be upgraded and capacity and/or facilities increased according to the increasing amount of recyclable waste and improved sorting practices.

- Increased amount of recyclables collected due to improved collection coverage and increased amount of waste collected in total.
- To promote material recycling, it is important to establish a system to discharge and collect recyclable materials separately from other waste.
- MRFs in waste parks will be constructed to promote recycling.

The following is a basic approach to this issue, the development of recycling facilities, and their operation and management The following is a basic approach to this issue, the development of recycling facilities, and their operation and management.

- Strengthening of the recyclable waste collection program in all LAs.
- Introduction of “SAMPATH PIYASA” (which accept the recyclables) as pilot project to improve the collection of recyclable waste. Promotion of “SAMPATH PIYASA”.
- Development of the existing “SAMPATH KENDRA (SK)”, or “mini-MRF facilities” in each LA.
- Improvement of the relationship between LAs and recyclable waste collectors to manage collected recyclable waste.

Table 4-22 Recyclable waste collected (ton/day)

Year	WP	District				Zone					
		Colombo	Gampaha	Kalutara	Kotte	Dehiwala	Negombo	Gampaha	Kelaniya	Horana	Kalutara
Informal recycling by waste collectors											
2025	224	125	72	27	76	49	35	18	19	11	16
2030	244	137	76	31	85	52	35	22	19	14	17
2042	229	133	67	29	85	48	25	26	16	15	14
Recycling carried out in LAs' recycling facilities											
2025	169	84	67	18	65	19	12	45	10	11	7
2030	255	153	77	25	120	33	18	46	13	14	11
2042	421	305	85	31	225	80	37	30	18	16	15
Total											
2025	393	209	139	45	141	68	47	63	29	22	23
2030	499	290	153	56	205	85	53	68	32	28	28
2042	650	438	152	60	310	128	62	56	34	31	29



Recyclable storing center operated by PS



Recyclable sorting and storing center operated by Biyagama PS



MRF of Moratuwa MC



“Sampath Piyasa” (Center accepting recyclables) managed by Mahara PS

Figure 4-21 Current situation of LAs' recycling facilities

■ Establishment of plastic waste management system

By 2042, which is the final year of the MP, the amount of plastic waste generated is expected to increase to 293,000 tons per year, a 65% increase from the current amount. The aim is to establish an integrated system to manage plastic waste, from generation to intermediate treatment

and final disposal, and to introduce appropriate waste management and environment conservation measures, such as the reduction of plastic waste generation at source, prevention of marine plastic pollution by improving waste collection, and reduction of the amount to be disposed by promoting material and thermal recycling of plastic waste.

According to the National Action Plan on Plastic Waste Management (2021-2030) formulated by the Ministry of Environment, Goal 9 sets a target to increase the recycling ratio of plastic waste to 15% by 2025. The estimated ratio of recycled plastics through this MP meets the targets set in the National Action Plan.

Table 4-23 Plastic waste recycling ratio

Items	Calculation	Unit	2022	2023	2024	2025
(a) MSW generated	(a)	ton/day	3,926	4,077	4,210	4,342
(b) Amount of plastic contained in the generated MSW	(b)	ton/day	196	204	211	217
(c) Percentage of plastic in the generated MSW *	(b) / (a)	%	5.0	5.0	5.0	5.0
(d) Recyclables collected **	(d)	ton/day	314	330	348	367
(e) Amount of plastic contained in the recyclables collected	(e)	ton/day	31	35	38	44
(f) Percentage of plastic in the recyclables collected ***	(e) / (d)	%	6.0	7.0	8.0	9.0
(g) Percentage of plastic collected out of total plastic generated	(e) / (b)	%	9.7	11.3	13.3	15.2

\* Based on SATREPS survey data

\*\* Informal recycling + recyclables sorted in recycling facilities

\*\*\* According to the results of the survey conducted in recycling facilities, the percentage of sorted plastics was about 6%. The sorting ratio of plastic is expected to increase to 9% by 2025.

## (5) Reduction of waste to be disposed

[Key strategic actions]

- Reduction of the amount of waste to be disposed by reducing waste generation and
- promoting separate collection, recycling and incineration.
- Closure of open dump sites

### a. Cluster-based disposal site (Aruwakkalu Final Disposal Site at Puttalam)

#### ■ Overview of Aruwakkalu Disposal Site (DS)

The outline of Aruwakkalu DS is described below.

- Project proponent: MoUD&H
- Operation management entity: MoUD&H
- Landfill capacity: 5,668,000 m<sup>3</sup>
- Expected commercial operation date: Rescheduled to start in January 2024

➤ Equipment:

The equipment list is shown the table below:

**Table 4-24 Equipment list of Aruwakkalu DS**

Equipment	Number
Stationary compactors	3
Transfer cranes	4
Special duty shovels	3
Trailers for loading at Kelaniya TS	8
Trailers for unloading at Aruwakkalu TS (ATS)	8
Prime movers at KTS	8
Prime movers at ATS	8
Containers	68
Weighbridges	2

- Environmental measures: leachate treatment plant, deodorizer, effluent treatment plant at Kelaniya TS, Contractor should suggest, design and build to fulfill the environmental requirements stipulated in the National Environmental Act and relevant Regulations under the Act.
- Operation management system: The facilities will be operated and managed by Project Management Unit/Contractor until a Special Purpose Vehicle (SPV) is formed.

■ Type of waste to be disposed

- Untreated waste
- Residues generated in composting, recycling
- Ash from thermal recovery facilities (with modification)

■ Amount of waste to be disposed and landfill capacity

Since the volume of waste destined for final disposal in the Western Province will exceed the total capacity of Aruwakkalu DS (5.6 million m<sup>3</sup>) of Phase 1 and Phase 2 in 2036, it is necessary to increase the total capacity of the final disposal sites by about 3.0 million m<sup>3</sup> by 2042.

**Table 4-25 Progression of the volume to be landfilled (million m<sup>3</sup>)**

Year	Cumulative volume for disposal at Aruwakkalu DS		Total volume to be landfilled
	Waste to be disposed	Soil cover	
2022	0.38	0.09	0.47
2023	0.4	0.10	0.50
2024	0.8	0.20	1.00
2025	1.23	0.31	1.54
2026	1.7	0.42	2.12
2027	2.2	0.55	2.75
2028	2.52	0.63	3.15
2029	2.86	0.71	3.57
2030	3.2	0.80	4.00
2031	3.57	0.89	4.46
2032	3.94	0.99	4.93
2033	4.34	1.09	5.43
2034	4.66	1.16	5.82
2035	4.98	1.24	6.22
2036	5.31	1.33	6.64
2037	5.66	1.42	7.08
2038	6.02	1.51	7.53
2039	6.4	1.60	8.00
2040	6.78	1.70	8.48
2041	7.19	1.80	8.99
2042	7.61	1.90	9.51

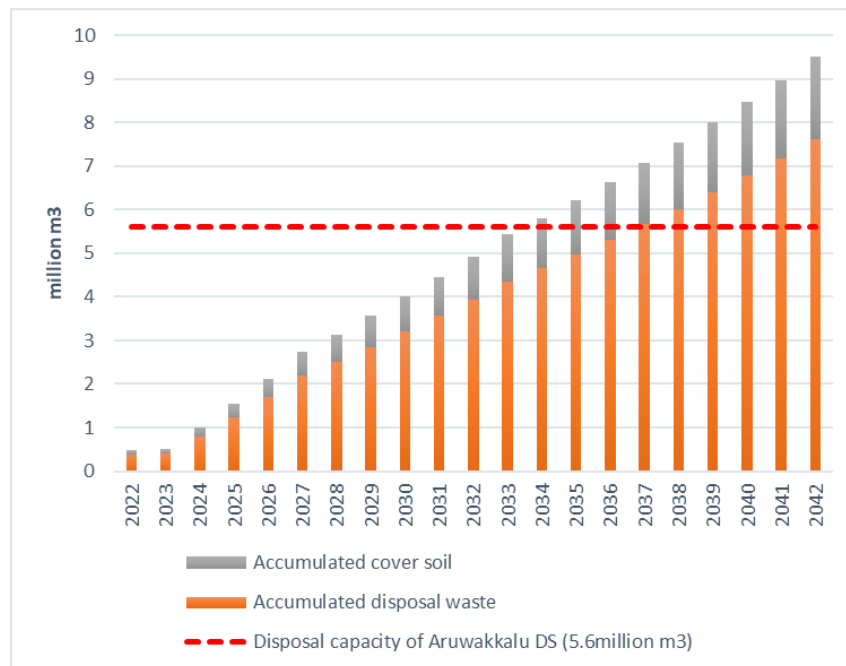

**Figure 4-22 Evolution of the volume to be landfilled (million m<sup>3</sup>)**

**b. Closure of current dump sites operated by LAs**

LAs aim to dispose of all waste in Aruwakkalu DS. The closure of other dump sites used by LAs will start as soon as the LAs are ready.

The main preparation works for the closure of the current dump sites are as follows:

- Preparation of a manual on the closure of existing dump sites.
- Briefing to LAs and approval of closure.
- Securing the budget need ed to close the current dump sites.
- Implementation of closure works in accordance with the manual.

The closure plan for existing dump sites should include the following:

- Final cover design
- Surface water and drainage control systems
- Control of landfill gases
- Control and treatment of leachate
- Environmental monitoring system



Figure 4-23 Current dump sites operated by LAs

**(6) Establishment of a data management system based on a database**

In order to implement, monitor, analyze and improve SWM in the Western Province using a PDCA cycle properly, it is necessary to collect and integrate related SWM data from each LA, cluster-based treatment facilities and disposal sites, intensifies the requirement of establishment of a database system for the entire Western Province.

The national level database system proposed in this MP will be established as a pilot project of JICA. MoPAHAPCLG (NSWMSC), as the main stakeholder, will coordinate as well as operate the database.

The database will be monitored by WMA, while the LAs will enter the waste-related data gathered within their respective jurisdiction for each stage of the SWM flow, such as collection, transportation, composting, recycling, disposal, etc.

## **4.5 Economic and financial analysis of the MP**

### **4.5.1 Framework of economic and financial analysis**

This section analyses the economic viability of the MP.

Cost-Benefit Analysis (CBA) is often used as a method for the economic evaluation of development projects (or programs). CBAs are monetary-term based, and two types exist: financial CBA and economic CBA. A financial CBA analyses project investment profitability by considering the project entity's direct income as a benefit and can be applied in the case of a revenue-generating cost-recovery project. An economic CBA, on the other hand, determines whether the decision to invest in a project is appropriate from the perspective of economic benefit. It considers the benefits not only for the project entity but also for the whole society.

Since MSW management is provided as a public service and not carried out as a profitable business, financial CBA cannot be applied, except for profitable segments like the recycling of materials with high commercial value. An economic CBA would require converting the environmental benefit of waste management into monetary value, but it is generally difficult to objectively and scientifically estimate this monetary value.

Thus, given the above considerations, a CBA is not carried out in this MP.

A Cost-Effectiveness Analysis (CEA) is an alternative to CBA. This method compares the relative costs to the outcomes (effects) of two or more courses of action. In this MP the costs of different alternatives for the management of 1 ton of waste are compared, and the cheapest one is judged to be cost-effective. CEA is performed according to the following procedure:

- Estimate the amount of waste collected, based on the collection improvement targets [Section 4.3 of this Master Plan],
- Set alternatives for intermediate treatment and final disposal of collected waste [Section 4.4 of this Master Plan],
- Calculate the cost-effectiveness ratio of each alternative (treatment cost per ton of waste), and
- Comparison and examination of the cost-effectiveness ratio of each alternative.

The CEA is based on a scenario in which the targets are fixed first, and then selects the method /means with the lowest cost. However, the financial situation of LAs in Sri Lanka is tight, and thus, affordability is limited. Since even the alternative with the minimum cost may be highly challenging to implement, a Financial Sustainability Analysis (FSA) of the LAs is also conducted.

In summary, the following two analyses are carried out as economic and financial analysis



of this MP:

- Cost-Effectiveness Analysis (CEA): To confirm that the selected method is the least expensive among the technically and environmentally feasible alternatives.
- Financial Sustainability Analysis (FSA): To confirm that the concerned authorities have sufficient financial capacity to afford the cost.

#### 4.5.2 Cost-effectiveness analysis (CEA)

##### (1) Evaluation standing point

The CEA is carried out from the standing point of waste management of the entire economy.

- Not only the public sector, i.e. LAs, the Western Provincial Council, WMA, and the Government of Sri Lanka, but also the concessionaires of waste-to-energy facilities and investors of future TRFs, all entities related to waste management are the target to evaluate economic cost of alternatives.
- All the costs related to the waste management activities are included as the project costs. Revenues from selling by-products such as compost and electricity are also counted (as negative costs).
- In the economic analysis (unlike the financial analysis), “cost” means “opportunity cost”. The opportunity cost of a particular activity is the loss of value or benefit that would be incurred (the cost) by engaging in that activity. For example, a waste-to-energy concessionaire sells electricity at the rate of Rs. 23.1/kWh. This rate is the financial value of electricity. The economic value of electricity is a social cost in the best available alternative, i.e. similar base-load generation technology such as natural gas combined-cycle generation at the cost of USDc 9.51/kWh (LKR 19.0/kWh). In the case of the sale of compost, the selling price of LKR10/kg is considered an economic benefit, as the market determines it.

##### (2) Levelized costs of the different treatment alternatives

The intermediate and final disposal technical options have different characteristics in the lifetime, project capacity, capital and operation costs. The levelized costs, calculated by dividing lifetime costs divided by the amount of waste, are an appropriate means for comparing different options. It uses the present value adjusted by the discount rate. In this analysis, if invested initially, the capital cost is converted into annual value by using the capital recovery factor (CRF).

$CRF = i(1+i)^n / ((1+i)^n - 1)$ , where  $i$ =discount rate;  $n$ =lifetime in years

In case the facility lifetime is 20 years and the discount rate 4%, the CRF is 7.4%. Other general conditions for cost calculation are as follows:

- Price as of September 2021, Constant price
- Exchange rate: USD 1 : LKR 200

The following three alternatives have been considered for the CEA.

Table 4-26 Specific Conditions of the Alternatives Considered: Intermediate Treatment and Final Disposal

	(1) Composting	(2) Thermal Recovery	(3) Direct Disposal
Input	Biodegradable waste only	Mixed waste (Biodegradable waste and recyclable waste can be included)	Any municipal waste
Process	From 1 ton of biodegradable waste, 100 kg of compost is produced.	Through the incineration with energy recovery process, 274 kWh of electricity is generated from 1 ton of mixed waste.	Waste is transported without intermediate treatment from Kelaniya TS to Aruwakkalu DS for disposal.
Output	250 kg of residues remain and are transported to Aruwakkalu DS for disposal. The compost is sold at the market at LKR 10/kg.	250 kg of residues remain and are transported to Aruwakkalu DS for disposal. The concessionaire sells electricity to CEB and the economic value of electricity is counted as revenue.	
Disposal			

Source: JICA Expert Team

The total cost per ton of waste management are compares among alternatives. The collection and transportation costs to the transfer station are assumed to be the same for all the above options and are thus not included in the calculation. The estimated costs (unit costs are taken from ANNEX 5 - Alternative B) are as follows:

**i. Composting**

CAPEX:	Unit-capacity Construction Cost	Rs. 500,000/ton
	Facility life 20 years; Interest rate 4% => Annal capital recovery factor 7.4% => Annualized capital cost	Rs. 37,000/ton year
	Per-ton Construction Cost	<u>Rs.100</u>
Operation:	Per-ton Composting operation cost	<u>Rs. 3,000</u>
Transportation:	Residue (250kg from 1 ton of organic waste) transportation & disposal: From III below Rs. 17,400 x 0.25	<u>Rs. 4,400</u>
Revenue:	100kg compost from 1 ton of organic waste @Rs 10/kg	<u>Rs. 1,000</u>

**ii. Thermal Recovery Facility (TRF)**

CAPEX:	Unit-capacity Construction Cost	Rs. 25,000,000/ton
	Facility life 20 years; Interest rate 4% => Annal capital recovery factor 7.4% => Annualized capital cost	Rs. 1,850,000/ton year
	Per-ton Construction Cost	<u>Rs.5,100</u>
Operation:	Per-ton TRF operation cost + 10% Overhead	<u>Rs. 7,700</u>
Transportation:	Residue (250kg from 1 ton of organic waste) transportation & disposal: From III below Rs. 17,400 x 0.25	<u>Rs. 4,400</u>
Revenue:	274kWh from 1 ton of waste; Avoidable cost for CEB Rs. 19.0kWh (from CEB Long-term Generaion Expansion Plan 2022-2041)	<u>Rs. 5,200</u>

**iii. Direct Disposal**

CAPEX: Aruwakkalu Construction Cost:	<u>Rs. 8,000</u>
OPEX: Operation cost at Aruwakkalu	<u>Rs. 4,000</u>
Transportation: From Kelaniya TS to Aruwakkalu	<u>Rs. 5,400</u>

**Table 4-27 Levelized costs of waste treatment and disposal per ton**

	(1) Composting	(2) Waste-to-Energy	(3) Direct Disposal
Capital Cost (CAPEX)	Rs. 100	Rs. 5,100	Rs. 8,000
Operation Cost	Rs. 3,000	Rs. 7,700	Rs. 4,000
Transportation	Rs. 4,400	Rs. 4,400	Rs. 5,400
Revenue (-)	- Rs. 1,000	- Rs. 5,200	
<b>TOTAL</b>	<b>Rs. 6,500</b>	<b>Rs. 12,000</b>	<b>Rs. 17,400</b>

Source: JICA Expert Team

As a result of the above cost-effective analysis, the least cost treatment method is (1) Composting organic waste, which costs Rs. 6,500 per ton. Second lowest is (2) Thermal recovery Rs. 12,000. And the highest is (3) Direct Disposal, Rs. 17,400.

- (1) Composting cost is lower by 63% from (3) Direct disposal costs. (2) Thermal recovery is lower by 31% from (3) Direct disposal cost. Thus, both (1) composting and (2) thermal recovery are more cost-effective than direct disposal.
- Since (1) composting and (2) thermal recovery are treatments for different types of waste, they are not mutually exclusive alternatives. Thus, both are to be implemented as technical and environmental conditions allow. Composting has a relative advantage in economic efficiency if there are financial resource constraints.
- The order of cost-effectiveness of alternatives is consistent with the waste management hierarchy. (1) Composting (recycling), (2) Thermal (energy) recovery, (3) Disposal. Acting according to cost-effectiveness is at the same time working according to the waste management hierarchy.

**4.5.3 Financial sustainability analysis (FSA)**

Financial sustainability analysis confirms that concerned authorities have sufficient financial capacity to afford the cost. This is critical from the following two considerations;

- It assumes from the past practice that the recurrent cost is financed by the local authorities, while the central government bears the capital investment cost. The capital cost is very small compared to the government's total capital budget. Therefore, the affordability of the government would not be an issue.
- The local authority's own revenue covers only one-quarter of total expenditure. The

remaining three quarters are transferred from the government (Western Province in 2020). Thus, the local authorities do not have the freedom to allocate a budget to their priority areas. Waste management currently receives 20% of total recurrent expenditure, the highest among other expenditure heads. It is unlikely to significantly increase the percentage allocated to waste management.

The Alternative B, which is considered as the best from the technical, environmental, and economic aspects, is assessed from the financial sustainability viewpoint.

The table below summarizes the waste management costs during the master plan period (20 years from 2023 to 42) by management process, separated for capital investment costs and operating costs. Process-wise comparison shows that collection costs account for 35%, transportation costs account for 23%, and these both together: transportation-related costs account more than the half. This is followed by incineration power generation, final disposal, and composting.

Table 4-28 Cost for the Master Plan (Total of 20 years)

Waste Management Process	Cost		Benefit (-)	Total Net Cost	%
	Capital	Operation			
Collection	7,513	95,754	0	103,267	29%
Transfer/Transportation	10,417	69,601	0	80,018	23%
Composting	503	19,638	- 6,546	13,595	4%
Recycling	2,000	4,164	0	6,164	2%
Thermal Recovery	53,748	99,437	- 73,953	79,232	23%
Final Disposal	31,291	38,046	0	69,337	20%
Total	105,472	326,640	80,499	351,613	100%
%	30%	93%	-23%	100%	

Source: JICA Expert Team

For the financial sustainability analysis, it is essential to recognize the total budget envelop of the respective organization. Since the capital budget fluctuates from year to year and depends on central Government, the comparison is made by the recurrent budget of 2020. The national government budget per person is Rs. 116,000, the same for Western Provincial Council is Rs. 12,000 (one-tenth of Government) and that for 49 Local Authorities is Rs. 4,000 (one-thirtieth of Government, one-third of WPC).

Table 4-29 Recurrent budget of the national government, WPC, and LAs (2020)

		Central Government	Western Provincial Council	Local Authorities in Western Province		
				49 LAs Total	CMC	48 LAs Excl. CMC
Recurrent Budget	(Rs. Mil)	2,548,359	73,774	22,533	10,895	11,638
Population	('000)	21,919	6,226	6,226	597	5,629
Recurrent /person	(Rs./ person)	128,036	11,849	3,619	18,250	2,068

Source: Budget Estimates 2020, Financial Statement (2020) Western Provincial Council, LA's Budget Data from Finance Commission

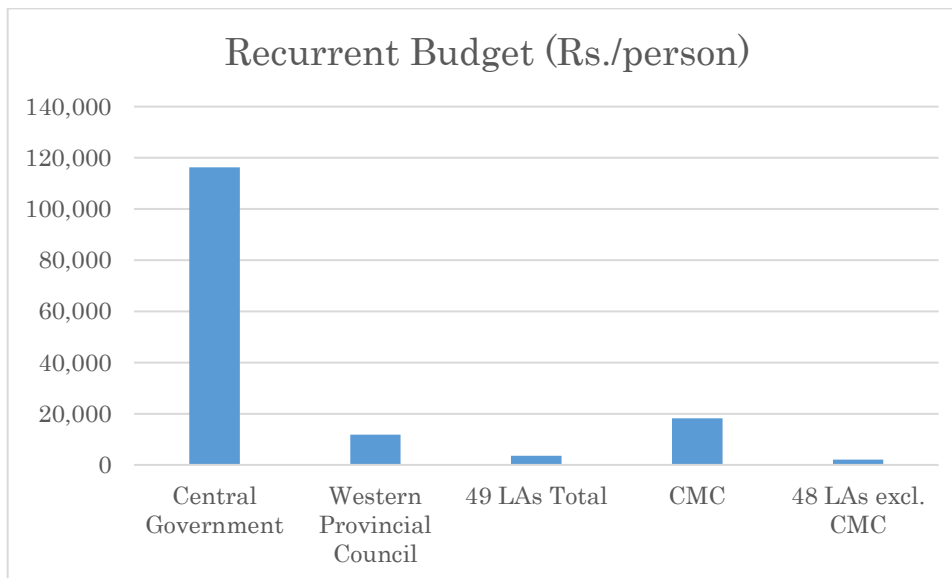

Figure 4-24 Comparison of recurrent budget per person (2020)

The table below shows the share of budget allocation for waste management in 42 local authorities in Western Province (data not available in 7 LAs). The average is 20%, the median is also 20%, and the most frequent range is 20%-30%.

Table 4-30 Share of Budget Allocation for Waste Management in LAs (2021)

	0% - 10%	10% - 20%	20% - 30%	30% - 40%	40% - 50%
No. of LA	9	12	15	5	1

Source: Local Authority's Budget Books 2021

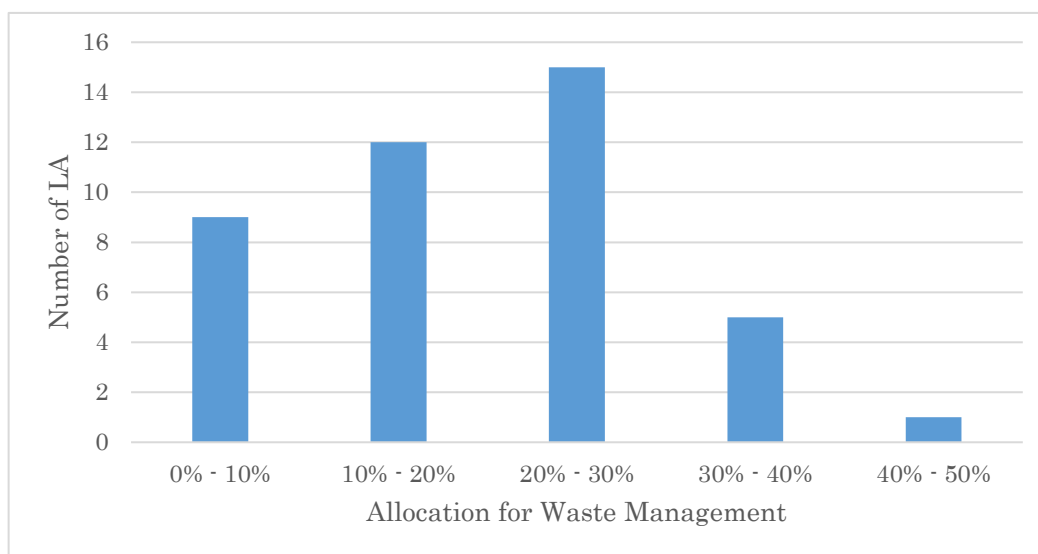

Figure 4-25 LAs' allocation to waste management in recurrent budget

To analyze the financial sustainability of LAs, the first step is to estimate their total recurrent

budget. It has been projected assuming a 5% per annum increase for 2023-2042 in real term.

Table 4-31 Projection of total recurrent budget in the 49 LAs in the Western Province (2022-2041)

	(Million LKR)						
	2021	2023	2027	2032	2037	2042	2023-42 Total
Recurrent Budget	26,426	29,135	35,413	45,197	57,685	73,622	963,365

Source: JICA Expert Team

Then, the costs estimated in the above sections for each activity of the waste management process are broken down into annual allocation, as shown below. These figures do not include the capital expenditure, which is supposed to be covered by the budget of the national government.

Table 4-32 Estimated operation cost of waste management (2022-2041) - Case 1

	(Million LKR)					
Waste Management Process	2023	2027	2032	2037	2042	2023-42
Collection	3,376	3,802	4,687	5,564	6,501	95,746
Transfer/Transportation	3,065	4,033	3,379	3,310	4,066	68,701
Composting	437	756	958	1,161	1,456	19,638
Recycling	96	147	208	258	307	4,164
Thermal Recovery	625	765	1,181	1,661	1,882	25,485
Final Disposal	2,010	2,513	1,895	1,751	2,113	38,056
<b>Total</b>	<b>9,610</b>	<b>12,015</b>	<b>12,308</b>	<b>13,705</b>	<b>16,325</b>	<b>251,790</b>
<b>% of Recurrent Budget</b>	<b>33%</b>	<b>34%</b>	<b>27%</b>	<b>24%</b>	<b>22%</b>	<b>26%</b>

Source: JICA Expert Team

The share of waste management in LAs' budget is indicated on the last line. It is within a reasonable range of financial affordability, except for the first five years (from 2023 to 2027).

The proportion of 33% in 2023 and peak of 34% in 2027 are 1.7 times the current level (20%). The sharp increase during this period is caused by the large volume of untreated waste transported to and disposed of in Aruwakkalu DS due to the lack of intermediate treatment facilities. The percentage then gradually lowers as intermediate treatment facilities develop and the amount of waste disposed of without treatment decreases.

The above scenario assumes that the capital expenditure is borne by the national government. Accordingly, it excludes the capital cost of thermal recovery. However, in operation phase, a payment in the form of a tipping fee is made to the TRF concessionaire for the waste it receives. In this case, both capital costs and operation costs are included in this fee. When part of the capital expenditure is included in the tipping fee, the share of waste management in the recurrent expenditure increases significantly, as shown in the table below (Case 2).

The share would double during the 2023-2027 period, which is unbearable. To avoid this unrealistic figure, the capital part should be removed from LAs' burden, either by financing the capital cost, e.g. through viability gap funding (VGF) by the national government at the

investment stage, or by subsidizing the capital portion through annual fund transfers from the Treasury to the concessionaire. It is essential that the national government, Provincial Council and LAs discuss and agree on this matter when formulating the project.

Table 4-33 Estimated Operation Cost of Waste Management (Case 2)

Waste Management Process	(Million LKR)					
	2023	2027	2032	2037	2042	2023-42
Collection	3,376	3,802	4,687	5,564	6,501	95,746
Transfer/Transportation	3,065	4,033	3,379	3,310	4,066	68,701
Composting	437	756	958	1,161	1,456	19,638
Recycling	96	147	208	258	307	4,164
Thermal Recovery	2,403	2,939	4,539	6,381	7,232	97,932
Final Disposal	2,010	2,513	1,895	1,751	2,113	38,056
<b>Total</b>	<b>11,388</b>	<b>14,190</b>	<b>15,666</b>	<b>18,426</b>	<b>21,675</b>	<b>324,238</b>
<b>% of Recurrent Budget</b>	<b>39%</b>	<b>40%</b>	<b>35%</b>	<b>32%</b>	<b>29%</b>	<b>34%</b>

Source: JICA Expert Team

## 4.6 Operation of the MP

### 4.6.1 Roles of the relevant organizations for M P implementation

#### (1) Roles and responsibilities for municipal waste management under the laws of Sri Lanka:

LAs and CEA are the entities that are legally responsible for municipal waste management in Sri Lanka; the former is responsible for managing waste from collection to disposal, and the latter is acting as the regulator. WMA, under the WMA Statute is also mandated to support the LAs and is operating cluster-based waste management facilities.

#### (2) Limited technical and financial capacities of LAs

Although continuous efforts have been made to strengthen LAs' capacity, their ability to provide services is generally still limited. Even pursuing the same efforts, it is rational to assume that their capacity will not drastically change in the medium term. In this context, it is recommended to put in place a complementary mechanism to overcome these limitations, especially on the financial side.

#### (3) Expected roles of stakeholder organizations to support MP implementation.

##### ■ Provincial Council (through WMA):

- Monitor waste management operations carried out by LAs and provide advice to LAs through WMA District/Zonal managers.
- Review and concur the SWM Action Plan and Annual Plan of each LA.
- Support LA's capital investment requests to relevant ministries at the national level.
- Provide services to the LAs through the development and operation of cluster-based intermediate treatment facilities, as well as for waste transfer, transportation and disposal.

- National Ministries Level
- Support at the national level is expected, among other things, for the provision of the capital budget:
  - To develop, in accordance with the MP, infrastructure and facilities for intermediate treatment, transfer, transport and disposal for use by LAs and WMA; and
  - To procure and deliver necessary transportation equipment for waste collection and transportation.

#### 4.6.2 Master Plan authorization

The Solid Waste Management Master Plan for the Western Province establishes a comprehensive waste management system with a long-term perspective in the Western Province. The central organization is the Western Provincial Council, represented by WMA. Once approved, the MP will be owned and operated by the Provincial Council and WMA. The MP will serve as a guideline to the LAs for their SMW Action Plan and Annual Work Programs.

##### (1) Authorization of the Provincial Master Plan

- For the recognition as a sectoral plan, the SWM MP must comply with the National Policy on Waste Management.
- Once developed by WMA through a consultation process with all stakeholders, the WMA Board submits the MP to the Minister for concurrence by the Board of Ministers of Western Province.
- Once concurred by the Board of Ministers, the Minister submits the SWM MP to the Western Provincial Council for approval.
- The Provincial Council, through the (national level) Minister in charge of Local Governments, forwards the MP to the Cabinet of Minister for approval. This process is necessary as the MP contains sectoral strategies and plans, and requires technical and financial support from the national government for its implementation.

##### (2) LAs' Action Plan in line with the Master Plan

- Every LA prepares its Action Plan on waste management in accordance with the Provincial Master Plan. Once the Council has approved the Action Plan, LAs submit it to WMA for WMA's review and concurrence. When LAs request a capital budget for development, WMA's concurrence provides evidence to justify such development.
- Every LA shall submit a progress report and Annual Work Program on the Action Plan to WMA for progress monitoring.



#### 4.6.3 Organizational development for MP implementation

- WMA is expected to play a central role in the implementation of the MP. However, this organization was created to meet the needs that existed 15 years ago. Since all projects and programs derived from the MP require technical and financial analysis and a consultation process with all relevant stakeholders, the current planning and implementation capacities of WMA are inadequate and need to be strengthened urgently as a prerequisite for effective implementation of the MP.
- The most critical ones, not visible now, are the planning and monitoring functions. Without an effective division for planning and monitoring, the organization will not be able to implement programs systematically. Planning is essential for evaluating project proposals, improving cost-effectiveness, and finally for proper decision-making. Currently, the functions are performed by several senior managers, but this system does not work well as all are busy with other duties. Proper monitoring and evaluation will guide the organization towards the targeted goals and outcomes. Although each division manager monitors the work of his/her team, review by a centralized team of professionals is essential for feedback and future planning.
- For WMA to play an effective driving role in the implementation of the MP, it is recommended to create a new division dedicated to Planning and Monitoring with two subdivisions, namely (a) Planning/R&D and (b) Monitoring and Evaluation. The Planning/R&D subdivision would primarily deal with strategic and long-term planning as well as project development, including implementation arrangement, while the Monitoring and Evaluation subdivision would be in charge of monitoring, performance review and feedback. The new division should be headed by a senior executive officer who would directly report to the Director/CEO.

## **5 Implementation of the SWM MP (short- and medium-term)**

### **5.1 Short- and medium-term implementation projects based on MP**

The solid waste management projects (SWM projects) that need to be prepared and implemented within eight years to achieve the Master Plan (MP) targets have been selected and planned.

#### **5.1.1 SWM projects and implementation schedule**

The short- and medium- (eight years) term SWM projects mainly consist of the following eight projects, and their overall implementation schedule is shown in the table below.

Project 1: Development of five Primary Transfer Stations (PTS)

Project 2: Implementation of Kelaniya Transfer Station (Kelaniya TS)

Project 3: Development of Cluster-based Waste Treatment Facilities (CWTF)

Project 4: Improvement of composting facilities

Project 5: Improvement of recycling facilities for recyclables collected by the formal collection service

Project 6: Procurement of collection and transfer vehicles

Project 7: Closure of current dump sites managed by LAs

Project 8: Encouragement of waste separation

Table 5-1 Schedule of short- and medium-term implementation plans

	2022	Short term				Medium term				
		2023	2024	2025	2026	2027	2028	2029	2030	
<b>Project 1: Development of five Primary Transfer Stations (PTS)</b>										
Colombo TS: 90 ton/day	Sites selection	Budgeting, Land parcels, Environmental process, DD, T/D	Tender, Contract, Construction	Operation						
Kalutara west TS: 90 ton/day				Operation						
Kalutara east TS: 40 ton/day				Operation						
Gampaha west TS: 130 ton/day				Operation						
Gampaha east TS: 170 ton/day				Operation						
<b>Project 2: Improvement of Kelaniya Transfer Station (KTS)</b>										
Amount of waste transferred (ton/day)	1,070	1,240	1,130	1,240	1,320	1,430	920	950	1,000	
Compared to 2022 (%)	100%	116%	106%	116%	123%	134%	86%	89%	93%	
<b>Project 3: Development of Thermal Recovery Facilities (TRF)</b>										
WPK WtE facility (750 ton/day)	Operation									
Additional WPK WtE facility (750 ton/day)		FS, EIA, Tender, Contract & DD	Construction				Operation			
TRF Colombo District (400 ton/day)		FS, EIA, Tender, Contract & DD	Construction				Operation			
<b>Project 4: Improvement of compost facilities</b>										
<b>Waste Park compost facilities</b>										
Waste Park (ton/day) No.1,2	Sites selection,	Construction	160	160	160	160	160	160	160	
Waste Park (ton/day) No.3		Sites selection, Tender, Contract	Construction	80	80	80	80	80	80	
Waste Park (ton/day) No.4			Sites selection, Tender, Contract	Construction	80	80	80	80	80	
Waste Park (ton/day) No.5				Sites selection, Tender, Contract	Construction	80	80	80	80	
Total			160	160	240	240	320	320	400	
<b>LAs and cluster-based compost facilities</b>										
Cluster-based facilities (ton/day)	232	300	340	340	340	340	340	340	340	
LA's facilities (ton/day)	92	100	110	120	130	130	130	130	130	
Total	324	400	450	460	470	470	470	470	470	
<b>Project 5: Improvement of recycling facilities for formal recyclables</b>										
Recyclable amount (ton/day)	120	130	150	170	190	200	220	240	260	
<b>Waste Park MRF facilities</b>										
Waste Park (ton/day) No.1,2	Sites selection,	Construction	60	60	60	60	60	60	60	
Waste Park (ton/day) No.3		Sites selection, Tender, Contract	Construction	30	30	30	30	30	30	
Waste Park (ton/day) No.4			Sites selection, Tender, Contract	Construction	30	30	30	30	30	
Waste Park (ton/day) No.5				Sites selection, Tender, Contract	Construction	30	30	30	30	
Total			60	60	90	90	120	120	150	
<b>Project 6: Procurement of collection and transfer vehicles</b>										
Compactor truck for organic waste	Subsidies and support systems	Procurement plan, approval, budgeting	99	101	108	108	111	114		
Compactor truck for other waste			358	378	407	360	373	391		
Tractor trailer for recyclable			94	105	115	126	137	144		
<b>Project 7: Closure of current dump sites operated by LA</b>										
Preparation of Guideline for closing dump sites	Guideline									
Technical guidance and budgeting secured for closure		Guidance Budgeting								
Implementation of closure			Implementation							
<b>Project 8: Development of waste separation promotion program</b>										
Development of waste separation guidelines	Guideline									
Seminar for LAs on understanding the guideline.		Seminar								
Preparation and implementation of promotion program		Preparation								
Implementation of separate collection of waste			Implementation							

### 5.1.2 Implementation of the projects

#### (1) Project 1: Development of Five Primary Transfer Stations (PTS)

##### i. Plan

Five primary transfer stations (PTSs) will be constructed in the Western Province to efficiently transport waste collected by LAs. The types of waste to be transferred, LAs that will use the PTSs, capacity of the PTSs, planned locations, transfer system, transfer equipment, implementation schedule and responsible organizations are shown below.

■ Types of waste to be transferred to the PTSs:

- Burnable waste
- Untreated waste

■ LAs that will use the PTSs and capacity of the stations

The five PTSs planned in the MP, the amount of waste to be transferred to those stations, and the 30 LAs that will use them are shown in the following table. The capacity of the stations was planned based on the amount of waste to be transferred in the medium-term (2030).

In addition, the following figure shows the approximate location of the proposed PTSs.

Table 5-2 PTSs, related LAs and amount of waste to be transferred

PTS	LAs that will use the PTS	Type of waste to be transferred	Amount of waste to be transferred (ton/day)		
			2025	2030	2042
Colombo TS	Homagama PS, Horana UC, Horana PS, Seethawakapura UC, Seethawaka PS	Burnable waste	40	80	140
		Untreated waste	50	10	0
		Total	90	90	140
Kalutara West TS	Kaluthara PS, Beruwala UC, Beruwala PS, Kaluthara UC, Madurawala PS, Mathugama PS, Dodangoda PS	Burnable waste	0	80	120
		Untreated waste	60	10	10
		Total	60	90	130
Kalutara East TS	Millaniya PS, Bulathsinhala PS, Palindanuwara PS, Agalawatta PS, Walallawita PS	Burnable waste	0	30	60
		Untreated waste	20	10	10
		Total	20	40	70
Gampaha West TS	Biyagama PS, Gampaha MC, Attanagalla PS, Gampaha PS, Mahara PS, Dompe PS	Burnable waste	0	0	230
		Untreated waste	110	130	10
		Total	110	130	240

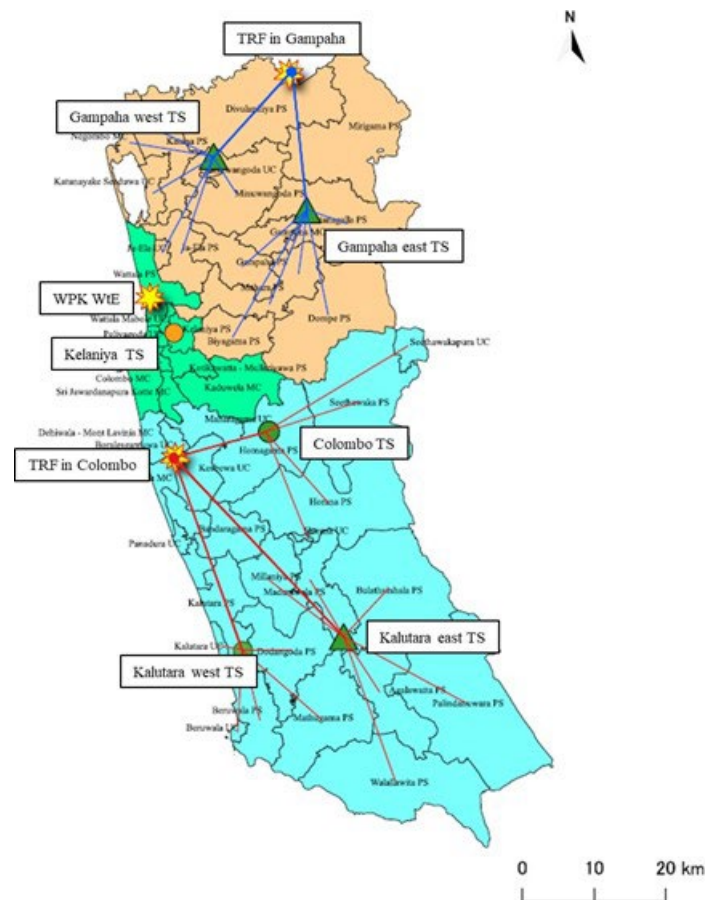

Figure 5-1 Location of the transfer stations

■ Transfer system: Mechanical compaction system

The waste collected is highly compressed by compactors and stored in large containers that are transported by arm-roll vehicles.

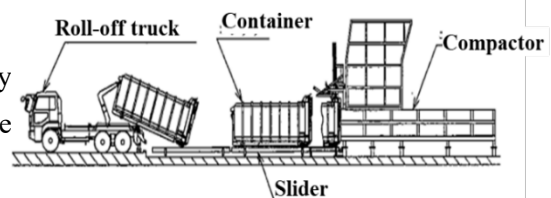

Figure 5-2 Mechanical compaction system

■ Required number of containers and transfer vehicles

➤ The number of containers required in the PTSs is calculated based on the following assumptions:

- Capacity of the containers: 15 m<sup>3</sup>/unit (9 ton/unit)
- Apparent specific gravity of waste: 0.2 ton/m<sup>3</sup>
- Compaction ratio for loading: 1:3

➤ The number of transfer vehicles required in the PTSs is calculated based on the following assumptions:

- Distance to TRF/Kelaniya TS and number of trips

Table 5-3 Distance to TRF/Kelaniya TS and number of trips

PTS	Average distance to TRF/Kelaniya TS (km)	Number of trips (Trips/day)
Colombo TS	20	8
Kalutara West TS	40	4
Kalutara East TS	45	3
Gampaha West TS	20	8
Gampaha East TS	20	8

- Speed per hour: 40 km/h
- Working hours per day: 8h/day

Table 5-4 Required number of containers and transfer vehicles by 2030

PTS	Required number of containers	Required number of transfer vehicles
Colombo TS	14	2
Kalutara West TS	14	4
Kalutara East TS	5	2
Gampaha West TS	22	3
Gampaha East TS	28	4

- Personnel structure: Managing and administrative staff (2), Control staff for waste reception (2), Operational staff (4), Maintenance staff (2)

**ii. Implementation schedule and responsible organizations**

The implementation schedule and responsible organizations are shown in Table 5-5. The PTSs will commence operation in 2025.

Table 5-5 Implementation schedule

Activities	2022				2023				2024				2025				2026				2027			
	Q1	Q2	Q3	Q4	Q1	Q2	Q3	Q4	Q1	Q2	Q3	Q4	Q1	Q2	Q3	Q4	Q1	Q2	Q3	Q4	Q1	Q2	Q3	Q4
Site identification																								
Preparation of project proposal																								
Proposal to MoPAHAPCLG																								
Budget preparation in MoPAHAPCLG																								
Government budget process																								
Preparation for land purchase																								
Obtention of environmental recommendation																								
Preparation of tender documents																								
Tender and contract																								
Construction																								
Commencement of operation																								

Table 5-6 Responsible organizations

Stage	Action	Responsible Organizations
	Site identification	WMA/UDA
Construction	Construction of PTS and procurement of equipment	WMA
	Financing of capital costs	MoPAHAPCLG
	Operation of PTS, including transportation to next destinations	WMA
Operation	Cost recovery	WMA charges a tipping fee to LAs

### iii. Project costs

The costs were calculated based on the following assumptions:

- Construction cost of PTS: LKR 10 million/ton
- Operation and maintenance costs: LKR 2,000/ton
- Roll-on/roll-off truck LKR 25 million
- Container (10 m<sup>3</sup>): LKR 1.0 million

Table 5-7 Project costs for the development of five PTSs (million LKR)

Cost items	2022	2023	2024	2025	2026	2027
Administrative costs (planning, preparation, etc.)	10	10	10	0	0	0
Operation and maintenance costs	0	0	0	41	43	46
Construction costs	0	0	4,790	0	0	0
Procurement of equipment/machinery	0	0	691	28	58	347
Miscellaneous expenses	1	1	549	7	10	39
<b>Total</b>	<b>11</b>	<b>11</b>	<b>6,040</b>	<b>76</b>	<b>111</b>	<b>432</b>

## (2) Project 2: Implementation of the Kelaniya Transfer Station (Kelaniya TS)

### i. Plan

- Types of waste to be transported:
  - Untreated waste (waste which exceeds the capacity of intermediate treatment facilities, non-burnable waste)
  - Residues generated in composting, recycling, and thermal recovery facilities
- Transfer system: Railway
- Amount of waste to be transferred, required number of containers, and number of trips per day:

The required number of containers and number of trips per day is calculated based on the following assumptions:

- Distance: 150 km (from Kelaniya TS to Aruwakkalu DS)
- Capacity of the containers: 5 m<sup>3</sup>
- Number of containers to be transported per trip: 100 containers/trip

**Table 5-8 Required number of containers and number of trips per day in Kelaniya TS**

	2023	2024	2025	2026	2027	2028	2029	2030
Total amount of waste to be transferred (ton/day)	1,147	1,134	1,242	1,315	1,434	915	954	997
Incineration residues (ton/day)	150	150	149?	150	150	310	323	340
Untreated waste (ton/day)	997	984	1,093	1,165	1,284	605	631	657
Required number of containers (unit/day)	1,027	1,014	1,123	1,195	1,314	667	696	725
Number of trips per day (trip/day)	11	11	12	12	14	7	7	8

## ii. Implementation schedule and responsible organizations

**Table 5-9 Implementation schedule of Kelaniya TS**

Project 2: Kelaniya Transfer Station  
(Kelaniya TS)

	2022				2023				2024				2025				2026				2027			
	Q1	Q2	Q3	Q4	Q1	Q2	Q3	Q4	Q1	Q2	Q3	Q4	Q1	Q2	Q3	Q4	Q1	Q2	Q3	Q4	Q1	Q2	Q3	Q4
Completion of works at Kelaniya TS																								
Operation, financial plan Aruwakkalu DS																								

**Table 5-10 Responsible organizations of Kelaniya TS**

Stage	Action	Responsible Organizations
Construction	Construction, including procurement of locomotive and wagons	MoUD&H
	Financing of capital costs	MoUD&H
Operation	Operation of KTS, including transportation to Aruwakkalu DS	MoUD&H (designated operator)
	Cost recovery	The operator charges a tipping fee to users

## iii. Project costs

The costs were calculated based on the following assumptions:

- Operation and maintenance costs: LKR 2,000 /ton



**Table 5-11 Project costs for the improvement of Kelaniya TS (million LKR)**

Cost items	2022	2023	2024	2025	2026	2027
Administrative costs (planning, preparation, etc.)	0	0	0	0	0	0
Operation and maintenance costs	976	1,065	1,147	1,134	1,242	1,315
Construction costs	-	-	0	0	0	0
Procurement of equipment/machinery	-	-	0	0	0	0
Miscellaneous expenses	98	107	115	113	124	132
<b>Total</b>	<b>1,074</b>	<b>1,172</b>	<b>1,262</b>	<b>1,247</b>	<b>1,366</b>	<b>1,447</b>

**(3) Project 3: Development of Thermal Recovery Facilities (TRFs)**

**i. Project 3-1: TRF in Colombo District**

**a. Plan**

Capacity of the TRF: 400 ton/day

**b. Implementation schedule and responsible organizations**

**Table 5-12 Implementation schedule of thermal Recovery Facility in Colombo**

	2022				2023				2024				2025				2026				2027			
	Q1	Q2	Q3	Q4	Q1	Q2	Q3	Q4	Q1	Q2	Q3	Q4	Q1	Q2	Q3	Q4	Q1	Q2	Q3	Q4	Q1	Q2	Q3	Q4
Site identification	■																							
Consensus among stakeholders to proceed with project preparation			▲		▲																			
Design of implementation mechanism (project proponent, tendering method, power purchase related matters, financing mechanism, consensus among authorities)			■		■																			
Feasibility study, EIA					■																			
Decision to implement the new TRF project, including gap financing by Treasury												▲												
Tender, evaluation, award, contract signing											■													
Financial closure and construction													■											
Commencement of operation																								▲

**Table 5-13 Responsible organizations of thermal recovery facility in Colombo**

Stage	Action	Responsible Organizations	
Construction	Design, procurement, construction	Investors	
	Approvals	WMA and relevant organizations	
	Financing of capital cost	Investors	
Operation	Operation of TRF	Investors	
	Waste supply	WMA in coordination with LAs	
	Revenue collection	Electricity, balance financed arrangement by WMA negotiation between MoF and LAs	

**c. Project costs**

The costs were calculated based on the following assumptions:

- Construction TRF costs: LKR 25 million/ton

**Table 5-14 Project costs for the development of a TRF in Colombo District (million LKR)**

Cost items	2022	2023	2024	2025	2026	2027
Administrative costs (planning, preparation, etc.)	10	10	10	0	0	0
Operation and maintenance costs	0	0	0	0	0	0
Construction costs	0	0	0	3,333	3,333	3,333
Procurement of equipment/machinery	0	0	0	0	0	0
Miscellaneous expenses	1	1	1	333	333	333
<b>Total</b>	<b>11</b>	<b>11</b>	<b>11</b>	<b>3,666</b>	<b>3,666</b>	<b>3,666</b>

**ii. Project 3-2: Development of a new TRF next to Western Power at Kerawalapitiya (WPK)**

**a. Plan**

Capacity of the TRF: 750 ton/day

**b. Implementation schedule and responsible organization**

Table 5-15 TRF Implementation schedule of TRF next to Western Power at Kerawalapitiya

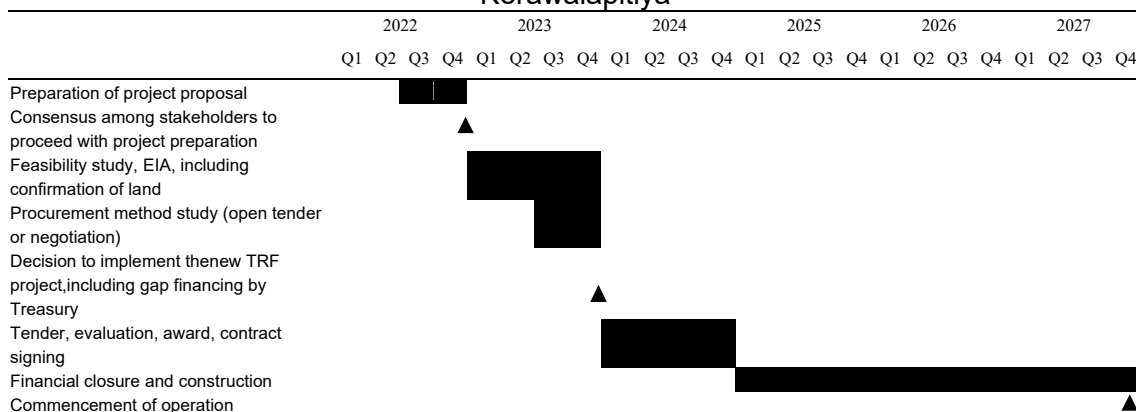

Table 5-16 Responsible organizations of TRF next to Western Power at Kerawalapitiya

Stage	Action	Responsible Organizations
	Project formulation	WMA in consultation with relevant organizations
Construction	Procurement method and procurement plan	WMA in consultation with relevant organizations
	Tender, award, and contract signing	CEB/WMA
	Design, procurement, construction	Investors
	Approvals	WMA and relevant organizations
	Financing of capital cost	Investors
Operation	Operation of the TRF	Investors
	Waste supply	WMA in coordination with the LAs
	Revenue collection	Electricity balance financed arrangement by WMA negotiation between MoF and LAs

**c. Project costs**

The costs were calculated based on the following assumptions:

- Construction TRF costs: LKR 25 million/ton

**Table 5-17 Project costs for the development of a new TRF next to WPK (million LKR)**

Item for expenditure	2022	2023	2024	2025	2026	2027
Administrative costs (planning, preparation, etc.)	10	10	10	0	0	0
Operation and maintenance costs	0	0	0	0	0	0
Construction costs	0	0	0	6250	6250	6250
Procurement of equipment/machinery	0	0	0	0	0	0
Miscellaneous expenses	1	1	1	625	625	625
<b>Total</b>	<b>11</b>	<b>11</b>	<b>11</b>	<b>6,875</b>	<b>6,875</b>	<b>6,875</b>

**(4) Project 4: Improvement of composting facilities**

**i. Plan**

- Breakdown of the treatment of collected biodegradable waste:
  - 80% of the collected biodegradable waste will be composted.
  - The remaining 20% will be incinerated in a TRF.
  - Biodegradable waste that exceeds the treatment capacity of the composting facilities and TRFs will be disposed of in Aruwakkalu DS.

Table 5-18 Biodegradable waste treatment and capacity of composting facilities (ton/day)

Year	Biodegradable waste				Capacity of composting facilities			Aruwakkalu DS
	Collected	Treated in TRFs*	Treated in composting facilities	Waste parks	LAs' composting facilities	Cluster-based composting facilities	Total capacity of composting facilities	
2022	896	237	325	0	92	232	324	334
2023	962	199	399	0	100	300	400	364
2024	1,021	171	596	160	110	340	610	254
2025	1,084	136	611	160	120	340	620	337
2026	1,146	108	677	240	130	340	710	361
2027	1,207	72	692	240	130	340	710	443
2028	1,266	566	700	320	130	340	790	0
2029	1,335	591	744	320	130	340	790	0
2030	1,402	616	786	400	130	340	870	0

- Increased treatment capacity of composting facilities operated and managed by LAs and cluster-based composting facilities

The capacity of current composting facilities is 324 tons per day. It will be increased to 460 tons per day in 2025 and 470 tons per day in 2030.

- Increased capacity of cluster-based composting facilities (Karadiyana, SLLDC Muthurajawela and other facilities)
- Increased capacity of LAs' composting facilities by accelerating the waste decomposition process.

- The sites for the waste parks planned by MoUD&H will be selected and composting facilities will be constructed in the parks. The capacity of waste park composting facilities is expected to be around 80 ton/day/facility.

ii. Implementation schedule and responsible organization

Table 5-19 Implementation schedule for waste park composting facilities

	2022		2023				2024				2025				2026				2027			
	Q1	Q2	Q3	Q4	Q1	Q2	Q3	Q4	Q1	Q2	Q3	Q4	Q1	Q2	Q3	Q4	Q1	Q2	Q3	Q4		
Preparation of project proposal (MoUD&H)			■	■					■	■						■	■					
Budget preparation in MoUD&H			■	■	■	■			■	■	■					■	■	■	■			
Government budget process			■	■	■	■			■	■	■					■	■	■	■			
Site identification			■	■					■	■						■	■					
Preparation for land purchase			■	■	■	■	■									■	■	■	■			
Obtention of environmental recommendation (or IEE/EIA)			■	■	■	■	■									■	■	■	■			
Preparation of tender documents			■	■	■	■	■									■	■	■	■			
Tender and contract			■	■	■	■	■									■	■	■	■			
Construction			■	■	■	■	■									■	■	■	■			
Commencement of operation of the first waste parks																				▲		

Table 5-20 Implementation schedule for Karadiyana Compost Plant

	2022				2023				2024				2025				2026				2027			
	Q1	Q2	Q3	Q4	Q1	Q2	Q3	Q4	Q1	Q2	Q3	Q4	Q1	Q2	Q3	Q4	Q1	Q2	Q3	Q4	Q1	Q2	Q3	Q4
Phase 1: Trommel setup and sieving practice																								
Phase 2: Landfill rehabilitation; landfill mining, stabilization and composting in Area 1																								
Phase 3: Windrow composting over the entire area of Site A																								

Table 5-21 Responsible organizations of composting facilities in waste parks

Stage	Action	Responsible Organization
Construction	Site identification	MoUD&H
	Construction of waste parks and procurement of equipment	MoUD&H
	Financing of capital costs	MoUD&H
Operation	Operation of waste parks	WMA (or other mechanism)
	Cost recovery for operation and maintenance	Revenues from the sale of compost, balance covered by charging a tipping fee to LAs

Table 5-22 Responsible Organizations of composting facility of WMA in Karadiyana

Stage	Action	Responsible Organization
Construction	Construction works and procurement of equipment	WMA
	Financing of capital costs	WMA and JICA
Operation	Operation of the composting facility	WMA
	Cost recovery for operation and maintenance	Revenues from the sale of compost, balance covered by charging a tipping fee to LAs

Table 5-23 Responsible Organizations of composting facility of SLLDC in Muthurajawela

Stage	Action	Responsible Organization
Construction	Construction works and procurement of equipment	MoUD&H
	Financing of capital costs	MoUD&H
Operation	Operation of the composting facility	SLLDC
	Cost recovery for operation and maintenance	Revenues from the sale of compost, balance covered by charging a tipping fee to LAs

### iii. Project costs

The costs were calculated based on the following assumptions:

- Construction cost of PTS: LKR 0.5 million /ton
- Operation and maintenance costs: LKR 3,000 /ton

**Table 5-24 Project costs for scheduled implementation of composting facilities in waste parks (million LKR)**

Cost items	2022	2023	2024	2025	2026	2027
Administrative costs (planning, preparation, etc.)	10	10	10	10	10	10
Operation and maintenance costs	0	0	175	175	263	263
Construction costs	0	80	0	40	0	40
Procurement of equipment/machinery	0	0	0	0	0	0
Miscellaneous expenses	1	9	19	23	27	31
<b>Total</b>	<b>11</b>	<b>99</b>	<b>204</b>	<b>248</b>	<b>300</b>	<b>344</b>

**Table 5-25 Project costs for implementation of the Karadiyana Compost Plant (million LKR)**

Cost item	2022	2023	2024	2025	2026	2027
Administrative costs (planning, preparation, etc.)	0	0	0	0	0	0
Operation and maintenance costs	0	23	23	10	10	10
Construction costs	0	6	0	0	0	0
Procurement of equipment/machinery	42	2	0	0	0	0
Miscellaneous expenses	4	3	2	1	0	0
<b>Total</b>	<b>46</b>	<b>34</b>	<b>25</b>	<b>10</b>	<b>0</b>	<b>0</b>

**(5) Project 5: Improvement of recycling facilities for recyclables collected by the formal collection service**

**i. Plan**

Improved quality of waste sorting by waste generators and at MRFs will increase the capacity of facilities to handle increasing amounts of recyclable waste.

- The amount of recyclables collected will increase due to the improved collection coverage and an increase in total waste collected.
- The promotion of separate discharge will reduce the proportion of other waste contained in the collected recyclables. Furthermore, the sorting efficiency of the recycling facilities and the quality of sorted recyclables will be improved.
- The construction of MRFs in waste parks with a capacity of 30 tons per day per facility will promote recycling.

Table 5-26 Recyclables to be collected (ton/day)

Year	WP	District					Zone				
		Colombo	Gampaha	Kalutara	Kotte	Dehiwala	Negambo	Gampaha	Kelaniya	Horana	Kalutara
2022	118	46	57	15	34	12	7	42	8	8	7
2023	132	59	58	15	45	14	8	42	8	8	7
2024	151	72	61	18	55	17	9	44	8	10	8
2025	169	84	67	18	65	19	12	45	10	11	7
2026	186	98	68	20	76	22	12	45	11	12	8
2027	202	110	70	22	85	25	13	46	11	13	9
2028	219	122	73	24	96	26	15	46	13	14	10
2029	241	139	77	25	109	30	18	46	13	14	11
2030	255	153	77	25	120	33	18	46	13	14	11

ii. Implementation schedule and responsible organizations

Table 5-27 Implementation schedule for LAs' recycling facilities

	2022		2023		2024		2025		2026		2027	
	Q1	Q2	Q3	Q4	Q1	Q2	Q3	Q4	Q1	Q2	Q3	Q4
Preparation of implementation plan			■	■								
Improvement works					■	■						

Table 5-28 Implementation schedule for MRFs in waste parks

	2022		2023		2024		2025		2026		2027	
	Q1	Q2	Q3	Q4	Q1	Q2	Q3	Q4	Q1	Q2	Q3	Q4
Preparation of project proposal (MoUD&H)			■				■				■	
Budget preparation in MoUD&H				■				■				■
Government budget process					■	■			■	■		
Site identification			■	■			■	■			■	■
Preparation for land purchase												
Obtention of environmental recommendation (or IEE/EIA)					■	■			■	■		
Preparation of tender documents												
Tender and contract												
Construction												
Commencement of operation of the first Waste Parks												

Table 5-29 Responsible organizations of Improved existing recycling facilities

Stage	Action	Responsible Organization
Upgrade of SK facilities	Upgrade of SK facilities for improved sorting efficient	LAs with the assistance of WMA
	Financing of improvement costs	WMA/WPC, MoPCLG
	Operation of SK facilities	LAs
Operation	Revenue generation	Revenues from the sale of recyclable materials



**Table 5-30 Responsible organizations of recycling facilities in waste parks**

Stage	Action	Responsible Organization
	Site identification	MoUD&H
Construction	Construction of waste parks and procurement of equipment	MoUD&H
	Financing of capital costs	MoUD&H
Operation	Operation of waste parks	WMA
	Cost recovery for operation and maintenance	Revenue from sales of recycled materials

### iii. Project costs

The costs were calculated based on the following assumptions:

- Operation and maintenance costs: LKR 2,000 /ton

**Table 5-31 Project costs for the improvement of recycling facilities (million LKR)**

Cost items	2022	2023	2024	2025	2026	2027
Administrative costs (planning, preparation, etc.)	10	0	0	0	0	0
Operation and maintenance costs	86	96	110	123	136	147
Construction costs	0	800	0	400	0	400
Procurement of equipment/machinery	0	0	0	0	0	0
Miscellaneous expenses	10	10	11	12	14	15
<b>Total</b>	<b>106</b>	<b>906</b>	<b>121</b>	<b>535</b>	<b>150</b>	<b>562</b>

## (6) Project 6: Procurement of collection and transfer vehicles

### i. Plan

- Required number of vehicles

**Table 5-32 Required number of compactor trucks for biodegradable waste (unit)**

Year	WP	District					Zone				
		Colombo	Gampaha	Kalutara	Kotte	Dehiwala	Negambo	Gampaha	Kelaniya	Horana	Kalutara
2022	86	35	28	23	12	23	7	10	11	11	12
2023	93	39	32	22	15	24	9	11	12	11	11
2024	98	40	35	23	15	25	10	13	12	11	12
2025	99	40	35	24	15	25	10	13	12	11	13
2026	101	41	36	24	16	25	10	14	12	11	13
2027	108	46	37	25	17	29	11	14	12	11	14
2028	108	45	41	22	19	26	11	16	14	11	11
2029	111	46	43	22	19	27	12	16	15	11	11
2030	114	47	44	23	20	27	13	16	15	11	12

Table 5-33 Required number of compactor trucks for other waste (unit)

Year	WP	District					Zone				
		Colombo	Gampaha	Kalutara	Kotte	Dehiwala	Negambo	Gampaha	Kelaniya	Horana	Kalutara
2022	299	194	67	38	138	56	26	20	21	20	18
2023	305	201	67	37	146	55	26	21	20	20	17
2024	293	199	63	31	151	48	26	18	19	16	15
2025	306	210	63	33	158	52	26	18	19	18	15
2026	316	219	65	32	169	50	27	19	19	17	15
2027	335	230	71	34	177	53	29	22	20	17	17
2028	357	246	71	40	185	61	29	22	20	22	18
2029	371	256	73	42	193	63	28	23	22	23	19
2030	389	268	78	43	203	65	30	25	23	24	19

Table 5-34 Required number of trailer tractors for recyclables (unit)

Year	WP	District					Zone				
		Colombo	Gampaha	Kalutara	Kotte	Dehiwala	Negambo	Gampaha	Kelaniya	Horana	Kalutara
2022	67	28	31	8	19	9	5	22	4	4	4
2023	73	34	31	8	24	10	5	22	4	4	4
2024	81	39	32	10	29	10	5	23	4	6	4
2025	94	46	37	11	34	12	8	23	6	7	4
2026	105	53	39	13	41	12	8	24	7	8	5
2027	115	60	40	15	45	15	8	25	7	9	6
2028	126	65	44	17	50	15	10	25	9	10	7
2029	137	73	46	18	57	16	11	26	9	10	8
2030	144	80	46	18	62	18	11	26	9	10	8

ii. Implementation schedule and responsible organizations

Table 5-35 Implementation schedule for waste collection and transportation

Activities	2022		2023				2024				2025				2026				2027			
	Q1	Q2	Q3	Q4	Q1	Q2	Q3	Q4	Q1	Q2	Q3	Q4	Q1	Q2	Q3	Q4	Q1	Q2	Q3	Q4		
Establishment of subsidies and support systems for the procurement of collection vehicles by MoPAHAPCLG and WMA																						
Development and submission of procurement plan for collection vehicles by LAs																						
Review and approval of procurement plan by MoPAHAPCLG and WMA																						
Budgeting based on procurement plan and allocation of vehicles by MoPAHAPCLG																						

Table 5-36 Responsible organizations of waste collection and transportation

Stage	Action	Responsible Organization
Procurement of vehicles	Preparation of LA Action Plan	LAs
	Approval of LA Action Plan	WMA
	Procurement of vehicles	NSWMS
	Financing of capital costs	MoPAHAPCLG
Operation	Operation of vehicles	LAs



### iii. Project costs

The costs were calculated based on the following assumptions:

- Compactor truck: LKR 9 million per unit
- Trailer tractor: LKR 3.5 million per unit

Table 5-37 Project costs for the procurement of collection and transfer vehicles (million LKR)

Cost items	2022	2023	2024	2025	2026	2027
Administrative costs (planning, preparation, etc.)	10	10	10	10	10	10
Operation and maintenance costs	0	0	0	0	0	0
Construction costs	0	0	0	0	0	0
Procurement of equipment/machinery	0	3,843	25	112	248	510
Miscellaneous expenses	1	385	4	12	26	52
Total	11	4,238	39	134	284	572

### (7) Project 7: Closure of current LA dump sites

The responsible government authorities are very keen to transport the untreated waste from the whole Western Province to Aruwakkalu DS via Kelaniya TS and close the open dumps to mitigate the adverse health and environmental impacts. However, there are several limitations, especially the affordability of LAs.

#### i. Plan

By 2024, LAs aim to dispose of all their waste at the Aruwakkalu DS via Kelaniya TS. The closure of existing dump sites currently used by LAs will begin as soon as the LAs are ready.

A manual on the closure of existing dump sites will be developed to ensure the proper closure of the disposal sites.

**ii. Implementation schedule and responsible organizations**

**Table 5-38 Implementation schedule of closure of dump sites**

Activities	2022		2023				2024				2025				2026				2027					
	Q1	Q2	Q3	Q4	Q1	Q2	Q3	Q4	Q1	Q2	Q3	Q4	Q1	Q2	Q3	Q4	Q1	Q2	Q3	Q4	Q1	Q2	Q3	Q4
Preparation of a manual for the closure the current LAs' dump sites			■	■																				
Securing the budget for the closure of the current dump sites					■	■	■	■																
Closure works at the current dump sites									■	■														
Cessation of waste disposal in current dump sites																								▲

**Table 5-39 Responsible organizations of closure of dump sites**

Stage	Action	Responsible Organization
Planning	Development of a closure manual	CEA, NSWMSC, WMA
	Planning of site closures	LAs with the assistance of WMA
Implementation	Implementation	LAs with the assistance of WMA assistance
	Financing of capital costs	WMA/WPC, NPD, MoPAHAPCLG

**iii. Project costs**

The costs were calculated based on the following assumptions:

- Closure works: LKR 10 million per site

**Table 5-40 Project costs for the closure of current LAs' dump sites (million LKR)**

Cost items	2022	2023	2024	2025	2026	2027
Administrative costs (planning, preparation, etc.)	10	10	0	0	0	0
Operation and maintenance costs	0	0	0	0	0	0
Construction costs	0	0	280	0	0	0
Procurement of equipment/machinery	0	0	0	0	0	0
Miscellaneous expenses	1	1	28	0	0	0
<b>Total</b>	<b>11</b>	<b>11</b>	<b>308</b>	<b>0</b>	<b>0</b>	<b>0</b>

**(8) Project 8: Encouragement of waste separation**

**i. Plan**

By 2nd quarter of 2023, the waste separation guidelines will be developed by WMA. Then, LAs will adopt the separation rules that correspond to the actual capacities of the intermediate treatment facilities and implement the promotion program for waste separation.

**ii. Implementation schedule and responsible organizations**

**Table 5-41 Implementation schedule of waste separation**

Activities	2022				2023				2024				2025				2026				2027			
	Q1	Q2	Q3	Q4	Q1	Q2	Q3	Q4	Q1	Q2	Q3	Q4	Q1	Q2	Q3	Q4	Q1	Q2	Q3	Q4	Q1	Q2	Q3	Q4
Understanding the actual situation and issues																								
Development of waste separation guidelines by WMA																								
Organization of seminars by WMA for LAs to understand the guidelines																								
Preparation and implementation of promotion program in line with the guidelines																								
Implementation of separate waste collection																								

**Table 5-42 Responsible organizations for waste separation**

Stage	Action	Responsible Organization
Guidelines	Development of guidelines in consideration of the intermediate treatment facilities located in the Western Province	CEA/NSWMS/WMA in line with national regulations and guidelines
	Adoption (amendment) of separation rules that correspond to the actual capacities of the intermediate treatment facilities	LAs
Implementation	Promotion of waste separation	LAs

**iii. Project costs**

The costs were calculated based on the following assumptions:

**Table 5-43 Project costs to encourage waste separation (million LKR)**

Cost items	2022	2023	2024	2025	2026	2027
Administrative costs (planning, preparation, etc.)	30	30	30	0	0	0
Operation and maintenance costs	0	0	0	0	0	0
Construction costs	0	0	0	0	0	0
Procurement of equipment/machinery	0	0	0	0	0	0
Miscellaneous expenses	3	3	3	0	0	0
<b>Total</b>	<b>33</b>	<b>33</b>	<b>33</b>	<b>0</b>	<b>0</b>	<b>0</b>

## 5.2 SWM Action Plan for LAs

### 5.2.1 Objectives of the SWM Action Plan

The SWM Action Plan for LAs will be formulated in line with the SWM MP for the Western Province. Quantitative targets and feasible SWM activities will be set in the Action Plan.

In addition, an Annual Work Program (AWP) will be prepared for each year of the SWM Action Plan period, including yearly activities, implementation schedules, and budgets in order to achieve the SWM Action Plan. The AWP is not only an annual implementation plan, but also an important monitoring instrument for the SWM Action Plan.

The SWM Action Plan will be reviewed every five years taking into account the progress made in waste management.

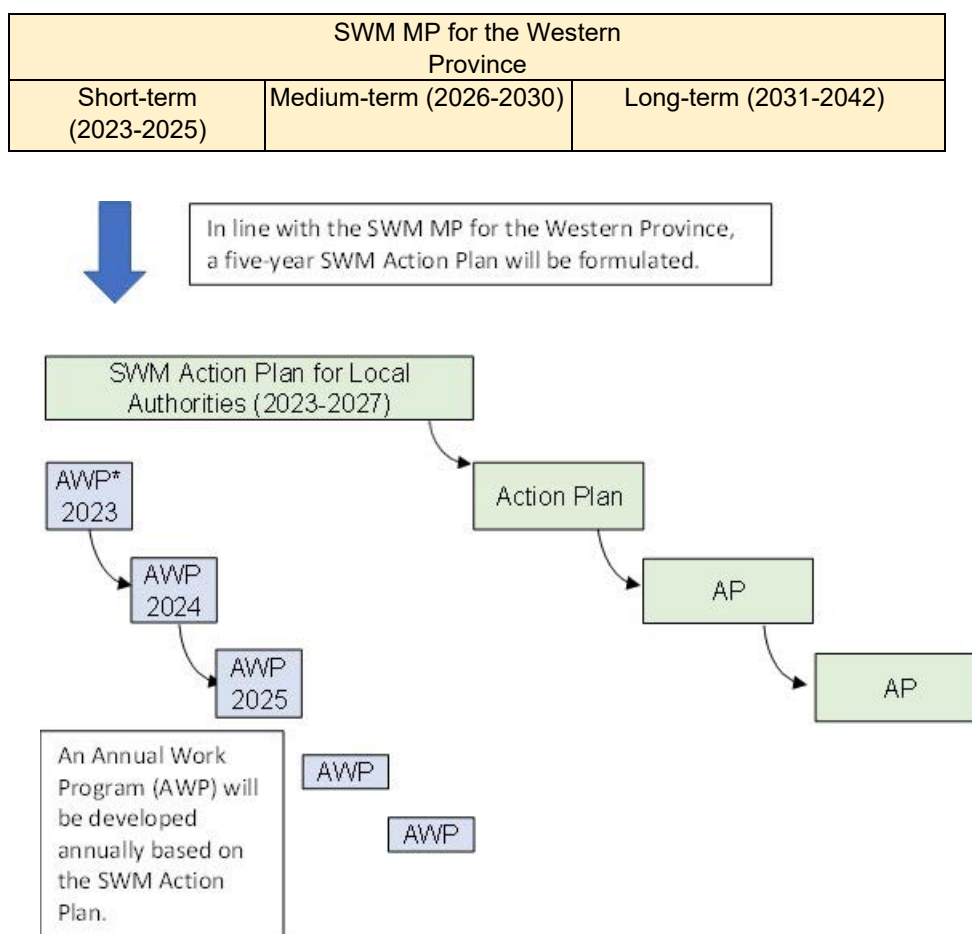

Figure 5-3 Relationship between the SWM MP for the Western Province, SWM Action Plans and Annual Work Programs

### 5.2.2 Preparing a template for the SWM Action Plan

A unified document template will be prepared for LAs that do not have enough SWM staff to develop the SWM Action Plan efficiently and effectively.

The main features of the SWM Action Plan are as follows:

- Understanding the current situation and issues of SWM using the created Western

Province SWM database.

- Understanding the current situation and issues of SWM quantitatively based on a waste flow analysis.
- Establishment of quantitative targets and future waste flow in line with the SWM MP for the Western Province.
- Establishment of feasible SWM actions.
- Preparation of the AWP to achieve the SWM Action Plan. A template for developing

The unified SWM Action Plans are attached to the ANNEX.

### 5.2.3 Formulation of the SWM Action Plan

#### (1) Training for WMA staff

Training will be provided to WMA staff to ensure that they: i) have a sound understanding of the content of the SWM Action Plan Form; and ii) are able to correctly explain the formulation process to the staff in charge of SWM in LAs.

##### 【Training materials】

- SWM Action Plan for LAs Form
- Western Province SWM Database
- Waste Flow Analysis Excel file

#### (2) Guidance on the development of the SWM Action Plan and AWP

Workshops will be organized, and guidance provided by WMA to help LA officials understand and develop their own SWM Action Plan and AWP.

#### (3) Monitoring the implementation of the SWM Action Plan

WMA will monitor the implementation of the SWM Action Plan by reviewing the progress of the AWP. The AWP is not only an annual implementation plan, but also an important monitoring instrument for the SWM Action Plan.

Table 5-44 Monitoring the implementation status of the SWM Action Plan

Frequency	Once a year
Participants	Managers in charge of SWM in the 49 LAs
Monitoring staff	Zonal managers of WMA
Monitoring contents	<ul style="list-style-type: none"> <li>• Confirmation of the AWP progress (twice a year).</li> <li>• Develop an AWP for the following year based on the progress of the previous year's AWP.</li> </ul>

#### (4) Securing budget for the implementation of the action plan

After the LA's SWM Action Plan is prepared, it must be approved by the LA's Council. Once the SWM Action Plan, which provides details on financial needs, becomes a formal document, it



---

will be a basis for securing the budgets for implementation for both the LA's recurrent budget and the National and Provincial authorities' capital budget support. For example, vehicles for waste collection are collectively procured based on the LAs' Action Plans by the MoPAHAPCLG. The number of vehicles is determined based on the request of the LAs and recommendations of the Western Provincial Council/WMA. The LA's SWM Action Plan, which is to be reviewed, concurred, and monitored by WMA, will be used to assess capital expenditure needs, and WMA will formulate its recommendations accordingly.

## 6 Recommendations

### 6.1 Master plan for optimal SWM system

The amount of waste generated in the Western Province is estimated at 3,730 tons per day. This amount is expected to increase in line with future population and economic growth. At present, about 50% of the waste generated is discharged to the LA's collection service, but it is expected that this amount will increase in the future as collection coverage improves. Therefore, in the Western Province, where there are waste disposal problems, it is necessary to enhance waste separation by conducting awareness-raising activities for residents and by increasing the capacity of intermediate treatment facilities in order to reduce amount of waste to be disposed of as much as possible. In the entire Western Province, 16% of the waste collected is carried to composting facilities, 6% to recycling-related facilities, 38% to TRFs and 40% to disposal sites, as of base year 2022. In order to collect and transport this waste efficiently and hygienically, it is necessary to select and procure appropriate collection vehicles and to set up in the future a transfer system in accordance with the separated waste and the distance to intermediate treatment facilities and/or disposal sites.

Recycling in the Western Province is carried out at the source of generation, at the collection stage and in intermediate treatment facilities such as composting and recycling facilities. The total amount of recyclables accounts for about 20% of the total waste generated, which is a relatively high rate compared to other developing countries. In the future, it is necessary to reduce the amount of waste disposed by promoting the separate collection of recyclables and expanding the capacity of composting facilities. The amount of waste disposed represents 32% of all waste generated. Approximately 70% of the total waste disposed is waste directly landfilled and the remaining 30% is residue generated from composting and recycling facilities. To reduce this amount despite the expected increase resulting from improved collection coverage, it is critical to develop intermediate treatment such as WtE. It is also necessary to gradually shift from disposal sites operated independently by LAs to cluster-based disposal sites, and to close the open dump sites currently used by LAs. In order to implement proper SWM, it is also necessary to collect and consolidate data related to SWM from each LA, cluster-based treatment facilities and disposal sites, and establish a database for the entire Western Province.

Waste management in urban areas requires cooperation and coordination between neighboring LAs and higher authorities. However, collaboration between relevant authorities is currently inadequate. In the recent past, some new, state-of-the-art, large-scale waste management technologies have been introduced in the Western Province, but they are not yet fully deployed. The amount of waste in urban areas is increasing at a higher pace than the population, and even than economic growth. This implies that costs for waste management are growing at a faster rate than the allocation of the government's budget.

Among alternatives A, B and C, the system in alternative B allows all the collected biodegradable waste to be composted, except for the 20% that is incinerated, while maximizing the recycling of recyclable materials.

<Alternative B>

Waste reduction and improved collection. Total capacity of TRFs: 2,900 ton/day. Total capacity of the composting facilities: 1,326 ton/day, including 930 ton/day in LAs and cluster-based composting facilities and 400 tons/day in the waste park composting facilities.

Economically, alternative B was evaluated as the cheapest system compared to the other options. Based on the above, alternative B is recommended as the Master plan for optimal SWM in the Western Province.

## 6.2 Economic financial aspects

A comparison of the waste management costs incurred during the MP period (20 years from 2022 to 2041) by management process, separated for capital investment costs and operating costs, shows that collection costs account for 29% and transportation costs for 23%, which means that transportation-related costs represent more than half. This is followed by thermal recovery (incineration with power generation), final disposal, and composting.

In 2020 in the Western Province, LAs' own revenue covered only one quarter of their total expenditure. The remaining three quarters have been taken over by the national government. In that context, LAs' room for maneuver to allocate a budget to their priority areas is limited. Waste management currently receives 20% of the total recurrent expenditure, the highest among expenditure heads. It is unlikely that the percentage allocated to waste management will increase significantly. The share of waste management in LAs' budget is within a reasonable range of financial affordability, except for the first five years (from 2023 to 2027). The proportion of 33% in 2023 and peak of 34% in 2027 are 1.7 times the current level (20%). The sharp increase during this period is caused by the large volume of untreated waste transported to and disposed of in Aruwakkalu DS due to the lack of intermediate treatment facilities. The percentage then gradually lowers as intermediate treatment facilities develop and the amount of waste disposed of without treatment decreases.

The above scenario is based on the assumption that capital expenditure is borne by the government. Removing the capital component from LAs' burden can be done either by financing the capital cost, e.g. through viability gap funding (VGF) by the national government at the initial stage, or by subsidizing the capital portion through annual fund transfers from the Treasury to the concessionaire. It is essential that the national government, Provincial Council and LAs discuss and agree on this matter when formulating the project.

## 6.3 Master Plan authorization

The Solid Waste Management Master Plan for the Western Province establishes a comprehensive waste management system with a long-term perspective in the Western Province. The central organization is the Western Provincial Council, represented by WMA. Once approved, the MP will be owned and operated by the Provincial Council and WMA. The MP will serve as a

guideline for the LAs for their SWM Action Plan and Annual Work Programs. Once developed by WMA through a consultation process with all stakeholders, the WMA Board will submit the MP to the Minister in charge of local authorities for concurrence by the Board of Ministers of Western Province. The Provincial Council, through the (national level) Minister in charge of Local Governments, will forward the MP to the Cabinet of Minister for approval. This process is necessary as the MP contains sectoral strategies and plans, and requires technical and financial support from the national government for its implementation.

#### 6.4 Monitoring of the Master Plan implementation

Monitoring of the MP implementation will be conducted by Coordination Committee. Details of the committee are shown below. Environmental effects of implementing the MP will also be monitored by the committee as it is a requirement of the SEA process. Recommended Environmental monitoring and evaluation plan are shown in the SEA report.

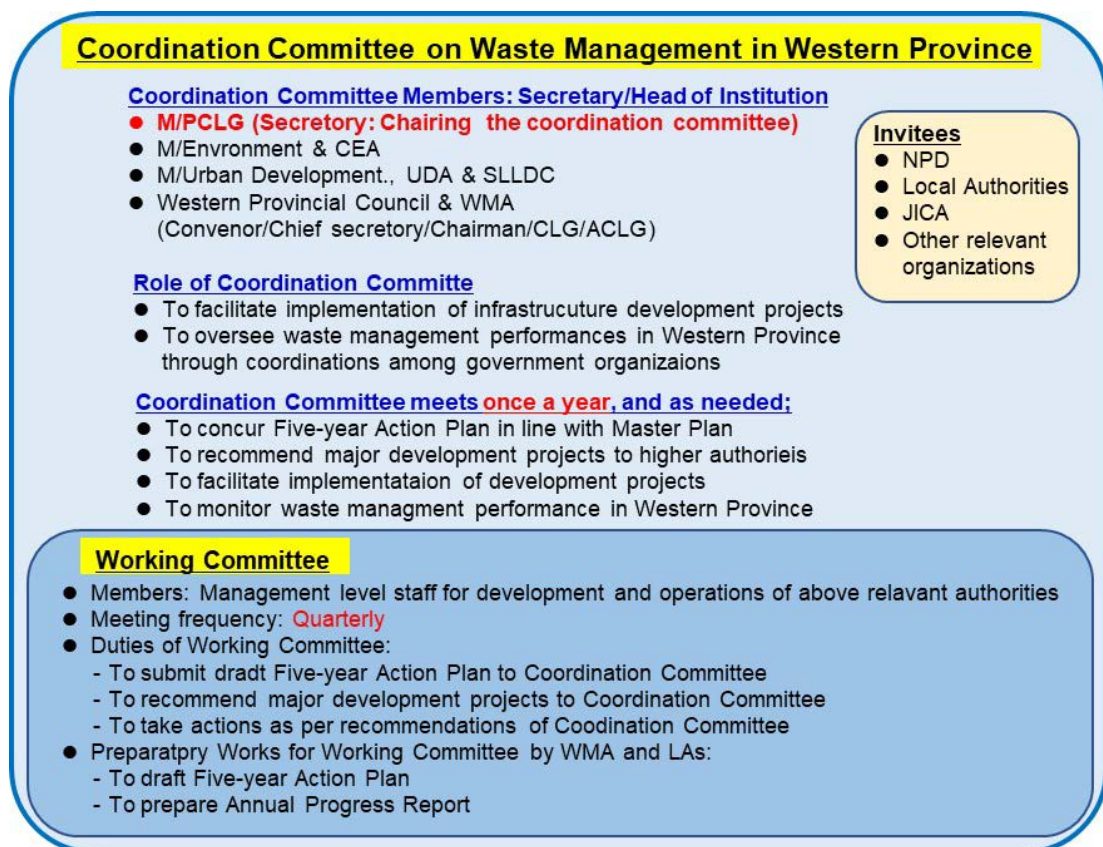

Figure 6-1 Structure of Coordination Committee on Waste Management in Western Province

Coordination Committee will also discuss the issue which is given by the stakeholder consultation meeting of SEA as comments and recommendations.

**Special Note: The present economic crisis or any future structural changes in the economy has not been considered during the planning of the Master Plan.**

End.





別添資料 11

**Project Completion Report**





**Project Completion Report**

**Project Title: Project for Formulation of Western Province Solid Waste**

**Management Master Plan**

**Name: N.D.N Pushpakumara**

**Title: Project Director**

**Name: Nalin Mannapperuma**

**Title: Project Coordinator**

**Submission Date: 12May2023**

**I. Basic Information of the Project**

1. **Country:** Sri Lanka
2. **Title of the Project:** Project for Formulation of Western Province Solid Waste Management Master Plan
3. **Duration of the Project:**

Planned	Actual
2019.2-2022.2 (3 years)	2019.2-2023.6 (4 years and 3 months)
<p>Reason:                      Because of the global spread of the coronavirus disease 2019 (COVID-19), some of the project activities were suspended for a while, and the project duration was extended from February 2022 to December 2022. However, in addition to above mentioned reason, Sri Lankan Government Cabinet decided to cancel the construction of Waste to Energy facility in Karadiyana Resource Management Centre, which is a core waste management facility in Solid Waste Management Master Plan, thus the draft Master Plan had to be modified with consensus among counterparts and relevant organizations. In order to achieve the project purpose after the resumption of the activities by the project team, the project duration was re-extended from December 2022 to June 2023.</p>	

**4. Background (from Record of Discussions(R/D)):**

Sri Lanka has been facing a number of environmental problems caused by poor municipal solid waste management, such as lack of effort for waste reduction, lack of success combatting illegal dumping and continuation of unsafe open dumping. The waste volume has been growing due to recent rapid economic growth and population increase, and it is now estimated to be as much as 10,800 ton/day.

Under such circumstances, a collapse at Meethotamulla Waste Disposal Site in April 2017 caused a disaster resulting in the loss of many lives of nearby residents and

massive physical damage. In response to this crisis, the Government of Japan (GOJ) provided emergency relief goods and dispatched the Japan Disaster Relief Expert Team, consisting of relevant technical expert members. The expert team recommended that 3Rs activities (reduce, reuse, recycle), and intermediate processing, once properly implemented, would be an effective measure to reduce waste volumes for final disposal. The expert team also recommended that a waste management master plan (MP) for the Western Province should be developed jointly with all stakeholders and the roles of every stakeholder be defined clearly in the MP.

Following the recommendations of the Japanese expert team, the Government of Sri Lanka (GOSL) made a request to GOJ to formulate a solid waste management MP for Western Province, coordinating with the Central Government, Provincial Government and Local Authorities (LAs). In response to the request made by GOSL, Japan International Cooperation Agency (JICA) conducted a detailed planning survey in May 2018 to formulate a technical cooperation project, and agreed on the framework and contents of the Project with GOSL.

The Project is designed to assist Western Province in filling the gaps in its management of solid waste by formulating an evidence-based solid waste management MP that encompasses medium- to long-term forecasts and a range of proposed solutions to the waste problems.

## **5. Overall Goal and Project Purpose (from Record of Discussions(R/D)):**

### **Overall Goal:**

Appropriate solid waste management practices in accordance with Western Province Solid Waste Management Master Plan (MP) are undertaken in Western Province.

### **Project Purpose:**

Western Province's planning capacity on solid waste management is strengthened through the formulation of Western Province Solid Waste Management Master Plan (MP).

## **6. Implementing Agency:**

- National Solid Waste Management Support Center (NSWMSC), Ministry of Public Administration, Home Affairs, Provincial Councils and Local Government
- Waste Management Authority (WMA), Western Provincial Council
- Other relevant organizations

<b>II. Results of the Project</b>
-----------------------------------

<b>1. Results of the Project</b>
----------------------------------

1-1 Input by the Japanese side (Planned and Actual):

Planned	Actual
<p>[Japanese side] Amount of input by the Japanese side: 320(million Japanese Yen)</p> <ul style="list-style-type: none"> <li>•Experts</li> <li>-Waste Management</li> <li>-Collection and Transportation</li> <li>-Intermediate Treatment and Final Disposal</li> <li>- 3Rs/ Public Awareness</li> <li>- Environmental and Social Considerations</li> <li>-Financial/Economic Analysis/Institutional plan</li> <li>- Database</li> <li>- Project Coordination / Training</li> </ul> <p>•Provision of machinery and equipment</p> <p>•Trainings in Japan/Third Countries</p> <p>• Overseas activities cost: 0 (million Japanese Yen)</p>	<p>[Japanese side] Amount of input by the Japanese side: 506(million Japanese Yen)</p> <ul style="list-style-type: none"> <li>•Experts</li> <li>-Waste Management</li> <li>-Collection and Transportation</li> <li>-Intermediate Treatment and Final Disposal</li> <li>- 3Rs/ Public Awareness</li> <li>-Financial/Economic Analysis/Institutional plan</li> <li>- Database</li> <li>- Waste Management Business Continuity Plan</li> <li>- Coastal Pollution Waste Treatment and Disposal Survey</li> <li>- Equipment procurement support</li> </ul> <p>•Provision of machinery and equipment</p> <ul style="list-style-type: none"> <li>- Small scale solid waste transfer station at Kalutara composting facility</li> <li>- Forced aeration system in existing Kalutara composting facility</li> <li>- Equipment for rehabilitating existing compost plant in Karadiyana</li> </ul> <p>•Video Trainings</p> <p>Overseas activities cost: 9.7 (million Japanese Yen) Provision of Personal Protective Equipment.</p>

**Reason:**

At the beginning of the project, the details of the pilot project had not been decided, so the estimate was provisional and was increased once the details of the capital investment were finalized. And due to the extension of the project period following global spread of the new coronavirus (COVID-19) pandemic in 2020, the assignment of experts has been increased. In addition, the war in Ukraine led to a sharp rise in prices around the world, which caused a significant increase compared to the initial estimate. All of these factors have contributed to the increase in project costs.

Taking into account the strict entry restrictions due to COVID-19 and the remaining duration of the project, video training is scheduled to be provided instead of training in Japan / third countries.

PM Form 4 Project Completion Report

1-2 Input by the Sri Lankan Side d and Actual):

Planned	Actual
<p>[Sri Lankan side]</p> <ul style="list-style-type: none"> <li>•Counterpart (C/P)</li> <li>•Personnel cost and operational cost for C/P</li> <li>•Office space and facilities for Experts                             <ol style="list-style-type: none"> <li>1. NSWMSC</li> <li>2. WMA</li> </ol> </li> </ul>	<p>[Sri Lankan side]</p> <ul style="list-style-type: none"> <li>•C/P (17)</li> <li>•Personnel cost and operational cost for C/P</li> <li>•Office space and facilities for Experts                             <ol style="list-style-type: none"> <li>1. NSWMSC</li> <li>2. WMA</li> </ol> </li> </ul>

1-3 Activities (Planned and Actual):

Planned	Actual
<p>1.1 Roles and responsibilities of relevant organizations relevant to solid waste management in Western Province are clarified by examining policies and legal documents (e.g. national laws, ordinances).</p> <p>1.2 A Working Group for MP formulation is established.</p> <p>1.3 Terms of Reference (TOR) of the Working Group for MP formulation are clarified.</p> <p>1.4 Regular meetings and special meetings or sub-group meetings, where necessary, are held.</p> <p>1.5 Draft Master Plan is prepared through discussions by the Working Group.</p> <p>1.6 The process and outputs of activities of the Working Group are shared with relevant organizations (including those which authorize the Master Plan) both at the Provincial and Central levels by holding workshops or, meetings.</p> <p>1.7 An inter-organizational coordination body such as Provincial Solid Waste Management Committee which takes over the work of the Working Group is proposed.</p>	<p>1.1 Roles and responsibilities of relevant organizations relevant to solid waste management in Western Province were clarified by examining policies and legal documents (e.g. national laws, ordinances).</p> <p>1.2 A Working Group for MP formulation was established.</p> <p>1.3 Terms of Reference (TOR) of the Working Group for MP formulation were clarified.</p> <p>1.4 Regular meetings and special meetings or sub-group meetings were held.</p> <p>1.5 Draft Master Plan was prepared through discussions by the Working Group.</p> <p>1.6 The process and outputs of activities of the Working Group were shared with relevant organizations (including those which authorize the Master Plan) both at the Provincial and Central levels by holding workshops or, meetings.</p> <p>1.7 An inter-organizational coordination body such as Provincial Solid Waste Management Committee which takes over the work of the JCC was proposed.</p>
<p>2.1The Working Group for MP formulation decides a. types of waste, b. target year, c. areas and population.</p> <p>2.2 Organizations in Western Province</p>	<p>2.1The Working Group for MP formulation decided a. types of waste, b. target year, c. areas and population.</p> <p>2.2 Organizations in Western Province</p>

<p>relevant to solid waste management are investigated and data on solid waste management is collected.</p> <p>2.3 A database is created using existing data on Western Province's solid waste management.</p> <p>2.4 Based on the data, current situations and challenges regarding solid waste management are clarified and reported.</p>	<p>relevant to solid waste management were investigated and data on solid waste management was collected.</p> <p>2.3 A database was created using existing data on Western Province's solid waste management.</p> <p>2.4 Based on the data, current situations and challenges regarding solid waste management were clarified and reported.</p>
<p>3.1 Trainings on appropriate waste management and 3Rs for LAs and other relevant organizations are conducted.</p> <p>3.2 Target LAs for pilot projects are selected.</p> <p>3.3 Capacity Assessment (pretest) for WMA and target LAs is conducted.</p> <p>3.4 The pilot projects on appropriate waste management and 3Rs are planned at the target LAs</p> <p>3.5 3.4 is implemented.</p> <p>3.6 Capacity Assessment (posttest) for WMA and target LAs is conducted.</p> <p>3.7 3.5 is monitored and its results and knowledge are reflected in the draft MP.</p>	<p>3.1 Trainings on appropriate waste management and 3Rs for LAs and other relevant organizations were conducted.</p> <p>3.2 Target LAs for pilot projects were selected.</p> <p>3.3 Capacity Assessment (pretest) for WMA and target LAs was conducted.</p> <p>3.4 The pilot projects on appropriate waste management and 3Rs were planned at the target LAs.</p> <p>3.5 3.4 was implemented.</p> <p>3.6 Capacity Assessment (posttest) for WMA and target LAs was conducted.</p> <p>3.7 3.5 was monitored and there was nothing special to be reported in the draft MP.</p>
<p>4.1 Complaints/ requests made by residents, NGOs and other stakeholders with regard to waste management are studied to identify important issues.</p> <p>4.2 Target waste management facilities for pilot activities are selected.</p> <p>4.3 Trainings on planning/ operation of waste management facilities are conducted for CMC and other relevant organizations.</p> <p>4.4 Capacity Assessment (pretest) for relevant organizations is conducted.</p> <p>4.5 Pilot activities for seeking optimal technical/ social interventions for improved planning and operation of waste management facilities are planned at the target waste management facilities.</p> <p>4.6 4.5 is implemented.</p> <p>4.7 Capacity Assessment (posttest) for relevant organizations is conducted.</p> <p>4.8 4.6 is monitored and its results and knowledge are reflected in written form</p>	<p>4.1 Complaints/ requests made by residents, NGOs and other stakeholders with regard to waste management were studied to identify important issues.</p> <p>4.2 Target waste management facilities for pilot activities were selected.</p> <p>4.3 Trainings on planning/ operation of waste management facilities were conducted for relevant organizations.</p> <p>4.4 Capacity Assessment (pretest) for relevant organizations was conducted.</p> <p>4.5 Pilot projects for seeking optimal technical/ social interventions for improved planning and operation of waste management facilities were planned at the target waste management facilities.</p> <p>4.6 4.5 was implemented.</p> <p>4.7 Capacity Assessment (posttest) for relevant organizations was conducted.</p> <p>4.8 4.6 was monitored and its results and knowledge were reported in written form.</p>

## PM Form 4 Project Completion Report

<p>5.1 Meetings for the explanation of the MP are organized for LAs in Western Province and other relevant organizations (including central government organizations) are held.</p> <p>5.2 The staff of WMA and other relevant organizations enhance their knowledge and skills for supporting LAs and other organizations in their formulation and implementation of the MP, its sub-plans and other related plans (e.g. LA action plans, plans on waste management facilities) through trainings and OJT.</p> <p>5.3 Support and guidance for the formulation of sub-plans and other related plans (e.g. LA action plans, plans on waste management facilities) in line with MP are given to LAs and other relevant organizations.</p> <p>5.4 A system to monitor the implementation of sub-plans and other related plans (e.g. LA action plans, plans on waste management facilities) in line with MP is established and documented.</p> <p>5.5 Budget plans for the implementation of the MP and a guidance for budget plan formulation to implement LAs' action plans are prepared.</p>	<p>5.1 Meetings for the explanation of the MP were organized for LAs in Western Province and other relevant organizations (including central government organizations) were held.</p> <p>5.2 The staff of WMA and other relevant organizations enhanced their knowledge and skills for supporting LAs and other organizations in their formulation and implementation of the MP, its sub-plans and other related plans (e.g. LA action plans, plans on waste management facilities) through trainings and OJT.</p> <p>5.3 Support and guidance for the formulation of sub-plans and other related plans (e.g. LA action plans, plans on waste management facilities) in line with MP were given to LAs and other relevant organizations.</p> <p>5.4 A system to monitor the implementation of sub-plans and other related plans (e.g. LA action plans, plans on waste management facilities) in line with MP was established and documented.</p> <p>5.5 Budget plans for the implementation of the MP and a guidance for budget plan formulation to implement LAs' action plans were prepared.</p>
--	--

## 2. Achievements of the Project

### 2-1 Outputs and indicators

(Target values and actual values achieved at completion)

Target values	Actual values
<p>Output 1: Roles and responsibilities of organizations relevant to solid waste management in Western Province are clarified and institutional arrangements for the formulation of the MP are established.</p> <p>Degree of Achievement: high 100% has been achieved,</p>	
<ol style="list-style-type: none"> <li>1. Roles and responsibilities of relevant organizations are clarified and documented in the MP and/or other documents.</li> <li>2. A Working Group for MP formulation is established.</li> <li>3. Regular meetings are held (at least once in three months) by the Working Group for MP formulation.</li> <li>4. The process and outputs of activities of the Working Group are shared at the Provincial and Central levels by holding workshops or meetings 6 times.</li> <li>5. Draft Master Plan is prepared by the Working Group</li> </ol>	<ol style="list-style-type: none"> <li>1. Roles and responsibilities of relevant organizations were clarified and documented in the MP and/or other documents.</li> <li>2. A Working Group for MP formulation was established.</li> <li>3. Regular meetings were held by the Working Group for MP formulation.</li> <li>4. The process and outputs of activities of the Working Group were shared at the Provincial and Central levels by holding workshops and meetings 6 times.</li> <li>5. Draft Master Plan was prepared by the Working Group.</li> </ol>
<p>Output 2: Current situation, trend, potentials and challenges of solid waste management in Western Province are clarified.</p> <p>Degree of Achievement: high 100% has been achieved.</p>	
<ol style="list-style-type: none"> <li>1. Data on current situations on solid waste management in Western Province are collected.</li> <li>2. A database using the collected data is created</li> <li>3. An analysis report on solid waste management in Western Province is prepared.</li> </ol>	<ol style="list-style-type: none"> <li>1. Data on current situations on solid waste management in Western Province was collected.</li> <li>2. A database using the collected data was created.</li> <li>3. An analysis report on solid waste management in Western Province was prepared.</li> </ol>
<p>Output 3: Knowledge and experience which contribute to MP formulation and implementation are acquired through the implementation of pilot projects on appropriate waste management and 3Rs.</p> <p>Degree of Achievement: high 87.5% has been achieved.</p>	

PM Form 4 Project Completion Report

<ol style="list-style-type: none"> <li>1. Trainings on appropriate waste management and 3Rs for LAs and other relevant organizations are conducted three times.</li> <li>2. Pilot projects are implemented at one or more than one LA.</li> <li>3. The results of Capacity Assessment (posttest) for WMA and target LAs improve from those of pretest.</li> <li>4. Progress of Pilot Projects are monitored by WG for MP formulation.</li> </ol>	<ol style="list-style-type: none"> <li>1. Trainings on appropriate waste management and 3Rs for LAs and other relevant organizations was conducted two times. One more training will be delivered by video training by distributing DVD.</li> <li>2. Pilot projects have been implemented at Sri Jayewardenepura Kotte MC.</li> <li>3. The results of Capacity Assessment (posttest) for WMA and target LAs improve from those of pretest.</li> <li>4. Progress of Pilot Projects are monitored by WG for MP formulation, however, the duration of monitoring was less than one month due to the delay of the pilot projects schedule.</li> </ol>
<p>Output 4: Knowledge and experience which contribute to MP formulation and implementation are acquired through pilot projects for improving planning/ operation of waste management facilities.</p> <p>Degree of Achievement: high 87.5% has been achieved.</p>	
<ol style="list-style-type: none"> <li>1. Trainings on planning/ operation of waste management facilities for relevant organizations are conducted more than three times.</li> <li>2. Pilot projects are implemented at one or more than one waste management facilities.</li> <li>3. The results of Capacity Assessment (posttest) for relevant organizations of target waste management facilities improve from those of pretest.</li> <li>4. Progress of pilot projects are monitored by WG for MP formulation.</li> </ol>	<ol style="list-style-type: none"> <li>1. Trainings on planning/ operation of waste management facilities for relevant organizations were conducted twice.</li> <li>2. Pilot projects have been implemented at Kalutara Compost Plant and Karadiyana Compost Plant.</li> <li>3. The results of Capacity Assessment (posttest) for WMA and target LAs were improved from those of pretest.</li> <li>4. Progress of Pilot Projects was monitored by WG for MP formulation, however, the duration of monitoring was less than one month due to the delay of the pilot projects schedule.</li> </ol>
<p>Output 5: Collaboration and coordination among relevant organizations in Western Province for the implementation of MP, and formulation and implementation of its related plans (e.g. LA action plans, plans on waste management facilities) are strengthened.</p> <p>Degree of Achievement: high 100% has been achieved.</p>	
<ol style="list-style-type: none"> <li>1. Meetings for the explanation of the MP</li> </ol>	<ol style="list-style-type: none"> <li>1. Meetings for the explanation of the MP</li> </ol>



## PM Form 4 Project Completion Report

<p>are organized for LAs in Western Province and other relevant organizations (including central government organizations) are held more than three times.</p> <ol style="list-style-type: none"> <li>2. 11 staff members of WMA and other related organization are given trainings and/or OJT on supporting LAs.</li> <li>3. Support and guidance for the formulation of sub-plans and other related plans (e.g. LA action plans, plans on waste management facilities) in line with the MP are given to LAs and other relevant organizations.</li> <li>4. The monitoring system is documented.</li> <li>5. Budget plans for the implementation of the MP and a guidance for budget plan formulation to implement LAs' action plans are prepared.</li> </ol>	<p>are organized for LAs in Western Province and other relevant organizations (including central government organizations) were held more than three times as follows:</p> <ul style="list-style-type: none"> <li>• The 3rd JCC: 4 November 2022</li> <li>• Validation Workshop: 13 March 2023</li> <li>• LAs workshop: 14 March 2023</li> <li>• 11 staff members of WMA have been given trainings.</li> </ul> <ol style="list-style-type: none"> <li>2. 11 staff members of WMA and other related organization were given training and/or OJT on supporting LAs.</li> <li>3. The following support and guidance on the formulation of action plans was implemented. <ul style="list-style-type: none"> <li>• Trainers' training for WMA staff organized: 17 Oct. 2022</li> <li>• Support to Mahara PS in formulating an AP: 27 Oct. &amp; 2 Nov. 2022</li> <li>• Workshops for 7 pilot local authorities held: 22 Feb. 2023</li> <li>• Workshop on the use of modified waste flow held: 28 Feb. 2023</li> <li>• Holding Validation workshop: 13 Mar. 2023</li> <li>• Organization of workshops for local authorities: 14 Mar. 2023</li> </ul> </li> <li>4. Monitoring of the implementation of sub-plans and other relevant plans in line with the Master Plan was carried out by the Coordination Committee on Waste Management in the Western Province. The establishment of such a committee was discussed and agreed upon at the JCC held on 4 November 2022. Each local authority prepares an Annual Work Plan (AWP) in line with its Action Plan. This AWP is positioned as an important monitoring instrument to check the progress of the action plan, as well as the implementation plan for each year.</li> <li>5. Eight projects requiring large budgets in the short and medium term of the MP were selected and the costs required for their implementation were specified. The Local Authority Action Plan shall be accompanied by an annual plan, specifying the annual waste management implementation</li> </ol>
---	--

## PM Form 4 Project Completion Report

	schedule as well as the budget required for implementation. In addition, the indicators were included in the budget so that the adequacy of the budget could be verified.
--	---

## 2-2 Project Purpose and indicators

(Target values and actual values achieved at completion)

Project Purpose	
Western Province's planning capacity on solid waste management is strengthened through the formulation of Western Province Solid Waste Management Master Plan (MP).	
Target values	Actual values
<ol style="list-style-type: none"> <li>The final draft of the MP is prepared.</li> <li>Western Provincial Council (WPC) and MoPAHAPCLG start the MP approval process.</li> <li>Sub-plans and other related plans (e.g. LA action plans, plans on waste management facilities) in line with the MP are formulated.</li> <li>An inter-organizational coordination body is established to monitor the progress and provide support implementation of the sub-plans and other related plans in Western Province.</li> </ol>	<ol style="list-style-type: none"> <li>The final draft of the MP is prepared. Achievement degree: high: 100% has been achieved.</li> <li>Final MP is scheduled to be forwarded to Western Provincial Council (WPC) and MoPAHAPCLG for approval process. Achievement degree: high: 100% has been achieved,</li> <li>Sub-plans and other related plans (e.g. LA action plans, plans on waste management facilities) in line with the MP are formulated. Achievement degree: high: 100% has been achieved,</li> <li>An inter-organizational coordination body is in the process of establishment to monitor the progress. Achievement degree: medium: 50% has been achieved.</li> </ol>

## 3. History of PDM Modification

Modification points	Reason for modification
Duration	Due to global spread of the coronavirus disease 2019 (COVID-19), some of the project activities have been suspended
Indicator for Overall goal	The indicators were not set in the original PDM
Means of Verification for Overall goal	Due to the reselection of the appropriate Means of Verification

## PM Form 4 Project Completion Report

Indicator for project purpose	To clarify the indicators for the achievement of the project purpose
Means of Verification for project purpose	Due to the reselection of the appropriate Means of Verification
Outputs	Due to change of target area, Colombo Municipality is excluded from Output 3
In indicator for outputs	The indicators were not set in the original PDM
Means of Verification for outputs	Due to the reselection of the appropriate Means of Verification
Activity	To add activities necessary for the implementation of the Project.
Inputs (Japanese side)	The provision of machinery and equipment are not set in the original PDM Video Training is scheduled instead of trainings in Japan / third countries due to COVID-19 situation Due to reconsider the appropriate experts

#### 4. Others

##### 4-1 Results of Environmental and Social Considerations (if applicable)

The procedure of strategic environmental assessment (SEA) for formulation of MP has been studied. Besides the procedure of environmental impact assessment (EIA) for formulation of MP and pilot project facilities have been studied.

##### 4-2 Results of Considerations on Gender/Peace Building/Poverty Reduction, Disability, Disease infection, Social System, Human Wellbeing, Human Right, and Gender Equality (if applicable)

Gender considerations are important in communication with the residents, as women, who are often at home for long periods of time, are most affected when environmental problems and health hazards occur at waste management facilities. Therefore, when designing Consensus-building pilot project for the improvement of operations, complaints / requests from women, children and young people with regard to identify important issues on waste management were also listened to.

III. Results of Joint Review				
1. Results of Review based on DAC Evaluation Criteria				
(1) Relevance Rating: ③				
Key Perspectives	Questions	Necessary Data	Source of information	Result
1 Consistency with Development Policy	Are the project objectives consistent with the country's development policy?	National Development Plan, Sector policy	<ul style="list-style-type: none"> <li>- National Strategy for Solid waste Management (NSSWM) (2000)</li> <li>- National Development 10 Year Plan (2006 – 2016)</li> <li>- National Policy on Waste Management (2020)</li> </ul>	<ul style="list-style-type: none"> <li>- NSSWM stipulates waste management.</li> <li>- National Policy on Waste Management clarifies the environmental and social responsibilities of waste-producing institutions, managers and service personnel, and states that environmentally sound waste management will be implemented with the participation of all institutions, organisations and individuals.</li> <li>- In the National</li> </ul>

PM Form 4 Project Completion Report

Key Perspectives	Questions	Necessary Data	Source of information	Result
				<p>Development 10 Year Plan, an appropriate and sustainable waste management system was identified as a priority, and investment plans were made to establish a sustainable waste management system, including the promotion of the 3Rs and the development of environmentally friendly final disposal facilities.</p>
2 Consistency with Development Needs	Are the project objectives consistent with the country's development needs?	Needs of target area, target group		<p>A collapse at Meethotamulla Waste Disposal Site in April 2017 caused a disaster resulting in the loss of many lives of nearby residents and massive physical damage, according to</p>

PM Form 4 Project Completion Report

Key Perspectives	Questions	Necessary Data	Source of information	Result
				<p>the analysis by the Japanese expert, it was recommended that 3Rs activities (reduce, reuse, and recycle), and intermediate processing, once properly implemented, would be an effective measure to reduce waste volumes for final disposal. as another recommendation was to formulate a waste management master plan (MP) for the Western Province jointly with all stakeholders and the roles of every stakeholder be defined clearly in the MP. The project can be assessed as being designed to provide timely support that meets the development needs of the target areas.</p>

PM Form 4 Project Completion Report

Key Perspectives	Questions	Necessary Data	Source of information	Result
3 Appropriateness of project plan and approach	Are the plan and approach appropriate to respond to problems and issues?	Selection process of the plan and approach, consideration of content for alternative approaches		Six pilot projects were selected with the aim of gaining knowledge and experience and contributing to the development and implementation of MPs. Plans and approaches can be assessed for their adequacy as addressing.

(2) Coherence Rating: ②

Key Perspectives	Major Questions	Necessary Data (example)	Source of information	Result
1 collaboration with JICA's other projects	- Was there concrete collaboration (complementarity, harmonization, and coordination) with JICA's other projects (Technical Cooperation, Loan Assistance/Private Sector Investment Finance Cooperation, Grants, the JICA Partnership Program, private sector partnership programs, JICA volunteers, etc.)?	Specific components; the names of the scheme(s) and project(s) with which the Project cooperated etc.	N/A	N/A

PM Form 4 Project Completion Report

Key Perspectives	Major Questions	Necessary Data (example)	Source of information	Result
2 Collaboration with other projects	<ul style="list-style-type: none"> <li>- Are any expected synergistic effect/mutual relations ascertained?</li> <li>- Was there concrete collaboration (complementarity, harmonization, and coordination) with other projects by Japan or other development partners, etc.?</li> <li>- Are any expected synergistic effect/mutual relations ascertained?</li> </ul>	<p>Specific components; the names of the organization(s), scheme(s), and project(s) with which the Project liaised; etc. (including specific efforts for cooperation, as well as the outcomes of consultations conducted to confirm complementarity)</p>	N/A	N/A
3 Consistency with global frameworks	<ul style="list-style-type: none"> <li>- Was the Project consistent with global frameworks (global goals and initiatives such as the SDGs, as well as international norms and standards)?</li> </ul>	<p>e.g., examples of activities in line with global frameworks</p>	N/A	<p>The MP's proposed actions were assessed in terms of potential compliance or conflict with Sri Lanka's Nationally Determined Contribution (NDC) to the UN Framework Convention on Climate Change, a set of waste management objectives developed in</p>



PM Form 4 Project Completion Report

Key Perspectives	Major Questions	Necessary Data (example)	Source of information	Result
				accordance with waste management policies and strategies.

(3) Effectiveness Rating: ③

Key Perspectives	Major Questions	Necessary Data (example)	Sub-rating for Effectiveness	Result
1 Degree of the achievement of the project purpose	-Have the produced outputs led to the achievement of the project purpose?	Actual data for each of the indicators for outputs and project purpose at the time of project completion	The Project produced the expected outcomes almost as successfully as planned	All but two of the indicators for the outputs scored 100% achievement (of the indicator for Output 3 and 4 are the exception, scored 87.5%). Therefore, the produced outputs were in line with the project purpose.
	-Has the project purpose been achieved by the time of project completion?	Actual data for each of the indicators for outputs and project purpose at the time of project completion	The Project produced the expected outcomes almost as successfully as planned	Out of the two indicators for the project purpose scored 100%. Therefore, the produced outputs were in line with the project purpose.

PM Form 4 Project Completion Report

(4) Efficiency Rating: ③

Key Perspectives	Questions	Comparison of planned and actual		Remarks
		Planned	Actual	
1 Project Cost	Was the project cost on the Japanese side within the planned amount?	320 million JPY	506 million JPY	<p>- At the beginning of the project, the details of the pilot project had not been decided, so the estimate was provisional and was increased once the details of the capital investment were finalized.</p> <p>- Due to the extension of the project period following global spread of the coronavirus disease 2019, the assignment of experts has been increased (COVID-19).</p> <p>- The war in Ukraine led to a sharp rise in prices around the world, which</p>

PM Form 4 Project Completion Report

Key Perspectives	Questions	Comparison of planned and actual		Remarks
		Planned	Actual	
2				caused a significant increase compared to the initial estimate.
Project Period	Was the project period within the planned period?	2019.2-2022.2 (3 years )	2019.2-2023.6 (4 years and 3 months)	- Due to the extension of the project period following global spread of the coronavirus disease 2019, the assignment of experts has been increased (COVID-19). - The war in Ukraine led to a sharp rise in prices around the world, which caused a significant increase compared to the initial estimate.
3	Were the activities necessary to produce outputs? Were the inputs quantitatively and qualitatively appropriate?	.Given the original situation of the waste management sector in the Western Province before the project, the activities planned were necessary in order to produce the target outputs. Each input is directly linked to the relevant output and pilot projects were appropriately designed to achieve their relevant		

PM Form 4 Project Completion Report

Key Perspectives	Questions	Comparison of planned and actual		Remarks
		Planned	Actual	
	Were those inputs provided timely?			<p>goals. The activities took into account a comprehensive and participatory approach involving all stakeholder and all stages of waste management (generation, collection treatment and disposal)</p> <ul style="list-style-type: none"> <li>- Considering the project cost and project period stated above, the planned activities were quantitatively and qualitatively appropriate as far as the budgetary and time limitations allow it. And the implementation of the inputs was achieved even in the cases where it was affected by uncontrollable factors (such as the global pandemic and the economic impact of the war on Ukraine) but efforts were made to achieve the planned activities.</li> </ul>

(5) Impact Rating: ③

Key Perspectives	Questions	Necessary Data	Result
1 Prospects to achieve the overall goal	<ul style="list-style-type: none"> <li>- Is the overall goal expected to be achieved as the project effect?</li> <li>- Can the Impact to the recipient country's development plan be expected through the achievement of the overall goal?</li> <li>- Are there any factors that impede the achievement of the overall goal?</li> </ul>	<ul style="list-style-type: none"> <li>- LA's Action Plans Reports on waste management from LAs</li> </ul>	<ul style="list-style-type: none"> <li>- As of May 2023, 1 Local Authority (LA) is prepared the solid waste management action plan (LA action plan) in line with the MP, and workshop for 6 pilot local authorities was held. In addition, Trainer's Training for WMA staff on formulation of LA action plan has conducted, thus all LAs expect to prepare/update and implement their LA action plan within one year after publishing the MP..</li> <li>- An inter-organizational coordination body is in the process of establishment to monitor the progress and support the implementation of LA action plan in Western Province.</li> </ul>
2 Causal relationship	<ul style="list-style-type: none"> <li>- Does the overall goal deviate from the</li> </ul>		<ul style="list-style-type: none"> <li>- The overall goal and project purpose are</li> </ul>

PM Form 4 Project Completion Report

Key Perspectives	Questions	Necessary Data	Result
	<p>project purpose?                      - Are the external conditions from the project purpose to the overall goal appropriate even at this stage?</p>		<p>not divergent.                      - The external conditions affecting the project purpose to the overall goal is still appropriate at this time.</p>
3  Ripple effect	<p>- Are the effects and influence other than the overall goal envisaged (e.g. impact on the development of social systems and norms [policy formulation and development of laws, systems, criteria, etc.]; impact on social and cultural aspects such as gender, human rights, disparity between the rich and the poor, and the socially vulnerable; environmental impact; economic impact on the target society, those concerned with the project, beneficiaries, etc.; impact on human well-being [whether the project helps ensure the physical and mental well-being of its beneficiaries])?                      - Is there any different positive or negative impact due to a difference in gender, race, and social class?                      - Is there any other negative impact? What are the measures to remove it?</p>		<p>- Contribute to sustainable cities and communities by strengthening waste management capacities, for example by reducing waste disposal through the introduction of intermediate treatment facilities and promoting the 3Rs.                      - There is no negative impact due to a difference in gender, race, and social class.</p>

(6) Sustainability Rating: ③

Key Perspectives	Questions	Necessary Data	Result
1 Policy and System	<p>- Is back-up from the policy and institutional aspects required for</p>	<p>for waste                      National Strategy for Solid</p>	<p>National strategy, policy and plan require for continuation of the project effectiveness.</p>

PM Form 4 Project Completion Report

Key Perspectives	Questions	Necessary Data	Result
	<p>continuation of the project effect to be established?</p> <ul style="list-style-type: none"> <li>- Do the project contents meet the development needs of the society and does the project have prospects to be continued and developed on a continuous basis?</li> <li>- For projects targeting pilot sites, are the initiatives to support future expansion also secured from the system aspect?</li> </ul>	<ul style="list-style-type: none"> <li>- Management (NSSWM) in 2000</li> <li>- National Development 10 Year Plan (2006 – 2016)</li> <li>- National Policy on Waste Management (2020)</li> <li>- Western Province Solid Waste Management Master Plan</li> <li>- Local Authority Action Plan</li> <li>- Inter-organizational coordination body</li> </ul>	
2	<p>Institutional and Organizational aspect of the implementing agency</p> <ul style="list-style-type: none"> <li>- Are the necessary organization and structure (within the organization, inter-organizational responsibility and structure, and availability of human resources) required for continuation of the project effect established at the implementing agency?</li> <li>- Is the project ownership of the implementing agency secured sufficiently?</li> </ul>	<ul style="list-style-type: none"> <li>- ditto</li> </ul>	<ul style="list-style-type: none"> <li>- An inter-organizational coordination body is in the process of establishment to monitor the progress and support the implementation of LA action plan in Western Province.</li> </ul>
3	<p>Technical Aspect of the implementing</p> <ul style="list-style-type: none"> <li>- Does the implementing agency sufficiently possess the skill level required for continuation of</li> </ul>	<ul style="list-style-type: none"> <li>- ditto</li> </ul>	<ul style="list-style-type: none"> <li>- The Project has provided sufficient technology transfer to C/P, through the implementation of pilot activities. Through</li> </ul>

PM Form 4 Project Completion Report

Key Perspectives	Questions	Necessary Data	Result
agency	the project? - For projects targeting pilot sites, can the skills be disseminated to other areas and can the implementing agency extend them?		this technology transfer, the technology of the implementing agencies has reached the level necessary to sustain the project effectiveness. - The skills transferred through this Project can be disseminated to other areas and the implementing agency can extend them.
4  Financial Aspect	- From the perspective of the financial balance of the implementing agency (current status of the securing of public and private funds, status of the distribution of maintenance and management budget, etc.), are the prospects high to secure the necessary financial resources required for continuation of the project effect in the future?		- It was decided that from 2021, waste management expenditure will be a separate expenditure item in the budgets of all LAs as Programme 8, which has been implemented in all LAs to accurately identify waste management costs since without an accurate cost, it would have been impossible to budget appropriately for the future. However, as of May 2023, the accumulated data for waste management expenditure is limited only to three years; budget and actual expenditure for 2021, budget and provisional expenditure for 2022 and budget for 2023.
5  (Only applicable) if Social and Environmental Aspect	- Assess near-term possible negative impacts on the environment and society that were anticipated at the time of planning, as well as the implementation status and results of measures designed to mitigate such impacts. Then predict and state such impacts, if any, as well as their scales. - <u>Even if the project confirms environmental and social</u>		- The pilot projects themselves will not have any negative impact on the environment or society, as it is an improvement or mitigation measure for the current situation such as offensive odors and scattering of waste at existing waste treatment facilities.

Key Perspectives	Questions	Necessary Data	Result
	<p><u>impacts that were not anticipated at the time of planning, analyze the scale of such impacts on the sustainability of outcomes in light of a number of factors, including (1) near-term trends in such impacts (increasing or decreasing); (2) mitigation measures, if any, to be taken by the implementing agency to mitigate them; and (3) the near-term schedule and capacity for such measures.</u></p>		
<p>6</p> <p>(Only applicable) Preventative Measures to risk</p>	<p>-Based on the findings of monitoring during project implementation, ascertain changes in risks as well as response actions and then assess the status of risk response and the scale of the near-term impacts of risks. -If <u>unanticipated risks occur during project implementation</u>, describe the response actions that were taken during project implementation with focus on the predictability of such risks (which is reflected in Relevance), subsequent actions, and near-term impacts.</p>	-	N/A



## 2. Key Factors Affecting Implementation and Outcomes

Since March 2020, in response to spread of infection of COVID-19, JICA suspended dispatching Japanese experts to any project site so that all activities were implemented by remote work before February 2021. Japanese experts have been dispatched to Sri Lanka since February 2021.

Since tax exemption of pilot projects had not been decided by Sri Lankan Government until August 2022, pilot projects of transfer station in Kalutara Compost Plant delayed for one (1) year.

Sri Lankan Government took a Cabinet Decision to cancel the construction of WtE facility in Karadiyana Resource Management Centre, which was a core waste management facility in the MP. Therefore, the draft MP must have been modified with consensus among counterpart and relevant organizations.

## 3. Evaluation on the results of the Project Risk Management

### (1) Risk management results

#### (a) The COVID-19 pandemic

The COVID-19 pandemic under global expansion from the end of 2019 posed a significant risk to project implementation. The project team identified the risks in consultation with JICA and stopped field surveys for about a year from March 2020, switching to online work. Subsequently, due to the prolonged impact of the COVID-19 pandemic, JICA and the Sri Lankan Government decided to extend the project period for one year until December 2022. JICA expert team field activities were then resumed in March 2021, but the resumption was relatively smooth as the online remote project continued to some extent for almost a year.

#### (b) Cancellation of Karadiyana WtE project

Around mid-2021, while the draft MP was being developed, the Sri Lankan Government decided to cancel the Karadiyana WtE project, one of the core treatment facilities in the draft MP. The sudden decision to cancel the project came after the tender selection of the project implementer had already been completed and the civil foundation works for the WtE facility were underway. The draft MP had planned three WtE facilities in the Western Province as core facilities for intermediate treatment, but one of these was canceled. It required a review of the MP, which postponed the project by a further six months to June 2023 after discussions between JICA and the Sri Lankan Government in October 2021. The WtE in the MP was addressed by amending it to read 'one WtE to be planned in the central region of the Western Province' instead of the Karadiyana WtE.

#### (c) Tax exemption of pilot project

In Sri Lanka, the COVID-19 pandemic, which began its global expansion in 2020, severely affected the country's main industry, tourism, which led to an economic crisis from 2021 and finally to the most serious economic situation in 2022. This series of crisis conditions led to significant delays in the tax exemption process for the pilot project, which is the burden of the Sri Lankan

Government as stated in the Record of Discussion for the project. However, by August 2022, the MoLGPC in Sri Lanka understood the importance of the pilot project and resolved the tax exemption issue. Following this, the JICA team started construction of the small-scale waste transfer station pilot project in September 2022.

(d)The economic crisis in Sri Lanka and the Ukrainian-Russian conflict have led to a surge in global material prices.

In 2022, Sri Lanka's economic crisis and the Ukraine-Russia conflict caused a global surge in material prices; the construction of the pilot project, which started in September 2022, could have been affected by this surge in material prices. The contract currency between the contractor and the JICA consultant was set at US dollars to avoid the effects of inflation in Sri Lanka. The Sri Lankan Government also assisted the contractor with the "L/C" (letter of credit) process so that the contractor could smoothly procure materials from overseas in US dollars, despite Sri Lanka's strict restrictions on taking foreign currency out of the country.

(e)Changes to 3Rs pilot project content

The 3Rs pilot project in communal housing, which was planned at the beginning of the project and required frequent face-to-face consultations with residents and joint activities, was canceled due to the impact of the COVID-19 pandemic, which spread globally from 2020. The Government of Sri Lanka and JICA, in consultation, decided to implement a pilot project on the development of a municipal 'waste App', which can work without contact, as an alternative to the 3Rs pilot project in communal housing.

(2) Results of the use of lessons learnt

None

#### **4. Lessons Learnt**

(1) Obtain basic data from each local authority

Basic data for each municipality was collected from local authority's waste officers under the guidance of the WMA's zonal and district managers through data collection forms. Among the basic data, the most important data for MP formulation is the amount of waste collected.

Local authorities that deliver waste to the Karadiyana and Kerawarapitiya compost plants have accurate data on the amount of waste collected through weight bridge. But many other local authorities in the Western Province do not have a weight bridge, and the amount of waste collected reported by the local authorities was not consistent with the waste flow.

Therefore, JICA expert team visited 25 local authorities, which do not have weigh bridge data, among 49 local authorities to investigate the collection schedule by collection vehicle, type of collection waste, number of collection trips, loading capacity (actual measurement), etc. WMA staff were instructed on how to estimate the amount of waste collected using these survey results, and this amount of waste collected was applied as data for the waste flow.

## (2) Functions of the MP formulation process and working groups

The MP formulation incorporated the individual projects that were initially decided to be implemented into the MP as a given condition. However, of the individual projects that were positioned as given, the following two major changes occurred in October 2021.

For the Karadiyana Waste-to-Energy (WtE) project, due to a change in the shareholder structure of the private operator holding the project rights, the Sri Lankan Government reassessed the project, including the implementation capacity of the new consortium. As a result of the discussions at the Cabinet meeting, a decision was taken to cancel the project concession agreement.

The Government had planned to implement the composting plant and other improvements from 2022 through the Government budget for high priority items. However, due to the deteriorating financial situation of the Sri Lankan government, the public investment budget has been reduced by 38% year-on-year due to austerity measures, and this has made it impossible to implement even priority projects in 2022.

The project team made the following flexible changes to the MP on the condition that the development of the MP would be postponed.

- (i) Since the Government canceled the Waste-to-Energy (WtE) project planned for the Karadiyana Resource Management Centre in accordance with the Cabinet decision, JICA expert team proposed a project for the construction of a new Thermal Recovery Facility (TRF) in the central part of Colombo District as an alternative, as well as a waste-to-energy project planned for other areas to TRF project.
- (ii) JICA expert team postponed the timing of the implementation of priority projects, taking into account the financial situation of the local authority; and the change led to the re-setting of the MP alternative, re-evaluation and re-selection of the most suitable proposal, as well as the selection of short- and medium-term priority projects.

## (3) Database system

The software for the waste management database was developed in consultation with the local counterpart agency (WMA) to determine its function, and was outsourced to a local IT developer. Lessons learned at each stage of the database development and operation are described below.

### (i) Software Development

During the database development phase, only the simplest functions possible should be developed. The more complex the functionality, the more expensive and time-consuming it would be to develop, and the less users would understand the functions. Counterpart organizations requested that more functions be added, but many were superfluous for the initial stage. Therefore, the development phase should be kept to the minimum necessary, and features to be added after the system is implemented and in operation should be considered.

## (ii) Installation

Before installing the database, it should be agreed to ensure the organization structure for the database management. In particular, it is important to ensure that personnel with basic IT knowledge are available. The project initially agreed that the database system would be installed to the Government's Cloud Space and managed by NSWMSC, with a view to a nationwide expansion after the database is successfully operational. However, NSWMSC did not have the IT base human resources to manage the database and decided to transfer management to WMA. After all, the database system was transferred to the cloud space of the Western Provincial Council, and managed by WMA with support from the IT department of the Western Provincial Council.

## (iii) Operation

The database should be improved and modified from the testing phase to allow user LAs to enter daily waste collection data. Especially for LAs with a large number of waste collection trips, inputting the data requires time-consuming effort. It is necessary to introduce solutions which reduce the amount of workload required LAs, such as connecting the database to the truck scale at final disposal sites.

## (4) SEA

In formulation of the MP, several alternative plans and programs for the facilities and equipment included in the MP were considered based on the Strategic Environmental Assessment (SEA). The SEA procedure was carried out according to the provisional procedure developed by the CEA, as the SEA is not yet a legal instrument in mid of 2023. In February 2023, the JICA project submitted a draft MP to the CEA for SEA review. This was followed by a stakeholder and technical meetings by the CEA in March 2023, and comments were issued in April 2023. As the SEA had not been formally finalized, the procedures and timelines were unclear with regard to the SEA.

## (5) Aeration pilot project Kalutara

Many local authority's composting plants in Sri Lanka are windrow composting plants with a input of 10-50 ton per day capacity, many of which cause environmental and social problems due to odour, leachate and pests. One of the reasons for this is that not enough oxygen is supplied to the windrow compost, resulting anaerobic conditions inside. In the pilot project, a perforated PVC pipe connected to a blower was inserted into the windrow compost with the aim of supplying sufficient oxygen to create an aerobic condition.

Initially, the perforated PVC pipes were placed on a concrete floor and the windrow was pile. Compost was placed over them. However, the perforated PVC pipes installed on the concrete floor intersected with the lines of flow of heavy machinery used to agitate the compost, reducing work efficiency, so this problem was solved by laying the perforated PVC pipes in covered trenches constructed on the concrete floor. The aeration system is designed to supply oxygen from the blower through a connecting pipe and through the perforated pipe, while collecting the leachate generated from the bio-degradable waste.

In the Western Province, there are more than 20 composting plants of a similar size to the

Kalutara composting plant (20-30 ton/day capacity), with odor and leachate problems. The experience of the Kalutara compost pilot project can be applied to the similar issues of the other composting plants to solve their problems.

(6) Small-scale waste transfer station pilot project at Kalutara

The MP mentions the establishment of five number of small-scale waste transfer stations in the Western Province, one of which was constructed and modelled in the pilot project. The purpose of the small-scale waste transfer stations is to efficiently transport the generated residues to a regional treatment and disposal facilities. In the Kalutara composting plant, the generated residues as well as mixed waste of two local authorities are open dumped in the vicinity of the facility, which caused environmental and social problems. Waste transfer stations can be of the compaction type, drum type or open dumping type, but the compaction type was selected for the Kalutara pilot project because of its efficiency, environment and initial cost.

The plan for the Kalutara small-scale waste transfer station considered the implementing entity, the method of operation, the person in charge of the operation and the necessary costs. Until now, no domestic contractor in Sri Lanka had experience in manufacturing the compaction type, but in the pilot project, a domestic contractor was commissioned and their capacity building was also carried out. At the time of production, there were tax exemptions, high material prices and difficulties with importation procedures, but these were resolved by using US dollars as the contract currency and support from the Sri Lankan Government. The experience of the pilot project of the Small-scale waste transfer station at Kalutara will help in the establishment of four other planned small-scale waste transfer stations in the Western Province.

(7) Compost plant rehabilitation PP, Karadiyana

At the inception it was decided to introduce Trommel technology as sieving method which largely used in landfill mining projects since Karadiyana PP involves landfill mining that has no previous experience in Sri Lanka. In the case of special machine, the specifications should be scrutinized after actual observation of the equipment to be installed. Since no previous experience the heavy-duty sieving machine was procured with reference to Indian machines.

The introduced sieving system consist of vibrating sieving unit with 6mm aperture size at the tail end with two stage trommel sieving. During the trial operation it was observed that the said vibrating sieving unit is not supported to reach the expected sieve efficiency of the raw material due to high moisture content and the texture of the mined material hence adjustment is necessary. To rectify it was decided to replace the vibrating unit with another trommel unit which already reached to site. Performance should be evaluated and all other required adjustment should be done to reach the expected efficiency. it is necessary to consider the moisture balance of the material when considering a similar system. In addition, moisture and temperature measurements at different depths of the organic waste pile should be included in the daily management of the organic waste pile in order to monitor the decomposition of organic matter in the organic waste.

## (8) Mobile App at Kotte MC

A pilot project was made to introduce an app to promote waste sorting by residents, encourage separation and building a good relationship with the residents and local authority.

The first issue was that the residents did not have better understanding about waste sorting and handling. This problem was solved by given guidance to the technical officers of WMA to develop 'waste classification dictionary' to identify nature of the garbage and the dispose of such waste category. Further this app provides facilities to link the recyclable waste collectors with the general public.

The next challenge is that local authorities have limited capacity to carry out separate collection, even if separate collection is mandatory at the state or national level. In this project, a pilot project was conducted in Sri Jayawardenepura Kotte Municipality, which is able to provide a relatively stable waste collection service, but is supposed to implement a three-category collection of 'recyclable waste, organic waste and other waste', but does not have its own segregation facilities or storage sites for 'recyclable waste', Collection workers have only been able to put on the recycling stream waste that they can clearly confirm has been separated at households and other discharge points. It is also a reality in Sri Lanka that some local authorities are still unable to implement basic waste collection on a regular, long-term and stable basis. Unless a system is in place whereby collection vehicles come on a set route on a set day, collect waste from households and other sources, and deliver it to a set disposal site or treatment facility, the basic sanitation service of 'household waste ready for discharge' cannot be provided. Even if the local authority sets rules, if the local authority itself cannot provide services in compliance with these rules, it cannot expect residents to comply with the rules. It is necessary to consider measures at national and state level on how to support municipalities without such 'capital'.

## (9) Making good relationship between WMA and residents

Consensus building with the surrounding community for the rehabilitation of existing compost plant and construction of transfer station in Kalutara was carried out by WMA. However, as the issue was very sensitive, it was difficult to move things forward at the working level. In view of the Sri Lankan context, things should have been discussed first between the decision makers (top level) and then brought down to the working level.

## (10) Action plans of each local authority

The planning period of MP was changed to 2023-2042 due to the delays of schedule, mainly due to the impact of COVID-19 pandemic. The planning period of the Local Authority Action Plans in line with the MP had to be changed accordingly.

The future waste volumes for the MP are projected based on the status of each local authority in 2020. Therefore, the action plan was also based on the 2022 forecast data based on the status in 2020, although it was planned to develop a five-year action plan for the period 2023-2027, it was pointed out by some local authority's officials that there was a difference between the current and projected waste volumes in 2022. Therefore, although the MP was not changed, the future waste

volume forecasting tool used to develop the Action Plan was revised to one that can forecast using the 2022 waste volume known by the local authorities, and the future waste volume and future waste management numerical targets for the Action Plan were set.

## 5. Performance

### (1) Extra budget for development of small-scale waste transfer station at Kalutara pilot project

JICA understood the importance of the Small-scale waste transfer station at Kalutara in the MP and decided to add the cost of equipment purchase to solve the issue. The estimated construction cost of the small-scale waste transfer station at Kalutara pilot project development in 2022 was found to exceed the initial budget prepared in 2019.

A breakdown of the original budget and final estimate is provided below.

- Estimate December 2019 LKR 37,790,000 (¥23,094,225, USD 210,935)
- Final estimate January 2022 LKR 87,689,800 (¥48,115,518, USD440,835)

The reasons for the excess of the final estimate over the original estimate are as follows:

- Price spike due to Sri Lanka's economic crisis following the spread of COVID-19 infection.
- Review of specifications by mechanical engineers involved in the establishment of the existing transfer station in Kelaniya.
- Technical assistance from manufacturers from OECD countries added to specifications for transfer stations in specifications.
- Reviewed operation of vehicles/equipment that could be procured and added costs for renovation of existing facilities (e.g. roof).

### (2) Extra budget for procurement of Karadiyana compost rehabilitation project

JICA understood the importance of the rehabilitation of the Karadiyana composting plant for large-scale composting in the MP and decided to budget the cost of equipment purchase to solve the issue. A breakdown of final estimate is provided below.

Table 1: Extra budget for procurement of Karadiyana compost trommel machine

No.	Machine	USD
1	Trommel	188,820.00
2	Tractor	56,996.00
3	Bagging Machine	15,283.00
4	Shredding Machine	21,992.00
5	Bob cat	37,929.51
		321,021.00

An overview of the challenges of the Karadiyana Compost Plant and its rehabilitation plan is

provided below.

(i) The condition of Karadiyana Compost Plant before the pilot project

The waste is transported to the Karadiyana Resource Management Center by seven local authorities. Those local authorities are, Moratuwa MC, Dehiwala Mount Lavinia MC, Sri Jayawardanepura Kotte MC, Maharagama MC, Kesbewa UC, Boralesgamuwa UC and Homagama PS. Biodegradable waste and non-biodegradable mixed waste were accepted on the site until recent. Acceptance of Non-biodegradable waste to the Site B has recently been discontinued under NBRO Recommendations.

At present 300 to 350 MT of municipal solid waste is received to the Karadiyana site. WMA instructed local authorities to sort their waste into four categories, namely biodegradable, burnable, recyclable, and residue. Recyclable waste collected by local authorities instructed to manage by their own recycling system. A Sampath Pyiasa has been opened at the site to accept recyclable waste those who want to discharge off. Then WMA has arranged temporary transfer station to facilitate the local authorities who need to diver their burnable waste to Kerawalapitiya WtE plant. Meanwhile local authority has instructed to diver their burnable waste directly to WtE plant if they have capacity to do so. Further WMA has arranged Dompe sanitary landfill site to diver their residual waste remain at local authority level. However, still some local authorities are bringing their residual waste to the site since they have not made arrangement to deliver to Dompe sanitary site.

Site A continues to receive biodegradable waste as usual. The amount of waste received per day is around 250 tons. Therefore, managing that amount is an essential requirement. At present, the receiving waste is deposited in layers on top of Site A and kept for about two months for natural decay. Occasional overturning of the waste that accumulates in layers is done using an excavator to create favorable conditions for composting and to speed up the process. This waste is brought into the shed for further processing and drying after keeping out for basic decay. This waste is further turned for five weeks using a backhoe loader and taken for sieving. Sieved compost are packed and sale through registered dealers in locally and overseas.

(ii) Issues of Karadiyana compost plant

There are mainly 3 issues in the Karadiyana compost plant.

- Inadequate treatment capacity for daily incoming biodegradable waste
- Inadequate sieving capacity for composted materials at compost plant
- Environmental impacts such as leachate and offensive odor

Karadiyana compost plant receives around 200-250 metric tons (MT) of Biodegradable waste per day. Based on the tests done at the site, the waste is having the density of 700 ton/m<sup>3</sup>. Handling this amount of waste with windrow composting process requires large area. Failure to manage such a large amount of biodegradable waste leads to serious health and environmental degradation.

The existing dump site is continuously receiving the biodegradable waste and part of that is accumulated on the top of the dump as decaying uncontrolled heaps due to inability to manage appropriately with available land extent. There is no any other alternative land surrounding the



dump site belong to WMA for the waste to be treated without occurring possible environmental hazards. As a result of this practice, the height of the dump site increases frequently and it became a danger leading to land slide. Other than that, it becomes difficult to manage daily receiving waste since the accumulated waste further restrict and reduce the available space for waste handling practices. Therefore, it is very much important to make space available for standardized composting process management by mining the dump site.

The matured materials sieving is done with existing two trammels at the moment. The sieving capacities of these two trammels are only 8 MT/day and it is not sufficient to address whole quantity of materials produce in this facility. Moreover, the frequent breakdown and the sieving machine is not match with the nature of the biodegradable waste to be seen. Therefore, introduction of another trammel system is required to daily manage the capacity of materials to be sieved.

Based on NBRO recommendations, disposal of waste at Karadiyana have to stop which could further buildup two dump sites. Therefore, biodegradable waste receiving to the Site A has to be managed with the aim of achieving zero waste balance. This could not be accomplished with the current process management, machineries and equipment. It is needed to improve the composting process from the initial stage to achieve desired level of production quantity and quality of output. To cope with above target, the stages of composting process have to be addressed and improved to optimize the process and standards. In active thermophilic composting process, the materials have to be handled providing optimum conditions for decomposing materials. In this case, the batching, mixing, temperature management, moisture management and aeration are important practices to be managed. Therefore, Sufficient space is required to handle the materials with such management practices.

(iii) Main purpose of pilot project

- To rehabilitate the organic waste landfill site properly and improve the treatment facility that are the cores of MP.
- To apply the improvement plan to the other organic waste landfill site and treatment facility as a model.

(iv) Objectives of pilot project

- To improve the treatment capacity of existing compost process.
- To improve the sieving capacity of produced compost
- To reduce environmental pollution such as offensive odor and leachate caused by inappropriate waste handling at site A.
- To develop the capacity of planning and management at Karadiyana compost plant for WMA staff.

**6. Additionality**

(1) BCP

In response to the spread of COVID-19 on a global scale since January 2020, Sri Lanka formulated guidelines for countermeasures against the COVID-19 in April 2020, indicating measures to be taken by waste management companies to prevent infection. Through the

formulation of the right, the need for a more comprehensive Business Continuity Plan (BCP) for waste management has been recognized, and Japan agreed with Sri Lanka to support the formulation of the BCP for the 49 local authorities in the Western Province and to provide them with equipment necessary for infection prevention.

## (2) PPE

In response to the rapid spread of the COVID-19 in the western province, WMA, requested JICA to provide personal protective equipment to reduce the risk of infection among waste management workers. The JICA expert team decided to provide the equipment after consultation with the client and arranged with WMA and NSWMS the target local authority, type and quantity of equipment to be provided. Equipment was provided on October 26, 2020 and on June 9, 2021.

Table 2: 1<sup>st</sup> supply of personal protective equipment

Item	Quantity	Unit price (LKR)	Total (LKR)
Surgical mask	17,000	15	255,000
Surgical gloves	3,000	14	42,000
Boots	366	2,200	805,200
Hand sanitizer	325	900	292,500
Personal Protective kit	266	850	226,100
Total			1,620,800

Table 3: 2<sup>nd</sup> supply of personal protective equipment

Item	Quantity	Unit price (LKR)	Total (LKR)
Surgical mask	31,700	9	285,300
Surgical gloves	634	1,752	1,110,768
Boots	475	390	185,250
Hand sanitizer	430	750	322,500
Personal Protective kit	9,750	80	780,000
Total			2,683,818

## IV. For the Achievement of Overall Goals after the Project Completion

### 1. Prospects to achieve Overall Goal

The proper municipal solid waste management in the Western Province depends on the relevant authorities cooperate to implement the MP as planned.

The relevant authorities consist of three administration tiers, namely central government, provincial government and local government, with the central and provincial government level focusing on the activities of the inter-organizational coordination bodies and the local government level following the action plans of the 49 local authorities. The inter-organizational coordination bodies will be authorized by the Cabinet at the same time as the MP is authorized and will have a legal basis. Action plan of local authorities describe activities related to collection, transport and treatment of municipal solid waste and are updated every five years.

Local authority's collection, transport and 3Rs activities will be managed by the annual OPEX expenditure of the respective local authority. The large-scale development projects that require large initial investments, such as small-scale waste transfer station, thermal recovery facilities and material recovery facilities, which are specified in the MP, need to be discussed and prepared in advance by the inter-organizational coordination bodies. The inter-organizational coordination

bodies need to be consulted and prepared in advance.

Overall Goal	Objectively Verifiable Indicators
Appropriate solid waste management practices in accordance with Western Province Solid Waste Management Master Plan (MP) are undertaken in Western Province.	<ol style="list-style-type: none"> <li>1. All Local Authorities (LAs) prepare/update and implement their solid waste management action plan (LA action plan) in line with the MP within one year after publishing the MP.</li> <li>2. An inter-organizational coordination body functions to monitor the progress and support the implementation of LA action plan in Western Province.</li> </ol>

## 2. Plan of Operation and Implementation Structure of the Sri Lankan side to achieve Overall Goal

### (1) MP authorization and formulation of LAs' SWM Action Plan

The Solid Waste Management Master Plan for the Western Province establishes a comprehensive waste management system with a long-term perspective in the Western Province. The central organization is the Western Provincial Council, represented by WMA. Once approved, the MP will be owned and operated by the Provincial Council and WMA. The MP will serve as a guideline to the LAs for their SMW Action Plan and Annual Work Programs.

#### (i) Authorization of the Provincial MP

- For the recognition as a sectoral plan, the SWM MP must comply with the National Policy on Waste Management.
- Once developed by WMA through a consultation process with all stakeholders, the WMA Board submits the MP to the Minister for concurrence by the Board of Ministers of Western Province.
- Once concurred by the Board of Ministers, the Minister submits the SWM MP to the Western Provincial Council for approval.
- The Provincial Council, through the (national level) Minister in charge of Local Governments, forwards the MP to the Cabinet of Minister for approval. This process is necessary as the MP contains sectoral strategies and plans, and requires technical and financial support from the national government for its implementation.

#### (ii) LAs' Action Plan in line with the MP

- Every LA prepares its Action Plan on waste management in accordance with the Provincial MP. Once the Council has approved the Action Plan, LAs submit it to WMA for WMA's review and concurrence. When LAs request a capital budget for development, WMA's concurrence provides evidence to justify such development.
- Every LA shall submit a progress report and Annual Work Program on the Action Plan to WMA for progress monitoring.

## (2) Organizational development for MP implementation

WMA is expected to play a central role in the implementation of the MP. However, this organization was created to meet the needs that existed 15 years ago. Since all projects and programs derived from the MP require technical and financial analysis and a consultation process with all relevant stakeholders, the current planning and implementation capacities of WMA are inadequate and need to be strengthened urgently as a prerequisite for effective implementation of the MP.

The most critical ones, not visible now, are the planning and monitoring functions. Without an effective division for planning and monitoring, the organization will not be able to implement programs systematically. Planning is essential for evaluating project proposals, improving cost-effectiveness, and finally for proper decision-making. Currently, the functions are performed by several senior managers, but this system does not work well as all are busy with other duties. Proper monitoring and evaluation will guide the organization towards the targeted goals and outcomes. Although each division manager monitors the work of his/her team, review by a centralized team of professionals is essential for feedback and future planning.

For WMA to play an effective driving role in the implementation of the MP, it is recommended to create a new division dedicated to Planning and Monitoring with two subdivisions, namely (a) Planning/R&D and (b) Monitoring and Evaluation. The Planning/R&D subdivision would primarily deal with strategic and long-term planning as well as project development, including implementation arrangement, while the Monitoring and Evaluation subdivision would be in charge of monitoring, performance review and feedback. The new division should be headed by a senior executive officer who would directly report to the Director/CEO.

## (3) Implementation of the SWM MP (short- and medium- term)

The solid waste management projects (SWM projects) that need to be prepared and implemented within eight years to achieve the MP targets have been selected and planned.

The short- and medium- (eight years) term SWM projects mainly consist of the following eight projects, and their overall implementation schedule is shown in the table below.

Project 1: Development of five Primary Transfer Stations (PTS)

Project 2: Implementation of Kelaniya Transfer Station (Kelaniya TS)

Project 3: Development of Cluster-based Waste Treatment Facilities (CWTF)

Project 4: Improvement of composting facilities

Project 5: Improvement of recycling facilities for recyclables collected by the formal collection service

Project 6: Procurement of collection and transfer vehicles

Project 7: Closure of current dump sites managed by LAs

Project 8: Encouragement of waste separation

	2022	Short term			Medium term				
		2023	2024	2025	2026	2027	2028	2029	2030
<b>Project 1: Development of five Primary Transfer Stations (PTS)</b>									
Colombo TS: 90 ton/day	Sites selection	Budgeting, Land parcels, Environmental process, DD, T/D	Tender, Contract, Construction	Operation					
Kalutara west TS: 90 ton/day				Operation					
Kalutara east TS: 40 ton/day				Operation					
Gampaha west TS: 130 ton/day				Operation					
Gampaha east TS: 170 ton/day				Operation					
<b>Project 2: Improvement of Kelaniya Transfer Station (KTS)</b>									
Amount of waste transferred (ton/day)	1,070	1,240	1,130	1,240	1,320	1,430	920	950	1,000
Compared to 2022 (%)	100%	116%	106%	116%	123%	134%	86%	89%	93%
<b>Project 3: Development of Thermal Recovery Facilities (TRF)</b>									
WPK WtE facility (750 ton/day)	Operation								
Additional WPK WtE facility (750 ton/day)		FS, EIA, Tender, Contract & DD	Construction			Operation			
TRF Colombo District (400 ton/day)		FS, EIA, Tender, Contract & DD	Construction			Operation			
<b>Project 4: Improvement of compost facilities</b>									
<b>Waste Park compost facilities</b>									
Waste Park (ton/day) No.1,2	Sites selection, Tender, Contract	Construction	160	160	160	160	160	160	160
Waste Park (ton/day) No.3		Sites selection, Tender, Contract	Construction	80	80	80	80	80	80
Waste Park (ton/day) No.4			Sites selection, Tender, Contract	Construction	80	80	80	80	80
Waste Park (ton/day) No.5				Sites selection, Tender, Contract	Construction	80	80	80	80
Total			160	160	240	240	320	320	400
<b>LAs and cluster-based compost facilities</b>									
Cluster-based facilities (ton/day)	232	300	340	340	340	340	340	340	340
LA's facilities (ton/day)	92	100	110	120	130	130	130	130	130
Total	324	400	450	460	470	470	470	470	470
<b>Project 5: Improvement of recycling facilities for formal recyclables</b>									
Recyclable amount (ton/day)	120	130	150	170	190	200	220	240	260
<b>Waste Park MRF facilities</b>									
Waste Park (ton/day) No.1,2	Sites selection, Tender, Contract	Construction	60	60	60	60	60	60	60
Waste Park (ton/day) No.3		Sites selection, Tender, Contract	Construction	30	30	30	30	30	30
Waste Park (ton/day) No.4			Sites selection, Tender, Contract	Construction	30	30	30	30	30
Waste Park (ton/day) No.5				Sites selection, Tender, Contract	Construction	30	30	30	30
Total			60	60	90	90	120	120	150
<b>Project 6: Procurement of collection and transfer vehicles</b>									
Compactor truck for organic waste	Subsidies and support systems	Procurement plan, approval, budgeting	99	101	108	108	111	114	
Compactor truck for other waste			358	378	407	360	373	391	
Tractor trailer for recyclable			94	105	115	126	137	144	
<b>Project 7: Closure of current dump sites operated by LA</b>									
Preparation of Guideline for closing dump sites	Guideline								
Technical guidance and budgeting secured for closure		Guidance Budgeting							
Implementation of closure			Implementation						
<b>Project 8: Development of waste separation promotion program</b>									
Development of waste separation guidelines	Guideline								
Seminar for LAs on understanding the guideline.		Seminar							
Preparation and implementation of promotion program		Preparation							
Implementation of separate collection of waste			Implementation						

Figure 1: Schedule of short- and medium-term implementation plans

(4) Objectives of the SWM Action Plan

The SWM Action Plan for LAs will be formulated in line with the SWM MP for the Western Province. Quantitative targets and feasible SWM activities will be set in the Action Plan. In addition, an Annual Work Program (AWP) will be prepared for each year of the SWM Action Plan period, including yearly activities, implementation schedules, and budgets in order to achieve the SWM Action Plan. The AWP is not only an annual implementation plan, but also an important monitoring instrument for the SWM Action Plan. The SWM Action Plan will be reviewed every five years taking into account the progress made in waste management.

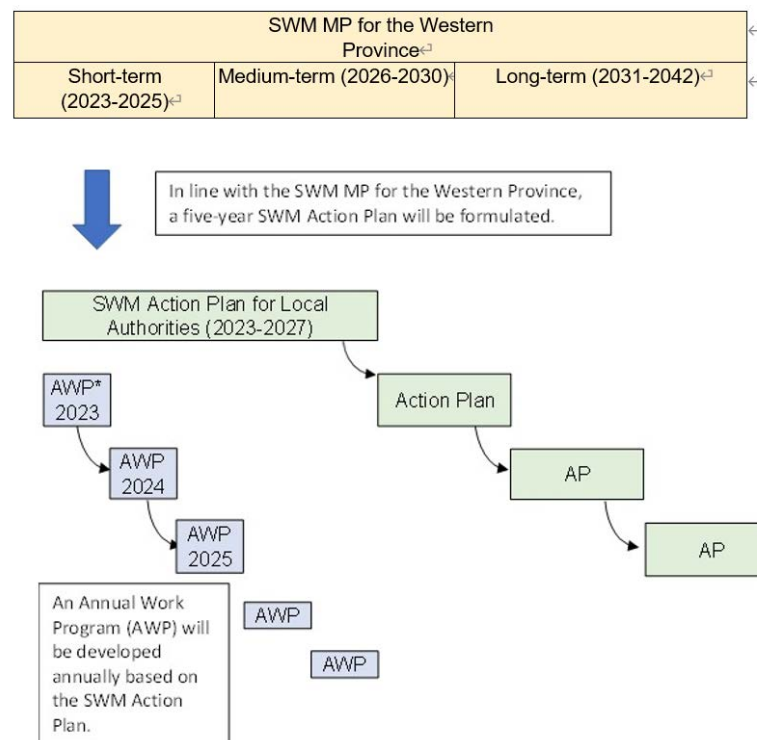

Figure 2: Relationship between the SWM MP for the Western Province, SWM Action Plans and Annual Work Programs

**3. Recommendations for the Sri Lankan side**

(1) MP authorization

The MP establishes a comprehensive waste management system in the Western Province with a long-term perspective. The central body is the Western Provincial Council, which is represented by the WMA. Once approved, the MP will be owned and operated by the Provincial Assembly and the WMA. The MP will act as a guideline for LAs in developing their SWM Action Plans and annual work programmes. After the WMA has developed it through a consultation process with all stakeholders, the WMA Board will submit the MP to the Minister responsible for local authorities for and submitted to the Western Provincial Council of Ministers for concurrence. The Provincial Council, through the Minister in charge of Local Authorities (at national level), submits the MP to the

Cabinet for approval; this process is necessary because the MP contains sector-specific strategies and plans, the implementation of which requires technical and financial support from the national government.

## (2) Implementation of MP for optimal SWM system

It is recommended that the Sri Lankan side should implement the detailed project activities according to alternative B of the MP immediately after the MP and the inter-organizational coordination body structure have been authorized; a summary of Alternative B of the MP is provided below.

The amount of waste generated in the Western Province is estimated at 3,730 ton per day. This amount is expected to increase in line with future population and economic growth. At present, about 50% of the waste generated is discharged to the LA's collection service, but it is expected that this amount will increase in the future as collection coverage improves. Therefore, in the Western Province, where there are waste disposal problems, it is necessary to enhance waste separation by conducting awareness-raising activities for residents and by increasing the capacity of intermediate treatment facilities in order to reduce amount of waste to be disposed of as much as possible. In the entire Western Province, 16% of the waste collected is carried to composting facilities, 6% to recycling-related facilities, 38% to TRFs and 40% to disposal sites, as of base year 2022. In order to collect and transport this waste efficiently and hygienically, it is necessary to select and procure appropriate collection vehicles and to set up in the future a transfer system in accordance with the separated waste and the distance to intermediate treatment facilities and/or disposal sites.

Recycling in the Western Province is carried out at the source of generation, at the collection stage and in intermediate treatment facilities such as composting and recycling facilities. The total amount of recyclables accounts for about 20% of the total waste generated, which is a relatively high rate compared to other developing countries. In the future, it is necessary to reduce the amount of waste disposed by promoting the separate collection of recyclables and expanding the capacity of composting facilities. The amount of waste disposed represents 32% of all waste generated. Approximately 70% of the total waste disposed is waste directly landfilled and the remaining 30% is residue generated from composting and recycling facilities. To reduce this amount despite the expected increase resulting from improved collection coverage, it is critical to develop intermediate treatment such as WtE. It is also necessary to gradually shift from disposal sites operated independently by LAs to cluster-based disposal sites, and to close the open dump sites currently used by LAs. In order to implement proper SWM, it is also necessary to collect and consolidate data related to SWM from each LA, cluster-based treatment facilities and disposal sites, and establish a database for the entire Western Province.

Waste management in urban areas requires cooperation and coordination between neighboring LAs and higher authorities. However, collaboration between relevant authorities is currently inadequate. In the recent past, some new, state-of-the-art, large-scale waste management technologies have been introduced in the Western Province, but they are not yet fully deployed. The amount of waste in urban areas is increasing at a higher pace than the population, and even than

economic growth. This implies that costs for waste management are growing at a faster rate than the allocation of the government's budget.

Among alternatives A, B and C, the system in alternative B allows all the collected biodegradable waste to be composted, except for the 20% that is incinerated, while maximizing the recycling of recyclable materials.

Economically, alternative B was evaluated as the cheapest system compared to the other options. Based on the above, alternative B is recommended as the MP for optimal SWM in the Western Province.

### (3) Economic financial aspects

A comparison of the waste management costs incurred during the MP period (20 years from 2022 to 2041) by management process, separated for capital investment costs and operating costs, shows that collection costs account for 29% and transportation costs for 23%, which means that transportation-related costs represent more than half. This is followed by thermal recovery (incineration with power generation), final disposal, and composting.

In 2020 in the Western Province, LAs' own revenue covered only one quarter of their total expenditure. The remaining three quarters have been taken over by the national government. In that context, LAs' room for maneuver to allocate a budget to their priority areas is limited. Waste management currently receives 20% of the total recurrent expenditure, the highest among expenditure heads. It is unlikely that the percentage allocated to waste management will increase significantly. The share of waste management in LAs' budget is within a reasonable range of financial affordability, except for the first five years (from 2023 to 2027). The proportion of 33% in 2023 and peak of 34% in 2027 are 1.7 times the current level (20%). The sharp increase during this period is caused by the large volume of untreated waste transported to and disposed of in Aruwakkalu DS due to the lack of intermediate treatment facilities. The percentage then gradually lowers as intermediate treatment facilities develop and the amount of waste disposed of without treatment decreases.

The above scenario is based on the assumption that capital expenditure is borne by the government. Removing the capital component from LAs' burden can be done either by financing the capital cost, e.g. through viability gap funding (VGF) by the national government at the initial stage, or by subsidizing the capital portion through annual fund transfers from the Treasury to the concessionaire. It is essential that the national government, Provincial Council and LAs discuss and agree on this matter when formulating the project.

## **4. Monitoring Plan from the end of the Project to Ex-post Evaluation**

### (1) Monitoring plan of MP implementation

Monitoring of the MP will be conducted by inter-organizational coordination body (Coordination Committee). Environmental effects of implementing the MP will also be monitored by the committee as it is a requirement of the SEA process. Recommended Environmental monitoring and evaluation plan are shown in the SEA report. Details of the committee are shown below.



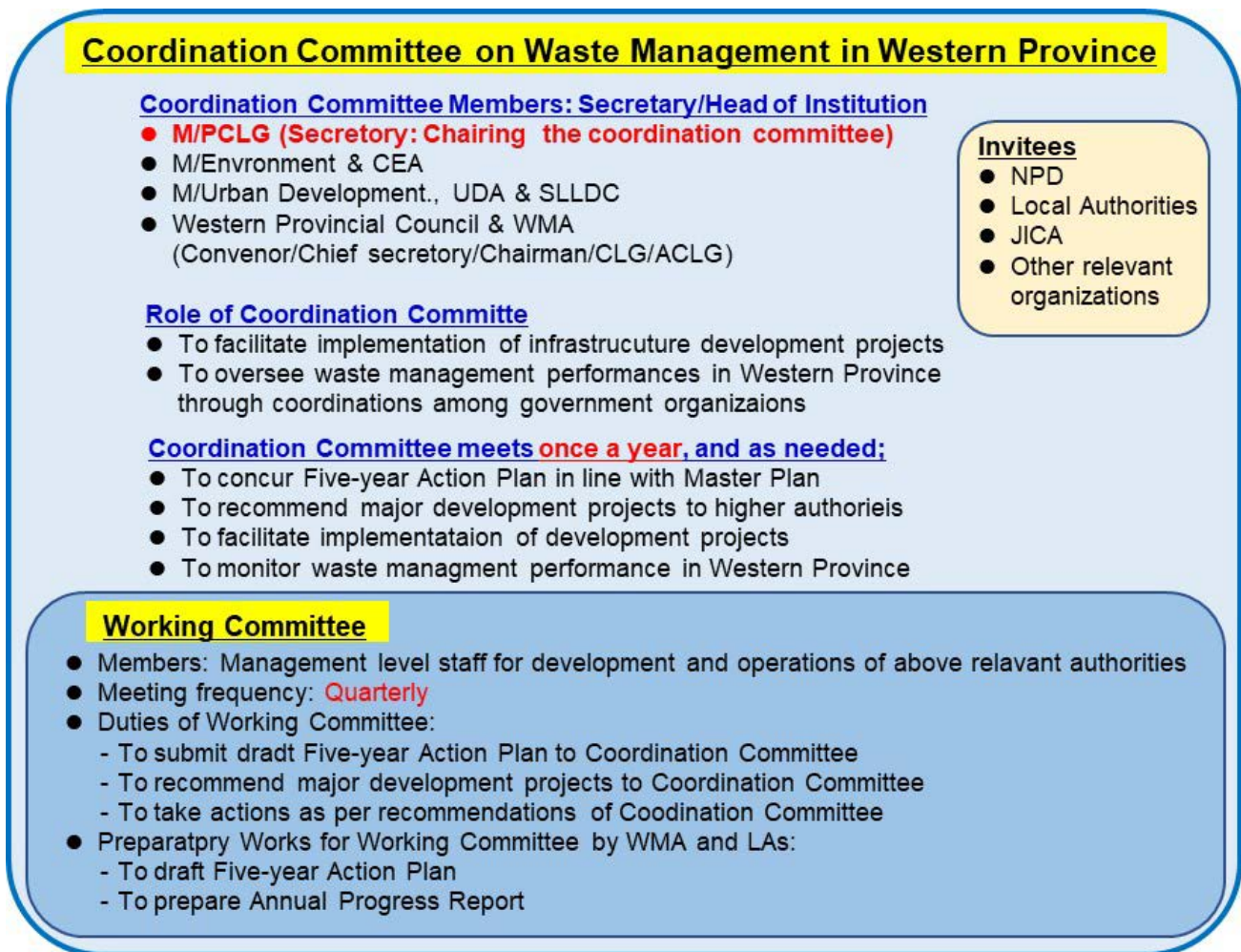

Figure 3: Structure of Coordination Committee on Waste Management in Western Province

(2) Monitoring the implementation of the SWM Action Plan

WMA will monitor the implementation of the SWM Action Plan by reviewing the progress of the AWP. The AWP is not only an annual implementation plan, but also an important monitoring instrument for the SWM Action Plan.

Table 4: Monitoring the implementation status of the SWM Action Plan

Frequency	Twice a year
Participants	Managers in charge of SWM in the 49 LAs
Monitoring staff	Zonal managers of WMA
Monitoring contents	Confirmation of the AWP progress (twice a year). Develop an AWP for the following year based on the progress of the previous year's AWP.