

# Manual for Landslide Hazard Zonation Mapping / Yellow and Red Zone Mapping (Total Impact Zone Map)

**Project for Capacity Strengthening  
on Development of Non-Structural  
Measures for Landslide Risk  
Reduction in Sri Lanka**

October, 2022



**National Building Research Organisation  
(NBRO)**



**Japan International Cooperation Agency  
(JICA)**



**Democratic Socialist Republic of Sri Lanka**

**Project for Capacity Strengthening on Development of Non-Structural  
Measures for Landslide Risk Reduction in Sri Lanka**

**Manual for Landslide Hazard Zonation  
Mapping/ Yellow and Red Zone Mapping  
(Total Impact Zone Map)**

**October, 2022**

**National Building Research Organisation (NBRO)**

**Japan International Cooperation Agency (JICA)**



## Preface

Landslide is a major geological hazard, which poses serious threat to life and property in hilly regions of Sri Lanka. Having been designated as the national focal point for landslide risk management in the country, the National Building Research Organisation (NBRO) has taken enormous efforts in landslide risk reduction through multiple measures including but not limited to landslide susceptibility mapping.

Under Landslide Hazard Zonation Mapping Project, NBRO has so far produced landslide susceptibility maps for all landslide prone areas of the country. However, hazard levels in these maps are only an indication of the likelihood of initiation of a landslide at a particular location and therefore only applicable to identify landside rupture zones excepting any paths of debris transport or zone of deposition. Yet, most disastrous landslides in Sri Lanka have been induced by intense rainfall as sudden events with, long run-out distances and rapid run-out velocities, due to their unexpected nature, leaves no time for people living in downstream impact zones to safely evacuate. Hence, development of landslide hazard zonation maps demarcating all impact zones is essential for reducing the risk of sediment disasters in Sri Lanka in the future.

Intended as a step towards the mentioned exertion, this manual was developed under project “SABO”, a technical cooperation project for capacity strengthening of development of non-structural measures for landslide risk reduction in Sri Lanka which was undertaken by the Japan International Cooperation Agency (JICA) conjointly with NBRO in 2022. Each manual in the project has been developed drawing on Japanese expertise and referencing to Japanese guidelines, “Guideline and Explanation for Hazard Mapping for Sediment Disaster” and “Guidelines for Basic Investigation of Risk Assessment”.

The content here provides an approach for risk identification through landslide hazard zonation, which will be especially useful to landslide risk reduction practitioners in Sri Lanka. Readers are most welcomed to make wide use of this manual by understanding, learning and replicating the techniques in their respective department/organizations to create hazard maps in the future.

Last but not least, it should be pointed out that this document is the outcome of extensive desk and field studies done by JICA and NBRO officials. While appreciating their hard work in bringing out this publication, it is expected that the users of this manual will find their efforts worthwhile and commendable.

## Table of Contents

	<u>Page</u>
Preface	i
Table of Contents	ii
List of Figures	iv
List of Tables	vi
List of Abbreviations	vii
<b>Chapter 1 Introduction</b>	
1.1 Necessity of Landslide Total Impact Zone Mapping .....	1
1.2 Objective of the Manual .....	2
1.3 Scope of the Manual .....	2
1.4 Key Definitions .....	3
1.5 General Process of Yellow and Red Zone Mapping .....	5
1.6 Preparation of Yellow and Red Zoning .....	5
<b>Chapter 2 Characteristics of Landslides in Sri Lanka</b>	
2.1 Distribution of Landslides in Sri Lanka .....	6
2.2 Classification of Landslides in the Manual .....	7
<b>Chapter 3 Hazard Zoning for Slope Failure</b>	
3.1 Procedure of Setting “Yellow Zone” and “Red Zone” for Slope Failure .....	11
3.2 Methodology .....	11
3.2.1 Selection of Target Area .....	11
3.2.2 Preparation Surveys for the Target Area .....	12
3.2.3 Setting of “Yellow Zone” and “Red Zone” .....	14
3.2.4 Field Verification to Finalize the Zones .....	21



3.2.5	Verification of the Methodology for Yellow and Red Zones of Slope Failures	21
-------	--	----

### 3.3 Reference Data

	Background Data for Setting Hazard Zone for Slope Failure	23
--	---	----

## Chapter 4 Hazard Zoning for Slide

4.1	Procedure of Setting “Yellow Zone” and “Red Zone” for Slide	26
4.2	Methodology	26
4.2.1	Selection of Target Area	26
4.2.2	Preparation Surveys for the Target Area	30
4.2.3	Setting of Slide Area	32
4.2.4	Setting of “Yellow Zone” and “Red Zone”	37
4.2.5	Field Verification to Finalize the Zones	40

## Chapter 5 Hazard Zoning for Debris Flow

5.1	Procedure of Setting “Yellow Zone” and “Red Zone” for Debris Flow	41
5.2	Methodology	41
5.2.1	Selection of Target Area	41
5.2.2	Preparation Surveys for the Target Area	43
5.2.3	Setting of “Yellow Zone” and “Red Zone”	44
5.2.4	Field Verification to Finalize the Zones	56

### 5.3 Reference Data

	Background Data for Setting Hazard Zone for Debris Flow	58
--	---	----

## Technical Note 1

Hazard Zoning For Slope Failure By Reference To Japanese Criteria

## Technical Note 2

Aerial Photograph Interpretation of Landslides

## List of Figures

	<u>Page</u>	
Figure 1.1	Structure of the Manual	2
Figure 1.2	Basic Concept for Yellow Zone and Red Zone	4
Figure 1.3	General Process of Development of Yellow Zone and Red Zone maps	5
Figure 2.1	Distribution of Landslides by District	6
Figure 2.2	Yearly Occurrence of Landslides (1976 to 2018)	7
Figure 3.1	General Process of Setting “Yellow Zone” and “Red Zone” for Slope Failure	11
Figure 3.2	Diagrammatic Illustration of Slope Failure Dimension	13
Figure 3.3	Flowchart of Desk Mapping of “Yellow Zone” and “Red Zone” for Slope Failure	14
Figure 3.4	Setting of Traverse Lines	15
Figure 3.5	Diagram of Setting Upper Edge	16
Figure 3.6	Diagrammatic Illustration of Setting Upper Edge for a Slope with Multiple Hazard Zones	17
Figure 3.7	Setting of Lower Edge	18
Figure 3.8	The Measurement of Hazardous Slope Height	18
Figure 3.9	Diagrammatic Representation of Setting Source Area of Possible Slope Failure	19
Figure 3.10	Representation of Yellow and Red Zones for Slope Failure	19
Figure 3.11	Representation of Red Zone for Slope Failure	20
Figure 3.12	3D Representation of Yellow Zone for Slope Failure	20
Figure 3.13	Diagrammatic Illustration of Excluded Part of the Yellow and Red Zones	21
Figure 3.14	Representation of Yellow and Red Zones for Slope Failure considering Break Points (as a reference)	22
Figure 3.15	Frequency Distribution of Slope Angle in Slope Failures	24
Figure 3.16	Frequency Distribution of Height of Slope Failures	24
Figure 3.17	Relationship between Slope Height and Reaching Distance	25
Figure 4.1	General Process of Setting “Yellow Zone” and “Red Zone” for Slide	26
Figure 4.2	Schematic Representation of Typical Slide Topography	27
Figure 4.3	Terminology of a Typical Slide	27
Figure 4.4	Slide Prone Areas Recognizable from the Condition of Water System	28
Figure 4.5	Some Typical Slide Topographies	29
Figure 4.6	An Example of Slide Blocks Identified by Aerial Photograph Interpretation (Udapotha in Kegalle District)	31

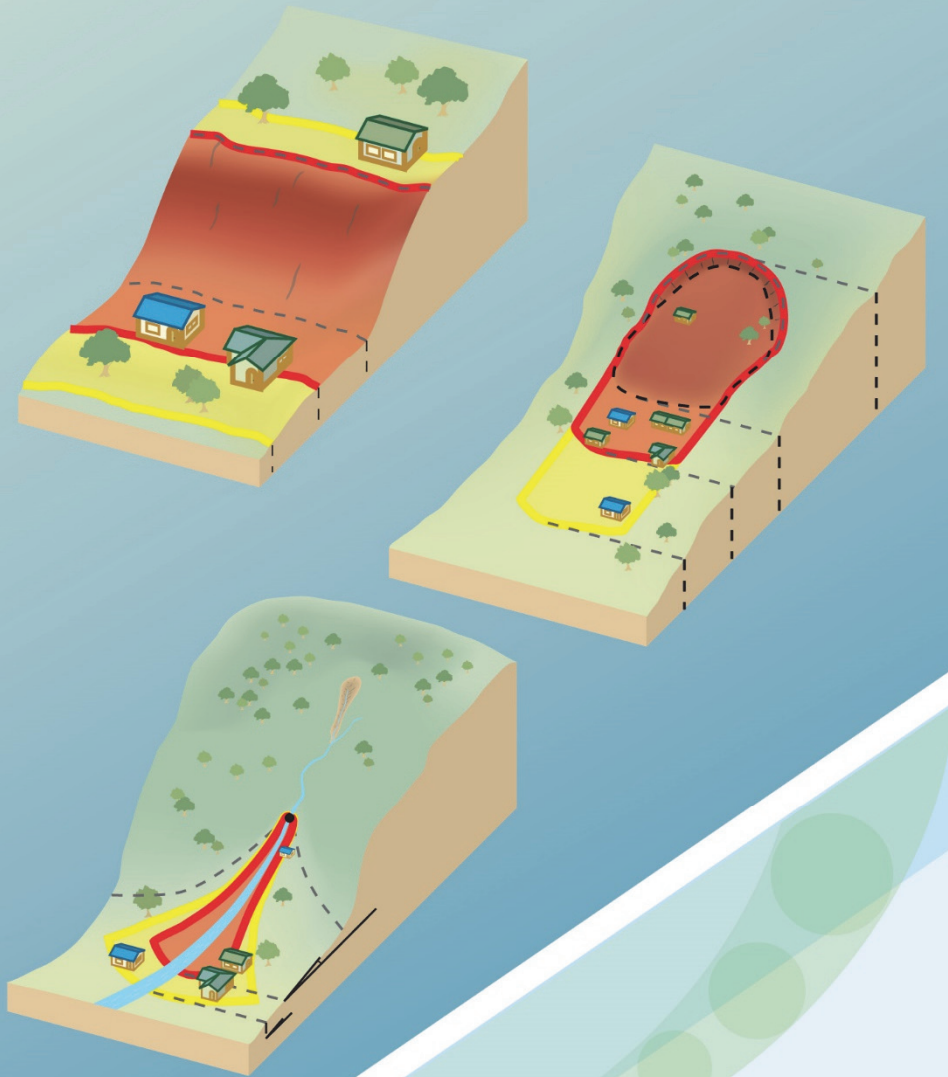
Figure 4.7	Process of Setting of Slide Area	32
Figure 4.8	Examples of United Slide Blocks	34
Figure 4.9	Diagrammatic Determination of Length and Width of a Slide Area	35
Figure 4.10	Typical Features of the Toe Line of a Slide Area	36
Figure 4.11	Concept of Hazard Area for Rank A Slide	37
Figure 4.12	Concept of Hazard Area for Rank B or C Slide	38
Figure 4.13	Ridge or Valley Controlling the Moving Direction of A Slide	39
Figure 4.14	Yellow and Red Zones in the Case that River or Valley Existing at the Toe Part of a Slide	39
Figure 5.1	General Process of Setting “Yellow Zone” and “Red Zone” for Debris Flow	41
Figure 5.2	Determination of Valley Topography	42
Figure 5.3	Conceptual Representation of Target Area for Survey	43
Figure 5.4	Flowchart of Desk Mapping of “Yellow Zone” and “Red Zone” for Debris Flow	44
Figure 5.5	Determination of Control Point	45
Figure 5.6	Shifting of Control Point	45
Figure 5.7	Determination of Flow Direction	46
Figure 5.8	Diagrammatic Representation of Setting Flow Direction at River Bend	46
Figure 5.9	Conceptual Diagram of Setting Flow Direction when Valley Topography or Water Channels is not Clear	47
Figure 5.10	Determination of the Lowermost End of the Zones	47
Figure 5.11	Setting of Cross Section	48
Figure 5.12	Measurement of Relative Height 5 m Point	48
Figure 5.13	Setting of Spreading Points for Yellow Zone	49
Figure 5.14	Setting of Spreading Points for Red Zone	49
Figure 5.15	Setting of Boundary Points for Yellow Zone	50
Figure 5.16	Setting of Boundary Points for Red Zone	51
Figure 5.17	Connection of the Boundary Points for Yellow Zone	52
Figure 5.18	Connection of the Boundary Points for Red Zone	52
Figure 5.19	Setting of End Line of Downstream for Yellow Zone (1)	53
Figure 5.20	Setting of End Line of Downstream for Yellow Zone (2)	53
Figure 5.21	Conceptual Lateral Profile of an Area where Debris Flow Cannot Be Reached	54
Figure 5.22	Setting of a Subsidiary Line of Flow Direction	55
Figure 5.23	Setting of Boundary Points of Main and Subsidiary Flow Directions for Yellow Zone	55
Figure 5.24	Frequency Distribution of Slope Angle of Source Area	58
Figure 5.25	Frequency Distribution of Streambed Gradient around Control Point	58
Figure 5.26	Frequency Distribution of Mean Streambed Gradient of Flow Paths	59
Figure 5.27	Frequency Distribution of Spreading Angle of Depositional Area	59
Figure 5.28	Frequency Distribution of Spreading Angle of Depositional Area Covering Completely Damaged Houses	60
Figure 5.29	Frequency Distribution of Streambed Gradient around End Point of Depositional Area	60

### List of Tables

		<u>Pages</u>
Table 2.2.1	Landslide Classification	8
Table 2.2.2	Distinction between Slide and Slope Failure	9
Table 4.2.1	Classification of Ranks of a Slide Block	33
Table 4.2.2	Hazard Zoning for Slide Area	37

## List of Abbreviation

NBRO	National Building Research Organisation
JICA	Japan International Cooperation Agency
LHZ	Landslide Hazard Zonation
UNISDR	
LHZM	Landslide Hazard Zonation Map
API	Aerial Photograph Interpretation
LIDAR	Light Detection and Ranging



# Chapter 1

# Introduction

**This chapter describes  
the objective and scope of  
the manual and  
the general process of  
landslide hazard zoning**

## CHAPTER 1

### INTRODUCTION

#### 1.1 Necessity of Landslide Total Impact Zone Mapping

Like in many other countries, in Sri Lanka landslides have become frequent major natural hazard, especially in the mountainous and hilly areas of the central highland. Landslides have caused major socioeconomic impacts on peoples, their homes and properties, and lifelines, such as highways, railways, and communications systems. Likewise, landslides in Sri Lanka have presented great problems in development and land use planning.

Landslide hazard mapping or zonation is an initial and important step towards landslide hazard and risk management. Varnes (1984) defines the term “zonation” as “the progress of division of land surface into areas and ranking of these areas according to the degree if actual or potential hazard from landslides or other mass movements.” Following a landslide hazard mapping program implemented from 1990 to 1996, NBRO in 1995 developed a model for regional level landslide susceptibility evaluation (Manual on Landslide Hazard Zonation, 1995). The model, using statistical method and expert knowledge, was developed considering six major landslide causative terrain factors, namely, a) Bedrock geology and geological structures, b) Soil type and thickness (colluvium and residual soil), c) Slope angle and category, d) Hydrology and drainage, e) Land use and management, and f) landform. The model identifies spatial distribution of landslide hazard and produces landslide hazard zonation (LHZ) maps with a scale of 10,000. The landslide hazard areas in the existing LHZ maps are divided, in terms of susceptibility to land sliding, into five levels as a) Landslides are most likely to occur (Brown color), b) Landslides are to be expected (Orange color), c) Modest level of landslide hazard exists (Yellow color), d) Landslides not likely to occur (Green), and e) Inaccessible slope or not mapped area (Gray color), in addition to areas on which landslides have occurred in the past (Red color).

The existing LHZ maps have been effectively used in the establishment of landslide early warning, in the regional assessment for the suitability of lands for development planning, and in the identification and prioritization of potential landslide areas for mitigation. However, because the existing LHZ maps neither identify different types of landslides nor consider the flow path and depositional area of various types of landslides, they cannot be used to properly assess the risk of the entire impact zone, different types of landslides. In addition, recently as development expands into unstable hill slope areas under the pressures of increasing population and urbanization, human activities such as excavation of slopes for road cuts and building sites, etc. have significantly increased not only the susceptibility of hilly areas to landsliding but also largely put people and their properties at extreme risk. Therefore, identification of different types of landslides and subsequent assessment of total impact zone of a landslide are increasingly becoming important in landslide hazard evaluation and risk reduction.



## 1.2 Objective of the Manual

The objectives of this manual are to provide a standard method or protocol for developing landslide hazard zoning in Sri Lanka to identify the total impact area of a landslide at a 1:2,500 or 1:5,000 scale. The manual is focused on the identification and zonation of the major types of landslides for further landslide hazard and risk management. The manual is mainly for internal use at NBRO as well as for relevant landslide hazard management organisations in Sri Lanka. Through the manual, users can quickly and consistently produce standardized landslide hazard zoning maps.

The manual has been prepared mainly based on the concept of “Landslide Hazard Yellow Zone” and “Landslide Hazard Red Zone” in Japan and the results of landslide inventory survey in Sri Lanka. The Japanese method of landslide hazard Yellow and Red Zone mapping was developed with the focus on the residents, under the Sediment Disaster Prevention Act in 2001, to prepare total impact zone maps that contain two zones, namely, landslide hazard yellow and red zones. The landslide hazard Yellow Zone is defined as an area to prone sediment disaster, while the landslide hazard Red Zone is defined as an area where a high risk of damage to buildings and threat to residents may be expected. The definition of the Yellow Zone and Red Zone is further described in Chapter 1.5.

## 1.3 Scope of the Manual

This manual describes the methodologies of landslide hazard zoning/ yellow and red zone mapping (total impact zone mapping) (hereafter refers as yellow and red zone mapping/maps) and reference data, mainly including three major types of landslides, such as slope failure, slide and debris flow. The manual consists of five chapters and technical notes, as shown in Figure 1.1 below.

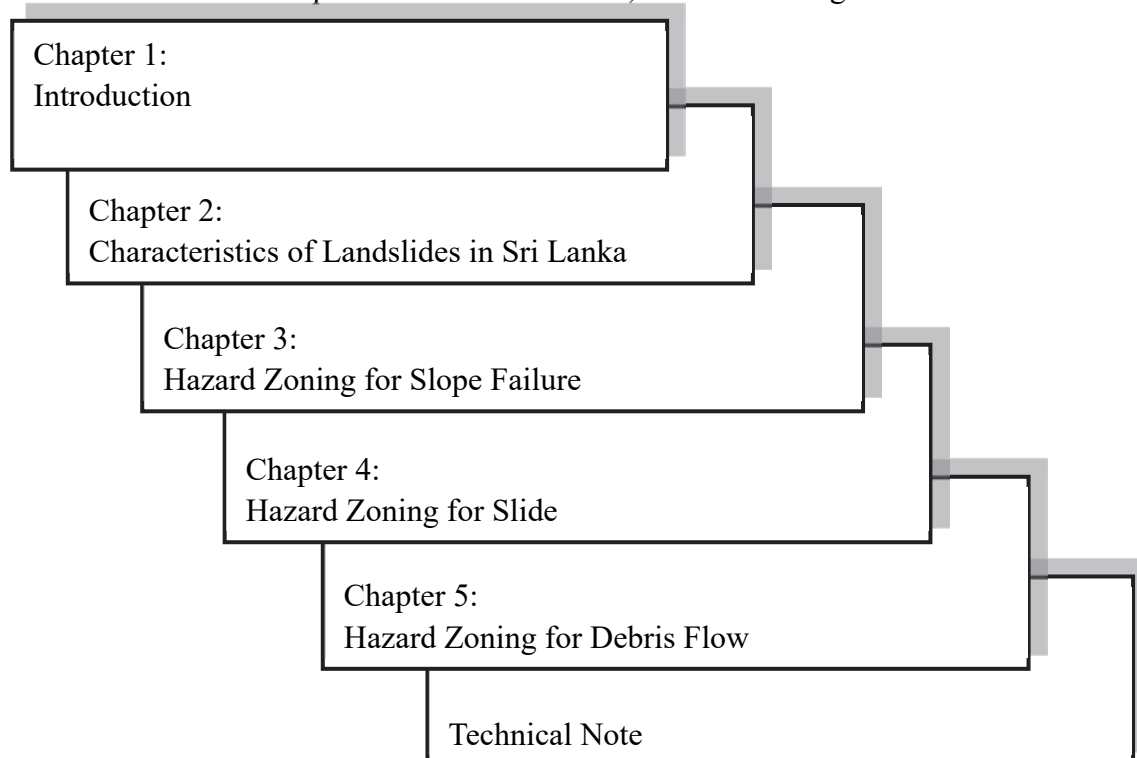


Figure 1.1 Structure of the Manual

Chapter 1, Introduction, describes the objective and scope of the manual as well as the general process of landslide hazard zoning.

Chapter 2, Characteristics of Landslides in Sri Lanka, summaries the distribution, characteristics and classification of landslides in Sri Lanka.

Chapter 3, Hazard Zoning for Slope Failure, Chapter 4, Hazard Zoning for Slide, and Chapter 5, Hazard Zoning for Debris Flow, provide the methodologies of landslide total impact zone mapping for each major type of landslides, respectively, such as slope failure, slide and debris flow.

Finally, two technical notes are attached. Technical Note 1, Hazard Zoning Methodology for Slope Failure, which was prepared by reference to Japanese criteria, similar to Chapter 3, describes an alternative method for hazard zoning for slope failure as a reference. Technical Note 2, Aerial Photograph Interpretation of Landslides, provides reference for Chapter 5.

In addition, the manual should be used together with the Manual on 1:10,000 scale Landslide Hazard Zonation (1995) to select target areas for further hazard zoning to map the total impact area.

The manual is useful to experts or organizations concerned with landslides when developing landslide total impact zone maps. This hazard map is contribute to land use planning and development regulation.

The target phenomena in the manual are Landslides, which are technically viable to identify the hazard area. Deep-seated landslides, rock slope failures, collapses of mountain body or huge-scale mass movement with far exceed assumptions are exempt from the manual because it is extremely difficult to identify and predict accurately the hazard area due to the phenomena.

## 1.4 Key Definitions

### Landslide:

“Landslide” is collectively defined as the movement of a mass of rock, debris, or earth down a slope. In the manual, landslide is synonymous with sediment disaster.

### Landslide Hazard:

“Landslide hazard” is defined as the probability of the occurrence of a landslide event in a given area in a specific time frame.

### Disaster Risk:

“Disaster risk” is defined as the potential loss of life, injury, or destroyed or damaged assets which could occur to a system, society or a community in a specific period of time, determined probabilistically as a function of hazard, exposure, and capacity. Disaster Risk equation is defined as follows where the risk of a disaster increases as the frequency or severity of hazards increases, vulnerability increases and capacity to cope is decreased.

$$\text{Disaster Risk} = \frac{\text{Hazard} \times \text{Vulnerability}}{\text{Capacity}}$$

### Vulnerability:

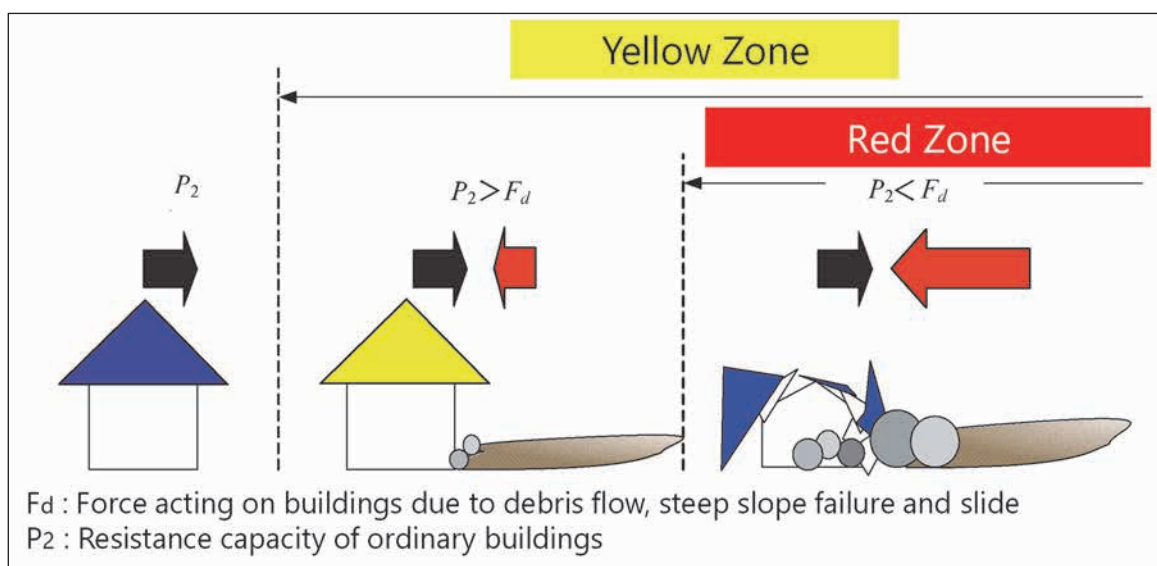
The characteristics are determined by physical, social, economic and environmental factors or processes that increase the susceptibility of an individual, a community, assets or systems to the impacts of hazards. (UNISDR Terminology, 2017).

### Landslide Hazard Yellow Zone:

“Landslide Hazard Yellow Zone” is defined as the area that is susceptible to landslide and is called as “Yellow Zone” for brevity. The resistance capacity of normal residential buildings in Yellow Zone is expected to be larger than the force acting on residential buildings due to the moving debris and earth from landslides, thereby causing partial or less damage to the residential buildings in the Yellow Zone, and consequently posing a lower risk to the residents in the Yellow Zone (Figure 1.2).

### Landslide Hazard Red Zone:

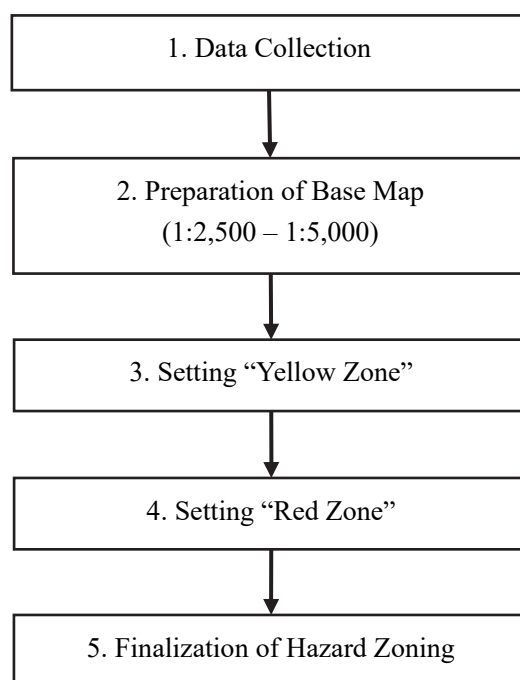
“Landslide Hazard Red Zone” is defined as the area where there is a high risk of damage to buildings and threat to people due to a landslide, and is called as “Red Zone” for brevity. The force acting on residential buildings due to the moving debris and earth from landslides in the Red Zone is expected to be larger than the resistance capacity of normal residential buildings. Therefore, normal residential buildings in the Red Zone would be completely destroyed by the moving debris and earth of landslides, consequently having an even higher risk to the residents in the Red Zone (Figure 1.2).



**Figure 1.2 Basic Concept for Yellow Zone and Red Zone**

## 1.5 General Process of Yellow and Red Zone Mapping

Yellow and Red zoning is conducted according to the steps shown below (Figure 1.3).



**Figure 1.3 General Process of Development of Yellow and Red Zone Maps**

## 1.6 Preparation of Yellow and Red Zoning

Relevant data such as base maps and landslides hazard area information for hazard mapping should be collected in accordance with the actual conditions at the target areas.

The following relevant data should be collected.

### a. Base Map

- Digital map and Ortho data (1:2,500 or 1:5,000 scale, 1m counter interval)

### b. Information on hazardous areas

- Location of residential houses and public buildings
- Past disaster records
- Location of the existing countermeasures against landslides

The accuracy of Yellow and Red zone maps to be produced depends on the resolution of base map and the quality or details of the disaster records at the target area. In addition, yellow and red zone maps to be created, shall be at map scale of 1:2,500 or 1:5,000, which allows to divide or delineate landslide areas into different hazard zones.



# **Chapter 2**

# **Characteristics of Landslides in Sri Lanka**

**This chapter summarizes  
the characteristics and  
classification of landslides  
in Sri Lanka**

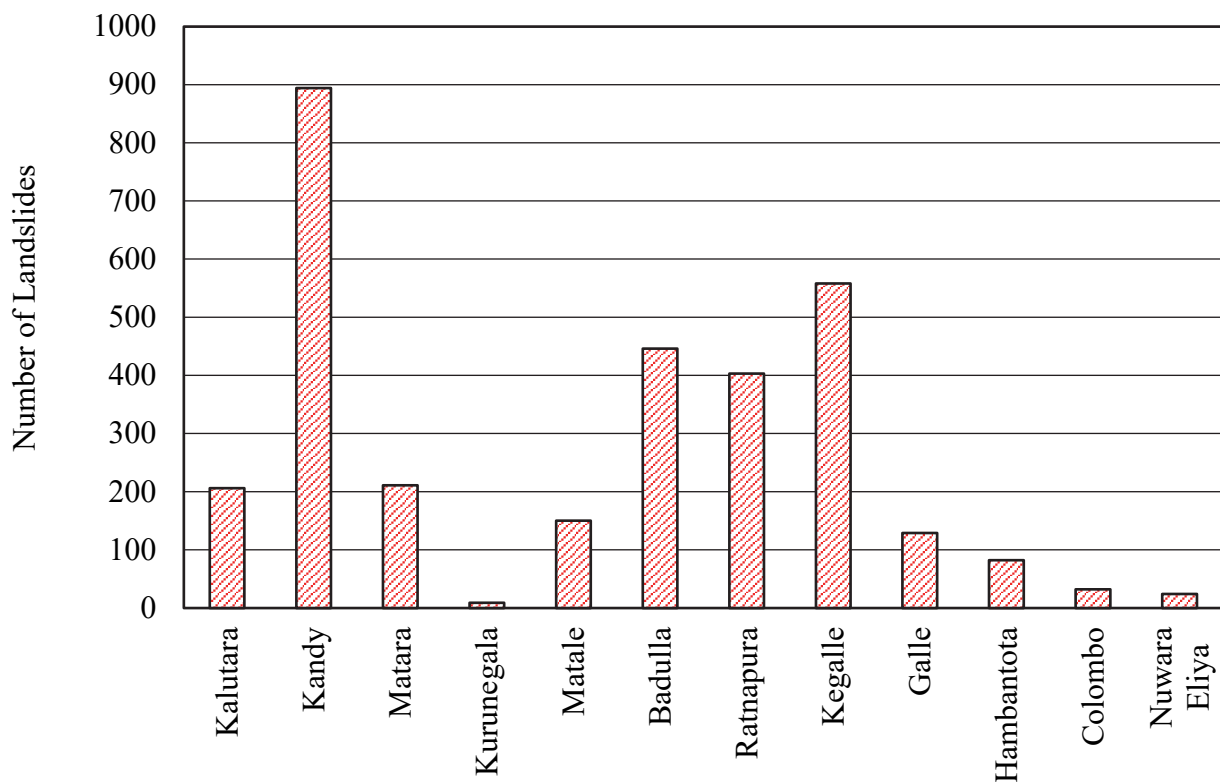


## CHAPTER 2

### CHARACTERISTICS OF LANDSLIDES IN SRI LANKA

#### 2.1 Distribution of Landslides in Sri Lanka

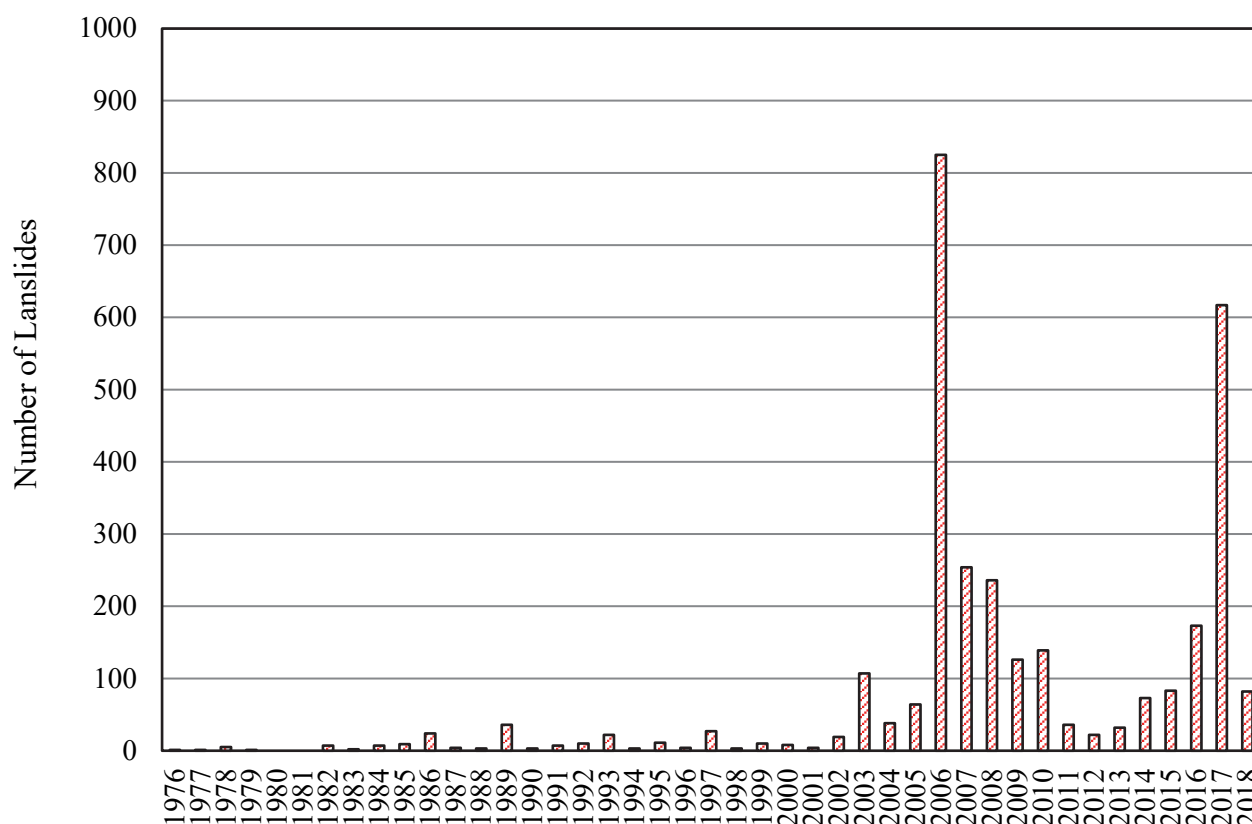
NBRO is compiling a landslide inventory database to better document the distribution and geologic and topographic attributes of landslides in Sri Lanka. As of 2018, the NBRO inventory database has more than 3,000 documented landslides. Out of the 14 landslide prone districts Landslides have occurred in 12 districts are shown in the Figure 2.1, and especially concentrated in Kandy, Badulla, Ratnapura and Kegalle districts, in the mountainous and hilly areas of central Sri Lanka. The distribution of landslides reflects regional geology, topography and land use and urbanization conditions.



**Figure 2.1 Distribution of Landslides by District**

Landslides are one of the most dangerous and destructive natural hazards in Sri Lanka, and the number of landslides has been recently increasing nationwide (Figure 2.2). Many landslides are associated with the slopes cut for house building and road construction. The recent increase in the number of landslides is largely due to inappropriate land use planning and unplanned development on sloping lands and previous landslide areas. Excavation at the base of slopes, particularly at the toes of potential and active landslides as well as colluvial slopes, is the most common human trigger of landslides. In addition, in Sri Lanka almost all landslides are associated with intense and/or prolonged periods of rainfall, indicating that rainfall is the main triggering factor of landslide

disasters. Improper planning and inappropriate maintenance of surface drainage system also increase the potential for slope instabilities.



**Figure 2.2 Occurrence of Landslides (1976 to 2018)**

Landslides in Sri Lanka are due to the combination of fragile geology, steep topography, heavy and intense rainfalls, and earthquakes and human activities. The susceptibility of lands and slopes to slope instability is generally increased largely by human causes, such as inappropriate land use and development; thereby exposing people, their property and infrastructure to increased risk, and consequently causing significant damage to residential houses and infrastructures as well as loss of human life. Rainfalls, earthquakes, and human activities are the main triggers of landslides. While rainfalls and earthquakes cannot be controlled, human activities can be controlled and regulated to reduce the potential adverse impacts from developments, thereby improving the susceptibility of landslides.

## 2.2 Classification of Landslides in the Manual

Landslide classification is an important initial step to hazard identification and risk evaluation of landslides. There have been various classifications of landslides and other types of mass movement with different purposes, generally in consideration of the following factors or criteria:

- a) Type and size of materials involved;
- b) Type and velocity of movement;
- c) State and distribution of activity;
- d) History and the age of movement;



- e) Dimension and size of landslide;
- f) Causes of movement and triggering mechanism;
- g) Underlying geology;
- h) Morphology of landslide deposits;
- i) Spatial composition and location; and
- j) Others.

An important classification is Varnes's classification (Varnes, 1972). This classification is based on the type of movement and the kind of material involved. Movement is subdivided into falls, slides and flows. Later two more movement types, topples and lateral spreads, were added into the classification (Varnes, 1978). Cruden and Varnes (1996) further revised the classification, as outlined in Table 2.1 below, which includes five types of movements belonging to mass movement and complex movement involving one of the main types of movement followed by two or more of the other main types of movement. The classification has been widely used worldwide.

**Table 2.1 Landslide Classification**

Type of Movement		Type of Materials		
		Bedrock	Debris	Earth
Topple		Rock topple	Debris topple	Earth topple
Fall		Rock fall	Debris fall	Earth fall
Slide	Translational	Translational rock slide	Translational debris slide	Translational earth slide
	Rotational	Rotational rock slide	Rotational debris slide	Rotational earth slide
Flow		Rock flow	Debris flow	Earth flow
Spread		Rock spread	Debris spread	Earth spread
Complex		Combination of two or more principal type of movement		

Source: Cruden and Varnes, 1996.

However, four types of landslides have been recognized and classified from past landslide inventory survey in Sri Lanka, including 1) slides, 2) slope failures, 3) debris flows and 4) rockfalls. The classification scheme is simple and considers some of the factors of the above-mentioned classification criteria, such as 1) type of movement and 2) velocity of movement. The classification scheme has also been used for landslide hazard identification and subsequent risk assessment and management in Sri Lanka. This landslide classification scheme is thus recommended to be used in the manual.

The typical features of each type of landslides are summarized below.

#### (1) Slides

Slides are used, in a narrow sense, to describe the downward movement of slope materials along pre-existing or potential rupture surfaces or zones. They are the major types of landslides in Sri Lanka and are deep, rotational or translational sliding phenomena caused primarily by groundwater pressures within a gentle hillside or around previous slide areas. They normally occur on gently slopes of less than 20 degrees move slowly with a relatively large volume of displaced mass, thereby causing significant damages to properties such as houses, roads and other lifelines, but less

loss of life.

## (2) Slope failures

Like slides, slope failures are also the major type of landslides in Sri Lanka, but shallow, fast-moving types on steep slopes, natural and artificial, with a relatively small volume of displaced mass. Slope failures, because of their fast-moving nature and without indication prior to movement, frequently result in serious injuries and fatalities, even in the case of small volume of displaced mass.

According to the landslide inventory survey and other landslide studies in Sri Lanka, slope failures are characterized by fast movement of a mass of rock, debris, or earth downward a steep slope, mostly over 25 degrees. They occur suddenly, in a small size and at a shallow depth, but in group in most cases, and are mainly triggered by heavy or intense rainfall. Because of its sudden collapse and fast movement, many people fail to escape from slope failures, and therefore, slope failures commonly cause a higher rate of fatalities.

On the other hand, slides are marked by slow movement of a mass of rock, debris, or earth downward a gentle slope of less than 25 degrees along a pre-existing zone or surface of rupture. They are generally larger at size with a deeper surface of rupture and are triggered mainly due to rising groundwater level or increased pore-water pressure as a result of cumulative rainfall.

Because of the lack of inventory survey data relating to difference between slide and slope failure in Sri Lanka, a clear distinction between slide and slope failure has been recognized in Japan and is given in Table 2.2 for reference.

**Table 2.2 Distinction between Slide and Slope Failure**

Item	Slide	Slope Failure
1) Geology	Occurs at sites with specific geological and geological structures	Less relation to geological condition
2) Topography	Occurs on gentle slopes of 5 to 30°	Occurs on steep slopes of over 30°
3) Soil Type	Occurs mainly on clayey soils	Occurs frequently on sandy soils
4) Activity	Continuous, recurrent	Sudden, sporadic
5) Movement speed	Slow, from 0.001 to 10 mm/day	Fast, over 10 mm/day
6) Displaced mass	Little disturbed	Strongly disturbed/deformed
7) Main Cause	Ground water - pore water pressure	Heavy rainfall - infiltration and erosion
8) Scale	Large, 1 to 100ha	Small, frequently in group
9) Slip Surface	Gentle, 10 to 25°	Steep, 35 to 60°
10) Indication	Development of cracks, subsidence, bulging, groundwater fluctuation	Without indications

Source: Mechanism and Mitigation Measures of Slope Disasters, Sankaido, by M. Watari, 1986.

Slope failures are subdivided from slides in the manual mainly because the former, fast-moving, poses a greater threat to human life and has a higher potential to cause sudden and catastrophic damage to human and property, while the latter, slowly-moving, causes predictable damage only to properties and less to human life.

### (3) Debris flows

Debris flows are also common types of very fast-moving landslides in Sri Lanka. They typically begin on upper steep hillsides, mostly as shallow slope failures or, on rare occasions, as slides during heavy rains, then rapidly flow down hills and/or into channels, before spreading widely on gently sloping grounds. Debris flows, normally together with driftwoods, generally claim many lives in addition to damage to roads, bridges, water supply lines, electricity and so on along their travelling paths because of their fast-moving velocity and long-travelling distance. Even small debris flows have the high potential to cause damage to properties and loss of life.

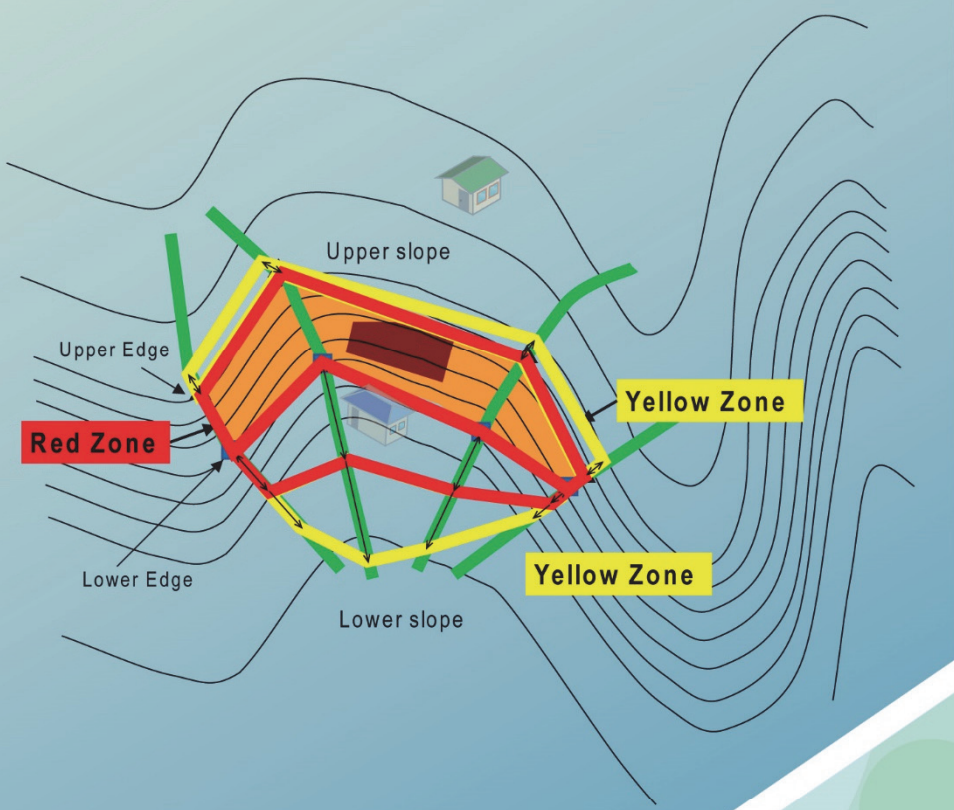
In Sri Lanka, two sub-types of debris flows have been recognized based on the landslide inventory survey, namely, channelized debris flow and hillslope debris flow. The channelized debris flows are generally formed by a source area, a stream transport channel and a depositional area showing a fan morphology. On the other hand, the open slope debris flows are formed similarly by a source area, by following their own path down valley slopes as tracks or sheets, before depositing materials on lower flatter areas. The clear difference is that the former flows along or in a preexisting channel, and the latter flows unconfined around an open valley slope or hillslope.

Hillslope debris flows are generally unpredictable or difficult to identify prior to occurrence because of the lack of evidence or indication, such as alluvial fans and mountain streams. Accordingly, the manual addresses channelized debris flow only.

### (4) Rockfalls

Rockfalls are very rapid to extremely rapid falls of loosed and fractured rock blocks along steep rock slopes, natural, artificial or both. The fall-down movement takes place mainly through the air by free-fall, leaping, bounding, or rolling. An inventory survey shows that rockfalls are common along many cut slopes for road constructions and house buildings, and therefore threaten or damage transportations and residential areas.

In addition, because mapping and delineation of hazardous rockfall sites and its downslope affected areas are very complicated, rockfalls are excluded from the manual.



# Chapter 3

## Hazard Zoning for Slope Failure

**This chapter presents  
the methodology and procedure of  
site-specific hazard zoning  
for slope failures**

## CHAPTER 3

### HAZARD ZONING FOR SLOPE FAILURE

#### 3.1 Procedure of Setting “Yellow Zone” and “Red Zone” for Slope Failure

Setting of “Yellow Zone” and “Red Zone” for slope failure is in accordance with the following steps (Figure 3.1).

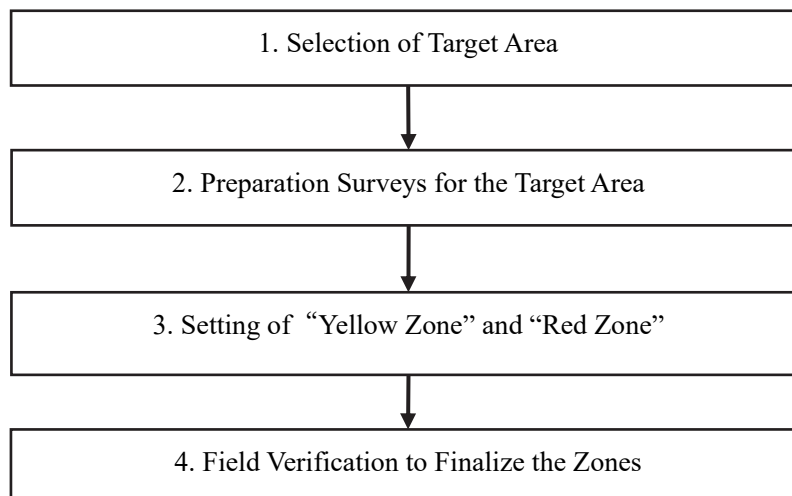


Figure 3.1 General Process of Setting “Yellow Zone” and “Red Zone” for Slope Failure

#### 3.2 Methodology

This methodology is applicable to either natural slopes, man-made slopes, or their combinations.

##### 3.2.1 Selection of the Target Area

In selecting the target area, the following three conditions are taken into consideration:

- Existing landslide hazard evaluation
- Present land use plan and social conditions
- Slope units

##### a) Existing Landslide Hazard Evaluation

The target area, as an “initial area or source area” related to potential slope failure, is selected by using the “Landslide Hazard Zonation Map (LHZM)” with a scale of 1:10,000 prepared by NBRO, which shows the areas that may have landslides in the future. The target area to be selected as the initial area of a slope failure shall be limited to the slopes or zones that are classified as “Landslides most likely to occur” which are indicated in brown color (hereinafter called “Brown zone”) and/or “Landslides are to be expected” which are indicated in orange color (hereinafter called “Orange zone”) in the LHZM, which both show higher likelihood of future landslides.

- b) Present Land Use Plan and Social Conditions
- The target area should include residential area in which at least one residential house or public building is located.
  - Areas that have no houses at present, but may be expected to be developed for housing or public building construction in future based on social conditions such as current land use and development plans should be also considered.
  - Areas where there is no possibility of residential house construction, such as high mountainous (inaccessible slopes) areas with no houses, etc. are excluded from target area selection.
  - Man-made slopes, either cutting or filling, along roads are excluded from target area selection.
- c) Slope Unit
- In the case of laterally continuous steep slopes that are classified as “Landslides most likely to occur” with brown zones and/or “Landslides are to be expected” with orange zones in the LHZM, the target area should be sectioned up to approximately 500 m in length based on topographical or administrative factor.
  - The setting of left and right edges of the area are described in Chapter 3.2.3 - (5) below.

### 3.2.2 Preparation Surveys for the Target Area

- a) Survey of Past Disaster History
- The past disaster history survey for the target area should be conducted to assess the size of the past slope failures and their damage conditions and set the range of hazard zone, by collecting the following:
- Date, time, location and cause of a slope failure
  - Size or scale of a slope failure (height, width, length, depth, slope gradient, reaching distance and volume of collapsed sediment), as illustrated in Figure 3.2
  - Damage to humans (the number of fatalities/injuries), damage to houses (the number of damaged houses, completely or partially), and structural types of the damaged houses (reinforced concrete, brick, clay, wooden, etc.)
  - Rainfall information (cumulative rainfall, daily rainfall, hourly rainfall)
  - Others (thickness of inundated sediment, etc.)
- b) Artificial structures
- It should be checked in relation to their associated damage conditions if any artificial structures exist in the target area. The artificial structures may include:
- Walls, Retaining walls
  - Pitching works
  - Embankments
  - Excavations
  - Drainage channels, ditches
  - Others



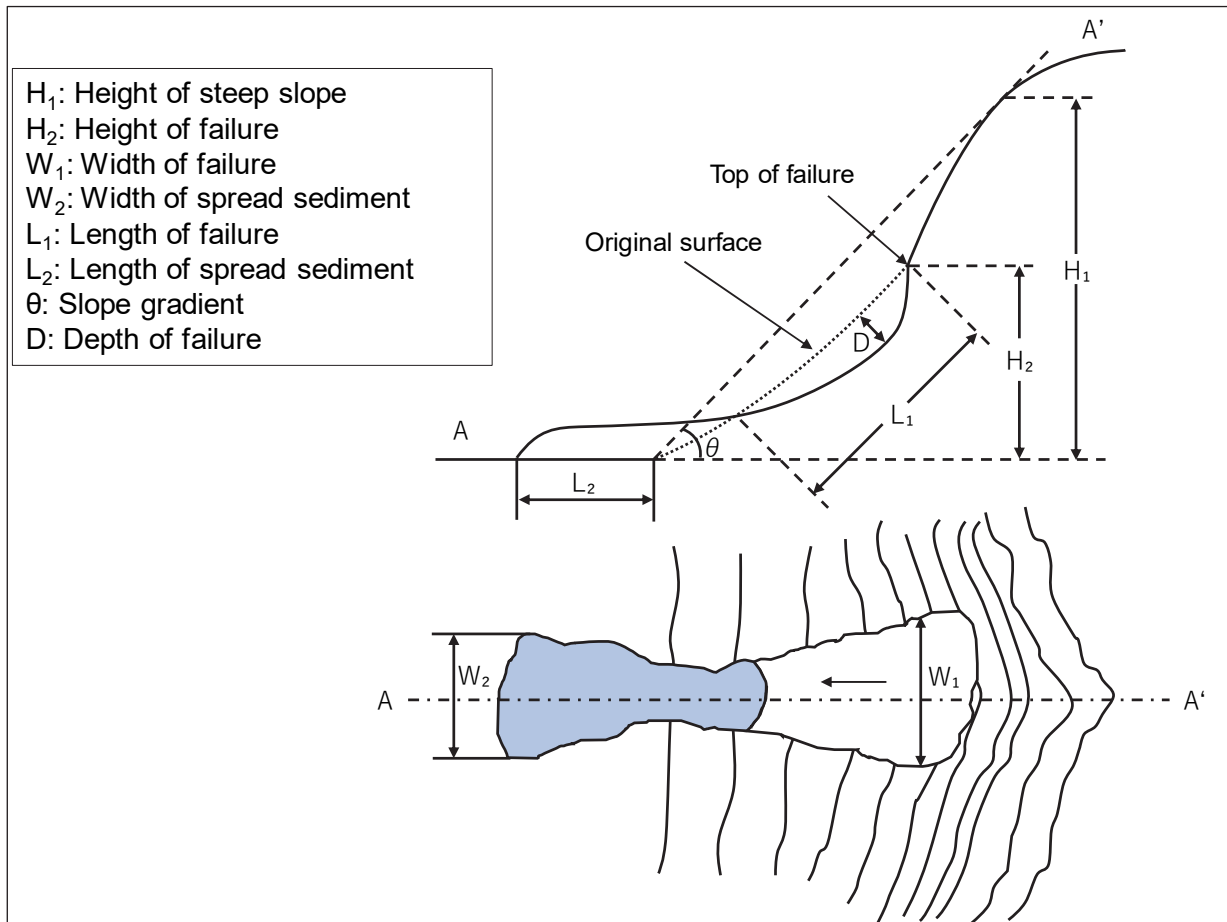


Figure 3.2 Diagrammatic Illustration of Slope Failure Dimension



### 3.2.3 Setting of “Yellow Zone” and “Red Zone”

Setting of “Yellow Zone” and “Red Zone” for slope failure is conducted according to the following steps (see Figure 3.3).

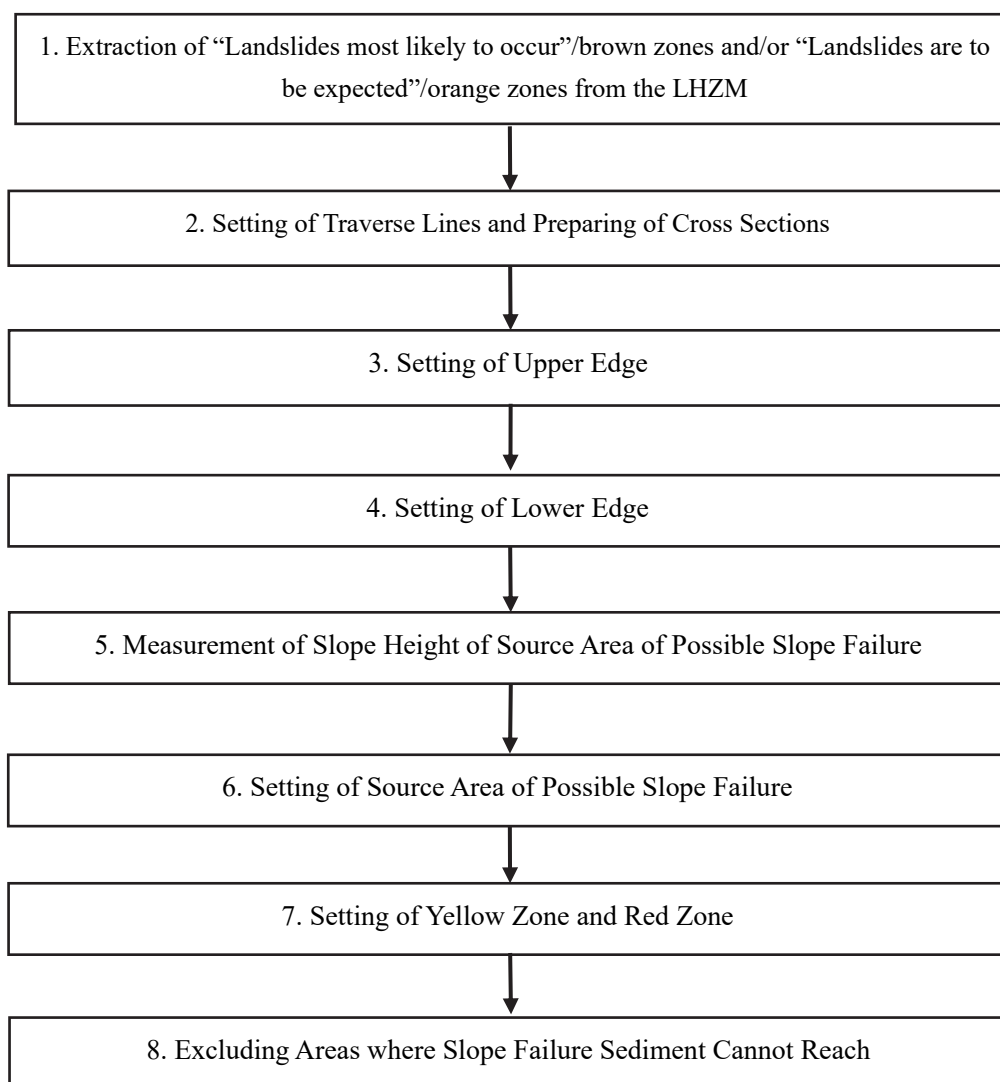


Figure 3.3 Flow chart of Desk Mapping of “Yellow Zone” and “Red Zone” for Slope Failure

**(1) Extraction of “Landslides most likely to occur”/brown zones and/or “Landslides are to be expected”/orange zones from the LHZM**

“Landslides most likely to occur”/brown zones and/or “Landslides are to be expected”/orange zones in the LHZM are extracted as source areas of possible or future slope failures, and delineated in a base map of 1:2,500 or 1:5,000 scale.

**(2) Setting of Traverse Lines and Preparing of Cross Sections**

Traverse lines are set in terms of their direction and location, as follows:

- a) The traverse line should be oriented toward the maximum slope angle (Figure 3.4 - (a))
- b) The location of traverse lines should be set at the lateral left and right edges of the Brown and/or Orange zone. Inside the Brown or Orange zones, traverse lines should be set at about 20 m interval along contours in consideration of topographical changing

points and artificial structures (Figure 3.4 - (b))

c) Then, a cross section must be prepared for each traverse line

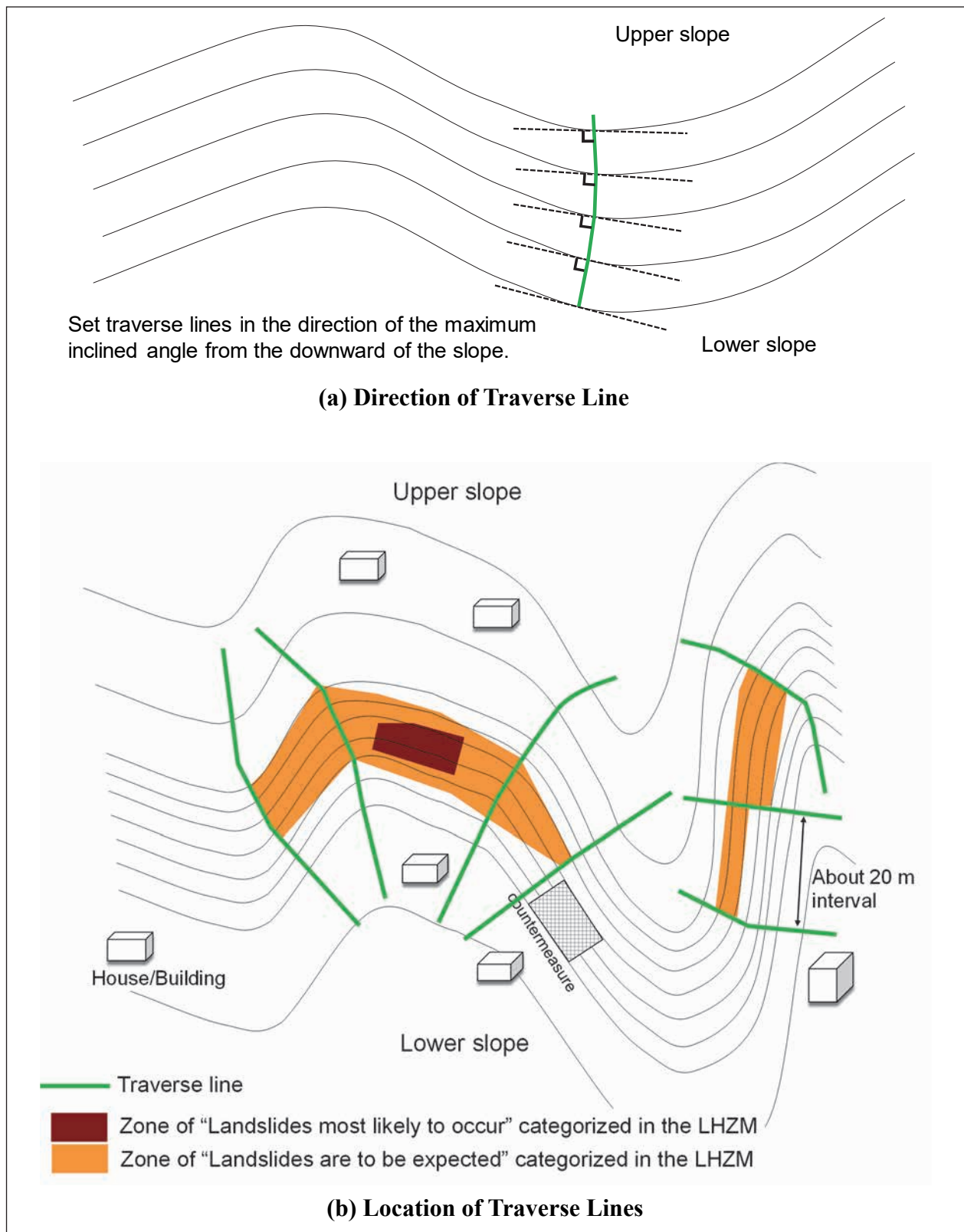
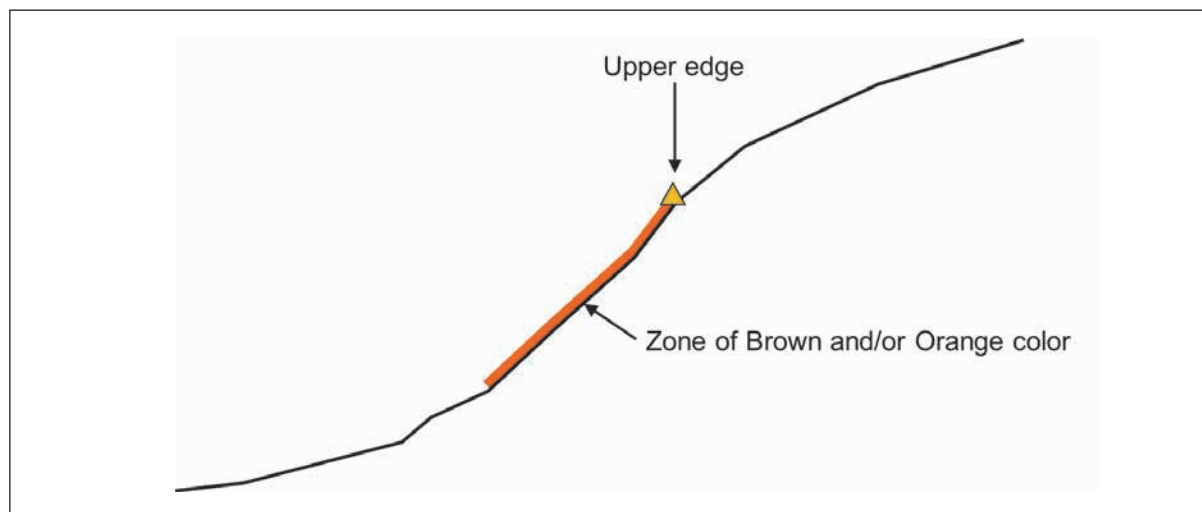


Figure 3.4 Setting of Traverse Lines

### (3) Setting of Upper Edge

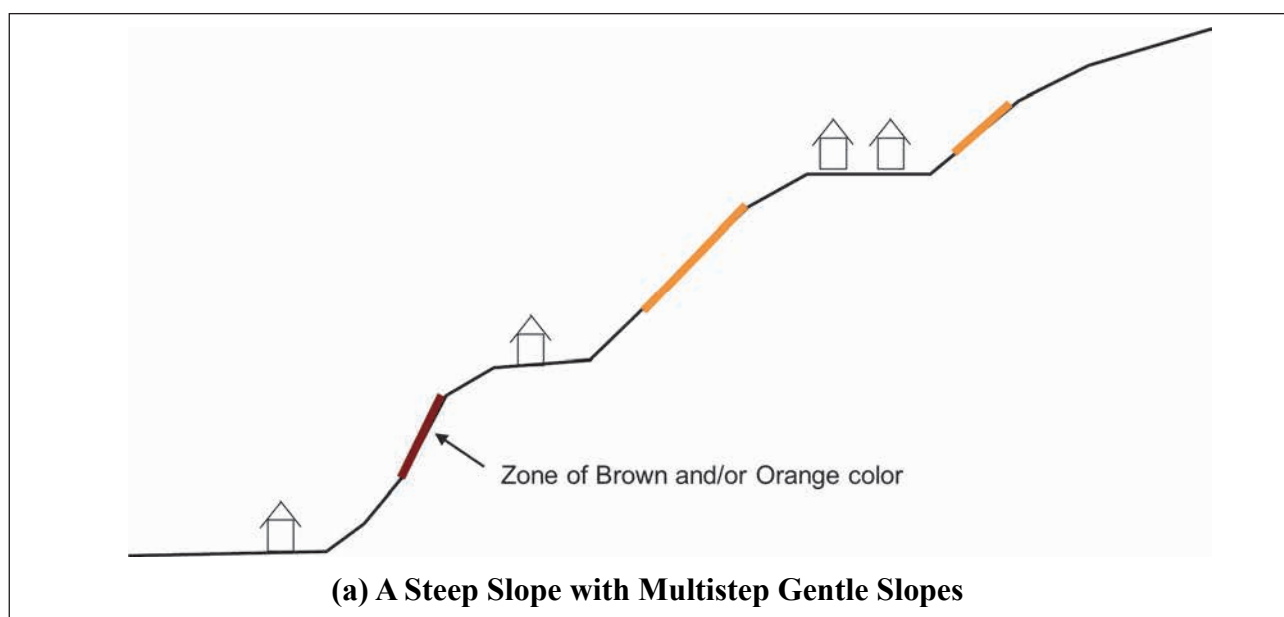
The upper edge shall be set at the highest point of the hazard area on the cross section of each traverse line (Figure 3.5).



**Figure 3.5 Diagram of Setting Upper Edge**

Furthermore, in the area where there are multiple Brown and/or Orange zones in the slope direction (Figure 3.6 - (a)), the hazard zones should be set as follows:

- a) In principle, the hazard zones should be set for each of the Brown and/or Orange zones. However, if the Red Zones of the upper and lower slopes overlap (Figure 3.6-(b)), the upper and lower slopes are treated as one continuous slope
- b) If there is no overlap between the Red Zones of the upper and lower slopes (Figure 3.6-(c)), the upper and lower slopes must be designated as separate Red Zones



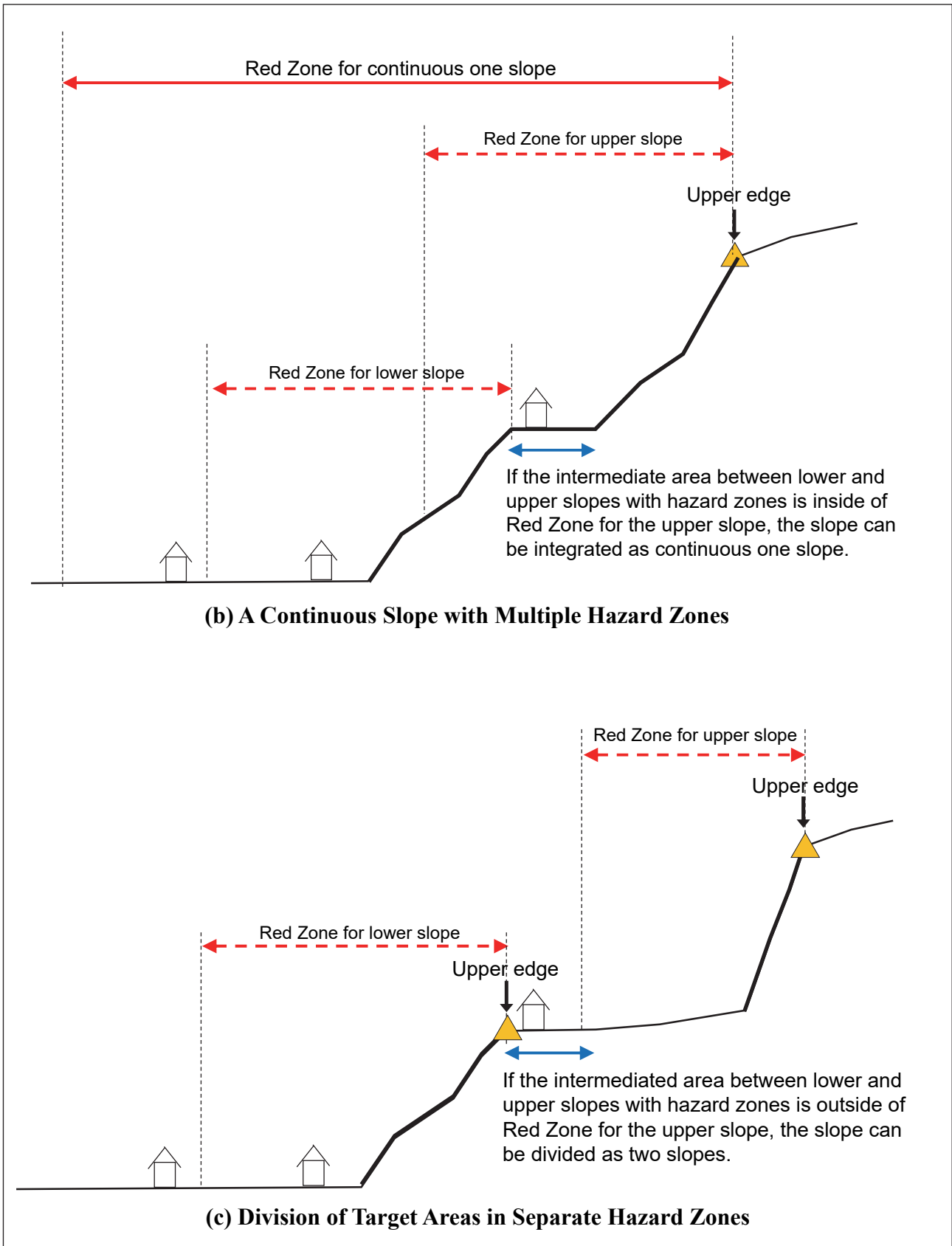
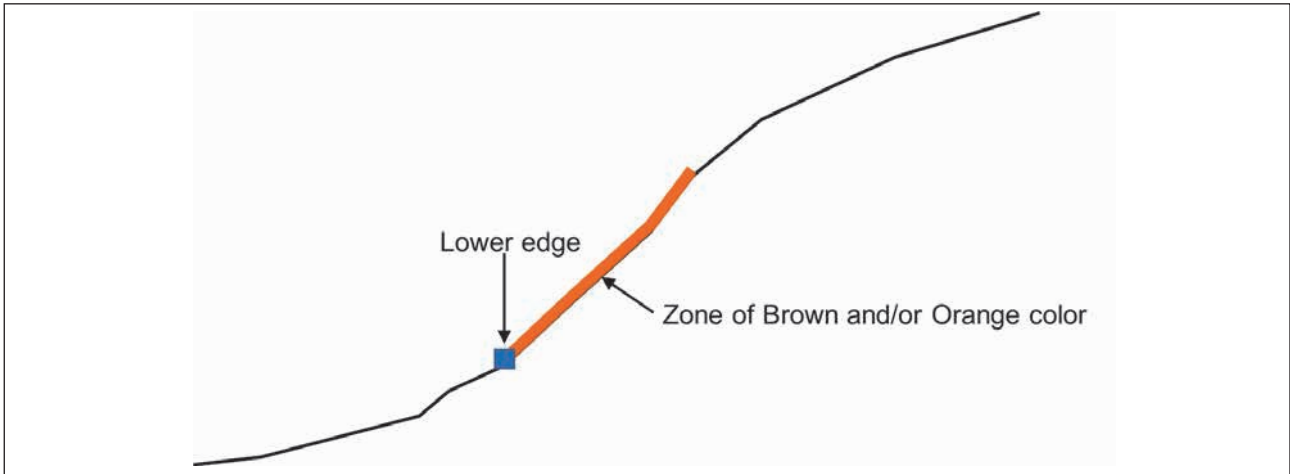


Figure 3.6 Diagrammatic Illustration of Setting Upper Edge for a Slope with Multiple Hazard Zones

**(4) Setting of Lower Edge**

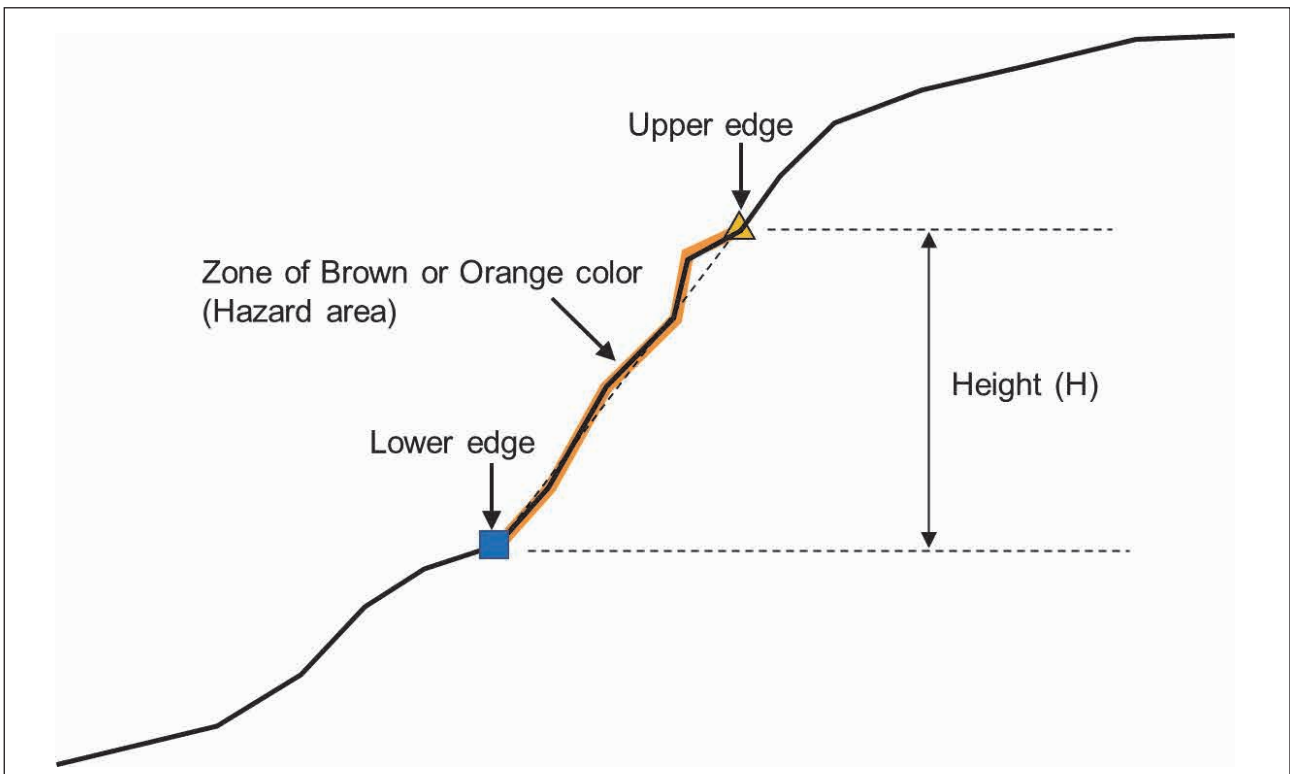
The lower edge shall be determined at the lowest point of the hazard zone on the cross section of each traverse line (see Figure 3.7).



**Figure 3.7 Setting of Lower Edge**

**(5) Measurement of Slope Height of Source Area of Possible Slope Failure**

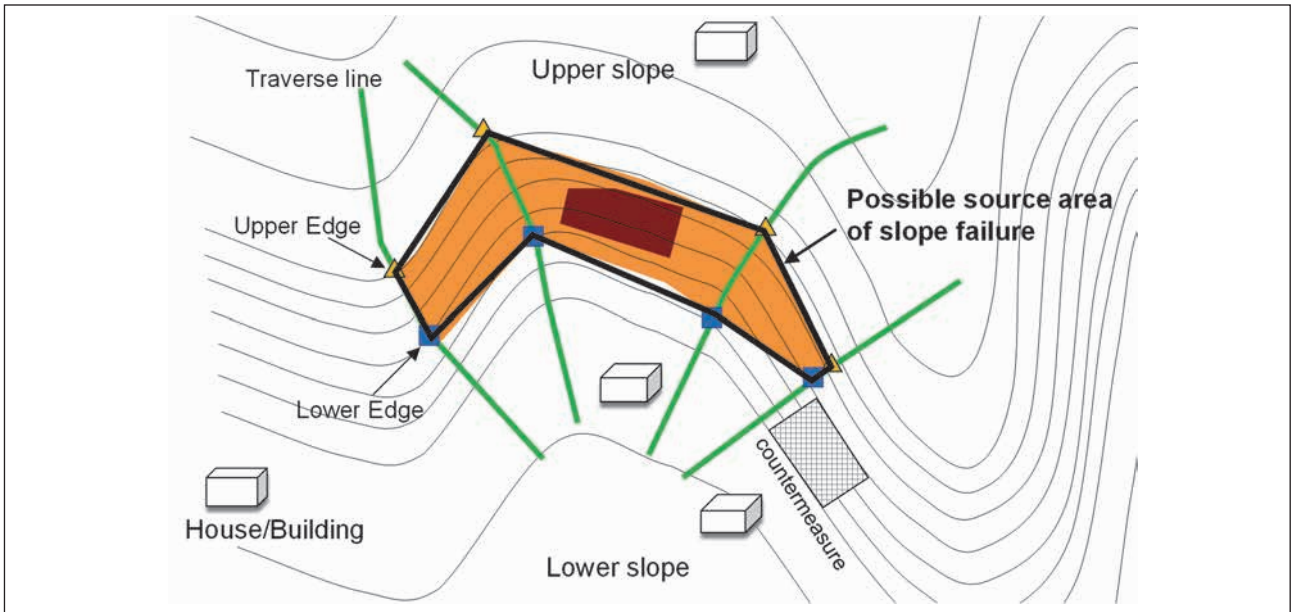
Slope height of the source area of possible slope failure is measured as the relative height between the lower and upper edges (Figure 3.8).



**Figure 3.8 Measurement of Hazardous Slope Height**

**(6) Setting of Source Area of Possible Slope Failure**

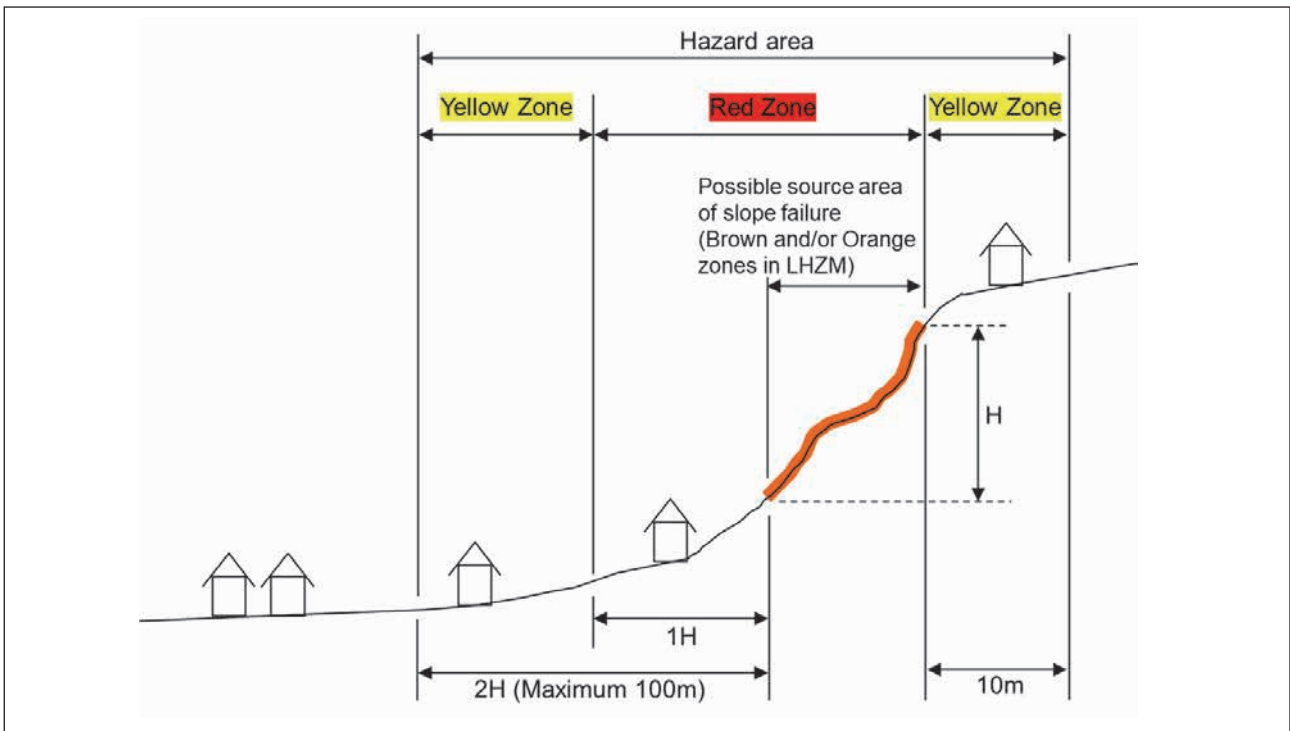
Source area of possible slope failure is set by straight lines connecting all upper and lower edges (Figure 3.9).



**Figure 3.9 Diagrammatic Representation of Setting Source Area of Possible Slope Failure**

**(7) Setting of Yellow Zone and Red Zone**

The Yellow and Red Zones are set as shown in Figure 3.10 below.



**Figure 3.10 Representation of Yellow and Red Zones for Slope Failure**



## I) Red Zone

The Red Zone for slope failure shall be set to include (see Figure 3.11):

- The source area (Brown and/or Orange zones)
- The area located within the distance equivalent to the height of source area from the lower edge of each traverse line

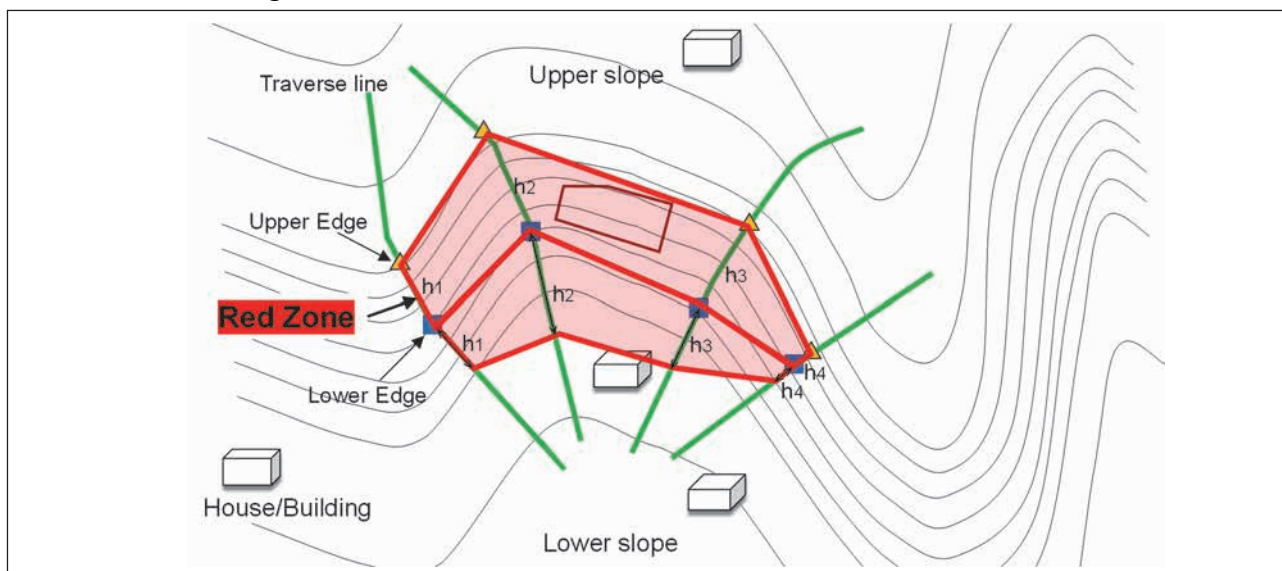


Figure 3.11 Representation of Red Zone for Slope Failure

## II) Yellow Zone

The Yellow Zone for slope failure shall be set to include (see Figure 3.12):

- The area located within a horizontal length of 10 m from the upper edge of each traverse line
- The area located within the distance equivalent to twice the height of the source area (Maximum limit 100 m) from the lower edge of each traverse line

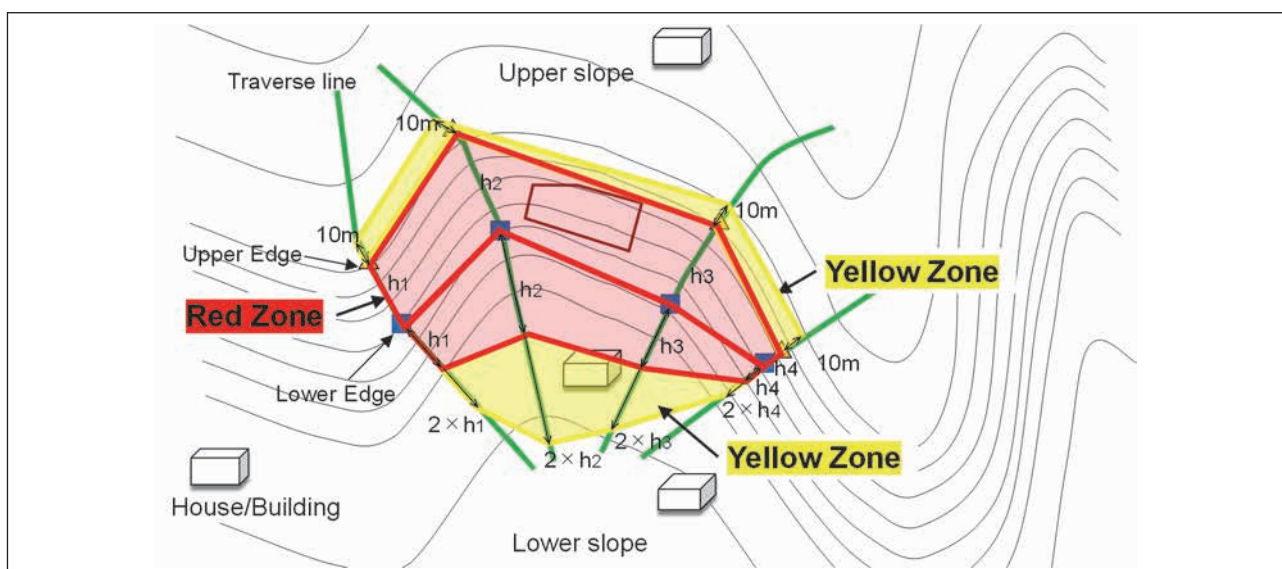


Figure 3.12 3D Representation of Yellow Zone for Slope Failure



### (8) Excluding Areas where Slope Failure Sediment Cannot Reach

Areas which are clearly observed to be not within the reach or runout range of the collapsed sediment due to topographical features or structural obstacles should be excluded from the Yellow and/or Red zones (Figure 3.13).

Such topographical features and structural obstacles are as follows:

- Embankment
- Excavation
- Channel, river
- Wall, Retaining wall
- Other structures

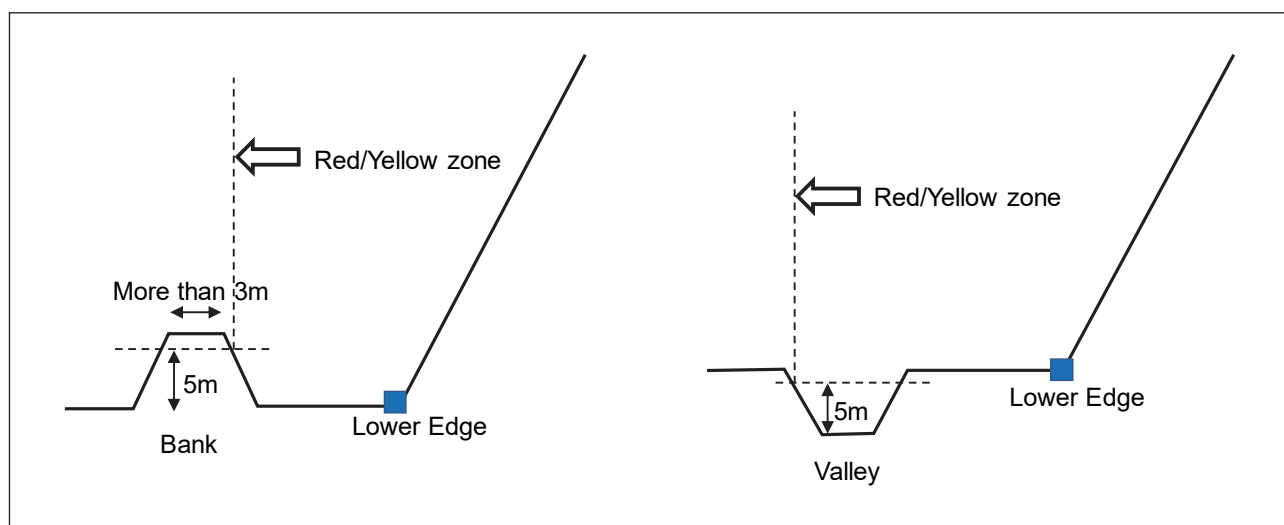


Figure 3.13 Diagrammatic Illustration of Excluded Part of the Yellow and Red Zones

#### 3.2.4 Field Verification to Finalize the Zones

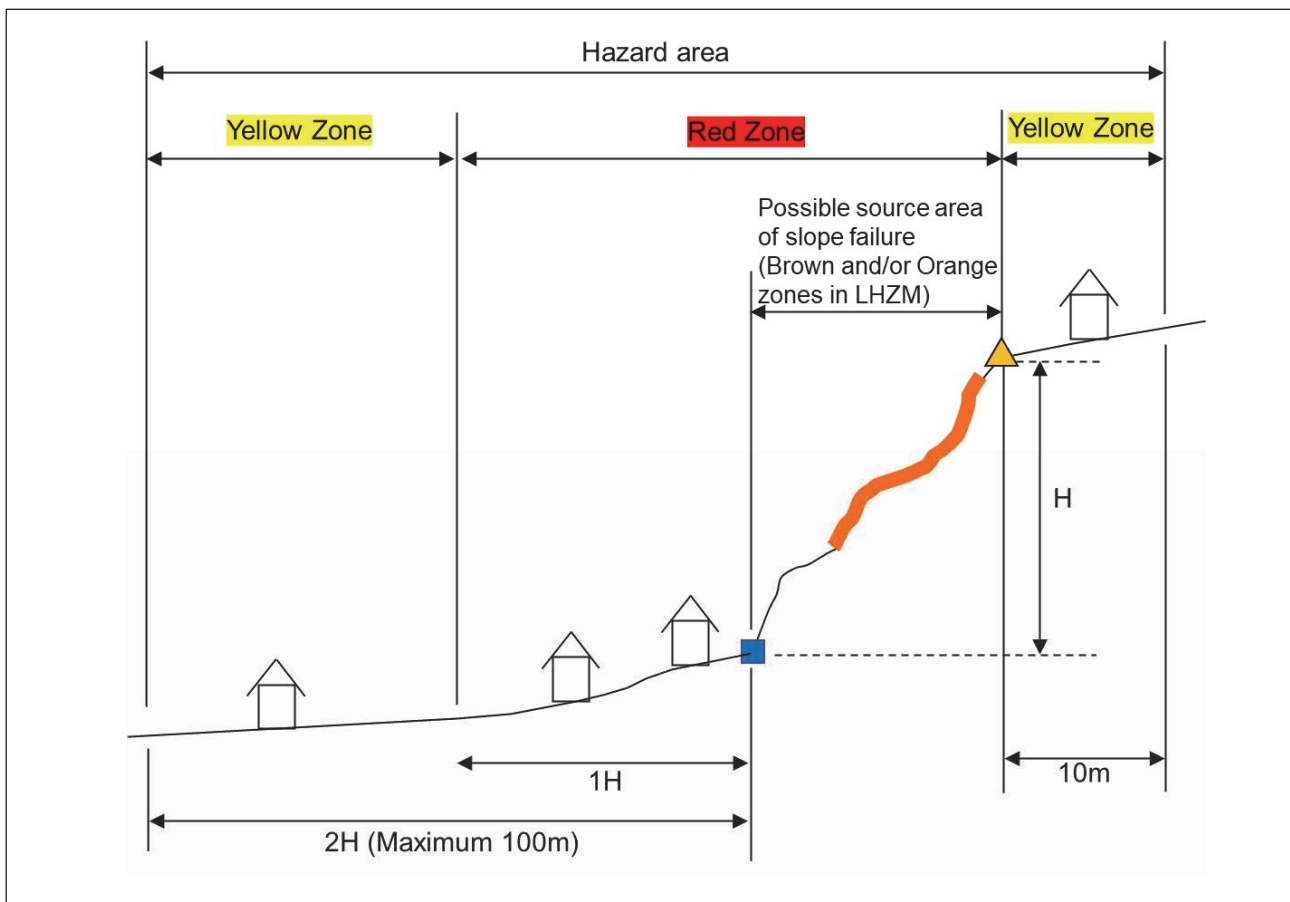
Field survey is conducted to finalize the Yellow and Red Zones set by the above-mentioned desk study. The field survey for the target area and its surroundings shall be conducted on the following items:

- Topographical conditions
- Location of Brown or Orange zones
- Lower and upper edges
- Slope angle and height
- Left and right edges
- Artificial structures, etc.

#### 3.2.5 Verification of the Methodology for Yellow and Red Zones of Slope Failures

In developing this manual, several methodologies have been examined especially for setting of the source area of possible slope failure. In future, the criteria for setting the Yellow and Red Zones for slope failure should be reviewed and re-defined according to the results of further actual slope failure occurrences and damage situation surveys.

Alternative criteria for setting the Yellow and Red Zones for slope failure is shown below. In the alternative criteria, topographical features, especially slope inclination or angle related to slope failure is taken into consideration. As shown in the following figure, in case that the source areas of possible slope failures delineated from the Brown and/or Orange zones in the LHZM are located within two clear break points of a uniform slope, the source area of possible slope failure shall be extended into the upper convex break point and the lower concave break point. Geomorphologically, a slope between two break points is classified as an unformed landform or a unit slope that has the same susceptibility to sliding or slope instability. In addition, most of slope failures especially due to heavy rainfall have been reported to occur on a slope at or below the convex breaks. Convex breaks are geologically located at the forefront of the most significant erosion zone on a slope.



**Figure 3.14 Representation of Yellow and Red Zones for Slope Failure considering Break Points (as a reference)**

### 3.3 Reference Data

#### Background Data for Setting Hazard Zone for Slope Failures

About 60 past slope failure disasters were collected from:

- a) Landslide Disaster May 2017 – Damages and Loss Assessment, Prepared by NBRO, including 35 disaster events occurring in 2017
- b) Reduction of Landslide Vulnerability by Mitigation Measure Projects - Cost Benefit Analysis, Prepared by NBRO, in October 2018, including 50 disaster events.

The main results of the collected past slope failure disasters are shown in Figures 3.15 to 3.17 and summarized below:

- a) Slope failures are related largely to slope steepness (Figure 3.15) and slope height (Figure 3.16). When slope angle is 25 degrees or more, the number of slope failures tends to increase rapidly. Most slope failures occurred intensively on slopes with a slope angle of 25 to 50 degrees and a slope height of 5 to 40 m, accounting for about 80% of the total number of the past slope failures.
- b) The reaching distances of the collapsed sediment are related to the heights of slope failures (Figure 3.17). In most cases, the reaching distances are within twice the height of slope failures (Figure 3.17 - a)), but with a limit of about 100 m (Figure 3.17 - b)).

Geologically, the average friction angles are generally around 25 to 35 degrees for loose sandy soils, and 30 to 50 degrees for loose gravelly soils, respectively. A steep slope with a gradient of 25 degrees or more may be likely to occur especially as excessive pore water pressure increases during intense rainfall.

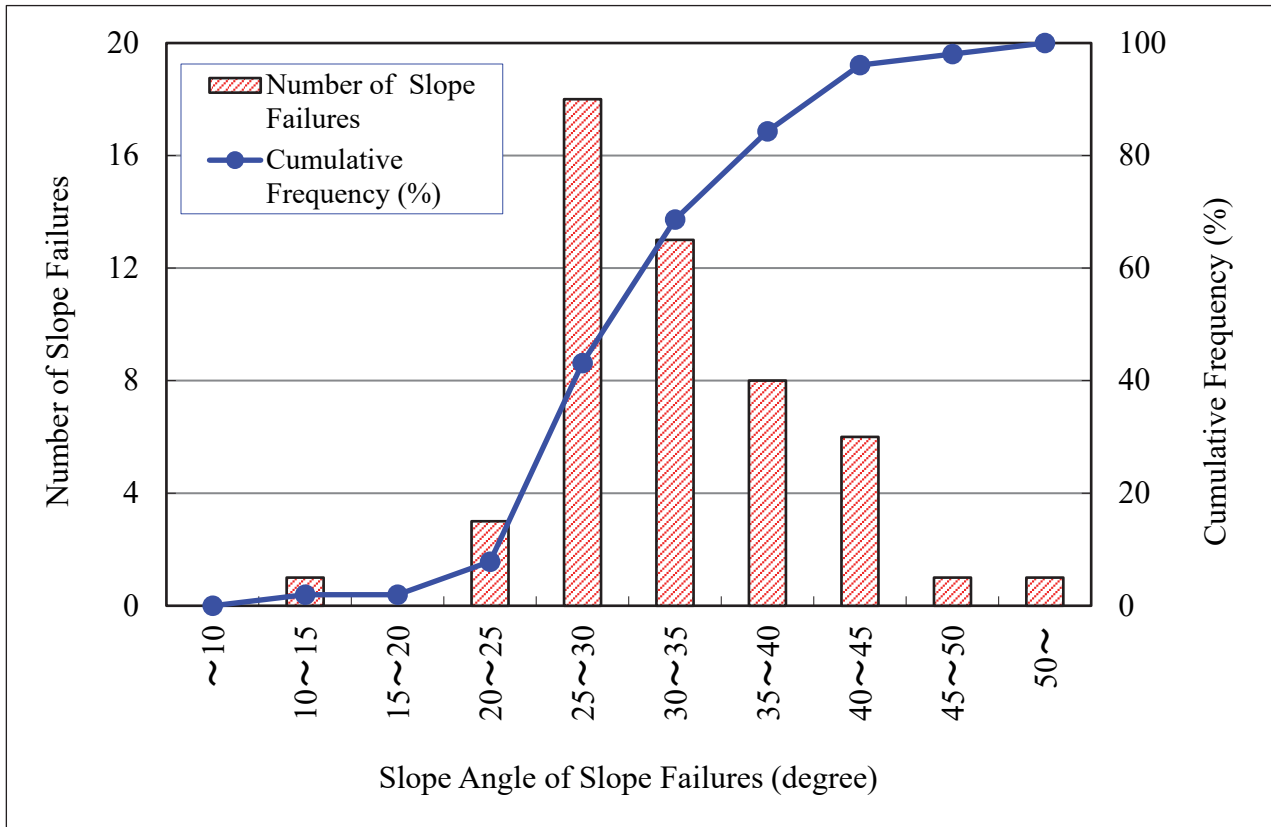


Figure 3.15 Frequency Distribution of Slope Angle in Slope Failures

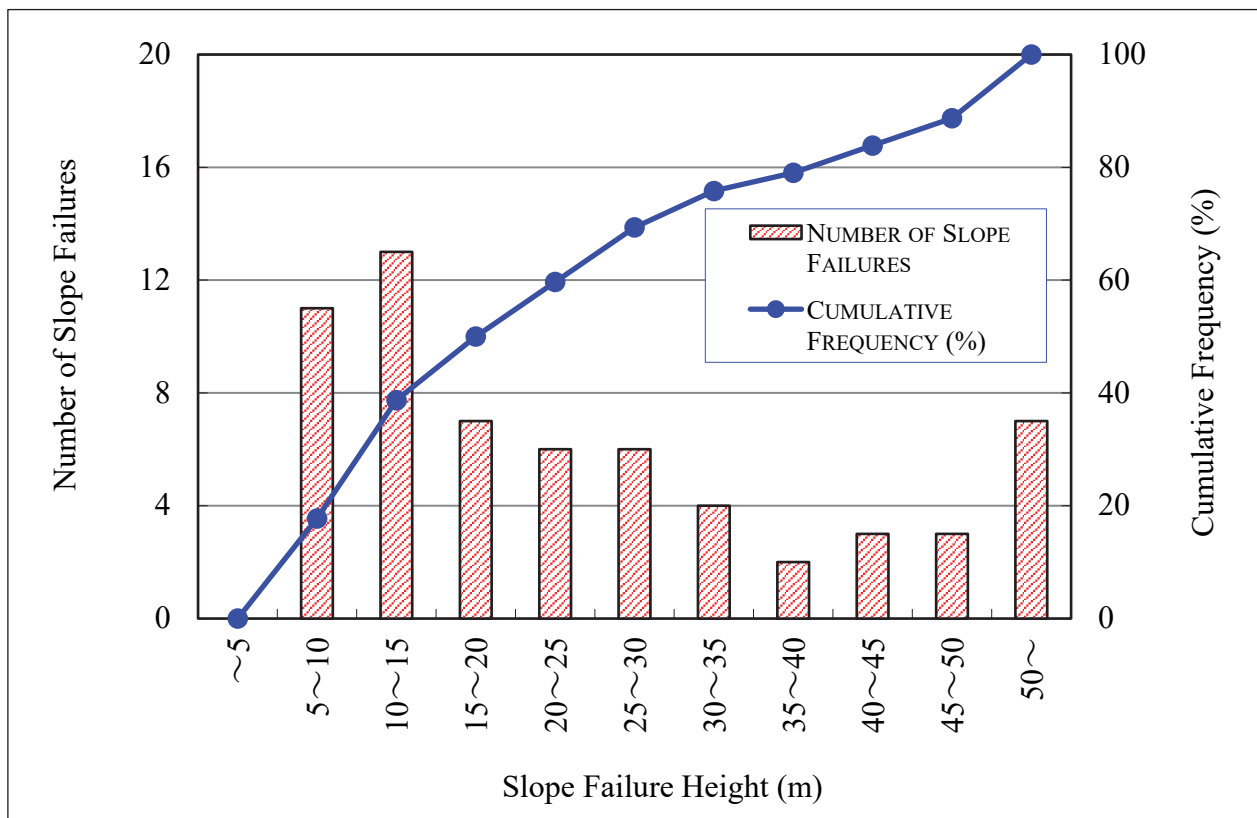


Figure 3.16 Frequency Distribution of Height of Slope Failures

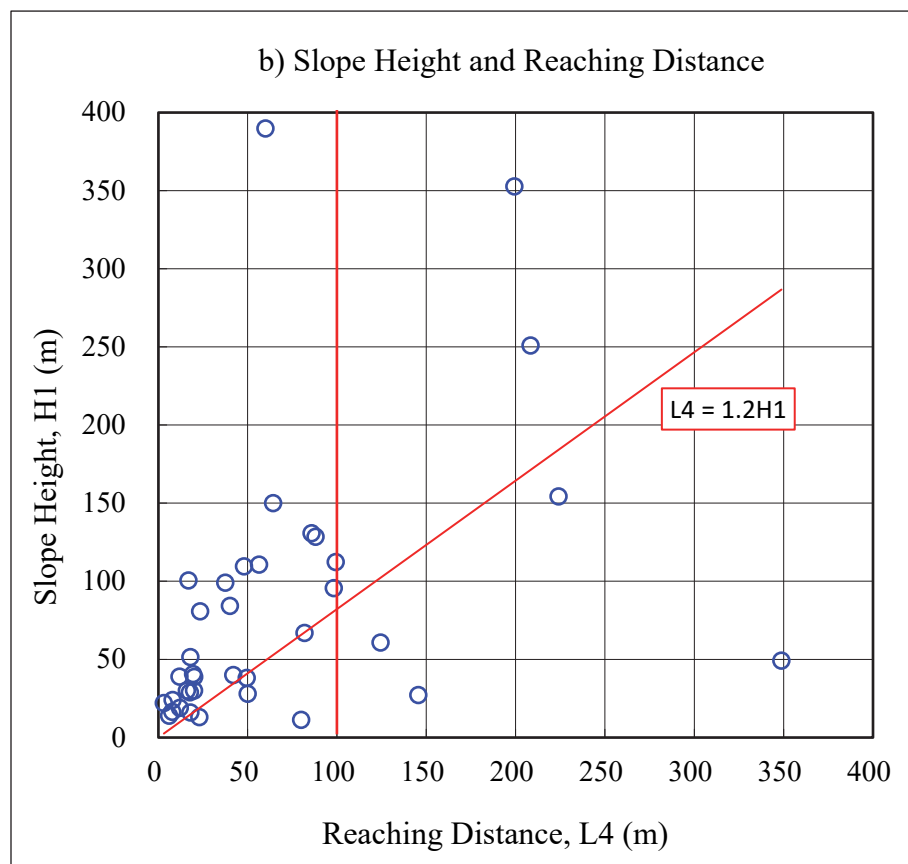
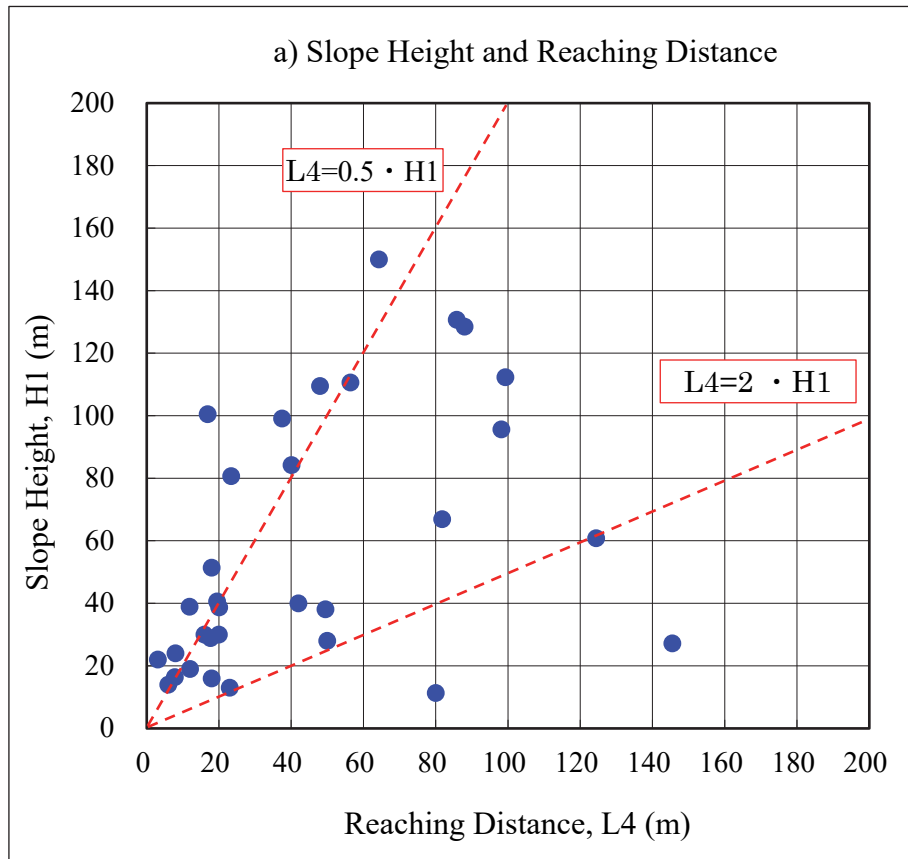


Figure 3.17 Relationship between Slope Height and Reaching Distance



## **Chapter 4**

# **Hazard Zoning for Slide**

**This chapter presents  
the methodology and  
procedure of site-specific  
hazard zoning for slides**

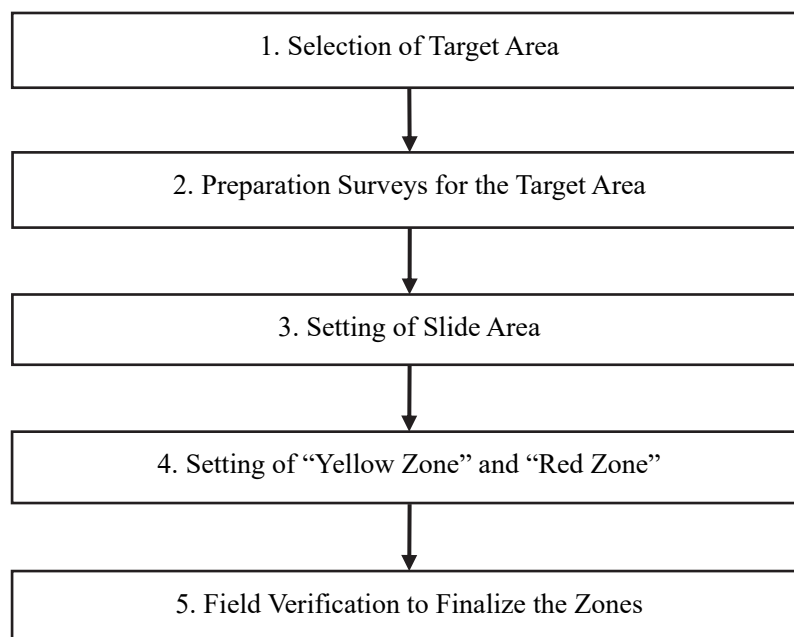


## CHAPTER 4

### HAZARD ZONING FOR SLIDE

#### 4.1 Procedure of Setting “Yellow Zone” and “Red Zone” for Slide

Setting of “Yellow Zone” and “Red Zone” for slide is conducted according to the following steps (Figure 4.1).



**Figure 4.1 General Process of Setting “Yellow Zone” and “Red Zone” for Slide**

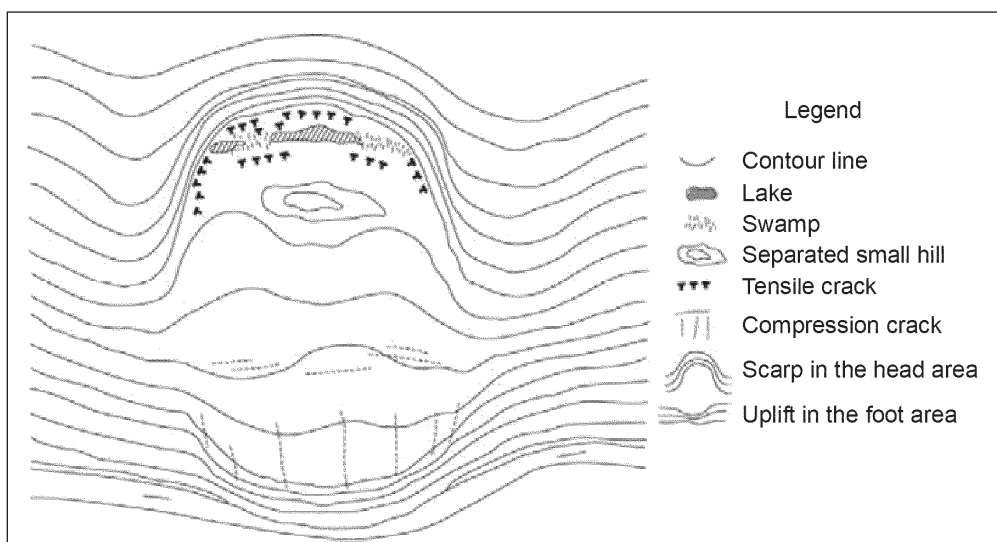
#### 4.2 Methodology

##### 4.2.1 Selection of Target Area

The target area for slide shall be selected using “Hazard Zonation Map” with a scale of 1:10,000 prepared by NBRO. In selecting the target area, the following topographical and social conditions are taken into consideration.

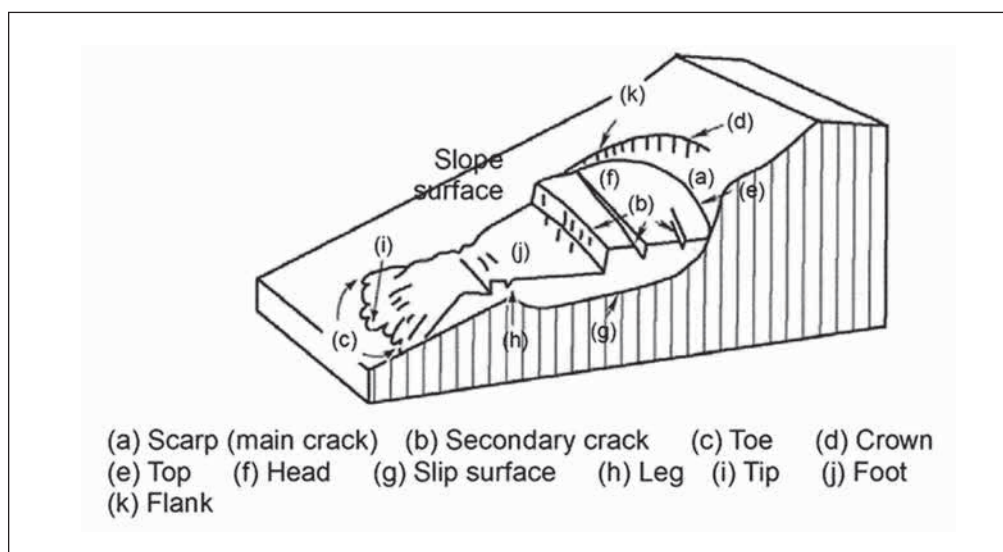
a) Topographical Conditions

The slide target area shall be limited to an area exhibiting distinctive topographies known as "slide topography," which are formed as a result of slide movement. Slide topographies, as shown in Figure 4.2.1 should be interpreted using Lidar, aerial photographs or topographical maps. Topographic interpretation of a slide is a very effective means for identifying slide distribution over a wide area, which is difficult to complete through field survey for a short period.



Source: PWRI Technical Note No.4077, Guidelines for Landslide Prevention Technologies (Draft), 2007, Public Works Research Institute, Japan

**Figure 4.2. Schematic Representation of Typical Slide Topography**



Source: PWRI Technical Note No.4077, Guidelines for Landslide Prevention Technologies (Draft), 2007, Public Works Research Institute, Japan

**Figure 4.3 Terminology of a Typical Slide**

Slide topographies are easily identified through the interpretation of Lidar, aerial photographs and topographical maps. However, the results of aerial photographs and topographical interpretations vary widely depending on a variety of factors, including the time of photographing, the scale of the photograph, vegetation cover, land use, and human activity. Therefore, following the interpretation of Lidar, aerial photographs or topographic maps and field survey shall be conducted to supplement the interpretation results.

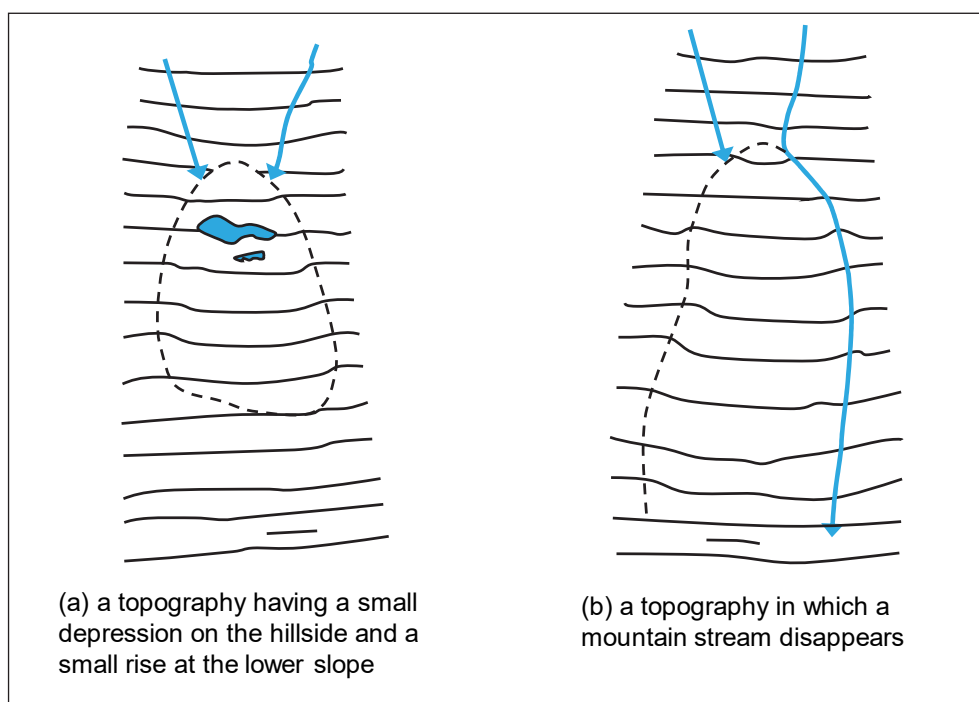
In interpreting slide topographies, the following geological and topographical features are also considered:

i) Geological Structure

- Areas adjacent to faults with fracture zones and areas along tectonic lines
- Areas on slopes consisting of strata that are parallel or nearly parallel to the slope (dip slopes)
- Areas near an axis of anticline or syncline of folds
- Areas around the boundary of igneous rock and intrusive rock

ii) Topography

- Areas categorized as water-collecting topographies, such as a topography having a small depression on a hillside and a small bulge at the foot of a slope, or a topography in which a mountain stream disappears (Figure 4.4)
- Areas where there is a scouring-prone slope consisting of rocks that is prone to slide, or areas on both sides of a scouring-prone slope consisting of hard rock
- Areas where a bend in a river has an unusual bulge that is being eroded
- Areas where a small- or large-scale terraced farm lands are present.



Source: Edited by JICA team based on Takeda and Imamura (1976)

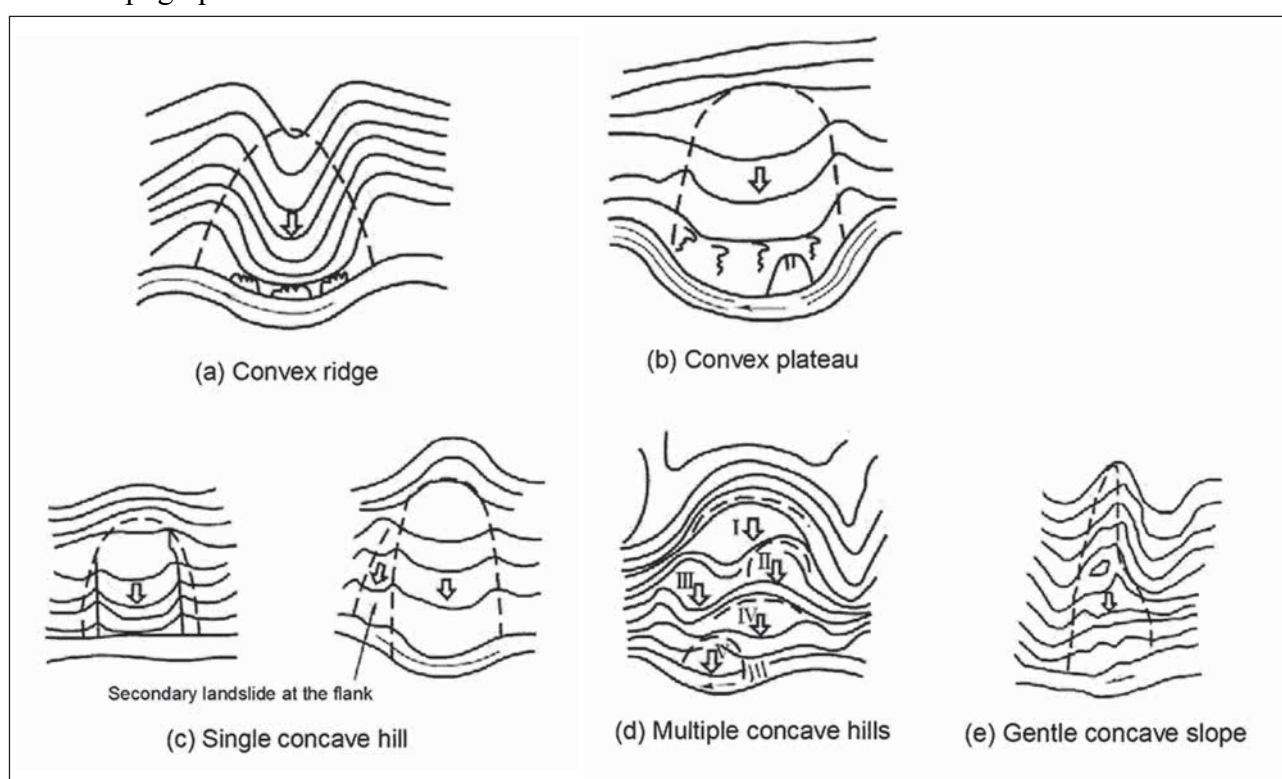
**Figure 4.4 Slide Prone Areas Recognizable from the Condition of Water System**

In addition, some characteristics of slide topographies should be considered, as listed below (Figure 4.5):

- Contour lines are disturbed. areas where the contour line interval is narrow in the upper part of a slope, sparse in the middle, and narrow again at the bottom
- A circular or rectangular scarp is present at the head of a slope, a flat, gentle slope at the middle part of a slope, and again a steep slope at the foot of a slope. An isolated small hill may exist especially at the upper part
- There are depressions, subsidence, cracks, etc. A long, narrow depression may be present in a mountainous slope or at the top of a mountain
- There are regularly arranged ponds, marshes, and swamps

- There is a marshy zone or a crack on one or both sides of a slide area
- A depression is present in a ridge behind a slide
- Areas at the base of a steep slope have an upheaval or bulge
- A road or a railroad is unusually curved, or a structure is displaced
- A swamp or river is unusually curved; a river is narrower than in other sections

After a slide occurs, the slide topography may be gradually modified with time. For example, the scarp becomes gentle and the plateau scarred by erosion. The slide topography is also changed with its repeated movements, and a new slide may occur on the upper slope or the lower slope of the existing slide. As the movement of a slide becomes large with a great displacement, its slide topography generally turns into an extensively gentle slope, making it difficult to recognize the characteristics of the slide. Figure 4.5 shows some typical slide topographies.



Source: PWRI Technical Note No.4077, Guidelines for Landslide Prevention Technologies (Draft), 2007, Public Works Research Institute, Japan

**Figure 4.5 Some Typical Slide Topographies**

b) Social Conditions

The target area shall include:

- Residential area on which at least one residential house or public building is located; and
- Areas which have no residential houses or public buildings at the moment but which may be expected to be developed for housing or public building construction in the future based on social conditions such as current land use and development plans.

In addition, areas where there is no possibility of residential house construction, such as high and steep mountainous areas with no houses, etc. are excluded from the target area selection.

#### 4.2.2 Preparation Survey for the Target Area

A preparation survey for the target area includes:

- a) Data collection survey
- b) Topographical survey
- c) Field survey

##### a) Data Collection Survey

Slides often occur in areas with specific topography and geology. Also, the same type of slides tends to occur in areas having similar topographic and geologic conditions. Accordingly, information on the topography, geology, weather conditions, and past slide history shall be collected, providing valuable clues for identifying the characteristics of slide occurrence and activity in a given area.

Data collection survey includes the following items:

##### i) Past disaster records

- Date, time, location; and cause of slide
- Scale of a slide (length, width, depth, area, volume of displaced mass, reaching distance of displaced mass, etc.)
- Damage to human (the number of fatalities/injuries)
- Damage to residential houses, including structural types of damaged houses (reinforced concrete, brick, clay, wooden), degrees of damage (completely or partially), and the number of damaged houses
- Rainfall information (cumulative rainfall, daily rainfall, hourly rainfall)
- Others (photo, etc.)

##### ii) Evaluation of effectiveness of existing countermeasures

- Data on the existing countermeasures if available should be collected to determine if the target area is in a hazard zone through evaluation of effectiveness of the existing countermeasures, if available
- Assessment of the various elements of countermeasure facilities (width, length, height, etc.), such as drainage channel, horizontal drainage boreholes, retaining wall, embankment, etc.

##### iii) Investigation reports (geological investigation/monitoring)

##### iv) Number of households and public buildings

##### b) Topographic Survey

Topographic survey is conducted to identify the shape of slide block and its movement direction. Lidar, aerial photographs and topographic maps are used for topographic interpretation in a general way. In contrast to phenomena of slope failure and debris flow, there is a technical challenge to identifying a slide block by the above interpretations since the method is highly subjective and hence depends on the skill, experience and knowledge of the interpreters. To avoid personal variation and oversights, a topographic survey should be conducted by at least two people.

A slide block is delineated on base map, as follows:

##### i) Shape of a slide block (top, sides or flanks and toe of slide)

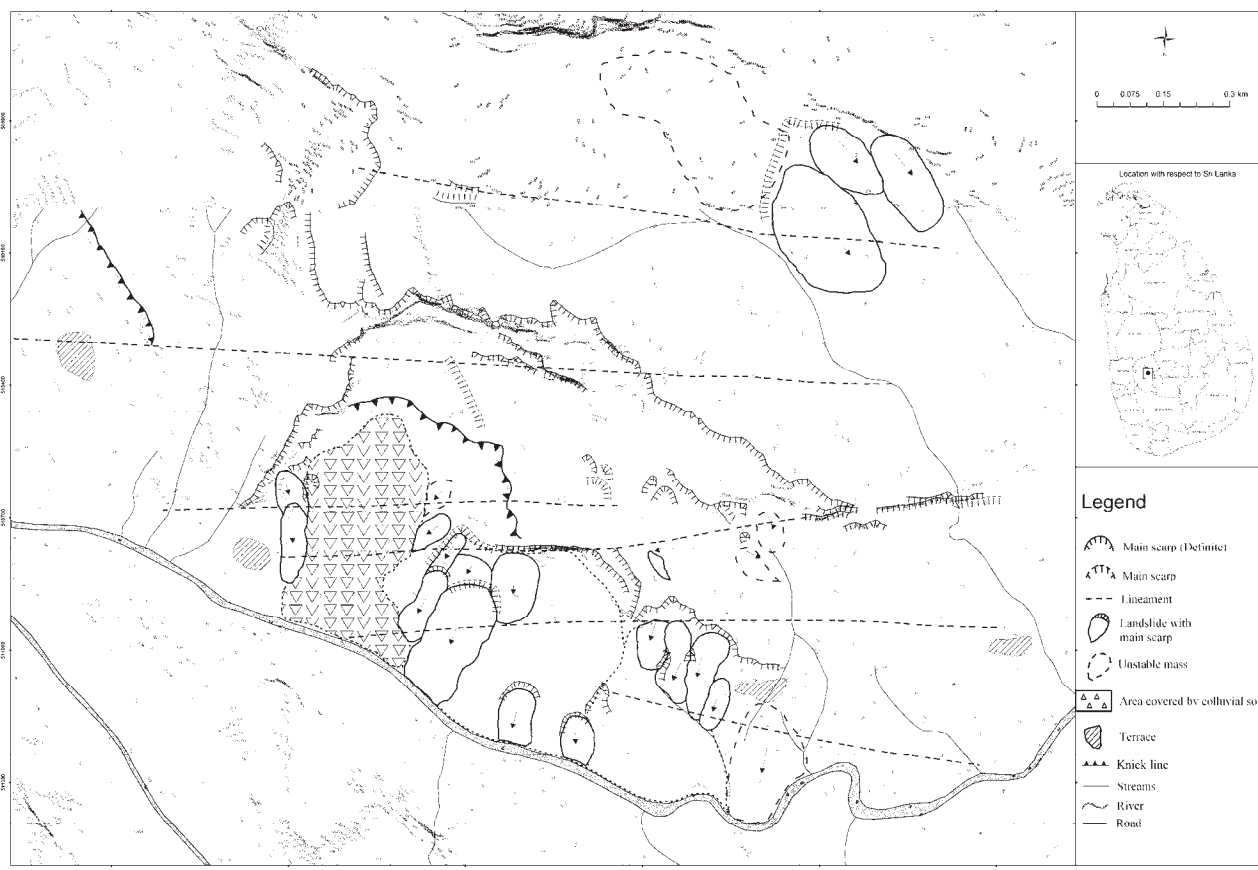
- If the shape of a slide block is definite, the block outline should be indicated by

solid line on base map; or

- If the shape of a slide block is indefinite, the block outline should be described by dash line.

ii) Movement direction of a slide block

- The movement direction of a slide block should be indicated on base map by arrowed line in consideration of its shape and the direction of maximum slope inclination.



**Figure 4.6 An Example of Slide Blocks Identified by Aerial Photograph Interpretation  
(Udapotha in Kegalle District)**

c) Field Survey

A field survey is conducted to verify the shape of slide block (or area) and its movement direction, and to determine its activity and any signs of slide movement.

Main survey items are as follows:

i) Uniting of the Extracted Slide Blocks

Some slide blocks extracted from topographic survey should be united as one block when they affect one another.

ii) Verification of Shape and Clarity of Slide Topography

The shape and clarity of a slide topography should be checked at field, such as:

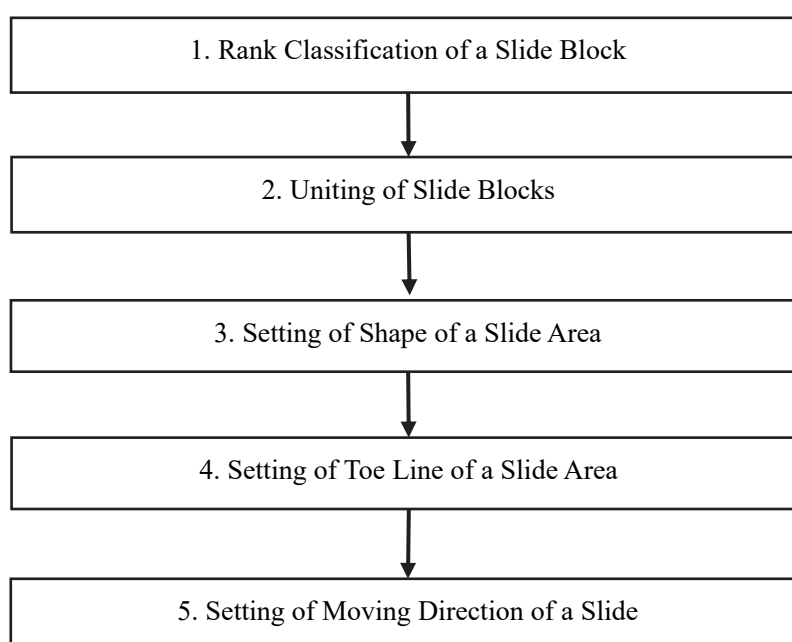
- Crown, main scarp, open crack, and depression at the upper slope
- Flank, gully erosion, convex and concaves



- Upheaval, bulge, abnormally crooked valleys and rivers
  - Abnormality in a road, waterway, retaining wall, drainage channel, etc.
- iii) Estimation of Movement Direction and Activity
- The movement direction and activity of a slide block is estimated from the following field information:
- Location and direction of tension cracks, side cracks and cracks above the scarp
  - Location and direction of upheaval, bulge and compressive cracks
  - Deformation of artificial facilities
- iv) Confirmation of the Lower Area Conditions of a Slide Block
- Areas where slide mass cannot be reached should be confirmed mainly on the following items at the lower area from the slide block:
- Location, height and width of an inversed slope or mount
  - Location, height and width of a river or stream
  - Location, height and width of artificial structures such as channel, cut slope or filling slope

### 4.2.3 Setting of Slide Area

Setting of slide area is conducted according to the following steps (Figure 4.7).



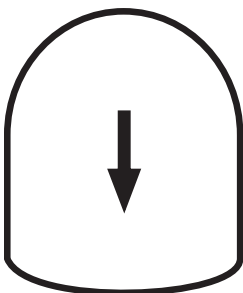
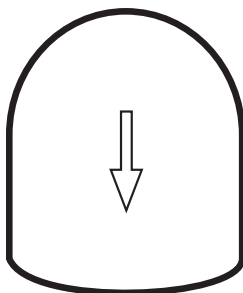
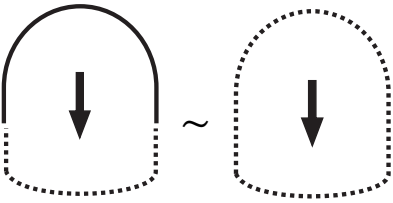
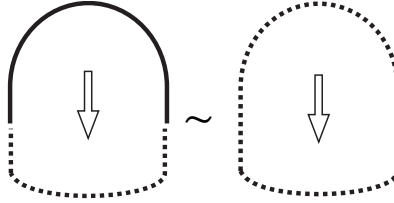
**Figure 4.7 Process of Setting of Slide Area**





#### (1) Rank Classification of a Slide Block

The extracted slide block is classified into three ranks, A, B and C, in terms of the clarity of slide topography and its activity based on the above-mentioned survey results. These ranks are defined and shown in Table 4.1

**Table 4.1 Classification of Ranks of a Slide Block**

Classification of Ranks	Definition
Rank A	- The slide is confirmed to be completely active at the field survey; and - Its shape including its foot is clearly identifiable.
Rank B	- The shape of the slide including its foot is clearly identifiable, but the slide is not confirmed to be active at the field survey; or - The slide is confirmed to be locally active, and its shape is not clearly identifiable.
Rank C	- The slide is not confirmed to be active at the field survey, and also its shape including its foot is not clearly identifiable.

		Activity of the Slide			
		Active		Not Active	
Clarity of the Shape of the Slide including Its Foot	Clear	A		B	
	Not Clear	B		C	

Legend	Shape	Clear	
		Not Clear	
	Activity	Active	
		Not Active	

Source: Edited by JICA team based on “Draft manual on Basic Investigation related to Sediment Disaster Prevention (2008)”, Gunma Prefecture

From the above rank assessment:

✓ When a slide is assessed as Rank A, Yellow Zone and Red Zone are set for the slide; and

- ✓ When a slide is assessed as Rank B or C, only the Yellow Zone is set for the slide.

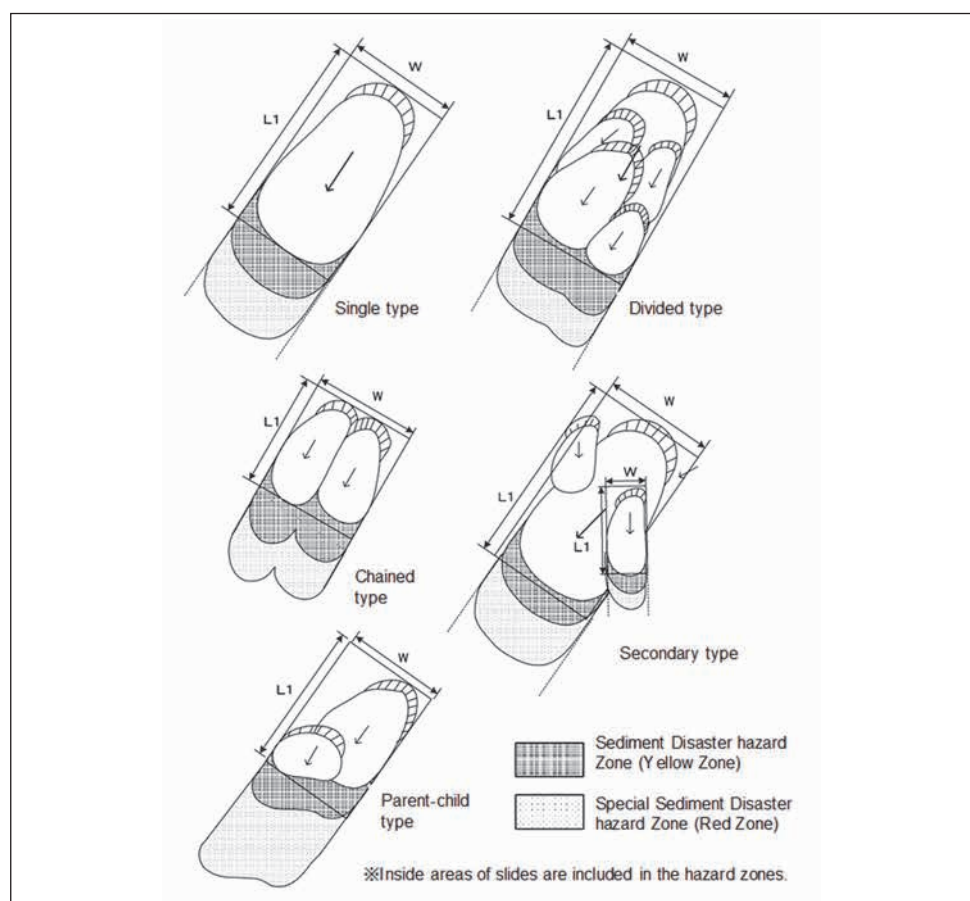
The present activity of a slide block shall be assessed according to the following criteria:

- a) Clear signs of slide movement are observed at the field survey; or
- b) Monitoring data by instruments show a cumulative movement or displacement, as listed below:
  - Cumulative displacement of 1mm/day or more over 5 consecutive days by extensometer; or
  - Cumulative movement of 1,000 $\mu$  strain/month or more by pipe strain gauge.

If countermeasures against a slide block have been installed, and then their effectiveness should be evaluated based on the field survey and monitoring results.

## (2) Uniting of Slide Blocks

Slides may occur as single block or in a group. If slides occur in a group and affect one another, for example, as secondary slide block or multiple slide blocks, these slides should be united as one slide area based on their rank assessment, such as a combination of slide blocks with Rank B and C (Figure 4.8).

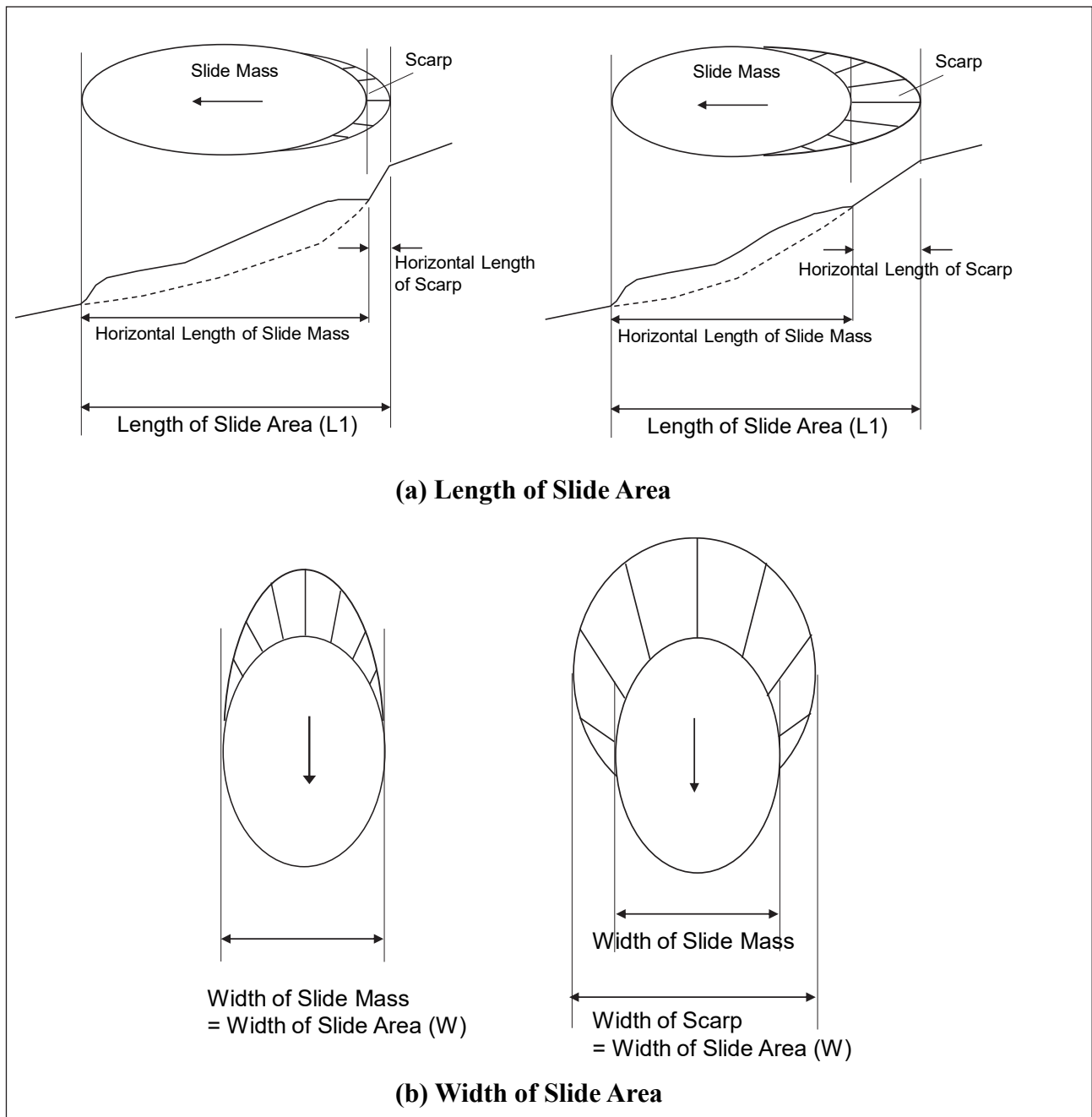


Source: Edited by JICA team based on "Draft manual on Basic Investigation related to Sediment Disaster Prevention (2008)", Gunma Prefecture

**Figure 4.8 Examples of United Slide Blocks**

### (3) Setting of Shape of a Slide Area

The length and width of a slide area should be set based on the following procedures (Figure 4.9).



Source: Edited by JICA team based on “Draft manual on Basic Investigation related to Sediment Disaster Prevention (2008)”, Gunma Prefecture

**Figure 4.9 Diagrammatic Determination of Length and Width of a Slide Area**

### (4) Setting of the Toe Line of a Slide Area

In general, it is more difficult to identify the toe line of a slide than its top. In determining the hazard area of a slide area, firstly, it is necessary to identify its toe line. The toe line of a slide area shall be determined based on the following survey results (Figure 4.10):

a) Existing geological investigation and monitoring data

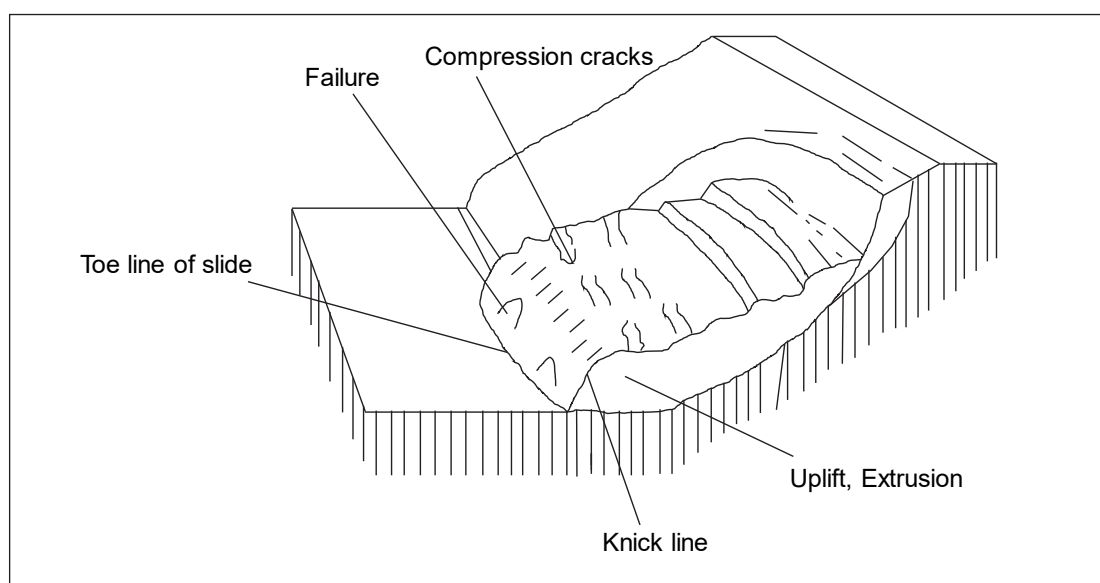
If geological investigation or monitoring data is available, the toe line of the slide area should be determined based on these investigations or monitoring results.

b) Clear ground deformations at the toe area

If clear ground deformations, such as upheaval, bulge or tension crack are observable at the site, the toe line of the slide area should be determined based on the distribution and locations of such ground deformations (Figure 4.10).

c) Topographical features

In the absence of ground deformations or geological investigation and monitoring results, the toe line of a slide area should be estimated based on the topographic features, such as an abnormally bent river or knick line (Figure 4.10).



**Figure 4.10 Typical Features of the Toe Line of a Slide Area**

**(5) Setting of Movement Direction of a Slide**

The movement direction of a slide block should be determined based on the following investigation and/or monitoring results:

- Present monitoring data (for example, by inclinometer, etc.)
- Distribution and direction of tension and compression cracks, upheaval, bulge, etc
- Interpretations of Lidar, aerial photographs and topographic maps

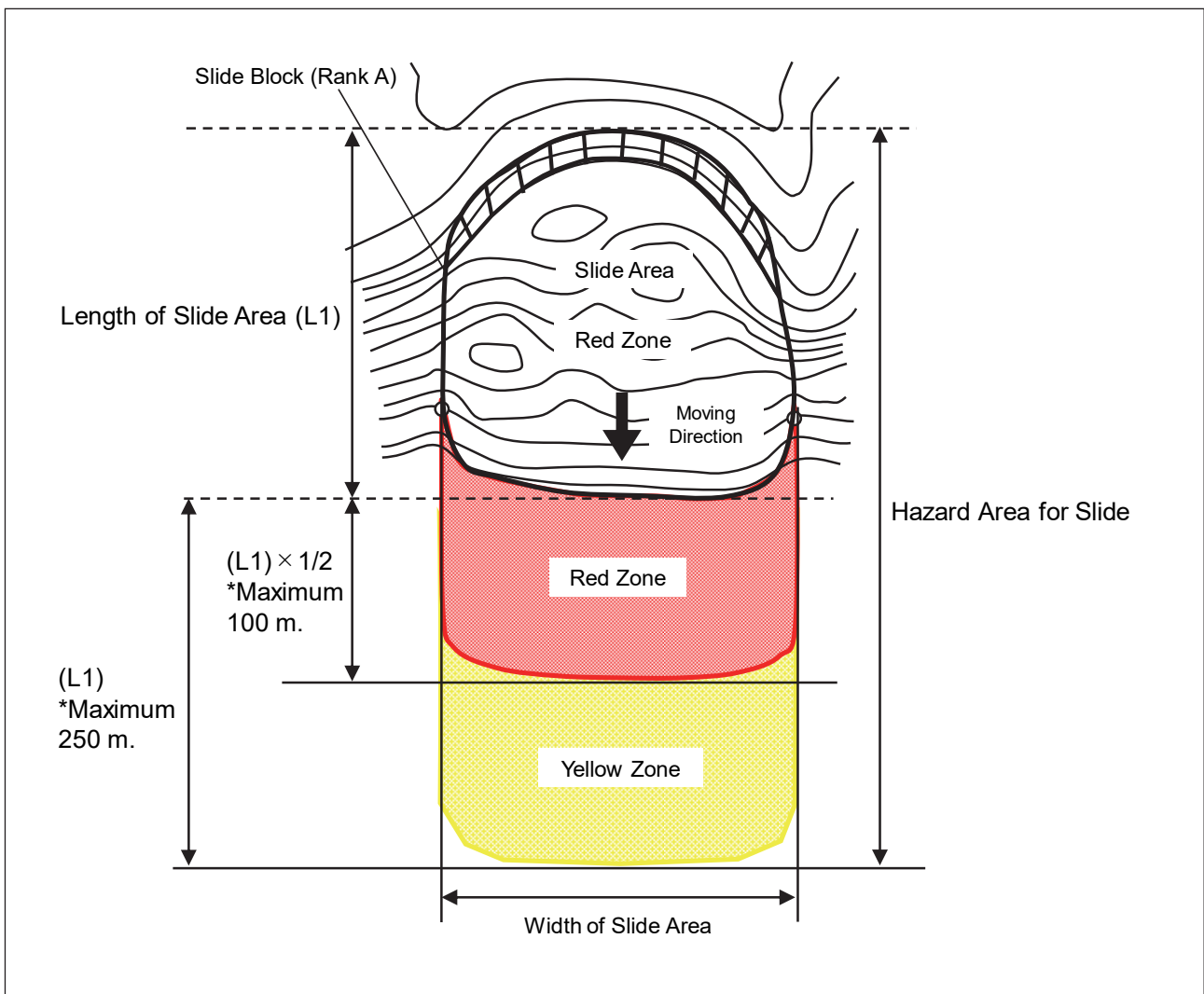
#### 4.2.4 Setting of “Yellow Zone” and “Red Zone”

##### (1) Setting of the Zones

Concept of setting a hazard area for slide is shown in Table 4.2., and Figures 4.11 and 4.12

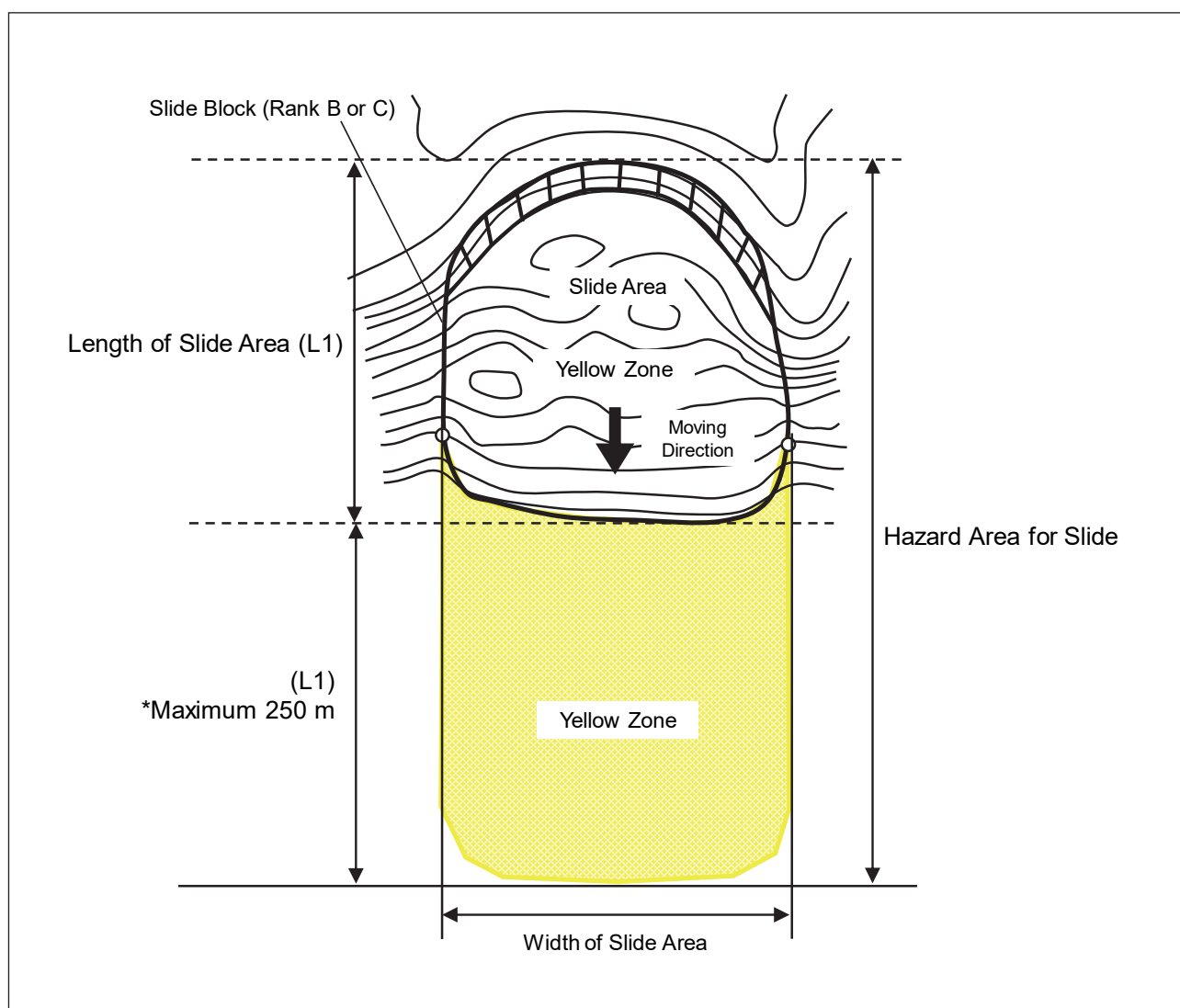
**Table 4.2 Hazard Zoning for Slide Area**

Area		Zoning	
		Rank A Slide	Rank B or C Slide
Slide block plus the area of main scarp and cracked or uneven slope behind the main scarp		Red Zone	Yellow Zone
Lower slope below slide block	Area which has half (1/2) of the length of the slide area	Red Zone (Maximum 100 m)	-
	Area which has same length and width of the slide area	Yellow Zone (Maximum 250 m)	Yellow Zone (Maximum 250 m)



**Figure 4.11 Concept of Hazard Area for Rank a Slide**





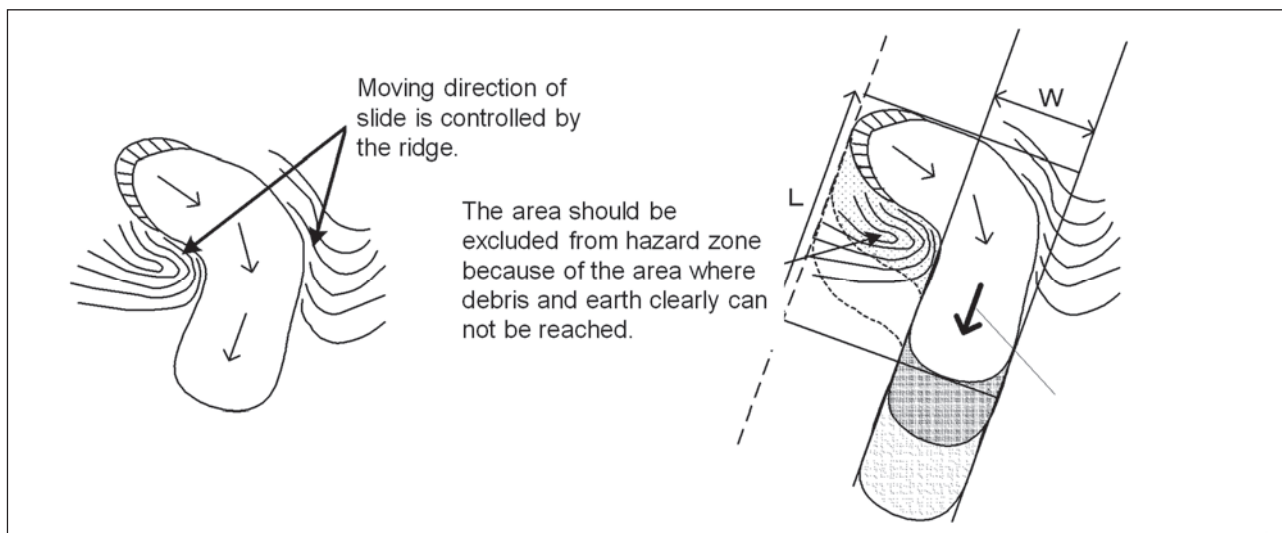
**Figure 4.12 Concept of Hazard Area for Rank B or C Slide**

In addition, the maximum lengths are set to be 100 m for the Red Zone (Figure 4.11) and 250 m for the Yellow Zone (Figure 4.12), respectively, which are based on past slide disaster survey in Japan and should be revised by following further past slide disaster survey in Sri Lanka.

**(2) Excluded Areas where Slide Mass Cannot Reach**

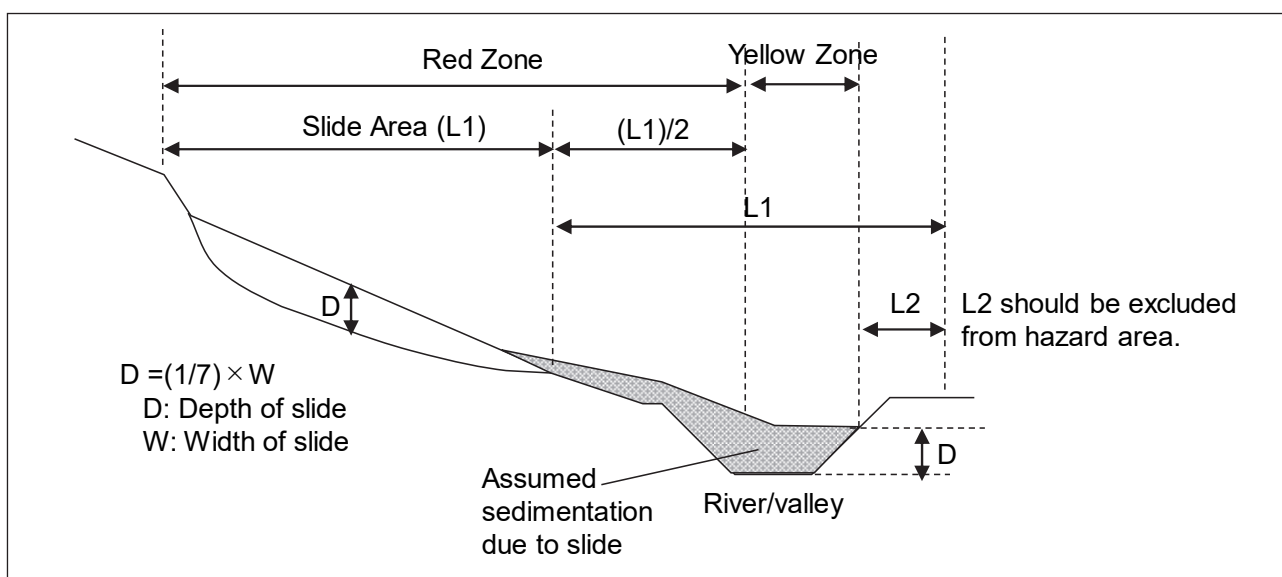
If the following landforms or obstacles are present within the Yellow or Red Zone, the zone should be modified properly to exclude areas where the slide mass cannot be reached, for example:

- Ridge or valley which controls the moving direction of slide mass (Figure 4.13); and
- River or valley which is at the toe part of a slide area (Figure 4.14).



Source: Edited by JICA team based on “Draft manual on Basic Investigation related to Sediment Disaster Prevention (2008)”, Gunma Prefecture

**Figure 4.13 Ridge or Valley Controlling the Moving Direction of a Slide**



**Figure 4.14 Yellow and Red Zones in the Case that River or Valley Existing at the Toe Part of a Slide**

### (3) Combination with Zoning of Debris Flow

A slide of Rank A may turn into a debris flow under the following conditions:

- On average, the slope gradient or streambed gradient beneath the toe of the slide is steeper than 10 degrees (Figure 5.3 of REFERENCE DATA, CHAPTER 5 HAZARD ZONING OF DEBRIS FLOW); or
- An existing debris fan is observable below Rank A slide.

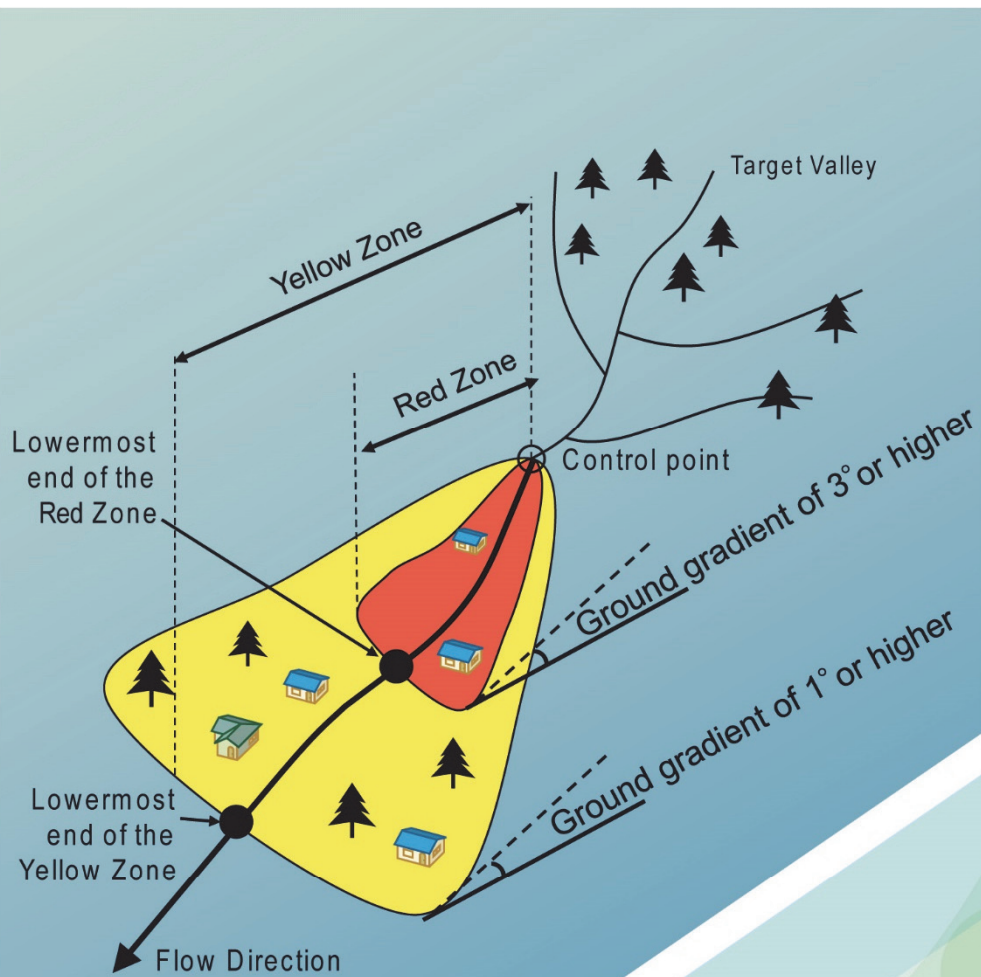
In the above-mentioned cases, the hazard zoning for slide should be combined with that of a debris flow.

#### **4.2.5 Field Verification to Finalize the Zones**

The field survey is conducted to finalize the Yellow and Red Zones which were set by desk study.

The following items should be checked in the field survey:

- Slide area;
- Activity of the slide;
- Movement direction;
- Areas which are unlikely to be reached by the sliding mass; and
- Artificial structures, etc.



# Chapter 5

## Hazard Zoning for Debris Flow

**This chapter presents  
the methodology and  
procedure of site-specific  
hazard zoning  
for debris flows**

## CHAPTER 5

### HAZARD ZONING FOR DEBRIS FLOW

#### 5.1 Procedure of Setting of “Yellow Zone” and “Red Zone” for Debris Flow

Setting of “Yellow Zone” and “Red Zone” for debris flow is conducted according to the following steps (Figure 5.1).

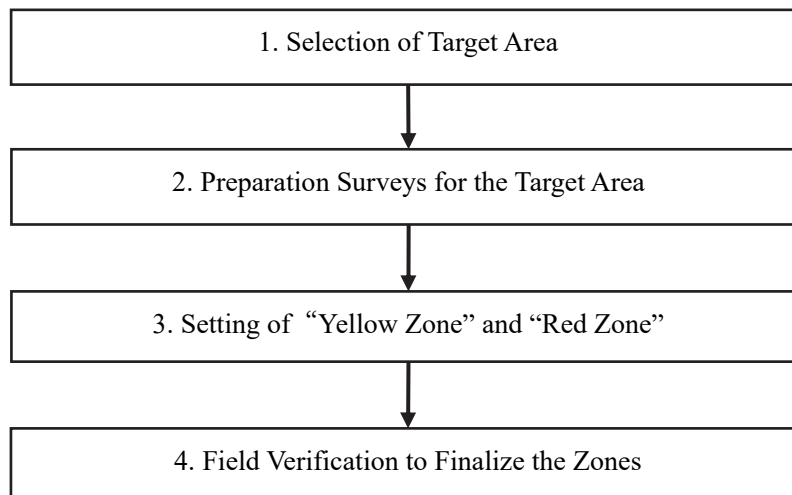


Figure 5.1 General Process of Setting “Yellow Zone” and “Red Zone” for Debris Flow

#### 5.2 Methodology

##### 5.2.1 Selection of Target Area

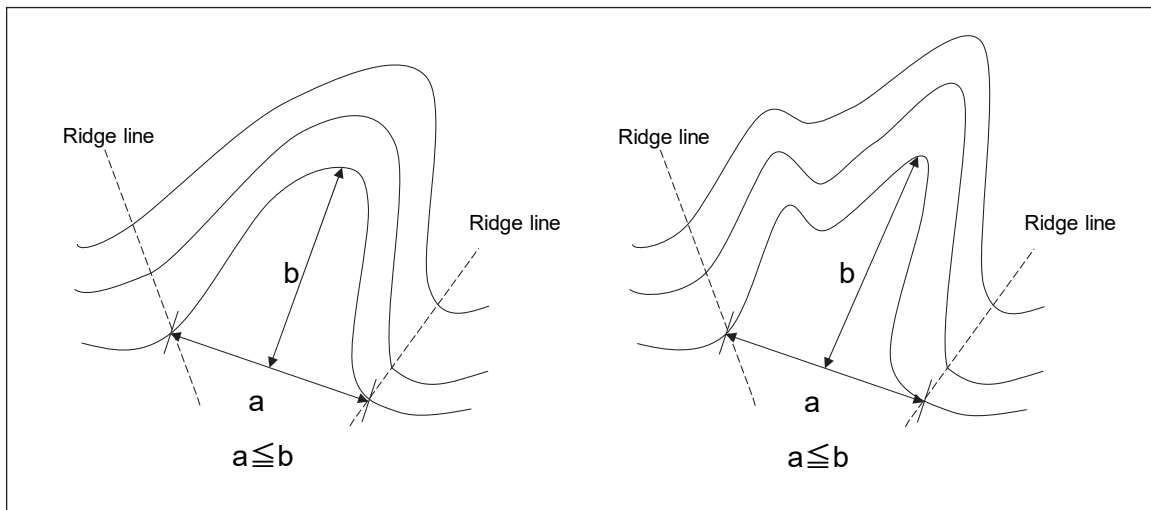
The target area for debris flow is selected by using the “Hazard Zonation Map” with a scale of 1:10,000 prepared by NBRO. In selecting the target area, the following topographical and social conditions are taken into consideration.

###### a) Topographical Conditions

A mountain stream at risk of debris flow is defined basically as valley topography on a 1:10,000 scale topographic map (Figure 5.2). In Figure 5.2, “a” is the valley width on a same contour line and “b” is the longest distance from front to back on the same contour line.

Valley topography is determined as follows (Figure 5.2):

- i) Point with  $a \leq b$  is to be a valley topography; or
- ii) Even if a point is with  $a > b$ , the point is to be considered as valley topography if one of the followings applies:
  - A mountain stream which has a history of debris flow (including alluvial fan topographies); or
  - A mountain stream which may be considered prone to debris flow in view of its topographical and geological features such as collapsed sediments, slope failure/landslide scars, bare lands, etc.



**Figure 5.2 Determination of Valley Topography**

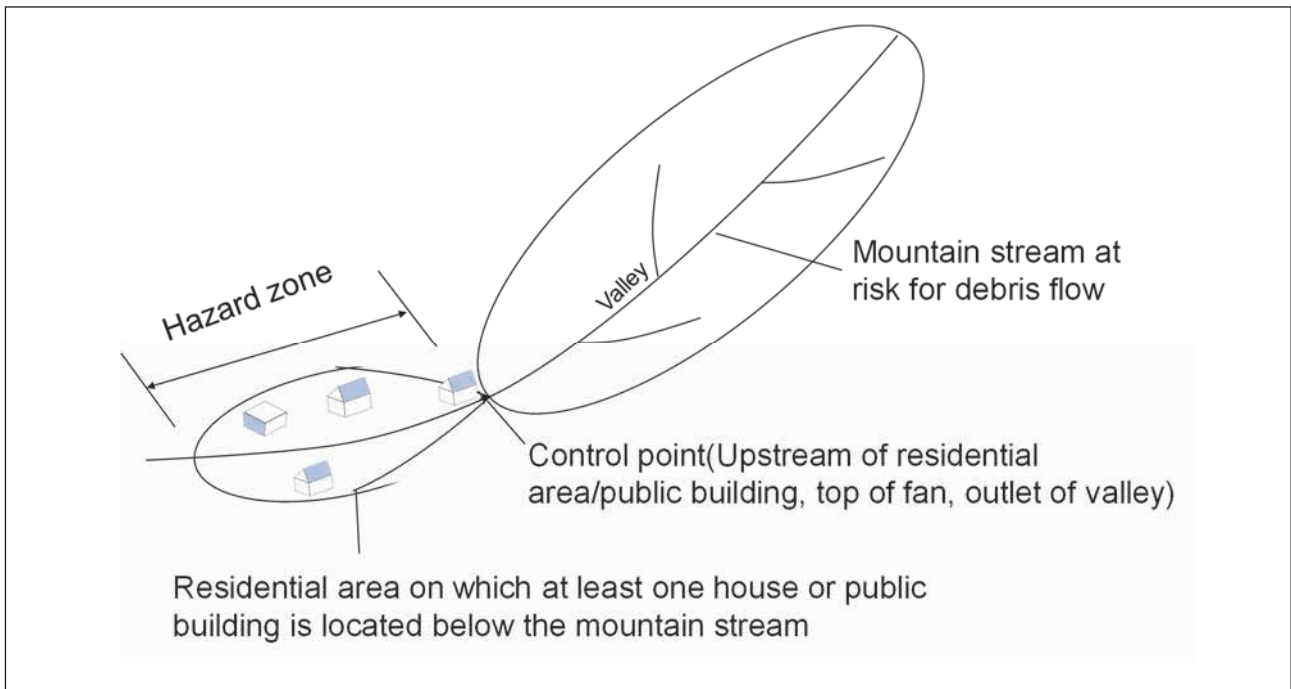
In addition, a mountain stream is also expected to be a target area of debris flow if the following topographical conditions are confirmed:

- A mountain stream has a clear alluvial fan topography at its downstream – possible evidence of past debris flows; or
- A mountain stream is covered with unstable sediment at its upper stream - as source of debris flows.

**b) Social Conditions**

- The target area should comprise a residential area in which at least one residential house or public building is located along and below the mountain stream at risk of debris flow.
- Areas that have no residential houses or public buildings at present, but may be expected to be developed for housing and/or public building construction later based on the social conditions such as the current land use and development plans should be considered for the target area selection.
- Areas where there is no possibility of residential house construction, such as high mountainous areas with no houses, etc. are excluded from the target area selection.





**Figure 5.3 Conceptual Representation of Target Area for Survey**

### 5.2.2 Preparation Surveys for the Target Area

a) Survey of Past Disaster History for the Target Area

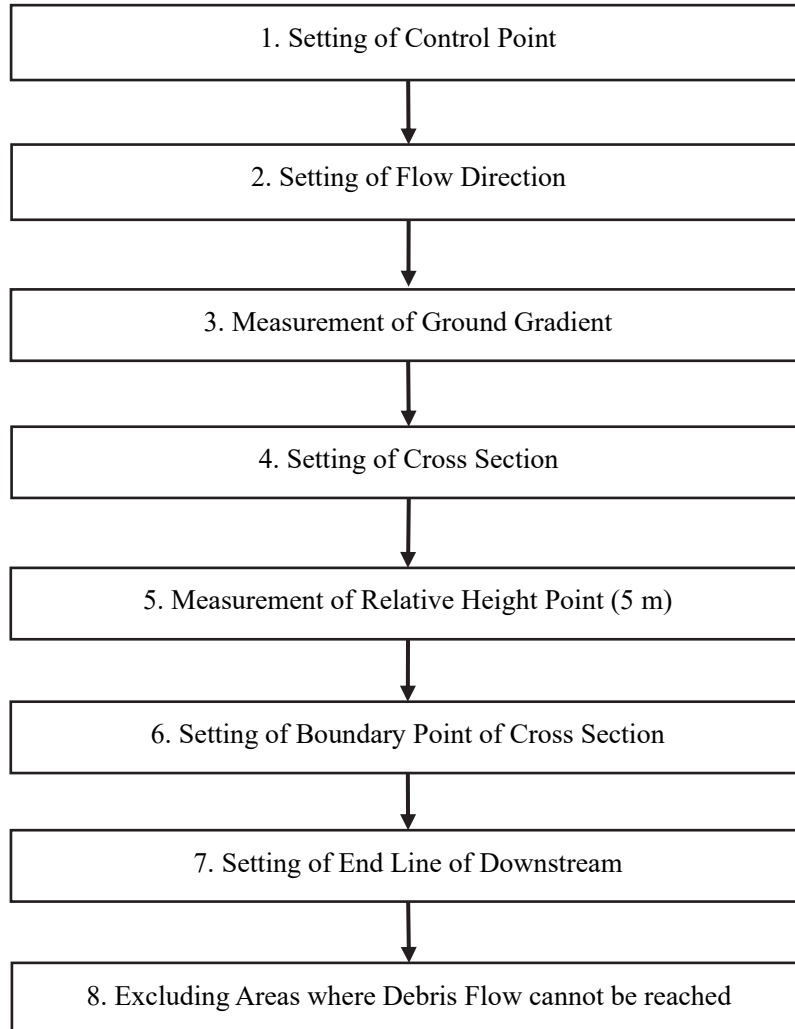
Survey of past disaster records for the target area is conducted to assess the past debris flow extent and its damage conditions and then to obtain data for setting the area of hazard zones, mainly on the following items:

- Date, time, and location, and cause of a debris flow disaster;
- the size of the debris flow (the amount of sediment discharged and the area inundated); Damage to human (the number of fatalities/injuries);
- The number of damaged houses; the structural type of damaged houses (reinforced concrete, brick, clay, and wooden); the degree of damage (completely or partially);
- Rainfall information (cumulative rainfall, daily rainfall, hourly rainfall, etc.); and
- Others (thickness of sedimentation due to flooding or debris flow, etc.).

b) The number of dwellings and public structures

### 5.2.3 Setting of “Yellow Zone” and “Red Zone”

Setting of “Yellow Zone” and “Red Zone” for debris flow is conducted according to the following steps (Figure 5.4).



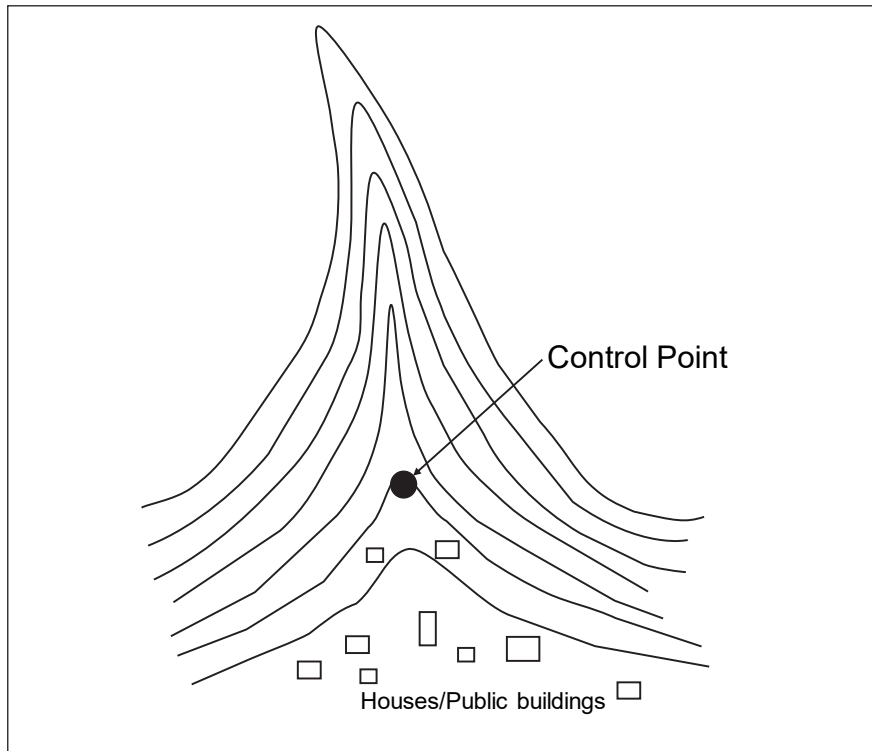
**Figure 5.4** Flow chart of Desk Mapping of “Yellow Zone” and “Red Zone” for Debris Flow

#### (1) Setting of Control Point

A Control point is the uppermost stream point of the set Red Zone in the target area. Basically, the control point is determined from topographic feature and field survey results, focusing on the following items (Figure 5.5):

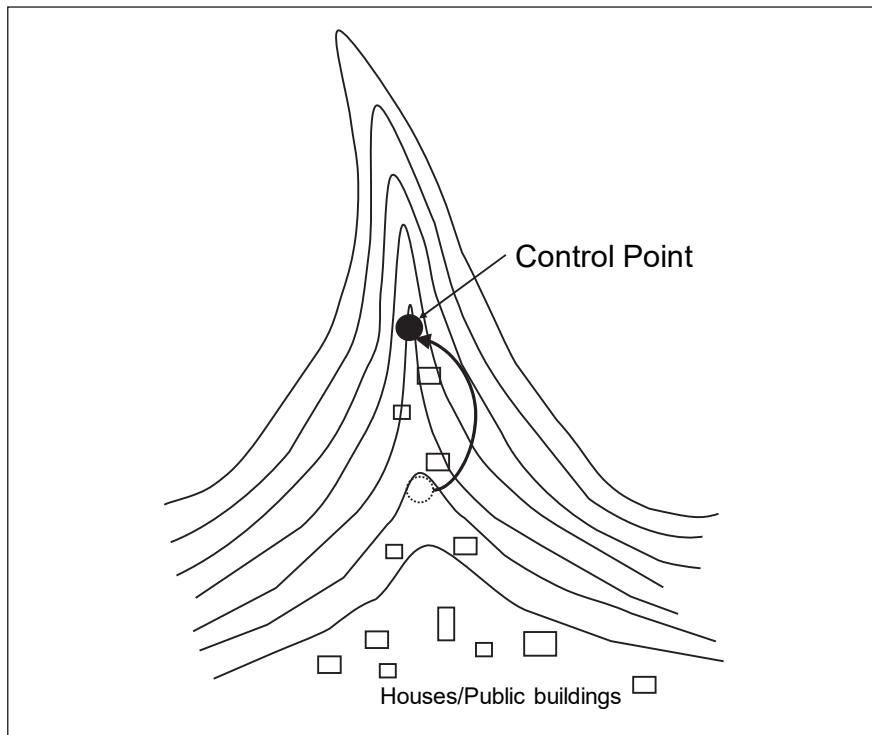
- a) Outlet of a valley: A point at which the valley becomes open and wide
- b) Top of fan: A point at which the valley becomes wide and the streambed gradient becomes gentle
- c) Point of gradient change: A point where the streambed gradient abruptly changes from steep to gentle (concave point)
- d) River bend: A point at which the river course is bent sharply (flooding may be occur on the exterior side because a debris flow flows straight)

- e) Outlet of a narrow valley section: A point At which the valley width abruptly changes from narrow to wide, morphologically similar to the outlet of a valley
- f) Debris flow flooding point: A point where a debris flow began to flood in the past debris flow disasters



**Figure 5.5 Determination of Control Point**

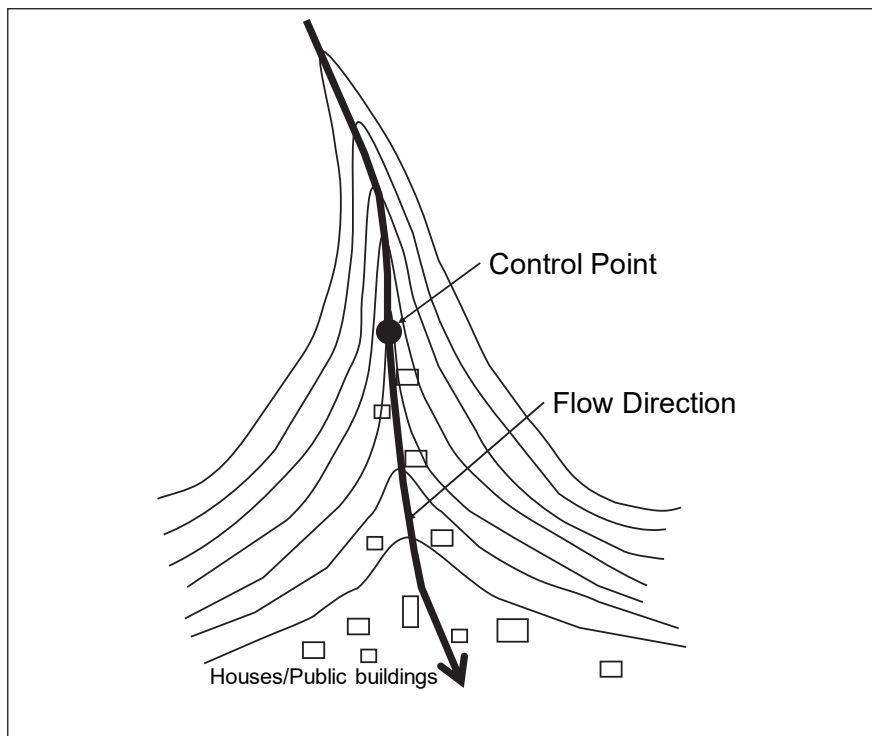
However, in Sri Lanka, some residential houses or public buildings are often located along the mountain stream above the top of alluvial fans; therefore the control point should be shifted to the upper stream of the residential houses or area to be protected (Figure 5.6).



**Figure 5.6 Shifting of Control Point**

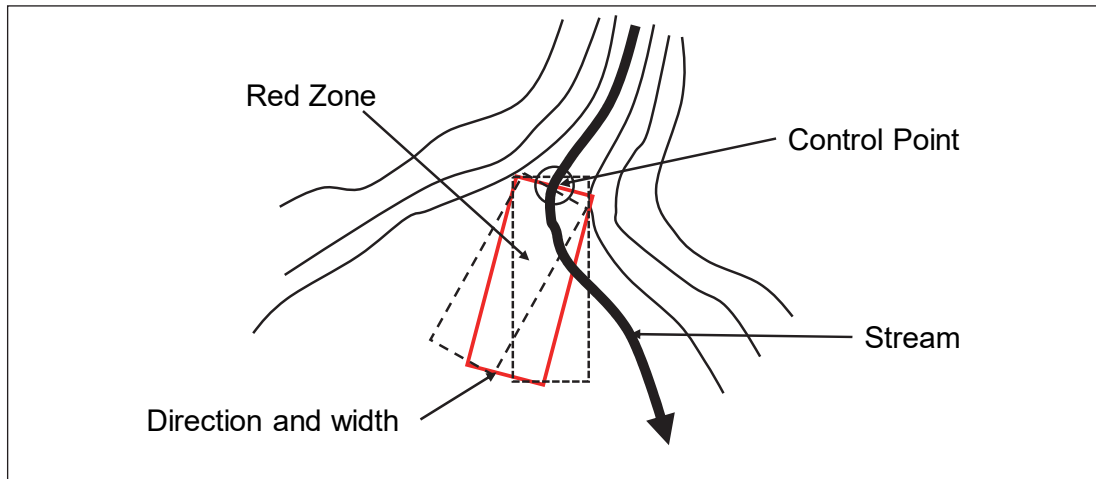
**(2) Setting of Flow Direction**

The direction of a debris flow shall be determined from topographical features and confirmed by field survey result (Figure 5.7).



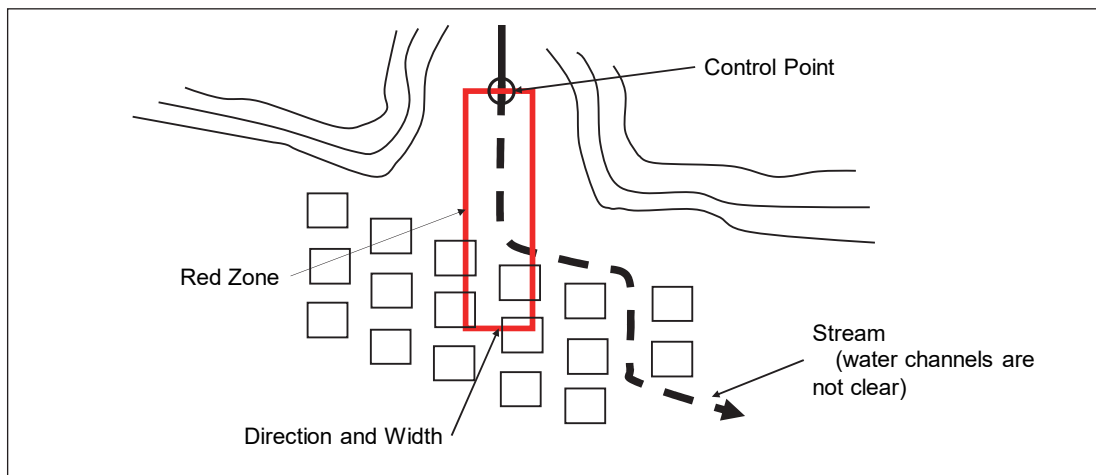
**Figure 5.7 Determination of Flow Direction**

If there is a bend in the course of the mountain stream, the straight-flowing nature of the debris flow is used to determine the flow direction (Figure 5.8).



**Figure 5.8 Diagrammatic Representation of Setting Flow Direction at River Bend**

If the original shape of a valley is obscured due to residential land developments or if there are ditches, the flow direction of a debris flow is set in view of its straight-flowing nature (Figure 5.9).



**Figure 5.9 Conceptual Diagram of Setting Flow Direction when Valley Topography or Water Channels is not clear**

### (3) Measurement of Ground Gradient

The lower ends of the Yellow Zone and Red Zone shall be determined based on the ground gradient or inclination from the profile of the target area. The ground gradient of the lowermost end is set as below (Figure 5.10):

- a) 1 degree for Yellow Zone
- b) 3 degrees for Red Zone

In addition, the ground gradient should be based on the average value of the section that has the same ground inclination along the valley profile.

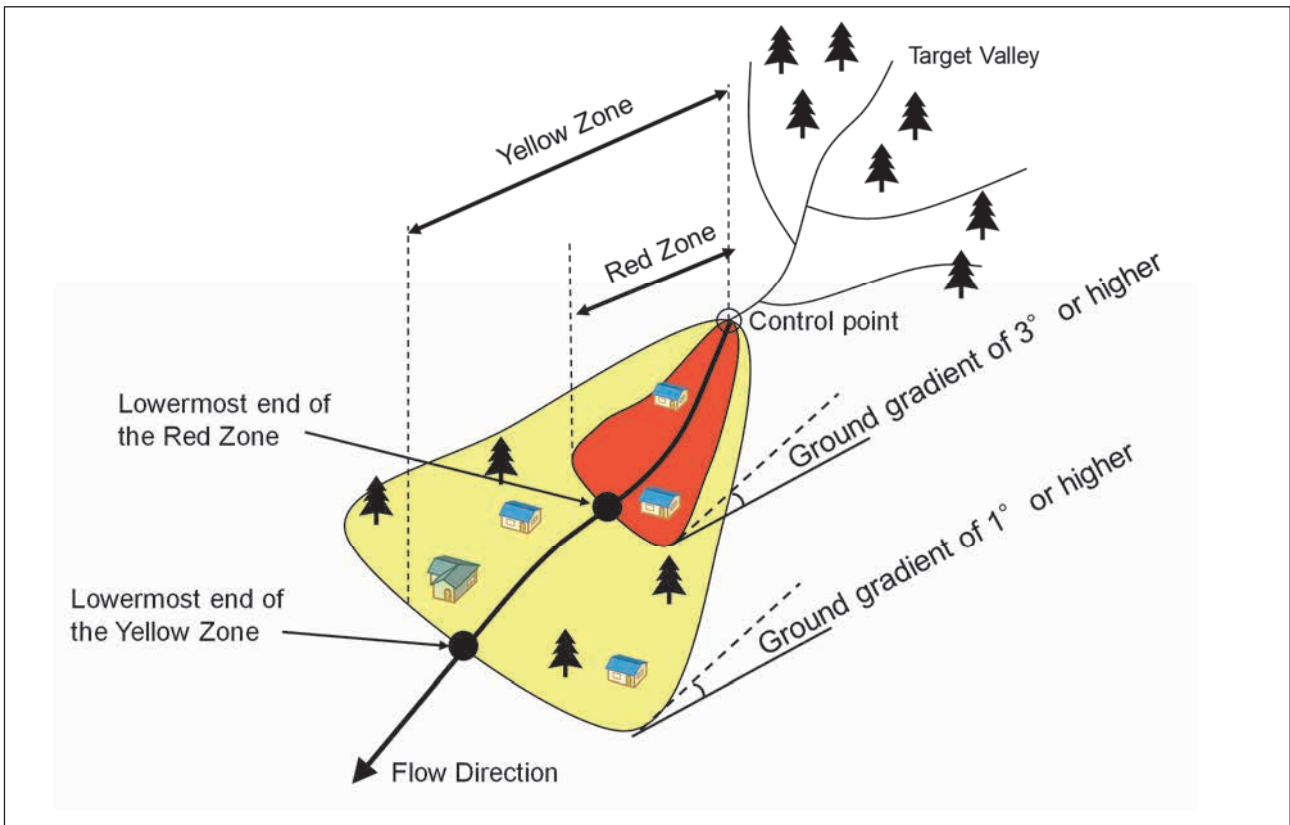


Figure 5.10 Determination of the Lowermost End of the Zones

#### (4) Setting of Cross Section

The cross sections shall be roughly set perpendicular to the flow direction every 20 m (Figure 5.11). The length of cross section should be drawn from the present streambed to about 10 m of the relative height.

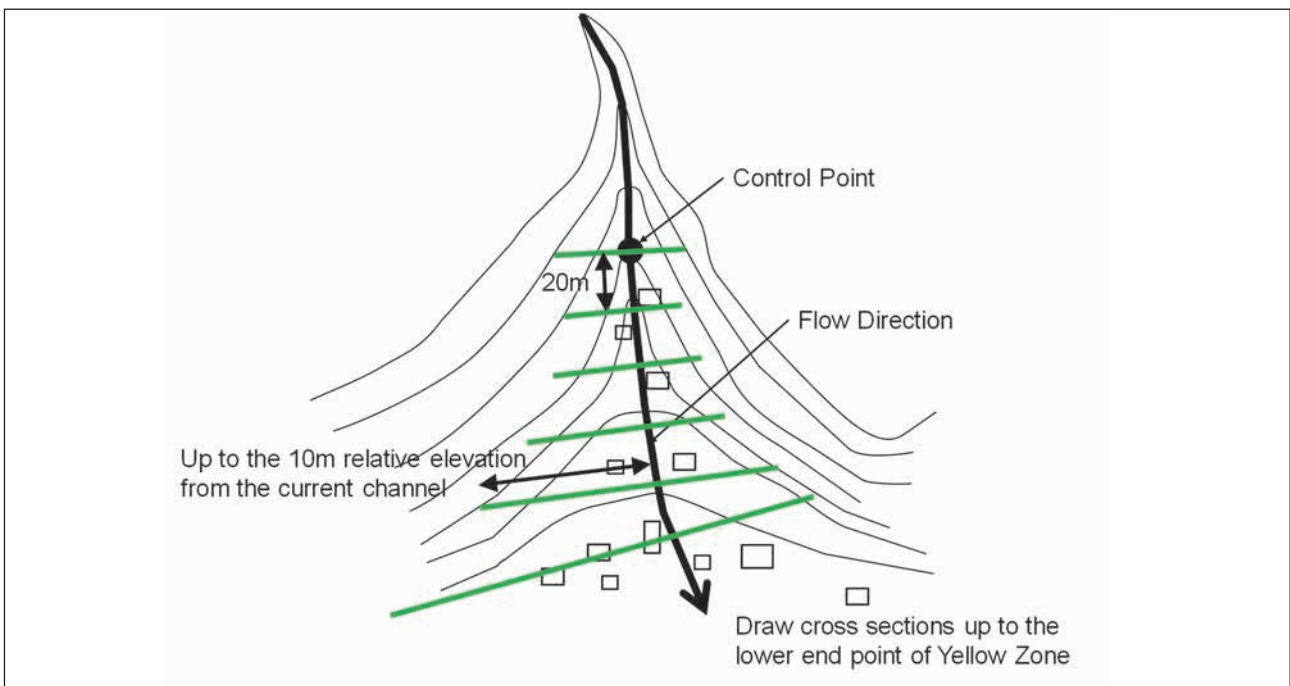


Figure 5.11 Setting of Cross Section



### (5) Measurement of Relative Height Point (5 m)

As the depth of debris flow is generally within 5 m, a point of relative height of 5 m shall be demarcated from the elevation of the current streambed or the center of flow direction toward both sides of the stream (Figure 5.12).

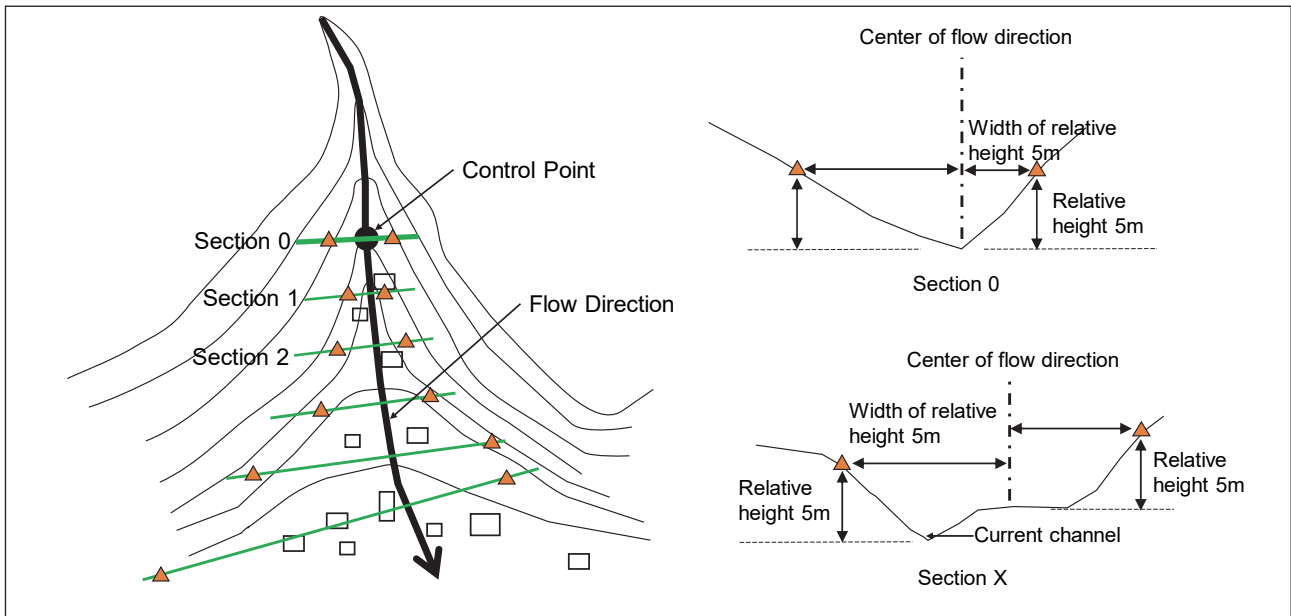


Figure 5.12 Measurement of Relative Height 5 m Point

### (6) Setting of Boundary Point of Cross Section

The boundary points of each cross section shall be set by the following steps.

- i. Set relative height points of 5 m on Section 0
- ii. Set spreading points on Section 1 from the 5 m relative height points on Section 0 with the spreading angle outside as follows for each zone (Figures 5.13 and 5.14).
  - 30 degrees for the Yellow Zone; and
  - 15 degrees for the Red Zone.

These angles were empirically derived by the results of the past debris flow survey in Sri Lanka.

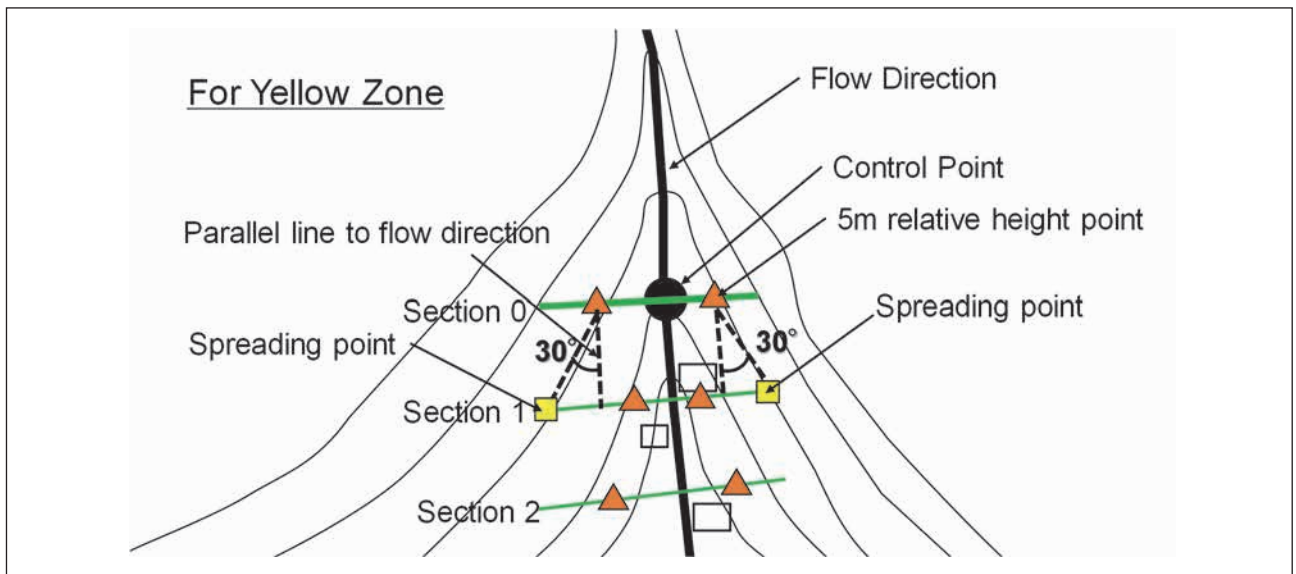


Figure 5.13 Setting of Spreading Points for Yellow Zone

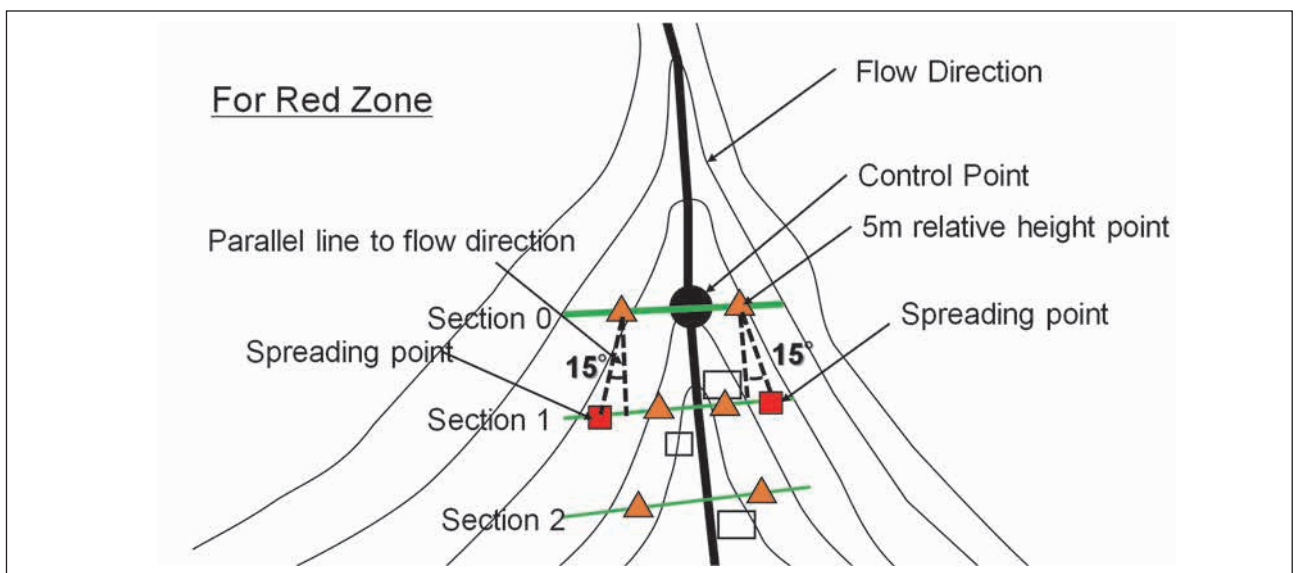


Figure 5.14 Setting of Spreading Points for Red Zone

- iii. Set spreading points on Section 2 at the points which have given dispersion angles outside of the closest point to the stream, which is either a 5 m relative height point or spreading point on Section 1 (Figures 5.15 and 5.16). The closest point to the stream is selected as the boundary point.
- iv. Set spreading points from the boundary points of the previous section again in the same way up to the lowermost end.

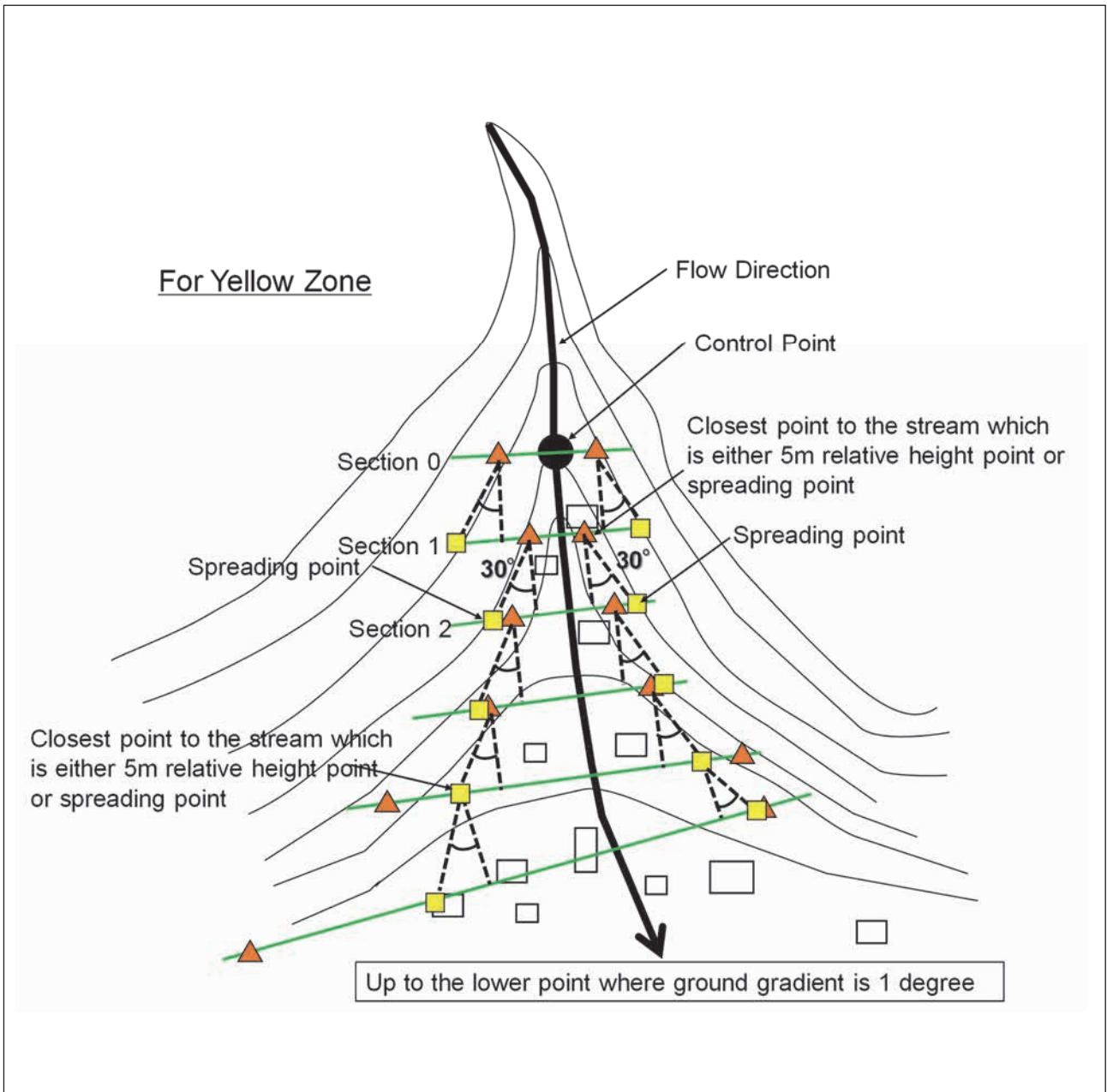
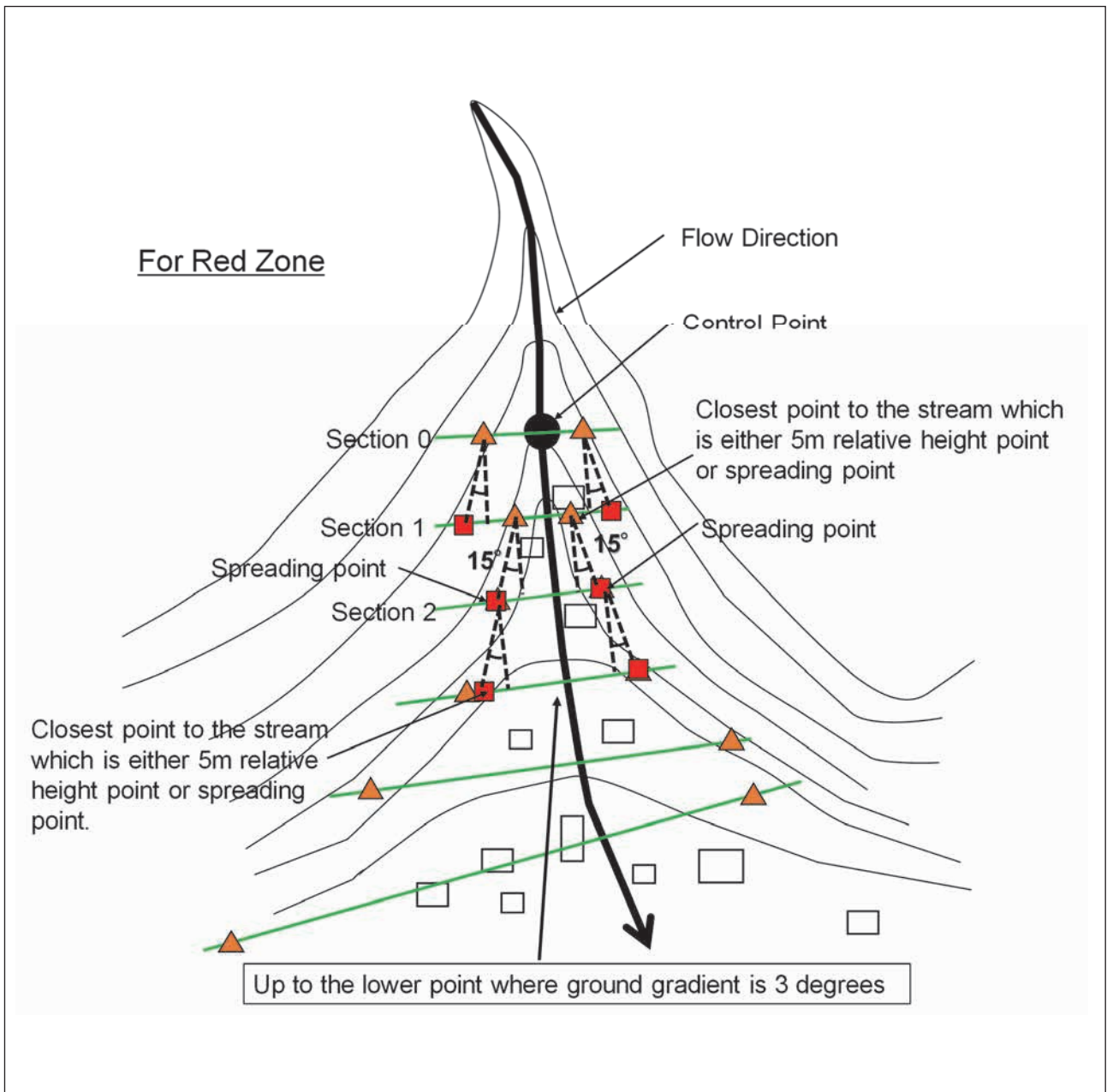


Figure 5.15 Setting of Boundary Points for Yellow Zone



**Figure 5.16 Setting of Boundary Points for Red Zone**

- v. Connect the boundary points on each cross section (Figures 5.17 and 5.18).

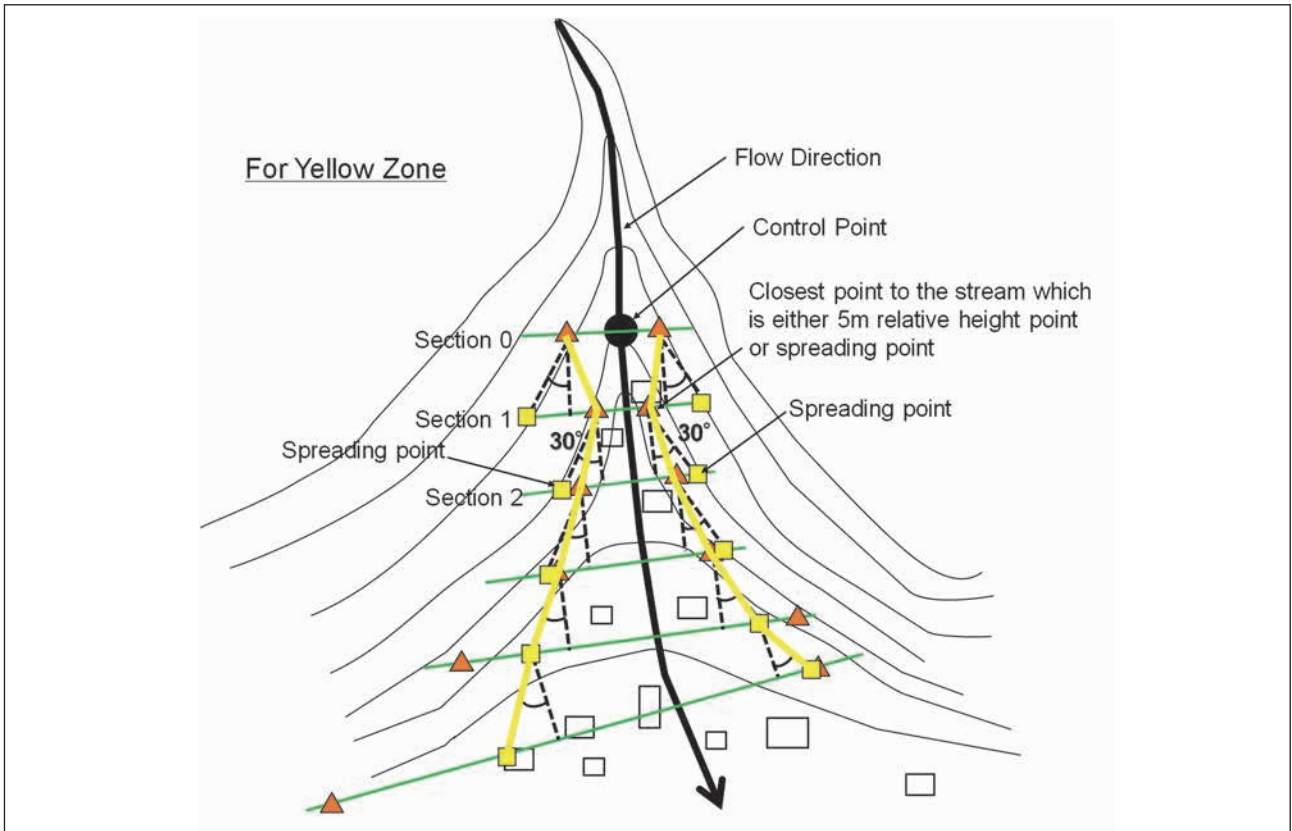


Figure 5.17 Connection of the Boundary Points for Yellow Zone

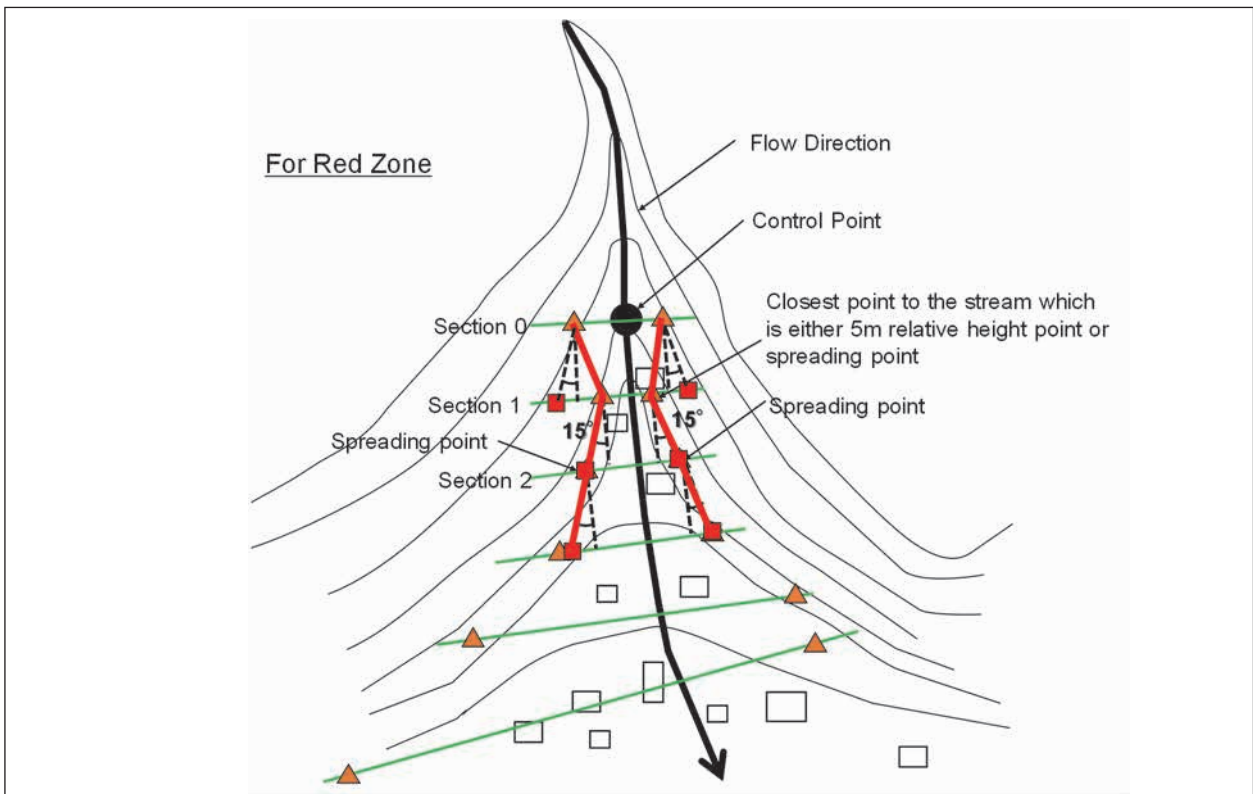


Figure 5.18 Connection of the Boundary Points for Red Zone

### (7) Setting of the End Line of Downstream

The end line of downstream shall be set by the following steps. (Figure 5.19)

- i. Set an auxiliary line from the lowermost point for Yellow or Red Zone connecting the lowermost point and the control point.
- ii. Turn the line around the lowermost point to the same direction as downstream.
- iii. Set a reference point on the rotated line.
- iv. Draw an arc line from the reference point with a radius of the distance between the reference and the lowermost point.
- v. Connect the arc line and the boundary line. (Figure 5.20)

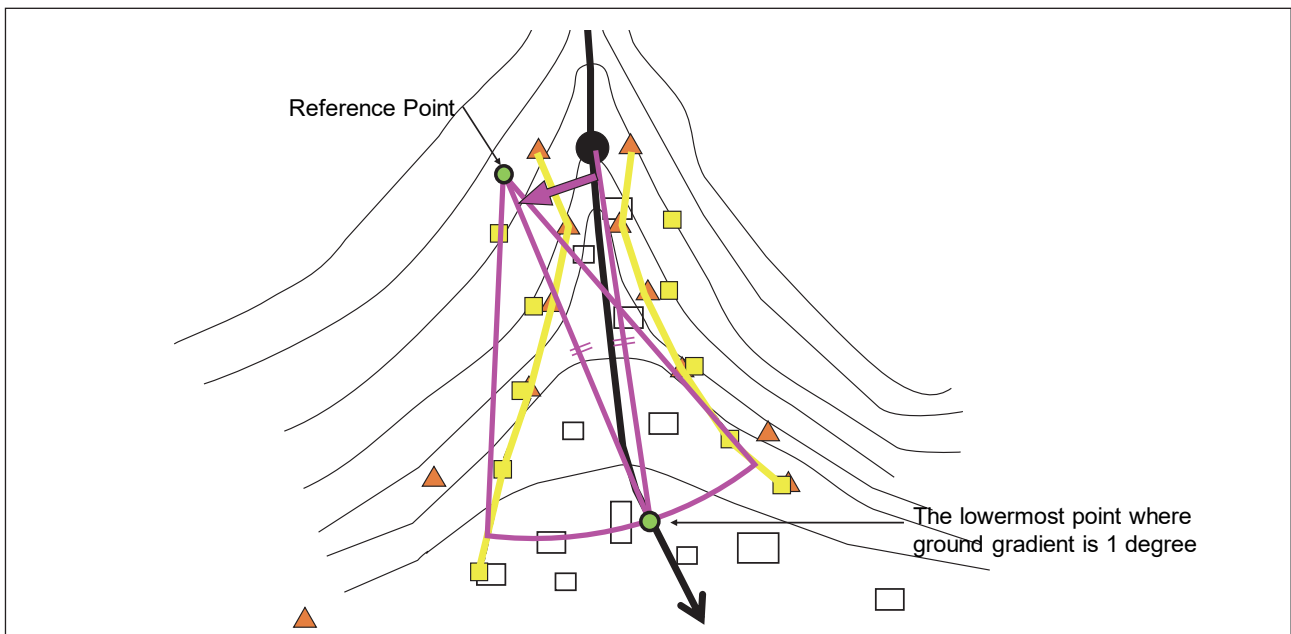


Figure 5.19 Setting of End Line of Downstream for Yellow Zone (1)

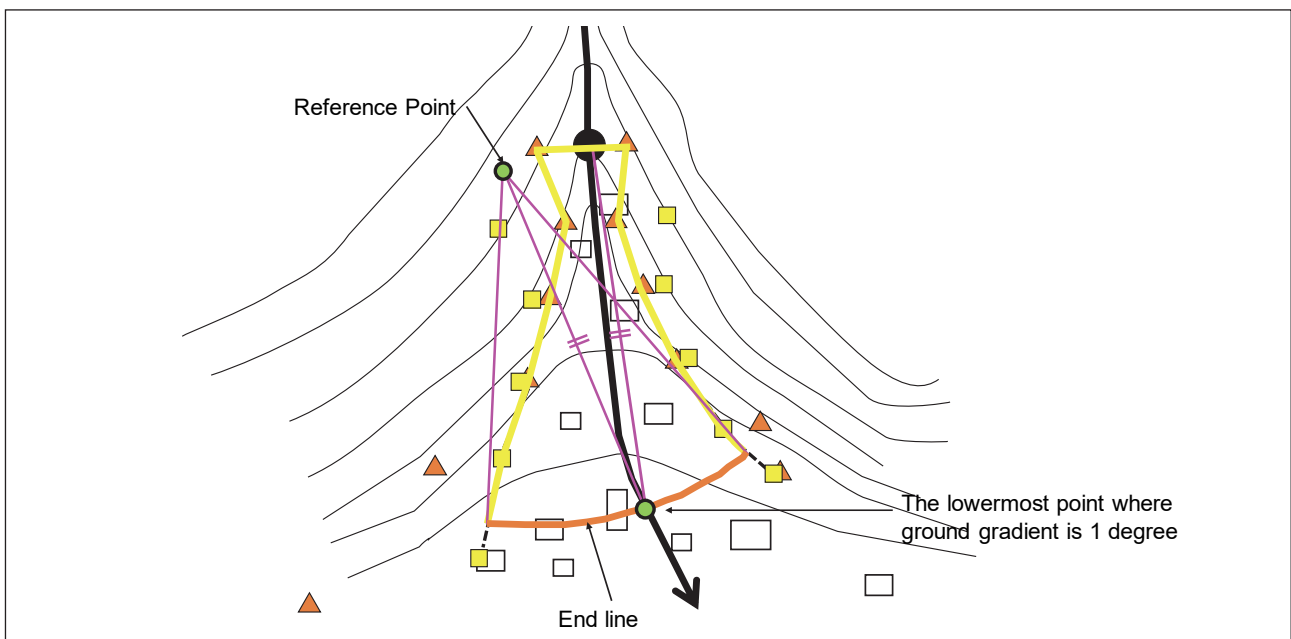


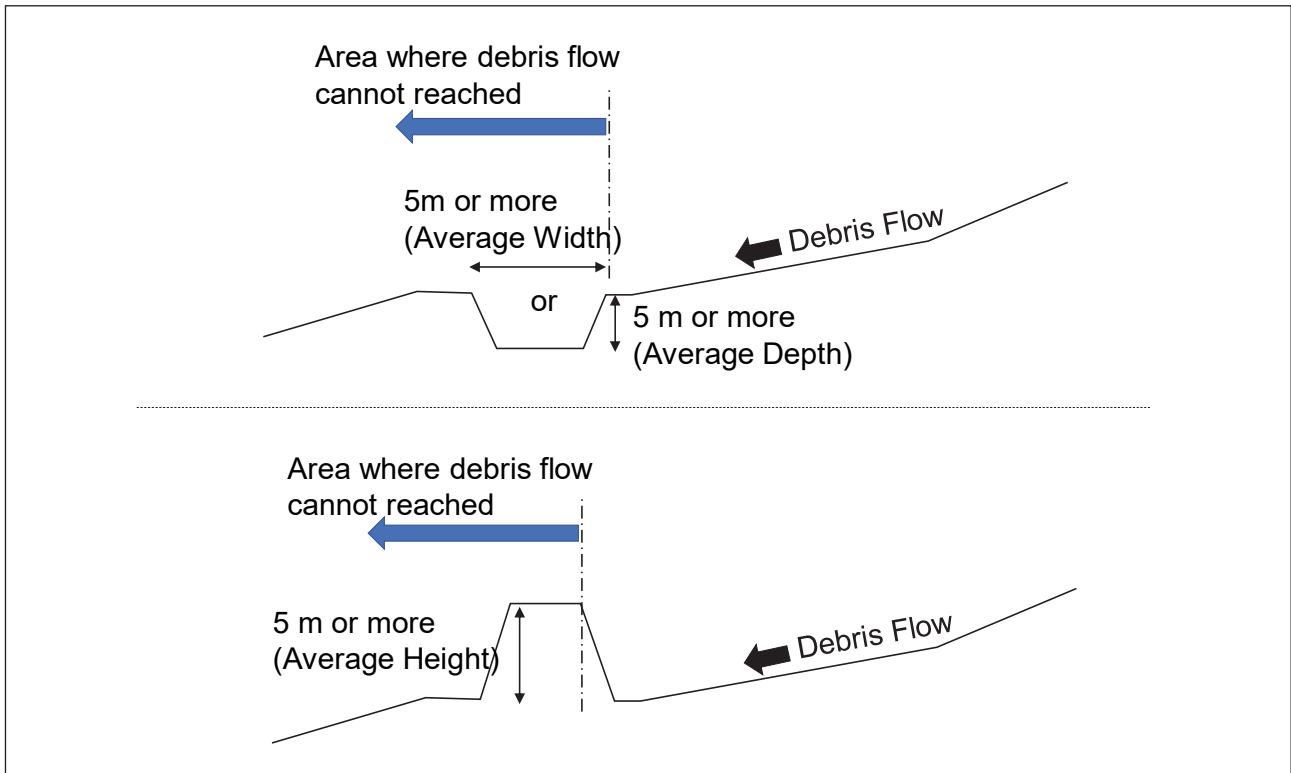
Figure 5.20 Setting of End Line of Downstream for Yellow Zone (2)



**(8) Excluding Areas where Debris Flow cannot be reached**

If the following landforms or obstacles are present in the drawn Yellow or Red Zone, the zone should be modified properly to exclude areas where debris flow cannot be reached. (Figure 5.21)

- Main stream/channel with a width or depth of 5 m or more; or
- Bank slope with a height of 5 m or more, etc.

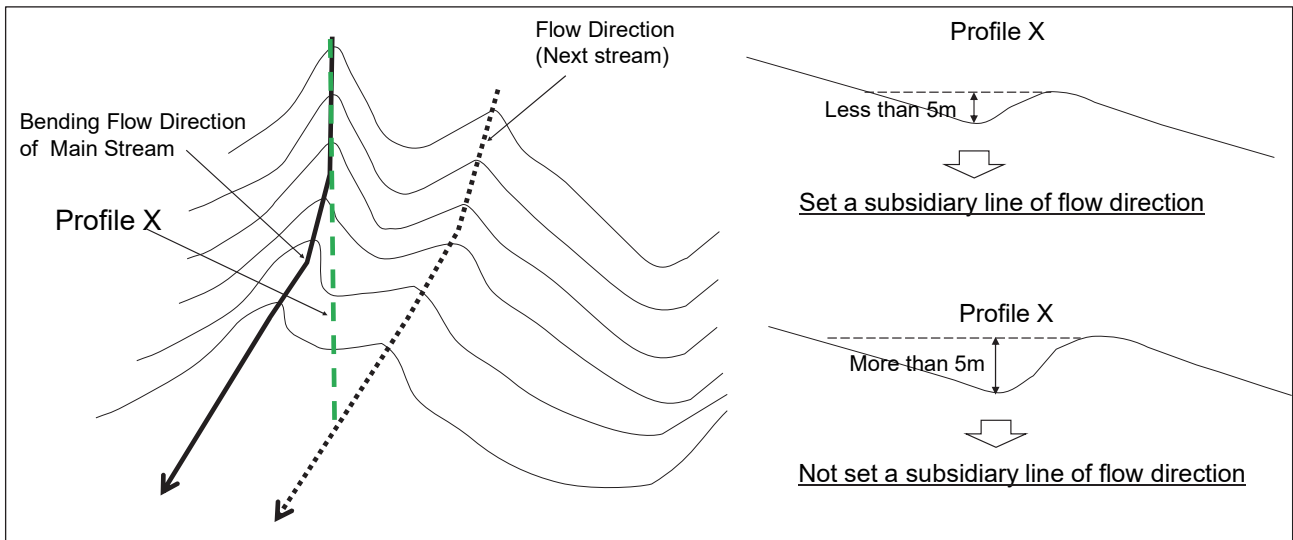


**Figure 5.21 Conceptual Lateral Profile of an Area where Debris Flow Cannot Be Reached**

**(9) Setting of Yellow and Red Zones in Case of the Bending Flow Direction**

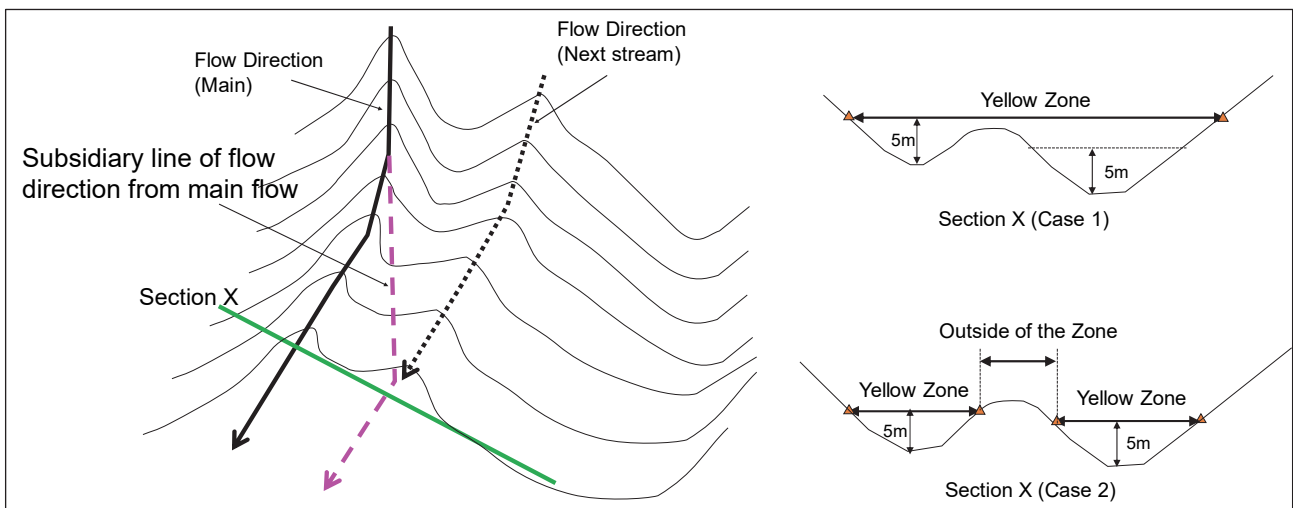
Debris flows generally move in a straight direction, especially with a large-scale volume of debris. In the case of bending flow direction, the Yellow and Red Zones shall be set by the following procedure:

- If the profile has a mountain ridge with a relative height of less than 5 m, set a subsidiary line of flow direction from main the flow (Figure 5.22). If the profile has a mountain ridge with a relative height of over 5 m, there is no need to set a subsidiary line.



**Figure 5.22 Setting of a Subsidiary Line of Flow Direction**

- ii. In cases where the mountain ridge is present between two mountain streams with a relative height of less than 5 m, set the boundary points for the Yellow Zone either at point of the relative height of 5 m or spreading point for the flow direction of main stream and the subsidiary line of flow direction as well (Figure 5.23, case 1).
- iii. In cases where the mountain ridge of relative height of 5m or more is present between two valleys, set the boundary points for the Yellow Zone either at point of the relative height of 5 m or spreading point for the flow direction of main stream and from where the relative height of the ridge drops below 5 m or from the spreading point of the flow direction of next valley (Figure 5.23, case 2).



**Figure 5.23 Setting of Boundary Points of Main and Subsidiary Flow Directions for Yellow Zone**

- iv. In setting of the Red Zone, only the main flow direction is used because the energy of debris flow is decreased by a mountain ridge or valley outlet.

#### 5.2.4 Field Verification to Finalize the Zones

The field verification is conducted to finalize the Yellow and Red Zones set by desk study, focusing mainly on the following items:

a) Ground Gradient

Field surveys are conducted to supplement the ground gradient data obtained from topographic maps and to obtain ground gradient data that cannot be obtained from maps. Measurement points are locations where there are drops caused by structures, etc., as well as gradient shift points and relative heights at upstream and downstream of structures in the river channel.

b) Cross-section profile

For the cross-section profile, field surveys are implemented to obtain base data used to predict the starting point/range of inundation of a debris flow on the following items:

- Cross-section profile: Sketch of outline shape, simple cross section measurements
- Embankment slope: Measure the slope of the stream's embankment (boundary between water flow area and slope surface is approximately equal to the cut bank)
- Channel width: Measure the distance between the banks of the stream, giving the width of water flow and stream topography
- Relative heights of protection targets and riverbed: Measure elevation differences between the ground height of the protection target and the stream bed

c) Plan Shape

Field surveys are implemented to assess the plan shape through its ground inclination, aerial photo interpretation, and the cross-section profile. This is done to obtain base data for predicting the size and extent of debris flow inundation. Through map surveys, unique landforms such as river bends, narrow passes, valley plains, flatlands (residential and arable land), and roads are assessed. These will then be confirmed through field surveys.

d) Artificial Structures

For artificial structures, field surveys are implemented to understand the detailed topographical conditions that restrict flow and inundation range of debris flow.

Survey targets include artificial structures that impact the flow of debris flow such as embankments (roads, railways, etc.), bridges, culverts (box culverts, etc.), and retaining walls, etc. Basically, the position and size of artificial structures is assessed through field surveys, assessing whether they are transverse or longitudinal to the flow direction of debris flow.

The following items set for desk study should be checked if they are appropriate:

- Location of control point
- Direction of debris flow
- Location of downstream end point of Yellow Zone and Red Zone
- Area where debris flows cannot be reached

### 5.3 Reference Data

#### Background Data for Setting Hazard Zone for Debris Flow

Nineteen (19) past debris flow disasters were collected from:

- a) Landslide Disaster May 2017 – Damages and Loss Assessment, Prepared by NBRO, including 35 disaster events occurring in 2017.
- b) Reduction of Landslide Vulnerability by Mitigation Measure Projects - Cost Benefit Analysis, Prepared by NBRO, in October 2018, including 50 disaster events.

The main results of the collected past debris flow disasters are shown in Figures 5.1 to 5.5 and summarized below:

- a) The slope angle at the source area of failures is in the range of 20 to 40 degrees, and mostly between 30 and 40 degrees (Figure 5.1).
- b) The streambed gradient around the control is mostly between 5 and 20 degrees (Figure 5.2).
- c) The streambed gradient within the flow paths is between 10 and 40 degrees on average (Figure 5.3).
- d) The spreading angle of the depositional area is mostly between 30 and 60 degrees, accounting for about 80% of the total number of past debris flow disasters (Figure 5.4). On the other hand, the spreading angle of the depositional area covering the completely damaged houses is between 5 and 30 degrees (Figure 5.5).
- e) The streambed gradient at the ending point of the depositional area is mostly in the range of 1 to 5 degrees (Figure 5.6). The streambed gradient at the end point of the depositional areas covering the completely damaged houses was found to be between 3 to 8 degrees based on the limited past debris flow disasters.

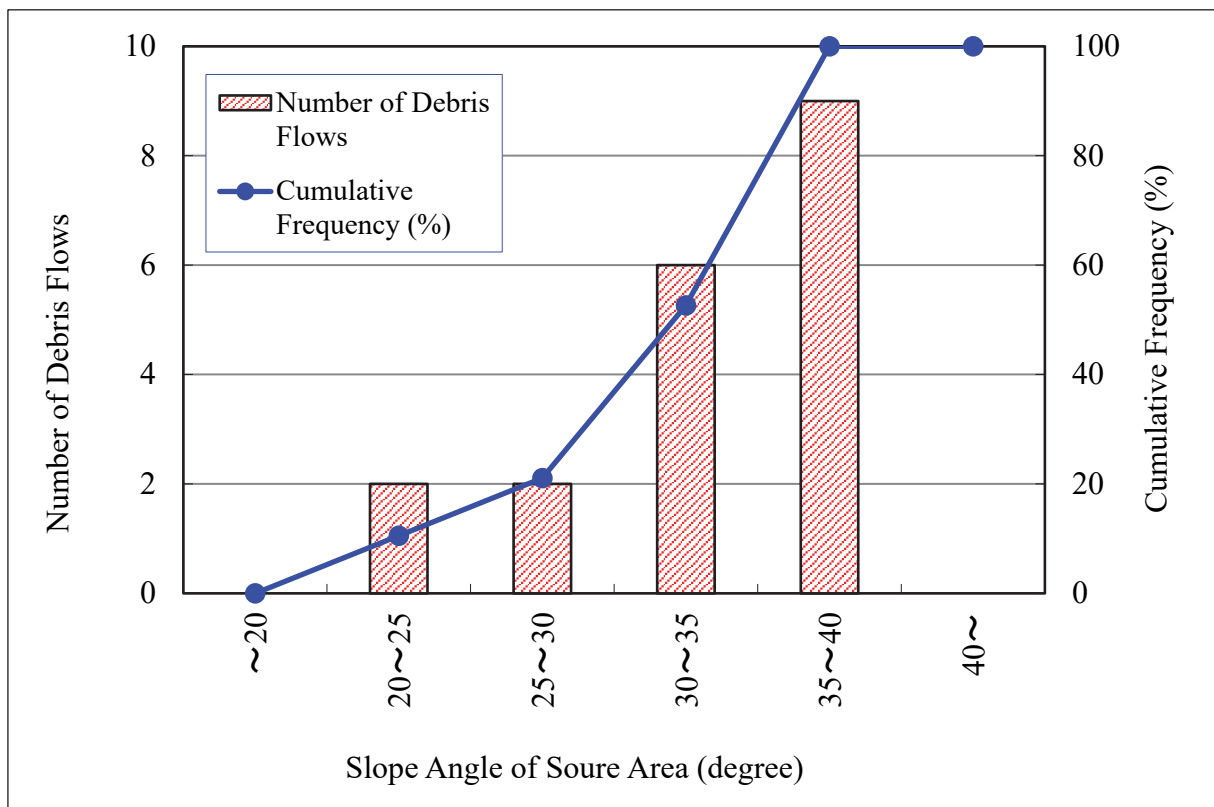


Figure 5.24 Frequency Distribution of Slope Angle of Source Area

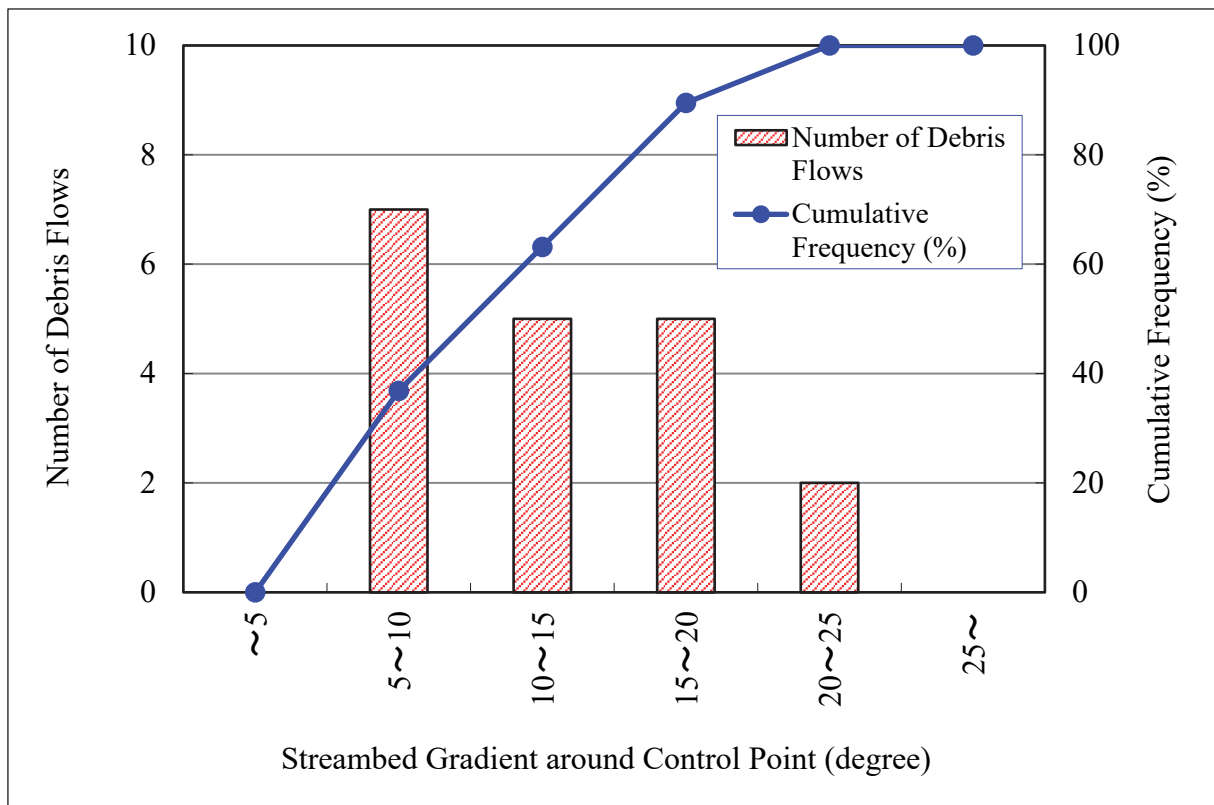


Figure 5.25 Frequency Distribution of Streambed Gradient around Control Point

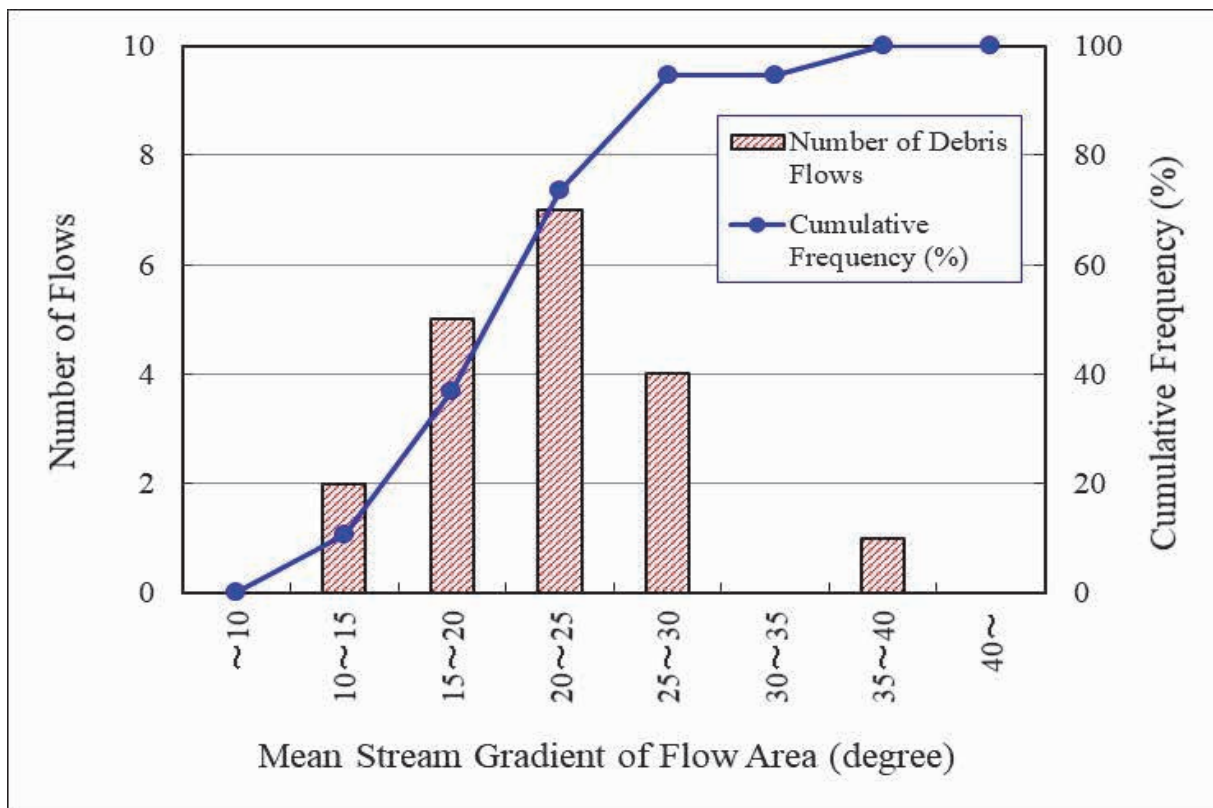


Figure 5.26 Frequency Distribution of Mean Streambed Gradient of Flow Paths

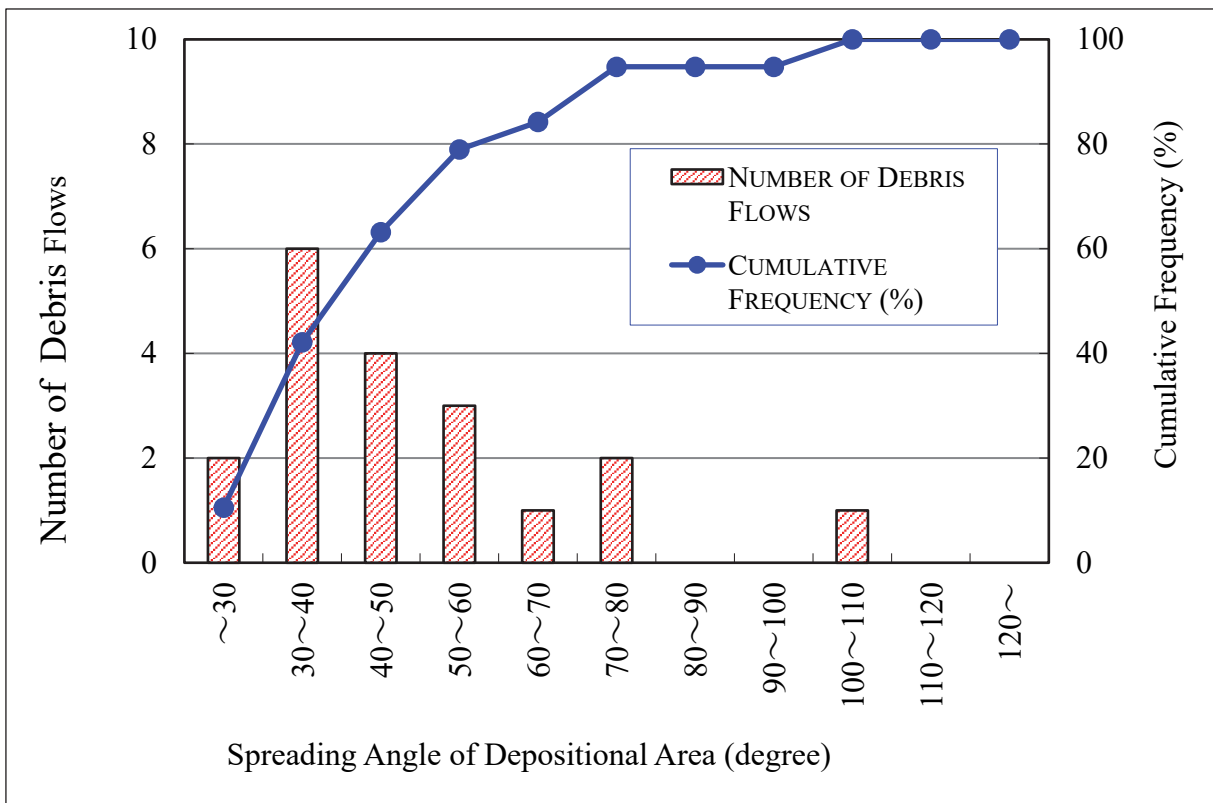


Figure 5.27 Frequency Distribution of Spreading Angle of Depositional Area



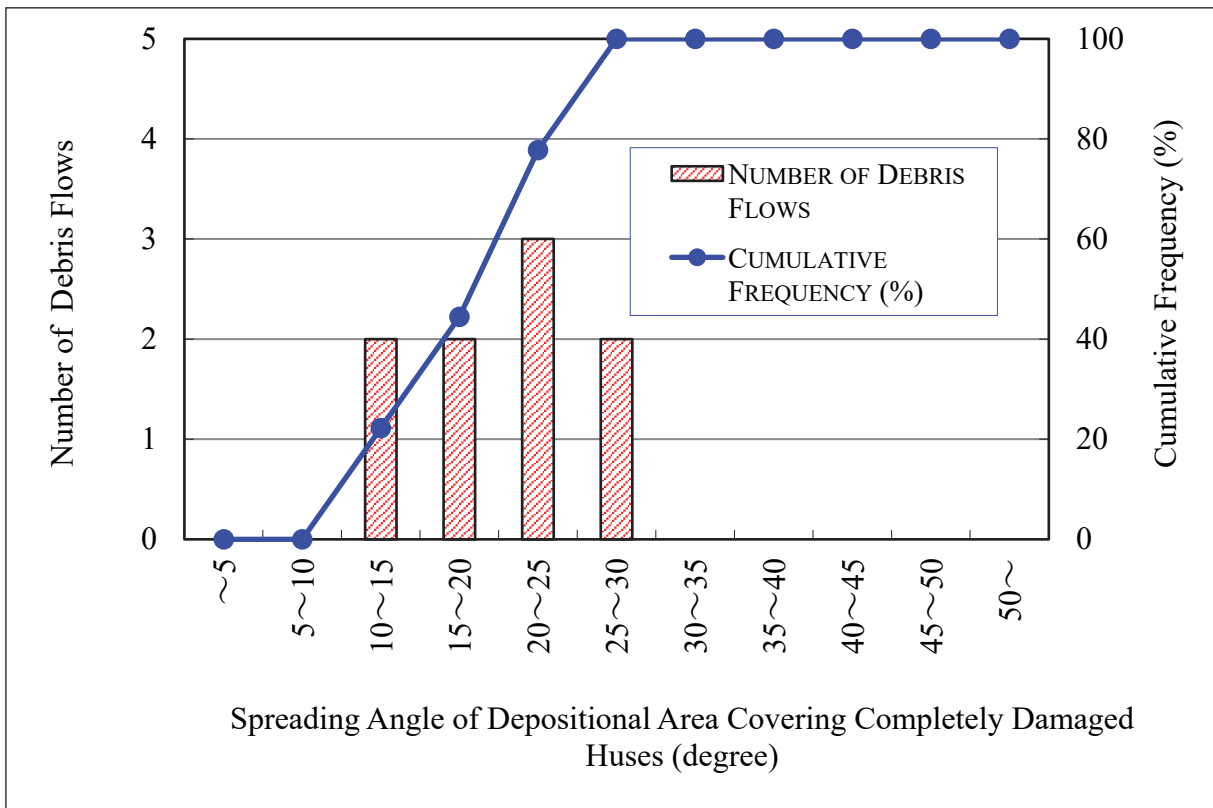


Figure 5.28 Frequency Distribution of Spreading Angle of Depositional Area Covering Completely Damaged Houses

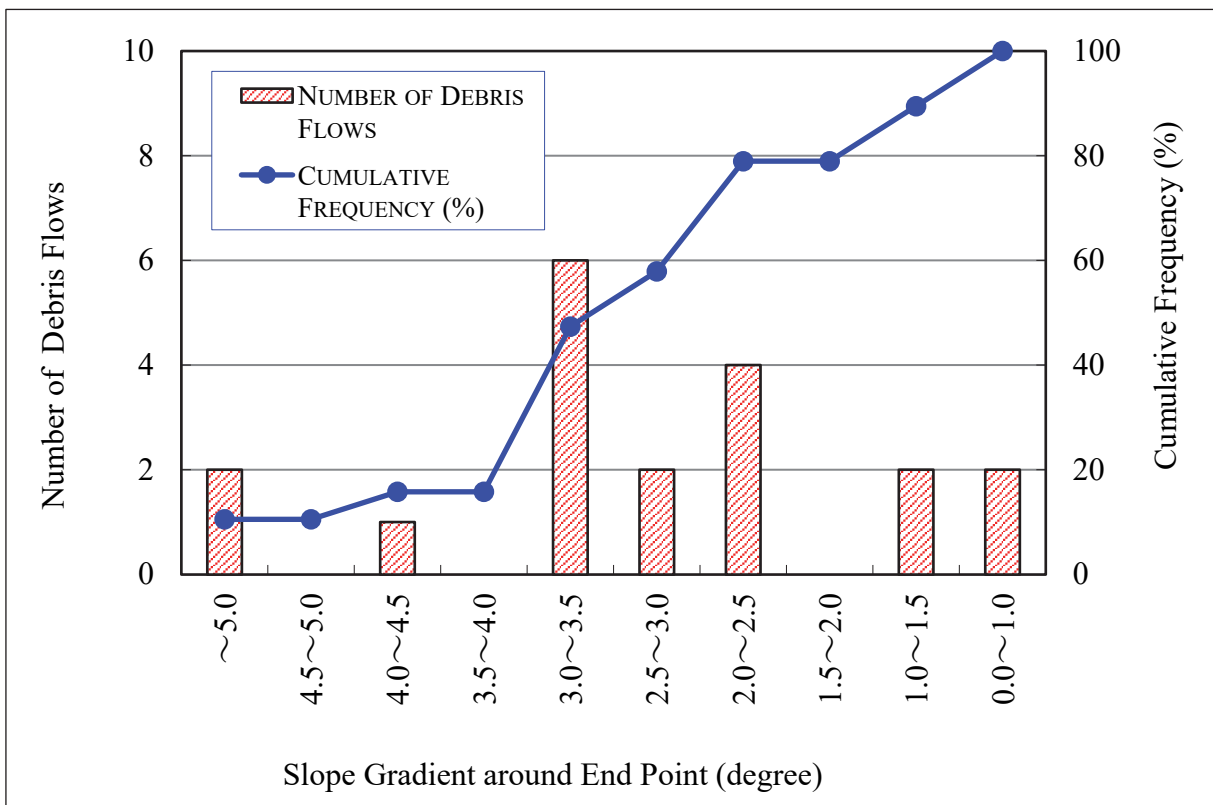
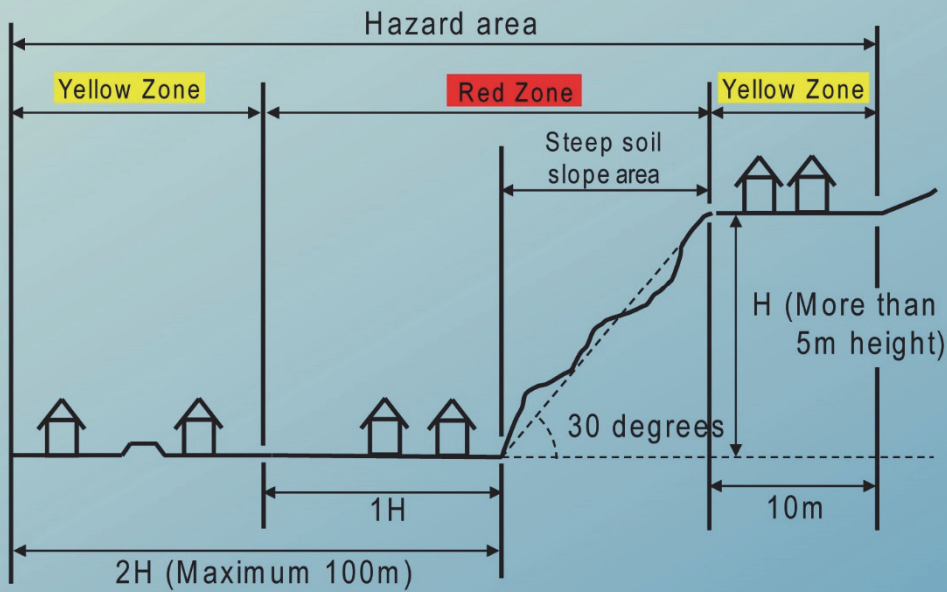


Figure 5.29 Frequency Distribution of Streambed Gradient around End Point of Depositional Area



# Technical Note 1

## Hazard Zoning Methodology for Slope Failure by Reference to Japanese Criteria

This technical note provides the methodology of slope failure hazard zoning by reference to Japanese concept

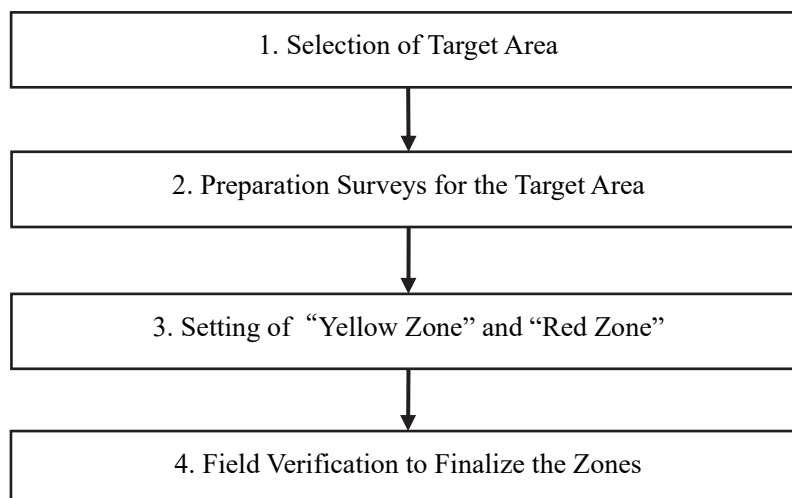
## TECHNICAL NOTE 1

### HAZARD ZONING FOR SLOPE FAILURE

#### BY REFERENCE TO JAPANESE CRITERIA

#### 1 Procedure of Setting “Yellow Zone” and “Red Zone” for Slope Failure

Setting of “Yellow Zone” and “Red Zone” for slope failure are in accordance with the following steps (Figure 1).



**Figure 1. General Process of Setting “Yellow Zone” and “Red Zone” for Slope Failure**

#### 2 Methodology

##### 2.1 Selection of Target Area

The target area including “Initial area” is selected using “Hazard Zonation Map” with a scale of 1:10,000 prepared by NBRO. The present land use plans and social conditions are also considered for the target area selection.

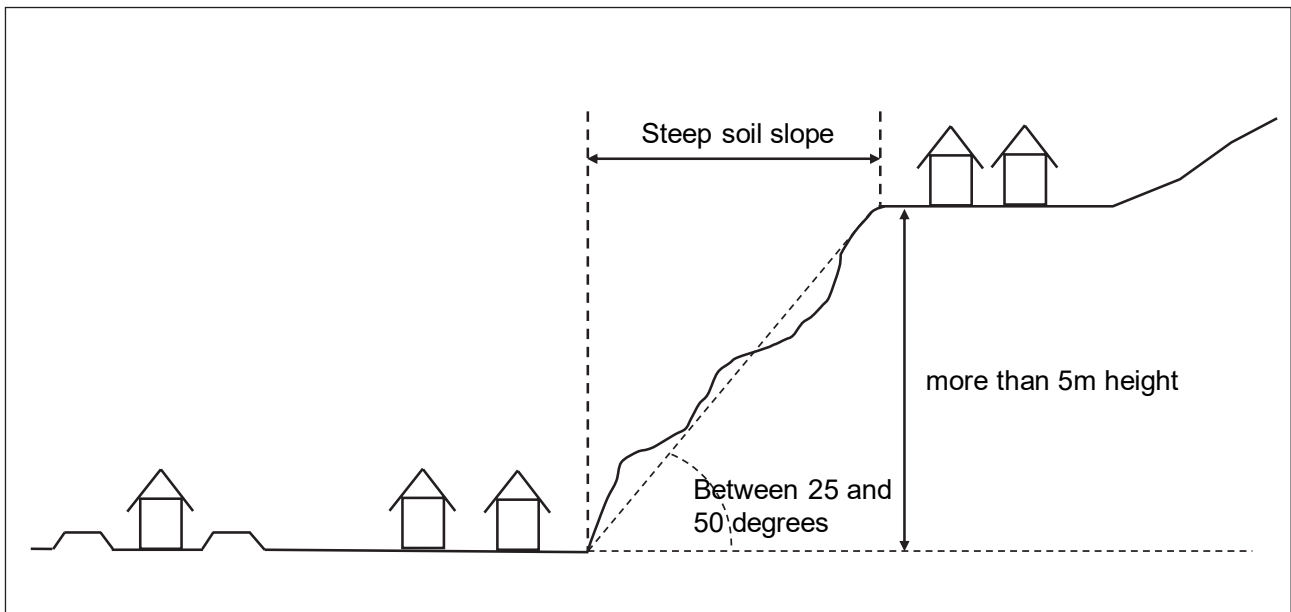
In selecting target area, the following three conditions are taken into consideration:

- Topographical conditions
- Social conditions
- Slope unit

This methodology is applicable not only to natural slope but also man-made cut slope.

##### a) Topographical Conditions

The target area to be selected for slope failure shall be a steep soil slope having a gradient between 25 and 50 degrees and a height of 5 m (Figure 2).



**Figure 2. Conceptual Representation of Target Area for Slope Failure**

**b) Social Conditions**

- The target area should include residential area on which at least one residential house or public building is located
- Areas with no houses at present, but may be expected to be developed for housing or public building construction later based on the social conditions such as current land use and development plans should be also considered
- Areas where there is no possibility of residential house construction, such as high mountainous areas with no houses, etc. are excluded from target area selection
- Cutting slopes along road are excluded from target area selection because such slopes have been managed by other administration authority

**c) Slope Unit**

- In the case of laterally continuous steep slope, the area should be sectioned up to approximately 500 m in length based on topographical or administrative factor.
- Setting of left and right edges of the area is described in Chapter 2.3 - (5) below.

**2.2 Preparation Surveys for the Target Area**

**a) Survey of Past Disaster History for the Target Area**

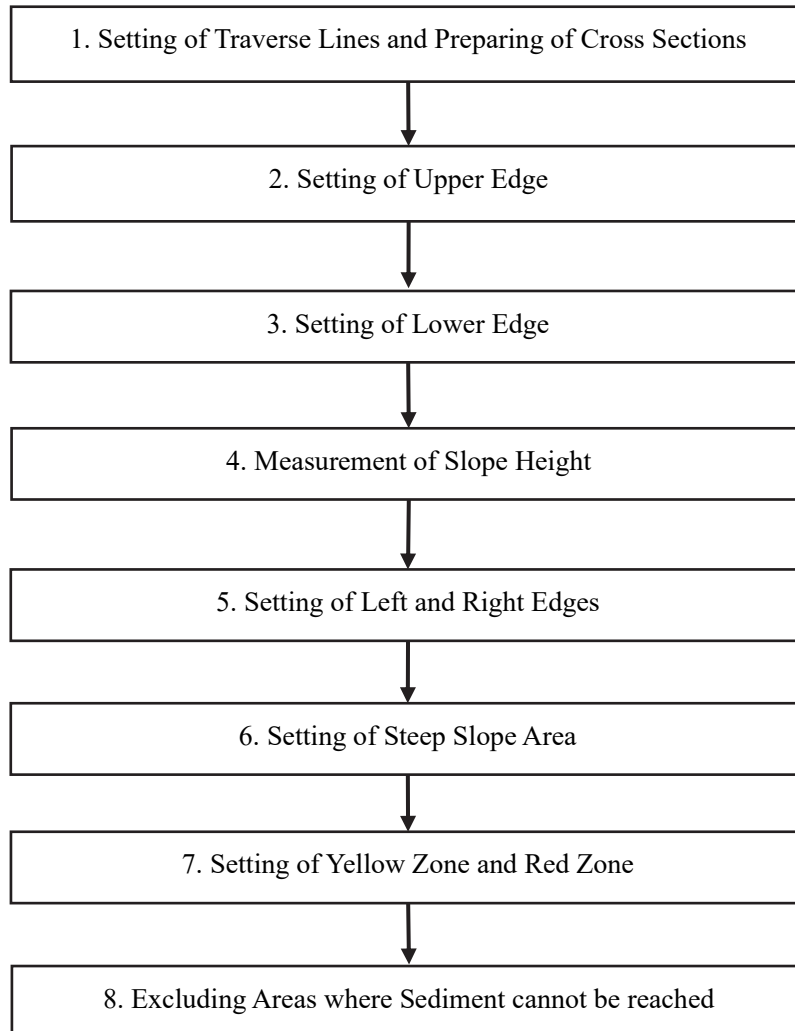
Survey of past disaster history for the target area is conducted to assess the past slope failure size and its damage conditions and then obtain data for setting the range of hazard zone mainly on the following items:

- Date, time, location and cause of a slope failure
- Size or scale of a slope failure (height, width, length, depth, slope gradient, reaching distance and volume of collapsed sediment), as illustrated in Figure 3
- Damage to human (the number of fatalities/injuries), damage to houses (the number of damaged houses, completely or partially), and structural types of the damaged houses (reinforced concrete, brick, clay, wooden, etc.)
- Rainfall information (cumulative rainfall, daily rainfall, hourly rainfall)
- Others (thickness of inundated sediment, etc.)



### 2.3 Setting of “Yellow Zone” and “Red Zone”

Setting of “Yellow Zone” and “Red Zone” for slope failure are conducted according to the following steps (Figure 4).



**Figure 4. Flowchart of Desk Mapping of “Yellow Zone” and “Red Zone” for Slope Failure**

#### (1) Setting of Traverse Lines and Preparing of Cross Sections

Traverse lines are set in terms of their direction and location, as follows:

- a) The direction of traverse line should be set toward maximum slope angle (Figure 5 - (a)).
- b) The location of traverse line should be set at about 20 m interval along contours in consideration of topographical changing points and artificial structures (Figure 5 - (b)).
- c) Cross section of each traverse line shall be then prepared.

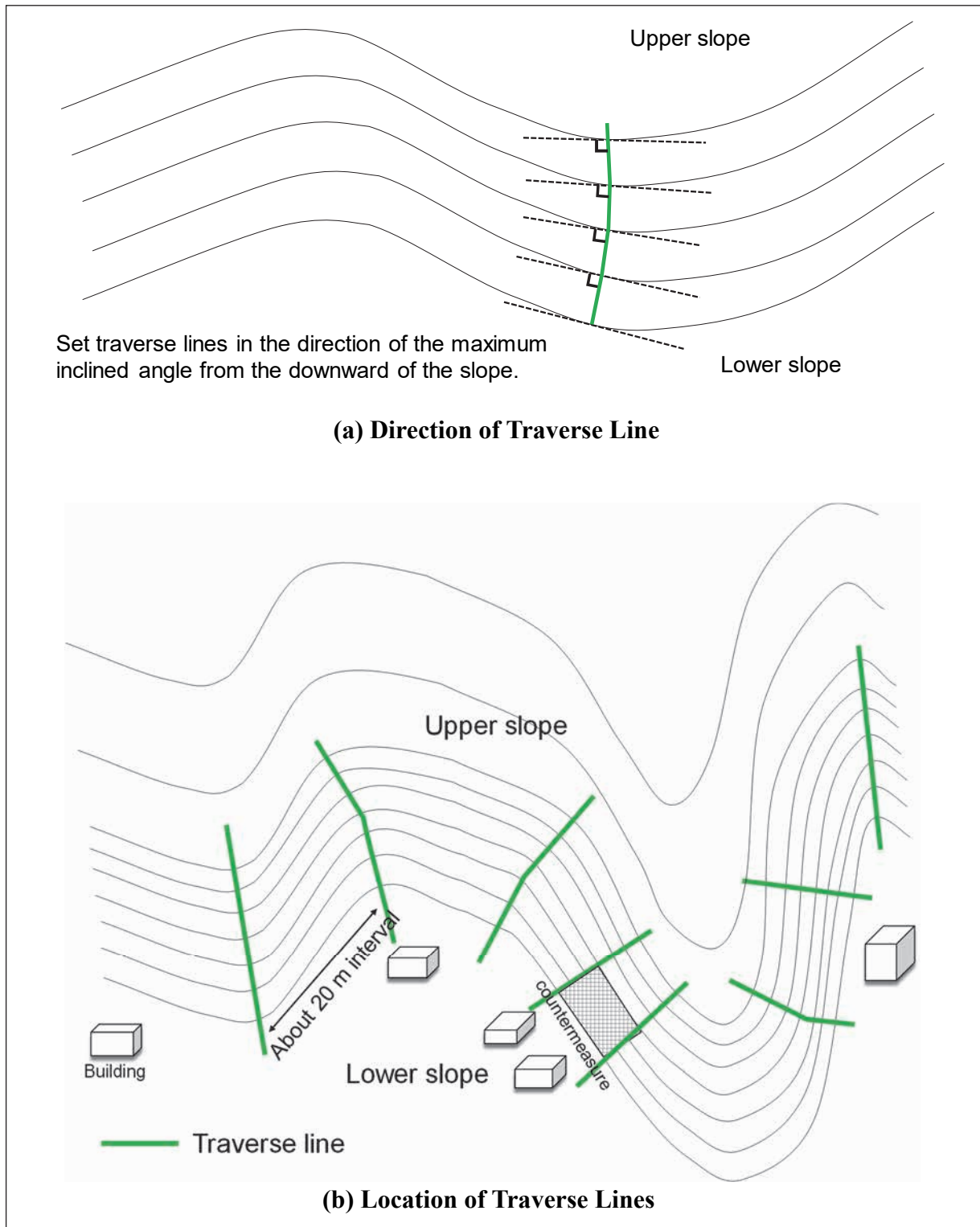
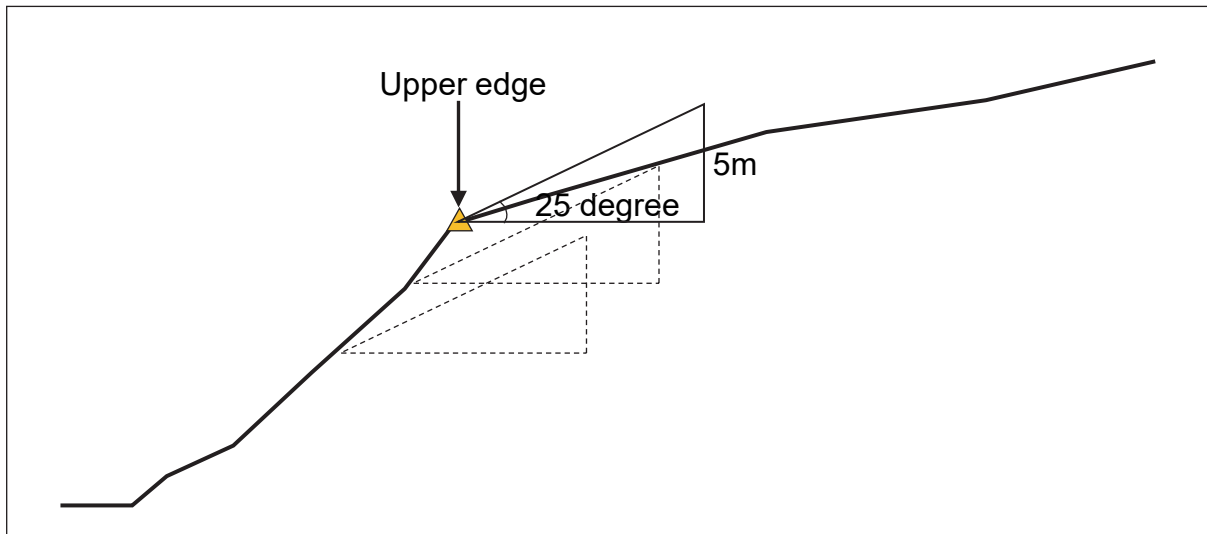


Figure 5. Setting of Traverse Lines

## (2) Setting of Upper Edge

The upper edge shall be determined basically at the topographical changing (or knick) point where a continuous upper slope has a gradient of less than 25 degrees or more than 50 degrees when observing upslope on cross section of each traverse line (Figure 6).

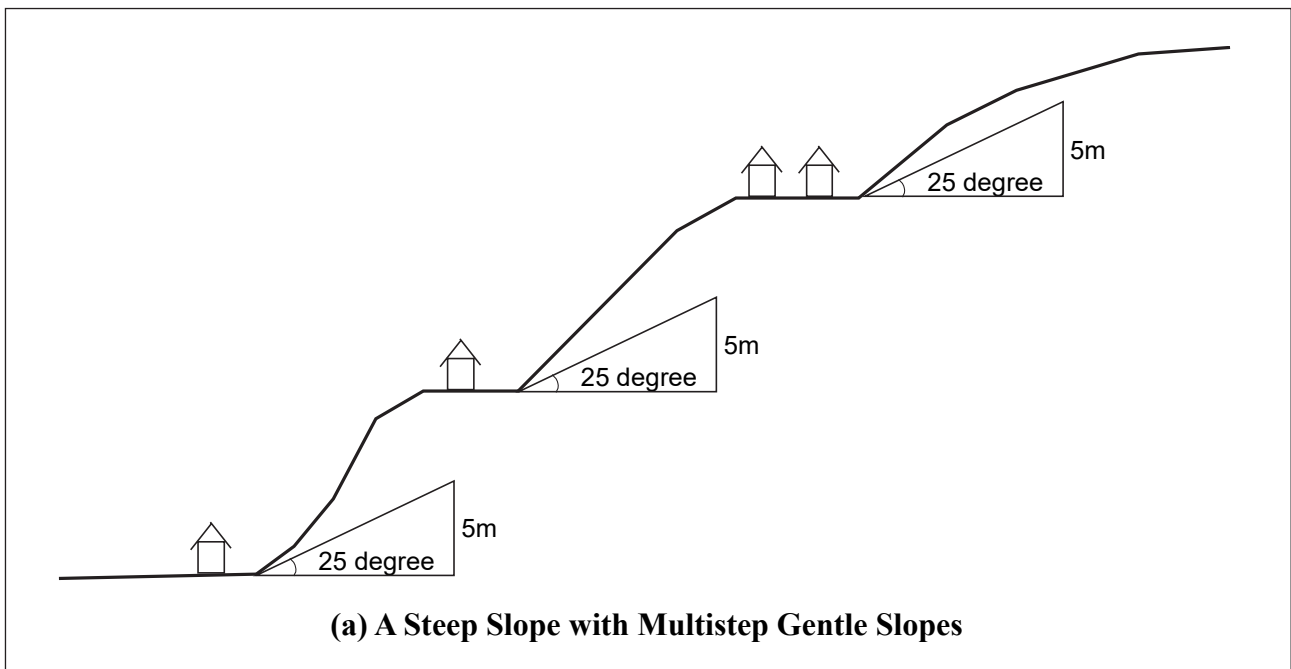




**Figure 6. Diagram of Setting Upper Edge**

In addition, in the case where a steep slope includes multistep gentle slopes (Figure 7- (a)), the target area should be set as follows:

- a) In principle, the target area shall be set for each steep slope. However, if there is an overlay between the Red zones of the upper and lower steep slopes (Figure 7 - (b)), the upper and lower steep slopes shall be considered as a continuous steep slope; and
- b) If there is no overlay between the Red zones of the upper and lower steep slopes (Figure 7 - (c)), the upper and lower steep slopes shall be set as different target areas, respectively.



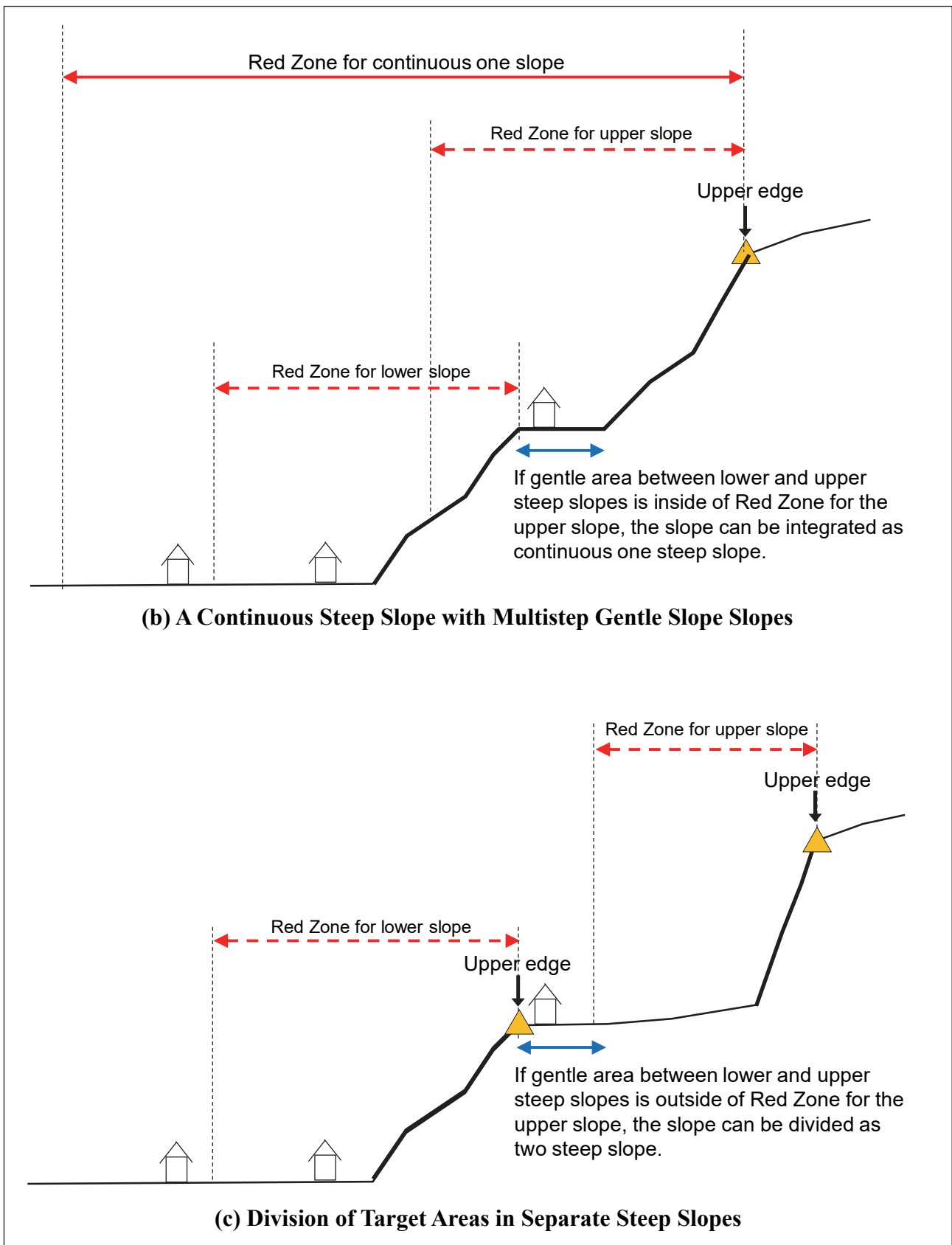


Figure 7. Diagrammatic Illustration of Setting Upper Edge for a Step Slope with Multistep Gentle Slopes

### (3) Setting of Lower Edge

The lower edge shall be determined at the topographical changing point where a continuous lower slope has a gradient of less than 25 degrees or more than 50 degrees when looking downslope on cross section of each traverse line (Figure 8).

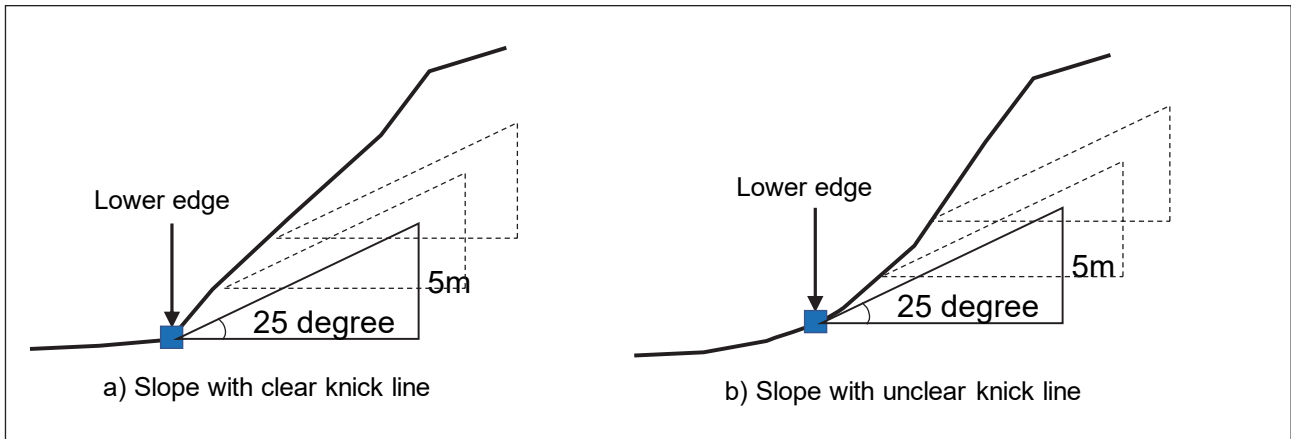


Figure 8. Setting of Lower Edge

### (4) Measurement of Slope Height

Slope height is measured as relative height between the lower and upper edges (Figure 9).

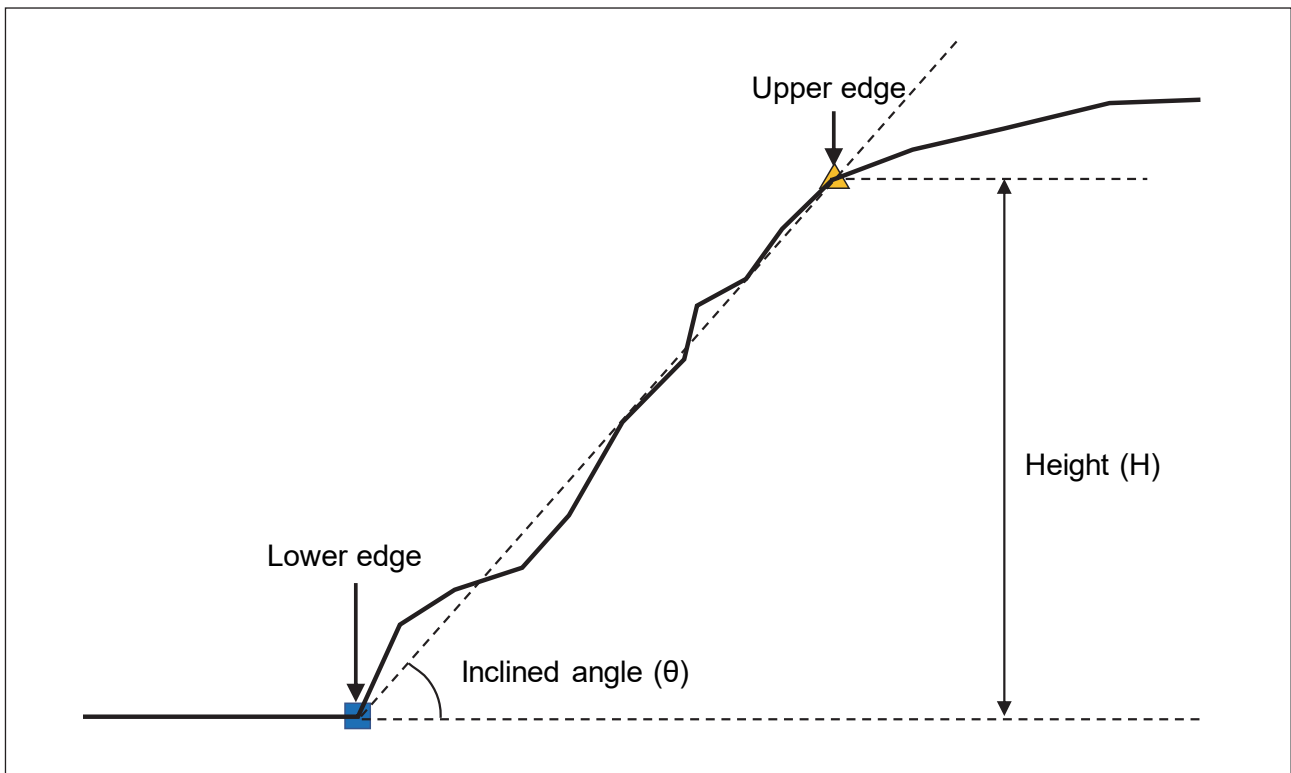


Figure 9. The Measurement of Slope Height

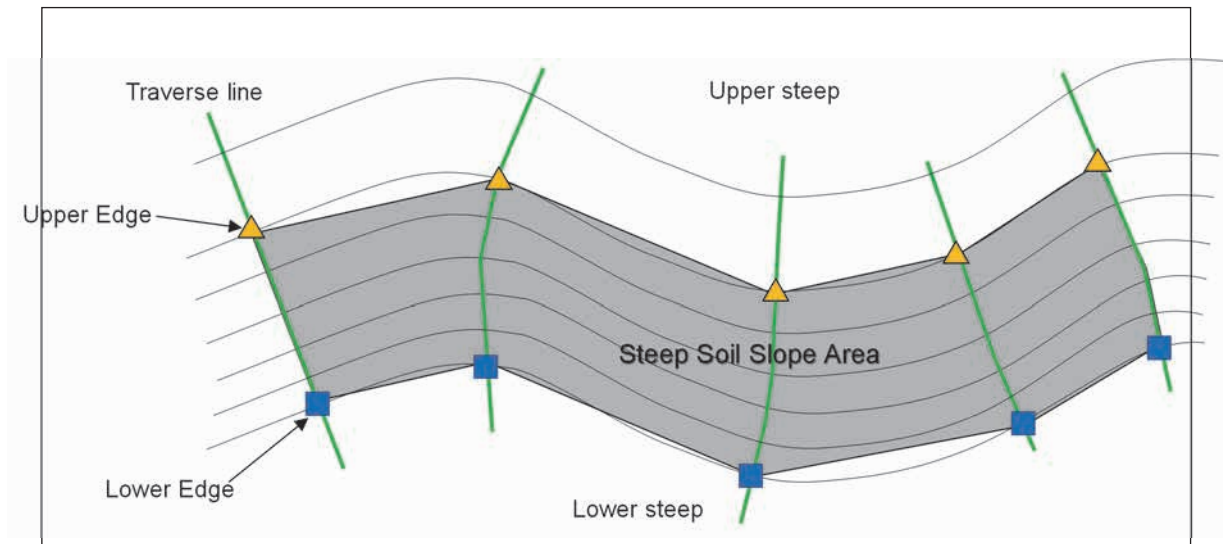
**(5) Setting of Left and Right Edges**

The left and right edges are set based on the following conditions:

- Boundary of the slope where the slope height is less than 5 m
- Boundary of the slope where the slope angle is less than 25 degrees and more than 50 degrees
- Boundary of mountain stream
- Boundary of a clear mountain ridge
- 

**(6) Setting of Steep Slope Area**

The steep soil slope area is set by straight lines connecting of all upper and lower edges (Figure 10).



**Figure 10. Diagrammatic Representation of Setting Steep Soil Slope Area**

### (7) Setting of Yellow Zone and Red Zone

The slope failure hazard zone is set as shown in Figure 11 below.

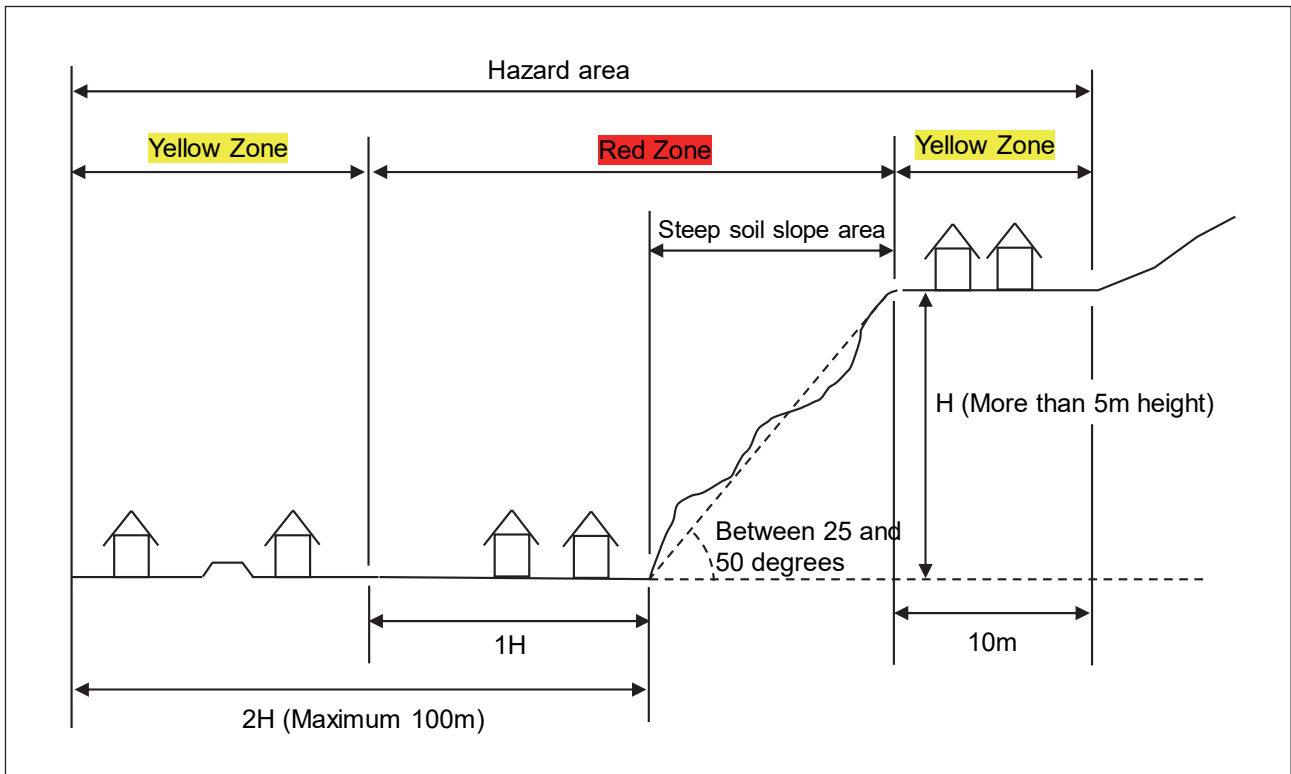


Figure 11. Representation of Yellow and Red Zones for Slope Failure

#### I) Red Zone

The Red Zone for slope failure shall be set to include (Figure 12):

- c) Steep soil slope area (an area having a gradient between 25 and 50 degrees and a height of more than 5 m); and
- d) An area located within the height of the steep slope from the bottom of a steep soil slope area.

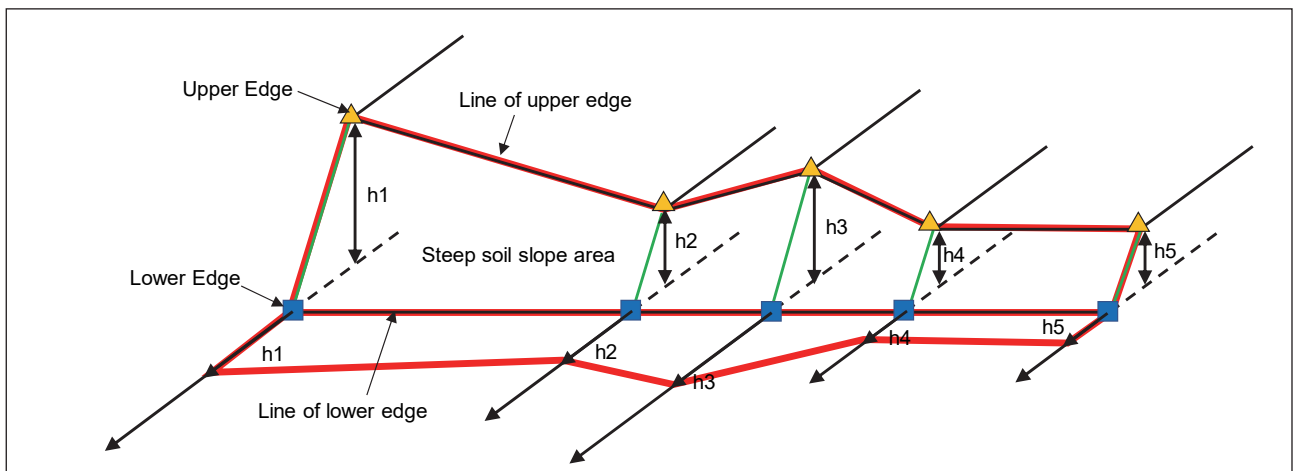


Figure 12. 3D Representation of Red Zone for Slope Failure

## II) Yellow Zone

The Yellow Zone for slope failure shall be set to include (Figure 13):

- Steep soil slope area (an area having a gradient between 25 and 50 degrees and a height of more than 5 m);
- An area located within a horizontal length of 10 m from the upper edge of a steep soil slope area; and
- An area located within twice the height of the steep soil slope area (if this exceeds 100 m, the limit is 100 m) from the bottom (or lower edge) of a steep slope area.

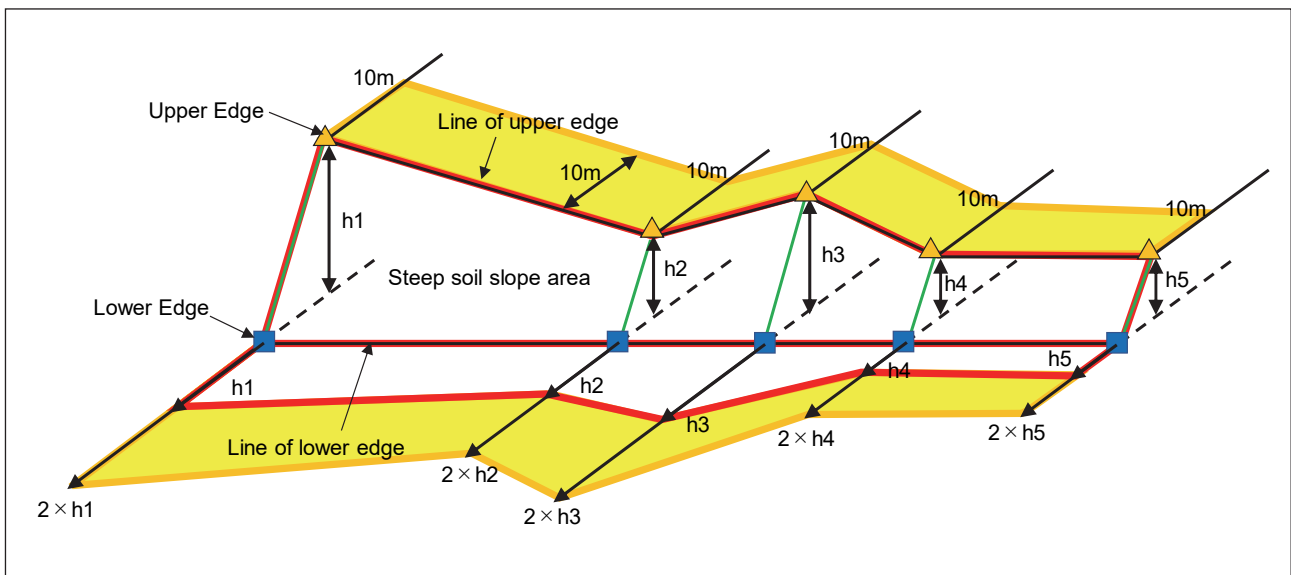
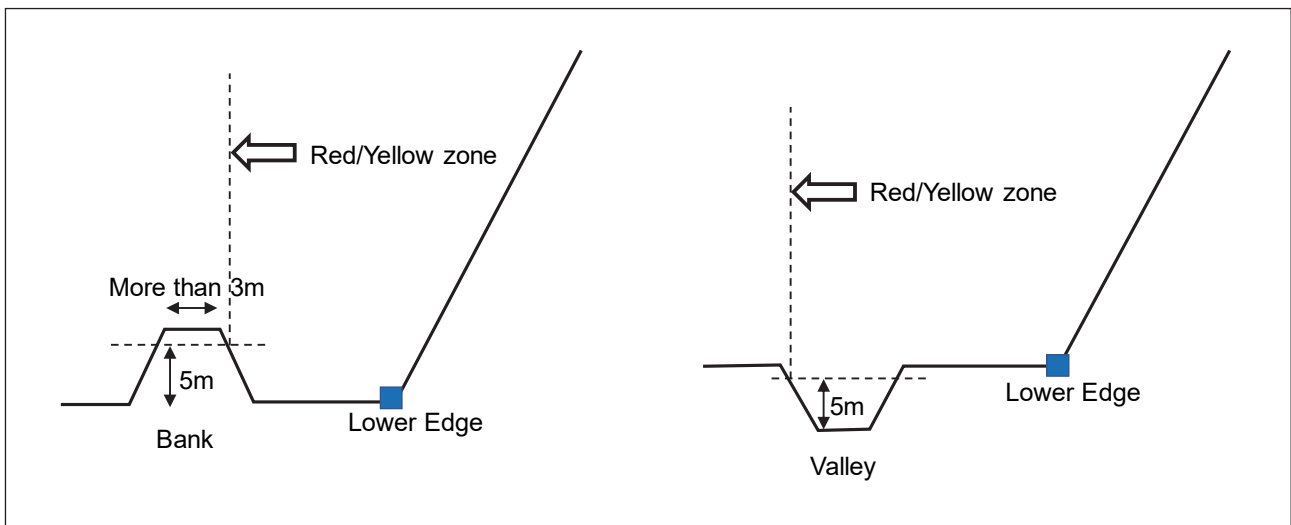


Figure 13. 3D Representation of Yellow Zone for Slope Failure

### (8) Excluded Part of the Area where No Collapsed Sediment Is Reached

A part of the area which is clearly not observed within the reach of the collapsed sediment from its topographical features or structural obstacles should be properly modified and then excluded from the Yellow and/or Red zones (Figure 14). These topographical features and structural obstacles are as follows:

- Embankment, Excavation
- Channel, river
- Wall, Retaining wall
- Other structures



**Figure 14. Diagrammatic Illustration of Excluded Part of the Yellow and Red Zones**

#### **2.4 Field Survey to Finalize the Zones**

Field survey is conducted to finalize the Yellow and Red Zones set by the above-mentioned desk study. The field survey for the target area and its surroundings shall be conducted on the following items:

- Topographical conditions
- Lower and upper edges
- Slope angle and height
- Left and right edges
- Artificial structures, etc.

In addition, if the target area is observed from the field survey to have a slope height of over 100 m and consist of fresh hard rocks with less fractures, it should be excluded from the hazard zones.



## REFERENCE DATA

### Background Data for Setting Hazard Zone for Slope Failures

About 60 past soil slope failure disasters were collected from:

- a) Landslide Disaster May 2017 – Damages and Loss Assessment, Prepared by NBRO, including 35 disaster events occurring in 2017
- b) Reduction of Landslide Vulnerability by Mitigation Measure Projects - Cost Benefit Analysis, Prepared by NBRO, in October 2018, including 50 disasters events

The main results of the collected past slope failure disasters are shown in Figures A.1 to A.3 and summarized below:

- a) Slope failures are related largely to slope steepness (Figure A.1) and slope height (Figure A.2). When slope angle is 25 degrees or more, the number of slope failures tends to increase rapidly. Most slope failures occurred intensively on slopes with a slope angle of 25 to 50 degrees and a slope height of 5 to 40 m, accounting for about 80% of the total number of the past slope failures.
- b) The reaching distances of the collapsed sediment are related to the heights of slope failures (Figure A.3). In most cases, the reaching distances are within twice the height of the slope failures (Figure A.3 - a)), but with a limit of about 100 m (Figure A.3 - b)).

Geologically, the average friction angles are generally around 25 to 35 degrees for loose sandy soils, and 30 to 50 degrees for loose gravelly soils, respectively. A steep slope with a gradient of 25 degrees or more may be likely to occur especially as excessive pore water pressure increase during intense rainfall.

In addition, the elevated steep slopes are more susceptible to become unstable, especially relating to soil slopes. Accordingly a slope height of 5 m or higher can be used to limit the target steep slope selection in consideration of its susceptibility or vulnerability.

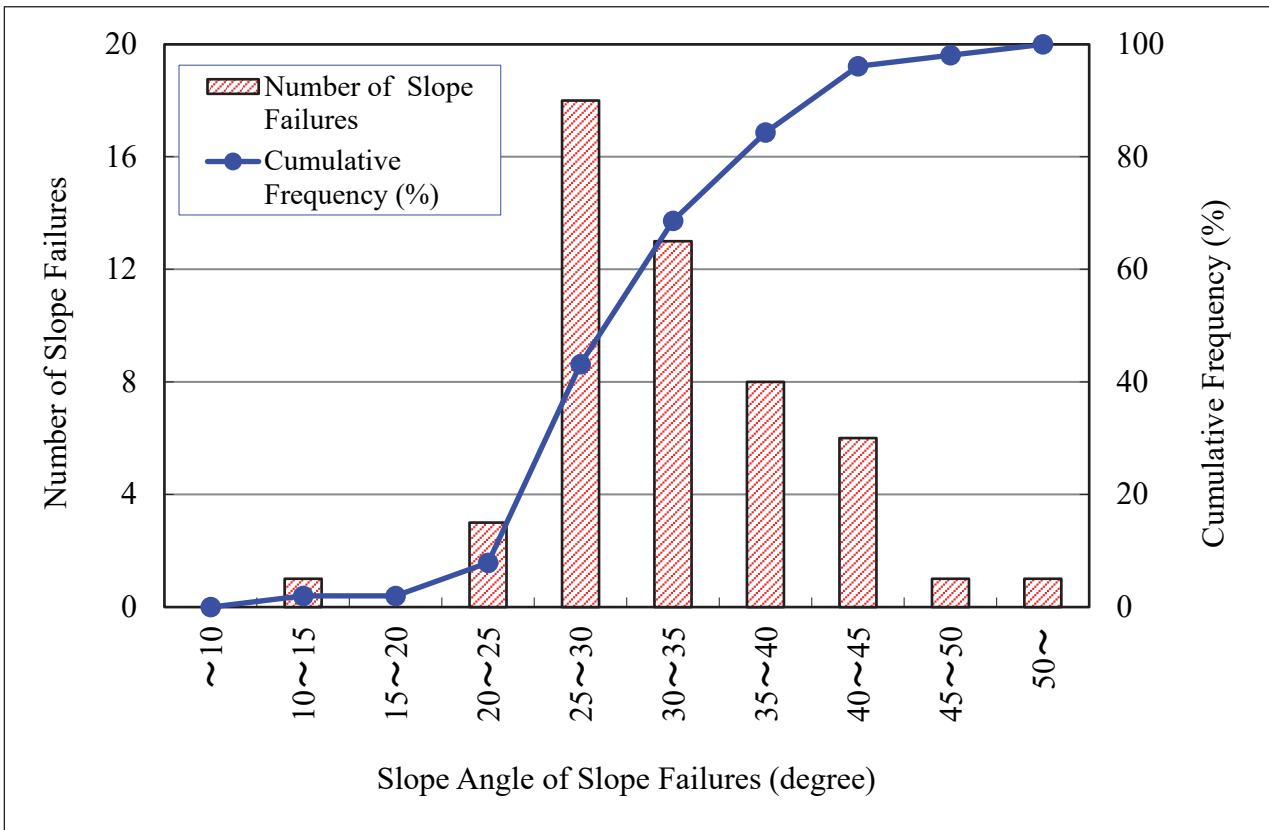


Figure A.1 Frequency Distribution of Slope Angle in Soil Slope Failures

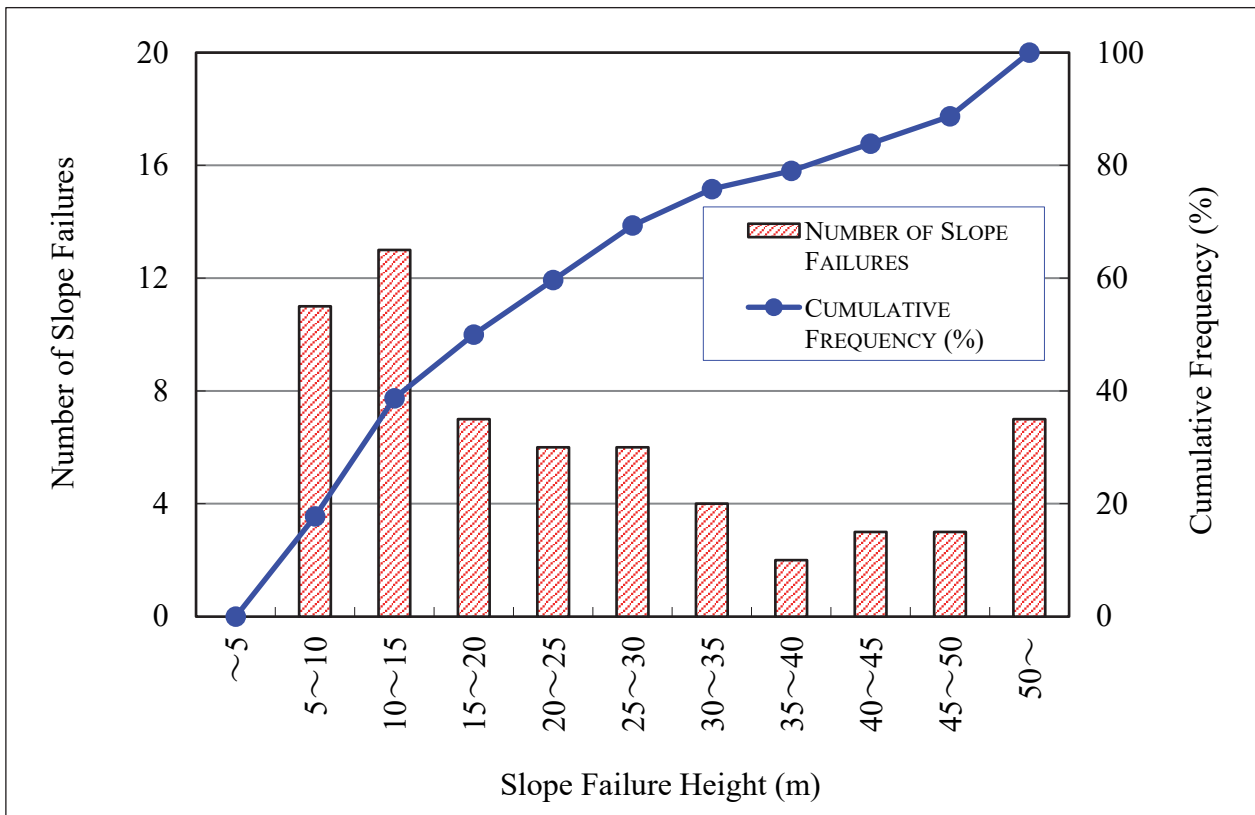


Figure A.2 Frequency Distribution of Height of Soil Slope Failures

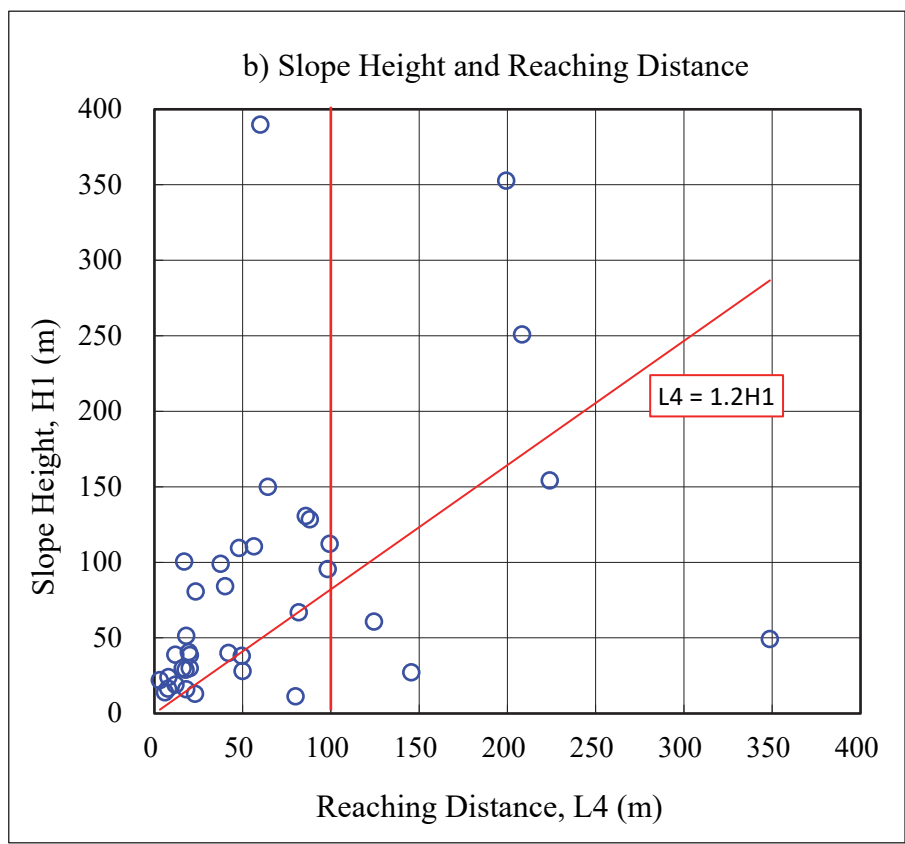
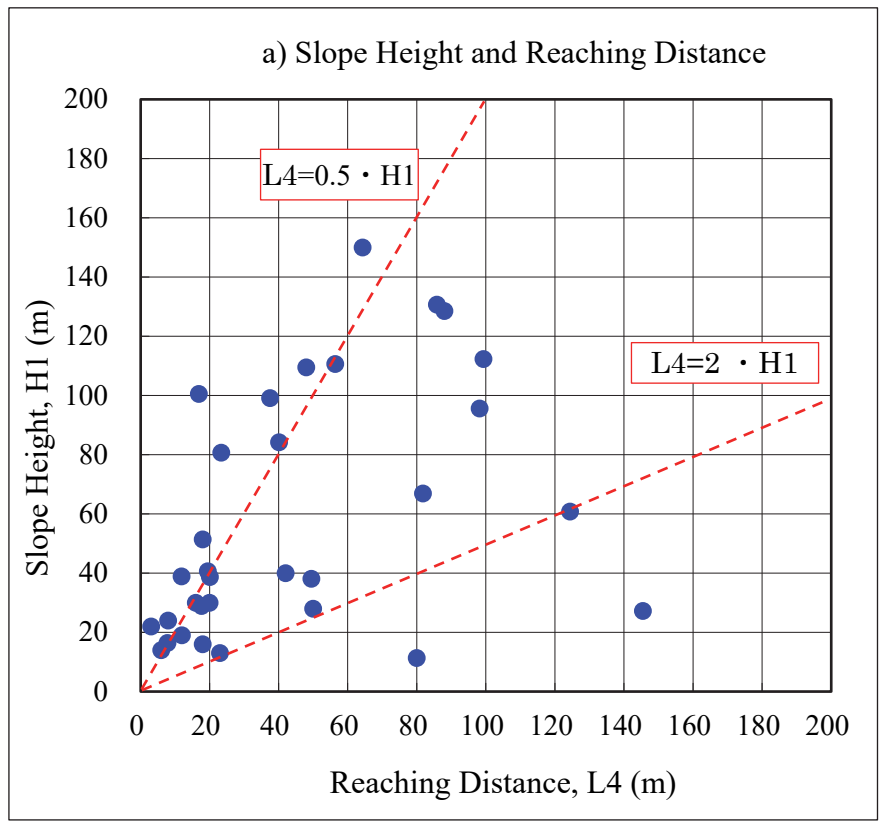
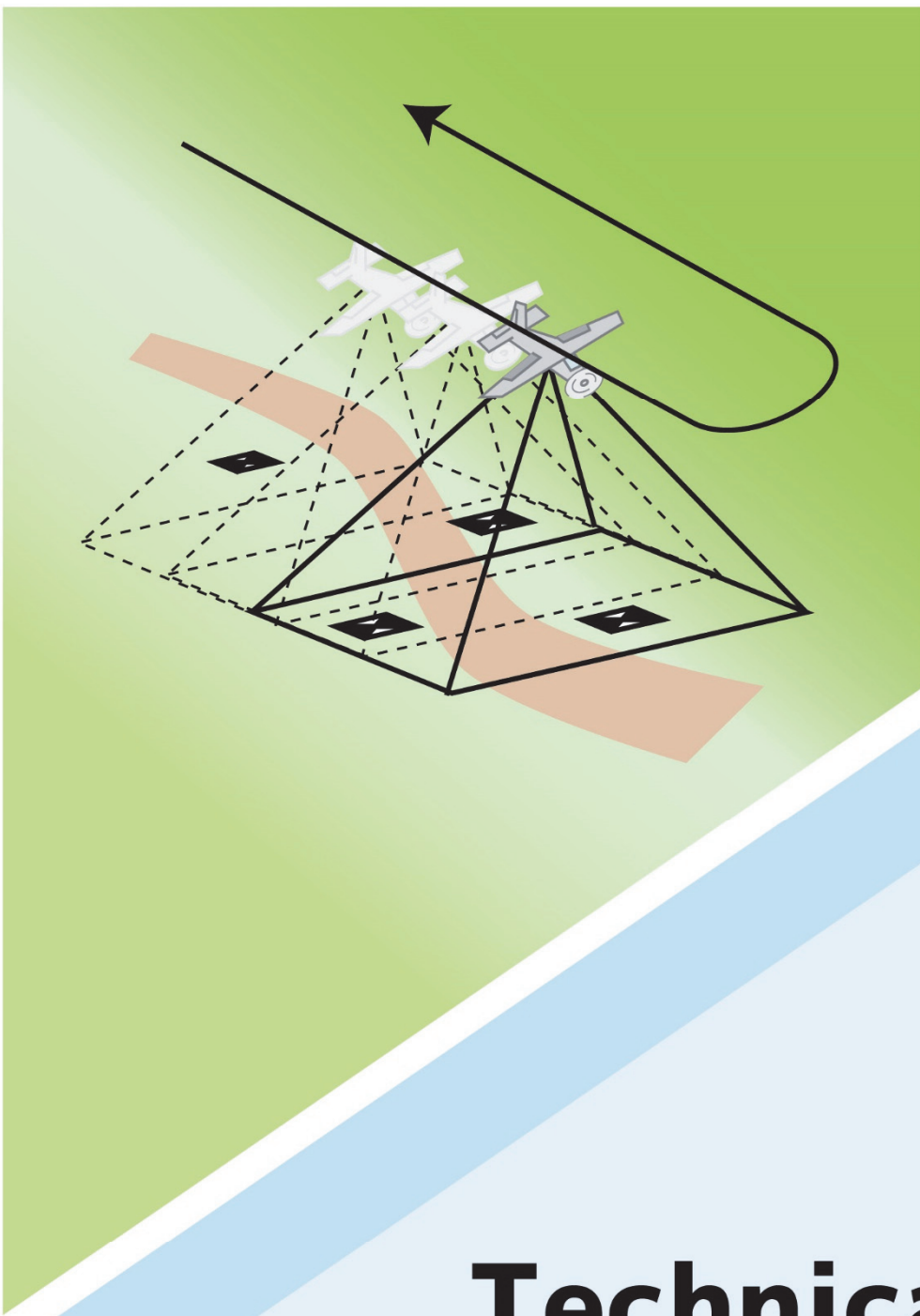


Figure A.3 Relationship between Slope Height and Reaching Distance



# Technical Note 2

## Aerial Photograph Interpretation of Landslides

**Under this technical note,  
aerial photograph interpretation of  
landslides is provided  
as reference for Chapter 5**

**TECHNICAL NOTE 2**

No. : WG01-01

Date : 2019/02/28

## **Aerial Photograph Interpretation of Landslides**

### **1. Introduction**

Previous studies on landslides have indicated that landslides are mostly likely to occur in areas where they have already occurred in the past. In many cases, the topographical features surrounding a landslide area provide evidence of past and ongoing landslide activity. Geologically, landslide activity or movement is one of the geomorphic processes through which hillslopes evolve. The history of landslide activity in any region through time can often be deciphered on scales ranging from some years to decades even longer period. Accordingly, landsliding areas, either past or ongoing, are particularly important to identify, as they may pose a substantial potential for future instability and help identify areas that are susceptible to future landslides.

Aerial photograph interpretation (API) of landslides is done through the visual analysis of stereoscopic aerial photographs, to identify landslide morphological forms - landforms or topographies that are formed associated with landslide activity, thereby identifying landslide areas. The API is the first and important step of landslide investigations. The API technique, as well as other image interpretations such as high-resolution satellite image and light detection and ranging (LIDAR), has become a useful tool for landslide inventory mapping, greatly contributing to assessing landslide hazard, susceptibility and risk, and to developing susceptibility models to predict landslides based on past conditions.

The term “landslide” has been widely used in general sense to describe all types of gravitational slope movements of a mass of rock, debris or earth down a slope, including fall, topple, flow, slide and spread (Varnes, 1978, and Cruden and Varnes, 1996). However, this technical note focuses mainly on landslides that narrowly refers to the slow movement of a mass of rock, debris or earth along a pre-existing shearing surface or zone (surface of rupture). Such landslides generally occur repeatedly over a long period of time.

This technical note is based on the synthesis of literature reviews of relevant references and our experiences. The purpose of this technical note is to provide basic knowledge and guidance on aerial photograph and topographical interpretations for identification and recognition of landslides.

### **2. Basic Knowledge and Information**

#### **2.1 Photograph Overlap**

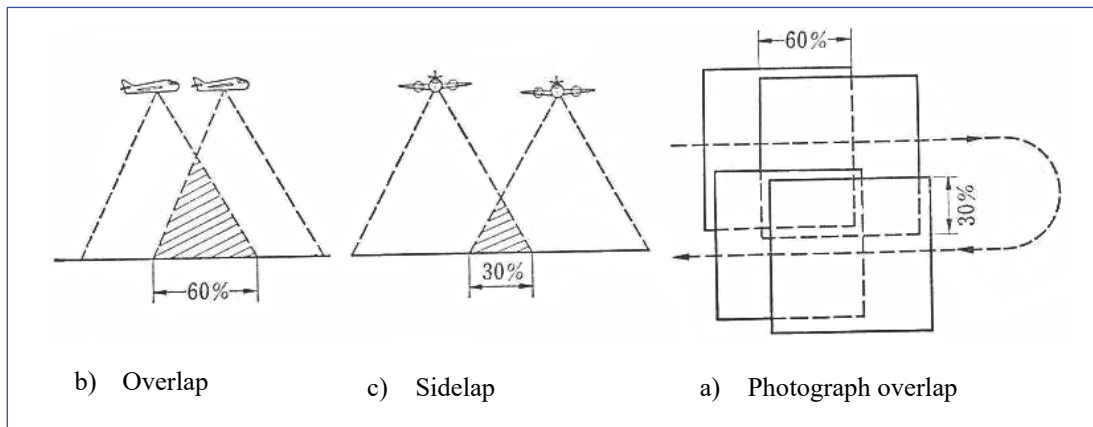
Aerial photographs are taken from high up in the sky looking down vertically at the ground. The aerial photographs record everything on the ground through the lens of the camera. They consist of a series of images taken from an airplane flying on pre-determined flight paths or lines. These lines are equidistant from, and parallel to one another. Thus, the resulting photographs line up at equal intervals within the flight path, generally with 60% overlap and 30% sidelap (Figure 1).

#### **2.2 Principle Point**

The exact center of an aerial photograph is called Principal Point. The principle point is the point on

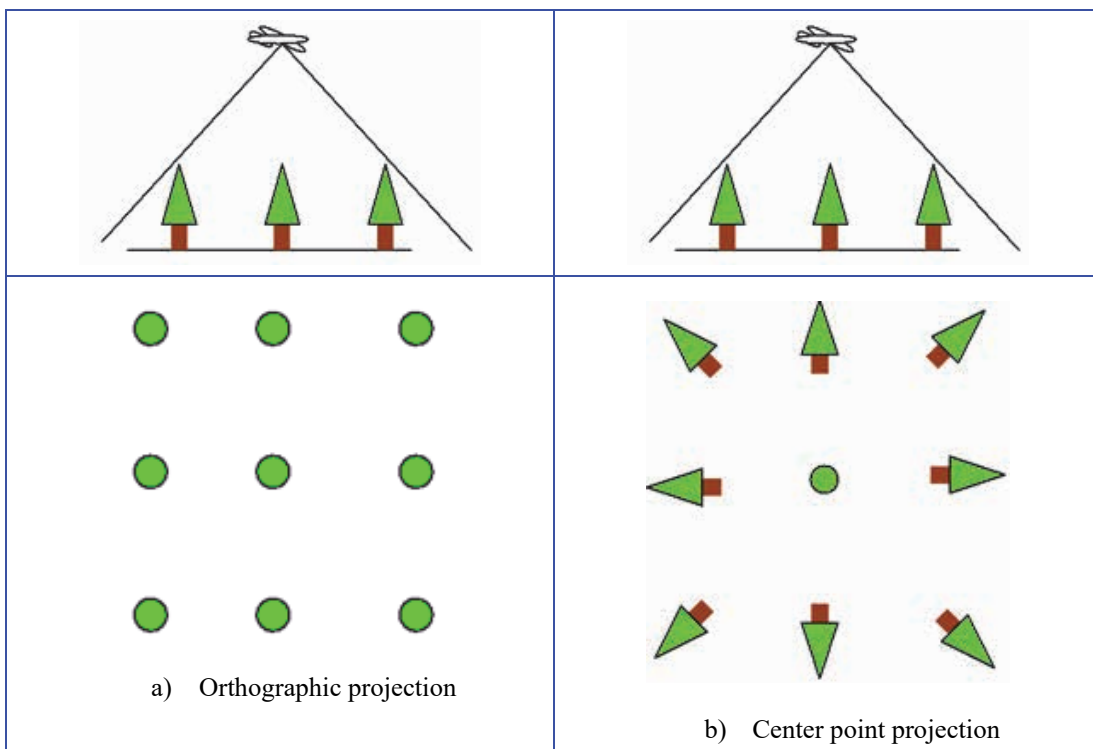
the ground located immediately below the camera lens looking down vertically. The principal point is defined as the intersection point of two diagonal lines between principal point indicating marks on the outer frame of an aerial photograph.

If the airplane is carrying the camera by maintaining a straight-and-level flight path, the appearance of objects at the principal point is identical to how they appear on the ground (Figure 2a). However, when the airplane deviates from a straight-and-level flight path due to air turbulence, the camera lens will tilt slightly, and the photograph will show a slightly slanting view of the objects (Figure 2b).



**Figure 1 Overlap and Sidelap of Aerial Photographs**

In the middle of a photograph (i.e. the principal point), objects are correctly presented in their standing (vertical) position. As airplane moves away from the principal point toward the edge of the photograph, objects appear in a slanting position.



## Figure 2 Difference between Center Point and Orthographic Projections

### 2.3 Principal Line

Because aerial photographs are taken with a 60% overlap., and therefore, the same scene is shown on the right half of the left photograph and the left half on the right photograph. This pair of two photographs is called Paired Photographs. Paired Photos show the same scene but from different slants (or angles). This is the basis for obtaining a stereo view. The principal points of each aerial photograph are also shown on the other aerial photographs of the same scene. The line connecting the principal point on the paired photographs is called the Principal Line. The line shows the flight path followed by the airplane used to take the aerial photographs.

### 2.4 Photograph Scale and Screen Size

Aerial photographs are generally taken at a scale of 1:10,000 to 1:50,000. The photograph scale, S, is the ratio of a distance between two points on a photograph (picture) to the corresponding actual distance, as in the case of topographic map.

$$S = f/h$$

Where, f: focal distance of lens (mm) and h: flight altitude (m).

For example, if the focal distance and the flight altitude of photographed ground surface are 150 mm and 1,500m respectively, then the aerial photograph scale is

$$S = 150\text{mm}/1,500 \times 1,000\text{mm} = 1/10,000$$

If the average flight altitude of photographed ground surface is 750m, then the aerial photograph scale is

$$S = 150\text{mm}/(1500-750) \times 1,000\text{mm} = 150/750,000 = 1/5,000$$

In addition, the effective screen size of aerial photograph is generally 230 mm×230 mm (or 9 inch×9 inch).

### 2.5 Interpretation Equipment

Aerial photograph interpretation is conducted with a zoom-stereoscope or pocket stereoscope. In addition, ruler, color pencil, and topographical map need to be prepared. The ruler is used for locating principal points and setting the principal lines. Topographic map is used to delineate landslide areas interpreted from aerial photographs for future field check and confirmation.

An experienced geologist can often obtain a stereo-view only through his naked eyes. The following is simple method to help beginners practice stereo-viewing with the naked eye.

- a) Place a card standing upright between photograph on the right side and photograph on the left side. This will block the right eye from seeing the left side photograph and the left eye from seeing the right-side photograph.
- b) Bring your face close to the photographs and focus each on the photograph (i.e. right eye on right photograph and left eye on left photograph).
- c) Focus intensively. You will image that the photographs move close to one another and finally overlap, producing a three-dimensional image.



- d) Repeat the above process, to become familiar with the phenomena of two pictures blending into one image.
- e) Try the same practice without a card between the right and left side pictures.

### 3. Aerial Photograph Interpretation (API)

The API generally involves the identification of significant differences appearing on the photographs (ground surface), and then determining what these differences mean. The main factors in interpreting the photographs include shape, size, photographic color, tone, mottling, texture, pattern of objects, site topography, and setting. Shape refers to the form of the topographic surface. Because of the vertical exaggeration of stereoscopic vision, shape is the most useful characteristic for the identification of a landslide from aerial photographs.

Once a landslide occur, the area leaves discernible signs, most of which can be recognized and mapped through the interpretation of (stereoscopic) aerial photographs or field investigation. Most of the signs left by a landslide are morphological i.e., they refer to changes in the form, shape, position, or appearance of the ground (or topographic) surface. Size describes the area extent of an object. The physical dimensions of an object are used to identify properties such as extent and depth. Color, tone, mottling and texture depend on the light reflected by the surface, and can be used to infer rock, soil and vegetation types. Mottling and texture are measures of terrain roughness and can be used to identify surface types and the size of debris. Pattern is the spatial arrangement of objects in a repeated or characteristic order or form.

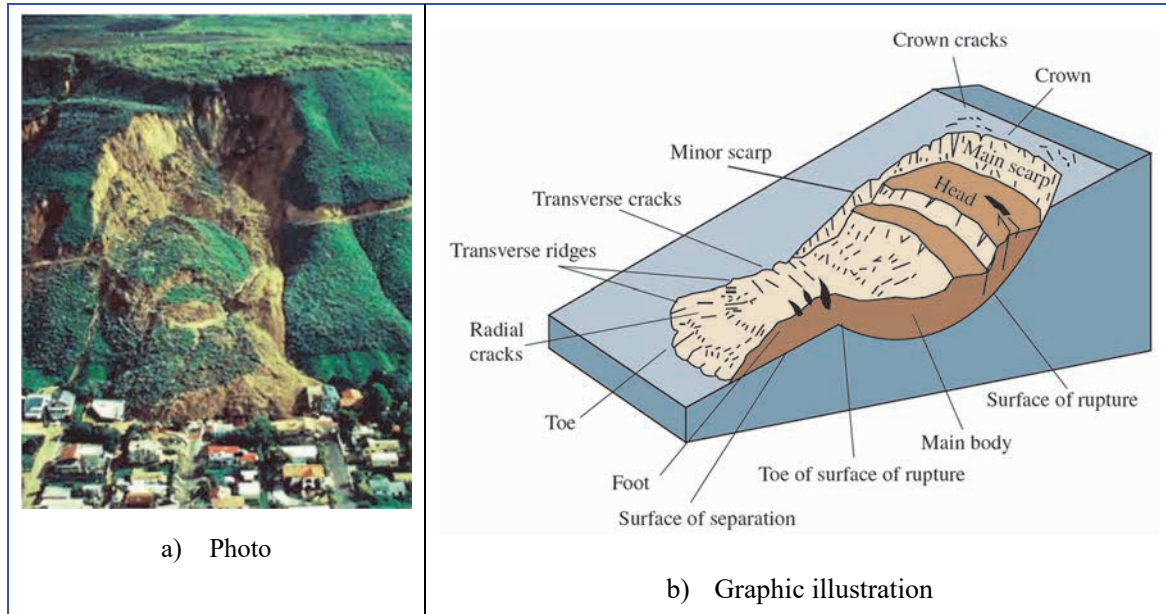
The interpretation of aerial photographs to recognize landslides generally involves the following three steps (Harold and Liang, 1978):

- a) To examine the photographs to get a 3D perception
- b) To identify and interpret ground conditions and ground surface features by looking for certain elements (for example, landforms, landscape unit, patterns, etc.) appearing in the photographs
- c) To analyze specific problems (landslide topography or similar landforms by geological processes) by the association of ground conditions using photograph interpretation techniques

Figure 3 schematically illustrates landslide features, while Table 1 summarizes typical points for the identification of landslide area. Typically, a landslide area shows below (Figure 3):

- a) A horseshoe-shaped or concave scarp – abrupt change in slope profile is interpreted and distinguished by a near vertical or concave slope at the head of the landslide.
- b) There are concavities, depressions, parallel cracks, etc. or there is a long and narrow depression at the upper part of the landslide.
- c) Gently, hummocky topography – local topography is uneven particularly in comparison to adjacent areas at the middle part of the landslide.
- d) Bulge toe - convex, hummocky zone of accumulation is characterized by the presence of a convex profile and arcuate plan.

- e) Deep gullies eroded into the weak, disturbed soils and rock, disrupted or poorly developed drainage patterns and high drainage density; closed depressions and ponds within the landslide area.



**Figure 3 Typical Landslide Topography**

In addition, the morphological signature of a landslide depends on landslide type, movement rate and activity. In general, the same type of landslide will result in a similar landslide signature. The morphological signature left by a landslide can be interpreted to determine the extent and arrange of the landslide, to infer the type of landslide, and to divide the landslide area into different movement blocks and their relationship (for example, main blocks, joining blocks, ending blocks, branch blocks, etc.). From the visual appearance of a landslide, qualitative information on the degree of activity, age, and depth and geometry of the rupture surface can be inferred.

Based on the landslide characteristics of the identified items, landslide areas are identified and plotted for further topographic interpretation and field investigation.

**Table 1 Summary of Main Features to Be Identified and Interpreted**

Item		Description
1	Surface deformation	Head or main scarps, cracks, toe collapses, a marshy zone or a crack on one or both sides of landslide area
2	Micro-relief	Depressions, bulge, small steps, and irregular undulation of slopes.
3	Abnormal landforms	Arch-shaped escarpments, convex ridge, concave mound, steep scarp above a gentle slope, hummocky topography, hillside benches, constrictions and widening of valleys and asymmetrical cross sections, hanging valleys, unusual changes in slope angle, colluvial slopes and alluvial filled river courses, active down cutting.

4	Water fluctuation	hillside ponds, swamps, marshes, linear arrangement of springs and ponds, small gullies, seepage areas, local infiltration sources, disrupted drainages
5	Vegetation	landslide area is generally covered by thin vegetation than its surrounding areas
6	Landslide area	bordered by head scarps (or cracks), toe bulges (or small collapses) and side cracks
7	Movement direction	perpendicular to head scarps or head cracks, and almost parallel to side cracks
8	Geologic information	lineament, rock type, joint condition, double ridges, weathering
9	Deformed facilities	Cracks on house walls, on or across a road, subsidence of house foundation, etc.

#### 4. Topographical Expression and Topographic Interpretation

Like aerial photograph interpretation, topographical maps have been used to delineate landslide areas. In general, topographic maps at a scale of 1:1,000 to 1:10 000 is most effective and useful for interpreting landslide areas.

Figure 4 shows the topographical expression of a typical landslide areas. On topographic map, a landslide area shows irregular contour lines compared to its surrounding areas, - contour lines are dense in the upper section of a landslide area, sparse in the middle section, and dense again in the lower section (Figure 4).

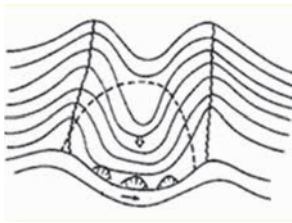
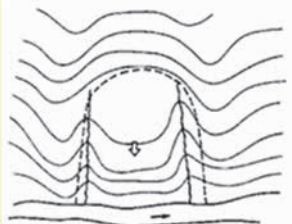

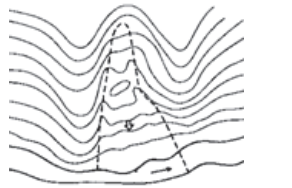
In general, different types of landslides have different diagnostic topographic features. As described above, a landslide may move again and again over a long time. In Japan, landslides are subdivided, in terms of movement process and material type, into the following four types (Watari, 1987), as shown in Figure 5, of which type has different topographical features, as summarized in Table 2.

- a) Bedrock landslide
- b) Weathered rock landslide
- c) Colluvial soil landslide
- d) Cohesive soil landslide

The classification scheme considers mainly a) type of landslide material, b) geology and topography, c) velocity of movement, and d) degree of activity, and has been used for the identification of landslides, and the management and reduction of landslide risks in Japan.



**Table 2 Summary of Topographic Features Related to Different Landslide Type**

Landslide Type	Main Topographic Feature	Plan sketch
Bedrock	<ul style="list-style-type: none"> <li>- Mostly occurs with a convex-ridge type landform, but generally without clear topographic features because of first-time slide</li> <li>- Involves fresh rock with joint controlled crown and rupture surface.</li> <li>- Main carps are near vertical, with chair-shaped or planar rupture surface.</li> <li>- Cracks occur in proportion to the movement distance, first developing at the flanks, toes and heads of the landslides.</li> <li>- Small collapses may be caused by compression at the toes.</li> </ul>	
Weathered rock	<ul style="list-style-type: none"> <li>- Has a clear landslide topography – convex-plateau landform due to its large-distance movement and recurrence.</li> <li>- The rupture surfaces tend to be planar near the toe and become circular towards the heads with further movement.</li> <li>- Accompanying colluvial and cohesive soil collapses may occur around the toes.</li> <li>- Shows clear vegetation contrast with surroundings, and absence of land use indicative for activity.</li> </ul>	
Colluvial soil	<ul style="list-style-type: none"> <li>- Has a clear landslide topography – concave landform, mostly subdivides into some blocks.</li> <li>- Shows stepped and hummocky slope within the landslide areas.</li> <li>- Accompanies the distribution of ponds, swamps and hollows. Sometime shows parallel drainage on both sides of landslide areas</li> </ul>	
Cohesive soil	<ul style="list-style-type: none"> <li>- Shows clear landslide topography – generally long, gently, narrow, concave slopes, and mostly subdivides into multiple small slide blocks.</li> <li>- Landslide mass displays clear flow structure (ground appearance) with arcuate convex toe part.</li> <li>- Drainage is generally defected or blocked by frontal bulges</li> </ul>	



## 5. Field Check and Confirmation

The identification of landslide areas and blocks based on the interpretation of aerial photographs and topographic maps is an essential part of landslide investigation. However, the results and precision of photograph and topographic interpretations generally vary with such factors as the time when the photographs are taken, photograph scale, difference in flight altitude within the landslide areas to be investigated, vegetation cover, colors, land use, etc.

In addition, landslides are mostly undergoing dissection due to erosion and human activity, and therefore are difficult to be recolonized from aerial photograph and topographic interpretations. Moreover, because morphological convergence is possible, resulting in the same or similar morphological forms from different geological processes, not from landslide activity.

Therefore, following the interpretation of aerial photographs and topographic maps, field investigation shall be further conducted to supplement the interpreted results.

In addition to the above-mentioned landslide topographies, field investigation should be carried out to verify landslide occurrences and to identify any landslide signs not observed on aerial photographs and topographical maps, particularly focusing on the followings:

- a) Shape of scarps and distribution of cracks: The location and direction of movement of landslide head part can be generally estimated from the shape of concave scarps. The boundaries of a landslide area and its blocks can be delineated from the distribution of cracks.
- b) Local small settlements and bulges: Geometric shape of topography and configuration of cracks indicate approximate locations and ranges of tension and compression zones. This information is very useful for delineating landslide area and subdividing movement blocks within a landslide area.
- c) Steps, land use (boundaries of land, location of roads and houses, etc.): These may show signs of previous ground movements. Such information is useful in identifying landslide area and its movement blocks.
- d) Coniferous trees with curved or bent roots and bamboo forest (which are usually wet/damp): These are places to check and determine if there is any potential or previous landslide areas.
- e) New cracks and signs of previous cracks: The arrange of landslide areas, and previous and present movements can be estimated from such cracks and signs of previous cracks. The information is useful in evaluating landslide activity and delineating landslide areas.
- f) Distribution and location of cracks, present and previous: The information provides clues to estimating or identifying landslide activity, movement direction, geometry of rupture surface, and tension and compression zones.

## 6. Summary and Recommendations

- a) Aerial photograph and topographic interpretations together with field investigation have been the most useful and widely used methods to locate and identify landslides particularly on a wide scale. They have been used to develop landslide inventory maps to a large region, providing the basis for assessing landslide hazard, susceptibility and risk.
- b) No standards of aerial photograph and topographic interpretations exist. Such interpretations, empirical and uncertain techniques, are based on interpreter's experience and on the analysis of a set of landslide morphological forms (or signatures by landslide) identified and interpreted from aerial photographs. An effort should be made to improve interpretation capacity through the repetition of interpretation and field confirmation.
- c) The interpretation of aerial photographs has been described in detail, including geological and topographic interpretations in many textbooks, to which reference is made for further information and guidance.

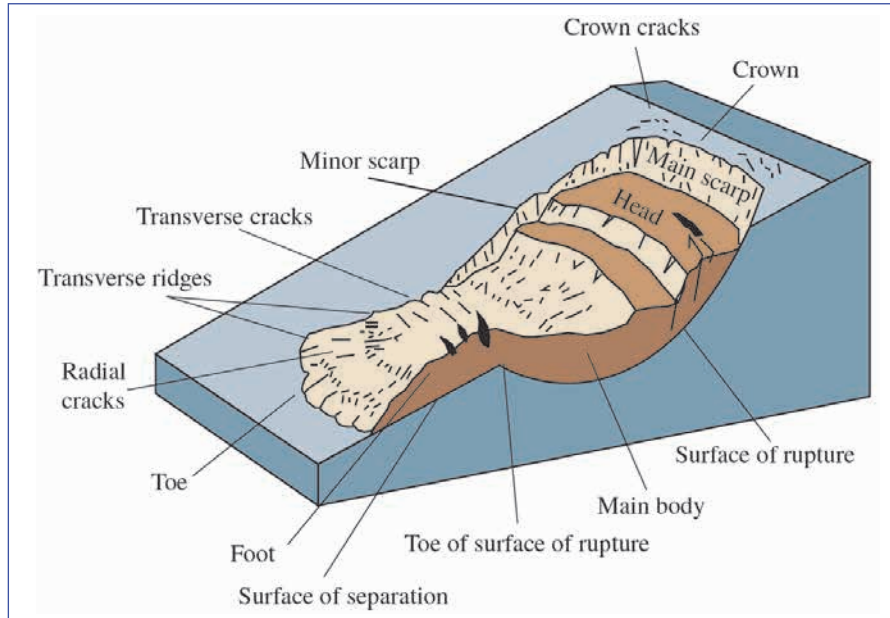
## 7. References

- Cruden, D. M., & Varnes, D. J. (1996). Landslide Types and Processes. In A. K. Turner & R. L. Schuster (Eds.), *Landslides Investigation and mitigation*. Washington, D. C.: Transportation Research Board, Transportation Research Board. Special Report 247, p. 36–75.
- Harold T. R. and T. Liang, 1978, Recognition and Identification, in Schuster, R.L., and Krizek, R.J., eds., *Landslides Analysis and Control*, Special Report 176: Washington, D.C., Transportation Research Board and National Academy of Sciences, p.34–79.
- Varnes, D.J., 1978, Slope movement types and processes, in Schuster, R.L., and Krizek, R.J., eds., *Landslides Analysis and Control*, Special Report 176: Washington, D.C., Transportation Research Board and National Academy of Sciences, p.11–33.



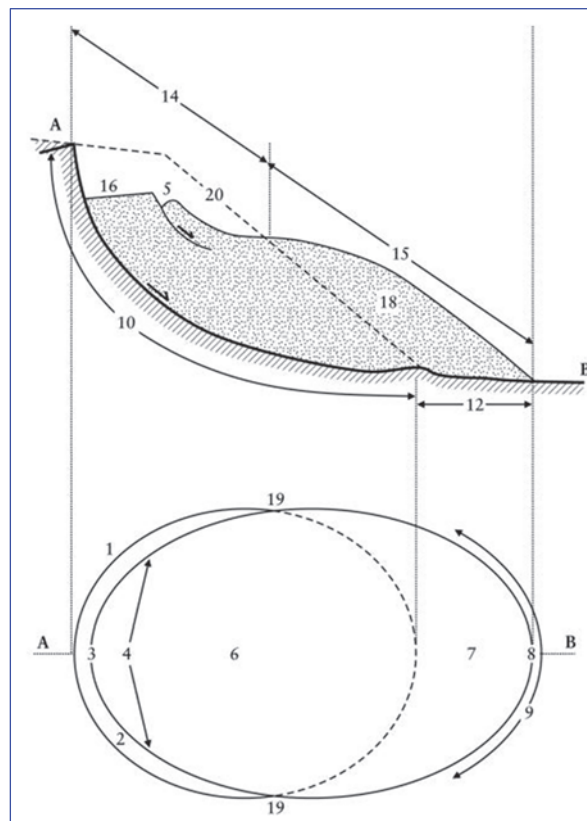
## Appendix A Definitions of Key Landslide Features

The key landslide features are generally defined as follows (see Table A01 and Figures A01 and A02):



Source: Varnes (1978)

**Figure A01. Typical Landslide with Commonly Accepted Terminology**



**Figure A02. Illustration of section and plan views of a landslide**

**Table A01. Definition of Key Landslide Features**

No.	Name	Definition
1	Crown	The practically un-displaced material still in place and adjacent to the highest parts of the main scarp.
2	Main Scarp	A steep surface on the undisturbed ground at the upper edge of the landslide, caused by movement of the displaced material away from the undisturbed ground. It is the visible part of the surface of rupture.
3	Top	The highest point of contact between the displaced material and the main scarp.
4	Head	The upper parts of the landslide along the contact between the displaced material and the main scarp.
5	Minor Scarp	A steep surface on the displaced material of the landslide produced by differential movements within the displaced material.
6	Main Body	The part of the displaced material of the landslide that overlies the surface of rupture between the main scarp and the toe of the surface of rupture.
7	Foot	The portion of the landslide that has moved beyond the toe of the surface of rupture and overlies the original ground surface.
8	Tip	The point of the toe farthest from the top of the landslide.
9	Toe	The lower, usually curved margin of the displaced material of a landslide, it is the most distant from the main scarp.
10	Surface of Rupture	The surface which forms (or which has formed) the lower boundary of the displaced material below the original ground surface.
11	Toe of the Surface of Rupture	The intersection (usually buried) between the lower part of the surface of rupture of a landslide and the original ground surface.
12	Surface of Separation	The part of the original ground surface overlain by the foot of the landslide.
13	Displaced Mass	Material displaced from its original position on the slope by movement in the landslide. It forms both the depleted mass and the accumulation.
14	Zone of Depletion	The area of the landslide within which the displaced material lies below the original ground surface.
15	Zone of Accumulation	The area of the landslide within which the displaced material lies below the original ground surface
16	Depletion	The volume bounded by the main scarp, the depleted mass and the original ground surface.
17	Depleted Mass	The volume of the displaced material, which overlies the rupture surface but underlies the original ground surface.
18	Accumulation	The volume of the displaced material, which lies above the original ground surface.
19	Flank	The un-displaced material adjacent to the sides of the rupture surface. Compass directions are preferable in describing the flanks but if left and

		right are used, they refer to the flanks as viewed from the crown.
20	Original Ground Surface	The surface of the slope that existed before the landslide took place.

Source: Modified from Multilingual Landslide Glossary (WP/WLI, (1993).



---

**Developed by Project for Capacity Strengthening on Development of  
Non-Structural Measures for Landslide Risk Reduction in Sri Lanka (2022)**

# Manual for Landslide Risk Assessment based on Yellow and Red Zone Map

**Project for Capacity Strengthening  
on Development of Non-Structural  
Measures for Landslide Risk  
Reduction in Sri Lanka**

October, 2022



**National Building Research Organisation  
(NBRO)**



**Japan International Cooperation Agency  
(JICA)**





**Democratic Socialist Republic of Sri Lanka**

**Project for Capacity Strengthening on Development of Non-Structural Measures  
for Landslide Risk Reduction in Sri Lanka**

**Manual for Landslide Risk Assessment  
Based on Yellow and Red Zone Maps**

**October, 2022**

**National Building Research Organisation (NBRO)**

**Japan International Cooperation Agency (JICA)**





## **Preface**

Landslides are the most pressing natural hazard faced by the inhabitants of mountain regions of Sri Lanka. As the leading provider of landslide risk management services in Sri Lanka, the National Building Research Organisation (NBRO) has been building upon its expertise in the field and multi-disciplinary capabilities towards minimizing the landslide risks faced by nation in their living environment.

Project “SABO” is a technical cooperation project undertaken by the Japan International Cooperation Agency (JICA) conjointly with NBRO intended at capacity strengthening of development of non-structural measures for landslide risk reduction in Sri Lanka. Drawing on Japanese expertise and adopting Japanese methods, the project was able to apply a methodology called Yellow/Red Zoning to map total impact zones of local landslides. As understanding the risk levels within the impact zones is essential for effective development of appropriate disaster risk reduction measures, a score based approach for determining the risks associated with impact zones was also developed under the project, and is explained at length in this manual.

We hope that this manual will be useful to the readers in various departments, especially landslide risk reduction practitioners in Sri Lanka. Readers are most welcomed to make wide use of this manual by understanding, learning and replicating the techniques in their respective department/organizations to create risk maps in the future.

Last but not least, it should be pointed out that this document is the outcome of extensive desk and field studies done by JICA and NBRO officials. While appreciating their hard work in bringing out this publication, it is expected that the users of this manual will find their efforts worthwhile and commendable.

# Manual for Landslide Risk Assessment Based on Yellow and Red Zone Maps

## Table of Contents

	<u>Page</u>
<b>Preface .....</b>	<b>i</b>
<b>Table of Content.....</b>	<b>ii</b>
<b>List of Figures .....</b>	<b>iv</b>
<b>List of Tables .....</b>	<b>v</b>
<b>Chapter 1 Introduction</b>	
1.1 Scope and Objective of the Manual .....	1- 1
1.2 Brief Overview of Manual on Site-Specific Landslide Zoning .....	1- 1
<b>Chapter 2 Preparation for Risk Evaluation</b>	
2.1 Collection of details of demarcated “Yellow/Red Zone” s in to a database .....	2- 1
2.2 Preparation of Data for Risk Evaluation .....	2- 1
<b>Chapter 3 Methodology</b>	
3.1 Items for Risk Evaluation .....	3- 1
3.2 Risk Evaluation Criteria .....	3- 2
3.2.1 Number of Facilities for Vulnerable People .....	3- 2
3.2.2 Evacuation Places .....	3- 2
3.2.3 Public Facilities .....	3- 3
3.2.4 Number of the Above-Mentioned Facilities in Sections 3.2.1 to 3.2.3 within the “Red Zone” .....	3- 3
3.2.5 Traffic Networks .....	3- 4
3.2.6 Number of Residential Houses within the Designated “Yellow/ “Red” Zones .....	3- 4
3.2.7 Number of Residential Houses within the Designated “Red” Zones .....	3- 5
3.2.8 Land Devastation Situation .....	3- 5
3.2.9 Impacts of Past Sediment Discharge on Nearby Facilities .....	3- 6
3.2.10 Request from Residents .....	3- 7
3.3 Risk Evaluation and Risk Level Classification .....	3- 7

### **Technical Note 1**

- Conceptual Planning of Structural Measures around the Designated “Red” Zones

### **Technical Note 2**

- Guide to Landslide Inventory Sheet Records
- Landslide Inventory Sheet

## List of Figures

	<u>Page</u>
Figure 1.1 Basic Concept for “Yellow Zone” and “Red Zone” for Landslide Hazard	1-2
Figure 3.1 Concept of Risk Evaluation for the Target “Yellow/Red Zone” (for Debris Flow)	3-1

## List of Tables

	<u>Page</u>	
Table 1.1	The classification and criteria of “Yellow/ “Red” Zones	1-3
Table 2.1	Items for Database for Designated “Yellow/ “Red” Zones	2-1
Table 3.1	Criteria and Scores for Risk Evaluation for “Yellow/Red Zone”	3-1
Table 3.2	Scores allocation based on the number of facilities available for vulnerable people	3-2
Table 3.3	Scores allocation based on the presence or absence of evacuation places	3-3
Table 3.4	Scores allocation based on the presence or absence of public facilities	3-3
Table 3.5	Scores allocation based on the availability of the facilities mentioned in sections 3.2.1. to 3.2.3	3-4
Table 3.6	Scores allocation based on the class of road networks	3-4
Table 3.7	Scores allocation based on the number of residential houses located within the demarcated “Yellow/Red Zone”s	3-5
Table 3.8	Scores allocation based on the number of residential houses located within the demarcated “Red” Zones	3-5
Table 3.9	Scores allocation based on the degree of land devastation within the demarcated “Yellow/Red” Zones	3-6
Table 3.10	Scores allocation based on the presence or absence of the impacts of past sediment discharges on nearby facilities around the demarcated “Yellow/Red Zone”s	3-6
Table 3.11	Scores allocation based on the presence or absence of requests from the relevant residents or local authority	3-7
Table 3.12	Risk Evaluation Sheet for “Yellow/Red zone”	3-8
Table 3.13	Classification of Risk Level	3-9

# CHAPTER 1

## INTRODUCTION

### 1.1 Scope and Objective of the Manual

Given the steep terrains of Sri Lanka and the regular occurrence of landslide disaster occurrences, the designated “Yellow/Red Zone”s would become significantly larger in terms of number and area, according to the manual for Landslide Hazard Zonation Mapping/ Yellow and Red Zone Mapping (Total Impact Zone Map). Because of the operational and financial constraints, it is necessary to conduct further risk evaluations on the designated “Yellow/Red Zone”s at the regional and local levels, and to prioritize these designated “Yellow/Red Zone”s for additional risk reduction measures, as well as development regulation and land use planning.

No standardized risk assessment procedure has yet been developed in Sri Lanka. The general concept of risk assessment for a landslide is to examine both the likelihood and adverse consequences of a landslide hazard, then thereby address risk in totality, and finally compares the level of the resulting risk against predetermined standards or other criteria to determine risk treatment and management prioritization. To simplify matters, this manual is not intended to cover the overall processes of hazard analysis (frequency and magnitude) for risk evaluation.

The purpose of this manual is to provide a technically practical and consistent guidance on the procedures of risk assessment and subsequent prioritization on the designated “Yellow/Red Zone”s at regional or local scale for further risk reduction measures as well as land use planning, as listed in detail below:

- a) To define all risk evaluation items used in the risk assessment of each designated “Yellow/Red Zone”;
- b) To provide uniform risk evaluation sheets and forms to ensure that the risk evaluation for each of the designated “Yellow/Red Zone”s will be carried out consistently and correctly;
- c) To provide a general procedure for the prioritization of each of the designated “Yellow/Red Zone”s for further risk reduction measures mainly allowing for socioeconomic loss.

In addition, this manual is based upon Japanese experience as well as the discussion between the NBRO and the JICA Study Team.

This manual applies to all technical staff and personnel of NBRO as well as relevant organizations for the risk evaluation of each of the designated “Yellow/Red Zone”s.

### 1.2 Brief Overview of manual for Landslide Hazard Zonation Mapping/ Yellow and Red Zone Mapping (Total Impact Zone Map)

This Manual on Risk Assessment for Landslide “Yellow/Red Zone” should be read in conjunction with the manual for Landslide Hazard Zonation Mapping/ Yellow and Red Zone Mapping (Total Impact Zone Map) (Hereafter refer as Yellow and Red Zone Mapping manual”) “. For ease of

reference, this section presents a brief overview of the Hazard Zonation Mapping manual.

According to the Yellow and Red Zone Mapping manual, total impact zone maps designating “Yellow” Zone” and “Red Zone” at a scale of 1:2,500 or 1:5,000 will be prepared to regulate or control new development for housing, promote relocation of existing houses and develop early warning systems for residents within landslide hazard zones.

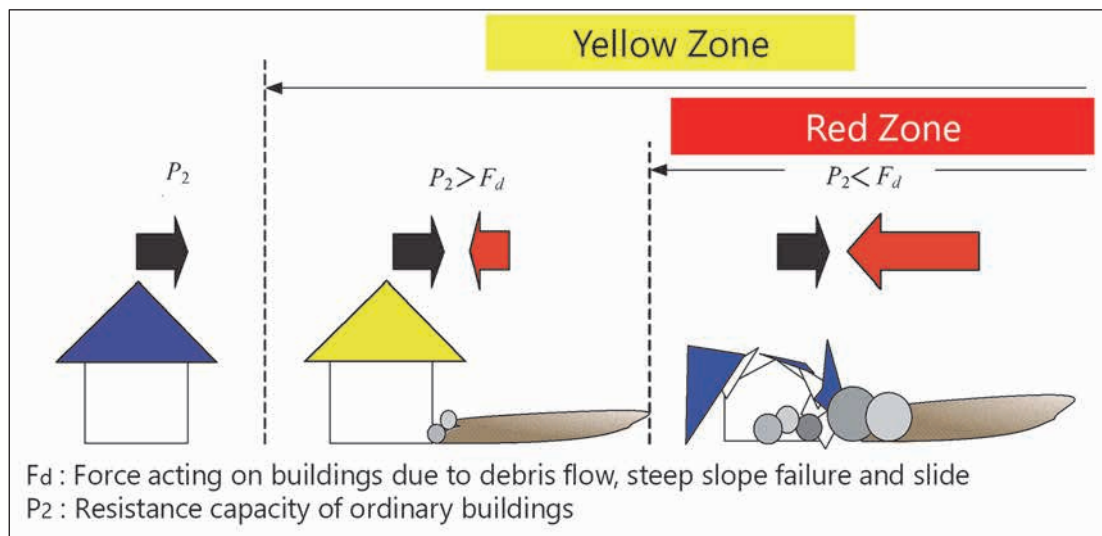
An area susceptible to landslide hazard shall be designated as a “Yellow Zone”, while an area where there is a serious risk of damage to buildings and houses and a threat to residents from landslides and associated displaced mass or landslide run out shall be designated as a “Red Zone”, as schematically illustrated in Figure 1.1 below.

If an area is designated as a “Yellow Zone”, the following actions or steps shall be taken:

- a) Establish an early warning system to monitor and predict landslide occurrence
- b) Raise awareness on landslide hazard and disaster among local people.

If an area is designated as a “Red Zone”, the following actions and steps shall be taken:

- a) Control new land development for housing and other buildings
- b) Recommend relocation of existing buildings and houses that are vulnerable to damage in case of a landslide disaster.

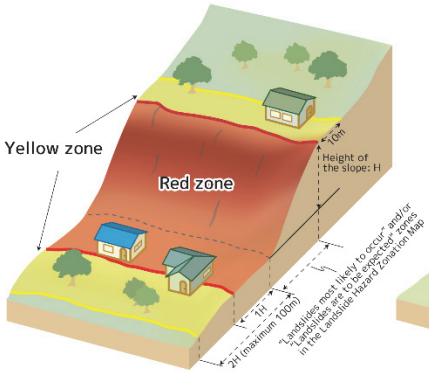
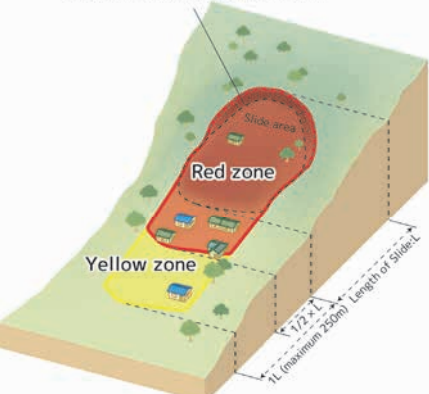


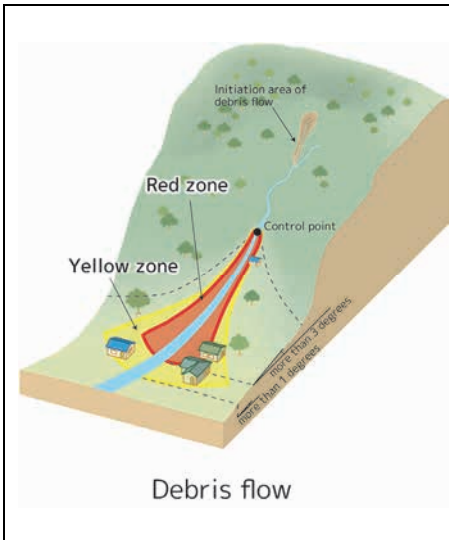
The Manual for Yellow and Red Zone Mapping focuses on three types of landslides, including a) slope failure b) slide c) debris flow. Other landslide phenomena, such as deep-seated landslides, collapse of mountain bodies or huge-scale mass movements, rock falls and lateral movements, are not common occurrences and their occurrence and run out are difficult to predict, and therefore excluded from the manual.



Table 1.1 gives the classification and criteria of “Yellow/Red Zone”.

Table 1.1 The classification and criteria of “Yellow/Red Zone” Zones

Landslide Type	Criteria of “Yellow/Red Zone”
 <p style="text-align: center;">Slope failure</p>	<p>The “Red Zone” for slope failure shall be set so that it includes:</p> <ol style="list-style-type: none"> <li>“Landslides most likely to occur” areas (brown zones) and/or “Landslides are to be expected” areas (orange zones) in the existing LHZM (Only Initiation Area maps) at NBRO as source areas.</li> <li>The area located within the distance equivalent to the height of source area from its lower edge.</li> </ol> <p>The “Yellow Zone” for slope failure shall be set so that it includes:</p> <ol style="list-style-type: none"> <li>An area located within a horizontal length of 10 m from the upper edge of the source area.</li> <li>The area located within the distance equivalent to twice the height of the source area (maximum limit 100 m) from its lower edge.</li> </ol>
<p>* If the slide is not active or the shape of the slide area is not clear, the Red zone should be changed to Yellow zone.</p>  <p style="text-align: center;">Slide</p>	<p>The “Red Zone” for an active or clear slide (Rank A) shall be set so that it includes:</p> <ol style="list-style-type: none"> <li>Slide area plus the area of main scarp.</li> <li>A section of the lower slope below the slide that is half the length of the slide area, with a maximum limit of 100 m.</li> </ol> <p>The “Yellow Zone” for an active or clear slide (Rank A) shall be set so that it includes:</p> <ol style="list-style-type: none"> <li>A section of the lower slope below the slide that is the same length and width of the slide area, with a maximum limit of 250 m.</li> </ol> <p>For potential or unclear slide (Rank B or C), only the “Yellow Zone” for slide shall be set so that it includes:</p> <ol style="list-style-type: none"> <li>Slide area plus the area of main scarp.</li> <li>A section of the lower slope below the slide that is the same length and width of the slide area, with a maximum limit of 250 m.</li> </ol>



The “Red Zone” for a debris flow shall be set so that it includes:

- a) Connected area of relative height 5 m points or spreading points with 15 degree of spreading angle on each cross section until ground gradient of 3 degrees at the lowermost end.

The “Yellow Zone” for a debris flow shall be set so that it includes:

- a) Connected area of relative height 5 m points or spreading points with 30 degree of spreading angle on each cross section until ground gradient of 1 degree at the lowermost end.

## CHAPTER 2

### PREPARATION FOR RISK EVALUATION

#### 2.1 Collection of details of demarcated “Yellow/Red Zone” s in to a database

Following the demarcation of “Yellow/Red Zone”s for the targeted area, details shown in Table 2.1 are collected and put into a database for assessing the risk. Out of these detail, some more important and vulnerable items or elements at risk as well as other data will be selected for further risk evaluation, as shown in Section 2.2 below.

Table 2.1 Items for Database for Designated “Yellow/ Red Zone”

Category	Item	
Basic information	District	
	DS Division	
	GN Division	
	ID No. (District code - GN P code- Landslide type - serial No.)	
	Name of PS	
	Landslide Type (Slope failure/Slide/Debris flow)	
	Area of “Yellow/Red Zone” (m <sup>2</sup> )	
Elements at risk	Number of facilities for vulnerable people	Facilities for the aged
		Facilities for physically handicapped persons
		Facilities for mentally retarded and disordered persons
		Kindergartens
		Maternity facilities
		Other similar facilities
	Number of evacuation places	
	Number of hospitals	
	Number of schools	
	Number of other important facilities	
	Road network	
Number of residential houses		
Impact of past sediment disaster	Land devastation situation (nothing/slight/significant)	
	Impacts of past sediment discharge on nearby facilities	
Local request	Request from residents and/or local authorities for risk reduction measures	
Countermeasures	Existing structural countermeasures	
	Existing non-structural countermeasures	
Land development plan	Presence of land development plan / land use plan	

#### 2.2 Preparation of Data for Risk Evaluation

The relevant data for further risk evaluation should be collected and assessed for each of the designated “Yellow/Red Zone”s in accordance with the actual site-specific and local conditions, as

sorted and listed below:

a) Basic information

- “Yellow/Red Zone” hazard maps (1:2,500 or 1:5,000 scale)
- Location information (ID No., District, GN division, Landslide type)

b) Information on important and vulnerable elements at risk

- Number of facilities for vulnerable people
- Number of evacuation places for a disaster
- Number of public facilities except for road networks
- Class of road networks
- Number of residential houses, within red and “Yellow Zone”s, respectively

c) Information on impact of past landslide disasters

- Land devastation situation
- Impact of past landslide disasters on nearby facilities

d) Other information

- Request of implementation of measures from residents and/or local authorities

The above-mentioned data and items will be described in further detail in Chapter 3 below.

## CHAPTER 3

### METHODOLOGY

#### 3.1 Items for Risk Evaluation

Risk evaluation for each of the demarcated “Yellow/Red Zone”s will be conducted in accordance with the criteria given in Table 3.1. Then the level of risk for each of the demarcated “Yellow/Red Zone” will be determined as very high, high, moderate or low according to the total scores derived using the risk evaluation sheet shown in Figure 3.1

Table 3.1 Criteria and Scores for Risk Evaluation for “Yellow/Red Zone”

	Criterion	Maximum Score (Total: 100)
1)	Number of facilities for vulnerable people	10
2)	Evacuation places	10
3)	Public facilities	10
4)	Number of facilities of the above items 1) to 3) within the “Red Zone”	10
5)	Traffic network	10
6)	Number of residential houses within the “ “Yellow/Red Zone”	10
7)	Number of residential houses within the “Red Zone”	10
8)	Land devastation situation	10
9)	Impacts of past sediment discharge on nearby facilities	10
10)	Request from residents	10

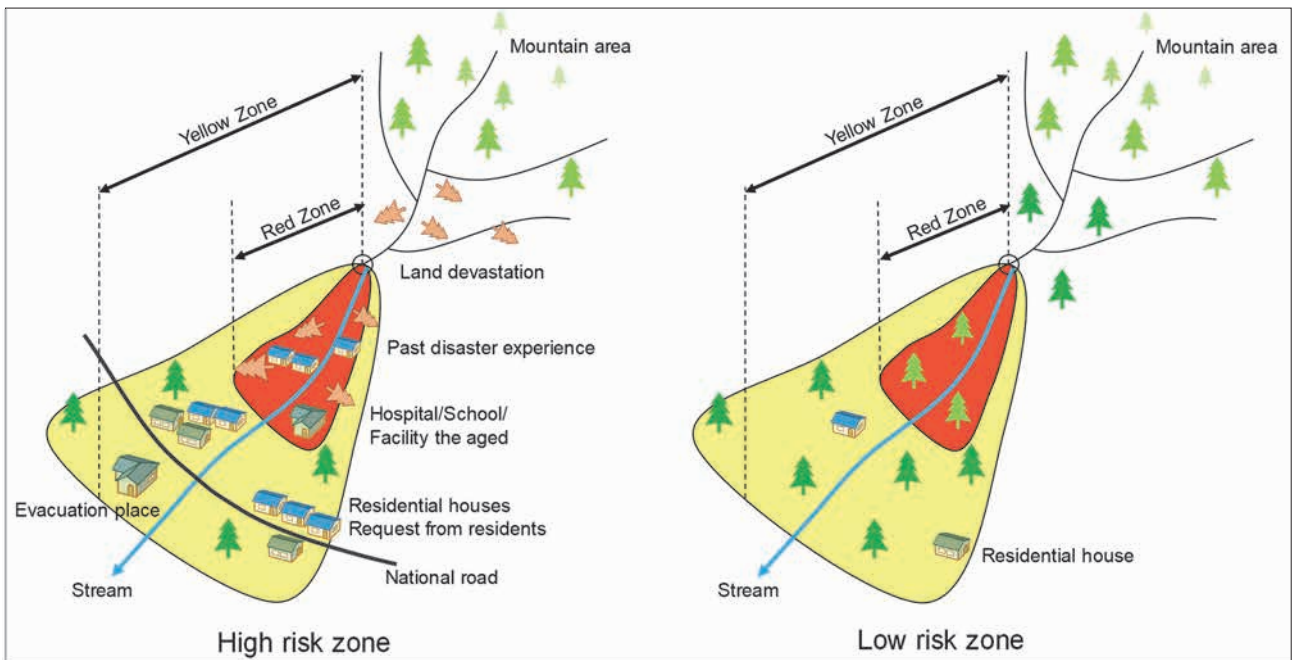


Figure 3.1 Concept of Risk Assessment for the Target “Yellow/Red Zone” (for Debris Flow)

## 3.2 Risk Evaluation Criteria

### 3.2.1 Number of Facilities for Vulnerable People

Vulnerable people are those that require assistance or support to move to a safer place from the demarcated “Yellow/Red Zone”s during a landslide disaster event. Accordingly, facilities for vulnerable people will include followings:

- a) Facilities for the aged (Eg. Homes for the elderly)
- b) Facilities for physically handicapped persons (Eg. Schools for disable children)
- c) Facilities for mentally retarded and disordered persons (Eg. Psychiatric hospital)
- d) Kindergartens
- e) Maternity facilities (Eg. Maternity clinic)
- f) Other similar facilities

Such facilities, if present, within the demarcated “Red/Yellow Zone”s, are vulnerable to major catastrophic consequences, especially loss of life, during a landslide disaster event. Therefore, the demarcated “Yellow/Red Zone”s with any of the above-mentioned facilities should be given priority when implementing risk reduction measures.

Based on the number of facilities available for vulnerable people within the demarcated “Yellow/Red Zone”s, scores shall be allotted as given in Table 3.2.

Table 3.2 Scores allocation based on the number of facilities available for vulnerable people

No.	Number of Facilities for Vulnerable People	Allotment Score
1	1 or more	10
2	0	0

### 3.2.2 Evacuation Places

An evacuation place is generally a site or an area identified or designated by a local authority as a place of protection for local or regional people from natural hazards or during times of relevant disasters. Such evacuation places are usually used to accommodate a large number of people during a disaster, and therefore must be kept at a higher level of safety and stability. Therefore, the demarcated “Yellow/Red Zone”s with any of the evacuation places should be given priority when implementing risk reduction measures.

Based on the presence or absence of evacuation places within the demarcated “Yellow/Red Zone”s, scores shall be allotted as given in Table 3.3.

Table 3.3 Scores allocation based on the presence or absence of evacuation places

No.	Evacuation Places	Allotment Score
1	Present	10
2	Absent	0

### 3.2.3 Public Facilities

Except for those listed in Section 3.2.1 and Section 3.2.2 above, public facilities are indicate important buildings and facilities financed and/or constructed by the government and are used to accommodate a lot of people. Those mainly include:

- a) Hospital buildings
- b) School buildings (element to senior high schools)
- c) College and university buildings
- d) City and government building
- e) Other similar facilities

Such facilities, if present, within the demarcated “Red/Yellow” Zone”s, are vulnerable to major catastrophic consequences, especially loss of life, during a landslide disaster event. Therefore, the demarcated “Yellow/Red Zone”s with any of the above-mentioned facilities should be given priority when implementing risk reduction measures.

Based on the presence or absence of public facilities within the demarcated “Yellow/Red Zone”s, scores shall be allotted as given in Table 3.4.

Table 3.4 Scores allocation based on the presence or absence of public facilities

No.	Public Facilities	Allotment Score
1	Hospital or school buildings	10
2	Public facilities excluding hospital or school building	5
3	No public facilities	0

### 3.2.4 Number of the Above-Mentioned Facilities in Sections 3.2.1 to 3.2.3 within the “Red Zone”

As stated in Section 1.2, within “Red Zone”, there is a higher potential for serious damage to buildings and houses and severe threat to residents due to landslide disasters. Therefore, in order to further reduce landslide risk, especially loss of life, “Red Zone”s with any of the facilities mentioned in sections 3.2.1. to 3.2.3 should be given priority when implementing risk reduction measures.

Based on the availability of the above-mentioned facilities within the demarcated “Yellow/Red Zone”s, scores shall be allotted as given in Table 3.5.



Table 3.5 Scores allocation based on the availability of the facilities mentioned in sections 3.2.1. to 3.2.3

No.	Number of the facilities in sections 3.2.1 to 3.2.3 within the “Red Zone”	Allotment Score
1	1 or more	10
2	0	0

### 3.2.5 Traffic Networks

Road networks are lifelines for the community and are essential for their socioeconomic well-being. In general, a landslide disaster event can cause widespread damage to traffic networks, leading to significant repair costs, access difficulties for emergency response and recovery, and disruption to road users and the relevant communities. Road networks are also crucial in enabling the community to survive in the aftermath of a major landslide disaster and to recover from it.

When assessing risk to a road network from a landslide hazard, it is important to consider the class of road networks or the level of service expected by the community. Obviously, a rural road may provide the sole access to small communities and require a lesser repair cost when damaged by a landslide disaster. On the other hand, a national road may provide more access to many and large communities and require a higher repair cost when damaged by a landslide disaster.

Therefore, demarcated “Yellow/Red Zone”s within and across which road networks are located should be given priority when implementing risk reduction measures.

Based on the class of road networks within the demarcated “Yellow/Red Zone”s, scores shall be allotted as given in Table 3.6.

Table 3.6 Scores allocation based on the class of road networks

No.	Traffic Networks	Allotment Score
1	Expressways	10
2	Railway or National roads	5
3	Other road or no road involved	0

### 3.2.6 Number of Residential Houses within the Demarcated “Yellow/Red Zone”s

The three scenarios in which a landslide disaster could cause significant damage to houses and residents are generally recognized as:

- a) Heavy rainfall triggers a slope failure or a slide on a sloping land where houses are located, leading to partially or completely destroyed houses mainly due to ground movement or landslide movement, and causing loss of life as a result of destroyed houses.
- b) Heavy rainfall triggers a slope failure or a slide on a sloping land within which no house is located, leading to destroyed houses due to landslide runout, and causing loss of life as a result of the destroyed houses within the landslide runout.

- c) Heavy rainfall trigger single or multiple slope failures or slides that is subsequently transformed into a fast-moving debris flow, leading to destroyed houses along the flow path and within the depositional zone due to the fast-moving debris flow, and causing loss of life as a result of either destroyed houses or the fast-moving debris flow.

These scenarios indicate that, more the number of houses located within the designated “Yellow/Red Zone”s, the more people would be killed by a landslide disaster and resulting damage to houses. Therefore, demarcated “Yellow/Red Zone”s within which residential houses are located should be should be given priority when implementing risk reduction measures.

Based on the number of residential houses within the demarcated “Yellow/Red Zone”s, scores shall be allotted as given in Table 3.7.

Table 3.7 Scores allocation based on the number of residential houses located within the demarcated “Yellow/Red Zone”s,

No.	Number of Residential Houses within the Demarcated “Yellow/Red Zone”s	Allotment Score
1	21 or more	10
2	1 to 20	5
3	0	0

### 3.2.7 Number of Residential Houses within the Demarcated “Red Zone”s

Similarly, the demarcated “Red Zone”s within which residential houses are located should be given priority when implementing risk reduction measures.

Based on the number of residential houses within the demarcated “Red Zone”s, scores shall be allotted as given in Table 3.8.

Table 3.8 Scores allocation based on the number of residential houses located within the demarcated “Red Zone”s,

No.	Number of Residential Houses within the Demarcated “Red Zone”s	Allotment Score
1	5 or more	10
2	1 to 4	5
3	0	0

### 3.2.8 Land Devastation Situation

Land devastations due to landslide movement can serve as evidence of past landslides. Similarly, the degree of land devastation shows the evidence of past landslide in terms of occurrence frequency and/or magnitude, and indicates the potential for future landslide occurrence corresponding to its frequency or magnitude. A significantly devastated land would be due to frequent landslide movements or a catastrophic landslide movement.

Accordingly, the demarcated “Yellow/Red Zone”s within which land devastation situations are observed should be given priority when implementing risk reduction measures.

The degree of land devastation due to landslide movement is roughly defined as:

- a) Significant: which means that the land has been significantly devastated due to landslide disasters and cannot be used even as farm lands
- b) Slight: which means that the land has been slightly or partially devastated, but can be used as farm lands or forest lands
- c) Zero: which means that no land devastation is observable within the designated “Yellow/Red Zone”s

Based on the degree of land devastation within the demarcated “Yellow/Red Zone”s, scores shall be allotted as given in Table 3.9.

Table 3.9 Scores allocation based on the degree of land devastation within the demarcated “Yellow/Red Zone”s

No.	Land Devastation Situation within the Demarcated “Yellow/Red Zone”s	Allotment Score
1	Significant	10
2	Slightly	5
3	0	0

### 3.2.9 Impacts of Past Sediment Discharge on Nearby Facilities

The impacts of past sediment discharge on nearby facilities serves as evidence of major to catastrophic past landslides or debris flows that have led to catastrophic and widespread damage. This further indicates likelihood or potential for future occurrence of the same type of landslide with the same consequential effects on facilities nearby or within the demarcated “Yellow/Red Zone”s.

Therefore, the impacts of past sediment discharges on nearby facilities around the demarcated “Yellow/Red Zone”s should be given priority when implementing risk reduction measures.

Based on the presence or absence of the impacts of past sediment discharges on nearby facilities around the demarcated “Yellow/Red Zone”s scores shall be allotted as given in Table 3.10.

Table 3.10 Scores allocation based on the presence or absence of the impacts of past sediment discharges on nearby facilities around the demarcated “Yellow/Red Zone”s

No.	Impacts of Past Sediment Discharges on Nearby Facilities	Allotment Score
1	Present	10
2	Absent	0

### 3.2.10 Request from Residents

It is also important to consider local requirements and requests from the relevant residents or from local authorities when prioritizing designated “Yellow/Red Zone”s for further risk reduction measures,

Based on the presence (Yes) or absence (No) of requests from the relevant residents or local authority, scores should be allotted as given in table 3.11.

Table 3.11 Scores allocation based on the presence or absence of requests from the relevant residents or local authority

No.	Request from Residents or Local Authority	Allotment Score
1	Present or Yes	10
2	Absent or No	0

### 3.3 Risk Evaluation and Risk Level Classification

The risk evaluation for each demarcated “Yellow/Red Zone” is carried out on the basis of the selected ten (10) criteria, as explained above. The risk for each demarcated “Yellow/Red Zone” is rated using the risk evaluation sheet for “Yellow/Red Zone” as shown in Table 3.12. and classified into four levels, namely, very high, high, moderate or low according to the total score as shown in table 3.13.

Table 3.12 Risk Evaluation Sheet for “Yellow/Red Zone”

Risk Evaluation Sheet for Yellow/Red Zone								
District						Prepared by		
GN Division						Organization		
Landslide Type	<input checked="" type="checkbox"/> Slope failure		<input type="checkbox"/> Slide		<input checked="" type="checkbox"/> Debris flow		Date	
Designation No.								
Result of Risk Evaluation	<b>Low Risk</b>							

No.	Item	Max Score	Allotment Score			Evaluation Score
			0	5	10	
1)	Number of facilities for vulnerable people	10	0	NA	1 or more	
2)	Evacuation places	10	Absent	NA	Present	
3)	Public facilities	10	0	Others	Hospitals or Schools	
4)	Number of facilities of the above items 1) to 3) within the Red Zone	10	0	NA	1 or more	
5)	Traffic network	10	0	Railway, or National roads	Expressways	
6)	Number of residential houses within the Yellow and Red Zone	10	0	1 to 20	21 or more	
7)	Number of residential houses within the Red Zones	10	0	1 to 4	5 or more	
8)	Land devastation situation	10	0	Slight	Significant	
9)	Impacts of past sediment discharge on nearby facilities	10	No past sediment discharge	Present, but no damage to facilities	Present and damage to facilities	
10)	Request from residents	10	No	NA	Yes	
<b>Total:</b>		<b>100</b>				<b>0</b>

Note: NA = not applicable,

Explanation and Description:

- 1) Facilities for vulnerable people mean facilities for people who require assistance during a disaster, mainly including a) facilities for the aged, b) facilities for physically handicapped persons, c) facilities for mentally retarded and disordered persons, d) kindergartens, f) maternity facilities, and g) Other similar facilities.
- 2) Evacuation places mean whether evacuation shelters are present or not around or within the Yellow/Red Zone.
- 3) Public facilities include a) Important facilities such as hospitals and schools, and b) others rather than important facilities.
- 8) Land devastation situation means the relevant lands are significantly devastated due to sediment disasters and almost cannot be used, or are slightly devastated and can be used as farm lands or forest land.
- 9) Impacts of past sediment discharge on nearby facilities mean a) presence or absence of past sediment discharge and its impacts on nearby facilities if present.

Classification of Risk Evaluation	
Risk Level	Evaluation Score
Very High	75 and more
High	50 to 74
Moderate	25 to 49
Low	0 to 24

Table 3.13 Classification of Risk Level

Risk Level	Total Evaluation Score
Very High	75 and more
High	50 to 74
Moderate	25 to 49
Low	0 to 24

The demarcated “Yellow/Red Zone”s can be prioritized for risk management (e.g. implementing further risk reduction measures, land use planning etc.) based on the calculated risk level thereby facilitating a rational and effective approach to risk treatment given the resources available.

## **Technical Note 1**

# **Conceptual Planning of Structural Measures around the Designated “Red Zones”**

## Conceptual Planning of Structural Measures around the Designated “Red Zone”s

---

### TABLE OF CONTENTS

1. Introduction
  - 1.1 Definitions of “Yellow/Red Zone”s and Their Expected Consequences
  - 1.2 Purpose of This Technical Note
2. Landslide Risk Reduction by Structural Measures
  - 2.1 Landslide Risk Reduction Concepts
  - 2.2 Selection of Structural Measures
3. Conceivable Structural Measures for the Selected “Red Zone”s
  - 3.1 Site 1 - A Debris Flow “Red Zone” within the Weeriyapura Pilot Site
  - 3.2 Site 2 - A Debris Flow “Red Zone” within the Weeriyapura Pilot Site
  - 3.3 Site 3 - A Slide “Red Zone” within the Weeriyapura Pilot Site
  - 3.4 Site 4 – A Slide “Red Zone” within the Weeriyapura Pilot Site
  - 3.5 Site 1 - A Debris Flow “Red Zone” within the Udapotha Pilot Site
  - 3.6 Site 2 - A Slide “Red Zone” within the Udapotha Pilot Site
  - 3.7 Site 1 - A Debris Flow “Red Zone” within the Morawakkanda Pilot Site

## 1. Introduction

### 1.1 Definitions of “Yellow/Red Zone”s and Their Expected Consequences

According to Manual for Site-Specific Landslide Hazard Zoning, Landslide Hazard “Yellow Zone” (or “Yellow Zone”) and Landslide Hazard “Red Zone” (or “Red Zone”) are respectively defined as follows:

- 1) Landslide Hazard “Yellow Zone” or “Yellow” Zone” as the area that is susceptible to landslide disaster, in which the resistance capacity of normal residential buildings is expected to be larger than force acting on residential buildings due to the moving debris and earth of landslides.
- 2) Landslide Hazard “Red Zone” or “Red Zone” as the area that is susceptible to landslide disaster, in which the force acting on residential buildings due to the moving debris and earth of landslides is expected to be larger than the resistance capacity of normal residential buildings.

In this regard, in the designated “Yellow Zone”s, the expected landslide disaster may cause a partial or less damage to the residential buildings and other infrastructures, consequently posing a lower risk to the residents or human life. On the other hand, in the designated “Red Zone”s, the landslide disaster may cause a complete or significant damage to the residential buildings and other infrastructures, consequently having a higher risk to the residents or human life.



## 1.2 Purpose of This Technical Note

As stated above, an area, when designated as “Red Zone”, would have a serious risk of damage to buildings and threat to people if the expected landslide disaster occurs. There is thus a need for comprehensive risk reduction measures, both non-structural and structural, to reduce landslide losses in the designated “Red Zone”s.

Non-structural measures typically concentrate on early warning system installation and land use control in landslide hazard areas. The installation of an early warning system, with the safe evacuation of the population at risk, has reduced the loss of human life due to landslide disasters in many countries, but done little to reduce socioeconomic losses and environmental damage. Land use control or limiting can mitigate further exacerbation of landslide hazards but cannot reduce the exist risk.

The relocation of residential houses to safe areas is an alternative solution to avoiding landslide hazards but is not always suitable methods due to the increasing population and associated growing urbanization extending into sloping areas.

Furthermore, structural measures are also permanent and cost-effective methods conceivable, especially for locally populated areas in which the Controlled Zones of “Red Zone”s are designated, to robustly reduce landslide risk – landslide damage and losses.

The purpose of this technical note is to develop structural measure plan, as examples of structural measures, to reduce the likelihood of a landslide occurrence and/or the consequence or impact of landslide disaster in a “Red Zone”, thereby improving the risk level – from “Red Zone” to “Yellow Zone” by the implementation of structural measures.

## 2. Landslide Risk Reduction by Structural Measures

### 2.1 Landslide Risk Reduction Concepts

In addition to non-structural measures, such as early warning, land use control and relocation, there are two basic strategies by structural measures to reduce landslide damages and losses due to landslide disasters:

- 1) **Stabilization or Prevention Measures.** Prevention measures, for potential landslides, such slide and slope failure, are performed to directly improve their stabilities into the required levels. Typical prevention measures include grading the unstable portion of the slope to a lower or stable gradient, construction of rock buttresses and retaining walls, drainage improvements, and increase of force resisting sliding or failure. In general, prevention measures are typically moderate to high cost, but provide a long-term solution with low, long-term maintenance costs.
- 2) **Protection Measures.** Protection measures for potential landslides primarily focus on control, containment and/or diversion of the moving debris of landslide disaster, thereby protecting the involved residential houses and buildings as well as other infrastructures from landslide disasters. Such measures include retaining (containment) walls, embankments, and nets, sabo dams. Protection measures are generally low to moderate in cost compared to the above-mentioned prevention measures. However, considerable long-term maintenance costs are often associated with these measures to clean out and dispose of accumulated debris behind and inside these facilities (measures).

It should be also noted that, stabilization measures seek to counter one or more key failure mechanisms and improve stability of the slope, thereby reducing the likelihood of landslide hazards; while protection measures allow landslide occurrence and seek to avoid, protect against, or limit the associated impacts, thereby reducing or controlling the consequence of landslide disasters.

## 2.2 Selection of Structural Measures

Structural measures for each “Red Zone”s or their combination should be firstly selected with respect to type or classification of landslides for zoning, including slide, slope failure, and debris flow.

In addition, all landslide disasters have occurred during heavy rainfalls, this indicated that the greatest cause of the landslide disasters is the action of rainwater and subsequent groundwater and so taking appropriate measures against surface water and groundwater is extremely important for the securing of slope stability. For this purpose, it is necessary to take full precautions for permanent drainage for all types of landslides.

### 1) Selection Criteria of Structural Measures for Slides

Generally, an adequate combination of two or more structural measures is cost-effective and is selected in consideration of the following points:

- The structural measures selected should address the mechanism(s) of the slide, the relationship between precipitation, groundwater, and slide movement, geological, topographical and soil properties, the scale and movement type of slide and its likely movement velocity.
- Drainage and earthwork (cutting and filling) should be regarded as the main methods of slide control, while anchoring and piling works should be adopted for the stabilization of small slides to protect the road, houses, etc.
- Where slide movement is closely related to rainfall, surface drainage work should be performed immediately to minimize the infiltration of rainwater.
- When a slide is moving, drainage and earthworks should be performed first; ground anchor, steel pile and other structures can then be done after drainage and earthworks halt the movement of slide.

Either or combination of the following countermeasure for slide is recommended and selected:

- Surface drainage (side ditch and drainage channel)
- Subsurface drainage (open drain and closed conduit, horizontal drain boreholes, drainage wells)
- Earth removal and counterweight fill methods
- Retaining wall and gabion wall
- Reinforced earth wall
- Crib works
- Rock bolts and soil nailing
- Steel piles
- Ground anchor

### 2) Selection Criteria of Structural Measures for Slope Failure

Generally, the following criteria are used for the selection of structural measures:

- Wherever possible, cutting or reshaping method is preferred. In planning cutting method, slope

stability and harmony with the surrounding environment should be considered.

- In principle, surface drainage is considered positively. Subsurface drainage work is adopted if spring water exists during normal times and/or rainfall, or a depression exists near the top of the slope (or “Red Zone”).
- Whenever the slope gradient and soil conditions will allow vegetation to grow, it shall be used to prevent erosion due to rainfall. Where slopes are unsuited to vegetation, other slope protection methods, such as pitching work, shotcrete work, and crib work shall be considered.
- Retaining walls are selected if the foot of a slope must be stabilized or if it is to be used as the foundation for other measures.
- Even though costly, anchoring or piling should be planned if other methods are not expected to control slope failure.
- When a potential slope failure is large, avoiding the unstable area by using an alternate route or by the construction of a bridge or similar structure shall be considered.
- In most cases, a retaining wall is constructed behind the houses to catch the collapsed sediment to protect the involved houses from slope failure disasters.

Either or combination of the following countermeasure for slope failures are recommended and selected:

- Surface drainage (Drainage channel, vertical and horizontal drainage, drainage at the top of slope)
- Subsurface drainage (horizontal drain boreholes)
- Slope protection (vegetation, mortar spraying, crib work)
- Retaining walls and gabion wall
- Reinforced earth wall
- Rock bolts and soil nailing
- Ground anchor
- Steep pile

### 3) Selection Criteria of Structural Measures for Debris Flow

Debris flow is the fast movement of rock fragments, earth and mud mixed with water, along a valley or a mountainous stream. Because of its speed, debris flow is dangerous to life and property, destroying objects in its path and depositional area. Debris flow structural measures for hazardous streams are, in principle, formulated to cope with debris flow rationally and effectively, considering the frequency and scale of debris flow occurrences.

Debris flows involve three areas, namely, the source area, flow path, and depositional area. The structural measures for debris flow are different for each of these areas and they should be considered separately. For source areas, the type and extent of conceivable structural measures shall basically be the same as those for slope collapse and sides, as mentioned above.

In selecting the structural measures for a stream prone to debris flow, various types of structural measures can be reasonably combined in consideration of the likely occurrence, frequency, volume (scale), flow characteristics, topography, and the objects (residential houses or other public buildings) to be protected. The basic sabo plan for debris flow should be formulated to effectively control the harmful sediments within the affected area, especially depositional area.

- If a residential house exists within the flow path of debris flow, it is advisable for these houses to be relocated.
- The design sediment volume (sediment discharge) is calculated based on surveys of deposits within

the streambed, including topographical analysis, field surveys, and records of past debris flow.

Either or combination of the following structural measure for debris flows are recommended and selected:

- Revetment
- Retaining wall and gabion wall
- Training wall and dike
- Sabo dam (permeable and non-permeable types)/ (spur consolidation dam, riverbed erosion control dam, riverbed sediment runoff control dam, and debris flow control dam)
- Debris flow deposition channel

### **3. Conceivable Structural Measures for the Selected “Red Zone”s**

#### **3.1 Site 1 – A Debris Flow “Red Zone” within the Weeriyapura Pilot Site**

##### **1) Hazard and Impacts**

Site 1, located in the northern part of the Weeriyapura Pilot Site (see Figure 1), is a “Red Zone” corresponding to debris flow with a source area of slope failure (Figure 2).

A potential slope failure above the zero valley together with an observable debris fan at the base of the slope indicates that the debris flow is highly expected to occur during or after a heavy rainfall.

Many residential houses are located on the source area – the upper potential slope failure, along the flow path, and on the depositional area – debris fan. A debris flow, once it occurs, originating from either slope failure, or sediments of stream erosion, or their combination, would cause a considerable damage to these residential houses, especially along the flow path and in the depositional area, thus posing a high risk to human lives (Figure 2).

##### **2) Suggested Structural Measures**

The impact or consequence of a debris flow on humans and infrastructures depends mainly upon its velocity and magnitude. It is an effective solution to mitigate debris flow risk basically by controlling the magnitude of a debris flow or by reducing the sediment discharge – by stabilizing unstable sediments from the upper potential slope failure and/or the streambed and stream bank slopes. It is an alternative solution to guide the debris flow up to a safe place by installing a training wall or dyke behind or within the populated area of the debris fan for the purpose of avoiding the direct hit of debris flow to the residential houses and infrastructures, if the space is enough for installation of such structural measures.

As shown in Figures 2 and 3, because many residential houses to be protected from the expected debris flow lie on the source area, along flow path and within the depositional area, the structural measures conceivable for Site 1 are as follows:

- Sabo dams to be installed at the toe part of the upper steep slope failures, to control the toe erosion of steep slopes, thereby stabilizing the steep slopes and reducing sediment yield amount.
- Sabo dams to be installed within the flow path, to control the streambed and valley slope erosions along the flow path and partially catch sediment from the upper slope, thereby reducing sediment discharge.

These sabo dams are planned to control sediment source supply, reducing the sediment discharge of debris flow and minimizing the magnitude and frequency of debris flow, consequently mitigating the impact of debris flow into human lives and infrastructures involved.

Quantity and specification of the planned sabo dams are summarized in Table 1.

**Table 1 Summary of the Suggested Structural Measures at Site 1**

No.	Measure Type	Description/Specification
1	Sabo dam No.1	1) Concrete, 2) Non-permeable type, 3) L=15 m, H=5 m
2	Sabo dam No.2	1) Concrete, 2) Non-permeable type, 3) L=15 m, H=5 m
3	Sabo dam No.3	1) Concrete, 2) Non-permeable type, 3) L=15 m, H=5 m
4	Sabo dam No.4	1) Concrete, 2) Non-permeable type, 3) L=15 m, H=5 m

Notes: L=length of sabo dam, H=height of sabo dam

### 3.2 Site 2 – A Debris Flow “Red Zone” within the Weeriyapura Pilot Site

#### 1) Hazard and Impacts

Site 2, located in the southern part of the Weeriyapura Pilot Site (see Figure 1), is a “Red Zone” corresponding to debris flow with a source area of slope failure (Figure 4).

Similar to Site 1 mentioned above, a potential slope failure above the zero valley together with an observable debris fan at the base of the slope indicates that the debris flow is highly expected to occur during or after a heavy rainfall.

Many residential houses are located on the source area – the upper potential slope failure, along the flow path, and on the depositional area – debris fan. A debris flow, once it occurs, originating from either slope failure, or sediments of stream erosion, or their combination, would cause a considerable damage to these residential houses, especially along the flow path and in the depositional area, thus posing a high risk to human lives (Figure 4).

#### 2) Suggested Structural Measures

As shown in Figure 4, because many residential houses to be protected from the expected debris flow lie on the source area, along flow path and within the depositional area, three sabo dams are similarly recommended to reduce the risk posed by debris flows for Site 2, as follows:

- Sabo dams to be installed at the toe part of the upper steep slope failures, to control the toe erosion of steep slopes, thereby stabilizing the steep slopes and reducing sediment yield amount.
- Sabo dams to be installed within the flow path, to control the streambed and valley slope erosions along the flow path and partially catch sediment from the upper slope, thereby reducing sediment discharge.

These sabo dams are planned to control sediment source supply, reducing the sediment discharge of debris flow and minimizing the magnitude and frequency of debris flow, consequently mitigating the impact of debris flow into human lives and infrastructures involved.

Quantity and specification of the planned sabo dams are summarized in Table 2 within the Weeriyapura

Pilot Site.

**Table 2 Summary of the Suggested Structural Measures at Site 2**

No.	Measure Type	Description/Specification
1	Sabo dam No.1	1) Concrete, 2) Non-permeable type, 3) L=10 m, H=5 m
2	Sabo dam No.2	1) Concrete, 2) Non-permeable type, 3) L=15 m, H=5 m
3	Sabo dam No.4	1) Concrete, 2) Non-permeable type, 3) L=10 m, H=5 m

Notes: L=length of sabo dam, H=height of sabo dam

### 3.3 Site 3 – A Slide “Red Zone” within the Weeriyapura Pilot Site

#### 1) Hazard and Impacts

Site 3 is a “Red Zone” corresponding to slide in the northern part of the Weeriyapura Pilot Site ( Figure 1).

The slide showed a clear landslide topography, including main scarp, depression, hummocky topography and so on. Some ground surface deformations were also observed in the slide slope (Figure 5). Accordingly, the slide is highly expected to occur during or after a heavy rainfall.

Many residential houses are located within and below the slide area. Once moving down, the slide would cause a considerable damage to these residential houses, both within the slide area and below the slide area, thus posing a high risk to human lives (Figure 5).

#### 2) Suggested Structural Measures

In general, slide movement is closely related to rainfall. In addition, as stated above, because of the depression in the upper part of the slide area and some ground surface deformations, rainwater would be infiltrated into the ground during a rainfall – forming shallow groundwater, causing a rise in ground level, consequently reactivating the slide.

Accordingly, horizontal drain hole work is recommended to drain shallow groundwater effectively and promptly, to stabilize the slide. In addition, drain ditch work is used to collect surface water and then drain out of the slide area (Figures 5 and 7). Quantity and specification of the planned structural measures are summarized in Table 3.

**Table 3 Summary of the Suggested Structural Measures at Site 3**

No.	Measure Type	Description/Specification
1	Horizontal drain holes	1) 50 m x 8 holes + 50 m x 6 holes = 700 m
2	Drain ditch	1) L= 200 m in total

Notes: L=length of drain ditch

### 3.4 Site 4 – A Slide “Red Zone” within the Weeriyapura Pilot Site

## 1) Hazard and Impacts

Site 4 is also a “Red Zone” corresponding to slide in the northern part of the Weeriyapura Pilot Site (Figure 1).

The slide showed a clear large landslide topography, including main scarp, depression, hummocky topography and so on. Some ground surface deformations were also observed in the upper slope of the slide area (Figure 6). Accordingly, the slide is highly expected to occur during or after a heavy rainfall.

Many residential houses are located within and below the slide area. Once moving down, the slide would cause a considerable damage to these residential houses, both within the slide area and below the slide area, thus posing a high risk to human lives (Figure 6).

## 2) Suggested Structural Measures

Similar to the slide at Site 3 above, the slide at Site 4 may be reactivated due to groundwater, both shallow and deep. Accordingly, horizontal drain hole work is recommended to drain shallow groundwater around the upper slope and drainage well work to drain deep groundwater in the middle slope of the slide, to improve the safety factor of the slide slope (Figures 6 and 7).

Quantity and specification of the planned structural measures are summarized in Table 4.

**Table 4 Summary of the Suggested Structural Measures at Site 4**

No.	Measure Type	Description/Specification
1	Horizontal drain holes	1) 30 m x 6 holes = 180 m
2	Drainage well No.1	1) Well depth = 15m, 2) Well diameter = 2 to 3m, 3) Collecting holes = 50 m x 10 holes x 2 lines = 1000 m, 4) Drainage hole length = 100 m
3	Drainage well No.2	1) Well depth = 15m, 2) Well diameter = 2 to 3m, 3) Collecting holes = 50 m x 10 holes x 2 lines = 1000 m, 4) Drainage hole length = 100 m
4	Outlet	1) Concrete, 2) 100cm (length) x 100cm (width) x 80cm (depth) x 2 locations
5	Drain ditch	1) L= 25 m in total

Notes: L=length of drain ditch



# Weeriyapura Y/R Zone Map

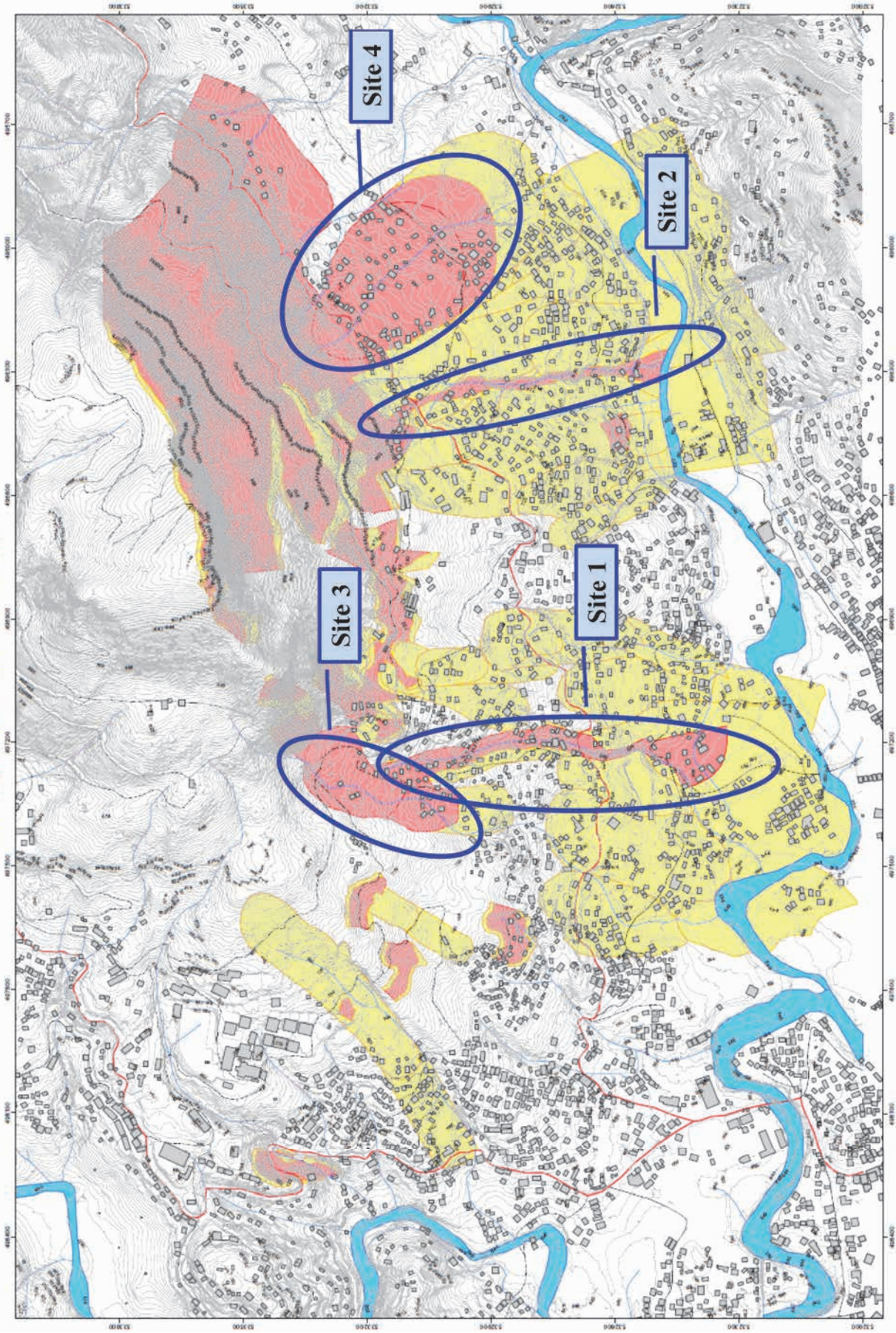


Figure 1 Location of the Selected Red Zones for Conceptually Planning Structural Measures



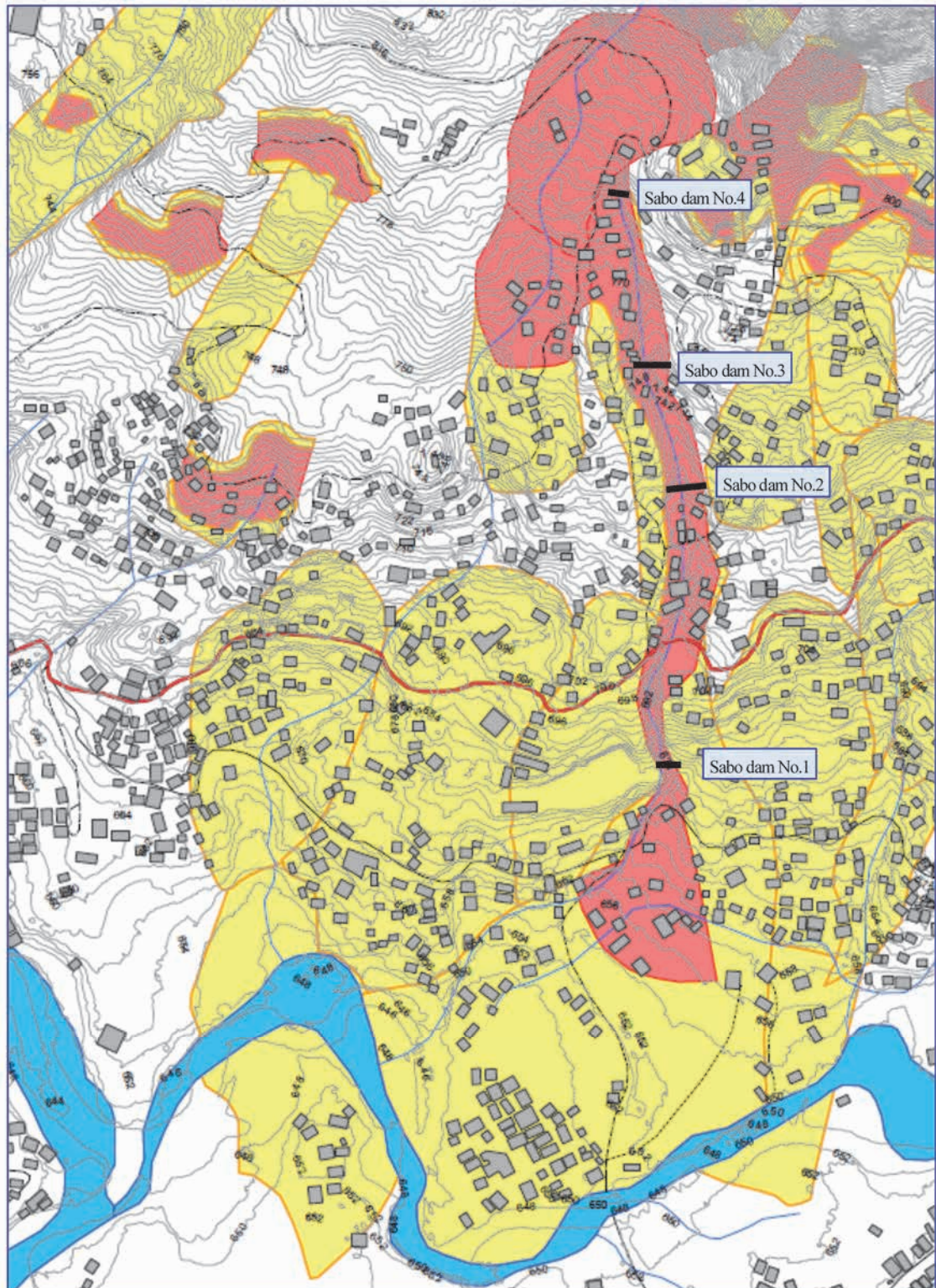
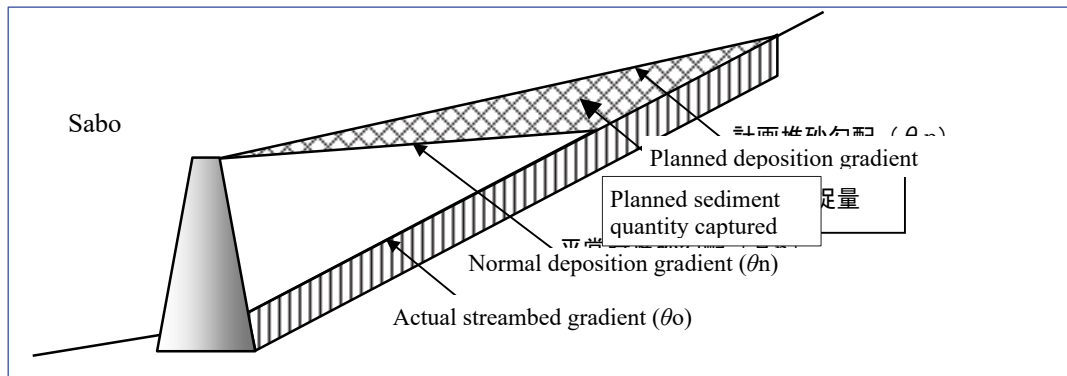


Figure 2 Layout of the Planned Structural Measures for Site 1 in the Weeriyapura Pilot Site



**Figure 3 Conceptual Illustration of Non-permeable Sabo Dam**

### **BOX 1 Sabo Dam Classifications and Their Functions**

- ✓ Sabo dams are a typical debris flow capturing works, and they are generally divided into the non-permeable type and the permeable type.
- ✓ The functions common to both the non-permeable type and permeable type sabo dams are as follows:
  - To capture debris flow and reduce the amount of sediment discharge
  - To delay the traveling time of debris flow from the debris flow occurrence source areas to the debris flow fan.
  - To capture boulders and driftwood flowing at the front of debris flow
  - To convert a debris flow into a sediment flow
  - To reduce the peak discharge of debris flow



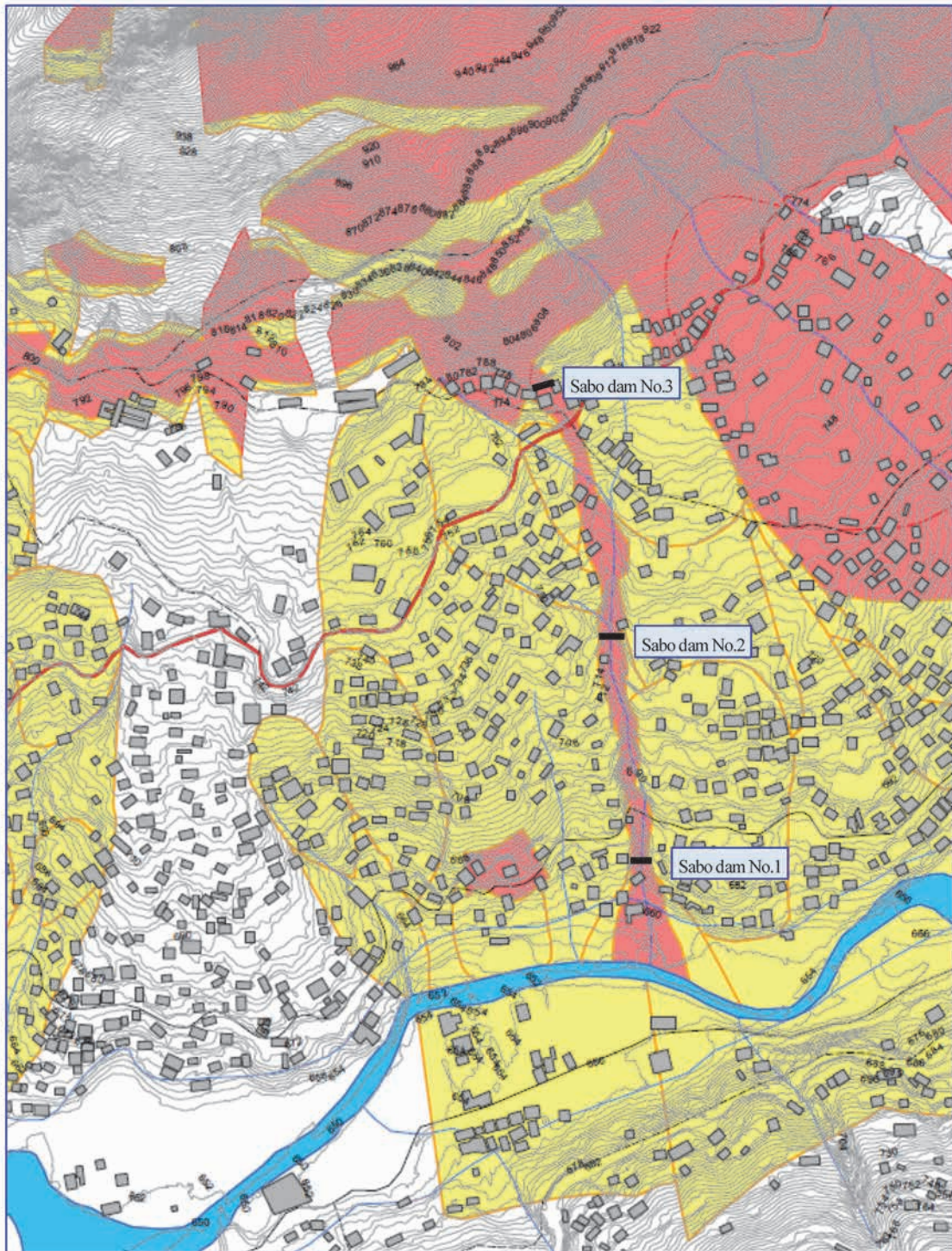


Figure 4 Layout of the Planned Structural Measures for Site 2 in the Weeriyapura Pilot Site



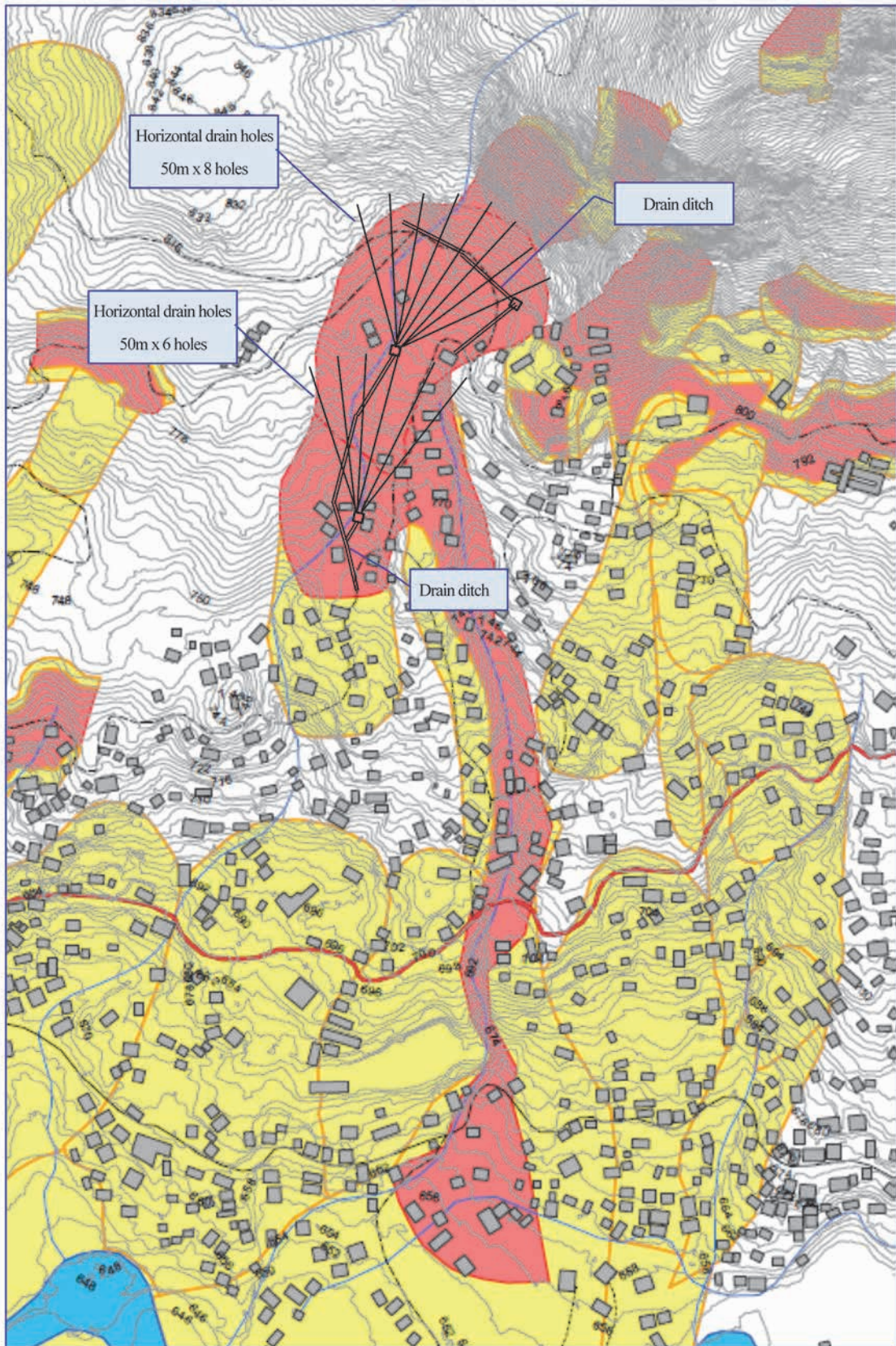


Figure 5 Layout of the Planned Structural Measures for Site 3 in the Weeriyapura Pilot Site



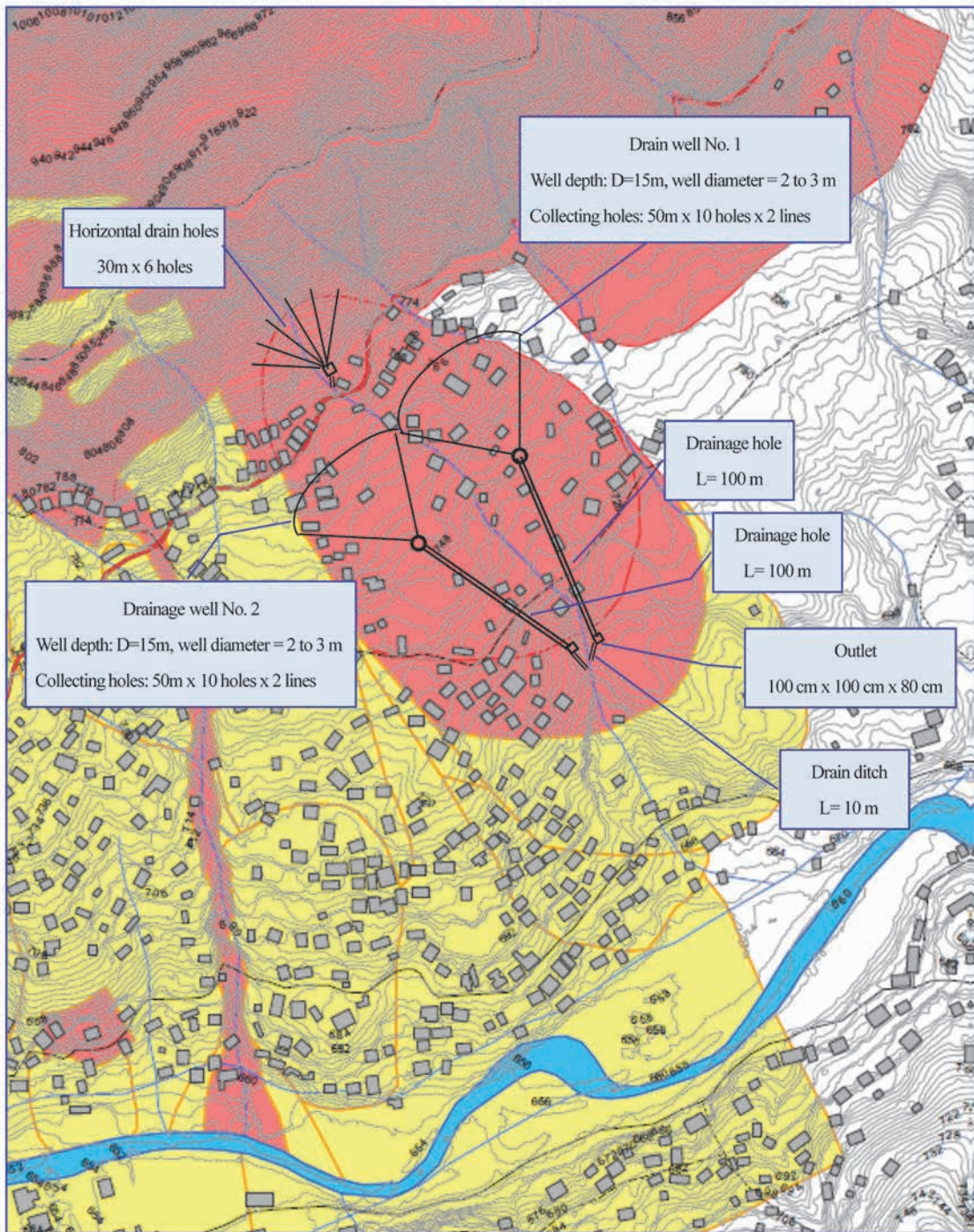
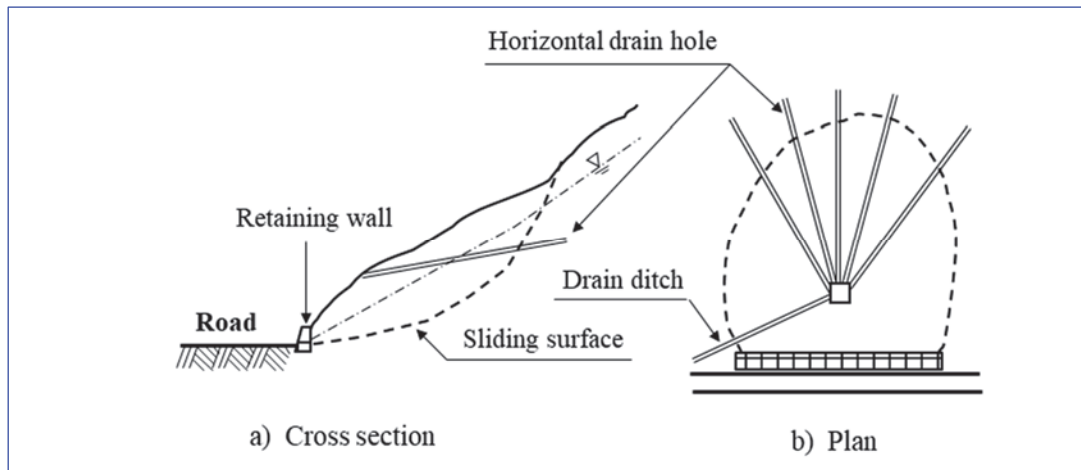


Figure 6 Layout of the Planned Structural Measures for Site 4 in the Weeriyapura Pilot Site



**Figure 7 Typical Layout of Horizontal Drain Holes**

### **BOX 2 Design of Horizontal Drain Hole Works**

- ✓ Horizontal drain holes are usually used to drain both shallow and deep groundwater within a slide area to stabilize the slide by decreasing the pore water pressure that is responsible for activating the sliding surface.
- ✓ Horizontal drain holes are designed in consideration of the following items:
  - Horizontal drain holes are designed to traverse aquifers or penetrate the sliding surface deeper than 5 meters.
  - Horizontal drain holes, usually 20 to 50 meters in length, should be excavated at a gradient of 5 to 10 degrees.
  - Hard vinyl chloride pipes or gas pipes with an internal diameter of 50 to 100 mm are used as casing pipes. Either the parts of the casing pipes traversing the aquifer or the whole of the pipes is perforated to collect the underground water.
  - Mouth protection for horizontal drain holes is undertaken with gabion or concrete.
  - The expected reduction or lower of groundwater level by horizontal drain hole work for a standard-size slide with a sliding surface depth of about 20m is 1 to 3 m.

### 3.5 Site 1 – A Debris Flow “Red Zone” within the Udapotha Pilot Site

#### 1) Hazard and Impacts

Site 1 is a “Red Zone” corresponding to debris flow with a source area of slope failure within the Udapotha Pilot Site (Figure 8).

A large red-zone slope failure above the zero valley together with an observable debris fan at the base of the slope indicates that the debris flow is highly expected to occur during or after a heavy rainfall.

A few residential houses are in the depositional area – debris fan. A debris flow, once it occurs, originating from either large slope failure, or sediments of stream erosion, or their combination, would cause a considerable damage to the residential houses in the depositional area, thus posing a high risk to human lives (Figure 9).

#### 2) Suggested Structural Measures

Because of a few residential houses affected, a training wall is recommended to control or guide the debris flow up to a safe place. The training wall is installed behind the populated area of the debris fan for the purpose of avoiding the direct hit of debris flow to the residential houses (Figure 9).

Quantity and specification of the planned sabo dams are summarized in Table 5.

**Table 5 Summary of the Suggested Structural Measures at Site 1**

No.	Measure Type	Description/Specification
1	Training wall	1) Reinforced concrete, 2) L=25 m, H=5 m, T=30 to 50 cm
2	Sabo dam No.4	1) Concrete, 2) Non-permeable type, 3) L=15 m, H=5 m

Notes: L=length of training wall, H=height of training wall, T= thickness of training wall

### 3.6 Site 2 – A Slide “Red Zone” within the Udapotha Pilot Site

#### 1) Hazard and Impacts

Site 2 is a “Red Zone” corresponding to slide in the Udapotha Pilot Site (Figure 8).

The slide showed a clear landslide topography, including circle-shaped main scarp, hummocky topography and so on. Some ground surface deformations were also observed in the slide slope (Figure 10). Accordingly, the slide is highly expected to occur during or after a heavy rainfall.

Many residential houses are located within and below the slide area. Once moving down, the slide would cause a considerable damage to these residential houses within the slide area (Figure 10).

#### 2) Suggested Structural Measures

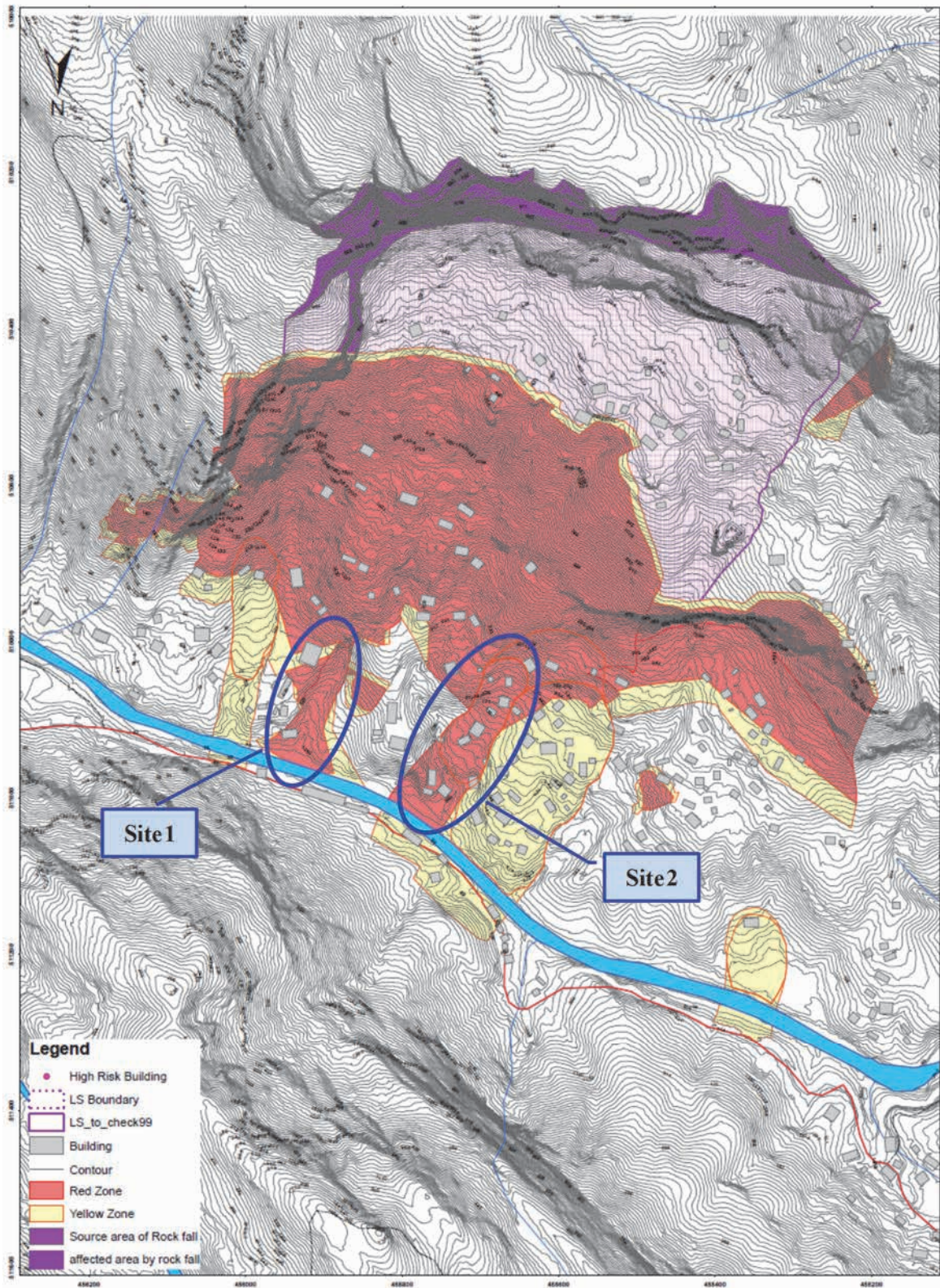
Similar to that stated above in 2) of 3.3 Site 3 – A Slide “Red Zone” within the Weeriyapura Pilot Site, horizontal drain hole work is recommended to drain shallow groundwater effectively and promptly, to stabilize the slide. In addition, drain ditch work is used to collect surface water and then drain out of the slide area (Figures 7 and 10). Quantity and specification of the planned structural measures are summarized in Table 6.



**Table 6 Summary of the Suggested Structural Measures at Site 2**

No.	Measure Type	Description/Specification
1	Horizontal drain holes	1) 30 m x 6 holes + 30 m x 4 holes = 300 m
2	Drain ditch	1) L= 200 m in total

Notes: L=length of drain ditch



**Figure 8 Location of the Selected “Red Zone”s for Conceptually Planning Structural Measures in the Udapotha Pilot Site**



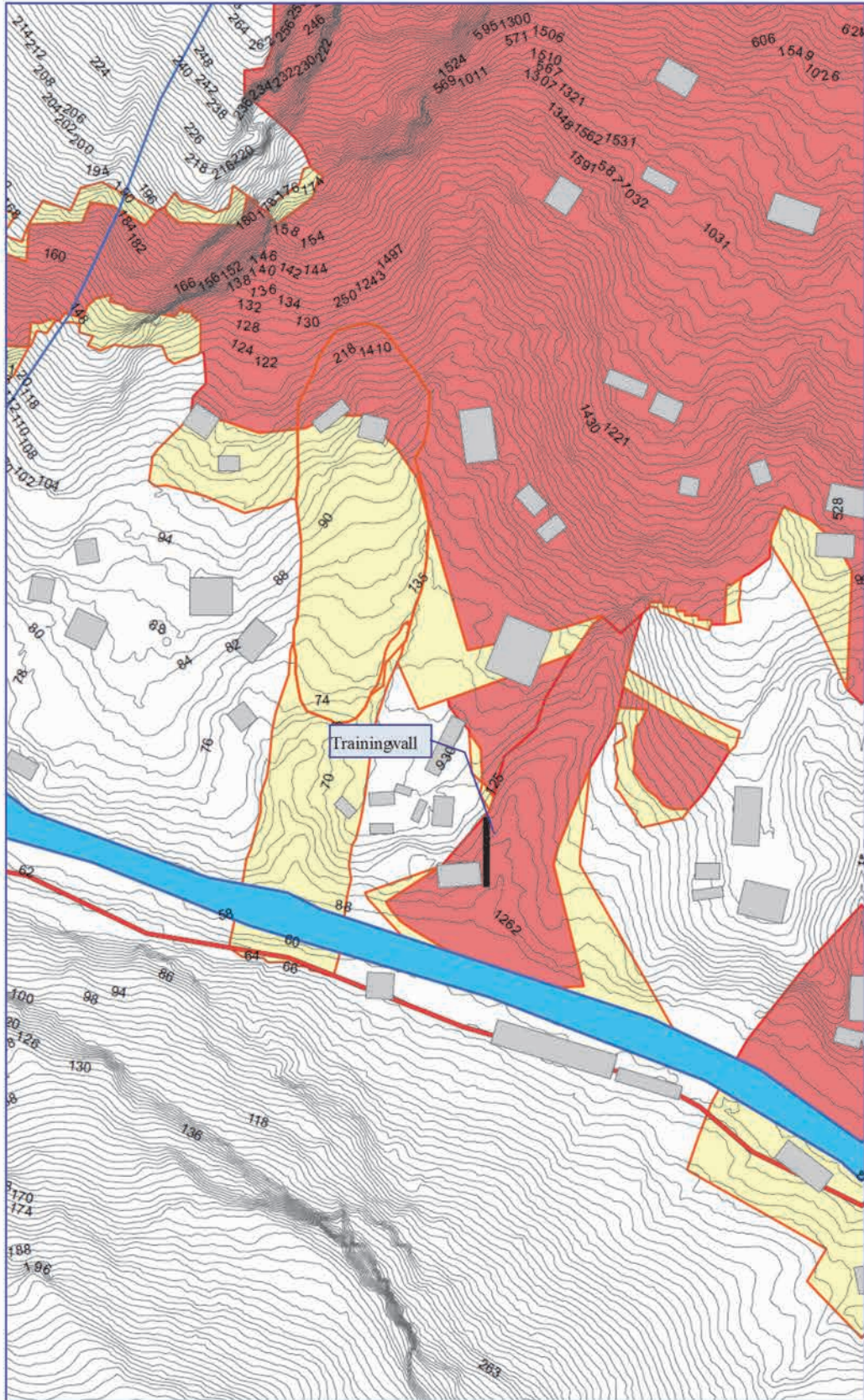


Figure 9 Layout of the Planned Structural Measures for Site 1 in the Udapotha Pilot Site



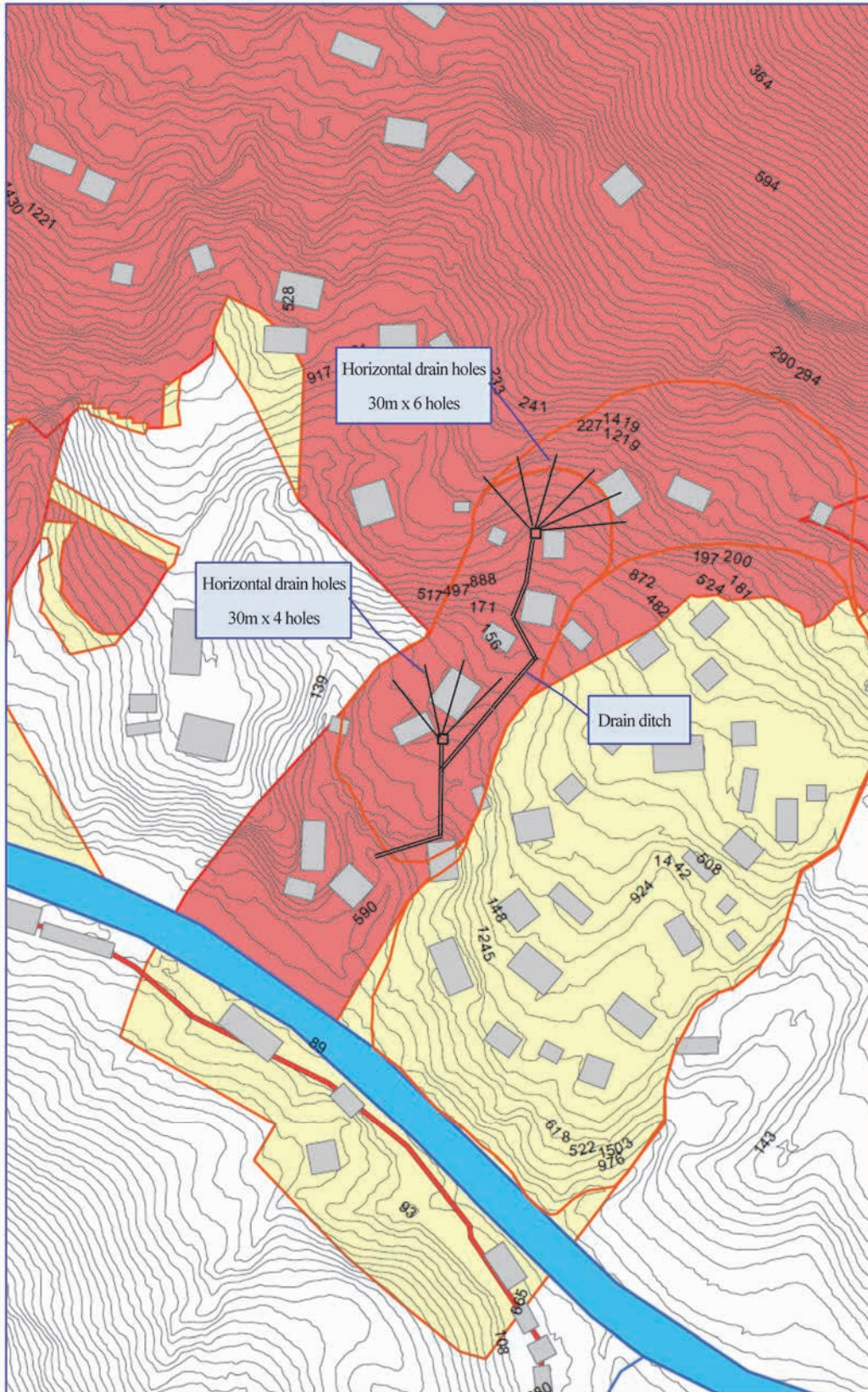


Figure 10 Layout of the Planned Structural Measures for Site 2 in the Udapotha Pilot Site

### 3.7 Site 1 – A Debris Flow “Red Zone” within the Morawakkanda Pilot Site

#### 1) Hazard and Impacts

Site 1 is a “Red Zone” corresponding to debris flow with a source area of slope failure (Figure 11).

At the site, a large-scale debris flow, which originated from a large slope failure, occurred on May 26<sup>th</sup>, 2017, killing 23 people and destroying 34 residential houses. The debris flow materials included big boulders of 1 to 5 m in diameter and driftwoods. Part of the slope failure remains in the upper slope – the source area. A debris flow is thus highly expected to occur in the future during or after a heavy rainfall.

Many residential houses are still located around the depositional area – debris fan. A debris flow with the same or bigger scale, once it occurs, would cause a huge loss to lives and properties in the same way (Figure 11).

#### 2) Suggested Structural Measures

The impact or consequence of a debris flow on humans and infrastructures depends mainly upon its velocity and magnitude. It is an effective solution to mitigate debris flow risk basically by controlling the magnitude of a debris flow or by reducing the sediment discharge – by stabilizing unstable sediments from the upper potential slope failure and/or the streambed and stream bank slopes.

As shown in Figure 10, because many residential houses to be protected from the expected debris flow is in the depositional area, the structural measures conceivable for Site 1 are as follows:

- Sabo dam (No. 4) to be installed at the toe part of the upper steep slope failures, to stable the remaining unstable sediments.
- Sabo dam (No.3) to be installed within the flow path, to control the streambed and valley slope erosions along the flow path and partially catch sediment from the upper slope, thereby reducing sediment discharge.
- Sabo dam (Nos. 1 & 2) to be installed within the depositional area, to control the pick flow of debris, thereby reducing the energy of debris flow, consequently mitigating the risk posed by debris flow.

These sabo dams are planned to control sediment source supply, reducing the sediment discharge of debris flow and minimizing the magnitude and frequency of debris flow, consequently mitigating the impact of debris flow into human lives and infrastructures involved. Quantity and specification of the planned sabo dams are summarized in Table 7.

**Table 7 Summary of the Suggested Structural Measures at Site 1**

No.	Measure Type	Description/Specification
1	Sabo dam No.1	1) Concrete, 2) Non-permeable type
2	Sabo dam No.2	1) Concrete, 2) Permeable type
3	Sabo dam No.3	1) Concrete, 2) Permeable type
4	Sabo dam No.4	1) Concrete, 2) Permeable type
5	Channel work	1) Concrete



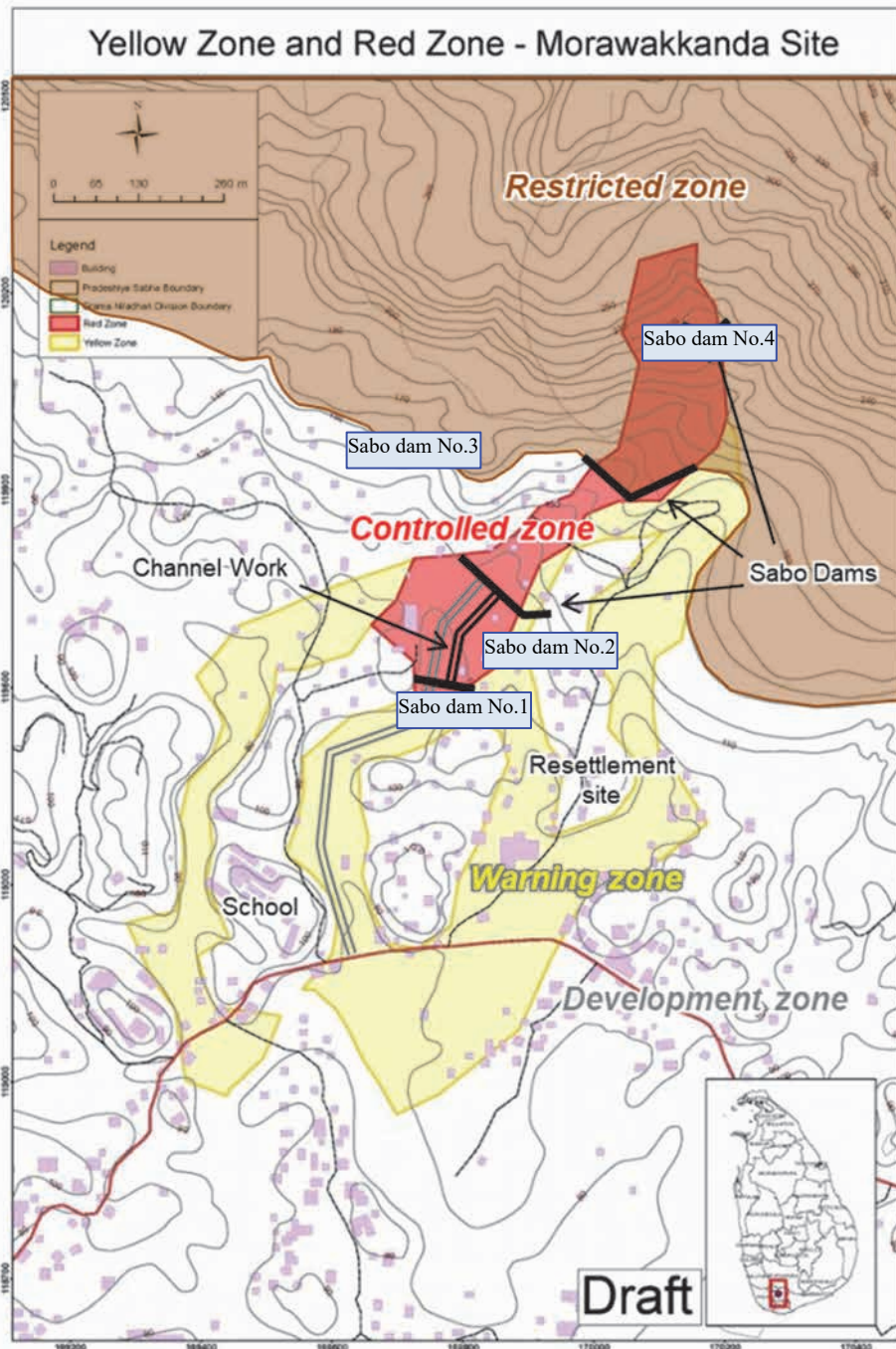


Figure 11 Layout of the Planned Structural Measures for the Morawakkanda Pilot Site

## **Technical Note 2**

# **Guide to Landslide Inventory Sheet Records**



# GUIDE TO LANDSLIDE INVENTORY SHEET RECORDS

This guidance presents a brief procedure or method to inspect landslide disaster site and record the relevant inventory items required in the Landslide Inventory Sheets (LIS).

This inventory sheet and guidance is to provide a uniformed inventory method to record the results of such inventory surveys. The results of the inventory surveys shall be recorded in Sheets A to D for each landslide site.

These inventory sheets will cover all types of landslides as classified by Cruden and Varnes (1996), Hungr et al. (2014), and consist of three forms related to the following types of movements:

- ✓ Part 1: Inventory Sheet for Slide and Slope Failure (SS)
- ✓ Part 2: Inventory Sheet for Debris and Earth Flows (DE)
- ✓ Part 3: Inventory Sheet for Topple and Rock Fall (TR)

In addition, for this inventory survey, the term landslide in general sense covers all sediment disasters or mass movements that occur from natural or manmade causes except spread and ground subsidence.

PART 1	INVENTORY SHEET FOR SLIDE AND SLOPE FAILURE
--------	---

## 00 Landslide Name and ID

Landslide Name – Write down the name of landslide to be inspected, which is probably named either by local government or local resident, if available.

Landslide ID – Enter the landslide ID that is probably designated in landslide maps or other documents.

Inventory No. – The number will be given by JICA team to manage and compile these inventory sheets to be recorded at the selected landslide sites for this project.

The inspection date and inspection persons shall be also mentioned in these sheets.

## 01 Landslide Location

Landslide Location – Write down the location (or address) of landslide site to be inspected, including

District, DS Division, GN Division and Village or Street No.

The coordinate and elevation of a landslide shall be measured at site by using GPS with the WGS84 Geographic coordinate system or be obtained from satellite imagery, and recoded with the following coordinate formats:

- ✓ dddd.ddddd° (Lat/Lon Degree)

## 02 Date/Time of Landslide Occurrence

Date/Time of Landslide Occurrence – Enter the date and time (time/date/month/year) of landslide that occurred recently and previously, if the landslide history is available.

## 03 Meteorological Conditions

Meteorological Conditions – Record all rainfall information before the landslide occurred, such as cumulative rainfall, 24-hour rainfall and maximum 1-hour rainfall, and rainfall data source such as rain gauge or weather observation station, as well as its distance to the inspected landslide site.

Additional description – Collect and describe additional rainfall information, such as (1) 10-day rainfall data prior to sliding, (2) Rainfall data in recent 10 years, (3) Recording interval and period, and (4) Storage method, etc.

## 04 Landslide Characteristics

### 4.1 Landslide Type

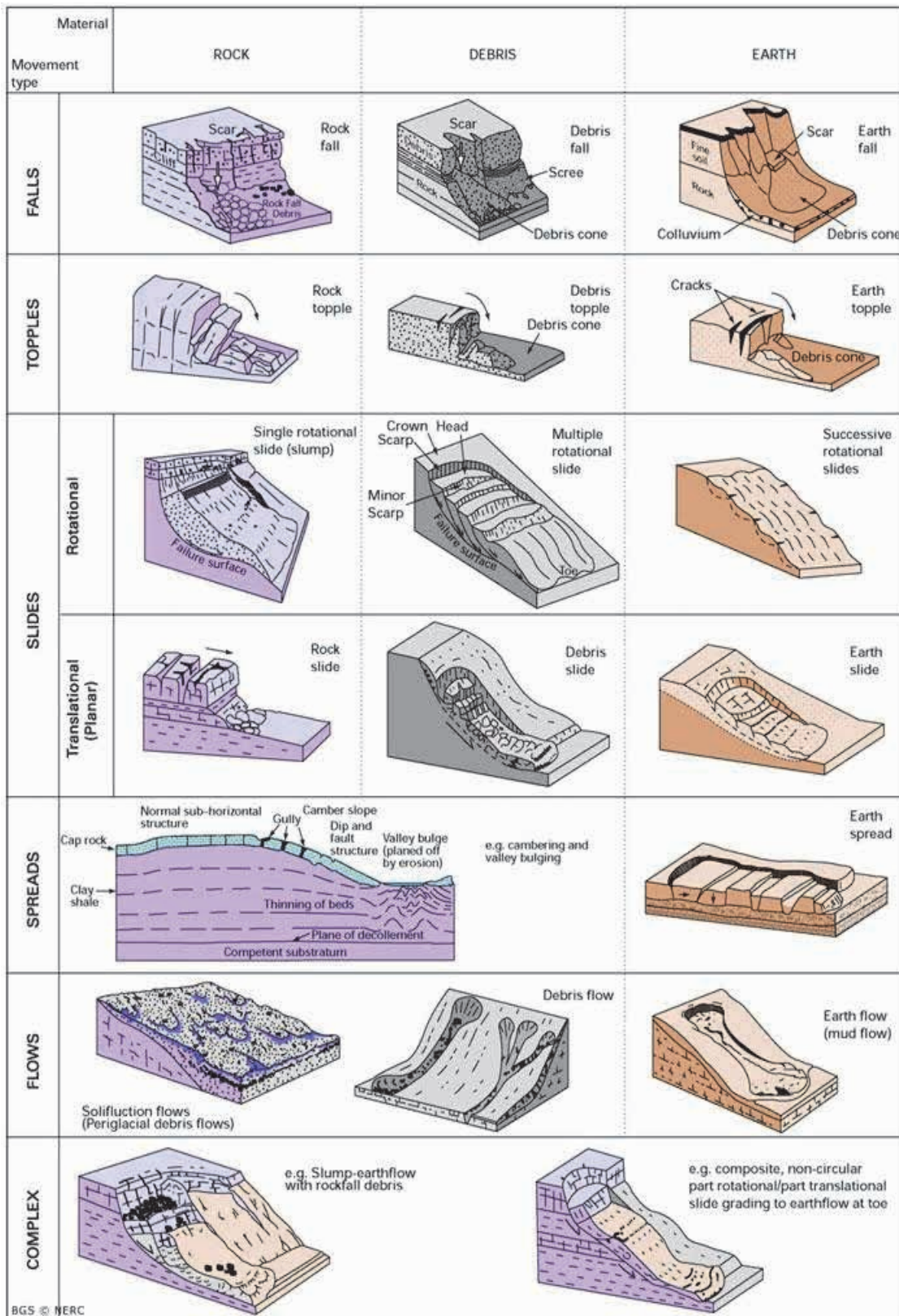
The classification of landslides in the inventory survey follows the scheme based on Varnes (1978) and Cruden & Varnes (1996), as shown in Table 1.1. The applicable number shall be entered (see Table 1.1).

**Table 1.1 Landslide Classification (Cruden and Varnes, 1996)**

Type of Movement	Type of Materials		
	Bedrock	Debris (predominantly coarse)	Earth (predominantly fine)
Topple	1. Rock topple	2. Debris topple	3. Earth topple
Fall	4. Rock fall	5. Debris fall	6. Earth fall
Slide	Translational	7. Translational rock slide	8. Translational debris slide
	Rotational	10. Rotational rock slide	11. Rotational debris slide
Flow	13. Rock flow	14. Debris flow	15. Earth flow
Spread	16. Rock spread	17. Debris spread	19. Earth spread
Complex	20. Combination of two or more principal type of movement		

Landslide movements are generally interpreted from the geomorphic expression of the landslide deposit and source area. The major types of landslides are schematically shown in Figure 1.1 and the movement types are described below:

- (1) **Topples**: Movements of rock, debris or earth masses by forward rotation around an axis or point at or near the base of the block. A topple often results in the formation of debris or a debris cone at the base of the slope.
- (2) **Falls**: Masses are detached from steep slope/cliff along surfaces with little or no shear displacement (e.g. joints/fissures) and descend mostly through air by free fall, bouncing or rolling. A fall type landslide results in the collection of rock or debris near the base of a slope.
- (3) **Translational (planar) slides**: Movements occur along planar failure surfaces that may run parallel to the slope.
- (4) **Rotational slides (slumps)**: masses slide outwards and downwards on one or more concave-upward surface of rupture or relatively thin zones of intense shear strain.



BGS © NERC

Figure 1.1 Schematic Illustrations of Major Types of Landslides (Hungr et al., 2014)

- (5) **Spreads:** Involve the fracturing and lateral extension of coherent rock or soil masses due to plastic flow or liquefaction of subjacent material. The rupture surface is not a surface of intense shear.
- (6) **Flows:** Slow to rapid movements of saturated or dry materials which advance by flowing like a viscous fluid, usually following an initial sliding movement. Some flows may be bounded by basal and marginal shear surfaces but dominant movement of the displaced material is by flowage.
- (7) **Complex slides:** A complex slide involves one of the main types of movement followed by two or more of the other main types of movement.

In addition, from Japanese experience, some slides move slowly and cause damage gradually, whereas others slides move so rapidly that they can destroy property and take lives suddenly and unexpectedly. They are classified for landside risk reduction and management, further into the following two types:

- (1) Slides that narrowly refers to the slow movement of a mass of rock, debris or earth along a pre-existing shearing surface (surface of rupture), and
- (2) Slope failures, sometimes referred to as shallow slope failure or steep slope failure, which are common type of fast-moving landslides.

A clear distinction between slide and slope failure has been recognized in Japan and given in Table 1.2 for reference.

**Table 1.2 Distinction between Slide and Slope Failure**

Item	Slide	Slope Failure
1) Geology	Occurs at sites with specific geological and geological structures	Less relation to geological condition
2) Topography	Occurs on gentle slopes of 5 to 30°	Occurs on steep slopes of over 30°
3) Soil Type	Occurs mainly on clayey soils	Occurs frequently on sandy soils
4) Activity	Continuous, recurrent	Sudden, sporadic
5) Movement speed	Slow, from 0.001 to 10 mm/day	Fast, over 10 mm/day
6) Displaced mass	Little disturbed	Strongly disturbed/deformed
7) Main Cause	Ground water - pore water pressure	Heavy rainfall - infiltration & erosion
8) Scale	Large, 1 to 100ha	Small, frequently in group

9)	Slip Surface	Gentle, 10 to 25°	Steep, 35 to 60°
10)	Indication	Development of cracks, subsidence, bulging, groundwater fluctuation	Without indications

Source: Modified from Mechanism and Mitigation Measures of Slope Disasters, Sankaido, by M. Watari, 1986

#### 4.2 Activity State of Landslide

The states of activity of landslides are generally classified, according to WP/WLI (1993), into four states: (1) active; (2) suspended; (3) re-activated; and (4) Inactive. State (4) inactive is subdivided into states: (5) dormant;

(6) abandoned; (7) stabilized; (8) relict. The applicable number shall be entered (see Figure 1.2).

The activity state of landslides are illustrated in Figure 1.2 and explained below:

- (1) **Active:** An active landslide is currently moving. In the example shown erosion at the toe causes a block to topple.
- (2) **Suspended:** A suspended landslide has moved within the last 12 months, but is not active at present. In the example shown local cracking can be seen in the crown of the topple.
- (3) **Reactivated:** A reactivated landslide is an active landslide which has been inactive. In the example shown another block topples and disturbs the previously displaced material.
- (4) **Inactive:** An inactive landslide has not moved within the last 12 months.
- (5) **Dormant:** A dormant landslide is an inactive landslide which can be reactivated by its original causes or other causes. In the example shown the displaced mass begins to regain its tree cover and scarps are modified by weathering.
- (6) **Abandoned:** An abandoned landslide is an inactive landslide which is no longer affected by its original causes. In the example shown the fluvial deposition has protected the toe of the slope, the scarp begins to regain its tree cover.
- (7) **Stabilized:** A stabilized landslide is an inactive landslide which has been protected from its original causes by remedial measures. In the example shown a retaining wall protects the toe of the slope.
- (8) **Relict:** A relict landslide is an inactive landslide which developed under climatic or geomorphological conditions considerably different from those at present. In the example shown uniform tree cover has been established.



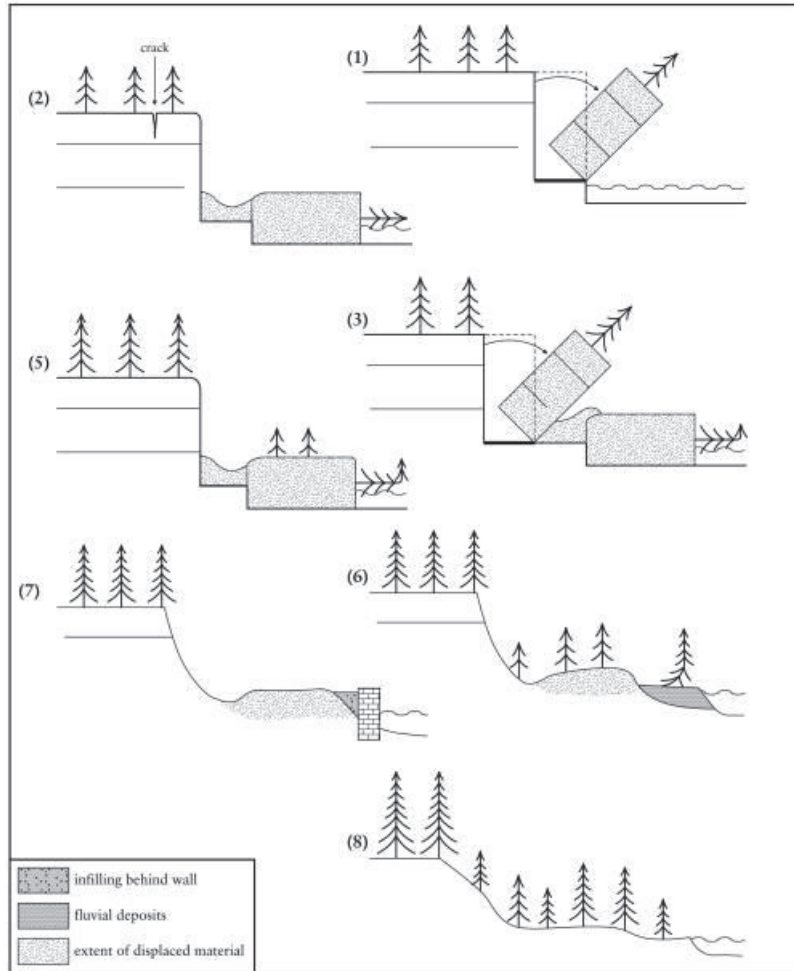
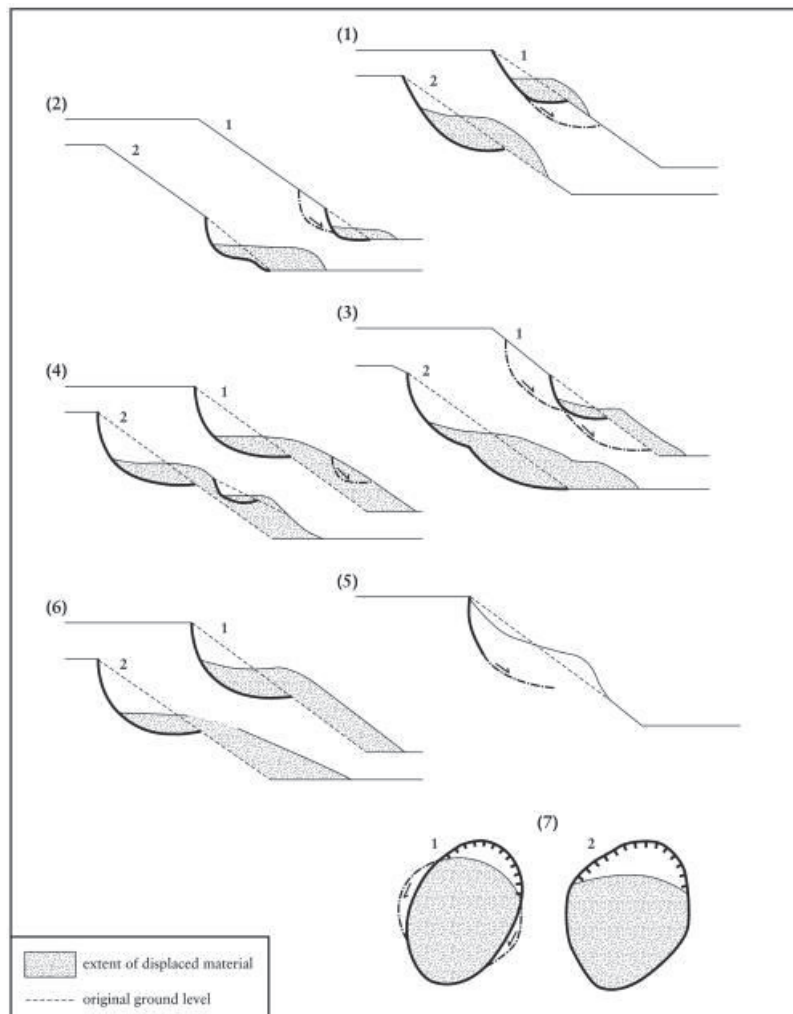


Figure 1.2 Schematic Illustrations of Activity State of Landslides

## 4.1 Landslide Activity Distribution

The distribution of the activity of landslides is categorized into: (1) advancing; (2) retrogressive; (3) enlarging; (4) diminishing; (5) confined; (6) moving; (7) widening. See below for explanation of terms (WP/WLI, 1993). The applicable number shall be entered (see Figure 1.3).



**Figure 1.3 Schematic Illustrations of Activity Distribution of Landslides**

- (1) **Advancing:** In an advancing landslide the rupture surface is extending in the direction of movement.
- (2) **Retrogressive:** In a retrogressive landslide the rupture surface is extending in the direction opposite to the movement of the displaced material.
- (3) **Enlarging:** in an enlarging landslide the rupture surface of the landslide is extending in two or more directions.
- (4) **Diminishing:** In a diminishing landslide the volume of displaced material is decreasing.
- (5) **Confined:** In a confined landslide there is a scarp but no rupture surface visible at the foot of the displaced mass.

- (6) **Moving:** In a moving landslide the displaced material continues to move without any visible change in the rupture surface and the volume of the displaced material.
- (7) **Widening:** In a widening landslide the rupture surface is extending into one or both flanks of the landslide.

### 4.3 Movement Velocity of Landslides

The velocity of a landslide can be correlated with the damage it may cause. The velocity of movement of a landslide can range from extremely slow, less than 16 mm/year or  $0.5 \times 10^{-6}$  mm/second, to extremely rapid, over 5m/second, as shown in Figure 1.4.

Velocity Class	Description	Velocity (mm/sec)	Typical Velocity	Probable Destructive Significance
7	Extremely Rapid			Catastrophe of major violence: buildings destroyed by impact of displaced material; many deaths; escape unlikely
		$5 \times 10^3$	5 m/sec	
6	Very Rapid			Some lives lost; velocity too great to permit all persons to escape
		$5 \times 10^1$	3 m/min	
5	Rapid			Escape evaluation possible; structures, possessions, and equipment destroyed
		$5 \times 10^{-1}$	1.8 m/hr	
4	Moderate			Some temporary and insensitive structures can be temporarily maintained
		$5 \times 10^{-3}$	13 m/month	
3	Slow			Remedial construction can be undertaken during movement; insensitive structures can be maintained with frequent maintenance work if total movement is not large during a particular acceleration phase
		$5 \times 10^{-5}$	1.6 m/year	
2	Very Slow			Some permanent structures undamaged by movement
		$5 \times 10^{-7}$	15 mm/year	
	Extremely SLOW			Imperceptible without instruments; construction POSSIBLE WITH PRECAUTIONS

Figure 1.4 Landslide Velocity Scale (After Cruden and Varnes, 1996)

If instrumentation of a landslide movement is not available, the velocity of landslide to be inspected shall be qualitatively defined below and the applicable number shall be entered (see Table 1.3).

**Table 1.3 Landslide Velocity Scale Used in this Inspections**

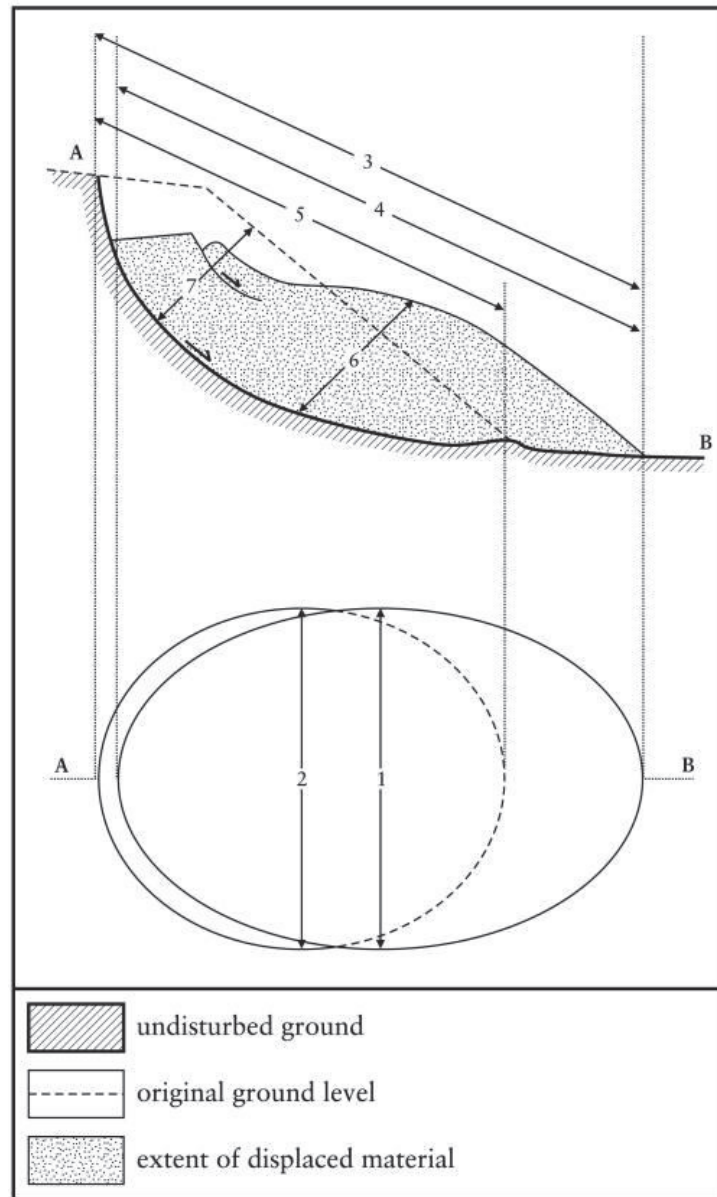
No	Description	Definition (or Criteria)
1	Rapid	Over 1 m/hr, displaced mass moves fast and far from the source area
2	Moderate	10 m/month to 1 m/hr, apparent ground deformation is slow but perceptible.
3	Slow	1 m/year to 10 m/month, imperceptible but increased deformation of ground surface is observable during within a period of time (ex., several months).
4	Very slow	Less than 1 m/year, imperceptible without instruments

#### 4.4 Width of Displaced Mass to 4.11 Depth of Rupture Surface

These inspection items are used to represent the size (or dimension) of a landslide, as recommended in The Multilingual Landslide Glossary (WP/WLI, 1993).

- (1) **Width of the Displaced Mass (Subsection 4.5):** The width of the displaced mass is the maximum breadth of the displaced mass perpendicular to the length of the displaced mass.
- (2) **Width of the Rupture Surface (Subsection 4.6):** The width of the rupture surface is the maximum width between the flanks of the landslide, perpendicular to the length of the rupture surface.
- (3) **Total length (Subsection 4.7):** The total length is the minimum from the tip of the landslide to the crown.

- (4) **Length of the Displaced Mass (Subsection 4.8):** The length of the displaced mass is the minimum distance from the tip to the top.

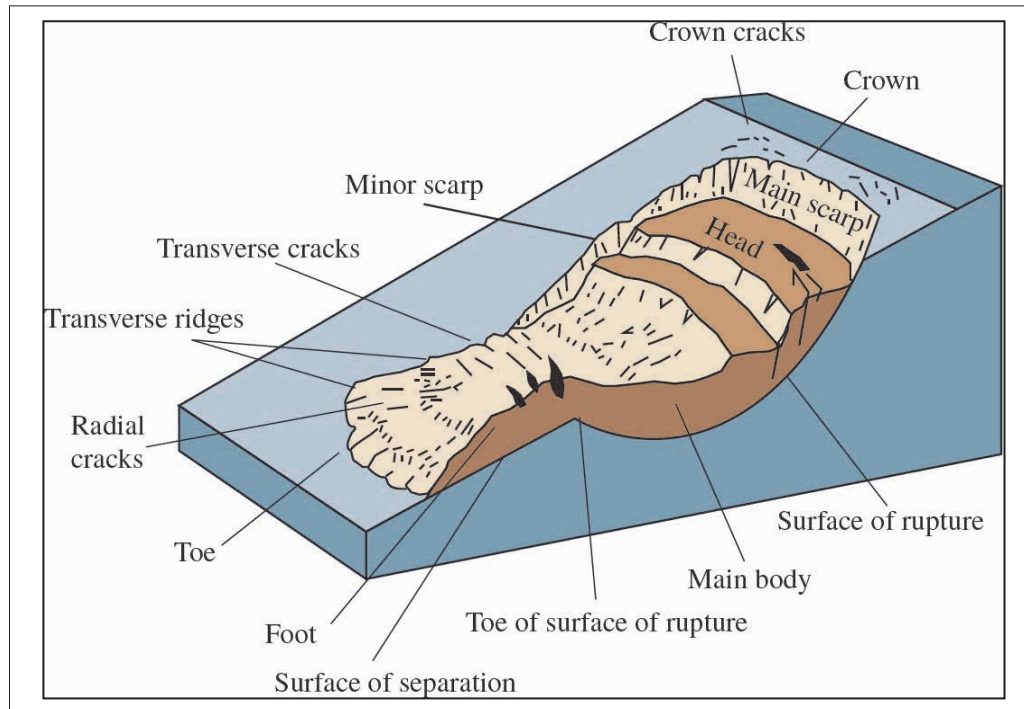


**Figure 1.5 Illustration of Profile and Plan Views of Landslides**

- (5) **Length of the Rupture Surface (Subsection 4.9):** The length of the rupture surface is the minimum distance from the toe of the surface of rupture to the crown.
- (6) **Depth of the Displaced Mass (Subsection 4.10):** the depth of the displaced mass is the maximum depth of the displaced mass, measured perpendicular to the plane containing the width and length of the displaced mass.
- (7) **Depth of the Rupture Surface (Subsection 4.11):** The depth of the rupture surface is the maximum depth of the rupture surface below the original ground surface measured

perpendicular to the plane containing the length and width of the rupture surface.

In estimating or measuring the dimension of a landslide, landslide terminology suggested by Cruden & Varnes (1996) (Figure 1.6) and in The Multilingual Landslide Glossary (WP/WLI, (1993) (Figure 1.7) shall be followed for the uniformity of inspection.

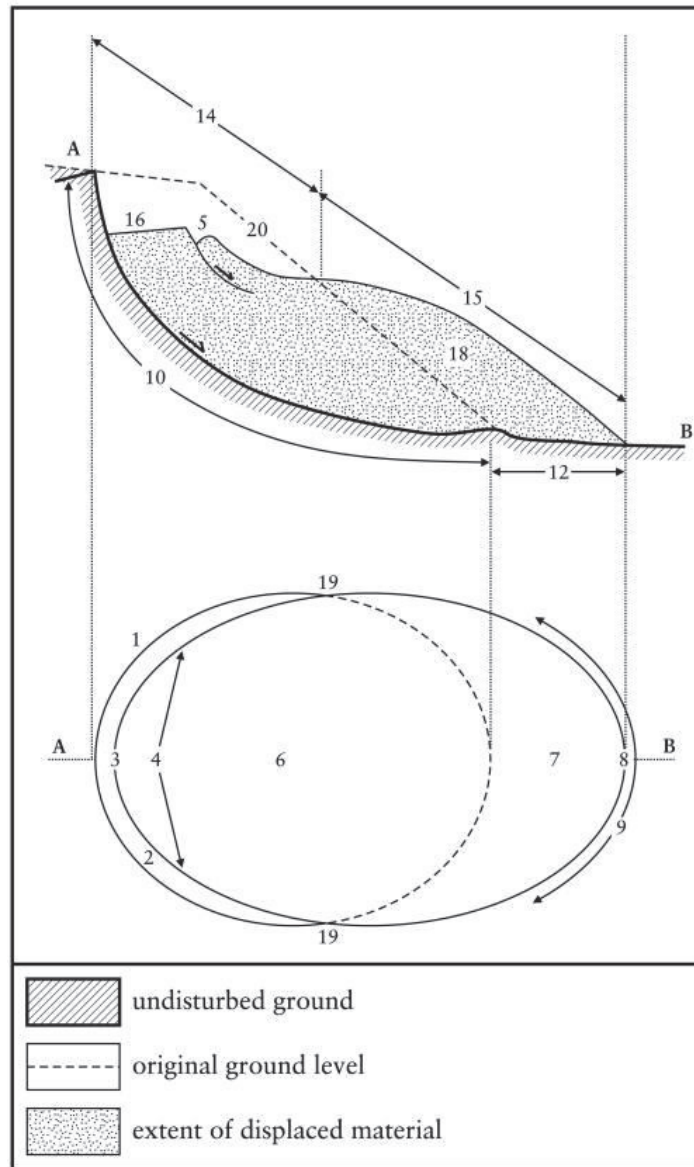


**Figure 1.6 Graphic Illustration of A Rotational Slide with the Commonly Accepted Terminology**

- (1) **Crown:** The practically un-displaced material still in place and adjacent to the highest parts of the main scarp.
- (2) **Main Scarp:** A steep surface on the undisturbed ground at the upper edge of the landslide, caused by movement of the displaced material away from the undisturbed ground. It is the visible part of the surface of rupture.
- (3) **Top:** The highest point of contact between the displaced material and the main scarp.
- (4) **Head:** The upper parts of the landslide along the contact between the displaced material and the main scarp.
- (5) **Minor Scarp:** A steep surface on the displaced material of the landslide produced by differential movements within the displaced material.
- (6) **Main Body:** The part of the displaced material of the landslide that overlies the surface of rupture between the main scarp and the toe of the surface of rupture.
- (7) **Foot:** The portion of the landslide that has moved beyond the toe of the surface of rupture and overlies the original ground surface.
- (8) **Tip:** The point of the toe farthest from the top of the landslide.



- (9) **Toe:** The lower, usually curved margin of the displaced material of a landslide, it is the most distant from the main scarp.
- (10) **Surface of Rupture:** The surface which forms (or which has formed) the lower boundary of the displaced material below the original ground surface.
- (11) **Toe of the Surface of Rupture:** The intersection (usually buried) between the lower part of the surface of rupture of a landslide and the original ground surface.



**Figure 1.7 Illustration of Profile and Plan Views of Landslides**

- (12) **Surface of Separation:** The part of the original ground surface overlain by the foot of the landslide.
- (13) **Displaced Mass:** Material displaced from its original position on the slope by movement in the landslide. It forms both the depleted mass and the accumulation.
- (14) **Zone of Depletion:** The area of the landslide within which the displaced material lies below

the original ground surface.

- (15) **Zone of Accumulation:** The area of the landslide within which the displaced material lies above the original ground surface.
- (16) **Depletion:** The volume bounded by the main scarp, the depleted mass and the original ground surface.
- (17) **Depleted Mass:** The volume of the displaced material, which overlies the rupture surface but underlies the original ground surface.
- (18) **Accumulation:** The volume of the displaced material, which lies above the original ground surface.
- (19) **Flank:** The un-displaced material adjacent to the sides of the rupture surface. Compass directions are preferable in describing the flanks but if left and right are used, they refer to the flanks as viewed from the crown.
- (20) **Original Ground Surface:** The surface of the slope that existed before the landslide took place.

#### 4.12 Reaching Distance

The reaching distance – Enter the travel distance of displaced mass that is equal to Subsection (12) Surface of Separation, as explained above.

#### 4.13 Displaced Volume

Displaced volume – Enter the volume of displaced mass,  $V$ , which is roughly estimated as follows:

$$V = 1/3 \times L \times W \times D$$

$L$ : Length of the Rupture Surface,

$W$ : Width of the Rupture Surface, and

$D$ : Depth of the Rupture Surface

#### 4.14 Affected Area

Affected area – Enter the square meter of hazard area – multiplying total length by whichever is wider, the width of displaced mass or the width of rupture surface.

#### 4.15 Additional Description

Additional description – Additionally mention whether a link with the actual situation of a landslide occurrence, such as landslide activity, surface deformation (crack, depression, bulge) and its occurrence location, amount and location of spring water, indication of further sliding, etc.

## 05 Geo-Environmental Characteristics at Landslide Site

### 5.1 Slide Material

Slide material is defined and given in Table 1.4. In the case of rocks, mention the name of bedrock (ex., Gneiss).

**Table 1.4 Classification of Engineering Material Involved in Landslides**

Type of Slide Material		Description
1	Rock	Bedrocks including weathered rocks but its original mass structure is still observable.
2	Debris	Coarse-grained engineering soils dominated by material of gravel size or greater.
3	Earth	Fine-grained engineering soils dominated by clay to sand-size fractions

### 5.2 Surface Geology

Surface (or surficial) geology – Select the type of surficial deposits or soils around where landslide occurred, including residual soils, colluvial soils, or others, and enter the number of the applicable type of surficial geology (see Table 1.5).

**Table 1.5 Classification of Surficial Geology**

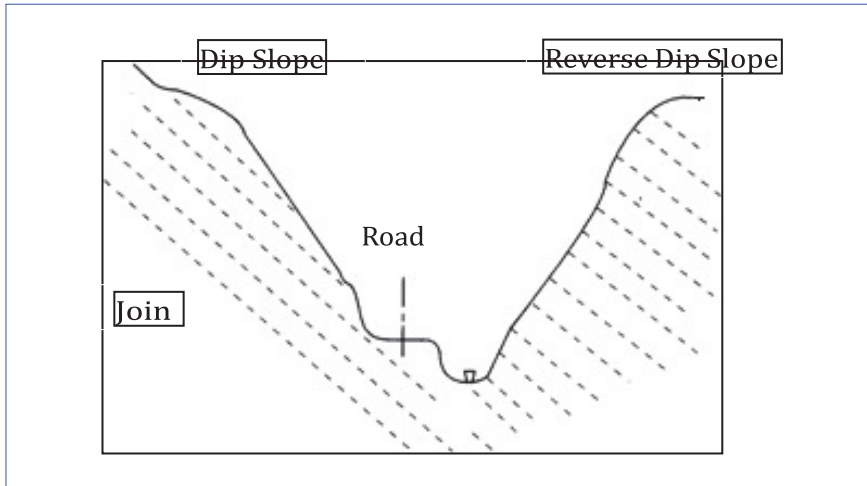
Surficial Geology		Description
1	Residual	Soil formed in situ by rock weathering/alteration and left as a residue after the leaching out of the more soluble products.
2	Colluvial	A loose deposit of rock blocks, debris and/or earth accumulated through the action of gravity at the base of a cliff or slope.
3	Other	Other relatively stable deposits, such as alluvial, glacial deposits.

### 5.3 Discontinuity/Slope

Discontinuity/Slope –Confirm the major discontinuity planes, such as foliation joints, shear, etc., measure their apparent dip on the slope, and enter the number of the applicable relationship of discontinuity and slope under the conditions shown in Table 1.6 and Figure 1.

**Table 1.6 Relationship between Major Discontinuity and Slope Direction**

Slope Type		Description
1	Dip Slope	The major discontinuities incline towards the same direction as the slope.
2	Reverse Slope	The major discontinuities incline towards the opposite direction to the slope.
3	None	No particular discontinuity plane is observed, or the plane is horizontal.



**Figure 1.8 Illustration of Dip Slope and Reverse Dip Slope**

### 5.4 Slope Type

Slope type – Select the type of slope where landslide occurred, including natural, artificial (cutting and filling), or both, and enter the number of the applicable type of slope (see Table 1.7).

**Table 1.7 Classification of Slope Type**

Slope Type		Description
1	Natural	A slope formed by the force of nature, including natural cliffs.
2	Artificial	A slope formed by applying artificial force as by cutting, embankment, the installation of structures, etc.
3	Both	A slope consisting of natural and artificial slopes as defined above.

### 5.5 Slope Angle

Slope angle – Enter the average gradient (or slope) of landslide slope (ex., 35 degrees). Note that the average gradient is the slope of original ground surface prior to sliding.

### 5.6 Slope Height

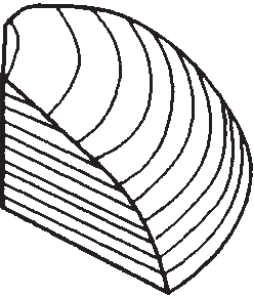
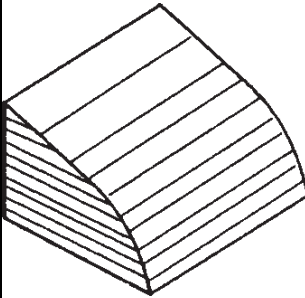
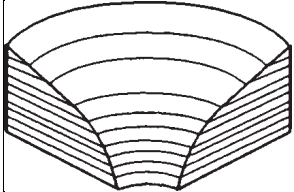
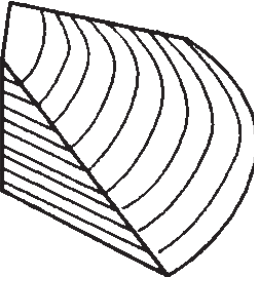
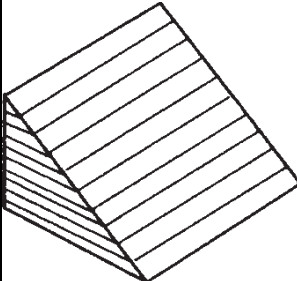
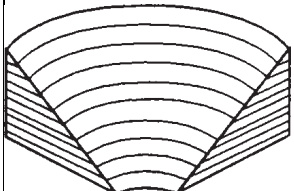
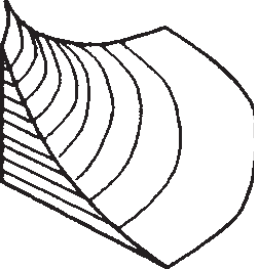
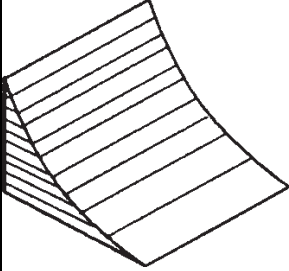
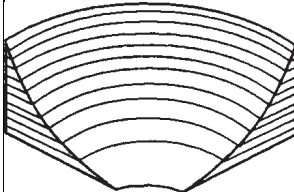
Slope height – Enter the height of landslide slope (or area) from the top to the foot of a landslide.

When there is any flat land (with its average angle of slope being roughly 5° or less) in the middle of the slope in a steep slope failure hazard area, etc, the over slope height shall be roughly estimated, by measuring the height from the toe of landslide to the point where the gradient of slope is about 20 degrees.

### 5.7 Slope Shape

The shape of slope in this inspection shall be classified into the 9 types as shown in Figure 1.9 from the transversal shape (straight line type, ridge type, and valley type) and the longitudinal shape (convex slope, straight line slope, and concave slope), and the number of the applicable shape of slope shall be entered (see Figure 1.9).

Note that if it is difficult to select the shape of the slope at inspection due to its complex shape, the shape of the slope shall be selected by judging its outline from the situation of the slope.

Classification		Classification of Slope by the Horizontal Cross-Sectional Shape		
		Ridge-type	Strait-type	Valley-type
Classification of Slope by the Vertical Cross-Sectional	Convex slope	 <p>(1) Convex ridge type slope</p>	 <p>(4) Convex straight line slope</p>	 <p>(7) Convex valley type slope</p>
	Straight line slope	 <p>(2) Straight line ridge typeslope</p>	 <p>(5) Straight line straight lineslope</p>	 <p>(8) Straight line valley type slope</p>
	Concave slope	 <p>(3) Concave ridge type slope</p>	 <p>(6) Concave straight line slope</p>	 <p>(8) Concave valley type slope</p>

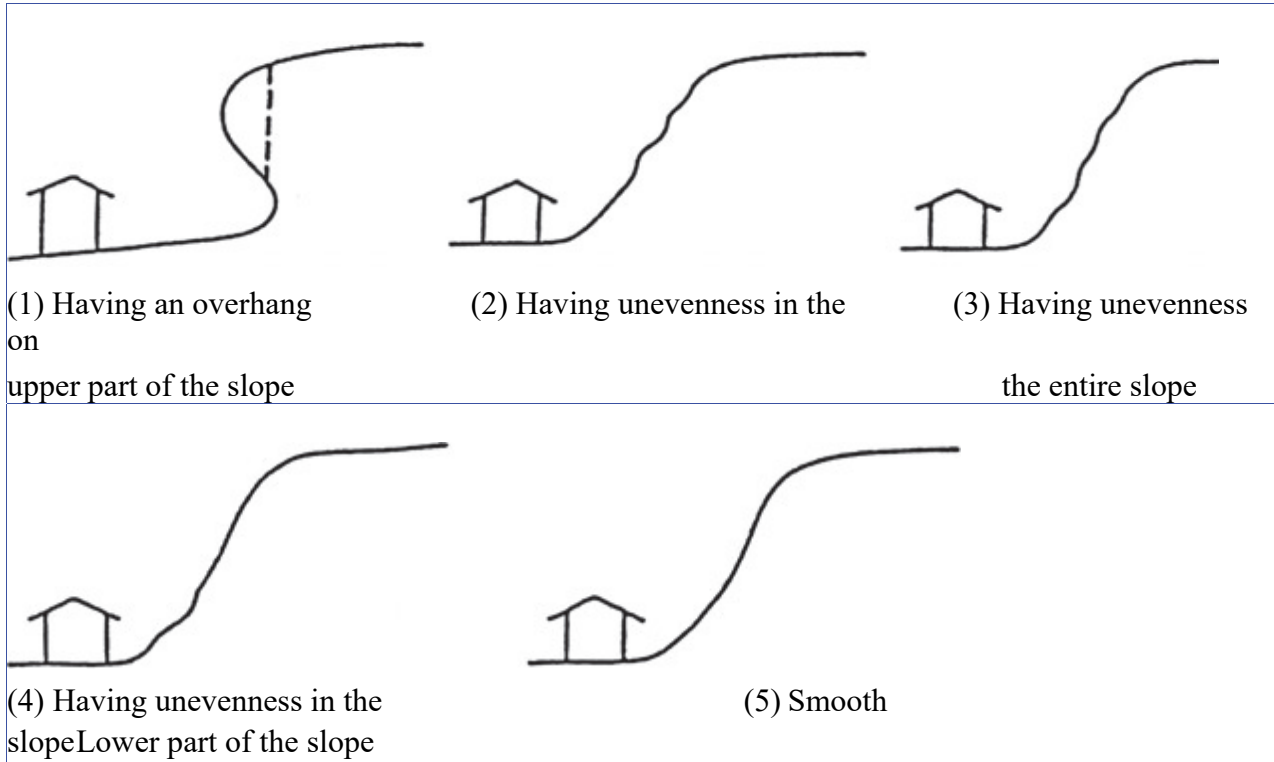
**Figure 1.9 Classification of the Shape of Slope**

In general, in the ridge type slope, the rock can be more shocked because sides of the ridge are not confined. The colluvial slope is probably formed by repetition of landslides in valley-type slope. The intermediate slope between the ridge type and the valley type is regarded comparatively stable due to being less weathered. In the case of the valley type slope, the bedrock is exposed only along streams because of the sedimentation of colluvial deposits.



### 5.8 Transversal Shape

The transversal shape of landslide slope to be inspected shall be classified into 5 types as shown in Figure 1.10 below, and the applicable number shall be entered (see Figure 1.10).



**Figure 1.10 Classification of the Transversal Shape**

### 5.9 Slope Drainage

Slope Drainage – Examine and enter the drainage pattern of landslide slope, including 1) drainage flows into the landslide slope, 2) drainage flows out of the landslide slope, and 3) no observable drainage associated with the landslide slope.

### 5.10 Spring Water

The spring water around the landslide area shall be classified into 3 types, as shown in Table 1.8 below. The number of the vegetation cover with the highest composition ratio there shall be entered (see Table 1.8).

**Table 1.8 Classification of Spring Water Conditions**

Spring Water		Description
1	Flow	Much spring water flows out of slope to cause weakening of soil slope.
2	Wet or Damp	The landslide slope is wet, but the water discharge is less than as the above “flow”.
3	No Spring Water	No evidence of spring water is observed around the landslide slope.

### 5.11 Vegetation Cover

The vegetation cover on the slope of landslide shall be classified into 6 types, as shown in Table 1.9 below. The number of the vegetation cover with the highest composition ratio there shall be entered (see Table 1.9).

**Table 1.9 Type of Vegetation Cover on Landslide Slopes**

No.	Vegetation Cover	No.	Vegetation Cover
1	No vegetation (bare land)	4	Broad-leaved trees
2	Grassland	5	Bamboo forest
3	Conifers	6	Mixture of several types

### 5.12 Land Use

The land use around the landslide area shall be classified into 3 types, namely; (1) Building land, (2) Agricultural land and (3) Other use. The applicable number shall be entered.

### 5.13 Additional Description

Additional description – Additionally describe the situation of the slope above the inspected landslide slope especially where the entire slope including landslide area is long and wide, mainly focusing on topography (slope

gradient, slope height, knick line distribution, slope direction), geology (soil composition, weathering and fracturing of rocks), ground deformation (rock fall, crack, depression), drainage (surface water, spring water distribution), etc.

Surface soils around the landslide area shall be also described in detail if observable, mainly including the origin of soils (residual, alluvial, colluvial, etc.), thickness of soils, hardness (density and consistency) of soils. Causative factors, if identifiable at inspection, shall be stated.

## 06 Landslide Maps

### 6.1 Availability of Landslide Maps to 6.4 Techniques Used for Mapping

Within the inspected landslide area, if landslide map is available or has been prepared, enter the scale of landslide map (ex., 1:50,000).

The applicable number of types of landslide maps shall be entered (see Table 1.10) and of mapping techniques used in the preparation of landslide maps (see Table 1.11).

Note that, in the case of several mapping methods used, enter all applicable numbers of mapping methods.

**Table 1.10 Types of Landslide Maps**

No.	Landslide Map	No.	Landslide Map
1	Landslide hazard zone map	3	Susceptibility map
2	Risk map	4	Others

**Table 1.11 Classification of Landslide Mapping Methods**

No.	Mapping Methods or Techniques
1	Aerial photograph interpretation (including topographic/satellite image interpretation)
2	Field survey (site inspection and reconnaissance)
3	Historical documents (e.g. newspapers, disaster survey reports, scientific papers)
4	LiDAR (Light Detection and Ranging) derived images
5	Combinations of the above several methods
6	Others or unknown

### 6.5 Additional Description

Indicate information on map preparation, such as preparation date, organization name, references used, reference coordinate system used, etc.

## 07 Human Damages

### 7.1 Fatalities to 7.3 Missing Number

The number of the fatalities, injuries and missing, if caused by the inspected landslide shall be entered separately. Specially, the number of the fatalities shall be checked and entered separately within

landslide area and affected area, at the 1<sup>st</sup> floor and other floors of the houses as well as outside houses.

#### 7.4 Additional Description

If available or obtainable, additional information on the landslide consequences including the age and sex of deaths, estimate of other damages, etc.

#### 08 House Damage

The number of houses damaged by the inspected landslide shall be entered separately with respect to destroying degree of houses (Table 1.12), types of damaged houses (Table 1.13) and position of damaged houses relative to landslide slope (Table 1.14) below.

**Table 1.12 Classification of Destroying Degree of Houses**

Damage Degree	Definition or Criteria
Completely damaged	<ul style="list-style-type: none"> <li>a) Completely collapsed and lost the basic function of buildings;</li> <li>b) Beyond repair or maintenance for living;</li> <li>c) The damaged floor space comes to over 70% of its total floor space;</li> <li>d) The loss of major structural parts of buildings amounts to 50% of the marketvalue of the relevant buildings.</li> </ul>
Partially damaged	<ul style="list-style-type: none"> <li>a) Significantly damaged, and require major repairs for living;</li> <li>b) The damaged floor space is between 50 and 70% of its total floor space; or</li> <li>c) The loss of major structural parts of buildings amounts to more than 40% and less than 50% of the market value of the relevant buildings</li> </ul>
Slightly damaged	<ul style="list-style-type: none"> <li>a) Slightly damaged, and partially lost the basic function of buildings;</li> <li>b) The damaged buildings generally require minor repairs for living;</li> <li>d) The damaged floor space is between 20 and 70% of its total floor space;</li> <li>c) The loss of major structural parts of buildings amounts to more than 20% and less than 50% of the market value of the relevant buildings.</li> </ul>

Source:

**Table 1.13 Types of Damaged Houses**

Type of House	Description
Concrete house	Including reinforced concrete houses and buildings
Block/Brick house	Including block and brick masonry houses
Others	All buildings except for the above-mentioned, e.g., mud house, wooden house

**Table 1.14 Position of Damaged Houses Relating to Landslide Slope**

Position of House	Description
Above landslide crown	The damaged houses are located above the landslide slope (area).
Within landslide	The damaged houses are located within the landslide slope (area).
Below landslide	The damaged houses are located below the landslide slope (area).

Additional information on the situation of damage to houses during and immediately after landslide shall be recorded in detailed, such as locations of damaged houses relating to landslide and displaced mass, damage causes (ex., due to landslide movement, earth pressure of displaced mass or inundated water), etc.

### **09 Other Facility Damages**

Other facilities, if damaged, especially public facilities such as road, administrative offices, schools and medical facilities shall be recorded, focusing mainly on their damage degrees and locations relative to landslide.

### **10 Mitigation Measures**

#### **10.1 Implementation State to 10.5 Guideline/Manual Applied**

If any mitigation measures (or works) have been implemented on the landslide slope to be inspected, enter the name of implementation organization, implementation period (from date/month/year to date/month/year), the types of implemented works, and guideline or manual applied for design and construction of these preventive works.

#### **10.6 Additional Description**

Additional information on abnormality in preventive works after landslide shall be inspected and recorded in detail, focusing mainly on the size and location of deformation/crack/local collapse in preventive works, and the influence of these abnormalities on the function of preventative works.

### **11 Emergency Measures**

If emergency measures (or works) have been done immediately after landslide, enter the required inspection items, similar to those recorded in Section 10 Prevention Measures above.

### **12 Restoration Measures**

See Section 10 Prevention Measures above.

If no restoration measures (or works) have been done, additional information on restoration plan, if available, shall be recorded, including implementation planning, types of works, construction costs, etc.

### **13 General Comments**

General comments shall be required to present an outline of the actual situation of the inspected landslide site, listed below:

- (1) Type and dimension of landslide, as well as triggering and causative factors of landslide occurrence;
- (2) Damage degree; and
- (3) Implementation and planning of prevention and restoration works.

## 14 Plan Sketch

The actual conditions of the inspection site shall be recorded by sketching, following the requirements listed below:

- (1) Base map – If landslide risk map or topographic map is available, the inspection site data by sketching shall be superimposed onto a topographic base map or risk map.
- (2) Sketch area – The plan sketch shall cover the landslide area and its upper/lower slopes. The upper slope shall include the area of a horizontal distance of about 10m from the top of the landslide site. The lower slope shall include the area of a horizontal distance of  $2H$  ( $H$ =slope height) or less than 50m from the foot of the landslide.
- (3) Sketch features – The following features and their marks shall be recorded and correspond to the inspection site, such as landslide area/ground deformation, soil types and distribution, rock types and distribution, existing countermeasure works (prevention and restoration), houses and other facilities (damaged and undamaged), springs, vegetation, etc.
- (4) Basic requirements – Basically, bar scale, direction and legend (see Figure 1.11 below) shall be prepared on the sketch. Additional description/explanation shall also be provided on the plan sketch.

In the case of large-scale landslide, the plan sketch shall be prepared separately in the form of A4 size in order to clearly and accurately depict those important features/elements and their locations.

## 15 Cross Section Sketch

Field-developed cross section shall be sketched to identify slope topography (gradient and height of slope before and after sliding), slope geology (soil and rock types, weathering degrees of rocks, etc.), landslide geometry (shape and location of rupture surface), distribution of displaced mass, and location of existing facilities/countermeasure works, location of springs by projection, etc.

## 16 Whole and Close Views

Like cross section sketching, the conditions of the inspection site shall be recorded by taking photographs; including the whole view of the landslide site, and close views of representative geological/topographical features, some deformation features as well as damage conditions.

## 17 Satellite Images

If available, satellite image or LiDAR shall be provided to show the inspected landslide blocks and their distribution.



## I. Boundary Structures

### A. Main scarp and lateral scarp (flank)



1. Main and/or lateral scarp of which crown is fresh or not dissected.



2. Partially dissected crown.



3. Mostly dissected crown.



4. Roundly subdued and vague crown.



5. The missing part of the scarp and crown by dissection.



6. Joint crown which divides two main scarps throwing opposite slope directions.



7. Exposed slide surface without sharp scarp ; dip of the slide surface is usually gentle ( $<25^\circ$ )  
The crown is defined by the intersection between the opposite slope and the slide surface.



8. Lunar or crown cracks, multiple scarps and ridges.

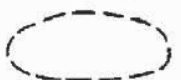
### B. Margine of moving mass



1. Definite and probable margin of the moving mass with a main scarp at the backward or upper slope.



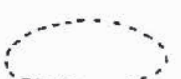
2. The questionable part of the margin is shown by a question mark “?”.



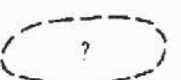
3. Moving mass margin without main scarp and crown symbols :  
Margin of residual part of the mass of which scarp has been almost eroded away.



4. A part of margin overlain by another moved mass or deposits



5. Margin of a mass movement at the initial stage from the original slope.  
Probable bounbary of an area inferred as an unstable or quasi-moving mass without clear detachment structures between the mass and bedrocks.



6. A mountain or hill difficult to identify whether mass is moving or not.



7. Foot line or toe of surface of rupture : usually by the moved mass.

**Figure 1.11 Symbols for Landslide Map and Sketch**

Source: Technical Note of the National Research Institute for Earth Science and Disaster Prevention, No. 309, March, 2007

II. Interior Structures



1. Secondary scarp: The crown is similarly shown in a main scarp.



2. Boundary between sub-units or an interior moving/moved mass.



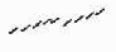
3. Ridge (interior)



4. Wide trench or open crack.



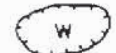
5. Narrow trench or open crack.



6. Echelon cracks.



7. Linear depression or valley floor line.  
Arrow shows the down stream.



8. Pond



9. Somewhat round and dry depression.



10. Front of bulging.

III. Movement Direction and Main Moving Direction of the Mass



1. Slide



2. Creep



3. Flow



4. Fall



5. Slow movement with external rotation.



6. Dip of the move slope surface ; usually shown in case of reverse dip from original slope.

IV. Others



1. Knick line



2. Fault



3. Dip and strike of bedding surface, schistosity etc. and joint.

Figure 1.11 Symbols for Landslide Map and Sketch (Continued)

**00 Landslide Name and ID**

Refer to 00 Landslide Name and ID of Part 1 above.

**01 Landslide Location**

Refer to 01 Landslide Location of Part 1 above.

**02 Date/Time of Landslide Occurrence**

Refer to 02 Date/Time of Landslide Occurrence of Part 1 above.

**03 Meteorological Conditions**

Refer to 03 Meteorological Conditions of Part 1 above.

**04 Source (or Initiation) Area**

Flow-type landslides generally originate from hillslope, then flow down valley slopes as tracks or sheets, and finally deposit on the lower areas with lower slope gradients or where flow rates are reduced. Topographically the flow-type landslide can be divided into three zones (or areas), that is, (1) Source area, (2) Flow path and (3) Depositional area, as shown in Figures 2.1 and 2.2 below.

The source area is the steep hillside above the maintain stream and has a slope gradient from 15% to as steep as 60% (Figure 2.2), commonly initiates as shallow slope failure of soil and weathered rocks together locally surface erosion.

**4.1 Slope Geology**

Refer to 5.1 Slide Material of Part 1 above.

**4.2 Surface Geology**

Refer to 5.2 Surface Geology of Part 1 above.

**4.3 Slope Type**

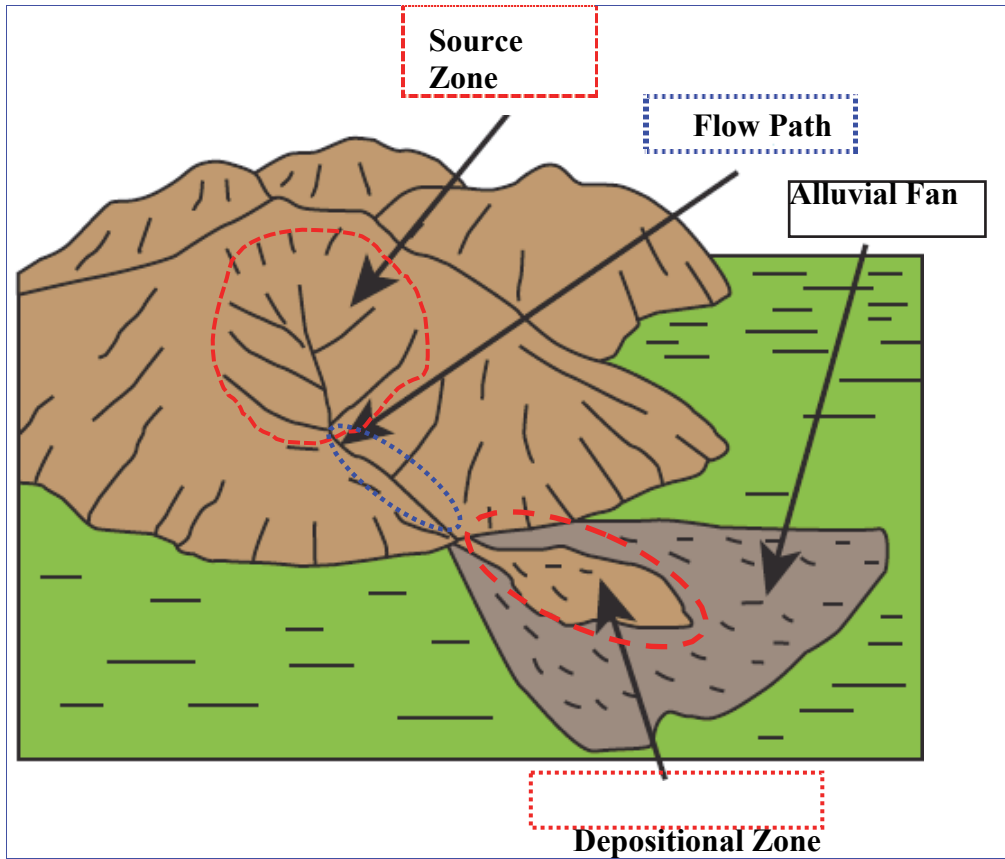
Refer to 5.4 Slope Type of Part 1 above.

**4.4 Slope and Streambed Gradients**

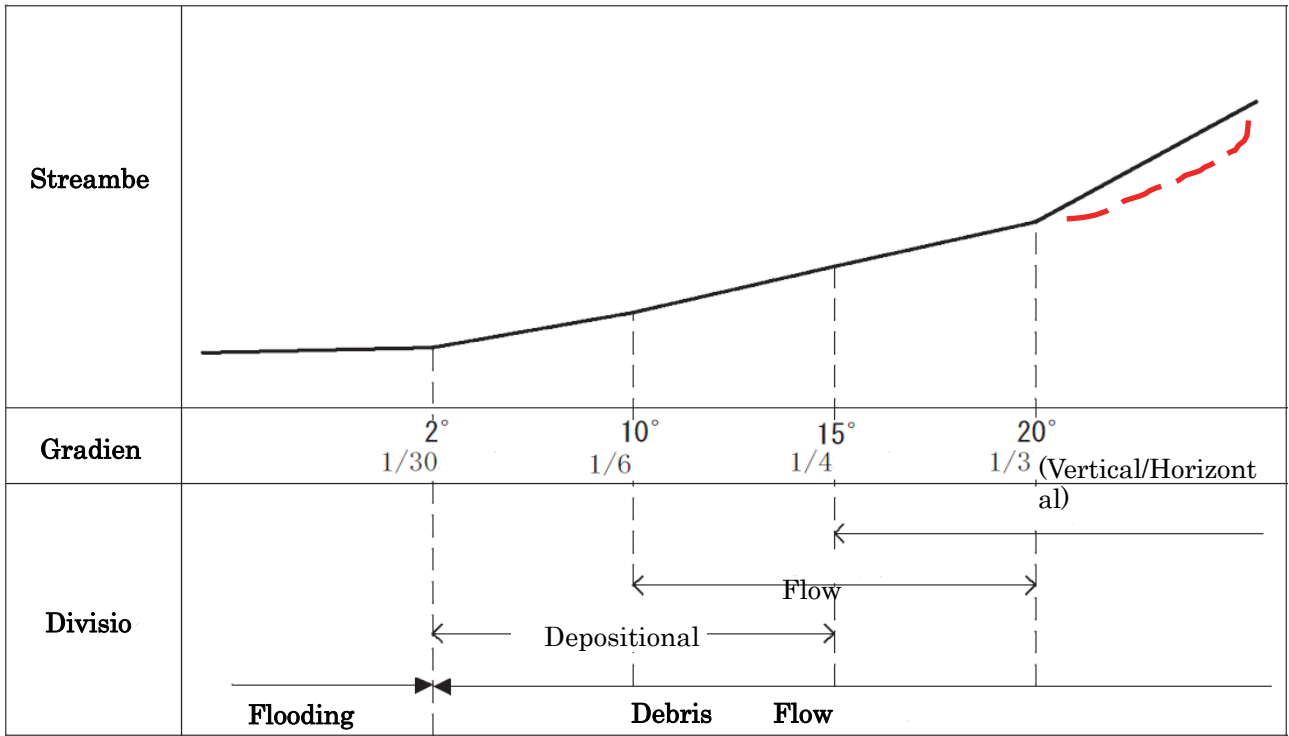
Slope gradient – Enter the average slope of hillslopes where landslide or erosion has occurred to

provide the deposit materials to generate flow-type landslide.

Streambed gradient – Enter the average streambed slope of the most upstream (above the first stage valley), if such stream exists (see Figure 2.1).



**Figure 2.1 Schematic Illustration of A Debris Flow and Its Source Area**

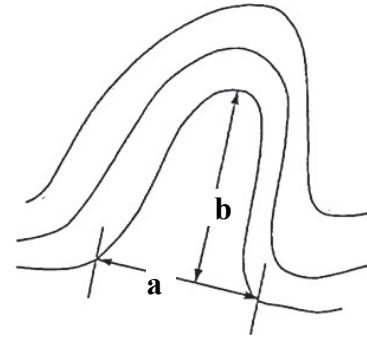


**Figure 2.2 Division Debris Flow Area by Streambed Gradient**

**First Stage Valley** is the most upper point of stream which starts to run debris (or earth) flow.

The first stage valley is topographically defined below (see the schematic illustration):

- (a) A spot with  $a < b$  is to be a first-stage valley
- (b) Even if a spot is with  $a > b$ , but the stream is running debris flow or has a past record of debris (or earth) flow.



#### 4.5 Slope Shape

Refer to 5.7 Slope Shape of Part 1 above.

#### 4.6 Depth of Rupture Surface

Refer to 4.11 Depth of Rupture Surface of Part 1 above.

#### 4.7 Width of Rupture Surface

Refer to 4.6 Width of Rupture Surface of Part 1 above.

#### 4.8 Length of Rupture Surface

Refer to 4.9 Length of Rupture Surface of Part 1 above.

#### 4.9 Erosion Process

Erosion process – Select the major process to generate the deposits of debris/earth flows, as defined below:

- (1) Surface erosion: Sediment source results mainly from sheet erosion and gully erosion on steep hill-slopes,
- (2) Streambed erosion: Sediment source results mainly from the streambed of unstable sediments on the streambed and locally involves bank erosion of stream, and
- (3) Landslide: Sediment source results mainly from the collapse of landslides on the steep hillslopes.

#### 4.10 Vegetation Cover

Refer to 5.11 Vegetation Cover of Part 1 above.

#### 4.11 Landslide Use

Refer to 5.12 Land Use of Part 1 above.

#### 4.12 Additional Description



Additional information on susceptibility to landslide and erosion within the inspected source area shall be described in more detail, focusing mainly on hillslope morphology, geology and vegetation.

## **05 Flow Path**

Flow path or travel zone is defined as steep stream below the first stage valley and above the starting point of deposition zone (see Figures 2.1 and 2.2 above).

### **5.1 Stream Length**

Stream length – Enter the length of the travel path stream.

### **5.2 Mean Stream Width**

Mean stream width – Enter the average width of the travel path stream.

### **5.3 Mean Stream Gradient**

Mean stream gradient – Enter the average slope of the travel path stream.

### **5.4 Mean Sediment Thickness**

Mean sediment thickness – Enter the average thickness of accumulated streambed sediments.

### **5.5 Max Size of Sediments**

Max size of sediments – Enter the maximum size of accumulated streambed sediments in m<sup>3</sup>.

### **5.6 Vegetation Cover on Surface**

Vegetation cover on surface – Inspect the type of vegetation on the surface of accumulated streambed sediments, and the applicable number of the vegetation cover shall be entered (see Table 1.5 above).

### **5.7 Additional Description**

Additional information on instability and composition of accumulated streambed sediments within the inspected travel path stream shall be described in more detail.

Additional information on driftwood shall be also described, such the accumulated scale of driftwood and its location, if it exists within the travel path stream.

## **06 Depositional Zone**

### **6.1 Stream/Slope Gradient**

Stream gradient and Slope Gradient – Enter the gradients of the starting point and the ending point of the depositional zone in degrees.

### **6.2 Stream Width**

Stream gradient – Enter the maximum, minimum and average widths of the stream/river within the

depositional zone in meter.

### 6.3 Catchment (or Drainage) Area above the Starting Point

Catchment area – Estimate the drainage area above the starting point of the depositional zone in square kilometer.

### 6.4 Deposited Area

Deposited Area – Enter the values of the following inspection items within the deposited area:

- (1) Maximum length from the starting point to the ending point of the deposition zone;
- (2) Maximum width within the deposition zone;
- (3) Maximum thickness of sediments within the deposition zone;
- (4) Average thickness of sediments within the deposition zone;
- (5) Spreading angle below the starting point of the depositional area;
- (6) Maximum size of sediments within the deposition zone; and
- (7) The slope of sediments accumulated at the ending point of the deposition zone.

### 6.5 Land Use

Land use – Enter the type of land use within the deposition zone.

### 6.6 Additional Description

Additional information on flooding consequence within the deposition zone shall be described in more detail.

## 07 Landslide Maps

Refer to 06 Landslide Maps of Part 1 above.

## 08 Human Damage

Refer to 07 Human Damage of Part 1 above.

## 09 House Damage in Depositional Area

Refer to 08 House Damages of Part 1 above.

## 10 Other Facility Damage

Refer to 09 Other Facility Damage of Part 1 above.

## 11 Existing Sabo Measure

Refer to 10 Prevention Measures of Part 1 above.

In addition, additional information on the effect of the existing sabo measures, if existing, shall be inspected and described in more detail, for example, the height of no sediment of a sabo dam on the stream.

## 12 Emergency Measures

Refer to 11 Emergency Measures of Part 1 above.

### **13 Restoration Measures**

Refer to 12 Restoration Measures of Part 1 above.

### **14 General Comments**

Refer to 13 General Comments of Part 1 above.

### **15 Plan Sketch (Three Zones)**

Refer to 14 Plan Sketch of Part 1 above

In addition, the plan sketch shall cover three zones of the inspected flow-type landslide, if it exists.

### **16 Cross-Section Sketch (Three Zones)**

Refer to 15 Cross-Section Sketch of Part 1 above.

In addition, the plan sketch shall cover three zones of the inspected flow-type landslide, if it exists. All zones, if identifiable, shall be delineated on the cross-section sketch and all inclinations of slopes or streambeds at the starting and ending points of each zone of the inspected flow-type landslides shall be shown.

### **17 Whole and Close Views**

Refer to 16 Whole and Close Views of Part 1 above.

### **18 Satellite Image or LiDAR**

Refer to 17 Satellite Image or LiDAR of Part 1 above

**00 Landslide Name and ID**

Refer to 00 Landslide Name and ID of Part 1 above.

**01 Landslide Location**

Refer to 01 Landslide Location of Part 1 above.

**02 Date/Time of Landslide Occurrence**

Refer to 02 Date/Time of Landslide Occurrence of Part 1 above.

**03 Meteorological Conditions**

Refer to 03 Meteorological Conditions of Part 1 above.

**04 Landslide Characteristics****4.1 Landslide Type**

Refer to 4.1 Landslide Type of Part 1 above.

**4.2 Fallen Material Volume**

Fallen material volume – Roughly estimate and enter the volume of the fallen materials on the lower slope.

**4.3 Size of Fallen Rocks**

Size of fallen rocks – Roughly estimate and enter the max and average sizes (scales) of the fallen rock blocks on the lower slope.

**4.4 Movement Distance from Slope Toe**

Movement distance from slope toe – Roughly estimate and enter the max and average (or typical) movement distance from the toe of a slope.

**4.5 Slope Deformation**

The slope deformation shall be inspected according to Table 3.1 below.

**Table 3.1 Classification of Slope Deformation**

Classification	Description
Visible	New and clear slope deformations, such as erosion, crack, local collapse, etc.
Obscure	Other than the above-mentioned

#### 4.6 Additional Information

Additional information on disaster records shall be described in more detail, such as frequency of the disaster and degree of damage to local residents or hindrance against traffic.

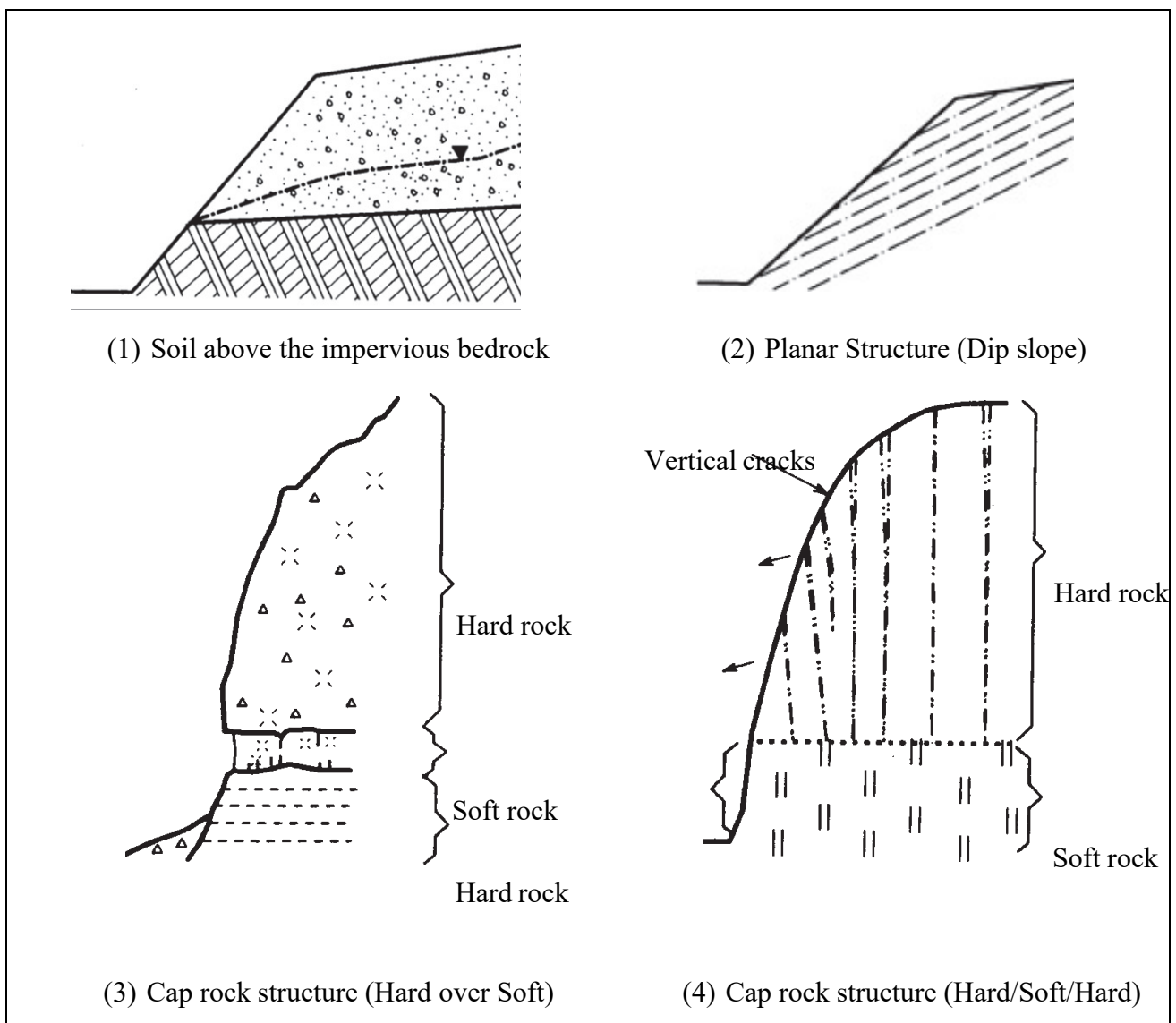
### 05 Geo-Environmental Characteristics at Landslide Site

#### 5.1 Slope Material

Refer to 5.1 Slide Material of Part 1 above.

#### 5.2 Geological Structure

Geological structure – Enter the geological structure of landslide slope (see Figure 3.1).



**Figure 3.1 Examples of Geological Structures around Landslide Slope**

### 5.3 Soil Slope Geometry

Soil slope geometry – Enter the inclination and height of soil slope at landslide site.

### 5.4 Rock Slope Geometry

Rock slope geometry – Enter the inclination and height of rock slope at landslide site.

### 5.5 Slope Shape

Refer to 5.7 Slope Shape of Part 1 above.

### 5.6 Transversal Shape

Refer to 5.8 Transversal Shape of Part 1 above.

### 5.7 Vegetation Cover

Refer to 5.11 Vegetation Cover of Part 1 above.

### 5.8 Land Use

Refer to 5.12 Land Use of Part 1 above.

### 5.9 Additional Information

Additional information on main causes of landslides shall be described in more detail, as listed below:

- (1) Landform or topography (talus slope, clear knick line, toe erosion slope, convex natural slope, etc.);
- (2) Slope geology (colluvial soils, soft rock, etc.) and geological structure (see Figure 3.1 above); and
- (3) Distribution and flow amount of springs.

## **06 Landslide Maps**

Refer to 06 Landslide Maps of Part 1 above.

## **07 Human Damages**

Refer to 07 Human Damages of Part 1 above.

## **08 House Damage**

Refer to 08 House Damages of Part 1 above.

## **09 Other Facility Damages**



Refer to 09 Other Facility Damages of Part 1 above.

### **10 Mitigation Measures to 12 Restoration Measures**

Refer to 10 Mitigation Measure to 12 Restoration Measures of Part 1 above.

### **11 General Comments to 17 Satellite Image or LiDAR**

Refer to 13 General Comments to 17 Satellite Image or LiDAR of Part 1 above.





---

**Developed by Project for Capacity Strengthening on Development of  
Non-Structural Measures for Landslide Risk Reduction in Sri Lanka (2022)**

# Manual for Landslide Early Warning



## Project for Capacity Strengthening on Development of Non-Structural Measures for Landslide Risk Reduction in Sri Lanka

October, 2022



**National Building Research Organisation  
(NBRO)**



**Japan International Cooperation Agency  
(JICA)**





**Democratic Socialist Republic of Sri Lanka**

**Project for Capacity Strengthening on Development of Non-Structural Measures for Landslide Risk Reduction in Sri Lanka**

# **Manual for landslide early warning**

**October, 2022**

**National Building Research Organization (NBRO)**

**Japan International Cooperation Agency (JICA)**

## Table of Contents

Chapter 1	Introduction.....	1
1.1	Landslide early warning in Sri Lanka.....	1
1.2	Causes of landslides.....	1
1.3	Occurrence of landslides.....	2
1.4	Types and approaches of landslide early warning .....	3
1.5	Current warning levels and thresholds.....	4
1.6	Target of this manual .....	4
1.6.1	Target phenomena.....	4
1.6.2	Rainfall indices and warning thresholds/critical lines .....	5
1.7	Overall flow of tasks on landslide early warning .....	5
1.7.1	Summary of tasks in normal period.....	6
1.7.2	Summary of tasks in emergency period.....	7
1.7.3	Tasks after emergency period .....	8
Chapter 2	Methodology and protocol of the tasks for landslide early warning - in normal periods – .....	9
2.1	Data collection.....	9
2.1.1	Rainfall observation.....	10
2.1.2	Past landslide records.....	11
2.1.3	Records of past disaster response .....	11
2.1.4	Other related data collection at specific sites.....	12
2.2	Study on necessary lead time.....	12
2.3	Determination of critical lines and warning thresholds .....	13
2.3.1	Critical lines and warning thresholds for nationwide landslide warnings .....	13
2.3.2	Warning thresholds for site-specific warnings based on direct landslide monitoring.....	21
2.4	Designation of evacuation places and routes, establishment of warning dissemination system and conducting evacuation drills .....	23
Chapter 3	Methodology and protocol of the tasks for landslide early warning – under/after emergency situation - .....	24
3.1	Tasks under emergency situation .....	24
3.1.1	Rainfall forecasting.....	24
3.1.2	Real time rainfall monitoring.....	24
3.1.3	Issuing landslide early warning .....	26
3.1.4	Dissemination of landslide early warning.....	30
3.1.5	Collecting landslide occurrence reports.....	31
3.1.6	Clearance of landslide warning.....	31



3.2	Tasks after emergency period .....	32
3.2.1	Information collection on the incidents .....	32
3.2.2	Analysis on the incidents .....	32
Chapter 4	Utilization of landslide early warning by relevant agencies and local people .....	33
4.1	Landslide hazard maps and evacuation places.....	33
4.1.1	Landslide hazard maps.....	33
4.1.2	Evacuation place and route .....	34
4.2	Landslide early warning .....	34
4.2.1	Issuing early warnings and dissemination to local people .....	34
4.2.2	Delivering early warning and evacuation order to grass root .....	37
4.3	Awareness and utilization of early warnings and hazard maps.....	38
4.3.1	Conducting awareness activities for sediment disaster risk, hazard maps, and NBRO early warning .....	38
4.3.2	Identifying evacuation routes, safe evacuation centres, and temporary camping sites.....	38

## Acknowledgment

Appendix 1: Correlation analysis between rainfall and landslide occurrence to determine warning thresholds and critical lines

Appendix 2: Site-specific landslide warning threshold

Appendix 3: Tank model parameter calibration for SWI calculation

Appendix 4: Leaflet: landslide early warning (for awareness)

## Figures

Figure 1.1	Predisposing factors and triggering factors of landslides.....	1
Figure 1.2	Map of mean annual rainfall and past landslides .....	2
Figure 1.3	Overall flow of tasks on landslide early warning .....	6
Figure 2.1	Summary of a method to determine thresholds and critical lines for nationwide landslide warnings .....	9
Figure 2.2	Correlation between landslides and rainfall .....	10
Figure 2.3	Procedures of rainfall-landslide correlation analysis.....	13
Figure 2.4	Rain gauges and landslides.....	14
Figure 2.5	Structure of tank model .....	16
Figure 2.6	Observed and simulated discharge at Nakkala .....	17
Figure 2.7	Observed groundwater level (upper), strain (lower) and SWI .....	17
Figure 2.8	Comparison of SWI calculated by using three parameter sets validated in Sri Lankan mountainous	

rivers .....	18
Figure 2.9 Example of snake curve chart .....	18
Figure 2.10 Snake curve charts of 24h rainfall (left) and SWI (right) at Kegalle.....	19
Figure 2.11 Correlation between SWI and 24 hour rainfall causing the past landslides .....	19
Figure 2.12 Snake curve chart with equal probability curve (left) and table of predictive ratio (right) .....	21
Figure 2.13 Regional variation of correlation between rainfall and landslides .....	21
Figure 2.14 An example of time series chart of surface displacement and rainfall .....	22
Figure 2.15 An example of surface displacement and rainfall in a major rainfall event (upper-left), hourly displacement (lower left), histogram of hourly displacement (lower right) and conceptual diagram of soil-mass creep stages (upper-right) .....	23
Figure 3.1 Weather forecast map distributed by DOM.....	24
Figure 3.2 Public web-site of real-time rainfall observed by NBRO.....	25
Figure 3.3 Web-site of site-specific landslide monitoring .....	25
Figure 3.4 NBRO automated rainfall monitoring system.....	26
Figure 3.5 Monitoring of rainfall spatial variation (real-time SWI monitoring site).....	28
Figure 3.6 Monitoring of rainfall time series variation (real-time SWI monitoring site) .....	28
Figure 3.7 Flowchart to issue nationwide early warning .....	28
Figure 3.8 Examples of wrong observation data .....	29
Figure 3.9 Example of displacement of landslide.....	30
Figure 3.10 Dissemination path of landslide early warning .....	31
Figure 3.11 Review of actual landslide early warning and disasters .....	32
Figure 4.1 Example of landslide hazard zonation map (LHZM, 1:10,000).....	33
Figure 4.2 Cause of Landslide and Soil Water Index.....	34
Figure 4.3 Dissemination flow of NBRO landslide early warning and evacuation order .....	35
Figure 4.4 Means to obtain NBRO early warning (NBRO EW App) and rainfall data (NBRO Website).....	36
Figure 4.5 NBRO automated rain gauge (left) and manual rain gauge (mid) and NBRO warning levels (right) .....	36
Figure 4.6 Signs of landslides.....	37
Figure 4.7 Conducting awareness activities utilizing hazard maps .....	38
Figure 4.8 Example of evacuation centre in Yellow and Red Zone (Weeriyapura, Imbulgoda in Badulla District).....	39

## Tables

Table 1.1	Comparison of nationwide landslide warning and site-specific landslide warning .....	3
Table 1.2	Current landslide warning levels and thresholds .....	4
Table 1.3	Rainfall indices for landslide early warning .....	5
Table 2.1	List of landslide related data .....	9
Table 2.2	Important information on past landslides to determine warning thresholds .....	11
Table 2.3	Important information on past disaster response records.....	11
Table 2.4	Recommendations on river discharge data.....	12
Table 2.5	Points to be considered for representative rainfall gauging stations .....	14
Table 2.6	Empirical warning thresholds for direct landslide monitoring in Japan .....	22
Table 3.1	Indices to issue landslide early warnings.....	27
Table 4.1	Classification of hazard areas and evacuation zone.....	34

# Chapter 1 Introduction

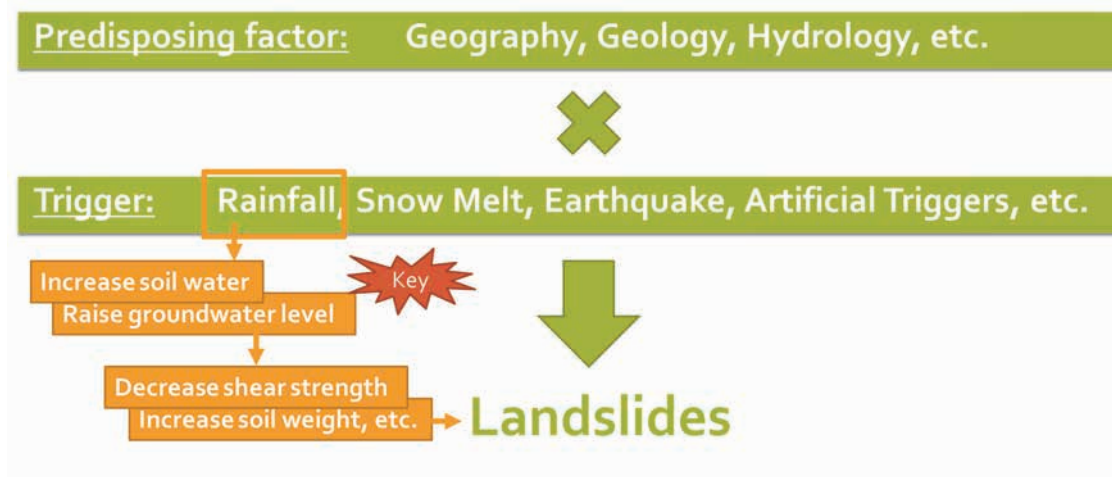
## 1.1 Landslide early warning in Sri Lanka

Landslides consisting of slides, debris flow, slope failures, cutting failures, rock falls, and other sediment-related disasters, are one of the major disasters in Sri Lanka. Especially, the landslides, debris flows and slope failures cause huge human loss in rainy seasons. According to DesInventar, a disaster database maintained by Disaster Management Center in Sri Lanka, ca. 35% of death and missing by disasters were caused by landslides and other sediment disasters in Sri Lanka in the decade from 2007 to 2016 (JICA, 2016).

Under these circumstances, National Building Research Organisation (NBRO), the focal organisation for implementing structural and non-structural countermeasures for landslides in Sri Lanka, operates landslide early warning system (EWS) in Sri Lanka. NBRO issues landslide early warnings for the landslide prone areas based on warning criteria, which resulted from the previous studies (Bandara, 2008; Kumara *et al.*, 2018; Rajapaksha *et al.*, 2019). To improve the accuracy of the early warning, continuous and further analysis on correlation between landslide occurrence and predisposing/triggering factors are needed. This manual guides EWS operators to analyze and improve the warning criteria and it aims to save the lives of local people living in landslide prone areas.

## 1.2 Causes of landslides

Causes of landslides consist of predisposing factors and triggering factors (Figure 1.1). The predisposing factors, such as geography, geology and hydrology, define likelihood and susceptibility of landslides. On the other hand, rainfall, snow melt, earthquake and artificial triggers are the direct triggers of landslides. Landslides are caused by the effects of both factors.



**Figure 1.1 Predisposing factors and triggering factors of landslides**

Most landslides in Sri Lanka, are triggered by heavy rainfall. The rapid infiltration of heavy rainfall causes soil saturation and a temporary rise in pore-water pressures. As the results, the shear strength of soil mass decreases, and soil weight increases. Finally, soil mass starts moving, and landslide occurs. This is the typical mechanism by which most shallow landslides are generated during storms (Wieczorek, 1996; McColl, 2015). Therefore, rainfall monitoring is effective approach to predict landslides and issue early warnings. Rainfall is the

common index utilized for landslide early warnings in a lot of countries in the world.

The amount of rainfall triggering landslides varies depending on the predisposing factors. The rainfall threshold is low in cases of weak geological condition and steep topography. Furthermore, rainfall pattern also affects the rainfall threshold of landslide occurrence. Concentrated short term rainfall usually causes sudden increase of soil water amount and shallow landslides. On the other hand, long-term rainfall continuously feeds rainwater to deeper soil layer and cause deep-seated landslides. In case that much soil water fed by antecedent rainfall remains in the soil layer, less rainfall can be a trigger of landslides. Therefore, it is necessary to consider the predisposing factors and to select proper rainfall indices when warning thresholds are determined.

### 1.3 Occurrence of landslides

The central region of Sri Lanka is mountainous and experiencing high rainfalls (Figure 1.2). As a result, most of the landslides are also occurred in that region.

Mean annual rainfall in the southwestern mountainous region exceeds 4,500mm/year (Burt and Weerasinghe, 2014). Rainfall pattern in Sri Lanka is determined by the southwest monsoon (May-Sep.), northeast monsoon (Dec.-Feb.) and two inter-monsoon seasons. The highest mean monthly number of people affected by sediment disasters during the decade from 2007 to 2016 was recorded in May; the second peak of the mean monthly number of affected people was from October to January (JICA, 2016). The seasonal rainfall by the southwest monsoon, tropical cyclones and convectional rainfall during the inter-monsoon periods is the major cause of landslides in Sri Lanka.

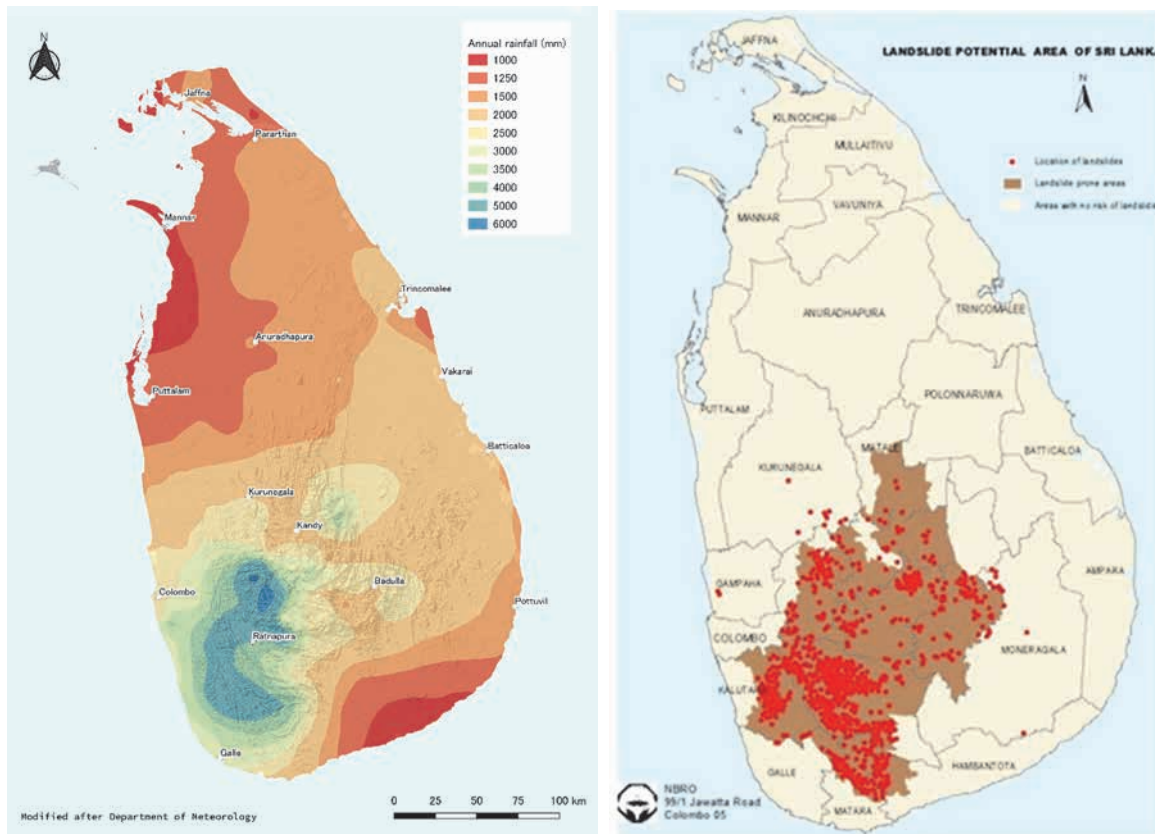


Figure 1.2 Map of mean annual rainfall and past landslides

## 1.4 Types and approaches of landslide early warning

There are two types of landslide early warnings. One is early warning for wider area, such as nationwide warnings. In general, statistical and conceptual approaches are utilized for the nationwide early warnings since it is unrealistic to conduct direct landslide observation and warnings in the wider area. Rainfall indices are commonly utilized for the nationwide landslide early warnings because rainfall is able to be easily observed in the wider area and has strong correlation with landslide occurrences. However, accuracy of the warning is lower than that is based on direct observation.

Direct observation approach is generally utilized for site-specific landslide early warning in high-risk landslide areas. The direct observation of soil mass movement is most accurate approach to detect the initiation of landslide without a delay. However, the cost of monitoring and warning system is expensive. Hence, it is impossible to install the observation instruments in all identified landslide prone sites.

A comparison of the nationwide landslide warning and a site-specific landslide warning is shown in **Table 1.1**.

**Table 1.1 Comparison of nationwide landslide warning and site-specific landslide warning**

	<b>Nationwide (wide area) warning</b>	<b>Site-specific warning</b>
General approach	<ul style="list-style-type: none"> <li>- Statistical and conceptual approach</li> <li>- Warnings based on real time rainfall</li> </ul>	<ul style="list-style-type: none"> <li>- Direct observation approach</li> <li>- Warnings based on real time direct observation of soil-mass movement</li> </ul>
Strong points	<ul style="list-style-type: none"> <li>- Easy observation in wider area =&gt; suitable for wider area warning (whole country)</li> </ul>	<ul style="list-style-type: none"> <li>- Proper and timely warning</li> </ul>
Weak points	<ul style="list-style-type: none"> <li>- Not based on detail/actual condition of landslide area =&gt; Relatively low accuracy</li> </ul>	<ul style="list-style-type: none"> <li>- High costs to install monitoring instruments =&gt; Impossible to conduct monitoring at all of landslide risk area in the whole country</li> </ul>
Monitoring method	<ul style="list-style-type: none"> <li>- Rainfall + (option) river discharge and groundwater level are utilized for tank model parameter calibration for soil water index</li> </ul>	<ul style="list-style-type: none"> <li>- Displacement of soil mass (displacement, inclination, strain...)</li> <li>- Rainfall</li> <li>- Groundwater level, soil water content (condition of soil)</li> </ul>
Simulation method	<ul style="list-style-type: none"> <li>- Conceptual model (tank model) is utilized for regional landslide warning in Japan</li> </ul>	<ul style="list-style-type: none"> <li>- Saturated-unsaturated seepage analysis</li> <li>- Landslide/mass movement simulation</li> </ul>

## 1.5 Current warning levels and thresholds

NBRO issues landslide warnings based on the warning thresholds shown in **Table 1.2** as of 2022. The warning thresholds are uniform for entire country. The landslide warnings are issued for each DS divisions based on real-time rainfall.

**Table 1.2 Current landslide warning levels and thresholds**

Level	Remarks	Thresholds
<b>1</b>	<b>Watch (Yellow):</b> Since the rainfall within past 24 hours has been exceeded 75mm, if the rain continues, be watchful on the possibility of landslides, slope failures, rock falls, cutting failures and ground subsidence.	<b>75mm/24h</b>
<b>2</b>	<b>Alert (Amber):</b> Since the rainfall within past 24 hours has been exceeded 100mm, if the rains continue, be on alert on the possibility of landslides, slope failures, rock falls, cutting failures and ground subsidence, being ready to evacuate to a safe location if the need arises.	<b>100mm/24h</b>
<b>3</b>	<b>Evacuate (Red):</b> Since the rainfall within past 24 hours has been exceeded 150mm, if the rains continue, evacuate to a safe location to avoid the risk of landslides, slope failures, rock falls, cutting failures and ground subsidence.	<b>150mm/24h or 75mm/h</b>

## 1.6 Target of this manual

### 1.6.1 Target phenomena

This manual is mainly developed for the wide area landslide warnings (nationwide / DS division wise warning) considering regional characteristics; some additional sections of the manual are for the site-specific early warning.

The target of this manual is rainfall-triggered landslides. Landslides triggered by other causes, such as snowmelt and earthquake, are out of the scope since the mechanism of landslide triggers are different and these causes are not observed in Sri Lanka.

Target phenomena of this manual are landslides, multiple-simultaneous slope failure and debris flows. Small scale single-occurrence cutting failures are basically excluded from the targets since it is difficult to issue early warning; those phenomena are triggered by even minor rainfall events.

Generally, it is difficult to issue early warning for deep-seated landslides based on only rainfall indices, because infiltration of rainwater into deeper sliding surface takes longer time to trigger deep-seated landslides. The mass-movements of deep-seated landslides are hence slower than shallow mass-movements. Thus, deep-seated landslides are sometimes caused at different times and difficult to issue warnings by using same warning procedure, which is used for shallow seated landslides. However, sliding surface of landslides are usually shallow and mass-movement is relatively rapid in Sri Lanka. Therefore, there is a possibility to issue warnings for most of the landslides in Sri Lanka based on rainfall indices, but it is necessary to study and clarify a range of warning target phenomena through analysis. Even though, the deep-seated landslides are caused with a delay to rainfall, most of initiation phenomena of deep-seated landslides triggered by continuous rainfall can be detect by long-term rainfall indices.

The site-specific landslide early warnings for deep-seated landslides are mentioned in the sections of “site-specific early warnings”, which are monitored by specific instruments.





### 1.6.2 Rainfall indices and warning thresholds/critical lines

As mentioned in the section 1.4, rainfall indices are utilized to issue landslide early warning. Table 1.3 shows general rainfall indices for landslide early warning. The rainfall indices are categorized into two categories. The short-term rainfall indices indicate effects of rapid increment of soil water amount near surface layer. On the other hand, the long-term rainfall indices focus on soil water infiltration into deeper layers. Furthermore, effects of remaining soil water fed by past rainfall events are also considered by the long-term rainfall indices.

In this manual, one-hour rainfall and Soil Water Index are focused as short term rainfall index and long term rainfall index, respectively.

**Table 1.3 Rainfall indices for landslide early warning**

<b>Types</b>	<b>Rainfall indices</b>
Short term rainfall indices	1 hour rainfall
	1.5 hours half period working rainfall
	3 hours half period working rainfall
Long term rainfall indices	24 hours rainfall
	72 hours rainfall
	Cumulative rainfall during rainfall events
	24 hours half period working rainfall
	48 hours half period working rainfall
	60 hours half period working rainfall
	72 hours half period working rainfall
	Soil Water Index (SWI)

Methodology to identify, effective rainfall indices and warning thresholds/critical lines for nationwide early warning based on rainfall monitoring is shown in the Chapter 2, Chapter 3 and appendix.

In contrast, the site-specific early warning system, which includes direct observation of deformation of soil mass in landslide sites, issues warnings based on the observed soil mass movement. Therefore, warning thresholds of each observation items should be determined for the site-specific early warning system, such as displacement, strain, inclination, etc. Methodology to set the warning thresholds for site-specific EWS is attached as appendix.

### 1.7 Overall flow of tasks on landslide early warning

Overall flow of tasks on landslide early warning in normal periods and emergency periods are shown in Figure 1.3. Before starting analysis, basic data, such as rainfall observation data and landslide records, should be collected and archived in normal periods. Those data sets are utilized for the analysis on correlation between rainfall and landslide occurrence to identify reasonable rainfall indices and warning thresholds/critical lines (CLs) for the landslide early warning. In emergency periods, the landslide early warnings will be issued based on real time rainfall observation data and the defined CLs. Simultaneously, landslide reports should be collected and archived. The accumulated new landslide records and rainfall data will be utilized to review the CLs in normal periods and hence to improve the accuracy of the landslide warnings.

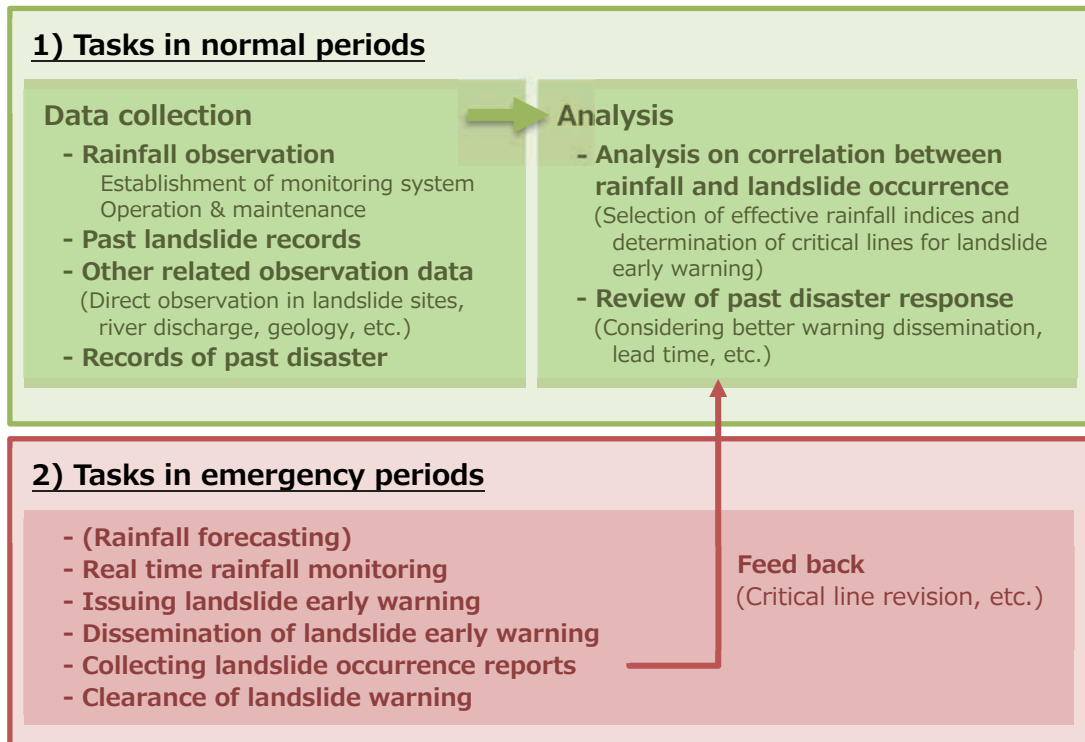


Figure 1.3 Overall flow of tasks on landslide early warning

### 1.7.1 Summary of tasks in normal period

#### a) Data collection

##### – Rainfall observation

Installation and maintenance of rainfall observation system is one of the most essential task in the normal period. The time series data of the observed rainfalls is utilized in the following procedures to determine thresholds and critical lines of landslide early warnings. It is ideal to gather more than 20 years rainfall data with less than one-hour observation interval at rainfall gauging stations covering entire landslide hazard areas.

##### – Past landslide records

Past landslide records are also required to determine the warning thresholds and hence the critical lines. This should include landslide properties such as location (longitude and latitude), date and time of occurrence; types of disasters (slides, debris flows, slope failures, cutting failures and rock falls), geological/topographical features and detail description of the disasters.

##### – Records of emergency response for past disasters

Actual records of emergency response for past disasters are also important information. Necessary lead time and path of warning dissemination should be clarified through survey and review of the actual emergency response records.

##### – Other related data collection at specific sites

Installation of observation instruments and continuous observation at specific sites to obtain landslide related data, such as displacement and inclination of landslide soil mass, ground water level and river discharge, are the other task in the normal period.

**b) Lead time of early warning**

Required lead-time of early warning should be clarified based on the past disaster response records. The lead-time includes necessary time to disseminate the early warnings to the local people living in landslide hazard areas and to complete evacuation from their residents to designated evacuation places. Two to three hours lead time is recommended for early warnings.

**c) Determination of critical Lines and warning thresholds**

Effective rainfall indices should be decided based on the correlation between actual past landslide records and rainfall. Critical lines and warning thresholds of landslide warnings should be determined by using the rainfall indices, landslide records and other related data. The determined critical lines and warning thresholds are utilized to issue warnings when required.

**d) Designation of evacuation places and routes, establishment of warning dissemination system and conducting evacuation drills**

District Disaster Management and Coordination Unit (DDMCU) and Divisional Secretariat (DS) division designate evacuation places and routes for communities located in landslide hazard areas. Disaster Management Centre (DMC), DDMCU and line agencies established a framework to disseminate the landslide early warnings issued by Early Warning Center (EWC) of NBRO to the communities. Based on that framework, DMC/DDMCU conduct evacuation drills in the normal period.

**1.7.2 Summary of tasks in emergency period**

**a) Rainfall forecasting**

Rainfall forecasting is a mandate of Department of Meteorology (DOM), and they produce Numerical Weather Prediction (NWP) information by using a physical weather model. However, the accuracy of forecasted precipitation data is not sufficient to utilize for the landslide early warnings, directly. Thus, it recommends utilizing the rainfall forecast as a reference information when NBRO initiates landslide early warnings.

**b) Real time monitoring (rainfall monitoring and direct observation of soil-mass movement)**

**– Nationwide rainfall monitoring**

The nationwide landslide early warnings are issued based on the real time rainfall data observed by NBRO's automated rain gauge system. The unit area of the landslide early warning is DS division.

**– Site-specific landslide monitoring**

NBRO conducts site-specific observation in some landslide areas. NBRO monitors displacement and inclination of landslide soil mass, strains, ground water level, rainfall etc. at the sites. The site-specific landslide early warnings are issued based on the monitoring data.

In addition, some communities have manual rain gauges. Community focal points observe rainfall for community-based disaster risk management activities.

**c) Issuing landslide early warning**

**– Nationwide landslide early warning**

The landslide early warnings are issued for DS divisions when rainfall in the DS divisions exceeds the warning

thresholds and observing the ground conditions. In some occasions, when severe rainfall is forecasted within the day and/or SWI is high, NBRO determines the necessity to issue early warnings in advance the rainfall exceeds the thresholds.

– **Site-specific early warning**

The site-specific landslide early warnings are issued based on the observed parameters such as displacement and inclination of landslide soil mass, strains, ground water level and rainfall.

**d) Dissemination of landslide early warning**

The landslide early warnings issued by EWC, NBRO are disseminated to DMC, media and other relevant agencies. NBRO also publish the landslide early warning on the web-site and mobile application.

DMC disseminate the landslide early warnings to community people through DDMCU, DS divisions, GN divisions and community leaders. Moreover, media and police are the alternative warning dissemination paths.

**e) Collecting landslide occurrence reports**

NBRO EWC also utilize current landslide occurrence incidents to fine-tune its upcoming landslide early warnings. These reports collected from NBRO district offices after thorough filed validations.

**f) Clearance of landslide warning**

Before the issued landslide early warnings are expired, EWC, NBRO, re-evaluate whether the landslide early warnings should be extended or not. In case that the rainfall indices fall below the warning threshold, the landslide early warnings are ended. However, the landslide early warnings should be extended in the cases that 1) rainfall still exceeds the warning thresholds, 2) Soil Water Index is still high, 3) signs of landslides are reported and/or 4) heavy rainfall is forecasted within the day.

### 1.7.3 Tasks after emergency period

**a) Information collection on the incidents**

Landslide reports and records of actual emergency response should be collected after the disasters. Information of disaster locations, date and time of occurrence, disaster types, geological/topographical features, detail of the disasters and actual emergency responses are important information to review and improve the existing landslide early warning.

**b) Analysis on the incidents**

NBRO reviews the collected information of the actual disasters to improve the early warnings. If the lead-time of early warnings was not enough, NBRO revise its processes.

DMC/DDMCU also review the reports of disasters and improve procedures of disaster responses based on lesson learnt from the actual disasters.

## Chapter 2 Methodology and protocol of the tasks for landslide early warning - in normal periods –

Summary of a method to determine thresholds and critical lines for nationwide landslide warnings are shown in Figure 2.1.

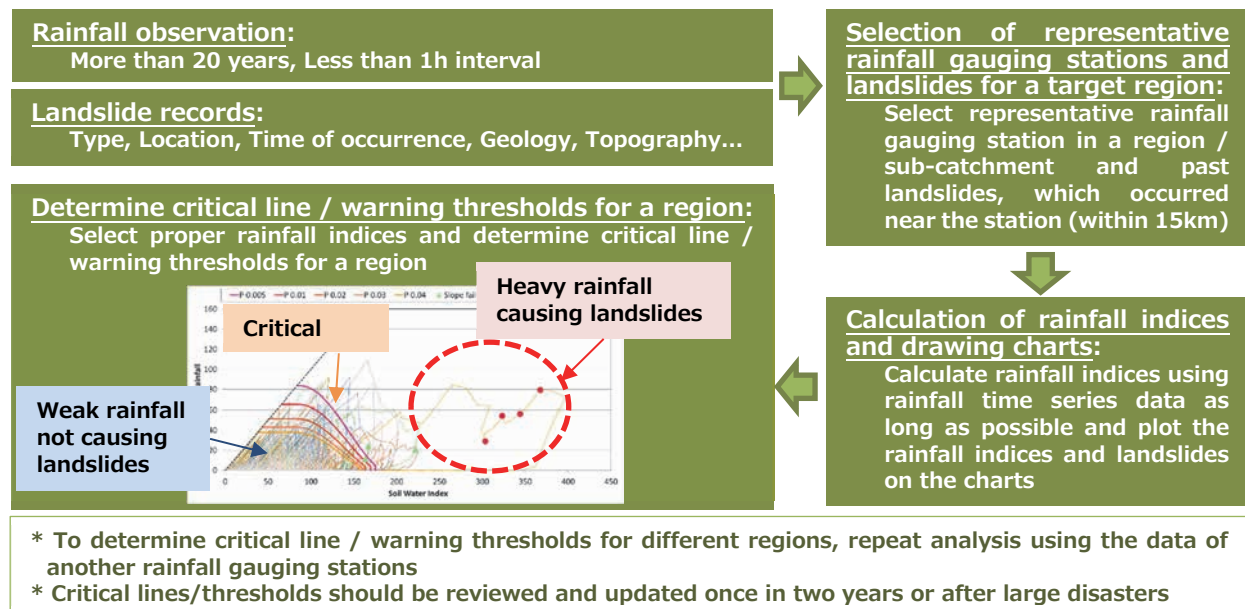


Figure 2.1 Summary of a method to determine thresholds and critical lines for nationwide landslide warnings

### 2.1 Data collection

Landslide, rainfall and other related data, which should be collected in normal period are listed in Table 2.1.

Table 2.1 List of landslide related data

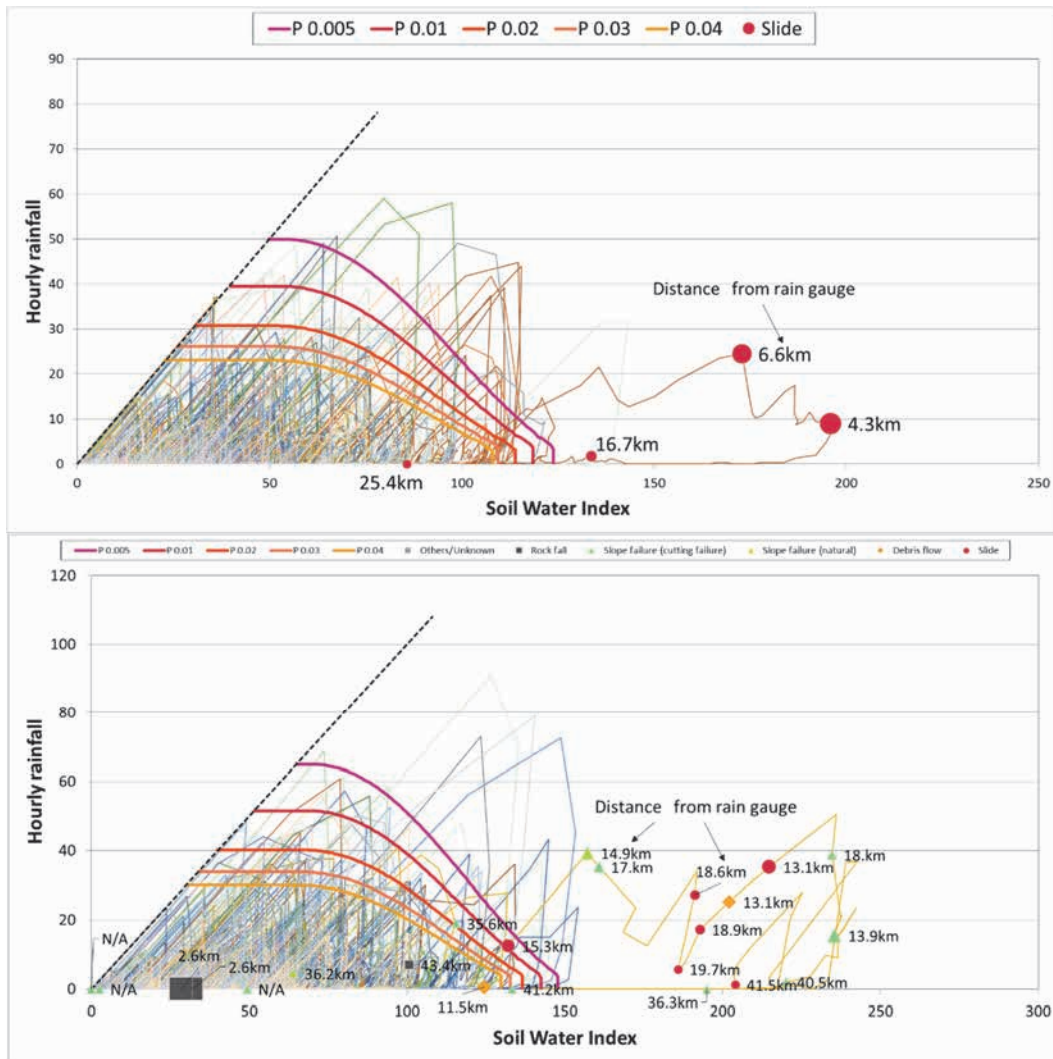
	Items	Remarks
Rainfall	<ul style="list-style-type: none"> <li>- Rainfall time series</li> <li>- SWI and other rainfall indices which will be calculated from rainfall</li> </ul>	Recommended observation condition Observation period: more than 20 years Observation interval: 1 hour or less Maximum distance of rain gauges: 15km
Other data observed at specific sites	<ul style="list-style-type: none"> <li>- Displacement of landslide soil mass</li> <li>- Inclination of landslide soil mass</li> <li>- Strain</li> <li>- Ground water level</li> <li>- Soil water content</li> <li>- River discharge</li> </ul>	It is recommended to observe the listed data by automatic instruments at specific sites. It is ideal to install the special instruments covering whole hazard area, but it is impossible due to costs. Thus, it is expected to install the special instruments at typical and important active landslides.
Past landslide records	<ul style="list-style-type: none"> <li>- Locations (longitude and latitude)</li> <li>- Date and time of occurrence</li> <li>- Types of disasters (slides, debris flows, slope failures, cutting failures and rock falls)</li> <li>- Geological/topographical features</li> <li>- Description of the disasters</li> </ul>	Past landslide, records are utilized to determine warning thresholds and critical lines by analyzing correlations with rainfall. Locations (longitude and latitude), Date and time of occurrence and Types of disasters are fundamental to the analysis.
Records of emergency response for past disasters	<ul style="list-style-type: none"> <li>- Necessary time to disseminate the warnings from NBRO to community people via DMC and other agencies</li> <li>- Necessary time for local people to evacuate to safe places</li> <li>- Landslide hazard maps</li> </ul>	Necessary lead-time and path of warning dissemination should be clarified.

### 2.1.1 Rainfall observation

In order to define accurate warning thresholds, long period (more than 20 years) and short interval (less than 1 hour) rainfall observation is required. However, such long period and short interval rainfall data is not available in Sri Lanka, at present. Therefore, it is recommended that the warning thresholds should be determined by using currently available data and continuously update by using obtained rainfall data in future.

The rainfall gauging stations should be located covering whole landslide hazard area since the rainfall and landslide characteristics varies depending on the site; especially, rainfall pattern, geology and topographical features vary by catchments. According to an analysis, the correlation between rainfall and landslide occurrence seems high in the cases that the distance between rain gauges and landslides is less than 15km (Figure 2.2). Therefore, it is ideal that rain gauges are installed in every sub-catchment with 15km or shorter rain gauge distance (cf. mean distance of rainfall gauging stations owned by Japan Meteorological Agency is ca. 17km).

The continuous, long period and dense rainfall observation is one of the keys of early warning. Thus, proper operation and maintenance of the rain gauges are very important tasks in the normal period.



**Figure 2.2 Correlation between landslides and rainfall**  
 (Upper: at Uva University, Badulla, Lower: Kalubowitiyana, Matara)



### 2.1.2 Past landslide records

Landslide records should be collected and summarized in normal period. Important information of past landslides to determine warning thresholds are shown in Table 2.2.

The past landslide reports achieved by NBRO are the base of analysis to determine warning thresholds. It is important to accumulate the past landslide reports in the electronic database so that the data can be easily utilized for the analysis.

**Table 2.2 Important information on past landslides to determine warning thresholds**

Items	Remarks
Types Slides, Debris Flows, Slope Failures (natural), Slope Failures (cutting failure), Rock falls and Others	Warning thresholds and critical lines depend on the disaster types. Thus, the records of the types of the past disasters are required.
Date and time	Date and time of disaster occurrence is one of the most important information. If exact time of occurrence is unclear, the time of occurrence is assumed as the time when rainfall indices were the highest.
Locations (longitude and latitude)	Detailed landslide location information is required to find rainfall gauging stations near the landslides.
Geological/topographical features Description of the disasters	Geological/topographical features and other detailed descriptions are helpful to study correlation between rainfall and disaster occurrence.

### 2.1.3 Records of past disaster response

Review of past disaster response is necessary to clarify required lead time for local people to receive early warnings and to evacuate to safe places. In addition, the reports of past disaster responses indicate bottle neck and weak points of the current warning system. Details of the dissemination of early warnings and response are shown in Chapter 4. Important information to study warning dissemination paths and required lead time is shown in Table 2.3.

**Table 2.3 Important information on past disaster response records**

Items	Remarks
Path and method to disseminate early warning	<ul style="list-style-type: none"> <li>- NBRO =&gt; DMC and relevant level agencies (national level)</li> <li>- DMC =&gt; DDMCU =&gt; DS division =&gt; GN (DMC dissemination route)</li> <li>- Local administration agencies =&gt; community leaders =&gt; community people (government to grass root level)               <ul style="list-style-type: none"> <li>By SMS / phone call</li> <li>By police / military</li> </ul> </li> <li>- Media / web</li> </ul>
Necessary time for local people to complete evacuation	<ul style="list-style-type: none"> <li>- Necessary time for local people to receive early warnings via DMC dissemination route via police / military via media / web</li> <li>- Necessary time for local people to prepare starting evacuation especially, elder people and people who requires helps take time to complete evacuate</li> <li>- Necessary time for DDMCU / DS division to set up evacuation sites</li> <li>- Necessary time for local people to reach evacuation sites</li> </ul>
Challenges of early warning dissemination	e.g. long warning dissemination time due to no mobile connection, missing of emergency committees, etc.



## 2.1.4 Other related data collection at specific sites

### a) Direct observation of landslides

Direct observation of landslides is the most effective method to detect initiation of landslides. However, it is impossible to install direct observation instruments for all landslides. Therefore, direct observation instruments are installed on important landslide sites. Displacement and inclination of landslide soil mass, strain, groundwater level and soil water content are the major observational items for landslide monitoring.

In case that real-time landslide monitoring system is established, the observed data can be utilized for “site-specific” early warnings. It is recommended to observe land movement with one hour or shorter observation interval. Moreover, the observed data can be utilized to study warning thresholds. Procedures of the analysis is shown in section 2.3.2.

### b) River discharge

Time series data of observed river discharge is the supporting data to improve landslide early warnings. The observed river discharge is utilized to calibrate and validate tank model parameters for SWI. Long term data of observed river discharge which recorded by Irrigation Department is useful for the analysis. Table 2.4 shows recommendations on the river discharge data for the analysis.

**Table 2.4 Recommendations on river discharge data**

Items	Recommendations
Location of catchments	<ul style="list-style-type: none"> <li>- Catchments should be located in mountainous landslide vulnerable areas.</li> <li>- Catchment areas should be small (up to 200km<sup>2</sup>). The observed river discharge data should represent characteristics of mountainous slopes.</li> </ul>
Number of catchments	<ul style="list-style-type: none"> <li>- It is recommended to select representative catchments in each region since geological and topographical characteristics are different</li> </ul>
Duration and interval of observed data	<ul style="list-style-type: none"> <li>- At least two rainfall events are necessary for parameter calibration and validation.</li> <li>- Observation interval should be one hour or shorter.</li> </ul>
Rainfall	<ul style="list-style-type: none"> <li>- Rainfall time series data is also necessary as input data of the tank model to calculate discharge and SWI.</li> </ul>
Characteristics of catchments	<ul style="list-style-type: none"> <li>- Geological and topographical characteristics of the catchments are utilized to classify the catchments and to study behavior of soil water.</li> </ul>

## 2.2 Study on necessary lead time

Necessary lead time consists of warning dissemination time from government to local people and evacuation time for local people to reach safe place. The warning dissemination from NBRO to DMC and from DMC to DDMCU, DS and GN division becomes smoother compared to the past situation by utilizing SMS, mobile call and mail. However, the warning dissemination from local governmental agencies to local focal points (community emergency committees) and from local focal points to all local people living in landslide hazard areas still needs time. Especially, it takes time for local government officers and/or police to physically visit remote areas as it is outside of mobile coverage area.

Necessary time for local people to complete evacuation depends on location of community and evacuation place. Generally, it takes 10 to 20 minutes to prepare the start evacuation and to reach evacuation place by walk. However, longer time is necessary in the remote areas. Furthermore, elder people and people who need physical supports for evacuation requires more time. Considering the worst condition of warning dissemination, two to

three hours lead time is recommended for early warnings.

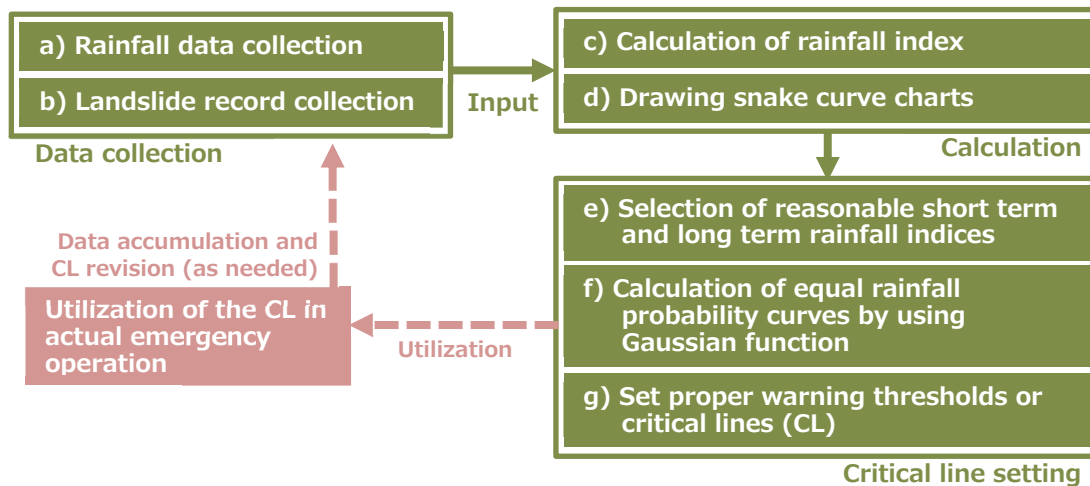
Review survey on necessary lead time should be done after a serious landslide or when the warning dissemination system is changed.

## 2.3 Determination of critical lines and warning thresholds

### 2.3.1 Critical lines and warning thresholds for nationwide landslide warnings

Critical lines and warning thresholds for landslide warning depends on topographical, hydro-meteorological and geographical characteristics of regions. Hence, the analysis to determine critical lines and warning thresholds should be done for each region or sub-catchments which have similar characteristics.

To improve accuracy of landslide warnings, revision of critical lines and warning thresholds should be done once in two years or after a major landslide event, as a routine work. Procedures to determine critical lines and warning thresholds for nationwide landslide warnings (Figure 2.3) and for site-specific landslide warnings are shown in this section and section 2.3.2, respectively.



**Figure 2.3 Procedures of rainfall-landslide correlation analysis**

#### a) Selection of rain gauges and rainfall data collection

The first step of the analysis to determine the warning thresholds and critical lines is selection of rain gauges located in a target region and collecting rainfall data. Representative rainfall gauging station for a target region should be selected considering observation period and data quality (Table 2.5). More than 20 years observation period with 1h or shorter observation interval and less missing data is ideal, but such long period and short observation interval rainfall data is not available at this moment in Sri Lanka. Thus, automated rain gauges which are operated more than five years with 1h or shorter observation interval should be selected as representative rain gauges in a target region for the analysis. Time series rainfall data should be collected during rainfall events causing landslides as well as not causing landslides. Then, time series data of the past observed rainfall will be utilized to the analysis in the following procedure.

**Table 2.5 Points to be considered for representative rainfall gauging stations**

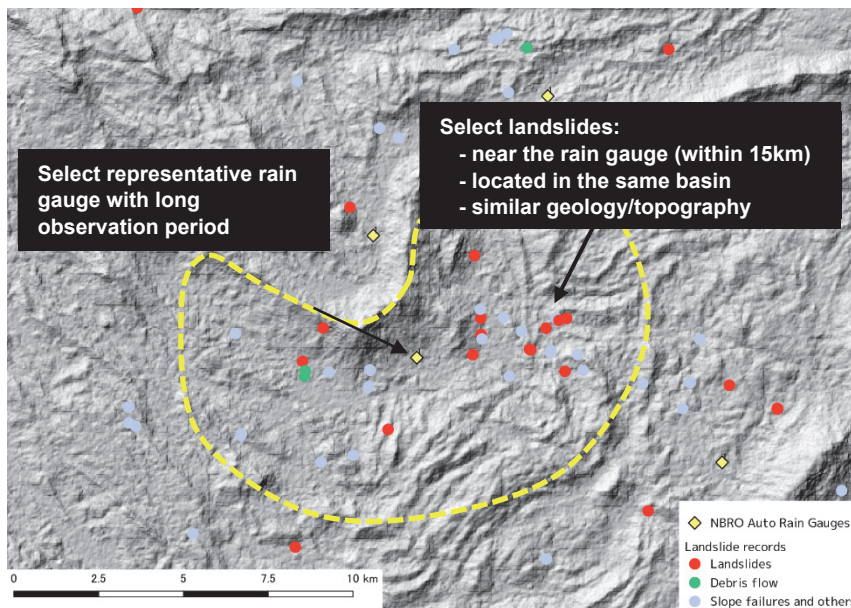
Item	Criteria
Representativeness	<p>One representative gauging station should be selected for each target region (strong correlation between observed rainfall and landslide occurrence is found within ca. 15km area).</p> <p>In case that regional characteristics vary (e.g. located in another basin, different geology) in the target region, it is ideal to divide the target region based on the characteristics and to select another representative gauging stations for the separated target regions.</p>
Data availability	<p>1 hour or shorter observation interval rainfall data should be available.</p> <p>Long-term observed rainfall time series data and landslide records should be available (at least, several years data should be available. Ideally, more than 20 years data should be utilized for the analysis).</p> <p>Data quality is reasonable.</p>

**b) Collecting past landslide records**

Past landslide records (slides, debris flows, slope failures and rock falls) which occurred near the selected rain gauges are necessary for the analysis. The landslides located within 15 km and in the same catchment of the rain gauges are suitable for the analysis (**Figure 2.4**). In addition, it is ideal if landslides with similar geological and topographical conditions could be utilized for the analysis.

In case that number of landslide records are not sufficient, landslide records located far from the rain gauges are able to be included and analyzed. If the correlation between rainfall and the landslides in remote areas is weak, the landslides should be excluded from the analysis.

Generally, isolated small cutting failures, rock falls and deep-seated landslides are difficult to be predicted by rainfall because of weak correlation with rainfall. Therefore, those landslide records should be included to the analysis once and check the correlation to rainfall, and excluded from the analysis if the correlation is weak.



**Figure 2.4 Rain gauges and landslides**

### c) Calculation of rainfall indices

As shown in section 1.6.2 and Table 1.3, short-term and long-term rainfall indices are utilized for landslide early warning. To improve the accuracy of the analysis, the rainfall indices should be calculated using rainfall time series data as long as possible. The cumulative rainfall in the specific durations, working rainfall and Soil Water Index (SWI) are able to be calculated from 1h or shorter observed rainfall time series. Calculation formula for working rainfall and SWI is shown below.

#### – Working rainfall

The general formula of the working rainfall is as follows.

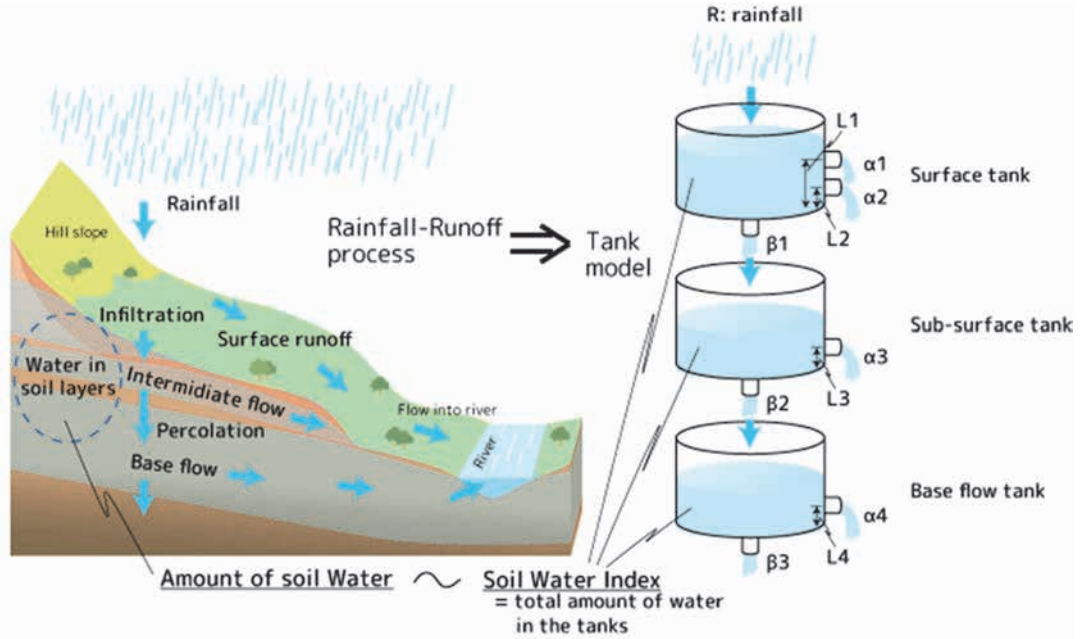
$$R_w = \sum_i 0.5^{i/T} R_i$$

where,  $R_w$ : Working rainfall (mm),  $R_i$ : Rainfall at time  $i$  (mm/h),  $i$ : Time step,  $T$ : Half period (h). A working rainfall increases when rainfall occurred and gradually decreases after the rainfall. The working rainfall falls to one-half of the initial amount by the half period ( $T$ ) simulating percolation and discharge.

#### – Soil Water Index (SWI)

SWI developed by Okada *et al.* (2001) is also an indicator of landslide risks and utilized to issue landslide early warnings in Japan. SWI is calculated by using a tank model, a conceptual runoff model developed by Sugawara (1972). The tank model, consisting of surface, sub-surface and base flow tanks, simulates amount of the water in soil layers and discharge. Parameters of the tank model depends on the condition of topography, geology, vegetation and other site conditions. The model parameters proposed by Ishihara and Kobatake (1979) according to the geological conditions of Japan were used and the effectiveness of the models and parameters should be validated by comparing to the actual landslide records in the study area.

A structure of the tank model is shown in Figure 2.5. The time step for the calculation is 10 minutes. SWI is calculated as the total amount of simulated water in the tanks ( $S_1+S_2+S_3$ ) at each time step. SWI represents behavior of soil water and a rise of landslide risks caused by the increment of soil water.



**Figure 2.5 Structure of tank model**

The general formula of the SWI is as follows.

$$SWI = S_1 + S_2 + S_3$$

$$S_1(t + \Delta t) = (1 - \beta_1 \Delta t) \cdot S_1(t) - q_1(t) \cdot \Delta t + R$$

$$S_2(t + \Delta t) = (1 - \beta_2 \Delta t) \cdot S_2(t) - q_2(t) \cdot \Delta t + \beta_1 \cdot S_1(t) \cdot \Delta t$$

$$S_3(t + \Delta t) = (1 - \beta_3 \Delta t) \cdot S_3(t) - q_3(t) \cdot \Delta t + \beta_2 \cdot S_2(t) \cdot \Delta t$$

$$q_1(t) = \alpha_1 [S_1(t) - L_1] + \alpha_2 [S_1(t) - L_2]$$

$$q_2(t) = \alpha_3 [S_2(t) - L_3]$$

$$q_3(t) = \alpha_4 [S_3(t) - L_4]$$

where,  $S_1, S_2, S_3$  : Water amount in the tank (mm),  $\beta_1, \beta_2, \beta_3$  : Infiltration rate,  $q_1, q_2, q_3$  : Discharge (mm/ $\Delta t$ ),  $\Delta t$  : Time step,  $R$  : rainfall (mm/ $\Delta t$ ),  $\alpha_1, \alpha_2, \alpha_3, \alpha_4$  : Runoff ratio,  $L_1, L_2, L_3, L_4$  : Height of runoff hole (mm).

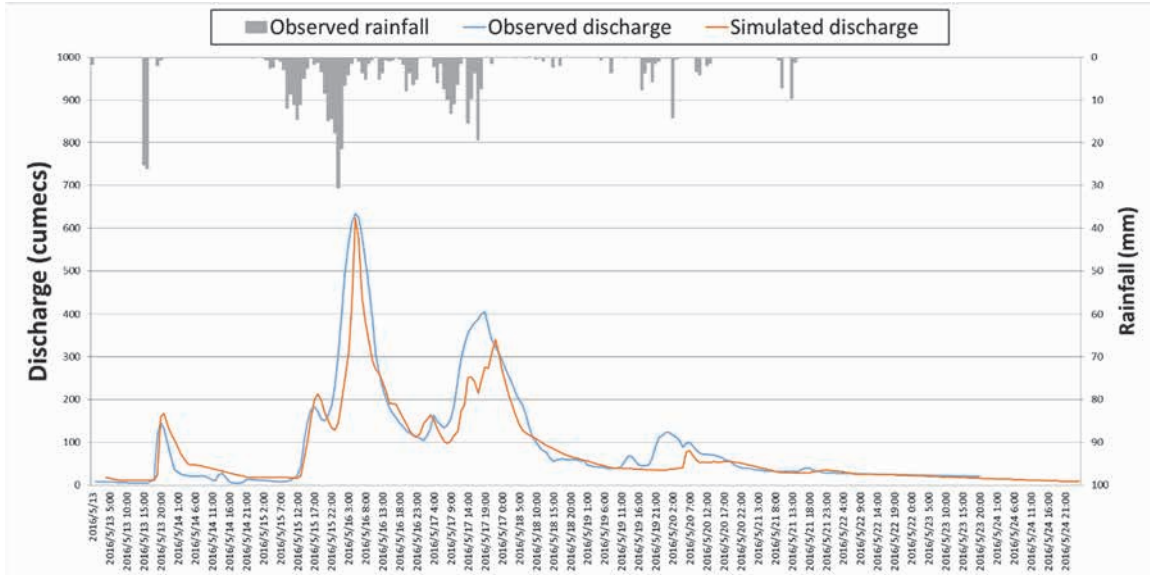
The tank model parameters to calculate SWI depends on the slope characteristics. The parameters are able to be calibrated and validated by following two methods; 1) comparing simulated discharge by the tank model and observed river discharge (Figure 2.6), and 2) comparing simulated SWI and observed ground water level, soil water content and/or strain (Figure 2.7). Detail of the procedures of the parameter calibration is shown in the appendix 3.

In case of the site-specific landslide warning, the tank model parameters for SWI calculation should be calibrated for each site since the parameter should clearly represents the slope characteristics.

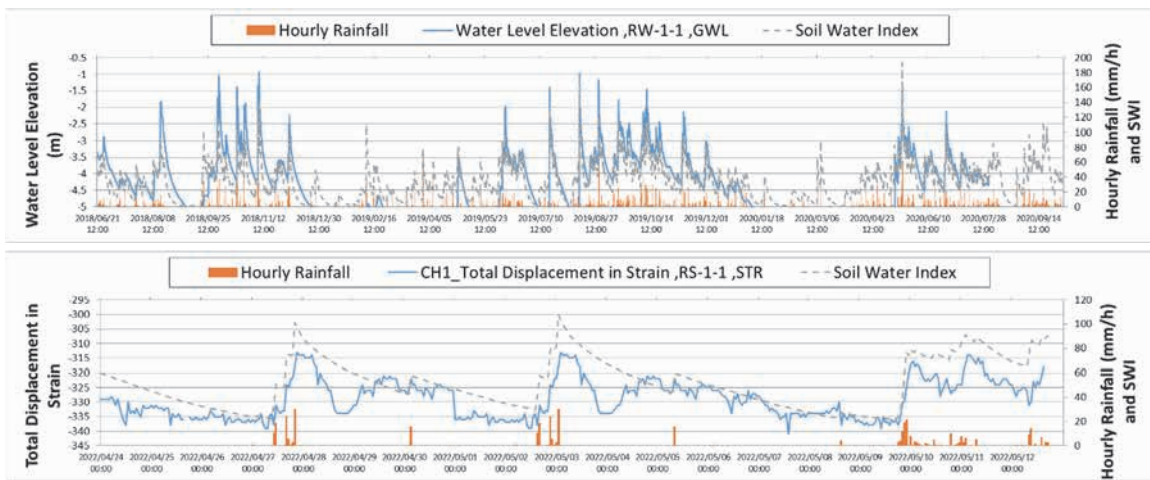
However, in case of nationwide early warning, it is recommended to utilize general parameters because the parameters should indicate general characteristics for wide area. Furthermore, the difference of the calibrated parameters for SWI is relatively small. Gamage *et al.* (2021) calibrate and validate the tank model parameter for SWI by using mountainous river basins in Sri Lanka. Gamage *et al.* (2021) utilizes three sets of parameters (P1-P3) to reproduce the river discharge in the nine Sri Lankan study basins and reports that the reproducibility of the



river discharge by P1-P3 is reasonable. The SWI calculated by P1-P3 are compared in **Figure 2.8**. The characteristics of the SWI calculated by P1-P3 seem to be similar, but absolute value is different. Considering this result, it is recommended that one representative parameter set is applicable for nationwide areas, but it is required to determine warning thresholds and critical lines for each regions reflecting difference of absolute values.

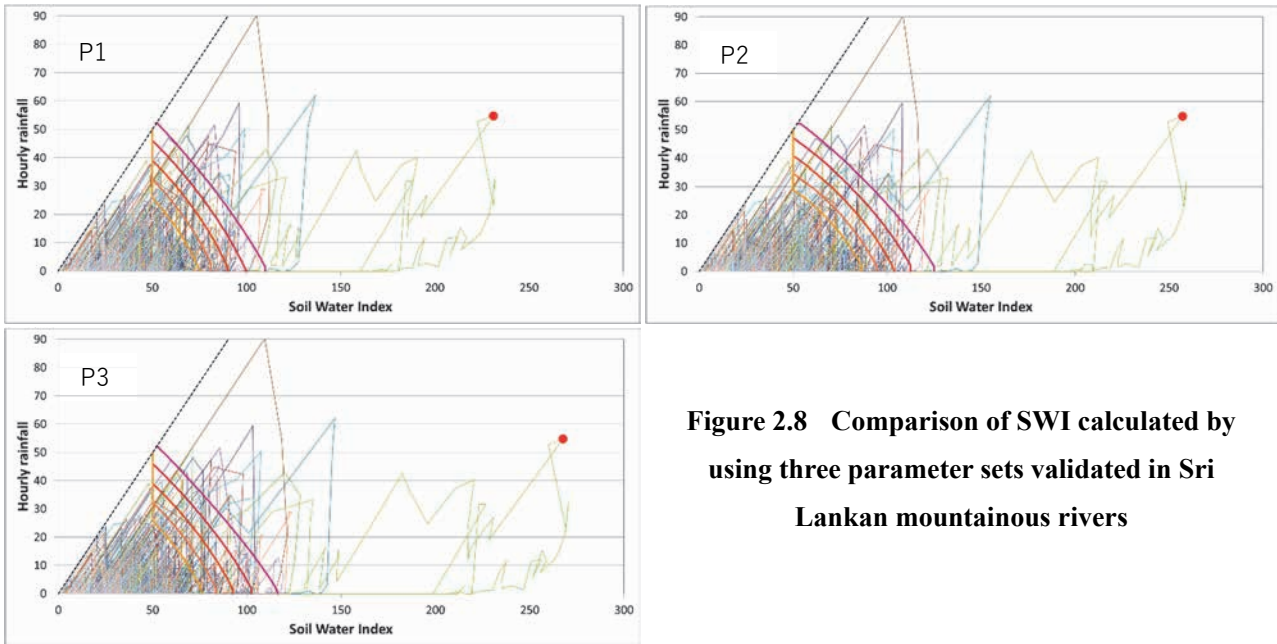


**Figure 2.6 Observed and simulated discharge at Nakkala**



**Figure 2.7 Observed groundwater level (upper), strain (lower) and SWI**

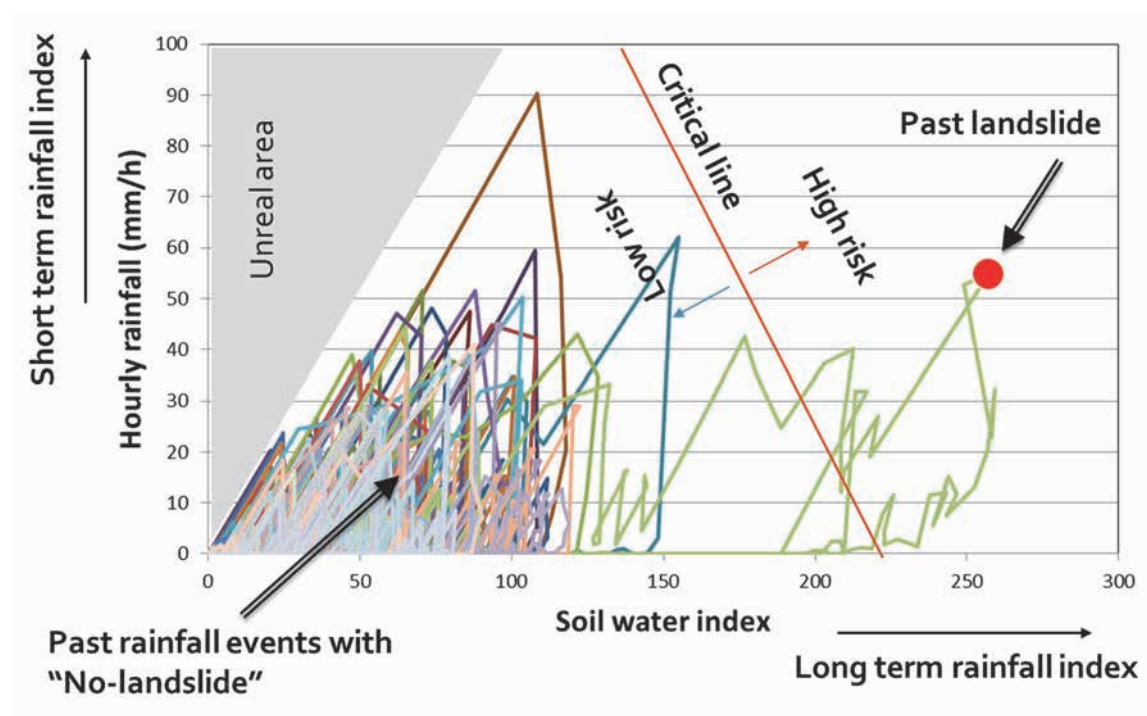




**Figure 2.8 Comparison of SWI calculated by using three parameter sets validated in Sri Lankan mountainous rivers**

**d) Drawing snake curve charts and time series charts**

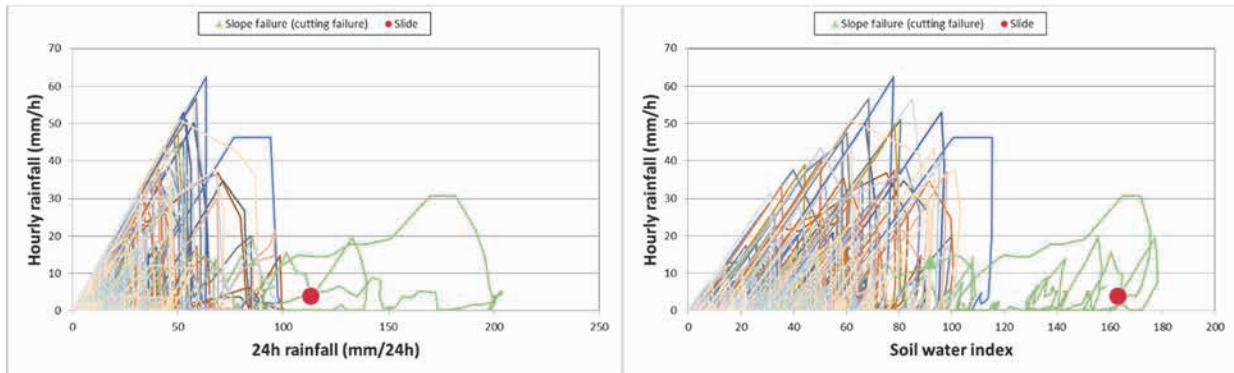
In order to identify correlations between the landslide occurrence and triggering rainfall, the rainfall indices calculated by the formulas shown above and the landslide records are plotted together on snake curve charts (Figure 2.9) and time series charts. Snake curve charts are scatter line charts consisting of short term rainfall index axis (Y axis) and long term rainfall index axis (X axis). Right-upper area of the snake curve chart (Figure 2.9) is severe rainfall area which has higher landslide hazards. The boundary of the past landslide points and rainfall with no landslide occurrence is the critical line or the warning threshold.



**Figure 2.9 Example of snake curve chart**

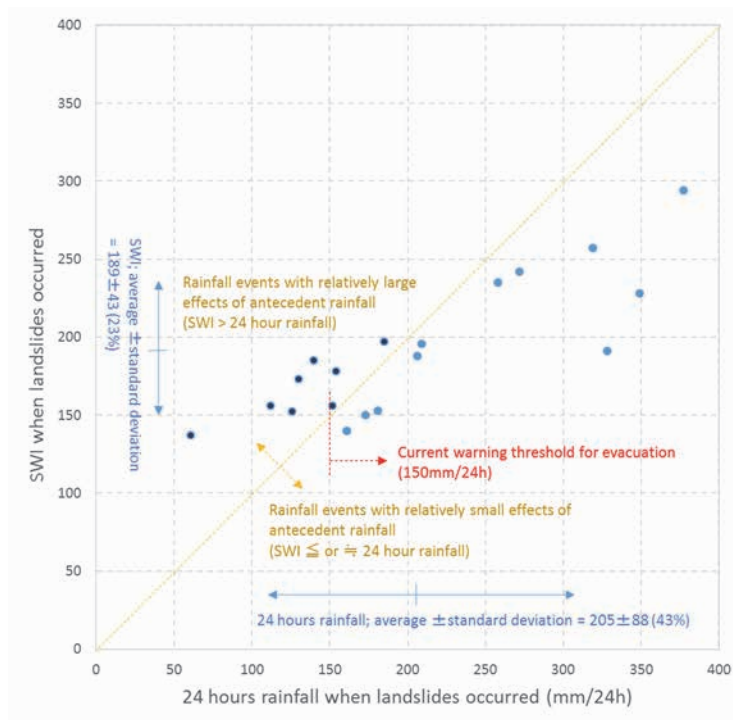
**e) Selection of reasonable rainfall indices for early warning**

Based on the calculated results of rainfall indices, most reasonable and effective short term and long term rainfall indices which clearly indicate differences of characteristics among rainfall events with/without landslides are able to be identified. Figure 2.10 shows an example of comparison between 24h rainfall and SWI. In this case, both 24h rainfall and SWI value causing landslides were significantly high. Thus, both indices seems effective for early warning. Though, SWI shows more clear difference between landslide occurrence and no-occurrence.



**Figure 2.10 Snake curve charts of 24h rainfall (left) and SWI (right) at Kegalle**

Figure 2.11 shows correlation between SWI and 24 hour rainfall causing the past 19 landslides in Sri Lanka. 74% (14 cases out of 19 cases) of the landslides occurred when 24h rainfall exceeded 150mm. Thus, the 24h rainfall thresholds of existing early warning system which NBRO uses are 150 mm/24h rainfall seems reasonable. However, remaining 26% (five cases out of 19 cases) landslides were triggered even if the rainfall is less than 150 mm/24h but SWI was still higher than 140. These cases were caused by continuous rainfall. Hence, it is recommended to utilize SWI as supplemental index to catch the landslides triggered by continuous rainfall.



**Figure 2.11 Correlation between SWI and 24 hour rainfall causing the past landslides**

#### **f) Calculation of equal rainfall probability curves by using Gaussian function**

In order to determine critical lines, equal probability curves of rainfall events are useful standards. It is assumed that landslides are caused by rainfall events of which occurrence probability is lower than a specific threshold. Thus, an equal rainfall probability curve which separates rainfall events causing landslides and no-landslides is estimated as a critical line. The equal rainfall probability curves can be calculated by using Gaussian function and utilized as a critical line.

#### **g) Determination of critical lines and warning thresholds**

Finally, a critical line should be defined on a boundary of landslide occurrence and non-occurrence. Figure 2.12 shows an example of snake curve chart with equal probability curve. In the case of Figure 2.12, the 0.005 probability curve separates hazardous rainfall events which caused landslides and small rainfall events which didn't triggered landslides. Therefore, the equal probability curve is able to be selected as a critical line. Constant warning thresholds can be also determined on the charts. In the case of Figure 2.12, ca. 170 SWI and 250 SWI seems the thresholds triggering slope failures and landslides, respectively.

The predictive ratio of landslides and air-shot ratio of warnings should be validated to select the critical line. In the case of Figure 2.12, the predictive ratio of landslides is 100% in case that 0.005 probability curve is determined as the critical line. On the other hand, air-shot ratio is 5.8%. If the smaller probability curve is selected as the critical line, the air-shot ratio decreases but prediction ratio becomes also low. A suitable critical line or warning thresholds should be selected considering the balance of predictive ratio and air-shot ratio.

In case that isolated slope failures and/or landslides located far from the rain gauge are caused by exceptionally small rainfall, those events should be excluded from the analysis.

The critical lines and warning thresholds for slope failures tend to be smaller than for landslides. Therefore, determining individual critical lines and warning thresholds for each disaster types is an alternative option.

The lead time should be considered when the critical line or warning thresholds are decided. It is necessary to ensure enough margin between the critical line and occurrence of landslides.

It is required to analyze the correlation between rainfall and landslides at many rainfall gauging stations, which are representative stations of regions/sub-catchments, to determine regional critical lines and thresholds (Figure 2.13). The critical lines and warning thresholds for the representative stations indicate geological, topographical and hydro-meteorological aspect of the region/sub-catchment (e.g. thresholds for regions with weak geology and steep topography are large). However, the records of landslides and rainfall data are not enough to analyze for whole region at present. If the critical lines and warning thresholds are determined by few landslides and rainfall data in several years only, the thresholds could be under/overestimated. Thus, continuous data accumulation and routine revision of the critical lines and warning thresholds are required.

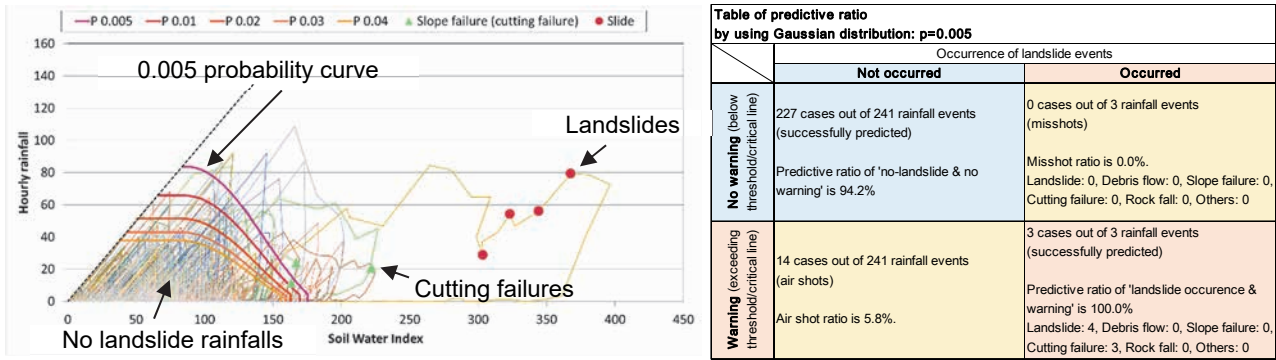


Figure 2.12 Snake curve chart with equal probability curve (left) and table of predictive ratio (right)

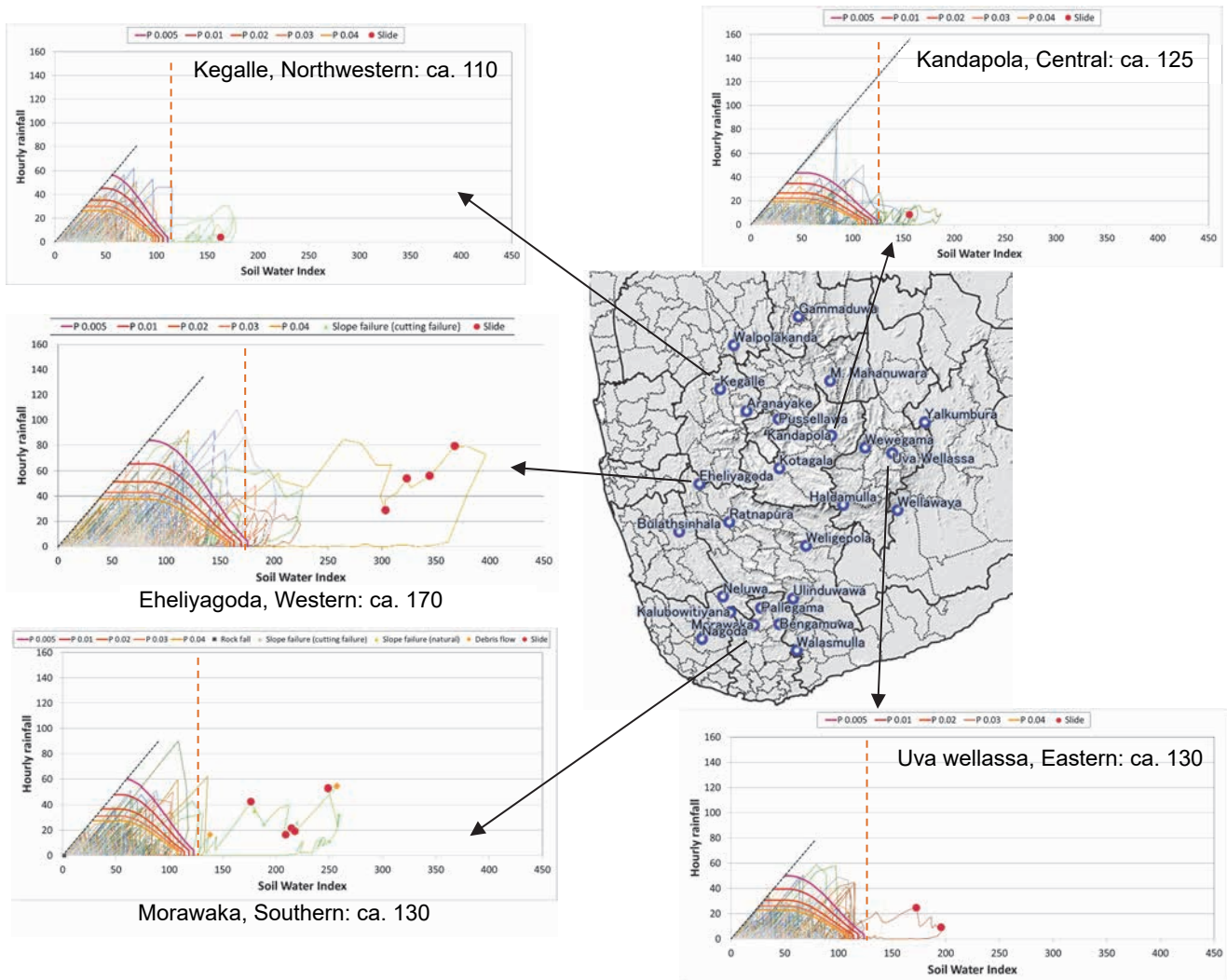


Figure 2.13 Regional variation of correlation between rainfall and landslides

### 2.3.2 Warning thresholds for site-specific warnings based on direct landslide monitoring

Procedures to determine warning thresholds of site-specific landslide early warnings for the communities, where the instruments for direct monitoring of landslide movements were installed, are shown in this section. The procedures for site-specific warnings are different from the nationwide warnings.



**a) Empirical warning thresholds**

The warning thresholds for direct landslide monitoring, such as extensometer, inclinometer, stain gauge, soil water content and ground water level gauge, should be determined based on the observed data at each site. However, it is difficult to decide the thresholds at the beginning of the monitoring without accumulation of the observed data.

In that case, empirical data is useful as reference to set tentative warning thresholds. Table 2.6 shows empirical warning thresholds for direct landslide monitoring in Japan (Nishijima, 1991). According to the Kimura and Yokoyama (2006), the steady velocity of landslide movement was less than 2 mm/h in the seven cases of landslides in Japan. The third phase creep (acceleration of landslide movement) was caused at 1.5-7mm/h. After starting the third creep, it takes 20 to 1000 hours to cause severe landslides. Considering these references, it is recommended to set the tentative warning thresholds at the beginning of the landslide monitoring.

**Table 2.6 Empirical warning thresholds for direct landslide monitoring in Japan**

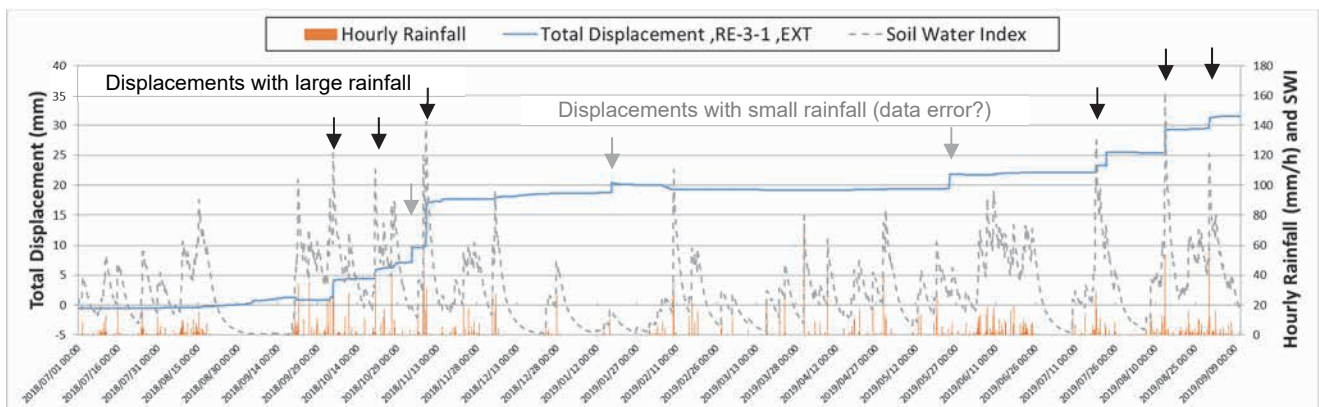
Data	Thresholds	
	Alert	Evacuation
Surface displacement observed by extensometers	5-10 mm/day or above	2-3 mm/h or above
Strain observed by pipe strain gauges	10 <sup>-4</sup> strain/day or above	2×10 <sup>-3</sup> strain/day or above
Inclination observed by borehole inclinometer	5 mm/day or above (ca. 0.6 degree/day)	10 mm/day or above (ca. 1.1 degree/day)

Reported by Nishijima (1991)

**b) Warning thresholds based on long-term observed data**

After the landslide direct monitoring data is accumulated, the characteristics of landslide movements should be analyzed to determine the warning thresholds.

At the first step of the analysis, the observed data of landslide movement is plotted on the time series charts with rainfall (Figure 2.14). The value of rainfall index which triggered the landslide movements can be found on the time series charts. In the case of Figure 2.14, the soil-mass movement started when SWI reached ca. 100.

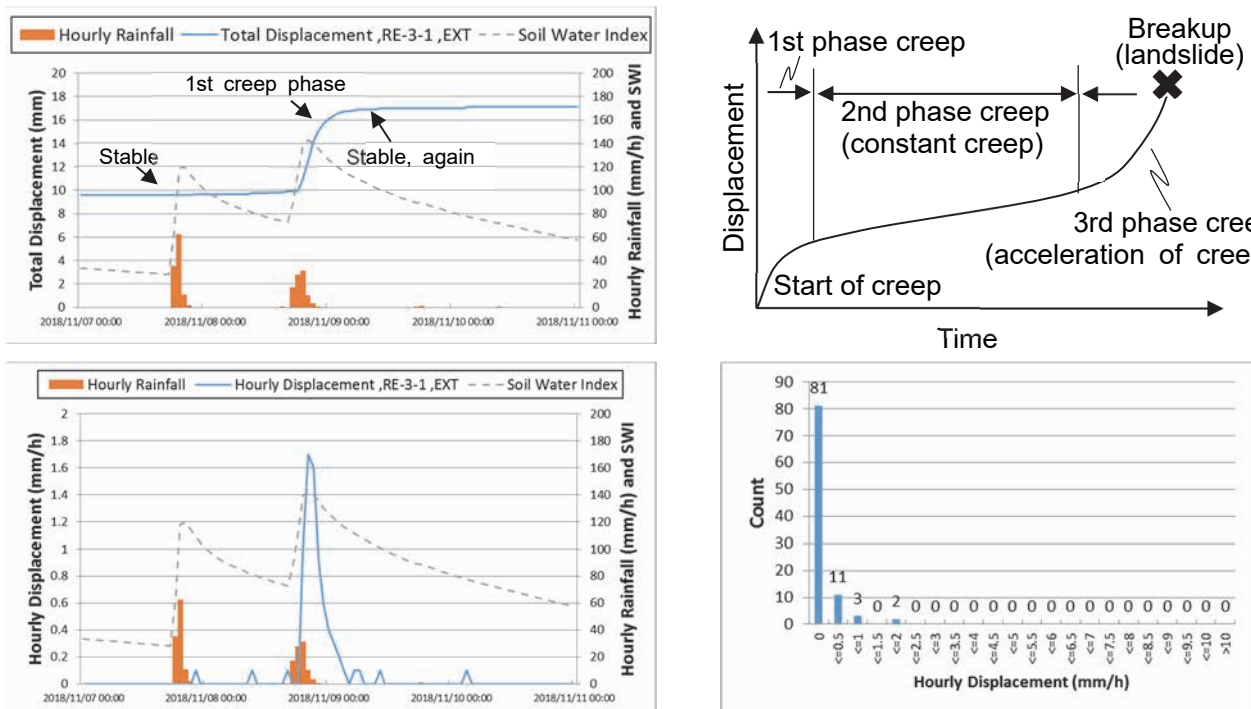


**Figure 2.14 An example of time series chart of surface displacement and rainfall**

The next step of the analysis is detail study on major events. Several severe rainfall events causing typical and significant landslide displacements should be selected and analyzed. Figure 2.15 shows an example of observed displacement data of soil-mass in a major rainfall event. The first creep phase was triggered by the rainfall

exceeding 100 SWI, but the creep stopped and didn't transit to the second and third phase creep in this case. The histogram of the hourly displacement in the event is shown in the Figure 2.15. The maximum value of the hourly displacement was lower than 2mm/h without catastrophic soil-mass movement. Therefore, the warning thresholds could be determined larger than the maximum value in the event. In this manner, the warning thresholds for the soil-mass displacement, inclination and other observation items are able to be determined based on the observed data.

The warning thresholds should be revised and improved regularly through the continuous data collection and analysis after major rainfall events.



**Figure 2.15** An example of surface displacement and rainfall in a major rainfall event (upper-left), hourly displacement (lower left), histogram of hourly displacement (lower right) and conceptual diagram of soil-mass creep stages (upper-right)

#### 2.4 Designation of evacuation places and routes, establishment of warning dissemination system and conducting evacuation drills

Considering landslide hazards, District Disaster Management and Coordination Unit (DDMCU) and Divisional Secretariat (DS) division designate evacuation places and routes. Local people living in the high hazard areas are requested to evacuate when the early warnings are issued. NBRO provides the landslide hazard maps and advises locations of landslide prone communities and suitable evacuation places which should be located outside of the high landslide hazard areas. The evacuation routes and dissemination paths of the early warnings should be secured by efforts of national and local governmental agencies and local people. Details of the framework of evacuation are shown in Chapter 4.



## Chapter 3 Methodology and protocol of the tasks for landslide early warning – under/after emergency situation -

### 3.1 Tasks under emergency situation

#### 3.1.1 Rainfall forecasting

Department Meteorology (DOM) distributes 10 days precipitation forecast (Figure 3.1) based on the Numerical Weather Prediction (NWP) as well as issues meteorological warnings. The forecast precipitation data helps for NBRO, DMC and relevant agencies to understand increase of landslide risk within several days and to start preparation for the forecasted severe weather.

However, the accuracy of the forecast precipitation data is not sufficient level to be utilized for the landslide early warning, directly. Thus, it is recommended to utilize the forecast rainfall as reference data when NBRO issue landslide early warnings. In cases that continuous heavy rainfall is forecasted within the day and next day, the forecast data could be a basis to issue new landslide early warnings earlier or to extend issued warnings even though the rainfall doesn't exceed the thresholds.

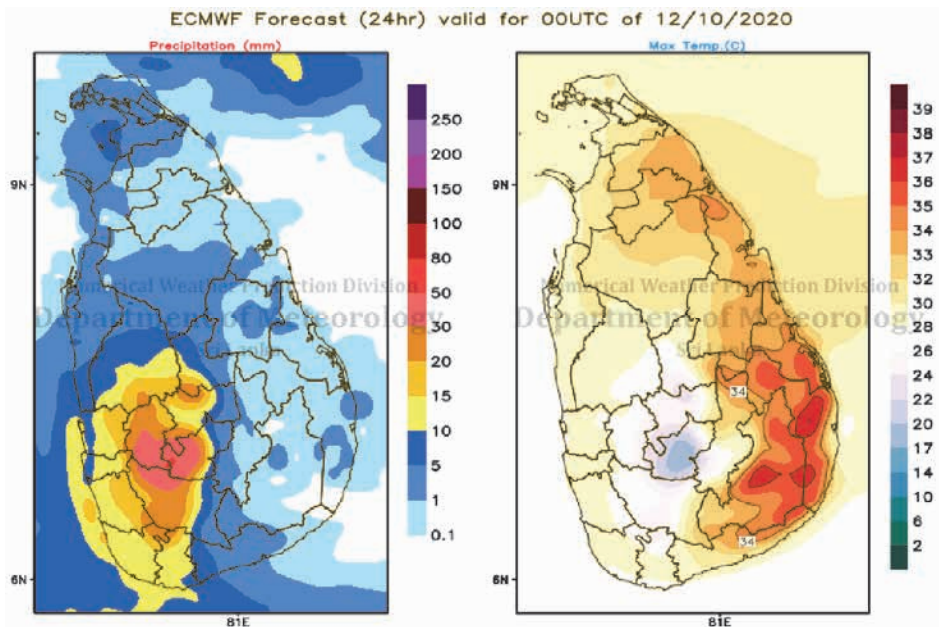


Figure 3.1 Weather forecast map distributed by DOM

#### 3.1.2 Real time rainfall monitoring

##### a) Nationwide rainfall monitoring

NBRO operates automated rainfall monitoring system in the landslide prone mountainous regions. NBRO have installed more than 330 automatic rain gauges. The detail real-time observed data is available on the web-site for NBRO and relevant agencies to monitor rainfall. In addition, real-time SWI monitoring data is available on the web-site for NBRO and relevant agencies.

The nationwide landslide early warnings will be issued for each DS division based on the real-time rainfall. Furthermore, real-time rainfall map is opened to public on NBRO web-site (Figure 3.2).

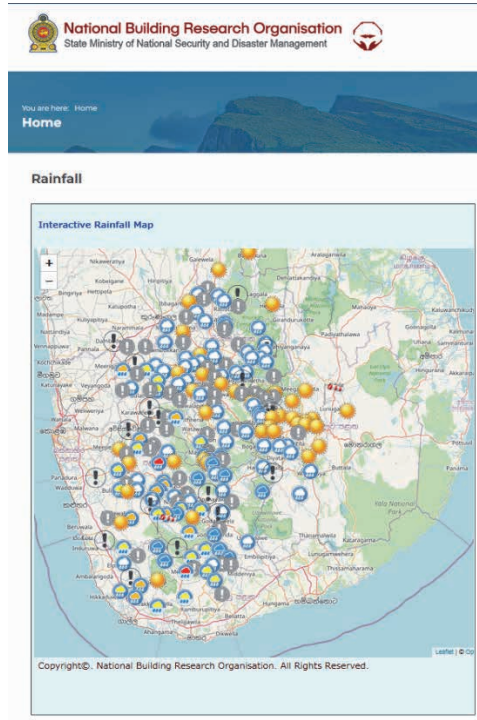


Figure 3.2 Public web-site of real-time rainfall observed by NBRO

**b) Site-specific landslide monitoring**

In several important landslide sites, NBRO conducts site-specific observation. NBRO monitors displacement and inclination of landslide soil mass, strains, ground water level, soil water content and rainfall by specialized instruments at the sites. The site-specific landslide early warnings will be issued for the community located in the sites based on the monitoring data. The site-specific monitoring data is available the web-site (Figure 3.3) for NBRO and relevant agencies.

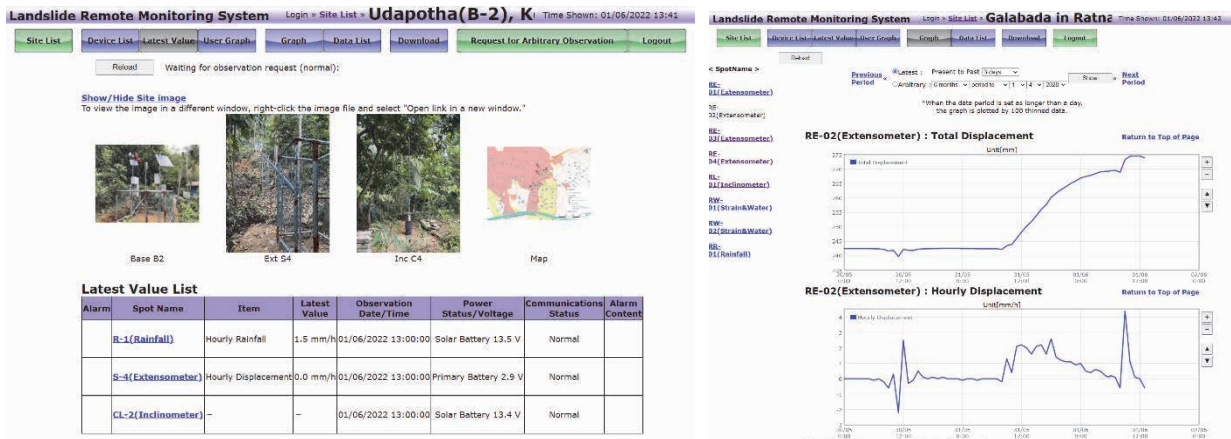


Figure 3.3 Web-site of site-specific landslide monitoring

In addition, some communities have manual rain gauges. Community focal points observe rainfall for community-based disaster risk mitigation activities.

### 3.1.3 Issuing landslide early warning

#### a) Nationwide landslide early warning

The landslide early warnings are issued for DS divisions in which rainfall exceeds the warning thresholds. The real-time rainfall is monitored through NBRO automated rainfall monitoring system (Figure 3.4).

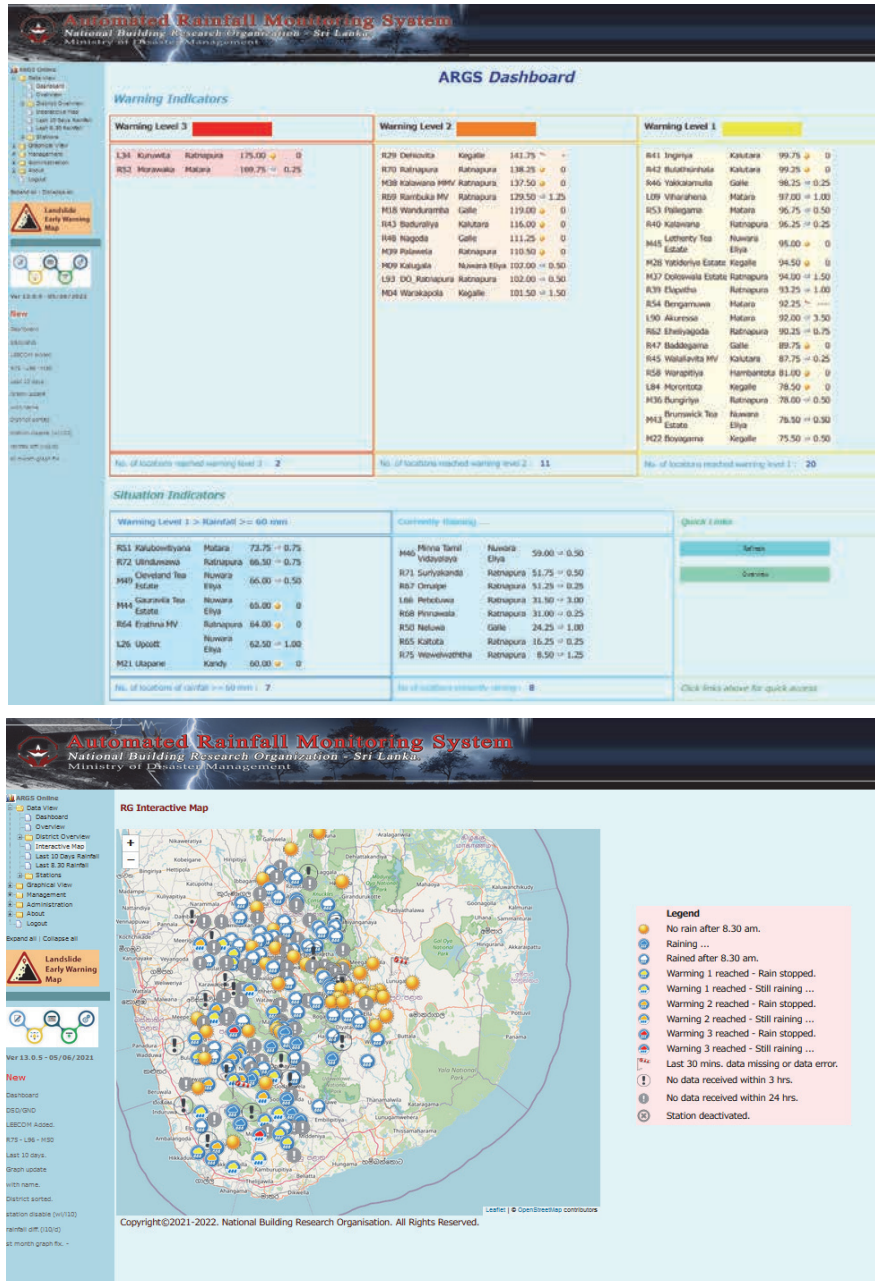


Figure 3.4 NBRO automated rainfall monitoring system

**Table 3.1 Indices to issue landslide early warnings**

Indices		Remarks	
Real-time rainfall	24h rainfall	- The main long-term rainfall index of landslide early warning Exceeding warning thresholds => issuing warnings	Check points Spatial distribution: - Trend of rainfall intensity (increasing / stable / decreasing) - Trend of spatial spreading of rainfall - Abnormal rainfall (isolated and extremely large value) Time series: - Trend (increasing / stable / decreasing)
	1h rainfall	- The main short-term rainfall index of landslide early warning Exceeding warning thresholds => considering to issue warnings	
	SWI	- The supporting long-term rainfall index which indicates effects of antecedent rainfall Exceeding warning thresholds => accelerating to issue warning / keeping warnings if already issued	
	Other long-term rainfall indices	- The supporting long-term rainfall index Increasing or keeping large value => keeping warnings if already issued	
Forecasted rainfall	24h forecasted rainfall (10 days, by DOM) Weather bulletin	- The supporting information of future rainfall Continuous and heavy forecasted rainfall => accelerating to issue warning / keeping warnings if already issued Less forecasted rainfall => conservative to issue warning	
Report of landslides		- In case that occurrences of landslides are reported, it is recommended to issue level 3 (evacuation) warning for same area.	

In addition to the 24 hours rainfall, supporting information listed in Table 3.1 should be considered when landslide early warnings are issued. Check points to issue early warnings are mentioned below.

**– Checking real-time rainfall at gauging stations**

Real-time rainfall monitoring is the base of early warning. On NBRO automated rainfall monitoring system, rain gauges are automatically highlighted if 24 hours rainfall, the main index of early warning, exceeds the warning thresholds (Figure 3.4). The status of rainfall is also illustrated in the web-map (Figure 3.4).

**– Checking spatial variation of rainfall**

If severe rainfall is observed by the rain gauges, it is necessary to confirm the ground conditions through district office or local focal points to avoid anomalous rainfall value due to error of instruments and misconduct of people living at the site. Especially, large and isolated observed rainfall values should be suspected as errors (Figure 3.5).

Spatial variation of rainfall is also important supporting information. Move of rainfall areas and increase/decrease of rainfall intensity can be identified by the real-time observed rainfall web-map. The expected future rainfall area (Figure 3.5) should be considered to accelerate issuing early warnings.

**– Checking time series variation of rainfall**

Time series variations of observed rainfall at representative gauging stations should be checked to expect future conditions. Figure 3.6 shows an example of three rainfall durations; 1) continuous small rainfall with high SWI, 2) start of heavy rainfall with increasing SWI, and 3) SWI exceeding critical line. The time series charts are helpful to detect the phase 1 and phase 2 in advance to that rainfall will exceed the critical line.

Based on the 24 hours rainfall which is the main rainfall index, NBRO EWC issues landslide early warning for DS divisions in which rainfall exceeds warning thresholds considering the supporting information, such as SWI and other rainfall indices, forecasted rainfall, spatial and time series variation of rainfall and actual ground



conditions which has been mentioned above (Figure 3.7).

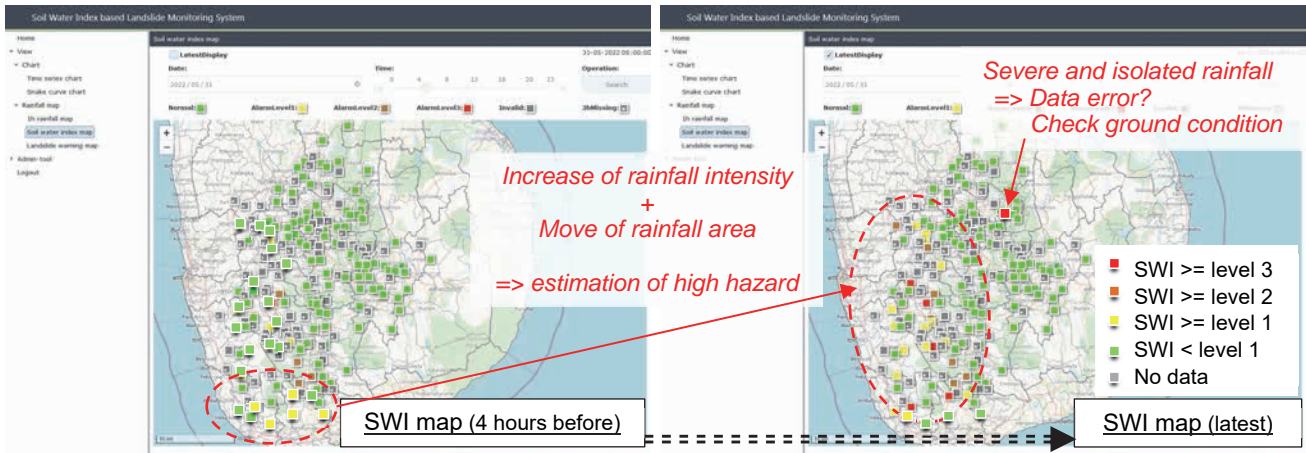


Figure 3.5 Monitoring of rainfall spatial variation (real-time SWI monitoring site)

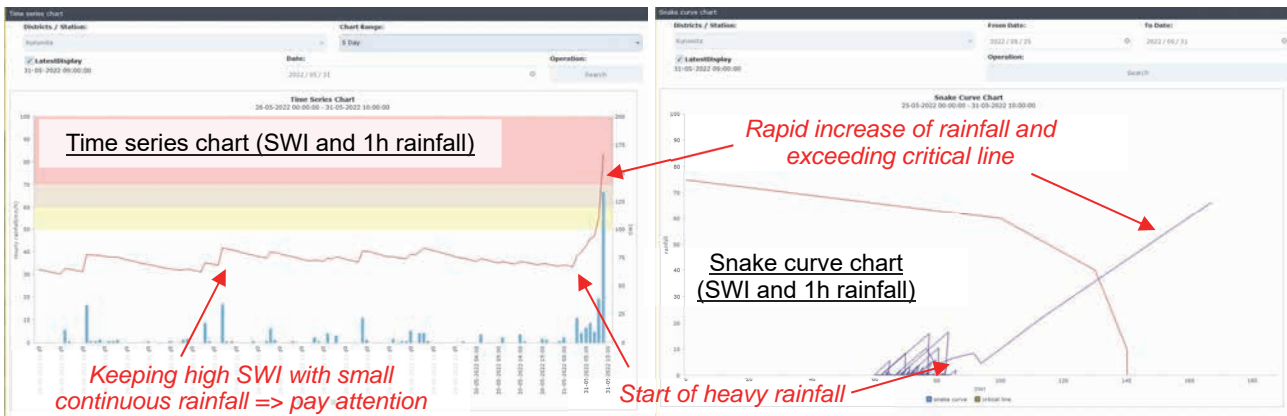


Figure 3.6 Monitoring of rainfall time series variation (real-time SWI monitoring site)

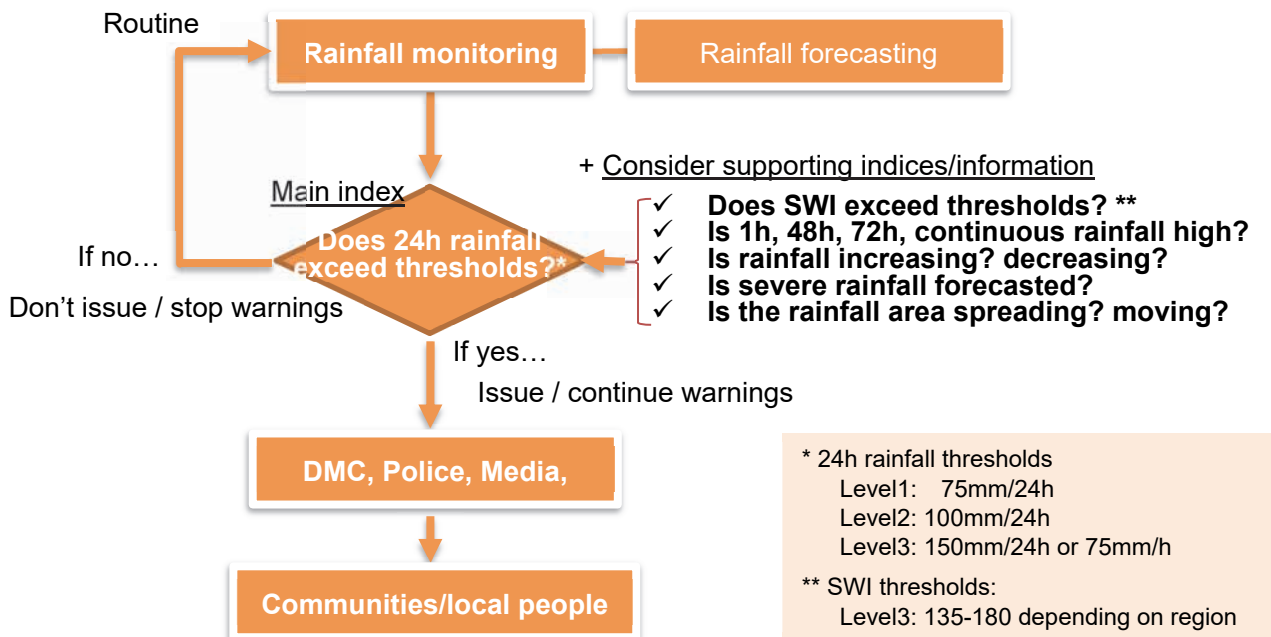


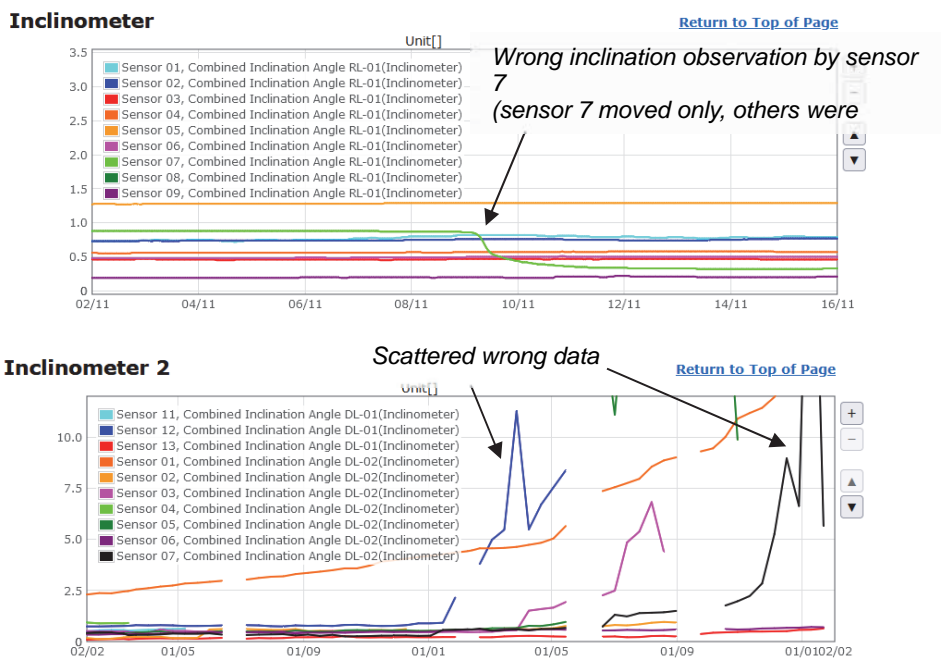
Figure 3.7 Flowchart to issue nationwide early warning

### b) Site-specific early warning

In some important landslide sites where site-specific landslide monitoring system is installed, the site-specific landslide early warnings are issued for the specific sites when displacement and inclination of landslide soil mass, strain, ground water level and rainfall at the sites exceed the warning thresholds.

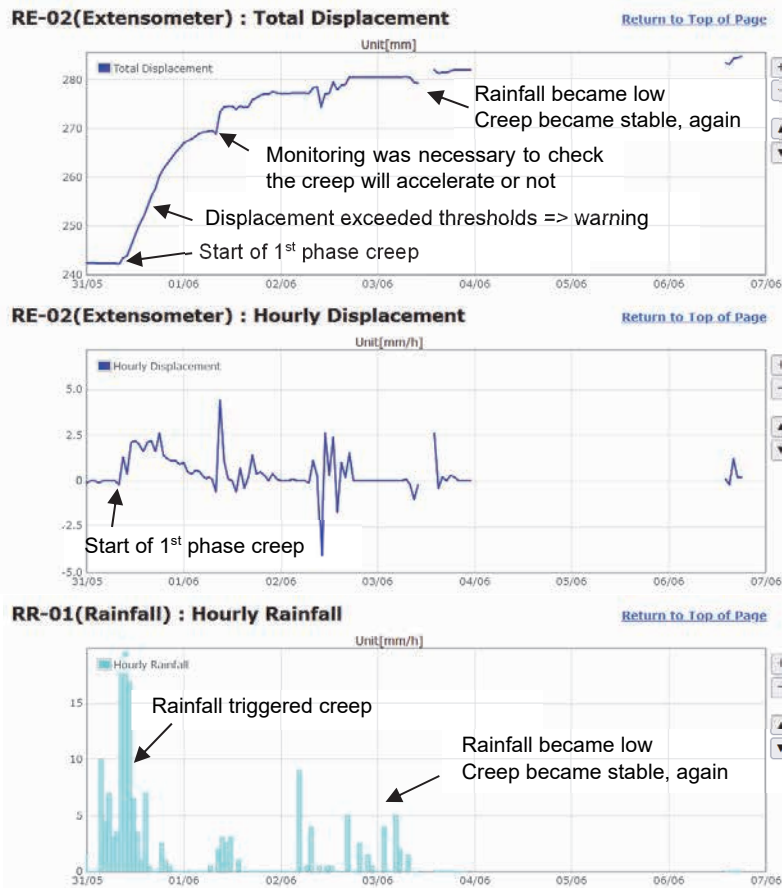
To stop wrong warning triggered by error of instruments, NBRO EWC needs to check the real-time data on the monitoring web-site. In case that abnormal and/or scattered data are recognized (Figure 3.9), NBRO EWC judges the warning is wrong and stops the warning.

After site-specific early warnings are issued, NBRO EWC should carefully monitor the landslide. Figure 3.9 shows an example of observed displacement of landslide soil-mass; the creep was triggered by heavy rainfall and reached warning thresholds. After the site-specific early warning was issued, it is necessary to monitor the landslides since acceleration of creep (third creep) must be caught through the monitoring system, in order to issue the highest warning and take actions. In this case, the rainfall didn't get severe and creep became stable again.



**Figure 3.8** Examples of wrong observation data





**Figure 3.9 Example of displacement of landslide**

### 3.1.4 Dissemination of landslide early warning

The nationwide landslide early warnings issued by NBRO EWC are disseminated to local people by two major paths: governmental line and media line (Figure 3.10). In addition to the two lines, site-specific warning line is established in communities.

#### a) Governmental line

When NBRO EWC issue the landslide early warnings, NBRO send the warnings to DMC/EOC by e-mail, SMS and call to DMC focal person. DMC disseminate the received warnings to DDMCU, DS division and GN division by the governmental line. At the local level, community leaders and local focal person receive the warnings from the governmental line by SMS or call. As needed basis, police, military and local officer physically visit communities to disseminate warnings and to help the evacuations.

#### b) Media line

Simultaneously, the nationwide early warnings are disseminated via media. NBRO and DMC release warning information to mass-media as well as their SNS and web-site. Furthermore, NBRO operates mobile application specialized for landslide early warnings.

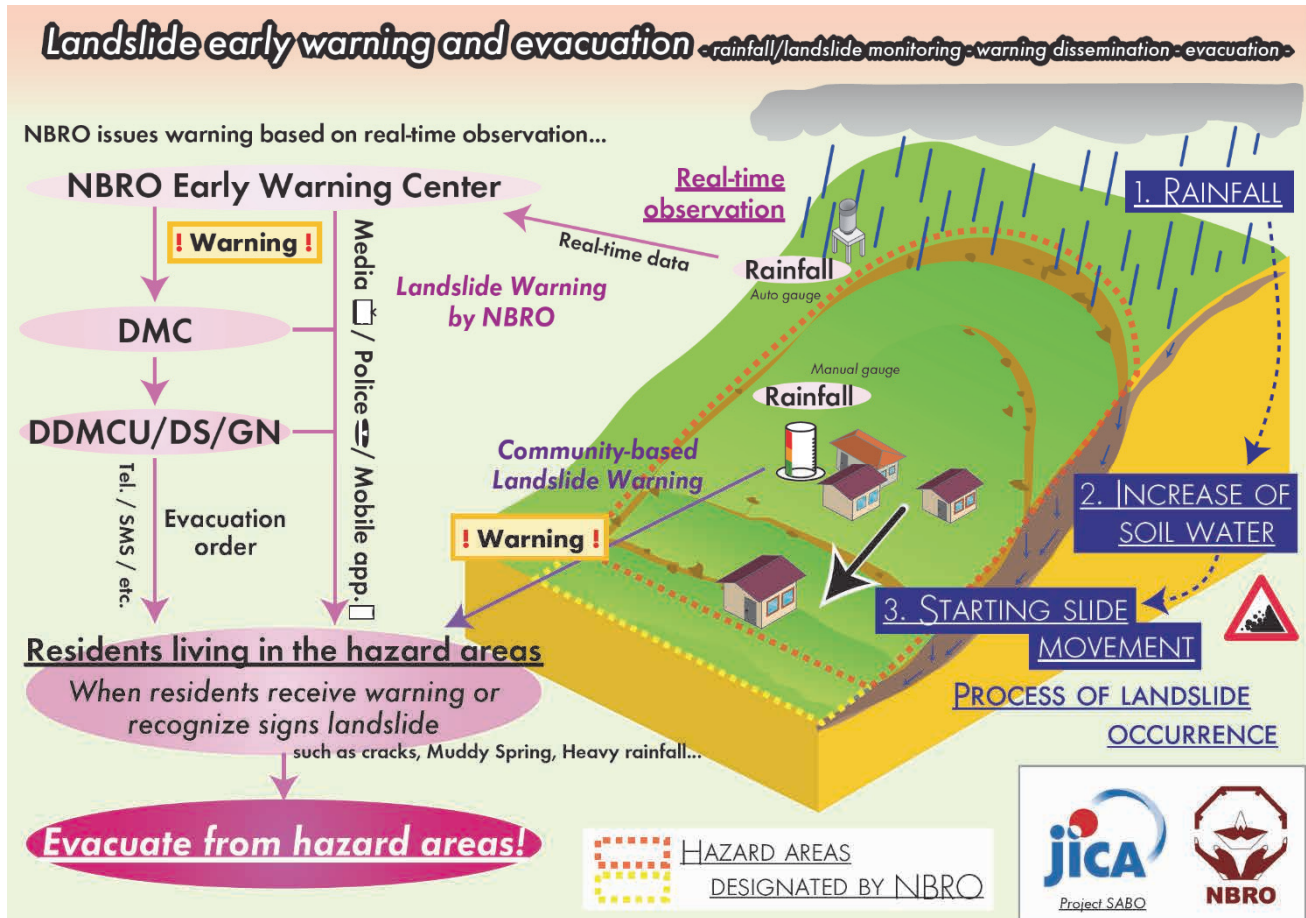


Figure 3.10 Dissemination path of landslide early warning

### 3.1.5 Collecting landslide occurrence reports

Occurrence of landslides and signs of landslide pre-motions are reported from local level to NBRO EWC through NBRO district offices, DMC and/or polices. When NBRO EWC receives the real-time landslide reports, NBRO EWC issues the landslide warnings even if rainfall doesn't exceed the warning thresholds.

### 3.1.6 Clearance of landslide warning

When the issued landslide early warnings are expired, NBRO EWC evaluates whether the landslide early warnings should be extended or not. In case that the rainfall indices fall below the warning threshold, the landslide early warnings step-wise reduced. However, the landslide early warnings should be extended in the cases listed below;

- Rainfall still exceeds the warning thresholds
- Soil Water Index is still high
- Signs of landslides are reported
- Heavy rainfall is forecasted

### 3.2 Tasks after emergency period

#### 3.2.1 Information collection on the incidents

Landslide reports and records of actual emergency response should be collected after the incidents. Information of incident locations, date and time of occurrence, incident types, geological/topographical features, detail of the incidents and actual emergency responses are important information to review and improve the existing landslide early warnings.

#### 3.2.2 Analysis on the incidents

NBRO reviews the collected information of the actual incidents to improve the early warnings by comparing actual date and time of landslide occurrence and issued warnings. Figure 3.11 shows an example of comparison chart between actual landslide early warning and incidents. In this case, level 3 landslide early warning was successfully issued five hours before the incident. If the lead time of early warnings is not enough, NBRO revises the warning thresholds and critical lines for future early warnings.

DMC/DDMCU also review the reports of incidents and improve procedures of incident responses based on lesson learnt from the actual incidents.

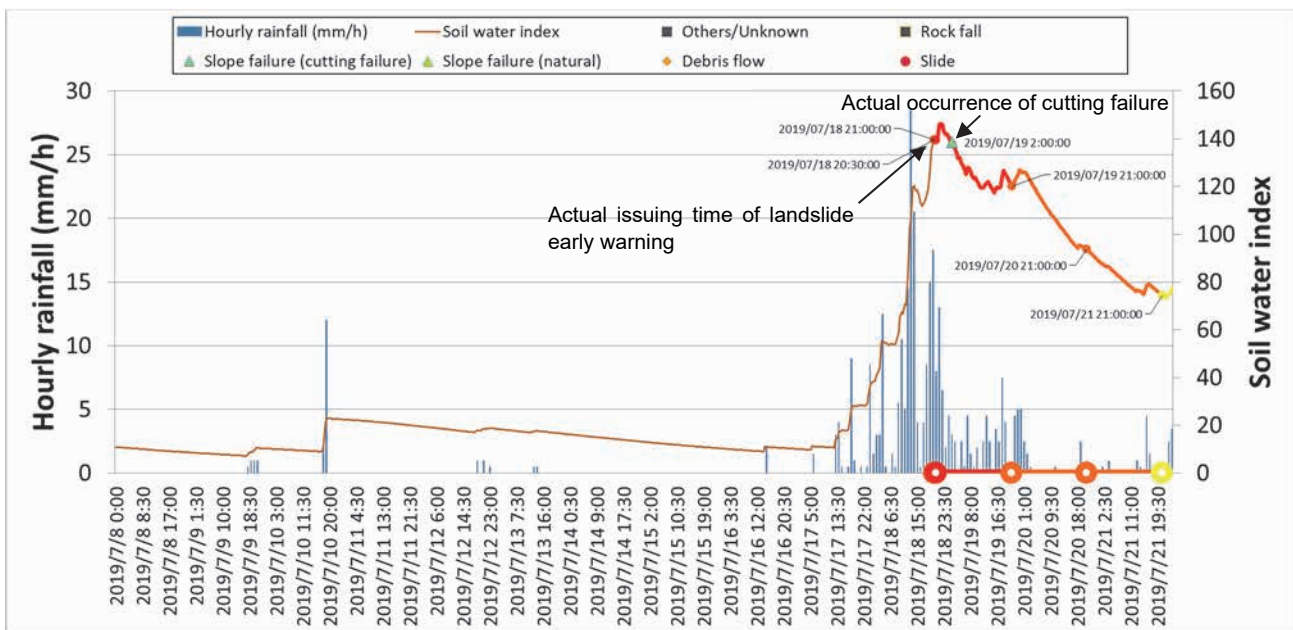


Figure 3.11 Review of actual landslide early warning and disasters



## Chapter 4 Utilization of landslide early warning by relevant agencies and local people

This chapter summarized general information for relevant agencies and local people to utilize of landslide early warnings

### 4.1 Landslide hazard maps and evacuation places

NBRO publishes two types of landslide zonation map, which can be utilized as the basic information to detect communities located in risk areas and to designate evacuation places and routes located outside of the hazard areas.

#### 4.1.1 Landslide hazard maps

##### – Landslide hazard zonation map (LHQM)

1:50,000 and 1:10,000 landslide hazard zonation maps (LHQM) are developed and published on the web-site by NBRO (Figure 4.1). The 1:50,000 LHQM has been prepared for 14 landslide prone districts. The 1:10,000 LHQM are being developed to cover the all landslide prone areas as of 2021.

Hazard zones are classified into five hazard levels (**Table 4.1**). Peoples living in the “Modest level of landslide hazard exists” or higher hazard zones are instructed to evacuate when Level 3 landslide early warnings are issued. Designated evacuation place should be located in “Landslide not likely occur” zones where are the outside of the hazard zones.

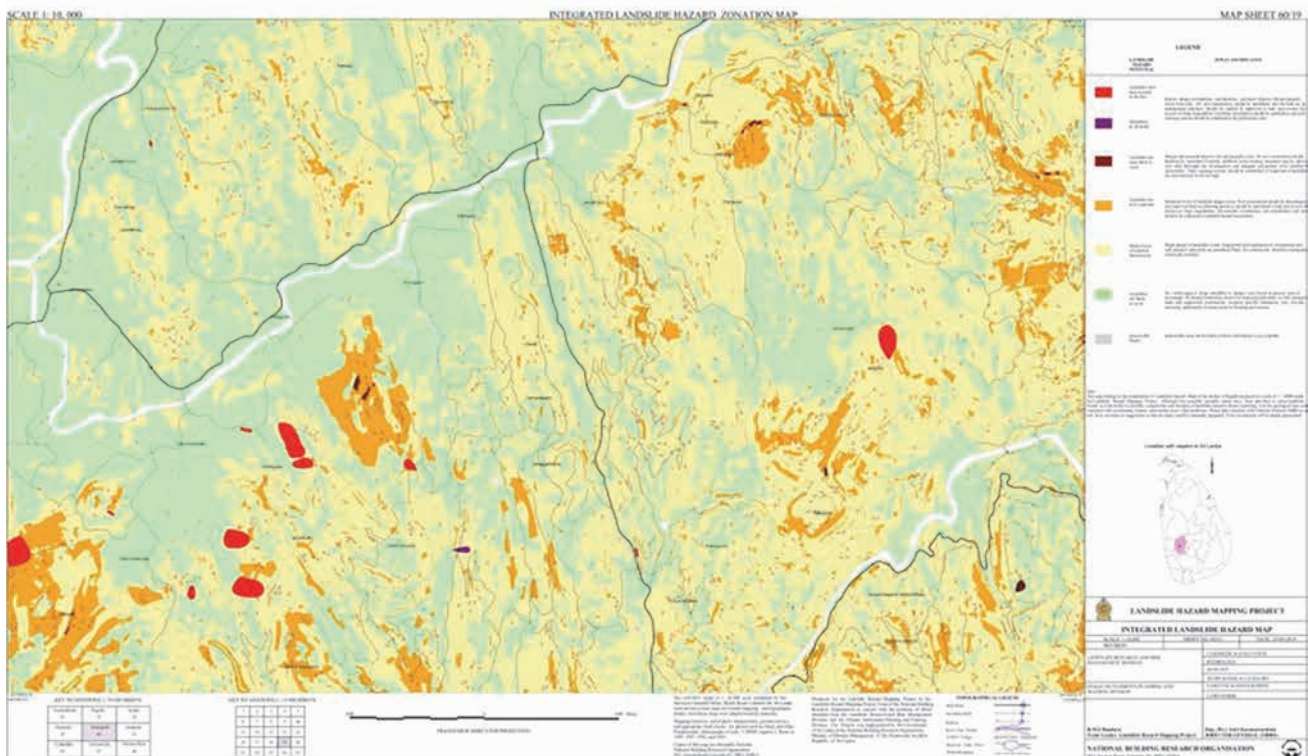


Figure 4.1 Example of landslide hazard zonation map (LHQM, 1:10,000)

– **Yellow/Red Zone hazard maps**

Yellow/Red Zone hazard maps are site-specific hazard maps for slope failure, landslide and debris flow. The hazard zones are classified as “Yellow Zone” and “Red Zone” (Table 4.1). Peoples living in both “Yellow Zone” and “Red Zone” are instructed to evacuate when Level 3 landslide early warnings are issued. Designated evacuation place should be located outside of the “Yellow Zone” and “Red Zone”.

**Table 4.1 Classification of hazard areas and evacuation zone**

	Yellow/Red Zoning	Landslide Hazard Zonation Map (LHZM)
<b>Evacuation Zone</b>	<b>Red Zone*</b> (Sediment Disaster Hazard Area)	Landslides have been occurred in the past
		Landslides most likely to occur
		Landslides are to be expected
	<b>Yellow Zone</b> (Special Sediment Disaster Hazard Area)	Modest level of landslide hazard exists
<b>Non-evacuation Zone</b>	Else	Landslide not likely occur

**4.1.2 Evacuation place and route**

Evacuation places and routes should be designated by DDMCU and DS divisions considering the landslide zonation maps. The evacuation places and routes should be announced through disaster awareness programs and/or evacuation drills in landslide prone communities.

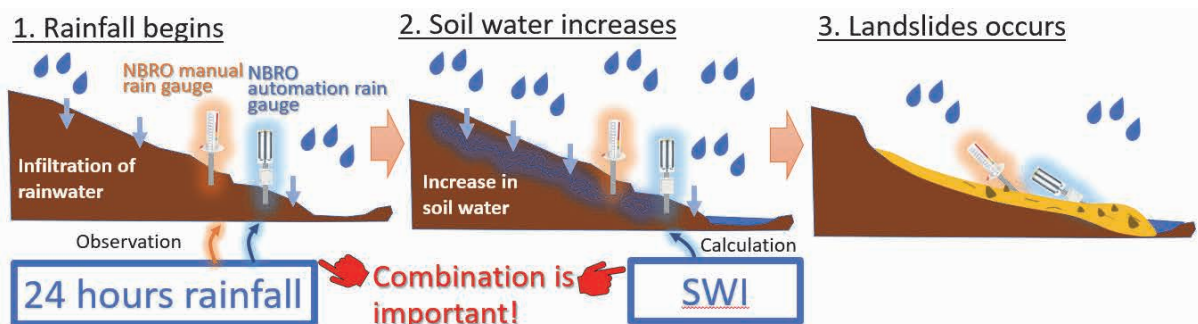
**4.2 Landslide early warning**

**4.2.1 Issuing early warnings and dissemination to local people**

**a) Nationwide early warning from NBRO**

Nationwide early warnings are issued by NBRO based on real-time rainfall observed by NBRO automated rain gauges. Based on historical records of disasters, warning thresholds are identified for three warning levels (level 1: watch, level2: alert, level 3: evacuation, Figure 4.5).

In addition to 24 hours rainfall, NBRO EWC considers Soil Water Index (SWI, Figure 4.2) which indicates behavior of soil water since high soil water contents saturated by heavy rainfall is one of major causes of landslides. It is important to remember that there are cases that NBRO keeps the warning even if the rainfall become little since there is still high risk of landslides due to high water saturation in the soil (high SWI).

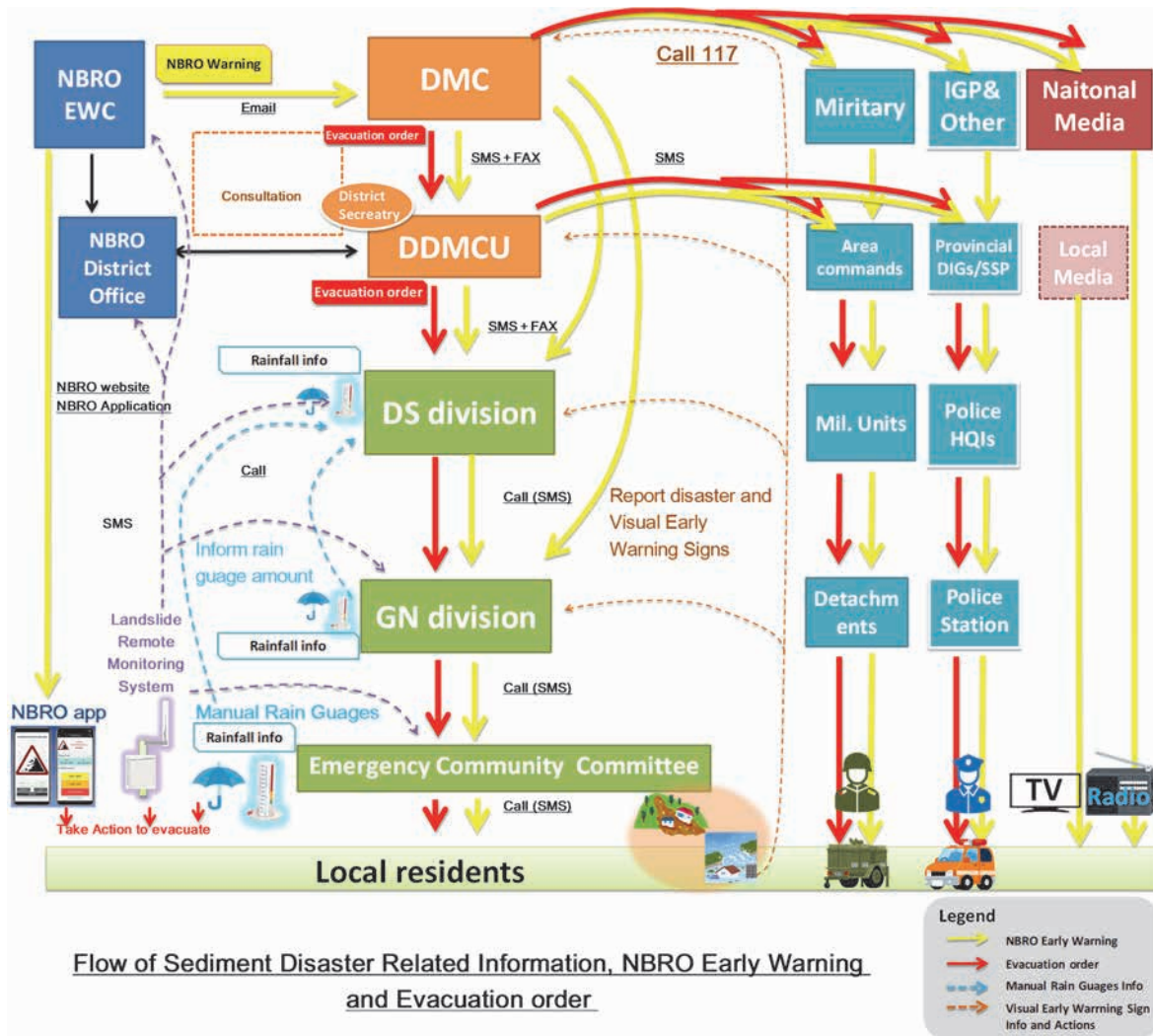


**Figure 4.2 Cause of Landslide and Soil Water Index**

After NBRO Early Warning EWC transmits the warning messages to Disaster Management Center (DMC), DMC is in charge of disseminating the NBRO warning to DDMCU at District Secretariat, DS division, GN

Division, and Emergency Community Committee as the flow shown in Figure 4.3 by SMS, mobile call or other methods.

According to National Emergency Operation Plan (NEOP) prepared by DMC, Secretary of Ministry of Disaster Management and District Secretary have an authority to issue evacuation orders. To make the decision for issuing evacuation orders, NBRO Head Office, NBRO District office, DMC, and DDMCU review not only NBRO Early Warning Levels below 3 but also the current rain gauge information, landslide reports, and residents call to 117. The local people living in Yellow/Red zones shall evacuate to safe places. The delivery of the evacuation order will follow the same routes.



**Figure 4.3 Dissemination flow of NBRO landslide early warning and evacuation order**

Although the direct Call/SMS comes to only focal people at respective level, the landslide warnings are also broadcasted by National and Local media such as TV and Radio and published on the NBRO websites (<https://www.nbro.gov.lk/index.php?lang=si>) and NBRO mobile application (Figure 4.4). Therefore, all residents can check the warning by themselves also.



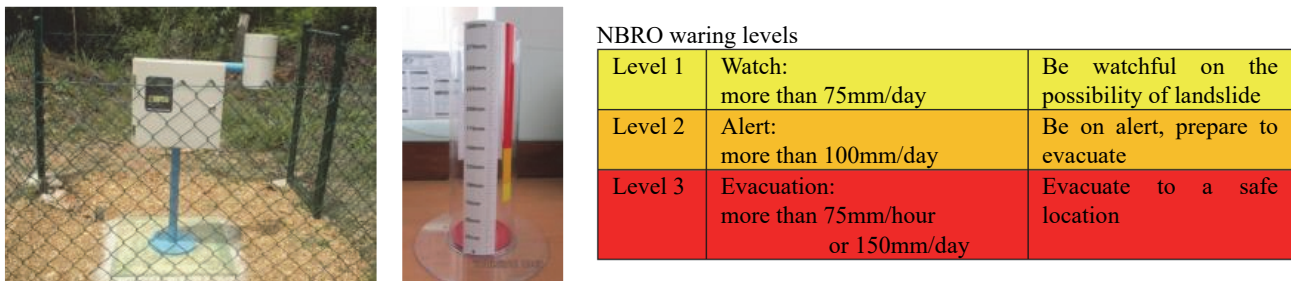


**Figure 4.4** Means to obtain NBRO early warning (NBRO EW App) and rainfall data (NBRO Website)

**b) Community-based early warning**

**– Manual rain gauges**

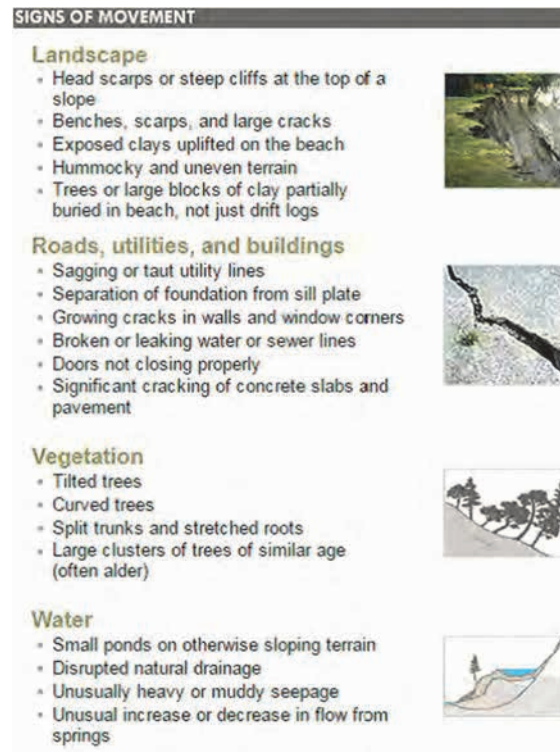
In addition to the automatic rain gauge network for nationwide warning, NBRO distributes manual rain gauges (Figure 4.5) at DS division level to vulnerable communities for community-based early warning. When considering the areas designated as hazard zone in the hazard maps, installing a simple rainfall observation system is effective to establish local evacuation warning system. If the amount of manual rain gauges exceeds NBRO early warning thresholds, those managers of manual rain gauges, ideally the member of Emergency Community Committee should inform DS and GN division as well as community residents and facilitate evacuation (blue lines in Figure 4.3). Through workshops and evacuation, drills coordinated by NBRO and DDMCU, rain gauges installation and its usage needs to be continuously promoted to community members. It is also crucial to check if the manual rain gauge is kept using by community occasionally.



**Figure 4.5** NBRO automated rain gauge (left) and manual rain gauge (mid) and NBRO warning levels (right)

**– Observing visual early warning signs**

Prior to sediment disasters, there are cases that minor premonitory phenomenon associated with ground deformation is observed. By detecting visual early warning signs at the early stage which is represented on the figure below, it is possible anticipate occurrence of sediment disasters beforehand and to earn a leading time to initiate actions for evacuation. Local Authorities (LA) and DS divisions should communicate with DDMCU to work together with NBRO to conduct educational activities for local residents regarding necessity of taking precautions on particular types of visual early warning signs in the area. Residents who observe these signs shall inform to GN Division, DS Division or DMC by calling Emergency Operation Centre on 117 (brown lines in Figure 4.3). When DDMCU, DS Divisions and GN Divisions receive information regarding the visual early warning sign, they need to take actions appropriately with the cooperation of NBRO.



**Figure 4.6 Signs of landslides**

#### 4.2.2 Delivering early warning and evacuation order to grass root

##### a) Delivering NBRO early warning

DDMCU is responsible to ensuring a communication route to deliver NBRO early warning to the community level (Yellow line in Figure 4.3). To deliver NBRO early warning to the grass root level, involvement of DS Division and GN Division are necessary; moreover, it is crucial to establish an Emergency Community Committee as a focal contact person to ensure delivering information to all local residents. Within the network of community message delivery system, involving a village community leader, religious priests, CBO and those assisting vulnerable people during evacuation etc. are recommended to function the communication system well. In addition, in case of black-outs or malfunction of telecommunication, not only utilizing calling or SMS but also utilizing a bell in a temple and megaphones, and visiting each house is also effective ways to deliver the early warnings. To determine the communication route, it is recommended to hold a community workshop by DDMCU as cooperation of motivated community members is vital for this system.

##### b) Delivering evacuation order

As described above, Secretary of Ministry of Disaster Management and District Secretary have an authority to issue evacuation orders. When evacuation order is issued, DDMCU and DS Division Secretary, GN Division, Emergency Community Committee members are responsible of delivering evaluation orders to local residents. This order should be delivered to community members with the same information channel as early warnings (Red line in Figure 4.3). In addition to the communication route, military or police will also visit the target evacuation area to facilitate the evacuation.

As a rule, the evacuation order will not be lifted without NBRO concern. Furthermore, even after cancelation

of NBRO landslide warnings, safety of residents needs to be confirmed by checking of visual signs of landslides with continuously observation. Moreover, Local Authority and GN should take into account the fact that evacuation is challenging for vulnerable groups within the warning zone. Establishing a supporting system for appropriate evacuation actions is necessary.

### 4.3 Awareness and utilization of early warnings and hazard maps

#### 4.3.1 Conducting awareness activities for sediment disaster risk, hazard maps, and NBRO early warning

##### a) Obtaining the hazard maps

DDMCU needs to let community members know about sediment disaster risk in the area. NBRO prepares regional landslide hazard maps as well as site specific hazard map and Yellow/Red zone. By collecting this information from NBRO, DDMCU and LA should notify hazard areas to community members. Hazard maps should be included in Local Sediment Disaster Risk Reduction Plan.

##### b) Conducting awareness activities

DDMCU conducts awareness activities (Figure 4.7) on landslide disaster risk by utilizing hazard maps, and NBRO early warnings. Community shall know location of risk areas and when and what kind of actions they need to take during heavy rains. If there is any site-specific equipment is installed, community needs to be aware about the importance of the equipment. Otherwise, the installed equipment will be neglected.



**Figure 4.7 Conducting awareness activities utilizing hazard maps**

##### c) Establishing emergency community committee

Through conducting awareness activities, DDMCU establishes Emergency Community Committee (ECC) as a focal point. The ECC will be in charge of disseminating NBRO early warning and evacuation order to the entire community, maintaining NBRO manual rain gauge and installed equipment to observe landslide block movement, and communicating DDMCU and NBRO to conduct awareness programs and evacuation drills etc. The members of committee shall be around five to six people including Chairman and Secretary. It is recommended to involve GN officer in the Emergency Community Committee so that sustainability of the Committee is ensured.

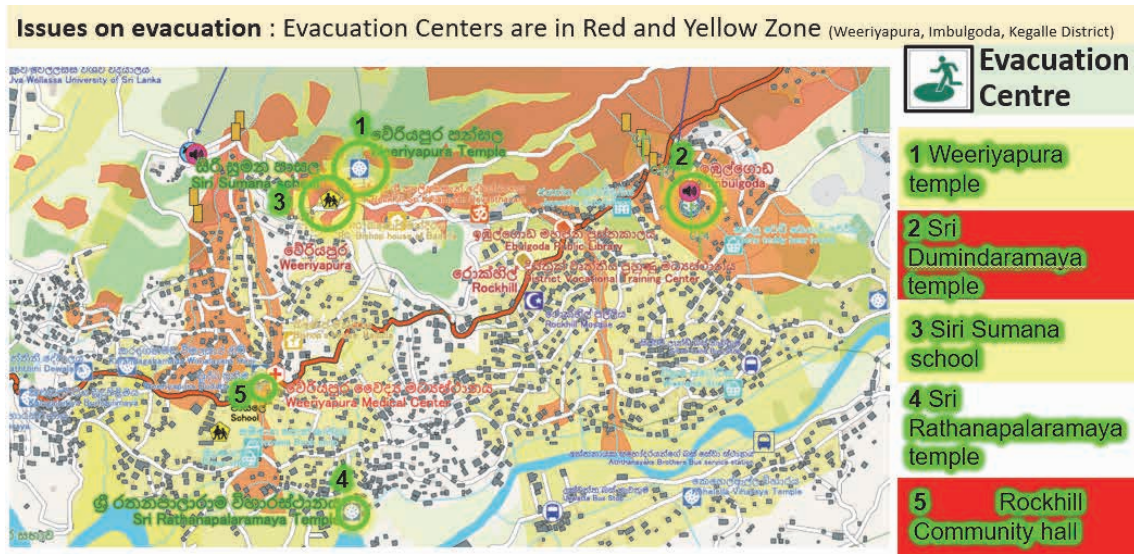
#### 4.3.2 Identifying evacuation routes, safe evacuation centres, and temporary camping sites

##### a) Securing appropriate evacuation routes, centres and temporary camping sites

Based on hazard maps, DDMCU shall analyze if the designated evacuation places and location of planned camping sites are in safe area (Figure 4.8). Based on the analysis, an evacuation map to instruct the evacuation routes and places shall be developed with the leadership of DDMCU. While developing the evacuation map,



participatory workshops with community members should be conducted with cooperation of NBRO and DDMCU to integrate opinions and experience of local residents.



**Figure 4.8 Example of evacuation centre in Yellow and Red Zone (Weeriyapura, Imbulgoda in Badulla District)**

Risk area of sediment disasters, evacuation centers/routes, and facilities used by vulnerable groups should be indicated on the map to utilize it as an evacuation map. In addition, the hazard maps and evacuation maps should be displayed at local community centers and schools so that community members can familiarize themselves with those maps on regular basis.

Two types of evacuation places need to be designated. The first is evacuation places where local residents can evacuate temporarily to secure safety during the heavy rainfall. The second is a temporary camping site where people who cannot go back to their houses stay for a longer period of time after disasters. Evacuation places and temporary camping sites need to be set up outside of Yellow/Red Zone as well as flood hazard zone in principle. In addition, since adverse weather is expected during evacuation, safety of evacuation routes needs to be confirmed beforehand. DDMCU should determine these places in evacuation plans with the cooperation of NBRO.

**b) Preparing evacuation centers and temporary camping sites**

It is necessary for DDMCU and community to prepare evacuation centers with sufficient facilities such as water, electricity, emergency medical kits and sanitary facilities, and temporary camping sites with security, privacy and lifeline facilities. It is crucial to decide an operation method for opening the temporary camping, in advance. DDMCU should establish a coordination system for opening and operating evacuation shelters with the coordination of ECC, Community Based Organization (CBO) and representatives of the community. During the preparation, the following chart indicates consideration points for evacuation centers and temporary camping sites for vulnerable groups. Moreover, it is recommended that each community member prepares an emergency backpack with necessary goods in case of urgent evacuation.

**c) Informing evacuation place and conducting evacuation drills**

LA and DS Division should ensure that designated evacuation places are available for residents to evacuate safely. It is crucial to inform these places to local residents before a disaster through awareness programs and

evacuation drills.

Evacuation drills coordinated with NBRO and DDMCU is an effective way to educate communities about local landslide risks as well as safe evacuation. Through evacuation drills, community members can learn a) list of belongings and essentials to be carried with, b) safety measures during travelling, c) the safest evacuation route, d) safe location of reach, and e) estimated travel time for escape.

## **Acknowledgment**

This work would not have been feasible without the assistance of our early warning team and the Japanese specialists mentioned below.

Early Warning Team of the National Building Research Organisation

Dr. K.P.G. Wasantha Senadeera

Mr. M.S.M. Aroos

Mr. R.M.S.A.K Rathnayake

Mr. D.M.L. Bandara

Japanese Expert Group

Dr. Tomoyuki Wada

Ms. Masae Kuroki

We would like to express my heartfelt gratitude to Eng. (Dr.) Asiri Karunawardena, Director General, Dr. H.A.G. Jayathissa, Director, Landslide and Risk Management Division, and Mr. Koike, Team Leader of Japanese expert team. We would also like to thank National Building Research Organisation and Japan International Cooperation Agency for supporting the Project.

- Appendix 1: Correlation analysis between rainfall and landslide occurrence to determine warning thresholds and critical lines**
- Appendix 2: Site-specific landslide warning threshold**
- Appendix 3: Tank model parameter calibration for SWI calculation**
- Appendix 4: Leaflet: landslide early warning (for awareness)**

## References

- Bandara, R. M. S. (2008). Landslide early warning in Sri Lanka. *In Regional seminar on experience of geotechnical investigations and mitigation for landslides, Bangkok, Thailand*, 13-14.
- Burt, T. P., and Weerasinghe, K. D. N. (2014). Rainfall Distributions in Sri Lanka in Time and Space: An Analysis Based on Daily Rainfall Data. *Climate*, **2**, 242-263.
- Gamage, H. G. C. P., Wada, T., Senadeera, K. P. G. W., Aroos, M. S. M., and Bandara, D. M. L. (2021). Rainfall Triggered Landslide Early Warning System Based on Soil Water Index. *Multi-Hazard Early Warning and Disaster Risks, Springer*, 529-542
- Kumara, G., Jayathissa, H., Nawagamuwa, U. (2018). Determination of Rainfall Thresholds for Landslides in Sri Lanka. *9th annual symposium, National Building Research Organisation*, 55-63.
- Rajapaksha, W. D. G. D. T., Wada, T., Jayathissa, H. A. G., Priyankara, N. H. (2019). Determination of thresholds based on rainfall indices for the occurrence of landslides in Kalu Ganga basin, Sri Lanka. *10th annual symposium, National Building Research Organisation*.
- Ishihara, Y., and Kobatake, S. (1979). Runoff model for flood forecasting. *Bulletin of the Disaster Prevention Research Institute, Kyoto Univ.*, **29(1)**, 27-43.
- JICA (2015). Data collection survey on disaster risk reduction sector in Sri Lanka: final report. *JICA*, (pp. 245)
- Kimura, T. and Yokoyama, N. (2006). Key Points in Field Work for Landslide Engineers No.8, 4.2 Monitoring of landslide movement and forecasting of slope failure occurrence, *Journal of the Japan Landslide Society*, **Vol. 43, No. 3**, 44-51. (in Japanese).
- McColl, M. T. (2015). Landslide Causes and Triggers. *Landslide Hazards, Risks and Disasters*, 17-42, ISBN 978-0-12-396452-6.
- Nishijima (1991). *Landslide Countermeasures in Emergency Situations. Ministry of Agriculture, Forestry and Fisheries Technical Review Committee, Japan* (in Japanese).
- Okada, K., Makihara, Y., Shimpo, A., Nagata, K., Kunitsugu, M. and Saito, K. (2001). Soil Water Index. *Tenki*, **48**, 349–356 (in Japanese).
- Sugawara, M. (1972). Rainfall–runoff analysis method. *Kyoritsu Publishing. Tokyo*, (in Japanese).
- Wieczorek, G. F. (1996). LANDSLIDES: INVESTIGATION AND MITIGATION. CHAPTER 4 - LANDSLIDE TRIGGERING MECHANISMS. *Transportation research board. National research council. Special report Washington: National academy Press*, **247**, 76-90.



## Appendix 1: Correlation analysis between rainfall and landslide occurrence to determine warning thresholds

### A1-1. Outline of correlation analysis between rainfall and landslide occurrence to determine warning thresholds and critical lines

Figure 1.1 shows overall procedures of rainfall-landslide correlation analysis to determine warning thresholds and critical lines for nationwide landslide warnings. Correlations between rainfall and landslide occurrence are analyzed by using statistical methods with hydrological models. Objectives of the rainfall-landslide correlation analysis are 1) clarify reasonable and effective rainfall indices for landslide early warning and 2) determine warning thresholds/critical lines (CLs) to issue landslide warnings.

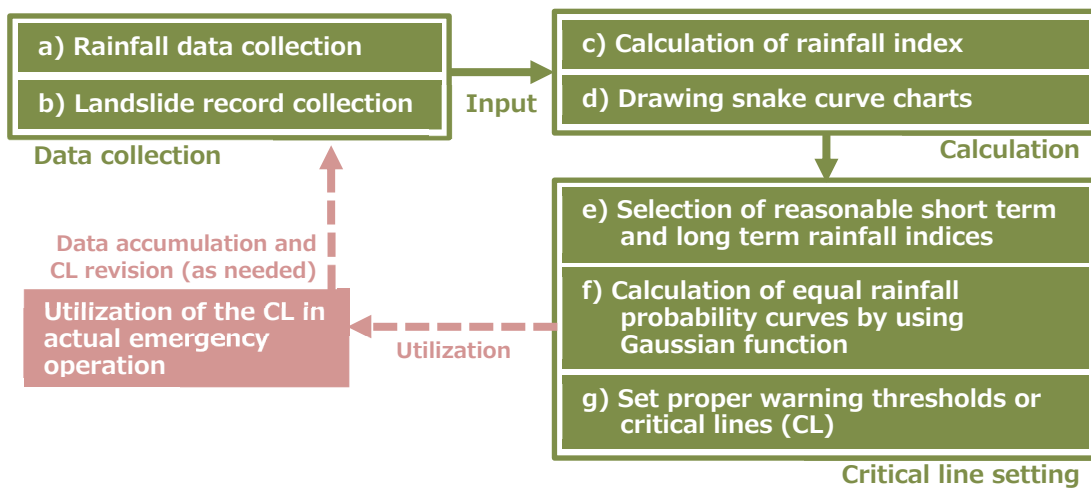


Figure 1.1 Procedures of rainfall-landslide correlation analysis

In order to achieve the objective, past observed rainfall and landslide records should be collected before starting the rainfall-landslide correlation analysis. Time series of rainfall indices are calculated from the collected rainfall time series data including rainfall events causing landslides as well as not causing landslides. The calculated rainfall indices and the landslide records are plotted together on snake curve and time series charts to identify correlations between the landslide occurrence and triggering rainfall. Snake curve charts are scatter line charts consisting of short term rainfall index axis (Y axis) and long term rainfall index axis (X axis). Based on the calculated results, most reasonable and effective short term and long term rainfall indices which clearly indicate differences of characteristics among rainfall events with/without landslides are able to be identified. Finally, CL is defined on a boundary of landslide occurrence and non-occurrence (Figure 1.2).

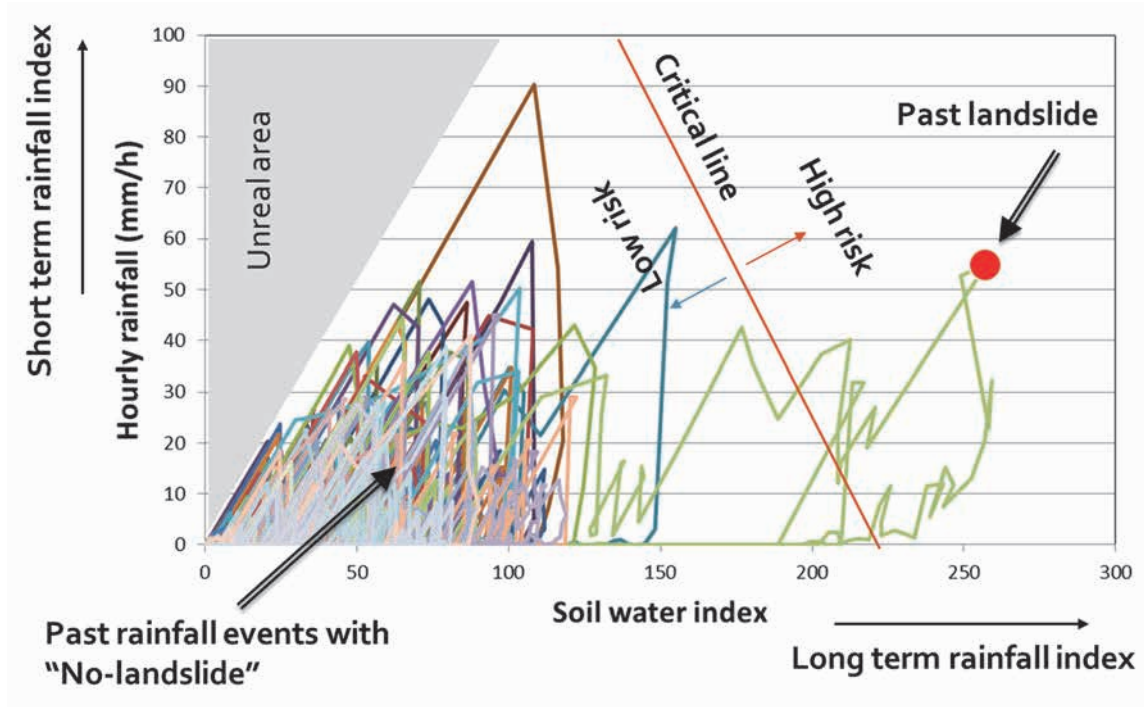


Figure 1.2 Sample of snake curve chart

## A1-2. Practical procedures of the analysis

Practical procedures of the landslide-rainfall correlation analysis by using the Excel analysis tool developed by the project are shown in this section.

### A1-2.1 Selection of rain gauges and rainfall data collection

Long time observed rainfall data including rainfall events with/without landslides should be collected for this analysis. Interval of rainfall observation must be less than one hour since a temporal rapid soil water increment is important to estimate landslide risks. Ideally, hourly or shorter observation interval rainfall time series in recent 20 years or more should be utilized for this analysis. However, 30 minutes rainfall data is available since 2014 only in Sri Lanka. Therefore, it is recommended to implement this analysis using the 30 minutes rainfall data which are available on the NBRO real-time rainfall monitoring system. Time series rainfall data should be collected during rainfall events causing landslides as well as not causing landslides and utilized to calculate rainfall indices.

### A1-2.2 Collecting past landslide records

Past landslide records (slides, debris flows, slope failures, cutting failures and rock falls) which occurred near the selected rain gauges are necessary for the analysis. The landslides located within 15 km and in the same catchment of the rain gauges are suitable for the analysis (Figure 2.1). In addition, it is ideal if landslides with similar geological and topographical conditions could be utilized for the analysis.

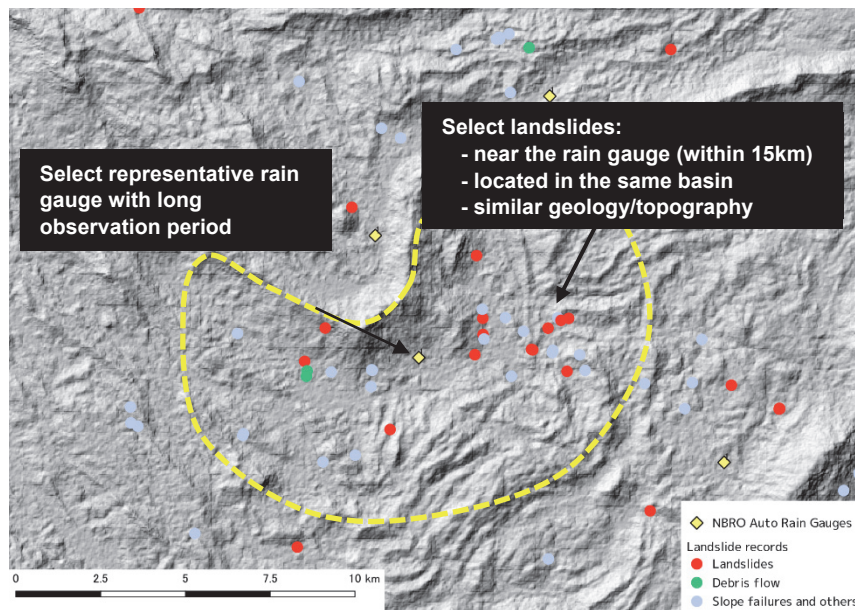


Figure 2.1 Rain gauges and landslides

### A1-2.3 Calculation of rainfall indices and drawing snake curve charts

After collecting rainfall data and landslide records, rainfall indices are calculated using the collected data. Detail of the rainfall indices (Soil Water Index: SWI and working rainfall) are explained in the section 2.3.1 of main text.

Practical procedure to calculate the rainfall indices by the Excel analysis tool developed by the project is shown below.

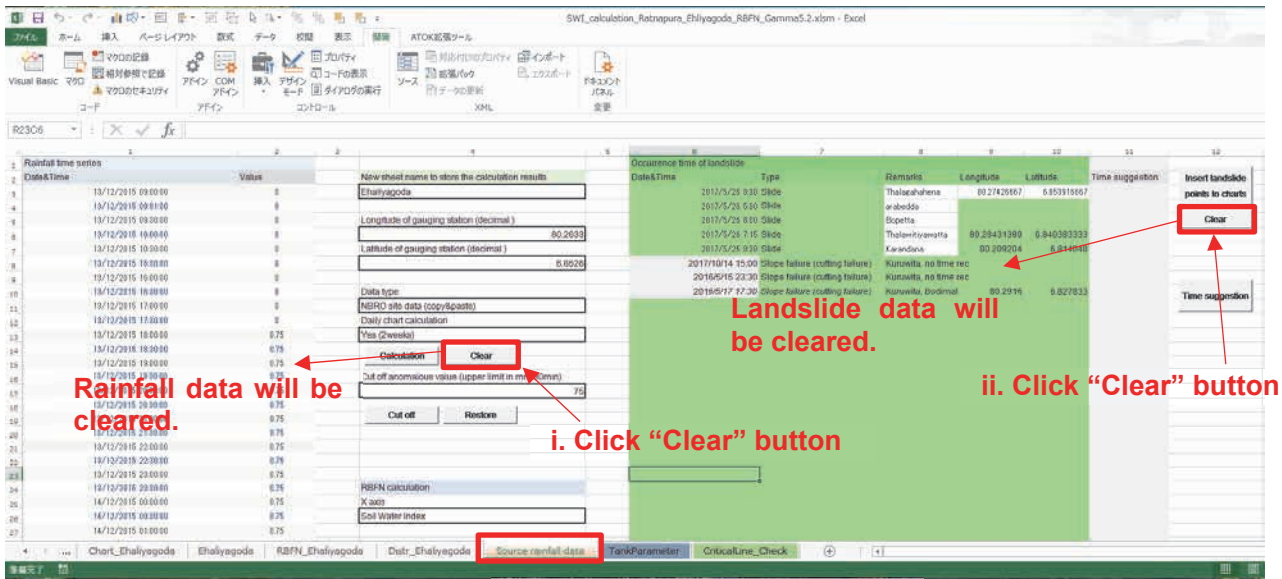
a) Clearing old input data and data sheets in the analysis tool (*if needed*)

Before starting this analysis, clear old input data and data sheets (Figure 2.2) if needed. In case users of the analysis tool continue the analysis using rainfall and landslide record data which had been inputted, users can skip this procedure.

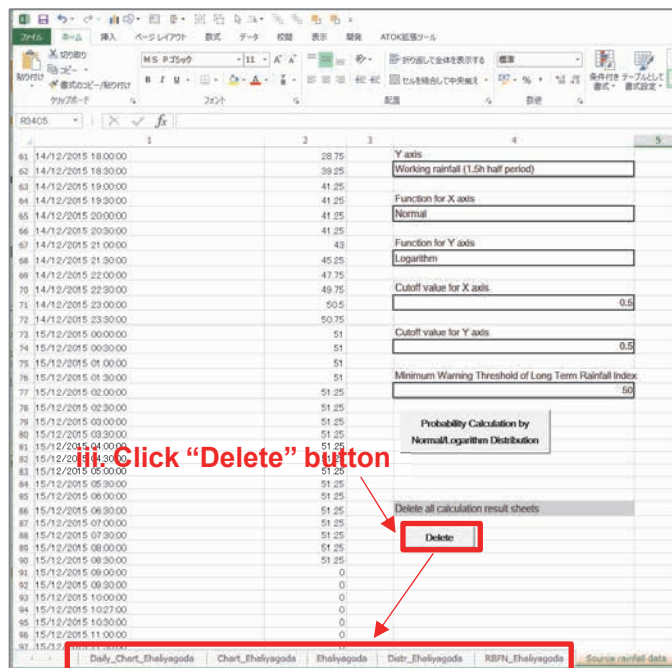
i. Clear rainfall time series data – Click “Clear” button located at the cell of (12, 4)

ii. Clear landslide records data – Click “Clear” button located at the cell of (5, 12)

iii. Delete worksheets of old calculation results – Click “Delete” button located at the cell of (88, 4)



“Source rainfall data” sheet



Worksheets of calculated results will be cleared.

Figure 2.2 Procedures to clear old input data and data sheets



b) Inputting rainfall time series data

At the first step of the analysis on the tool, the observed rainfall time series data and information of rainfall gauging station should be inputted into the “Source rainfall data” sheet of the analysis tool. The procedures are shown in Figure 2.3.

i. Input a name and longitude/latitude of the selected rainfall gauging station

ii. Input the observed 30 minutes rainfall time series data

iii. Select data type of rainfall time series

“30min NBRO site data (copy&paste type A)” : for 30min interval rainfall data of NBRO rainfall monitoring site

“30min NBRO site data (copy&paste type B)” : for 30min interval rainfall data of NBRO rainfall monitoring site (in case type A doesn’t work properly, please select “type B”)

“10min NBRO site data (copy&paste B&W)” : for 10min interval rainfall data of NBRO rainfall monitoring site

“Common 30min rainfall” : for normal 30 minutes rainfall time series data

“Common 1h rainfall” : for normal 1 hour rainfall time series data

iv. Select daily chart calculation type

Yes (1week): Snake curve charts and time series charts in the last 1 week will be drawn

Yes (2weeks): Snake curve charts and time series charts in the last 2 weeks will be drawn

No: No daily snake curve and time series charts will be drawn

**Copy and paste**

Station ID	Date & Time	rainfall (mm)
R52	02/04/2015 17:00:00	1.50
R52	02/04/2015 17:30:00	1.50
R52	02/04/2015 18:00:00	1.50
R52	02/04/2015 18:30:00	1.50
R52	02/04/2015 19:00:00	1.50
R52	02/04/2015 19:30:00	1.50
R52	02/04/2015 20:00:00	1.50
R52	02/04/2015 20:30:00	1.50
R52	02/04/2015 21:00:00	1.50
R52	02/04/2015 21:30:00	1.50
R52	02/04/2015 22:00:00	1.50
R52	02/04/2015 22:30:00	1.50
R52	02/04/2015 23:00:00	1.50
R52	02/04/2015 23:30:00	1.50
R52	03/04/2015 00:00:00	1.50
R52	03/04/2015 00:30:00	1.50
R52	03/04/2015 01:00:00	1.50
R52	03/04/2015 01:30:00	1.50
R52	03/04/2015 02:00:00	1.50

**ii. Input the observed rainfall time series data**

**i. Input name and longitude/latitude of gauging station**

**iii. Select data type**

**iv. Select daily chart calculation type**

**NBRO rainfall monitoring site** → **Excel analysis tool**

Figure 2.3 Procedures to input rainfall time series data





e) Calculation of rainfall indices

After completing data input, start calculation by clicking “Calculation” button in “Source rainfall data” sheet (Figure 2.6).

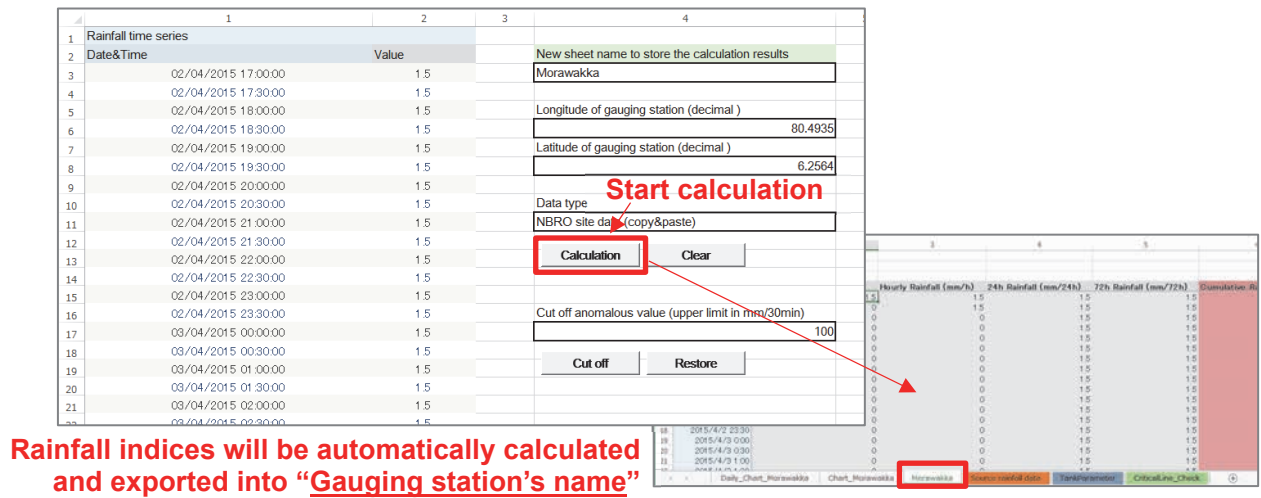


Figure 2.6 Procedures to start calculation of rainfall indices

f) Drawing charts

- Time series charts and snake curve charts

Time series charts and snake curve charts are automatically exported into the “Chart\_gauging station’s name” sheet. There are five time series charts and 35 snake curve charts in which plotted rainfall indices are different (Figure 2.7). Characteristics of a correlation between rainfall and landslides can be studied using the charts.

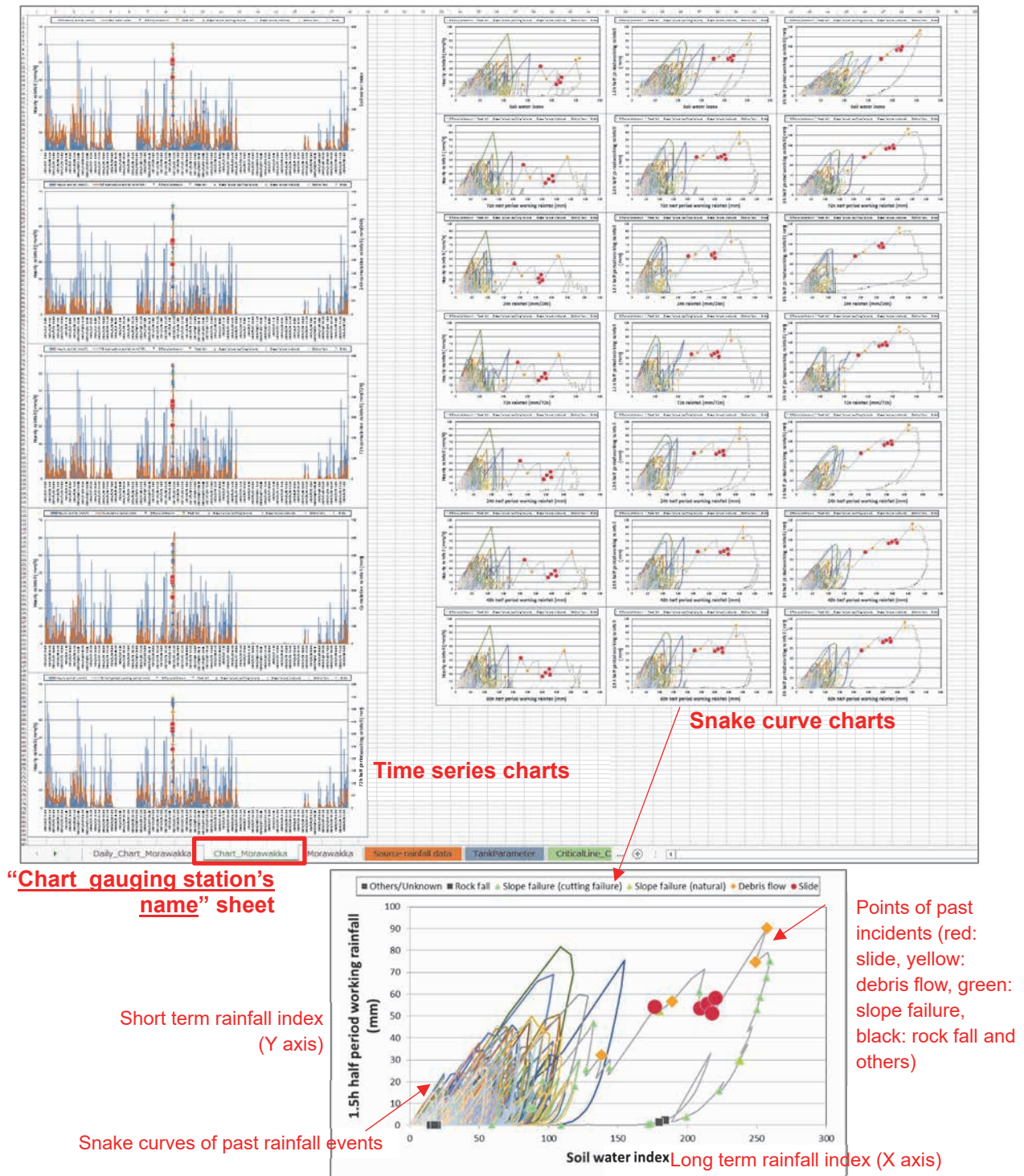
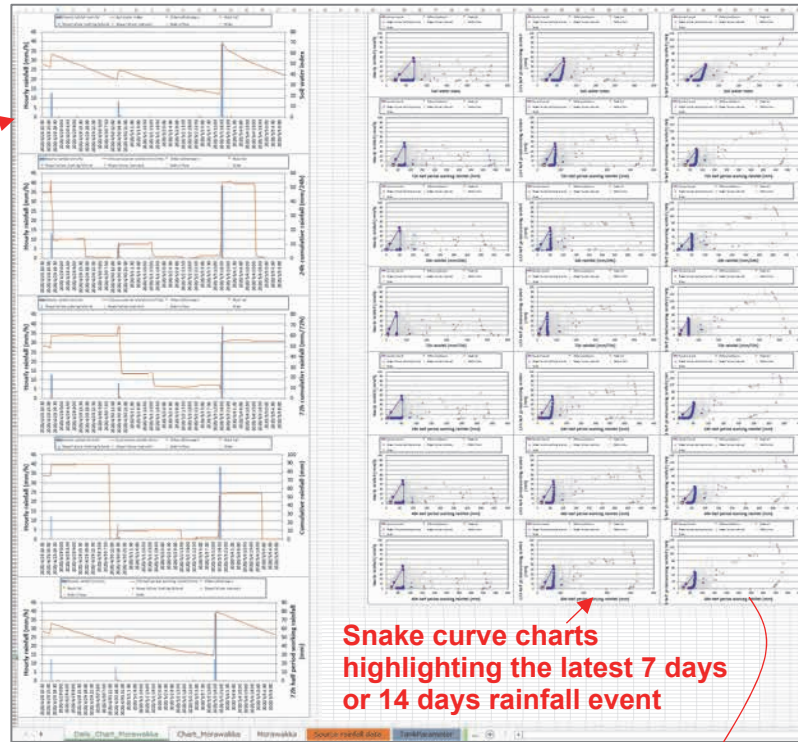


Figure 2.7 Time series charts and snake curve charts

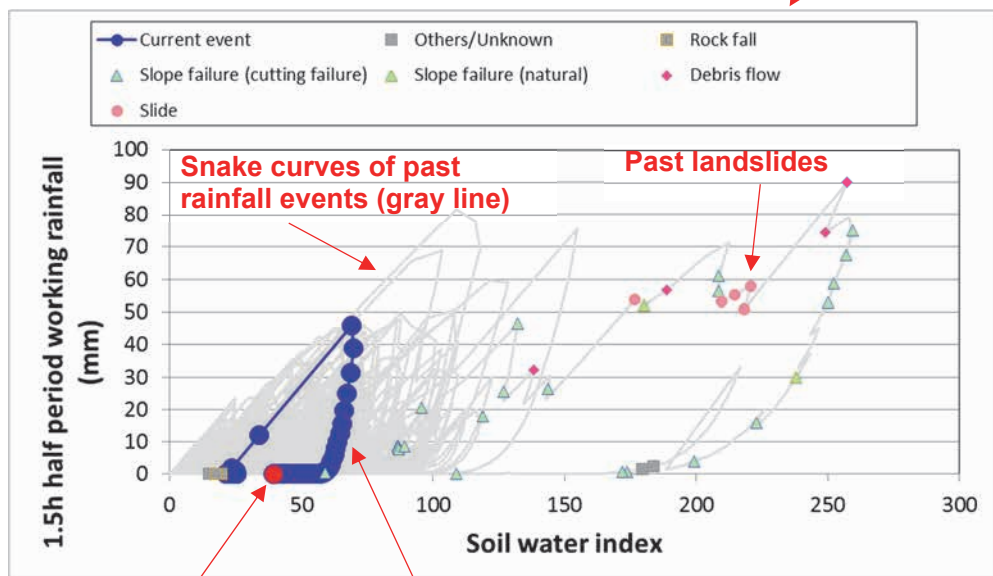
– Daily charts (*in case that the option to calculate the daily charts was selected*)

The “Daily\_Chart\_gauging station’s name” sheet includes time series charts and snake curve charts in past one or two weeks highlighting a current rainfall event (Figure 2.8). Users of the analysis tool can see current condition of rainfall amount from the charts.

Time series charts in the latest 7 days or 14 days



Snake curve charts highlighting the latest 7 days or 14 days rainfall event



Current (latest) rainfall index value (red point)

Snake curve of the latest 7 days or 14 days rainfall event (blue line and points)

Figure 2.8 Daily charts of snake curves and rainfall time series

– Cutting off anomalous value (*if needed*)

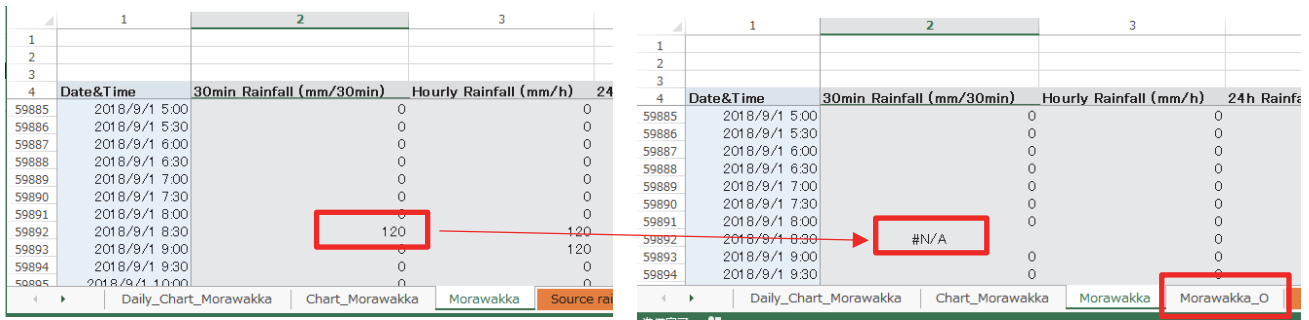
In some case, abnormally high rainfall amounts are recorded by the rainfall monitoring system due to data errors or troubles of rainfall gauges. Users of the analysis tool can remove some unrealistic rainfall data exceeding an arbitrary value. The procedures are shown in Figure 2.9 and Figure 2.10.

- i. Check abnormal rainfall value
- ii. Input maximum rainfall value
- iii. Re-calculate rainfall indices



Figure 2.9 Procedures to cut off anomalous value





Then, the rainfall indices will be re-calculated without the abnormal values. The charts will be updated, too.

Old data sheets of rainfall indices is renamed as **“Gauging station’s name O”**.

If users want to restore the old (original) rainfall data without cutting off the abnormal data, click **“Restore”** button in the **“Source rainfall data”**

Figure 2.10 An example of re-calculation

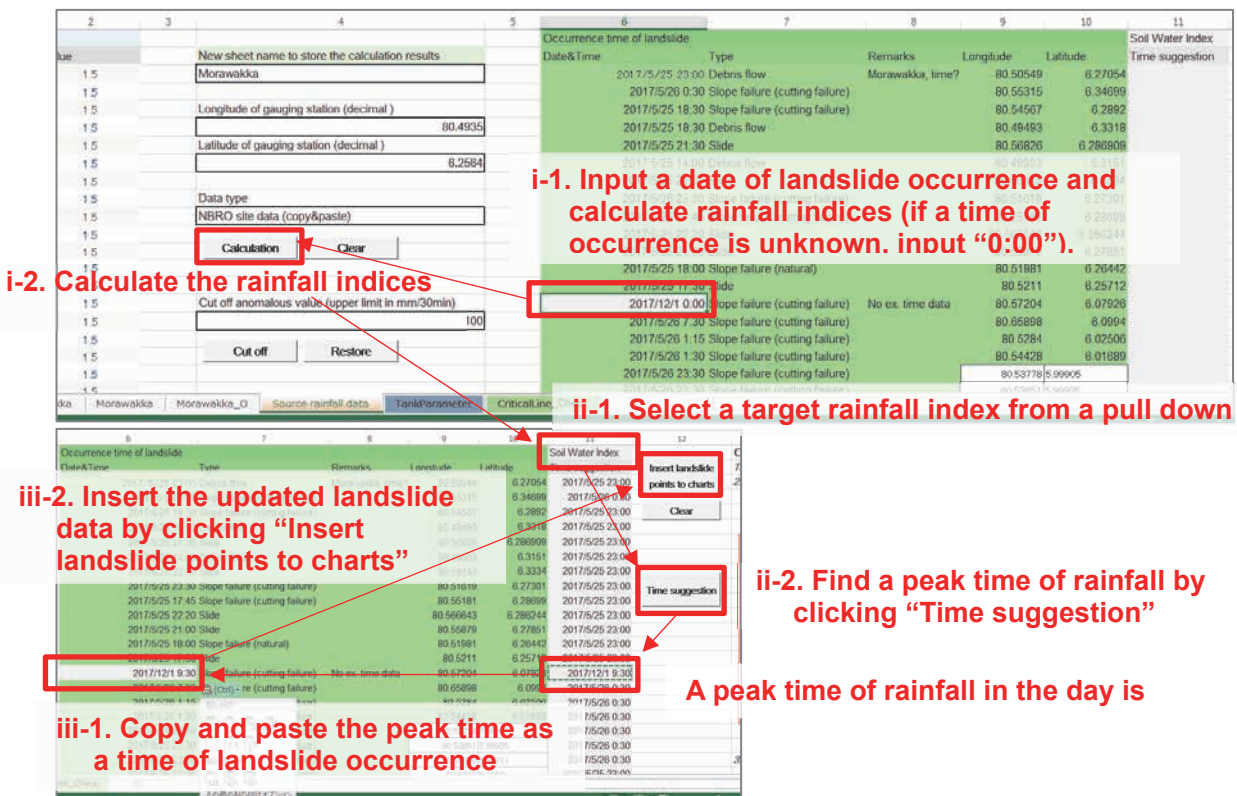
– Estimation of unknown landslide occurrence time (*if needed*)

In case that a time of landslide occurrence is not recorded but date of occurrence is known, users of the analysis tool can estimate the occurrence time as a peak time of rainfall in the day. The procedures are shown in Figure 2.11.

i. Input a date of landslide occurrence and calculate rainfall indices

ii. Select a target rainfall index and find peak time of rainfall

iii. Insert the updated landslide occurrence data into the snake curve and time series charts



i-1. Input a date of landslide occurrence and calculate rainfall indices (if a time of occurrence is unknown, input **“0:00”**).

i-2. Calculate the rainfall indices

ii-1. Select a target rainfall index from a pull down

iii-2. Insert the updated landslide data by clicking **“Insert landslide points to charts”**

ii-2. Find a peak time of rainfall by clicking **“Time suggestion”**

iii-1. Copy and paste the peak time as a time of landslide occurrence

A peak time of rainfall in the day is

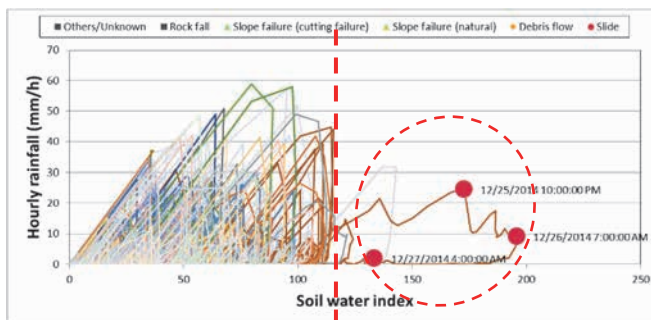
Figure 2.11 Procedures to estimate unknown landslide occurrence time

### A1-2.4 Selection of rainfall indices (*if needed*)

Most reasonable short term and long term rainfall indices should be selected by comparing snake curve charts. It is recommended to select “one” specific pair of short term and long term rainfall indices for landslide warnings in Sri Lanka. Because it is confusing if different rainfall indices are utilized in different region in spite of one country. The regional characteristics of landslides should be considered when CLs and warning thresholds would be determined for each region.

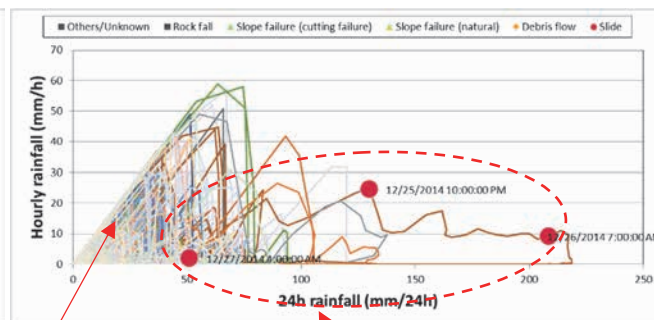
Key point to select rainfall indices is whether the rainfall indices can clearly separate cases of rainfall which cause landslide or not. An example of comparison on rainfall indices is shown in Figure 2.12. The chart of “A) 1h rainfall and SWI” clearly separates landslides and no-landslide rainfall events, but the boundary of landslide occurrence and non-occurrence is unclear on the chart of “B) hourly rainfall and 24 hours rainfall”. Therefore, it can be judged that the pair of 1h rainfall and SWI is reasonable for landslide risk prediction through rainfall monitoring.

**A) Short term rainfall index: hourly rainfall  
 Long term rainfall index: Soil Water Index (SWI)**



Rainfall events with “no landslides” | A rainfall event caused landslides  
**Clearly separated**

**B) Short term rainfall index: hourly rainfall  
 Long term rainfall index: 24 hours rainfall**



Rainfall events with “no landslides” | A rainfall event caused landslides  
**Not clearly separated**

Figure 2.12 Comparison of rainfall indices on snake curve charts



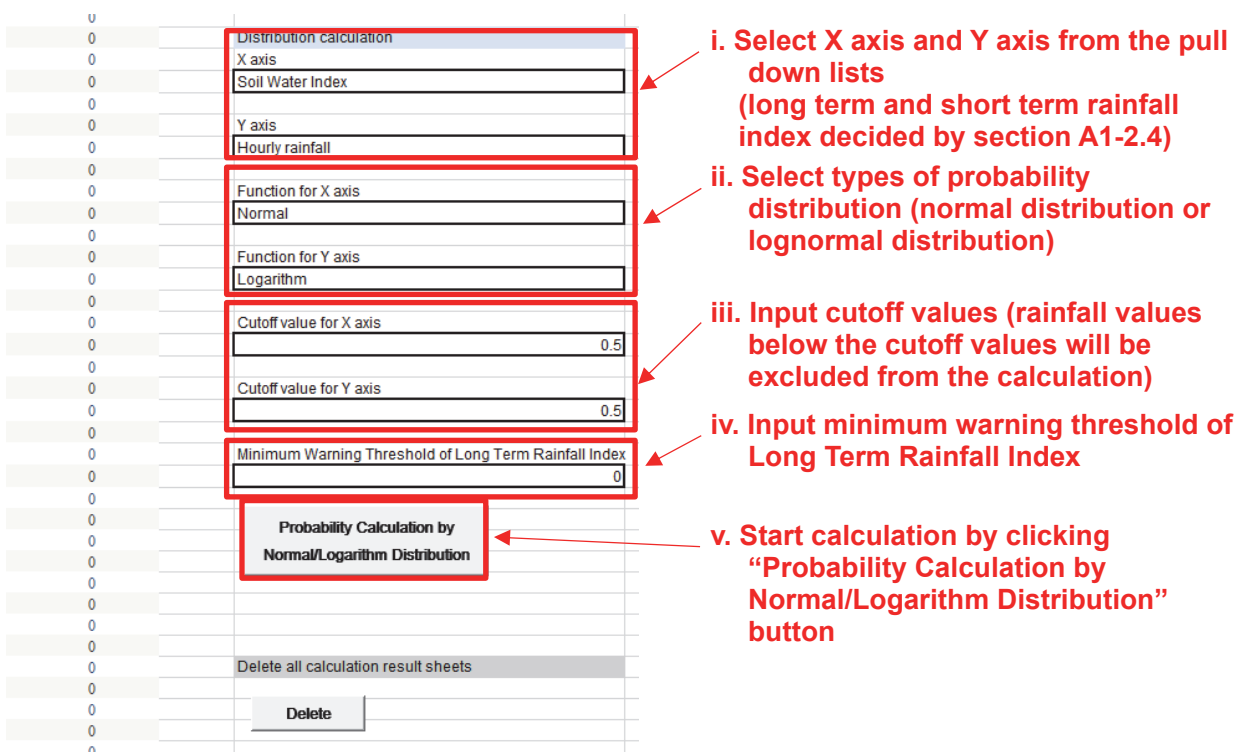
### A1-2.5 Calculation of equal probability curves by using Gaussian probability density function

In order to determine critical lines, equal probability curves of rainfall events are useful standards. It is assumed that landslides are caused by rainfall events of which occurrence probability is lower than a specific threshold. Thus, an equal rainfall probability curve which separates rainfall events causing landslides and no-landslides is estimated as a critical line.

Users of the analysis tool can draw equal probability curves ( $p = 0.005, 0.01, 0.02, 0.04, 0.04$ ) on the snake curve charts by using Gaussian probability density function and/or lognormal probability density function. Rainfall records smaller than cutoff value and rainfall events which caused landslides are excluded to calculate the probability curves. The procedures are shown in Figure 2.13.

\* before starting these procedures, rainfall indices must be calculated by A1-2.3.

- i. Select X axis (long term rainfall index) and Y axis (short term rainfall index)
- ii. Select types of probability distribution (normal distribution or lognormal distribution)
- iii. Input cutoff values (rainfall values below the cutoff values will be excluded from the calculation)
- iv. Input minimum warning threshold of long term rainfall Index (no landslide may occur below this value)
- v. Start calculation



The screenshot shows a software interface with the following components:

- Distribution calculation:** A dropdown menu for 'X axis' (set to 'Soil Water Index') and a dropdown menu for 'Y axis' (set to 'Hourly rainfall').
- Function for X axis:** A dropdown menu set to 'Normal'.
- Function for Y axis:** A dropdown menu set to 'Logarithm'.
- Cutoff value for X axis:** An input field containing '0.5'.
- Cutoff value for Y axis:** An input field containing '0.5'.
- Minimum Warning Threshold of Long Term Rainfall Index:** An input field containing '0'.
- Probability Calculation by Normal/Logarithm Distribution:** A button to initiate the calculation.
- Delete all calculation result sheets:** A button to clear results.
- Delete:** A button to delete the current sheet.

Red arrows point from the numbered instructions to these elements:

- i. Select X axis and Y axis from the pull down lists (long term and short term rainfall index decided by section A1-2.4)** points to the X and Y axis dropdowns.
- ii. Select types of probability distribution (normal distribution or lognormal distribution)** points to the function dropdowns.
- iii. Input cutoff values (rainfall values below the cutoff values will be excluded from the calculation)** points to the cutoff value input fields.
- iv. Input minimum warning threshold of Long Term Rainfall Index** points to the minimum warning threshold input field.
- v. Start calculation by clicking "Probability Calculation by Normal/Logarithm Distribution" button** points to the calculation button.

Figure 2.13 Procedures to calculate equal probability curves

Then, snake curve charts with equal probability curves of rainfall events are exported in the “Distr\_Gaugings station’s name” sheet. Examples of the exported charts are shown in Figure 2.14.



### A1-2.6 Determination of critical lines / warning thresholds

– Selection of candidate CLs at a target region

Based on the calculated results, critical lines / warning thresholds should be determined. The critical lines / warning thresholds are estimated as the boundary between severe rainfall causing landslides and small rainfall not causing disasters. Figure 2.15 shows an example of a snake curve chart with equal rainfall probability curves of rainfall events. The thin lines in the chart are the snake curves of the past rainfall events. The thick lines are the equal probability curves (purple:  $p=0.005$ , red-purple:  $p=0.01$ , orange-red:  $p=0.02$ , orange:  $p=0.03$ , yellow:  $p=0.04$ ). Points in the chart are the past occurrence records of landslides, debris flows, slope failures and cutting failures. Those incidents are often caused by severe rainfall events exceeding the probability line of  $p=0.005$ . However, cutting failures and rock falls occurred even if rainfall amount is less; in other words, there is no incident in the most cases of minor rainfall events but a few cases cause cutting failures and rock falls. This result indicates that the equal probability line of  $p=0.005$  is assumed as a boundary of landslides and debris flows, but it is difficult to separate rainfall events causing cutting failures and rock falls and not causing incidents.

As stated above, candidate CLs should be selected by studying the correlation between rainfall and landslide occurrence. Then, a CL at a target region should be finally determined by evaluating the CL through procedures mentioned in the next section.

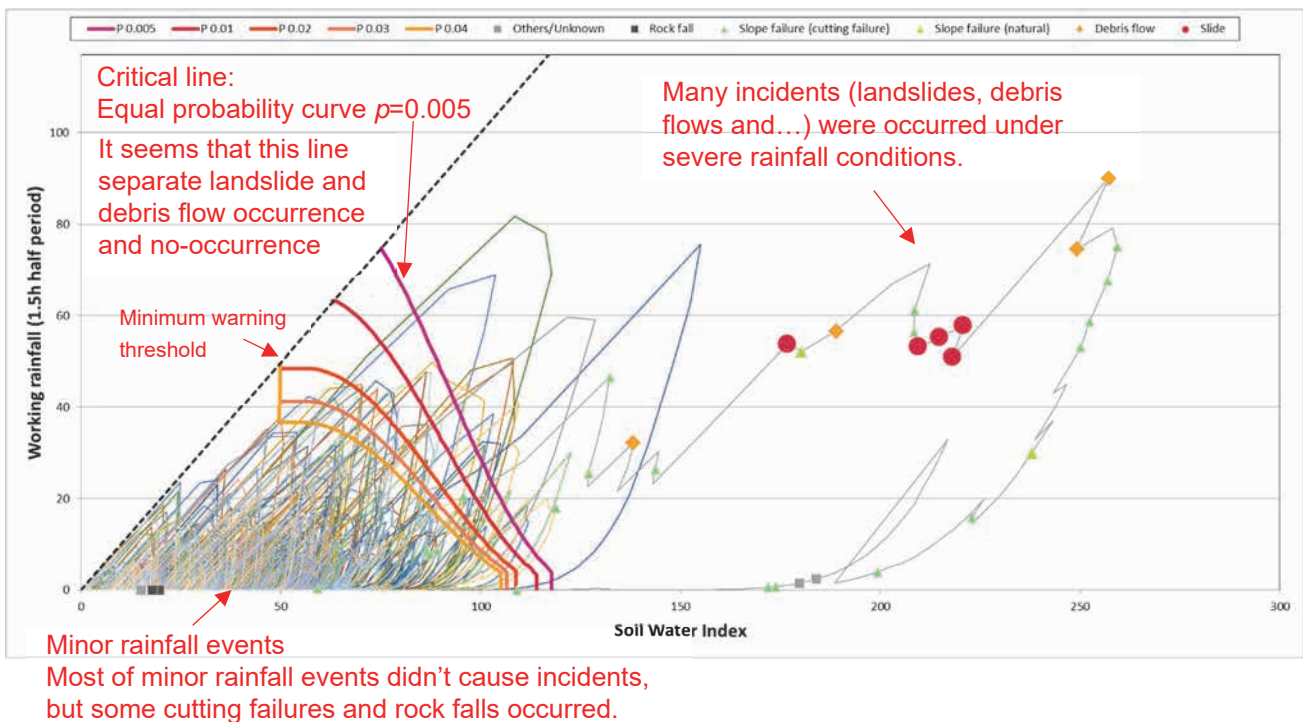


Figure 2.15 An example of a snake curve chart and a CL

(red points: landslide, yellow points: debris flow, green points: slope failure and cutting failure, black points: rock fall and others)

– Determine proper warning thresholds or critical lines (CL)

To select the best CL, predictive ratio can be calculated by the analysis tool to evaluate the accuracy of the CL (Figure 2.16). Procedures are shown in Figure 2.16.

\* before starting these procedures, rainfall indices and probability curves must be calculated by A1-2.3 and A1-2.5

i. Select an equal probability curve or a warning threshold to be evaluated

ii. Calculate predictive ratio

iii. Define CL considering the “Miss shot”, “Air shot” ratio and lead time (2-3 hours)

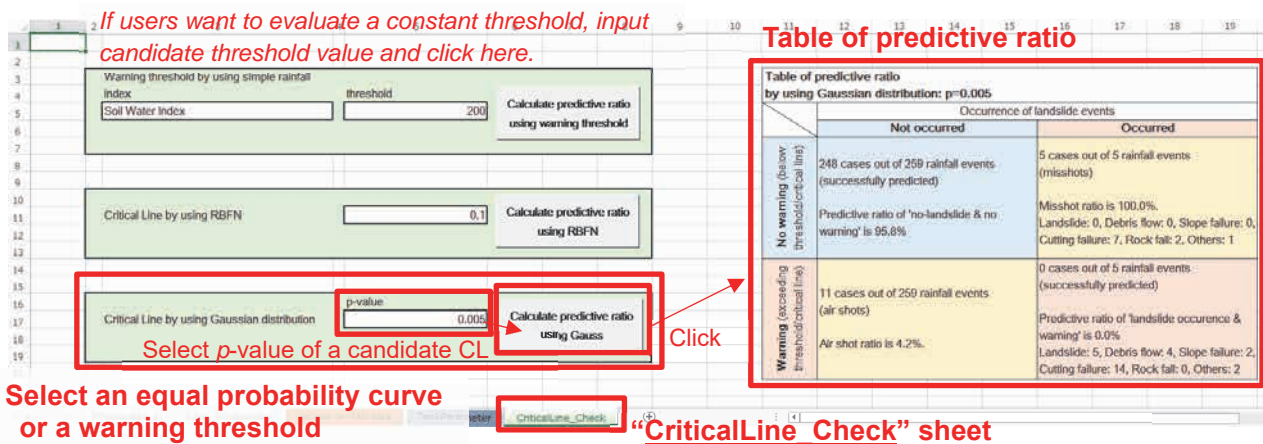


Figure 2.16 Procedures to evaluate accuracy of CL

Examples of the evaluation of CL is shown in Figure 2.17. The information shown in the column of “Not Occurred” and the row of “No Warning” is the ratio and the number of rainfall events which didn’t cause landslides and was below the selected CL. Conversely, the ratio and the number of rainfall events which didn’t cause landslides but exceeded the selected CL are shown in the column of “Not Occurred” and the row of “Warning”. If this ratio is high, the number of “air shot” warning is large. The number and ratio of “miss shot” (landslides occurred but rainfall didn’t exceed the selected CL) is shown in the column of “Occurred” and the row of “No Warning”. The ratio and number of successfully predicted (landslides occurred and rainfall exceeded the selected CL) are shown in the column of “Occurred” and the row of “Warning”.

The most important ratio is the “Miss shot” ratio. If the “Miss shot” ratio is high, it is recommended to reduce the values of CL to catch more rainfall events causing landslides. On the other hand, the ratio of “Air shot” increases if the values of CL is reduced. The best CL which has low “Miss shot” and low “Air shot” ratios should be selected by trying different CLs. Moreover, lead time for dissemination of the warning to grass-root level and evacuation is also necessary to be considered. CLs should be determined so that NBRO can issue warning ca. 2-3 hours before landslide occurrences.

In case of the example shown in Figure 2.17, all of past landslides and cutting failures, which are shown in the red and green points, are able to be captured by the equal probability curve of  $p=0.005$ . However, the “Air shot” ratio is 5.8%. On the other hand, the constant threshold of  $SWI=250$  catches all landslides and no “Air shot”, but cutting failures are missed. If the cutting failures are excluded from the target of the warnings, the “Miss shot”

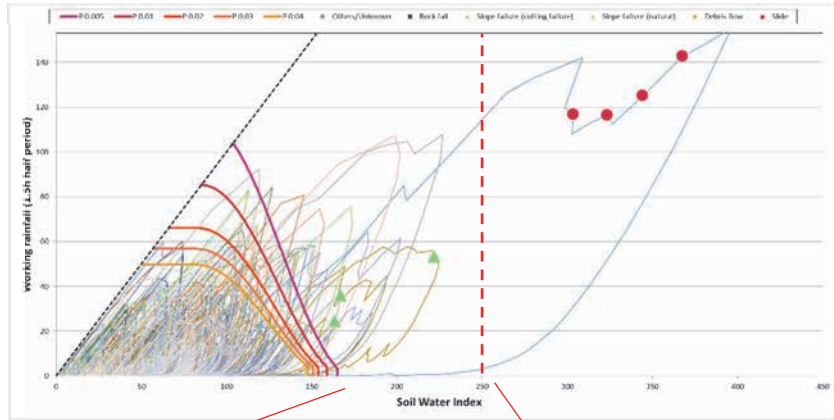
and “Air shot” ratio of SWI=250 is the best. However, no enough lead time is secured; landslides occurred 1.5 hour after SWI exceeded 250. Moreover, there are possibilities that landslides are caused by smaller rainfall events because accumulation of past landslide records and observed rainfall data is not enough; more than 20 years data accumulation is necessary for highly accurate analysis. Therefore, it is recommended to use the he equal probability curve of  $p=0.005$  as the CL in this case, considering safety margin and lead time.

Figure 2.17 Evaluation of critical line (CL)

Snake curve (upper right)

Predictive ratio in case that a CL is defined as equal probability curve of  $p=0.005$  (lower left)

Predictive ratio in case that a CL is defined as an exact value of SWI=250 (lower right)



A case of  $p=0.005$

A case of SWI=250

Table of predictive ratio by using Gaussian distribution: $p=0.005$		Table of predictive ratio Rainfall Index: Soil Water Index, Threshold: 250			
	Occurrence of landslide events			Occurrence of landslide events	
	Not occurred	Occurred		Not occurred	Occurred
<b>No warning</b> (below threshold/critical line)	227 cases out of 241 rainfall events (successfully predicted) Predictive ratio of 'no-landslide & no warning' is 94.2%	0 cases out of 3 rainfall events (misshots) Missshot ratio is 0.0%. Landslide: 0, Debris flow: 0, Slope failure: 0, Cutting failure: 0, Rock fall: 0, Others: 0	<b>No warning</b> (below threshold/critical line)	241 cases out of 241 rainfall events (successfully predicted) Predictive ratio of 'no-landslide & no warning' is 100.0%	2 cases out of 3 rainfall events (misshots) Missshot ratio is 66.7%. Landslide: 0, Debris flow: 0, Slope failure: 0, Cutting failure: 3, Rock fall: 0, Others: 0
<b>Warning</b> (exceeding threshold/critical line)	14 cases out of 241 rainfall events (air shots) Air shot ratio is 5.8%.	3 cases out of 3 rainfall events (successfully predicted) Predictive ratio of 'landslide occurrence & warning' is 100.0%. Landslide: 4, Debris flow: 0, Slope failure: 0, Cutting failure: 3, Rock fall: 0, Others: 0	<b>Warning</b> (exceeding threshold/critical line)	0 cases out of 241 rainfall events (air shots) Air shot ratio is 0.0%.	1 cases out of 3 rainfall events (successfully predicted) Predictive ratio of 'landslide occurrence & warning' is 33.3%. Landslide: 4, Debris flow: 0, Slope failure: 0, Cutting failure: 0, Rock fall: 0, Others: 0

Considering the “Miss shot” and “Air shot” ratio, the critical lines / warning thresholds should be finally determined in the target region. Furthermore, critical lines / warning thresholds for other regions should be determine through the same procedure by using rainfall and landslide data at other rainfall gauging stations.



### A1-2.7 Calculation of cumulative rainfall and study on thresholds (if needed)

For further analysis, cumulative rainfall, duration of rainfall can be plotted on charts (hourly and daily) with past landslides by the analysis tool.

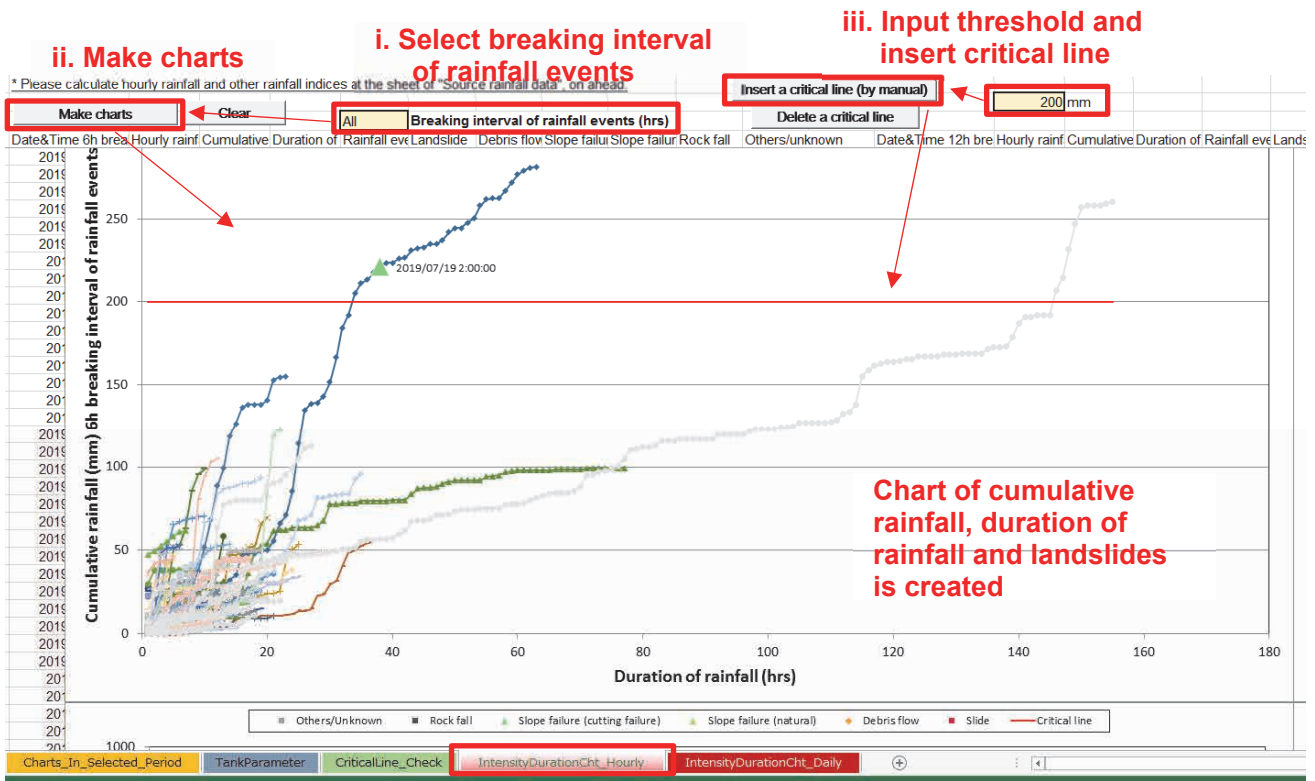
– Hourly cumulative rainfall

\* before starting these procedures, rainfall indices must be calculated by A1-2.3.

i. Select breaking interval of rainfall events (hrs)

ii. Make charts (Figure 2.18)

iii. Insert critical line



“IntensityDurationCht\_Hourly” sheet

Figure 2.18 Chart of cumulative rainfall, duration of rainfall and landslides (hourly)



– Daily cumulative rainfall

i. Input daily rainfall data

ii. Input date and time of landslides

iii. Make charts (Figure 2.19)

iv. Insert critical line

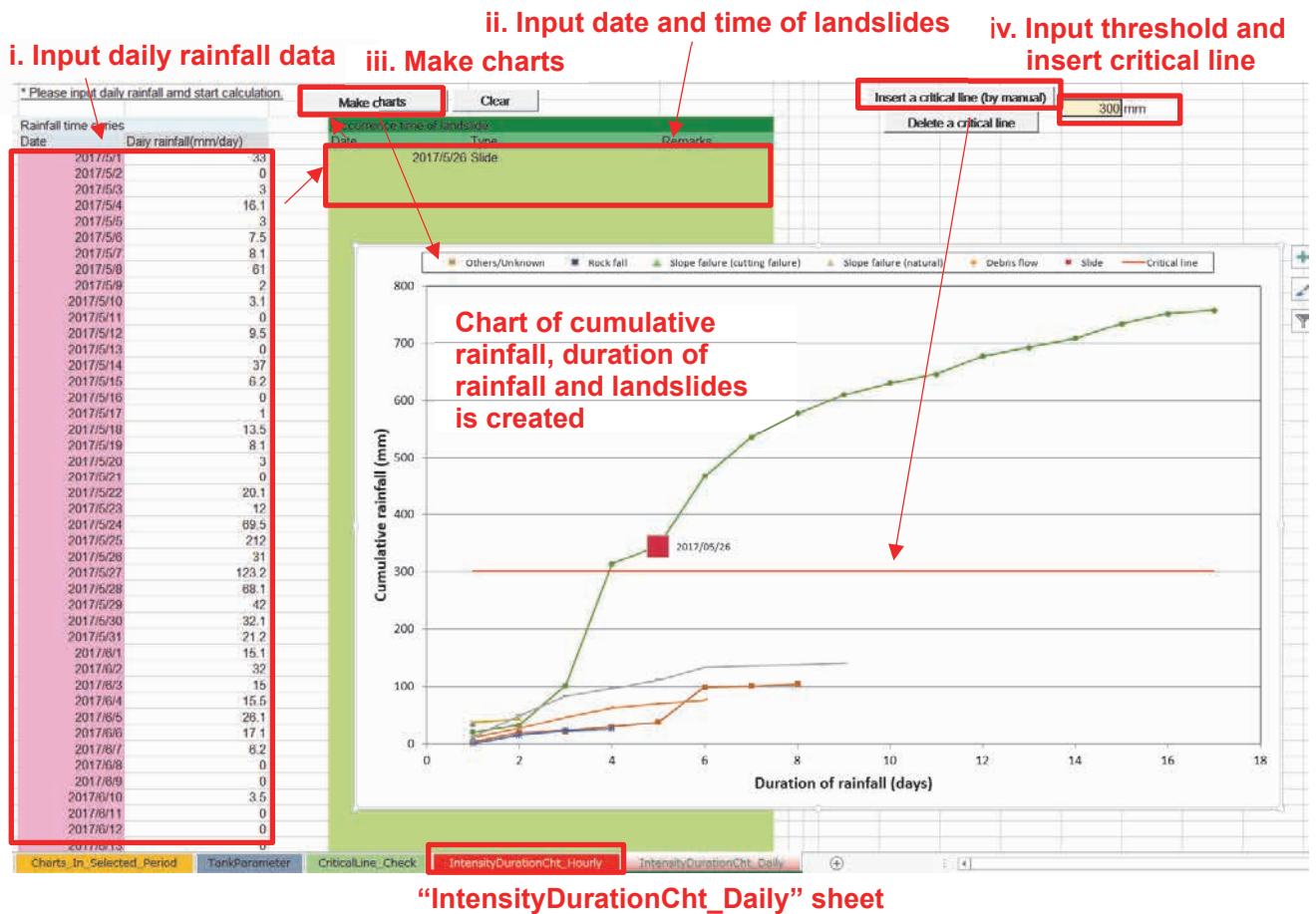


Figure 2.19 Chart of cumulative rainfall, duration of rainfall and landslides (daily)

### A1-2.8 Review of actual landslides and early warning

After actual landslides are caused by heavy rainfall, it is recommended to compare actual date and time of landslide occurrence and issued warnings in order to improve early warning.

\* before starting these procedures, rainfall indices must be calculated by A1-2.3.

i. Input actual date and time of landslide warning

ii. Select date and duration of charts

iii. Make charts

Figure 2.20 shows an example of comparison chart between actual landslide early warning and disasters. In this case, level 3 landslide early warning was successfully issued five hours before the disaster. If the lead time of early warnings was not enough, NBRO revises the warning thresholds and critical lines.

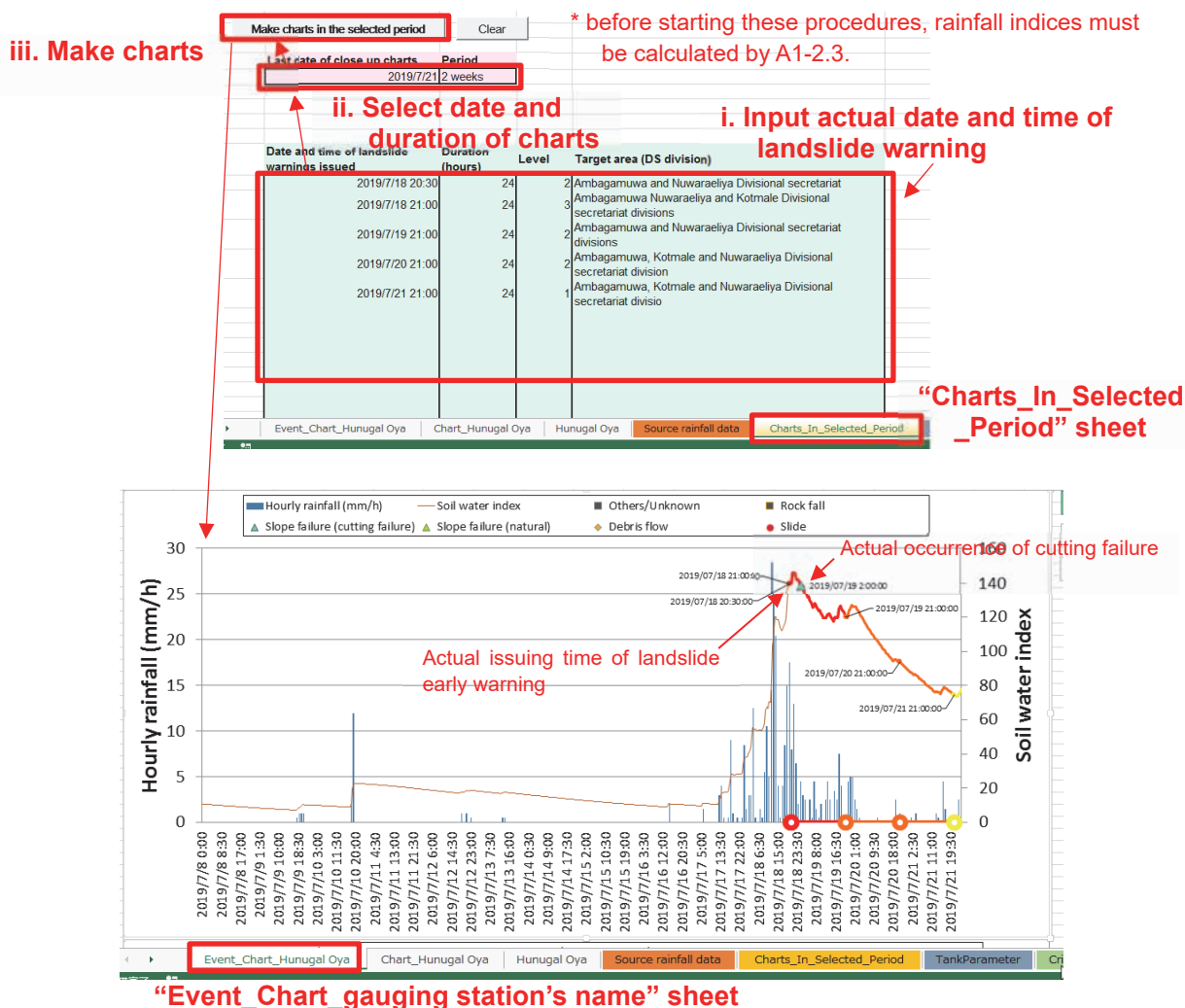


Figure 2.20 An example of comparison chart between actual landslide early warning and disasters

### A1-3. Summary of the analysis tool

The Excel analysis tool developed by the project consists of the worksheets listed in Table 3.1.

Table 3.1 Worksheets of the Excel analysis tool

Name of worksheets	Screenshots of worksheets																																																																																																																																																																																																								
<p>“Source rainfall data” sheet: main controller of the analysis tool</p> <ul style="list-style-type: none"> <li>- Input forms of rainfall and landslide data</li> <li>- Starting calculation and drawing charts</li> </ul>																																																																																																																																																																																																									
<p>“TankParameter” sheet</p> <ul style="list-style-type: none"> <li>- Inputting tank model parameters</li> </ul>																																																																																																																																																																																																									
<p>“Gauging station’s name” sheet: calculation results</p> <ul style="list-style-type: none"> <li>- Calculated results of rainfall indices</li> <li>* This worksheet is created after the calculation</li> </ul>	<table border="1"> <thead> <tr> <th>Date&amp;Time</th> <th>24h Rainfall (mm/24h)</th> <th>72h Rainfall (mm/72h)</th> <th>Cumulative Rainfall (mm)</th> <th>1.5h HP work</th> </tr> </thead> <tbody> <tr><td>7442</td><td>2016/5/16 7:30</td><td>293</td><td>382.25</td><td>313.5</td></tr> <tr><td>7443</td><td>2016/5/16 8:00</td><td>288.5</td><td>382.75</td><td>314</td></tr> <tr><td>7444</td><td>2016/5/16 8:30</td><td>285.5</td><td>383.25</td><td>314.5</td></tr> <tr><td>7445</td><td>2016/5/16 9:00</td><td>284</td><td>384.75</td><td>316</td></tr> <tr><td>7446</td><td>2016/5/16 9:30</td><td>283</td><td>386.5</td><td>318.75</td></tr> <tr><td>7447</td><td>2016/5/16 10:00</td><td>278</td><td>391.25</td><td>322.5</td></tr> <tr><td>7448</td><td>2016/5/16 10:30</td><td>271.5</td><td>393</td><td>324.25</td></tr> <tr><td>7449</td><td>2016/5/16 11:00</td><td>272.75</td><td>398.25</td><td>329.5</td></tr> <tr><td>7450</td><td>2016/5/16 11:30</td><td>271.5</td><td>400.75</td><td>332</td></tr> <tr><td>7451</td><td>2016/5/16 12:00</td><td>266.75</td><td>401.25</td><td>332.5</td></tr> <tr><td>7452</td><td>2016/5/16 12:30</td><td>257.25</td><td>401.25</td><td>332.5</td></tr> <tr><td>7453</td><td>2016/5/16 13:00</td><td>254</td><td>401.75</td><td>333</td></tr> <tr><td>7454</td><td>2016/5/16 13:30</td><td>252.5</td><td>402</td><td>333.25</td></tr> <tr><td>7455</td><td>2016/5/16 14:00</td><td>248.5</td><td>399</td><td>333.25</td></tr> <tr><td>7456</td><td>2016/5/16 14:30</td><td>244</td><td>384.75</td><td>333.25</td></tr> <tr><td>7457</td><td>2016/5/16 15:00</td><td>244</td><td>369.5</td><td>335</td></tr> <tr><td>7458</td><td>2016/5/16 15:30</td><td>243.25</td><td>356.5</td><td>336.25</td></tr> <tr><td>7459</td><td>2016/5/16 16:00</td><td>240.5</td><td>351</td><td>336.25</td></tr> <tr><td>7460</td><td>2016/5/16 16:30</td><td>239</td><td>348.25</td><td>336.5</td></tr> <tr><td>7461</td><td>2016/5/16 17:00</td><td>234.5</td><td>347</td><td>336.5</td></tr> <tr><td>7462</td><td>2016/5/16 17:30</td><td>211.25</td><td>345</td><td>336.5</td></tr> <tr><td>7463</td><td>2016/5/16 18:00</td><td>196.75</td><td>341.75</td><td>337</td></tr> <tr><td>7464</td><td>2016/5/16 18:30</td><td>180.75</td><td>338.25</td><td>337</td></tr> <tr><td>7465</td><td>2016/5/16 19:00</td><td>168.25</td><td>337.5</td><td>337.25</td></tr> <tr><td>7466</td><td>2016/5/16 19:30</td><td>152.75</td><td>337.5</td><td>337.25</td></tr> <tr><td>7467</td><td>2016/5/16 20:00</td><td>142</td><td>337.25</td><td>337.25</td></tr> <tr><td>7468</td><td>2016/5/16 20:30</td><td>132.5</td><td>337.5</td><td>337.5</td></tr> <tr><td>7469</td><td>2016/5/16 21:00</td><td>118.75</td><td>338.25</td><td>338.25</td></tr> <tr><td>7470</td><td>2016/5/16 21:30</td><td>109</td><td>339.5</td><td>339.5</td></tr> <tr><td>7471</td><td>2016/5/16 22:00</td><td>101.75</td><td>342.25</td><td>342.25</td></tr> <tr><td>7472</td><td>2016/5/16 22:30</td><td>80.75</td><td>343</td><td>343</td></tr> <tr><td>7473</td><td>2016/5/16 23:00</td><td>80.25</td><td>344.5</td><td>344.5</td></tr> <tr><td>7474</td><td>2016/5/16 23:30</td><td>71.5</td><td>344.75</td><td>344.75</td></tr> <tr><td>7475</td><td>2016/5/17 0:00</td><td>62.25</td><td>344.75</td><td>344.75</td></tr> <tr><td>7476</td><td>2016/5/17 0:30</td><td>54</td><td>344.75</td><td>344.75</td></tr> <tr><td>7477</td><td>2016/5/17 1:00</td><td>51</td><td>346.5</td><td>346.5</td></tr> <tr><td>7478</td><td>2016/5/17 1:30</td><td>51.75</td><td>348.25</td><td>348.25</td></tr> <tr><td>7479</td><td>2016/5/17 2:00</td><td>50.75</td><td>348.25</td><td>348.25</td></tr> <tr><td>7480</td><td>2016/5/17 2:30</td><td>48.25</td><td>348.25</td><td>348.25</td></tr> </tbody> </table>	Date&Time	24h Rainfall (mm/24h)	72h Rainfall (mm/72h)	Cumulative Rainfall (mm)	1.5h HP work	7442	2016/5/16 7:30	293	382.25	313.5	7443	2016/5/16 8:00	288.5	382.75	314	7444	2016/5/16 8:30	285.5	383.25	314.5	7445	2016/5/16 9:00	284	384.75	316	7446	2016/5/16 9:30	283	386.5	318.75	7447	2016/5/16 10:00	278	391.25	322.5	7448	2016/5/16 10:30	271.5	393	324.25	7449	2016/5/16 11:00	272.75	398.25	329.5	7450	2016/5/16 11:30	271.5	400.75	332	7451	2016/5/16 12:00	266.75	401.25	332.5	7452	2016/5/16 12:30	257.25	401.25	332.5	7453	2016/5/16 13:00	254	401.75	333	7454	2016/5/16 13:30	252.5	402	333.25	7455	2016/5/16 14:00	248.5	399	333.25	7456	2016/5/16 14:30	244	384.75	333.25	7457	2016/5/16 15:00	244	369.5	335	7458	2016/5/16 15:30	243.25	356.5	336.25	7459	2016/5/16 16:00	240.5	351	336.25	7460	2016/5/16 16:30	239	348.25	336.5	7461	2016/5/16 17:00	234.5	347	336.5	7462	2016/5/16 17:30	211.25	345	336.5	7463	2016/5/16 18:00	196.75	341.75	337	7464	2016/5/16 18:30	180.75	338.25	337	7465	2016/5/16 19:00	168.25	337.5	337.25	7466	2016/5/16 19:30	152.75	337.5	337.25	7467	2016/5/16 20:00	142	337.25	337.25	7468	2016/5/16 20:30	132.5	337.5	337.5	7469	2016/5/16 21:00	118.75	338.25	338.25	7470	2016/5/16 21:30	109	339.5	339.5	7471	2016/5/16 22:00	101.75	342.25	342.25	7472	2016/5/16 22:30	80.75	343	343	7473	2016/5/16 23:00	80.25	344.5	344.5	7474	2016/5/16 23:30	71.5	344.75	344.75	7475	2016/5/17 0:00	62.25	344.75	344.75	7476	2016/5/17 0:30	54	344.75	344.75	7477	2016/5/17 1:00	51	346.5	346.5	7478	2016/5/17 1:30	51.75	348.25	348.25	7479	2016/5/17 2:00	50.75	348.25	348.25	7480	2016/5/17 2:30	48.25	348.25	348.25
Date&Time	24h Rainfall (mm/24h)	72h Rainfall (mm/72h)	Cumulative Rainfall (mm)	1.5h HP work																																																																																																																																																																																																					
7442	2016/5/16 7:30	293	382.25	313.5																																																																																																																																																																																																					
7443	2016/5/16 8:00	288.5	382.75	314																																																																																																																																																																																																					
7444	2016/5/16 8:30	285.5	383.25	314.5																																																																																																																																																																																																					
7445	2016/5/16 9:00	284	384.75	316																																																																																																																																																																																																					
7446	2016/5/16 9:30	283	386.5	318.75																																																																																																																																																																																																					
7447	2016/5/16 10:00	278	391.25	322.5																																																																																																																																																																																																					
7448	2016/5/16 10:30	271.5	393	324.25																																																																																																																																																																																																					
7449	2016/5/16 11:00	272.75	398.25	329.5																																																																																																																																																																																																					
7450	2016/5/16 11:30	271.5	400.75	332																																																																																																																																																																																																					
7451	2016/5/16 12:00	266.75	401.25	332.5																																																																																																																																																																																																					
7452	2016/5/16 12:30	257.25	401.25	332.5																																																																																																																																																																																																					
7453	2016/5/16 13:00	254	401.75	333																																																																																																																																																																																																					
7454	2016/5/16 13:30	252.5	402	333.25																																																																																																																																																																																																					
7455	2016/5/16 14:00	248.5	399	333.25																																																																																																																																																																																																					
7456	2016/5/16 14:30	244	384.75	333.25																																																																																																																																																																																																					
7457	2016/5/16 15:00	244	369.5	335																																																																																																																																																																																																					
7458	2016/5/16 15:30	243.25	356.5	336.25																																																																																																																																																																																																					
7459	2016/5/16 16:00	240.5	351	336.25																																																																																																																																																																																																					
7460	2016/5/16 16:30	239	348.25	336.5																																																																																																																																																																																																					
7461	2016/5/16 17:00	234.5	347	336.5																																																																																																																																																																																																					
7462	2016/5/16 17:30	211.25	345	336.5																																																																																																																																																																																																					
7463	2016/5/16 18:00	196.75	341.75	337																																																																																																																																																																																																					
7464	2016/5/16 18:30	180.75	338.25	337																																																																																																																																																																																																					
7465	2016/5/16 19:00	168.25	337.5	337.25																																																																																																																																																																																																					
7466	2016/5/16 19:30	152.75	337.5	337.25																																																																																																																																																																																																					
7467	2016/5/16 20:00	142	337.25	337.25																																																																																																																																																																																																					
7468	2016/5/16 20:30	132.5	337.5	337.5																																																																																																																																																																																																					
7469	2016/5/16 21:00	118.75	338.25	338.25																																																																																																																																																																																																					
7470	2016/5/16 21:30	109	339.5	339.5																																																																																																																																																																																																					
7471	2016/5/16 22:00	101.75	342.25	342.25																																																																																																																																																																																																					
7472	2016/5/16 22:30	80.75	343	343																																																																																																																																																																																																					
7473	2016/5/16 23:00	80.25	344.5	344.5																																																																																																																																																																																																					
7474	2016/5/16 23:30	71.5	344.75	344.75																																																																																																																																																																																																					
7475	2016/5/17 0:00	62.25	344.75	344.75																																																																																																																																																																																																					
7476	2016/5/17 0:30	54	344.75	344.75																																																																																																																																																																																																					
7477	2016/5/17 1:00	51	346.5	346.5																																																																																																																																																																																																					
7478	2016/5/17 1:30	51.75	348.25	348.25																																																																																																																																																																																																					
7479	2016/5/17 2:00	50.75	348.25	348.25																																																																																																																																																																																																					
7480	2016/5/17 2:30	48.25	348.25	348.25																																																																																																																																																																																																					

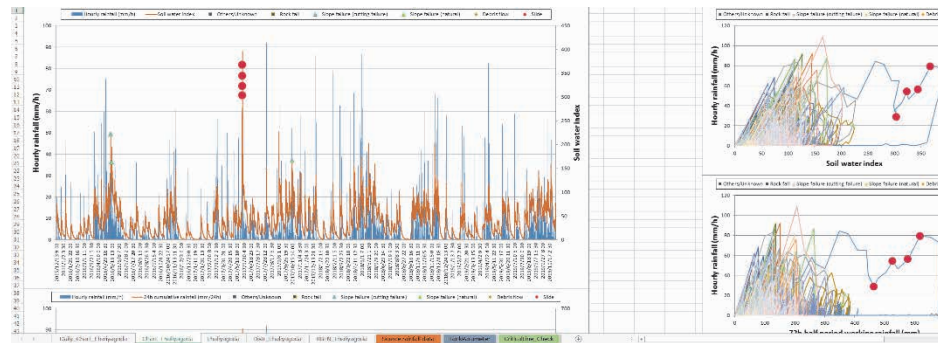
**Name of worksheets**

**Screenshots of worksheets**

“Chart\_gauging station’s name” sheet: time series and snake curve charts

- Time series charts of rainfall indices with landslide occurrence points
- Snake curve charts with landslide occurrence points

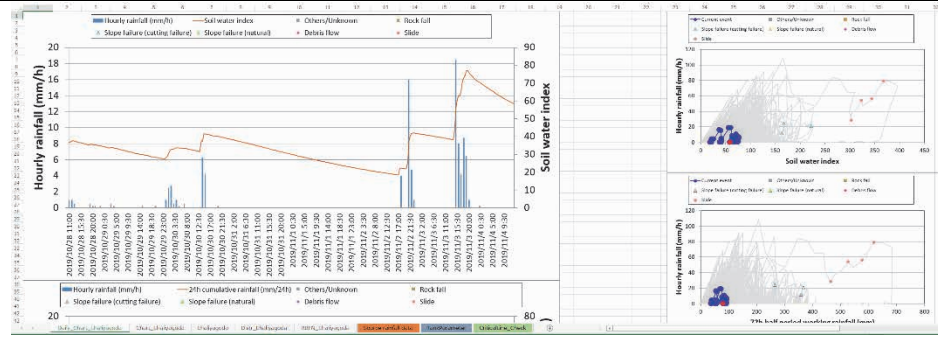
\* This worksheet is created after the calculation



“Daily\_Chart\_gauging station’s name” sheet

- Time series charts in past one week
- Snake curve charts highlighting a current rainfall event

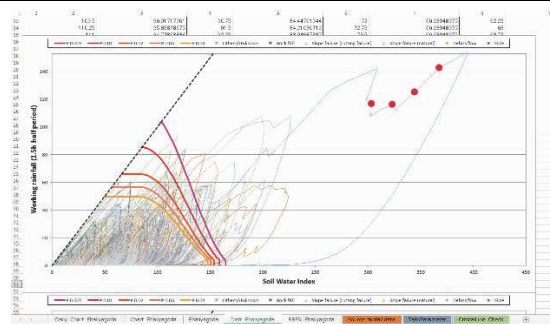
\* This worksheet is created after the calculation



“Distr\_gauging station’s name” sheet

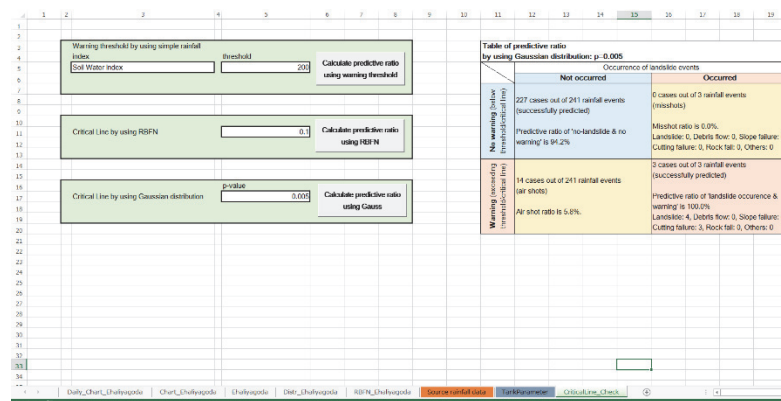
- Snake curve charts with probability lines

\* This worksheet is created after the calculation



“CriticalLine\_Check” sheet: checking accuracy of CLs

- Calculating predictive ratio of selected rainfall index and CL

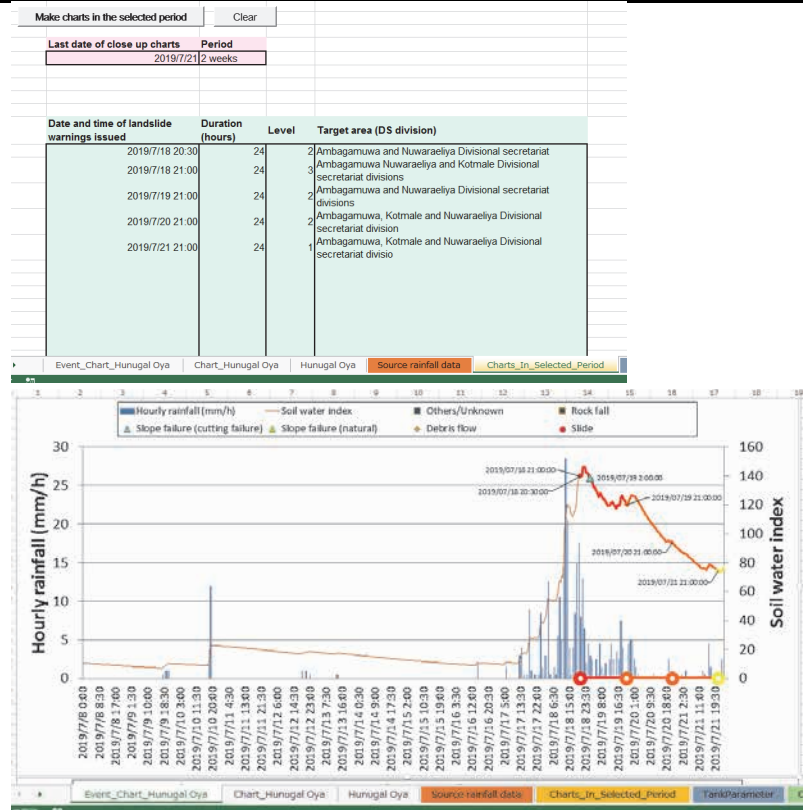


**Name of worksheets**

**Screenshots of worksheets**

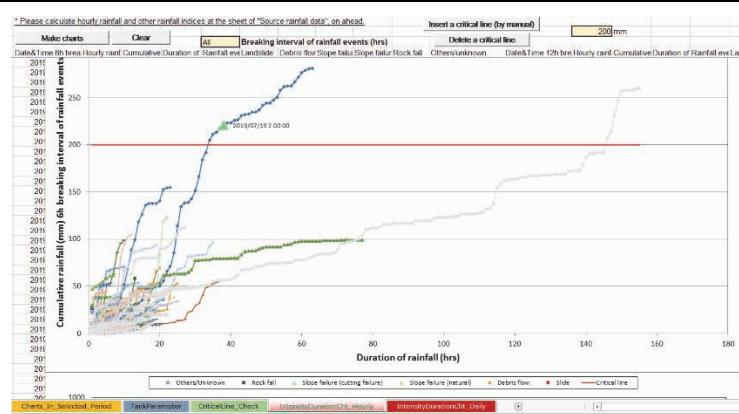
“Charts\_In\_Selected\_Period” and “Event\_Chart\_gauging station’s name” sheets

- Charts in selected specific period with landslide warning issued in the selected period



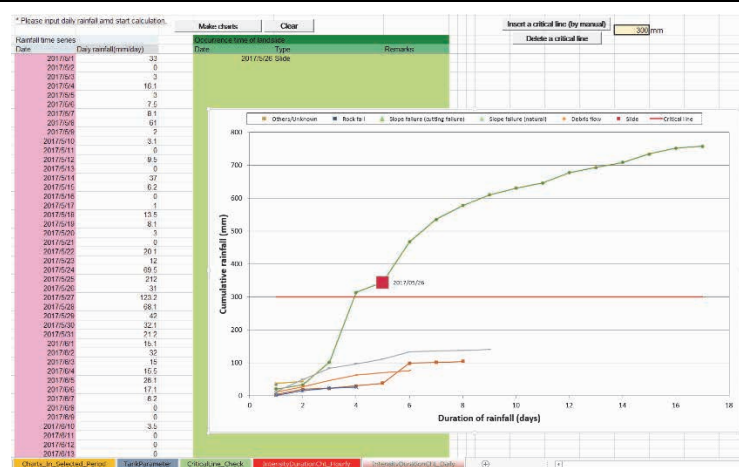
“IntensityDurationCht\_Hourly” sheet

- Charts of cumulative rainfall and duration of continuous rainfall (hourly)



“IntensityDurationCht\_daily” sheet

- Charts of cumulative rainfall and duration of continuous rainfall (daily)





## Appendix 2: Site-specific landslide warning threshold

### A2-1. Site-specific landslide monitoring

NBRO operates site-specific landslide monitoring system in some landslide sites in Sri Lanka. Soil-mass movement is observed at the sites by extensometers, inclinometers and strain gauges (Figure 1.1). Furthermore, rainfall, groundwater level and soil water content are also observed.

The observation data is transmitted to a data server in real-time and can be monitored through a web-site. In case that the observed values exceed specific warning thresholds, NBRO issue warnings to peoples living in the sites.



Figure 1.1 Instruments of landslide monitoring

### A2-2. Site-specific warning thresholds

The warning thresholds vary from site to site depending on characteristics of each landslide block. Thus, it is necessary to determine site-specific warning thresholds based on the observed data in the sites.

#### A2-2.1 Rainfall triggering soil-mass movement

Rainfall triggering soil-mass movement can be estimated through comparison between time series data of rainfall and displacement and inclination of soil-mass. Figure 2.1 is an example of time series chart to compare Soil Water Index (SWI) and surface displacement of soil-mass. The displacement of soil-mass was not observed during no-rainfall or small rainfall periods, but observed when severe rainfall occurred. In this case, the soil-mass movement started when SWI reached ca. 100. The value of rainfall index triggering soil-mass movement is the threshold to initiate enhanced landslide monitoring. The rainfall threshold should be determined for each sites



respectively, based on the observed series data.

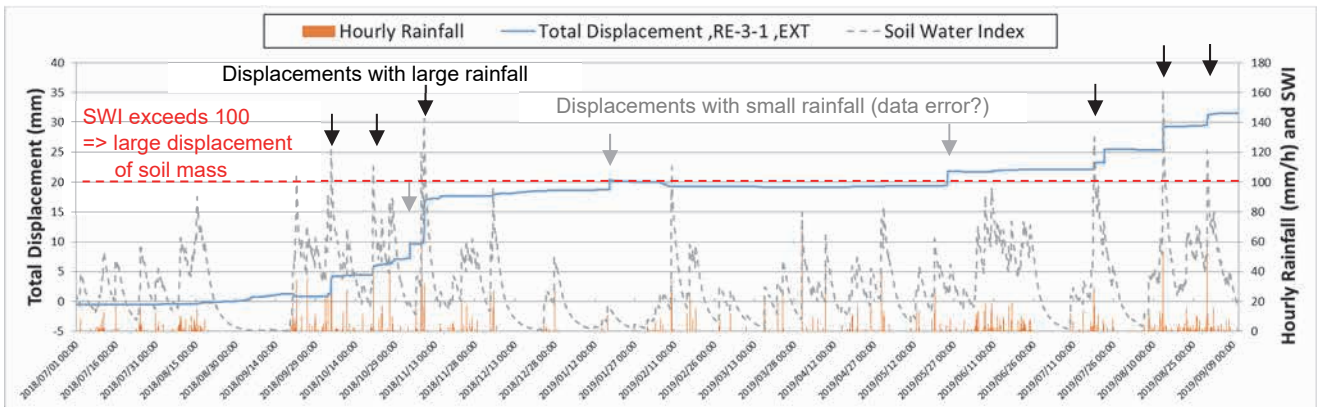


Figure 2.1 An example of time series chart of surface displacement and rainfall

### A2-2.2 Warning thresholds of soil-mass movement

After soil-mass movement begins, there are three creep phases before a landslide occurs Figure 2.2. The beginning of soil-mass movement is the 1st phase; the movement speed is large at the beginning and converges into a constant value. The soil-mass movement speed is almost constant in the 2nd phase creep. The 3rd creep phase is the catastrophic phase. The soil-mass movement speed accelerates; finally, catastrophic landslide occurs.

To study the creep phase of landslides and determine warning thresholds, time series charts and histogram should be created based on the observed data in the sites. Figure 2.2 shows an example of observed displacement data of soil-mass in a major rainfall event. The 1st creep phase was triggered by heavy rainfall exceeding 100 SWI, but the creep stopped and didn't transit to the second and third phase creep in this case. The maximum hourly displacement was 1.7mm/h and 7.1mm/day. Therefore, the warning thresholds could be determined larger than the maximum values in this event, which didn't reach a catastrophic landslide.

In this manner, the warning thresholds for the observed soil displacement, inclination and other observation items are able to be determined based on the observed data. The warning thresholds should be revised and improved regularly through the continuous data collection and studies after major rainfall events.

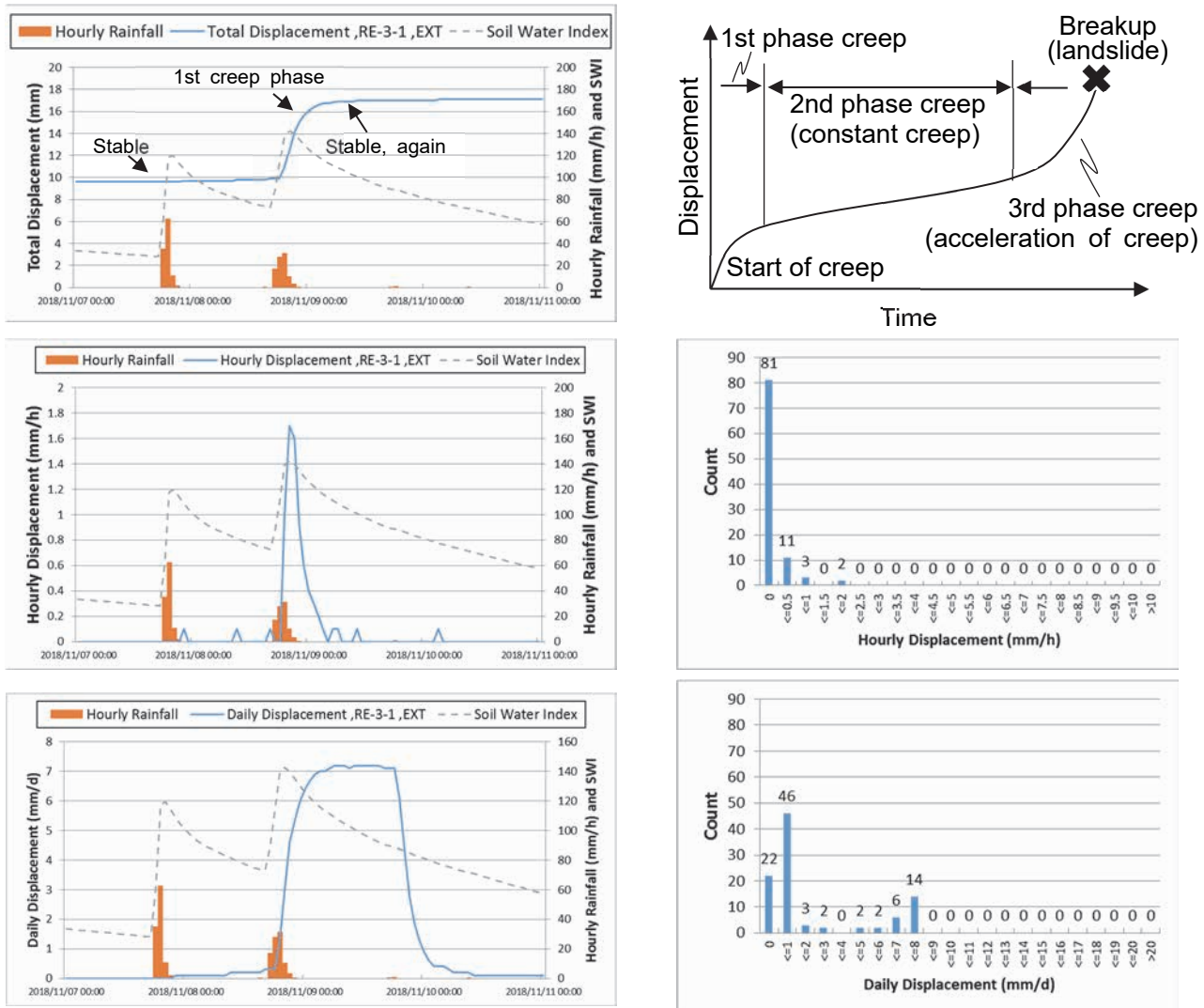


Figure 2.2 An example of surface displacement and rainfall in a major rainfall event (upper-left), hourly displacement (middle left), histogram of hourly displacement (middle right), daily displacement (lower left), histogram of daily displacement (lower right) and conceptual diagram of soil-mass creep stages (upper-right)

## Appendix 3: Tank model parameter calibration for SWI calculation

### A3-1. Outline of tank model parameter calibration for SWI calculation

Soil Water Index (SWI) developed by Okada et al. (2001) is an indicator of landslide risks and utilized to issue landslide early warnings in Japan. SWI is calculated by using a tank model, a conceptual runoff model developed by Sugawara (1972). The tank model, consisting of surface, sub-surface and base flow tanks, simulates amount of the water in soil layers and discharge. Parameters of the tank model depends on the condition of topography, geology, vegetation and other site conditions.

A structure of the tank model is shown in Figure 1.1. The time step for the calculation is 10 minutes. SWI is calculated as the total amount of simulated water in the tanks ( $S_1+S_2+S_3$ ) at each time step. SWI represents behavior of soil water and a rise of landslide risks caused by the increment of soil water.

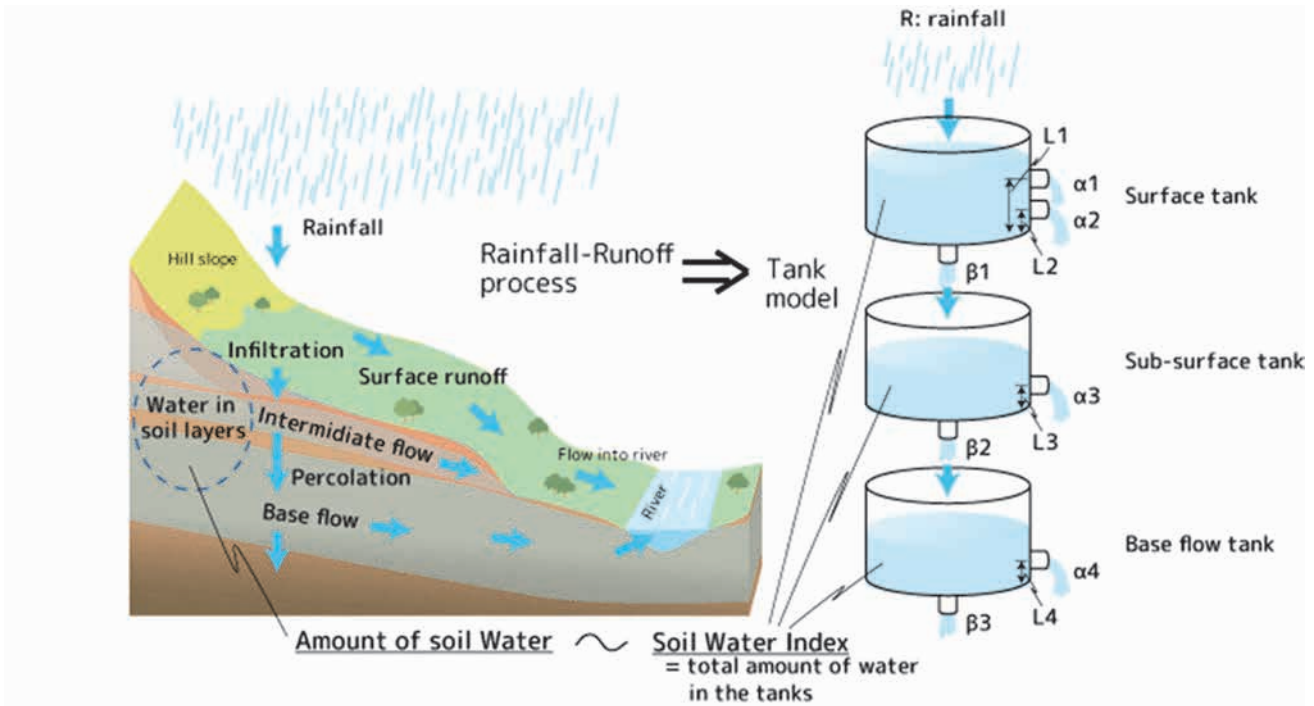


Figure 1.1 Structure of tank model

The general formula of the SWI is as follows.

$$SWI = S_1 + S_2 + S_3$$

$$S_1(t + \Delta t) = (1 - \beta_1 \Delta t) \cdot S_1(t) - q_1(t) \cdot \Delta t + R$$

$$S_2(t + \Delta t) = (1 - \beta_2 \Delta t) \cdot S_2(t) - q_2(t) \cdot \Delta t + \beta_1 \cdot S_1(t) \cdot \Delta t$$

$$S_3(t + \Delta t) = (1 - \beta_3 \Delta t) \cdot S_3(t) - q_3(t) \cdot \Delta t + \beta_2 \cdot S_2(t) \cdot \Delta t$$

$$q_1(t) = \alpha_1 [S_1(t) - L_1] + \alpha_2 [S_1(t) - L_2]$$

$$q_2(t) = \alpha_3 [S_2(t) - L_3]$$

$$q_3(t) = \alpha_4 [S_3(t) - L_4]$$

where,  $S_1, S_2, S_3$  : Water amount in the tank (mm),  $\beta_1, \beta_2, \beta_3$  : Infiltration rate,  $q_1, q_2, q_3$  : Discharge (mm/ $\Delta t$ ),  $\Delta t$  :



Time step,  $R$  : rainfall ( $\text{mm}/\Delta t$ ),  $\alpha_1, \alpha_2, \alpha_3, \alpha_4$  : Runoff ratio,  $L_1, L_2, L_3, L_4$  : Height of runoff hole (mm). Simulated discharge is  $(q_1+q_2+q_3)$ .

The tank model parameters to calculate SWI depends on the slope characteristics. The parameters are able to be calibrated and validated by following two methods; 1) comparing simulated discharge by the tank model and observed river discharge, and 2) comparing simulated SWI and observed ground water level, soil water content and/or strain.

Procedures to calibrate tank model parameters are following.

- Collect time series data of observed river discharge, rainfall, groundwater level and/or soil water content
- Calculate river discharge and SWI by the tank model
- Calibrate and validate tank model parameters by comparing observed value and simulated value by the tank model

## A3-2. Practical procedures to calibrate tank model parameters

### A3-2.1 Collect time series data of observed river discharge, rainfall, groundwater level and/or soil water content

#### a) River discharge

River discharge is useful data to calibrate the tank model parameters. Typical small river basins located in mountainous areas should be selected as study basins when model parameters are calibrated. It is recommended that the catchment area is ca.  $100\text{km}^2$ - $500\text{km}^2$ . Topographical, geological and hydrological condition should be similar to landslide prone areas. Flat and large river basins are not suitable for the analysis since effects of the flow down process along rivers are high. In addition, catchments with large reservoirs should be avoided. River basins with special geological features such as limestone should also be avoided.

Long-term river discharge data which should include at least two large rainfall events are necessary for the analysis. The calibrated tank model parameters by the river discharge represent characteristics of runoff and water storage in the soil in the catchment. Thus, the parameters indicate general basin wide soil characteristics.

#### b) Groundwater level and soil water content

Groundwater level and soil water content are also useful data to calibrate the tank model parameters. The groundwater level and soil water content should be observed in a shallow layer above sliding surface.

Long-term groundwater level and soil water content data more than several rainy seasons are necessary for the analysis. The calibrated tank model parameters by the groundwater level and soil water content represent characteristics of runoff and water storage in the soil at the observation site.

#### c) Rainfall

Time series data of observed rainfall for the analysis period is required. The rainfall gauging stations should be located in/near the target basin or sites. Time interval of the rainfall data should be 1 hour or less.

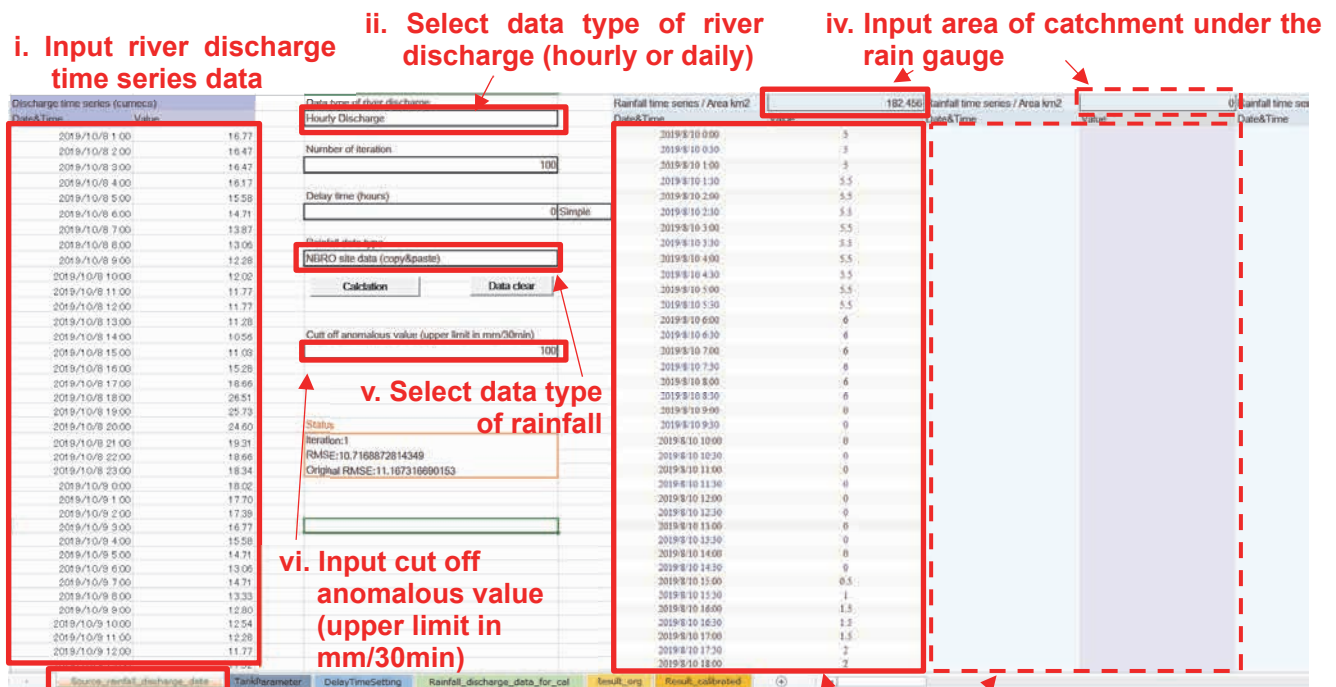
### A3-2.2 Calculation of river discharge and SWI

Practical procedures by the Excel analysis tool developed by the project to calculate river discharge and SWI are shown in this section.

#### a) River discharge and rainfall data input

Time series data of river discharge and rainfall should be inputted and utilized to run the tank model (Figure 2.1). Areas of catchment under each rainfall gauging stations are also need to be inputted.

- i. Input river discharge time series data
- ii. Select data type of river discharge (hourly or daily)
- iii. Input rainfall time series data
- iv. Input area of catchment under the rain gauge
- v. Select data type of rainfall (NBRO site data (copy&paste) or Common 30min rainfall)



**i. Input river discharge time series data**

**ii. Select data type of river discharge (hourly or daily)**

**iv. Input area of catchment under the rain gauge**

**v. Select data type of rainfall**

**vi. Input cut off anomalous value (upper limit in mm/30min)**

**“Source rainfall discharge data” sheet**

**iii. Input rainfall time series data**  
(if more than two rainfall gauging station data are utilized, please input data to following columns)

Figure 2.1 River discharge and rainfall data input

#### b) Delay time

Delay time, which is the delay of river discharge increase to rainfall, setting is necessary to calculate discharge (Figure 2.2). The delay time can be estimated by flood propagation velocity estimation, empirical formula or try and error. It is recommended to use “try and error” method to estimate delay time by following; 1) calculate river discharge with no delay time, and 2) find a time gap between peaks of simulated and observed river discharge, 3) utilize the time gap as the delay time and run calculation again to fit the simulated and observed river discharge.



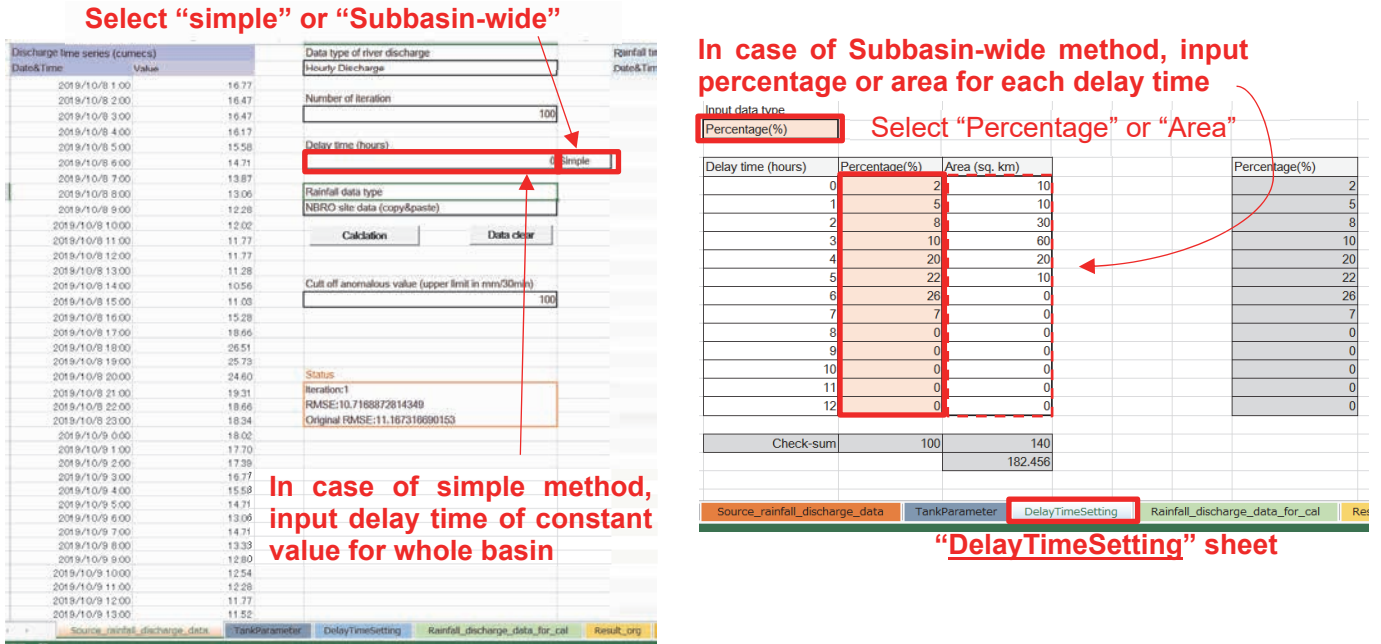


Figure 2.2 Delay time setting

c) Tank model parameter setting

Tank model parameters and calibration settings should be inputted to the analysis tool (Figure 2.3). The “Original” tank parameters, which are in “TankParameter”, will be utilized to calculate river discharge and automatically calibrated.

However, it is not recommended to calibrate parameters by automatic function since auto-calibrated parameters would often become strange value. Thus, it is better to calibrate tank parameters by changing parameters manually.

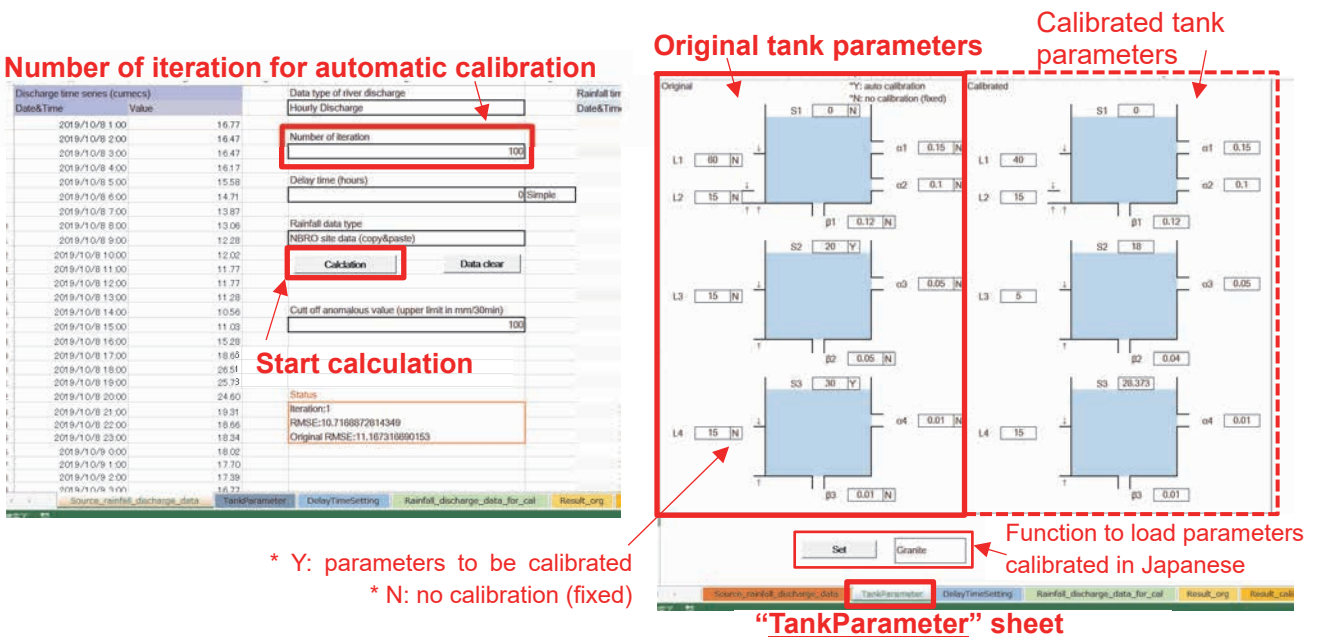


Figure 2.3 Tank model parameter setting



d) Calculation of river discharge and parameter calibration

After inputting original tank parameters, calculation can be started by “Calibration” button. The simulated and observed discharges with original and calibrated parameters are shown in the sheets of “Result\_org” and “Result\_calibrated”, respectively (Figure 2.4). Data table of discharges and SWI are also in the same sheet.

Validity of the parameters can be judged by comparing simulated and observed discharges; if the observed river discharge is reproduced by the simulated discharge, the tank parameters are reasonable. Root Mean Square Error (RMSE) and Nash-Sutcliffe model efficiency coefficient (NSE) are the indices of reproducibility. If the reproducibility is high, RMSE is small and NSE is near to 1.

In case that the reproducibility is low, it is necessary to calibrate the parameters. If peaks of simulated discharge are lower or higher than observed, runoff ratio should be increased or decreased, respectively. After revision of the parameters, it is necessary to run the model again and to check the reproducibility.

e) Validation of parameters by other rainfall events

After the parameters are calibrated, the parameters should be validated. River discharge in the other rainfall period should be calculated by using the same parameters and compared with observed discharge whether the parameters are reasonable in the other rainfall events.

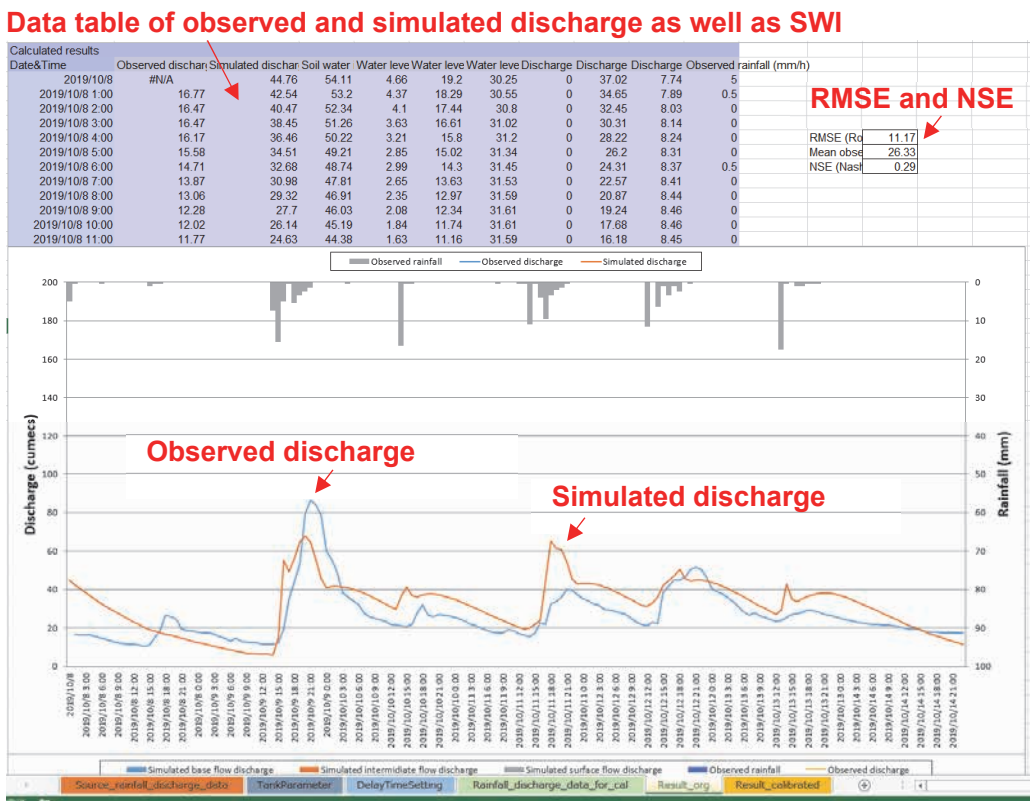


Figure 2.4 Calculated results of river discharge

f) Validation of parameters by groundwater level and/or soil moisture contents

The parameters can be validated by groundwater level and/or soil moisture contents, too. Figure 2.5 shows a comparison between calculated SWI and groundwater level. If the behavior of SWI and the groundwater level are similar, it can be judged that the parameters are reasonable.

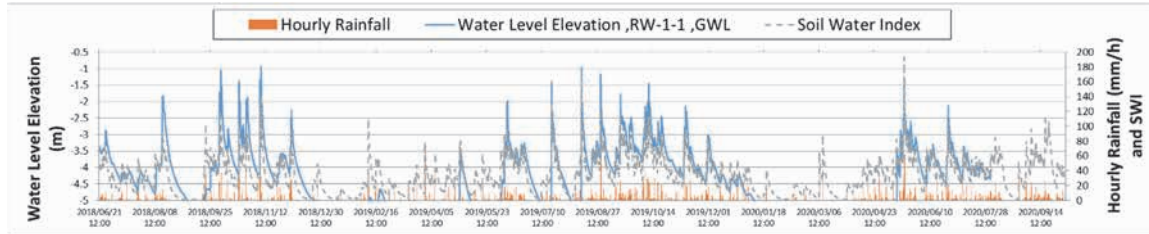
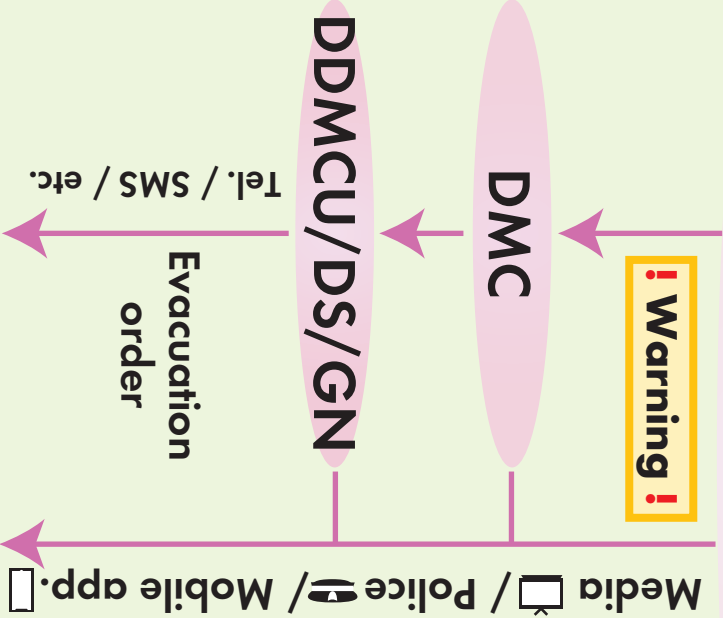


Figure 2.5 Observed groundwater level and SWI

# Landslide early warning and evacuation • rainfall/landslide monitoring • warning dissemination • evacuation

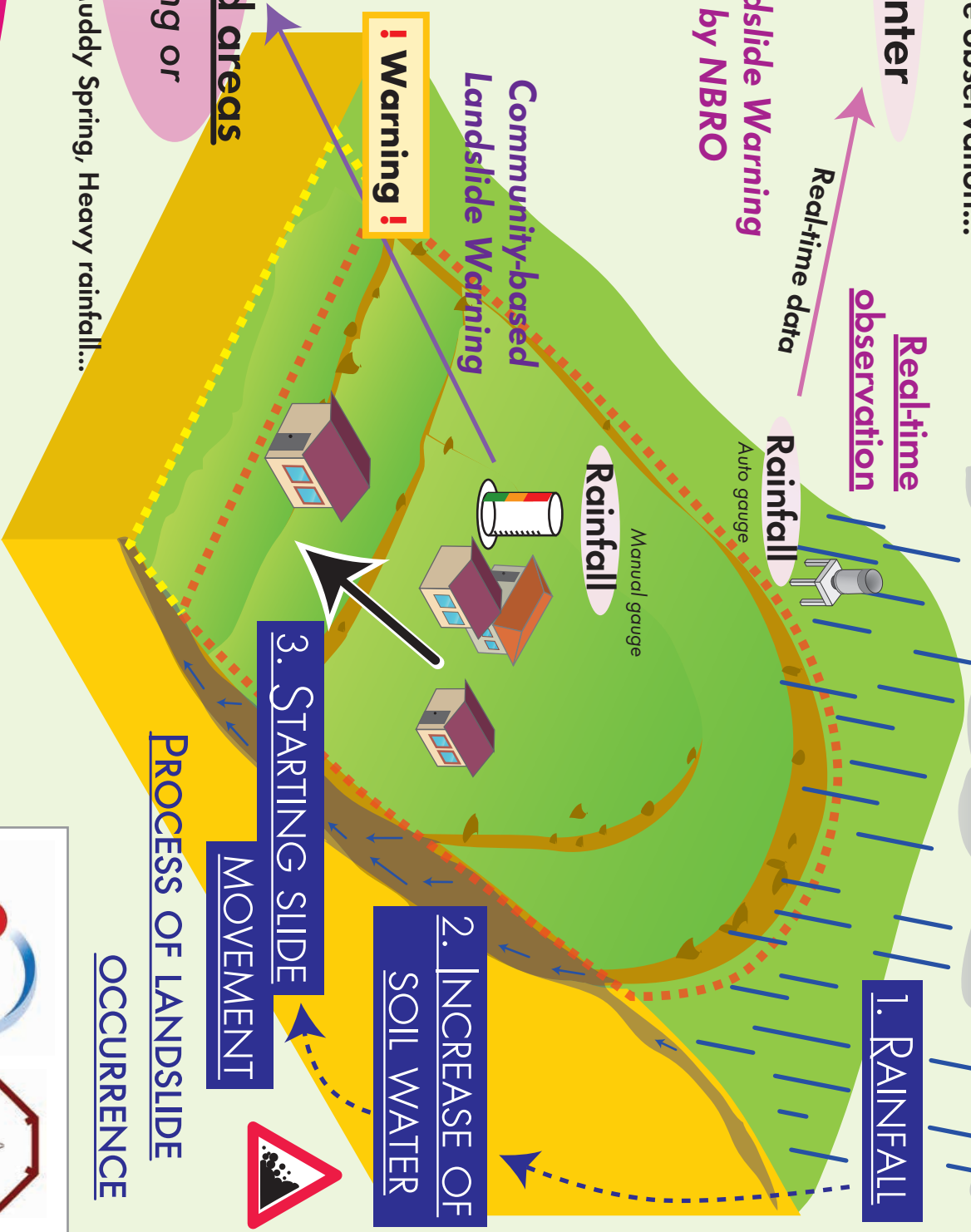
NBRO issues warning based on real-time observation...

## NBRO Early Warning Center



Real-time observation

Landslide Warning by NBRO



## Residents living in the hazard areas

When residents receive warning or recognize signs landslide such as cracks, Muddy Spring, Heavy rainfall...

**Evacuate from hazard areas!**

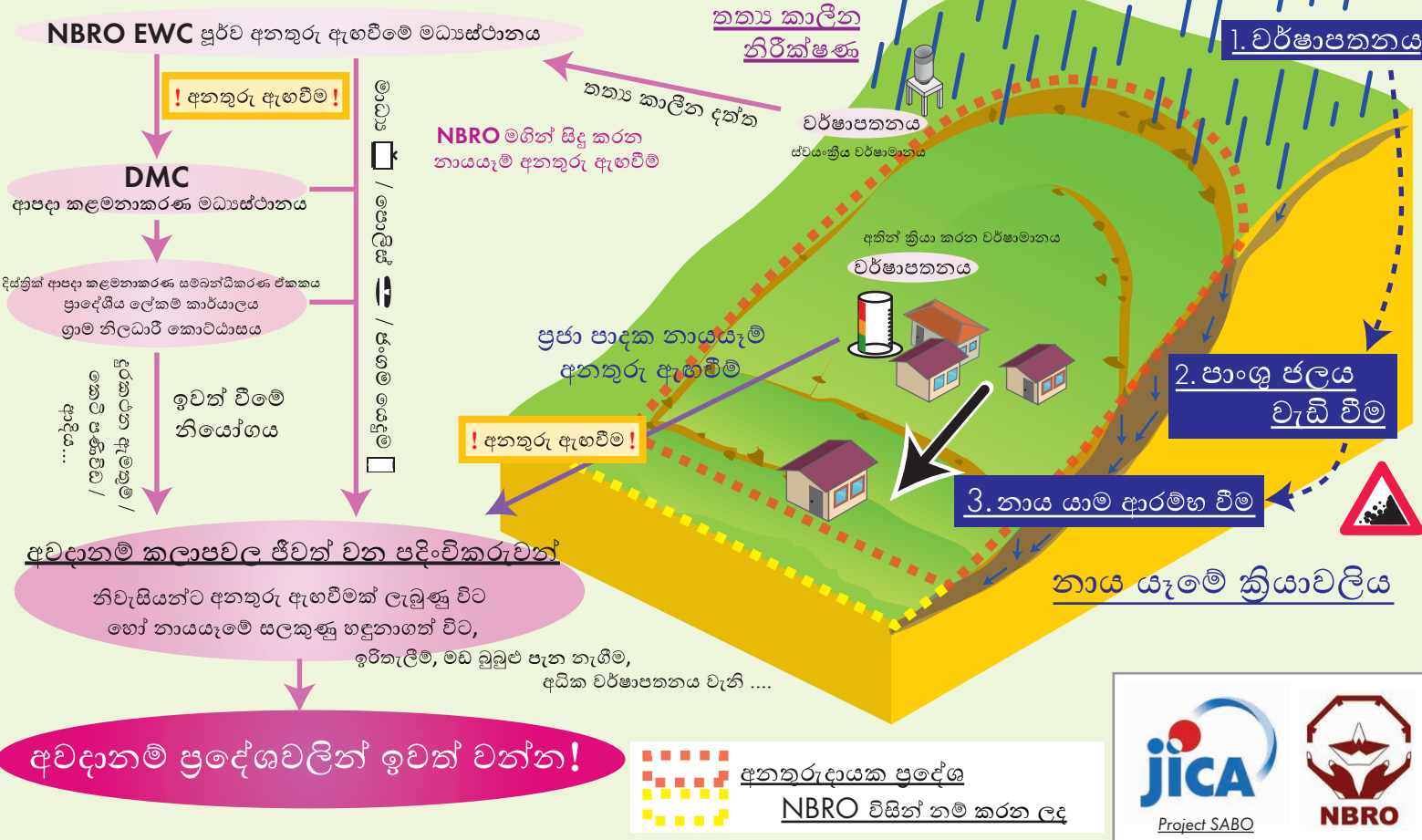
HAZARD AREAS DESIGNATED BY NBRO

PROCESS OF LANDSLIDE OCCURRENCE



# නාය යෑම් පූර්ව අනතුරු ඇඟවීම සහ ඉවත් වීම - වර්ෂාපතනය/නාය යෑම් නිරීක්ෂණ-අනතුරු ඇඟවීම බෙදා හරිම-ඉවත් වීම-

NBRO තනා කාලීන නිරීක්ෂණ මත පදනම්ව අනතුරු ඇඟවීම් නිකුත් කරයි...



## ඔබ ගත යුතු ක්‍රියාමාර්ග මොනවාද?

අනතුරු ඇඟවීමේ මට්ටම	ගත යුතු පියවර	පැය 24 ක වර්ෂාපතනය
1 Watch (විමසිලිමත්)	නාය යෑමේ හැකියාව පිළිබඳව විමසිලිමත්ව සිටින්න	මි.මි. 75 ට වැඩි
2 Alert (අවධාන)	අවධානයෙන් සිටින්න, ඉවත් වීමට සූදානම් වන්න	මි.මි. 100 ට වැඩි
3 Evacuation (ඉවත්වීම)	ආරක්ෂිත ස්ථානයකට ඉවත් වන්න	මි.මි. 150 ට වැඩි

වර්ෂාපතනය අඩු වුවද **NBRO** අනතුරු ඇඟවීම තබා ගන්නේ ඇයි?

- තවම නාය යාමේ ඉඩක් පවතින නිසා!
- වර්ෂාපතනය දිගු කාලයක් පැවතුනහොත් කුඩා වර්ෂාපතනයකින් වුවද නාය යෑමක් ඇති විය හැක!
- එබැවින් වර්ෂාපතනය නතර වුවද අනතුරු ඇඟවීම කෙරෙහි අවධානය යොමු කරන්න





# NBRO ජංගම දුරකථන යෙදුම සමඟ ඔබේ ප්‍රදේශයේ NBRO අනතුරු ඇඟවීමද පරීක්ෂා කළ හැකිය

**Welcome to "NBRO EW" App**

**Download Now**

## ... ඔබට NBRO වෙබ් අඩවියෙන් NBRO ස්වයංක්‍රීය වර්ෂාමාන දත්ත ද පරීක්ෂා කළ හැක.

**තත්‍ය කාලීන වර්ෂාපතන සිතියම**

- No rain after 8.30 am.
- Raining ...
- Rained after 8.30 am.
- Warning 1 reached - Rain stopped.
- Warning 1 reached - Still raining ...
- Warning 2 reached - Rain stopped.
- Warning 2 reached - Still raining ...
- Warning 3 reached - Rain stopped.
- Warning 3 reached - Still raining ...

[https://www.nbro.gov.lk/index.php?option=com\\_content&view=article&layout=edit&id=215&lang=en](https://www.nbro.gov.lk/index.php?option=com_content&view=article&layout=edit&id=215&lang=en)

## ... ඔබට NBRO වෙබ් අඩවියෙන් NBRO ස්වයංක්‍රීය පාංශු ජල දත්ත ද පරීක්ෂා කළ හැක.

**තත්‍ය කාලීන SWI සිතියම**

අනතුරු ඇඟවීමේ මට්ටම 1: විමසිලිමත් (කහ)

අනතුරු ඇඟවීමේ මට්ටම 2: අවධාන (ඇමරි)

අනතුරු ඇඟවීමේ මට්ටම 3: ඉවත්වීම (රතු)

<http://swi.nbro.gov.lk/>



---

**Developed by Project for Capacity Strengthening on Development of  
Non-Structural Measures for Landslide Risk Reduction in Sri Lanka (2022)**