

# **APPENDIX-I**

## **Report of the Development Plan of Experienced-based Training Facility (Small-Scale Sewerage System Master Plan in CUWC)**



MOC of Viet Nam



Japanese International Cooperation Agency

**TECHNICAL ASSISTANCE PROJECT**  
**The Project for Enhancing Management Capacity**  
**of Sewage Works**

**SMALL-SCALE SEWERAGE SYSTEM**  
**MASTER PLAN FOR CUWC**

**FINAL REPORT**

**November 2019**

**JAPAN INTERNATIONAL COOPERATION AGENCY**  
**(JICA)**

**NIPPON KOEI CO., LTD**  
**SEWERAGE BUSINESS MANAGEMENT CENTRE**

**SMALL-SCALE SEWERAGE SYSTEM  
MASTER PLAN FOR CUWC**

**FINAL REPORT**

**TABLE OF CONTENTS**

<b>CHAPTER 1</b>	<b>OUTLINE OF THE MASTER PLAN .....</b>	<b>1-1</b>
1.1	Background .....	1-1
1.2	Objectives.....	1-1
1.3	Outline of the Master Plan.....	1-1
<b>CHAPTER 2</b>	<b>BASIC SURVEY .....</b>	<b>2-1</b>
2.1	Natural Condition.....	2-1
2.1.1	Topographic Survey .....	2-1
2.1.2	Geographical Survey .....	2-1
2.1.3	Water Quality Survey .....	2-2
2.2	Related Plan.....	2-3
2.2.1	Drainage System Mater Plan on Hanoi City .....	2-3
2.2.2	Admission Plan of CUWC .....	2-4
2.2.3	Construction Plan of CUWC .....	2-4
2.3	Exiting Facilities .....	2-5
2.3.1	Underground Facilities .....	2-5
2.3.2	Well and Water Treatment Plant .....	2-6
2.3.3	Septic Tank .....	2-6
2.3.4	Electric Facilities.....	2-7
<b>CHAPTER 3</b>	<b>CONCEPTS FOR DEVELOPMENT OF SEWERAGE SYSTEM .....</b>	<b>3-1</b>
3.1	Concept of Planning Area .....	3-1
3.2	Method of Development.....	3-1
3.3	Collection System .....	3-1
3.3.1	Type of Collection System .....	3-1
3.3.2	Selection of Collection System .....	3-2
<b>CHAPTER 4</b>	<b>BASIC CONDITIONS OF PLAN .....</b>	<b>4-1</b>
4.1	Planned Target Year.....	4-1
4.2	Collection Area.....	4-1
4.3	Frame of Population .....	4-2
4.3.1	Basis of Population Forecast .....	4-2
4.3.2	Frame of Population for Sewer Pipe .....	4-3
4.3.3	Frame of Population for Sewage Treatment Plant.....	4-3

4.4	Unit Amount of Sewage .....	4-4
4.4.1	Unit Amount of Sewage .....	4-4
4.4.2	Fluctuation Rate (Peak Coefficient) .....	4-4
4.5	Planned Sewage flow rate .....	4-5
4.5.1	Planned Sewage flow rate into Sewer Pipe .....	4-5
4.5.2	Planned Sewage Flow Rate into Sewage Treatment Plant .....	4-5
4.6	Unit Pollutant Load of Sewage.....	4-6
4.7	Planned Pollutant Load of Sewage.....	4-7
4.8	Rainfall Intensity of Drainage Planning .....	4-7
4.8.1	Probability Year of Rainfall.....	4-7
4.8.2	Formulas for Intensity of Rainfall .....	4-8
4.9	Setting of Runoff Coefficient .....	4-9
4.10	Design Conditions of Sewerage/Drainage Network.....	4-9
4.10.1	Hydraulic Calculation Formula and Roughness Coefficients.....	4-9
4.10.2	Material and Minimum Diameter .....	4-10
4.10.3	Minimum and Maximum Velocity of Pipe .....	4-10
4.10.4	Maximum Calculated Filling of Pipe .....	4-11
4.10.5	Method for Connection of Pipe .....	4-11
4.10.6	Minimum Earth Covering of Pipe .....	4-11
<b>CHAPTER 5</b>	<b>STUDY FOR LAYOUT OF MAIN FACILITIES .....</b>	<b>5-1</b>
5.1	Selecting the Location of Sewage Treatment Plant .....	5-1
5.2	Outflow Water Quality .....	5-1
5.2.1	National Technical Regulation on Domestic Wastewater.....	5-1
5.2.2	Setting of Outflow Water Quality.....	5-3
5.3	Layout of Sewer and Drainage Lines .....	5-3
5.3.1	Layout of Sewer Lines .....	5-3
5.3.2	Layout of Drainage Lines .....	5-3
5.4	Considering the Necessity of Pumping Stations.....	5-5
<b>CHAPTER 6</b>	<b>PLAN OF SEWAGE PIPE .....</b>	<b>6-1</b>
6.1	Outline of Sewage Pipe .....	6-1
6.2	Drawings of Sewage Pipe.....	6-1
<b>CHAPTER 7</b>	<b>PLAN OF DRAINAGE PIPE .....</b>	<b>7-1</b>
7.1	Outline of Drainage Pipe .....	7-1
7.2	Drawings of Drainage Pipe .....	7-1
<b>CHAPTER 8</b>	<b>PLAN OF SEWAGE TREATMENT PLANT .....</b>	<b>8-1</b>
8.1	Sewage Treatment Process .....	8-1
8.1.1	Comparison of Sewage Treatment Technologies.....	8-1
8.1.2	Proposed Sewage Treatment Process .....	8-2
8.2	Study on Sludge Treatment and Disposal Method .....	8-5

8.2.1	Sludge Treatment Method .....	8-5
8.2.2	Sludge Disposal Method .....	8-6
<b>CHAPTER 9 ENVIRONMENTAL IMPACT SURVEY.....</b>		<b>9-1</b>
9.1	Objective of Environmental Impact Assessment (Another Consideration is Required).....	9-1
9.2	Simplified Evaluation of Improving Water Quality .....	9-1
<b>CHAPTER 10 STUDY OF PROJECT COST .....</b>		<b>10-1</b>
10.1	Construction Cost Estimate .....	10-1
10.1.1	Summary of Construction Works .....	10-1
10.1.2	Construction Cost Estimate .....	10-1
10.2	Project Implementation Plan .....	10-2
<b>CHAPTER 11 EXPERIMENTAL TRAINING FACILITIES.....</b>		<b>11-1</b>
11.1	Purpose and Example Case of Experimental Training Facilities .....	11-1
11.2	Proposed Pipe Facilities.....	11-2
11.3	Proposed Sewerage Treatment Facilities .....	11-3
11.4	Proposed Multipurpose Underground Utility Conduit .....	11-5

### **TABLE OF CONTENTS OF APPENDIX**

<b>A</b>	<b>Flow Calculation Sheet of Sewage Pipe .....</b>	<b>a-1</b>
<b>B</b>	<b>Flow Calculation Sheet of Drainage Pipe .....</b>	<b>b-1</b>
<b>C</b>	<b>Design Calculation of Sewerage Treatment Plant (for OD System).....</b>	<b>c-1</b>
<b>D</b>	<b>Alternative Plan of "Johkasou" (Advanced Septic Tank Technology in Japan).....</b>	<b>d-1</b>
<b>E</b>	<b>Drawings of Small-Scale Sewerage System Master Plan .....</b>	<b>e-1</b>

## ABBREVIATION

ADB	Asian Development Bank
ATI	Administration of Technical Infrastructure
BOD	Biochemical Oxygen Demand
CAS	Conventional Activated Sludge Process
CIRD	Center for Infrastructure Research and Development
CNEE	Training Center of Water and Environment
COD	Chemical Oxygen Demand
C/P	Counterpart
CPC	City People's Committee
CUWC	College of Urban Works Construction
DOC	Department of Construction
DONRE	Department of Natural Resources and Environment
DPI	Department of Planning and Investment
F/S	Feasibility Study
GCUS	Japan Global Center for Urban Sanitation
GI	General Information
GIZ	Deutsche Gesellschaft fuer Internationale Zusammenarbeit
JICA	Japan International Cooperation Agency
JS	Japan Sewage Works Agency
JSWA	Japan Sewage Works Association
MABUTIP	Management Board of Urban Technical Infrastructure Development Project
M/D	Minutes of Discussion
MOC	Ministry of Construction
M/P	Master Plan
ODA	Official Development Aid
O&M	Operation and Maintenance
PIS	Project Implementation Support
PMB	Project Management Board
PMU	Project Management Unit
PPC	Provincial People's Committee
R & D	Research and Development
TOT	Training of Trainer
VSC	Vietnam Sewerage Center
VWSA	Vietnam Water Supply and Sewerage Association
WB	World Bank
WWTP	Wastewater Treatment Plant
STP	Sewage Treatment Plant

## CHAPTER 1 OUTLINE OF THE MASTER PLAN

### 1.1 Background

Watching the actual facilities and equipment in the training course is very useful for everyone to promote an understanding of sewerage system as well as lecture style training. Therefore, this master plan is proposed the development of "Experienced-based training" facility, the small-scale sewerage facilities, in CUWC for the reason that the facility will be utilized for trainees to get a greater understanding of the structure and mechanism of sewerage facilities in the training courses to be organized in expected next phase.

Based on the above-described background, the study to prepare the draft development plan of "Experienced-based training" facility and the small-scale sewerage facilities, in CUWC is implemented.

### 1.2 Objectives

The main objective of the study is to formulate the small-scale sewerage system master plan for CUWC. And, this project is intended for provide various "Experiential Training" facilities to learn exceptional technique of sewerage system in Japan.

### 1.3 Outline of the Master Plan

Comprehensive summary of the master plan for CUWC is shown in the table below.

**Table 1.3.1 Comprehensive Summary of the Master Plan**

No.	Items	Contents		Remarks	
1	Target year	2030			
2	Collection area	5.0 ha			
3	Collection system	Separate sewerage system			
4	Frame of population of each building for sewer pipe	5,166 persons		hourly maximum	
5	Frame of population for sewage treatment plant	9,350 persons		1 day maximum	
6	Unit amount of sewage	Classified by use	20 to 150 L/person		
		Amount of infiltration	Total amount of daily average x 10 %		
7	Planned sewage flow late (2030)	Daily average	232 m <sup>3</sup> /day		
		Daily maximum	310 m <sup>3</sup> /day		
8	Designed influent/ Standards effluent water quality	Parameters	Designed inflow	Standard effluent	QCVN14:2008
		BOD <sub>5</sub> (mg/l)	185	30	Column: Class A
		SS (mg/l)	145	50	
		N (mg/l)	36	30	
		P (mg/l)	4	6	
Total coliforms (MPN/100ml)	-	3000			
9	Water treatment method	Sewage treatment plant (300 m <sup>3</sup> /day)	Anoxic–Oxic (AO) system, or Oxidation Ditch (OD) system		Main STP
		Johkasou (36 m <sup>3</sup> /day)	Advanced aerobics septic tank system		Building: D8
10	Sludge treatment method	Thickening process	1.7 m <sup>3</sup> /day		1.5%
		Dewatering process	0.15 m <sup>3</sup> /day (25.6kg·DS/day)		17%
11	Planned rainfall condition	Rainfall runoff flow	Rational runoff formula: Q = q·C·F		
		Return period	P = 2 year		Grade II
		Rainfall intensity	q = 5890 x (1+0.65lg x 2) / (t+20) <sup>0.84</sup>		for Hanoi

Source: JICA Consultant Team

## CHAPTER 2 BASIC SURVEY OF PLANNING AREA

### 2.1 Natural Condition

#### 2.1.1 Topographic Survey

##### (1) Terrain Features

The CUWC locates in Yen Thuong, Gia Lam, Hanoi with the total area of 5.1 ha. With spacious campus, the college offers beautiful view of suburban area. This location is the basin of Duong river of a tributary of Red river, and adjacent to Duc Tu lake. The land of CUWC has natural terrain which is relatively flat, tilted and lowered from northwest to southeast, altitude from 7.9 to 6.6 m of the ground elevation.

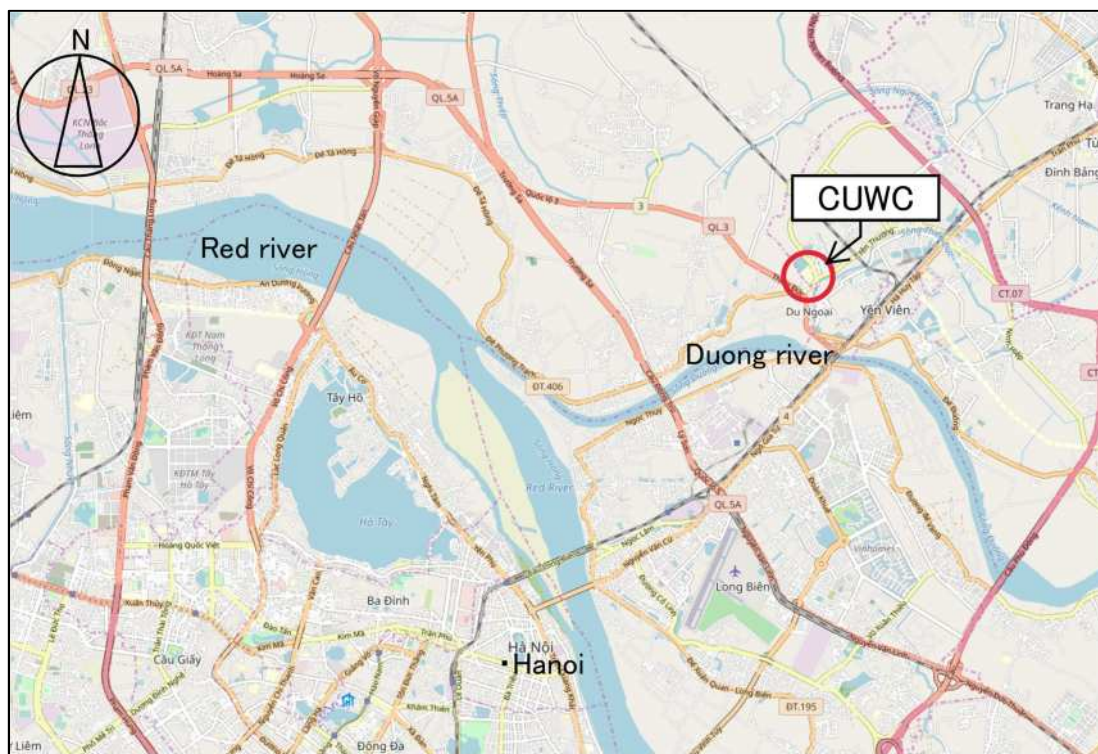

Source: JICA Consultant Team (Base map: OpenStreetMap)

**Figure 2.1.1 Location Map of CUWC**

##### (2) On-site Survey

The JICA consultant team surveyed on the site for ground elevation, bottom level of existing drain, cross-sectional shape and material of the drain. The result of survey is compiled to the drawing "Layout of Existing Drainage System".

#### 2.1.2 Geographical Survey

According to the inquiring survey to a technical management staff in CUWC, the geological condition of land located near river is the clay layer with backfilling (concrete, block, construction waste) is deposited from 0.0m to 3.0m in elevation, and a loose sandy silt (N=5-15) exists below the clay mixed soil. The on-site geographical survey is not including the scope of works in this study, then it should be



referred existing data/result and conducted in next stage. The report of geological survey in the past is shown the below.

- No.1: for construction of Multifunctional Building (No. B6), 2014
- No.2: for construction of Green Technology Building (No. 01), 2016

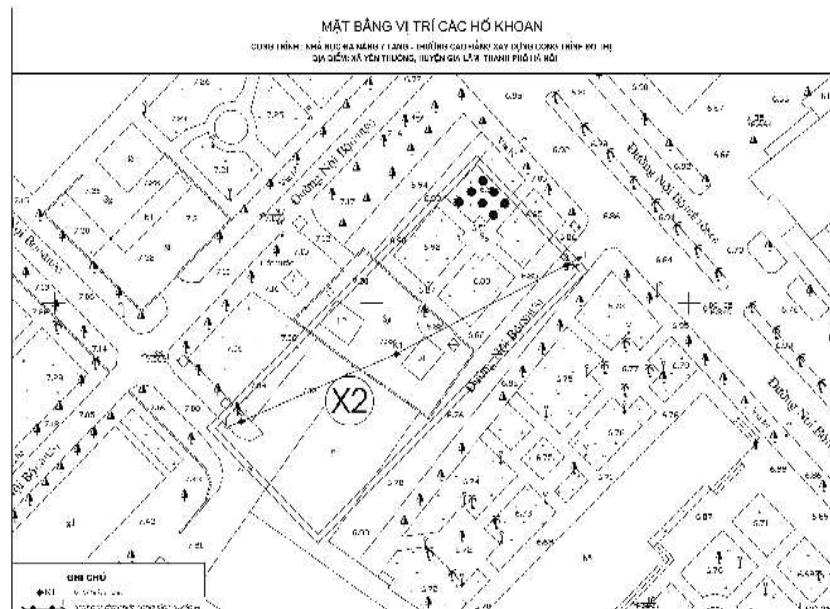

Source: CUWC

**Figure 2.1.2 Location Map of Geological Survey on Multifunctional Building**

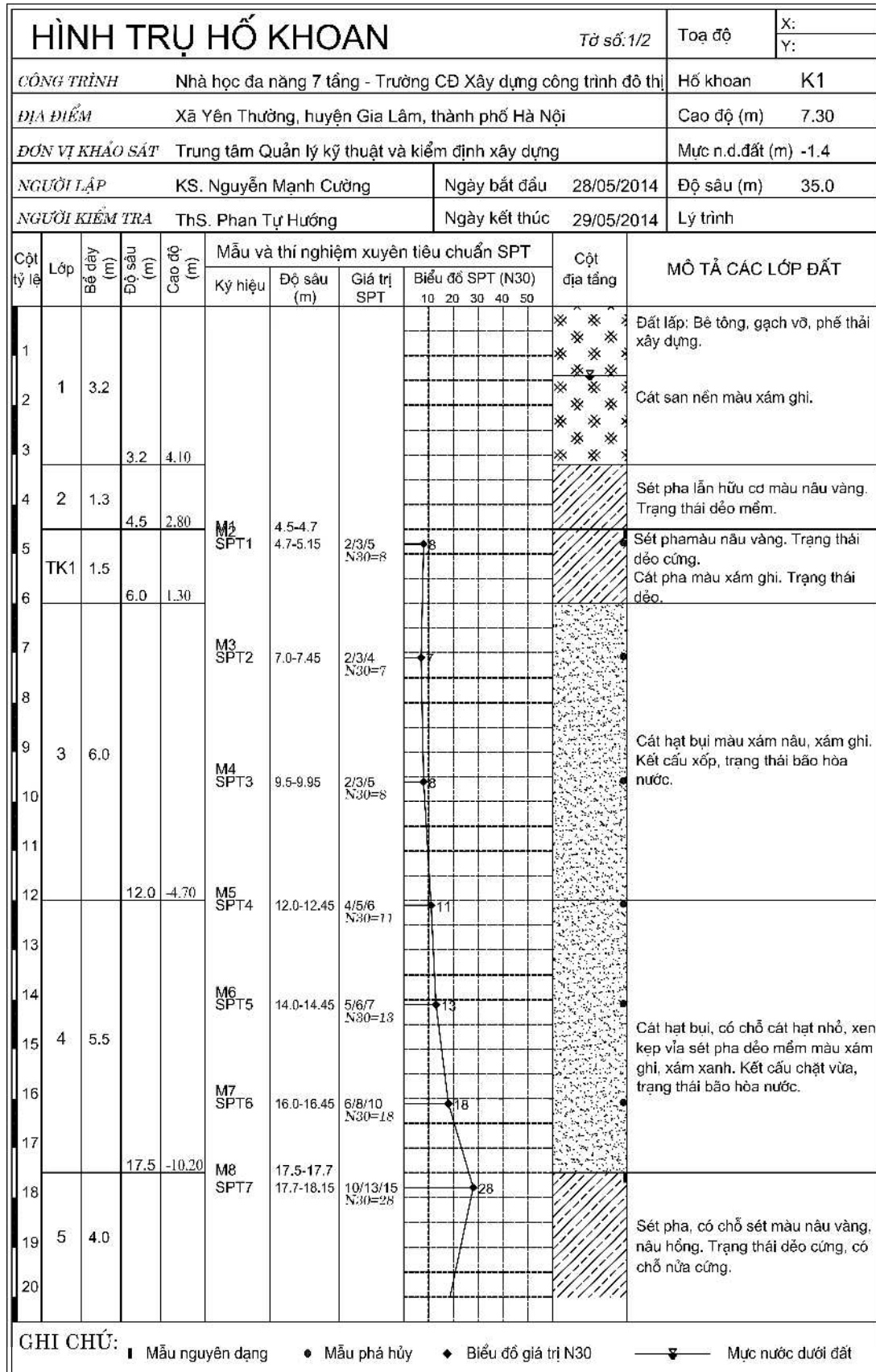

Source: CUWC

Figure 2.1.3 Soil Boring Log (K1) on Multifunctional Building

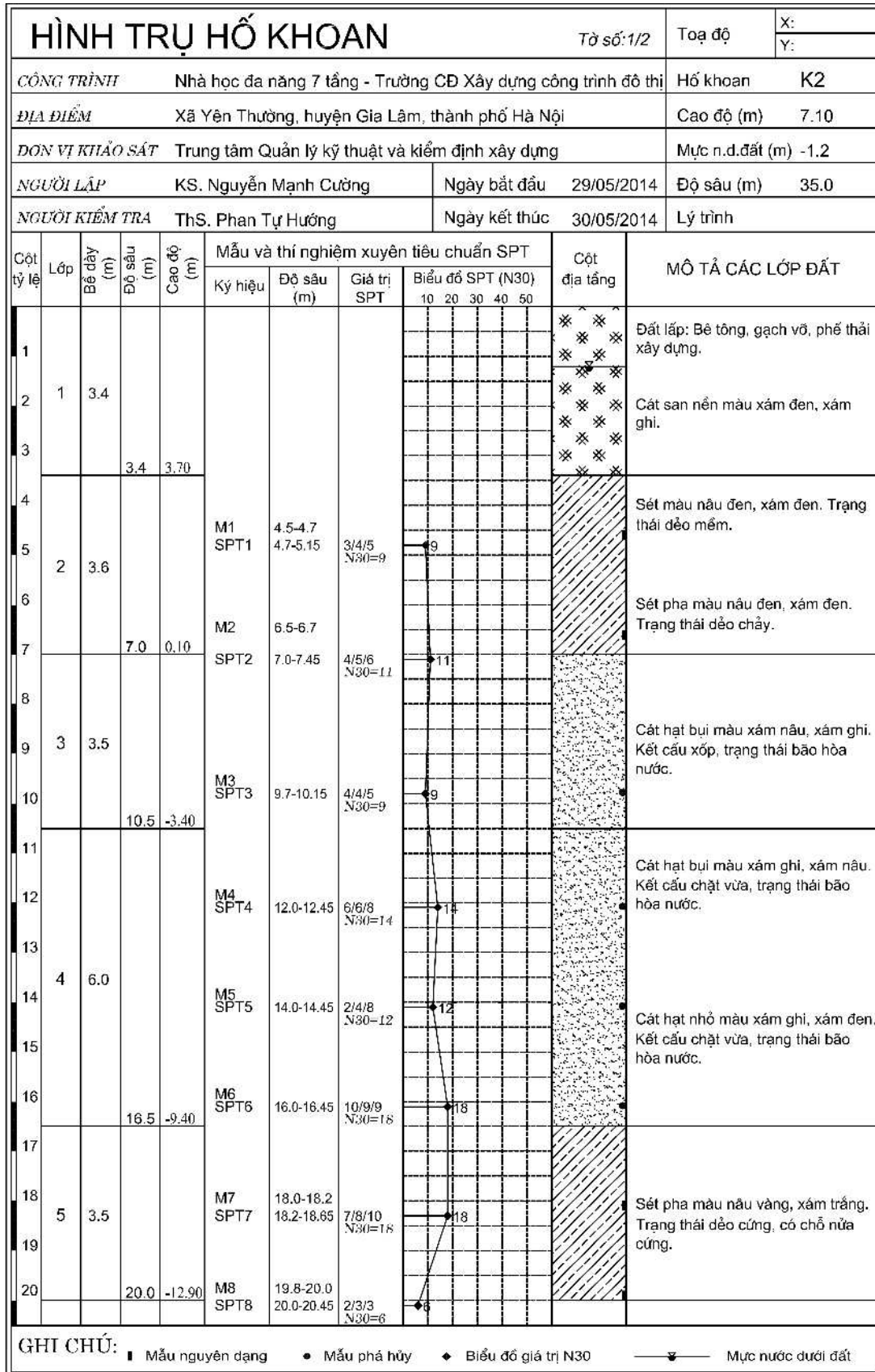

Source: CUWC

Figure 2.1.4 Soil Boring SPT Log (K2) on Multifunctional Building

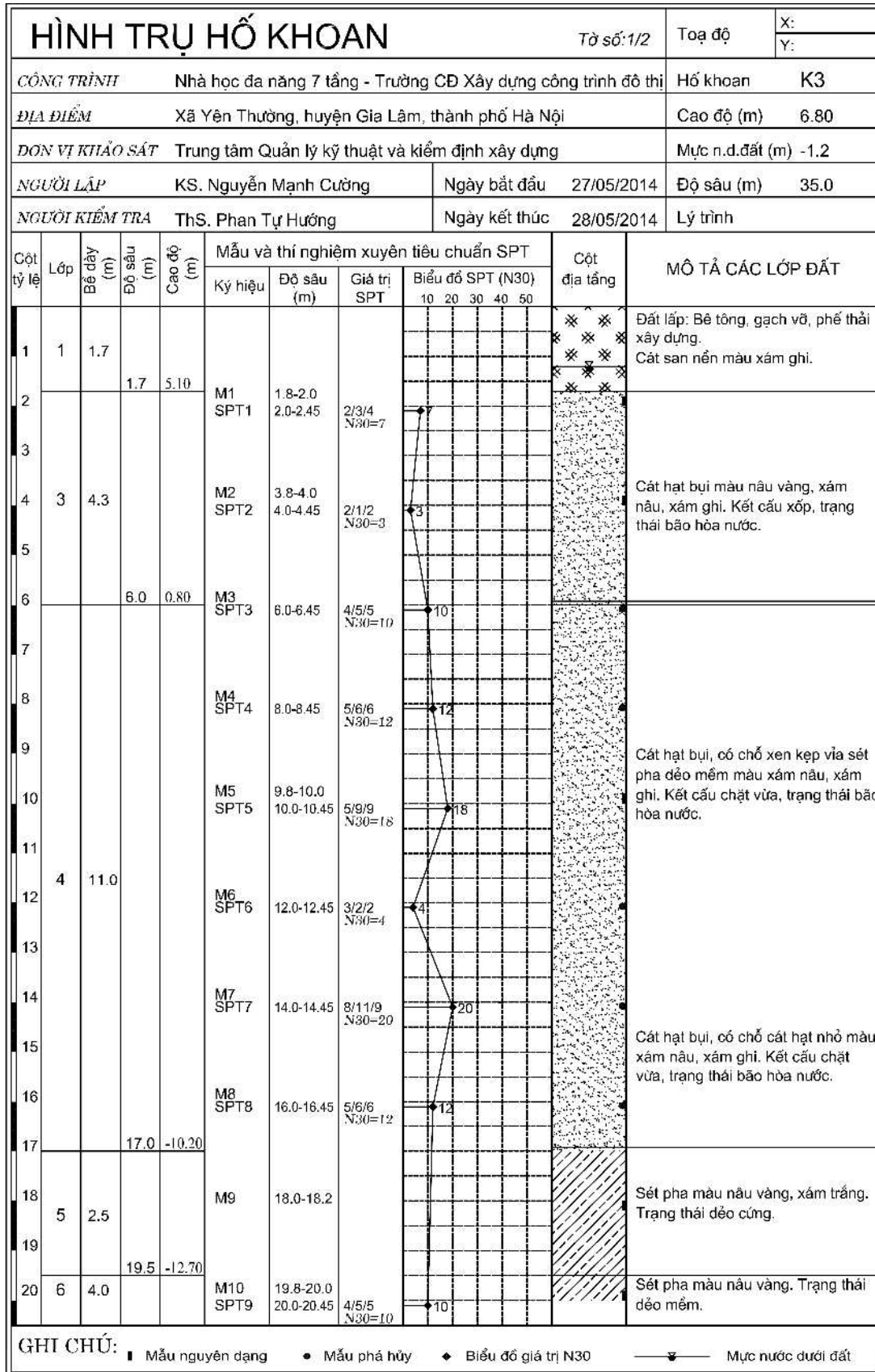

Source: CUWC

Figure 2.1.5 Soil Boring Log (K3) on Multifunctional Building

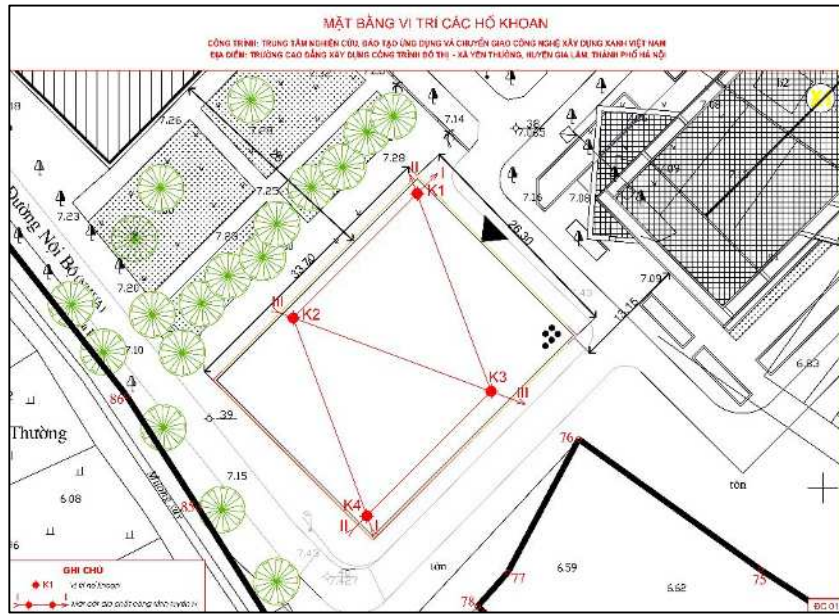

Source: CUWC

Figure 2.1.6 Location Map of Geological Survey on Green Technology Building

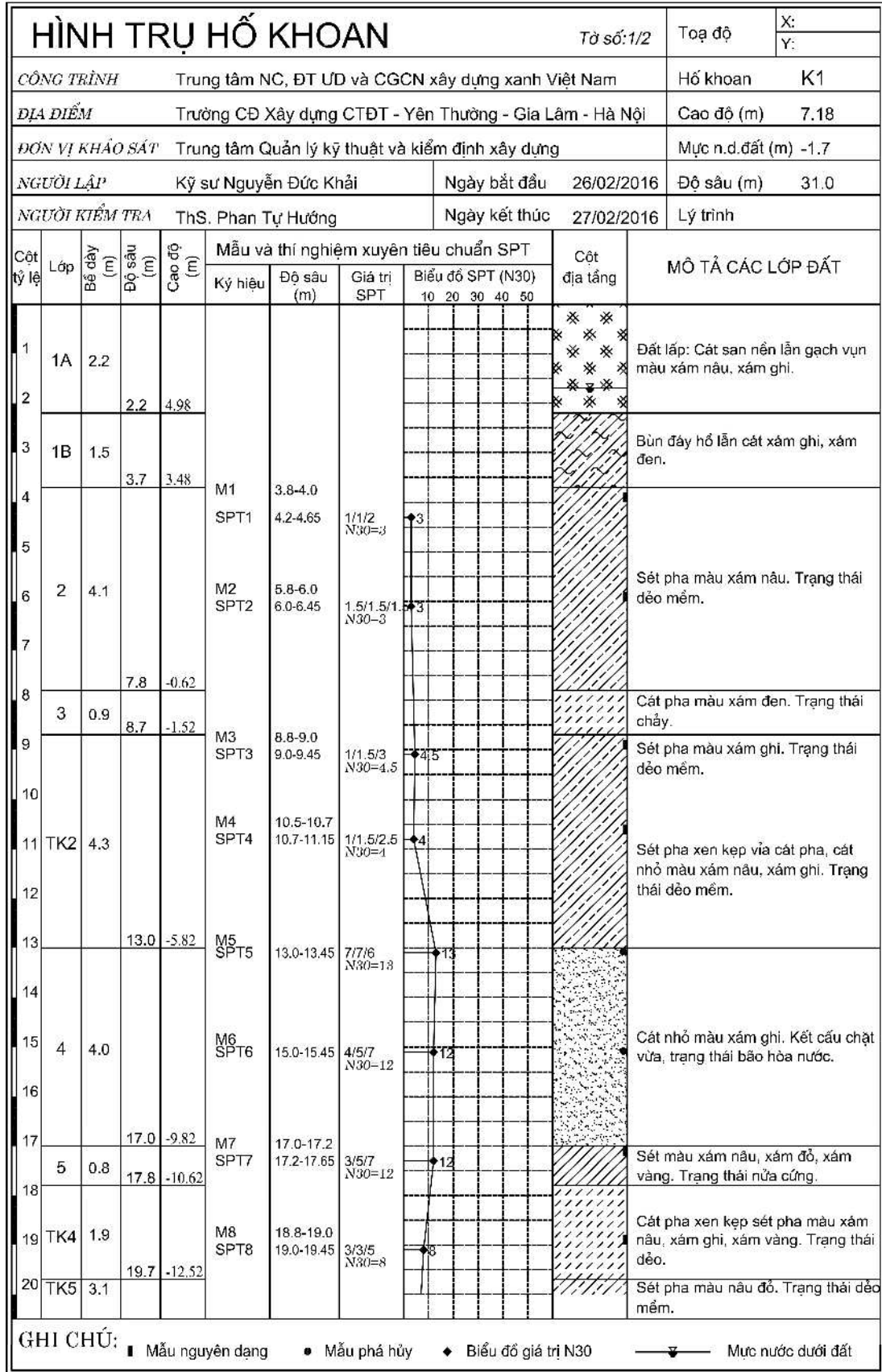

Source: CUWC

**Figure 2.1.7 Soil Boring Log (K1) on Green Technology Building**

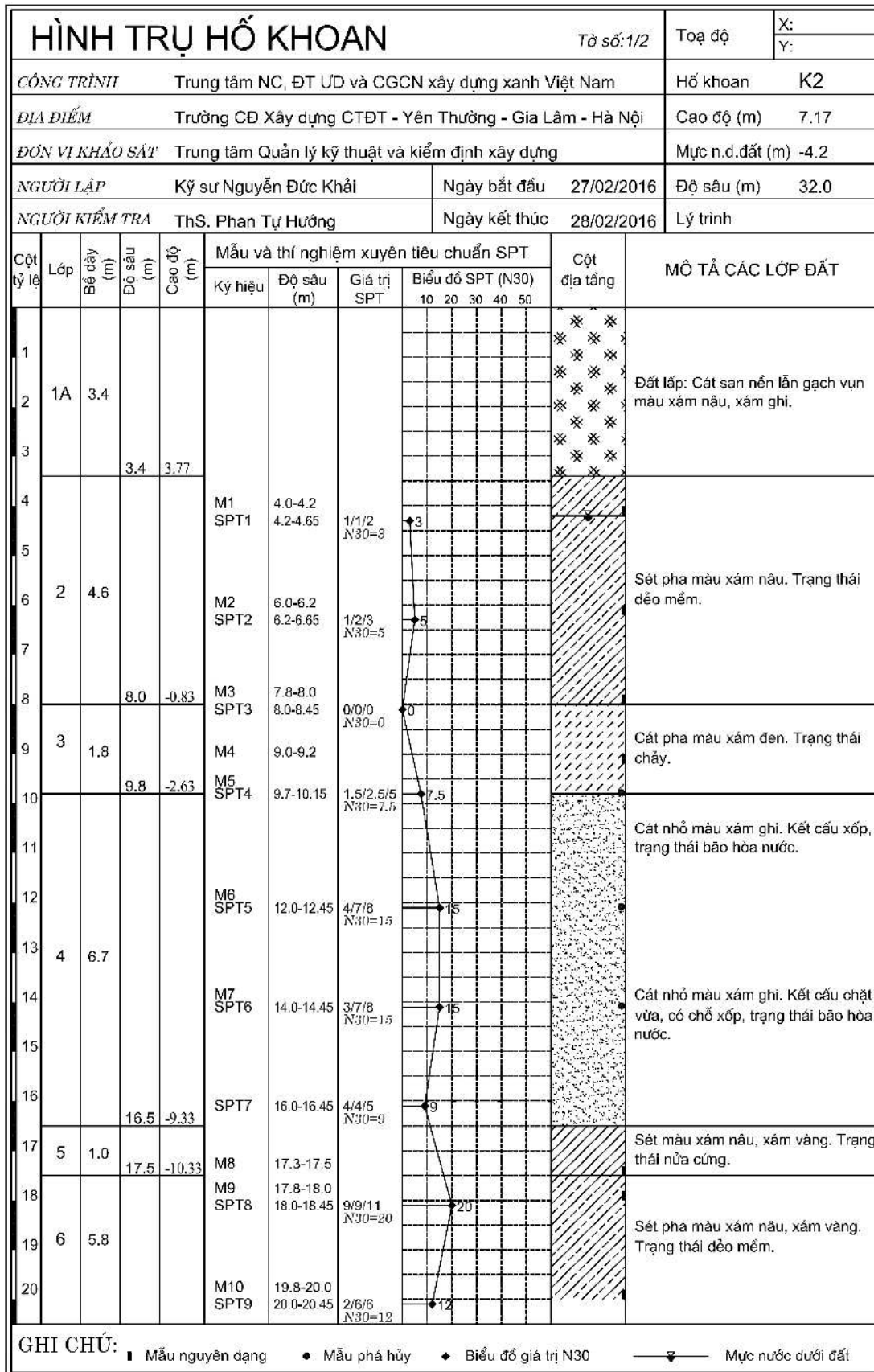

Source: CUWC

Figure 2.1.8 Soil Boring Log (K2) on Green Technology Building

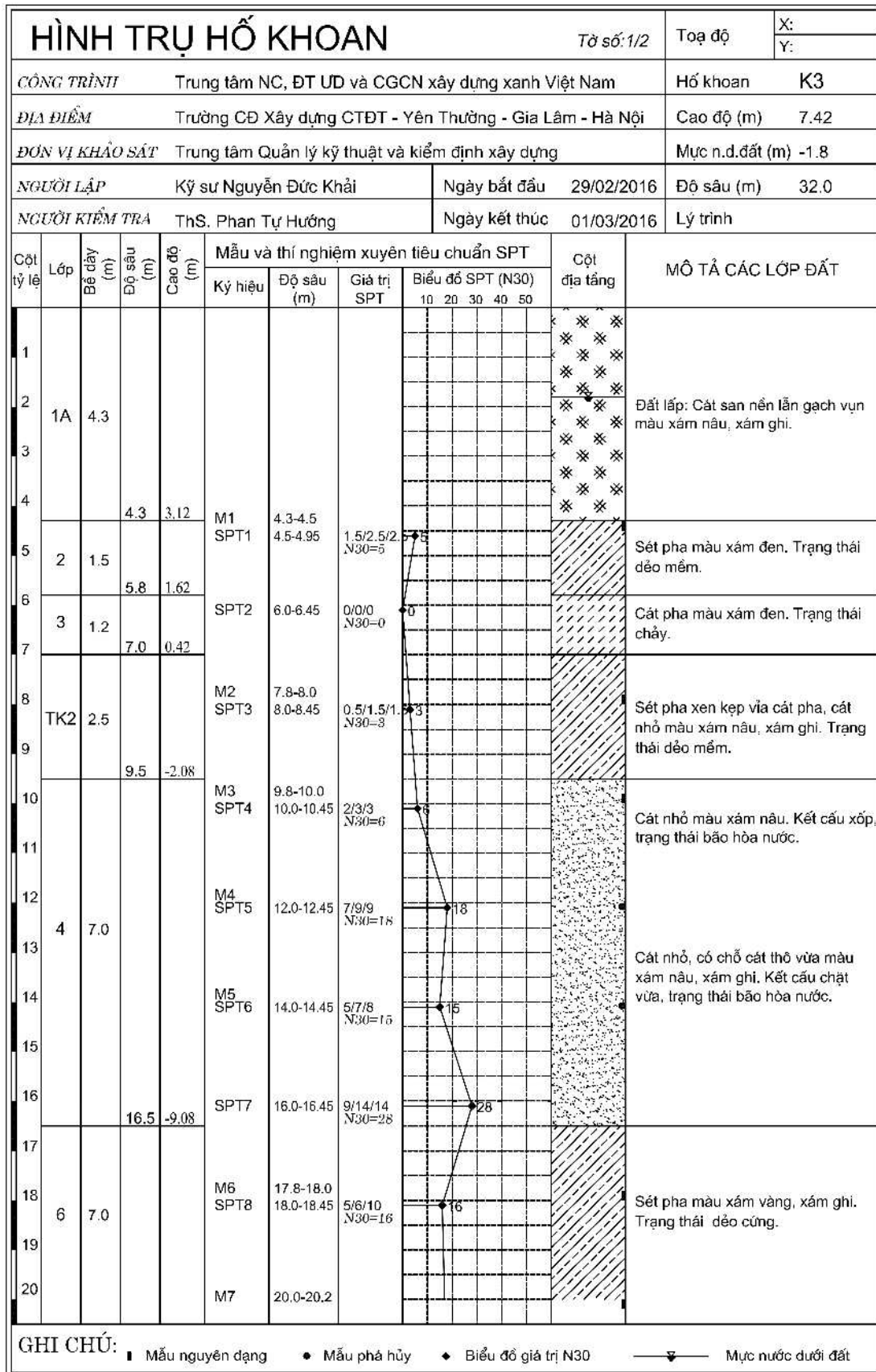

Source: CUWC

Figure 2.1.9 Soil Boring Log (K3) on Green Technology Building



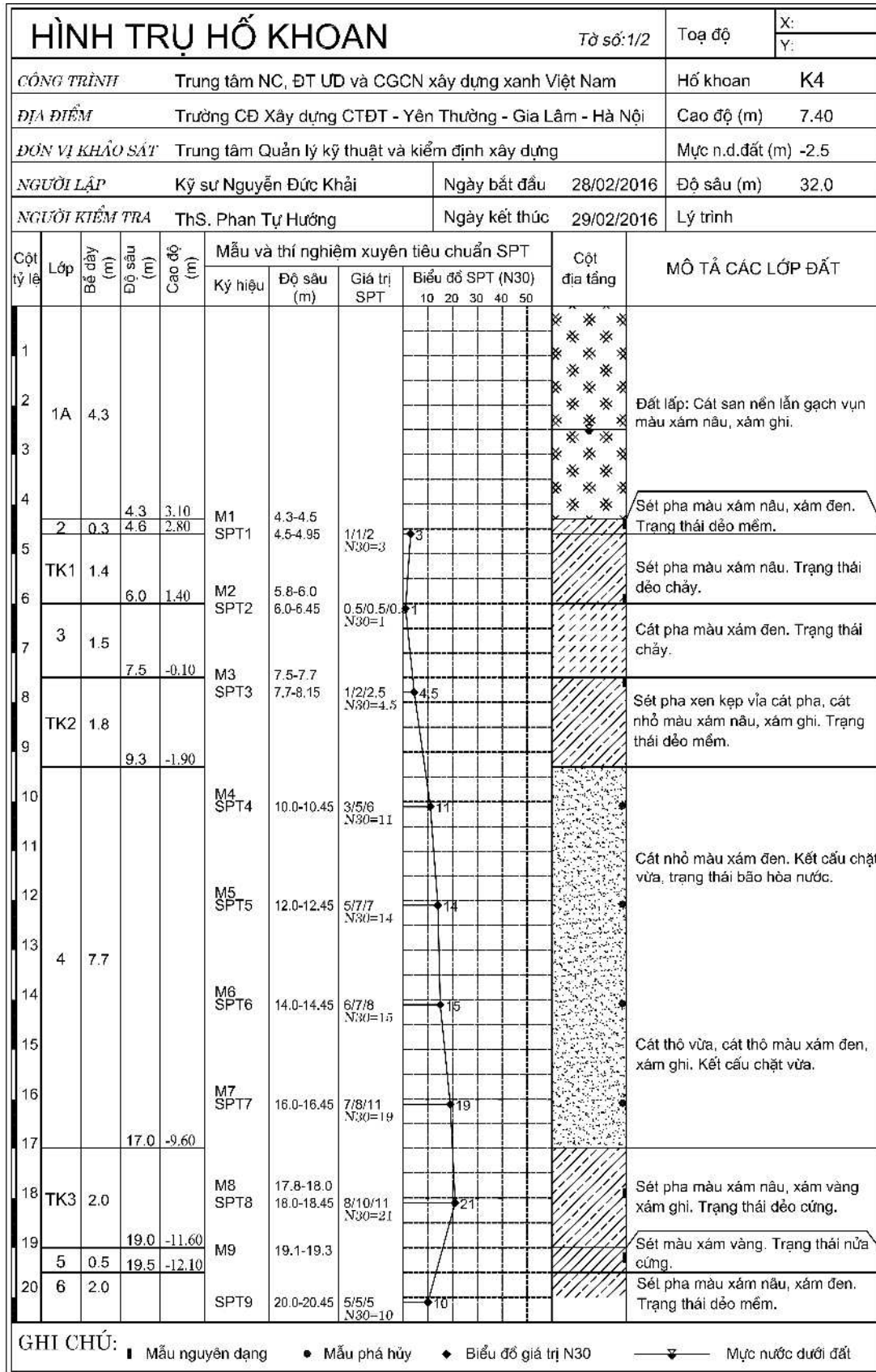

Source: CUWC

Figure 2.1.10 Soil Boring Log (K4) on Green Technology Building

### 2.1.3 Water Quality Survey

About existing condition of drainage system in CUWC, the system is combined with stormwater and gray water. Human waste from buildings/toilets is collected and pre-treated in septic tanks, and discharge into existing drainage of the college. And, human waste from some households above the garage is collected and pre-treated in septic tanks under the garage. These septic tanks are often clogged and dredged 1-2 times a year. Gray water from the kitchen of canteen and laundry drain of the dormitory are not treated in treatment facilities, and it directly discharge into existing drainage.

The samples water of drainage and lake were taken at junction boxes in January 2019 and tested in laboratory of the college. The results are shown in the table below.

**Table 2.1.1 Result of Water Quality Survey (1)**

No.	Parameters	Unit	Class A	Result of Water Quality					
				No.1	No.2	No.3	No.4	No.5	No.6
1	pH	-	5 - 9	8.2	8.3	8.3	8.2	8.5	8.5
2	BOD <sub>5</sub> (20° C)	mg/l	30	14.2	8.2	13.7	<u>325</u>	<u>300</u>	<u>195</u>
3	Total suspended solids (TSS)	mg/l	50	15	13	10	<u>130</u>	<u>70</u>	24
4	Ammonium Nitrogen (NH <sub>4</sub> -N)	mg/l	5	<u>24</u>	0.5	<u>27</u>	90	<u>93.5</u>	<u>36.6</u>
5	Nitrate (NO <sub>3</sub> <sup>-</sup> ) (as N)	mg/l	30	21	3	20	<u>140</u>	<u>210</u>	<u>70</u>
6	Phosphates (PO <sub>4</sub> <sup>3-</sup> ) (as P)	mg/l	6	0.3	1	0.5	<u>18.8</u>	<u>34.2</u>	<u>8.4</u>

Note: Sampling 07/Jan/2019, Standard water quality on QCVN14: 2008 / BTNMT  
Source: CUWC

**Table 2.1.2 Result of Water Quality Survey (2)**

No.	Parameters	Unit	Class A	Result of Water Quality (No.1)		
				Time 8:30	Time 11:30	Time 17:30
1	pH	-	5 - 9	8.2	8.2	8.2
2	BOD <sub>5</sub> (20° C)	mg/l	30	14.2	<u>43</u>	16
3	Total suspended solids (TSS)	mg/l	50	15	<u>66</u>	17
4	Ammonium Nitrogen (NH <sub>4</sub> -N)	mg/l	5	<u>24</u>	<u>19</u>	<u>17</u>
5	Nitrate (NO <sub>3</sub> <sup>-</sup> ) (as N)	mg/l	30	21	<u>33</u>	25
6	Phosphates (PO <sub>4</sub> <sup>3-</sup> ) (as P)	mg/l	6	0.3	0.5	0.3

Note: Sampling 14/Jan/2019, Standard water quality on QCVN14: 2008 / BTNMT  
Source: CUWC.



Source: JICA Consultant Team

**Figure 2.1.11 Sampling and Laboratory in CUWC**

The location of sampling water is shown in the Figure below.

- No.1: Manhole near dormitory (B8) (3 times/day)
- No.2: Youth Union pond
- No.3: Duc Tu lake
- No.4: Outlet of septic tank behind dormitory (B8)
- No.5: Manhole behind building (A12)
- No.6: Manhole behind Head Office (A2)

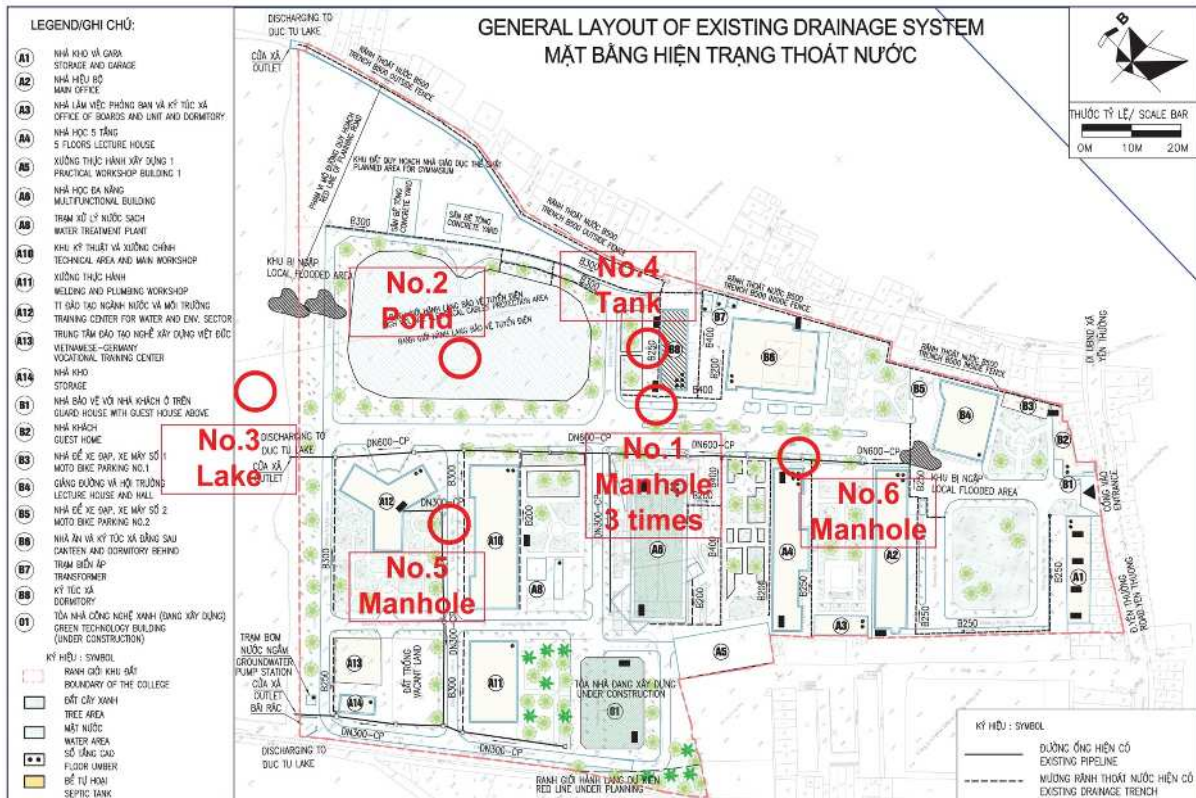

Source: JICA Consultant Team

Figure 2.1.12 Location of Sampling

## 2.2 Related Plan

### 2.2.1 Drainage System Mater Plan on Hanoi City

According to the Mater Plan of Drainage System by 2030 on Hanoi City, these catchments areas included CUWC is planned as "N9 Zoning" in the study. There are 3 catchments in the zoning as the below.

- (1) North-West Catchment (with area of 858 ha): discharging into Duc Tu Wastewater Treatment Plant with capacity of 65,000 m<sup>3</sup>/day;
- (2) The catchment including Yen Vien Town in north of Ha Huy Tap Road: discharging into Yen Thuong Wastewater Treatment Plant with capacity of 10,000 m<sup>3</sup>/day;
- (3) Last catchment discharges into Yen Vien Wastewater Treatment Plant with capacity of 10,000 m<sup>3</sup>/day;

The college is located in the catchment (2) as shown in the figure below.

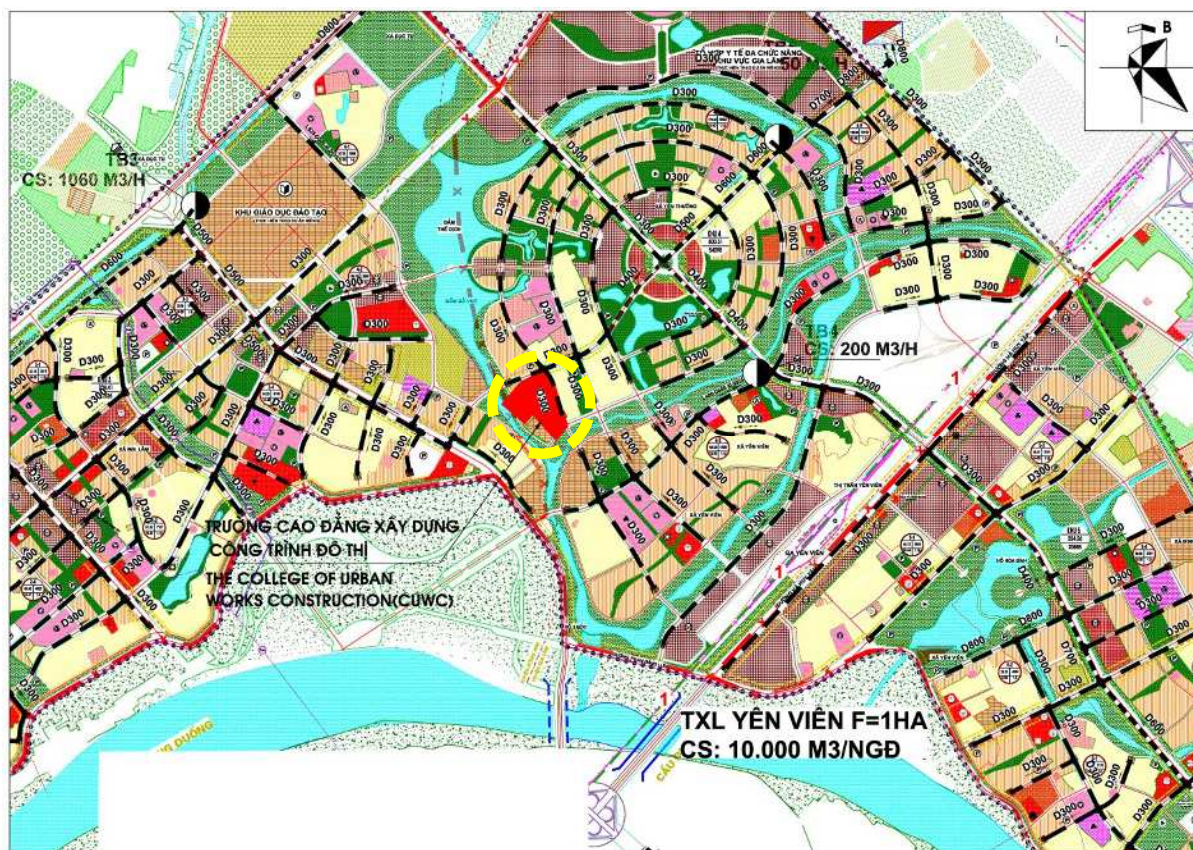

Source: Vietnam Water, Sanitation and Environment Joint stock company

**Figure 2.2.1 Mater Plan of Drainage System by 2030 (N9 Zoning)**

### 2.2.2 Admission Plan of CUWC

The Admission Plan of CUWC by 2030 is calculated by data of students, residences in dormitory and staffs of the college and presented in table below.

**Table 2.2.1 Admission Plan of CUWC by 2030**

No.	Object	Existing number (person)	Forecast 2030 number (person)	Remarks
1	College	900	2,500	3 years course
	Intermediate	1,200	3,500	1.5 years course
	Pre-intermediate	450	1,000	1.5 years course
	Short-term training courses	188	188	For 8 months
	Other training courses	250	250	For 8 months
2	Lectures and staffs	201	244	
3	Dormitory	638	878	
4	Canteen	600	750	Lunch + Dinner
5	Tenement (A1)	40	40	
	Total	4,467	9,350	

Source: JICA Consultant Team (Based on the Admission Plan of CUWC by 2030)

### 2.2.3 Construction Plan of CUWC

The CUWC have the construction plan of new buildings. The CAD data of the construction plan which is received from CUWC use for base map for sewage system.



Source: CUWC

Figure 2.2.2 Construction Plan of CUWC

## 2.3 Exiting Facilities

### 2.3.1 Underground Facilities

The collected data of underground facilities is for the below.

- Water distribution pipe
- Electrical cable
- Drainage (by existing drawing and on-site survey)

The result of survey is compiled to the drawing "Layout of Existing Underground Facilities".

### 2.3.2 Well and Water Treatment Plant



Source: JICA Consultant Team

**Figure 2.3.1 Well in CUWC**



Source: JICA Consultant Team

**Figure 2.3.2 Water Treatment Plant in CUWC**

About the water supply facility in CUWC, there are the well and the water treatment plant funded by the French ODA which is supplying treated water for whole college and surrounding residential area. The operation conditions of the WTP are not monitored and recorded regular so it is difficult to assess. The existing capacity of WTP is about 200-300 m<sup>3</sup>/day. Based on the capacity of existing well pump, the maximum demand is about 250-300 m<sup>3</sup>/day because the flow of pump is 350-1,300 liters/minute and it's operated in 4-6 hours per day. At the beginning of October, the College has monitored and recorded, and at the end of November, the average water consumption is about 210 m<sup>3</sup>/day.

### 2.3.3 Septic Tank

Human waste from buildings/toilets is collected and pre-treated in septic tanks. These septic tanks are not adapted gray water from the kitchen of canteen or laundry drain of the dormitory.



Source: JICA Consultant Team

**Figure 2.3.3** Septic Tank in CUWC

### 2.3.4 Electric Facilities

Existing electric facilities works of the college have been built in the past and is continuing to be invested under issued plan including.

- Completed internal roads connect all facilities and traffic works in the College by concrete or asphalt roads with width of 3.5m to 7.5m.
- Power supply: There is a transformer with capacity of 320KVA. The electric cables from transformer to facilities are put underground on cable trenches.



Source: JICA Consultant Team

**Figure 2.3.4** Transformer and Electric Cable in CUWC

## **CHAPTER 3 CONCEPTS FOR DEVELOPMENT OF SEWERAGE SYSTEM**

### **3.1 Concept of Planning Area**

About catchment area model of sewerage system, in general, it is economic and easy to minimize the number of sewage treatment plant. However, planning several sewage treatment plants become economic when the centralized treatment area is distributed in several locations or existing sewage treatment plant is available.

According to the master plan of sewerage system by 2030 on Hanoi city, the study area of CUWC is planned N9 zoning area (as North-West catchment). However, the plan is not to be implemented immediately.

Regarding determination of the concept of sewerage system in CUWC, it shall be studied to the decentralized treatment to make early effect of the project even if the large treatment area is reasonable like the master plan. Therefore, on this project, small sewerage system is proposed inside CUWC area. And, the sewerage facilities will be used "experiential training" facilities on site for participants of the sewerage system training.

### **3.2 Method of Development**

For method of development the project, it is necessary to study the financial sources of construction cost and O&M cost to define the investment amount.

In the case of public sewerage system, generally, financial resources of construction cost include i) financial support from international financial institution or bilateral financial supporting organization, ii) subsidy or debt loan from the central government, fundamental fund, own fund of project implementation organization (generally local government), iii) private-sector fund, iv) beneficiary liability. It is necessary to consider the funding method that combines the above-mentioned financial resources effectively.

In the case of this project in CUWC, generally, financial resources of construction cost will be done by subsidy or debt loan from the central government, fundamental fund, own fund of project implementation organization. In addition, i) private-sector fund (with trial operation for promotion of their technologies), ii) pilot /model project by JICA fund are thought as other methods. The funding method of financial resources will be considered on feasibility study as next step, so it still hasn't been decided.

### **3.3 Collection System**

#### **3.3.1 Type of Collection System**

The type of sewerage system must be determined by taking into account the topography, meteorology, and the present condition of wastewater/storm drainage facilities.



There are mainly two types of sewerage system as "Separate" and "Combined". The separate system carries sanitary wastewater and stormwater in different conduits, while the combined system receives and convey both sanitary wastewater and stormwater in the same conduit. Besides these, "Interceptor" system is widely adopted in Vietnam. On the interceptor system, existing drainage pipe is used for transferring sewage and rainwater, and CSO (Combined Sewer Overflow) and interceptor (sewage transferring pipe) is newly installed as same as combined system, but septic tank remains.

### 3.3.2 Selection of Collection System

In this project, the separate sewerage system is adopted by the following reasons.

- As two separate sewers are provided to carry sewage and storm water, the volume of sewage to be inflow/treated at sewerage treatment plant is small due to which cost of the plant can be made economical.
- The separate system is generally cheaper due to the fact that only sanitary sewage is required to be taken in closed sewer. In the case of using a part of existing drainage, the storm water can be taken in small drains which are constructed with much less cost.
- There is no fear of stream/lake pollution in the separate system, since without CSO. (On the combined system, there may be some overflow in heavy rain)
- This project is intended for provide various "experiential training" facilities to learn exceptional technique of Japan. The separate system is widely adopted in Japan on nowadays. Hence, the system can effectively utilize exceptional technique/material like house connection and house inlet etc. in Japan.

**Table 3.3.1 Selection of Collection System**

Collection system	Separate sewerage system
-------------------	--------------------------

Source: JICA Consultant Team

## CHAPTER 4 BASIC CONDITIONS OF PLAN

### 4.1 Planned Target Year

In case that the target year of public sewerage system was planned to be set for 10 or 20 years, the target area is supposed to be formulated based on the degree of development plan in the city or basin (region) after 10 or 20 years.

In this project, the future population follow to the Construction Master Plan 2030 of CUWC.

**Table 4.1.1 Planned Target Year**

Target year	2030
-------------	------

Source: JICA Consultant Team

### 4.2 Collection Area

The collection area is all buildings and facilities in boundary of CUWC, and the area is about 5.0 ha. In basically, the collection area of sewage system and drainage system is same, but inflow of rainwater from outside is including in the collection area of drainage system.

**Table 4.2.1 Collection Area**

Collection area	About 5.0 ha
-----------------	--------------

Source: JICA Consultant Team

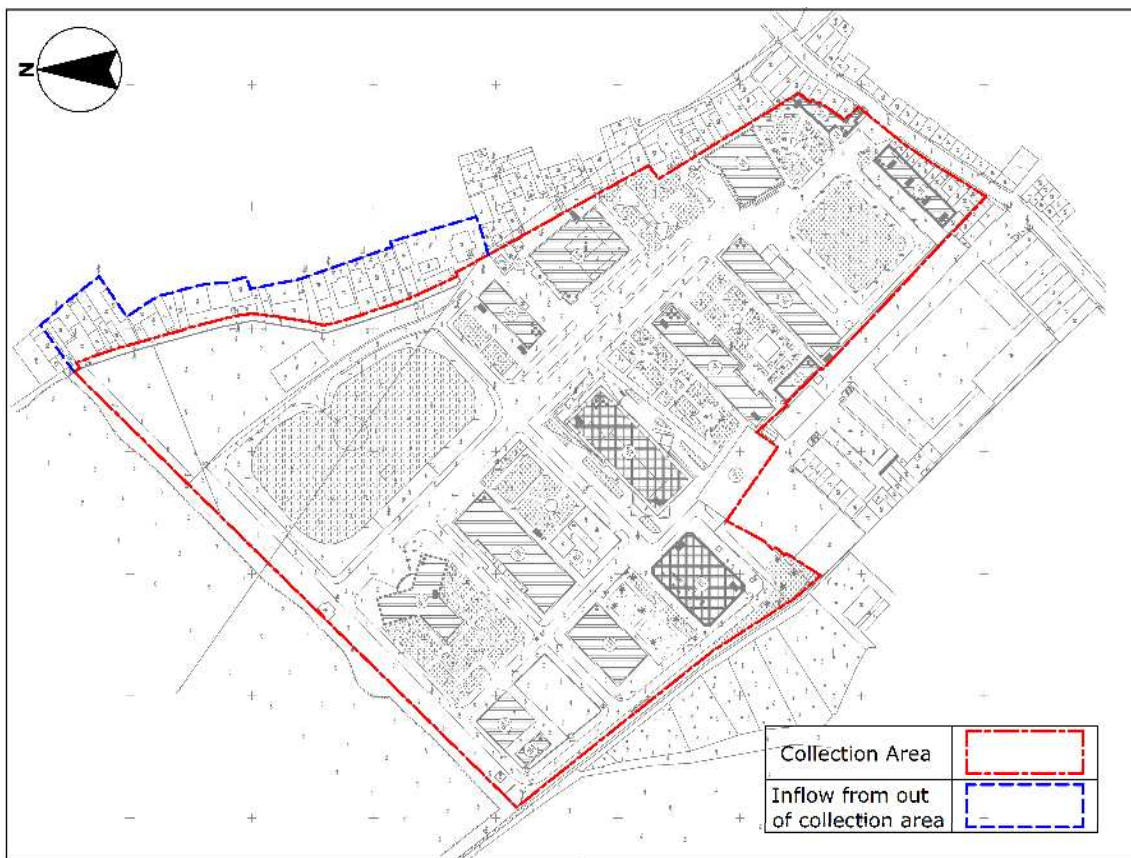

Source: JICA Consultant Team

**Figure 4.2.1 Collection Area of the Project**

### 4.3 Frame of Population

#### 4.3.1 Basis of Population Forecast

Based on discussion with staff of Equipment Management Department of CUWC, the maximum service capacity of each building / facility is shown in the table below.

**Table 4.3.1 Maximum Service Capacity of Each Building**

No.	Main facilities	Maximum number of residence or /student/staff (person)
1	Storage and Garage A1 (households above)	8 HHs x 5 residences (= 40 person)
2	Main Office A2	150 students + 50 lectures and staffs
3	Office of Boards and Unit and Dormitory A3	80 residences
4	5 floors Lecture House A4	50 residences + 700 students + 50 lectures and staffs
5	Workshop for Construction Practices No. 1 A5	It will be destroyed in future
6	Multifunctional Building A6	1,450 students and 50 staffs *
7	Workshop for construction practices No. 2 A7	now it is destroyed and rebuilt Green Technology Building with 300 students + 50 staffs expected *
8	Water Treatment Plant A8	-
9	Electric Practices Workshop A9 (now is destroyed and rebuilt Green Technology Building)	150 students and staffs (no septic tank)
10	Technical area and Main Workshop A10	200 students + 20 staffs
11	Welding and Plumbing Workshop A11	120-150 students (no septic tank)
12	Training Center for Water and Environment Sector A12	meeting and working area for 100 persons
13	Vietnam Germany Vocational Training Center A13	meeting and working area for 80 persons (no septic tank)
14	Workshop for bench and assembly practices A14	now is storage (no septic tank)
15	Guard House with Guest house above B1	30 residences
16	Guest House B2	60 residences
17	Moto bike parking No.1 B3	-
18	Lecture House and Hall B4	200 persons (no septic tank)
19	Moto bike parking No.2 B5	-
20	Canteen and dormitory behind B6	500 guests and 330 students
21	Transformer B7	-
22	Dormitory B8, B8 (future)	378 residences + 378 residences (future)
23	Gymnasium (future)	200 persons (future)

Note: \* Forecast based on the drawing.

Source: CUWC

**Table 4.3.2 Number of beds in Dormitories**

No.	Name of dormitory	Number of current residences in October 2018 (person)	Number of maximum beds (bed)
1	Dormitory – B1	10	30
2	Dormitory – B2	54	60
3	Dormitory – B6	200	330
4	Dormitory – B8	304	(378)
5	Dormitory – B8 (future)	-	378

No.	Name of dormitory	Number of current residences in October 2018 (person)	Number of maximum beds (bed)
6	Dormitory – A3	70	80
	Total	638	878

Note: Dormitory–B8 will be connected Johkasou. It is not counted in here.

Source: CUWC

### 4.3.2 Frame of Population for Sewer Pipe

Maximum frame of population of each building is calculated under collected data of students, residences in dormitory and staffs of the College and presented in table below.

**Table 4.3.3 Maximum Frame of Population of Each Building**

Area No.	Main facilities	Number of maximum Population (person)
1	A1 Tenement	40
2	A2 (students)	150
	A2 (staffs)	50
	A3 Dormitory	80
3	A4 Residences	50
	A4 (students)	700
	A4 (staffs)	50
4	A6 (students)	1,450
	A6 (staffs)	50
5	Green Building (students)	300
	Green Building (staffs)	50
6	A10 (students)	200
	A10 (staffs)	20
7	A12 (trainee)	100
8	B1+B2 Dormitory	90
9	B6 Canteen	500
	B6 Dormitory	330
10	B8 Dormitory	378
	B8 Dormitory [future 2030]	378
11	Gymnasium [future 2030]	200
	Total	5,166

Source: JICA Consultant Team

### 4.3.3 Frame of Population for Sewage Treatment Plant

The CUWC have some classes in the morning, the afternoon and the evening (not regularly). The students and staffs use the canteen in lunch time and dinner time. Therefore, the number of users on daily maximum is larger than maximum frame of population of each building.

Based on the admission plan of CUWC by 2030, the maximum frame of population for sewage treatment plant (STP) is calculated under collected data of students, residences in dormitory and staffs of the college and presented in table below.

**Table 4.3.4 Maximum Frame of Population for Sewage Treatment Plant**

No.	Object		Existing number (person)	Forecast 2030 number (person)	Remarks
1	Students	College	900	2,500	3 years course
		Intermediate	1,200	3,500	1.5 years course
		Pre-intermediate	450	1,000	1.5 years course
		Short-term training courses	188	188	For 8 months
		Other training courses	250	250	For 8 months
2	Lectures and staffs		201	244	
3	Dormitory		638	878	
4	Canteen		600	750	Lunch + Dinner
5	Tenement (A1)		40	40	
	Total		4,467	9,350	

Source: JICA Consultant Team (Based on the admission plan of CUWC for 2030)

#### 4.4 Unit Amount of Sewage

##### 4.4.1 Unit Amount of Sewage

In general, the water supplied to ordinary households is said to change according to lifestyle, the spread of water use equipment, or family composition. In addition, the commercial water is supplied to shops, restaurants, educational facilities, public offices, offices, school and service facilities, etc., and it is largely dependent on land use and city characteristics. In Vietnam, the water consumption unit shall be set by TCVN 4513:1998 (Internal water supply - Design standards).

The unit amount of sewage is calculated based on the water consumption unit of daily water as described above, and the amount of infiltration and inflow as underground penetration is added in it. The unit amount of sewage referring from TCVN 4513:1998 is shown in table below.

**Table 4.4.1 Unit Amount of Sewage**

No.	Water use place	Unit	Unit amount (liter)	Remarks
1	School (student)	1 person	20	TCVN 4513:1998
2	Lectures and staffs	1 person	76	From the regulation 99:1999
3	Dormitory	1 person (bed)	100	TCVN 4513:1998
4	Canteen	1 person	25	TCVN 4513:1998
5	Tenement	1 person	150	TCVN 4513:1998
6	(Infiltration)*	-	(10 %)	TCVN 7957:2008

Note: \* The Amount of infiltration and inflow can be estimated by "total daily average amount" x 10 %.

Source: TCVN 4513:1998 Internal water supply - Design standards

##### 4.4.2 Fluctuation Rate (Peak Coefficient)

###### (1) Fluctuation Rate of Sewer Pipe

For designing of sewer pipe as hourly maximum sewage flow rate, the fluctuation rate (Ko) is referred as the table below. It is set based on TCVN 7957:2008 (Drainage and Sewerage - External Network and Facilities - Design Standard) depending on the average sewage flow rate. When the average sewage flow rate is less than 5 l/s, Ko max coefficient is determined to be 5.0.

**Table 4.4.2 Fluctuation Rate of Sewer Pipe**

Coefficient	Average sewage flow rate (l/s)								
	5	10	20	50	100	300	500	1000	>5000
Ko max	2.5	2.1	1.9	1.7	1.6	1.55	1.5	1.47	1.44

Coefficient	Average sewage flow rate (l/s)								
	5	10	20	50	100	300	500	1000	>5000
Ko min	0.38	0.45	0.5	0.55	0.59	0.62	0.66	0.69	0.71

Source: TCVN 7957:2008 Drainage and Sewerage - External Network and Facilities - Design Standard

## (2) Fluctuation Rate of Inflow into Sewage Treatment Plant

In general, the peak coefficient depends on many factors, such as the effects of flow from domestic, commercial, and public facilities, and the socioeconomic conditions in the area. The facilities must be designed to apply to the largest sewage flow. Peak coefficient 1.3 for direct area and 1.4 for indirect area are applied to the target area according to TCVN7957:2008.

### 4.5 Planned Sewage flow rate

#### 4.5.1 Planned Sewage flow rate into Sewer Pipe

Since this project is small sewerage system as targeted to the college, the flow rate of sewage should be calculated in detail by each building in CUWC. The flow rate of sewage by each building is used to calculate the flow rate of pipes by point injection method. For designing of sewer pipe as hourly maximum sewage flow rate, the sewage flow rate on the flow rate calculation sheet take advantage of fluctuation rate (Ko). Planned sewage flow rate into sewer pipe is shown to the table below.

**Table 4.5.1 Planned Sewage Flow rate into Sewer Pipe**

Area No.	Main facilities	Population (person)	Unit amount (l/person/day)	Sewage flow rate (m <sup>3</sup> /day)	Sewage flow rate (l/sec)
1	A1 Tenement	40	120	4.80	0.000056
2	A2 (students)	150	20	3.0	0.000035
	A2 (staffs)	50	76	3.8	0.000044
	A3 Dormitory	80	100	8.0	0.000093
3	A4 Residences	50	100	5.0	0.000058
	A4 (students)	700	20	14.0	0.000162
	A4 (staffs)	50	76	3.8	0.000044
4	A6 (students)	1,450	20	29.0	0.000336
	A6 (staffs)	50	76	3.8	0.000044
5	Green Building (students)	300	20	6.0	0.000069
	Green Building (staffs)	50	76	3.8	0.000044
6	A10 (students)	200	20	4.0	0.000046
	A10 (staffs)	20	76	1.5	0.000018
7	A12 (trainee)	100	76	7.6	0.000088
8	B1+B2 Dormitory	90	100	9.0	0.000104
9	B6 Canteen	500	25	12.5	0.000145
	B6 Dormitory	330	100	33.0	0.000382
10	B8 Dormitory	378	100	37.8	0.000438
	B8 Dormitory [future]	378	100	37.8	0.000438
11	Gymnasium [future]	200	20	4.0	0.000046
	Total	5,166	-	232.2	0.002688

Source: JICA Consultant Team

#### 4.5.2 Planned Sewage Flow Rate into Sewage Treatment Plant

The planned sewage flow rate into sewage treatment plant is calculated based on unit amount of sewage and the admission plan of CUWC by 2030, and it is shown in table below.

**Table 4.5.2 Planned Sewage Flow Rate into Sewage Treatment Plant**

No.	Object	Forecast 2030 Number (person)	Unit amount (liter/person/day)	Sewage flow rate (m <sup>3</sup> /day)
1	Students	College	2,500	50
		Intermediate	3,500	70
		Pre-intermediate	1,000	20
		Short-term training courses	188	4
		Other training courses	250	5
2	Lectures and staffs	244	76	19
3	Dormitory	878	100	88
4	Canteen	750	25	19
5	Tenement (A1)	40	120	5
6	Infiltration	-	(10 %)	28
	Total	9,350	-	308 (Round 310)

Source: JICA Consultant Team

On this project, the frame of population for sewage treatment plant is calculated as maximum amount based on the admission plan of CUWC by 2030. On the premise of these, the daily average sewage flow is about 70 to 80 % of the daily maximum sewage flow rate (referenced the design standard for sewerage system by Japan Sewage Works Association). The factor 75 % as intermediate value is adopted to the fluctuation rate for sewage treatment plant.

**Table 4.5.3 Planned Sewage Flow rate into Sewage Treatment Plant**

Items	Fluctuation rate	Sewage flow rate (m <sup>3</sup> /day)
Daily average sewage flow rate	0.75	232
Daily maximum sewage flow rate	1.00	310

Source: JICA Consultant Team

#### 4.6 Unit Pollutant Load of Sewage

On setting of inflow quality into sewage treatment plant, while BOD and SS are mainly used as a parameter of inflow of water quality, COD and nutrition concentrations (T-N, T-P) should also be examined at the discharging point in the public water body. In Vietnam, pollution load per person in domestic waste water is determined in according to TCVN 7957:2008. The unit pollution load is shown in table below. And Japan standards are attached for referring.

**Table 4.6.1 Unit Pollutant Load of Sewage in Vietnam**

Parameter	Unit pollution load (g/person/day)
Suspended solid (SS)	60-65
BOD <sub>5</sub> of sediment sewage	30-35
BOD <sub>5</sub> of un-sediment sewage	65
Ammonia (N-NH <sub>4</sub> )	8
Phosphate (P <sub>2</sub> O <sub>5</sub> )	3.3
Chloride (Cl <sup>-</sup> )	10
Surfactant	2.0-2.5

Source: TCVN 7957:2008

**Table 4.6.2 Unit Pollutant Load of Sewage in Japan**

Parameter	Unit pollution load (g/person/day)	Breakdown (g/person/day)	
		Human waste	Grey water
BOD <sub>5</sub>	58	18	40
COD	27	10	17
SS	45	20	25
T-N	11	9	2
T-P	1.3	0.9	0.4

Source: Japan Sewage Works Association

#### 4.7 Planned Pollutant Load of Sewage

In generally, planned pollutant load into sewage treatment plant is calculated using with unit pollutant load of sewage, planned population, and sewage flow rate (average) against each facility/building. Since this study is preliminary master plan, the planned pollutant load roughly is calculated using the simple method (average rate of unit sewage amount) is shown in table below.

**Table 4.7.1 Planned Pollutant Load of Sewage (by Simple Method)**

Parameter	Unit pollutant load (g/p/d)	Use rate*	Target unit pollutant load (g/p/d)	Planned Population (person)	Pollutant load (kg/day)	Average Sewage flow rate (m <sup>3</sup> /day)	Inflow quality into STP (mg/l)
BOD <sub>5</sub>	58	0.08	4.6	9,350	43.0	232	185
COD	27		2.2		20.6		89
SS	45		3.6		33.7		145
T-N	11		0.9		8.4		36
T-P	1.3		0.1		0.9		4

Note: The use rate is roughly estimated by the average rate of unit sewage amount. There are many types of sewage source in CUWC like students, staffs, dormitory, canteen etc. On this stage, the rate is roughly estimated by the average on total.

The rate (20/250=0.08) is based on the students average as 20 l/person/day and the general average as 250 l/person/day.

Source: JICA Consultant Team

#### 4.8 Rainfall Intensity of Drainage Planning

##### 4.8.1 Probability Year of Rainfall

The intensity of rainfall is generally indicated by assumed hourly rainfall flow, and unit is shown as "mm/hour", and the probability year means what year is occurrence interval of some intensity of rainfall.

If the probability year is determined as 20 to 30 years and more for short duration rainfall, prevention of inundation (flood) is more safety. However, the development of sewer is not economical due to increasing construction cost. While, if the target rainfall occurs a few times per year, frequency of inundation is high, and purpose of sewerage facilities is not achieved. Thus, the probability year is basically determined as 5 to 10 years for planning and design of sewer. In Vietnam, the probability year (the rainfall frequency) is determined to the Vietnam Standard TCVN 7957:2008. Normally it is designed with the probability year of 5-10 years for primary drainage system (Grade I) and 2 years for secondary drainage system (Grade II). 2 years as probability year is adapted to drainage system in CUWC.

**Table 4.8.1 Probably Year of Urban Area**



City properties	Facility scale		
	Canal, river	Main sewer	Branch sewer
Special and grade I city	10	5	2 - 1
City grade II, III	5	<u>2</u>	1 - 0.5
Other town and city	2	1	0.5 - 0.33

Source: TCVN 7957:2008

#### 4.8.2 Formulas for Intensity of Rainfall

##### (1) Rational Formula

The rational formula is the most suitable to estimate planned runoff flow of rainfall. The rational formula is below.

$$Q_t = I / 360 \times C \times I \times A$$

Where,

Q: The planned maximum runoff flow of rainfall (m<sup>3</sup>/s), C: Outflow coefficient, I: Intensity of rainfall during concentration time of “t”, A: Catchment area (ha)

##### (2) Rainfall Intensity Formula

According to TCVN7957:2008, rainfall intensity formula is adapted to the below.

$$q = \frac{A(1 + C \lg P)}{(t + b)^n}$$

Where,

q: Rainfall intensity (l /s.ha),

t: Concentration time (minutes),

P: Probably year (2 years in this case),

A, C, b, n- Parameters determined according to local rainfall conditions, can be selected according to Appendix B of TCVN 7957:2008; or refer that of neighbor area.

The parameters is for the below table applied to drainage system in CUWC.

**Table 4.8.2 Climatic constants in the rain intensity formula of some cities**

No.	City	A	C	b	n
13.	Ha Noi	5890	0.65	20	0.84

Source: TCVN 7957:2008 Appendix B

##### (3) Concentration Time

The concentration time is total time with inflow time and flow-down time. The inflow time is the time that rainfall at the upper end flows into the most upstream of sewer. The flow down time is the time that rainfall flowed into sewer reaches to some point in sewer.

$$\text{Concentration time } (t) = \text{Inflow time } (t_1) + \text{flow-down time } (t_2)$$

##### (4) Inflow Time

The inflow time is determined as a range of 5 to 10 minutes. The inflow time is depending on penetration

capacity, pavement rate of road, density of houses, gradient of ground surface and distance of flowing down. In addition, the inflow time varies depend on the development condition of drainage facilities inside houses and street drain. The Kerby formula is a common to estimate the inflow time.

$$t_I = (2/3 \times 3.28 \times L \times n / \sqrt{S})^{0.467}$$

Where,

$t_I$ : Inflow time (minutes),  $L$ : Distance of flow (m),  $S$ : Gradient of flow,  $n$ : Delayed coefficient like roughness coefficient, 3.28: Corresponding value from feet into a meter

The value of “n” in the formula varies under the condition of the catchment area, and it is difficult to estimate this value of “n”. The inflow time is practically considered within 5 to 30 minutes.

#### (5) Flow-down Time

The flow-down time is total of each flow-down time that is estimated from distance of sewer and flow velocity in planned flow. It is necessary virtual sewer dimension and layout to determine the flow-down time.

#### 4.9 Setting of Runoff Coefficient

The runoff coefficient is varied depend on topography, geology and condition of ground surface, frequency and intensity of rainfall. In Vietnam, runoff coefficient “C” is determined by the permeability calculation model. If the model could not determine by the mathematical model, the coefficient depends on the surface nature of the catchment area and probably year “P” that is selected in the following table.

**Table 4.9.1 Runoff Coefficient**

Properties of drainage surface	Probably year P (year)		
	2	5	10
Asphalt road	0.73	0.77	0.81
Roofs, concrete surfaces	0.75	0.80	0.81
Grass, garden, park (grass area less than 50%)			
- Low slope 1-2%	0.32	0.34	0.37
- Average slope 2-7%	0.37	0.40	0.43
- High slope	0.40	0.43	0.45

Note: When the surface area has many different types of surfaces, C value is determined in average of different areas.  
Source: TCVN 7957:2008

#### 4.10 Design Conditions of Sewerage/Drainage Network

##### 4.10.1 Hydraulic Calculation Formula and Roughness Coefficients

###### (1) Manning Formula

The diameter and gradient of sewerage/drainage network is calculated by Manning formula.

$$Q = A \times V$$

$$V = (1/n) \times R^{2/3} \times I^{1/2}$$

Where,

$Q$ : Flow (m<sup>3</sup>/s),  $A$ : Cross sectional area of pipe (m<sup>2</sup>),  $V$ : Velocity (m/s),  $n$ : Roughness

coefficient,  $R$ : Hydraulic radius ( $= A/P$ ),  $P$ : Wet area perimeter (m),  $I$ : Hydraulic gradient

The points of consideration for the design is below.

- The sewer gradient is determined in accordance with ground slope as much as possible.
- The low velocity is determined as slightly increasing at downstream to avoid sedimentation of sewage in pipeline.
- The earth covering depth is determined as to minimize.

## (2) Manning's Roughness Coefficients

Manning's roughness coefficients according to TCVN7957:2008 is shown to the table below.

**Table 4.10.1 Manning's Roughness Coefficients**

Material	Roughness coefficients (n)
Reinforced concrete	0.013
Cast pipe	0.012
Steel pipe	0.012
Plastic pipe (nPVC, HDPE)	0.011

Source: TCVN 7957:2008

### 4.10.2 Material and Minimum Diameter

#### (1) Material and Minimum Diameter for Sewerage

Material of pipe for sewerage that have resistance against external pressure (earth pressure and upper loads) should be selected. Considering a quality (corrosion resistance) of material and existing construction of sewerage in recently, HDPE or nPVC is selected. Minimum diameter of D200 mm is determined from appropriately maintenance point of view.

#### (2) Material and Minimum Diameter for Drainage

Pipe and box-culvert is used for drainage. Reinforced concrete pipe and box-culvert is selected on experiential grounds. Minimum diameter of D300 mm or □300 x 300mm is determined.

### 4.10.3 Minimum and Maximum Velocity of Pipe

The calculated speed of minimum sewage depends on the components and dimensions of suspended particles in wastewater, hydraulic radius or filling of channel or pipe. For sewerage and drainage, the minimum velocity corresponding to maximum calculated filling of the pipe shall be regulated as follows:

(Source: QCVN 07-2:2016BXD)

- Diameter of 150 - 200 mm,  $V_{min} = 0.7$  m/s;
- Diameter of 300 - 400 mm,  $V_{min} = 0.8$  m/s;
- Diameter of 400 - 500 mm,  $V_{min} = 0.9$  m/s;
- Diameter of 600 - 800 mm,  $V_{min} = 1$  m/s;
- Diameter of 900 - 1200 mm,  $V_{min} = 1.15$  m/s;
- Diameter of 1300 - 1500 mm,  $V_{min} = 1.2$  m/s;
- Diameter of > 1500 mm,  $V_{min} = 1.3$  m/s.

The minimum velocity in culvert or pipe of sewage after biological treatment, it is allowed to be equal to 0.4 m/s. The maximum velocity of sewage in the metallic culvert shall not be more than 8 m/s, in the nonmetallic culvert shall not be more than 4 m/s. For drainage, it shall be 10 m/s and 7 m/s, respectively. However, maximum velocity should be applied the most appropriate velocity for sewer pipe such as less 3.0m/sec.

Minimum gradient of sewer is adopted as the below.

- Minimum gradient of sewer is  $1/D$  (D: pipe diameter, mm)
- Minimum gradient of drainage ditch/trench on roadside must not less than 0.003

#### **4.10.4 Maximum Calculated Filling of Pipe**

The maximum calculated filling of pipe (h/D: water depth as margin) depends on the diameters and can be as follows: (Source: QCVN 07-2:2016BXD)

- For the pipe  $D = 200 - 300$  mm, filling is not more than 0.6 D;
- For the pipe  $D = 350 - 450$  mm, filling is not more than 0.7 D;
- For the pipe  $D = 500 - 900$  mm, filling is not more than 0.75 D.
- For the pipe  $D > 900$  mm, filling is not more than 0.8 D.

Notes:

- 1) For the channels with the height from 0.9 m and the horizontal section have any shapes, the filling is not more than 0.8 H;
- 2) For the drainage and combined sewer culverts are designed to be filled completely.

#### **4.10.5 Method for Connection of Pipe**

There are some methods for connection of pipes as the below.

- Pipe top connection
- Water surface connection
- Pipe center connection
- Pipe bottom connection
- Drop connection

In order to reduce the construction cost of sewer line, it is necessary to make the earth covering of pipe as small as possible. However, the depth of excavation is relied on topographic condition of drainage basin and point of connection. The initial depth of a sewer is low, but it is increased when the pipeline is longer. On the pipe top connection, the installed depth will be increased but the flow of sewage will be smooth. The pipe top connection is adopted on this project.

#### **4.10.6 Minimum Earth Covering of Pipe**

The earth covering of pipe is decided based on the earth covering of starting point and the slope of pipe. In standard of QCVN 07-2:2016BXD, minimum earth covering of pipe (to top of pipe) is adopted to the below.

- In area without vehicle, minimum earth covering is 0.3 m
- In area where traffic is busy, minimum earth covering is 0.5 m
- In special cases where the depth is less than 0.5 m, protective measures must be taken

In addition, the maximum pipe depth is determined by calculation depending on pipe material, geotechnical and geotechnical conditions, construction methods and other technical factors. On this project, 0.6 m of minimum earth covering is adopted considering to connecting from house inlet and connection pipe of each building. On the detailed design of pipeline, actual bottom level of inlet box should be used based on measured survey.

## CHAPTER 5 STUDY FOR LAYOUT OF MAIN FACILITIES

### 5.1 Selecting the Location of Sewage Treatment Plant

The location and site area of sewage treatment plant should be selected with consider the following points, as it affects the cost of sewer lines and pumping stations or the selection of sewage treatment methods.

- Getting enough site area of sewage treatment plant against inflow rate
- Locating at near outflow point (Duc Tu lake)
- Layout of sewer lines with rational and reasonable cost
- Unaffected to land use, odor, noise, vibration, and damage to nearby residents.

After the site survey with staff of CUWC and JICA consultant team, the location of sewage treatment plant is decided in consideration of the above conditions, and it is shown in the figure below.

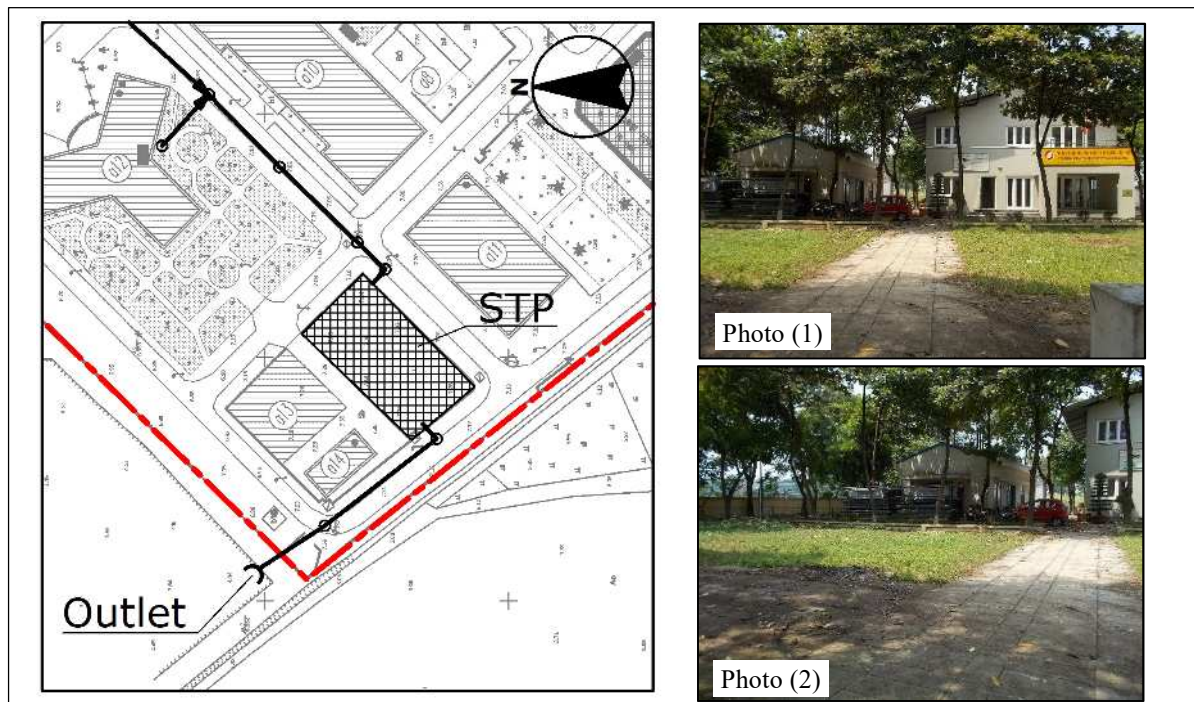

Source: JICA Consultant Team

Figure 5.1.1 Location of Sewage Treatment Plant

### 5.2 Outflow Water Quality

#### 5.2.1 National Technical Regulation on Domestic Wastewater

The regulation of QCVN 14: 2008 / BTNMT specifies the permissible maximum value of the pollution parameters in the effluent of domestic wastewater as being discharged into the environment.

##### (1) Permissible maximum value of pollution parameters in domestic wastewater

Permissible maximum value of pollution parameters in domestic wastewater as being discharged into the water resource receiving wastewater must not exceed  $C_{max}$  value calculated as follows:

$$C_{max} = C \times K$$

In which:

C<sub>max</sub> is the permissible maximum concentration of pollution parameters in domestic wastewater as being discharged into the receiving water resource calculated by milligram per liter of wastewater (mg/l);

C is the concentration values of pollution parameters specified in Table 5.2.1.

K is a coefficient taking into account the size and type of services facilities, public facilities and condominium specified in Table 5.2.2.

Do not apply the formula for calculating the permissible maximum concentration in effluent for parameter pH and total coliforms.

**(2) C value of pollution parameters as a basis for calculating the permissible maximum value**

C value of pollution parameters as a basis for calculating the permissible maximum value C<sub>max</sub> in domestic wastewater as being discharged into water resources receiving wastewater is specified in the Table below.

**Table 5.2.1 Pollution Parameters as a Basis for Calculating the Permissible Maximum Value**

No.	Parameters	Unit	C value	
			A	B
1	pH	-	5 - 9	5 - 9
2	BOD <sub>5</sub> (20° C)	mg/l	30	50
3	Total suspended solids (TSS)	mg/l	50	100
4	Total dissolved solids	mg/l	500	1000
5	Sulfide (as H <sub>2</sub> S)	mg/l	1.0	4.0
6	Ammonium (as N)	mg/l	5	10
7	Nitrate (NO <sub>3</sub> <sup>-</sup> ) (as N)	mg/l	30	50
8	Animal fat and vegetable grease	mg/l	10	20
9	Total surface-active substances	mg/l	5	10
10	Phosphates (PO <sub>4</sub> <sup>3-</sup> ) (as P)	mg/l	6	10
11	Total coliforms	MPN/	3000	5000

Note:

- Column A specifies value of pollution parameters as a basis for calculating the permissible maximum value in domestic wastewater as being discharged into water resources used for the purpose of domestic water supply (with water quality equivalent to that in column A1 and A2 of the national technical Regulation on surface water quality).

- Column B specifies C value of pollution parameters as a basis for calculating the permissible maximum value in domestic wastewater as being discharged into water resources not used for the purpose of domestic water supply (with water quality equivalent to that in column B1 and B2 of the national technical Regulation on surface water or coastal water quality).

Source: QCVN14: 2008 / BTNMT

**(3) Value of K coefficient**

Depending on the type, size and area of use of service facilities, public facilities, apartment buildings and residential areas, businesses, the K value is applied to the Table below.

**Table 5.2.2 Value of K Coefficient Corresponding to Type of Service**

Type of facilities	Size and area of use of facilities	Value of K coefficient
1. Hotel, rest house	From 50 rooms or hotel rated 3 stars or higher	1.0

Type of facilities	Size and area of use of facilities	Value of K coefficient
	Less than 50 rooms	1.2
2. Agencies, offices, schools, research institutions	Greater than or equal to 10,000m <sup>2</sup>	1.0
	Less than 10,000m <sup>2</sup>	1.2
3. Department stores, supermarkets	Greater than or equal to 5,000m <sup>2</sup>	1.0
	Less than 5,000m <sup>2</sup>	1.2
4. Markets	Greater than or equal to 1,500m <sup>2</sup>	1.0
	Less than 1,500m <sup>2</sup>	1.2
5. Restaurants, food stores	Greater than or equal to 500m <sup>2</sup>	1.0
	Less than 500m <sup>2</sup>	1.2
6. Production facilities, armed force barracks	From 500 people or more	1.0
	Less than 500 people	1.2
7. Condominiums, residential areas	From 50 apartments or more	1.0
	Less than 50 apartments	1.2

Source: QCVN14: 2008 / BTNMT

### **5.2.2 Setting of Outflow Water Quality**

It's expected to discharge treated water from STP to Duc Tu Lake, after that it inflows into Ngu Huyen Khe River to Duong River. In addition, according to N9 Zone planning, the CUWC area is located in the basin of Yen Thuong WWTP with the capacity of 10,000 m<sup>3</sup>/day. Therefore, it's proposed effluent wastewater meet column B of QCVN 14:2008/BTNMT in the future.

However, column A ( $C_{max} = CA \times K$ ,  $K=1.0$ ) as outflow water quality is adopted on this study, and the reason is shown below.

- The decision may be different at the design approval stage of each project depending on the environmental conditions etc.
- The regulation and application conditions may be changed to more severe values in the future
- For the purpose of introduce facilities of high-grade treatment method as "experiential training" facilities on site for participants of the sewerage system training.

## **5.3 Layout of Sewer and Drainage Lines**

### **5.3.1 Layout of Sewer Lines**

The point to be considered when considering the layout plan of sewer lines is shown below.

- In priority to plan by a gravity flow system (without pump station)
- Select route with pipe lines as short/shallow as possible
- Avoid touch to other underground cables/facilities
- Following the plans of land use and construction in future

### **5.3.2 Layout of Drainage Lines**

When planning the layout of drainage lines, it's necessary to consider for layout of outlets with current topographic condition and drainage system. According to the site survey at CUWC area, there are existing 3 outlets to Duc Tu lake. As the situation of flooding in the past, those damage are not much.



So, existing drainage system would be working to some extent, but the drainage lines don't have enough capacity to flow and have many sediments such as sand and mud in the bottom, because it has no regularly cleaning works and appropriate gradient. Therefore, it is desirable to use the existing drainage lines as much as possible, and to improve the parts of low capacity.

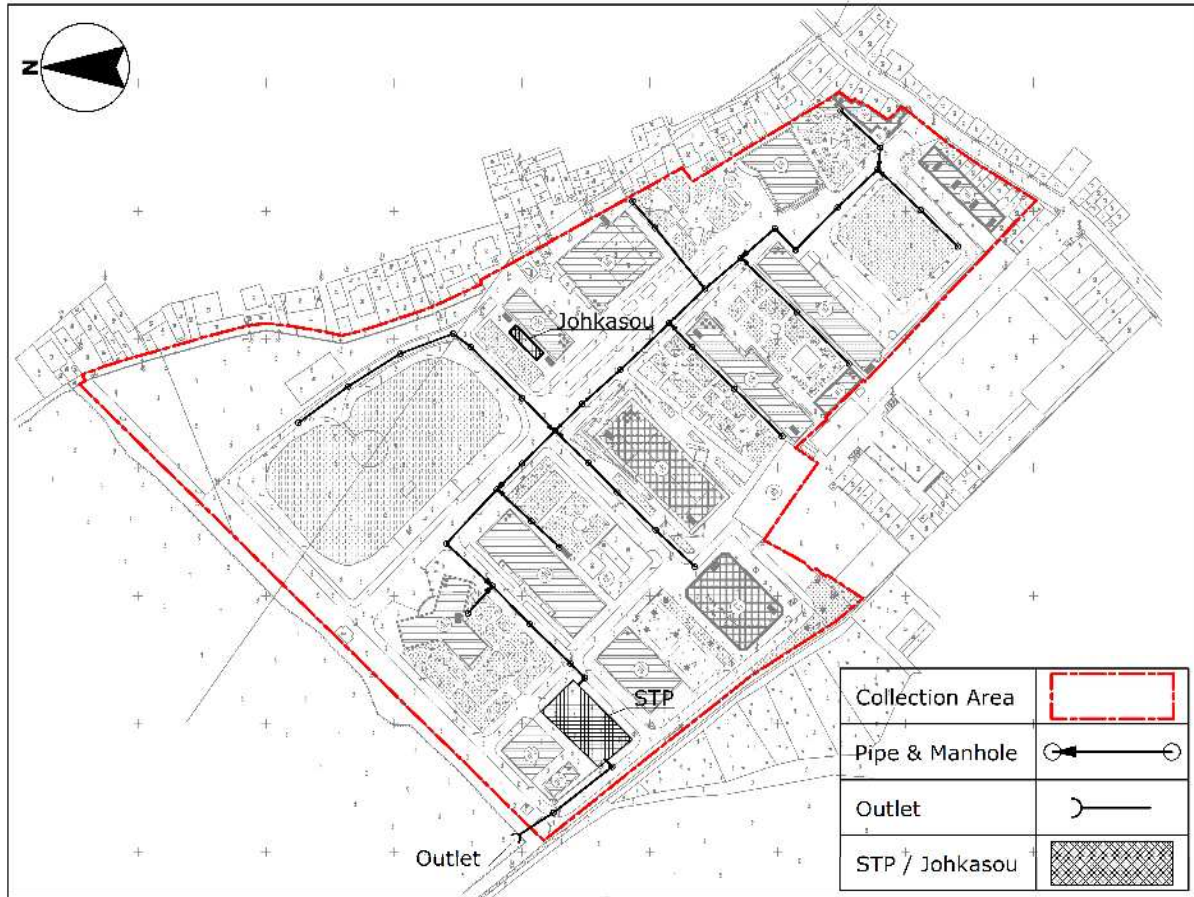

Source: JICA Consultant Team

**Figure 5.3.1** Layout of Sewer Lines

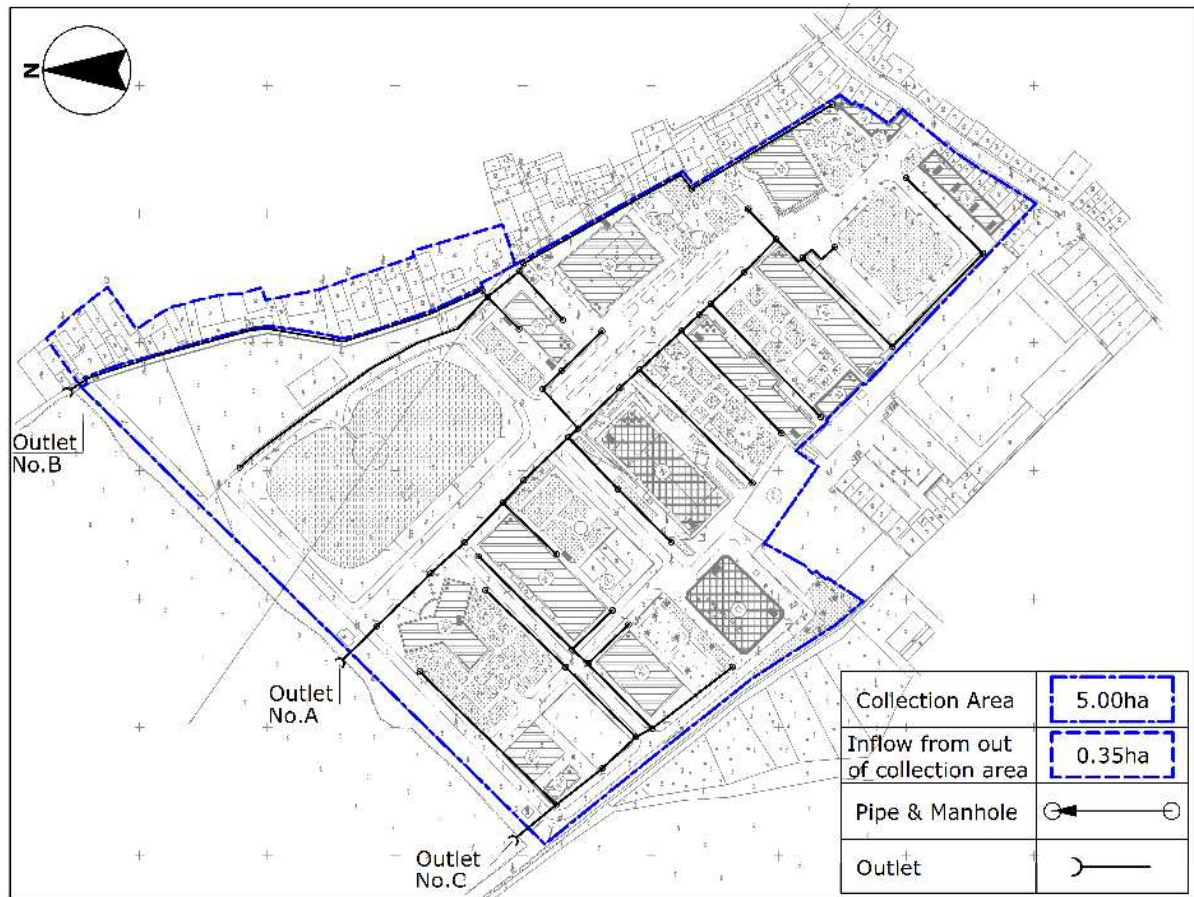

Source: JICA Consultant Team

**Figure 5.3.2 Layout of Drainage Lines**

#### 5.4 Considering the Necessity of Pumping Stations

According to the Section 5.3.1 Layout of Sewer Lines, it's not needed a relay type pump station in the sewer system of CUWC, the sewer lines will be planned by a gravity flow system. The inflow/storage pump need to set inside the sewage treatment plant.

Regarding the drainage pump station, it's needed to consider with relation of water level of outflow point (Duc Tu lake). Based on the results of the data collection and hearing to staffs in CUWC, the water level of Duc Tu lake was not so high (less than 6.5 m) in spite of rainy season. According to the current situation, it would be not needed the drainage pump station against the water level with high frequency. However, there are a lot of inflow outlets of storm water into Duc Tu lake from around area, and large land developments are advancing at the area. So, it's expected to increase discharge water into the lake in future, and the water level of the lake may up more.

## CHAPTER 6 PLAN OF SEWAGE PIPE

### 6.1 Outline of Sewage Pipe

The sewage pipe has an important function of eliminate the sewage and transport it to the sewage treatment plant and it is designed based on the Chapter 4 and 5. The procedure of the sewage pipe plan is as follows.

- Plan the sewage pipe route on general layout plan
- Make the flow calculation sheet of sewage pipe
- Draw the plan and profile drawings of sewage pipe
- Complete the general layout plan (diameter, gradient, length of pipe, etc.)

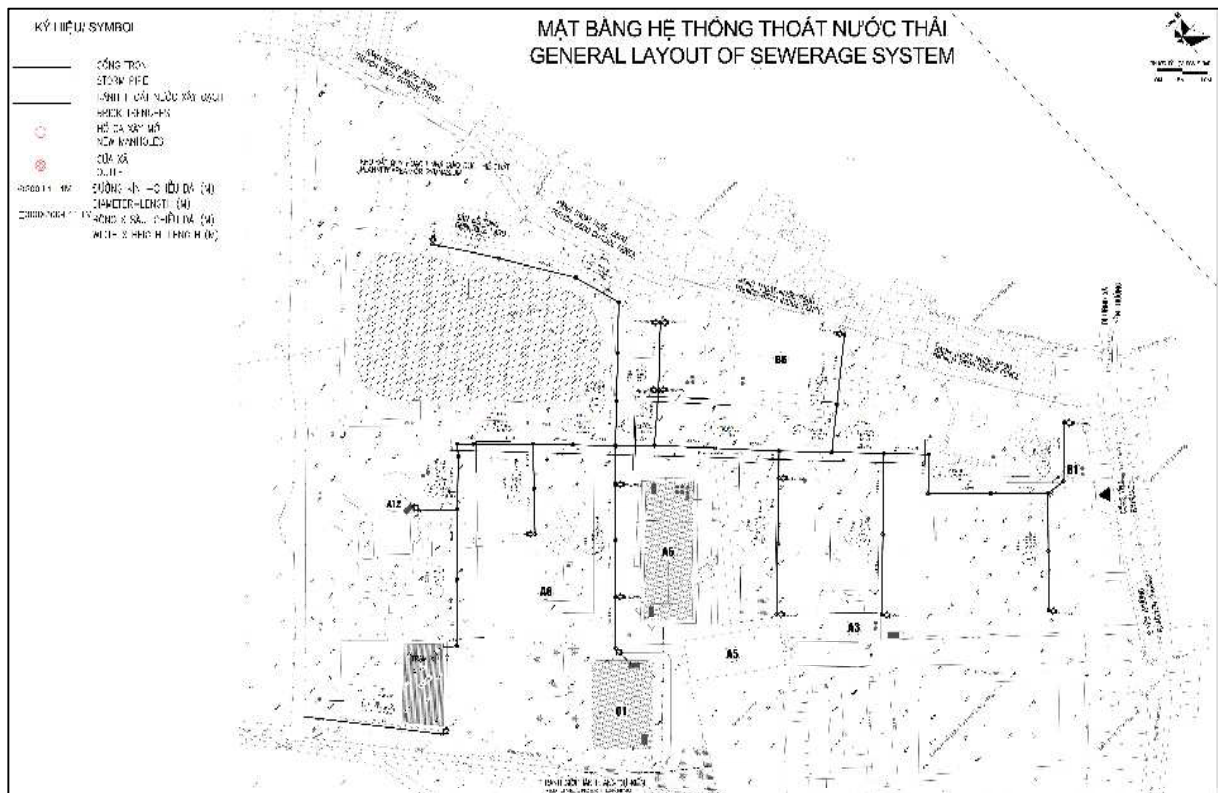

Source: JICA Consultant Team

Figure 6.1.1 General Layout Plan of Sewerage System

### 6.2 Drawings of Sewage Pipe

DWG-1: General Layout Plan of Sewerage System

DWG-2: Plan and Profile of Sewage Pipe

Document A-1: Flow Calculation Sheet of Sewage Pipe

## **CHAPTER 7 PLAN OF DRAINAGE PIPE**

### **7.1 Outline of Drainage Pipe**

The drainage pipe has an important function of immediately eliminate rainwater and minimize flood damage. It is designed based on the Chapter 4 and 5. The procedure of the sewage pipe plan is as follows.

- Plan the sewage pipe route on general layout plan
- Make the flow calculation sheet of drainage pipe
- Draw the plan and profile drawings of drainage pipe
- Complete the general layout plan (diameter, gradient, length of pipe, etc.)

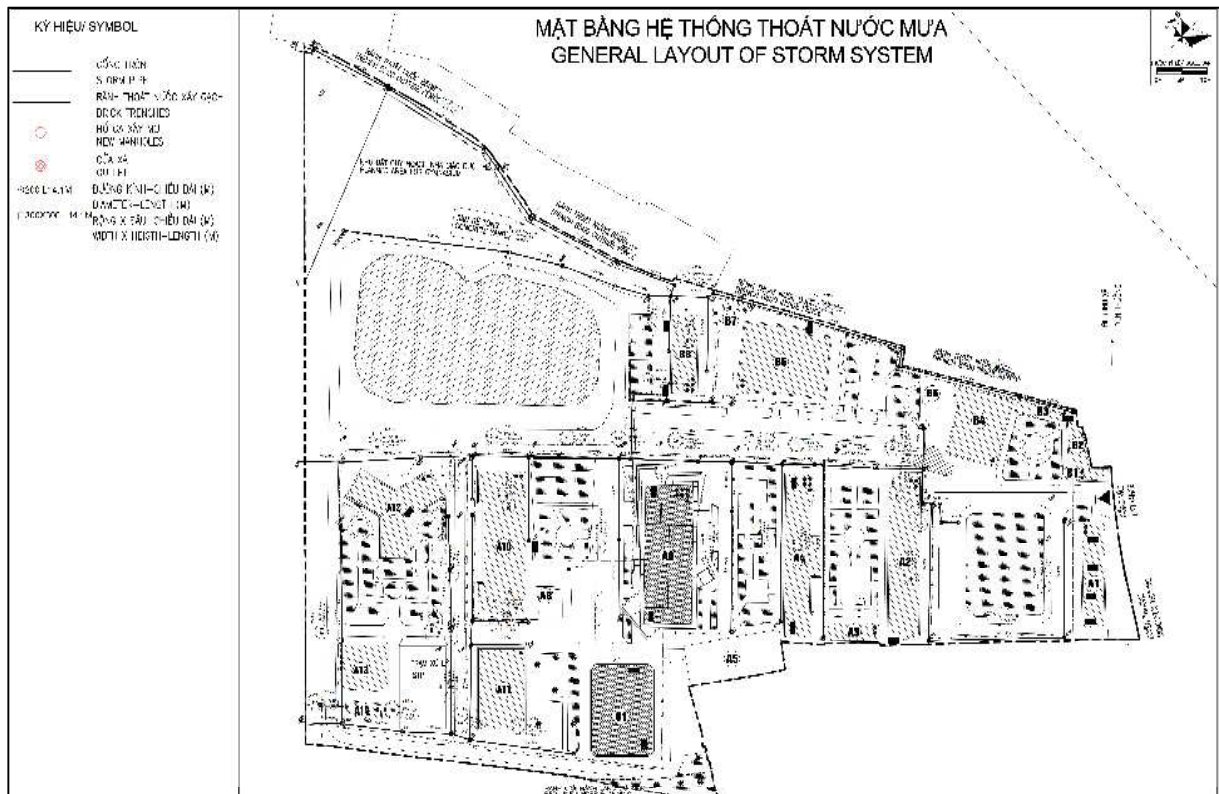

Source: JICA Consultant Team

**Figure 7.1.1 General Layout Plan of Drainage System**

### **7.2 Drawings of Drainage Pipe**

DWG-1: General Layout Plan of Drainage System

DWG-2: Plan and Profile of Drainage Pipe

Document A-1: Flow Calculation Sheet of Drainage Pipe

## CHAPTER 8 PLAN OF SEWAGE TREATMENT PLANT

### 8.1 Sewage Treatment Process

#### 8.1.1 Comparison of Sewage Treatment Technologies

Among the sewage treatment technologies, the technologies that have been applied in Vietnam include: i) Conventional Activated Sludge (CAS); ii) Anaerobic – Anoxic – Oxidic (A2O); iii) Sequencing Batch Reactor (SBR); iv) Oxidation Ditch (OD); and v) Biological Trickling Filter (TF).

In general, for areas where available land for construction of sewage treatment plant is limited or land acquisition costs are high, it is appropriate to use CAS or A2O. These technologies require small land area. However, the operation is quite complicated and requires high investment capital and O&M costs.

Based on the review of currently applied sewage treatment technologies in Vietnam, generalized comparisons and evaluation have been conducted to select the technology which is shown in table below.

**Table 8.1.1 Generalized Comparison of Sewage Treatment Technologies**

No	Items	CAS	A2O	SBR	OD	TF
A	Technical Aspect					
1	Quality of effluent meets QCVN 14: 2008 / BTNMT	Yes	Yes	Yes	Yes	Yes
2	Treatment capability	Medium	High	High	High	Medium
3	N and P removal capability	Limited	Good	Good	Good	Limited
4	Requirement of pre-sedimentation tank	Yes	No	No	No	Yes
5	Requirement of sedimentation tank	Yes	Yes	No	Yes	Yes
6	Odor generation	Yes	Yes	Yes	Yes	Yes
7	Odor controlling	Yes	Yes	Yes	Hard	Hard
8	Requirement for technology equipment	Medium,	Rather complicated	Complicated	Medium	Medium
9	Flexibility in treating different flows and loads	Less flexible	Less flexible	Flexible	Flexible	Flexible
10	Requirement of land area (/1,000 m <sup>3</sup> )*	Medium 0.28 ha	Low 0.1 ha	Low 0.13-0.17 ha	High 0.25-0.52 ha	Medium 1.04 ha (Low 0.2 ha ***)
11	Capability to withstand shock loads	Poor	Medium	Medium	Good	Good
12	Ability of future expansion	Easy	Easy	Easy	Easy	Easy
B	Operation and Maintenance					
1	Operation	Rather	Complicated	Very	Simple	Rather

No	Items	CAS	A2O	SBR	OD	TF
	requirement	complicated		complicated		Complicated
2	Requirement for operators' competence	Medium	Medium	High	Medium	Rather high
3	Suitability to manual control	Difficult	Difficult	Impossible	Easy	Easy
C	Construction and Operation Cost					
1	Construction cost (capacity range from 5,000-10,000m <sup>3</sup> /day)**	Medium 12-14 VND mil./m <sup>3</sup>	High 12-20 VND mil./m <sup>3</sup>	High 18-20 VND mil./m <sup>3</sup>	Medium 16-18 VND mil./m <sup>3</sup>	Medium 12-14 VND mil./m <sup>3</sup>
2	Operation cost *	Medium 1,182 VND/m <sup>3</sup>	High 2,800 - 5,060 VND/m <sup>3</sup>	Medium 1,830 VND/m <sup>3</sup>	Medium 1,231 VND/m <sup>3</sup>	Low 1,100 VND/m <sup>3</sup>
3	Electric consumption*	0.20 kWh/m <sup>3</sup>	0.65 kWh/m <sup>3</sup>	0.20 -0.43 kWh/m <sup>3</sup>	0.44-0.51 kWh/m <sup>3</sup>	0.22 kWh/m <sup>3</sup> (0.1 kWh/m <sup>3</sup> ***)

Note: \*Assessment Report on Operations of Vietnam Water and Wastewater Sector in 2013 and 2014 (Investment and Technology Transfer Consulting Ltd Co., 2016)

\*\* Vietnam Urban Wastewater Management Review (WB, 2013)

\*\*\* MetaWater for Pre-Treatment Trickling Filter Technology (PTF)

Source: JICA Consultant Team

In addition to the above, Pre-treated Trickling Filter (PTF) system is advanced technology against TF system. PTF system is developed by of METAWATER Co., Ltd. (Japan) for developing countries. The system is adapted to “The Project for Water Quality Improvement for Japanese Bridge Area in Hoi An City” which is Japanese ODA grant aid project implemented by the JICA. The system is characterized by “low electricity consumption”, “easy operation & maintenance”, “stable treated water quality”, “low life cycle cost”.

Anoxic – Oxidation (AO) system is similar technology to CAS or A2O, and the biological reaction tank is composed of two processes as anoxic and oxic condition. The system is characterized by “advanced BOD and P removal capability” and “space-saving of site area”.

### 8.1.2 Proposed Sewage Treatment Process

The final selected sewage treatment process will be discussed and confirmed in detail by the CUWC and contracted consultant in next period of the implementation project.

In this study stage, the proposed 2 options of sewage treatment process conforming to the conditions of the project are as follows.

- Anoxic – Oxidation (AO) system (under the condition of narrow site area)
- Oxidation Ditch (OD) system (under the condition of wide site area)

#### (1) In case of AO system

The AO system will include an equalization tank with lifting stations and a package for secondary treatment. The secondary treatment will be of the biological treatment process with contact media and all necessary tanks, distribution chambers, pumping stations, auxiliary equipment and interconnecting

pipe work and chambers. In addition, sludge dewatering will be included to yield the excess of sludge to be stored before disposal, if necessary. The main process shall comprise the following components.

### 1) Equalization (or Retention) tank

The tank is integrated with lifting station with fine screens, submersible aerator, etc., an operation room above that tank (also underground) (including blowers, chemical system). The step should be installed to take easy when the operator needs to go down and check the equipment.

### 2) Secondary treatment process

The component should include all bioreactor systems (including anoxic tanks, aeration tank with contact media, mixed liquor mixing system, activated sludge recirculation system, waste activated sludge removal system, treated effluent storage tank, final pumping facility, all connecting piping, control instrumentations, backwashing equipment, and conveyance pumps, etc.).

It's proposed sewage treatment process under AO system as below.

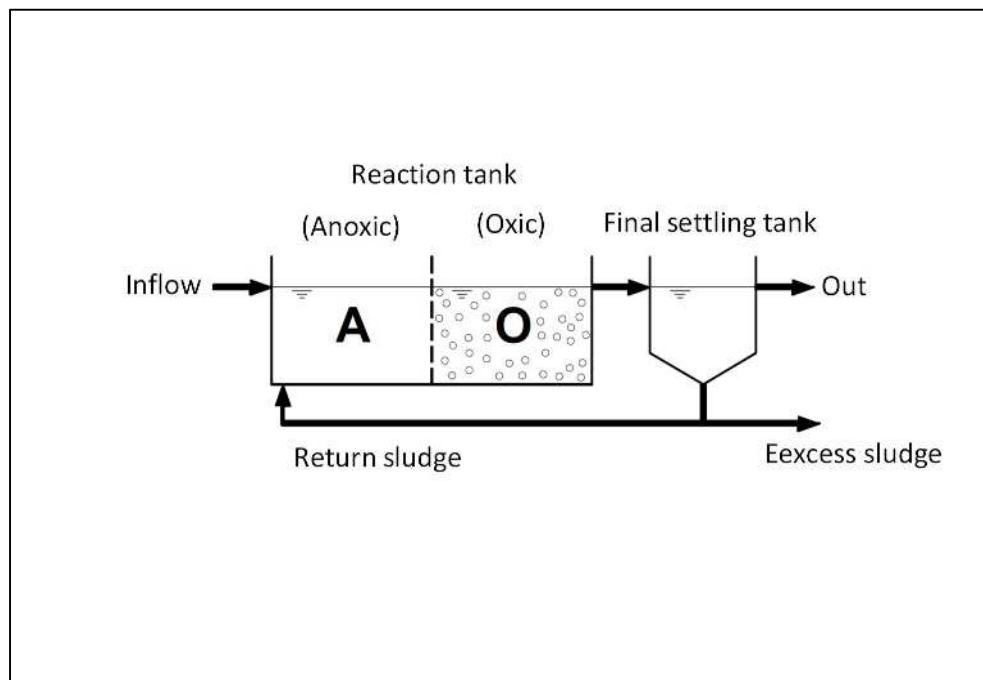

Source: JICA Consultant Team

**Figure 8.1.1 Sewage Treatment Process under AO System**

### (2) In case of OD system

The OD system is a large circular basin equipped with aerators that is used to remove organic matter and pollutants from sewage through the processes of adsorption, oxidation, and decomposition. The features of the system are the followings.

- Structure is simple and not heavy, so maintenance work is very easy
- It is hard to be effected by load fluctuations and forms only a little sludge
- Low operating costs, since simple O & M

- Adoption rate is highest on small scale facility (less than 5,000 m<sup>3</sup>/day) in Japan

The main process shall comprise the following components.

### 1) Oxidation Ditch

The oxidation ditch is integrated with shallow ditch (depth 2 to 3 m) as large round or oval and mechanical aerators. The treatment process is controlled by the hydraulic residence time (HRT: 24 to 48 hours).

### 2) Final Settling Tank

Purpose of the final settling tank is an allowing the microorganisms and other solids to settle after biological treatment. The water aerobically treated is introduced into a final settling tank and subjected to solid-liquid separation, and the supernatant water is discharged outside as the treated water (after chlorination). A part of the sludge settled in the final settling tank is recirculated to the oxidation ditch through a sludge recirculation pipe and excess sludge is discharged from a pipe as the excess sludge. The sludge collector on the tank incorporates durable drives and bottom scraping rakes that will continuously remove settled sludge. The rake employs multiple bottom scraping blades that are angled to ensure that all settling sludge is captured and brought to the central sludge well.

It's proposed sewage treatment process under OD system as below.

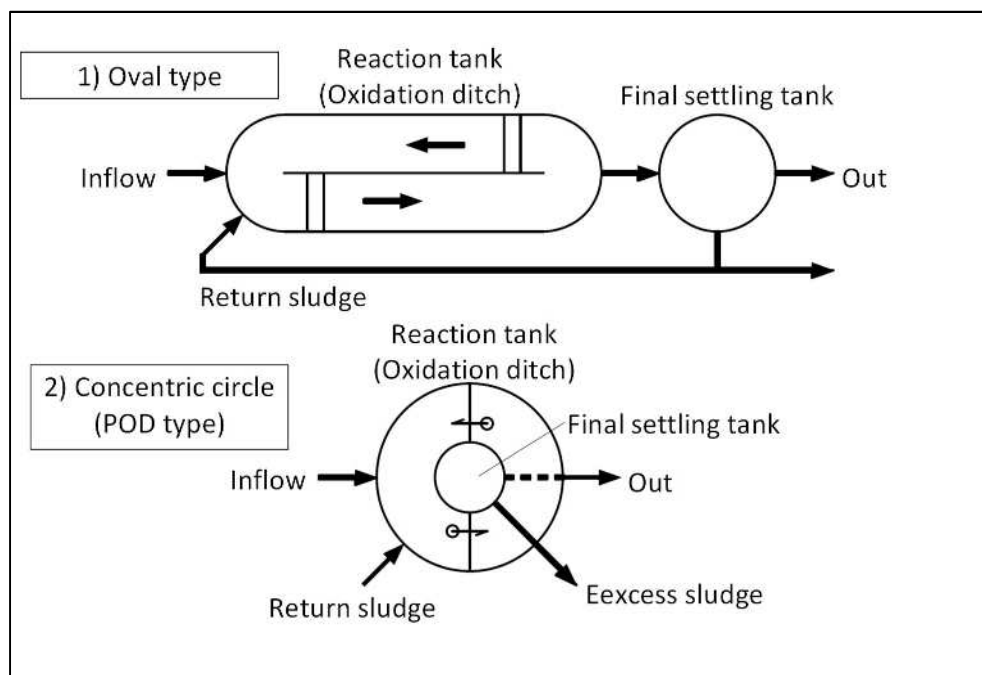

Source: JICA Consultant Team

**Figure 8.1.2 Sewage Treatment Process under OD System**

The capacity calculation sheet of sewage treatment plant and the layout plan is attached to Appendix-C (Design Calculation of Sewage Treatment Plant) for reference.



## 8.2 Study on Sludge Treatment and Disposal Method

### 8.2.1 Sludge Treatment Method

The purpose of sludge treatment is volume reduction, solids weight reduction, sanitary stabilization and utilization. The followings are typical sludge treatment process.

**Table 8.2.1 Unit Process for Sludge Treatment**

Purpose	Unit process
Volume reduction	Thickening, Dewatering, Drying
Solids weight reduction	Digestion, Incineration, Melting furnace
Sanitary stabilization	Anaerobic digestion, Heat treatment, Composting, Incineration, Melting furnace
Utilization	Composting, Incineration and Melting furnace

Source: JICA Consultant Team

In case of sludge treatment of small-scale sewage system, the thickening or dewatering process is adapted in mostly the projects, since the process is low cost and simple operation. The drying process need wide site area, and the process is holding an issue of odor in urban area.

In this study stage, the proposed 2 options of sludge treatment method conforming to the conditions of the project are as follows.

- Thickening process (under on the condition of low cost)
- Dewatering process (under on the condition of using as experienced-based training facility)

#### (1) In case of Thickening Process

The gravity thickener tank is adapted in small-scale sewage system. The thickening is often the first step in a sludge treatment process. Sludge from settling tanks may be stirred (often after addition of clarifying agents) to form larger, more rapidly settling aggregates. The sludge may be thickened to about 4 % solids.

#### (2) In case of Dewatering Process

There are some methods to the mechanical dewatering process like the followings.

- Centrifuge Dewatering
- Belt Filter Press
- Chamber Filter Press
- Screw Press
- Multi-Disc-Type Screw Press

The recommended Multi-Disc-Type Screw Press on this study is as follow.

The Multi-Disc-Type Screw Press is invented by Japanese manufacturer. The dehydrator is an organic sludge dehydrator in which the feature of multi-disc dehydrator is added on the principle of the screw press. The cylinder screen, that incorporates the screw shaft, is comprised of a large number of fixed discs and movable discs that are placed alternately.

The features of the dehydrator are the followings.

- Immune to clogging, since only the movable discs move by contacting the outer periphery of the rotating screw.
- The dehydrator can be, in addition to the use for excess sludge generated from various types of sewage treatment methods, used for low concentration sludge (about 0.5%).
- It saves energy as it is operated by small-sized motors
- The dehydrator does not produce noise and vibration problems, since the screw shaft rotates in a very low speed

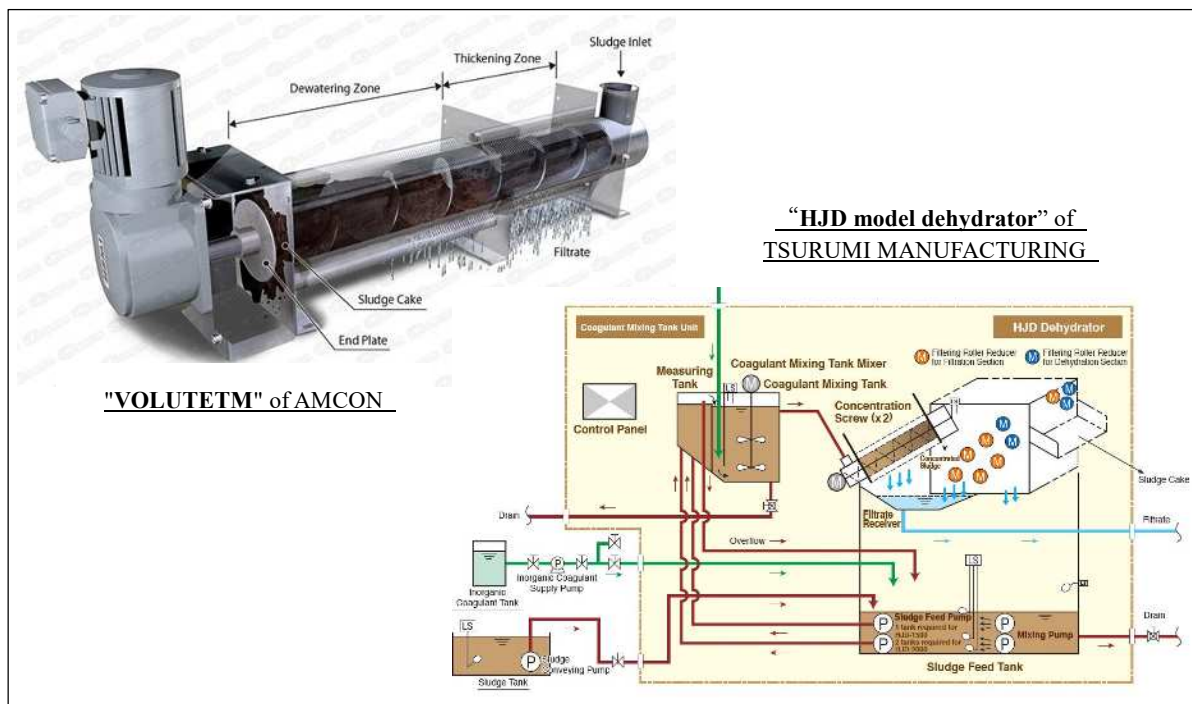

Source: AMCON INC. / TSURUMI MANUFACTURING CO., LTD.

**Figure 8.2.1 Sample Image of Dehydrator**

## 8.2.2 Sludge Disposal Method

In Vietnam, sludge brings to disposal site by vacuum truck or dump truck, then it dumps at there. There are no other methods for sludge disposal at this moment unless particular environmental issue may arise. Therefore, on this section introduce some advanced sludge disposal methods of Japan, in order to promote the recycling and reuse of resources, and to reduce the amount of wastes which cause environmental issue in future.

- Facilities for Recycling Sludge (Compost, Material Use for Cement)

While the way of treating sludge such as compost and construction material is recommended in principle, it should be clearly clarified which entity/organization is the user of this product. For example, manufacturing of compost is little demand in the urban areas without little farmland around the city. Since almost all the user is very conservative for using the new products made of sludge, proposal of very attractive price might be the condition of using it, which is not feasible from the financial point of

view. In addition, the incinerator requires huge investment and O&M cost for complying with the standard of air pollution and the O&M itself is very sophisticated, it is not recommended to install these facilities except in the developed country such as Japan where landfill area is very limited.

However, in large cities in developing countries, acquisition of disposal site is getting difficult and sludge treatment and disposal process should be flexibly examined depending on the acquired site. Since the reduction of simple treatment is not effective, resulting in the requirement of large disposal site while O&M cost is less, and the transportation cost of sludge depends on the distance between sewage treatment plant and disposal site. So, the level of sludge treatment will be carefully decided based on the various factors such as the size of acquisition land including procedure of acquiring land, total investment and O&M cost, location and lifetime of disposal site, and so on.

## CHAPTER 9 ENVIRONMENTAL IMPACT SURVEY

### 9.1 Objective of Environmental Impact Assessment (Another Consideration is Required)

Environmental Impact Assessment (EIA) is needed from the concept that EIA procedures at an earlier stage is essential for preventing serious environmental impacts and promoting a sustainable society.

The main objective of the EIA of sewerage system project is to study the socio-economic analysis on the project and their impact on the inhabitants that are living in near areas and their impact on the environment and how the results would affect the related policies. Sewage/wastewater is a very significant pollution source that has serious adverse impact both on the environment and local residents. Many, especially in developing urban areas in Vietnam, leave the sewage/wastewater to simply seep into the streets inducing bad odors, and possibly causing diseases.

The survey for EIA (Social Environment/ Natural Environment/ Deterioration of Environment) based on the environmental law should be done on the next stage of actual master plan.

### 9.2 Simplified Evaluation of Improving Water Quality

In this study, the improving water quality under the sewage system development is considered by simple method of evaluation.

In current, much grey water without treated is discharging from the college (canteen, dormitory, shower, laundry, etc.) into Duc Tu lake and public water body. The amount of pollution load will increase to future/2030 as shown in the table below.

In the case of OD system at the sewage treatment plant, the processing capability is 90% as removal rate against the design influent quality. Therefore, it will be expected to improving effect (as reduction rate; 86 % of BOD, 82 % of SS) of water quality under the sewage system development as shown the below table.

**Table 9.2.1 Improving Effect of Water Quality under the Sewage System Development**

Item	Year	Number (person)	Removal rate	Calculation of generated pollution load	Generated pollution load (kg/day)	Reduction rate
BOD	Existing (2018)	4,467	0%	$4,467 * 40 * 0.08 * 1.0 * 1 / 1000$	14.3	86%
	Undeveloped (2030)	9,350	0%	$9,350 * (40+18) * 0.08 * 1.0 * 1 / 1000$	29.9	
	Developed (2030)	9,350	90%	$9,350 * (40+18) * 0.08 * 0.1 * 1 / 1000$	4.3	
SS	Existing (2018)	4,467	0%	$4,467 * 25 * 0.08 * 1.0 * 1 / 1000$	8.9	82%
	Undeveloped (2030)	9,350	0%	$9,350 * (25+20) * 0.08 * 1.0 * 1 / 1000$	18.7	
	Developed (2030)	9,350	90%	$9,350 * (25+20) * 0.08 * 0.1 * 1 / 1000$	3.4	

Source: JICA Consultant Team

## CHAPTER 10 STUDY OF PROJECT COST

### 10.1 Construction Cost Estimate

#### 10.1.1 Summary of Construction Works

Construction work items for sewerage and drainage for the small-scale sewerage system in CUWC are listed in below.

**Table 10.1.1 Summary of Construction Works (Sewerage Works)**

No.	Work items	Unit	Quantity	Remarks
1	Sewer pipe (D200 mm)	m	849	@5,627,800VND
2	Manhole	nos	44	@3,652,400VND
3	Connection box	nos	17	@2,000,000VND
4	House connection pipe and demolish septic tank	nos	17	@6,700,000VND
5	Discharge pipe	m	52	@5,627,000VND
6	Sewage treatment plant	m <sup>3</sup> /day	310	@56,100,629VND

Source: JICA Consultant Team

**Table 10.1.2 Summary of Construction Works (Drainage System)**

No.	Work items	Unit	Quantity	Remarks
1	Drainage pipe (D300)	m	334	@6,923,339VND
2	Drainage pipe (D600)	m	217	@11,088,701VND
3	Box culvert (B300x300)	m	481	@3,620,777VND
4	Box culvert (B400x300)	m	125	@4,827,702VND
5	Box culvert (B500x500)	m	510	@7,241,553VND

Source: JICA Consultant Team

#### 10.1.2 Construction Cost Estimate

Following preconditions are applied to the construction cost estimate.

- Construction unit cost of the same kind of sewerage and drainage are applied to pipe cost estimate
- Unit cost of sewer and drainage pipe is including all material cost, installation cost, and overhead cost.
- The cost of the sewage treatment plant by OD system refers to the existing project cost estimate in Japan. (as Prefabricated OD system: 300m<sup>3</sup>/day, dewatering facility is not including)
- Exchange rate is VND 1.0 = JPY 0.00477 as of April 2019.

**Table 10.1.3 Construction Cost Estimate**

No	Works items	Estimated cost (million VND)	Estimated cost (million JPY)	Remarks
<b>1</b>	<b>Sewerage Works</b>			
1.1	Sewer system (for all)	5,379	25.7	
1.2	Sewage treatment plant (in case of OD system)	17,391	83.0	
	<b>Total of Sewerage Works</b>	<b>22,770</b>	<b>108.6</b>	
<b>2</b>	<b>Drainage Works</b>			
2.1	Drainage pipe	4,719	30.8	
2.2	Box culvert	6,038	20.5	
	<b>Total of Drainage Works</b>	<b>10,757</b>	<b>51.3</b>	
	<b>Total Construction Cost</b>	<b>33,527</b>	<b>159.9</b>	

Source: JICA Consultant Team

## 10.2 Project Implementation Plan

### (1) Selection of Priority Project

The development goal of this master plan is set at 2030. The proposed sewerage and drainage system components shall be selected to attain the project objectives by 2030.

The sewerage system is a priority project in this master plan. So, it is selected that Phase1 (sewerage system project) implementation period is up to 2022. In general, project approval procedures for implementation takes long period in Vietnam. It assumes that this process takes about 1 years until 2020. Then, the project implementation stage will be proceeded from 2021. The implementation period of 2 years is relatively common as the scale of small-scale sewerage system.

On the other hand, the existing drainage system is installing in CUWC. It is early to construct Phase2 of the upgrade drainage system at this moment, therefore, it keeps studying more.

- Phase1: Sewerage system - 2021 ~ 2022 (design and approval in 2020)
- Phase2: Drainage system - 2025 ~ 2030

### (2) Staged Construction (Alternative Proposal)

In this study, based on the admission plan of CUWC by 2030, the maximum frame of population for sewage treatment plant is forecasted for the table below.

**Table 10.2.1 Maximum Frame of Population for Sewage Treatment Plant**

Item	Existing number (person)	Forecast 2030 number (person)
Maximum Frame of Population	4,467	9,350

Source: JICA Consultant Team

According to the basic survey, the existing water consumption is about 200 m<sup>3</sup>/day, and the amount of discharging sewage will be less more since there are existing septic tanks. As an alternative, the sewage treatment plant is able to be proposed staged construction by 2 steps, in consideration of different of existing frame and forecast frame. In that case, it is also possible to adopt two kinds of processing methods for the purpose of introduction various Japanese technologies.

- Phase1: Stage1 Sewage treatment plant 110 m<sup>3</sup>/day - 2021 ~ 2022
  - Phase1: Stage2 Sewage treatment plant 200 m<sup>3</sup>/day – 2023 ~ 2024
- or
- Phase1: Stage1 Sewage treatment plant 200 m<sup>3</sup>/day - 2021 ~ 2022
  - Phase1: Stage2 Sewage treatment plant 110 m<sup>3</sup>/day - 2023 ~ 2024

## CHAPTER 11 EXPERIMENTAL TRAINING FACILITIES

### 11.1 Purpose and Example Case of Experimental Training Facilities



#### (1) Purpose of Experimental Training Facilities

The experimental training facilities of small-scale sewerage system in CUWC is available for use for human resource development of sewerage system. The trainees or visitors can directly see and touch the facilities and receive training. The content of experimental training will be very effective measures more than ever.

#### (2) Example Case of Experimental Training Facilities in Japan

The Sewerage Technology Training Center has been established for human resource development and technology inheritance by Bureau of Sewerage Tokyo Metropolitan Government. The training center is located in Sunamachi Water Reclamation Center which is the second oldest waste water treatment plant in Tokyo. By providing simulated exercise opportunities or hands-on practices of various arenas, the training center promotes effective, efficient early-stage acquisition of knowledge and skills for the workers, and successful inheritance of technology and operational know-hows. These details are shown the below figure.

<p>Sewerage Technology Training Center</p> <p>Practical training in a manhole</p> <p>Electricity supply testing switchboard</p> <p>Walking in a pipe</p> <p>Experimental equipment for industrial wastewater treatment</p>	<p>By providing hands-on training and simulated experiences, it promotes early knowledge and technology acquisition, and technology and operational know-how inheritance effectively. For the human resource development of the whole sewerage industry, besides inside staff, the center is available for use for other municipal or private organizations. Since its opening, over 3,000 visitors from all around Japan and overseas, for example Thailand, New Zealand, Brazil, and Vietnam have come to see the facility and receive training.</p>
	<p>The training facility is constructed to resemble the actual site using the real material, structure and scale as much as possible, so that the conditions on-site can be reproduced in the training. In this training center, practical training in areas such as civil engineering, machinery, electrical engineering and water quality inspection wastewater can be conducted. By utilizing this facility, technology transfer can be conducted effectively by the self-experiencing process such as practical training and simulation in each domain.</p>

	<p>Pipeline in-water walking model (Safety Management) This model lets users experience in-water walking just like how it would be inside sewerage pipe. The floor surface of the water tank has three different materials; concrete, vinyl chloride and stainless, to replicate that of sewerage pipes. This facility is created for users to experience and understand how to conduct in-pipe examination and realize how difficult and dangerous the in-water walking in sewerage pipe.</p>
	<p>Hydrogen sulfide (H<sub>2</sub>S) is generated by the anaerobic growth of bacteria in the waste water, and it represents the main cause of corrosion in concrete pipes. Usually, it is necessary to replace concrete pipes after just few years of usage in spite of a much longer life expectancy. H<sub>2</sub>S-degradation can shorten concrete pipes lifespan by as much as 70%. Hence, the development of concrete pipes with improved resistance to for chemical attack is essential. (Photo; The Training in Japan of VSC project)</p>

Source: JICA Consultant Team (Photo from Leaflet of Bureau of Sewerage Tokyo Metropolitan Government)

**Figure 11.1.1 Sewerage Technology Training Center in Tokyo**

## 11.2 Proposed Pipe Facilities

### (1) Open-cut Construction Site Model

This facility has an open-cut construction site model including earth retaining, sewer pipe, covering plate and suspended guard. As trainees can see and touch the model of open-cut construction site, they can learn names and usage of materials for earth retaining, piping method of sewer pipes and suspended guard method to understand the proper construction process and the points of construction supervising (See below Figure).





Source: Bureau of Sewerage Tokyo Metropolitan Government

**Figure 11.2.1 Example Case of Open-cut Construction Site Model**

## (2) Manhole Model

Trainees can easily see manhole and pipe. Trainees can understand names and structures of manholes, pipes and attached equipment and performing visual inspection of pipe (See below Figure).



Source: Bureau of Sewerage Tokyo Metropolitan Government

**Figure 11.2.2 Example Case of Manhole Model**

## 11.3 Proposed Sewerage Treatment Facilities

### (1) Treatment Tank with Removable Strengthened Glass Covers

In the case of experimental training facilities, the treatment tanks need to be constructed on ground or underground with high visibility. Example case of sewerage treatment plant with removable strengthened glass covers is shown for the below Figure.



Source: Sewerage treatment plant in Tongji University, China

**Figure 11.3.1 Example Case of Treatment Tank with Removable Strengthened Glass Covers**

**(2) Signboard of the Treatment System and Coloring Pipes**

Signboard of explaining for the technology of treatment system (process flow diagram) should be installed in order to in all trainees or visitors can easily understand. Also, a scale model of the sewerage treatment plant should come in useful for explaining. All pipes in the sewerage treatment plant should be painted each color by sewage, water, sludge, chemical etc. And, flow direction and connection destination are marked on the pipes. Example case of signboard of the treatment system and coloring pipes are shown for the below Figure.

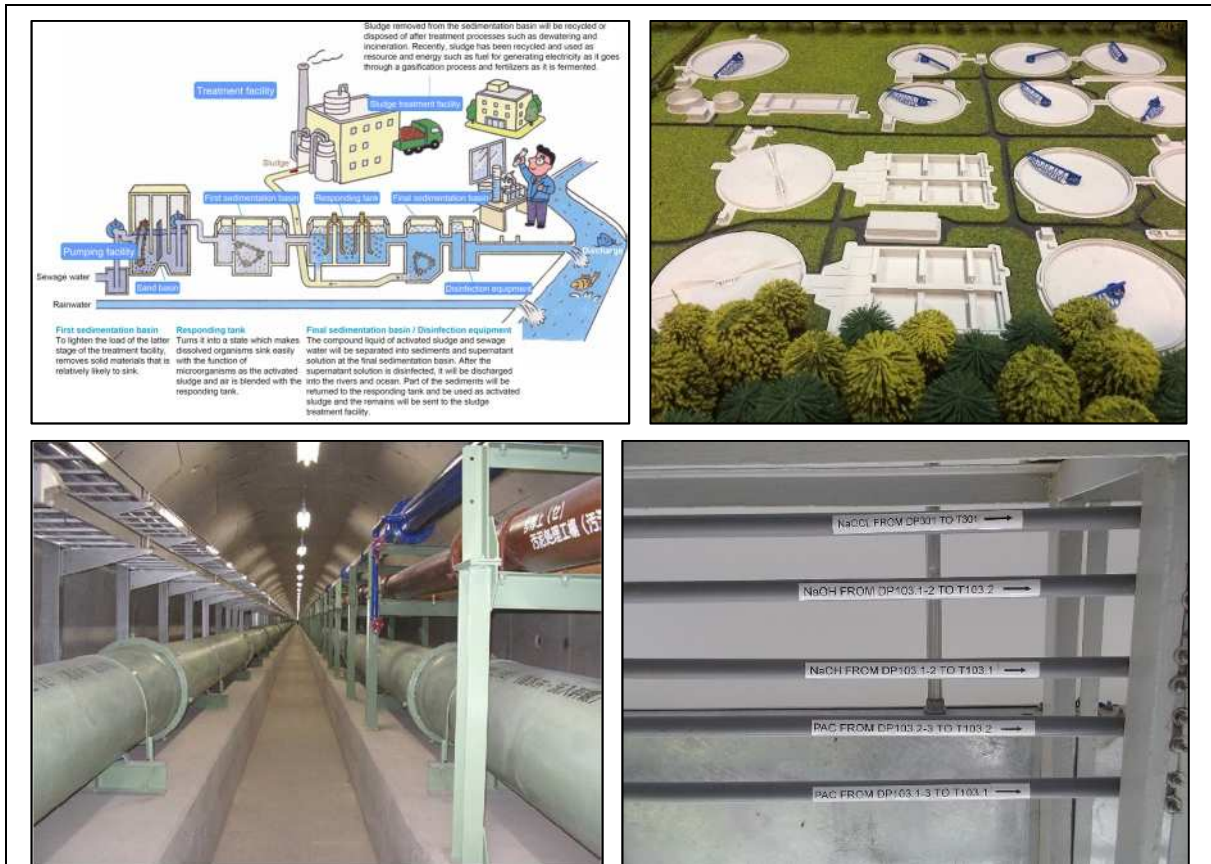

Source: MLIT of Japan, Bureau of Sewerage Tokyo Metropolitan Government, Thanh Binh Phu My Joint Stock Company

**Figure 11.3.2 Example Case of Signboard of the Treatment System and Coloring Pipes**

## 11.4 Proposed Multipurpose Underground Utility Conduit

### (1) Explanation of Multipurpose Underground Utility Conduit

Multipurpose underground utility conduit is situated under roads, and electrical and telephone cables, gas piping, and water supply and sewerage lines in single conduit (box-culvert or pipe). This precludes the need to dig up roads, which in turn minimizes interruptions to traffic flow and maintains a stable supply of essential utilities when inspection and maintenance works. Example case of multipurpose underground utility conduit is shown for the below Figure.

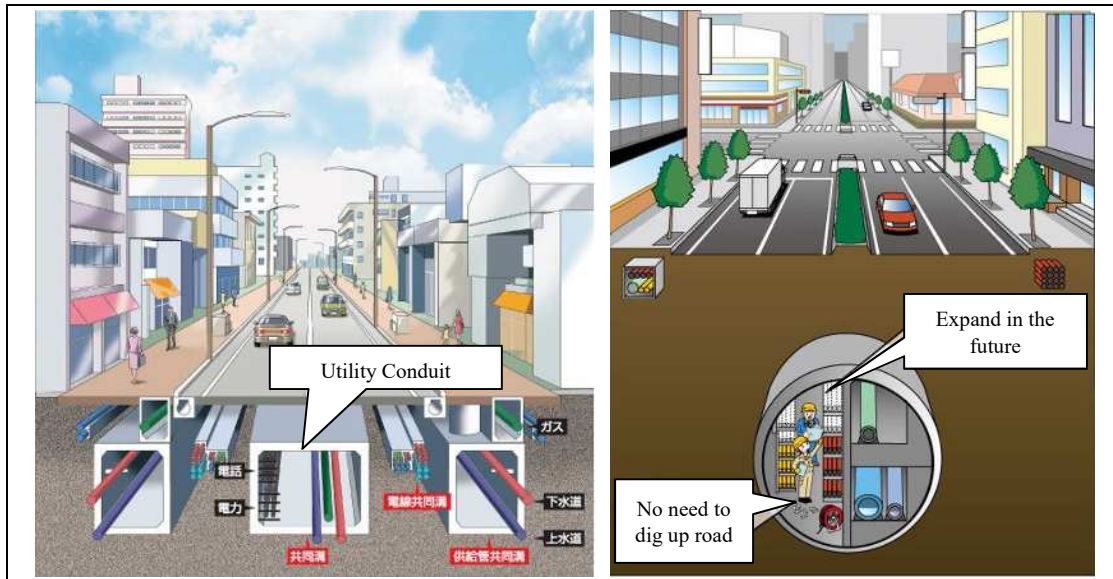

Source: Ministry of Land, Infrastructure, Transport and Tourism, Japan

**Figure 11.4.1 Example Case of Multipurpose Underground Utility Conduit**

### (2) Considering the Utility Conduit for Adoption

The multipurpose underground utility conduit is very useful for inspection and maintenance works of existing facilities. Also, it is best for experimental training facilities, since it makes arrangement to directly see the facilities for trainees. For adoption the utility conduit in this project, it is needed to consider for the below.

- Detailed information from the manager of infrastructures are needed for the planning, because all pipes/cables are related to the construction of utility conduit (Adjusting it in detailed design).
- The utility conduit (box-culvert or pipe) which is inserted all infrastructure will be so large size (Probably more than 3.0 m).
- The utility conduit is too costly for the small-scale sewerage system (That doesn't merit much).

Adapting/installing of utility conduit should be as far as practicable confined to a part of short span. Therefore, the cost of utility conduit isn't included in this master plan.

**SMALL-SCALE SEWERAGE SYSTEM MASTER PLAN  
FOR  
CUWC**

**APPENDIX - A**

**Flow Calculation Sheet of Sewage Pipe**

**Appendix: Sewerage system hydraulic calculation flowsheet**

Manhole number		Distance		Runoff							Sewer plan								
		Each line	Longest	Sewage quantity	Total flow	Aver. Flow Qa (l/s)	Coeff. of dilution	Expected Flow Qe (l/s)	Kch	Max flow Qp (l/s)	Pipe section	h/d	Depth of Water	Gradient	Flow velocity	Bottom Level		Ground Level	Cover
																Start	End		
Up	Down	m	m	l/s	l/s	l/s		l/s		mm		(m)	(permille)	m/s	m	m	m	m	
	Fix flow from Building A1			0.000														6.81	0.60
S1-1	S1-2	22.00	22.00	1.000	1.056	1.056	0.000	0.000	5.000	1.056	⊕ VU200	0.160	0.032	2.000		6.003	5.959	7.13	0.97
S1-2	S2-1	21.50	43.50	1.000	1.056	1.056	0.000	0.000	5.000	1.056	⊕ VU200	0.160	0.032	2.000		5.939	5.896	7.13	0.99
S2-1	S2-2	21.50	65.00	1.000	1.160	1.160	0.000	0.000	5.000	1.160	⊕ VU200	0.165	0.033	2.000		5.866	5.823	7.45	1.38
S2-2	S2-3	23.50	88.50	1.000	1.160	1.160	0.000	0.000	5.000	1.160	⊕ VU200	0.165	0.033	2.000		5.803	5.756	7.12	1.09
S2-3	S2-4	14.50	103.00	1.000	1.160	1.160	0.000	0.000	5.000	1.160	⊕ VU200	0.165	0.033	2.000		5.736	5.707	7.12	1.11
S2-4	S3-1	17.00	120.00	1.000	1.160	1.160	0.000	0.000	5.000	1.160	⊕ VU200	0.165	0.033	2.000		5.707	5.678	6.75	0.79
S3-1	S4-1	19.50	139.50	1.000	1.331	1.331	0.000	0.000	5.000	1.331	⊕ VU200	0.180	0.036	2.000		5.678	5.649	6.75	0.81
S4-1	S5-1	20.00	159.50	1.000	1.858	1.858	0.000	0.000	5.000	1.858	⊕ VU200	0.210	0.042	2.000		5.649	5.620	6.63	1.39
S5-1	S5-2	24.00	183.50	1.000	2.122	2.122	0.000	0.000	5.000	2.122	⊕ VU200	0.225	0.045	2.000		5.620	5.591	6.73	1.52
S5-2	S6-1	23.00	206.50	1.000	2.122	2.122	0.000	0.000	5.000	2.122	⊕ VU200	0.225	0.045	2.000		5.591	5.562	6.73	1.55
S6-1	S7-1	14.63	221.13	1.000	2.998	2.998	0.000	0.000	5.000	2.998	⊕ VU200	0.270	0.054	2.000		5.562	5.533	6.84	1.70
S7-1	S7-2	15.95	237.08	1.000	3.537	3.537	0.000	0.000	5.000	3.537	⊕ VU200	0.290	0.058	2.000		5.533	5.504	6.84	1.73
S7-2	S8-1	15.00	252.08	1.000	3.537	3.537	0.000	0.000	5.000	3.537	⊕ VU200	0.290	0.058	2.000		5.504	5.475	6.84	1.77
S8-1	S8-2	22.50	274.58	1.000	3.601	3.601	0.000	0.000	5.000	3.601	⊕ VU200	0.295	0.059	2.000		5.475	5.446	6.84	1.79
S8-2	S9-1	6.00	280.58	1.000	3.601	3.601	0.000	0.000	5.000	3.601	⊕ VU200	0.295	0.059	2.000		5.446	5.417	6.84	1.99
S9-1	S9-2	4.64	285.23	1.000	3.601	3.601	0.000	0.000	5.000	3.601	⊕ VU200	0.295	0.059	2.000		5.417	5.388	6.84	1.99
				0.003														6.88	2.10
				0.002														6.88	2.10
				0.003														6.92	2.19
				0.003														6.92	2.22
				0.003														6.83	2.16
				0.003														6.83	2.21
				0.003														6.89	2.30
				0.003														6.89	2.32
				0.003														6.95	2.41
				0.003														6.95	2.44
				0.003														6.85	2.38
				0.003														6.85	2.40
				0.003														6.92	2.49
				0.003														6.92	2.51
				0.003														6.86	2.46
				0.003														6.86	2.48

S9-2	S10-1	19.50	304.73	1.000	3.601	3.601	0.000	0.000	5.000	3.601	⊕ VU200	0.295	0.059	2.000		4.178	4.139	6.93	2.58	
				0.003														6.93	2.61	
S10-1	S10-2	26.00	330.73	1.000	3.689	3.689	1.000	3.689	5.000	3.689	⊕ VU200	0.300	0.060	2.000		4.109	4.057	7.01	2.75	
				0.003														7.01	2.77	
S10-2	S10-3	24.48	355.20	1.000	3.689	3.689	1.000	3.689	5.000	3.689	⊕ VU200	0.300	0.060	2.000		4.037	3.988	7.09	2.90	
				0.003														7.09	2.92	
S10-3		5.14	360.34	1.000	3.689	3.689	1.000	3.689	5.000	3.689	⊕ VU200	0.300	0.060	2.000		3.968	3.958	7.24	3.08	
Fix flow from Dormitory B1 and B2				0.000															7.34	0.50
S11-1	S11-2	22.00	22.00	1.000	1.104	1.104	0.000	0.000	5.000	1.104	⊕ VU200	0.165	0.033	2.000		6.633	6.589	7.88	1.08	
				0.000														7.88	1.10	
S11-2	S2-1	7.50	29.50	1.000	1.104	1.104	0.000	0.000	5.000	1.104	⊕ VU200	0.165	0.033	2.000		6.569	6.554	7.45	0.69	
From Building A2 and Dormitory A3				0.000															6.74	0.50
S12-1	S12-2	30.00	30.00	1.000	1.171	1.171	0.000	0.000	5.000	1.171	⊕ VU200	0.170	0.034	2.000		6.033	5.973	6.74	0.56	

Manhole number		Distance		Runoff							Sewer plan								
		Each line	Longest	Sewage quantity	Total flow	Aver. Flow Qa (l/s)	Coeff. of dilution	Expected Flow Qe (l/s)	Kch	Max flow Qp (l/s)	Pipe section	h/d	Depth of Water	Gradient	Flow velocity	Bottom Level		Ground Level	Cover
																Start	End		
Up	Down	m	m	l/s	l/s	l/s		l/s		mm		(m)	(permille)	m/s	m	m	m	m	
S12-2	S3-1	30.00	60.00	0.000 1.000	1.171	1.171	0.000	0.000	5.000	1.171	⊕ VU200	0.170	0.034	2.000		5.928	5.868	6.74 6.73	0.60 0.66
w from Dormitory and Canteen B6				0.001														6.53	0.60
S13-1	S13-2	26.00	26.00	1.000	1.527	1.527	0.000	0.000	5.000	1.527	⊕ VU200	0.150	0.030	5.800		5.723	5.572	6.75	0.97
S13-2	S4-1	18.00	44.00	0.001 1.000	1.527	1.527	0.000	0.000	5.000	1.527	⊕ VU200	0.190	0.038	2.000		5.552	5.516	6.75 6.84	0.99 1.12
Fix flow from Office Building A4				0.000														6.70	0.60
S14-1	S14-2	26.00	26.00	1.000	1.132	1.132	0.000	0.000	5.000	1.132	⊕ VU200	0.165	0.033	2.000		5.893	5.841	6.73	0.68
S14-2	S14-3	24.50	50.50	0.000 1.000	1.132	1.132	0.000	0.000	5.000	1.132	⊕ VU200	0.165	0.033	2.000		5.821	5.772	6.73 6.76	0.70 0.78
Fix flow from Office Building A4				0.000														6.76	1.40
S14-3	S5-1	10.00	60.50	1.000	1.264	1.264	0.000	0.000	5.000	1.264	⊕ VU200	0.080	0.016	48.800		5.157	4.669	6.84	1.96
Fix flow from Dormitory B8				0.000														6.85	0.60
S15-1	S15-2	25.00	25.00	1.000	1.438	1.438	0.000	0.000	5.000	1.438	⊕ VU200	0.185	0.037	2.000		6.043	5.993	6.90	0.70
Fix flow from Dormitory B8				0.000														6.90	0.89
S15-2	S6-1	20.50	45.50	1.000	1.876	1.876	0.000	0.000	5.000	1.876	⊕ VU200	0.210	0.042	2.000		5.807	5.766	6.92	0.95
Fix flow from Gymnasium				0.000														6.65	0.60
S16-1	S17-1	25.51	25.51	1.000	1.046	1.046	0.000	0.000	5.000	1.046	⊕ VU200	0.160	0.032	2.000		5.843	5.792	6.63	0.63
S17-1	S17-2	29.74	55.25	0.000 1.000	1.046	1.046	0.000	0.000	5.000	1.046	⊕ VU200	0.160	0.032	2.000		5.772	5.713	6.63 6.61	0.65 0.69
S17-2	S17-3	18.49	73.74	0.000 1.000	1.046	1.046	0.000	0.000	5.000	1.046	⊕ VU200	0.160	0.032	2.000		5.693	5.656	6.61 6.60	0.71 0.73
S17-3	S18-1	18.66	92.40	0.000 1.000	1.046	1.046	0.000	0.000	5.000	1.046	⊕ VU200	0.160	0.032	2.000		5.636	5.599	6.60 6.58	0.75 0.77
S18-1	S18-2	18.00	110.40	0.000 1.000	1.046	1.046	0.000	0.000	5.000	1.046	⊕ VU200	0.160	0.032	2.000		5.579	5.543	6.58 6.71	0.79 0.96

S18-2	S7-1	16.47	126.87	0.000 1.000	1.046	1.046	1.000	1.046	5.000	1.046	⊕ VU200	0.160	0.032	2.000		5.523	5.490	6.71 6.83	0.98 1.13
Fix flow from Green Building				0.000														7.05	0.60
S19-1	S19-2	19.00	19.00	1.000	1.113	1.113	0.000	0.000	5.000	1.113	⊕ VU200	0.165	0.033	2.000		6.243	6.205	7.21	0.80
Flow from Multi-function Building A6				0.000														7.21	0.82
S19-2	S19-3	21.00	40.00	1.000	1.303	1.303	0.000	0.000	5.000	1.303	⊕ VU200	0.135	0.027	6.200		6.185	6.055	7.21	0.95
				0.000														7.21	0.97
S19-3	S19-4	21.00	61.00	1.000	1.303	1.303	0.000	0.000	5.000	1.303	⊕ VU200	0.175	0.035	2.000		6.035	5.993	7.21	1.01
Flow from Multi-function Building A6				0.000														7.21	1.03
S19-4	S7-1	14.10	75.10	1.000	1.493	1.493	0.000	0.000	5.000	1.493	⊕ VU200	0.190	0.038	2.000		5.973	5.945	6.83	0.68
Fix flow from Office Building A10				0.000														7.26	0.60
S20-1	S20-2	17.00	17.00	1.000	1.064	1.064	0.000	0.000	5.000	1.064	⊕ VU200	0.110	0.022	9.200		6.452	6.296	7.10	0.60



Manhole number		Distance		Runoff							Sewer plan								
		Each line	Longest	Sewage quantity	Total flow	Aver. Flow Qa (l/s)	Coeff. of dilution	Expected Flow Qe (l/s)	Kch	Max flow Qp (l/s)	Pipe section	h/d	Depth of Water	Gradient	Flow velocity	Bottom Level		Ground Level	Cover
																Start	End		
Up	Down	m	m	l/s	l/s	l/s		l/s		mm		(m)	(permille)	m/s	m	m	m	m	
S20-2	S8-1	16.50	33.50	0.000 1.000	1.064	1.064	0.000	0.000	5.000	1.064	⊕ VU200	0.110	0.022	9.300		6.276	6.123	7.10 6.95	0.62 0.62
raining Centre for Water and Env.				0.000														7.06	0.60
S21-1	S10-1	14.00	14.00	1.000	1.088	1.088	0.000	0.000	5.000	1.088	⊕ VU200	0.110	0.022	9.300		6.253	6.123	6.93	0.60
P1-1		52.36	52.36	0.004 1.000	4.590	4.590	1.000	4.590	1.000	4.590	⊕ HDPE160	0.373	0.056	10.500		6.364	5.814	7.12 6.57	0.60 0.60

**SMALL-SCALE SEWERAGE SYSTEM MASTER PLAN  
FOR  
CUWC**

**APPENDIX - B**

**Flow Calculation Sheet of Drainage Pipe**

**Appendix: Drainage system Hydraulic calculation sheet**

Manhole number		Area				Distance		Concentration time			Runoff			Sewer plan							
		Rounding drainage area		Conversion area		Each line	Longest	Pipe average flow velocity m/s	Each line	Longest	Amount of Storm water		Total flow	Pipe section	Gradient	Flow velocity	Flow Rate	Bottom Level		Ground Level Start End	Cover Start End
		Each line	increasing	Each line	increasing						Unit	Total						Start	End		
Up	Down	ha	ha	ha	ha	m	m	m/s	min	min	m³/s	m³/s	m³/s	mm	(permille)	m/s	m³/s	m	m	m	m
A1-1	A2-1	0.23	0.23	0.18	0.18	42.50	42.50	1.9	0.4	10.4	0.548	0.099	0.001	3C300x300	13.2000	1.88	0.147	6.97	6.41	7.37	0.00
A2-1	A3-1	0.13	0.36	0.10	0.28	51.00	93.50	0.7	1.2	11.6	0.531	0.149	0.001	3C300x300	1.7000	0.67	0.053	6.41	6.32	6.81	0.00
A3-1	A4-1	0.08	0.44	0.06	0.34	50.50	144.00	0.6	1.4	13.0	0.512	0.174	0.001	3C300x300	1.4000	0.61	0.048	6.32	6.25	6.72	0.00
A4-1	A4-2	0.07	0.61	0.06	0.48	3.00	147.00	0.6	0.1	13.1	0.510	0.245	0.001	3C300x300	1.4000	0.61	0.048	6.25	6.25	6.75	0.10
A4-2	A5-1	0.00	0.61	0.00	0.48	12.50	159.50	0.6	0.3	13.4	0.506	0.243	0.001	3C300x300	1.4000	0.61	0.048	6.25	6.23	6.75	0.11
A5-1	A6-1	0.04	0.68	0.03	0.53	18.00	177.50	0.6	0.5	13.9	0.500	0.265	0.001	⊙ HP300	2.0000	0.61	0.043	5.56	5.52	6.63	0.74
A6-1	A7-1	0.04	0.72	0.03	0.56	19.50	197.00	0.6	0.5	14.4	0.494	0.277	0.001	⊙ HP600	0.8000	0.61	0.174	5.22	5.21	6.83	0.96
A7-1	A7-2	0.10	0.95	0.08	0.74	3.50	200.50	0.6	0.1	14.5	0.493	0.365	0.001	⊙ HP600	0.8000	0.61	0.174	5.18	5.17	6.88	1.02
A7-2	A8-1	0.00	0.95	0.00	0.74	12.00	212.50	0.6	0.3	14.8	0.489	0.362	0.001	⊙ HP600	0.8000	0.61	0.174	5.15	5.14	6.88	1.05
A8-1	A9-1	0.03	1.08	0.02	0.84	18.50	231.00	0.6	0.5	15.3	0.483	0.406	0.001	⊙ HP600	0.8000	0.61	0.174	5.11	5.10	6.88	1.08
A9-1	A9-2	0.14	1.44	0.11	1.13	13.00	244.00	0.6	0.4	15.7	0.479	0.541	0.001	⊙ HP600	0.8000	0.61	0.174	5.07	5.06	6.95	1.20
A9-2	A10-1	0.00	1.44	0.00	1.13	25.00	269.00	0.6	0.7	16.4	0.471	0.532	0.001	⊙ HP600	0.8000	0.61	0.174	5.04	5.02	6.95	1.23
A10-1	A11-1	0.04	1.66	0.03	1.30	4.50	273.50	0.6	0.1	16.5	0.470	0.611	0.001	⊙ HP600	0.8000	0.61	0.174	4.99	4.98	6.79	1.08
A11-1	A11-2	0.07	1.93	0.05	1.51	22.50	296.00	0.6	0.6	17.1	0.464	0.700	0.001	⊙ HP600	0.8000	0.61	0.174	4.95	4.94	6.98	1.34
A11-2	A12-1	0.00	1.93	0.00	1.51	11.00	307.00	0.6	0.3	17.4	0.461	0.695	0.001	⊙ HP600	0.8000	0.61	0.174	4.92	4.91	6.98	1.38
A12-1	CX1-1	0.11	2.10	0.09	1.65	21.00	328.00	0.6	0.6	18.0	0.454	0.750	0.001	⊙ HP600	0.8000	0.61	0.174	4.88	4.86	7.13	1.54
CX1-1	CX1-2	0.31	2.52	0.25	1.99	19.50	347.50	0.6	0.5	18.5	0.449	0.894	0.001	⊙ HP600	0.8000	0.61	0.174	4.83	4.81	7.17	1.61
CX1-2	CX1-3	0.00	2.52	0.00	1.99	30.00	377.50	0.6	0.8	19.3	0.442	0.879	0.001	⊙ HP600	0.8000	0.61	0.174	4.79	4.77	7.17	1.64
CX1-3		0.00	2.52	0.00	1.99	16.50	394.00	0.6	0.5	19.8	0.437	0.870	0.001	⊙ HP600	0.8000	0.61	0.174	4.75	4.74	6.94	1.46
																				6.92	1.48
																				6.67	1.25
																				6.67	1.27
																				6.11	0.72



Manhole number		Area				Distance		Concentration time			Runoff			Sewer plan								
		Rounding drainage area		Conversion area		Each line	Longest	Pipe average flow velocity	Each line	Longest	Amount of Storm water		Total flow	Pipe section	Gradient	Flow velocity	Flow Rate	Bottom Level		Ground Level	Cover	
		Each line	increasing	Each line	increasing						Unit	Total						Start	End			Start
		Up	Down	ha	ha	ha	ha	m	m	m/s	min	min	m³/s	m³/s	m³/s	mm	(permille)	m/s	m³/s	m	m	m
																					6.86	0.00
A7-1-1	A7-1	0.13	0.13	0.10	0.10	63.50	63.50	0.6	1.8	11.8	0.528	0.053	0.001	□3C300x300	1.4000	0.61	0.048	6.46	6.37	6.88	0.11	
A8-1-1	A8-1	0.10	0.10	0.08	0.08	57.50	57.50	0.6	1.6	11.6	0.531	0.042	0.001	□3C300x300	1.4000	0.61	0.048	6.30	6.22	6.88	0.26	
A9-1-1	A9-1-2	0.22	0.22	0.18	0.18	44.00	44.00	0.6	1.2	11.2	0.536	0.097	0.001	□3C300x300	1.4000	0.61	0.048	6.32	6.26	6.72	0.06	
A9-1-2	A9-1	0.00	0.22	0.00	0.18	18.00	62.00	0.6	0.5	11.7	0.529	0.095	0.001	□3C300x300	1.4000	0.61	0.048	6.26	6.23	6.72	0.06	
																					6.72	0.06
A10-1-1	A10-1-2	0.18	0.18	0.14	0.14	7.50	7.50	0.6	0.2	10.2	0.551	0.077	0.001	□3C300x300	1.4000	0.61	0.048	6.22	6.21	6.62	0.01	
A10-1-2	A10-1-3	0.00	0.18	0.00	0.14	16.50	24.00	0.6	0.5	10.7	0.544	0.076	0.001	□3C300x300	1.4000	0.61	0.048	6.21	6.19	6.62	0.01	
A10-1-3	A10-1-4	0.00	0.18	0.00	0.14	13.50	37.50	2.3	0.1	10.8	0.542	0.076	0.001	□3C300x300	20.2000	2.32	0.181	6.19	5.91	6.90	0.31	
A10-1-4	A10-1	0.00	0.18	0.00	0.14	21.50	59.00	0.6	0.6	11.4	0.533	0.075	0.001	□3C300x300	1.4000	0.61	0.048	6.19	5.91	6.96	0.65	
																					6.96	0.65
																					6.98	0.70
A11-1-1	A11-1-2	0.20	0.20	0.16	0.16	29.50	29.50	2.9	0.2	10.2	0.551	0.088	0.001	⊙ HP300	43.8000	2.86	0.202	6.88	5.59	7.21	0.00	
A11-1-2	A11-1	0.00	0.20	0.00	0.16	30.00	59.50	0.6	0.8	11.0	0.539	0.086	0.001	⊙ HP300	2.0000	0.61	0.043	5.57	5.51	7.13	1.23	
																					7.13	1.23
A12-1-1	A12-1	0.06	0.06	0.05	0.05	31.00	31.00	0.9	0.6	10.6	0.545	0.027	0.001	□3C300x300	2.9000	0.88	0.069	6.86	6.77	6.98	1.14	
																					7.26	0.00
																					7.17	0.00
A13-1	CX1-1	0.11	0.11	0.09	0.09	16.00	16.00	0.6	0.4	10.4	0.548	0.049	0.001	□3C300x300	1.4000	0.61	0.048	5.93	5.91	6.93	0.60	
																					6.94	0.63











**SMALL-SCALE SEWERAGE SYSTEM MASTER PLAN  
FOR  
CUWC**

**APPENDIX - C**

**Design Calculation of Sewage Treatment Plant (for OD System)**

## APPENDIX - C

### DESIGN CALCULATION OF SEWAGE TREATMENT PLANT (FOR OXIDATION DITCH SYSTEM)

#### 1.1 Technical Features of Oxidation Ditch System

An oxidation ditch system is a modified activated sludge biological treatment process that uses long solids retention times (SRT) to remove biodegradable organics. The typical oxidation ditch is equipped with aeration rotors or brushes that provide aeration and circulation. Because of this feature, this process may be adaptable to the fluctuations in flows and loadings associated with wastewater of collection area. In general, the structure of oxidation ditch is a large circular ditch equipped with aerators, and it has the following features

- Ensures stable, continuous dissolved oxygen measurement
- Generated sludge volume is relatively small
- Reduces operating costs
- Requires a large land area for layout

The number of tanks for reactor and sedimentation should be two or more for cleanings and repair works. If it is uneconomical to have two tanks, single tank system is accepted. Biological reactor tank should be 1.0 - 5.0 m in depth and 2.0 - 6.0 m in width. Capacity of the tank shall be calculated using planned maximum daily flow and the table below.

**Table.1 Design Parameter for Oxidation Ditch Process**

Design Parameter	Range
HRT, h	24 - 36
MLSS, mg/l	3,000 - 4,000
Loading, kg BOD/kg MLSS/d	0.03 - 0.05
Return sludge recycle ratio, %	100 - 200
Required Oxygen, kgO <sub>2</sub> /kg BOD	1.4 - 2.2

Source: Japan Sewage Works Association

**Table.2 Design Parameter for Final Sedimentation**

Design Parameter	Range
Detention Time, hrs	6 - 12
Side Wall Depth, m	3.0 - 4.0
Overflow Rate, m <sup>3</sup> /m <sup>2</sup> /d	8 - 12

Source: Japan Sewage Works Association

#### 2.1 Proposed Prefabricated Oxidation Ditch System

For small scale oxidation system, precast concrete products are available. The prefabricated oxidation ditch (POD) system is suitable for wastewater treatment in small-scale sewerage facilities. Inside the round reactor is final sedimentation tank. Aerator for POD system is screw type device. The factory-made units (precast concrete wall) can be built in a shorter period and at a lower cost than traditional construction methods. The plan and section of this POD system is shown in Figure below.

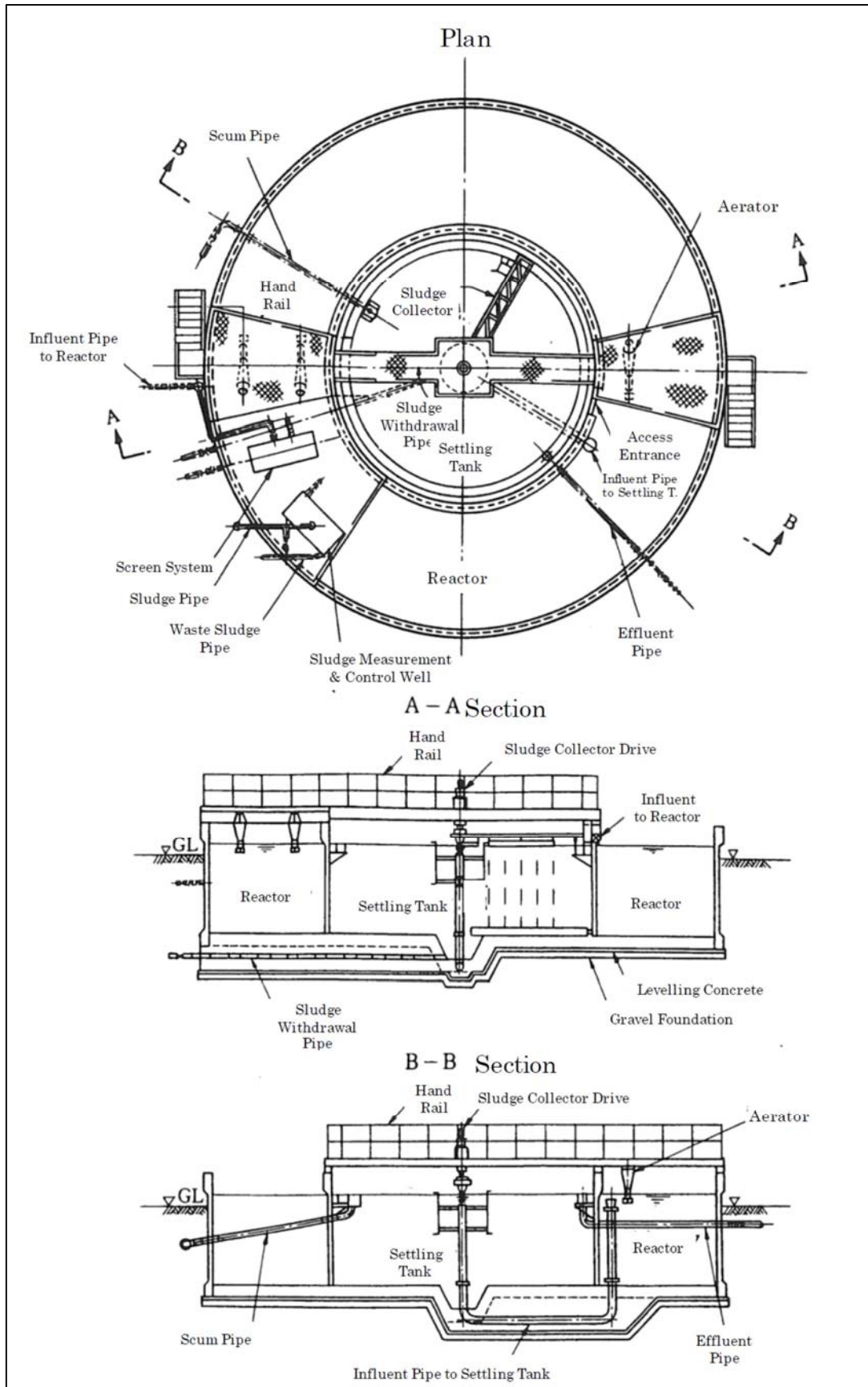

Source: Japan Sewage Works Association

**Figure.1 Prefabricated Oxidation Ditch System**

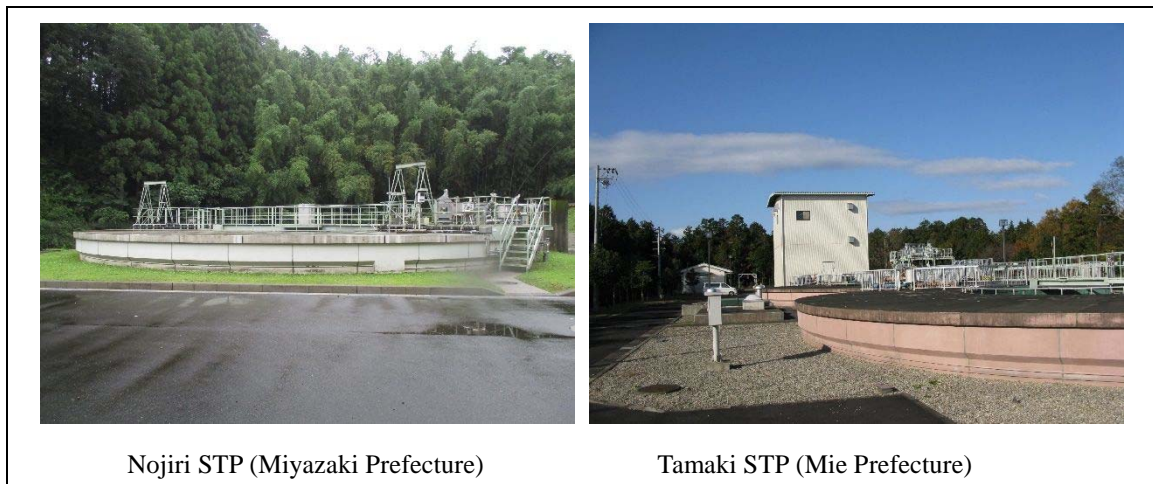

Source: JICA Consultant Team

**Figure.2 Sample Case of Prefabricated Oxidation Ditch System in Japan**

### 3.1 Basic Design Condition of Sewage Treatment Plant

Effluent quality shall meet law requirements. Design inflow shall be the planned maximum daily flow. Design influent quality shall combine planned raw sewage quality and load of return from sludge treatment process. Design inflow and influent quality shall consider variation along the time.

**Table.3 Basic Design Condition of Sewage Treatment Plant in CUWC**

Design Parameters	Design Conditions	Remarks
Maximum daily flow (m <sup>3</sup> /d)	300	Calculated value (310)
Influent BOD (mg/l)	200	Calculated value (185)
Influent SS (mg/l)	200	Calculated value (145)
Standard effluent BOD (mg/l)	20	QCVN-14:2008, Column A (30)
Standard effluent SS (mg/l)	20	QCVN-14:2008, Column A (50)
Total removal rate (%)	90	Oxidation Ditch process

Source: JICA Consultant Team

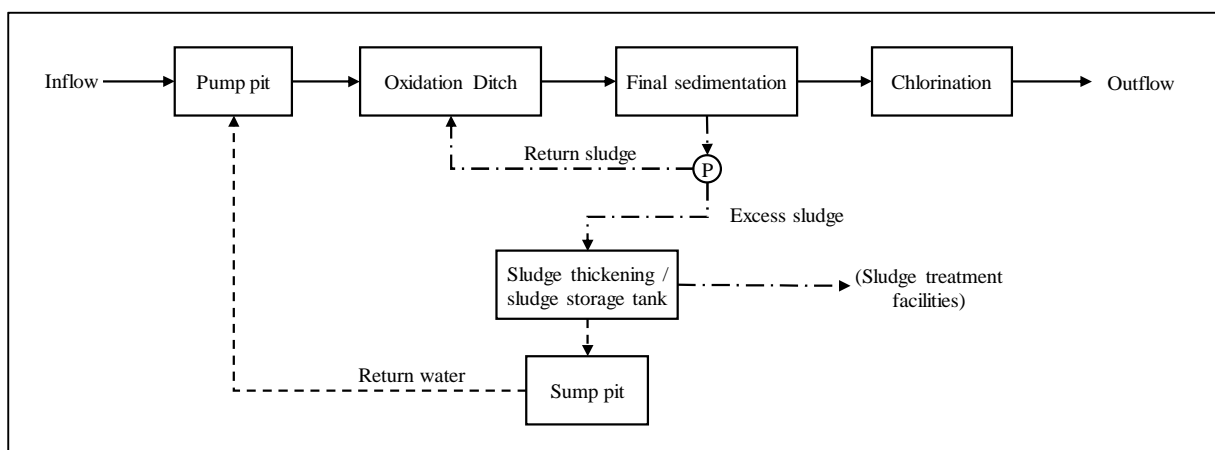

### 4.1 Flow Diagram of Prefabricated Oxidation Ditch System



Source: JICA Consultant Team

**Figure.3 Flow Diagram of Prefabricated Oxidation Ditch System**

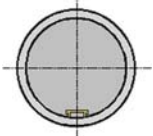
5.1 Design Calculation of Sewage Treatment Plant (Prefabricated Oxidation Ditch)

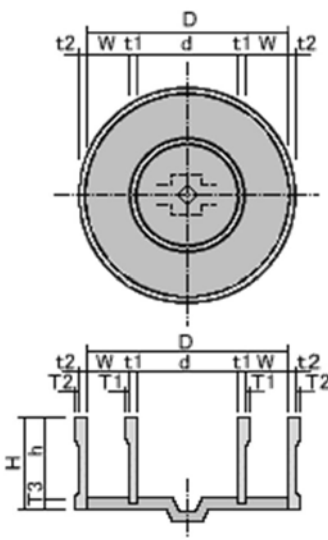
Items	Design Calculation	Remarks																				
<p><b>1. Pump pit</b></p> <ul style="list-style-type: none"> <li>- Structure type</li> <li>- Size</li> <li>- Pump type</li> <li>- Number of pumps</li> <li>- Pump capacity</li> </ul> <p><b>Screen</b></p> <ul style="list-style-type: none"> <li>- Type</li> <li>- Flow rate</li> <li>- Screen width</li> <li>- Number of screens</li> </ul>	<ul style="list-style-type: none"> <li>- Precast concrete manhole</li> <li>- Diameter 1.8 m</li> <li>- Submersible pump</li> <li>- 2 sets (1 set stand-by)</li> <li>- <math>300 \text{ m}^3/\text{day} \times 2.0 \times 1/24 \times 1/60 = 0.42 \text{ m}^3/\text{min}</math></li> </ul> <ul style="list-style-type: none"> <li>- Automatic screen with dewatering</li> <li>- <math>1.0 \text{ m}^3/\text{min}</math> (for 2 sets pumps)</li> <li>- 2.5 – 5.0 mm</li> <li>- 1 set</li> </ul>	<p>(D:1.8m)</p>  																				
<p><b>2. Oxidation Ditch</b></p> <ul style="list-style-type: none"> <li>- Type</li> <li>- Maximum daily flow</li> <li>- Influent BOD</li> <li>- Influent SS</li> <li>- Effluent BOD</li> <li>- Effluent SS</li> <li>- HRT</li> <li>- MLSS</li> <li>- BOD-SS Loading</li> <li>- Return sludge ratio</li> <li>- Tank size</li> </ul>	<ul style="list-style-type: none"> <li>- Precast concrete round reactor (with final sedimentation)</li> <li>- <math>300 \text{ m}^3/\text{day}</math></li> <li>- 200 mg/l</li> <li>- 200 mg/l</li> <li>- 20 mg/l</li> <li>- 20 mg/l</li> <li>- 24 hours</li> <li>- 3,500 mg/l</li> <li>- <math>0.05 \text{ kgBOD/kgSS/day}</math></li> <li>- 100 – 200 %</li> </ul> <table border="1" style="width: 100%; text-align: center;"> <thead> <tr> <th>D</th> <th>d</th> <th>w</th> <th>H</th> <th>h</th> <th>t1</th> <th>t2</th> <th>T1</th> <th>T2</th> <th>T3</th> </tr> </thead> <tbody> <tr> <td>13,500</td> <td>7,000</td> <td>3,100</td> <td>4,100</td> <td>3,700</td> <td>150</td> <td>150</td> <td>300</td> <td>300</td> <td>400</td> </tr> </tbody> </table> 	D	d	w	H	h	t1	t2	T1	T2	T3	13,500	7,000	3,100	4,100	3,700	150	150	300	300	400	
D	d	w	H	h	t1	t2	T1	T2	T3													
13,500	7,000	3,100	4,100	3,700	150	150	300	300	400													
<p><b>3. Final sedimentation</b></p> <ul style="list-style-type: none"> <li>- Type</li> <li>- Overflow Rate,</li> <li>- Water depth</li> <li>- Tank diameter</li> <li>- Water area</li> <li>- Capacity</li> </ul>	<ul style="list-style-type: none"> <li>- Precast concrete round tank (inside Oxidation Ditch)</li> <li>- <math>8 \text{ m}^3/\text{m}^2/\text{day}</math></li> <li>- 3.0 m</li> <li>- Diameter 7.0 m</li> <li>- <math>7.0 \times 7.0 \times 3.14/4 = 38.5 \text{ m}^2</math></li> <li>- <math>38.5 \times 3.0 = 115.5 \text{ m}^3</math></li> </ul>																					

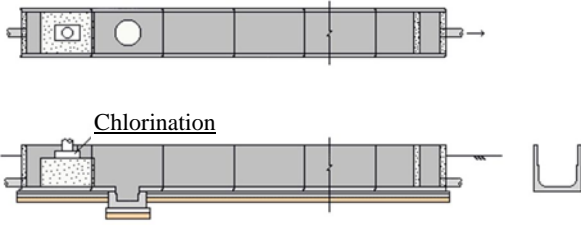
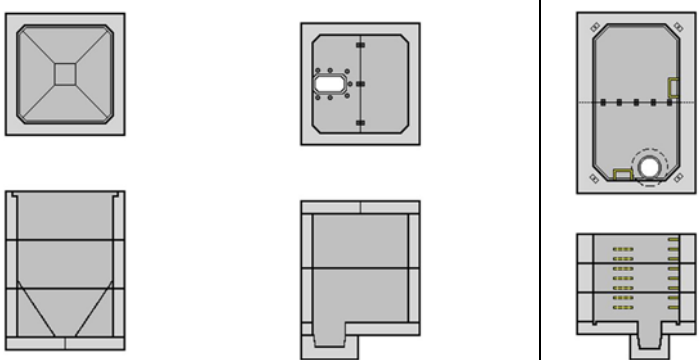
Items	Design Calculation	Remarks
<p><b>4. Chlorination</b></p> <ul style="list-style-type: none"> <li>- Type</li> <li>- Maximum daily flow</li> <li>- Contact time</li> <li>- Design capacity</li> <li>- Tank size</li> </ul>	<ul style="list-style-type: none"> <li>- Precast concrete ditch block</li> <li>- <math>300 \text{ m}^3/\text{day} = 0.208 \text{ m}^3/\text{min}</math></li> <li>- 15 minutes</li> <li>- <math>0.208 \times 15 = 3.2 \text{ m}^3</math></li> <li>- <math>B1.2\text{m} \times H0.7\text{m (WL)} \times L4.0 \text{ m} = 3.36 \text{ m}^3</math></li> </ul>  <p style="text-align: center;">(U ditch block: 1.2 m x 1.2 m x 4.0 m)</p>	
<p><b>5. Sludge thickening tank</b></p> <ul style="list-style-type: none"> <li>- Type</li> <li>- Maximum daily flow</li> <li>- SS removal rate</li> <li>- Sludge generation rate</li> <li>- Moisture of excess sludge</li> <li>- Moisture of thickening sludge</li> <li>- Sludge loading</li> <li>- Solid amount</li> <li>- Excess sludge</li> <li>- Required area</li> <li>- Tank size</li> </ul> <p><b>Sludge storage tank</b></p> <ul style="list-style-type: none"> <li>- Type</li> <li>- Storage days</li> <li>- Thickening sludge</li> <li>- Tank size</li> </ul> <p><b>Sludge pump pit</b></p> <ul style="list-style-type: none"> <li>- Type</li> <li>- Tank size</li> </ul>	<ul style="list-style-type: none"> <li>- Precast concrete block</li> <li>- <math>300 \text{ m}^3/\text{day}</math></li> <li>- 90 %</li> <li>- 75 %</li> <li>- 99.4 %</li> <li>- 98.5 %</li> <li>- <math>30 \text{ kg}/\text{m}^2</math></li> <li>- <math>300 \times 200 \times 0.90 \times 0.75 \times 10^{-3} = 40.5 \text{ kg}/\text{day}</math></li> <li>- <math>40.5 \times (100/0.6) \times 10^{-3} = 6.8 \text{ m}^3/\text{day}</math></li> <li>- <math>40.5/30 = 1.4 \text{ m}^3</math></li> <li>- <math>B2.5\text{m} \times L2.5\text{m} \times H4.5\text{m} (1.5\text{m} \times 3)</math></li> </ul> <ul style="list-style-type: none"> <li>- Precast concrete block</li> <li>- About 4 days</li> <li>- <math>40.5 \times (100/1.5) \times 10^{-3} = 2.7 \text{ m}^3/\text{day}</math></li> <li>- <math>B2.5\text{m} \times L2.5\text{m} \times H3.0\text{m} (1.5\text{m} \times 2)</math></li> </ul>  <p style="text-align: center;">Sludge thickening tank      Sludge storage tank</p> <p style="text-align: right;">Sludge pump pit</p> <ul style="list-style-type: none"> <li>- Precast concrete block</li> <li>- <math>B2.5\text{m} \times L4.0\text{m} \times H2.4\text{m} (0.8\text{m} \times 3)</math></li> </ul>	

Source: JICA Consultant Team, Asahi Concrete Works Co., Ltd.

LAYOUT PLAN OF STP (Prefabricated Oxidation Ditch System)

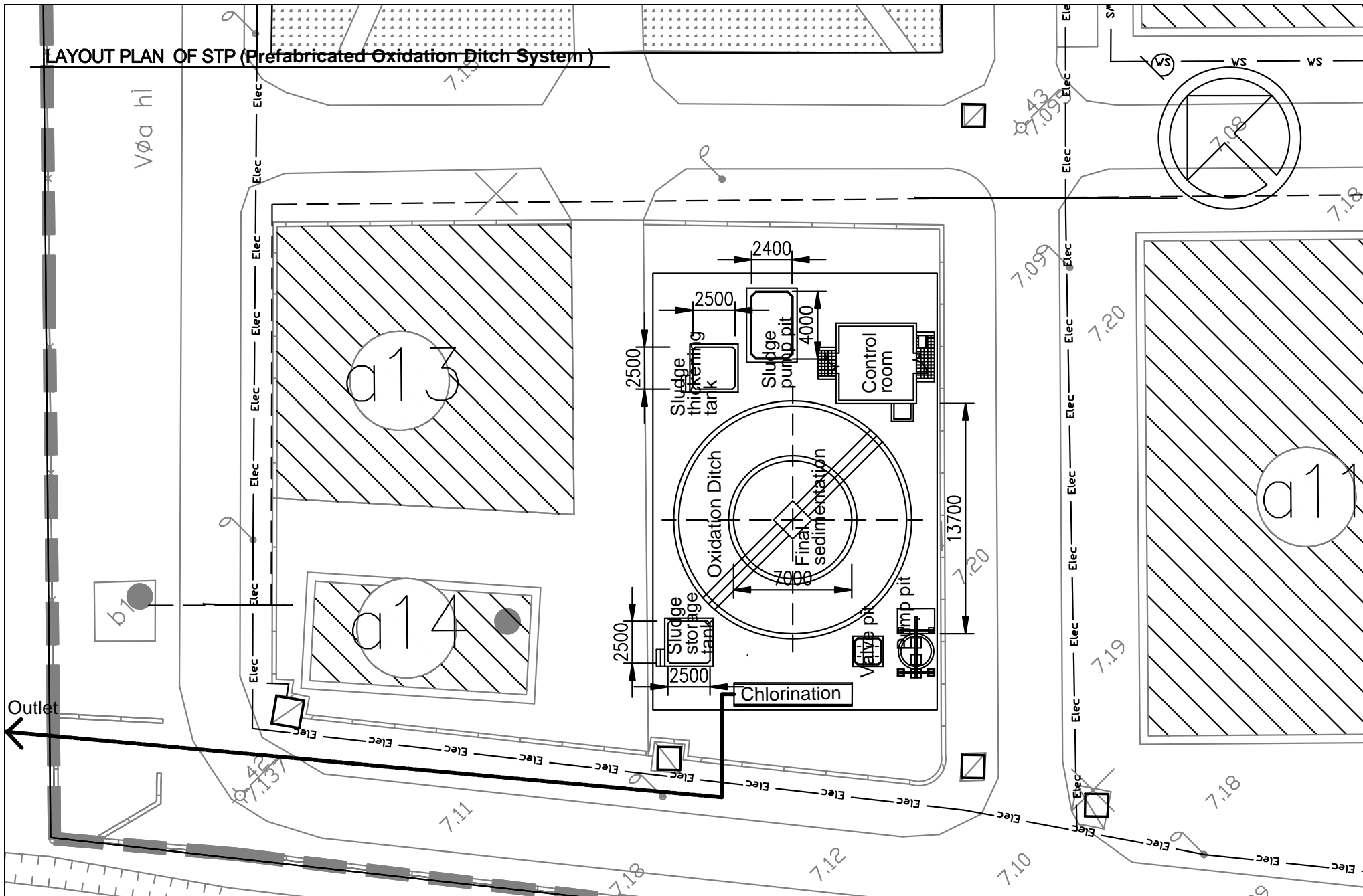

Study on M/P of Small-scale Sewerage System for CUWC					Package
MẶT BẰNG HỆ THỐNG THOÁT NƯỚC THẢI					Items
LAYOUT PLAN OF STP (POD SYSTEM)					
Scale	DWG Number: CUWC-SWWTP-01	Sheet 1/1	Rev A	Date	



**SMALL-SCALE SEWERAGE SYSTEM MASTER PLAN  
FOR  
CUWC**

**APPENDIX - D**

**Alternative Plan of Johkasou (Advanced Septic Tank Technology in Japan)**

## APPENDIX - D

### ALTERNATIVE PLAN BY JOHKASOU (ADVANCED SEPTIC TANK TECHNOLOGY IN JAPAN)

#### 1.1 Technical Features of Johkasou

Johkasou is decentralized wastewater treatment technology unique to Japan for purifying wastewater discharged from general households using the properties of microorganisms to degrade organic contaminants. The structure of Johkasou is designed to fully demonstrate the purification functions of microorganisms. Septic tanks are widely used in Vietnam, but these tanks have structural, maintenance and control problems that make it difficult to ensure hygienic treatment of wastewater. On the other hand, Johkasou demonstrates excellent sewage treatment performance by combining anaerobic and aerobic treatments, and its structure is convenient in terms of maintenance and management. Example of the structure of small-scale Johkasou is shown the below figure.

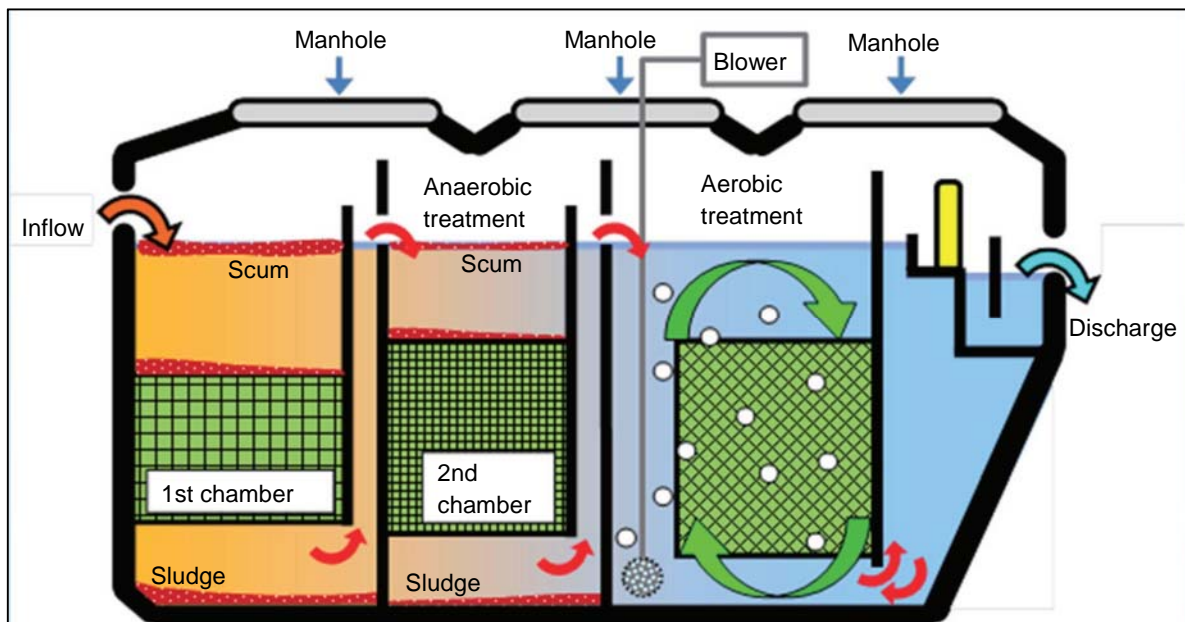

Source: Ministry of the Environment Government of Japan

**Figure.1 Example of the Structure of Small-Scale Johkasou (FRP-made)**

The capacity, the treatment process and the material of Johkasou are selectable, depending on the usage of the building, quantity and quality of wastewater to be treated, and the regulation issues of discharge areas. However, Johkasou are usually classified by the capacity in terms of number of users for design.

- **Small-scale Johkasou:**

Johkasou used for individual household and small-scale wastewater treatment with capacity of 5 to 50 persons, or average amount of wastewater less than 10 m<sup>3</sup>/day. Most small-scale Johkasou are made of plastics such as FRP (fiberglass reinforced plastic) or DCPD (Dicyclopentadiene) at factories.

- **Medium-scale Johkasou:**

Johkasou used for medium-scale wastewater treatment with capacity of 51 to 500 persons, or average amount of wastewater less than 100 m<sup>3</sup>/day. Medium-scale Johkasou are made of FRP at factories, or are built of reinforced concrete (RC) at sites of installation.

- **Large-scale Johkasou:**

Johkasou used for large-scale wastewater treatment with capacity of 501 persons, or average amount of wastewater more than 100 m<sup>3</sup>/day. Large-scale Johkasou are mainly built of reinforced concrete (RC) at sites of installation.

Example of the structure of Medium-scale Johkasou is shown the below figure.



Source: Okamura Vietnam Co., LTD

**Figure.2 Example of the Structure of Medium-Scale Johkasou (FRP-made)**

## 1.2 Proposed Johkasou as Pilot Project

The experimental training facilities of small-scale sewerage system in CUWC is aimed for human resource development of sewerage system. The many contents of installed facilities will be very effective trainings. Johkasou of Japanese technology shall be expected for understanding advanced sewage treatment process.

Installation of Johkasou for a building like dormitory (building: B8) in CUWC is proposed as a pilot project. A manufacturer of Johkasou can collect some test data on the site, and introduce the technology to trainees or visitors.

## 1.3 Basic Design Condition of Johkasou

Effluent quality shall meet law requirements. Design inflow shall be the planned average daily flow.

Design inflow and influent quality is shown in below table.

**Table.1 Basic Design Condition of Johkasou (B8: Dormitory)**

Design Parameters	Design Conditions	Remarks
Average daily flow (m <sup>3</sup> /d)	36	Calculated value (37.8)
Influent BOD (mg/l)	200	Calculated value (185)
Influent SS (mg/l)	200	Calculated value (145)
Standard effluent BOD (mg/l)	30	QCVN-14:2008, Column A (30)
Standard effluent SS (mg/l)	50	QCVN-14:2008, Column A (50)

Source: JICA Consultant Team

### 1.4 Flow Diagram of Johkasou

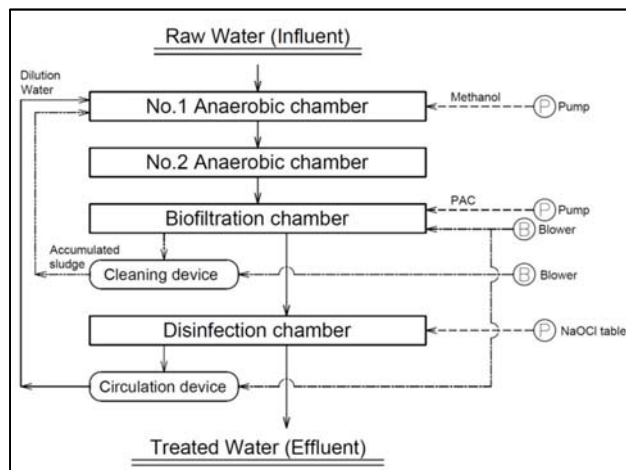

Source: JICA Consultant Team

**Figure.3 Flow Diagram of Johkasou**

### 1.5 Design of Johkasou

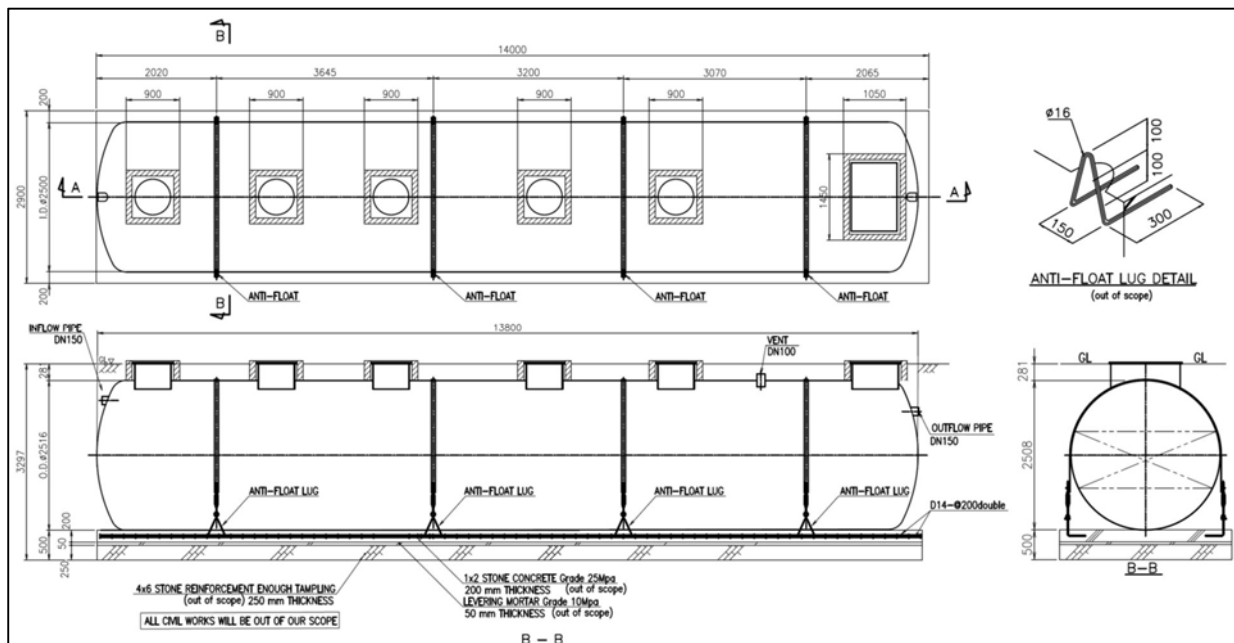

Source: JICA Consultant Team

**Figure.4 Flow Diagram of Johkasou**

LAYOUT PLAN OF JOHKASOU (36m<sup>3</sup>/day)

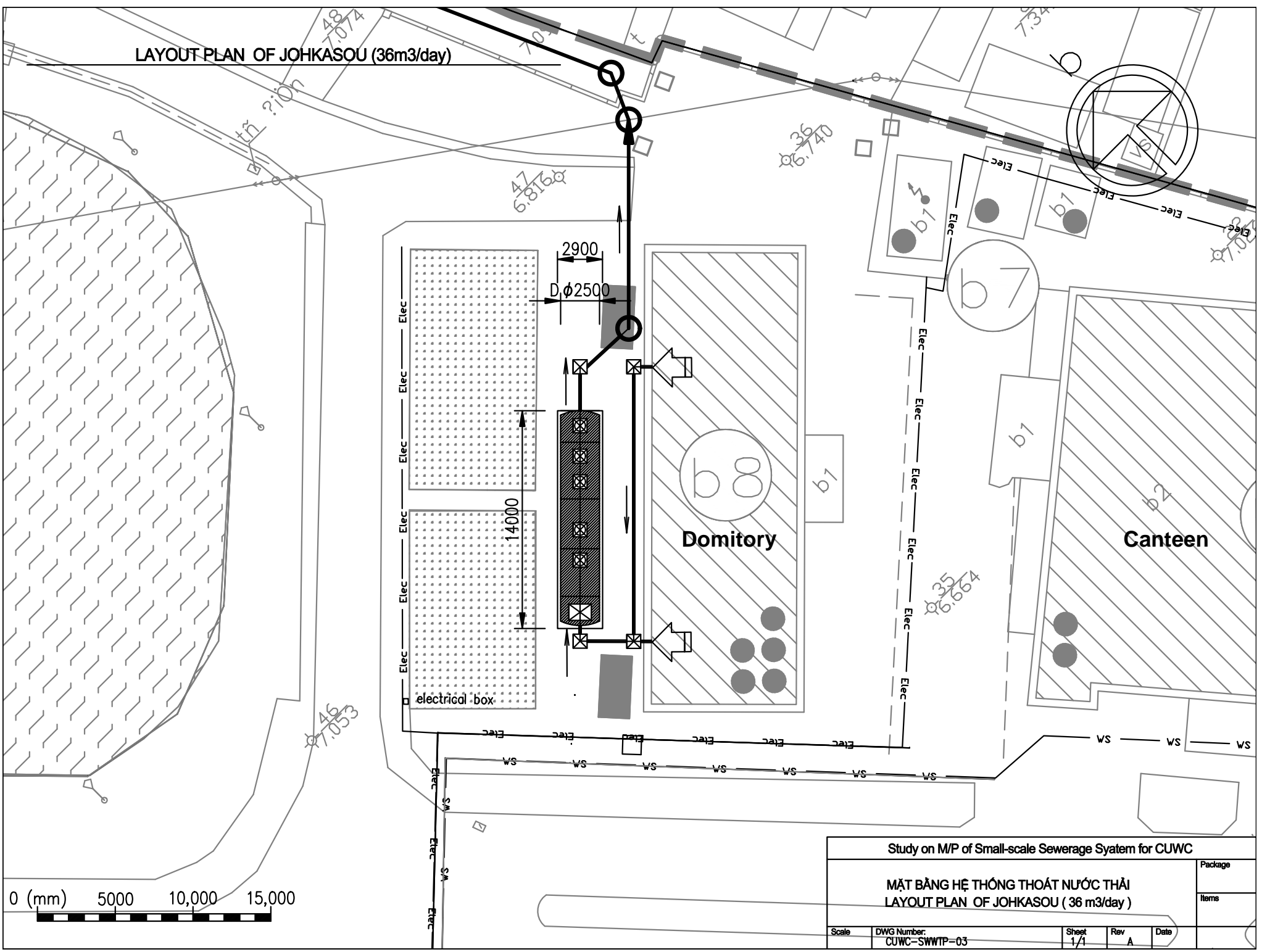

Study on M/P of Small-scale Sewerage System for CUWC					Package
MẶT BẰNG HỆ THỐNG THOÁT NƯỚC THẢI LAYOUT PLAN OF JOHKASOU ( 36 m <sup>3</sup> /day )					Items
Scale	DWG Number: CUWC-SWWTP-03	Sheet 1/1	Rev A	Date	