

2.3.7 Branch 3

ID: B03-01	JICA 2003 M/P	SLLCD 2017	2018 F/S
			B-01
COORDINATE	E		N
	79.921555		7.025133
PURPOSE	Railroad Bridge		
OPERATION	in use		
DRAWING			
Railway Bridge # B-1			
			
Invert : U/S : 0.937 D/S : 0.807 (Source: 2018 F/S Report)			

SITE CONDITION

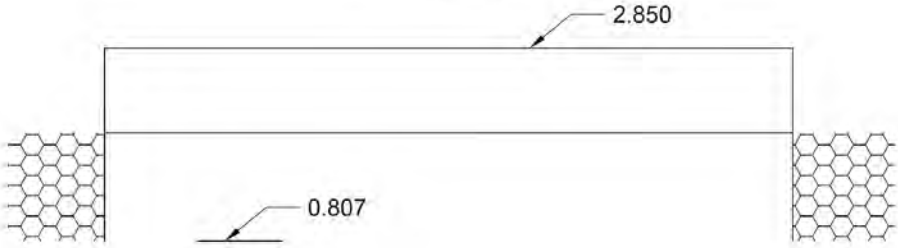

ID: B03-02	JICA 2003 M/P	SLDLC 2017	2018 F/S
			B-02
COORDINATE	E		N
	79.921900		7.025236
PURPOSE	Bridge		
OPERATION	in use		



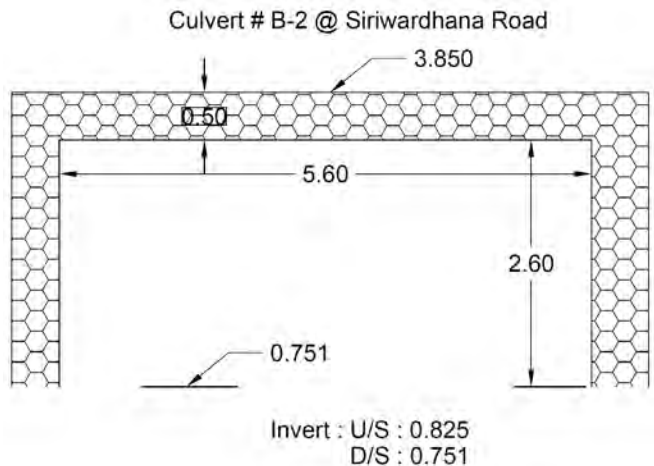

DRAWING

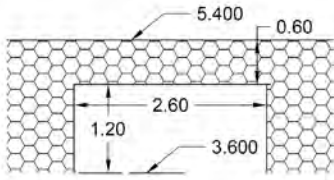

(Source: 2018 F/S Report)

SITE CONDITION



ID: B03-03	JICA 2003 M/P	SLDLC 2017	2018 F/S
			B-03
COORDINATE	E		N
	79.926251		7.025739
PURPOSE	Bridge		
OPERATION	in use		
DRAWING			
<p>Culvert # B-3 @ Ragama - Kadawatha Road Culvert No.5/1</p>  <p>Invert : U/S : 3.710 D/S : 3.600</p> <p>(Source: 2018 F/S Report)</p>			
SITE CONDITION			
			
			

ID: B03-04	JICA 2003 M/P	SLDC 2017	2018 F/S
			B-04
COORDINATE	E		N
	79.929172		7.024995
PURPOSE	Culvert		
OPERATION	in use		

DRAWING

Culvert # B-4 @ Cross Road

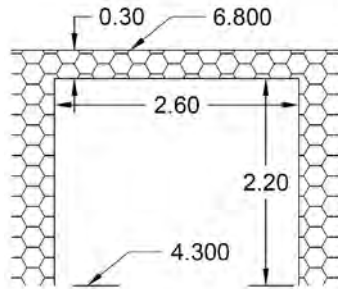

Invert : U/S : 4.550
D/S : 4.300

(Source: 2018 F/S Report)

SITE CONDITION



2.3.8 Branch 4

ID: B04-01	JICA 2003 M/P	SLDC 2017	2018 F/S
COORDINATE	E		N
	79.916707		7.006728
PURPOSE	Bridge		
OPERATION	in use		

DRAWING

SITE CONDITION

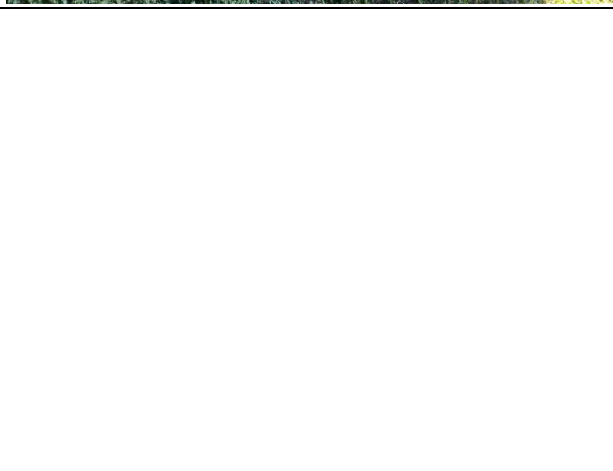

ID: B04-02	JICA 2003 M/P	SLDC 2017	2018 F/S
COORDINATE	E		N
	79.916787		7.006858
PURPOSE	Bridge		
OPERATION	in use (temporary)		
DRAWING			
SITE CONDITION			
			

ID: B04-03	JICA 2003 M/P	SLDC 2017	2018 F/S
			C-01
COORDINATE	E		N
	79.917882		7.006754
PURPOSE	Pipe Culvert		
OPERATION	in use		
DRAWING			
(Source: 2018 F/S Report)			
SITE CONDITION			
			

ID: B04-04	JICA 2003 M/P	SLDC 2017	2018 F/S
			C-02
COORDINATE	E		N
	79.921094		7.007323
PURPOSE	Bridge		
OPERATION	in use		

DRAWING

Bridge # C-2 @ Pinnameda Road

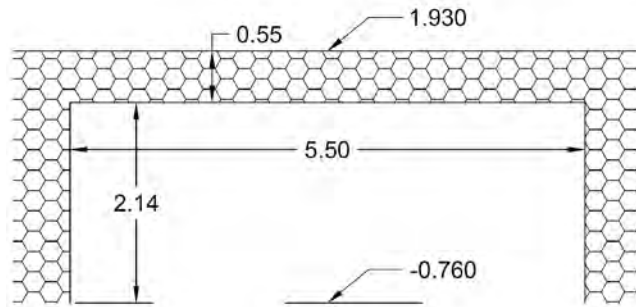

**BRIDGE
PINNAMEDA ROAD**

Invert : U/S : -0.522
D/S : -0.760

(Source: 2018 F/S Report)

SITE CONDITION



ID: B04-05	JICA 2003 M/P	SLDC 2017	2018 F/S
			C-03
COORDINATE	E		N
	79.922044		7.011623
PURPOSE	Culvert		
OPERATION	in use		

DRAWING

(Source: 2018 F/S Report)

SITE CONDITION



ID: B04-06	JICA 2003 M/P	SLDLC 2017	2018 F/S
			C-4
COORDINATE	E		N
	79.920184		7.013185
PURPOSE	Culvert		
OPERATION	in use		

DRAWING

(Source: 2018 F/S Report)

SITE CONDITION



ID: B04-07	JICA 2003 M/P	SLDC 2017	2018 F/S
			C-05
COORDINATE	E		N
	79.915177		7.010034
PURPOSE	Railroad Bridge		
OPERATION	in use		
DRAWING			
<p style="text-align: center;">RAILWAY BRIDGE</p> <p style="text-align: center;">Invert : U/S : -0.045 D/S : -0.523</p>			
(Source: 2018 F/S Report)			





2.3.9 Branch 5

ID: B05-01	JICA 2003 M/P	SLDC 2017	2018 F/S
			D-01
COORDINATE	E		N
	79.926268		7.003954
PURPOSE	Culvert		
OPERATION	in use		

DRAWING

Bridge # D-1 @ Kurukulawa Road

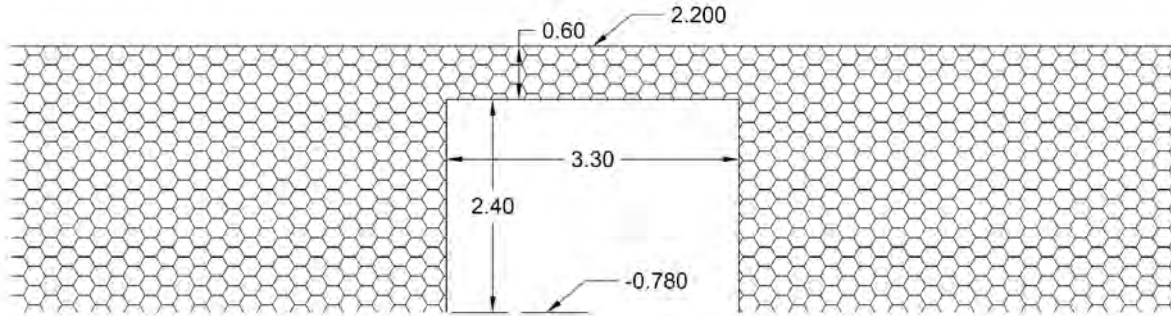

BRIDGE
KURUKULAWA ROAD

(Source: 2018 F/S Report)

SITE CONDITION



2.3.10 Branch 6

ID: B06-01	JICA 2003 M/P	SLLCD 2017	2018 F/S
			E-01
COORDINATE	E		N
	79.926154		7.002770
PURPOSE	Bridge		
OPERATION	in use		

DRAWING

Bridge # E-1 @ Kurukulawa Road

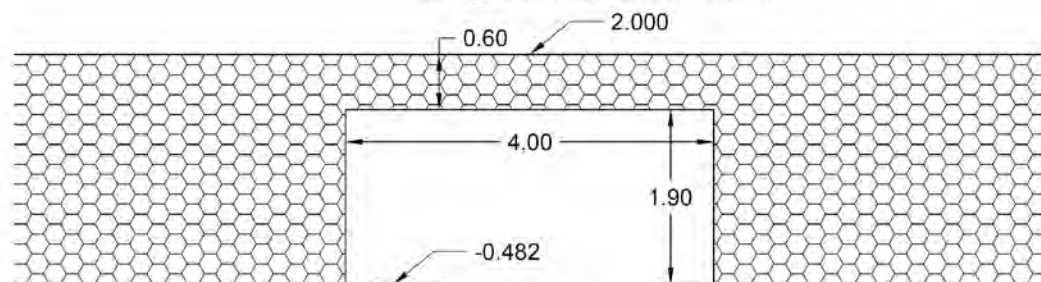

BRIDGE
KURUKULAWA ROAD

Invert : U/S : -0.391
D/S : -0.482

(Source: 2018 F/S Report)

SITE CONDITION



ID: B06-02	JICA 2003 M/P	SLDC 2017	2018 F/S
			E-02
COORDINATE	E		N
	79.928778		7.002455
PURPOSE	Anicut		
OPERATION	Not confirmed		
DRAWING			
Anicut # E-2			
<p>The drawing shows a cross-section of an anicut with a central channel. The channel width is 1.50. On either side, there are embankments with a top width of 1.70. The total width of the structure is 1.70 + 1.50 + 1.70 = 4.90. The height of the embankments is 1.10. The invert of the channel is 0.272 (U/S) and 0.109 (D/S). The channel depth is 0.40 on both sides.</p>			
Invert : U/S : 0.272 D/S : 0.109 (Source: 2018 F/S Report)			
SITE CONDITION			
No access			

ID: B06-03	JICA 2003 M/P	SLDC 2017	2018 F/S
			E-03
COORDINATE	E		N
	79.932253		7.002164
PURPOSE	Culvert		
OPERATION	in use		

DRAWING

Culvert # E-3 @ Lazaras Road

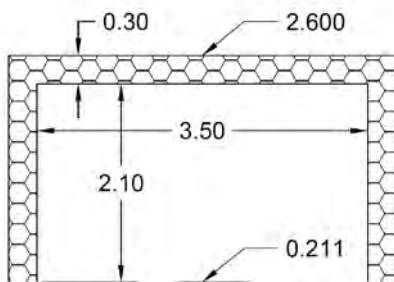

Invert : U/S : 0.588
D/S : 0.211

(Source: 2018 F/S Report)

SITE CONDITION



ID: B06-04	JICA 2003 M/P	SLDC 2017	2018 F/S
COORDINATE	E		N
	79.933175		7.003041
PURPOSE	Anicut		
OPERATION	in use		
DRAWING			
Anicut # E-4			
Invert : U/S : 0.988 D/S : 0.965 (Source: 2018 F/S Report)			
SITE CONDITION			

ID: B06-05	JICA 2003 M/P	SLDC 2017	2018 F/S
			E-05
COORDINATE	E		N
	79.935122		7.004828
PURPOSE	Anicut		
OPERATION	in use		

DRAWING

Anicut # E-5

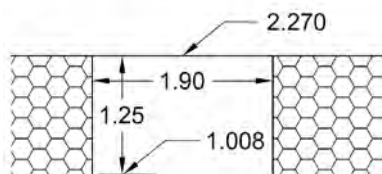

Invert : U/S : 1.242
D/S : 1.008

(Source: 2018 F/S Report)

SITE CONDITION



ID: B06-06	JICA 2003 M/P	SLDC 2017	2018 F/S
			E-06
COORDINATE	E		N
	79.935729		7.006618
PURPOSE	Bridge		
OPERATION	in use		

DRAWING

Culvert # E-6 @ Church Road

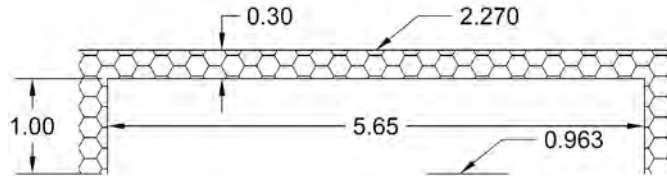

Invert : U/S : 1.378
D/S : 0.963

(Source: 2018 F/S Report)

SITE CONDITION



ID: B06-07	JICA 2003 M/P	SLDC 2017	2018 F/S
			E-07
COORDINATE	E		N
	79.936242		7.008337
PURPOSE	Anicut		
OPERATION	in use		

DRAWING

Anicut # E-7

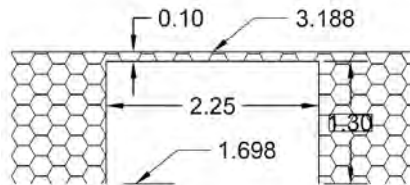

Invert : U/S : 1.809
D/S : 1.698

(Source: 2018 F/S Report)

SITE CONDITION



ID: B06-08	JICA 2003 M/P	SLDC 2017	2018 F/S
			E-08
COORDINATE	E		N
	79.939138		7.009156
PURPOSE	Bridge		
OPERATION	in use		

DRAWING

Culvert # E-8 @ Kadawatha - Ragama Road
(No.2/3)

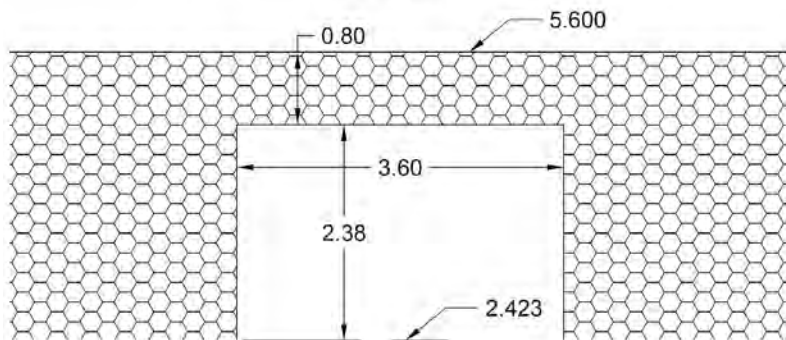





Invert : U/S : 2.563
D/S : 2.423

(Source: 2018 F/S Report)

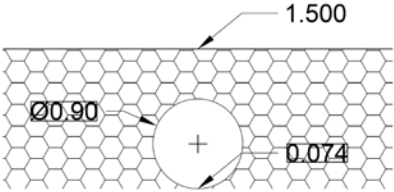
SITE CONDITION



ID: B06a-01	JICA 2003 M/P	SLDC 2017	2018 F/S
			E01-01
COORDINATE	E		N
	79.930666		7.003743
PURPOSE	Pipe Culvert		
OPERATION	in use		
DRAWING			
Culvert # E1-1 @ Church Road			
			
Invert : U/S : 0.095 D/S : 0.074 (Source: 2018 F/S Report)			
SITE CONDITION			
			
			

ID: B06b-01	JICA 2003 M/P	SLDC 2017	2018 F/S
			E02-01
COORDINATE	E		N
	79.929826		7.000882
PURPOSE	Pipe Culvert		
OPERATION	in use		
DRAWING			
Culvert # E2-1 @ Cross Road			
Invert : U/S : 0.633 D/S : 0.412 (Source: 2018 F/S Report)			

SITE CONDITION



2.3.11 Branch 7

ID: B07-01	JICA 2003 M/P	SLDC 2017	2018 F/S
	Culvert at 4+743		F-01
COORDINATE	E		N
	79.934581		6.982060
PURPOSE	Culvert		
OPERATION	in use		

DRAWING

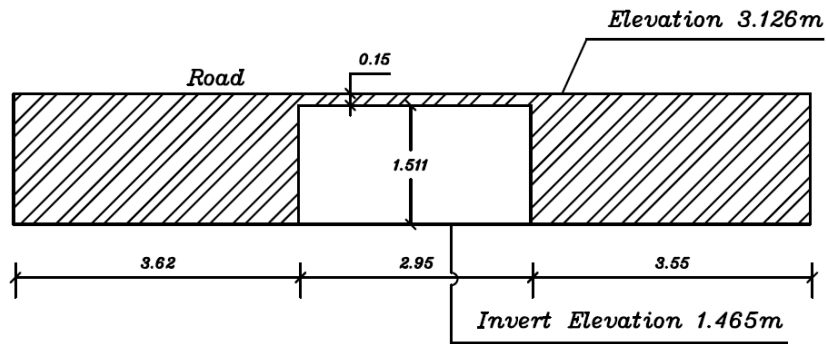

(Source: JICA 2003 M/P Report)

SITE CONDITION

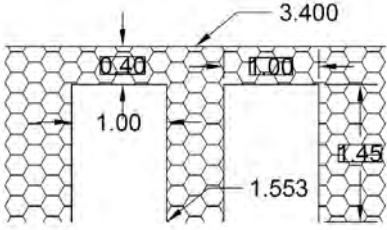

ID: B07-02	JICA 2003 M/P	SLDC 2017	2018 F/S
			F-02
COORDINATE	E		N
	79.933874		6.981126
PURPOSE	Bridge		
OPERATION	in use		
<p>Culvert # F-2 @ Cross Road</p>  <p>Invert : U/S : 1.590 D/S : 1.553</p> <p>(Source: 2018 F/S Report)</p>			

SITE CONDITION



ID: B07-03	JICA 2003 M/P	SLDC 2017	2018 F/S
			F-03
COORDINATE	E		N
	79.930472		6.979379
PURPOSE	Bridge		
OPERATION	in use		
DRAWING			
Bridge # F-3 @ Cross Road (In front of Kiribathgoda Bus Stand)			
Invert : U/S : 1.601 D/S : 1.530 (Source: 2018 F/S Report)			
SITE CONDITION			

ID: B07-04	JICA 2003 M/P	SLDLC 2017	2018 F/S
	Culvert at 3+964		F-04
COORDINATE	E		N
	79.929577		6.977703
PURPOSE	Bridge		
OPERATION	in use		

DRAWING

Culvert # F-4 @ Jinadasa Nandasena Mawatha

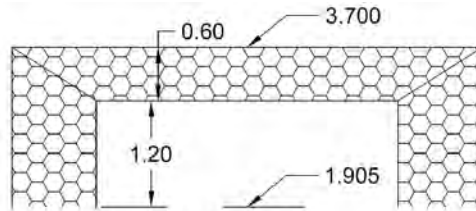

Invert : U/S : 1.920
D/S : 1.905

(Source: 2018 F/S Report)

SITE CONDITION



ID: B07-05	JICA 2003 M/P	SLDC 2017	2018 F/S
	Culvert at 3+932		F-05
COORDINATE	E		N
	79.929469		6.977460
PURPOSE	Culvert		
OPERATION	in use		

DRAWING

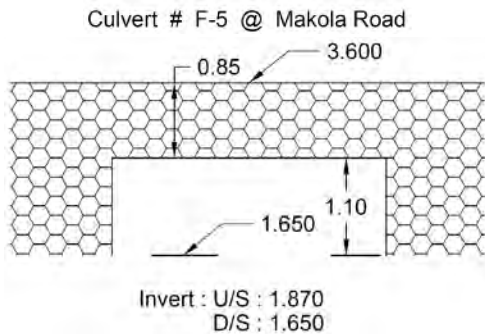

(Source: 2018 F/S Report)

SITE CONDITION



ID: B07-06	JICA 2003 M/P	SLDC 2017	2018 F/S
			F-06
COORDINATE	E		N
	79.929334		6.976658
PURPOSE	Bridge		
OPERATION	in use		

DRAWING

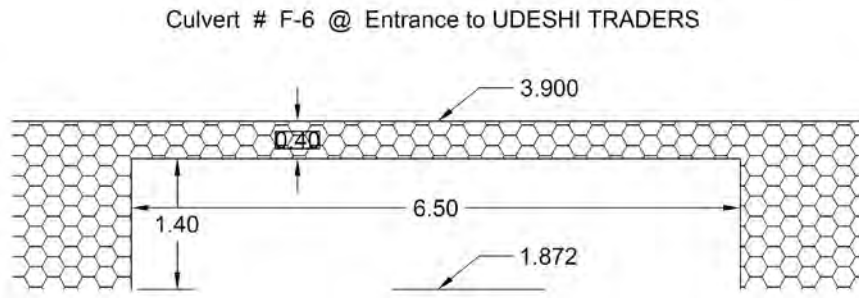

Invert : U/S : 1.910
D/S : 1.872

(Source: 2018 F/S Report)

SITE CONDITION



2.3.12 Peliyagoda and Others

ID: CW1	JICA 2003 M/P	SLLCD 2017	2018 F/S
		CW1	
COORDINATE	E		N
	79.899522		6.978209
PURPOSE	Pipe Culvert		
OPERATION	in use		

DRAWING

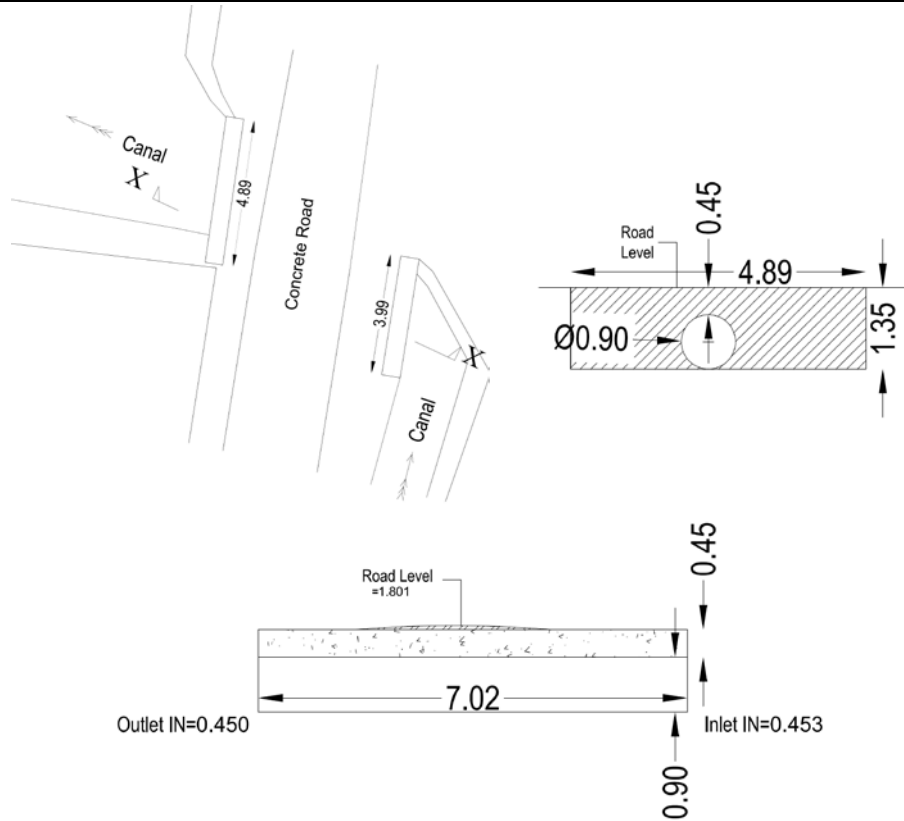

(Source: SLLDC 2017 Survey)

SITE CONDITION





ID: CW2	JICA 2003 M/P	SLLCD 2017	2018 F/S
		CW2	
COORDINATE	E		N
	79.900074		6.975619
PURPOSE	Box and Pipe Culvert		
OPERATION	in use		

DRAWING

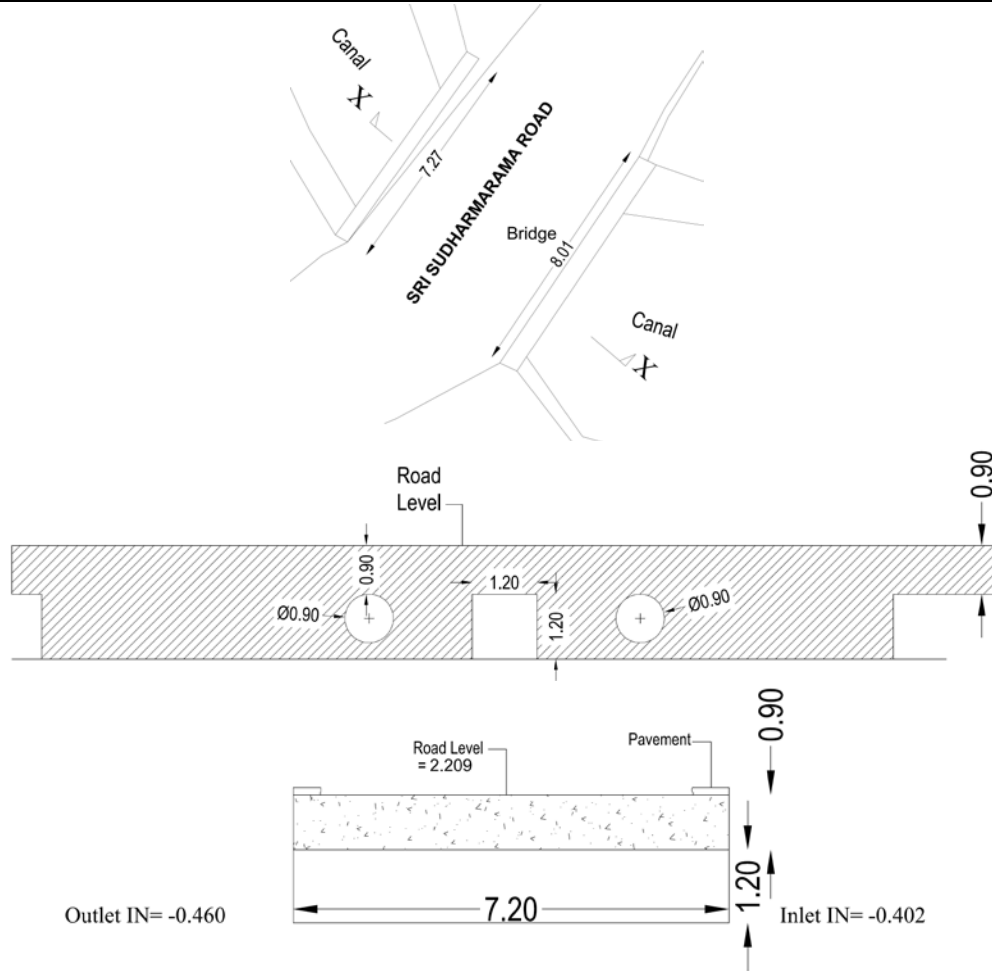

(Source: SLLCD 2017 Survey)

SITE CONDITION





ID: CW4	JICA 2003 M/P	SLDC 2017	2018 F/S
		CW4	
COORDINATE	E		N
	79.901973		6.973193
PURPOSE	Pipe Culvert		
OPERATION	in use		

DRAWING

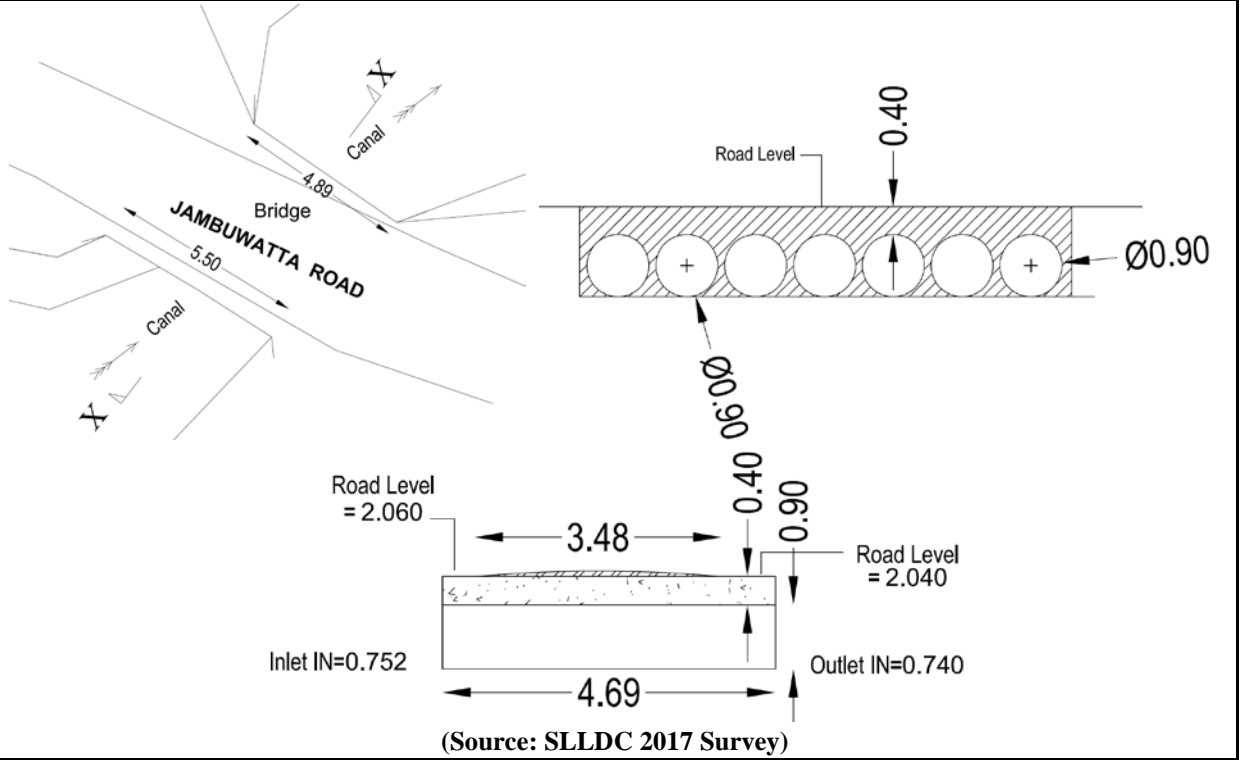

SITE CONDITION





ID: CW6	JICA 2003 M/P	SLDC 2017	2018 F/S
		CW6	
COORDINATE	E		N
	79.903795		6.970815
PURPOSE	Bridge and Pipe Culvert		
OPERATION	in use		

DRAWING

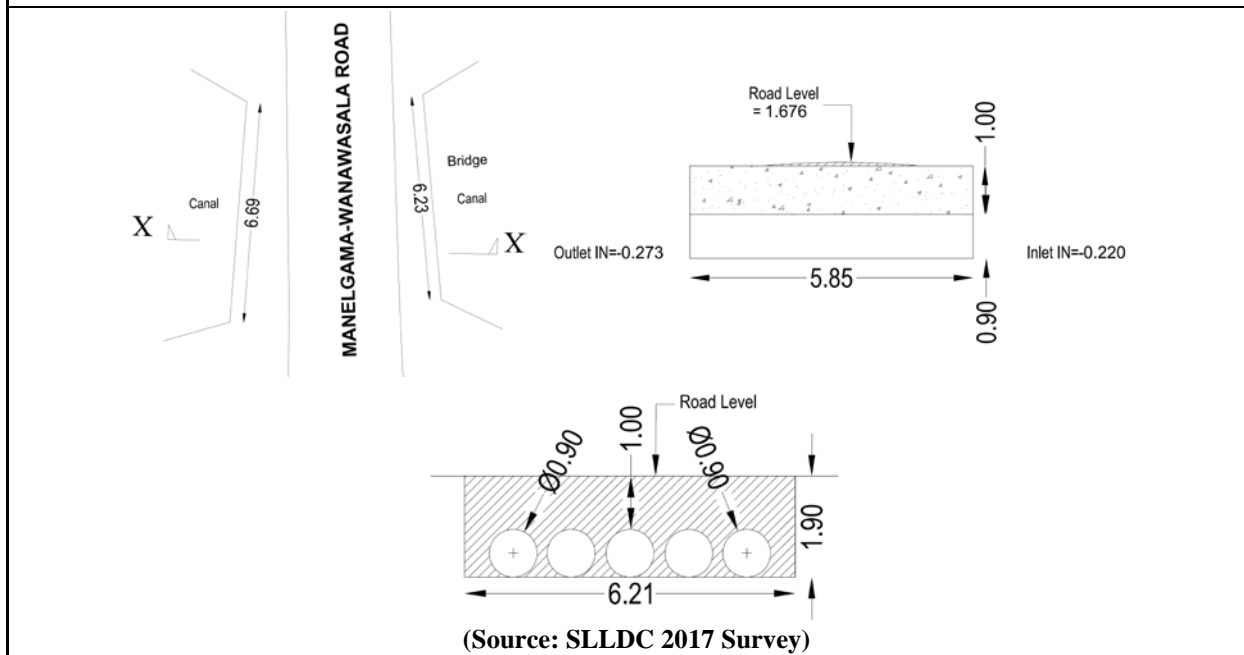

SITE CONDITION





ID: CW7	JICA 2003 M/P	SLDC 2017	2018 F/S
		CW7	
COORDINATE	E		N
	79.906065		6.967804
PURPOSE	Culvert		
OPERATION	in use		

DRAWING

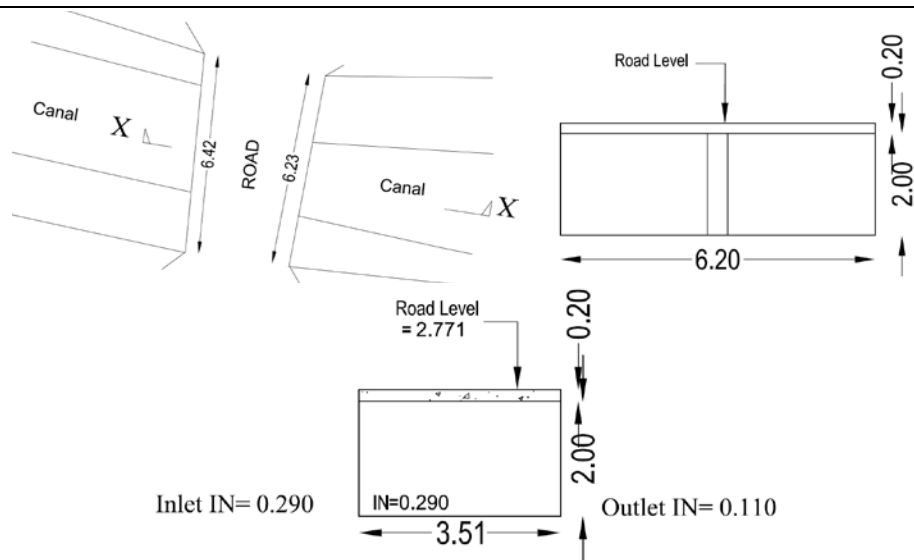

(Source: SLDC 2017 Survey)

SITE CONDITION



ID: CW9	JICA 2003 M/P	SLDC 2017	2018 F/S
		CW9	
COORDINATE	E		N
	79.909376		6.968175
PURPOSE	Culvert		
OPERATION	in use		

DRAWING

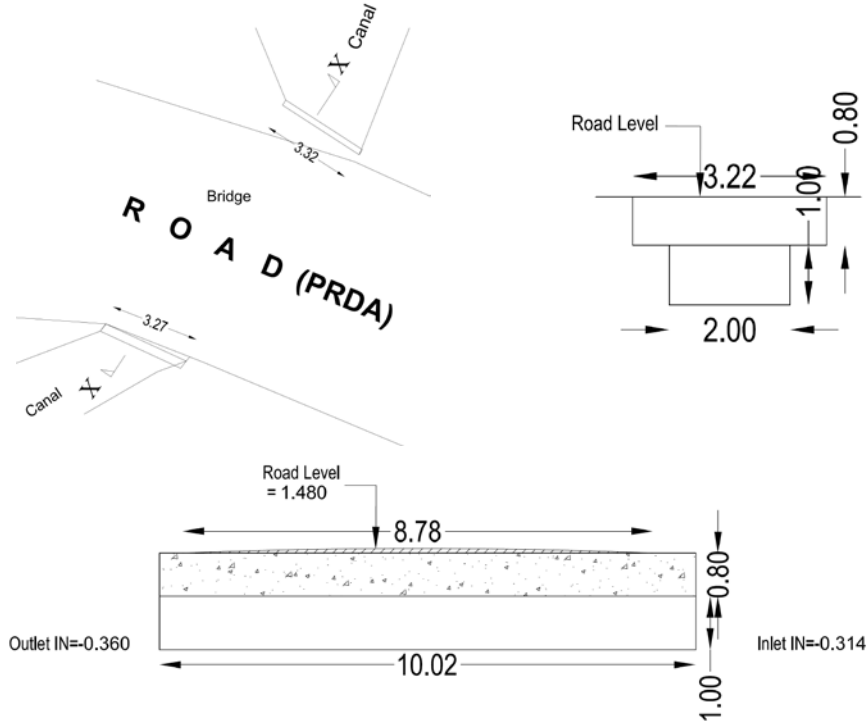

(Source: SLLDC 2017 Survey)

SITE CONDITION





ID: CW10	JICA 2003 M/P	SLDC 2017	2018 F/S
		CW10	
COORDINATE	E		N
	79.907360		6.968928
PURPOSE	Culvert		
OPERATION	in use		

DRAWING

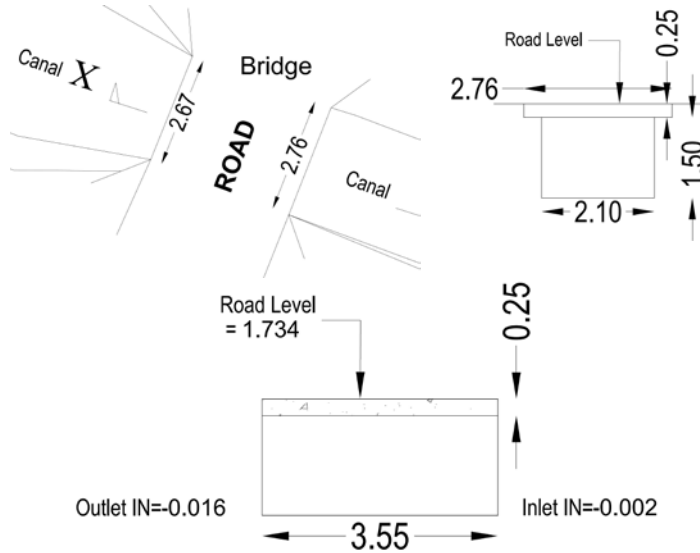

(Source: SLDC 2017 Survey)

SITE CONDITION



ID: CW12	JICA 2003 M/P	SLDC 2017	2018 F/S
		CW12	
COORDINATE	E		N
	79.910145		6.970920
PURPOSE	Bridge		
OPERATION	in use		

DRAWING

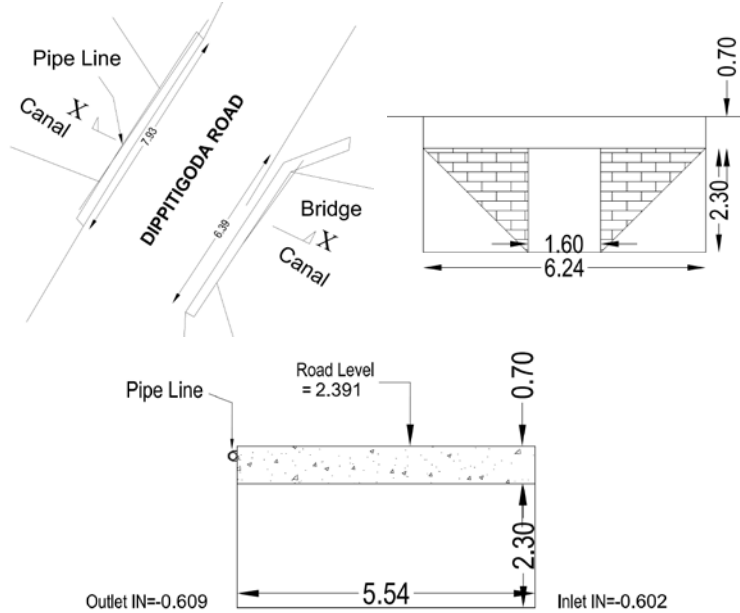

(Source: SLLDC 2017 Survey)

SITE CONDITION





ID: CW14	JICA 2003 M/P	SLDC 2017	2018 F/S
		CW14	
COORDINATE	E		N
	79.898878		6.972712
PURPOSE	Pipe Culvert		
OPERATION	in use		

DRAWING

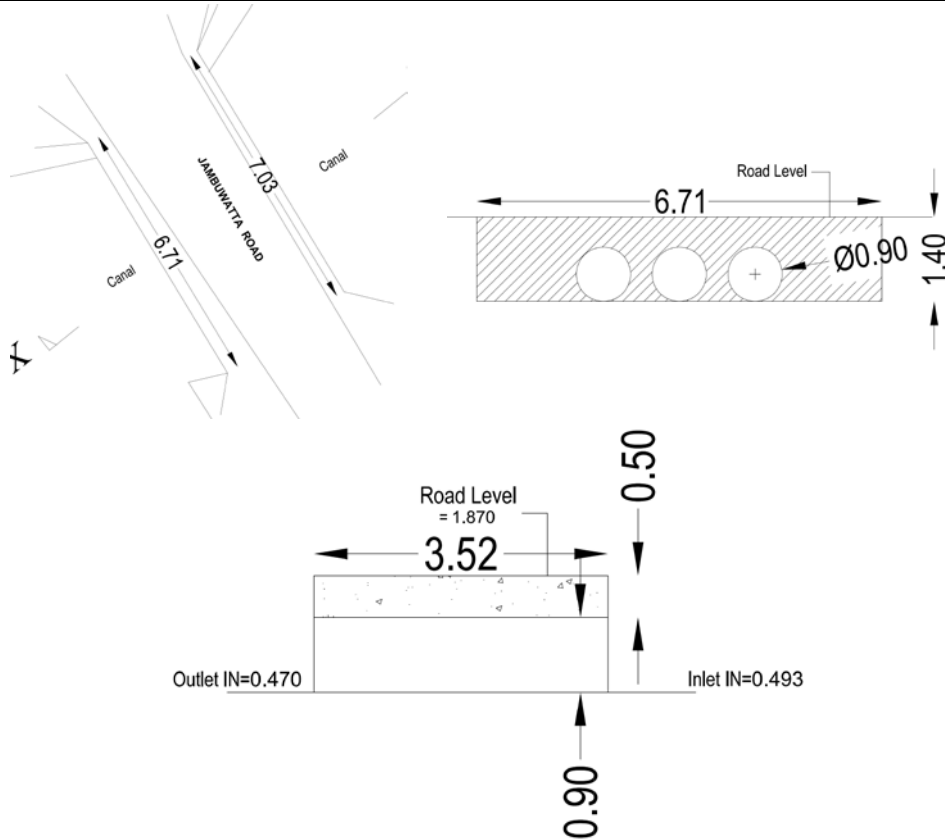

(Source: SLDC 2017 Survey)

SITE CONDITION





ID: CW15	JICA 2003 M/P	SLDC 2017	2018 F/S
		CW15	
COORDINATE	E		N
	79.895985		6.972837
PURPOSE	Bridge		
OPERATION	in use		

DRAWING

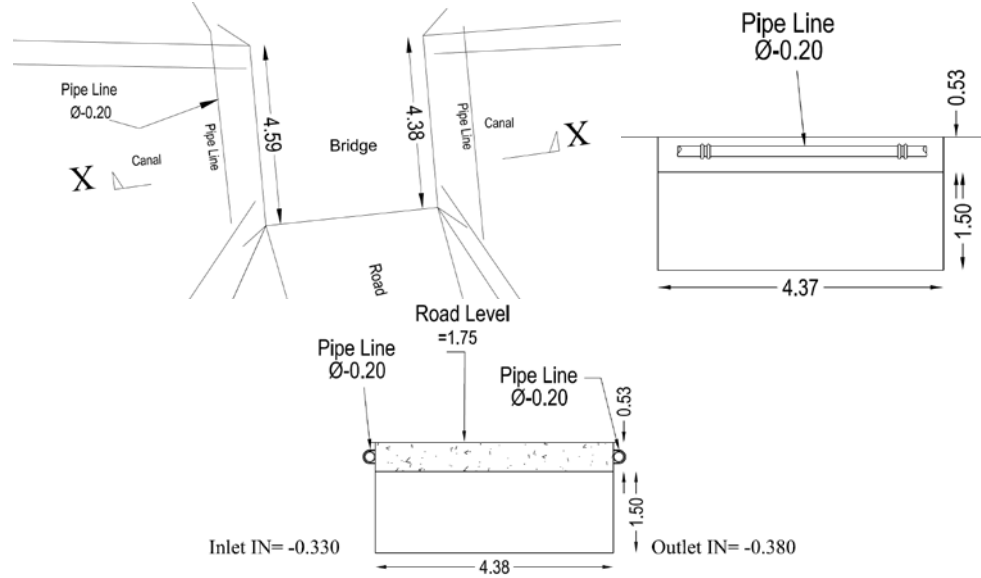

(Source: SLDC 2017 Survey)

SITE CONDITION



ID: CW17	JICA 2003 M/P	SLDC 2017	2018 F/S
		CW17	
COORDINATE	E		N
	79.894451		6.970861
PURPOSE	Bridge		
OPERATION	in use		

DRAWING

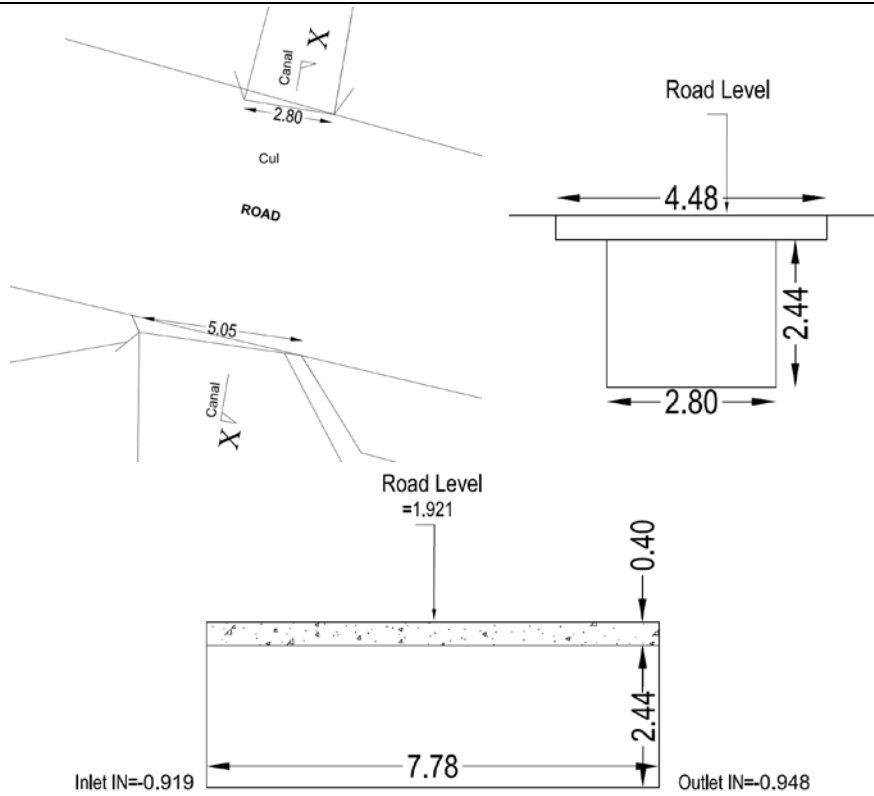

(Source: SLDC 2017 Survey)

SITE CONDITION



ID: CW18	JICA 2003 M/P	SLLCD 2017	2018 F/S
		CW18	
COORDINATE	E		N
	79.894312		6.970739
PURPOSE	Bridge		
OPERATION	in use		

DRAWING

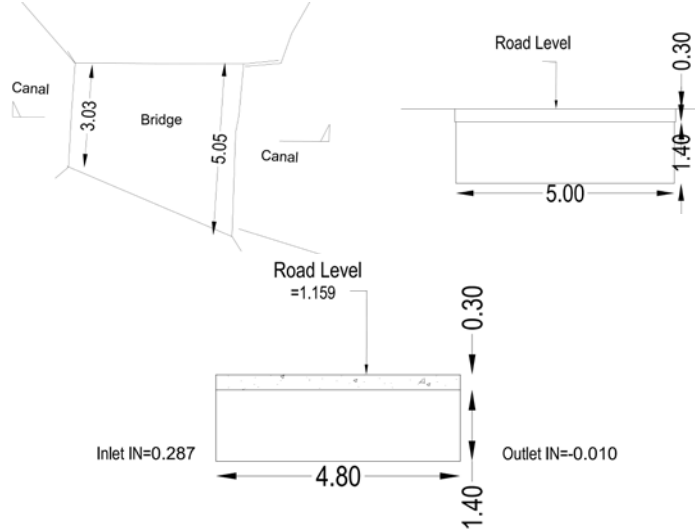

(Source: SLLDC 2017 Survey)

SITE CONDITION



ID: CW18A	JICA 2003 M/P	SLLDC 2017	2018 F/S
COORDINATE	E		N
	79.893966		6.970722
PURPOSE	Culvert		
OPERATION	in use		
DRAWING			
(No drawing is available.)			
SITE CONDITION			
			

ID: CW20	JICA 2003 M/P	SLDC 2017	2018 F/S
		CW20	
COORDINATE	E		N
	79.895117		6.970594
PURPOSE	Bridge		
OPERATION	in use		

DRAWING

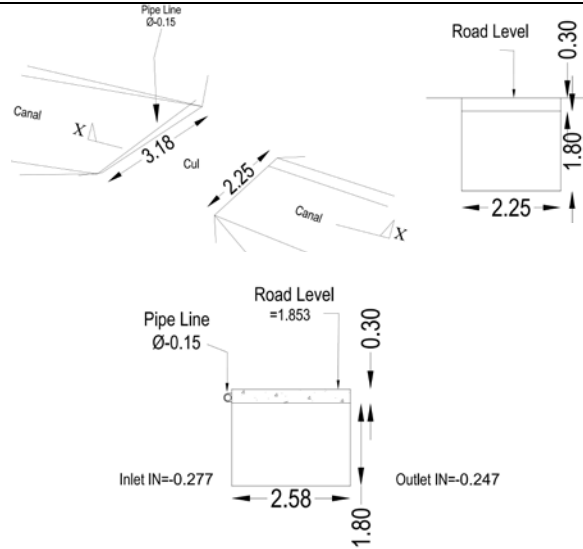

(Source: SLDC 2017 Survey)

SITE CONDITION



ID: CW21	JICA 2003 M/P	SLLCD 2017	2018 F/S
		CW21	
COORDINATE	E		N
	79.897055		6.960016
PURPOSE	Culvert		
OPERATION	in use		

DRAWING

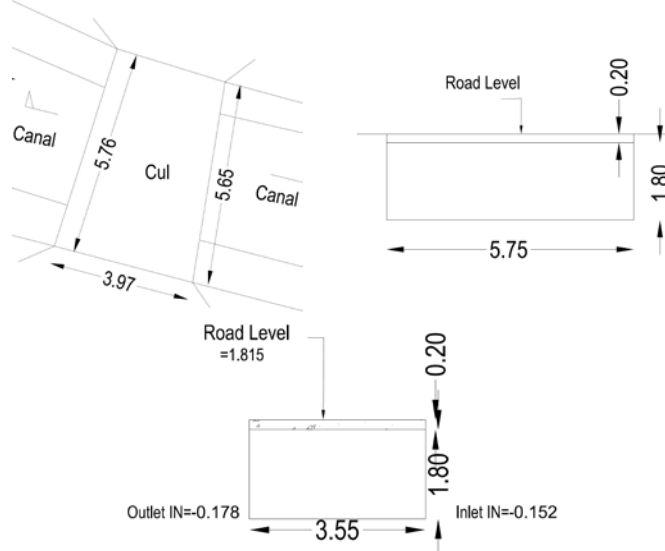

(Source: SLLDC 2017 Survey)

SITE CONDITION



ID: CW22	JICA 2003 M/P	SLDC 2017	2018 F/S
		CW22	
COORDINATE	E		N
	79.898093		6.969996
PURPOSE	Bridge		
OPERATION	in use		

DRAWING

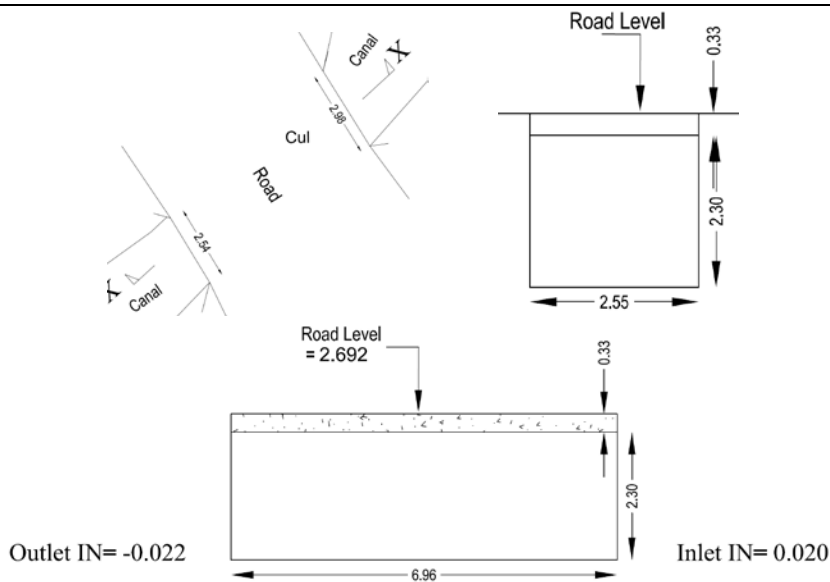

(Source: SLDC 2017 Survey)

SITE CONDITION



ID: CW22A	JICA 2003 M/P	SLDC 2017	2018 F/S
COORDINATE	E		N
	79.898628		6.969964
PURPOSE	Pipe Culvert		
OPERATION	in use		
DRAWING			
(No drawing is available.)			
SITE CONDITION			

ID: CW23	JICA 2003 M/P	SLLCD 2017	2018 F/S
		CW23	
COORDINATE	E		N
	79.895161		6.968599
PURPOSE	Bridge		
OPERATION	in use		

DRAWING

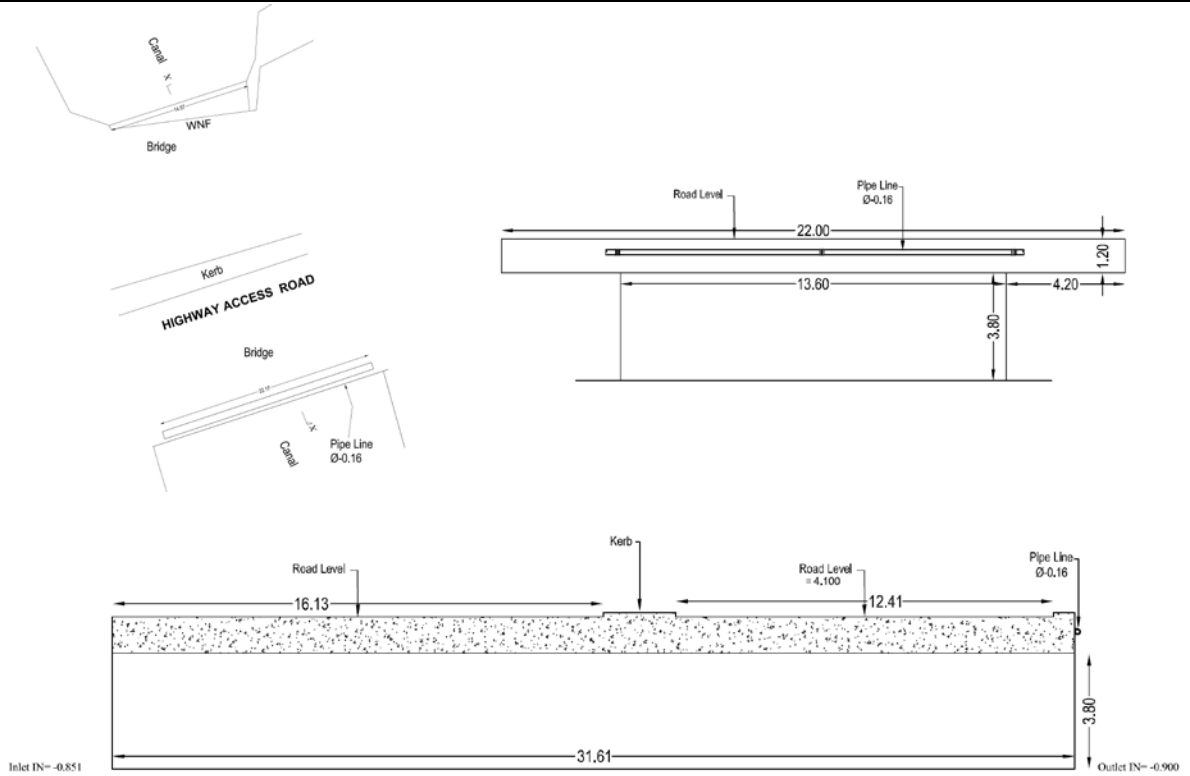

(Source: SLLDC 2017 Survey)

SITE CONDITION



No access

ID: CW27	JICA 2003 M/P	SLDC 2017	2018 F/S
	Culvert at 1+443	CW27	
COORDINATE	E		N
	79.890807		6.969426
PURPOSE	Bridge and Pipe Culvert		
OPERATION	in use		

DRAWING

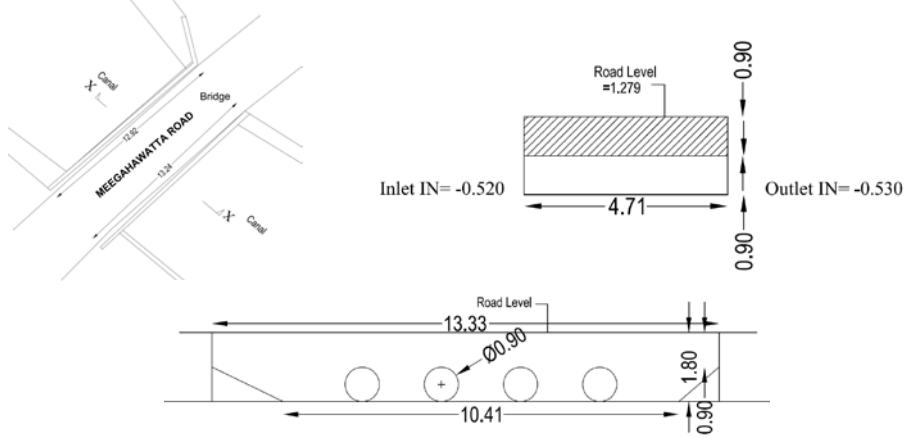

(Source: SLDC 2017 Survey)

SITE CONDITION



ID: CW29	JICA 2003 M/P	SLDC 2017	2018 F/S
		CW29	
COORDINATE	E		N
	79.891634		6.970972
PURPOSE	Bridge		
OPERATION	in use		

DRAWING

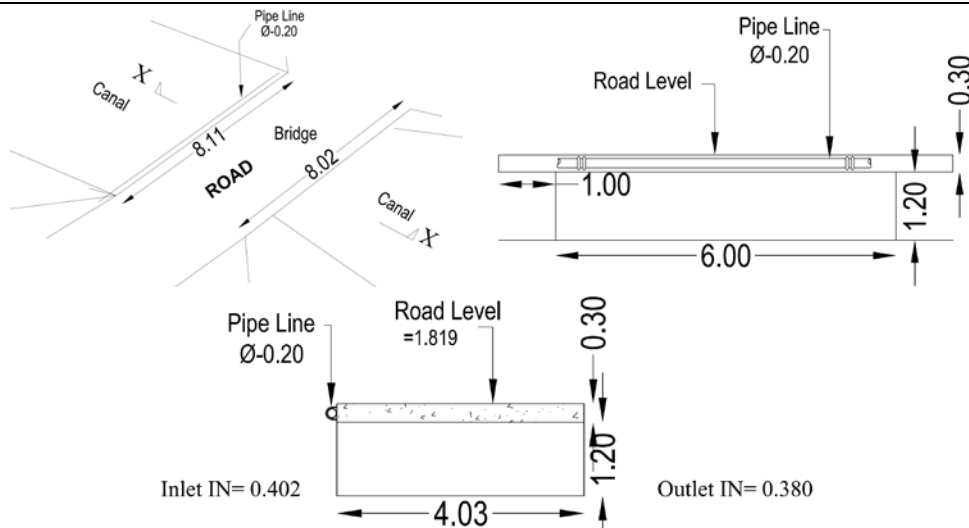

(Source: SLDC 2017 Survey)

SITE CONDITION

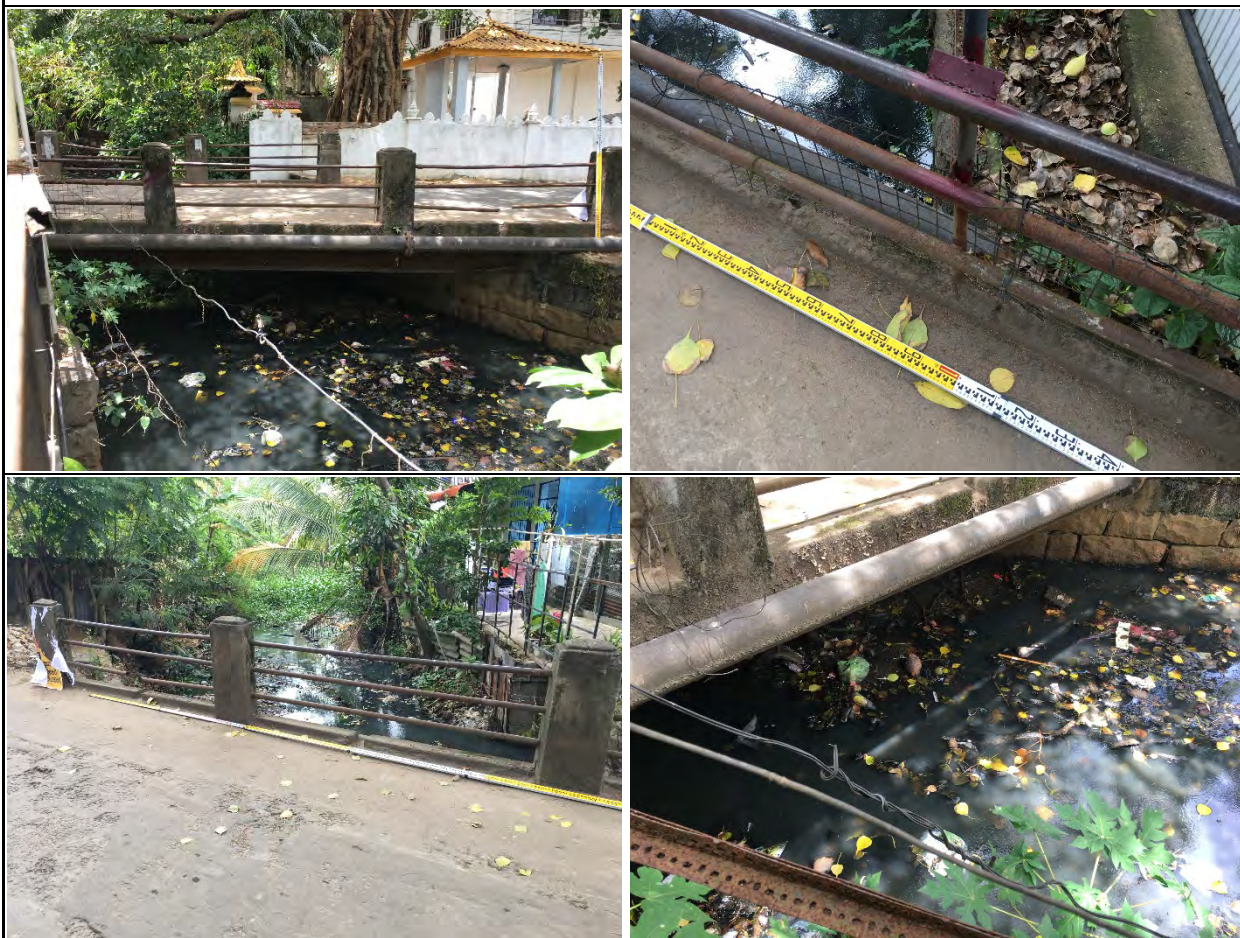

ID: CW30	JICA 2003 M/P	SLLCD 2017	2018 F/S
		CW30	
COORDINATE	E		N
	79.891259		6.971417
PURPOSE	Bridge		
OPERATION	in use		

DRAWING

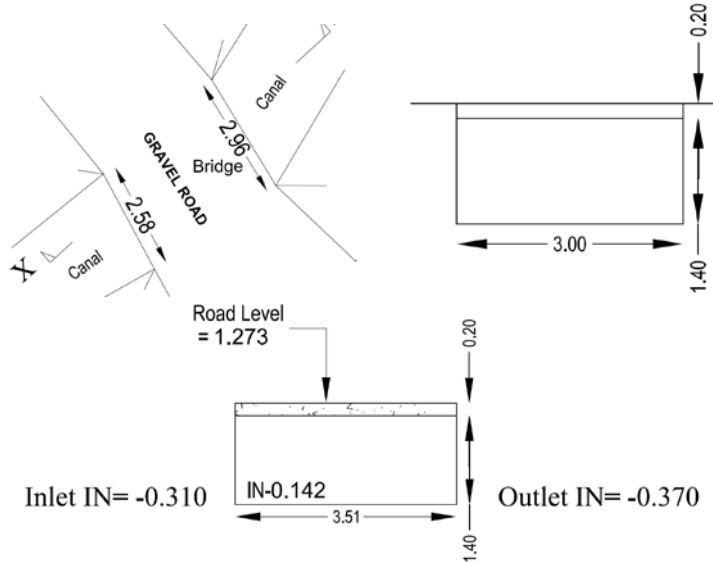

(Source: SLLDC 2017 Survey)

SITE CONDITION



ID: CW35	JICA 2003 M/P	SLDC 2017	2018 F/S
	Culvert & Gate at 1+477		CW35
COORDINATE	E		N
	79.887092		6.973766
PURPOSE	Bridge		
OPERATION	in use		

DRAWING

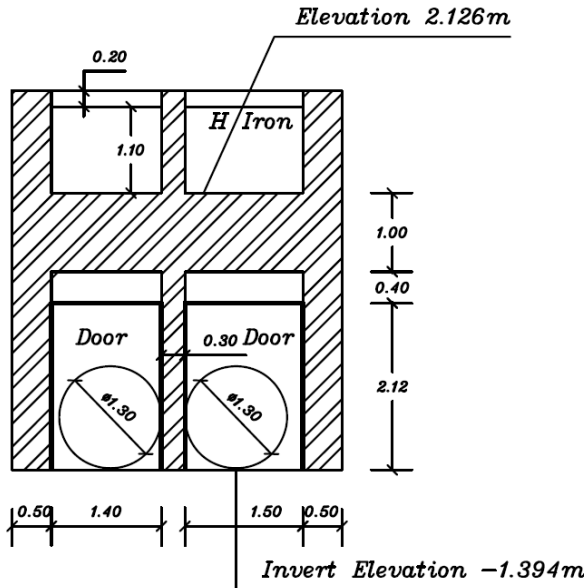

(Source: JICA 2003 M/P Report)

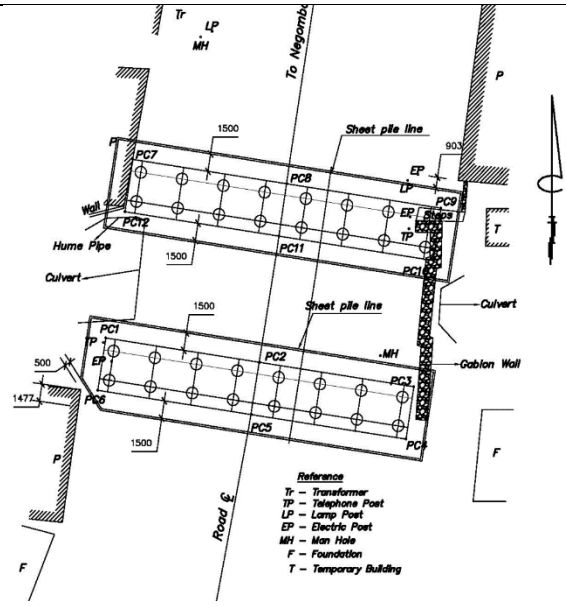

New Bridge (15 m in length)
(Source: SLDC presentation material)

SITE CONDITION





ID: CW37	JICA 2003 M/P	SLDC 2017	2018 F/S
		CW37	
COORDINATE	E		N
	79.885552		6.971742
PURPOSE	Gate for flood control		
OPERATION	in use		

DRAWING

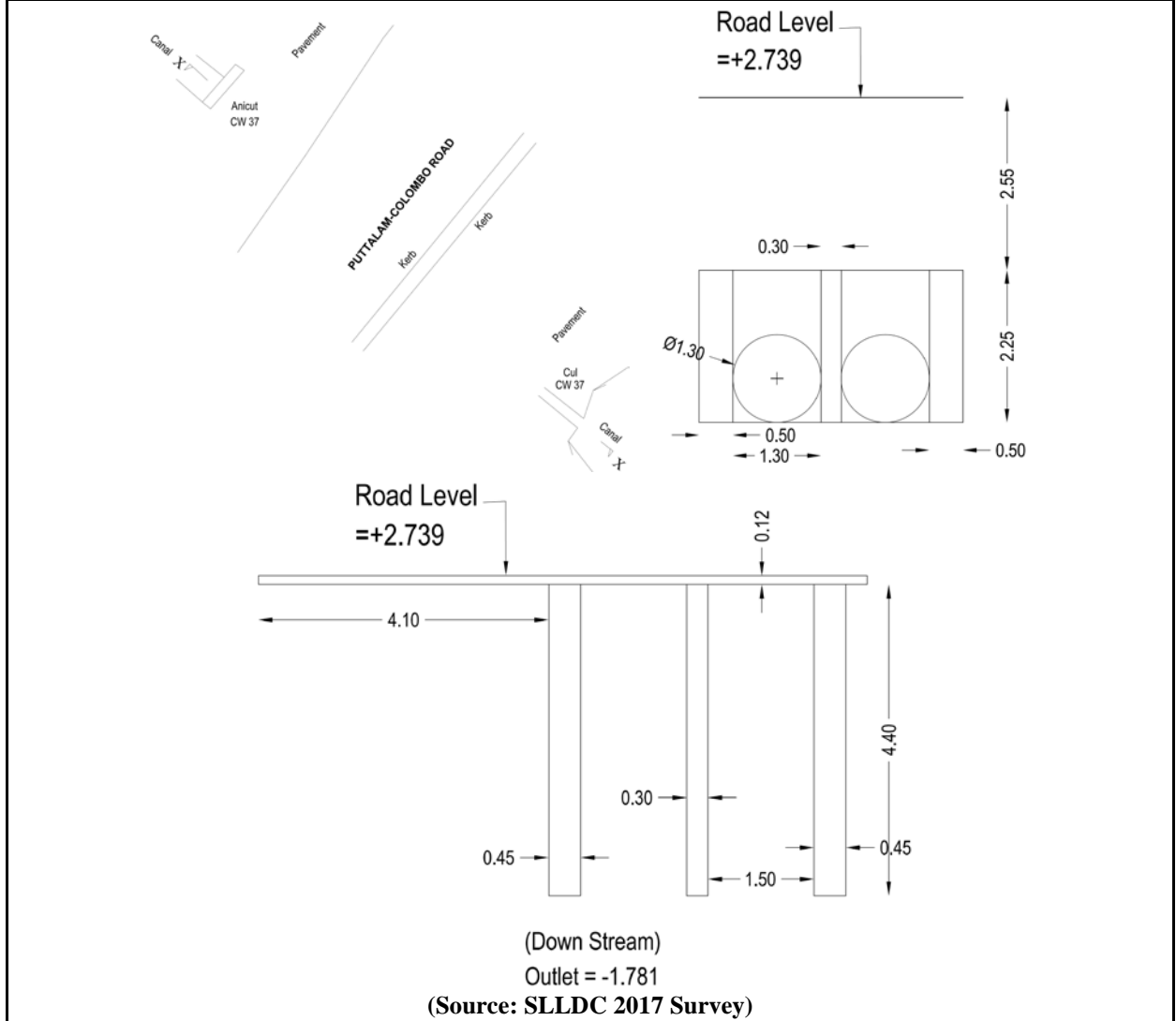

SITE CONDITION

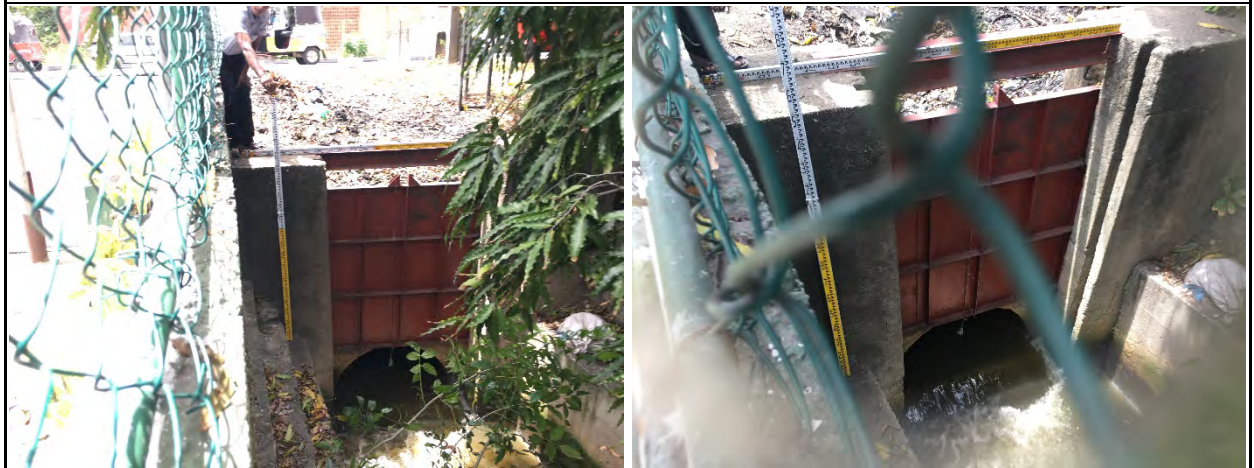



ID: CW38	JICA 2003 M/P	SLLCD 2017	2018 F/S
		CW38	
COORDINATE	E		N
	79.888129		6.969968
PURPOSE	Culvert		
OPERATION	in use		

DRAWING

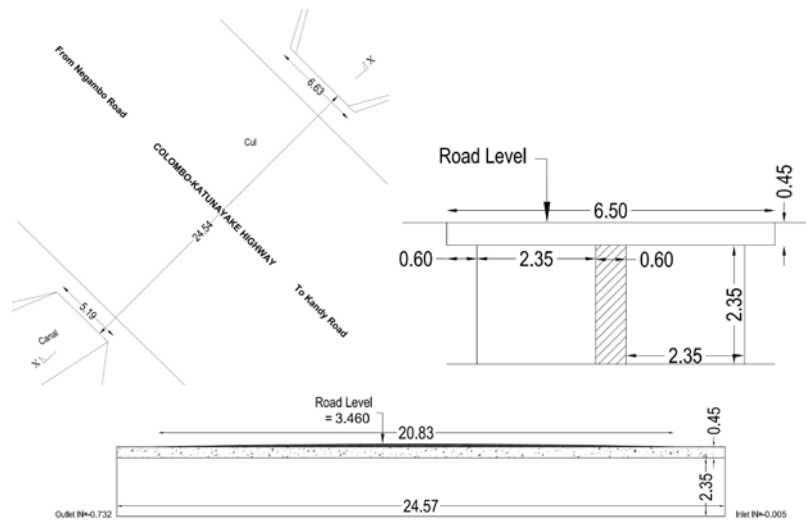

(Source: SLLDC 2017 Survey)

SITE CONDITION





ID: CW42	JICA 2003 M/P	SLDC 2017	2018 F/S
		CW42	
COORDINATE	E		N
	79.890300		6.964067
PURPOSE	Bridge		
OPERATION	in use		

DRAWING

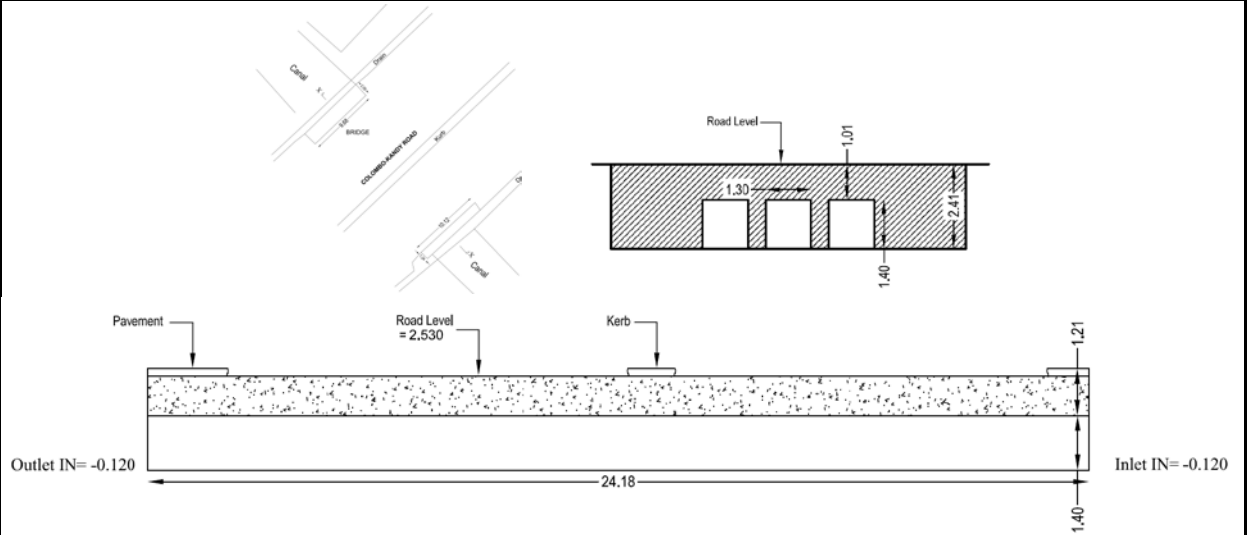

(Source: SLDC 2017 Survey)

SITE CONDITION



No access

ID: CW47	JICA 2003 M/P	SLDC 2017	2018 F/S
	Bridge at 0+050	CW47	
COORDINATE	E		N
	79.892635		6.960417
PURPOSE	Bridge		
OPERATION	in use		

DRAWING

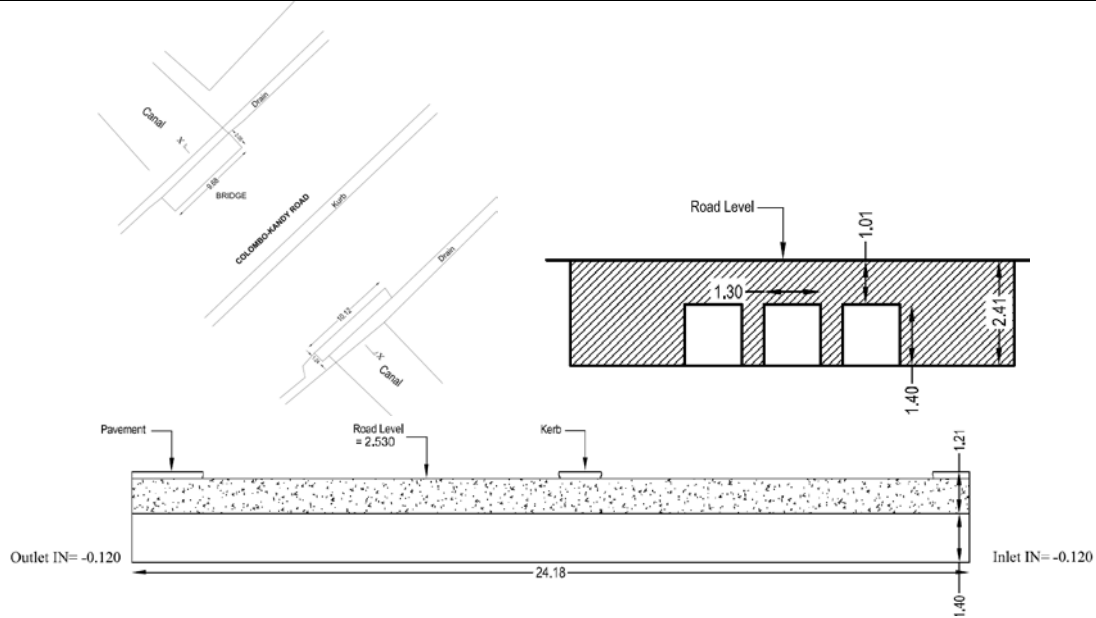

(Source: SLDC 2017 Survey)

SITE CONDITION





ID: CW48	JICA 2003 M/P	SLDC 2017	2018 F/S
		CW48	
COORDINATE	E		N
	79.892635		6.960417
PURPOSE	Railroad Bridge		
OPERATION	in use		

DRAWING

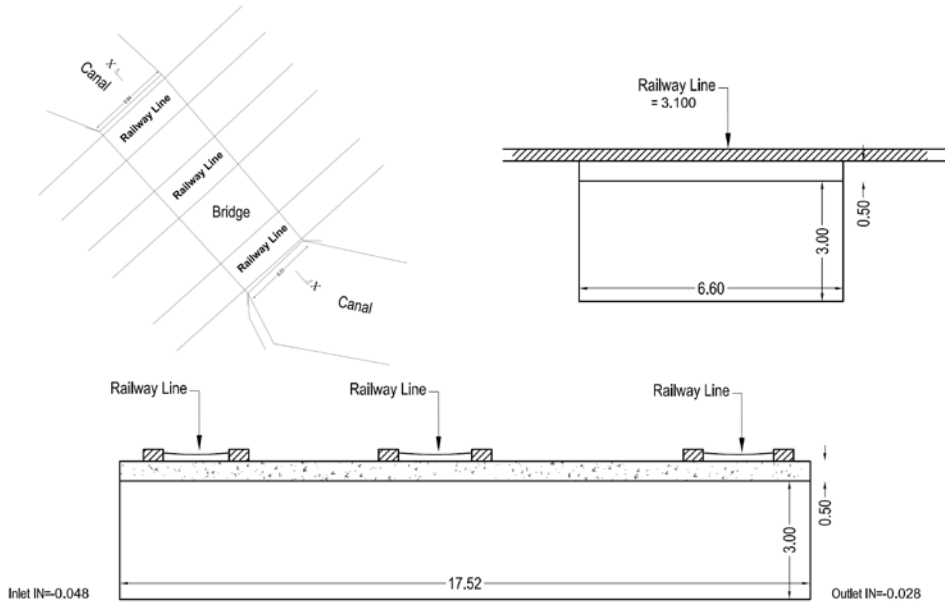

(Source: SLDC 2017 Survey)

SITE CONDITION

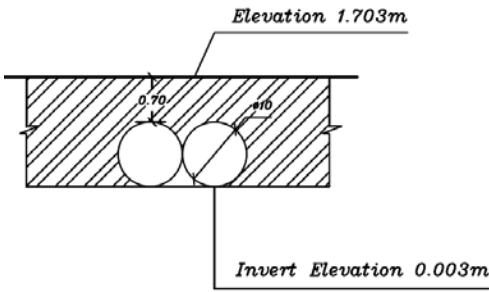
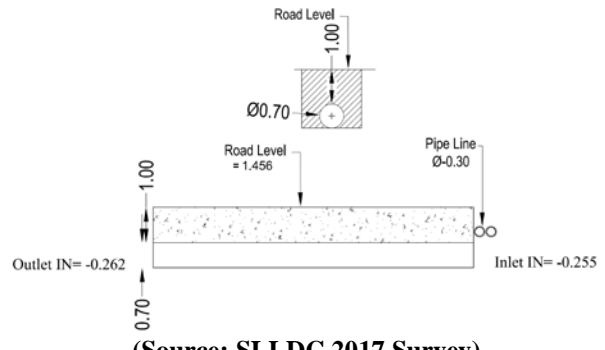

No access

ID: CW49	JICA 2003 M/P	SLDC 2017	2018 F/S
	Culvert at 0+409	CW49	
COORDINATE	E		N
	79.891570		6.962447
PURPOSE	Pipe Culvert		
OPERATION	in use		
DRAWING			
 <p>(Source: JICA 2003 M/P Report)</p>		 <p>(Source: SLDC 2017 Survey)</p>	

SITE CONDITION



ID: CW52	JICA 2003 M/P	SLDC 2017	2018 F/S
		CW52	
COORDINATE	E		N
	79.882028		6.965077
PURPOSE	Pipe Culvert next to Peliyagoda Pump Station		
OPERATION	in use		
DRAWING			
(Source: SLDC 2017 Survey)			





ID: CW53	JICA 2003 M/P	SLDC 2017	2018 F/S
		CW53	
COORDINATE	E		N
	79.890947		6.968179
PURPOSE	Culvert		
OPERATION	in use		

DRAWING

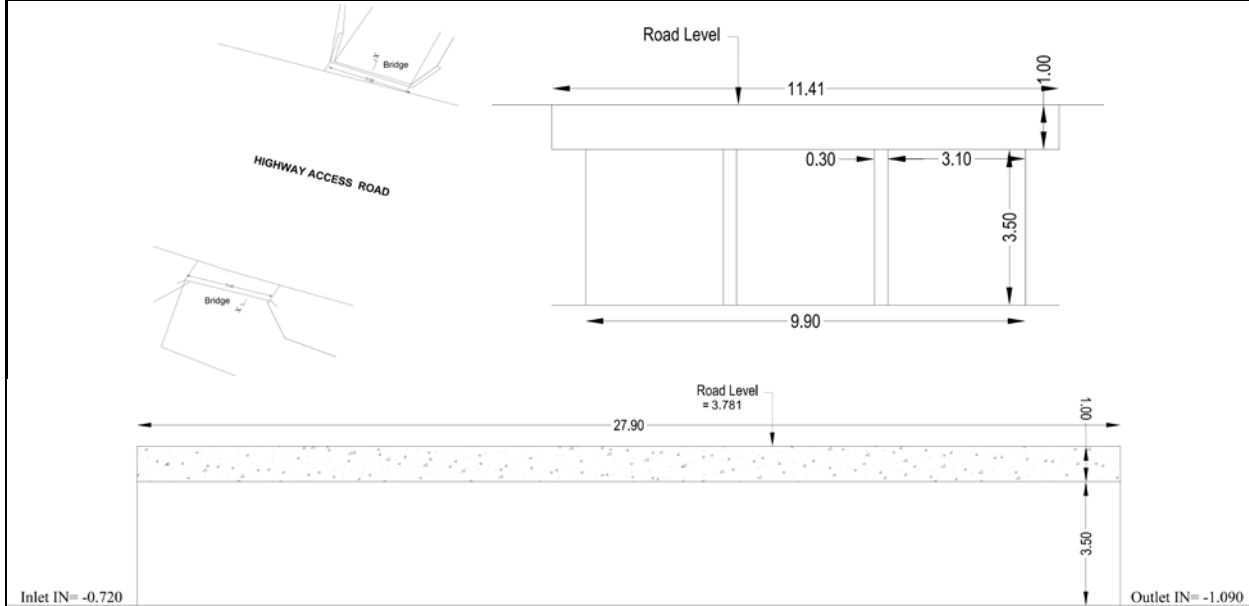

(Source: SLDC 2017 Survey)

SITE CONDITION



ID: RCW1	JICA 2003 M/P	SLDLC 2017	2018 F/S
		RCW1	
COORDINATE	E		N
	79.899693		6.978052
PURPOSE	Railroad Bridge		
OPERATION	in use		
DRAWING			
(Source: SLLDC 2017 Survey)			
SITE CONDITION			
No access			

ID: RCW2	JICA 2003 M/P	SLLD 2017	2018 F/S
		RCW2	
COORDINATE	E		N
	79.898730		6.972663
PURPOSE	Railroad Bridge		
OPERATION	in use		

DRAWING

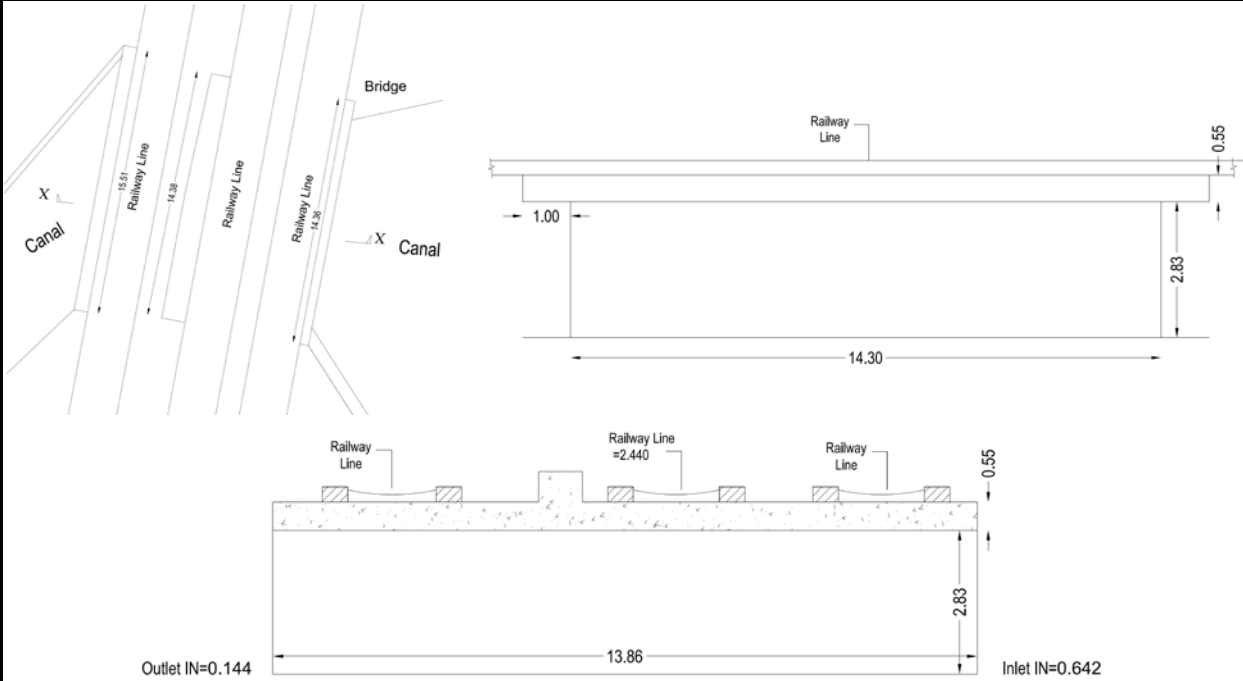

(Source: SLLD 2017 Survey)

SITE CONDITION





ID: RCW3	JICA 2003 M/P	SLDC 2017	2018 F/S
		RCW3	
COORDINATE	E		N
	79.898241		6.970074
PURPOSE	Railroad Bridge		
OPERATION	in use		

DRAWING

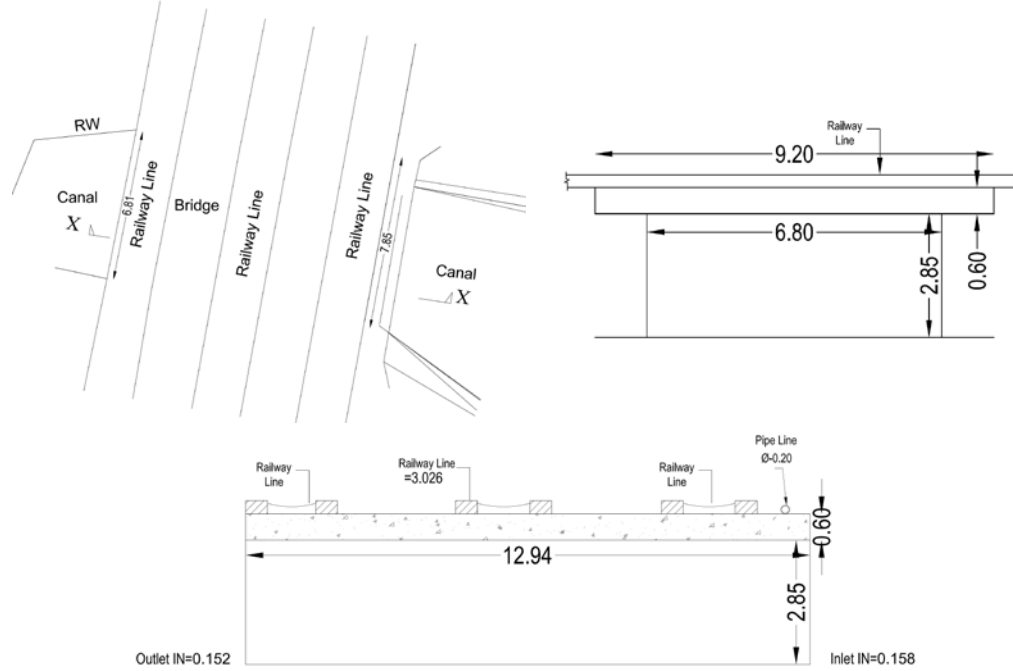

(Source: SLDC 2017 Survey)

SITE CONDITION



ID: Culvert 17	JICA 2003 M/P	SLLCD 2017	2018 F/S
		Culvert 17	
COORDINATE	E		N
	79.901313		6.954495
PURPOSE	Gate for Flood Control		
OPERATION	in use		
DRAWING			
(No drawing was available in SLLDC 2017 Survey.)			

SITE CONDITION



第3章 Bolgoda 流域

3.1 Bolgoda 流域における排水施設位置図

図 3.1.1 に、Bolgoda 流域における排水施設の位置を示す。これらの施設は、JICA 2003 M/P 及び現地踏査にて確認した。



図 3.1.1 Bolgoda 流域における排水施設位置図

3.2 Bolgoda 流域における排水施設の座標

表 3.2.1 に、Bolgoda 流域における排水施設の座標を示す。

表 3.2.1 Bolgoda 流域における排水施設の座標

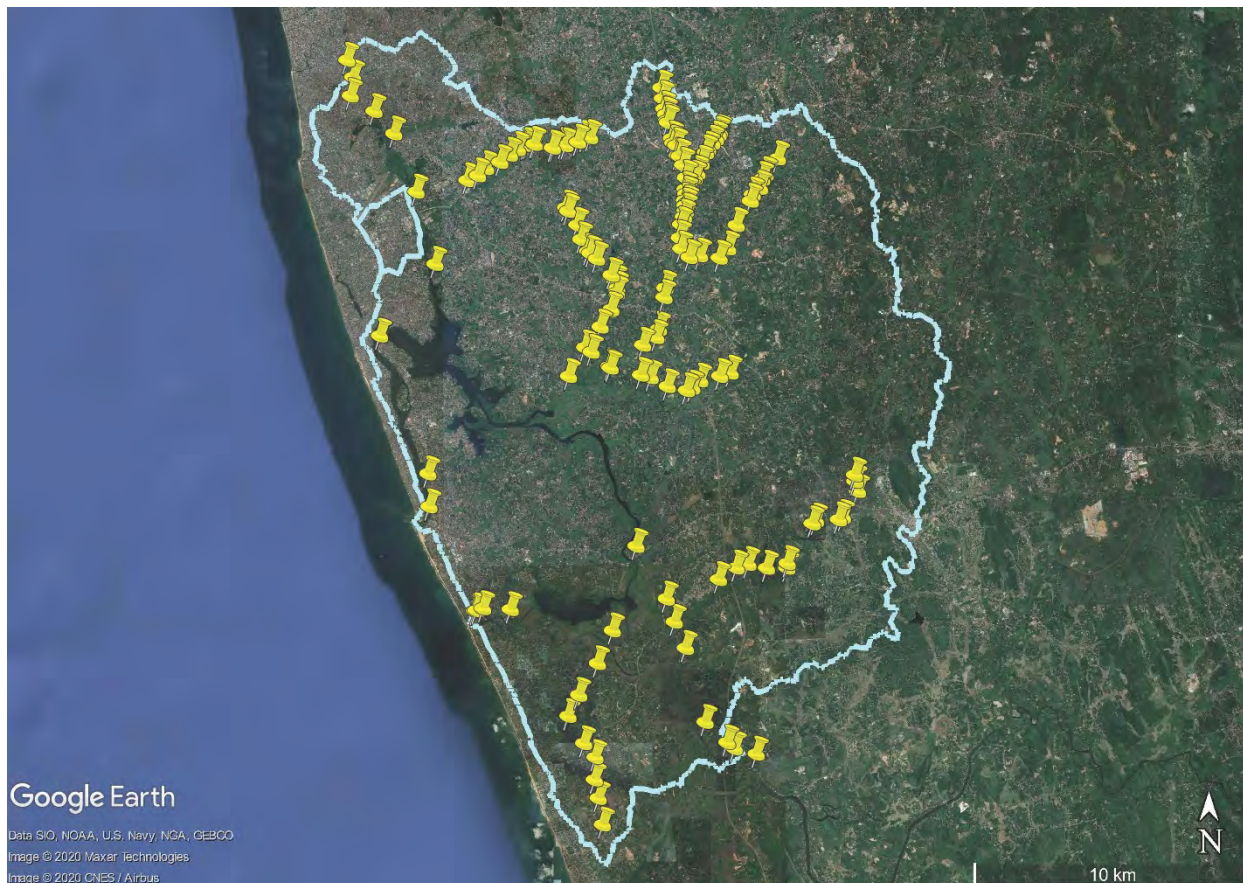
No.	ID	COORDINATE		No.	ID	COORDINATE		No.	ID	COORDINATE	
	JICA 2003 M/P	E	N		JICA 2003 M/P	E	N		JICA 2003 M/P	E	N
Maha Oya				Maha Oya Tributary 2				MT4-2			
MA-1	20	79.948488	6.758687	MT2-1	58	79.961732	6.761810	MT4-3	47	79.989597	6.822957
MA-2	19	79.955918	6.766518	MT2-2	57	79.962117	6.761381	MT4-4	46	79.990497	6.824555
MA-3	17	79.972751	6.768800	MT2-3	56	79.972068	6.759061	MT4-5	45	79.991887	6.827826
MA-4	16	79.977082	6.771271	MT2-4	55	79.975204	6.758288	MT4-6	44	79.993310	6.831273
MA-5	902	79.977932	6.773952	MT2-5	54	79.980802	6.755364	MT4-7	43	79.994017	6.832375
MA-6	901	79.979748	6.784284	MT2-6	53	79.987068	6.754064	MT4-8	42	79.995404	6.834374
MA-7	14	79.979982	6.787307	MT2-7	52	79.988810	6.754879	MT4-9	41	79.996531	6.835733
MA-8	13	79.987943	6.797293	MT2-8	913	79.991448	6.757223	MT4-10	40	79.997455	6.837201
MA-9	12	79.991354	6.797806	MT2-9	51	79.997921	6.758726	MT4-11	39	79.997868	6.837805
MA-10	11	79.997765	6.797068	MT2-10	50	80.001367	6.759778	Bolgoda Ganga			
MA-11	10	80.000550	6.800091	Maha Oya Tributary 3				BG1-1	103	79.902883	6.716388
MA-12	8	80.003337	6.807653	MT3-1		79.985268	6.800022	BG1-2	919	79.902496	6.727058
MA-13	9	80.003336	6.807690	MT3-2		79.984737	6.803563	BG1-3	101	79.886766	6.771669
MA-14	7	80.007978	6.815535	MT3-3		79.985219	6.807910	BG1-4	918	79.886714	6.771795
MA-15	6	80.008574	6.817612	MT3-4		79.986083	6.810370	BG2-1	100	79.970590	6.703565
MA-16	5	80.010998	6.819742	MT3-5		79.986691	6.812330	Bolgoda Canal			
MA-17	4	80.011660	6.822645	MT3-6		79.986633	6.814017	BC-1	916	79.891302	6.837412
MA-18	3	80.011912	6.822676	MT3-7		79.986419	6.815638	BC-2	915	79.884862	6.844686
MA-19	2	80.012795	6.824176	MT3-8		79.986883	6.817851	BC-3	75	79.877091	6.849679
MA-20	1	80.016889	6.829356	MT3-9		79.986656	6.819344	BC-4	914	79.877919	6.855756
Maha Oya Tributary 1				MT3-10		79.986754	6.823081	BC-5	913	79.875947	6.861295
MT1-1	73	79.953805	6.767988	MT3-11		79.985844	6.827177	Weras Ganga			
MT1-2	72	79.958835	6.774701	MT3-12		79.984711	6.830047	WG-1	99	79.904798	6.795055
MT1-3	71	79.962057	6.779892	MT3-13		79.984078	6.830188	WG-2	98	79.898626	6.818511
MT1-4	70	79.962341	6.780326	MT3-14		79.983605	6.833560	Madiwela South Diversion			
MT1-5	69	79.964156	6.785608	MT3-15		79.982646	6.834299	MSD-1	94	79.915276	6.822245
MT1-6	68	79.964222	6.787084	MT3-16		79.982163	6.835800	MSD-2	93	79.918777	6.823825
MT1-7	67	79.963718	6.789324	MT3-17		79.980871	6.840989	MSD-3	92	79.921356	6.826121
MT1-8	66	79.962411	6.791446	MT3-18		79.980662	6.841656	MSD-4	91	79.926079	6.828120
MT1-9	64	79.957651	6.796754	MT3-19		79.980214	6.843571	MSD-5	90	79.929191	6.830515
MT1-10	65	79.955516	6.798592	MT3-20		79.979679	6.845432	MSD-6	89	79.931744	6.832308
MT1-11	63	79.954770	6.799163	MT3-21		79.979209	6.848809	MSD-7	88	79.934310	6.833521
MT1-12	62	79.952520	6.803044	MT3-22		79.978726	6.852282	MSD-8	87	79.934814	6.833667
MT1-13	61	79.951267	6.807733	Maha Oya Tributary 4				MSD-9	86	79.935288	6.833840
MT1-14	60	79.948242	6.812251	MT4-1	49	79.987192	6.814826	MSD-10	85	79.937233	6.833992
MT1-15	59	79.947561	6.813389					MSD-11	84	79.937642	6.833975

No.	ID	COORDINATE	
	JICA 2003 M/P	E	N
MSD-12	83	79.943193	6.832808
MSD-13	917	79.943727	6.832835
MSD-14	82	79.946535	6.833725
MSD-15	81	79.947398	6.833583
MSD-16	80	79.951450	6.834704
MSD-17	79	79.953526	6.835918
MSD-18	78	79.955427	6.836213
Talpitiya Ela			
TP-1	104	79.929469	6.683002
TP-2	105	79.920431	6.683337
TP-3	920	79.918276	6.682654
TP-4	106	79.917752	6.682487
Alut Ela			
AE-1	126	79.962846	6.676144
AE-2	127	79.957949	6.665485
AE-3	128	79.951819	6.655221
AE-4	129	79.948310	6.648371
AE-5	130	79.953451	6.639514
AE-6	131	79.957165	6.635007
AE-7	132	79.956942	6.627714
AE-8	133	79.958215	6.621722
AE-9	134	79.959594	6.613102
Kapput Ela			
KE-1	107	79.980464	6.686451
KE-2	108	79.983087	6.678947
KE-3	109	79.986716	6.670445
KE-4	922	79.993142	6.646406
KE-5	921	80.000308	6.639808
KE-6	111	80.002609	6.637968
KE-7	110	80.002724	6.637900
KE-8	112	80.009892	6.636096
Panape Ela			
PE-1	125	79.997562	6.692770
PE-2	923	80.003280	6.696532
PE-3	124	80.007160	6.697707
PE-4	123	80.013259	6.696423
PE-5	122	80.013288	6.696342
PE-6	121	80.019878	6.696448
PE-7	120	80.020022	6.697967
PE-8	119	80.028162	6.710860
PE-9	118	80.029251	6.711812
PE-10	117	80.036784	6.712124
PE-11	116	80.038105	6.712908

No.	ID	COORDINATE	
	JICA 2003 M/P	E	N
PE-12	115	80.043017	6.721354
PE-13	114	80.042169	6.724555
PE-14	113	80.042080	6.726638

3.3 Bolgoda 流域における排水施設台帳

3.3.1 Maha Oya

ID: MA-1	JICA 2003 M/P	SLDLC 2017	2018 F/S
	Bridge at 16+900		
COORDINATE	E		N
	79.948488		6.758687
PURPOSE	Bridge		
OPERATION	in use		
DRAWING			
(Source: JICA 2003 M/P Report)			
SITE CONDITION			

ID: MA-2	JICA 2003 M/P	SLDC 2017	2018 F/S
	Bridge at 15+331		
COORDINATE	E		N
	79.955918		6.766518
PURPOSE	Bridge		
OPERATION	in use		

DRAWING

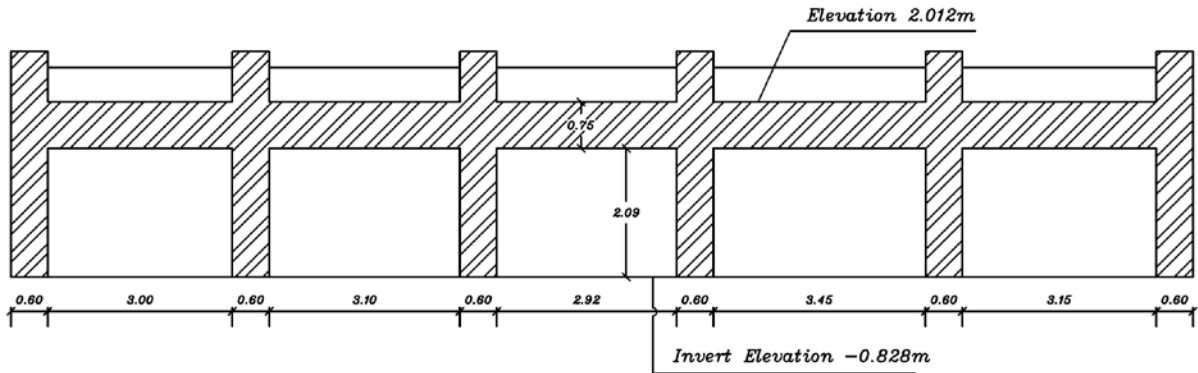

(Source: JICA 2003 M/P Report)

SITE CONDITION



ID: MA-3	JICA 2003 M/P	SLDC 2017	2018 F/S
	Bridge at 12+750		
COORDINATE	E		N
	79.972751		6.768800
PURPOSE	Bridge		
OPERATION	in use		

DRAWING

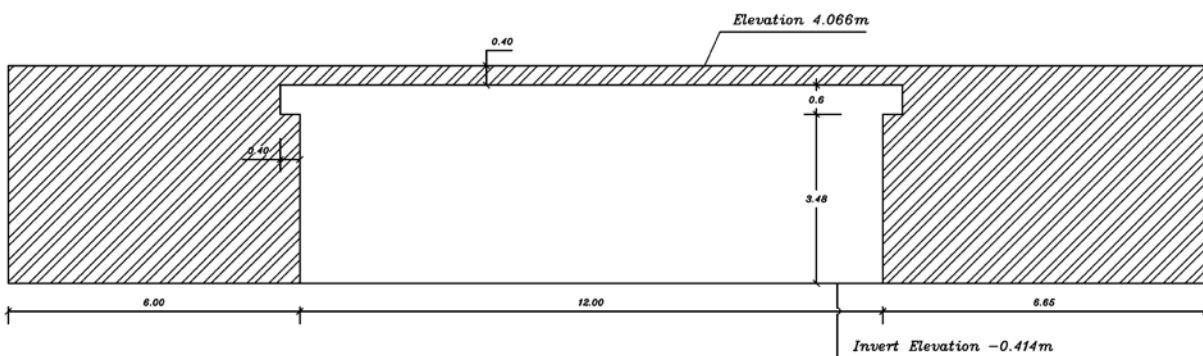

(Source: JICA 2003 M/P Report)

SITE CONDITION



ID: MA-4	JICA 2003 M/P	SLLCD 2017	2018 F/S
	Anicut at 12+075		
COORDINATE	E		N
	79.977082		6.771271
PURPOSE	Anicut		
OPERATION	broken		

DRAWING

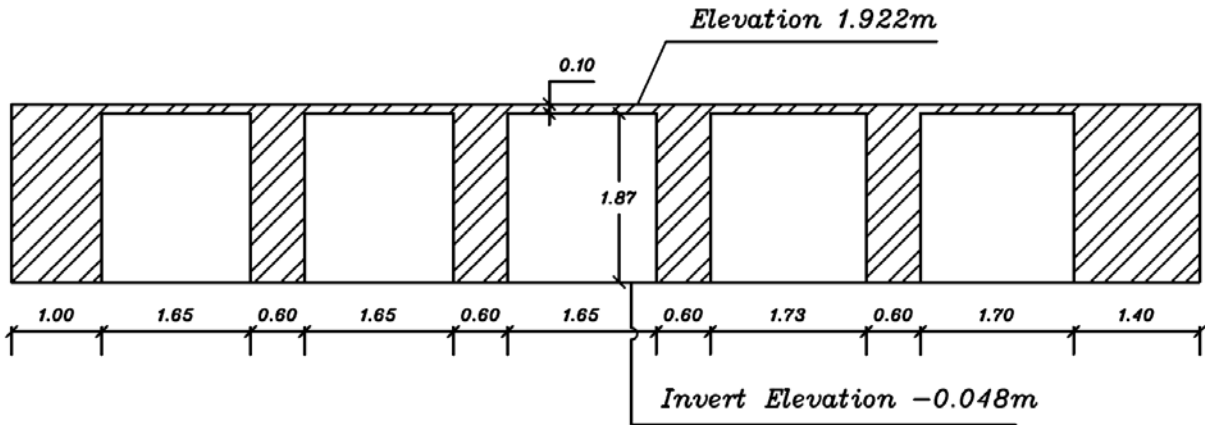

(Source: JICA 2003 M/P Report)

SITE CONDITION



ID: MA-5	JICA 2003 M/P	SLDC 2017	2018 F/S
COORDINATE	E		N
	79.977932		6.773952
PURPOSE	Bridge		
OPERATION	in use		
DRAWING			
(No drawing is available.)			
SITE CONDITION			
			

ID: MA-6	JICA 2003 M/P	SLLCD 2017	2018 F/S
	Bridge at 10+006		
COORDINATE	E		N
	79.979748		6.784284
PURPOSE	Bridge		
OPERATION	in use		

DRAWING

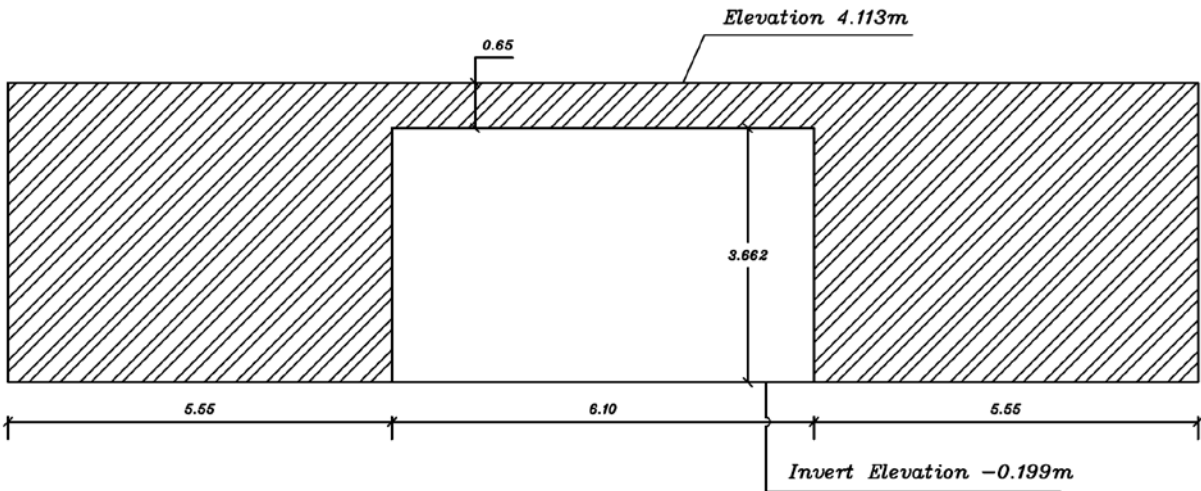

(Source: JICA 2003 M/P Report)

SITE CONDITION





ID: MA-7	JICA 2003 M/P	SLDC 2017	2018 F/S
	Bridge at 9+594		
COORDINATE	E		N
	79.979982		6.787307
PURPOSE	Bridge		
OPERATION	broken		
DRAWING			
(Source: JICA 2003 M/P Report)			
SITE CONDITION			

ID: MA-8	JICA 2003 M/P	SLDLC 2017	2018 F/S
	Bridge at 7+576		
COORDINATE	E		N
	79.987943		6.797293
PURPOSE	Gate for flood control		
OPERATION	in use		
DRAWING			
(Source: JICA 2003 M/P Report)			

SITE CONDITION



ID: MA-9	JICA 2003 M/P	SLDC 2017	2018 F/S
	Bridge at 7+083		
COORDINATE	E		N
	79.991354		6.797806
PURPOSE	Bridge		
OPERATION	in use		

DRAWING

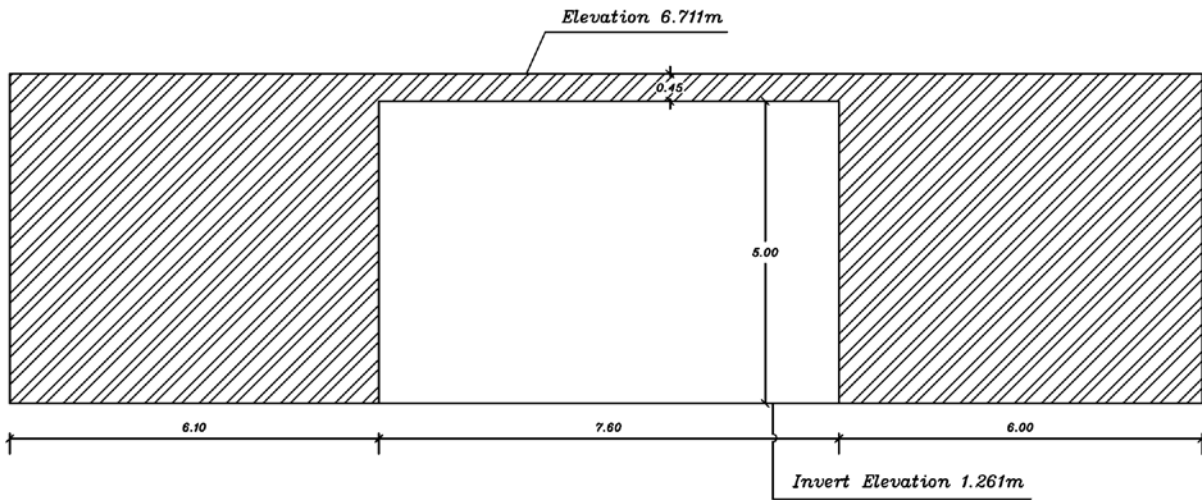

(Source: JICA 2003 M/P Report)

SITE CONDITION



ID: MA-10	JICA 2003 M/P	SLDC 2017	2018 F/S
	Anicut at 6+321		
COORDINATE	E		N
	79.997765		6.797068
PURPOSE	Anicut		
OPERATION	in use		

DRAWING

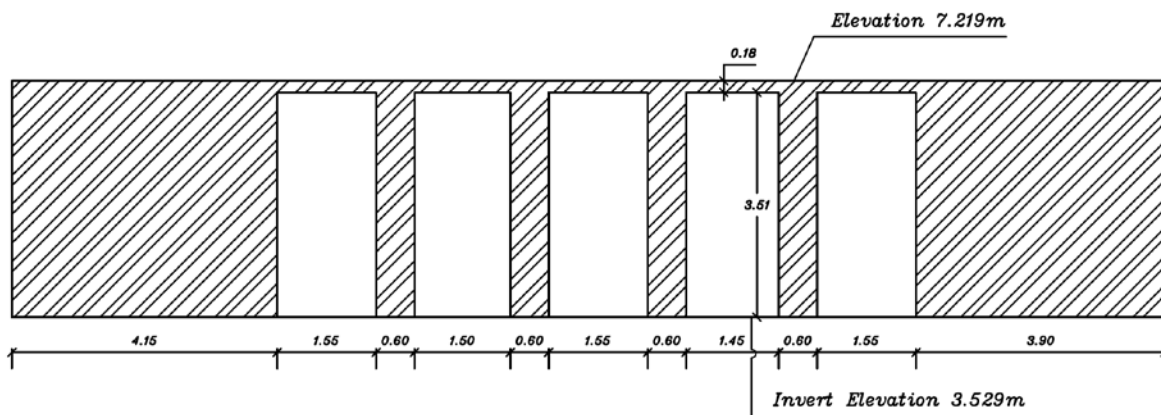

(Source: JICA 2003 M/P Report)

SITE CONDITION



ID: MA-11	JICA 2003 M/P	SLDC 2017	2018 F/S
	Bridge at 5+729		
COORDINATE	E		N
	80.000550		6.800091
PURPOSE	Bridge		
OPERATION	in use		

DRAWING

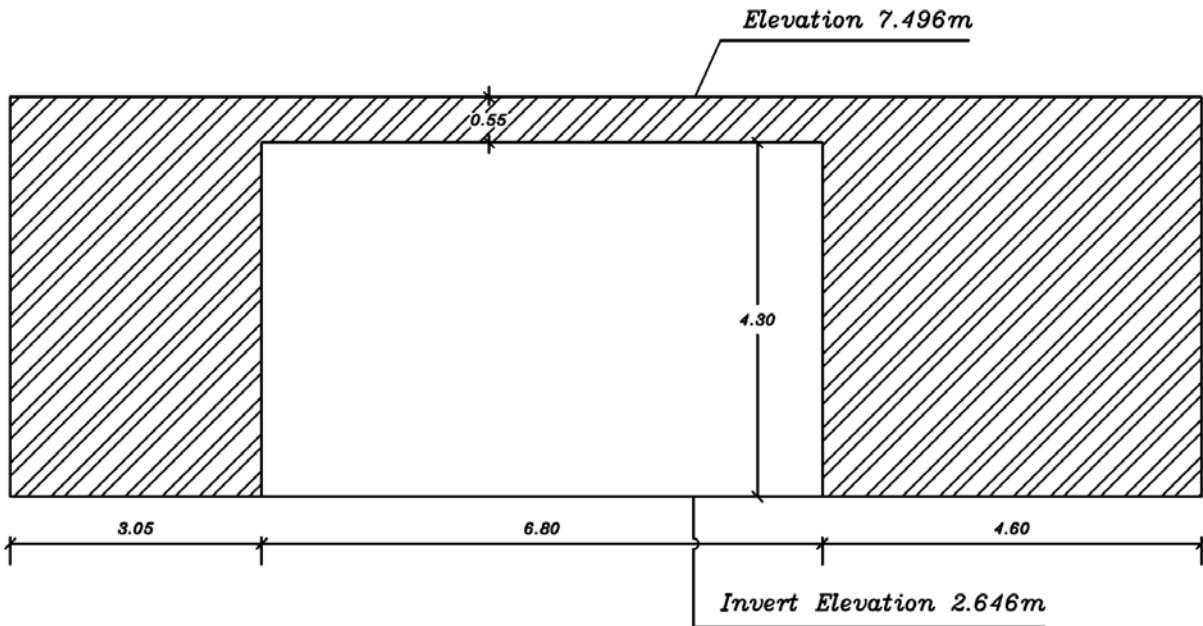

(Source: JICA 2003 M/P Report)

SITE CONDITION





ID: MA-12	JICA 2003 M/P	SLDC 2017	2018 F/S
	Culvert at 4+680		
COORDINATE	E		N
	80.003337		6.807653
PURPOSE	Gate for flood control		
OPERATION	in use		

DRAWING

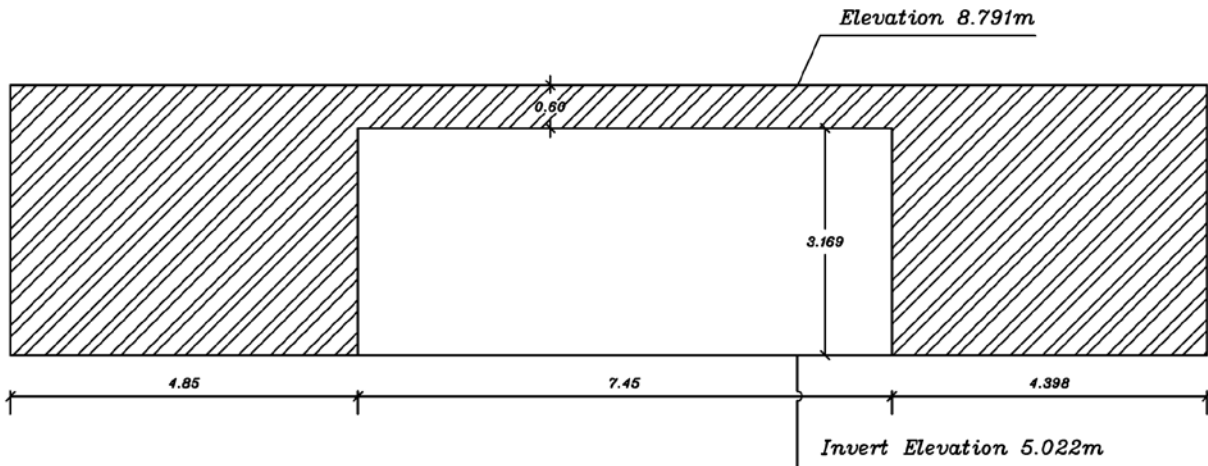

(Source: JICA 2003 M/P Report)

SITE CONDITION



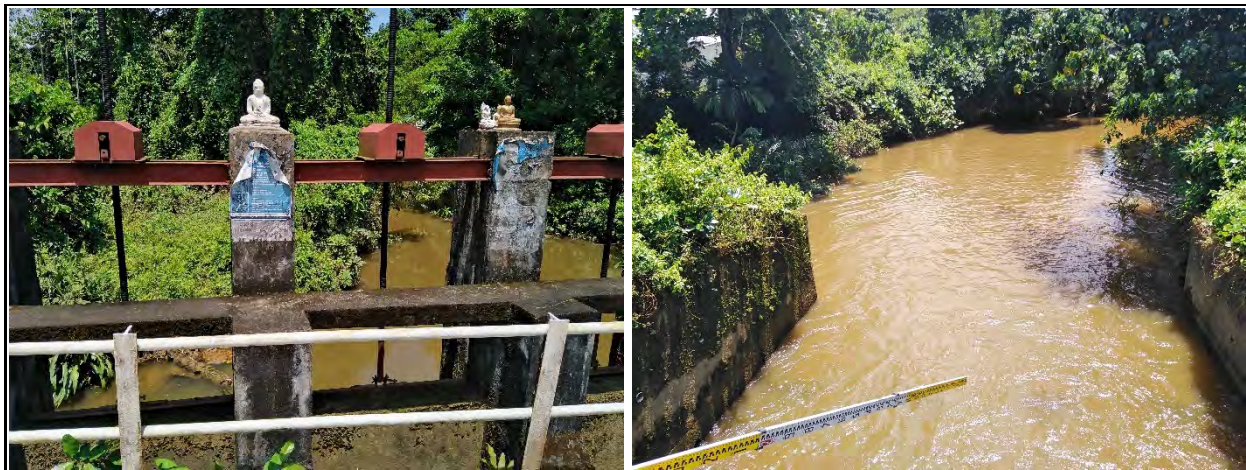

ID: MA-13	JICA 2003 M/P	SLDLC 2017	2018 F/S
	Anicut at 4+680		
COORDINATE	E		N
	80.003336		6.807690
PURPOSE	Anicut		
OPERATION	in use		

DRAWING

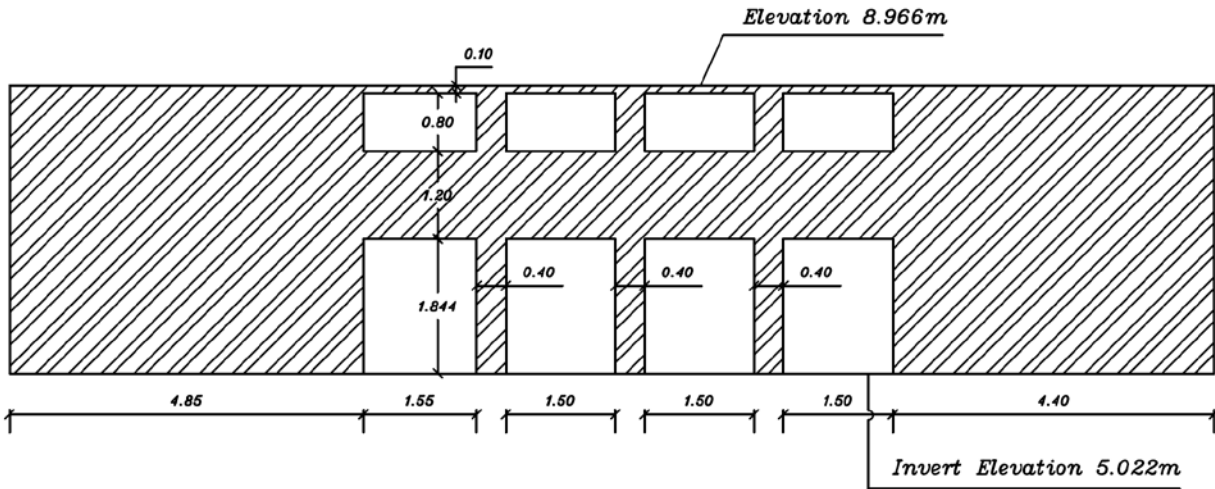

(Source: JICA 2003 M/P Report)

SITE CONDITION





ID: MA-14	JICA 2003 M/P	SLDC 2017	2018 F/S
	Anicut at 3+250		
COORDINATE	E		N
	80.007978		6.815535
PURPOSE	Anicut		
OPERATION	Not confirmed		
DRAWING			
(Source: JICA 2003 M/P Report)			
SITE CONDITION			
No access			

ID: MA-15	JICA 2003 M/P	SLDC 2017	2018 F/S
	Bridge at 2+922		
COORDINATE	E		N
	80.008574		6.817612
PURPOSE	Bridge		
OPERATION	in use		
DRAWING			
(Source: JICA 2003 M/P Report)			
SITE CONDITION			



ID: MA-16	JICA 2003 M/P	SLDC 2017	2018 F/S
	Bridge at 2+541		
COORDINATE	E		N
	80.010998		6.819742
PURPOSE	Bridge		
OPERATION	Not confirmed		
DRAWING			
<p style="text-align: center;">(Source: JICA 2003 M/P Report)</p>			
SITE CONDITION			
No access			

ID: MA-17	JICA 2003 M/P	SLDC 2017	2018 F/S
	Bridge at 2+178		
COORDINATE	E		N
	80.011660		6.822645
PURPOSE	Bridge		
OPERATION	in use		

DRAWING

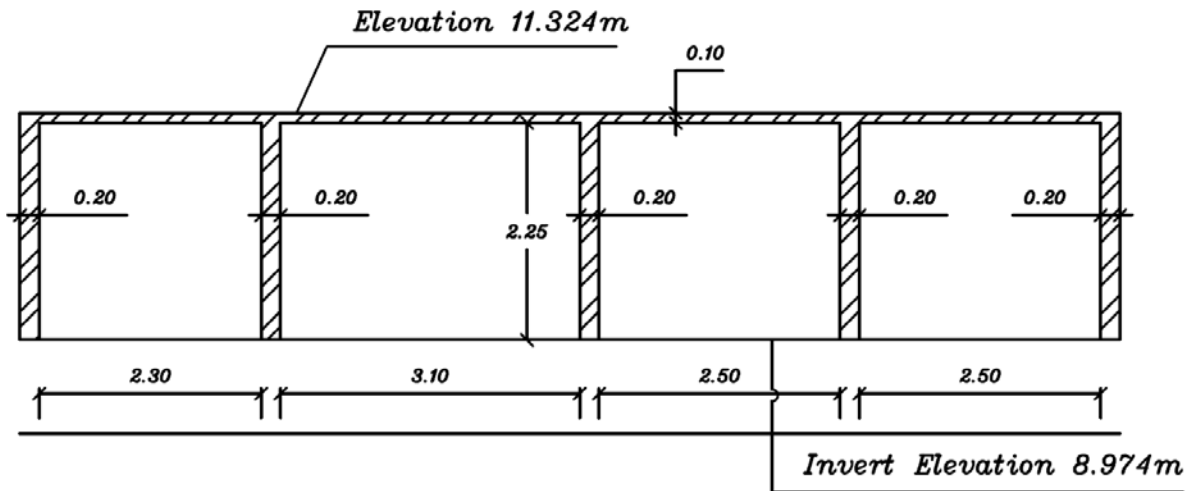

(Source: JICA 2003 M/P Report)

SITE CONDITION



ID: MA-18	JICA 2003 M/P	SLLD 2017	2018 F/S
	Anicut at 2+146		
COORDINATE	E		N
	80.011912		6.822676
PURPOSE	Anicut		
OPERATION	broken		

DRAWING

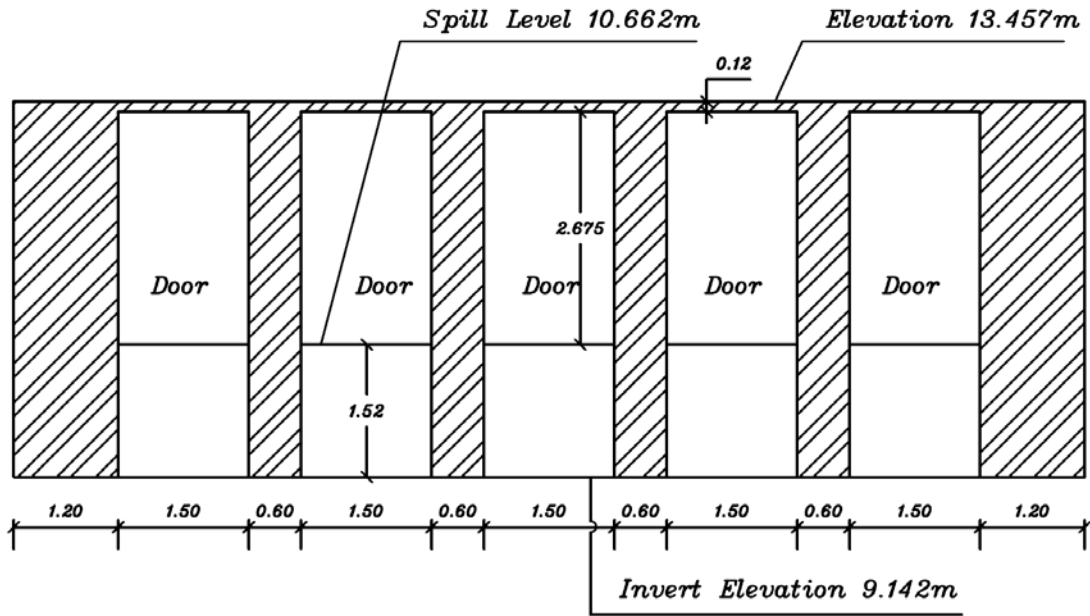

(Source: JICA 2003 M/P Report)

SITE CONDITION



ID: MA-19	JICA 2003 M/P	SLDC 2017	2018 F/S
	Bridge at 1+879		
COORDINATE	E		N
	80.012795		6.824176
PURPOSE	Bridge		
OPERATION	in use		

DRAWING

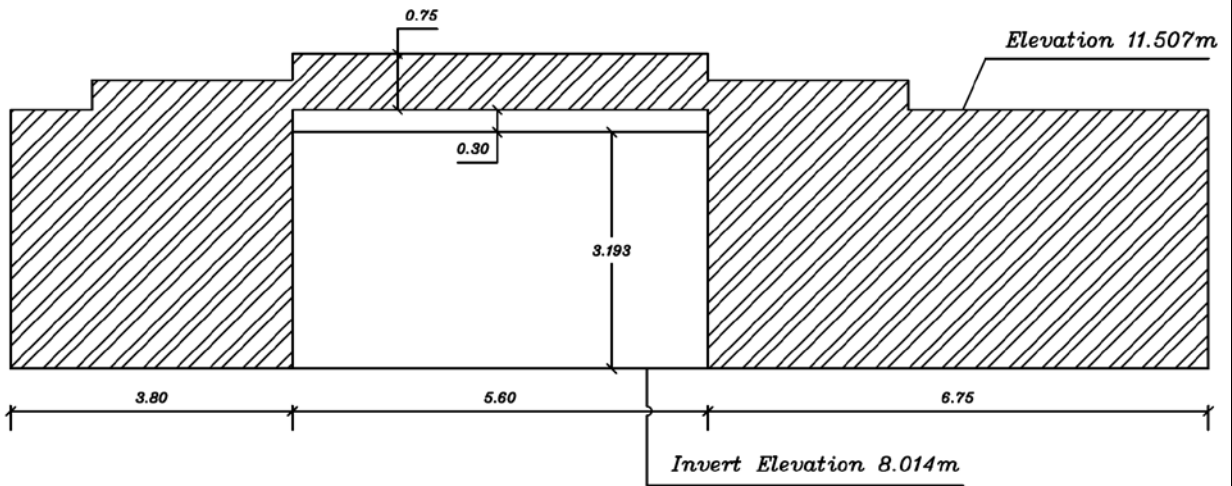

(Source: JICA 2003 M/P Report)

SITE CONDITION



ID: MA-20	JICA 2003 M/P	SLDC 2017	2018 F/S
	Anicut at 0+991		
COORDINATE	E		N
	80.016889		6.829356
PURPOSE	Anicut		
OPERATION	Not confirmed		
DRAWING			
<p style="text-align: center;"> <i>Spill Level 11.922m</i> <i>Elevation 12.142m</i> <i>Invert Elevation 10.047m</i> </p> <p style="text-align: center;"> (Source: JICA 2003 M/P Report) </p>			
SITE CONDITION			
No access			

3.3.2 Maha Oya Tributary 1

ID: MT1-1	JICA 2003 M/P	SLLDLC 2017	2018 F/S
	Bridge at 6+317		
COORDINATE	E		N
	79.953805		6.767988
PURPOSE	Bridge		
OPERATION	in use		

DRAWING

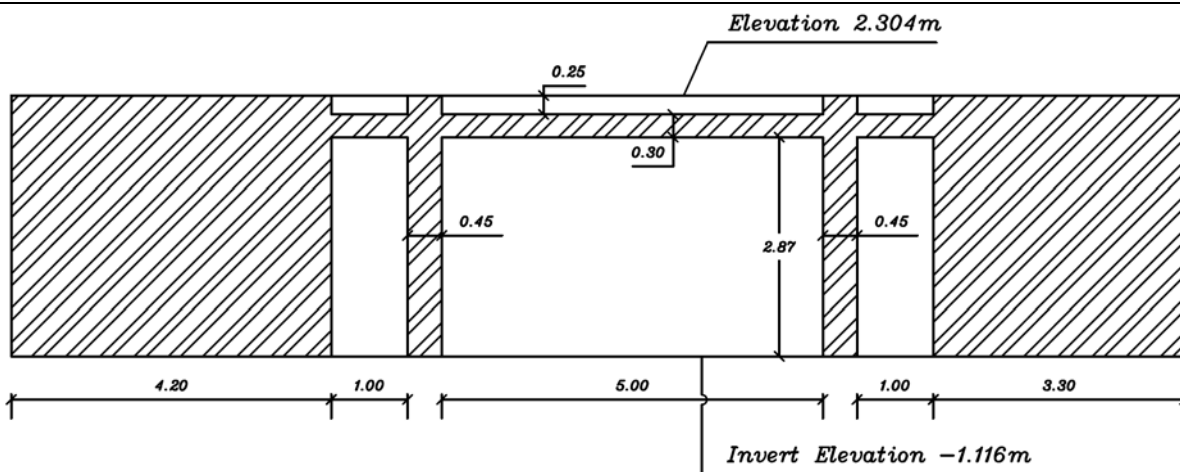

(Source: JICA 2003 M/P Report)

SITE CONDITION



ID: MT1-2	JICA 2003 M/P	SLDC 2017	2018 F/S
	Anicut at 5+350		
COORDINATE	E		N
	79.958835		6.774701
PURPOSE	Anicut		
OPERATION	Not Confirmed		
DRAWING			
<p style="text-align: center;">(Source: JICA 2003 M/P Report)</p>			
SITE CONDITION			
No access			

ID: MT1-3	JICA 2003 M/P	SLDC 2017	2018 F/S
	Anicut at 4+658		
COORDINATE	E		N
	79.962057		6.779892
PURPOSE	Anicut		
OPERATION	Not Confirmed		
DRAWING			
<p style="text-align: center;">(Source: JICA 2003 M/P Report)</p>			
SITE CONDITION			
No access			

ID: MT1-4	JICA 2003 M/P	SLDC 2017	2018 F/S
	Anicut at 4+606		
COORDINATE	E		N
	79.962341		6.780326
PURPOSE	Anicut		
OPERATION	Not Confirmed		
DRAWING			
<p>(Source: JICA 2003 M/P Report)</p>			
SITE CONDITION			
No access			

ID: MT1-5	JICA 2003 M/P	SLDC 2017	2018 F/S
	Anicut at 3+933		
COORDINATE	E		N
	79.964156		6.785608
PURPOSE	Anicut		
OPERATION	Not Confirmed		
DRAWING			
<p>(Source: JICA 2003 M/P Report)</p>			
SITE CONDITION			
No access			

ID: MT1-6	JICA 2003 M/P	SLDC 2017	2018 F/S
	Bridge at 3+750		
COORDINATE	E		N
	79.964222		6.787084
PURPOSE	Bridge		
OPERATION	in use		

DRAWING

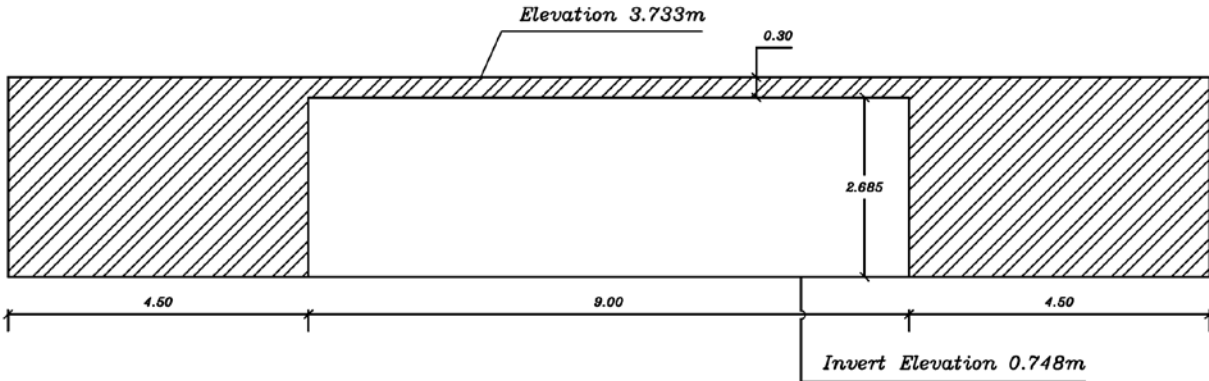

(Source: JICA 2003 M/P Report)

SITE CONDITION



ID: MT1-7	JICA 2003 M/P	SLDC 2017	2018 F/S
	Anicut 3+487		
COORDINATE	E		N
	Anicut		6.789324
PURPOSE	Gate for flood control		
OPERATION	in use		

DRAWING

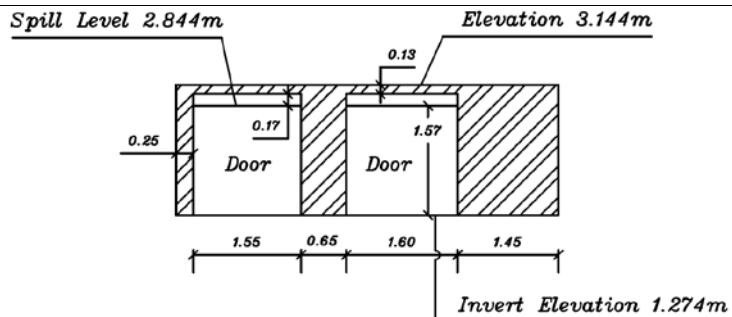

(Source: JICA 2003 M/P Report)

SITE CONDITION



ID: MT1-8	JICA 2003 M/P	SLDC 2017	2018 F/S
	Anicut 3+187		
COORDINATE	E		N
	79.962411		6.791446
PURPOSE	Anicut		
OPERATION	Not confirmed		
DRAWING			
<p style="text-align: center;">(Source: JICA 2003 M/P Report)</p>			
SITE CONDITION			
No access			

ID: MT1-9	JICA 2003 M/P	SLDC 2017	2018 F/S
	Anicut at 2+337		
COORDINATE	E		N
	79.957651		6.796754
PURPOSE	Anicut		
OPERATION	in use		

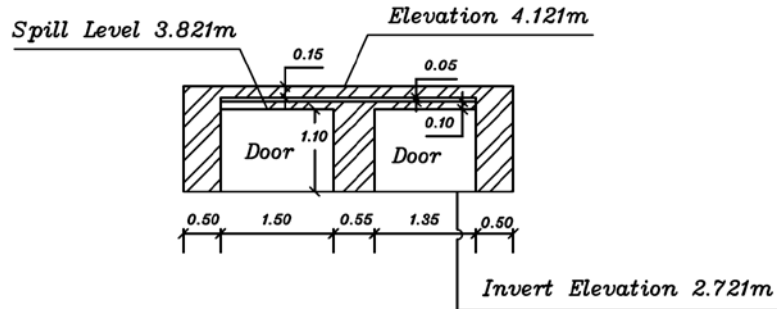

DRAWING



(Source: JICA 2003 M/P Report)

SITE CONDITION

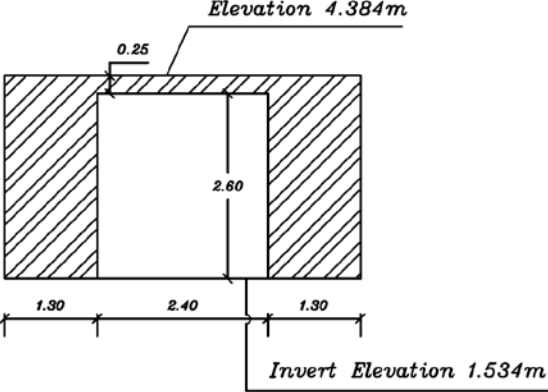

ID: MT1-10	JICA 2003 M/P	SLDC 2017	2018 F/S
	Culvert at 2+009		
COORDINATE	E		N
	79.955516		6.798592
PURPOSE	Culvert		
OPERATION	in use		
DRAWING			
 <p style="text-align: center;">(Source: JICA 2003 M/P Report)</p>			
SITE CONDITION			
			

ID: MT1-11	JICA 2003 M/P	SLDC 2017	2018 F/S
	Anicut at 1+907		
COORDINATE	E		N
	79.954770		6.799163
PURPOSE	Anicut		
OPERATION	in use		

DRAWING

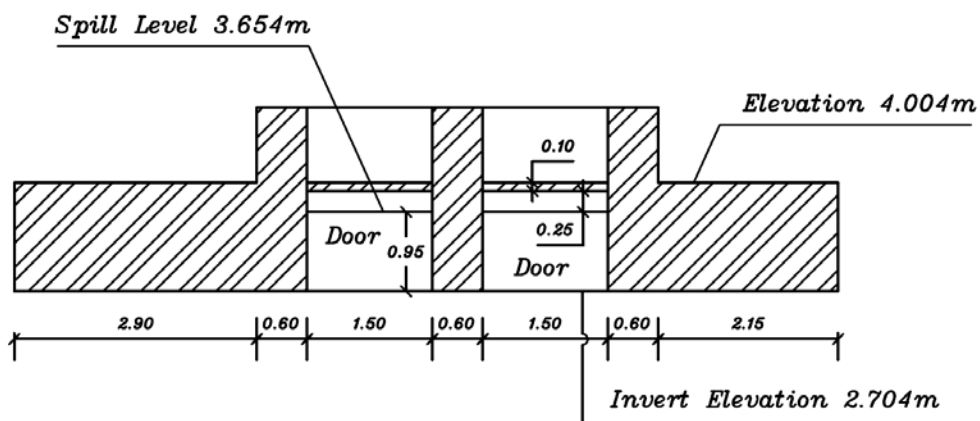

(Source: JICA 2003 M/P Report)

SITE CONDITION

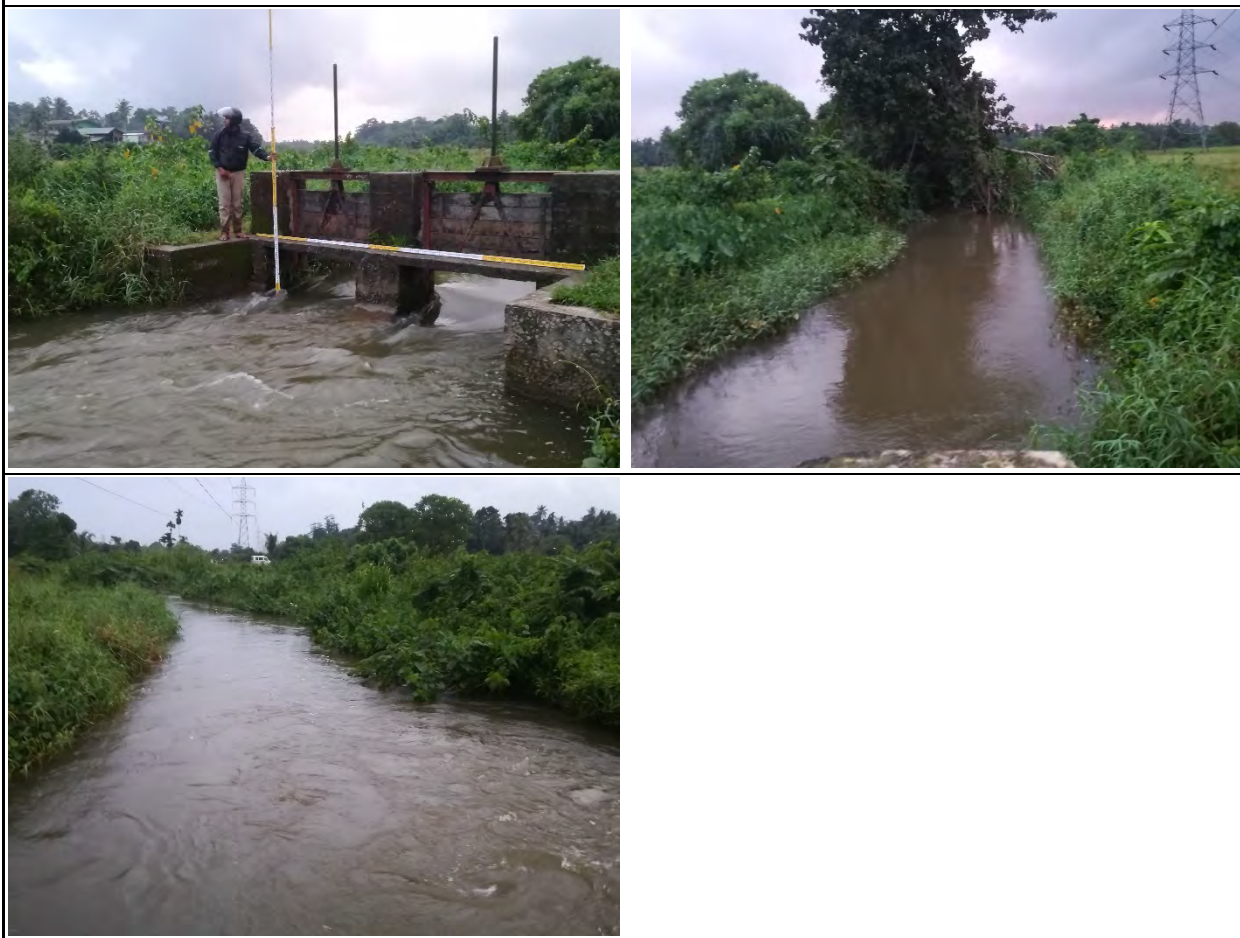

ID: MT1-12	JICA 2003 M/P	SLDC 2017	2018 F/S
	Culvert at 1+353		
COORDINATE	E		N
	6.799163		6.803044
PURPOSE	-		
OPERATION	Removed		
DRAWING			
<p style="text-align: center;"><i>Elevation 4.654m</i></p> <p style="text-align: center;"><i>Invert Elevation 3.674m</i></p>			
(Source: JICA 2003 M/P Report)			

SITE CONDITION



ID: MT1-13	JICA 2003 M/P	SLDC 2017	2018 F/S
	Culvert at 0+839		
COORDINATE	E		N
	79.951267		6.807733
PURPOSE	Culvert		
OPERATION	in use		

DRAWING

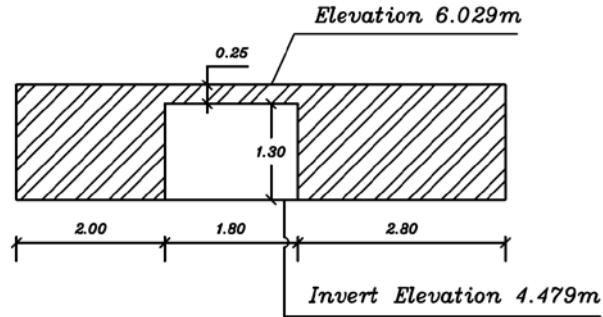

(Source: JICA 2003 M/P Report)

SITE CONDITION



ID: MT1-14	JICA 2003 M/P	SLDC 2017	2018 F/S
	Anicut at 0+168		
COORDINATE	E		N
	79.948242		6.812251
PURPOSE	Anicut		
OPERATION	in use		

DRAWING

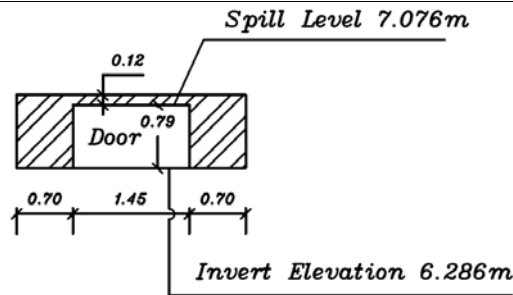

(Source: JICA 2003 M/P Report)

SITE CONDITION



ID: MT1-15	JICA 2003 M/P	SLDLC 2017	2018 F/S
	Culvert at 0+000		
COORDINATE	E		N
	79.947561		6.813389
PURPOSE	Culvert		
OPERATION	in use		

DRAWING

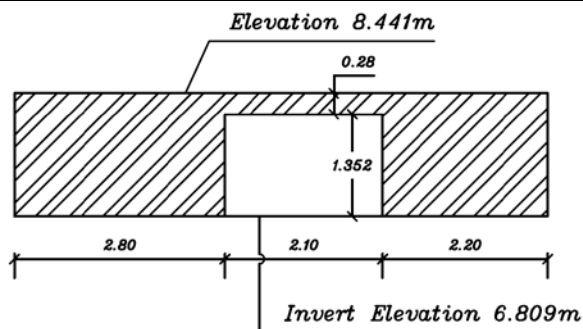

(Source: JICA 2003 M/P Report)

SITE CONDITION

