













LEGEND

● Pole (New)	— Line (New)
● Pole (Replaced)	— Line (Existing)
● Pole (Rearranged)	 Cable (New)
○ Pole (Existing)	 Cable (Existing)
□ MH Manhole	— Communication Line



LEGEND





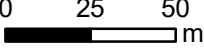





 Pole (New)	 Line (New)
 Pole (Replaced)	 Line (Existing)
 Pole (Rearranged)	 Cable (New)
 Pole (Existing)	 Cable (Existing)
 Manhole	 Communication Line







LEGEND

 Pole (New)	 Line (New)
 Pole (Replaced)	 Line (Existing)
 Pole (Rearranged)	 Cable (New)
 Pole (Existing)	 Cable (Existing)
 Manhole	 Communication Line



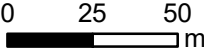



LEGEND

● Pole (New)	— Line (New)
● Pole (Replaced)	— Line (Existing)
● Pole (Rearranged)	 Cable (New)
○ Pole (Existing)	 Cable (Existing)
□ MH Manhole	— Communication Line

0 25 50 m













LEGEND

● Pole (New)	— Line (New)
● Pole (Replaced)	— Line (Existing)
● Pole (Rearranged)	 Cable (New)
 Pole (Existing)	 Cable (Existing)
MH Manhole	— Communication Line



LEGEND

 Pole (New)	 Line (New)
 Pole (Replaced)	 Line (Existing)
 Pole (Rearranged)	 Cable (New)
 Pole (Existing)	 Cable (Existing)
 Manhole	 Communication Line



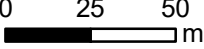



LEGEND

● Pole (New)	— Line (New)
● Pole (Replaced)	— Line (Existing)
● Pole (Rearranged)	 Cable (New)
○ Pole (Existing)	 Cable (Existing)
□ MH Manhole	— Communication Line

0 25 50 m



LEGEND

● Pole (New)	— Line (New)
● Pole (Replaced)	— Line (Existing)
● Pole (Rearranged)	 Cable (New)
○ Pole (Existing)	 Cable (Existing)
□ MH Manhole	— Communication Line













LEGEND

● Pole (New)	— Line (New)
● Pole (Replaced)	— Line (Existing)
● Pole (Rearranged)	 Cable (New)
 Pole (Existing)	 Cable (Existing)
MH Manhole	— Communication Line



LEGEND

 Pole (New)	 Line (New)
 Pole (Replaced)	 Line (Existing)
 Pole (Rearranged)	 Cable (New)
 Pole (Existing)	 Cable (Existing)
 Manhole	 Communication Line



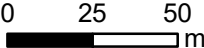



LEGEND

● Pole (New)	— Line (New)
● Pole (Replaced)	— Line (Existing)
● Pole (Rearranged)	 Cable (New)
 Pole (Existing)	 Cable (Existing)
MH Manhole	— Communication Line

0 25 50 m



LEGEND

● Pole (New)	— Line (New)
● Pole (Replaced)	— Line (Existing)
● Pole (Rearranged)	 Cable (New)
 Pole (Existing)	 Cable (Existing)
MH Manhole	— Communication Line



LEGEND

● Pole (New)	— Line (New)
● Pole (Replaced)	— Line (Existing)
● Pole (Rearranged)	 Cable (New)
 Pole (Existing)	 Cable (Existing)
MH Manhole	— Communication Line



LEGEND

● Pole (New)	— Line (New)
● Pole (Replaced)	— Line (Existing)
● Pole (Rearranged)	 Cable (New)
 Pole (Existing)	 Cable (Existing)
MH Manhole	— Communication Line













LEGEND

● Pole (New)	— Line (New)
● Pole (Replaced)	— Line (Existing)
● Pole (Rearranged)	 Cable (New)
 Pole (Existing)	 Cable (Existing)
MH Manhole	— Communication Line

0 25 50 m



LEGEND





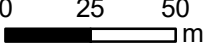





 Pole (New)	 Line (New)
 Pole (Replaced)	 Line (Existing)
 Pole (Rearranged)	 Cable (New)
 Pole (Existing)	 Cable (Existing)
 Manhole	 Communication Line







LEGEND





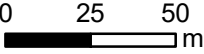





 Pole (New)	 Line (New)
 Pole (Replaced)	 Line (Existing)
 Pole (Rearranged)	 Cable (New)
 Pole (Existing)	 Cable (Existing)
 Manhole	 Communication Line







LEGEND

	Pole (New)		Line (New)
	Pole (Replaced)		Line (Existing)
	Pole (Rearranged)		Cable (New)
	Pole (Existing)		Cable (Existing)
	Manhole		Communication Line



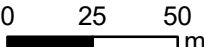



LEGEND

● Pole (New)	— Line (New)
● Pole (Replaced)	— Line (Existing)
● Pole (Rearranged)	 Cable (New)
○ Pole (Existing)	 Cable (Existing)
□ MH Manhole	— Communication Line



LEGEND

● Pole (New)	— Line (New)
● Pole (Replaced)	— Line (Existing)
● Pole (Rearranged)	 Cable (New)
○ Pole (Existing)	 Cable (Existing)
MH Manhole	— Communication Line

0 25 50 m



LEGEND

● Pole (New)	— Line (New)
● Pole (Replaced)	— Line (Existing)
● Pole (Rearranged)	 Cable (New)
 Pole (Existing)	 Cable (Existing)
MH Manhole	— Communication Line

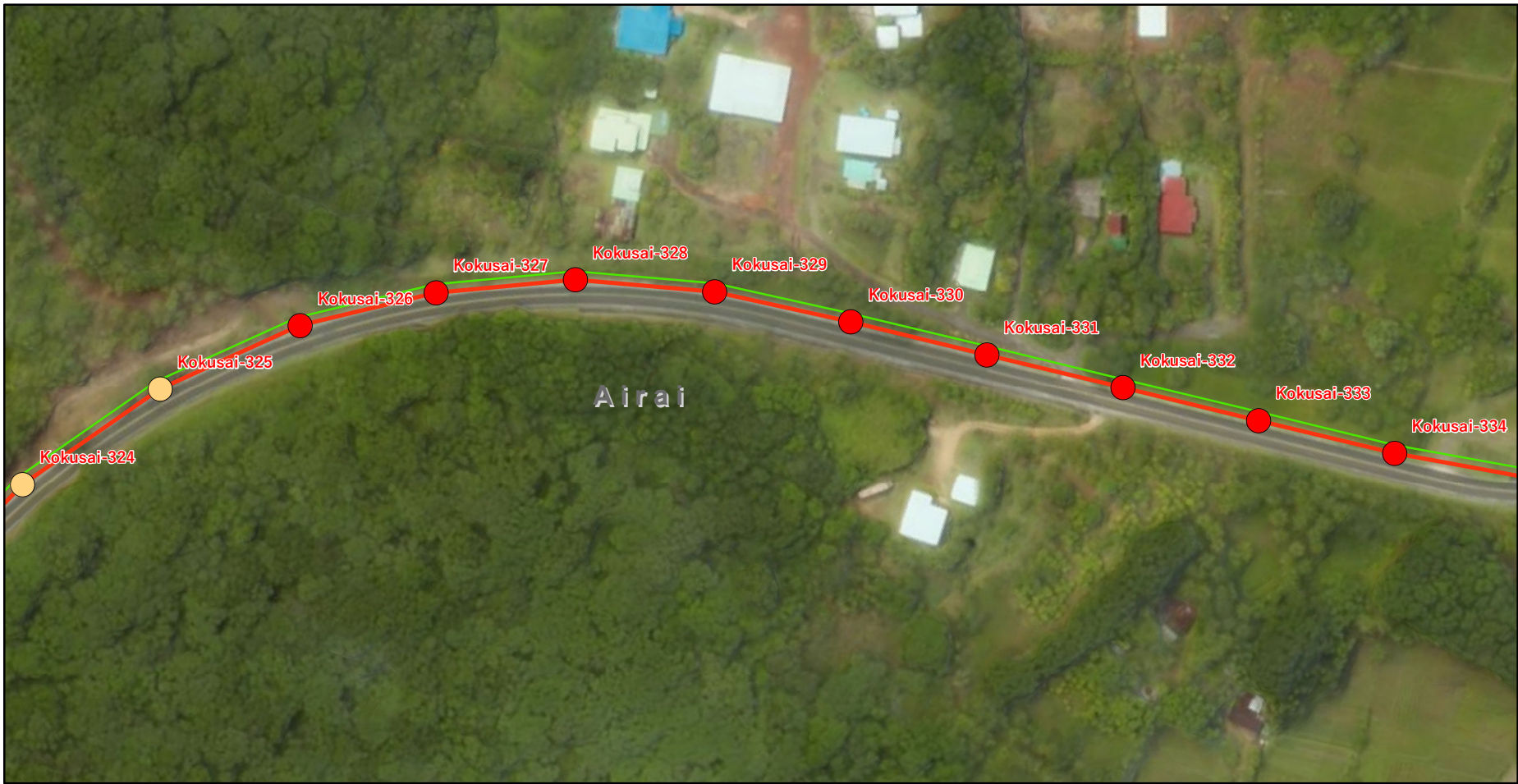

LEGEND

● Pole (New)	— Line (New)
● Pole (Replaced)	— Line (Existing)
● Pole (Rearranged)	 Cable (New)
○ Pole (Existing)	 Cable (Existing)
□ MH Manhole	— Communication Line

0 25 50 m



LEGEND

<ul style="list-style-type: none"> ● Pole (New) ● Pole (Replaced) ● Pole (Rearranged) ○ Pole (Existing) MH Manhole 	<ul style="list-style-type: none"> — Line (New) — Line (Existing) Cable (New) Cable (Existing) — Communication Line
--	---



LEGEND

● Pole (New)	— Line (New)
● Pole (Replaced)	— Line (Existing)
● Pole (Rearranged)	 Cable (New)
○ Pole (Existing)	 Cable (Existing)
MH Manhole	— Communication Line



LEGEND

<ul style="list-style-type: none"> ● Pole (New) ● Pole (Replaced) ● Pole (Rearranged) ○ Pole (Existing) MH Manhole 	<ul style="list-style-type: none"> — Line (New) — Line (Existing) Cable (New) Cable (Existing) — Communication Line
--	---



LEGEND

● Pole (New)	— Line (New)
● Pole (Replaced)	— Line (Existing)
● Pole (Rearranged)	— Cable (New)
 Pole (Existing)	— Cable (Existing)
MH Manhole	— Communication Line



LEGEND

● Pole (New)	— Line (New)
● Pole (Replaced)	— Line (Existing)
● Pole (Rearranged)	 Cable (New)
 Pole (Existing)	 Cable (Existing)
MH Manhole	— Communication Line

0 25 50 m



LEGEND

● Pole (New)	— Line (New)
● Pole (Replaced)	— Line (Existing)
● Pole (Rearranged)	 Cable (New)
 Pole (Existing)	 Cable (Existing)
MH Manhole	— Communication Line

0 25 50 m







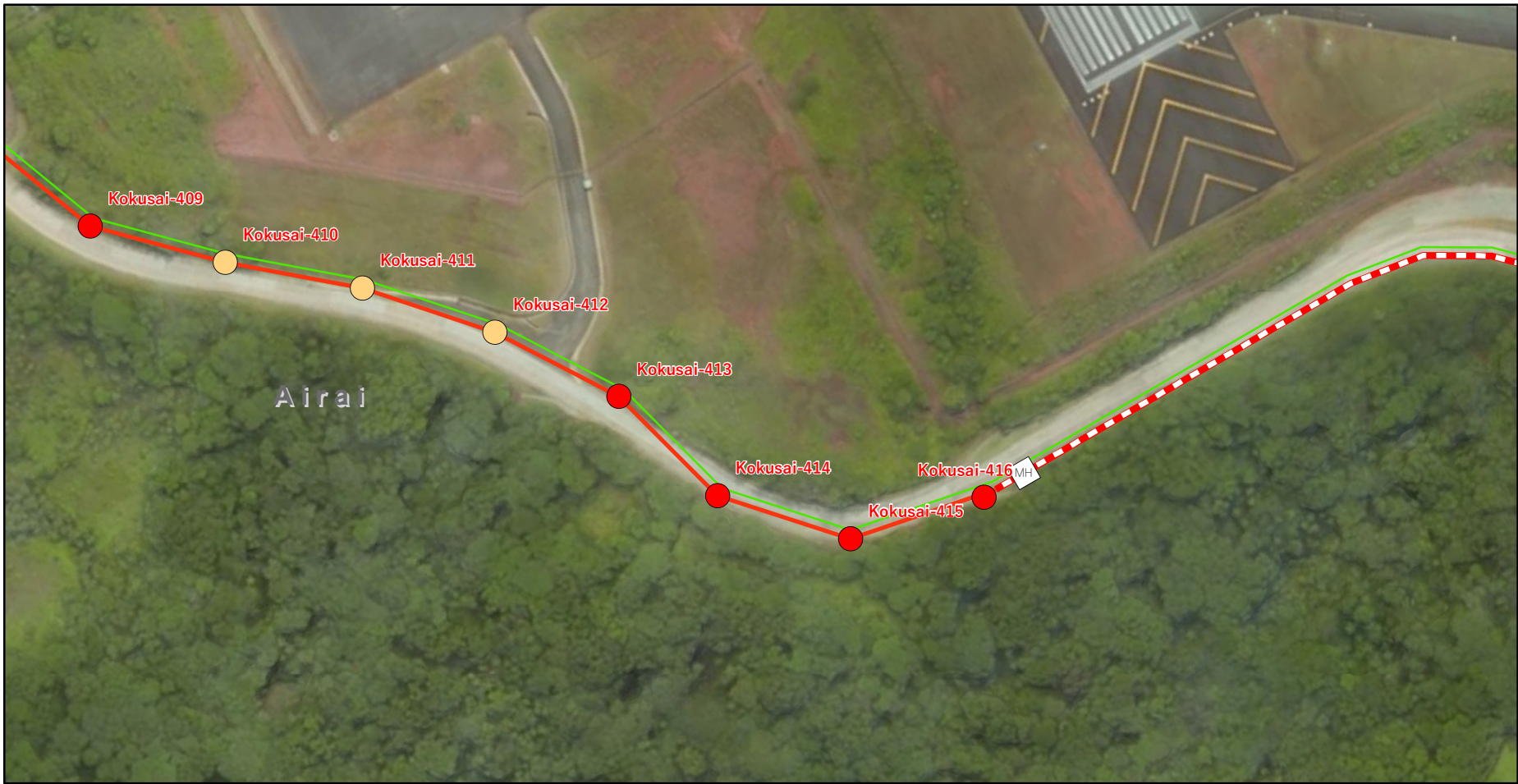





LEGEND

● Pole (New)	— Line (New)
● Pole (Replaced)	— Line (Existing)
● Pole (Rearranged)	- - - Cable (New)
○ Pole (Existing)	- - - Cable (Existing)
MH Manhole	— Communication Line



LEGEND

 Pole (New)	 Line (New)
 Pole (Replaced)	 Line (Existing)
 Pole (Rearranged)	 Cable (New)
 Pole (Existing)	 Cable (Existing)
 Manhole	 Communication Line



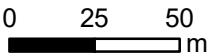













LEGEND

● Pole (New)	— Line (New)
● Pole (Replaced)	— Line (Existing)
● Pole (Rearranged)	 Cable (New)
 Pole (Existing)	 Cable (Existing)
MH Manhole	— Communication Line



LEGEND





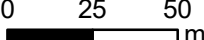





 Pole (New)	 Line (New)
 Pole (Replaced)	 Line (Existing)
 Pole (Rearranged)	 Cable (New)
 Pole (Existing)	 Cable (Existing)
 Manhole	 Communication Line







LEGEND





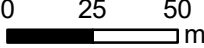





 Pole (New)	 Line (New)
 Pole (Replaced)	 Line (Existing)
 Pole (Rearranged)	 Cable (New)
 Pole (Existing)	 Cable (Existing)
 Manhole	 Communication Line







LEGEND

 Pole (New)	 Line (New)
 Pole (Replaced)	 Line (Existing)
 Pole (Rearranged)	 Cable (New)
 Pole (Existing)	 Cable (Existing)
 Manhole	 Communication Line



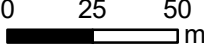



LEGEND

● Pole (New)	— Line (New)
● Pole (Replaced)	— Line (Existing)
● Pole (Rearranged)	- - - Cable (New)
○ Pole (Existing)	- - - Cable (Existing)
MH Manhole	— Communication Line

0 25 50 m



LEGEND

● Pole (New)	— Line (New)
● Pole (Replaced)	— Line (Existing)
● Pole (Rearranged)	 Cable (New)
 Pole (Existing)	 Cable (Existing)
MH Manhole	— Communication Line

0 25 50 m

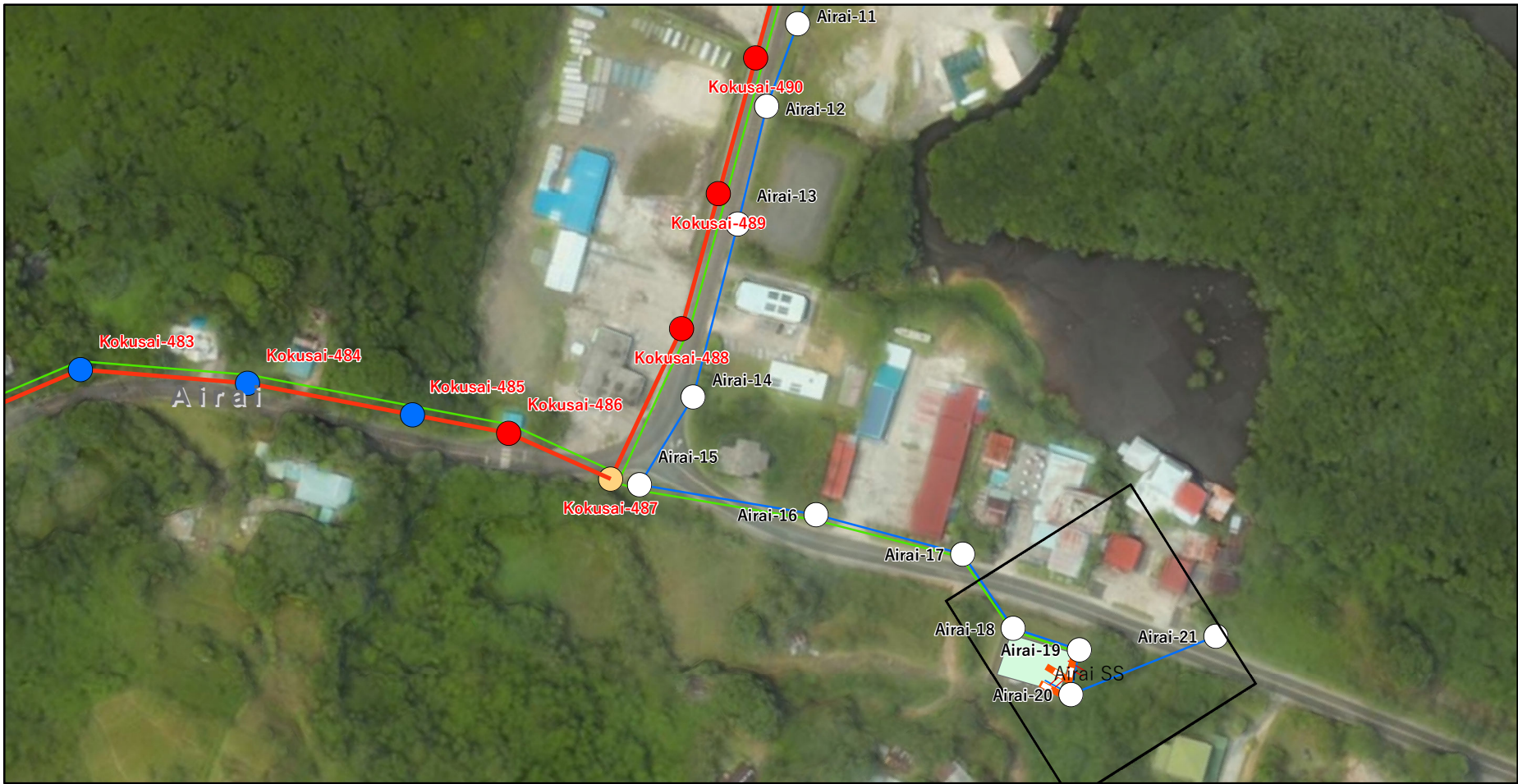

LEGEND

● Pole (New)	— Line (New)
● Pole (Replaced)	— Line (Existing)
● Pole (Rearranged)	 Cable (New)
 Pole (Existing)	 Cable (Existing)
MH Manhole	— Communication Line

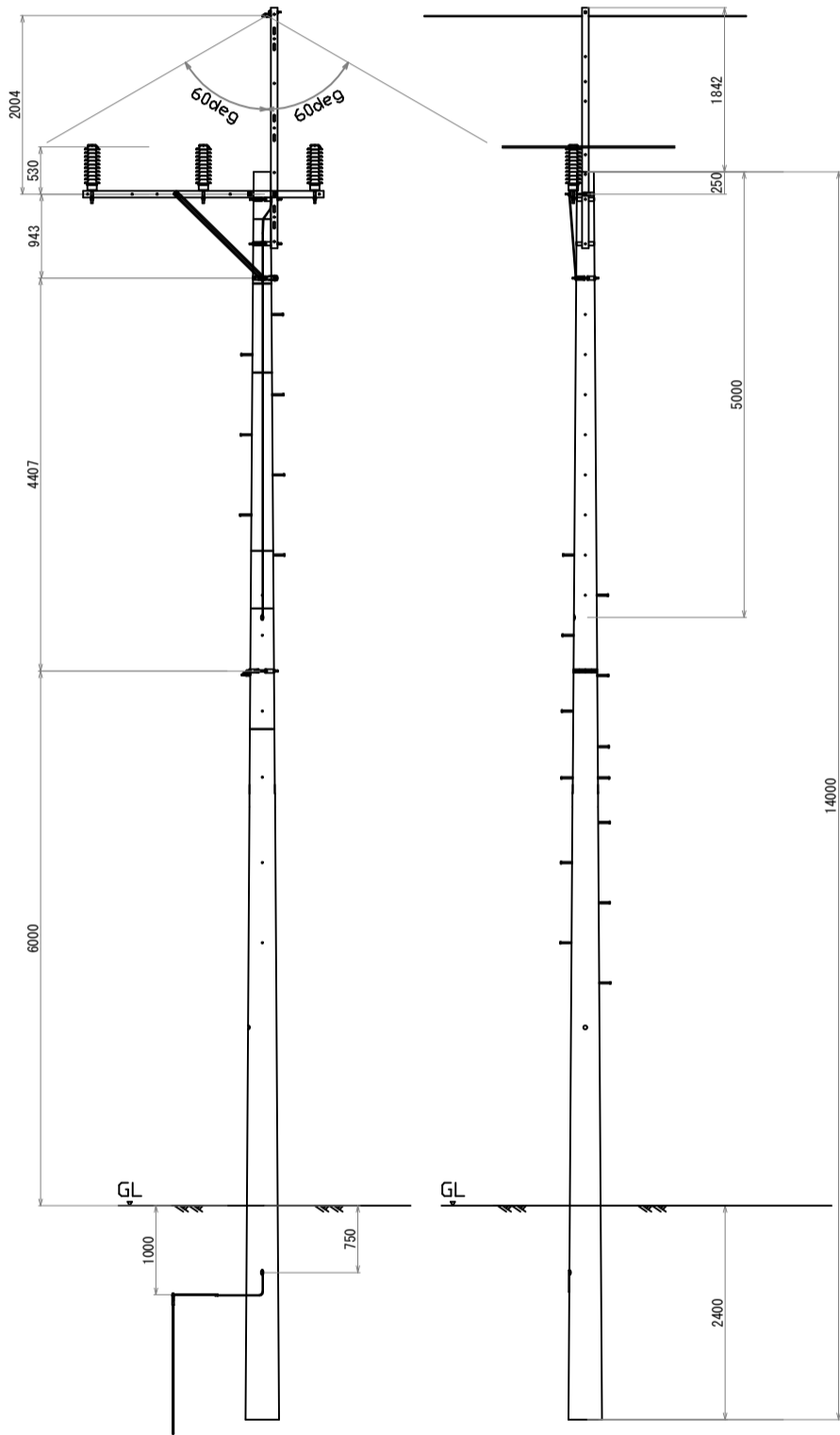
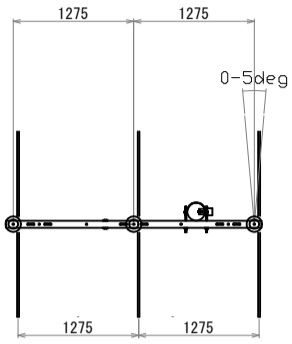

14m Pole Type A

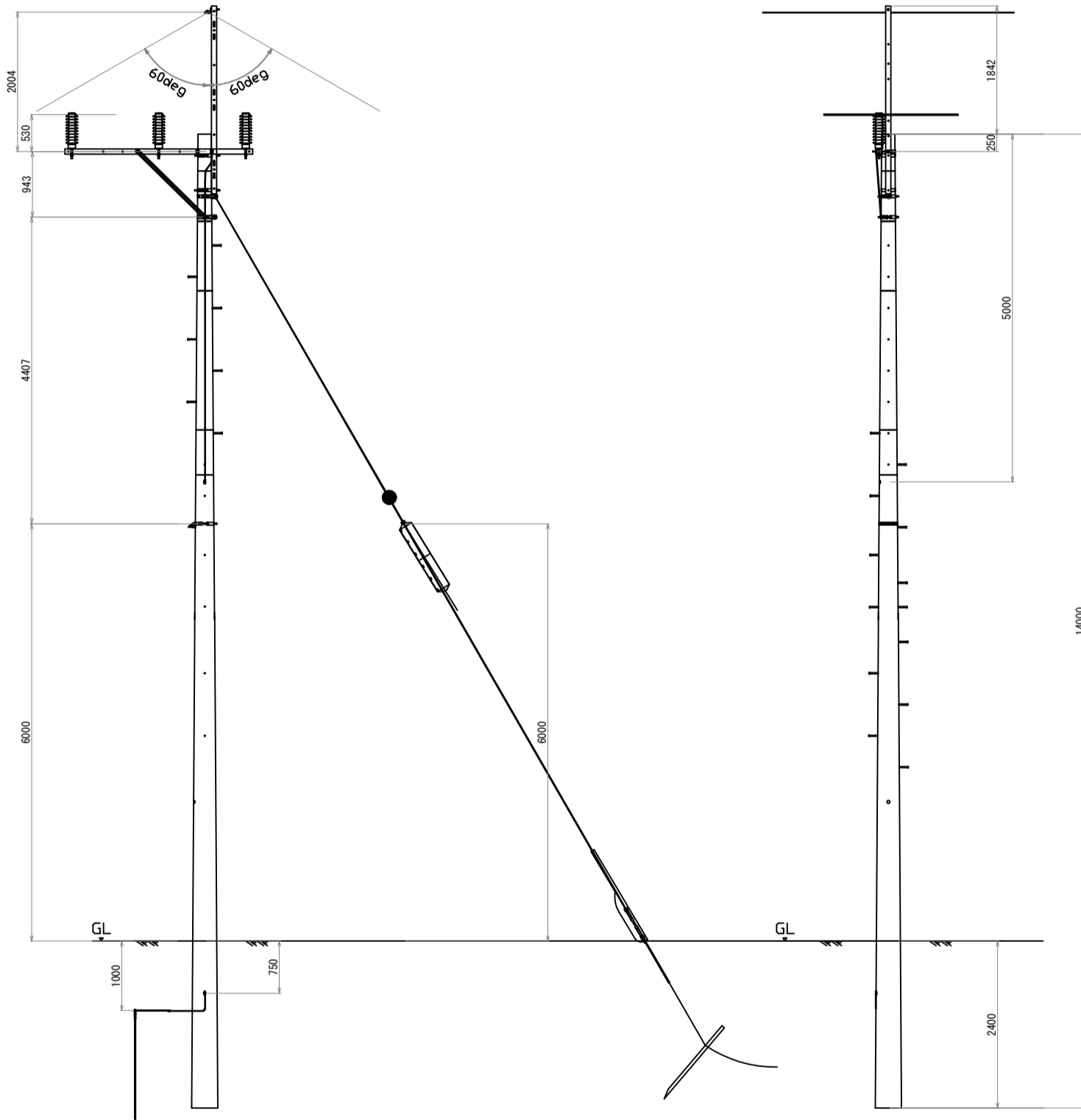
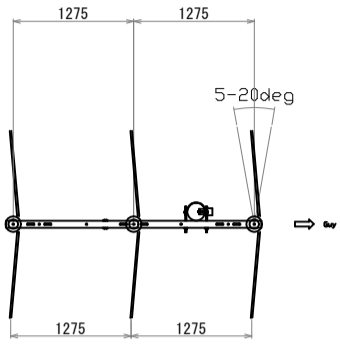

14m Pole Type B

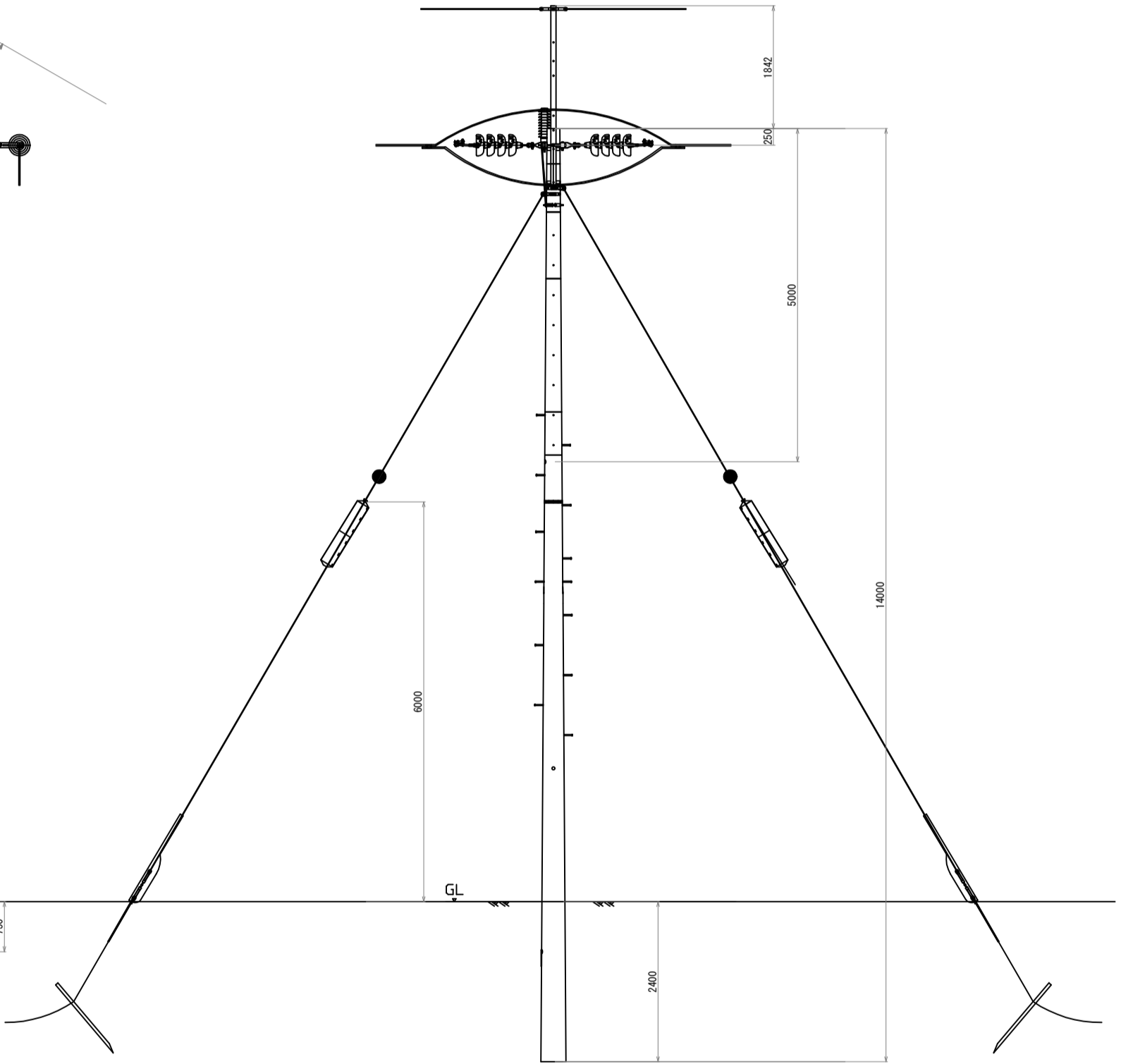
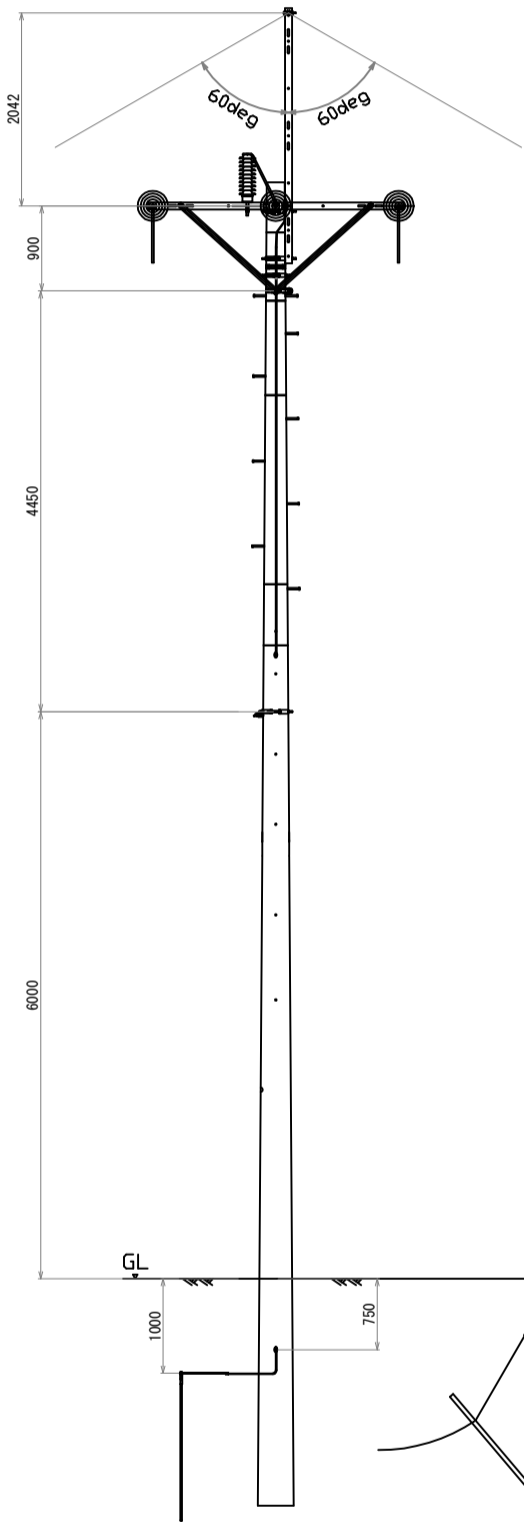
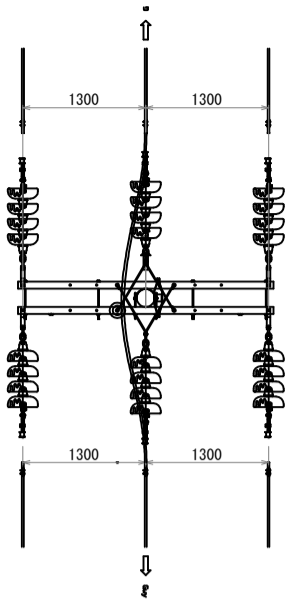

14m Pole Type C

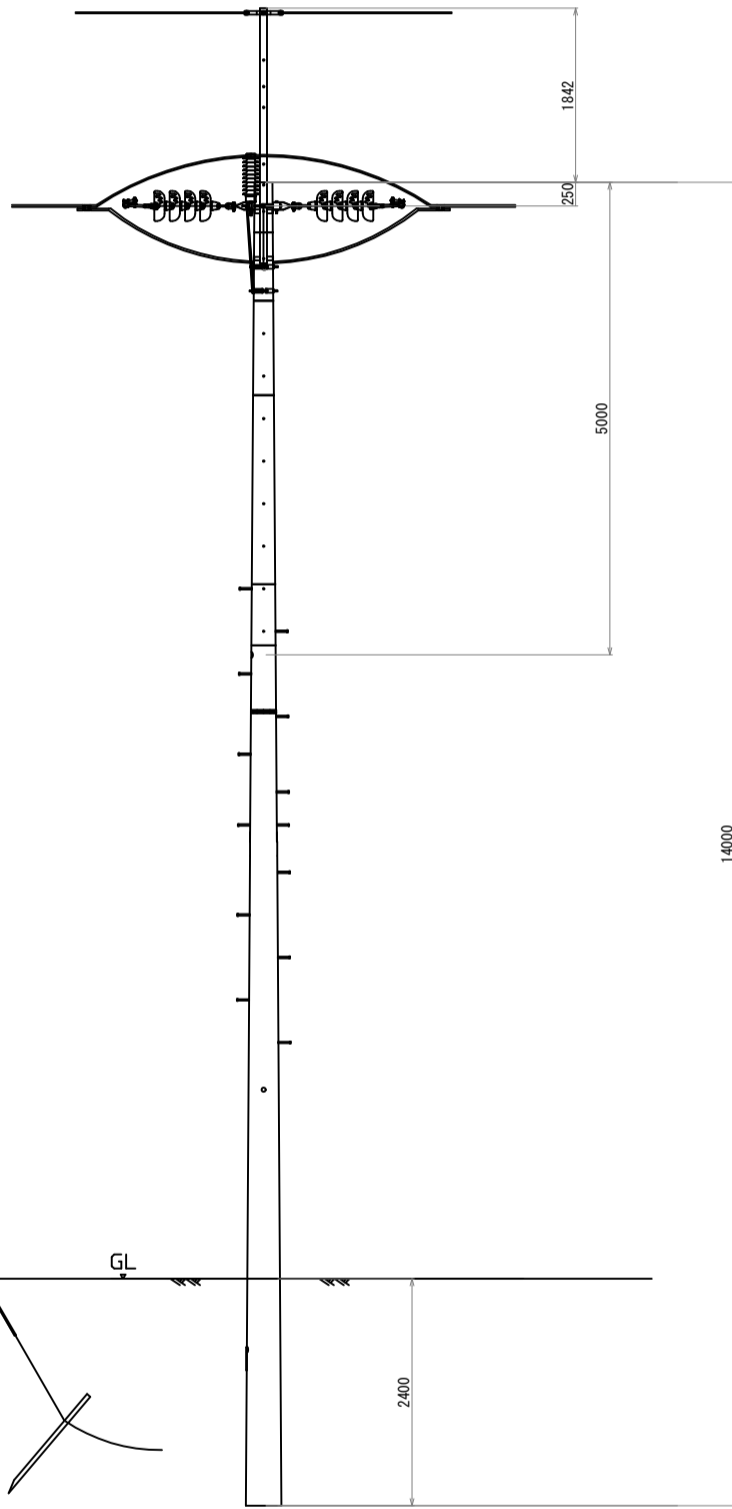
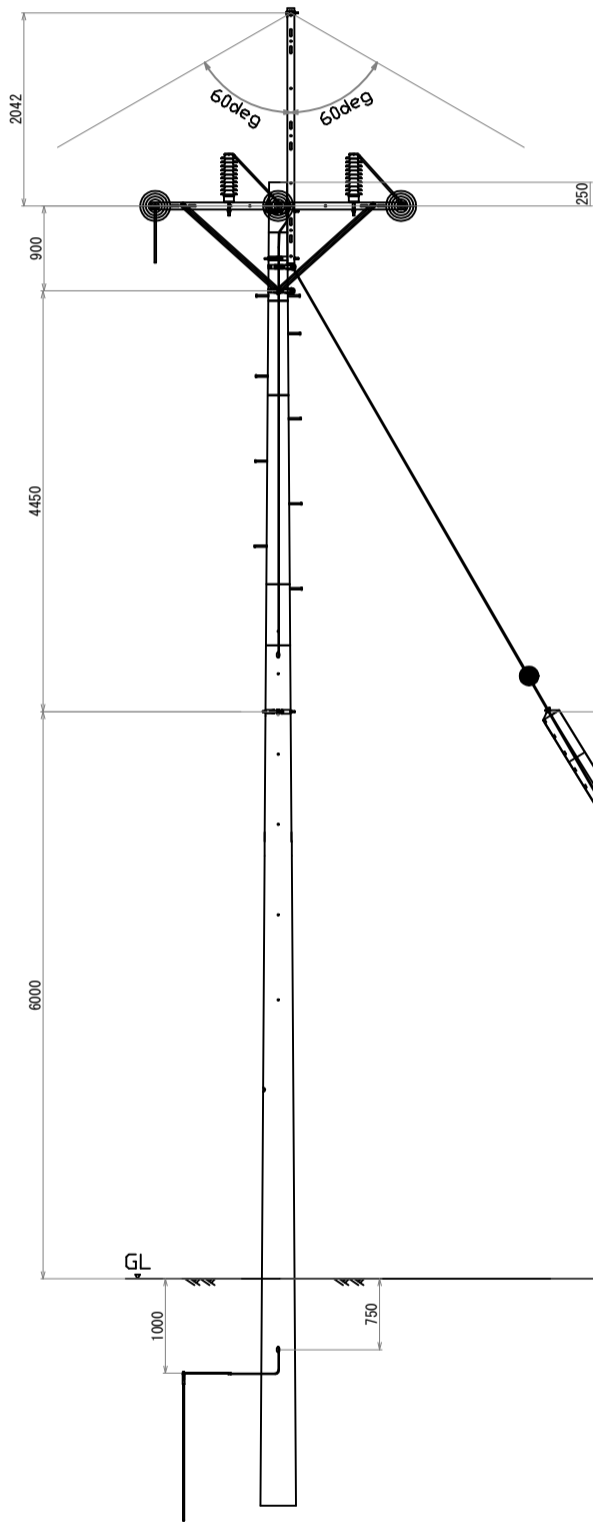
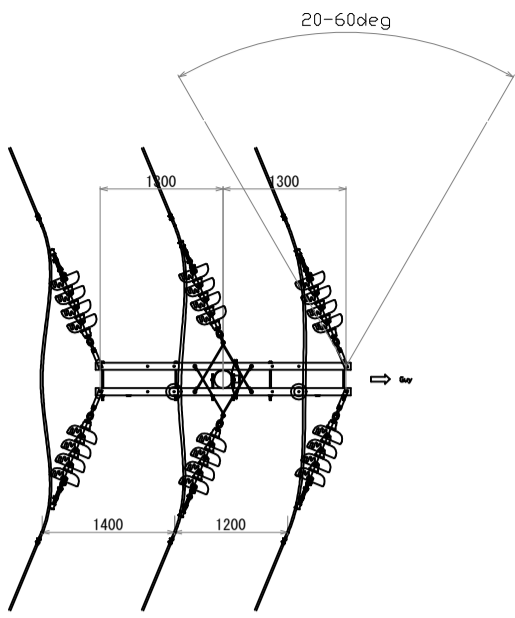

14m Pole Type D

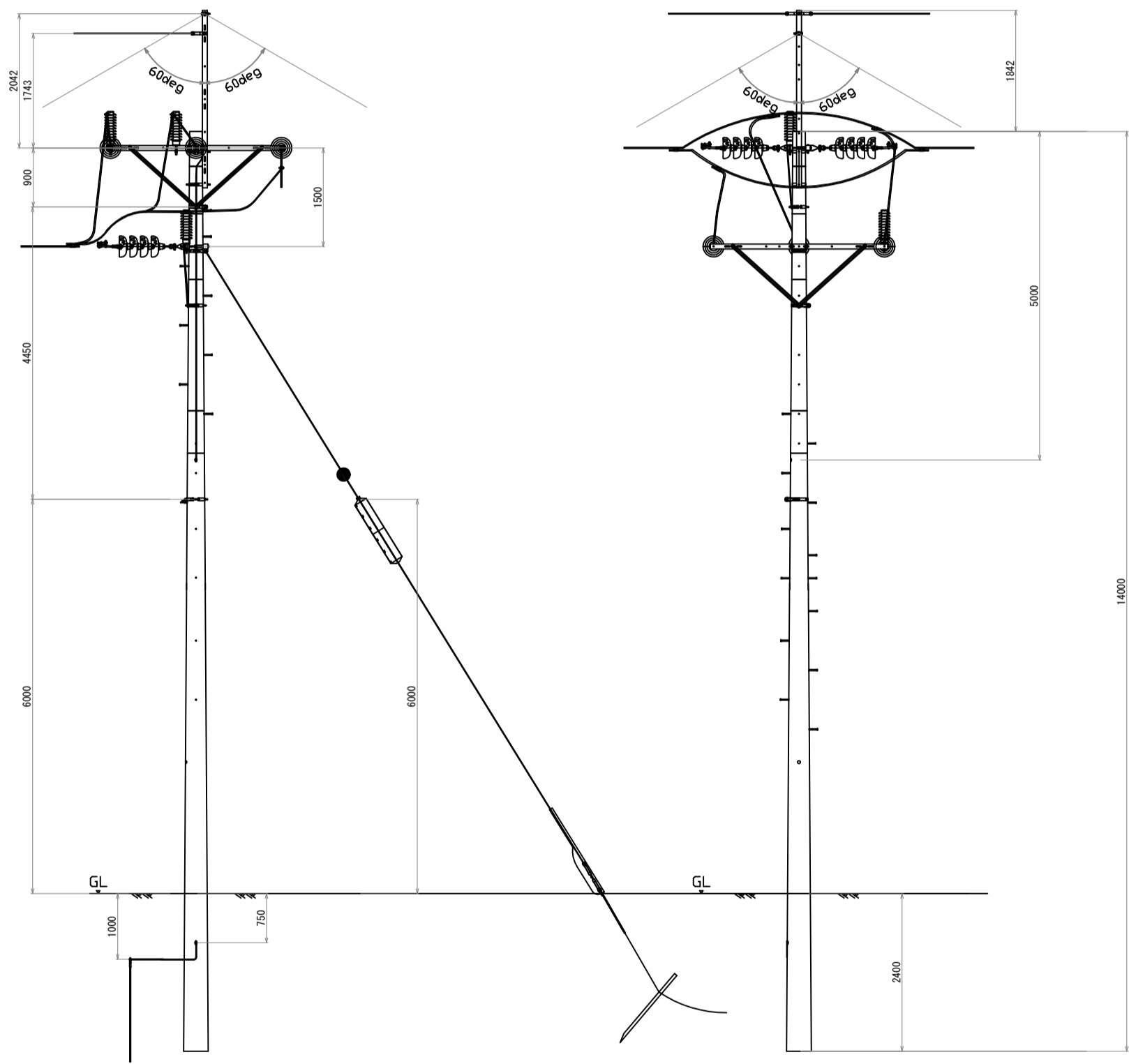
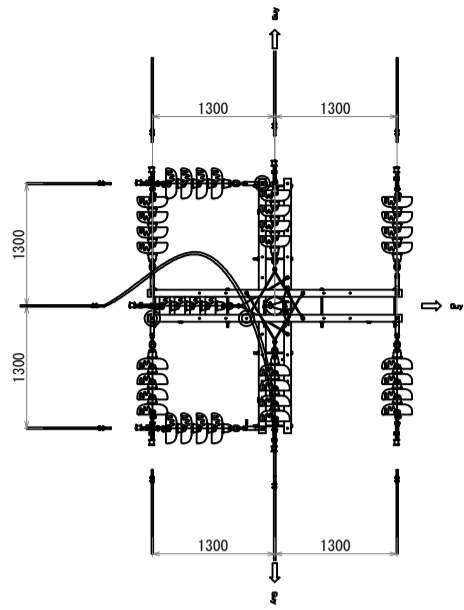

14m Pole Type E

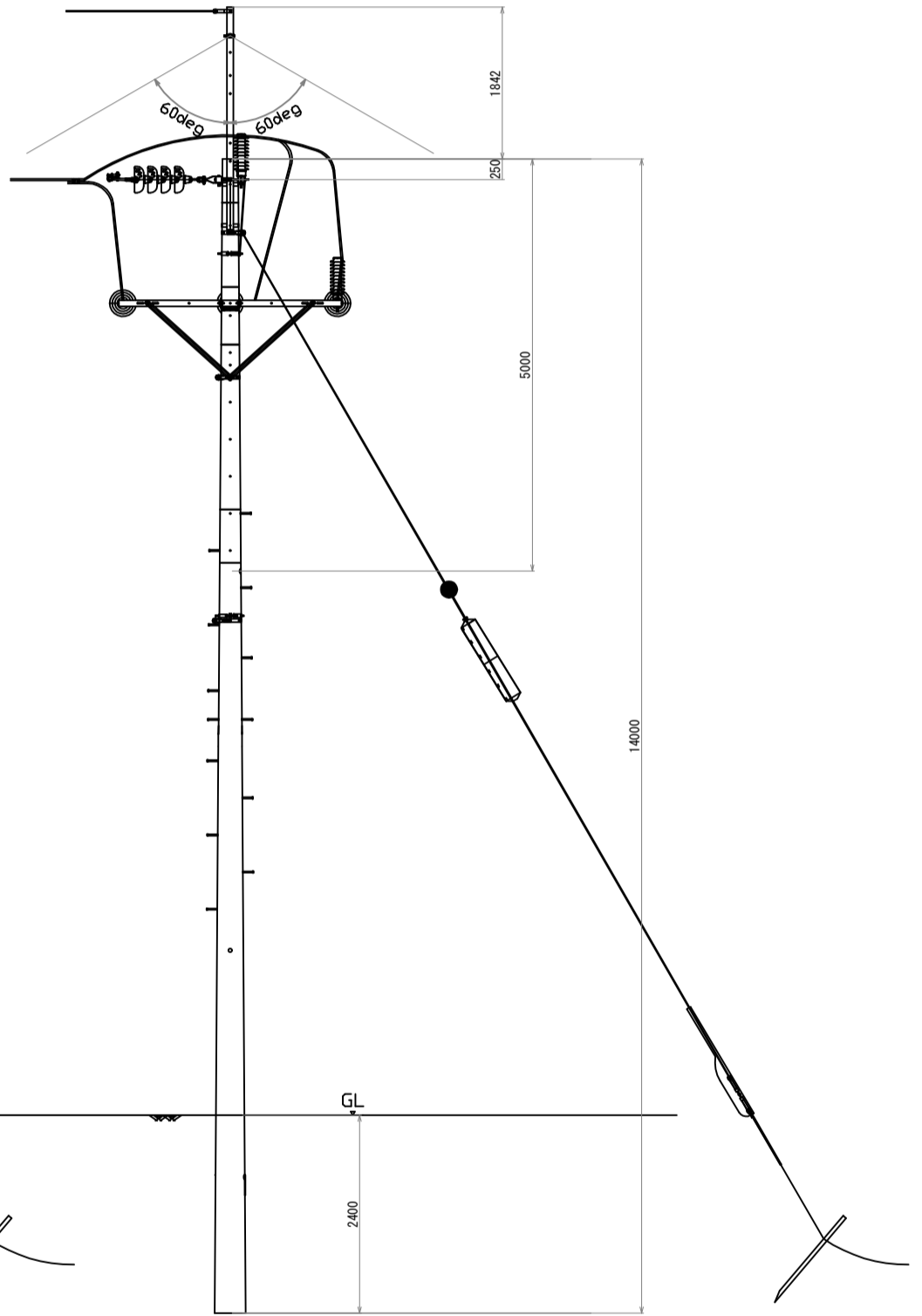
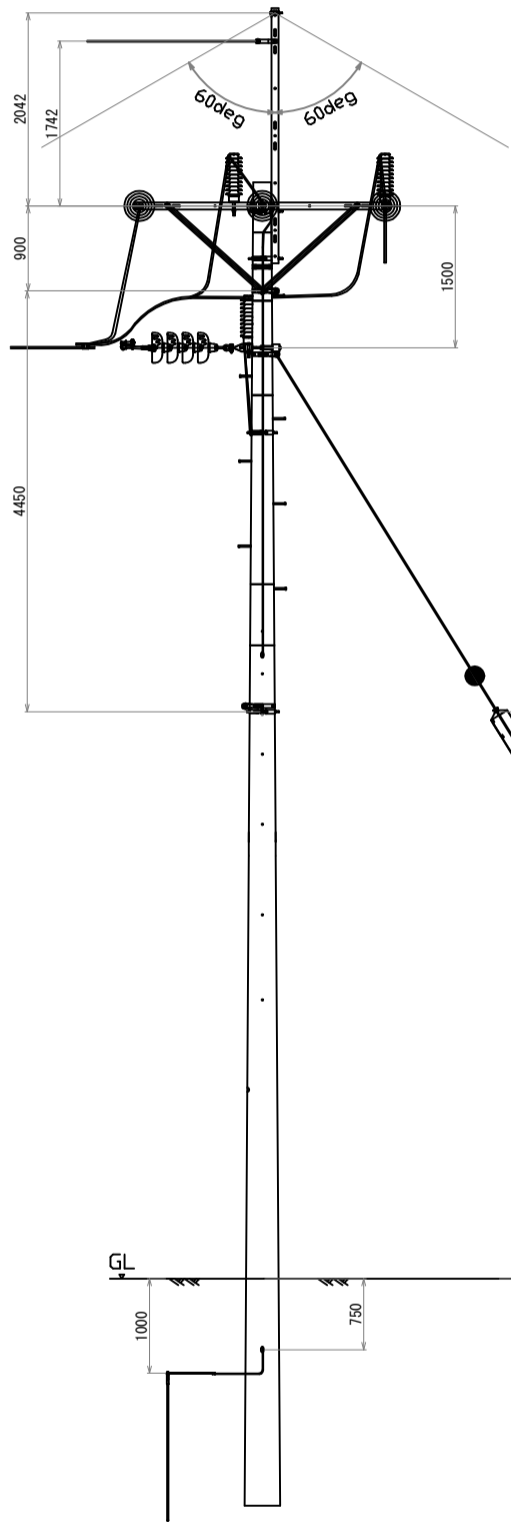
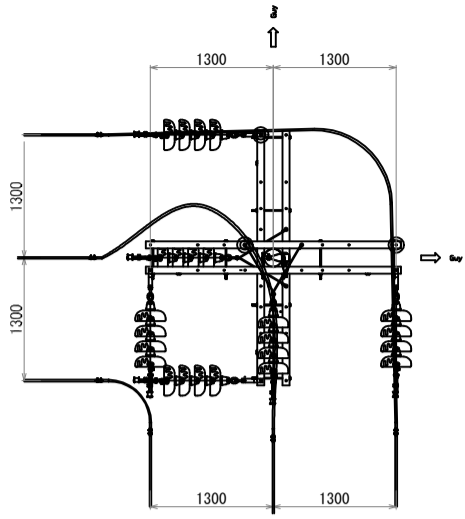

14m Pole Type F

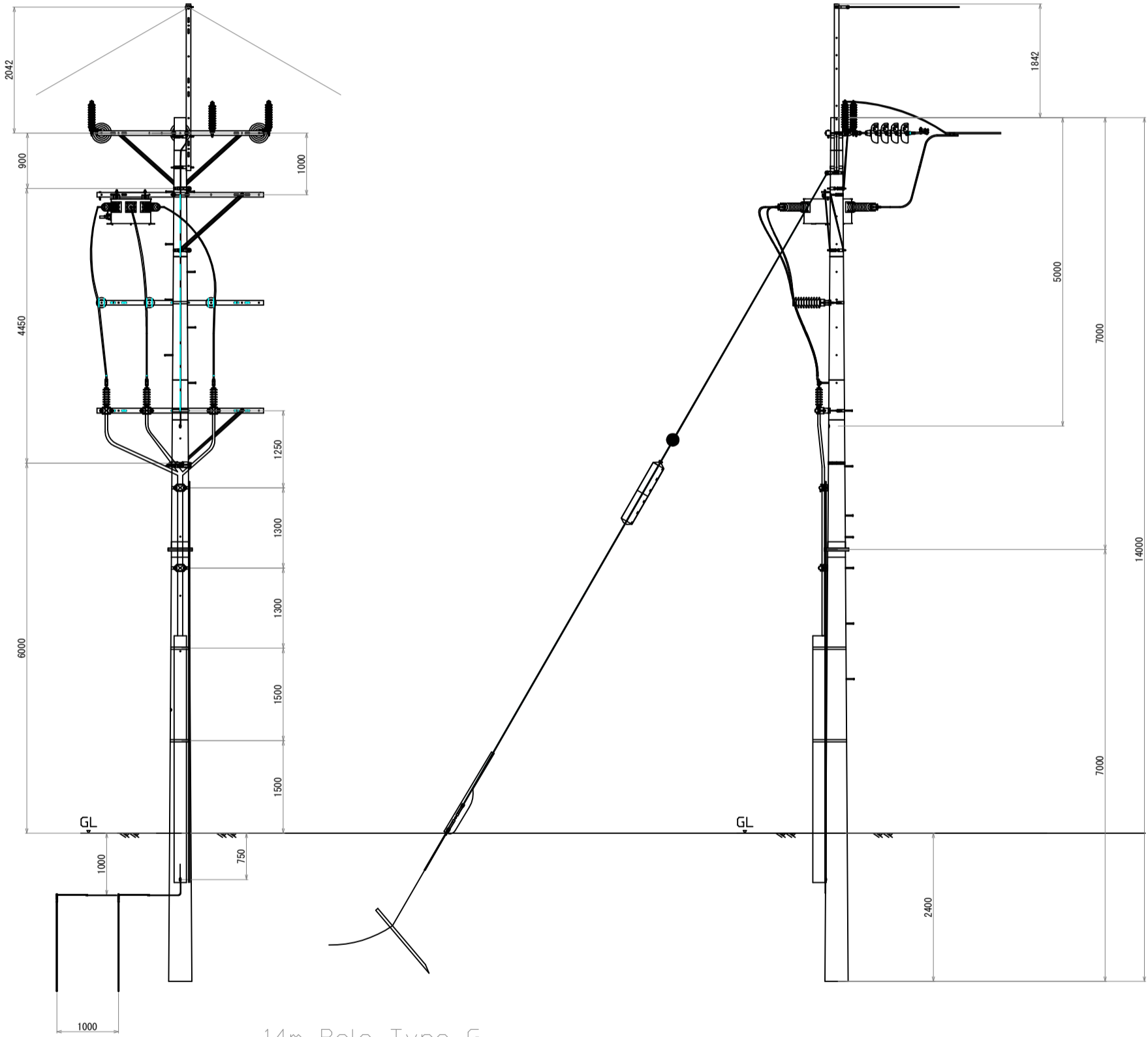
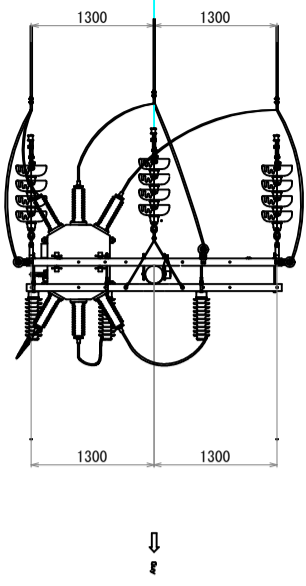

14m Pole Type G

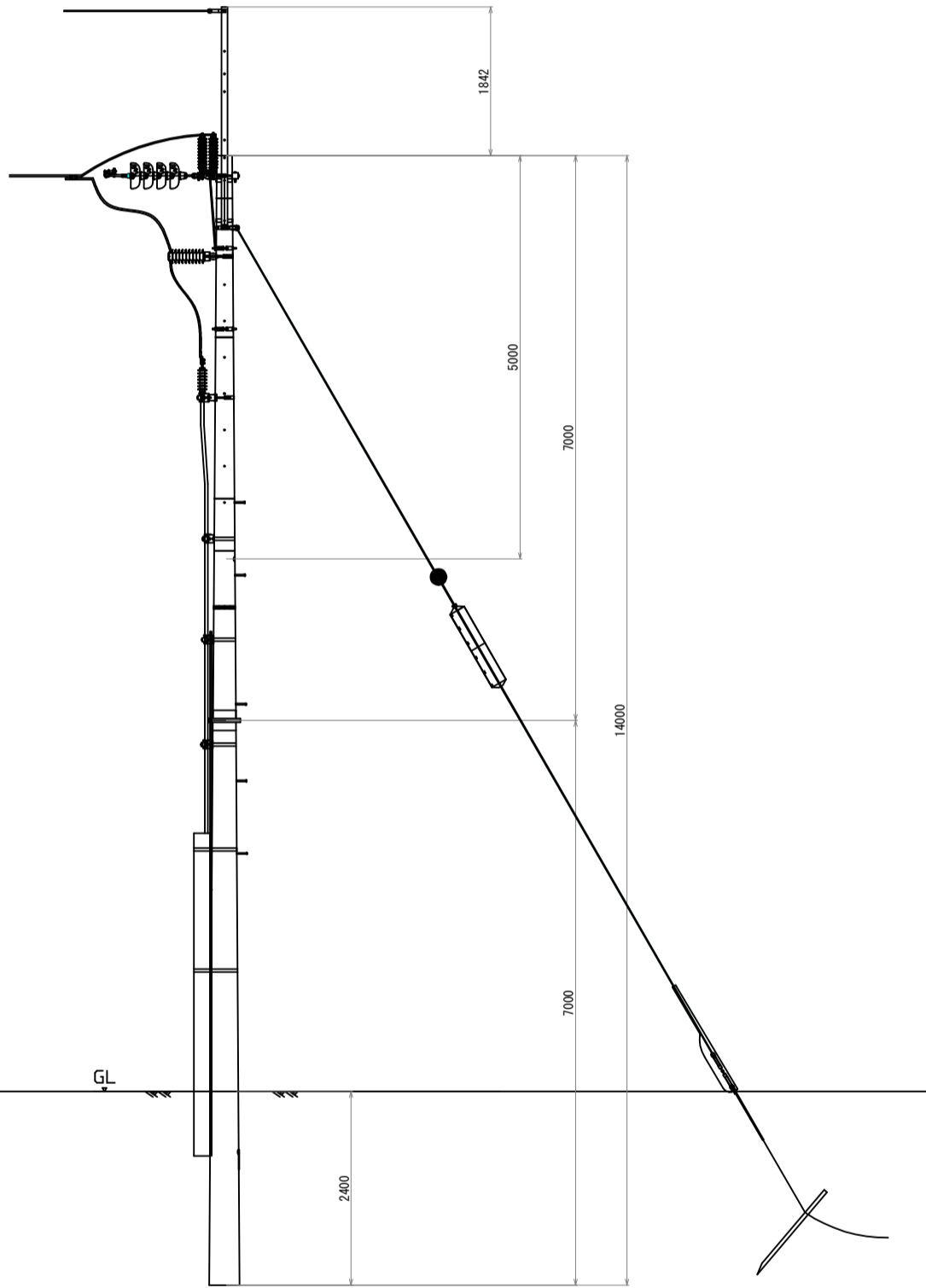
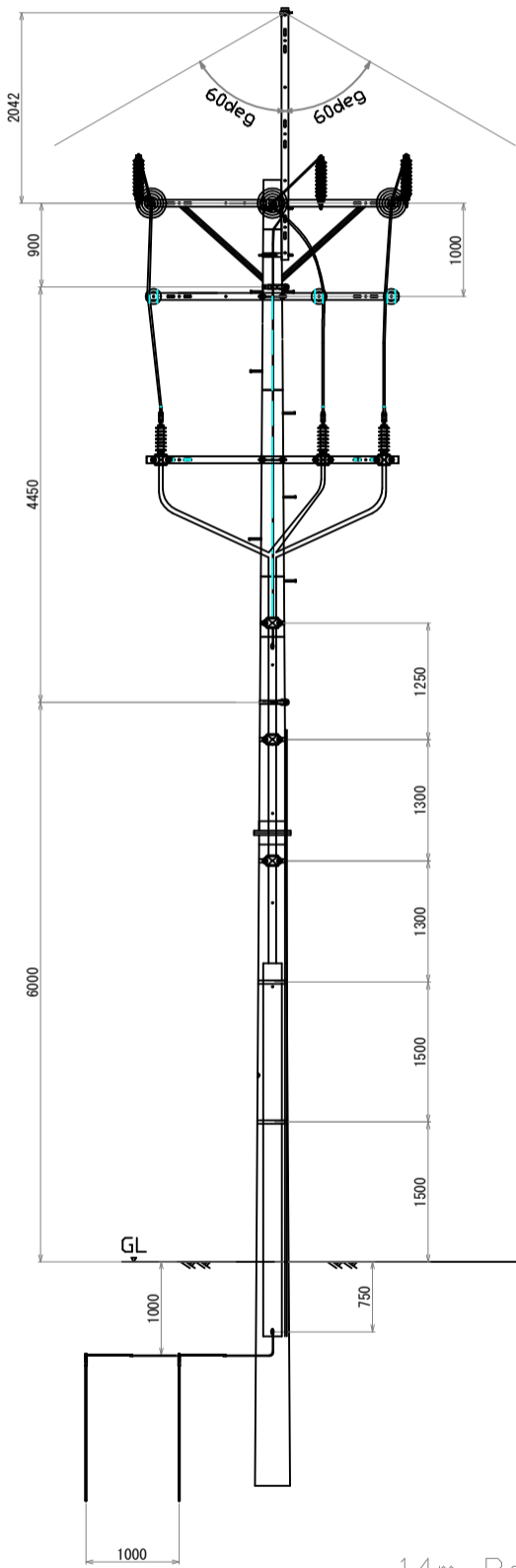
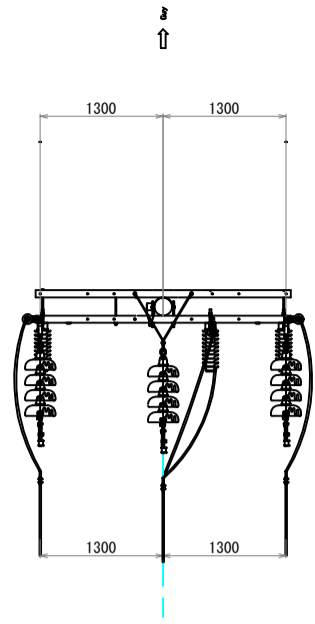

14m Pole Type H

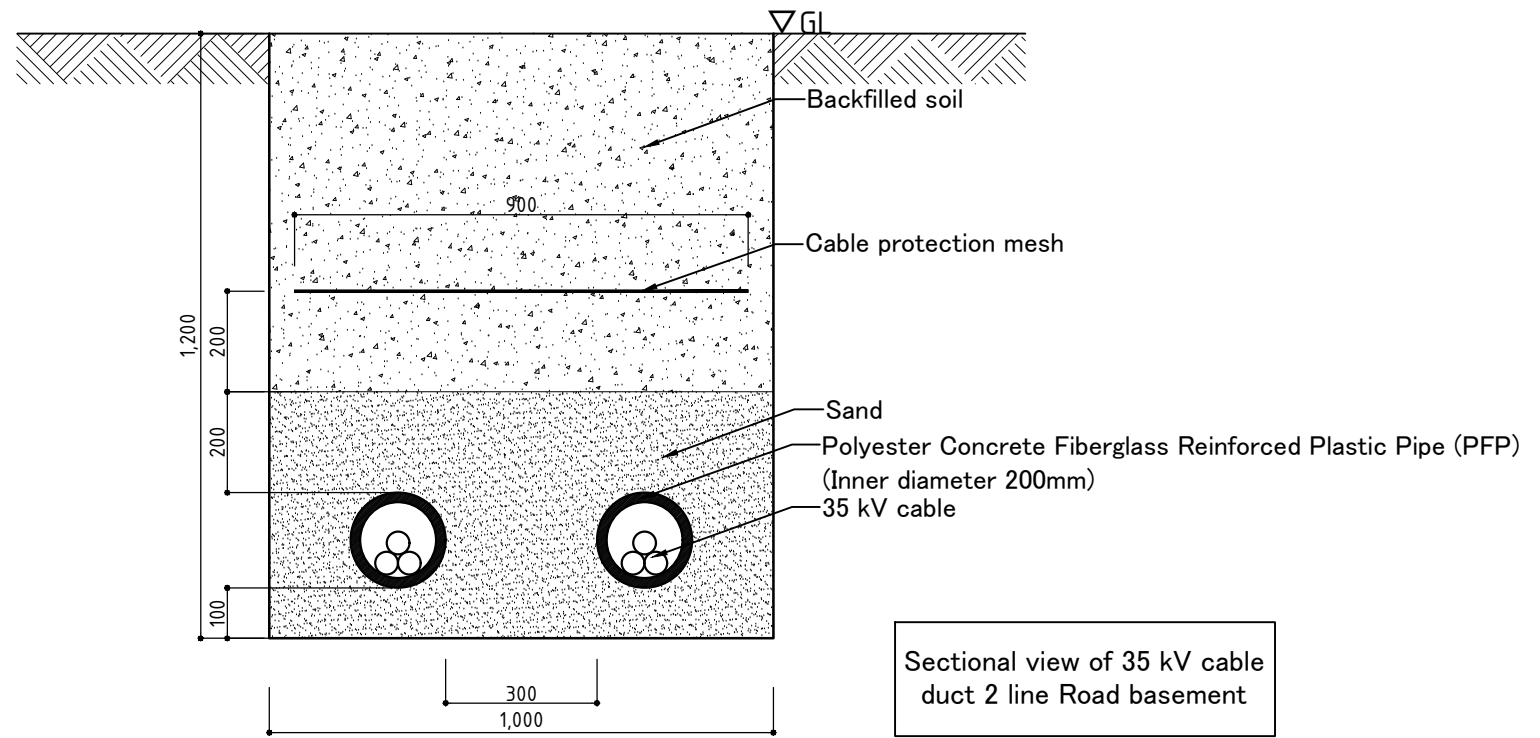

ET-04 Installation method of 34.5 kV underground cable

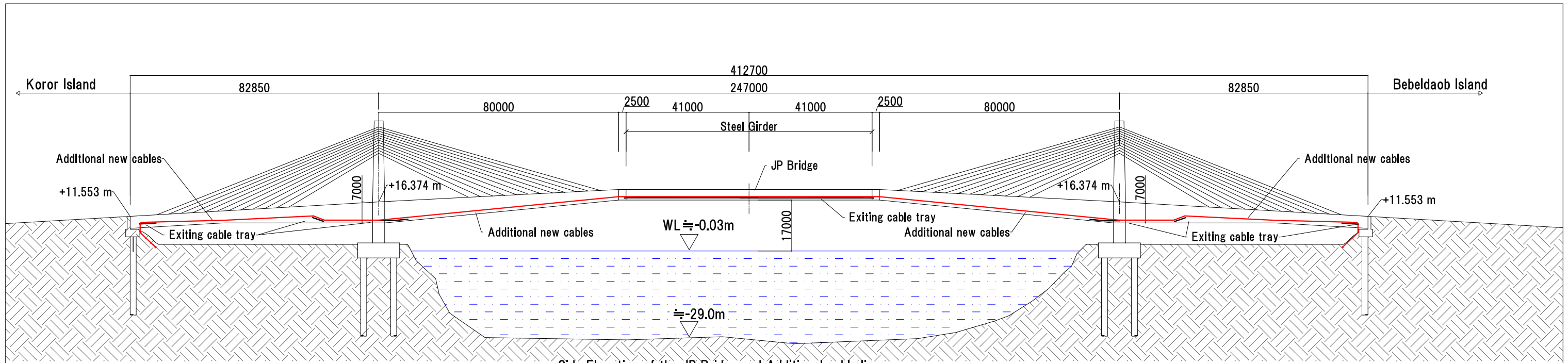

Side Elevation of the JP Bridge and Additional cable line

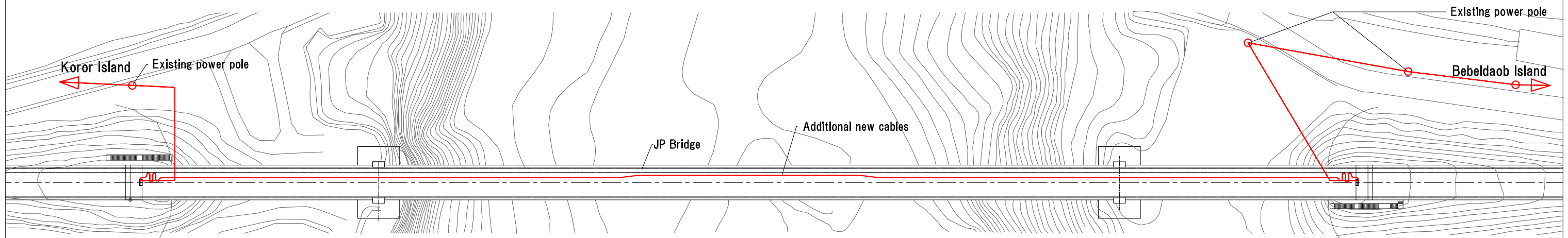

Plan of the JP Bridge and Additional cable line

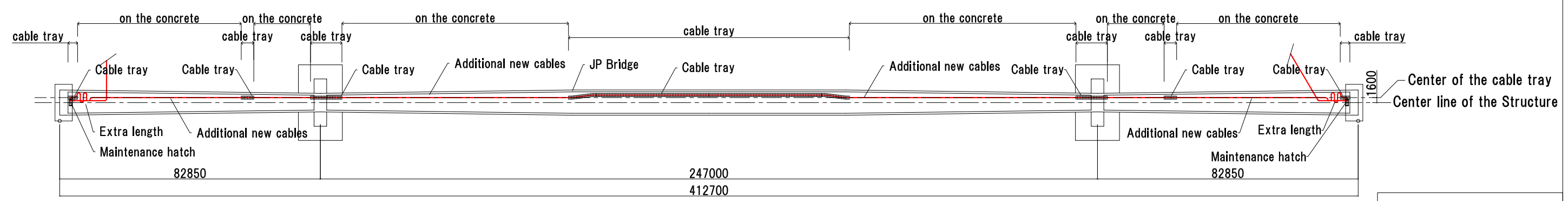

Inside plan of the JP Bridge and Additional cable line (Section A-A)

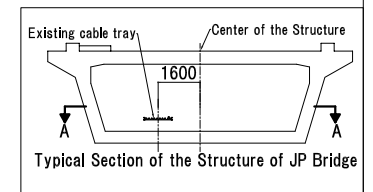

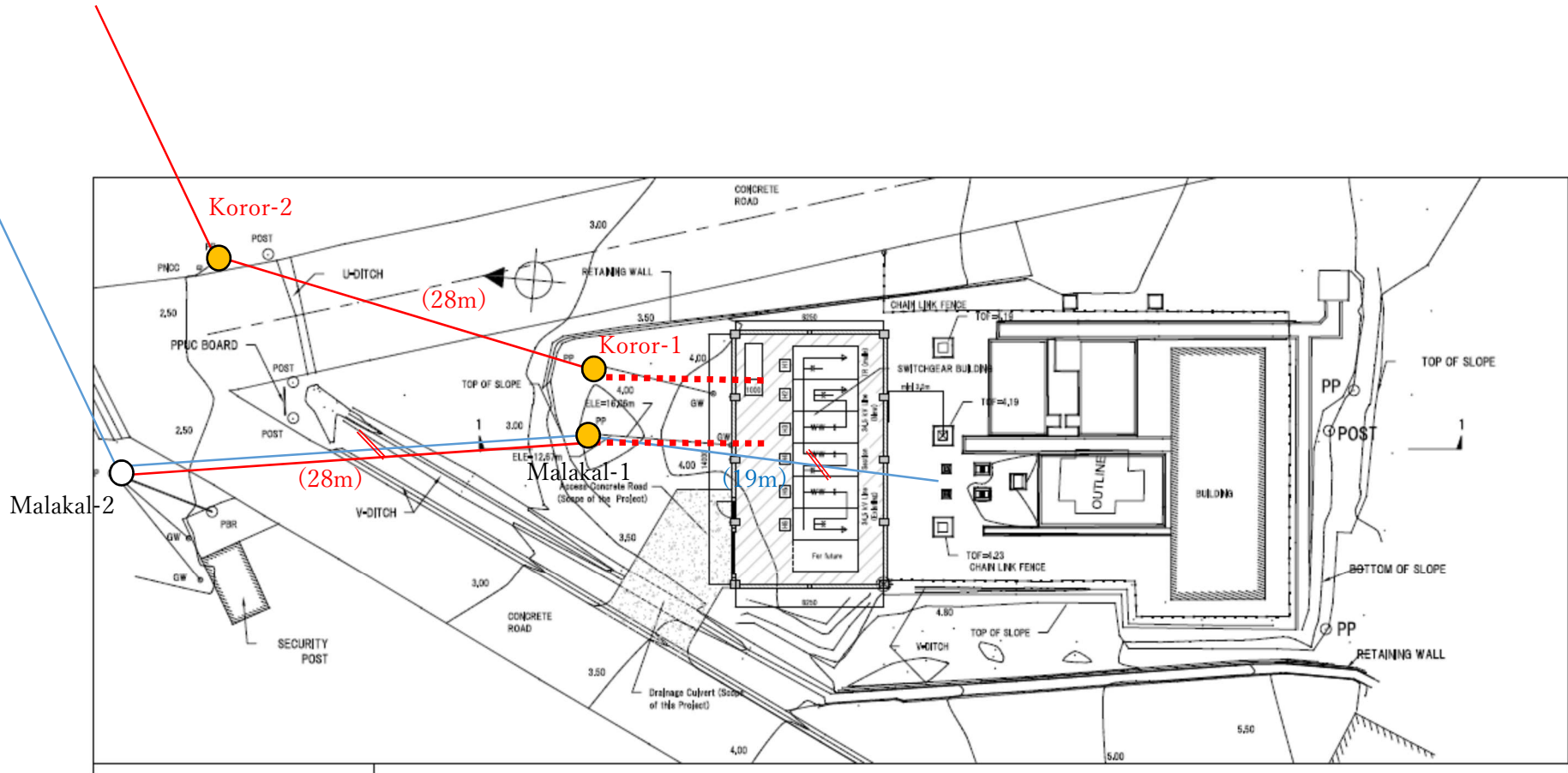

34.5kV Malakal Substation



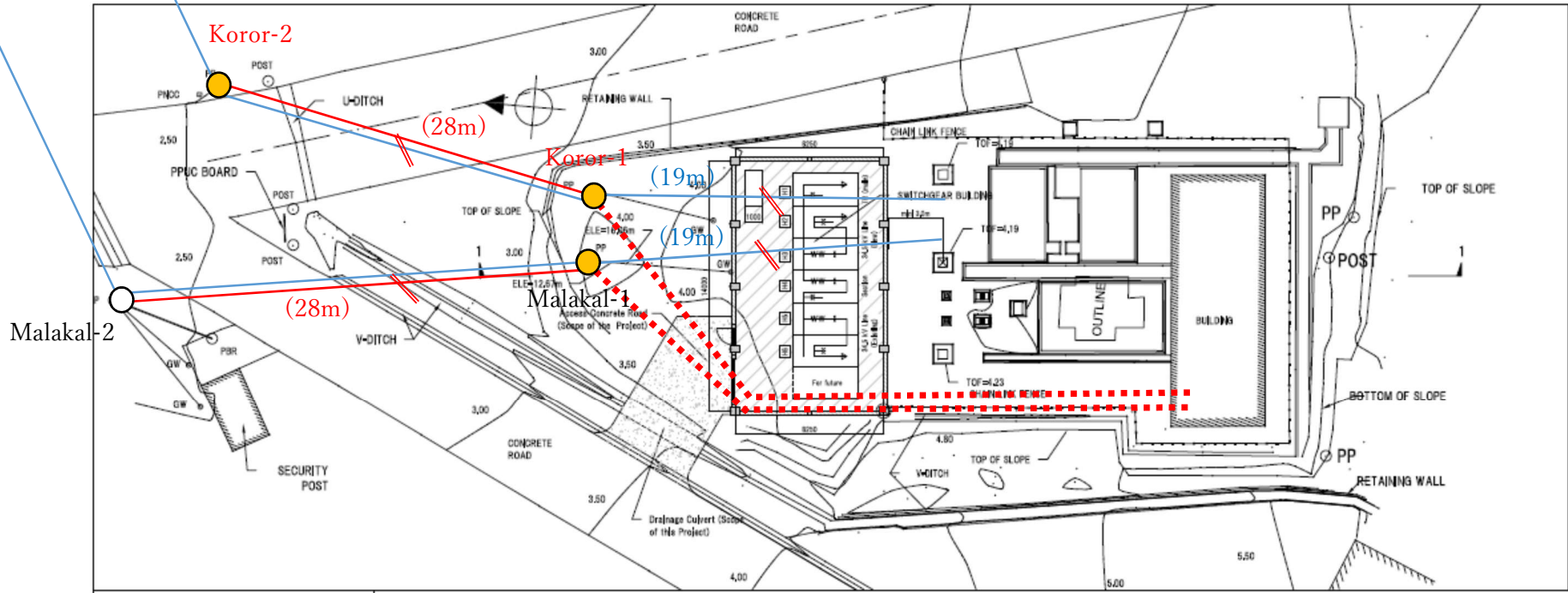

13.8kV Malakal Substation

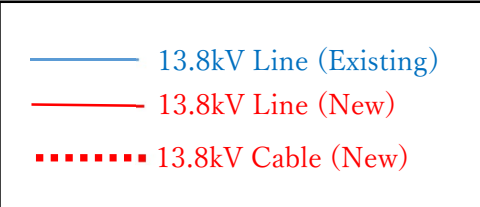

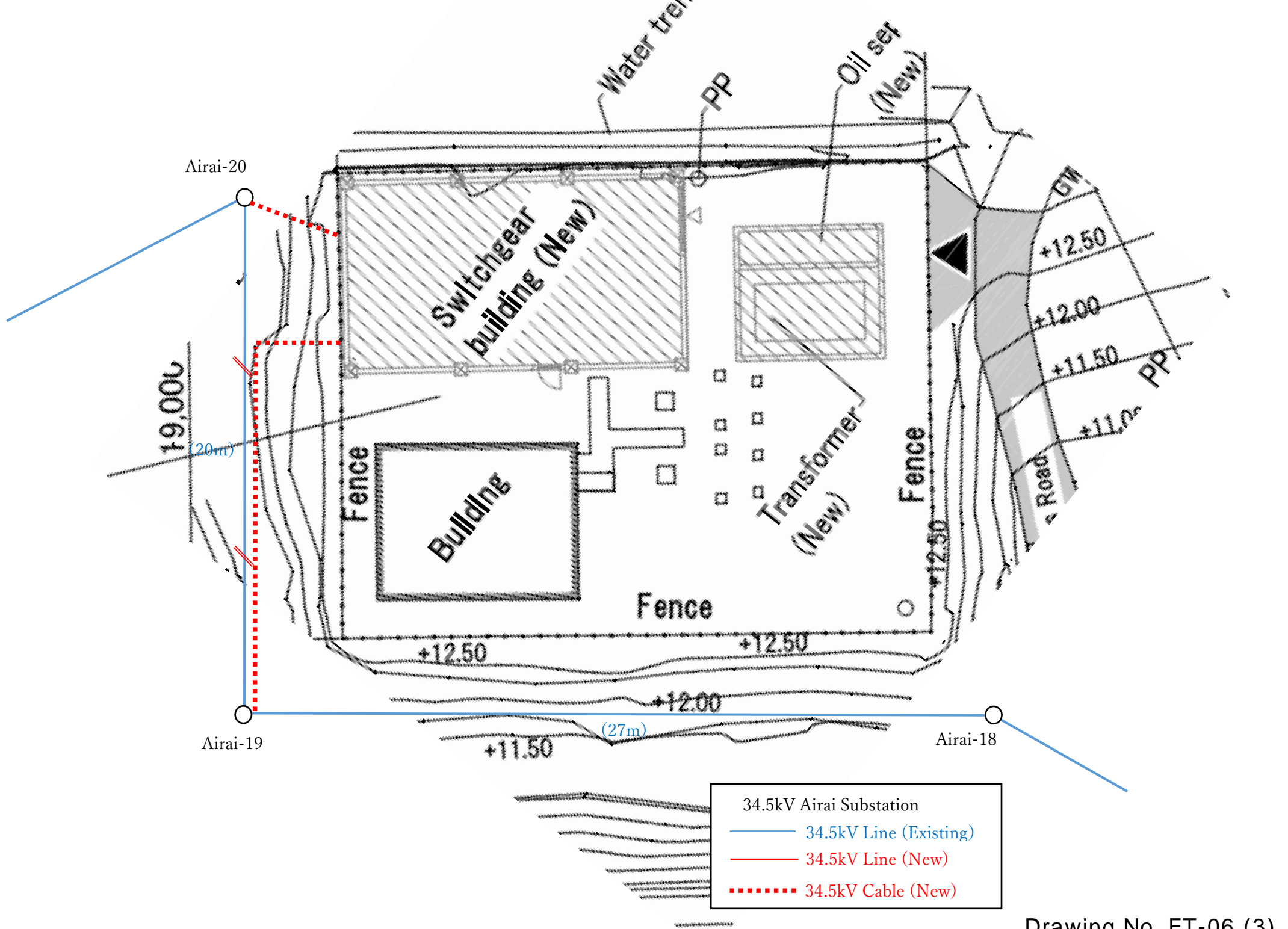

- 34.5kV Airai Substation
- 34.5kV Line (Existing)
- 34.5kV Line (New)
- 34.5kV Cable (New)

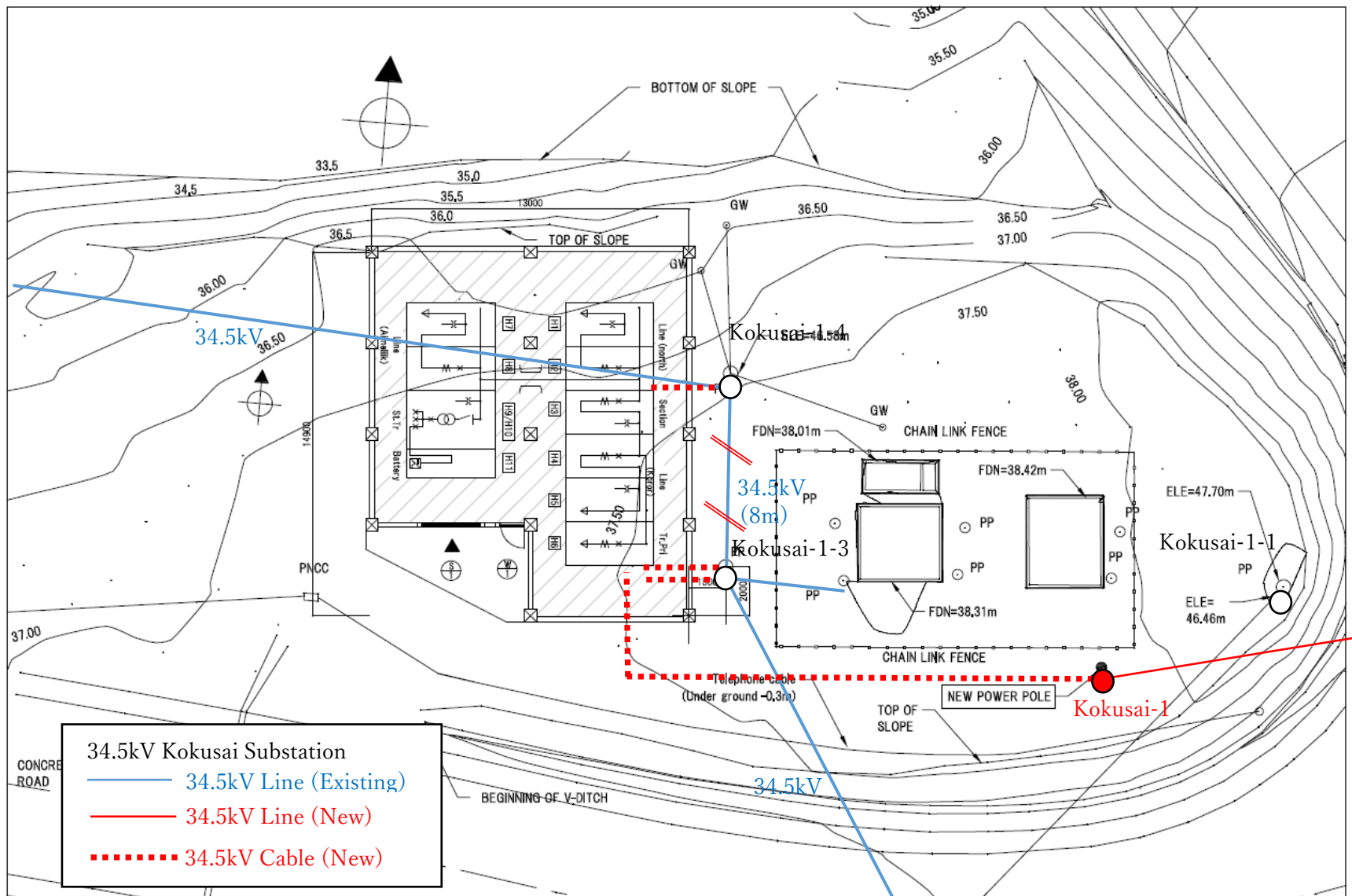

34.5kV Kokusai Substation

- 34.5kV Line (Existing)
- 34.5kV Line (New)
- 34.5kV Cable (New)

Kokusai-1-2

