

5 Minutes of Discussions in Second Field Survey

Minutes of Discussions on the Preparatory Survey for the Project for the Snowdrift Protection on Bishkek-Osh Road (The Second Field Survey)

On the basis of discussion and the First Field Survey in Kyrgyz in October, 2017 and subsequent technical examination in Japan, Japan International Cooperation Agency(hereinafter referred to as "JICA") prepare an Interim Report(hereinafter referred to as "the Report") on the Project for now Drifting Protection on Bishkek-Osh Road (hereinafter referred to as "the Project").

The Preparatory Survey Team (hereinafter referred to as "the Team"), headed by Mr.Seiju IMAI, Senior Representative of JICA Kyrgyz Office, JICA, explained the Report to and consulted with the Government of the Kyrgyz Republic (hereinafter referred to as "GOKR") and the concerned officials of the Ministry of Transport and Roads (hereinafter referred to as "MOTR").

As the result of discussions, both sides confirmed the main items described in the attached sheets.

Bishkek, February 2, 2018



Seiju IMAI
Leader, Preparatory Survey Team
Japan International Cooperation Agency
Japan



Melisbek Alypsatarov
Head, Road Department
Ministry of Transport and Roads
Kyrgyz Republic

ATTACHMENT

1. Description of Minutes of Discussion of the Second Field Survey

The First Field Survey was conducted in October 2017 and Minutes of Discussion of the First Field Survey (hereinafter referred to as "the M/D-1") was signed on 4 October, 2017 as Annex 1. Both sides confirmed that the M/D-1 is still effective unless Minutes of Discussion of the Second Field Survey (hereinafter referred to as "the M/D-2") makes changes from the M/D-1. Description in the MD-2 focuses on necessary points to be added to and/or amended from the M/D-1.

2. Explanation of Interim Report (1)

The Team conducted the 1st Field survey to investigate condition of project sites and collect related information. And the Team compiled the Interim Report (1) and explained to GOKR.

3. Schedule of the Survey

The Team explained the outline of rest of field survey missions and steps for Preparatory Survey as following.

[Outline of field survey mission]

- 1) The Third Field Survey (May/June 2018)
 - To explain the results and analysis of second field survey
 - To collect necessary information for preparing draft outline design and cost estimation of the Project
- 2) Appraisal Mission (Explanation of Draft Outline Design) (November 2018)
 - To explain the contents of Draft Final Report of Preparatory Survey

Annex 1 Minutes of Discussion of the First Field Survey (October 2017)

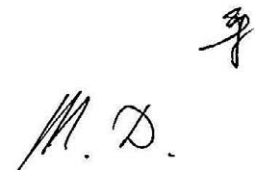

Handwritten signature and initials, possibly 'M. D.', located in the bottom right corner of the page.

Minutes of Discussions
on the Preparatory Survey for the Project for
the Snowdrift Protection on Bishkek-Osh Road

In response to the request from the Government of the Kyrgyz Republic (hereinafter referred to as “the GOKR”), Japan International Cooperation Agency (hereinafter referred to as “JICA”) dispatched the Preparatory Survey Team for the Outline Design (hereinafter referred to as “the Team”) of the Project for the Snowdrift Protection on Bishkek-Osh Road (hereinafter referred to as “the Project”) to the GOKR, headed by Mr. Nobuyuki Tsuneoka, Senior Advisor for Traffic and Transportation of Infrastructure and Peacebuilding Department, from 24 September to 12 October, 2017. The Team held a series of discussions with the officials of the Government of the Kyrgyz Republic and conducted a field survey.

In the course of the discussions, both sides have confirmed the main items described in the attached sheets.

Bishkek, October 4, 2017



Nobuyuki Tsuneoka
Leader, Preparatory Survey Team
Japan International Cooperation Agency
Japan

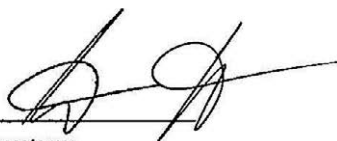

Melisbek Alypsatarov
Head, Road Department
Ministry of Transport and Roads
Kyrgyz Republic



ATTACHMENT

1. Objective of the Project

The objective of the Project is to secure reliable and efficient transportation on Bishkek-Osh Road in winter season through development of snow drifting protection facilities, thereby contributing to revitalizing local economy.

2. Title of the Preparatory Survey

Both sides agreed to change the title of the Project and its Preparatory Survey from "Preparatory Survey for the Project for the Snowdrift Protection on Bishkek-Osh Road" to "Preparatory Survey for the Project for Snow Drifting Protection on Bishkek-Osh Road".

3. Project Site

Both sides confirmed that the site of the Project is in Chuy and Jalal-Abad Oblast, located at 125km to 129km and 216km to 222km of Bishkek-Osh Road, which is shown in Annex 1.

4. Responsible authority for the Project

Both sides confirmed the authorities responsible for the Project are as follows:

- 4-1. The responsible and implementing organization is Ministry of Transport and Roads (hereinafter referred to as "MOTR").
- 4-2. The organization charts of MOTR is shown in Annex 2.

5. Items requested by the Government of the Kyrgyz Republic

- 5-1. According to the Request form of Grant dated on 4th August 2014, both sides confirmed that the items requested by the GOKR are as follows:
 - Blowing-out snow protection fence
 - Retaining Wall
 - Weather Survey
 - Design and supervision
- 5-2. JICA will assess the feasibility of the above requested items through the survey and will report the findings to the Government of Japan. The final scope of the Project will be decided by the Government of Japan.

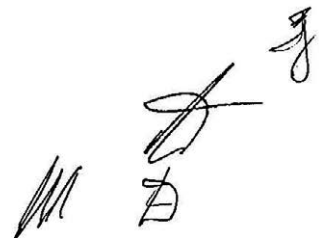

6. Procedures and Basic Principles of Japanese Grant

6-1. The GOKR side agreed that the procedures and basic principles of Japanese Grant as described in Annex 3 and Annex 4 shall be applied to the Project.

As for the monitoring of the implementation of the Project, JICA requires the GOKR side to submit the Project Monitoring Report of which the form is attached as Annex 5.

6-2. The GOKR agreed to take the necessary measures, as described in Annex 6, for smooth implementation of the Project. The contents of the Annex 6 will be elaborated and refined during the Preparatory Survey and be agreed in the mission dispatched for explanation of the Draft Preparatory Survey Report.

The contents of Annex 6 will be updated as the Preparatory Survey progresses, and eventually, will be used as an attachment to the Grant Agreement.

7. Schedule of the Survey

The Team explained the outline of field survey missions and steps for Preparatory Survey as followed and the GOKR side agreed it.

[Outline of field survey mission]

- 1) The First Field Survey Mission (September 2017)
 - To explain the plan of Preparatory Survey and discuss relevant issues with
 - To conduct site visit, investigate condition of project site, and collect related information
- 2) The Second Field Survey (January/February 2018)
 - To explain the results and analysis of first field survey
 - To conduct traffic survey and necessary investigation activities for verifying the site condition in winter season
- 3) The Third Field Survey (May/June 2018)
 - To explain the results and analysis of second field survey
 - To collect necessary information for preparing draft outline design and cost estimation of the Project
- 4) Appraisal Mission (Explanation of Draft Outline Design) (November 2018)
 - To explain the contents of Draft Final Report of Preparatory Survey

[Steps for Preparatory Survey]

7-1. The Team will proceed with further survey in the Kyrgyz Republic until 2nd week of October 2018.

7-2. JICA will prepare the interim report(1) including the results of this survey (first



field survey) and explain it to GOKR side at the timing of next survey in January/February 2018(second field survey).

- 7-3 If the Project is deemed feasible as the result of the first and second field survey, JICA will send a mission team to explain the contents of interim report(2) to the GOKR side in May/June 2018 (third field survey). And the team will continue to conduct the third field survey for outline design and cost estimation until end of June 2018.
- 7-4. JICA will prepare a draft Preparatory Survey Report in Russian and dispatch a mission to Kyrgyzstan in order to explain its contents around November 2018.
- 7-5. If the contents of the draft Preparatory Survey Report is accepted and the undertakings for the Project are fully agreed by the GOKR, JICA will finalize the Preparatory Survey Report and send it to the GOKR around February 2019.
- 7-6. The above schedule is tentative and subject to change.

8. Environmental and Social Considerations

8-1. The GOKR side confirmed to give due environmental and social considerations during implementation, and after completion of the Project, in accordance with the JICA Guidelines for Environmental and Social Considerations (April, 2010) (hereinafter referred to as "the Guidelines").

8-2. The Project is categorized as "B" from the following considerations: The Project is not considered to be a large-scale road disaster prevention project, is not located in a sensitive area, and has none of the sensitive characteristics under the Guidelines, it is not likely to have a significant adverse impact on the environment.

The GOKR side confirmed to conduct the necessary procedures concerning the environmental assessment (including stakeholder meetings, Environmental Impact Assessment (EIA) /Initial Environmental Examination (IEE) and information disclosure, etc.) and make EIA/IEE report of the Project. The EIA/IEE approval shall be received from the responsible authorities and submitted to JICA by October 2018.

8-3. For the Project that will result in involuntary resettlement, the GOKR side confirmed to prepare a Resettlement Action Plan (RAP)/Abbreviated Resettlement Action Plan (ARAP) and make it available to the public. In addition, the GOKR side confirmed to provide the affected people with sufficient compensation and/or support in accordance with RAP/ARAP, which is based on the Guidelines, in a timely manner.



9. Major Undertakings to be taken by the GOKR Side

9-1. The GOKR agreed that the following undertakings should be taken by the GOKR side at the GOKR expenses under the Project if implementation of the Project is approved by the Government of Japan;

- (1) To provide tax exemption for construction materials, equipment, and sub-contractors for the Project.
- (2) The GOKR side agreed that customs duties, internal taxes and other fiscal levies which may be imposed in the GOKR are exempted under mutual agreement of Exchange of Notes (E/N).
- (3) If any expenses stated above are caused by some reasons such as the delay of execution of tax exemption, the GOKR side shall pay for it.
- (4) To secure the lots of land necessary for the implementation of the Project including land for site office, plant yards, material storing yard, motor pool, temporary construction yard and waste disposal site;
- (5) To relocate existing utilities (e.g. snow drifting protection fences) within the Project site if necessary;
- (6) To relocate existing buildings and obstructions if necessary;
- (7) To arrange issuance of license, permission and other necessary procedures for the Project;
- (8) To obtain the royalties/permission for taking raw materials such as stone/rock/filling materials from the quarry/river-bed/borrow pit;
- (9) To conduct traffic controls of existing road for the Project;
- (10) To provide security measures for all concerned working for the Project; and
- (11) To provide utility services for all concerned working for the Project such as electricity and water

10. Sustainable operation and maintenance of the Project

The Team explained the importance of proper operation and maintenance of the Project, including inspection and removal of drifted snow, which is a critical factor for success of the Project. The GOKR side agreed that MOTR, together with relevant DEPs, would establish a Sustainable Operational and Maintenance plan for the Project (hereinafter referred to as "O&M Plan") with assistance of the Survey.

Both sides confirmed that O&M Plan would be reviewed by both sides before dispatching the Team for explanation on Draft Final Report of Preparatory Survey

in November 2018.

The Team explained that any countermeasures against snowdrift should not be able to remove all the risks as it is usual in the case of natural disaster prevention measures. The GOKR side understood the remaining risks and will take care of road users being kept accountable properly.

11. Other Relevant Issues

11-1. Assistance to the Preparatory Survey

The GOKR side shall, at its own expense, provide the Team with the following items in cooperation with other organizations concerned;

- (1) Security-related information as well as measures to ensure the safety of the survey team;
- (2) Counterpart personnel;
- (3) Identification cards if necessary;
- (4) Entry permits necessary for the survey team members to conduct field surveys;
- (5) Permission for the implementation of traffic survey; and
- (6) Supports in obtaining other privileges and benefits, if necessary.

The Team acknowledged that MOTR had provided the consultant team with the office space in MOTR Building.

11-2. Government Ratification of the Project

Both sides confirmed that MOTR side shall take necessary actions to take government ratification of the Project before and after signing of G/A and E/N of the Project.

11-3. Safety Measures

To avoid accidents on site during the implementation of the Project, the GOKR side agreed to cause the consultant and the contractor to enforce safety measures such as setting safety assurance to the site, providing information for security control to public, and deploying adequate security personnel, based on "The Guidance for the Management of Safety for Construction Works in Japanese ODA Projects" which has been published on JICA's URL below.

http://www.jica.go.jp/activities/schemes/oda_safety/ku57pq00001nz4eu-att/guidance_spa.pdf

The Team recommended to the GOKR to explain to the residents about the Project

(necessity and significance, construction period, sites, impact etc.), so that consensus support can be obtained from them for the smooth operation of the Project.

11-4. Misconduct

If JICA receives information related to suspected corrupt or fraudulent practices in the implementation of the Project, MOTR and relevant organizations shall provide JICA with additional such information as JICA may reasonably request, including information related to any concerned official of the government and/or public organizations in the Kyrgyz Republic.

MOTR and relevant organizations shall not, unfairly or unfavorably treat the person(s) and/or company which provided the information related to suspected corrupt or fraudulent practices in the implementation of the Project.

11-5. Questionnaire

The Team, including the consultants, explained and discussed the plan of preparatory survey and requested necessary information. MOTR shall answer to the Questionnaire submitted by the Team in Russian with relevant documents by 10th October 2017.

Annex 1 Project Site

Annex 2 Organization Chart

Annex 3 Japanese Grant

Annex 4 Financial Flow of Japanese Grant

Annex 5 Project Monitoring Report

Annex 6 Major Undertakings to be taken by the Government of the Kyrgyz Republic



Project Location Map
KYRGYZ REPUBLIC

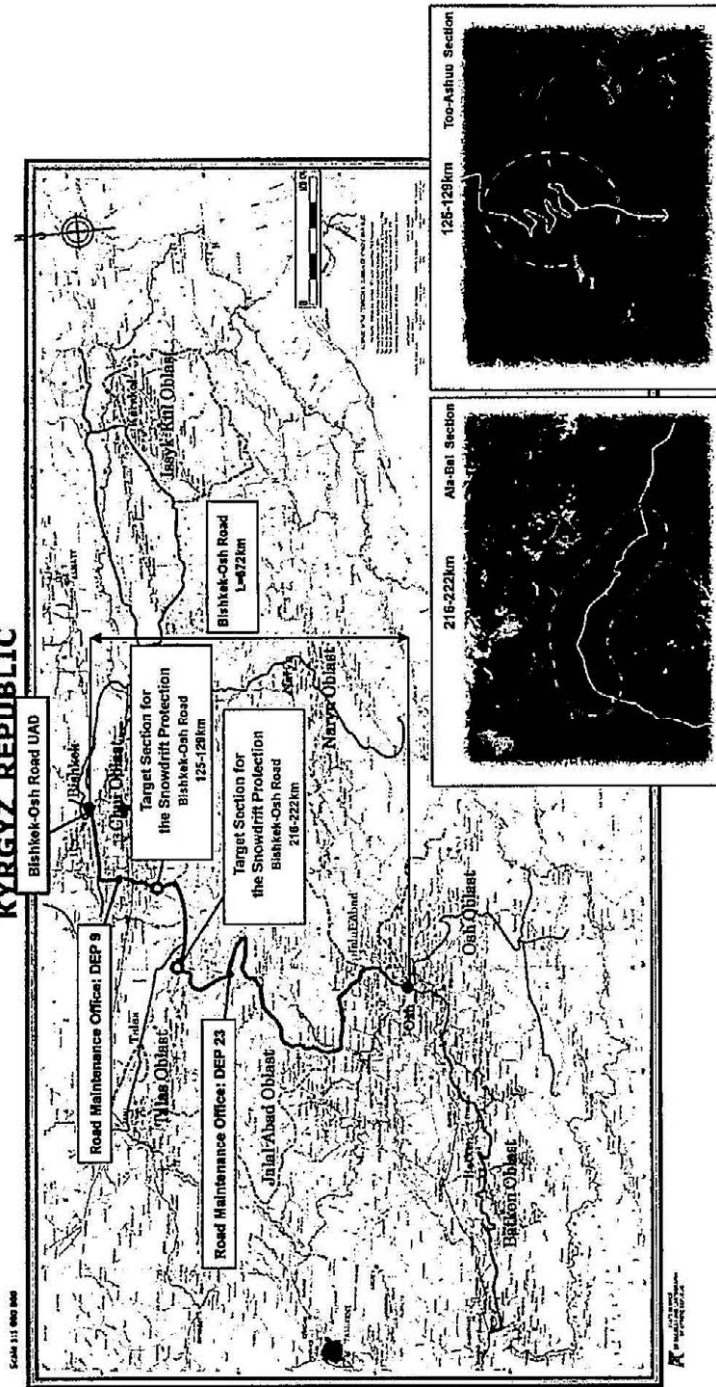

[Handwritten signature]

[Handwritten signature]

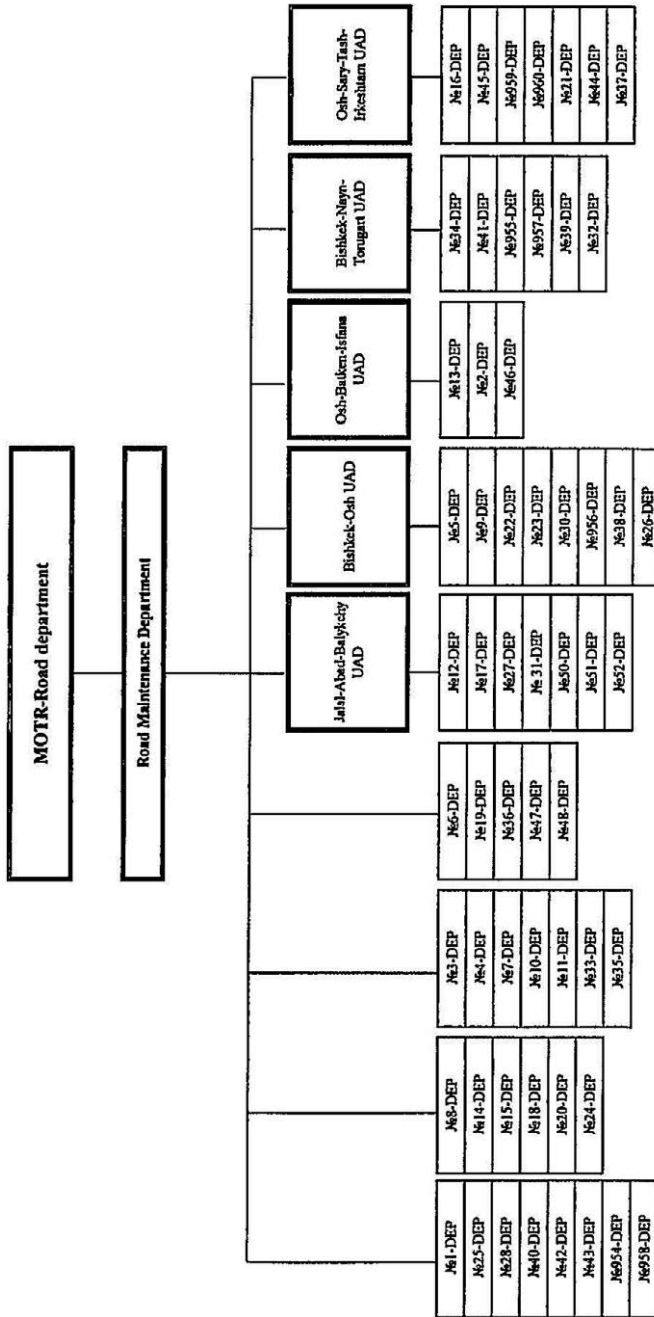

[Handwritten signature]

[Handwritten signature]

JAPANESE GRANT

The Japanese Grant is non-reimbursable fund provided to a recipient country (hereinafter referred to as “the Recipient”) to purchase the products and/or services (engineering services and transportation of the products, etc.) for its economic and social development in accordance with the relevant laws and regulations of Japan. Followings are the basic features of the project grants operated by JICA (hereinafter referred to as “Project Grants”).

1. Procedures of Project Grants

Project Grants are conducted through following procedures (See “PROCEDURES OF JAPANESE GRANT” for details):

- (1) Preparation
 - The Preparatory Survey (hereinafter referred to as “the Survey”) conducted by JICA
- (2) Appraisal
 - Appraisal by the government of Japan (hereinafter referred to as “GOJ”) and JICA, and Approval by the Japanese Cabinet
- (3) Implementation
 - Exchange of Notes
 - The Notes exchanged between the GOJ and the government of the Recipient
 - Grant Agreement (hereinafter referred to as “the G/A”)
 - Agreement concluded between JICA and the Recipient
 - Banking Arrangement (hereinafter referred to as “the B/A”)
 - Opening of bank account by the Recipient in a bank in Japan (hereinafter referred to as “the Bank”) to receive the grant
 - Construction works/procurement
 - Implementation of the project (hereinafter referred to as “the Project”) on the basis of the G/A
- (4) Ex-post Monitoring and Evaluation
 - Monitoring and evaluation at post-implementation stage

2. Preparatory Survey

(1) Contents of the Survey

The aim of the Survey is to provide basic documents necessary for the appraisal of the the Project

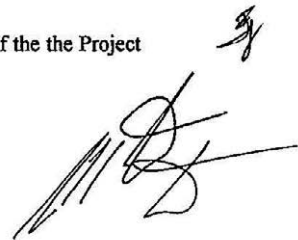

made by the GOJ and JICA. The contents of the Survey are as follows:

- Confirmation of the background, objectives, and benefits of the Project and also institutional capacity of relevant agencies of the Recipient necessary for the implementation of the Project.
- Evaluation of the feasibility of the Project to be implemented under the Japanese Grant from a technical, financial, social and economic point of view.
- Confirmation of items agreed between both parties concerning the basic concept of the Project.
- Preparation of an outline design of the Project.
- Estimation of costs of the Project.
- Confirmation of Environmental and Social Considerations

The contents of the original request by the Recipient are not necessarily approved in their initial form. The Outline Design of the Project is confirmed based on the guidelines of the Japanese Grant.

JICA requests the Recipient to take measures necessary to achieve its self-reliance in the implementation of the Project. Such measures must be guaranteed even though they may fall outside of the jurisdiction of the executing agency of the Project. Therefore, the contents of the Project are confirmed by all relevant organizations of the Recipient based on the Minutes of Discussions.

(2) Selection of Consultants

For smooth implementation of the Survey, JICA contracts with (a) consulting firm(s). JICA selects (a) firm(s) based on proposals submitted by interested firms.

(3) Result of the Survey

JICA reviews the report on the results of the Survey and recommends the GOJ to appraise the implementation of the Project after confirming the feasibility of the Project.

3. Basic Principles of Project Grants

(1) Implementation Stage

1) The E/N and the G/A



After the Project is approved by the Cabinet of Japan, the Exchange of Notes (hereinafter referred to as "the E/N") will be signed between the GOJ and the Government of the Recipient to make a pledge for assistance, which is followed by the conclusion of the G/A between JICA and the Recipient to define the necessary articles, in accordance with the E/N, to implement the Project, such as conditions of disbursement, responsibilities of the Recipient, and procurement conditions. The terms and conditions generally applicable to the Japanese Grant are stipulated in the "General Terms and Conditions for Japanese Grant (January 2016)."

2) Banking Arrangements (B/A) (See "Financial Flow of Japanese Grant (A/P Type)" for details)

- a) The Recipient shall open an account or shall cause its designated authority to open an account under the name of the Recipient in the Bank, in principle. JICA will disburse the Japanese Grant in Japanese yen for the Recipient to cover the obligations incurred by the Recipient under the verified contracts.
- b) The Japanese Grant will be disbursed when payment requests are submitted by the Bank to JICA under an Authorization to Pay (A/P) issued by the Recipient.

3) Procurement Procedure

The products and/or services necessary for the implementation of the Project shall be procured in accordance with JICA's procurement guidelines as stipulated in the G/A.

4) Selection of Consultants

In order to maintain technical consistency, the consulting firm(s) which conducted the Survey will be recommended by JICA to the Recipient to continue to work on the Project's implementation after the E/N and G/A.

5) Eligible source country

In using the Japanese Grant disbursed by JICA for the purchase of products and/or services, the eligible source countries of such products and/or services shall be Japan and/or the Recipient. The Japanese Grant may be used for the purchase of the products and/or services of a third country as eligible, if necessary, taking into account the quality, competitiveness and economic rationality of products and/or services necessary for achieving the objective of the Project. However, the prime contractors, namely, constructing and procurement firms, and the prime consulting firm, which enter into contracts with the Recipient, are limited to "Japanese nationals", in principle.

6) Contracts and Concurrence by JICA

The Recipient will conclude contracts denominated in Japanese yen with Japanese nationals. Those contracts shall be concurred by JICA in order to be verified as eligible for using the Japanese Grant.



7) Monitoring

The Recipient is required to take their initiative to carefully monitor the progress of the Project in order to ensure its smooth implementation as part of their responsibility in the G/A, and to regularly report to JICA about its status by using the Project Monitoring Report (PMR).

8) Safety Measures

The Recipient must ensure that the safety is highly observed during the implementation of the Project.

9) Construction Quality Control Meeting

Construction Quality Control Meeting (hereinafter referred to as the "Meeting") will be held for quality assurance and smooth implementation of the Works at each stage of the Works. The member of the Meeting will be composed by the Recipient (or executing agency), the Consultant, the Contractor and JICA. The functions of the Meeting are as follows:

- a) Sharing information on the objective, concept and conditions of design from the Contractor, before start of construction.
- b) Discussing the issues affecting the Works such as modification of the design, test, inspection, safety control and the Client's obligation, during of construction.

(2) Ex-post Monitoring and Evaluation Stage

1) After the project completion, JICA will continue to keep in close contact with the Recipient in order to monitor that the outputs of the Project is used and maintained properly to attain its expected outcomes.

2) In principle, JICA will conduct ex-post evaluation of the Project after three years from the completion. It is required for the Recipient to furnish any necessary information as JICA may reasonably request.

(3) Others

1) Environmental and Social Considerations

The Recipient shall carefully consider environmental and social impacts by the Project and must comply with the environmental regulations of the Recipient and JICA Guidelines for

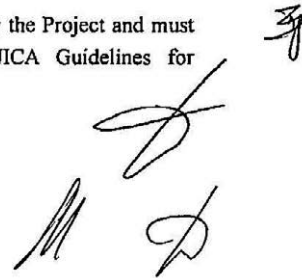

Environmental and Social Considerations (April, 2010).

2) Major undertakings to be taken by the Government of the Recipient

For the smooth and proper implementation of the Project, the Recipient is required to undertake necessary measures including land acquisition, and bear an advising commission of the A/P and payment commissions paid to the Bank as agreed with the GOJ and/or JICA. The Government of the Recipient shall ensure that customs duties, internal taxes and other fiscal levies which may be imposed in the Recipient with respect to the purchase of the Products and/or the Services be exempted or be borne by its designated authority without using the Grant and its accrued interest, since the grant fund comes from the Japanese taxpayers.

3) Proper Use

The Recipient is required to maintain and use properly and effectively the products and/or services under the Project (including the facilities constructed and the equipment purchased), to assign staff necessary for this operation and maintenance and to bear all the expenses other than those covered by the Japanese Grant.

4) Export and Re-export

The products purchased under the Japanese Grant should not be exported or re-exported from the Recipient.

PROCEDURES OF JAPANESE GRANT

Stage	Procedures	Remarks	Recipient Government	Japanese Government	JICA	Consultants	Contractors	Agent Bank
Official Request	Request for grants through diplomatic channel	Request shall be submitted before appraisal stage.	x	x				
1. Preparation	(1) Preparatory Survey Preparation of outline design and cost estimate		x		x	x		
	(2) Preparatory Survey Explanation of draft outline design, including cost estimate, undertakings, etc.		x		x	x		
2. Appraisal	(3) Agreement on conditions for implementation	Conditions will be explained with the draft notes (EN) and Grant Agreement (G/A) which will be signed before approval by Japanese government.	x	x (EN)	x (G/A)			
	(4) Approval by the Japanese cabinet			x				
3. Implementation	(5) Exchange of Notes (EN)		x	x				
	(6) Signing of Grant Agreement (G/A)		x		x			
	(7) Banking Arrangement (B/A)	Need to be informed to JICA	x					x
	(8) Contracting with consultant and issuance of Authorization to Pay (A/P)	Concurrence by JICA is required	x			x		x
	(9) Detail design (D/D)		x			x		
	(10) Preparation of bidding documents	Concurrence by JICA is required	x			x		
	(11) Bidding	Concurrence by JICA is required	x			x	x	
	(12) Contracting with contractor/supplier and issuance of A/P	Concurrence by JICA is required	x				x	x
	(13) Construction works/procurement	Concurrence by JICA is required for major modification of design and amendment of contracts.	x			x	x	
	(14) Completion certificate		x			x	x	
4. Ex-post monitoring & evaluation	(15) Ex-post monitoring	To be implemented generally after 1, 3, 10 years of completion, subject to change.	x		x			
	(16) Ex-post evaluation	To be implemented basically after 3 years of completion	x		x			

notes:

1. Project Monitoring Report and Report for Project Completion shall be submitted to JICA as agreed in the G/A.
2. Concurrence by JICA is required for allocation of grant for remaining amount and/or contingencies as agreed in the G/A.

Financial Flow of Japanese Grant (A/P Type)

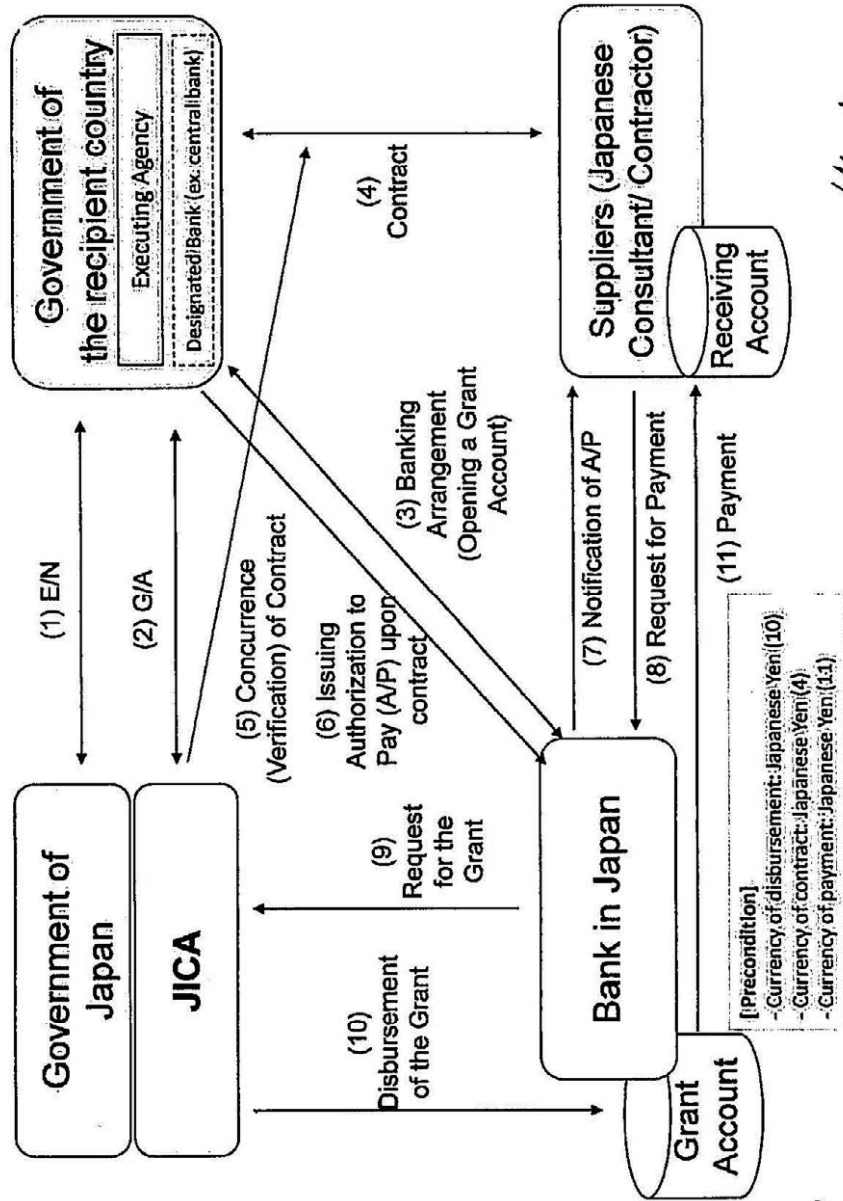

[Handwritten signature]

[Handwritten signature]

Project Monitoring Report
on
Project for Snow Drifting Protection on Bishkek-Osh Road
Grant Agreement No. XXXXXXXX
 20XX, Month

Organizational Information

Signer of the G/A (Recipient)	Person in Charge (Designation) _____ Contacts Address: _____ Phone/FAX: _____ Email: _____
Executing Agency	Person in Charge (Designation) _____ Contacts Address: _____ Phone/FAX: _____ Email: _____
Line Ministry	Person in Charge (Designation) _____ Contacts Address: _____ Phone/FAX: _____ Email: _____

General Information:

Project Title	
E/N	Signed date: Duration:
G/A	Signed date: Duration:
Source of Finance	Government of Japan: Not exceeding JPY _____ mil. Government of (_____): _____

1: Project Description

1-1 Project Objective

--

1-2 Project Rationale

- Higher-level objectives to which the project contributes (national/regional/sectoral policies and strategies)
- Situation of the target groups to which the project addresses

--

1-3 Indicators for measurement of "Effectiveness"

Quantitative indicators to measure the attainment of project objectives		
Indicators	Original (Yr)	Target (Yr)
Qualitative indicators to measure the attainment of project objectives		

2: Details of the Project

2-1 Location

Components	Original <i>(proposed in the outline design)</i>	Actual
1.		

2-2 Scope of the work

Components	Original* <i>(proposed in the outline design)</i>	Actual*
1.		

Reasons for modification of scope (if any).

(PMR)

2-3 Implementation Schedule

Items	Original		Actual
	<i>(proposed in the outline design)</i>	<i>(at the time of signing the Grant Agreement)</i>	

Reasons for any changes of the schedule, and their effects on the project (if any)

--

2-4 Obligations by the Recipient

2-4-1 Progress of Specific Obligations
 See Attachment 2.

2-4-2 Activities
 See Attachment 3.

2-4-3 Report on RD
 See Attachment 11.

2-5 Project Cost

2-5-1 Cost borne by the Grant (Confidential until the Bidding)

Components			Cost (Million Yen)	
	Original <i>(proposed in the outline design)</i>	Actual <i>(in case of any modification)</i>	Original ^{1),2)} <i>(proposed in the outline design)</i>	Actual
1.				
Total				

Note: 1) Date of estimation:
 2) Exchange rate: 1 US Dollar = Yen

2-5-2 Cost borne by the Recipient

Components			Cost (1,000 Taka)	
	Original <i>(proposed in the outline design)</i>	Actual <i>(in case of any modification)</i>	Original ^{1),2)} <i>(proposed in the outline design)</i>	Actual
1.				

Note: 1) Date of estimation:
2) Exchange rate: 1 US Dollar =

Reasons for the remarkable gaps between the original and actual cost, and the countermeasures (if any)

(PMR)

2-6 Executing Agency

- Organization's role, financial position, capacity, cost recovery etc,
- Organization Chart including the unit in charge of the implementation and number of employees.

Original (at the time of outline design) name: role: financial situation: institutional and organizational arrangement (organogram): human resources (number and ability of staff):
Actual (PMR)

2-7 Environmental and Social Impacts

- The results of environmental monitoring based on Attachment 5 (in accordance with Schedule 4 of the Grant Agreement).
- The results of social monitoring based on in Attachment 5 (in accordance with Schedule 4 of the Grant Agreement).
- Disclosed information related to results of environmental and social monitoring to local stakeholders (whenever applicable).

3: Operation and Maintenance (O&M)

3-1 Physical Arrangement

- Plan for O&M (number and skills of the staff in the responsible division or section, availability of manuals and guidelines, availability of spareparts, etc.)

Original (at the time of outline design)
Actual (PMR)

3-2 Budgetary Arrangement

- Required O&M cost and actual budget allocation for O&M

Original (at the time of outline design)

Actual (PMR)

4: Potential Risks and Mitigation Measures

- Potential risks which may affect the project implementation, attainment of objectives, sustainability
- Mitigation measures corresponding to the potential risks

Assessment of Potential Risks (at the time of outline design)

Potential Risks	Assessment
1. (Description of Risk)	Probability: High/Moderate/Low
	Impact: High/Moderate/Low
	Analysis of Probability and Impact:
	Mitigation Measures:
	Action required during the implementation stage:
2. (Description of Risk)	Probability: High/Moderate/Low
	Impact: High/Moderate/Low
	Analysis of Probability and Impact:
	Mitigation Measures:
	Action required during the implementation stage:
3. (Description of Risk)	Probability: High/Moderate/Low
	Impact: High/Moderate/Low
	Analysis of Probability and Impact:
	Mitigation Measures:
	Action required during the implementation stage:

	Contingency Plan (if applicable):
Actual Situation and Countermeasures (PMR)	

5: Evaluation and Monitoring Plan (after the work completion)

5-1 Overall evaluation

Please describe your overall evaluation on the project.

5-2 Lessons Learnt and Recommendations

Please raise any lessons learned from the project experience, which might be valuable for the future assistance or similar type of projects, as well as any recommendations, which might be beneficial for better realization of the project effect, impact and assurance of sustainability.

5-3 Monitoring Plan of the Indicators for Post-Evaluation

Please describe monitoring methods, section(s)/department(s) in charge of monitoring, frequency, the term to monitor the indicators stipulated in 1-3.



Attachment

1. Project Location Map
2. Specific obligations of the Recipient which will not be funded with the Grant
3. Monthly Report submitted by the Consultant
- Appendix - Photocopy of Contractor's Progress Report (if any)
 - Consultant Member List
 - Contractor's Main Staff List
4. Check list for the Contract (including Record of Amendment of the Contract/Agreement and Schedule of Payment)
5. Environmental Monitoring Form / Social Monitoring Form
6. Monitoring sheet on price of specified materials (Quarterly)
7. Report on Proportion of Procurement (Recipient Country, Japan and Third Countries) (PMR (final) only)
8. Pictures (by JPEG style by CD-R) (PMR (final) only)
9. Equipment List (PMR (final) only)
10. Drawing (PMR (final) only)
11. Report on RD (After project)



7



Monitoring sheet on price of specified materials

1. Initial Conditions (Confirmed)

Items of Specified Materials	Initial Volume A	Initial Unit Price (¥) B	Initial Total Price C=A×B	1% of Contract Price D	Condition of Payment Price (Decreased) E=C-D	Condition of Payment Price (Increased) F=C+D
Item 1	●●t	●	●●	●	●	●
Item 2	●●t	●	●●	●		
Item 3						
Item 4						
Item 5						

2. Monitoring of the Unit Price of Specified Materials

(1) Method of Monitoring : ●●

(2) Result of the Monitoring Survey on Unit Price for each specified materials

Items of Specified Materials	1st month, 2015	2nd month, 2015	3rd month, 2015	4th	5th	6th
Item 1	●	●	●			
Item 2						
Item 3						
Item 4						
Item 5						

(3) Summary of Discussion with Contractor (if necessary)

...

Handwritten signatures and initials, including a large signature that appears to be 'M & S' and another signature above it.

Report on Proportion of Procurement (Recipient Country, Japan and Third Countries)
 (Actual Expenditure by Construction and Equipment each)

	Domestic Procurement (Recipient Country) A	Foreign Procurement (Japan) B	Foreign Procurement (Third Countries) C	Total D
Construction Cost	(A/D%)	(B/D%)	(C/D%)	
Direct Construction Cost	(A/D%)	(B/D%)	(C/D%)	
others	(A/D%)	(B/D%)	(C/D%)	
Equipment Cost	(A/D%)	(B/D%)	(C/D%)	
Design and Supervision Cost	(A/D%)	(B/D%)	(C/D%)	
Total	(A/D%)	(B/D%)	(C/D%)	

Major Undertakings to be taken by the Government of the Kyrgyz Republic

1. Before the Tender

NO	Items	Deadline	In charge	Cost	Ref.
1	To open Bank Account (Banking Arrangement (B/A))	within 1 month after G/A	MOTR		
2	To issue A/P to a bank in Japan (the Agent Bank) for the payment to the consultant	within 1 month after G/A	MOTR		
3	To approve the operational and maintenance plan for the Project with budgetary request	before start of the construction	MOTR		
4	To secure the following lands 1) right of way for the Project location 2) temporary construction yard and stockyard near the Project area 3) borrow pit and disposal site near the Project area	before notice of the tender document	MOTR		
5	To clear, level and reclaim the following sites 1) remove utilities 2) existing facilities	before notice of the tender document	MOTR		
6	To obtain the planning, zoning, building permit	before notice of the tender document	MOTR		
7	To submit the result of DD	end of DD	MOTR		

2. During the Project Implementation

NO	Items	Deadline	In charge	Cost	Ref.
1	To bear the following commissions to a bank of Japan for the banking services based upon the B/A				
	1) Advising commission of A/P	within 1 month after the signing of the contract	MOTR		
	2) Payment commission for A/P	every payment	MOTR		
2	To ensure prompt unloading and customs clearance at the port of disembarkation in recipient country				
	1) Tax exemption and customs clearance of the products at the port of disembarkation	during the Project	MOTR		
	2) Internal transportation from the port of disembarkation to the project site	during the Project	MOTR		
3	To accord Japanese nationals and/or physical persons of third countries whose services may be required in connection with the supply of the products and the services under the verified contract such facilities as may be necessary for their entry into the recipient country and stay therein for the performance of their work	during the Project	MOTR		
4	To ensure that customs duties, internal taxes and other fiscal levies which may be imposed in the country of the Recipient with respect to the purchase of the Products and/or the Services be exempted; Such customs duties, internal taxes and other fiscal levies mentioned above include VAT, commercial tax, income tax and corporate tax of Japanese nationals, resident tax, fuel tax, but not	during the Project	MOTR		

	limited, which may be imposed in the recipient country with respect to the supply of the products and services under the verified contract				
5	To bear all the expenses, other than those to be borne by the Grant Aid, necessary for construction of the facilities as well as for the transportation and installation of the equipment	during the Project	MOTR		
6	To submit Project Monitoring Report.	every month	MOTR		
7	To implement EMP and EMoP	during the construction	MOTR		
8	To submit results of environmental monitoring to JICA, by using the monitoring form, on a quarterly basis as a part of Project Monitoring Report	during the construction	MOTR		
9	To implement social monitoring, and to submit the monitoring results to JICA, by using the monitoring form, on a quarterly basis as a part of Project Monitoring Report	- for two years after land acquisition complete	MOTR		

3. After the Project

NO	Items	Deadline	In charge	Cost	Ref.
1	To maintain and use properly and effectively the facilities constructed and equipment provided under the Grant Aid 1) Allocation of maintenance cost 2) Operation and maintenance structure 3) Routine check/Periodic inspection	After completion of the construction	MOTR		
2	To implement EMP and EMoP	for a period based on EMP and EMoP	MOTR		
3	To submit results of environmental monitoring to JICA, by using the monitoring form, semiannually - The period of environmental monitoring may be extended if any significant negative impacts on the environment are found. The extension of environmental monitoring will be decided based on the agreement between MOTR and JICA.	for three years after the Project	MOTR		

(B/A: Banking Arrangement, A/P: Authorization to pay, N/A: Not Applicable)

6 Minutes of Discussions in Fourth Field Survey

**Minutes of Discussions
on the Preparatory Survey for the Project for
Snow Drifting Protection on Bishkek-Osh Road
(Explanation on Draft Preparatory Survey Report)**

On the basis of the discussions and first field survey on the Project for the Snow Drifting Protection on Bishkek-Osh Road (hereinafter referred to as “the Project”) in Kyrgyz Republic (hereinafter referred to as “Kyrgyz”) in October, 2017; the second field survey and explanation and discussions based on the Interim Report in February, 2018; the third field survey in August, 2018, and subsequent technical examination in Japan, the Japan International Cooperation Agency (hereinafter referred to as “JICA”) dispatched a Preparatory Survey Team (hereinafter referred to as “the Team”), headed by Kenshiro Tanaka, the senior deputy director of Team 1 from the Transport and ICT Group, part of the Infrastructure and Peacebuilding Department of JICA, from November 25 to December 1, 2018 for explanation of Draft Preparatory Survey Report (hereinafter referred to as the “Draft Report”) and held a series of discussions on the Project with the officials of the Government of Kyrgyz Republic (hereinafter referred to as the “GOKR”).

As a result of the discussions, both sides agreed on the main items described in the attached sheets.

Bishkek, November 29, 2018

Kenshiro TANAKA
Leader
Preparatory Survey Team
Japan International Cooperation Agency
(JICA)

Azimkan JUSUBALIEV
Deputy Minister
Ministry of Transport and Roads
Kyrgyz Republic



ATTACHEMENT

1. Objective of the Project
The objective of the Project is to secure reliable and efficient transportation on Bishkek-Osh Road in winter season through development of snow drifting protection facilities, thereby contributing to revitalizing local economy.
2. Title of the Preparatory Survey
Both sides confirmed the title of the Preparatory Survey as "the Preparatory Survey for the Project for Snow Drifting Protection on Bishkek-Osh Road".
3. Project sites
Both sides confirmed that the sites of the Project are in Chuy and Talas Oblast, Located at 125KP to 129KP and 216KP to 222KP of Bishkek-Osh Road, which is shown in Annex 1.
4. Responsible Ministry for the Project
Both sides confirmed a responsible and executing ministry for the Project are as follows:
 - 4-1. The responsible and executing ministry is Ministry of Transport and Roads (hereinafter referred to as "MOTR").
 - 4-2. The executing department in MOTR is Road department. It shall coordinate with all the relevant organizations to ensure smooth implementation of the Project and ensure that the undertakings shall be taken by relevant ministries properly and on time.
5. Contents of the Draft Report
After the explanation of the contents of the Draft Report by the Team, the GOKR side agreed to its contents.
6. Cost estimate
Both sides confirmed that the cost estimate explained by the Team is provisional and will be examined further by the Government of Japan for its approval.
Both sides also confirmed that the cost estimate including the contingency explained by the Team is provisional and will be examined further by the Government of Japan for its approval. The contingency would cover the additional

12/17

HL

cost against natural disaster, unexpected natural conditions, etc.

7. Confidentiality of the cost estimate and technical specifications

Both sides confirmed that the cost estimate in Annex 3 should never be disclosed to any third parties until all the contracts under the Project are concluded.

8. Procedures and Basic Principles of Japanese Grant

The GOKR side agreed that the procedures and basic principles of Japanese Grant as described in Annex 4 shall be applied to the Project. In addition, the GOKR side agreed to take necessary measures according to the procedures.

9. Timeline for the project implementation

The Team explained to the GOKR side that the expected timeline for the project implementation is as attached in Annex 5.

10. Expected outcomes and indicators

Both sides agreed that key indicators for expected outcomes are as follows. The GOKR side will be responsible for the achievement of agreed key indicators targeted in year 2024 and shall monitor the progress based on those indicators.

[Quantitative indicators]

Indicators	Current Value (2018)* ¹	Design Value (2024)* ² [3 years after completion of the Project]
Snow removal work at the time of snow drifting (hour x machine number / time)	a: 51.5	a: 33.5
	b: 74.0	b: 37.8
Traffic difficulty hour at the time of snow drifting (hour / time)	a: 7.25	a: 4.72
	b: 12.33	b: 6.30

*1: The current value is the average value for four winter seasons (from October to April, 2014-2018)

*2: The design value is the average value for three winter seasons (from October to April, 2021-2023)

a: KP 125-129, b: KP216-222

The design value was calculated from the reduction effect of the snowdrift speed on the route before and after installing the snow protection fences which were obtained

from the numerical simulation of snowstorm / snowdrift.

[Qualitative indicators]

- Improvement of safe and smooth winter traffic
- Promotion of utilization of winter traffic

11. Undertakings of the Project

Both sides confirmed the undertakings of the Project as described in Annex 6. With regard to exemption of customs duties, internal taxes and other fiscal levies as stipulated in (2)-3 of Annex 6, both sides confirmed that such customs duties, internal taxes and other fiscal levies, which shall be clarified in the bid documents by MOTR during the implementation stage of the Project.

The GOKR side assured to take the necessary measures and coordination including allocation of the necessary budget which are preconditions of implementation of the Project. It is further agreed that the costs are indicative, i.e. at Outline Design level. More accurate costs will be calculated at the Detailed Design stage.

Both sides also confirmed that the Annex 6 will be used as an attachment of G/A.

12. Monitoring during the implementation

The Project will be monitored by the Executing Agency and reported to JICA by using the form of Project Monitoring Report (PMR) attached as Annex 7. The timing of submission of the PMR is described in Annex 7.

13. Project completion

Both sides confirmed that the project completes when all the facilities installed and equipment procured by the grant are in operation. The completion of the Project will be reported to JICA promptly, but in any event not later than six months after completion of the Project.

14. Ex-Post Evaluation

JICA will conduct ex-post evaluation after three (3) years from the project completion, in principle, with respect to five evaluation criteria (Relevance, Effectiveness, Efficiency, Impact, Sustainability). The result of the evaluation will be publicized. The GOKR side is required to provide necessary support for the data collection.

15. Schedule of the Study

12/19

ALL

JICA will finalize the Preparatory Survey Report based on the confirmed items. The report will be sent to the GOKR side around April 2019.

16. Environmental and Social Considerations

16-1 General Issues

16-1-1 Environmental Guidelines and Environmental Category

The Team explained that 'JICA Guidelines for Environmental and Social Considerations (April 2010)' (hereinafter referred to as "the Guidelines") is applicable for the Project. The Project is categorized as C because the Project is likely to have minimal adverse impact on the environment under the Guidelines.

16-2 Environmental Issues

16-2-1 Environmental Impact Assessment (EIA)

Both sides confirmed the EIA report has been approved by State Agency for Environmental Protection and Forestry in November 2018.

17. Other Relevant Issues

17-1 Disclosure of Information

Both sides confirmed that the Preparatory Survey Report from which project cost is excluded will be disclosed to the public after completion of the Preparatory Survey. The comprehensive report including the project cost will be disclosed to the public after all the contracts under the Project are concluded.

17-2 Safety Measures

To avoid accidents on site during the implementation of the Project, the GOKR side agreed to cause the consultant and the contractor to enforce safety measures such as setting safety assurance to the site, providing information for security control to public, and deploying adequate security personnel.

17-3. Operation and Maintenance of the Facilities

The team explained the importance of operation and maintenance of the facilities installed by the Project considering that proper operation and maintenance impacts greatly effects. The GOKR side shall secure enough staff for appropriate operation and maintenance of the facilities.

12/17

HL

- Annex 1 Project Site
- Annex 2 Organization Chart
- Annex 3 Project Cost Estimation
- Annex 4 Japanese Grant (including attachment 1,2)
- Annex 5 Project Implementation Schedule
- Annex 6 Major Undertakings to be taken by the Government of Kyrgyz Republic
- Annex 7 Project Monitoring Report (template)
- Annex 8 Tax Refund and Exemption Procedure

田中

山本

AMP

Project Site

KYRGYZ REPUBLIC

Scale 1:1,000,000

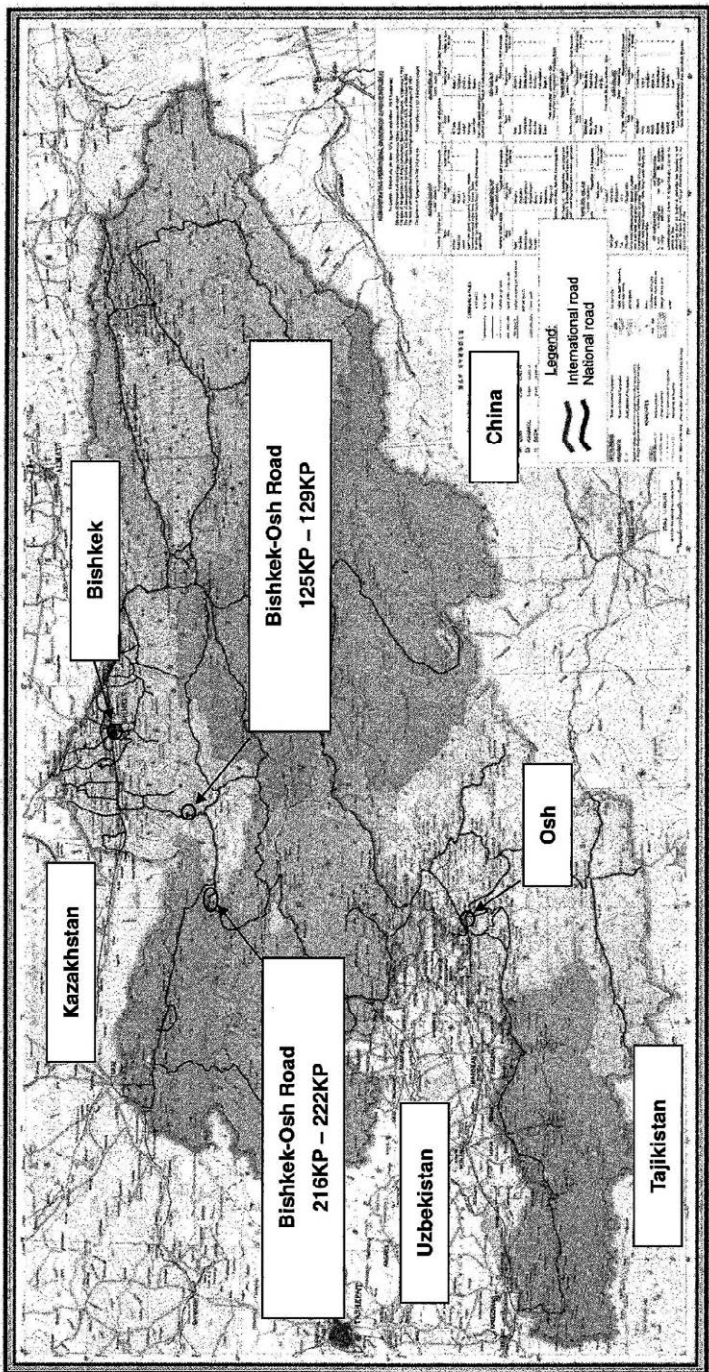

JHL

17/11

Organization Chart

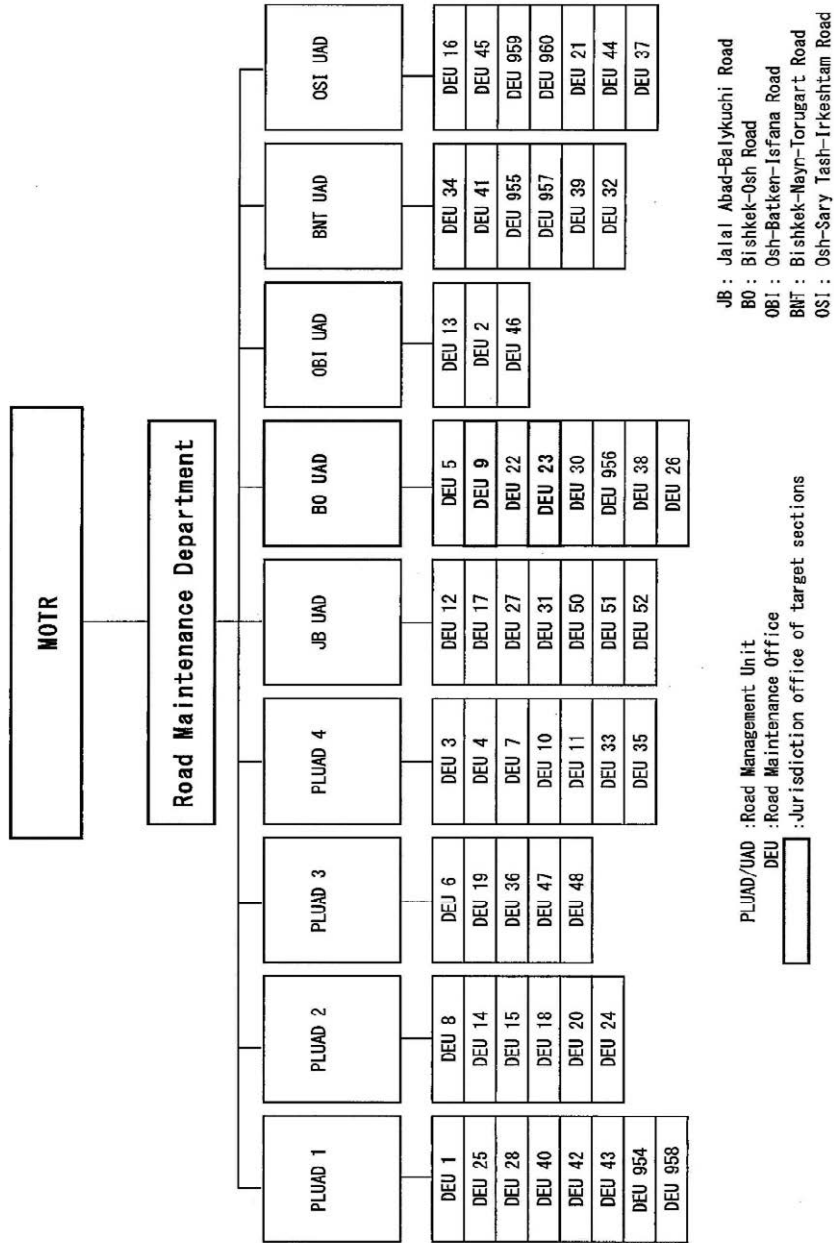

HL

CONFIDENTIAL

(1) Cost borne by the Government of Japan

Undisclosed until completion of the contract of the construction

(2) Cost borne by the Government of Kyrgyz Republic

Total : USD 5,154

- Bank Charge : USD 4,143
- Removal of Existing Snow Fences : USD 1,011

(3) Cost Estimation Condition

- Estimated timing : June 2018
- Exchange rates : USD 1.00 = JPY 108.75

(4) Others

The project is implemented in accordance with the system of Japan's Grant Aid. The above cost estimation does not assure the ceiling cost on the E/N and shall be reviewed by the Government of Japan before signing of the E/N between the two Governments. Cost borne by the Government of Kyrgyz Republic is also provisional and will be assured according to progress of the Project.

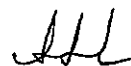

JAPANESE GRANT

The Japanese Grant is non-reimbursable fund provided to a recipient country (hereinafter referred to as "the Recipient") to purchase the products and/or services (engineering services and transportation of the products, etc.) for its economic and social development in accordance with the relevant laws and regulations of Japan. Followings are the basic features of the project grants operated by JICA (hereinafter referred to as "Project Grants").

1. Procedures of Project Grants

Project Grants are conducted through following procedures (See "PROCEDURES OF JAPANESE GRANT" for details):

- (1) Preparation
 - The Preparatory Survey (hereinafter referred to as "the Survey") conducted by JICA
- (2) Appraisal
 - Appraisal by the government of Japan (hereinafter referred to as "GOJ") and JICA, and Approval by the Japanese Cabinet
- (3) Implementation
 - Exchange of Notes
 - The Notes exchanged between the GOJ and the government of the Recipient
 - Grant Agreement (hereinafter referred to as "the G/A")
 - Agreement concluded between JICA and the Recipient
 - Banking Arrangement (hereinafter referred to as "the B/A")
 - Opening of bank account by the Recipient in a bank in Japan (hereinafter referred to as "the Bank") to receive the grant
 - Construction works/procurement
 - Implementation of the project (hereinafter referred to as "the Project") on the basis of the G/A
- (4) Ex-post Monitoring and Evaluation
 - Monitoring and evaluation at post-implementation stage

2. Preparatory Survey

(1) Contents of the Survey

The aim of the Survey is to provide basic documents necessary for the appraisal of the the Project made by the GOJ and JICA. The contents of the Survey are as follows:

- Confirmation of the background, objectives, and benefits of the Project and also institutional capacity of relevant agencies of the Recipient necessary for the implementation of the Project.

- Evaluation of the feasibility of the Project to be implemented under the Japanese Grant from a technical, financial, social and economic point of view.
- Confirmation of items agreed between both parties concerning the basic concept of the Project.
- Preparation of an outline design of the Project.
- Estimation of costs of the Project.
- Confirmation of Environmental and Social Considerations

The contents of the original request by the Recipient are not necessarily approved in their initial form. The Outline Design of the Project is confirmed based on the guidelines of the Japanese Grant.

JICA requests the Recipient to take measures necessary to achieve its self-reliance in the implementation of the Project. Such measures must be guaranteed even though they may fall outside of the jurisdiction of the executing agency of the Project. Therefore, the contents of the Project are confirmed by all relevant organizations of the Recipient based on the Minutes of Discussions.

(2) Selection of Consultants

For smooth implementation of the Survey, JICA contracts with (a) consulting firm(s). JICA selects (a) firm(s) based on proposals submitted by interested firms.

(3) Result of the Survey

JICA reviews the report on the results of the Survey and recommends the GOJ to appraise the implementation of the Project after confirming the feasibility of the Project.

3. Basic Principles of Project Grants

(1) Implementation Stage

1) The E/N and the G/A

After the Project is approved by the Cabinet of Japan, the Exchange of Notes (hereinafter referred to as "the E/N") will be signed between the GOJ and the Government of the Recipient to make a pledge for assistance, which is followed by the conclusion of the G/A between JICA and the Recipient to define the necessary articles, in accordance with the E/N, to implement the Project, such as conditions of disbursement, responsibilities of the Recipient, and procurement conditions. The terms and conditions generally applicable to the Japanese Grant are stipulated in the "General Terms and Conditions for Japanese Grant (January 2016)."

2) Banking Arrangements (B/A) (See "Financial Flow of Japanese Grant (A/P Type)" for details)

a) The Recipient shall open an account or shall cause its designated authority to open an account under the name of the Recipient in the Bank, in principle. JICA will disburse the Japanese Grant in Japanese yen for the Recipient to cover the obligations incurred by the Recipient under the verified contracts.

b) The Japanese Grant will be disbursed when payment requests are submitted by the Bank to JICA under an Authorization to Pay (A/P) issued by the Recipient.

3) Procurement Procedure

The products and/or services necessary for the implementation of the Project shall be procured in accordance with JICA's procurement guidelines as stipulated in the G/A.

4) Selection of Consultants

In order to maintain technical consistency, the consulting firm(s) which conducted the Survey will be recommended by JICA to the Recipient to continue to work on the Project's implementation after the E/N and G/A.

5) Eligible source country

In using the Japanese Grant disbursed by JICA for the purchase of products and/or services, the eligible source countries of such products and/or services shall be Japan and/or the Recipient. The Japanese Grant may be used for the purchase of the products and/or services of a third country as eligible, if necessary, taking into account the quality, competitiveness and economic rationality of products and/or services necessary for achieving the objective of the Project. However, the prime contractors, namely, constructing and procurement firms, and the prime consulting firm, which enter into contracts with the Recipient, are limited to "Japanese nationals", in principle.

6) Contracts and Concurrence by JICA

The Recipient will conclude contracts denominated in Japanese yen with Japanese nationals. Those contracts shall be concurred by JICA in order to be verified as eligible for using the Japanese Grant.

7) Monitoring

The Recipient is required to take their initiative to carefully monitor the progress of the Project in order to ensure its smooth implementation as part of their responsibility in the G/A, and to regularly report to JICA about its status by using the Project Monitoring Report (PMR).

8) Safety Measures

The Recipient must ensure that the safety is highly observed during the implementation of the Project.

9) Construction Quality Control Meeting

Construction Quality Control Meeting (hereinafter referred to as the "Meeting") will be held for quality assurance and smooth implementation of the Works at each stage of the Works. The member of the Meeting will be composed by the Recipient (or executing agency), the Consultant, the Contractor and JICA. The functions of the Meeting are as

12/19

JLL

followings:

- a) Sharing information on the objective, concept and conditions of design from the Contractor, before start of construction.
- b) Discussing the issues affecting the Works such as modification of the design, test, inspection, safety control and the Client's obligation, during of construction.

(2) Ex-post Monitoring and Evaluation Stage

- 1) After the project completion, JICA will continue to keep in close contact with the Recipient in order to monitor that the outputs of the Project is used and maintained properly to attain its expected outcomes.
- 2) In principle, JICA will conduct ex-post evaluation of the Project after three years from the completion. It is required for the Recipient to furnish any necessary information as JICA may reasonably request.

(3) Others

1) Environmental and Social Considerations

The Recipient shall carefully consider environmental and social impacts by the Project and must comply with the environmental regulations of the Recipient and JICA Guidelines for Environmental and Social Considerations (April, 2010).

2) Major undertakings to be taken by the Government of the Recipient

For the smooth and proper implementation of the Project, the Recipient is required to undertake necessary measures including land acquisition, and bear an advising commission of the A/P and payment commissions paid to the Bank as agreed with the GOJ and/or JICA. The Government of the Recipient shall ensure that customs duties, internal taxes and other fiscal levies which may be imposed in the Recipient with respect to the purchase of the Products and/or the Services be exempted or be borne by its designated authority without using the Grant and its accrued interest, since the grant fund comes from the Japanese taxpayers.

3) Proper Use

The Recipient is required to maintain and use properly and effectively the products and/or services under the Project (including the facilities constructed and the equipment purchased), to assign staff necessary for this operation and maintenance and to bear all the expenses other than those covered by the Japanese Grant.

(A) 11

111

4) Export and Re-export

The products purchased under the Japanese Grant should not be exported or re-exported from the Recipient.

田中

山本

PROCEDURES OF JAPANESE GRANT

Stage	Procedures	Remarks	Recipient Government	Japanese Government	JICA	Consultants	Contractors	Agent Bank
Official Request	Request for grants through diplomatic channel	Request shall be submitted before appraisal stage.	x	x				
1. Preparation	(1) Preparatory Survey Preparation of outline design and cost estimate		x		x	x		
2. Appraisal	(2) Preparatory Survey Explanation of draft outline design, including cost estimate, undertakings, etc.		x		x	x		
	(3) Agreement on conditions for implementation	Conditions will be explained with the draft notes (E/N) and Grant Agreement (G/A) which will be signed before approval by Japanese government.	x	x (E/N)	x (G/A)			
	(4) Approval by the Japanese cabinet			x				
3. Implementation	(5) Exchange of Notes (E/N)		x	x				
	(6) Signing of Grant Agreement (G/A)		x		x			
	(7) Banking Arrangement (B/A)	Need to be informed to JICA	x					x
	(8) Contracting with consultant and issuance of Authorization to Pay (A/P)	Concurrence by JICA is required	x			x		x
	(9) Detail design (D/D)		x			x		
	(10) Preparation of bidding documents	Concurrence by JICA is required	x			x		
	(11) Bidding	Concurrence by JICA is required	x			x	x	
	(12) Contracting with contractor/supplier and issuance of A/P	Concurrence by JICA is required	x				x	x
	(13) Construction works/procurement	Concurrence by JICA is required for major modification of design and amendment of contracts.	x			x	x	
(14) Completion certificate		x			x	x		
4. Ex-post monitoring & evaluation	(15) Ex-post monitoring	To be implemented generally after 1, 3, 10 years of completion, subject to change	x		x			
	(16) Ex-post evaluation	To be implemented basically after 3 years of completion	x		x			

notes:

- Project Monitoring Report and Report for Project Completion shall be submitted to JICA as agreed in the G/A.
- Concurrence by JICA is required for allocation of grant for remaining amount and/or contingencies as agreed in the G/A.

12/17

JHL

Financial Flow of Japanese Grant (A/P Type)

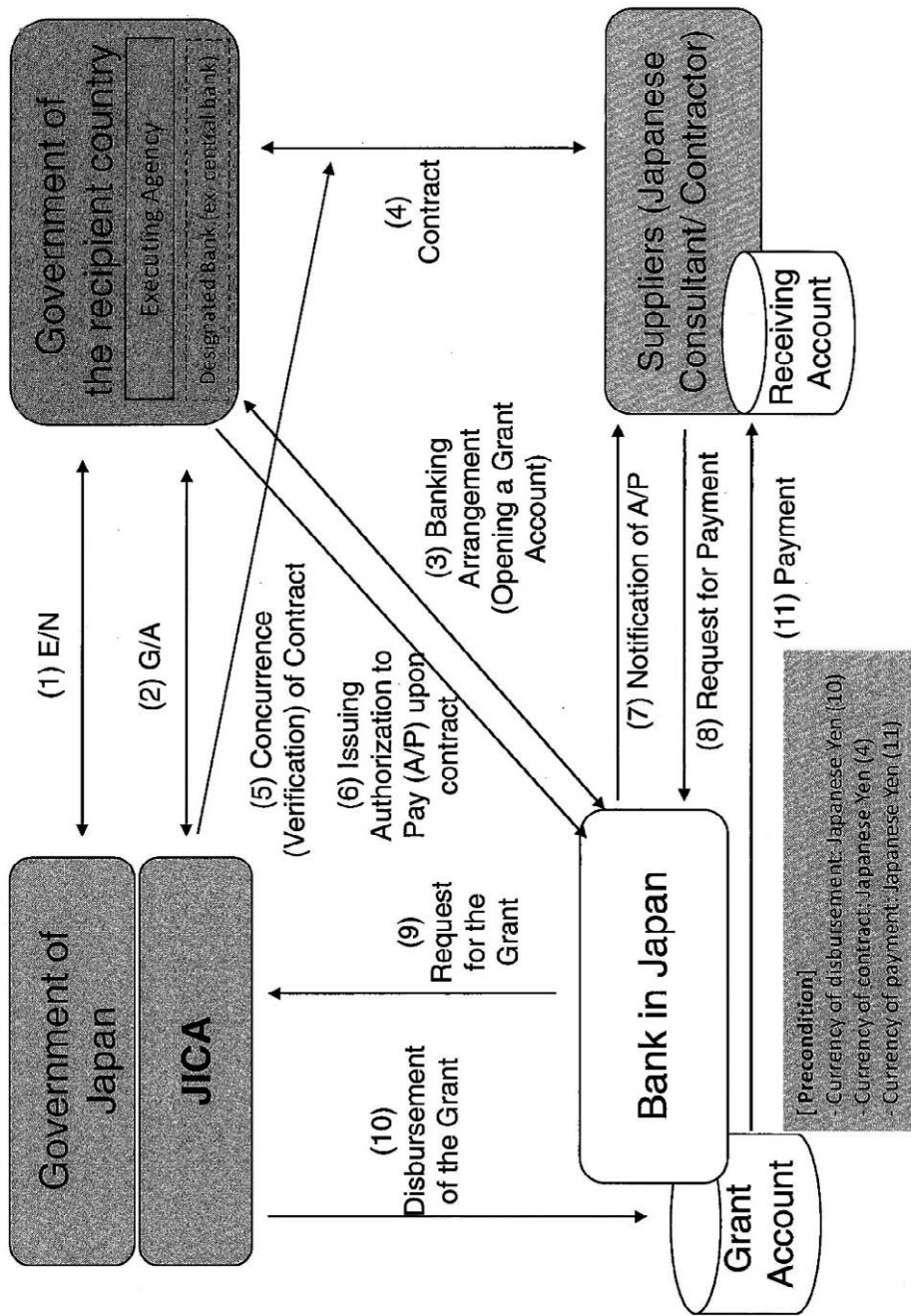

Handwritten mark

Handwritten mark

	2018				2019				2020				2021				2022			
	11	12	1	2	11	12	1	2	11	12	1	2	11	12	1	2	11	12	1	2
Approval of Cabinet, Exchange Note, Grant Agreement																				
Detailed Design																				
Tender Related Services																				
Construction Supervision																				
Defect Inspection																				
Major Undertakings to be taken by the government of Kyrgyz Republic																				
Before the Tender																				
1 Approval of EIA																				
2 Bidding arrangement																				
3 Issue of A/P for consultant																				
4 Lands necessary for the construction including temporary works																				
5 Removal of the existing snow protection fence																				
6 Related permission of the construction																				
7 Submission of the project monitoring report																				
During the Construction																				
1 Issue of A/P for contractor																				
2 Advising & payment commission																				
3 Permission of entry and stay of Japanese and third countries persons in the Kyrgyz Republic																				
4 Insurance and assistance of tax exemption, customs clearance of the products on disembarkation of internal transport																				
5 All the expenses, other than those to be borne by the Grant Aid																				
6 Submission of project monitoring report																				
After the Project																				
Proper and effective maintenance and uses of the facilities constructed under the Grant Aid (maintenance cost, operation and maintenance structure routine check/periodic inspection)																				

Note: Above items regarding major undertaking items correspond to the items in tables of Annex 6

Handwritten signature/initials.

Handwritten signature/initials.

Major Undertakings to be taken by the Government of Kyrgyz Republic

1. Specific obligations of the Government of Kyrgyz Republic which will not be funded with the Grant

(1) Before the Tender

NO.	Items	Deadline	In charge	Estimated Cost (USD) (KGS)	Ref.
1	To approve EIA	until November, 2018	SAEPF		
2	To open bank account	within 1 month after the signing of the G/A	MOTR	4,143 (287,000)	
3	To issue A/P to a bank in Japan (the Agent Bank) for the payment to the consultant	within 1 month after the signing of the G/A	MOTR		
4	To secure and clear the following lands 1) project sites (KP125+000-129+000, KP215+740-222+000 on Bishkek-Osh Road 2) temporary construction yard and stock yard near the Project area 3) borrow pit and disposal site near the Project area	before notice of the tender document	MOTR		
5	To remove existing snow fences at KP218+900-KP219+010	before notice of the tender document	MOTR	1,011 (70,000)	
6	To obtain the planning, zoning, building permission, traffic permission	before notice of the tender document	MOTR		
7	To submit Project Monitoring Report	before notice of tender	MOTR		

(2) During the Project Implementation

NO	Items	Deadline	In charge	Estimated Cost	Ref.
1	To issue A/P to a bank in Japan (the Agent Bank) for the payment to the Supplier(s)	within 1 month after the signing of the contract(s)	MOTR		
2	To bear the following commissions to a bank in Japan for the banking services based upon the B/A		MOTR		
	1) Advising commission of A/P	within 1 month after the signing of the contract(s)			
	2) Payment commission for A/P	every payment			
3	To accord Japanese physical persons and/or physical persons of third countries whose services may be required in connection with the supply of the products and the services such facilities as may be necessary for their entry into the country of the Recipient and stay therein for the performance of their work	during the Project	MOTR		
4	To ensure that customs duties, internal taxes and other fiscal levies which may be imposed in the country of the Recipient with respect to the purchase of the products and/or the services be exempted	during the Project	MOTR		
5	To bear all the expenses, other than those covered by the Grant, necessary for the implementation of the Project	during the Project	MOTR		
6	1) To submit Project Monitoring Report after each work under the contract(s) such as shipping, hand over, installation and operational training	within one month after completion of each work	MOTR		
	2) To submit Project Monitoring Report (final)	within one month after signing of Certificate of Completion for the works under the contract(s)	MOTR		

(3) After the Project

NO	Items	Deadline	In charge	Estimated Cost	Ref.
1	To maintain and use properly and effectively the facilities constructed and equipment provided under the Grant Aid - Operation and maintenance structure Routine check/Periodic inspection	After completion of the construction	MOTR		

1B/1P

HL

2. Other obligations of the Government of Kyrgyz Republic funded with the Grant

NO	Items	Deadline	Amount (Million Japanese Yen)*
1	To install snow protection facilities and provide equipment 1) To conduct the following transportation a) Marine transportation of the products from Japan to the country of the Recipient b) Internal transportation from the port of disembarkation to the project site 2) To provide equipment with installation - snow fence KP125+000-129+000: 2,008m KP215+740-222+000: 3,908m - visual guidance facility KP126+240-126+520: 12 poles KP215+740-216+020: 12 poles KP217+030-217+470: 20 poles		Undisclosed until completion of the contract of the construction
	3) To implement bidding support and procurement supervision (Consulting Service)		
3	Contingencies		
	Total		

* The Amount is provisional. This is subject to the approval of the Government of Japan.

12/17

HL

Project Monitoring Report
on
the Project for Snow Drifting Protection on Bishkek-Osh Road
Grant Agreement No. XXXXXXX
 20XX, Month

Organizational Information

Signer of the G/A (Recipient)	Person in Charge (Designation) _____ Contacts Address: _____ Phone/FAX: _____ Email: _____
Executing Agency	Person in Charge (Designation) _____ Contacts Address: _____ Phone/FAX: _____ Email: _____
Line Ministry	Person in Charge (Designation) _____ Contacts Address: _____ Phone/FAX: _____ Email: _____

General Information:

Project Title	
E/N	Signed date: Duration:
G/A	Signed date: Duration:
Source of Finance	Government of Japan: Not exceeding JPY _____ mil. Government of (_____): _____

12/18

HL

1: Project Description

1-1 Project Objective

--

1-2 Project Rationale

- Higher-level objectives to which the project contributes (national/regional/sectoral policies and strategies)
- Situation of the target groups to which the project addresses

--

1-3 Indicators for measurement of "Effectiveness"

Quantitative indicators to measure the attainment of project objectives		
Indicators	Original (Yr)	Target (Yr)
Qualitative indicators to measure the attainment of project objectives		

2: Details of the Project

2-1 Location

Components	Original <i>(proposed in the outline design)</i>	Actual
1.		

2-2 Scope of the work

Components	Original* <i>(proposed in the outline design)</i>	Actual*
1.		

Reasons for modification of scope (if any).

Handwritten mark

Handwritten signature

(PMR)

2-3 Implementation Schedule

Items	Original		Actual
	(proposed in the outline design)	(at the time of signing the Grant Agreement)	

Reasons for any changes of the schedule, and their effects on the project (if any)

2-4 Obligations by the Recipient

2-4-1 Progress of Specific Obligations
 See Attachment 2.

2-4-2 Activities
 See Attachment 3.

2-4-3 Report on RD
 See Attachment 11.

2-5 Project Cost

2-5-1 Cost borne by the Grant (Confidential until the Bidding)

Components	Original (proposed in the outline design)	Actual (in case of any modification)	Cost (Million Yen)	
			Original ¹⁾²⁾ (proposed in the outline design)	Actual
1.				
Total				

Note: 1) Date of estimation:
 2) Exchange rate: 1 US Dollar = Yen

2-5-2 Cost borne by the Recipient

Components	Original (proposed in the outline design)	Actual (in case of any modification)	Cost (1,000 Taka)	
			Original ¹⁾²⁾ (proposed in the outline design)	Actual
1.				

Handwritten mark

Handwritten signature

Note: 1) Date of estimation:
2) Exchange rate: 1 US Dollar =

Reasons for the remarkable gaps between the original and actual cost, and the countermeasures (if any)

(PMR)

2-6 Executing Agency

- Organization's role, financial position, capacity, cost recovery etc,
- Organization Chart including the unit in charge of the implementation and number of employees.

Original (at the time of outline design) name: role: financial situation: institutional and organizational arrangement (organogram): human resources (number and ability of staff):
Actual (PMR)

2-7 Environmental and Social Impacts

- The results of environmental monitoring based on Attachment 5 (in accordance with Schedule 4 of the Grant Agreement).
- The results of social monitoring based on in Attachment 5 (in accordance with Schedule 4 of the Grant Agreement).
- Disclosed information related to results of environmental and social monitoring to local stakeholders (whenever applicable).

3: Operation and Maintenance (O&M)

3-1 Physical Arrangement

- Plan for O&M (number and skills of the staff in the responsible division or section, availability of manuals and guidelines, availability of spareparts, etc.)

Original (at the time of outline design)
Actual (PMR)

3-2 Budgetary Arrangement

- Required O&M cost and actual budget allocation for O&M

Original (at the time of outline design)
Actual (PMR)

4: Potential Risks and Mitigation Measures

- Potential risks which may affect the project implementation, attainment of objectives, sustainability
- Mitigation measures corresponding to the potential risks

Assessment of Potential Risks (at the time of outline design)

Potential Risks	Assessment
1. (Description of Risk)	Probability: High/Moderate/Low
	Impact: High/Moderate/Low
	Analysis of Probability and Impact:
	Mitigation Measures:
2. (Description of Risk)	Action required during the implementation stage:
	Contingency Plan (if applicable):
	Probability: High/Moderate/Low
	Impact: High/Moderate/Low
3. (Description of Risk)	Analysis of Probability and Impact:
	Mitigation Measures:
	Probability: High/Moderate/Low
	Impact: High/Moderate/Low

12/11

JLL

	Action required during the implementation stage:
	Contingency Plan (if applicable):
Actual Situation and Countermeasures (PMR)	

5: Evaluation and Monitoring Plan (after the work completion)

5-1 Overall evaluation

Please describe your overall evaluation on the project.

--

5-2 Lessons Learnt and Recommendations

Please raise any lessons learned from the project experience, which might be valuable for the future assistance or similar type of projects, as well as any recommendations, which might be beneficial for better realization of the project effect, impact and assurance of sustainability.

--

5-3 Monitoring Plan of the Indicators for Post-Evaluation

Please describe monitoring methods, section(s)/department(s) in charge of monitoring, frequency, the term to monitor the indicators stipulated in 1-3.

--

12/4

HL

Attachment

1. Project Location Map
2. Specific obligations of the Recipient which will not be funded with the Grant
3. Monthly Report submitted by the Consultant
- Appendix - Photocopy of Contractor's Progress Report (if any)
 - Consultant Member List
 - Contractor's Main Staff List
4. Check list for the Contract (including Record of Amendment of the Contract/Agreement and Schedule of Payment)
5. Environmental Monitoring Form / Social Monitoring Form
6. Monitoring sheet on price of specified materials (Quarterly)
7. Report on Proportion of Procurement (Recipient Country, Japan and Third Countries) (PMR (final) only)
8. Pictures (by JPEG style by CD-R) (PMR (final) only)
9. Equipment List (PMR (final) only)
10. Drawing (PMR (final) only)
11. Report on RD (After project)

124

Monitoring sheet on price of specified materials

1. Initial Conditions (Confirmed)

Item No.	Material Name	Unit	Initial Price	Initial Total Price	% of Contract Price	Contract Price
1	Item 1	●●●	●●	●●	●●	●●
2	Item 2	●●●	●●	●●	●●	●●
3	Item 3					
4	Item 4					
5	Item 5					

2. Monitoring of the Unit Price of Specified Materials

(1) Method of Monitoring : ●●

(2) Result of the Monitoring Survey on Unit Price for each specified materials

Item No.	Material Name	Unit	Initial Price	Initial Total Price	% of Contract Price	Contract Price
1	Item 1	●●●	●●	●●	●●	●●
2	Item 2					
3	Item 3					
4	Item 4					
5	Item 5					

(3) Summary of Discussion with Contractor (if necessary)

HL

Report on Proportion of Procurement (Recipient Country, Japan and Third Countries)
 (Actual Expenditure by Construction and Equipment each)

	Domestic Procurement (Recipient Country) A	Foreign Procurement (Japan) B	Foreign Procurement (Third Countries) C	Total D
Construction Cost	(A/D%)	(B/D%)	(C/D%)	
Direct Construction Cost	(A/D%)	(B/D%)	(C/D%)	
others	(A/D%)	(B/D%)	(C/D%)	
Equipment Cost	(A/D%)	(B/D%)	(C/D%)	
Design and Supervision Cost	(A/D%)	(B/D%)	(C/D%)	
Total	(A/D%)	(B/D%)	(C/D%)	

Dp

HL

Tax Refund and Exemption Procedure

Outline of Tax Exemption Procedures

Tax Exemption Procedures are implemented before implementation of the Project. Ministry of Transport and Roads shall timely initiate and implement Tax Exemption Procedures regarding this Project.

Following are legal base for the Tax Exemption Procedures:

1. AGREEMENT BETWEEN THE GOVERNMENT OF JAPAN AND THE KYRGYZ REPUBLIC ON SCIENTIFIC AND TECHNOLOGICAL CO-OPERATION, 6th day of October 2004
2. REGULATION on the procedure of exemption of taxes, duties and other payments in the frame of implementation of international treaties and other agreements to which Kyrgyz is a party, N 155 12 April 2011

Following is the general outline of Tax Exemption Procedures:

1. Ministry of Transport and Roads will draft a tax exemption bill and after obtaining the approval of the Prime Minister's Office based on the E / N (draft) and G / A (draft), and after coordinating with relevant ministries and agencies, submit it to the Jogorku Kenesh (Parliamentary)
2. The parliamentary approval takes a standard 90 days, but it will be held in about one month if requested
3. After parliamentary resolution, the bill will be approved by the president's signature. The Ministry of Economy will issue tax exemption letter to Ministry of Transport and Roads, Ministry of Foreign Affairs, Tax office, Customs office
4. Ministry of Transport and Roads provides the tax exemption letter including the tax exemption list, the name of the project, the procurement documents by Japanese contractor, and the tax exemption application is made to the Ministry of Economy
5. The Ministry of Economy conducts an examination and makes notification to the tax office / customs office. This will take about two weeks.

Following is a list of expected but not limited taxes types

Activity	Tax Rate	Tax Exemption
Temporary Importation of equipment and components for use on the project	Varies depending on type of equipment	Exempted by the tax exemption bill and the tax exemption letter.
Purchases of local goods and services for use on the project	Value Added Tax 12%	Exempted by the tax exemption bill and the tax exemption letter.

②

HL

Activity	Tax Rate	Tax Exemption
Engagement of local contractors	10% from Net income	Exempted by the tax exemption bill and the tax exemption letter.

* Goods and services imported from the Eurasian Economic Union countries are exempted from import taxes, based on The Treaty on the Eurasian Economic Union of May 29, 2014

* In case if fuel materials are procured from the local supplier, the local supplier would not be exempted from fuel taxes.

12/11

HL

7 **Technical Note (MOTR)**

Technical Note
on the Preparatory Survey on the Project for the Snow Drifting Protection
on the Bishkek – Osh Road in the Kyrgyz Republic

Ministry of Transport and Roads of Kyrgyz Republic and the joint venture between Katahira & Engineers International and Japan Weather Association, who are the consultants for the above mentioned survey by the Japan International Cooperation Agency (JICA), have agreed on the points listed in the annex hereto regarding the design. However, the contents of the design will be finalized after the survey team has returned to Japan through discussions with those concerned on the Japanese side, such as the Head Office of JICA.

August 3, 2018
Bishkek, Kyrgyz Republic



JICA Study Team
Katahira & Engineers International
Chief Consultant

Mr. Kiyohito KOBAYASHI

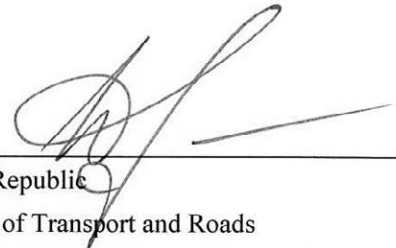

Kyrgyz Republic
Ministry of Transport and Roads
Director of Department of Automobile Roads

Mr. Alysatarov MELIS

Annex

This study aims to gather the information required for the planning and design of the snow drifting fence on Bishkek – Osh Road (125 km-129 km, 216 km-222 km) while checking the contents that were determined during the conceptual stage of the project. Therefore, the contents of the design will be unchanged in principle. However, the following key points related to planning and design have been confirmed.

1. Scope of the Project

- To install the collector snow fences
- To install the visual guidance pole

The total length of snow drifting fences is approximately 6000 m. The location map is shown in Figure 1-1 to 1-4 and the summary of snow drifting fences is shown in Table 1-1.

Table 1-1 Summary of Snow Drifting Fences

Location	Type	Fence height	Porosity	Length
Too-Ashuu Pass	I	4 m	50 %	1140 m
	III	3 m	30 %	900 m
Ala-Bel Pass	I	4 m	50 %	2692 m
	II	4 m	30 %	756 m
	III	3 m	30 %	460 m
Total				5948 m

The total section of visual guidance pole is 1000 m. The location map is shown in Figure 1-1 and 1-2, and the summary of visual guidance pole is shown in Table 1-2.

Table 1-2 Summary of Visual guidance pole

Pass	Section	Number of Facility	Length
Too-Ashuu	KP126+240-KP126+520	12	280 m
Ala-Bel	KP215+740-KP216+020	12	280 m
	KP217+030-KP217+470	20	440 m
Total		44	1000 m

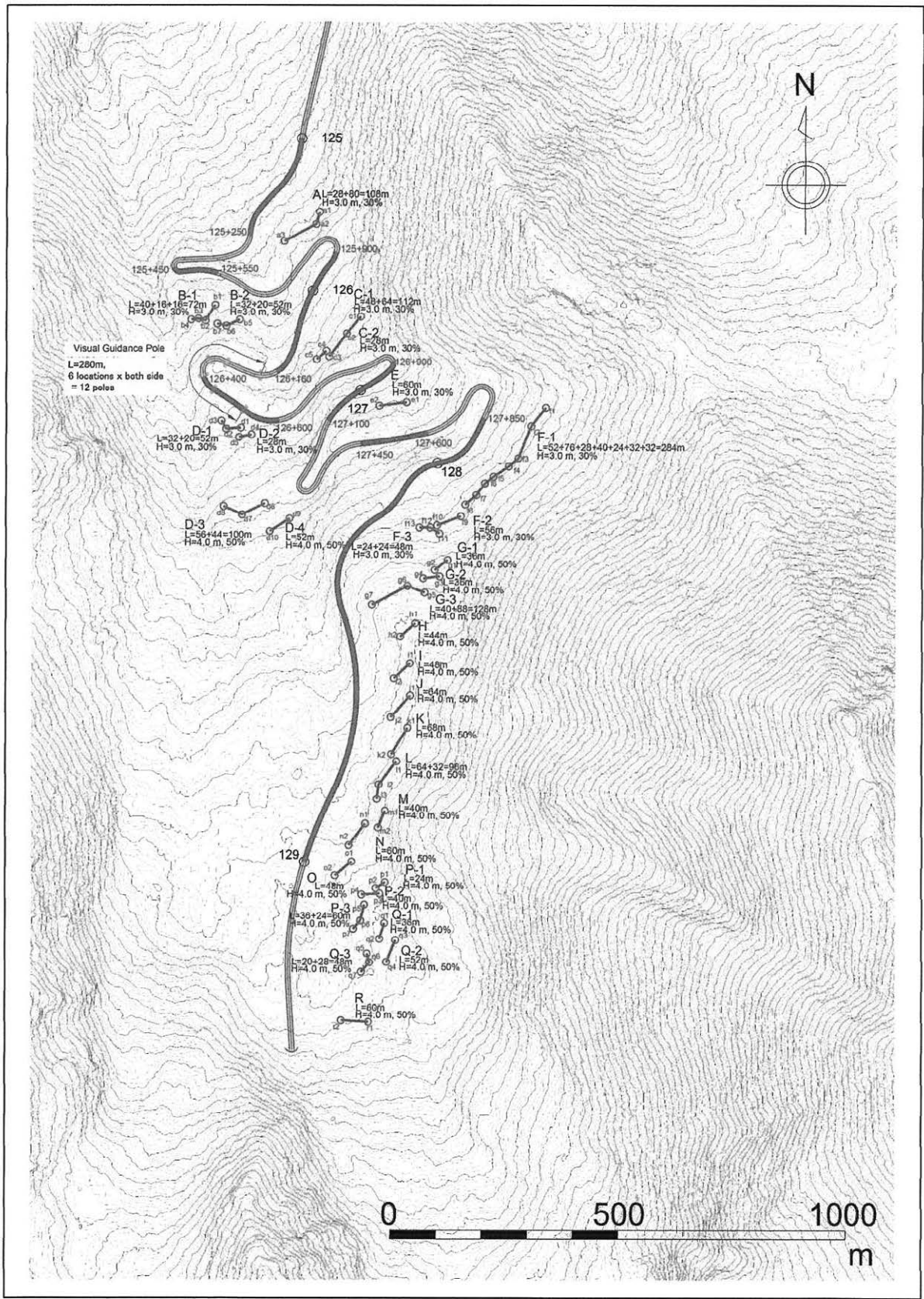

Figure 1-1 Location Map in Too-Ashuu Pass

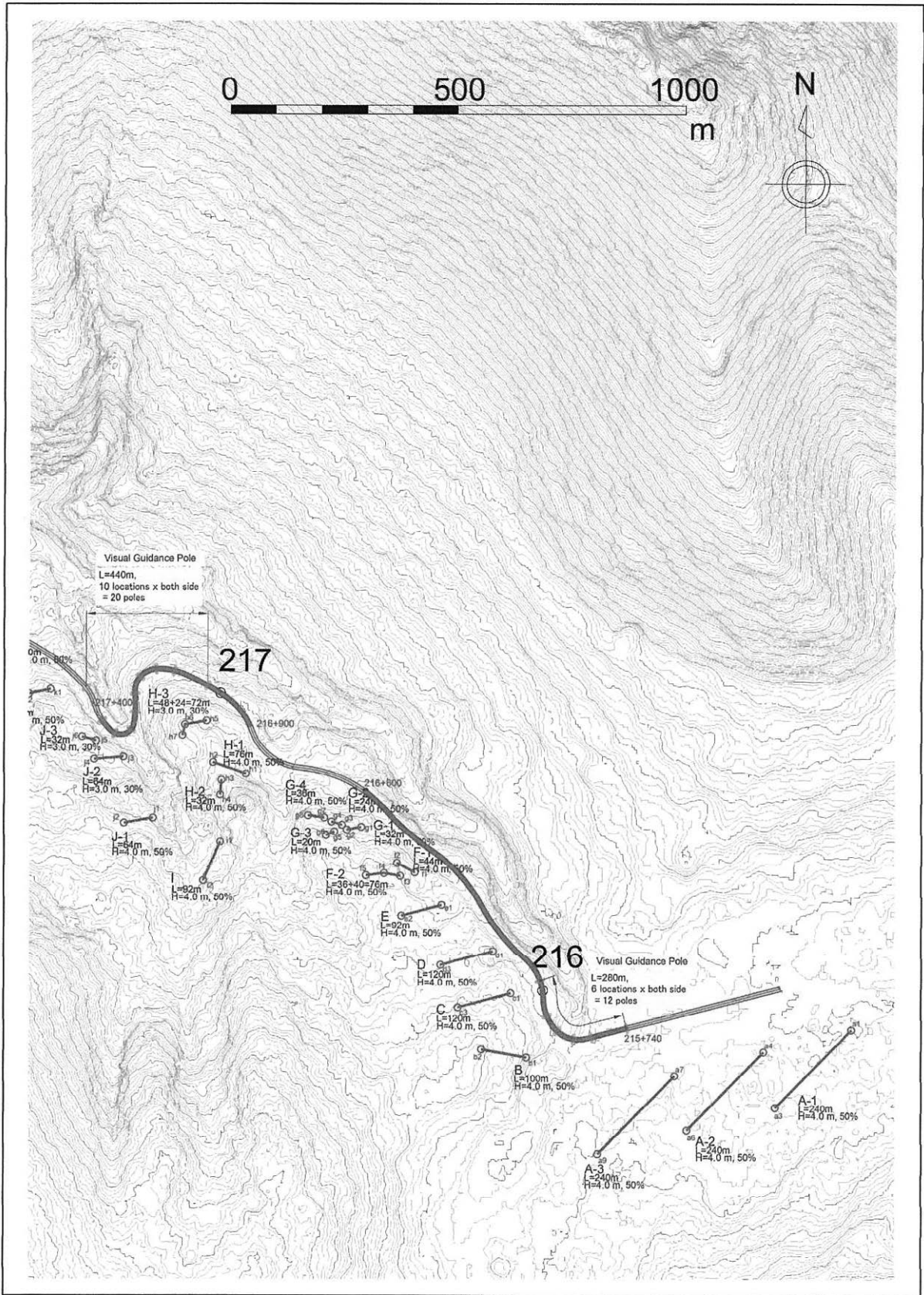

Figure 1-2 Location Map in Ala-Bel Pass (1)

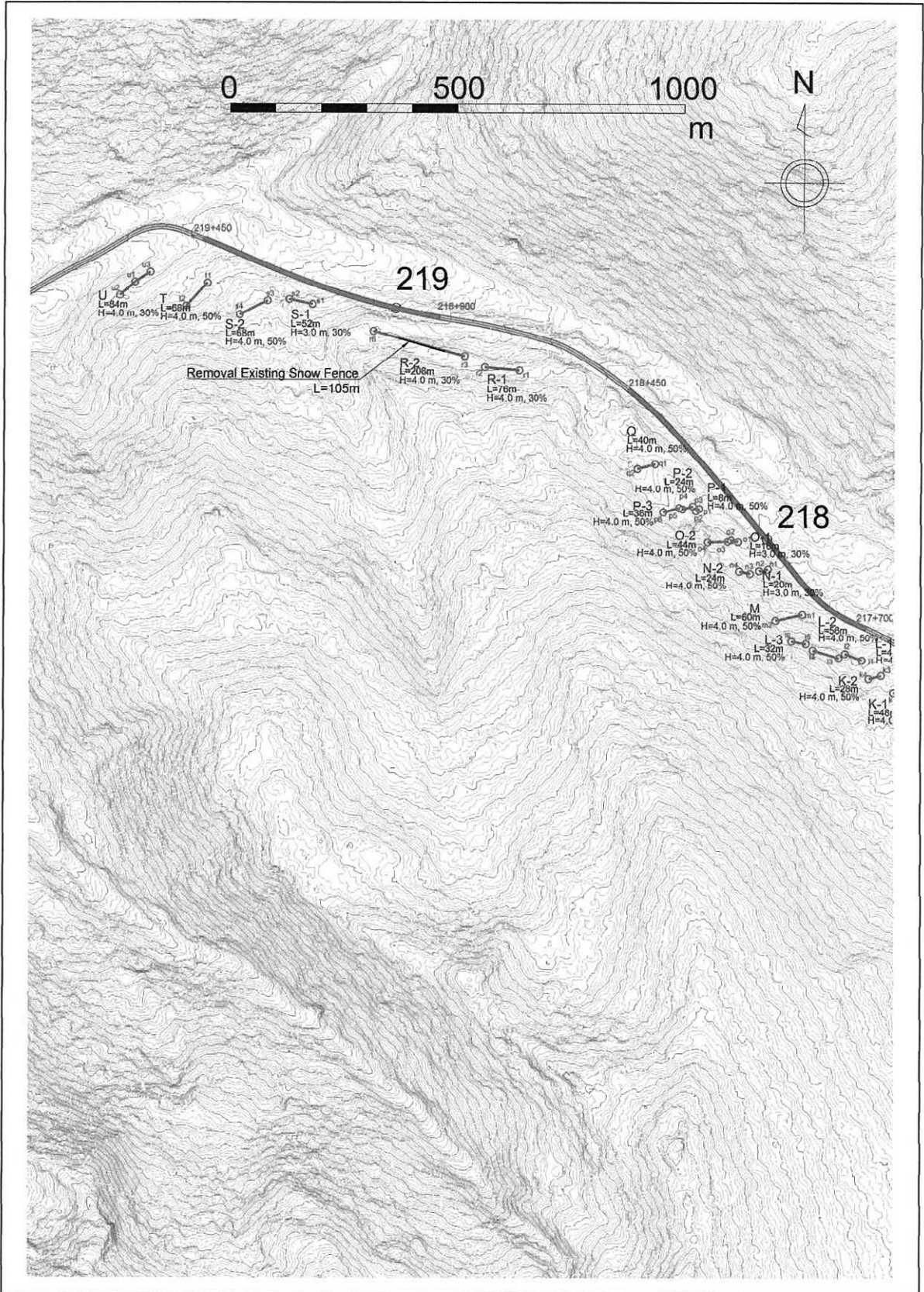

Figure 1-3 Location Map in Ala-Bel Pass (2)

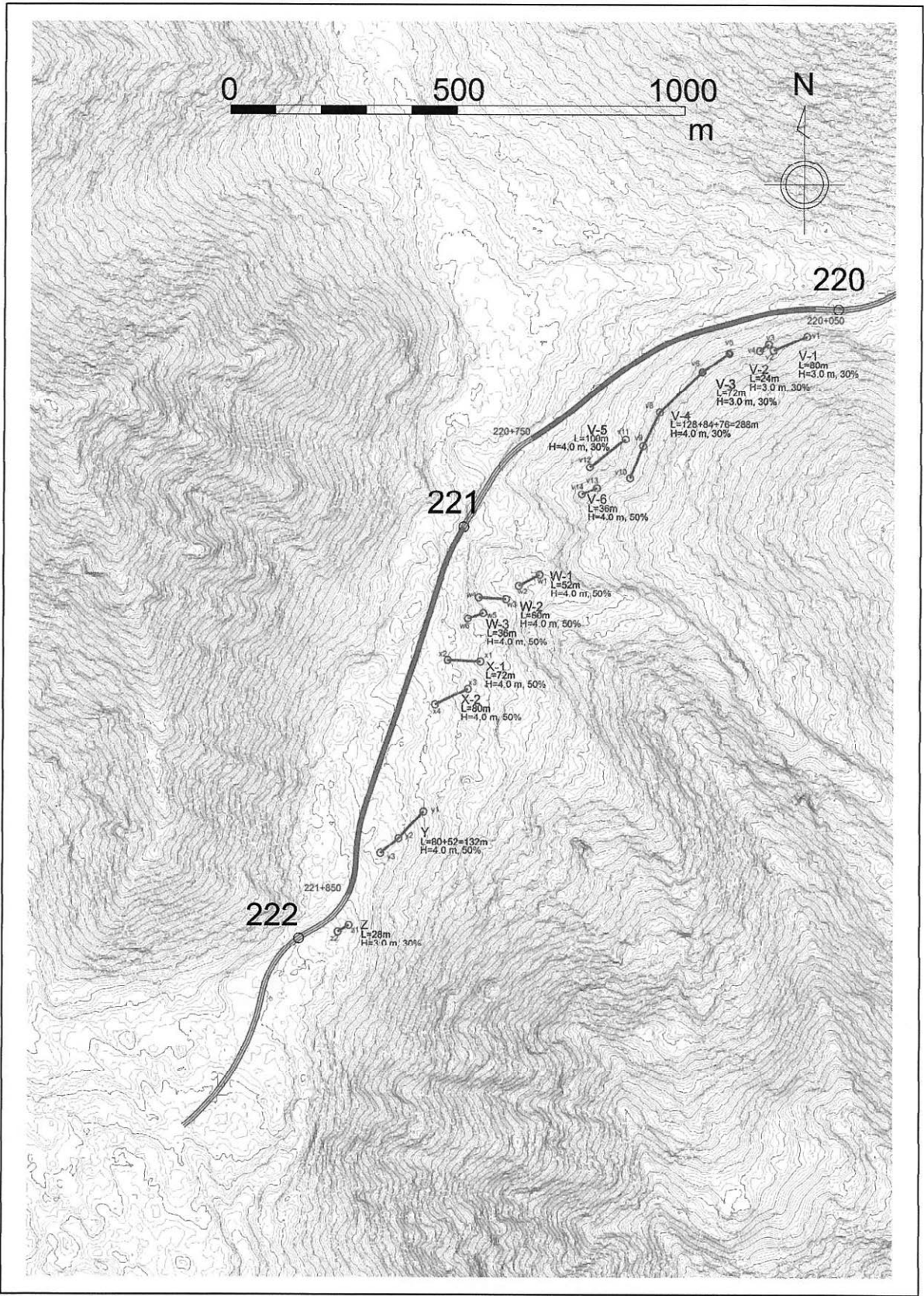

Figure 1-4 Location Map in Ala-Bel Pass (3)

2. General View of Snow Drifting Fence

Collector snow fences will be applied in this project. There are 3 types of snow drifting fence which are different height and porosity. The general views of fences are shown in Figure 2-1 to Figure 2-3.

Table 2-1 Three Types of Snow Drifting Fence

Name	Fence Height (H)	Porosity (P)	Number of Board
Type I	4.0m	50%	6
Type II	4.0m	30%	8
Type III	3.0m	30%	6

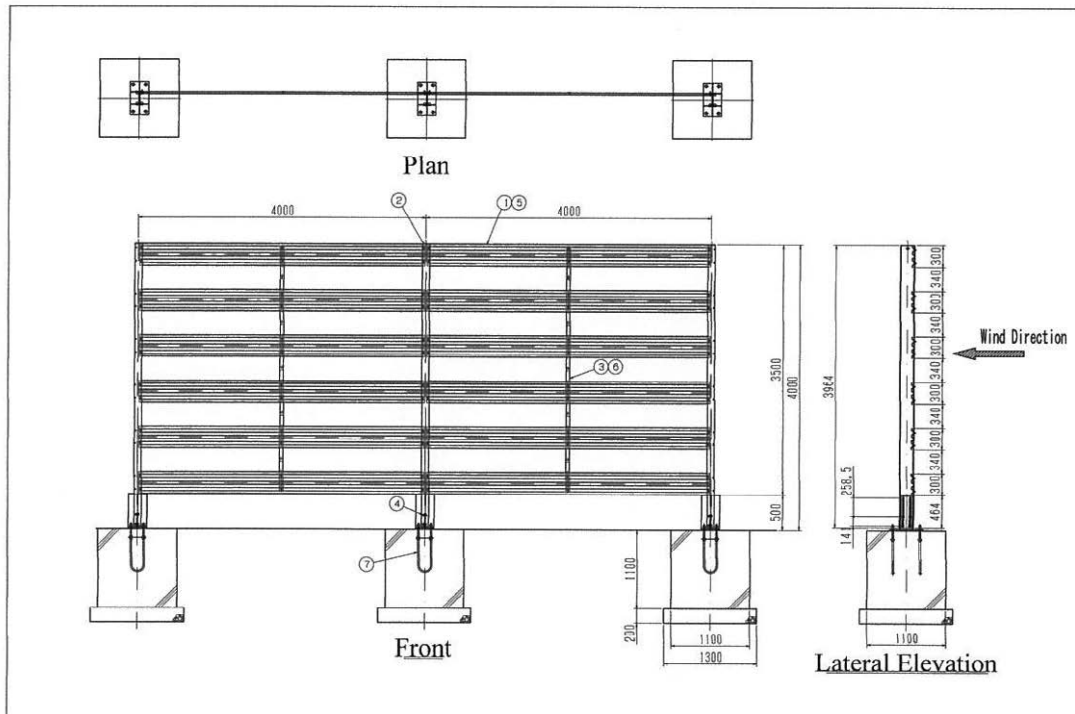

Figure 2-1 General View of Collector Snow Fences (Type I, H=4.0m, P=50%)

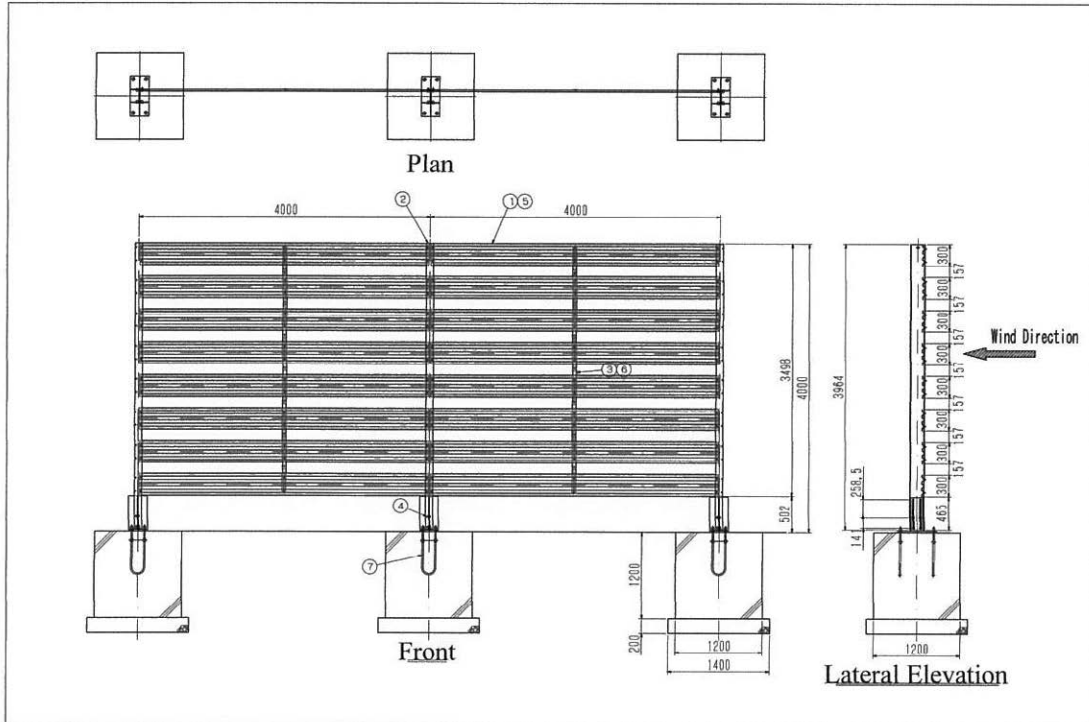

Figure 2-2 General View of Collector Snow Fences (Type II, H=4.0m, P=30%)

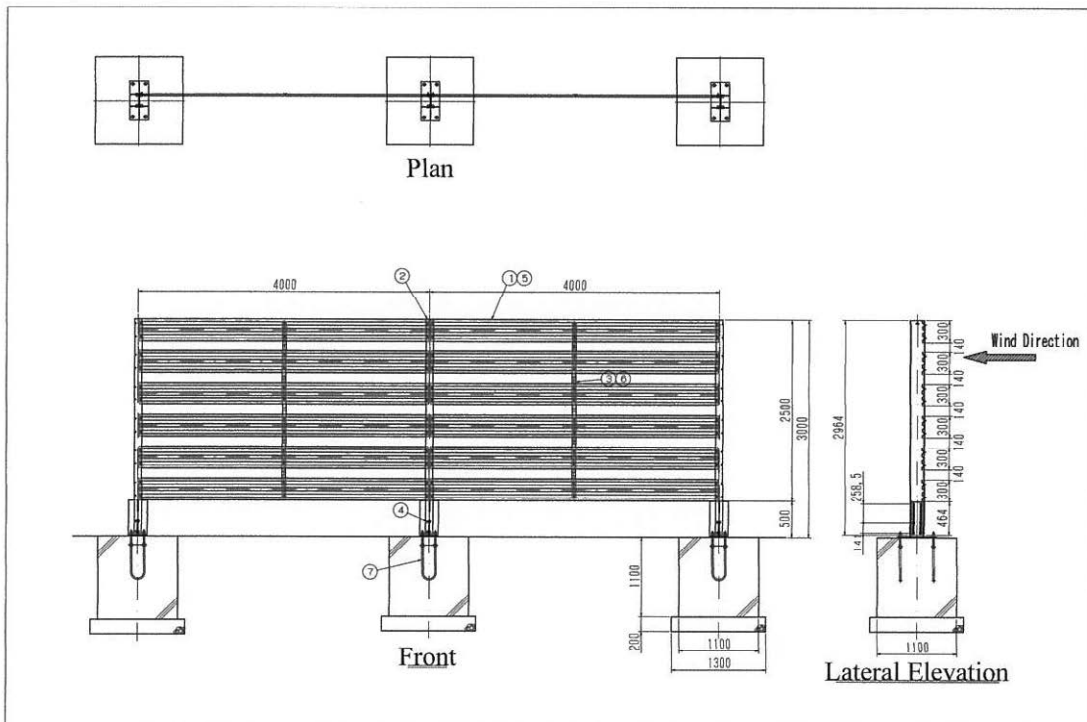

Figure 2-3 General View of Collector Snow Fences (Type III, H=3.0m, P=30%)

3) Removal of existing snow fence

The existing snow fence, which has a length of 105 m at KP219, shall be removed by MOTR before the construction, because new installation fences are planning at same position of existing snow fence.

8 References List

1. Meteorological Data (Too-Ashuu Station, It-Agar Station) 1987-2016
2. Meteorological Chart 2016-17
3. Road Maintenance Annual Budget of MOTR for 2007-2016
4. NATIONAL SUSTAINABLE DEVELOPMENT STRATEGY 2013-2017, Kyrgyz Republic
5. Main Directions of the road sector development for 2016-2025, Kyrgyz Republic
6. Kyrgyz Standards – Highway construction standards, 1998

9 Project Monitoring Report

G/A NO. *****
PMR prepared on 2019/1/17

Project Monitoring Report
on
The Project for the Protection from Ground Blizzard
on Bishkek-Osh Road Grant Agreement No. *****
****, *****

Organization Information

Authority (Signer of the G/A)	<u>Ministry of Foreign Affairs, The Government of Kyrgyz Republic</u> Person in Charge _____ Contacts <u>Address:58 Erkindik doulevard, 720040</u> <u>Phone/FAX:</u> <u>Email:</u>
Executing Agency	<u>Ministry of Transport and Roads</u> Person in Charge <u>Alypsatarov Melisbek</u> <u>Head of Department of Road</u> Contacts <u>Address: 42, Isanova Str., Bishkek, 720040</u> <u>Phone/FAX: +996(312) 661767, +996(312) 661787</u> <u>Email:</u>
Line Agency	<u>Road Maintenance Department</u> Person in Charge _____ Contacts <u>Address: 42, Isanova Str., Bishkek, 720040</u> <u>Phone/FAX: +996(312) 661767, +996(312) 661787</u> <u>Email:</u>

Outline of Grant Agreement:

Source of Finance	Government of Japan: <u>Undisclosed until completion of the contract of the construction</u> Government of Kyrgyz Republic: JPY 0.567 mil.
Project Title	THE PROJECT FOR THE PROTECTION FROM GROUND BLIZZARD ON BISHKEK - OSH ROAD
E/N	Signed date: Duration:
G/A	Signed date: Duration:

1: Project Description

1-1 Project Objective

This Project aims to reduce the traffic disturbance caused by snow drifting and ensure the safe and smooth traffic in the winter season by implementation of snow drifting protection on the BO Road. The scope of Japanese assistance in this Project consists of the procurement of snow protection fences and visual guide poles for the target area.

1-2 Necessity and Priority of the Project

- Higher-level objectives to which the project contributes (national/regional/sectoral policies and strategies)
- Situation of the target groups to which the project addresses

The snow drifting occurs at some points on the BO Road, but the section between 125 km and 129 km near “Too-Ashuu Pass” and located at an altitude of 3,130 m and the section between 216 km and 222 km near “Ala-Bel Pass” and located at an altitude of 3,184 m, are especially severe. In these sections, there are frequent situations wherein it is difficult to drive a vehicle due to snow drifting. In the winter season of 2015-16, these sections were closed 21 times and 65 times, respectively.

Such traffic disturbances caused by snow drifting in the winter season have some disadvantages for transporting domestic goods and trade with neighboring countries, and an obstacle to Kyrgyz’s economic revitalization.

The Government of Kyrgyz specifies the improvement of the quality of the main arterial road connecting major cities and surrounding cities as a priority issue of the transportation and road sector in The Development Program of the Kyrgyz Republic for the period 2018-2022 « Unity. Trust. Creation» (hereinafter referred to as “National Development Program”).

Under such circumstances, the Government of Kyrgyz requested assistance for “The Project for the Protection from Ground Blizzard on BO Road in Kyrgyz” (hereinafter referred to as “the Project”). The project which implements snow drifting protections on the BO Road is consistent with National Development Program and positioned as part of realizing National Development Program.

1-3 Indicators for measurement of “Effectiveness”

Quantitative indicators to measure the attainment of project objectives		
Indicators	Original (Yr 2018)	Target (Yr 2024)
Snow removal work at the time of snow drifting (hour × machine number / time) a: KP125-129section, b: KP216-222section	a : 51.5 b : 74.0	a : 33.5 b : 37.8
Traffic difficulty hour at the time of snow drifting (hour / time) a: KP125-129section, b: KP216-222section	a : 7.25 b : 12.33	a : 4.72 b : 6.30
Qualitative indicators to measure the attainment of project objectives		
① Improvement of safe and smooth traffic in winter		
② Promotion of utilization of traffic in winter		

2: Detail of the Project

2-1 Location

Components	Original (proposed in the outline design)	Actual
Procurement and installation of Collector Snow Fences and Visual Guide Poles	Bishkek – Osh Road a:KP125-129 section b:KP216-222 section	

2-2 Scope of the work

Items	Original	Actual
1. Procurement and installation of Collector Snow Fences	1. Collector Snow Fences a:KP125-129 section: 2,008m Type A: 1,128m Type B: 0m Type C: 880m b:KP216-222 section: 3,980m Type A: 2,692m Type B: 756m Type C: 460m	
2. Procurement and installation of Visual Guide Poles	2. Visual Guide Poles a:KP125-129 section: 12 set b:KP216-222 section: 32 set	
2. Consulting services	2. Consulting services	

Reasons for modification of scope (if any).

--

2-3 Implementation Schedule

Items	Original		Actual
	<i>(proposed in the outline design)</i>	<i>(at the time of signing the Grant Agreement)</i>	
Cabinet Approval	2/2019	13/2/2019	
E/N	4/2019		
G/A	4/2019		
Detail Design	8/2019-10/2019		
Tender Notice	11/2019		
Tender	1/2019		
Installation of Equipment	5/2020-10/2021		
Assistance the start-up or operation and maintenance	11/2021		
Defect Liability Period	10/2022		
Project Completion	10/2021		

*Project Completion was defined as the commencement of operation.

Reasons for any changes of the schedule, and their effects on the project. (if any)

--

2-4 Obligations by Recipient

2-4-1 Progress of Specific Obligations

See Attachment 2.

2-4-2 Activities

N/A

2-4-3 Report on RD

N/A

2-5 Project Cost

2-5-1 Cost borne by the Grant (Confidential until the Bidding)

Items	Original		Actual	Cost (1,000 JPY)	
	Original	Actual		Original	Actual
Collector Snow Fences and Visual Guide Poles	- Procurement - Installation - Maintenance Training Work			Undisclosed until completion of the contract of the construction	
Consulting Services	- Detailed design - Procurement Management				
Total					

Note: 1) Date of estimation: June 2018
2) Exchange rate: 1 US Dollar = 108.75 Yen

2-5-2 Cost borne by the Recipient

Items		Cost (1,000 JPY)	
Original	Actual	Original	Actual
Advising commission of A/P		456.0	
Removal of existing snow fence		111.0	
	Total	567.0	

Note: 1) Date of estimation: June 2014
 2) Exchange rate: 1 US Dollar = 103.16 Yen (1 US Dollar = 53.18 Som)

Reason(s) for the remarkable gap between the original and actual cost, and the countermeasures (if any)

(PMR) N/A

2-6 Executing Agency

- Organization's role, financial position, capacity, cost recovery etc,
- Organization Chart including the unit in charge of the implementation and number of employees.

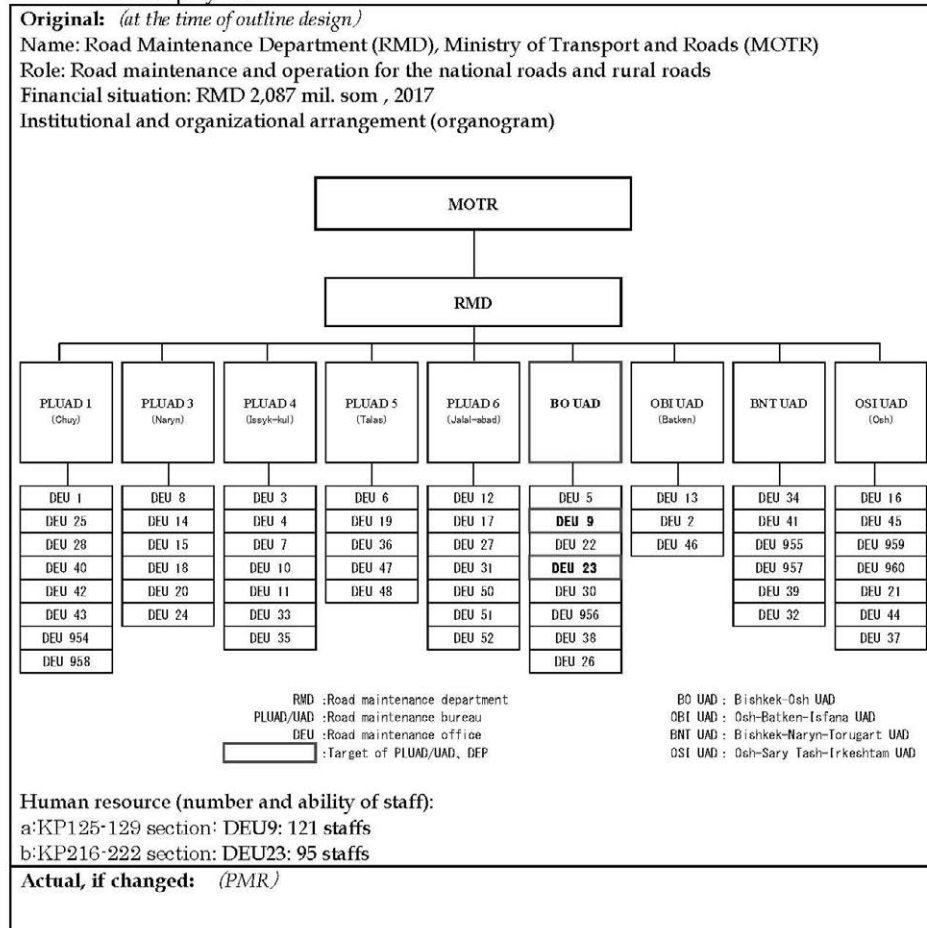

2-7 Environmental and Social Impacts

N/A

3: Operation and Maintenance (O&M)

3-1 Physical Arrangement

- Plan for O&M (number and skills of the staff in the responsible division or section, availability of manuals and guidelines, availability of spare parts, etc.)

<p>Original: <i>(at the time of outline design)</i> Operation including inspection, maintenance and repair of the equipment procured in this Project will be implemented by DEU 9 and DEU 23 under the BO UAD. Since maintenance management works are simple, additional personnel is not required, appropriate maintenance is deemed possible.</p>
<p>Actual: <i>(PMR)</i></p>

3-2 Budgetary Arrangement

- Required O&M cost and actual budget allocation for O&M.

<p>Original <i>(at the time of outline design)</i> Operation including inspection, maintenance and repair of the equipment procured in this Project will be implemented by DEU 9 and DEU 23 under the BO UAD. Since maintenance management works are simple, additional budget is not required, appropriate maintenance is deemed possible.</p>
<p>Actual: <i>(PMR)</i></p>

4: Precautions (Risk Management)

N/A

- Potential risks which may affect the project implementation, attainment of objectives, sustainability
- Mitigation measures corresponding to the potential risks

Assessment of Potential Risk *(at the time of outline design)*

Potential Project Risks	Assessment
1. (Description of Risk)	Probability: H/M/L
	Impact: H/M/L
	Analysis of Probability and Impact:
	Mitigation Measures:
	Action during the Implementation:
2. (Description of Risk)	Probability: H/M/L
	Impact: H/M/L
	Analysis of Probability and Impact:
	Mitigation Measures:

	Action during the Implementation:
	Contingency Plan (if applicable):
3. (Description of Risk)	Probability: H/M/L
	Impact: H/M/L
	Analysis of Probability and Impact:
	Mitigation Measures:
	Action during the Implementation:
	Contingency Plan (if applicable):
Actual issues and Countermeasure(s) (PMR)	

5: Evaluation and Monitoring Plan (after the work completion)

5-1 Overall evaluation

Please describe your overall evaluation on Project.

5-2 Lessons Learnt and Recommendations

Please raise any lessons learned from the project experience, which might be valuable for the future assistance or similar type of projects, as well as any recommendations, which might be beneficial for better realization of the project effect, impact and assurance of sustainability.

5-3 Monitoring Plan for the Indicators for Post-Evaluation

Please describe monitoring methods, section(s)/department(s) in charge of monitoring, frequency, the term to monitor the indicators stipulated in 1-3.

Information necessary for monitoring can be obtained from MOTR's monitoring record. The information is compiled by Road Maintenance Department of MOTR on an annual basis.

10 Technical Data

(1) Geotechnical investigation

	No.	Location	N Value	Unit volume weight(kN/m ³)		Adhesive (kN/m ²)	Internal friction angle (°)	Remark
				Dry state	Wet state			
Too-Ashuu	BH 1	a3	15	16.263	17.662	28	22	
	BH 2	b5	39	16.241	17.313	28	21	
	BH 3	c4	60	15.805	17.338	39	24	
	BH 4	Sta. 126+320	80	15.391	16.761	23	21	Visual guidance pole
	BH 5	Sta. 126+900	22	14.951	20.229	34	23	
	BH 6	d9	54	15.962	17.095	19	28	
	BH 7	f3	28	16.224	17.441	23	21	
	BH 8	g2	37	16.295	18.185	39	24	
	BH 9	h1	22	16.064	18.040	34	23	
	BH 10	k2	19	14.954	18.334	18	19	
	BH 11	p1	45	15.956	16.786	28	22	
	BH 12	q4	90	14.845	19.641	18	19	
Ala-Bel	BH 13	Sta. 217+300	66	16.193	17.732	23	21	Visual guidance pole
	BH 14	a4	24	14.940	18.511	18	17	
	BH 15	Sta. 215+900	43	15.410	16.427	15	26	Visual guidance pole
	BH 16	c1	18	16.172	17.805	23	21	
	BH 17	e1	31	15.613	16.816	13	24	
	BH 18	g1	31	14.775	20.937	34	23	
	BH 19	h4	66	15.522	16.872	21	30	
	BH 20	i1	71	15.971	17.424	34	23	
	BH 21	j4	99	15.403	18.253	21	30	
	BH 22	l2	7	14.906	20.466	31	24	
	BH 23	n1	32	15.996	17.420	28	22	
	BH 24	p3	42	16.052	17.449	15	26	
	BH 25	r1	40	15.859	17.032	13	24	
	BH 26	t1	21	16.114	17.516	15	26	
	BH 27	v3	15	16.213	17.900	28	22	
	BH 28	v9	28	14.788	18.263	23	21	
	BH 29	v12	10	15.006	19.238	34	23	
	BH 30	w1	78	15.898	17.185	15	26	
	BH 31	x3	24	14.727	19.911	28	22	
	BH 32	y2	46	14.580	19.989	34	23	
	BH 33	z1	15	14.624	17.915	16	19	