

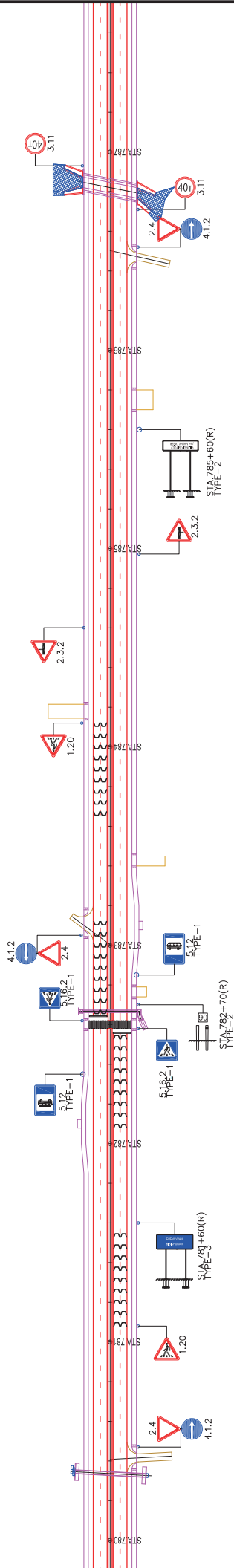

# LAYOUT PLAN OF TYPICAL TRAFFIC SIGNS(13)



REPUBLIC OF TAJIKISTAN MINISTRY OF TRANSPORT	THE PREPARATORY SURVEY FOR THE PROJECT FOR REHABILITATION OF KIZILKALA-BOKHTAR SECTION OF DUSHANBE-BOKHTAR ROAD IN THE REPUBLIC OF TAJIKISTAN	JAPAN INTERNATIONAL COOPERATION AGENCY CTI ENGINEERING INTERNATIONAL CO., LTD.	TITLE: <b>LAYOUT PLAN OF TYPICAL TRAFFIC SIGNS (8)</b>	CHECKED	APPROVED	SCALE (A1 SIZE) 1:1000	DATE	DRAWING NO. RA-10	SHEET NO. 10/33
---	---	---	---	---------	----------	------------------------------	------	----------------------	--------------------

# LAYOUT PLAN OF TYPICAL TRAFFIC SIGNS(9)

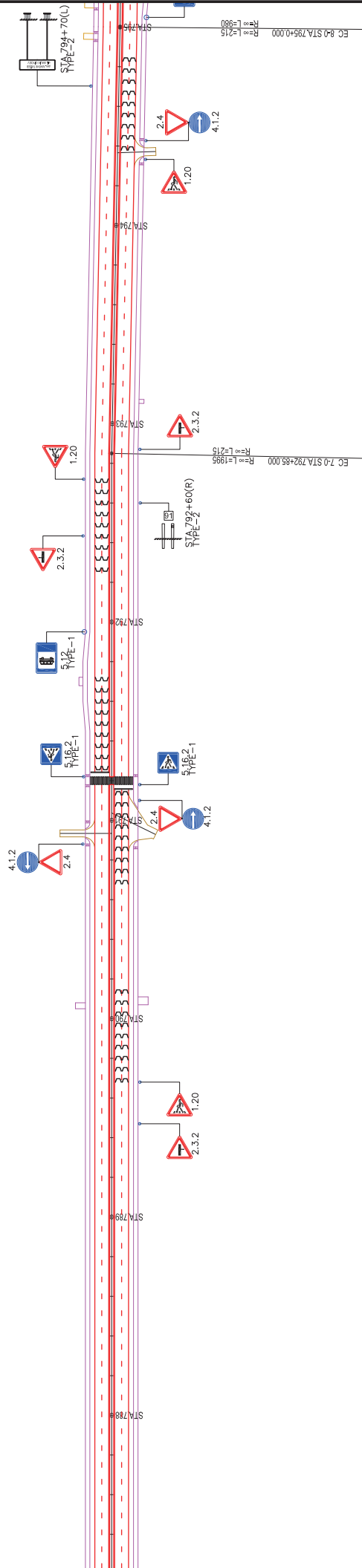

REPUBLIC OF TAJIKISTAN MINISTRY OF TRANSPORT	THE PREPARATORY SURVEY FOR THE PROJECT FOR REHABILITATION OF KZILKALA-BOKHTAR SECTION OF DUSHANBE-BOKHTAR ROAD IN THE REPUBLIC OF TAJIKISTAN	JAPAN INTERNATIONAL COOPERATION AGENCY CTI ENGINEERING INTERNATIONAL CO., LTD.	TITLE: <b>LAYOUT PLAN OF TYPICAL TRAFFIC SIGNS (9)</b>	DRAWING NO. RA-11	DATE	SCALE (A1 SIZE) 1:1000	CHECKED	APPROVED	SHEET NO. 11/33
---	--	---	---	----------------------	------	------------------------------	---------	----------	--------------------

# LAYOUT PLAN OF TYPICAL TRAFFIC SIGNS(10)

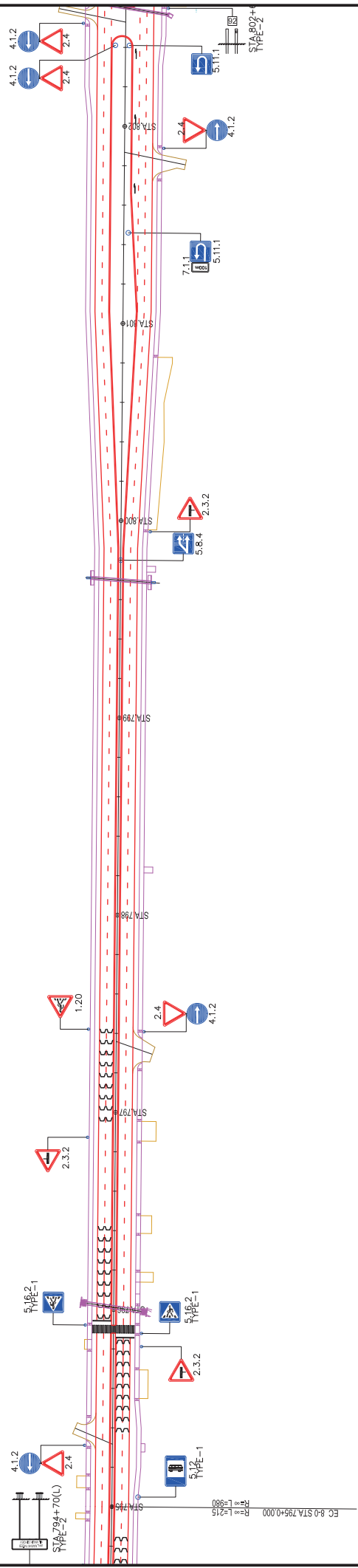

REPUBLIC OF TAJIKISTAN MINISTRY OF TRANSPORT	THE PREPARATORY SURVEY FOR THE PROJECT FOR REHABILITATION OF KIZILKALA-BOKHTAR SECTION OF DUSHANBE-BOKHTAR ROAD IN THE REPUBLIC OF TAJIKISTAN	JAPAN INTERNATIONAL COOPERATION AGENCY CTI ENGINEERING INTERNATIONAL CO., LTD.	TITLE: <b>LAYOUT PLAN OF TYPICAL TRAFFIC SIGNS (10)</b>	DRAWING NO. RA-12	DATE	SCALE (A1 SIZE) 1:1000	CHECKED	APPROVED	SHEET NO. 12/33
---	---	---	--	----------------------	------	------------------------------	---------	----------	--------------------



# LAYOUT PLAN OF TYPICAL TRAFFIC SIGNS(11)

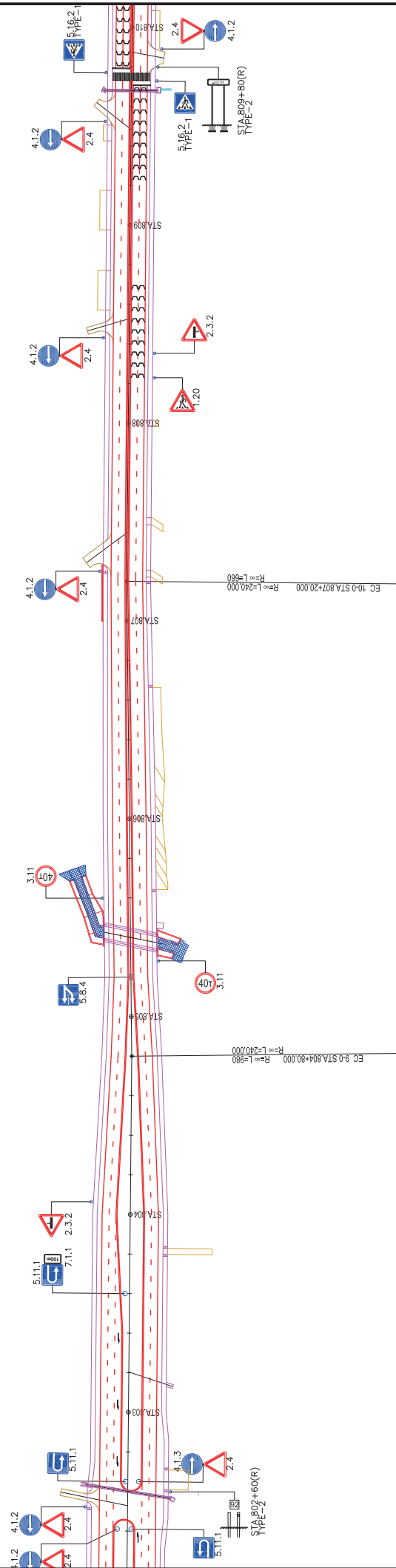

REPUBLIC OF TAJIKISTAN MINISTRY OF TRANSPORT	THE PREPARATORY SURVEY FOR THE PROJECT FOR REHABILITATION OF KIZILKALA-BOKHTAR SECTION OF DUSHANBE-BOKHTAR ROAD IN THE REPUBLIC OF TAJIKISTAN	JAPAN INTERNATIONAL COOPERATION AGENCY CTI ENGINEERING INTERNATIONAL CO., LTD.	TITLE: LAYOUT PLAN OF TYPICAL TRAFFIC SIGNS (11)	DRAWING NO. RA-13	DATE	SCALE (A1 SIZE) 1:1000	APPROVED	CHECKED	SHEET NO. 13/33
---	---	---	--	----------------------	------	------------------------------	----------	---------	--------------------

# LAYOUT PLAN OF TYPICAL TRAFFIC SIGNS(12)

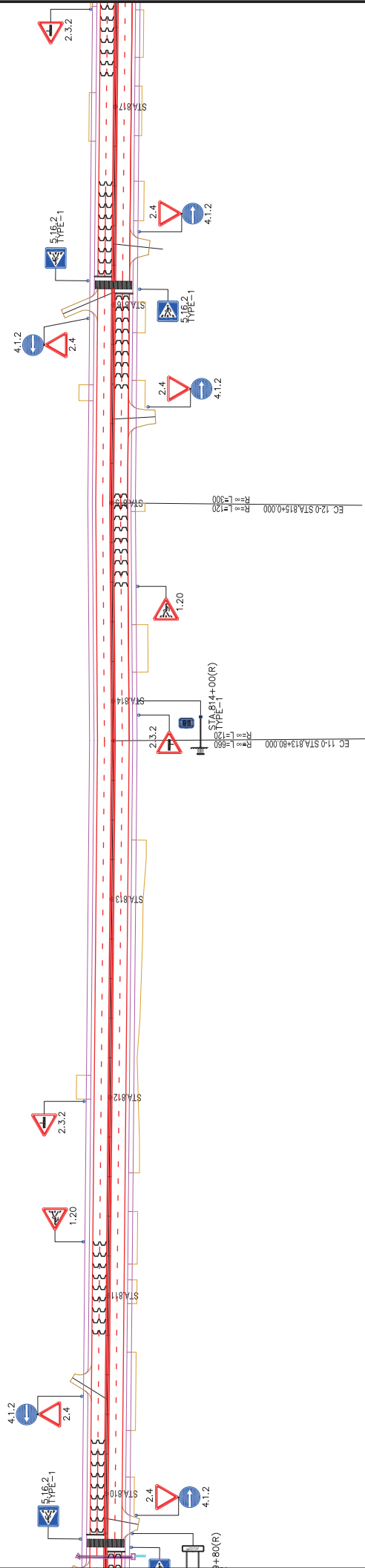

REPUBLIC OF TAJIKISTAN MINISTRY OF TRANSPORT	THE PREPARATORY SURVEY FOR THE PROJECT FOR REHABILITATION OF KIZILKALA-BOKHTAR SECTION OF DUSHANBE-BOKHTAR ROAD IN THE REPUBLIC OF TAJIKISTAN	JAPAN INTERNATIONAL COOPERATION AGENCY CTI ENGINEERING INTERNATIONAL CO., LTD.	TITLE: <b>LAYOUT PLAN OF TYPICAL TRAFFIC SIGNS (12)</b>	CHECKED APPROVED SCALE (A1 SIZE) 1:1000 DATE DRAWING NO. RA-14 SHEET NO. 14/33
---	---	---	--	---

# LAYOUT PLAN OF TYPICAL TRAFFIC SIGNS(13)

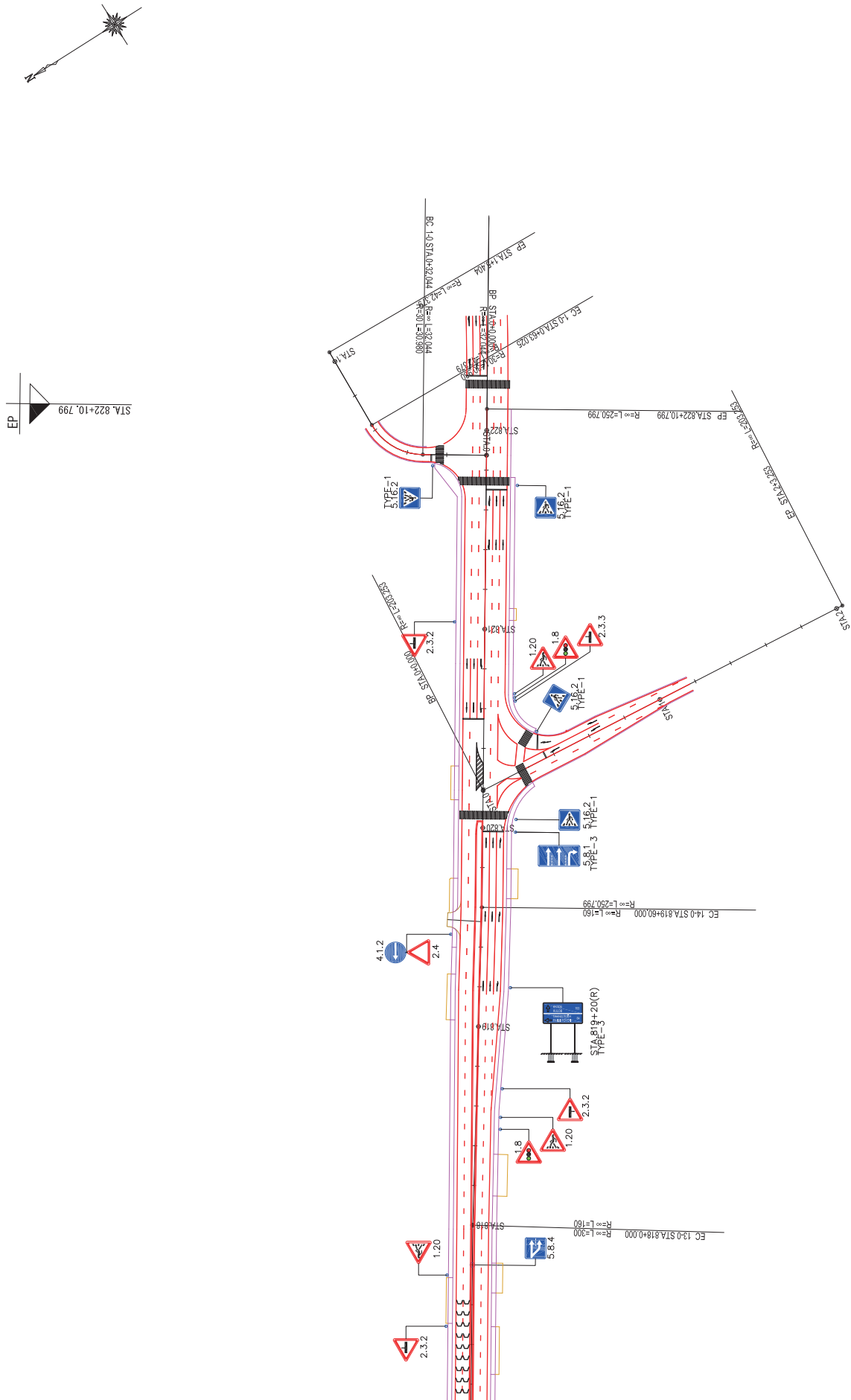

SHEET NO.	DRAWING NO.	DATE	SCALE (A1 SIZE)	APPROVED	CHECKED	TITLE:	JAPAN INTERNATIONAL COOPERATION AGENCY CTI ENGINEERING INTERNATIONAL CO., LTD.	SHEET NO.
15/33	RA-15		1:1000			LAYOUT PLAN OF TYPICAL TRAFFIC SIGNS (13)	THE PREPARATORY SURVEY FOR THE PROJECT FOR REHABILITATION OF KIZILKALA-BOKHTAR SECTION OF DUSHANBE-BOKHTAR ROAD IN THE REPUBLIC OF TAJIKISTAN	15/33

# TYPICAL TRAFFIC SIGNS

## WARNING SIGN AND REGULATORY SIGN

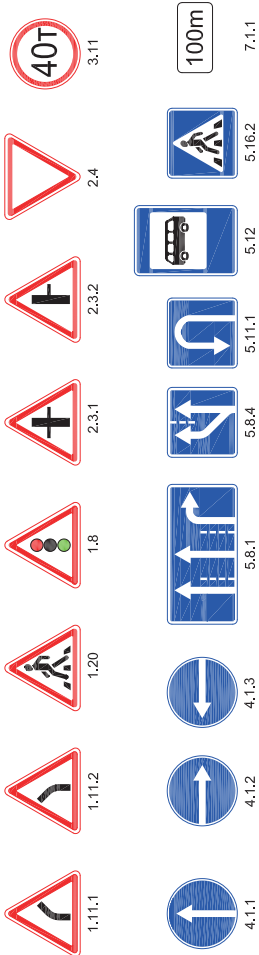

## INFORMATION / GUIDE SIGNS

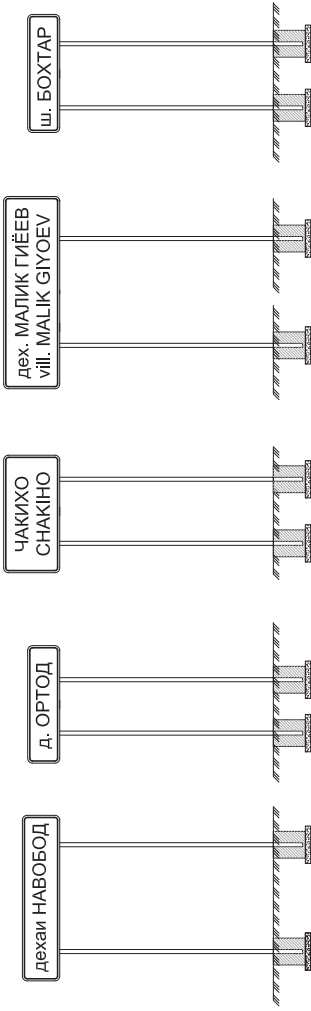

## CONCRETE FOUNDATION FOR INFORMATION/GUIDE SIGNS

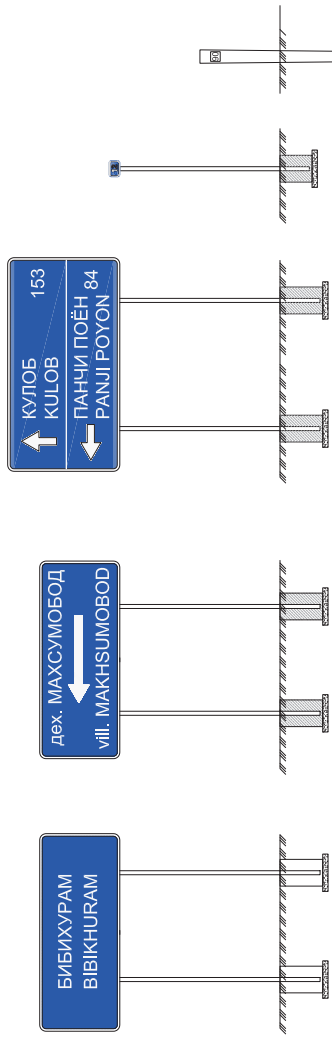

## SIZE FOR INFORMATION / VILLAGE SIGNS

SCALE=1:150

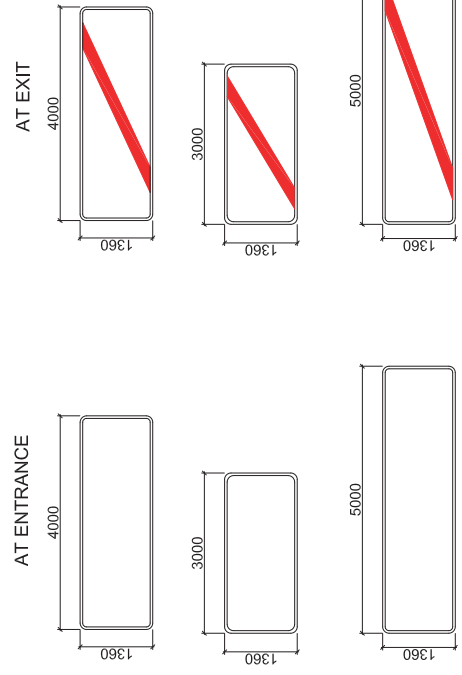

FRONT VIEW

SIDE VIEW

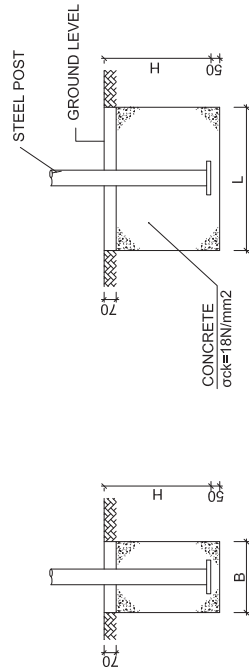

## TYPICAL INSTALLATION OF TRAFFIC SIGN

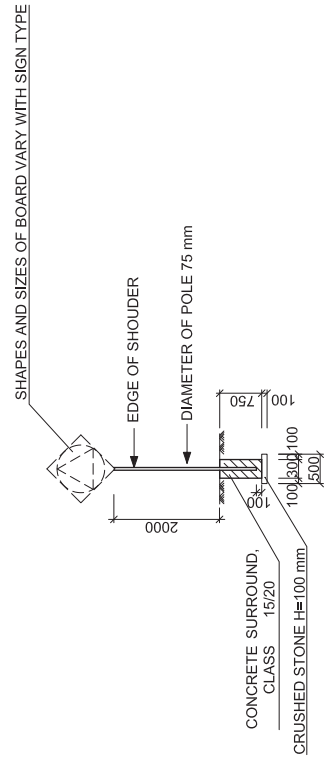

REPUBLIC OF TAJIKISTAN MINISTRY OF TRANSPORT	THE PREPARATORY SURVEY FOR THE PROJECT FOR REHABILITATION OF KIZILKALA-BOKHTAR SECTION OF DUSHANBE-BOKHTAR ROAD IN THE REPUBLIC OF TAJIKISTAN	TITLE: TYPICAL TRAFFIC SIGNS	CHECKED	APPROVED	SCALE (A1 SIZE) 1:150	DATE	DRAWING NO. RA-16	SHEET NO. 16/33
---	---	---------------------------------	---------	----------	-----------------------------	------	----------------------	--------------------

# LAYOUT PLAN OF ROAD MARKINGS (1)



RUMBLE STRIPS L=2250.00

EDGE LINE (SOLID/WHITE) W=10cm L=1544.00

LANE LINE (BROKEN/WHITE) W=10cm L=1544.00

EDGE LINE (SOLID/WHITE) W=10cm L=678.00

TRAFFIC LANE SHIFTING ANGLE  $\theta=1^{\circ}34'45''$

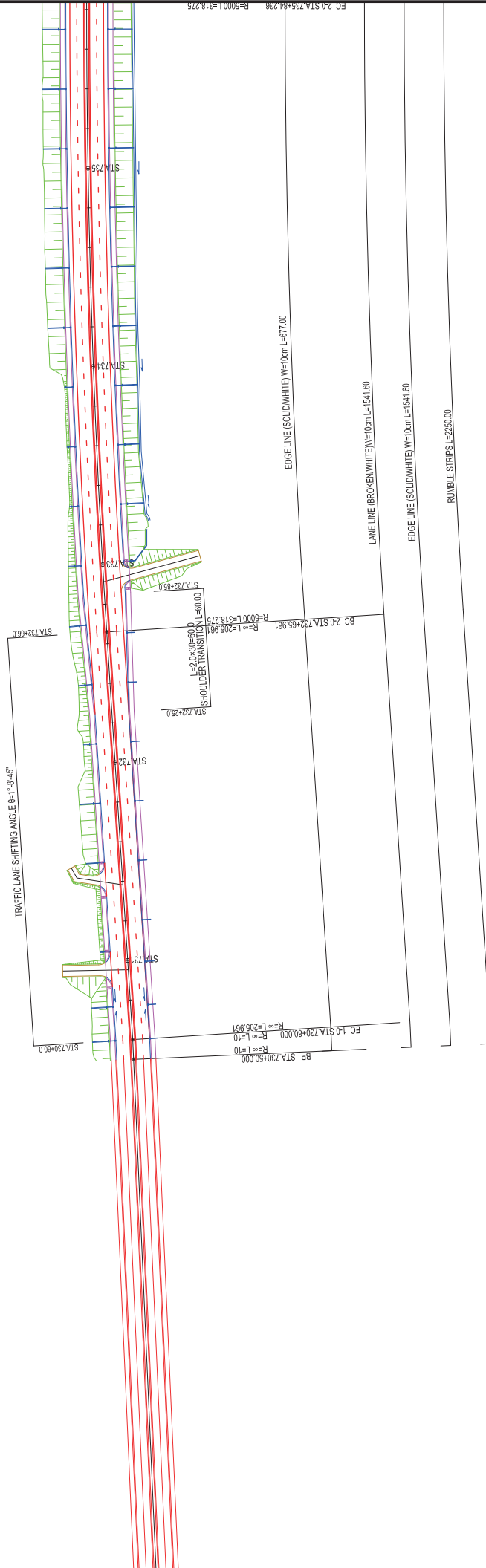

EDGE LINE (SOLID/WHITE) W=10cm L=677.00

LANE LINE (BROKEN/WHITE) W=10cm L=1541.60

EDGE LINE (SOLID/WHITE) W=10cm L=1541.60

RUMBLE STRIPS L=2250.00

REPUBLIC OF TAJIKISTAN MINISTRY OF TRANSPORT	THE PREPARATORY SURVEY FOR THE PROJECT FOR REHABILITATION OF KZILKALA-BOKHTAR SECTION OF DUSHANBE-BOKHTAR ROAD IN THE REPUBLIC OF TAJIKISTAN	JAPAN INTERNATIONAL COOPERATION AGENCY CTI ENGINEERING INTERNATIONAL CO., LTD.	TITLE: <b>LAYOUT PLAN OF ROAD MARKINGS (1)</b>	CHECKED	APPROVED	SCALE (A1 SIZE) 1:1000	DATE	DRAWING NO. <b>RA-17</b>	SHEET NO. <b>17/33</b>
---	--	---	---	---------	----------	------------------------------	------	-----------------------------	---------------------------



# LAYOUT PLAN OF ROAD MARKINGS (3)

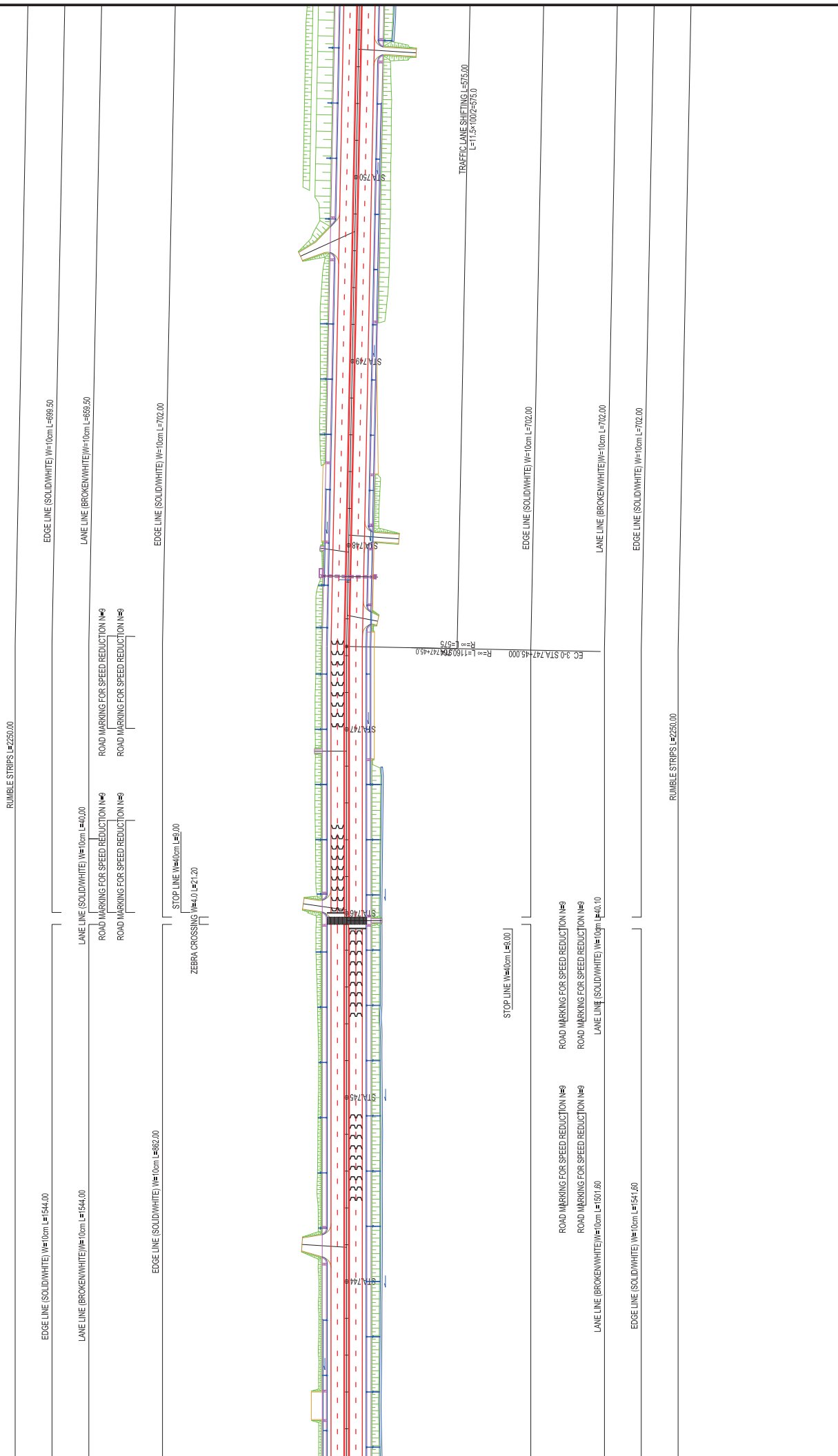

REPUBLIC OF TAJIKISTAN MINISTRY OF TRANSPORT	THE PREPARATORY SURVEY FOR THE PROJECT FOR REHABILITATION OF KZILKALA-BOKHTAR SECTION OF DUSHANBE-BOKHTAR ROAD IN THE REPUBLIC OF TAJIKISTAN	TITLE: <b>LAYOUT PLAN OF ROAD MARKINGS (3)</b>	CHECKED  APPROVED  SCALE (A1 SIZE) 1:1000	DATE  DRAWING NO. RA-19	SHEET NO. 19/33
---	--	---	---	----------------------------------	--------------------

# LAYOUT PLAN OF ROAD MARKINGS (4)

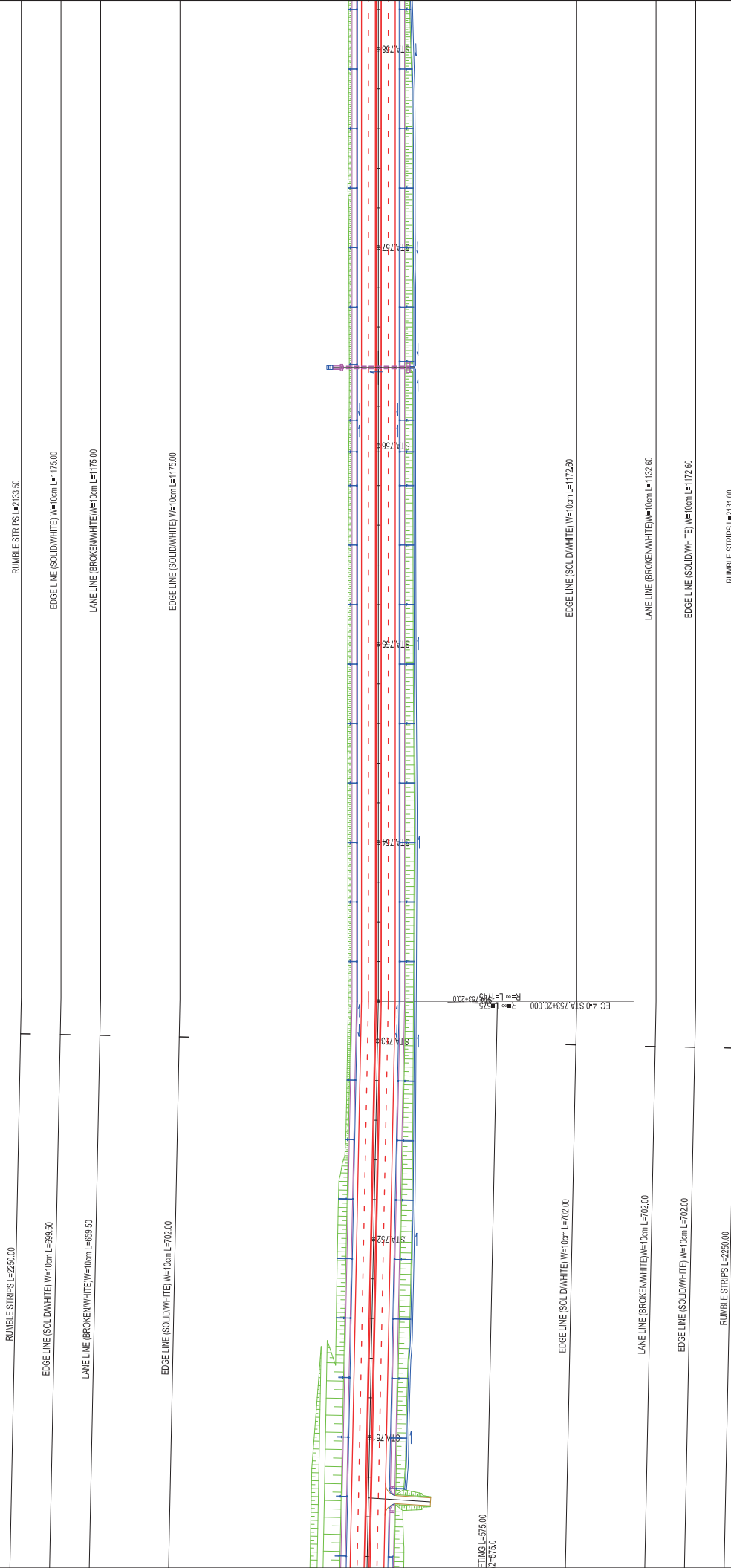

RUMBLE STRIPS L=2133.50

EDGE LINE (SOLID/WHITE) W=10cm L=175.00

LANE LINE (BROKEN/WHITE) W=10cm L=175.00

EDGE LINE (SOLID/WHITE) W=10cm L=175.00

EDGE LINE (SOLID/WHITE) W=10cm L=172.60

LANE LINE (BROKEN/WHITE) W=10cm L=1132.60

EDGE LINE (SOLID/WHITE) W=10cm L=172.60

RUMBLE STRIPS L=2131.00

REPUBLIC OF TAJIKISTAN MINISTRY OF TRANSPORT	THE PREPARATORY SURVEY FOR THE PROJECT FOR REHABILITATION OF KZILKALA-BOKHTAR SECTION OF DUSHANBE-BOKHTAR ROAD IN THE REPUBLIC OF TAJIKISTAN	JAPAN INTERNATIONAL COOPERATION AGENCY CTI ENGINEERING INTERNATIONAL CO., LTD.	TITLE: <b>LAYOUT PLAN OF ROAD MARKINGS (4)</b>	CHECKED	APPROVED	SCALE (A1 SIZE) 1:1000	DATE	DRAWING NO. RA-20	SHEET NO. 20/33
---	--	---	---	---------	----------	------------------------------	------	----------------------	--------------------



# LAYOUT PLAN OF ROAD MARKINGS (5)



RUMBLE STRIPS L=2133.50

EDGE LINE (SOLID/WHITE) W=10cm L=1175.00

LANE LINE (BROKEN/WHITE) W=10cm L=1175.00

EDGE LINE (SOLID/WHITE) W=10cm L=1175.00

STOP LINE W=40cm L=9.00  
ZEBRA CROSSING W=4.0 L=21.20

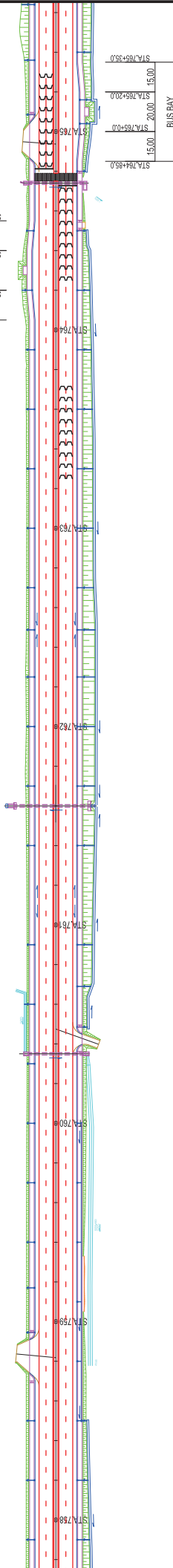
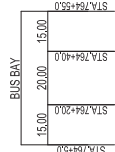

STOP LINE W=40cm L=9.00

EDGE LINE (SOLID/WHITE) W=10cm L=1172.60

LANE LINE (BROKEN/WHITE) W=10cm L=1132.60

EDGE LINE (SOLID/WHITE) W=10cm L=1172.60

RUMBLE STRIPS L=2133.00

ROAD MARKING FOR SPEED REDUCTION N=9  
ROAD MARKING FOR SPEED REDUCTION N=9  
ROAD MARKING FOR SPEED REDUCTION N=9  
LANE LINE (SOLID/WHITE) W=10cm L=1132.00

REPUBLIC OF TAJIKISTAN MINISTRY OF TRANSPORT	THE PREPARATORY SURVEY FOR THE PROJECT FOR REHABILITATION OF KIZILKALA-BOKHTAR SECTION OF DUSHANBE-BOKHTAR ROAD IN THE REPUBLIC OF TAJIKISTAN	JAPAN INTERNATIONAL COOPERATION AGENCY CTI ENGINEERING INTERNATIONAL CO., LTD.	TITLE: LAYOUT PLAN OF ROAD MARKINGS (5)	CHECKED APPROVED SCALE (A1 SIZE) 1:1000 DATE DRAWING NO. RA-21 SHEET NO. 21/33
---	---	---	--	--

# LAYOUT PLAN OF ROAD MARKINGS (6)



RUMBLE STRIPS L=2133.50

EDGE LINE (SOLID/WHITE) W=10cm L=62.00

LANE LINE (BROKEN/WHITE) W=10cm L=912.00

ROAD MARKING FOR SPEED REDUCTION W=6

ROAD MARKING FOR SPEED REDUCTION W=6

cm L=62.00

EDGE LINE (SOLID/WHITE) W=10cm L=64.50

TRAFFIC LANE SHIFTING L=225.00  
L=4.5% 100P=225.0



EDGE LINE (SOLID/WHITE) W=10cm L=62.00

LANE LINE (BROKEN/WHITE) W=10cm L=912.00

EDGE LINE (SOLID/WHITE) W=10cm L=62.00

RUMBLE STRIPS L=2133.00

REPUBLIC OF TAJIKISTAN MINISTRY OF TRANSPORT	THE PREPARATORY SURVEY FOR THE PROJECT FOR REHABILITATION OF KIZILKALA-BOKHTAR SECTION OF DUSHANBE-BOKHTAR ROAD IN THE REPUBLIC OF TAJIKISTAN	JAPAN INTERNATIONAL COOPERATION AGENCY CTI ENGINEERING INTERNATIONAL CO., LTD.	TITLE: <b>LAYOUT PLAN OF ROAD MARKINGS (6)</b>	CHECKED	APPROVED	SCALE (A1 SIZE) 1:1000	DATE	DRAWING NO. RA-22	SHEET NO. 22/33
---	---	---	---	---------	----------	------------------------------	------	----------------------	--------------------



# LAYOUT PLAN OF ROAD MARKINGS (8)



RUMBLE STRIPS L=2020.00

EDGE LINE (SOLID/WHITE) W=10cm L=488.00

EDGE LINE (SOLID/WHITE) W=10cm L=483.50

LANE LINE (BROKEN/WHITE) W=10cm L=458.00

LANE LINE (BROKEN/WHITE) W=10cm L=413.50

ROAD MARKING FOR SPEED REDUCTION №9

ROAD MARKING FOR SPEED REDUCTION №9

EDGE LINE (SOLID/WHITE) W=10cm L=488.00

EDGE LINE (SOLID/WHITE) W=10cm L=486.00

STOP LINE W=40cm L=21.00

ZEBRA CROSSING W=4.0 L=21.20

BUS BAY	
15.00	STA.781+85.0
20.00	STA.782+20.0
15.00	STA.782+35.0

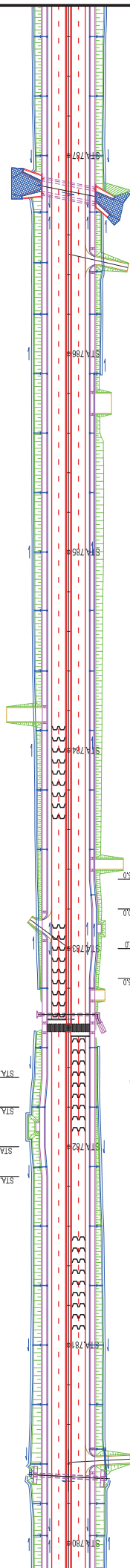

BUS BAY	
15.00	STA.782+48.0
20.00	STA.783+03.0
15.00	STA.783+58.0

STOP LINE W=40cm L=31.00

EDGE LINE (SOLID/WHITE) W=10cm L=488.00

EDGE LINE (SOLID/WHITE) W=10cm L=486.00

ROAD MARKING FOR SPEED REDUCTION №9

ROAD MARKING FOR SPEED REDUCTION №9

LANE LINE (BROKEN/WHITE) W=10cm L=415.60

LANE LINE (BROKEN/WHITE) W=10cm L=413.50

EDGE LINE (SOLID/WHITE) W=10cm L=455.60

EDGE LINE (SOLID/WHITE) W=10cm L=453.50

RUMBLE STRIPS L=2020.00

REPUBLIC OF TAJIKISTAN  
MINISTRY OF TRANSPORT

THE PREPARATORY SURVEY FOR THE PROJECT FOR REHABILITATION OF  
KZILKALA-BOKHTAR SECTION OF DUSHANBE-BOKHTAR ROAD  
IN THE REPUBLIC OF TAJIKISTAN

JAPAN INTERNATIONAL COOPERATION AGENCY  
CTI ENGINEERING INTERNATIONAL CO., LTD.

TITLE:  
LAYOUT PLAN OF ROAD MARKINGS (8)

CHECKED  
APPROVED  
SCALE (A1 SIZE)  
1:1000  
DATE

DRAWING NO.  
RA-24  
SHEET NO.  
24/33

# LAYOUT PLAN OF ROAD MARKINGS (9)



RUMBLE STRIPS L=5200.00

EDGE LINE (SOLID/WHITE) W=10cm L=4633.60

LANE LINE (BROKEN/WHITE) W=10cm L=4633.60

EDGE LINE (SOLID/WHITE) W=10cm L=4633.60

LANE LINE (SOLID/WHITE) W=10cm L=40.00

ROAD MARKING FOR SPEED REDUCTION N=9

ROAD MARKING FOR SPEED REDUCTION N=9

EDGE LINE (SOLID/WHITE) W=10cm L=4666.00

EDGE LINE (SOLID/WHITE) W=10cm L=4666.00

STOP LINE W=40.0 L=21.20

ZEBRA CROSSING W=4.0 L=21.20

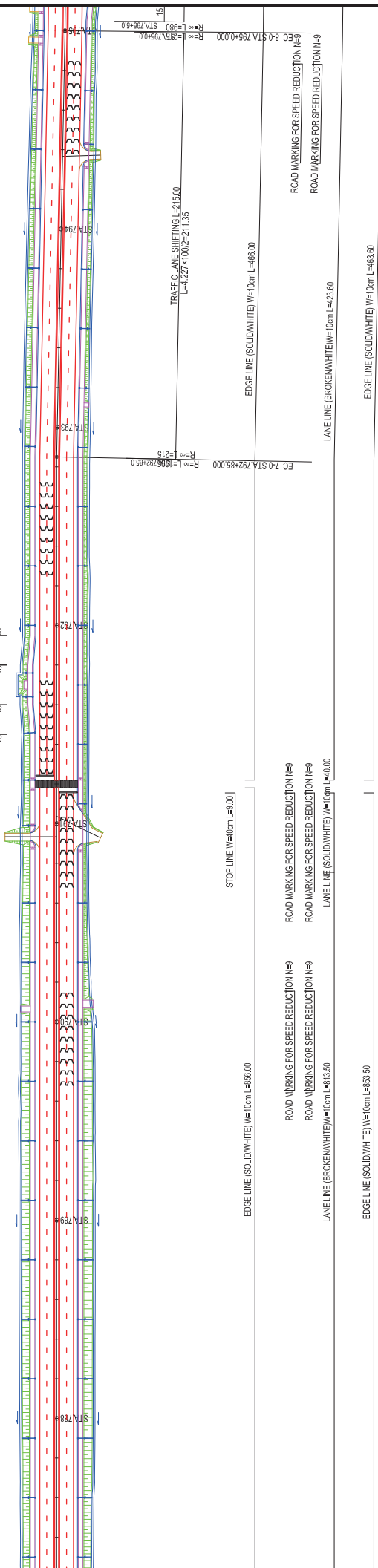
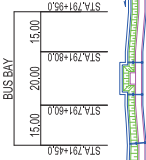

STOP LINE W=40cm L=60.00

EDGE LINE (SOLID/WHITE) W=10cm L=4666.00

ROAD MARKING FOR SPEED REDUCTION N=9

ROAD MARKING FOR SPEED REDUCTION N=9

LANE LINE (SOLID/WHITE) W=10cm L=40.00

EDGE LINE (SOLID/WHITE) W=10cm L=4666.00

ROAD MARKING FOR SPEED REDUCTION N=9

ROAD MARKING FOR SPEED REDUCTION N=9

LANE LINE (BROKEN/WHITE) W=10cm L=423.80

EDGE LINE (SOLID/WHITE) W=10cm L=4666.00

EDGE LINE (SOLID/WHITE) W=10cm L=4666.00

RUMBLE STRIPS L=5200.00

REPUBLIC OF TAJIKISTAN MINISTRY OF TRANSPORT	THE PREPARATORY SURVEY FOR THE PROJECT FOR REHABILITATION OF KZILKALA-BOKHTAR SECTION OF DUSHANBE-BOKHTAR ROAD IN THE REPUBLIC OF TAJIKISTAN	JAPAN INTERNATIONAL COOPERATION AGENCY CTI ENGINEERING INTERNATIONAL CO., LTD.	TITLE: <b>LAYOUT PLAN OF ROAD MARKINGS (9)</b>	CHECKED APPROVED SCALE (A1 SIZE) 1:1000	DRAWING NO. <b>RA-25</b> DATE SHEET NO. <b>26/33</b>
---	--	---	---	--	--

# LAYOUT PLAN OF ROAD MARKINGS (10)

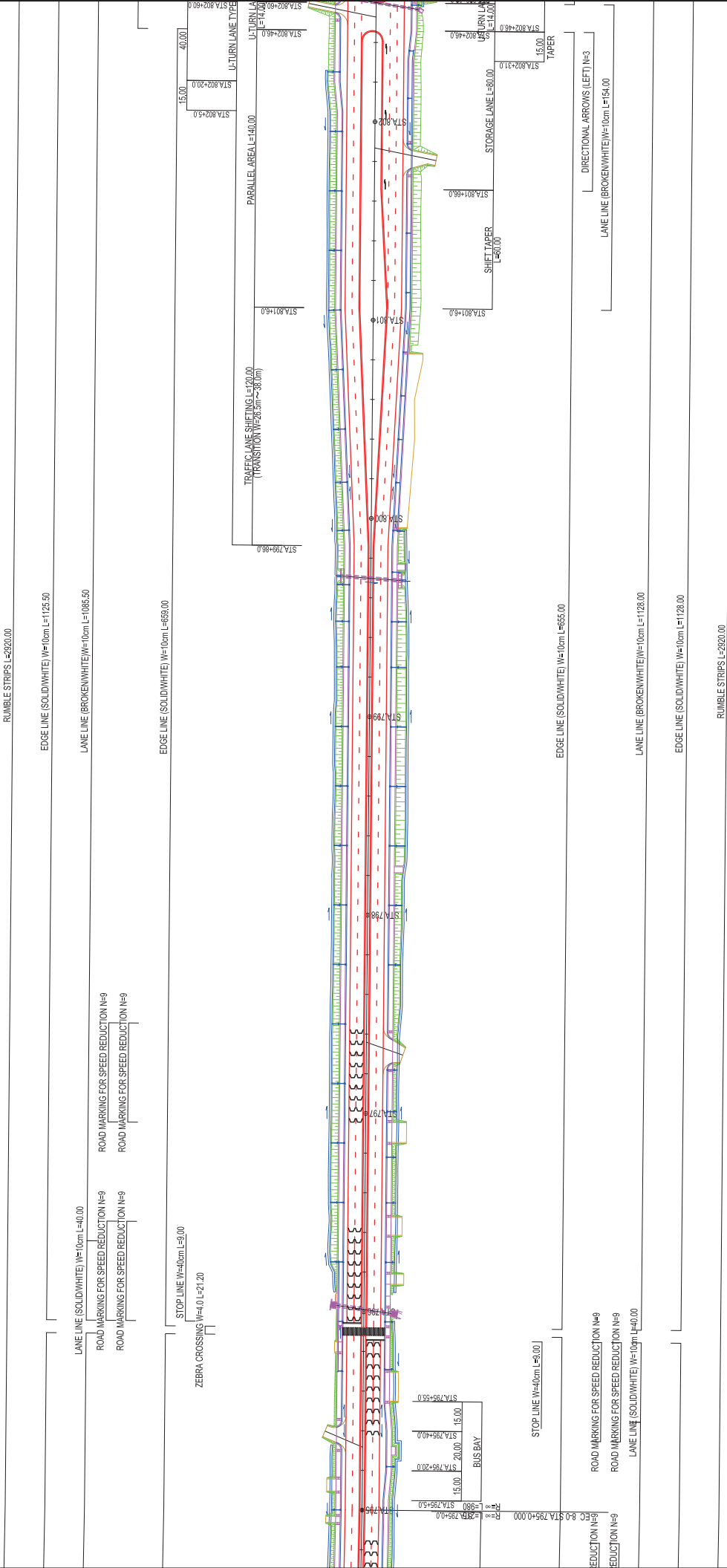

REPUBLIC OF TAJIKISTAN MINISTRY OF TRANSPORT	THE PREPARATORY SURVEY FOR THE PROJECT FOR REHABILITATION OF KZILKALA-BOKHTAR SECTION OF DUSHANBE-BOKHTAR ROAD IN THE REPUBLIC OF TAJIKISTAN	JAPAN INTERNATIONAL COOPERATION AGENCY CTI ENGINEERING INTERNATIONAL CO., LTD.	TITLE: <b>LAYOUT PLAN OF ROAD MARKINGS (10)</b>		CHECKED	APPROVED	SCALE (A1 SIZE) 1:1000	DATE	DRAWING NO. RA-26	SHEET NO. 26/33



# LAYOUT PLAN OF ROAD MARKINGS (12)

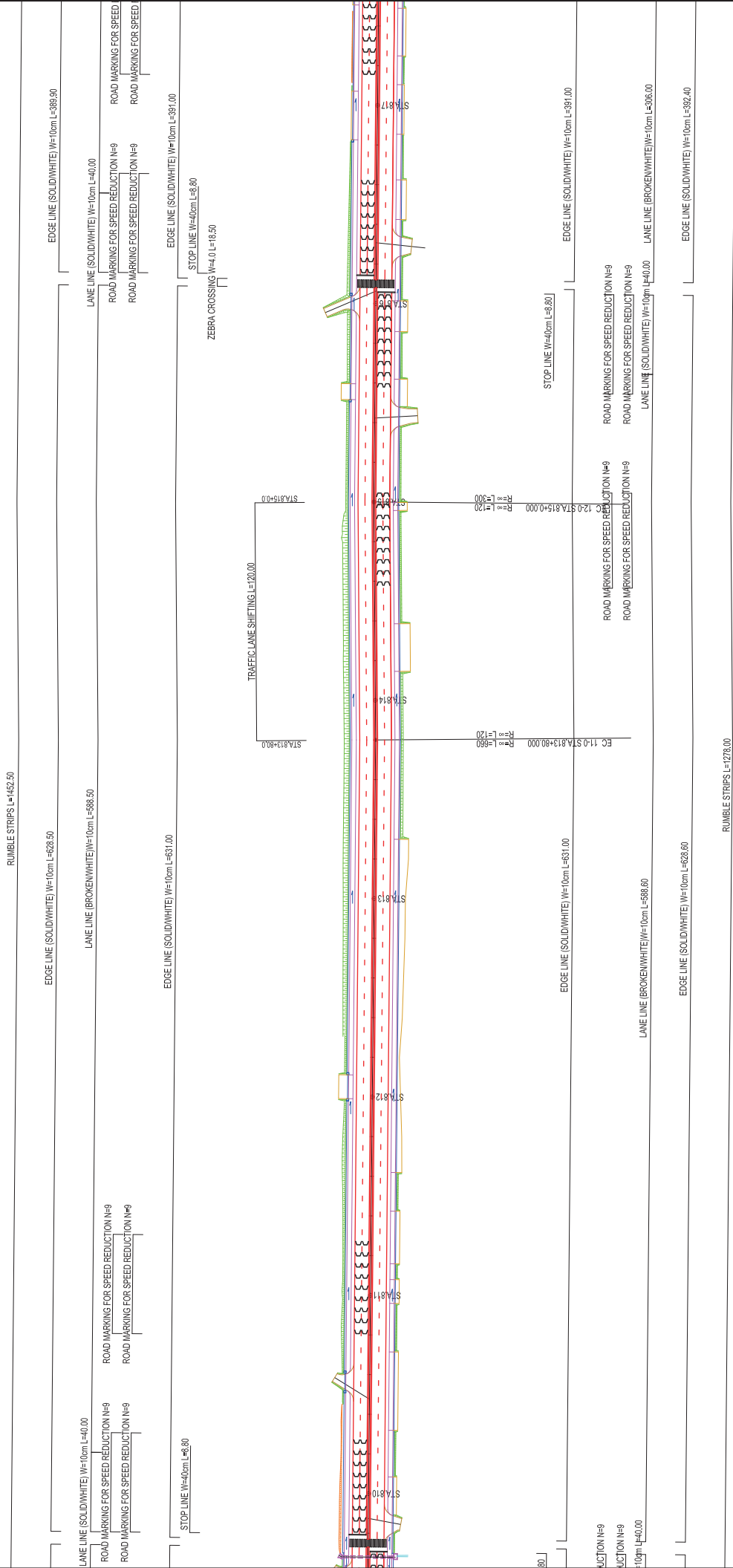

REPUBLIC OF TAJIKISTAN MINISTRY OF TRANSPORT	THE PREPARATORY SURVEY FOR THE PROJECT FOR REHABILITATION OF KIZILKALA-BOKHTAR SECTION OF DUSHANBE-BOKHTAR ROAD IN THE REPUBLIC OF TAJIKISTAN	JAPAN INTERNATIONAL COOPERATION AGENCY CITI ENGINEERING INTERNATIONAL CO., LTD.	TITLE: <b>LAYOUT PLAN OF ROAD MARKINGS (12)</b>	CHECKED	APPROVED	SCALE (A1 SIZE) 1:1000	DATE	DRAWING NO. <b>RA-28</b>	SHEET NO. <b>28/33</b>
---	---	--	--	---------	----------	------------------------------	------	-----------------------------	---------------------------





# ROAD MARKING GENERAL DRAWINGS

S=1:100

TYPE	GOST ID NO.	DESIGN AND DIMENSIONS	TYPE	GOST ID NO.	DESIGN AND DIMENSIONS	TYPE	GOST ID NO.	DESIGN AND DIMENSIONS	TYPE	GOST ID NO.	DESIGN AND DIMENSIONS
EDGE LINE (SOLID/WHITE)	1.1		DIRECTIONAL ARROWS (STRAIGHT)	1.18.1		DIRECTIONAL ARROWS (STRAIGHT & RIGHT)	1.18.2		DIRECTIONAL ARROWS (STRAIGHT & LEFT)	1.18.3	
LANE LINE (SOLID/WHITE)	1.2		DIRECTIONAL ARROWS (RIGHT)	1.18.4		DIRECTIONAL ARROWS (LEFT)	1.18.5		DIRECTIONAL ARROWS (RIGHT & LEFT)	1.18.6	
LANE LINE (BROKEN/WHITE)	1.5		DIRECTIONAL ARROWS (RIGHT)	1.18.4		DIRECTIONAL ARROWS (LEFT)	1.18.5		DIRECTIONAL ARROWS (RIGHT & LEFT)	1.18.6	
STOP LINE	1.12										
CHEVRONS (SOLID/WHITE)	1.16.1										

## MARKING FOR PEDESTRIAN CROSSING (ZEBRA CROSSING)

S=1:50

## ROAD MARKING FOR SPEED REDUCTION

S=1:50

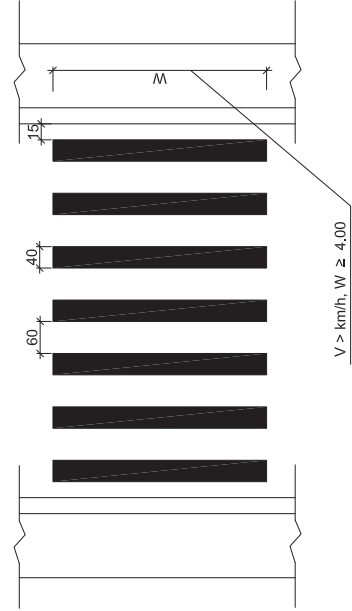

NOTE: ALL DIMENSIONS ARE IN CENTIMETER, UNLESS OTHERWISE MENTIONED.

# PEDESTRIAN GUARDRAIL GENERAL DRAWINGS

CROSS SECTION  
1-1  
S=1:20

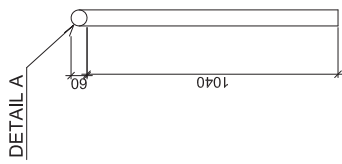

FRONT VIEW S=1:20

INTERMEDIATE SECTION

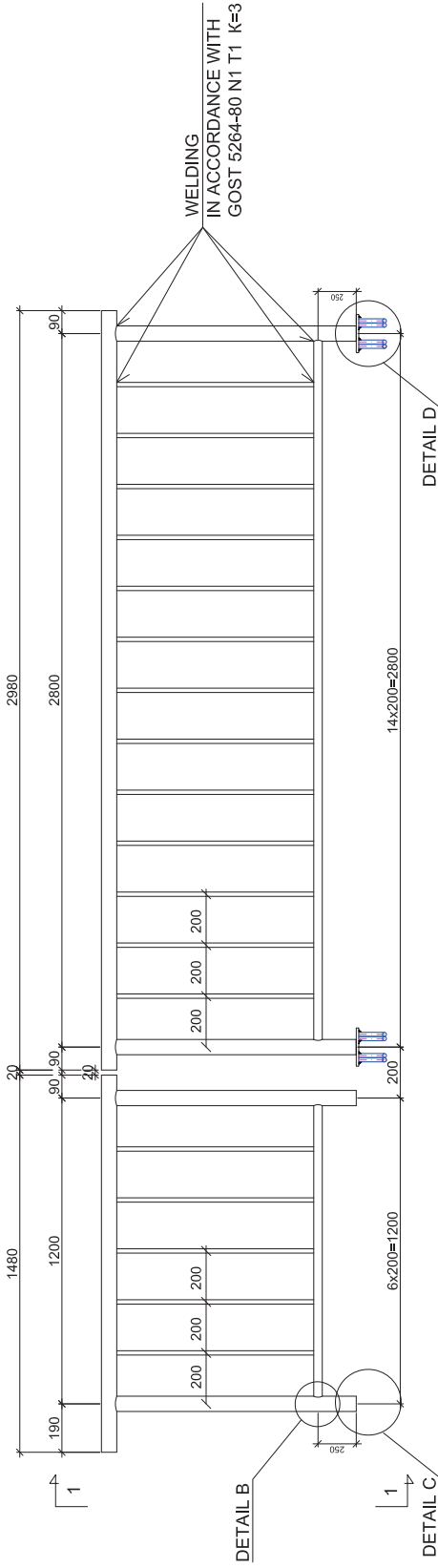

DETAIL A S=1:10

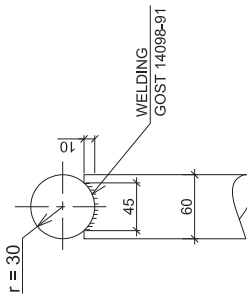

DETAIL C S=1:20  
(INSTALLATION ON SOIL)

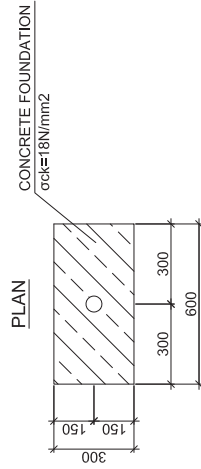

DETAIL D S=1:10  
(INSTALLATION ON CONCRETE STRUCTURE)

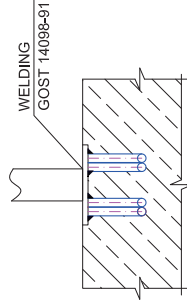

DETAIL B S=1:10

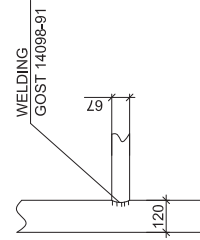

FRONT VIEW

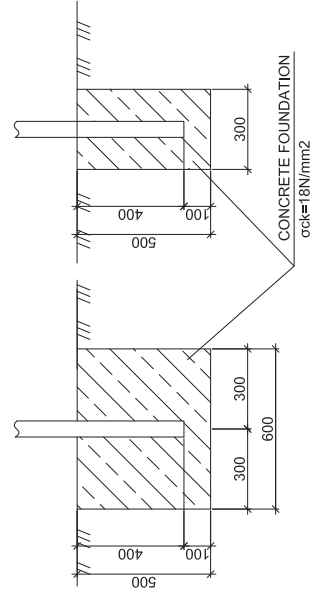

SIDE VIEW

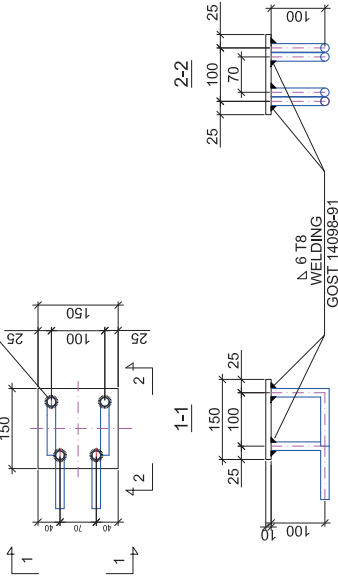

REPUBLIC OF TAJIKISTAN MINISTRY OF TRANSPORT	THE PREPARATORY SURVEY FOR THE PROJECT FOR REHABILITATION OF KIZILKALA-BOKHTAR SECTION OF DUSHANBE-BOKHTAR ROAD IN THE REPUBLIC OF TAJIKISTAN	JAPAN INTERNATIONAL COOPERATION AGENCY CIT ENGINEERING INTERNATIONAL CO., LTD.	TITLE: <b>PEDESTRIAN GUARDRAIL GENERAL DRAWINGS</b>	CHECKED	APPROVED	SCALE (A1 SIZE) 1:20 1:10	DATE	DRAWING NO. RA-31	SHEET NO. 31/33
---	---	---	--	---------	----------	------------------------------------	------	----------------------	--------------------

# CONCRETE PROTECTIVE BARRIER GENERAL DRAWINGS S=1:25

(Note: Specification SECTION 905)

### FRONT VIEW

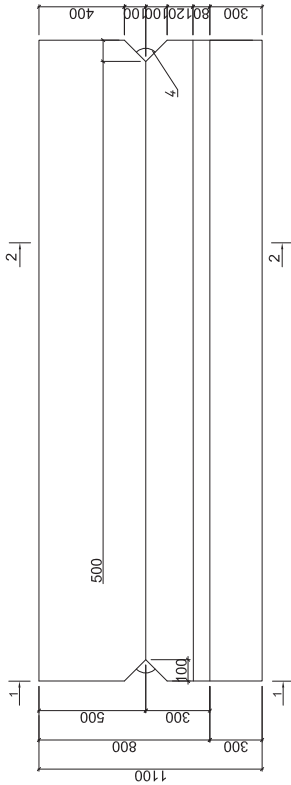

### PLAN

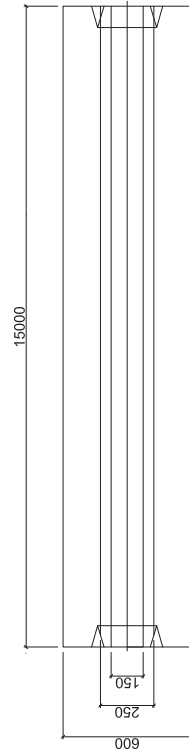

### CROSS SECTION

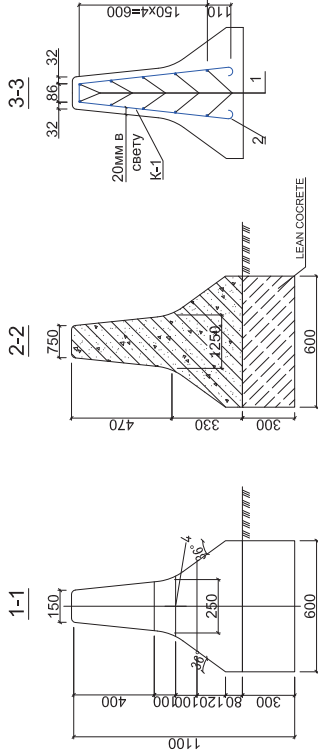

### DETAIL S=1:10

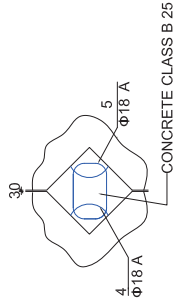

### REINFORCEMENT BAR ARRANGEMENT

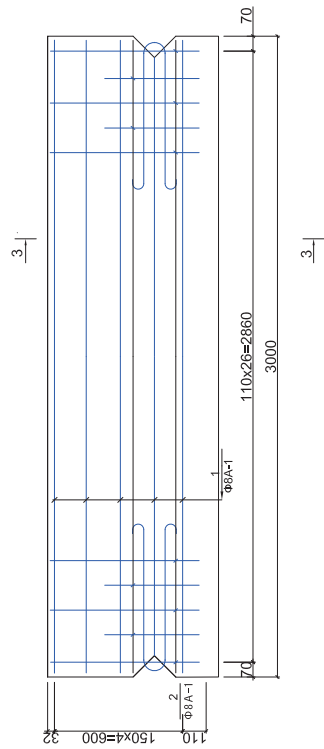

### REINFORCEMENT LIST

LABEL POS:	DESIGN:	Φ,mm	LENGTH mm	QTY:	TOTAL LENGTH m	WEIGHT - 1m Kg	TOTAL WEIGHT Kg	
1	2960	8A-1	2960	10	29.6	0.395	11.7	
2	722	8A-1	1678	14	23.5	0.395	9.3	
3	430	8A-1	492	13	6.4	0.395	2.5	
4	138	18A-1	1450	2	2.9	2.0	5.8	
5	78	18A-1	546	2	1.1	2.0	2.2	
Sub - Total:							Φ8A-1	23.5
Total:							Φ18A-1	8.0
								31.5

# ROAD ANCILLARIES GENERAL DRAWINGS

REFLECTIVE ROAD STUDS SCALE=1:1

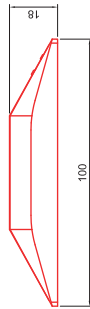
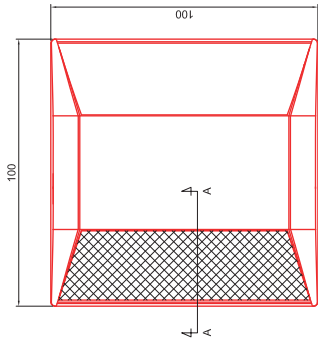

A-A CROSS SECTION SCALE=1:1

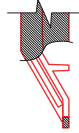

INSTALLED POSITION

SCALE=1:10

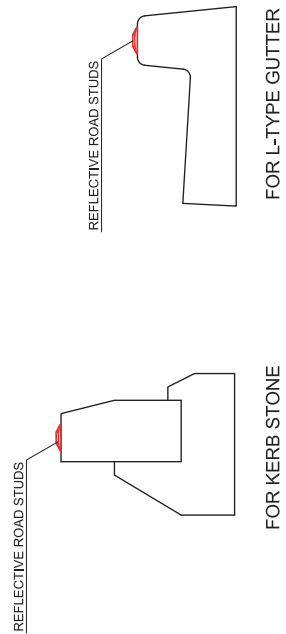

SHOULDER LINE RUMBLE STRIPS

CROSS SECTION SCALE=1:50

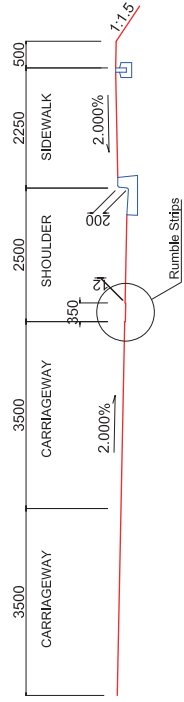

PLAN SCALE=1:50

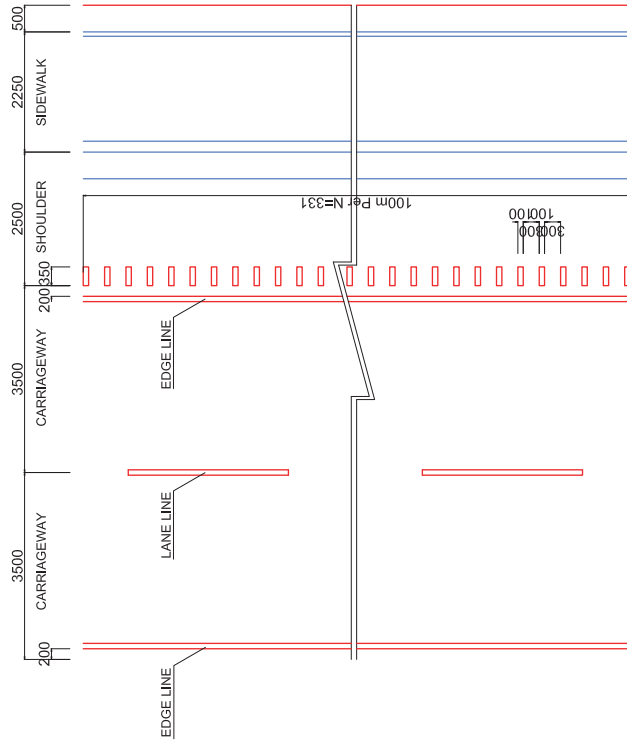

REPUBLIC OF TAJIKISTAN MINISTRY OF TRANSPORT	THE PREPARATORY SURVEY FOR THE PROJECT FOR REHABILITATION OF KIZILKALA-BOKHTAR SECTION OF DUSHANBE-BOKHTAR ROAD IN THE REPUBLIC OF TAJIKISTAN		JAPAN INTERNATIONAL COOPERATION AGENCY CIT ENGINEERING INTERNATIONAL CO., LTD.		TITLE: <b>ROAD ANCILLARIES GENERAL DRAWINGS</b>		CHECKED	APPROVED	SCALE (A1 SIZE) 1:1 1:50	DATE	DRAWING NO. <b>RA-33</b>	SHEET NO. <b>33/33</b>

# LAYOUT PLAN OF STREET LIGHT (1)

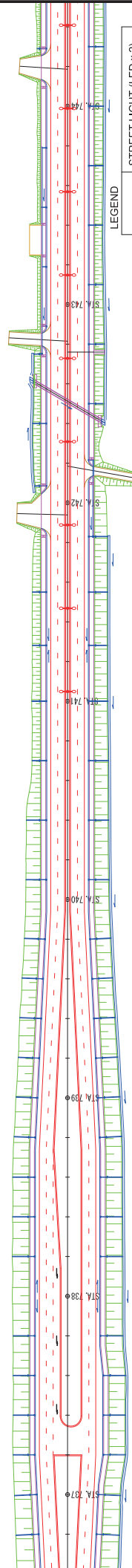
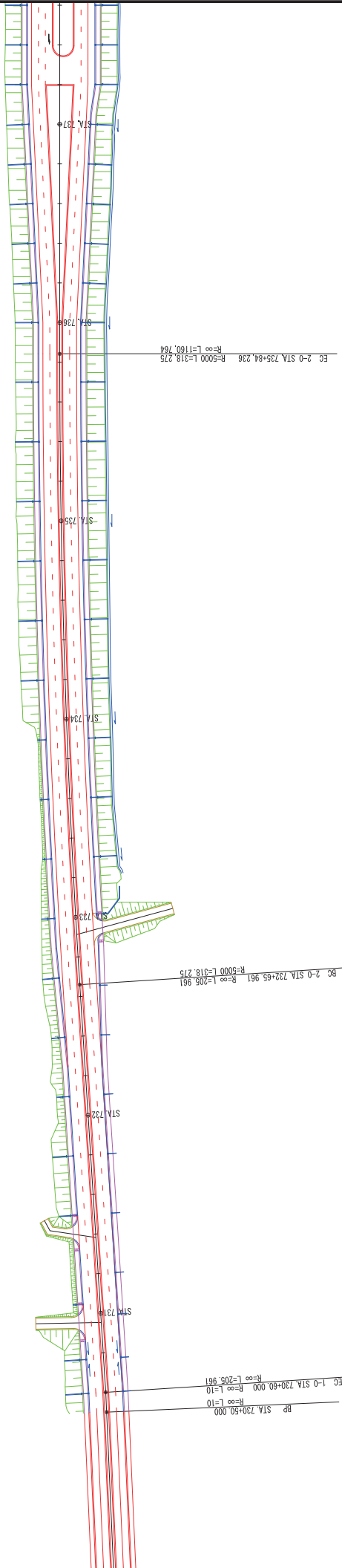

### LEGEND

	STREET LIGHT (LED x 2)
	STREET LIGHT (LED x 1)
	RETRACTABLE POST
	DISTRIBUTION BOARD
	HAND HOLE (600x600x900)
	HAND HOLE (600x600x600)
	FRP (GL-600mm)
	FRP (GL-800mm)



REPUBLIC OF TAJIKISTAN MINISTRY OF TRANSPORT	THE PREPARATORY SURVEY FOR THE PROJECT FOR REHABILITATION OF KZILKALA-BOKHTAR SECTION OF DUSHANBE-BOKHTAR ROAD IN THE REPUBLIC OF TAJIKISTAN	JAPAN INTERNATIONAL COOPERATION AGENCY CTI ENGINEERING INTERNATIONAL CO., LTD.	TITLE:	LAYOUT PLAN OF STREET LIGHT (1)	CHECKED	APPROVED	SCALE (A1 SIZE)	DATE	DRAWING NO.	SHEET NO.
						1:1000		SL-01	1/7	

# LAYOUT PLAN OF STREET LIGHT (2)

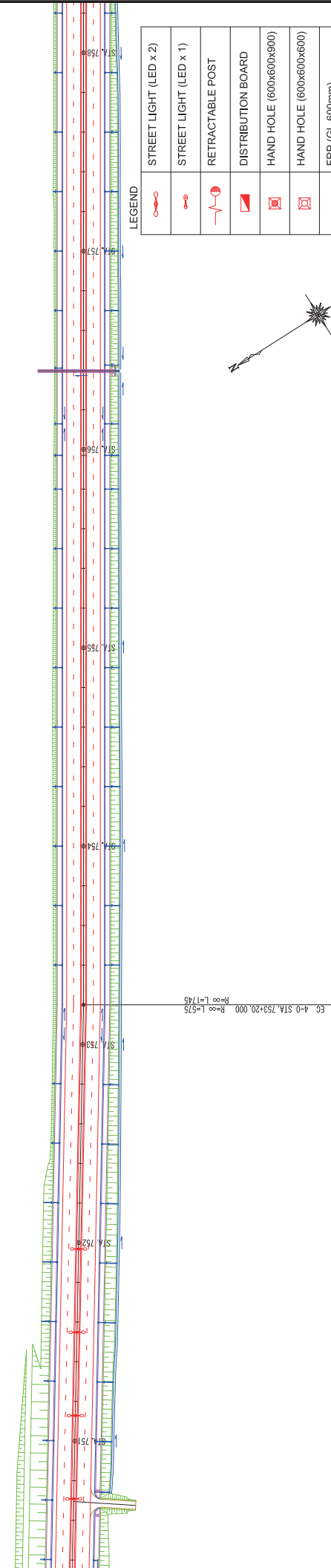
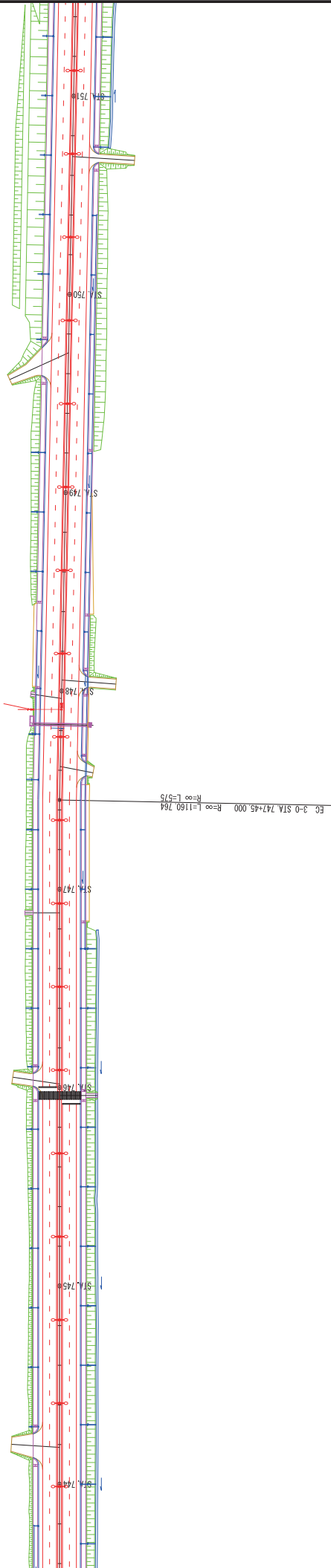

### LEGEND

	STREET LIGHT (LED x 2)
	STREET LIGHT (LED x 1)
	RETRACTABLE POST
	DISTRIBUTION BOARD
	HAND HOLE (600x600x900)
	HAND HOLE (600x600x600)
	FRP (GL-600mm)
	FRP (GL-800mm)



REPUBLIC OF TAJIKISTAN MINISTRY OF TRANSPORT	THE PREPARATORY SURVEY FOR THE PROJECT FOR REHABILITATION OF KIZILKALA-BOKHTAR SECTION OF DUSHANBE-BOKHTAR ROAD IN THE REPUBLIC OF TAJIKISTAN	JAPAN INTERNATIONAL COOPERATION AGENCY CTI ENGINEERING INTERNATIONAL CO., LTD.	TITLE: LAYOUT PLAN OF STREET LIGHT (2)		CHECKED	APPROVED	SCALE (A1 SIZE) 1:1000	DATE	DRAWING NO. SL-02	SHEET NO. 2/7

# LAYOUT PLAN OF STREET LIGHT (3)

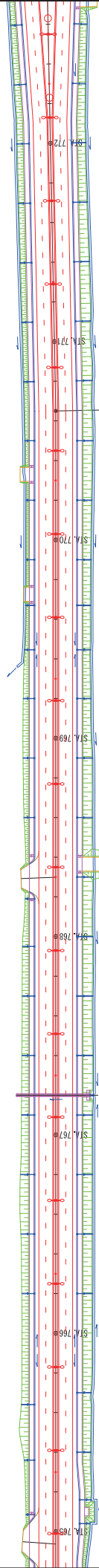
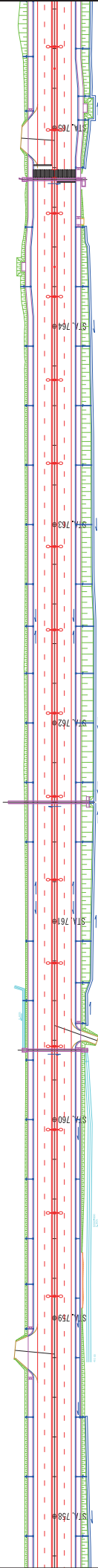

LEGEND

	STREET LIGHT (LED x 2)
	STREET LIGHT (LED x 1)
	RETRACTABLE POST
	DISTRIBUTION BOARD
	HAND HOLE (600x600x900)
	HAND HOLE (600x600x600)
	FRP (GL-600mm)
	FRP (GL-800mm)

EC-5-0 STA 770+65.000 R=∞ L=225  
R=∞ L=1745

REPUBLIC OF TAJIKISTAN MINISTRY OF TRANSPORT	THE PREPARATORY SURVEY FOR THE PROJECT FOR REHABILITATION OF KIZILKALA-BOKHTAR SECTION OF DUSHANBE-BOKHTAR ROAD IN THE REPUBLIC OF TAJIKISTAN	JAPAN INTERNATIONAL COOPERATION AGENCY CTI ENGINEERING INTERNATIONAL CO., LTD.	TITLE:	LAYOUT PLAN OF STREET LIGHT (3)	CHECKED	APPROVED	SCALE (A1 SIZE)	1:1000	DATE	DRAWING NO.	SHEET NO.
										SL-03	3/7



# LAYOUT PLAN OF STREET LIGHT (4)

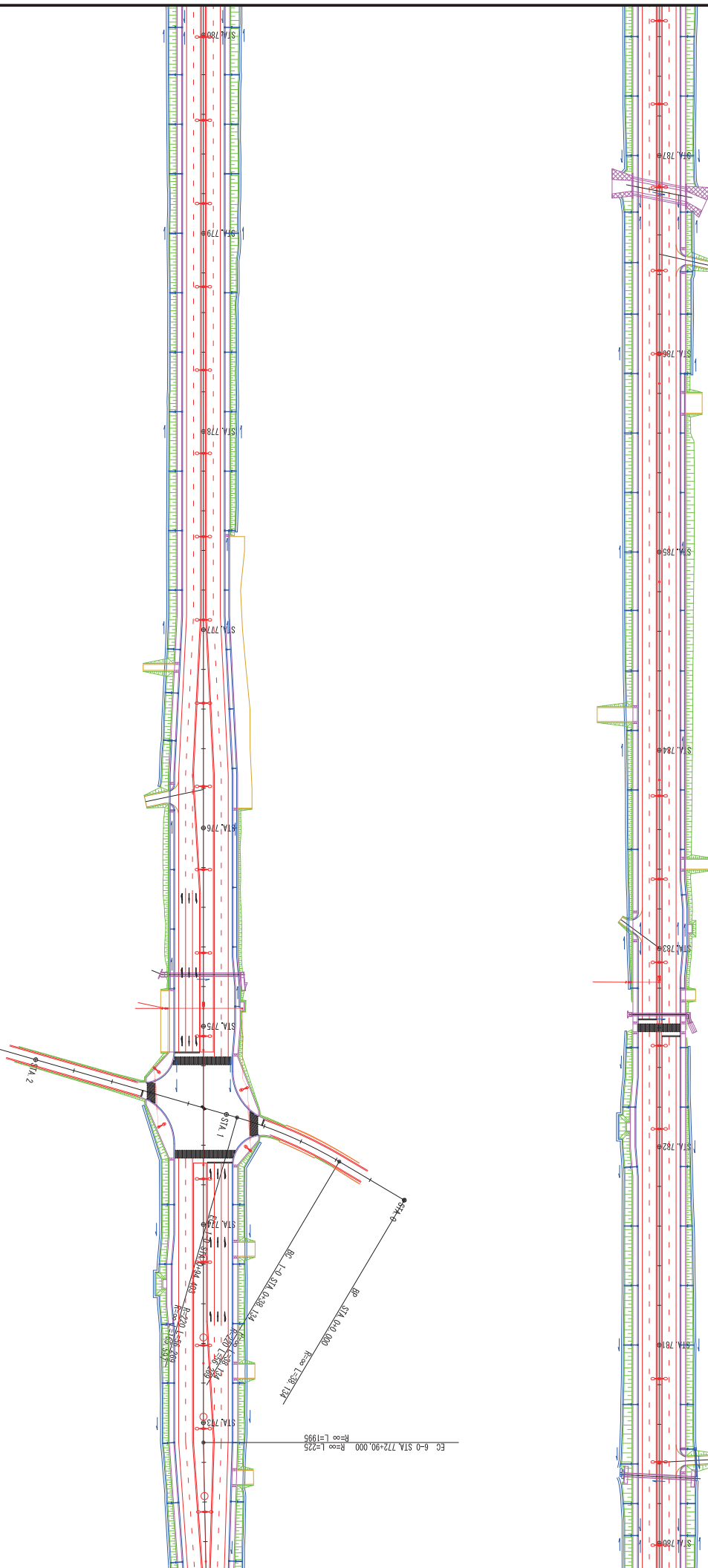

**LEGEND**

	STREET LIGHT (LED x 2)
	STREET LIGHT (LED x 1)
	RETRACTABLE POST
	DISTRIBUTION BOARD
	HAND HOLE (600x600x900)
	HAND HOLE (600x600x600)
	FRP (GL-600mm)
	FRP (GL-800mm)

REPUBLIC OF TAJIKISTAN MINISTRY OF TRANSPORT	THE PREPARATORY SURVEY FOR THE PROJECT FOR REHABILITATION OF KIZILKALA-BOKHTAR SECTION OF DUSHANBE-BOKHTAR ROAD IN THE REPUBLIC OF TAJIKISTAN	JAPAN INTERNATIONAL COOPERATION AGENCY CTI ENGINEERING INTERNATIONAL CO., LTD.	TITLE: <b>LAYOUT PLAN OF STREET LIGHT (4)</b>		CHECKED	APPROVED	SCALE (A1 SIZE) 1:1000	DATE	DRAWING NO. SL-04	SHEET NO. 4/7

# LAYOUT PLAN OF STREET LIGHT (5)

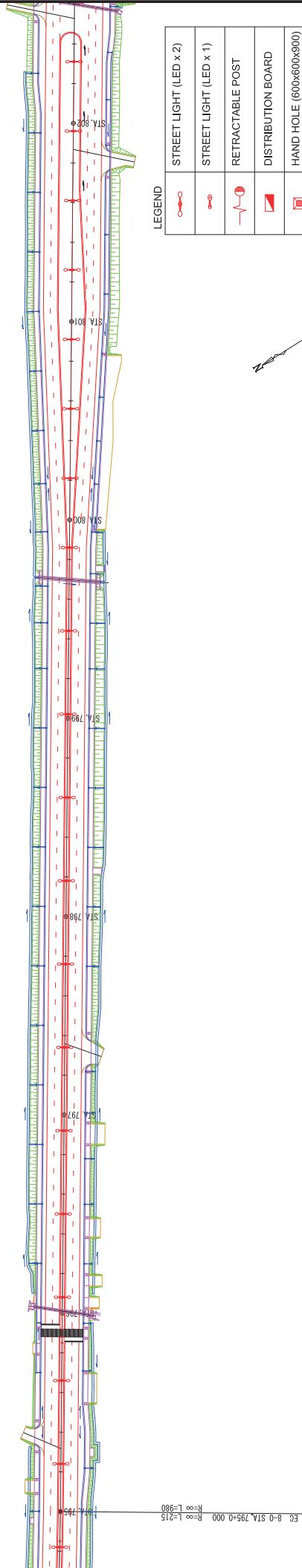
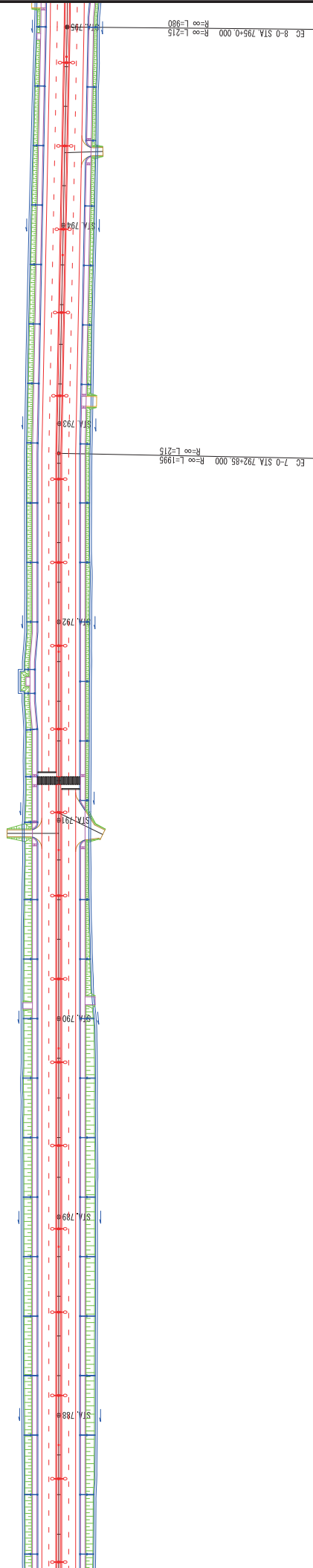

LEGEND

	STREET LIGHT (LED x 2)
	STREET LIGHT (LED x 1)
	RETRACTABLE POST
	DISTRIBUTION BOARD
	HAND HOLE (600x600x900)
	HAND HOLE (600x600x600)
	FRP (GL-600mm)
	FRP (GL-800mm)



REPUBLIC OF TAJIKISTAN MINISTRY OF TRANSPORT	THE PREPARATORY SURVEY FOR THE PROJECT FOR REHABILITATION OF KZILKALA-BOKHTAR SECTION OF DUSHANBE-BOKHTAR ROAD IN THE REPUBLIC OF TAJIKISTAN	JAPAN INTERNATIONAL COOPERATION AGENCY CTI ENGINEERING INTERNATIONAL CO., LTD.	TITLE:	LAYOUT PLAN OF STREET LIGHT (5)	CHECKED	APPROVED	SCALE (A1 SIZE)	1:1000	DATE	DRAWING NO.	SHEET NO.
										SL-05	5/7

# LAYOUT PLAN OF STREET LIGHT (6)

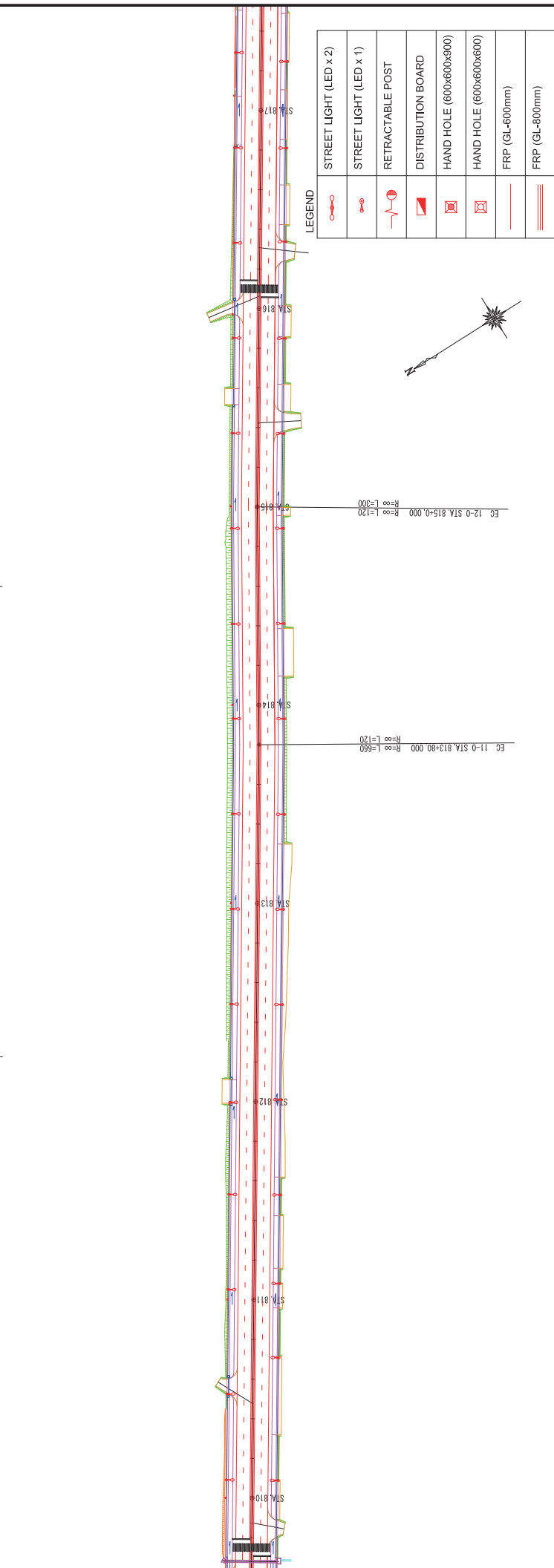
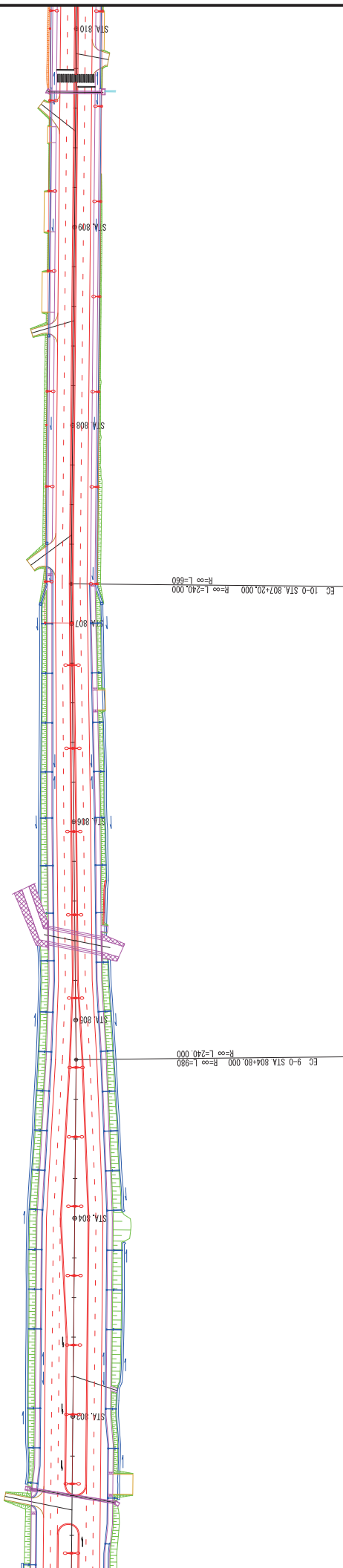

LEGEND

	STREET LIGHT (LED x 2)
	STREET LIGHT (LED x 1)
	RETRACTABLE POST
	DISTRIBUTION BOARD
	HAND HOLE (600x600x900)
	HAND HOLE (600x600x600)
	FRP (GL-600mm)
	FRP (GL-800mm)

REPUBLIC OF TAJIKISTAN MINISTRY OF TRANSPORT	THE PREPARATORY SURVEY FOR THE PROJECT FOR REHABILITATION OF KZILKALA-BOKHTAR SECTION OF DUSHANBE-BOKHTAR ROAD IN THE REPUBLIC OF TAJIKISTAN	JAPAN INTERNATIONAL COOPERATION AGENCY CTI ENGINEERING INTERNATIONAL CO., LTD.	TITLE: <b>LAYOUT PLAN OF STREET LIGHT (6)</b>			CHECKED	APPROVED	SCALE (A1 SIZE) 1:1000	DATE	DRAWING NO. SL-06	SHEET NO. 6/7

# LAYOUT PLAN OF STREET LIGHT (7)

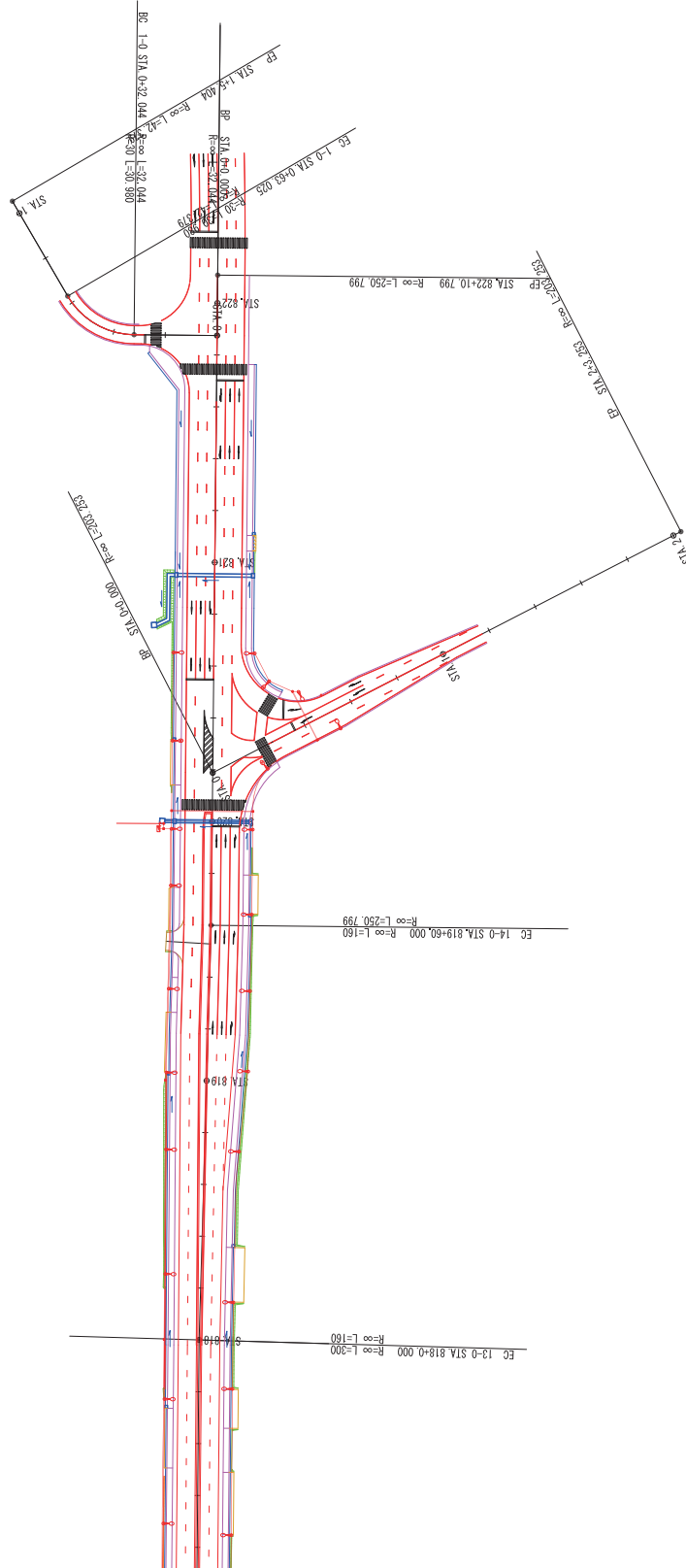

LEGEND

	STREET LIGHT (LED x 2)
	STREET LIGHT (LED x 1)
	RETRACTABLE POST
	DISTRIBUTION BOARD
	HAND HOLE (600x600x600)
	HAND HOLE (600x600x600)
	FRP (GL-600mm)
	FRP (GL-800mm)



REPUBLIC OF TAJIKISTAN MINISTRY OF TRANSPORT	THE PREPARATORY SURVEY FOR THE PROJECT FOR REHABILITATION OF KIZILKALA-BOKHTAR SECTION OF DUSHANBE-BOKHTAR ROAD IN THE REPUBLIC OF TAJIKISTAN	JAPAN INTERNATIONAL COOPERATION AGENCY CTI ENGINEERING INTERNATIONAL CO., LTD.	TITLE: LAYOUT PLAN OF STREET LIGHT (7)		CHECKED	APPROVED	SCALE (A1 SIZE) 1:1000	DATE	DRAWING NO. SL-07	SHEET NO. 7/7

# LAYOUT PLAN OF TRAFFIC SIGNAL(1)

## INTERSECTION-01

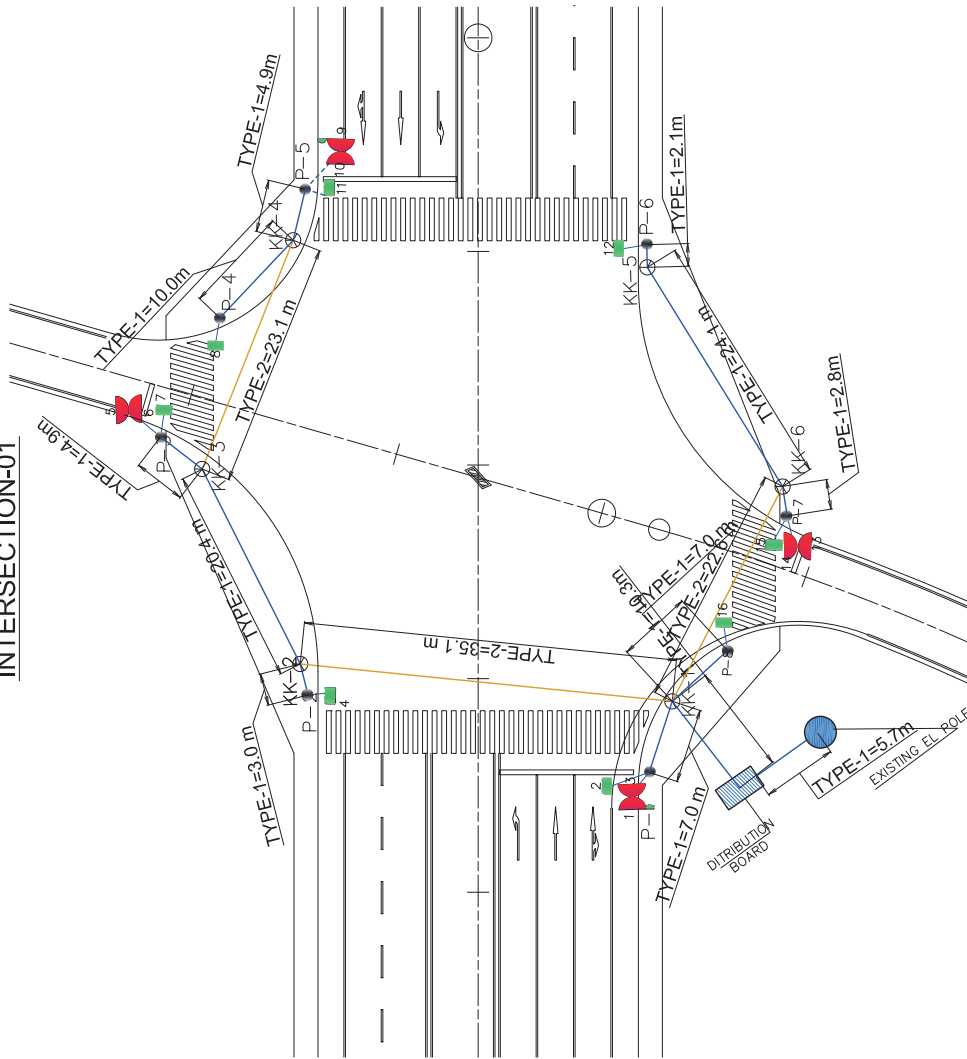

### DISTRIBUTING BOARD

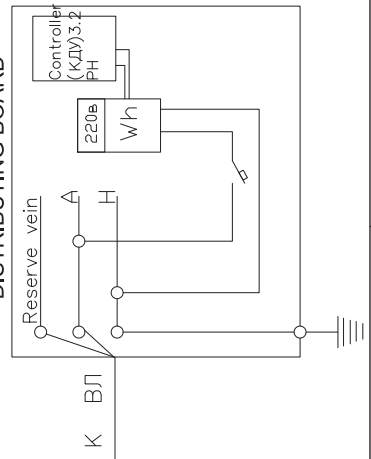

### LEGEND

- |  |          |                                |  |                        |
|--|----------|--------------------------------|--|------------------------|
|  | 1.2.3... | TRAFFIC SIGNALS FOR VEHICLE    |  | CABLE HANDHOLES        |
|  | 1.2.3... | TRAFFIC SIGNALS FOR PEDESTRIAN |  | P-1, P-2, P-3,...      |
|  |          | DISTRIBUTING BOARD             |  | EXISTING ELECTRIC POLE |

### DESCRIPTION

- |  |                    |
|--|--------------------|
|  | AUTOMATICAL SWITCH |
|  | ELECTRICAL COUNTER |

REPUBLIC OF TAJIKISTAN MINISTRY OF TRANSPORT	THE PREPARATORY SURVEY FOR THE PROJECT FOR REHABILITATION OF KZILKALA-BOKHTAR SECTION OF DUSHANBE-BOKHTAR ROAD IN THE REPUBLIC OF TAJIKISTAN	JAPAN INTERNATIONAL COOPERATION AGENCY CTI ENGINEERING INTERNATIONAL CO., LTD.	TITLE:	LAYOUT OF TRAFFIC SIGNAL(1)			CHECKED	APPROVED	SCALE (A1 SIZE) 1:500	DATE	DRAWING NO. TS-01	SHEET NO. 1/3

LAYOUT PLAN OF TRAFFIC SIGNAL(2)

INTERSECTION-02

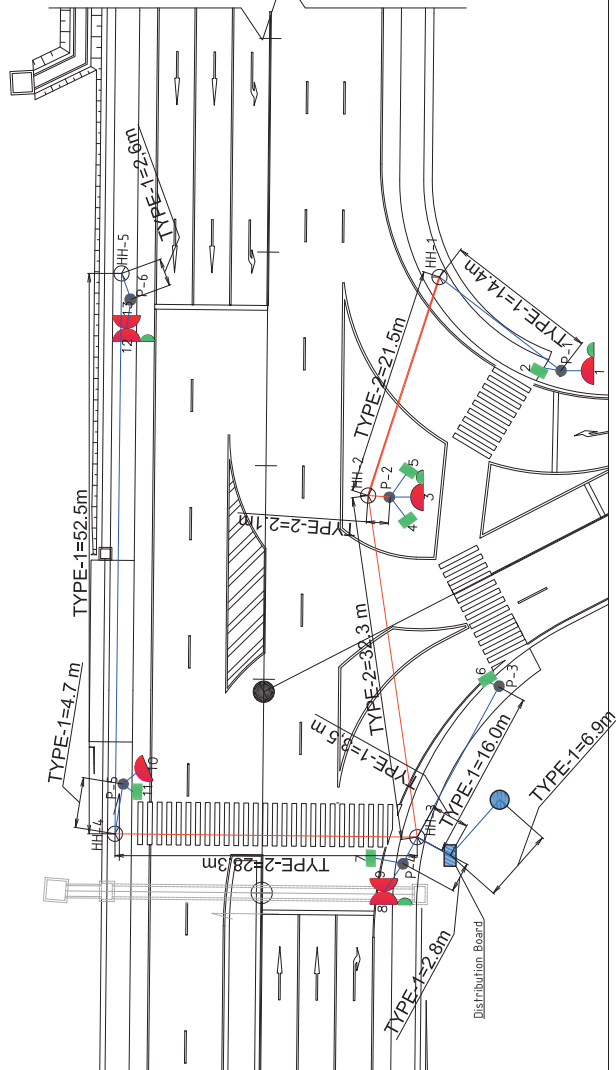

INTERSECTION-03

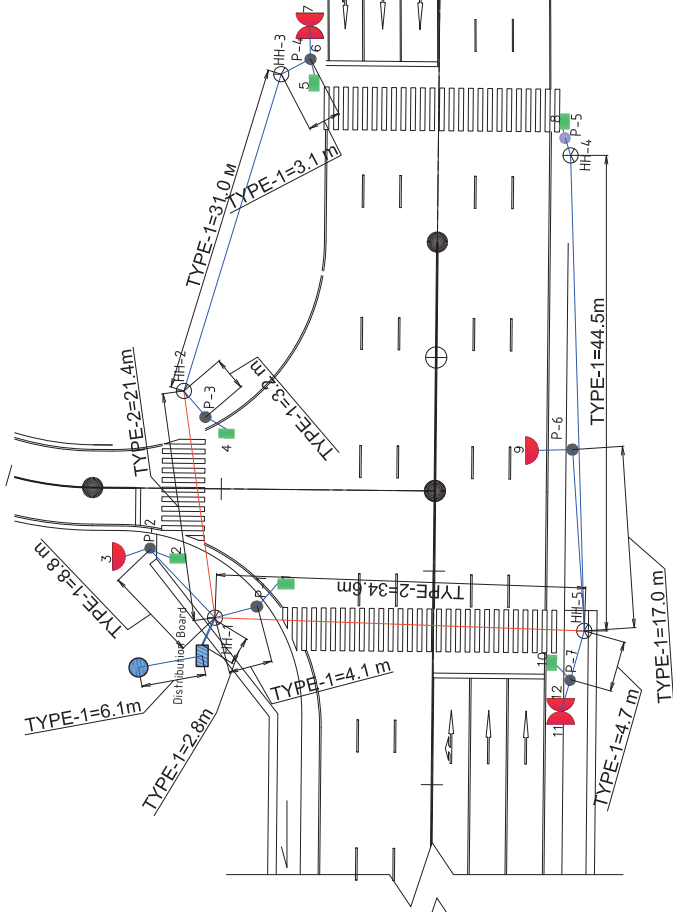

DISTRIBUTING BOARD

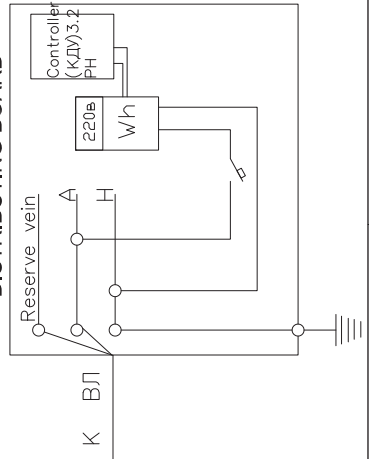

DESCRIPTION



LEGEND

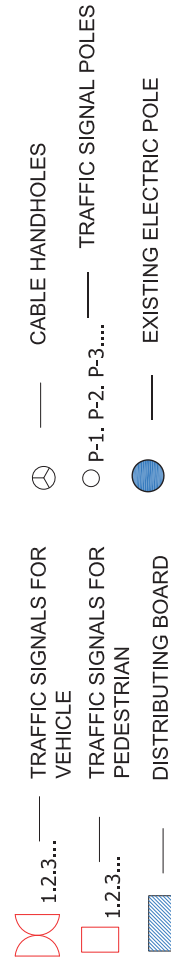

TRAFFIC SIGNAL  
GENERAL DRAWINGS

BINDING OF PEDESTRIAN TRAFFIC LIGHTS  
S=1:20

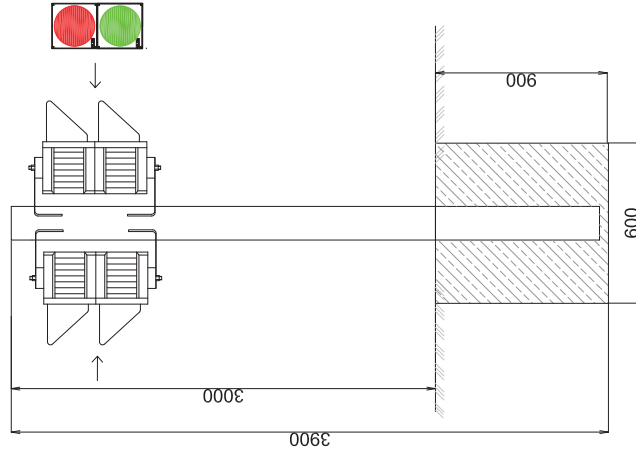

BINDING OF TRANSPORT TRAFFIC LIGHTS  
S=1:20

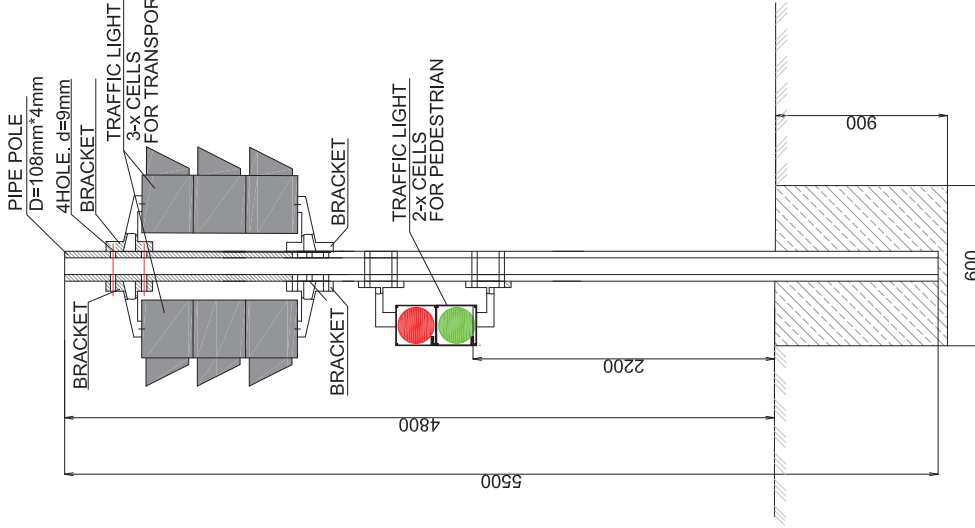

BINDING OF PEDESTRIAN TRAFFIC LIGHTS

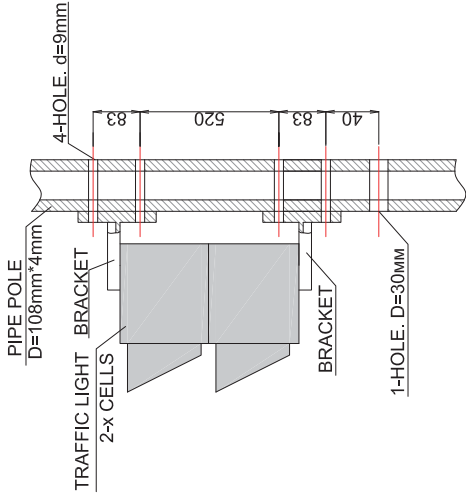

BINDING OF TRANSPORT TRAFFIC LIGHTS

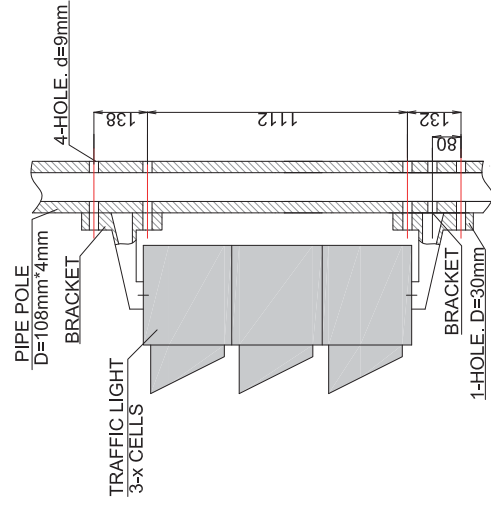

# PROFILE (SECONDARY ROAD)

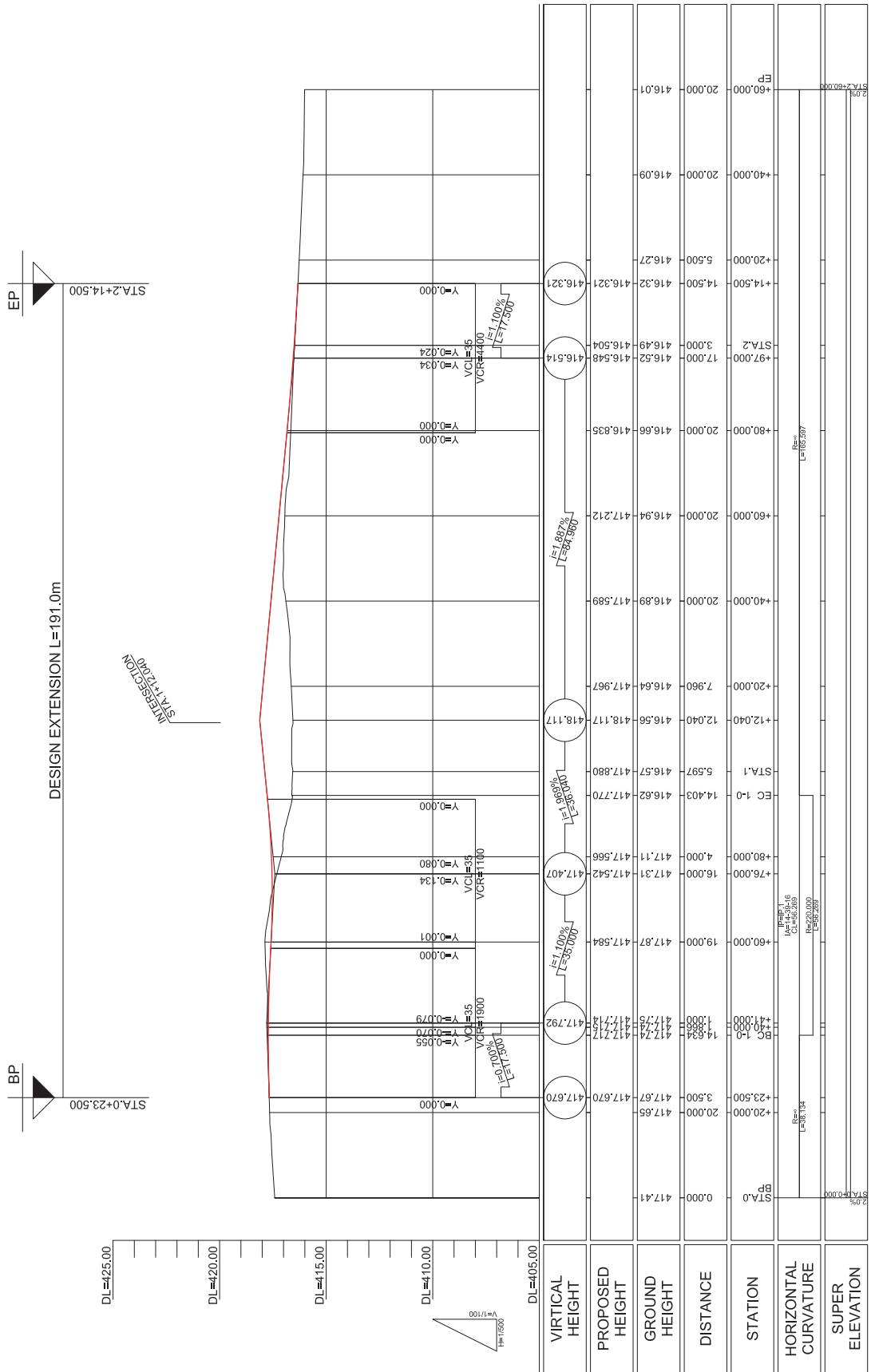

REPUBLIC OF TAJIKISTAN MINISTRY OF TRANSPORT	THE PREPARATORY SURVEY FOR THE PROJECT FOR REHABILITATION OF KZILKALA-BOKHTAR SECTION OF DUSHANBE-BOKHTAR ROAD IN THE REPUBLIC OF TAJIKISTAN	TITLE: <b>PROFILE (SECONDARY ROAD)</b>	JAPAN INTERNATIONAL COOPERATION AGENCY CTI ENGINEERING INTERNATIONAL CO., LTD.	CHECKED	APPROVED	SCALE (A1 SIZE) H=1/100 H=1/500	DATE	DRAWING NO. SR-01	SHEET NO. 1/4
---	--	---	---	---------	----------	--	------	----------------------	------------------



# CROSS SECTION (1) (SECONDARY ROAD)

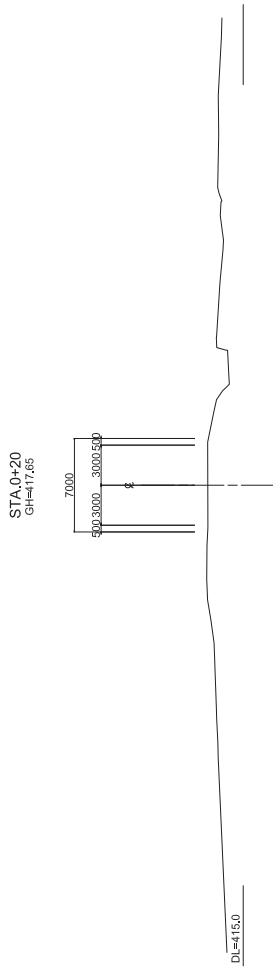
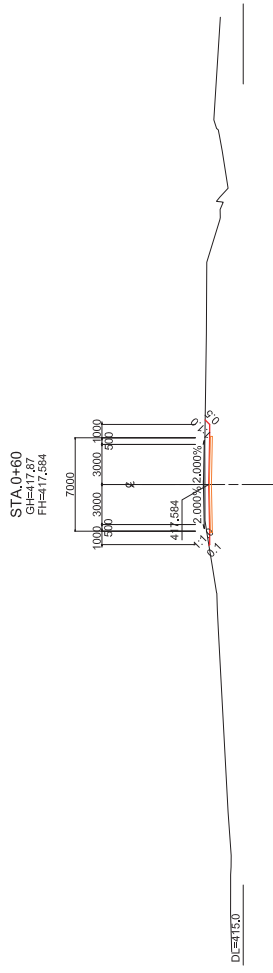
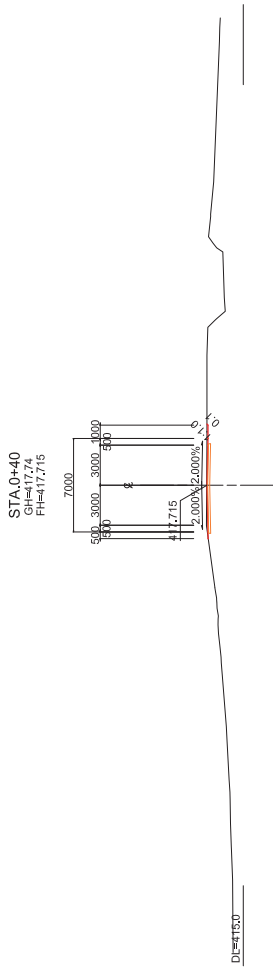
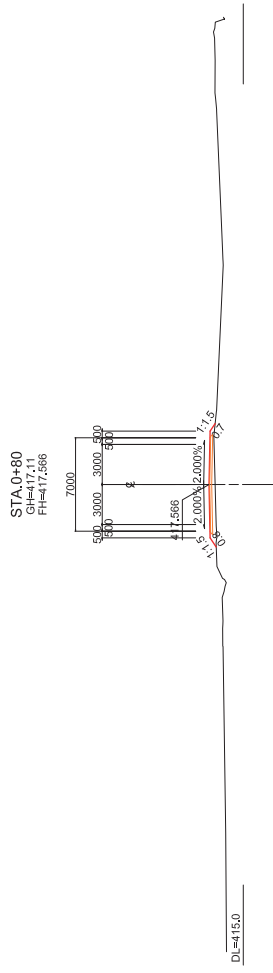

REPUBLIC OF TAJIKISTAN MINISTRY OF TRANSPORT	THE PREPARATORY SURVEY FOR THE PROJECT FOR REHABILITATION OF KZILKALA-BOKHTAR SECTION OF DUSHANBE-BOKHTAR ROAD IN THE REPUBLIC OF TAJIKISTAN	JAPAN INTERNATIONAL COOPERATION AGENCY CTI ENGINEERING INTERNATIONAL CO., LTD.	TITLE: CROSS SECTION (1) (SECONDARY ROAD)	CHECKED	APPROVED	SCALE (A1 SIZE) 1:200	DATE	DRAWING NO. SR-02	SHEET NO. 2/4
---	--	---	---	---------	----------	-----------------------------	------	----------------------	------------------

# CROSS SECTION (2) (SECONDARY ROAD)

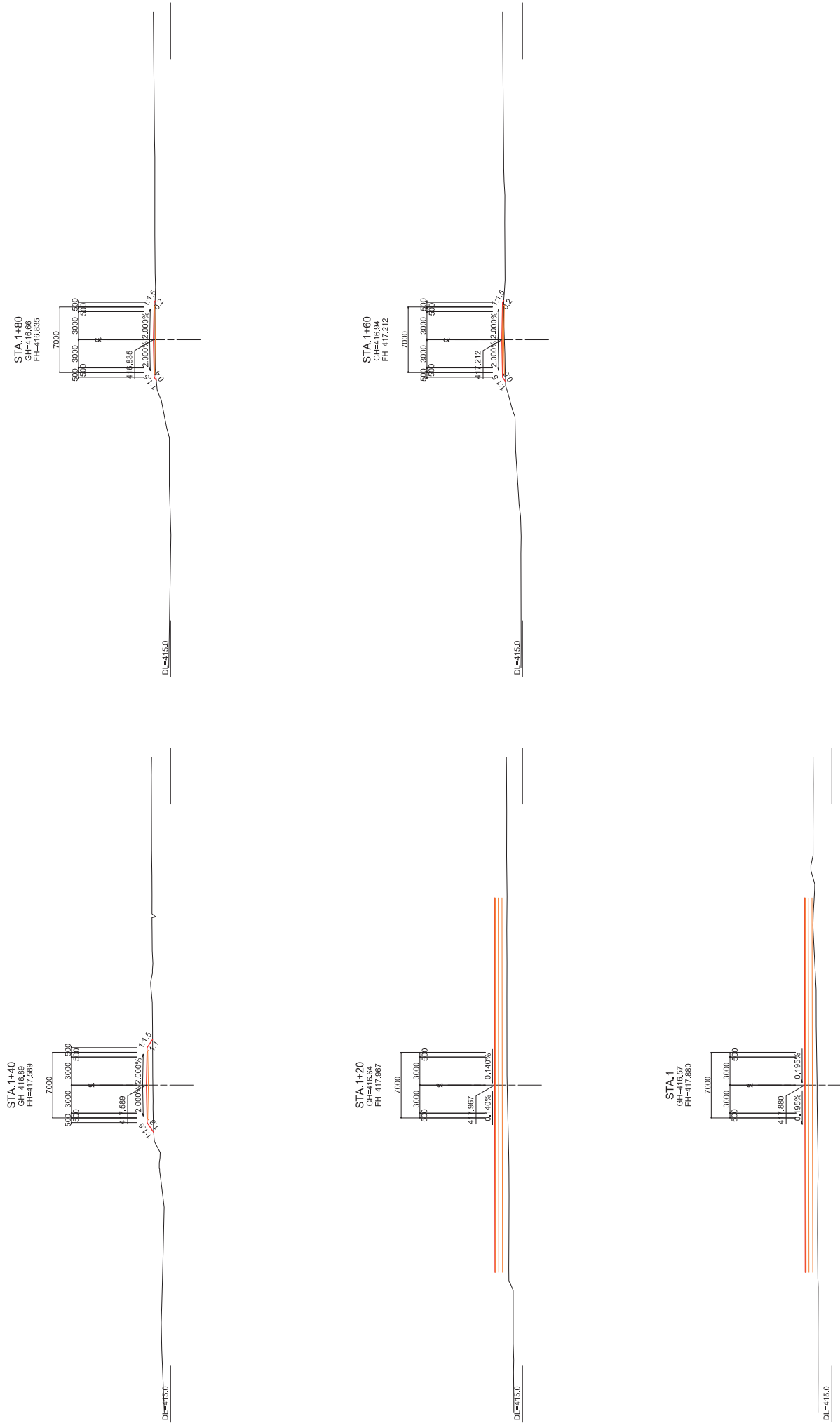

REPUBLIC OF TAJIKISTAN MINISTRY OF TRANSPORT	THE PREPARATORY SURVEY FOR THE PROJECT FOR REHABILITATION OF KZILKALA-BOKHTAR SECTION OF DUSHANBE-BOKHTAR ROAD IN THE REPUBLIC OF TAJIKISTAN	JAPAN INTERNATIONAL COOPERATION AGENCY CTI ENGINEERING INTERNATIONAL CO., LTD.	TITLE: CROSS SECTION (2) (SECONDARY ROAD)	CHECKED	APPROVED	SCALE (A1 SIZE) 1:200	DATE	DRAWING NO. SR-03	SHEET NO. 3/4
---	--	---	---	---------	----------	-----------------------------	------	----------------------	------------------

# CROSS SECTION (3) (SECONDARY ROAD)

STA.2+20  
GH=416.27

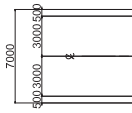

DL=410.0

STA.2  
GH=416.49  
FH=416.504

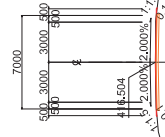

DL=410.0

REPUBLIC OF TAJIKISTAN MINISTRY OF TRANSPORT	THE PREPARATORY SURVEY FOR THE PROJECT FOR REHABILITATION OF KIZILKALA-BOKHTAR SECTION OF DUSHANBE-BOKHTAR ROAD IN THE REPUBLIC OF TAJIKISTAN	JAPAN INTERNATIONAL COOPERATION AGENCY CTI ENGINEERING INTERNATIONAL CO., LTD.	TITLE: <b>CROSS SECTION (3) (SECONDARY ROAD)</b>	CHECKED	APPROVED	SCALE (A1 SIZE) 1:200	DATE	DRAWING NO. SR-04	SHEET NO. 4/4
---	---	---	---	---------	----------	-----------------------------	------	----------------------	------------------

## 【添付資料－10】環境承認通知書

---



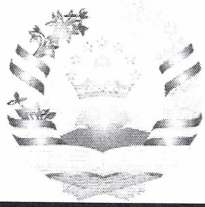

COMMITTEE FOR ENVIRONMENTAL PROTECTION UNDER  
THE GOVERNMENT OF THE REPUBLIC OF TAJIKISTAN

STATE ENVIRONMENTAL APPRAISAL

734034, st.Shamsi 5/1,  
Dushanbe, Republic of Tajikistan  
Tel.: (+992) 37 2359583, (+992) 37 2359577  
Fax: (+992) 37 2361353

No. 1383-15

November 27, 2018

«APPROVE»

Head of State Ecological Appraisal

\_\_\_\_\_ **Kh.R. Mahmaddulloev**

RESOLUTION

of

the State Ecological Appraisal

*General information:*

1. *Project name:* Project for Rehabilitation of Kizilkala – Kurgonteppa section of the Dushanbe – Bokhtar road.
2. *Project location:* Khuroson district – the city of Bokhtar.
3. *Presented documents:* Request for ecological appraisal, Materials indicating project's environmental impact.
4. *Requester:* SUE 'Design Institute for Transport Infrastructure' of the Ministry of Transport of the Republic of Tajikistan.
5. *Date of receipt:* November 26, 2018.

State ecological appraisal of the Committee for Environmental Protection under the Government of the Republic of Tajikistan has reviewed the Initial Environmental Examination Report prepared and submitted by the SUE 'Design Institute for Transport Infrastructure' of the Ministry of Transport of the Republic of Tajikistan under the Project for Rehabilitation of Kizilkala – Kurgonteppa section of the Dushanbe – Kurgonteppa road.

According to the submitted materials, it is planned to carry out reconstruction and rehabilitation of the existing road under the Project for Rehabilitation of Dushanbe – Kurgonteppa road starting from the village of Kizilkala to the city of Kurgontappa. As reported, the length of road section to be repaired makes 9.2 km. Indeed, it is projected to remove the upper concrete layer of road and lay a new asphalt coating. The width of road to one side varies from two to four lanes. In addition, under this project it is planned to rehabilitate two bridges, eight irrigation canals and six drains.

In connection with Project implementation, the State Unitary Enterprise ‘Design Institute for Transport Infrastructure’ of the Ministry of Transport of the Republic of Tajikistan has prepared a report on initial environmental examination and submitted it to the State ecological appraisal. The report consists of eight chapters and expands on the following: description of environmental conditions in the project site, project description, impacts on environmental components, impacts mitigation plan, monitoring of impacts on environmental components, and types of impacts.

The Project doesn’t show the sources of inert materials and asphalt, along with the allocation of construction wastes at the dump sites. However, in the report it is written that the Contractor shall develop a special environmental management plan prior to construction works and submit this plan for the approval. Concerning the production and everyday need in water, it is proposed to use the existing sources of water.

Geologically, the soil in the surveyed section consists of loam with thickness varying from 18mm (at the beginning of the project) to 20mm (at the end).

The Project shows the sources of impacts on environmental components and provides the qualitative characteristics of these impacts. During the reparation and rehabilitation of road, it is expected that different types of environmental components will be affected. The following can be referred to probable environmental impacts:

- physical presence of machinery and people;
- emission of atmospheric air pollutants and dust;
- formation of industrial, domestic and water wastes;
- physical factor effects (noise, light, din and vibration).

On a territorial scale the above-listed impacts refer to point-type.

During the construction works the main sources of atmospheric emissions are as follows:

- atmospheric air pollutants, emitting from the operation of machinery and vehicles;



- dust occurring during the transportation and storage of construction materials;
- dust occurring during the allocation of machinery;
- dust emerging during the construction works.

The background concentration at the project site is shown below:

- |                      |                         |
|----------------------|-------------------------|
| - dust               | - 1.2 mg/m <sup>3</sup> |
| - nitrogen oxides    | - 0.1 mg/m <sup>3</sup> |
| - sulphate anhydride | - 0.1 mg/m <sup>3</sup> |
| - carbon oxide       | - 1.5 mg/m <sup>3</sup> |

As it comes from the report, the main sources of atmospheric air pollution during works execution are the following ones: atmospheric air pollutants, emitting from the operation of machinery and vehicles, dust occurring during the transportation and storage of construction and welding materials, dust occurring during the allocation of machinery.

During the operation of construction machinery, as well as execution of construction works and welding, the following contaminants are emitted into atmosphere: dust, nitrogen dioxide (NO<sub>2</sub>), nitric oxide (NO), benzpyrene, fumes, sulphur dioxide (SO<sub>2</sub>), aldehydes, carbohydrates C12 – C19, carbon monoxide (CO).

Moreover, when the construction machinery leave the construction site they disperse dust along their way to destination. Therefore, it is required to wash the machinery to avoid dusting of the public roads and splash water over these roads to prevent further spreading of dust.

Meanwhile, in case of accumulation of construction wastes / debris it is expected that its volume shall depend on the scope of construction works. These wastes are composed of surplus of asphaltic concrete, scrap metal, depreciated pipes, worn cables, insulating wastes and other similar trash.

All the construction waste should be distinguished by types and disposed from the construction site with the concurrence of local authorized body in charge of environmental protection.

The dumping of soil excavated at the construction site should be performed after routing, by agreement with local authorities and through the mobilization of freight transportation.

The sanitary wastes accumulate as the result of activity of workers, canteen and in the issue of construction site cleaning. It is expected the volume of these wastes shall depend on total number of people in the construction site, on amount of food and the area of cleaned site. The chemical composition of these wastes includes nitrogen (0.8-1.5%), phosphorus (0.4-0.6%), carbon (23-40%), potassium (0.3-0.6%) and sweepings. While their physical properties are characterized by solidity,



combustibility and solubility. In terms of infectiousness these wastes refer to the fourth group of hazardous waste. The sanitary wastes should be collected in special boxes and can be disposed by an organization providing communal services on contract bases or by the Contractor itself by permission of the local responsible authority for environmental protection to the determined dumps.

In the pre-construction period, execution of the following activities is designated in the report:

- development of a construction site;
- cutting and uprooting of trees and shrubs;
- removal of operated man-made structures;
- unearthing and reconstruction of utility;
- removal of fertile layer of ground;
- removal of existing asphaltic concrete pavement;
- mounting of signs and temporary surrounding of the construction site.

In addition to all the above-mentioned impacts the generation of noise and vibration is expected during the execution of construction works as well. And this may break the silence for some time. So, in order not to trouble people it is recommended to set up a special operating schedule and to use modern machinery/equipments.

As it is stated above, the project proposes cutting and uprooting of trees, which stay as an obstacle in the way of construction process. Therefore, cutting and uprooting of trees, as well as planting of seedling should be carried out on basis of certificate, with the concurrence of local responsible authority for environmental protection and observation of safety rules.

Planting of greenery in the improvement road section is one of the purposes of architectural planning of the territory and this arrangement shall contribute to environmental refinement. Prior to development activities the list of trees, shrubs and other plants selected for the arrangement of green spaces should be confirmed, along with their ability to adapt to the local environmental conditions and their endurance to unfavourable urban conditions.

Several activities are planned at the biological stage, such as: planting, manuring, dissemination of seeds and agrochemical minerals. All these measures shall favour blossoming of trees, shrubs, seedlings and grass.

Ecologically, the reparation and reconstruction of the project road shall contribute to the reduction of man's impact on environment (especially on atmospheric air).

The below mandatory instructions are given for the purpose of environmental protection and maintenance:

- During project implementation it is required to adhere to acting rules and standards for road construction, as well as environmental standards and other laws of the Republic of Tajikistan related to the field of environmental protection;
- A responsible person from the Contractor's team should be assigned to carry out sectoral control;
- The Contractor should develop an action plan on environmental protection and submit it for the endorsement to the local body in charge of environmental protection;
- The construction area should be periodically watered in order to protect atmospheric air and to prevent dusting;
- During the construction works execution the protective line of the river should be observed according to requirements, and at the same time all necessary measures for the protection of water resources should be taken;
- Those trees which hinder the construction process can be removed only in agreement with local body in scope of environmental protection;
- The planting and transplanting of seedlings should be performed following the design documents and agrotechnical rules;
- The engineering part of construction works should be executed adhering to the environmental standards and keeping the lowest level of environmental impact;
- In accordance with established procedure, a management control should be organized over the adherence to the requirements of arrangements made in the field of environmental protection;
- All domestic waste should be disposed in official dumps in accordance with established procedure;
- As the construction works are completed all the construction waste should be separated by types and disposed in official dumps in agreement with local body in scope of environmental protection;
- In order to prevent dispersion of dust along the way of construction machinery to destination when they leave the construction site, it is required to wash the machinery and provide for their cleanness;
- All the technological works should be performed under the compliance with environmental impact standards;
- The environmental management plan, particularly the location of dumps for the construction waste and their further usage, in line with emission of inert materials and allocation of asphalt processing plant should be

developed and submitted for the approval of State Environmental Appraisal prior to the commencement of construction works;

- Environmental protection action plan should be developed and agreed in accordance with established procedure;

Current resolution has legal effect on condition that all the above-listed recommendations are fulfilled.

The control over the observance of the acting laws of the Republic of Tajikistan related to the field of environmental protection and maintenance is imposed on the Public administration for environmental protection in the Khatlon region and on the local body in scope of environmental protection of the project area.

After the review of the Initial Environmental Examination Report prepared and submitted by the SUE 'Design Institute for Transport Infrastructure' of the Ministry of Transport of the Republic of Tajikistan under the Project for Reparation and Rehabilitation of Kizilkala – Kurgonteppa section of the Dushanbe – Kurgonteppa road, the State ecological appraisal of the Committee for Environmental Protection under the Government of the Republic of Tajikistan approves it subject to the adherence to acting legislation related to the field of environmental protection and the above-listed conditions.

Expert

J.Khalilov

## 【添付資料－11】 住民説明会参加者リスト

---



## Consultations with spokesmen of local executive authority of Bokhtar city

Mr. A. A. Ismoilzoda	Chairman of the local executive authority
Mr. U. Gurezzoda	Senior vice-chairman of the local executive authority
Mr. Saifiddini I.	Vice-chairman of the local executive authority
Mr. V. Yatimzoda	Chief architect
Mr. B. Yusufzoda	Land manager
Mr. Kh. Madaliev	Leading specialist to the architecture department
Mr. N. Nematzoda	Head of ecology department
Mr. Kh. Manonov	SIRM in the city of Bokhtar, Chief Engineer
Mr. Kh. Ishmurodov	Head of department of local community council
Mr. S. Kamolov	LBTI

Date	Hukumat/ Local executive body	Jamoat	Name of atendant	Position	Phone No.	Subject	Signature
May 16, 2018	Bokhtar city						
May 16, 2018	Bokhtar city						
May 16, 2018	Bokhtar city						
May 16, 2018	Bokhtar city						
May 16, 2018	Bokhtar city						
May 16, 2018	Bokhtar city						
May 16, 2018	Bokhtar city						
May 16, 2018	Bokhtar city						
May 16, 2018	Bokhtar city						
May 16, 2018	Bokhtar city						
May 16, 2018	Bokhtar city						

**Consultation with local communities  
of local executive authority of Kushoniyon district**

Mr.Sharif Safarzoda Vice-chairman of the local executive authority of  
Kushoniyon district

Mr.Jamshed Ashurov Vice-chairman of the local executive authority in the  
jamoat of Oriyono

Mr.Y.Qalandarov Vice-chairman of the local executive authority in the  
jamoat of Oriyono

Mr.B.Yodgorov Secretary to the jamoat of Oriyono

Mr.A.Qurbonov Chairman of the local executive authority in the  
jamoat of Bokhtariyon

Mr.A.Yorov Vice-chairman of the local executive authority in the  
jamoat of Bokhtariyon

Mr.N.Ismoilov Vice-chairman of the local executive authority in the  
jamoat of Bokhtariyon

	Date	Hukumat/ Local executive body	Jamoat	Name of atendant	Position	Phone No.	Subject	Signature
1	May 25, 2018	Kushoniyon	Oriyono					
2	May 25, 2018	Kushoniyon	Oriyono					
3	May 25, 2018	Kushoniyon	Oriyono					
4	May 25, 2018	Kushoniyon	Oriyono					
5	May 25, 2018	Kushoniyon	Bokhtariyon					
6	May 25, 2018	Kushoniyon	Oriyono					
7	May 25, 2018	Kushoniyon	Oriyono					
8	May 25, 2018	Kushoniyon	city of Bokhtar					
9	May 25, 2018	Kushoniyon	Dushanbe					
10	May 25, 2018	Kushoniyon	Bokhtariyon					
11	May 25, 2018	Kushoniyon	Bokhtariyon					
12	May 25, 2018	Kushoniyon	Bokhtariyon					
13	May 25, 2018	Kushoniyon	Bokhtariyon					
14	May 25, 2018	Kushoniyon	Bokhtariyon					
15	May 25, 2018	Kushoniyon	Bokhtariyon					
16	May 25, 2018	Kushoniyon						
17	May 25, 2018	Kushoniyon	Bokhtariyon					
18	May 25, 2018	Kushoniyon	Bokhtariyon					

19	May 25, 2018	Kushoniyon	Bokhtariyon					
20	May 25, 2018	Kushoniyon	Bokhtariyon					
21	May 25, 2018	Kushoniyon	Oriyono					
22	May 25, 2018	Kushoniyon	Oriyono					
23	May 25, 2018	Kushoniyon	Bokhtariyon					
24	May 25, 2018	Kushoniyon	Bokhtariyon					
25	May 25, 2018	Kushoniyon	Oriyono					
26	May 25, 2018	Kushoniyon	Oriyono					
27	May 25, 2018	Kushoniyon	Oriyono					
28	May 25, 2018	Kushoniyon	Oriyono					
29	May 25, 2018	Kushoniyon	Oriyono					
30	May 25, 2018	Kushoniyon	Oriyono					
31	May 25, 2018	Kushoniyon	Bokhtariyon					
32	May 25, 2018	Kushoniyon	Bokhtariyon					
33	May 25, 2018	Kushoniyon	Bokhtariyon					
34	May 25, 2018	Kushoniyon	Bokhtariyon					
35	May 25, 2018	Kushoniyon	Bokhtariyon					
36	May 25, 2018	Kushoniyon	Bokhtariyon					
37	May 25, 2018	Kushoniyon	Bokhtariyon					
38	May 25, 2018	Kushoniyon	Bokhtariyon					



## Consultation with local communities of local executive authority of Bokhtar city

Mr. U. Gurezzoda Senior vice-chairman of the local executive authority  
 Mr. Saifiddini I. Vice-chairman of the local executive authority  
 Mr. V. Yatimzoda Chief architect  
 Mr. B. Yusufzoda Land manager  
 Mr. Kh. Madaliev Leading specialist to the architecture department  
 Mr. N. Nematzoda Head of ecology department  
 Mr. Kh. Manonov SIRM in the city of Bokhtar, Chief Enigneer  
 Mr. Kh. Ishmurodov Head of department of local community council  
 Mr. S. Kamolov LBTI

	Name of attendant	Phone No.	City	Mahal
May 28, 2018			Bokhtar	Hayoti nav
			Bokhtar	Hayoti nav
			Bokhtar	Hayoti nav
			Bokhtar	Hayoti nav
			Bokhtar	Hayoti nav
			Bokhtar	Hayoti nav
			Bokhtar	Hayoti nav
			Bokhtar	Hayoti nav
			Bokhtar	Vahdat
			Bokhtar	Vahdat
			Bokhtar	Vahdat
			Bokhtar	Vahdat
			Bokhtar	Hayoti nav
			Bokhtar	Hayoti nav
			Bokhtar	Hayoti nav
			Bokhtar	Hayoti nav
			Bokhtar	Hayoti nav
			Bokhtar	Hayoti nav
			Bokhtar	Hayoti nav
			Bokhtar	Hayoti nav
			Bokhtar	Hayoti nav
			Bokhtar	Hayoti nav
			Bokhtar	Hayoti nav

## Consultations with the communities of Local government of Bokhtar city

Mr Sayfiddini I.

Deputy Chairman of the Hukumat Bokhtar

Mr. Yatimzoda Valijon

Chief architect of the Bokhtar city

Mr.Nematzoda Naim

Chief ecologist of Bokhtar city

	Date	Hukumat/ Local executive body	Jamoat	Name of atendant	Position	Phone No.	Subject	Signature
1	August 16, 2018	Bokhtar	st.Zebuniso					
2	August 16, 2018	Bokhtar	Vahdat					
3	August 16, 2018	Bokhtar	Umari Khaiyom					
4	August 16, 2018	Bokhtar						
5	August 16, 2018	Bokhtar	Hayoti nav					
6	August 16, 2018	Bokhtar						
7	August 16, 2018	Bokhtar						
8	August 16, 2018	Bokhtar						
9	August 16, 2018	Bokhtar	Kaihonavardon					
10	August 16, 2018	Bokhtar	Vahdat					
11	August 16, 2018	Bokhtar	Vahdat					
12	August 16, 2018	Bokhtar						
13	August 16, 2018	Bokhtar	Umari Khaiyom					
14	August 16, 2018	Bokhtar	Hayoti nav					
15	August 16, 2018	Bokhtar	city of Bokhtar					
16	August 16, 2018	Bokhtar	Hayoti nav					
17	August 16, 2018	Bokhtar	Hayoti nav					
18	August 16, 2018	Bokhtar	Hayoti nav					
19	August 16, 2018	Bokhtar	Hayoti nav					
20	August 16, 2018	Bokhtar	Hayoti nav					
21	August 16, 2018	Bokhtar	Hayoti nav					
22	August 16, 2018	Bokhtar	city of Bokhtar					
23	August 16, 2018	Bokhtar	city of Bokhtar					
24	August 16, 2018	Bokhtar	city of Bokhtar					
25	August 16, 2018	Bokhtar						
26								
27								

## Consultations with communities Hukumat of Kushonyon district

Mr. Sharif Safarzoda Deputy Chairman of Local government of the District  
 Mr. Jamshed Ashurov Deputy Chairman of the Jamoat Oriyon  
 Mr.B.Yodgorov Secretary of the Jamoat Oriyon  
 Mr.A.Qurbonov Chairman of the local executive authority in the  
 jamoat of Bokhtariyon  
 Mr.N.Ismoilov Deputy Chairman of the Jamoat Bokhtariyon

Date	Hukumat/ Local executive body	Jamoat	Name of atendant	Position	Phone No.	Subject	Signature
August 17, 2018	Kushoniyon	Bokhtariyon					
August 17, 2018	Kushoniyon	Bokhtariyon					
August 17, 2018	Kushoniyon	Bokhtariyon					
August 17, 2018	Kushoniyon	Zahmatobod					
August 17, 2018	Kushoniyon	Bokhtariyon					
August 17, 2018	Kushoniyon	Bokhtariyon					
August 17, 2018	Kushoniyon	Bokhtariyon					
August 17, 2018	Kushoniyon	Bokhtariyon					
August 17, 2018	Kushoniyon	Bokhtariyon					
August 17, 2018	Kushoniyon	Bokhtariyon					
August 17, 2018	Kushoniyon	Bokhtariyon					
August 17, 2018	Kushoniyon	Bokhtariyon					
August 17, 2018	Kushoniyon	Bokhtariyon					
August 17, 2018	Kushoniyon	Bokhtariyon					
August 17, 2018	Kushoniyon	Bokhtariyon					
August 17, 2018	Kushoniyon	Bokhtariyon					
August 17, 2018	Kushoniyon	Oriyono					
August 17, 2018	Kushoniyon	Oriyono					
August 17, 2018	Kushoniyon	Bokhtariyon					
August 17, 2018	Kushoniyon	Oriyono					
August 17, 2018	Kushoniyon	Oriyono					
August 17, 2018	Kushoniyon	Oriyono					
August 17, 2018	Kushoniyon	Oriyono					
August 17, 2018	Kushoniyon	Oriyono					
August 17, 2018							
August 17, 2018							
August 17, 2018							
August 17, 2018							
August 17, 2018							