

Appendix 8-4

Report of design
for countermeasure works
of the pilot sites

Democratic Socialist Republic of Sri Lanka

National Building Research Organization (NBRO)

**Proposal for Rectification
on Landslide, Slope Failure
and Rock Fall
in Pilot Sites**

FINAL REPORT

September, 2015

Japan International Corporation Agency (JICA)

**EARTH SYSTEM SCIENCE Co., Ltd. (ESS)
NIPPON KOEI Co., Ltd. (NK)**

Democratic Socialist Republic of Sri Lanka

National Building Research Organization (NBRO)

**Proposal for Rectification
on Landslide at Badulusirigama
in Badulla District**

FINAL REPORT

September, 2015

Japan International Corporation Agency (JICA)

**EARTH SYSTEM SCIENCE Co., Ltd. (ESS)
NIPPON KOEI Co., Ltd. (NK)**

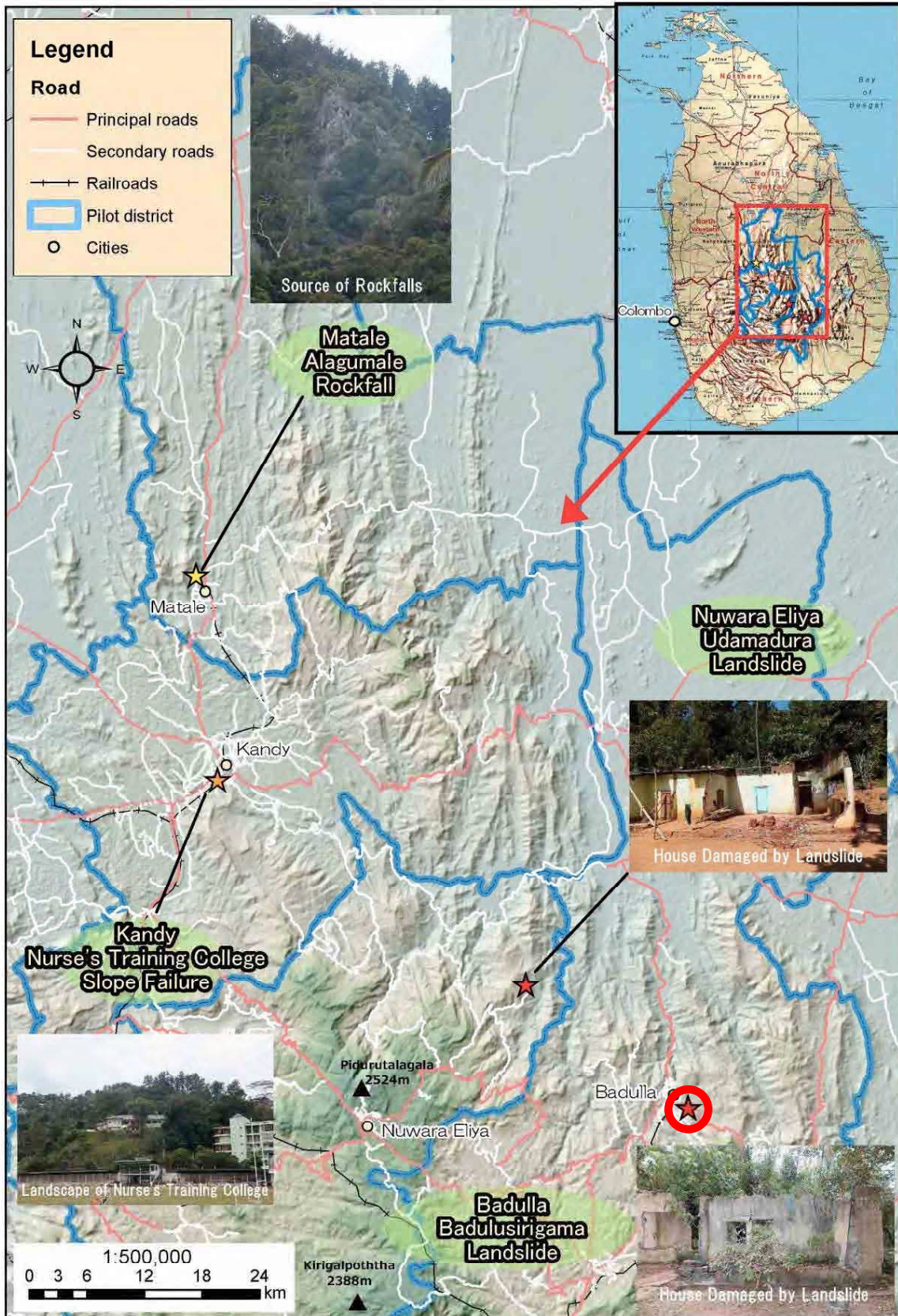

Location Map of Pilot Project Sites

**Technical Cooperation for Landslide Mitigation Project
in
the Democratic Socialist Republic of Sri Lanka
Progress Report for Badulusirigama Landslide**

Table of Contents

Location Map

	<u>Page</u>
Chapter 1 Outline of the Survey	1
1.1 Background	1
1.2 Objective	1
1.3 Target Survey Area	1
Chapter 2 Preliminary Survey	2
2.1 Site Condition.....	2
2.2 Investigation Plan.....	3
Chapter 3 Geomorphological and Geological Survey	5
3.1 Geomorphological Survey.....	5
3.2 Geological Survey	6
3.3 Geophysical Survey.....	7
Chapter 4 Monitoring Survey	10
4.1 Extensometer.....	10
4.2 Inclinator.....	11
4.3 Pipe Strain Gauge.....	12
4.4 Groundwater Level Gauge	13
Chapter 5 Design of Countermeasures	14
5.1 Landslide Mechanism.....	14
5.2 Stability Analysis.....	14
5.3 Design Concept of Countermeasures	15
5.4 Design of Countermeasures.....	15

APPENDIX

Appendix-1	Photo of Boring Core Sample
Appendix-2	Borehole Log

Table 1.1	Pilot Sites in the Project.....	1
Table 2.1	Summary of Badulusirigama Landslide.....	2
Table 2.2	Geomorphological Investigation Items for Badulusirigama Landslide.....	3
Table 2.3	Geological Investigation Items for Badulusirigama Landslide	3
Table 2.4	Monitoring Items for Badulusirigama Landslide.....	3
Table 2.5	Geophysical Investigation Items for Badulusirigama Landslide	3
Figure 2.1	Investigation Plan for Badulusirigama Landslide.....	4
Figure 3.1	Detailed Aerial Photo Image of Badulusirigama Site prepared by using UAV	5
Figure 3.2	DEM Data of Badulusirigama Site prepared by using UAV.....	6
Figure 3.5	Geological Main Cross Section of Badulusirigama Landslide	7
Figure 3.6	Geological Cross Section of Badulusirigama Landslide.....	7
Figure 3.7	Result of Seismic Refraction Survey of Badulusirigama Landslide	8
Figure 3.8	Result of Resistivity Survey of Badulusirigama Landslide (1)	8
Figure 3.9	Result of Resistivity Survey of Badulusirigama Landslide (2)	9
Figure 4.2	Graph of Extensometer and Groundwater Level in Badulusirigama Landslide	10
Figure 4.1	Monitoring Survey of Extensometer	10
Figure 4.3	Graph of Inclinator (BB-4) in Badulusirigama Landslide.....	11
Figure 4.4	Graph of Inclinator (BB-2) in Badulusirigama Landslide.....	12
Figure 4.5	Graph of Pipe Strain Gauge (BB-1) in Badulusirigama Landslide.....	13
Table 5.1	Coefficient Condition of Stability Analysis of Badulusirigama Landslide	14
Figure 5.1	Plan of Basic Design of Countermeasures against Badulusirigama Landslide	16
Figure 5.2	Cross Section of Basic Design of Countermeasures against Badulusirigama Landslide	17
Figure 5.3	The Result of Runoff Calculation for Design of Surface Drainage Ditch.....	18

Table 5.1 The Summary of Designed Countermeasures against Badulusirigama
Landslide18

Chapter 1 Outline of the Survey

1.1 Background

Sediment disasters (Landslides) have become one of the major natural disasters in Sri Lanka. The hilly and mountainous areas in central region of Sri Lanka known as Central Highlands cover nearly 20% of the total land area of Sri Lanka and are occupied by about 30% of the total population of the country.

On March 14, 2013, Japanese ODA Loan Agreements for "Landslide Disaster Protection Project of the National Road Network" which covers seven districts including the target districts of this Project was signed. This loan project will carry out countermeasure construction on slopes on major national roads with a high risk of landslides, alleviating the risk of a disaster and making the road network and lives of nearby residents safer.

The Government of the Democratic Socialist Republic of Sri Lanka has requested the Government of Japan to implement the Landslide Mitigation Project (hereinafter referred to as "the Project") to enhance the capacity of National Building Research Organization (hereinafter referred to as "NBRO") staff through on-the-job training, preparation of technical guidelines and manuals and the construction of mitigation measures.

1.2 Objective

The main object of this Project is to strengthen "Sediment disaster management capacity of NBRO" through application of appropriate mitigation measure with Japanese and other technology in the pilot project sites.

1.3 Target Survey Area

This Project has four pilot sites, which are located in Kandy District, Matale District, Nuwara Eliya District and Badulla District, as shown in Table 1.1.

Table 1.1 Pilot Sites in the Project

Pilot Sites	Location	Type of Mass Movement
Nurse's Training College	Kandy District	Slope Failure
Matale	Alagumale in Matale District	Rockfall
Badulusirigama	Uva Wellasa University in Badulla District	Landslide
Udamadura	Nuwara Eliya District	Landslide





This progress report is written for Badulusirigama landslide in Badulla District.

Chapter 2 Preliminary Survey

2.1 Site Condition

Preliminary survey such as collection of existing data, data review, interpretation of aerial photographs and field reconnaissance has been conducted. The site condition of Badulusirigama Landslide is summarized in Table 2.1.

Table 2.1 Summary of Badulusirigama Landslide

Outline of Preliminary Survey in the Pilot Site					
Site Name	Badulusirigama/Uva Wellasa University (Badulla District)	Surveyed by	Mr. Kalum Senivirathna, Ms. Harsahni Perera (Badulla District Office) Mr. Handa, Mr. Ohkawara, Mr. Hara, Mr. Yang, Mr. Nishikawa	Survey Date	2014/11/13
Disaster Type and Scale	Landslide	Scale	Approximately 120m wide and 500 to 600m long		
Geostructure	The disaster is a colluvial landslide formed on a gentle valley-type slope and the landslide mass consists of earth mixed with gravels.				
Vegetation Cover/Land Use	The landslide occurs on gentle slope of 10 to 15 degrees, which is covered with herb and plants. A lot of residential houses are concentrated around the toe parts of the landslide and the slope before the landslide.				
Existing Conditions	The landslide area is subdivided into several stepped slopes, and the ground surface of the landslide has been highly deformed, typically in the form of pond, stream, depression and steps. The walls of some residential houses located around the landslide toe have been inclined and cracked due to the movement of landslide. The landslide moved slowly and sporadically in the rainy seasons of 2007, 2011 and 2012, accompanied by some retrogressive local collapses around the crown and flank slopes. It has been concerned that a heavy rainfall could cause the landslide movement active, destroying these houses around the landslide toe and killing people.				
Occurrence Mechanism	The sliding surface has been formed with a weak strength due to the repeated movement of the landslide. In addition, a lot of cracks and steps formed in the landslide slope promote the infiltration of rainwater and the formation of water pressure in cracks, reactivating landslide movement.				
Affected Area	The landslide poses considerable risk to the residential houses around the lower part of the landslide slope.				
Survey Plan	Topographic survey: 120x580m (1:200), Cross-section survey: 400mx2lines + 800m x 1line Boring survey: 20m x 6 boreholes Seismic refraction: 400m x 2 lines + 800m x 1 lines, High density electric sounding: 400m x 2 lines + 800m x 1 line Laboratory test: Unit weight, moisture content, atterberg limits, particle size analysis by sieve				
Mitigation Measures and Selection Reasons	The activity of the landslide is related closely to the rainfall, a combination of horizontal boring work (shallow groundwater drainage) and surface drainage works has been thus proposed to stabilize the landslide. In addition, gabion wall has been proposed to maintain the deformation of the village road around the landslide toe.				
Construction Problems	Because of no available access road, new construction road will be required for the construction of the proposed mitigation works.				
Landslide Site Photos					
					
Whole view (looking down from upslope)		Pond observed in landslide area			
					
Ground deformation due to landslide movement		Colluvial deposits (earth mixed with gravel)			

2.2 Investigation Plan

Based on the preliminary survey, a detailed investigation has been planned. The items of planned investigation for geomorphology, geology and geophysics are shown in Table 2.2 - Table 2.5.

Table 2.2 Geomorphological Investigation Items for Badulusirigama Landslide

Investigation Items
Topo mapping
Cross section survey
Unmanned Aerial Vehicles (UAV) analysis

Table 2.3 Geological Investigation Items for Badulusirigama Landslide

Investigation Items	Quantity
Borehole drilling	BB-1 (Drilling depth=20m)
	BB-2 (Drilling depth=20m)
	BB-3 (Drilling depth=20m)
	BB-4 (Drilling depth=20m)
	BB-5 (Drilling depth=20m)
	BB-6 (Drilling depth=20m) Plan
Standard penetration test (SPT)	Each borehole (at 1.0m interval)
Laboratory tests (Unit weight, Moisture content and Particle size analysis)	Some samples

Table 2.4 Monitoring Items for Badulusirigama Landslide

Monitoring Equipment No.	Monitoring Equipment	Monitoring Frequency
SB-1	Extensometer	1 time / 1 month
SB-2		
SB-3		
SB-4		
BB-1	Pipe strain gauge (L=20m)	1 time / 1 month
BB-2	Inclinometer (L=20m)	1 time / 1 month
BB-3	Groundwater level gauge	1 time / 1 month
BB-4	Inclinometer (L=20m)	1 time / 1 month
BB-5	Groundwater level gauge	1 time / 1 month
BB-6 (Plan)	(PVC pipe for groundwater level measurement)	-

Table 2.5 Geophysical Investigation Items for Badulusirigama Landslide

Investigation Items	Quantity
Seismic refraction survey	800m * 1 line + 400m * 2 lines
High density electric sounding	800m * 1 line + 400m * 2 lines

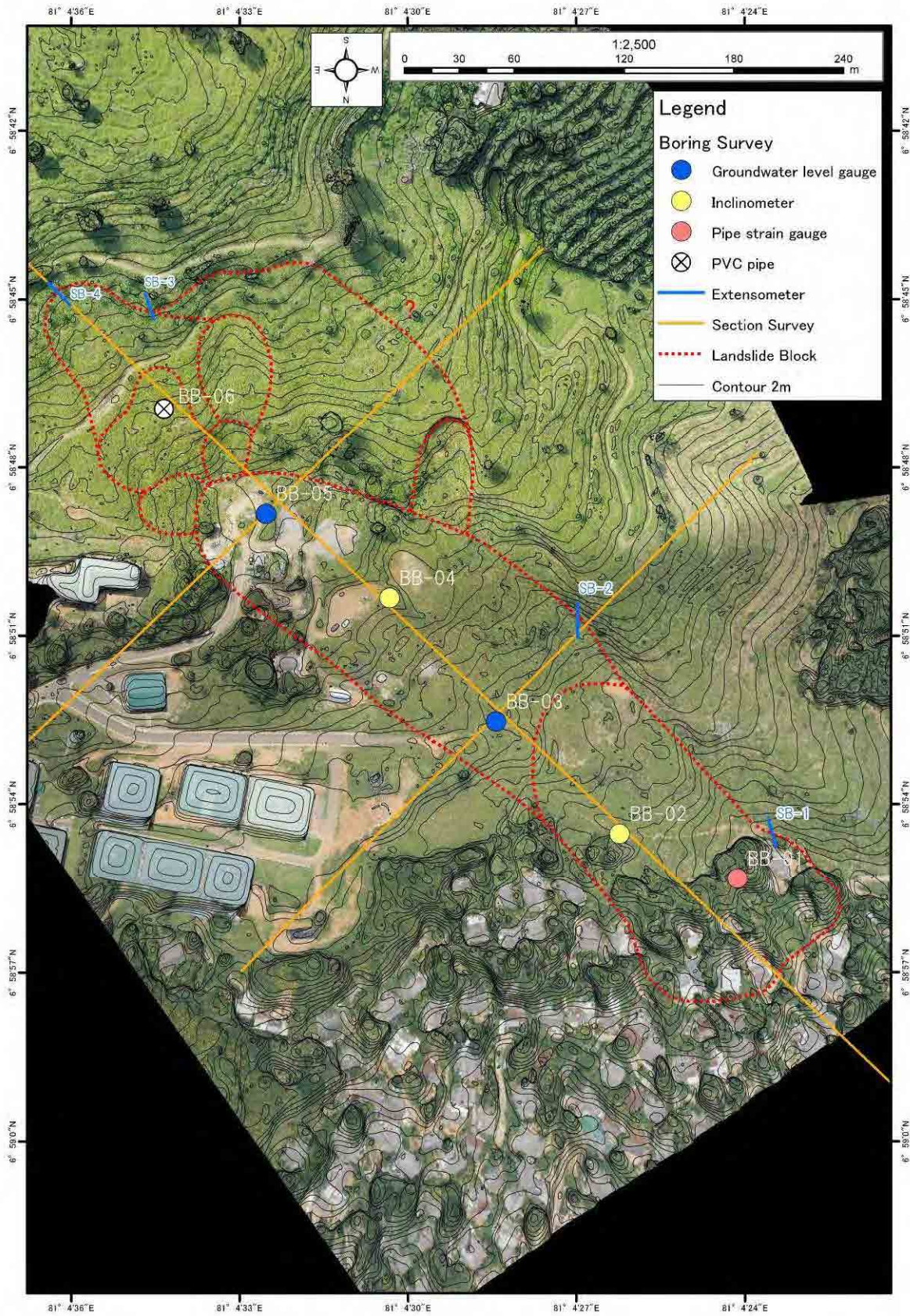

Figure 2.1 Investigation Plan for Badulusirigama Landslide

Chapter 3 Geomorphological and Geological Survey

3.1 Geomorphological Survey

Topographical surveys such as plane survey, cross section survey and Unmanned Aerial Vehicles (UAV) analysis have been conducted. The Digital Elevation Model (DEM) data has been made by UAV. The products of topographical surveys by using UAV are shown below.



Figure 3.1 Detailed Aerial Photo Image of Badulusirigama Site prepared by using UAV



Figure 3.2 DEM Data of Badulusirigama Site prepared by using UAV

3.2 Geological Survey

Five boreholes drilling have been performed in Badulusirigama Landslide, and core samples were recovered from borehole. Geological assessments based on the core samples and SPT have been conducted in order to determine geological structure and slip surface of the landslide. The core samples and boring logs are shown in Appendix of this report. Guide pipes of inclinometers, pipe strain gauge and groundwater level sensors have been installed into the boreholes in order to measure landslide activity and define the depth of slip surface. The borehole BB-6 only will be surveyed by Japanese drilling machine in near future. The geological cross section prepared based on the results of these geological surveys is shown in Figure 3.5 and Figure 3.6.



Figure 3.3 Drilling Work at the Site



Figure 3.4 Core sample check with Japanese expert

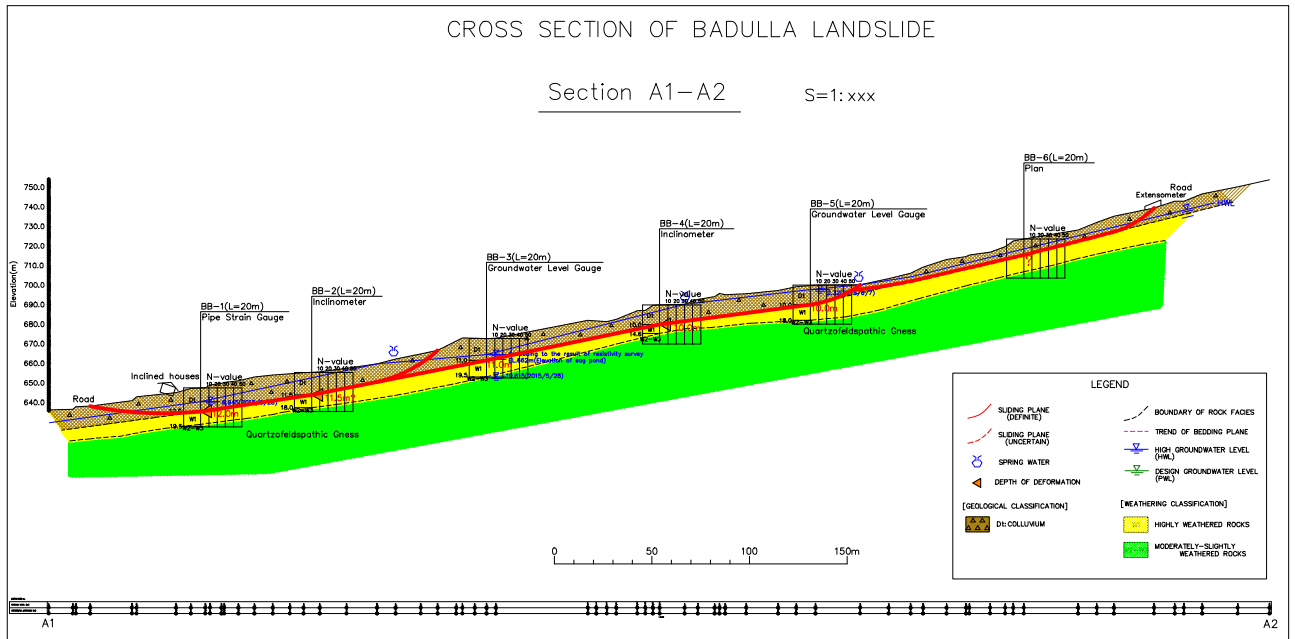

Figure 3.5 Geological Main Cross Section of Badulusirigama Landslide

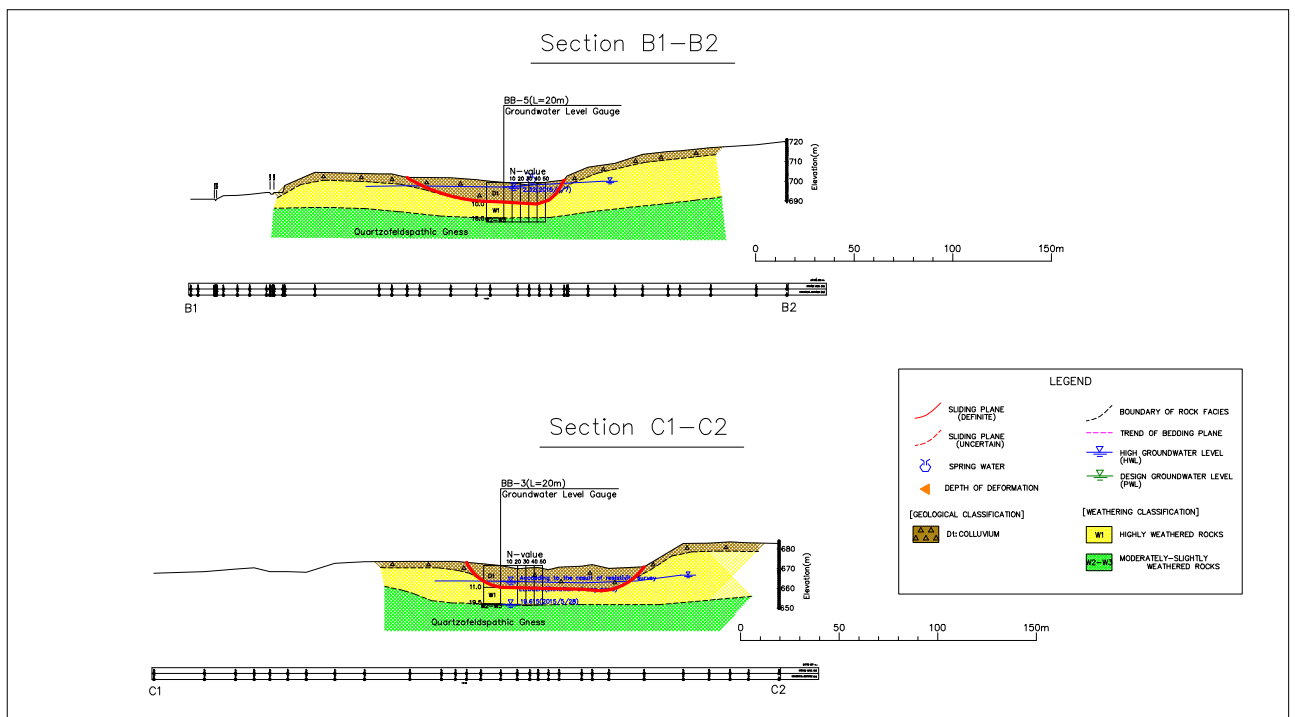

Figure 3.6 Geological Cross Section of Badulusirigama Landslide

3.3 Geophysical Survey

3.3.1 Seismic Refraction Survey

The seismic refraction survey has been performed along the section lines. The result is shown in Figure 3.7.

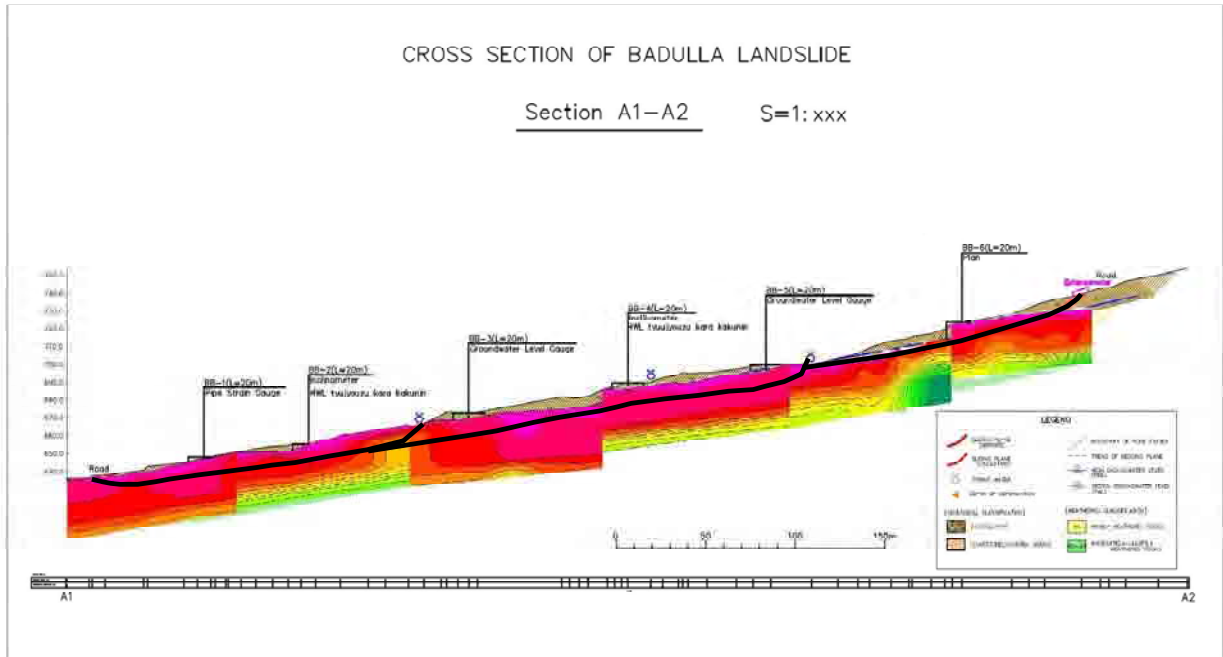

Figure 3.7 Result of Seismic Refraction Survey of Badulusirigama Landslide

3.3.2 High Density Electric Sounding

The high density electric sounding survey has been performed along the section lines. The result is shown in Figure 3.8 and 3.9. We can determine the distribution of aquifer and understand the geologic structure by this electric survey. These findings have been applied to the design of landslide countermeasures.

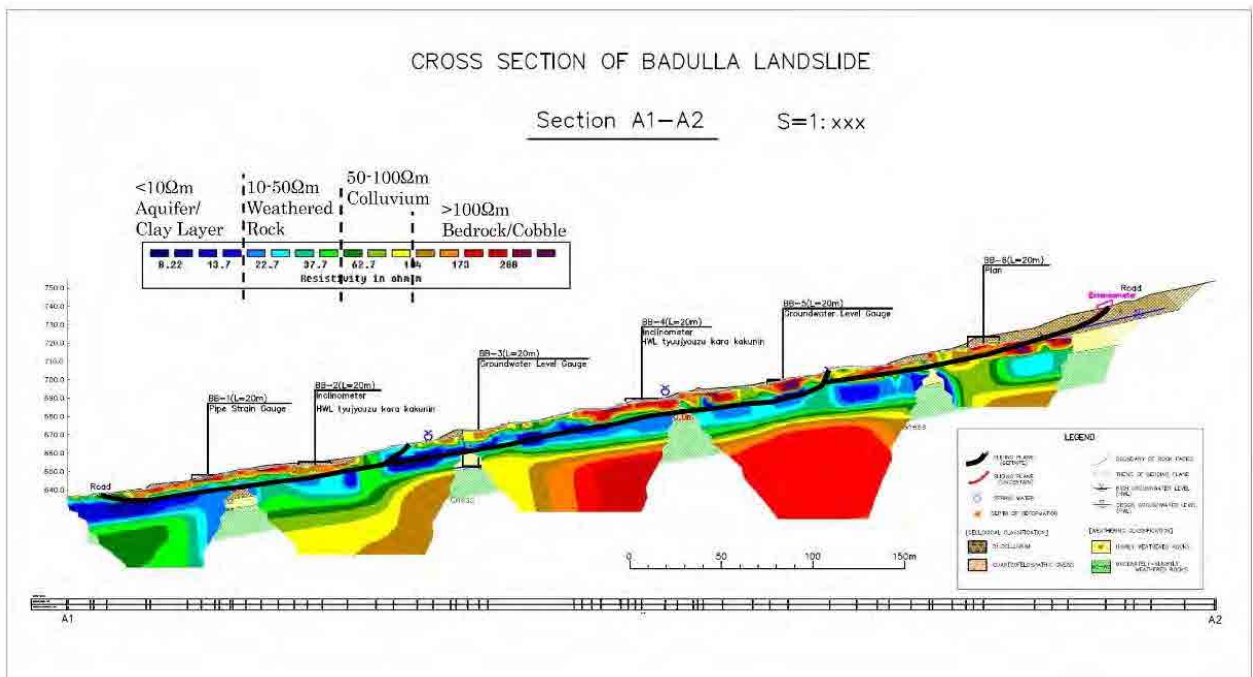

Figure 3.8 Result of Resistivity Survey of Badulusirigama Landslide (1)

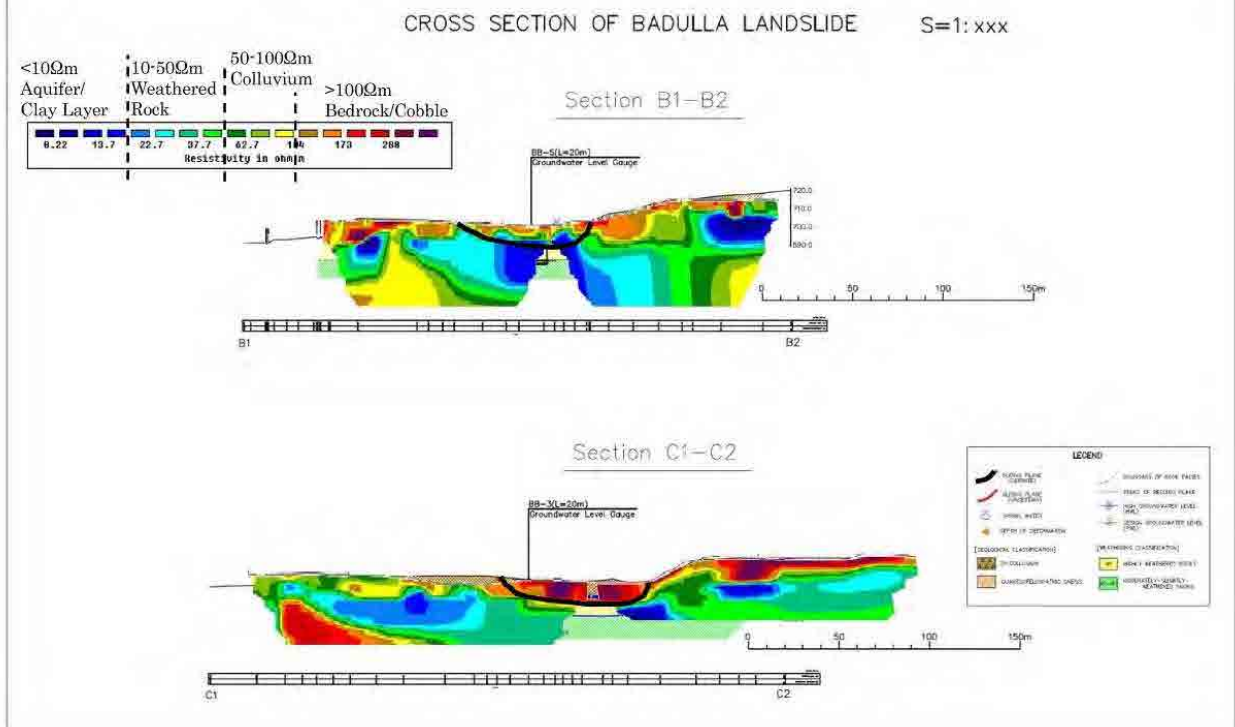

Figure 3.9 Result of Resistivity Survey of Badulusirigama Landslide (2)

Chapter 4 Monitoring Survey

4.1 Extensometer

The extensometer is used to measure amount of relative displacement between two points which are set on a moving and unmoving ground. The extensometers are generally installed across the main scarp, at transverse cracks and transverse ridges near the toe or front portion of the slide and parallel to the suspected slide direction.

According to the monitoring data of extensometer SB-3 and SB-4 which have been installed across the main scarp, the upper area of the landslide was actively moving during and after heavy rain (total cumulative rainfall; 622 mm/18 days) at the end of December 2014 (see Figure 4.2).

On the other hand, as the monitoring data of SB-1 and SB-2 shows, compression displacement is monitored at the bottom and lateral area of the landslide (see Figure 4.2). It is seemed that the bottom part of the the landslide is slightly mounting due to rotational sliding.



Figure 4.1 Monitoring Survey of Extensometer

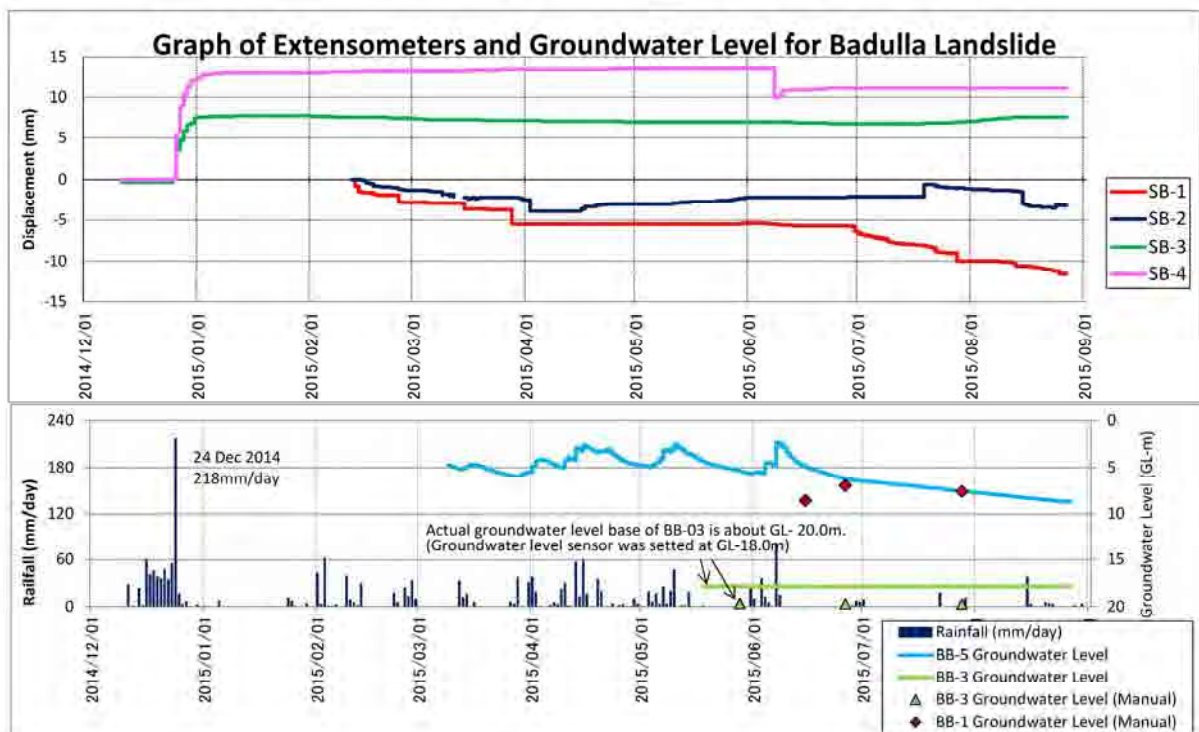

Figure 4.2 Graph of Extensometer and Groundwater Level in Badulusirigama Landslide

4.2 Inclinometer

A grooved casing was inserted in to the borehole extending into the bedrock formation, and an adequate quality of grout should be placed into the borehole to assure an intimate contact with the borehole. By lowering a probe equipped with a tilt sensor, deformation in the casing can be detected and movement of a landslide can determined.

According to the monitoring data of inclinometer BB-4, definitely cumulative displacement is observed at the depth of GL- 9.5m - 10.0m (see Figure 4.3).

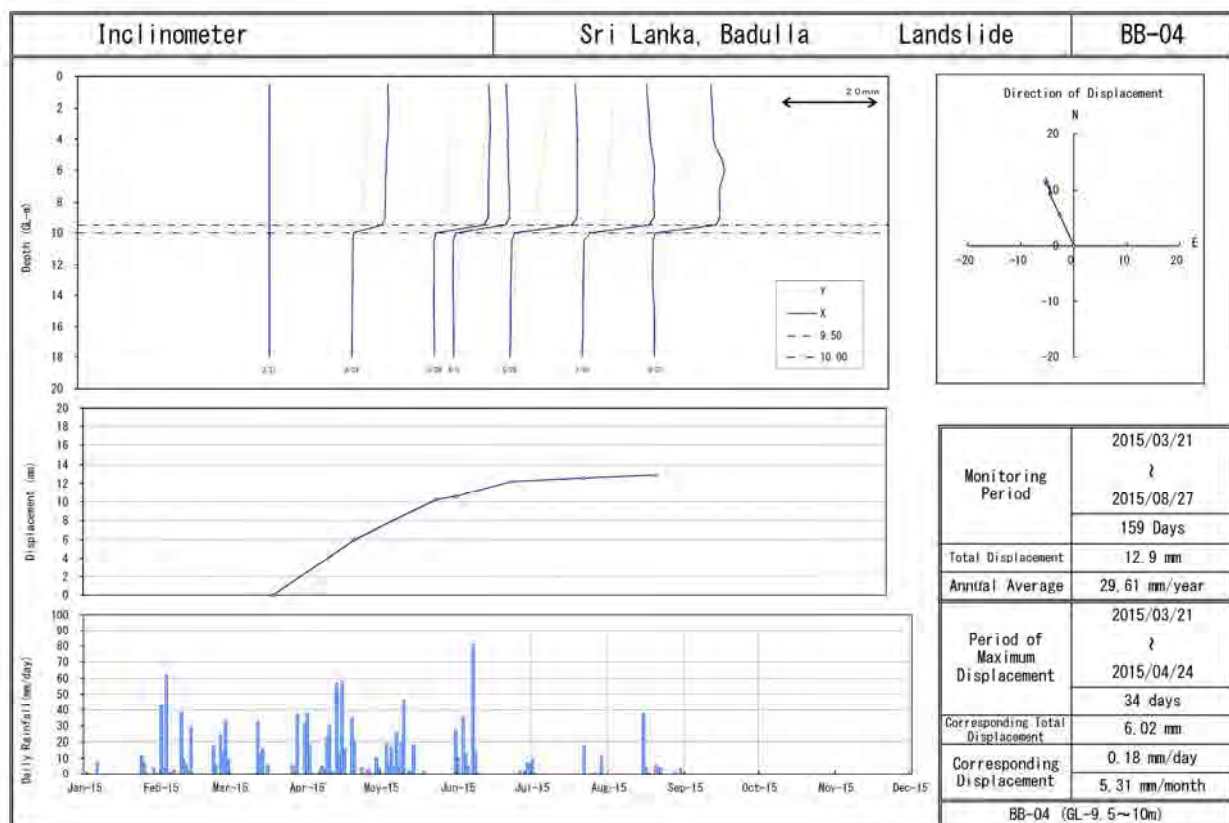

Figure 4.3 Graph of Inclinometer (BB-4) in Badulusirigama Landslide

According to the monitoring data of inclinometer BB-2, slightly cumulative displacement is observed at the depth of GL- 9.5m - 11.5m (see Figure 4.4), but more monitoring time including heavy rainfall event is needed for evaluation of BB-2.

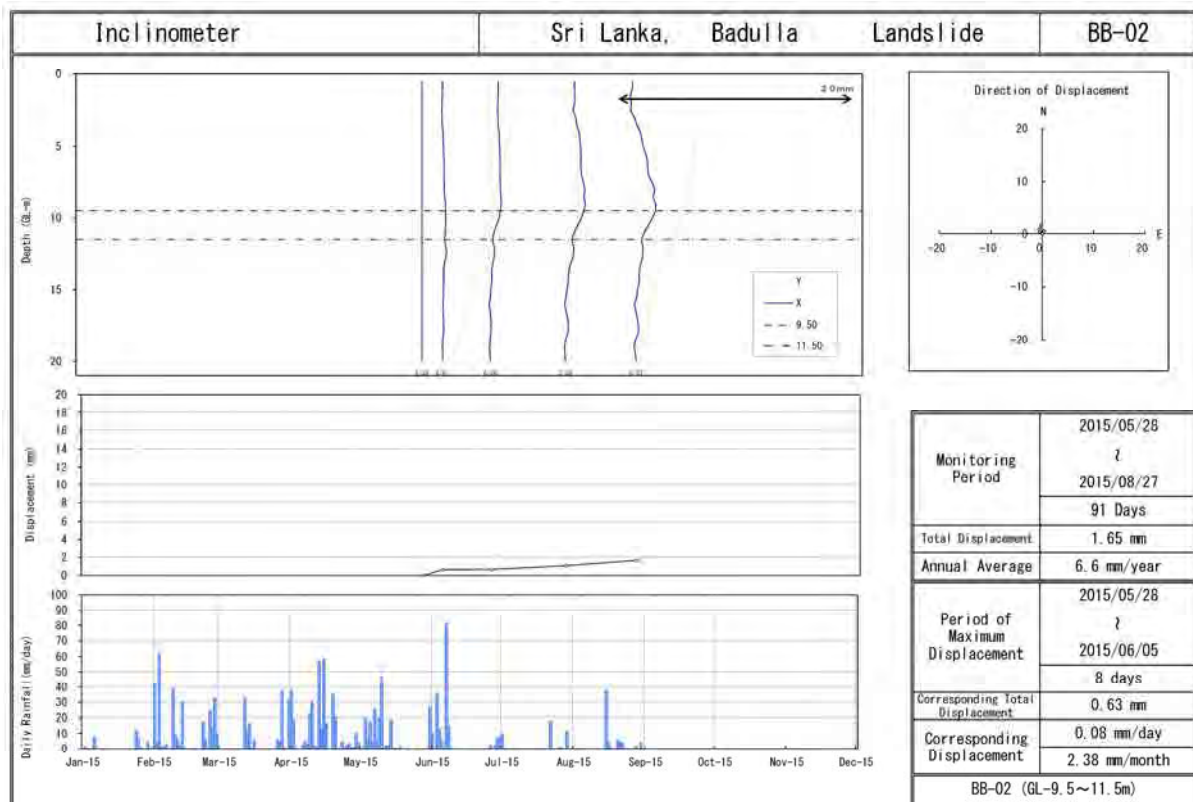

Figure 4.4 Graph of Incliner (BB-2) in Badulusirigama Landslide

4.3 Pipe Strain Gauge

PVC pipe with strain gauges was inserted into the borehole, and the movement is detected by change in the strain as the PVC pipe bends.

According to the monitoring data of pipe strain gauge BB-1, slightly cumulative displacement is observed at the depth of GL- 12.0m - 13.0m (see Figure 4.5), but more monitoring time including heavy rainfall event is needed for evaluation of BB-1.

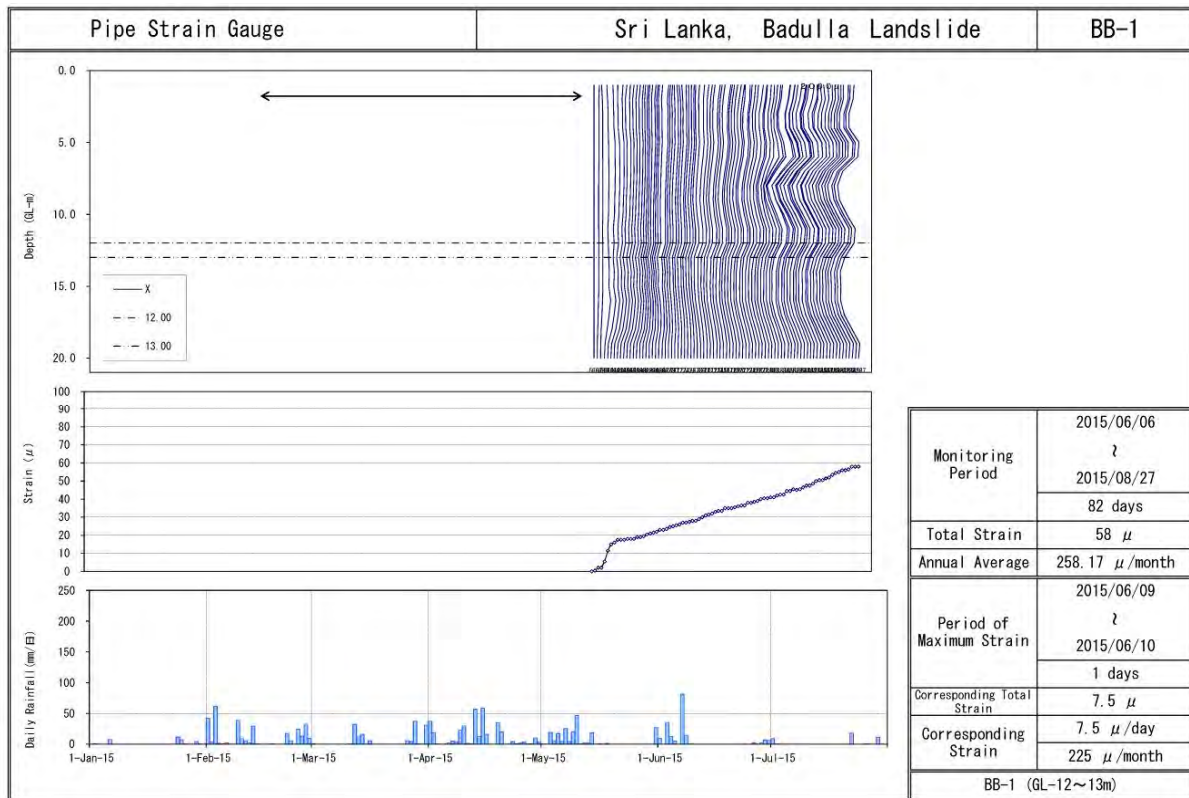

Figure 4.5 Graph of Pipe Strain Gauge (BB-1) in Badulusirigama Landslide

4.4 Groundwater level Gauge

Investigation of groundwater, which is a driving force of sliding, includes determining groundwater level.

According to the monitoring data of groundwater level gauge BB-5, the high groundwater table of BB-5 is near ground surface, which is about GL-2.5m (see Figure 4.2). The groundwater table fluctuates in conjunction with precipitation.

Chapter 5 Design of Countermeasures

5.1 Landslide Mechanism

According to the results of investigation described above, the outline of Badulusirigama landslide mechanism is as follows.

- The Badulusirigama landslide has dimensions with approximately length of 600 m, width of 120 m and depths of 10 m to 13 m.
- The landslide is moving actively during heavy rain like the rainfall event of December 24, 2014 (amount of precipitation was over 200 m/day).
- This indicates that the main trigger of this landslide is heavy or prolonged precipitation which causes rising of groundwater level, and countermeasures of groundwater control methods such as surface drainage ditch or horizontal drainage are effective against this landslide.

5.2 Stability Analysis

Stability analysis had been conducted to determine the scale and quantity of landslide countermeasure works required to maintain the stability of the landslide slope and so ensure the target safety factor. The Fellenius Method which is widely used for simple landslide stability analysis in Japan is used.

Table 5.1 Coefficient Condition of Stability Analysis of Badulusirigama Landslide

Item		Unit	Lower Slide	Middle Slide	Upper Slide
Formula	-	-	Fellenius Method		
Factor of Safety	Fs	-	0.98	0.98	
Proposed Factor of Safety	P·Fs	-	1.20	1.20	
Length of slip surface	L	m	184.092	402.094	Under
Area	A	m ²	1714.96	3879.11	Investigation
Normal Force	N	kN/m	30251.4	68746.6	
Pore pressure	U	kN/m	9762.2	23641.6	
Pore pressure(drainage)	Up	kN/m	1819.6	7574.7	
Resistance force	S	kN/m	4496.732	10737.346	
Resistance force(drainage)	Sp	kN/m	5526.178	13129.725	
Tangential force	T	kN/m	4588.502	10956.471	
Cohesion	C	kN/m	10.0	10.0	
Shear resistance angle	Φ	degree	7.39	8.47	
Wet weight	Γt	kN/m ³	18.0	18.0	

5.3 Design Concept of Countermeasures

The outlines of design concept of countermeasures are as follows.

- Groundwater and surface water control methods should be mainly designed for Badulusirigama Landslide. The groundwater and surface water control works are highly effective to the landslide with abundant groundwater and rainfall and whose movement tends to accelerate during the intense rain.
- Surface drainage ditch should be design at the natural channels in order to prevent infiltration of rain water and spring flows.
- Horizontal drainage which removes groundwater by gravity drainage pipes should be designed throughout each landslide block. The length of the drainage pipes are 45 m to 60 m in order to create a 5 to 10 m overbreak penetrating through the potential slip surface, and their tip intervals are 5 to 10 m.
- The design groundwater level has been set at -3.0 m from the highest groundwater level measured in monitoring survey, which is used as reference value in Japan.

5.4 Design of Countermeasures

The drawings of basic design of countermeasures are shown in Figure 5.1 and 5.2.

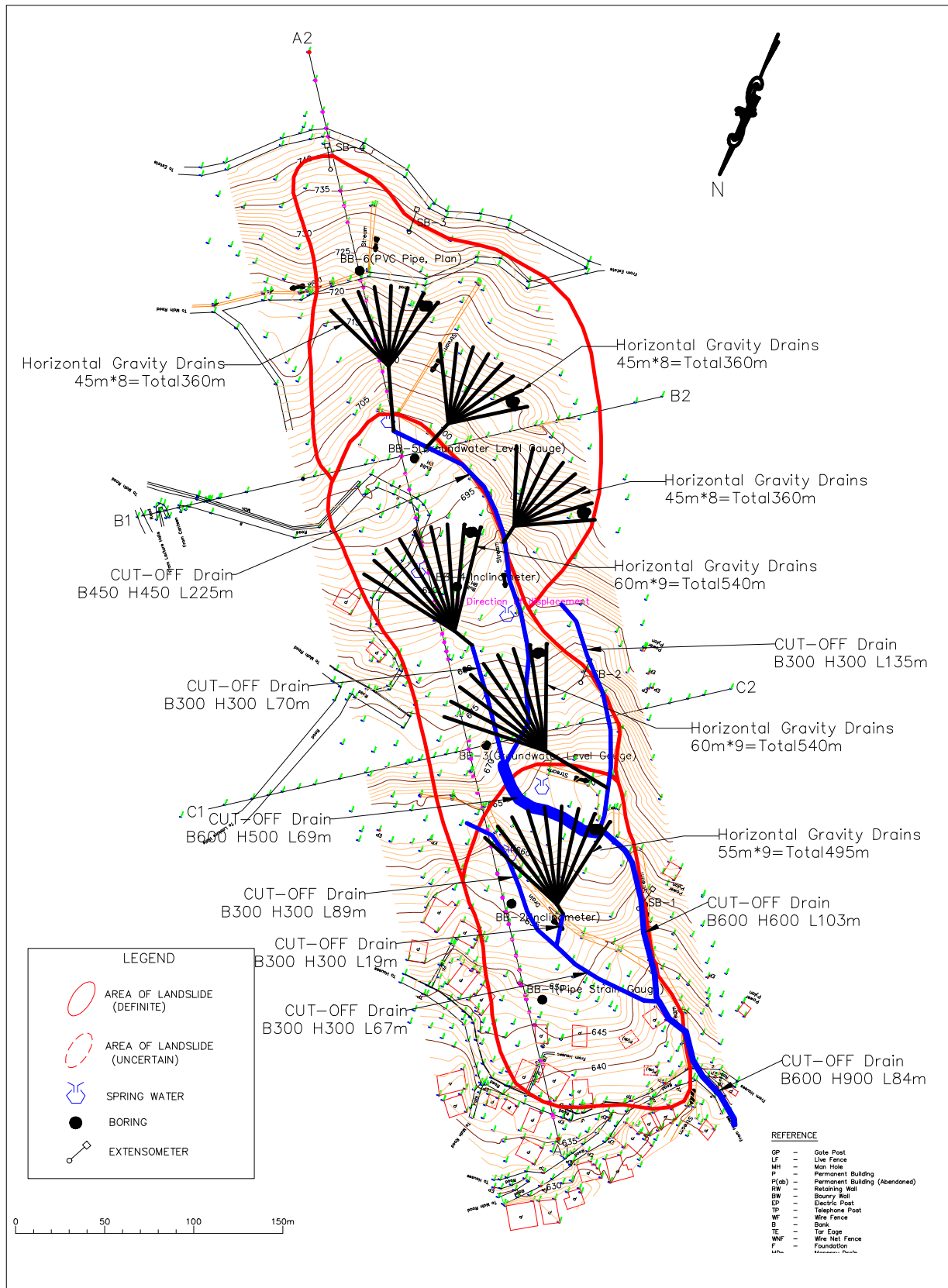

Figure 5.1 Plan of Basic Design of Countermeasures against Badulusirigama Landslide

CROSS SECTION OF BADULLA LANDSLIDE

Section A1-A2

S=1:xxx

Lower Block
 FS=0.98
 C=10kN/m²
 φ=7.38°
 PFS=1.20
 After groundwater drainage works
 Decrease in groundwater level(-3m)

Middle Block
 FS=0.98
 C=10kN/m²
 φ=8.47°
 PFS=1.20
 After groundwater drainage works
 Decrease in groundwater level(-3m)

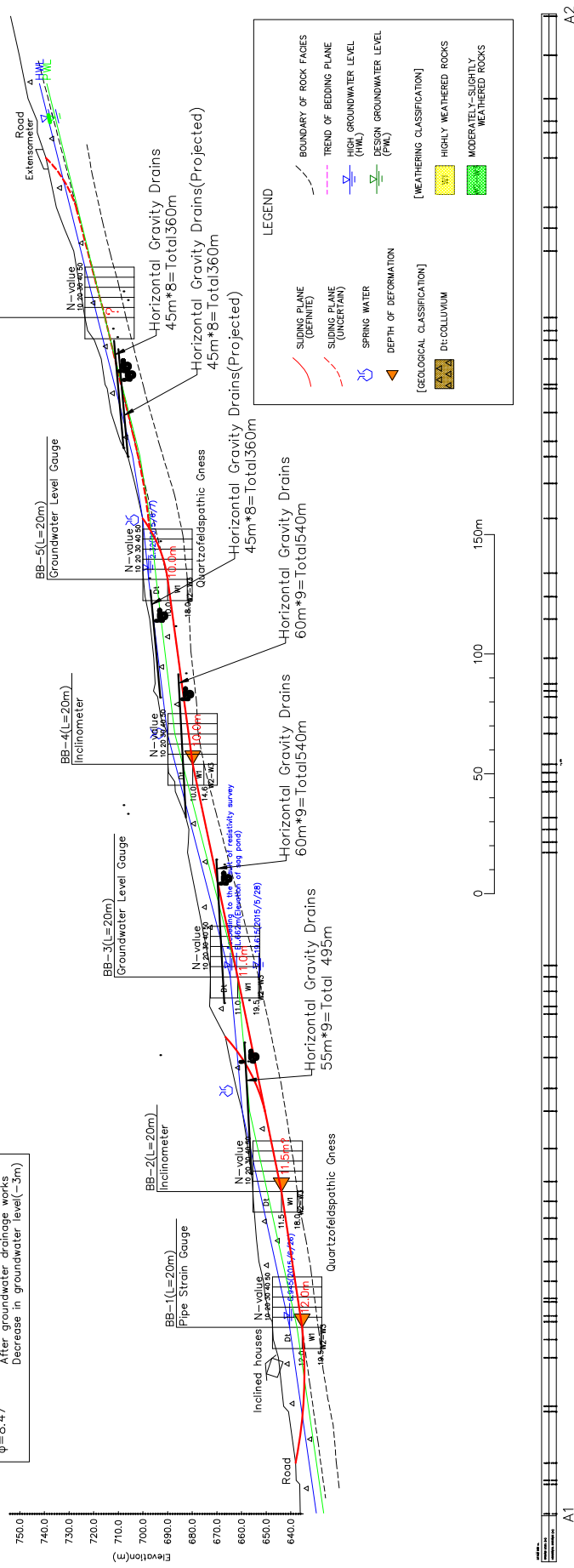

Figure 5.2 Cross Section of Basic Design of Countermeasures against Badulusirigama Landslide

The runoff calculation is shown below.

■ Rational formula

$$Q_p = f \times (1/3.6) \times r \times A$$

Q_p: Peak Discharge (m³/s)

f: Coefficient of Runoff (mountain area 0.8)

r: Probable Rainfall Rate in flowing time
(Estimate 150mm/hr)

A: Discharge Area (0.196km²)

$$Q_p = 0.8 \times (1/3.6) \times 150 \times 0.196 = 6.533 \text{ m}^3/\text{s}$$

■ Manning Formula

$$Q = A \times V$$

Q: Capacity of Flow (m³/s)

A: Flow Section (m²) depends on the height

V: Velocity (m²/s)

$$V = (1/n) \times R^{(2/3)} \times I^{(1/2)}$$

V: Velocity (m²/s)

n: Coefficient of Roughness (0.015)

R: Hydraulic depth in the water way (0.355m)

I: Gradient (10.1%)

$$Q = A \times V = 0.734 \times 10.62 = 7.79 \text{ m}^3/\text{s} \geq Q_p(6.533) \dots \text{OK}$$

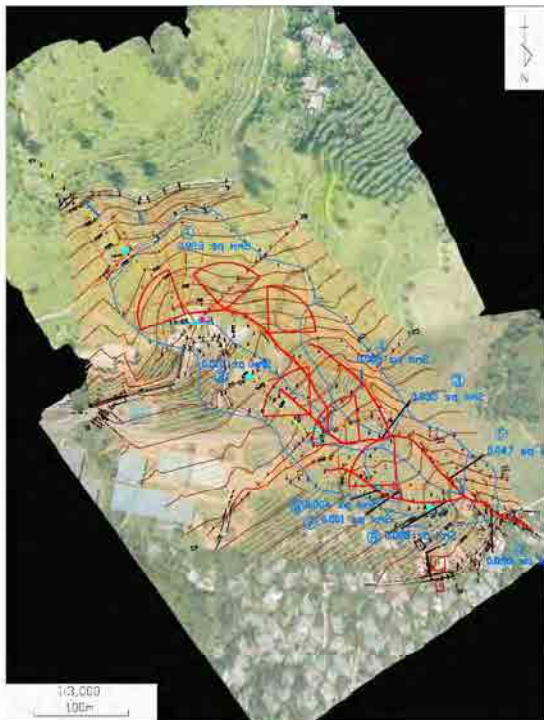

Size of water drainage

Area No.	Length m	Height Distance m	Angle %	Area km ²	Total Area		Concrete Type			Polyethylene Type		
					km ²	km ²	Shoer m	Width m	Height m	Area m ²	Area m ²	
1	225.0	31.5	14.0	0.023			Trapezium	0.45	0.45		0.4	0.5
2	70.0	13.5	16.3	0.010			Rectangle	0.3	0.3		0.3	0.375
3	69.0	5.5	9.4	0.008	1~3	0.068	Trapezium	0.6	0.3		0.7	0.7
4	135.0	21.6	16.1	0.008			Rectangle	0.3	0.3		0.24	0.3
5	105.0	21.2	20.0	0.047	1~3	0.123	Trapezium	0.6	0.6	known	0.7	0.7
6	36.0	10.2	11.5	0.004			Rectangle	0.3	0.3		0.34	0.3
7	19.0	1.6	8.4	0.001			Rectangle	0.3	0.3		0.24	0.3
8	67.0	12.3	16.4	0.006	1~3	0.013	Rectangle	0.3	0.3		0.3	0.375
9	64.0	9.5	10.1	0.060	1~3	0.190	Trapezium	0.6	0.9		1.0	1.0



Concrete Type



Polyethylene Type

Figure 5.3 The Result of Runoff Calculation for Design of Surface Drainage Ditch

Table 5.1 The Summary of Designed Countermeasures against Badulusirigama Landslide

Pilot Area	Type of measure works	Details	Priority	Quantity	Unit	Remarks ex.concrete type
Badulu sirigama	Ditch	Type1	A	256	m	600 × 900 600 × 600 600 × 500
		Type2	A	225	m	450 × 450
		Type3	A	380	m	300 × 300
	Horizontal Drilling	Upper slope	A	1080	m	45m × 8nos × 3area
		Upper slope	A	1575	m	(55~60)m × 9nos × 3area

APPENDIX

Appendix-1 Photo of Boring Core Sample

Appendix-2 Borehole Log

Appendix-1
Photo of Boring Core Sample

1. Badulla

(1) BB-1 (L=20m)

0m



5m



10m



15m



19m



(2) BB-2 (L=20m)

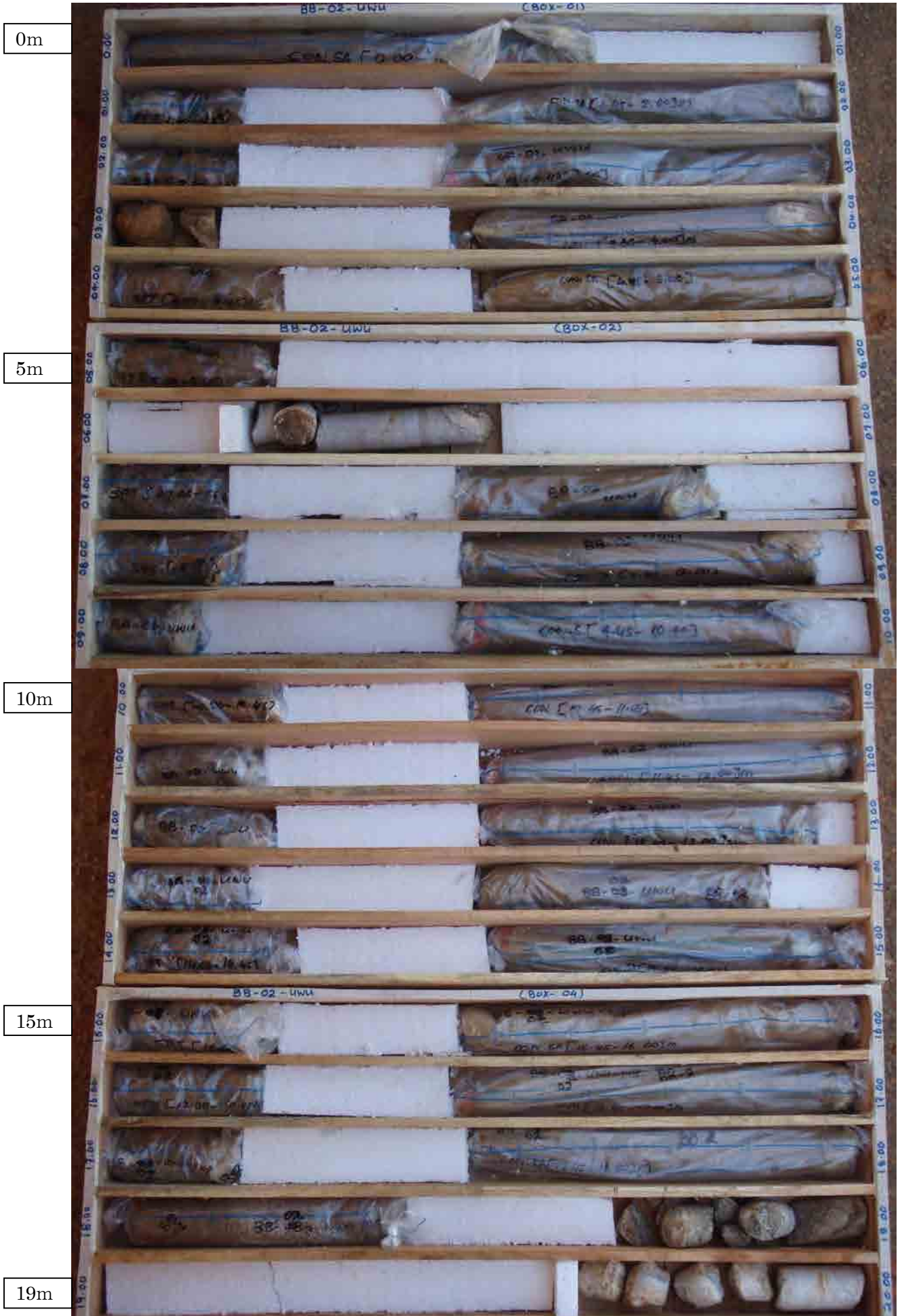

(4) BB-4 (L=20m)



(5) BB-5 (L=20m)

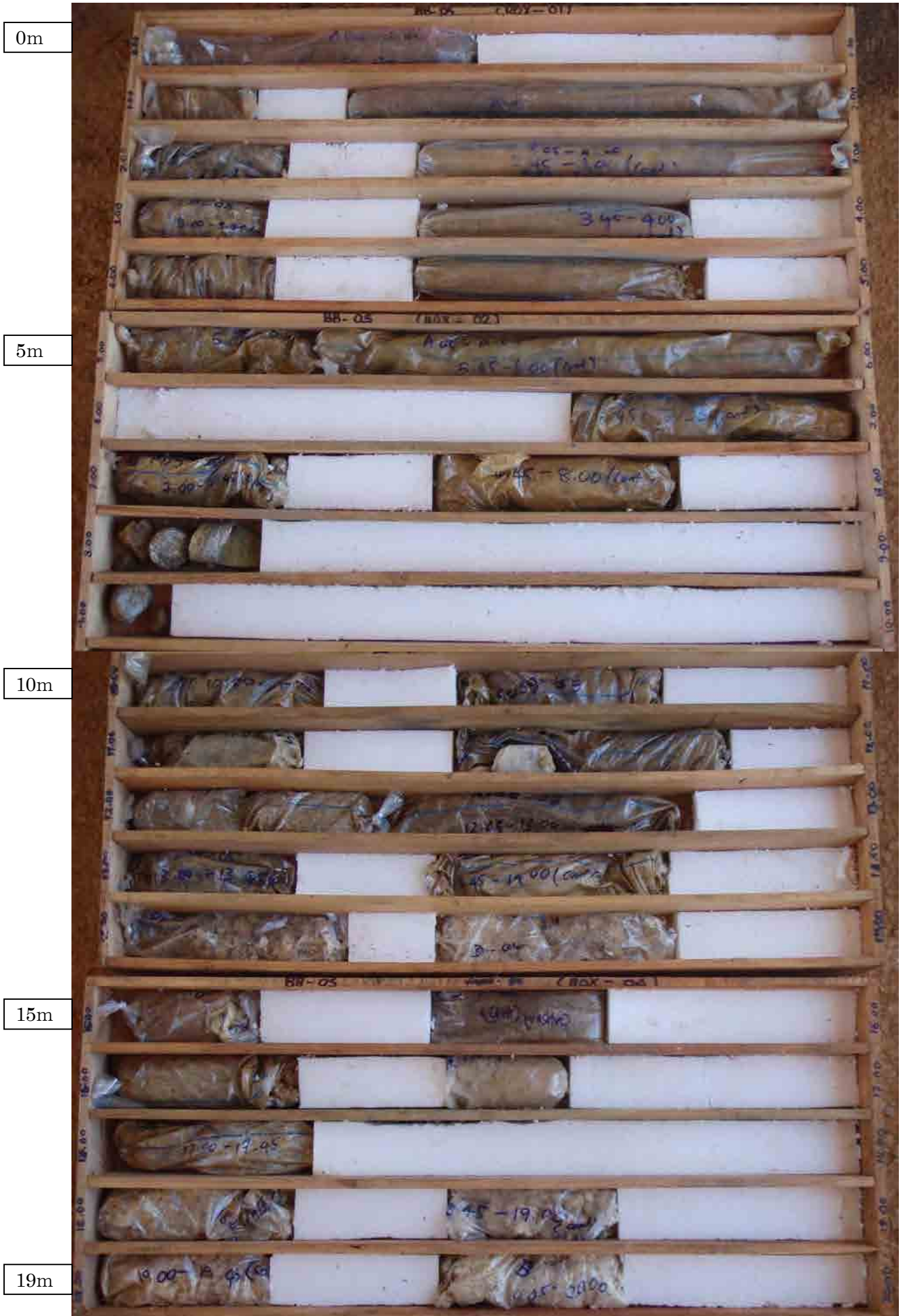

Appendix-2
Borehole Log

BOREHOLE LOG



NATIONAL BUILDING RESEARCH ORGANISATION
GEOTECHNICAL ENGINEERING DIVISION
 99/1, Jawatta Road, Colombo 05.

SHEET NO.

1 of 2

PROJECT	TECHNICAL CORPORATION FOR LANDSLIDE MITIGATION PROJECT AT BADULLA		CLIENT	JAPAN INTERNATIONAL CORPORATION AGENCY	BOREHOLE NO	BB 1
LOCATION	BADULLA		CONTRACT NO	30/24871	DEPTH OF HOLE (m)	20.00
DRILING METHOD	CORE DRILLING		ELEVATION (m RL)		CHAINAGE / OFFSET	
CORE SIZE [mm]	54	CASING SIZE	NX	CO-ORDINATES	N	DATE COMMENCED
VANE SIZE [mm*mm]		UDS SAMPLER SIZE [mm]			E	DATE COMPLETED

DEPTH [m]	ELEVATION [m RL]	LAYER THICKNESS [m]	SAMPLE TYPE	SAMPLE NO.	SOIL PROFILE				Y - [g/cm ³]	OTHER TESTS	DEPTH TESTED [m]	STANDARD PENETRATION TEST DATA				MOISTURE CONTENT - %				
					SOIL DESCRIPTION	STRATA	LEGEND	GWL				NUMBER OF BLOWS				UNDRAINED SHEAR STRENGTH - kN/m ²				
												PER 15cm			FOR 30cm	SPT RESISTANCE - Blows/30 cm				
											1	2	3	30cm	10	20	30	40	50	60
0.00	0.00				GROUND LEVEL															
0.30	-0.30	0.30			Dark brown, silty SAND, medium grained, moist															
					Brown, SILT, intermediate plasticity with fine to medium grained sand, moist															
1.00	-1.00	0.70			Medium dense, yellowish brown mottled with grey, silty SAND, fine to medium grained with completely weathered rock fragments, moist						1.00	14	12	9	21					
1.45	-1.45	0.45	X																	
2.00			X								2.00	11	18	14	32					
3.00			X		Dense, yellowish brown mottled with grey, SILT, intermediate plasticity with pockets of clay, sand and completely weathered rock fragments, moist						3.00	11	17	15	32					
4.00			X								4.00	11	16	17	33					
5.00	-5.00	3.55	X		Medium dense, dark brown, silty SAND, angular to subangular, fine to coarse grained with occasionally gravel, moist						5.00	17	16	14	30					
5.45	-5.45	0.45	X																	
6.00			X		Medium dense, orangish brown, SILT, intermediate plasticity with fine to medium grained sand and occasionally gravel, moist						6.00	12	13	15	28					
6.50	-6.50	1.05	X																	
7.00	-7.00	0.50	X		Moderately strong, massive, whitish grey, QUARTZITE, medium to coarse grained, meta-sedimentary, moderately weathered, highly fractured rock (Boulder)				Rock		6.50	50	20							
8.00			X		Medium dense to dense, brown to yellowish brown, SILT, intermediate plasticity with fine to medium grained sand, gravel and completely weathered rock fragments, moist						7.00	9	12	14	26					
8.00			X								8.00	11	16	22	38					
9.00	-9.00	2.00	X																	
10.00			X		Strong, thinly foliated, dark grey, GARNET BEARING HORNBLende BIOTITE GNEISS, medium to coarse grained, meta-igneous, slightly weathered (Boulder)				Rock		9.00	90	90							

Draft

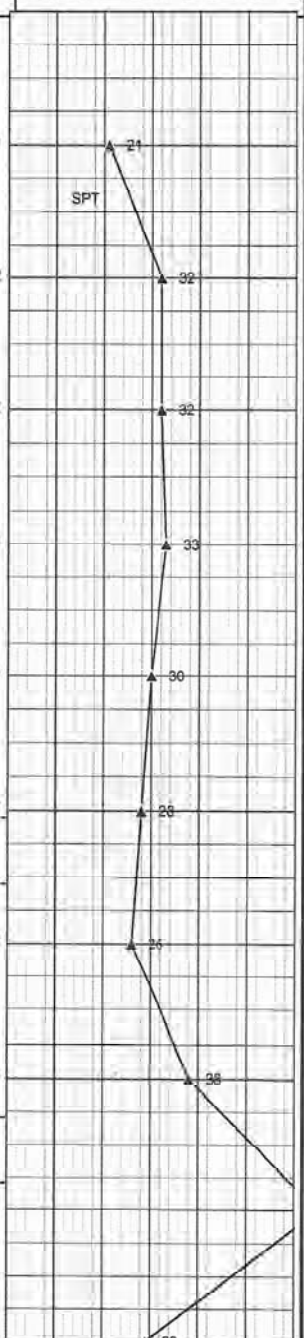

<ul style="list-style-type: none"> ⋯ Natural moisture content, Atterberg Limits (LL, PL) ▲ SPT 'N', blows/ft → Vane shear strength, peak ⋯ Vane shear strength, residual 	<ul style="list-style-type: none"> W - Wet unit weight G - Grainsize Analysis U - Unconfined compression CU - Consolidated undrained triaxial 	<ul style="list-style-type: none"> W - Wash sample SPT - SPT Sample ☐ - Undisturbed sample ⊗ - Disturbed Sample 	Drilled By: GNB Logged By: GKJ Date: 10/8/2015 Checked By: CKJ
--	---	---	---

BOREHOLE LOG



NATIONAL BUILDING RESEARCH ORGANISATION
 GEOTECHNICAL ENGINEERING DIVISION
 99/1, Jawatta Road, Colombo 05.

SHEET NO.
 2 of 2

PROJECT	TECHNICAL CORPORATION FOR LANDSLIDE MITIGATION PROJECT AT BADULLA		CLIENT	JAPAN INTERNATIONAL CORPORATION AGENCY	BOREHOLE NO	BB 1	
LOCATION	BADULLA		CONTRACT NO	30/24871	DEPTH OF HOLE (m)	20.00	
DRILING METHOD	CORE DRILLING		ELEVATION (m RL)	0	CHAINAGE / OFFSET	-	
CORE SIZE [mm]	54	CASING SIZE	NX	CO-ORDINATES	N	DATE COMMENCED	0
VANE SIZE [mm*mm]	-	UDS SAMPLER SIZE [mm]	-		E	DATE COMPLETED	0

DEPTH [m]	ELEVATION [m RL]	LAYER THICKNESS (m)	SAMPLE TYPE	SAMPLE NO.	SOIL PROFILE			OTHER TESTS	DEPTH TESTED [m]	STANDARD PENETRATION TEST DATA				MOISTURE CONTENT - %							
					SOIL DESCRIPTION	STRATA	LEGEND			GWL	NUMBER OF BLOWS				UNDRAINED SHEAR STRENGTH - kN/m ²						
											PER 15cm			FOR 30cm	SPT RESISTANCE - Blows/30 cm						
											1	2	3		10	20	30	40	50	60	
10.00	-10.00	1.00							12	14	15	29									
11.00						MS			11.00	13	14	8	22								
12.00	-12.00	2.00							12.00	18	19	19	38								
13.00	-13.00	1.00				MI			13.00	12	10	14	24								
13.45	-13.45	0.45				MI															
14.00									14.00	14	17	15	32								
15.00									15.00	8	13	20	33								
16.00									16.00	8	11	21	32								
17.00									17.00	6	15	19	34								
18.00									18.00	15	17	20	37								
19.00	-19.00	5.55							19.00	10	16	35	51								
19.45	-19.45	0.45				MI															
20.00	-20.00	0.55																			

	Natural moisture content, Atterberg Limits (LL, PL)	γ - Wet unit weight	W - Wash sample	Drilled By	CNB
	SPT N, blows/ft	G - Grainsize Analysis	SPT - SPT Sample	Logged By	CKJ
	Vane shear strength, peak	U - Unconfined compression		Date	10/8/2015
	Vane shear strength, residual	CU - Consolidated undrained triaxial		Checked By	CKJ

BOREHOLE LOG



NATIONAL BUILDING RESEARCH ORGANISATION
 GEOTECHNICAL ENGINEERING DIVISION
 99/1, Jawatta Road, Colombo 05.

SHEET NO.
 1 of 2

PROJECT	TECHNICAL CORPORATION FOR LANDSLIDE MITIGATION PROJECT AT BADULLA		CLIENT	JAPAN INTERNATIONAL CORPORATION AGENCY	BOREHOLE NO	BB 2
LOCATION	BADULLA		CONTRACT NO	30/24871	DEPTH OF HOLE (m)	20.00
DRILING METHOD	CORE DRILLING		ELEVATION (m RL)		CHAINAGE / OFFSET	-
CORE SIZE [mm]	54	CASING SIZE	NX	CO-ORDINATES	N	DATE COMMENCED
VANE SIZE [mm*mm]	-	UDS SAMPLER SIZE [mm]	-		E	DATE COMPLETED

DEPTH [m]	ELEVATION [m RL]	LAYER THICKNESS [m]	SAMPLE TYPE	SAMPLE NO.	SOIL PROFILE			Y - [g/cm ³]	OTHER TESTS	STANDARD PENETRATION TEST DATA				MOISTURE CONTENT - %					
					SOIL DESCRIPTION	STRATA	LEGEND			GWL	NUMBER OF BLOWS				UNDRAINED SHEAR STRENGTH - kN/m ²				
											PER 15cm			FOR 30cm	SPT RESISTANCE - Blows/30 cm				
											1	2	3	10	20	30	40	50	60
0.00	0.00				GROUND LEVEL														
1.00	-1.00	1.00			Organigish brown, silty SAND, angular to subangular, fine to coarse grained with gravel and plant roots, moist	SM				1.00	20	26	20	46					
2.00	-2.00	1.00			Dense, dark brown, silty SAND, angular to subangular, fine to coarse grained with intermediate plastic silt and gravel, moist	SM				2.00	19	18	20	38					
3.00	-3.00	1.00			Dense, yellowish brown, SILT, intermediate plasticity with fine to medium grained sand, moist	MI													
3.50	-3.50	0.50			Moderately strong, thinly foliated, dark grey, BIOTITE GNEISS, fine to coarse grained, meta-sedimentary, highly weathered with QUARTZITE boulder (Boulder)	Rock				3.00	20	Nll							
4.00					Dense to medium dense, yellowish brown, SILT, intermediate plasticity with angular to subangular, medium to coarse grained sand, moist	MI				4.00	16	22	17	39					
5.00										5.00	19	10	19	29					
6.00					Strong, thinly foliated, greyish brown, QUARTZITE, fine to coarse grained, meta-sedimentary, moderately to slightly weathered, moderately fractured (Boulder)	Rock				6.00	35/135	20/135							
7.00	-7.00	1.55			Dense, yellowish brown, SILT, intermediate plasticity with fine to coarse grained sand, moist	MI				7.00	9	17	19	36					
7.60	-7.60	0.60																	
8.00	-8.00	0.40			Dense, brown to dark brown, silty SAND, angular to subangular, fine to coarse grained with gravel, moist	SM				8.00	18	26	24	50					
9.00	-9.00	1.00			Dense, yellowish brown, SILT, intermediate plasticity with fine to medium grained sand, moist	MI													
10.00					Dense, greyish brown, SILT, high plasticity with fine to coarse grained sand and completely weathered rock fragments, moist	MH				9.00	18	22	16	38					

Draft

	Natural moisture content, Atterberg Limits (LL, PL)	γ - Wet unit weight	W - Wash sample	Drilled By	CNB
	SPT 'N', blows/ft	G - Grainsize Analysis	SPT - SPT Sample	Logged By	CKJ
	Vane shear strength, peak	U - Unconfined compression	<input checked="" type="checkbox"/> - Undisturbed sample	Date	10/8/2015
	Vane shear strength, residual	CU - Consolidated undrained triaxial	<input checked="" type="checkbox"/> - Disturbed Sample	Checked By	CKJ

BOREHOLE LOG



NATIONAL BUILDING RESEARCH ORGANISATION
GEOTECHNICAL ENGINEERING DIVISION

99/1, Jawatta Road, Colombo 05.

SHEET NO.

1 of 2

PROJECT	TECHNICAL CORPORATION FOR LANDSLIDE MITIGATION PROJECT AT BADULLA		CLIENT	JAPAN INTERNATIONAL CORPORATION AGENCY	BOREHOLE NO	BB 3
LOCATION	BADULLA		CONTRACT NO	30/24871	DEPTH OF HOLE (m)	20.00
DRILING METHOD	CORE DRILLING		ELEVATION (m RL)		CHAINAGE / OFFSET	-
CORE SIZE [mm]	54	CASING SIZE	NX	CO-ORDINATES	N	DATE COMMENCED
VANE SIZE [mm*mm]	-	UDS SAMPLER SIZE [mm]	-		E	DATE COMPLETED

DEPTH [m]	ELEVATION [m RL]	LAYER THICKNESS [m]	SAMPLE TYPE	SAMPLE NO.	SOIL PROFILE			Y - [g/cm ³]	OTHER TESTS	DEPTH TESTED [m]	STANDARD PENETRATION TEST DATA			MOISTURE CONTENT - %					
					SOIL DESCRIPTION	STRATA	LEGEND				GWL	NUMBER OF BLOWS			UNDRAINED SHEAR STRENGTH - kN/m ²				
												PER 15cm	FOR 30cm	1	2	3	SPT RESISTANCE - Blows/30 cm		
0.00	0.00				GROUND LEVEL														
1.00	-1.00	1.00			Moderately strong, massive, brownish grey, KHONDERLITE and QUARTZITE, coarse grained, meta-sedimentary, moderately weathered, highly fractured	Rock				0.00	50	-	-						
1.45	-1.45	0.45			Medium dense, yellowish brown, silty SAND, fine to medium grained, moist	SM				1.00	8	9	17	26					
2.00	-2.00	0.55			Medium dense, orangish brown, silty SAND, fine to medium grained, moist	SM				2.00	18	16	21	37					
2.45	-2.45	0.45			Medium dense, dark brown, silty SAND, fine to medium grained, moist	SM													
3.00					Dense to medium dense, orangish brown, SILT, intermediate plasticity with fine to coarse grained sand, moist	MI				3.00	16	22	15	37					
4.00	-4.00	1.55			Medium dense, yellowish brown, silty SAND, angular to subangular, fine to coarse grained, moist	SM				4.00	7	11	18	29					
4.50	-4.50	0.50			Medium dense, brown, SAND, poorly graded, angular to subangular, fine to coarse grained, moist	SP													
5.00	-5.00	0.50			Very dense, orangish brown mottled with grey, silty SAND, angular, fine to coarse grained with gravel, moist	SM				5.00	21	22	-	>50					
6.00	-6.00	1.00			Dense to medium dense, greyish brown, silty SAND, fine to medium grained with completely weathered rock fragments, moist (completely weathered rock)	SM				6.00	16	18	18	36					
7.00					Highly to completely weathered rock (washing sample)														
8.00					Dense, yellowish brown, SILT, intermediate plasticity with fine to medium grained sand and completely weathered rock fragments, moist	MI				7.00	17	26	16	42					
8.50	-8.50	2.50			Dense, silty SAND, fine to medium grained with completely weathered rock fragments, moist	SM				8.00	9	15	15	30					
9.00	-9.00	0.90								8.50									
9.45	-9.45	0.45								9.00	14	19	24	43					
10.00																			

Draft

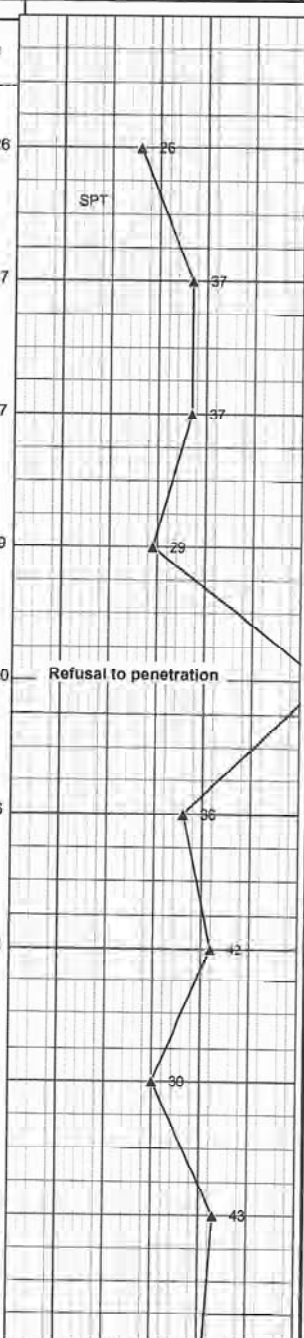

	Natural moisture content, Atterberg Limits (LL, PL)	γ - Wet unit weight	W - Wash sample	Drilled By	CNB
	SPT 'N', blows/ft	G - Grainsize Analysis	SPT - SPT Sample	Logged By	CKJ
	Vane shear strength, peak	U - Unconfined compression	<input checked="" type="checkbox"/> Undisturbed sample	Date	13/8/2015
	Vane shear strength, residual	CU - Consolidated undrained triaxial	<input checked="" type="checkbox"/> Disturbed Sample	Checked By	CKJ

BOREHOLE LOG



NATIONAL BUILDING RESEARCH ORGANISATION
 GEOTECHNICAL ENGINEERING DIVISION
 99/1, Jawatta Road, Colombo 05.

SHEET NO
 2 of 2

PROJECT	TECHNICAL CORPORATION FOR LANDSLIDE MITIGATION PROJECT AT BADULLA		CLIENT	JAPAN INTERNATIONAL CORPORATION AGENCY	BOREHOLE NO	BB 3	
LOCATION	BADULLA		CONTRACT NO	30/24871	DEPTH OF HOLE (m)	20.00	
DRILING METHOD	CORE DRILLING		ELEVATION (m RL)	0	CHAINAGE / OFFSET	-	
CORE SIZE [mm]	54	CASING SIZE	MX	CO-ORDINATES	N	DATE COMMENCED	0
VANE SIZE [mm*mm]		UDS SAMPLER SIZE [mm]			E	DATE COMPLETED	0

DEPTH [m]	ELEVATION [m RL]	LAYER THICKNESS [m]	SAMPLE TYPE	SAMPLE NO.	SOIL PROFILE			OTHER TESTS	DEPTH TESTED [m]	STANDARD PENETRATION TEST DATA				MOISTURE CONTENT - %					
					SOIL DESCRIPTION	STRATA	LEGEND			GWL	NUMBER OF BLOWS				UNDRAINED SHEAR STRENGTH - kN/m ²				
											PER 15cm			FOR 30cm	SPT RESISTANCE - Blows/30 cm				
											1	2	3		10	20	30	40	50
10.00	-10.00	0.55						10.00	19	15	26	41							
11.00	-11.00	1.00						11.00	21	18	16	34							
11.50	-11.50	0.50						12.00	20	23	18	41							
12.00								13.00	11	16	18	34							
14.00	-14.00	2.50						14.00	18	24	30	54							
14.45	-14.45	0.45						15.00	23	26	20	46							
16.00								16.00	15	13	18	31							
17.00								17.00	15	22	13	35							
18.00								18.00	14	27	26	53							
19.00	-19.00	4.55						19.00	Nil	Nil									
19.50	-19.50	0.50						19.50	40/50	18/50									
20.00	-20.00	0.50						20.00											

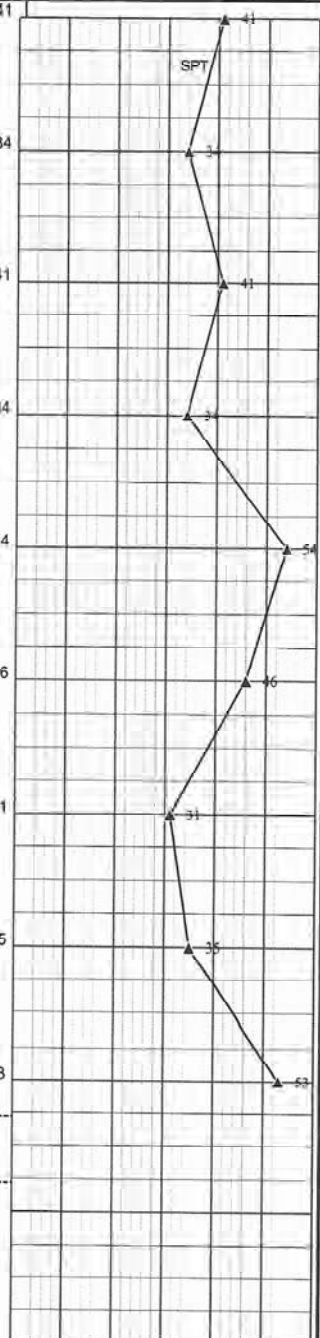

Natural moisture content, Atterberg Limits (LL, PL) γ - Wet unit weight W - Wash sample
 SPT 'N', blows/ft G - Grainsize Analysis SPT - SPT Sample
 Vane shear strength, peak U - Unconfined compression Undisturbed sample
 Vane shear strength, residual CU - Consolidated undrained triaxial Disturbed Sample

Drilled By: CNB
 Logged By: CKJ
 Date: 13/8/2015
 Checked By: CKJ

BOREHOLE LOG



NATIONAL BUILDING RESEARCH ORGANISATION
 GEOTECHNICAL ENGINEERING DIVISION
 99/1, Jawatta Road, Colombo 05.

SHEET NO.
 1 of 2

PROJECT	TECHNICAL CORPORATION FOR LANDSLIDE MITIGATION PROJECT AT BADULLA		CLIENT	JAPAN INTERNATIONAL CORPORATION AGENCY	BOREHOLE NO	BB 4
LOCATION	BADULLA		CONTRACT NO	30/24871	DEPTH OF HOLE (m)	20.00
DRILING METHOD	CORE DRILLING		ELEVATION (m RL)		CHAINAGE / OFFSET	-
CORE SIZE [mm]	54	CASING SIZE	NX	CO-ORDINATES	N	DATE COMMENCED
VANE SIZE [mm*mm]	-	UDS SAMPLER SIZE [mm]	-		E	DATE COMPLETED

DEPTH [m]	ELEVATION [m RL]	LAYER THICKNESS [m]	SAMPLE TYPE	SAMPLE NO.	SOIL PROFILE				OTHER TESTS	STANDARD PENETRATION TEST DATA			MOISTURE CONTENT - %						
					SOIL DESCRIPTION	STRATA	LEGEND	GWL		DEPTH TESTED [m]	NUMBER OF BLOWS			UNDRAINED SHEAR STRENGTH - kN/m ²	SPT RESISTANCE - Blows/30 cm				
											1	2	3		10	20	30	40	50
0.00	0.00				GROUND LEVEL														
1.00					Medium dense, dark brown mottled with yellow, silty SAND, angular to subangular, medium to coarse grained with gravel, moist	SM				1.00	3	8	9	17					
1.50	-1.50	1.50																	
2.00					Medium dense, yellowish brown, SILT, intermediate plasticity with fine to coarse grained sand, moist	MI				2.00	6	6	10	16					
2.50	-2.50	1.00			QUARTZITE (Rock boulder)														
3.00	-3.00	0.50								3.00	5	7	6	13					
4.00					Medium dense, yellowish brown, silty SAND, angular to subangular, fine to coarse grained, moist	SM				4.00	6	5	8	13					
5.00	-5.00									5.00	7	6	8	14					
5.45	-5.45	0.45			Medium dense, yellowish brown, SILT, intermediate, plasticity with fine to medium grained sand, moist	MI													
6.00	-6.00	0.55			Highly to completely weathered rock (washing sample)					6.00	3	8	13/10	>50	Refusal to penetration				
6.45	-6.45	0.45			Very dense, yellowish brown, silty SAND, fine to medium grained with completely weathered rock fragments, moist (completely weathered rock)	SM													
7.00	-7.00	0.55			Highly to completely weathered rock (washing sample)					7.00	10	Nil	-	-					
8.00	-8.00	1.00			Moderately strong, thinly foliated, greyish brown, BIOTITE GNEISS, medium to coarse grained, meta-sedimentary, moderately weathered, highly fractured	Rock				8.00	9	27	15	42					
9.00					Dense to very dense, yellowish brown mottled with grey, silty SAND, fine to medium grained with completely weathered rock fragments, moist	SM				9.00	23	24	37	>50	Refusal to penetration				
9.50	-9.50	1.50																	
10.00						SM													

Draft

	Natural moisture content, Atterberg Limits (LL, PL)	γ - Wet unit weight	W - Wash sample	Drilled By	CNB
	SPT 'N', blows/ft	G - Grainsize Analysis	SPT - SPT Sample	Logged By	CKJ
	Vane shear strength, peak	U - Unconfined compression	<input checked="" type="checkbox"/> - Undisturbed sample	Date	13/8/2015
	Vane shear strength, residual	CU - Consolidated undrained triaxial	<input checked="" type="checkbox"/> - Disturbed Sample	Checked By	CKJ

BOREHOLE LOG



NATIONAL BUILDING RESEARCH ORGANISATION
GEOTECHNICAL ENGINEERING DIVISION
 99/1, Jawatta Road, Colombo 05.

SHEET NO.

2 of 2

PROJECT	TECHNICAL CORPORATION FOR LANDSLIDE MITIGATION PROJECT AT BADULLA		CLIENT	JAPAN INTERNATIONAL CORPORATION AGENCY	BOREHOLE NO	BB 4	
LOCATION	BADULLA		CONTRACT NO	30/24871	DEPTH OF HOLE (m)	20.00	
DRILING METHOD	CORE DRILLING		ELEVATION (m RL)	0	CHAINAGE / OFFSET	-	
CORE SIZE (mm)	54	CASING SIZE	NX	CO-ORDINATES	N	DATE COMMENCED	0
VANE SIZE (mm*mm)	-	UDS SAMPLER SIZE (mm)	-		E	DATE COMPLETED	0

DEPTH [m]	ELEVATION [m RL]	LAYER THICKNESS(m)	SAMPLE TYPE	SAMPLE NO.	SOIL PROFILE			Y - [g/cm ³]	OTHER TESTS	STANDARD PENETRATION TEST DATA				MOISTURE CONTENT - %					
					SOIL DESCRIPTION	STRATA	LEGEND			GWL	NUMBER OF BLOWS				UNDRAINED SHEAR STRENGTH - kN/m ²				
											PER 15cm			FOR 30cm	SPT RESISTANCE - Blows/30 cm				
											1	2	3		10	20	30	40	50
10.00			X		Very dense, yellowish brown mottled with grey, silty SAND, angular to subangular, medium to coarse grained with completely weathered rock fragments	SM			10.00	23	27	37	>50	Refusal to penetration					
11.00			X						11.00	27	99	57	>50	Refusal to penetration					
12.00	-12.00	2.50	X						12.00					>50	Refusal to penetration				
12.50	-12.50	0.50	X		Very dense, light brown mottled with grey, silty SAND, fine to medium grained with completely weathered rock fragments, moist (completely weathered rock)	SM			Core Depth in Core Recovery %	RCD %	Return of Water %								
13.00	-13.00	0.50			Highly to completely weathered rock (washing sample)				12.50	10	Nil								
14.00	-14.00	1.00			Highly to completely weathered rock (washing sample)				13.50	Nil	Nil								
14.50	-14.50	0.50			Highly to completely weathered rock (washing sample)				14.50	Nil	Nil								
15.00	-15.00	0.50			Moderately strong, massive, whitish grey, MARBLE, medium to coarse grained, meta-sedimentary, moderately weathered, moderately fractured	Rock			15.00	60	Nil								
16.00					Weak to moderately strong, thinly foliated, greyish brown, CALC GNEISS, medium to coarse grained, meta-igneous, moderately weathered, moderately fractured	Rock			16.50	28	Nil								
16.50	-16.50	1.50			Weak to moderately strong, thinly foliated, greyish brown, CALC GNEISS, medium to coarse grained, meta-igneous, moderately weathered, moderately fractured	Rock			17.50	49	Nil								
17.50	-17.50	1.00			Weak to moderately strong, thinly foliated, greyish brown, CALC GNEISS, medium to coarse grained, meta-igneous, moderately weathered, moderately fractured	Rock			17.50	92	89								
18.50	-18.50	1.00			Highly to completely weathered rock (washing sample)				18.50	Nil	Nil								
19.00					Highly to completely weathered rock (washing sample)				20.00	Nil	Nil								
20.00	-20.00	1.50			Borehole terminated at 20.00m depth														

- Natural moisture content, Atterberg Limits (LL, PL)
- SPT 'N', blows/ft
- Vane shear strength, peak
- Vane shear strength, residual

- γ - Wet unit weight
- G - Grainsize Analysis
- U - Unconfined compression
- CU - Consolidated undrained triaxial

- W - Wash sample
- SPT - SPT Sample
- Undisturbed sample
- Disturbed Sample

Drilled By	CNB
Logged By	CKJ
Date	13/8/2015
Checked By	CKJ

BOREHOLE LOG



NATIONAL BUILDING RESEARCH ORGANISATION
 GEOTECHNICAL ENGINEERING DIVISION
 99/1, Jawatta Road, Colombo 05.

SHEET NO.
 1 of 2

PROJECT	TECHNICAL CORPORATION FOR LANDSLIDE MITIGATION PROJECT AT BADULLA		CLIENT	JAPAN INTERNATIONAL CORPORATION AGENCY	BOREHOLE NO	BB 5
LOCATION	BADULLA		CONTRACT NO	30/24871	DEPTH OF HOLE (m)	20.00
DRILLING METHOD	CORE DRILLING		ELEVATION (m RL)		CHAINAGE / OFFSET	-
CORE SIZE [mm]	54	CASING SIZE	NX	CO-ORDINATES	N	DATE COMMENCED
VANE SIZE [mm*mm]	-	UDS SAMPLER SIZE [mm]	-		E	DATE COMPLETED

DEPTH [m]	ELEVATION [m RL]	LAYER THICKNESS [m]	SAMPLE TYPE	SAMPLE NO.	SOIL PROFILE			OTHER TESTS	DEPTH TESTED [m]	STANDARD PENETRATION TEST DATA			MOISTURE CONTENT - %					
					SOIL DESCRIPTION	STRATA	LEGEND			GWL	NUMBER OF BLOWS			UNDRAINED SHEAR STRENGTH - kN/m ²				
											PER 15cm	FOR 30cm	SPT RESISTANCE - Blows/30 cm	10	20	30	40	50
0.00	0.00				GROUND LEVEL													
1.00					Medium dense, dark brown mottled with yellowish brown, silty SAND, angular to subangular, fine to coarse grained with completely weathered rock fragments, moist	SM			1.00	5	7	5	12					
2.00	-2.00				Loose, dark brown mottled with pockets of yellowish brown, silty SAND, fine to medium grained with completely weathered rock fragments, moist	SM			2.00	4	3	6	9					
2.45	-2.45	0.45			Loose, yellowish brown mottled with grey, silty SAND, fine to medium grained with completely weathered rock fragments, moist	SM												
3.00	-3.00	0.66			Medium dense, dark brown mottled with grey, silty SAND, fine to medium grained with completely weathered rock fragments, moist	SM			3.00	5	7	9	16					
3.45	-3.45	0.45			Medium dense, yellowish brown with pockets of blackish brown. SILT, intermediate plasticity with fine to medium grained sand, moist	MI												
4.00	-4.00	0.55			Medium dense, dark brown mottled with grey, silty SAND, fine to medium grained with completely weathered rock fragments, moist	SM			4.00	5	8	8	16					
4.45	-4.45	0.45			Medium dense, yellowish brown with pockets of blackish brown, SILT, intermediate plasticity with fine to medium grained sand, moist													
5.00	-5.00	0.55			Dense to medium dense, brown, SILT, intermediate plasticity with fine to medium grained sand, moist	MI			5.00	9	16	21	37					
6.00					Dense to medium dense, brown, SILT, intermediate plasticity with fine to medium grained sand, moist	MI			6.00	7	8	10	18					
7.00	-7.00	2.00			Medium dense, brown, SILT, intermediate plasticity with pockets of silty sand, moist	MI			7.00	7	7	9	16					
8.00	-8.00	1.00			Moderately strong, thinly foliated, blackish grey, BIOTITE GNEISS, medium to coarse grained, meta-sedimentary, moderately weathered, moderately fractured (Boulder)	Rock			8.00	8	Nil			Refusal to penetration				
9.00	-9.00	1.00			Moderately strong, thinly foliated, blackish grey, BIOTITE GNEISS, medium to coarse grained, meta-sedimentary, moderately weathered, moderately fractured (Boulder)	Rock			9.00	2	Nil							

<ul style="list-style-type: none"> Natural moisture content, Atterberg Limits (LL, PL) SPT N, blows/ft Vane shear strength, peak Vane shear strength, residual 	<ul style="list-style-type: none"> γ - Wet unit weight G - Grainsize Analysis U - Unconfined compression CU - Consolidated undrained triaxial 	<ul style="list-style-type: none"> W - Wash sample SPT - SPT Sample <input checked="" type="checkbox"/> - Undisturbed sample <input checked="" type="checkbox"/> - Disturbed Sample 	Drilled By: CNB Logged By: CKJ Date: 13/8/2015 Checked By: CKJ
--	---	---	---

BOREHOLE LOG



NATIONAL BUILDING RESEARCH ORGANISATION
 GEOTECHNICAL ENGINEERING DIVISION
 99/1, Jawatta Road, Colombo 05.

SHEET NO.
 2 of 2

PROJECT	TECHNICAL CORPORATION FOR LANDSLIDE MITIGATION PROJECT AT BADULLA		CLIENT	JAPAN INTERNATIONAL CORPORATION AGENCY	BOREHOLE NO	BB 5	
LOCATION	BADULLA		CONTRACT NO	30/24871	DEPTH OF HOLE (m)	20.00	
DRILING METHOD	CORE DRILLING		ELEVATION (m RL)	0	CHAINAGE / OFFSET	-	
CORE SIZE [mm]	54	CASING SIZE	NX	CO-ORDINATES	N	DATE COMMENCED	0
VANE SIZE [mm*mm]	-	UDS SAMPLER SIZE [mm]	-		E	DATE COMPLETED	0

DEPTH [m]	ELEVATION [m RL]	LAYER THICKNESS [m]	SAMPLE TYPE	SAMPLE NO.	SOIL PROFILE				OTHER TESTS	DEPTH TESTED [m]	STANDARD PENETRATION TEST DATA				MOISTURE CONTENT - %					
					SOIL DESCRIPTION	STRATA	LEGEND	GWL			NUMBER OF BLOWS				UNDRAINED SHEAR STRENGTH - kN/m ²					
											PER 15cm			FOR	SPT RESISTANCE - Blows/30 cm					
											1	2	3	30cm	10	20	30	40	50	60
10.00	-10.00								10.00	8	15	22	37							
10.50	-10.50	0.50			Very dense, yellowish brown, silty SAND, fine to medium grained with completely weathered rock fragments rock	Rock	SM													
11.00					Highly to completely weathered rock				11.00	15	26	-	>50	Refusal to penetration						
12.00									12.00	13	20	-	>50	Refusal to penetration						
13.00									13.00	6	9	17	26							
14.00	-14.00	3.50			Very dense, whitish grey, silty SAND, fine to medium grained with completely weathered rock fragments, moist (completely weathered rock)				14.00	11	29	38	>50	Refusal to penetration						
15.00									15.00	45	71	-	>50	Refusal to penetration						
16.00									16.00	20	24	49	>50	Refusal to penetration						
17.00									17.00	24	42	33	>50	Refusal to penetration						
18.00									18.00	11	70	32	>50	Refusal to penetration						
19.00								19.00	21	33	41	>50	Refusal to penetration							
20.00	-20.00	6.00			Borehole terminated at 20.00m depth															

Natural moisture content, Atterberg Limits (LL, PL)	Wet unit weight	Wash sample	Drilled By CNB
SPT 'N', blows/ft	Grainsize Analysis	SPT - SPT Sample	Logged By CKJ
Vane shear strength, peak	Unconfined compression	Undisturbed sample	Date 13/8/2015
Vane shear strength, residual	Consolidated undrained triaxial	Disturbed Sample	Checked By CKJ

Democratic Socialist Republic of Sri Lanka

National Building Research Organization (NBRO)

**Proposal for Rectification
on Landslide at Udamadula
in Nuwara Eliya District**

FINAL REPORT

September, 2015

Japan International Corporation Agency (JICA)

**EARTH SYSTEM SCIENCE Co., Ltd. (ESS)
NIPPON KOEI Co., Ltd. (NK)**

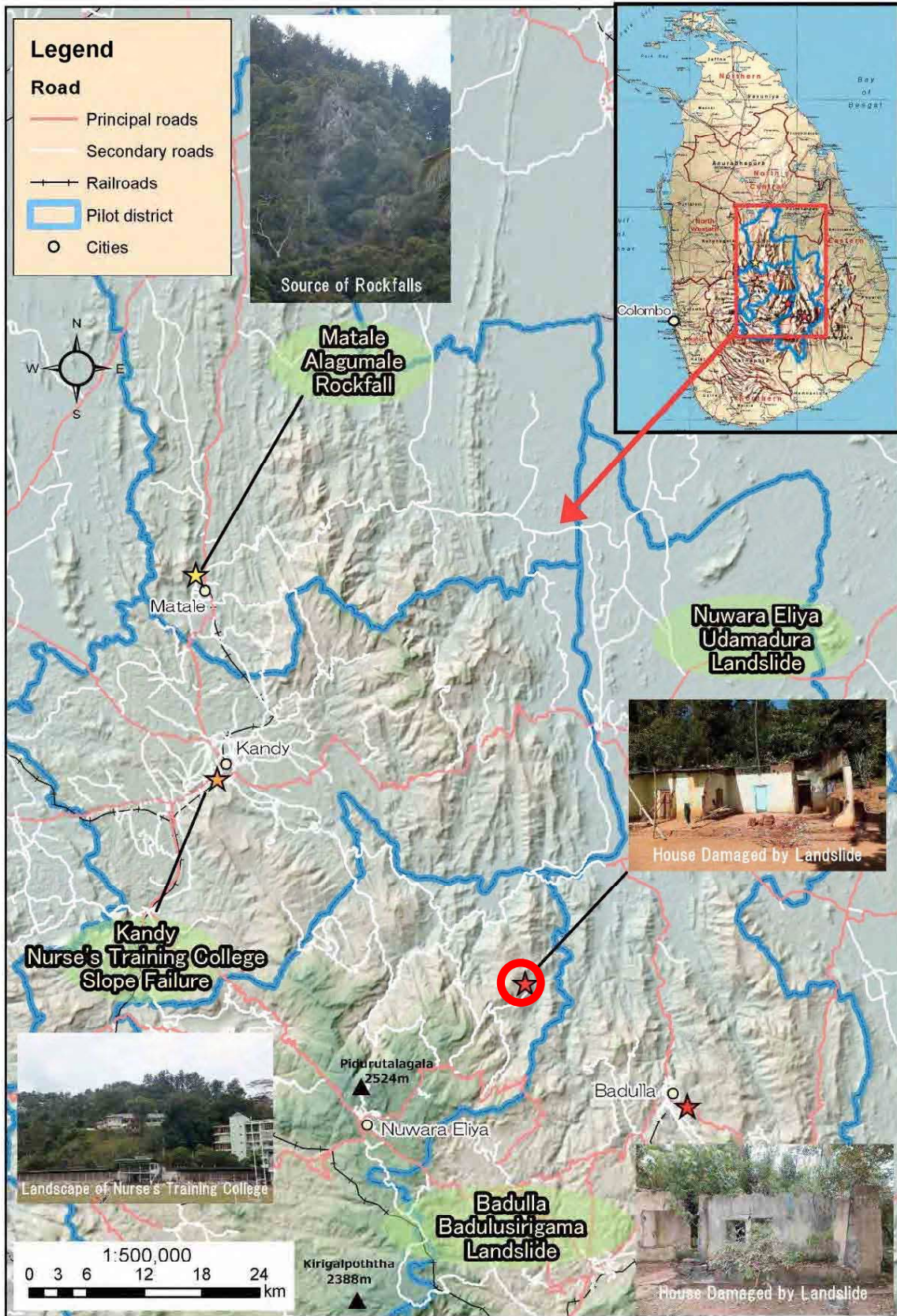

Location Map of Pilot Project Sites

**Technical Cooperation for Landslide Mitigation Project
in
the Democratic Socialist Republic of Sri Lanka
Progress Report for Udamadura Landslide**

Table of Contents

Location Map

	<u>Page</u>
Chapter 1 Outline of the Survey	1
1.1 Background	1
1.2 Objective	1
1.3 Target Survey Area	1
Chapter 2 Preliminary Survey	2
2.1 Site Condition.....	2
2.2 Investigation Plan.....	3
Chapter 3 Geomorphological and Geological Survey	5
3.1 Geomorphological Survey.....	5
3.2 Geological Survey	6
3.3 Geophysical Survey.....	9
Chapter 4 Monitoring Survey	10
4.1 Extensometer.....	10
4.2 Inclinator.....	10
4.3 Pipe Strain Gauge.....	11
4.4 Groundwater Level Gauge	12
Chapter 5 Design of Countermeasures	13
5.1 Landslide Mechanism.....	13
5.2 Stability Analysis.....	13
5.3 Design Concept of Countermeasures	14
5.4 Design of Countermeasures.....	16

APPENDIX

Appendix-1	Photo of Boring Core Sample
Appendix-2	Borehole Log

Table 1.1	Pilot Sites in the Project.....	1
Table 2.1	Summary of Udamadura Landslide	2
Table 2.2	Geomorphological Investigation Items for Udamadura Landslide	3
Table 2.3	Geological Investigation Items for Udamadura Landslide.....	3
Table 2.4	Monitoring Items for Udamadura Landslide	3
Table 2.5	Geophysical Investigation Items for Udamadura Landslide.....	3
Table 5.1	Coefficient Condition of Stability Analysis for the Lower Landslide Block.....	13
Table 5.2	The Summary of Designed High-Priority Countermeasures against Udamadura Landslide.....	18
Figure 2.1	Investigation Plan for Udamadura Landslide.....	4
Figure 3.1	Detailed Aerial Photo Image of Udamadura Site prepared by using UAV	5
Figure 3.2	DEM Data of Udamadura Site prepared by using UAV	6
Figure 3.5	Geological Main Cross Section of Udamadura Landslide	7
Figure 3.6	Geological Cross Section of Udamadura Landslide	8
Figure 4.1	Graph of Extensometer and Groundwater Level in Udamadura Landslide	10
Figure 4.2	Graph of Inclinator (BN-2) in Udamadura Landslide	11
Figure 4.3	Monitoring Survey of Pipe Strain Gauge BN-3	11
Figure 4.4	Graph of Pipe Strain Gauge (BN-3) in Udamadura Landslide	12
Figure 5.1	Integral Planning of Countermeasures against Udamadura Landslide.....	15
Figure 5.2	Plan of Basic Design for High-Priority Countermeasures against Udamadura Landslide.....	16
Figure 5.3	Cross Section of Basic Design of Countermeasures against the Lower Landslide Block in Udamadura Landslide	17

Chapter 1 Outline of the Survey

1.1 Background

Sediment disasters (Landslides) have become one of the major natural disasters in Sri Lanka. The hilly and mountainous areas in central region of Sri Lanka known as Central Highlands cover nearly 20% of the total land area of Sri Lanka and are occupied by about 30% of the total population of the country.

On March 14, 2013, Japanese ODA Loan Agreements for "Landslide Disaster Protection Project of the National Road Network" which covers seven districts including the target districts of this Project was signed. This loan project will carry out countermeasure construction on slopes on major national roads with a high risk of landslides, alleviating the risk of a disaster and making the road network and lives of nearby residents safer.

The Government of the Democratic Socialist Republic of Sri Lanka has requested the Government of Japan to implement the Landslide Mitigation Project (hereinafter referred to as "the Project") to enhance the capacity of National Building Research Organization (hereinafter referred to as "NBRO") staff through on-the-job training, preparation of technical guidelines and manuals and the construction of mitigation measures.

1.2 Objective

The main object of this Project is to strengthen "Sediment disaster management capacity of NBRO" through application of appropriate mitigation measure with Japanese and other technology in the pilot project sites.

1.3 Target Survey Area

This Project has four pilot sites, which are located in Kandy District, Matale District, Nuwara Eliya District and Badulla District, as shown in Table 1.1.

Table 1.1 Pilot Sites in the Project

Pilot Sites	Location	Type of Mass Movement
Nurse's Training College	Kandy District	Slope Failure
Matale	Alagumale in Matale District	Rockfall
Badulusirigama	Uva Wellasa University in Badulla District	Landslide
Udamadura	Nuwara Eliya District	Landslide





This progress report is written for Udamadura landslide in Nuwara Eliya District.

Chapter 2 Preliminary Survey

2.1 Site Condition

Preliminary survey such as collection of existing data, data review, interpretation of aerial photographs and field reconnaissance has been conducted. The site condition of Udamadura Landslide is summarized in Table 2.1.

Table 2.1 Summary of Udamadura Landslide

Outline of Preliminary Survey in the Pilot Site					
Site name	Udamadura (Nuwara Eliya District)	Surveyed by	Ms Chaturi Subasingha (Nuwara Eliya Office) Mr. Handa, Mr. Ohkawara, Mr. Hara, Mr. Yang, Mr. Nishikawa	Survey Date	2014/11/11
Disaster Type and Scale	Landslide	Scale	Approximately 400m to 500m wide, 900 to 1000m long		
Geostructure	The landslide is located in the Highland Complex. The structural geology of the Highland Complex is characterized by distribution of many NW-SE folds and NE-SW faults. The landslide slope is underlain by hornblende gneiss. The highly weathered hornblende gneiss and its overlying colluvial deposits form the potential landslide mass. The potential sliding surface is presumably due to foliation joints and shear zones.				
Vegetation Cover/Land Use	The upper and middle slopes of landslide are covered by herbs and shrub with some scattered houses, while the lower part of landslide is used as paddy field. In addition, farm land reclamation and residential land are observable in places and the village roads cross the landslide.				
Existing Conditions	The landslide can be classified into three landslide blocks, the upper block, the middle block and the lower block based on topographic interpretation. The landslide topography is characterized by the presence of multiple concave and plateau in the upper and middle parts of landslide, and by the presence of stepped landforms in the lower part. The landslide slope is gentle, ranging from 5 to 10 degrees in the lower part and from 20 to 25 degrees in the middle and upper parts of landslide. At the time of the 2007 heavy rain, cracks and gaps of the road surface crossing the lower landslide block were formed, and some cracks on the walls of houses around the road were also observed. The 2012 heavy rainfall reactivated the landslide and caused the local subsidence of road surface and the partial damages of residential houses such as cracks of house wall.				
Occurrence Mechanism	A large quantity of rainwater penetrates from the ground surface at the time of the rain, resulting in the rise of groundwater level, consequently reactivating landslide movement.				
Affected Area	The gap and crack of road crossing the lower landslide block could be expanded due to further landslide movement, causing impassableness. In addition, because mitigation works such as groundwater drainage works have not been implemented, the cracks of the damaged residential houses are likely to further be expanded as a result of continuous landslide movement.				
Survey Plan	Topographic survey: 200×300m (1:200), Cross-section survey: 600m×2 lines + 1200m×1line Boring survey: 20m×1 borehole + 40m×2 borehole+50m×1borehole Seismic refraction: 600m×2 lines + 1200m×1 line, High density electric sounding: 600m×2 lines + 1200m×1line Laboratory test: Unit weight, moisture content, atterberg limits, particle size analysis by sieve				
Mitigation Measures and Selection Reasons	The lower landslide block has repeatedly moved during rainy periods, and therefore horizontal boring and surface drainage works have been planned to remove the main triggering factors – rainwater and shallow groundwater. In addition, a small check dam has been proposed to prevent the riverbed and bank erosion of the landslide side stream.				
Construction Problems	New construction road will be required for the construction of the proposed mitigation works.				
Landslide Site Photos					
					
Whole view (looking at the lower slope from the upslope)		The gap of road surface formed due to landslide movement			
					
Close view of the lower slope of landslide		Crack caused by landslide on the residence wall			

2.2 Investigation Plan

Based on the preliminary survey, a detailed investigation has been planned. The items of planned investigation for geomorphology, geology and geophysics are shown in Table 2.2 - Table 2.5.

Table 2.2 Geomorphological Investigation Items for Udamadura Landslide

Investigation Items
Topo mapping
Cross section survey
Unmanned Aerial Vehicles (UAV) analysis

Table 2.3 Geological Investigation Items for Udamadura Landslide

Investigation Items	Quantity
Borehole drilling	BN-1 (Drilling depth=20m)
	BN-2 (Drilling depth=40m)
	BN-3 (Drilling depth=30m)
	BN-4 (Drilling depth=40m) Plan
Standard penetration test (SPT)	Each borehole (at 1.0m interval)
Laboratory tests (Unit weight, Moisture content and Particle size analysis)	Some samples

Table 2.4 Monitoring Items for Udamadura Landslide

Monitoring Equipment No.	Monitoring Equipment	Monitoring Frequency
SN-1	Extensometer	1 time / 1 month
SN-2		
SN-3		
BN-1	Groundwater level gauge	1 time / 1 month
BN-2	Inclinometer (L=40m)	1 time / 1 month
BN-3	Pipe strain gauge (L=30m)	1 time / 1 month
BN-4 (Plan)	(PVC pipe for groundwater level measurement)	-

Table 2.5 Geophysical Investigation Items for Udamadura Landslide

Investigation Items	Quantity
Seismic refraction survey	1,200m * 1 line + 600m * 2 lines
High density electric sounding	1,200m * 1 line + 600m * 2 lines

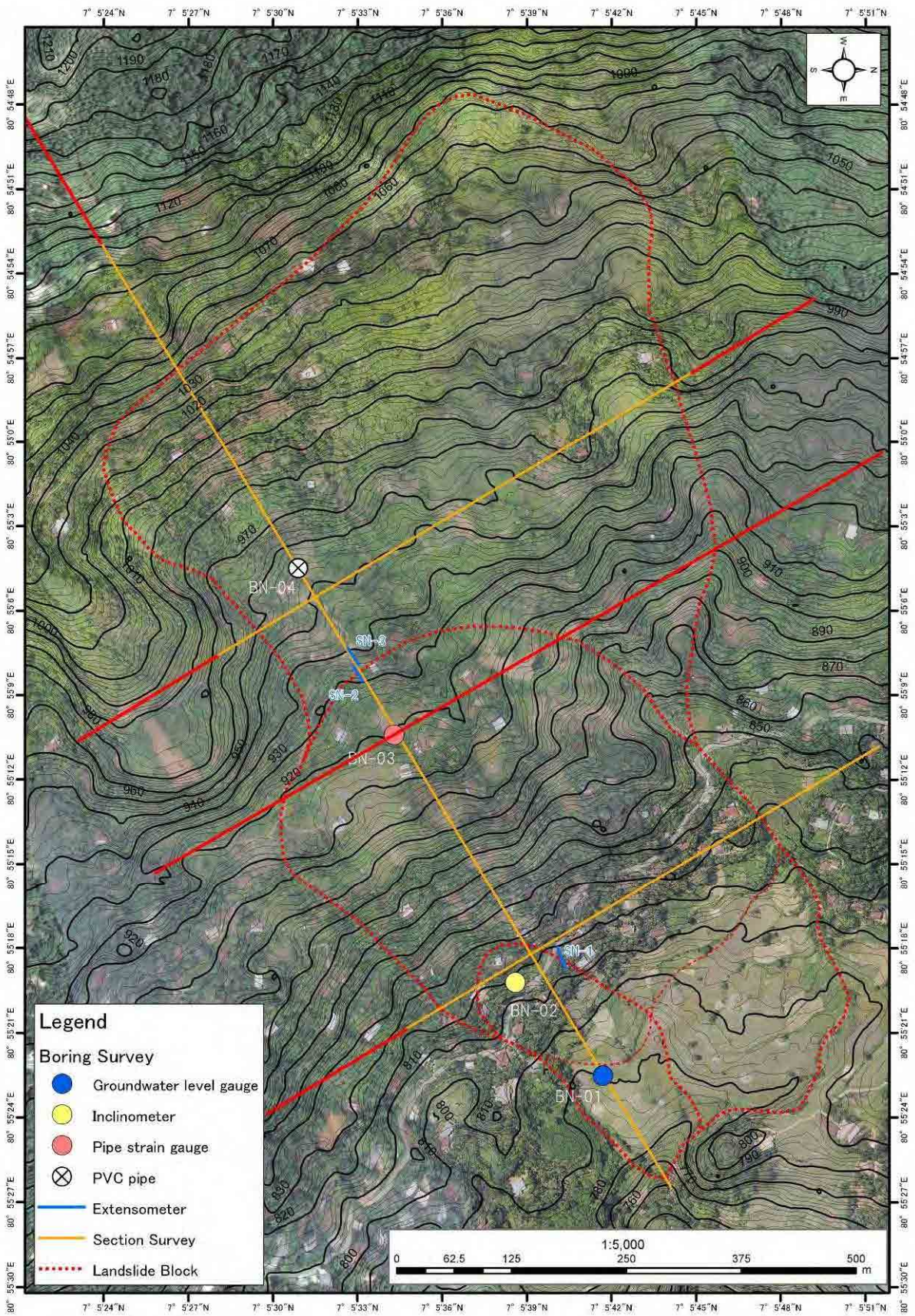

Figure 2.1 Investigation Plan for Udamadura Landslide

Chapter 3 Geomorphological and Geological Survey

3.1 Geomorphological Survey

Topographical surveys such as plane survey, cross section survey and Unmanned Aerial Vehicles (UAV) analysis have been conducted. The Digital Elevation Model (DEM) data has been made by UAV. The products of topographical surveys by using UAV are shown below.



Figure 3.1 Detailed Aerial Photo Image of Udamadura Site prepared by using UAV



Figure 3.2 DEM Data of Udamadura Site prepared by using UAV

3.2 Geological Survey

Three boreholes drilling have been performed in Udamadura Landslide, and core samples were recovered from the boreholes. Geological assessments based on the core samples and SPT have been conducted in order to determine geological structure and slip surface of the landslide. The core samples and boring logs are shown in Appendix of this report. Guide pipes of inclinometers, pipe strain gauge and groundwater level sensors have been installed into the boreholes in order to measure landslide activity and define the depth of slip surface. The borehole BN-4 only will be surveyed by Japanese drilling machine in the 2nd term. The geological cross section prepared based on the results of these geological surveys is shown in Figure 3.5 and Figure 3.6.



Figure 3.3 Drilling Work at the Site



Figure 3.4 Core sample check with Japanese expert

CROSS SECTION OF NUWARA ELIYA LANDSLIDE

Section A1-A2 S=1:xxx

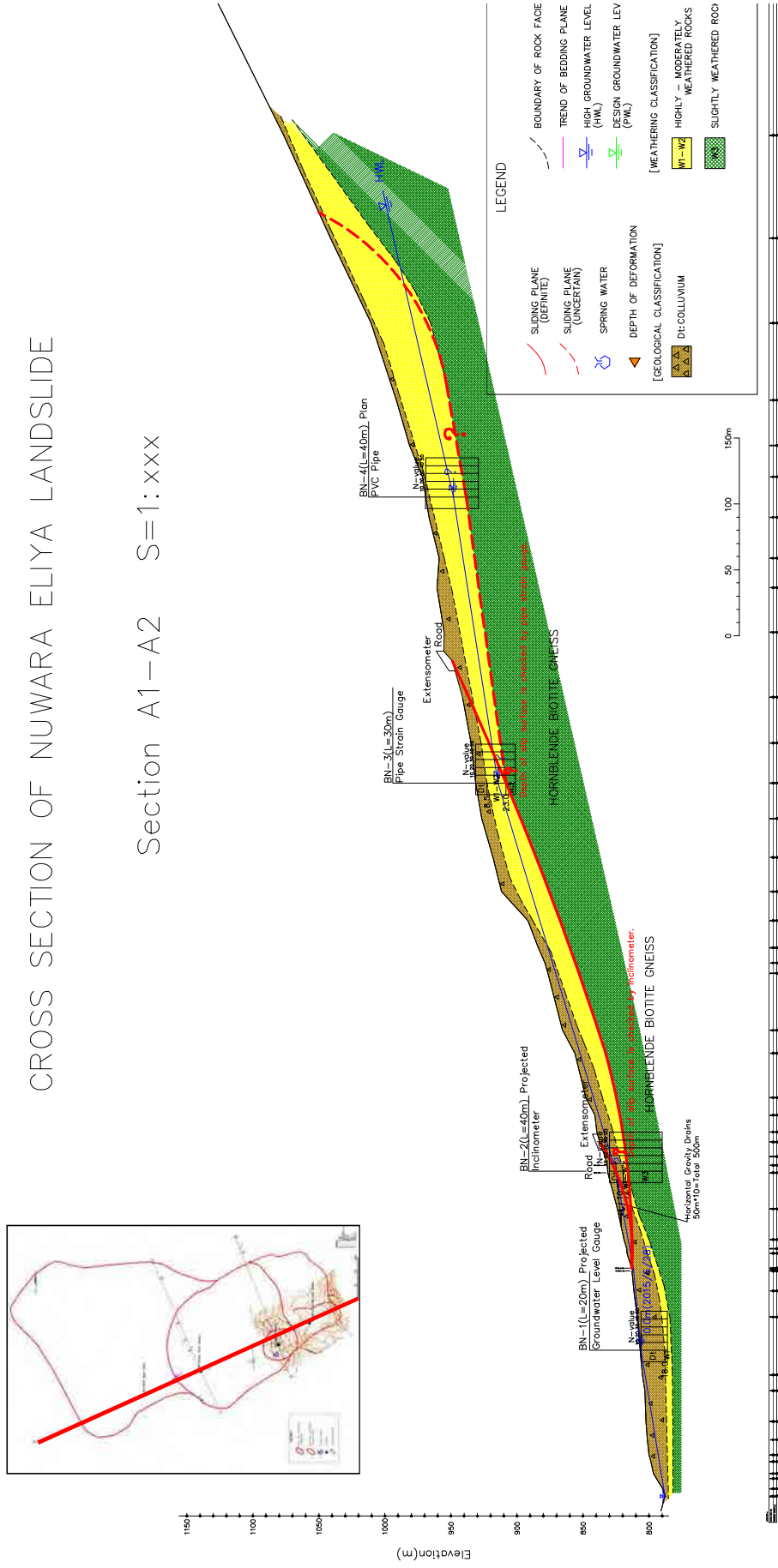
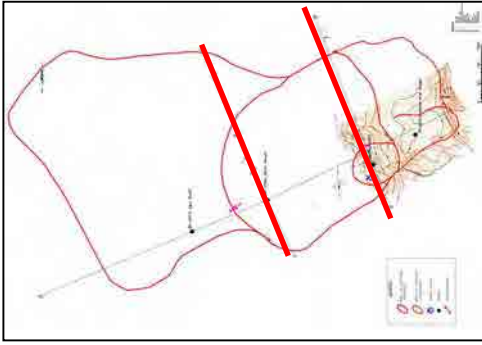
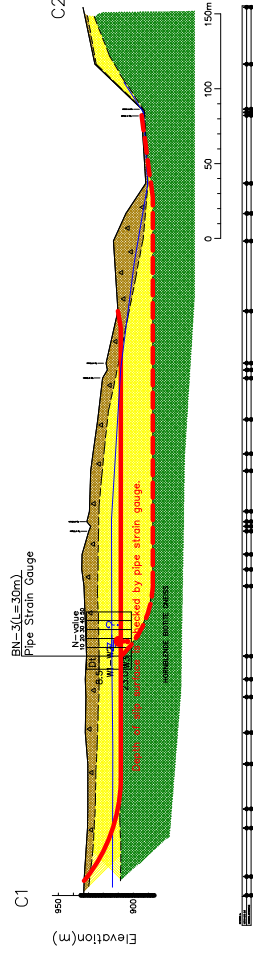

Figure 3.5 Geological Main Cross Section of Udamadura Landslide



CROSS SECTION OF NUWARA ELIYA LANDSLIDE

Section C1–C2 S=1:xxx



Section B1–B2

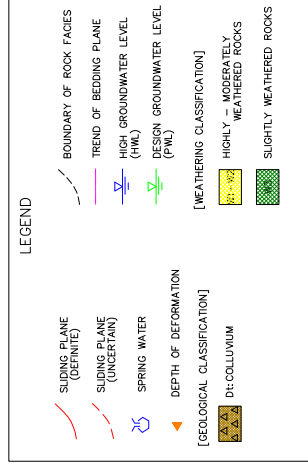
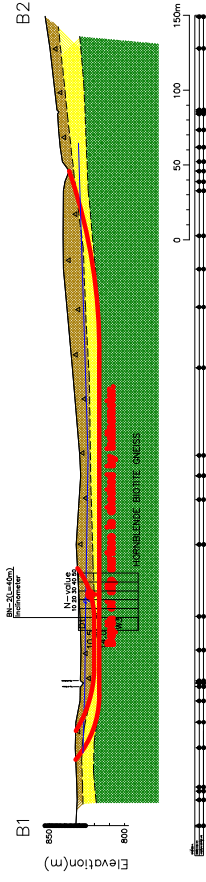

Figure 3.6 Geological Cross Section of Udamadura Landslide

3.3 Geophysical Survey

3.3.1 Seismic Refraction Survey

The seismic refraction survey is in process at this moment.

3.3.2 High Density Electric Sounding

The analysis of high density electric sounding is in process at this moment.

Chapter 4 Monitoring Survey

4.1 Extensometer

The extensometer is used to measure amount of relative displacement between two points which are set on a moving and unmoving ground. The extensometers are generally installed across the main scarp, at transverse cracks and transverse ridges near the toe or front portion of the slide and parallel to the suspected slide direction.

A heavy rainfall event has not occurred up to the present date since extensometers were installed in Udamadura landslide area, and there is no clear cumulative displacement of these extensometers (see Figure 4.1). More monitoring time including heavy rainfall event is needed for evaluation of these extensometers.

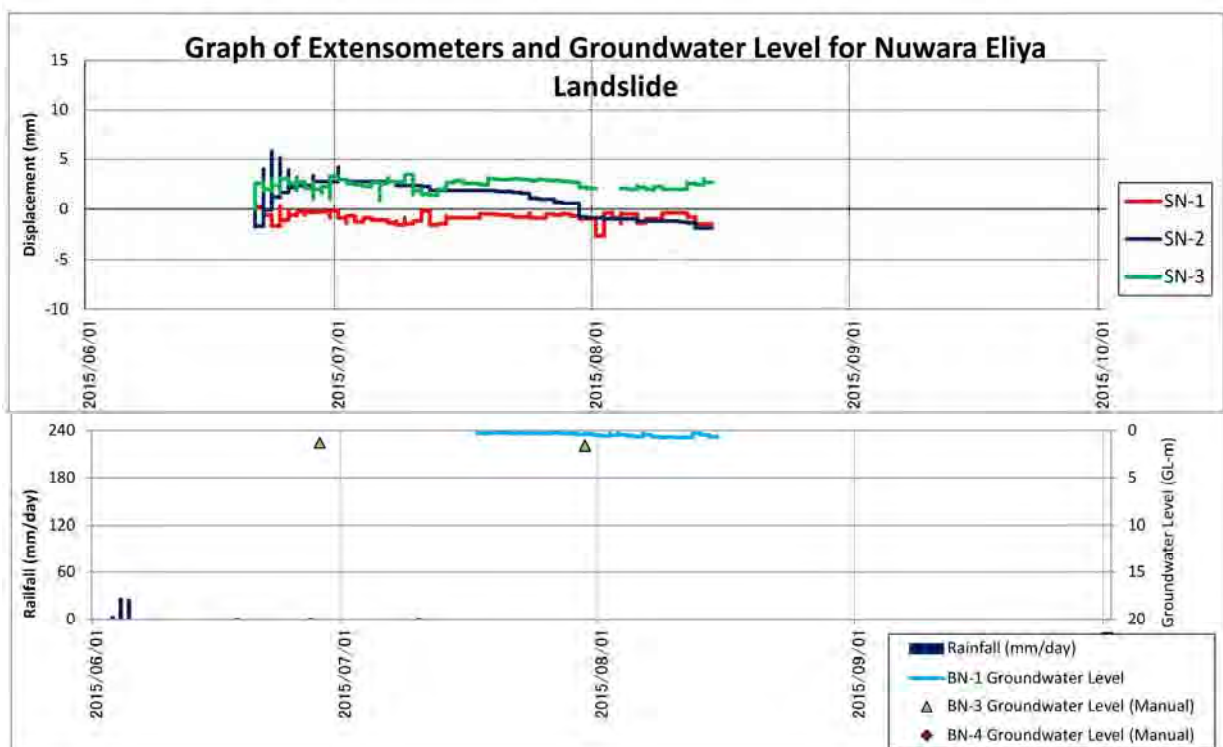

Figure 4.1 Graph of Extensometer and Groundwater Level in Udamadura Landslide

4.2 Inclinometer

A grooved casing was inserted in to the borehole extending into the bedrock formation, and an adequate quality of grout should be placed into the borehole to assure an intimate contact with the borehole. By lowering a probe equipped with a tilt sensor, deformation in the casing can be detected and movement of a landslide can determined. Inclinometer BN-2 has been installed at the lower landslide block which is relatively active.

A heavy rainfall event has not occurred up to the present date since inclinometer BN-2 was installed, and there is no clear cumulative displacement at BN-2 so far (see Figure 4.2). It is seemed that the displacement of the depth of near GL-20m is compressive buckling behavior of inclinometer pipe. More monitoring time including heavy rainfall event is needed for evaluation of inclinometer BN-2.

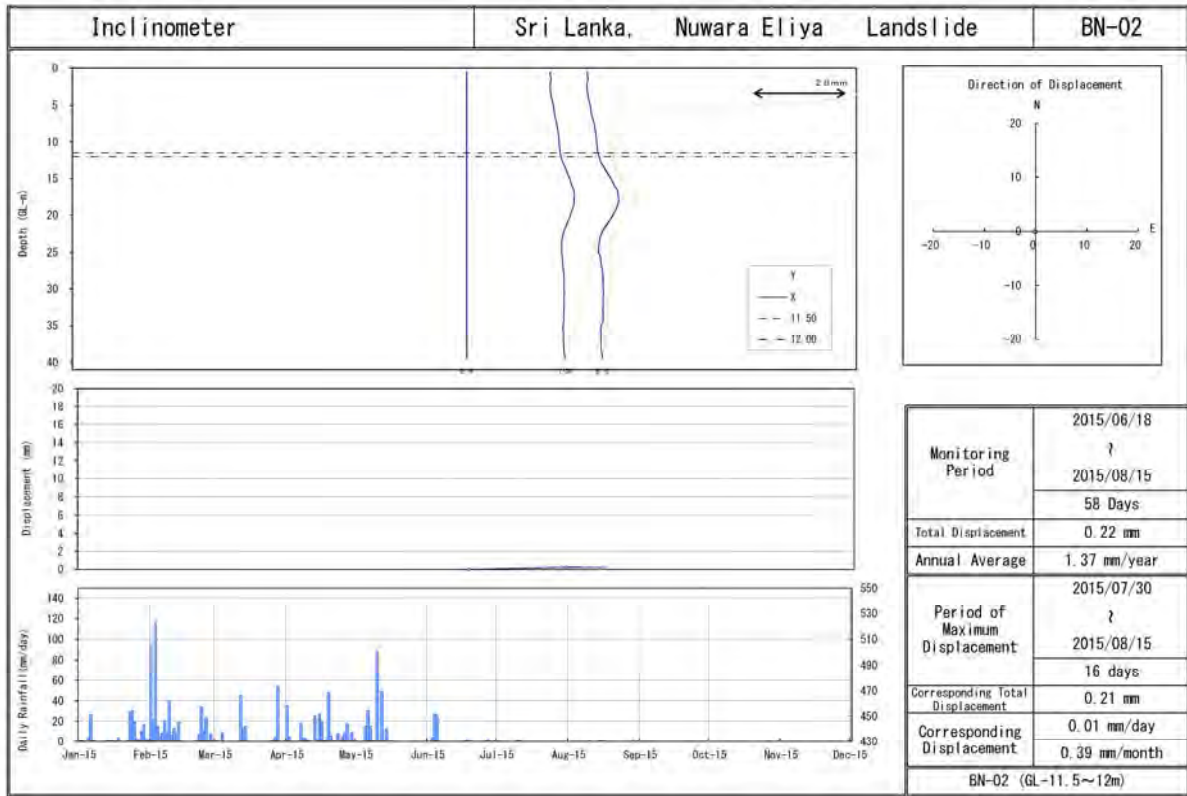

Figure 4.2 Graph of Inclinometer (BN-2) in Udamadura Landslide

4.3 Pipe Strain Gauge

PVC pipe with strain gauges was inserted into the borehole, and the movement is detected by change in the strain as the PVC pipe bends.

A heavy rainfall event has not occurred up to the present date since pipe strain gauge BN-3 was installed, and there is no clear cumulative displacement at BN-3 so far (see Figure 4.4). More monitoring time including heavy rainfall event is needed for evaluation of pipe strain gauge BN-3.



Figure 4.3 Monitoring Survey of Pipe Strain Gauge BN-3

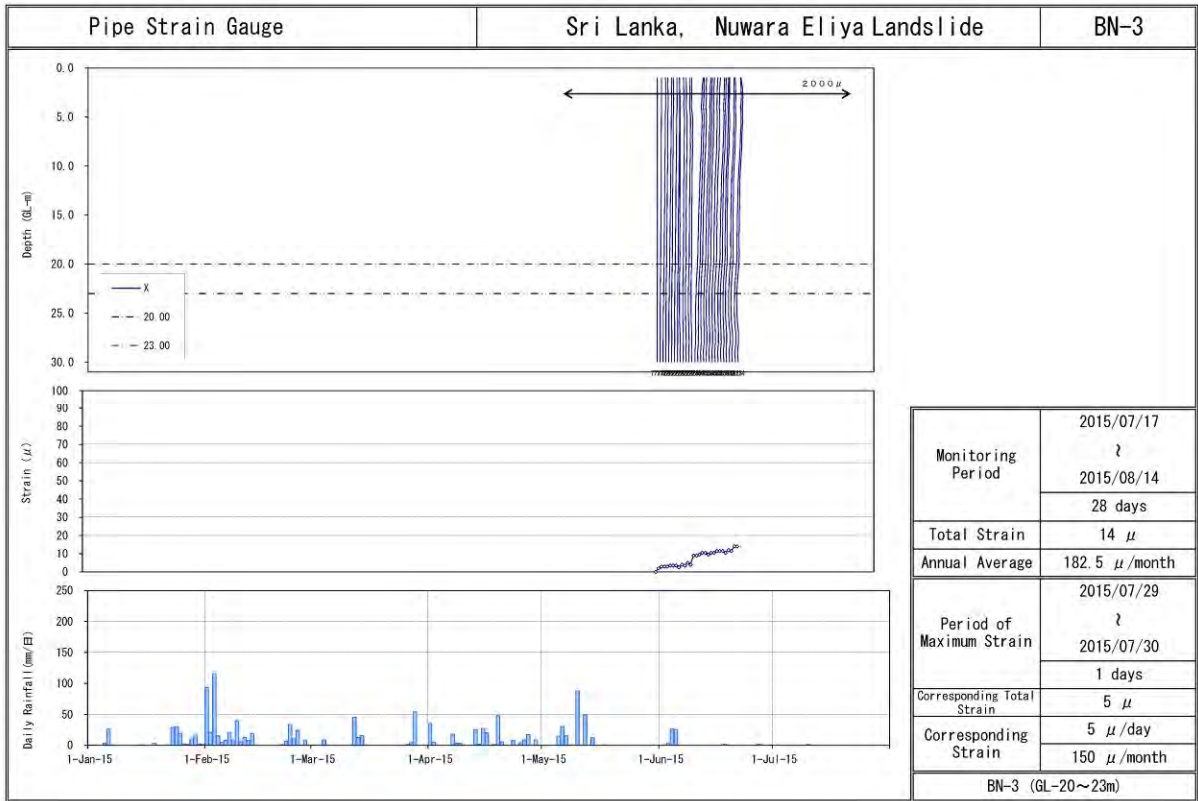

Figure 4.4 Graph of Pipe Strain Gauge (BN-3) in Udamadura Landslide

4.4 Groundwater level Gauge

Investigation of groundwater, which is a driving force of sliding, includes determining groundwater level.

According to the monitoring data of groundwater level gauge BN-1, the groundwater level of BN-1 is continuously near ground surface even when it is not raining (see Figure 4.1).

Chapter 5 Design of Countermeasures

5.1 Landslide Mechanism

According to the results of investigation described above, the outline of Udamadura landslide mechanism is as follows.

- The Udamadura landslide has dimensions with approximately length of 900 m, approximately width of 600 m and approximately depth of 23 m.
- The damage of the road indicates that a lower landslide block is moving.
- A heavy rainfall event has not occurred up to the present date since some monitoring equipments were installed, and certain landslide activity is not monitored so far.
- The groundwater level at the lower area of landslide slope is continuously near ground surface. Countermeasures of groundwater control methods such as surface drainage ditch or horizontal drainage are effective against the Udamadura landslide.

5.2 Stability Analysis

Stability analysis had been conducted to determine the scale and quantity of landslide countermeasure works required to maintain the stability of the landslide slope and so ensure the target safety factor. The Fellenius Method which is widely used for simple landslide stability analysis in Japan is used.

Table 5.1 Coefficient Condition of Stability Analysis for the Lower Landslide Block

Item		Unit	Lower Slide
Formula	-	-	FelleniusMethod
Factor of Safety	Fs	-	1.00
Proposed Factor of Safety	P·Fs	-	1.20
Length of slip surface	L	m	150.205
Area	A	m ²	1025.52
Normal Force	N	kN/m	17735.9
Pore pressure	U	kN/m	6475.4
Pore pressure(drainage)	Up	kN/m	3002.3
Resistance force	S	kN/m	4293.753
Resistance force(drainage)	Sp	kN/m	5526.178
Tangential force	T	kN/m	4293.541
Cohesion	C	kN/m	10.0
Shear resistance angle	Φ	degree	13.9240
Wet weight	Γt	kN/m ³	18.0

5.3 Design Concept of Countermeasures

The outlines of design concept of countermeasures are as follows.

- The groundwater and surface water control works are highly effective to the landslide with abundant groundwater and rainfall and whose movement tends to accelerate during the intense rain. These countermeasure works should be mainly designed for Udamadura Landslide.
- Surface drainage ditch should be designed at the natural channels in the landslide area in order to prevent infiltration of rain water and spring flows. In addition, check dams should be designed also in order to prevent from further erosion.
- Horizontal drainage which removes groundwater by gravity drainage pipes should be designed against the lower landslide block. The length of the drainage pipes is 50 m in order to create a 5 to 10 m overbreak penetrating through the potential slip surface, and their tip intervals are 5 to 10 m.
- The design groundwater level has been set at -3.0 m from the assumed highest groundwater level, which is used as reference value in Japan.

Figure 5.1 shows integral planning of countermeasures against Udamadura Landslide, and represents an ordering priority of the countermeasures. Countermeasures against the lower landslide block should be constructed because of the existing condition of the landslide block. Therefore, the countermeasures targeted to the lower landslide block are relatively high priority. On the other hand, the countermeasures targeted to the large-scale landslide block are relatively low priority and the large-scale block should be managed by monitoring in the immediate future. The high priority countermeasure is represented as “Rank A” in Figure 5.1 and the low priority is as “Rank B”.

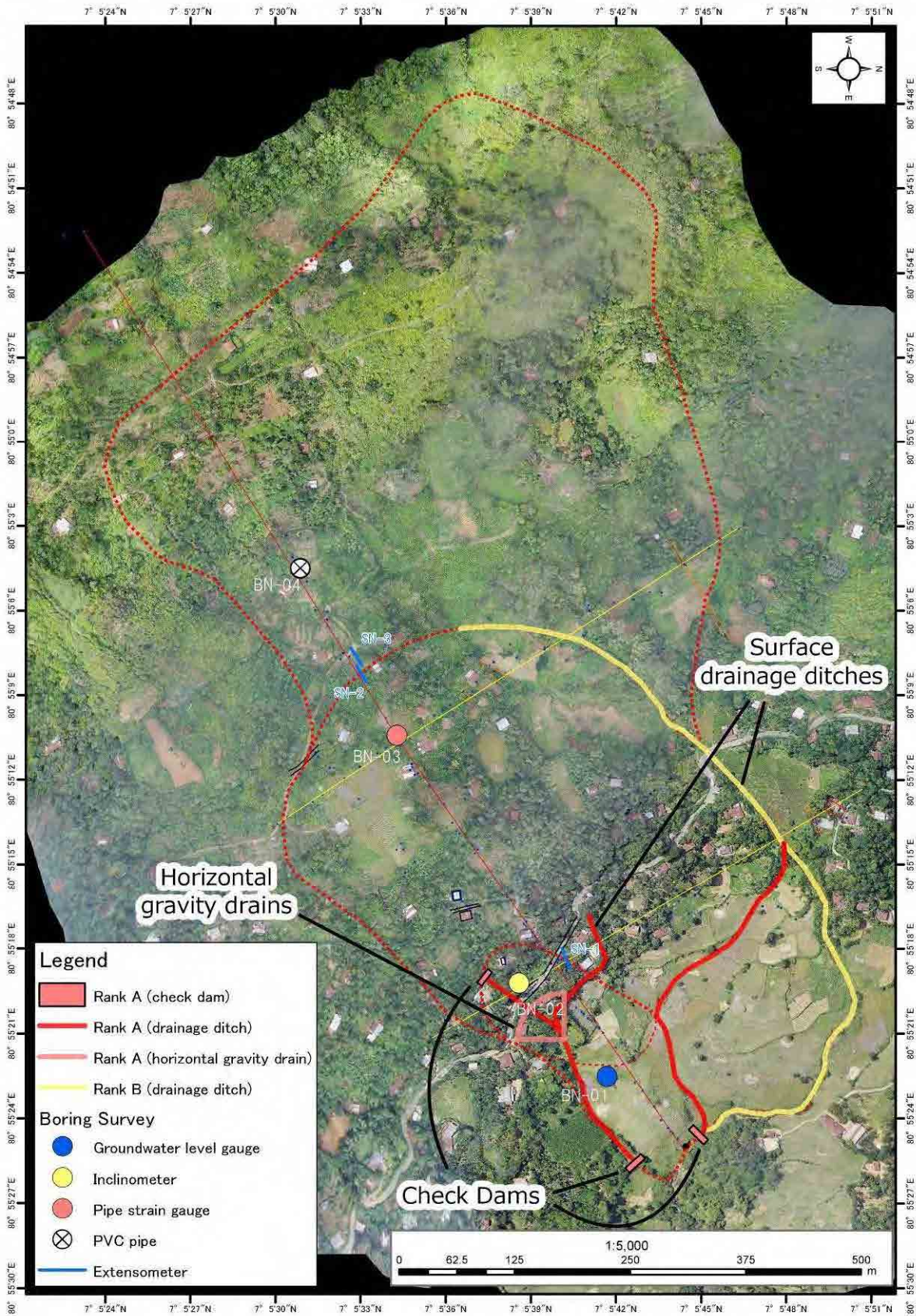

Figure 5.1 Integral Planning of Countermeasures against Udamadura Landslide

5.4 Design of Countermeasures

The basic design for the further high priority countermeasures are shown in Figure 5.2 and 5.3.

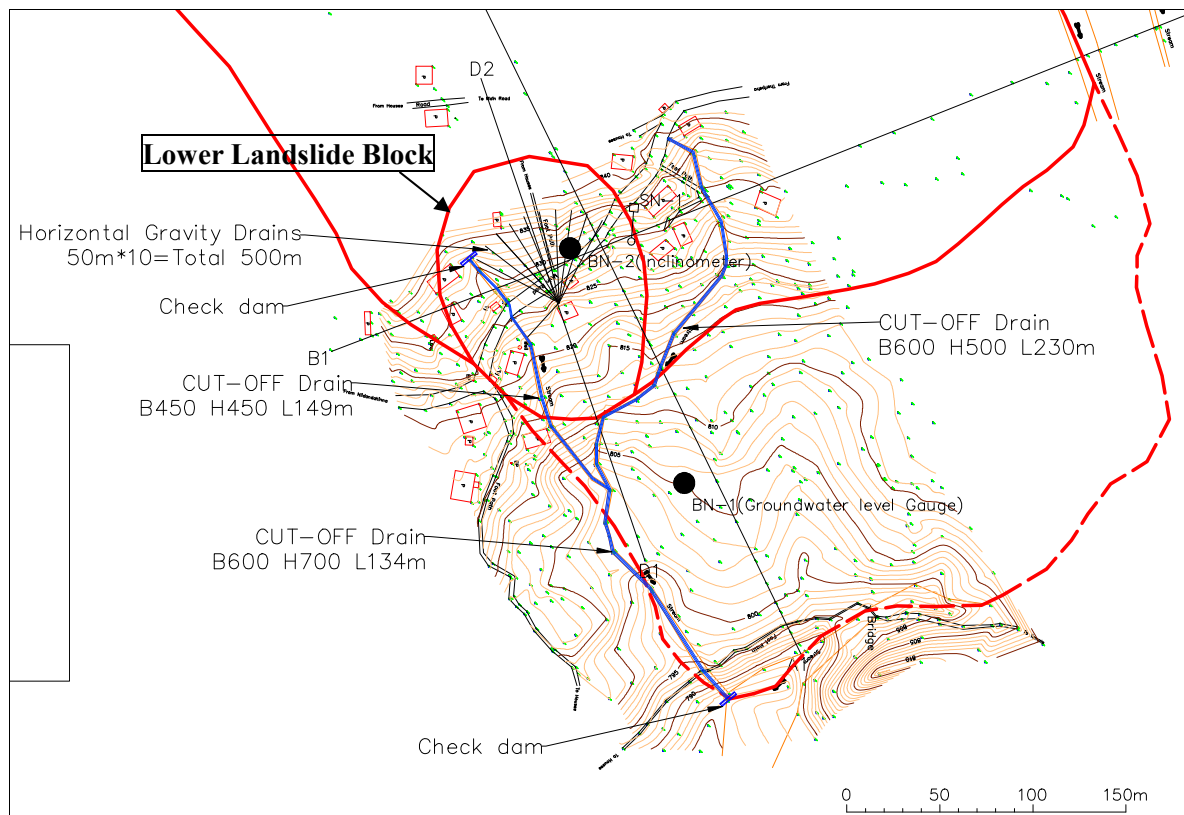

Figure 5.2 Plan of Basic Design for High-Priority Countermeasures against Udamadura Landslide

CROSS SECTION OF NUWARA ELIYA LANDSLIDE

Section D1-D2 S=1:xxx

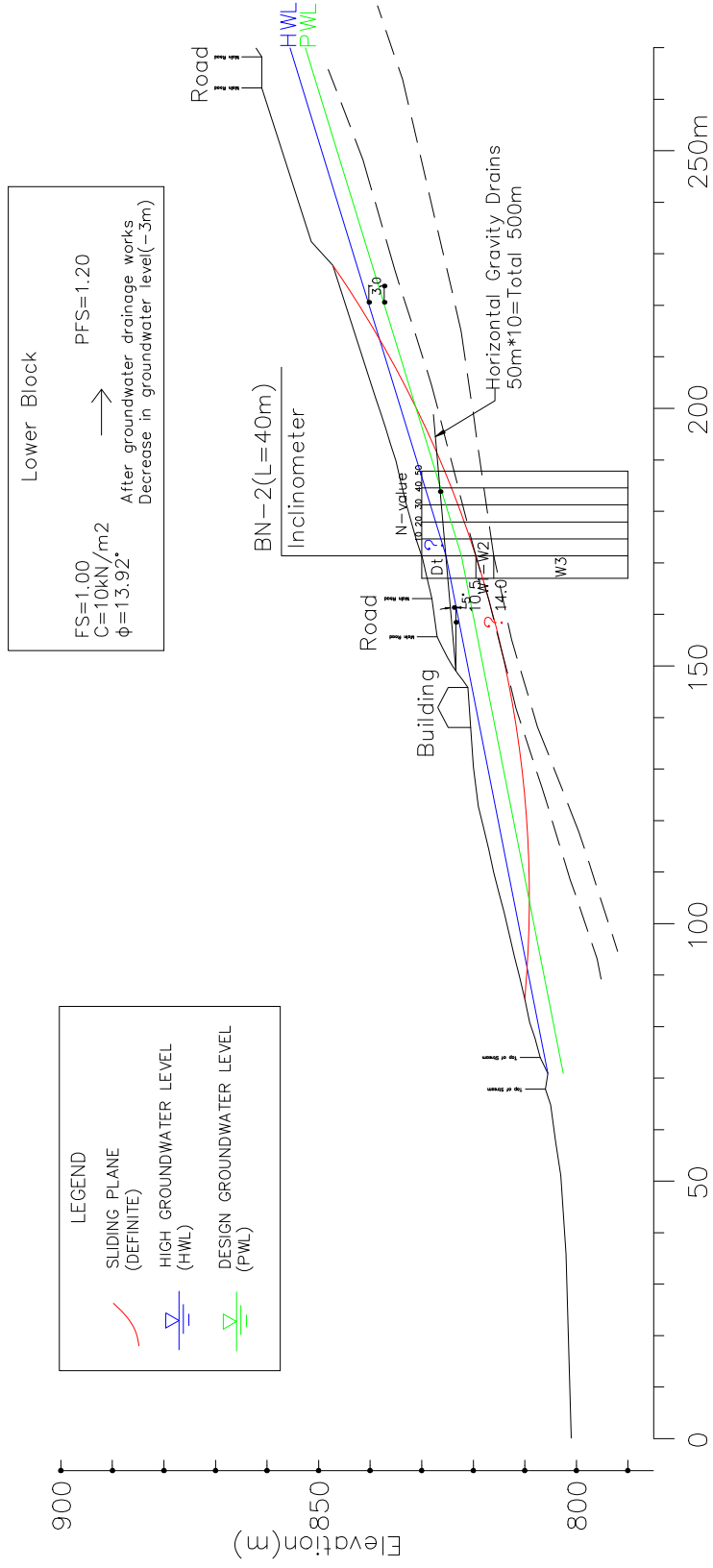

Figure 5.3 Cross Section of Basic Design of Countermeasures against the Lower Landslide Block in Udamadura Landslide

Table 5.2 The Summary of Designed High-Priority Countermeasures against Udamadura Landslide

Pilot Area	Type of countermeasure works	Priority	Quantity	Unit	Remarks ex.concrete type
Udamadura Landslide	Surface Drainage Ditch	A	149	m	450 × 450
		A	230	m	600 × 500
		A	134	m	600 × 700
	Check Dam	A	2	Site	-
	Horizontal Drainage Drilling	A	500	m	50m × 10nos × 1 area

APPENDIX

Appendix-1 Photo of Boring Core Sample

Appendix-2 Borehole Log

Appendix-1
Photo of Boring Core Sample

2. Nuwara Eliya

(1) BN-1 (L=20m)

0m



5m

10m

15m

19m

(2) BN-2 (L=40m)

0m

10m

20m

30m

39m



(3) BN-3 (L=30m)

0m



10m



20m



29m

Appendix-2
Borehole Log

BOREHOLE LOG



NATIONAL BUILDING RESEARCH ORGANISATION
GEOTECHNICAL ENGINEERING DIVISION
 99/1, Jawatta Road, Colombo 05.

SHEET NO.

1 of 2

PROJECT	TECHNICAL CORPORATION FOR LANDSLIDE MITIGATION PROJECT AT BADULLA		CLIENT	JAPAN INTERNATIONAL CORPORATION AGENCY	BOREHOLE NO	BN 01	
LOCATION	NUWARAELIYA		CONTRACT NO	30/24871	DEPTH OF HOLE (m)	20.00	
DRILING METHOD	CORE DRILLING		ELEVATION (m RL)		CHAINAGE / OFFSET	-	
CORE SIZE [mm]	54	CASING SIZE	NX	CO-ORDINATES	N	DATE COMMENCED	13/05/2015
VANE SIZE [mm*mm]	-	UDS SAMPLER SIZE [mm]			E	DATE COMPLETED	13/05/2015

DEPTH [m]	ELEVATION [m RL]	LAYER THICKNESS [m]	SAMPLE TYPE	SAMPLE NO.	SOIL PROFILE			OTHER TESTS	DEPTH TESTED [m]	STANDARD PENETRATION TEST DATA			MOISTURE CONTENT - %					
					SOIL DESCRIPTION	STRATA	LEGEND			GWL	NUMBER OF BLOWS			UNDRAINED SHEAR STRENGTH - kN/m ²				
											SPT RESISTANCE - Blows/30 cm							
											1	2	3					
0.00	0.00				GROUND LEVEL													
1.00					Loose dark brown, silty SAND, fine to medium grained with occasionally gravel, moist.				1.00	1	2	2	4					
1.50	-1.50	1.50	X															
2.00	-2.00	0.50	X		Loose, brown mottled with grey, SILT, intermediate plasticity with fine to medium grained sand and completely weathered rock fragments, moist.				2.00	1	2	3	5					
2.45	-2.45	0.45	X		Loose, yellowish brown, silty SAND, fine to medium grained with completely weathered rock fragments, moist.													
3.00	-3.00	0.55	X		Loose, greyish brown, silty SAND, fine to medium grained with completely weathered rock fragments, moist.				3.00	2	3	3	6					
4.00	-4.00	1.00	X		Loose, brown mottled with grey, silty SAND, fine to medium grained with completely weathered rock fragments and pockets of clay, moist.													
4.45	-4.45	0.45	X		Loose, orangish brown, silty SAND, fine to medium grained with completely weathered rock fragments, moist.				4.00	3	3	5	8					
5.00			X															
6.00			X						5.00	2	4	6	10					
6.50	-6.50	2.05	X															
7.00	-7.00	0.50	X		Medium dense, greyish brown, silty SAND, subangular, fine to coarse grained with completely weathered rock fragments, and gravel, moist.				6.00	3	5	6	11					
8.00			X															
9.00			X						7.00	5	6	7	13					
9.50	-9.50	2.50	X															
10.00	-10.00		X		Very dense, yellowish brown, silty SAND, fine to medium grained with completely weathered rock fragments, moist.(completely weathered rock)				8.00	5	7	9	16					
			X						9.00	5	6	7	13					

Draft

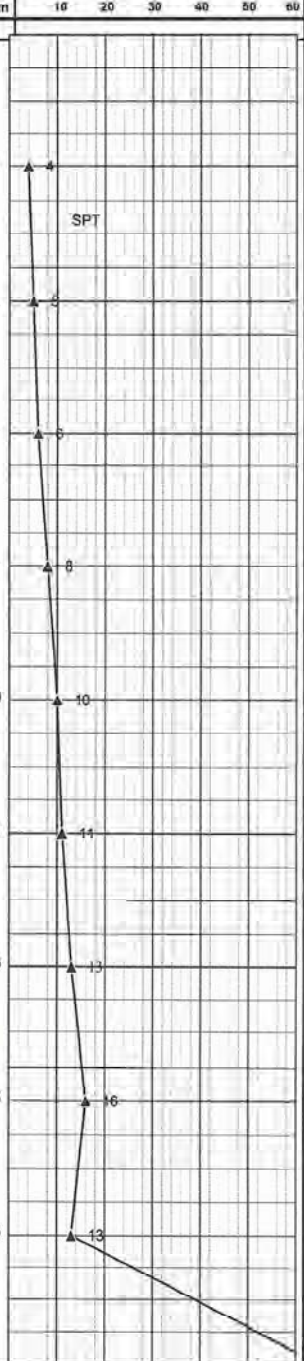

	Natural moisture content, Atterberg Limits (LL, PL)	γ - Wet unit weight	W - Wash sample	Drilled By	CNB
	SPT 'N', blows/ft	G - Grainsize Analysis	SPT - SPT Sample	Logged By	CKJ
	Vane shear strength, peak	U - Unconfined compression		Date	10/8/2015
	Vane shear strength, residual	CU - Consolidated undrained triaxial		Checked By	CKJ

BOREHOLE LOG



NATIONAL BUILDING RESEARCH ORGANISATION
GEOTECHNICAL ENGINEERING DIVISION
 99/1, Jawatta Road, Colombo 05.

SHEET NO.

2 of 2

PROJECT	TECHNICAL CORPORATION FOR LANDSLIDE MITIGATION PROJECT AT BADULLA			CLIENT	JAPAN INTERNATIONAL CORPORATION AGENCY	BOREHOLE NO	BN 01
LOCATION	NUWARAEIYA			CONTRACT NO	30/24871	DEPTH OF HOLE (m)	20.00
DRILING METHOD	CORE DRILLING			ELEVATION (m RL)	0	CHAINAGE / OFFSET	-
CORE SIZE (mm)	54	CASING SIZE	NX	CO-ORDINATES	N	DATE COMMENCED	13/05/2015
VANE SIZE (mm*mm)		UDS SAMPLER SIZE (mm)				E	DATE COMPLETED

DEPTH [m]	ELEVATION [m RL]	LAYER THICKNESS (m)	SAMPLE TYPE	SAMPLE NO.	SOIL PROFILE				OTHER TESTS	DEPTH TESTED [m]	STANDARD PENETRATION TEST DATA				MOISTURE CONTENT - %					
					SOIL DESCRIPTION	STRATA	LEGEND	GWL			γ - [g/cm ³]	NUMBER OF BLOWS			FOR 30cm	UNDRAINED SHEAR STRENGTH - kN/m ²				
												PER 15cm				SPT RESISTANCE - Blows/30 cm				
												1	2	3		10	20	30	40	50
10.00	-10.00		⊗		Very dense, yellowish brown, silty SAND, fine to medium grained with completely weathered rock, fragments, moist. (completely weathered rock)					10.00	-	-	-	>50	Refusal to penetration					
11.00	-11.00	1.50			Weak to very weak, thinly foliated, greyish brown, QUARTZO FELDSPHIC GNEISS, medium to coarse grained meta-sedimentary, highly weathered, highly fracture rock.					11.00	15/50	NII								
12.00										12.50	NII	NII								
12.50	-12.50	1.50			Highly to completely weathered rock (washing sample)					14.00										
13.00										14.00										
14.00	-14.00	1.50			Highly to completely weathered rock (washing sample)					15.00										
15.00																				
15.50	-15.50	1.50			Highly to completely weathered rock (washing sample)															
16.00																				
16.00					brown SILT, intermediate plasticity with fine to medium grained sand and completely weathered rock fragments, moist															
17.00	-17.00	1.50			Highly to completely weathered rock (washing sample)															
17.00					silty SAND, orangish brown, fine to medium grained with completely weathered fragments, moist															
18.00	-18.00	1.00			Highly to completely weathered rock															
19.00																				
20.00	-20.00	2.00			Borehole terminated at 20.00m depth															

- ⊗ Natural moisture content, Atterberg Limits (LL, PL)
- ▲ SPT 'N', blows/ft
- Vane shear strength, peak
- ⊗ Vane shear strength, residual
- γ - Wet unit weight
- G - Grainsize Analysis
- U - Unconfined compression
- CU - Consolidated undrained triaxial
- W - Wash sample
- SPT - SPT Sample
- ☐ - Undisturbed sample
- ⊗ - Disturbed Sample

Drilled By	CNB
Logged By	CKJ
Date	10/8/2015
Checked By	CKJ

Democratic Socialist Republic of Sri Lanka

National Building Research Organization (NBRO)

**Proposal for Rectification on
Slope Failure at Nurse's Training
School at Kandy District**

FINAL REPORT

September, 2015

Japan International Corporation Agency (JICA)

EARTH SYSTEM SCIENCE Co., Ltd. (ESS)

NIPPON KOEI Co., Ltd. (NK)

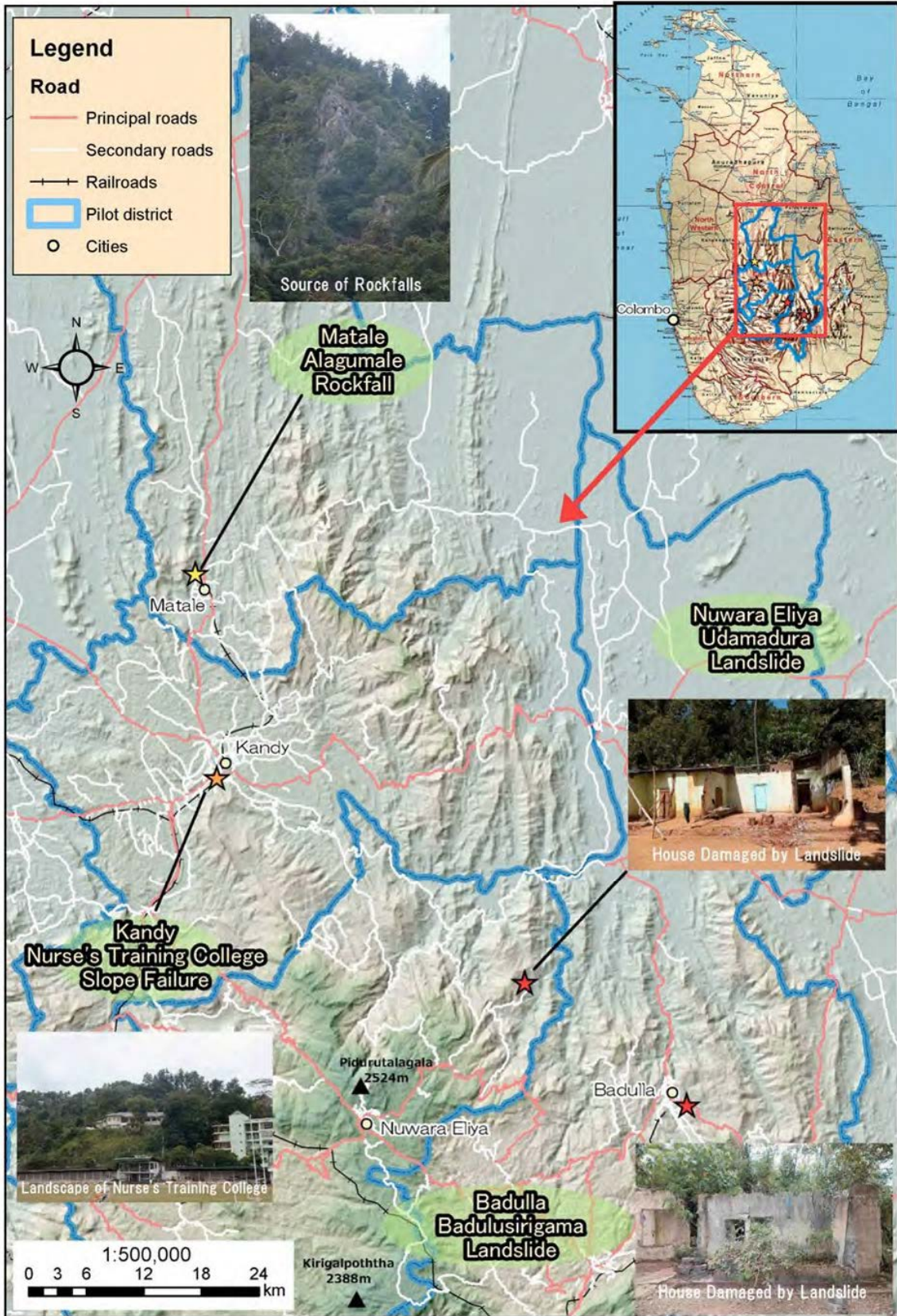

Location Map of Pilot Project Sites

Table of Contents

Location Map of Pilot Project Sites

1. Outline of the Survey.....	1
1.1 Background.....	1
1.2 Objective.....	1
1.3 Target Survey Area	1
2. Preliminary Survey	2
2.1 Site Condition.....	2
2.2 Investigation Plan	3
3. Geomorphological and Geological Survey.....	4
3.1 Geomorphological Survey	4
3.2 Geological Survey	5
4. Monitoring Survey.....	8
4.1 Groundwater level Gauge.....	8
5. Design of Countermeasures.....	9
5.1 Slope Failure Mechanism	9
5.2 Stability Analysis.....	9
5.3 Design Concept of Countermeasures	13
5.4 Design of Countermeasures.....	14

List of Figure

Figure 2.1 Investigation Plan for Kandy Nursing School Site.....	3
Figure 3.1 Detailed Aerial Photo Image of Kandy Nursing School Site prepared by using UAV	4
Figure 3.2 DEM Data of Kandy Nursing School Site prepared by using UAV	5
Figure 3.3 Drilling Work at the Site	6
Figure 3.4 Core sample check with Japanese expert.....	6
Figure 3.5 Geological Cross Section of Lower slope of Kandy Nursing School Site.....	6
Figure 3.6 Geological Cross Section of Upper slope of Kandy Nursing School Site.....	7
Figure 5.1 Plan of Basic Design of Countermeasures against Kandy Nursing School site	14
Figure 5.2 Cross Section of Basic Design of Countermeasures against Upper Slope of Kandy Nursing School Site.....	15

Figure 5.3 Cross Section of Basic Design of Countermeasures against Lower Slope of Kandy Nursing School Site.....	15
---	----

List of Table

Table 1.1 Pilot Sites in the Project	1
Table 2.1 Summary of Kandy Nurse’s Training School Site	2
Table 2.2 Geomorphological Investigation Items for Kandy Nursing School Site.....	3
Table 2.3 Geological Investigation Items for Kandy Nursing School Site	3
Table 2.4 Monitoring Items for Kandy Nursing School Site	3
Table 5.1 Coefficient Condition of Stability Analysis of Lower slope of Kandy Nursing School site Case-1 (Minimum factor of safety) 【thick slope failure】	10
Table 5.2 Coefficient Condition of Stability Analysis of Lower slope of Kandy Nursing School site Case-2 (Maximum deterrent force) 【thick slope failure】	10
Table 5.3 Coefficient Condition of Stability Analysis of Lower slope of Kandy Nursing School site Case-1 (Minimum factor of safety) 【shallow slope failure】	11
Table 5.4 Coefficient Condition of Stability Analysis of Lower slope of Kandy Nursing School site Case-2 (Maximum deterrent force) 【shallow slope failure】	11
Table 5.5 Coefficient Condition of Stability Analysis of Upper slope of Kandy Nursing School site Case-1 (Minimum factor of safety).....	12
Table 5.6 Coefficient Condition of Stability Analysis of Upper slope of Kandy Nursing School site Case-2 (Maximum deterrent force).....	12

1. Outline of the Survey

1.1 Background

Sediment disasters (Slope Failure) have become one of the major natural disasters in Sri Lanka. The hilly and mountainous areas in central region of Sri Lanka known as Central Highlands cover nearly 20% of the total land area of Sri Lanka and are occupied by about 30% of the total population of the country.

On March 14, 2013, Japanese ODA Loan Agreements for "Landslide Disaster Protection Project of the National Road Network" which covers seven districts including the target districts of this Project was signed. This loan project will carry out countermeasure construction on slopes on major national roads with a high risk of landslides, alleviating the risk of a disaster and making the road network and lives of nearby residents safer.

The Government of the Democratic Socialist Republic of Sri Lanka has requested the Government of Japan to implement the Landslide Mitigation Project (hereinafter referred to as "the Project") to enhance the capacity of National Building Research Organization (hereinafter referred to as "NBRO") staff through on-the-job training, preparation of technical guidelines and manuals and the construction of mitigation measures.

1.2 Objective

The main object of this Project is to strengthen "Sediment disaster management capacity of NBRO" through application of appropriate mitigation measure with Japanese and other technology in the pilot project sites.

1.3 Target Survey Area

This Project has four pilot sites, which are located in Kandy District, Matale District, Nuwara Eliya District and Badulla District, as shown in Table 1.1.

Table 1.1 Pilot Sites in the Project

Pilot Sites	Location	Type of Mass Movement
Nurse's Training College	Kandy District	Slope Failure
Matale	Alagumale in Matale District	Rockfall
Badulusirigama	Uva Wellasa University in Badulla District	Landslide
Udamadura	Nuwara Eliya District	Landslide





This progress report is written for Nurse's Training College site in Kandy District.

2. Preliminary Survey

2.1 Site Condition

Preliminary survey such as collection of existing data, data review, interpretation of aerial photographs and field reconnaissance has been conducted. The site condition of Kandy Nurse's Training College is summarized in Table 2.1.

Table 2.1 Summary of Kandy Nurse's Training School Site

Outline of Preliminary Survey in the Pilot Site					
Site name	Nurse's Training College (Kandy District)	Surveyed by	Mr.R.Peris (Kandy Office) Mr.Handa,Mr.Hara,Mr.Kawaka mi,Mr.Wada	Survey Date	2014/10/22
Disaster Type and Scale	Slope Failure	Scale	Upper slope: 100m wide, 20~30m long Lower slope 90m wide, 15~20m long		
Geostructure	Bed rock is gneiss. Surface is unstable and covered by highly weathered gneiss and colluvial deposits.				
Vegetation Cover/Land Use	Mainly covered by weed, scattered shrub. Some part is artificial modification land, but no area of land using.				
Existing Conditions	The site is upper and lower slope of the Kandy Nursing school. Slope gradient is 30 to 45 degree, difference in height is 15 to 18m. Shallow slope failure is repeated several time. At the time of October and December of 2015, some slope failure is occurred around the site.				
Occurrence Mechanism	Rain water penetrates into the ground. Then surface material will unstabilize and fall down. Slope failure is easy to occur at steep slope. Shallow slope failure is repeated several time(0.5 to 1.0m depth,10 to 20m width) .				
Affected Area	Slope failure at the upper slope will hit the Nursing school directly.(Distance from the foot of slope is 2m) Slope failure at the lower slope will bury the arterial road. Then road traf f ic will shut down and schoolyard will be unstable.				
Survey Plan	Contour mapping: 100 × 150m(1:200) Cross section profile survey:L50m×6 Line Boring core sample:15~20m×4site, some physical test				
Mitigation Measures and Selection Reasons	Cutting soil and grating crib works with soil nailing				
Construction Problems	Power line along the arterial road and steel plate in the lower slope will disturb the construction work. It is imprtant that check the land owner before the construction work				
Site Photos					
					
Whole view (Centre building is Nursing school)		Road along the foot of the lower slope			
					
Upper slope and Nursing school		View of the lower slope from vestibule of the Nursing School			

2.2 Investigation Plan

Based on the preliminary survey, a detailed investigation has been planned. The items of planned investigation for geomorphology, geology and geophysics are shown in Table 2.2 - Table 2.5.

Table 2.2 Geomorphological Investigation Items for Kandy Nursing School Site

Investigation Items
Topo mapping
Cross section survey
Unmanned Aerial Vehicles (UAV) analysis

Table 2.3 Geological Investigation Items for Kandy Nursing School Site

Investigation Items	Quantity
Borehole drilling	BK-1 (Drilling depth=15.0m)
	BK-2 (Drilling depth=20.0m)
	BK-3 (Drilling depth=20.0m)
Standard penetration test (SPT)	Each borehole (at 1.0m interval)
Laboratory tests (Unit weight, Moisture content and Particle size analysis)	Some samples

Table 2.4 Monitoring Items for Kandy Nursing School Site

Monitoring Equipment No.	Monitoring Equipment	Monitoring Frequency
BK-1	Groundwater level gauge	1 time / 1 month
BK-2		
BK-3		

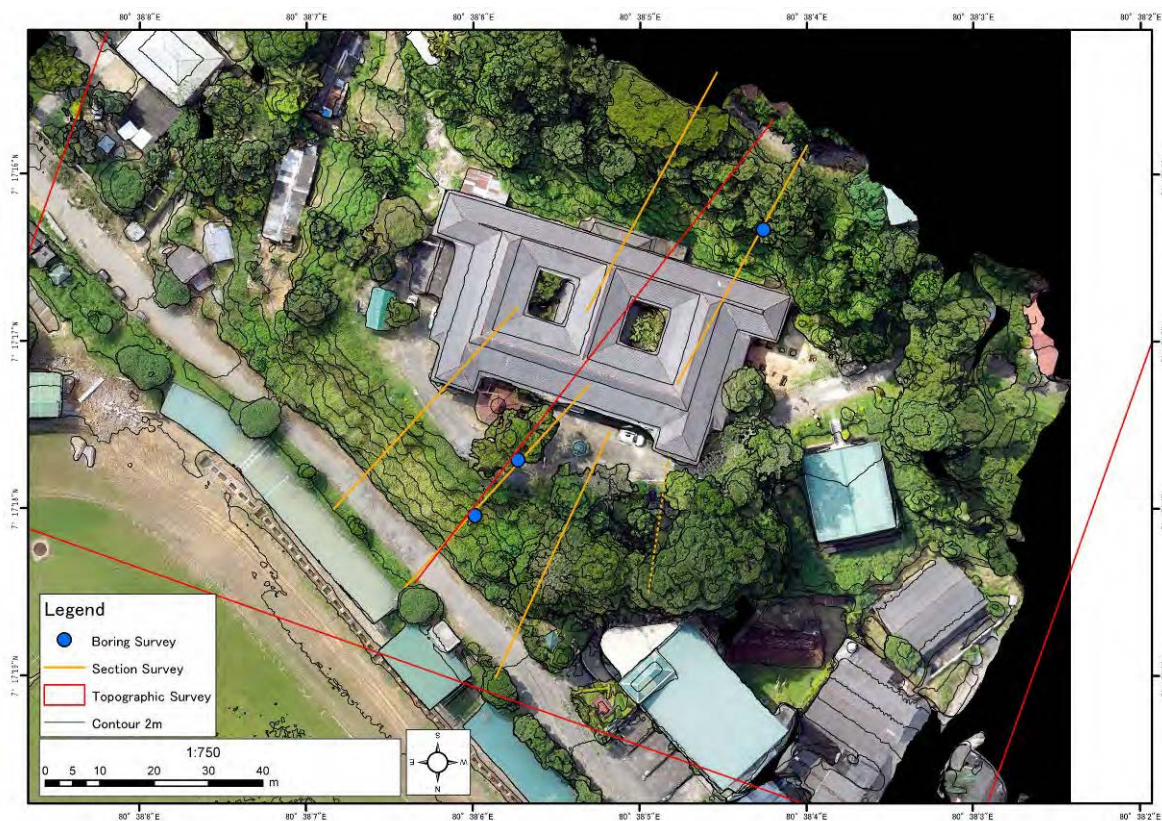

Figure 2.1 Investigation Plan for Kandy Nursing School Site

3. Geomorphological and Geological Survey

3.1 Geomorphological Survey

Topographical surveys such as plane survey, cross section survey and Unmanned Aerial Vehicles (UAV) analysis have been conducted. The Digital Elevation Model (DEM) data has been made by UAV. The products of topographical surveys by using UAV are shown below.

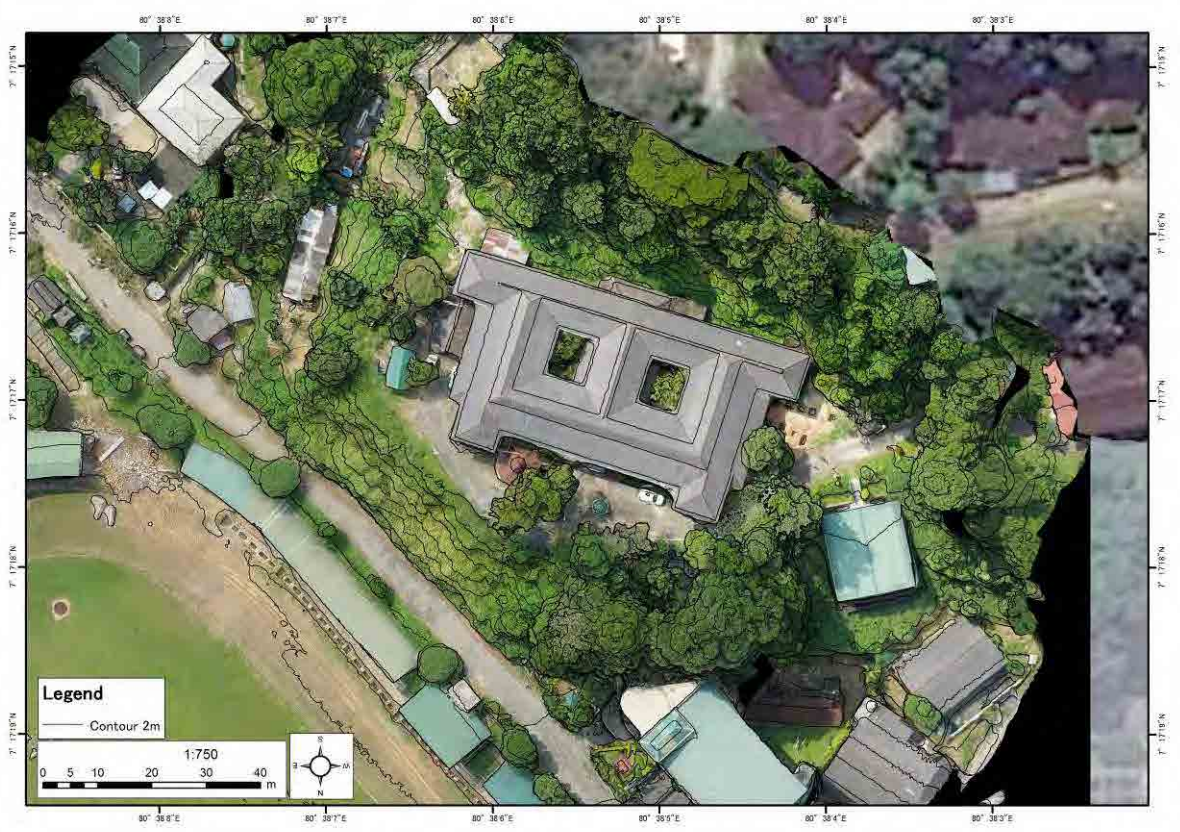

Figure 3.1 Detailed Aerial Photo Image of Kandy Nursing School Site prepared by using UAV

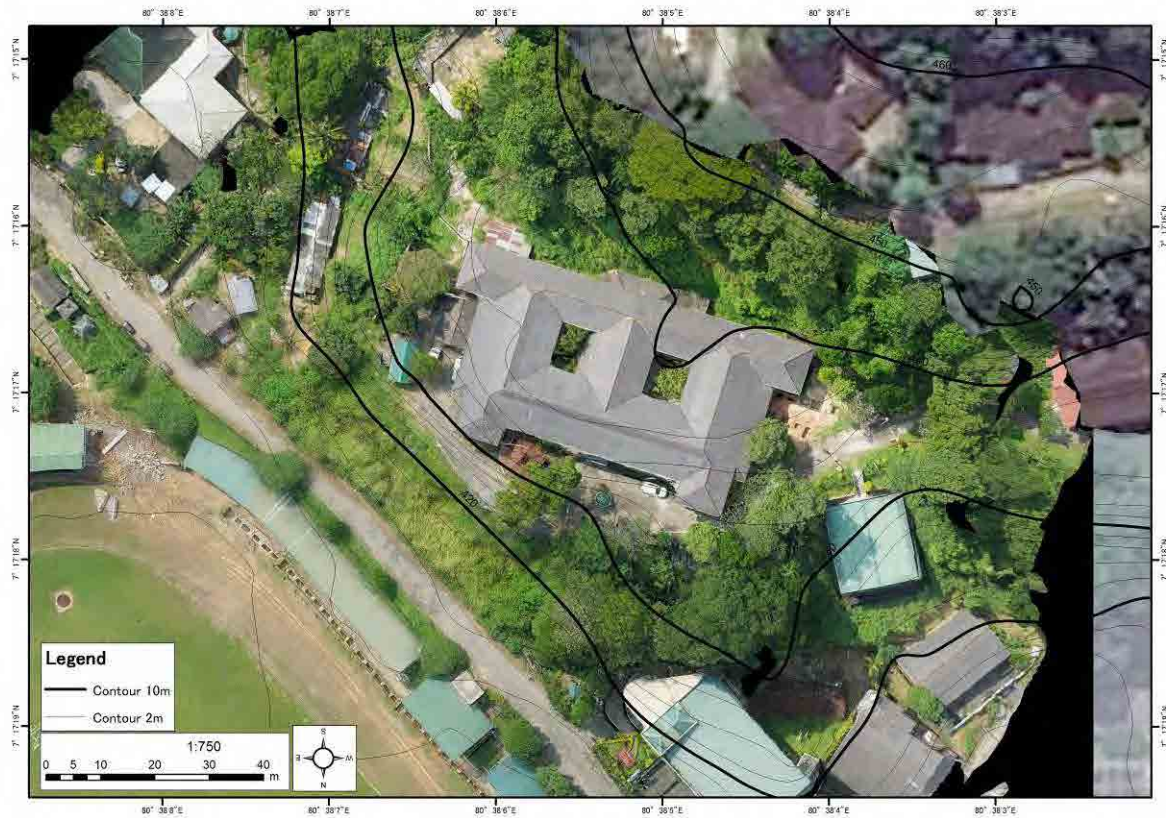

Figure 3.2 DEM Data of Kandy Nursing School Site prepared by using UAV

3.2 Geological Survey

Three (3) boreholes drilling have been performed in Kandy Nursing School Site, and core samples were recovered from borehole. Geological assessments based on the core samples and SPT have been conducted in order to determine geological structure and slip surface of the slope failure. The core samples and boring logs are shown in Appendix of this report. Guide pipes of groundwater level sensors have been installed into the boreholes in order to measure groundwater activity. The geological cross section prepared based on the results of these geological surveys is shown in Figure 3.5 and Figure 3.6.



Figure 3.3 Drilling Work at the Site



Figure 3.4 Core sample check with Japanese expert

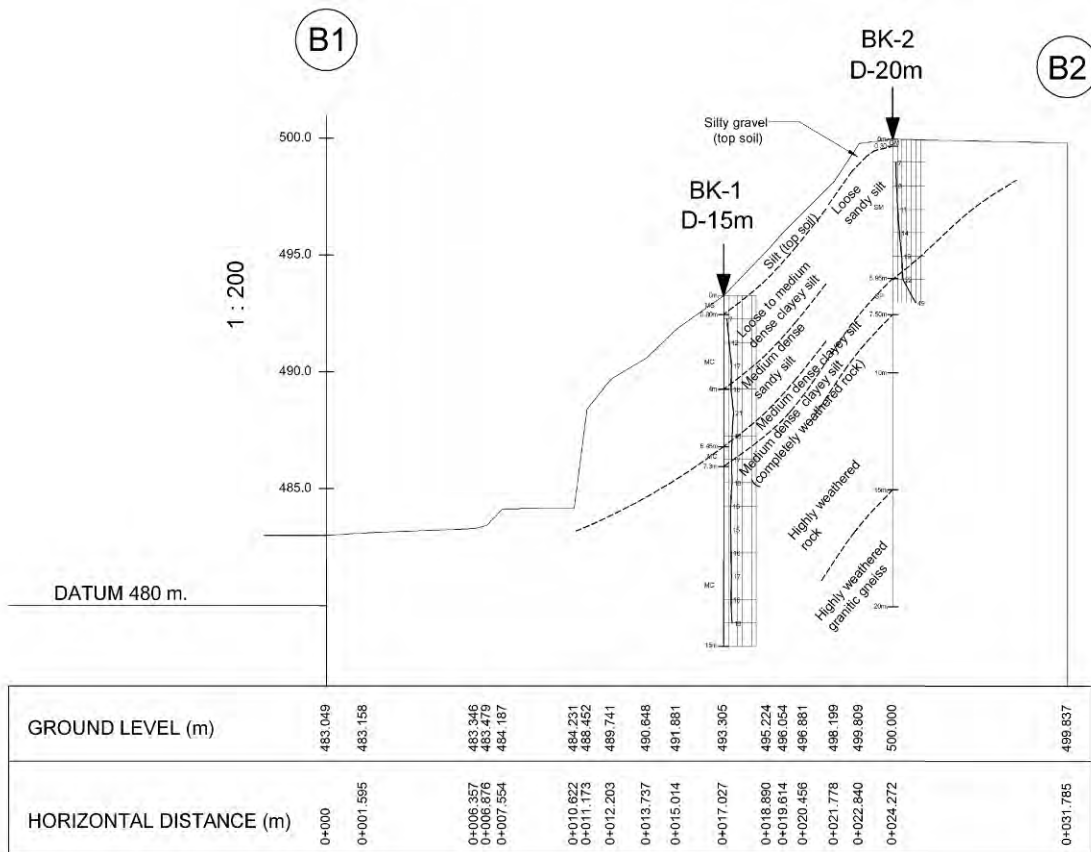

Figure 3.5 Geological Cross Section of Lower slope of Kandy Nursing School Site

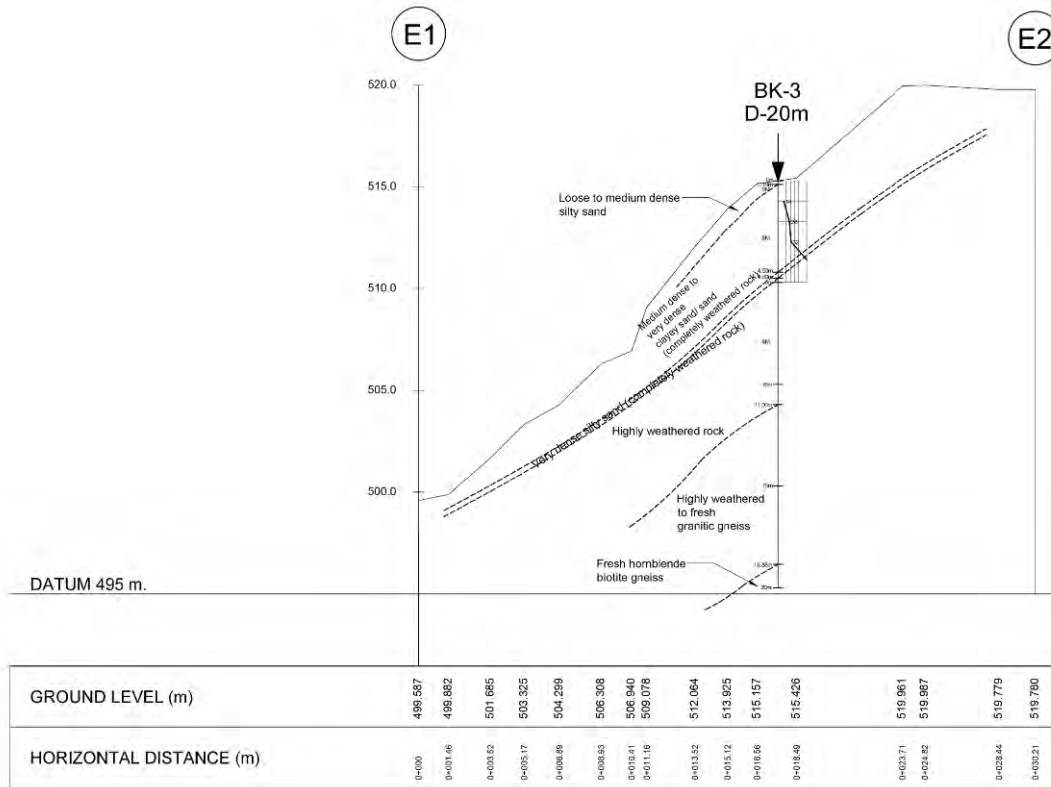

Figure 3.6 Geological Cross Section of Upper slope of Kandy Nursing School Site

4. Monitoring Survey

4.1 Groundwater level Gauge

Investigation of groundwater, which is a driving force of sliding, includes determining groundwater level.

At the Kandy Nursing school site, three (3) bore holes provide underground water level by manually piezo meter once a month. According to the monitoring data, all the groundwater level is deeper than eight (8) meter.

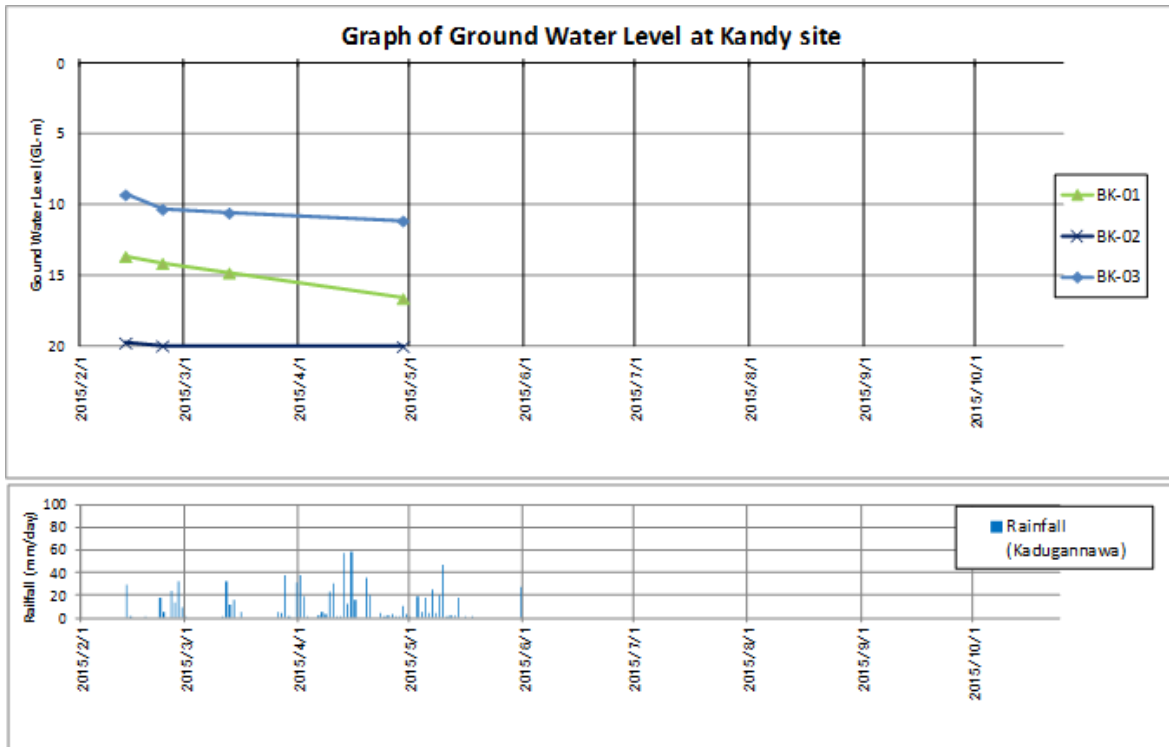

5. Design of Countermeasures

5.1 Slope Failure Mechanism

According to the results of investigation described above, the outline of slope failure mechanism of the Kandy Nursing School Site is as follows.

- There are two unstable slopes around Kandy Nursing School Building, one is backyard (Upper slope) and the other is in front of the school yard (lower slope).
- Recently in October and December 2015, some slope failure was occurred around the site. These event was reported for Appendix _ . According to the report, depth of slope failure is not so deep, less than 3m.
- The Slope Failure of Kandy Nursing School Site has dimensions with approximately length of 20 m, width of 50 m and depths of less than 5 m as predicted.
- Underground water level is deeper than 8 (eight) m. Therefore surface water will affect the slope failure when it heavy rains.

5.2 Stability Analysis

Stability analysis had been conducted to determine the scale and quantity of slope failure (landslide) countermeasure works required to maintain the stability of the slope failure (landslide) slope and so ensure the target safety factor. The Fellenius Method which is widely used for simple landslide stability analysis in Japan is used.

To analysis the slope disaster which occur at the any part of the slope like Slope Failure, generally circular arc repeating method is used for calculate the safety factor. To determine the deterrent force of slope stability, compare the result for two conditions of stability analysis. One case is calculating minimum factor of safety, the other case is calculating the maximum deterrent force. Higher deterrent force from two calculating cases is selected for designing the countermeasure work.

Following calculate results show the deterrent force of the countermeasure work. 64.0 kN/m of the maximum deterrent force from the stability analysis Case-2 is the deterrent force of the countermeasure work.

**Table 5.1 Coefficient Condition of Stability Analysis of Lower slope of
Kandy Nursing School site Case-1 (Minimum factor of safety) [thick slope failure]**

Stability calculation results		Item	Symbol	Unit	Normally
Calculation results	Safety factor		Fs	-	<u>1.006</u>
	Planned safety factor		Fsp	-	1.200
	Required prevention force		Pr	kN/m	<u>51.6</u>
Circular arc	Central coordinates		X	m	6.000
			Y	m	438.000
	Radius		r	m	17.916
Calculation elements	Skid resistance		S	kN/m	267.53
	Sliding force		T	kN/m	265.91
	Normal force		N	kN/m	315.19
	Pore water pressure		U	kN/m	0.00
	Sliding surface length		l	m	18.564
	Area		A	m ²	24.91

**Table 5.2 Coefficient Condition of Stability Analysis of Lower slope of
Kandy Nursing School site Case-2 (Maximum deterrent force) [thick slope failure]**

Stability calculation results		Item	Symbol	Unit	Normally
Calculation results	Safety factor		Fs	-	<u>1.014</u>
	Planned safety factor		Fsp	-	1.200
	Required prevention force		Pr	kN/m	64.1
Circular arc	Central coordinates		X	m	10.000
			Y	m	433.000
	Radius		r	m	12.524
Calculation elements	Skid resistance		S	kN/m	350.95
	Sliding force		T	kN/m	345.81
	Normal force		N	kN/m	463.58
	Pore water pressure		U	kN/m	0.00
	Sliding surface length		l	m	18.796
	Area		A	m ²	35.66

**Table 5.3 Coefficient Condition of Stability Analysis of Lower slope of
Kandy Nursing School site Case-1 (Minimum factor of safety) [shallow slope failure]**

Stability calculation results		Symbol	Unit	Normally
Item		Symbol	Unit	Normally
Calculation results	Safety factor	Fs	-	<u>1.002</u>
	Planned safety factor	Fsp	-	1.200
	Required prevention force	Pr	kN/m	<u>11.2</u>
Circular arc	Central coordinates	X	m	17.000
		Y	m	433.000
	Radius	r	m	5.747
Calculation elements	Skid resistance	S	kN/m	56.93
	Sliding force	T	kN/m	56.76
	Normal force	N	kN/m	62.74
	Pore water pressure	U	kN/m	0.00
	Sliding surface length	l	m	7.634
	Area	A	m ²	5.15

**Table 5.4 Coefficient Condition of Stability Analysis of Lower slope of
Kandy Nursing School site Case-2 (Maximum deterrent force) [shallow slope failure]**

Stability calculation results		Symbol	Unit	Normally
Item		Symbol	Unit	Normally
Calculation results	Safety factor	Fs	-	<u>1.015</u>
	Planned safety factor	Fsp	-	1.200
	Required prevention force	Pr	kN/m	11.6
Circular arc	Central coordinates	X	m	17.000
		Y	m	432.000
	Radius	r	m	5.233
Calculation elements	Skid resistance	S	kN/m	63.41
	Sliding force	T	kN/m	62.46
	Normal force	N	kN/m	74.59
	Pore water pressure	U	kN/m	0.00
	Sliding surface length	l	m	7.610
	Area	A	m ²	5.95

**Table 5.5 Coefficient Condition of Stability Analysis of Upper slope of
Kandy Nursing School site Case-1 (Minimum factor of safety)**

Stability calculation results		Item	Symbol	Unit	Normally
Calculation results	Safety factor		Fs	-	<u>1.001</u>
	Planned safety factor		Fsp	-	1.200
	Required prevention force		Pr	kN/m	<u>39.4</u>
Circular arc	Central coordinates	X	X	m	2.000
		Y	Y	m	455.000
	Radius	r	r	m	17.213
Calculation elements	Skid resistance	S	S	kN/m	198.44
	Sliding force	T	T	kN/m	198.19
	Normal force	N	N	kN/m	192.85
	Pore water pressure	U	U	kN/m	0.00
	Sliding surface length	l	l	m	11.393
	Area	A	A	m ²	16.44

**Table 5.6 Coefficient Condition of Stability Analysis of Upper slope of
Kandy Nursing School site Case-2 (Maximum deterrent force)**

Stability calculation results		Item	Symbol	Unit	Normally
Calculation results	Safety factor		Fs	-	<u>0.939</u>
	Planned safety factor		Fsp	-	1.200
	Required prevention force		Pr	kN/m	<u>152.3</u>
Circular arc	Central coordinates	X	X	m	-16.000
		Y	Y	m	473.000
	Radius	r	r	m	44.097
Calculation elements	Skid resistance	S	S	kN/m	548.96
	Sliding force	T	T	kN/m	584.35
	Normal force	N	N	kN/m	599.26
	Pore water pressure	U	U	kN/m	0.00
	Sliding surface length	l	l	m	24.126
	Area	A	A	m ²	49.55

5.3 Design Concept of Countermeasures

The outlines of design concept of countermeasures are as follows.

- First, comparing the countermeasure work of Japanese method and Sri Lankan method.
- Safety of permanent slope is the most important, and comparing the other factors
- To secure a predetermined safety, surface covering way like frame work is required.
- In addition, unstable soil mass on the slope surface are not allowed to move.
- In the above condition, most suitable countermeasure work is shotcrete frame work with ground anchor or soil nailing.
- As the other countermeasure work, embankment and cutting is popular method for slope disaster. But they are inappropriate way for coasts and land use.
- Unstable weathered deposits are so thick at lower slope. Using only Soil nailing is not suitable way for the lower slope cause of their limit of the length.
- Ground anchor method is suitable for lower slope using with soil nailing. Long and thick Slope failure is stabilized by ground anchor. Also shallow slope failure is stabilized by soil nailing.
- Two types of countermeasure works become effective using by combining.

5.4 Design of Countermeasures

The drawings of basic design of countermeasures are shown in Figure 5.1 and 5.2.

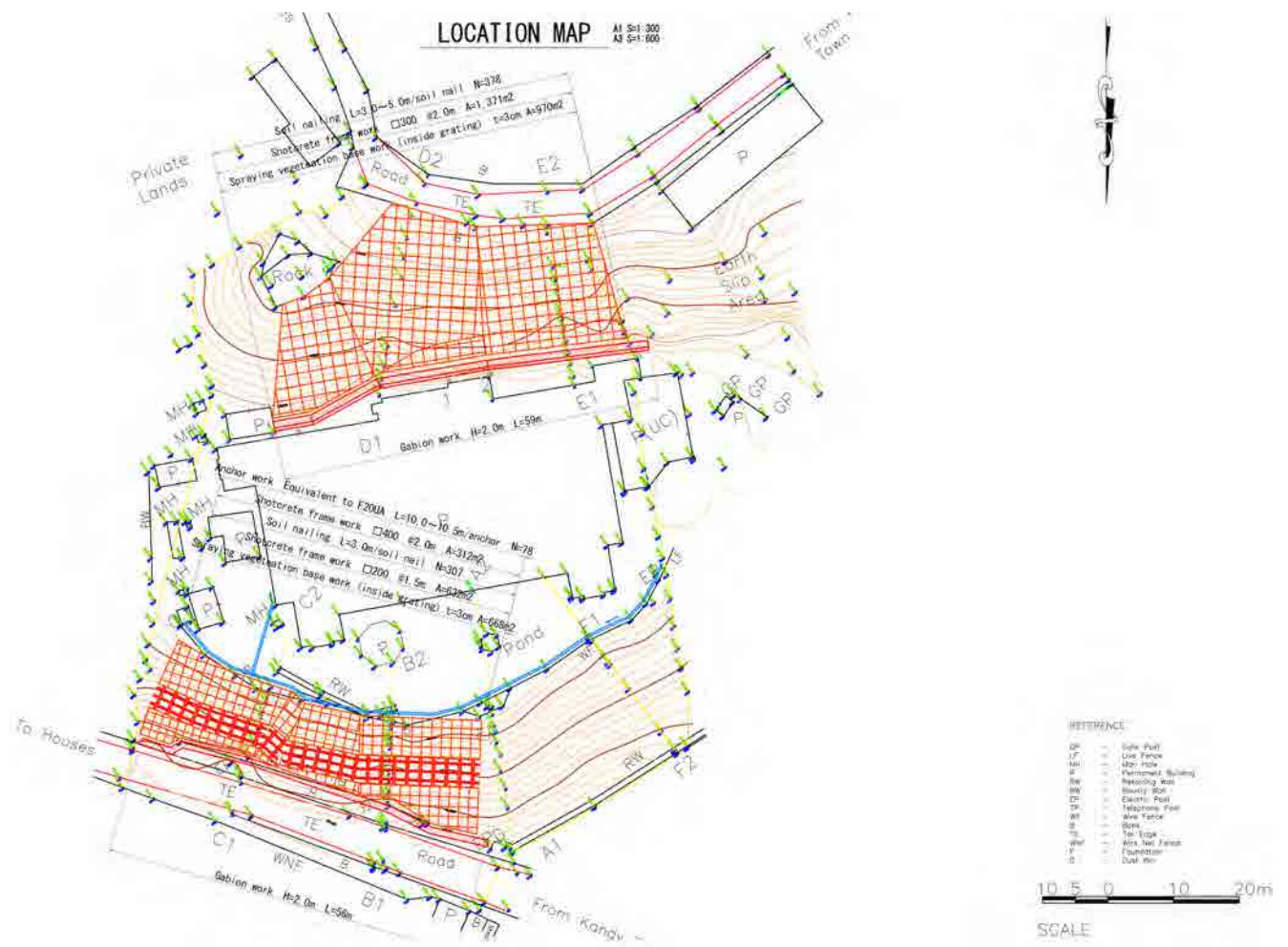

Figure 5.1 Plan of Basic Design of Countermeasures against Kandy Nursing School site

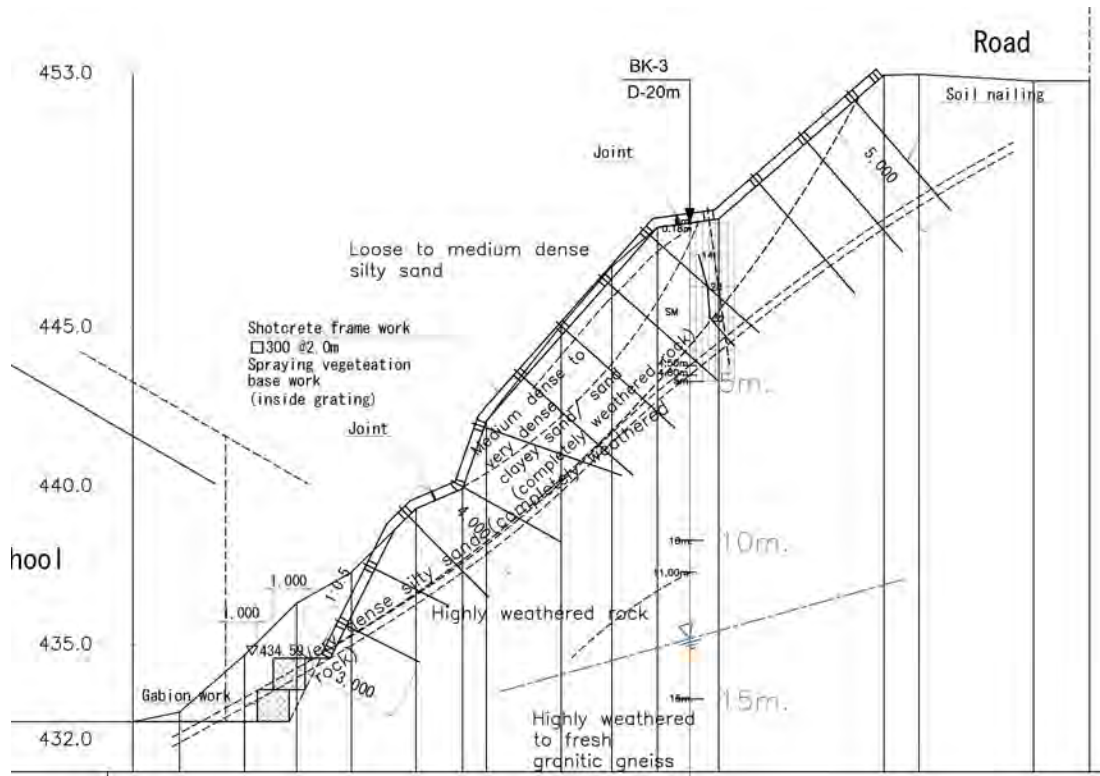

Figure 5.2 Cross Section of Basic Design of Countermeasures against Upper Slope of Kandy Nursing School Site

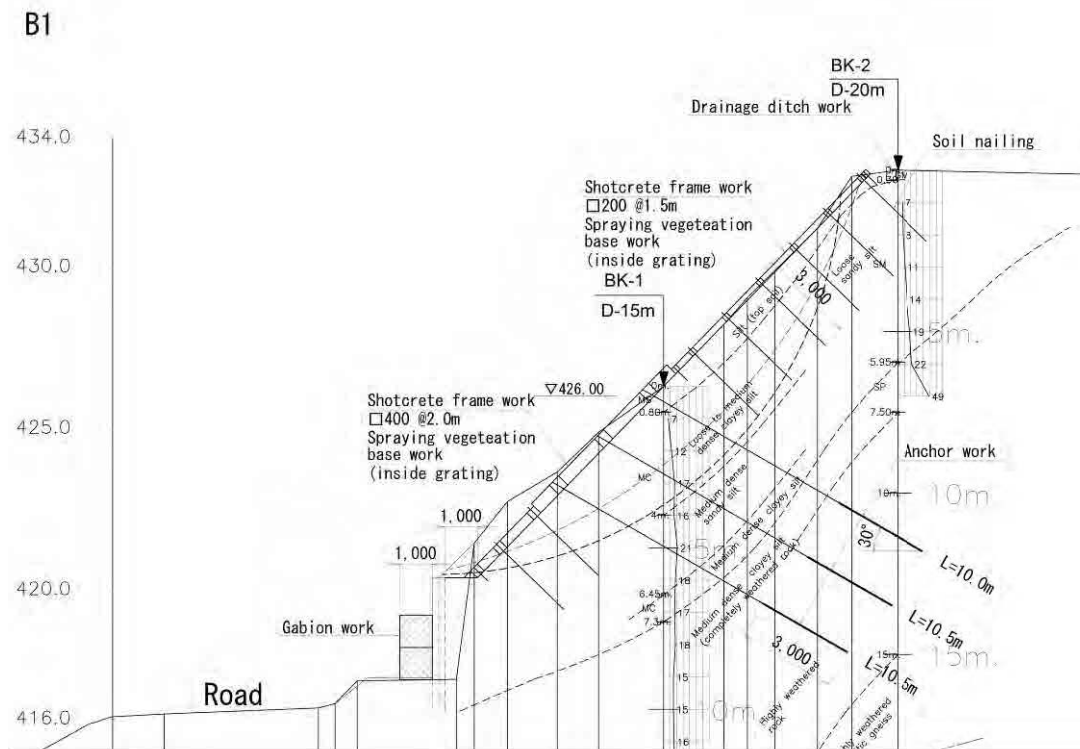

Figure 5.3 Cross Section of Basic Design of Countermeasures against Lower Slope of Kandy Nursing School Site

APPENDIX

- Appendix-1 Photo of Boring Core Sample
- Appendix-2 Borehole Log
- Appendix-3 Stability Analysis
- Appendix-4 Ground Anchor Design Calculation Report
- Appendix-5 Design calculation report on Grating crib works
- Appendix-6 Arrangement of Reinforcements
- Appendix-7 Drawings of countermeasure works
- Appendix-8 Bill of quantities
- Appendix-9 Comparison of the Countermeasure Works

Appendix-1

Photo of Boring Core Sample

BORING CORE PHOTO

JICA Technical Cooperation for Landslide Mitigation Project

BOREHOLE NO.	BK - 1	BOX NO.	1 - 3.
LOCATION	Kandy Pilot Site	DEPTH (M)	0.0m - 15.0m

Depth (m)



1
2
3
4
5
6
7
8
9
10
11
12
13
14
15

BORING CORE PHOTO

JICA Technical Cooperation for Landslide Mitigation Project

BOREHOLE NO.	BK - 2	BOX NO.	1. - 4.
LOCATION	Kandy Pilot Site	DEPTH (M)	0.0m - 20.0m

Depth (m)



BORING CORE PHOTO

JICA Technical Cooperation for Landslide Mitigation Project

BOREHOLE NO.	BK - 3	BOX NO.	1 - 4.
LOCATION	Kandy Pilot Site	DEPTH (M)	0.0m - 20.0m

Depth (m)



Appendix-2

Borehole Log

BOREHOLE LOG			NATIONAL BUILDING RESEARCH ORGANISATION GEOTECHNICAL ENGINEERING DIVISION 99/1, Jawatta Road, Colombo 05.				SHEET NO.											
							2 of 2											
PROJECT		SOIL INVESTIGATION FOR PROPOSED THREE STORED BUILDING FOR TEA GREEN PROPOSED AT NUWARA ELIYA		CLIENT	MR. S.A.S. AMARASINGHE	BOREHOLE NO	BK 2											
LOCATION		NUWARA ELIYA		CONTRACT NO	30/24871		DEPTH OF HOLE (m)	20.00										
DRILLING METHOD		CORE DRILLING		ELEVATION (m MSL)	499.951		CHAINAGE / OFFSET	-										
CORE SIZE [mm]		54	CASING SIZE	NX	N		DATE COMMENCED	24/01/2015										
VANE SIZE [mm*mm]		-		UDS SAMPLER SIZE [mm]	-		E	DATE COMPLETED	30/01/2015									
DEPTH [m]	ELEVATION [m MSL]	LAYER THICKNESS (m)	SAMPLE TYPE	SAMPLE NO.	SOIL PROFILE					STANDARD PENETRATION TEST DATA			MOISTURE CONTENT - %					
					SOIL DESCRIPTION	STRATA	LEGEND	GWL	γ - [g/cm ³]	DEPTH TESTED [m]	NUMBER OF BLOWS			UNDRAINED SHEAR STRENGTH - kN/m ²				
											PER 15cm			SPT RESISTANCE - Blows/30 cm				
											1	2	3					
10.00																		
11.00																		
12.00																		
13.00																		
14.00																		
15.00	494.951	7.50																
16.00	483.951	1.00																
17.00	482.951	1.00																
18.00	481.951	1.00																
19.00	480.951	1.00																
20.00	479.951	1.00																
							18.50m GWL 30/01/2015											

<p>----- Natural moisture content, Atterberg Limits (LL, PL)</p> <p>▲ SPT N', blows/ft</p> <p>→ Vane shear strength, peak</p> <p>----- Vane shear strength, residual</p>	<p>γ - Wet unit weight</p> <p>G - Grainsize Analysis</p> <p>U - Unconfined compression</p> <p>CU - Consolidated undrained triaxial</p>	<p>W - Wash sample</p> <p>SPT - SPT Sample</p> <p>☑ - Undisturbed sample</p> <p>⊗ - Disturbed Sample</p>
Drilled By RDS	Logged By LW	Date 30/1/2015
Checked By	LW	

BOREHOLE LOG



NATIONAL BUILDING RESEARCH ORGANISATION
GEOTECHNICAL ENGINEERING DIVISION
 99/1, Jawatta Road, Colombo 05.

SHEET NO.
1 of 2













PROJECT	SOIL INVESTIGATION FOR THE STABILISATION OF CUT SLOPE AT NURSES TRAINING SCHOOL		CLIENT	JAPAN INTERNATIONAL CORPORATION AGENCY	BOREHOLE NO	BK 3	
LOCATION	KANDY		CONTRACT NO	30/24871	DEPTH OF HOLE (m)	20.00	
DRILING METHOD	CORE DRILLING		ELEVATION (m MSL)	515.299	CHAINAGE / OFFSET	-	
CORE SIZE [mm]	54	CASING SIZE	NX	N		DATE COMMENCED	29/01/2015
VANE SIZE [mm*mm]	-	UDS SAMPLER SIZE [mm]	-	E		DATE COMPLETED	02/02/2015

DEPTH [m]	ELEVATION [m MSL]	LAYER THICKNESS(m)	SAMPLE TYPE	SAMPLE NO.	SOIL PROFILE			Y - [g/cm ³]	DEPTH TESTED [m]	STANDARD PENETRATION TEST DATA			MOISTURE CONTENT - %					
					SOIL DESCRIPTION	STRATA	LEGEND			GWL	NUMBER OF BLOWS			UNDRAINED SHEAR STRENGTH - kN/m ²				
											PER 15cm	FOR 30cm	FOR 45cm	SPT RESISTANCE - Blows/30 cm				
1	2	3	10	20	30	40	50	60										
0.00	515.299				GROUND LEVEL													
0.18	515.119	0.18			Blackish brown, silty SAND, angular to sub angular, medium to coarse grained with plant roots and highly decomposed organic matters, moist (top soil)	SM												
1.00					Medium dense, reddish brown, clayey SAND, fine grained with completely weathered rock fragments, moist	SC			1.00	4	4	10	14					
1.60	513.699	1.42			Medium dense to very dense, whitish grey mottled with brown and black, clayey SAND, angular to sub angular, fine to coarse grained with completely weathered rock fragments, moist (completely weathered rock)	SC			2.00	8	10	18	28					
2.00										3.00	10	16	16	32				
3.00										4.00	32	12/5	-	>50	Refusal to penetration			
4.50	510.790	2.90			Very dense, blackish brown, silty SAND, fine grained with completely weathered rock fragments and occasionally gravel, moist (completely weathered rock)	SM												
4.80	510.490	0.30																
5.00					Rock Level													
6.00	509.299	1.00			Highly to completely weathered rock (washing sample)				5.00	Nil	Nil							
7.00	508.299	1.00			Highly to completely weathered rock (washing sample)				6.00	Nil	Nil							
8.00	507.299	1.00			Highly to completely weathered rock (washing sample)				7.00	Nil	Nil							
9.00	506.299	1.00			Highly to completely weathered rock (washing sample)				8.00	Nil	Nil							
10.00					Highly to completely weathered rock (washing sample)				9.00	Nil	Nil							
					Highly to completely weathered rock (washing sample)				10.00	Nil	Nil							

Natural moisture content, Atterberg Limits (LL, PL)	Wet unit weight	W - Wash sample	Drilled By RDS
SPT 'N', blows/ft	G - Grainsize Analysis	SPT - SPT Sample	Logged By LW
Vane shear strength, peak	U - Unconfined compression	Undisturbed sample	Date 02/02/2015
Vane shear strength, residual	CU - Consolidated undrained triaxial	Disturbed Sample	Checked By LW

BOREHOLE LOG				 NATIONAL BUILDING RESEARCH ORGANISATION GEOTECHNICAL ENGINEERING DIVISION 99/1, Jawatta Road, Colombo 05.				SHEET NO. 2 of 2													
PROJECT		SOIL INVESTIGATION FOR PROPOSED THREE STORED BUILDING FOR TEA GREEN PROPOSED AT NUWARA ELIYA		CLIENT		MR. S.A.S. AMARASINGHE		BOREHOLE NO BK 3													
LOCATION		NUWARA ELIYA		CONTRACT NO		30/24871		DEPTH OF HOLE (m) 20.00													
DRILING METHOD		CORE DRILLING		ELEVATION (m MSL)		515.299		CHAINAGE / OFFSET -													
CORE SIZE [mm]		54		CASING SIZE		NX		CO-ORDINATES N													
VANE SIZE [mm*mm]		-		UDS SAMPLER SIZE [mm]		-		DATE COMMENCED 29/01/2015													
								DATE COMPLETED 02/02/2015													
DEPTH [m]	ELEVATION [m MSL]	LAYER THICKNESS [m]	SAMPLE TYPE	SOIL PROFILE			STANDARD PENETRATION TEST DATA			MOISTURE CONTENT - %											
				SOIL DESCRIPTION	STRATA	LEGEND	GWL	NUMBER OF BLOWS			UNDRAINED SHEAR STRENGTH - kN/m ²										
DEPTH [m]	PER 15cm							SPT RESISTANCE - Blows/30 cm													
10.00	505.299	1.00																			
				Highly to completely weathered rock (washing sample)																SPT	
11.00	504.299	1.00																			
				Weak to moderately weak, pink, thinly foliated, medium to coarse grained, GRANITIC GNEISS, meta-ingneous, highly to moderately weathered, moderately fractured, metamorphic rock			Rock														
12.00	503.299	1.00																			
				Moderately weak, pink, thinly foliated, medium to coarse grained, GRANITIC GNEISS, meta-ingneous, moderately weathered, metamorphic rock			Rock														
13.00	502.299	1.00																			
				Moderately weak, pink, thinly foliated, medium to coarse grained, GRANITIC GNEISS, meta-ingneous, moderately weathered, moderately fractured, metamorphic rock			Rock														
14.00	501.299	1.00																			
				Weak to moderately weak, light pink, thinly foliated, medium to coarse grained, GRANITIC GNEISS, meta-ingneous, moderately weathered, moderately fractured, metamorphic rock			Rock														
15.00	500.299	1.00																			
				Weak to moderately weak, light pink, thinly foliated, medium to coarse grained, GRANITIC GNEISS, meta-ingneous, moderately weathered, moderately fractured, metamorphic rock			Rock														
16.00	499.299	1.00																			
				Weak to moderately weak, light pink, thinly foliated, medium to coarse grained, GRANITIC GNEISS, meta-ingneous, moderately weathered, moderately fractured, metamorphic rock			Rock														
17.00	498.299	1.00																			
				Weak to moderately strong, pink, thinly foliated, medium to coarse grained, GRANITIC GNEISS, meta-ingneous, moderately weathered, moderately fractured, metamorphic rock			Rock														
18.00	497.299	1.00																			
				Strong, pink, thinly foliated, medium to coarse grained, GRANITIC GNEISS, meta-ingneous, fresh, slightly fractured, metamorphic rock			Rock														
18.85	496.443	0.85																			
19.00	495.299	1.15																			
				Strong, black, thinly foliated, medium to coarse grained, HORNBLENDE BIOTITE GNEISS, meta-ingneous, fresh, moderately fractured, metamorphic rock			Rock														
20.00	495.299	1.15		Borehole terminated at 20.00m depth																	

13.50m GWL 02/02/2015

	Natural moisture content, Atterberg Limits (LL, PL)		Wet unit weight		W - Wash sample	Drilled By	RDS
	SPT N, blows/ft		G - Grainsize Analysis		SPT - SPT Sample	Logged By	LW
	Vane shear strength, peak		U - Unconfined compression		U - Undisturbed sample	Date	02/02/2015
	Vane shear strength, residual		CU - Consolidated undrained triaxial		X - Disturbed Sample	Checked By	LW

Appendix-3

Stability Analysis

Stability Analysis

Site	KANDY UPPER
Case	Line E, Fs(min)
Remarks	ϕ 34 C6

Site	KANDY
Case	Line E, Fs(min)
Remarks	φ 34 C6

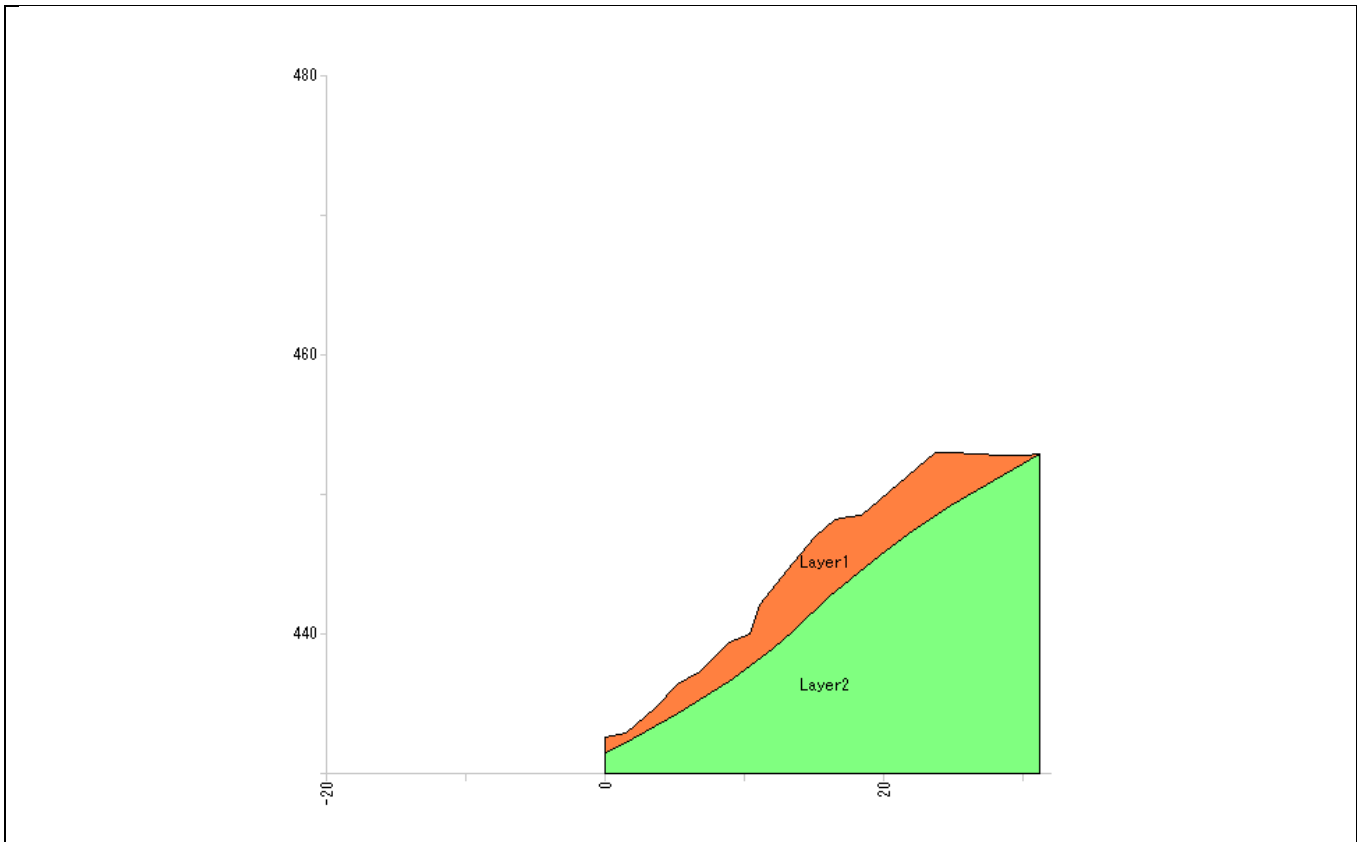

Soil constant		Soil quality	Wet weight γ_t (kN/m ³)	Saturated weight γ_{sat} (kN/m ³)	Cohesion C (kN/m ²)	Internal friction angle	
No.	Geology					ϕ (°)	$\tan\phi$
1	Layer1		17.00	17.00	6.00	34.0000	0.674509
2	Layer2		24.00	24.00	1000.00	38.0000	0.781286

* Unit weight of water $\gamma_w = 9.80$ (kN/m³)

Coordinate input data								
No.	Distance X (m)	Original topographic altitude Y _G (m)	Planned topographic altitude Y (m)	Water level altitude Y _W (m)	Sliding surface			Launching
					Altitude Y _S (m)	Shape	Strength	
1	0.000		432.587					
2	1.460		432.882					
3	3.520		434.685					
4	5.170		436.325					
5	6.890		437.299					
6	8.930		439.308					
7	10.410		439.940					
8	11.160		442.078					
9	13.520		445.064					
10	15.120		446.925					
11	16.560		448.157					
12	17.581		448.300					
13	18.490		448.426					
14	23.710		452.961					
15	24.820		452.987					
16	28.440		452.779					
17	30.210		452.780					
18	31.260		452.850					

Coordinates of stratum boundary line		
No.	No.1	
	X (m)	Y (m)
1	0.000	431.420
2	1.230	432.090
3	5.170	434.270
4	5.695	434.587
5	9.220	436.770
6	11.670	438.560
7	12.200	439.000
8	13.520	440.140
9	16.190	442.670
10	19.700	445.530
11	22.130	447.340
12	24.820	449.120
13	31.260	452.850

1. Design Requirements

1.1. Planned Safety Factor of the Reinforcement Slope

Considering the site as permanent construction, set a planned safety factor.

The Cut Earth Reinforcement Method, Design and Construction Procedures prescribes as follows.

Planned safety factor of the reinforcement slope

Item	Planned safety factor
Permanent construction (long term)	$F_{sp} \geq 1.20$
Temporary construction (short term)	$F_{sp} \geq 1.05, 1.10$

[Cut Earth Reinforcement Method, Design and Construction Procedures Page 31]

Taking account of the importance of the said slope, the planned safety factor shall be $F_{sp} = 1.200$.

1.2. Soil Quality Requirements

The following shows the geological and soil composition and constants of the said slope.

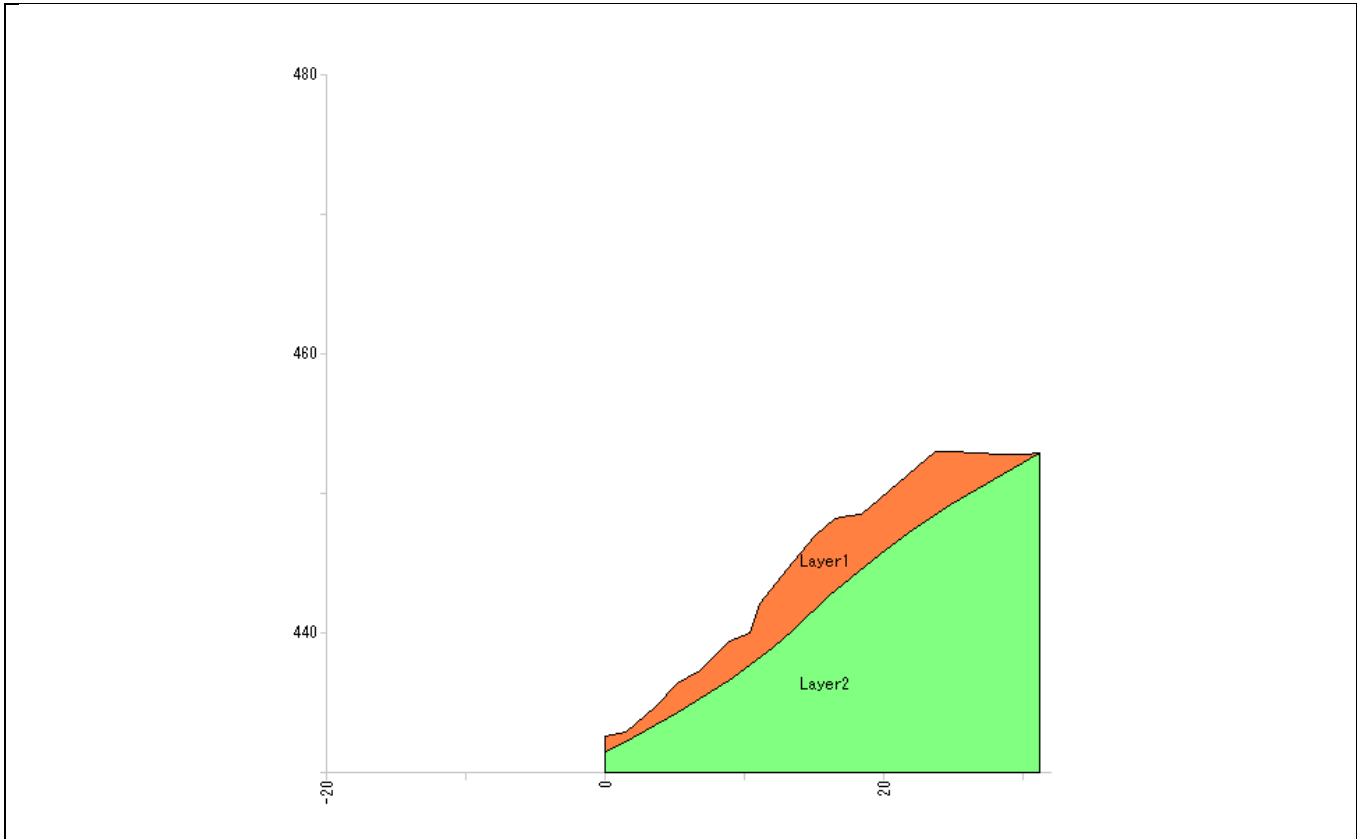

Soil constant							
No.	Geology	Soil quality	Wet weight γ_t (kN/m ³)	Saturated weight γ_{sat} (kN/m ³)	Cohesion C (kN/m ²)	Internal friction angle	
						ϕ (°)	$\tan\phi$
1	Layer1		17.00	17.00	6.00	34.0000	0.674509
2	Layer2		24.00	24.00	1000.00	38.0000	0.781286

* Unit weight of water $\gamma_w = 9.80$ (kN/m³)

2. Repeated Circular Calculation

As a result of studying with repeated circular slip as to slope stability, it is determined that the following sliding surface is most dangerous.

< Circular arc A >

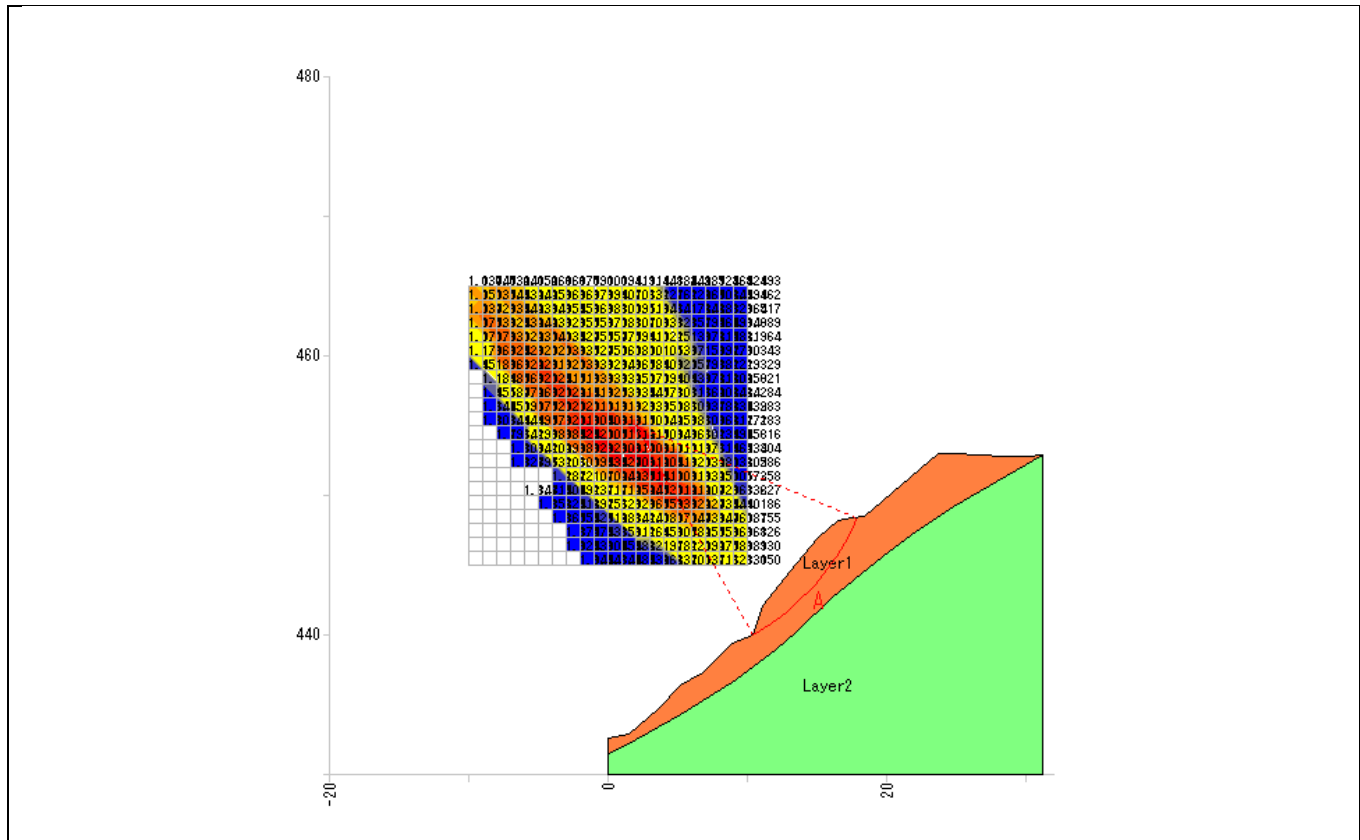

Stability calculation results				
Item		Symbol	Unit	Normally
Calculation results	Safety factor	Fs	-	1.001
	Planned safety factor	Fsp	-	1.200
	Required prevention force	Pr	kN/m	39.4
Circular arc	Central coordinates	X	m	2.000
		Y	m	455.000
	Radius	r	m	17.213
Calculation elements	Skid resistance	S	kN/m	198.44
	Sliding force	T	kN/m	198.19
	Normal force	N	kN/m	192.85
	Pore water pressure	U	kN/m	0.00
	Sliding surface length	l	m	11.393
	Area	A	m ²	16.44

2.1. Stability Calculation Formula

Stability calculation is conducted using the modified Fellenius method.

Basically, the limit balance method shall be used to secure the required planned safety factor.

$$\text{Safety factor (Fs)} = \frac{\text{Skid resistance } (\Sigma S)}{\text{Sliding force } (\Sigma T)}$$

Concerning the calculation method, the cross section of the sliding clod shall be split into several slices based on the “slicing method” to consider the balance of force on each slice (split piece).

< Normally >

$$F_s = \frac{\Sigma\{(N-U)\cdot\tan\phi\}+\Sigma(C\cdot l)}{\Sigma T}$$

$$Pr = F_{sp}\cdot\Sigma T - [\Sigma\{(N-U)\cdot\tan\phi\}+\Sigma(C\cdot l)]$$

where;

F _s	:	Safety factor	
F _{sp}	:	Planned safety factor	
Pr	:	Required prevention force	(kN/m)
N	:	Normal force by gravity of slice	(N = W·cosθ+Q _N) (kN/m)
U	:	Pore water pressure working on slice	(U = u·b·cosθ) (kN/m)
T	:	Tangential force by gravity of slice	(T = W·sinθ+Q _T) (kN/m)
b	:	Slice width	(m)
l	:	Sliding surface length of slice	(m)
φ	:	Internal friction angle of sliding surface	(°)
C	:	Cohesion of sliding surface	(kN/m ²)
W	:	Slice weight	(kN/m)
θ	:	Sliding surface inclination angle	(°)
u	:	Unit pore water pressure	(kN/m ²)
Q _N	:	Vertical load component force (normal direction)	(kN/m)
Q _T	:	Vertical load component force (tangential direction)	(kN/m)

2.2. Stability Evaluation (Normally)

< Circular arc A >

Slice element summary table			Sliding surface length l (m)	Normal force N (kN/m)	Pore water pressure U (kN/m)	Sliding force T (kN/m)	Skid resistance S (kN/m)
Internal friction angle		Cohesion C (kN/m ²)					
φ(°)	tanφ						
34.0000	0.674509	6.00	11.393	192.85	0.00	198.19	198.44

The safety factor is calculated by the following formula.

$$\begin{aligned}
 F_s &= \frac{\Sigma\{(N-U)\cdot\tan\phi\}+\Sigma(C\cdot l)}{\Sigma T} \\
 &= \frac{(192.85-0.00)\times 0.674509+6.00\times 11.393}{198.19} \\
 &= 1.001
 \end{aligned}$$

where;

F _s	:	Safety factor		
N	:	Normal force by gravity of slice	(N = W·cosθ+Q _N)	(kN/m)
U	:	Pore water pressure working on slice	(U = u·b·cosθ)	(kN/m)
T	:	Tangential force by gravity of slice	(T = W·sinθ+Q _T)	(kN/m)
b	:	Slice width		(m)
l	:	Sliding surface length of slice		(m)
φ	:	Internal friction angle of sliding surface		(°)
C	:	Cohesion of sliding surface		(kN/m ²)
W	:	Slice weight		(kN/m)
θ	:	Sliding surface inclination angle		(°)
u	:	Unit pore water pressure		(kN/m ²)
Q _N	:	Vertical load component force (normal direction)		(kN/m)
Q _T	:	Vertical load component force (tangential direction)		(kN/m)

2.3. Calculation of the Required Prevention Force (Normally)

Calculate the required prevention force which satisfies the planned safety factor $F_{sp} = 1.200$.

< Circular arc A >

$$\begin{aligned} Pr &= F_{sp} \cdot \Sigma T - [\Sigma \{(N-U) \cdot \tan \phi\} + \Sigma (C \cdot l)] \\ &= 1.200 \times 198.19 - \{(192.85 - 0.00) \times 0.674509 + 6.00 \times 11.393\} \\ &= 39.4 \text{ (kN/m)} \end{aligned}$$

where;

F_{sp}	: Planned safety factor		
Pr	: Required prevention force		(kN/m)
N	: Normal force by gravity of slice	$(N = W \cdot \cos \theta + Q_N)$	(kN/m)
U	: Pore water pressure working on slice	$(U = u \cdot b \cdot \cos \theta)$	(kN/m)
T	: Tangential force by gravity of slice	$(T = W \cdot \sin \theta + Q_T)$	(kN/m)
b	: Slice width		(m)
l	: Sliding surface length of slice		(m)
ϕ	: Internal friction angle of sliding surface		(°)
C	: Cohesion of sliding surface		(kN/m ²)
W	: Slice weight		(kN/m)
θ	: Sliding surface inclination angle		(°)
u	: Unit pore water pressure		(kN/m ²)
Q_N	: Vertical load component force (normal direction)		(kN/m)
Q_T	: Vertical load component force (tangential direction)		(kN/m)

Repeated Circular Calculation Requirements

- Circular arc requirements

Center change range

X coordinate (m) : -10.000 ~ 10.000 Pitch (m) : 1.000
Y coordinate (m) : 445.000 ~ 465.000 Pitch (m) : 1.000
Secondary chase : None

Depth change range from the ground surface

Depth (m) : 1.000 ~ 10.000 Pitch (m) : 0.500

- Pass line

Start point (m) : [X = - , Y = -]

End point (m) : [X = - , Y = -]

- No-Pass line

Start point (m) : [X = - , Y = -]

End point (m) : [X = - , Y = -]

- No-Pass layer

Layer2

- Calculation requirements

Planned safety factor (Normally) Fsp = 1.200
Stability calculation formula Modified Fellenius method
Sliding surface strength Stratum value

- Output requirements

Safety factor : All
Required prevention force : All
Sliding force : All
Depth : All

List of Repeated Circular Calculation Results
(Normally)

No.	Reg.	Circular arc requirements				Skid resistance S (kN/m)	Sliding force T (kN/m)	Safety factor Fs	Required prevention force Pr (kN/m)
		Central coordinates		Radius r (m)	Max. depth (m)				
		X (m)	Y (m)						
1	A	2.000	455.000	17.213	2.000	198.44	198.19	* 1.001	39.4
2		2.000	453.000	16.459	2.500	299.98	298.96	1.003	58.8
3		3.000	452.000	15.054	2.500	290.36	289.16	1.004	56.7
4		-2.000	455.000	21.337	3.000	475.67	473.62	1.004	92.7
5		-1.000	454.000	19.933	3.000	462.38	460.27	1.005	90.0
6		0.000	453.000	18.528	3.000	448.08	445.39	1.006	86.4
7		3.000	454.000	15.803	2.000	195.20	194.03	1.006	37.7
8		6.000	450.000	10.960	2.000	180.26	179.07	1.007	34.7
9		4.000	451.000	14.150	3.000	361.11	358.40	1.008	69.0
10		-1.000	455.000	20.553	3.000	446.32	442.28	1.009	84.5
11		4.000	451.000	13.650	2.500	280.12	277.72	1.009	53.2
12		1.000	452.000	17.123	3.000	432.92	428.90	1.009	81.8
13		3.000	452.000	15.554	3.000	377.04	373.68	1.009	71.4
14		0.000	454.000	19.148	3.000	433.98	429.84	1.010	81.9
15		1.000	453.000	17.743	3.000	420.30	416.20	1.010	79.2
16		3.000	453.000	16.174	3.000	363.28	359.69	1.010	68.4
17		4.000	453.000	14.394	2.000	191.81	189.65	1.011	35.8
18		3.000	451.000	14.434	2.500	299.64	296.51	1.011	56.2
19		-2.000	456.000	21.957	3.000	458.91	453.86	1.011	85.8
20		4.000	450.000	13.030	2.500	284.79	281.40	1.012	52.9
21		5.000	450.000	12.745	3.000	345.72	341.54	1.012	64.2
22		1.000	454.000	17.863	2.500	311.68	308.12	1.012	58.1
23		2.000	452.000	16.339	3.000	405.58	400.93	1.012	75.6
24		4.000	452.000	14.770	3.000	351.99	347.49	1.013	65.0
25		-3.000	457.000	23.362	3.000	471.11	464.77	1.014	86.7
26		3.000	453.000	15.674	2.500	282.48	278.52	1.014	51.8
27		2.000	453.000	16.959	3.000	392.87	387.40	1.014	72.1
28		3.000	451.000	14.934	3.000	389.76	384.29	1.014	71.4
29		2.000	452.000	15.839	2.500	313.77	309.37	1.014	57.5
30		2.000	451.000	15.719	3.000	416.71	411.05	1.014	76.6
31		-4.000	458.000	24.766	3.000	483.14	475.80	1.015	87.9
32		2.000	454.000	17.079	2.500	290.68	286.47	1.015	53.1
33		1.000	455.000	18.484	2.500	297.88	293.37	1.015	54.2
34		4.000	450.000	13.530	3.000	371.44	365.70	1.016	67.4
35		1.000	454.000	18.363	3.000	405.98	399.78	1.016	73.8
36		0.000	456.000	19.889	2.500	304.98	300.07	1.016	55.2
37		2.000	454.000	17.579	3.000	377.29	371.09	1.017	68.1
38		5.000	450.000	12.245	2.500	268.50	263.96	1.017	48.3
39		4.000	452.000	14.270	2.500	273.69	269.15	1.017	49.3
40		-5.000	459.000	26.171	3.000	494.13	485.32	1.018	88.3
41		0.000	455.000	19.768	3.000	419.20	411.63	1.018	74.8
42		5.000	451.000	13.365	3.000	340.01	333.88	1.018	60.7

* denotes the minimum safety factor and maximum prevention force.

No.	Reg.	Circular arc requirements				Skid resistance S (kN/m)	Sliding force T (kN/m)	Safety factor Fs	Required prevention force Pr (kN/m)
		Central coordinates		Radius r (m)	Max. depth (m)				
		X (m)	Y (m)						
43		-1.000	456.000	19.673	1.500	151.56	148.74	1.019	27.0
44		-2.000	457.000	21.077	1.500	153.29	150.44	1.019	27.3
45		-3.000	455.000	21.622	2.500	400.51	392.88	1.019	71.0
46		5.000	453.000	14.134	2.500	246.18	241.69	1.019	43.9
47		-3.000	458.000	22.482	1.500	154.86	151.95	1.019	27.5
48		-1.000	454.000	19.433	2.500	363.42	356.27	1.020	64.2
49		5.000	452.000	12.986	2.000	187.76	184.04	1.020	33.1
50		1.000	453.000	17.243	2.500	327.28	320.98	1.020	57.9
51		-5.000	460.000	25.292	1.500	157.62	154.47	1.020	27.8
52		-6.000	460.000	27.576	3.000	505.04	495.16	1.020	89.2
53		-4.000	459.000	23.887	1.500	156.19	153.09	1.020	27.6
54		5.000	451.000	12.865	2.500	264.06	258.94	1.020	46.7
55		-4.000	456.000	23.026	2.500	411.48	403.60	1.020	72.9
56		-5.000	456.000	23.811	2.500	440.02	431.24	1.020	77.5
57		-2.000	455.000	20.837	2.500	374.40	367.09	1.020	66.2
58		3.000	450.000	14.314	3.000	399.13	390.85	1.021	69.9
59		-4.000	455.000	22.406	2.500	428.22	419.31	1.021	75.0
60		-3.000	456.000	22.242	2.500	384.51	376.76	1.021	67.7
61		-6.000	458.000	25.836	2.500	431.94	423.03	1.021	75.7
62		0.000	453.000	18.028	2.500	351.67	344.53	1.021	61.8
63		-2.000	454.000	20.217	2.500	388.67	380.84	1.021	68.4
64		-5.000	457.000	24.431	2.500	421.74	413.25	1.021	74.2
65		0.000	454.000	18.648	2.500	338.82	331.82	1.021	59.4
66		-1.000	456.000	21.173	3.000	431.61	422.83	1.021	75.8
67		-7.000	461.000	28.980	3.000	515.70	504.72	1.022	90.0
68		0.000	455.000	19.268	2.500	323.07	316.22	1.022	56.4
69		-4.000	457.000	23.646	2.500	393.87	385.55	1.022	68.8
70		0.000	455.000	18.268	1.500	149.29	146.09	1.022	26.1
71		5.000	449.000	12.125	3.000	352.15	344.63	1.022	61.5
72		-7.000	459.000	27.240	2.500	441.54	431.85	1.022	76.7
73		-1.000	453.000	18.812	2.500	376.50	368.05	1.023	65.2
74		1.000	452.000	16.623	2.500	339.02	331.38	1.023	58.7
75		-1.000	455.000	20.053	2.500	349.28	341.45	1.023	60.5
76		-2.000	457.000	22.577	3.000	443.20	432.98	1.024	76.4
77		-8.000	460.000	28.645	2.500	450.45	439.87	1.024	77.4
78		1.000	455.000	18.984	3.000	391.10	381.86	1.024	67.2
79		-8.000	462.000	30.385	3.000	525.53	513.46	1.024	90.7
80		-5.000	458.000	25.051	2.500	403.41	394.01	1.024	69.5
81		-3.000	454.000	21.002	2.500	415.85	406.30	1.024	71.8
82		-2.000	456.000	21.457	2.500	358.80	350.18	1.025	61.5
83		-1.000	457.000	21.296	2.500	313.66	306.04	1.025	53.6
84		1.000	454.000	16.863	1.500	146.89	143.29	1.025	25.1
85		-3.000	458.000	23.982	3.000	454.04	442.77	1.025	77.3
86		-6.000	459.000	26.456	2.500	411.89	401.49	1.026	69.9
87		-9.000	463.000	31.790	3.000	535.29	521.86	1.026	91.0

* denotes the minimum safety factor and maximum prevention force.

No.	Reg.	Circular arc requirements				Skid resistance S (kN/m)	Sliding force T (kN/m)	Safety factor Fs	Required prevention force Pr (kN/m)
		Central coordinates		Radius r (m)	Max. depth (m)				
		X (m)	Y (m)						
88		2.000	451.000	15.219	2.500	325.35	316.69	1.027	54.7
89		-2.000	460.000	23.506	2.000	207.75	202.22	1.027	35.0
90		-3.000	457.000	22.862	2.500	367.94	358.31	1.027	62.1
91		0.000	452.000	17.408	2.500	363.38	353.73	1.027	61.1
92		6.000	449.000	11.340	3.000	330.55	321.86	1.027	55.7
93		-4.000	459.000	25.387	3.000	464.77	452.74	1.027	78.6
94		-3.000	461.000	24.916	2.000	209.28	203.81	1.027	35.3
95		-5.000	460.000	26.792	3.000	475.30	462.14	1.028	79.3
96		5.000	449.000	11.625	2.500	271.76	264.38	1.028	45.5
97		7.000	450.000	10.676	2.500	234.54	228.24	1.028	39.4
98		-4.000	462.000	26.326	2.000	211.13	205.34	1.028	35.3
99		-7.000	460.000	27.860	2.500	420.33	408.90	1.028	70.4
100		6.000	450.000	11.960	3.000	326.93	317.95	1.028	54.7
101		-2.000	453.000	19.597	2.500	402.57	391.79	1.028	67.6
102		6.000	450.000	11.460	2.500	253.10	246.14	1.028	42.3
103		-4.000	458.000	24.266	2.500	376.30	365.75	1.029	62.6
104		-1.000	459.000	22.096	2.000	205.94	200.05	1.029	34.2
105		2.000	455.000	18.213	3.000	367.31	356.81	1.029	60.9
106		1.000	456.000	19.623	3.000	378.18	367.47	1.029	62.8
107		-1.000	456.000	20.673	2.500	333.73	324.16	1.030	55.3
108		4.000	453.000	14.894	2.500	266.72	258.86	1.030	44.0
109		3.000	454.000	16.803	3.000	356.47	346.01	1.030	58.8
110		-6.000	461.000	28.199	3.000	485.52	471.30	1.030	80.1
111		2.000	453.000	15.459	1.500	144.12	139.87	1.030	23.8
112		3.000	454.000	16.303	2.500	274.78	266.63	1.031	45.2
113		2.000	455.000	17.713	2.500	282.22	273.81	1.031	46.4
114		1.000	453.000	16.743	2.000	238.41	231.31	1.031	39.2
115		-8.000	461.000	29.265	2.500	428.15	415.41	1.031	70.4
116		-5.000	459.000	25.671	2.500	384.03	372.52	1.031	63.0
117		0.000	456.000	20.389	3.000	404.65	392.35	1.031	66.2
118		4.000	453.000	15.394	3.000	344.86	334.22	1.032	56.3
119		6.000	451.000	11.581	2.000	183.39	177.62	1.032	29.8
120		6.000	449.000	10.840	2.500	256.16	248.17	1.032	41.7
121		-8.000	465.000	32.815	3.500	600.96	582.28	1.032	* 97.8
122		-7.000	464.000	31.405	3.500	589.40	570.99	1.032	95.8
123		0.000	458.000	20.685	2.000	204.16	197.92	1.032	33.4
124		6.000	452.000	12.724	2.500	241.15	233.76	1.032	39.4
125		-7.000	462.000	29.606	3.000	495.53	480.19	1.032	80.7
126		-5.000	462.000	28.584	3.500	565.41	547.22	1.033	91.3
127		4.000	449.000	12.909	3.000	380.05	367.92	1.033	61.5
128		-6.000	463.000	29.995	3.500	577.81	559.56	1.033	93.7
129		5.000	452.000	13.486	2.500	257.92	249.79	1.033	41.9
130		-9.000	462.000	30.669	2.500	435.92	421.98	1.033	70.5
131		-1.000	452.000	18.192	2.500	388.60	375.86	1.034	62.5
132		-4.000	461.000	27.174	3.500	553.46	535.11	1.034	88.7

* denotes the minimum safety factor and maximum prevention force.

No.	Reg.	Circular arc requirements				Skid resistance S (kN/m)	Sliding force T (kN/m)	Safety factor Fs	Required prevention force Pr (kN/m)
		Central coordinates		Radius r (m)	Max. depth (m)				
		X (m)	Y (m)						
133		-2.000	457.000	22.077	2.500	342.12	331.01	1.034	55.1
134		1.000	456.000	19.123	2.500	290.04	280.57	1.034	46.7
135		2.000	453.000	15.959	2.000	224.08	216.76	1.034	36.1
136		-8.000	463.000	31.014	3.000	505.33	488.80	1.034	81.3
137		1.000	454.000	17.363	2.000	230.76	223.19	1.034	37.1
138		5.000	452.000	13.986	3.000	332.86	322.02	1.034	53.6
139		1.000	457.000	19.275	2.000	202.14	195.54	1.034	32.6
140		-1.000	457.000	21.796	3.000	416.55	402.77	1.034	66.8
141		-6.000	460.000	27.076	2.500	391.48	378.78	1.034	63.1
142		7.000	449.000	9.556	2.000	173.96	168.26	1.034	28.0
143		-9.000	464.000	32.423	3.000	515.42	497.78	1.035	82.0
144		1.000	451.000	16.003	2.500	349.39	337.44	1.035	55.6
145		2.000	452.000	15.339	2.000	230.62	222.89	1.035	36.9
146		-3.000	460.000	25.764	3.500	540.66	522.19	1.035	86.0
147		3.000	450.000	13.814	2.500	310.07	299.64	1.035	49.5
148		3.000	452.000	14.554	2.000	216.88	209.39	1.036	34.4
149		-3.000	458.000	23.482	2.500	350.48	338.23	1.036	55.4
150		0.000	455.000	18.768	2.000	236.77	228.52	1.036	37.5
151		6.000	448.000	10.720	3.000	331.44	319.83	1.036	52.4
152		-2.000	459.000	24.354	3.500	527.30	508.79	1.036	83.3
153		0.000	457.000	21.033	3.000	391.16	377.58	1.036	62.0
154		-2.000	458.000	23.204	3.000	428.06	413.17	1.036	67.8
155		6.000	451.000	12.081	2.500	248.69	239.74	1.037	39.0
156		0.000	457.000	20.533	2.500	297.51	286.85	1.037	46.8
157		-10.000	463.000	32.074	2.500	443.84	428.07	1.037	69.9
158		-10.000	465.000	33.832	3.000	524.84	506.29	1.037	82.8
159		-1.000	456.000	20.173	2.000	242.39	233.48	1.038	37.8
160		-1.000	458.000	22.944	3.500	513.87	495.28	1.038	80.5
161		2.000	456.000	17.865	2.000	199.88	192.64	1.038	31.3
162		-3.000	459.000	24.613	3.000	439.26	423.34	1.038	68.8
163		-7.000	461.000	28.480	2.500	399.47	384.97	1.038	62.5
164		0.000	457.000	21.533	3.500	499.64	481.10	1.039	77.7
165		-2.000	458.000	22.704	2.500	324.64	312.40	1.039	50.3
166		4.000	449.000	12.409	2.500	291.73	280.82	1.039	45.3
167		-4.000	460.000	26.022	3.000	450.10	433.18	1.039	69.8
168		0.000	454.000	18.148	2.000	247.98	238.60	1.039	38.4
169		3.000	452.000	14.054	1.500	140.68	135.32	1.040	21.8
170		4.000	451.000	13.150	2.000	208.69	200.64	1.040	32.1
171		1.000	456.000	20.123	3.500	484.29	465.73	1.040	74.6
172		6.000	451.000	12.581	3.000	321.05	308.68	1.040	49.4
173		-4.000	459.000	24.887	2.500	358.06	344.18	1.040	55.0
174		3.000	453.000	15.174	2.000	210.45	202.24	1.041	32.3
175		-7.000	465.000	32.057	3.500	574.04	551.66	1.041	88.0
176		-5.000	461.000	27.432	3.000	460.41	442.44	1.041	70.6
177		-2.000	457.000	21.577	2.000	247.42	237.66	1.041	37.8

* denotes the minimum safety factor and maximum prevention force.

No.	Reg.	Circular arc requirements				Skid resistance S (kN/m)	Sliding force T (kN/m)	Safety factor Fs	Required prevention force Pr (kN/m)
		Central coordinates		Radius r (m)	Max. depth (m)				
		X (m)	Y (m)						
178		-1.000	458.000	21.944	2.500	304.61	292.51	1.041	46.5
179		4.000	452.000	13.770	2.000	203.62	195.59	1.041	31.1
180		3.000	455.000	16.455	2.000	197.12	189.11	1.042	29.9
181		2.000	454.000	16.579	2.000	216.47	207.70	1.042	32.8
182		3.000	451.000	13.934	2.000	222.19	213.32	1.042	33.8
183		7.000	449.000	10.056	2.500	241.33	231.50	1.042	36.5
184		-6.000	464.000	30.647	3.500	563.19	540.63	1.042	85.6
185		-6.000	462.000	28.843	3.000	470.22	451.47	1.042	71.6
186		0.000	451.000	16.788	2.500	373.98	358.81	1.042	56.6
187		2.000	456.000	19.365	3.500	457.82	439.16	1.042	69.2
188		-7.000	463.000	30.253	3.000	480.16	460.69	1.042	72.7
189		-8.000	462.000	29.885	2.500	407.01	390.63	1.042	61.8
190		-4.000	462.000	27.826	3.500	540.57	518.04	1.043	81.1
191		-5.000	463.000	29.236	3.500	551.78	529.10	1.043	83.2
192		-2.000	459.000	23.354	2.500	311.58	298.53	1.044	46.7
193		-1.000	458.000	22.444	3.000	404.72	387.83	1.044	60.7
194		7.000	449.000	10.556	3.000	312.23	298.97	1.044	46.6
195		-8.000	464.000	31.663	3.000	489.76	469.19	1.044	73.3
196		5.000	451.000	12.365	2.000	196.14	187.95	1.044	29.4
197		1.000	457.000	20.775	3.500	472.95	453.20	1.044	70.9
198		8.000	449.000	9.271	2.500	224.44	214.94	1.044	33.5
199		-9.000	465.000	33.073	3.000	499.19	477.64	1.045	74.0
200		1.000	455.000	17.984	2.000	222.07	212.54	1.045	33.0
201		-3.000	461.000	26.416	3.500	528.54	505.93	1.045	78.6
202		4.000	451.000	12.650	1.500	135.91	130.07	1.045	20.2
203		-1.000	459.000	23.096	3.000	390.50	373.57	1.045	57.8
204		2.000	457.000	19.017	2.500	261.76	250.37	1.045	38.7
205		2.000	450.000	14.599	2.500	333.60	319.15	1.045	49.4
206		-2.000	460.000	25.006	3.500	516.08	493.38	1.046	76.0
207		0.000	458.000	22.185	3.500	488.37	466.85	1.046	71.9
208		-5.000	460.000	26.292	2.500	365.87	349.92	1.046	54.1
209		-9.000	463.000	31.290	2.500	414.54	396.43	1.046	61.2
210		0.000	458.000	21.685	3.000	381.44	364.68	1.046	56.2
211		-3.000	460.000	24.764	2.500	318.14	303.82	1.047	46.5
212		-3.000	459.000	23.113	1.500	155.44	148.43	1.047	22.7
213		-1.000	459.000	23.596	3.500	503.12	480.36	1.047	73.4
214		7.000	448.000	9.936	3.000	312.59	298.54	1.047	45.7
215		5.000	448.000	11.005	2.500	272.75	260.47	1.047	39.9
216		-1.000	457.000	20.296	1.500	152.11	145.22	1.047	22.2
217		3.000	455.000	17.955	3.500	444.47	424.53	1.047	65.0
218		1.000	457.000	20.275	3.000	372.36	355.48	1.047	54.3
219		0.000	456.000	19.389	2.000	227.17	216.70	1.048	32.9
220		-5.000	461.000	25.932	1.500	158.14	150.85	1.048	22.9
221		4.000	454.000	15.044	2.000	194.03	185.08	1.048	28.1
222		5.000	448.000	11.505	3.000	357.55	341.20	1.048	51.9

* denotes the minimum safety factor and maximum prevention force.

No.	Reg.	Circular arc requirements				Skid resistance S (kN/m)	Sliding force T (kN/m)	Safety factor Fs	Required prevention force Pr (kN/m)
		Central coordinates		Radius r (m)	Max. depth (m)				
		X (m)	Y (m)						
223		6.000	448.000	10.220	2.500	256.07	244.31	1.048	37.2
224		-2.000	458.000	21.704	1.500	153.76	146.75	1.048	22.4
225		2.000	456.000	18.865	3.000	362.68	345.67	1.049	52.2
226		-6.000	462.000	27.343	1.500	159.41	152.00	1.049	23.0
227		0.000	459.000	22.837	3.500	475.15	452.93	1.049	68.4
228		-7.000	463.000	28.753	1.500	160.63	153.12	1.049	23.2
229		-2.000	459.000	23.854	3.000	416.99	397.48	1.049	60.0
230		-4.000	460.000	24.522	1.500	156.70	149.45	1.049	22.7
231		-6.000	461.000	27.699	2.500	373.77	356.11	1.050	53.6
232		-8.000	464.000	30.163	1.500	161.49	153.77	1.050	23.1
233		7.000	451.000	11.314	2.500	235.10	224.01	1.050	33.8
234		-10.000	464.000	32.695	2.500	421.43	401.39	1.050	60.3
235		4.000	450.000	12.530	2.000	211.77	201.65	1.050	30.3
236		1.000	455.000	17.484	1.500	148.29	141.18	1.050	21.2
237		0.000	456.000	18.889	1.500	150.18	143.06	1.050	21.5
238		-3.000	460.000	25.264	3.000	427.56	406.89	1.051	60.8
239		7.000	450.000	11.176	3.000	308.63	293.61	1.051	43.8
240		1.000	458.000	21.427	3.500	462.86	440.39	1.051	65.7
241		-1.000	460.000	24.247	3.500	489.08	465.19	1.051	69.2
242		5.000	450.000	11.745	2.000	199.75	190.13	1.051	28.5
243		-1.000	457.000	20.796	2.000	232.16	220.92	1.051	33.0
244		3.000	456.000	17.607	2.500	257.81	245.35	1.051	36.7
245		3.000	455.000	17.455	3.000	352.65	335.36	1.052	49.8
246		-6.000	465.000	31.298	3.500	548.59	521.56	1.052	77.3
247		-4.000	461.000	26.674	3.000	437.82	416.20	1.052	61.7
248		4.000	454.000	15.544	2.500	261.53	248.55	1.052	36.8
249		7.000	450.000	10.176	2.000	177.92	169.08	1.052	25.0
250		-9.000	465.000	31.573	1.500	162.28	154.26	1.052	22.9
251		1.000	450.000	15.383	2.500	357.03	339.41	1.052	50.3
252		-5.000	464.000	29.888	3.500	537.92	511.02	1.053	75.4
253		-3.000	459.000	24.113	2.500	335.52	318.56	1.053	46.8
254		-1.000	455.000	19.553	2.000	258.37	245.35	1.053	36.1
255		3.000	450.000	13.314	2.000	224.89	213.60	1.053	31.5
256		-7.000	462.000	29.106	2.500	381.35	362.21	1.053	53.4
257		-2.000	460.000	24.506	3.000	402.01	381.77	1.053	56.2
258		-5.000	462.000	28.084	3.000	447.54	425.11	1.053	62.6
259		-6.000	463.000	29.495	3.000	457.17	433.85	1.054	63.5
260		4.000	454.000	16.544	3.500	430.94	409.00	1.054	59.9
261		-4.000	463.000	28.478	3.500	526.74	499.70	1.054	72.9
262		-7.000	464.000	30.905	3.000	466.20	442.12	1.054	64.4
263		4.000	454.000	16.044	3.000	341.95	324.31	1.054	47.3
264		2.000	454.000	16.079	1.500	146.02	138.55	1.054	20.3
265		-2.000	458.000	22.204	2.000	236.84	224.54	1.055	32.7
266		7.000	448.000	9.436	2.500	241.41	228.81	1.055	33.2
267		-2.000	461.000	25.658	3.500	502.89	476.79	1.055	69.3

* denotes the minimum safety factor and maximum prevention force.

No.	Reg.	Circular arc requirements				Skid resistance S (kN/m)	Sliding force T (kN/m)	Safety factor Fs	Required prevention force Pr (kN/m)
		Central coordinates		Radius r (m)	Max. depth (m)				
		X (m)	Y (m)						
268		-8.000	465.000	32.315	3.000	474.93	450.06	1.055	65.2
269		-3.000	462.000	27.068	3.500	515.42	488.70	1.055	71.1
270		3.000	455.000	16.955	2.500	269.76	255.67	1.055	37.1
271		6.000	447.000	10.100	3.000	329.37	312.14	1.055	45.2
272		-3.000	458.000	22.982	2.000	254.21	241.05	1.055	35.1
273		-8.000	463.000	30.514	2.500	388.89	368.26	1.056	53.1
274		7.000	447.000	9.316	3.000	307.22	291.02	1.056	42.1
275		2.000	457.000	20.017	3.500	451.39	427.45	1.056	61.6
276		3.000	449.000	13.194	2.500	315.75	299.08	1.056	43.2
277		-2.000	462.000	26.311	3.500	486.71	460.90	1.056	66.4
278		5.000	453.000	13.634	2.000	190.25	179.92	1.057	25.7
279		5.000	450.000	11.245	1.500	130.56	123.56	1.057	17.8
280		-1.000	461.000	24.900	3.500	475.75	450.12	1.057	64.4
281		2.000	456.000	18.365	2.500	277.38	262.39	1.057	37.5
282		2.000	451.000	14.719	2.000	238.91	225.80	1.058	32.1
283		4.000	455.000	16.196	2.500	253.28	239.44	1.058	34.1
284		5.000	453.000	14.634	3.000	330.51	312.50	1.058	44.5
285		-4.000	460.000	25.522	2.500	344.04	325.14	1.058	46.2
286		-3.000	463.000	27.723	3.500	499.96	472.05	1.059	66.5
287		-3.000	459.000	23.613	2.000	241.37	228.03	1.059	32.3
288		1.000	456.000	18.623	2.000	215.06	202.97	1.060	28.6
289		5.000	449.000	11.125	2.000	200.49	189.23	1.060	26.6
290		-9.000	464.000	31.923	2.500	395.87	373.57	1.060	52.5
291		3.000	453.000	14.674	1.500	143.52	135.42	1.060	19.0
292		1.000	457.000	19.775	2.500	284.50	268.39	1.060	37.6
293		6.000	449.000	10.340	2.000	188.60	177.82	1.061	24.8
294		-3.000	461.000	25.916	3.000	413.95	390.26	1.061	54.4
295		8.000	448.000	8.651	2.500	225.99	213.02	1.061	29.7
296		-3.000	462.000	26.568	3.000	397.70	374.78	1.061	52.1
297		0.000	460.000	23.489	3.500	465.91	439.24	1.061	61.2
298		3.000	456.000	18.607	3.500	439.50	413.79	1.062	57.1
299		6.000	447.000	9.600	2.500	252.61	237.82	1.062	32.8
300		5.000	453.000	15.134	3.500	416.53	392.22	1.062	54.2
301		0.000	458.000	21.185	2.500	291.35	274.26	1.062	37.8
302		-4.000	460.000	25.022	2.000	245.41	231.10	1.062	32.0
303		-4.000	461.000	26.174	2.500	328.52	309.32	1.062	42.7
304		4.000	449.000	11.909	2.000	212.78	200.36	1.062	27.7
305		-5.000	461.000	26.932	2.500	352.34	331.71	1.062	45.8
306		-2.000	461.000	25.158	3.000	390.15	367.30	1.062	50.7
307		6.000	452.000	13.224	3.000	318.39	299.50	1.063	41.1
308		-10.000	465.000	33.332	2.500	403.24	379.21	1.063	51.9
309		-3.000	464.000	28.398	3.500	489.54	460.53	1.063	63.1
310		-4.000	464.000	29.135	3.500	513.25	482.66	1.063	66.0
311		1.000	452.000	16.123	2.000	252.12	237.09	1.063	32.4
312		0.000	457.000	20.033	2.000	219.94	206.91	1.063	28.4

* denotes the minimum safety factor and maximum prevention force.

No.	Reg.	Circular arc requirements				Skid resistance S (kN/m)	Sliding force T (kN/m)	Safety factor Fs	Required prevention force Pr (kN/m)
		Central coordinates		Radius r (m)	Max. depth (m)				
		X (m)	Y (m)						
313		-4.000	465.000	29.811	3.500	500.15	470.69	1.063	64.7
314		-5.000	465.000	30.547	3.500	524.63	493.39	1.063	67.5
315		7.000	447.000	8.816	2.500	236.23	222.04	1.064	30.3
316		-1.000	460.000	23.747	3.000	382.35	359.44	1.064	49.0
317		-1.000	459.000	22.596	2.500	298.17	280.25	1.064	38.2
318		-4.000	462.000	27.326	3.000	425.16	399.08	1.065	53.8
319		-2.000	455.000	20.337	2.000	281.94	264.83	1.065	35.9
320		0.000	459.000	22.337	3.000	374.36	351.52	1.065	47.5
321		-1.000	454.000	18.933	2.000	273.10	256.43	1.065	34.7
322		-5.000	461.000	26.432	2.000	249.69	234.47	1.065	31.7
323		2.000	449.000	13.981	2.500	339.68	319.00	1.065	43.2
324		1.000	459.000	22.079	3.500	455.43	427.45	1.065	57.6
325		-4.000	463.000	27.978	3.000	407.23	382.14	1.066	51.4
326		-4.000	456.000	22.526	2.000	312.64	293.30	1.066	39.4
327		-5.000	463.000	28.736	3.000	434.40	407.37	1.066	54.5
328		0.000	453.000	17.528	2.000	263.59	247.24	1.066	33.1
329		-2.000	456.000	20.957	2.000	268.27	251.67	1.066	33.8
330		-2.000	460.000	24.006	2.500	304.15	285.20	1.066	38.1
331		5.000	454.000	14.786	2.500	248.53	233.16	1.066	31.3
332		-3.000	456.000	21.742	2.000	290.10	272.19	1.066	36.6
333		8.000	448.000	9.151	3.000	294.39	276.16	1.066	37.1
334		-2.000	463.000	26.984	3.500	480.21	450.32	1.066	60.2
335		-5.000	457.000	23.931	2.000	320.53	300.79	1.066	40.5
336		-1.000	458.000	21.444	2.000	224.54	210.61	1.066	28.2
337		-4.000	457.000	23.146	2.000	297.83	279.14	1.067	37.2
338		-6.000	458.000	25.336	2.000	328.29	307.81	1.067	41.1
339		-6.000	464.000	30.147	3.000	443.32	415.47	1.067	55.3
340		1.000	458.000	20.927	3.000	366.10	343.24	1.067	45.8
341		-6.000	462.000	28.343	2.500	360.04	337.58	1.067	45.1
342		-3.000	455.000	21.122	2.000	304.20	285.00	1.067	37.8
343		-8.000	459.000	27.525	2.000	361.60	338.45	1.068	44.6
344		6.000	452.000	12.224	2.000	186.07	174.20	1.068	23.0
345		7.000	451.000	11.814	3.000	304.90	285.62	1.068	37.9
346		-7.000	465.000	31.557	3.000	451.80	423.16	1.068	56.0
347		9.000	447.000	7.247	2.500	203.59	190.63	1.068	25.2
348		8.000	450.000	10.404	3.000	288.74	270.32	1.068	35.7
349		-6.000	457.000	24.716	2.000	345.40	323.35	1.068	42.7
350		-6.000	462.000	27.843	2.000	253.62	237.48	1.068	31.4
351		-7.000	458.000	26.120	2.000	353.73	331.11	1.068	43.7
352		-7.000	459.000	26.740	2.000	335.65	314.18	1.068	41.4
353		-3.000	461.000	25.416	2.500	310.28	290.43	1.068	38.3
354		-9.000	460.000	28.929	2.000	369.27	345.45	1.069	45.3
355		2.000	457.000	19.517	3.000	357.01	333.82	1.069	43.6
356		8.000	447.000	7.531	2.000	158.18	147.97	1.069	19.4
357		8.000	448.000	8.151	2.000	165.24	154.56	1.069	20.3

* denotes the minimum safety factor and maximum prevention force.

No.	Reg.	Circular arc requirements				Skid resistance S (kN/m)	Sliding force T (kN/m)	Safety factor Fs	Required prevention force Pr (kN/m)
		Central coordinates		Radius r (m)	Max. depth (m)				
		X (m)	Y (m)						
358		8.000	449.000	9.771	3.000	294.61	275.50	1.069	36.0
359		-5.000	458.000	24.551	2.000	304.62	284.89	1.069	37.3
360		-1.000	462.000	25.571	3.500	470.28	439.40	1.070	57.0
361		-3.000	457.000	22.362	2.000	275.29	257.30	1.070	33.5
362		-2.000	459.000	22.854	2.000	228.84	213.89	1.070	27.9
363		-7.000	463.000	29.753	2.500	367.13	343.07	1.070	44.6
364		4.000	448.000	11.789	2.500	297.19	277.76	1.070	36.2
365		-5.000	456.000	23.311	2.000	336.59	314.67	1.070	41.1
366		-10.000	461.000	30.334	2.000	376.61	351.92	1.070	45.7
367		4.000	455.000	17.196	3.500	426.90	399.07	1.070	52.0
368		-2.000	454.000	19.717	2.000	294.98	275.58	1.070	35.8
369		8.000	447.000	8.531	3.000	288.76	269.81	1.070	35.1
370		-4.000	462.000	26.826	2.500	315.70	294.85	1.071	38.2
371		8.000	447.000	8.031	2.500	220.92	206.24	1.071	26.6
372		-6.000	459.000	25.956	2.000	311.01	290.34	1.071	37.4
373		2.000	458.000	20.669	3.500	444.72	415.25	1.071	53.6
374		-8.000	460.000	28.145	2.000	342.36	319.63	1.071	41.2
375		4.000	452.000	13.270	1.500	140.20	130.88	1.071	16.9
376		-4.000	455.000	21.906	2.000	327.11	305.04	1.072	39.0
377		-2.000	461.000	24.158	2.000	207.15	193.27	1.072	24.8
378		-7.000	457.000	25.500	2.000	371.58	346.69	1.072	44.5
379		6.000	452.000	13.724	3.500	401.28	374.22	1.072	47.8
380		-1.000	460.000	22.747	2.000	205.14	191.34	1.072	24.5
381		3.000	456.000	18.107	3.000	347.67	324.17	1.072	41.4
382		6.000	449.000	9.840	1.500	124.97	116.56	1.072	15.0
383		-8.000	464.000	31.163	2.500	374.63	349.25	1.073	44.5
384		-1.000	461.000	23.900	2.500	271.68	253.17	1.073	32.2
385		-3.000	460.000	24.264	2.000	232.86	216.94	1.073	27.5
386		-5.000	463.000	28.236	2.500	321.14	299.37	1.073	38.2
387		-3.000	462.000	25.568	2.000	208.69	194.56	1.073	24.8
388		-6.000	465.000	29.798	2.000	213.46	199.03	1.073	25.4
389		-5.000	464.000	28.388	2.000	212.01	197.67	1.073	25.2
390		-4.000	458.000	23.766	2.000	281.99	262.74	1.073	33.3
391		-7.000	460.000	27.360	2.000	317.26	295.63	1.073	37.5
392		0.000	459.000	21.337	2.000	202.99	189.21	1.073	24.1
393		-9.000	461.000	29.549	2.000	349.05	325.25	1.073	41.3
394		-4.000	463.000	26.978	2.000	210.42	196.19	1.073	25.1
395		-6.000	464.000	29.647	2.500	326.39	303.84	1.074	38.3
396		8.000	450.000	9.904	2.500	228.35	212.65	1.074	26.9
397		-1.000	453.000	18.312	2.000	284.97	265.26	1.074	33.4
398		-4.000	459.000	24.387	2.000	263.02	244.83	1.074	30.8
399		-9.000	465.000	32.573	2.500	381.63	354.84	1.075	44.2
400		-6.000	456.000	24.095	2.000	362.23	336.92	1.075	42.1
401		1.000	458.000	19.927	2.000	200.77	186.81	1.075	23.5
402		-10.000	462.000	30.954	2.000	355.73	330.96	1.075	41.5

* denotes the minimum safety factor and maximum prevention force.

No.	Reg.	Circular arc requirements				Skid resistance S (kN/m)	Sliding force T (kN/m)	Safety factor Fs	Required prevention force Pr (kN/m)
		Central coordinates		Radius r (m)	Max. depth (m)				
		X (m)	Y (m)						
403		0.000	461.000	24.157	3.500	460.37	428.30	1.075	53.6
404		7.000	446.000	8.696	3.000	300.90	280.00	1.075	35.1
405		6.000	448.000	9.720	2.000	187.86	174.69	1.075	21.8
406		-3.000	465.000	29.094	3.500	488.26	454.25	1.075	56.9
407		-5.000	464.000	29.388	3.000	418.26	389.26	1.075	48.9
408		-5.000	465.000	30.047	3.000	402.69	374.24	1.076	46.4
409		6.000	453.000	13.376	2.500	243.14	226.00	1.076	28.1
410		-8.000	461.000	28.765	2.000	323.08	300.22	1.076	37.2
411		-3.000	454.000	20.502	2.000	317.26	294.78	1.076	36.5
412		-5.000	462.000	27.584	2.500	338.93	314.58	1.077	38.6
413		0.000	460.000	22.489	2.500	268.88	249.59	1.077	30.7
414		7.000	448.000	8.936	2.000	176.38	163.74	1.077	20.2
415		4.000	455.000	16.696	3.000	337.74	313.48	1.077	38.5
416		-4.000	461.000	25.674	2.000	236.83	219.97	1.077	27.2
417		-4.000	464.000	28.635	3.000	395.76	367.40	1.077	45.2
418		-5.000	459.000	25.171	2.000	288.25	267.55	1.077	32.9
419		-5.000	462.000	26.584	1.500	158.45	147.05	1.078	18.1
420		-2.000	459.000	22.354	1.500	154.62	143.44	1.078	17.6
421		-1.000	458.000	20.944	1.500	153.30	142.18	1.078	17.4
422		6.000	453.000	13.876	3.000	313.62	290.92	1.078	35.5
423		-7.000	464.000	29.405	1.500	160.33	148.69	1.078	18.1
424		-4.000	461.000	25.174	1.500	157.30	145.95	1.078	17.9
425		3.000	457.000	19.259	3.500	433.47	402.14	1.078	49.1
426		-3.000	460.000	23.764	1.500	156.13	144.88	1.078	17.8
427		5.000	448.000	10.505	2.000	200.36	185.79	1.078	22.6
428		2.000	457.000	18.517	2.000	198.62	184.06	1.079	22.3
429		-5.000	455.000	22.691	2.000	352.21	326.49	1.079	39.6
430		-2.000	464.000	27.680	3.500	479.08	444.12	1.079	53.9
431		-3.000	463.000	27.223	3.000	388.67	360.28	1.079	43.7
432		-6.000	463.000	27.995	1.500	159.35	147.72	1.079	18.0
433		5.000	454.000	15.786	3.500	413.74	383.59	1.079	46.6
434		-9.000	462.000	30.169	2.000	328.83	304.57	1.080	36.7
435		-2.000	462.000	25.811	3.000	381.27	352.90	1.080	42.3
436		1.000	460.000	22.744	3.500	450.21	416.79	1.080	50.0
437		0.000	457.000	19.533	1.500	151.38	140.18	1.080	16.9
438		7.000	452.000	12.466	3.000	300.83	278.44	1.080	33.3
439		0.000	452.000	16.908	2.000	273.90	253.68	1.080	30.6
440		-5.000	462.000	27.084	2.000	240.20	222.32	1.080	26.6
441		3.000	448.000	12.582	2.500	322.12	297.93	1.081	35.4
442		-6.000	460.000	26.576	2.000	293.85	271.78	1.081	32.3
443		-8.000	465.000	30.815	1.500	160.85	148.86	1.081	17.8
444		5.000	454.000	15.286	3.000	327.32	302.63	1.082	35.9
445		-2.000	453.000	19.097	2.000	306.28	283.04	1.082	33.4
446		-6.000	465.000	30.798	3.000	428.96	396.59	1.082	47.0
447		5.000	447.000	10.385	2.500	274.96	254.20	1.082	30.1

* denotes the minimum safety factor and maximum prevention force.

No.	Reg.	Circular arc requirements				Skid resistance S (kN/m)	Sliding force T (kN/m)	Safety factor Fs	Required prevention force Pr (kN/m)
		Central coordinates		Radius r (m)	Max. depth (m)				
		X (m)	Y (m)						
448		1.000	456.000	18.123	1.500	149.45	138.15	1.082	16.4
449		-1.000	463.000	26.265	3.500	469.15	433.15	1.083	50.7
450		-1.000	461.000	24.400	3.000	374.17	345.63	1.083	40.6
451		1.000	459.000	21.079	2.500	265.60	245.34	1.083	28.9
452		-10.000	463.000	31.574	2.000	334.30	308.54	1.083	36.0
453		5.000	451.000	11.865	1.500	136.46	125.90	1.084	14.7
454		2.000	459.000	20.831	3.000	336.17	310.12	1.084	36.0
455		-6.000	463.000	28.995	2.500	347.38	320.51	1.084	37.3
456		-6.000	463.000	28.495	2.000	243.42	224.57	1.084	26.1
457		1.000	451.000	15.503	2.000	261.23	241.02	1.084	28.0
458		3.000	456.000	17.107	2.000	196.45	181.19	1.084	21.0
459		-4.000	454.000	21.286	2.000	341.22	314.66	1.084	36.4
460		0.000	460.000	22.989	3.000	366.60	337.97	1.085	39.0
461		2.000	455.000	16.713	1.500	147.20	135.69	1.085	15.7
462		7.000	451.000	10.814	2.000	180.97	166.85	1.085	19.3
463		-7.000	461.000	27.980	2.000	299.09	275.72	1.085	31.8
464		8.000	449.000	8.771	2.000	171.76	158.13	1.086	18.0
465		5.000	455.000	15.938	3.000	317.95	292.90	1.086	33.6
466		4.000	456.000	17.848	3.500	421.84	388.52	1.086	44.4
467		7.000	451.000	12.314	3.500	385.14	354.71	1.086	40.6
468		7.000	446.000	8.196	2.500	230.48	212.19	1.086	24.2
469		1.000	458.000	20.427	2.500	278.56	256.42	1.086	29.2
470		-7.000	464.000	30.405	2.500	354.34	325.91	1.087	36.8
471		2.000	459.000	21.331	3.500	439.42	404.38	1.087	45.9
472		9.000	448.000	8.367	3.000	275.27	253.24	1.087	28.7
473		0.000	459.000	21.837	2.500	284.65	261.78	1.087	29.5
474		-5.000	454.000	22.082	2.000	368.06	338.29	1.088	37.9
475		1.000	459.000	21.579	3.000	358.49	329.49	1.088	36.9
476		0.000	462.000	24.851	3.500	459.50	422.16	1.088	47.1
477		-3.000	453.000	19.883	2.000	329.24	302.49	1.088	33.8
478		8.000	446.000	7.911	3.000	281.58	258.71	1.088	28.9
479		-1.000	452.000	17.692	2.000	294.41	270.68	1.088	30.5
480		-5.000	460.000	25.792	2.000	271.01	248.76	1.089	27.6
481		9.000	446.000	6.127	2.000	141.27	129.68	1.089	14.4
482		-1.000	460.000	23.247	2.500	290.56	266.76	1.089	29.6
483		9.000	448.000	7.867	2.500	214.42	196.97	1.089	22.0
484		2.000	450.000	14.099	2.000	247.65	227.33	1.089	25.2
485		7.000	447.000	7.816	1.500	109.93	100.99	1.089	11.3
486		-8.000	462.000	29.385	2.000	304.22	279.43	1.089	31.1
487		2.000	458.000	19.669	2.500	262.27	240.93	1.089	26.9
488		-7.000	464.000	29.905	2.000	247.01	226.69	1.090	25.1
489		-2.000	465.000	28.396	3.500	481.64	441.89	1.090	48.7
490		-2.000	461.000	24.658	2.500	296.18	271.68	1.090	29.9
491		6.000	453.000	14.376	3.500	399.47	366.49	1.090	40.4
492		3.000	454.000	15.303	1.500	144.58	132.68	1.090	14.7

* denotes the minimum safety factor and maximum prevention force.

No.	Reg.	Circular arc requirements				Skid resistance S (kN/m)	Sliding force T (kN/m)	Safety factor Fs	Required prevention force Pr (kN/m)
		Central coordinates		Radius r (m)	Max. depth (m)				
		X (m)	Y (m)						
493		8.000	446.000	7.411	2.500	214.24	196.56	1.090	21.7
494		-8.000	465.000	31.815	2.500	361.08	331.34	1.090	36.6
495		7.000	452.000	11.966	2.500	237.31	217.64	1.090	23.9
496		9.000	447.000	7.747	3.000	271.00	248.44	1.091	27.2
497		2.000	458.000	20.169	3.000	350.50	321.25	1.091	35.0
498		3.000	449.000	12.694	2.000	232.24	212.73	1.092	23.1
499		-9.000	463.000	30.790	2.000	308.87	282.80	1.092	30.5
500		6.000	446.000	8.981	2.500	249.43	228.42	1.092	24.7
501		-7.000	465.000	31.057	2.500	336.52	308.10	1.092	33.2
502		4.000	455.000	15.696	2.000	193.63	177.37	1.092	19.3
503		4.000	456.000	17.348	3.000	330.42	302.65	1.092	32.8
504		-3.000	462.000	26.068	2.500	301.63	276.31	1.092	30.0
505		-4.000	453.000	20.685	2.000	357.03	326.67	1.093	35.0
506		-4.000	463.000	27.478	2.500	306.71	280.56	1.093	30.0
507		0.000	465.000	27.064	3.500	469.02	428.67	1.094	45.4
508		-5.000	464.000	28.888	2.500	311.68	284.87	1.094	30.2
509		1.000	461.000	23.437	3.500	449.41	410.68	1.094	43.5
510		-1.000	464.000	26.982	3.500	472.61	431.82	1.094	45.6
511		-4.000	465.000	29.311	3.000	390.31	356.75	1.094	37.8
512		-2.000	452.000	18.481	2.000	317.20	289.91	1.094	30.7
513		0.000	462.000	24.351	3.000	350.69	320.48	1.094	33.9
514		0.000	451.000	16.288	2.000	281.68	257.41	1.094	27.3
515		3.000	458.000	19.918	3.500	428.52	391.78	1.094	41.7
516		-7.000	463.000	29.253	2.000	262.86	240.36	1.094	25.6
517		-6.000	461.000	27.199	2.000	276.32	252.48	1.094	26.7
518		3.000	458.000	19.418	3.000	330.75	302.10	1.095	31.8
519		-10.000	464.000	32.195	2.000	313.42	286.21	1.095	30.1
520		1.000	463.000	24.896	3.500	453.07	413.74	1.095	43.5
521		3.000	457.000	18.759	3.000	341.87	312.07	1.095	32.7
522		-8.000	465.000	31.315	2.000	250.49	228.84	1.095	24.2
523		4.000	448.000	11.289	2.000	216.09	197.10	1.096	20.5
524		-3.000	464.000	27.898	3.000	383.12	349.52	1.096	36.4
525		5.000	455.000	16.438	3.500	409.74	373.95	1.096	39.0
526		3.000	457.000	18.259	2.500	258.37	235.69	1.096	24.5
527		-6.000	465.000	30.298	2.500	316.15	288.37	1.096	29.9
528		-4.000	465.000	28.811	2.500	281.53	256.82	1.096	26.7
529		6.000	450.000	10.460	1.500	131.12	119.53	1.097	12.4
530		9.000	446.000	6.627	2.500	198.38	180.79	1.097	18.6
531		4.000	453.000	13.894	1.500	141.53	128.95	1.098	13.3
532		-2.000	463.000	26.484	3.000	376.06	342.40	1.098	34.9
533		7.000	448.000	8.436	1.500	118.50	107.81	1.099	10.9
534		5.000	454.000	14.286	2.000	190.67	173.46	1.099	17.5
535		7.000	447.000	8.316	2.000	174.01	158.37	1.099	16.1
536		-7.000	462.000	28.606	2.000	281.63	256.35	1.099	26.0
537		0.000	463.000	25.569	3.500	463.11	420.98	1.100	42.1

* denotes the minimum safety factor and maximum prevention force.

No.	Reg.	Circular arc requirements				Skid resistance S (kN/m)	Sliding force T (kN/m)	Safety factor Fs	Required prevention force Pr (kN/m)
		Central coordinates		Radius r (m)	Max. depth (m)				
		X (m)	Y (m)						
538		-1.000	465.000	27.719	3.500	477.17	433.76	1.100	43.4
539		-3.000	452.000	19.290	2.000	345.68	314.36	1.100	31.6
540		-3.000	464.000	27.398	2.500	278.94	253.53	1.100	25.3
541		9.000	449.000	8.993	3.000	277.59	252.16	1.101	25.1
542		-1.000	462.000	25.071	3.000	368.46	334.56	1.101	33.1
543		2.000	460.000	22.023	3.500	438.96	398.77	1.101	39.6
544		-2.000	465.000	27.896	3.000	367.42	333.34	1.102	32.6
545		6.000	454.000	14.528	3.000	311.27	282.38	1.102	27.6
546		-1.000	451.000	17.082	2.000	304.96	276.78	1.102	27.2
547		-8.000	463.000	30.014	2.000	286.66	260.07	1.102	25.5
548		4.000	457.000	18.505	3.500	416.87	378.06	1.103	36.9
549		8.000	450.000	10.904	3.500	368.23	333.78	1.103	32.4
550		1.000	450.000	14.883	2.000	268.35	243.21	1.103	23.6
551		1.000	461.000	22.937	3.000	345.94	313.42	1.104	30.2
552		-5.000	463.000	27.736	2.000	231.36	209.54	1.104	20.1
553		7.000	452.000	12.966	3.500	384.84	348.47	1.104	33.4
554		4.000	458.000	19.194	3.500	412.14	373.16	1.104	35.7
555		-2.000	463.000	25.984	2.500	275.79	249.50	1.105	23.7
556		3.000	460.000	21.328	3.500	427.24	386.55	1.105	36.7
557		4.000	447.000	11.189	2.500	303.45	274.60	1.105	26.1
558		6.000	447.000	9.100	2.000	186.73	169.00	1.105	16.1
559		8.000	451.000	11.056	3.000	292.33	264.57	1.105	25.2
560		9.000	447.000	6.747	2.000	152.85	138.35	1.105	13.2
561		4.000	456.000	16.848	2.500	254.27	230.01	1.105	21.8
562		0.000	461.000	23.657	3.000	361.10	326.83	1.105	31.1
563		-9.000	464.000	31.423	2.000	291.60	263.64	1.106	24.8
564		5.000	452.000	12.486	1.500	138.50	125.19	1.106	11.8
565		1.000	464.000	25.654	3.500	464.56	420.16	1.106	39.7
566		1.000	462.000	24.155	3.500	453.50	409.85	1.107	38.4
567		5.000	447.000	9.885	2.000	199.26	180.08	1.107	16.9
568		-2.000	451.000	17.899	2.000	334.56	302.27	1.107	28.2
569		0.000	464.000	26.307	3.500	469.00	423.51	1.107	39.3
570		6.000	454.000	15.028	3.500	396.68	357.98	1.108	32.9
571		1.000	460.000	22.244	3.000	353.31	318.84	1.108	29.3
572		4.000	457.000	18.005	3.000	325.04	293.34	1.108	27.0
573		8.000	450.000	9.404	2.000	175.02	157.85	1.109	14.4
574		3.000	459.000	20.608	3.500	428.36	386.32	1.109	35.3
575		5.000	456.000	17.093	3.500	403.65	363.93	1.109	33.1
576		2.000	462.000	23.485	3.500	447.63	403.71	1.109	36.9
577		9.000	446.000	7.127	3.000	263.00	237.22	1.109	21.7
578		6.000	455.000	15.681	3.500	387.60	349.57	1.109	31.9
579		-6.000	464.000	29.147	2.000	234.69	211.52	1.110	19.2
580		-10.000	465.000	32.832	2.000	296.27	267.03	1.110	24.2
581		-1.000	464.000	26.482	3.000	363.10	326.98	1.110	29.3
582		2.000	461.000	22.742	3.500	442.09	398.36	1.110	36.0

* denotes the minimum safety factor and maximum prevention force.

No.	Reg.	Circular arc requirements				Skid resistance S (kN/m)	Sliding force T (kN/m)	Safety factor Fs	Required prevention force Pr (kN/m)
		Central coordinates		Radius r (m)	Max. depth (m)				
		X (m)	Y (m)						
583		-1.000	462.000	24.571	2.500	272.64	245.35	1.111	21.8
584		6.000	453.000	12.876	2.000	187.02	168.35	1.111	15.0
585		-3.000	465.000	28.594	3.000	381.47	342.99	1.112	30.2
586		9.000	449.000	8.493	2.500	220.06	197.98	1.112	17.6
587		0.000	450.000	15.686	2.000	292.54	263.07	1.112	23.2
588		-3.000	461.000	24.416	1.500	155.28	139.47	1.113	12.1
589		-2.000	460.000	23.006	1.500	154.16	138.45	1.113	12.0
590		-4.000	462.000	25.826	1.500	156.14	140.23	1.113	12.2
591		8.000	451.000	10.556	2.500	231.13	207.61	1.113	18.1
592		-5.000	463.000	27.236	1.500	157.06	141.14	1.113	12.4
593		2.000	465.000	26.264	4.000	571.27	512.84	1.114	44.2
594		2.000	460.000	21.523	3.000	340.87	305.90	1.114	26.3
595		8.000	446.000	6.911	2.000	155.55	139.61	1.114	12.0
596		-1.000	459.000	21.596	1.500	152.96	137.29	1.114	11.8
597		-6.000	464.000	28.647	1.500	157.61	141.53	1.114	12.3
598		-7.000	465.000	30.557	2.000	238.07	213.78	1.114	18.5
599		-7.000	465.000	30.057	1.500	158.34	142.14	1.114	12.3
600		7.000	453.000	13.618	3.500	380.00	341.03	1.114	29.3
601		-2.000	462.000	25.311	2.500	288.10	258.33	1.115	21.9
602		-2.000	464.000	27.180	3.000	374.28	335.49	1.116	28.4
603		2.000	449.000	13.481	2.000	254.49	227.99	1.116	19.1
604		5.000	455.000	15.438	2.500	249.53	223.68	1.116	18.9
605		-5.000	465.000	29.047	2.000	210.66	188.75	1.116	15.9
606		0.000	458.000	20.185	1.500	151.39	135.61	1.116	11.4
607		7.000	445.000	7.584	2.500	224.79	201.43	1.116	17.0
608		5.000	457.000	17.780	3.500	401.76	360.11	1.116	30.4
609		-3.000	463.000	26.723	2.500	292.84	262.40	1.116	22.1
610		0.000	461.000	23.157	2.500	269.39	241.18	1.117	20.1
611		-4.000	464.000	28.135	2.500	297.95	266.78	1.117	22.2
612		-4.000	464.000	27.635	2.000	209.09	187.19	1.117	15.6
613		-8.000	464.000	30.663	2.000	271.89	243.36	1.117	20.2
614		-1.000	450.000	16.513	2.000	323.27	289.51	1.117	24.2
615		-5.000	465.000	29.547	2.500	302.94	271.27	1.117	22.6
616		7.000	449.000	9.056	1.500	125.28	112.20	1.117	9.4
617		8.000	451.000	11.556	3.500	367.04	328.35	1.118	27.0
618		7.000	446.000	7.696	2.000	168.38	150.43	1.119	12.2
619		2.000	463.000	24.244	3.500	459.37	410.67	1.119	33.5
620		1.000	465.000	26.414	3.500	474.33	423.79	1.119	34.3
621		-1.000	463.000	25.765	3.000	367.34	328.35	1.119	26.7
622		-3.000	463.000	26.223	2.000	207.26	185.26	1.119	15.1
623		0.000	463.000	25.069	3.000	358.55	320.33	1.119	25.9
624		5.000	446.000	9.803	2.500	280.78	250.75	1.120	20.2
625		4.000	459.000	19.915	3.500	419.93	374.98	1.120	30.1
626		1.000	457.000	18.775	1.500	149.66	133.62	1.120	10.7
627		-2.000	462.000	24.811	2.000	205.49	183.39	1.121	14.6

* denotes the minimum safety factor and maximum prevention force.

No.	Reg.	Circular arc requirements				Skid resistance S (kN/m)	Sliding force T (kN/m)	Safety factor Fs	Required prevention force Pr (kN/m)
		Central coordinates		Radius r (m)	Max. depth (m)				
		X (m)	Y (m)						
628		-9.000	465.000	32.073	2.000	276.70	246.76	1.121	19.5
629		2.000	456.000	17.365	1.500	147.74	131.69	1.122	10.3
630		3.000	461.000	22.074	3.500	440.94	392.82	1.122	30.5
631		-1.000	461.000	23.400	2.000	203.41	181.14	1.123	14.0
632		8.000	445.000	6.791	2.500	206.89	184.28	1.123	14.3
633		7.000	453.000	13.118	3.000	304.09	270.77	1.123	20.9
634		5.000	456.000	16.593	3.000	318.96	283.91	1.123	21.8
635		-2.000	456.000	20.457	1.500	182.27	162.31	1.123	12.6
636		9.000	449.000	9.493	3.500	347.90	309.74	1.123	23.8
637		4.000	462.000	22.684	4.000	549.40	489.44	1.123	38.0
638		6.000	451.000	11.081	1.500	134.85	120.00	1.124	9.2
639		1.000	460.000	21.744	2.500	265.89	236.54	1.124	18.0
640		0.000	454.000	17.648	1.500	173.30	154.04	1.125	11.6
641		-1.000	455.000	19.053	1.500	177.96	158.23	1.125	12.0
642		8.000	446.000	6.411	1.500	101.10	89.84	1.125	6.8
643		0.000	460.000	21.989	2.000	201.43	179.10	1.125	13.5
644		-3.000	457.000	21.862	1.500	186.08	165.31	1.126	12.3
645		3.000	455.000	15.955	1.500	145.68	129.38	1.126	9.6
646		7.000	452.000	11.466	2.000	182.58	162.18	1.126	12.1
647		1.000	449.000	14.294	2.000	280.40	249.05	1.126	18.5
648		10.000	447.000	6.962	3.000	254.04	225.71	1.126	16.9
649		3.000	464.000	24.854	4.000	565.11	501.37	1.127	36.6
650		3.000	459.000	20.108	3.000	335.37	297.57	1.127	21.8
651		2.000	452.000	14.839	1.500	161.07	142.87	1.127	10.4
652		1.000	459.000	20.579	2.000	199.26	176.74	1.127	12.9
653		1.000	453.000	16.243	1.500	167.71	148.64	1.128	10.7
654		3.000	451.000	13.434	1.500	153.79	136.35	1.128	9.9
655		-4.000	458.000	23.266	1.500	189.53	167.97	1.128	12.1
656		6.000	454.000	14.028	2.500	244.14	216.27	1.129	15.4
657		0.000	449.000	15.132	2.000	311.88	276.35	1.129	19.8
658		9.000	445.000	5.506	2.000	134.50	119.06	1.130	8.4
659		6.000	446.000	8.481	2.000	182.67	161.70	1.130	11.4
660		1.000	462.000	23.655	3.000	353.64	313.05	1.130	22.1
661		10.000	446.000	5.842	2.500	185.45	164.05	1.130	11.5
662		2.000	458.000	19.169	2.000	196.83	174.10	1.131	12.1
663		3.000	448.000	12.082	2.000	239.83	212.00	1.131	14.6
664		-1.000	454.000	18.433	1.500	184.78	163.32	1.131	11.3
665		4.000	450.000	12.030	1.500	146.21	129.28	1.131	9.0
666		4.000	454.000	14.544	1.500	143.07	126.45	1.131	8.7
667		2.000	464.000	25.004	3.500	469.32	414.73	1.132	28.4
668		-1.000	465.000	27.219	3.000	373.05	329.54	1.132	22.4
669		-5.000	459.000	24.671	1.500	192.80	170.34	1.132	11.7
670		8.000	452.000	12.207	3.500	365.98	322.91	1.133	21.6
671		0.000	453.000	17.028	1.500	178.15	157.29	1.133	10.6
672		3.000	462.000	22.834	3.500	454.00	400.63	1.133	26.8

* denotes the minimum safety factor and maximum prevention force.

No.	Reg.	Circular arc requirements				Skid resistance S (kN/m)	Sliding force T (kN/m)	Safety factor Fs	Required prevention force Pr (kN/m)
		Central coordinates		Radius r (m)	Max. depth (m)				
		X (m)	Y (m)						
673		2.000	459.000	20.331	2.500	261.92	231.14	1.133	15.5
674		1.000	452.000	15.623	1.500	171.16	150.95	1.134	10.0
675		7.000	454.000	14.270	3.500	378.73	333.91	1.134	22.0
676		-3.000	465.000	28.094	2.500	282.01	248.75	1.134	16.5
677		10.000	446.000	6.342	3.000	244.44	215.31	1.135	14.0
678		-6.000	460.000	26.076	1.500	195.78	172.46	1.135	11.2
679		3.000	457.000	17.759	2.000	193.99	170.91	1.135	11.2
680		9.000	450.000	9.645	3.000	282.39	248.63	1.136	16.0
681		9.000	448.000	7.367	2.000	163.42	143.80	1.136	9.2
682		6.000	456.000	16.366	3.500	393.03	345.63	1.137	21.8
683		6.000	445.000	8.430	2.500	257.37	226.39	1.137	14.3
684		2.000	451.000	14.219	1.500	163.91	144.10	1.137	9.1
685		9.000	445.000	6.006	2.500	191.45	168.26	1.138	10.5
686		5.000	458.000	18.502	3.500	412.07	361.93	1.139	22.3
687		-2.000	464.000	26.680	2.500	279.16	245.00	1.139	14.9
688		9.000	450.000	10.145	3.500	349.14	306.57	1.139	18.8
689		5.000	449.000	10.625	1.500	137.81	120.98	1.139	7.4
690		4.000	460.000	20.664	3.500	433.87	381.00	1.139	23.4
691		5.000	453.000	13.134	1.500	140.25	123.18	1.139	7.6
692		4.000	456.000	16.348	2.000	191.05	167.68	1.139	10.2
693		5.000	461.000	21.274	4.000	541.74	475.47	1.139	28.9
694		9.000	445.000	6.506	3.000	254.33	222.98	1.141	13.3
695		4.000	458.000	18.694	3.000	329.30	288.58	1.141	17.0
696		2.000	461.000	22.242	3.000	348.42	305.31	1.141	18.0
697		0.000	464.000	25.807	3.000	368.67	323.09	1.141	19.1
698		4.000	463.000	23.444	4.000	558.36	489.24	1.141	28.8
699		2.000	448.000	12.908	2.000	267.12	234.13	1.141	13.9
700		1.000	448.000	13.760	2.000	300.49	263.18	1.142	15.4
701		-2.000	455.000	19.837	1.500	192.96	168.93	1.142	9.8
702		8.000	445.000	6.291	2.000	148.76	130.28	1.142	7.6
703		6.000	455.000	15.181	3.000	312.43	273.55	1.142	15.9
704		3.000	458.000	18.918	2.500	257.75	225.61	1.142	13.0
705		10.000	447.000	6.462	2.500	198.45	173.45	1.144	9.7
706		8.000	447.000	7.031	1.500	111.26	97.28	1.144	5.5
707		3.000	450.000	12.814	1.500	155.83	136.27	1.144	7.7
708		7.000	453.000	12.618	2.500	238.34	208.21	1.145	11.6
709		4.000	447.000	10.689	2.000	223.57	195.31	1.145	10.9
710		-6.000	461.000	26.699	1.500	184.70	161.31	1.145	8.9
711		9.000	450.000	9.145	2.500	223.82	195.39	1.146	10.7
712		8.000	451.000	10.056	2.000	177.27	154.62	1.146	8.3
713		3.000	463.000	23.594	3.500	463.74	404.74	1.146	22.0
714		-1.000	463.000	25.265	2.500	275.79	240.43	1.147	12.8
715		2.000	465.000	25.764	3.500	477.09	415.52	1.148	21.6
716		7.000	450.000	9.676	1.500	130.08	113.29	1.148	5.9
717		3.000	465.000	25.623	4.000	573.48	499.75	1.148	26.3

* denotes the minimum safety factor and maximum prevention force.

No.	Reg.	Circular arc requirements				Skid resistance S (kN/m)	Sliding force T (kN/m)	Safety factor Fs	Required prevention force Pr (kN/m)
		Central coordinates		Radius r (m)	Max. depth (m)				
		X (m)	Y (m)						
718		9.000	449.000	7.993	2.000	167.94	146.33	1.148	7.7
719		5.000	455.000	14.938	2.000	188.38	163.99	1.149	8.5
720		-7.000	462.000	28.106	1.500	187.25	162.92	1.149	8.3
721		10.000	445.000	5.222	2.500	174.41	151.72	1.150	7.7
722		8.000	452.000	11.707	3.000	295.74	257.24	1.150	13.0
723		7.000	445.000	7.084	2.000	163.81	142.33	1.151	7.0
724		8.000	448.000	7.651	1.500	118.29	102.77	1.151	5.1
725		6.000	452.000	11.724	1.500	136.74	118.79	1.151	5.9
726		4.000	461.000	21.424	3.500	447.73	389.09	1.151	19.2
727		-6.000	465.000	29.298	1.500	154.80	134.34	1.152	6.5
728		1.000	463.000	24.396	3.000	363.93	315.66	1.153	14.9
729		-4.000	463.000	26.478	1.500	153.49	133.07	1.153	6.2
730		4.000	457.000	17.505	2.500	253.81	220.22	1.153	10.5
731		4.000	449.000	11.409	1.500	147.32	127.63	1.154	5.9
732		-5.000	464.000	27.888	1.500	154.05	133.51	1.154	6.2
733		6.000	448.000	9.220	1.500	128.54	111.34	1.154	5.1
734		10.000	448.000	7.584	3.000	264.75	229.16	1.155	10.3
735		3.000	460.000	20.828	3.000	342.84	296.86	1.155	13.4
736		-3.000	462.000	25.068	1.500	152.60	132.12	1.155	6.0
737		-8.000	463.000	29.514	1.500	189.63	164.24	1.155	7.5
738		0.000	462.000	23.851	2.500	272.32	235.87	1.155	10.8
739		-2.000	461.000	23.658	1.500	151.73	131.30	1.156	5.9
740		2.000	450.000	13.599	1.500	166.55	143.92	1.157	6.2
741		5.000	446.000	9.303	2.000	206.68	178.62	1.157	7.7
742		5.000	459.000	19.254	3.500	426.02	368.23	1.157	15.9
743		5.000	462.000	22.035	4.000	551.02	476.13	1.157	20.4
744		10.000	448.000	8.084	3.500	326.51	282.18	1.157	12.2
745		-1.000	460.000	22.247	1.500	150.61	130.02	1.158	5.5
746		3.000	447.000	11.530	2.000	253.70	218.89	1.159	9.0
747		6.000	460.000	19.864	4.000	533.14	459.86	1.159	18.7
748		5.000	457.000	17.280	3.000	322.61	278.47	1.159	11.6
749		-9.000	464.000	30.923	1.500	192.03	165.73	1.159	6.9
750		0.000	465.000	26.564	3.000	381.12	328.66	1.160	13.3
751		6.000	457.000	17.090	3.500	403.51	347.75	1.160	13.8
752		9.000	445.000	5.006	1.500	89.21	76.92	1.160	3.1
753		0.000	459.000	20.837	1.500	149.45	128.79	1.160	5.1
754		6.000	454.000	13.528	2.000	184.96	159.25	1.161	6.2
755		-4.000	465.000	28.311	2.000	208.94	179.75	1.162	6.8
756		4.000	462.000	22.184	3.500	457.35	393.62	1.162	15.0
757		4.000	464.000	24.218	4.000	567.52	488.46	1.162	18.7
758		-7.000	459.000	25.740	1.000	107.02	92.07	1.162	3.5
759		3.000	464.000	24.354	3.500	471.26	405.58	1.162	15.5
760		1.000	458.000	19.427	1.500	148.12	127.44	1.162	4.9
761		6.000	445.000	7.930	2.000	188.04	161.66	1.163	6.0
762		1.000	461.000	22.437	2.500	268.76	231.06	1.163	8.6

* denotes the minimum safety factor and maximum prevention force.

No.	Reg.	Circular arc requirements				Skid resistance S (kN/m)	Sliding force T (kN/m)	Safety factor Fs	Required prevention force Pr (kN/m)
		Central coordinates		Radius r (m)	Max. depth (m)				
		X (m)	Y (m)						
763		7.000	455.000	14.952	3.500	383.63	329.92	1.163	12.3
764		-10.000	465.000	32.332	1.500	194.25	166.99	1.163	6.2
765		2.000	447.000	12.353	2.000	282.23	242.44	1.164	8.7
766		-3.000	455.000	20.122	1.000	97.47	83.69	1.165	3.0
767		7.000	454.000	13.770	3.000	304.88	261.77	1.165	9.3
768		8.000	453.000	12.859	3.500	368.79	316.44	1.165	11.0
769		2.000	462.000	22.985	3.000	358.82	308.04	1.165	10.9
770		8.000	452.000	11.207	2.500	231.69	198.95	1.165	7.1
771		1.000	451.000	15.003	1.500	177.73	152.57	1.165	5.4
772		-3.000	464.000	26.898	2.000	206.97	177.52	1.166	6.1
773		5.000	448.000	10.005	1.500	137.39	117.81	1.166	4.0
774		5.000	456.000	16.093	2.500	248.73	213.33	1.166	7.3
775		2.000	457.000	18.017	1.500	146.70	125.85	1.166	4.4
776		10.000	448.000	7.084	2.500	208.45	178.64	1.167	6.0
777		-3.000	456.000	21.242	1.500	202.27	173.16	1.168	5.6
778		3.000	449.000	12.194	1.500	157.28	134.66	1.168	4.4
779		-2.000	463.000	25.484	2.000	204.85	175.17	1.169	5.4
780		3.000	456.000	16.607	1.500	144.71	123.75	1.169	3.8
781		4.000	459.000	19.415	3.000	337.11	288.11	1.170	8.7
782		7.000	451.000	10.314	1.500	132.48	113.21	1.170	3.4
783		-10.000	462.000	29.954	1.000	112.48	96.16	1.170	3.0
784		10.000	446.000	5.342	2.000	138.35	118.15	1.171	3.5
785		1.000	464.000	25.154	3.000	376.57	321.61	1.171	9.4
786		5.000	460.000	20.014	3.500	440.65	376.26	1.171	10.9
787		-2.000	465.000	27.396	2.500	284.09	242.43	1.172	6.9
788		9.000	451.000	10.797	3.500	354.72	302.28	1.173	8.1
789		10.000	445.000	5.722	3.000	235.45	200.75	1.173	5.5
790		-1.000	462.000	24.071	2.000	202.72	172.73	1.174	4.6
791		2.000	460.000	21.023	2.500	264.45	225.29	1.174	5.9
792		-2.000	455.000	19.337	1.000	100.13	85.22	1.175	2.2
793		8.000	449.000	8.271	1.500	123.84	105.41	1.175	2.7
794		7.000	453.000	12.118	2.000	180.95	153.81	1.176	3.7
795		10.000	445.000	4.722	2.000	126.55	107.58	1.176	2.6
796		9.000	450.000	8.645	2.000	170.92	145.33	1.176	3.5
797		6.000	461.000	20.627	4.000	542.60	461.40	1.176	11.1
798		-5.000	458.000	23.551	1.000	107.07	91.04	1.176	2.2
799		4.000	463.000	22.944	3.500	465.09	395.08	1.177	9.1
800		4.000	455.000	15.196	1.500	142.44	120.99	1.177	2.8
801		-10.000	463.000	30.574	1.000	113.70	96.54	1.178	2.2
802		5.000	463.000	22.814	4.000	560.87	476.14	1.178	10.5
803		6.000	458.000	17.844	3.500	418.04	354.98	1.178	8.0
804		0.000	452.000	16.408	1.500	189.38	160.74	1.178	3.6
805		3.000	461.000	21.574	3.000	353.55	300.11	1.178	6.6
806		-9.000	462.000	29.169	1.000	112.88	95.78	1.179	2.1
807		0.000	461.000	22.657	2.000	200.26	169.92	1.179	3.7

* denotes the minimum safety factor and maximum prevention force.

No.	Reg.	Circular arc requirements				Skid resistance S (kN/m)	Sliding force T (kN/m)	Safety factor Fs	Required prevention force Pr (kN/m)
		Central coordinates		Radius r (m)	Max. depth (m)				
		X (m)	Y (m)						
808		6.000	456.000	15.866	3.000	315.59	267.78	1.179	5.8
809		-9.000	460.000	28.429	1.500	266.99	226.42	1.179	4.8
810		-10.000	461.000	29.834	1.500	272.22	230.85	1.179	4.8
811		-10.000	460.000	29.214	1.500	290.72	246.61	1.179	5.3
812		3.000	465.000	25.123	3.500	478.73	405.81	1.180	8.3
813		-8.000	459.000	27.025	1.500	261.49	221.56	1.180	4.4
814		5.000	461.000	20.774	3.500	450.44	381.70	1.180	7.6
815		-1.000	464.000	25.982	2.500	280.79	237.97	1.180	4.8
816		0.000	452.000	15.908	1.000	88.23	74.77	1.180	1.5
817		-7.000	459.000	26.240	1.500	240.65	203.74	1.181	3.9
818		-7.000	461.000	27.480	1.500	205.72	174.25	1.181	3.4
819		7.000	459.000	18.454	4.000	523.21	442.80	1.182	8.2
820		1.000	465.000	25.914	3.000	385.64	326.24	1.182	5.9
821		-4.000	457.000	22.646	1.500	210.61	178.18	1.182	3.3
822		-7.000	458.000	25.620	1.500	255.50	216.13	1.182	3.9
823		-7.000	460.000	26.360	1.000	110.83	93.76	1.182	1.7
824		4.000	446.000	10.164	2.000	240.98	203.89	1.182	3.7
825		4.000	448.000	10.789	1.500	147.07	124.40	1.182	2.3
826		-8.000	460.000	27.645	1.500	245.45	207.66	1.182	3.8
827		6.000	447.000	8.600	1.500	126.47	107.00	1.182	2.0
828		6.000	455.000	14.681	2.500	243.44	205.89	1.182	3.7
829		-6.000	458.000	24.836	1.500	235.46	199.13	1.182	3.5
830		-9.000	459.000	27.809	1.500	284.41	240.47	1.183	4.2
831		-9.000	461.000	29.049	1.500	250.01	211.35	1.183	3.7
832		9.000	451.000	10.297	3.000	286.41	242.06	1.183	4.1
833		5.000	454.000	13.786	1.500	140.05	118.39	1.183	2.1
834		-5.000	458.000	24.051	1.500	215.90	182.37	1.184	3.0
835		2.000	463.000	23.744	3.000	371.12	313.49	1.184	5.1
836		-9.000	458.000	27.189	1.500	300.27	253.51	1.184	4.0
837		-5.000	457.000	23.431	1.500	229.92	194.18	1.184	3.1
838		1.000	460.000	21.244	2.000	197.68	166.96	1.184	2.7
839		-10.000	462.000	30.454	1.500	254.22	214.70	1.184	3.5
840		10.000	447.000	5.962	2.000	148.90	125.71	1.184	2.0
841		4.000	465.000	25.010	4.000	578.12	488.43	1.184	8.0
842		-6.000	457.000	24.216	1.500	249.35	210.40	1.185	3.2
843		3.000	459.000	19.608	2.500	260.24	219.58	1.185	3.3
844		-8.000	458.000	26.405	1.500	277.59	234.26	1.185	3.6
845		9.000	446.000	5.627	1.500	100.73	84.99	1.185	1.3
846		7.000	456.000	15.677	3.500	394.11	332.40	1.186	4.8
847		10.000	449.000	8.235	3.000	272.06	229.31	1.186	3.2
848		-6.000	459.000	25.456	1.500	220.90	186.24	1.186	2.6
849		-7.000	457.000	25.000	1.500	269.88	227.56	1.186	3.2
850		-5.000	456.000	22.811	1.500	242.05	203.90	1.187	2.7
851		-3.000	455.000	20.622	1.500	216.35	182.20	1.187	2.3
852		-8.000	457.000	25.785	1.500	292.25	246.26	1.187	3.3

* denotes the minimum safety factor and maximum prevention force.

No.	Reg.	Circular arc requirements				Skid resistance S (kN/m)	Sliding force T (kN/m)	Safety factor Fs	Required prevention force Pr (kN/m)
		Central coordinates		Radius r (m)	Max. depth (m)				
		X (m)	Y (m)						
853		-4.000	456.000	22.026	1.500	223.89	188.64	1.187	2.5
854		-1.000	453.000	17.812	1.500	200.21	168.52	1.188	2.1
855		2.000	450.000	13.099	1.000	79.59	66.98	1.188	0.8
856		-6.000	456.000	23.595	1.500	261.99	220.46	1.188	2.6
857		-2.000	454.000	19.217	1.500	208.56	175.53	1.188	2.1
858		1.000	452.000	15.123	1.000	91.22	76.73	1.189	0.9
859		5.000	458.000	18.002	3.000	330.43	278.01	1.189	3.2
860		2.000	459.000	19.831	2.000	195.16	164.18	1.189	1.9
861		0.000	463.000	24.569	2.500	277.38	233.33	1.189	2.7
862		-7.000	460.000	26.860	1.500	225.26	189.50	1.189	2.2
863		-4.000	455.000	21.406	1.500	234.54	197.13	1.190	2.1
864		-7.000	456.000	24.382	1.500	284.44	238.98	1.190	2.4
865		9.000	451.000	9.797	2.500	224.29	188.51	1.190	2.0
866		-5.000	455.000	22.191	1.500	253.84	213.09	1.191	1.9
867		8.000	453.000	12.359	3.000	296.79	248.91	1.192	2.0
868		-8.000	461.000	28.265	1.500	229.59	192.64	1.192	1.6
869		-3.000	454.000	20.002	1.500	226.56	189.89	1.193	1.4
870		6.000	459.000	18.604	3.500	432.17	362.20	1.193	2.5
871		6.000	453.000	12.376	1.500	136.90	114.77	1.193	0.9
872		10.000	449.000	8.735	3.500	335.97	281.60	1.193	2.0
873		3.000	449.000	11.694	1.000	75.13	62.97	1.193	0.5
874		4.000	460.000	20.164	3.000	347.71	291.17	1.194	1.7
875		10.000	449.000	7.735	2.500	214.78	179.94	1.194	1.2
876		5.000	462.000	21.535	3.500	458.37	383.93	1.194	2.4
877		8.000	454.000	13.537	3.500	373.55	312.83	1.194	1.9
878		4.000	464.000	23.718	3.500	473.10	396.09	1.194	2.3
879		8.000	452.000	10.707	2.000	176.45	147.72	1.194	0.9
880		6.000	462.000	21.411	4.000	553.97	463.43	1.195	2.2
881		-2.000	456.000	19.957	1.000	104.29	87.25	1.195	0.5
882		-8.000	462.000	28.385	1.000	112.54	94.20	1.195	0.5
883		-6.000	455.000	22.981	1.500	276.31	231.16	1.195	1.1
884		3.000	458.000	18.418	2.000	192.08	160.64	1.196	0.7
885		-6.000	454.000	22.395	1.500	296.14	247.55	1.196	1.0
886		-4.000	454.000	20.786	1.500	245.18	204.93	1.196	0.8
887		2.000	464.000	24.504	3.000	381.25	318.84	1.196	1.4
888		-9.000	462.000	29.669	1.500	233.23	195.06	1.196	0.9
889		0.000	454.000	17.148	1.000	99.35	83.08	1.196	0.4
890		2.000	451.000	13.719	1.000	87.80	73.43	1.196	0.4
891		7.000	460.000	19.220	4.000	533.51	445.63	1.197	1.3
892		3.000	446.000	10.941	2.000	262.13	219.06	1.197	0.8
893		-1.000	455.000	18.553	1.000	101.76	84.96	1.198	0.2
894		-5.000	465.000	28.547	1.500	150.38	125.52	1.198	0.3
895		3.000	462.000	22.334	3.000	365.70	305.37	1.198	0.8
896		-2.000	453.000	18.597	1.500	217.83	181.90	1.198	0.5
897		1.000	462.000	23.155	2.500	273.69	228.27	1.199	0.3

* denotes the minimum safety factor and maximum prevention force.

No.	Reg.	Circular arc requirements				Skid resistance S (kN/m)	Sliding force T (kN/m)	Safety factor Fs	Required prevention force Pr (kN/m)
		Central coordinates		Radius r (m)	Max. depth (m)				
		X (m)	Y (m)						
898		-9.000	463.000	29.790	1.000	112.90	94.16	1.199	0.1
899		-10.000	464.000	31.195	1.000	113.65	94.79	1.199	0.1
900		5.000	447.000	9.385	1.500	136.19	113.56	1.199	0.1
901		1.000	453.000	15.743	1.000	96.48	80.50	1.199	0.2
902		-10.000	463.000	31.074	1.500	237.12	197.78	1.199	0.3
903		8.000	450.000	8.904	1.500	127.55	106.41	1.199	0.2
904		4.000	458.000	18.194	2.500	255.36	212.99	1.199	0.3
905		-4.000	464.000	27.135	1.500	149.60	124.67	1.200	0.1
906		-5.000	454.000	21.582	1.500	268.22	223.56	1.200	0.1
907		5.000	445.000	8.818	2.000	226.77	188.99	1.200	0.1
908		6.000	460.000	19.364	3.500	442.55	368.34	1.201	-0.5
909		-5.000	459.000	24.171	1.000	109.74	91.35	1.201	-0.1
910		7.000	454.000	13.270	2.500	237.52	197.83	1.201	-0.1
911		-5.000	453.000	21.005	1.500	288.72	240.28	1.202	-0.3
912		3.000	450.000	12.314	1.000	83.39	69.39	1.202	-0.1
913		-3.000	453.000	19.383	1.500	236.46	196.58	1.203	-0.5
914		4.000	457.000	17.005	2.000	188.94	157.01	1.203	-0.5
915		7.000	455.000	14.452	3.000	308.12	256.23	1.203	-0.6
916		7.000	457.000	16.434	3.500	408.62	339.57	1.203	-1.1
917		2.000	452.000	14.339	1.000	93.40	77.62	1.203	-0.2
918		-1.000	452.000	17.192	1.500	208.77	173.46	1.204	-0.6
919		-3.000	463.000	25.723	1.500	148.59	123.44	1.204	-0.4
920		7.000	446.000	7.196	1.500	114.64	95.12	1.205	-0.4
921		9.000	452.000	11.449	3.500	357.94	296.97	1.205	-1.5
922		-2.000	462.000	24.311	1.500	147.74	122.58	1.205	-0.6
923		9.000	447.000	6.247	1.500	110.74	91.85	1.206	-0.5
924		-4.000	453.000	20.185	1.500	259.76	215.32	1.206	-1.3
925		-4.000	452.000	19.616	1.500	280.56	232.64	1.206	-1.3
926		2.000	465.000	25.264	3.000	387.79	321.19	1.207	-2.3
927		-1.000	461.000	22.900	1.500	146.80	121.57	1.208	-0.9
928		7.000	452.000	10.966	1.500	133.20	110.22	1.208	-0.9
929		-1.000	465.000	26.719	2.500	288.26	238.48	1.209	-2.0
930		6.000	457.000	16.590	3.000	323.50	267.51	1.209	-2.4
931		-8.000	462.000	28.885	1.500	213.03	176.23	1.209	-1.5
932		8.000	458.000	17.044	4.000	512.28	423.67	1.209	-3.8
933		2.000	461.000	21.742	2.500	269.65	222.86	1.210	-2.2
934		0.000	460.000	21.489	1.500	145.85	120.50	1.210	-1.2
935		5.000	463.000	22.314	3.500	467.24	386.04	1.210	-3.9
936		3.000	463.000	23.094	3.000	376.22	310.42	1.212	-3.7
937		10.000	448.000	6.584	2.000	158.35	130.70	1.212	-1.5
938		3.000	451.000	12.934	1.000	90.04	74.26	1.212	-0.9
939		5.000	459.000	18.754	3.000	341.74	282.00	1.212	-3.3
940		-3.000	465.000	27.594	2.000	208.21	171.76	1.212	-2.0
941		5.000	457.000	16.780	2.500	250.60	206.55	1.213	-2.7
942		5.000	456.000	15.593	2.000	185.16	152.67	1.213	-1.9

* denotes the minimum safety factor and maximum prevention force.

No.	Reg.	Circular arc requirements				Skid resistance S (kN/m)	Sliding force T (kN/m)	Safety factor Fs	Required prevention force Pr (kN/m)
		Central coordinates		Radius r (m)	Max. depth (m)				
		X (m)	Y (m)						
943		-3.000	452.000	18.790	1.500	251.79	207.61	1.213	-2.6
944		4.000	465.000	24.510	3.500	482.43	397.71	1.213	-5.1
945		-2.000	452.000	17.981	1.500	227.59	187.65	1.213	-2.4
946		0.000	451.000	15.788	1.500	198.94	164.06	1.213	-2.0
947		6.000	461.000	20.127	3.500	450.66	371.37	1.214	-5.0
948		4.000	461.000	20.924	3.000	359.71	296.40	1.214	-4.0
949		1.000	459.000	20.079	1.500	144.43	118.87	1.215	-1.7
950		7.000	461.000	20.011	4.000	545.89	449.15	1.215	-6.9
951		8.000	445.000	5.791	1.500	99.76	82.09	1.215	-1.2
952		-9.000	463.000	30.290	1.500	216.49	178.25	1.215	-2.5
953		8.000	455.000	14.266	3.500	383.89	315.44	1.217	-5.3
954		9.000	448.000	6.867	1.500	116.34	95.61	1.217	-1.6
955		5.000	448.000	9.505	1.000	73.83	60.67	1.217	-1.0
956		5.000	447.000	8.885	1.000	65.16	53.48	1.218	-0.9
957		7.000	458.000	17.194	3.500	422.18	346.51	1.218	-6.3
958		-2.000	464.000	26.180	2.000	205.80	168.90	1.218	-3.1
959		4.000	447.000	10.189	1.500	150.49	123.48	1.219	-2.3
960		0.000	464.000	25.307	2.500	284.71	233.62	1.219	-4.3
961		3.000	448.000	11.582	1.500	162.92	133.70	1.219	-2.4
962		-2.000	451.000	17.399	1.500	242.77	199.15	1.219	-3.7
963		2.000	458.000	18.669	1.500	143.16	117.39	1.220	-2.2
964		-10.000	464.000	31.695	1.500	219.69	180.08	1.220	-3.5
965		-8.000	463.000	29.014	1.000	112.32	92.02	1.221	-1.8
966		-7.000	462.000	27.606	1.000	111.47	91.26	1.221	-1.9
967		9.000	451.000	9.297	2.000	170.66	139.74	1.221	-2.9
968		-9.000	464.000	30.423	1.000	113.01	92.52	1.221	-1.9
969		-3.000	451.000	18.201	1.500	267.03	218.75	1.221	-4.5
970		2.000	446.000	11.631	2.000	270.48	221.49	1.221	-4.6
971		3.000	464.000	23.854	3.000	382.73	313.22	1.222	-6.8
972		-6.000	461.000	26.199	1.000	110.69	90.61	1.222	-1.9
973		6.000	455.000	14.181	2.000	181.54	148.56	1.222	-3.2
974		-10.000	465.000	31.832	1.000	113.69	93.03	1.222	-2.0
975		-4.000	459.000	23.387	1.000	108.98	89.17	1.222	-1.9
976		8.000	459.000	17.815	4.000	523.61	428.53	1.222	-9.3
977		10.000	449.000	7.235	2.000	162.95	133.38	1.222	-2.8
978		-5.000	460.000	24.792	1.000	109.79	89.83	1.222	-1.9
979		8.000	453.000	11.859	2.500	231.37	189.25	1.223	-4.2
980		3.000	460.000	20.328	2.500	265.40	217.04	1.223	-4.9
981		1.000	450.000	14.383	1.500	188.58	154.20	1.223	-3.5
982		-1.000	451.000	16.582	1.500	218.45	178.66	1.223	-4.0
983		2.000	449.000	12.981	1.500	175.92	143.72	1.224	-3.4
984		0.000	455.000	17.768	1.000	102.87	83.99	1.225	-2.0
985		-1.000	463.000	24.765	2.000	203.44	166.11	1.225	-4.1
986		3.000	457.000	17.259	1.500	141.55	115.56	1.225	-2.8
987		8.000	451.000	9.556	1.500	129.03	105.33	1.225	-2.6

* denotes the minimum safety factor and maximum prevention force.

No.	Reg.	Circular arc requirements				Skid resistance S (kN/m)	Sliding force T (kN/m)	Safety factor Fs	Required prevention force Pr (kN/m)
		Central coordinates		Radius r (m)	Max. depth (m)				
		X (m)	Y (m)						
988		6.000	446.000	7.981	1.500	124.73	101.83	1.225	-2.5
989		-3.000	458.000	21.982	1.000	107.95	88.09	1.225	-2.2
990		4.000	450.000	11.530	1.000	86.35	70.42	1.226	-1.8
991		-1.000	450.000	16.013	1.500	234.17	191.06	1.226	-4.8
992		1.000	454.000	16.363	1.000	100.32	81.79	1.227	-2.1
993		10.000	450.000	9.387	3.500	341.94	278.76	1.227	-7.4
994		7.000	459.000	17.954	3.500	433.92	353.50	1.227	-9.7
995		-2.000	457.000	20.577	1.000	106.93	87.13	1.227	-2.3
996		9.000	452.000	10.949	3.000	287.73	234.32	1.228	-6.5
997		2.000	453.000	14.959	1.000	97.47	79.35	1.228	-2.2
998		-1.000	456.000	19.173	1.000	104.98	85.50	1.228	-2.3
999		5.000	464.000	23.112	3.500	477.35	388.56	1.229	-11.0
1000		1.000	463.000	23.896	2.500	281.34	228.86	1.229	-6.7
1001		6.000	462.000	20.911	3.500	460.43	374.72	1.229	-10.7
1002		10.000	450.000	8.887	3.000	275.24	223.91	1.229	-6.5
1003		4.000	456.000	15.848	1.500	139.59	113.37	1.231	-3.5
1004		0.000	462.000	23.351	2.000	201.09	163.33	1.231	-5.0
1005		3.000	452.000	13.554	1.000	94.57	76.82	1.231	-2.3
1006		4.000	462.000	21.684	3.000	370.83	301.08	1.232	-9.5
1007		8.000	454.000	13.037	3.000	299.46	243.03	1.232	-7.8
1008		10.000	450.000	8.387	2.500	216.03	175.31	1.232	-5.6
1009		0.000	450.000	15.186	1.500	208.48	169.16	1.232	-5.4
1010		6.000	456.000	15.366	2.500	245.03	198.96	1.232	-6.2
1011		5.000	460.000	19.514	3.000	353.12	286.55	1.232	-9.2
1012		6.000	458.000	17.344	3.000	334.90	271.64	1.233	-8.9
1013		5.000	446.000	8.803	1.500	140.04	113.55	1.233	-3.7
1014		8.000	456.000	15.024	3.500	398.25	322.71	1.234	-10.9
1015		5.000	449.000	10.125	1.000	81.62	66.15	1.234	-2.2
1016		7.000	456.000	15.177	3.000	315.56	255.64	1.234	-8.7
1017		9.000	453.000	12.123	3.500	361.91	293.36	1.234	-9.8
1018		7.000	454.000	12.770	2.000	177.04	143.50	1.234	-4.8
1019		7.000	460.000	18.720	3.500	442.47	358.17	1.235	-12.6
1020		6.000	447.000	8.100	1.000	68.55	55.51	1.235	-1.9
1021		3.000	465.000	24.623	3.000	388.99	314.84	1.236	-11.1
1022		0.000	449.000	14.632	1.500	225.87	182.81	1.236	-6.4
1023		-2.000	450.000	16.787	1.500	253.26	204.67	1.237	-7.6
1024		4.000	445.000	9.530	2.000	241.33	195.03	1.237	-7.2
1025		4.000	459.000	18.915	2.500	260.69	210.51	1.238	-8.0
1026		9.000	456.000	14.874	4.000	487.30	393.18	1.239	-15.4
1027		4.000	463.000	22.444	3.000	377.28	304.49	1.239	-11.8
1028		9.000	449.000	7.493	1.500	120.96	97.59	1.239	-3.8
1029		5.000	455.000	14.438	1.500	137.29	110.82	1.239	-4.3
1030		1.000	461.000	21.937	2.000	198.36	160.12	1.239	-6.2
1031		4.000	451.000	12.150	1.000	91.32	73.67	1.240	-2.9
1032		1.000	449.000	13.794	1.500	198.77	160.19	1.241	-6.5

* denotes the minimum safety factor and maximum prevention force.

No.	Reg.	Circular arc requirements				Skid resistance S (kN/m)	Sliding force T (kN/m)	Safety factor Fs	Required prevention force Pr (kN/m)
		Central coordinates		Radius r (m)	Max. depth (m)				
		X (m)	Y (m)						
1033		2.000	462.000	22.485	2.500	277.36	223.40	1.242	-9.2
1034		9.000	457.000	15.634	4.000	500.03	402.73	1.242	-16.7
1035		0.000	465.000	26.064	2.500	294.27	236.67	1.243	-10.2
1036		-6.000	462.000	26.843	1.000	111.10	89.28	1.244	-3.9
1037		1.000	448.000	13.260	1.500	218.09	175.27	1.244	-7.7
1038		-8.000	464.000	29.663	1.000	112.60	90.47	1.245	-4.0
1039		-9.000	465.000	31.073	1.000	113.27	91.01	1.245	-4.0
1040		-7.000	463.000	28.253	1.000	111.83	89.81	1.245	-4.0
1041		-5.000	461.000	25.432	1.000	110.21	88.48	1.246	-4.0
1042		6.000	463.000	21.716	3.500	472.02	378.96	1.246	-17.2
1043		-4.000	460.000	24.022	1.000	109.16	87.61	1.246	-4.0
1044		-4.000	465.000	27.811	1.500	146.42	117.55	1.246	-5.3
1045		2.000	460.000	20.523	2.000	195.38	156.62	1.247	-7.4
1046		7.000	461.000	19.511	3.500	453.43	363.29	1.248	-17.4
1047		6.000	454.000	13.028	1.500	134.62	107.84	1.248	-5.2
1048		-3.000	459.000	22.613	1.000	108.13	86.67	1.248	-4.1
1049		8.000	457.000	15.784	3.500	411.87	330.14	1.248	-15.7
1050		6.000	448.000	8.720	1.000	76.51	61.25	1.249	-3.0
1051		5.000	465.000	23.928	3.500	489.00	391.63	1.249	-19.0
1052		-3.000	464.000	26.398	1.500	145.46	116.42	1.249	-5.7
1053		-2.000	458.000	21.204	1.000	107.03	85.62	1.250	-4.2
1054		5.000	461.000	20.274	3.000	363.84	291.17	1.250	-14.4
1055		9.000	458.000	16.411	4.000	512.07	409.66	1.250	-20.4
1056		4.000	464.000	23.218	3.000	384.02	306.94	1.251	-15.6
1057		2.000	448.000	12.408	1.500	189.03	151.16	1.251	-7.6
1058		9.000	452.000	10.449	2.500	223.72	178.77	1.251	-9.1
1059		5.000	450.000	10.745	1.000	87.62	69.96	1.252	-3.6
1060		7.000	455.000	13.952	2.500	238.72	190.62	1.252	-9.9
1061		8.000	453.000	11.359	2.000	172.60	137.79	1.253	-7.2
1062		10.000	450.000	7.887	2.000	163.24	130.23	1.253	-6.9
1063		6.000	459.000	18.104	3.000	345.99	275.98	1.254	-14.8
1064		5.000	458.000	17.502	2.500	255.56	203.56	1.255	-11.2
1065		7.000	445.000	6.584	1.500	112.10	89.34	1.255	-4.8
1066		9.000	450.000	8.145	1.500	123.22	98.18	1.255	-5.4
1067		1.000	464.000	24.654	2.500	290.66	231.58	1.255	-12.7
1068		3.000	459.000	19.108	2.000	192.33	153.07	1.256	-8.6
1069		3.000	461.000	21.074	2.500	273.08	217.46	1.256	-12.1
1070		-2.000	463.000	24.984	1.500	144.17	114.78	1.256	-6.4
1071		9.000	454.000	12.855	3.500	372.52	296.60	1.256	-16.6
1072		-1.000	449.000	15.373	1.500	238.97	190.29	1.256	-10.6
1073		-1.000	457.000	19.796	1.000	105.59	83.98	1.257	-4.8
1074		8.000	458.000	16.544	3.500	423.88	337.06	1.258	-19.4
1075		7.000	453.000	11.618	1.500	131.00	104.11	1.258	-6.0
1076		7.000	457.000	15.934	3.000	326.97	259.91	1.258	-15.0
1077		10.000	451.000	10.039	3.500	345.35	274.61	1.258	-15.8

* denotes the minimum safety factor and maximum prevention force.

No.	Reg.	Circular arc requirements				Skid resistance S (kN/m)	Sliding force T (kN/m)	Safety factor Fs	Required prevention force Pr (kN/m)
		Central coordinates		Radius r (m)	Max. depth (m)				
		X (m)	Y (m)						
1078		7.000	446.000	6.696	1.000	63.08	50.09	1.259	-2.9
1079		0.000	456.000	18.389	1.000	104.38	82.90	1.259	-4.9
1080		5.000	462.000	21.035	3.000	371.09	294.75	1.259	-17.3
1081		10.000	445.000	4.222	1.500	87.98	69.84	1.260	-4.1
1082		8.000	459.000	17.315	3.500	433.36	343.59	1.261	-21.0
1083		-1.000	462.000	23.571	1.500	143.09	113.50	1.261	-6.8
1084		4.000	465.000	24.010	3.000	392.13	310.16	1.264	-19.9
1085		7.000	462.000	20.323	3.500	466.13	368.80	1.264	-23.5
1086		3.000	447.000	11.030	1.500	178.88	141.53	1.264	-9.0
1087		-2.000	465.000	26.896	2.000	208.70	165.05	1.264	-10.6
1088		6.000	464.000	22.540	3.500	484.73	383.24	1.265	-24.8
1089		8.000	455.000	13.766	3.000	307.24	242.90	1.265	-15.7
1090		3.000	445.000	10.216	2.000	249.92	197.38	1.266	-13.0
1091		0.000	461.000	22.157	1.500	141.76	112.00	1.266	-7.3
1092		4.000	458.000	17.694	2.000	188.84	149.08	1.267	-9.9
1093		2.000	454.000	15.579	1.000	100.37	79.24	1.267	-5.2
1094		8.000	452.000	10.207	1.500	126.80	100.07	1.267	-6.7
1095		3.000	453.000	14.174	1.000	97.73	77.14	1.267	-5.1
1096		10.000	446.000	4.842	1.500	98.05	77.32	1.268	-5.2
1097		2.000	463.000	23.244	2.500	286.77	226.23	1.268	-15.2
1098		6.000	445.000	7.430	1.500	130.82	103.17	1.268	-7.0
1099		5.000	463.000	21.814	3.000	378.53	298.44	1.268	-20.4
1100		1.000	455.000	16.984	1.000	102.57	80.83	1.269	-5.5
1101		9.000	453.000	11.623	3.000	289.63	228.23	1.269	-15.7
1102		8.000	460.000	18.113	3.500	445.32	350.76	1.270	-24.4
1103		4.000	452.000	12.770	1.000	94.78	74.55	1.271	-5.3
1104		6.000	460.000	18.864	3.000	356.27	280.36	1.271	-19.8
1105		9.000	455.000	13.614	3.500	386.61	304.20	1.271	-21.5
1106		4.000	460.000	19.664	2.500	268.78	211.54	1.271	-14.9
1107		-1.000	464.000	25.482	2.000	206.35	162.19	1.272	-11.7
1108		1.000	460.000	20.744	1.500	140.46	110.45	1.272	-7.9
1109		4.000	446.000	9.664	1.500	169.24	133.04	1.272	-9.5
1110		6.000	449.000	9.340	1.000	83.48	65.60	1.273	-4.7
1111		2.000	447.000	11.853	1.500	203.95	160.23	1.273	-11.6
1112		9.000	452.000	9.949	2.000	166.74	130.86	1.274	-9.7
1113		7.000	447.000	7.316	1.000	71.05	55.78	1.274	-4.1
1114		10.000	451.000	9.539	3.000	277.00	217.28	1.275	-16.2
1115		-4.000	461.000	24.674	1.000	109.30	85.73	1.275	-6.4
1116		-6.000	463.000	27.495	1.000	110.86	86.93	1.275	-6.5
1117		6.000	457.000	16.090	2.500	249.99	196.06	1.275	-14.7
1118		-5.000	462.000	26.084	1.000	110.06	86.28	1.276	-6.5
1119		-7.000	464.000	28.905	1.000	111.36	87.27	1.276	-6.6
1120		-2.000	459.000	21.854	1.000	107.49	84.24	1.276	-6.4
1121		-3.000	460.000	23.264	1.000	108.39	84.90	1.277	-6.5
1122		5.000	464.000	22.612	3.000	386.84	302.70	1.278	-23.6

* denotes the minimum safety factor and maximum prevention force.

No.	Reg.	Circular arc requirements				Skid resistance S (kN/m)	Sliding force T (kN/m)	Safety factor Fs	Required prevention force Pr (kN/m)
		Central coordinates		Radius r (m)	Max. depth (m)				
		X (m)	Y (m)						
1123		1.000	465.000	25.414	2.500	299.75	234.43	1.279	-18.4
1124		8.000	454.000	12.537	2.500	231.63	181.07	1.279	-14.3
1125		2.000	459.000	19.331	1.500	138.81	108.55	1.279	-8.5
1126		7.000	458.000	16.694	3.000	337.65	263.94	1.279	-20.9
1127		-8.000	465.000	30.315	1.000	111.73	87.34	1.279	-6.9
1128		10.000	447.000	5.462	1.500	106.28	83.05	1.280	-6.6
1129		5.000	451.000	11.365	1.000	91.41	71.41	1.280	-5.7
1130		5.000	457.000	16.280	2.000	184.93	144.49	1.280	-11.5
1131		-1.000	458.000	20.444	1.000	106.26	83.03	1.280	-6.6
1132		0.000	463.000	24.069	2.000	203.64	158.92	1.281	-12.9
1133		6.000	461.000	19.627	3.000	364.34	284.44	1.281	-23.0
1134		7.000	463.000	21.155	3.500	479.44	374.18	1.281	-30.4
1135		0.000	457.000	19.033	1.000	105.05	81.93	1.282	-6.7
1136		5.000	445.000	8.318	1.500	159.65	124.56	1.282	-10.1
1137		8.000	461.000	18.934	3.500	459.10	358.03	1.282	-29.4
1138		9.000	456.000	14.374	3.500	400.00	311.86	1.283	-25.7
1139		3.000	462.000	21.834	2.500	282.35	220.02	1.283	-18.3
1140		0.000	448.000	13.959	1.500	224.46	174.93	1.283	-14.5
1141		10.000	456.000	14.225	4.000	485.55	378.48	1.283	-31.3
1142		10.000	455.000	13.464	4.000	471.88	367.70	1.283	-30.6
1143		10.000	457.000	15.011	4.000	499.66	389.08	1.284	-32.7
1144		6.000	465.000	23.380	3.500	498.05	387.48	1.285	-33.0
1145		6.000	462.000	20.411	3.000	371.89	289.43	1.285	-24.5
1146		9.000	451.000	8.797	1.500	121.61	94.64	1.285	-8.0
1147		10.000	452.000	10.709	3.500	349.02	271.48	1.286	-23.2
1148		3.000	458.000	17.918	1.500	137.04	106.51	1.287	-9.2
1149		-4.000	451.000	18.804	1.500	255.61	198.55	1.287	-17.3
1150		10.000	451.000	9.039	2.500	214.89	166.85	1.288	-14.6
1151		8.000	456.000	14.524	3.000	318.39	247.21	1.288	-21.7
1152		5.000	459.000	18.254	2.500	263.96	204.81	1.289	-18.1
1153		1.000	456.000	17.623	1.000	103.34	80.09	1.290	-7.2
1154		1.000	462.000	22.655	2.000	201.02	155.77	1.290	-14.0
1155		9.000	458.000	15.911	3.500	422.59	327.64	1.290	-29.4
1156		5.000	465.000	23.428	3.000	396.60	307.23	1.291	-27.9
1157		9.000	457.000	15.134	3.500	411.87	318.76	1.292	-29.3
1158		-3.000	450.000	17.430	1.500	249.55	193.18	1.292	-17.7
1159		9.000	459.000	16.718	3.500	436.13	337.25	1.293	-31.4
1160		2.000	464.000	24.004	2.500	295.30	228.45	1.293	-21.1
1161		6.000	463.000	21.216	3.000	381.83	295.37	1.293	-27.3
1162		6.000	456.000	14.866	2.000	180.71	139.64	1.294	-13.1
1163		4.000	457.000	16.505	1.500	134.57	104.03	1.294	-9.7
1164		7.000	448.000	7.936	1.000	78.10	60.27	1.296	-5.7
1165		7.000	459.000	17.454	3.000	347.49	268.12	1.296	-25.7
1166		5.000	456.000	15.093	1.500	132.17	101.95	1.296	-9.8
1167		6.000	450.000	9.960	1.000	87.53	67.50	1.297	-6.5

* denotes the minimum safety factor and maximum prevention force.

No.	Reg.	Circular arc requirements				Skid resistance S (kN/m)	Sliding force T (kN/m)	Safety factor Fs	Required prevention force Pr (kN/m)
		Central coordinates		Radius r (m)	Max. depth (m)				
		X (m)	Y (m)						
1168		-2.000	449.000	16.062	1.500	244.28	188.32	1.297	-18.2
1169		10.000	448.000	6.084	1.500	112.27	86.52	1.298	-8.4
1170		-3.000	465.000	27.094	1.500	142.60	109.78	1.299	-10.8
1171		8.000	462.000	19.776	3.500	474.76	365.52	1.299	-36.1
1172		7.000	456.000	14.677	2.500	243.99	187.88	1.299	-18.5
1173		10.000	449.000	6.735	1.500	116.17	89.46	1.299	-8.8
1174		2.000	455.000	16.213	1.000	101.59	78.19	1.299	-7.7
1175		4.000	461.000	20.424	2.500	277.59	213.61	1.300	-21.2
1176		10.000	451.000	8.539	2.000	159.94	123.03	1.300	-12.3
1177		9.000	454.000	12.355	3.000	297.79	228.90	1.301	-23.1
1178		2.000	461.000	21.242	2.000	198.21	152.33	1.301	-15.4
1179		7.000	464.000	22.004	3.500	494.39	379.78	1.302	-38.6
1180		7.000	461.000	19.011	3.000	365.16	280.23	1.303	-28.8
1181		9.000	460.000	17.550	3.500	452.03	346.84	1.303	-35.8
1182		-2.000	464.000	25.680	1.500	141.62	108.60	1.304	-11.3
1183		7.000	460.000	18.220	3.000	356.31	273.29	1.304	-28.3
1184		6.000	455.000	13.681	1.500	129.08	99.00	1.304	-10.2
1185		10.000	453.000	11.445	3.500	359.93	276.08	1.304	-28.6
1186		8.000	445.000	5.291	1.000	56.79	43.51	1.305	-4.5
1187		7.000	455.000	13.452	2.000	175.50	134.45	1.305	-14.1
1188		6.000	464.000	22.040	3.000	392.77	301.07	1.305	-31.4
1189		3.000	446.000	10.441	1.500	188.22	144.07	1.306	-15.3
1190		8.000	457.000	15.284	3.000	328.90	251.55	1.307	-27.0
1191		3.000	463.000	22.594	2.500	290.44	222.00	1.308	-24.0
1192		9.000	453.000	11.123	2.500	223.81	170.81	1.310	-18.8
1193		7.000	462.000	19.823	3.000	375.82	286.97	1.310	-31.4
1194		10.000	450.000	7.387	1.500	115.76	88.36	1.310	-9.7
1195		6.000	458.000	16.844	2.500	258.35	197.22	1.310	-21.6
1196		-1.000	463.000	24.265	1.500	140.38	107.07	1.311	-11.8
1197		7.000	454.000	12.270	1.500	125.89	95.97	1.312	-10.7
1198		1.000	447.000	12.545	1.500	209.49	159.68	1.312	-17.8
1199		3.000	454.000	14.803	1.000	99.54	75.87	1.312	-8.4
1200		8.000	446.000	5.911	1.000	65.07	49.61	1.312	-5.5
1201		2.000	465.000	24.764	2.500	303.31	230.78	1.314	-26.3
1202		3.000	460.000	19.828	2.000	194.87	148.34	1.314	-16.8
1203		4.000	453.000	13.394	1.000	97.15	73.86	1.315	-8.5
1204		10.000	454.000	12.204	3.500	373.50	283.72	1.316	-33.0
1205		-1.000	465.000	26.219	2.000	210.96	160.27	1.316	-18.6
1206		10.000	452.000	10.209	3.000	278.61	211.73	1.316	-24.5
1207		-4.000	462.000	25.326	1.000	107.96	81.95	1.317	-9.6
1208		-3.000	461.000	23.916	1.000	107.33	81.49	1.317	-9.5
1209		7.000	449.000	8.556	1.000	83.43	63.34	1.317	-7.4
1210		-2.000	460.000	22.506	1.000	106.47	80.79	1.318	-9.5
1211		-5.000	463.000	26.736	1.000	108.58	82.41	1.318	-9.6
1212		-1.000	448.000	14.661	1.500	232.15	176.07	1.319	-20.8

* denotes the minimum safety factor and maximum prevention force.

No.	Reg.	Circular arc requirements				Skid resistance S (kN/m)	Sliding force T (kN/m)	Safety factor Fs	Required prevention force Pr (kN/m)
		Central coordinates		Radius r (m)	Max. depth (m)				
		X (m)	Y (m)						
1213		9.000	461.000	18.403	3.500	469.69	356.01	1.319	-42.4
1214		5.000	460.000	19.014	2.500	272.23	206.46	1.319	-24.4
1215		8.000	463.000	20.634	3.500	491.36	372.15	1.320	-44.7
1216		7.000	463.000	20.655	3.000	388.63	294.37	1.320	-35.3
1217		-6.000	464.000	28.147	1.000	109.03	82.62	1.320	-9.8
1218		6.000	465.000	22.880	3.000	404.74	306.57	1.320	-36.8
1219		8.000	453.000	10.859	1.500	122.27	92.55	1.321	-11.2
1220		10.000	458.000	15.329	3.500	426.61	322.88	1.321	-39.1
1221		0.000	462.000	22.851	1.500	138.78	105.06	1.321	-12.7
1222		8.000	454.000	12.037	2.000	169.69	128.44	1.321	-15.5
1223		-1.000	459.000	21.096	1.000	105.43	79.84	1.321	-9.6
1224		-7.000	465.000	29.557	1.000	109.43	82.82	1.321	-10.0
1225		8.000	458.000	16.044	3.000	337.71	255.51	1.322	-31.0
1226		0.000	458.000	19.685	1.000	104.33	78.85	1.323	-9.7
1227		7.000	465.000	22.867	3.500	510.83	385.68	1.324	-48.0
1228		10.000	457.000	14.511	3.500	410.91	310.31	1.324	-38.5
1229		8.000	455.000	13.266	2.500	236.95	178.77	1.325	-22.4
1230		8.000	460.000	17.613	3.000	357.94	270.18	1.325	-33.7
1231		4.000	462.000	21.184	2.500	285.57	215.48	1.325	-26.9
1232		5.000	452.000	11.986	1.000	93.78	70.76	1.325	-8.8
1233		9.000	455.000	13.114	3.000	308.68	232.96	1.325	-29.1
1234		1.000	457.000	18.275	1.000	103.19	77.87	1.325	-9.7
1235		1.000	461.000	21.437	1.500	136.99	103.28	1.326	-13.0
1236		10.000	455.000	12.964	3.500	386.19	291.23	1.326	-36.7
1237		8.000	447.000	6.531	1.000	72.36	54.51	1.327	-6.9
1238		0.000	464.000	24.807	2.000	208.39	157.01	1.327	-19.9
1239		8.000	461.000	18.434	3.000	370.28	278.74	1.328	-35.7
1240		4.000	459.000	18.415	2.000	191.38	144.16	1.328	-18.3
1241		10.000	459.000	16.173	3.500	444.82	334.81	1.329	-43.0
1242		2.000	456.000	16.865	1.000	101.72	76.53	1.329	-9.8
1243		3.000	464.000	23.354	2.500	298.02	224.18	1.329	-29.0
1244		10.000	456.000	13.725	3.500	397.48	299.14	1.329	-38.5
1245		8.000	459.000	16.815	3.000	347.53	261.15	1.331	-34.1
1246		2.000	460.000	20.023	1.500	134.93	101.39	1.331	-13.2
1247		7.000	457.000	15.434	2.500	251.76	188.75	1.334	-25.2
1248		6.000	451.000	10.581	1.000	90.15	67.53	1.335	-9.1
1249		7.000	464.000	21.504	3.000	402.35	301.42	1.335	-40.6
1250		3.000	455.000	15.455	1.000	100.15	75.02	1.335	-10.1
1251		3.000	465.000	24.123	2.500	303.53	227.22	1.336	-30.8
1252		3.000	459.000	18.608	1.500	132.83	99.45	1.336	-13.4
1253		9.000	452.000	9.449	1.500	117.97	88.28	1.336	-12.0
1254		8.000	462.000	19.276	3.000	384.69	287.68	1.337	-39.4
1255		9.000	453.000	10.623	2.000	163.41	122.15	1.338	-16.8
1256		1.000	463.000	23.396	2.000	205.82	153.85	1.338	-21.2
1257		6.000	459.000	17.604	2.500	266.05	198.69	1.339	-27.6

* denotes the minimum safety factor and maximum prevention force.

No.	Reg.	Circular arc requirements				Skid resistance S (kN/m)	Sliding force T (kN/m)	Safety factor Fs	Required prevention force Pr (kN/m)
		Central coordinates		Radius r (m)	Max. depth (m)				
		X (m)	Y (m)						
1258		9.000	462.000	19.273	3.500	488.42	364.43	1.340	-51.1
1259		9.000	456.000	13.874	3.000	318.00	237.33	1.340	-33.2
1260		5.000	458.000	17.002	2.000	187.09	139.48	1.341	-19.7
1261		5.000	461.000	19.774	2.500	279.38	208.24	1.342	-29.4
1262		4.000	458.000	17.194	1.500	130.33	97.02	1.343	-13.9
1263		10.000	460.000	17.038	3.500	464.93	346.16	1.343	-49.5
1264		4.000	463.000	21.944	2.500	292.16	217.37	1.344	-31.3
1265		8.000	464.000	21.508	3.500	509.19	378.94	1.344	-54.4
1266		4.000	454.000	14.044	1.000	98.28	73.09	1.345	-10.5
1267		10.000	452.000	9.709	2.500	214.26	159.36	1.345	-23.0
1268		10.000	453.000	10.945	3.000	286.81	212.91	1.347	-31.3
1269		4.000	445.000	9.030	1.500	171.04	126.89	1.348	-18.7
1270		0.000	447.000	13.246	1.500	217.20	160.87	1.350	-24.1
1271		4.000	464.000	22.718	2.500	299.10	221.52	1.350	-33.2
1272		9.000	460.000	17.050	3.000	364.56	270.00	1.350	-40.5
1273		5.000	457.000	15.780	1.500	127.63	94.47	1.351	-14.2
1274		2.000	462.000	21.985	2.000	202.92	150.19	1.351	-22.6
1275		4.000	465.000	23.510	2.500	305.44	225.92	1.352	-34.3
1276		8.000	463.000	20.134	3.000	399.95	295.93	1.352	-44.8
1277		9.000	459.000	16.218	3.000	350.23	259.06	1.352	-39.3
1278		7.000	465.000	22.367	3.000	417.02	308.16	1.353	-47.2
1279		2.000	446.000	11.131	1.500	194.10	143.45	1.353	-21.9
1280		9.000	457.000	14.634	3.000	326.69	241.44	1.353	-36.9
1281		6.000	457.000	15.590	2.000	182.74	135.04	1.353	-20.6
1282		7.000	450.000	9.176	1.000	86.11	63.62	1.354	-9.7
1283		9.000	454.000	11.855	2.500	228.51	168.61	1.355	-26.1
1284		8.000	448.000	7.151	1.000	78.30	57.70	1.357	-9.0
1285		9.000	461.000	17.903	3.000	380.84	280.72	1.357	-43.9
1286		8.000	456.000	14.024	2.500	244.55	180.07	1.358	-28.4
1287		9.000	458.000	15.411	3.000	337.71	248.67	1.358	-39.3
1288		10.000	451.000	8.039	1.500	112.86	83.04	1.359	-13.2
1289		6.000	456.000	14.366	1.500	124.87	91.82	1.360	-14.6
1290		7.000	458.000	16.194	2.500	259.00	190.27	1.361	-30.6
1291		5.000	453.000	12.634	1.000	95.85	70.42	1.361	-11.3
1292		5.000	462.000	20.535	2.500	285.68	209.84	1.361	-33.8
1293		6.000	460.000	18.364	2.500	272.64	200.24	1.362	-32.3
1294		10.000	452.000	9.209	2.000	156.09	114.64	1.362	-18.5
1295		-2.000	465.000	26.396	1.500	140.22	102.87	1.363	-16.7
1296		3.000	461.000	20.574	2.000	199.84	146.57	1.363	-23.9
1297		10.000	461.000	17.921	3.500	486.25	356.52	1.364	-58.4
1298		10.000	454.000	11.704	3.000	297.04	217.61	1.365	-35.9
1299		9.000	463.000	20.157	3.500	508.52	372.67	1.365	-61.3
1300		-1.000	464.000	24.982	1.500	138.39	101.31	1.366	-16.8
1301		5.000	464.000	22.112	2.500	301.55	220.82	1.366	-36.5
1302		0.000	465.000	25.564	2.000	214.75	157.00	1.368	-26.3

* denotes the minimum safety factor and maximum prevention force.

No.	Reg.	Circular arc requirements				Skid resistance S (kN/m)	Sliding force T (kN/m)	Safety factor Fs	Required prevention force Pr (kN/m)
		Central coordinates		Radius r (m)	Max. depth (m)				
		X (m)	Y (m)						
1303		8.000	465.000	22.393	3.500	528.04	385.64	1.369	-65.2
1304		5.000	465.000	22.928	2.500	310.25	226.66	1.369	-38.2
1305		5.000	463.000	21.314	2.500	293.97	214.74	1.369	-36.2
1306		7.000	456.000	14.177	2.000	177.64	129.71	1.370	-21.9
1307		0.000	463.000	23.569	1.500	136.43	99.61	1.370	-16.8
1308		9.000	462.000	18.773	3.000	398.07	290.47	1.370	-49.5
1309		7.000	455.000	12.952	1.500	121.65	88.70	1.371	-15.2
1310		8.000	464.000	21.008	3.000	416.38	303.78	1.371	-51.8
1311		-4.000	463.000	25.978	1.000	105.21	76.63	1.373	-13.2
1312		-3.000	462.000	24.568	1.000	104.68	76.24	1.373	-13.1
1313		-1.000	460.000	21.747	1.000	103.16	75.06	1.374	-13.0
1314		-2.000	461.000	23.158	1.000	103.95	75.64	1.374	-13.1
1315		10.000	459.000	15.673	3.000	358.77	260.96	1.375	-45.6
1316		-5.000	464.000	27.388	1.000	105.54	76.73	1.375	-13.4
1317		1.000	462.000	22.155	1.500	134.24	97.64	1.375	-17.0
1318		4.000	460.000	19.164	2.000	195.81	142.28	1.376	-25.0
1319		-6.000	465.000	28.798	1.000	105.93	76.98	1.376	-13.5
1320		1.000	458.000	18.927	1.000	101.35	73.59	1.377	-13.0
1321		0.000	459.000	20.337	1.000	102.22	74.20	1.378	-13.1
1322		8.000	449.000	7.771	1.000	81.73	59.29	1.378	-10.5
1323		6.000	452.000	11.224	1.000	93.14	67.53	1.379	-12.1
1324		10.000	460.000	16.538	3.000	377.13	273.54	1.379	-48.8
1325		9.000	445.000	4.506	1.000	58.20	42.19	1.379	-7.5
1326		6.000	461.000	19.127	2.500	279.28	202.37	1.380	-36.4
1327		1.000	464.000	24.154	2.000	212.08	153.72	1.380	-27.6
1328		10.000	455.000	12.464	3.000	306.10	221.74	1.380	-40.0
1329		2.000	461.000	20.742	1.500	132.02	95.69	1.380	-17.1
1330		6.000	464.000	21.540	2.500	307.26	222.26	1.382	-40.5
1331		3.000	456.000	16.107	1.000	98.46	71.25	1.382	-12.9
1332		6.000	463.000	20.716	2.500	297.20	214.93	1.383	-39.2
1333		2.000	457.000	17.517	1.000	100.04	72.35	1.383	-13.2
1334		10.000	458.000	14.829	3.000	342.78	247.91	1.383	-45.2
1335		7.000	459.000	16.954	2.500	265.47	191.81	1.384	-35.2
1336		4.000	455.000	14.696	1.000	96.39	69.67	1.384	-12.7
1337		8.000	454.000	11.537	1.500	117.94	85.08	1.386	-15.8
1338		6.000	465.000	22.380	2.500	318.67	229.85	1.386	-42.8
1339		3.000	460.000	19.328	1.500	129.79	93.60	1.387	-17.4
1340		8.000	457.000	14.784	2.500	251.32	181.23	1.387	-33.8
1341		1.000	446.000	11.832	1.500	202.09	145.56	1.388	-27.4
1342		5.000	454.000	13.286	1.000	94.12	67.76	1.389	-12.8
1343		9.000	463.000	19.657	3.000	416.34	299.71	1.389	-56.6
1344		5.000	459.000	17.754	2.000	191.87	138.09	1.389	-26.1
1345		10.000	462.000	18.819	3.500	508.75	366.31	1.389	-69.1
1346		10.000	456.000	13.225	3.000	314.88	226.48	1.390	-43.1
1347		8.000	455.000	12.766	2.000	172.26	123.96	1.390	-23.5

* denotes the minimum safety factor and maximum prevention force.

No.	Reg.	Circular arc requirements				Skid resistance S (kN/m)	Sliding force T (kN/m)	Safety factor Fs	Required prevention force Pr (kN/m)
		Central coordinates		Radius r (m)	Max. depth (m)				
		X (m)	Y (m)						
1348		6.000	462.000	19.911	2.500	288.73	207.68	1.390	-39.5
1349		2.000	463.000	22.744	2.000	208.75	150.17	1.390	-28.5
1350		9.000	446.000	5.127	1.000	65.87	47.37	1.391	-9.0
1351		10.000	461.000	17.421	3.000	396.83	285.24	1.391	-54.5
1352		9.000	455.000	12.614	2.500	236.26	169.90	1.391	-32.3
1353		9.000	464.000	21.054	3.500	529.32	380.41	1.391	-72.8
1354		8.000	465.000	21.893	3.000	433.54	311.36	1.392	-59.9
1355		6.000	453.000	11.876	1.000	91.68	65.84	1.392	-12.6
1356		10.000	453.000	10.445	2.500	219.53	157.66	1.392	-30.3
1357		7.000	451.000	9.814	1.000	88.71	63.71	1.392	-12.2
1358		10.000	457.000	14.011	3.000	327.03	234.74	1.393	-45.3
1359		4.000	459.000	17.915	1.500	127.62	91.45	1.396	-17.8
1360		7.000	463.000	20.155	2.500	304.23	217.72	1.397	-42.9
1361		7.000	462.000	19.323	2.500	292.95	209.19	1.400	-41.9
1362		3.000	445.000	9.716	1.500	177.91	126.98	1.401	-25.5
1363		7.000	464.000	21.004	2.500	316.86	226.24	1.401	-45.3
1364		7.000	460.000	17.720	2.500	272.52	194.40	1.402	-39.2
1365		3.000	462.000	21.334	2.000	205.02	146.08	1.403	-29.7
1366		-4.000	450.000	17.965	1.500	227.23	161.90	1.404	-32.9
1367		7.000	452.000	10.466	1.000	88.55	63.05	1.404	-12.8
1368		9.000	453.000	10.123	1.500	114.03	81.17	1.405	-16.6
1369		5.000	458.000	16.502	1.500	125.31	89.15	1.406	-18.3
1370		6.000	458.000	16.344	2.000	187.37	133.25	1.406	-27.4
1371		8.000	450.000	8.404	1.000	83.56	59.37	1.407	-12.3
1372		9.000	447.000	5.747	1.000	71.96	51.14	1.407	-10.5
1373		10.000	462.000	18.319	3.000	417.13	295.96	1.409	-61.9
1374		7.000	461.000	18.511	2.500	283.19	200.79	1.410	-42.2
1375		7.000	465.000	21.867	2.500	330.08	234.18	1.410	-49.0
1376		8.000	458.000	15.544	2.500	257.63	182.55	1.411	-38.5
1377		9.000	464.000	20.554	3.000	435.22	308.18	1.412	-65.4
1378		-3.000	449.000	16.580	1.500	220.09	155.71	1.413	-33.2
1379		1.000	465.000	24.914	2.000	217.27	153.74	1.413	-32.7
1380		8.000	462.000	18.776	2.500	301.45	213.23	1.414	-45.5
1381		9.000	454.000	11.355	2.000	166.20	117.42	1.415	-25.2
1382		8.000	463.000	19.634	2.500	315.41	222.89	1.415	-47.9
1383		4.000	461.000	19.924	2.000	201.17	142.02	1.416	-30.7
1384		10.000	463.000	19.728	3.500	531.52	375.10	1.417	-81.4
1385		9.000	456.000	13.374	2.500	242.96	171.23	1.419	-37.4
1386		6.000	457.000	15.090	1.500	122.58	86.34	1.420	-18.9
1387		9.000	465.000	21.962	3.500	550.58	387.49	1.421	-85.5
1388		8.000	461.000	17.934	2.500	288.69	203.14	1.421	-44.9
1389		8.000	464.000	20.508	2.500	330.32	232.17	1.423	-51.7
1390		9.000	448.000	6.367	1.000	76.32	53.62	1.423	-11.9
1391		2.000	464.000	23.504	2.000	213.75	150.03	1.425	-33.7
1392		-2.000	448.000	15.201	1.500	213.30	149.65	1.425	-33.7

* denotes the minimum safety factor and maximum prevention force.

No.	Reg.	Circular arc requirements				Skid resistance S (kN/m)	Sliding force T (kN/m)	Safety factor Fs	Required prevention force Pr (kN/m)
		Central coordinates		Radius r (m)	Max. depth (m)				
		X (m)	Y (m)						
1393		8.000	451.000	9.056	1.000	84.97	59.62	1.425	-13.4
1394		7.000	457.000	14.934	2.000	182.42	127.86	1.427	-28.9
1395		8.000	459.000	16.315	2.500	265.33	185.81	1.428	-42.3
1396		4.000	456.000	15.348	1.000	92.01	64.40	1.429	-14.7
1397		5.000	455.000	13.938	1.000	90.22	63.12	1.429	-14.4
1398		10.000	452.000	8.709	1.500	109.47	76.58	1.429	-17.5
1399		9.000	449.000	6.993	1.000	77.70	54.34	1.430	-12.4
1400		3.000	457.000	16.759	1.000	93.64	65.49	1.430	-15.0
1401		9.000	461.000	17.403	2.500	298.48	208.54	1.431	-48.2
1402		6.000	454.000	12.528	1.000	88.25	61.69	1.431	-14.2
1403		9.000	462.000	18.273	2.500	314.37	219.70	1.431	-50.7
1404		2.000	458.000	18.169	1.000	95.01	66.39	1.431	-15.3
1405		10.000	454.000	11.204	2.500	227.09	158.66	1.431	-36.6
1406		1.000	459.000	19.579	1.000	96.31	67.27	1.432	-15.5
1407		0.000	460.000	20.989	1.000	97.46	68.04	1.432	-15.8
1408		-1.000	465.000	25.719	1.500	139.62	97.48	1.432	-22.6
1409		10.000	463.000	19.228	3.000	438.35	305.66	1.434	-71.5
1410		5.000	460.000	18.514	2.000	196.91	137.34	1.434	-32.1
1411		8.000	460.000	17.113	2.500	276.59	192.80	1.435	-45.2
1412		7.000	456.000	13.677	1.500	119.68	83.37	1.436	-19.6
1413		7.000	453.000	11.118	1.000	85.69	59.65	1.437	-14.1
1414		8.000	465.000	21.393	2.500	345.49	240.36	1.437	-57.0
1415		-1.000	461.000	22.400	1.000	98.31	68.42	1.437	-16.2
1416		-1.000	447.000	13.830	1.500	206.85	143.87	1.438	-34.2
1417		9.000	463.000	19.157	2.500	330.68	229.93	1.438	-54.7
1418		9.000	465.000	21.462	3.000	454.72	316.10	1.439	-75.4
1419		2.000	445.000	10.418	1.500	186.27	129.43	1.439	-30.9
1420		-2.000	462.000	23.811	1.000	99.32	69.02	1.439	-16.4
1421		0.000	464.000	24.307	1.500	137.86	95.83	1.439	-22.8
1422		3.000	463.000	22.094	2.000	209.84	145.68	1.440	-35.0
1423		-4.000	464.000	26.635	1.000	101.20	70.26	1.440	-16.8
1424		-3.000	463.000	25.223	1.000	100.18	69.53	1.441	-16.7
1425		0.000	451.000	15.288	1.000	117.37	81.37	1.442	-19.7
1426		8.000	452.000	9.707	1.000	82.90	57.47	1.442	-13.9
1427		9.000	457.000	14.134	2.500	249.26	172.71	1.443	-42.0
1428		-7.000	455.000	23.288	1.000	206.02	142.71	1.444	-34.7
1429		-6.000	454.000	21.895	1.000	200.90	139.15	1.444	-33.9
1430		-5.000	465.000	28.047	1.000	101.82	70.52	1.444	-17.1
1431		9.000	460.000	16.550	2.500	284.35	196.89	1.444	-48.0
1432		-5.000	453.000	20.505	1.000	195.83	135.65	1.444	-33.0
1433		10.000	453.000	9.945	2.000	159.70	110.42	1.446	-27.1
1434		1.000	463.000	22.896	1.500	135.66	93.76	1.447	-23.1
1435		-1.000	452.000	16.692	1.000	124.76	86.17	1.448	-21.3
1436		10.000	461.000	16.921	2.500	313.80	216.72	1.448	-53.7
1437		8.000	456.000	13.524	2.000	177.47	122.50	1.449	-30.4

* denotes the minimum safety factor and maximum prevention force.

No.	Reg.	Circular arc requirements				Skid resistance S (kN/m)	Sliding force T (kN/m)	Safety factor Fs	Required prevention force Pr (kN/m)
		Central coordinates		Radius r (m)	Max. depth (m)				
		X (m)	Y (m)						
1438		9.000	450.000	7.645	1.000	79.75	55.04	1.449	-13.7
1439		-4.000	452.000	19.116	1.000	190.25	131.33	1.449	-32.6
1440		-8.000	456.000	24.676	1.000	209.81	144.70	1.450	-36.1
1441		10.000	460.000	16.038	2.500	296.27	204.22	1.451	-51.2
1442		-10.000	459.000	28.094	1.000	205.96	141.93	1.451	-35.6
1443		9.000	464.000	20.054	2.500	347.87	239.52	1.452	-60.4
1444		6.000	459.000	17.104	2.000	192.42	132.47	1.453	-33.4
1445		2.000	462.000	21.485	1.500	133.85	92.03	1.454	-23.4
1446		0.000	446.000	12.466	1.500	200.93	138.16	1.454	-35.1
1447		8.000	455.000	12.266	1.500	116.59	80.21	1.454	-20.3
1448		4.000	462.000	20.684	2.000	205.86	141.53	1.455	-36.0
1449		10.000	462.000	17.819	2.500	332.29	228.35	1.455	-58.2
1450		-9.000	457.000	26.065	1.000	213.44	146.69	1.455	-37.4
1451		1.000	450.000	13.883	1.000	111.18	76.38	1.456	-19.5
1452		-9.000	458.000	26.689	1.000	200.67	137.70	1.457	-35.4
1453		2.000	465.000	24.264	2.000	218.24	149.65	1.458	-38.6
1454		9.000	458.000	14.911	2.500	257.38	176.34	1.460	-45.7
1455		9.000	459.000	15.718	2.500	270.33	185.06	1.461	-48.2
1456		10.000	464.000	20.147	3.000	459.66	314.42	1.462	-82.3
1457		10.000	455.000	11.964	2.500	233.87	160.00	1.462	-41.8
1458		-10.000	460.000	28.714	1.000	191.30	130.75	1.463	-34.4
1459		3.000	461.000	20.074	1.500	131.70	89.92	1.465	-23.7
1460		10.000	445.000	3.722	1.000	56.57	38.62	1.465	-10.2
1461		-9.000	459.000	27.309	1.000	187.02	127.58	1.466	-33.9
1462		-8.000	457.000	25.285	1.000	195.13	133.05	1.467	-35.4
1463		9.000	451.000	8.297	1.000	79.26	54.04	1.467	-14.4
1464		2.000	449.000	12.481	1.000	104.89	71.40	1.469	-19.2
1465		10.000	463.000	18.728	2.500	351.68	239.19	1.470	-64.6
1466		10.000	459.000	15.173	2.500	279.88	190.29	1.471	-51.5
1467		-3.000	451.000	17.701	1.000	180.52	122.69	1.471	-33.2
1468		-7.000	456.000	23.882	1.000	189.73	128.82	1.473	-35.1
1469		3.000	464.000	22.854	2.000	214.23	145.43	1.473	-39.7
1470		5.000	461.000	19.274	2.000	201.36	136.71	1.473	-37.3
1471		4.000	446.000	9.164	1.000	103.17	70.04	1.473	-19.1
1472		5.000	445.000	7.818	1.000	99.48	67.54	1.473	-18.4
1473		9.000	465.000	20.962	2.500	365.62	248.23	1.473	-67.7
1474		10.000	448.000	5.584	1.000	70.89	48.08	1.474	-13.1
1475		-8.000	458.000	25.905	1.000	182.35	123.74	1.474	-33.8
1476		10.000	449.000	6.235	1.000	73.78	50.06	1.474	-13.7
1477		9.000	454.000	10.855	1.500	113.28	76.84	1.474	-21.0
1478		-6.000	455.000	22.481	1.000	183.68	124.55	1.475	-34.2
1479		7.000	458.000	15.694	2.000	187.37	127.00	1.475	-34.9
1480		4.000	460.000	18.664	1.500	129.43	87.72	1.475	-24.1
1481		3.000	448.000	11.082	1.000	99.04	67.06	1.477	-18.5
1482		-7.000	457.000	24.500	1.000	177.68	120.22	1.478	-33.4

* denotes the minimum safety factor and maximum prevention force.

No.	Reg.	Circular arc requirements				Skid resistance S (kN/m)	Sliding force T (kN/m)	Safety factor Fs	Required prevention force Pr (kN/m)
		Central coordinates		Radius r (m)	Max. depth (m)				
		X (m)	Y (m)						
1483		-5.000	454.000	21.082	1.000	177.83	120.12	1.480	-33.6
1484		1.000	445.000	11.103	1.500	193.47	130.69	1.480	-36.6
1485		9.000	455.000	12.114	2.000	171.51	115.91	1.480	-32.4
1486		1.000	460.000	20.244	1.000	91.27	61.53	1.483	-17.4
1487		10.000	456.000	12.725	2.500	239.98	161.71	1.484	-45.9
1488		-3.000	464.000	25.898	1.000	95.54	64.32	1.485	-18.3
1489		-1.000	462.000	23.071	1.000	93.46	62.94	1.485	-17.9
1490		-2.000	463.000	24.484	1.000	94.58	63.67	1.485	-18.1
1491		-4.000	453.000	19.685	1.000	172.19	115.84	1.486	-33.1
1492		2.000	459.000	18.831	1.000	89.91	60.50	1.486	-17.3
1493		-4.000	465.000	27.311	1.000	96.39	64.85	1.486	-18.5
1494		0.000	461.000	21.657	1.000	92.37	62.17	1.486	-17.7
1495		3.000	458.000	17.418	1.000	88.47	59.50	1.487	-17.0
1496		5.000	459.000	17.254	1.500	126.85	85.23	1.488	-24.5
1497		-6.000	456.000	23.095	1.000	172.44	115.74	1.490	-33.5
1498		4.000	457.000	16.005	1.000	86.90	58.32	1.490	-16.9
1499		5.000	456.000	14.593	1.000	85.22	57.17	1.491	-16.6
1500		10.000	464.000	19.647	2.500	371.09	248.82	1.491	-72.5
1501		4.000	463.000	21.444	2.000	210.02	140.88	1.491	-40.9
1502		-3.000	452.000	18.290	1.000	166.57	111.62	1.492	-32.6
1503		10.000	458.000	14.329	2.500	263.39	176.54	1.492	-51.5
1504		-10.000	461.000	29.334	1.000	178.29	119.52	1.492	-34.8
1505		10.000	465.000	21.075	3.000	481.32	322.35	1.493	-94.5
1506		-9.000	460.000	27.929	1.000	174.60	116.98	1.493	-34.2
1507		6.000	455.000	13.181	1.000	83.43	55.88	1.493	-16.3
1508		-8.000	459.000	26.525	1.000	170.46	114.17	1.493	-33.4
1509		-7.000	458.000	25.120	1.000	166.18	111.12	1.496	-32.8
1510		10.000	450.000	6.887	1.000	75.34	50.37	1.496	-14.8
1511		6.000	460.000	17.864	2.000	196.65	131.49	1.496	-38.8
1512		4.000	447.000	9.689	1.000	92.51	61.81	1.497	-18.3
1513		10.000	457.000	13.511	2.500	249.52	166.73	1.497	-49.4
1514		7.000	454.000	11.770	1.000	81.32	54.34	1.497	-16.1
1515		10.000	447.000	4.962	1.000	69.04	46.08	1.498	-13.7
1516		3.000	447.000	10.530	1.000	109.67	73.20	1.498	-21.8
1517		10.000	446.000	4.342	1.000	64.38	42.94	1.499	-12.8
1518		-6.000	457.000	23.716	1.000	161.39	107.65	1.499	-32.2
1519		-2.000	450.000	16.287	1.000	170.44	113.69	1.499	-34.0
1520		3.000	465.000	23.623	2.000	220.00	146.68	1.500	-43.9
1521		-2.000	451.000	16.899	1.000	160.88	107.21	1.501	-32.2
1522		-5.000	455.000	21.691	1.000	166.98	111.20	1.502	-33.5
1523		8.000	453.000	10.359	1.000	79.03	52.60	1.502	-15.9
1524		6.000	458.000	15.844	1.500	124.44	82.86	1.502	-25.0
1525		10.000	453.000	9.445	1.500	109.49	72.85	1.503	-22.0
1526		-5.000	456.000	22.311	1.000	156.54	104.15	1.503	-31.5
1527		8.000	457.000	14.284	2.000	181.95	120.99	1.504	-36.7

* denotes the minimum safety factor and maximum prevention force.

No.	Reg.	Circular arc requirements				Skid resistance S (kN/m)	Sliding force T (kN/m)	Safety factor Fs	Required prevention force Pr (kN/m)
		Central coordinates		Radius r (m)	Max. depth (m)				
		X (m)	Y (m)						
1528		-1.000	450.000	15.513	1.000	155.37	103.16	1.506	-31.5
1529		0.000	449.000	14.132	1.000	149.98	99.57	1.506	-30.4
1530		0.000	465.000	25.064	1.500	141.06	93.65	1.506	-28.6
1531		1.000	448.000	12.760	1.000	144.85	96.03	1.508	-29.6
1532		5.000	446.000	8.303	1.000	86.19	57.17	1.508	-17.5
1533		-2.000	453.000	18.097	1.000	136.19	90.34	1.508	-27.7
1534		5.000	462.000	20.035	2.000	205.56	136.07	1.511	-42.2
1535		-4.000	454.000	20.286	1.000	160.40	106.10	1.512	-33.0
1536		-4.000	455.000	20.906	1.000	151.09	99.93	1.512	-31.1
1537		1.000	464.000	23.654	1.500	139.05	91.64	1.517	-29.0
1538		10.000	465.000	20.575	2.500	390.91	257.59	1.518	-81.8
1539		4.000	464.000	22.218	2.000	215.98	142.31	1.518	-45.2
1540		7.000	457.000	14.434	1.500	121.59	80.12	1.518	-25.4
1541		7.000	459.000	16.454	2.000	191.76	126.23	1.519	-40.2
1542		9.000	452.000	8.949	1.000	75.99	50.00	1.520	-15.9
1543		10.000	454.000	10.704	2.000	164.79	108.45	1.520	-34.6
1544		2.000	448.000	11.908	1.000	117.51	77.21	1.522	-24.8
1545		-3.000	453.000	18.883	1.000	153.81	101.09	1.522	-32.5
1546		7.000	465.000	21.367	2.000	250.04	164.19	1.523	-53.0
1547		-3.000	454.000	19.502	1.000	145.33	95.35	1.524	-30.9
1548		6.000	445.000	6.930	1.000	79.86	52.41	1.524	-16.9
1549		6.000	465.000	21.880	2.000	238.66	156.25	1.527	-51.1
1550		2.000	463.000	22.244	1.500	137.19	89.76	1.528	-29.4
1551		8.000	465.000	20.893	2.000	264.40	173.08	1.528	-56.7
1552		-3.000	465.000	26.594	1.000	91.93	60.13	1.529	-19.7
1553		-2.000	452.000	17.481	1.000	147.10	96.13	1.530	-31.7
1554		-2.000	446.000	13.542	1.500	159.54	104.25	1.530	-34.4
1555		-2.000	464.000	25.180	1.000	90.97	59.45	1.530	-19.6
1556		8.000	464.000	20.008	2.000	250.55	163.60	1.531	-54.2
1557		5.000	465.000	22.428	2.000	231.09	150.89	1.532	-50.0
1558		-1.000	463.000	23.765	1.000	89.91	58.67	1.532	-19.5
1559		6.000	461.000	18.627	2.000	201.11	131.25	1.532	-43.6
1560		4.000	465.000	23.010	2.000	224.97	146.78	1.533	-48.8
1561		10.000	451.000	7.539	1.000	72.80	47.45	1.534	-15.8
1562		-1.000	449.000	14.873	1.000	160.06	104.30	1.535	-34.9
1563		9.000	464.000	19.554	2.000	267.57	174.36	1.535	-58.3
1564		5.000	463.000	20.814	2.000	212.19	138.12	1.536	-46.4
1565		1.000	461.000	20.937	1.000	87.58	56.97	1.537	-19.2
1566		0.000	462.000	22.351	1.000	88.62	57.65	1.537	-19.4
1567		7.000	464.000	20.504	2.000	238.07	154.93	1.537	-52.1
1568		9.000	456.000	12.874	2.000	175.87	114.34	1.538	-38.6
1569		9.000	463.000	18.657	2.000	252.13	163.86	1.539	-55.4
1570		2.000	460.000	19.523	1.000	86.39	56.15	1.539	-19.0
1571		8.000	456.000	13.024	1.500	118.19	76.76	1.540	-26.0
1572		9.000	465.000	20.462	2.000	283.32	183.80	1.541	-62.7

* denotes the minimum safety factor and maximum prevention force.

No.	Reg.	Circular arc requirements				Skid resistance S (kN/m)	Sliding force T (kN/m)	Safety factor Fs	Required prevention force Pr (kN/m)
		Central coordinates		Radius r (m)	Max. depth (m)				
		X (m)	Y (m)						
1573		-1.000	451.000	16.082	1.000	140.50	91.16	1.541	-31.1
1574		3.000	462.000	20.834	1.500	134.90	87.41	1.543	-30.0
1575		-1.000	445.000	12.145	1.500	153.59	99.52	1.543	-34.1
1576		3.000	459.000	18.108	1.000	84.91	54.98	1.544	-18.9
1577		10.000	463.000	18.228	2.000	271.28	175.75	1.544	-60.3
1578		2.000	447.000	11.353	1.000	134.00	86.75	1.545	-29.9
1579		1.000	449.000	13.294	1.000	126.02	81.50	1.546	-28.2
1580		5.000	464.000	21.612	2.000	221.88	143.43	1.547	-49.7
1581		6.000	464.000	21.040	2.000	228.82	147.95	1.547	-51.2
1582		8.000	463.000	19.134	2.000	237.51	153.57	1.547	-53.2
1583		4.000	458.000	16.694	1.000	83.35	53.80	1.549	-18.7
1584		10.000	462.000	17.319	2.000	253.98	163.90	1.550	-57.3
1585		10.000	464.000	19.147	2.000	288.97	186.30	1.551	-65.4
1586		8.000	458.000	15.044	2.000	185.97	119.89	1.551	-42.1
1587		0.000	450.000	14.686	1.000	133.61	86.11	1.552	-30.2
1588		-3.000	448.000	15.750	1.500	196.07	126.08	1.555	-44.7
1589		5.000	457.000	15.280	1.000	81.64	52.48	1.556	-18.6
1590		6.000	462.000	19.411	2.000	208.22	133.78	1.556	-47.6
1591		9.000	462.000	17.773	2.000	237.13	152.30	1.557	-54.3
1592		4.000	461.000	19.424	1.500	132.52	85.04	1.558	-30.4
1593		7.000	460.000	17.220	2.000	196.12	125.86	1.558	-45.0
1594		7.000	463.000	19.655	2.000	226.83	145.22	1.562	-52.5
1595		6.000	456.000	13.866	1.000	79.77	51.06	1.562	-18.4
1596		6.000	463.000	20.216	2.000	218.41	139.54	1.565	-50.9
1597		10.000	465.000	20.075	2.000	306.54	195.75	1.566	-71.6
1598		7.000	455.000	12.452	1.000	77.88	49.73	1.566	-18.2
1599		10.000	461.000	16.421	2.000	237.46	151.37	1.569	-55.8
1600		9.000	455.000	11.614	1.500	114.39	72.92	1.569	-26.8
1601		-2.000	465.000	25.896	1.000	88.48	56.29	1.572	-20.9
1602		8.000	454.000	11.037	1.000	75.61	48.02	1.575	-17.9
1603		5.000	460.000	18.014	1.500	129.90	82.41	1.576	-31.0
1604		-2.000	447.000	14.359	1.500	188.48	119.62	1.576	-44.9
1605		0.000	448.000	13.459	1.000	149.38	94.65	1.578	-35.8
1606		8.000	462.000	18.276	2.000	224.78	142.37	1.579	-53.9
1607		-1.000	464.000	24.482	1.000	87.25	55.26	1.579	-20.9
1608		10.000	455.000	11.464	2.000	169.45	107.27	1.580	-40.7
1609		0.000	463.000	23.069	1.000	86.27	54.56	1.581	-20.7
1610		7.000	461.000	18.011	2.000	203.62	128.77	1.581	-49.0
1611		7.000	462.000	18.823	2.000	214.81	135.43	1.586	-52.2
1612		9.000	457.000	13.634	2.000	179.89	113.34	1.587	-43.8
1613		1.000	465.000	24.414	1.500	142.16	89.56	1.587	-34.6
1614		8.000	459.000	15.815	2.000	190.92	120.26	1.588	-46.6
1615		3.000	446.000	9.941	1.000	122.02	76.79	1.589	-29.8
1616		1.000	462.000	21.655	1.000	84.99	53.46	1.590	-20.8
1617		9.000	453.000	9.623	1.000	72.87	45.83	1.590	-17.8

* denotes the minimum safety factor and maximum prevention force.

No.	Reg.	Circular arc requirements				Skid resistance S (kN/m)	Sliding force T (kN/m)	Safety factor Fs	Required prevention force Pr (kN/m)
		Central coordinates		Radius r (m)	Max. depth (m)				
		X (m)	Y (m)						
1618		2.000	461.000	20.242	1.000	83.88	52.62	1.594	-20.7
1619		9.000	461.000	16.903	2.000	223.28	139.91	1.596	-55.3
1620		6.000	459.000	16.604	1.500	127.09	79.56	1.597	-31.6
1621		3.000	460.000	18.828	1.000	82.71	51.75	1.598	-20.6
1622		10.000	454.000	10.204	1.500	110.17	68.81	1.601	-27.5
1623		2.000	464.000	23.004	1.500	139.98	87.36	1.602	-35.1
1624		4.000	459.000	17.415	1.000	81.38	50.76	1.603	-20.4
1625		8.000	461.000	17.434	2.000	211.56	131.78	1.605	-53.4
1626		8.000	460.000	16.613	2.000	199.70	124.36	1.606	-50.4
1627		-1.000	446.000	12.975	1.500	180.92	112.57	1.607	-45.8
1628		-2.000	449.000	15.562	1.000	162.67	101.00	1.611	-41.4
1629		10.000	452.000	8.209	1.000	69.90	43.40	1.611	-17.8
1630		10.000	460.000	15.538	2.000	221.93	137.66	1.612	-56.7
1631		5.000	458.000	16.002	1.000	79.74	49.42	1.614	-20.4
1632		4.000	445.000	8.530	1.000	107.90	66.65	1.619	-27.9
1633		-3.000	450.000	16.930	1.000	165.65	102.23	1.620	-42.9
1634		-1.000	465.000	25.219	1.000	85.70	52.88	1.621	-22.2
1635		3.000	463.000	21.594	1.500	137.70	84.96	1.621	-35.7
1636		7.000	458.000	15.194	1.500	123.90	76.40	1.622	-32.2
1637		9.000	458.000	14.411	2.000	185.56	114.33	1.623	-48.3
1638		6.000	457.000	14.590	1.000	77.98	47.92	1.627	-20.4
1639		0.000	464.000	23.807	1.000	84.70	52.02	1.628	-22.2
1640		-4.000	451.000	18.304	1.000	168.79	103.70	1.628	-44.3
1641		9.000	460.000	16.050	2.000	208.17	127.62	1.631	-55.0
1642		-5.000	452.000	19.685	1.000	172.73	105.83	1.632	-45.7
1643		1.000	447.000	12.045	1.000	138.24	84.69	1.632	-36.6
1644		10.000	456.000	12.225	2.000	173.11	106.01	1.633	-45.8
1645		1.000	463.000	22.396	1.000	83.73	51.25	1.634	-22.2
1646		7.000	456.000	13.177	1.000	76.30	46.65	1.636	-20.3
1647		9.000	459.000	15.218	2.000	194.95	119.09	1.637	-52.0
1648		4.000	462.000	20.184	1.500	135.04	82.27	1.641	-36.3
1649		-6.000	453.000	21.070	1.000	176.48	107.56	1.641	-47.4
1650		0.000	445.000	11.599	1.500	173.99	105.95	1.642	-46.8
1651		2.000	462.000	20.985	1.000	82.67	50.35	1.642	-22.2
1652		-9.000	456.000	25.247	1.000	188.55	114.83	1.642	-50.7
1653		-1.000	448.000	14.161	1.000	154.26	93.97	1.642	-41.4
1654		-7.000	454.000	22.460	1.000	180.36	109.87	1.642	-48.5
1655		-8.000	455.000	23.852	1.000	184.33	112.09	1.644	-49.8
1656		8.000	455.000	11.766	1.000	74.35	45.11	1.648	-20.2
1657		8.000	457.000	13.784	1.500	120.61	73.10	1.650	-32.8
1658		10.000	459.000	14.673	2.000	205.11	123.87	1.656	-56.4
1659		3.000	461.000	19.574	1.000	81.33	49.12	1.656	-22.3
1660		5.000	461.000	18.774	1.500	132.40	79.61	1.663	-36.8
1661		4.000	460.000	18.164	1.000	80.18	48.17	1.665	-22.3
1662		9.000	454.000	10.355	1.000	72.23	43.38	1.665	-20.1

* denotes the minimum safety factor and maximum prevention force.

No.	Reg.	Circular arc requirements				Skid resistance S (kN/m)	Sliding force T (kN/m)	Safety factor Fs	Required prevention force Pr (kN/m)
		Central coordinates		Radius r (m)	Max. depth (m)				
		X (m)	Y (m)						
1663		10.000	457.000	13.011	2.000	179.58	107.82	1.666	-50.1
1664		10.000	465.000	19.575	1.500	228.89	137.20	1.668	-64.2
1665		10.000	458.000	13.829	2.000	190.36	113.95	1.671	-53.6
1666		0.000	465.000	24.564	1.000	83.77	50.11	1.672	-23.6
1667		5.000	459.000	16.754	1.000	78.91	47.10	1.675	-22.3
1668		10.000	464.000	18.647	1.500	213.18	127.10	1.677	-60.6
1669		2.000	465.000	23.764	1.500	142.35	84.85	1.678	-40.5
1670		1.000	464.000	23.154	1.000	82.75	49.22	1.681	-23.6
1671		9.000	465.000	19.962	1.500	207.60	123.16	1.686	-59.8
1672		9.000	456.000	12.374	1.500	116.82	69.29	1.686	-33.6
1673		6.000	458.000	15.344	1.000	77.48	45.89	1.688	-22.4
1674		10.000	453.000	8.945	1.000	69.73	41.25	1.690	-20.2
1675		2.000	463.000	21.744	1.000	81.79	48.37	1.691	-23.7
1676		6.000	460.000	17.364	1.500	129.11	76.28	1.693	-37.5
1677		0.000	447.000	12.746	1.000	143.79	84.83	1.695	-41.9
1678		2.000	446.000	10.631	1.000	126.78	74.72	1.697	-37.1
1679		3.000	464.000	22.354	1.500	139.93	82.40	1.698	-41.0
1680		10.000	463.000	17.728	1.500	197.55	115.77	1.706	-58.6
1681		3.000	462.000	20.334	1.000	80.45	47.09	1.708	-23.9
1682		7.000	457.000	13.934	1.000	75.71	44.33	1.708	-22.5
1683		7.000	459.000	15.954	1.500	126.18	73.45	1.718	-38.0
1684		9.000	464.000	19.054	1.500	193.26	112.39	1.720	-58.3
1685		4.000	463.000	20.944	1.500	137.05	79.57	1.722	-41.5
1686		8.000	456.000	12.524	1.000	74.08	42.91	1.726	-22.5
1687		4.000	461.000	18.924	1.000	79.05	45.80	1.726	-24.0
1688		8.000	465.000	20.393	1.500	190.41	110.22	1.728	-58.1
1689		10.000	455.000	10.964	1.500	112.42	64.80	1.735	-34.6
1690		5.000	460.000	17.514	1.000	77.71	44.58	1.743	-24.2
1691		1.000	465.000	23.914	1.000	80.86	46.36	1.744	-25.2
1692		5.000	462.000	19.535	1.500	134.27	76.64	1.752	-42.3
1693		9.000	455.000	11.114	1.000	71.95	41.02	1.754	-22.7
1694		8.000	458.000	14.544	1.500	122.41	69.66	1.757	-38.8
1695		2.000	464.000	22.504	1.000	79.69	45.32	1.758	-25.3
1696		10.000	462.000	16.819	1.500	182.24	103.19	1.766	-58.4
1697		3.000	465.000	23.123	1.500	143.05	80.82	1.770	-46.0
1698		6.000	459.000	16.104	1.000	75.92	42.90	1.770	-24.4
1699		1.000	446.000	11.332	1.000	133.02	75.04	1.773	-42.9
1700		3.000	463.000	21.094	1.000	78.44	44.11	1.778	-25.5
1701		9.000	463.000	18.157	1.500	179.65	101.00	1.779	-58.4
1702		6.000	461.000	18.127	1.500	131.40	73.77	1.781	-42.8
1703		3.000	445.000	9.216	1.000	114.55	64.25	1.783	-37.4
1704		10.000	454.000	9.704	1.000	69.51	38.84	1.790	-22.9
1705		8.000	464.000	19.508	1.500	177.86	99.38	1.790	-58.6
1706		7.000	458.000	14.694	1.000	74.24	41.43	1.792	-24.5
1707		4.000	464.000	21.718	1.500	140.79	78.48	1.794	-46.6

* denotes the minimum safety factor and maximum prevention force.

No.	Reg.	Circular arc requirements				Skid resistance S (kN/m)	Sliding force T (kN/m)	Safety factor Fs	Required prevention force Pr (kN/m)
		Central coordinates		Radius r (m)	Max. depth (m)				
		X (m)	Y (m)						
1708		-6.000	452.000	20.248	1.000	120.49	67.11	1.795	-39.9
1709		7.000	465.000	20.867	1.500	176.74	98.40	1.796	-58.6
1710		-8.000	454.000	23.042	1.000	124.70	69.44	1.796	-41.3
1711		0.000	445.000	11.099	1.000	102.71	57.16	1.797	-34.1
1712		-7.000	453.000	21.644	1.000	122.26	67.93	1.800	-40.7
1713		4.000	462.000	19.684	1.000	76.92	42.69	1.802	-25.6
1714		-9.000	455.000	24.442	1.000	126.51	70.15	1.803	-42.3
1715		9.000	457.000	13.134	1.500	118.22	65.47	1.806	-39.6
1716		-1.000	446.000	12.475	1.000	104.29	57.63	1.810	-35.1
1717		-3.000	448.000	15.250	1.000	109.15	60.20	1.813	-36.9
1718		-2.000	447.000	13.859	1.000	106.60	58.75	1.814	-36.1
1719		7.000	460.000	16.720	1.500	128.26	70.67	1.815	-43.4
1720		-5.000	450.000	18.042	1.000	114.15	62.75	1.819	-38.8
1721		-4.000	449.000	16.644	1.000	111.32	61.16	1.820	-37.9
1722		5.000	463.000	20.314	1.500	138.37	76.00	1.821	-47.1
1723		8.000	457.000	13.284	1.000	72.42	39.75	1.822	-24.7
1724		-7.000	452.000	20.845	1.000	119.39	65.50	1.823	-40.7
1725		5.000	461.000	18.274	1.000	75.26	41.12	1.830	-25.9
1726		2.000	465.000	23.264	1.000	76.88	41.91	1.834	-26.5
1727		4.000	465.000	22.510	1.500	146.76	79.51	1.846	-51.3
1728		-6.000	450.000	18.657	1.000	114.82	62.17	1.847	-40.2
1729		-5.000	449.000	17.251	1.000	111.30	60.09	1.852	-39.1
1730		6.000	462.000	18.911	1.500	135.78	73.21	1.855	-47.9
1731		8.000	459.000	15.315	1.500	125.00	67.28	1.858	-44.2
1732		10.000	456.000	11.725	1.500	113.87	61.21	1.860	-40.4
1733		-4.000	448.000	15.846	1.000	107.90	58.00	1.860	-38.3
1734		6.000	460.000	16.864	1.000	73.39	39.37	1.864	-26.1
1735		3.000	464.000	21.854	1.000	75.30	40.40	1.864	-26.8
1736		9.000	456.000	11.874	1.000	70.06	37.54	1.866	-25.0
1737		5.000	464.000	21.112	1.500	144.90	77.44	1.871	-51.9
1738		2.000	445.000	9.918	1.000	122.10	65.21	1.872	-43.8
1739		-3.000	447.000	14.443	1.000	104.12	55.63	1.872	-37.3
1740		10.000	461.000	15.921	1.500	167.70	89.51	1.874	-60.2
1741		-2.000	446.000	13.042	1.000	100.57	53.50	1.880	-36.3
1742		6.000	465.000	21.380	1.500	165.75	88.08	1.882	-60.0
1743		9.000	462.000	17.273	1.500	166.61	88.42	1.884	-60.5
1744		8.000	463.000	18.634	1.500	166.20	88.08	1.887	-60.5
1745		5.000	465.000	21.928	1.500	154.19	81.73	1.887	-56.1
1746		7.000	461.000	17.511	1.500	133.40	70.70	1.887	-48.5
1747		7.000	464.000	20.004	1.500	165.64	87.74	1.888	-60.3
1748		-1.000	445.000	11.645	1.000	97.07	51.41	1.888	-35.3
1749		6.000	463.000	19.716	1.500	143.07	75.47	1.896	-52.5
1750		4.000	463.000	20.444	1.000	73.69	38.84	1.897	-27.0
1751		7.000	459.000	15.454	1.000	71.44	37.54	1.903	-26.3
1752		6.000	464.000	20.540	1.500	153.18	80.46	1.904	-56.6

* denotes the minimum safety factor and maximum prevention force.

No.	Reg.	Circular arc requirements				Skid resistance S (kN/m)	Sliding force T (kN/m)	Safety factor Fs	Required prevention force Pr (kN/m)
		Central coordinates		Radius r (m)	Max. depth (m)				
		X (m)	Y (m)						
1753		9.000	458.000	13.911	1.500	121.44	63.67	1.907	-45.0
1754		10.000	465.000	19.075	1.000	158.63	82.87	1.914	-59.1
1755		10.000	455.000	10.464	1.000	67.52	35.25	1.915	-25.2
1756		-3.000	446.000	13.663	1.000	101.78	52.91	1.924	-38.2
1757		7.000	463.000	19.155	1.500	151.95	78.96	1.924	-57.1
1758		7.000	462.000	18.323	1.500	141.13	73.30	1.925	-53.1
1759		8.000	460.000	16.113	1.500	130.46	67.66	1.928	-49.2
1760		5.000	462.000	19.035	1.000	72.01	37.32	1.930	-27.2
1761		8.000	462.000	17.776	1.500	151.19	78.01	1.938	-57.5
1762		-2.000	445.000	12.255	1.000	96.36	49.57	1.944	-36.8
1763		8.000	458.000	14.044	1.000	69.28	35.59	1.947	-26.5
1764		9.000	461.000	16.403	1.500	150.65	77.25	1.950	-57.9
1765		8.000	461.000	16.934	1.500	139.41	71.36	1.954	-53.7
1766		3.000	465.000	22.623	1.000	72.32	36.99	1.955	-27.9
1767		10.000	460.000	15.038	1.500	150.35	76.75	1.959	-58.2
1768		10.000	457.000	12.511	1.500	117.79	60.02	1.963	-45.7
1769		6.000	461.000	17.627	1.000	70.21	35.66	1.969	-27.4
1770		9.000	459.000	14.718	1.500	127.78	64.76	1.973	-50.0
1771		9.000	460.000	15.550	1.500	137.72	69.48	1.982	-54.3
1772		4.000	464.000	21.218	1.000	70.83	35.59	1.990	-28.1
1773		9.000	457.000	12.634	1.000	66.97	33.63	1.991	-26.6
1774		10.000	459.000	14.173	1.500	136.01	67.60	2.012	-54.8
1775		7.000	460.000	16.220	1.000	68.18	33.87	2.013	-27.5
1776		10.000	464.000	18.147	1.000	144.17	71.57	2.014	-58.2
1777		10.000	458.000	13.329	1.500	125.15	62.02	2.018	-50.7
1778		5.000	463.000	19.814	1.000	69.04	33.96	2.033	-28.2
1779		10.000	456.000	11.225	1.000	64.22	31.15	2.062	-26.8
1780		8.000	459.000	14.815	1.000	65.86	31.70	2.078	-27.8
1781		6.000	462.000	18.411	1.000	67.33	32.38	2.079	-28.4
1782		4.000	465.000	22.010	1.000	68.41	32.81	2.085	-29.0
1783		9.000	465.000	19.462	1.000	138.49	66.28	2.089	-58.9
1784		7.000	461.000	17.011	1.000	65.30	30.51	2.140	-28.6
1785		9.000	458.000	13.411	1.000	63.65	29.73	2.141	-27.9
1786		10.000	463.000	17.228	1.000	130.62	59.69	2.188	-58.9
1787		8.000	460.000	15.613	1.000	63.54	28.83	2.204	-28.9
1788		10.000	457.000	12.011	1.000	61.31	27.56	2.225	-28.2
1789		5.000	464.000	20.612	1.000	70.35	31.28	2.249	-32.8
1790		9.000	464.000	18.554	1.000	126.43	55.21	2.290	-60.1
1791		9.000	459.000	14.218	1.000	63.72	27.04	2.357	-31.2
1792		6.000	463.000	19.216	1.000	71.62	30.02	2.386	-35.5
1793		8.000	465.000	19.893	1.000	122.53	50.97	2.404	-61.3
1794		10.000	462.000	16.319	1.000	115.46	46.27	2.495	-59.9
1795		7.000	462.000	17.823	1.000	72.08	28.54	2.526	-37.8
1796		10.000	458.000	12.829	1.000	64.16	25.05	2.561	-34.1
1797		9.000	463.000	17.657	1.000	111.64	43.17	2.586	-59.8

* denotes the minimum safety factor and maximum prevention force.

No.	Reg.	Circular arc requirements				Skid resistance S (kN/m)	Sliding force T (kN/m)	Safety factor Fs	Required prevention force Pr (kN/m)
		Central coordinates		Radius r (m)	Max. depth (m)				
		X (m)	Y (m)						
1798		5.000	465.000	21.428	1.000	80.12	30.54	2.623	-43.4
1799		8.000	461.000	16.434	1.000	72.57	27.33	2.655	-39.7
1800		8.000	464.000	19.008	1.000	108.40	40.71	2.663	-59.5
1801		6.000	464.000	20.040	1.000	80.75	29.73	2.716	-45.0
1802		7.000	465.000	20.367	1.000	105.66	38.75	2.727	-59.1
1803		10.000	461.000	15.421	1.000	98.84	35.98	2.747	-55.6
1804		9.000	460.000	15.050	1.000	72.96	26.23	2.782	-41.4
1805		7.000	463.000	18.655	1.000	81.56	29.22	2.791	-46.4
1806		9.000	462.000	16.773	1.000	96.15	34.17	2.814	-55.1
1807		6.000	465.000	20.880	1.000	91.05	32.15	2.832	-52.4
1808		8.000	463.000	18.134	1.000	94.25	33.24	2.835	-54.3
1809		7.000	464.000	19.504	1.000	92.46	32.53	2.842	-53.4
1810		8.000	462.000	17.276	1.000	82.30	28.67	2.871	-47.8
1811		10.000	459.000	13.673	1.000	73.60	25.45	2.892	-43.0
1812		9.000	461.000	15.903	1.000	83.42	28.64	2.913	-49.0
1813		10.000	460.000	14.538	1.000	84.85	28.95	2.931	-50.1

* denotes the minimum safety factor and maximum prevention force.

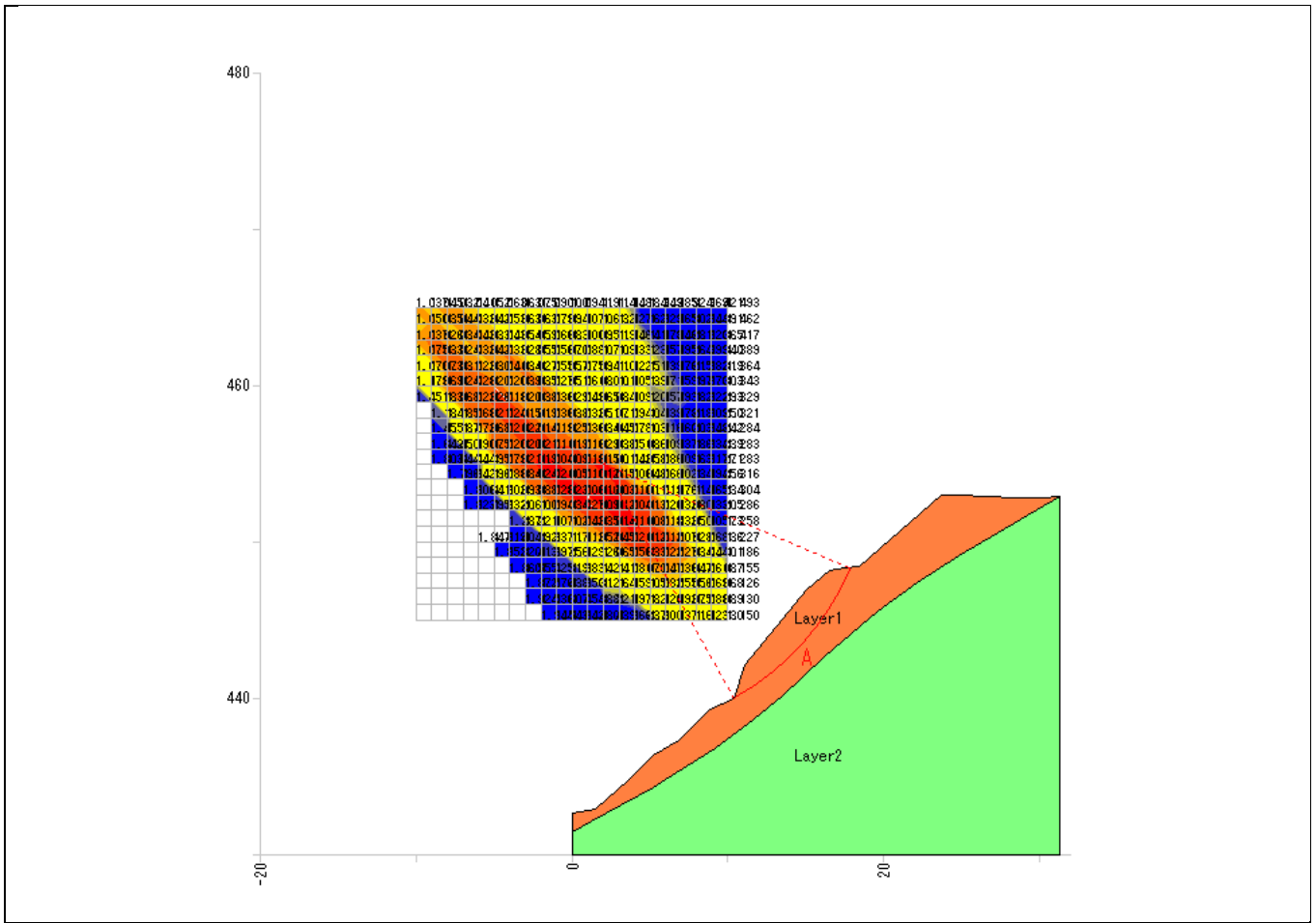

Isoline Map (Minimum Safety Factor - Normally)

Stability Analysis

Site	KANDY UPPER
Case	Line E, Pr(max)
Remarks	ϕ 34 C6

Site	KANDY
Case	Line E, Pr(max)
Remarks	φ 34 C6

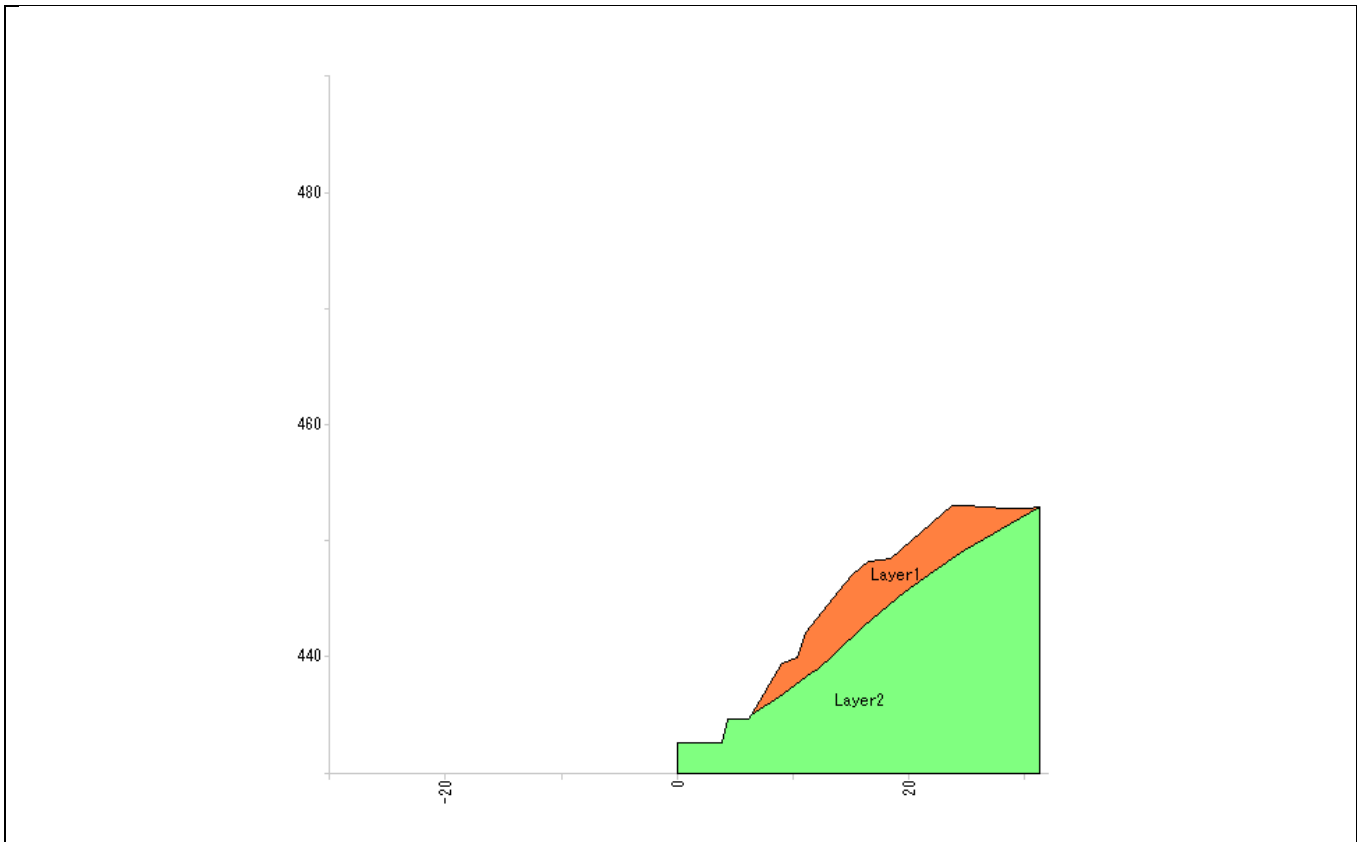

Soil constant		Soil quality	Wet weight γ_t (kN/m ³)	Saturated weight γ_{sat} (kN/m ³)	Cohesion C (kN/m ²)	Internal friction angle	
No.	Geology					ϕ (°)	$\tan\phi$
1	Layer1		17.00	17.00	6.00	34.0000	0.674509
2	Layer2		24.00	24.00	1000.00	38.0000	0.781286

* Unit weight of water $\gamma_w = 9.80$ (kN/m³)

Coordinate input data								
No.	Distance X (m)	Original topographic altitude Y _G (m)	Planned topographic altitude Y (m)	Water level altitude Y _W (m)	Sliding surface			Launching
					Altitude Y _S (m)	Shape	Strength	
1	0.000		432.587					
2	2.144		432.587					
3	3.962		432.587					
4	4.426		434.587					
5	6.226		434.587					
6	6.437		435.010					
7	9.102		439.381					
8	10.410		439.940					
9	11.160		442.078					
10	13.520		445.064					
11	15.120		446.925					
12	16.560		448.157					
13	17.581		448.300					
14	18.490		448.426					
15	23.710		452.961					
16	24.820		452.987					
17	28.440		452.779					
18	30.210		452.780					
19	31.260		452.850					

Coordinates of stratum boundary line		
No.	No.1	
	X (m)	Y (m)
1	6.437	435.010
2	9.220	436.770
3	11.670	438.560
4	12.200	439.000
5	13.520	440.140
6	16.190	442.670
7	19.700	445.530
8	22.130	447.340
9	24.820	449.120
10	31.260	452.850

2. Design Requirements

2.4. Planned Safety Factor of the Reinforcement Slope

Considering the site as permanent construction, set a planned safety factor.

The Cut Earth Reinforcement Method, Design and Construction Procedures prescribes as follows.

Planned safety factor of the reinforcement slope

Item	Planned safety factor
Permanent construction (long term)	$F_{sp} \geq 1.20$
Temporary construction (short term)	$F_{sp} \geq 1.05, 1.10$

[Cut Earth Reinforcement Method, Design and Construction Procedures Page 31]

Taking account of the importance of the said slope, the planned safety factor shall be $F_{sp} = 1.200$.

2.5. Soil Quality Requirements

The following shows the geological and soil composition and constants of the said slope.

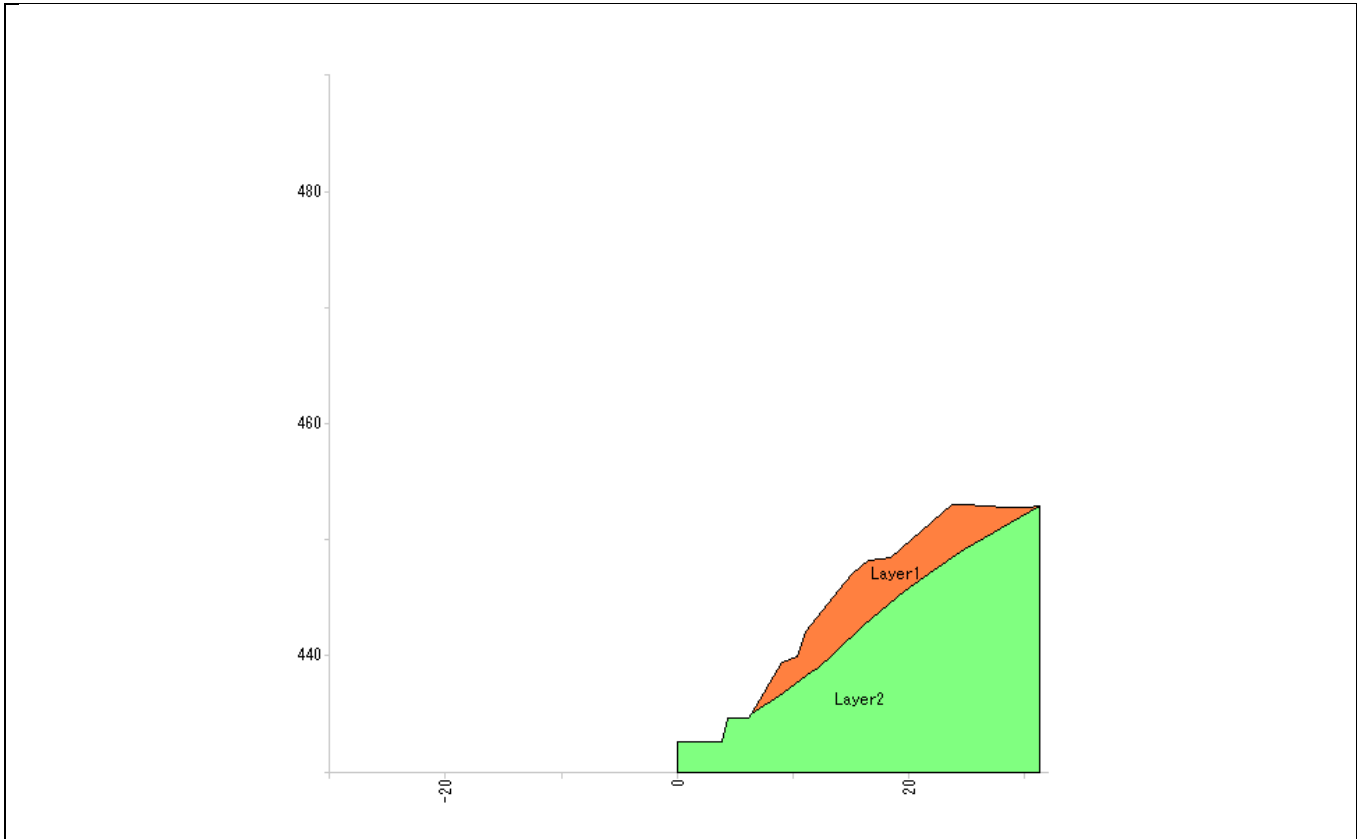

Soil constant							
No.	Geology	Soil quality	Wet weight γ_t (kN/m ³)	Saturated weight γ_{sat} (kN/m ³)	Cohesion C (kN/m ²)	Internal friction angle	
						ϕ (°)	$\tan\phi$
1	Layer1		17.00	17.00	6.00	34.0000	0.674509
2	Layer2		24.00	24.00	1000.00	38.0000	0.781286

* Unit weight of water $\gamma_w = 9.80$ (kN/m³)

3. Repeated Circular Calculation

As a result of studying with repeated circular slip as to slope stability, it is determined that the following sliding surface is most dangerous.

< Circular arc A >

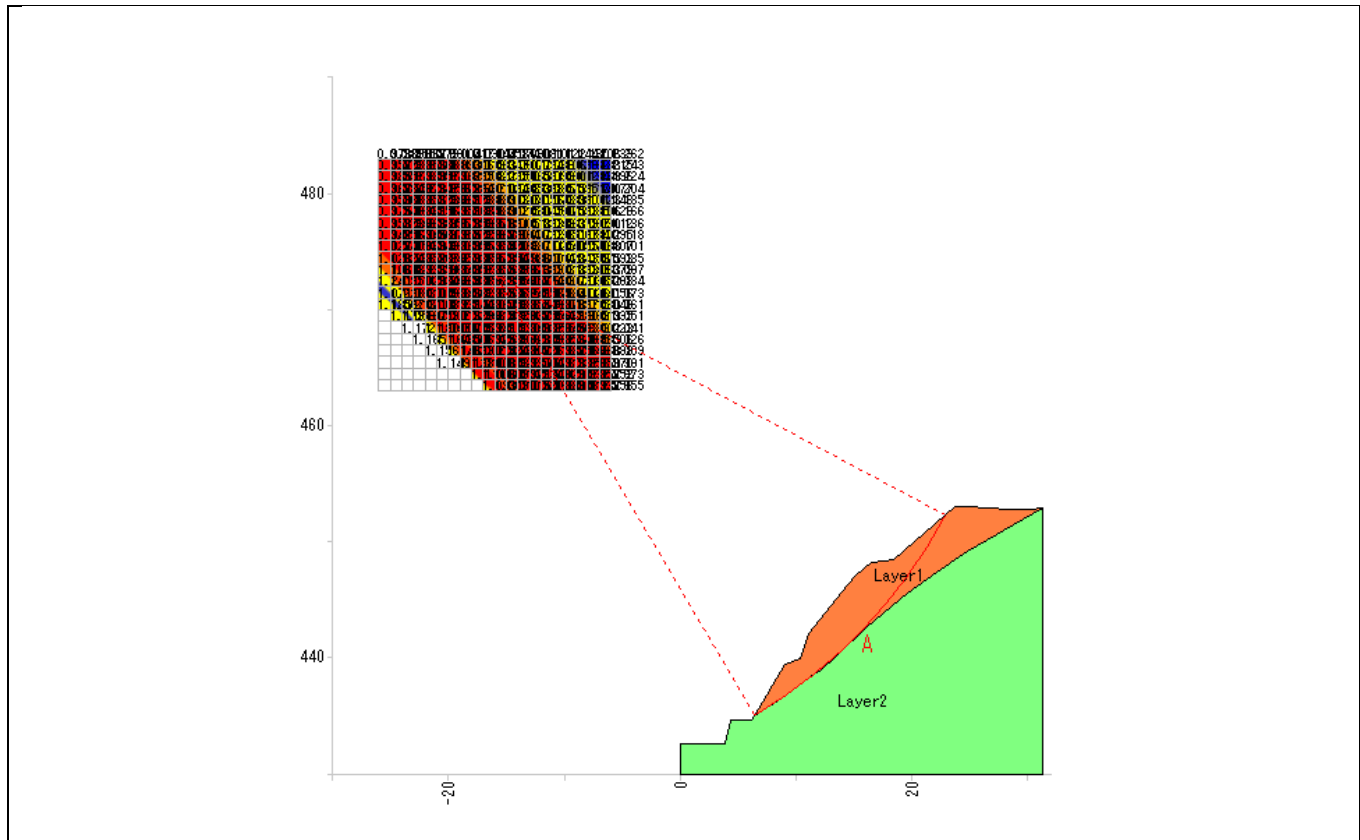

Stability calculation results				
Item		Symbol	Unit	Normally
Calculation results	Safety factor	Fs	-	0.939
	Planned safety factor	Fsp	-	1.200
	Required prevention force	Pr	kN/m	152.3
Circular arc	Central coordinates	X	m	-16.000
		Y	m	473.000
	Radius	r	m	44.097
Calculation elements	Skid resistance	S	kN/m	548.96
	Sliding force	T	kN/m	584.35
	Normal force	N	kN/m	599.26
	Pore water pressure	U	kN/m	0.00
	Sliding surface length	l	m	24.126
	Area	A	m ²	49.55

3.1. Stability Calculation Formula

Stability calculation is conducted using the Fellenius method.

Basically, the limit balance method shall be used to secure the required planned safety factor.

$$\text{Safety factor (Fs)} = \frac{\text{Skid resistance } (\Sigma S)}{\text{Sliding force } (\Sigma T)}$$

Concerning the calculation method, the cross section of the sliding clod shall be split into several slices based on the “slicing method” to consider the balance of force on each slice (split piece).

< Normally >

$$F_s = \frac{\Sigma\{(N-U)\cdot\tan\phi\}+\Sigma(C\cdot l)}{\Sigma T}$$

$$Pr = F_{sp}\cdot\Sigma T - [\Sigma\{(N-U)\cdot\tan\phi\}+\Sigma(C\cdot l)]$$

where;

F _s	:	Safety factor	
F _{sp}	:	Planned safety factor	
Pr	:	Required prevention force	(kN/m)
N	:	Normal force by gravity of slice	(N = W·cosθ+Q _N) (kN/m)
U	:	Pore water pressure working on slice	(U = u·l) (kN/m)
T	:	Tangential force by gravity of slice	(T = W·sinθ+Q _T) (kN/m)
l	:	Sliding surface length of slice	(m)
φ	:	Internal friction angle of sliding surface	(°)
C	:	Cohesion of sliding surface	(kN/m ²)
W	:	Slice weight	(kN/m)
θ	:	Sliding surface inclination angle	(°)
u	:	Unit pore water pressure	(kN/m ²)
Q _N	:	Vertical load component force (normal direction)	(kN/m)
Q _T	:	Vertical load component force (tangential direction)	(kN/m)

3.2. Stability Evaluation (Normally)

< Circular arc A >

Slice element summary table			Sliding surface length l (m)	Normal force N (kN/m)	Pore water pressure U (kN/m)	Sliding force T (kN/m)	Skid resistance S (kN/m)
Internal friction angle		Cohesion C (kN/m ²)					
φ(°)	tanφ						
34.0000	0.674509	6.00	24.126	599.26	0.00	584.35	548.96

The safety factor is calculated by the following formula.

$$\begin{aligned}
 F_s &= \frac{\Sigma\{(N-U)\cdot\tan\phi\}+\Sigma(C\cdot l)}{\Sigma T} \\
 &= \frac{(599.26-0.00)\times 0.674509+6.00\times 24.126}{584.35} \\
 &= 0.939
 \end{aligned}$$

where;

F _s	: Safety factor		
N	: Normal force by gravity of slice	(N = W·cosθ+Q _N)	(kN/m)
U	: Pore water pressure working on slice	(U = u·l)	(kN/m)
T	: Tangential force by gravity of slice	(T = W·sinθ+Q _T)	(kN/m)
l	: Sliding surface length of slice		(m)
φ	: Internal friction angle of sliding surface		(°)
C	: Cohesion of sliding surface		(kN/m ²)
W	: Slice weight		(kN/m)
θ	: Sliding surface inclination angle		(°)
u	: Unit pore water pressure		(kN/m ²)
Q _N	: Vertical load component force (normal direction)		(kN/m)
Q _T	: Vertical load component force (tangential direction)		(kN/m)

3.3. Calculation of the Required Prevention Force (Normally)

Calculate the required prevention force which satisfies the planned safety factor $F_{sp} = 1.200$.

< Circular arc A >

$$\begin{aligned} Pr &= F_{sp} \cdot \Sigma T - [\Sigma \{(N-U) \cdot \tan \varphi\} + \Sigma (C \cdot l)] \\ &= 1.200 \times 584.35 - \{(599.26 - 0.00) \times 0.674509 + 6.00 \times 24.126\} \\ &= 152.3 \text{ (kN/m)} \end{aligned}$$

where;

F_{sp}	: Planned safety factor		
Pr	: Required prevention force		(kN/m)
N	: Normal force by gravity of slice	$(N = W \cdot \cos \theta + Q_N)$	(kN/m)
U	: Pore water pressure working on slice	$(U = u \cdot l)$	(kN/m)
T	: Tangential force by gravity of slice	$(T = W \cdot \sin \theta + Q_T)$	(kN/m)
l	: Sliding surface length of slice		(m)
φ	: Internal friction angle of sliding surface		(°)
C	: Cohesion of sliding surface		(kN/m ²)
W	: Slice weight		(kN/m)
θ	: Sliding surface inclination angle		(°)
u	: Unit pore water pressure		(kN/m ²)
Q_N	: Vertical load component force (normal direction)		(kN/m)
Q_T	: Vertical load component force (tangential direction)		(kN/m)

Repeated Circular Calculation Requirements

- Circular arc requirements

Center change range

X coordinate (m) : -26.000 ~ -6.000 Pitch (m) : 1.000
Y coordinate (m) : 463.000 ~ 483.000 Pitch (m) : 1.000
Secondary chase : None

Depth change range from the ground surface

Depth (m) : 1.000 ~ 10.000 Pitch (m) : 0.500

- Pass line

Start point (m) : [X = - , Y = -]

End point (m) : [X = - , Y = -]

- No-Pass line

Start point (m) : [X = - , Y = -]

End point (m) : [X = - , Y = -]

- No-Pass layer

Layer2

- Calculation requirements

Planned safety factor (Normally) Fsp = 1.200
Stability calculation formula Fellenius method
Sliding surface strength Stratum value

- Output requirements

Safety factor : All
Required prevention force : All
Sliding force : All
Depth : All

List of Repeated Circular Calculation Results
(Normally)

No.	Reg.	Circular arc requirements				Skid resistance S (kN/m)	Sliding force T (kN/m)	Safety factor Fs	Required prevention force Pr (kN/m)
		Central coordinates		Radius r (m)	Max. depth (m)				
		X (m)	Y (m)						
1	A	-16.000	473.000	44.097	3.500	548.96	584.35	0.939	* 152.3
2		-22.000	480.000	53.218	3.500	565.81	597.39	0.947	151.1
3		-15.000	472.000	42.687	3.500	545.04	579.77	0.940	150.7
4		-21.000	479.000	51.806	3.500	563.13	593.60	0.949	149.2
5		-14.000	471.000	41.276	3.500	540.81	574.48	0.941	148.6
6		-20.000	478.000	50.394	3.500	560.22	589.32	0.951	147.0
7		-13.000	470.000	39.866	3.500	536.62	569.45	0.942	146.8
8		-24.000	483.000	56.714	3.500	567.46	594.50	0.955	146.0
9		-19.000	477.000	48.983	3.500	556.96	585.19	0.952	145.3
10		-12.000	469.000	38.456	3.500	532.05	563.89	0.944	144.7
11		-23.000	482.000	55.301	3.500	564.93	590.97	0.956	144.3
12		-18.000	476.000	47.571	3.500	553.07	580.60	0.953	143.7
13		-22.000	481.000	53.888	3.500	562.31	587.31	0.957	142.5
14		-11.000	468.000	37.046	3.500	527.21	557.92	0.945	142.3
15		-17.000	475.000	46.160	3.500	549.59	576.36	0.954	142.1
16		-21.000	480.000	52.476	3.500	559.41	583.29	0.959	140.6
17		-16.000	474.000	44.749	3.500	545.85	571.92	0.954	140.5
18		-10.000	467.000	35.635	3.500	522.23	551.81	0.946	140.0
19		-15.000	473.000	43.339	3.500	541.77	566.92	0.956	138.6
20		-20.000	479.000	51.063	3.500	556.47	579.08	0.961	138.5
21		-9.000	466.000	34.225	3.500	517.24	545.59	0.948	137.5
22		-14.000	472.000	41.928	3.500	537.62	561.72	0.957	136.5
23		-19.000	478.000	49.650	3.500	553.43	574.71	0.963	136.3
24		-23.000	483.000	55.984	3.500	562.18	581.65	0.967	135.8
25		-8.000	465.000	32.815	3.500	511.72	538.60	0.950	134.6
26		-13.000	471.000	40.518	3.500	533.68	556.89	0.958	134.6
27		-22.000	482.000	54.570	3.500	559.62	578.13	0.968	134.2
28		-18.000	477.000	48.237	3.500	550.30	570.19	0.965	134.0
29		-13.000	467.000	37.417	3.000	435.82	474.31	0.919	133.4
30		-12.000	470.000	39.108	3.500	529.35	551.55	0.960	132.6
31		-12.000	466.000	36.009	3.000	432.28	470.71	0.918	132.6
32		-21.000	481.000	53.156	3.500	556.90	574.33	0.970	132.3
33		-7.000	464.000	31.405	3.500	506.25	531.68	0.952	131.8
34		-11.000	465.000	34.602	3.000	428.42	466.74	0.918	131.7
35		-17.000	476.000	46.825	3.500	547.08	565.51	0.967	131.6
36		-10.000	464.000	33.195	3.000	424.88	463.20	0.917	131.0
37		-11.000	469.000	37.698	3.500	524.88	546.04	0.961	130.4
38		-20.000	480.000	51.743	3.500	553.90	570.14	0.972	130.3
39		-9.000	463.000	31.790	3.000	421.01	459.29	0.917	130.2
40		-16.000	475.000	45.413	3.500	543.65	560.55	0.970	129.1
41		-6.000	463.000	29.995	3.500	500.09	523.84	0.955	128.6
42		-19.000	479.000	50.329	3.500	550.79	565.84	0.973	128.3

* denotes the minimum safety factor and maximum prevention force.

No.	Reg.	Circular arc requirements				Skid resistance S (kN/m)	Sliding force T (kN/m)	Safety factor Fs	Required prevention force Pr (kN/m)
		Central coordinates		Radius r (m)	Max. depth (m)				
		X (m)	Y (m)						
43		-10.000	468.000	36.287	3.500	519.84	539.58	0.963	127.7
44		-15.000	474.000	44.000	3.500	539.46	555.51	0.971	127.2
45		-20.000	475.000	47.934	3.000	456.67	486.32	0.939	127.0
46		-19.000	474.000	46.523	3.000	454.23	484.02	0.938	126.6
47		-22.000	483.000	55.262	3.500	557.95	570.18	0.979	126.3
48		-18.000	473.000	45.113	3.000	451.22	481.02	0.938	126.1
49		-18.000	478.000	48.916	3.500	547.56	561.19	0.976	125.9
50		-9.000	467.000	34.877	3.500	515.11	533.79	0.965	125.5
51		-14.000	473.000	42.588	3.500	535.10	550.14	0.973	125.1
52		-17.000	472.000	43.703	3.000	447.85	477.36	0.938	125.0
53		-16.000	471.000	42.293	3.000	444.79	474.31	0.938	124.4
54		-21.000	482.000	53.848	3.500	554.91	565.91	0.981	124.2
55		-17.000	477.000	47.502	3.500	544.31	556.58	0.978	123.6
56		-15.000	470.000	40.883	3.000	441.47	470.89	0.938	123.6
57		-13.000	472.000	41.176	3.500	530.73	544.66	0.974	122.9
58		-14.000	469.000	39.472	3.000	437.80	467.09	0.937	122.8
59		-8.000	466.000	33.467	3.500	509.75	526.85	0.968	122.5
60		-20.000	481.000	52.434	3.500	552.32	562.35	0.982	122.5
61		-13.000	468.000	38.062	3.000	434.28	463.52	0.937	122.0
62		-16.000	476.000	46.089	3.500	540.87	551.69	0.980	121.2
63		-12.000	467.000	36.652	3.000	430.51	459.50	0.937	120.9
64		-12.000	471.000	39.764	3.500	526.21	539.09	0.976	120.7
65		-19.000	480.000	51.020	3.500	549.37	558.26	0.984	120.6
66		-11.000	466.000	35.242	3.000	426.59	455.42	0.937	120.0
67		-7.000	465.000	32.057	3.500	504.47	520.16	0.970	119.8
68		-10.000	465.000	33.832	3.000	422.72	451.36	0.937	119.0
69		-26.000	482.000	57.047	3.000	467.77	488.67	0.957	118.7
70		-15.000	475.000	44.675	3.500	537.37	546.58	0.983	118.6
71		-25.000	481.000	55.637	3.000	465.75	486.80	0.957	118.5
72		-18.000	479.000	49.606	3.500	546.09	553.70	0.986	118.4
73		-11.000	470.000	38.353	3.500	521.52	533.23	0.978	118.4
74		-24.000	480.000	54.226	3.000	463.64	484.66	0.957	118.0
75		-23.000	479.000	52.816	3.000	461.39	482.51	0.956	117.7
76		-9.000	464.000	32.423	3.000	418.22	446.45	0.937	117.6
77		-21.000	483.000	54.550	3.500	554.46	559.64	0.991	117.2
78		-22.000	478.000	51.406	3.000	458.98	480.10	0.956	117.2
79		-21.000	477.000	49.996	3.000	456.59	477.88	0.955	116.9
80		-6.000	464.000	30.647	3.500	498.56	512.58	0.973	116.6
81		-8.000	463.000	31.014	3.000	413.82	441.76	0.937	116.3
82		-20.000	476.000	48.586	3.000	454.01	475.18	0.955	116.3
83		-17.000	478.000	48.192	3.500	542.90	549.16	0.989	116.1
84		-14.000	474.000	43.262	3.500	533.76	541.40	0.986	116.0
85		-10.000	469.000	36.941	3.500	516.69	527.02	0.980	115.8
86		-19.000	475.000	47.175	3.000	451.55	472.72	0.955	115.8
87		-11.000	463.000	32.859	2.500	344.78	383.54	* 0.899	115.5

* denotes the minimum safety factor and maximum prevention force.

No.	Reg.	Circular arc requirements				Skid resistance S (kN/m)	Sliding force T (kN/m)	Safety factor Fs	Required prevention force Pr (kN/m)
		Central coordinates		Radius r (m)	Max. depth (m)				
		X (m)	Y (m)						
88		-12.000	464.000	34.263	2.500	347.15	385.31	0.901	115.3
89		-18.000	474.000	45.765	3.000	448.87	470.02	0.955	115.2
90		-20.000	482.000	53.135	3.500	551.77	555.72	0.993	115.1
91		-13.000	465.000	35.668	2.500	349.68	386.97	0.904	114.7
92		-17.000	473.000	44.355	3.000	445.83	466.83	0.955	114.4
93		-14.000	466.000	37.073	2.500	352.12	388.40	0.907	114.0
94		-16.000	477.000	46.778	3.500	539.56	544.43	0.991	113.8
95		-16.000	472.000	42.945	3.000	442.97	463.79	0.955	113.6
96		-9.000	468.000	35.530	3.500	512.07	521.29	0.982	113.5
97		-15.000	467.000	38.477	2.500	354.30	389.66	0.909	113.3
98		-13.000	473.000	41.849	3.500	529.92	535.72	0.989	113.0
99		-19.000	481.000	51.721	3.500	548.61	551.31	0.995	113.0
100		-15.000	471.000	41.535	3.000	439.79	460.47	0.955	112.8
101		-16.000	468.000	39.882	2.500	356.50	391.05	0.912	112.8
102		-17.000	469.000	41.286	2.500	358.44	392.19	0.914	112.2
103		-14.000	470.000	40.124	3.000	436.38	456.85	0.955	111.9
104		-18.000	480.000	50.307	3.500	545.75	547.32	0.997	111.1
105		-15.000	476.000	45.364	3.500	535.70	538.87	0.994	111.0
106		-13.000	469.000	38.714	3.000	432.92	453.24	0.955	111.0
107		-8.000	467.000	34.119	3.500	506.65	514.28	0.985	110.5
108		-12.000	472.000	40.436	3.500	525.38	529.67	0.992	110.3
109		-12.000	468.000	37.304	3.000	429.19	449.25	0.955	110.0
110		-17.000	479.000	48.893	3.500	542.52	542.86	0.999	109.0
111		-11.000	467.000	35.894	3.000	425.63	445.41	0.956	108.9
112		-14.000	475.000	43.950	3.500	532.34	534.20	0.997	108.7
113		-26.000	483.000	57.702	3.000	463.88	476.66	0.973	108.2
114		-20.000	483.000	53.847	3.500	551.95	549.96	1.004	108.1
115		-25.000	482.000	56.290	3.000	461.87	474.77	0.973	107.9
116		-7.000	466.000	32.709	3.500	501.24	507.37	0.988	107.7
117		-11.000	471.000	39.023	3.500	520.58	523.53	0.994	107.7
118		-10.000	466.000	34.484	3.000	421.40	440.72	0.956	107.5
119		-24.000	481.000	54.879	3.000	459.64	472.49	0.973	107.4
120		-23.000	480.000	53.469	3.000	457.46	470.33	0.973	107.0
121		-16.000	478.000	47.479	3.500	539.22	538.24	1.002	106.7
122		-22.000	479.000	52.058	3.000	455.26	468.15	0.972	106.6
123		-9.000	465.000	33.073	3.000	417.28	436.27	0.956	106.3
124		-19.000	482.000	52.433	3.500	549.20	546.06	1.006	106.1
125		-13.000	474.000	42.536	3.500	528.36	528.48	1.000	105.9
126		-21.000	478.000	50.648	3.000	452.74	465.43	0.973	105.8
127		-20.000	477.000	49.238	3.000	450.21	462.87	0.973	105.3
128		-10.000	470.000	37.610	3.500	515.30	516.98	0.997	105.1
129		-8.000	464.000	31.663	3.000	412.88	431.41	0.957	104.9
130		-19.000	476.000	47.827	3.000	447.95	460.65	0.972	104.9
131		-6.000	465.000	31.298	3.500	495.86	500.32	0.991	104.6
132		-15.000	477.000	46.064	3.500	535.50	532.97	1.005	104.1

* denotes the minimum safety factor and maximum prevention force.

No.	Reg.	Circular arc requirements				Skid resistance S (kN/m)	Sliding force T (kN/m)	Safety factor Fs	Required prevention force Pr (kN/m)
		Central coordinates		Radius r (m)	Max. depth (m)				
		X (m)	Y (m)						
133		-18.000	475.000	46.417	3.000	445.19	457.65	0.973	104.0
134		-18.000	481.000	51.019	3.500	545.95	541.49	1.008	103.9
135		-10.000	463.000	32.074	2.500	337.86	368.10	0.918	103.9
136		-11.000	464.000	33.479	2.500	340.65	370.16	0.920	103.6
137		-17.000	474.000	45.007	3.000	442.53	454.92	0.973	103.4
138		-7.000	463.000	30.253	3.000	408.26	426.25	0.958	103.3
139		-12.000	473.000	41.122	3.500	524.49	522.86	1.003	103.0
140		-12.000	465.000	34.883	2.500	343.01	371.59	0.923	102.9
141		-16.000	473.000	43.597	3.000	439.55	451.66	0.973	102.5
142		-9.000	469.000	36.197	3.500	510.24	510.51	0.999	102.4
143		-13.000	466.000	36.288	2.500	345.19	372.92	0.926	102.4
144		-14.000	467.000	37.693	2.500	347.48	374.50	0.928	102.0
145		-17.000	480.000	49.605	3.500	543.16	537.58	1.010	102.0
146		-14.000	476.000	44.650	3.500	532.09	528.16	1.007	101.8
147		-15.000	472.000	42.187	3.000	436.84	448.85	0.973	101.8
148		-15.000	468.000	39.099	2.500	349.73	376.07	0.930	101.6
149		-16.000	469.000	40.505	2.500	351.76	377.39	0.932	101.2
150		-14.000	471.000	40.776	3.000	433.51	445.23	0.974	100.8
151		-17.000	470.000	41.912	2.500	353.78	378.70	0.934	100.7
152		-18.000	471.000	43.319	2.500	355.71	379.84	0.936	100.1
153		-19.000	472.000	44.727	2.500	357.87	381.54	0.938	100.0
154		-16.000	479.000	48.191	3.500	539.95	533.09	1.013	99.8
155		-13.000	470.000	39.366	3.000	430.23	441.62	0.974	99.8
156		-11.000	472.000	39.708	3.500	520.23	516.68	1.007	99.8
157		-8.000	468.000	34.784	3.500	504.86	503.67	1.002	99.6
158		-20.000	473.000	46.135	2.500	359.73	382.72	0.940	99.6
159		-19.000	483.000	53.155	3.500	550.34	541.32	1.017	99.3
160		-21.000	474.000	47.544	2.500	361.66	384.02	0.942	99.2
161		-22.000	475.000	48.952	2.500	363.64	385.60	0.943	99.1
162		-13.000	475.000	43.236	3.500	528.09	522.48	1.011	98.9
163		-23.000	476.000	50.362	2.500	365.57	386.99	0.945	98.9
164		-12.000	469.000	37.956	3.000	426.75	437.85	0.975	98.7
165		-24.000	477.000	51.771	2.500	367.24	388.03	0.946	98.4
166		-25.000	478.000	53.181	2.500	368.87	389.08	0.948	98.1
167		-25.000	483.000	56.954	3.000	459.02	464.23	0.989	98.1
168		-26.000	479.000	54.591	2.500	370.59	390.23	0.950	97.7
169		-15.000	478.000	46.777	3.500	536.87	528.78	1.015	97.7
170		-11.000	468.000	36.546	3.000	423.16	433.86	0.975	97.5
171		-24.000	482.000	55.542	3.000	456.62	461.71	0.989	97.5
172		-18.000	482.000	51.741	3.500	547.47	537.20	1.019	97.2
173		-23.000	481.000	54.130	3.000	454.16	459.14	0.989	96.9
174		-10.000	467.000	35.135	3.000	419.63	430.11	0.976	96.6
175		-10.000	471.000	38.294	3.500	515.90	510.31	1.011	96.5
176		-7.000	467.000	33.371	3.500	499.14	496.22	1.006	96.4
177		-22.000	480.000	52.718	3.000	451.75	456.55	0.989	96.2

* denotes the minimum safety factor and maximum prevention force.

No.	Reg.	Circular arc requirements				Skid resistance S (kN/m)	Sliding force T (kN/m)	Safety factor Fs	Required prevention force Pr (kN/m)
		Central coordinates		Radius r (m)	Max. depth (m)				
		X (m)	Y (m)						
178		-12.000	474.000	41.822	3.500	524.45	517.17	1.014	96.2
179		-21.000	479.000	51.306	3.000	449.19	453.87	0.990	95.5
180		-17.000	481.000	50.327	3.500	544.63	533.13	1.022	95.2
181		-14.000	477.000	45.363	3.500	533.23	523.61	1.018	95.2
182		-9.000	466.000	33.725	3.000	415.36	425.24	0.977	95.0
183		-20.000	478.000	49.894	3.000	446.64	451.12	0.990	94.8
184		-19.000	477.000	48.483	3.000	443.90	448.13	0.991	93.9
185		-8.000	465.000	32.315	3.000	411.21	420.56	0.978	93.5
186		-6.000	466.000	31.959	3.500	493.26	488.70	1.009	93.2
187		-11.000	473.000	40.407	3.500	520.16	511.08	1.018	93.2
188		-18.000	476.000	47.071	3.000	441.05	445.05	0.991	93.1
189		-9.000	470.000	36.880	3.500	511.31	503.53	1.015	93.0
190		-16.000	480.000	48.914	3.500	541.36	528.48	1.024	92.9
191		-13.000	476.000	43.949	3.500	529.66	518.49	1.022	92.6
192		-17.000	475.000	45.660	3.000	438.40	442.29	0.991	92.4
193		-7.000	464.000	30.905	3.000	406.89	415.71	0.979	92.0
194		-9.000	463.000	31.290	2.500	330.50	351.93	0.939	91.9
195		-10.000	464.000	32.695	2.500	333.14	353.79	0.942	91.5
196		-16.000	474.000	44.249	3.000	435.58	439.23	0.992	91.5
197		-12.000	466.000	35.509	2.500	338.68	358.12	0.946	91.1
198		-11.000	465.000	34.102	2.500	335.84	355.77	0.944	91.1
199		-13.000	467.000	36.917	2.500	341.21	359.99	0.948	90.8
200		-14.000	468.000	38.325	2.500	343.76	362.11	0.949	90.8
201		-18.000	483.000	52.473	3.500	549.51	533.44	1.030	90.7
202		-15.000	469.000	39.733	2.500	346.24	364.09	0.951	90.7
203		-15.000	479.000	47.500	3.500	538.06	523.82	1.027	90.6
204		-15.000	473.000	42.839	3.000	432.58	435.94	0.992	90.6
205		-16.000	470.000	41.142	2.500	348.56	365.76	0.953	90.4
206		-6.000	463.000	29.495	3.000	402.29	410.50	0.980	90.4
207		-17.000	471.000	42.552	2.500	350.90	367.62	0.955	90.3
208		-18.000	472.000	43.962	2.500	353.16	369.49	0.956	90.3
209		-10.000	472.000	38.993	3.500	516.00	505.14	1.021	90.2
210		-20.000	474.000	46.782	2.500	357.58	373.01	0.959	90.1
211		-19.000	473.000	45.372	2.500	355.35	371.19	0.957	90.1
212		-21.000	475.000	48.192	2.500	359.56	374.47	0.960	89.9
213		-12.000	475.000	42.535	3.500	525.79	513.03	1.025	89.9
214		-8.000	469.000	35.466	3.500	505.47	496.12	1.019	89.9
215		-22.000	476.000	49.602	2.500	361.56	376.07	0.961	89.8
216		-14.000	472.000	41.428	3.000	429.62	432.77	0.993	89.8
217		-23.000	477.000	51.012	2.500	363.53	377.65	0.963	89.7
218		-24.000	478.000	52.423	2.500	365.18	378.71	0.964	89.3
219		-25.000	479.000	53.833	2.500	366.76	379.81	0.966	89.1
220		-26.000	480.000	55.243	2.500	368.46	381.18	0.967	89.0
221		-13.000	471.000	40.018	3.000	426.57	429.37	0.993	88.7
222		-17.000	482.000	51.060	3.500	546.68	529.41	1.033	88.7

* denotes the minimum safety factor and maximum prevention force.

No.	Reg.	Circular arc requirements				Skid resistance S (kN/m)	Sliding force T (kN/m)	Safety factor Fs	Required prevention force Pr (kN/m)
		Central coordinates		Radius r (m)	Max. depth (m)				
		X (m)	Y (m)						
223		-24.000	483.000	56.214	3.000	455.14	453.01	1.005	88.5
224		-14.000	478.000	46.087	3.500	535.16	519.71	1.030	88.5
225		-23.000	482.000	54.801	3.000	452.74	450.40	1.005	87.8
226		-12.000	470.000	38.608	3.000	423.30	425.80	0.994	87.7
227		-9.000	471.000	37.579	3.500	511.42	498.61	1.026	87.0
228		-11.000	474.000	41.121	3.500	521.45	507.02	1.028	87.0
229		-22.000	481.000	53.388	3.000	449.96	447.34	1.006	86.9
230		-7.000	468.000	34.052	3.500	499.71	488.82	1.022	86.9
231		-11.000	469.000	37.198	3.000	420.02	422.13	0.995	86.6
232		-16.000	481.000	49.647	3.500	544.00	525.37	1.035	86.5
233		-21.000	480.000	51.976	3.000	447.43	444.62	1.006	86.2
234		-13.000	477.000	44.673	3.500	531.71	514.83	1.033	86.1
235		-20.000	479.000	50.563	3.000	444.50	441.40	1.007	85.2
236		-10.000	468.000	35.787	3.000	416.07	417.68	0.996	85.2
237		-14.000	464.000	35.332	2.000	278.43	302.36	0.921	84.5
238		-15.000	465.000	36.737	2.000	280.29	303.84	0.922	84.4
239		-16.000	466.000	38.142	2.000	281.95	305.24	0.924	84.4
240		-19.000	478.000	49.150	3.000	441.69	438.30	1.008	84.3
241		-13.000	463.000	33.928	2.000	276.42	300.56	0.920	84.3
242		-17.000	467.000	39.546	2.000	283.47	306.38	0.925	84.2
243		-15.000	480.000	48.234	3.500	540.81	520.80	1.038	84.2
244		-18.000	468.000	40.951	2.000	284.84	307.40	0.927	84.1
245		-10.000	473.000	39.707	3.500	517.30	501.10	1.032	84.1
246		-9.000	467.000	34.377	3.000	412.45	413.60	0.997	83.9
247		-6.000	467.000	32.639	3.500	493.77	481.09	1.026	83.6
248		-8.000	470.000	36.165	3.500	506.65	491.79	1.030	83.5
249		-12.000	476.000	43.260	3.500	528.05	509.62	1.036	83.5
250		-19.000	469.000	42.355	2.000	285.84	307.75	0.929	83.5
251		-18.000	477.000	47.737	3.000	438.74	435.05	1.008	83.4
252		-20.000	470.000	43.760	2.000	286.88	308.21	0.931	83.0
253		-21.000	471.000	45.165	2.000	287.78	308.61	0.933	82.6
254		-17.000	476.000	46.325	3.000	435.68	431.69	1.009	82.4
255		-17.000	483.000	51.802	3.500	549.79	526.68	1.044	82.3
256		-8.000	466.000	32.967	3.000	408.36	408.88	0.999	82.3
257		-22.000	472.000	46.569	2.000	288.63	308.97	0.934	82.2
258		-14.000	479.000	46.822	3.500	537.70	516.33	1.041	81.9
259		-23.000	473.000	47.974	2.000	289.19	308.87	0.936	81.5
260		-16.000	475.000	44.913	3.000	432.53	428.16	1.010	81.3
261		-9.000	472.000	38.293	3.500	512.97	494.93	1.036	81.0
262		-24.000	474.000	49.379	2.000	289.86	309.00	0.938	81.0
263		-16.000	471.000	41.793	2.500	346.81	356.45	0.973	81.0
264		-11.000	475.000	41.847	3.500	524.07	504.03	1.040	80.8
265		-17.000	472.000	43.203	2.500	349.05	358.15	0.975	80.8
266		-15.000	470.000	40.383	2.500	344.25	354.16	0.972	80.8
267		-13.000	468.000	37.562	2.500	339.05	349.80	0.969	80.8

* denotes the minimum safety factor and maximum prevention force.

No.	Reg.	Circular arc requirements				Skid resistance S (kN/m)	Sliding force T (kN/m)	Safety factor Fs	Required prevention force Pr (kN/m)
		Central coordinates		Radius r (m)	Max. depth (m)				
		X (m)	Y (m)						
268		-7.000	465.000	31.557	3.000	404.21	404.15	1.000	80.8
269		-19.000	474.000	46.023	2.500	353.15	361.46	0.977	80.7
270		-18.000	473.000	44.613	2.500	351.12	359.84	0.976	80.7
271		-14.000	469.000	38.972	2.500	341.57	351.78	0.971	80.6
272		-21.000	476.000	48.844	2.500	357.13	364.72	0.979	80.6
273		-11.000	466.000	34.742	2.500	333.32	344.88	0.966	80.6
274		-20.000	475.000	47.434	2.500	355.28	363.19	0.978	80.6
275		-12.000	467.000	36.152	2.500	336.11	347.13	0.968	80.5
276		-23.000	478.000	51.664	2.500	360.68	367.49	0.981	80.4
277		-15.000	474.000	43.500	3.000	429.51	424.87	1.011	80.4
278		-22.000	477.000	50.254	2.500	358.78	365.84	0.981	80.3
279		-25.000	475.000	50.783	2.000	290.26	308.74	0.940	80.3
280		-10.000	465.000	33.332	2.500	330.32	342.17	0.965	80.3
281		-8.000	463.000	30.514	2.500	323.86	336.64	0.962	80.2
282		-9.000	464.000	31.923	2.500	327.13	339.39	0.964	80.2
283		-16.000	482.000	50.390	3.500	547.16	522.76	1.047	80.2
284		-24.000	479.000	53.075	2.500	362.20	368.63	0.983	80.2
285		-25.000	480.000	54.485	2.500	363.88	369.85	0.984	80.0
286		-7.000	469.000	34.751	3.500	501.74	484.59	1.035	79.8
287		-26.000	481.000	55.895	2.500	365.30	370.88	0.985	79.8
288		-26.000	476.000	52.188	2.000	290.62	308.50	0.942	79.6
289		-13.000	478.000	45.409	3.500	534.43	511.54	1.045	79.5
290		-23.000	483.000	55.484	3.000	452.10	442.80	1.021	79.3
291		-14.000	473.000	42.088	3.000	426.26	421.20	1.012	79.2
292		-6.000	464.000	30.147	3.000	399.71	398.86	1.002	79.0
293		-22.000	482.000	54.070	3.000	449.34	439.71	1.022	78.4
294		-10.000	474.000	40.433	3.500	520.23	498.61	1.043	78.2
295		-14.000	465.000	35.952	2.000	275.34	294.47	0.935	78.1
296		-12.000	463.000	33.143	2.000	271.73	291.38	0.933	78.0
297		-15.000	481.000	48.979	3.500	544.47	518.70	1.050	78.0
298		-13.000	472.000	40.676	3.000	422.86	417.34	1.013	78.0
299		-8.000	471.000	36.879	3.500	508.68	488.77	1.041	77.9
300		-13.000	464.000	34.548	2.000	273.48	292.79	0.934	77.9
301		-15.000	466.000	37.357	2.000	276.73	295.39	0.937	77.8
302		-21.000	481.000	52.656	3.000	446.77	437.01	1.022	77.7
303		-12.000	477.000	43.997	3.500	531.51	507.38	1.048	77.4
304		-16.000	467.000	38.762	2.000	277.95	296.01	0.939	77.3
305		-17.000	468.000	40.166	2.000	278.98	296.54	0.941	76.9
306		-12.000	471.000	39.264	3.000	419.41	413.45	1.014	76.8
307		-18.000	469.000	41.571	2.000	280.01	297.03	0.943	76.5
308		-20.000	480.000	51.243	3.000	443.68	433.38	1.024	76.4
309		-19.000	470.000	42.976	2.000	280.92	297.49	0.944	76.1
310		-11.000	480.000	46.113	4.000	654.73	609.02	1.075	76.1
311		-14.000	480.000	47.567	3.500	541.62	514.53	1.053	75.9
312		-6.000	468.000	33.336	3.500	496.50	476.82	1.041	75.7

* denotes the minimum safety factor and maximum prevention force.

No.	Reg.	Circular arc requirements				Skid resistance S (kN/m)	Sliding force T (kN/m)	Safety factor Fs	Required prevention force Pr (kN/m)
		Central coordinates		Radius r (m)	Max. depth (m)				
		X (m)	Y (m)						
313		-11.000	470.000	37.853	3.000	415.85	409.50	1.016	75.6
314		-20.000	471.000	44.380	2.000	281.67	297.60	0.946	75.5
315		-19.000	479.000	49.829	3.000	440.86	430.25	1.025	75.5
316		-9.000	473.000	39.020	3.500	516.08	492.68	1.047	75.2
317		-11.000	476.000	42.585	3.500	528.06	502.50	1.051	75.0
318		-21.000	472.000	45.785	2.000	282.35	297.77	0.948	75.0
319		-18.000	478.000	48.416	3.000	437.73	426.75	1.026	74.4
320		-7.000	470.000	35.465	3.500	503.64	481.54	1.046	74.3
321		-22.000	473.000	47.189	2.000	282.63	297.30	0.951	74.2
322		-10.000	469.000	36.441	3.000	412.09	405.08	1.017	74.1
323		-23.000	474.000	48.594	2.000	283.37	297.56	0.952	73.8
324		-16.000	483.000	51.143	3.500	551.12	520.73	1.058	73.8
325		-17.000	477.000	47.002	3.000	434.76	423.48	1.027	73.5
326		-13.000	479.000	46.156	3.500	538.45	509.86	1.056	73.4
327		-24.000	475.000	49.999	2.000	283.74	297.39	0.954	73.2
328		-13.000	483.000	49.693	4.000	663.41	613.55	1.081	72.9
329		-9.000	468.000	35.030	3.000	408.30	400.72	1.019	72.6
330		-25.000	476.000	51.405	2.000	283.97	296.92	0.956	72.4
331		-10.000	479.000	44.703	4.000	650.68	602.56	1.080	72.4
332		-8.000	472.000	37.607	3.500	511.85	486.75	1.052	72.3
333		-16.000	476.000	45.589	3.000	431.55	419.76	1.028	72.2
334		-10.000	475.000	41.173	3.500	524.32	497.01	1.055	72.1
335		-26.000	477.000	52.811	2.000	284.39	296.86	0.958	71.9
336		-22.000	483.000	54.762	3.000	449.17	434.05	1.035	71.7
337		-15.000	482.000	49.733	3.500	548.49	516.81	1.061	71.7
338		-17.000	473.000	43.855	2.500	346.20	347.84	0.995	71.3
339		-18.000	474.000	45.265	2.500	348.24	349.53	0.996	71.2
340		-19.000	475.000	46.675	2.500	350.14	351.10	0.997	71.2
341		-20.000	476.000	48.086	2.500	351.84	352.39	0.998	71.1
342		-16.000	472.000	42.445	2.500	344.02	345.90	0.995	71.1
343		-21.000	477.000	49.496	2.500	353.56	353.83	0.999	71.1
344		-15.000	471.000	41.035	2.500	341.80	343.92	0.994	71.0
345		-8.000	467.000	33.619	3.000	404.27	396.03	1.021	71.0
346		-12.000	478.000	44.745	3.500	535.45	505.36	1.060	71.0
347		-12.000	464.000	33.763	2.000	267.69	282.19	0.949	71.0
348		-23.000	479.000	52.316	2.500	357.00	356.66	1.001	71.0
349		-15.000	475.000	44.175	3.000	428.20	416.00	1.029	71.0
350		-14.000	470.000	39.624	2.500	339.36	341.89	0.993	71.0
351		-22.000	478.000	50.906	2.500	355.21	355.14	1.000	71.0
352		-11.000	463.000	32.359	2.000	265.87	280.59	0.948	70.9
353		-13.000	465.000	35.168	2.000	269.26	283.34	0.950	70.8
354		-13.000	469.000	38.214	2.500	336.96	339.77	0.992	70.8
355		-6.000	469.000	34.051	3.500	498.70	474.55	1.051	70.8
356		-24.000	480.000	53.726	2.500	358.35	357.58	1.002	70.8
357		-25.000	481.000	55.137	2.500	359.83	358.75	1.003	70.7

* denotes the minimum safety factor and maximum prevention force.

No.	Reg.	Circular arc requirements				Skid resistance S (kN/m)	Sliding force T (kN/m)	Safety factor Fs	Required prevention force Pr (kN/m)
		Central coordinates		Radius r (m)	Max. depth (m)				
		X (m)	Y (m)						
358		-21.000	482.000	53.348	3.000	447.29	431.53	1.037	70.6
359		-14.000	466.000	36.573	2.000	270.60	284.31	0.952	70.6
360		-12.000	468.000	36.804	2.500	334.19	337.23	0.991	70.5
361		-26.000	482.000	56.547	2.500	360.99	359.44	1.004	70.4
362		-11.000	467.000	35.394	2.500	331.36	334.66	0.990	70.3
363		-15.000	467.000	37.977	2.000	271.63	284.74	0.954	70.1
364		-10.000	466.000	33.984	2.500	328.44	332.05	0.989	70.1
365		-9.000	465.000	32.573	2.500	325.49	329.51	0.988	70.0
366		-14.000	474.000	42.762	3.000	424.91	412.34	1.030	69.9
367		-16.000	468.000	39.382	2.000	272.61	285.13	0.956	69.6
368		-7.000	466.000	32.209	3.000	400.26	391.41	1.023	69.5
369		-8.000	464.000	31.163	2.500	322.06	326.28	0.987	69.5
370		-12.000	482.000	48.283	4.000	659.65	607.50	1.086	69.4
371		-9.000	474.000	39.761	3.500	520.50	491.53	1.059	69.4
372		-14.000	481.000	48.323	3.500	545.94	512.74	1.065	69.4
373		-17.000	469.000	40.786	2.000	273.71	285.82	0.958	69.3
374		-7.000	471.000	36.194	3.500	507.39	480.36	1.056	69.1
375		-7.000	463.000	29.753	2.500	318.52	322.92	0.986	69.0
376		-20.000	481.000	51.934	3.000	444.60	427.82	1.039	68.8
377		-9.000	478.000	43.293	4.000	646.56	596.11	1.085	68.8
378		-18.000	470.000	42.191	2.000	274.26	285.75	0.960	68.7
379		-13.000	473.000	41.349	3.000	421.17	408.03	1.032	68.5
380		-11.000	477.000	43.334	3.500	532.15	500.50	1.063	68.5
381		-19.000	471.000	43.596	2.000	274.91	285.79	0.962	68.1
382		-19.000	480.000	50.520	3.000	441.79	424.50	1.041	67.7
383		-6.000	465.000	30.798	3.000	395.98	386.33	1.025	67.7
384		-20.000	472.000	45.002	2.000	275.51	285.87	0.964	67.6
385		-13.000	480.000	46.913	3.500	543.18	508.63	1.068	67.2
386		-21.000	473.000	46.408	2.000	276.17	286.06	0.965	67.2
387		-6.000	474.000	38.303	4.000	630.48	581.30	1.085	67.1
388		-12.000	472.000	39.936	3.000	417.40	403.69	1.034	67.1
389		-22.000	474.000	47.814	2.000	276.85	286.24	0.967	66.7
390		-18.000	479.000	49.106	3.000	438.51	420.76	1.042	66.5
391		-23.000	475.000	49.222	2.000	277.58	286.57	0.969	66.4
392		-8.000	473.000	38.349	3.500	516.36	485.56	1.063	66.4
393		-10.000	476.000	41.924	3.500	528.98	495.87	1.067	66.1
394		-11.000	481.000	46.874	4.000	656.05	601.68	1.090	66.0
395		-24.000	476.000	50.629	2.000	278.03	286.50	0.970	65.8
396		-11.000	471.000	38.523	3.000	413.66	399.48	1.035	65.8
397		-6.000	470.000	34.781	3.500	502.73	473.68	1.061	65.7
398		-25.000	477.000	52.037	2.000	278.75	286.80	0.972	65.5
399		-21.000	483.000	54.050	3.000	446.36	426.50	1.047	65.5
400		-17.000	478.000	47.692	3.000	435.38	417.24	1.043	65.4
401		-15.000	483.000	50.493	3.500	552.30	514.30	1.074	64.9
402		-8.000	477.000	41.883	4.000	642.01	589.06	1.090	64.9

* denotes the minimum safety factor and maximum prevention force.

No.	Reg.	Circular arc requirements				Skid resistance S (kN/m)	Sliding force T (kN/m)	Safety factor Fs	Required prevention force Pr (kN/m)
		Central coordinates		Radius r (m)	Max. depth (m)				
		X (m)	Y (m)						
403		-12.000	479.000	45.503	3.500	540.22	504.11	1.072	64.8
404		-26.000	478.000	53.445	2.000	279.65	286.88	0.975	64.7
405		-16.000	477.000	46.278	3.000	432.01	413.35	1.045	64.1
406		-10.000	470.000	37.110	3.000	409.70	394.83	1.038	64.1
407		-20.000	482.000	52.635	3.000	443.99	423.28	1.049	64.0
408		-9.000	475.000	40.513	3.500	525.71	491.11	1.070	63.7
409		-10.000	463.000	31.574	2.000	259.54	269.22	0.964	63.6
410		-11.000	464.000	32.979	2.000	261.12	270.45	0.966	63.5
411		-7.000	472.000	36.937	3.500	512.31	479.75	1.068	63.4
412		-12.000	465.000	34.383	2.000	262.42	271.29	0.967	63.2
413		-15.000	476.000	44.864	3.000	428.76	409.64	1.047	62.9
414		-13.000	466.000	35.788	2.000	263.62	271.96	0.969	62.8
415		-14.000	482.000	49.083	3.500	549.78	510.39	1.077	62.7
416		-19.000	481.000	51.221	3.000	441.59	420.09	1.051	62.6
417		-9.000	469.000	35.697	3.000	405.76	390.27	1.040	62.6
418		-10.000	480.000	45.466	4.000	652.38	595.57	1.095	62.4
419		-14.000	467.000	37.193	2.000	264.70	272.55	0.971	62.4
420		-11.000	478.000	44.093	3.500	537.21	499.55	1.075	62.3
421		-15.000	468.000	38.599	2.000	265.66	272.99	0.973	62.0
422		-16.000	469.000	40.005	2.000	266.75	273.72	0.975	61.8
423		-20.000	477.000	48.738	2.500	347.67	341.05	1.019	61.6
424		-21.000	478.000	50.148	2.500	349.28	342.39	1.020	61.6
425		-19.000	476.000	47.327	2.500	345.78	339.32	1.019	61.5
426		-18.000	475.000	45.917	2.500	344.01	337.87	1.018	61.5
427		-17.000	470.000	41.412	2.000	267.66	274.21	0.976	61.4
428		-25.000	482.000	55.790	2.500	355.16	347.07	1.023	61.4
429		-16.000	473.000	43.097	2.500	340.22	334.62	1.017	61.4
430		-26.000	483.000	57.202	2.500	356.69	348.38	1.024	61.4
431		-24.000	481.000	54.379	2.500	353.68	345.88	1.023	61.4
432		-22.000	479.000	51.558	2.500	350.68	343.34	1.021	61.4
433		-23.000	480.000	52.969	2.500	352.07	344.43	1.022	61.3
434		-14.000	475.000	43.450	3.000	424.90	405.13	1.049	61.3
435		-17.000	474.000	44.507	2.500	341.97	336.03	1.018	61.3
436		-18.000	471.000	42.819	2.000	268.63	274.79	0.978	61.2
437		-15.000	472.000	41.687	2.500	338.18	332.76	1.016	61.2
438		-7.000	476.000	40.473	4.000	637.70	582.20	1.095	61.0
439		-8.000	468.000	34.284	3.000	401.43	385.24	1.042	60.9
440		-14.000	471.000	40.276	2.500	335.79	330.52	1.016	60.9
441		-8.000	474.000	39.103	3.500	522.11	485.77	1.075	60.9
442		-18.000	480.000	49.807	3.000	439.04	416.52	1.054	60.8
443		-13.000	470.000	38.866	2.500	333.44	328.43	1.015	60.7
444		-19.000	472.000	44.227	2.000	269.40	274.95	0.980	60.6
445		-12.000	469.000	37.456	2.500	330.96	326.17	1.015	60.5
446		-20.000	473.000	45.635	2.000	270.22	275.46	0.981	60.4
447		-13.000	481.000	47.673	3.500	547.09	506.24	1.081	60.4

* denotes the minimum safety factor and maximum prevention force.

No.	Reg.	Circular arc requirements				Skid resistance S (kN/m)	Sliding force T (kN/m)	Safety factor Fs	Required prevention force Pr (kN/m)
		Central coordinates		Radius r (m)	Max. depth (m)				
		X (m)	Y (m)						
448		-6.000	471.000	35.526	3.500	507.70	473.29	1.073	60.3
449		-11.000	468.000	36.046	2.500	328.28	323.66	1.014	60.2
450		-21.000	474.000	47.044	2.000	271.17	275.99	0.983	60.1
451		-13.000	474.000	42.036	3.000	421.23	400.93	1.051	59.9
452		-10.000	467.000	34.635	2.500	325.48	321.01	1.014	59.8
453		-10.000	477.000	42.683	3.500	533.92	494.62	1.079	59.7
454		-20.000	483.000	53.347	3.000	444.21	419.66	1.058	59.4
455		-9.000	466.000	33.225	2.500	322.57	318.25	1.014	59.4
456		-8.000	465.000	31.815	2.500	319.78	315.86	1.012	59.3
457		-12.000	483.000	49.052	4.000	661.41	600.49	1.101	59.2
458		-17.000	479.000	48.393	3.000	436.47	413.01	1.057	59.2
459		-22.000	475.000	48.452	2.000	272.10	276.08	0.986	59.2
460		-7.000	467.000	32.871	3.000	397.27	380.36	1.044	59.2
461		-23.000	476.000	49.862	2.000	273.27	276.57	0.988	58.7
462		-7.000	464.000	30.405	2.500	316.39	312.53	1.012	58.7
463		-9.000	479.000	44.058	4.000	648.50	589.09	1.101	58.5
464		-12.000	473.000	40.622	3.000	417.56	396.70	1.053	58.5
465		-6.000	463.000	28.995	2.500	312.87	309.13	1.012	58.1
466		-24.000	477.000	51.271	2.000	274.36	276.93	0.991	58.0
467		-19.000	482.000	51.933	3.000	441.92	416.51	1.061	57.9
468		-12.000	480.000	46.263	3.500	543.93	501.47	1.085	57.9
469		-7.000	473.000	37.693	3.500	518.32	480.18	1.079	57.9
470		-25.000	478.000	52.681	2.000	275.68	277.64	0.993	57.5
471		-16.000	478.000	46.979	3.000	433.62	409.12	1.060	57.4
472		-6.000	466.000	31.459	3.000	392.52	374.77	1.047	57.3
473		-9.000	476.000	41.273	3.500	530.60	489.69	1.084	57.1
474		-11.000	472.000	39.208	3.000	413.59	392.11	1.055	57.0
475		-6.000	475.000	39.064	4.000	632.82	574.77	1.101	57.0
476		-26.000	479.000	54.091	2.000	276.73	278.00	0.995	56.9
477		-18.000	481.000	50.519	3.000	439.34	413.03	1.064	56.3
478		-11.000	482.000	47.645	4.000	658.38	595.17	1.106	55.9
479		-9.000	463.000	30.790	2.000	252.34	256.63	0.983	55.7
480		-14.000	483.000	49.842	3.500	552.54	506.69	1.090	55.5
481		-10.000	471.000	37.794	3.000	409.59	387.49	1.057	55.4
482		-10.000	464.000	32.195	2.000	253.65	257.52	0.985	55.4
483		-11.000	465.000	33.602	2.000	255.22	258.74	0.986	55.3
484		-15.000	477.000	45.564	3.000	430.53	404.85	1.063	55.3
485		-11.000	479.000	44.853	3.500	540.77	496.69	1.089	55.3
486		-12.000	466.000	35.009	2.000	256.77	259.97	0.988	55.2
487		-13.000	467.000	36.417	2.000	258.02	260.83	0.989	55.0
488		-6.000	472.000	36.283	3.500	514.15	474.29	1.084	55.0
489		-17.000	480.000	49.105	3.000	437.06	410.00	1.066	55.0
490		-14.000	468.000	37.825	2.000	259.41	261.92	0.990	54.9
491		-15.000	469.000	39.233	2.000	260.55	262.63	0.992	54.7
492		-8.000	478.000	42.650	4.000	644.33	582.43	1.106	54.6

* denotes the minimum safety factor and maximum prevention force.

No.	Reg.	Circular arc requirements				Skid resistance S (kN/m)	Sliding force T (kN/m)	Safety factor Fs	Required prevention force Pr (kN/m)
		Central coordinates		Radius r (m)	Max. depth (m)				
		X (m)	Y (m)						
493		-16.000	470.000	40.642	2.000	261.64	263.40	0.993	54.5
494		-8.000	475.000	39.863	3.500	526.92	484.49	1.088	54.5
495		-17.000	471.000	42.052	2.000	262.59	263.84	0.995	54.1
496		-14.000	476.000	44.150	3.000	426.89	400.63	1.066	53.9
497		-9.000	470.000	36.380	3.000	405.33	382.44	1.060	53.6
498		-19.000	483.000	52.655	3.000	442.91	413.73	1.071	53.6
499		-18.000	472.000	43.462	2.000	264.02	264.67	0.998	53.6
500		-19.000	473.000	44.872	2.000	265.43	265.47	1.000	53.2
501		-16.000	479.000	47.691	3.000	434.32	406.17	1.069	53.1
502		-13.000	482.000	48.433	3.500	549.58	502.20	1.094	53.1
503		-25.000	483.000	56.454	2.500	351.85	337.33	1.043	53.0
504		-24.000	482.000	55.042	2.500	350.30	335.98	1.043	52.9
505		-10.000	478.000	43.443	3.500	537.66	491.97	1.093	52.8
506		-22.000	480.000	52.218	2.500	346.74	332.71	1.042	52.6
507		-23.000	481.000	53.630	2.500	348.34	334.02	1.043	52.5
508		-20.000	474.000	46.282	2.000	266.86	266.03	1.003	52.4
509		-21.000	479.000	50.806	2.500	344.96	331.08	1.042	52.4
510		-13.000	475.000	42.736	3.000	423.27	396.39	1.068	52.4
511		-18.000	482.000	51.241	3.000	440.71	410.66	1.073	52.1
512		-10.000	481.000	46.239	4.000	654.81	589.06	1.112	52.1
513		-20.000	478.000	49.394	2.500	343.04	329.23	1.042	52.1
514		-19.000	477.000	47.983	2.500	341.32	327.74	1.041	52.0
515		-21.000	475.000	47.692	2.000	268.17	266.65	1.006	51.9
516		-18.000	476.000	46.571	2.500	339.40	326.02	1.041	51.9
517		-8.000	469.000	34.966	3.000	400.66	376.98	1.063	51.8
518		-7.000	474.000	38.453	3.500	523.33	479.24	1.092	51.8
519		-17.000	475.000	45.160	2.500	337.39	324.15	1.041	51.6
520		-22.000	476.000	49.102	2.000	269.61	267.52	1.008	51.5
521		-16.000	474.000	43.749	2.500	335.46	322.41	1.040	51.5
522		-15.000	478.000	46.277	3.000	431.40	402.14	1.073	51.2
523		-15.000	473.000	42.339	2.500	333.41	320.49	1.040	51.2
524		-14.000	472.000	40.928	2.500	331.40	318.72	1.040	51.1
525		-23.000	477.000	50.512	2.000	270.75	268.05	1.010	51.0
526		-7.000	477.000	41.242	4.000	640.27	575.75	1.112	50.7
527		-12.000	474.000	41.322	3.000	419.30	391.66	1.071	50.7
528		-13.000	471.000	39.518	2.500	328.95	316.27	1.040	50.6
529		-24.000	478.000	51.923	2.000	271.95	268.71	1.012	50.6
530		-17.000	481.000	49.827	3.000	438.22	407.25	1.076	50.5
531		-12.000	481.000	47.023	3.500	546.53	497.48	1.099	50.5
532		-12.000	470.000	38.108	2.500	326.80	314.38	1.040	50.5
533		-11.000	469.000	36.698	2.500	324.27	312.00	1.039	50.2
534		-6.000	474.000	37.803	3.500	513.09	469.38	1.093	50.2
535		-7.000	468.000	33.552	3.000	396.47	372.12	1.065	50.1
536		-9.000	477.000	42.033	3.500	533.98	486.61	1.097	50.0
537		-25.000	479.000	53.333	2.000	272.86	268.85	1.015	49.8

* denotes the minimum safety factor and maximum prevention force.

No.	Reg.	Circular arc requirements				Skid resistance S (kN/m)	Sliding force T (kN/m)	Safety factor Fs	Required prevention force Pr (kN/m)
		Central coordinates		Radius r (m)	Max. depth (m)				
		X (m)	Y (m)						
538		-10.000	468.000	35.287	2.500	321.55	309.32	1.040	49.7
539		-14.000	477.000	44.863	3.000	428.61	398.33	1.076	49.4
540		-26.000	480.000	54.743	2.000	273.93	269.38	1.017	49.4
541		-11.000	473.000	39.907	3.000	415.36	387.10	1.073	49.2
542		-9.000	467.000	33.877	2.500	318.77	306.61	1.040	49.2
543		-16.000	480.000	48.414	3.000	435.53	403.60	1.079	48.8
544		-8.000	466.000	32.467	2.500	315.84	303.79	1.040	48.8
545		-6.000	473.000	37.043	3.500	519.00	472.95	1.097	48.6
546		-9.000	480.000	44.832	4.000	651.35	583.07	1.117	48.4
547		-7.000	465.000	31.057	2.500	312.87	300.96	1.040	48.3
548		-12.000	467.000	35.652	2.000	252.37	250.40	1.008	48.2
549		-11.000	480.000	45.613	3.500	543.29	492.76	1.103	48.1
550		-13.000	468.000	37.062	2.000	253.79	251.54	1.009	48.1
551		-8.000	463.000	30.014	2.000	245.44	244.61	1.003	48.1
552		-9.000	464.000	31.423	2.000	247.14	245.96	1.005	48.1
553		-11.000	466.000	34.242	2.000	250.60	248.81	1.007	48.0
554		-10.000	465.000	32.832	2.000	248.95	247.43	1.006	48.0
555		-18.000	483.000	51.973	3.000	442.73	408.92	1.083	48.0
556		-6.000	467.000	32.139	3.000	391.63	366.27	1.069	47.9
557		-6.000	464.000	29.647	2.500	309.74	298.00	1.039	47.9
558		-14.000	469.000	38.472	2.000	255.26	252.42	1.011	47.7
559		-10.000	472.000	38.493	3.000	411.37	382.43	1.076	47.6
560		-13.000	476.000	43.449	3.000	425.19	393.68	1.080	47.3
561		-15.000	479.000	47.000	3.000	432.97	400.22	1.082	47.3
562		-8.000	476.000	40.623	3.500	530.36	481.30	1.102	47.2
563		-15.000	470.000	39.883	2.000	256.81	253.18	1.014	47.1
564		-6.000	476.000	39.836	4.000	636.09	568.94	1.118	46.7
565		-16.000	471.000	41.293	2.000	258.49	254.17	1.017	46.6
566		-17.000	482.000	50.560	3.000	440.29	405.50	1.086	46.4
567		-11.000	483.000	48.425	4.000	661.26	589.41	1.122	46.1
568		-17.000	472.000	42.703	2.000	259.90	254.80	1.020	45.9
569		-9.000	471.000	37.079	3.000	407.00	377.32	1.079	45.8
570		-18.000	473.000	44.113	2.000	261.57	255.99	1.022	45.7
571		-14.000	478.000	45.587	3.000	430.26	396.52	1.085	45.6
572		-13.000	483.000	49.193	3.500	550.82	496.72	1.109	45.3
573		-12.000	475.000	42.035	3.000	422.06	389.33	1.084	45.2
574		-10.000	479.000	44.203	3.500	539.91	487.58	1.107	45.2
575		-7.000	476.000	39.973	3.500	520.32	471.17	1.104	45.1
576		-24.000	483.000	55.714	2.500	347.90	327.44	1.062	45.1
577		-19.000	474.000	45.523	2.000	262.72	256.37	1.025	45.0
578		-16.000	481.000	49.147	3.000	438.03	402.45	1.088	45.0
579		-23.000	482.000	54.301	2.500	346.03	325.55	1.063	44.7
580		-20.000	475.000	46.934	2.000	264.08	257.19	1.027	44.6
581		-8.000	479.000	43.427	4.000	647.64	576.73	1.123	44.5
582		-22.000	481.000	52.888	2.500	344.15	323.67	1.063	44.3

* denotes the minimum safety factor and maximum prevention force.

No.	Reg.	Circular arc requirements				Skid resistance S (kN/m)	Sliding force T (kN/m)	Safety factor Fs	Required prevention force Pr (kN/m)
		Central coordinates		Radius r (m)	Max. depth (m)				
		X (m)	Y (m)						
583		-21.000	480.000	51.476	2.500	342.18	321.86	1.063	44.1
584		-7.000	475.000	39.213	3.500	526.45	475.43	1.107	44.1
585		-21.000	476.000	48.344	2.000	265.16	257.58	1.029	44.0
586		-8.000	470.000	35.665	3.000	402.52	372.01	1.082	43.9
587		-20.000	479.000	50.063	2.500	340.13	319.91	1.063	43.8
588		-13.000	477.000	44.173	3.000	427.32	392.45	1.089	43.7
589		-22.000	477.000	49.754	2.000	266.37	258.27	1.031	43.6
590		-9.000	479.000	43.558	3.500	529.29	477.16	1.109	43.4
591		-19.000	478.000	48.650	2.500	337.95	317.68	1.064	43.3
592		-15.000	480.000	47.734	3.000	435.40	398.85	1.092	43.3
593		-11.000	474.000	40.621	3.000	418.74	384.73	1.088	43.0
594		-23.000	478.000	51.164	2.000	267.31	258.57	1.034	43.0
595		-18.000	477.000	47.237	2.500	335.69	315.40	1.064	42.8
596		-17.000	476.000	45.825	2.500	333.82	313.80	1.064	42.8
597		-12.000	482.000	47.783	3.500	547.80	492.05	1.113	42.7
598		-17.000	483.000	51.302	3.000	443.37	404.93	1.095	42.6
599		-24.000	479.000	52.575	2.000	268.39	259.11	1.036	42.6
600		-16.000	475.000	44.413	2.500	331.60	311.68	1.064	42.5
601		-9.000	478.000	42.793	3.500	536.14	482.10	1.112	42.4
602		-10.000	482.000	47.021	4.000	657.93	583.36	1.128	42.2
603		-25.000	480.000	53.985	2.000	269.40	259.56	1.038	42.1
604		-7.000	469.000	34.251	3.000	398.03	366.72	1.085	42.1
605		-21.000	469.000	43.425	1.500	217.69	216.16	1.007	41.8
606		-12.000	476.000	42.760	3.000	424.39	388.47	1.092	41.8
607		-22.000	470.000	44.829	1.500	218.85	217.20	1.008	41.8
608		-15.000	474.000	43.000	2.500	329.16	309.13	1.065	41.8
609		-26.000	481.000	55.395	2.000	270.31	259.97	1.040	41.7
610		-20.000	468.000	42.020	1.500	216.54	215.08	1.007	41.6
611		-23.000	471.000	46.234	1.500	219.55	217.46	1.010	41.5
612		-14.000	473.000	41.588	2.500	326.93	306.99	1.065	41.5
613		-14.000	479.000	46.322	3.000	432.63	395.07	1.095	41.5
614		-19.000	467.000	40.615	1.500	215.36	214.00	1.006	41.5
615		-15.000	483.000	49.993	3.000	434.96	396.93	1.096	41.4
616		-24.000	472.000	47.638	1.500	220.32	218.02	1.011	41.4
617		-6.000	475.000	38.564	3.500	517.80	465.93	1.111	41.4
618		-11.000	482.000	47.145	3.500	537.44	482.23	1.114	41.3
619		-13.000	472.000	40.176	2.500	324.45	304.55	1.065	41.1
620		-9.000	465.000	32.073	2.000	243.05	236.66	1.027	41.0
621		-8.000	464.000	30.663	2.000	241.23	235.15	1.026	41.0
622		-17.000	464.000	37.187	1.500	212.39	211.15	1.006	41.0
623		-7.000	463.000	29.253	2.000	239.32	233.55	1.025	41.0
624		-18.000	466.000	39.211	1.500	213.79	212.30	1.007	41.0
625		-16.000	482.000	49.890	3.000	441.00	401.56	1.098	40.9
626		-10.000	473.000	39.207	3.000	415.24	380.06	1.093	40.9
627		-10.000	466.000	33.484	2.000	244.72	237.94	1.028	40.9

* denotes the minimum safety factor and maximum prevention force.

No.	Reg.	Circular arc requirements				Skid resistance S (kN/m)	Sliding force T (kN/m)	Safety factor Fs	Required prevention force Pr (kN/m)
		Central coordinates		Radius r (m)	Max. depth (m)				
		X (m)	Y (m)						
628		-10.000	476.000	41.424	3.000	414.96	379.73	1.093	40.8
629		-12.000	471.000	38.764	2.500	321.97	302.17	1.066	40.7
630		-11.000	467.000	34.894	2.000	246.72	239.20	1.031	40.4
631		-12.000	479.000	45.003	3.000	425.01	387.80	1.096	40.4
632		-7.000	478.000	42.022	4.000	643.72	570.08	1.129	40.4
633		-17.000	465.000	37.806	1.500	212.12	210.43	1.008	40.4
634		-11.000	481.000	46.374	3.500	544.56	487.14	1.118	40.1
635		-12.000	468.000	36.304	2.000	248.67	240.48	1.034	40.0
636		-16.000	464.000	36.401	1.500	210.49	208.66	1.009	40.0
637		-11.000	470.000	37.353	2.500	319.26	299.33	1.067	40.0
638		-18.000	465.000	38.576	1.485	211.94	209.93	1.010	40.0
639		-13.000	478.000	44.909	3.000	430.23	391.82	1.098	40.0
640		-6.000	468.000	32.836	3.000	393.11	360.92	1.089	40.0
641		-8.000	478.000	42.150	3.500	527.43	472.81	1.116	40.0
642		-16.000	463.000	35.784	1.500	210.53	208.62	1.009	39.9
643		-10.000	469.000	35.941	2.500	316.68	296.91	1.067	39.7
644		-11.000	475.000	41.347	3.000	421.12	384.00	1.097	39.7
645		-8.000	477.000	41.383	3.500	532.32	476.58	1.117	39.6
646		-13.000	469.000	37.714	2.000	250.42	241.55	1.037	39.5
647		-15.000	481.000	48.479	3.000	438.58	398.30	1.101	39.4
648		-14.000	482.000	48.583	3.000	433.60	394.08	1.100	39.3
649		-9.000	472.000	37.793	3.000	410.85	374.97	1.096	39.2
650		-9.000	468.000	34.530	2.500	314.00	294.33	1.067	39.2
651		-15.000	463.000	34.997	1.500	208.65	206.49	1.010	39.2
652		-14.000	470.000	39.124	2.000	252.08	242.61	1.039	39.1
653		-25.000	473.000	49.021	1.478	217.80	213.97	1.018	39.0
654		-18.000	467.000	39.831	1.500	212.23	209.21	1.014	38.9
655		-20.000	469.000	42.640	1.500	214.44	211.09	1.016	38.9
656		-17.000	466.000	38.426	1.500	211.01	208.17	1.014	38.8
657		-19.000	468.000	41.235	1.500	213.38	210.15	1.015	38.8
658		-8.000	467.000	33.119	2.500	311.04	291.40	1.067	38.7
659		-21.000	470.000	44.045	1.500	215.39	211.74	1.017	38.7
660		-16.000	465.000	37.022	1.500	209.71	206.95	1.013	38.7
661		-15.000	471.000	40.535	2.000	253.59	243.38	1.042	38.5
662		-9.000	481.000	45.617	4.000	654.85	577.66	1.134	38.4
663		-11.000	478.000	43.593	3.000	423.65	384.99	1.100	38.4
664		-9.000	475.000	40.013	3.000	413.26	376.38	1.098	38.4
665		-22.000	471.000	45.449	1.500	215.89	211.80	1.019	38.3
666		-15.000	464.000	35.617	1.500	208.13	205.35	1.014	38.3
667		-23.000	472.000	46.854	1.500	216.69	212.35	1.020	38.2
668		-16.000	472.000	41.945	2.000	255.18	244.46	1.044	38.2
669		-12.000	477.000	43.497	3.000	427.45	387.97	1.102	38.2
670		-10.000	481.000	45.739	3.500	535.96	478.36	1.120	38.1
671		-7.000	466.000	31.709	2.500	307.98	288.25	1.068	38.0
672		-17.000	473.000	43.355	2.000	256.57	245.28	1.046	37.8

* denotes the minimum safety factor and maximum prevention force.

No.	Reg.	Circular arc requirements				Skid resistance S (kN/m)	Sliding force T (kN/m)	Safety factor Fs	Required prevention force Pr (kN/m)
		Central coordinates		Radius r (m)	Max. depth (m)				
		X (m)	Y (m)						
673		-24.000	473.000	48.258	1.500	217.25	212.49	1.022	37.8
674		-14.000	463.000	34.212	1.500	206.24	203.24	1.015	37.7
675		-14.000	480.000	47.067	3.000	436.07	394.78	1.105	37.7
676		-25.000	474.000	49.663	1.500	217.71	212.53	1.024	37.4
677		-10.000	480.000	44.966	3.500	541.41	482.28	1.123	37.4
678		-10.000	474.000	39.933	3.000	417.61	379.16	1.101	37.4
679		-18.000	474.000	44.765	2.000	257.84	245.99	1.048	37.4
680		-8.000	471.000	36.379	3.000	406.67	370.01	1.099	37.4
681		-13.000	481.000	47.173	3.000	432.15	391.20	1.105	37.3
682		-6.000	465.000	30.298	2.500	304.88	285.15	1.069	37.3
683		-7.000	472.000	36.437	3.000	401.41	365.40	1.099	37.1
684		-23.000	483.000	54.984	2.500	344.35	317.82	1.083	37.1
685		-19.000	475.000	46.175	2.000	259.27	246.92	1.050	37.1
686		-26.000	475.000	51.068	1.500	217.94	212.31	1.027	36.9
687		-16.000	483.000	50.643	3.000	444.60	401.14	1.108	36.8
688		-22.000	482.000	53.570	2.500	342.34	315.81	1.084	36.7
689		-20.000	476.000	47.586	2.000	260.32	247.36	1.052	36.6
690		-7.000	477.000	40.742	3.500	525.18	467.92	1.122	36.4
691		-6.000	477.000	40.618	4.000	639.88	563.49	1.136	36.4
692		-21.000	481.000	52.156	2.500	340.43	313.96	1.084	36.4
693		-10.000	477.000	42.183	3.000	422.10	381.94	1.105	36.3
694		-11.000	476.000	42.085	3.000	424.32	383.75	1.106	36.2
695		-8.000	474.000	38.603	3.000	411.42	372.90	1.103	36.1
696		-13.000	479.000	45.656	3.000	433.85	391.54	1.108	36.0
697		-21.000	477.000	48.996	2.000	261.19	247.62	1.055	36.0
698		-19.000	466.000	39.937	1.442	207.42	202.77	1.023	36.0
699		-17.000	467.000	39.046	1.500	208.69	203.80	1.024	35.9
700		-15.000	465.000	36.237	1.500	206.30	201.77	1.022	35.9
701		-26.000	474.000	50.398	1.451	214.27	208.39	1.028	35.8
702		-20.000	480.000	50.743	2.500	338.24	311.68	1.085	35.8
703		-22.000	478.000	50.406	2.000	262.39	248.45	1.056	35.8
704		-16.000	466.000	37.642	1.500	207.42	202.56	1.024	35.7
705		-14.000	464.000	34.832	1.500	204.77	200.35	1.022	35.7
706		-18.000	468.000	40.451	1.500	209.59	204.35	1.026	35.7
707		-19.000	479.000	49.329	2.500	336.19	309.67	1.086	35.5
708		-19.000	469.000	41.855	1.500	210.54	205.02	1.027	35.5
709		-15.000	482.000	49.233	3.000	442.45	398.13	1.111	35.4
710		-12.000	480.000	45.763	3.000	430.92	388.59	1.109	35.4
711		-13.000	463.000	33.428	1.500	203.24	198.85	1.022	35.4
712		-7.000	470.000	34.965	3.000	401.84	364.29	1.103	35.4
713		-20.000	470.000	43.260	1.500	211.30	205.44	1.029	35.3
714		-9.000	473.000	38.520	3.000	414.29	374.61	1.106	35.3
715		-23.000	479.000	51.816	2.000	263.24	248.65	1.059	35.2
716		-18.000	478.000	47.916	2.500	333.85	307.34	1.086	35.0
717		-12.000	483.000	48.552	3.500	549.40	486.90	1.128	34.9

* denotes the minimum safety factor and maximum prevention force.

No.	Reg.	Circular arc requirements				Skid resistance S (kN/m)	Sliding force T (kN/m)	Safety factor Fs	Required prevention force Pr (kN/m)
		Central coordinates		Radius r (m)	Max. depth (m)				
		X (m)	Y (m)						
718		-9.000	480.000	44.332	3.500	534.42	474.31	1.127	34.8
719		-24.000	480.000	53.226	2.000	264.05	249.00	1.060	34.8
720		-21.000	471.000	44.665	1.500	211.75	205.34	1.031	34.7
721		-17.000	477.000	46.502	2.500	331.66	305.19	1.087	34.6
722		-8.000	480.000	44.214	4.000	651.51	571.62	1.140	34.5
723		-6.000	471.000	35.026	3.000	399.18	361.40	1.105	34.5
724		-12.000	478.000	44.245	3.000	431.10	387.83	1.112	34.3
725		-25.000	481.000	54.637	2.000	264.82	249.21	1.063	34.3
726		-10.000	475.000	40.673	3.000	421.34	379.54	1.110	34.2
727		-22.000	472.000	46.069	1.500	212.16	205.24	1.034	34.2
728		-16.000	476.000	45.089	2.500	329.21	302.69	1.088	34.1
729		-14.000	483.000	49.342	3.000	438.28	393.55	1.114	34.0
730		-26.000	482.000	56.047	2.000	265.71	249.68	1.064	34.0
731		-9.000	476.000	40.773	3.000	420.37	378.62	1.110	34.0
732		-23.000	473.000	47.474	1.500	212.66	205.44	1.035	33.9
733		-14.000	481.000	47.823	3.000	440.41	395.16	1.115	33.8
734		-15.000	475.000	43.675	2.500	326.96	300.53	1.088	33.7
735		-7.000	473.000	37.193	3.000	409.47	369.13	1.109	33.5
736		-24.000	474.000	48.879	1.500	213.04	205.37	1.037	33.5
737		-11.000	479.000	44.353	3.000	429.48	385.61	1.114	33.3
738		-6.000	463.000	28.495	2.000	232.35	221.30	1.050	33.3
739		-6.000	469.000	33.551	3.000	396.99	358.42	1.108	33.2
740		-11.000	483.000	47.925	3.500	542.33	479.41	1.131	33.0
741		-14.000	474.000	42.262	2.500	324.23	297.65	1.089	33.0
742		-8.000	472.000	37.107	3.000	410.54	369.49	1.111	32.9
743		-7.000	464.000	29.905	2.000	234.77	222.94	1.053	32.8
744		-25.000	475.000	50.283	1.500	213.15	204.88	1.040	32.8
745		-11.000	477.000	42.834	3.000	428.64	384.39	1.115	32.7
746		-6.000	476.000	39.336	3.500	523.04	463.06	1.130	32.7
747		-13.000	464.000	34.048	1.500	201.07	194.78	1.032	32.7
748		-13.000	473.000	40.849	2.500	321.85	295.36	1.090	32.6
749		-8.000	465.000	31.315	2.000	237.05	224.62	1.055	32.5
750		-20.000	467.000	41.303	1.403	203.39	196.53	1.035	32.5
751		-12.000	463.000	32.643	1.500	199.46	193.15	1.033	32.4
752		-14.000	465.000	35.452	1.500	202.15	195.43	1.034	32.4
753		-15.000	466.000	36.857	1.500	203.19	196.15	1.036	32.2
754		-26.000	476.000	51.688	1.500	213.34	204.57	1.043	32.2
755		-10.000	483.000	47.812	4.000	661.67	578.22	1.144	32.2
756		-9.000	466.000	32.725	2.000	239.27	226.18	1.058	32.2
757		-12.000	472.000	39.436	2.500	319.27	292.80	1.090	32.1
758		-9.000	474.000	39.261	3.000	417.94	375.00	1.115	32.1
759		-13.000	480.000	46.413	3.000	438.13	391.85	1.118	32.1
760		-16.000	467.000	38.262	1.500	204.21	196.80	1.038	32.0
761		-13.000	482.000	47.933	3.000	436.99	390.75	1.118	32.0
762		-10.000	467.000	34.135	2.000	241.28	227.66	1.060	32.0

* denotes the minimum safety factor and maximum prevention force.

No.	Reg.	Circular arc requirements				Skid resistance S (kN/m)	Sliding force T (kN/m)	Safety factor Fs	Required prevention force Pr (kN/m)
		Central coordinates		Radius r (m)	Max. depth (m)				
		X (m)	Y (m)						
763		-17.000	468.000	39.666	1.500	205.01	197.26	1.039	31.8
764		-8.000	475.000	39.363	3.000	418.56	375.09	1.116	31.6
765		-11.000	468.000	35.546	2.000	243.02	228.72	1.063	31.5
766		-18.000	469.000	41.071	1.500	205.80	197.65	1.041	31.4
767		-11.000	471.000	38.023	2.500	316.47	289.82	1.092	31.4
768		-8.000	479.000	42.927	3.500	532.46	469.78	1.133	31.3
769		-12.000	469.000	36.956	2.000	244.66	229.72	1.065	31.1
770		-19.000	470.000	42.476	1.500	206.34	197.70	1.044	30.9
771		-6.000	472.000	35.783	3.000	407.30	365.04	1.116	30.8
772		-10.000	478.000	42.943	3.000	427.66	381.99	1.120	30.8
773		-10.000	470.000	36.610	2.500	313.40	286.67	1.093	30.7
774		-13.000	470.000	38.366	2.000	246.31	230.81	1.067	30.7
775		-7.000	471.000	35.694	3.000	406.85	364.46	1.116	30.6
776		-14.000	471.000	39.776	2.000	247.97	232.02	1.069	30.5
777		-20.000	471.000	43.880	1.500	206.76	197.64	1.046	30.5
778		-7.000	479.000	42.812	4.000	647.95	565.28	1.146	30.4
779		-21.000	472.000	45.285	1.500	207.21	197.68	1.048	30.1
780		-15.000	472.000	41.187	2.000	249.23	232.65	1.071	30.0
781		-8.000	473.000	37.849	3.000	414.49	370.36	1.119	30.0
782		-9.000	469.000	35.197	2.500	310.31	283.50	1.095	29.9
783		-16.000	473.000	42.597	2.000	250.82	233.86	1.073	29.9
784		-12.000	481.000	46.523	3.000	435.49	387.67	1.123	29.8
785		-10.000	482.000	46.521	3.500	541.01	475.57	1.138	29.7
786		-22.000	483.000	54.262	2.500	341.98	309.68	1.104	29.7
787		-6.000	467.000	31.639	2.500	286.99	263.66	1.088	29.5
788		-22.000	473.000	46.689	1.500	207.40	197.39	1.051	29.5
789		-17.000	474.000	44.007	2.000	251.98	234.48	1.075	29.4
790		-21.000	482.000	52.848	2.500	340.12	307.89	1.105	29.4
791		-21.000	468.000	42.671	1.367	199.72	190.78	1.047	29.3
792		-8.000	468.000	33.784	2.500	307.25	280.45	1.096	29.3
793		-18.000	475.000	45.417	2.000	253.16	235.27	1.076	29.2
794		-7.000	474.000	37.953	3.000	416.79	371.46	1.122	29.0
795		-11.000	463.000	31.859	1.500	195.05	186.59	1.045	28.9
796		-23.000	474.000	48.094	1.500	207.60	197.06	1.053	28.9
797		-19.000	476.000	46.827	2.000	254.30	235.86	1.078	28.8
798		-20.000	481.000	51.434	2.500	337.85	305.53	1.106	28.8
799		-12.000	464.000	33.263	1.500	196.43	187.64	1.047	28.8
800		-9.000	477.000	41.533	3.000	426.22	378.95	1.125	28.6
801		-13.000	465.000	34.668	1.500	197.41	188.19	1.049	28.5
802		-7.000	467.000	32.371	2.500	303.94	277.00	1.097	28.5
803		-20.000	477.000	48.238	2.000	255.27	236.36	1.080	28.4
804		-24.000	475.000	49.499	1.500	207.87	196.88	1.056	28.4
805		-14.000	466.000	36.073	1.500	198.43	188.90	1.050	28.3
806		-19.000	480.000	50.020	2.500	335.65	303.27	1.107	28.3
807		-21.000	478.000	49.648	2.000	256.22	236.85	1.082	28.0

* denotes the minimum safety factor and maximum prevention force.

No.	Reg.	Circular arc requirements				Skid resistance S (kN/m)	Sliding force T (kN/m)	Safety factor Fs	Required prevention force Pr (kN/m)
		Central coordinates		Radius r (m)	Max. depth (m)				
		X (m)	Y (m)						
808		-6.000	470.000	34.281	3.000	402.91	359.01	1.122	28.0
809		-15.000	467.000	37.477	1.500	199.13	189.08	1.053	27.8
810		-7.000	478.000	41.522	3.500	530.75	465.39	1.140	27.8
811		-18.000	479.000	48.606	2.500	333.28	300.76	1.108	27.7
812		-22.000	479.000	51.058	2.000	257.28	237.46	1.083	27.7
813		-6.000	466.000	30.959	2.500	300.54	273.51	1.099	27.7
814		-25.000	476.000	50.905	1.500	207.91	196.33	1.059	27.7
815		-11.000	480.000	45.113	3.000	433.76	384.24	1.129	27.4
816		-26.000	477.000	52.311	1.500	208.29	196.40	1.061	27.4
817		-23.000	480.000	52.469	2.000	258.09	237.85	1.085	27.4
818		-17.000	478.000	47.192	2.500	330.99	298.51	1.109	27.3
819		-16.000	468.000	38.882	1.500	199.63	189.02	1.056	27.2
820		-24.000	481.000	53.879	2.000	258.85	238.08	1.087	26.9
821		-17.000	469.000	40.286	1.500	200.19	189.07	1.059	26.7
822		-16.000	477.000	45.778	2.500	328.46	295.84	1.110	26.6
823		-25.000	482.000	55.290	2.000	259.59	238.34	1.089	26.5
824		-24.000	469.000	45.611	1.327	198.89	187.76	1.059	26.5
825		-18.000	470.000	41.691	1.500	200.76	189.27	1.061	26.4
826		-6.000	473.000	36.543	3.000	414.42	367.19	1.129	26.3
827		-26.000	483.000	56.702	2.000	260.55	238.96	1.090	26.3
828		-9.000	481.000	45.117	3.500	539.51	471.42	1.144	26.2
829		-22.000	469.000	44.043	1.334	196.17	185.17	1.059	26.1
830		-15.000	476.000	44.364	2.500	325.98	293.30	1.111	26.0
831		-8.000	476.000	40.123	3.000	424.07	375.00	1.131	26.0
832		-10.000	472.000	37.993	2.500	299.72	271.29	1.105	25.9
833		-13.000	483.000	48.693	3.000	440.36	388.48	1.134	25.9
834		-19.000	471.000	43.096	1.500	201.14	189.11	1.064	25.8
835		-11.000	470.000	36.853	2.000	219.52	204.29	1.075	25.7
836		-8.000	467.000	32.619	2.000	216.11	201.44	1.073	25.7
837		-10.000	469.000	35.441	2.000	218.43	203.37	1.074	25.7
838		-9.000	468.000	34.030	2.000	217.15	202.22	1.074	25.6
839		-20.000	472.000	44.502	1.500	201.72	189.42	1.065	25.6
840		-14.000	473.000	41.088	2.000	222.57	206.79	1.076	25.6
841		-12.000	471.000	38.264	2.000	220.61	205.15	1.075	25.6
842		-7.000	466.000	31.209	2.000	214.79	200.25	1.073	25.6
843		-13.000	472.000	39.676	2.000	221.49	205.78	1.076	25.5
844		-6.000	465.000	29.798	2.000	213.46	199.03	1.073	25.4
845		-14.000	475.000	42.950	2.500	323.32	290.54	1.113	25.4
846		-21.000	473.000	45.908	1.500	202.03	189.22	1.068	25.1
847		-10.000	479.000	43.703	3.000	432.17	380.97	1.134	25.0
848		-13.000	474.000	41.536	2.500	320.61	287.77	1.114	24.8
849		-9.000	471.000	36.579	2.500	297.57	268.59	1.108	24.8
850		-25.000	470.000	46.997	1.311	197.37	185.06	1.067	24.8
851		-10.000	463.000	31.074	1.500	189.76	178.63	1.062	24.6
852		-22.000	474.000	47.314	1.500	202.27	188.93	1.071	24.5

* denotes the minimum safety factor and maximum prevention force.

No.	Reg.	Circular arc requirements				Skid resistance S (kN/m)	Sliding force T (kN/m)	Safety factor Fs	Required prevention force Pr (kN/m)
		Central coordinates		Radius r (m)	Max. depth (m)				
		X (m)	Y (m)						
853		-11.000	464.000	32.479	1.500	190.88	179.30	1.065	24.3
854		-6.000	477.000	40.118	3.500	528.87	460.77	1.148	24.1
855		-12.000	473.000	40.122	2.500	317.71	284.76	1.116	24.1
856		-23.000	475.000	48.722	1.500	202.58	188.77	1.073	24.0
857		-6.000	464.000	29.147	2.000	228.33	210.24	1.086	24.0
858		-7.000	465.000	30.557	2.000	230.70	212.12	1.088	23.9
859		-12.000	465.000	33.883	1.500	191.63	179.49	1.068	23.8
860		-8.000	470.000	35.165	2.500	295.35	265.88	1.111	23.8
861		-26.000	471.000	48.385	1.296	196.41	183.47	1.071	23.8
862		-24.000	476.000	50.129	1.500	203.10	188.96	1.075	23.7
863		-8.000	466.000	31.967	2.000	232.79	213.61	1.090	23.6
864		-12.000	482.000	47.283	3.000	438.79	385.29	1.139	23.6
865		-13.000	466.000	35.288	1.500	192.67	180.20	1.069	23.6
866		-7.000	475.000	38.713	3.000	422.15	371.31	1.137	23.5
867		-9.000	467.000	33.377	2.000	234.70	214.96	1.092	23.3
868		-23.000	470.000	45.417	1.304	192.97	180.17	1.071	23.3
869		-11.000	472.000	38.708	2.500	314.88	281.80	1.117	23.3
870		-14.000	467.000	36.693	1.500	193.42	180.54	1.071	23.3
871		-7.000	463.000	28.753	1.500	160.63	153.12	1.049	23.2
872		-25.000	477.000	51.537	1.500	203.25	188.68	1.077	23.2
873		-8.000	464.000	30.163	1.500	161.49	153.77	1.050	23.1
874		-14.000	477.000	44.363	2.500	312.97	280.02	1.118	23.1
875		-26.000	478.000	52.945	1.500	203.68	188.80	1.079	22.9
876		-9.000	465.000	31.573	1.500	162.28	154.26	1.052	22.9
877		-10.000	468.000	34.787	2.000	236.41	216.07	1.094	22.9
878		-11.000	469.000	36.198	2.000	238.22	217.45	1.096	22.8
879		-21.000	483.000	53.550	2.500	340.82	303.01	1.125	22.8
880		-8.000	480.000	43.714	3.500	538.09	467.32	1.151	22.7
881		-11.000	467.000	34.394	1.500	163.83	155.38	1.054	22.7
882		-12.000	468.000	35.804	1.500	164.55	155.88	1.056	22.6
883		-15.000	468.000	38.099	1.500	193.86	180.33	1.075	22.6
884		-10.000	466.000	32.984	1.500	162.99	154.61	1.054	22.6
885		-10.000	471.000	37.294	2.500	311.91	278.75	1.119	22.6
886		-9.000	478.000	42.293	3.000	430.28	377.38	1.140	22.6
887		-12.000	470.000	37.608	2.000	239.87	218.63	1.097	22.5
888		-20.000	482.000	52.135	2.500	338.81	300.99	1.126	22.4
889		-13.000	469.000	37.214	1.500	164.95	156.06	1.057	22.4
890		-7.000	469.000	33.751	2.500	292.90	262.74	1.115	22.4
891		-13.000	471.000	39.018	2.000	241.23	219.54	1.099	22.3
892		-16.000	469.000	39.505	1.500	194.50	180.52	1.077	22.2
893		-13.000	476.000	42.949	2.500	311.17	277.76	1.120	22.2
894		-14.000	470.000	38.624	1.500	165.57	156.45	1.058	22.2
895		-14.000	472.000	40.428	2.000	242.77	220.66	1.100	22.1
896		-17.000	470.000	40.912	1.500	195.38	181.11	1.079	22.0
897		-9.000	470.000	35.880	2.500	308.83	275.56	1.121	21.9

* denotes the minimum safety factor and maximum prevention force.

No.	Reg.	Circular arc requirements				Skid resistance S (kN/m)	Sliding force T (kN/m)	Safety factor Fs	Required prevention force Pr (kN/m)
		Central coordinates		Radius r (m)	Max. depth (m)				
		X (m)	Y (m)						
898		-15.000	471.000	40.035	1.500	165.92	156.45	1.061	21.9
899		-16.000	472.000	41.445	1.500	166.34	156.73	1.061	21.8
900		-19.000	481.000	50.721	2.500	336.53	298.58	1.127	21.8
901		-15.000	473.000	41.839	2.000	244.15	221.51	1.102	21.7
902		-17.000	473.000	42.855	1.500	166.72	156.88	1.063	21.6
903		-18.000	471.000	42.319	1.500	195.81	181.10	1.081	21.6
904		-16.000	474.000	43.249	2.000	245.46	222.40	1.104	21.5
905		-17.000	475.000	44.660	2.000	246.74	223.31	1.105	21.3
906		-11.000	481.000	45.874	3.000	437.31	382.11	1.144	21.3
907		-10.000	483.000	47.312	3.500	546.57	473.21	1.155	21.3
908		-18.000	474.000	44.265	1.500	166.92	156.80	1.065	21.3
909		-18.000	480.000	49.307	2.500	334.12	296.09	1.128	21.2
910		-19.000	475.000	45.675	1.500	167.18	156.83	1.066	21.1
911		-19.000	472.000	43.727	1.500	196.34	181.18	1.084	21.1
912		-6.000	468.000	32.336	2.500	290.33	259.45	1.119	21.1
913		-12.000	475.000	41.535	2.500	309.06	275.13	1.123	21.1
914		-8.000	469.000	34.466	2.500	305.35	271.90	1.123	21.0
915		-18.000	476.000	46.071	2.000	247.75	223.83	1.107	20.9
916		-6.000	474.000	37.303	3.000	419.98	367.24	1.144	20.8
917		-20.000	473.000	45.135	1.500	196.93	181.39	1.086	20.8
918		-20.000	476.000	47.086	1.500	167.43	156.84	1.068	20.8
919		-18.000	482.000	50.741	2.500	326.14	289.01	1.128	20.7
920		-19.000	477.000	47.483	2.000	248.99	224.73	1.108	20.7
921		-20.000	478.000	48.894	2.000	250.32	225.75	1.109	20.6
922		-21.000	477.000	48.496	1.500	167.67	156.89	1.069	20.6
923		-17.000	479.000	47.893	2.500	331.62	293.43	1.130	20.5
924		-24.000	471.000	46.794	1.276	189.90	175.31	1.083	20.5
925		-22.000	478.000	49.906	1.500	167.81	156.83	1.070	20.4
926		-21.000	479.000	50.306	2.000	251.39	226.38	1.110	20.3
927		-21.000	474.000	46.544	1.500	197.35	181.35	1.088	20.3
928		-7.000	468.000	33.052	2.500	302.19	268.69	1.125	20.3
929		-23.000	479.000	51.316	1.500	167.86	156.64	1.072	20.2
930		-22.000	475.000	47.952	1.500	198.07	181.81	1.089	20.2
931		-8.000	477.000	40.883	3.000	428.21	373.55	1.146	20.1
932		-11.000	474.000	40.121	2.500	307.16	272.68	1.126	20.1
933		-22.000	480.000	51.718	2.000	252.37	227.03	1.112	20.1
934		-24.000	480.000	52.726	1.500	168.15	156.80	1.072	20.1
935		-17.000	481.000	49.327	2.500	324.63	287.17	1.130	20.0
936		-9.000	463.000	30.290	1.500	183.46	169.36	1.083	19.8
937		-16.000	478.000	46.479	2.500	329.14	290.75	1.132	19.8
938		-23.000	481.000	53.130	2.000	253.38	227.64	1.113	19.8
939		-25.000	481.000	54.137	1.500	168.19	156.62	1.074	19.8
940		-23.000	476.000	49.362	1.500	198.48	181.77	1.092	19.7
941		-24.000	482.000	54.542	2.000	254.48	228.39	1.114	19.6
942		-26.000	482.000	55.547	1.500	168.21	156.41	1.075	19.5

* denotes the minimum safety factor and maximum prevention force.

No.	Reg.	Circular arc requirements				Skid resistance S (kN/m)	Sliding force T (kN/m)	Safety factor Fs	Required prevention force Pr (kN/m)
		Central coordinates		Radius r (m)	Max. depth (m)				
		X (m)	Y (m)						
943		-24.000	477.000	50.771	1.500	198.99	182.02	1.093	19.5
944		-10.000	464.000	31.695	1.500	184.59	170.04	1.086	19.5
945		-25.000	483.000	55.954	2.000	255.64	229.27	1.115	19.5
946		-11.000	465.000	33.102	1.500	185.88	170.99	1.087	19.4
947		-25.000	478.000	52.181	1.500	199.51	182.25	1.095	19.2
948		-16.000	480.000	47.914	2.500	323.06	285.12	1.133	19.1
949		-15.000	477.000	45.064	2.500	326.42	287.90	1.134	19.1
950		-12.000	466.000	34.509	1.500	186.78	171.47	1.089	19.0
951		-10.000	473.000	38.707	2.500	305.03	269.98	1.130	19.0
952		-7.000	479.000	42.312	3.500	536.52	462.93	1.159	19.0
953		-10.000	480.000	44.466	3.000	435.58	378.69	1.150	18.9
954		-26.000	479.000	53.591	1.500	199.77	182.11	1.097	18.8
955		-23.000	483.000	54.484	2.000	231.27	208.39	1.110	18.8
956		-22.000	482.000	53.070	2.000	230.29	207.44	1.110	18.7
957		-21.000	481.000	51.656	2.000	229.55	206.81	1.110	18.7
958		-20.000	480.000	50.243	2.000	228.77	206.19	1.110	18.7
959		-19.000	479.000	48.829	2.000	227.75	205.24	1.110	18.6
960		-13.000	467.000	35.917	1.500	187.58	171.77	1.092	18.6
961		-18.000	478.000	47.416	2.000	226.91	204.50	1.110	18.5
962		-14.000	476.000	43.650	2.500	323.84	285.20	1.135	18.4
963		-17.000	477.000	46.002	2.000	225.84	203.52	1.110	18.4
964		-14.000	468.000	37.325	1.500	188.50	172.20	1.095	18.2
965		-16.000	476.000	44.589	2.000	224.70	202.39	1.110	18.2
966		-15.000	475.000	43.175	2.000	223.70	201.51	1.110	18.2
967		-7.000	464.000	29.405	1.500	160.33	148.69	1.078	18.1
968		-15.000	479.000	46.500	2.500	321.05	282.55	1.136	18.1
969		-14.000	474.000	41.762	2.000	222.63	200.50	1.110	18.0
970		-6.000	463.000	27.995	1.500	159.35	147.72	1.079	18.0
971		-13.000	473.000	40.349	2.000	221.58	199.59	1.110	18.0
972		-15.000	469.000	38.733	1.500	189.41	172.82	1.096	18.0
973		-25.000	472.000	48.173	1.250	187.06	170.88	1.095	18.0
974		-9.000	482.000	45.911	3.500	545.26	469.22	1.162	17.9
975		-12.000	472.000	38.936	2.000	220.55	198.67	1.110	17.9
976		-9.000	472.000	37.293	2.500	302.94	267.36	1.133	17.9
977		-9.000	466.000	32.225	1.500	161.57	149.42	1.081	17.8
978		-8.000	465.000	30.815	1.500	160.85	148.86	1.081	17.8
979		-11.000	468.000	35.046	1.500	162.74	150.30	1.083	17.7
980		-13.000	475.000	42.236	2.500	321.18	282.37	1.137	17.7
981		-16.000	470.000	40.142	1.500	190.23	173.27	1.098	17.7
982		-11.000	471.000	37.523	2.000	219.18	197.25	1.111	17.6
983		-10.000	467.000	33.635	1.500	162.08	149.73	1.082	17.6
984		-17.000	471.000	41.552	1.500	191.12	173.85	1.099	17.5
985		-12.000	469.000	36.456	1.500	163.15	150.50	1.084	17.5
986		-10.000	470.000	36.110	2.000	218.04	196.16	1.112	17.4
987		-17.000	463.000	36.342	1.260	176.82	161.82	1.093	17.4

* denotes the minimum safety factor and maximum prevention force.

No.	Reg.	Circular arc requirements				Skid resistance S (kN/m)	Sliding force T (kN/m)	Safety factor Fs	Required prevention force Pr (kN/m)
		Central coordinates		Radius r (m)	Max. depth (m)				
		X (m)	Y (m)						
988		-12.000	483.000	48.052	3.000	442.42	383.14	1.155	17.4
989		-13.000	470.000	37.866	1.500	163.46	150.58	1.086	17.3
990		-7.000	476.000	39.473	3.000	426.08	369.48	1.153	17.3
991		-14.000	471.000	39.276	1.500	163.91	150.89	1.086	17.2
992		-18.000	472.000	42.962	1.500	191.75	174.07	1.102	17.2
993		-14.000	478.000	45.087	2.500	319.48	280.45	1.139	17.1
994		-9.000	469.000	34.697	2.000	216.59	194.74	1.112	17.1
995		-15.000	472.000	40.687	1.500	164.19	150.95	1.088	17.0
996		-8.000	468.000	33.284	2.000	215.40	193.61	1.113	17.0
997		-12.000	474.000	40.822	2.500	318.29	279.36	1.139	17.0
998		-18.000	483.000	51.473	2.500	331.90	290.61	1.142	16.9
999		-19.000	473.000	44.372	1.500	192.45	174.40	1.103	16.9
1000		-16.000	473.000	42.097	1.500	164.38	150.92	1.089	16.8
1001		-17.000	474.000	43.507	1.500	164.69	151.10	1.090	16.7
1002		-20.000	474.000	45.782	1.500	193.21	174.91	1.105	16.7
1003		-7.000	467.000	31.871	2.000	213.77	191.89	1.114	16.5
1004		-8.000	471.000	35.879	2.500	300.57	264.21	1.138	16.5
1005		-18.000	475.000	44.917	1.500	164.75	150.94	1.091	16.4
1006		-21.000	475.000	47.192	1.500	193.81	175.12	1.107	16.4
1007		-11.000	473.000	39.407	2.500	315.54	276.54	1.141	16.4
1008		-9.000	479.000	43.058	3.000	433.85	375.11	1.157	16.3
1009		-19.000	476.000	46.327	1.500	164.99	151.03	1.092	16.3
1010		-20.000	483.000	52.847	2.500	340.61	297.32	1.146	16.2
1011		-6.000	466.000	30.459	2.000	212.10	190.18	1.115	16.2
1012		-22.000	476.000	48.602	1.500	194.35	175.35	1.108	16.1
1013		-13.000	477.000	43.673	2.500	317.44	277.83	1.143	16.0
1014		-20.000	477.000	47.738	1.500	165.04	150.86	1.094	16.0
1015		-23.000	477.000	50.012	1.500	194.89	175.61	1.110	15.9
1016		-21.000	478.000	49.148	1.500	165.24	150.94	1.095	15.9
1017		-26.000	473.000	49.554	1.227	184.46	166.81	1.106	15.8
1018		-22.000	479.000	50.558	1.500	165.34	150.91	1.096	15.8
1019		-19.000	482.000	51.433	2.500	338.51	295.13	1.147	15.7
1020		-23.000	480.000	51.969	1.500	165.47	150.88	1.097	15.6
1021		-24.000	478.000	51.423	1.500	195.33	175.72	1.112	15.6
1022		-17.000	482.000	50.060	2.500	330.66	288.45	1.146	15.5
1023		-25.000	479.000	52.833	1.500	195.84	175.97	1.113	15.4
1024		-6.000	478.000	40.911	3.500	535.06	458.69	1.166	15.4
1025		-8.000	463.000	29.514	1.500	177.71	160.82	1.105	15.3
1026		-24.000	481.000	53.379	1.500	165.34	150.44	1.099	15.2
1027		-25.000	482.000	54.790	1.500	165.49	150.55	1.099	15.2
1028		-18.000	481.000	50.019	2.500	336.20	292.77	1.148	15.2
1029		-7.000	470.000	34.465	2.500	298.13	261.05	1.142	15.2
1030		-9.000	464.000	30.923	1.500	179.17	161.90	1.107	15.2
1031		-11.000	482.000	46.645	3.000	440.97	380.00	1.160	15.1
1032		-12.000	476.000	42.260	2.500	315.71	275.59	1.146	15.0

* denotes the minimum safety factor and maximum prevention force.

No.	Reg.	Circular arc requirements				Skid resistance S (kN/m)	Sliding force T (kN/m)	Safety factor Fs	Required prevention force Pr (kN/m)
		Central coordinates		Radius r (m)	Max. depth (m)				
		X (m)	Y (m)						
1033		-26.000	483.000	56.202	1.500	165.52	150.39	1.101	15.0
1034		-10.000	465.000	32.332	1.500	180.48	162.85	1.108	15.0
1035		-26.000	480.000	54.243	1.500	196.02	175.73	1.115	14.9
1036		-11.000	466.000	33.742	1.500	181.67	163.66	1.110	14.8
1037		-6.000	475.000	38.064	3.000	423.80	365.28	1.160	14.6
1038		-17.000	480.000	48.605	2.500	333.80	290.26	1.150	14.6
1039		-12.000	467.000	35.152	1.500	182.89	164.47	1.112	14.5
1040		-13.000	468.000	36.562	1.500	183.86	165.09	1.114	14.3
1041		-16.000	481.000	48.647	2.500	329.49	286.41	1.150	14.3
1042		-8.000	481.000	44.510	3.500	544.29	465.44	1.169	14.3
1043		-18.000	464.000	37.705	1.223	173.33	156.08	1.111	14.0
1044		-14.000	469.000	37.972	1.500	184.84	165.64	1.116	14.0
1045		-11.000	475.000	40.847	2.500	313.84	273.11	1.149	13.9
1046		-8.000	478.000	41.650	3.000	432.05	371.53	1.163	13.8
1047		-15.000	474.000	42.500	2.000	239.27	210.84	1.135	13.8
1048		-15.000	470.000	39.383	1.500	185.74	166.26	1.117	13.8
1049		-16.000	479.000	47.191	2.500	331.42	287.67	1.152	13.8
1050		-16.000	475.000	43.913	2.000	240.75	211.98	1.136	13.7
1051		-6.000	469.000	33.051	2.500	295.54	257.60	1.147	13.6
1052		-17.000	483.000	50.802	2.500	335.77	291.10	1.153	13.6
1053		-17.000	476.000	45.325	2.000	242.30	213.24	1.136	13.6
1054		-18.000	477.000	46.737	2.000	243.74	214.42	1.137	13.6
1055		-16.000	471.000	40.793	1.500	186.39	166.51	1.119	13.5
1056		-20.000	479.000	49.563	2.000	246.40	216.40	1.139	13.3
1057		-19.000	478.000	48.150	2.000	244.94	215.15	1.138	13.3
1058		-15.000	480.000	47.234	2.500	328.49	284.61	1.154	13.1
1059		-17.000	472.000	42.203	1.500	187.24	166.95	1.122	13.1
1060		-21.000	480.000	50.976	2.000	247.47	217.09	1.140	13.1
1061		-23.000	482.000	53.801	2.000	250.18	219.36	1.140	13.1
1062		-22.000	481.000	52.388	2.000	248.84	218.24	1.140	13.1
1063		-15.000	478.000	45.777	2.500	328.59	284.67	1.154	13.1
1064		-18.000	473.000	43.613	1.500	187.93	167.30	1.123	12.9
1065		-24.000	483.000	55.214	2.000	251.18	220.03	1.142	12.9
1066		-19.000	474.000	45.023	1.500	188.66	167.82	1.124	12.8
1067		-10.000	474.000	39.433	2.500	311.67	270.27	1.153	12.7
1068		-10.000	481.000	45.239	3.000	439.40	376.69	1.166	12.7
1069		-22.000	483.000	53.762	2.000	231.94	203.82	1.138	12.7
1070		-20.000	475.000	46.434	1.500	189.22	168.07	1.126	12.5
1071		-8.000	466.000	31.467	1.500	159.02	142.77	1.114	12.4
1072		-21.000	482.000	52.348	2.000	230.99	202.81	1.139	12.4
1073		-16.000	482.000	49.390	2.500	334.54	288.96	1.158	12.3
1074		-7.000	465.000	30.057	1.500	158.34	142.14	1.114	12.3
1075		-6.000	464.000	28.647	1.500	157.61	141.53	1.114	12.3
1076		-10.000	468.000	34.287	1.500	159.88	143.41	1.115	12.3
1077		-20.000	481.000	50.934	2.000	230.02	201.80	1.140	12.2

* denotes the minimum safety factor and maximum prevention force.

No.	Reg.	Circular arc requirements				Skid resistance S (kN/m)	Sliding force T (kN/m)	Safety factor Fs	Required prevention force Pr (kN/m)
		Central coordinates		Radius r (m)	Max. depth (m)				
		X (m)	Y (m)						
1078		-9.000	467.000	32.877	1.500	159.32	142.92	1.115	12.2
1079		-21.000	476.000	47.844	1.500	189.51	168.00	1.128	12.1
1080		-11.000	469.000	35.698	1.500	160.10	143.42	1.116	12.1
1081		-19.000	480.000	49.520	2.000	228.99	200.79	1.140	12.0
1082		-12.000	470.000	37.108	1.500	160.56	143.78	1.117	12.0
1083		-13.000	471.000	38.518	1.500	160.80	143.90	1.117	11.9
1084		-14.000	472.000	39.928	1.500	161.22	144.26	1.118	11.9
1085		-18.000	479.000	48.106	2.000	228.09	199.89	1.141	11.8
1086		-22.000	477.000	49.254	1.500	189.98	168.11	1.130	11.8
1087		-14.000	479.000	45.822	2.500	327.28	282.54	1.158	11.8
1088		-15.000	473.000	41.339	1.500	161.27	144.15	1.119	11.8
1089		-17.000	475.000	44.160	1.500	161.80	144.51	1.120	11.7
1090		-16.000	474.000	42.749	1.500	161.51	144.26	1.120	11.7
1091		-23.000	478.000	50.664	1.500	190.56	168.50	1.131	11.7
1092		-17.000	478.000	46.692	2.000	226.85	198.65	1.142	11.6
1093		-18.000	476.000	45.571	1.500	161.94	144.52	1.121	11.5
1094		-19.000	477.000	46.983	1.500	162.06	144.50	1.122	11.4
1095		-16.000	477.000	45.278	2.000	225.89	197.73	1.142	11.4
1096		-9.000	473.000	38.020	2.500	309.59	267.44	1.158	11.4
1097		-20.000	478.000	48.394	1.500	162.26	144.62	1.122	11.3
1098		-24.000	479.000	52.075	1.500	190.75	168.30	1.133	11.3
1099		-21.000	479.000	49.806	1.500	162.46	144.75	1.122	11.3
1100		-15.000	476.000	43.864	2.000	224.86	196.69	1.143	11.2
1101		-7.000	477.000	40.242	3.000	430.30	367.88	1.170	11.2
1102		-23.000	481.000	52.630	1.500	162.82	144.97	1.123	11.2
1103		-22.000	480.000	51.218	1.500	162.56	144.71	1.123	11.1
1104		-14.000	475.000	42.450	2.000	223.71	195.51	1.144	11.0
1105		-25.000	483.000	55.454	1.500	163.01	144.95	1.125	11.0
1106		-25.000	480.000	53.485	1.500	191.15	168.42	1.135	11.0
1107		-24.000	482.000	54.042	1.500	162.85	144.83	1.124	11.0
1108		-19.000	465.000	39.071	1.189	170.15	150.86	1.128	10.9
1109		-15.000	481.000	47.979	2.500	333.42	286.86	1.162	10.9
1110		-13.000	478.000	44.409	2.500	325.66	280.27	1.162	10.7
1111		-26.000	481.000	54.895	1.500	191.27	168.24	1.137	10.7
1112		-13.000	474.000	41.036	2.000	222.34	194.10	1.145	10.6
1113		-19.000	483.000	52.155	2.500	342.13	293.81	1.164	10.5
1114		-7.000	480.000	43.111	3.500	542.97	461.16	1.177	10.5
1115		-12.000	473.000	39.622	2.000	221.18	192.88	1.147	10.3
1116		-16.000	483.000	50.143	2.500	340.15	291.88	1.165	10.2
1117		-9.000	480.000	43.832	3.000	438.00	373.36	1.173	10.1
1118		-8.000	472.000	36.607	2.500	307.29	264.43	1.162	10.1
1119		-11.000	472.000	38.208	2.000	219.82	191.41	1.148	9.9
1120		-10.000	471.000	36.794	2.000	218.53	190.04	1.150	9.6
1121		-14.000	480.000	46.567	2.500	332.45	284.97	1.167	9.6
1122		-12.000	477.000	42.997	2.500	323.65	277.57	1.166	9.5

* denotes the minimum safety factor and maximum prevention force.

No.	Reg.	Circular arc requirements				Skid resistance S (kN/m)	Sliding force T (kN/m)	Safety factor Fs	Required prevention force Pr (kN/m)
		Central coordinates		Radius r (m)	Max. depth (m)				
		X (m)	Y (m)						
1123		-9.000	483.000	46.713	3.500	551.57	467.47	1.180	9.4
1124		-9.000	470.000	35.380	2.000	217.20	188.70	1.151	9.3
1125		-11.000	483.000	47.425	3.000	445.24	378.39	1.177	8.9
1126		-15.000	482.000	48.733	2.500	339.40	290.25	1.169	8.9
1127		-8.000	469.000	33.966	2.000	215.67	187.11	1.153	8.9
1128		-7.000	471.000	35.194	2.500	304.89	261.26	1.167	8.7
1129		-6.000	476.000	38.836	3.000	428.24	363.89	1.177	8.5
1130		-13.000	479.000	45.156	2.500	331.51	283.25	1.170	8.4
1131		-11.000	476.000	41.585	2.500	321.87	275.18	1.170	8.4
1132		-7.000	468.000	32.552	2.000	213.91	185.07	1.156	8.2
1133		-20.000	466.000	40.441	1.158	167.27	145.99	1.146	8.0
1134		-6.000	467.000	31.139	2.000	212.42	183.48	1.158	7.8
1135		-14.000	481.000	47.323	2.500	338.39	288.35	1.174	7.7
1136		-8.000	479.000	42.427	3.000	436.37	369.86	1.180	7.5
1137		-21.000	465.000	40.621	1.128	165.70	144.23	1.149	7.4
1138		-6.000	470.000	33.781	2.500	302.49	258.00	1.172	7.2
1139		-10.000	475.000	40.173	2.500	319.88	272.49	1.174	7.2
1140		-24.000	483.000	54.714	1.500	160.64	139.64	1.150	7.0
1141		-18.000	477.000	46.237	1.500	159.33	138.53	1.150	7.0
1142		-23.000	482.000	53.301	1.500	160.35	139.39	1.150	7.0
1143		-21.000	480.000	50.476	1.500	159.98	139.10	1.150	7.0
1144		-16.000	475.000	43.413	1.500	158.82	138.11	1.150	7.0
1145		-12.000	478.000	43.745	2.500	330.37	281.08	1.175	7.0
1146		-19.000	478.000	47.650	1.500	159.46	138.58	1.151	6.9
1147		-22.000	481.000	51.888	1.500	160.19	139.23	1.151	6.9
1148		-15.000	474.000	42.000	1.500	158.41	137.72	1.150	6.9
1149		-14.000	473.000	40.588	1.500	158.12	137.44	1.150	6.9
1150		-20.000	479.000	49.063	1.500	159.72	138.84	1.150	6.9
1151		-17.000	476.000	44.825	1.500	158.89	138.03	1.151	6.8
1152		-6.000	479.000	41.713	3.500	541.97	457.21	1.185	6.7
1153		-12.000	471.000	37.764	1.500	157.39	136.74	1.151	6.7
1154		-13.000	472.000	39.176	1.500	157.64	136.91	1.151	6.7
1155		-10.000	469.000	34.941	1.500	156.58	135.92	1.152	6.6
1156		-11.000	470.000	36.353	1.500	156.91	136.23	1.152	6.6
1157		-9.000	468.000	33.530	1.500	156.02	135.40	1.152	6.5
1158		-7.000	466.000	30.709	1.500	155.36	134.86	1.152	6.5
1159		-6.000	465.000	29.298	1.500	154.80	134.34	1.152	6.5
1160		-8.000	467.000	32.119	1.500	155.56	134.98	1.152	6.5
1161		-10.000	482.000	46.021	3.000	443.73	375.05	1.183	6.4
1162		-22.000	466.000	42.005	1.117	165.14	142.81	1.156	6.3
1163		-21.000	483.000	53.050	2.000	232.98	199.37	1.169	6.3
1164		-15.000	483.000	49.493	2.500	344.67	292.41	1.179	6.3
1165		-13.000	480.000	45.913	2.500	337.36	286.30	1.178	6.2
1166		-20.000	482.000	51.635	2.000	232.15	198.57	1.169	6.2
1167		-9.000	474.000	38.761	2.500	317.74	269.62	1.178	5.9

* denotes the minimum safety factor and maximum prevention force.

No.	Reg.	Circular arc requirements				Skid resistance S (kN/m)	Sliding force T (kN/m)	Safety factor Fs	Required prevention force Pr (kN/m)
		Central coordinates		Radius r (m)	Max. depth (m)				
		X (m)	Y (m)						
1168		-19.000	481.000	50.221	2.000	231.10	197.42	1.171	5.9
1169		-8.000	482.000	45.316	3.500	550.64	463.62	1.188	5.8
1170		-21.000	471.000	44.165	1.000	118.52	103.40	1.146	5.6
1171		-23.000	473.000	46.974	1.000	119.53	104.24	1.147	5.6
1172		-18.000	480.000	48.807	2.000	230.12	196.38	1.172	5.6
1173		-11.000	477.000	42.334	2.500	328.93	278.55	1.181	5.4
1174		-24.000	474.000	48.379	1.000	119.85	104.33	1.149	5.4
1175		-17.000	479.000	47.393	2.000	229.10	195.31	1.173	5.3
1176		-21.000	467.000	41.814	1.128	164.56	141.41	1.164	5.2
1177		-14.000	482.000	48.083	2.500	343.88	290.74	1.183	5.1
1178		-16.000	478.000	45.979	2.000	227.94	194.02	1.175	4.9
1179		-17.000	468.000	39.166	1.000	117.17	101.65	1.153	4.9
1180		-23.000	467.000	43.391	1.107	164.56	141.21	1.165	4.9
1181		-7.000	478.000	41.022	3.000	434.86	366.32	1.187	4.8
1182		-16.000	467.000	37.762	1.000	116.41	100.94	1.153	4.8
1183		-12.000	479.000	44.503	2.500	336.36	284.20	1.184	4.7
1184		-15.000	477.000	44.564	2.000	226.65	192.58	1.177	4.5
1185		-14.000	465.000	34.952	1.000	114.86	99.45	1.155	4.5
1186		-21.000	472.000	44.785	1.000	119.00	102.77	1.158	4.4
1187		-8.000	473.000	37.349	2.500	315.70	266.71	1.184	4.4
1188		-12.000	463.000	32.143	1.000	112.34	97.20	1.156	4.3
1189		-14.000	476.000	43.150	2.000	225.60	191.48	1.178	4.2
1190		-22.000	473.000	46.189	1.000	119.22	102.73	1.161	4.1
1191		-24.000	468.000	44.779	1.097	164.25	140.18	1.172	4.0
1192		-13.000	475.000	41.736	2.000	224.49	190.22	1.180	3.8
1193		-9.000	481.000	44.617	3.000	442.41	371.80	1.190	3.8
1194		-10.000	476.000	40.924	2.500	327.62	276.05	1.187	3.7
1195		-13.000	465.000	34.168	1.000	115.25	99.04	1.164	3.6
1196		-16.000	468.000	38.382	1.000	117.04	100.48	1.165	3.6
1197		-15.000	467.000	36.977	1.000	116.56	100.11	1.164	3.6
1198		-13.000	481.000	46.673	2.500	342.64	288.48	1.188	3.6
1199		-12.000	464.000	32.763	1.000	114.47	98.28	1.165	3.5
1200		-12.000	474.000	40.322	2.000	223.03	188.70	1.182	3.5
1201		-11.000	478.000	43.093	2.500	335.16	282.03	1.188	3.3
1202		-23.000	483.000	53.984	1.500	158.24	134.38	1.178	3.1
1203		-22.000	482.000	52.570	1.500	158.02	134.21	1.177	3.1
1204		-25.000	469.000	46.169	1.088	163.90	139.03	1.179	3.0
1205		-20.000	480.000	49.743	1.500	157.68	133.87	1.178	3.0
1206		-21.000	481.000	51.156	1.500	157.71	133.79	1.179	2.9
1207		-7.000	472.000	35.937	2.500	313.45	263.58	1.189	2.9
1208		-18.000	470.000	41.191	1.000	117.69	100.49	1.171	2.9
1209		-11.000	473.000	38.907	2.000	221.60	187.04	1.185	2.9
1210		-22.000	468.000	43.190	1.101	162.22	137.46	1.180	2.8
1211		-19.000	479.000	48.329	1.500	157.15	133.22	1.180	2.8
1212		-18.000	478.000	46.916	1.500	156.88	132.91	1.180	2.7

* denotes the minimum safety factor and maximum prevention force.

No.	Reg.	Circular arc requirements				Skid resistance S (kN/m)	Sliding force T (kN/m)	Safety factor Fs	Required prevention force Pr (kN/m)
		Central coordinates		Radius r (m)	Max. depth (m)				
		X (m)	Y (m)						
1213		-19.000	471.000	42.596	1.000	118.02	100.59	1.173	2.7
1214		-17.000	477.000	45.502	1.500	156.53	132.50	1.181	2.5
1215		-21.000	473.000	45.408	1.000	118.70	100.94	1.176	2.5
1216		-10.000	472.000	37.493	2.000	220.08	185.34	1.187	2.4
1217		-16.000	476.000	44.089	1.500	156.23	132.18	1.182	2.4
1218		-15.000	475.000	42.675	1.500	155.77	131.65	1.183	2.3
1219		-10.000	463.000	30.574	1.000	113.70	96.54	1.178	2.2
1220		-26.000	470.000	47.560	1.079	163.78	138.22	1.185	2.1
1221		-14.000	474.000	41.262	1.500	155.38	131.22	1.184	2.1
1222		-9.000	475.000	39.513	2.500	326.12	273.38	1.193	2.0
1223		-13.000	473.000	39.849	1.500	154.97	130.78	1.185	2.0
1224		-12.000	465.000	33.383	1.000	114.92	97.38	1.180	2.0
1225		-12.000	480.000	45.263	2.500	341.45	286.17	1.193	2.0
1226		-7.000	481.000	43.920	3.500	549.89	459.86	1.196	2.0
1227		-6.000	477.000	39.618	3.000	433.00	362.50	1.194	2.0
1228		-9.000	471.000	36.079	2.000	218.79	183.90	1.190	1.9
1229		-14.000	467.000	36.193	1.000	115.94	98.09	1.182	1.8
1230		-10.000	477.000	41.683	2.500	333.98	279.78	1.194	1.8
1231		-24.000	476.000	49.629	1.000	119.48	101.01	1.183	1.8
1232		-12.000	472.000	38.436	1.500	154.44	130.10	1.187	1.7
1233		-25.000	477.000	51.037	1.000	119.68	101.01	1.185	1.6
1234		-14.000	483.000	48.842	2.500	347.76	291.07	1.195	1.6
1235		-11.000	471.000	37.023	1.500	153.93	129.52	1.188	1.5
1236		-10.000	470.000	35.610	1.500	153.42	128.97	1.190	1.4
1237		-8.000	470.000	34.665	2.000	217.32	182.22	1.193	1.4
1238		-6.000	471.000	34.526	2.500	311.10	260.28	1.195	1.3
1239		-8.000	480.000	43.214	3.000	441.26	368.71	1.197	1.2
1240		-17.000	470.000	40.412	1.000	117.11	98.52	1.189	1.2
1241		-9.000	469.000	34.197	1.500	152.89	128.39	1.191	1.2
1242		-8.000	468.000	32.784	1.500	152.36	127.80	1.192	1.0
1243		-7.000	467.000	31.371	1.500	151.67	126.98	1.194	0.8
1244		-7.000	469.000	33.251	2.000	215.55	180.17	1.196	0.7
1245		-6.000	466.000	29.959	1.500	151.09	126.39	1.195	0.6
1246		-23.000	469.000	44.569	1.075	160.07	133.78	1.197	0.5
1247		-21.000	474.000	46.044	1.000	118.49	99.15	1.195	0.5
1248		-11.000	479.000	43.853	2.500	340.10	283.72	1.199	0.4
1249		-20.000	483.000	52.347	2.000	235.23	196.35	1.198	0.4
1250		-10.000	483.000	46.812	3.000	448.68	374.10	1.199	0.3
1251		-6.000	468.000	31.836	2.000	213.93	178.37	1.199	0.2
1252		-23.000	476.000	48.862	1.000	119.15	99.37	1.199	0.1
1253		-8.000	474.000	38.103	2.500	324.70	270.66	1.200	0.1
1254		-9.000	463.000	29.790	1.000	112.90	94.16	1.199	0.1
1255		-19.000	482.000	50.933	2.000	234.26	195.26	1.200	0.1
1256		-10.000	464.000	31.195	1.000	113.65	94.79	1.199	0.1
1257		-25.000	478.000	51.681	1.000	119.81	99.78	1.201	0.0

* denotes the minimum safety factor and maximum prevention force.

No.	Reg.	Circular arc requirements				Skid resistance S (kN/m)	Sliding force T (kN/m)	Safety factor Fs	Required prevention force Pr (kN/m)
		Central coordinates		Radius r (m)	Max. depth (m)				
		X (m)	Y (m)						
1258		-9.000	476.000	40.273	2.500	332.39	276.97	1.200	0.0
1259		-13.000	482.000	47.433	2.500	346.57	288.77	1.200	0.0
1260		-12.000	466.000	34.009	1.000	114.76	95.53	1.201	-0.1
1261		-18.000	481.000	49.519	2.000	233.32	194.23	1.201	-0.2
1262		-26.000	479.000	53.091	1.000	120.04	99.78	1.203	-0.3
1263		-15.000	469.000	38.233	1.000	116.14	96.25	1.207	-0.6
1264		-17.000	480.000	48.105	2.000	232.09	192.78	1.204	-0.7
1265		-18.000	472.000	42.462	1.000	117.54	97.15	1.210	-0.9
1266		-16.000	479.000	46.691	2.000	231.03	191.55	1.206	-1.1
1267		-19.000	473.000	43.872	1.000	117.87	97.28	1.212	-1.1
1268		-21.000	482.000	51.848	1.500	156.29	129.19	1.210	-1.2
1269		-20.000	474.000	45.282	1.000	118.29	97.54	1.213	-1.2
1270		-22.000	483.000	53.262	1.500	156.71	129.48	1.210	-1.3
1271		-10.000	478.000	42.443	2.500	338.70	281.12	1.205	-1.3
1272		-20.000	481.000	50.434	1.500	155.72	128.62	1.211	-1.3
1273		-19.000	480.000	49.020	1.500	155.21	128.18	1.211	-1.3
1274		-7.000	479.000	41.812	3.000	440.12	365.65	1.204	-1.3
1275		-18.000	479.000	47.606	1.500	154.69	127.73	1.211	-1.4
1276		-22.000	476.000	48.102	1.000	118.97	97.96	1.214	-1.4
1277		-17.000	478.000	46.192	1.500	154.47	127.53	1.211	-1.4
1278		-12.000	481.000	46.023	2.500	345.21	286.37	1.205	-1.5
1279		-23.000	477.000	49.512	1.000	119.21	97.98	1.217	-1.6
1280		-15.000	478.000	45.277	2.000	229.88	190.18	1.209	-1.6
1281		-24.000	470.000	45.949	1.051	158.08	130.35	1.213	-1.6
1282		-8.000	475.000	38.863	2.500	331.01	274.45	1.206	-1.6
1283		-16.000	477.000	44.778	1.500	153.98	126.83	1.214	-1.7
1284		-24.000	478.000	50.923	1.000	119.42	98.01	1.218	-1.8
1285		-7.000	473.000	36.693	2.500	323.10	267.73	1.207	-1.8
1286		-8.000	463.000	29.014	1.000	112.32	92.02	1.221	-1.8
1287		-14.000	477.000	43.863	2.000	228.73	188.98	1.210	-1.9
1288		-9.000	464.000	30.423	1.000	113.01	92.52	1.221	-1.9
1289		-6.000	480.000	42.525	3.500	549.15	456.02	1.204	-1.9
1290		-11.000	466.000	33.242	1.000	114.40	93.69	1.221	-1.9
1291		-15.000	476.000	43.364	1.500	153.43	126.17	1.216	-2.0
1292		-10.000	465.000	31.832	1.000	113.69	93.03	1.222	-2.0
1293		-25.000	479.000	52.333	1.000	119.57	97.89	1.221	-2.1
1294		-13.000	468.000	36.062	1.000	115.44	94.34	1.224	-2.2
1295		-12.000	467.000	34.652	1.000	114.92	93.93	1.223	-2.2
1296		-9.000	482.000	45.411	3.000	447.76	371.22	1.206	-2.2
1297		-14.000	475.000	41.950	1.500	152.89	125.48	1.218	-2.3
1298		-15.000	470.000	38.883	1.000	116.43	94.98	1.226	-2.4
1299		-14.000	469.000	37.472	1.000	115.90	94.58	1.225	-2.4
1300		-13.000	476.000	42.449	2.000	227.39	187.37	1.214	-2.5
1301		-13.000	474.000	40.536	1.500	152.40	124.88	1.220	-2.5
1302		-16.000	471.000	40.293	1.000	116.86	95.26	1.227	-2.5

* denotes the minimum safety factor and maximum prevention force.

No.	Reg.	Circular arc requirements				Skid resistance S (kN/m)	Sliding force T (kN/m)	Safety factor Fs	Required prevention force Pr (kN/m)
		Central coordinates		Radius r (m)	Max. depth (m)				
		X (m)	Y (m)						
1303		-12.000	473.000	39.122	1.500	152.18	124.63	1.221	-2.6
1304		-8.000	483.000	46.129	3.500	557.62	462.41	1.206	-2.7
1305		-17.000	472.000	41.703	1.000	117.15	95.29	1.229	-2.8
1306		-11.000	472.000	37.708	1.500	151.54	123.79	1.224	-2.9
1307		-9.000	477.000	41.033	2.500	337.12	278.43	1.211	-3.0
1308		-18.000	473.000	43.113	1.000	117.31	95.16	1.233	-3.1
1309		-11.000	480.000	44.613	2.500	343.88	283.93	1.211	-3.1
1310		-12.000	475.000	41.035	2.000	226.00	185.74	1.217	-3.1
1311		-10.000	471.000	36.294	1.500	150.95	123.09	1.226	-3.2
1312		-19.000	474.000	44.523	1.000	117.62	95.32	1.234	-3.2
1313		-20.000	475.000	45.934	1.000	117.93	95.48	1.235	-3.3
1314		-25.000	471.000	47.332	1.029	156.48	127.62	1.226	-3.3
1315		-9.000	470.000	34.880	1.500	150.34	122.36	1.229	-3.5
1316		-21.000	476.000	47.344	1.000	118.04	95.39	1.237	-3.5
1317		-7.000	474.000	37.453	2.500	329.31	271.42	1.213	-3.6
1318		-11.000	474.000	39.621	2.000	224.69	184.23	1.220	-3.6
1319		-22.000	477.000	48.754	1.000	118.18	95.32	1.240	-3.7
1320		-6.000	472.000	35.283	2.500	321.24	264.58	1.214	-3.7
1321		-23.000	478.000	50.164	1.000	118.45	95.48	1.241	-3.8
1322		-8.000	469.000	33.466	1.500	149.57	121.41	1.232	-3.8
1323		-9.000	465.000	31.073	1.000	113.27	91.01	1.245	-4.0
1324		-24.000	479.000	51.575	1.000	118.56	95.39	1.243	-4.0
1325		-13.000	483.000	48.193	2.500	349.32	287.76	1.214	-4.0
1326		-8.000	464.000	29.663	1.000	112.60	90.47	1.245	-4.0
1327		-7.000	463.000	28.253	1.000	111.83	89.81	1.245	-4.0
1328		-10.000	473.000	38.207	2.000	223.37	182.68	1.223	-4.1
1329		-7.000	468.000	32.052	1.500	149.07	120.75	1.235	-4.1
1330		-10.000	466.000	32.484	1.000	113.68	91.16	1.247	-4.2
1331		-6.000	478.000	40.411	3.000	438.35	361.76	1.212	-4.2
1332		-25.000	480.000	52.985	1.000	118.58	95.19	1.246	-4.3
1333		-11.000	467.000	33.894	1.000	114.24	91.57	1.248	-4.3
1334		-26.000	481.000	54.395	1.000	118.60	95.02	1.248	-4.5
1335		-12.000	468.000	35.304	1.000	114.63	91.72	1.250	-4.5
1336		-6.000	467.000	30.639	1.500	148.18	119.64	1.239	-4.6
1337		-13.000	469.000	36.714	1.000	115.01	91.87	1.252	-4.7
1338		-8.000	476.000	39.623	2.500	335.68	275.78	1.217	-4.7
1339		-10.000	479.000	43.203	2.500	342.32	281.25	1.217	-4.8
1340		-9.000	472.000	36.793	2.000	221.93	180.94	1.227	-4.8
1341		-14.000	470.000	38.124	1.000	115.34	92.05	1.253	-4.8
1342		-8.000	481.000	44.010	3.000	446.63	367.97	1.214	-5.0
1343		-15.000	471.000	39.535	1.000	115.58	92.10	1.255	-5.0
1344		-16.000	472.000	40.945	1.000	115.89	92.27	1.256	-5.1
1345		-26.000	472.000	48.716	1.009	154.82	124.74	1.241	-5.1
1346		-12.000	482.000	46.783	2.500	348.35	285.75	1.219	-5.4
1347		-17.000	473.000	42.355	1.000	116.06	92.18	1.259	-5.4

* denotes the minimum safety factor and maximum prevention force.

No.	Reg.	Circular arc requirements				Skid resistance S (kN/m)	Sliding force T (kN/m)	Safety factor Fs	Required prevention force Pr (kN/m)
		Central coordinates		Radius r (m)	Max. depth (m)				
		X (m)	Y (m)						
1348		-8.000	471.000	35.379	2.000	220.29	179.07	1.230	-5.4
1349		-18.000	474.000	43.765	1.000	116.37	92.39	1.260	-5.5
1350		-19.000	475.000	45.175	1.000	116.56	92.43	1.261	-5.6
1351		-19.000	483.000	51.655	2.000	237.87	193.49	1.229	-5.6
1352		-6.000	473.000	36.043	2.500	327.33	268.00	1.221	-5.7
1353		-18.000	482.000	50.241	2.000	237.10	192.63	1.231	-5.9
1354		-21.000	477.000	47.996	1.000	116.78	92.29	1.265	-6.0
1355		-20.000	476.000	46.586	1.000	116.52	92.09	1.265	-6.0
1356		-22.000	478.000	49.406	1.000	116.79	92.09	1.268	-6.2
1357		-21.000	483.000	52.550	1.500	156.51	125.11	1.251	-6.3
1358		-7.000	470.000	33.965	2.000	218.42	176.76	1.236	-6.3
1359		-23.000	479.000	50.816	1.000	116.87	92.05	1.270	-6.4
1360		-17.000	481.000	48.827	2.000	235.91	191.13	1.234	-6.5
1361		-20.000	482.000	51.135	1.500	155.86	124.42	1.253	-6.5
1362		-6.000	463.000	27.495	1.000	110.86	86.93	1.275	-6.5
1363		-9.000	478.000	41.793	2.500	340.72	278.39	1.224	-6.6
1364		-24.000	480.000	52.226	1.000	116.81	91.76	1.273	-6.6
1365		-7.000	482.000	44.736	3.500	557.17	458.76	1.215	-6.6
1366		-7.000	464.000	28.905	1.000	111.36	87.27	1.276	-6.6
1367		-7.000	475.000	38.213	2.500	333.94	272.75	1.224	-6.6
1368		-24.000	472.000	47.138	1.000	150.48	119.87	1.255	-6.6
1369		-19.000	467.000	40.115	1.000	145.48	115.62	1.258	-6.7
1370		-19.000	481.000	49.721	1.500	155.31	123.82	1.254	-6.7
1371		-17.000	479.000	46.893	1.500	154.21	122.79	1.256	-6.8
1372		-6.000	469.000	32.551	2.000	216.98	175.12	1.239	-6.8
1373		-18.000	480.000	48.307	1.500	154.61	123.16	1.255	-6.8
1374		-17.000	464.000	36.687	1.000	140.97	111.78	1.261	-6.8
1375		-15.000	477.000	44.064	1.500	153.16	121.81	1.257	-6.9
1376		-9.000	466.000	31.725	1.000	112.26	87.76	1.279	-6.9
1377		-16.000	464.000	35.901	1.000	140.54	111.31	1.263	-6.9
1378		-8.000	465.000	30.315	1.000	111.73	87.34	1.279	-6.9
1379		-15.000	463.000	34.497	1.000	138.67	109.71	1.264	-7.0
1380		-16.000	478.000	45.479	1.500	153.53	122.08	1.258	-7.0
1381		-16.000	480.000	47.414	2.000	234.90	189.89	1.237	-7.0
1382		-16.000	463.000	35.284	1.000	139.24	110.14	1.264	-7.0
1383		-25.000	481.000	53.637	1.000	116.74	91.44	1.277	-7.0
1384		-21.000	469.000	42.925	1.000	148.10	117.48	1.261	-7.1
1385		-10.000	467.000	33.135	1.000	112.66	87.95	1.281	-7.1
1386		-11.000	481.000	45.374	2.500	346.86	283.07	1.225	-7.1
1387		-14.000	476.000	42.650	1.500	152.47	121.11	1.259	-7.1
1388		-11.000	468.000	34.546	1.000	113.01	88.13	1.282	-7.2
1389		-26.000	482.000	55.047	1.000	116.72	91.26	1.279	-7.2
1390		-22.000	470.000	44.329	1.000	149.14	118.28	1.261	-7.2
1391		-13.000	475.000	41.236	1.500	151.75	120.37	1.261	-7.3
1392		-23.000	472.000	46.354	1.000	147.63	116.80	1.264	-7.4

* denotes the minimum safety factor and maximum prevention force.

No.	Reg.	Circular arc requirements				Skid resistance S (kN/m)	Sliding force T (kN/m)	Safety factor Fs	Required prevention force Pr (kN/m)
		Central coordinates		Radius r (m)	Max. depth (m)				
		X (m)	Y (m)						
1393		-21.000	470.000	43.545	1.000	146.80	116.14	1.264	-7.4
1394		-12.000	469.000	35.956	1.000	113.28	88.20	1.284	-7.4
1395		-13.000	470.000	37.366	1.000	113.51	88.28	1.286	-7.5
1396		-16.000	465.000	36.522	1.000	141.24	111.38	1.268	-7.5
1397		-17.000	466.000	37.926	1.000	142.92	112.85	1.266	-7.5
1398		-7.000	480.000	42.611	3.000	445.69	365.01	1.221	-7.6
1399		-20.000	469.000	42.140	1.000	146.11	115.35	1.267	-7.6
1400		-15.000	479.000	46.000	2.000	233.57	188.29	1.240	-7.6
1401		-12.000	474.000	39.822	1.500	150.78	119.27	1.264	-7.6
1402		-18.000	467.000	39.331	1.000	144.29	113.76	1.268	-7.7
1403		-11.000	473.000	38.407	1.500	150.02	118.54	1.266	-7.7
1404		-26.000	475.000	50.568	1.000	148.43	117.22	1.266	-7.7
1405		-14.000	471.000	38.776	1.000	113.68	88.22	1.289	-7.8
1406		-15.000	472.000	40.187	1.000	114.05	88.52	1.288	-7.8
1407		-19.000	468.000	40.735	1.000	145.30	114.46	1.269	-7.9
1408		-10.000	472.000	36.993	1.500	149.29	117.78	1.268	-7.9
1409		-14.000	478.000	44.587	2.000	232.59	187.12	1.243	-8.0
1410		-16.000	473.000	41.597	1.000	114.20	88.48	1.291	-8.0
1411		-13.000	463.000	32.928	1.000	136.76	107.15	1.276	-8.1
1412		-9.000	471.000	35.579	1.500	148.43	116.91	1.270	-8.1
1413		-8.000	470.000	34.165	1.500	147.53	116.05	1.271	-8.2
1414		-14.000	464.000	34.332	1.000	138.37	108.39	1.277	-8.3
1415		-17.000	474.000	43.007	1.000	114.15	88.18	1.295	-8.3
1416		-18.000	475.000	44.417	1.000	114.34	88.24	1.296	-8.4
1417		-18.000	468.000	39.951	1.000	142.42	111.56	1.277	-8.5
1418		-15.000	465.000	35.737	1.000	139.87	109.43	1.278	-8.5
1419		-19.000	469.000	41.355	1.000	142.91	111.97	1.276	-8.5
1420		-8.000	477.000	40.383	2.500	338.76	275.07	1.232	-8.6
1421		-13.000	477.000	43.173	2.000	231.35	185.62	1.246	-8.6
1422		-6.000	474.000	36.803	2.500	332.03	269.51	1.232	-8.6
1423		-19.000	476.000	45.827	1.000	114.44	88.20	1.298	-8.6
1424		-9.000	483.000	46.213	3.000	452.93	370.27	1.223	-8.6
1425		-7.000	469.000	32.751	1.500	146.45	114.67	1.277	-8.8
1426		-10.000	480.000	43.966	2.500	345.12	280.19	1.232	-8.8
1427		-20.000	477.000	47.238	1.000	114.47	88.04	1.300	-8.8
1428		-21.000	478.000	48.648	1.000	114.36	87.77	1.303	-9.0
1429		-6.000	468.000	31.336	1.500	145.75	113.81	1.281	-9.1
1430		-12.000	476.000	41.760	2.000	230.18	184.19	1.250	-9.1
1431		-22.000	479.000	50.058	1.000	114.27	87.47	1.306	-9.3
1432		-12.000	483.000	47.552	2.500	351.15	284.63	1.234	-9.5
1433		-23.000	480.000	51.469	1.000	114.19	87.18	1.310	-9.5
1434		-24.000	481.000	52.879	1.000	114.35	87.27	1.310	-9.6
1435		-11.000	475.000	40.347	2.000	228.70	182.43	1.254	-9.7
1436		-25.000	482.000	54.290	1.000	114.40	87.23	1.311	-9.7
1437		-6.000	464.000	28.147	1.000	109.03	82.62	1.320	-9.8

* denotes the minimum safety factor and maximum prevention force.

No.	Reg.	Circular arc requirements				Skid resistance S (kN/m)	Sliding force T (kN/m)	Safety factor Fs	Required prevention force Pr (kN/m)
		Central coordinates		Radius r (m)	Max. depth (m)				
		X (m)	Y (m)						
1438		-26.000	483.000	55.702	1.000	114.31	86.95	1.315	-9.9
1439		-7.000	465.000	29.557	1.000	109.43	82.82	1.321	-10.0
1440		-8.000	466.000	30.967	1.000	109.82	83.04	1.322	-10.1
1441		-9.000	467.000	32.377	1.000	110.33	83.51	1.321	-10.1
1442		-10.000	468.000	33.787	1.000	110.58	83.59	1.323	-10.2
1443		-10.000	474.000	38.933	2.000	227.35	180.73	1.258	-10.4
1444		-7.000	476.000	38.973	2.500	337.17	272.30	1.238	-10.4
1445		-9.000	479.000	42.558	2.500	343.91	277.76	1.238	-10.5
1446		-11.000	469.000	35.198	1.000	110.58	83.34	1.327	-10.5
1447		-6.000	479.000	41.213	3.000	444.43	361.56	1.229	-10.5
1448		-6.000	481.000	43.345	3.500	556.55	454.77	1.224	-10.8
1449		-12.000	470.000	36.608	1.000	110.68	83.18	1.331	-10.8
1450		-13.000	471.000	38.018	1.000	110.91	83.25	1.332	-11.0
1451		-14.000	472.000	39.428	1.000	111.19	83.49	1.332	-11.0
1452		-15.000	473.000	40.839	1.000	111.21	83.32	1.335	-11.2
1453		-9.000	473.000	37.520	2.000	225.88	178.88	1.263	-11.2
1454		-11.000	482.000	46.145	2.500	349.88	282.16	1.240	-11.2
1455		-8.000	482.000	44.816	3.000	452.25	367.44	1.231	-11.3
1456		-18.000	483.000	50.973	2.000	241.65	191.82	1.260	-11.4
1457		-16.000	474.000	42.249	1.000	111.14	83.06	1.338	-11.4
1458		-17.000	475.000	43.660	1.000	111.33	83.17	1.339	-11.5
1459		-20.000	483.000	51.847	1.500	156.81	121.00	1.296	-11.6
1460		-18.000	476.000	45.071	1.000	111.46	83.15	1.340	-11.6
1461		-19.000	482.000	50.433	1.500	156.23	120.40	1.298	-11.7
1462		-19.000	477.000	46.483	1.000	111.64	83.24	1.341	-11.7
1463		-20.000	478.000	47.894	1.000	111.72	83.22	1.342	-11.8
1464		-8.000	472.000	36.107	2.000	224.30	176.94	1.268	-11.9
1465		-17.000	482.000	49.560	2.000	240.83	190.77	1.262	-11.9
1466		-21.000	479.000	49.306	1.000	111.72	83.07	1.345	-12.0
1467		-18.000	481.000	49.019	1.500	155.52	119.56	1.301	-12.0
1468		-23.000	481.000	52.130	1.000	111.95	83.15	1.346	-12.1
1469		-22.000	480.000	50.718	1.000	111.88	83.15	1.346	-12.1
1470		-17.000	480.000	47.605	1.500	154.99	118.93	1.303	-12.2
1471		-6.000	475.000	37.564	2.500	335.12	268.97	1.246	-12.3
1472		-24.000	482.000	53.542	1.000	111.80	82.76	1.351	-12.4
1473		-8.000	478.000	41.150	2.500	342.11	274.70	1.245	-12.4
1474		-16.000	479.000	46.191	1.500	154.31	118.20	1.305	-12.4
1475		-16.000	481.000	48.147	2.000	239.75	189.36	1.266	-12.5
1476		-25.000	483.000	54.954	1.000	111.95	82.86	1.351	-12.5
1477		-15.000	478.000	44.777	1.500	153.66	117.47	1.308	-12.6
1478		-7.000	471.000	34.694	2.000	222.62	174.82	1.273	-12.8
1479		-14.000	477.000	43.363	1.500	153.09	116.83	1.310	-12.8
1480		-10.000	481.000	44.739	2.500	348.46	279.60	1.246	-12.9
1481		-15.000	480.000	46.734	2.000	238.71	188.08	1.269	-13.0
1482		-13.000	476.000	41.949	1.500	152.10	115.73	1.314	-13.2

* denotes the minimum safety factor and maximum prevention force.

No.	Reg.	Circular arc requirements				Skid resistance S (kN/m)	Sliding force T (kN/m)	Safety factor Fs	Required prevention force Pr (kN/m)
		Central coordinates		Radius r (m)	Max. depth (m)				
		X (m)	Y (m)						
1483		-12.000	475.000	40.535	1.500	151.52	115.11	1.316	-13.3
1484		-6.000	465.000	28.798	1.000	105.93	76.98	1.376	-13.5
1485		-11.000	474.000	39.121	1.500	150.73	114.23	1.320	-13.6
1486		-14.000	479.000	45.322	2.000	237.64	186.65	1.273	-13.6
1487		-8.000	467.000	31.619	1.000	106.76	77.57	1.376	-13.6
1488		-7.000	466.000	30.209	1.000	106.40	77.33	1.376	-13.6
1489		-6.000	470.000	33.281	2.000	221.04	172.82	1.279	-13.6
1490		-9.000	468.000	33.030	1.000	106.91	77.59	1.378	-13.8
1491		-10.000	469.000	34.441	1.000	107.27	77.79	1.379	-13.9
1492		-10.000	473.000	37.707	1.500	149.82	113.23	1.323	-13.9
1493		-11.000	470.000	35.853	1.000	107.43	77.79	1.381	-14.0
1494		-14.000	473.000	40.088	1.000	108.24	78.38	1.381	-14.1
1495		-13.000	478.000	43.909	2.000	236.70	185.47	1.276	-14.1
1496		-7.000	481.000	43.420	3.000	451.50	364.49	1.239	-14.1
1497		-12.000	471.000	37.264	1.000	107.77	78.03	1.381	-14.1
1498		-13.000	472.000	38.676	1.000	108.06	78.25	1.381	-14.1
1499		-7.000	477.000	39.742	2.500	340.54	271.92	1.252	-14.2
1500		-15.000	474.000	41.500	1.000	108.36	78.38	1.382	-14.3
1501		-9.000	472.000	36.293	1.500	148.74	111.96	1.329	-14.3
1502		-16.000	475.000	42.913	1.000	108.41	78.26	1.385	-14.4
1503		-18.000	477.000	45.737	1.000	108.79	78.51	1.386	-14.5
1504		-17.000	476.000	44.325	1.000	108.70	78.50	1.385	-14.5
1505		-19.000	478.000	47.150	1.000	109.05	78.72	1.385	-14.5
1506		-8.000	471.000	34.879	1.500	147.92	111.05	1.332	-14.6
1507		-20.000	479.000	48.563	1.000	109.15	78.72	1.387	-14.6
1508		-9.000	480.000	43.332	2.500	347.23	277.14	1.253	-14.6
1509		-21.000	480.000	49.976	1.000	109.32	78.83	1.387	-14.7
1510		-23.000	482.000	52.801	1.000	109.66	79.06	1.387	-14.7
1511		-7.000	470.000	33.465	1.500	147.14	110.23	1.335	-14.8
1512		-22.000	481.000	51.388	1.000	109.41	78.81	1.388	-14.8
1513		-24.000	483.000	54.214	1.000	109.65	78.91	1.390	-14.9
1514		-12.000	477.000	42.497	2.000	235.13	183.44	1.282	-15.0
1515		-11.000	483.000	46.925	2.500	353.30	281.75	1.254	-15.2
1516		-7.000	483.000	45.561	3.500	564.64	457.81	1.233	-15.2
1517		-6.000	469.000	32.051	1.500	145.72	108.66	1.341	-15.3
1518		-11.000	476.000	41.085	2.000	233.83	181.74	1.287	-15.7
1519		-6.000	476.000	38.336	2.500	338.66	268.58	1.261	-16.3
1520		-10.000	475.000	39.673	2.000	232.75	180.34	1.291	-16.3
1521		-8.000	479.000	41.927	2.500	345.92	274.56	1.260	-16.4
1522		-6.000	480.000	42.025	3.000	450.84	361.62	1.247	-16.8
1523		-10.000	482.000	45.521	2.500	352.31	279.55	1.260	-16.8
1524		-19.000	483.000	51.155	1.500	157.78	117.38	1.344	-16.9
1525		-20.000	480.000	49.243	1.000	107.09	75.03	1.427	-17.0
1526		-16.000	476.000	43.589	1.000	106.17	74.25	1.430	-17.0
1527		-17.000	483.000	50.302	2.000	246.69	191.36	1.289	-17.0

* denotes the minimum safety factor and maximum prevention force.

No.	Reg.	Circular arc requirements				Skid resistance S (kN/m)	Sliding force T (kN/m)	Safety factor Fs	Required prevention force Pr (kN/m)
		Central coordinates		Radius r (m)	Max. depth (m)				
		X (m)	Y (m)						
1528		-15.000	475.000	42.175	1.000	105.98	74.11	1.430	-17.0
1529		-11.000	471.000	36.523	1.000	104.52	72.77	1.436	-17.1
1530		-12.000	472.000	37.936	1.000	104.82	73.02	1.435	-17.1
1531		-21.000	481.000	50.656	1.000	107.21	75.03	1.429	-17.1
1532		-14.000	474.000	40.762	1.000	105.50	73.61	1.433	-17.1
1533		-6.000	466.000	29.459	1.000	102.47	71.13	1.441	-17.1
1534		-22.000	482.000	52.070	1.000	107.39	75.16	1.429	-17.1
1535		-7.000	467.000	30.871	1.000	102.85	71.40	1.440	-17.1
1536		-13.000	473.000	39.349	1.000	105.29	73.49	1.433	-17.1
1537		-9.000	474.000	38.261	2.000	231.14	178.29	1.296	-17.1
1538		-23.000	483.000	53.484	1.000	107.61	75.41	1.427	-17.1
1539		-17.000	477.000	45.002	1.000	106.38	74.37	1.430	-17.1
1540		-18.000	478.000	46.416	1.000	106.57	74.54	1.430	-17.1
1541		-19.000	479.000	47.829	1.000	106.83	74.77	1.429	-17.1
1542		-9.000	469.000	33.697	1.000	103.67	72.00	1.440	-17.2
1543		-10.000	470.000	35.110	1.000	104.02	72.27	1.439	-17.2
1544		-18.000	482.000	49.741	1.500	157.17	116.64	1.347	-17.2
1545		-8.000	468.000	32.284	1.000	103.32	71.75	1.440	-17.2
1546		-17.000	481.000	48.327	1.500	156.46	115.79	1.351	-17.5
1547		-16.000	482.000	48.890	2.000	245.67	189.96	1.293	-17.7
1548		-8.000	483.000	45.629	3.000	458.16	367.04	1.248	-17.7
1549		-16.000	480.000	46.914	1.500	155.97	115.12	1.355	-17.8
1550		-8.000	473.000	36.849	2.000	229.97	176.75	1.301	-17.8
1551		-15.000	479.000	45.500	1.500	155.27	114.26	1.359	-18.1
1552		-7.000	478.000	40.522	2.500	344.47	271.87	1.267	-18.2
1553		-15.000	481.000	47.479	2.000	244.89	188.86	1.297	-18.2
1554		-14.000	478.000	44.087	1.500	154.63	113.49	1.362	-18.4
1555		-9.000	481.000	44.117	2.500	351.20	277.18	1.267	-18.5
1556		-13.000	477.000	42.673	1.500	153.89	112.61	1.367	-18.7
1557		-14.000	480.000	46.067	2.000	243.91	187.52	1.301	-18.8
1558		-6.000	467.000	30.139	1.000	98.07	66.02	1.485	-18.8
1559		-7.000	472.000	35.437	2.000	228.21	174.38	1.309	-18.9
1560		-7.000	468.000	31.552	1.000	98.85	66.52	1.486	-19.0
1561		-22.000	483.000	52.762	1.000	105.57	71.92	1.468	-19.2
1562		-12.000	476.000	41.260	1.500	152.88	111.39	1.372	-19.2
1563		-9.000	470.000	34.380	1.000	100.34	67.53	1.486	-19.3
1564		-19.000	480.000	48.520	1.000	104.86	71.26	1.472	-19.3
1565		-10.000	471.000	35.794	1.000	101.04	68.04	1.485	-19.3
1566		-8.000	469.000	32.966	1.000	99.45	66.77	1.489	-19.3
1567		-20.000	481.000	49.934	1.000	105.07	71.39	1.472	-19.4
1568		-21.000	482.000	51.348	1.000	105.16	71.40	1.473	-19.4
1569		-12.000	473.000	38.622	1.000	102.43	69.04	1.484	-19.5
1570		-18.000	479.000	47.106	1.000	104.52	70.85	1.475	-19.5
1571		-6.000	471.000	34.026	2.000	226.95	172.82	1.313	-19.5
1572		-13.000	479.000	44.656	2.000	242.83	186.09	1.305	-19.5

* denotes the minimum safety factor and maximum prevention force.

No.	Reg.	Circular arc requirements				Skid resistance S (kN/m)	Sliding force T (kN/m)	Safety factor Fs	Required prevention force Pr (kN/m)
		Central coordinates		Radius r (m)	Max. depth (m)				
		X (m)	Y (m)						
1573		-11.000	472.000	37.208	1.000	101.66	68.41	1.486	-19.5
1574		-6.000	482.000	44.173	3.500	564.73	454.35	1.243	-19.5
1575		-17.000	478.000	45.692	1.000	104.16	70.47	1.478	-19.5
1576		-15.000	476.000	42.864	1.000	103.58	69.95	1.481	-19.6
1577		-16.000	477.000	44.278	1.000	103.88	70.21	1.480	-19.6
1578		-13.000	474.000	40.036	1.000	103.00	69.42	1.484	-19.6
1579		-11.000	475.000	39.847	1.500	152.17	110.43	1.378	-19.6
1580		-14.000	475.000	41.450	1.000	103.30	69.70	1.482	-19.6
1581		-10.000	474.000	38.433	1.500	151.40	109.55	1.382	-19.9
1582		-6.000	477.000	39.118	2.500	342.78	268.82	1.275	-20.1
1583		-6.000	468.000	30.836	1.000	94.54	61.97	1.526	-20.1
1584		-12.000	478.000	43.245	2.000	241.83	184.73	1.309	-20.1
1585		-7.000	469.000	32.251	1.000	95.40	62.63	1.523	-20.2
1586		-8.000	480.000	42.714	2.500	350.01	274.73	1.274	-20.3
1587		-9.000	473.000	37.020	1.500	150.43	108.42	1.387	-20.3
1588		-8.000	470.000	33.665	1.000	96.13	63.15	1.522	-20.3
1589		-9.000	471.000	35.079	1.000	96.96	63.80	1.520	-20.4
1590		-10.000	472.000	36.493	1.000	97.59	64.20	1.520	-20.5
1591		-7.000	482.000	44.236	3.000	457.94	364.50	1.256	-20.5
1592		-11.000	473.000	37.907	1.000	98.37	64.85	1.517	-20.5
1593		-12.000	474.000	39.322	1.000	98.88	65.14	1.518	-20.7
1594		-8.000	472.000	35.607	1.500	149.55	107.36	1.393	-20.7
1595		-13.000	475.000	40.736	1.000	99.47	65.54	1.518	-20.8
1596		-14.000	476.000	42.150	1.000	100.12	66.05	1.516	-20.8
1597		-10.000	483.000	46.312	2.500	356.49	279.73	1.274	-20.8
1598		-11.000	477.000	41.834	2.000	240.57	183.02	1.314	-20.9
1599		-16.000	478.000	44.979	1.000	101.24	66.84	1.515	-21.0
1600		-15.000	477.000	43.564	1.000	100.60	66.33	1.517	-21.0
1601		-17.000	479.000	46.393	1.000	101.77	67.23	1.514	-21.0
1602		-7.000	470.000	32.965	1.000	92.87	59.73	1.555	-21.1
1603		-7.000	471.000	34.194	1.500	148.50	106.06	1.400	-21.2
1604		-8.000	471.000	34.379	1.000	93.60	60.27	1.553	-21.2
1605		-18.000	480.000	47.807	1.000	102.23	67.51	1.514	-21.2
1606		-19.000	481.000	49.221	1.000	102.74	67.90	1.513	-21.2
1607		-6.000	469.000	31.551	1.000	91.87	58.81	1.562	-21.2
1608		-20.000	482.000	50.635	1.000	103.24	68.29	1.512	-21.2
1609		-9.000	472.000	35.793	1.000	94.22	60.72	1.552	-21.3
1610		-21.000	483.000	52.050	1.000	103.63	68.55	1.512	-21.3
1611		-10.000	473.000	37.207	1.000	94.95	61.25	1.550	-21.4
1612		-11.000	474.000	38.621	1.000	95.64	61.78	1.548	-21.5
1613		-13.000	476.000	41.449	1.000	96.89	62.74	1.544	-21.6
1614		-12.000	475.000	40.035	1.000	96.25	62.20	1.547	-21.6
1615		-6.000	470.000	32.781	1.500	147.61	104.98	1.406	-21.6
1616		-14.000	477.000	42.863	1.000	97.39	63.04	1.545	-21.7
1617		-10.000	476.000	40.424	2.000	239.39	181.38	1.320	-21.7

* denotes the minimum safety factor and maximum prevention force.

No.	Reg.	Circular arc requirements				Skid resistance S (kN/m)	Sliding force T (kN/m)	Safety factor Fs	Required prevention force Pr (kN/m)
		Central coordinates		Radius r (m)	Max. depth (m)				
		X (m)	Y (m)						
1618		-15.000	478.000	44.277	1.000	97.95	63.45	1.544	-21.8
1619		-17.000	480.000	47.105	1.000	98.94	64.14	1.543	-21.9
1620		-16.000	479.000	45.691	1.000	98.30	63.62	1.545	-21.9
1621		-19.000	482.000	49.933	1.000	99.99	64.96	1.539	-22.0
1622		-20.000	483.000	51.347	1.000	100.51	65.36	1.538	-22.0
1623		-18.000	481.000	48.519	1.000	99.48	64.54	1.541	-22.0
1624		-7.000	479.000	41.312	2.500	348.87	272.28	1.281	-22.1
1625		-6.000	470.000	32.281	1.000	89.95	56.38	1.595	-22.2
1626		-8.000	472.000	35.107	1.000	91.59	57.75	1.586	-22.2
1627		-9.000	473.000	36.520	1.000	92.11	58.10	1.585	-22.3
1628		-12.000	476.000	40.760	1.000	94.13	59.78	1.575	-22.3
1629		-7.000	471.000	33.694	1.000	90.59	56.85	1.593	-22.3
1630		-13.000	477.000	42.173	1.000	94.61	60.10	1.574	-22.4
1631		-10.000	474.000	37.933	1.000	92.81	58.64	1.583	-22.4
1632		-16.000	483.000	49.643	2.000	253.04	192.19	1.317	-22.4
1633		-11.000	475.000	39.347	1.000	93.48	59.20	1.579	-22.4
1634		-9.000	475.000	39.013	2.000	238.20	179.73	1.325	-22.5
1635		-9.000	482.000	44.911	2.500	355.50	277.48	1.281	-22.5
1636		-14.000	478.000	43.587	1.000	95.16	60.52	1.572	-22.5
1637		-18.000	483.000	50.473	1.500	159.19	113.79	1.399	-22.6
1638		-16.000	480.000	46.414	1.000	96.18	61.25	1.570	-22.6
1639		-15.000	479.000	45.000	1.000	95.63	60.84	1.572	-22.6
1640		-17.000	481.000	47.827	1.000	96.72	61.68	1.568	-22.7
1641		-18.000	482.000	49.241	1.000	97.24	62.10	1.566	-22.7
1642		-19.000	483.000	50.655	1.000	97.74	62.50	1.564	-22.7
1643		-17.000	482.000	49.060	1.500	158.64	113.06	1.403	-22.9
1644		-15.000	482.000	48.233	2.000	251.97	190.66	1.322	-23.1
1645		-8.000	473.000	35.849	1.000	89.92	55.52	1.620	-23.2
1646		-7.000	472.000	34.437	1.000	89.13	54.80	1.626	-23.3
1647		-16.000	481.000	47.647	1.500	158.15	112.36	1.408	-23.3
1648		-12.000	477.000	41.497	1.000	92.28	57.48	1.605	-23.3
1649		-13.000	478.000	42.909	1.000	92.97	58.05	1.602	-23.3
1650		-14.000	479.000	44.322	1.000	93.39	58.39	1.599	-23.3
1651		-8.000	474.000	37.603	2.000	236.88	177.95	1.331	-23.3
1652		-15.000	480.000	45.734	1.000	93.94	58.81	1.597	-23.3
1653		-9.000	474.000	37.261	1.000	90.50	55.97	1.617	-23.3
1654		-16.000	481.000	47.147	1.000	94.48	59.26	1.594	-23.3
1655		-10.000	475.000	38.673	1.000	90.99	56.34	1.615	-23.3
1656		-6.000	471.000	33.026	1.000	88.63	54.40	1.629	-23.3
1657		-17.000	482.000	48.560	1.000	95.07	59.80	1.590	-23.3
1658		-11.000	476.000	40.085	1.000	91.66	56.93	1.610	-23.3
1659		-18.000	483.000	49.973	1.000	95.42	60.00	1.590	-23.4
1660		-6.000	481.000	42.845	3.000	457.44	361.61	1.265	-23.5
1661		-15.000	480.000	46.234	1.500	157.56	111.60	1.412	-23.6
1662		-14.000	481.000	46.823	2.000	251.23	189.52	1.326	-23.8

* denotes the minimum safety factor and maximum prevention force.

No.	Reg.	Circular arc requirements				Skid resistance S (kN/m)	Sliding force T (kN/m)	Safety factor Fs	Required prevention force Pr (kN/m)
		Central coordinates		Radius r (m)	Max. depth (m)				
		X (m)	Y (m)						
1663		-13.000	479.000	43.656	1.000	91.69	56.37	1.627	-24.0
1664		-14.000	480.000	45.067	1.000	92.13	56.71	1.625	-24.0
1665		-14.000	479.000	44.822	1.500	157.00	110.80	1.417	-24.0
1666		-15.000	481.000	46.479	1.000	92.63	57.17	1.620	-24.0
1667		-6.000	478.000	39.911	2.500	347.49	269.53	1.289	-24.0
1668		-10.000	476.000	39.424	1.000	90.08	54.94	1.640	-24.1
1669		-11.000	477.000	40.834	1.000	90.53	55.32	1.636	-24.1
1670		-12.000	478.000	42.245	1.000	91.07	55.78	1.633	-24.1
1671		-17.000	483.000	49.302	1.000	93.41	57.73	1.618	-24.1
1672		-16.000	482.000	47.890	1.000	92.99	57.40	1.620	-24.1
1673		-9.000	475.000	38.013	1.000	89.43	54.33	1.646	-24.2
1674		-8.000	474.000	36.603	1.000	88.86	53.83	1.651	-24.2
1675		-7.000	473.000	36.193	2.000	235.46	176.05	1.337	-24.2
1676		-7.000	473.000	35.193	1.000	88.11	53.12	1.659	-24.3
1677		-6.000	472.000	33.783	1.000	87.61	52.69	1.663	-24.3
1678		-8.000	481.000	43.510	2.500	354.34	274.92	1.289	-24.4
1679		-13.000	478.000	43.409	1.500	156.15	109.71	1.423	-24.4
1680		-13.000	480.000	45.413	2.000	250.28	188.16	1.330	-24.4
1681		-13.000	480.000	44.413	1.000	90.55	54.73	1.654	-24.8
1682		-14.000	481.000	45.823	1.000	91.08	55.16	1.651	-24.8
1683		-16.000	483.000	48.643	1.000	91.90	55.89	1.644	-24.8
1684		-15.000	482.000	47.233	1.000	91.58	55.64	1.646	-24.8
1685		-12.000	477.000	41.997	1.500	155.48	108.76	1.430	-24.9
1686		-12.000	479.000	43.003	1.000	90.12	54.33	1.659	-24.9
1687		-10.000	477.000	40.183	1.000	89.03	53.34	1.669	-25.0
1688		-11.000	478.000	41.593	1.000	89.50	53.73	1.666	-25.0
1689		-9.000	476.000	38.773	1.000	88.19	52.51	1.679	-25.1
1690		-12.000	479.000	44.003	2.000	249.31	186.78	1.335	-25.1
1691		-8.000	475.000	37.363	1.000	87.43	51.80	1.688	-25.2
1692		-7.000	474.000	35.953	1.000	86.83	51.27	1.694	-25.3
1693		-6.000	472.000	34.783	2.000	233.71	173.63	1.346	-25.3
1694		-6.000	473.000	34.543	1.000	86.04	50.52	1.703	-25.4
1695		-11.000	476.000	40.585	1.500	154.71	107.73	1.436	-25.4
1696		-14.000	482.000	46.583	1.000	89.80	53.45	1.680	-25.6
1697		-15.000	483.000	47.993	1.000	90.34	53.93	1.675	-25.6
1698		-10.000	475.000	39.173	1.500	154.17	107.01	1.441	-25.7
1699		-13.000	481.000	45.173	1.000	89.09	52.77	1.688	-25.7
1700		-12.000	480.000	43.763	1.000	88.45	52.17	1.695	-25.8
1701		-11.000	478.000	42.593	2.000	248.33	185.38	1.340	-25.8
1702		-10.000	478.000	40.943	1.000	87.20	51.07	1.707	-25.9
1703		-11.000	479.000	42.353	1.000	87.79	51.55	1.703	-25.9
1704		-9.000	477.000	39.533	1.000	86.27	50.11	1.722	-26.1
1705		-9.000	474.000	37.761	1.500	153.17	105.76	1.448	-26.2
1706		-8.000	476.000	38.123	1.000	85.56	49.46	1.730	-26.2
1707		-7.000	480.000	42.111	2.500	353.47	272.66	1.296	-26.2

* denotes the minimum safety factor and maximum prevention force.

No.	Reg.	Circular arc requirements				Skid resistance S (kN/m)	Sliding force T (kN/m)	Safety factor Fs	Required prevention force Pr (kN/m)
		Central coordinates		Radius r (m)	Max. depth (m)				
		X (m)	Y (m)						
1708		-7.000	475.000	36.713	1.000	84.56	48.51	1.743	-26.3
1709		-6.000	474.000	35.303	1.000	83.75	47.75	1.754	-26.4
1710		-8.000	473.000	36.349	1.500	152.02	104.59	1.453	-26.5
1711		-14.000	483.000	47.342	1.000	87.66	50.95	1.721	-26.5
1712		-13.000	482.000	45.933	1.000	87.03	50.34	1.729	-26.6
1713		-12.000	481.000	44.523	1.000	86.26	49.62	1.738	-26.7
1714		-7.000	472.000	34.937	1.500	150.89	103.49	1.458	-26.7
1715		-9.000	483.000	45.713	2.500	360.04	277.70	1.297	-26.8
1716		-11.000	480.000	43.113	1.000	85.38	48.81	1.749	-26.8
1717		-10.000	477.000	41.183	2.000	247.00	183.50	1.346	-26.8
1718		-10.000	479.000	41.703	1.000	84.59	48.07	1.760	-26.9
1719		-6.000	471.000	33.526	1.500	149.66	102.30	1.463	-26.9
1720		-8.000	477.000	38.883	1.000	82.77	46.40	1.784	-27.0
1721		-9.000	478.000	40.293	1.000	83.70	47.23	1.772	-27.0
1722		-7.000	476.000	37.473	1.000	81.84	45.55	1.797	-27.1
1723		-7.000	483.000	45.061	3.000	464.51	364.50	1.274	-27.1
1724		-13.000	483.000	46.693	1.000	84.58	47.77	1.771	-27.2
1725		-6.000	475.000	36.064	1.000	80.81	44.57	1.813	-27.3
1726		-12.000	482.000	45.283	1.000	83.74	46.95	1.784	-27.4
1727		-11.000	481.000	43.874	1.000	82.77	46.02	1.799	-27.5
1728		-10.000	480.000	42.466	1.000	81.96	45.32	1.808	-27.5
1729		-9.000	479.000	41.058	1.000	81.06	44.47	1.823	-27.6
1730		-15.000	483.000	48.993	2.000	260.13	193.72	1.343	-27.6
1731		-9.000	476.000	39.773	2.000	245.71	181.70	1.352	-27.6
1732		-8.000	478.000	39.650	1.000	80.16	43.61	1.838	-27.8
1733		-7.000	477.000	38.242	1.000	79.16	42.65	1.856	-27.9
1734		-6.000	476.000	36.836	1.000	78.34	41.89	1.870	-28.0
1735		-12.000	483.000	46.052	1.000	81.37	44.45	1.831	-28.0
1736		-6.000	479.000	40.713	2.500	352.47	270.27	1.304	-28.1
1737		-11.000	482.000	44.645	1.000	80.39	43.53	1.847	-28.1
1738		-10.000	481.000	43.239	1.000	79.62	42.79	1.861	-28.2
1739		-17.000	483.000	49.802	1.500	161.92	111.41	1.453	-28.2
1740		-14.000	482.000	47.583	2.000	259.11	192.29	1.347	-28.3
1741		-6.000	483.000	45.009	3.500	572.68	453.61	1.262	-28.3
1742		-9.000	480.000	41.832	1.000	78.83	42.07	1.874	-28.3
1743		-8.000	475.000	38.363	2.000	244.11	179.61	1.359	-28.5
1744		-8.000	479.000	40.427	1.000	77.86	41.12	1.893	-28.5
1745		-8.000	482.000	44.316	2.500	359.24	275.59	1.304	-28.5
1746		-16.000	482.000	48.390	1.500	161.32	110.53	1.460	-28.6
1747		-11.000	483.000	45.425	1.000	78.39	41.39	1.894	-28.7
1748		-7.000	478.000	39.022	1.000	76.87	40.14	1.915	-28.7
1749		-10.000	482.000	44.021	1.000	77.63	40.63	1.911	-28.8
1750		-6.000	477.000	37.618	1.000	76.07	39.37	1.932	-28.8
1751		-13.000	481.000	46.173	2.000	258.04	190.79	1.352	-29.0
1752		-9.000	481.000	42.617	1.000	76.68	39.71	1.931	-29.0

* denotes the minimum safety factor and maximum prevention force.

No.	Reg.	Circular arc requirements				Skid resistance S (kN/m)	Sliding force T (kN/m)	Safety factor Fs	Required prevention force Pr (kN/m)
		Central coordinates		Radius r (m)	Max. depth (m)				
		X (m)	Y (m)						
1753		-15.000	481.000	46.979	1.500	160.81	109.70	1.466	-29.1
1754		-7.000	474.000	36.953	2.000	242.61	177.57	1.366	-29.5
1755		-14.000	480.000	45.567	1.500	160.30	108.91	1.472	-29.6
1756		-14.000	483.000	48.342	2.000	262.84	194.15	1.354	-29.8
1757		-13.000	479.000	44.156	1.500	159.76	108.11	1.478	-30.0
1758		-12.000	480.000	44.763	2.000	256.64	188.85	1.359	-30.0
1759		-7.000	481.000	42.920	2.500	358.42	273.49	1.311	-30.2
1760		-6.000	482.000	43.673	3.000	464.49	361.88	1.284	-30.2
1761		-12.000	478.000	42.745	1.500	159.23	107.28	1.484	-30.4
1762		-6.000	473.000	35.543	2.000	240.79	175.14	1.375	-30.6
1763		-11.000	477.000	41.334	1.500	158.20	106.13	1.491	-30.8
1764		-13.000	482.000	46.933	2.000	261.78	192.47	1.360	-30.8
1765		-11.000	479.000	43.353	2.000	255.53	187.19	1.365	-30.9
1766		-10.000	476.000	39.924	1.500	157.37	105.29	1.495	-31.0
1767		-9.000	475.000	38.513	1.500	156.35	104.20	1.500	-31.3
1768		-8.000	474.000	37.103	1.500	155.41	103.21	1.506	-31.5
1769		-10.000	478.000	41.943	2.000	254.24	185.40	1.371	-31.7
1770		-6.000	480.000	41.525	2.500	357.44	271.44	1.317	-31.7
1771		-7.000	473.000	35.693	1.500	154.45	102.22	1.511	-31.7
1772		-12.000	481.000	45.523	2.000	260.82	190.82	1.367	-31.8
1773		-6.000	472.000	34.283	1.500	153.17	100.89	1.518	-32.1
1774		-8.000	483.000	45.129	2.500	364.12	276.29	1.318	-32.5
1775		-9.000	477.000	40.533	2.000	252.67	183.32	1.378	-32.6
1776		-13.000	483.000	47.693	2.000	263.98	192.71	1.370	-32.7
1777		-11.000	480.000	44.113	2.000	259.50	188.77	1.375	-32.9
1778		-8.000	476.000	39.123	2.000	251.16	181.29	1.385	-33.6
1779		-12.000	482.000	46.283	2.000	262.58	190.55	1.378	-33.9
1780		-7.000	482.000	43.736	2.500	363.45	274.55	1.324	-33.9
1781		-16.000	483.000	49.143	1.500	165.61	109.61	1.511	-34.0
1782		-10.000	479.000	42.703	2.000	258.08	186.56	1.383	-34.2
1783		-15.000	482.000	47.733	1.500	165.33	109.04	1.516	-34.4
1784		-7.000	475.000	37.713	2.000	249.13	178.76	1.394	-34.6
1785		-14.000	481.000	46.323	1.500	164.56	108.10	1.522	-34.8
1786		-11.000	481.000	44.874	2.000	261.46	188.85	1.384	-34.8
1787		-13.000	480.000	44.913	1.500	164.08	107.61	1.525	-34.9
1788		-12.000	479.000	43.503	1.500	163.24	106.67	1.530	-35.2
1789		-9.000	478.000	41.293	2.000	256.56	184.24	1.393	-35.4
1790		-11.000	478.000	42.093	1.500	162.43	105.82	1.535	-35.4
1791		-6.000	481.000	42.345	2.500	362.76	272.64	1.331	-35.5
1792		-6.000	474.000	36.303	2.000	247.42	176.48	1.402	-35.6
1793		-10.000	477.000	40.683	1.500	161.37	104.65	1.542	-35.7
1794		-12.000	483.000	47.052	2.000	265.19	191.16	1.387	-35.7
1795		-10.000	480.000	43.466	2.000	260.29	187.00	1.392	-35.8
1796		-9.000	476.000	39.273	1.500	160.46	103.64	1.548	-36.0
1797		-8.000	475.000	37.863	1.500	159.17	102.20	1.557	-36.5

* denotes the minimum safety factor and maximum prevention force.

No.	Reg.	Circular arc requirements				Skid resistance S (kN/m)	Sliding force T (kN/m)	Safety factor Fs	Required prevention force Pr (kN/m)
		Central coordinates		Radius r (m)	Max. depth (m)				
		X (m)	Y (m)						
1798		-11.000	482.000	45.645	2.000	263.82	189.26	1.394	-36.7
1799		-8.000	477.000	39.883	2.000	255.04	181.93	1.402	-36.7
1800		-7.000	474.000	36.453	1.500	157.99	100.99	1.564	-36.8
1801		-6.000	483.000	44.509	3.000	471.68	362.39	1.302	-36.8
1802		-9.000	479.000	42.058	2.000	258.73	184.71	1.401	-37.0
1803		-6.000	473.000	35.043	1.500	156.71	99.65	1.573	-37.1
1804		-10.000	481.000	44.239	2.000	262.59	187.73	1.399	-37.3
1805		-7.000	476.000	38.473	2.000	253.55	179.85	1.410	-37.7
1806		-8.000	478.000	40.650	2.000	257.09	182.69	1.407	-37.8
1807		-7.000	483.000	44.561	2.500	368.71	275.63	1.338	-37.9
1808		-11.000	483.000	46.425	2.000	266.02	190.02	1.400	-37.9
1809		-9.000	480.000	42.832	2.000	260.96	185.77	1.405	-38.0
1810		-6.000	475.000	37.064	2.000	251.49	177.39	1.418	-38.6
1811		-7.000	477.000	39.242	2.000	255.15	180.35	1.415	-38.7
1812		-8.000	479.000	41.427	2.000	259.51	183.99	1.410	-38.7
1813		-10.000	482.000	45.021	2.000	264.57	188.13	1.406	-38.8
1814		-15.000	483.000	48.493	1.500	169.47	108.66	1.560	-39.0
1815		-14.000	482.000	47.083	1.500	168.82	107.95	1.564	-39.2
1816		-9.000	481.000	43.617	2.000	263.69	187.02	1.410	-39.2
1817		-6.000	476.000	37.836	2.000	253.50	178.47	1.420	-39.3
1818		-7.000	478.000	40.022	2.000	257.81	181.85	1.418	-39.5
1819		-6.000	482.000	43.173	2.500	368.66	274.25	1.344	-39.5
1820		-13.000	481.000	45.673	1.500	167.91	106.89	1.571	-39.6
1821		-12.000	480.000	44.263	1.500	166.86	105.70	1.579	-40.0
1822		-8.000	480.000	42.214	2.000	262.38	185.31	1.416	-40.0
1823		-10.000	483.000	45.812	2.000	267.77	189.70	1.412	-40.1
1824		-6.000	477.000	38.618	2.000	256.31	180.07	1.423	-40.2
1825		-7.000	479.000	39.812	1.000	86.28	38.24	2.256	-40.3
1826		-11.000	479.000	42.853	1.500	165.99	104.73	1.585	-40.3
1827		-10.000	478.000	41.443	1.500	165.11	103.90	1.589	-40.4
1828		-7.000	479.000	40.812	2.000	261.14	183.73	1.421	-40.6
1829		-9.000	482.000	44.411	2.000	266.87	188.45	1.416	-40.7
1830		-9.000	477.000	40.033	1.500	163.83	102.47	1.599	-40.8
1831		-8.000	476.000	38.623	1.500	162.60	101.10	1.608	-41.2
1832		-8.000	481.000	43.010	2.000	265.97	187.16	1.421	-41.3
1833		-6.000	478.000	39.411	2.000	259.99	182.20	1.427	-41.3
1834		-7.000	475.000	37.213	1.500	161.34	99.74	1.618	-41.6
1835		-6.000	474.000	35.803	1.500	159.85	98.16	1.628	-42.0
1836		-7.000	480.000	41.611	2.000	265.07	185.82	1.426	-42.0
1837		-9.000	483.000	45.213	2.000	270.50	190.08	1.423	-42.4
1838		-6.000	478.000	38.411	1.000	87.82	37.57	2.338	-42.7
1839		-6.000	479.000	40.213	2.000	264.07	184.37	1.432	-42.8
1840		-8.000	482.000	43.816	2.000	269.72	188.84	1.428	-43.1
1841		-7.000	481.000	42.420	2.000	269.37	187.97	1.433	-43.8
1842		-14.000	483.000	47.842	1.500	172.40	107.09	1.610	-43.8

* denotes the minimum safety factor and maximum prevention force.

No.	Reg.	Circular arc requirements				Skid resistance S (kN/m)	Sliding force T (kN/m)	Safety factor Fs	Required prevention force Pr (kN/m)
		Central coordinates		Radius r (m)	Max. depth (m)				
		X (m)	Y (m)						
1843		-6.000	483.000	44.009	2.500	374.69	275.64	1.359	-43.9
1844		-13.000	482.000	46.433	1.500	171.52	106.16	1.616	-44.1
1845		-6.000	480.000	41.025	2.000	268.60	186.69	1.439	-44.5
1846		-12.000	481.000	45.023	1.500	170.38	104.86	1.625	-44.5
1847		-11.000	480.000	43.613	1.500	169.40	103.77	1.632	-44.8
1848		-8.000	483.000	44.629	2.000	274.10	191.01	1.435	-44.8
1849		-10.000	479.000	42.203	1.500	168.09	102.35	1.642	-45.2
1850		-10.000	483.000	44.812	1.000	92.48	39.22	2.358	-45.4
1851		-7.000	482.000	43.236	2.000	274.01	190.40	1.439	-45.5
1852		-9.000	478.000	40.793	1.500	167.05	101.24	1.650	-45.5
1853		-8.000	477.000	39.383	1.500	165.59	99.72	1.661	-45.9
1854		-7.000	476.000	37.973	1.500	164.31	98.36	1.670	-46.2
1855		-6.000	481.000	41.845	2.000	273.70	189.44	1.445	-46.3
1856		-6.000	475.000	36.564	1.500	162.77	96.68	1.684	-46.7
1857		-9.000	482.000	43.411	1.000	93.79	38.70	2.424	-47.3
1858		-7.000	483.000	44.061	2.000	278.95	192.80	1.447	-47.5
1859		-13.000	483.000	47.193	1.500	175.04	105.39	1.661	-48.5
1860		-6.000	482.000	42.673	2.000	279.09	192.15	1.452	-48.5
1861		-12.000	482.000	45.783	1.500	174.06	104.34	1.668	-48.8
1862		-8.000	481.000	42.010	1.000	95.16	38.38	2.479	-49.1
1863		-11.000	481.000	44.374	1.500	172.93	103.04	1.678	-49.2
1864		-10.000	480.000	42.966	1.500	171.65	101.62	1.689	-49.7
1865		-9.000	479.000	41.558	1.500	170.76	100.62	1.697	-50.0
1866		-8.000	478.000	40.150	1.500	169.66	99.39	1.707	-50.3
1867		-7.000	480.000	40.611	1.000	96.23	37.89	2.540	-50.7
1868		-7.000	477.000	38.742	1.500	168.56	98.16	1.717	-50.7
1869		-6.000	483.000	43.509	2.000	284.77	194.96	1.461	-50.8
1870		-6.000	476.000	37.336	1.500	167.45	96.95	1.727	-51.1
1871		-6.000	479.000	39.213	1.000	97.43	37.60	2.591	-52.3
1872		-12.000	483.000	46.552	1.500	178.65	104.52	1.709	-53.2
1873		-11.000	482.000	45.145	1.500	177.83	103.57	1.717	-53.5
1874		-10.000	481.000	43.739	1.500	177.12	102.69	1.725	-53.8
1875		-9.000	480.000	42.332	1.500	176.09	101.49	1.735	-54.3
1876		-8.000	479.000	40.927	1.500	175.22	100.37	1.746	-54.7
1877		-7.000	478.000	39.522	1.500	174.46	99.44	1.754	-55.1
1878		-6.000	477.000	38.118	1.500	173.62	98.43	1.764	-55.5
1879		-9.000	483.000	44.213	1.000	103.42	39.29	2.632	-56.2
1880		-9.000	483.000	44.713	1.500	188.10	109.57	1.717	-56.6
1881		-10.000	483.000	45.312	1.500	185.18	107.04	1.730	-56.7
1882		-9.000	482.000	43.911	1.500	184.84	106.66	1.733	-56.8
1883		-8.000	482.000	43.316	1.500	187.81	109.15	1.721	-56.8
1884		-8.000	483.000	44.129	1.500	191.93	112.60	1.705	-56.8
1885		-7.000	481.000	41.920	1.500	187.59	108.83	1.724	-56.9
1886		-8.000	481.000	42.510	1.500	184.37	106.18	1.736	-56.9
1887		-11.000	483.000	45.925	1.500	183.45	105.34	1.742	-57.0

* denotes the minimum safety factor and maximum prevention force.

No.	Reg.	Circular arc requirements				Skid resistance S (kN/m)	Sliding force T (kN/m)	Safety factor Fs	Required prevention force Pr (kN/m)
		Central coordinates		Radius r (m)	Max. depth (m)				
		X (m)	Y (m)						
1888		-7.000	480.000	41.111	1.500	183.72	105.52	1.741	-57.0
1889		-6.000	480.000	40.525	1.500	187.51	108.73	1.725	-57.0
1890		-7.000	482.000	42.736	1.500	191.96	112.45	1.707	-57.0
1891		-6.000	481.000	41.345	1.500	192.24	112.64	1.707	-57.0
1892		-6.000	479.000	39.713	1.500	183.31	105.12	1.744	-57.1
1893		-10.000	482.000	44.521	1.500	182.60	104.48	1.748	-57.2
1894		-9.000	481.000	43.117	1.500	181.84	103.73	1.753	-57.3
1895		-7.000	483.000	43.561	1.500	196.69	116.15	1.693	-57.3
1896		-8.000	480.000	41.714	1.500	181.05	102.95	1.759	-57.5
1897		-7.000	479.000	40.312	1.500	180.18	102.07	1.765	-57.6
1898		-6.000	482.000	42.173	1.500	197.08	116.22	1.696	-57.6
1899		-8.000	482.000	42.816	1.000	104.69	39.23	2.669	-57.6
1900		-6.000	478.000	38.911	1.500	179.54	101.48	1.769	-57.7
1901		-6.000	483.000	43.009	1.500	202.51	120.17	1.685	-58.3
1902		-7.000	481.000	41.420	1.000	106.19	39.47	2.690	-58.8
1903		-6.000	480.000	40.025	1.000	107.31	39.30	2.731	-60.1
1904		-6.000	483.000	42.509	1.000	127.86	52.54	2.434	-64.8
1905		-8.000	483.000	43.629	1.000	115.11	41.85	2.751	-64.8
1906		-6.000	482.000	41.673	1.000	123.12	47.75	2.578	-65.8
1907		-7.000	482.000	42.236	1.000	116.70	42.31	2.758	-65.9
1908		-7.000	483.000	43.061	1.000	122.47	46.89	2.612	-66.2
1909		-6.000	481.000	40.845	1.000	118.48	43.10	2.749	-66.7

* denotes the minimum safety factor and maximum prevention force.

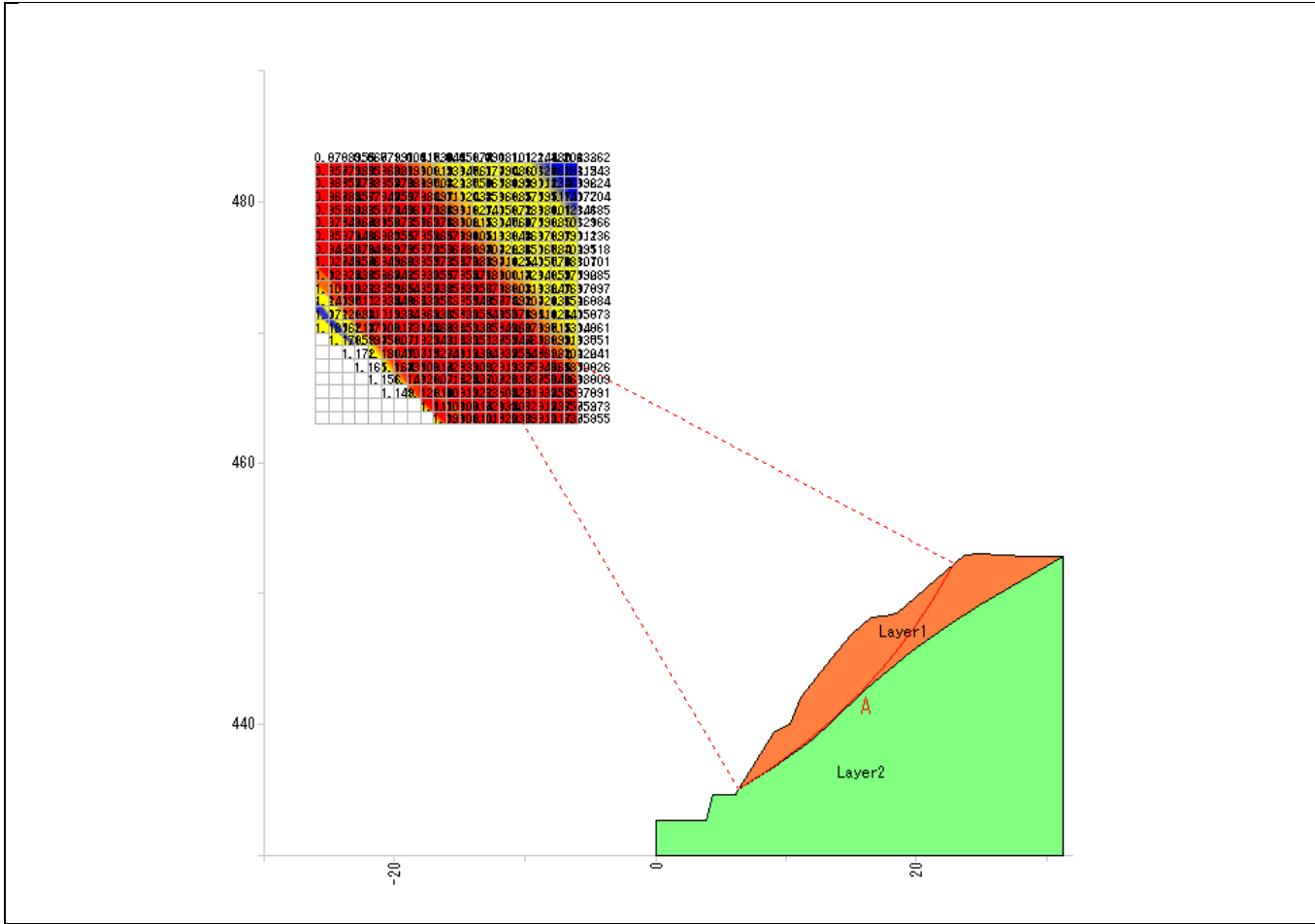

Isoline Map (Minimum Safety Factor - Normally)

Stability Analysis

Site	KANDY	LOWER
Case	B	Fs(min)
Remarks	ϕ 29	C5

Site	KANDY
Case	B Fs(min)
Remarks	φ 29 C5

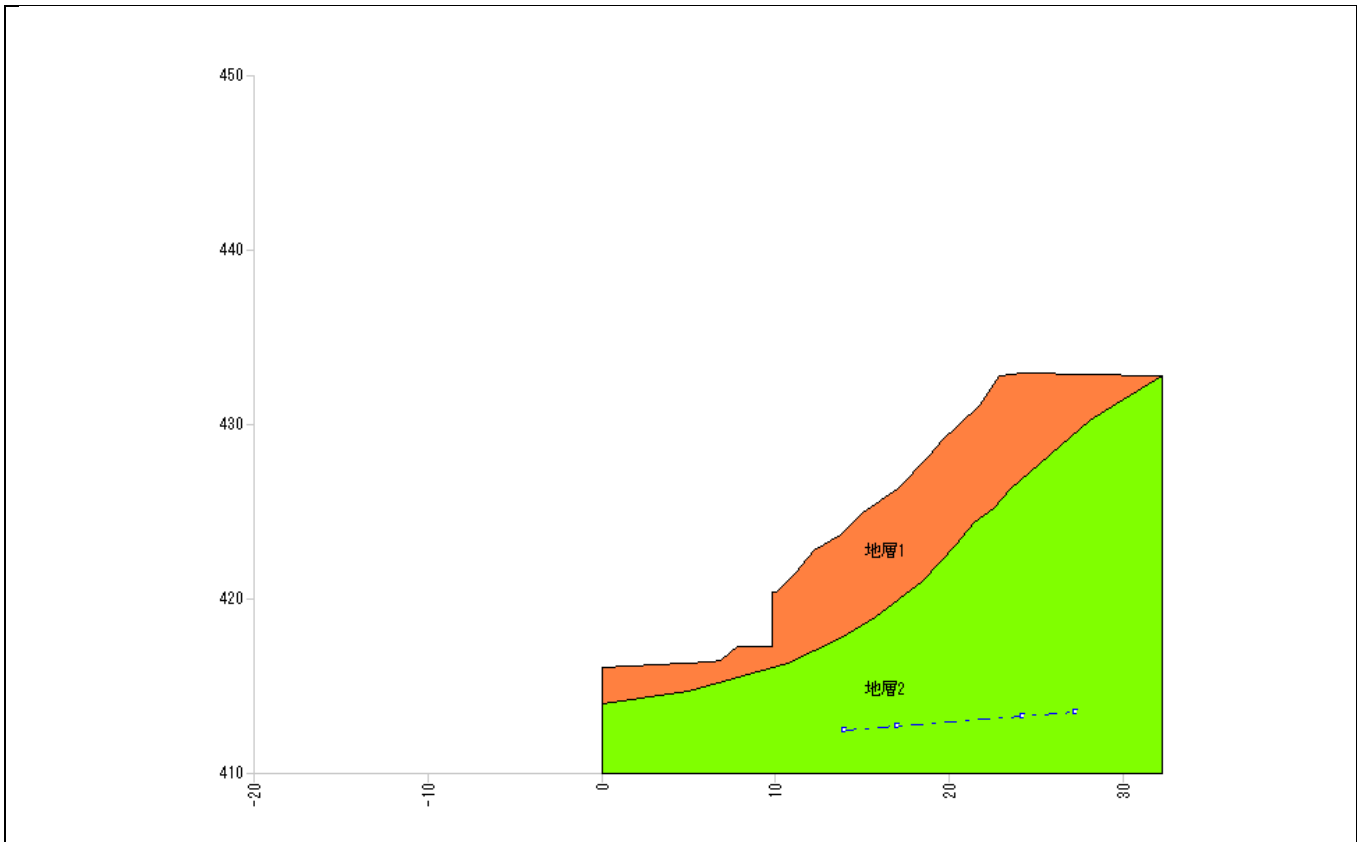

Soil constant		Soil quality	Wet weight γ_t (kN/m ³)	Saturated weight γ_{sat} (kN/m ³)	Cohesion C (kN/m ²)	Internal friction angle	
No.	Geology					ϕ (°)	$\tan\phi$
1	地層 1		17.00	17.00	5.00	29.0000	0.554309
2	地層 2		20.00	20.00	7.00	32.0000	0.624869

* Unit weight of water $\gamma_w = 9.80$ (kN/m³)

Coordinate input data								
No.	Distance X (m)	Original topographic altitude Y _G (m)	Planned topographic altitude Y (m)	Water level altitude Y _W (m)	Sliding surface			Launching
					Altitude Y _S (m)	Shape	Strength	
1	0.000		416.049					
2	1.595		416.158					
3	6.357		416.346					
4	6.876		416.479					
5	7.876		417.279					
6	9.876		417.279					
7	9.876		420.379					
8	10.076		420.379					
9	11.173		421.452					
10	12.203		422.741					
11	13.737		423.648					
12	14.037			412.420				
13	15.014		424.881					
14	17.027		426.305	412.665				
15	18.890		428.224					
16	19.614		429.054					
17	20.456		429.881					
18	21.778		431.199					
19	22.840		432.809					
20	24.272		433.000	413.260				
21	27.262			413.510				
22	31.785		432.837					
23	32.200		432.840					

Coordinates of stratum boundary line		
No.	No.1	
	X (m)	Y (m)
1	0.000	414.000
2	5.000	414.700
3	10.718	416.240
4	13.740	417.700
5	15.770	418.950
6	18.490	421.010
7	20.400	423.080
8	21.410	424.350
9	22.570	425.160
10	23.540	426.300
11	28.080	430.270
12	29.570	431.230
13	32.200	432.840

3. Design Requirements

3.4. Planned Safety Factor of the Reinforcement Slope

Considering the site as permanent construction, set a planned safety factor.

The Cut Earth Reinforcement Method, Design and Construction Procedures prescribes as follows.

Planned safety factor of the reinforcement slope

Item	Planned safety factor
Permanent construction (long term)	$F_{sp} \geq 1.20$
Temporary construction (short term)	$F_{sp} \geq 1.05, 1.10$

[Cut Earth Reinforcement Method, Design and Construction Procedures Page 31]

Taking account of the importance of the said slope, the planned safety factor shall be $F_{sp} = 1.200$.

3.5. Soil Quality Requirements

The following shows the geological and soil composition and constants of the said slope.

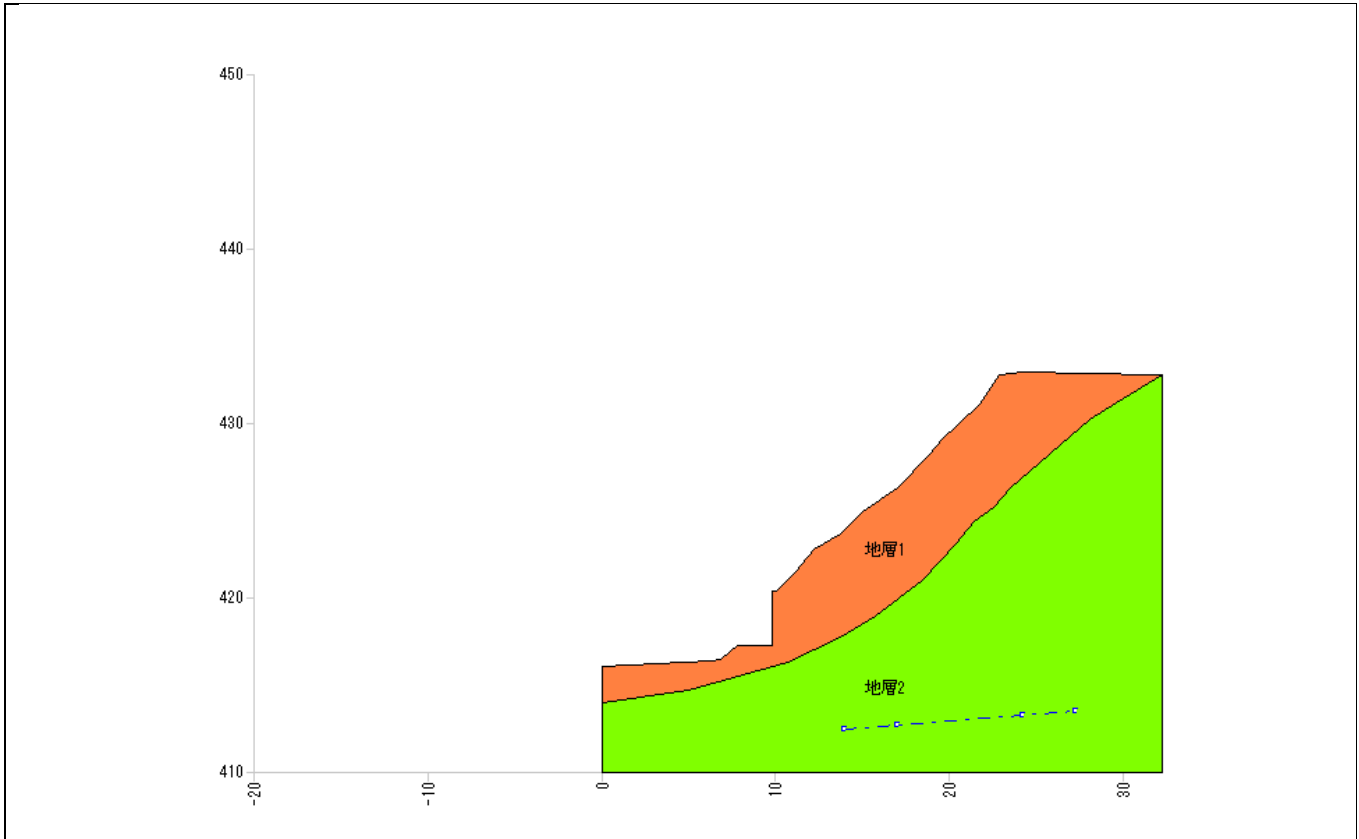

Soil constant							
No.	Geology	Soil quality	Wet weight γ_t (kN/m^3)	Saturated weight γ_{sat} (kN/m^3)	Cohesion C (kN/m^2)	Internal friction angle	
						ϕ ($^\circ$)	$\tan\phi$
1	地層 1		17.00	17.00	5.00	29.0000	0.554309
2	地層 2		20.00	20.00	7.00	32.0000	0.624869

* Unit weight of water $\gamma_w = 9.80$ (kN/m^3)

4. Repeated Circular Calculation

As a result of studying with repeated circular slip as to slope stability, it is determined that the following sliding surface is most dangerous.

< Circular arc A >

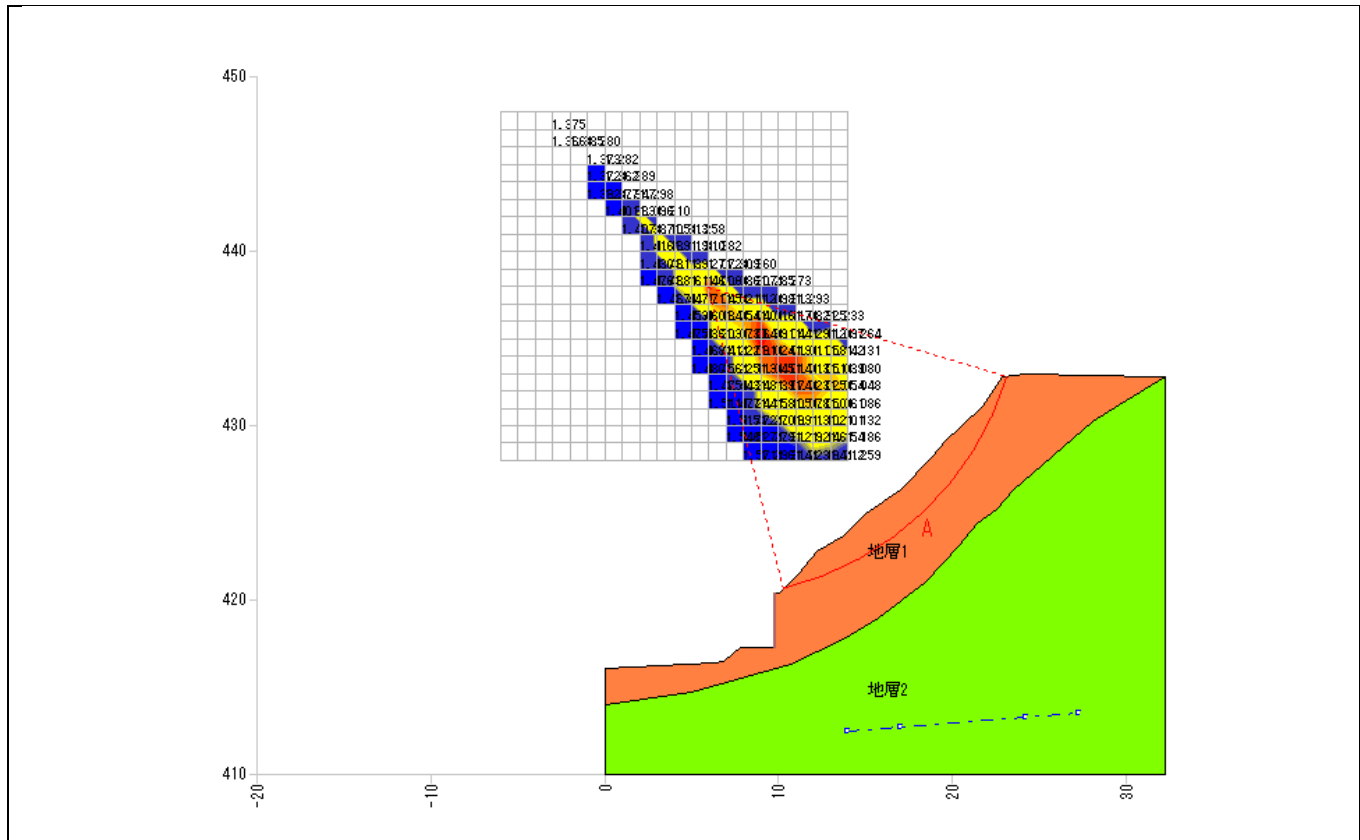

Stability calculation results				
Item		Symbol	Unit	Normally
Calculation results	Safety factor	Fs	-	1.006
	Planned safety factor	Fsp	-	1.200
	Required prevention force	Pr	kN/m	51.6
Circular arc	Central coordinates	X	m	6.000
		Y	m	438.000
	Radius	r	m	17.916
Calculation elements	Skid resistance	S	kN/m	267.53
	Sliding force	T	kN/m	265.91
	Normal force	N	kN/m	315.19
	Pore water pressure	U	kN/m	0.00
	Sliding surface length	l	m	18.564
Area	A	m ²	24.91	

4.1. Stability Calculation Formula

Stability calculation is conducted using the modified Fellenius method.

Basically, the limit balance method shall be used to secure the required planned safety factor.

$$\text{Safety factor (Fs)} = \frac{\text{Skid resistance } (\Sigma S)}{\text{Sliding force } (\Sigma T)}$$

Concerning the calculation method, the cross section of the sliding clod shall be split into several slices based on the “slicing method” to consider the balance of force on each slice (split piece).

< Normally >

$$Fs = \frac{\Sigma\{(N-U)\cdot\tan\phi\}+\Sigma(C\cdot l)}{\Sigma T}$$

$$Pr = F_{sp}\cdot\Sigma T - [\Sigma\{(N-U)\cdot\tan\phi\}+\Sigma(C\cdot l)]$$

where;

Fs	:	Safety factor	
Fsp	:	Planned safety factor	
Pr	:	Required prevention force	(kN/m)
N	:	Normal force by gravity of slice	(N = W·cosθ+Q _N) (kN/m)
U	:	Pore water pressure working on slice	(U = u·b·cosθ) (kN/m)
T	:	Tangential force by gravity of slice	(T = W·sinθ+Q _T) (kN/m)
b	:	Slice width	(m)
l	:	Sliding surface length of slice	(m)
φ	:	Internal friction angle of sliding surface	(°)
C	:	Cohesion of sliding surface	(kN/m ²)
W	:	Slice weight	(kN/m)
θ	:	Sliding surface inclination angle	(°)
u	:	Unit pore water pressure	(kN/m ²)
Q _N	:	Vertical load component force (normal direction)	(kN/m)
Q _T	:	Vertical load component force (tangential direction)	(kN/m)

4.2. Stability Evaluation (Normally)

< Circular arc A >

Slice element summary table			Sliding surface length l (m)	Normal force N (kN/m)	Pore water pressure U (kN/m)	Sliding force T (kN/m)	Skid resistance S (kN/m)
Internal friction angle		Cohesion C (kN/m ²)					
φ(°)	tanφ						
29.0000	0.554309	5.00	18.564	315.19	0.00	265.91	267.53

The safety factor is calculated by the following formula.

$$\begin{aligned}
 F_s &= \frac{\Sigma\{(N-U)\cdot\tan\phi\}+\Sigma(C\cdot l)}{\Sigma T} \\
 &= \frac{(315.19-0.00)\times 0.554309+5.00\times 18.564}{265.91} \\
 &= 1.006
 \end{aligned}$$

where;

F _s	:	Safety factor		
N	:	Normal force by gravity of slice	(N = W·cosθ+Q _N)	(kN/m)
U	:	Pore water pressure working on slice	(U = u·b·cosθ)	(kN/m)
T	:	Tangential force by gravity of slice	(T = W·sinθ+Q _T)	(kN/m)
b	:	Slice width		(m)
l	:	Sliding surface length of slice		(m)
φ	:	Internal friction angle of sliding surface		(°)
C	:	Cohesion of sliding surface		(kN/m ²)
W	:	Slice weight		(kN/m)
θ	:	Sliding surface inclination angle		(°)
u	:	Unit pore water pressure		(kN/m ²)
Q _N	:	Vertical load component force (normal direction)		(kN/m)
Q _T	:	Vertical load component force (tangential direction)		(kN/m)

4.3. Calculation of the Required Prevention Force (Normally)

Calculate the required prevention force which satisfies the planned safety factor $F_{sp} = 1.200$.

< Circular arc A >

$$\begin{aligned} Pr &= F_{sp} \cdot \Sigma T - [\Sigma \{(N-U) \cdot \tan \phi\} + \Sigma (C \cdot l)] \\ &= 1.200 \times 265.91 - \{(315.19 - 0.00) \times 0.554309 + 5.00 \times 18.564\} \\ &= 51.6 \text{ (kN/m)} \end{aligned}$$

where;

F_{sp}	: Planned safety factor		
Pr	: Required prevention force		(kN/m)
N	: Normal force by gravity of slice	$(N = W \cdot \cos \theta + Q_N)$	(kN/m)
U	: Pore water pressure working on slice	$(U = u \cdot b \cdot \cos \theta)$	(kN/m)
T	: Tangential force by gravity of slice	$(T = W \cdot \sin \theta + Q_T)$	(kN/m)
b	: Slice width		(m)
l	: Sliding surface length of slice		(m)
ϕ	: Internal friction angle of sliding surface		(°)
C	: Cohesion of sliding surface		(kN/m ²)
W	: Slice weight		(kN/m)
θ	: Sliding surface inclination angle		(°)
u	: Unit pore water pressure		(kN/m ²)
Q_N	: Vertical load component force (normal direction)		(kN/m)
Q_T	: Vertical load component force (tangential direction)		(kN/m)

Repeated Circular Calculation Requirements

- Circular arc requirements

Center change range

X coordinate (m) : -6.000 ~ 14.000 Pitch (m) : 1.000
Y coordinate (m) : 428.000 ~ 448.000 Pitch (m) : 1.000
Secondary chase : None

Depth change range from the ground surface

Depth (m) : 1.000 ~ 7.000 Pitch (m) : 0.500

- Pass line

Start point (m) : [X = - , Y = -]

End point (m) : [X = - , Y = -]

- No-Pass line

Start point (m) : [X = 9.876 , Y = 420.379]

End point (m) : [X = 9.876 , Y = 417.279]

- No-Pass layer

地層 2

- Calculation requirements

Planned safety factor (Normally) Fsp = 1.200
Stability calculation formula Modified Fellenius method
Sliding surface strength Stratum value

- Output requirements

Safety factor : All
Required prevention force : All
Sliding force : All
Depth : All

List of Repeated Circular Calculation Results
(Normally)

No.	Reg.	Circular arc requirements				Skid resistance S (kN/m)	Sliding force T (kN/m)	Safety factor Fs	Required prevention force Pr (kN/m)
		Central coordinates		Radius r (m)	Max. depth (m)				
		X (m)	Y (m)						
1		9.000	435.000	14.234	2.500	312.46	315.29	* 0.991	65.9
2	A	6.000	438.000	17.916	2.000	267.53	265.91	1.006	51.6
3		11.000	434.000	12.184	2.500	293.61	290.28	1.011	54.8
4		11.000	433.000	11.946	3.000	357.20	352.35	1.013	65.7
5		10.000	433.000	12.524	3.000	350.95	345.81	1.014	64.1
6		9.000	436.000	14.513	2.000	253.21	248.99	1.016	45.6
7		10.000	434.000	12.840	2.500	299.54	293.86	1.019	53.1
8		7.000	437.000	16.522	2.000	259.96	254.52	1.021	45.5
9		11.000	432.000	11.630	3.500	407.81	398.38	1.023	* 70.3
10		9.000	434.000	13.418	2.500	290.63	283.58	1.024	49.7
11		12.000	432.000	11.052	3.500	409.83	399.69	1.025	69.8
12		13.000	433.000	10.053	2.500	258.47	248.61	1.039	39.9
13		8.000	436.000	15.128	2.000	251.18	241.45	1.040	38.6
14		10.000	435.000	13.098	2.000	240.75	230.45	1.044	35.8
15		9.000	433.000	12.604	2.500	270.00	258.14	1.045	39.8
16		6.000	437.000	17.104	2.000	249.70	238.92	1.045	37.1
17		14.000	432.000	9.139	3.000	299.44	285.63	1.048	43.4
18		12.000	431.000	10.736	4.000	459.61	437.56	1.050	65.5
19		12.000	433.000	10.770	2.500	275.69	262.26	1.051	39.1
20		7.000	436.000	15.706	2.000	239.54	227.13	1.054	33.1
21		13.000	432.000	9.856	3.000	320.13	303.72	1.054	44.4
22		12.000	434.000	10.967	2.000	211.78	200.02	1.058	28.3
23		13.000	431.000	10.159	4.000	459.63	432.93	1.061	59.9
24		8.000	435.000	14.312	2.000	229.81	215.85	1.064	29.3
25		6.000	439.000	18.232	1.500	211.99	197.62	1.072	25.2
26		7.000	435.000	14.908	2.000	224.20	208.92	1.073	26.6
27		10.000	432.000	11.207	2.500	256.43	238.55	1.074	29.9
28		11.000	431.000	10.314	3.000	308.38	285.99	1.078	34.9
29		14.000	433.000	8.825	2.000	182.00	168.44	1.080	20.2
30		11.000	436.000	12.557	1.500	159.88	147.72	1.082	17.4
31		7.000	438.000	16.838	1.500	206.57	190.04	1.086	21.5
32		14.000	431.000	8.942	3.500	360.47	331.67	1.086	37.6
33		8.000	434.000	13.504	2.000	214.13	196.21	1.091	21.4
34		2.000	442.000	23.004	1.500	217.35	198.15	1.096	20.5
35		13.000	435.000	10.394	1.500	137.98	125.76	1.097	13.0
36		9.000	437.000	14.709	1.500	186.56	169.77	1.098	17.2
37		13.000	430.000	9.842	4.500	508.96	462.02	1.101	45.5
38		12.000	430.000	9.420	3.500	354.43	321.37	1.102	31.3
39		3.000	441.000	21.604	1.500	212.86	192.54	1.105	18.2
40		10.000	431.000	10.411	2.500	240.60	217.66	1.105	20.6
41		12.000	435.000	11.146	1.500	151.04	135.75	1.112	11.9
42		8.000	437.000	15.427	1.500	198.07	178.08	1.112	15.7

* denotes the minimum safety factor and maximum prevention force.

No.	Reg.	Circular arc requirements				Skid resistance S (kN/m)	Sliding force T (kN/m)	Safety factor Fs	Required prevention force Pr (kN/m)
		Central coordinates		Radius r (m)	Max. depth (m)				
		X (m)	Y (m)						
43		11.000	430.000	9.505	3.000	287.89	258.50	1.113	22.4
44		8.000	433.000	12.729	2.000	203.50	182.71	1.113	15.8
45		10.000	436.000	13.295	1.500	175.84	157.38	1.117	13.1
46		4.000	440.000	20.205	1.500	208.15	185.95	1.119	15.0
47		5.000	439.000	18.810	1.500	202.01	179.24	1.127	13.1
48		11.000	435.000	11.881	1.500	162.43	143.86	1.129	10.3
49		14.000	434.000	8.982	1.500	127.86	113.03	1.131	7.8
50		14.000	430.000	8.746	4.000	422.90	373.57	1.132	25.4
51		9.000	432.000	11.319	2.000	192.22	168.66	1.139	10.2
52		4.000	439.000	19.407	1.500	189.23	166.05	1.139	10.1
53		3.000	440.000	20.811	1.500	196.63	172.54	1.139	10.5
54		13.000	434.000	9.735	1.500	140.07	122.60	1.142	7.1
55		5.000	438.000	18.004	1.500	183.72	160.22	1.146	8.6
56		12.000	429.000	8.604	3.500	328.83	286.85	1.146	15.4
57		13.000	429.000	9.026	4.500	473.97	410.42	1.154	18.6
58		9.000	431.000	10.579	2.000	186.15	160.71	1.158	6.8
59		4.000	438.000	18.629	1.500	179.83	154.88	1.161	6.1
60		5.000	437.000	17.221	1.500	173.31	147.89	1.171	4.2
61		6.000	436.000	15.814	1.500	166.76	140.82	1.184	2.3
62		14.000	429.000	8.448	4.500	470.07	396.02	1.186	5.2
63		11.000	429.000	8.251	2.500	214.17	179.67	1.192	1.5
64		12.000	428.000	7.837	3.500	310.17	259.68	1.194	1.5
65		10.000	430.000	9.165	2.000	173.16	144.37	1.199	0.1
66		6.000	435.000	15.052	1.500	159.62	132.59	1.203	-0.5
67		10.000	429.000	8.446	2.000	168.71	139.15	1.212	-1.7
68		13.000	428.000	8.209	4.500	441.08	363.81	1.212	-4.5
69		7.000	434.000	13.640	1.500	152.19	124.53	1.222	-2.7
70		11.000	428.000	7.532	2.500	207.12	169.24	1.223	-4.0
71		7.000	433.000	12.907	1.500	148.07	120.82	1.225	-3.0
72		13.000	436.000	10.590	1.000	88.02	71.37	1.233	-2.3
73		8.000	431.000	10.748	1.500	135.16	108.59	1.244	-4.8
74		8.000	432.000	11.493	1.500	139.71	111.92	1.248	-5.4
75		5.000	441.000	19.865	1.000	153.76	122.15	1.258	-7.1
76		14.000	428.000	7.632	4.500	435.25	345.63	1.259	-20.4
77		8.000	439.000	16.290	1.000	124.43	98.74	1.260	-5.9
78		14.000	435.000	9.176	1.000	82.05	64.91	1.264	-4.1
79		9.000	430.000	9.360	1.500	128.85	101.44	1.270	-7.1
80		10.000	438.000	14.132	1.000	108.89	85.50	1.273	-6.2
81		9.000	429.000	8.518	1.500	114.93	89.83	1.279	-7.1
82		-1.000	446.000	27.504	1.000	166.08	129.74	1.280	-10.3
83		0.000	445.000	26.104	1.000	163.80	127.67	1.282	-10.5
84		6.000	440.000	18.451	1.000	148.02	115.42	1.282	-9.5
85		9.000	438.000	14.879	1.000	119.28	92.80	1.285	-7.9
86		1.000	444.000	24.705	1.000	161.74	125.43	1.289	-11.2
87		11.000	437.000	12.719	1.000	103.04	79.64	1.293	-7.4

* denotes the minimum safety factor and maximum prevention force.

No.	Reg.	Circular arc requirements				Skid resistance S (kN/m)	Sliding force T (kN/m)	Safety factor Fs	Required prevention force Pr (kN/m)
		Central coordinates		Radius r (m)	Max. depth (m)				
		X (m)	Y (m)						
88		9.000	428.000	7.658	1.500	101.13	78.00	1.296	-7.5
89		2.000	443.000	23.308	1.000	159.52	122.89	1.298	-12.0
90		8.000	438.000	15.623	1.000	130.91	100.13	1.307	-10.7
91		7.000	439.000	17.037	1.000	141.32	107.94	1.309	-11.7
92		5.000	440.000	19.126	1.000	149.49	114.10	1.310	-12.5
93		3.000	442.000	21.914	1.000	157.09	119.84	1.310	-13.2
94		4.000	441.000	20.520	1.000	154.33	117.46	1.313	-13.3
95		10.000	437.000	13.468	1.000	113.08	86.06	1.313	-9.8
96		10.000	428.000	7.148	1.500	109.72	83.46	1.314	-9.5
97		12.000	436.000	11.306	1.000	96.26	72.63	1.325	-9.1
98		1.000	443.000	23.906	1.000	144.19	106.98	1.347	-15.8
99		0.000	444.000	25.310	1.000	149.58	109.81	1.362	-17.8
100		-3.000	446.000	28.758	1.000	147.98	108.28	1.366	-18.0
101		-1.000	444.000	25.940	1.000	141.43	103.03	1.372	-17.7
102		-1.000	445.000	26.714	1.000	155.05	112.88	1.373	-19.5
103		-3.000	447.000	29.526	1.000	163.21	118.67	1.375	-20.8
104		0.000	443.000	24.531	1.000	138.08	100.26	1.377	-17.7
105		1.000	442.000	23.124	1.000	134.51	97.19	1.383	-17.8
106		-2.000	446.000	28.120	1.000	160.16	115.63	1.385	-21.4
107		2.000	441.000	21.717	1.000	131.05	94.44	1.387	-17.7
108		-1.000	443.000	25.182	1.000	135.78	97.49	1.392	-18.7
109		0.000	442.000	23.770	1.000	131.91	94.14	1.401	-18.9
110		1.000	441.000	22.359	1.000	128.24	91.09	1.407	-18.9
111		2.000	440.000	20.949	1.000	124.45	87.86	1.416	-19.0
112		2.000	439.000	20.195	1.000	119.74	83.71	1.430	-19.2
113		3.000	439.000	19.539	1.000	120.29	84.01	1.431	-19.4
114		5.000	435.000	15.218	1.000	102.92	71.67	1.436	-16.9
115		3.000	438.000	18.789	1.000	115.84	80.51	1.438	-19.2
116		6.000	434.000	13.821	1.000	99.83	69.27	1.441	-16.7
117		7.000	432.000	11.618	1.000	87.35	60.53	1.443	-14.7
118		4.000	437.000	17.376	1.000	111.20	76.82	1.447	-19.0
119		4.000	436.000	16.591	1.000	102.78	70.73	1.453	-17.9
120		6.000	433.000	12.989	1.000	87.75	60.26	1.456	-15.4
121		5.000	436.000	15.964	1.000	106.37	72.84	1.460	-18.9
122		3.000	437.000	17.971	1.000	103.04	70.22	1.467	-18.7
123		5.000	434.000	14.366	1.000	88.31	60.15	1.468	-16.1
124		8.000	430.000	9.388	1.000	74.89	50.86	1.472	-13.8
125		4.000	435.000	15.750	1.000	89.28	60.52	1.475	-16.6
126		6.000	432.000	12.145	1.000	77.74	52.68	1.475	-14.5
127		2.000	438.000	19.356	1.000	103.67	70.19	1.476	-19.4
128		7.000	431.000	10.761	1.000	76.13	51.52	1.477	-14.3
129		5.000	433.000	13.535	1.000	79.14	53.47	1.480	-14.9
130		6.000	431.000	11.329	1.000	70.53	46.66	1.511	-14.5
131		7.000	430.000	9.931	1.000	68.05	44.89	1.515	-14.1
132		8.000	429.000	8.539	1.000	65.35	42.77	1.527	-14.0

* denotes the minimum safety factor and maximum prevention force.

No.	Reg.	Circular arc requirements				Skid resistance S (kN/m)	Sliding force T (kN/m)	Safety factor Fs	Required prevention force Pr (kN/m)
		Central coordinates		Radius r (m)	Max. depth (m)				
		X (m)	Y (m)						
133		7.000	429.000	9.139	1.000	62.67	40.52	1.546	-14.0
134		8.000	428.000	7.732	1.000	58.88	37.47	1.571	-13.9
135		14.000	428.000	4.132	1.000	57.27	33.44	1.712	-17.1

* denotes the minimum safety factor and maximum prevention force.

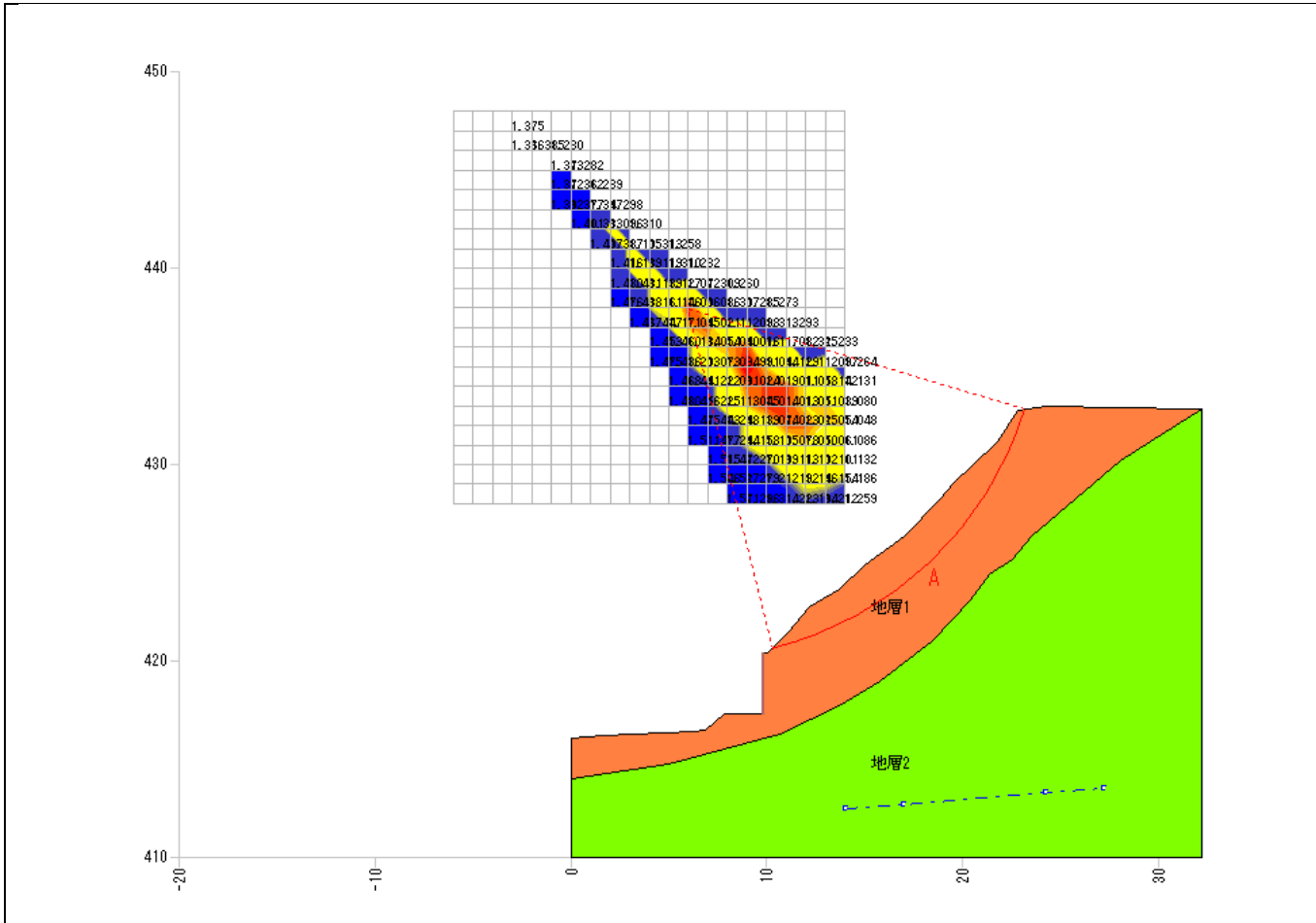

Isoline Map (Minimum Safety Factor - Normally)

Stability Analysis

Site	KANDY LOWER
Case	B Pr(max)
Remarks	ϕ 29 C5

Site	KANDY
Case	B Pr(max)
Remarks	φ 29 C5

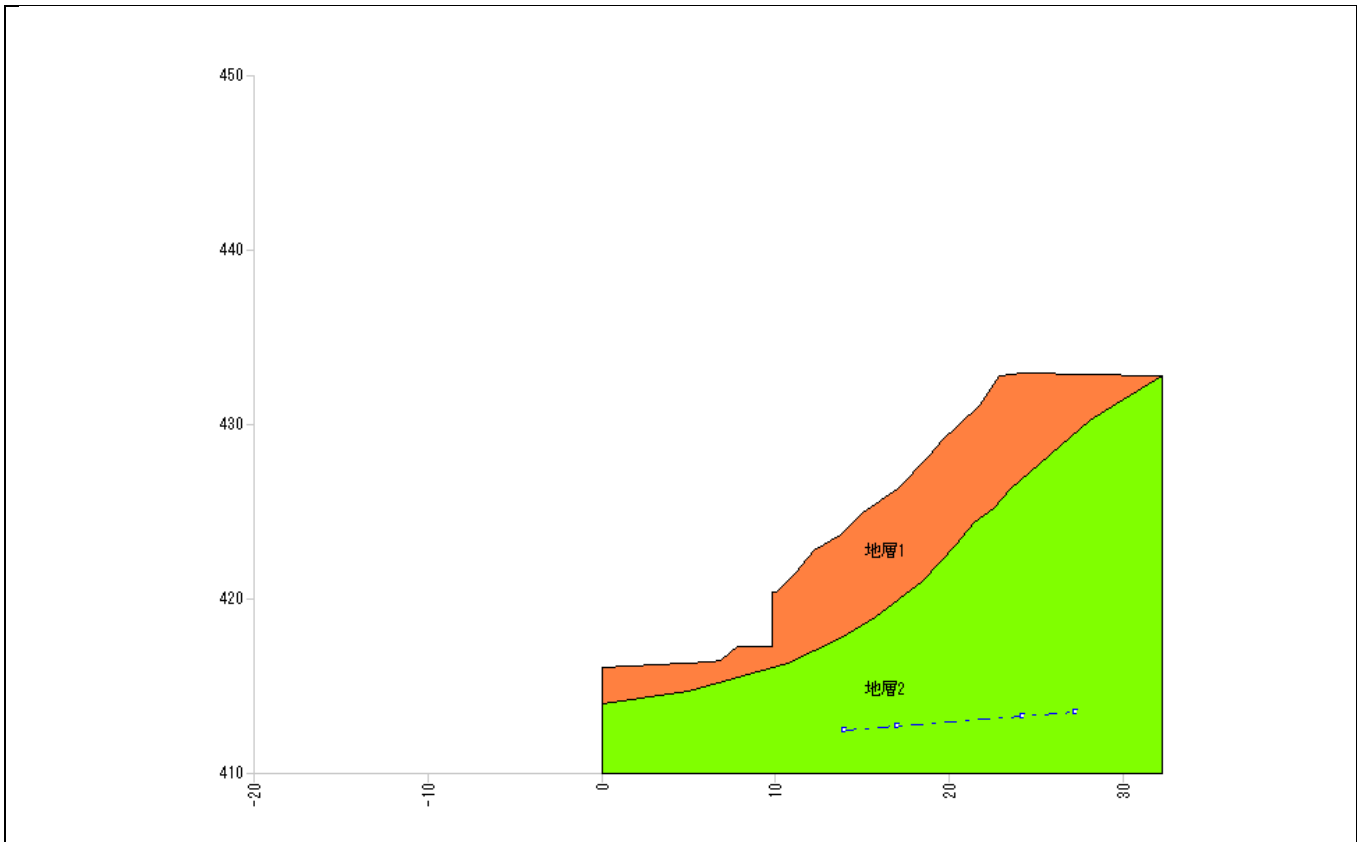

Soil constant		Soil quality	Wet weight γ_t (kN/m ³)	Saturated weight γ_{sat} (kN/m ³)	Cohesion C (kN/m ²)	Internal friction angle	
No.	Geology					ϕ (°)	$\tan\phi$
1	地層 1		17.00	17.00	5.00	29.0000	0.554309
2	地層 2		20.00	20.00	7.00	32.0000	0.624869

* Unit weight of water $\gamma_w = 9.80$ (kN/m³)

Coordinate input data								
No.	Distance X (m)	Original topographic altitude Y _G (m)	Planned topographic altitude Y (m)	Water level altitude Y _w (m)	Sliding surface			Launching
					Altitude Y _S (m)	Shape	Strength	
1	0.000		416.049					
2	1.595		416.158					
3	6.357		416.346					
4	6.876		416.479					
5	7.876		417.279					
6	9.876		417.279					
7	9.876		420.379					
8	10.076		420.379					
9	11.173		421.452					
10	12.203		422.741					
11	13.737		423.648					
12	14.037			412.420				
13	15.014		424.881					
14	17.027		426.305	412.665				
15	18.890		428.224					
16	19.614		429.054					
17	20.456		429.881					
18	21.778		431.199					
19	22.840		432.809					
20	24.272		433.000	413.260				
21	27.262			413.510				
22	31.785		432.837					
23	32.200		432.840					

Coordinates of stratum boundary line		
No.	No.1	
	X (m)	Y (m)
1	0.000	414.000
2	5.000	414.700
3	10.718	416.240
4	13.740	417.700
5	15.770	418.950
6	18.490	421.010
7	20.400	423.080
8	21.410	424.350
9	22.570	425.160
10	23.540	426.300
11	28.080	430.270
12	29.570	431.230
13	32.200	432.840

4. Design Requirements

4.4. Planned Safety Factor of the Reinforcement Slope

Considering the site as permanent construction, set a planned safety factor.

The Cut Earth Reinforcement Method, Design and Construction Procedures prescribes as follows.

Planned safety factor of the reinforcement slope

Item	Planned safety factor
Permanent construction (long term)	$F_{sp} \geq 1.20$
Temporary construction (short term)	$F_{sp} \geq 1.05, 1.10$

[Cut Earth Reinforcement Method, Design and Construction Procedures Page 31]

Taking account of the importance of the said slope, the planned safety factor shall be $F_{sp} = 1.200$.

4.5. Soil Quality Requirements

The following shows the geological and soil composition and constants of the said slope.

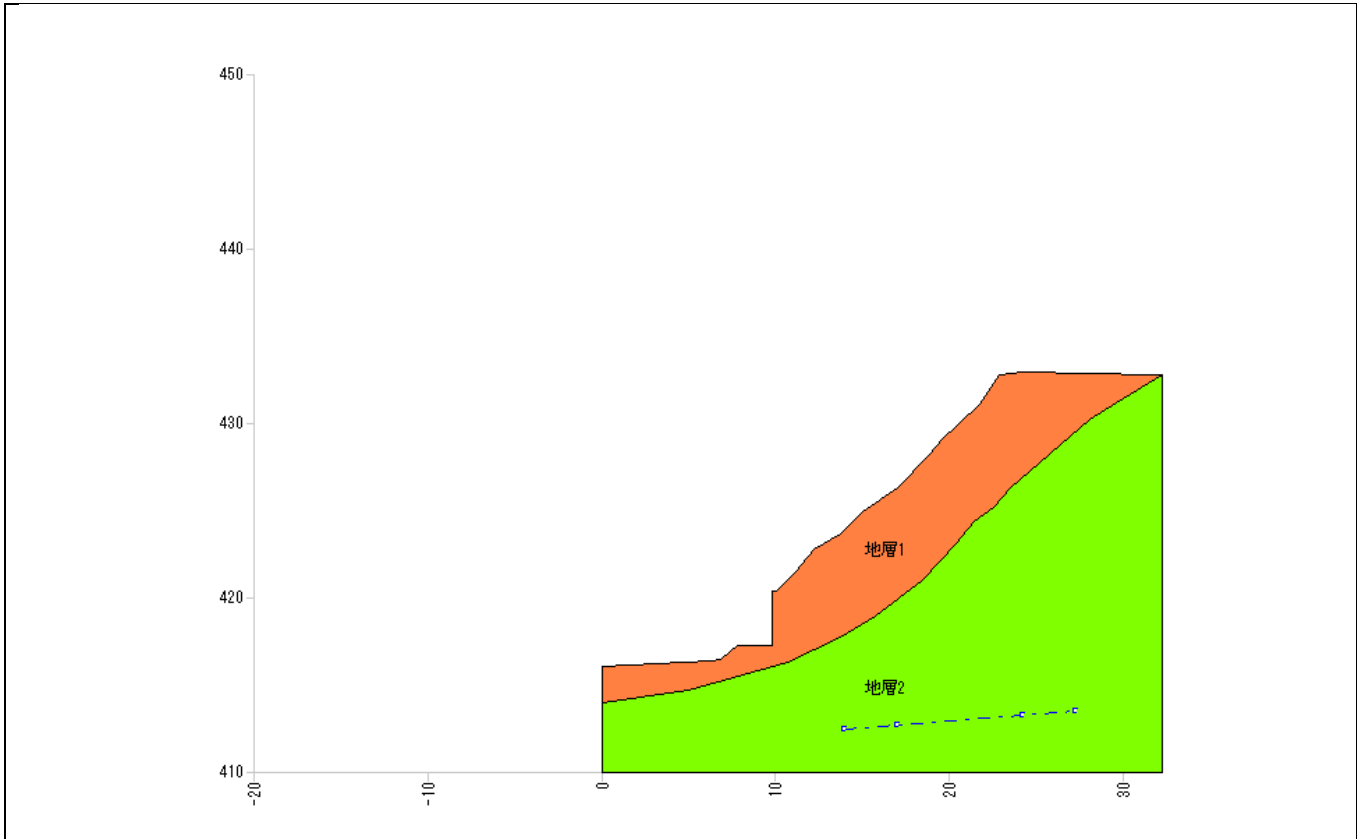

Soil constant							
No.	Geology	Soil quality	Wet weight γ_t (kN/m ³)	Saturated weight γ_{sat} (kN/m ³)	Cohesion C (kN/m ²)	Internal friction angle	
						ϕ (°)	$\tan\phi$
1	地層 1		17.00	17.00	5.00	29.0000	0.554309
2	地層 2		20.00	20.00	7.00	32.0000	0.624869

* Unit weight of water $\gamma_w = 9.80$ (kN/m³)

5. Repeated Circular Calculation

As a result of studying with repeated circular slip as to slope stability, it is determined that the following sliding surface is most dangerous.

< Circular arc A >

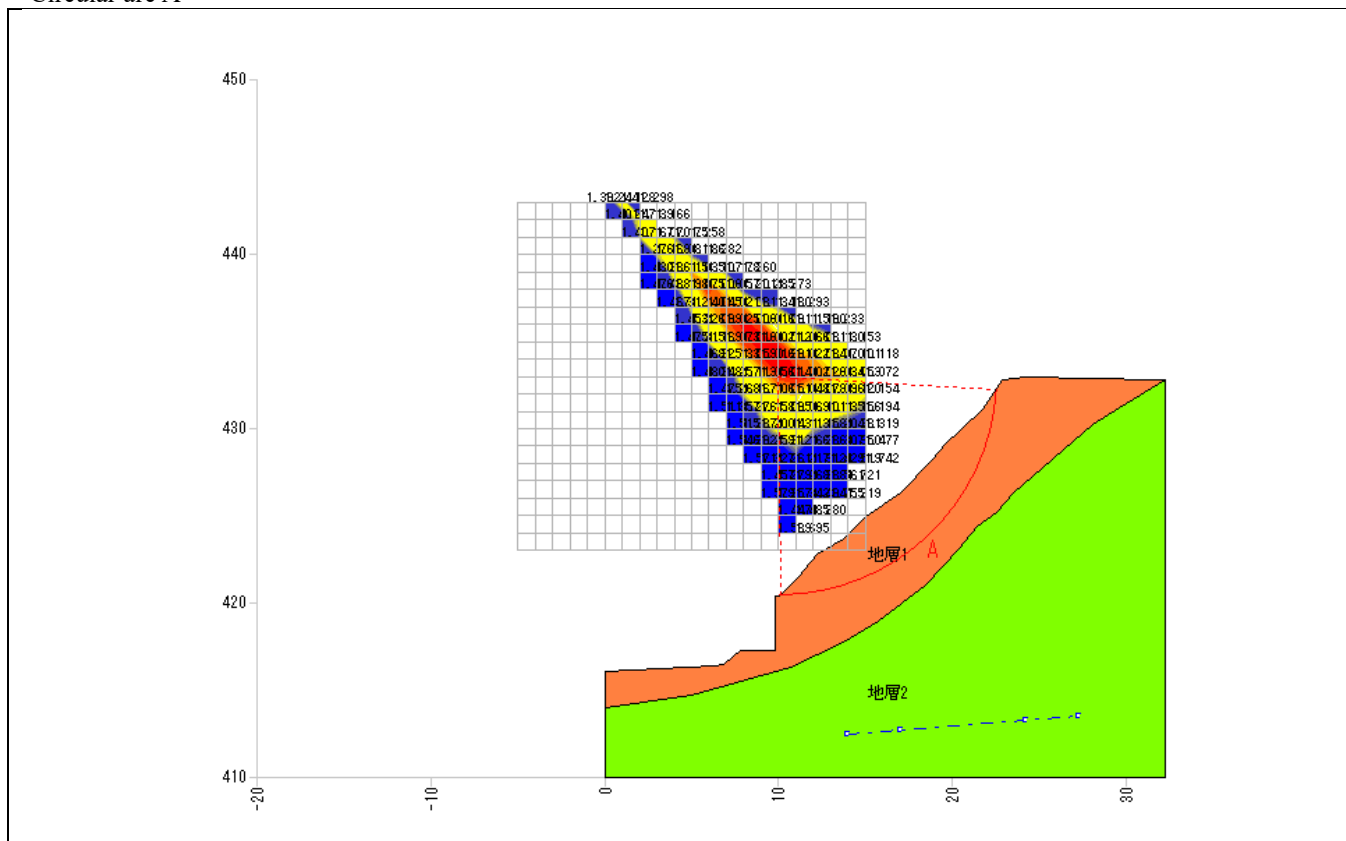

Stability calculation results				
Item		Symbol	Unit	Normally
Calculation results	Safety factor	Fs	-	1.014
	Planned safety factor	Fsp	-	1.200
	Required prevention force	Pr	kN/m	64.1
Circular arc	Central coordinates	X	m	10.000
		Y	m	433.000
	Radius	r	m	12.524
Calculation elements	Skid resistance	S	kN/m	350.95
	Sliding force	T	kN/m	345.81
	Normal force	N	kN/m	463.58
	Pore water pressure	U	kN/m	0.00
	Sliding surface length	l	m	18.796
	Area	A	m ²	35.66

5.1. Stability Calculation Formula

Stability calculation is conducted using the modified Fellenius method.

Basically, the limit balance method shall be used to secure the required planned safety factor.

$$\text{Safety factor (Fs)} = \frac{\text{Skid resistance } (\Sigma S)}{\text{Sliding force } (\Sigma T)}$$

Concerning the calculation method, the cross section of the sliding clod shall be split into several slices based on the “slicing method” to consider the balance of force on each slice (split piece).

< Normally >

$$F_s = \frac{\Sigma\{(N-U)\cdot\tan\phi\}+\Sigma(C\cdot l)}{\Sigma T}$$

$$Pr = F_{sp}\cdot\Sigma T - [\Sigma\{(N-U)\cdot\tan\phi\}+\Sigma(C\cdot l)]$$

where;

F _s	:	Safety factor	
F _{sp}	:	Planned safety factor	
Pr	:	Required prevention force	(kN/m)
N	:	Normal force by gravity of slice	(N = W·cosθ+Q _N) (kN/m)
U	:	Pore water pressure working on slice	(U = u·b·cosθ) (kN/m)
T	:	Tangential force by gravity of slice	(T = W·sinθ+Q _T) (kN/m)
b	:	Slice width	(m)
l	:	Sliding surface length of slice	(m)
φ	:	Internal friction angle of sliding surface	(°)
C	:	Cohesion of sliding surface	(kN/m ²)
W	:	Slice weight	(kN/m)
θ	:	Sliding surface inclination angle	(°)
u	:	Unit pore water pressure	(kN/m ²)
Q _N	:	Vertical load component force (normal direction)	(kN/m)
Q _T	:	Vertical load component force (tangential direction)	(kN/m)

5.2. Stability Evaluation (Normally)

< Circular arc A >

Slice element summary table			Sliding surface length l (m)	Normal force N (kN/m)	Pore water pressure U (kN/m)	Sliding force T (kN/m)	Skid resistance S (kN/m)
Internal friction angle		Cohesion C (kN/m ²)					
φ(°)	tanφ						
29.0000	0.554309	5.00	18.796	463.58	0.00	345.81	350.95

The safety factor is calculated by the following formula.

$$\begin{aligned}
 F_s &= \frac{\Sigma\{(N-U)\cdot\tan\phi\}+\Sigma(C\cdot l)}{\Sigma T} \\
 &= \frac{(463.58-0.00)\times 0.554309+5.00\times 18.796}{345.81} \\
 &= 1.014
 \end{aligned}$$

where;

F _s	:	Safety factor		
N	:	Normal force by gravity of slice	(N = W·cosθ+Q _N)	(kN/m)
U	:	Pore water pressure working on slice	(U = u·b·cosθ)	(kN/m)
T	:	Tangential force by gravity of slice	(T = W·sinθ+Q _T)	(kN/m)
b	:	Slice width		(m)
l	:	Sliding surface length of slice		(m)
φ	:	Internal friction angle of sliding surface		(°)
C	:	Cohesion of sliding surface		(kN/m ²)
W	:	Slice weight		(kN/m)
θ	:	Sliding surface inclination angle		(°)
u	:	Unit pore water pressure		(kN/m ²)
Q _N	:	Vertical load component force (normal direction)		(kN/m)
Q _T	:	Vertical load component force (tangential direction)		(kN/m)

5.3. Calculation of the Required Prevention Force (Normally)

Calculate the required prevention force which satisfies the planned safety factor $F_{sp} = 1.200$.

< Circular arc A >

$$\begin{aligned} Pr &= F_{sp} \cdot \Sigma T - [\Sigma \{(N-U) \cdot \tan \phi\} + \Sigma (C \cdot l)] \\ &= 1.200 \times 345.81 - \{(463.58 - 0.00) \times 0.554309 + 5.00 \times 18.796\} \\ &= 64.1 \text{ (kN/m)} \end{aligned}$$

where;

F_{sp}	: Planned safety factor		
Pr	: Required prevention force		(kN/m)
N	: Normal force by gravity of slice	$(N = W \cdot \cos \theta + Q_N)$	(kN/m)
U	: Pore water pressure working on slice	$(U = u \cdot b \cdot \cos \theta)$	(kN/m)
T	: Tangential force by gravity of slice	$(T = W \cdot \sin \theta + Q_T)$	(kN/m)
b	: Slice width		(m)
l	: Sliding surface length of slice		(m)
ϕ	: Internal friction angle of sliding surface		(°)
C	: Cohesion of sliding surface		(kN/m ²)
W	: Slice weight		(kN/m)
θ	: Sliding surface inclination angle		(°)
u	: Unit pore water pressure		(kN/m ²)
Q_N	: Vertical load component force (normal direction)		(kN/m)
Q_T	: Vertical load component force (tangential direction)		(kN/m)

Repeated Circular Calculation Requirements

- Circular arc requirements

Center change range

X coordinate (m) : -5.000 ~ 15.000 Pitch (m) : 1.000
Y coordinate (m) : 423.000 ~ 443.000 Pitch (m) : 1.000
Secondary chase : None

Depth change range from the ground surface

Depth (m) : 1.000 ~ 10.000 Pitch (m) : 0.200

- Pass line

Start point (m) : [X = - , Y = -]

End point (m) : [X = - , Y = -]

- No-Pass line

Start point (m) : [X = - , Y = -]

End point (m) : [X = - , Y = -]

- No-Pass layer

地層 2

- Calculation requirements

Planned safety factor (Normally) Fsp = 1.200
Stability calculation formula Modified Fellenius method
Sliding surface strength Stratum value

- Output requirements

Safety factor : All
Required prevention force : All
Sliding force : All
Depth : All

List of Repeated Circular Calculation Results
(Normally)

No.	Reg.	Circular arc requirements				Skid resistance S (kN/m)	Sliding force T (kN/m)	Safety factor Fs	Required prevention force Pr (kN/m)
		Central coordinates		Radius r (m)	Max. depth (m)				
		X (m)	Y (m)						
1		11.000	433.000	12.146	3.200	387.74	386.85	1.002	* 76.5
2		10.000	434.000	13.140	2.800	343.44	346.46	* 0.991	72.4
3	A	10.000	433.000	12.524	3.000	350.95	345.81	1.014	64.1
4		9.000	435.000	14.134	2.400	297.82	297.10	1.002	58.7
5		9.000	434.000	13.518	2.600	305.77	300.76	1.016	55.2
6		8.000	436.000	15.328	2.200	279.76	278.01	1.006	53.9
7		12.000	433.000	11.070	2.800	317.40	309.09	1.026	53.6
8		8.000	435.000	14.712	2.400	288.82	284.16	1.016	52.2
9		6.000	438.000	17.916	2.000	267.53	265.91	1.006	51.6
10		10.000	435.000	13.298	2.200	267.63	264.21	1.012	49.5
11		11.000	434.000	12.084	2.400	279.83	273.78	1.022	48.8
12		11.000	432.000	11.130	3.000	331.98	316.49	1.048	47.9
13		7.000	436.000	15.906	2.200	270.06	263.26	1.025	45.9
14		9.000	436.000	14.513	2.000	253.21	248.99	1.016	45.6
15		7.000	437.000	16.522	2.000	259.96	254.52	1.021	45.5
16		13.000	433.000	10.153	2.600	272.14	263.01	1.034	43.5
17		10.000	432.000	11.507	2.800	297.49	283.04	1.051	42.2
18		11.000	431.000	10.514	3.200	336.98	315.03	1.069	41.1
19		5.000	439.000	19.110	1.800	245.27	236.87	1.035	39.0
20		8.000	437.000	15.727	1.800	237.21	230.07	1.031	38.9
21		12.000	434.000	11.167	2.200	237.72	229.90	1.034	38.2
22		6.000	437.000	17.104	2.000	249.70	238.92	1.045	37.1
23		9.000	433.000	12.504	2.400	256.28	242.55	1.056	34.8
24		8.000	434.000	13.704	2.200	240.87	227.26	1.059	31.9
25		12.000	432.000	10.152	2.600	279.71	259.32	1.078	31.5
26		7.000	438.000	16.938	1.600	219.76	207.84	1.057	29.7
27		14.000	433.000	9.025	2.200	204.36	194.03	1.053	28.5
28		3.000	441.000	21.704	1.600	227.17	212.23	1.070	27.6
29		7.000	435.000	14.908	2.000	224.20	208.92	1.073	26.6
30		5.000	438.000	18.304	1.800	227.79	211.83	1.075	26.5
31		12.000	431.000	9.536	2.800	284.12	257.92	1.101	25.4
32		11.000	435.000	12.181	1.800	201.04	188.57	1.066	25.3
33		4.000	440.000	20.305	1.600	222.09	205.33	1.081	24.4
34		10.000	431.000	10.511	2.600	253.33	231.20	1.095	24.2
35		13.000	432.000	9.256	2.400	240.59	219.32	1.096	22.6
36		11.000	430.000	9.505	3.000	287.89	258.50	1.113	22.4
37		13.000	434.000	10.035	1.800	172.92	161.46	1.070	20.9
38		15.000	433.000	8.071	2.000	166.17	154.96	1.072	19.8
39		6.000	436.000	16.114	1.800	205.97	187.33	1.099	18.9
40		10.000	436.000	13.395	1.600	188.66	172.84	1.091	18.8
41		9.000	432.000	11.519	2.200	216.84	196.02	1.106	18.4
42		12.000	435.000	11.246	1.600	161.78	149.54	1.081	17.7

* denotes the minimum safety factor and maximum prevention force.

No.	Reg.	Circular arc requirements				Skid resistance S (kN/m)	Sliding force T (kN/m)	Safety factor Fs	Required prevention force Pr (kN/m)
		Central coordinates		Radius r (m)	Max. depth (m)				
		X (m)	Y (m)						
43		6.000	439.000	18.132	1.400	198.59	179.37	1.107	16.7
44		8.000	433.000	12.729	2.000	203.50	182.71	1.113	15.8
45		4.000	439.000	19.507	1.600	205.03	183.86	1.115	15.7
46		13.000	431.000	8.559	2.400	234.81	206.82	1.135	13.4
47		1.000	443.000	24.306	1.400	207.26	183.68	1.128	13.2
48		14.000	432.000	8.139	2.000	176.24	157.34	1.120	12.6
49		14.000	434.000	9.082	1.600	137.81	125.06	1.101	12.3
50		11.000	436.000	12.457	1.400	149.00	133.60	1.115	11.4
51		7.000	434.000	13.940	1.800	188.39	166.26	1.133	11.2
52		10.000	430.000	9.565	2.400	219.47	191.97	1.143	10.9
53		2.000	442.000	22.904	1.400	202.95	178.05	1.139	10.8
54		9.000	437.000	14.609	1.400	174.32	153.68	1.134	10.1
55		5.000	437.000	17.321	1.600	186.58	163.57	1.140	9.8
56		12.000	430.000	8.520	2.600	238.06	205.50	1.158	8.6
57		15.000	434.000	8.162	1.400	108.66	97.19	1.118	8.0
58		13.000	435.000	10.294	1.400	127.85	113.11	1.130	7.9
59		11.000	429.000	8.551	2.800	250.15	214.38	1.166	7.2
60		9.000	431.000	10.579	2.000	186.15	160.71	1.158	6.8
61		14.000	431.000	7.442	2.000	170.86	147.71	1.156	6.4
62		15.000	432.000	7.214	1.800	143.60	124.42	1.154	5.8
63		3.000	442.000	22.114	1.200	183.38	157.23	1.166	5.3
64		2.000	441.000	22.117	1.400	187.31	160.37	1.167	5.2
65		3.000	440.000	20.711	1.400	181.01	154.97	1.168	5.0
66		8.000	432.000	11.793	1.800	173.81	148.85	1.167	4.9
67		6.000	435.000	15.152	1.600	172.02	147.14	1.169	4.6
68		14.000	435.000	9.376	1.200	99.37	86.12	1.153	4.0
69		4.000	441.000	20.720	1.200	180.31	153.40	1.175	3.8
70		7.000	439.000	17.237	1.200	165.96	140.87	1.178	3.1
71		10.000	437.000	13.668	1.200	134.64	114.09	1.180	2.3
72		5.000	440.000	19.326	1.200	177.01	149.14	1.186	2.0
73		12.000	436.000	11.506	1.200	116.20	97.58	1.190	0.9
74		15.000	431.000	6.525	1.800	138.88	116.25	1.194	0.7
75		4.000	438.000	18.529	1.400	166.23	138.67	1.198	0.2
76		8.000	438.000	15.823	1.200	158.59	132.02	1.201	-0.1
77		9.000	430.000	9.660	1.800	159.69	132.97	1.200	-0.1
78		13.000	430.000	7.542	2.200	192.44	159.73	1.204	-0.7
79		10.000	429.000	8.446	2.000	168.71	139.15	1.212	-1.7
80		13.000	436.000	10.590	1.000	88.02	71.37	1.233	-2.3
81		11.000	428.000	7.632	2.600	218.29	179.33	1.217	-3.0
82		5.000	436.000	16.364	1.400	154.32	125.86	1.226	-3.2
83		14.000	430.000	6.546	1.800	146.05	118.57	1.231	-3.7
84		12.000	429.000	7.504	2.400	196.93	159.27	1.236	-5.8
85		9.000	429.000	8.618	1.600	124.09	98.50	1.259	-5.8
86		0.000	443.000	24.731	1.200	166.40	133.73	1.244	-5.9
87		8.000	439.000	16.290	1.000	124.43	98.74	1.260	-5.9

* denotes the minimum safety factor and maximum prevention force.

No.	Reg.	Circular arc requirements				Skid resistance S (kN/m)	Sliding force T (kN/m)	Safety factor Fs	Required prevention force Pr (kN/m)
		Central coordinates		Radius r (m)	Max. depth (m)				
		X (m)	Y (m)						
88		1.000	442.000	23.324	1.200	162.24	130.07	1.247	-6.1
89		10.000	438.000	14.132	1.000	108.89	85.50	1.273	-6.2
90		7.000	433.000	12.807	1.400	136.61	108.64	1.257	-6.2
91		10.000	428.000	7.448	1.800	136.91	108.54	1.261	-6.6
92		7.000	432.000	12.018	1.400	127.58	100.60	1.268	-6.8
93		5.000	441.000	19.865	1.000	153.76	122.15	1.258	-7.1
94		11.000	437.000	12.719	1.000	103.04	79.64	1.293	-7.4
95		8.000	431.000	10.648	1.400	124.76	97.72	1.276	-7.4
96		8.000	430.000	9.788	1.400	109.17	84.79	1.287	-7.4
97		10.000	427.000	6.587	1.800	120.78	94.43	1.279	-7.4
98		9.000	438.000	14.879	1.000	119.28	92.80	1.285	-7.9
99		2.000	440.000	21.149	1.200	150.31	117.78	1.276	-8.9
100		15.000	430.000	5.428	1.400	98.95	74.98	1.319	-8.9
101		9.000	428.000	7.558	1.400	93.01	70.04	1.327	-8.9
102		6.000	440.000	18.451	1.000	148.02	115.42	1.282	-9.5
103		3.000	439.000	19.739	1.200	145.62	113.19	1.286	-9.7
104		10.000	424.000	3.507	1.000	45.28	29.41	1.539	-9.9
105		11.000	427.000	6.678	2.400	185.88	146.54	1.268	-10.0
106		10.000	426.000	5.534	1.600	90.67	66.77	1.357	-10.5
107		7.000	431.000	10.961	1.200	93.42	68.84	1.357	-10.8
108		5.000	435.000	15.418	1.200	125.40	95.31	1.315	-11.0
109		8.000	429.000	8.739	1.200	80.76	57.99	1.392	-11.1
110		6.000	434.000	14.021	1.200	121.27	91.46	1.325	-11.5
111		4.000	437.000	17.576	1.200	135.73	103.43	1.312	-11.6
112		10.000	425.000	4.155	1.000	43.94	26.83	1.637	-11.7
113		10.000	425.000	4.555	1.400	68.58	47.37	1.447	-11.7
114		6.000	433.000	13.189	1.200	108.30	80.31	1.348	-11.9
115		9.000	426.000	5.569	1.000	49.83	31.55	1.579	-11.9
116		2.000	443.000	23.308	1.000	159.52	122.89	1.298	-12.0
117		9.000	427.000	6.529	1.200	68.32	46.88	1.457	-12.0
118		11.000	424.000	2.741	1.000	36.92	20.76	1.778	-12.0
119		14.000	429.000	5.548	1.600	114.39	84.68	1.350	-12.7
120		13.000	429.000	6.526	2.000	155.43	118.92	1.307	-12.7
121		11.000	426.000	5.418	2.000	128.93	96.06	1.342	-13.6
122		11.000	424.000	2.941	1.200	46.96	27.69	1.695	-13.7
123		8.000	428.000	7.732	1.000	58.88	37.47	1.571	-13.9
124		7.000	429.000	9.139	1.000	62.67	40.52	1.546	-14.0
125		12.000	428.000	6.537	2.200	164.09	125.04	1.312	-14.0
126		7.000	430.000	9.931	1.000	68.05	44.89	1.515	-14.1
127		11.000	425.000	3.557	1.000	45.13	25.53	1.767	-14.4
128		6.000	432.000	12.145	1.000	77.74	52.68	1.475	-14.5
129		6.000	431.000	11.329	1.000	70.53	46.66	1.511	-14.5
130		5.000	433.000	13.535	1.000	79.14	53.47	1.480	-14.9
131		15.000	429.000	4.532	1.200	79.61	53.89	1.477	-14.9
132		14.000	426.000	2.510	1.000	40.99	21.36	1.919	-15.3

* denotes the minimum safety factor and maximum prevention force.

No.	Reg.	Circular arc requirements				Skid resistance S (kN/m)	Sliding force T (kN/m)	Safety factor Fs	Required prevention force Pr (kN/m)
		Central coordinates		Radius r (m)	Max. depth (m)				
		X (m)	Y (m)						
133		11.000	425.000	4.157	1.600	82.42	55.50	1.485	-15.8
134		5.000	434.000	14.366	1.000	88.31	60.15	1.468	-16.1
135		14.000	427.000	3.316	1.000	48.14	26.48	1.817	-16.3
136		4.000	435.000	15.750	1.000	89.28	60.52	1.475	-16.6
137		13.000	427.000	3.923	1.000	52.36	29.74	1.760	-16.6
138		14.000	428.000	4.132	1.000	57.27	33.44	1.712	-17.1
139		13.000	428.000	4.709	1.000	57.32	33.40	1.716	-17.2
140		12.000	426.000	3.899	1.000	60.40	35.67	1.693	-17.5
141		13.000	426.000	3.204	1.000	51.52	28.23	1.825	-17.6
142		12.000	427.000	4.618	1.000	62.16	37.00	1.680	-17.7
143		15.000	428.000	3.554	1.000	57.47	32.99	1.742	-17.8
144		4.000	436.000	16.591	1.000	102.78	70.73	1.453	-17.9
145		14.000	428.000	4.532	1.400	85.40	56.20	1.519	-17.9
146		12.000	425.000	3.048	1.000	50.22	26.71	1.880	-18.1
147		14.000	427.000	3.516	1.200	60.25	34.99	1.721	-18.2
148		-1.000	443.000	25.182	1.000	135.78	97.49	1.392	-18.7
149		3.000	437.000	17.971	1.000	103.04	70.22	1.467	-18.7
150		12.000	427.000	5.618	2.000	139.07	100.15	1.388	-18.8
151		0.000	442.000	23.770	1.000	131.91	94.14	1.401	-18.9
152		1.000	441.000	22.359	1.000	128.24	91.09	1.407	-18.9
153		2.000	439.000	20.195	1.000	119.74	83.71	1.430	-19.2
154		3.000	438.000	18.789	1.000	115.84	80.51	1.438	-19.2
155		2.000	438.000	19.356	1.000	103.67	70.19	1.476	-19.4
156		13.000	428.000	5.509	1.800	121.62	85.06	1.429	-19.5
157		12.000	426.000	4.499	1.600	101.31	67.81	1.494	-19.9
158		13.000	426.000	3.404	1.200	64.12	36.53	1.755	-20.2
159		13.000	427.000	4.523	1.600	94.90	60.76	1.561	-21.9

* denotes the minimum safety factor and maximum prevention force.

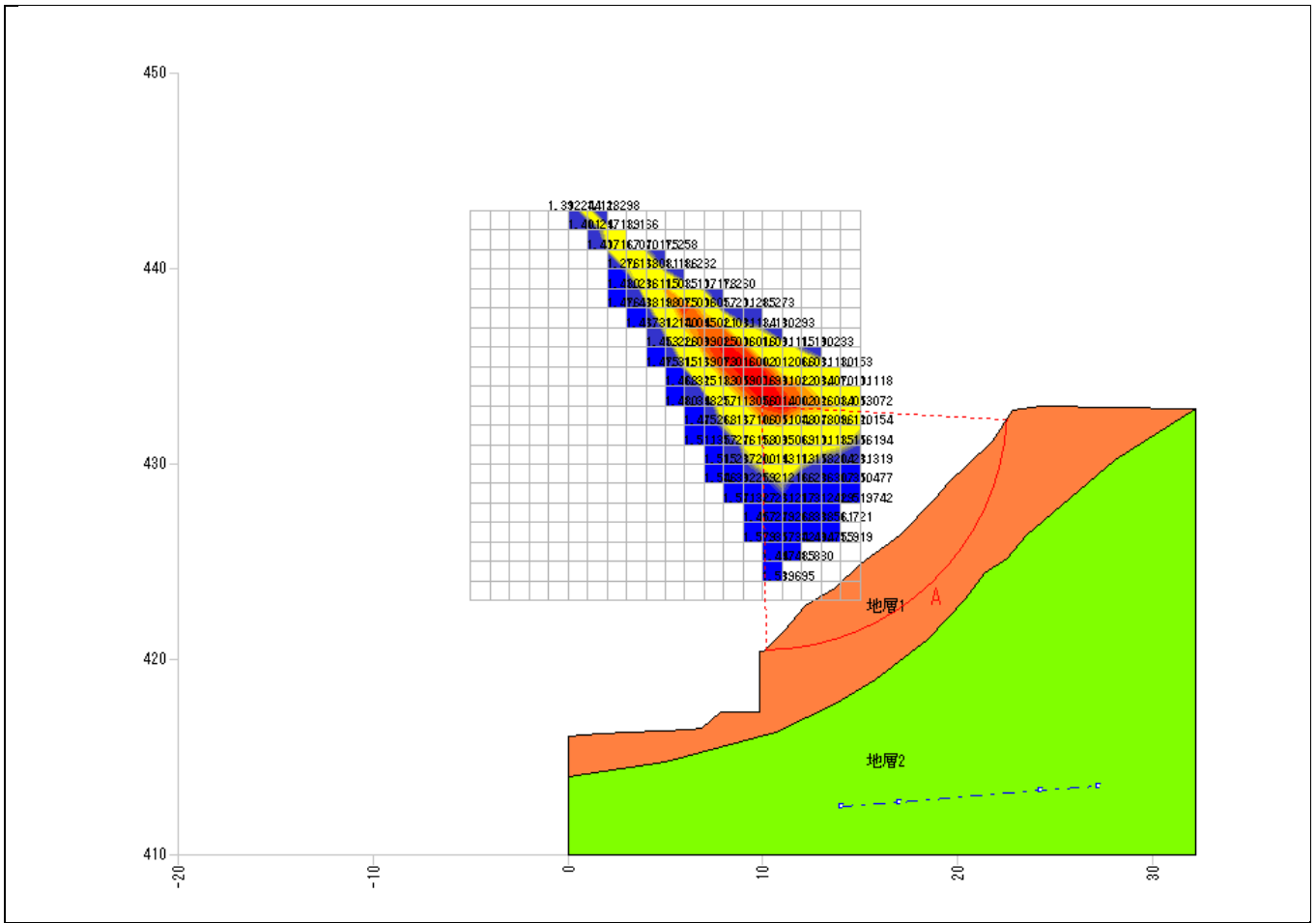

Isoline Map (Minimum Safety Factor - Normally)

Stability Analysis

Site	KANDY LOWER Shallow slope failure
Case	B Fs(min)
Remarks	ϕ 29

Site	KANDY
Case	B Fs(min)
Remarks	ϕ 29

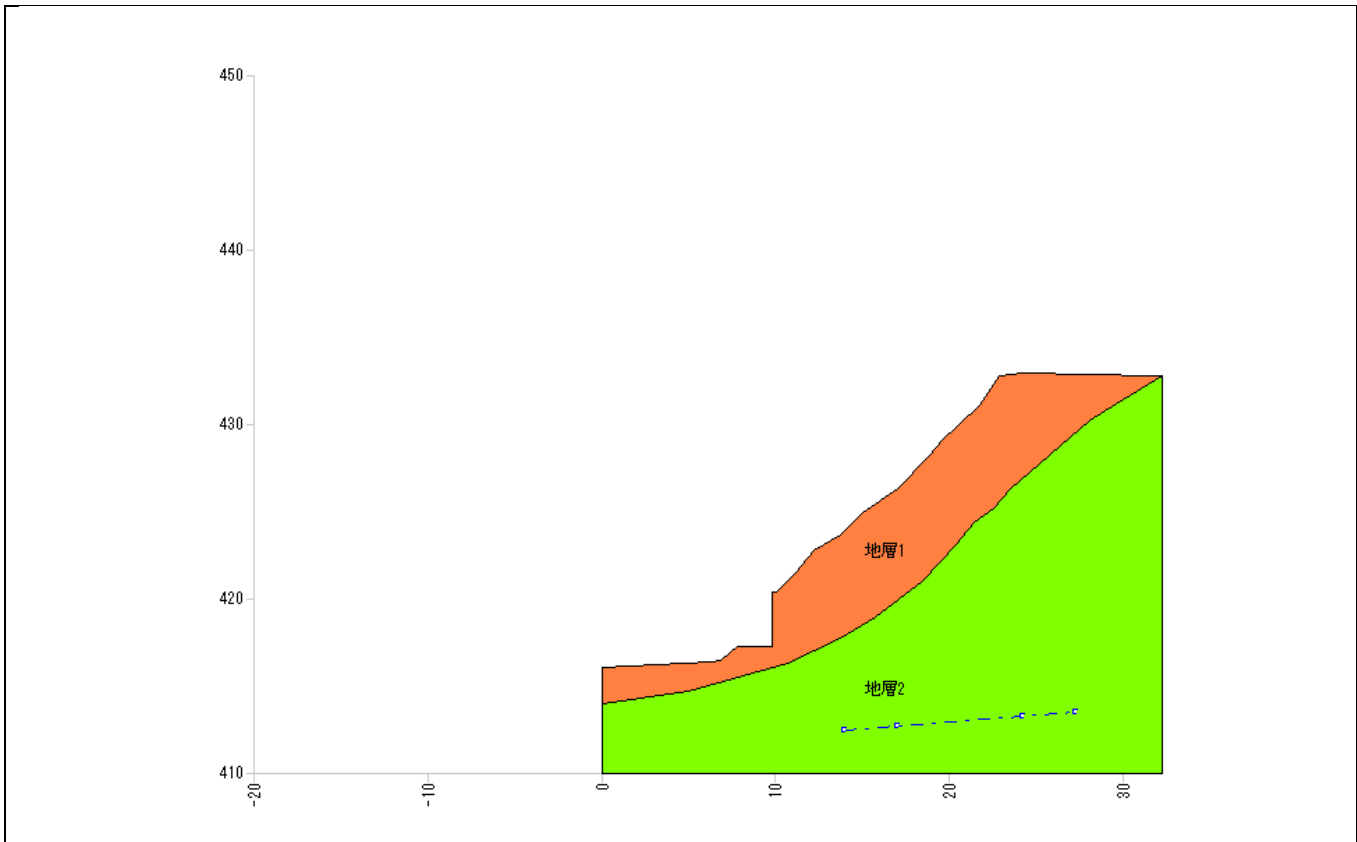

Soil constant		Soil quality	Wet weight γ_t (kN/m ³)	Saturated weight γ_{sat} (kN/m ³)	Cohesion C (kN/m ²)	Internal friction angle	
No.	Geology					ϕ (°)	$\tan\phi$
1	地層 1		17.00	17.00	2.90	29.0000	0.554309
2	地層 2		20.00	20.00	7.00	32.0000	0.624869

* Unit weight of water $\gamma_w = 9.80$ (kN/m³)

Coordinate input data								
No.	Distance X (m)	Original topographic altitude Y _G (m)	Planned topographic altitude Y (m)	Water level altitude Y _W (m)	Sliding surface			Launching
					Altitude Y _S (m)	Shape	Strength	
1	0.000		416.049					
2	1.595		416.158					
3	6.357		416.346					
4	6.876		416.479					
5	7.876		417.279					
6	9.876		417.279					
7	9.876		420.379					
8	10.076		420.379					
9	11.173		421.452					
10	12.203		422.741					
11	13.737		423.648					
12	14.037			412.420				
13	15.014		424.881					
14	17.027		426.305	412.665				
15	18.890		428.224					
16	19.614		429.054					
17	20.456		429.881					
18	21.778		431.199					
19	22.840		432.809					
20	24.272		433.000	413.260				
21	27.262			413.510				
22	31.785		432.837					
23	32.200		432.840					

Coordinates of stratum boundary line		
No.	No.1	
	X (m)	Y (m)
1	0.000	414.000
2	5.000	414.700
3	10.718	416.240
4	13.740	417.700
5	15.770	418.950
6	18.490	421.010
7	20.400	423.080
8	21.410	424.350
9	22.570	425.160
10	23.540	426.300
11	28.080	430.270
12	29.570	431.230
13	32.200	432.840

5. Design Requirements

5.4. Planned Safety Factor of the Reinforcement Slope

Considering the site as permanent construction, set a planned safety factor.

The Cut Earth Reinforcement Method, Design and Construction Procedures prescribes as follows.

Planned safety factor of the reinforcement slope

Item	Planned safety factor
Permanent construction (long term)	$F_{sp} \geq 1.20$
Temporary construction (short term)	$F_{sp} \geq 1.05, 1.10$

[Cut Earth Reinforcement Method, Design and Construction Procedures Page 31]

Taking account of the importance of the said slope, the planned safety factor shall be $F_{sp} = 1.200$.

5.5. Soil Quality Requirements

The following shows the geological and soil composition and constants of the said slope.

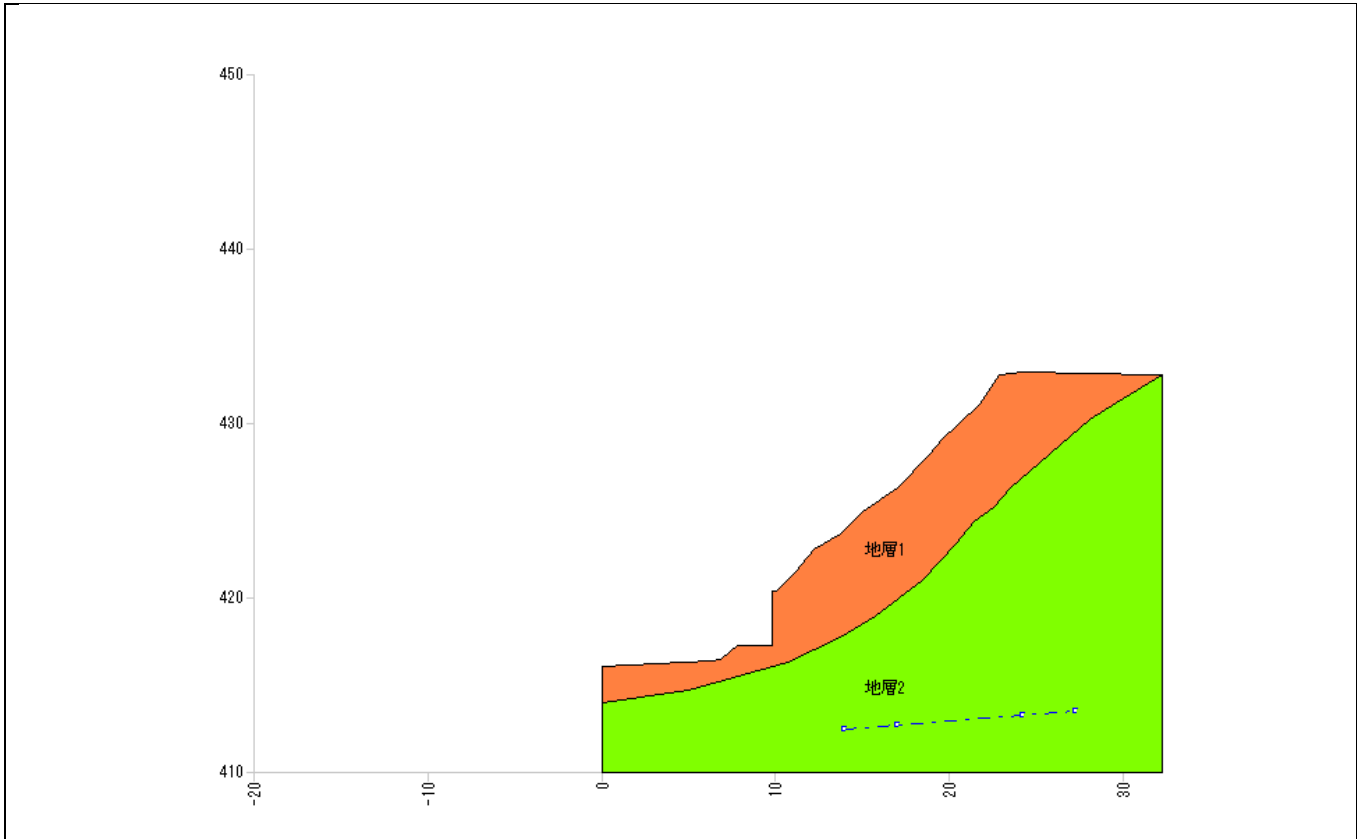

Soil constant							
No.	Geology	Soil quality	Wet weight γ_t (kN/m ³)	Saturated weight γ_{sat} (kN/m ³)	Cohesion C (kN/m ²)	Internal friction angle	
						ϕ (°)	$\tan\phi$
1	地層 1		17.00	17.00	2.90	29.0000	0.554309
2	地層 2		20.00	20.00	7.00	32.0000	0.624869

* Unit weight of water $\gamma_w = 9.80$ (kN/m³)

6. Repeated Circular Calculation

As a result of studying with repeated circular slip as to slope stability, it is determined that the following sliding surface is most dangerous.

< Circular arc A >

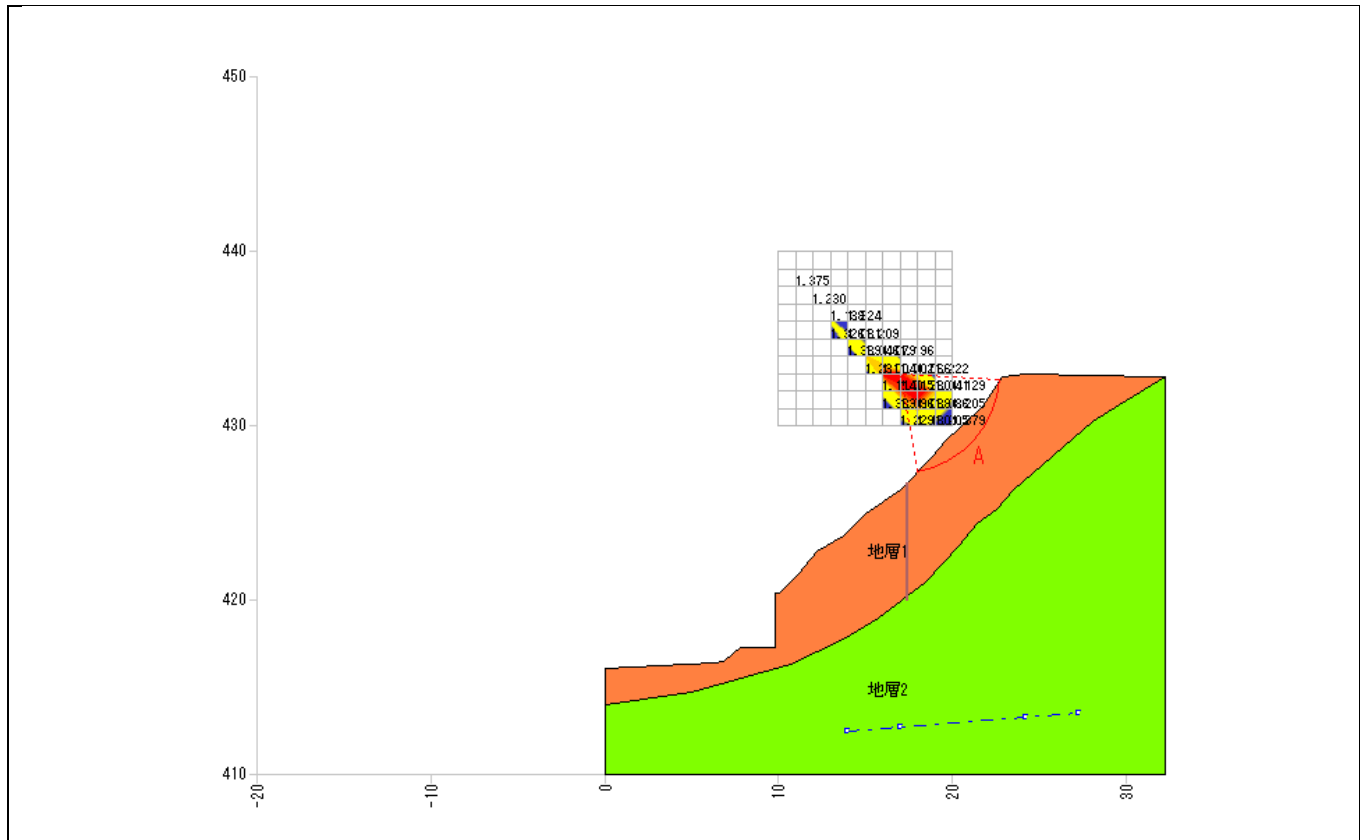

Stability calculation results				
Item		Symbol	Unit	Normally
Calculation results	Safety factor	Fs	-	1.002
	Planned safety factor	Fsp	-	1.200
	Required prevention force	Pr	kN/m	11.2
Circular arc	Central coordinates	X	m	17.000
		Y	m	433.000
	Radius	r	m	5.747
Calculation elements	Skid resistance	S	kN/m	56.93
	Sliding force	T	kN/m	56.76
	Normal force	N	kN/m	62.74
	Pore water pressure	U	kN/m	0.00
	Sliding surface length	l	m	7.634
	Area	A	m ²	5.15

6.1. Stability Calculation Formula

Stability calculation is conducted using the modified Fellenius method.

Basically, the limit balance method shall be used to secure the required planned safety factor.

$$\text{Safety factor (Fs)} = \frac{\text{Skid resistance } (\Sigma S)}{\text{Sliding force } (\Sigma T)}$$

Concerning the calculation method, the cross section of the sliding clod shall be split into several slices based on the “slicing method” to consider the balance of force on each slice (split piece).

< Normally >

$$F_s = \frac{\Sigma\{(N-U)\cdot\tan\phi\}+\Sigma(C\cdot l)}{\Sigma T}$$

$$Pr = F_{sp}\cdot\Sigma T - [\Sigma\{(N-U)\cdot\tan\phi\}+\Sigma(C\cdot l)]$$

where;

F _s	:	Safety factor	
F _{sp}	:	Planned safety factor	
Pr	:	Required prevention force	(kN/m)
N	:	Normal force by gravity of slice	(N = W·cosθ+Q _N) (kN/m)
U	:	Pore water pressure working on slice	(U = u·b·cosθ) (kN/m)
T	:	Tangential force by gravity of slice	(T = W·sinθ+Q _T) (kN/m)
b	:	Slice width	(m)
l	:	Sliding surface length of slice	(m)
φ	:	Internal friction angle of sliding surface	(°)
C	:	Cohesion of sliding surface	(kN/m ²)
W	:	Slice weight	(kN/m)
θ	:	Sliding surface inclination angle	(°)
u	:	Unit pore water pressure	(kN/m ²)
Q _N	:	Vertical load component force (normal direction)	(kN/m)
Q _T	:	Vertical load component force (tangential direction)	(kN/m)

6.2. Stability Evaluation (Normally)

< Circular arc A >

Slice element summary table			Sliding surface length l (m)	Normal force N (kN/m)	Pore water pressure U (kN/m)	Sliding force T (kN/m)	Skid resistance S (kN/m)
Internal friction angle		Cohesion C (kN/m ²)					
φ(°)	tanφ						
29.0000	0.554309	2.90	7.634	62.74	0.00	56.76	56.93

The safety factor is calculated by the following formula.

$$\begin{aligned}
 F_s &= \frac{\Sigma\{(N-U)\cdot\tan\phi\}+\Sigma(C\cdot l)}{\Sigma T} \\
 &= \frac{(62.74-0.00)\times 0.554309+2.90\times 7.634}{56.76} \\
 &= 1.002
 \end{aligned}$$

where;

F _s	:	Safety factor		
N	:	Normal force by gravity of slice	(N = W·cosθ+Q _N)	(kN/m)
U	:	Pore water pressure working on slice	(U = u·b·cosθ)	(kN/m)
T	:	Tangential force by gravity of slice	(T = W·sinθ+Q _T)	(kN/m)
b	:	Slice width		(m)
l	:	Sliding surface length of slice		(m)
φ	:	Internal friction angle of sliding surface		(°)
C	:	Cohesion of sliding surface		(kN/m ²)
W	:	Slice weight		(kN/m)
θ	:	Sliding surface inclination angle		(°)
u	:	Unit pore water pressure		(kN/m ²)
Q _N	:	Vertical load component force (normal direction)		(kN/m)
Q _T	:	Vertical load component force (tangential direction)		(kN/m)

6.3. Calculation of the Required Prevention Force (Normally)

Calculate the required prevention force which satisfies the planned safety factor $F_{sp} = 1.200$.

< Circular arc A >

$$\begin{aligned} Pr &= F_{sp} \cdot \Sigma T - [\Sigma \{(N-U) \cdot \tan \phi\} + \Sigma (C \cdot l)] \\ &= 1.200 \times 56.76 - \{(62.74 - 0.00) \times 0.554309 + 2.90 \times 7.634\} \\ &= 11.2 \text{ (kN/m)} \end{aligned}$$

where;

F_{sp}	: Planned safety factor		
Pr	: Required prevention force		(kN/m)
N	: Normal force by gravity of slice	$(N = W \cdot \cos \theta + Q_N)$	(kN/m)
U	: Pore water pressure working on slice	$(U = u \cdot b \cdot \cos \theta)$	(kN/m)
T	: Tangential force by gravity of slice	$(T = W \cdot \sin \theta + Q_T)$	(kN/m)
b	: Slice width		(m)
l	: Sliding surface length of slice		(m)
ϕ	: Internal friction angle of sliding surface		(°)
C	: Cohesion of sliding surface		(kN/m ²)
W	: Slice weight		(kN/m)
θ	: Sliding surface inclination angle		(°)
u	: Unit pore water pressure		(kN/m ²)
Q_N	: Vertical load component force (normal direction)		(kN/m)
Q_T	: Vertical load component force (tangential direction)		(kN/m)

Repeated Circular Calculation Requirements

- Circular arc requirements

Center change range

X coordinate (m) : 10.000 ~ 20.000 Pitch (m) : 1.000
Y coordinate (m) : 430.000 ~ 440.000 Pitch (m) : 1.000
Secondary chase : None

Depth change range from the ground surface

Depth (m) : 0.500 ~ 3.000 Pitch (m) : 0.100

- Pass line

Start point (m) : [X = - , Y = -]

End point (m) : [X = - , Y = -]

- No-Pass line

Start point (m) : [X = 17.405 , Y = 426.694]

End point (m) : [X = 17.405 , Y = 420.000]

- No-Pass layer

地層 2

- Calculation requirements

Planned safety factor (Normally) Fsp = 1.200
Stability calculation formula Modified Fellenius method
Sliding surface strength Stratum value

- Output requirements

Safety factor : All
Required prevention force : All
Sliding force : All
Depth : All

List of Repeated Circular Calculation Results
(Normally)

No.	Reg.	Circular arc requirements				Skid resistance S (kN/m)	Sliding force T (kN/m)	Safety factor Fs		Required prevention force Pr (kN/m)
		Central coordinates		Radius r (m)	Max. depth (m)					
		X (m)	Y (m)							
1		18.000	432.000	4.833	1.600	79.40	80.95	* 0.980	* 17.8	
2		18.000	432.000	4.733	1.500	72.55	73.21	0.990	15.4	
3	A	17.000	433.000	5.747	1.100	56.93	56.76	1.002	11.2	
4		16.000	433.000	6.448	1.100	58.02	57.76	1.004	11.3	
5		18.000	432.000	4.633	1.400	66.13	65.82	1.004	12.9	
6		17.000	432.000	5.233	1.300	63.41	62.46	1.015	11.6	
7		18.000	432.000	4.533	1.300	60.13	58.69	1.024	10.3	
8		17.000	432.000	5.133	1.200	57.06	55.30	1.031	9.3	
9		16.000	433.000	6.348	1.000	51.55	49.90	1.033	8.4	
10		17.000	433.000	5.647	1.000	50.52	48.77	1.035	8.1	
11		18.000	431.000	4.319	1.800	84.04	80.91	1.038	13.1	
12		19.000	432.000	3.829	1.300	56.36	54.09	1.041	8.6	
13		18.000	432.000	4.433	1.200	54.23	51.83	1.046	8.0	
14		15.000	434.000	7.662	0.900	50.51	48.27	1.046	7.5	
15		18.000	431.000	4.219	1.700	77.36	73.83	1.047	11.3	
16		17.000	432.000	5.033	1.100	50.87	48.35	1.052	7.2	
17		18.000	431.000	4.119	1.600	71.01	67.44	1.052	10.0	
18		19.000	432.000	3.729	1.200	50.84	47.91	1.061	6.7	
19		18.000	431.000	4.019	1.500	64.91	60.97	1.064	8.3	
20		18.000	433.000	4.843	0.900	43.77	41.06	1.066	5.6	
21		17.000	433.000	5.547	0.900	44.43	41.47	1.071	5.4	
22		16.000	433.000	6.248	0.900	45.09	42.03	1.072	5.4	
23		18.000	432.000	4.333	1.100	48.79	45.41	1.074	5.8	
24		18.000	431.000	3.919	1.400	59.15	54.82	1.078	6.7	
25		16.000	434.000	6.861	0.800	44.32	41.05	1.079	5.0	
26		17.000	432.000	4.933	1.000	44.92	41.54	1.081	5.0	
27		14.000	435.000	8.976	0.800	48.67	45.01	1.081	5.4	
28		19.000	432.000	3.629	1.100	45.47	41.94	1.084	4.9	
29		19.000	431.000	3.819	2.000	92.44	85.08	1.086	9.7	
30		19.000	431.000	3.719	1.900	85.10	78.02	1.090	8.6	
31		19.000	431.000	3.619	1.800	78.38	71.56	1.095	7.5	
32		18.000	431.000	3.819	1.300	53.57	48.91	1.095	5.2	
33		17.000	431.000	4.249	1.000	42.08	38.37	1.096	4.0	
34		15.000	434.000	7.562	0.800	43.91	39.94	1.099	4.1	
35		17.000	432.000	4.833	0.900	39.44	35.72	1.104	3.5	
36		19.000	431.000	3.519	1.700	71.91	65.01	1.106	6.2	
37		18.000	432.000	4.233	1.000	43.29	39.12	1.106	3.7	
38		18.000	433.000	4.743	0.800	38.08	34.34	1.108	3.2	
39		19.000	431.000	3.419	1.600	65.56	59.05	1.110	5.3	
40		18.000	431.000	3.719	1.200	48.32	43.48	1.111	3.9	
41		16.000	432.000	5.460	0.800	36.94	33.14	1.114	2.9	
42		16.000	433.000	6.148	0.800	39.07	35.01	1.115	3.0	

* denotes the minimum safety factor and maximum prevention force.

No.	Reg.	Circular arc requirements				Skid resistance S (kN/m)	Sliding force T (kN/m)	Safety factor Fs	Required prevention force Pr (kN/m)
		Central coordinates		Radius r (m)	Max. depth (m)				
		X (m)	Y (m)						
43		19.000	432.000	3.529	1.000	40.30	36.03	1.118	3.0
44		19.000	431.000	3.319	1.500	59.59	53.09	1.122	4.2
45		17.000	433.000	5.447	0.800	38.73	34.46	1.123	2.7
46		17.000	431.000	4.149	0.900	36.89	32.77	1.125	2.5
47		20.000	432.000	2.823	1.000	36.95	32.71	1.129	2.4
48		18.000	430.000	3.338	1.500	59.53	52.66	1.130	3.7
49		18.000	431.000	3.619	1.100	43.14	38.05	1.133	2.6
50		18.000	430.000	3.238	1.400	53.82	47.41	1.135	3.1
51		19.000	431.000	3.219	1.400	54.09	47.60	1.136	3.1
52		13.000	436.000	10.290	0.700	45.91	40.33	1.138	2.5
53		18.000	432.000	4.133	0.900	38.02	33.28	1.142	2.0
54		18.000	430.000	3.138	1.300	48.49	42.34	1.145	2.4
55		16.000	434.000	6.761	0.700	38.03	33.13	1.147	1.8
56		17.000	432.000	4.733	0.800	34.22	29.79	1.148	1.6
57		19.000	431.000	3.119	1.300	48.74	42.30	1.152	2.1
58		18.000	430.000	3.038	1.200	43.52	37.76	1.152	1.8
59		14.000	435.000	8.876	0.700	41.66	36.10	1.154	1.7
60		18.000	431.000	3.519	1.000	38.44	33.18	1.158	1.4
61		15.000	434.000	7.462	0.700	37.58	32.35	1.161	1.3
62		20.000	432.000	2.723	0.900	32.38	27.82	1.163	1.1
63		17.000	431.000	4.049	0.800	32.08	27.54	1.164	1.0
64		19.000	432.000	3.429	0.900	35.68	30.65	1.164	1.1
65		18.000	430.000	2.938	1.100	38.74	33.19	1.167	1.1
66		16.000	433.000	6.048	0.700	33.13	28.36	1.168	1.0
67		16.000	432.000	5.360	0.700	31.70	27.04	1.172	0.8
68		19.000	431.000	3.019	1.200	43.77	37.34	1.172	1.1
69		18.000	433.000	4.643	0.700	32.81	27.84	1.178	0.6
70		18.000	432.000	4.033	0.800	32.88	27.75	1.184	0.5
71		18.000	431.000	3.419	0.900	33.58	28.33	1.185	0.5
72		17.000	433.000	5.347	0.700	33.24	28.02	1.186	0.4
73		18.000	430.000	2.838	1.000	34.37	28.95	1.187	0.4
74		19.000	431.000	2.919	1.100	39.17	32.87	1.191	0.3
75		17.000	434.000	5.957	0.600	32.68	27.32	1.196	0.2
76		20.000	432.000	2.623	0.800	28.04	23.34	1.201	0.0
77		17.000	432.000	4.633	0.700	29.22	24.28	1.203	0.0
78		19.000	430.000	3.605	2.500	117.85	97.78	1.205	-0.5
79		20.000	431.000	2.814	1.700	65.98	54.71	1.205	-0.3
80		15.000	435.000	8.075	0.600	36.47	30.15	1.209	-0.2
81		19.000	430.000	3.505	2.400	109.85	90.77	1.210	-0.9
82		17.000	431.000	3.949	0.700	27.50	22.68	1.212	-0.2
83		19.000	430.000	3.405	2.300	102.24	84.24	1.213	-1.1
84		19.000	430.000	3.305	2.200	94.98	77.95	1.218	-1.4
85		20.000	431.000	2.714	1.600	60.03	49.26	1.218	-0.9
86		19.000	430.000	3.205	2.100	87.79	71.80	1.222	-1.6
87		19.000	433.000	3.837	0.600	27.34	22.37	1.222	-0.4

* denotes the minimum safety factor and maximum prevention force.

No.	Reg.	Circular arc requirements				Skid resistance S (kN/m)	Sliding force T (kN/m)	Safety factor Fs	Required prevention force Pr (kN/m)
		Central coordinates		Radius r (m)	Max. depth (m)				
		X (m)	Y (m)						
88		18.000	430.000	2.738	0.900	30.13	24.62	1.223	-0.5
89		19.000	432.000	3.329	0.800	31.28	25.56	1.223	-0.6
90		20.000	431.000	2.614	1.500	54.20	44.26	1.224	-1.0
91		18.000	431.000	3.319	0.800	28.94	23.60	1.226	-0.6
92		19.000	431.000	2.819	1.000	34.63	28.18	1.228	-0.8
93		19.000	430.000	3.105	2.000	81.32	66.12	1.229	-1.9
94		17.000	430.000	3.292	0.700	26.77	21.78	1.229	-0.6
95		12.000	437.000	11.604	0.600	42.31	34.39	1.230	-1.0
96		15.000	433.000	6.671	0.600	29.84	24.23	1.231	-0.7
97		19.000	430.000	3.005	1.900	74.98	60.63	1.236	-2.2
98		19.000	430.000	2.905	1.800	68.87	55.56	1.239	-2.1
99		20.000	431.000	2.514	1.400	48.75	39.32	1.239	-1.5
100		16.000	434.000	6.661	0.600	32.15	25.89	1.241	-1.0
101		15.000	434.000	7.362	0.600	31.18	25.06	1.244	-1.1
102		13.000	436.000	10.190	0.600	38.62	31.04	1.244	-1.3
103		14.000	435.000	8.776	0.600	34.94	28.06	1.245	-1.2
104		18.000	432.000	3.933	0.700	27.99	22.46	1.246	-1.0
105		16.000	432.000	5.260	0.600	26.74	21.39	1.250	-1.0
106		19.000	430.000	2.805	1.700	63.08	50.42	1.251	-2.5
107		16.000	433.000	5.948	0.600	28.00	22.34	1.253	-1.1
108		19.000	430.000	2.705	1.600	57.51	45.84	1.254	-2.5
109		19.000	431.000	2.719	0.900	30.56	24.27	1.259	-1.4
110		20.000	431.000	2.414	1.300	43.63	34.63	1.259	-2.0
111		19.000	430.000	2.605	1.500	52.11	41.30	1.261	-2.5
112		20.000	432.000	2.523	0.700	23.98	18.94	1.266	-1.2
113		18.000	430.000	2.638	0.800	26.26	20.71	1.267	-1.4
114		18.000	431.000	3.219	0.700	24.67	19.44	1.269	-1.3
115		19.000	430.000	2.505	1.400	47.01	37.02	1.269	-2.5
116		17.000	433.000	5.247	0.600	27.91	21.93	1.272	-1.5
117		18.000	433.000	4.543	0.600	27.84	21.82	1.275	-1.6
118		20.000	431.000	2.314	1.200	38.92	30.50	1.276	-2.3
119		17.000	432.000	4.533	0.600	24.65	19.26	1.279	-1.5
120		17.000	431.000	3.849	0.600	23.29	18.19	1.280	-1.4
121		19.000	430.000	2.405	1.300	42.24	32.94	1.282	-2.7
122		19.000	432.000	3.229	0.700	27.03	21.06	1.283	-1.7
123		19.000	430.000	2.305	1.200	37.44	29.18	1.283	-2.4
124		17.000	430.000	3.192	0.600	22.52	17.33	1.299	-1.7
125		20.000	431.000	2.214	1.100	34.41	26.43	1.301	-2.6
126		19.000	430.000	2.205	1.100	32.95	25.29	1.302	-2.6
127		18.000	432.000	3.833	0.600	23.59	18.00	1.310	-1.9
128		18.000	430.000	2.538	0.700	22.46	17.10	1.313	-1.9
129		19.000	431.000	2.619	0.800	26.62	20.23	1.315	-2.3
130		19.000	430.000	2.105	1.000	29.08	22.07	1.317	-2.5
131		14.000	436.000	9.389	0.500	33.71	25.45	1.324	-3.1
132		13.000	435.000	9.394	0.500	29.22	22.03	1.326	-2.7

* denotes the minimum safety factor and maximum prevention force.

No.	Reg.	Circular arc requirements				Skid resistance S (kN/m)	Sliding force T (kN/m)	Safety factor Fs	Required prevention force Pr (kN/m)
		Central coordinates		Radius r (m)	Max. depth (m)				
		X (m)	Y (m)						
133		19.000	433.000	3.737	0.500	22.68	17.02	1.332	-2.2
134		16.000	431.000	4.503	0.500	22.28	16.71	1.333	-2.2
135		20.000	431.000	2.114	1.000	30.04	22.49	1.335	-3.0
136		17.000	434.000	5.857	0.500	27.28	20.39	1.337	-2.8
137		14.000	434.000	7.982	0.500	27.00	20.15	1.339	-2.8
138		18.000	431.000	3.119	0.600	20.68	15.37	1.345	-2.2
139		14.000	435.000	8.676	0.500	28.32	21.05	1.345	-3.0
140		15.000	434.000	7.262	0.500	25.77	19.14	1.346	-2.8
141		15.000	433.000	6.571	0.500	24.64	18.26	1.349	-2.7
142		19.000	430.000	2.005	0.900	25.18	18.64	1.350	-2.8
143		15.000	435.000	7.975	0.500	30.05	22.24	1.351	-3.3
144		16.000	432.000	5.160	0.500	22.22	16.44	1.351	-2.4
145		20.000	432.000	2.423	0.600	20.45	15.11	1.353	-2.3
146		19.000	431.000	2.519	0.700	22.74	16.69	1.362	-2.7
147		19.000	432.000	3.129	0.600	22.77	16.70	1.363	-2.7
148		16.000	433.000	5.848	0.500	23.21	16.99	1.366	-2.8
149		16.000	434.000	6.561	0.500	26.52	19.37	1.369	-3.2
150		11.000	438.000	12.918	0.500	37.87	27.54	1.375	-4.8
151		20.000	431.000	2.014	0.900	26.34	19.13	1.376	-3.3
152		13.000	436.000	10.090	0.500	31.46	22.84	1.377	-4.0
153		17.000	433.000	5.147	0.500	22.83	16.57	1.377	-2.9
154		20.000	430.000	2.804	2.400	100.46	72.84	1.379	-13.0
155		12.000	437.000	11.504	0.500	34.66	25.10	1.380	-4.5
156		18.000	430.000	2.438	0.600	18.93	13.70	1.381	-2.4
157		20.000	430.000	2.704	2.300	93.04	67.05	1.387	-12.5
158		17.000	431.000	3.749	0.500	19.20	13.82	1.389	-2.6
159		17.000	430.000	3.092	0.500	18.59	13.35	1.392	-2.5
160		19.000	430.000	1.905	0.800	21.66	15.53	1.394	-3.0
161		17.000	432.000	4.433	0.500	20.22	14.48	1.396	-2.8
162		18.000	433.000	4.443	0.500	23.24	16.63	1.397	-3.2
163		20.000	430.000	2.604	2.200	85.77	61.33	1.398	-12.1
164		20.000	430.000	2.504	2.100	78.89	55.93	1.410	-11.7
165		18.000	432.000	3.733	0.500	19.54	13.80	1.415	-2.9
166		20.000	431.000	1.914	0.800	22.62	15.96	1.417	-3.4
167		19.000	430.000	1.805	0.700	18.39	12.88	1.427	-2.9
168		20.000	430.000	2.404	2.000	72.54	50.79	1.428	-11.5
169		19.000	431.000	2.419	0.600	19.17	13.36	1.434	-3.1
170		20.000	430.000	2.304	1.900	66.45	46.12	1.440	-11.1
171		18.000	431.000	3.019	0.500	17.01	11.75	1.447	-2.9
172		20.000	430.000	2.204	1.800	60.57	41.54	1.458	-10.7
173		20.000	430.000	2.104	1.700	55.14	37.56	1.468	-10.0
174		20.000	432.000	2.323	0.500	17.18	11.57	1.484	-3.2
175		18.000	430.000	2.338	0.500	15.41	10.30	1.496	-3.0
176		20.000	430.000	2.004	1.600	49.91	33.24	1.501	-10.0
177		20.000	431.000	1.814	0.700	19.34	12.85	1.505	-3.9

* denotes the minimum safety factor and maximum prevention force.

No.	Reg.	Circular arc requirements				Skid resistance S (kN/m)	Sliding force T (kN/m)	Safety factor Fs	Required prevention force Pr (kN/m)
		Central coordinates		Radius r (m)	Max. depth (m)				
		X (m)	Y (m)						
178		19.000	432.000	3.029	0.500	18.52	12.23	1.514	-3.8
179		20.000	430.000	1.904	1.500	45.05	29.68	1.517	-9.4
180		19.000	430.000	1.705	0.600	15.32	10.05	1.524	-3.2
181		19.000	431.000	2.319	0.500	15.77	10.32	1.528	-3.3
182		20.000	430.000	1.804	1.400	40.53	26.20	1.546	-9.0
183		20.000	430.000	1.704	1.300	36.12	22.94	1.574	-8.5
184		20.000	431.000	1.714	0.600	16.24	10.31	1.575	-3.8
185		20.000	430.000	1.604	1.200	31.73	20.06	1.581	-7.6
186		20.000	430.000	1.504	1.100	27.83	17.34	1.604	-7.0
187		20.000	430.000	1.404	1.000	24.20	14.74	1.641	-6.5
188		19.000	430.000	1.605	0.500	12.61	7.65	1.648	-3.4
189		20.000	430.000	1.304	0.900	20.71	12.26	1.689	-5.9
190		20.000	431.000	1.614	0.500	13.38	7.89	1.695	-3.9
191		20.000	430.000	1.204	0.800	17.51	10.18	1.720	-5.2
192		20.000	430.000	1.104	0.700	14.61	8.10	1.803	-4.8
193		20.000	430.000	1.004	0.600	11.95	6.38	1.873	-4.2
194		20.000	430.000	0.904	0.500	9.53	4.81	1.981	-3.7

* denotes the minimum safety factor and maximum prevention force.

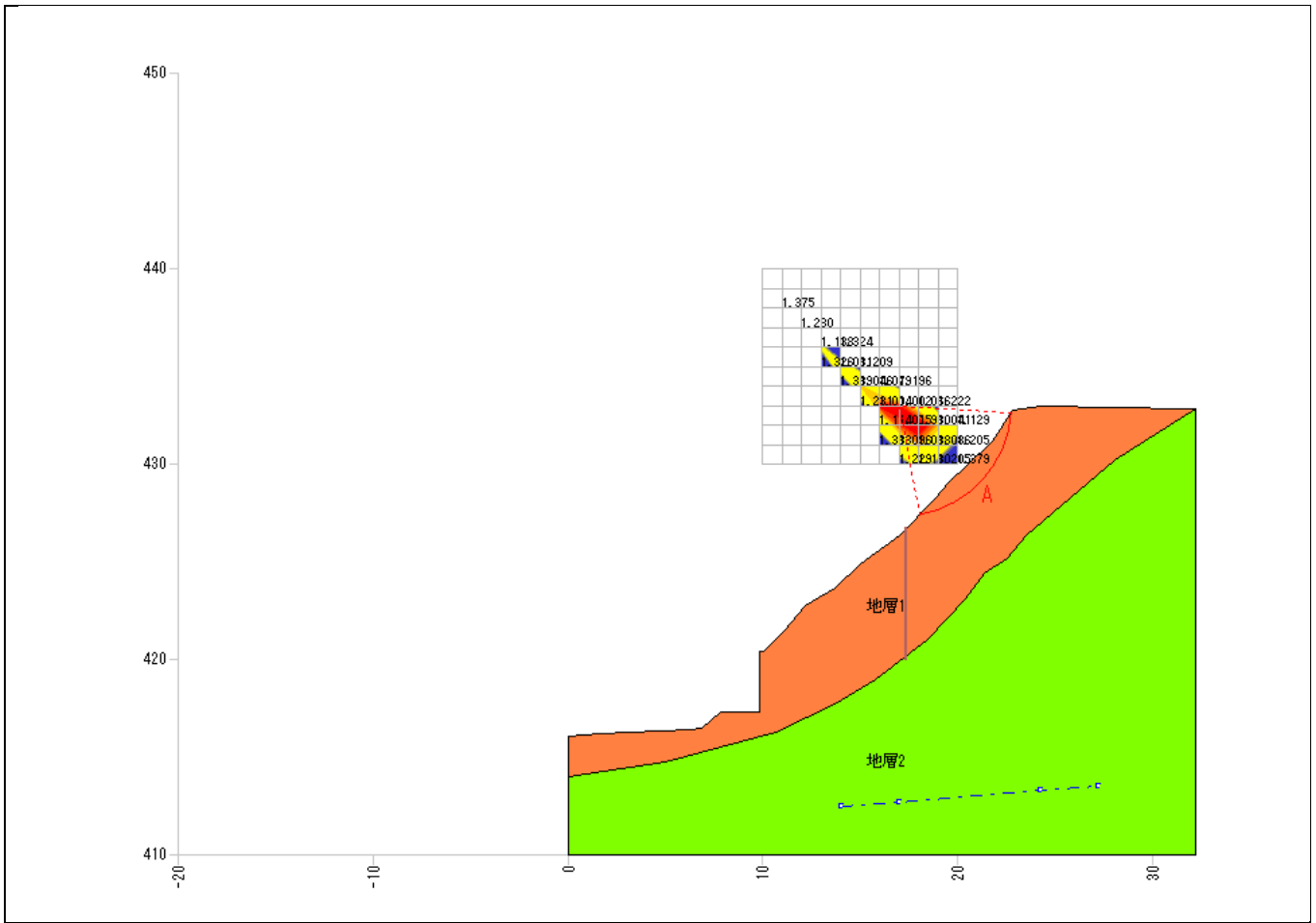

Isoline Map (Minimum Safety Factor - Normally)

Stability Analysis

Site	KANDY LOWER Shallow slope failure
Case	B Pr(max)
Remarks	ϕ 29

Site	KANDY
Case	B Pr(max)
Remarks	φ 29

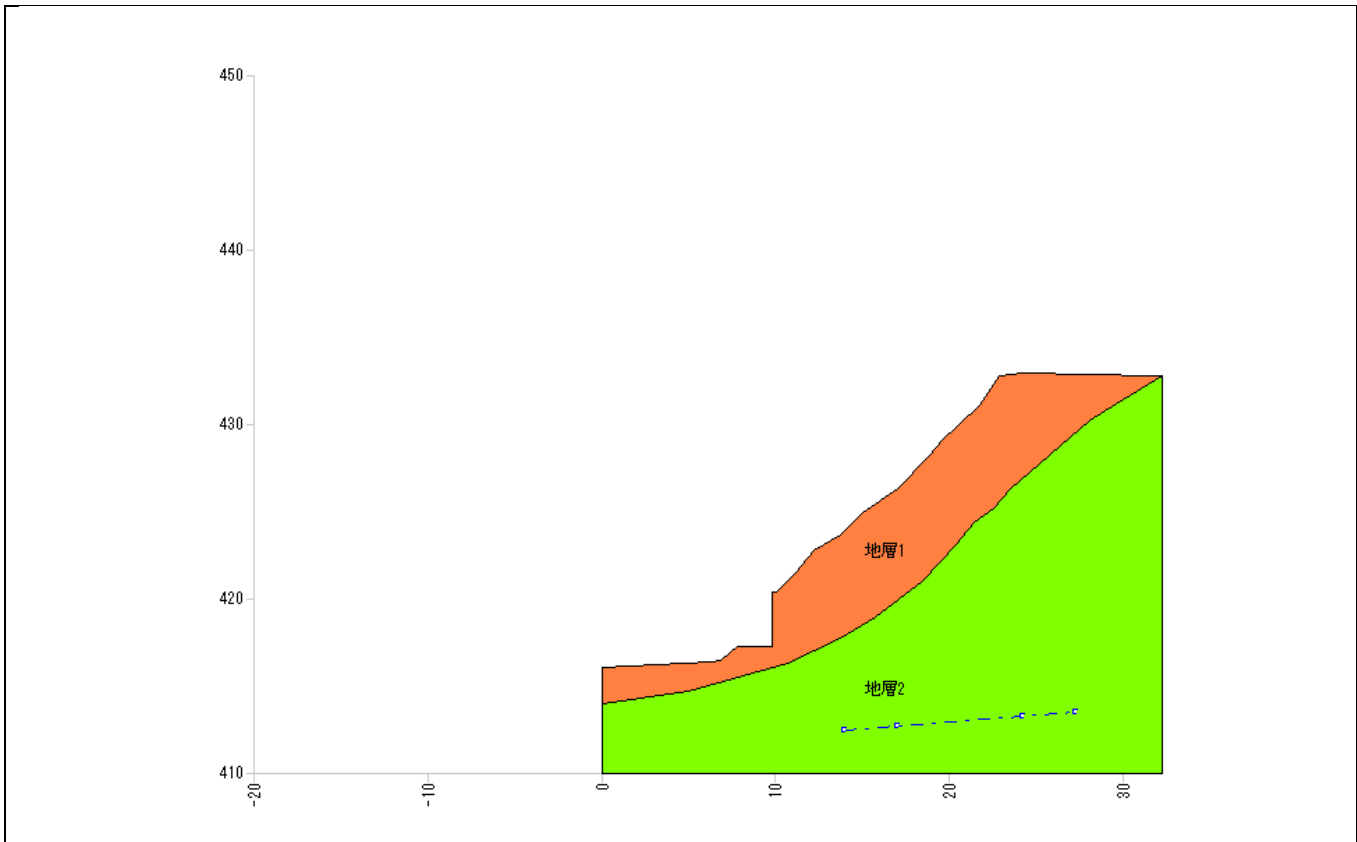

Soil constant		Soil quality	Wet weight γ_t (kN/m ³)	Saturated weight γ_{sat} (kN/m ³)	Cohesion C (kN/m ²)	Internal friction angle	
No.	Geology					ϕ (°)	$\tan\phi$
1	地層 1		17.00	17.00	2.90	29.0000	0.554309
2	地層 2		20.00	20.00	7.00	32.0000	0.624869

* Unit weight of water $\gamma_w = 9.80$ (kN/m³)

Coordinate input data								
No.	Distance X (m)	Original topographic altitude Y _G (m)	Planned topographic altitude Y (m)	Water level altitude Y _W (m)	Sliding surface			Launching
					Altitude Y _S (m)	Shape	Strength	
1	0.000		416.049					
2	1.595		416.158					
3	6.357		416.346					
4	6.876		416.479					
5	7.876		417.279					
6	9.876		417.279					
7	9.876		420.379					
8	10.076		420.379					
9	11.173		421.452					
10	12.203		422.741					
11	13.737		423.648					
12	14.037			412.420				
13	15.014		424.881					
14	17.027		426.305	412.665				
15	18.890		428.224					
16	19.614		429.054					
17	20.456		429.881					
18	21.778		431.199					
19	22.840		432.809					
20	24.272		433.000	413.260				
21	27.262			413.510				
22	31.785		432.837					
23	32.200		432.840					

Coordinates of stratum boundary line		
No.	No.1	
	X (m)	Y (m)
1	0.000	414.000
2	5.000	414.700
3	10.718	416.240
4	13.740	417.700
5	15.770	418.950
6	18.490	421.010
7	20.400	423.080
8	21.410	424.350
9	22.570	425.160
10	23.540	426.300
11	28.080	430.270
12	29.570	431.230
13	32.200	432.840

6. Design Requirements

6.4. Planned Safety Factor of the Reinforcement Slope

Considering the site as permanent construction, set a planned safety factor.

The Cut Earth Reinforcement Method, Design and Construction Procedures prescribes as follows.

Planned safety factor of the reinforcement slope

Item	Planned safety factor
Permanent construction (long term)	$F_{sp} \geq 1.20$
Temporary construction (short term)	$F_{sp} \geq 1.05, 1.10$

[Cut Earth Reinforcement Method, Design and Construction Procedures Page 31]

Taking account of the importance of the said slope, the planned safety factor shall be $F_{sp} = 1.200$.

6.5. Soil Quality Requirements

The following shows the geological and soil composition and constants of the said slope.

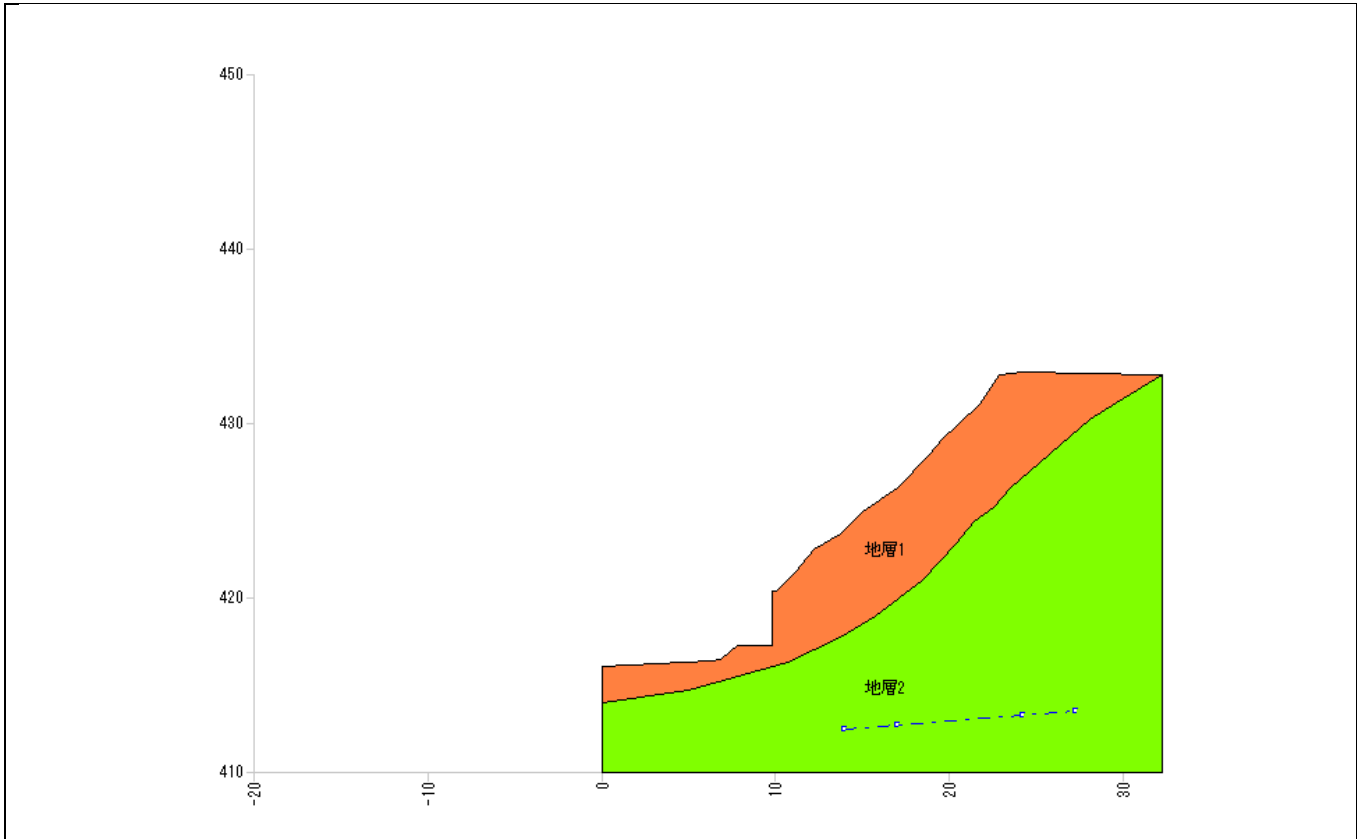

Soil constant								
No.	Geology	Soil quality	Wet weight γ_t (kN/m ³)	Saturated weight γ_{sat} (kN/m ³)	Cohesion C (kN/m ²)	Internal friction angle		
						ϕ (°)	$\tan\phi$	
1	地層 1		17.00	17.00	2.90	29.0000	0.554309	
2	地層 2		20.00	20.00	7.00	32.0000	0.624869	

* Unit weight of water $\gamma_w = 9.80$ (kN/m³)

7. Repeated Circular Calculation

As a result of studying with repeated circular slip as to slope stability, it is determined that the following sliding surface is most dangerous.

< Circular arc A >

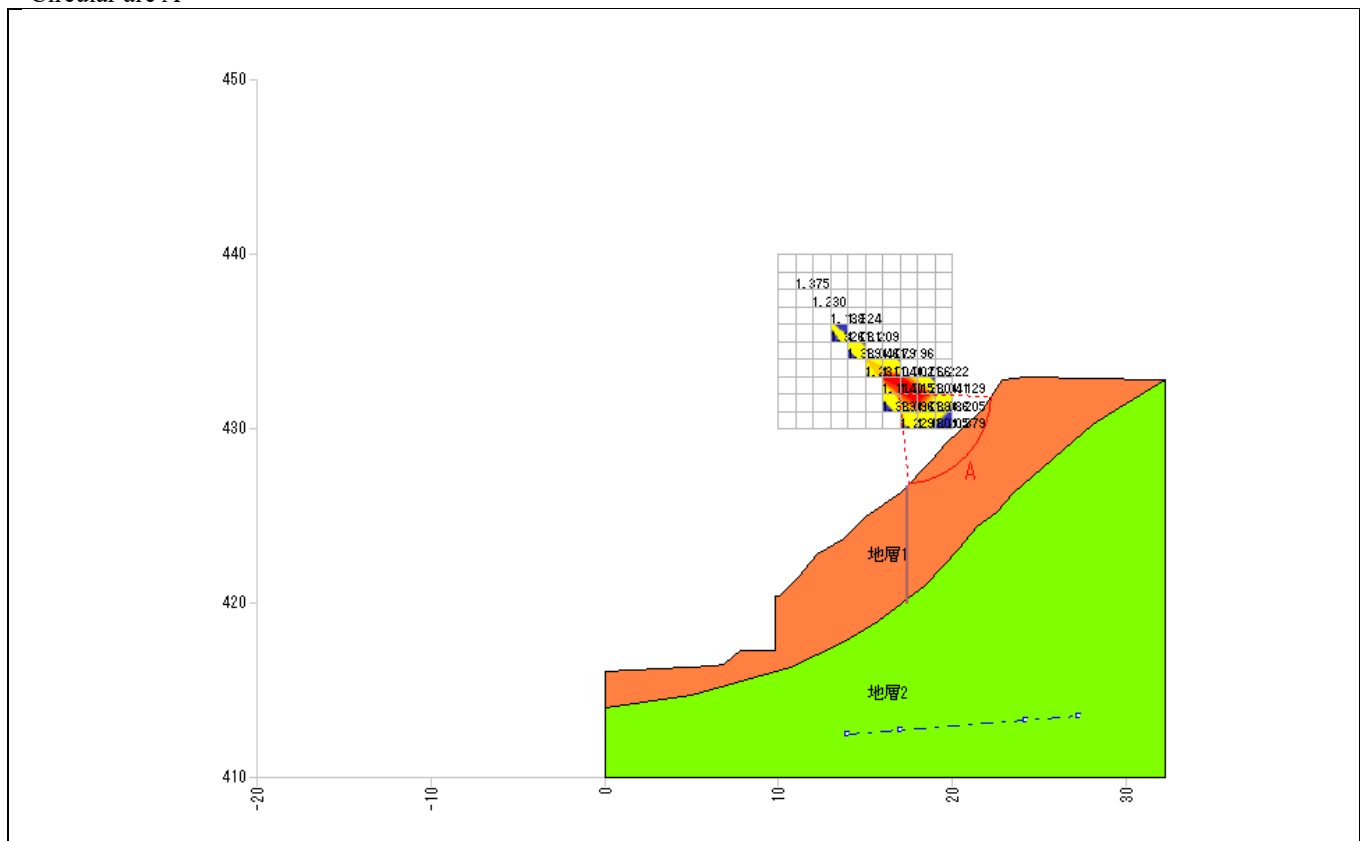

Stability calculation results				
Item		Symbol	Unit	Normally
Calculation results	Safety factor	Fs	-	1.015
	Planned safety factor	Fsp	-	1.200
	Required prevention force	Pr	kN/m	11.6
Circular arc	Central coordinates	X	m	17.000
		Y	m	432.000
	Radius	r	m	5.233
Calculation elements	Skid resistance	S	kN/m	63.41
	Sliding force	T	kN/m	62.46
	Normal force	N	kN/m	74.59
	Pore water pressure	U	kN/m	0.00
	Sliding surface length	l	m	7.610
	Area	A	m ²	5.95

7.1. Stability Calculation Formula

Stability calculation is conducted using the modified Fellenius method.

Basically, the limit balance method shall be used to secure the required planned safety factor.

$$\text{Safety factor (Fs)} = \frac{\text{Skid resistance } (\Sigma S)}{\text{Sliding force } (\Sigma T)}$$

Concerning the calculation method, the cross section of the sliding clod shall be split into several slices based on the “slicing method” to consider the balance of force on each slice (split piece).

< Normally >

$$Fs = \frac{\Sigma\{(N-U)\cdot\tan\phi\}+\Sigma(C\cdot l)}{\Sigma T}$$

$$Pr = F_{sp}\cdot\Sigma T - [\Sigma\{(N-U)\cdot\tan\phi\}+\Sigma(C\cdot l)]$$

where;

Fs	:	Safety factor	
Fsp	:	Planned safety factor	
Pr	:	Required prevention force	(kN/m)
N	:	Normal force by gravity of slice	(N = W·cosθ+Q _N) (kN/m)
U	:	Pore water pressure working on slice	(U = u·b·cosθ) (kN/m)
T	:	Tangential force by gravity of slice	(T = W·sinθ+Q _T) (kN/m)
b	:	Slice width	(m)
l	:	Sliding surface length of slice	(m)
φ	:	Internal friction angle of sliding surface	(°)
C	:	Cohesion of sliding surface	(kN/m ²)
W	:	Slice weight	(kN/m)
θ	:	Sliding surface inclination angle	(°)
u	:	Unit pore water pressure	(kN/m ²)
Q _N	:	Vertical load component force (normal direction)	(kN/m)
Q _T	:	Vertical load component force (tangential direction)	(kN/m)

7.2. Stability Evaluation (Normally)

< Circular arc A >

Slice element summary table			Sliding surface length l (m)	Normal force N (kN/m)	Pore water pressure U (kN/m)	Sliding force T (kN/m)	Skid resistance S (kN/m)
Internal friction angle		Cohesion C (kN/m ²)					
φ(°)	tanφ						
29.0000	0.554309	2.90	7.610	74.59	0.00	62.46	63.41

The safety factor is calculated by the following formula.

$$\begin{aligned}
 F_s &= \frac{\Sigma\{(N-U)\cdot\tan\phi\}+\Sigma(C\cdot l)}{\Sigma T} \\
 &= \frac{(74.59-0.00)\times 0.554309+2.90\times 7.610}{62.46} \\
 &= 1.015
 \end{aligned}$$

where;

F _s	: Safety factor		
N	: Normal force by gravity of slice	(N = W·cosθ+Q _N)	(kN/m)
U	: Pore water pressure working on slice	(U = u·b·cosθ)	(kN/m)
T	: Tangential force by gravity of slice	(T = W·sinθ+Q _T)	(kN/m)
b	: Slice width		(m)
l	: Sliding surface length of slice		(m)
φ	: Internal friction angle of sliding surface		(°)
C	: Cohesion of sliding surface		(kN/m ²)
W	: Slice weight		(kN/m)
θ	: Sliding surface inclination angle		(°)
u	: Unit pore water pressure		(kN/m ²)
Q _N	: Vertical load component force (normal direction)		(kN/m)
Q _T	: Vertical load component force (tangential direction)		(kN/m)

7.3. Calculation of the Required Prevention Force (Normally)

Calculate the required prevention force which satisfies the planned safety factor $F_{sp} = 1.200$.

< Circular arc A >

$$\begin{aligned} Pr &= F_{sp} \cdot \Sigma T - [\Sigma \{(N-U) \cdot \tan \phi\} + \Sigma (C \cdot l)] \\ &= 1.200 \times 62.46 - \{(74.59 - 0.00) \times 0.554309 + 2.90 \times 7.610\} \\ &= 11.6 \text{ (kN/m)} \end{aligned}$$

where;

F_{sp}	: Planned safety factor		
Pr	: Required prevention force		(kN/m)
N	: Normal force by gravity of slice	$(N = W \cdot \cos \theta + Q_N)$	(kN/m)
U	: Pore water pressure working on slice	$(U = u \cdot b \cdot \cos \theta)$	(kN/m)
T	: Tangential force by gravity of slice	$(T = W \cdot \sin \theta + Q_T)$	(kN/m)
b	: Slice width		(m)
l	: Sliding surface length of slice		(m)
ϕ	: Internal friction angle of sliding surface		(°)
C	: Cohesion of sliding surface		(kN/m ²)
W	: Slice weight		(kN/m)
θ	: Sliding surface inclination angle		(°)
u	: Unit pore water pressure		(kN/m ²)
Q_N	: Vertical load component force (normal direction)		(kN/m)
Q_T	: Vertical load component force (tangential direction)		(kN/m)

Repeated Circular Calculation Requirements

- Circular arc requirements

Center change range

X coordinate (m) : 10.000 ~ 20.000 Pitch (m) : 1.000
Y coordinate (m) : 430.000 ~ 440.000 Pitch (m) : 1.000
Secondary chase : None

Depth change range from the ground surface

Depth (m) : 0.500 ~ 3.000 Pitch (m) : 0.100

- Pass line

Start point (m) : [X = - , Y = -]

End point (m) : [X = - , Y = -]

- No-Pass line

Start point (m) : [X = 17.405 , Y = 426.694]

End point (m) : [X = 17.405 , Y = 420.000]

- No-Pass layer

地層 2

- Calculation requirements

Planned safety factor (Normally) Fsp = 1.200
Stability calculation formula Modified Fellenius method
Sliding surface strength Stratum value

- Output requirements

Safety factor : All
Required prevention force : All
Sliding force : All
Depth : All

List of Repeated Circular Calculation Results
(Normally)

No.	Reg.	Circular arc requirements				Skid resistance S (kN/m)	Sliding force T (kN/m)	Safety factor Fs		Required prevention force Pr (kN/m)
		Central coordinates		Radius r (m)	Max. depth (m)					
		X (m)	Y (m)							
1		18.000	432.000	4.833	1.600	79.40	80.95	* 0.980	* 17.8	
2		18.000	432.000	4.733	1.500	72.55	73.21	0.990	15.4	
3		18.000	431.000	4.319	1.800	84.04	80.91	1.038	13.1	
4		18.000	432.000	4.633	1.400	66.13	65.82	1.004	12.9	
5	A	17.000	432.000	5.233	1.300	63.41	62.46	1.015	11.6	
6		16.000	433.000	6.448	1.100	58.02	57.76	1.004	11.3	
7		18.000	431.000	4.219	1.700	77.36	73.83	1.047	11.3	
8		17.000	433.000	5.747	1.100	56.93	56.76	1.002	11.2	
9		18.000	432.000	4.533	1.300	60.13	58.69	1.024	10.3	
10		18.000	431.000	4.119	1.600	71.01	67.44	1.052	10.0	
11		19.000	431.000	3.819	2.000	92.44	85.08	1.086	9.7	
12		17.000	432.000	5.133	1.200	57.06	55.30	1.031	9.3	
13		19.000	432.000	3.829	1.300	56.36	54.09	1.041	8.6	
14		19.000	431.000	3.719	1.900	85.10	78.02	1.090	8.6	
15		16.000	433.000	6.348	1.000	51.55	49.90	1.033	8.4	
16		18.000	431.000	4.019	1.500	64.91	60.97	1.064	8.3	
17		17.000	433.000	5.647	1.000	50.52	48.77	1.035	8.1	
18		18.000	432.000	4.433	1.200	54.23	51.83	1.046	8.0	
19		15.000	434.000	7.662	0.900	50.51	48.27	1.046	7.5	
20		19.000	431.000	3.619	1.800	78.38	71.56	1.095	7.5	
21		17.000	432.000	5.033	1.100	50.87	48.35	1.052	7.2	
22		19.000	432.000	3.729	1.200	50.84	47.91	1.061	6.7	
23		18.000	431.000	3.919	1.400	59.15	54.82	1.078	6.7	
24		19.000	431.000	3.519	1.700	71.91	65.01	1.106	6.2	
25		18.000	432.000	4.333	1.100	48.79	45.41	1.074	5.8	
26		18.000	433.000	4.843	0.900	43.77	41.06	1.066	5.6	
27		14.000	435.000	8.976	0.800	48.67	45.01	1.081	5.4	
28		17.000	433.000	5.547	0.900	44.43	41.47	1.071	5.4	
29		16.000	433.000	6.248	0.900	45.09	42.03	1.072	5.4	
30		19.000	431.000	3.419	1.600	65.56	59.05	1.110	5.3	
31		18.000	431.000	3.819	1.300	53.57	48.91	1.095	5.2	
32		16.000	434.000	6.861	0.800	44.32	41.05	1.079	5.0	
33		17.000	432.000	4.933	1.000	44.92	41.54	1.081	5.0	
34		19.000	432.000	3.629	1.100	45.47	41.94	1.084	4.9	
35		19.000	431.000	3.319	1.500	59.59	53.09	1.122	4.2	
36		15.000	434.000	7.562	0.800	43.91	39.94	1.099	4.1	
37		17.000	431.000	4.249	1.000	42.08	38.37	1.096	4.0	
38		18.000	431.000	3.719	1.200	48.32	43.48	1.111	3.9	
39		18.000	432.000	4.233	1.000	43.29	39.12	1.106	3.7	
40		18.000	430.000	3.338	1.500	59.53	52.66	1.130	3.7	
41		17.000	432.000	4.833	0.900	39.44	35.72	1.104	3.5	
42		18.000	433.000	4.743	0.800	38.08	34.34	1.108	3.2	

* denotes the minimum safety factor and maximum prevention force.

No.	Reg.	Circular arc requirements				Skid resistance S (kN/m)	Sliding force T (kN/m)	Safety factor Fs	Required prevention force Pr (kN/m)
		Central coordinates		Radius r (m)	Max. depth (m)				
		X (m)	Y (m)						
43		19.000	431.000	3.219	1.400	54.09	47.60	1.136	3.1
44		18.000	430.000	3.238	1.400	53.82	47.41	1.135	3.1
45		16.000	433.000	6.148	0.800	39.07	35.01	1.115	3.0
46		19.000	432.000	3.529	1.000	40.30	36.03	1.118	3.0
47		16.000	432.000	5.460	0.800	36.94	33.14	1.114	2.9
48		17.000	433.000	5.447	0.800	38.73	34.46	1.123	2.7
49		18.000	431.000	3.619	1.100	43.14	38.05	1.133	2.6
50		13.000	436.000	10.290	0.700	45.91	40.33	1.138	2.5
51		17.000	431.000	4.149	0.900	36.89	32.77	1.125	2.5
52		20.000	432.000	2.823	1.000	36.95	32.71	1.129	2.4
53		18.000	430.000	3.138	1.300	48.49	42.34	1.145	2.4
54		19.000	431.000	3.119	1.300	48.74	42.30	1.152	2.1
55		18.000	432.000	4.133	0.900	38.02	33.28	1.142	2.0
56		16.000	434.000	6.761	0.700	38.03	33.13	1.147	1.8
57		18.000	430.000	3.038	1.200	43.52	37.76	1.152	1.8
58		14.000	435.000	8.876	0.700	41.66	36.10	1.154	1.7
59		17.000	432.000	4.733	0.800	34.22	29.79	1.148	1.6
60		18.000	431.000	3.519	1.000	38.44	33.18	1.158	1.4
61		15.000	434.000	7.462	0.700	37.58	32.35	1.161	1.3
62		20.000	432.000	2.723	0.900	32.38	27.82	1.163	1.1
63		19.000	432.000	3.429	0.900	35.68	30.65	1.164	1.1
64		19.000	431.000	3.019	1.200	43.77	37.34	1.172	1.1
65		18.000	430.000	2.938	1.100	38.74	33.19	1.167	1.1
66		16.000	433.000	6.048	0.700	33.13	28.36	1.168	1.0
67		17.000	431.000	4.049	0.800	32.08	27.54	1.164	1.0
68		16.000	432.000	5.360	0.700	31.70	27.04	1.172	0.8
69		18.000	433.000	4.643	0.700	32.81	27.84	1.178	0.6
70		18.000	432.000	4.033	0.800	32.88	27.75	1.184	0.5
71		18.000	431.000	3.419	0.900	33.58	28.33	1.185	0.5
72		17.000	433.000	5.347	0.700	33.24	28.02	1.186	0.4
73		18.000	430.000	2.838	1.000	34.37	28.95	1.187	0.4
74		19.000	431.000	2.919	1.100	39.17	32.87	1.191	0.3
75		17.000	434.000	5.957	0.600	32.68	27.32	1.196	0.2
76		20.000	432.000	2.623	0.800	28.04	23.34	1.201	0.0
77		17.000	432.000	4.633	0.700	29.22	24.28	1.203	0.0
78		15.000	435.000	8.075	0.600	36.47	30.15	1.209	-0.2
79		17.000	431.000	3.949	0.700	27.50	22.68	1.212	-0.2
80		20.000	431.000	2.814	1.700	65.98	54.71	1.205	-0.3
81		19.000	433.000	3.837	0.600	27.34	22.37	1.222	-0.4
82		19.000	430.000	3.605	2.500	117.85	97.78	1.205	-0.5
83		18.000	430.000	2.738	0.900	30.13	24.62	1.223	-0.5
84		19.000	432.000	3.329	0.800	31.28	25.56	1.223	-0.6
85		18.000	431.000	3.319	0.800	28.94	23.60	1.226	-0.6
86		17.000	430.000	3.292	0.700	26.77	21.78	1.229	-0.6
87		15.000	433.000	6.671	0.600	29.84	24.23	1.231	-0.7

* denotes the minimum safety factor and maximum prevention force.

No.	Reg.	Circular arc requirements				Skid resistance S (kN/m)	Sliding force T (kN/m)	Safety factor Fs	Required prevention force Pr (kN/m)
		Central coordinates		Radius r (m)	Max. depth (m)				
		X (m)	Y (m)						
88		19.000	431.000	2.819	1.000	34.63	28.18	1.228	-0.8
89		20.000	431.000	2.714	1.600	60.03	49.26	1.218	-0.9
90		19.000	430.000	3.505	2.400	109.85	90.77	1.210	-0.9
91		12.000	437.000	11.604	0.600	42.31	34.39	1.230	-1.0
92		16.000	434.000	6.661	0.600	32.15	25.89	1.241	-1.0
93		18.000	432.000	3.933	0.700	27.99	22.46	1.246	-1.0
94		16.000	432.000	5.260	0.600	26.74	21.39	1.250	-1.0
95		20.000	431.000	2.614	1.500	54.20	44.26	1.224	-1.0
96		15.000	434.000	7.362	0.600	31.18	25.06	1.244	-1.1
97		16.000	433.000	5.948	0.600	28.00	22.34	1.253	-1.1
98		19.000	430.000	3.405	2.300	102.24	84.24	1.213	-1.1
99		14.000	435.000	8.776	0.600	34.94	28.06	1.245	-1.2
100		20.000	432.000	2.523	0.700	23.98	18.94	1.266	-1.2
101		13.000	436.000	10.190	0.600	38.62	31.04	1.244	-1.3
102		18.000	431.000	3.219	0.700	24.67	19.44	1.269	-1.3
103		19.000	431.000	2.719	0.900	30.56	24.27	1.259	-1.4
104		17.000	431.000	3.849	0.600	23.29	18.19	1.280	-1.4
105		19.000	430.000	3.305	2.200	94.98	77.95	1.218	-1.4
106		18.000	430.000	2.638	0.800	26.26	20.71	1.267	-1.4
107		17.000	433.000	5.247	0.600	27.91	21.93	1.272	-1.5
108		17.000	432.000	4.533	0.600	24.65	19.26	1.279	-1.5
109		20.000	431.000	2.514	1.400	48.75	39.32	1.239	-1.5
110		18.000	433.000	4.543	0.600	27.84	21.82	1.275	-1.6
111		19.000	430.000	3.205	2.100	87.79	71.80	1.222	-1.6
112		19.000	432.000	3.229	0.700	27.03	21.06	1.283	-1.7
113		17.000	430.000	3.192	0.600	22.52	17.33	1.299	-1.7
114		18.000	432.000	3.833	0.600	23.59	18.00	1.310	-1.9
115		19.000	430.000	3.105	2.000	81.32	66.12	1.229	-1.9
116		18.000	430.000	2.538	0.700	22.46	17.10	1.313	-1.9
117		20.000	431.000	2.414	1.300	43.63	34.63	1.259	-2.0
118		19.000	430.000	2.905	1.800	68.87	55.56	1.239	-2.1
119		19.000	433.000	3.737	0.500	22.68	17.02	1.332	-2.2
120		18.000	431.000	3.119	0.600	20.68	15.37	1.345	-2.2
121		16.000	431.000	4.503	0.500	22.28	16.71	1.333	-2.2
122		19.000	430.000	3.005	1.900	74.98	60.63	1.236	-2.2
123		20.000	432.000	2.423	0.600	20.45	15.11	1.353	-2.3
124		20.000	431.000	2.314	1.200	38.92	30.50	1.276	-2.3
125		19.000	431.000	2.619	0.800	26.62	20.23	1.315	-2.3
126		16.000	432.000	5.160	0.500	22.22	16.44	1.351	-2.4
127		19.000	430.000	2.305	1.200	37.44	29.18	1.283	-2.4
128		18.000	430.000	2.438	0.600	18.93	13.70	1.381	-2.4
129		19.000	430.000	2.805	1.700	63.08	50.42	1.251	-2.5
130		19.000	430.000	2.705	1.600	57.51	45.84	1.254	-2.5
131		19.000	430.000	2.605	1.500	52.11	41.30	1.261	-2.5
132		19.000	430.000	2.505	1.400	47.01	37.02	1.269	-2.5

* denotes the minimum safety factor and maximum prevention force.

No.	Reg.	Circular arc requirements				Skid resistance S (kN/m)	Sliding force T (kN/m)	Safety factor Fs	Required prevention force Pr (kN/m)
		Central coordinates		Radius r (m)	Max. depth (m)				
		X (m)	Y (m)						
133		19.000	430.000	2.105	1.000	29.08	22.07	1.317	-2.5
134		17.000	430.000	3.092	0.500	18.59	13.35	1.392	-2.5
135		20.000	431.000	2.214	1.100	34.41	26.43	1.301	-2.6
136		17.000	431.000	3.749	0.500	19.20	13.82	1.389	-2.6
137		19.000	430.000	2.205	1.100	32.95	25.29	1.302	-2.6
138		13.000	435.000	9.394	0.500	29.22	22.03	1.326	-2.7
139		15.000	433.000	6.571	0.500	24.64	18.26	1.349	-2.7
140		19.000	432.000	3.129	0.600	22.77	16.70	1.363	-2.7
141		19.000	431.000	2.519	0.700	22.74	16.69	1.362	-2.7
142		19.000	430.000	2.405	1.300	42.24	32.94	1.282	-2.7
143		17.000	434.000	5.857	0.500	27.28	20.39	1.337	-2.8
144		15.000	434.000	7.262	0.500	25.77	19.14	1.346	-2.8
145		14.000	434.000	7.982	0.500	27.00	20.15	1.339	-2.8
146		16.000	433.000	5.848	0.500	23.21	16.99	1.366	-2.8
147		17.000	432.000	4.433	0.500	20.22	14.48	1.396	-2.8
148		19.000	430.000	2.005	0.900	25.18	18.64	1.350	-2.8
149		17.000	433.000	5.147	0.500	22.83	16.57	1.377	-2.9
150		18.000	432.000	3.733	0.500	19.54	13.80	1.415	-2.9
151		18.000	431.000	3.019	0.500	17.01	11.75	1.447	-2.9
152		19.000	430.000	1.805	0.700	18.39	12.88	1.427	-2.9
153		14.000	435.000	8.676	0.500	28.32	21.05	1.345	-3.0
154		20.000	431.000	2.114	1.000	30.04	22.49	1.335	-3.0
155		19.000	430.000	1.905	0.800	21.66	15.53	1.394	-3.0
156		18.000	430.000	2.338	0.500	15.41	10.30	1.496	-3.0
157		14.000	436.000	9.389	0.500	33.71	25.45	1.324	-3.1
158		19.000	431.000	2.419	0.600	19.17	13.36	1.434	-3.1
159		16.000	434.000	6.561	0.500	26.52	19.37	1.369	-3.2
160		18.000	433.000	4.443	0.500	23.24	16.63	1.397	-3.2
161		20.000	432.000	2.323	0.500	17.18	11.57	1.484	-3.2
162		19.000	430.000	1.705	0.600	15.32	10.05	1.524	-3.2
163		15.000	435.000	7.975	0.500	30.05	22.24	1.351	-3.3
164		20.000	431.000	2.014	0.900	26.34	19.13	1.376	-3.3
165		19.000	431.000	2.319	0.500	15.77	10.32	1.528	-3.3
166		20.000	431.000	1.914	0.800	22.62	15.96	1.417	-3.4
167		19.000	430.000	1.605	0.500	12.61	7.65	1.648	-3.4
168		20.000	430.000	0.904	0.500	9.53	4.81	1.981	-3.7
169		19.000	432.000	3.029	0.500	18.52	12.23	1.514	-3.8
170		20.000	431.000	1.714	0.600	16.24	10.31	1.575	-3.8
171		20.000	431.000	1.814	0.700	19.34	12.85	1.505	-3.9
172		20.000	431.000	1.614	0.500	13.38	7.89	1.695	-3.9
173		13.000	436.000	10.090	0.500	31.46	22.84	1.377	-4.0
174		20.000	430.000	1.004	0.600	11.95	6.38	1.873	-4.2
175		12.000	437.000	11.504	0.500	34.66	25.10	1.380	-4.5
176		11.000	438.000	12.918	0.500	37.87	27.54	1.375	-4.8
177		20.000	430.000	1.104	0.700	14.61	8.10	1.803	-4.8

* denotes the minimum safety factor and maximum prevention force.

No.	Reg.	Circular arc requirements				Skid resistance S (kN/m)	Sliding force T (kN/m)	Safety factor Fs	Required prevention force Pr (kN/m)
		Central coordinates		Radius r (m)	Max. depth (m)				
		X (m)	Y (m)						
178		20.000	430.000	1.204	0.800	17.51	10.18	1.720	-5.2
179		20.000	430.000	1.304	0.900	20.71	12.26	1.689	-5.9
180		20.000	430.000	1.404	1.000	24.20	14.74	1.641	-6.5
181		20.000	430.000	1.504	1.100	27.83	17.34	1.604	-7.0
182		20.000	430.000	1.604	1.200	31.73	20.06	1.581	-7.6
183		20.000	430.000	1.704	1.300	36.12	22.94	1.574	-8.5
184		20.000	430.000	1.804	1.400	40.53	26.20	1.546	-9.0
185		20.000	430.000	1.904	1.500	45.05	29.68	1.517	-9.4
186		20.000	430.000	2.104	1.700	55.14	37.56	1.468	-10.0
187		20.000	430.000	2.004	1.600	49.91	33.24	1.501	-10.0
188		20.000	430.000	2.204	1.800	60.57	41.54	1.458	-10.7
189		20.000	430.000	2.304	1.900	66.45	46.12	1.440	-11.1
190		20.000	430.000	2.404	2.000	72.54	50.79	1.428	-11.5
191		20.000	430.000	2.504	2.100	78.89	55.93	1.410	-11.7
192		20.000	430.000	2.604	2.200	85.77	61.33	1.398	-12.1
193		20.000	430.000	2.704	2.300	93.04	67.05	1.387	-12.5
194		20.000	430.000	2.804	2.400	100.46	72.84	1.379	-13.0

* denotes the minimum safety factor and maximum prevention force.

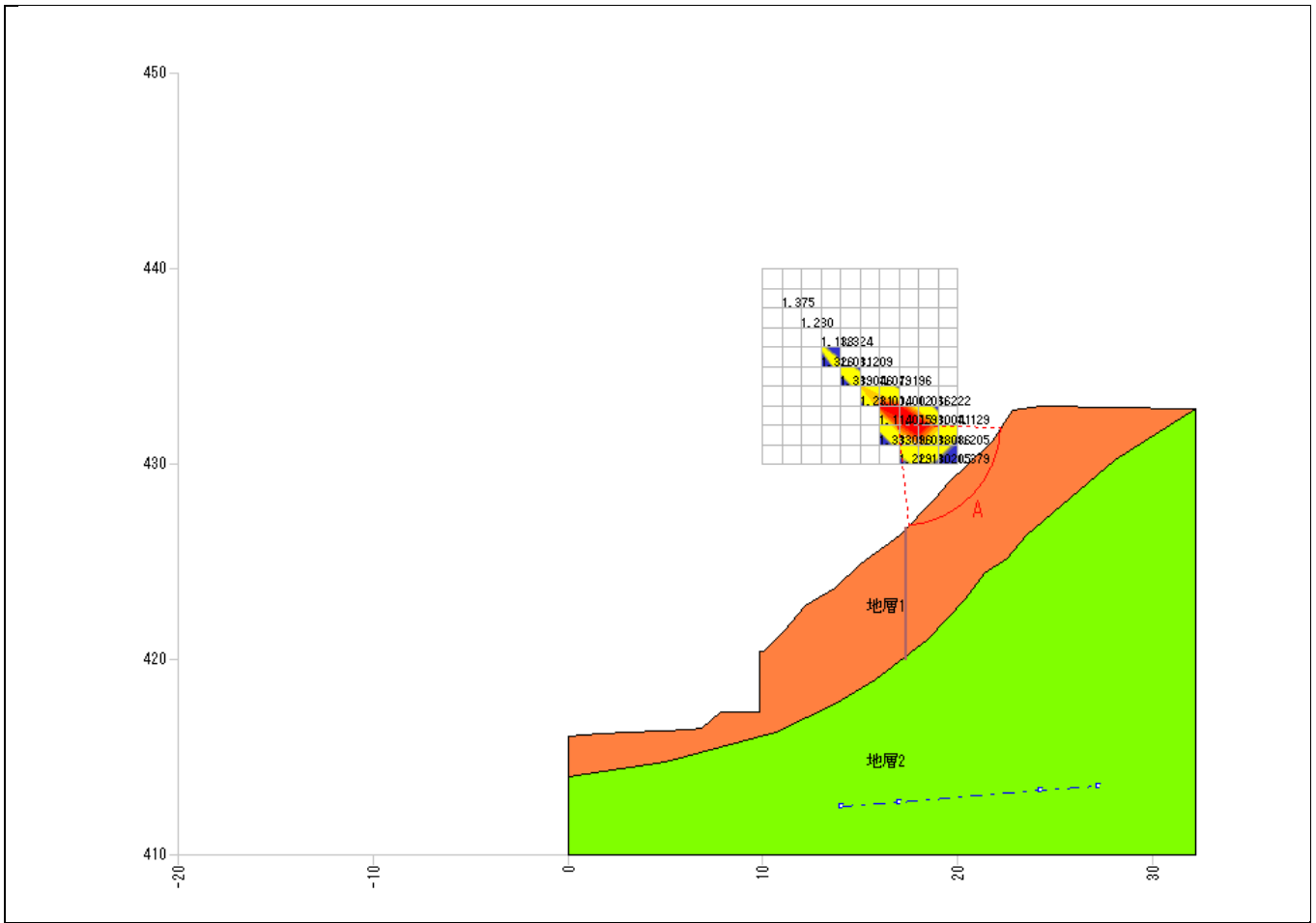

Isoline Map (Minimum Safety Factor - Normally)

Appendix-4

Ground Anchor Design Calculation Report

Ground Anchorage Design Calculation Report

<u>Area</u>	<u>Kandy LOWER</u>
<u>Traverse line</u>	<u>B</u>
<u>Remarks</u>	_____

Item	Symbol	Unit	Numerical value
Required prevention force	Pr	kN/m	64.0
Sliding surface	Average angle	θ	37.00
	tanφ	-	0.55431(φ=29.000°)
Horizontal interval	a	m	2.00
Number of constructed steps	m	step	3
Angle of inclination of anchorage	α	°	30.0
Effect of anchorage	Stressing+Anchoring effect		
Materials and type of anchorage	PC multi-strand bundle(SEEE ground anchorage) F-UA type		
Rank of anchorage	Rank A (Normally)		
Allowable adhesive stress of tendon and grout	τ _b	N/mm ²	1.00
Skin friction of fixed anchor	τ	N/mm ²	0.14
Design safety factor	Fs	-	2.5

Calculation results							
Angle of inclination of anchorage α(°)	Working load of anchorage Td(kN/pc.)	Tendon standard	Circumference U(mm)	Borehole diameter d _A (mm)	Fixed anchor length (m)		
					l _{sa}	l _a	L _a
30.0	47.4	F20UA	119.7	90	1.39	3	3.0

1 Ground Anchorage Design Calculation

1. 1 Design Requirements

1. 1. 1 Sliding Surface

(1) Required prevention force $P_r = 64.0$ (kN/m)

(2) Sliding surface gradient $\theta = 37.00$ (°)

1. 1. 2 Layout and Functions of Ground Anchorage

(1) Horizontal interval of anchorage $a = 2.00$ (m)

(2) Number of constructed steps $m = 3$ (step)

(3) Angle of inclination of anchorage $\alpha = 30.0$ (°)

(4) Angle formed between anchorage and sliding surface $\beta = \alpha + \theta = 67.00$ (°)

(5) Inhibiting function of anchorage Stressing+Anchoring effect

(6) Internal friction angle of sliding surface $\tan\phi = 0.55431(\phi=29.000^\circ)$

1. 1. 3 Fixed Anchor

(1) Applicable standards Japanese Geotechnical Society

(2) Supporting system of anchorage Friction compression

(3) Materials and type of anchorage PC multi-strand bundle(SEEE ground anchorage) F-UA type
Rank A (Normally)

(4) Allowable adhesive stress of tendon and grout $\tau_b = 1.00$ (N/mm²)

Allowable adhesive stress

(N/mm²)

Restraining force to fixed anchor		Ground with high restraining force*			Ground with low restraining force
		24	30	40	24 or more
Permanent	F-TA Type F-UA Type	1.60	1.80	2.00	1.00

* The ground with high restraining force to the fixed anchor shall be the sandy ground (N-value of 50 or more) and the feasible bedrock as a guide.

Source : SEEE Permanent Ground Anchorage Construction Method
(SE Corporation Aug. 2009)

(5) Skin friction of the fixed anchor $\tau = 0.14 \text{ (N/mm}^2\text{)}$

Skin friction of ground anchorage

Type of ground		Friction resistance (N/mm ²)	
Bedrock	Hard rock	1.50 ~ 2.50	
	Soft rock	1.00 ~ 1.50	
	Weathered rock	0.60 ~ 1.00	
	Hardpan	0.60 ~ 1.20	
Sand and gravel	N-value	10	0.10 ~ 0.20
		20	0.17 ~ 0.25
		30	0.25 ~ 0.35
		40	0.35 ~ 0.45
		50	0.45 ~ 0.70
Sand	N-value	10	0.10 ~ 0.14
		20	0.18 ~ 0.22
		30	0.23 ~ 0.27
		40	0.29 ~ 0.35
		50	0.30 ~ 0.40
Cohesive soil		1.0c (c: cohesion)	

Source : Design and Construction Standards for Ground Anchorage
(Issued by Japanese Geotechnical Society on May 31 2012)

(6) Design safety factor $F_s = 2.5$

Safety factor for ultimate pull-out capacity

		Safety factor
Rank B		1.5
Rank A	(Normally)	2.5
	(At earthquake)	1.5 ~ 2.0

Source : Design and Construction Standards for Ground Anchorage
(Issued by Japanese Geotechnical Society on May 31 2012)

(7) Borehole diameter (fixed anchor diameter) $d_A = 90 \text{ (mm)}$

1. 2 Calculation of Working Load of Anchorage

1. 2. 1 Calculation of Required Anchorage Force

The following shows the relationship between the planned safety factor (PFs) and required prevention force (Pr) of the slope after executing a countermeasure.

$$PFs = \frac{[\text{Resistance to slide}] + Pr}{[\text{Sliding force}]}$$

$$Pr = PFs \cdot [\text{Sliding force}] - [\text{Resistance to slide}]$$

Suppose the required anchorage force is assumed to be P_o , the formula, which regards both the stressing force to press against the sliding surface by the anchorage and the anchoring force to pull up along the sliding surface as “resistance to slide,” is as follows.

$$PFs = \frac{[\text{Resistance to slide}] + P_o \cdot \sin\beta \cdot \tan\phi + P_o \cdot \cos\beta}{[\text{Sliding force}]}$$

$$P_o = \frac{PFs \cdot [\text{Sliding force}] - [\text{Resistance to slide}]}{\cos\beta + \sin\beta \cdot \tan\phi}$$

Accordingly, the required anchorage force is calculated as follows in case of the stressing + anchoring effect.

$$\begin{aligned} P_o &= \frac{Pr}{\cos\beta + \sin\beta \cdot \tan\phi} \\ &= \frac{64.0}{\cos(67.00) + \sin(67.00) \cdot 0.55431} = 71.1 \quad (\text{kN/m}) \end{aligned}$$

1. 2. 2 Calculation of Working Load of Anchorage

The working load of anchorage (Td) is calculated as follows.

$$\begin{aligned} Td &= \frac{P_o \cdot a}{m} \\ &= \frac{71.1 \times 2.00}{3} = 47.4 \quad (\text{kN/pc.}) \end{aligned}$$

Based on the above, the working load of anchorage (Td) per piece is 47.4 kN/pc.

1. 3 Determination of Tendon Standard

Materials and type of anchorage : PC multi-strand bundle(SEE ground anchorage) F-UA type

Tendon standard : F20UA

In the above-mentioned case, the allowable tension is calculated as follows respectively with respect to tensile strength (Tus) and yield strength (Tys).

$$0.60 \cdot T_{us} = 0.60 \times 261.000 = 156.600 \text{ (kN)} \geq 47.4 \text{ (kN/pc.)} \quad \dots \quad \text{OK}$$

$$0.75 \cdot T_{ys} = 0.75 \times 222.000 = 166.500 \text{ (kN)} \geq 47.4 \text{ (kN/pc.)} \quad \dots \quad \text{OK}$$

Tus: Tensile strength (261.000 kN per strand)

Tys: Yield strength (222.000 kN per strand)

Based on the above, F20UA is safe for the working load of anchorage.

1. 4 Calculation of Fixed Anchor Length

1. 4. 1 Calculation Requirements

Allowable adhesive stress of tendon and grout	τ_b	=	1.00 (N/mm ²)
Skin friction of fixed anchor	τ	=	0.14 (N/mm ²)
Design safety factor	F_s	=	2.5
Circumference of tendon's anchoring device with accessory	U	=	119.7 (mm)
Borehole diameter (fixed anchor diameter)	d_A	=	90 (mm)

1. 4. 2 Calculation Results

(1) Tendon restraint length

Tendon restraint length calculated from adhesion between the grout and anchor tendon.

$$l_{sa}' = \frac{Td \cdot 10^3}{U \cdot \tau_b}$$

$$= \frac{47.4 \times 10^3}{119.7 \times 1.00} = 396 \text{ (mm)} = 0.40 \text{ (m)}$$

The following table lists the F-UA Type fixed anchor minimum length (l) according to the maker. It shall be assumed that.

$$l_{sa} = l = 1.39 \text{ m} > l_{sa}' = 0.40 \text{ m}$$

List of F-UA Type Fixed Anchor Minimum Length

Use	Restraining force of ground (large)	Dimensions of fixed anchor			Minimum length a+b+c l(mm)
		anchoring device with accessory a(mm)	Anchoring device with accessory b(mm)	Bearing pressure ring c(mm)	
o	F20UA	170	1200	20	1390
	F40UA	240	1400	20	1660
	F50UA	240	1700	20	1960
	F60UA	280	1800	20	2100
	F70UA	240	2100	20	2360
	F100UA	280	2400	20	2700
	F110UA	340	2600	20	2960
	F130UA	350	2800	20	3170
	F170UA	420	3400	20	3840
	F190UA	450	3500	25	3975

(2) Calculation of the fixed anchor length

Fixed anchor length calculated from friction between the grout and the ground.

$$\begin{aligned} l_a &= \frac{Td \cdot 10^3 \cdot F_s}{\pi \cdot d_A \cdot \tau} \\ &= \frac{47.4 \times 10^3 \times 2.5}{\pi \times 90 \times 0.14} = 2994 \text{ (mm)} = 3.00 \text{ (m)} \end{aligned}$$

(3) Determination of the fixed anchor length

Based on the following; $l_{sa} = 1.39 \text{ (m)} < l_a = 3.00 \text{ (m)}$

The fixed anchor length (L_a) is $L_a = 3.00 \text{ m}$.

Appendix-5

Design calculation report on
Grating crib works

Design Calculation Report on Grating Crib Works

<u>Site</u>	KANDY UPPER 300-300 for soil nailing
<u>Case</u>	Line E, Pr(max)
<u>Remarks</u>	φ 34 C6

Calculation requirement								
Item				Symbol	Unit	Numerical value		
Design tension				Td	kN/pc.	49.420		
Slope protection reduction coefficient				μ	-	1.00		
Reinforcement tension working on slope protection				To	kN/pc.	49.420		
Vertical frame	Number of spans			n ₁	Span	12		
	Span length			l ₁	m	2.000		
	Projection length	Top	Bottom	l _{1a}	l _{1b}	1.000	1.000	
Horizontal frame	Number of spans			n ₂	Span	4		
	Span length			l ₂	m	2.000		
	Projection length	Left	Right	l _{2a}	l _{2b}	1.000	1.000	
Frame height × Frame width				h×b	mm	300 × 300		
Effective height				d	mm	235		
Design strength of mortar				f' _{ck}	N/mm ²	18		
Characteristic value of tensile yield strength of reinforcing bar				f _{yk}	N/mm ²	345		
Characteristic value of tensile yield strength of shear reinforcement				f _{wyk}	N/mm ²	-		
Partial safety factors	Material factor		Member factor			Structural analysis factor	Load factor	Structure factor
	Mortar	Steel						
Ultimate limit state	1.30	1.00	Bend, axial load strength		1.15	1.00	1.20	1.20
			Shear strength borne by mortar		1.30			
			Shear strength borne by shear reinforcement		-			
			Diagonal compressive breaking strength		-			

Calculation results					
Item			Symbol	Unit	Numerical value
Ultimate limit state	Design bending moment		M _d	kN·m	6.88
	Design shearing force		V _d	kN	19.46

Main reinforcing bar		Stirrup		Ultimate limit state				Evaluation
Nominal diameter	Quantity (one side)	Nominal diameter	Interval (mm)	Bending moment check		Shear force check		
				Reinforcement ratio	Safety	Compression failure	Safety	
D13	2	-	-	0.00359	0.49	-	0.88	OK
Evaluation requirement				≤ 0.01372	≤ 1.00	≤ -	≤ 1.00	/

1. Design Policy

1.1. Structural Model

The structural model shall ensure that ground reaction generated by the design tension works on the slope frame as a uniformly distributed load, and shall be a beam model taking the reinforcement installation position as a fulcrum.

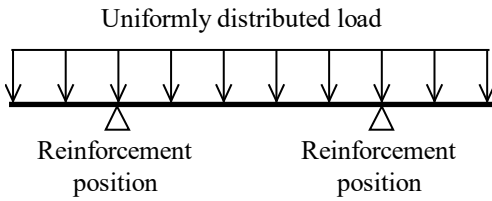

1.2. Bearing of Load

The load applied to the slope frame shall be applied to the vertical and horizontal frames as a uniformly distributed load by the tensile load of the reinforcement, and the uniformly distributed load shall be calculated by distributing the load per reinforcement by the slope frame length.

When this is done, take account of the slope frame width of the intersection point.

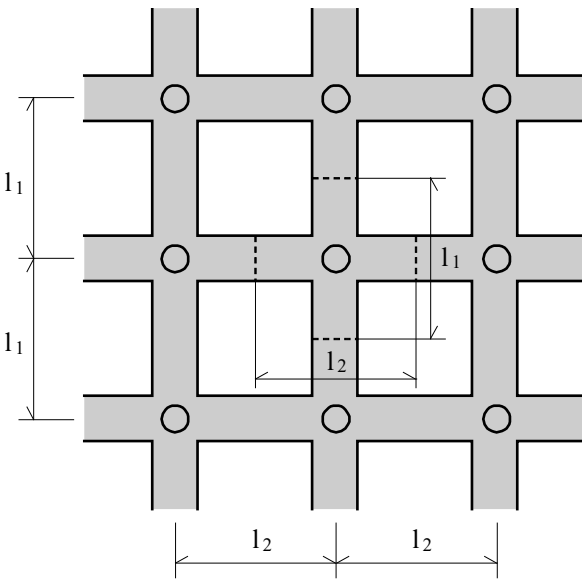

1.3. Safety Check

Study the safety of the slope frame by the limit state design method (performance check type).

Check that the slope frame does not reach the limit state during its in-service period. The limit state is divided into the ultimate limit state, use limit state and fatigue limit state.

The ultimate limit state refers to the limit state for the maximum load assumed during the in-service period. In case of reinforcement insertion work, the tension is generated to the reinforcement by deformation of the natural ground, etc., causing ground reaction to work on the slope frame structure as a load. Taking this as the maximum load, check safety.

The use limit state refers to the limit state related to normal usability, functional securement and durability. In case of reinforcement insertion work, ground reaction does not work on the slope frame because the tension is not given to the reinforcement during construction. Accordingly, checking of the use limit state is omitted because it is conceived that the load generally does not work during the in-service period. Accordingly, checking of the use limit state is omitted because it is generally presumed that the load does not work during the in-service period.

The fatigue limit state refers to the limit state of fatigue fracture resulting from a repeated load and a fluctuating load. Checking of the fatigue limit state is omitted because it is conceived that the slope frame structure is hardly affected by them.

2. Design Requirements

2.1. Calculation of Reinforcement Tension Working on Slope Protection

The design tension T_d uses the maximum value [Reinforcement No. 1] 49.420 kN/pc.

The reinforcement tension T_o working on slope protection is as follows.

$$\begin{aligned} T_o &= \mu \cdot T_d = 1.00 \times 49.420 \\ &= 49.420 \text{ (kN/pc.)} \end{aligned}$$

μ : Slope protection reduction coefficient

2.2. Shape and Dimensions of Slope Frame

Number of spans of vertical fame	n_1	=	12
Span length	l_1	=	2.000 (m)
Upper projection length	l_{1a}	=	1.000 (m)
Lower projection length	l_{1b}	=	1.000 (m)
Number of spans of horizontal fame	n_2	=	4
Span length	l_2	=	2.000 (m)
Left projection length	l_{2a}	=	1.000 (m)
Right projection length	l_{2b}	=	1.000 (m)
Frame width	b	=	300 (mm)
Frame height	h	=	300 (mm)
Effective height	d	=	235 (mm)

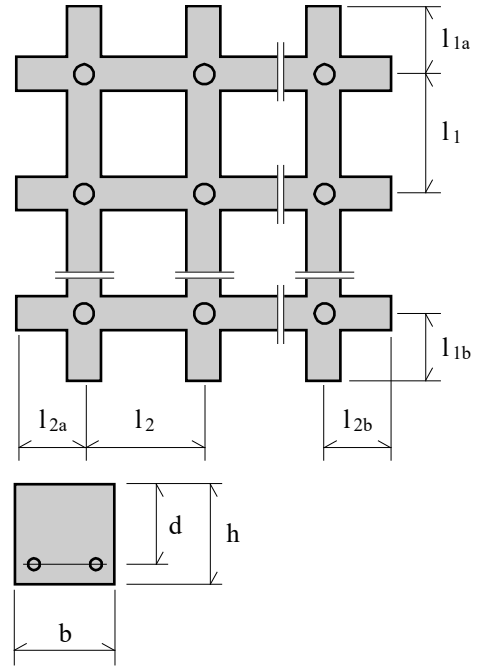

3. Calculation of Maximum Bending Moment and Maximum Shear Force

3.1. Working Load

The uniformly distributed loads w_1 and w_2 working on the slope frame are calculated as follows.

Vertical frame length bearing the load per reinforcement.

$$l_h = l_1 = 2.000 \text{ (m)}$$

Horizontal frame length bearing the load per reinforcement.

$$l_w = l_2 = 2.000 \text{ (m)}$$

Accordingly;

$$\begin{aligned} w_1 = w_2 &= \frac{T_o}{l_h + l_w - b} = \frac{49.420}{2.000 + 2.000 - 0.300} \\ &= 13.36 \text{ (kN/m)} \end{aligned}$$

3.2. Maximum bending moment and maximum shear force generated to the vertical frame
 In case of 4 spans or more, calculate as a continuous beam. When this is done, take no account of the projection parts.

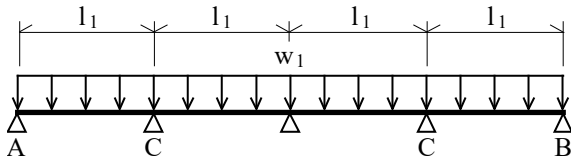

· Maximum bending moment generated at the first internal fulcrum (C)

$$\begin{aligned} M_{\max_C} &= \frac{3}{28} \cdot w_1 \cdot l_1^2 \\ &= \frac{3}{28} \times 13.36 \times 2.000^2 \\ &= 5.73 \text{ (kN}\cdot\text{m)} \end{aligned}$$

· Maximum shear force generated outside the first internal fulcrum (C)

$$\begin{aligned} S_{\max_C} &= \frac{17}{28} \cdot w_1 \cdot l_1 \\ &= \frac{17}{28} \times 13.36 \times 2.000 \\ &= 16.22 \text{ (kN)} \end{aligned}$$

3.3. Maximum bending moment and maximum shear force generated to the horizontal frame
 In case of 4 spans or more, calculate as a continuous beam. When this is done, take no account of the projection parts.

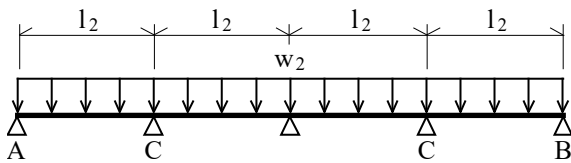

· Maximum bending moment generated at the first internal fulcrum (C)

$$\begin{aligned} M_{\max_C} &= \frac{3}{28} \cdot w_2 \cdot l_2^2 \\ &= \frac{3}{28} \times 13.36 \times 2.000^2 \\ &= 5.73 \text{ (kN}\cdot\text{m)} \end{aligned}$$

· Maximum shear force generated outside the first internal fulcrum (C)

$$\begin{aligned} S_{\max_C} &= \frac{17}{28} \cdot w_2 \cdot l_2 \\ &= \frac{17}{28} \times 13.36 \times 2.000 \\ &= 16.22 \text{ (kN)} \end{aligned}$$

3.4. Determination of Maximum Stress

The following table lists the stresses working on the vertical and horizontal frames.

Position		Bending moment (kN·m)	Shear force (kN)
Vertical frame	First internal fulcrum	5.73	16.22
	Projection part	-	-
Horizontal frame	First internal fulcrum	5.73	16.22
	Projection part	-	-

Accordingly, the maximum stresses generated to the vertical and horizontal frames are as follows in comparison with each other.

$$\begin{aligned} \text{Maximum bending moment} \quad M_{\max} &= 5.73 \text{ (kN}\cdot\text{m)} \\ \text{Maximum shear force} \quad S_{\max} &= 16.22 \text{ (kN)} \end{aligned}$$

4. Limit State Check

4.1. Materials and Cross-sectional Specifications

(1) Slope frame

Frame width	b	=	300 (mm)
Frame height	h	=	300 (mm)
Effective height	d	=	235 (mm)
Blockout diameter (outer diameter)	D	=	89 (mm)
Design strength of mortar (Characteristic value of compressive strength)	f_{ck}	=	18 (N/mm ²)

(2) Main reinforcing bar (Tensile reinforcement)

Type	SD345	D13
Reinforcing bar diameter	ϕ	= 13 (mm)
Number of reinforcing bars (one side)	n	= 2 (pcs.)
Tensile reinforcement volume	A_s	= 253.4 (mm ²)
Characteristic value of tensile yield strength of reinforcing bar	f_{yk}	= 345 (N/mm ²)
Young's modulus of reinforcing bar	E_s	= 200 (kN/mm ²)

(3) Shear reinforcement

The shear reinforcement is not studied because the stirrups are not arranged.

(4) Arrangement

Arrangement length of steel bar	l	=	186 (mm)
Covering of tensile reinforcement	c	=	$h - (d + \frac{\phi}{2}) = 59$ (mm)
Reinforcing bar center distance (Value when reinforcing bars are equally spaced in the arrangement section)	c_s	=	$\frac{l - \phi}{n - 1} = 173$ (mm)
Reinforcing bar interval (Value when reinforcing bars are equally spaced in the arrangement section)	a	=	$c_s - \phi = 160$ (mm)

4.2. Partial Safety Factors

Partial safety factors are set as follows, taking account of variations of material strength and member dimensions, importance of the structure and members, and uncertainty of structural analysis.

Partial safety factors	Material factor		Member factor γ_b	Structural analysis factor γ_a	Load factor γ_f	Structure factor γ_i	
	Mortar γ_c	Steel γ_s					
Ultimate limit state	1.30	1.00	Bend, axial load strength	1.15	1.00	1.20	1.20
			Shear strength borne by mortar	1.30			
			Shear strength borne by shear reinforcement	-			
			Diagonal compressive breaking strength	-			

The partial safety factors are used in calculating the design cross-sectional strength and design cross-sectional force.

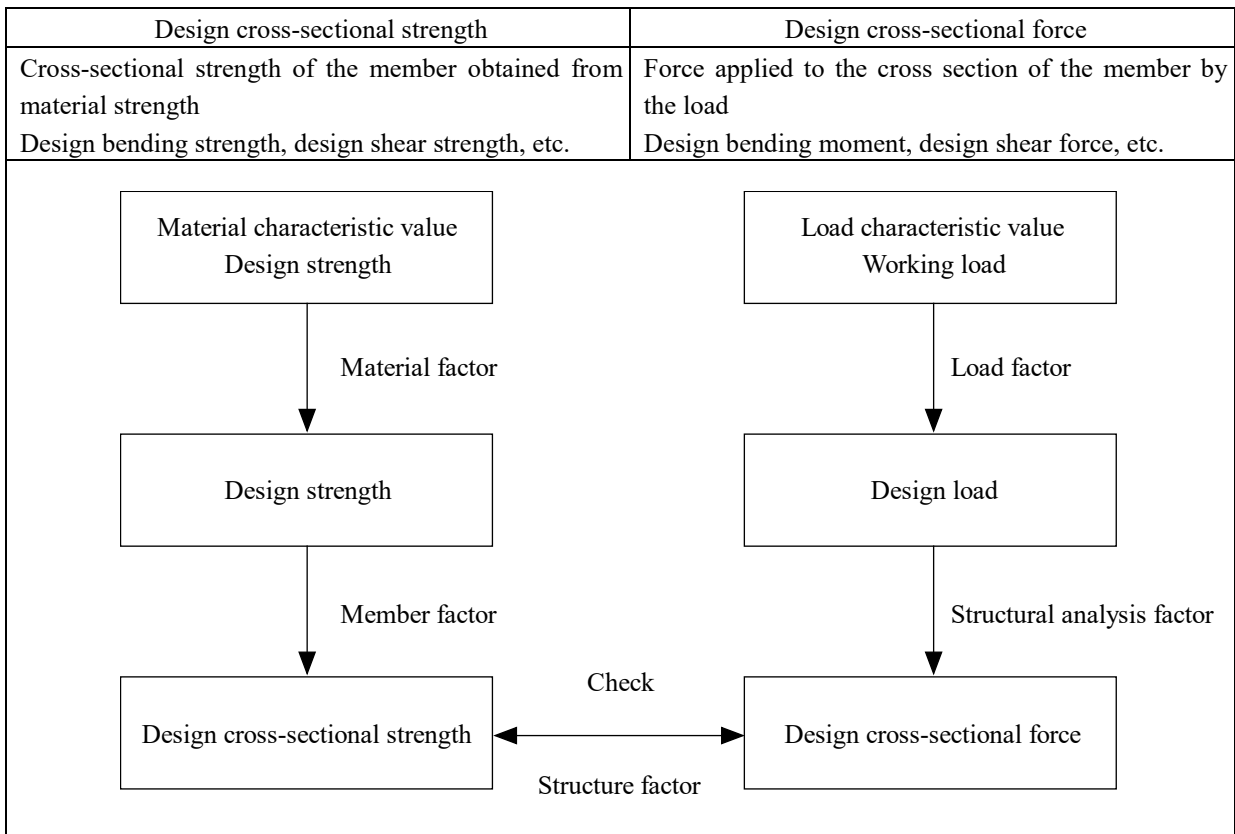

4.3. Design Load and Design Cross-sectional Force

The design load used for calculating the design cross-sectional force for grating crib works is obtained by multiplying the working load by the load factor.

Accordingly, the cross-sectional force allowing for the design load can be obtained by multiplying the previously obtained maximum bending moment and maximum shear force by the load factor.

Limit state	Design load (Working load $\times\gamma_f$)	Cross-sectional force allowing for design load	
Ultimate limit state	Working load $\times 1.20$	Maximum bending moment M'	6.88 (kN·m)
		Maximum shear force V'	19.46 (kN)

The design cross-sectional force is obtained by multiplying the cross-sectional force allowing the design load by the structural analysis factor.

Limit state	Structural analysis factor γ_a	Design cross-sectional force	
Ultimate limit state	1.00	Design bending moment M_d	6.88 (kN·m)
		Design shearing force V_d	19.46 (kN)

4.4. Safety Performance Check

In safety performance check of the slope frame, check that the ultimate limit state of cross-sectional fracture does not result from action of the bending moment and shear force.

4.4.1 Bending Moment Check

(1) Study of the tensile reinforcement volume

If the axial tensile reinforcement volume is too high, compression fracture of mortar may advance at the time of cross-sectional fracture, resulting in brittle fracture. Assuming that the maximum value of tensile reinforcement volume is 75% of the balanced percentage of reinforcement, accordingly, check that a tension reinforcement ratio is lower than this.

Coefficient related to balanced percentage of reinforcement	α	$=$	$0.88-0.004 \cdot f_{ck}$	$=$	$0.88-0.004 \times 18$
					$= 0.81$ ($\alpha \leq 0.68$) Therefore, $\alpha=0.68$
Ultimate strain of mortar	ε'_{cu}	$=$	$\frac{155-f_{ck}}{30000}$	$=$	$\frac{155-18}{30000}$
					$= 0.0046$ ($0.0025 \leq \varepsilon'_{cu} \leq 0.0035$) Therefore, $\varepsilon'_{cu}=0.0035$
Design compressive strength of mortar	f'_{cd}	$=$	$\frac{f_{ck}}{\gamma_c}$	$=$	$\frac{18}{1.30} = 13.85$ (N/mm ²)
Design tensile yield strength of reinforcement bar	f_{yd}	$=$	$\frac{f_{yk}}{\gamma_s}$	$=$	$\frac{345}{1.00} = 345$ (N/mm ²)

The reinforcement ratio p is calculated as follows.

$$p = \frac{A_s}{b \cdot d} = \frac{253.4}{300 \times 235} = 0.00359$$

The balanced percentage of reinforcement p_b is calculated as follows.

$$p_b = \alpha \cdot \frac{\varepsilon'_{cu}}{\varepsilon'_{cu} + \frac{f_{yd}}{E_s}} \cdot \frac{f'_{cd}}{f_{yd}} = 0.68 \times \frac{0.0035}{0.0035 + \frac{345}{200 \times 10^3}} \times \frac{13.85}{345} = 0.01829$$

Accordingly, $p = 0.00359 \leq 0.75 \cdot p_b = 0.01372$.

Tensile reinforcement will yield first. ... OK

(2) Design bending strength

The design cross-sectional strength of the slope frame subject to the bending moment is calculated based on the following assumptions.

- Longitudinal strain is proportional to the distance from the neutral axis of the cross section.
- Tensile stress of the mortar is ignored.
- A non-linear model is used for the mortar and reinforcing bar stress-strain curve.

Assuming that all of cross-sectional strain is not compressed, make calculation, considering the compressive stress distribution of the mortar as an equivalent stress block.

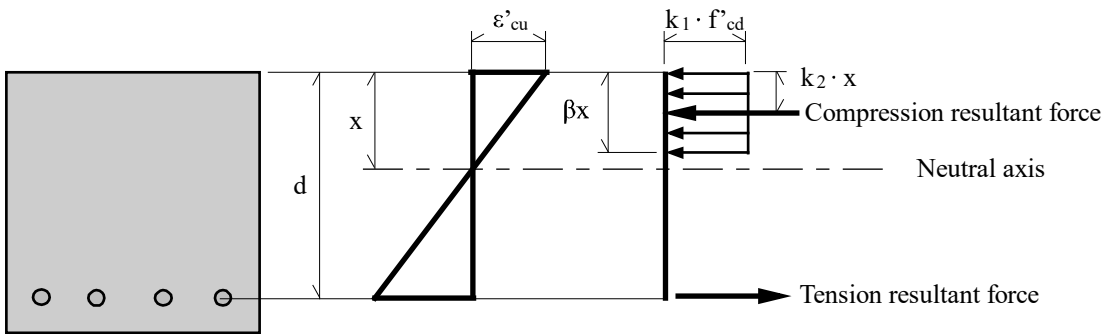

Frame cross section

Ultimate strain distribution

Equivalent stress block

Coefficient related to equivalent stress block of bending strength	$\beta = 0.52 + 80 \cdot \epsilon'_{cu} = 0.52 + 80 \times 0.0035$	$= 0.8$
Strength reduction coefficient	$k_1 = 1 - 0.003 \cdot f_{ck} = 1 - 0.003 \times 18$	$= 0.95 (k_1 \leq 0.85)$ Therefore, $k_1 = 0.85$
Ratio of distance to compression resultant force to distance x from extreme compression fiber to neutral axis	$k_2 = \frac{\beta}{2} = \frac{0.8}{2}$	$= 0.4$

The ultimate bending strength M_u is calculated as follows.

$$\begin{aligned}
 M_u &= \frac{b \cdot d^2 \cdot p \cdot f_{yd} \cdot \left(1 - \frac{k_2}{\beta \cdot k_1} \cdot \frac{p \cdot f_{yd}}{f_{cd}}\right)}{1} \\
 &= \frac{300 \times 235^2 \times 0.00359 \times 345 \times \left(1 - \frac{0.4}{0.8 \times 0.85} \times \frac{0.00359 \times 345}{13.85}\right)}{1} \\
 &= 19.44 \times 10^6 \text{ (N}\cdot\text{mm)} = 19.44 \text{ (kN}\cdot\text{m)}
 \end{aligned}$$

The design bending strength M_{ud} is calculated as follows.

$$\begin{aligned}
 M_{ud} &= \frac{M_u}{\gamma_b} = \frac{19.44}{1.15} \\
 &= 16.90 \text{ (kN}\cdot\text{m)}
 \end{aligned}$$

(3) Safety check

$$\gamma_i \cdot \frac{M_d}{M_{ud}} = 1.20 \times \frac{6.88}{16.90} = 0.49 \leq 1.00 \quad \dots \quad \text{OK}$$

4.4.2 Shear Force Check

(1) Design shear strength borne by the mortar

Shear strength of mortar	$f_{vcd} = \frac{0.20 \cdot f_{cd}}{\sqrt[3]{f_{cd}}} = 0.20 \times \sqrt[3]{13.85}$ $= 0.48 \text{ (N/mm}^2\text{)} \quad (f_{vcd} \leq 0.72)$
Coefficient related to effective height of shear strength	$\beta_d = \sqrt[4]{1000/d} = \sqrt[4]{1000/235}$ $= 1.44 \quad (\beta_d \leq 1.5)$
Coefficient related to axial reinforcement ratio of shear strength	$\beta_p = \sqrt[3]{100 \cdot p} = \sqrt[3]{100 \times 0.00359}$ $= 0.71 \quad (\beta_p \leq 1.5)$
Coefficient related to axial force of shear strength	$\beta_n = 1.00 \text{ (The axial force does not work on the slope frame.)}$

The design shear strength V_{cd} borne by the mortar is calculated as follows.

$$V_{cd} = \frac{\beta_d \cdot \beta_p \cdot \beta_n \cdot f_{vcd} \cdot b \cdot d}{\gamma_b} = \frac{1.44 \times 0.71 \times 1.00 \times 0.48 \times 300 \times 235}{1.30}$$

$$= 26.61 \times 10^3 \text{ (N)} = 26.61 \text{ (kN)}$$

(2) Design shear strength borne by the shear reinforcement

It shall be $V_{sd} = 0.0$ (kN) because no shear reinforcements are arranged.

(3) Design shear strength

Since the design shear strength V_{yd} is a combination of the design shear strength borne by the mortar and that borne by the shear reinforcement, it will be as follows.

$$V_{yd} = V_{cd} + V_{sd} = 26.61 + 0.00$$

$$= 26.61 \text{ (kN)}$$

(4) Study of the design diagonal compressive breaking strength of the mortar abdomen

Study of the design diagonal compressive breaking strength of the mortar abdomen is omitted because no shear reinforcements are arranged.

(5) Safety check

$$\gamma_i \cdot \frac{V_d}{V_{yd}} = 1.20 \times \frac{19.46}{26.61} = 0.88 \leq 1.00 \quad \dots \quad \text{OK}$$

5. Study of Bearing Stress

5.1. Allowable Bearing Stress

(1) Study requirements

Design strength of mortar	f_{ck}	=	18	(N/mm ²)
Plate width	u	=	150	(mm)
Blockout diameter	D	=	89	(mm)
Frame width	b	=	300	(mm)
Total area of mortar surface	A	=	b^2	= 300 ²
		=	90000	(mm ²)
Plate effective area	A_a	=	$u^2 - \pi \cdot D^2 / 4$	= 150 ² - $\pi \times 89^2 / 4$
		=	16279	(mm ²)

(2) Calculation of the allowable bearing stress

In case of local loading, the allowable bearing stress σ_{ba} is calculated as follows.

$$\begin{aligned} \sigma_{ba} &\leq \left(0.25 + 0.05 \cdot \frac{A}{A_a}\right) \cdot f_{ck} = \left(0.25 + 0.05 \times \frac{90000}{16279}\right) \times 18 \\ &= 9.48 \text{ (N/mm}^2\text{)} \end{aligned}$$

However, it shall be restrained within 50% of the design strength.

$$\begin{aligned} \sigma_{ba} &\leq 0.5 \cdot f_{ck} = 0.5 \times 18 \\ &= 9.00 \text{ (N/mm}^2\text{)} \end{aligned}$$

Accordingly, the allowable bearing stress σ_{ba} shall be the following value.

$$\sigma_{ba} = 9.00 \text{ (N/mm}^2\text{)}$$

5.2. Bearing Stress

Check the bearing stress σ_b .

$$\begin{aligned} \sigma_b &= \frac{T_o}{A_a} = \frac{49.420 \times 10^3}{16279} \\ &= 3.04 \text{ (N/mm}^2\text{)} \leq \sigma_{ba} = 9.00 \text{ (N/mm}^2\text{)} \quad \dots \text{ OK} \end{aligned}$$

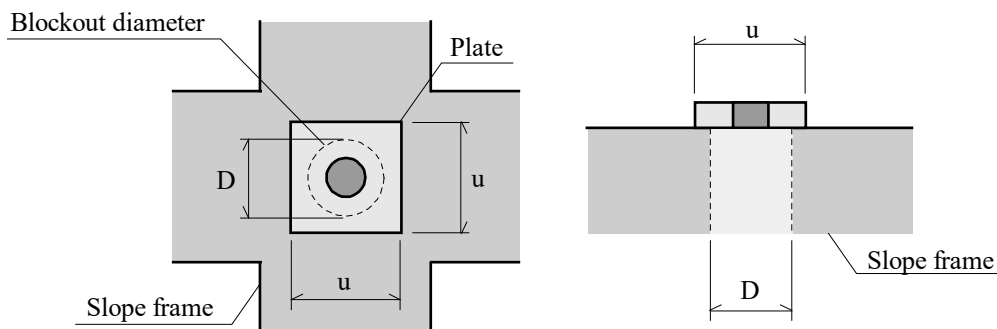

6. Lap Joint of Reinforcing Bar

The lap joint length of reinforcing bars shall be equal to or longer than the basic development length.

Main reinforcing bar	D13 - 2 pcs. ($\phi=13(\text{mm})$)
Covering of tensile reinforcement	$c = 59$ (mm)
Reinforcing bar interval (Value when reinforcing bars are equally spaced in the arrangement section)	$a = 160$ (mm)
Design tensile yield strength of reinforcing bar	$f_{yd} = 345$ (N/mm ²)
Design strength of mortar	$f_{ck} = 18$ (N/mm ²)
Material factor of mortar	$\gamma_c = 1.30$
Design adhesive strength of mortar	$f_{bod} = \frac{0.28 \cdot f_{ck}^{2/3}}{\gamma_c} = \frac{0.28 \times 18^{2/3}}{1.30}$ $= 1.479$ (N/mm ²) ($f_{bod} \leq 3.2$)

“c” used here is either covering of the tensile reinforcement or half value of the interval of anchored reinforcing bars, whichever is lower. Accordingly;

$$c = \min \left(59, \frac{160}{2} \right) = 59 \text{ (mm)}$$

The coefficients k_c and α related to the basic development length will be as follows.

$$k_c = \frac{c}{\phi} + \frac{15 \cdot A_t}{s \cdot \phi} = \frac{59}{13} \quad (* \text{ It shall be } \frac{15 \cdot A_t}{s \cdot \phi} = 0 \text{ because no stirrups are arranged.})$$

$$= 4.538$$

In case of	$k_c \leq 1.0$	$\alpha = 1.0$
In case of	$1.0 < k_c \leq 1.5$	$\alpha = 0.9$
In case of	$1.5 < k_c \leq 2.0$	$\alpha = 0.8$
In case of	$2.0 < k_c \leq 2.5$	$\alpha = 0.7$
In case of	$2.5 < k_c$	$\alpha = 0.6$

Based on $k_c = 4.538$, $\alpha = 0.6$.

The basic development length l_d is calculated as follows.

$$l_d = \frac{\alpha \cdot f_{yd} \cdot \phi}{4 \cdot f_{bod}} = \frac{0.6 \times 345 \times 13}{4 \times 1.479}$$

$$= 455 \text{ (mm)}$$

Accordingly, the lap joint length of reinforcing bars needs to be 455 mm or more.

Design Calculation Report on Grating Crib Works
(Spraying Crib Works)

Area	Kandy LOWER
Traverse line	B
Remarks	400×400 for Ground Anchor

Calculation requirement							
Item				Symbol	Unit	Numerical value	
Working load of anchorage				Td	kN/pc.	47.4	
Vertical beam	Number of spans			l_{1n}	Span	2	
	Span length			l_1	m	2.00	
	Projection length	Top	Bottom	-	m	1.00	1.00
Horizontal beam	Number of spans			l_{2n}	Span	3	
	Span length			l_2	m	2.00	
	Projection length	Left	Right	-	m	1.00	1.00
Beam height × Beam width				$h \times b$	mm	400×400	
Effective height				d	mm	315	
Design strength of mortar				f'_{ck}	N/mm ²	18	
Young's modulus of mortar				E_c	kN/mm ²	22.0	
Characteristic value of tensile yield strength of reinforcing bar				f_{yk}	N/mm ²	345	
Young's modulus of reinforcing bar				E_s	kN/mm ²	200	
Characteristic value of tensile yield strength of shear reinforcement				f_{wyk}	N/mm ²	345	
Coefficient indicating the effect of steel surface shape on cracks				k_1	-	1.00	
Coefficient indicating the effect of mortar quality on crack width				k_2	-	0.90	
Numerical value for allowing for increased crack width by mortar contraction, etc.				ε'_{csd}	-	150×10^{-6}	
Stress intensity limit value of shear reinforcement				σ_a	N/mm ²	120	

Safety factors				
Item	Symbol	Unit	Ultimate limit state	Use limit state
Mortar	γ_c	-	1.30	1.00
Steel	γ_s	-	1.00	-
Bend, axial load strength	γ_b	-	1.15	1.00
Shear strength borne by mortar			1.30	
Shear strength borne by shear reinforcement			1.10	
Diagonal compressive breaking strength			1.30	
Structural analysis factor	γ_a	-	1.00	1.00
Load factor	γ_f	-	1.20	1.00
Structure factor	γ_i	-	1.20	1.00

Calculation results				
Item	Symbol	Unit	Ultimate limit state	Use limit state
Design bending moment	M_d	kN·m	7.91	6.59
Design shear force	V_d	kN	19.75	16.46

Main reinforcing bar		Stirrup		Ultimate limit state				Use limit state		Evaluation
Dia.	Qty. (one side)	Dia.	Interval (mm)	Bending moment		Shear force		Flexural crack	Shear crack	
				Reinforcement ratio	Safety	Compression failure	Safety			
D16	2	D13	300	0.00315	0.27	114.64	0.21	0.55	Omitted	OK
Evaluation requirement				≤ 0.01372	≤ 1.00	≤ 450.69	≤ 1.00	≤ 1.00	≤ 1.00	

1 Design Calculation of Grating Crib Works

1.1 Design Policy

1.1.1 Structural Model

The structural model shall ensure that ground reaction generated by the design tension works on the slope frame as a uniformly distributed load, and shall be a beam model taking the reinforcement installation position as a fulcrum.

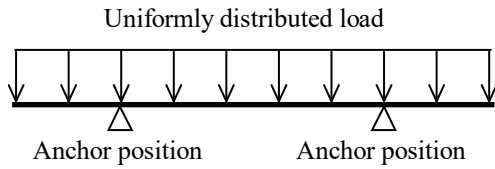

1.1.2 Bearing of Load

Distribute the load per anchor uniformly by the load bearing slope frame area.

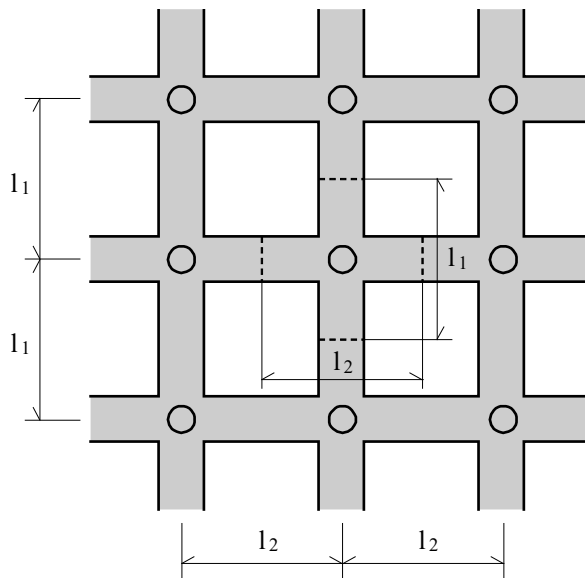

1.1.3 Safety Check

Study the safety of the slope frame by the limit state design method (performance check type).

Check that the slope frame does not reach the limit state during its in-service period. The limit state is divided into the ultimate limit state, use limit state and fatigue limit state.

The ultimate limit state refers to the limit state for the maximum load assumed during the in-service period. In case of ground anchorage construction, the anchorage force is always acting and its acting force is considered as ground reaction. Taking this as the maximum load, check safety.

The use limit state refers to the limit state related to normal usability, functional securement and durability. In case of ground anchorage construction, the anchorage force is always acting on the slope frame structure from the anchor head during use. Accordingly, check the use limit state as well.

The fatigue limit state refers to the limit state of fatigue fracture resulting from a repeated load and a fluctuating load. Checking of the fatigue limit state is omitted because it is conceived that the slope frame structure is hardly affected by them.

1.2 Design Requirements

1.2.1 Working Load of Anchorage

Working load of anchorage

$$T_d = 47.4 \text{ (kN/pc.)}$$

1.2.2 Shape and Dimensions of Slope Frame

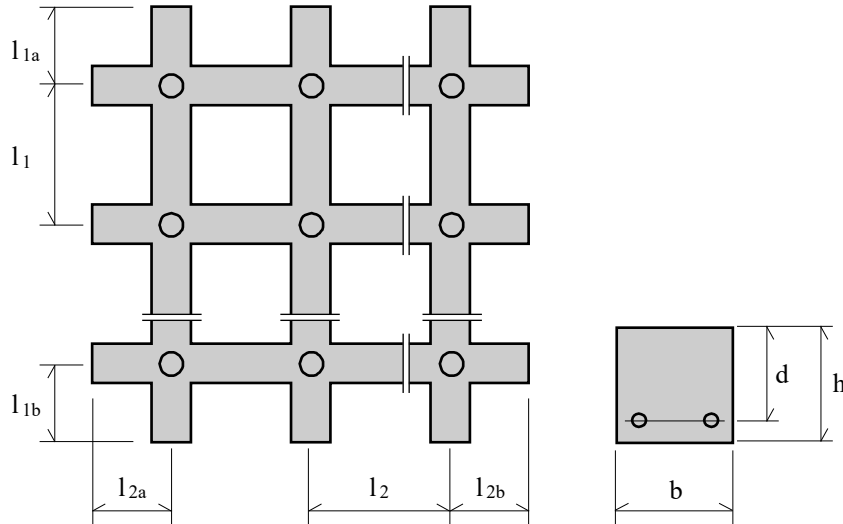

Number of spans of vertical beam

$$l_{1n} = 2$$

Span length

$$l_1 = 2.00 \text{ (m)}$$

Upper projection length

$$l_{1a} = 1.00 \text{ (m)}$$

Lower projection length

$$l_{1b} = 1.00 \text{ (m)}$$

Number of spans of horizontal beam

$$l_{2n} = 3$$

Span length

$$l_2 = 2.00 \text{ (m)}$$

Left projection length

$$l_{2a} = 1.00 \text{ (m)}$$

Right projection length

$$l_{2b} = 1.00 \text{ (m)}$$

Beam width

$$b = 400 \text{ (mm)}$$

Beam height

$$h = 400 \text{ (mm)}$$

Effective height

$$d = 315 \text{ (mm)}$$

1.3 Study of Bearing Capacity of Ground

1.3.1 Study Requirements

Allowable bearing capacity	q_a	=	100	(kN/m ²)
Vertical span length	l_1	=	2.00	(m)
Horizontal span length	l_2	=	2.00	(m)
Beam width	b	=	0.400	(m)

1.3.2 Study Results

The loading area (A) borne by each anchorage is as follows.

$$\begin{aligned} A &= b \cdot (l_1 + l_2 - b) \\ &= 0.400 \times (2.00 + 2.00 - 0.400) \\ &= 1.44 \text{ (m}^2\text{)} \end{aligned}$$

Accordingly, the bearing capacity of ground is calculated as follows.

$$\begin{aligned} q &= \frac{Td}{A} = \frac{47.4}{1.44} \\ &= 33 \text{ (kN/m}^2\text{)} \leq 100 \text{ (kN/m}^2\text{)} \quad \dots \text{ OK} \end{aligned}$$

1.4 Calculation of Maximum Bending Moment and Maximum Shear Force

1.4.1 Working Load

The uniformly distributed loads w_1 and w_2 working on the slope frame are calculated as follows.

Vertical frame length bearing the load per anchorage

$$\begin{aligned}l_h &= \frac{l_{1a}+l_1 \cdot l_{1n}+l_{1b}}{l_{1n}+1} \\&= \frac{1.00+2.00 \times 2+1.00}{2+1} \\&= 2.00 \text{ (m)}\end{aligned}$$

Horizontal frame length bearing the load per anchorage

$$\begin{aligned}l_w &= \frac{l_{2a}+l_2 \cdot l_{2n}+l_{2b}}{l_{1n}+1} \\&= \frac{1.00+2.00 \times 3+1.00}{3+1} \\&= 2.00 \text{ (m)}\end{aligned}$$

Accordingly;

$$w_1 = w_2 = \frac{Td}{l_h+l_w-b} = \frac{47.4}{2.00+2.00-0.400} = 13.17 \text{ (kN/m)}$$

1.4.2 Maximum Bending Moment and Maximum Shear Force

(1) Maximum bending moment and maximum shear force generated to the vertical beam

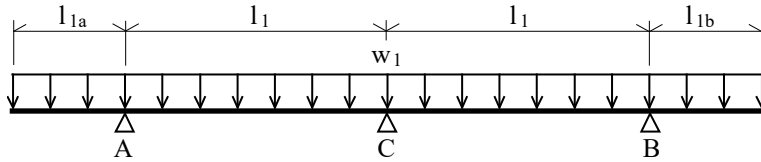

In case of 2 spans, M_{max_1} and S_{max_1} are calculated as follows.

· Maximum bending moment generated at the first internal fulcrum (C)

$$\begin{aligned} M_{max_c} &= \frac{1}{8} \cdot w_1 \cdot l_1^2 \\ &= \frac{1}{8} \times 13.17 \times 2.00^2 \\ &= 6.59 \text{ (kN}\cdot\text{m)} \end{aligned}$$

· Maximum bending moment generated to the projection part

$$\begin{aligned} M_{max_A} &= \frac{1}{2} \cdot w_1 \cdot l_{1a}^2 \\ &= \frac{1}{2} \times 13.17 \times 1.00^2 \\ &= 6.59 \text{ (kN}\cdot\text{m)} \end{aligned}$$

· Maximum shear force generated outside the first internal fulcrum (C)

$$\begin{aligned} S_{max_c} &= \frac{5}{8} \cdot w_1 \cdot l_1 \\ &= \frac{5}{8} \times 13.17 \times 2.00 \\ &= 16.46 \text{ (kN)} \end{aligned}$$

· Maximum shear force generated to the projection part

$$\begin{aligned} S_{max_A} &= w_1 \cdot l_{1a} \\ &= 13.17 \times 1.00 \\ &= 13.17 \text{ (kN)} \end{aligned}$$

Based on the above, the maxim stresses generated to the vertical beam are as follows.

$$\text{Maximum bending moment} \quad M_{max_1} = 6.59 \text{ (kN}\cdot\text{m)}$$

$$\text{Maximum shear force} \quad S_{max_1} = 16.46 \text{ (kN)}$$

(2) Maximum bending moment and maximum shear force generated to the horizontal beam

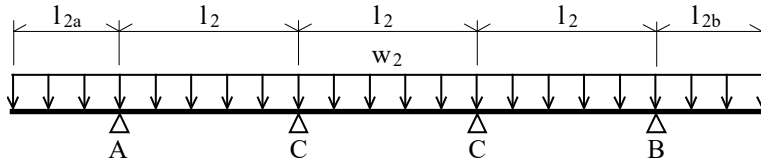

In case of 3 spans, M_{max_2} and S_{max_2} are calculated as follows.

· Maximum bending moment generated at the first internal fulcrum (C)

$$\begin{aligned}
 M_{max_c} &= \frac{1}{10} \cdot w_2 \cdot l_2^2 \\
 &= \frac{1}{10} \times 13.17 \times 2.00^2 \\
 &= 5.27 \text{ (kN}\cdot\text{m)}
 \end{aligned}$$

· Maximum bending moment generated to the projection part

$$\begin{aligned}
 M_{max_A} &= \frac{1}{2} \cdot w_2 \cdot l_{2a}^2 \\
 &= \frac{1}{2} \times 13.17 \times 1.00^2 \\
 &= 6.59 \text{ (kN}\cdot\text{m)}
 \end{aligned}$$

· Maximum shear force generated outside the first internal fulcrum (C)

$$\begin{aligned}
 S_{max_c} &= \frac{3}{5} \cdot w_2 \cdot l_2 \\
 &= \frac{3}{5} \times 13.17 \times 2.00 \\
 &= 15.80 \text{ (kN)}
 \end{aligned}$$

· Maximum shear force generated to the projection part

$$\begin{aligned}
 S_{max_A'} &= w_2 \cdot l_{2a} \\
 &= 13.17 \times 1.00 \\
 &= 13.17 \text{ (kN)}
 \end{aligned}$$

Based on the above, the maximum stresses generated to the horizontal beam are as follows.

Maximum bending moment $M_{max_2} = 6.59 \text{ (kN}\cdot\text{m)}$

Maximum shear force $S_{max_2} = 15.80 \text{ (kN)}$

Accordingly, the maximum stresses generated to the vertical and horizontal beams are as follows in comparison with each other.

$$\text{Maximum bending moment} \quad M_{\max} = 6.59 \text{ (kN}\cdot\text{m)}$$

$$\text{Maximum shear force} \quad S_{\max} = 16.46 \text{ (kN)}$$

1.5 Limit State Check

1.5.1 Materials and Cross-sectional Specifications

(1) Slope frame

Beam width	b	=	400 (mm)
Beam height	h	=	400 (mm)
Effective height	d	=	315 (mm)
Anchorage breakout diameter (outer diameter)	D_1	=	140 (mm)
Design strength of mortar (characteristic value of compressive strength)	f_{ck}	=	18 (N/mm ²)
Young's modulus of mortar	E_c	=	22.0 (kN/mm ²)

(2) Main reinforcing bar (Tensile reinforcement)

Type	SD345	D16	
Reinforcing bar diameter	φ	=	16 (mm)
Number of reinforcing bars (one side)	n	=	2 (pcs.)
Tensile reinforcement volume	A_s	=	397.2 (mm ²)
Characteristic value of tensile yield strength of reinforcing bar	f_{yk}	=	345 (N/mm ²)
Young's modulus of reinforcing bar	E_s	=	200 (kN/mm ²)

(3) Shear reinforcement

Arrange stirrups as shear reinforcements.

Type	SD345	D13	
Stirrup diameter	φ_w	=	13 (mm)
Number of stirrups	n_w	=	2 (pcs.)
Stirrup arrangement interval	s	=	300 (mm)
Total cross-sectional area of stirrups in section s	A_w	=	253.4 (mm ²)
Characteristic value of tensile yield strength of sear reinforcement	f_{wyk}	=	345 (N/mm ²)

(4) Arrangement

Arrangement length of steel bar	l	=	286 (mm)
Covering of tensile reinforcement	c	=	$h - (d + \frac{\varphi}{2})$
		=	77 (mm)
Reinforcing bar center distance (Value when reinforcing bars are equally spaced in the arrangement section)	c_s	=	$\frac{l - \varphi}{n - 1}$
		=	270 (mm)
Reinforcing bar interval (Value when reinforcing bars are equally spaced in the arrangement section)	a	=	$c_s - \varphi$
		=	254 (mm)

1.5.2 Partial Safety Factors

Partial safety factors are set as follows, taking account of variations of material strength and member dimensions, importance of the structure and members, and uncertainty of structural analysis.

Safety factor Limit state	Material factor		Member factor γ_b		Structural analysis factor γ_a	Load factor γ_f	Structure factor γ_i
	Mortar γ_c	Steel γ_s					
Ultimate limit state	1.30	1.00	Bend, axial load strength	1.15	1.00	1.20	1.20
			Shear strength borne by mortar	1.30			
			Shear strength borne by shear reinforcement	1.10			
			Diagonal compressive breaking strength	1.30			
Use limit state	1.00	-	1.00		1.00	1.00	1.00

The partial safety factors are used in calculating the design cross-sectional strength and design cross-sectional force.

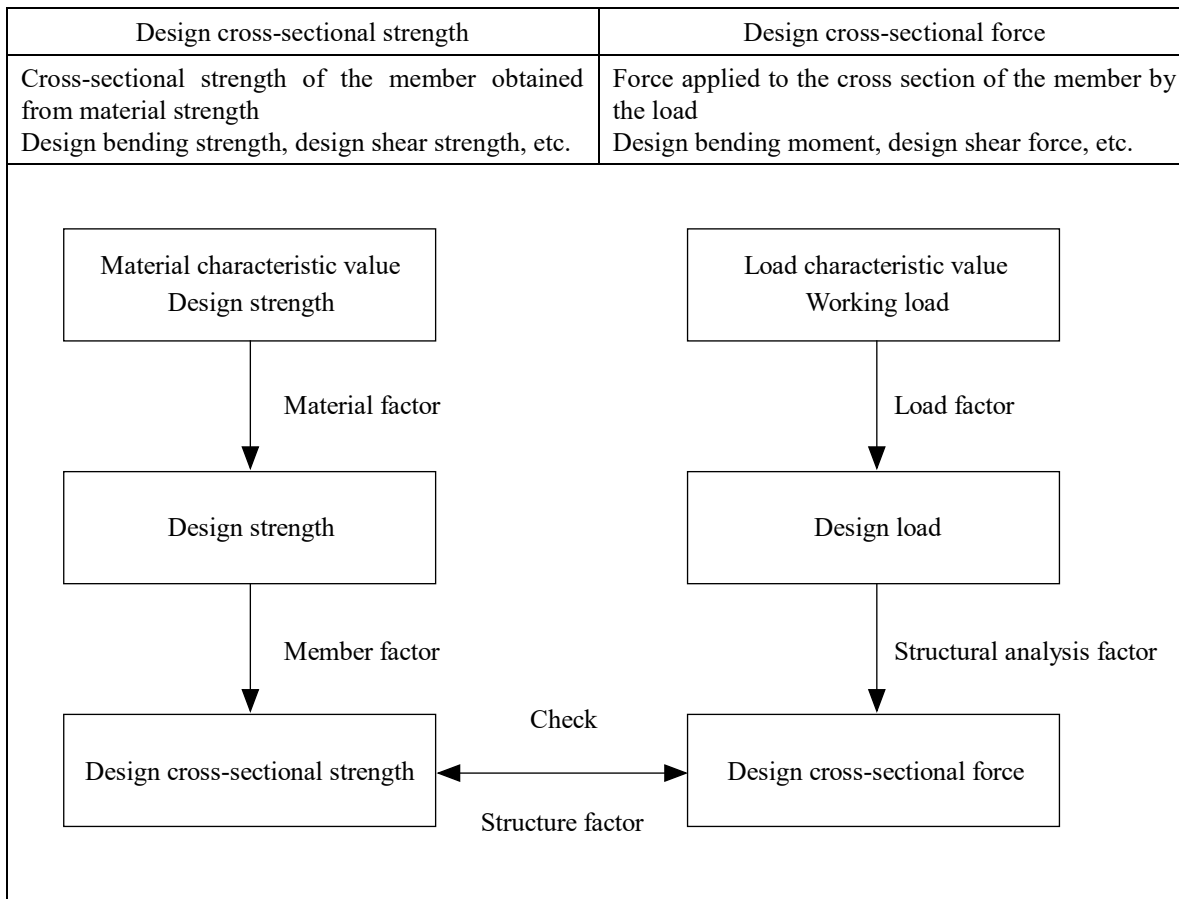

1.5.3 Design Load and Design Cross-sectional Force

The design load used for calculating the design cross-sectional force for grating crib works is obtained by multiplying the working load by the load factor.

Accordingly, the cross-sectional force allowing for the design load can be obtained by multiplying the previously obtained maximum bending moment and maximum shear force by the load factor.

Limit state	Design load (Working load $\times \gamma_f$)	Cross-sectional force allowing for design load	
Ultimate limit state	Working load $\times 1.20$	Maximum bending moment M'	7.91 (kN·m)
		Maximum shear force V'	19.75 (kN)
Use limit state	Working load $\times 1.00$	Maximum bending moment M'	6.59 (kN·m)
		Maximum shear force V'	16.46 (kN)

The design cross-sectional force is obtained by multiplying the cross-sectional force allowing the design load by the structural analysis factor.

Limit state	Structural analysis factor γ_a	Design cross-sectional force	
Ultimate limit state	1.00	Design bending moment M_d	7.91 (kN·m)
		Design shear force V_d	19.75 (kN)
Use limit state	1.00	Design bending moment M_d	6.59 (kN·m)
		Design shear force V_d	16.46 (kN)

1.5.4 Bending Moment Check

It is necessary to study a bend as safety performance check of the slope frame.

The following checks that the ultimate limit state of cross-sectional fracture does not result from action of the bending moment.

(1) Study of the tensile reinforcement volume

If the axial tensile reinforcement volume is too high, compression fracture of mortar may advance at the time of cross-sectional fracture, resulting in brittle fracture. Assuming that the maximum value of tensile reinforcement volume is 75% of the balanced percentage of reinforcement, accordingly, check that a tension reinforcement ratio is lower than this.

$$\begin{aligned} \text{Coefficient related to balanced} \quad \alpha &= 0.88 - 0.004 \cdot f_{ck} = 0.88 - 0.004 \times 18 \\ \text{percentage of reinforcement} &= 0.81 \quad (\alpha \leq 0.68) \quad \text{Therefore } \alpha = 0.68 \end{aligned}$$

$$\begin{aligned} \text{Ultimate strain of mortar} \quad \varepsilon'_{cu} &= \frac{155 - f_{ck}}{30000} = \frac{155 - 18}{30000} \\ &= 0.0046 \quad (0.0025 \leq \varepsilon'_{cu} \leq 0.0035) \quad \text{Therefore } \varepsilon'_{cu} = 0.0035 \end{aligned}$$

$$\text{Design compressive strength of mortar} \quad f_{cd} = \frac{f_{ck}}{\gamma_c} = \frac{18}{1.30} = 13.85 \text{ (N/mm}^2\text{)}$$

$$\text{Design tensile yield strength of reinforcement bar} \quad f_{yd} = \frac{f_{yk}}{\gamma_s} = \frac{345}{1.00} = 345 \text{ (N/mm}^2\text{)}$$

The reinforcement ratio p is calculated as follows.

$$\begin{aligned} p &= \frac{A_s}{b \cdot d} = \frac{397.2}{400 \times 315} \\ &= 0.00315 \end{aligned}$$

The balanced percentage of reinforcement p_b is calculated as follows.

$$\begin{aligned} p_b &= \alpha \cdot \frac{\varepsilon'_{cu}}{\varepsilon'_{cu} + \frac{f_{yd}}{E_s}} \cdot \frac{f_{cd}}{f_{yd}} \\ &= 0.68 \times \frac{0.0035}{0.0035 + \frac{345}{200 \times 10^3}} \times \frac{13.85}{345} \\ &= 0.01829 \end{aligned}$$

Accordingly, $p = 0.00315 \leq 0.75 \cdot p_b = 0.01372$.

Tensile reinforcement will yield first. ... OK

(2) Design bending strength

The design cross-sectional strength of the slope frame subject to the bending moment is calculated based on the following assumptions.

- Longitudinal strain is proportional to the distance from the neutral axis of the cross section
- Tensile stress of the mortar is ignored.
- A non-linear model is used for the mortar and reinforcing bar stress-strain curve.

Assuming that all of cross-sectional strain is not compressed, make calculation, considering the compressive stress distribution of the mortar as an equivalent stress block.

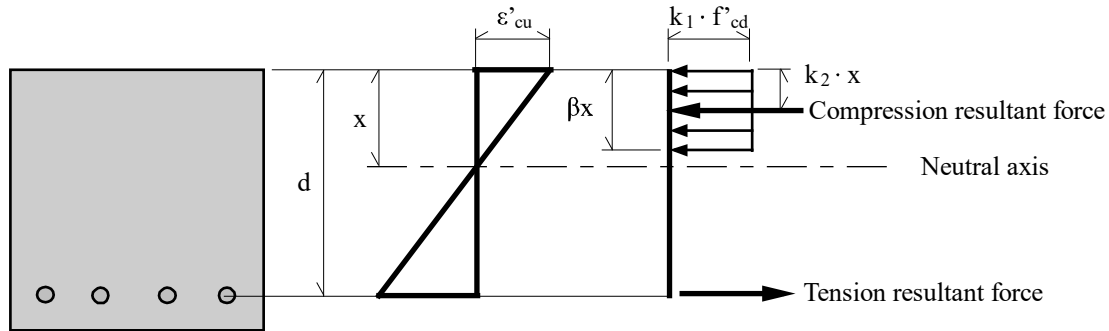

Frame cross section	Ultimate strain distribution	Equivalent stress block
Coefficient related to equivalent stress block of bending strength	$\beta = 0.52 + 80 \cdot \epsilon'_{cu} = 0.52 + 80 \times 0.0035 = 0.8$	
Strength reduction coefficient	$k_1 = 1 - 0.003 \cdot f_{ck} = 1 - 0.003 \times 18 = 0.95$ ($k_1 \leq 0.85$) Therefore $k_1 = 0.85$	
Ratio of distance to compression resultant force to distance x from extreme compression fiber to neutral axis	$k_2 = \frac{\beta}{2} = \frac{0.8}{2} = 0.4$	

The ultimate bending strength M_u is calculated as follows.

$$\begin{aligned}
 M_u &= b \cdot d^2 \cdot \rho \cdot f_{yd} \cdot \left(1 - \frac{k_2}{\beta \cdot k_1} \cdot \frac{\rho \cdot f_{yd}}{f_{cd}} \right) \\
 &= 400 \times 315^2 \times 0.00315 \times 345 \times \left(1 - \frac{0.4}{0.8 \times 0.85} \times \frac{0.00315 \times 345}{13.85} \right) \\
 &= 41.14 \times 10^6 \text{ (N}\cdot\text{mm)} = 41.14 \text{ (kN}\cdot\text{m)}
 \end{aligned}$$

The design bending strength M_{ud} is calculated as follows.

$$\begin{aligned}
 M_{ud} &= \frac{M_u}{\gamma_b} = \frac{41.14}{1.15} \\
 &= 35.77 \text{ (kN}\cdot\text{m)}
 \end{aligned}$$

(3) Safety check

$$\gamma_i \cdot \frac{M_d}{M_{ud}} = 1.20 \times \frac{7.91}{35.77} = 0.27 \leq 1.00 \quad \dots \quad \text{OK}$$

1.5.5 Shear Force Check

It is necessary to study shear as safety performance check of the slope frame.

The following checks that the ultimate limit state of cross-sectional fracture does not result from action of the shear force.

(1) Design shear strength borne by the mortar

$$\begin{aligned} \text{Shear strength of mortar } f_{vcd} &= 0.20 \cdot \sqrt[3]{f_{cd}} = 0.20 \times \sqrt[3]{13.85} \\ &= 0.48 \text{ (N/mm}^2\text{)} \quad (f_{vcd} \leq 0.72) \end{aligned}$$

$$\begin{aligned} \text{Coefficient related to effective height of shear strength } \beta_d &= \sqrt[4]{1000/d} = \sqrt[4]{1000/315} \\ &= 1.33 \quad (\beta_d \leq 1.5) \end{aligned}$$

$$\begin{aligned} \text{Coefficient related to axial reinforcement ratio of shear strength } \beta_p &= \sqrt[3]{100 \cdot p} = \sqrt[3]{100 \times 0.00315} \\ &= 0.68 \quad (\beta_p \leq 1.5) \end{aligned}$$

$$\begin{aligned} \text{Coefficient related to axial force of shear strength } \beta_n &= 1.00 \\ &\text{(The axial force does not work on the slope frame)} \end{aligned}$$

The design shear strength V_{cd} borne by the mortar is calculated as follows.

$$\begin{aligned} V_{cd} &= \frac{\beta_d \cdot \beta_p \cdot \beta_n \cdot f_{vcd} \cdot b \cdot d}{\gamma_b} \\ &= \frac{1.33 \times 0.68 \times 1.00 \times 0.48 \times 400 \times 315}{1.30} \\ &= 42.08 \times 10^3 \text{ (N)} = 42.08 \text{ (kN)} \end{aligned}$$

(2) Design shear strength borne by the shear reinforcement

$$\begin{aligned} \text{Design tensile yield strength of shear reinforcement } f_{wyd} &= \frac{f_{wyk}}{\gamma_s} = \frac{345}{1.00} \\ &= 345 \text{ (N/mm}^2\text{)} \end{aligned}$$

$$\begin{aligned} \text{Distance from working position of compressive stress resultant force to the tensile reinforcement centroid } z &= \frac{d}{1.15} = \frac{315}{1.15} \\ &= 273.9 \text{ (mm)} \end{aligned}$$

The design shear strength V_{sd} borne by the shear reinforcement is calculated as follows.

$$\begin{aligned} V_{sd} &= \frac{A_w \cdot f_{wyd}}{s} \times \frac{z}{\gamma_b} \\ &= \frac{253.4 \times 345}{300} \times \frac{273.9}{1.10} \\ &= 72.56 \times 10^3 \text{ (N)} = 72.56 \text{ (kN)} \end{aligned}$$

(3) Design shear strength

Since the design shear strength V_{yd} is a combination of the design shear strength borne by the mortar and that borne by the shear reinforcement, it will be as follows.

$$\begin{aligned} V_{yd} &= V_{cd} + V_{sd} = 42.08 + 72.56 \\ &= 114.64 \quad (\text{kN}) \end{aligned}$$

(4) Study of design diagonal compressive breaking strength of the mortar abdomen

If many shear reinforcements have been arranged, they may not yield, resulting in brittle fracture due to compression fracture of the mortar abdomen. In order to avoid this fracture, accordingly, check that the design shear strength is lower than the design diagonal compressive breaking strength of the mortar abdomen

$$\begin{aligned} \text{Design diagonal compression strength of mortar} \quad f_{wcd} &= 1.25\sqrt{f_{cd}} = 1.25\sqrt{13.85} \\ &= 4.65 \text{ (N/mm}^2\text{)} \quad (f_{wcd} \leq 9.8) \end{aligned}$$

The design diagonal compressive breaking strength V_{wcd} of the mortar abdomen is calculated as follows.

$$\begin{aligned} V_{wcd} &= \frac{f_{wcd} \cdot b \cdot d}{\gamma_b} = \frac{4.65 \times 400 \times 315}{1.30} \\ &= 450.69 \times 10^3 \text{ (N)} = 450.69 \text{ (kN)} \end{aligned}$$

Accordingly, $V_{yd} = 114.64 \leq V_{wcd} = 450.69$.

The shear reinforcement will yield first. ... OK

(5) Safety check

$$\gamma_i \cdot \frac{V_d}{V_{yd}} = 1.20 \times \frac{19.75}{114.64} = 0.21 \leq 1.00 \quad \dots \quad \text{OK}$$

1.5.6 Flexural Crack Check

It is necessary to study flexural cracks as usability check of the slope frame.

The following checks that the flexural crack width is lower than the allowable crack width.

(1) Allowable crack width

The allowable crack width w_a is decided by the environmental requirements for covering of the tensile reinforcement and corrosion of the reinforcement.

Using covering of the tensile reinforcement $c = 77$ mm, calculate the allowable crack width as a “general environment.”

$$\begin{aligned}w_a &= 0.0050 \cdot c = 0.0050 \times 77 \\ &= 0.385 \text{ (mm)}\end{aligned}$$

(2) Increased reinforcement stress

The increased reinforcement stress from mortar stress “0” at the reinforcement position results in the tensile stress of the reinforcement in case of the slope frame.

$$\text{Reinforcement ratio} \quad p = 0.00315$$

$$\begin{aligned}\text{Ratio of Young's modulus} \quad n' &= \frac{E_s}{E_c} = \frac{200}{22.0} \\ &= 9.09\end{aligned}$$

$$\begin{aligned}\text{Coefficient} \quad k &= \sqrt{2 \cdot n' \cdot p + (n' \cdot p)^2} - n' \cdot p \\ &= \sqrt{2 \times 9.09 \times 0.00315 + (9.09 \times 0.00315)^2} - 9.09 \times 0.00315 \\ &= 0.212\end{aligned}$$

$$\begin{aligned}\text{Coefficient} \quad j &= 1 - \frac{k}{3} = 1 - \frac{0.212}{3} \\ &= 0.929\end{aligned}$$

The increased reinforcement stress σ_{se} is calculated as follows.

$$\sigma_{se} = \frac{M_d}{A_s \cdot j \cdot d} = \frac{6.59 \times 10^6}{397.2 \times 0.929 \times 315} = 56.70 \text{ (N/mm}^2\text{)}$$

(3) Flexural crack width

Coefficient indicating the effect of steel surface shape on crack width	k_1	=	1.00
Coefficient indicating the effect of mortar quality on crack width	k_2	=	0.90
Coefficient indicating the effect of number of tensile reinforcement steps (Steps: $N = 1$)	k_3	=	$\frac{5 \cdot (N+2)}{7 \cdot N+8} = 1.0$
Numerical value for allowing for increased crack width by mortar contraction, etc.	ε'_{csd}	=	150×10^{-6}

The flexural crack width w is calculated as follows.

$$\begin{aligned}w &= 1.1 \cdot k_1 \cdot k_2 \cdot k_3 \cdot \{4 \cdot c + 0.7 \cdot (c_s - \phi)\} \left(\frac{\sigma_{se}}{E_s} + \varepsilon'_{csd} \right) \\&= 1.1 \times 1.00 \times 0.90 \times 1.0 \times \{4 \times 77 + 0.7 \times (270 - 16)\} \times \left(\frac{56.70}{200 \times 10^3} + 150 \times 10^{-6} \right) \\&= 0.208 \text{ (mm)}\end{aligned}$$

(4) Safety check

$$\gamma_i \cdot \frac{w}{w_a} = 1.00 \times \frac{0.208}{0.385} = 0.55 \leq 1.00 \quad \dots \quad \text{OK}$$

1.5.7 Shear Crack Check

It is necessary to study shear cracks as usability check of the slope frame.

The following checks that the shear reinforcement stress is lower than the limit value under the design load.

(1) Design shear strength borne by the mortar

$$\text{Design compressive strength of mortar } f_{cd} = \frac{f_{ck}}{\gamma_c} = \frac{18}{1.00} = 18.00 \text{ (N/mm}^2\text{)}$$

$$\begin{aligned} \text{Shear strength of mortar } f_{vcd} &= 0.20 \sqrt[3]{f_{cd}} = 0.20 \times \sqrt[3]{18.00} \\ &= 0.52 \text{ (N/mm}^2\text{)} \quad (f_{vcd} \leq 0.72) \end{aligned}$$

$$\text{Coefficient related to effective height of shear strength } \beta_d = 1.33$$

$$\text{Coefficient related to axial reinforcement ratio of shear strength } \beta_p = 0.68$$

$$\text{Coefficient related to axial force of shear strength } \beta_n = 1.00$$

The design shear strength V_{cd} borne by the mortar is calculated as follows.

$$\begin{aligned} V_{cd} &= \frac{\beta_d \cdot \beta_p \cdot \beta_n \cdot f_{vcd} \cdot b \cdot d}{\gamma_b} \\ &= \frac{1.33 \times 0.68 \times 1.00 \times 0.52 \times 400 \times 315}{1.00} \\ &= 59.26 \times 10^3 \text{ (N)} = 59.26 \text{ (kN)} \end{aligned}$$

(2) Study of shear cracks

When the design shear force V_d is lower than 70% of the design shear strength V_{cd} borne by the mortar, study of shear cracks may be omitted.

As a result, $V_d = 16.46 \text{ (kN)} < 0.7 \cdot V_{cd} = 41.48 \text{ (kN)}$, and it is necessary to study shear cracks.

1.6 Study of Bearing Stress

1.6.1 Allowable Bearing Stress

(1) Study requirements

Design strength of mortar	f_{ck}	=	18.0 (N/mm ²)
Plate width	u	=	200 (mm)
Anchorage breakout diameter	D_1	=	140 (mm)
Beam width	b	=	400 (mm)
Total area of mortar surface	A	=	$b^2 = 400^2 = 160000$ (mm ²)
Plate effective area	A_a	=	$u^2 - \frac{\pi \cdot D_1^2}{4} = 200^2 - \frac{\pi \times 140^2}{4}$
		=	24606 (mm ²)

(2) Calculation of the allowable bearing stress

In case of local loading, the allowable bearing stress σ_{ba} is calculated as follows.

$$\begin{aligned} \sigma_{ba} &\leq (0.25 + 0.05 \cdot \frac{A}{A_a}) \cdot f_{ck} \\ &= (0.25 + 0.05 \times \frac{160000}{24606}) \times 18.0 \\ &= 10.35 \text{ (N/mm}^2\text{)} \end{aligned}$$

However, it shall be restrained within 50% of the design strength.

$$\sigma_{ba} \leq 0.5 \cdot f_{ck} = 0.5 \times 18.0 = 9.00 \text{ (N/mm}^2\text{)}$$

Accordingly, the allowable bearing stress σ_{ba} shall be the following value.

$$\sigma_{ba} = 9.00 \text{ (N/mm}^2\text{)}$$

1.6.2 Bearing Stress

Check the bearing stress σ_b .

$$\begin{aligned} \sigma_b &= \frac{Td}{A_a} = \frac{47.4 \times 10^3}{24606} \\ &= 1.93 \text{ (N/mm}^2\text{)} \leq \sigma_{ba} = 9.00 \text{ (N/mm}^2\text{)} \dots \text{OK} \end{aligned}$$

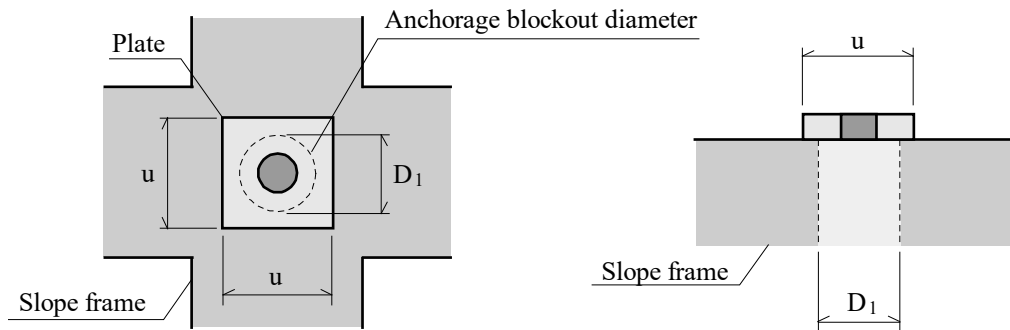

1.7 Lap Joint of Reinforcing Bar

The lap joint length of reinforcing bars shall be equal to or longer than the basic development length.

Main reinforcing bar		D16 - 2 pcs. ($\phi = 16$ (mm))
Covering of tensile reinforcement	c	= 77 (mm)
Reinforcing bar interval (Value when reinforcing bars are equally spaced in the arrangement section)	a	= 254 (mm)
Design tensile yield strength of reinforcing bar	f_{yd}	= 345 (N/mm ²)
Design strength of mortar	f_{ck}	= 18 (N/mm ²)
Material factor of mortar	γ_c	= 1.30
Design adhesive strength of mortar	f_{bod}	= $\frac{0.28 \cdot f_{ck}^{2/3}}{\gamma_c} = \frac{0.28 \times 18^{2/3}}{1.30}$ = 1.479 (N/mm ²) ($f_{bod} \leq 3.2$)
Stirrup		D13 - 2 pcs.
Cross-sectional area of stirrup perpendicular to splitting failure cross section	A_t	= 253.4 (mm ²)
Stirrup center distance	s	= 300 (mm)

“c” used here is either covering of the tensile reinforcement or half value of the interval of anchored reinforcing bars, whichever is lower. Accordingly;

$$c = \min\left(77, \frac{254}{2}\right) = 77 \text{ (mm)}$$

The coefficients k_c and α related to the basic development length will be as follows.

$$\begin{aligned} k_c &= \frac{c}{\phi} + \frac{15 \cdot A_t}{s \cdot \phi} \\ &= \frac{77}{16} + \frac{15 \times 253.4}{300 \times 16} \\ &= 5.604 \end{aligned}$$

Based on $k_c = 5.604$, $\alpha = 0.6$.

In case of $k_c \leq 1.0$	$\alpha = 1.0$
In case of $1.0 < k_c \leq 1.5$	$\alpha = 0.9$
In case of $1.5 < k_c \leq 2.0$	$\alpha = 0.8$
In case of $2.0 < k_c \leq 2.5$	$\alpha = 0.7$
In case of $2.5 < k_c$	$\alpha = 0.6$

The basic development length l_d is calculated as follows.

$$\begin{aligned} l_d &= \frac{\alpha \cdot f_{yd} \cdot \phi}{4 \cdot f_{bod}} = \frac{0.6 \times 345 \times 16}{4 \times 1.479} \\ &= 560 \text{ (mm)} \end{aligned}$$

Accordingly, the lap joint length of reinforcing bars needs to be 560 mm or more.

Site	KANDY LOWER 200- 200 for soil nailing		
Case	B	Pr(max)	
Remarks	φ 29		

Calculation requirement

Item				Symbol	Unit	Numerical value		
Design tension				Td	kN/pc.	15.123		
Slope protection reduction coefficient				μ	-	1.00		
Reinforcement tension working on slope protection				To	kN/pc.	15.123		
Vertical frame	Number of spans			n ₁	Span	5		
	Span length			l ₁	m	1.500		
	Projection length	Top	Bottom	l _{1a}	l _{1b}	0.279	0.750	
Horizontal frame	Number of spans			n ₂	Span	4		
	Span length			l ₂	m	1.500		
	Projection length	Left	Right	l _{2a}	l _{2b}	0.750	0.750	
Frame height × Frame width				h×b	mm	200 × 200		
Effective height				d	mm	155		
Design strength of mortar				f' _{ck}	N/mm ²	18		
Characteristic value of tensile yield strength of reinforcing bar				f _{yk}	N/mm ²	295		
Characteristic value of tensile yield strength of shear reinforcement				f _{wyk}	N/mm ²	-		
Partial safety factors	Material factor		Member factor			Structural analysis factor	Load factor	Structure factor
	Mortar	Steel						
	γ _c	γ _s						
Ultimate limit state	1.30	1.00	Bend, axial load strength		1.15	1.00	1.20	1.20
			Shear strength borne by mortar		1.30			
			Shear strength borne by shear reinforcement		-			
			Diagonal compressive breaking strength		-			

Calculation results

Item		Symbol	Unit	Numerical value
Ultimate limit state	Design bending moment	M _d	kN·m	1.56
	Design shearing force	V _d	kN	5.90

Main reinforcing bar		Stirrup		Ultimate limit state				Evaluation
Nominal diameter	Quantity (one side)	Nominal diameter	Interval (mm)	Bending moment check		Shear force check		
				Reinforcement ratio	Safety	Compression failure	Safety	
D10	2	-	-	0.00460	0.36	-	0.54	OK
Evaluation requirement				≤ 0.01685	≤ 1.00	≤ -	≤ 1.00	

7. Design Policy

7.1. Structural Model

The structural model shall ensure that ground reaction generated by the design tension works on the slope frame as a uniformly distributed load, and shall be a beam model taking the reinforcement installation position as a fulcrum.

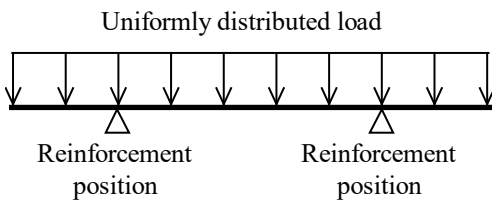

7.2. Bearing of Load

The load applied to the slope frame shall be applied to the vertical and horizontal frames as a uniformly distributed load by the tensile load of the reinforcement, and the uniformly distributed load shall be calculated by distributing the load per reinforcement by the slope frame length.

When this is done, take account of the slope frame width of the intersection point.

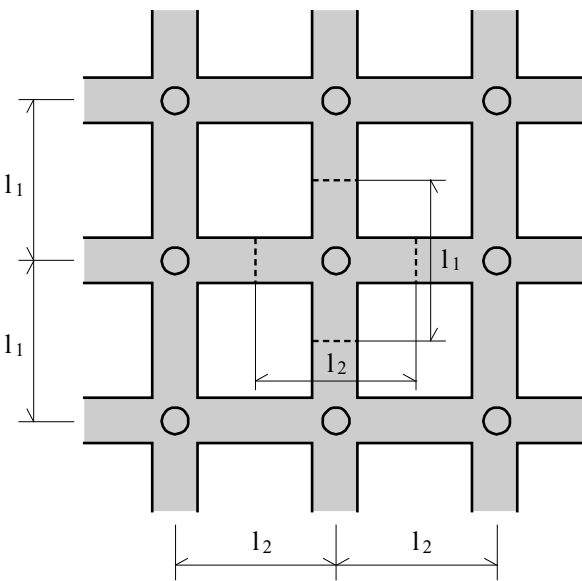

7.3. Safety Check

Study the safety of the slope frame by the limit state design method (performance check type).

Check that the slope frame does not reach the limit state during its in-service period. The limit state is divided into the ultimate limit state, use limit state and fatigue limit state.

The ultimate limit state refers to the limit state for the maximum load assumed during the in-service period. In case of reinforcement insertion work, the tension is generated to the reinforcement by deformation of the natural ground, etc., causing ground reaction to work on the slope frame structure as a load. Taking this as the maximum load, check safety.

The use limit state refers to the limit state related to normal usability, functional securement and durability. In case of reinforcement insertion work, ground reaction does not work on the slope frame because the tension is not given to the reinforcement during construction. Accordingly, checking of the use limit state is omitted because it is conceived that the load generally does not work during the in-service period. Accordingly, checking of the use limit state is omitted because it is generally presumed that the load does not work during the in-service period.

The fatigue limit state refers to the limit state of fatigue fracture resulting from a repeated load and a fluctuating load. Checking of the fatigue limit state is omitted because it is conceived that the slope frame structure is hardly affected by them.

8. Design Requirements

8.1. Calculation of Reinforcement Tension Working on Slope Protection

The design tension T_d uses the maximum value [Reinforcement No. 2] 15.123 kN/pc.

The reinforcement tension T_o working on slope protection is as follows.

$$\begin{aligned} T_o &= \mu \cdot T_d = 1.00 \times 15.123 \\ &= 15.123 \text{ (kN/pc.)} \end{aligned}$$

μ : Slope protection reduction coefficient

8.2. Shape and Dimensions of Slope Frame

Number of spans of vertical fame	n_1	=	5
Span length	l_1	=	1.500 (m)
Upper projection length	l_{1a}	=	0.279 (m)
Lower projection length	l_{1b}	=	0.750 (m)
Number of spans of horizontal fame	n_2	=	4
Span length	l_2	=	1.500 (m)
Left projection length	l_{2a}	=	0.750 (m)
Right projection length	l_{2b}	=	0.750 (m)
Frame width	b	=	200 (mm)
Frame height	h	=	200 (mm)
Effective height	d	=	155 (mm)

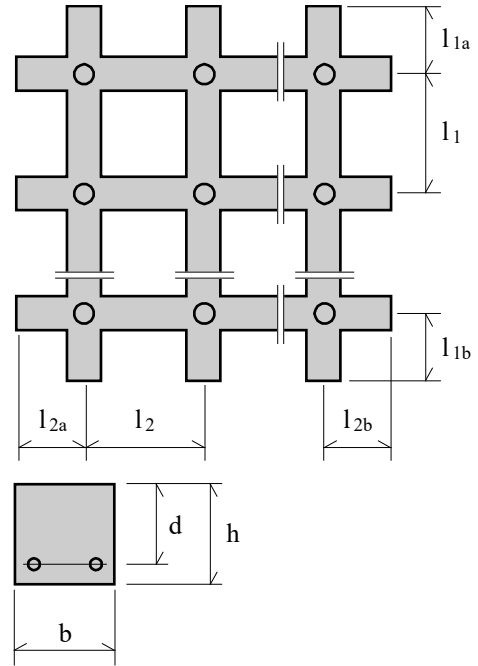

9. Calculation of Maximum Bending Moment and Maximum Shear Force

9.1. Working Load

The uniformly distributed loads w_1 and w_2 working on the slope frame are calculated as follows.

Vertical frame length bearing the load per reinforcement.

$$l_h = l_1 = 1.500 \text{ (m)}$$

Horizontal frame length bearing the load per reinforcement.

$$l_w = l_2 = 1.500 \text{ (m)}$$

Accordingly;

$$\begin{aligned} w_1 = w_2 &= \frac{T_o}{l_h + l_w - b} = \frac{15.123}{1.500 + 1.500 - 0.200} \\ &= 5.40 \text{ (kN/m)} \end{aligned}$$

9.2. Maximum bending moment and maximum shear force generated to the vertical frame
 In case of 4 spans or more, calculate as a continuous beam. When this is done, take no account of the projection parts.

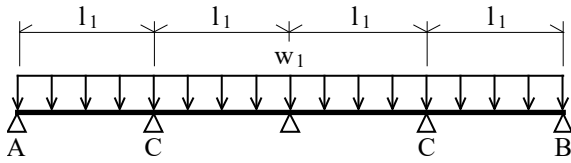

· Maximum bending moment generated at the first internal fulcrum (C)

$$\begin{aligned} M_{\max_C} &= \frac{3}{28} \cdot w_1 \cdot l_1^2 \\ &= \frac{3}{28} \times 5.40 \times 1.500^2 \\ &= 1.30 \text{ (kN}\cdot\text{m)} \end{aligned}$$

· Maximum shear force generated outside the first internal fulcrum (C)

$$\begin{aligned} S_{\max_C} &= \frac{17}{28} \cdot w_1 \cdot l_1 \\ &= \frac{17}{28} \times 5.40 \times 1.500 \\ &= 4.92 \text{ (kN)} \end{aligned}$$

9.3. Maximum bending moment and maximum shear force generated to the horizontal frame
 In case of 4 spans or more, calculate as a continuous beam. When this is done, take no account of the projection parts.

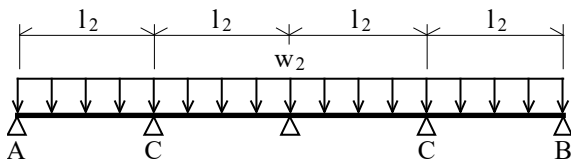

· Maximum bending moment generated at the first internal fulcrum (C)

$$\begin{aligned} M_{\max_C} &= \frac{3}{28} \cdot w_2 \cdot l_2^2 \\ &= \frac{3}{28} \times 5.40 \times 1.500^2 \\ &= 1.30 \text{ (kN}\cdot\text{m)} \end{aligned}$$

· Maximum shear force generated outside the first internal fulcrum (C)

$$\begin{aligned} S_{\max_C} &= \frac{17}{28} \cdot w_2 \cdot l_2 \\ &= \frac{17}{28} \times 5.40 \times 1.500 \\ &= 4.92 \text{ (kN)} \end{aligned}$$

9.4. Determination of Maximum Stress

The following table lists the stresses working on the vertical and horizontal frames.

Position		Bending moment (kN·m)	Shear force (kN)
Vertical frame	First internal fulcrum	1.30	4.92
	Projection part	-	-
Horizontal frame	First internal fulcrum	1.30	4.92
	Projection part	-	-

Accordingly, the maximum stresses generated to the vertical and horizontal frames are as follows in comparison with each other.

$$\begin{aligned} \text{Maximum bending moment} \quad M_{\max} &= 1.30 \text{ (kN}\cdot\text{m)} \\ \text{Maximum shear force} \quad S_{\max} &= 4.92 \text{ (kN)} \end{aligned}$$

10. Limit State Check

10.1. Materials and Cross-sectional Specifications

(1) Slope frame

Frame width	b	=	200 (mm)
Frame height	h	=	200 (mm)
Effective height	d	=	155 (mm)
Blockout diameter (outer diameter)	D	=	89 (mm)
Design strength of mortar (Characteristic value of compressive strength)	f_{ck}	=	18 (N/mm ²)

(2) Main reinforcing bar (Tensile reinforcement)

Type	SD295A	D10
Reinforcing bar diameter	ϕ	= 10 (mm)
Number of reinforcing bars (one side)	n	= 2 (pcs.)
Tensile reinforcement volume	A_s	= 142.7 (mm ²)
Characteristic value of tensile yield strength of reinforcing bar	f_{yk}	= 295 (N/mm ²)
Young's modulus of reinforcing bar	E_s	= 200 (kN/mm ²)

(3) Shear reinforcement

The shear reinforcement is not studied because the stirrups are not arranged.

(4) Arrangement

Arrangement length of steel bar	l	=	120 (mm)
Covering of tensile reinforcement	c	=	$h - (d + \frac{\phi}{2}) = 40$ (mm)
Reinforcing bar center distance (Value when reinforcing bars are equally spaced in the arrangement section)	c_s	=	$\frac{l - \phi}{n - 1} = 110$ (mm)
Reinforcing bar interval (Value when reinforcing bars are equally spaced in the arrangement section)	a	=	$c_s - \phi = 100$ (mm)

10.2. Partial Safety Factors

Partial safety factors are set as follows, taking account of variations of material strength and member dimensions, importance of the structure and members, and uncertainty of structural analysis.

Partial safety factors	Material factor		Member factor γ_b	Structural analysis factor γ_a	Load factor γ_f	Structure factor γ_i	
	Mortar γ_c	Steel γ_s					
Ultimate limit state	1.30	1.00	Bend, axial load strength	1.15	1.00	1.20	1.20
			Shear strength borne by mortar	1.30			
			Shear strength borne by shear reinforcement	-			
			Diagonal compressive breaking strength	-			

The partial safety factors are used in calculating the design cross-sectional strength and design cross-sectional force.

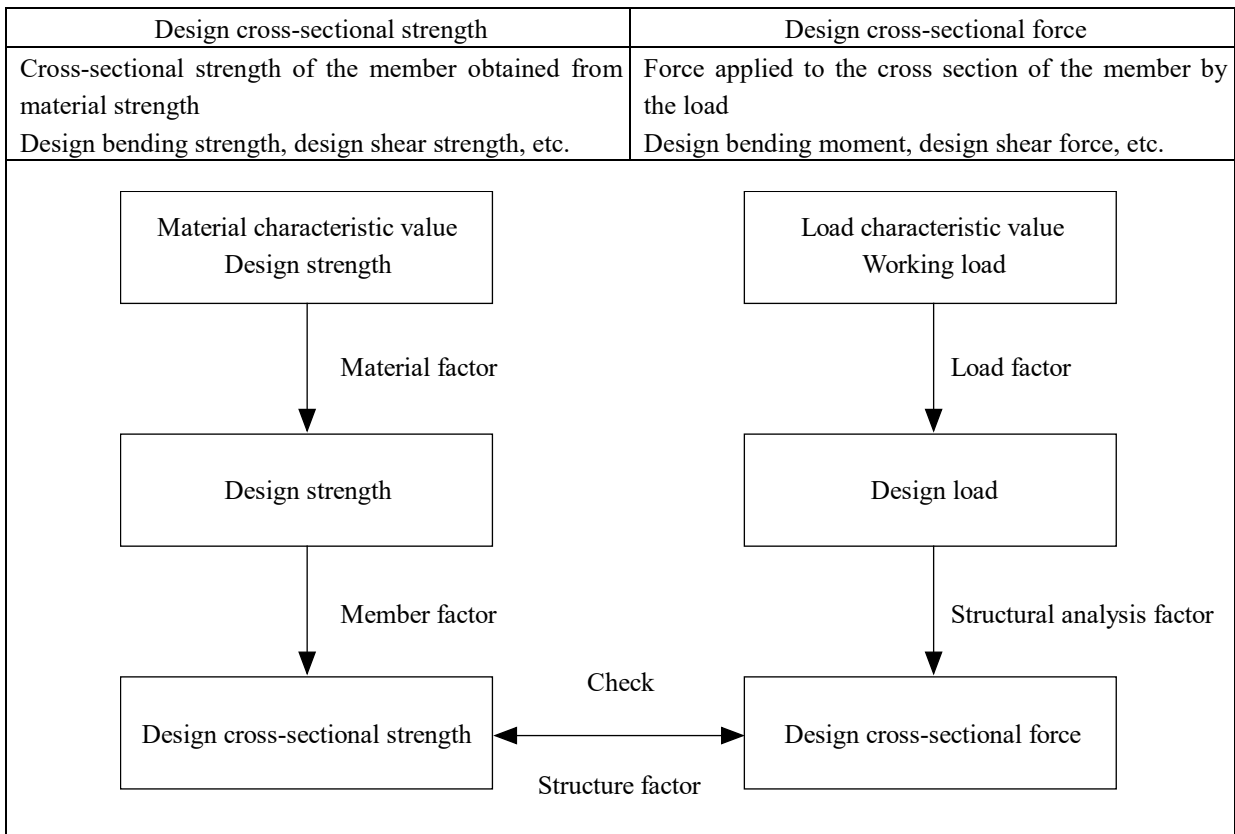

10.3. Design Load and Design Cross-sectional Force

The design load used for calculating the design cross-sectional force for grating crib works is obtained by multiplying the working load by the load factor.

Accordingly, the cross-sectional force allowing for the design load can be obtained by multiplying the previously obtained maximum bending moment and maximum shear force by the load factor.

Limit state	Design load (Working load $\times\gamma_f$)	Cross-sectional force allowing for design load	
Ultimate limit state	Working load $\times 1.20$	Maximum bending moment M'	1.56 (kN·m)
		Maximum shear force V'	5.90 (kN)

The design cross-sectional force is obtained by multiplying the cross-sectional force allowing the design load by the structural analysis factor.

Limit state	Structural analysis factor γ_a	Design cross-sectional force	
Ultimate limit state	1.00	Design bending moment M_d	1.56 (kN·m)
		Design shearing force V_d	5.90 (kN)

10.4. Safety Performance Check

In safety performance check of the slope frame, check that the ultimate limit state of cross-sectional fracture does not result from action of the bending moment and shear force.

10.4.1 Bending Moment Check

(1) Study of the tensile reinforcement volume

If the axial tensile reinforcement volume is too high, compression fracture of mortar may advance at the time of cross-sectional fracture, resulting in brittle fracture. Assuming that the maximum value of tensile reinforcement volume is 75% of the balanced percentage of reinforcement, accordingly, check that a tension reinforcement ratio is lower than this.

Coefficient related to balanced percentage of reinforcement	α	$=$	$0.88-0.004 \cdot f_{ck}$	$=$	$0.88-0.004 \times 18$
					$= 0.81$ ($\alpha \leq 0.68$) Therefore, $\alpha=0.68$
Ultimate strain of mortar	ε'_{cu}	$=$	$\frac{155-f_{ck}}{30000}$	$=$	$\frac{155-18}{30000}$
					$= 0.0046$ ($0.0025 \leq \varepsilon'_{cu} \leq 0.0035$) Therefore, $\varepsilon'_{cu}=0.0035$
Design compressive strength of mortar	f_{cd}	$=$	$\frac{f_{ck}}{\gamma_c}$	$=$	$\frac{18}{1.30} = 13.85$ (N/mm ²)
Design tensile yield strength of reinforcement bar	f_{yd}	$=$	$\frac{f_{yk}}{\gamma_s}$	$=$	$\frac{295}{1.00} = 295$ (N/mm ²)

The reinforcement ratio p is calculated as follows.

$$p = \frac{A_s}{b \cdot d} = \frac{142.7}{200 \times 155} = 0.00460$$

The balanced percentage of reinforcement p_b is calculated as follows.

$$p_b = \alpha \cdot \frac{\varepsilon'_{cu}}{\varepsilon'_{cu} + \frac{f_{yd}}{E_s}} \cdot \frac{f_{cd}}{f_{yd}} = 0.68 \times \frac{0.0035}{0.0035 + \frac{295}{200 \times 10^3}} \times \frac{13.85}{295} = 0.02246$$

Accordingly, $p = 0.00460 \leq 0.75 \cdot p_b = 0.01685$.

Tensile reinforcement will yield first. ... OK

(2) Design bending strength

The design cross-sectional strength of the slope frame subject to the bending moment is calculated based on the following assumptions.

- Longitudinal strain is proportional to the distance from the neutral axis of the cross section.
- Tensile stress of the mortar is ignored.
- A non-linear model is used for the mortar and reinforcing bar stress-strain curve.

Assuming that all of cross-sectional strain is not compressed, make calculation, considering the compressive stress distribution of the mortar as an equivalent stress block.

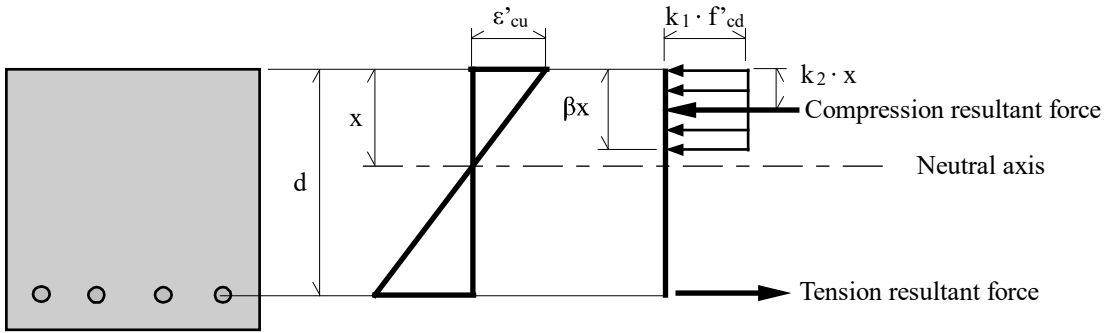

Frame cross section Ultimate strain distribution Equivalent stress block

Coefficient related to equivalent stress block of bending strength	$\beta = 0.52 + 80 \cdot \epsilon'_{cu} = 0.52 + 80 \times 0.0035 = 0.8$
Strength reduction coefficient	$k_1 = 1 - 0.003 \cdot f_{ck} = 1 - 0.003 \times 18 = 0.95 \text{ (} k_1 \leq 0.85 \text{) Therefore, } k_1 = 0.85$
Ratio of distance to compression resultant force to distance x from extreme compression fiber to neutral axis	$k_2 = \frac{\beta}{2} = \frac{0.8}{2} = 0.4$

The ultimate bending strength M_u is calculated as follows.

$$\begin{aligned}
 M_u &= \frac{b \cdot d^2 \cdot \rho \cdot f_{yd} \cdot \left(1 - \frac{k_2}{\beta \cdot k_1} \cdot \frac{\rho \cdot f_{yd}}{f_{cd}}\right)}{1} \\
 &= \frac{200 \times 155^2 \times 0.00460 \times 295 \times \left(1 - \frac{0.4}{0.8 \times 0.85} \times \frac{0.00460 \times 295}{13.85}\right)}{1} \\
 &= 6.14 \times 10^6 \text{ (N}\cdot\text{mm)} = 6.14 \text{ (kN}\cdot\text{m)}
 \end{aligned}$$

The design bending strength M_{ud} is calculated as follows.

$$\begin{aligned}
 M_{ud} &= \frac{M_u}{\gamma_b} = \frac{6.14}{1.15} \\
 &= 5.34 \text{ (kN}\cdot\text{m)}
 \end{aligned}$$

(3) Safety check

$$\gamma_i \cdot \frac{M_d}{M_{ud}} = 1.20 \times \frac{1.56}{5.34} = 0.36 \leq 1.00 \quad \dots \text{ OK}$$

10.4.2 Shear Force Check

(1) Design shear strength borne by the mortar

Shear strength of mortar	$f_{vcd} = \frac{0.20 \cdot \sqrt[3]{f_{cd}}}{\sqrt[3]{f_{cd}}} = 0.20 \times \sqrt[3]{13.85}$ $= 0.48 \text{ (N/mm}^2\text{)} \quad (f_{vcd} \leq 0.72)$
Coefficient related to effective height of shear strength	$\beta_d = \sqrt[4]{1000/d} = \sqrt[4]{1000/155}$ $= 1.59 \quad (\beta_d \leq 1.5) \quad \text{Therefore, } \beta_d = 1.50$
Coefficient related to axial reinforcement ratio of shear strength	$\beta_p = \sqrt[3]{100 \cdot p} = \sqrt[3]{100 \times 0.00460}$ $= 0.77 \quad (\beta_p \leq 1.5)$
Coefficient related to axial force of shear strength	$\beta_n = 1.00 \text{ (The axial force does not work on the slope frame.)}$

The design shear strength V_{cd} borne by the mortar is calculated as follows.

$$V_{cd} = \frac{\beta_d \cdot \beta_p \cdot \beta_n \cdot f_{vcd} \cdot b \cdot d}{\gamma_b} = \frac{1.50 \times 0.77 \times 1.00 \times 0.48 \times 200 \times 155}{1.30}$$

$$= 13.22 \times 10^3 \text{ (N)} = 13.22 \text{ (kN)}$$

(2) Design shear strength borne by the shear reinforcement

It shall be $V_{sd} = 0.0$ (kN) because no shear reinforcements are arranged.

(3) Design shear strength

Since the design shear strength V_{yd} is a combination of the design shear strength borne by the mortar and that borne by the shear reinforcement, it will be as follows.

$$V_{yd} = V_{cd} + V_{sd} = 13.22 + 0.00$$

$$= 13.22 \text{ (kN)}$$

(4) Study of the design diagonal compressive breaking strength of the mortar abdomen

Study of the design diagonal compressive breaking strength of the mortar abdomen is omitted because no shear reinforcements are arranged.

(5) Safety check

$$\gamma_i \cdot \frac{V_d}{V_{yd}} = 1.20 \times \frac{5.90}{13.22} = 0.54 \leq 1.00 \quad \dots \quad \text{OK}$$

11. Study of Bearing Stress

11.1. Allowable Bearing Stress

(1) Study requirements

Design strength of mortar	f_{ck}	=	18	(N/mm ²)
Plate width	u	=	150	(mm)
Blockout diameter	D	=	89	(mm)
Frame width	b	=	200	(mm)
Total area of mortar surface	A	=	b^2	= 200 ²
			=	40000 (mm ²)
Plate effective area	A_a	=	$u^2 - \pi \cdot D^2 / 4$	= 150 ² - $\pi \times 89^2 / 4$
			=	16279 (mm ²)

(2) Calculation of the allowable bearing stress

In case of local loading, the allowable bearing stress σ_{ba} is calculated as follows.

$$\begin{aligned} \sigma_{ba} &\leq \left(0.25 + 0.05 \cdot \frac{A}{A_a}\right) \cdot f_{ck} = \left(0.25 + 0.05 \times \frac{40000}{16279}\right) \times 18 \\ &= 6.71 \text{ (N/mm}^2\text{)} \end{aligned}$$

However, it shall be restrained within 50% of the design strength.

$$\begin{aligned} \sigma_{ba} &\leq 0.5 \cdot f_{ck} = 0.5 \times 18 \\ &= 9.00 \text{ (N/mm}^2\text{)} \end{aligned}$$

Accordingly, the allowable bearing stress σ_{ba} shall be the following value.

$$\sigma_{ba} = 6.71 \text{ (N/mm}^2\text{)}$$

11.2. Bearing Stress

Check the bearing stress σ_b .

$$\begin{aligned} \sigma_b &= \frac{T_o}{A_a} = \frac{15.123 \times 10^3}{16279} \\ &= 0.93 \text{ (N/mm}^2\text{)} \leq \sigma_{ba} = 6.71 \text{ (N/mm}^2\text{)} \quad \dots \text{ OK} \end{aligned}$$

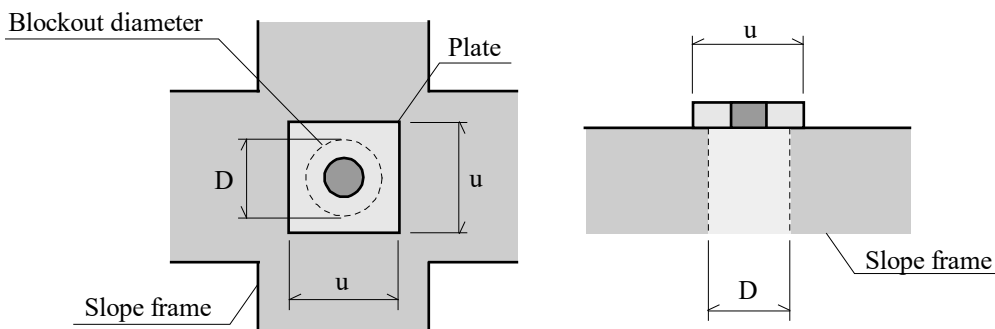

12. Lap Joint of Reinforcing Bar

The lap joint length of reinforcing bars shall be equal to or longer than the basic development length.

Main reinforcing bar	D10 - 2 pcs. ($\phi=10(\text{mm})$)
Covering of tensile reinforcement	$c = 40$ (mm)
Reinforcing bar interval (Value when reinforcing bars are equally spaced in the arrangement section)	$a = 100$ (mm)
Design tensile yield strength of reinforcing bar	$f_{yd} = 295$ (N/mm ²)
Design strength of mortar	$f_{ck} = 18$ (N/mm ²)
Material factor of mortar	$\gamma_c = 1.30$
Design adhesive strength of mortar	$f_{bod} = \frac{0.28 \cdot f_{ck}^{2/3}}{\gamma_c} = \frac{0.28 \times 18^{2/3}}{1.30}$ $= 1.479$ (N/mm ²) ($f_{bod} \leq 3.2$)

“c” used here is either covering of the tensile reinforcement or half value of the interval of anchored reinforcing bars, whichever is lower. Accordingly;

$$c = \min \left(40, \frac{100}{2} \right) = 40 \text{ (mm)}$$

The coefficients k_c and α related to the basic development length will be as follows.

$$k_c = \frac{c}{\phi} + \frac{15 \cdot A_t}{s \cdot \phi} = \frac{40}{10} \quad (* \text{ It shall be } \frac{15 \cdot A_t}{s \cdot \phi} = 0 \text{ because no stirrups are arranged.})$$

$$= 4.000$$

In case of	$k_c \leq 1.0$	$\alpha = 1.0$
In case of	$1.0 < k_c \leq 1.5$	$\alpha = 0.9$
In case of	$1.5 < k_c \leq 2.0$	$\alpha = 0.8$
In case of	$2.0 < k_c \leq 2.5$	$\alpha = 0.7$
In case of	$2.5 < k_c$	$\alpha = 0.6$

Based on $k_c = 4.000$, $\alpha = 0.6$.

The basic development length l_d is calculated as follows.

$$l_d = \frac{\alpha \cdot f_{yd} \cdot \phi}{4 \cdot f_{bod}} = \frac{0.6 \times 295 \times 10}{4 \times 1.479}$$

$$= 300 \text{ (mm)}$$

Accordingly, the lap joint length of reinforcing bars needs to be 300 mm or more.

Appendix-6

Arrangement of Reinforcements

Arrangement of Reinforcements

Site	KANDY UPPER
Case	Line E, Pr(max)
Remarks	ϕ 34 C6

Site	KANDY
Case	Line E, Pr(max)
Remarks	ϕ 34 C6

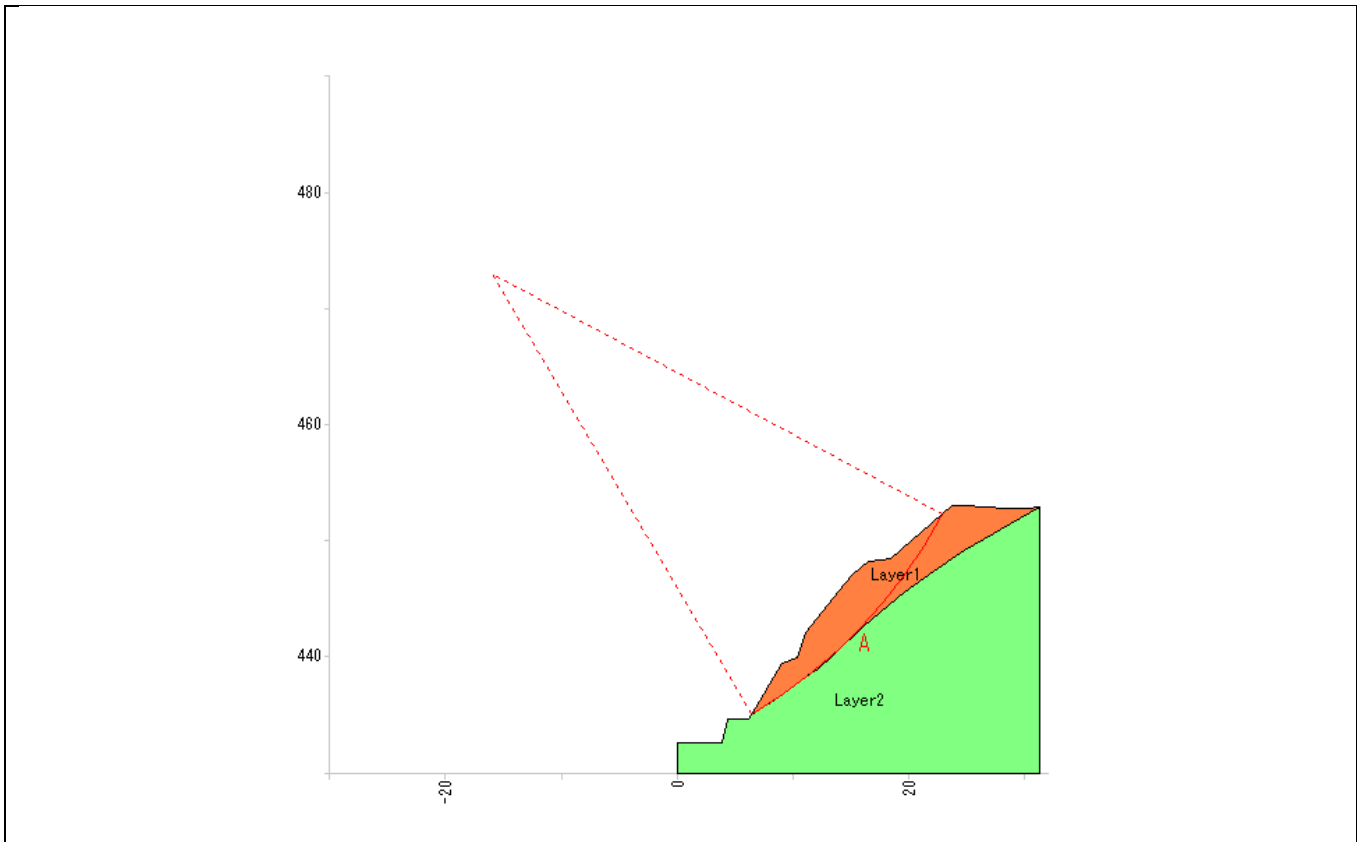

Stability calculation results				
Item		Symbol	Unit	Normally
				Circular arc A
Calculation results	Safety factor	Fs	-	0.939
	Planned safety factor	Fsp	-	1.200
	Required prevention force	Pr	kN/m	152.3
Circular arc	Central coordinates	X	m	-16.000
		Y	m	473.000
	Radius	r	m	44.097
Calculation elements	Skid resistance	S	kN/m	548.96
	Sliding force	T	kN/m	584.35
	Normal force	N	kN/m	599.26
	Pore water pressure	U	kN/m	0.00
	Sliding surface length	l	m	24.126
	Area	A	m ²	49.55

Requirements for Automatic Arrangement of Reinforcements

Upon studying automatic arrangement of reinforcements, the following lists various requirements.

(1) Selection of the reinforcements studied

Type	Material	Nominal diameter	Borehole diameter D (mm)	Corrosion allowance
Screw-knotted steel bar	Screw-knotted steel bar (SD345)	D22~ D22	Fix at 65.0	To be considered

(2) Automatic calculation ranges

Arrangement slope	Start point		End point		Slope length (m)	Type	Remarks
	X (m)	Y (m)	X (m)	Y (m)			
Range 1	6.226	434.587	23.710	452.961	26.299	Continuous line	From above, fixed length = 1.150m

(3) Reinforcement calculation elements

Item	Symbol	Unit	Start	End	Pitch
Number of constructed steps	n	steps	13	13	1
Horizontal interval	SH	m	2.00	2.00	0.50
Vertical interval	SV	m	Horizontal interval × 1.00		
Installation angle	α	°	Perpendicular to the slope		
Insertion length (Length of borehole)	L_B	m	4.00	5.00	0.50

(4) Supplementary requirements

Item	Symbol	Unit	Numerical value
Excess length	-	m	Secure 0.10m
Increment of rounding full length	-	m	Round in increments of 0.5m

List of Reinforcement Automatic Arrangement Results (Normally)

Reinforcement : Screw-knotted steel bar (SD345)

Slope protection : Grating Crib Works

Reinforcement Automatic Arrangement Results			Planned safety factor $F_{sp} = 1.200$								
No.	Reinforcement		Arrangement requirements						Safety factor F_s ^{*3}	Slope protection dimension $h \times b$ (mm) ^{*4}	Length of borehole (Construction : 10 m) ΣL_B (m)
	Reg.	Nominal diameter	Vertical interval SV (m)	Horizontal interval SH (m)	No. of constructed steps n (steps)	Installation angle α (°) ^{*1}	Length condition (m)	Full length (m) ^{*2}	Circular arc A (0.939)		
1		D22	2.00	2.00	13	-	4.00	4.50	1.204	300×300 D13	266.500
2	o	D22	2.00	2.00	13	-	4.50	5.00	1.265	300×300 D13	299.000
3		D22	2.00	2.00	13	-	5.00	5.50	1.298	300×300 D13	331.500

*1. "-" is indicated when arranged at a right angle to the slope.

*2. When the full length of reinforcement differs from one step to another, the maximum full length is indicated.

*3. Parenthesized values are safety factors before reinforcement.

*4. When the slope protection size differs from one step to another, the maximum slope protection size is indicated.

Site	KANDY
Case	Line E, Pr(max)
Remarks	φ 34 C6

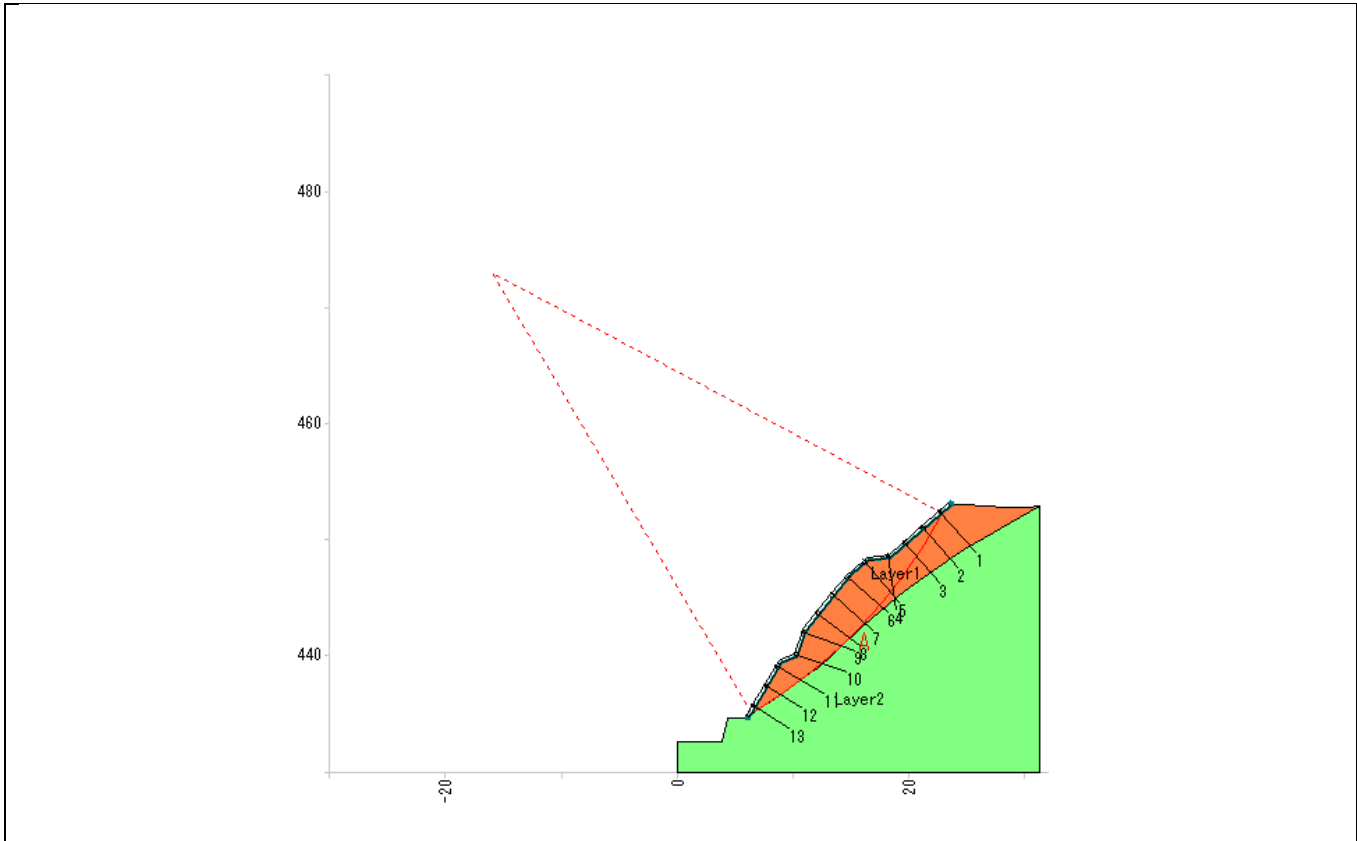

Reinforcement standard						
No.	Material	Nominal diameter	Reinforcement diameter d (mm)	Cross-sectional area As (cm ²)	Borehole diameter D (mm)	Corrosion allowance
Material-1	Screw-knotted steel bar (SD345)	D22	21.2	3.530	65.0	To be considered

Reinforcement arrangement results									
No.	Standard No.	Arrangement coordinates		Horizontal interval SH (m)	Vertical interval SV (m)	Installation angle α (°)	Full length L (m)	Insertion length L _B (m)	Arrangement slope
		X (m)	Y (m)						
[1]	Material-1	22.842	452.207	2.00	-	49.02	5.000	4.600	Range 1
[2]	Material-1	21.332	450.895	2.00	2.00	49.02	5.000	4.600	Range 1
[3]	Material-1	19.822	449.583	2.00	2.00	49.02	5.000	4.600	Range 1
[4]	Material-1	18.257	448.394	2.00	2.00	82.11	5.000	4.600	Range 1
[5]	Material-1	16.342	447.971	2.00	2.00	49.45	5.000	4.600	Range 1
[6]	Material-1	14.865	446.628	2.00	2.00	40.69	5.000	4.600	Range 1
[7]	Material-1	13.561	445.112	2.00	2.00	40.69	5.000	4.600	Range 1
[8]	Material-1	12.319	443.544	2.00	2.00	38.32	5.000	4.600	Range 1
[9]	Material-1	11.117	441.954	2.00	2.00	19.33	5.000	4.600	Range 1
[10]	Material-1	10.455	440.067	2.00	2.00	19.33	5.000	4.600	Range 1
[11]	Material-1	8.871	439.003	2.00	2.00	31.37	5.000	4.600	Range 1
[12]	Material-1	7.830	437.295	2.00	2.00	31.37	4.000	3.600	Range 1
[13]	Material-1	6.789	435.588	2.00	2.00	31.37	4.000	3.600	Range 1

Reinforcement tensile strength calculation requirements				
Item	Symbol	Unit	Normally	Remarks
Reinforcement allowable tensile stress	σ_{sa}	N/mm ²	200.0	Screw-knotted steel bar (SD345) D22
Reinforcement allowable shear stress	τ_{sa}	N/mm ²	-	
Allowable adhesive stress of reinforcement and grouting material	τ_c	N/mm ²	1.6	$\sigma_{ck} = 24$ (N/mm ²)
Skin friction safety factor	Fsa	-	2.00	
Slope protection reduction coefficient	μ	-	1.00	
Reinforcement tension reduction coefficient	λ	-	0.7	
Skin friction of natural ground and grouting material	τ_p	N/mm ²	0.080	Layer1
			0.480	Layer2

Reinforcement Resistance Calculation Method

(1) Calculation of the allowable adhesive force

The following shows an allowable adhesive force calculation formula.

The allowable adhesive force t_a (kN/m) shall be the lowest value of t_{pa} and t_{ca} .

However, the allowable adhesive force t_{pa} of the natural ground and grouting material and that t_{ca} of the reinforcement and grouting material are based on the following formulas.

$$t_{pa} = \frac{\tau_p \cdot \pi \cdot D}{F_{sa}}$$

t_{pa}	: Allowable adhesive force of natural ground and grouting material	(kN/m)
τ_p	: Skin friction of natural ground and grouting material	(kN/m ²)
D	: Borehole diameter	(m)
F_{sa}	: Skin friction safety factor	

$$t_{ca} = \tau_c \cdot \pi \cdot d$$

t_{ca}	: Allowable adhesive force of reinforcement and grouting material	(kN/m)
τ_c	: Allowable adhesive stress of reinforcement and grouting material	(kN/m ²)
d	: Reinforcement diameter	(m)

(2) Calculation of the allowable reinforcement force of the reinforcement

The following shows a method and formula for calculating the allowable reinforcement force of the reinforcement.

The allowable reinforcement force T_{pa} (kN/pc.) shall be the lowest value of T_{1pa} , T_{2pa} and T_{sa} .

Based on t_a calculated in the previous paragraph, the following formulas are used to calculate the pull-out resistance T_{1pa} received from the moving clod, pull-out resistance T_{2pa} received from the unmoving natural ground, and reinforcement allowable tension T_{sa} by the reinforcement material.

$$T_{1pa} = \frac{1}{1-\mu} \cdot L_1 \cdot t_a$$

T_{1pa}	: Pull-out resistance received from moving clod	(kN/pc.)
μ	: Slope protection reduction coefficient	
L_1	: Effective development length of moving clod	(m)

$$T_{2pa} = L_2 \cdot t_a$$

T_{2pa}	: Pull-out resistance received from unmoving natural ground	(kN/pc.)
L_2	: Effective development length of unmoving natural ground	(m)

$$T_{sa} = \sigma_{sa} \cdot A_s$$

T_{sa}	: Reinforcement allowable tension	(kN/pc.)
σ_{sa}	: Reinforcement allowable tensile stress	(kN/m ²)
A_s	: Reinforcement cross-sectional area	(m ²)

Based on the above results, the following shows a stability calculation formula after reinforcement.

< Normally >

$$F_s = \frac{\Sigma\{(N-U) \cdot \tan\phi + C \cdot l\} + Sh + Ss}{\Sigma T}$$

where;

F_s	:	Safety factor		
N	:	Normal force by gravity of slice	$(N = W \cdot \cos\theta + Q_N)$	(kN/m)
U	:	Pore water pressure working on slice	$(U = u \cdot l)$	(kN/m)
T	:	Tangential force by gravity of slice	$(T = W \cdot \sin\theta + Q_T)$	(kN/m)
l	:	Sliding surface length of slice		(m)
ϕ	:	Internal friction angle of sliding surface		(°)
C	:	Cohesion of sliding surface		(kN/m ²)
W	:	Slice weight		(kN/m)
θ	:	Sliding surface inclination angle		(°)
u	:	Unit pore water pressure		(kN/m ²)
Q_N	:	Vertical load component force (normal direction)		(kN/m)
Q_T	:	Vertical load component force (tangential direction)		(kN/m)
Sh	:	Anchoring force by reinforcement	$(Sh = T_m \cdot \cos\beta)$	(kN/m)
Ss	:	Stressing force by reinforcement	$(Ss = T_m \cdot \sin\beta \cdot \tan\phi)$	(kN/m)
T_m	:	Reinforcement design tension		(kN/m)
β	:	Angle formed between sliding surface and reinforcement		(°)

Calculation of Resistance by Reinforcement (Circular arc A - Normally)

The following shall describe how to calculate reinforcement resistance, using the requirements, numerical values and numerical formulas mentioned above.

< Reinforcement No. 1 >

(1) Calculation of the allowable reinforcement force Tpa of the reinforcement

$$T1pa = \frac{1}{1-\mu} \cdot \min(\Sigma(L1 \cdot tpa), \Sigma(L1 \cdot tca))$$

Here, T1pa shall not be considered.

$$T2pa = \min(\Sigma(L2 \cdot tpa), \Sigma(L2 \cdot tca)) = 72.762 \text{ (kN)}$$

$$Tsa = \sigma_{sa} \cdot A_s = 200.0 \times 10^3 \times 3.530 \times 10^{-4} = 70.600 \text{ (kN)}$$

μ	: Slope protection reduction coefficient	
L1	: Effective development length of moving clod	(m)
L2	: Effective development length of unmoving natural ground	(m)
σsa	: Reinforcement allowable tensile stress	(kN/m ²)
As	: Reinforcement cross-sectional area	(m ²)

Accordingly, Tpa shall be Tsa because Tsa < T2pa.

(2) Calculation of resistance by reinforcement

Based on Tpa calculated in the previous paragraph, calculate the anchoring force Sh by the reinforcement and the stressing force Ss by the reinforcement.

$$\begin{aligned} Sh &= T_m \cdot \cos\beta_i = \frac{\lambda \cdot Tpa}{SH} \cdot \cos\beta_i = \frac{0.7 \times 70.600}{2.00} \times \cos(110.84) \\ &= -8.791 \text{ (kN/m)} \end{aligned}$$

$$\begin{aligned} Ss &= T_m \cdot \sin\beta_i \cdot \tan\varphi_i = \frac{\lambda \cdot Tpa}{SH} \cdot \sin\beta_i \cdot \tan\varphi_i = \frac{0.7 \times 70.600}{2.00} \times \sin(110.84) \times 0.674509 \\ &= 15.577 \text{ (kN/m)} \end{aligned}$$

Tm	: Reinforcement design tension (Tm = Td/SH, Td = λ·Tpa)	(kN/m)
λ	: Reinforcement tension reduction coefficient	
Tpa	: Allowable reinforcement force of the reinforcement	(kN/pc.)
β _i	: Angle formed between sliding surface and reinforcement	(°)
φ _i	: Internal friction angle	(°)
Td	: Design tension per reinforcement	(kN/pc.)
SH	: Horizontal interval	(m)

List of Resistances by Each Reinforcement (Circular arc A - Normally)

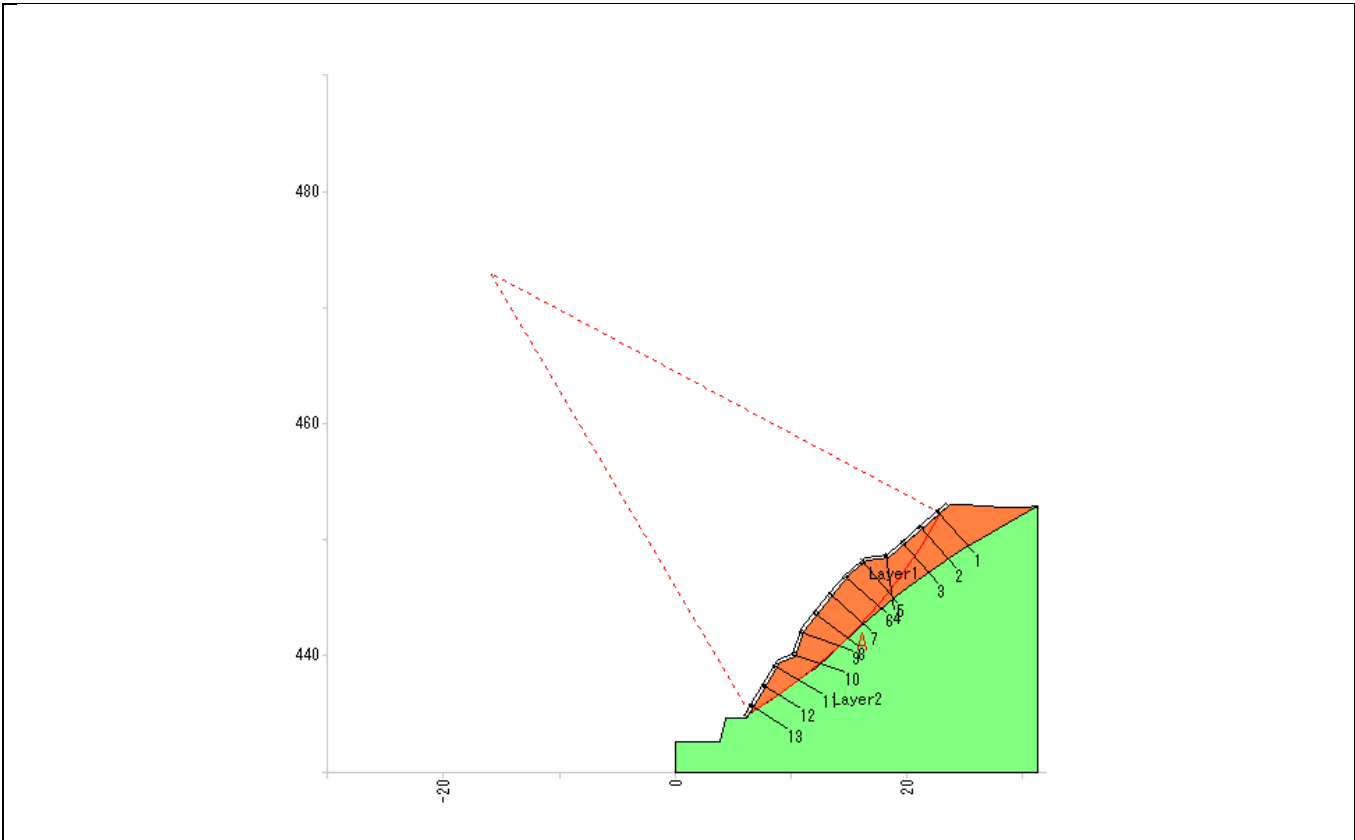

List of resistances by each reinforcement									
No.	β ($^{\circ}$)	T1pa (kN/pc.)	T2pa (kN/pc.)	Tsa (kN/pc.)	Tpa (kN/pc.)	Td (kN/pc.)	Tm (kN/m)	Sh (kN/m)	Ss (kN/m)
[1]	110.84	-	72.762	70.600	70.600	49.420	24.710	-8.791	15.577
[2]	108.08	-	79.083	70.600	70.600	49.420	24.710	-7.669	15.844
[3]	105.37	-	84.255	70.600	70.600	49.420	24.710	-6.549	16.071
[4]	133.86	-	53.591	70.600	53.591	37.514	18.757	-12.997	9.122
[5]	100.85	-	34.853	70.600	34.853	24.397	12.198	-2.296	8.081
[6]	90.16	-	34.797	70.600	34.797	24.358	12.179	-0.034	8.215
[7]	87.56	-	49.744	70.600	49.744	34.821	17.410	0.741	11.733
[8]	82.77	-	62.739	70.600	62.739	43.917	21.958	2.763	14.693
[9]	62.56	-	62.306	70.600	62.306	43.614	21.807	10.049	13.054
[10]	59.59	-	115.971	70.600	70.600	49.420	24.710	12.508	14.374
[11]	68.61	-	119.280	70.600	70.600	49.420	24.710	9.012	15.519
[12]	65.79	-	111.854	70.600	70.600	49.420	24.710	10.133	15.201
[13]	62.91	-	160.088	70.600	70.600	49.420	24.710	11.253	14.839
Total								18.123	172.323

* The enclosed values in the T1pa, T2pa and Tsa columns indicate the values used as Tpa.

Site	KANDY
Case	Line E, Pr(max)
Remarks	φ 34 C6

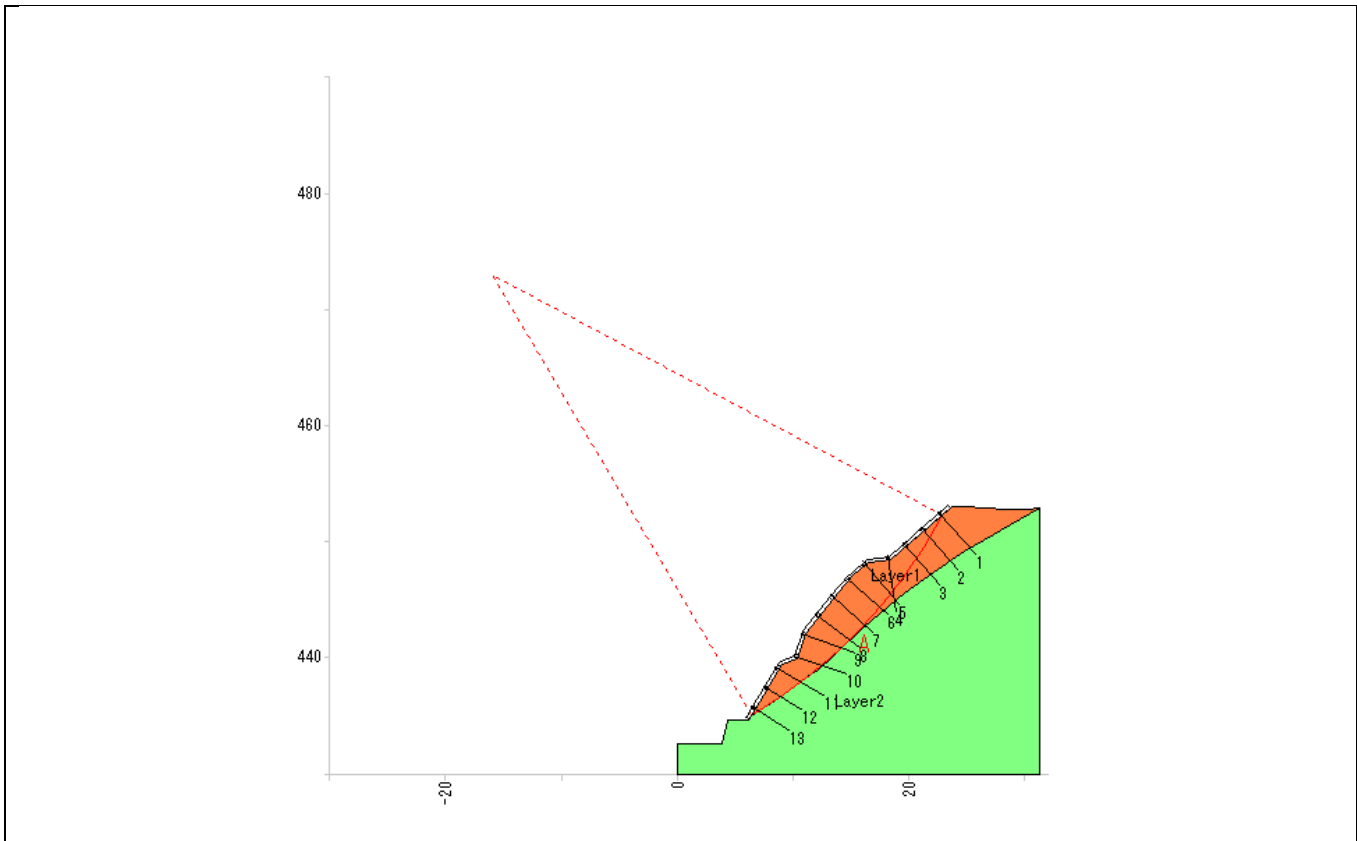

Safety factor results after arrangement of reinforcements				
Item		Symbol	Unit	Normally
				Circular arc A
Calculation results	Safety factor before reinforcement	Fs	-	0.939
	Planned safety factor	Fsp	-	1.200
	Safety factor after reinforcement	Fs	-	1.265
Circular arc	Central coordinates	X	m	-16.000
		Y	m	473.000
	Radius	r	m	44.097
Calculation elements	Anchoring force	Sh	kN/m	18.123
	Stressing force	Ss	kN/m	172.323

Number of constructed steps : 13 steps

Calculation of the safety factor after reinforcement (Circular arc A)

< Normally >

$$\begin{aligned} F_s &= \frac{\Sigma\{(N-U)\cdot\tan\phi+C\cdot l\}+Sh+S_s}{\Sigma T} \\ &= \frac{548.96+18.123+172.323}{584.35} \\ &= 1.265 \end{aligned}$$

Arrangement of Reinforcements

Site	KANDY LOWER
Case	B Pr(max)
Remarks	ϕ 29

Site	KANDY
Case	B Pr(max)
Remarks	ϕ 29

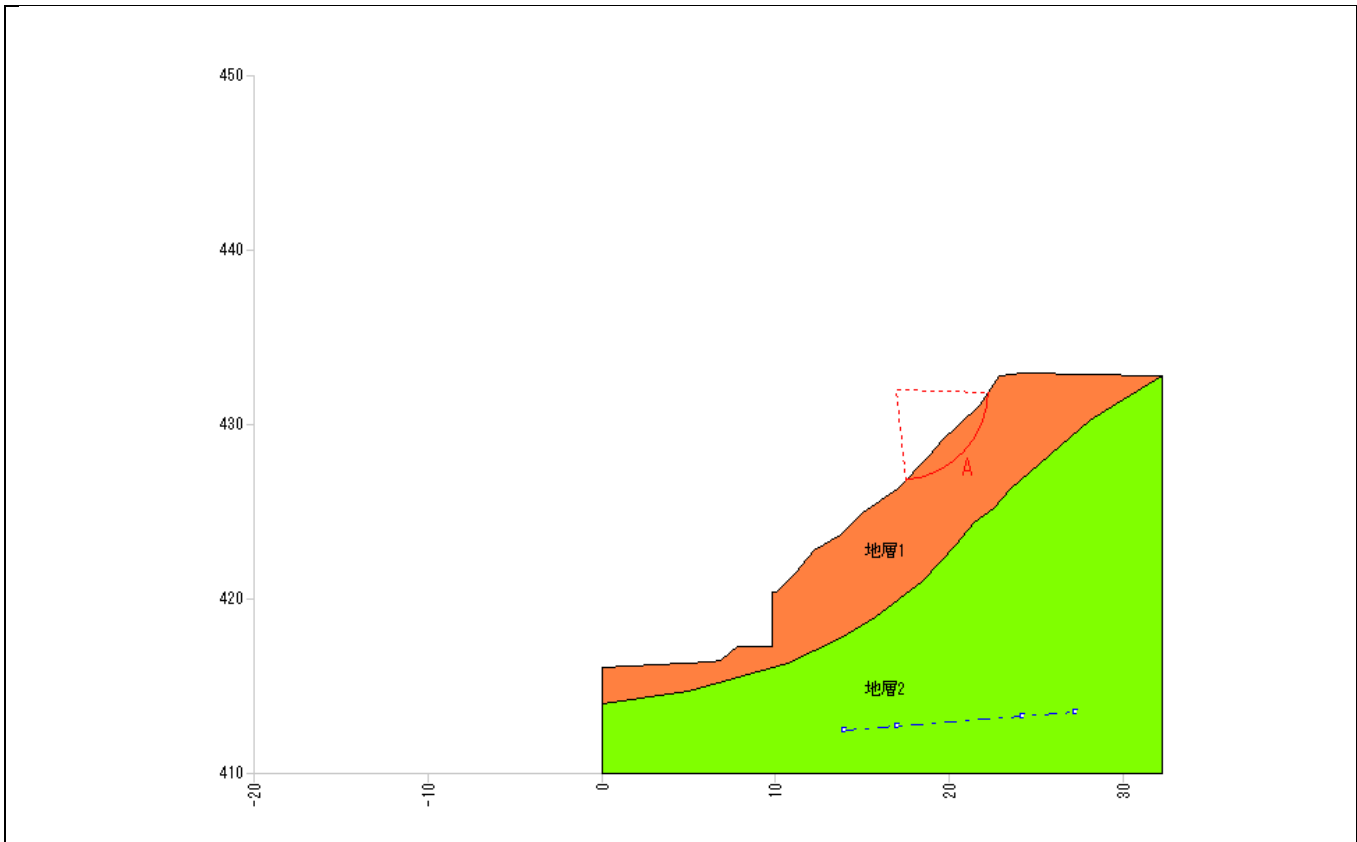

Stability calculation results				
Item		Symbol	Unit	Normally
				Circular arc A
Calculation results	Safety factor	Fs	-	1.015
	Planned safety factor	Fsp	-	1.200
	Required prevention force	Pr	kN/m	11.6
Circular arc	Central coordinates	X	m	17.000
		Y	m	432.000
	Radius	r	m	5.233
Calculation elements	Skid resistance	S	kN/m	63.41
	Sliding force	T	kN/m	62.46
	Normal force	N	kN/m	74.59
	Pore water pressure	U	kN/m	0.00
	Sliding surface length	l	m	7.610
	Area	A	m ²	5.95

Requirements for Automatic Arrangement of Reinforcements

Upon studying automatic arrangement of reinforcements, the following lists various requirements.

(1) Selection of the reinforcements studied

Type	Material	Nominal diameter	Borehole diameter D (mm)	Corrosion allowance
Screw-knotted steel bar	Screw-knotted steel bar (SD345)	D19~ D25	Fix at 65.0	To be considered

(2) Automatic calculation ranges

Arrangement slope	Start point		End point		Slope length (m)	Type	Remarks
	X (m)	Y (m)	X (m)	Y (m)			
Range 1	17.405	426.694	23.416	432.886	8.629	Single line	From below, fixed length = 0.850m

(3) Reinforcement calculation elements

Item	Symbol	Unit	Start	End	Pitch
Number of constructed steps	n	steps	6	6	1
Horizontal interval	SH	m	1.50	1.50	0.50
Vertical interval	SV	m	Horizontal interval × 1.00		
Installation angle	α	°	Perpendicular to the slope		
Insertion length (Length of borehole)	L_B	m	2.70	4.70	0.50

(4) Supplementary requirements

Item	Symbol	Unit	Numerical value
Excess length	-	m	Secure 0.10m
Increment of rounding full length	-	m	Round in increments of 0.5m

List of Reinforcement Automatic Arrangement Results (Normally)

Reinforcement : Screw-knotted steel bar (SD345)

Slope protection : Grating Crib Works

Reinforcement Automatic Arrangement Results			Planned safety factor Fsp = 1.200								
No.	Reinforcement		Arrangement requirements						Safety factor Fs ^{*3}	Slope protection dimension h×b (mm) ^{*4}	Length of borehole (Construction : 10 m) ΣLB (m)
	Reg .	Nominal diameter	Vertical interval SV (m)	Horizontal interval SH (m)	No. of constructed steps n (steps)	Installation angle α (°) ^{*1}	Length condision n (m)	Full length (m) ^{*2}	Circular arc A (1.015)		
1	o	D19	1.50	1.50	6	-	2.70	3.00	1.250	200×200 D10	108.000
2		D19	1.50	1.50	6	-	3.20	3.50	1.317	200×200 D10	128.000
3		D19	1.50	1.50	6	-	3.70	4.00	1.384	200×200 D10	148.000
4		D19	1.50	1.50	6	-	4.20	4.50	1.452	200×200 D10	168.000
5		D19	1.50	1.50	6	-	4.70	5.00	1.519	200×200 D10	188.000
6		D22	1.50	1.50	6	-	2.70	3.00	1.250	200×200 D10	108.000
7		D22	1.50	1.50	6	-	3.20	3.50	1.317	200×200 D10	128.000
8		D22	1.50	1.50	6	-	3.70	4.00	1.384	200×200 D10	148.000
9		D22	1.50	1.50	6	-	4.20	4.50	1.452	200×200 D10	168.000
10		D22	1.50	1.50	6	-	4.70	5.00	1.519	200×200 D10	188.000
11		D25	1.50	1.50	6	-	2.70	3.00	1.250	200×200 D10	108.000
12		D25	1.50	1.50	6	-	3.20	3.50	1.317	200×200 D10	128.000
13		D25	1.50	1.50	6	-	3.70	4.00	1.384	200×200 D10	148.000
14		D25	1.50	1.50	6	-	4.20	4.50	1.452	200×200 D10	168.000
15		D25	1.50	1.50	6	-	4.70	5.00	1.519	200×200 D10	188.000

*1. “-“ is indicated when arranged at a right angle to the slope.

*2. When the full length of reinforcement differs from one step to another, the maximum full length is indicated.

*3. Parenthesized values are safety factors before reinforcement.

*4. When the slope protection size differs from one step to another, the maximum slope protection size is indicated.

Site	KANDY	
Case	B	Pr(max)
Remarks	φ 29	

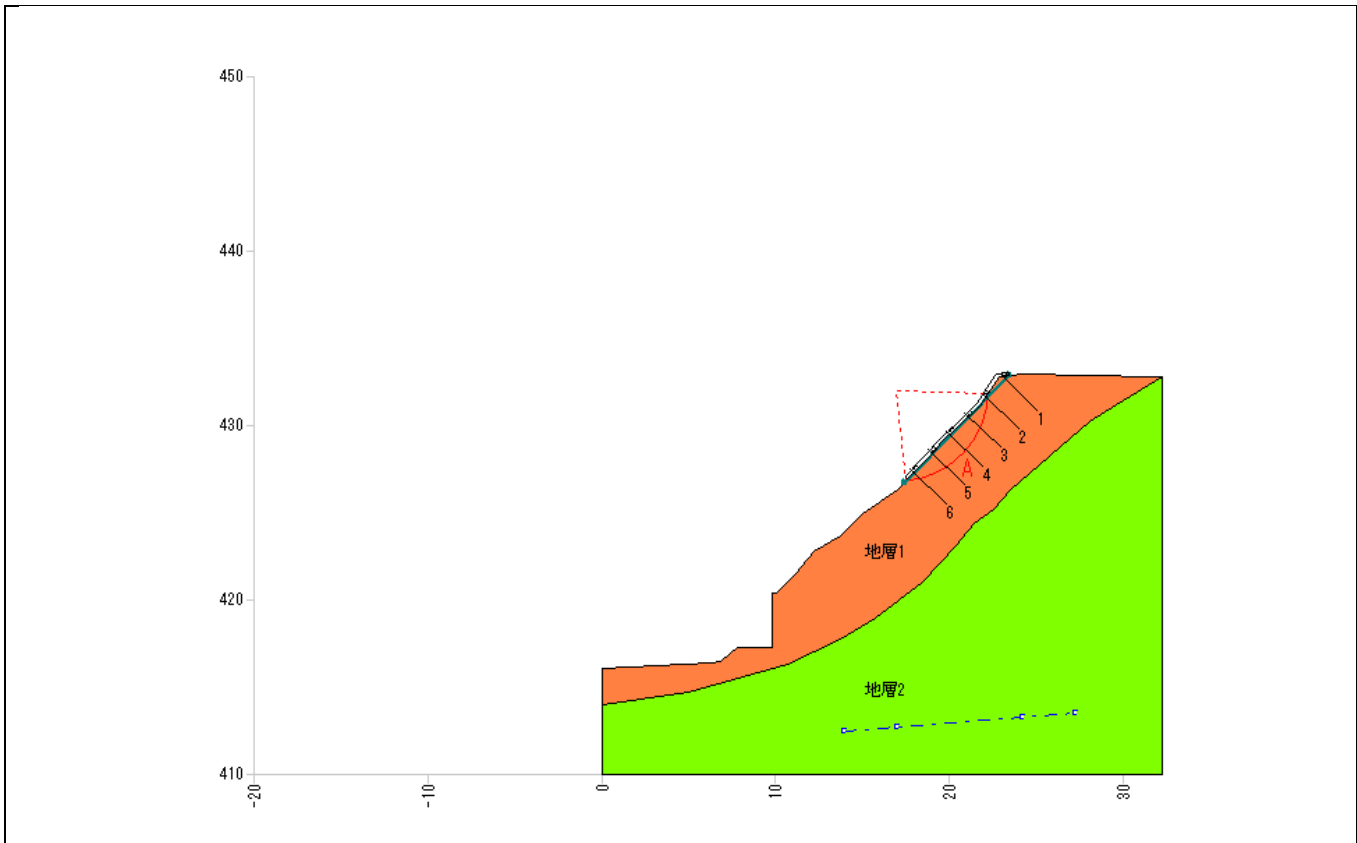

Reinforcement standard						
No.	Material	Nominal diameter	Reinforcement diameter d (mm)	Cross-sectional area As (cm ²)	Borehole diameter D (mm)	Corrosion allowance
Material-1	Screw-knotted steel bar (SD345)	D19	18.1	2.573	65.0	To be considered

Reinforcement arrangement results									
No.	Standard No.	Arrangement coordinates		Horizontal interval SH (m)	Vertical interval SV (m)	Installation angle α (°)	Full length L (m)	Insertion length L _B (m)	Arrangement slope
		X (m)	Y (m)						
[1]	Material-1	23.221	432.685	1.50	-	44.15	3.000	2.700	Range 1
[2]	Material-1	22.177	431.609	1.50	1.50	44.15	3.000	2.700	Range 1
[3]	Material-1	21.132	430.533	1.50	1.50	44.15	3.000	2.700	Range 1
[4]	Material-1	20.087	429.457	1.50	1.50	44.15	3.000	2.700	Range 1
[5]	Material-1	19.042	428.380	1.50	1.50	44.15	3.000	2.700	Range 1
[6]	Material-1	17.997	427.304	1.50	1.50	44.15	3.000	2.700	Range 1

Reinforcement tensile strength calculation requirements				
Item	Symbol	Unit	Normally	Remarks
Reinforcement allowable tensile stress	σ_{sa}	N/mm ²	200.0	Screw-knotted steel bar (SD345) D19
Reinforcement allowable shear stress	τ_{sa}	N/mm ²	-	
Allowable adhesive stress of reinforcement and grouting material	τ_c	N/mm ²	1.6	$\sigma_{ck} = 24$ (N/mm ²)
Skin friction safety factor	Fsa	-	2.00	
Slope protection reduction coefficient	μ	-	1.00	
Reinforcement tension reduction coefficient	λ	-	0.7	
Skin friction of natural ground and grouting material	τ_p	N/mm ²	0.080	地層 1
			0.080	地層 2

Reinforcement Resistance Calculation Method

(1) Calculation of the allowable adhesive force

The following shows an allowable adhesive force calculation formula.

The allowable adhesive force t_a (kN/m) shall be the lowest value of t_{pa} and t_{ca} .

However, the allowable adhesive force t_{pa} of the natural ground and grouting material and that t_{ca} of the reinforcement and grouting material are based on the following formulas.

$$t_{pa} = \frac{\tau_p \cdot \pi \cdot D}{F_{sa}}$$

t_{pa}	:	Allowable adhesive force of natural ground and grouting material	(kN/m)
τ_p	:	Skin friction of natural ground and grouting material	(kN/m ²)
D	:	Borehole diameter	(m)
F_{sa}	:	Skin friction safety factor	

$$t_{ca} = \tau_c \cdot \pi \cdot d$$

t_{ca}	:	Allowable adhesive force of reinforcement and grouting material	(kN/m)
τ_c	:	Allowable adhesive stress of reinforcement and grouting material	(kN/m ²)
d	:	Reinforcement diameter	(m)

(2) Calculation of the allowable reinforcement force of the reinforcement

The following shows a method and formula for calculating the allowable reinforcement force of the reinforcement.

The allowable reinforcement force T_{pa} (kN/pc.) shall be the lowest value of T_{1pa} , T_{2pa} and T_{sa} .

Based on t_a calculated in the previous paragraph, the following formulas are used to calculate the pull-out resistance T_{1pa} received from the moving clod, pull-out resistance T_{2pa} received from the unmoving natural ground, and reinforcement allowable tension T_{sa} by the reinforcement material.

$$T_{1pa} = \frac{1}{1-\mu} \cdot L_1 \cdot t_a$$

T_{1pa}	:	Pull-out resistance received from moving clod	(kN/pc.)
μ	:	Slope protection reduction coefficient	
L_1	:	Effective development length of moving clod	(m)

$$T_{2pa} = L_2 \cdot t_a$$

T_{2pa}	:	Pull-out resistance received from unmoving natural ground	(kN/pc.)
L_2	:	Effective development length of unmoving natural ground	(m)

$$T_{sa} = \sigma_{sa} \cdot A_s$$

T_{sa}	:	Reinforcement allowable tension	(kN/pc.)
σ_{sa}	:	Reinforcement allowable tensile stress	(kN/m ²)
A_s	:	Reinforcement cross-sectional area	(m ²)

Based on the above results, the following shows a stability calculation formula after reinforcement.

< Normally >

$$F_s = \frac{\Sigma\{(N-U) \cdot \tan\phi + C \cdot l\} + Sh + Ss}{\Sigma T}$$

where;

F_s	:	Safety factor		
N	:	Normal force by gravity of slice	$(N = W \cdot \cos\theta + Q_N)$	(kN/m)
U	:	Pore water pressure working on slice	$(U = u \cdot b \cdot \cos\theta)$	(kN/m)
T	:	Tangential force by gravity of slice	$(T = W \cdot \sin\theta + Q_T)$	(kN/m)
b	:	Slice width		(m)
l	:	Sliding surface length of slice		(m)
ϕ	:	Internal friction angle of sliding surface		(°)
C	:	Cohesion of sliding surface		(kN/m ²)
W	:	Slice weight		(kN/m)
θ	:	Sliding surface inclination angle		(°)
u	:	Unit pore water pressure		(kN/m ²)
Q_N	:	Vertical load component force (normal direction)		(kN/m)
Q_T	:	Vertical load component force (tangential direction)		(kN/m)
Sh	:	Anchoring force by reinforcement	$(Sh = T_m \cdot \cos\beta)$	(kN/m)
Ss	:	Stressing force by reinforcement	$(Ss = T_m \cdot \sin\beta \cdot \tan\phi)$	(kN/m)
T_m	:	Reinforcement design tension		(kN/m)
β	:	Angle formed between sliding surface and reinforcement		(°)

Calculation of Resistance by Reinforcement (Circular arc A - Normally)

The following shall describe how to calculate reinforcement resistance, using the requirements, numerical values and numerical formulas mentioned above.

< Reinforcement No. 2 >

(1) Calculation of the allowable reinforcement force Tpa of the reinforcement

$$T1pa = \frac{1}{1-\mu} \cdot \min(\Sigma(L1 \cdot tpa), \Sigma(L1 \cdot tca))$$

Here, T1pa shall not be considered.

$$T2pa = \min(\Sigma(L2 \cdot tpa), \Sigma(L2 \cdot tca)) = 21.604 \text{ (kN)}$$

$$Tsa = \sigma_{sa} \cdot A_s = 200.0 \times 10^3 \times 2.573 \times 10^{-4} = 51.460 \text{ (kN)}$$

μ	: Slope protection reduction coefficient	
$L1$: Effective development length of moving clod	(m)
$L2$: Effective development length of unmoving natural ground	(m)
σ_{sa}	: Reinforcement allowable tensile stress	(kN/m ²)
A_s	: Reinforcement cross-sectional area	(m ²)

Accordingly, Tpa shall be T2pa because T2pa < Tsa.

(2) Calculation of resistance by reinforcement

Based on Tpa calculated in the previous paragraph, calculate the anchoring force Sh by the reinforcement and the stressing force Ss by the reinforcement.

$$\begin{aligned} Sh &= T_m \cdot \cos\beta_i = \frac{\lambda \cdot Tpa}{SH} \cdot \cos\beta_i = \frac{0.7 \times 21.604}{1.50} \times \cos(129.45) \\ &= -6.406 \text{ (kN/m)} \end{aligned}$$

$$\begin{aligned} Ss &= T_m \cdot \sin\beta_i \cdot \tan\varphi_i = \frac{\lambda \cdot Tpa}{SH} \cdot \sin\beta_i \cdot \tan\varphi_i = \frac{0.7 \times 21.604}{1.50} \times \sin(129.45) \times 0.554309 \\ &= 4.315 \text{ (kN/m)} \end{aligned}$$

T_m	: Reinforcement design tension ($T_m = T_d / SH$, $T_d = \lambda \cdot Tpa$)	(kN/m)
λ	: Reinforcement tension reduction coefficient	
Tpa	: Allowable reinforcement force of the reinforcement	(kN/pc.)
β_i	: Angle formed between sliding surface and reinforcement	(°)
φ_i	: Internal friction angle	(°)
T_d	: Design tension per reinforcement	(kN/pc.)
SH	: Horizontal interval	(m)

List of Resistances by Each Reinforcement (Circular arc A - Normally)

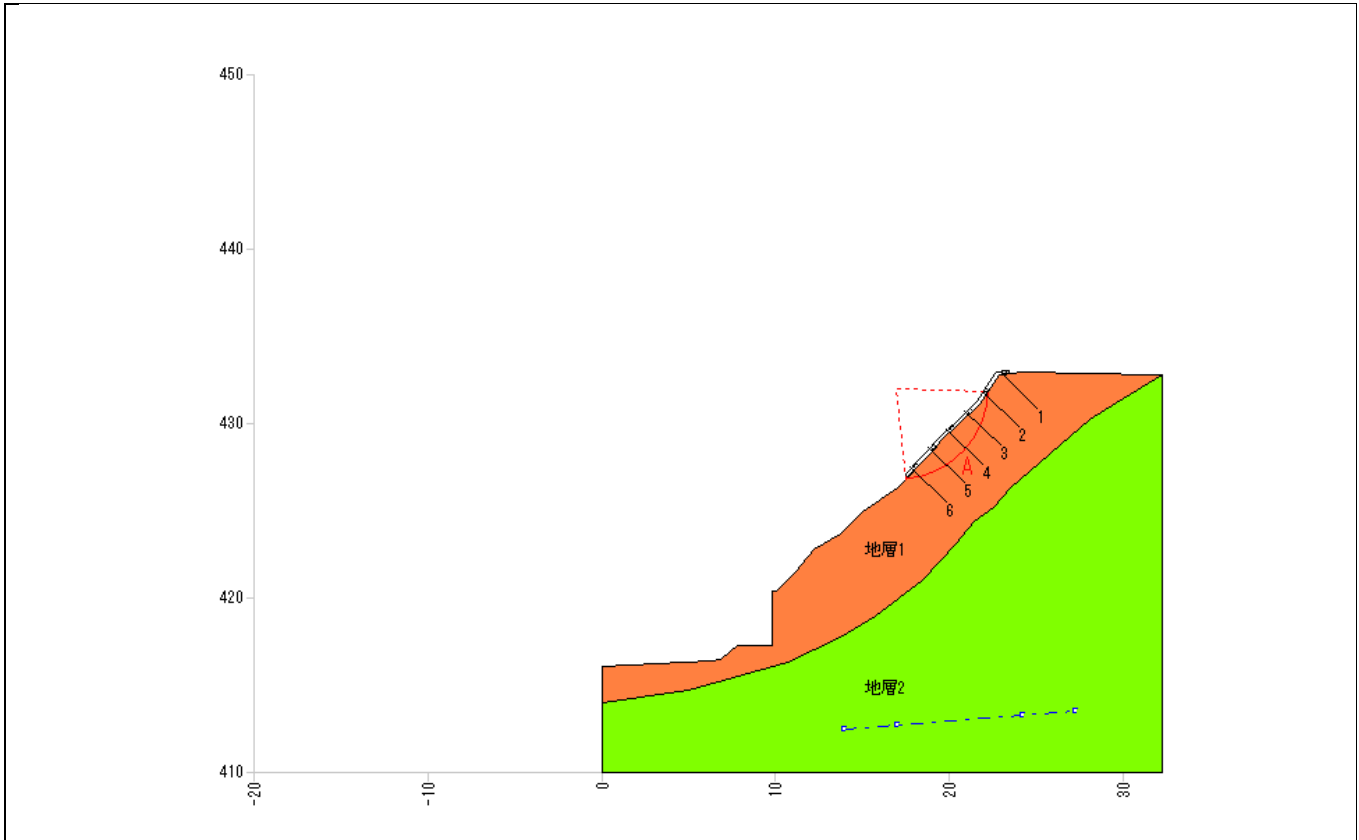

List of resistances by each reinforcement									
No.	β ($^{\circ}$)	T1pa (kN/pc.)	T2pa (kN/pc.)	Tsa (kN/pc.)	Tpa (kN/pc.)	Td (kN/pc.)	Tm (kN/m)	Sh (kN/m)	Ss (kN/m)
[1]		-	22.054	51.460	22.054	15.438	10.292		
[2]	129.45	-	21.604	51.460	21.604	15.123	10.082	-6.406	4.315
[3]	110.41	-	14.555	51.460	14.555	10.189	6.793	-2.369	3.529
[4]	93.56	-	11.950	51.460	11.950	8.365	5.577	-0.346	3.085
[5]	77.03	-	12.954	51.460	12.954	9.068	6.045	1.357	3.265
[6]	59.26	-	17.872	51.460	17.872	12.510	8.340	4.263	3.973
Total								-3.501	18.167

* The enclosed values in the T1pa, T2pa and Tsa columns indicate the values used as Tpa.

Site	KANDY
Case	B Pr(max)
Remarks	φ 29

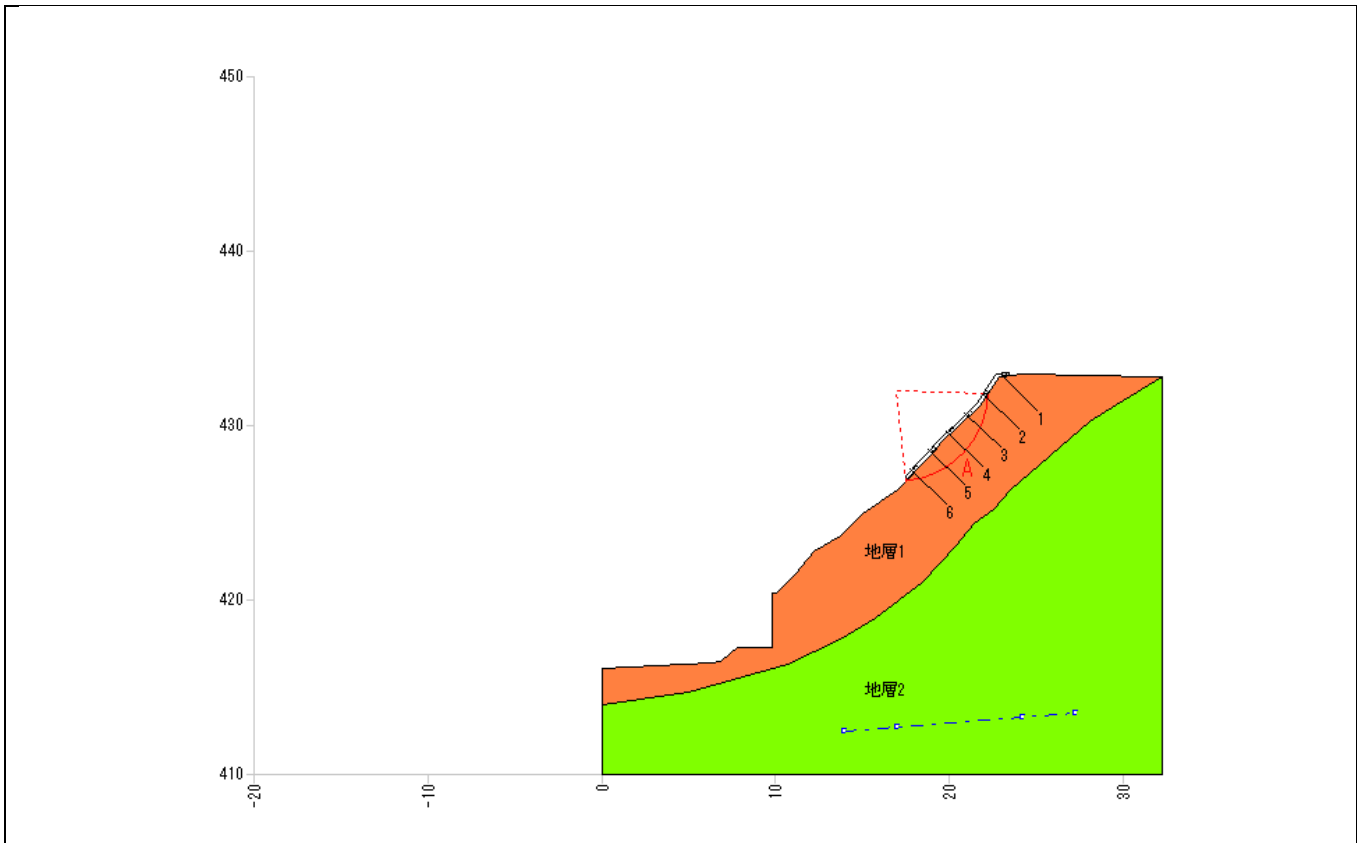

Safety factor results after arrangement of reinforcements				
Item		Symbol	Unit	Normally
				Circular arc A
Calculation results	Safety factor before reinforcement	Fs	-	1.015
	Planned safety factor	Fsp	-	1.200
	Safety factor after reinforcement	Fs	-	1.250
Circular arc	Central coordinates	X	m	17.000
		Y	m	432.000
	Radius	r	m	5.233
Calculation elements	Anchoring force	Sh	kN/m	-3.501
	Stressing force	Ss	kN/m	18.167

Number of constructed steps : 6 steps

Calculation of the safety factor after reinforcement (Circular arc A)

< Normally >

$$\begin{aligned} F_s &= \frac{\Sigma\{(N-U)\cdot\tan\phi+C\cdot l\}+Sh+S_s}{\Sigma T} \\ &= \frac{63.41-3.501+18.167}{62.46} \\ &= 1.250 \end{aligned}$$

Appendix-7

Drawings of countermeasure works



LOCATION MAP
 A1 S-1:300
 A3 S-1:600

SK1 nail N100, L=3.0m/soil nail N=378
 Shotcrete frame work (inside grate) t=3cm A=970m²
 Road
 Spraying vegetation on base work

Anchor work Equivalent to F200A L=10.0m/10.5m/anchor N=78
 Shotcrete frame work t=400 t=2.0m A=312m²
 Soil nailing L=3.0m/soil nail N=207
 Shotcrete frame work t=200 t=1.5m A=632m²
 Spraying vegetation base work (inside spraying) t=3cm A=668m²

REFERENCE
 GP Gate Post
 LF Live Fence
 PB Permanent Building
 RW Retaining Wall
 EP Electric Post
 WP Wire Post
 B Bank
 WNF Wire Net Fence
 F Foundation
 DB Dust Bin

SCALE
 1: 300



NATIONAL BUILDING RESEARCH ORGANIZATION
 (NBRO)

APPROVED BY

PROJECT MANAGEMENT ASSOCIATE INTERNATIONAL (PMA) LTD.
 (Incorporated in Sri Lanka)
 21/1, Rajalingham Road, Rajapalaya, Sri Lanka

APPROVED BY

Section C1-C2
At S+1.00
At S+1.000

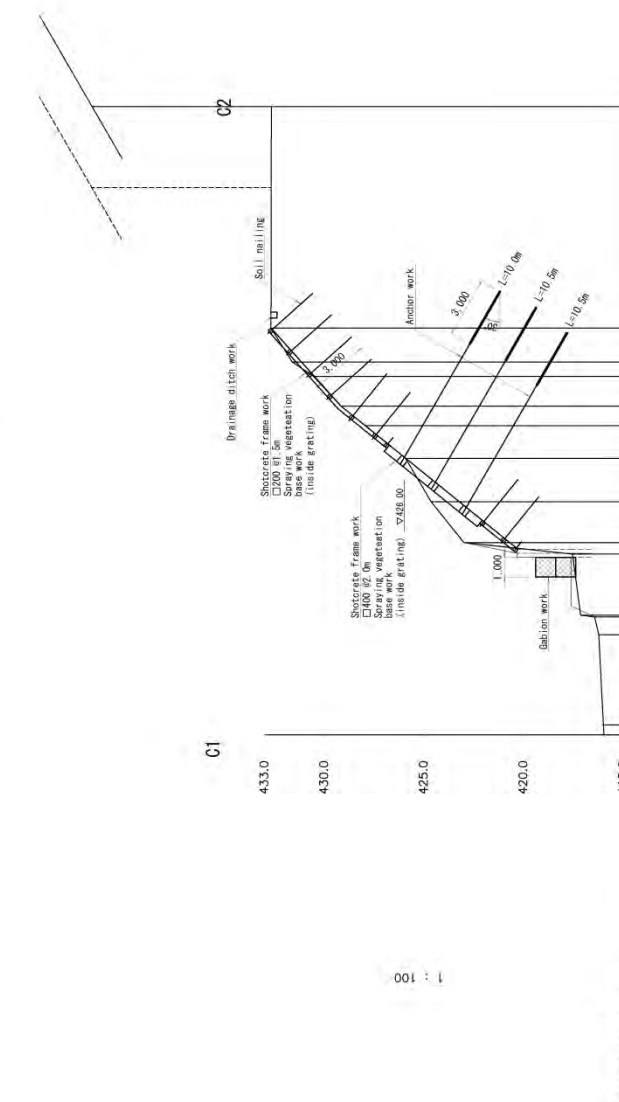

DATUM 414 m.

GROUND LEVEL (m)	HORIZONTAL DISTANCE (m)
0+000	415.973
0+000.3	416.008
0+000.528	418.241
0+000.808	419.757
0+000.871	417.556
0+008.46	422.013
0+111.30	424.651
0+173.88	425.934
0+175.333	427.965
0+182.11	429.188
0+177.897	430.962
0+187.73	431.834
0+200.60	432.602
0+217.33	432.876

1 : 100

Section B1-B2 A1 S1:100
A3 S1:200

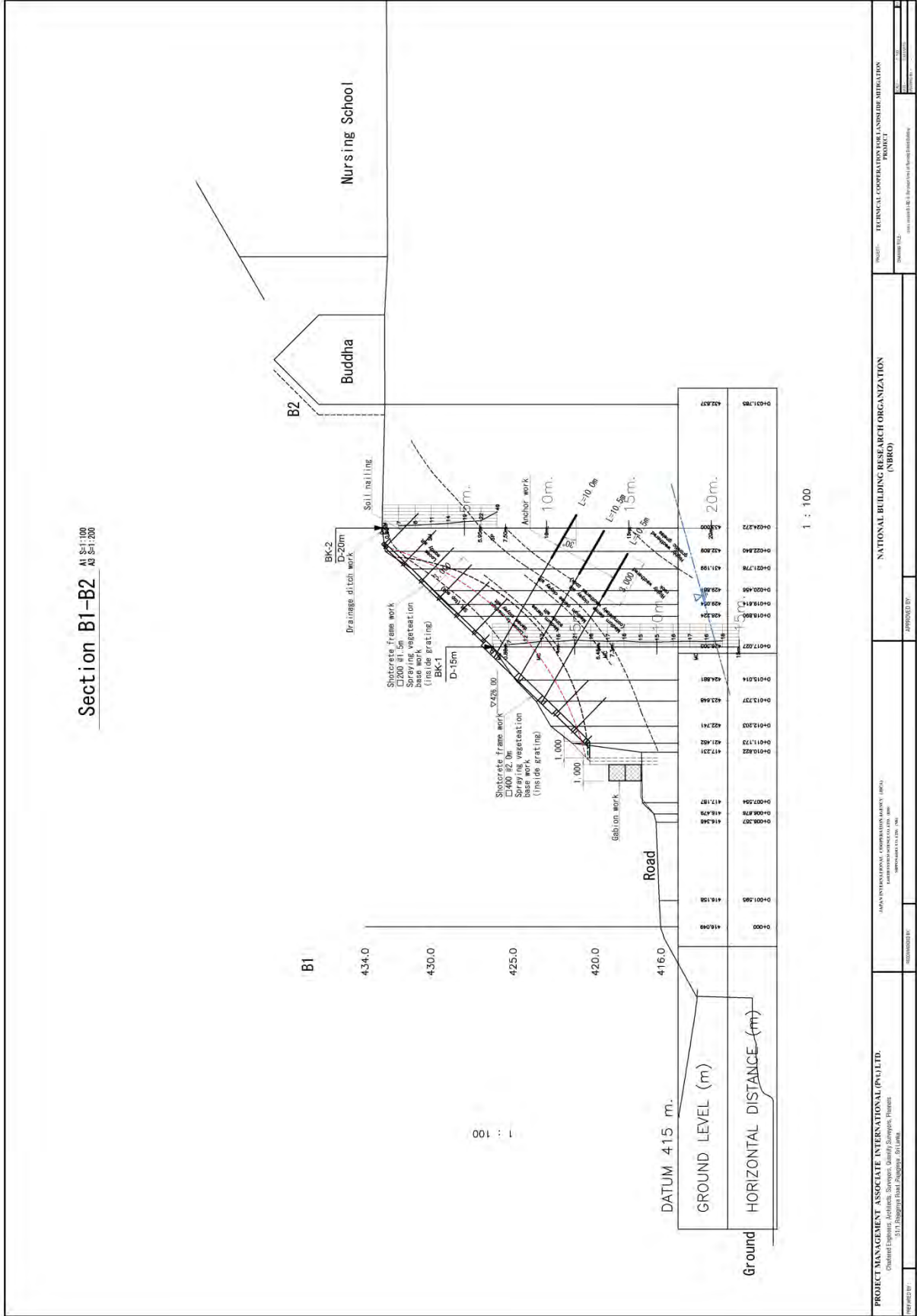

PROJECT MANAGEMENT ASSOCIATE INTERNATIONAL (PMA) LTD.
Chartered Engineers, Architects, Surveyors, Quantity Surveyors, Planners
231, Singapore Street, Singapore 048541

APPROVED BY: _____
APPROVED BY: _____

NATIONAL BUILDING RESEARCH ORGANIZATION (NBRO)

TECHNICAL COOPERATION PROGRAMME IMPLEMENTATION
PROJECT 1
RESEARCH 101 - new standard for the use of building materials

DEVELOPMENT VIEW OF THE GROUND ANCHOR WORK
(Lower Slope)

At S=1:100
At S=1:200

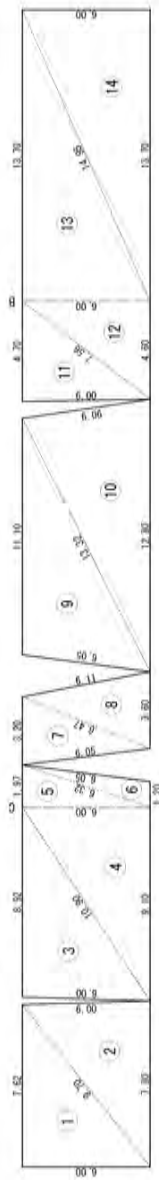
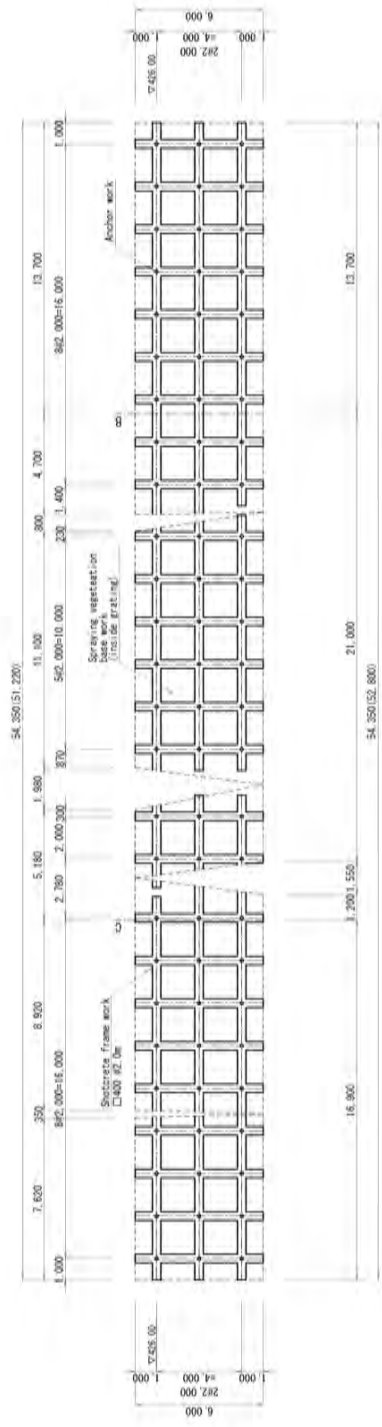

No.	A (m)	B (m)	C (m)	# (m ²)
1	1.50	1.50	1.50	1.50
2	1.50	1.50	1.50	1.50
3	1.50	1.50	1.50	1.50
4	1.50	1.50	1.50	1.50
5	1.50	1.50	1.50	1.50
6	1.50	1.50	1.50	1.50
7	1.50	1.50	1.50	1.50
8	1.50	1.50	1.50	1.50
9	1.50	1.50	1.50	1.50
10	1.50	1.50	1.50	1.50
11	1.50	1.50	1.50	1.50
12	1.50	1.50	1.50	1.50
13	1.50	1.50	1.50	1.50
14	1.50	1.50	1.50	1.50
Total	18.90	18.90	18.90	18.90

Numbers of anchor
L=10.0m = 25
L=10.5m = 52

This development view shows the outlines of the placement of the Shotcrete frame work.
This figure is made from data from cross section B and C.
At the time of actual construction, a survey will be made of the cross section at ten anchor intervals and a review of the placement of the Shotcrete frame work will be done.

FIGURE OF THE MEASUREMENT FOR THE SHOTCRETE FRAME WORK AREA (Lower Slope)

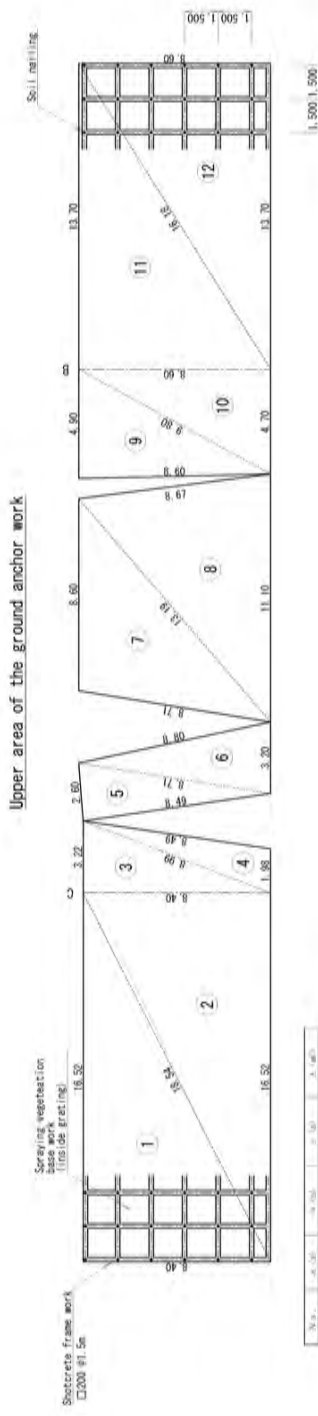

No.	Area (sq.m)	Volume (cu.m)	Weight (kg)
1	8.46	18.24	89.4
2	5.45	11.54	55.2
3	5.45	11.54	55.2
4	5.45	11.54	55.2
5	5.45	11.54	55.2
6	5.45	11.54	55.2
7	5.45	11.54	55.2
8	5.45	11.54	55.2
9	5.45	11.54	55.2
10	5.45	11.54	55.2
11	5.45	11.54	55.2
12	5.45	11.54	55.2
13	5.45	11.54	55.2
14	5.45	11.54	55.2
15	5.45	11.54	55.2
16	5.45	11.54	55.2
17	5.45	11.54	55.2
18	5.45	11.54	55.2
19	5.45	11.54	55.2
20	5.45	11.54	55.2
21	5.45	11.54	55.2
22	5.45	11.54	55.2
23	5.45	11.54	55.2
24	5.45	11.54	55.2
25	5.45	11.54	55.2
26	5.45	11.54	55.2
27	5.45	11.54	55.2
28	5.45	11.54	55.2
29	5.45	11.54	55.2
30	5.45	11.54	55.2
31	5.45	11.54	55.2
32	5.45	11.54	55.2
33	5.45	11.54	55.2
34	5.45	11.54	55.2
35	5.45	11.54	55.2
36	5.45	11.54	55.2
37	5.45	11.54	55.2
38	5.45	11.54	55.2
39	5.45	11.54	55.2
40	5.45	11.54	55.2
41	5.45	11.54	55.2
42	5.45	11.54	55.2
43	5.45	11.54	55.2
44	5.45	11.54	55.2
45	5.45	11.54	55.2
46	5.45	11.54	55.2
47	5.45	11.54	55.2
48	5.45	11.54	55.2
49	5.45	11.54	55.2
50	5.45	11.54	55.2
51	5.45	11.54	55.2
52	5.45	11.54	55.2
53	5.45	11.54	55.2
54	5.45	11.54	55.2
55	5.45	11.54	55.2
56	5.45	11.54	55.2
57	5.45	11.54	55.2
58	5.45	11.54	55.2
59	5.45	11.54	55.2
60	5.45	11.54	55.2
61	5.45	11.54	55.2
62	5.45	11.54	55.2
63	5.45	11.54	55.2
64	5.45	11.54	55.2
65	5.45	11.54	55.2
66	5.45	11.54	55.2
67	5.45	11.54	55.2
68	5.45	11.54	55.2
69	5.45	11.54	55.2
70	5.45	11.54	55.2
71	5.45	11.54	55.2
72	5.45	11.54	55.2
73	5.45	11.54	55.2
74	5.45	11.54	55.2
75	5.45	11.54	55.2
76	5.45	11.54	55.2
77	5.45	11.54	55.2
78	5.45	11.54	55.2
79	5.45	11.54	55.2
80	5.45	11.54	55.2
81	5.45	11.54	55.2
82	5.45	11.54	55.2
83	5.45	11.54	55.2
84	5.45	11.54	55.2
85	5.45	11.54	55.2
86	5.45	11.54	55.2
87	5.45	11.54	55.2
88	5.45	11.54	55.2
89	5.45	11.54	55.2
90	5.45	11.54	55.2
91	5.45	11.54	55.2
92	5.45	11.54	55.2
93	5.45	11.54	55.2
94	5.45	11.54	55.2
95	5.45	11.54	55.2
96	5.45	11.54	55.2
97	5.45	11.54	55.2
98	5.45	11.54	55.2
99	5.45	11.54	55.2
100	5.45	11.54	55.2

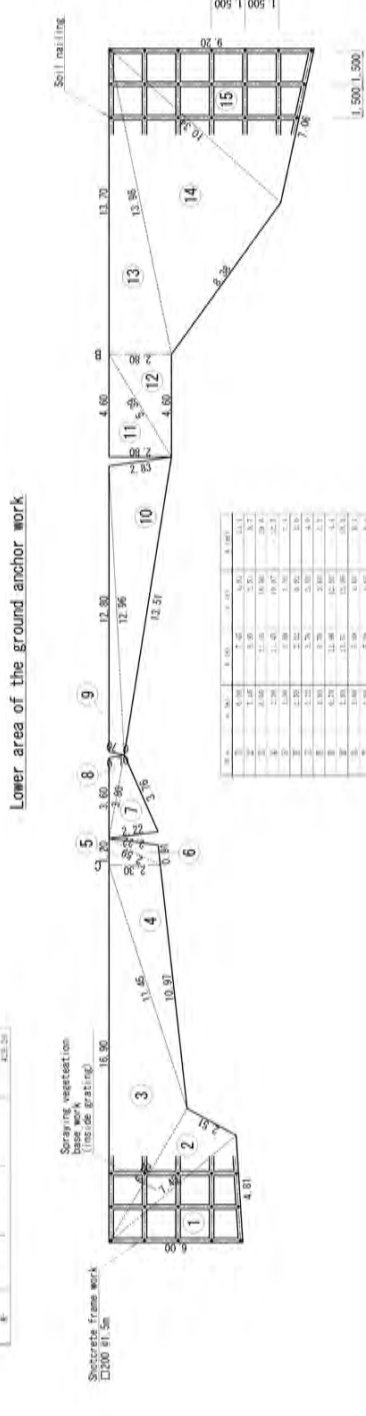

No.	Area (sq.m)	Volume (cu.m)	Weight (kg)
1	8.46	18.24	89.4
2	5.45	11.54	55.2
3	5.45	11.54	55.2
4	5.45	11.54	55.2
5	5.45	11.54	55.2
6	5.45	11.54	55.2
7	5.45	11.54	55.2
8	5.45	11.54	55.2
9	5.45	11.54	55.2
10	5.45	11.54	55.2
11	5.45	11.54	55.2
12	5.45	11.54	55.2
13	5.45	11.54	55.2
14	5.45	11.54	55.2
15	5.45	11.54	55.2
16	5.45	11.54	55.2
17	5.45	11.54	55.2
18	5.45	11.54	55.2
19	5.45	11.54	55.2
20	5.45	11.54	55.2
21	5.45	11.54	55.2
22	5.45	11.54	55.2
23	5.45	11.54	55.2
24	5.45	11.54	55.2
25	5.45	11.54	55.2
26	5.45	11.54	55.2
27	5.45	11.54	55.2
28	5.45	11.54	55.2
29	5.45	11.54	55.2
30	5.45	11.54	55.2
31	5.45	11.54	55.2
32	5.45	11.54	55.2
33	5.45	11.54	55.2
34	5.45	11.54	55.2
35	5.45	11.54	55.2
36	5.45	11.54	55.2
37	5.45	11.54	55.2
38	5.45	11.54	55.2
39	5.45	11.54	55.2
40	5.45	11.54	55.2
41	5.45	11.54	55.2
42	5.45	11.54	55.2
43	5.45	11.54	55.2
44	5.45	11.54	55.2
45	5.45	11.54	55.2
46	5.45	11.54	55.2
47	5.45	11.54	55.2
48	5.45	11.54	55.2
49	5.45	11.54	55.2
50	5.45	11.54	55.2
51	5.45	11.54	55.2
52	5.45	11.54	55.2
53	5.45	11.54	55.2
54	5.45	11.54	55.2
55	5.45	11.54	55.2
56	5.45	11.54	55.2
57	5.45	11.54	55.2
58	5.45	11.54	55.2
59	5.45	11.54	55.2
60	5.45	11.54	55.2
61	5.45	11.54	55.2
62	5.45	11.54	55.2
63	5.45	11.54	55.2
64	5.45	11.54	55.2
65	5.45	11.54	55.2
66	5.45	11.54	55.2
67	5.45	11.54	55.2
68	5.45	11.54	55.2
69	5.45	11.54	55.2
70	5.45	11.54	55.2
71	5.45	11.54	55.2
72	5.45	11.54	55.2
73	5.45	11.54	55.2
74	5.45	11.54	55.2
75	5.45	11.54	55.2
76	5.45	11.54	55.2
77	5.45	11.54	55.2
78	5.45	11.54	55.2
79	5.45	11.54	55.2
80	5.45	11.54	55.2
81	5.45	11.54	55.2
82	5.45	11.54	55.2
83	5.45	11.54	55.2
84	5.45	11.54	55.2
85	5.45	11.54	55.2
86	5.45	11.54	55.2
87	5.45	11.54	55.2
88	5.45	11.54	55.2
89	5.45	11.54	55.2
90	5.45	11.54	55.2
91	5.45	11.54	55.2
92	5.45	11.54	55.2
93	5.45	11.54	55.2
94	5.45	11.54	55.2
95	5.45	11.54	55.2
96	5.45	11.54	55.2
97	5.45	11.54	55.2
98	5.45	11.54	55.2
99	5.45	11.54	55.2
100	5.45	11.54	55.2

This figure shows the outline of the measurement for the Shotcrete frame work area.
 This figure is made from data from cross section B and C.
 At the time of actual construction, a survey will be made of the cross section of ten meter intervals and a review of the area of the Shotcrete frame work will be done.

AS345 Galvanized nail (D19) Standard working drawing (1:2) **DETAIL DESIGN OF SOIL NAIL WORK**

(Lower Slope)

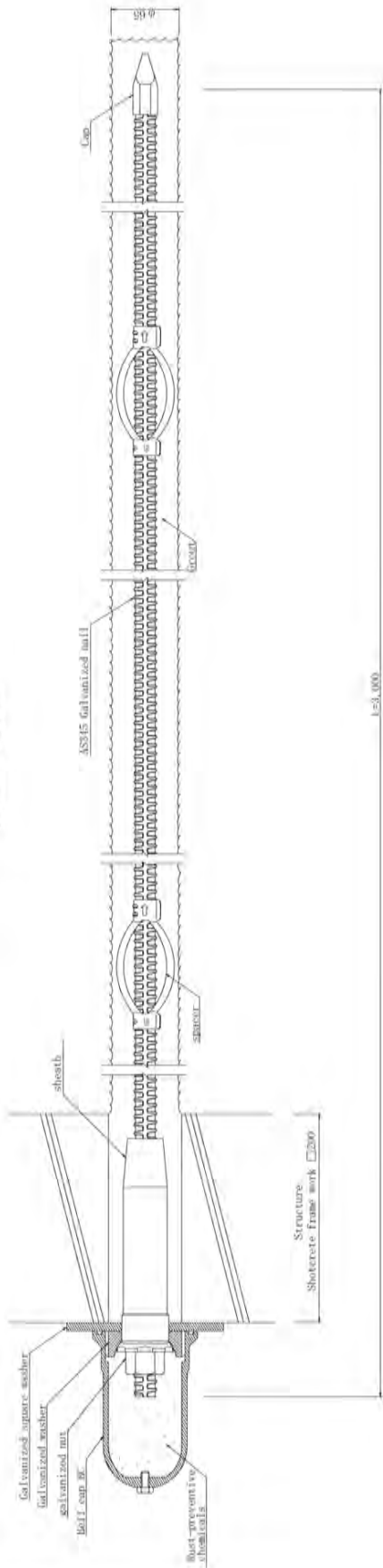

AS345 Galvanized nail (D19) part (1:2)

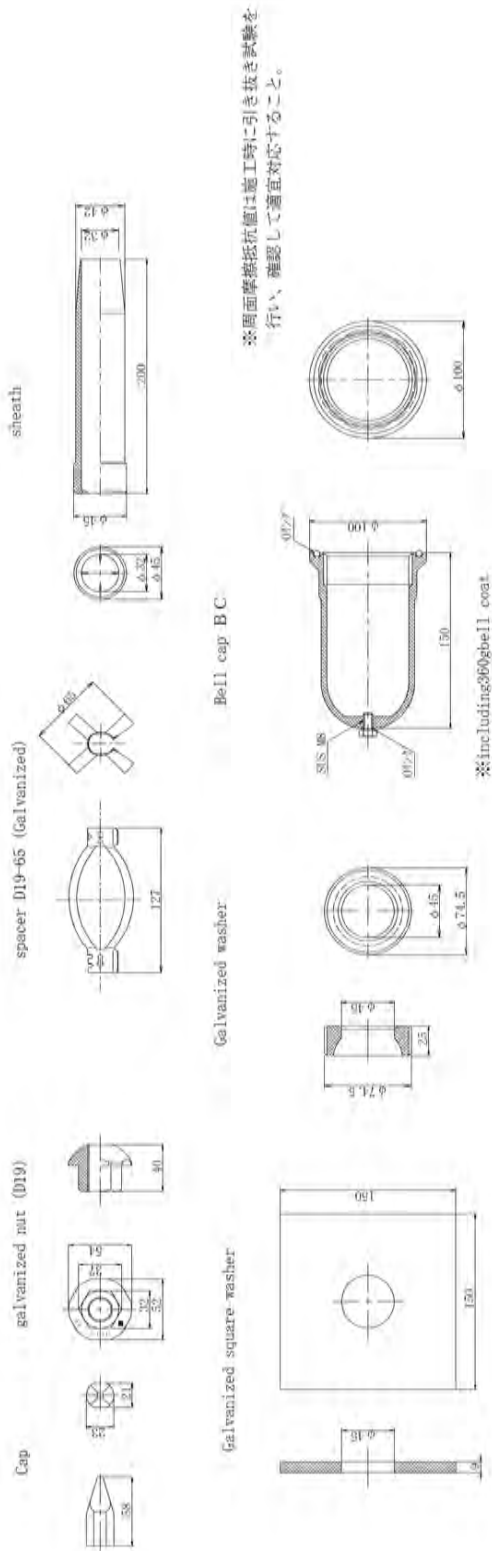

※ 固面摩擦抵抗値は施工時に引き抜き試験を行い、確認して適宜対応すること。

※ including S90/bell coat

DETAIL DESIGN OF SHOTCRETE FRAME WORK

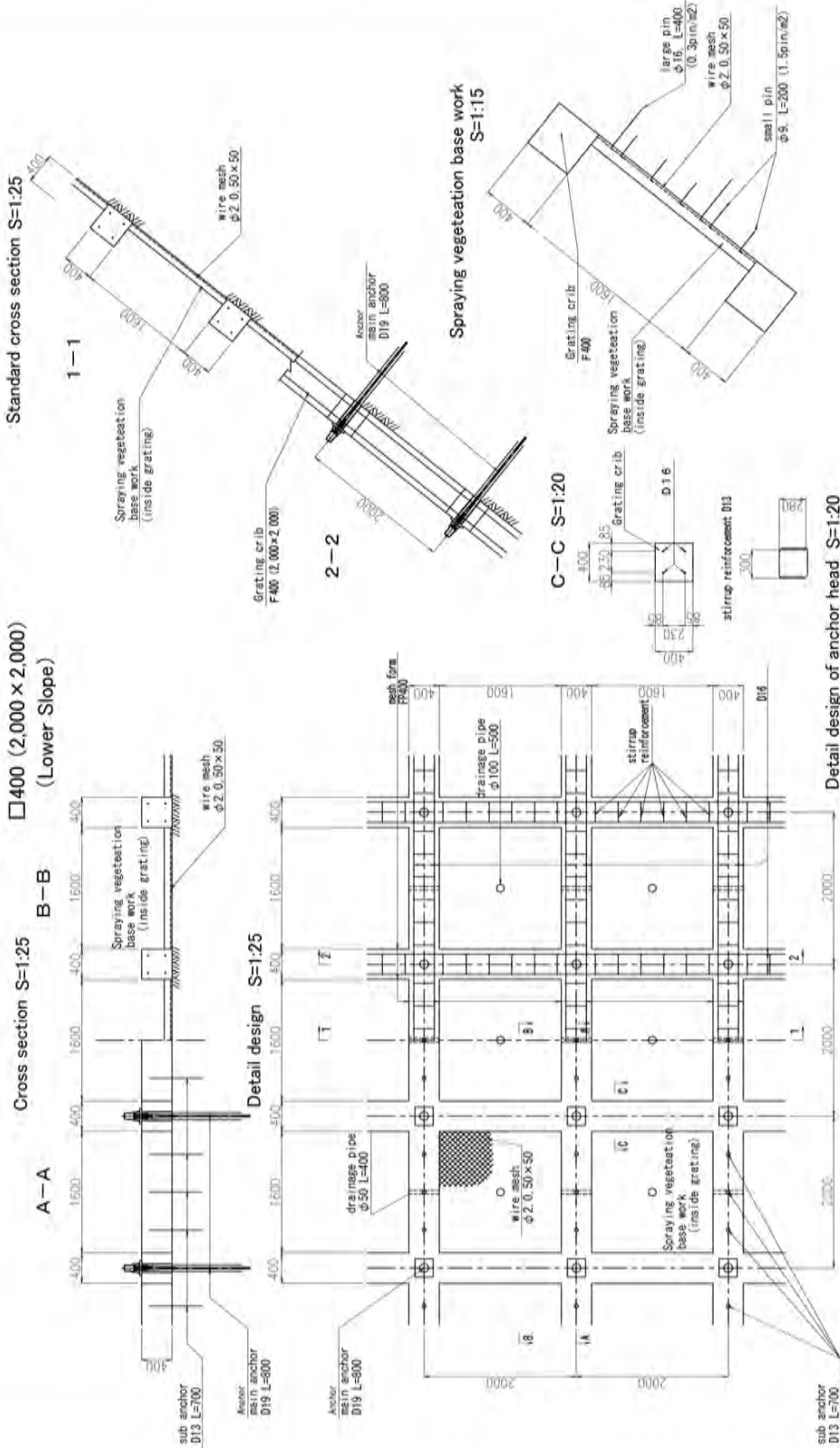

○ main anchor D19 L=800
 ○ sub anchor D13 L=700
 ※ Design standard strength of shotcrete mortar $\sigma_{ck} = 18 \text{ N/mm}^2$
 ※ Reinforcement S D 3 4 5

DETAIL DESIGN OF SHOTCRETE FRAME WORK

Cross section S=1:20

C-C

□200 (1,500 x 1,500)
(Lower Slope)

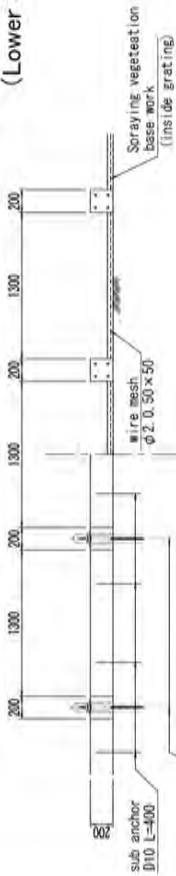

Standard cross section S=1:50

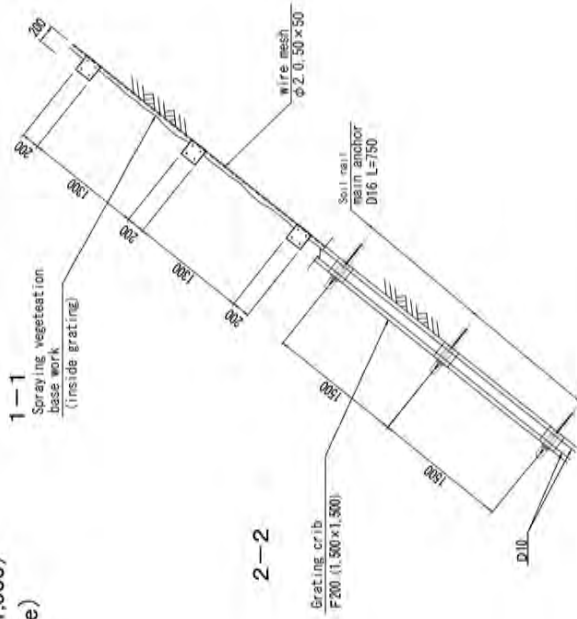

Detail design S=1:20

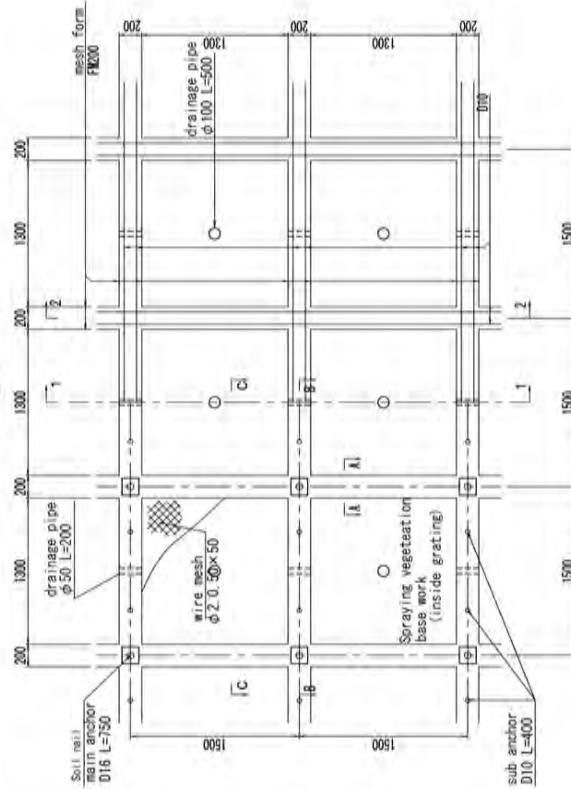

Spraying vegetation base work S=1:10

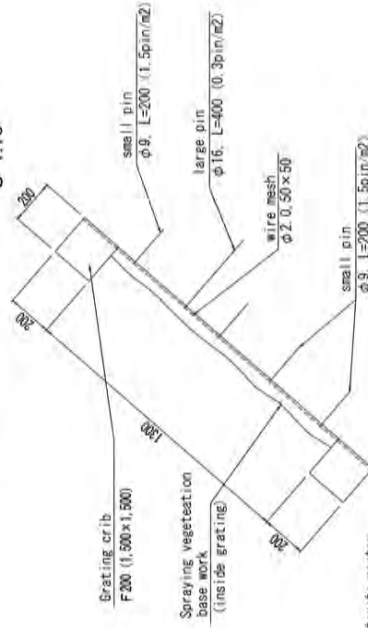

A-A S=1:5

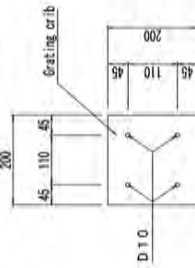

※ Design standard strength of shotcrete mortar
σ_c k = 18N/mm²

※ Reinforcement S D 2 9 5

○ main anchor D16 L=750
● sub anchor D10 L=400

Section D1-D2 A1 S-1:100
A2 S-1:200

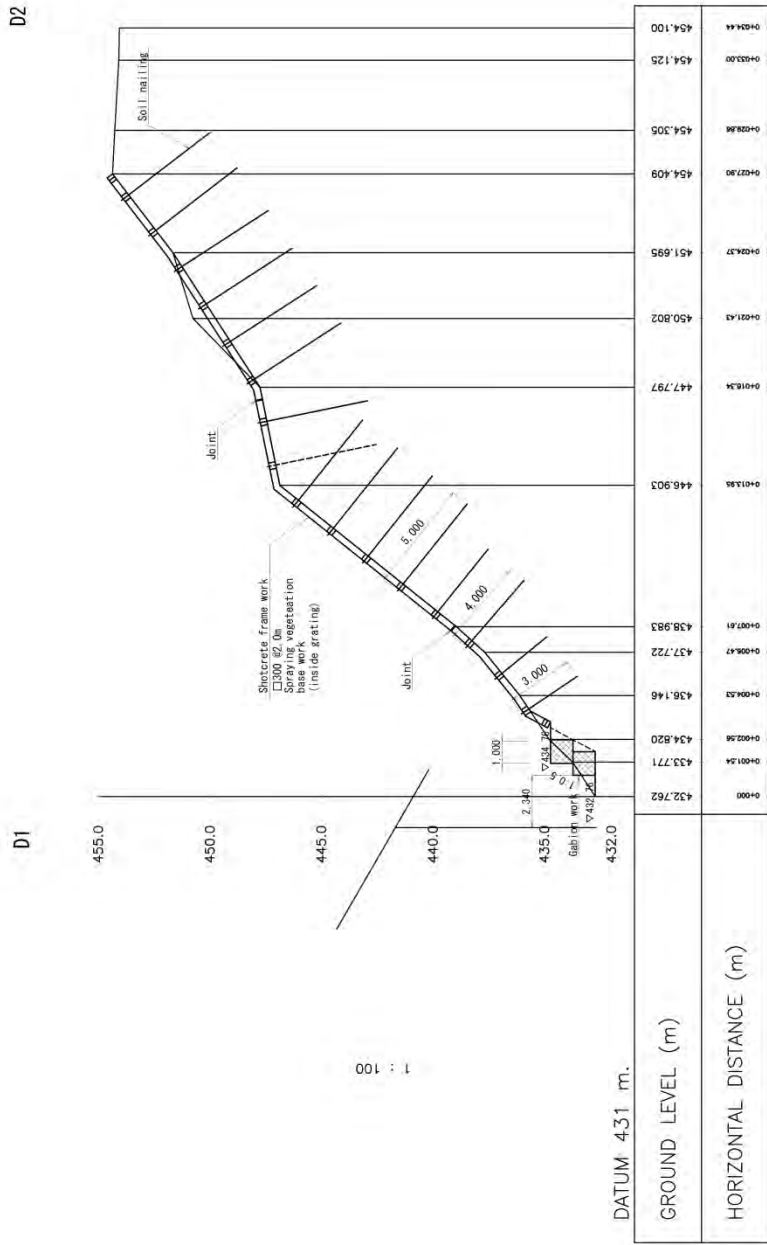

1 : 100

Section E1-E2 At Sp. 100

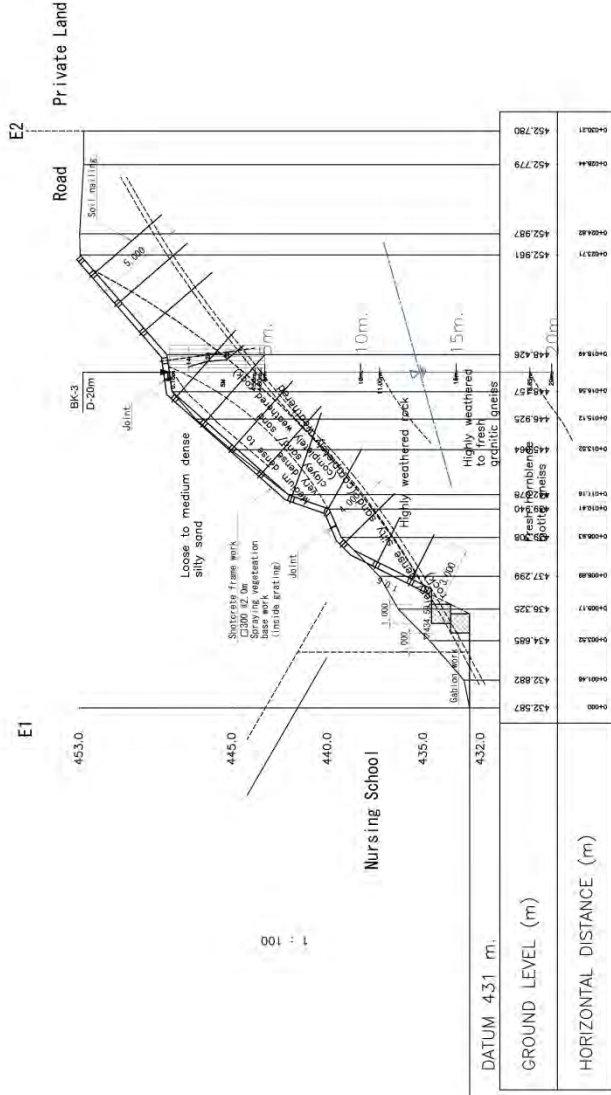

1 : 100

<p>PROJECT MANAGEMENT ASSOCIATE INTERNATIONAL (PMA) LTD. 15th Floor, 15th Avenue, Suite 1501, District Office, Phnom Penh 11172, Cambodia. Phone: 855 93 962 2222, Fax: 855 93 962 2222</p>	<p>PROJECT: NATIONAL BUILDING RESEARCH ORGANIZATION (NBRO)</p>	<p>DATE: 15/05/2014</p>	<p>PROJECT: NATIONAL BUILDING RESEARCH ORGANIZATION (NBRO)</p>
---	--	-------------------------	--

FIGURE OF THE MEASUREMENT FOR THE SHOTCRETE FRAME WORK AREA A1 S1:100
(Upper Slope)

S.No.	6.163	6.602	6.60	6.64
1	24.26	20.50	16.78	18.20
2	25.82	24.17	2.11	33.0
3	22.42	24.22	24.98	18.18
4	25.86	24.06	1.00	18.2
5	21.00	20.26	1.18	5.2
6	20.29	16.96	18.34	14.0
7	31.24	26.27	3.22	26.0
8	31.24	26.27	3.22	26.0
9	35.82	24.67	1.39	41.5
10	24.26	20.50	16.78	18.20
11	18.20	20.50	16.78	18.20
12	18.20	20.50	16.78	18.20
13	18.20	20.50	16.78	18.20
14	18.20	20.50	16.78	18.20
15	18.20	20.50	16.78	18.20
16	18.20	20.50	16.78	18.20
17	18.20	20.50	16.78	18.20
18	18.20	20.50	16.78	18.20
19	18.20	20.50	16.78	18.20
20	18.20	20.50	16.78	18.20
21	18.20	20.50	16.78	18.20
22	18.20	20.50	16.78	18.20
23	18.20	20.50	16.78	18.20
24	18.20	20.50	16.78	18.20
25	18.20	20.50	16.78	18.20
26	18.20	20.50	16.78	18.20
27	18.20	20.50	16.78	18.20
28	18.20	20.50	16.78	18.20
29	18.20	20.50	16.78	18.20
30	18.20	20.50	16.78	18.20
31	18.20	20.50	16.78	18.20
32	18.20	20.50	16.78	18.20
33	18.20	20.50	16.78	18.20
34	18.20	20.50	16.78	18.20
35	18.20	20.50	16.78	18.20
36	18.20	20.50	16.78	18.20
37	18.20	20.50	16.78	18.20
38	18.20	20.50	16.78	18.20
39	18.20	20.50	16.78	18.20
40	18.20	20.50	16.78	18.20
41	18.20	20.50	16.78	18.20
42	18.20	20.50	16.78	18.20
43	18.20	20.50	16.78	18.20
44	18.20	20.50	16.78	18.20
45	18.20	20.50	16.78	18.20
46	18.20	20.50	16.78	18.20
47	18.20	20.50	16.78	18.20
48	18.20	20.50	16.78	18.20
49	18.20	20.50	16.78	18.20
50	18.20	20.50	16.78	18.20
51	18.20	20.50	16.78	18.20
52	18.20	20.50	16.78	18.20
53	18.20	20.50	16.78	18.20
54	18.20	20.50	16.78	18.20
55	18.20	20.50	16.78	18.20
56	18.20	20.50	16.78	18.20
57	18.20	20.50	16.78	18.20
58	18.20	20.50	16.78	18.20
59	18.20	20.50	16.78	18.20
60	18.20	20.50	16.78	18.20
61	18.20	20.50	16.78	18.20
62	18.20	20.50	16.78	18.20
63	18.20	20.50	16.78	18.20
64	18.20	20.50	16.78	18.20
65	18.20	20.50	16.78	18.20
66	18.20	20.50	16.78	18.20
67	18.20	20.50	16.78	18.20
68	18.20	20.50	16.78	18.20
69	18.20	20.50	16.78	18.20
70	18.20	20.50	16.78	18.20
71	18.20	20.50	16.78	18.20
72	18.20	20.50	16.78	18.20
73	18.20	20.50	16.78	18.20
74	18.20	20.50	16.78	18.20
75	18.20	20.50	16.78	18.20
76	18.20	20.50	16.78	18.20
77	18.20	20.50	16.78	18.20
78	18.20	20.50	16.78	18.20
79	18.20	20.50	16.78	18.20
80	18.20	20.50	16.78	18.20
81	18.20	20.50	16.78	18.20
82	18.20	20.50	16.78	18.20
83	18.20	20.50	16.78	18.20
84	18.20	20.50	16.78	18.20
85	18.20	20.50	16.78	18.20
86	18.20	20.50	16.78	18.20
87	18.20	20.50	16.78	18.20
88	18.20	20.50	16.78	18.20
89	18.20	20.50	16.78	18.20
90	18.20	20.50	16.78	18.20
91	18.20	20.50	16.78	18.20
92	18.20	20.50	16.78	18.20
93	18.20	20.50	16.78	18.20
94	18.20	20.50	16.78	18.20
95	18.20	20.50	16.78	18.20
96	18.20	20.50	16.78	18.20
97	18.20	20.50	16.78	18.20
98	18.20	20.50	16.78	18.20
99	18.20	20.50	16.78	18.20
100	18.20	20.50	16.78	18.20

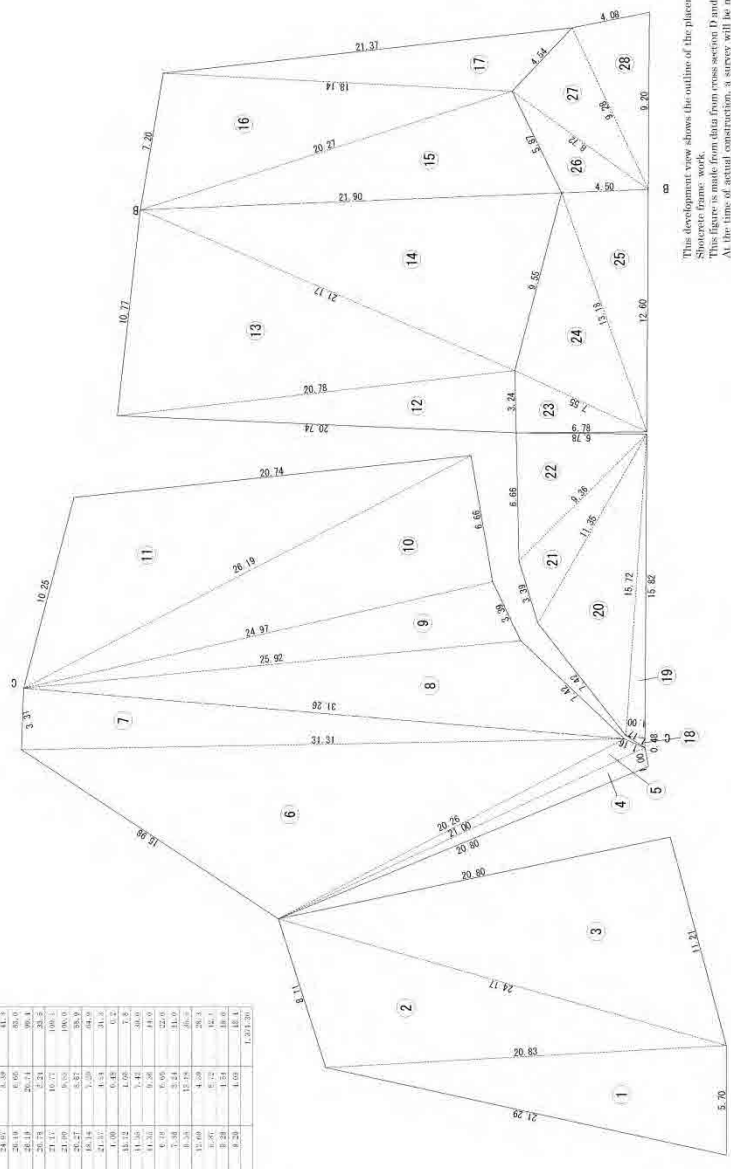

This development view shows the outline of the placement of the Shotcrete frame work. This figure is made from data from cross section D and E. At the time of actual construction, a survey will be made of the cross section at minor intervals and the placement of the Shotcrete frame work will be done.

PROJECT:	NATIONAL BUILDING RESEARCH ORGANIZATION (NBRO)		
	PROJECT NO:	100/2008	
	REVISIONS:		
DRAWN BY:	NATIONAL BUILDING RESEARCH ORGANIZATION (NBRO)		
	PROJECT NO:	100/2008	
	REVISIONS:		
DATE:	10/11/2008		
	PROJECT NO:	100/2008	
	REVISIONS:		

**DEVELOPMENT VIEW OF THE SHOTCRETE FRAME WORK AREA
(Upper Slope)**

At S=1:100
AS S=1:200

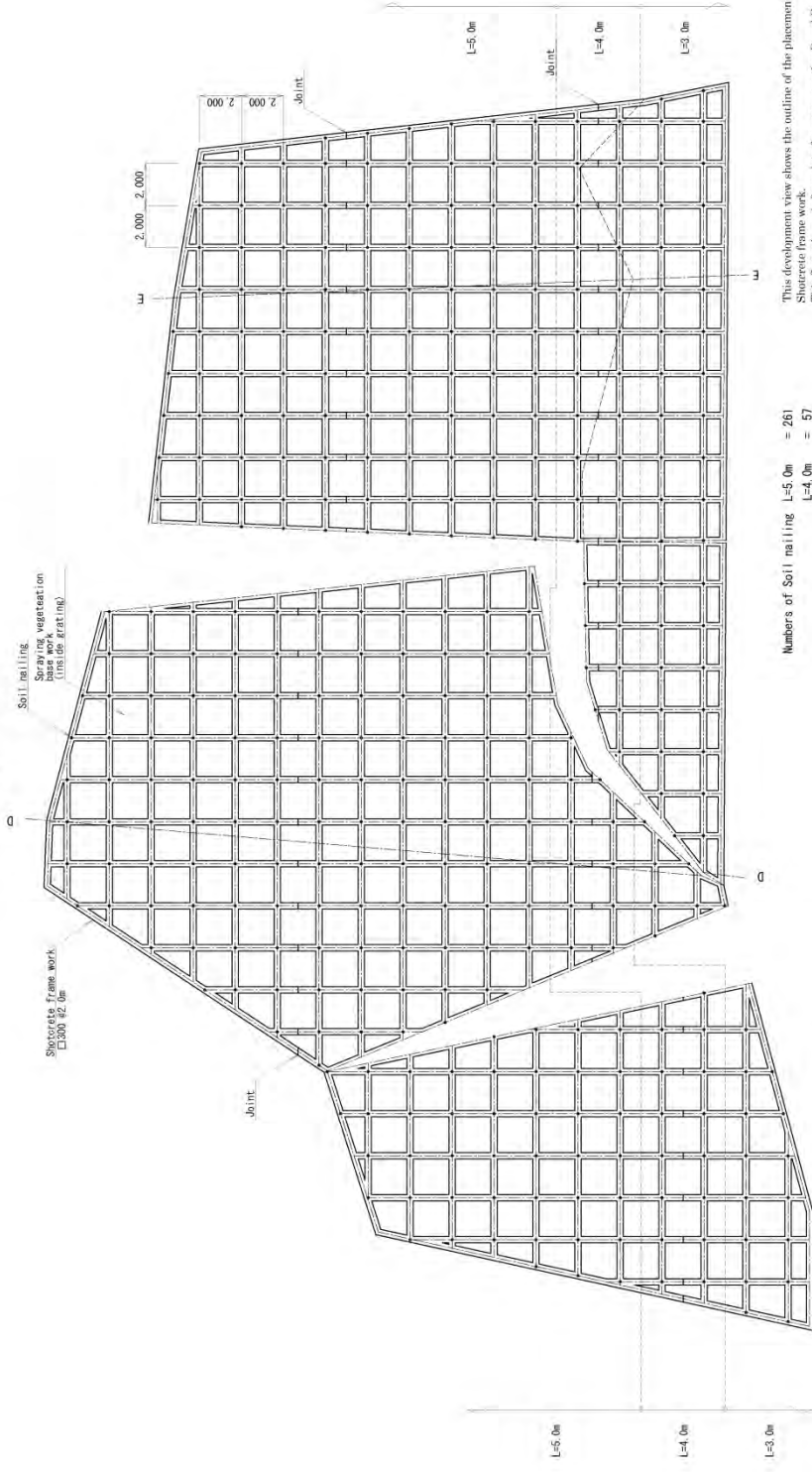

This development view shows the outline of the placement of the Shotcrete frame work.
This figure is made from data from cross section D and E.
At the time of actual construction, a survey will be made of the cross section at ten meter intervals and a review of the placement of the Shotcrete frame work will be done.

<p>PROJECT MANAGEMENT ASSOCIATE INTERNATIONAL (PMA) LTD. Chartered Engineers, Architects, Surveyors, Quantity Surveyors, Planners 5111 Rajaghat Road, Rajahmundry, 520 002, India</p>	<p>NATIONAL BUILDING RESEARCH ORGANIZATION (NBRO)</p>	<p>TECHNICAL COOPERATION FOR LANDSLIDE MITIGATION PROJECT</p>	<p>PROJECT NO. 1001 DRAWING NO. 1001-1001-1001-1001</p>
<p>PROJECT NO. 1001</p>	<p>PROJECT NO. 1001</p>	<p>PROJECT NO. 1001</p>	<p>PROJECT NO. 1001</p>

AS345 Galvanized nail (D22) Standard working drawing (1:2)

DETAIL DESIGN OF SOIL NAIL WORK
(Upper Slope)

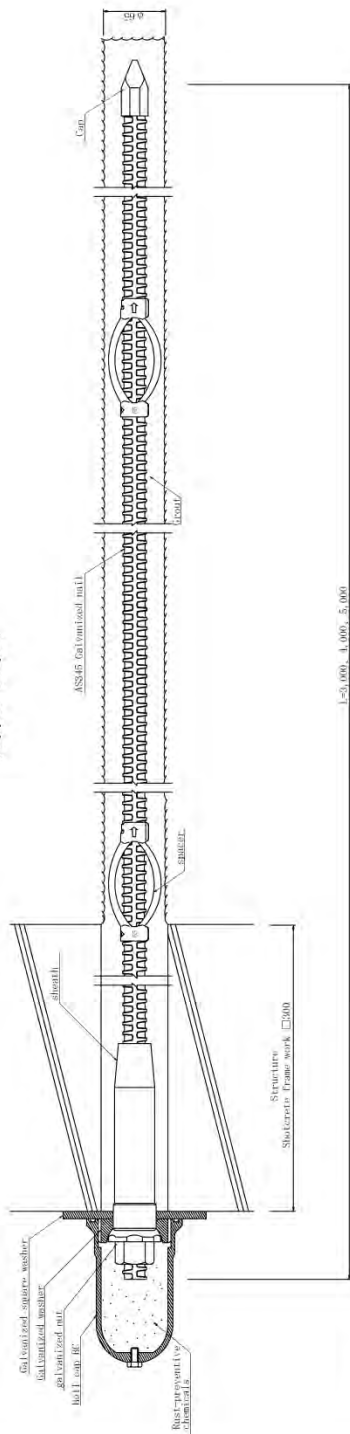

AS345 Galvanized nail (D22) part (1:2)

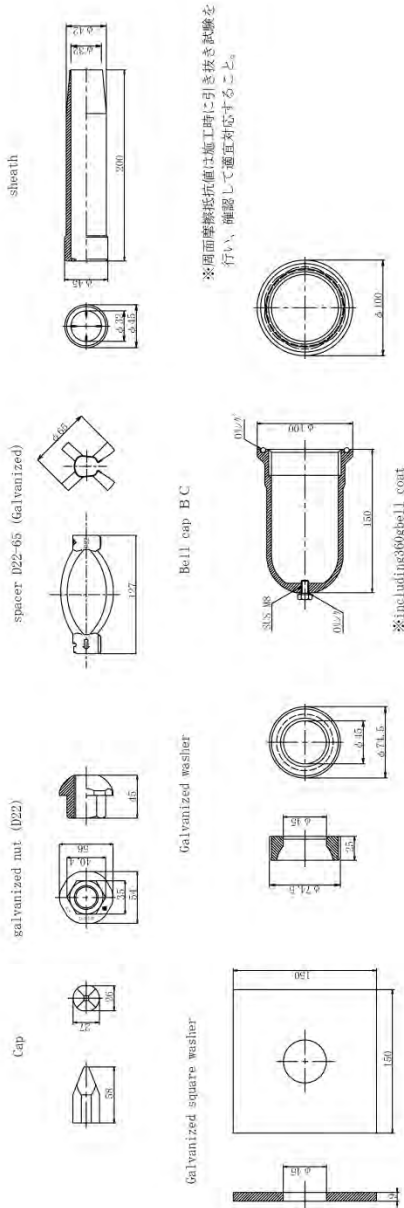

※: 周面摩擦抵抗値は施工時に引き抜き試験を行い、確認して適正対応すること。

DETAIL DESIGN OF SHOTCRETE FRAME WORK

□ 300 (2,000 × 2,000)
(Upper Slope)

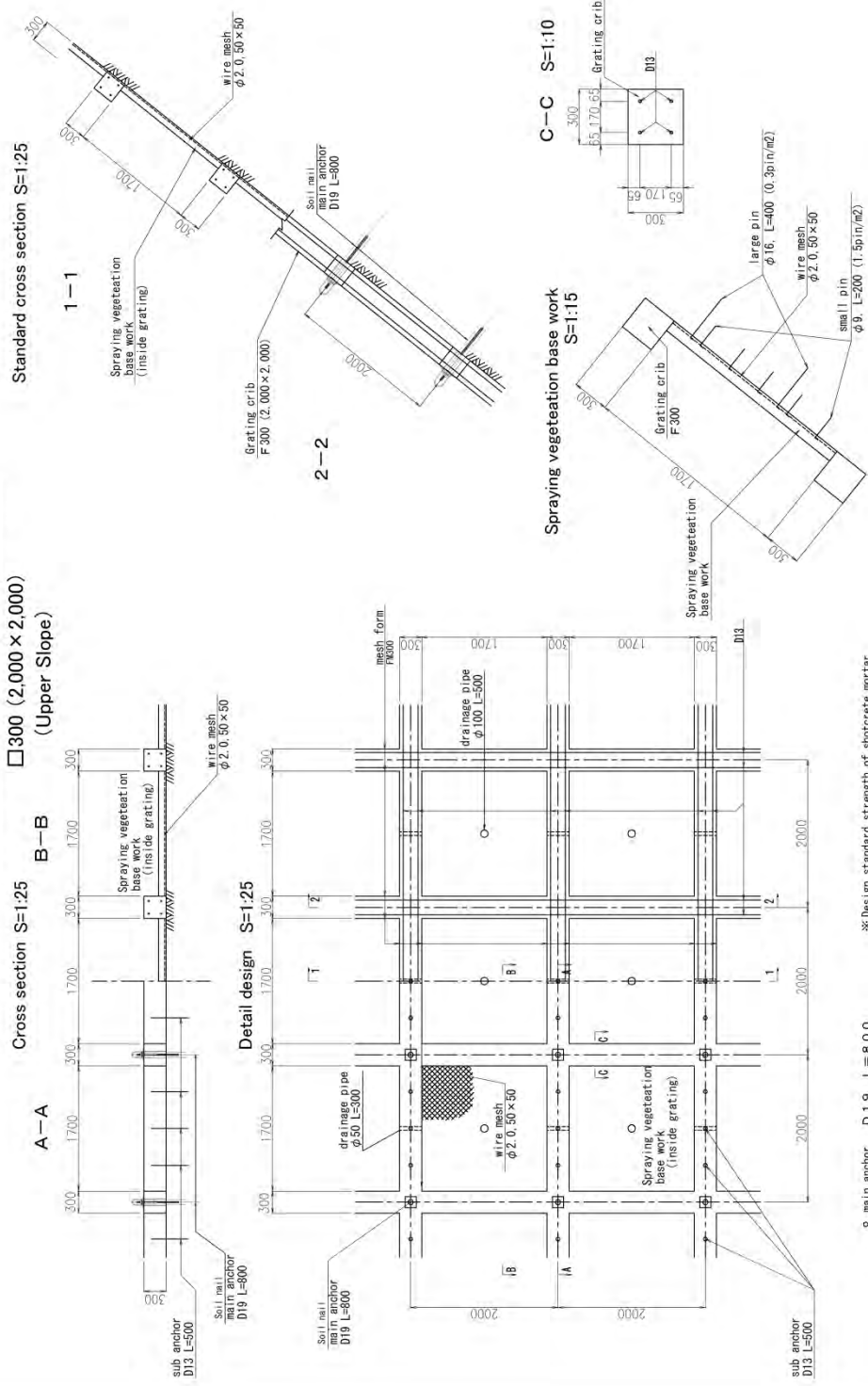

- main anchor D19 L=800
- sub anchor D13 L=500
- ※ Design standard strength of shotcrete mortar
σ c k = 16N/mm²
- ※ Reinforcement S D 3 4 5

DETAIL FIGURE OF THE DRAINAGE DITCH WORK

A1 S&T 20
A3 S&T 40

(Kandy)

Reinforced concrete
U 2 x 1.0

Drainage ditch work
(600 x 600 x 600)

Plan view

Cross section

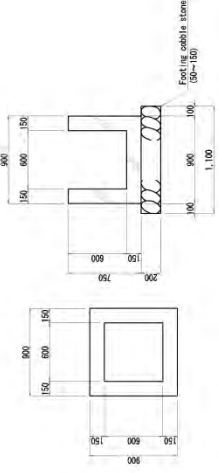
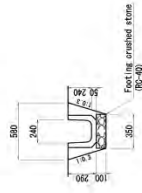

PROJECT MANAGEMENT ASSOCIATE INTERNATIONAL (P.M.A.I.)
Civil Engineering, Architects, Surveyors, Quantity Surveyors, Planners
111, Singapore Road, Singapore, SINGAPORE

PROJECT MANAGEMENT ASSOCIATE INTERNATIONAL (P.M.A.I.)
Civil Engineering, Architects, Surveyors, Quantity Surveyors, Planners
111, Singapore Road, Singapore, SINGAPORE

NATIONAL BUILDING RESEARCH ORGANIZATION
(NBRO)

TECHNICAL COOPERATION AGREEMENT FOR MITIGATION
PROJECT

Appendix-8

Bill of quantities

Kandy Upper Slope

1. Earthwork

(1) Slope excavation

Manpower, Sandy soils

$$V = \text{Following average cross section area} = 386.0 \text{ m}^3$$

(2) Slope clearing (and Leveling)

Manpower, Sandy soils

$$A = \text{based on measuring area diagram} = 1,371.3 \text{ m}^2$$

(3) Soil disposal

Sandy soils within 4km

$$V = 386.0 - 29.5 = 356.5 \text{ m}^3$$

2. Soil nailing

(1) Total length of soil nail

SD345 D22 L=3.0~5.0m/bolt

$$N = \text{SD345 D22 L=5.0m/bolt} = 261 \text{ nos.}$$

$$N = \text{SD345 D22 L=4.0m/bolt} = 57 \text{ nos.}$$

$$N = \text{SD345 D22 L=3.0m/bolt} = 60 \text{ nos.}$$

$$\text{Total} = 378 \text{ nos.}$$

$$L = 261 \times 5.0 + 57 \times 4.0 + 60 \times 3.0 = 1,713.0 \text{ m}$$

(2) Total length of drilling

φ65(Scaffolding)

$$L = 261 \times 4.6 + 57 \times 3.6 + 60 \times 2.6 = 1,561.8 \text{ m}$$

(3) Vertical shift (Up-down)

$$N = 16 \text{ times}$$

(4) Scaffolding							
B=2.0m Pipe scaffolding(slope)							
V =	Following average cross section (2)			=	1,291.2	m ³	
(5) Pullout test							
φ65							
N =				=	1	L.S.	
3. Shotcrete frame work							
(1) Area							
□ 300 @2.0m							
A =				=	1,371.3	m ²	
(2) Frame length							
□ 300 @2.0m							
L =	1371.3	÷	1,000.0	×	974.8	=	1,336.7 m
	Area		Unit Area		Unit Quantity		
(3) Wire mesh work							
φ2.0 50×50							
A =	equal to Slope clearing (and Leveling)			=	1371.3	m ²	
(4) Hydroseeding							
t=3cm							
A =	1,371.3	÷	1,336.7	×	0.3	=	970.3 m ²
	frame area		frame length		frame width		
(5) Weep pipe							
φ100 L=0.5m							
L =	1,371.3	÷	4.00	×	0.5	=	171.4 m
	□ 300Area		2.0*2.0				

4. Gabion work									
(1) Gabion work									
1.0×1.0×1.0m									
L	=	59.0	×	2		=	118.0	m	
		total length		steps					
V	=	118.0	×	1.0	×	1.0	×	1.0	= 118.0 m ³
(2) Back filling									
Common Soil									
V	=	59.0	×	0.5		=	29.5	m ³	
		L		m ² /m					
5. Temporary work									
(1) Temporary fence									
L	=	59.0	+	10.0		=	69.0	m	
		distance		preliminary extension					

Kandy Lower Slope

Bill of Quantities

Work Item	Detailed Specification	unit	Q'ty	unit price	Amount (Yen)	Remarks
1. Earthwork						
(1) Slope Excavation	Manpower, Sandy Soil	m3	284	4,000	1,136,000	
(2) Slope Clearing (and Leveling)	Manpower, Sandy Soil	m2	944	1,170	1,104,480	
(3) Soil disposal	Sandy soil, less than 4km transfer	m3	284	1,000	284,000	
2. Anchor work						
(1) Number of anchor	Equivalent to F20UA, Drilling φ90	nos	78			
(2) Total length of anchor	Equivalent to F20UA, Drilling φ90	m	806	12,400	9,994,400	
(3) Scaffolding work	B=4.5m pipe scaffolding, slope	m3	1,406	3,400	4,780,400	
(4) Drilling machine transfer		times	3	37,500	112,500	
(5) Pull out test	Equivalent to F20UA, drilling φ90	LS	1	500,000	500,000	
3. Soil nailing						
(1) Total length of soil nail	SD345 D19 L=3.0m/soil nail	m	921	3,600	3,315,600	307nos
(2) Total length of drilling	Drilling φ65, scaffolding	m	829	8,900	7,378,100	
(3) Drilling machine vertical shift		times	8	14,800	118,400	
(4) Scaffolding work	B=2.0m pipe scaffolding, slope	m3	544	3,200	1,740,800	
(5) Pull out test	Drilling φ65	L.S.	1	150,000	150,000	
4. Shotcrete frame work						
4.1 □400 @2.0m						
(1) Area	□400 @2.0m	m2	312			
(2) Beam length	□400 @2.0m	m	279	22,100	6,165,900	
4.2 □200 @1.5m						
(1) Area	□200 @1.5m	m2	632			
(2) Beam length	□200 @1.5m	m	819	8,900	7,289,100	
4.3 Wire mesh work	φ2.0 50×50	m2	944	1,500	1,416,000	
4.4 Hydroseeding	t=3cm	m2	668	3,400	2,271,200	
4.5 Weep pipe	φ100 L=0.5m	m	179	4,500	805,500	
5. Gabion work						
(1) Gabion work	1.0×1.0×1.0m	m	112	15,000	1,680,000	
6. Temporary work						
(1) Temporary enclosure		m	66	6,300	415,800	
7. Drainage ditch work						
(1) Drainage ditch	U-240	m	96.0	11,500	1,104,000	
(2) Water collecting pit	500×500×500	nos	2.0	60,000	120,000	
Direct construction cost					51,882,180	
Total construction cost			60%		83,000,000	excluding VAT

Kandy Lower Slope

Kandy Lower Slope							
1. Earthwork							
(1) Slope Excavation							
Manpower, Sandy Soil							
V =	Following Average Cross-Section Area Calculation					=	284.3 m ³
(2) Slope Clearing (and Leveling)							
Manpower, Sandy Soil							
A =	Area of anchor		Based on development diagram		=	312.1 m ²	
A =	Upper slope of anchor		Based on measuring area diagram		=	429.2 m ²	
A =	Lower slope of anchor		Based on measuring area diagram		=	202.3 m ²	
					Total =	943.6 m ²	
(3) Soil disposal							
Sandy soil, less than 4km transfer							
V =						=	284.3 m ³
2. Anchor work							
(1) Number of anchor							
Equivalent to F20UA, Drilling φ90							
N =	26	×	1	L=10.0m/anchor		=	26 nos
N =	26	×	2	L=10.5m/anchor		=	52 nos
		lines	steps			Total =	78 nos
(2) Total length of anchor							
Equivalent to F20UA, Drilling φ90							
L =	26	×	1	×	10.0	=	260.0 m
L =	26	×	2	×	10.5	=	546.0 m
		lines	steps	m/anchor		Total length =	806.0 m
(3) Scaffolding work							
B=4.5m pipe scaffolding, slope							
V =	Based on average cross section area calculation					=	1,405.7 m ³

(4) Drilling machine transfer

$$N = 3 \text{ times}$$

(5) Pull out test

Equivalent to F20UA, drilling $\phi 90$

$$N = 1 \text{ LS}$$

3. Soil nailing

(1) Total length of soil nail

SD345 D19 L=3.0m/soil nail

$$N = 429.2 \div 1,000.0 \times 486 \text{ Upper slope of anchor} = 209 \text{ nos}$$

$$N = 202.3 \div 1,000.0 \times 486 \text{ Lower slope pf anchor} = 98 \text{ nos}$$

$$\text{area} \quad \text{unit area} \quad \text{unit number} \quad \text{Total} = 307 \text{ nos}$$

$$L = 307 \times 3.0 = 921.0 \text{ m}$$

(2) Total length of drilling

Drilling $\phi 65$, scaffolding

$$L = 307 \times 2.7 = 828.9 \text{ m}$$

number m/soil nail

(3) Drilling machine vertical shift

$$N = 8 \text{ times}$$

(4) Scaffolding work

B=2.0m pipe scaffolding, slope

$$V = \text{Based on average cross section area calculation} = 544.2 \text{ m}^3$$

(5) Pull out test

Drilling $\phi 65$

$$N = 1 \text{ L.S.}$$

4. Shotcrete frame work											
4.1 □400 @2.0m											
(1) Area											
□400 @2.0m											
A =	Based on development diagram						=	312.1	m ²		
(2) Frame length											
□400 @2.0m											
Vertical beam											
N =	Based on development diagram						=	26	lines		
L =	26	×	6.0				=	156.0	m		
	line		m/line								
Horizontal beam											
L3 =	7.65	+	10.05	+	0.33	+	3.27	+	11.38		
	+	18.38				=	51.06	m			
L2 =	7.71	+	10.60	+	3.51	+	11.68	+	18.35		
				=	51.85	m					
L1 =	7.77	+	10.40	+	3.25	+	12.00	+	18.00		
				=	51.42	m					
				Total =	154.33	m					
L =	154.33	−	78	×	0.40				=	123.1	m
	length		place	beam breadth							
ΣL =	156.0	+	123.1				=	279.1	m		
4.2 □200 @1.5m											
(1) Area											
□200 @1.5m											
A =	429.2	+	202.3				=	631.5	m ²		
	Upper slope of anchor		Lower slope of anchor								

(2) Beam length									
□200 @1.5m									
L =	429.2	÷	1,000.0	×	1,296.6	Upper slope of anchor	=	556.5	m
L =	202.3	÷	1,000.0	×	1,296.6	Lower slope of anchor	=	262.3	m
	area		unit area		unit munber		total	=	818.8 m
4.3 Wire mesh work									
φ2.0 50×50									
A =	Same as slope clearing area						=	943.6	m ²
4.4 Hydroseeding									
t=3cm									
A =	943.6	—	279.1	×	0.4	—	818.8	×	0.2 = 668.2 m ²
	slope clearing area		beam length		beam breadth		beam length		beam breadth
4.5 Weep pipe									
φ100 L=0.5m									
L =	(312.1 ÷	4.00	+	631.50 ÷	2.25)	×	0.5	=	179.3 m
	□400 area	2.0*2.0		□200 area	1.5*1.5				
5. Gabion work									
(1) Gabion work									
1.0×1.0×1.0m									
L =	56.0	×	2				=	112.0	m
	total length		step						
V =	112.0	×	1.0	×	1.0	×	1.0	=	112.0 m ³
6. Temporary work									
(1) Temporary enclosure									
L =	56.0	+	10.0				=	66.0	m
	disatance		extra length						

7.	Drainage ditch work								
	(1) Drainage ditch								
	U-240								
	L =						=	96.0	m
	(2) Water collecting pit								
	500×500×500								
	N =						=	2	nos

Appendix-9

Comparison of the Countermeasure Works

Japan International Cooperation Agency (JICA)

The Democratic Socialist Republic of Sri Lanka

**Technical Cooperation for
Landslide Mitigation Project**

**References for
Grating crib works with soil nailing**

1. Grating Crib Works with Soil Nailing

1.1 Grating crib works in Sri Lanka



Photo 1 Example of grating crib work in Sri Lanka (Source: Web site of Soil Tech Ltd)



Photo 2 Example of soil nailing in Diyatawala (Source: TCLMP)

1.2 Grating crib works in Japan



Photo 3 Example of grating crib works in Japan
(Source: Web site of Higashiryokkakaihatsu Co; Upper, Web site of Aura C. E; Lower)



Photo 4 Example of grating crib works in Japan
(Source: Web site of OKABE Co. Ltd; Top, Web site of Shiisaka Kensetsu; Middle, Web site of Free Frame Association; Bottom)

2. Comparison for the construction work

		Sri Lanka	Japan	Necessary correspondence
Grating crib works	Method of the construction	<ul style="list-style-type: none"> - Cut and shape slope surface into flat plane - Excavate along grating crib line - Set reinforcing bars - Spray shotcrete along excavated area 	<ul style="list-style-type: none"> - Set wire form for grating crib works - Spray shotcrete to the wire form. 	
	Specification	<ul style="list-style-type: none"> - Cross section of grating crib : 200mm × 200 mm (general size in Sri Lanka) - Span of the intersection : 1.5m (general in Sri Lanka) - Main reinforcing bars : D10 × 2~4 nos (an example in a site) • No use of stirrup reinforcement 	<ul style="list-style-type: none"> - Cross section of crib : 150mm × 150mm - 600mm × 600mm - Span of intersection : 1.15 ~ 3.0m - Main reinforcing bars : D16 × 4 ~ 8 nos (general in Japan) - Use stirrup reinforcement for necessary 	<ul style="list-style-type: none"> - Check strength of grating crib
	Construction machinery	<ul style="list-style-type: none"> - Dry mortar spraying machine - Compressor - Generator 	<ul style="list-style-type: none"> - Wet process spraying machine - Compressor - Generator - Belt conveyor - Aggregate batcher 	
	Quality	<ul style="list-style-type: none"> - Strength standard of shotcrete should be confirmed - Quality and shape of grating crib itself under the ground can not be confirmed because it is impossible to see directly inside the grating crib under the ground 	<ul style="list-style-type: none"> - Mortar : 18N/mm² 	<ul style="list-style-type: none"> - Check strength of dry mortar
	Material required	<ul style="list-style-type: none"> - Type of wire mesh net for wire form is insufficient in Sri Lanka. - Type of reinforcement bar for grating crib works is insufficient - Number of experienced worker for wire form assembling is insufficient 	<ul style="list-style-type: none"> - Wire form is produced at factory. 	<ul style="list-style-type: none"> - Procure materials for wire form. - Train assembling worker of wire form
Soil nailing	Specification	<ul style="list-style-type: none"> - Patternized specifications (not so many types) - Screw connection by hand (head of soil nailing bar) - Head of soil nailing bar is covered by shotcrete 	<ul style="list-style-type: none"> - Specification is decided based on result of stability analysis - Diameter of soil nailing bar is mainly D19, D22 and D25 - Head of soil nailing bar is protected by cap for considering maintenance. 	
	Construction machinery	<ul style="list-style-type: none"> - Lightweight drilling machine (mainly single tube) 	<ul style="list-style-type: none"> - Select appropriate drilling machine in accordance with drilling diameter, geological condition and drilling length - Many tools are available for drilling condition.(ex. Double tube drilling device is common) 	<ul style="list-style-type: none"> - Procure appropriate machines and tools.
	Quality	<ul style="list-style-type: none"> - No use of spacer for soil nailing bar. 	<ul style="list-style-type: none"> - Use spacer for soil nailing bar to increase closely contact strength of a soil nailing bar and grout 	
Others	Scaffolding	<ul style="list-style-type: none"> - Work at slope with holding ladder and safety belt on to soil nailing bar - Use vehicle for work at height, if possible - These works above are not enough for stability and safety. 	<ul style="list-style-type: none"> - Single pipe scaffold is used and stable with dense structure. - Work at slope with fastening with a rope 	<ul style="list-style-type: none"> - Train workers for special skill for grating crib works - Training for safety
	Designing	<ul style="list-style-type: none"> - Experience for designing of grating crib works and soil nailing are insufficient 	<ul style="list-style-type: none"> - Design work is done by experienced engineer - Design work is done in accordance with slope condition - Consider economic efficiency and workability 	<ul style="list-style-type: none"> - Training for design engineer

Alternative Countermeasure Works on the Lower Slope

No		Case1	Case2	Case3																																				
Condition		Secure the school premises	Secure the school buildings (keep the pass)	Secure the school premises																																				
Works		Excavation Type Grating Crib Work with Soil Nailing	Cutting Soil and Grating Crib Works with Soil Nailing	Slope Surface Type Grating Crib Works with Anchoring																																				
Cross section																																								
Outline of the measure works		- Excavation type grating crib work is applied. Slope is shaped for the installation of grating crib work. - The length of soil nailing is 8m with 1.5m span of transverse direction and 2.0m span of longitudinal direction. - Eight (8)m and five (5)m length of horizontal drainage is planned.	- Most of the unstable soils are removed. - The length of soil nailing is 4-5m with 1.5m span of each direction. - Gabion wall is installed with some space to catch weathered soil mass of slope failure in the future.	- Japanese style grating crib work with anchoring and soil nailing is applied. - Slope is shaped for installation of grating crib work. - The length of the anchoring work is 10-10.5m with 2m span of each direction.																																				
Stability of each assumed slope failure	Assumed slip surface	Proposed Factor of Safety ≥ 1.2 with soil nail.	Proposed Factor of Safety ≥ 1.2 with cutting works and soil nailing.	Proposed Factor of Safety ≥ 1.2 with anchors and soil nails.																																				
	Surface slope failure	Reliability of effectiveness of excavation type grating crib work for shallow slope failure is not efficient.	Slope Angle (1: 1.2 for free and 1: 1.0 with soil nailing) and catchment space.	Reinforced by slope surface type grating crib work																																				
	Unstable soils	Stability is expected to be raised with horizontal drainage. However, most of the unstable soils are remained on the slope.	Most of the unstable soils are removed. (drainage is not required because of observed ground water level)	Reinforced by slope surface type grating crib work with anchoring																																				
Design	Soil nailing	Based on the Hong Kong Guide with stability analysis. No limitation of length of soil nail. Length is allowed to be more than 5m.	- Based on the analysis. Checked by Japanese design method. Based on the analysis. Checked by Japanese design method. Limitation of length of soil nail is less than 5m in this design.	Design based on the Japanese Standard. Based on the Japanese standard. Limitation of length of soil nail is less than 5m.																																				
	Crib work	No design method and standard. Enough strength for stabilization of all of the excavation type grating crib work is not assured.	No design method and standard. In this case, function of the crib work is expected as fixing of soil nail, strength as a structure is not expected.	Design based on the Japanese Standard.																																				
Supervision and procurement of materials for grating crib work	Excavation type grating crib work	Material (Steel net)	Steel net in Sri Lanka is difficult to install along natural slope because the steel net is not flexible.	Slope is smooth surface by cutting, therefore steel net is easy to be installed.	Steel net in Sri Lanka is difficult to install along natural slope. Procurement of steel net from Japan (or other countries) is necessary.																																			
		Material (Shotcrete machine)	Dry shotcrete is used in Sri Lanka. Enough strength for stabilization of all of the excavation type grating crib work is not assured with using dry shotcrete.	Dry shotcrete is used in Sri Lanka. Enough strength for stabilization of all of the excavation type grating crib work is not assured with using dry shotcrete.	-																																			
		Worker (Assembling wire formwork, installing steel net and iron reinforcing bar)	Enough strength for stabilization of all of the excavation type grating crib work is not assured.	Enough strength for stabilization of all of the excavation type grating crib work is not assured.	-																																			
		Worker (Nozzle man for shotcrete)	There are no qualified nozzle man for shotcrete in Sri Lanka. Enough strength for stabilization of all of the excavation type grating crib work is not assured.	There are no qualified nozzle man for shotcrete in Sri Lanka. Enough strength for stabilization of all of the excavation type grating crib work is not assured.	-																																			
	Slope surface type grating crib work	Material (Wire formwork)	-	-	There are no wire formwork in Sri Lanka. Procurement of the materials from Japan (or other countries) is necessary.																																			
		Material (Shotcrete machine)	-	-	Wet type shotcrete machine must be used in Japanese standard. Procurement of wet type shotcrete machine is necessary.																																			
		Worker (Assembling wire formwork, installing steel net and iron reinforcing bar)	-	-	There are no skilled worker for assembling wire formwork, installing steel net and iron reinforcing bar. Procurement of skilled workers from Japan (or other countries) is necessary.																																			
		Worker (Nozzle man for shotcrete)	-	-	There are no qualified nozzle man for shotcrete in Sri Lanka. Procurement of qualified nozzle man from Japan is necessary.																																			
Dissemination of the grating crib work method	Grating crib work	-	-	There are no experience to install ground surface type grating crib work method. Procurement of contractors who have experiences of installation of grating crib work from Japan (or other countries).																																				
Period		5month (If the construction starts in Oct 2015, completion is expected be March. 2016) Two (2) parties, excavate by machine ※Moving and reconstructing period of the school is excluded.	8.1 month (If the construction starts in Oct. 2015, completion is expected to be Jun 2016) Two (2) parties, excavate by machine	Not yet determined.																																				
Possibility of implementation in the TCLMP		<table border="1"> <tr> <th>Safety</th> <th>Procurement</th> <th>Social Impact</th> <th>Environment / Scenery</th> <th>Cost</th> <th>Evaluation</th> </tr> <tr> <td>×</td> <td>○</td> <td>○</td> <td>△</td> <td>△</td> <td>×</td> </tr> </table> <p>1. More than 5m of soil nail is not allowed in the Japanese standard. 2. Excavation type grating crib work for natural slope is not satisfied with proposed factor of safety checked by Japanese standard. 3. Excavation type grating crib work is not reliable to mitigate the shallow slope failure. 4. Most of the unstable soils are remained on the slope, the stability is not assured with this alternative. Based on above, it is impossible to implement the countermeasure works in the TCLMP.</p>	Safety	Procurement	Social Impact	Environment / Scenery	Cost	Evaluation	×	○	○	△	△	×	<table border="1"> <tr> <th>Safety</th> <th>Procurement</th> <th>Social Impact</th> <th>Environment / Scenery</th> <th>Cost</th> <th>Evaluation</th> </tr> <tr> <td>○</td> <td>○</td> <td>○</td> <td>△</td> <td>○</td> <td>○</td> </tr> </table> <p>1. The length of soil nail is less than five (5) m. It follows the Japanese standard. 2. Excavation type grating crib work for natural slope is satisfied with proposed factor of safety checked by Japanese standard. 3. Most of the unstable soils are removed, therefore excavation type grating crib work is almost reliable to mitigate the shallow slope failure. If shallow slope failure occurs, gabion wall is installed to protect the road. 4. Most of the unstable soils are removed, the stability is assured with this alternative. Based on above, it is possible to implement the countermeasure works in the TCLMP.</p>	Safety	Procurement	Social Impact	Environment / Scenery	Cost	Evaluation	○	○	○	△	○	○	<table border="1"> <tr> <th>Safety</th> <th>Procurement</th> <th>Social Impact</th> <th>Environment / Scenery</th> <th>Cost</th> <th>Evaluation</th> </tr> <tr> <td>○</td> <td>×</td> <td>○</td> <td>△</td> <td>-</td> <td>×</td> </tr> </table> <p>1. Procurement of necessary materials such as wet shotcretemachine is required. 2. Procurement of experienced workers such as nozzle man is required. 3. Procurement of experienced contractors for these types of countermeasure work is required. Therefore, it is impossible to implement this alternative in the TCLMP. Other schemes such as Yen Loan or other donors should be selected when this countermeasure work will be implemented. Or pilot test to assure the method is applicable should be conducted.</p>	Safety	Procurement	Social Impact	Environment / Scenery	Cost	Evaluation	○	×	○	△	-	×
Safety	Procurement	Social Impact	Environment / Scenery	Cost	Evaluation																																			
×	○	○	△	△	×																																			
Safety	Procurement	Social Impact	Environment / Scenery	Cost	Evaluation																																			
○	○	○	△	○	○																																			
Safety	Procurement	Social Impact	Environment / Scenery	Cost	Evaluation																																			
○	×	○	△	-	×																																			

Democratic Socialist Republic of Sri Lanka

National Building Research Organization (NBRO)

**Proposal for Rectification
on Rock Fall at Alagumale
in Matale District**

FINAL REPORT

September, 2015

Japan International Corporation Agency (JICA)

**EARTH SYSTEM SCIENCE Co., Ltd. (ESS)
NIPPON KOEI Co., Ltd. (NK)**

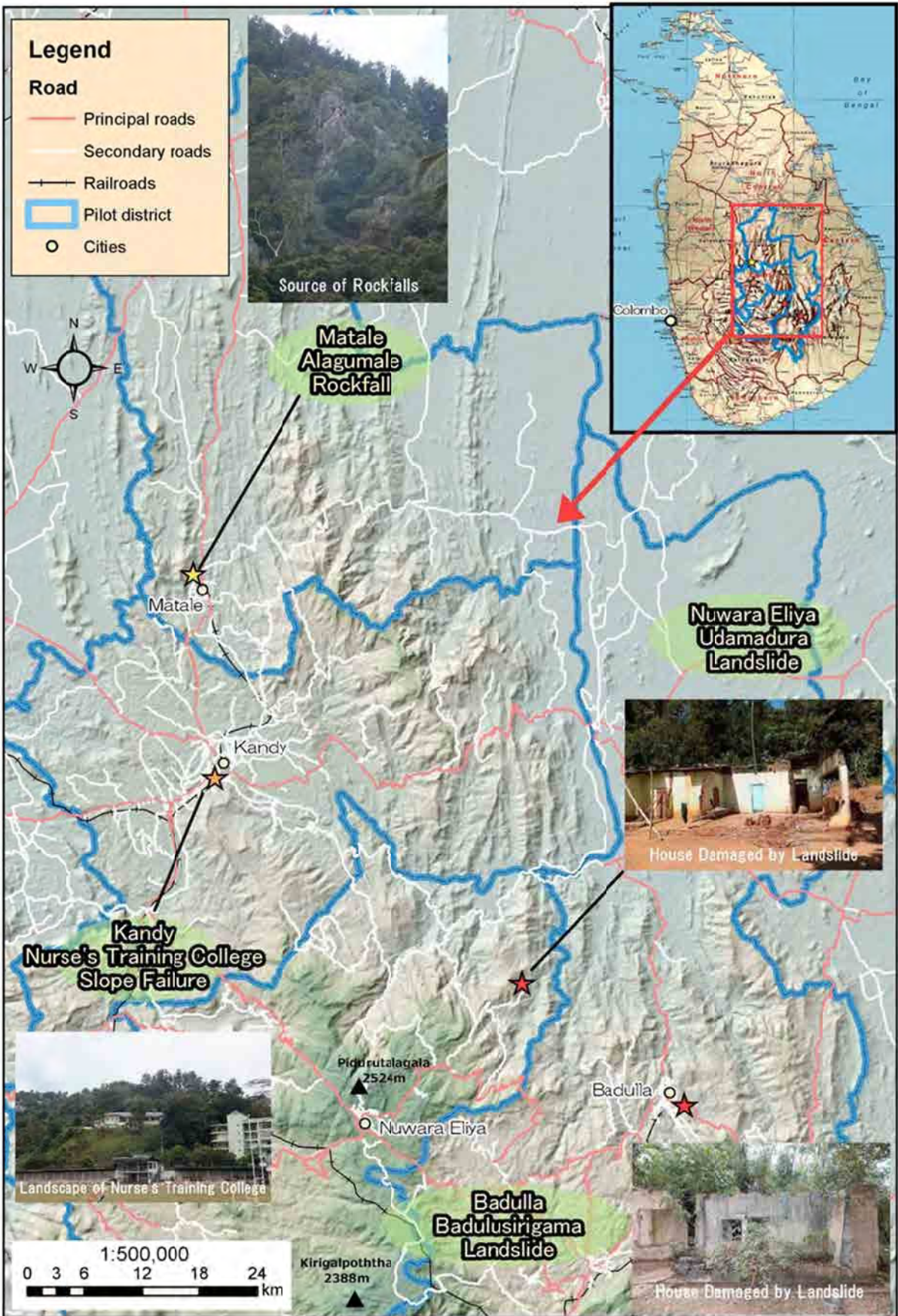

Location Map of Pilot Project Sites

Table of Contents

Location Map of Pilot Project Sites

1.	Introduction.....	1
1.1	Background of the Project	1
1.2	Site Condition/ Description of Disaster	1
2.	Geomorphological and Geological Survey	2
2.1	Geomorphological Survey	2
2.2	Fallen Rock Survey.....	5
2.3	Geological Survey.....	7
3.	Rock Fall Analysis.....	8
3.1	Flow of Rock Fall Simulation.....	8
3.2	Method of Rock Fall Simulation	8
3.3	Results of Rock Fall Simulation	9
4.	Design of Countermeasure Work of Rock Fall.....	12
4.1	Mechanism of Rock Fall.....	12
4.2	Design Concept of Countermeasure Work	12
4.3	Design of Countermeasure Works	13

List of Figure

Figure 2.1	Satellite Image of Alagumale	2
Figure 2.2	Photo by the UAV Survey	3
Figure 2.3	Cross section generated by DEM and UAV data.....	4
Figure 2.4	Plan by Topographic Survey.....	4
Figure 2.5	Fallen rock survey.....	5
Figure 2.6	Geological cross section	7
Figure 3.1	Flowchart of Rock Fall Simulation.....	8
Figure 3.2	Method of Rock Fall Simulation	9
Figure 3.3	A Result of Rock Fall Simulation.....	11
Figure 4.1	Rough indication of range of application for the countermeasure works against rock fall	12
Figure 4.2	Plan of Countermeasure Work.....	13
Figure 4.3	Cross Section of Countermeasure Work.....	14

List of Table

Table 2.1	Result of Fallen Rock Survey	6
Table 2.2	Summary of Geological Survey	7
Table 3.1	Parameters of Rock Fall	8
Table 3.2	Results of Rick Fall Simulation.....	10

1. Introduction

1.1 Background of the Project

“Technical Cooperation for Landslide Mitigation Project (TCLMP)” has being implemented by Japan International Cooperation Agency (JICA). Under the project, four (4) sites are selected for pilot projects. The purpose of the project is to improve sediment disaster (Landslide) management capacity of NBRO through application of appropriate mitigation measure with Japanese and other technology in the pilot project sites. Alagumale in Matale District is one of the sites of the pilot project for rock fall.

Five (5) outputs are expected through the project. This proposal is for “Output 4”, one of the outputs. Output 4 is that “Capacity of design, construction supervision, and monitoring for rock fall mitigation measure is strengthened”.

1.2 Site Condition/ Description of Disaster

The pilot project site in Alagumale is located at the western end of Matale City. The source of rock fall is from the steep slope of Alagumale Mountain. A part of the slope is cover by trees and vegetation; however, large size (over 1m diameter) boulders and cracked rocks are distributed widely on the upper slope above residential area.

11 families have already evacuated by the guidance of NBRO after the historical events of rock falls.

The present site conditions are shown in Photo 1.1.



Overall view



Source of the rock fall



Rock fall area



Fallen rock

Photo 1.1

Site condition

2. Geomorphological and Geological Survey

2.1 Geomorphological Survey

For rock fall, it is necessary to obtain topographic data of a wider area, not only around the location of countermeasure works but also including the source area of rock fall. Therefore, ALOS World 3D with 5m resolution provided by Japan Aerospace Exploration Agency (JAXA) was adopted in the project. A map will be generated with DEM (Digital Elevation Model) data of several km² including source area of rock fall in order to get an overview of the whole area of rock fall and analyze the mechanism of rock fall. Based on the satellite image, the area for the UAV (Unmanned Aerial Vehicle) survey was selected.

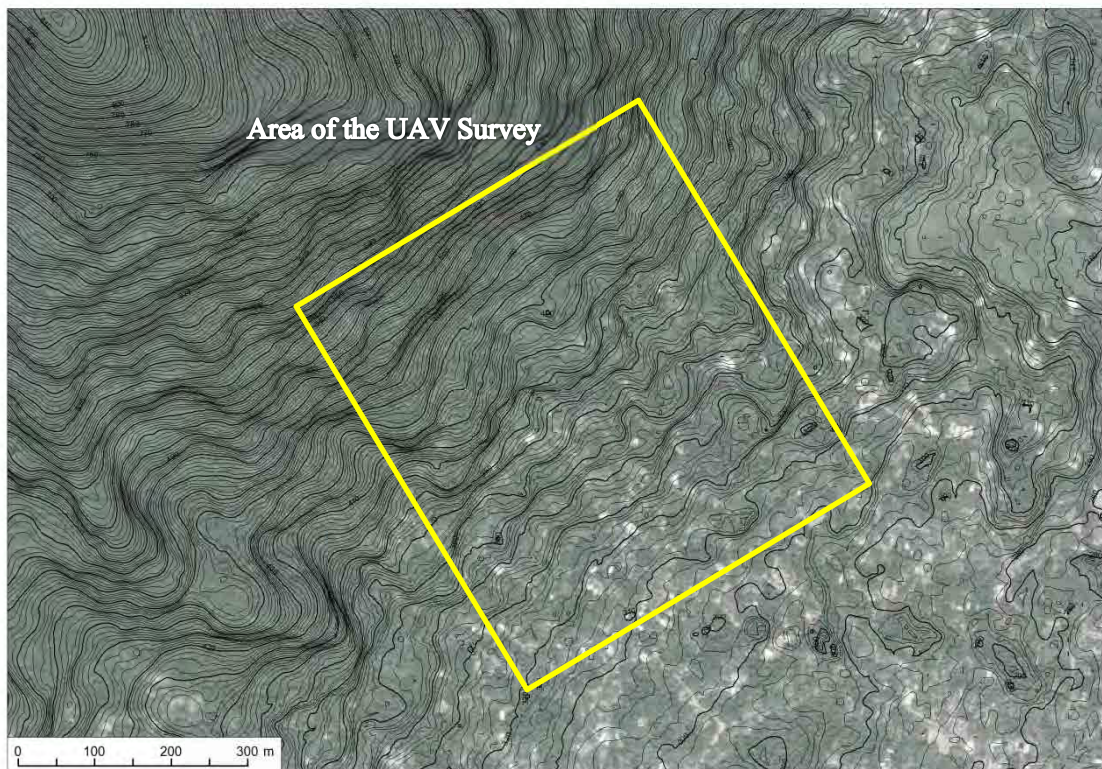

Figure 2.1 Satellite Image of Alagumale

For a wider area topographic survey, it is better to apply DEM for gathering topographical information described above. To obtain more detailed topographical data of source area of rock fall, it is better to apply UAV than DEM. It will be effective and efficient combining both methods of DEM and UAV, and it will be able to generate topographic information with higher accuracy.

However, these methods cannot obtain ground surface data. They can obtain elevation of tree or vegetation. Therefore, their data is useful to understand the general information around the

site. To design a countermeasure work, more detailed topographic data is required. Therefore, based on these data, area of a topographic survey was selected. At the same time, location of cross section and bore holes were selected.

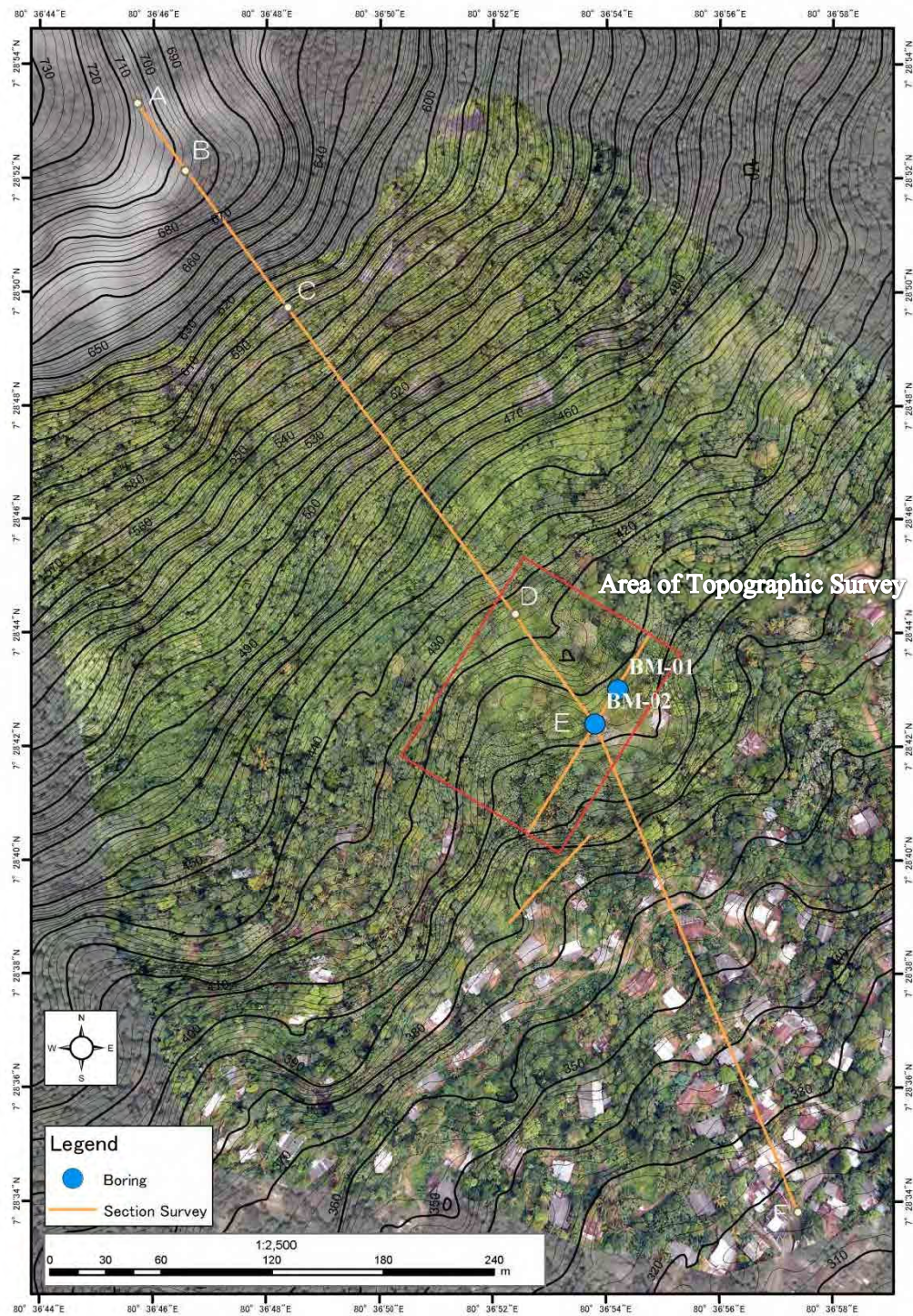

Figure 2.2 Photo by the UAV Survey

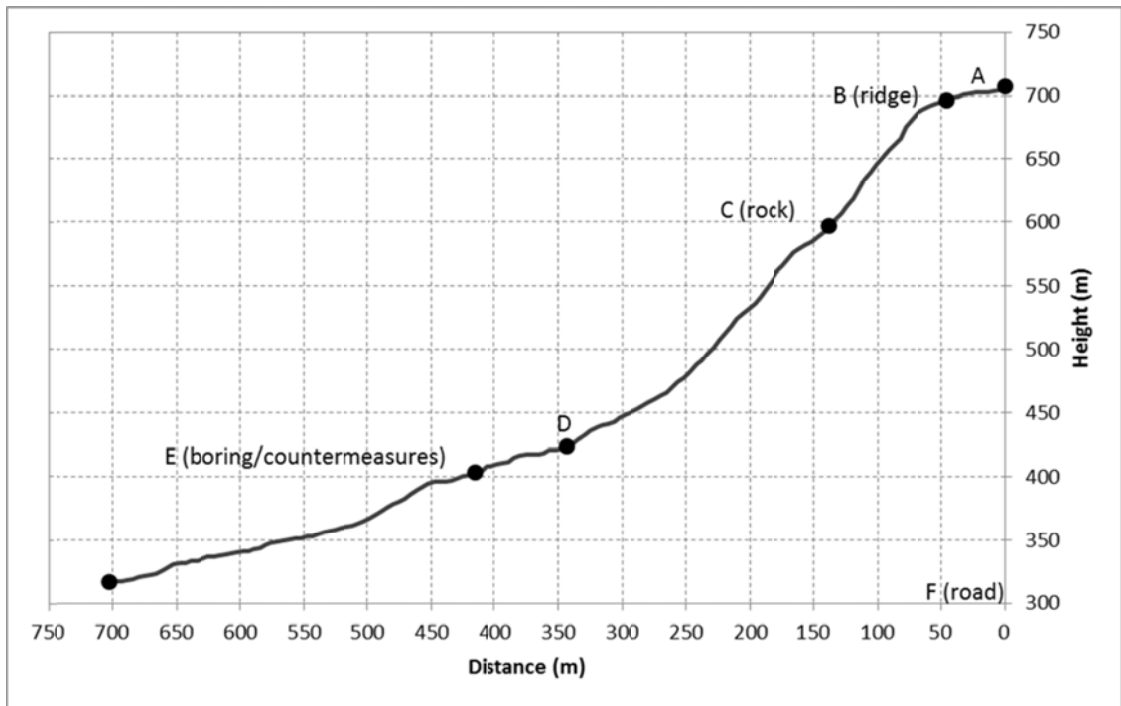

Figure 2.3 Cross section generated by DEM and UAV data

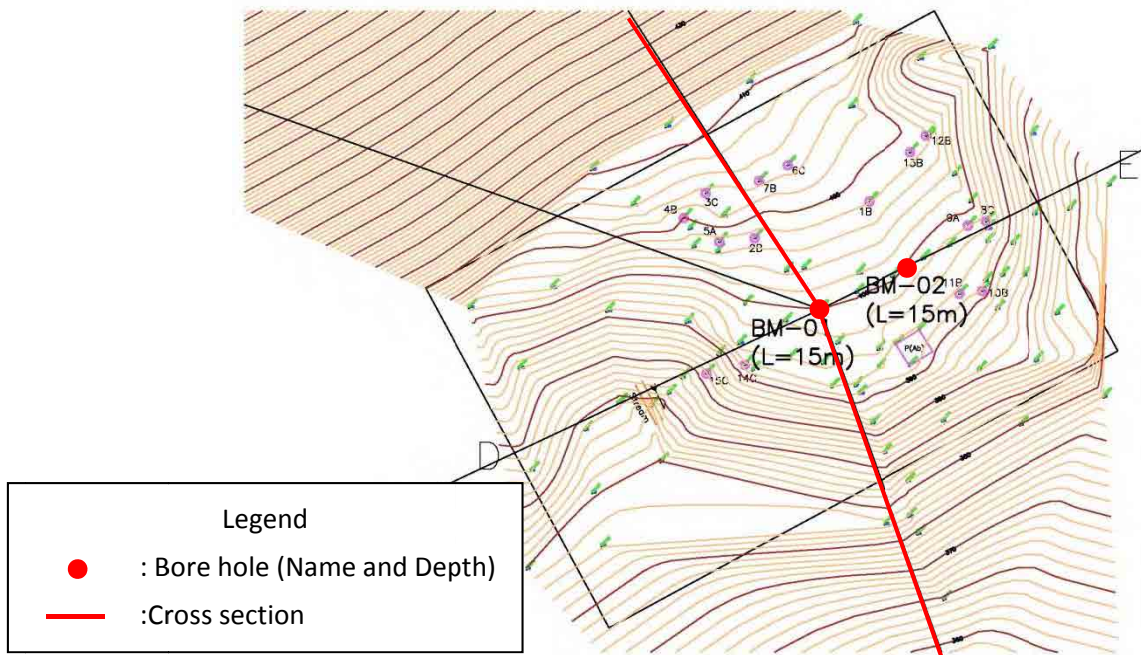

Figure 2.4 Plan by Topographic Survey

2.2 Fallen Rock Survey

When topographic survey was conducted, fallen rock survey was conducted simultaneously. Fallen rocks in the target area more than 2.0 m were surveyed, size of the rocks and location were recorded. The sizes of the fallen rock are shown in Table 2.1, and locations of the fallen rocks are shown in Figure 2.5.

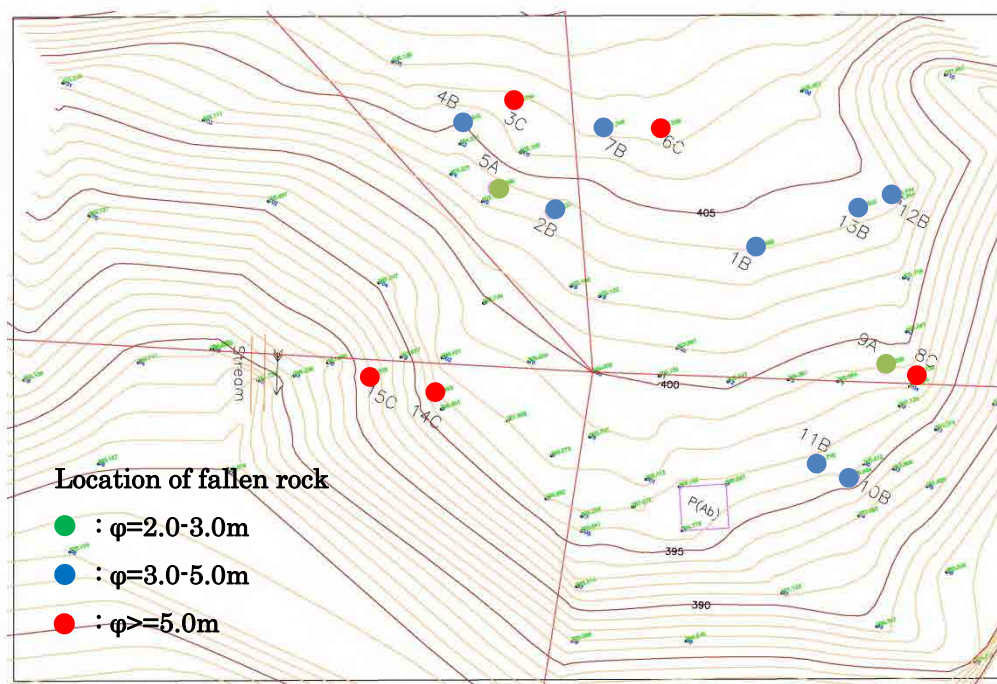

Figure 2.5 Fallen rock survey

Table 2.1 Result of Fallen Rock Survey

No	Width (m)	Height (m)	Length (m)	type of the maximum scale A:2.0-3.0 B:3.0-5.0 C:5.0-	Rock Shape Type				volume (m3)
					Round (a)	Round to Angular (b)	Angular (c)	Rock Shape Type	
1	2.0	3.0	2.5	B		○		b	15.0
2	2.5	3.2	4.5	B		○		b	36.0
3	6.0	5.0	12.0	C		○		b	360.0
4	3.0	4.5	4.0	B		○		b	54.0
5	2.0	2.0	2.0	A		○		b	8.0
6	6.0	6.0	3.0	C		○		b	108.0
7	2.5	3.0	4.0	B		○		b	30.0
8	3.5	5.0	8.0	C		○		b	140.0
9	2.0	1.5	2.0	A		○		b	6.0
10	3.0	1.0	4.0	B		○		b	12.0
11	2.5	2.0	4.5	B		○		b	22.5
12	4.0	2.0	4.0	B		○		b	32.0
13	2.0	3.0	4.0	B		○		b	24.0
14	3.5	6.0	4.0	C		○		b	84.0
15	2.5	6.0	4.0	C		○		b	60.0
min	2.0	1.0	2.0						6.0
max	6.0	6.0	12.0						360.0
average	3.1	3.5	4.4						66.1

2.3 Geological Survey

At the location indicated in Figure 2.5, borings were conducted. Details of drilling are shown in Table 2.2.

Table 2.2 Summary of Geological Survey

Survey Item	Details and Descriptions
1. Borehole drilling	2 boreholes, 15m * 2 holes = 30m
2. Standard Penetration Test (SPT)	10 times * 2 holes = 20 times (at 1.0 m interval)

Based on the result of the survey, debris mainly consisting of silty sand is distributed up to around five (5) m below the ground. The debris includes gravels of gneiss. Under the debris, gneiss is distributed as bed rock.

Geological cross section is shown in Figure 2.6 and borehole log is attached in the Annex X.

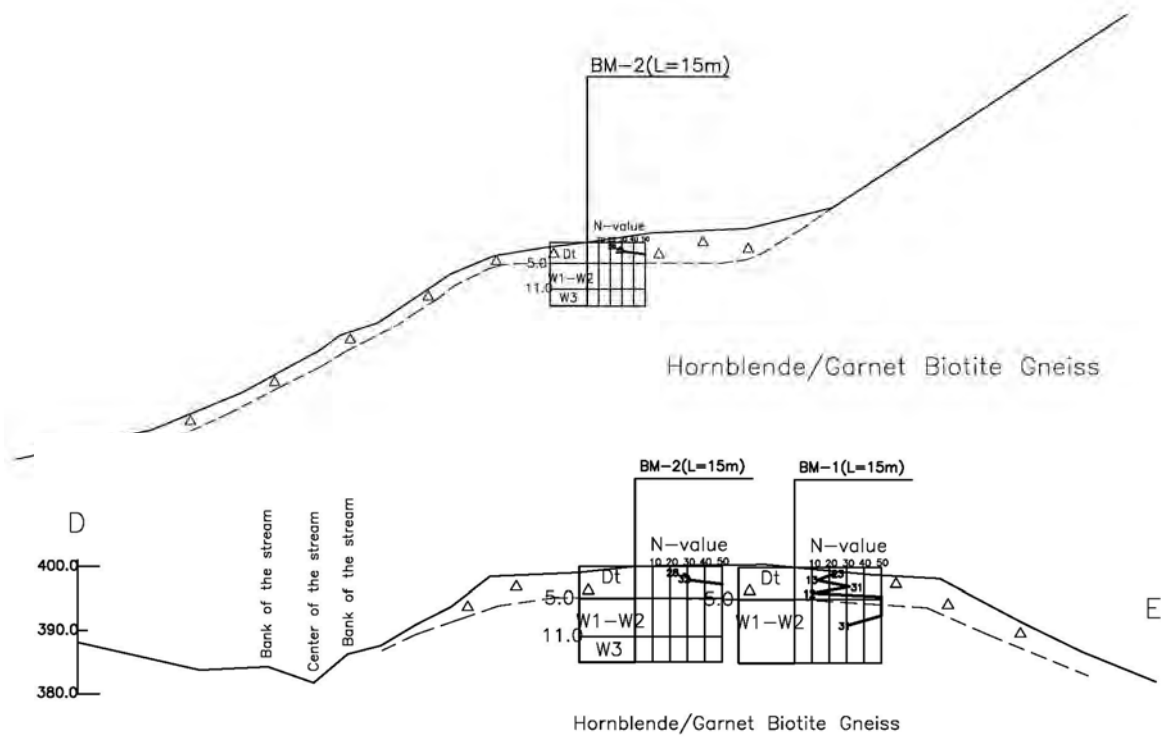

Figure 2.6 Geological cross section

3. Rock Fall Analysis

3.1 Flow of Rock Fall Simulation

The flowchart of the simulation is shown in Figure 3.1.

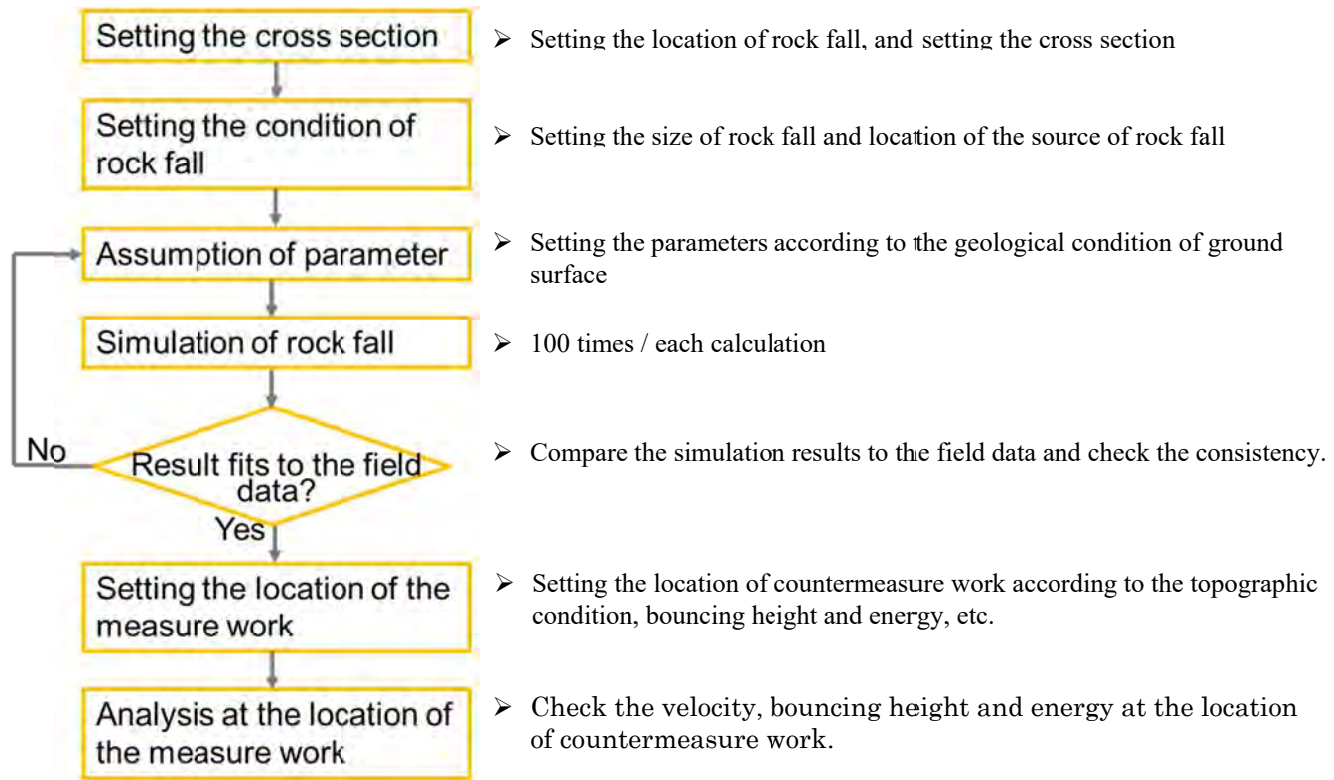

Figure 3.1 Flowchart of Rock Fall Simulation

3.2 Method of Rock Fall Simulation

Parameters of the rock fall simulation are based on the result of the field survey. The parameters are shown in Table 3.1.

Table 3.1 Parameters of Rock Fall

Item	Parameter
Size of rock	Diameter: 1 - 5m
Mass	2.6 t/m ³
Shape	Sphere
Equivalent friction coefficient	Rock : 0.05
	Soil : 0.25
Initial velocity	0 m/s
Number of simulation	100 times for each simulation

Based on the parameters, a rock is dropped down from the point C which is the source of the rock fall. In the simulation, a rock is dropped down 100 times for each case with generated random numbers of parameters of the ground.

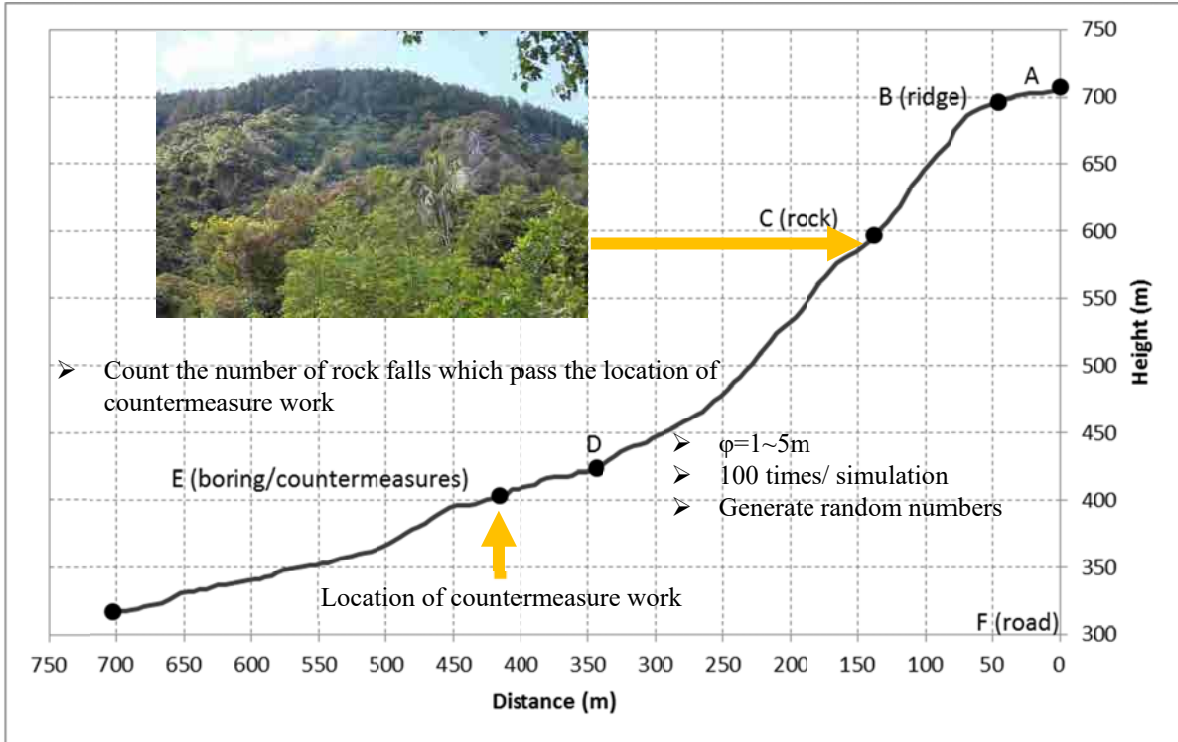

Figure 3.2 Method of Rock Fall Simulation

3.3 Results of Rock Fall Simulation

Numbers of the fallen rocks which pass the location of countermeasure work are counted. For each case, numbers of the fallen rocks are counted, and the energy of rocks are analyzed also the bounce heights are also analyzed.

The results of rock fall simulation are shown in Table 3.2. Based on the results of the simulation, two (2) or three (3) rocks pass the location of the countermeasure work for each case. And the bounce heights are less than two (2) meter. The maximum energy of rock fall is 1,111 kj.

Table 3.2 Results of Rick Fall Simulation

Size	Case No.	Real Bouncing Height (Height from the bottom of rock)	Energy	Number of rocks (pass the location of countermeasure)
m	—	m	kJ	Nos out of 100
φ1.0	1	0.128	330	2
		1.232	180	
	2	0.124	783	2
		1.026	927	
	3	0.790	675	3
		1.366	303	
		0.060	969	
	4	0.162	524	2
1.277		652		
φ2.0	1	0.117	558	2
		0.093	889	
φ3.0	1	0.174	993	1
	2	0.764	607	2
		1.041	733	
	3	0.215	220	2
		0.171	592	
φ4.0	1	0.759	405	1
	2	0.197	952	1
	3	0.328	254	2
		0.965	967	
φ5.0	1	0.106	1,111	1
Max		1.366	1,111	

A result of rock fall simulation is shown in Figure 3.3, and other results are shown in Annex X. In each case, rock falls are simulated in cases of with countermeasure work and cases of without countermeasure work.

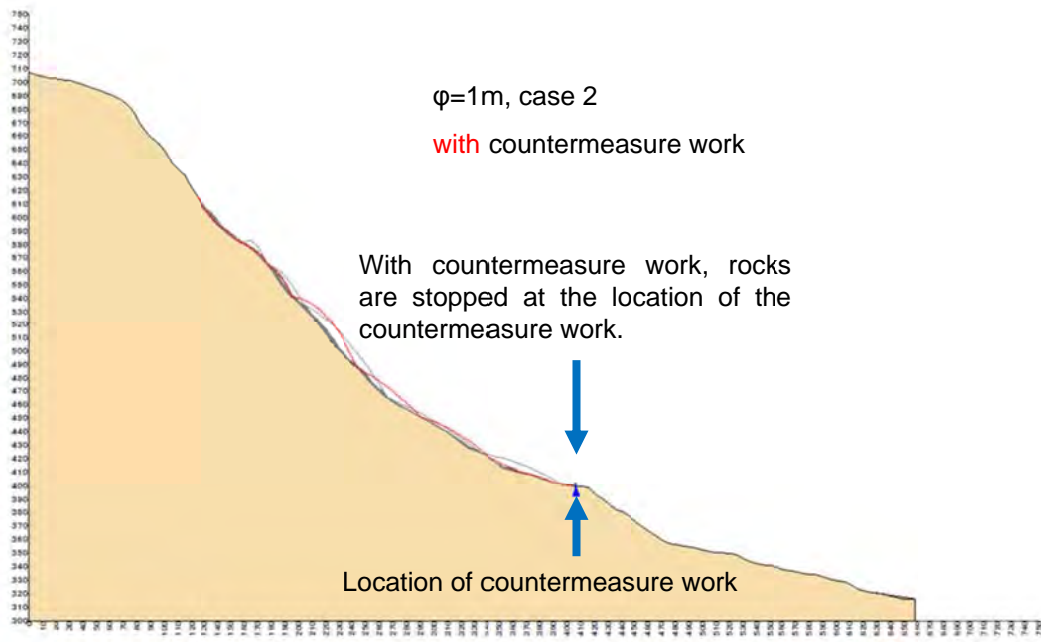
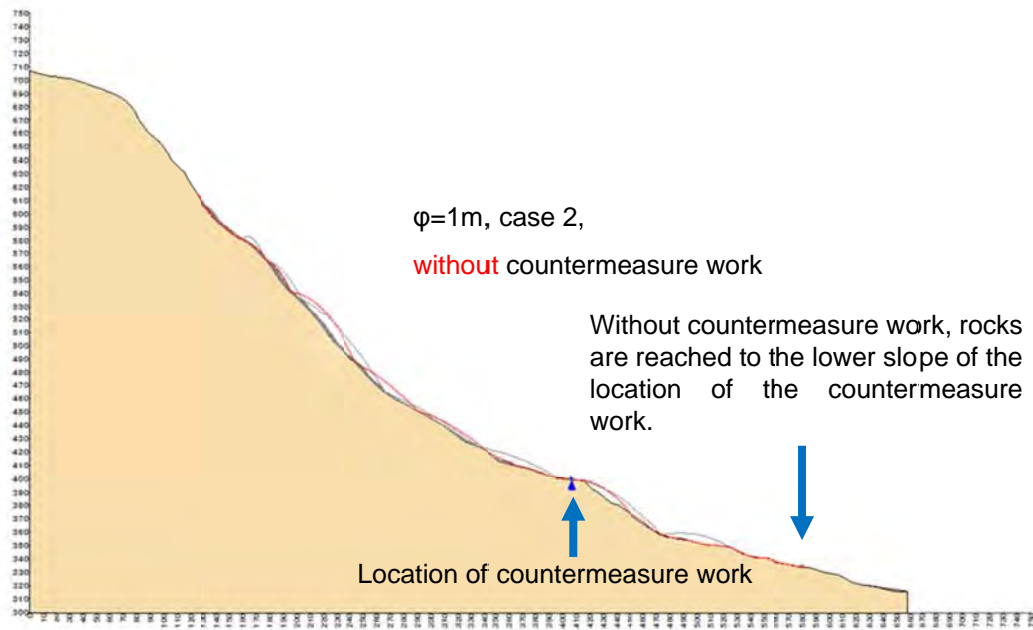

Figure 3.3 A Result of Rock Fall Simulation

4. Design of Countermeasure Work of Rock Fall

4.1 Mechanism of Rock Fall

Based on the results of surveys and simulations, the mechanism of the rock fall in Alagumale is as follows.

- Rocks are fallen from the source of the rock fall, the elevation of the source is around 600m.
- The average size of fallen rock is around three (3) to four (4) m in diameter.
- Most of the fallen rocks stopped on the gentle slope, the elevation of the gentle slope is around 400m.
- Rock fall occurred after the heavy rain. Therefore, main trigger of the rock falls is heavy rain.
- Based on the result of simulation, the energy of rock fall is around 1,000 kj at the proposed location of countermeasure work.

4.2 Design Concept of Countermeasure Work

Based on the mechanism of the rock fall in Alagumale, design concept of countermeasure work is shown below.

- Most of the fallen rocks stopped around the gentle slope. Therefore around the gentle slope is suitable for the location of the countermeasure work. In order to protect residences, countermeasure work should be installed at upper slope of residences.

- The energy of rock fall is around 1,000kj at the proposed location of countermeasure.

According to the standard for countermeasure work against rock fall in Japan, earth dyke is suitable as a countermeasure work at

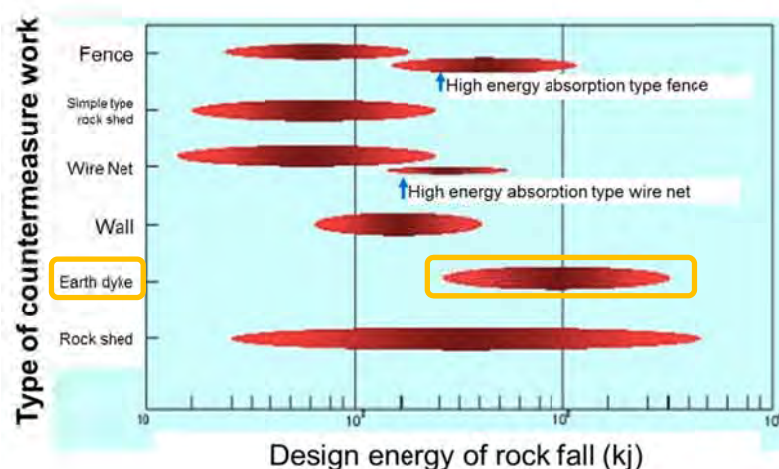

Figure 4.1 Rough indication of range of application for the countermeasure works against rock fall

Alagumale.

- Based on the result of simulation, the highest bouncing height is 1.366m. According to the result of experiment of rock fall in Japan, 80 to 85 % of bouncing height is less than two (2) m. Therefore, required height of the earth dyke is more than two (2) m.

4.3 Design of Countermeasure Works

The drawings of countermeasure works are shown in Figure 4.2 and Figure 4.3.

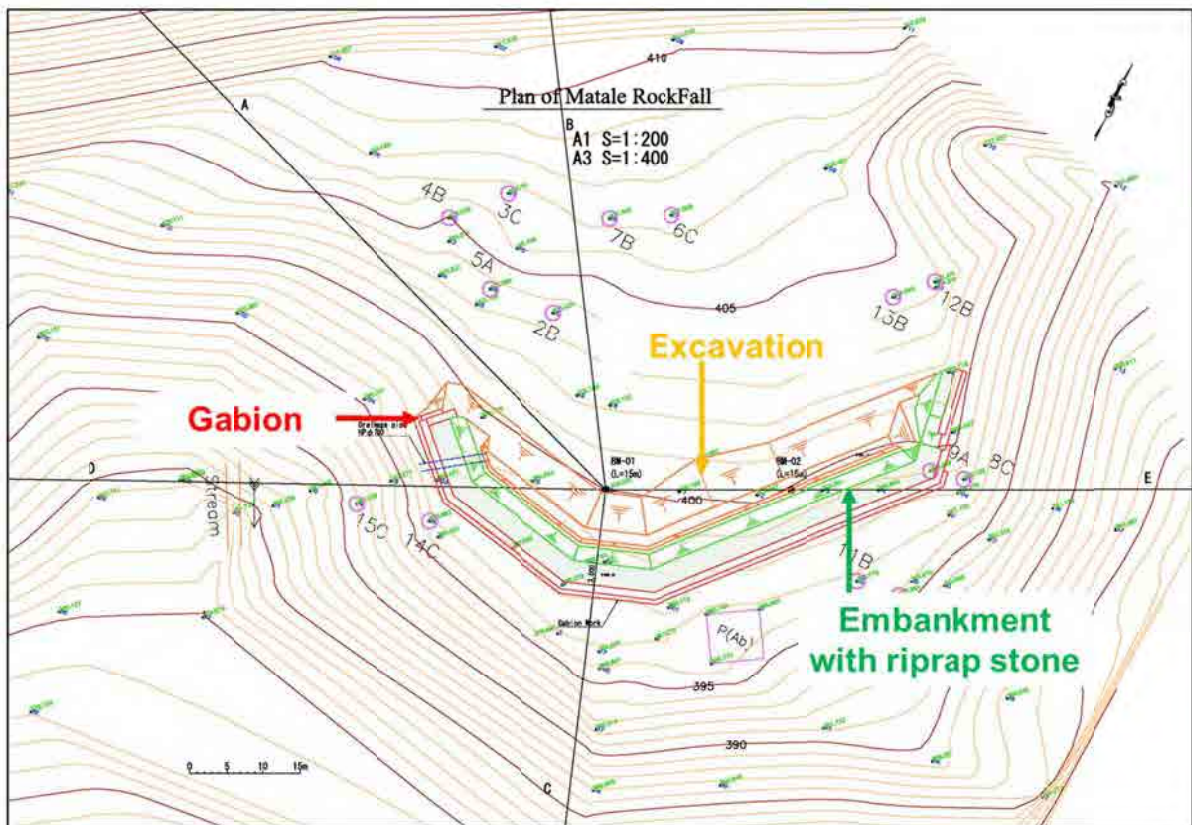

Figure 4.2 Plan of Countermeasure Work

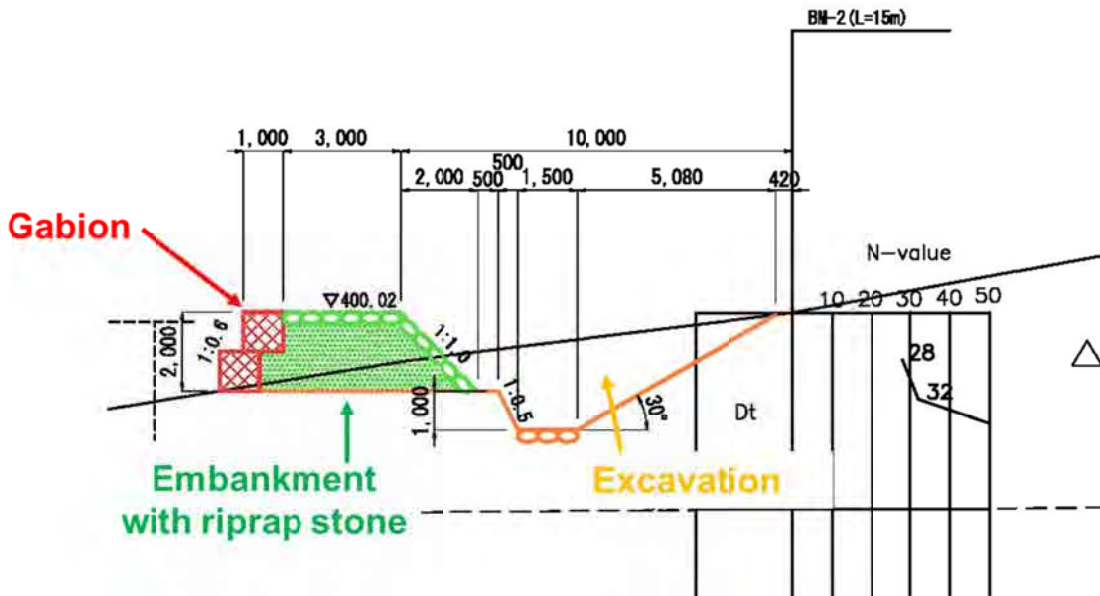
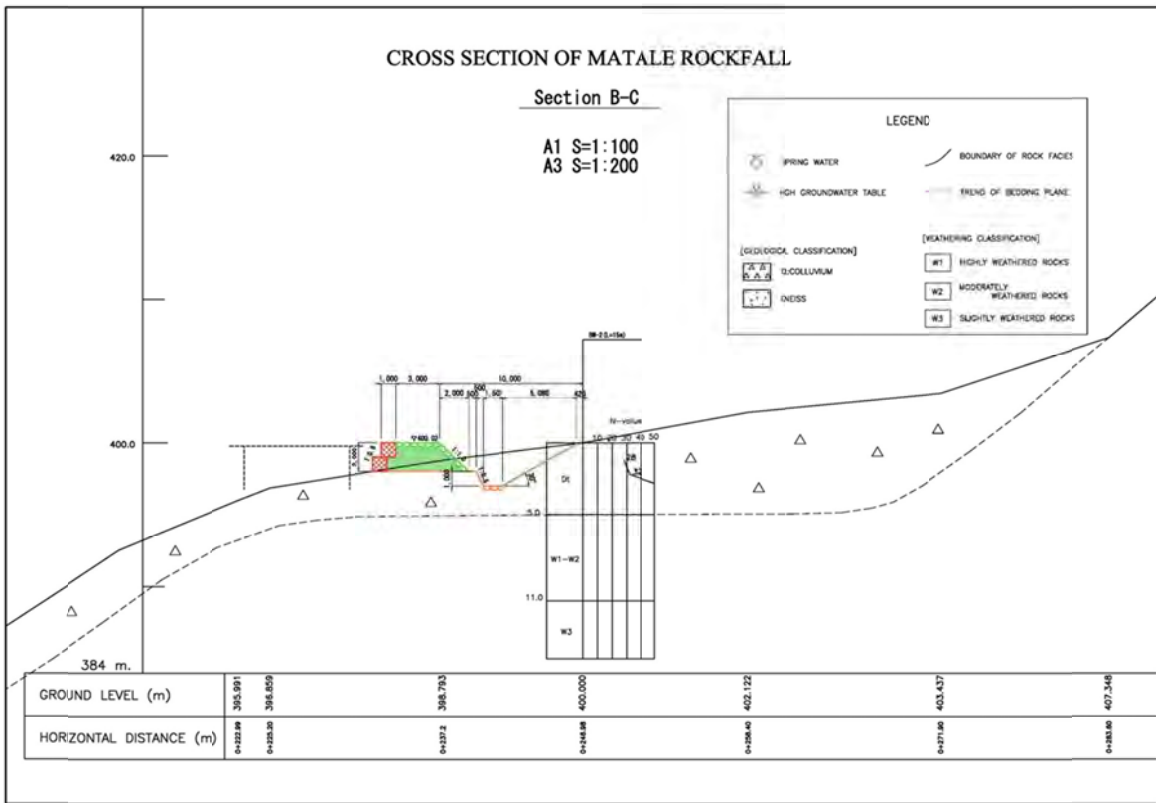

Figure 4.3 Cross Section of Countermeasure Work

"Appendix
Borehole Log

BOREHOLE LOG



NATIONAL BUILDING RESEARCH ORGANISATION
GEOTECHNICAL ENGINEERING DIVISION
 99/1, Jawatta Road, Colombo 05.

SHEET NO.

1 of 2

PROJECT	TECHNICAL CORPORATION FOR LANDSLIDE MITIGATION PROJECT AT MATALE		CLIENT	JAPAN INTERNATIONAL CORPORATION AGENCY	BOREHOLE NO	BM 01	
LOCATION	MATALE		CONTRACT NO	30/24871	DEPTH OF HOLE (m)	15.00	
DRILING METHOD	CORE DRILLING		ELEVATION (m MSL)		CHAINAGE / OFFSET	-	
CORE SIZE [mm]	54	CASING SIZE	NX	CO-ORDINATES	07° 28' 43.0" N	DATE COMMENCED	26/04/2015
VANE SIZE [mm*mm]	-	UDS SAMPLER SIZE [mm]	-		80° 36' 54.2" E	DATE COMPLETED	30/04/2015

DEPTH [m]	ELEVATION [m MSL]	LAYER THICKNESS(m)	SAMPLE TYPE	SAMPLE NO.	SOIL PROFILE				Y - [g/cm ³]	OTHER TESTS	STANDARD PENETRATION TEST DATA				MOISTURE CONTENT - %					
					SOIL DESCRIPTION	STRATA	LEGEND	GWL			NUMBER OF BLOWS				UNDRAINED SHEAR STRENGTH - kN/m ²					
											PER 15cm			FOR 30cm	SPT RESISTANCE - Blows/30 cm					
											1	2	3		10	20	30	40	50	60
0.00					GROUND LEVEL															
0.30		0.30			Dark brown, silty SAND, fine to medium grained with gravel, plant roots and decomposed organic matter (top soil)	SM				Core Depth m	Core Recovery %	ROD %	Return of Water %							
0.60		0.30			Reddish brown, silty SAND, fine to medium grained with occasionally gravel, moist	SM				0.60	26	26	-							
1.00		0.40	X		Strong, thinly foliated, whitish grey, fine to medium grained, GARNET BEARING QUARTZO FELDSPATHIC GNEISS, meta-sedimentary, slightly weathered (Boulder)	Rock				1.00	7	9	14	23						
2.00			X		Medium dense, reddish brown, clayey SAND, subangular, fine to coarse grained with completely weathered rock fragments, moist	SC				2.00	10	7	6	13						
2.45		1.45	X		Moderately strong, thinly foliated, black, medium to coarse grained, BIOTITE GNEISS, meta-sedimentary, moderately weathered (Boulder)	Rock				2.45	15	Nil	-	-						
3.00		0.55	X		Dense, reddish brown mottled with grey, silty SAND, subangular, medium to coarse grained with completely weathered rock fragments, moist	SM				3.00	13	17	14	31						
3.45		0.45	X		Dense, reddish brown, silty SAND, fine to medium grained with high plastic silt and clay, moist	SM				4.00	3	5	7	12						
3.60		0.15	X		Dense, orangish brown, silty SAND, fine to medium grained with completely weathered rock fragments, moist	SM														
4.00		0.40	X		Medium dense, dark brown, cleyey SAND, subangular, fragments fine to coarse grained with completely weathered rock and pockets of poorly graded sand, moist	SC				5.00	15	Nil	-	-						
5.00		1.00			Rock Level															
6.00					Moderately weak, thinly foliated, whitish grey with black layering, HORNBLLENDE BIOTITE GNEISS, meta-igneous, moderately to highly weathered, highly fractured rock	Rock				6.50	33	27	-	-						
6.50		1.50			Strong to weak, thinly foliated, black, medium to coarse grained, HORNBLLENDE BIOTITE GNEISS, meta-igneous, slightly to highly weathered, slightly fractured	Rock				8.00	40	25	-	-						
7.00					Weak to moderately weak, thinly foliated, whitish grey with black layers, medium to coarse grained, GARNET BEARING HORNBLLENDE BIOTITE GNEISS, meta-igneous, moderately to highly weathered, highly fractured rock	Rock				9.50	12	15	16	31						
8.00		1.50																		
9.00																				
9.50		0.20	X		Dense, blackish brown, silty SAND, angular to subangular, medium to coarse grained with gravel and mica, moist	SM														
9.70																				
10.00																				

	Natural moisture content, Atterberg Limits (LL, PL) SPT 'N', blows/ft Vane shear strength, peak Vane shear strength, residual	γ - Wet unit weight G - Grainsize Analysis U - Unconfined compression CU - Consolidated undrained triaxial	W - Wash sample SPT - SPT Sample <input checked="" type="checkbox"/> - Undisturbed sample <input checked="" type="checkbox"/> - Disturbed Sample	Drilled By: RDS Logged By: LW Date: 30/4/2015 Checked By: RB
--	--	---	---	---

BOREHOLE LOG



NATIONAL BUILDING RESEARCH ORGANISATION
GEOTECHNICAL ENGINEERING DIVISION
 99/1, Jawatta Road, Colombo 05.

SHEET NO.
1 of 2

PROJECT	TECHNICAL CORPORATION FOR LANDSLIDE MITIGATION PROJECT AT MATALE		CLIENT	JAPAN INTERNATIONAL CORPORATION AGENCY	BOREHOLE NO	BM 02	
LOCATION	MATALE		CONTRACT NO	30/24871	DEPTH OF HOLE (m)	15.00	
DRILING METHOD	CORE DRILLING		ELEVATION (m MSL)		CHAINAGE / OFFSET	-	
CORE SIZE [mm]	54	CASING SIZE	NX	CO-ORDINATES	07° 28' 42.4" N	DATE COMMENCED	5/5/2015
VANE SIZE [mm*mm]	-	UDS SAMPLER SIZE [mm]	-		80° 36' 53.8" E	DATE COMPLETED	9/5/2015

DEPTH [m]	ELEVATION [m MSL]	LAYER THICKNESS(m)	SAMPLE TYPE	SAMPLE NO.	SOIL PROFILE				DEPTH TESTED [m]	STANDARD PENETRATION TEST DATA				MOISTURE CONTENT - %							
					SOIL DESCRIPTION	STRATA	LEGEND	GWL		γ - [g/cm ³]	OTHER TESTS	NUMBER OF BLOWS				UNDRAINED SHEAR STRENGTH - kN/m ²					
												PER 15cm			FOR 30cm	SPT RESISTANCE - Blows/30 cm					
												1	2	3	10	20	30	40	50	60	
0.00					GROUND LEVEL																
0.30		0.30			Reddish brown, silty SAND, fine to medium grained with rock fragments and plant roots, moist	SM															
1.00			X		Medium dense, reddish brown, silty SAND, fine to medium grained with gravel and clay, moist	SM			1.00	12	12	16	28								
2.00		1.70			Dense, reddish brown, silty SAND, fine to medium grained with clay and occasionally gravel, moist	SM			2.00	12	14	18	32								
2.50		2.50			Dense, reddish brown, silty SAND, angular to subangular, fine to coarse grained with low plastic silt and completely weathered rock fragments, moist (silt content increase with depth)	SM															
3.00		0.50			Strong, thinly foliated, whitish grey, medium to coarse grained, GARNET BEARING QUARTZOFELDSPATHIC GNEISS, meta-sedimentary, moderately weathered, moderately fractured	Rock															
4.00					(Boulder)																
4.50		1.50			Reddish brown, clayey SAND, fine to medium grained with low plastic clay and completely weathered rock fragments, moist	SC			4.50	20	22	-	>50								
5.00		0.50			(Rock Level)																
6.00					Completely to highly weathered rock (washing sample)	Rock			5.00	Nil	Nil										
6.50		0.50			Highly weathered rock	Rock			6.00	5	Nil										
7.00					Moderately strong to weak, thinly foliated, greyish brown, medium to coarse grained, QUARTZOFELDSPATHIC GNEISS, meta-sedimentary, highly to moderately weathered, moderately fractured	Rock			6.50	9	Nil										
8.00		2.00			Moderately strong, thinly foliated, greyish brown, medium to coarse grained, QUARTZOFELDSPATHIC GNEISS, meta-sedimentary, highly to moderately weathered, moderately fractured rock	Rock			8.00	13	Nil										
9.00									9.50	17	15										
9.50		1.50							11.00												
10.00																					

Natural moisture content, Atterberg Limits (LL, PL) SPT 'N', blows/ft Vane shear strength, peak Vane shear strength, residual	γ - Wet unit weight G - Grainsize Analysis U - Unconfined compression CU - Consolidated undrained triaxial	W - Wash sample SPT - SPT Sample <input checked="" type="checkbox"/> - Undisturbed sample <input checked="" type="checkbox"/> - Disturbed Sample	Drilled By: RDS Logged By: <i>Chandana</i> of LW Date: 9/5/2015 Checked By: RB
--	---	---	---

BOREHOLE LOG



NATIONAL BUILDING RESEARCH ORGANISATION
GEOTECHNICAL ENGINEERING DIVISION
 99/1, Jawatta Road, Colombo 05.

SHEET NO.
2 of 2

PROJECT	TECHNICAL CORPORATION FOR LANDSLIDE MITIGATION PROJECT AT MATALE		CLIENT	JAPAN INTERNATIONAL CORPORATION AGENCY	BOREHOLE NO	BM 02
LOCATION	MATALE		CONTRACT NO	30/24871	DEPTH OF HOLE (m)	15.00
DRILING METHOD	CORE DRILLING		ELEVATION (m MSL)		CHAINAGE / OFFSET	-
CORE SIZE [mm]	54	CASING SIZE	NX	CO-ORDINATES 07° 28' 42.4" N 80° 36' 53.8" E	DATE COMMENCED	5/5/2015
VANE SIZE [mm*mm]	-	UDS SAMPLER SIZE [mm]	-		DATE COMPLETED	9/5/2015

DEPTH [m]	ELEVATION [m MSL]	LAYER THICKNESS(m)	SAMPLE TYPE	SAMPLE NO.	SOIL PROFILE			Y - [g/cm ³]	OTHER TESTS	STANDARD PENETRATION TEST DATA				MOISTURE CONTENT - %					
					SOIL DESCRIPTION	STRATA	LEGEND			GWL	NUMBER OF BLOWS				UNDRAINED SHEAR STRENGTH - kN/m ²				
											PER 15cm			FOR 30cm	SPT RESISTANCE - Blows/30 cm				
											1	2	3	10	20	30	40	50	60
10.00					Strong to moderately strong, thinly foliated, black with white colour layers, medium to coarse grained, HORNBLLENDE BIOTITE GNEISS, meta-igneous, slightly to highly weathered, moderately fractured	Rock			11.00	35	23								
11.00		1.50			Strong to moderately strong, thinly foliated, black with white colour layers, medium to coarse grained, HORNBLLENDE BIOTITE GNEISS, meta-igneous, highly to slightly weathered, moderately fractured	Rock			12.50										
12.00																			
12.50		1.50							12.50	68	68								
13.00					Strong, thinly foliated, black with white colour layers, medium to coarse grained, HORNBLLENDE BIOTITE GNEISS, meta-igneous, fresh	Rock			14.00										
14.00		1.50							14.00	10	Nil								
15.00		1.00			Reddish brown, silty SAND, fine to medium grained with high plastic silt, occasionally gravel and completely weathered of fragments, moist (completely weathered rock)	Rock			15.00										
15.00					Borehole terminated at 15.00m depth														
16.00																			
17.00																			
18.00																			
19.00																			
20.00																			

Natural moisture content, Atterberg Limits (LL, PL)	γ - Wet unit weight	W - Wash sample	Drilled By RDS
SPT 'N', blows/ft	G - Grainsize Analysis	SPT - SPT Sample	Logged By <i>Chal</i> LW
Vane shear strength, peak	U - Unconfined compression	<input checked="" type="checkbox"/> - Undisturbed sample	Date 9/5/2015
Vane shear strength, residual	CU - Consolidated undrained triaxial	<input checked="" type="checkbox"/> - Disturbed Sample	Checked By RB