



\* Proposed location in this survey.  
Detail location will be considered in  
detailed design.

Clients:  Japan International Cooperation Agency	Consultants:  Department of Roads Ministry of Physical Infrastructure and Transport Federal Democratic Republic of Nepal	Project Title: Additional Study of the Suryabinayak-Dhulikhel Road Improvement Project	Sheet Contents: TUNNEL PLAN	Scale: (A1size) 1:1000 Submission Date March, 2018	SHT. NO. TU-01
---	--	--	--------------------------------	---	-------------------





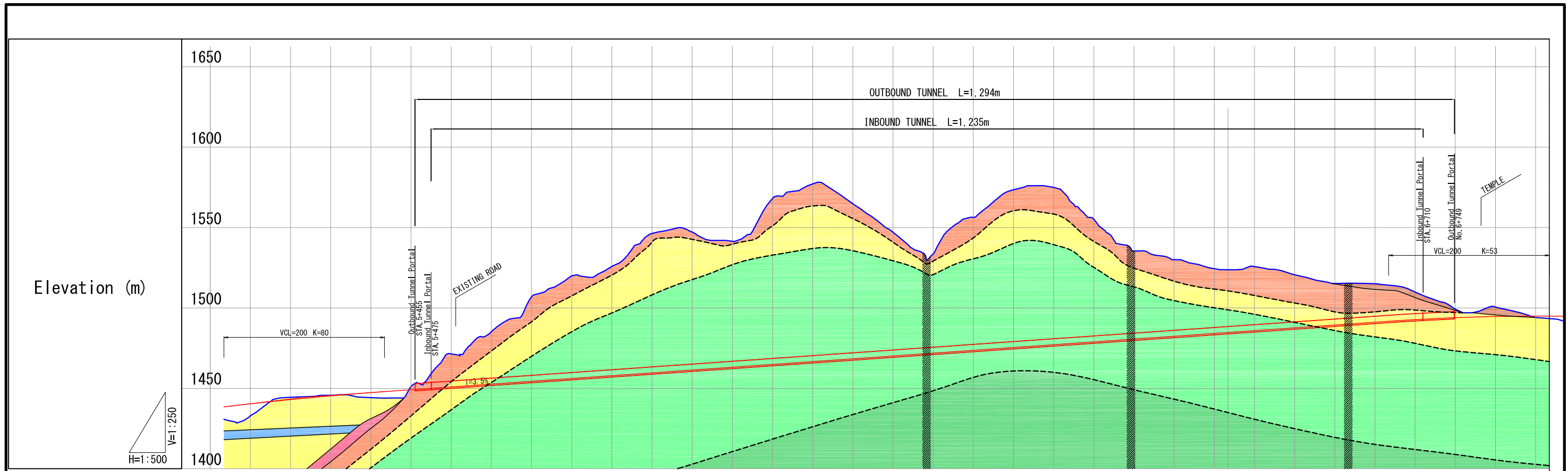

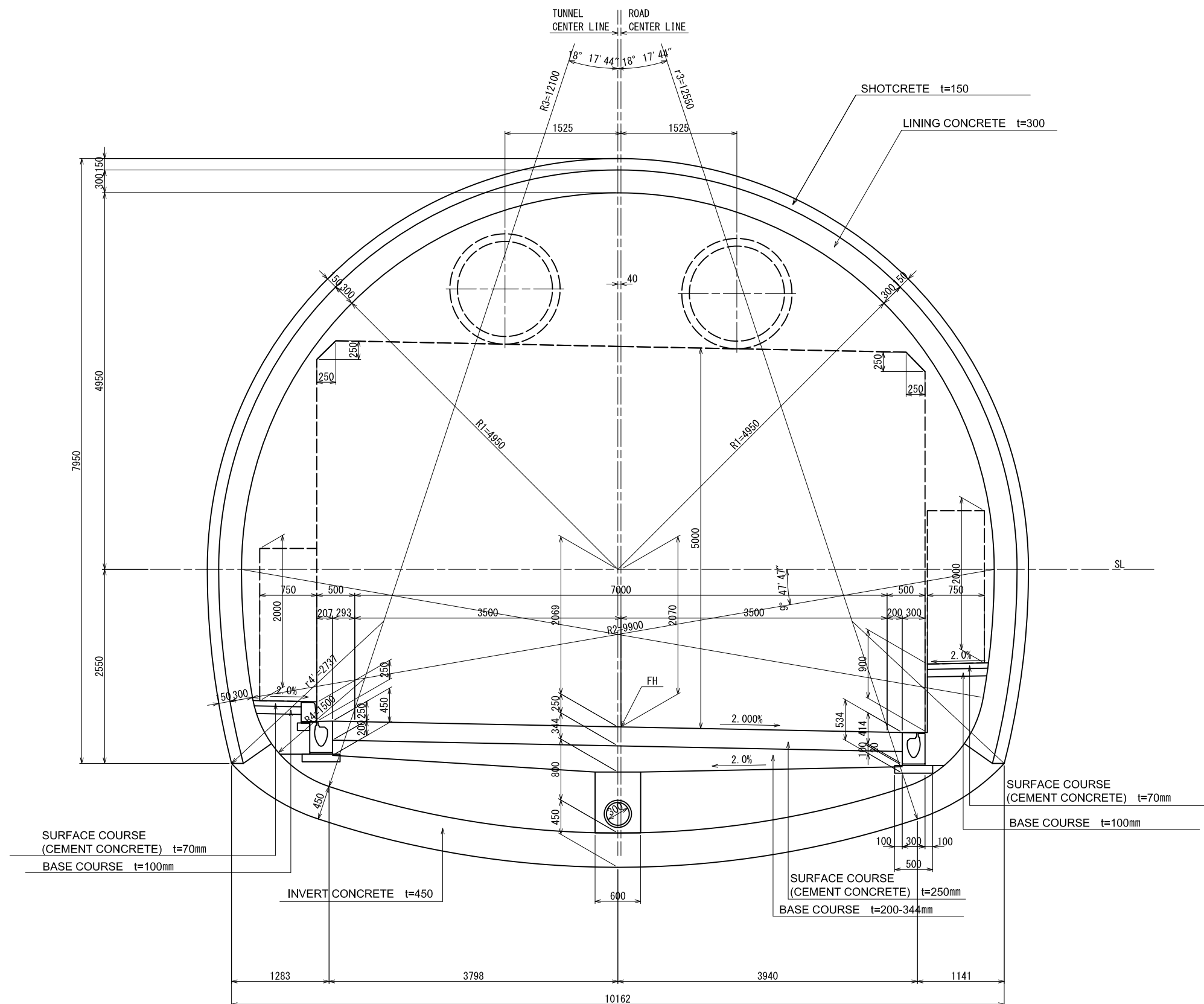
Station		5+200	5+250	5+300	5+350	5+400	5+450	5+500	5+550	5+600	5+650	5+700	5+750	5+800	5+850	5+900	5+950	6+000	6+050	6+100	6+150	6+200	6+250	6+300	6+350	6+400	6+450	6+500	6+550	6+600	6+650	6+700	6+750	6+800	6+850			
Formation Height		1437.950	1440.894	1443.550	1445.894	1447.925	1449.700	1451.450	1453.200	1454.950	1456.700	1458.450	1460.200	1461.950	1463.700	1465.450	1467.200	1468.950	1470.700	1472.450	1474.200	1475.950	1477.700	1479.450	1481.200	1482.950	1484.700	1486.450	1488.200	1489.950	1491.700	1493.450	1495.200	1496.950	1498.700	1499.450		
Ground Height		1435.43	1433.02	1444.68	1445.89	1444.07	1451.26	1471.42	1485.24	1507.03	1520.00	1525.91	1546.34	1547.18	1541.45	1568.09	1577.13	1564.67	1546.96	1533.68	1556.34	1573.62	1574.94	1555.01	1535.44	1530.49	1524.39	1525.63	1520.64	1515.12	1514.97	1509.84	1499.20	1500.62	1493.99			
Basic Geology		Kalimati Clay					Phyllite with Sand Stone Presumed Fault												Sand Stone with Phyllite				Phyllite with Sand Stone															
Geological Condition		Lacustrine soil, from the bottom with a talus, fine sand, black clay, fine sand. As a foundation of the structure, it is soft ground.					The surface layer is weathered soil, and the lower layer is a rock where cracks develop. In the deep part phyllite and sandstone alternation. The phyllite part is cracky, the sandstone part is hard. The fault surroundings are assumed to be fractured rocks. $q_u=20\sim30\text{Mpa}$												Mainly composed of sandstone and quartzite. in the deep part it is estimated that hard rock is distributed. $q_u=30\sim50\text{Mpa}$				The surface layer is weathered soil, and the lower layer is a rock where cracks develop. In the deep part phyllite and sandstone alternation. $q_u=20\sim30\text{Mpa}$															
Excavation Pattern	Outbound						DIIIp 98m	DII 86m									DI 443m			DII 20m	DI-L 20m	DI-L 31m		DI 194m		DII 20m	DI 76m			DII 152m		DIIIp 154m						
	Inbound						DIIIp 78m	DII 86m										DI 392m			DI-L 31m	DI-L 20m	DII 20m		DI 245m		DII 20m	DI 76m			DII 152m		DIIIp 115m					
Excavation Method	Outbound	Mechanical Excavation Short-Bench Cut Method																																				
	Inbound	Mechanical Excavation Short-Bench Cut Method																																				
Auxiliary Method	Outbound						Long Span Fore-Poling (AGF)																												Long Span Fore-Poling (AGF)			
	Inbound						Long Span Fore-Poling (AGF)																												Long Span Fore-Poling (AGF)			



Clients:  
 Japan International Cooperation Agency

 Department of Roads  
 Ministry of Physical Infrastructure and Transport  
 Federal Democratic Republic of Nepal





Consultants:  
 CTI Engineering International Co., Ltd.  
 CTI Engineering Co., Ltd.

Project Title:  
 Additional Study of the Suryabinayak-Dhulikhel Road  
 Improvement Project

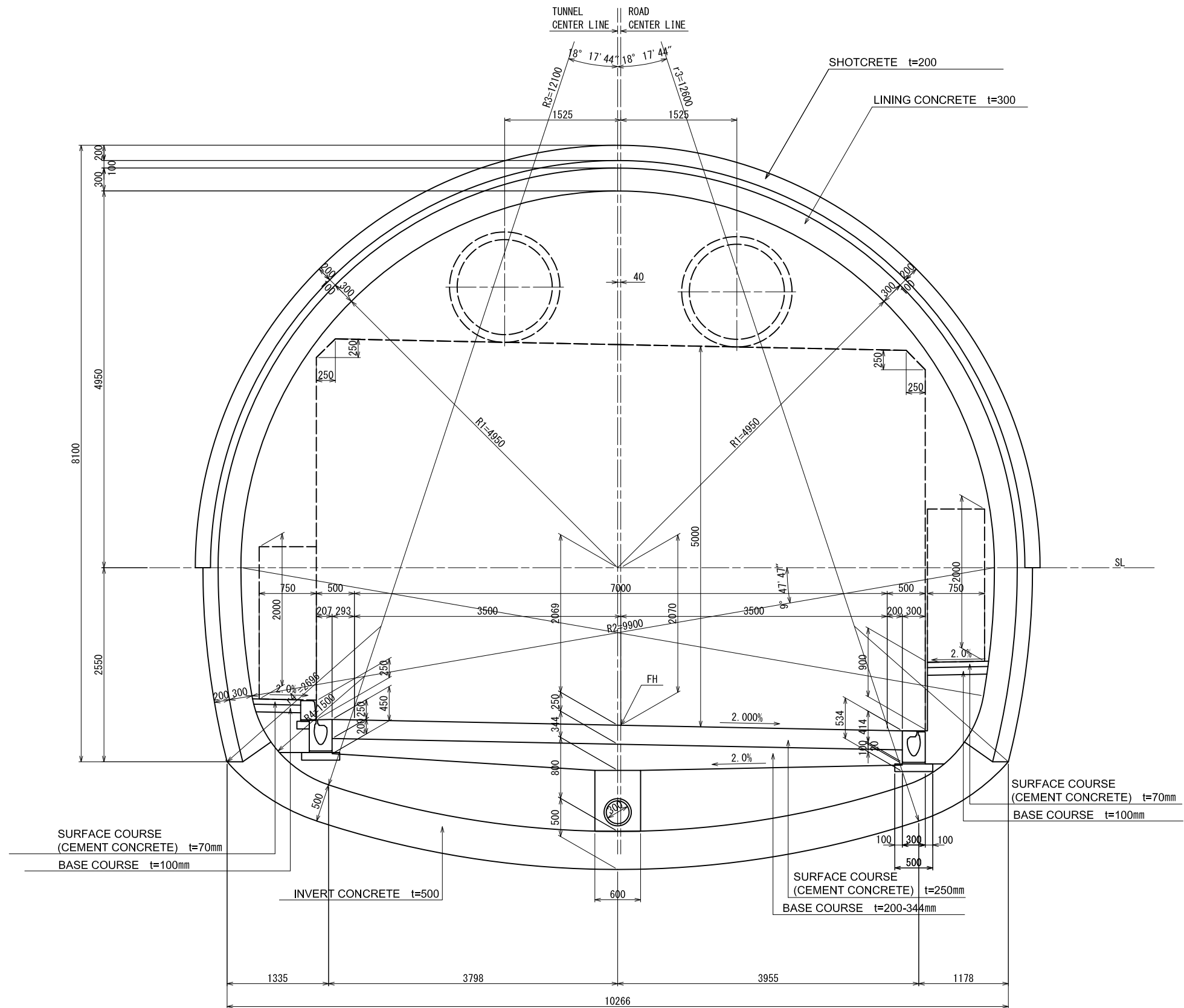
Sheet Contents:  
 TYPICAL CROSS SECTION  
 SECTION DI

Scale: (A1size)  
 1:30  
 Submission Date  
 March, 2018  
 SHT. NO.  
 TU-03





Clients:	 Department of Roads Ministry of Physical Infrastructure and Transport Federal Democratic Republic of Nepal	Consultants:	Project Title:	Sheet Contents:	Scale: (A1size)	SHT. NO.
 Japan International Cooperation Agency		 CTI Engineering International Co., Ltd.  CTI Engineering Co., Ltd.	Additional Study of the Suryabinayak-Dhulikhel Road Improvement Project	TYPICAL CROSS SECTION SECTION DII	1:30 Submission Date March, 2018	TU-04

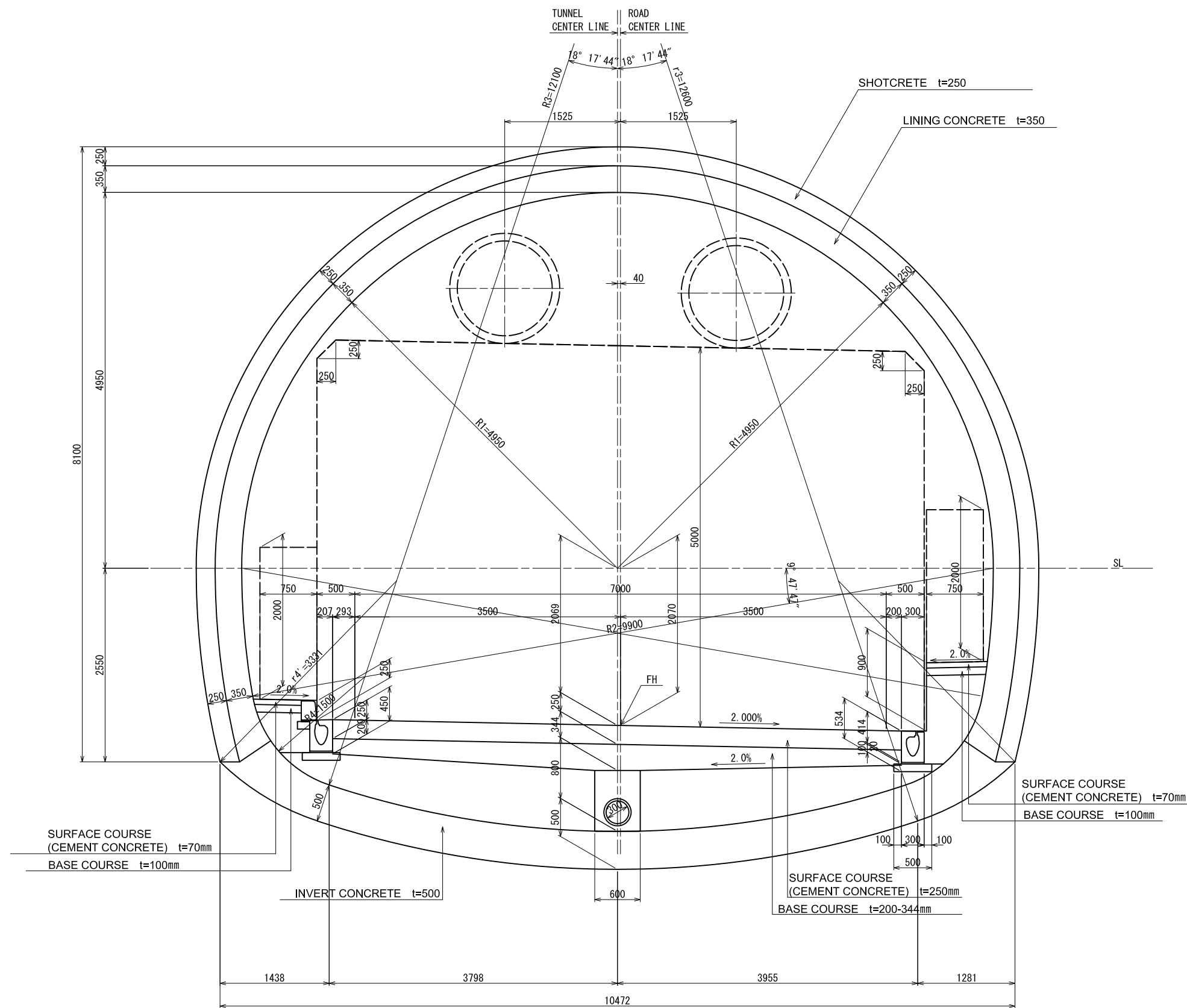



Clients:  
 Japan International Cooperation Agency

 Department of Roads  
 Ministry of Physical Infrastructure and Transport  
 Federal Democratic Republic of Nepal

Consultants:  
 CTI Engineering International Co., Ltd.  
 CTI Engineering Co., Ltd.

Project Title:  
 Additional Study of the Suryabinayak-Dhulikhel Road  
 Improvement Project

Sheet Contents:  
 TYPICAL CROSS SECTION  
 SECTION DIII

Scale: (A1size)	SHT. NO.
1:30	TU-05
Submission Date	
March, 2018	



**GENERAL VIEW OF C-2 CULVERT (20.0+19.9) × 7.0 (1)**  
**PROFILE SCALE=1:200 (STA. 6+937.00)**

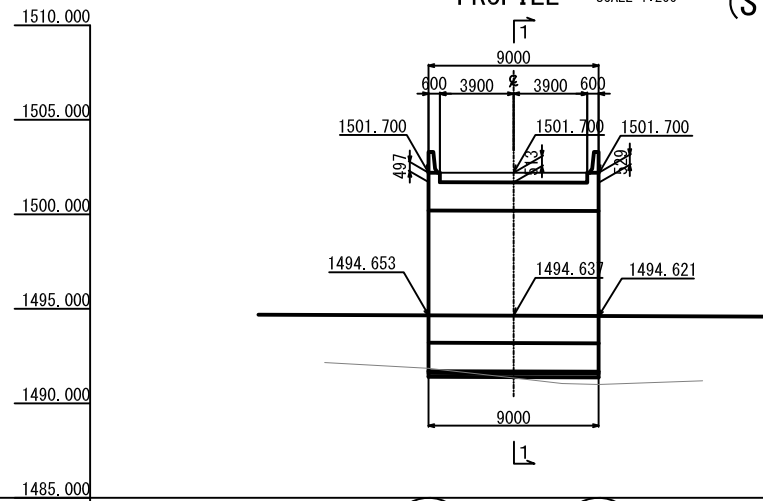

Slope		
Height of Plan	1494.653	1494.621
Height of Ground	1491.85	1491.05
Distance	5.000	1.830
Observation Point	6+831.804	6+942.196

**PLAN S=1:200**

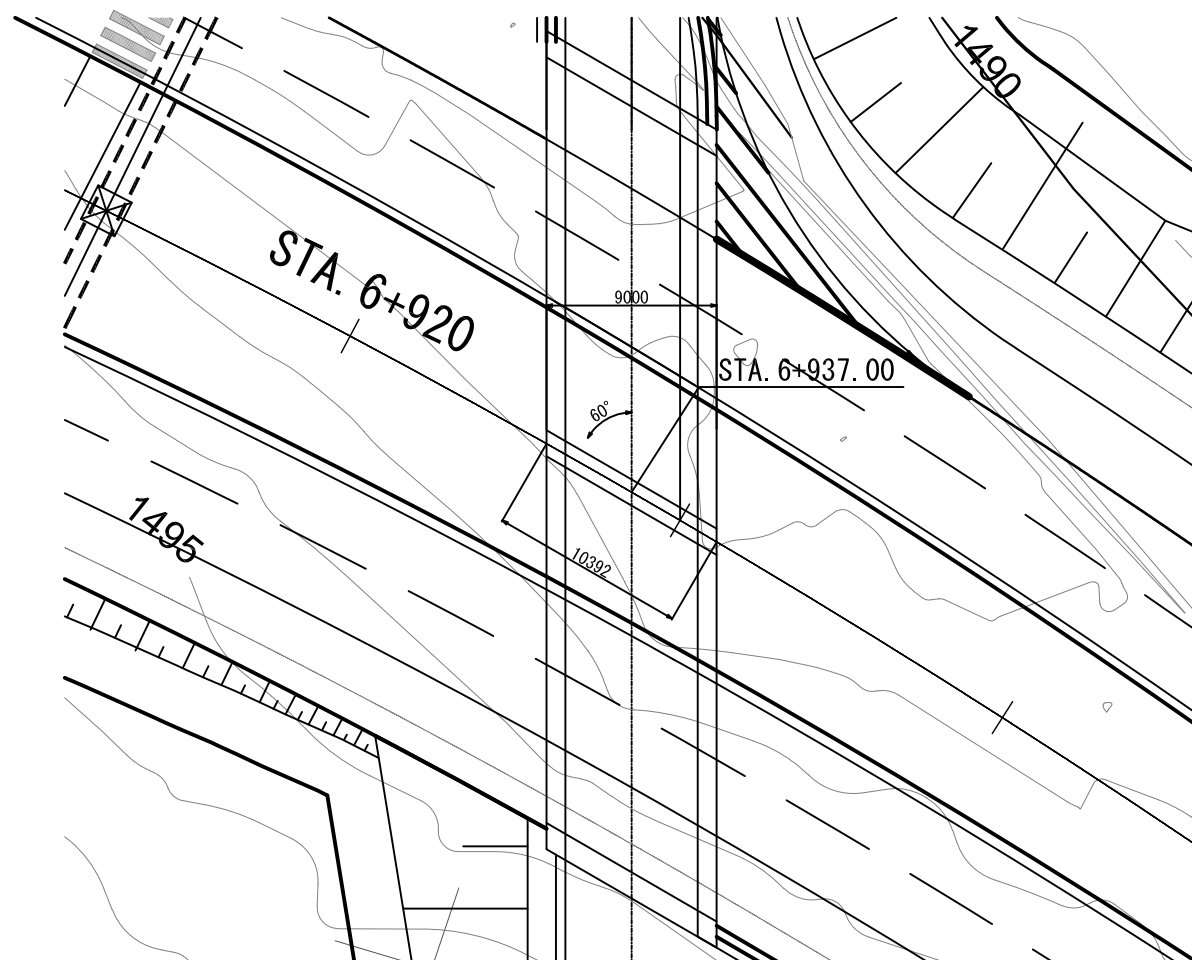

Clients:	Consultants:	Project Title:	Sheet Contents:	Scale: (A1size)	SHT. NO.
Japan International Cooperation Agency	Department of Roads Ministry of Physical Infrastructure and Transport Federal Democratic Republic of Nepal	CTI Engineering International Co., Ltd. CTI Engineering Co., Ltd.	Additional Study of the Suryabinayak-Dhulikhel Road Improvement Project	OUTLINE OF BOX CULVERT (20.0+19.9)×7.0(1) (STA.6+937.00)	1:200
					Submission Date March, 2018



GENERAL VIEW OF C-2 CULVERT (20.0+19.8) × 7.0 (2)  
(STA. 6+937.00)

STANDARD SECTION OF BOX CULVERT SCALE=1:100

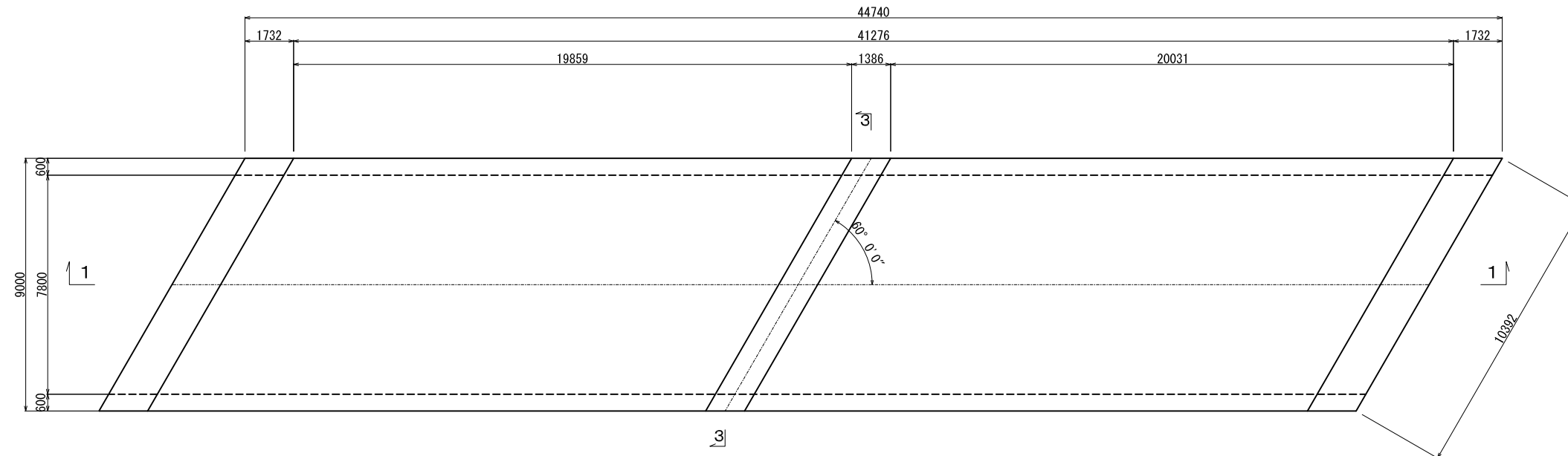
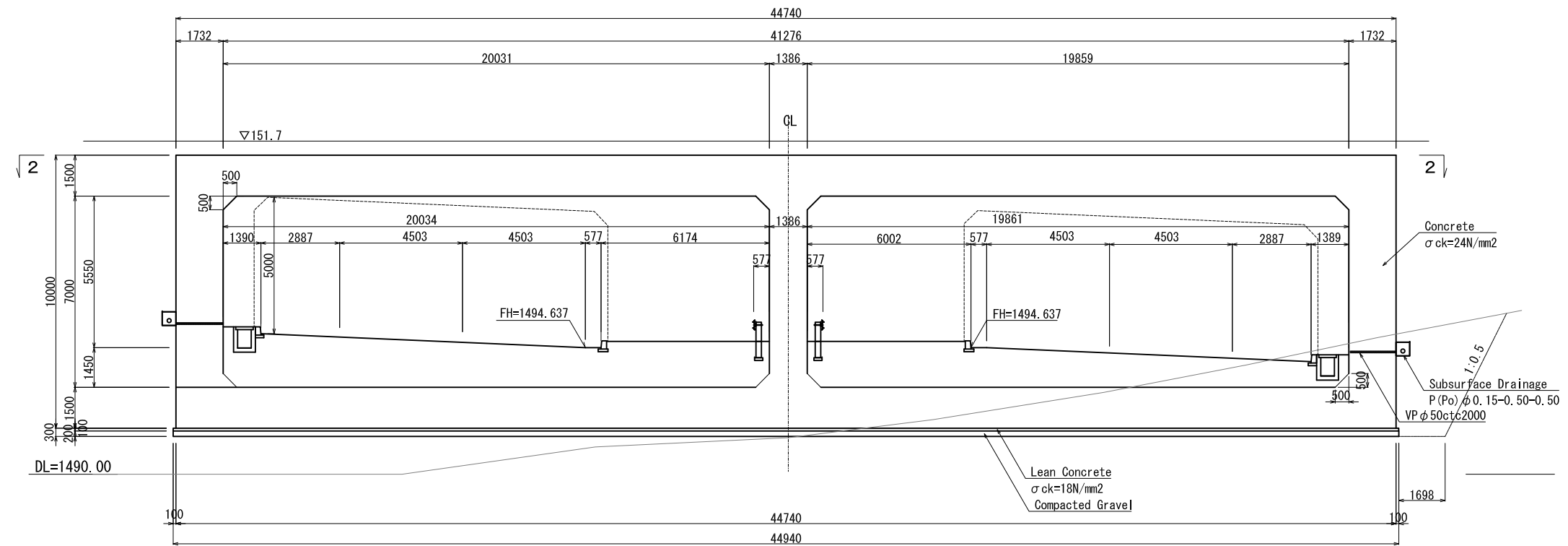

Clients:	Department of Roads Ministry of Physical Infrastructure and Transport Federal Democratic Republic of Nepal	Consultants:	Project Title:	Sheet Contents:	Scale: (A1size)	SHT. NO.
Japan International Cooperation Agency		CTI Engineering International Co., Ltd. CTI Engineering Co., Ltd.	Additional Study of the Suryabinayak-Dhulikhel Road Improvement Project	OUTLINE OF BOX CULVERT (20.0+19.9)×7.0(2) (STA.6+937.00)	1:100 Submission Date March, 2018	BC-02



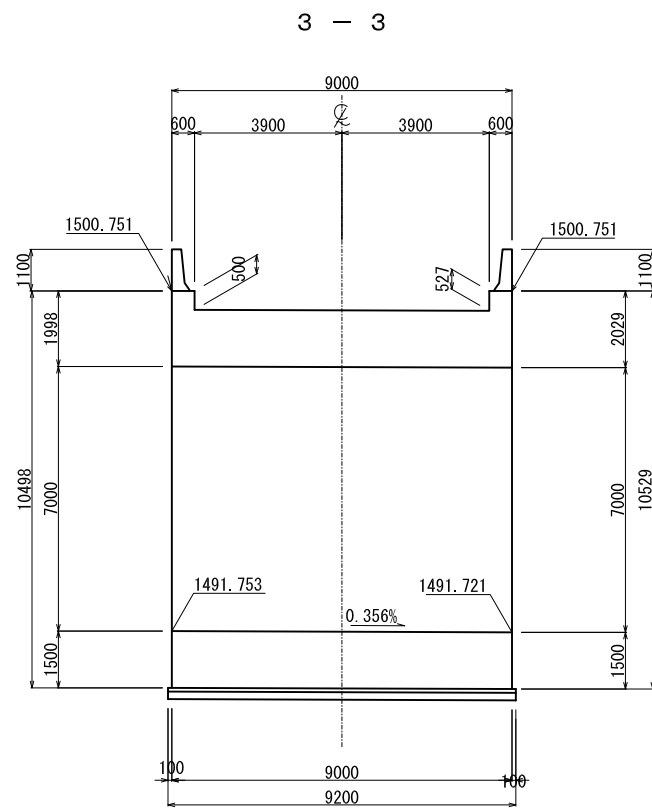

**STIFFNESS WALL HANDRAIL  
FLORIDA TYPE** SCALE=1:20

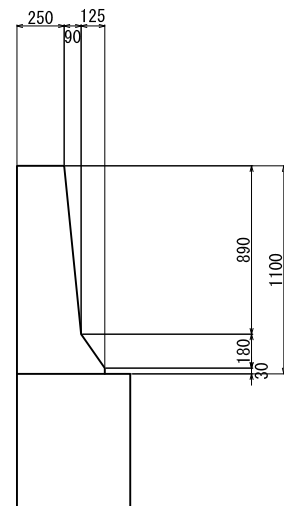



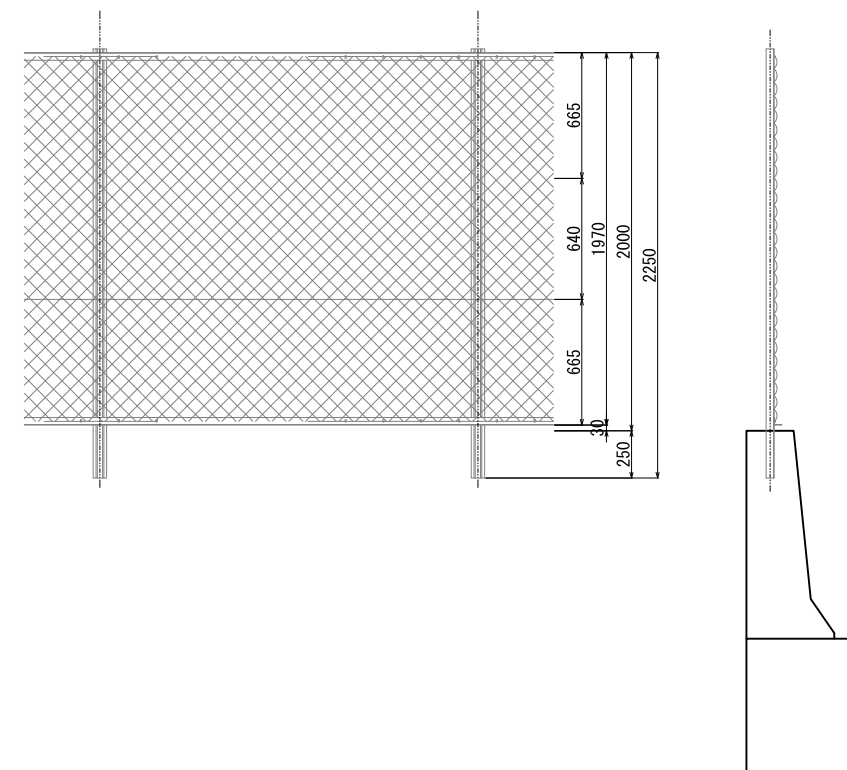

**NET FENCE DETAIL** SCALE=1:20

FRONT VIEW

SIDE VIEW



<p>Clients:</p>  Japan International Cooperation Agency	 Department of Roads Ministry of Physical Infrastructure and Transport Federal Democratic Republic of Nepal	<p>Consultants:</p>  CTI Engineering International Co., Ltd.  CTI Engineering Co., Ltd.	<p>Project Title:</p> Additional Study of the Suryabinayak-Dhulikhel Road Improvement Project	<p>Sheet Contents:</p> OUTLINE OF BOX CULVERT (13.0+13.0)×6.9(3) (STA.6+372.00)	<p>Scale: (A1size)</p> AS SHOWN Submission Date March, 2018 SHT. NO. BC-03
--	--	--	---	---	--



# REINFORCED EARTH WALL

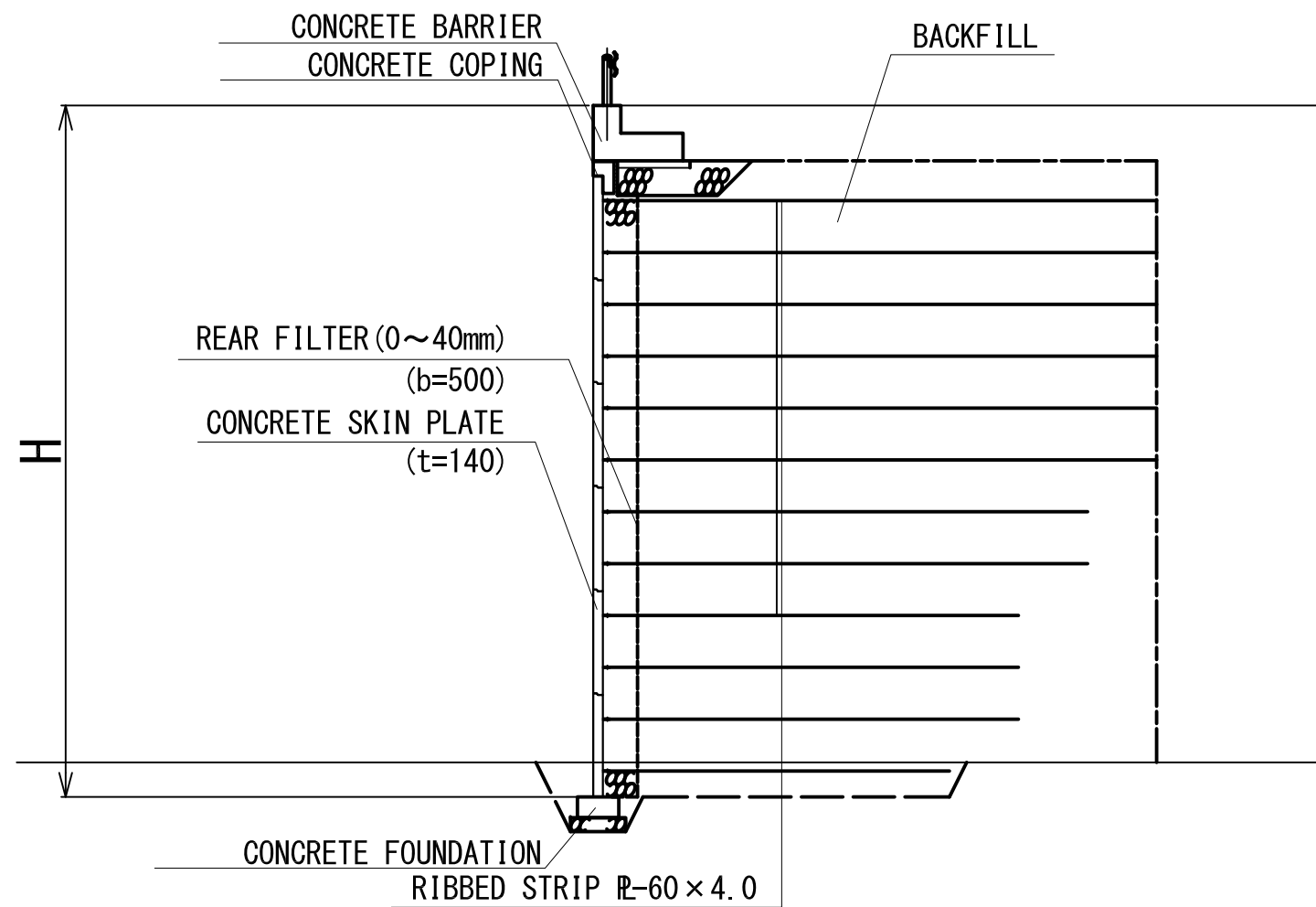

Reinforced Earth Wall				
Station	Side	Average Height(m)	Length (m)	Remarks
STA.4+335 - STA.4+600	Left	5.0	280.0	
STA.4+490 - STA.4+840	Right	10.0	350.0	
STA.4+600 - STA.5+455	Left	10.0	960.0	
STA.6+860 - STA.6+960	Left	5.0	100.0	
STA.6+860 - STA.6+965	Left	5.0	105.0	
STA.6+970 - STA.7+095	Right	5.0	125.0	

## DETAIL OF RETAINING WALL

### CUT TYPE

SCALE 1/50

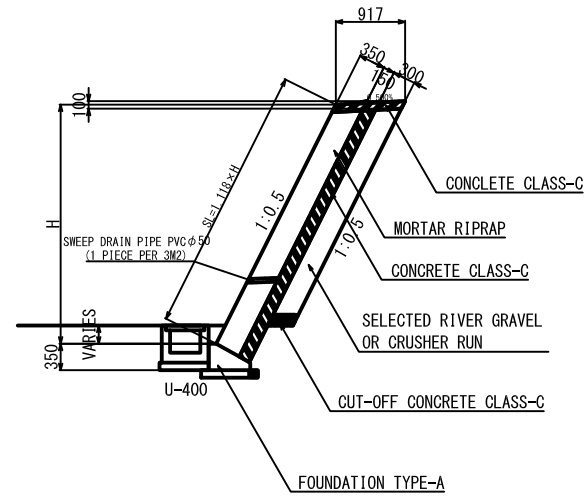

### EMBANKMENT TYPE

SCALE 1/50

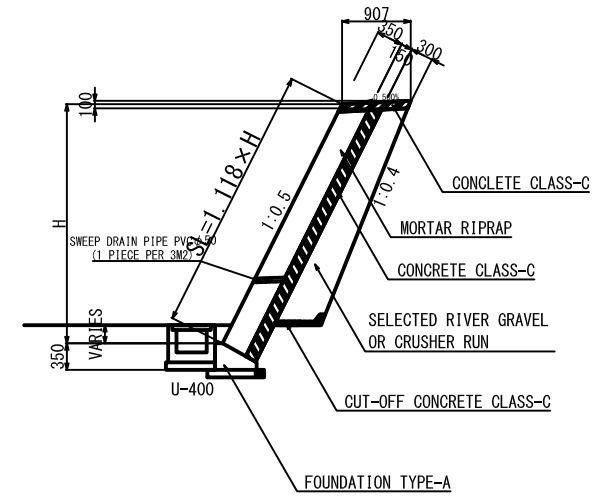

### DETAIL OF FOUNDATION TYPE-A

SCALE 1/20

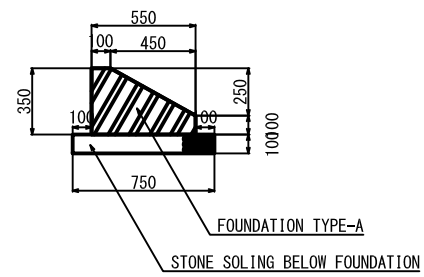

### DETAIL OF FOUNDATION TYPE-B

SCALE 1/20

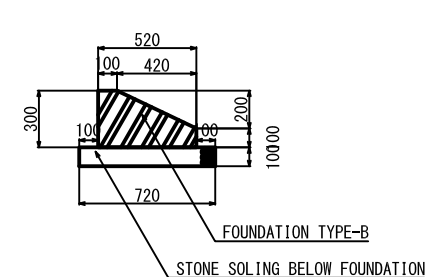

Clients:	Japan International Cooperation Agency	Consultants:	CTI Engineering International Co., Ltd. CTI Engineering Co., Ltd.	Project Title:	Additional Study of the Suryabinayak-Dhulikhel Road Improvement Project	Sheet Contents:	DETAIL OF STONE MASONRY	Scale: (A1size)	SHT. NO.
	Department of Roads Ministry of Physical Infrastructure and Transport Federal Democratic Republic of Nepal						AS SHOWN		SP-02
							Submission Date		
							May, 2018		



STA. 8+340

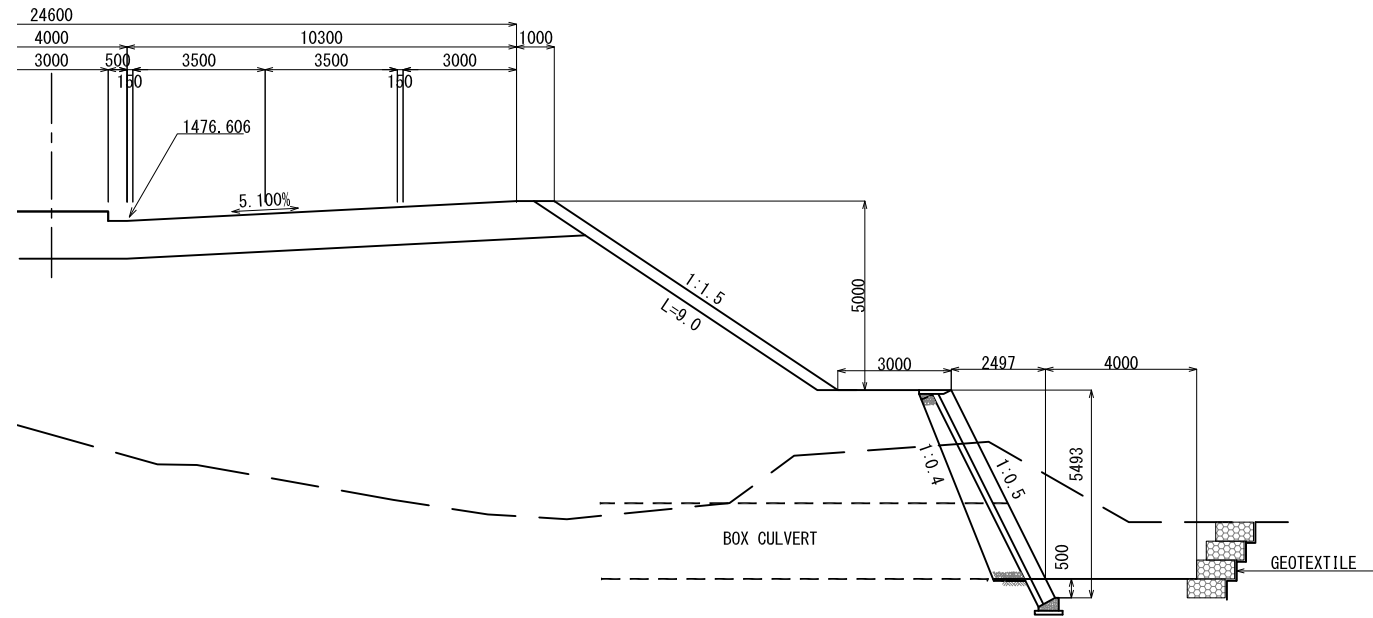

STA. 8+940

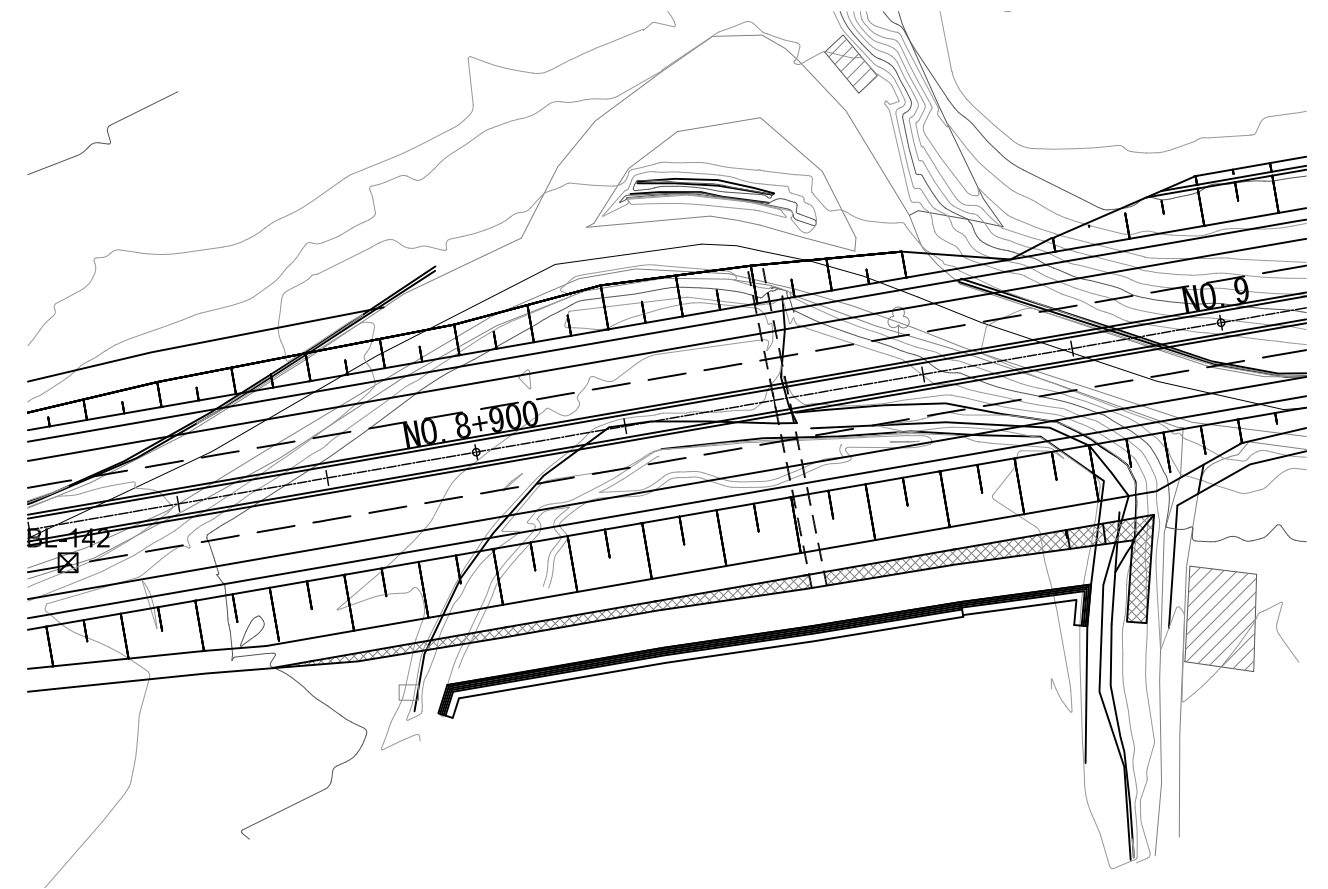
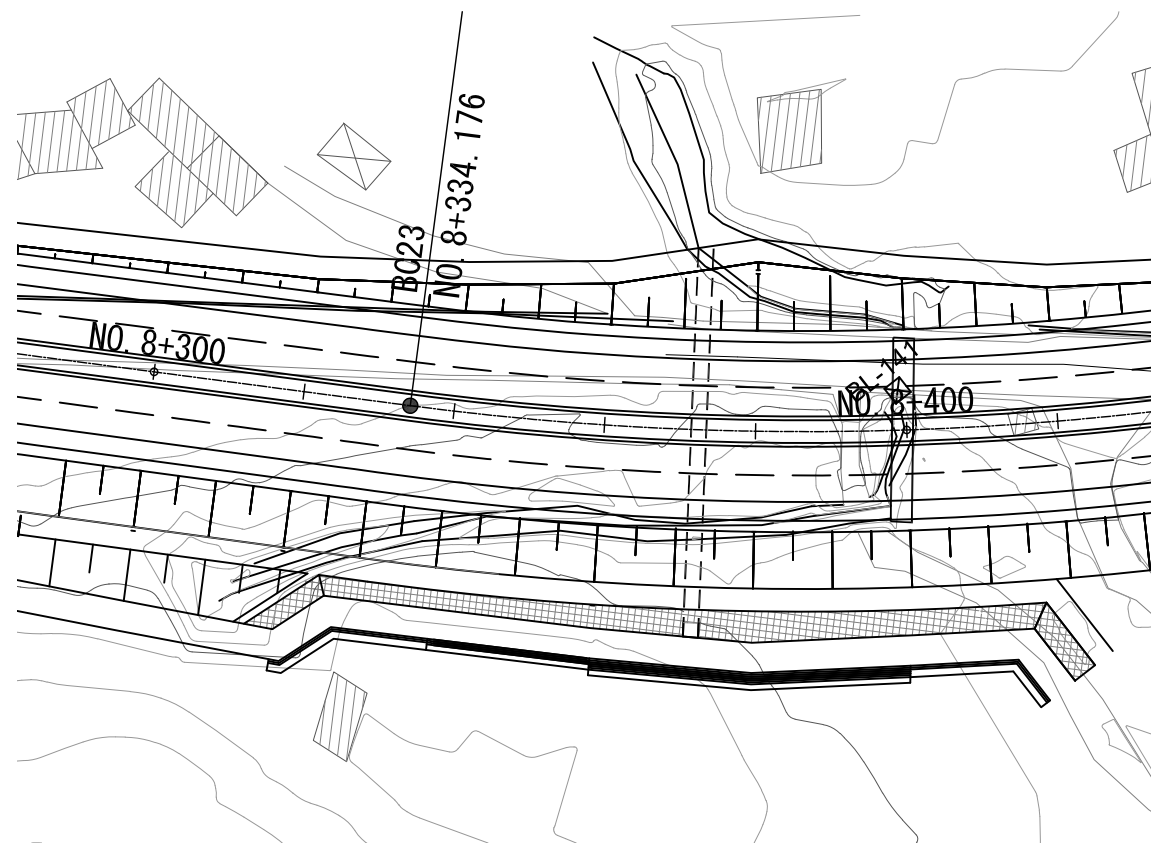
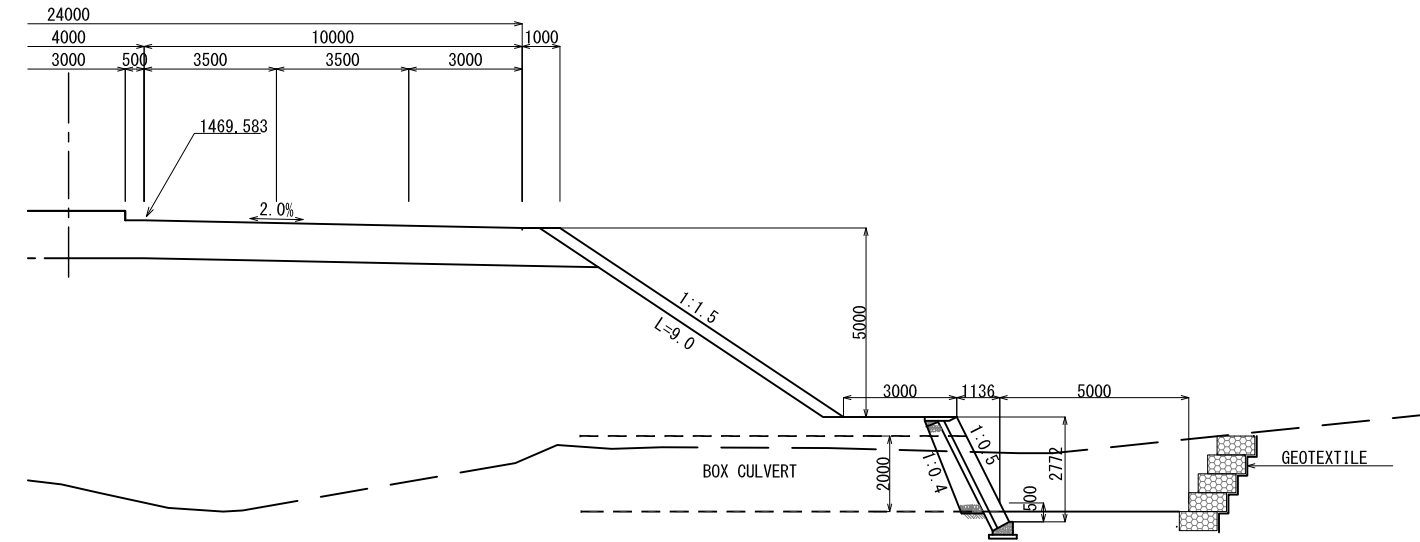

<p>Clients: Japan International Cooperation Agency</p>	<p>Department of Roads Ministry of Physical Infrastructure and Transport Federal Democratic Republic of Nepal</p>	<p>Consultants: CTI Engineering International Co., Ltd. CTI Engineering Co., Ltd.</p>	<p>Project Title: Additional Study of the Suryabinayak-Dhulikhel Road Improvement Project</p>	<p>Sheet Contents: SLOPE PROTECTION BEYOND SANGA</p>	<p>Scale: (A1size) AS SHOWN Submission Date March, 2018</p>	<p>SHT. NO. SB-01</p>
--	---	---	---	--	---	---------------------------

# GENERAL VIEW OF C-1 CULVERT 8.0×5.8 (1) (STA. 1+714.30)

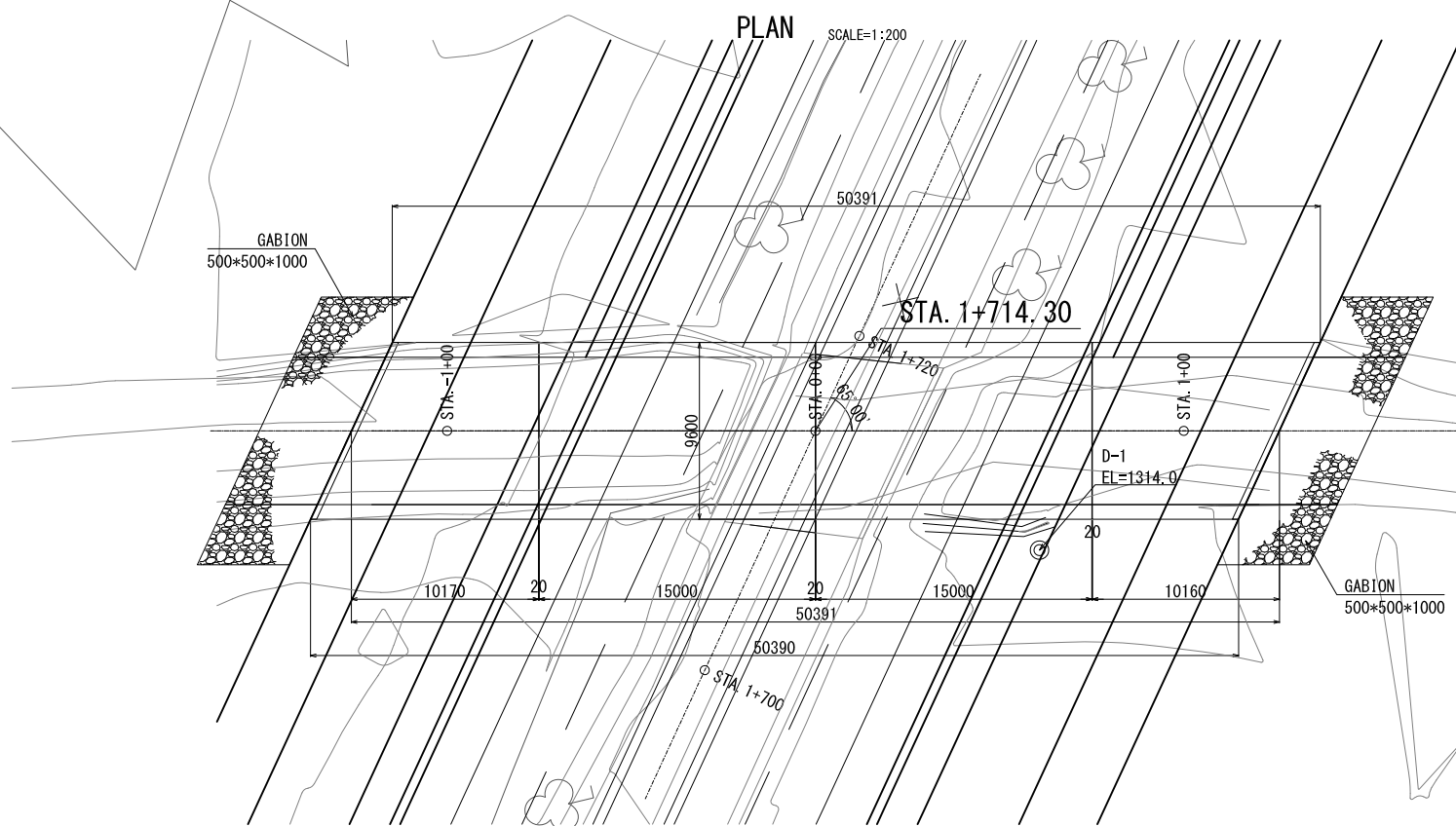
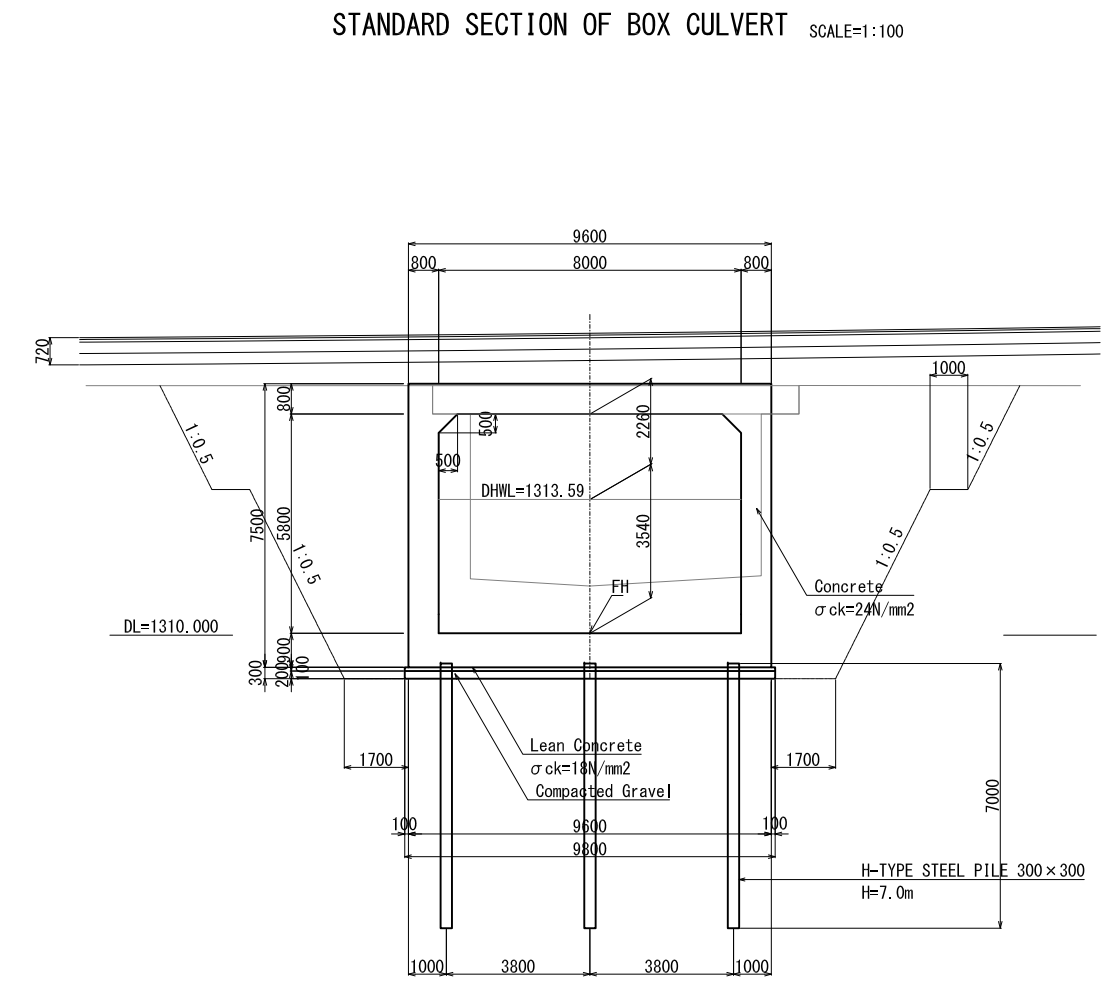
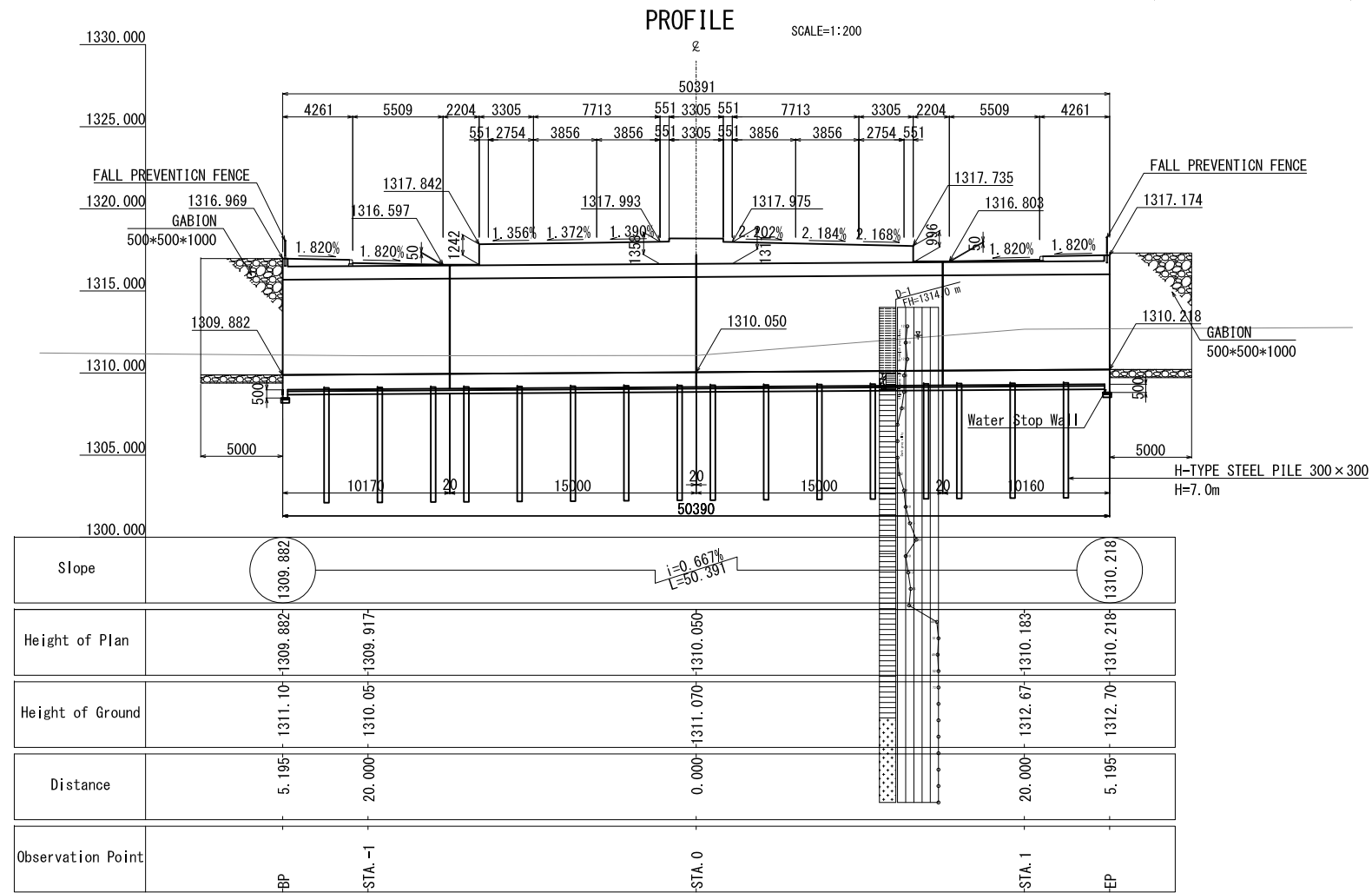

**DETAILED DRAWING PLAN OF WATER STOP** SCALE=1:20

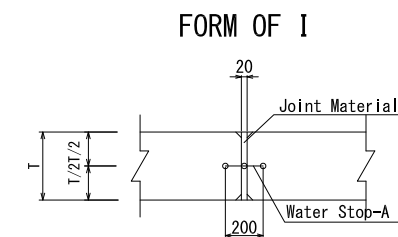

**JOINT ENGINEERING** SCALE=1:100

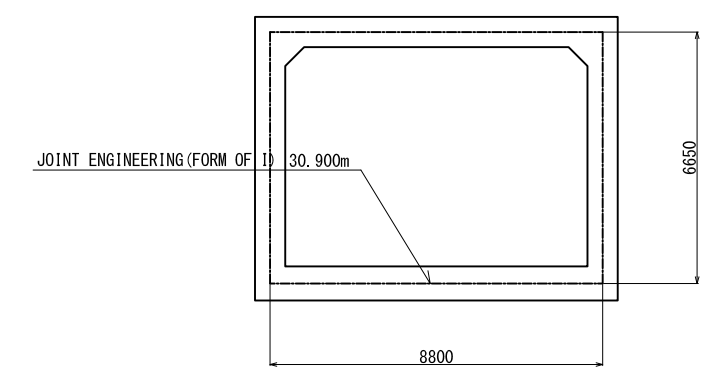

Clients: Japan International Cooperation Agency	Department of Roads Ministry of Physical Infrastructure and Transport Federal Democratic Republic of Nepal	Consultants: CTI Engineering International Co., Ltd. CTI Engineering Co., Ltd.	Project Title: Additional Study of the Suryabinayak-Dhulikhel Road Improvement Project	Sheet Contents: GENERAL VIEW OF CULVERT AT JAGATI 8.0×5.8 (1) (STA.1+714.30)	Scale: (A1size) AS SHOWN Submission Date March, 2018	SHT. NO. CD-01
--	--	--	---	---	---	-------------------



# GENERAL VIEW OF C-1 CULVERT 8.0×5.8 (2)

## (STA. 1+714.30)

**INLET SECTION** SCALE=1:100

**OUTLET SECTION** SCALE=1:100

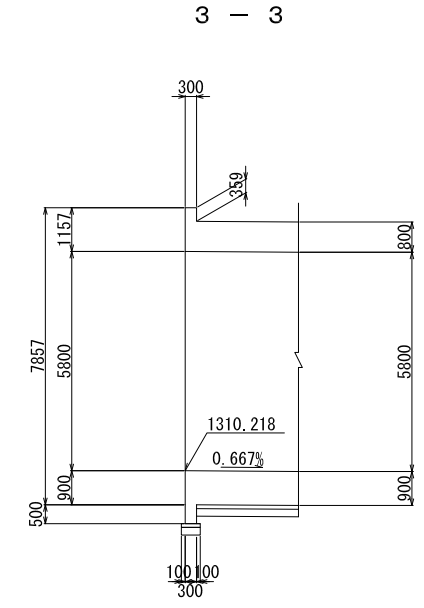
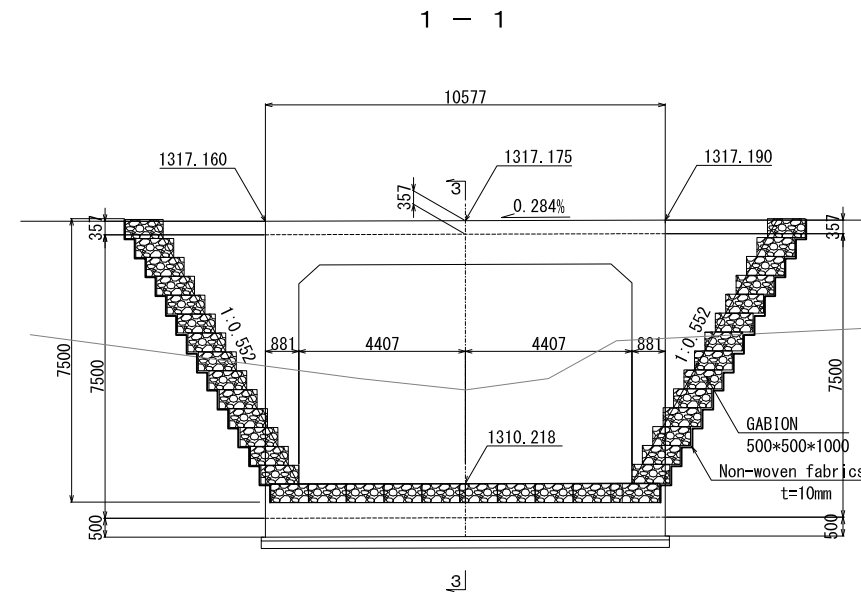
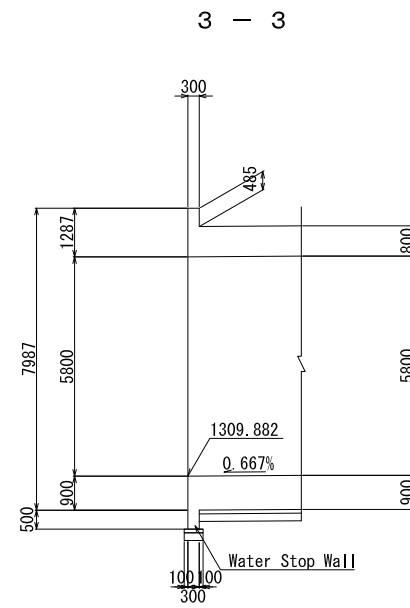
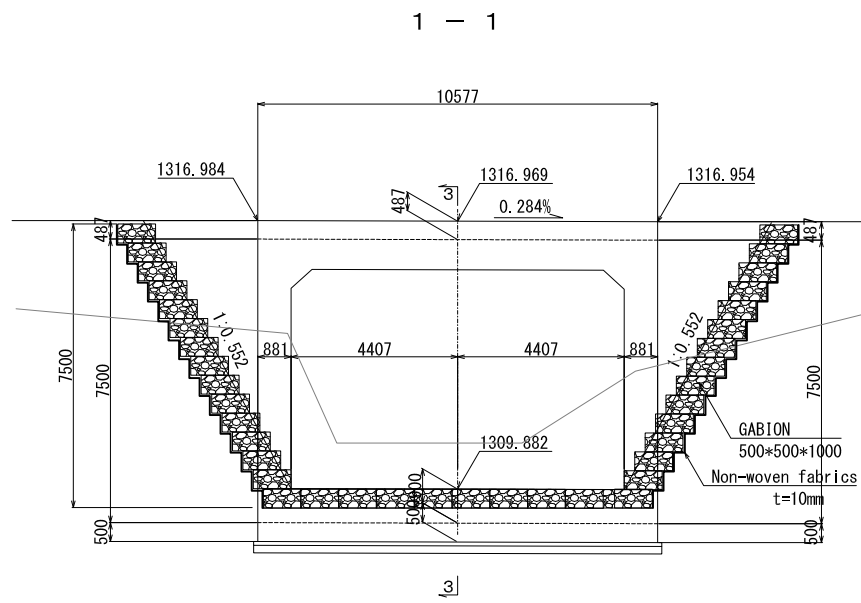

**2 - 2**

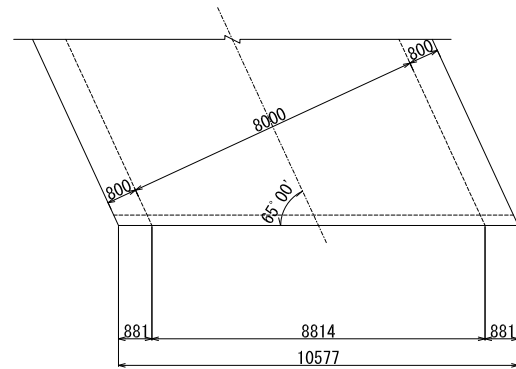

**2 - 2**

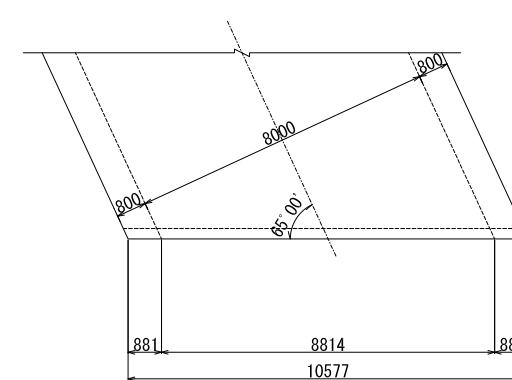

**GROUND PLAN OF THE BASIC PLACEMENT IF THE STAKE**  
(H-TYPE STEEL PILE 300×300 50PIECE) SCALE = 1:200

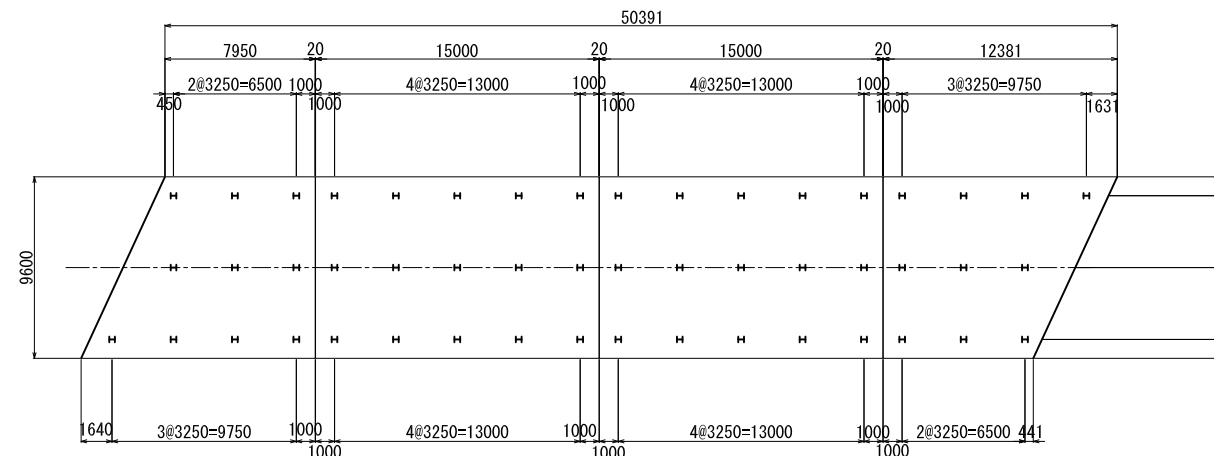

<p>Clients:</p> Japan International Cooperation Agency	<p>Department of Roads Ministry of Physical Infrastructure and Transport Federal Democratic Republic of Nepal</p>	<p>Consultants:</p> CTI Engineering International Co., Ltd. CTI Engineering Co., Ltd.	<p>Project Title:</p> <p style="text-align: center;">Additional Study of the Suryabinayak-Dhulikhel Road Improvement Project</p>	<p>Sheet Contents:</p> <p style="text-align: center;">GENERAL VIEW OF CULVERT AT JAGATI 8.0×5.8(2) (STA.1+714.30)</p>	<p>Scale: (A1size)</p> <p style="text-align: center;">AS SHOWN</p> <p style="text-align: center;">Submission Date March, 2018</p>	<p>SHT. NO.</p> <p style="text-align: center;">CD-02</p>
--	---	--	--	---	---	--



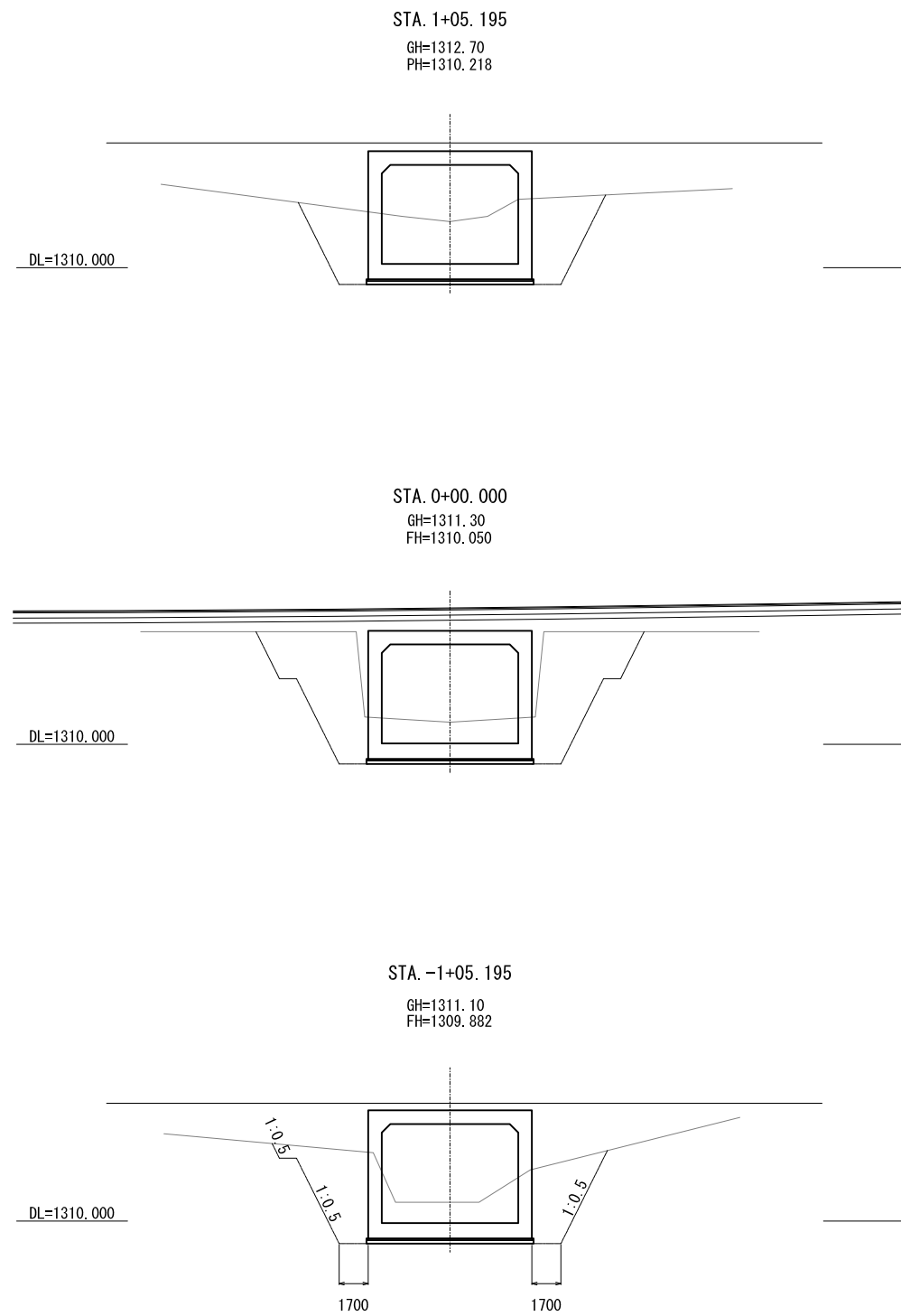

# GENERAL VIEW OF C-1 CULVERT 8.0×5.8 (3) (STA. 1+714.30)

SECTION SCALE=1:200

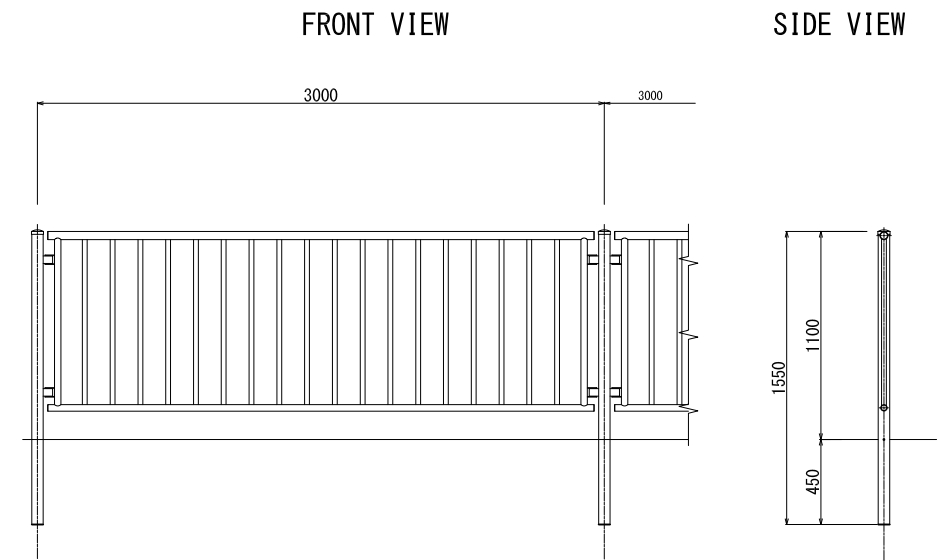

FALL PREVENTION FENCE DETAIL SCALE=1:20



Clients:	 Department of Roads Ministry of Physical Infrastructure and Transport Federal Democratic Republic of Nepal	Consultants:	 CTI Engineering International Co., Ltd.  CTI Engineering Co., Ltd.	Project Title:	Additional Study of the Suryabinayak-Dhulikhel Road Improvement Project	Sheet Contents:	Scale: (A1size) SHT. NO.
 Japan International Cooperation Agency				GENERAL VIEW OF CULVERT AT JAGATI 8.0×5.8(3) (STA.1+714.30)	AS SHOWN Submission Date March, 2018	CD-03	



# GENERAL VIEW OF C-3 CULVERT 10.0×6.4 (1) (STA. 7+857.00)

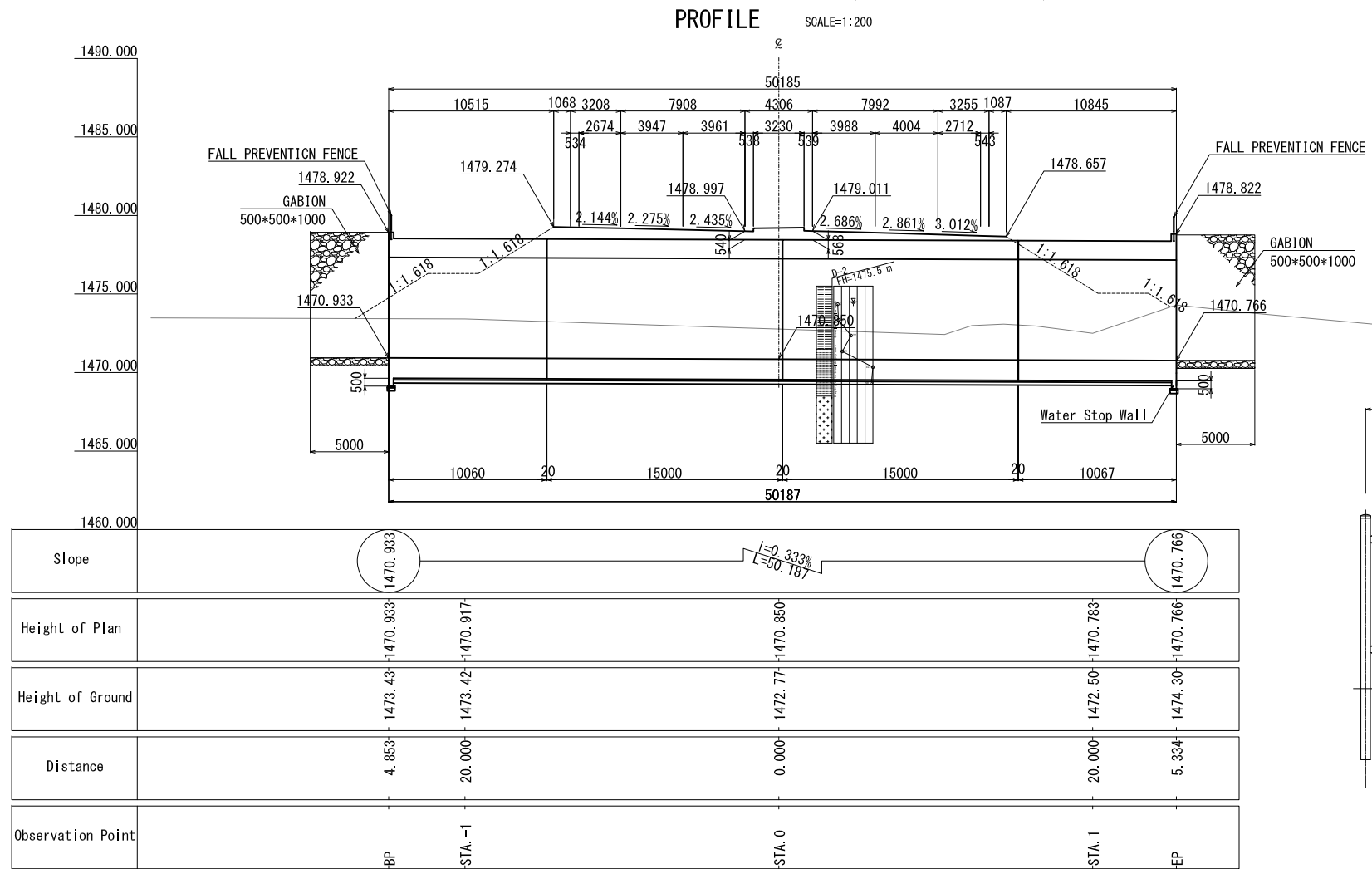

**FALL PREVENTION FENCE DETAIL** SCALE=1:20

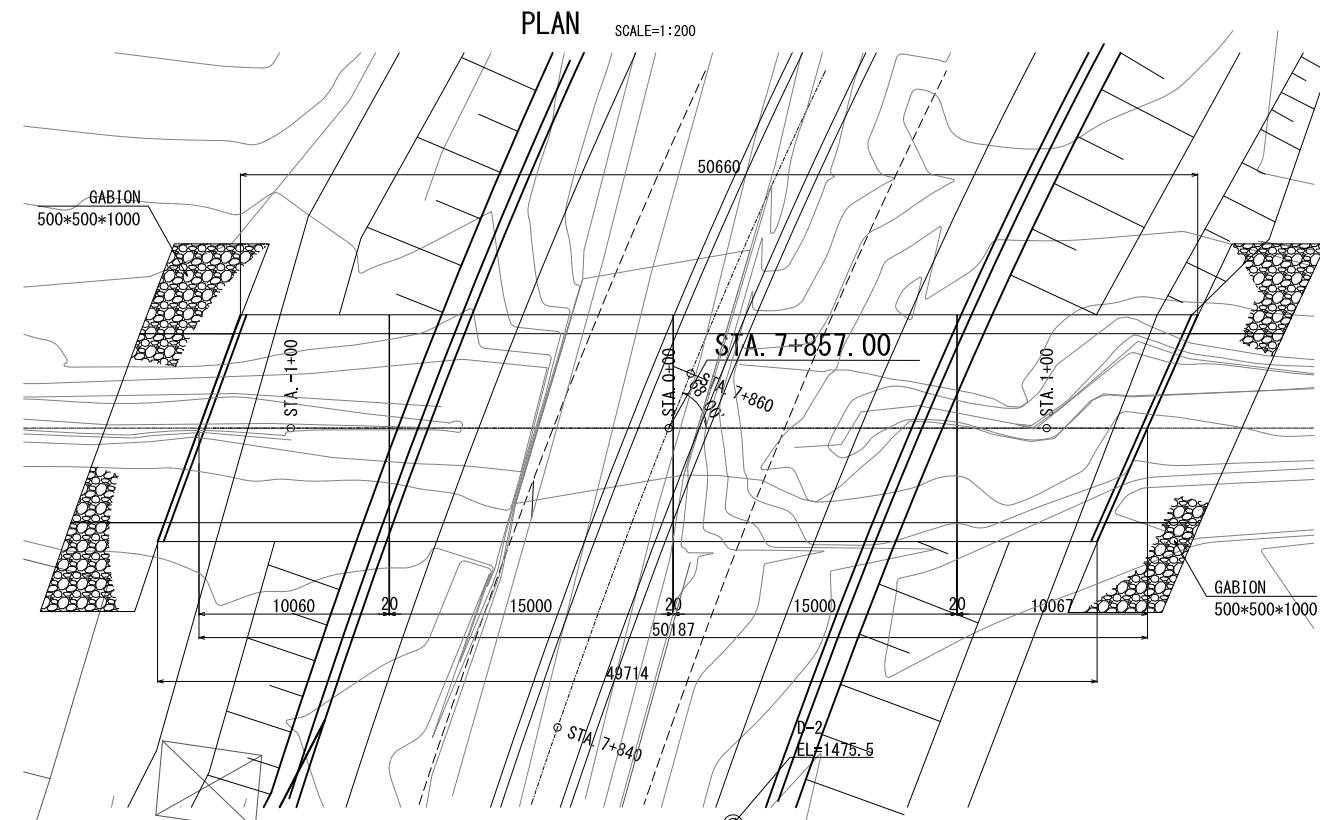
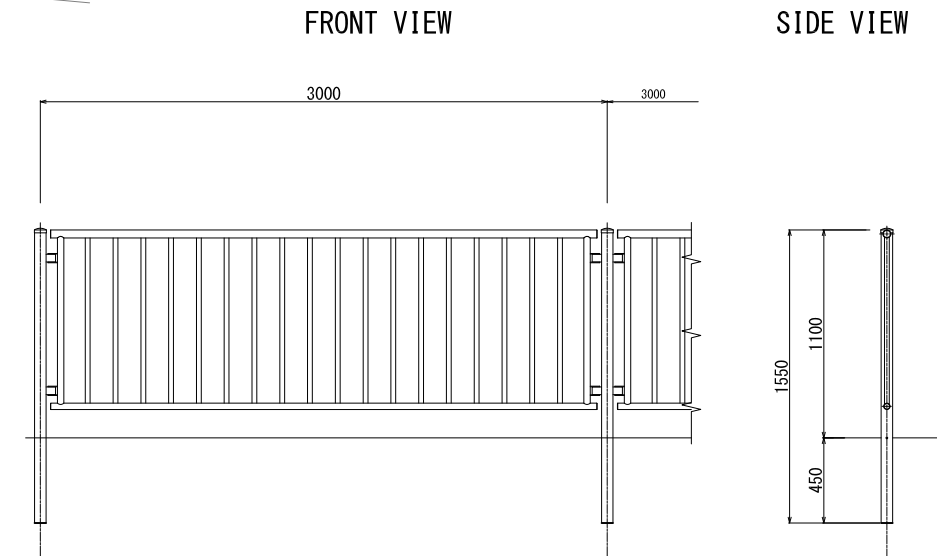

Clients:	Japan International Cooperation Agency	Consultants:	CTI Engineering International Co., Ltd. CTI Engineering Co., Ltd.	Project Title:	Additional Study of the Suryabinayak-Dhulikhel Road Improvement Project
	Department of Roads Ministry of Physical Infrastructure and Transport Federal Democratic Republic of Nepal			Sheet Contents:	GENERAL VIEW OF CULVERT BEYOND SANGA 10.0×6.4 (1) (STA.7+857.00)
				Scale: (A1size)	AS SHOWN
				Submission Date	March, 2018
				SHT. NO.	CD-04

GENERAL VIEW OF C-3 CULVERT 10.0×6.4 (2)  
(STA. 7+857.00)

INLET SECTION SCALE=1:100

STANDARD SECTION OF BOX CULVERT SCALE=1:100

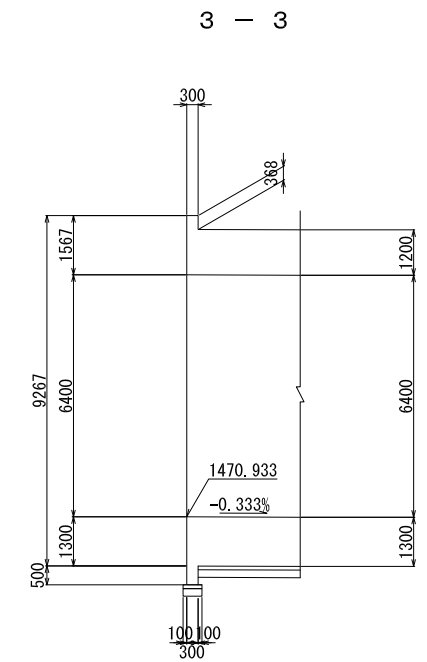
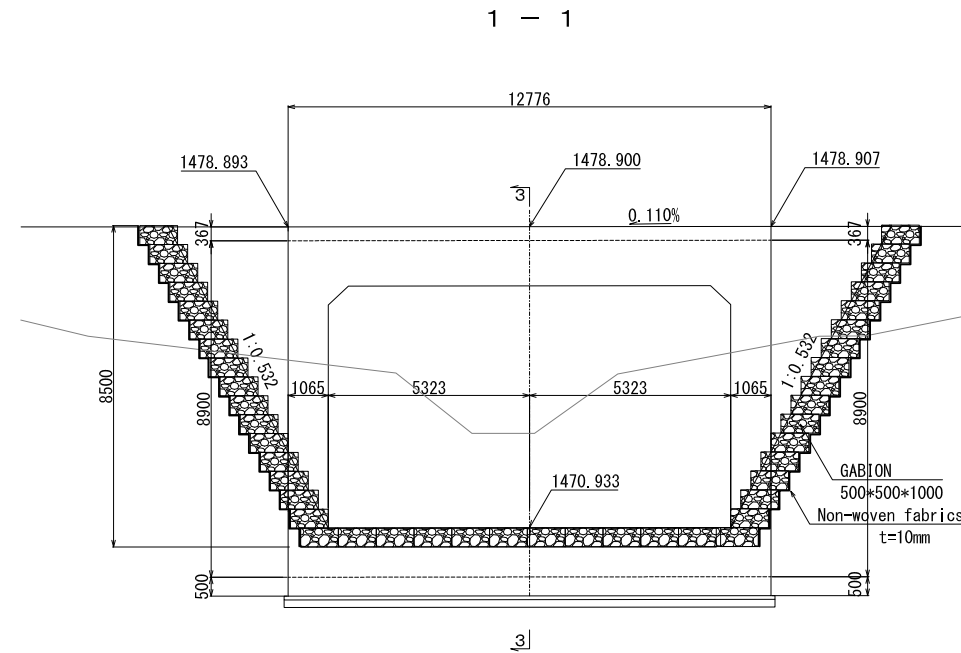
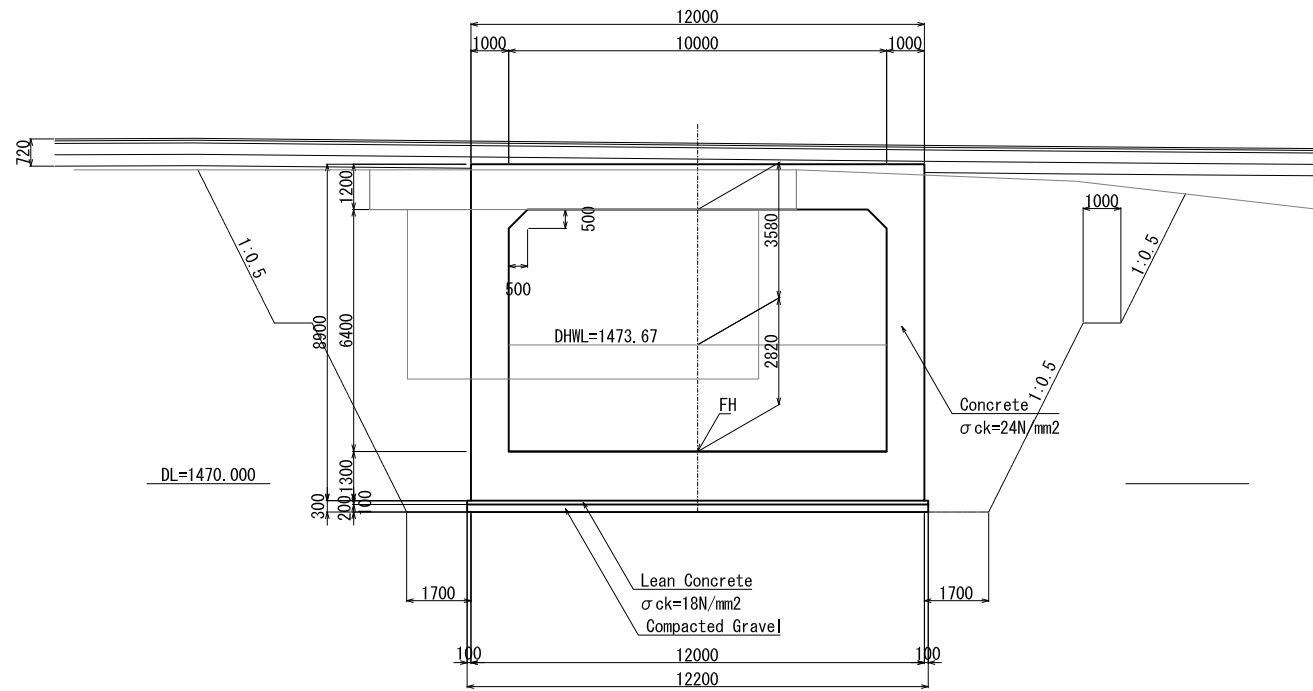

DETAILED DRAWING PLAN OF WATER STOP SCALE=1:20

FORM OF I

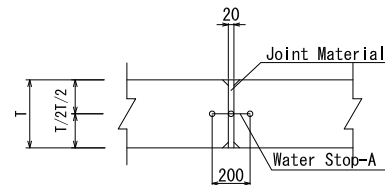

JOINT ENGINEERING

SCALE=1:100

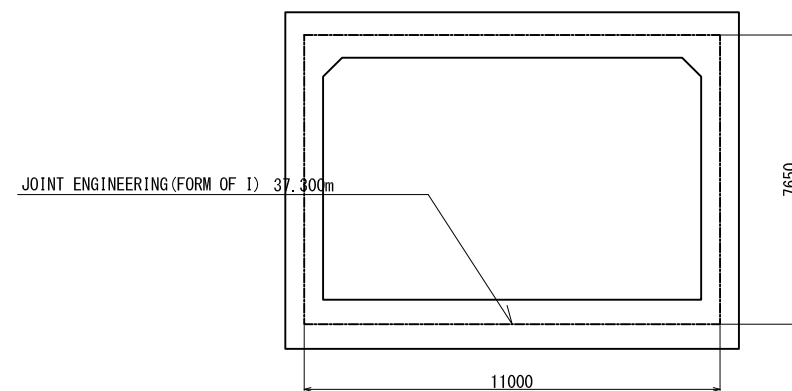

2 - 2

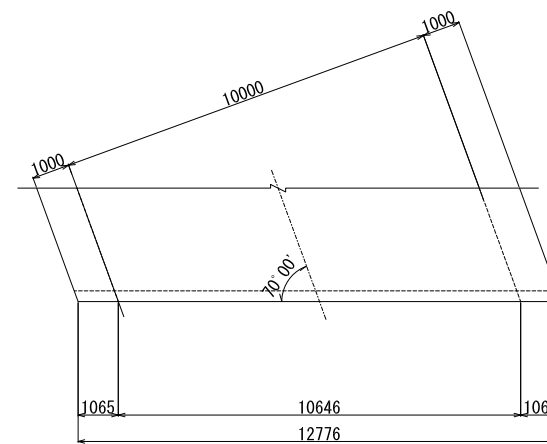

Clients:	Consultants:	Project Title:	Sheet Contents:	Scale: (A1size)	SHT. NO.
Japan International Cooperation Agency	Department of Roads Ministry of Physical Infrastructure and Transport Federal Democratic Republic of Nepal	CTI Engineering International Co., Ltd. CTI Engineering Co., Ltd.	Additional Study of the Suryabinayak-Dhulikhel Road Improvement Project	AS SHOWN	CD-05
				Submission Date	
				March, 2018	
			GENERAL VIEW OF CULVERT BEYOND SANGA 10.0×6.4 (2) (STA.7+857.00)		

# GENERAL VIEW OF C-3 CULVERT 10.0×6.4 (3) (STA. 7+857.00)

OUTLET SECTION SCALE=1:100

SECTION SCALE=1:200

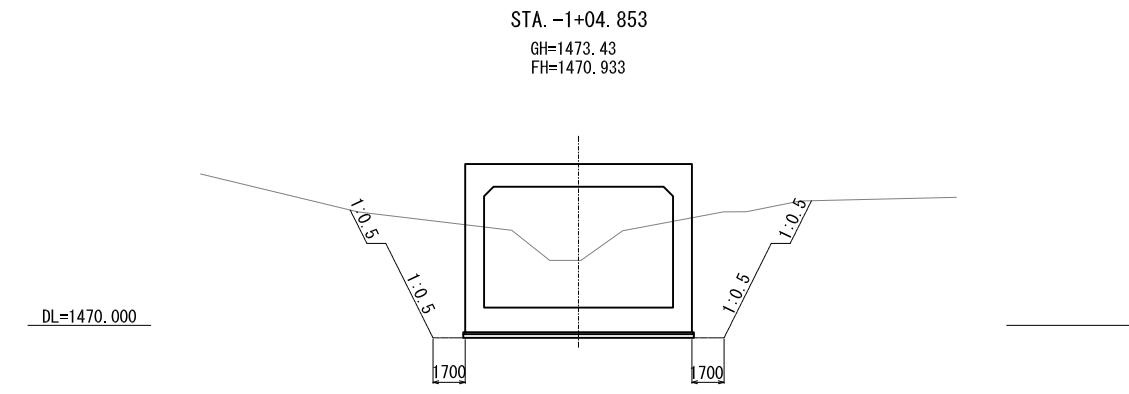
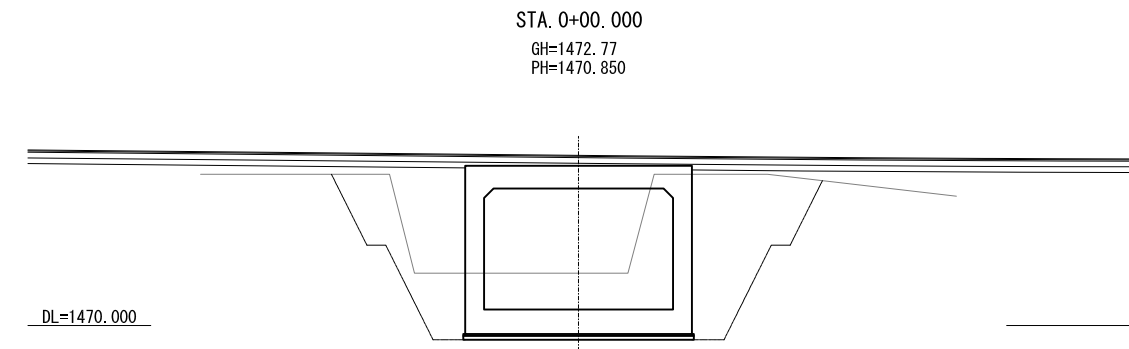
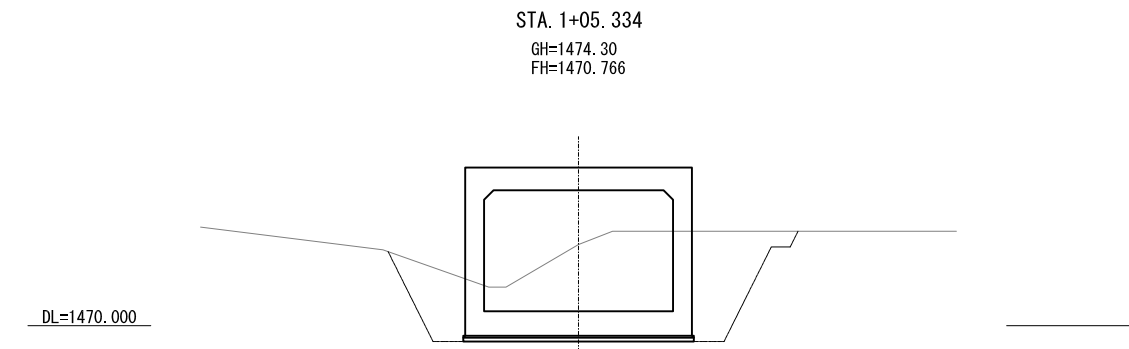
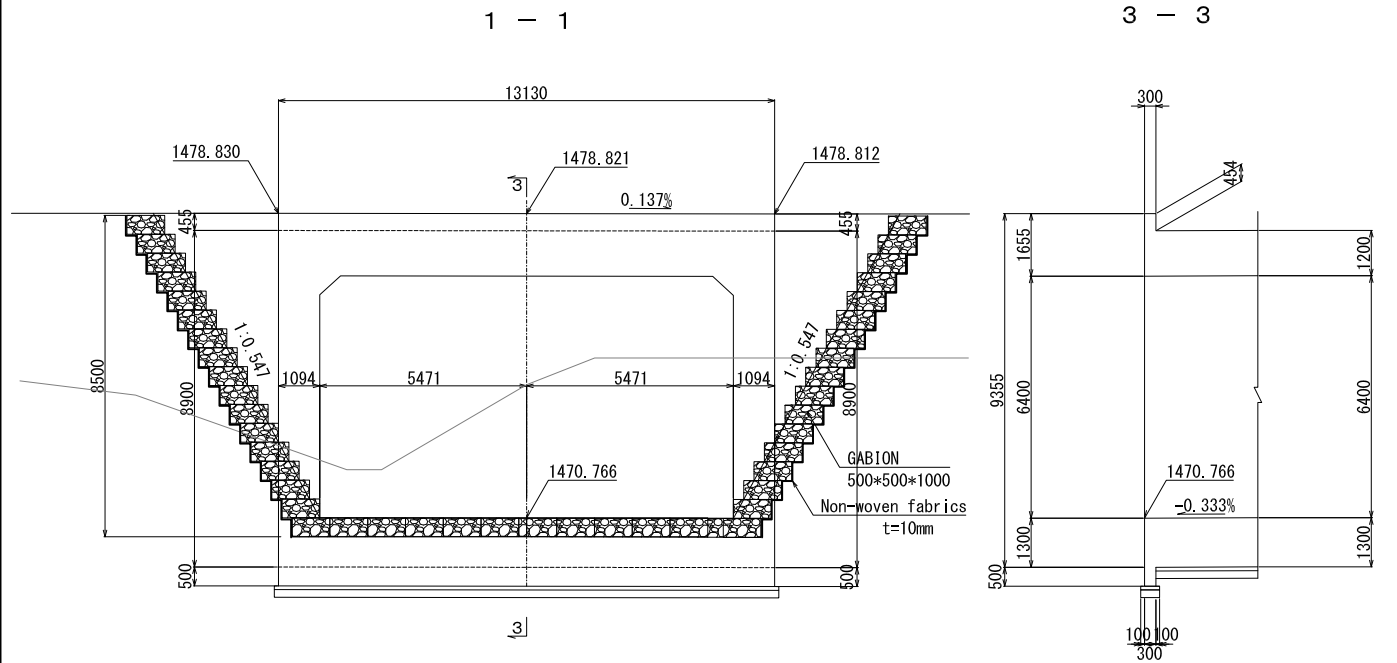

DL=1465.000

2 - 2

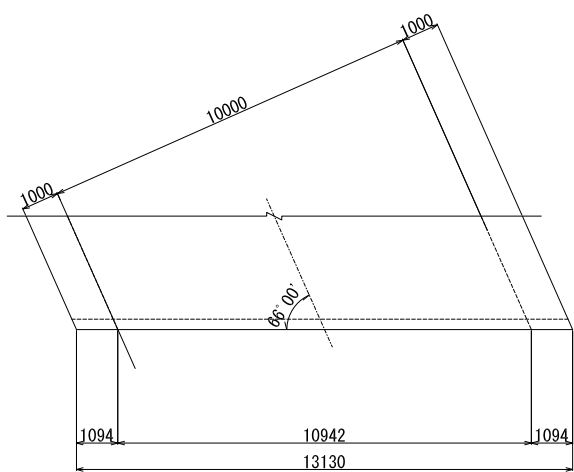

Clients:		Consultants:	Project Title:	Sheet Contents:	Scale: (A1size)	SHT. NO.
			Additional Study of the Suryabinayak-Dhulikhel Road Improvement Project	GENERAL VIEW OF CULVERT BEYOND SANGA 10,0×6.4 (3) (STA.7+857.00)	AS SHOWN	CD-06
					Submission Date	
					March, 2018	



# GENERAL VIEW OF C-4 CULVERT (8.5+8.5) × 4.6 (1)

(STA. 10+534.70)

## PROFILE

SCALE=1:200

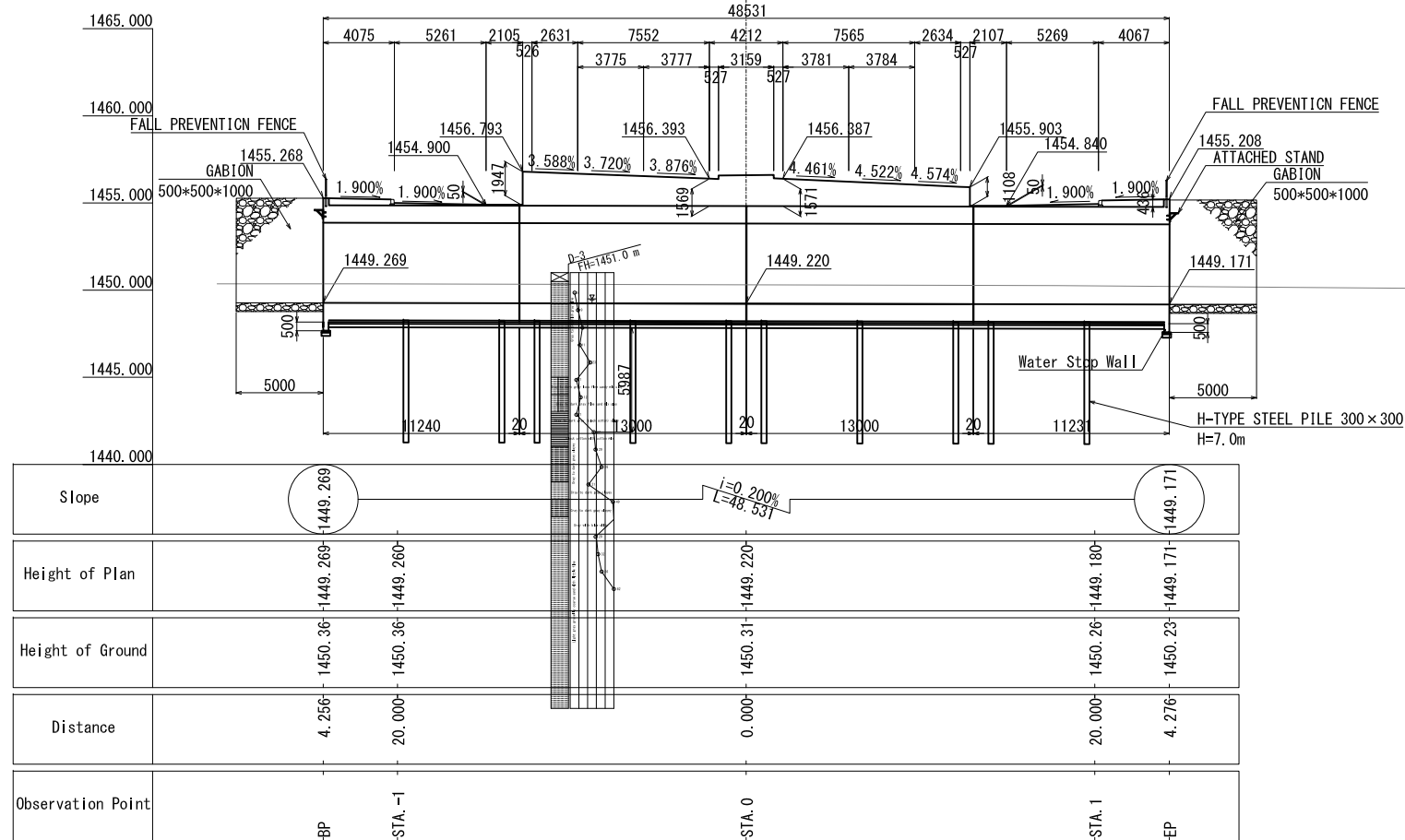

## STANDARD SECTION OF BOX CULVERT

SCALE=1:100

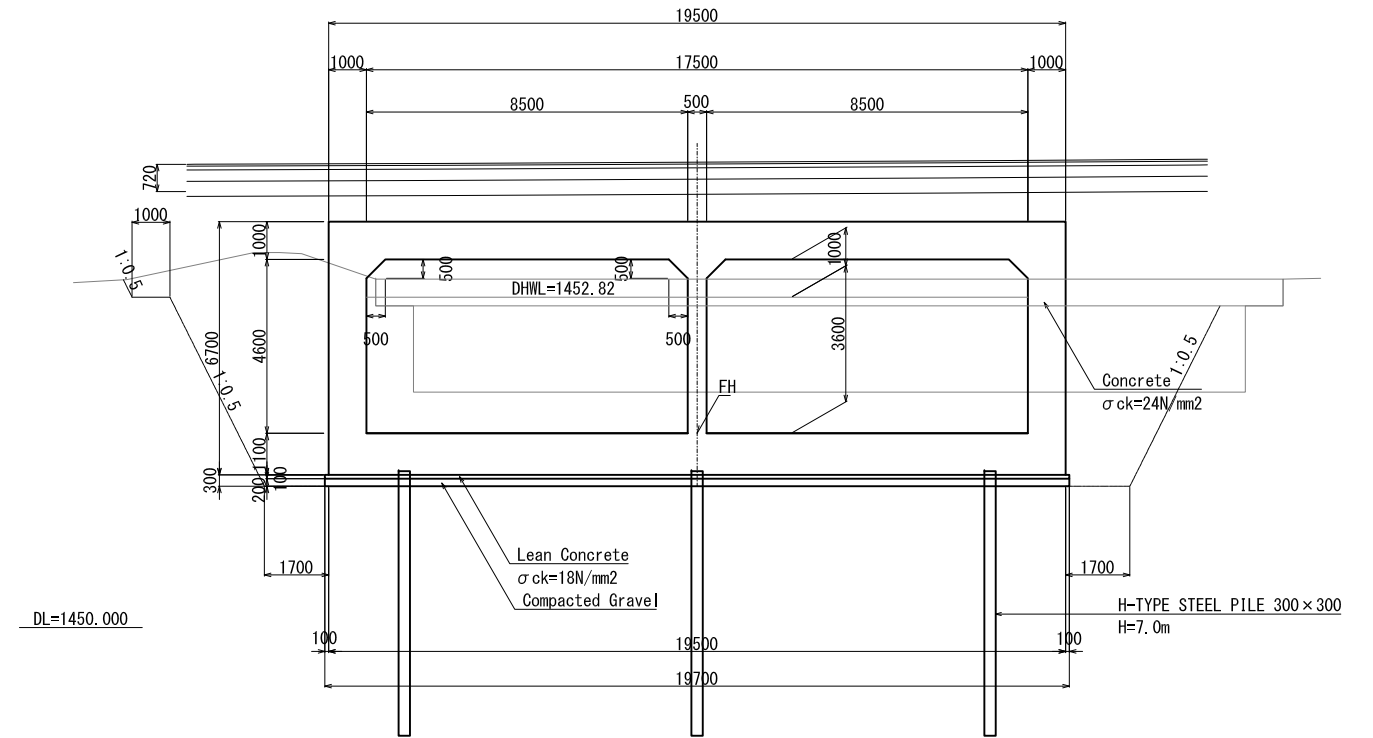

## PLAN

SCALE=1:200

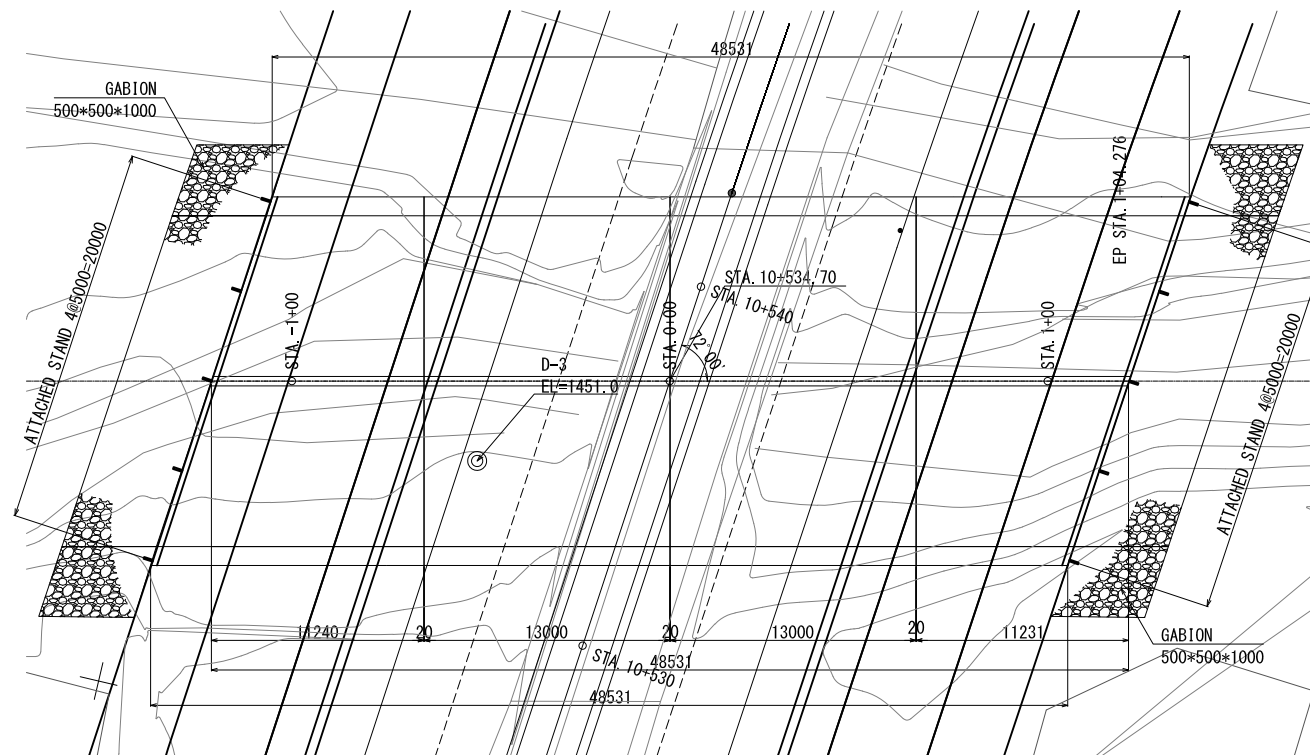

## DETAILED DRAWING PLAN OF WATER STOP

SCALE=1:20

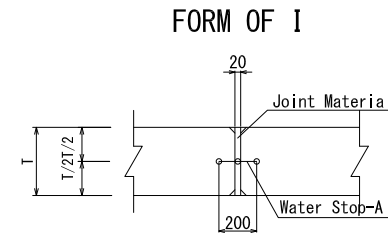

## ATTACHED STAND

SCALE=1:20

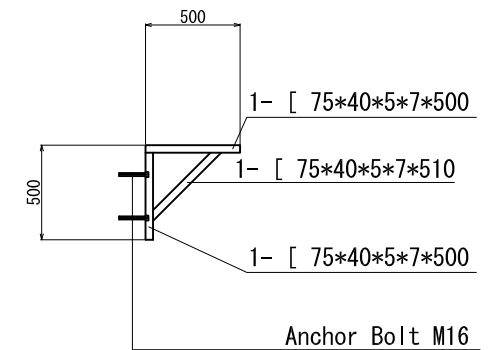

## JOINT ENGINEERING

SCALE=1:200

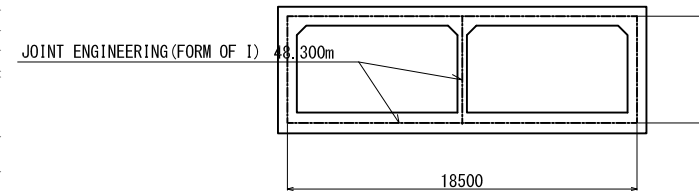

## CHANNEL STEEL SECTIONAL VIEW

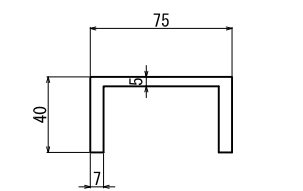

Unit Weight 6.92kg/m

Clients: Japan International Cooperation Agency	Department of Roads Ministry of Physical Infrastructure and Transport Federal Democratic Republic of Nepal	Consultants: CTI Engineering International Co., Ltd. CTI Engineering Co., Ltd.	Project Title: Additional Study of the Suryabinayak-Dhulikhel Road Improvement Project	Sheet Contents: GENERAL VIEW OF CULVERT AT WEST BANEPA (8.5+8.5)×4.6(1) (STA.10+534.70)	Scale: (A1size) AS SHOWN Submission Date March, 2018	SHT. NO. CD-07
--	--	--	---	--	---	-------------------

# GENERAL VIEW OF C-4 CULVERT (8.5+8.5) × 4.6 (2)



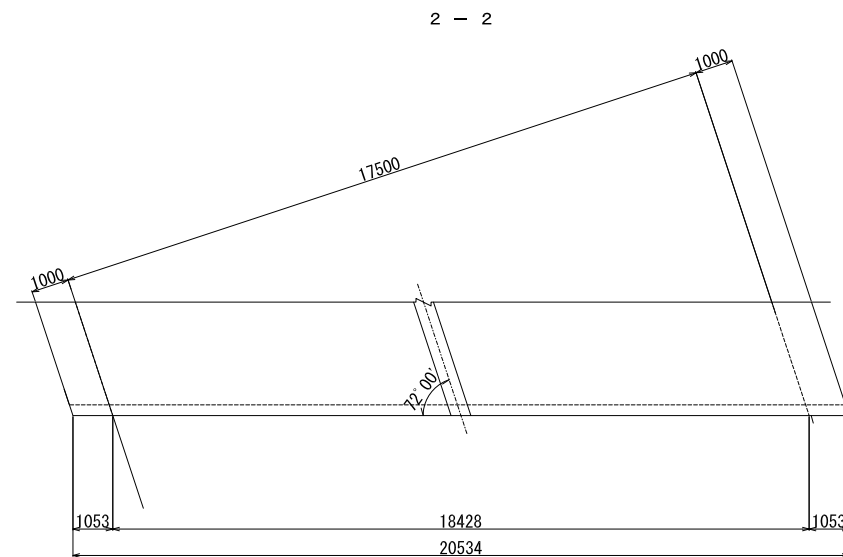
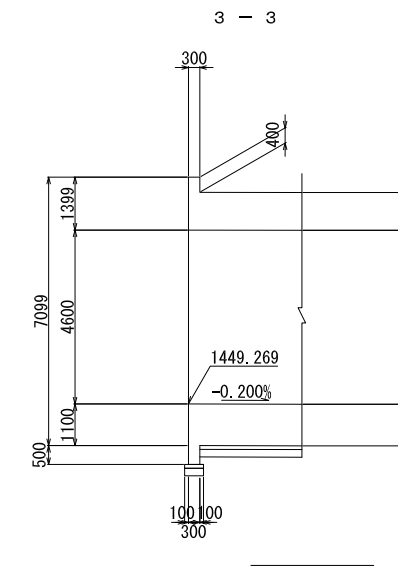
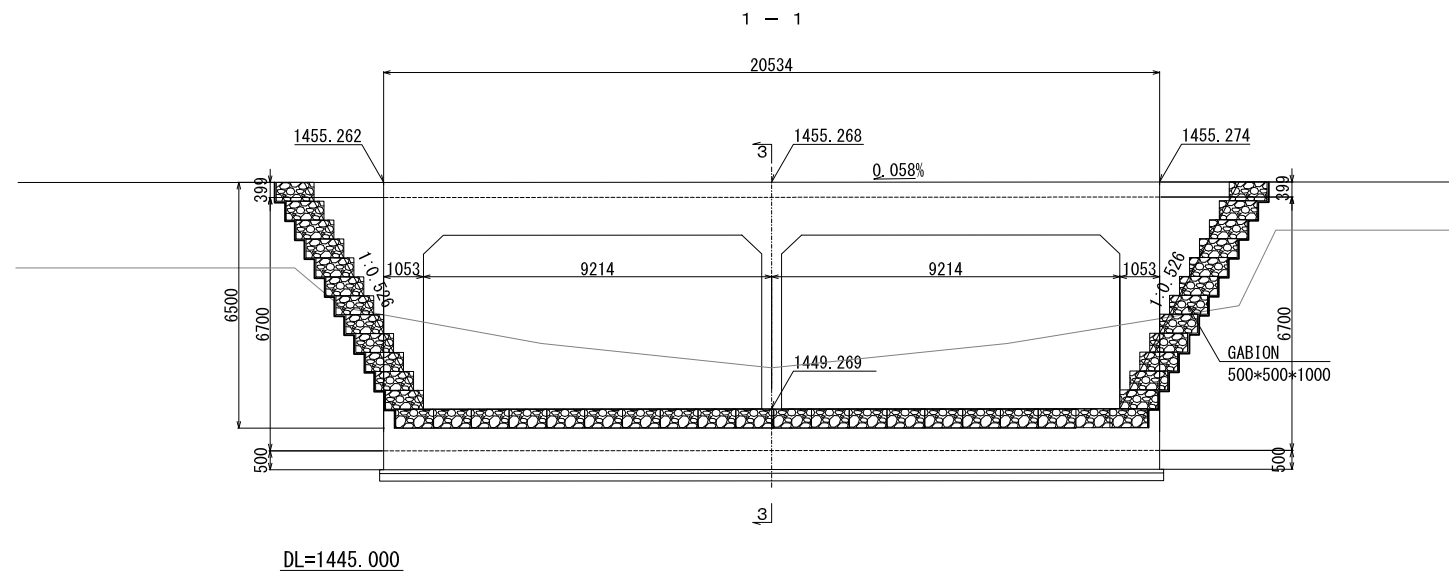

(STA. 10+534.70)

INLET SECTION SCALE=1:100

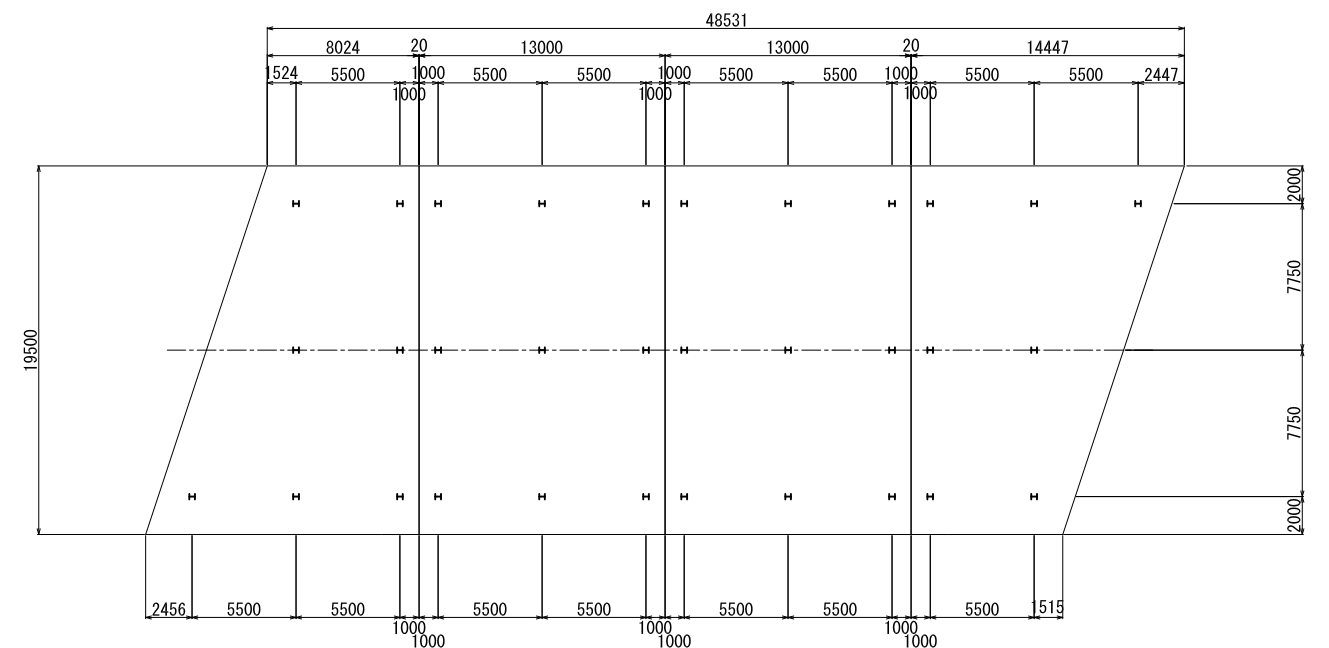

GROUND PLAN OF THE BASIC PLACEMENT IF THE STAKE  
(H-TYPE STEEL PILE 300 × 300 32PIECE) SCALE = 1:200



<p>Clients:</p>  Japan International Cooperation Agency	 Department of Roads Ministry of Physical Infrastructure and Transport Federal Democratic Republic of Nepal	<p>Consultants:</p>  CTI Engineering International Co., Ltd.  CTI Engineering Co., Ltd.	<p>Project Title:</p> Additional Study of the Suryabinayak-Dhulikhel Road Improvement Project	<p>Sheet Contents:</p> GENERAL VIEW OF CULVERT AT WEST BANEPA (8.5+8.5)×4.6(2) (STA.10+534.70)	<p>Scale: (A1size) AS SHOWN Submission Date March, 2018</p>	<p>SHT. NO. CD-08</p>
--	--	--	---	--	---	---------------------------

**GENERAL VIEW OF C-4 CULVERT (8.5+8.5) × 4.6 (3)**  
(STA. 10+534.70)

**OUTLET SECTION** SCALE=1:100

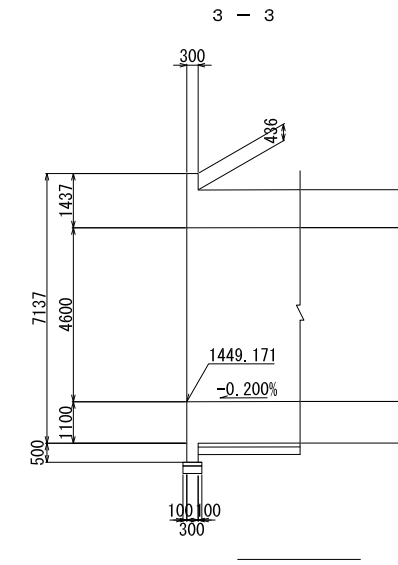
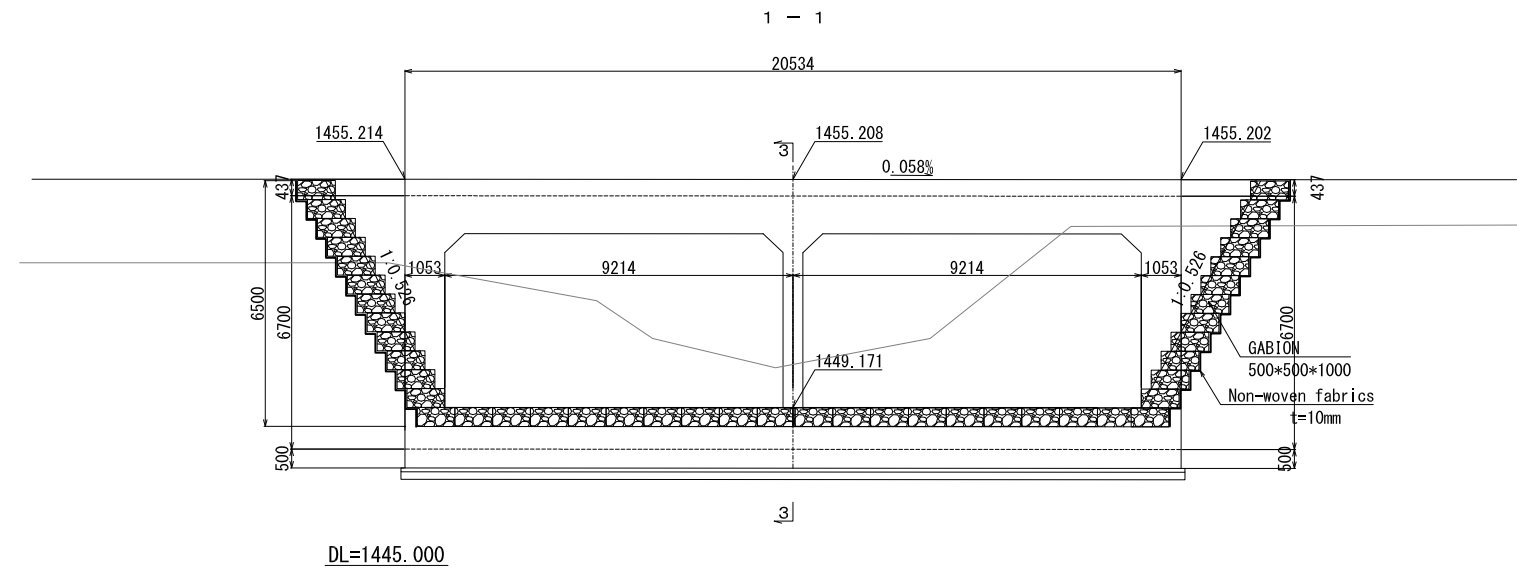

2 - 2

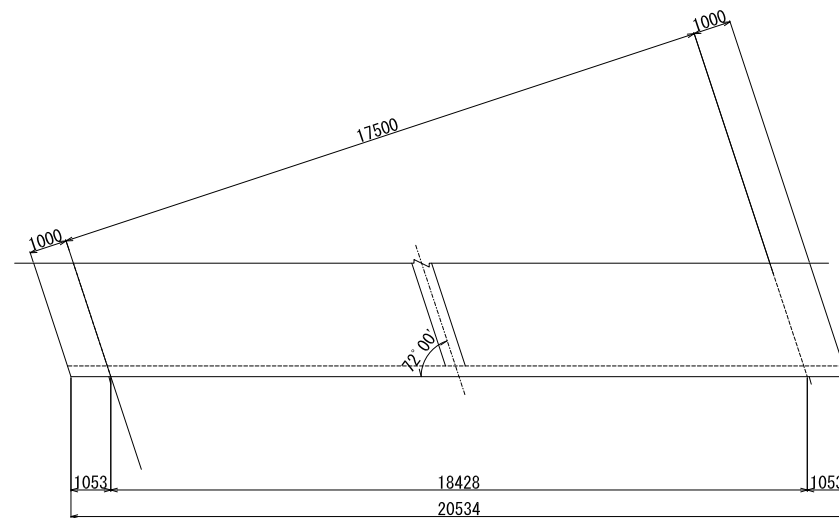



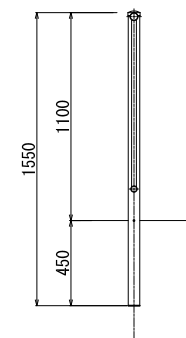
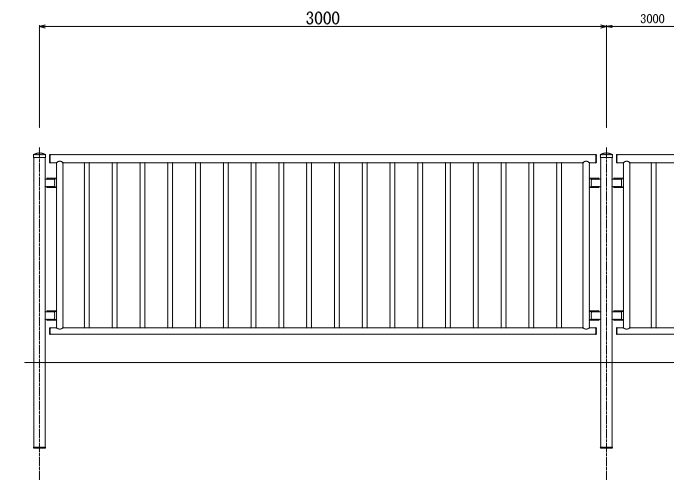

**FALL PREVENTION FENCE DETAIL** SCALE=1:20

FRONT VIEW

SIDE VIEW



<p>Clients:</p>  Japan International Cooperation Agency	<p>Department of Roads Ministry of Physical Infrastructure and Transport Federal Democratic Republic of Nepal</p> 	<p>Consultants:</p>  CTI Engineering International Co., Ltd.  CTI Engineering Co., Ltd.	<p>Project Title:</p> <p align="center">Additional Study of the Suryabinayak-Dhulikhel Road Improvement Project</p>	<p>Sheet Contents:</p> <p align="center">GENERAL VIEW OF CULVERT AT WEST BANEPA (8.5+8.5)×4.6(3) (STA.10+534.70)</p>	<p>Scale: (A1size) AS SHOWN Submission Date March, 2018</p>	<p>SHT. NO. CD-09</p>
--	---	--	---	--	---	---------------------------



**GENERAL VIEW OF C-4 CULVERT (8.5+8.5) × 4.6 (4)**  
 (STA. 10+534.70)

SECTION SCALE=1:200

STA. 1+04.276

GH=1450.23  
 FH=1449.171

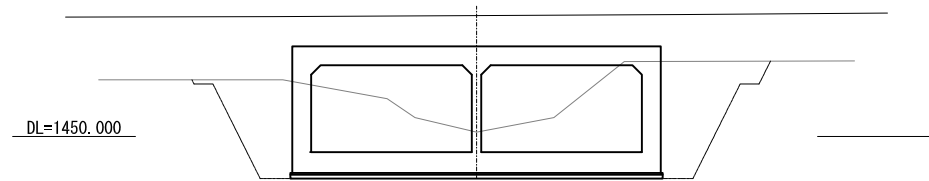

STA. 0+00.000



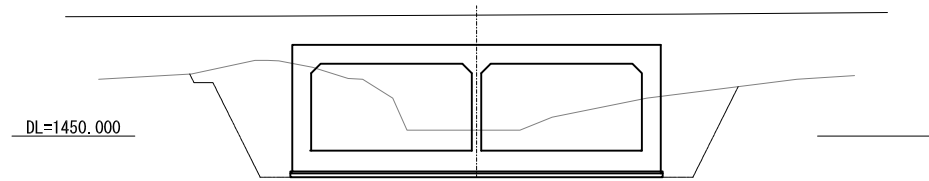

GH=1450.31  
 FH=1449.220

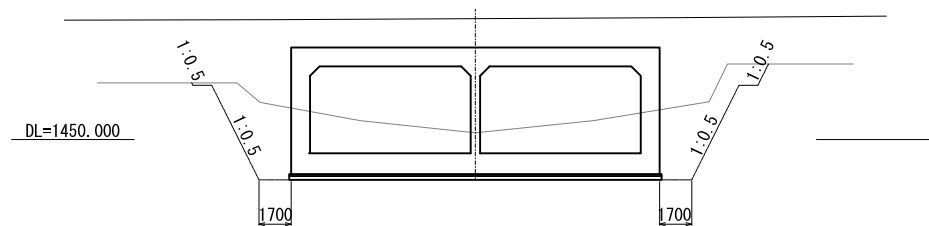

STA. -1+04.256

GH=1450.36  
 FH=1449.269



Clients:  Japan International Cooperation Agency	 Department of Roads Ministry of Physical Infrastructure and Transport Federal Democratic Republic of Nepal	Consultants:  CTI Engineering International Co., Ltd.  CTI Engineering Co., Ltd.	Project Title: Additional Study of the Suryabinayak-Dhulikhel Road Improvement Project	Sheet Contents: GENERAL VIEW OF CULVERT AT WEST BANEPA (8.5+8.5)×4.6(4) (STA.10+534.70)	Scale: (A1size) AS SHOWN Submission Date March, 2018	SHT. NO. CD-10
--	--	--	---	--	---	-------------------

# GENERAL VIEW OF C-5 CULVERT 7.0×3.5 (1)

(STA. 12+94.70)

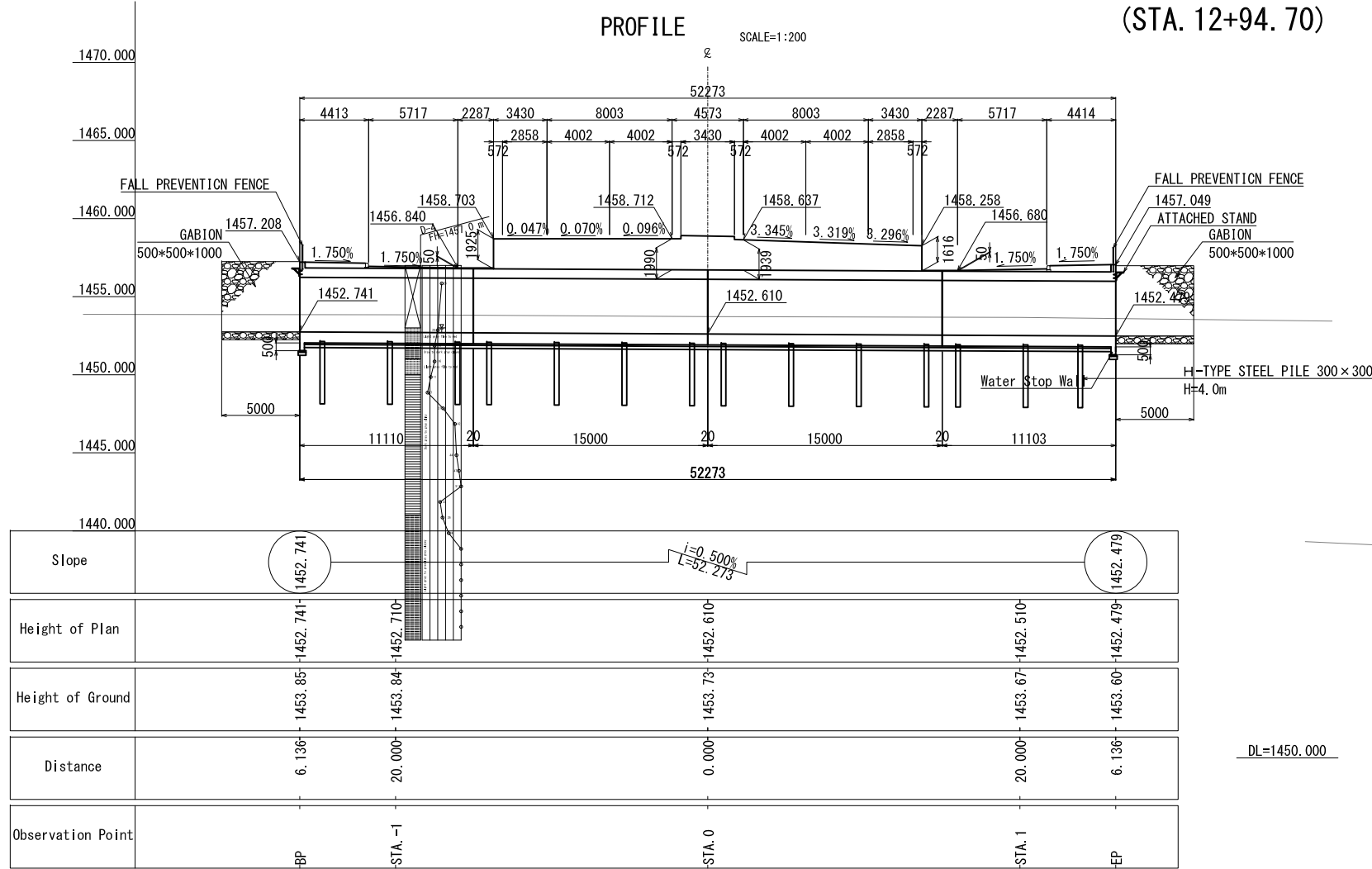

## STANDARD SECTION OF BOX CULVERT SCALE=1:100

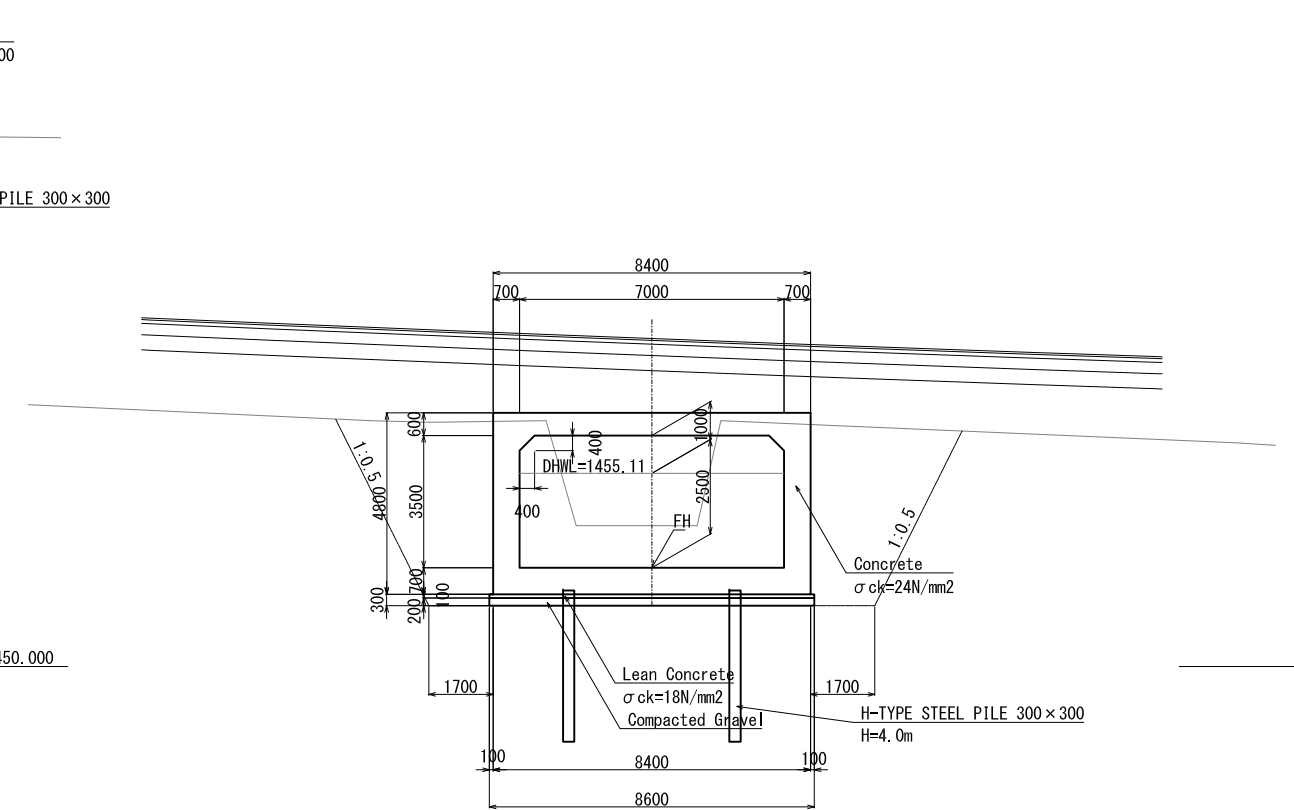

## PLAN SCALE=1:200

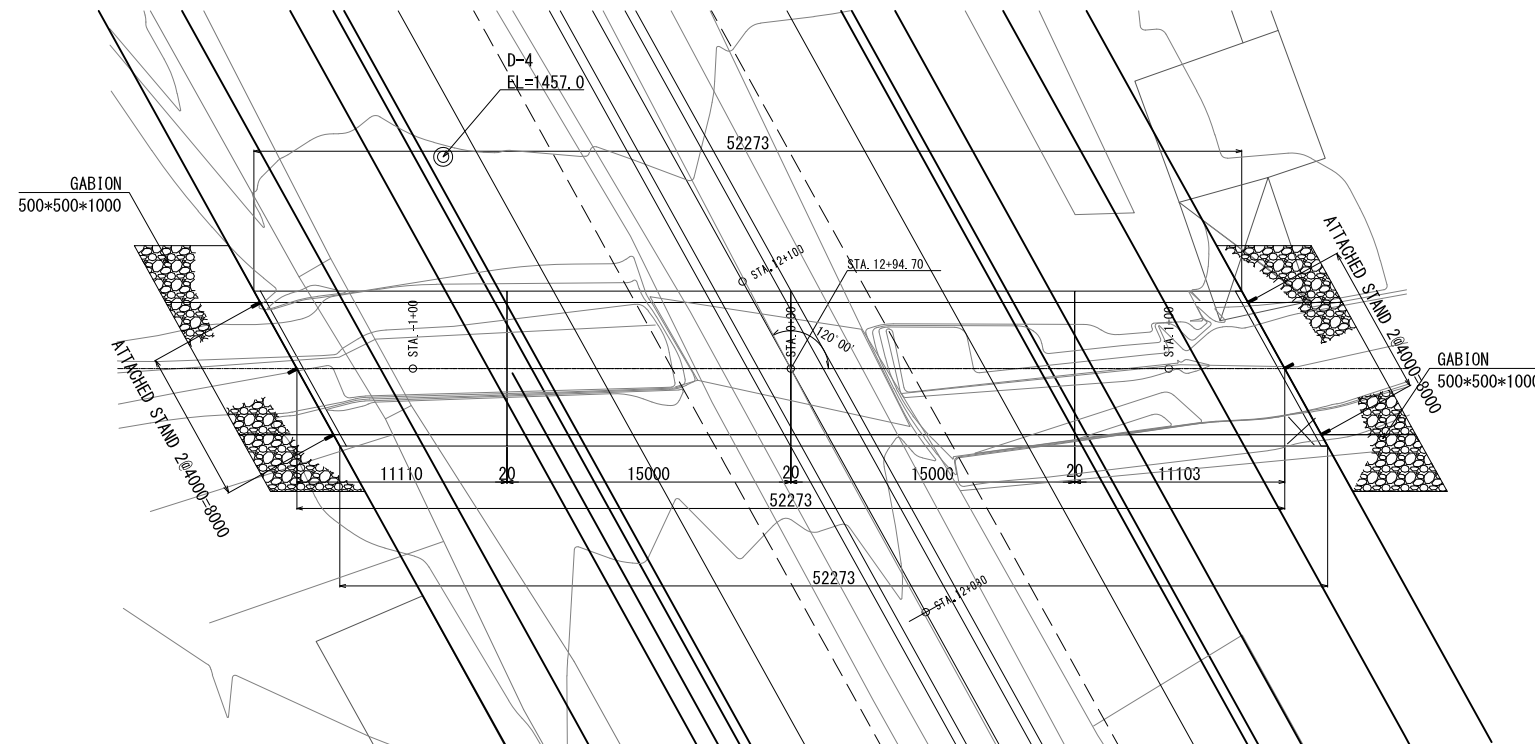

## DETAILED DRAWING PLAN OF WATER STOP SCALE=1:20

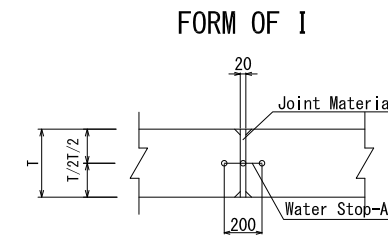

## ATTACHED STAND SCALE=1:20

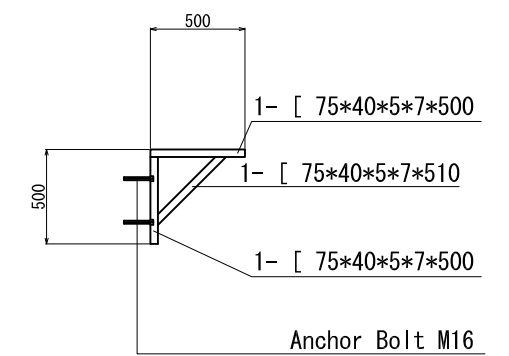

## JOINT ENGINEERING SCALE=1:100

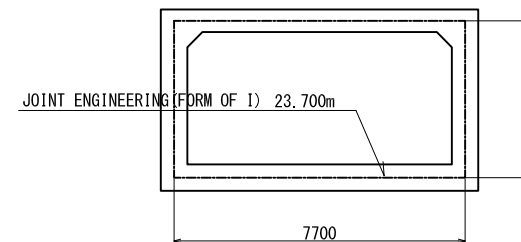

## CHANNEL STEEL SECTIONAL VIEW

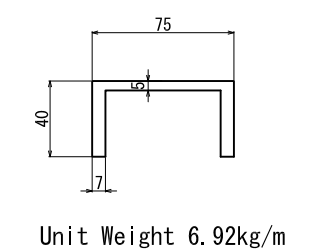

Clients: Japan International Cooperation Agency	Department of Roads Ministry of Physical Infrastructure and Transport Federal Democratic Republic of Nepal	Consultants: CTI Engineering International Co., Ltd. CTI Engineering Co., Ltd.	Project Title: Additional Study of the Suryabinayak-Dhulikhel Road Improvement Project	Sheet Contents: GENERAL VIEW OF CULVERT AT EAST BANEPA 7.5×3.5(1) (STA.12+094.70)	Scale: (A1size) AS SHOWN Submission Date March, 2018	SHT. NO. CD-11
--	--	--	---	--	---	-------------------

**GENERAL VIEW OF C-5 CULVERT 7.0×3.5 (2)**  
(STA. 12+94.70)

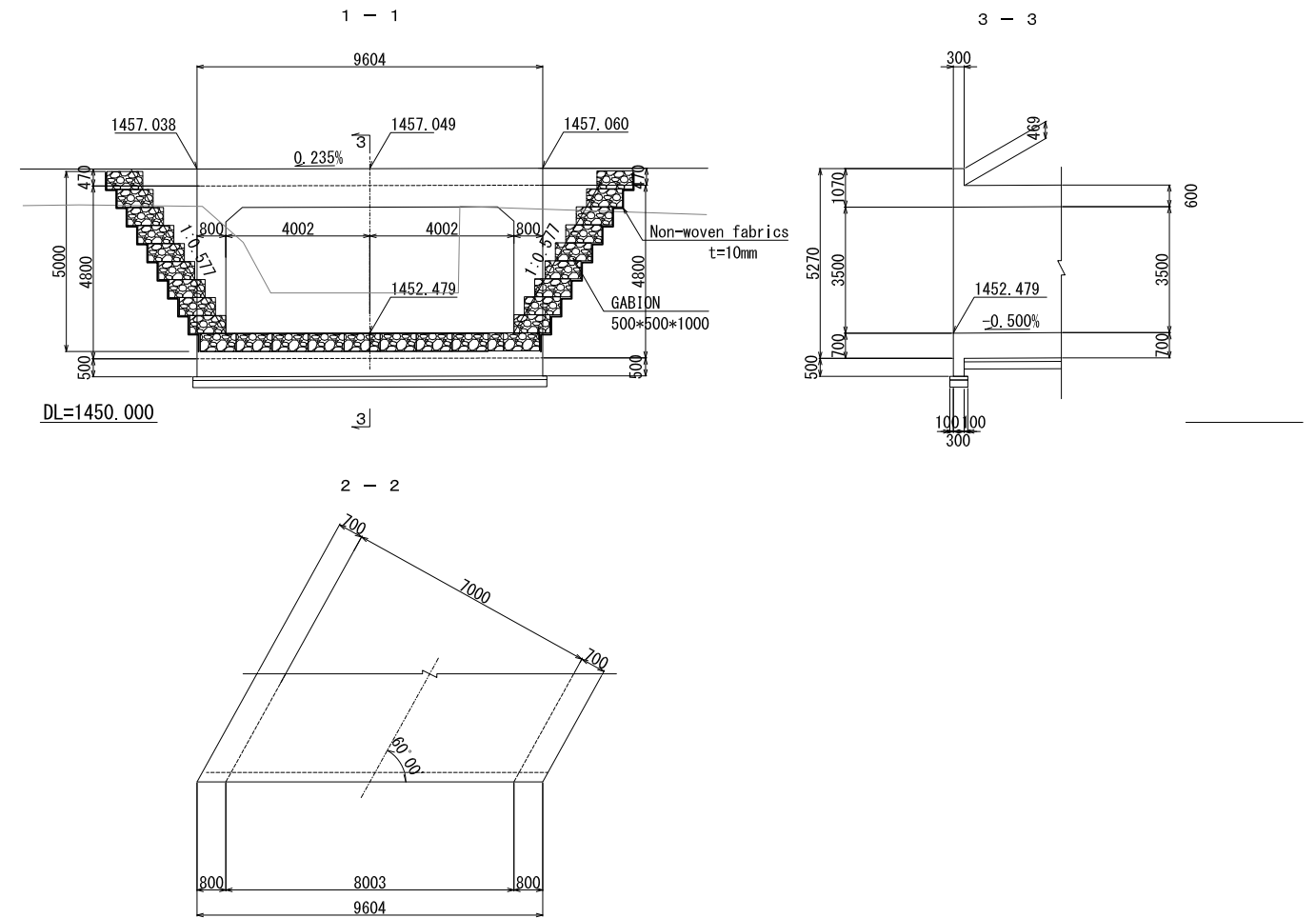
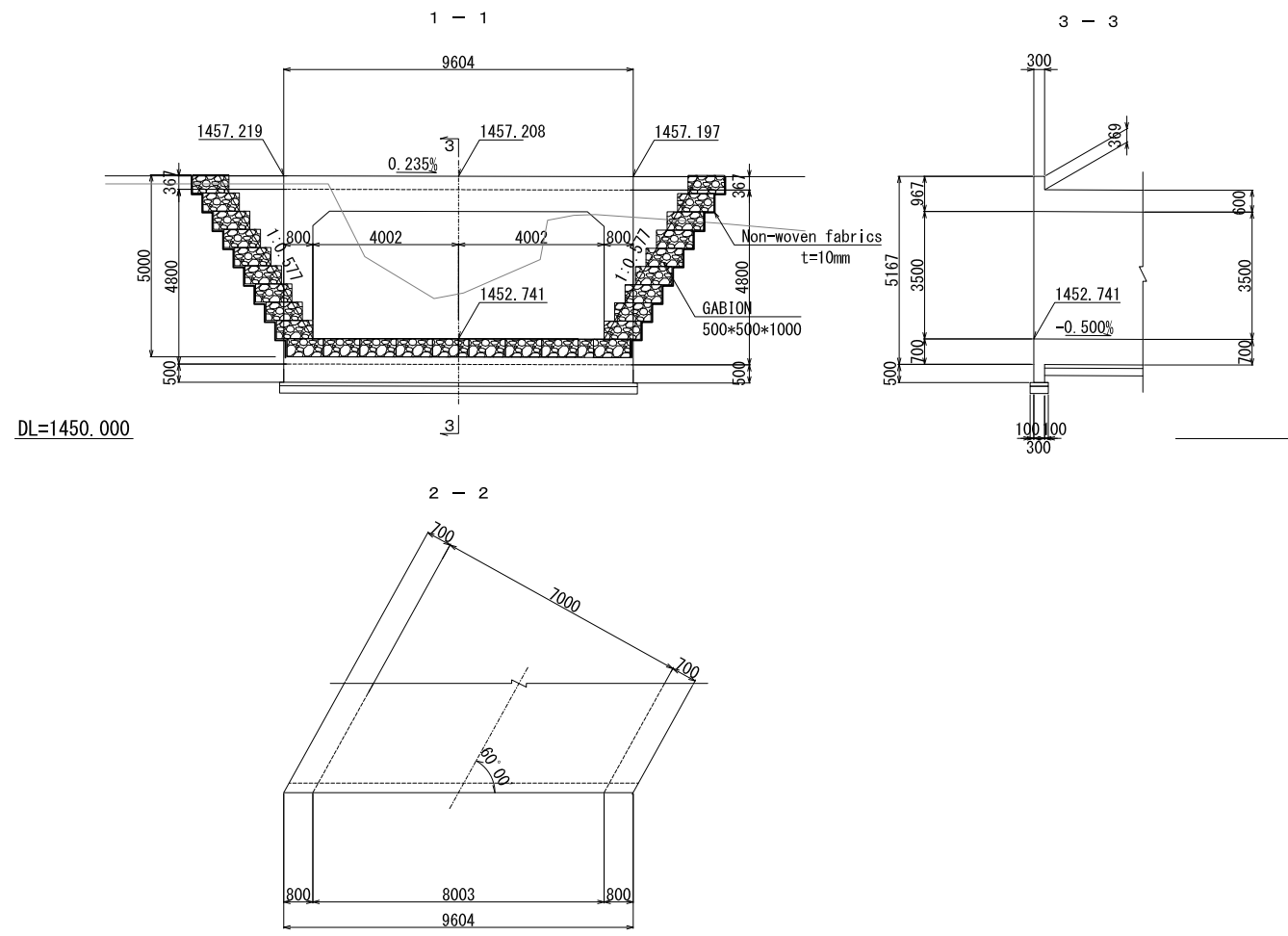

**INLET SECTION** SCALE=1:100

**OUTLET SECTION** SCALE=1:100

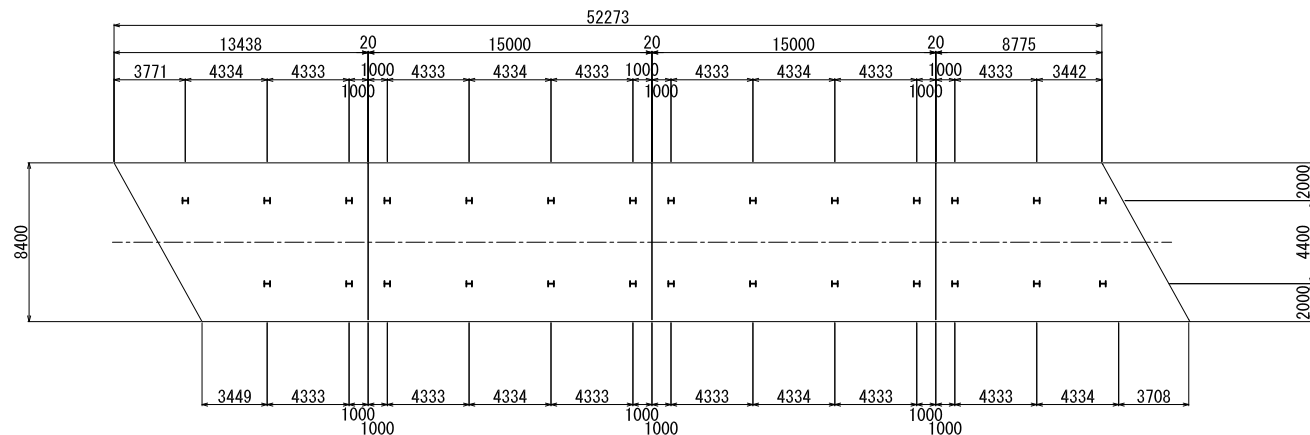

**GROUND PLAN OF THE BASIC PLACEMENT IF THE STAKE**  
(H-TYPE STEEL PILE 300×300 27PIECE) SCALE = 1:200

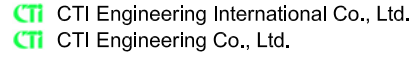

Clients:	Consultants:	Project Title:	Sheet Contents:	Scale: (A1size)	SHT. NO.
 Japan International Cooperation Agency	 Department of Roads Ministry of Physical Infrastructure and Transport Federal Democratic Republic of Nepal	 CTI Engineering International Co., Ltd. CTI Engineering Co., Ltd.	Additional Study of the Suryabinayak-Dhulikhel Road Improvement Project	AS SHOWN	CD-12
				Submission Date	
				March, 2018	
			GENERAL VIEW OF CULVERT AT EAST BANEPA 7.5×3.5(2) (STA.12+094.70)		

# GENERAL VIEW OF C-5 CULVERT 7.0 × 3.5 (3) (STA. 12+94.70)

**SECTION** SCALE=1:100

STA. 1+06.136  
GH=1453.60  
FH=1452.479

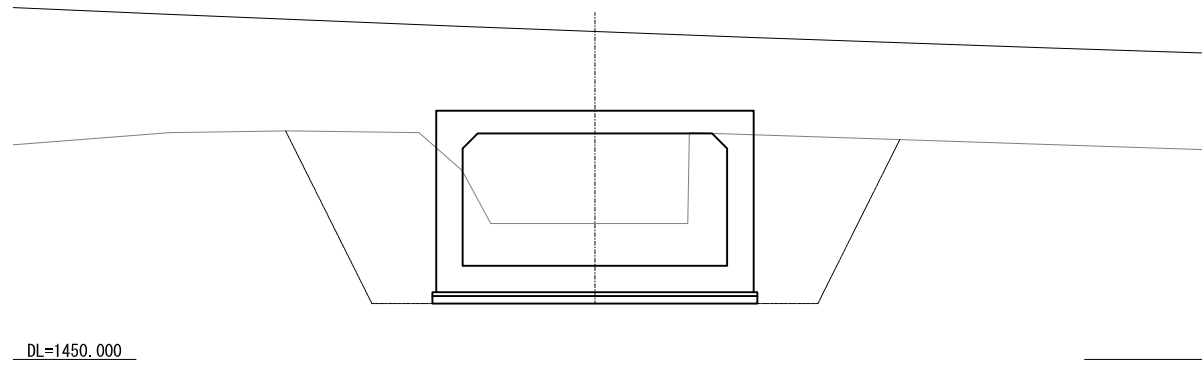

STA. 0+00.000  
GH=1453.73  
FH=1452.610

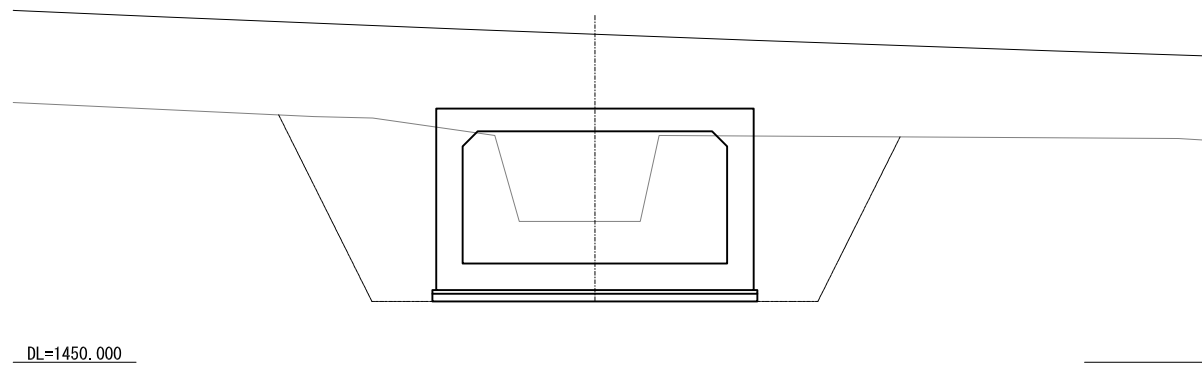

STA. -1+06.136  
GH=1453.85  
FH=1452.741

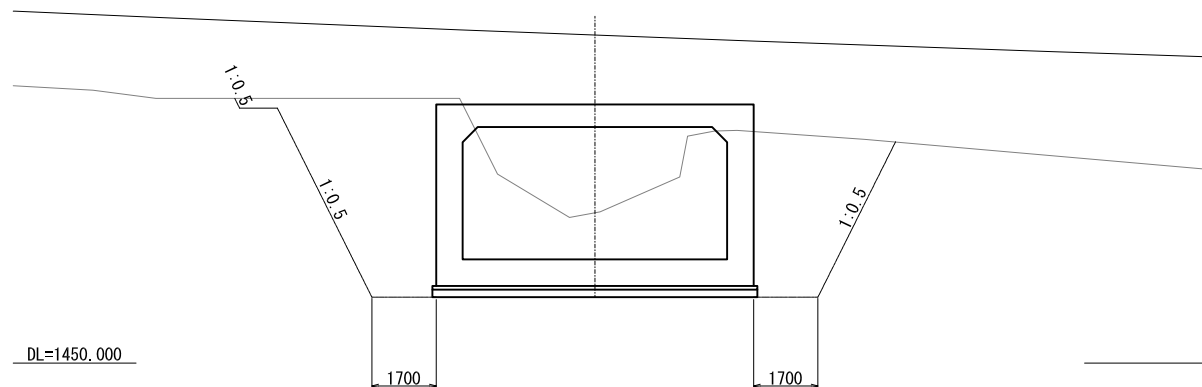



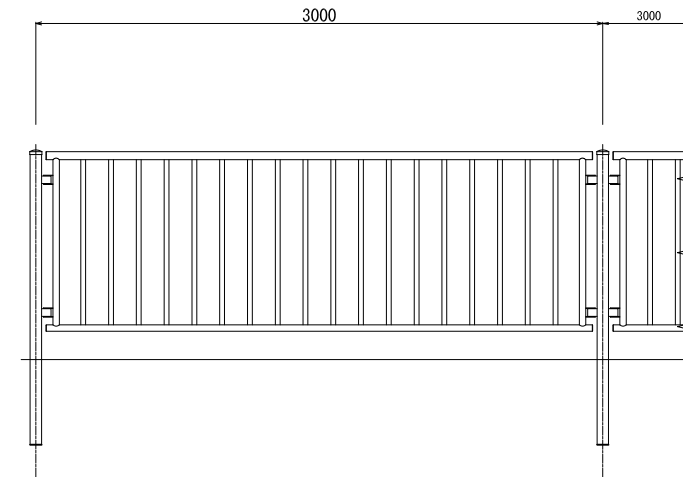

**FALL PREVENTION FENCE DETAIL** SCALE=1:20

**FRONT VIEW**

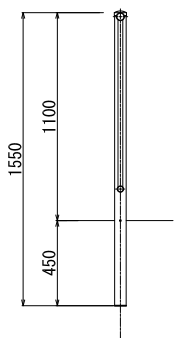

**SIDE VIEW**



Clients:	 Department of Roads Ministry of Physical Infrastructure and Transport Federal Democratic Republic of Nepal	Consultants:	 CTI Engineering International Co., Ltd.  CTI Engineering Co., Ltd.	Project Title:	Additional Study of the Suryabinayak-Dhulikhel Road Improvement Project	Sheet Contents:	GENERAL VIEW OF CULVERT AT EAST BANEPA 7.5×3.5(3) (STA.12+094.70)	Scale: (A1size)	AS SHOWN	SHT. NO.	CD-13
							Submission Date		March, 2018		



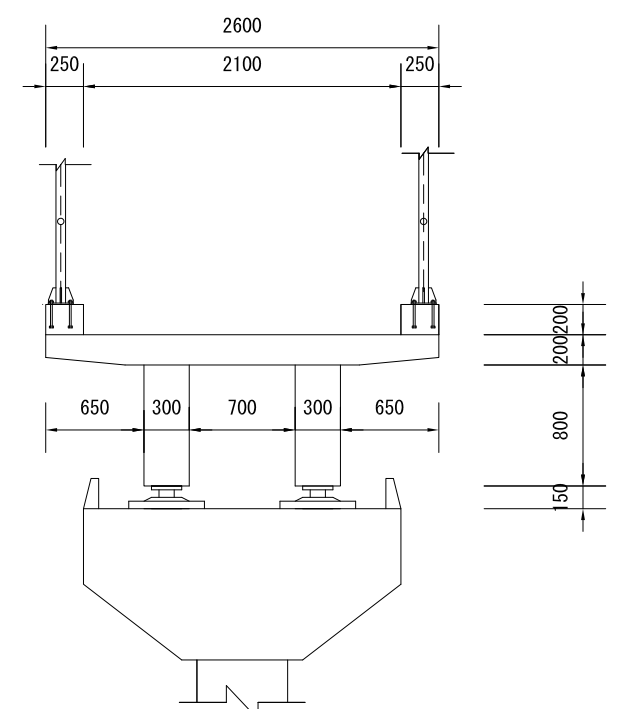
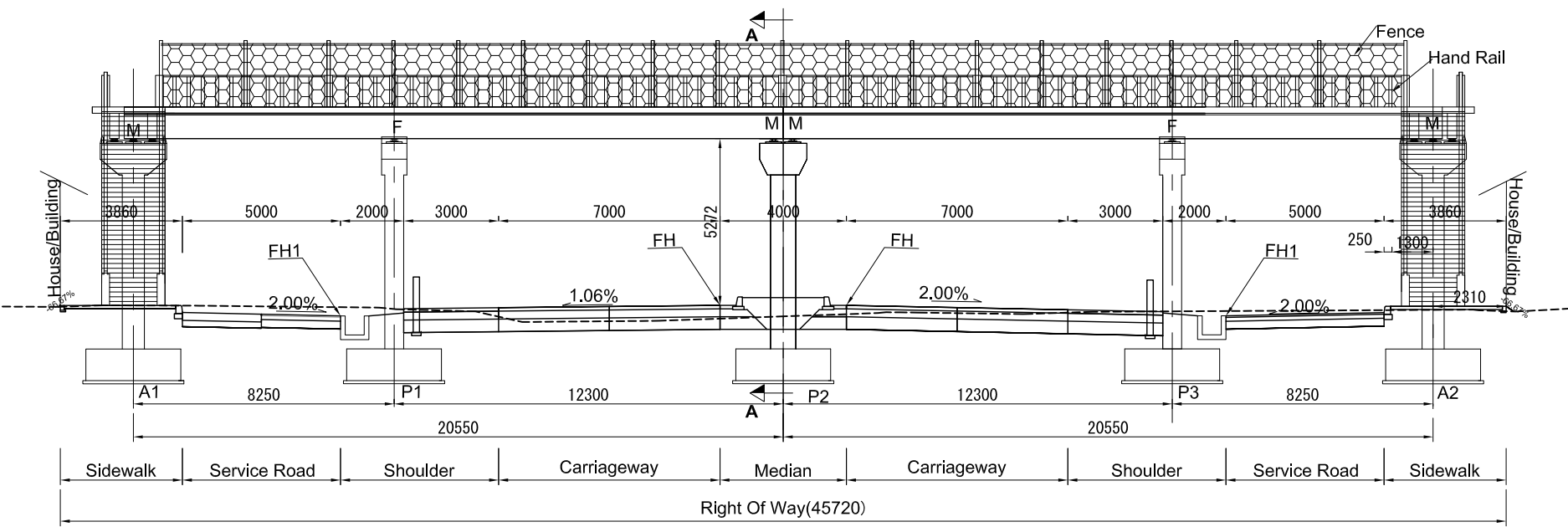
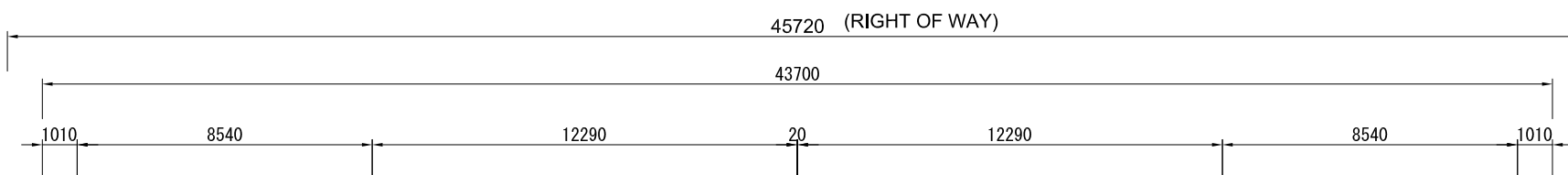
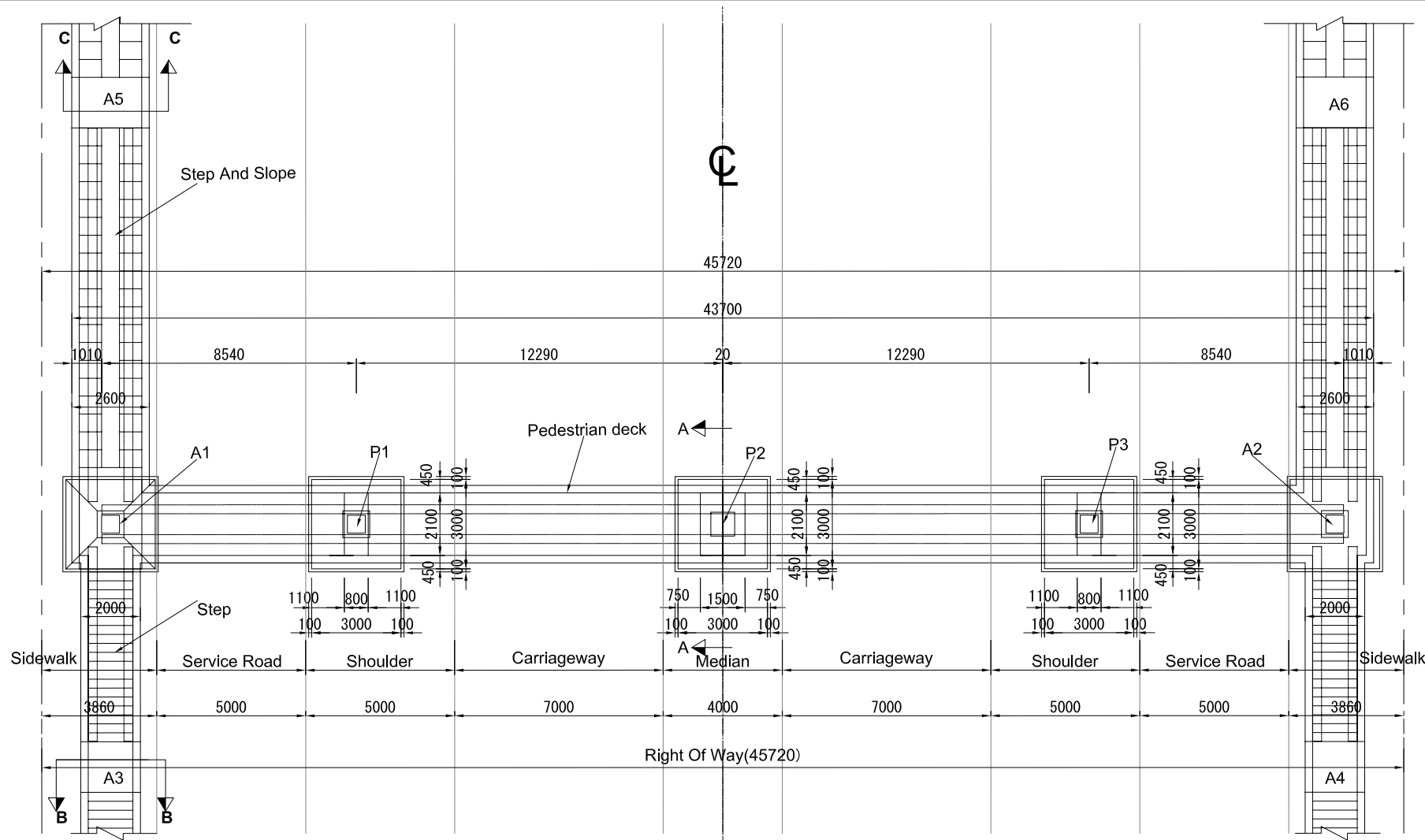

Cross Section Of Pedestrian Deck At Section A-A (Scale 1:50)

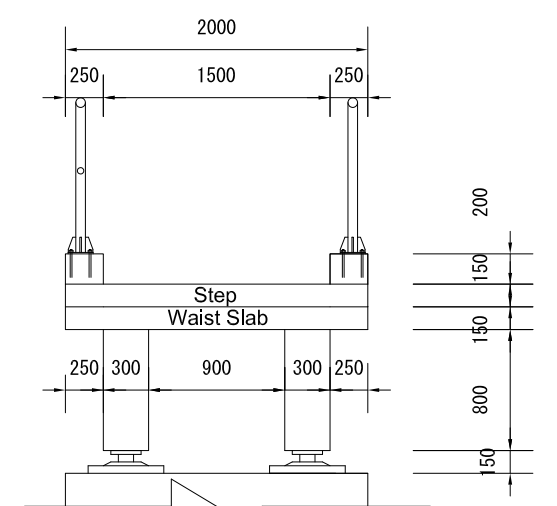



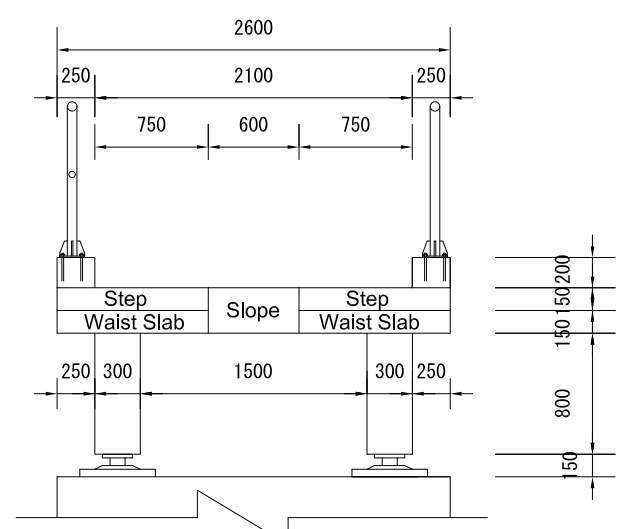

Cross Section Of Stairway Section B-B (Scale 1:50)

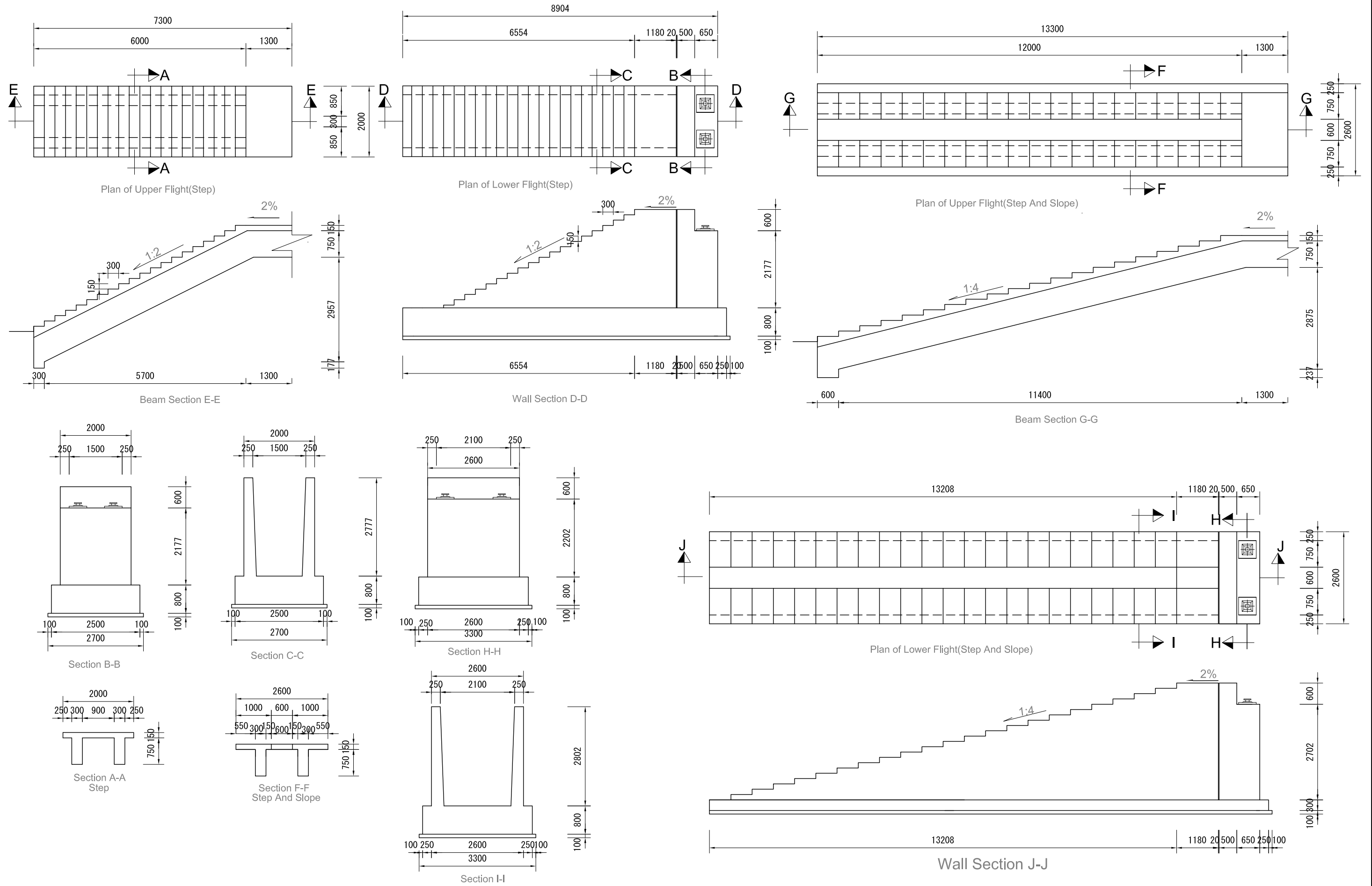

Cross Section Of Stairway With Slope Section C-C (Scale 1:50)

Clients: Japan International Cooperation Agency	Department of Roads Ministry of Physical Infrastructure and Transport Federal Democratic Republic of Nepal	Consultants: CTI Engineering International Co., Ltd. CTI Engineering Co., Ltd.	Project Title: Additional Study of the Suryabinayak-Dhulikhel Road Improvement Project	Sheet Contents: OUTLINE OF PEDESTRIAN BRIDGE AT SURYABINAYAK (0+100)	Scale: (A1size) AS SHOWN Submission Date March, 2018	SHT. NO. PB-01
--	--	--	--	--	---	-------------------



<p>Clients:</p>  Japan International Cooperation Agency	 Department of Roads Ministry of Physical Infrastructure and Transport Federal Democratic Republic of Nepal	<p>Consultants:</p>  CTI Engineering International Co., Ltd.  CTI Engineering Co., Ltd.	<p>Project Title:</p> Additional Study of the Suryabinayak-Dhulikhel Road Improvement Project	<p>Sheet Contents:</p> OUTLINE OF PEDESTRIAN BRIDGE AT SURYABINAYAK (0+100)	<p>Scale: (A1size)          AS SHOWN          Submission Date          March, 2018          SHT. NO.          PB-02</p>
--	--	--	---	---	---

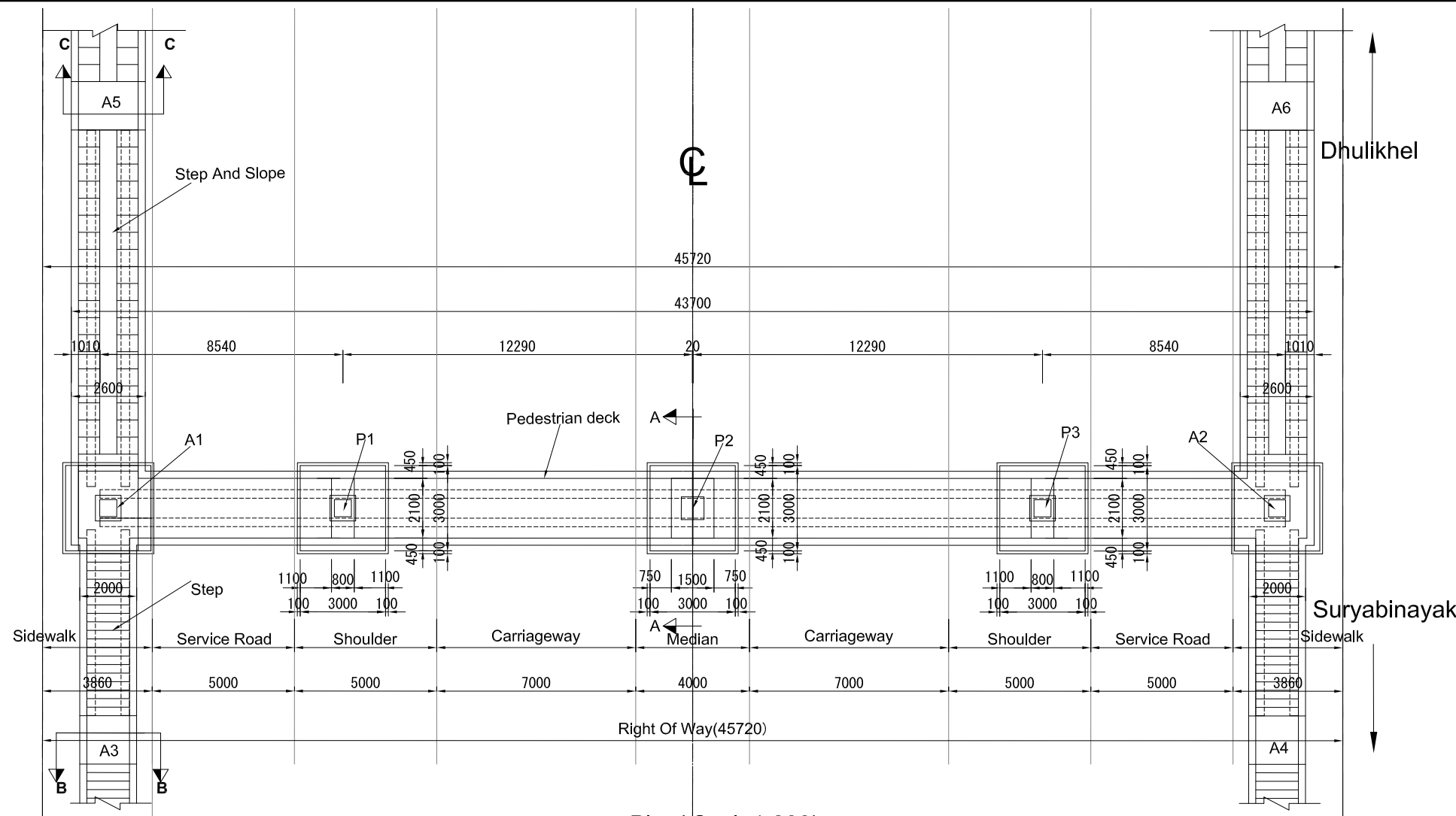

Plan( Scale1:200)

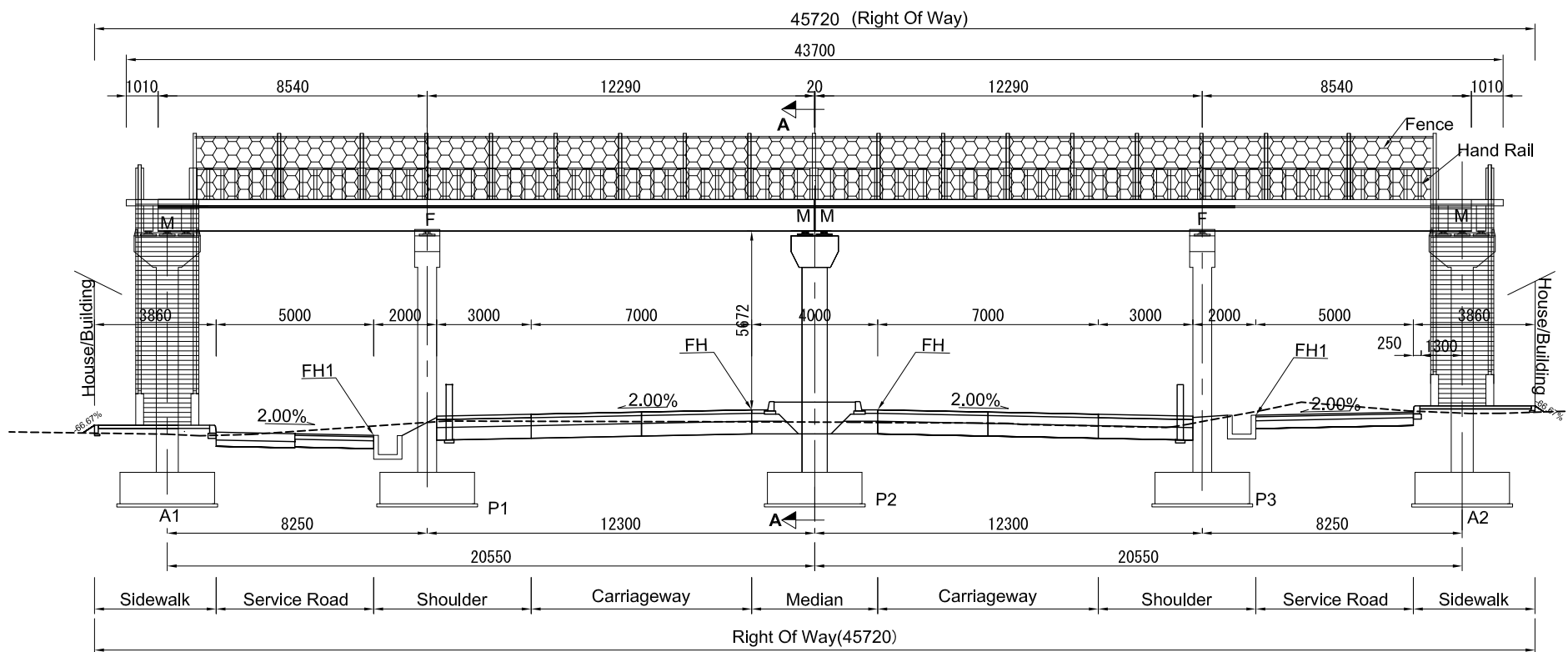

Profile(Scale1:200)

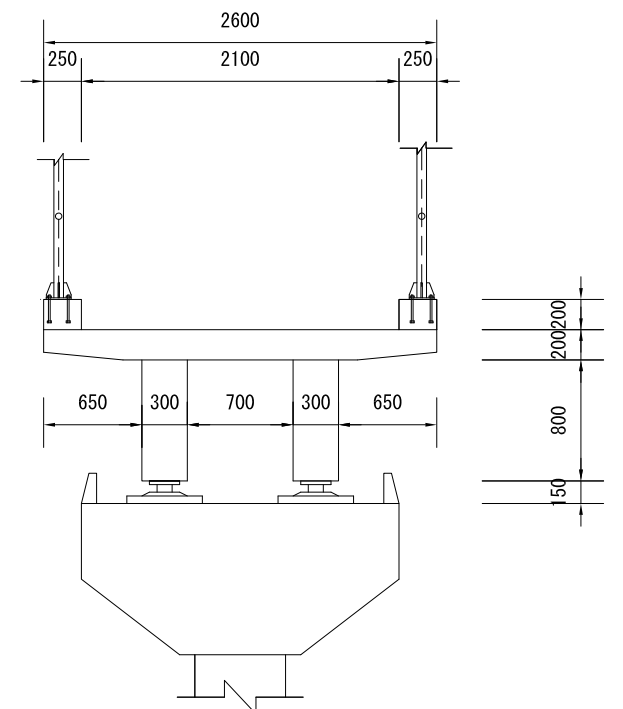



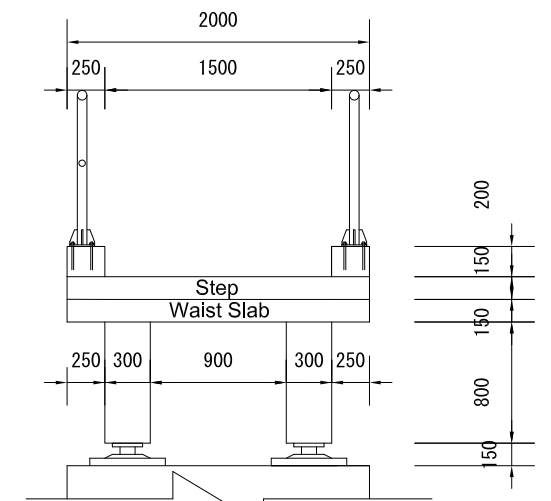

Cross Section Of Pedistrian Deck At Section A-A(Scale 1:50)

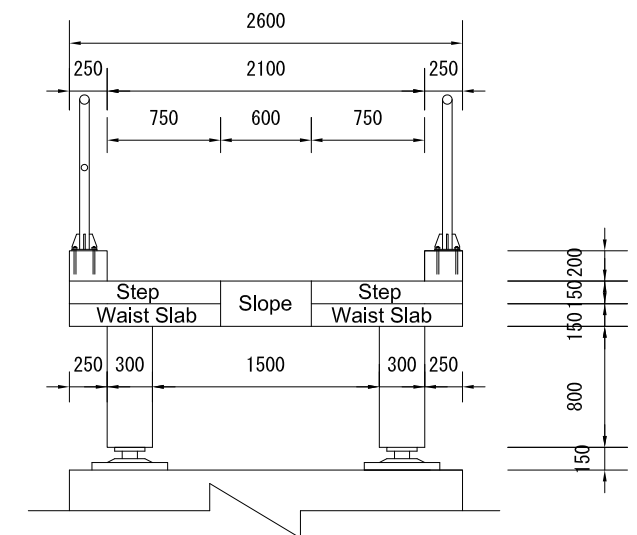





Cross Section Of Stairway Section B-B(Scale 1:50)

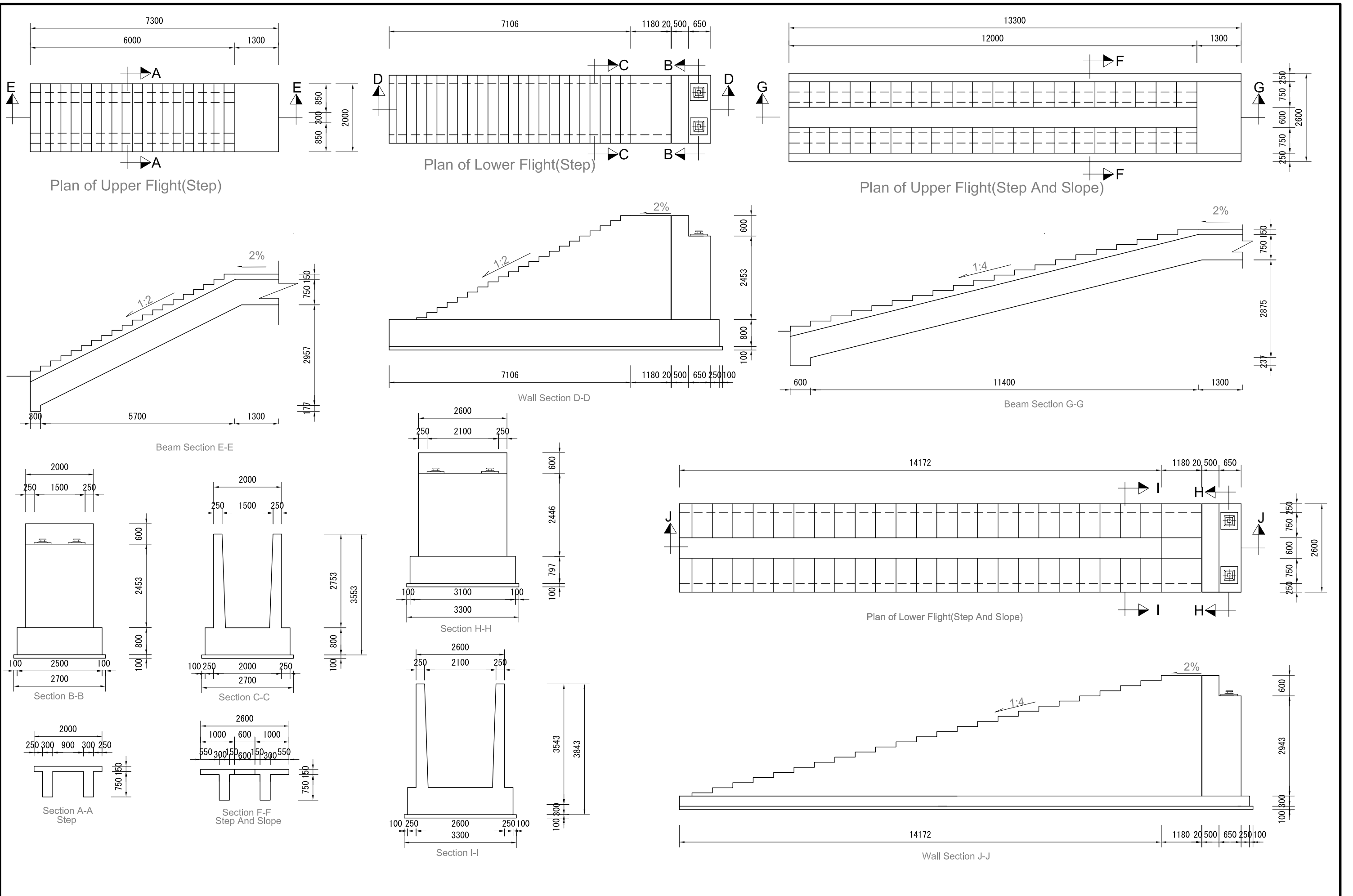

Cross Section Of Stairway With Slope Section C-C(Scale 1:50)

<p>Clients:</p>  Japan International Cooperation Agency	 Department of Roads Ministry of Physical Infrastructure and Transport Federal Democratic Republic of Nepal	<p>Consultants:</p>  CTI Engineering International Co., Ltd.  CTI Engineering Co., Ltd.	<p>Project Title:</p> Additional Study of the Suryabinayak-Dhulikhel Road Improvement Project	<p>Sheet Contents:</p> OUTLINE OF PEDESTRIAN BRIDGE AT JAGATI (0+960)	<p>Scale: (A1size)</p> AS SHOWN Submission Date March, 2018	<p>SHT. NO.</p> PB-03
--	--	--	---	---	---	-----------------------



<p>Clients:</p>  Japan International Cooperation Agency	<p>Department of Roads Ministry of Physical Infrastructure and Transport Federal Democratic Republic of Nepal</p> 	<p>Consultants:</p>  CTI Engineering International Co., Ltd.  CTI Engineering Co., Ltd.	<p>Project Title:</p> <p>Additional Study of the Suryabinayak-Dhulikhel Road Improvement Project</p>	<p>Sheet Contents:</p> <p>OUTLINE OF PEDESTRIAN BRIDGE AT JAGATI (0+960)</p>	<p>Scale: (A1size) AS SHOWN Submission Date March, 2018</p> <p>SHT. NO. PB-04</p>
--	---	--	--	--	---



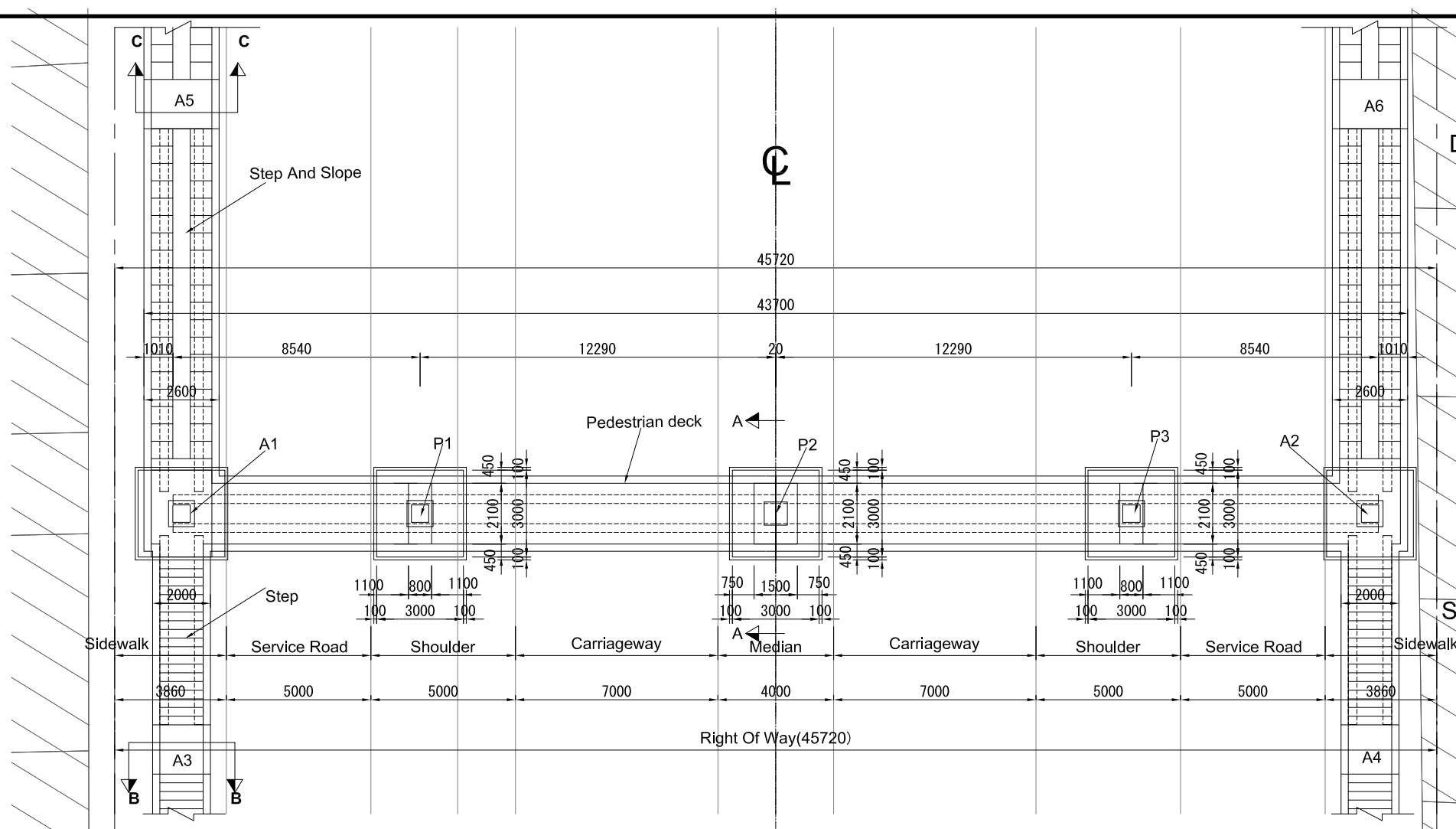

Plan( Scale1:200)

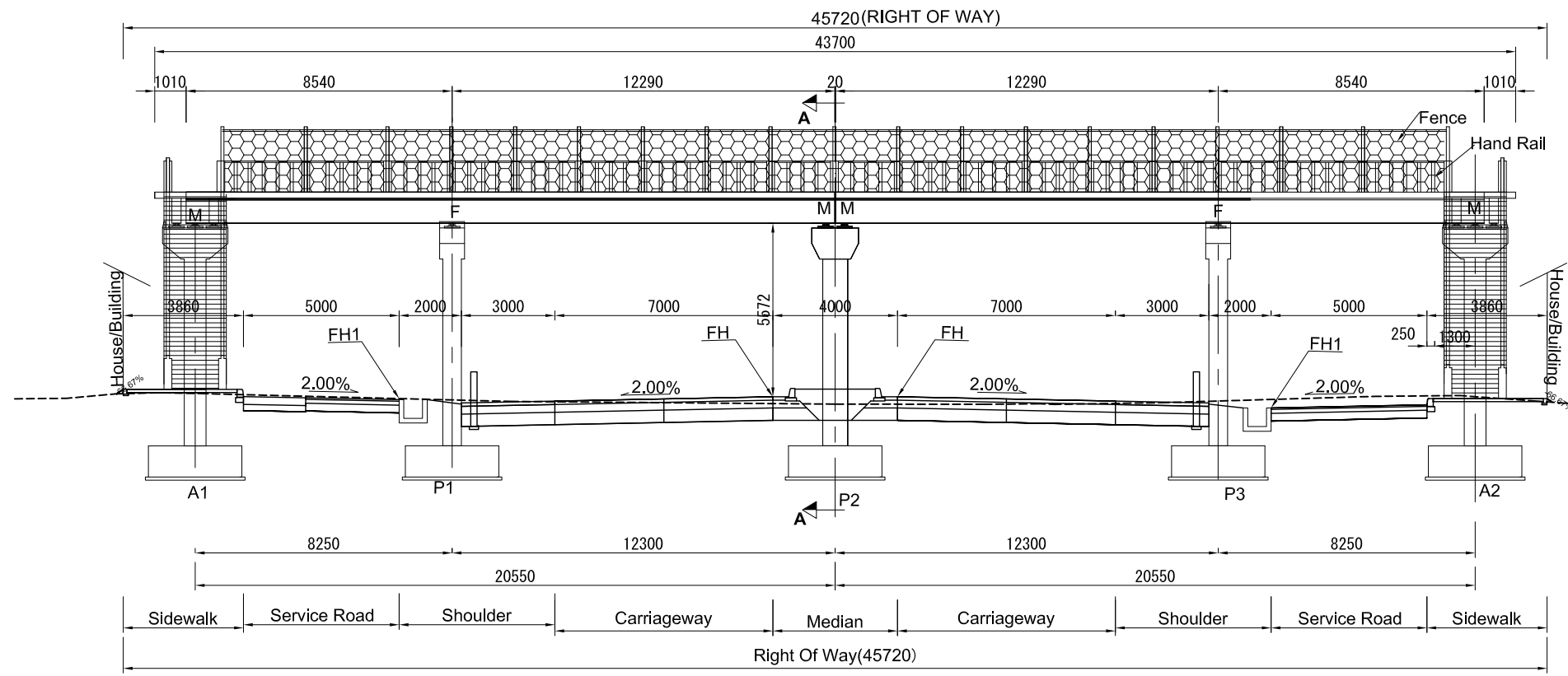

Profile(Scale1:200)

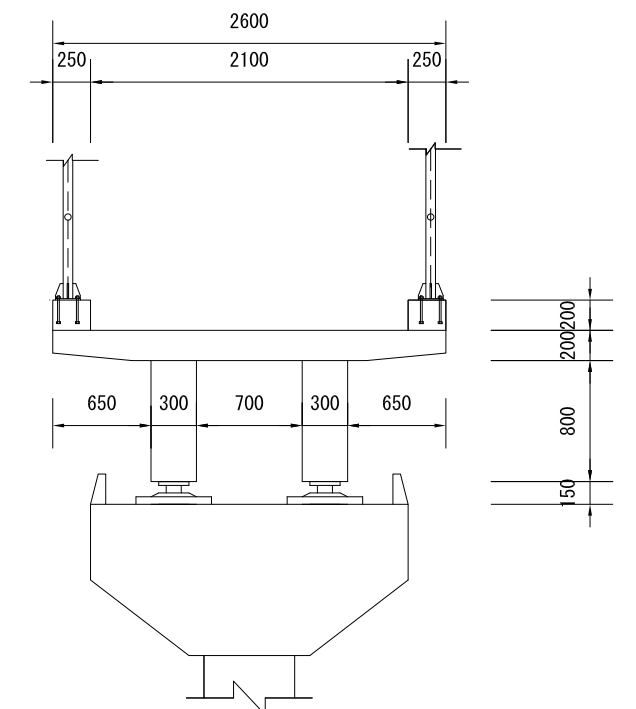

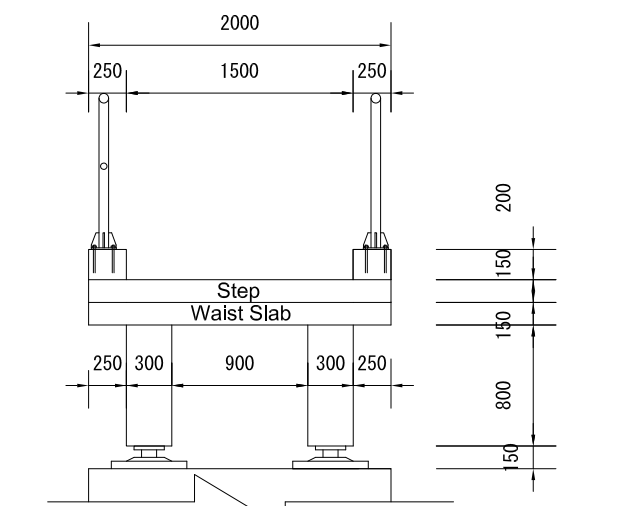

Cross Section Of Pedistrian Deck At Section A-A(Scale 1:50)

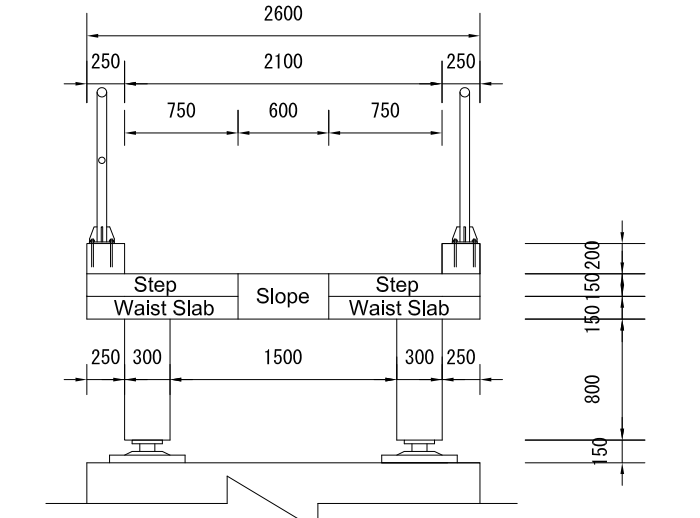

Cross Section Of Stairway Section B-B(Scale 1:50)



Cross Section Of Stairway With Slope Section C-C(Scale 1:50)

<p>Clients:</p>  Japan International Cooperation Agency	<p>Department of Roads Ministry of Physical Infrastructure and Transport Federal Democratic Republic of Nepal</p>	<p>Consultants:</p>  CTI Engineering International Co., Ltd.  CTI Engineering Co., Ltd.	<p>Project Title:</p> <p>Additional Study of the Suryabinayak-Dhulikhel Road Improvement Project</p>	<p>Sheet Contents:</p> <p>OUTLINE OF PEDESTRIAN BRIDGE AT BANEPA (11+000)</p>	<p>Scale: (A1size) AS SHOWN Submission Date March, 2018</p> <p>SHT. NO. PB-05</p>
--	---	--	--	---	---

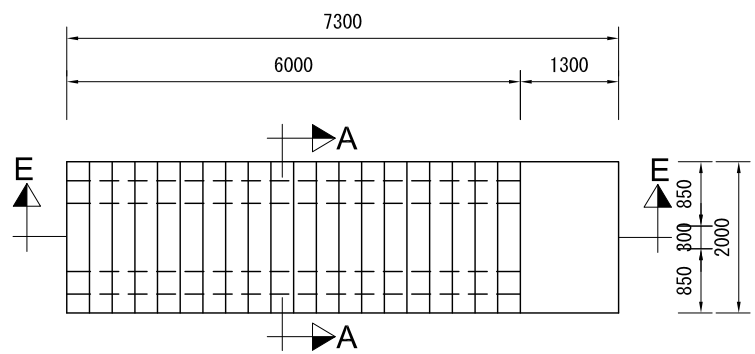

Plan of Upper Flight(Step)

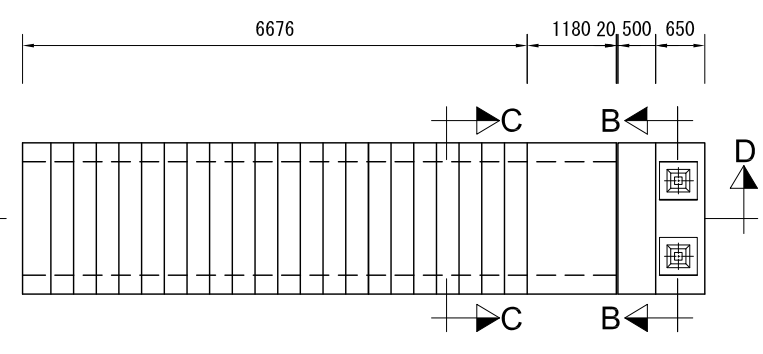

Plan of Lower Flight(Step)

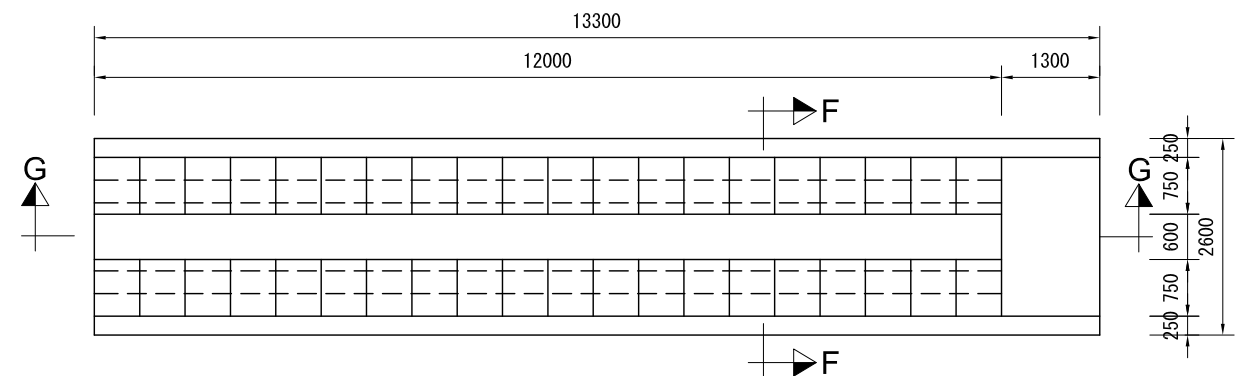

Plan of Upper Flight(Step And Slope)

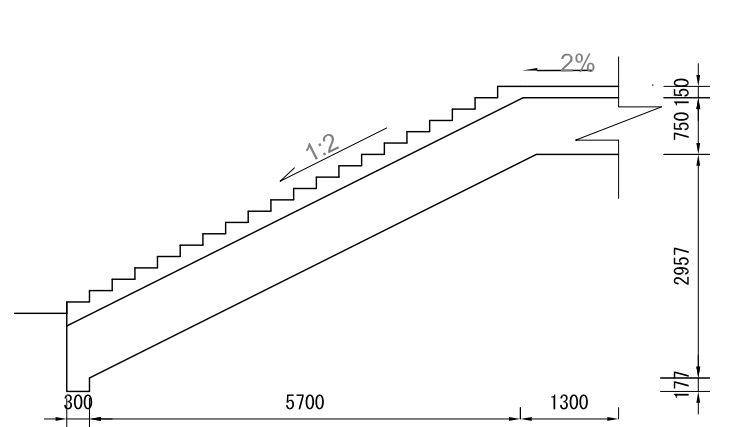

Beam Section E-E

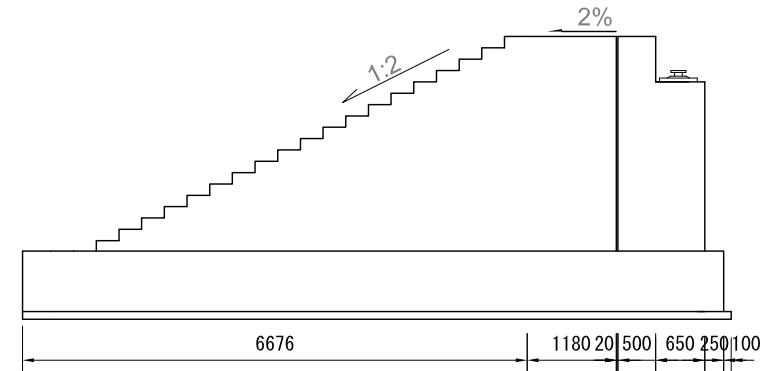

Wall Section D-D

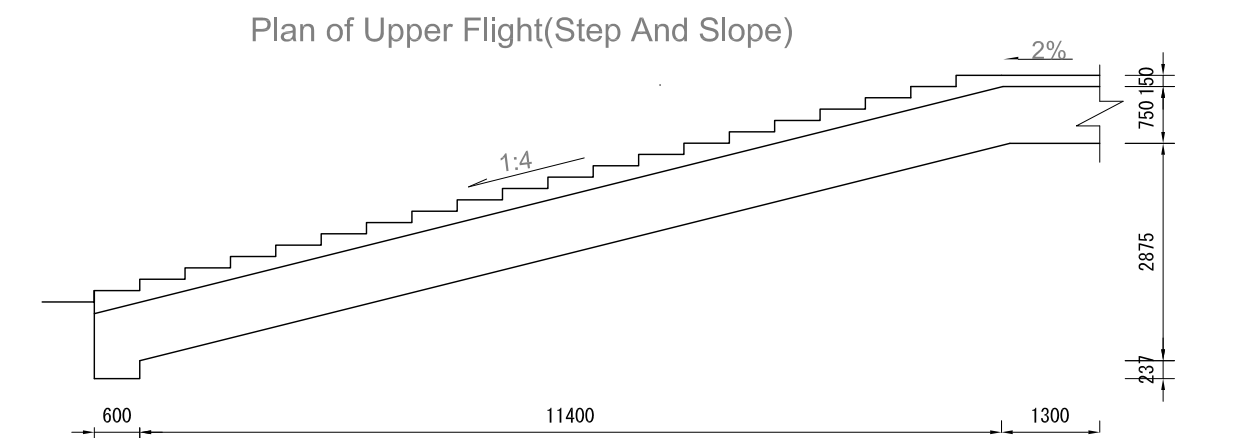

Beam Section G-G

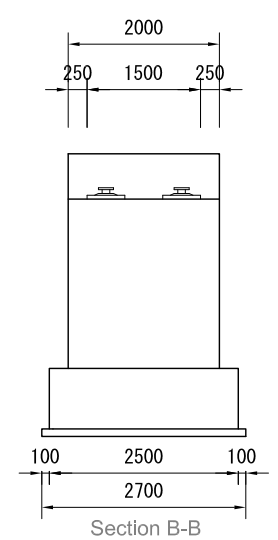

Section B-B

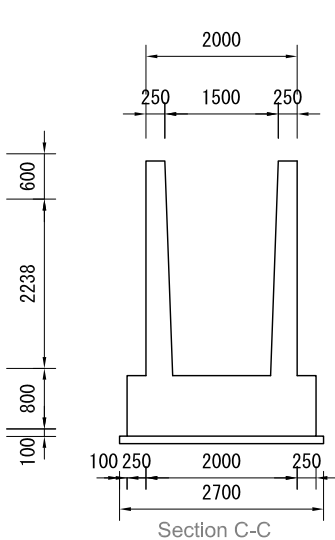

Section C-C

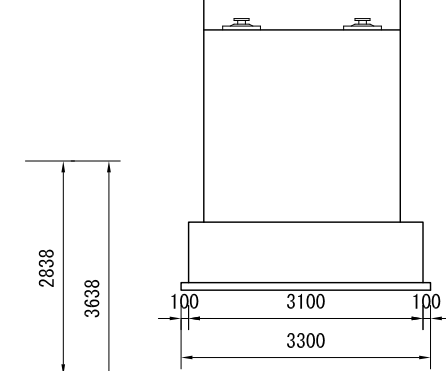

Section H-H

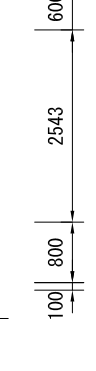

Section I-I

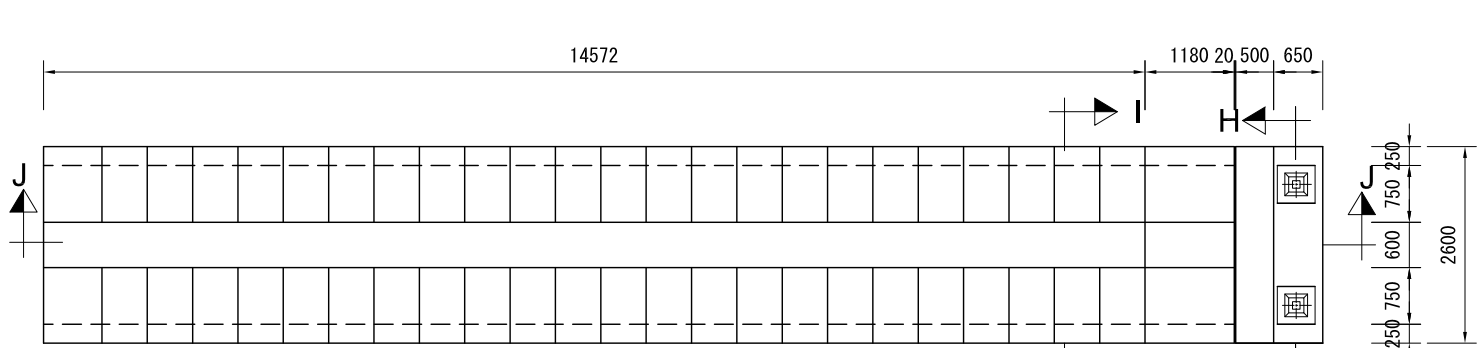

Plan of Lower Flight(Step And Slope)

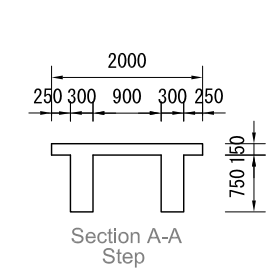



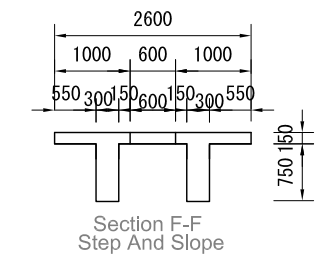

Section A-A Step

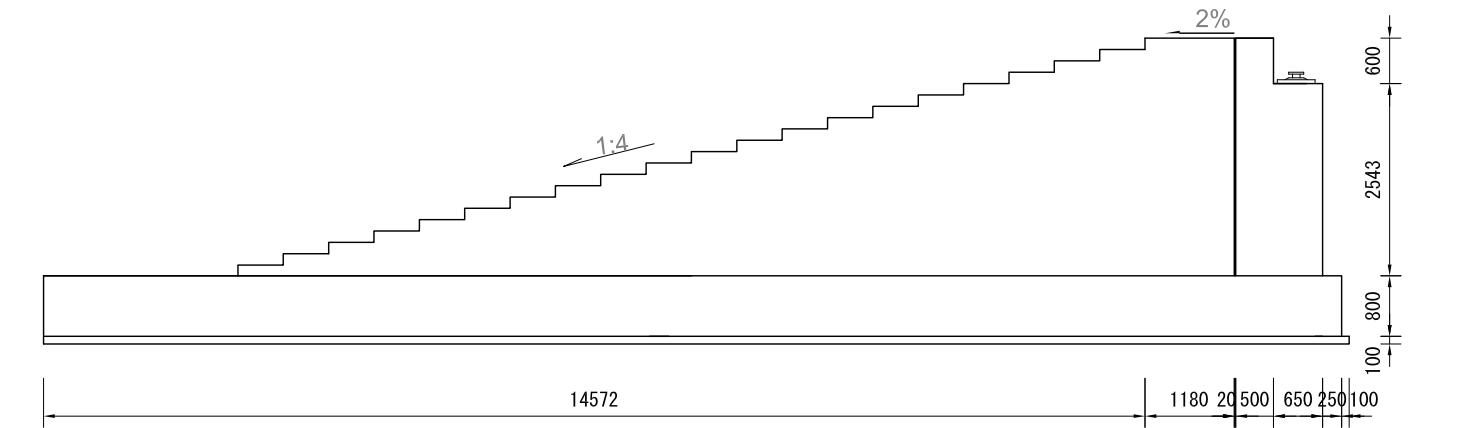

Section F-F Step And Slope



Wall Section J-J

<p>Clients:</p>  Japan International Cooperation Agency	 Department of Roads Ministry of Physical Infrastructure and Transport Federal Democratic Republic of Nepal	<p>Consultants:</p>  CTI Engineering International Co., Ltd.  CTI Engineering Co., Ltd.	<p>Project Title:</p> Additional Study of the Suryabinayak-Dhulikhel Road Improvement Project	<p>Sheet Contents:</p> OUTLINE OF PEDESTRIAN BRIDGE AT BANEPA (11+000)	<p>Scale: (A1size)</p> AS SHOWN Submission Date March, 2018 SHT. NO. PB-06
--	--	--	---	--	--

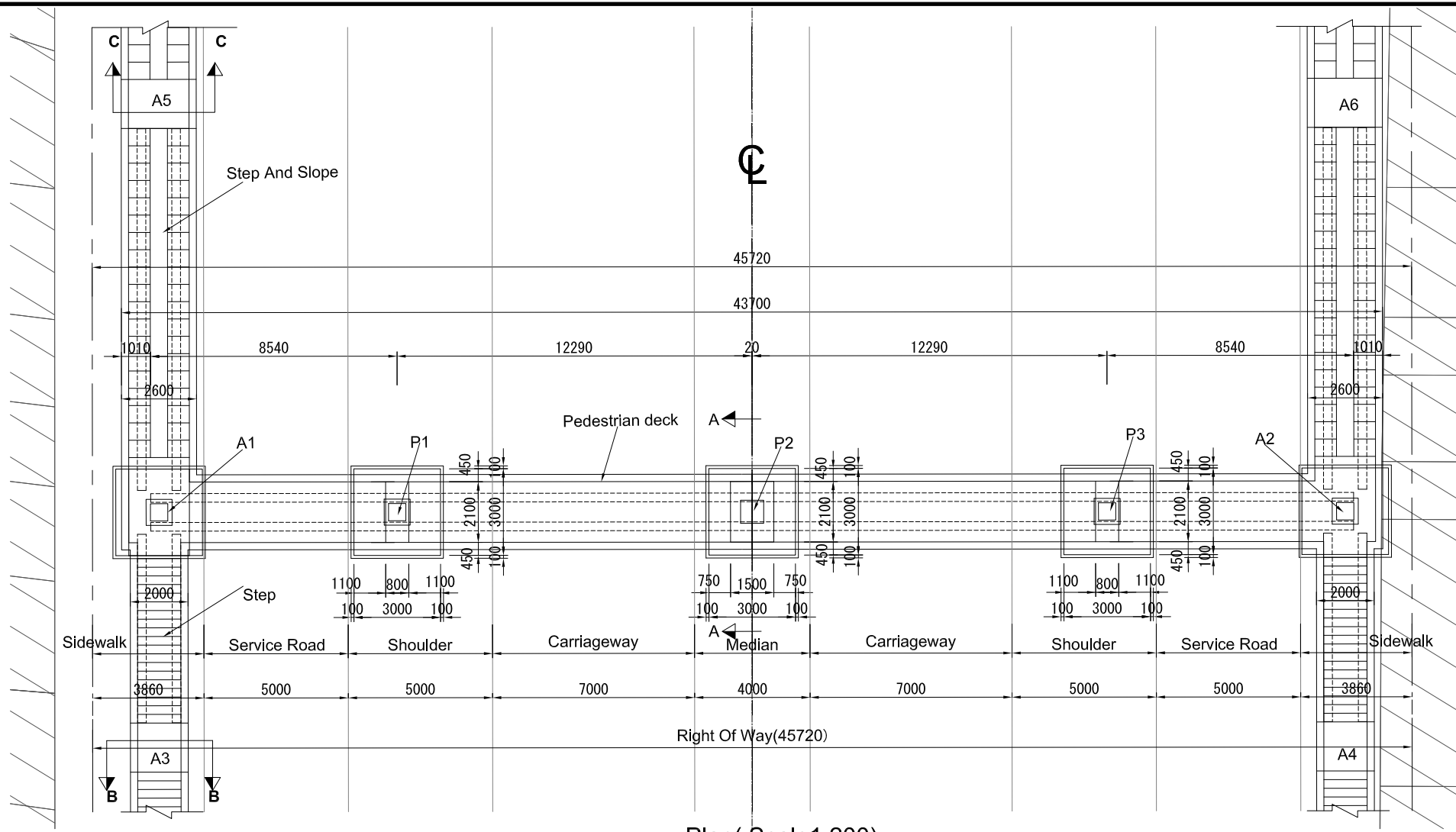

Plan( Scale1:200)

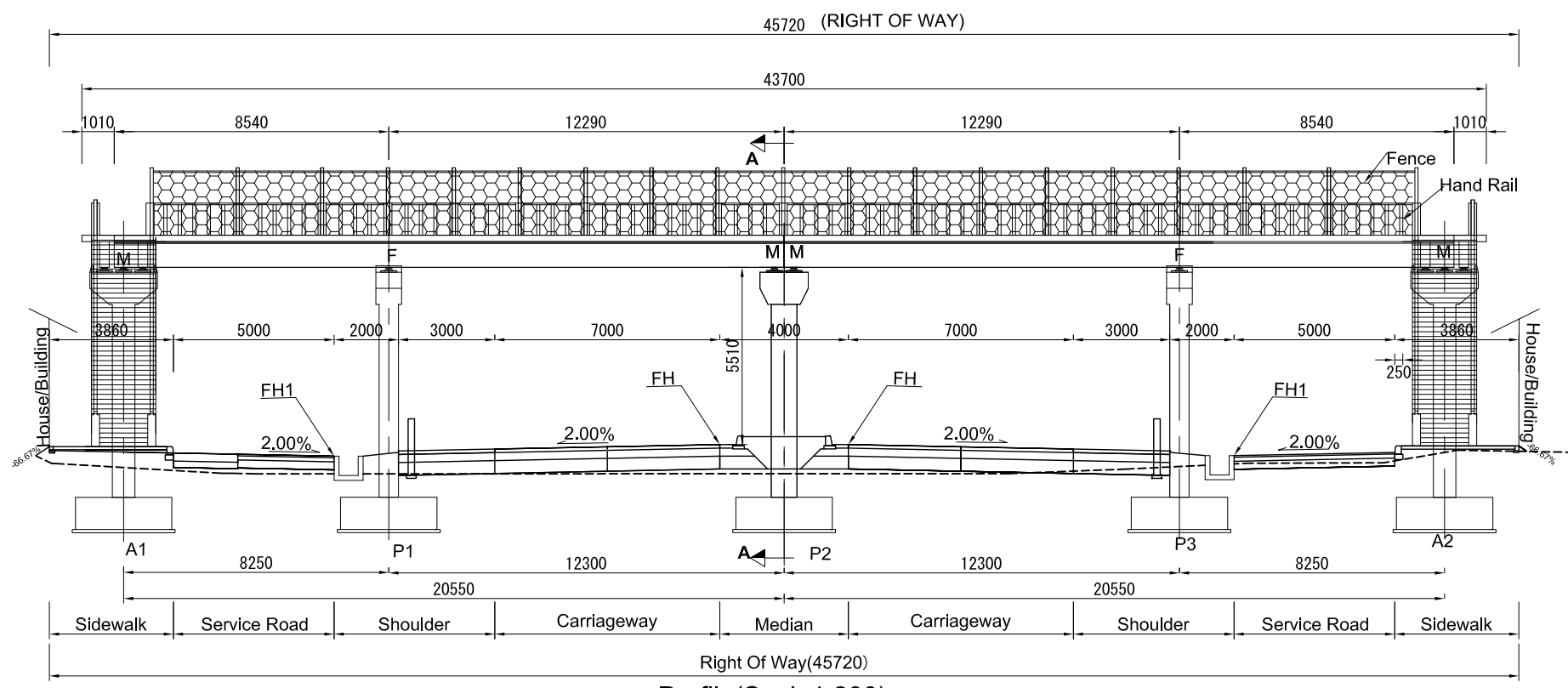

Profile(Scale1:200)

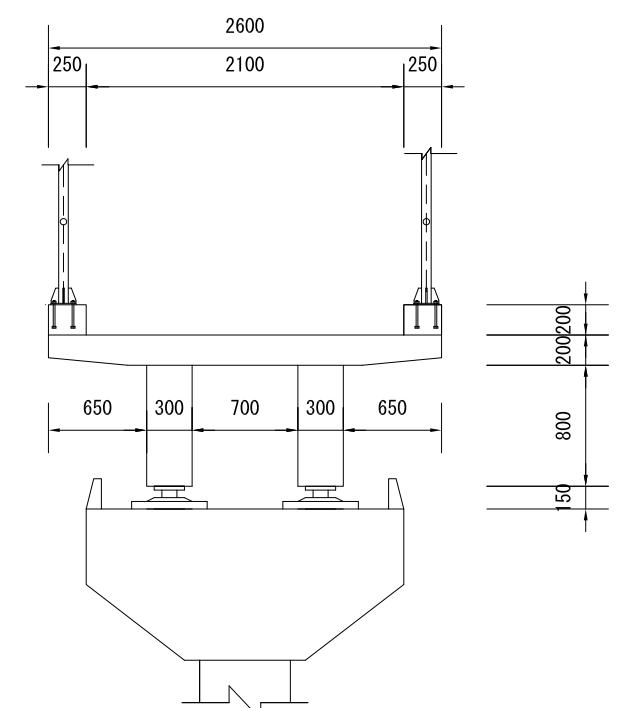

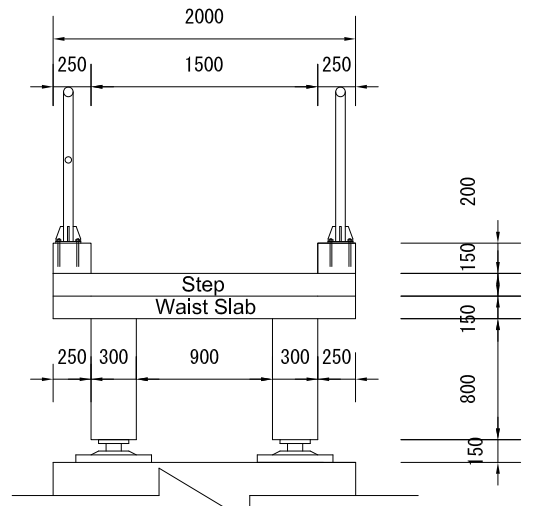

Cross Section Of Pedestrian Deck At Section A-A(Scale 1:50)

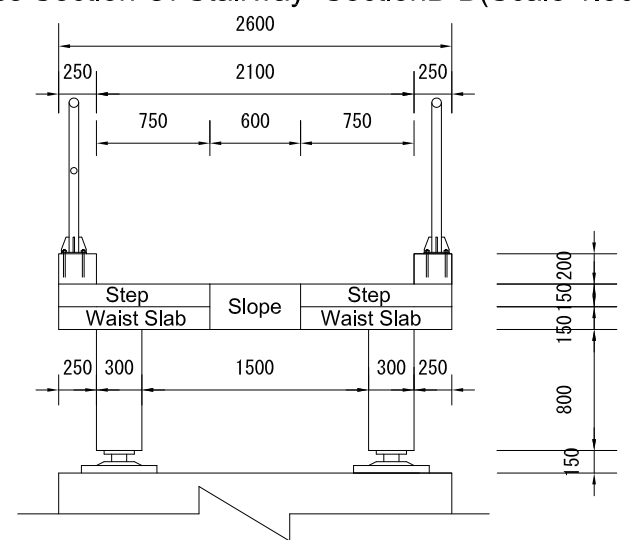

Cross Section Of Stairway Section B-B(Scale 1:50)



Cross Section Of Stairway With Slope Section C-C(Scale 1:50)

<p>Clients:</p>  Japan International Cooperation Agency	 Department of Roads Ministry of Physical Infrastructure and Transport Federal Democratic Republic of Nepal	<p>Consultants:</p>  CTI Engineering International Co., Ltd. CTI Engineering Co., Ltd.	<p>Project Title:</p> Additional Study of the Suryabinayak-Dhulikhel Road Improvement Project	<p>Sheet Contents:</p> OUTLINE OF PEDESTRIAN BRIDGE AT BANEPA (11+340)	<p>Scale: (A1size) AS SHOWN Submission Date March, 2018</p> <p>SHT. NO. PB-07</p>
--	--	--	---	--	---

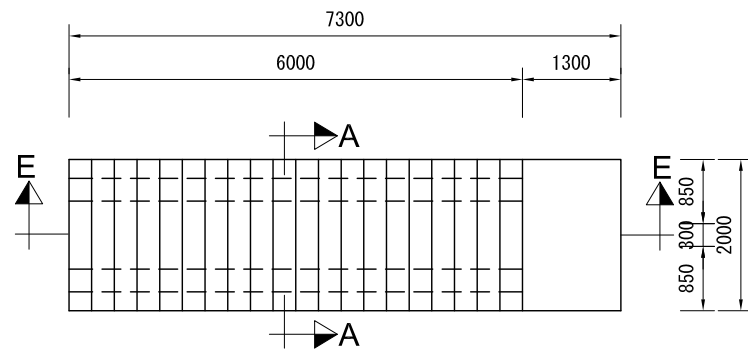

Plan of Upper Flight(Step)

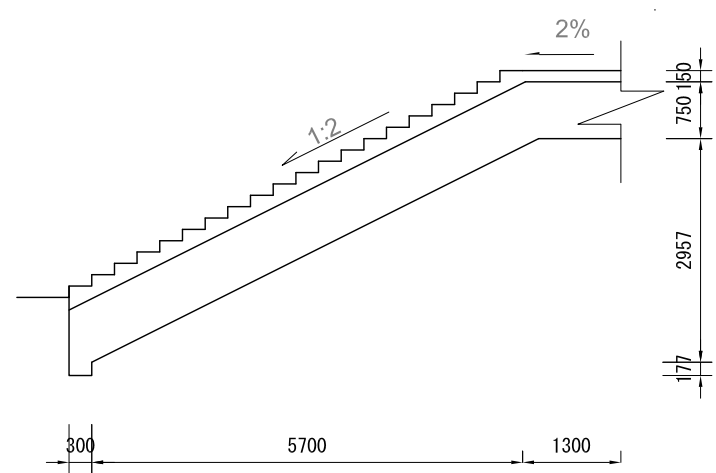

Beam Section E-E

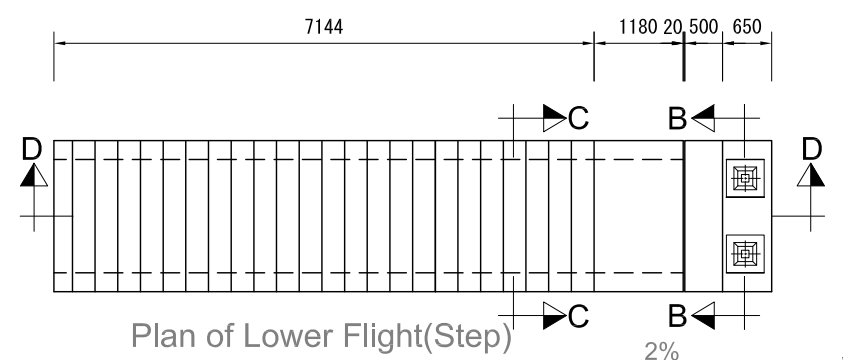

Plan of Lower Flight(Step)

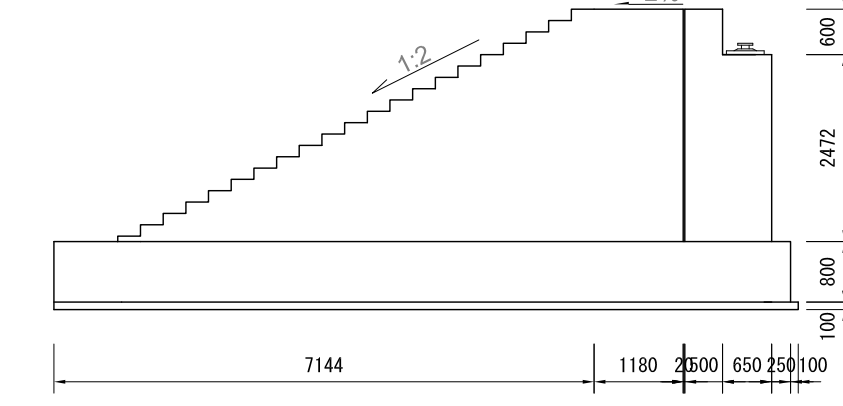

Wall Section D-D

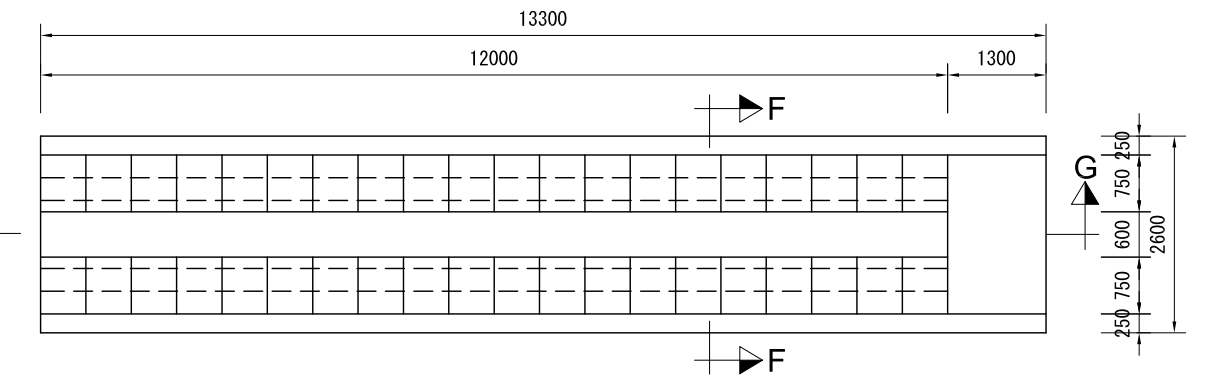

Plan of Upper Flight(Step And Slope)

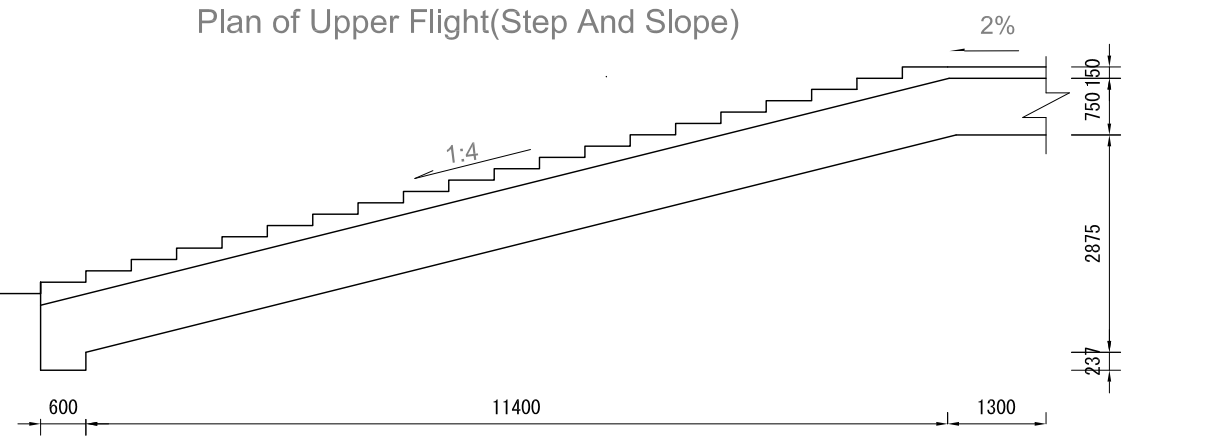

Beam Section G-G

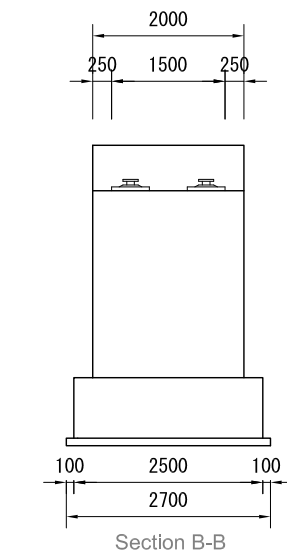

Section B-B

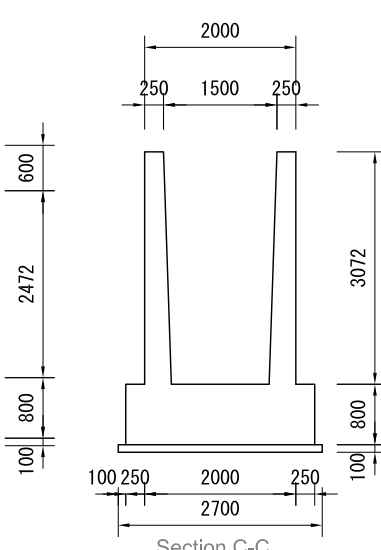

Section C-C

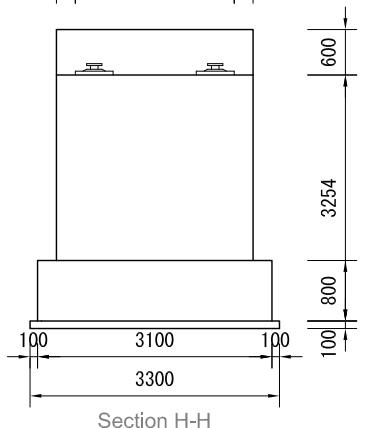

Section H-H

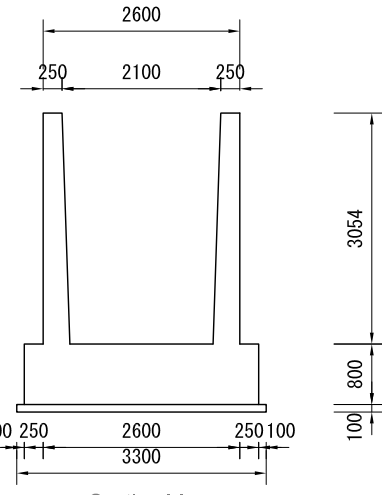

Section I-I

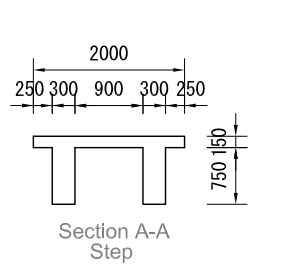

Section A-A Step

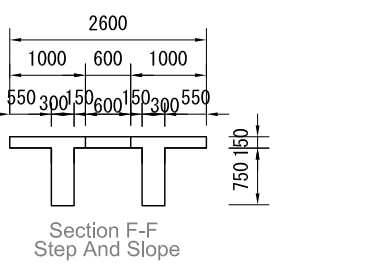

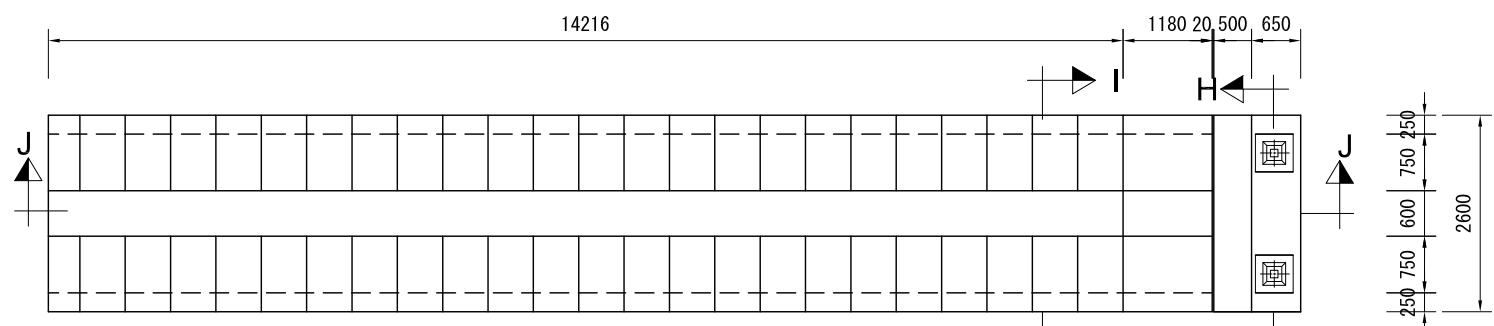

Section F-F Step And Slope

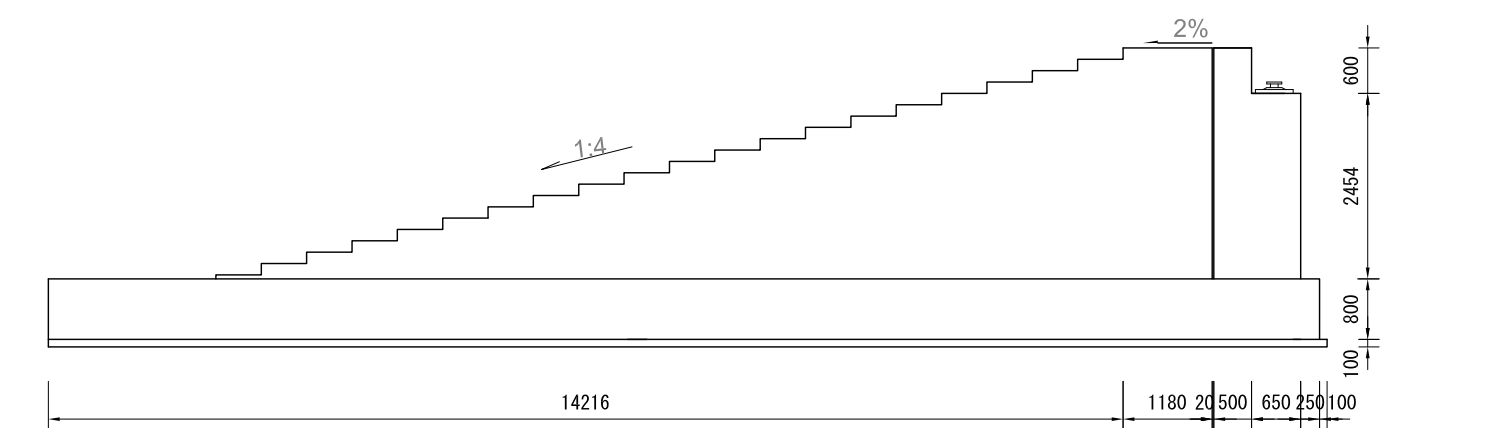

Plan of Lower Flight(Step And Slope)



Wall Section J-J

<p>Clients:</p>  Japan International Cooperation Agency	 Department of Roads Ministry of Physical Infrastructure and Transport Federal Democratic Republic of Nepal	<p>Consultants:</p>  CTI Engineering International Co., Ltd. CTI Engineering Co., Ltd.	<p>Project Title:</p> Additional Study of the Suryabinayak-Dhulikhel Road Improvement Project	<p>Sheet Contents:</p> OUTLINE OF PEDESTRIAN BRIDGE AT BANEPA (11+340)	<p>Scale: (A1size)</p> AS SHOWN Submission Date March, 2018 SHT. NO. PB-08
--	--	--	---	--	---



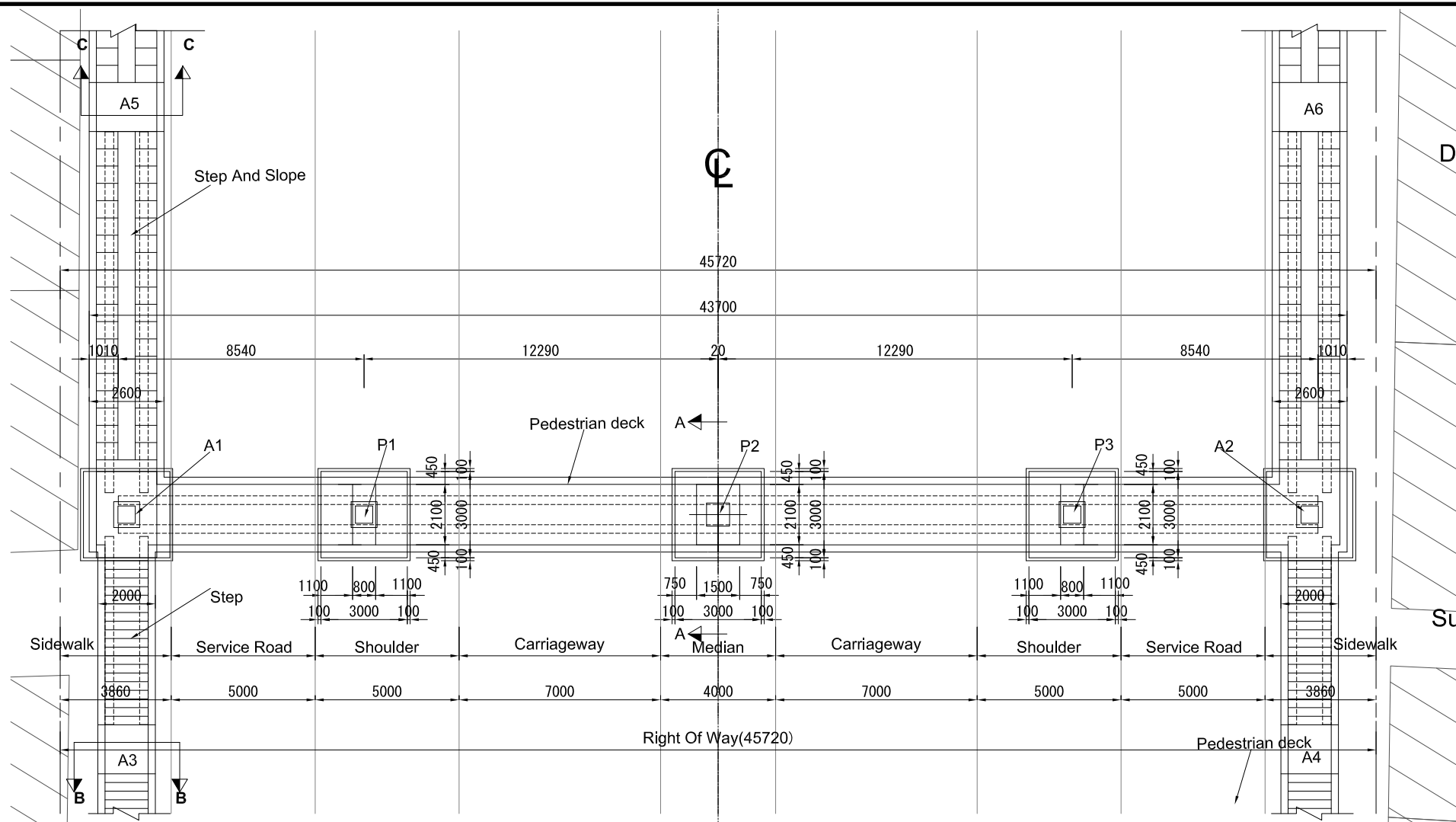

Plan (Scale 1:200)  
45720 (RIGHT OF WAY)  
43700

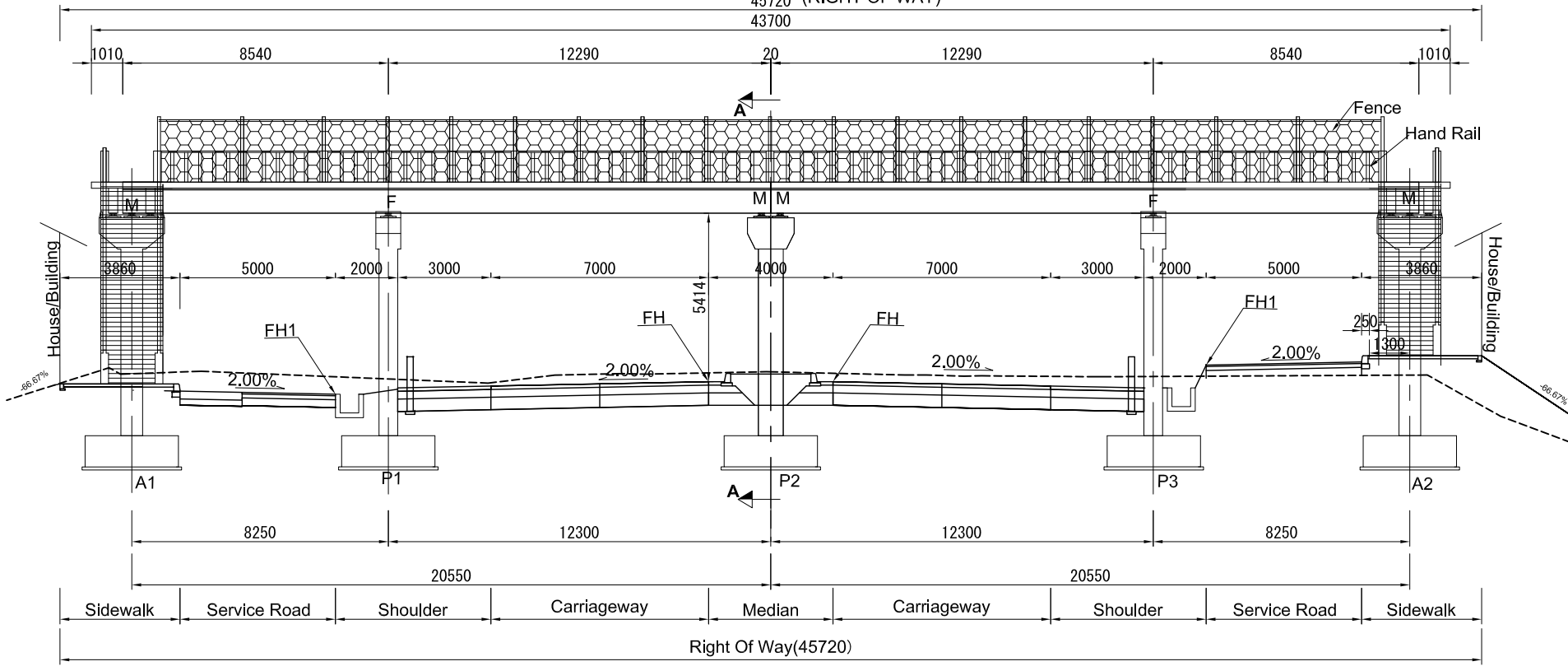

Profile (Scale 1:200)

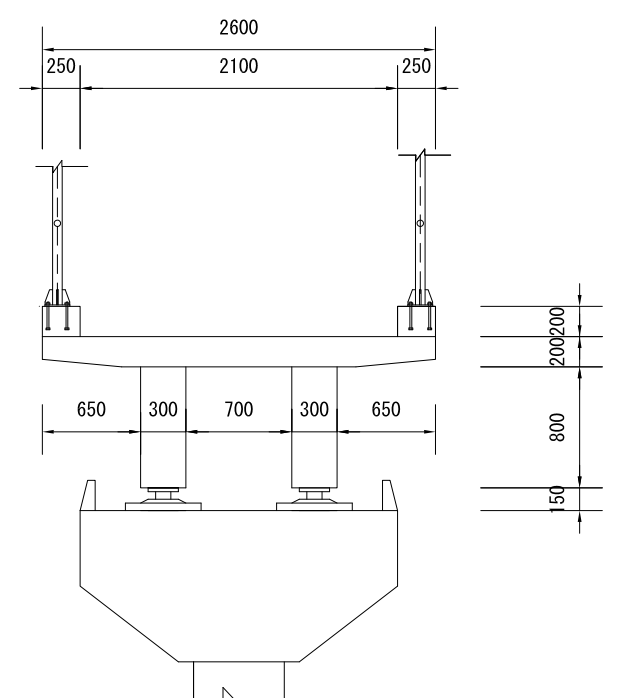

Cross Section Of Pedistrian Deck At Section A-A (Scale 1:50)

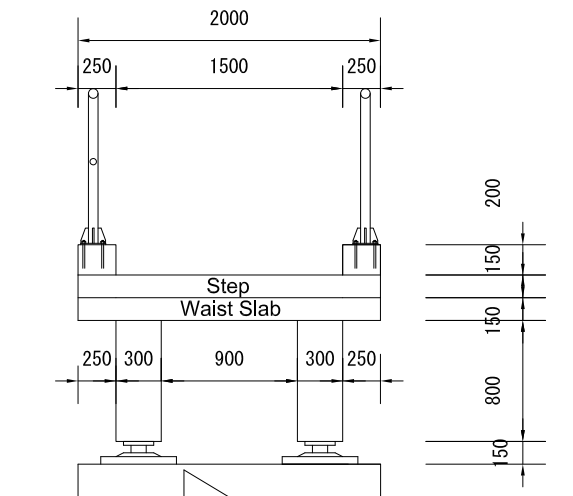

Cross Section Of Stairway Section B-B (Scale 1:50)

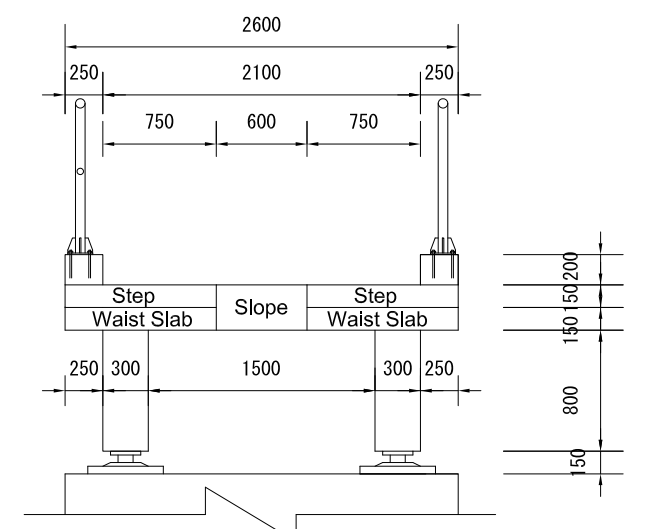

Cross Section Of Stairway With Slope Section C-C (Scale 1:50)

<p>Clients: Japan International Cooperation Agency</p>	<p>Department of Roads Ministry of Physical Infrastructure and Transport Federal Democratic Republic of Nepal</p>	<p>Consultants: CTI Engineering International Co., Ltd. CTI Engineering Co., Ltd.</p>	<p>Project Title: Additional Study of the Suryabinayak-Dhulikhel Road Improvement Project</p>	<p>Sheet Contents: OUTLINE OF PEDESTRIAN BRIDGE AT BANEPA (11+820)</p>	<p>Scale: (A1size) AS SHOWN Submission Date March, 2018 SHT. NO. PB-09</p>
--	---	---	---	--	--

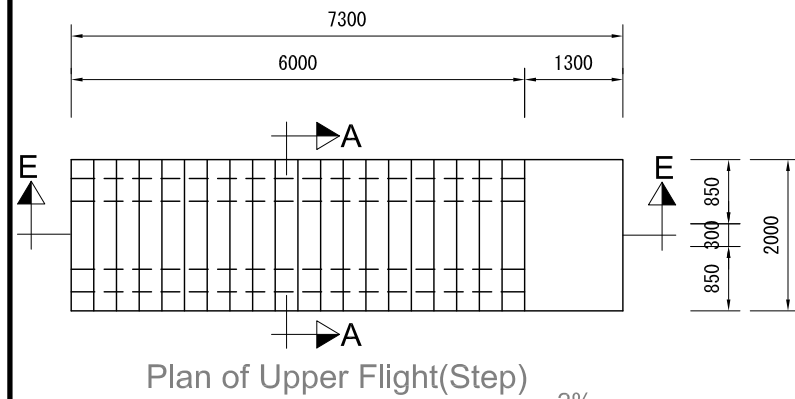

Plan of Upper Flight(Step)

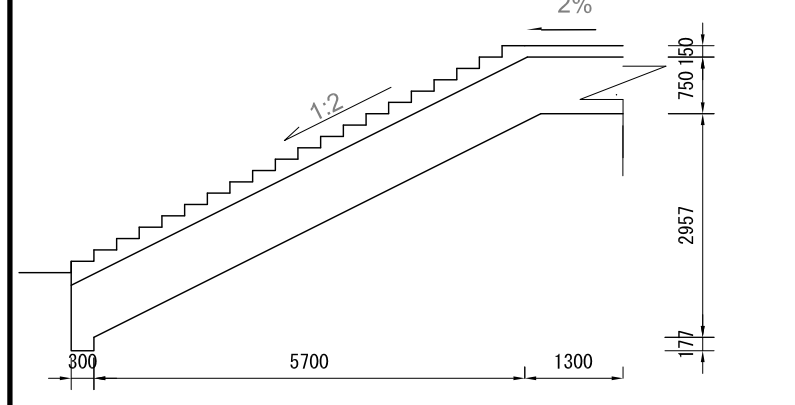

Beam Section E-E

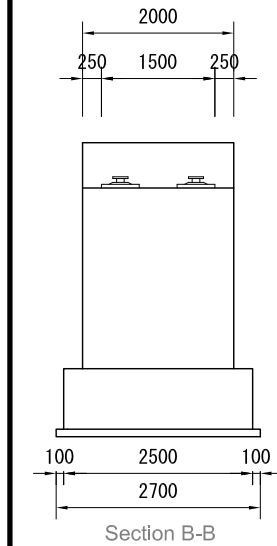

Section B-B

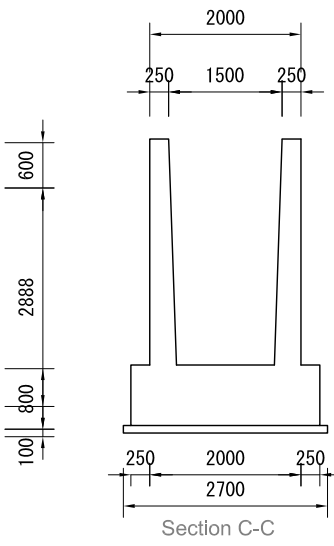

Section C-C

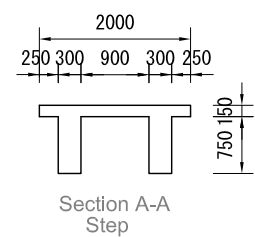

Section A-A Step

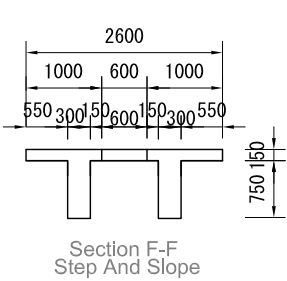

Section F-F Step And Slope

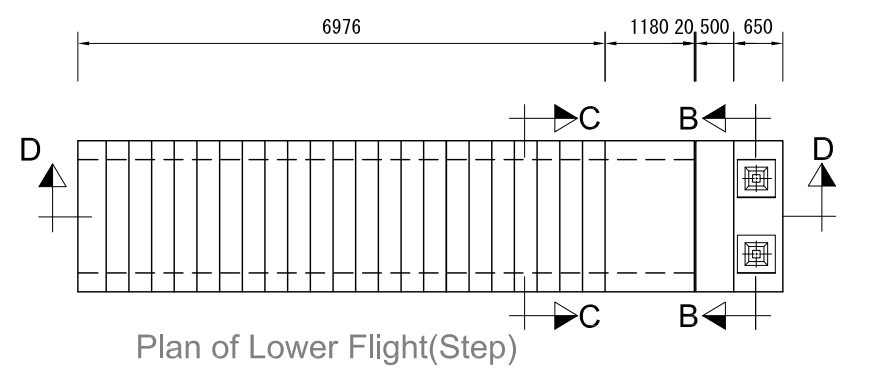

Plan of Lower Flight(Step)

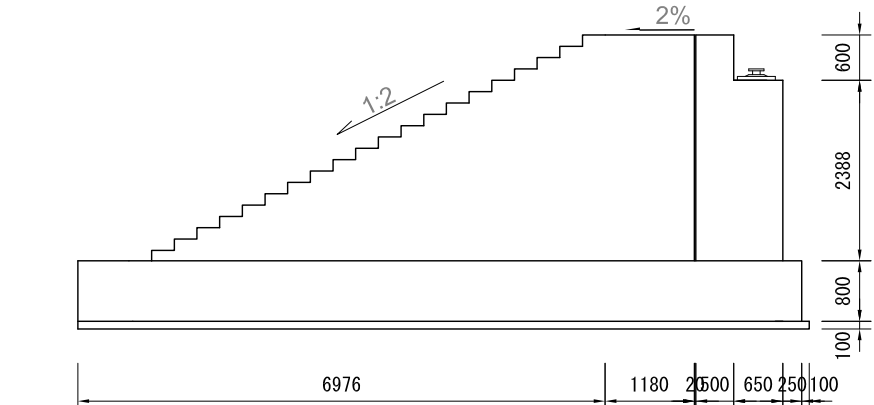

Wall Section D-D

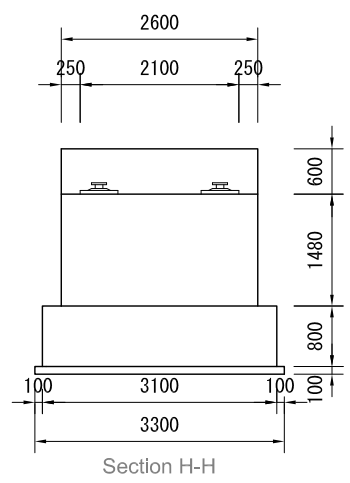

Section H-H

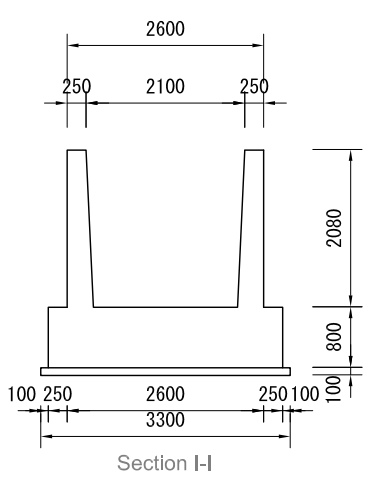

Section I-I

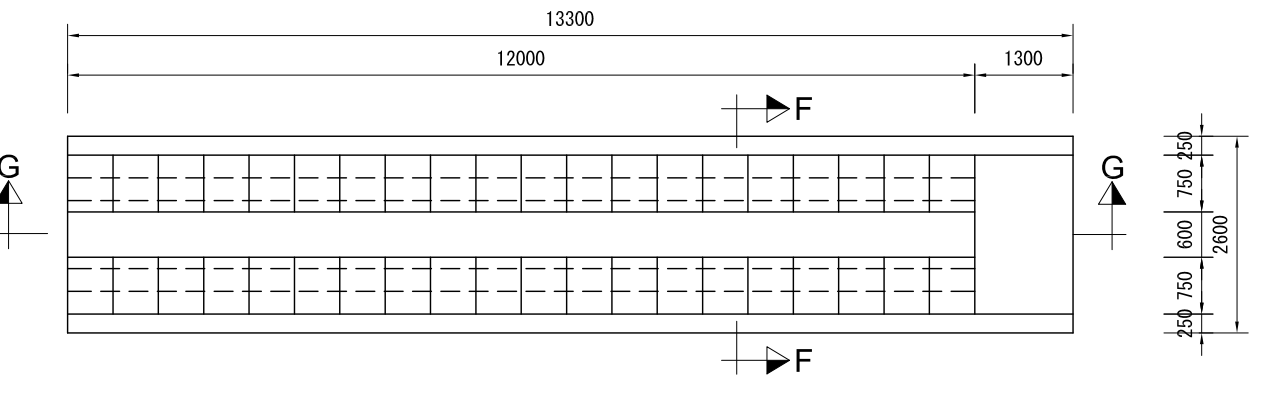

Plan of Upper Flight(Step And Slope)

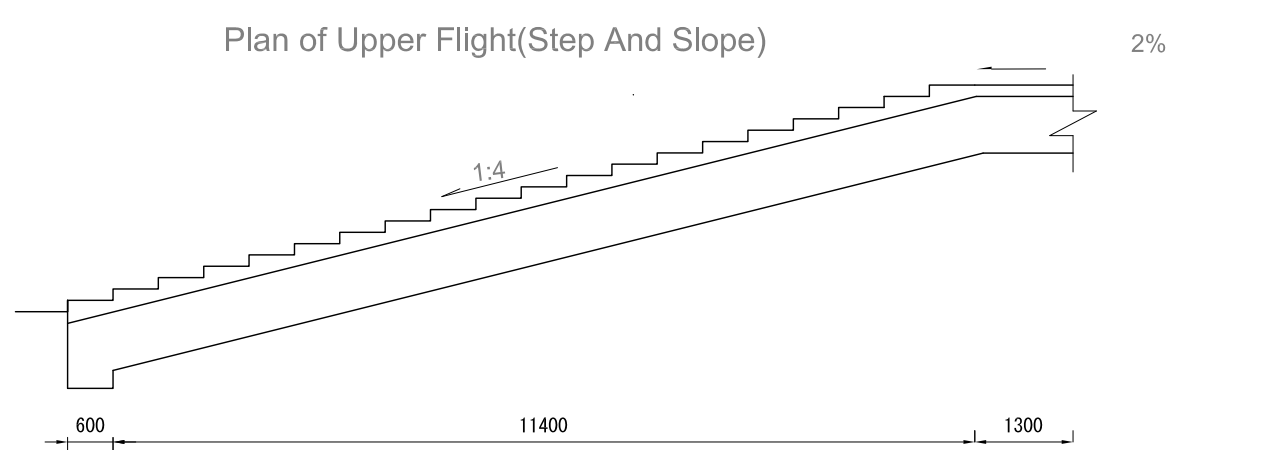

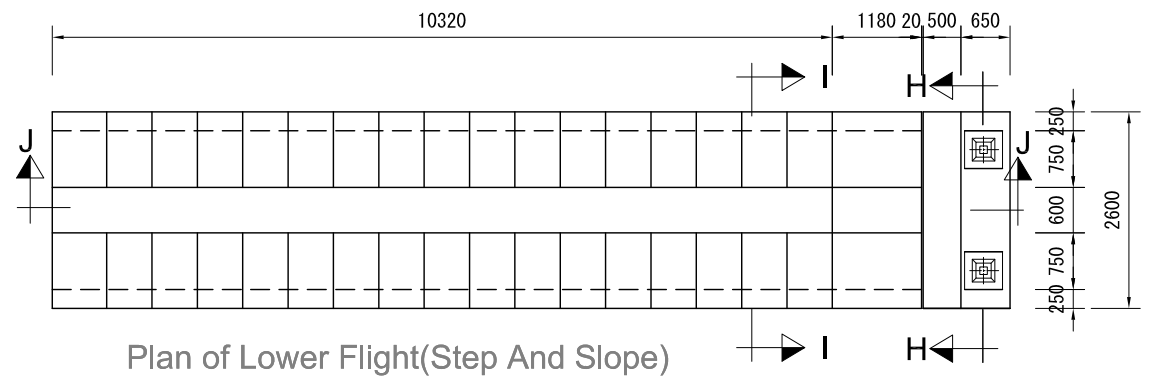

Beam Section G-G

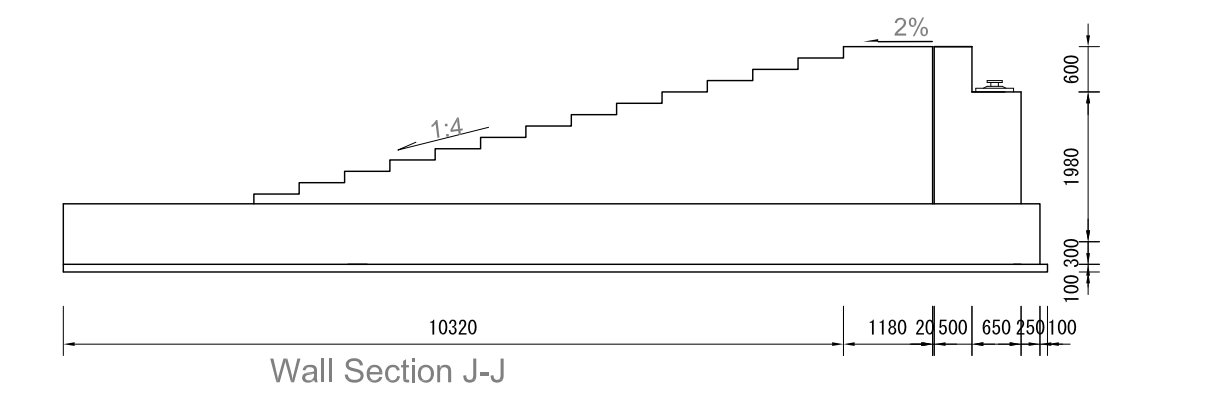

Plan of Lower Flight(Step And Slope)



Wall Section J-J

<p>Clients:</p>  Japan International Cooperation Agency	 Department of Roads Ministry of Physical Infrastructure and Transport Federal Democratic Republic of Nepal	<p>Consultants:</p>  CTI Engineering International Co., Ltd. CTI Engineering Co., Ltd.	<p>Project Title:</p> Additional Study of the Suryabinayak-Dhulikhel Road Improvement Project	<p>Sheet Contents:</p> OUTLINE OF PEDESTRIAN BRIDGE AT BANEPA (11+820)	<p>Scale: (A1size)</p> AS SHOWN Submission Date March, 2018 SHT. NO. PB-10
--	--	--	---	--	---

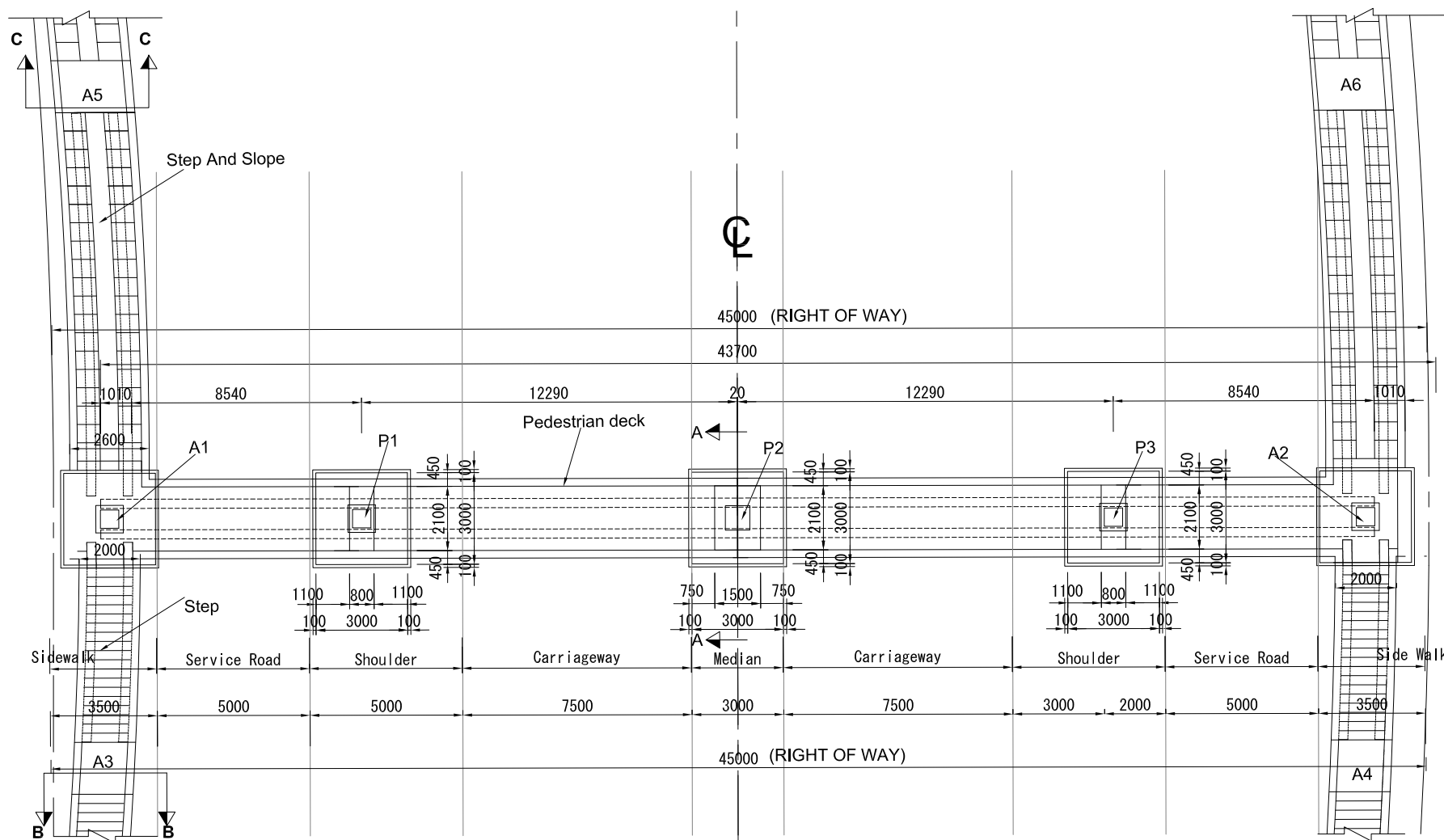

Plan( Scale1:200)

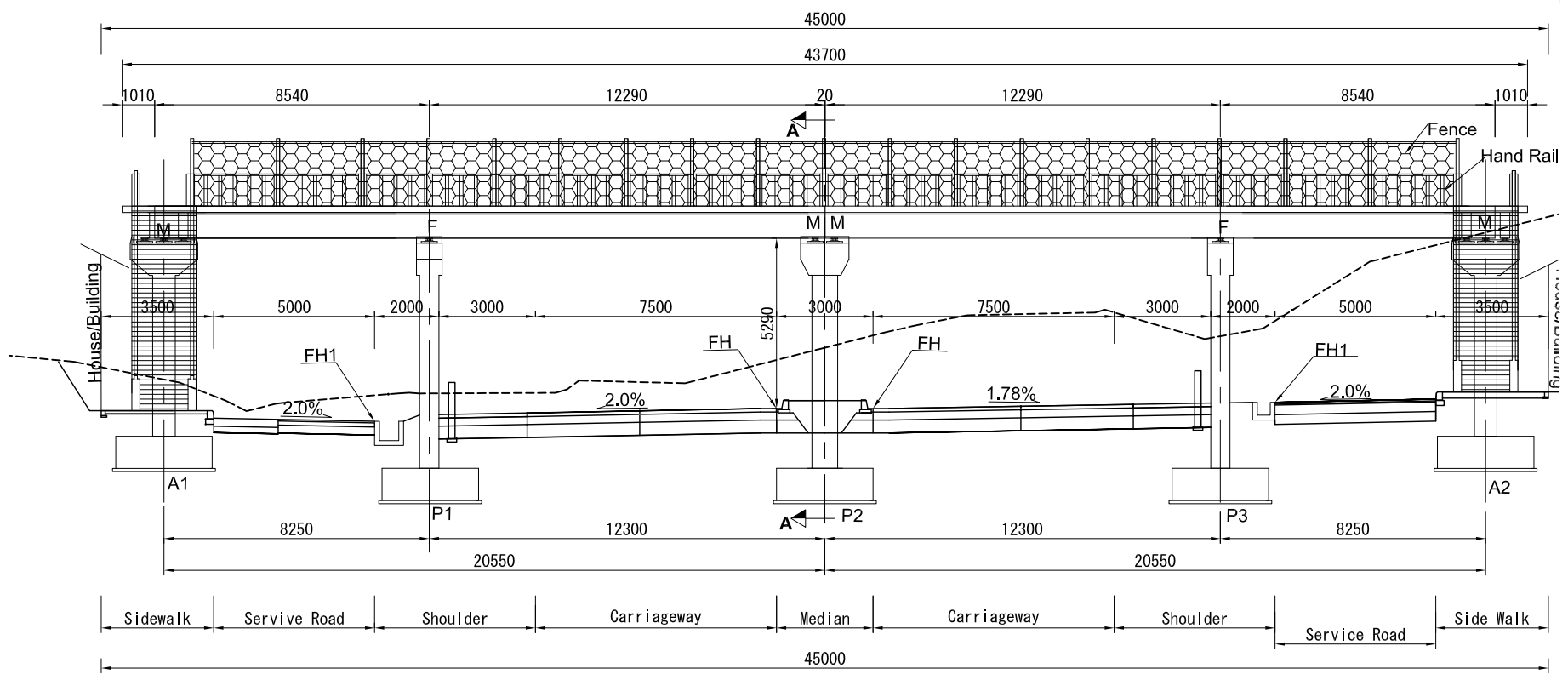

Profile(Scale1:200)

Dhulikhel  
↑

Suryabinayak  
↓

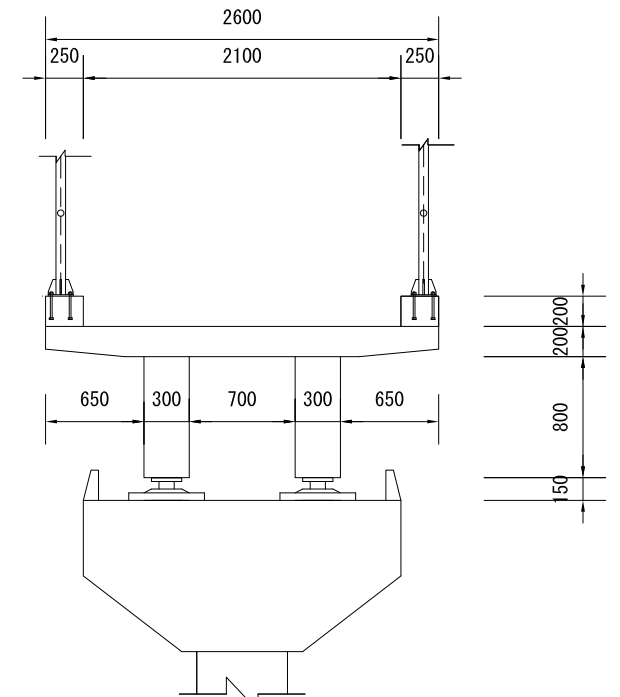



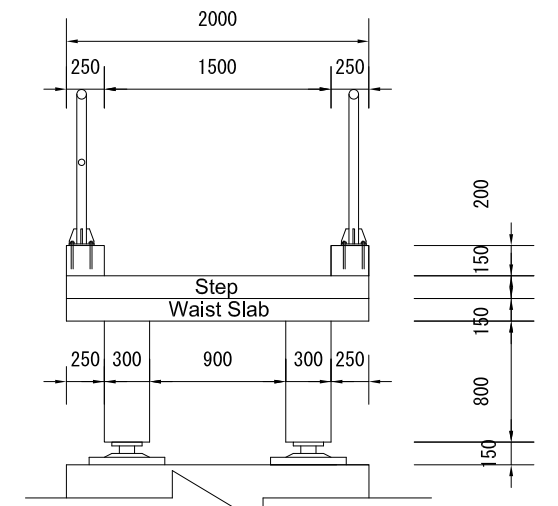

Cross Section Of Pedistrian Deck At Section A-A(Scale 1:50)

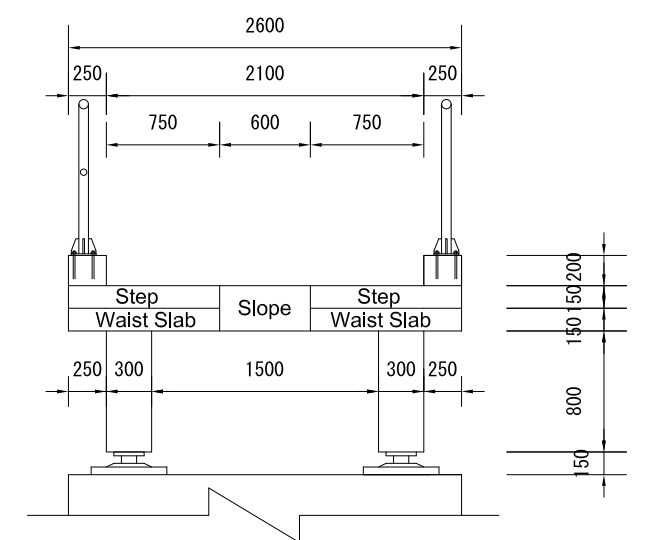

Cross Section Of Stairway Section B-B(Scale 1:50)



Cross Section Of Stairway With Slope Section C-C(Scale 1:50)

<p>Clients:</p>  Japan International Cooperation Agency	<p>Department of Roads Ministry of Physical Infrastructure and Transport Federal Democratic Republic of Nepal</p> 	<p>Consultants:</p>  CTI Engineering International Co., Ltd.  CTI Engineering Co., Ltd.	<p>Project Title:</p> <p>Additional Study of the Suryabinayak-Dhulikhel Road Improvement Project</p>	<p>Sheet Contents:</p> <p>OUTLINE OF PEDESTRIAN BRIDGE AT KATHMANDU UNIVERSITY (13+270)</p>	<p>Scale: (A1size) AS SHOWN Submission Date March, 2018</p> <p>SHT. NO. PB-11</p>
--	---	--	--	---	---

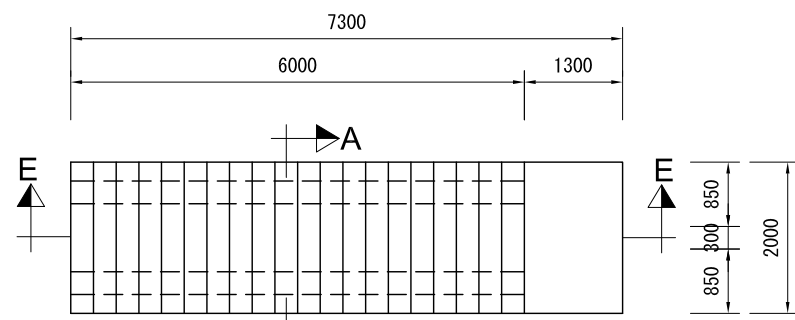

Plan of Upper Flight(Step)

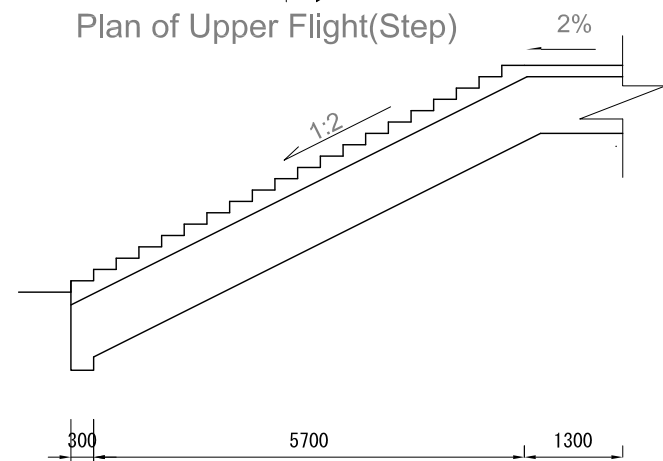

Beam Section E-E

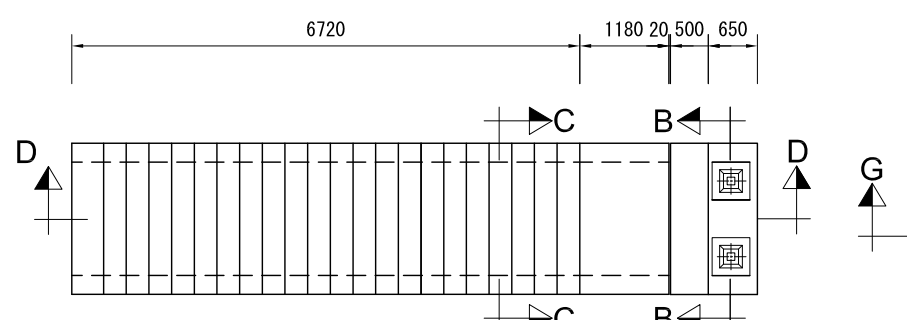

Plan of Lower Flight(Step)

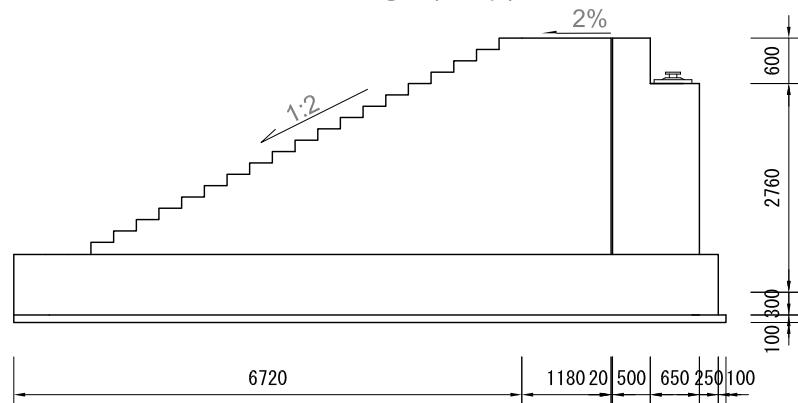

Wall Section D-D

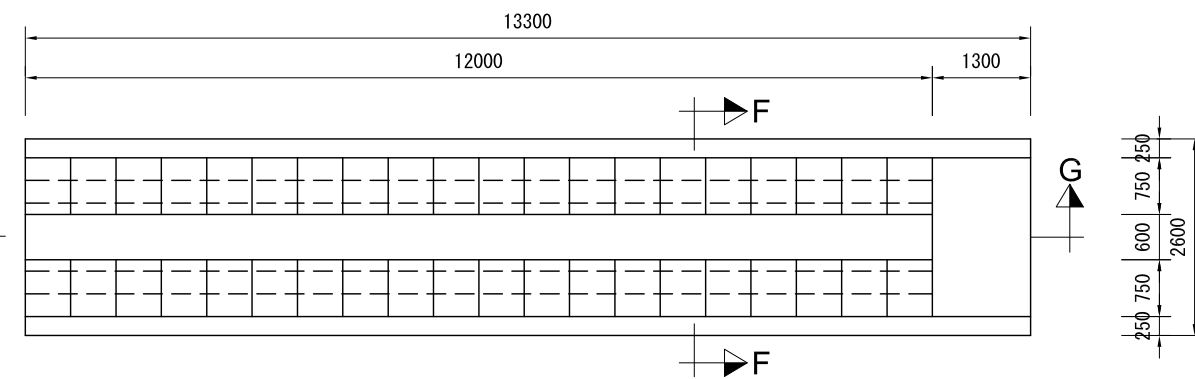

Plan of Upper Flight(Step And Slope)

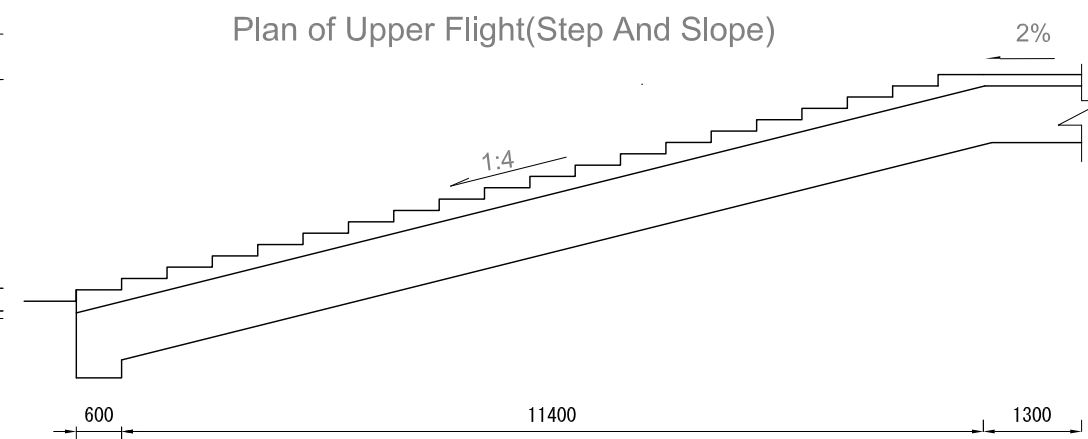

Beam Section G-G

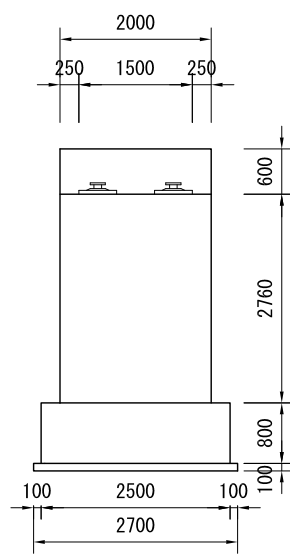

Section B-B

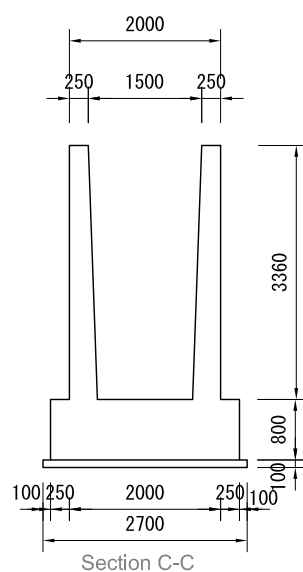

Section C-C

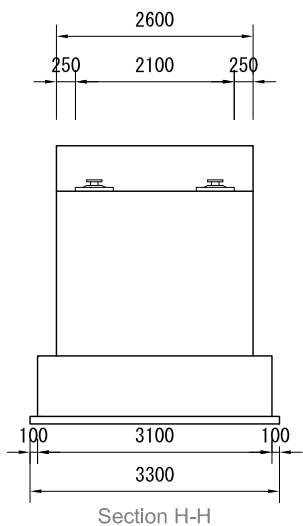

Section H-H

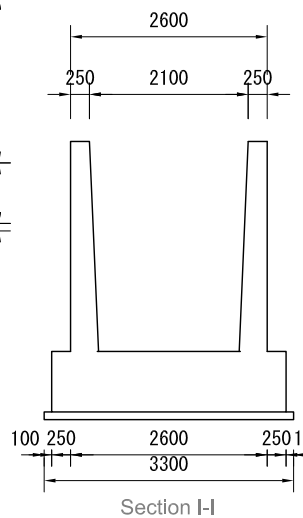

Section I-I

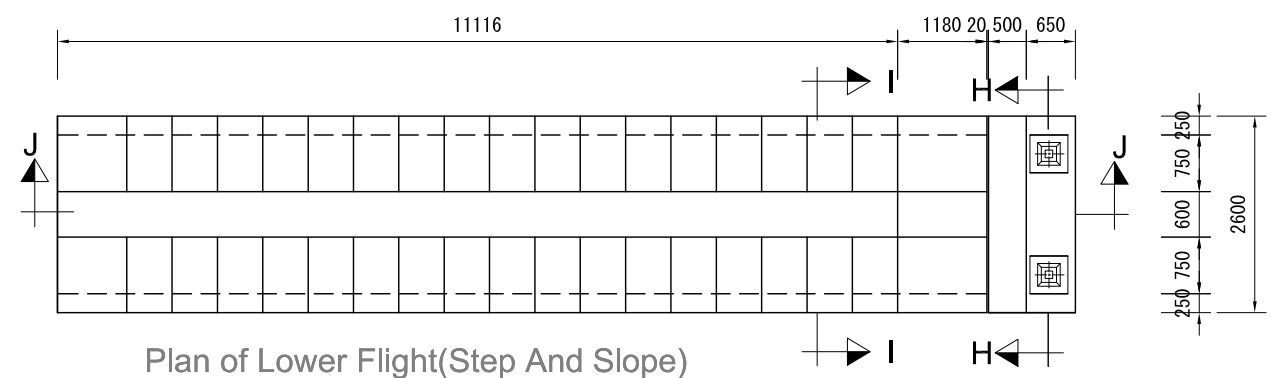

Plan of Lower Flight(Step And Slope)

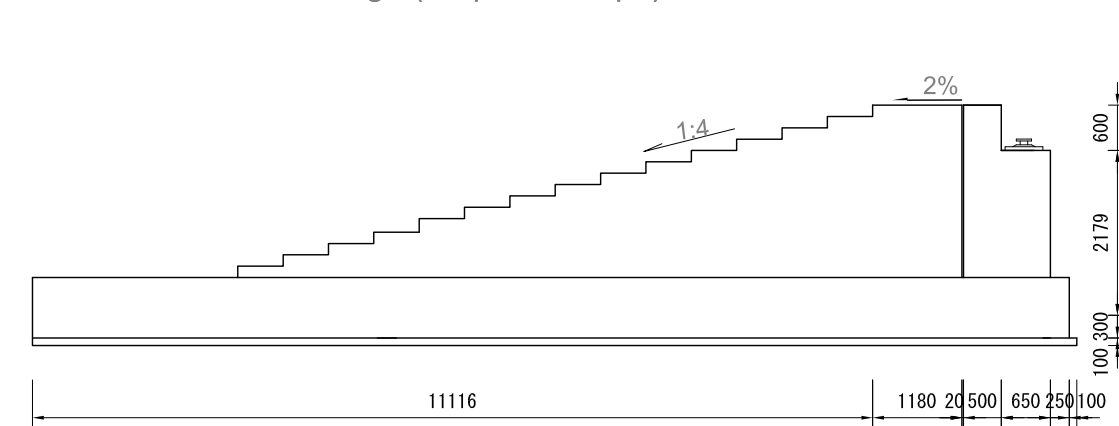

Wall Section J-J

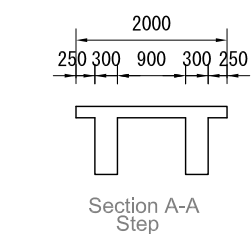

Section A-A Step

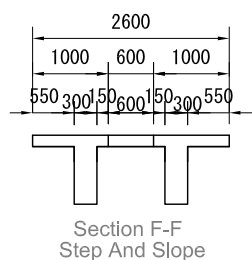

Section F-F Step And Slope



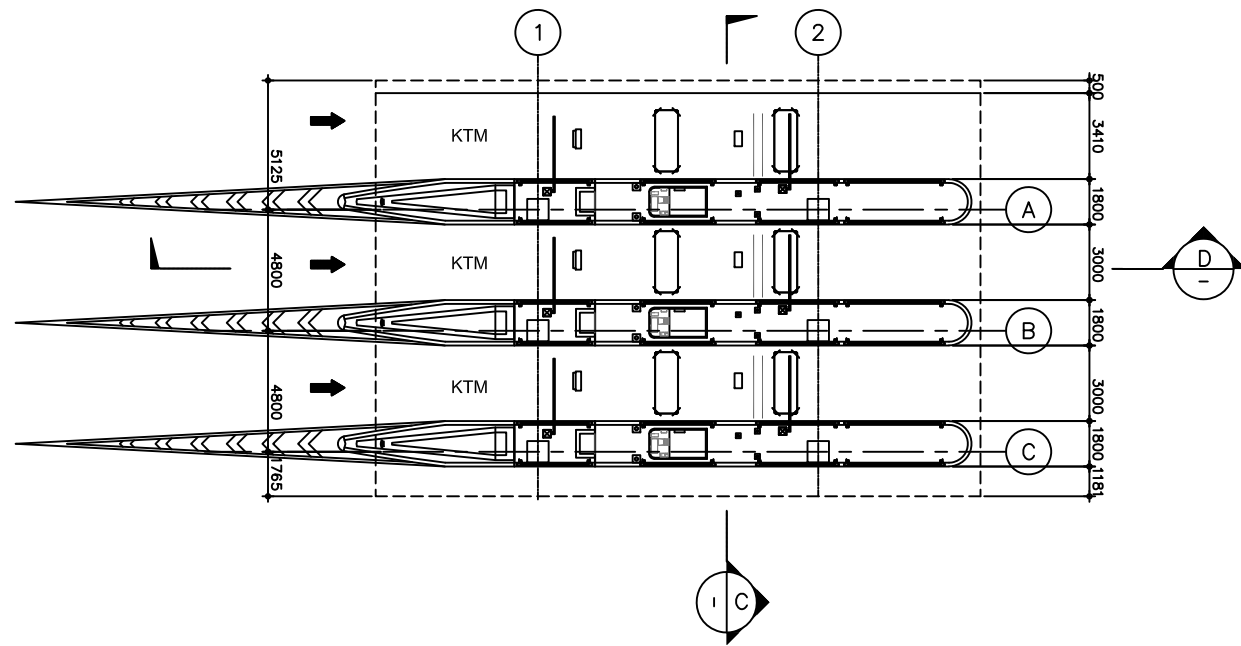

Toll Plaza Plan (Portal Side)

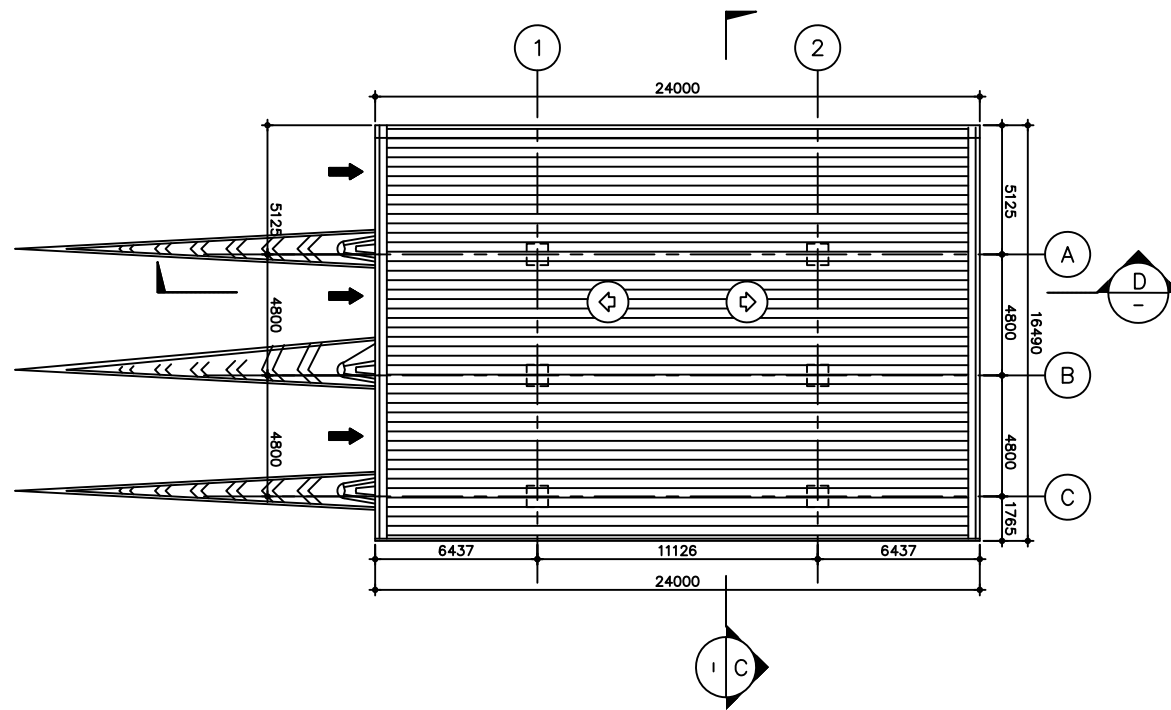

Portal side (Roof Plan)

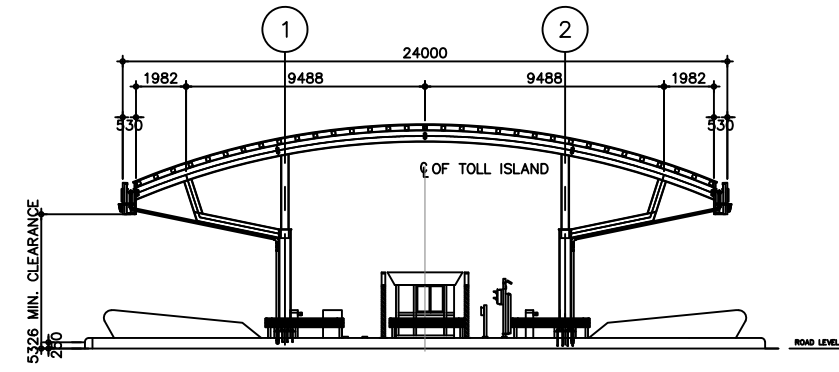

Section D-D (for Portal)

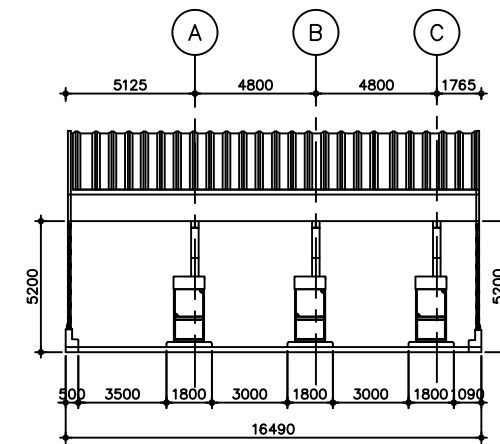



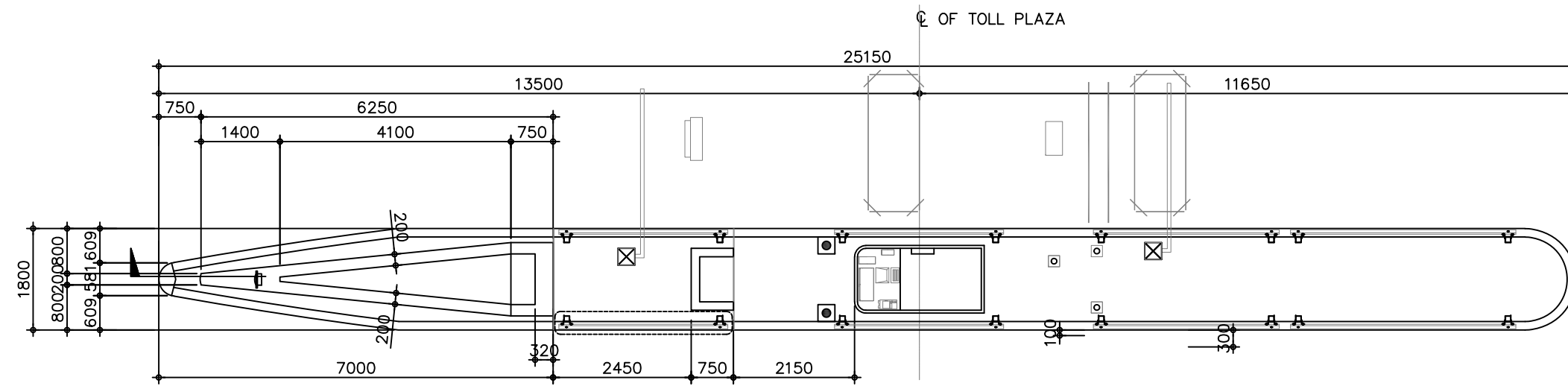

Section C-C

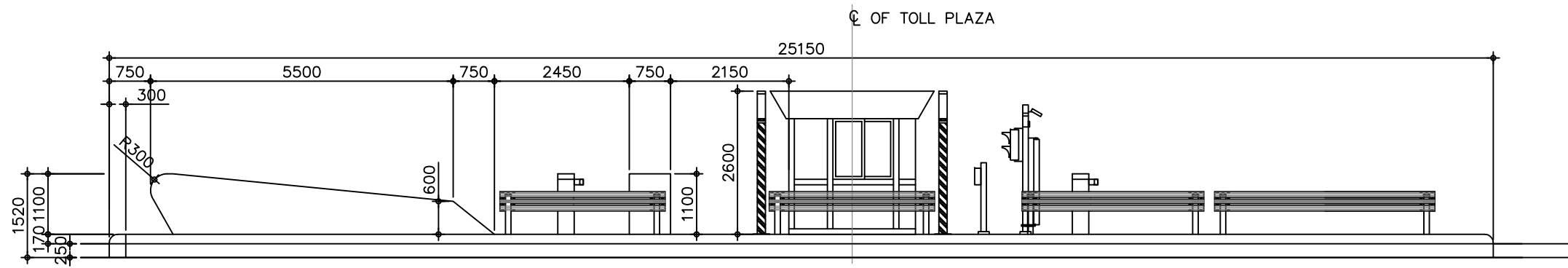

Toll Island Plan



Toll Island Section

<p>Clients:</p>  Japan International Cooperation Agency	 Department of Roads Ministry of Physical Infrastructure and Transport Federal Democratic Republic of Nepal	<p>Consultants:</p>  CTI Engineering International Co., Ltd.  CTI Engineering Co., Ltd.	<p>Project Title:</p> <p>Additional Study of the Suryabinayak-Dhulikhel Road Improvement Project</p>	<p>Sheet Contents:</p> <p><b>TOLL ISLAND</b></p>	<p>Scale: (A1size)</p> <p><b>1:100</b></p> <p>Submission Date</p> <p>March, 2018</p>	<p>SHT. NO.</p> <p><b>TG-02</b></p>
--	--	--	--	--	--	-------------------------------------

# L-TYPE RETAINING WALL S=1:40

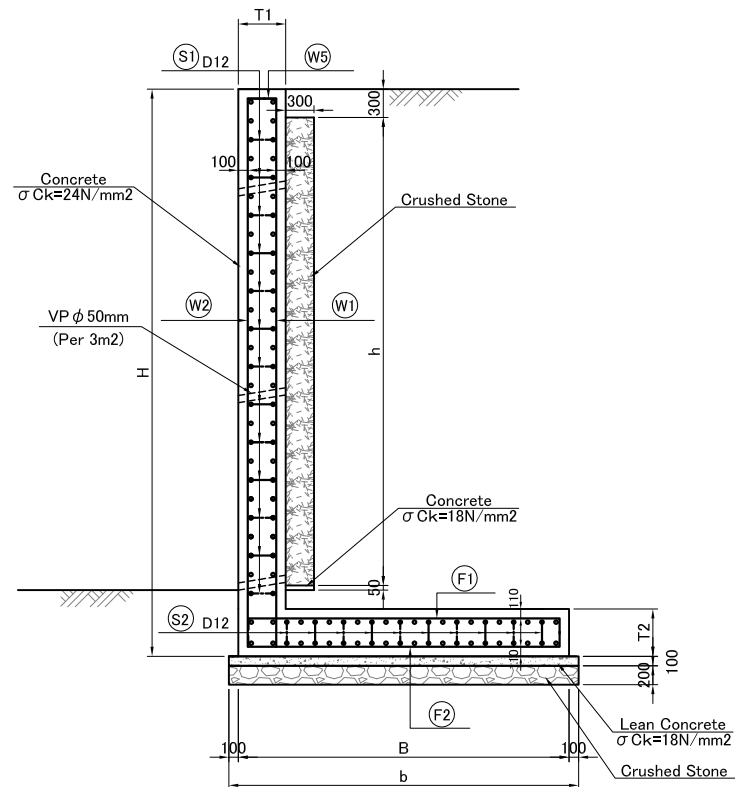

DIMENSION TABLE (L-TYPE RETAINING WALL)

Type	H (mm)	B (mm)	h (mm)	b (mm)	T1 (mm)	T2 (mm)	MAIN REINFORCEMENT					Remarks
							W1	W2	W5	F1	F2	
H=3.0m	3000	2500	2150	2700	400	400	D12	D12	D12	D12	D12	
H=3.5m	3500	2500	2650	2700	400	400	D20	D12	D12	D20	D12	
H=4.0m	4000	3000	3150	3200	400	400	D25	D12	D12	D25	D12	
H=4.5m	4500	3000	3650	3200	400	400	D25	D12	D12	D25	D12	
H=5.0m	5000	3500	4150	3700	400	400	D25	D16	D12	D25	D16	
H=5.5m	5500	4000	4650	4200	400	500	D25	D16	D12	D25	D16	
H=6.0m	6000	4000	5150	4200	500	500	D25	D16	D12	D25	D16	

MATERIALS (L-TYPE RETAINING WALL)

(PER 1m)

KIND	UNIT	QUANTITY							
		H=3.0m	H=3.5m	H=4.0m	H=4.5m	H=5.0m	H=5.5m	H=6.0m	
CONCRETE	WALL	m <sup>3</sup>	1.040	1.240	1.440	1.640	1.840	2.000	2.750
	FOOTING	m <sup>3</sup>	1.000	1.000	1.200	1.200	1.400	2.000	2.000
	TOTAL	m <sup>3</sup>	2.040	2.240	2.640	2.840	3.240	4.000	4.750
FORM	WALL	m <sup>2</sup>	5.200	6.200	7.200	8.200	9.200	10.000	11.000
	FOOTING	m <sup>2</sup>	0.800	0.800	0.800	0.800	0.800	1.000	1.000
	TOTAL	m <sup>2</sup>	6.000	7.000	8.000	9.000	10.000	11.000	12.000
REINFORCING BAR	D12	kg	99.544	86.212	100.418	107.352	54.809	62.272	67.648
	D16	kg					106.328	119.184	123.428
	D20	kg		57.600					
	D25	kg			91.320	129.428	219.120	287.232	338.456
	TOTAL	kg	99.544	143.812	191.738	236.780	380.257	468.688	529.532
FOUNDATION	LEAN CONCRETE	m <sup>3</sup>	0.270	0.270	0.320	0.320	0.370	0.420	0.420
	CRUSHED STONE t=200	m <sup>2</sup>	2.700	2.700	3.200	3.200	3.700	4.200	4.200

# GRAVITY-TYPE RETAINING WALL S=1:30

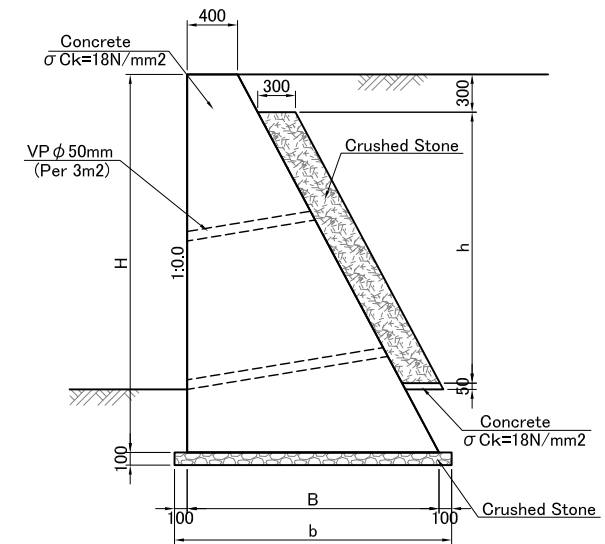

DIMENSION TABLE (GRAVITY-TYPE RETAINING WALL)

Type	H (mm)	B (mm)	h (mm)	b (mm)	Remarks
H=1.0m	1000	900	150	1100	
H=1.5m	1500	1200	650	1400	
H=2.0m	2000	1600	1150	1800	
H=2.5m	2500	1900	1650	2100	
H=3.0m	3000	2200	2150	2400	

L-Type Retaining Wall

Station	Height(m)	Average Height(m)	Length (m)	Remarks
STA.0+000 - STA.1+860	3.0-6.0	4.3	1160.0	
STA.10+020 - STA.12+200	3.0-6.0	4.1	740.0	

Gravity-Type Retaining Wall

Station	Side	Height(m)	Average Height(m)	Length (m)	Remarks
STA.0+000 - STA.1+860	-	1.0-3.0	1.7	4.340.0	
STA.4+290 - STA.4+490	Right	1.0-3.0	3.0	220.0	
STA.4+520 - STA.4+720	Right	1.0-3.0	2.0	200.0	
STA.10+020 - STA.12+200	-	1.0-3.0	1.5	5.080.0	

### MAIN ROAD SURFACE COURSE (ASPHALT CONCRETE) S=1:10

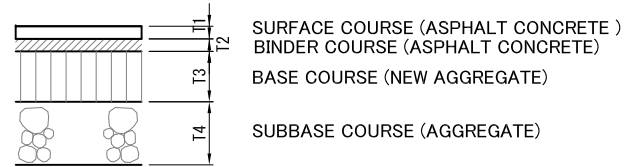

STATION		LENGTH (m)	SURFACE(T1) (cm)	BINDER(T2) (cm)	BASE(T3) (BASE COURSE) (cm)	SUB BASE(T4) (SUBBASE COURSE) (cm)	LOCATION	Design C.B.R.
FROM	TO							
0+000	8+150	6701 m	5	7	30	40		7.1
8+150	11+200	3050 m	5	9	35	45		4.9
11+200	14+000	2800 m	5	9	30	40		5.0
14+000	14+914	914 m	5	7	25	35		9.1

### SERVICE TRACK (ASPHALT CONCRETE) S=1:10

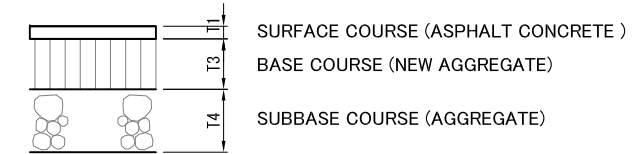

STATION		SIDE/ LENGTH (m)	SURFACE(T1) (cm)	BASE(T2) (BASE COURSE) (cm)	SUB BASE(T3) (SUBBASE COURSE) (cm)	Design C.B.R.
FROM	TO					
0+000	0+000	L/ 1860m R/ 1860m	5	30	30	7.1
10+020	11+200	L/ 1180m	7	30	35	4.5
10+160	11+200	R/ 1040m				
11+200	12+200	L/ 1000m	7	30	35	6.0
11+200	12+200	R/ 1000m				
13+240	13+340	L/ 100m	7	30	35	5.0
13+220	13+340	R/ 120m				
14+600	14+920	L/ 320m	5	20	35	9.1

### CONCRETE PAVEMENT FOR BUS STOP S=1:10

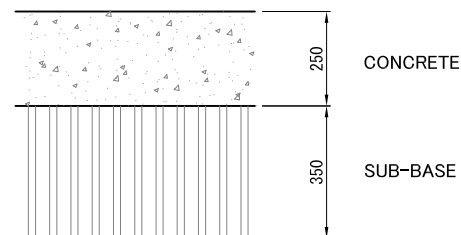



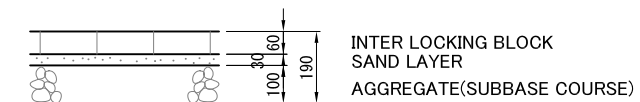

### INTER LOCKING BLOCK TYPE S=1:10

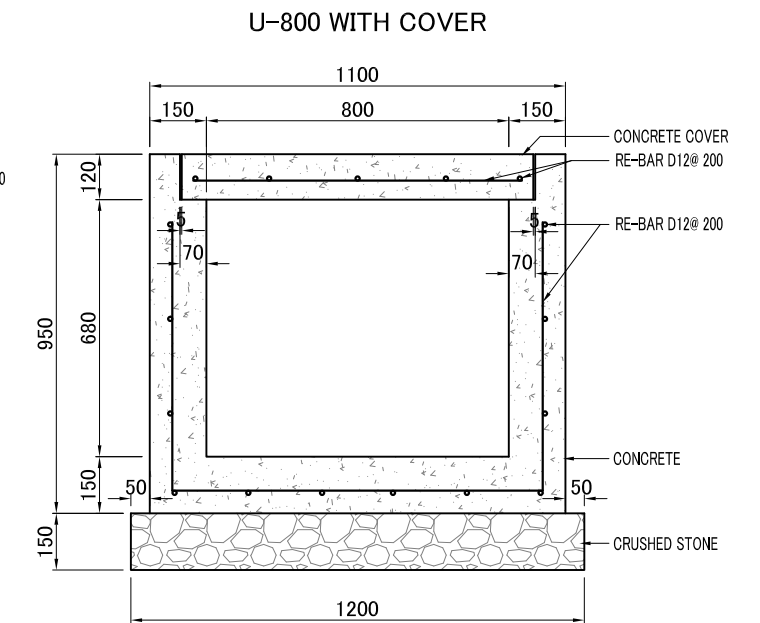
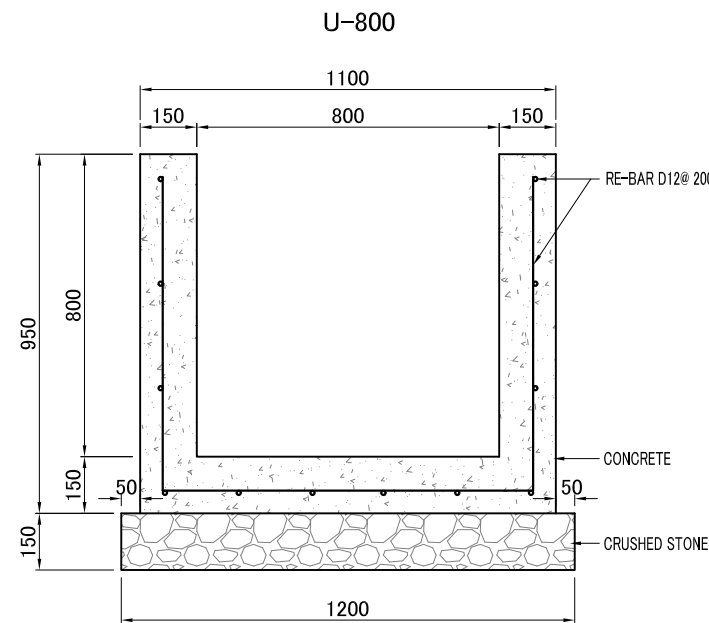
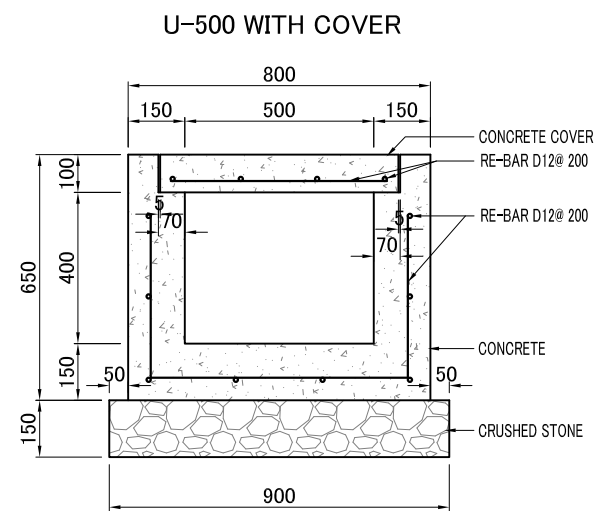
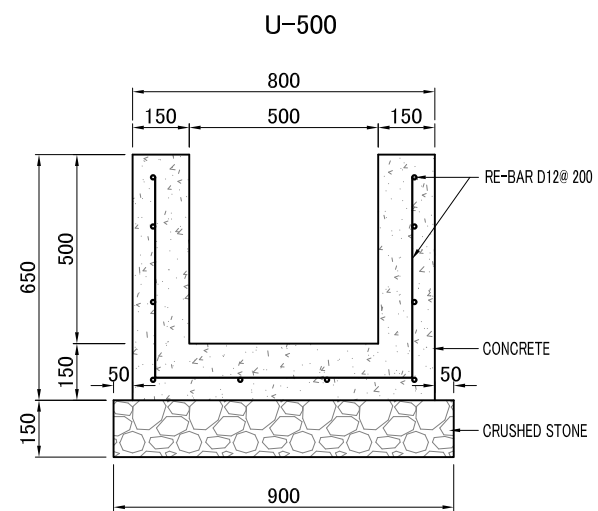
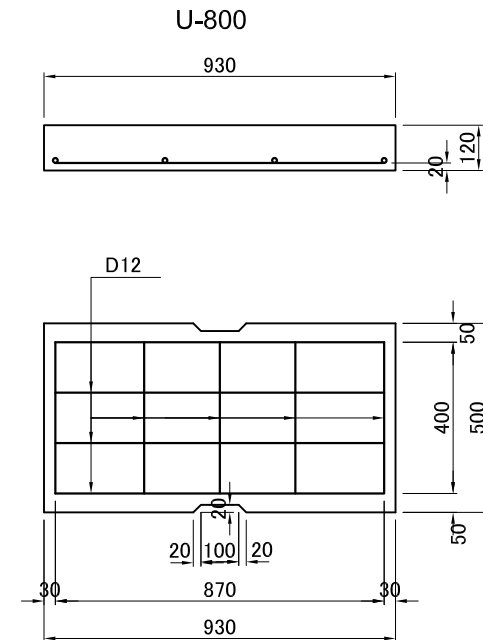
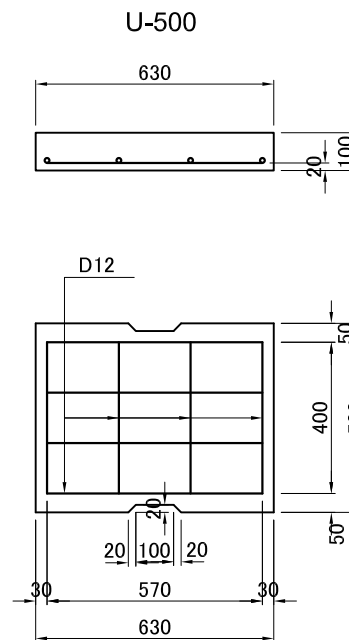
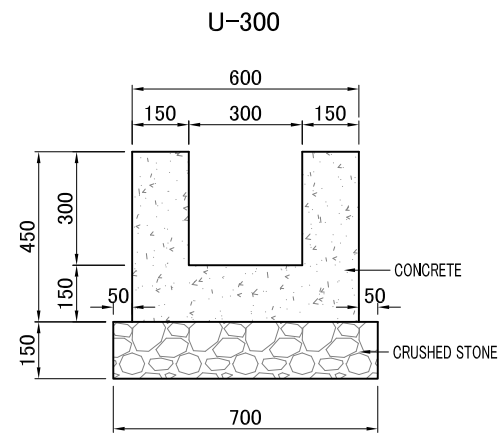

DRAINAGE S=1:10

COVER S=1:10



<p>Clients:</p>  Japan International Cooperation Agency	 Department of Roads Ministry of Physical Infrastructure and Transport Federal Democratic Republic of Nepal	<p>Consultants:</p>  CTI Engineering International Co., Ltd. CTI Engineering Co., Ltd.	<p>Project Title:</p> Additional Study of the Suryabinayak-Dhulikhel Road Improvement Project	<p>Sheet Contents:</p> OUTLINE OF DRAINAGE STRUCTURES SIDE DITCH	<p>Scale: (A1size)</p> 1:10 Submission Date May, 2018	<p>SHT. NO.</p> DR-01
---	--	--	---	---	---	-----------------------



# CATCH BASIN S=1:10

## PLAN

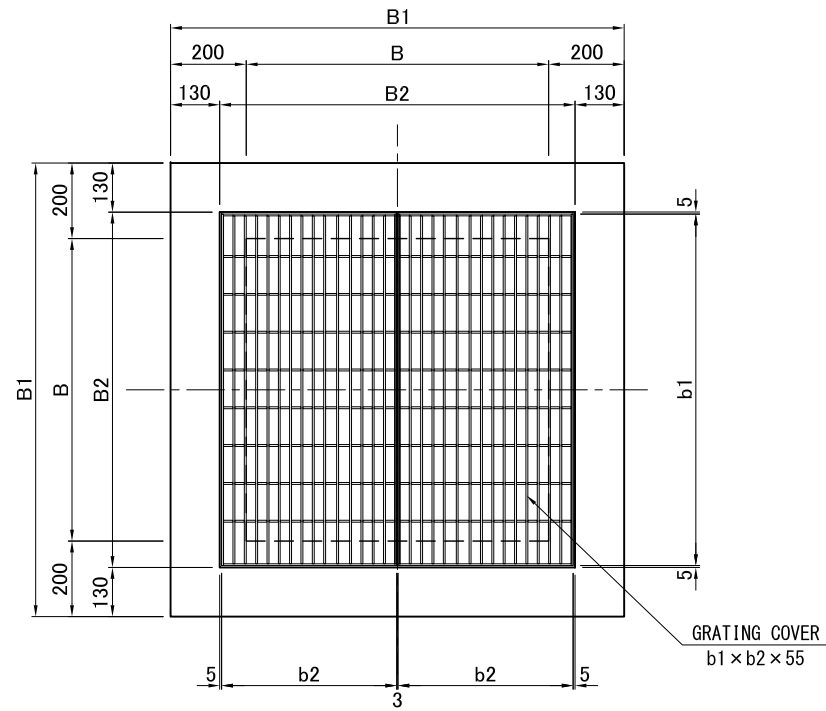

## SECTION

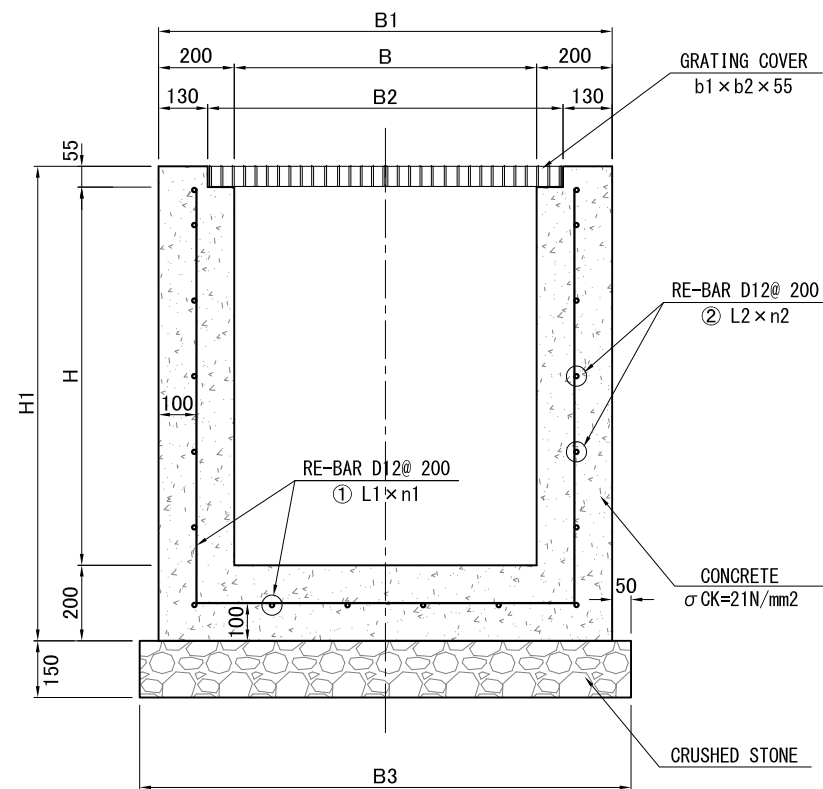

DIMENSION TABLE (CATCH PIT)

Type	B (mm)	H (mm)	B1 (mm)	B2 (mm)	B3 (mm)	H1 (mm)	b1 (mm)	b2 (mm)	RE-BAR D12				Remarks
									L1	n1	L2	n2	
800 × 800 × 1000	800	1000	1200	940	1300	1255	930	463.5	3200	12	4420	6	
1100 × 1100 × 1500	1100	1500	1500	1240	1600	1755	1230	613.5	4500	16	5620	8	
1300 × 1300 × 1800	1300	1800	1700	1440	1800	2055	1430	713.5	5300	18	6420	10	
2000 × 2000 × 2000	2000	2000	2000	2140	2500	2355	2130	1064.5	6400	22	9220	12	

U-DITCH 0.50 * 0.50			
STATION	RIGHT-LEFT	LENGTH (m)	REMARKS
0+020.0	0+327.5	LEFT	307.5
0+020.0	0+292.0	RIGHT	272.0
0+334.5	1+086.2	LEFT	751.7
0+297.5	1+094.8	RIGHT	797.3
1+104.2	1+703.2	LEFT	599.0
1+108.4	1+714.8	RIGHT	606.4
1+707.8	1+860.0	LEFT	152.2
1+714.0	1+840.0	LEFT	126.0
1+725.4	1+859.3	RIGHT	133.9
1+730.2	1+860.0	RIGHT	129.8
1+860.0	1+879.1	RIGHT	19.1
5+430.0	5+478.0	RIGHT	48.0
5+620.0	5+731.0	RIGHT	111.0
5+620.0	5+720.0	LEFT	100.0
6+712.0	7+512.0	LEFT	800.0
7+850.0	9+127.0	LEFT	1,277.0
10+014.5	10+020.0	LEFT	5.5
10+020.0	10+520.3	LEFT	500.3
10+163.0	10+528.6	RIGHT	365.6
10+540.8	10+923.1	LEFT	382.3
10+549.3	10+933.4	RIGHT	384.1
10+943.2	11+468.4	LEFT	525.2
10+947.1	11+466.1	RIGHT	519.0
11+485.4	12+083.1	RIGHT	597.7
11+486.3	12+097.0	LEFT	610.7
12+092.5	12+180.0	RIGHT	87.5
12+106.4	12+180.0	LEFT	73.6
12+880.0	13+090.0	LEFT	210.0
13+090.0	13+172.6	RIGHT	82.6
13+240.0	13+320.0	LEFT	80.0
13+241.0	13+327.5	RIGHT	86.5
13+340.0	13+350.0	LEFT	10.0
13+350.0	13+575.8	LEFT	225.8
13+702.6	13+759.0	LEFT	56.4
14+276.0	14+407.4	LEFT	131.4
14+339.6		LEFT	3.5
14+630.0	14+887.5	LEFT	257.5

U-DITCH 0.50 * 0.50 (COVER)			
STATION	RIGHT-LEFT	LENGTH (m)	REMARKS
1+880.8	3+084.5	RIGHT	1,203.7
3+145.3	3+200.0	RIGHT	54.7
1+860.0	2+140.0	LEFT	280.0
3+200.0	3+640.0	RIGHT	440.0
5+478.0	5+520.0	RIGHT	42.0
5+731.0	6+250.0	RIGHT	519.0
5+720.0	6+250.0	LEFT	530.0
6+250.0	6+545.0	RIGHT	295.0
6+280.0	6+520.0	RIGHT	260.0
6+250.0	6+555.2	LEFT	305.2
6+520.0	6+580.0	RIGHT	60.0
6+555.2	6+580.0	LEFT	24.8
6+580.0	7+775.0	LEFT	1,195.0
6+580.0	7+764.2	RIGHT	1,184.2
9+590.0	10+001.0	LEFT	411.0
12+200.0	12+720.0	LEFT	520.0
12+204.0	12+384.0	RIGHT	180.0
13+172.6	13+210.0	RIGHT	37.4
13+210.0	13+225.0	RIGHT	15.0
13+235.8	13+340.6	LEFT	104.8
13+223.0	13+334.3	RIGHT	111.3
13+759.0	13+960.5	LEFT	201.5
13+719.2	13+962.8	RIGHT	243.6
14+025.2	14+305.0	RIGHT	279.8
14+036.3	14+300.0	LEFT	263.7
14+407.4	14+600.0	LEFT	192.6
14+600.0	14+630.0	LEFT	30.0

U-DITCH 0.80 * 0.80 (COVER)			
STATION	RIGHT-LEFT	LENGTH (m)	REMARKS
0+006.0	0+282.2	RIGHT	276.2
0+286.8	1+719.0	RIGHT	1,432.2
14+620.0	14+925.5	LEFT	305.5

Catch Basin with Grating Cover 0.80*0.80*1.00		
STATION	RIGHT-LEFT	REMARKS
0+277.2	RIGHT	
0+309.7	LEFT	
0+313.1	RIGHT	
0+355.2	LEFT	
1+086.2	LEFT	
1+094.8	RIGHT	
1+675.5	LEFT	
1+687.5	RIGHT	
1+841.0	LEFT	
1+841.0	LEFT	
1+860.6	LEFT	
1+879.1	RIGHT	
1+880.8	RIGHT	
3+084.5	RIGHT	
3+145.3	RIGHT	
6+545.0	RIGHT	
6+555.2	LEFT	
6+566.7	LEFT	
6+575.4	RIGHT	
7+764.2	RIGHT	
7+775.0	LEFT	
7+825.1	RIGHT	
7+837.0	LEFT	
7+924.6	LEFT	
7+930.8	LEFT	
9+132.7	LEFT	
10+001.0	LEFT	
10+494.0	LEFT	
10+502.5	RIGHT	
10+566.5	LEFT	
10+577.0	RIGHT	
10+923.1	LEFT	
10+933.4	RIGHT	
10+943.2	LEFT	
10+947.1	RIGHT	

Catch Basin with Grating Cover 0.80*0.80*1.00		
STATION	RIGHT-LEFT	REMARKS
11+466.1	RIGHT	
11+468.4	LEFT	
11+466.1	RIGHT	
11+468.4	LEFT	
11+485.4	RIGHT	
11+486.3	LEFT	
12+054.0	RIGHT	
1+266.5	LEFT	
12+121.0	RIGHT	
12+135.0	LEFT	
12+100.8	RIGHT	
12+115.1	LEFT	
12+180.0	RIGHT	
12+180.0	LEFT	
12+200.0	LEFT	
12+204.0	RIGHT	
12+720.0	LEFT	
13+220.0	LEFT	
13+223.0	RIGHT	
13+224.0	RIGHT	
13+235.8	LEFT	
13+240.0	LEFT	
13+241.0	RIGHT	
13+320.0	LEFT	
13+240.0	LEFT	
13+575.8	LEFT	
13+702.6	LEFT	
13+719.2	LEFT	
13+960.5	LEFT	
13+962.8	RIGHT	
14+036.3	LEFT	
14+025.2	RIGHT	
14+544.9	LEFT	

U-DITCH 0.30 * 0.30			
STATION	RIGHT-LEFT	LENGTH (m)	REMARKS
4+185.0	4+825.0	RIGHT	660.0

Catch Basin with Grating Cover 1.10*1.10*1.50		
STATION	RIGHT-LEFT	REMARKS
0+266.8	RIGHT	
0+301.8	RIGHT	
0+754.7	RIGHT	
0+756.2	LEFT	
0+758.0	LEFT	
0+763.5	RIGHT	
0+765.6	RIGHT	
1+018.5	RIGHT	
1+027.4	RIGHT	
0+102.8	LEFT	
0+104.2	LEFT	
0+108.4	RIGHT	
0+109.9	RIGHT	
1+344.3	RIGHT	
1+352.1	RIGHT	
1+691.4	RIGHT	
14+276.0	LEFT	
14+276.0	RIGHT	
14+620.0	LEFT	
14+836.0	LEFT	
14+925.5	LEFT	

Catch Basin with Grating Cover 1.30*1.30*1.80		
STATION	RIGHT-LEFT	REMARKS
9+703.3	LEFT	
14+286.0	LEFT	
14+286.0	RIGHT	

Catch Basin with Grating Cover 2.00*2.00*2.50		
STATION	RIGHT-LEFT	REMARKS
6+761.0	LEFT	
6+769.5	LEFT	
6+801.5	LEFT	
6+843.0	LEFT	
6+879.0	LEFT	
6+901.5	LEFT	
6+901.5	RIGHT-LEFT	
6+901.5	RIGHT	

PIPE  $\phi 600$  (CON. 360°) S=1:30

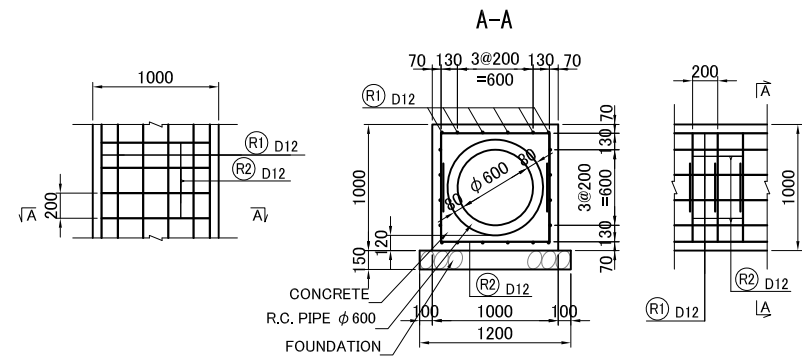

WORK QUANTITIES PER UNIT (PER 10.0m)			
ITEM	UNIT	QUANTITY	REMARKS
R.C. PIPE $\phi 600$	m	10.00	
CONCRETE	m <sup>3</sup>	5.47	
FORM WORK	m <sup>2</sup>	20.00	
REINFORCEMENT BAR $\phi 12$	kgf	364	
FOUNDATION	m <sup>3</sup>	1.80	SELECTED RIVER GRAVEL
EXCAVATION	m <sup>3</sup>		

PIPE  $\phi 600$  (CON. 360°) S=1:30

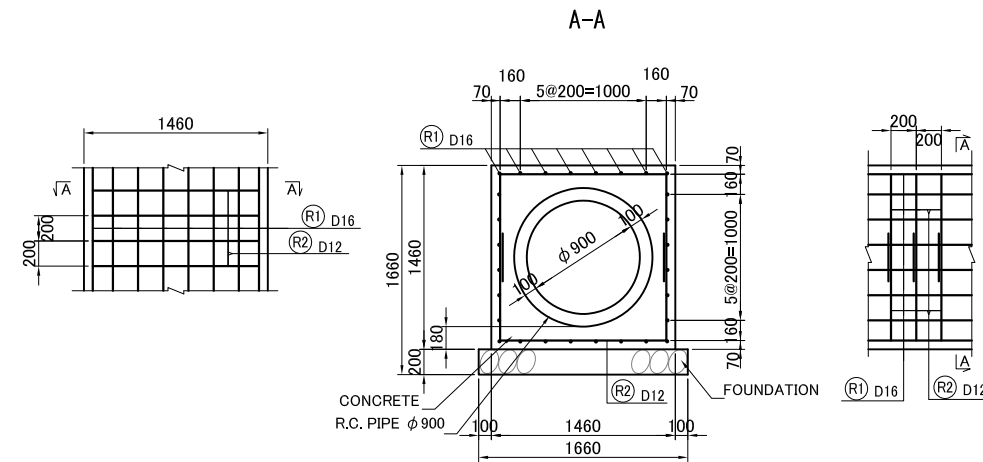

WORK QUANTITIES PER UNIT (PER 10.0m)			
ITEM	UNIT	QUANTITY	REMARKS
R.C. PIPE $\phi 900$	m	10.00	
CONCRETE	m <sup>3</sup>	11.82	
FORM WORK	m <sup>2</sup>	29.20	
REINFORCEMENT BAR	$\phi 12$	kgf	268
	$\phi 16$	kgf	442
	TOTAL	kgf	710
FOUNDATION	m <sup>3</sup>	3.32	SELECTED RIVER GRAVEL
EXCAVATION	m <sup>3</sup>		

PIPE  $\phi 600$  (CON. 360°) S=1:30

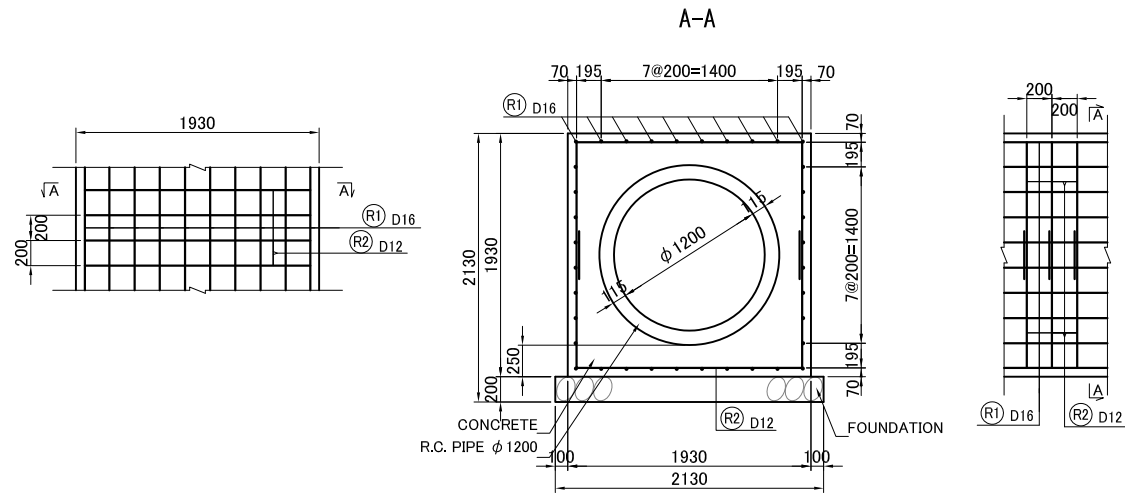

WORK QUANTITIES PER UNIT (PER 10.0m)			
ITEM	UNIT	QUANTITY	REMARKS
R.C. PIPE $\phi 600$	m	10.00	
CONCRETE	m <sup>3</sup>	21.19	
FORM WORK	m <sup>2</sup>	38.60	
REINFORCEMENT BAR	$\phi 12$	kgf	352
	$\phi 16$	kgf	569
	TOTAL	kgf	921
FOUNDATION	m <sup>3</sup>	4.26	SELECTED RIVER GRAVEL
EXCAVATION	m <sup>3</sup>		

PIPE  $\phi D$  (CON. 90°) S=1:30

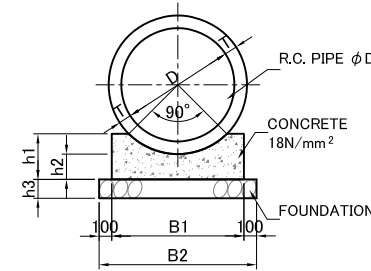

PIPE  $\phi D$  (CON. 180°) S=1:30

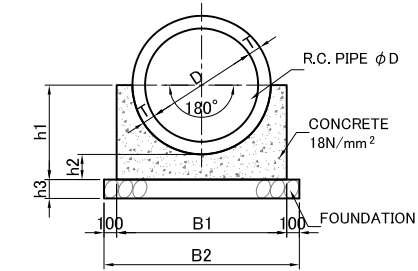

DETAIL OF R. C. PIPE S=1:30

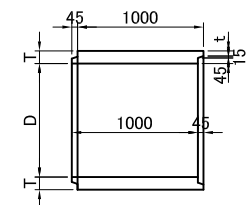

(mm)								
TYPE NO.	D	T	t	h1	h2	h3	B1	B2
$\phi D$ (CON.90°)	600	80	20	261	150	150	750	950
	900	100	40	361	200	150	1050	1250
	1200	115	55	459	250	200	1400	1600
$\phi D$ (CON.180°)	600	80	20	530	150	150	1000	1200
	900	100	40	750	200	150	1350	1550
	1200	115	55	965	250	200	1700	1900

PIPE CULVERT D600(90° )			
STATION	RIGHT-LEFT	LENGTH (m)	REMARKS
6+711.5	6+921.5 RIGHT-LEFT	210.0	
6+750.0	0+682.0 RIGHT-LEFT	36.0	
10+555.6		30.3	
10+553.0	10+560.8 RIGHT	22.5	
12+070.6	12+076.9 RIGHT	20.4	
12+078.6		32.8	

PIPE CULVERT D900(90° )			
STATION	RIGHT-LEFT	LENGTH (m)	REMARKS
9+703.3		35.0	

PIPE CULVERT D1200(90°)			
STATION	RIGHT-LEFT	LENGTH (m)	REMARKS
6+095.5		30.0	

PIPE CULVERT D1200(180°)			
STATION	RIGHT-LEFT	LENGTH (m)	REMARKS
9-197.5		40.0	
9-416.2		34.0	
9-547.1		35.0	
13-089.7		48.0	

PIPE CULVERT D900(360° )			
STATION	RIGHT-LEFT	LENGTH (m)	REMARKS
0+266.8	0+282.2 RIGHT	15.4	
0+286.8	0+301.6 RIGHT	14.8	
0+754.7	0+765.6 RIGHT	10.9	
0+756.2	0+765.6 RIGHT-LEFT	46.7	
1+018.5	1+027.4 RIGHT	8.9	
1+102.8	1+109.9 RIGHT-LEFT	46.3	
1+344.3	1+352.1 RIGHT	7.8	
1+691.4	1+719.0 RIGHT	27.6	
14+276.0		25.0	

PIPE CULVERT D600(360° )			
STATION	RIGHT-LEFT	LENGTH (m)	REMARKS
0+277.2	0+292.0 RIGHT	14.8	
0+309.7	0+327.5 LEFT	17.8	
0+297.5	0+313.1 RIGHT	15.6	
0+334.5	0+355.2 LEFT	20.7	
0+986.8	1+003.6 LEFT	16.8	
0+995.5	1+007.5 RIGHT	12.0	
1+675.5	1+703.3 LEFT	27.8	
1+687.5	1+714.3 RIGHT	26.8	
1+841.0		9.2	
1+860.0	1+879.1 RIGHT	19.1	
1+879.1	1+880.8 RIGHT	3.2	
3+084.5	3+145.3 RIGHT	60.8	
6+711.5		RIGHT-LEFT	10.0
6+750.0		RIGHT-LEFT	10.0
7+775.0	7+837.0 LEFT	62.0	
7+764.2	7+825.1 RIGHT	60.9	
7+837.0	7+845.6 LEFT	8.6	
7+825.1	7+854.2 RIGHT	29.1	
7+924.6	7+930.8 LEFT	6.2	
9+132.7	9+197.0 LEFT	64.3	
10+001.0	10+004.3 LEFT	3.3	
10+494.0	10+520.3 LEFT	26.3	
10+502.5	10+528.6 RIGHT	26.1	
10+540.8	10+566.5 LEFT	25.7	
10+549.3	10+577.0 RIGHT	27.7	
10+923.1	10+943.2 LEFT	20.1	
10+933.4	10+947.1 RIGHT	13.7	
11+466.1	11+485.4 RIGHT	19.3	
11+468.4	11+486.3 LEFT	17.9	
12+054.0	12+083.1 RIGHT	29.1	
12+066.5	12+097.0 LEFT	30.5	
12+092.5	12+121.0 RIGHT	28.5	
12+106.5	12+135.0 LEFT	28.5	
12+180.0	12+200.0 RIGHT	20.0	
12+180.0	12+200.0 LEFT	20.0	
12+200.0	12+204.0 RIGHT	4.0	
13+223.0	13+224.0 RIGHT	3.7	
13+220.0	13+240.0 LEFT	20.0	
13+224.0	13+241.0 RIGHT	17.0	
13+320.0	13+340.0 LEFT	20.0	
13+711.0		36.0	
13+960.5	14+036.3 LEFT	75.8	
13+962.8	14+025.2 RIGHT	62.4	

# BOX CULVERT S=1:30

# φ100 PVC PIPE S=1:10

GENERAL DRAWING

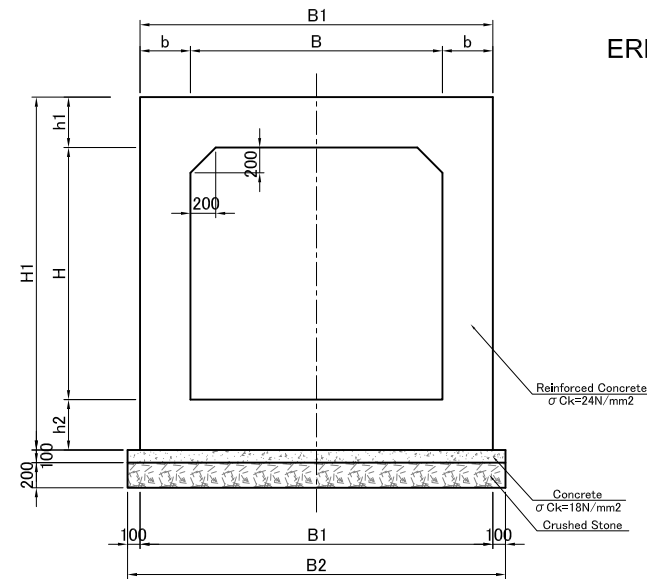

ERECTION DIAGRAM OF MAIN REINFORCEMENT

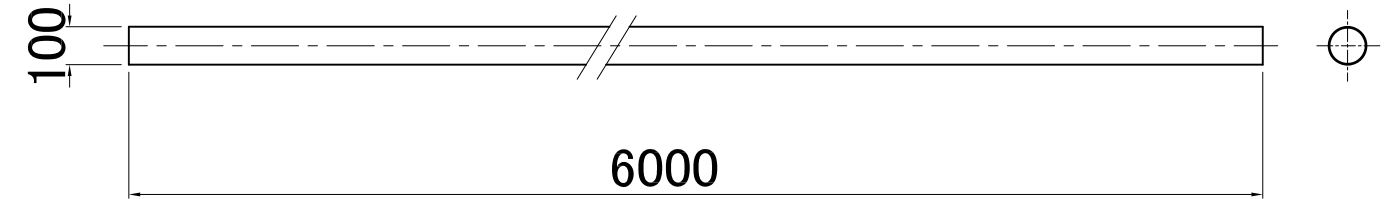
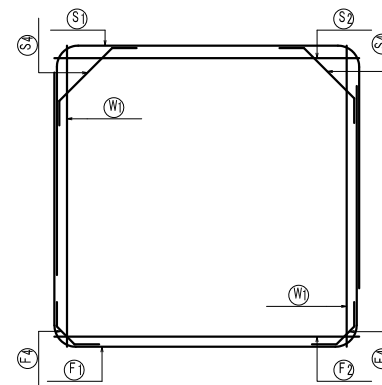

DIMENSION TABLE (BOX CULVERT)

Type	B (mm)	H (mm)	b (mm)	h1 (mm)	h2 (mm)	B1 (mm)	B2 (mm)	H1 (mm)	MAIN REINFORCEMENT								Remarks
									S1	S2	S4	W1	F1	F2	F4		
1500 × 1500	1500	1500	300	300	300	2100	2300	2100	D16	D16	D12	D12	D16	D16	D12		
2000 × 2000	2000	2000	400	400	400	2800	3000	2800	D16	D16	D12	D12	D16	D16	D12		
3000 × 2500	3000	2500	500	500	500	4000	4200	3500	D20	D25	D12	D12	D25	D25	D12		
3000 × 3000	3000	3000	500	500	500	4000	4200	4000	D20	D20	D12	D12	D25	D20	D12		
5000 × 5000	5000	5000	700	600	700	6400	6400	6400	D32	D25	D12	D12	D32	D25	D12		

MATERIALS (BOX CULVERT)

KIND	UNIT	QUANTITY (PER 1m)					
		1500 × 1500	2000 × 2000	3000 × 2500	3000 × 3000	5000 × 5000	
CONCRETE	TOP	m <sup>2</sup>	0.630	1.120	2.000	2.000	3.840
	SIDE	m <sup>2</sup>	0.840	1.640	2.540	3.040	7.090
	BOTTOM	m <sup>2</sup>	0.630	1.120	2.000	2.000	4.480
	TOTAL	m <sup>2</sup>	2.200	3.880	6.540	7.040	15.410
FORM	m <sup>2</sup>	8.466	11.366	14.766	16.766	27.249	
REINFORCING BAR	D12	kg	106.250	146.960	192.572	208.894	341.657
	D16	kg	78.752	104.208			
	D20	kg			72.000	144.000	
	D25	kg			183.616	97.280	197.408
	D32	kg					564.480
	TOTAL	kg	183.002	251.168	448.188	451.074	1,103.545
FOUNDATION	LEVELING CONCRETE	m <sup>3</sup>	0.230	0.300	0.420	0.420	0.640
	CRUSHED STONE t=200	m <sup>3</sup>	2.300	3.000	4.200	4.200	6.400

BOX CULVERT 1.5*1.5		
STATION	LENGTH (m)	REMARKS
9+989.5	59.0	
6+901.5	215.0	

BOX CULVERT 3.0*3.0		
STATION	LENGTH (m)	REMARKS
0+311.4	80.0	
5+011.3	44.0	
5+243.3	53.0	
5+428.0	40.0	

BOX CULVERT 2.0*2.0		
STATION	LENGTH (m)	REMARKS
8+372.4	52.0	
8+856.4	43.0	
8+943.4	41.0	
9+357.5	40.0	
11+537.8	56.0	

BOX CULVERT 5.0*5.0		
STATION	LENGTH (m)	REMARKS
4+921.5	33.0	



PLAN S=1:100

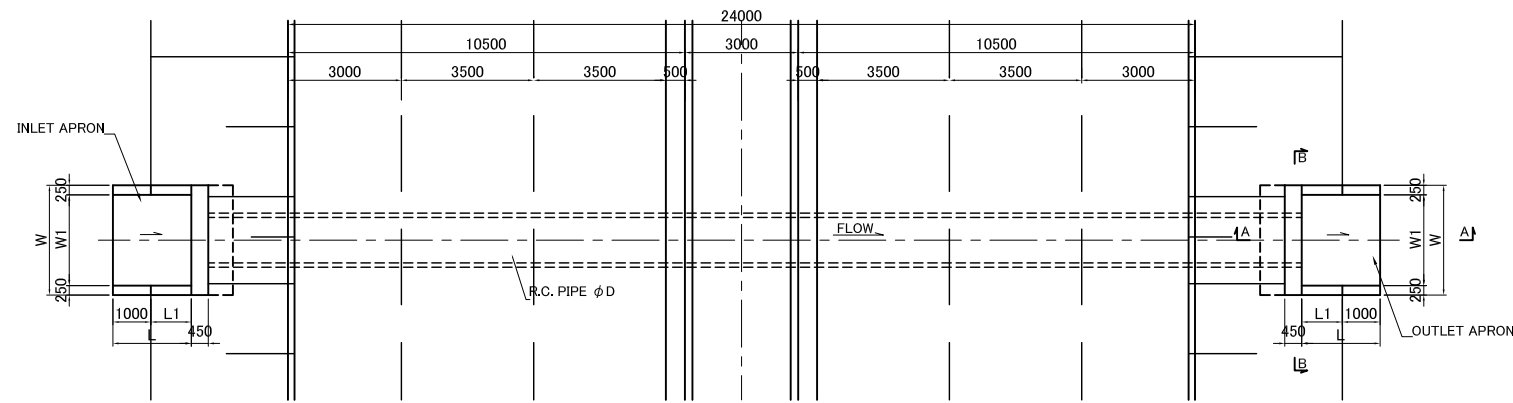

SIDE ELEVATION S=1:100

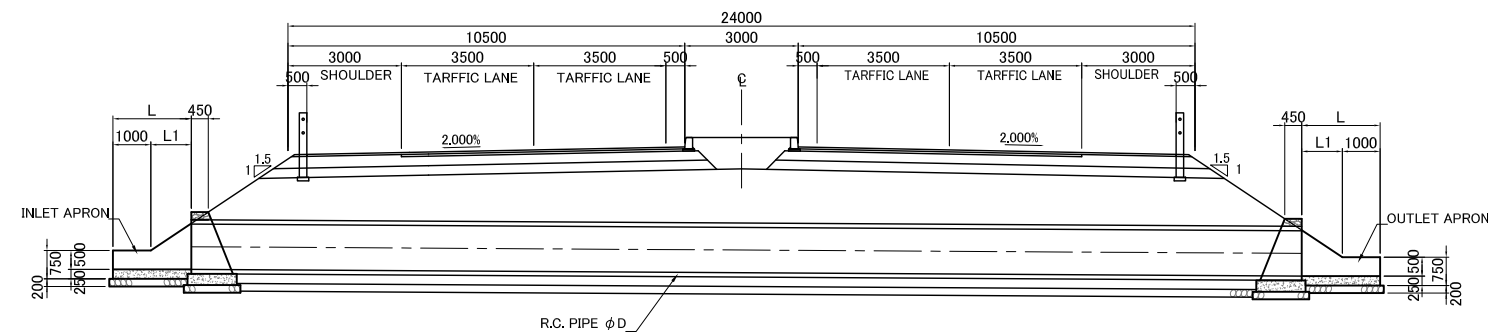

A-A SECTION S=1:30

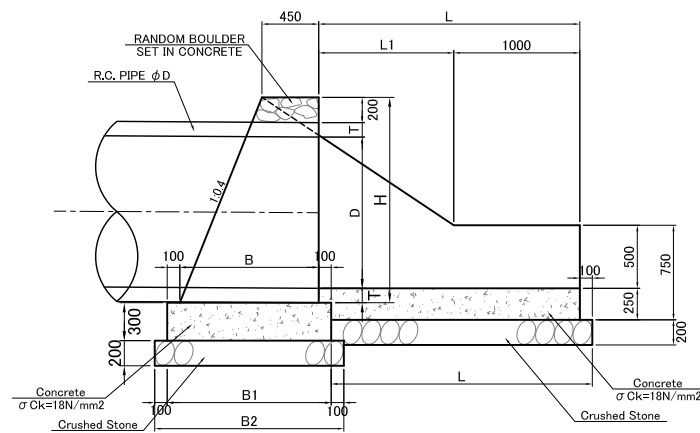

B-B SECTION S=1:30

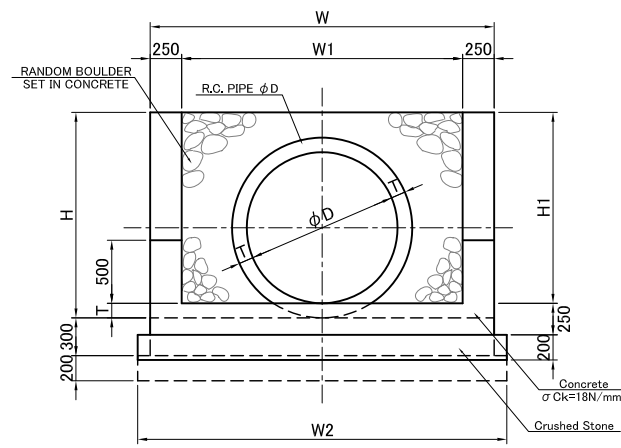

DIMENSION TABLE (PIPE INLET-OUTLET)

Type	D (mm)	T (mm)	H (mm)	H1 (mm)	W (mm)	W1 (mm)	W2 (mm)	L (mm)	L1 (mm)	B (mm)	B1 (mm)	B2 (mm)	Remarks
φ 900	900	100	1300	1200	2400	1900	2600	1600	600	970	1170	1370	
φ 1200	1200	115	1630	1515	2730	2230	2930	2070	1070	1100	1300	1500	
φ 1500	1500	150	2000	1850	3100	2600	3300	2575	1575	1250	1450	1650	
φ 2000	2000	150	2500	2350	3600	3100	3800	3325	2325	1450	1650	1850	

Inlet/Outlet D900		
STATION	RIGHT - LEFT	REMARKS
9+703.3	RIGHT	

Inlet/Outlet D1200		
STATION	RIGHT - LEFT	REMARKS
9+197.5	RIGHT	
9+197.5	LEFT	
9+416.2	RIGHT	
9+416.2	LEFT	
9+547.1	RIGHT	
9+547.1	LEFT	
13+089.7	RIGHT	
13+089.7	LEFT	

PLAN S=1:100

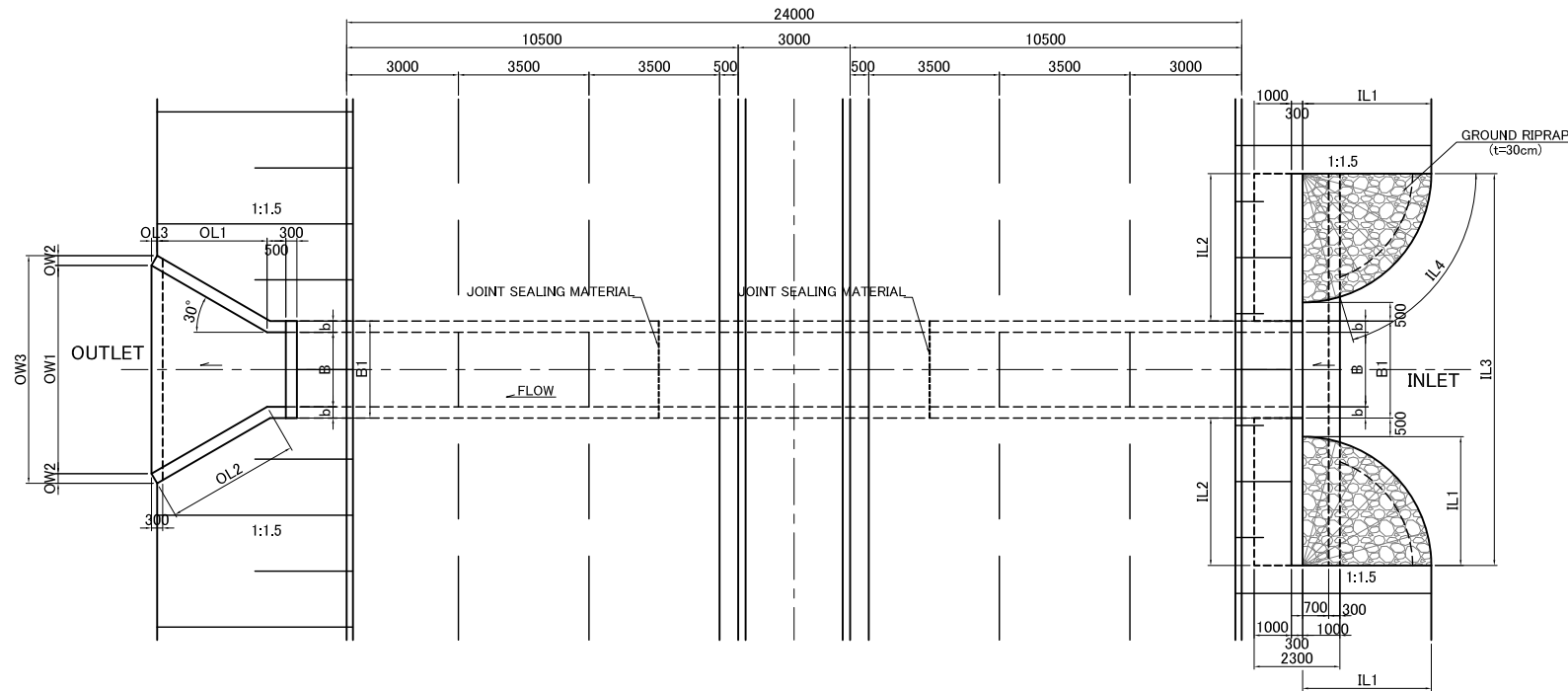

FRONT ELEVATION (INLET) S=1:50

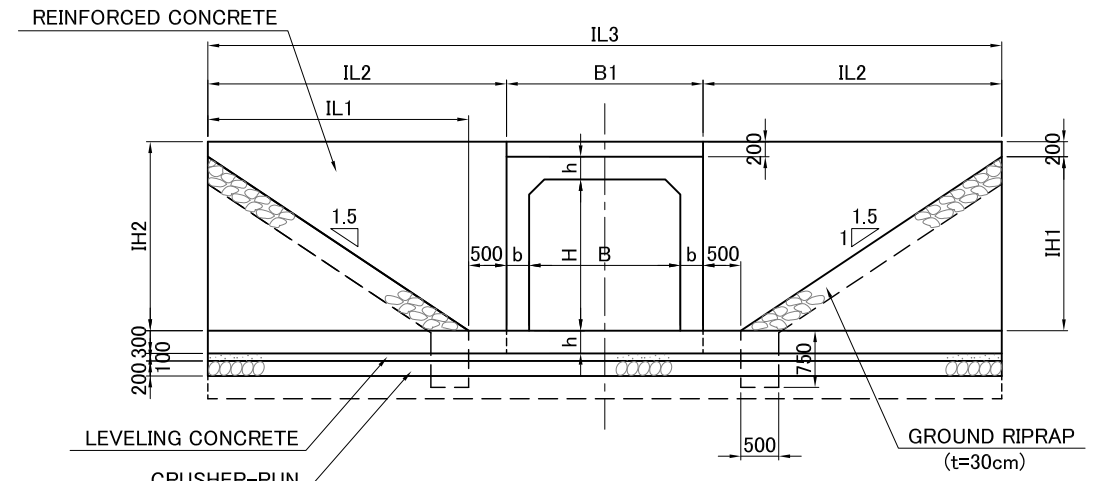

DIMENSION TABLE (BOX CULVERT INLET)

Type	BOX CULVERT				INLET				Remarks				
	B (mm)	H (mm)	b (mm)	h (mm)	B1 (mm)	IH1 (mm)	IH2 (mm)	IH3 (mm)		IH4 (mm)			
1500 × 1500	1500	1500	300	300	2100	2100	1800	2000	2700	3200	8500	3240	
2000 × 2000	2000	2000	400	400	2800	2800	2400	2600	3600	4100	11000	4650	
3000 × 2500	3000	2500	500	500	4000	3500	3000	3200	4500	5000	14000	6070	
3000 × 3000	3000	3000	500	500	4000	4000	3500	3700	5250	5750	15500	7240	

SIDE ELEVATION S=1:100

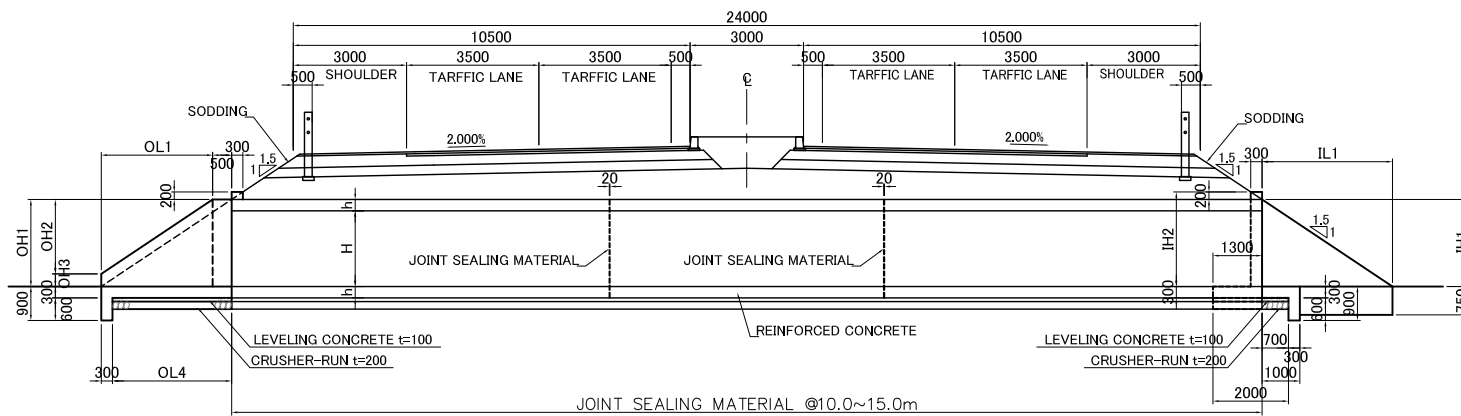

FRONT ELEVATION (OUTLET) S=1:50

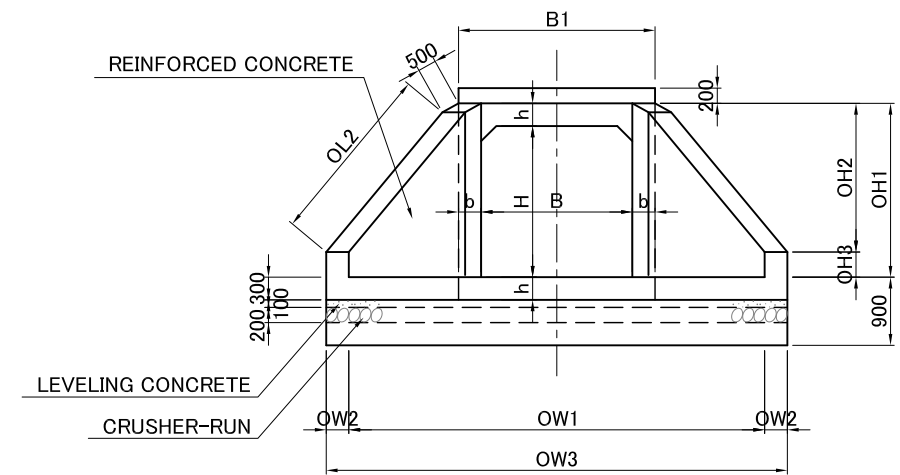

DIMENSION TABLE (BOX CULVERT OUTLET)

Type	BOX CULVERT				OUTLET									Remarks		
	B (mm)	H (mm)	b (mm)	h (mm)	B1 (mm)	OH1 (mm)	OH2 (mm)	OH3 (mm)	OL1 (mm)	OL2 (mm)	OL3 (mm)	OL4 (mm)	OW1 (mm)		OW2 (mm)	OW3 (mm)
1500 × 1500	1500	1500	300	300	2100	2100	1800	1470	330	2200	2540	150	2400	4210	280	4730
2000 × 2000	2000	2000	400	400	2800	2800	2400	2070	330	3100	3580	200	3300	5800	350	6500
3000 × 2500	3000	2500	500	500	4000	3500	3000	2670	330	4000	4620	250	4200	7910	430	8770
3000 × 3000	3000	3000	500	500	4000	4000	3500	3170	330	4750	5480	250	4950	8780	430	9640

Inlet/Outlet 1.5*1.5		
STATION	RIGHT · LEFT	REMARKS
9+963.6	RIGHT	
10+009.8	LEFT	

Inlet/Outlet D1200		
STATION	RIGHT · LEFT	REMARKS
9+197.5	RIGHT	
9+197.5	LEFT	
9+416.2	RIGHT	
9+416.2	LEFT	
9+547.1	RIGHT	
9+547.1	LEFT	

MANHOLE S=1:20

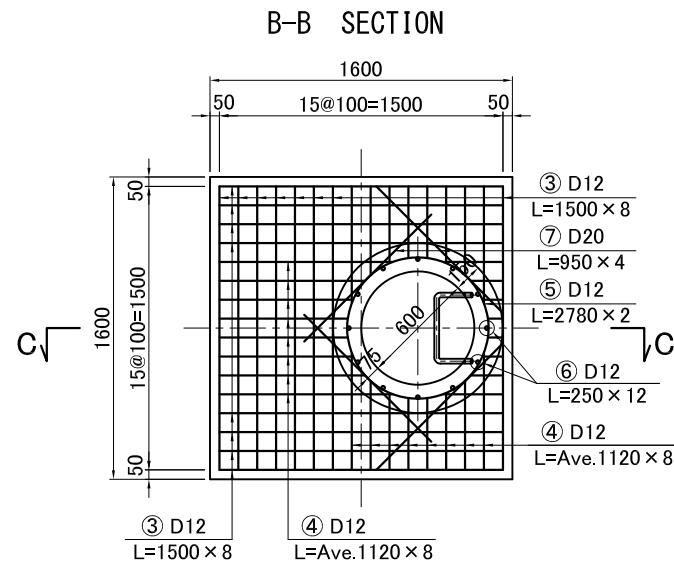
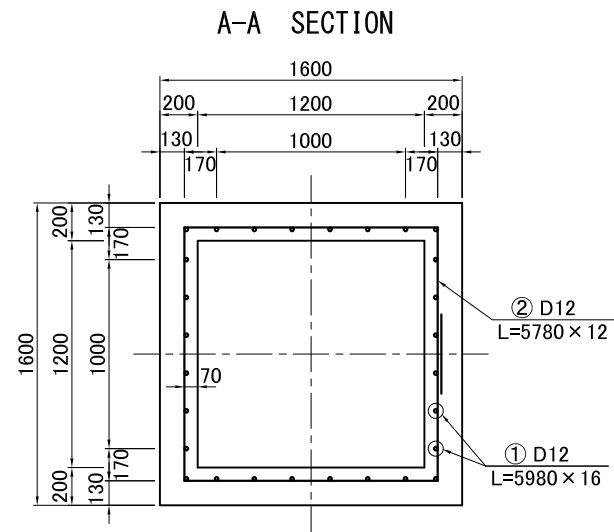

MANHOLE HEIGHT ADJUSTMENT S=1:10

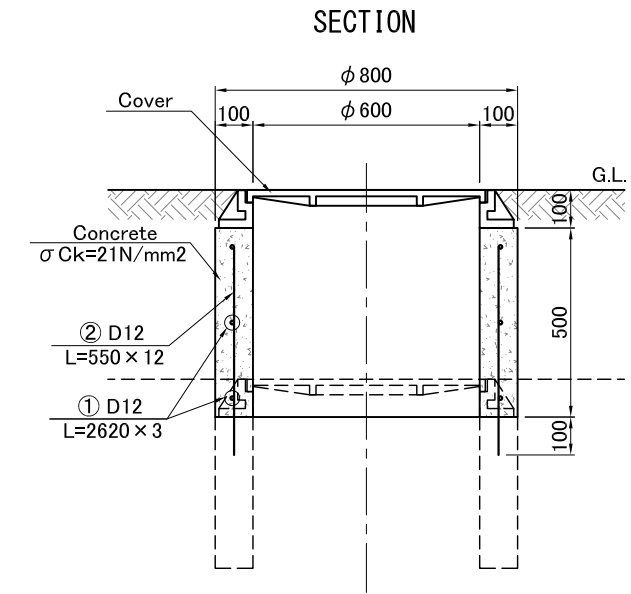

GENERAL DRAWING

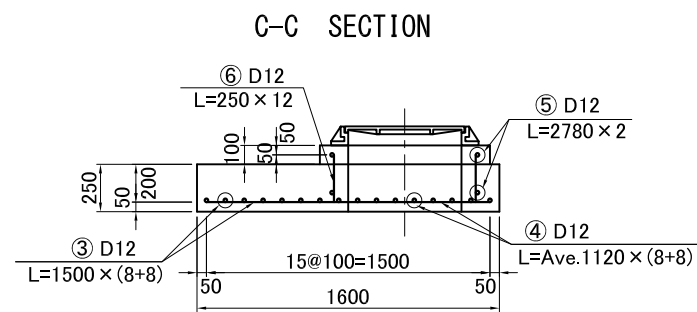
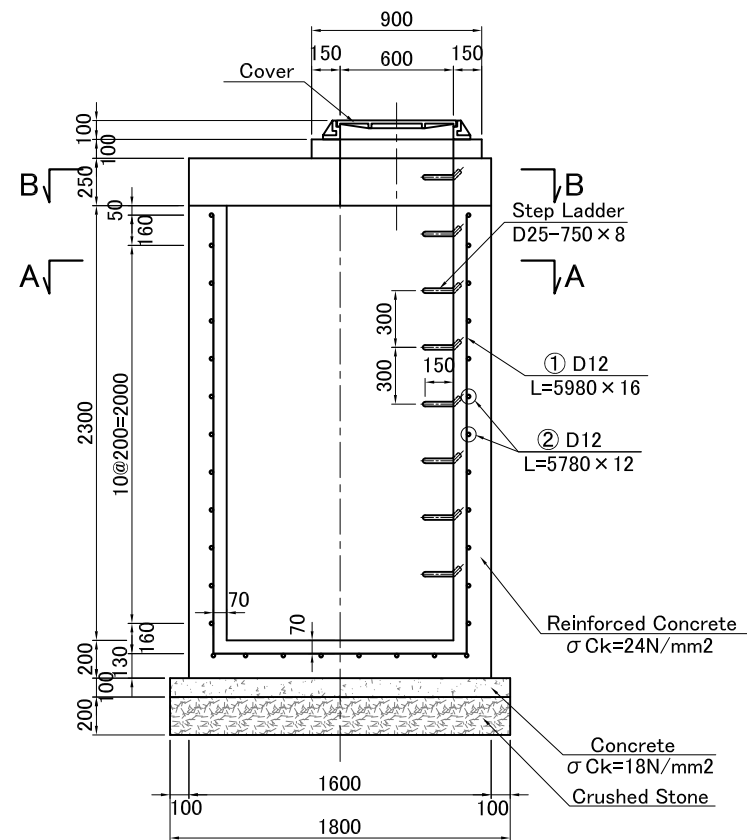

PLAN

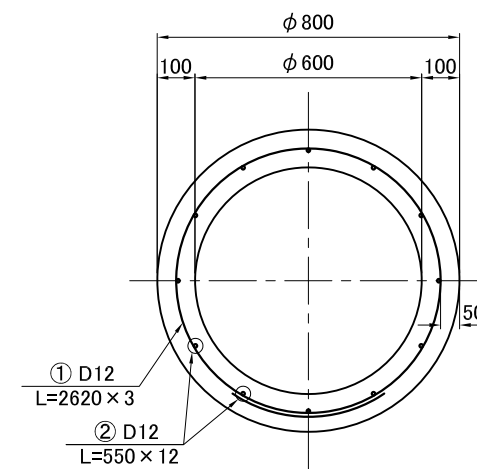

Manhole 1.00*1.00*2.30		
STATION	NO.	REMARKS
10+020.0 - 12+200.0	6	

  

Manhole Height Adjustment		
STATION	NO.	REMARKS
10+020.0 - 12+200.0	2	

**TYPICAL CONNECTING ROAD WITH SERVICE ROAD (FOR EMBANKMENT AREA)**

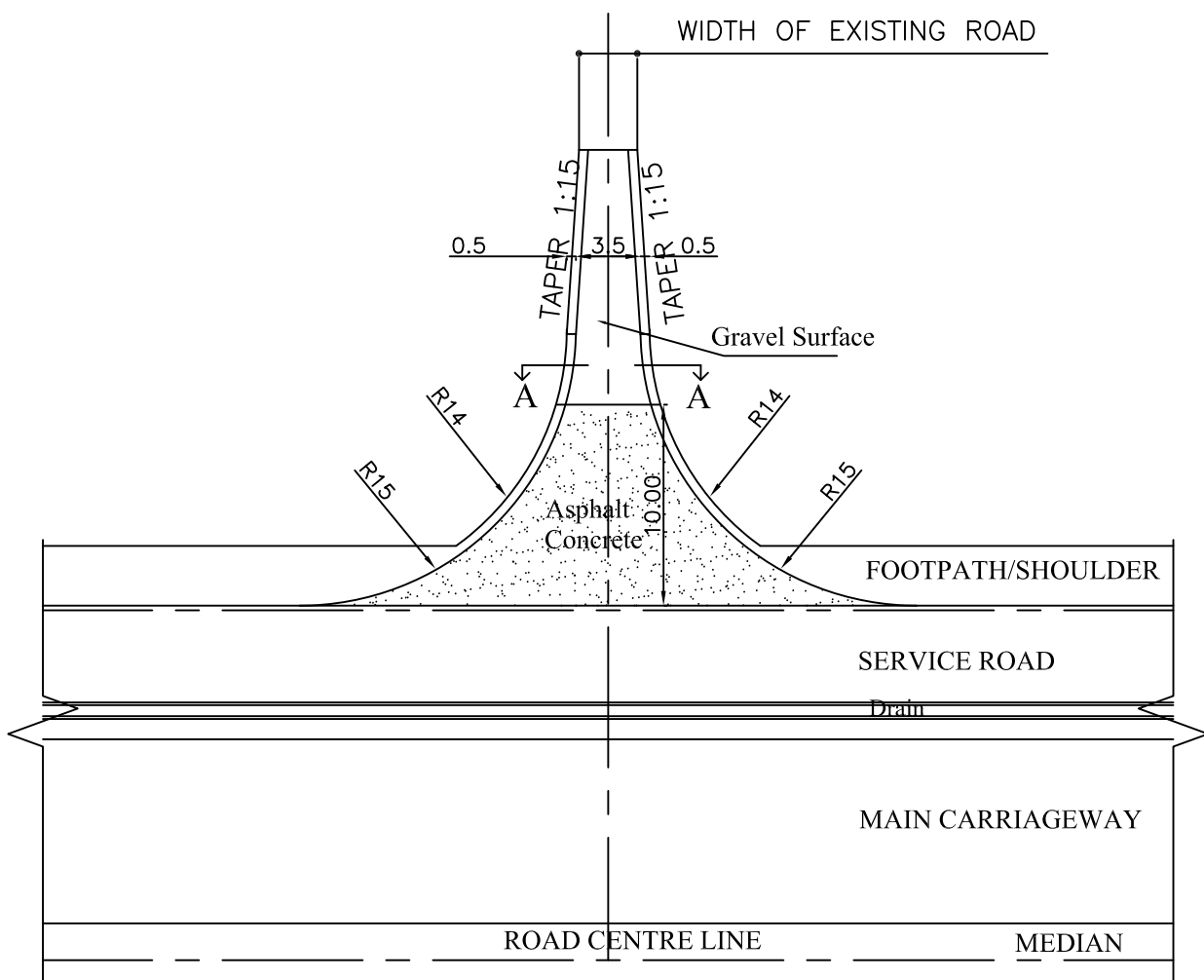

PLAN  
SCALE 1:400

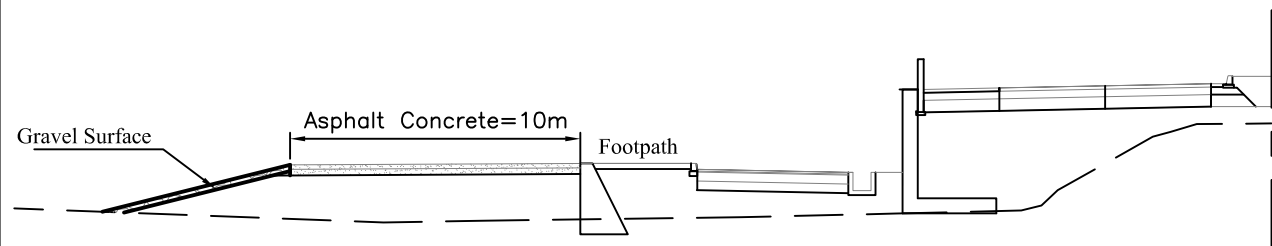

PROFILE  
SCALE 1:250

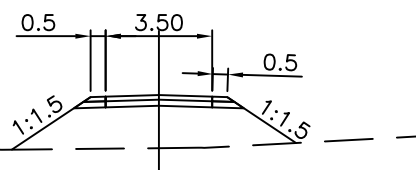

CROSS SECTION  
SECTION AT C-C  
SCALE 1:250

**TYPICAL CONNECTING ROAD WITHOUT SERVICE ROAD (FOR EMBANKMENT AREA)**

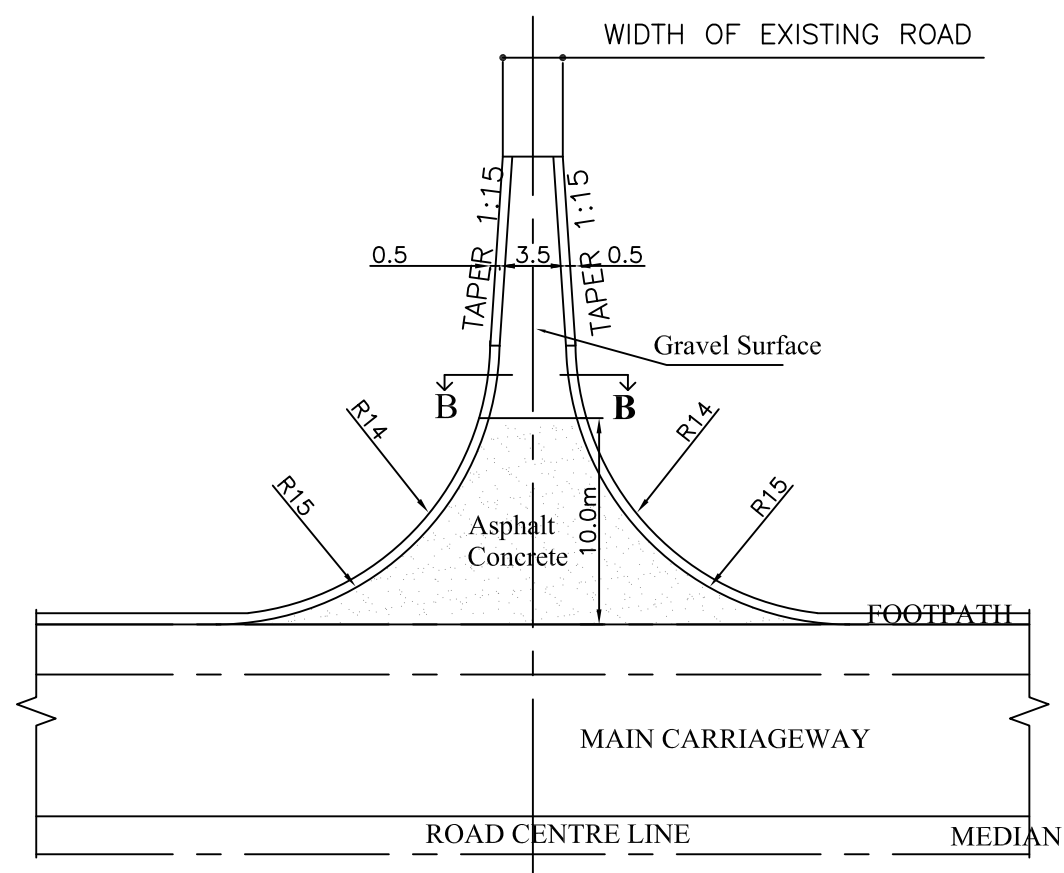



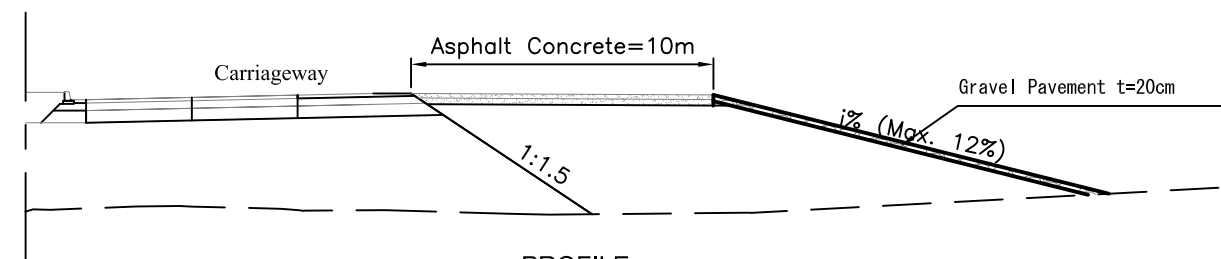

PLAN  
SCALE 1:400

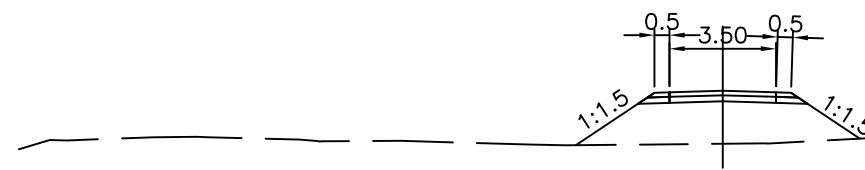

PROFILE  
SCALE 1:250



CROSS SECTION  
SECTION AT C-C  
SCALE 1:250

<p>Clients:</p>  Japan International Cooperation Agency	 Department of Roads Ministry of Physical Infrastructure and Transport Federal Democratic Republic of Nepal	<p>Consultants:</p>  CTI Engineering International Co., Ltd.  CTI Engineering Co., Ltd.	<p>Project Title:</p> Additional Study of the Suryabinayak-Dhulikhel Road Improvement Project	<p>Sheet Contents:</p> <b>OUTLINE OF CROSSROAD TREATMENT</b>	<p>Scale: (A1size) AS SHOWN Submission Date March, 2018</p>	<p>SHT. NO. CT-01</p>
--	--	--	---	--	---	---------------------------

**TYPICAL CONNECTING ROAD  
(FOR CUTTING AREA)**

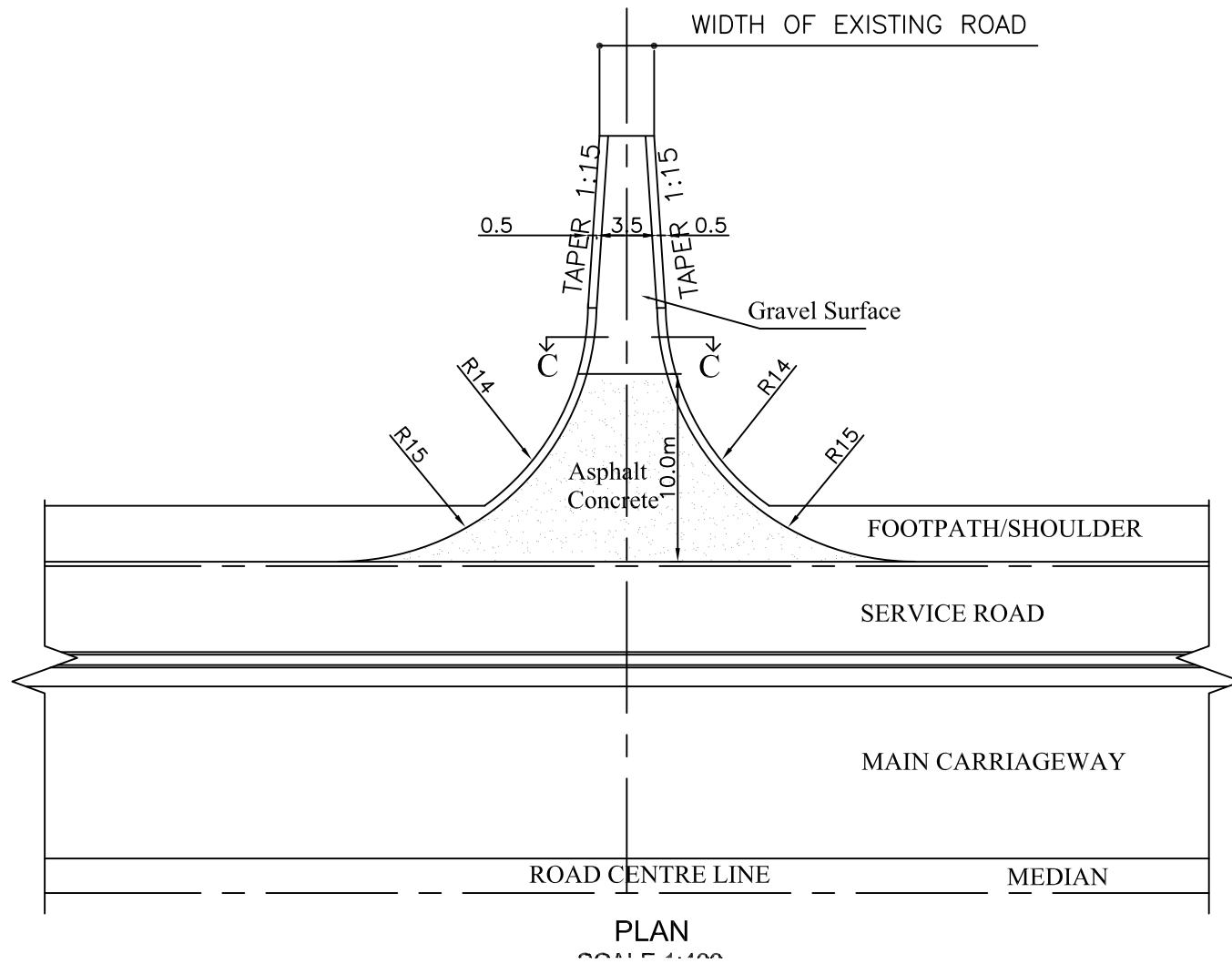

**TYPICAL CONNECTING ROAD  
FOR OBLIQUE ROAD**

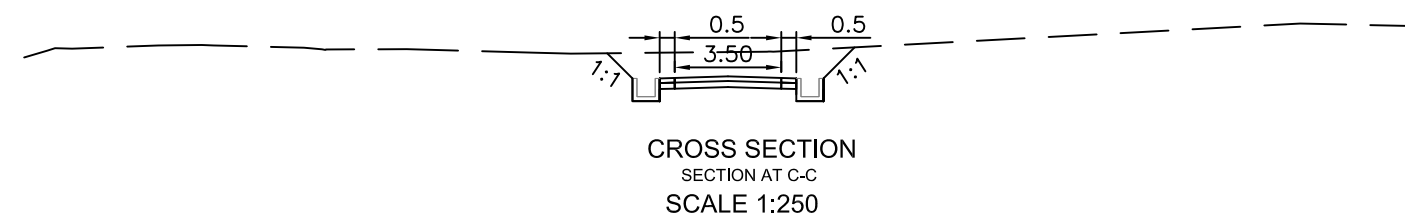
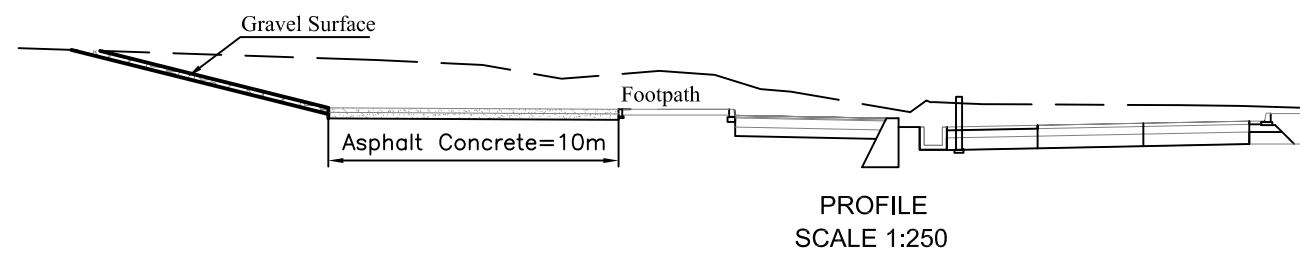
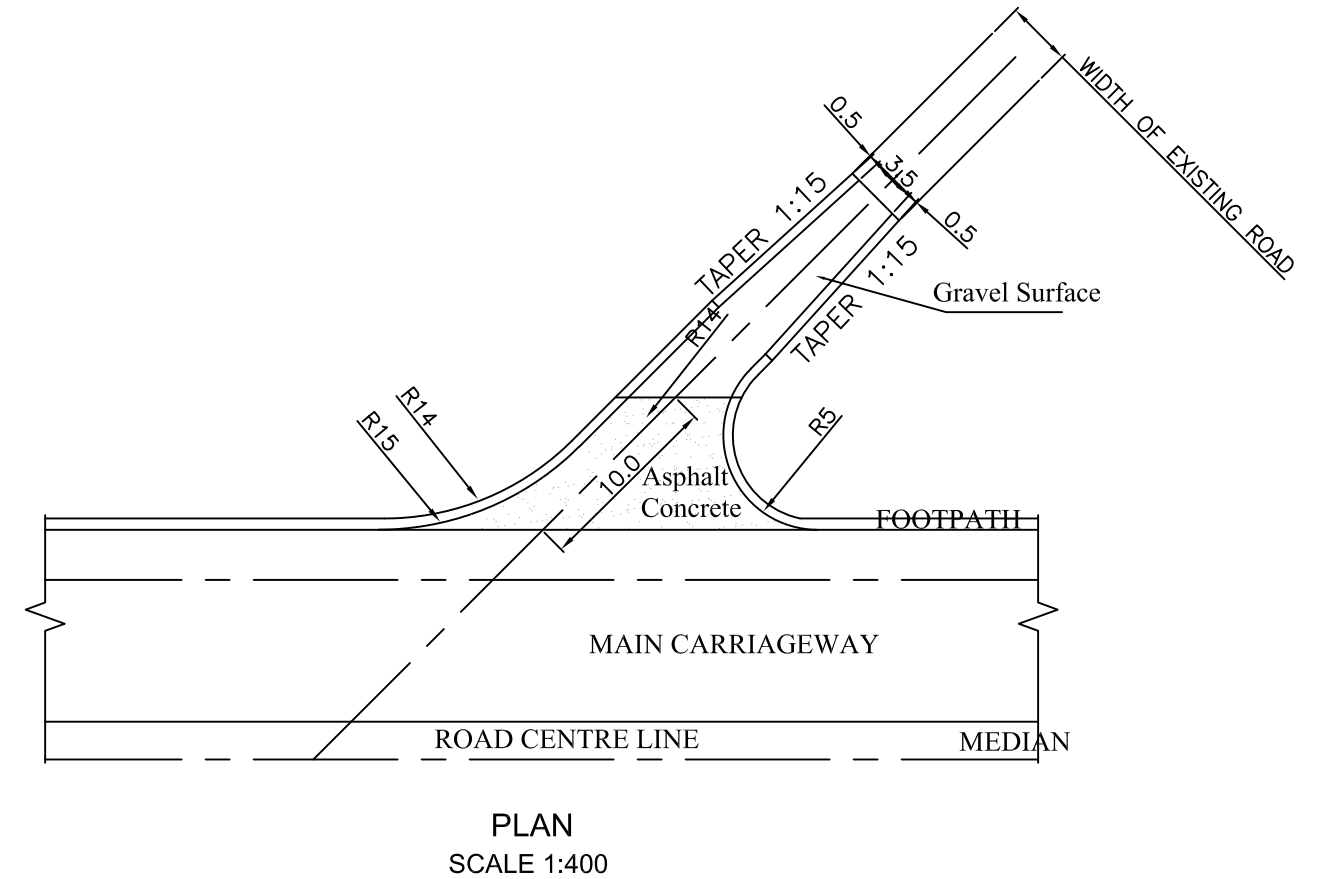

Clients:	Department of Roads Ministry of Physical Infrastructure and Transport Federal Democratic Republic of Nepal	Consultants:	Project Title:	Sheet Contents:	Scale: (A1size)	SHT. NO.
Japan International Cooperation Agency		CTI Engineering International Co., Ltd. CTI Engineering Co., Ltd.	Additional Study of the Suryabinayak-Dhulikhel Road Improvement Project	<b>OUTLINE OF CROSSROAD TREATMENT</b>	AS SHOWN Submission Date March, 2018	CT-02



List of High Priority Connecting Roads

S.N.	Station	Side		Existing Width	Length (m)	Design Road	Access Road	Level Differen	Grade %	Direction	Priority
		Left	Right								
1	0+155	Left		7.0	7.20	1318.440	1317.575	-0.865	-12.02	Perpendicular	High
2	0+220	Left		7.5	7.20	1316.497	1316.389	-0.108	-1.50	Angular	High
3	0+420		Right	4.7	3.84	1316.790	1317.262	0.472	12.29	Angular	High
4	0+460	Left		3.2	7.14	1313.260	1310.663	-2.597	-36.38	Angular	High
5	0+475		Right	3.2	7.14	1317.737	1317.967	0.230	3.22	Perpendicular	High
6	0+620	Left		3.3	8.24	1318.600	1317.107	-1.493	-18.11	Angular	High
7	0+660	Left		3.0	7.18	1319.166	1317.578	-1.588	-22.13	Angular	High
8	0+760	Left		4.2	7.29	1318.661	1317.114	-1.547	-21.22	Angular	High
9	0+760		Right	7.2	7.14	1319.938	1319.889	-0.049	-0.69	Angular	High
10	0+840	Left		3.9	5.46	1318.688	1318.780	0.092	1.68	Angular	High
11	0+850		Right	4.5	4.11	1320.450	1321.047	0.598	14.54	Angular	High
12	0+885	Left		2.8	6.06	1319.049	1318.378	-0.671	-11.07	Perpendicular	High
13	0+925	Left		2.9	7.15	1319.304	1319.617	0.313	4.38	Angular	High
14	1+020		Right	6.5	6.30	1319.984	1319.709	-0.275	-4.37	Perpendicular	High
15	1+180	Left		5.5	7.14	1320.573	1320.286	-0.287	-4.02	Angular	High
16	1+280		Right	1.5	7.12	1321.641	1320.692	-0.949	-13.33	Angular	High
17	1+350		Right	3.8	5.82	1321.000	1321.487	0.487	8.37	Angular	High
18	1+380		Right	5.2	7.16	1321.675	1321.206	-0.469	-6.55	Angular	High
19	1+400	Left		3.2	7.18	1321.551	1320.823	-0.728	-10.14	Angular	High
20	1+420	Left		2.8	7.14	1321.510	1319.894	-1.616	-22.63	Angular	High
21	1+440	Left		2.8	7.41	1321.368	1319.408	-1.960	-26.47	Angular	High
22	1+500		Right	5.1	7.14	1319.969	1319.352	-0.617	-8.64	Angular	High
23	1+800	Left		2.8	7.15	1317.740	1317.212	-0.528	-7.38	Angular	High
24	1+980	Left		5.3	10.81	1323.791	1323.469	-0.322	-2.98	Perpendicular	High
25	2+260	Left		4.8	3.98	1331.060	1331.162	0.102	2.56	Angular	High
26	2+280		Right	5.8	9.76	1332.216	1332.339	0.123	1.26	Angular	High
27	2+380	Left		6.2	8.33	1336.907	1336.528	-0.379	-4.55	Angular	High
28	2+620		Right	4.6	18.30	1349.410	1344.907	-4.503	-24.61	Perpendicular	High
29	2+700	Left		4.12	16.98	1352.843	1347.740	-5.103	-30.05	Perpendicular	High
30	3+240	Left		3.3	17.06	1361.620	1360.957	-0.663	-3.89	Angular	High
31	4+310	Left		3	8.14	1396.485	1396.102	-0.383	-4.71	Angular	High
32	7+310		Right	5.1	18.17	1491.313	1495.965	4.652	25.60	Angular	High

List of High Priority Connecting Roads

S.N.	Station	Side		Existing Width	Length (m)	Design Road	Access Road	Level Differen	Grade %	Direction	Priority
		Left	Right								
32	7+310		Right	5.1	18.17	1491.313	1495.965	4.652	25.60	Angular	High
33	7+960	Left		5	18.85	1479.973	1486.461	6.488	34.42	Perpendicular	High
34	8+150	Left		3	15.60	1480.918	1482.204	1.286	8.25	Perpendicular	High
35	8+220		Right	3.1	19.83	1479.571	1471.931	-7.640	-38.53	Perpendicular	High
36	8+400		Right	3.25	19.40	1475.544	1468.575	-6.969	-35.93	Angular	High
37	8+420		Right	4	19.52	1475.019	1467.723	-7.296	-37.39	Angular	High
38	8+800		Right	4.8	17.10	1469.851	1467.946	-1.905	-11.14	Perpendicular	High
39	9+120	Left		5.4	5.29	1468.806	1469.680	0.874	16.52	Angular	High
40	9+945	Left		4.5	15.45	1466.499	1467.604	1.105	7.15	Angular	High
41	10+160		Right	4	7.12	1462.193	1460.595	-1.598	-22.44	Angular	High
42	10+180	Left		3.1	4.28	1462.957	1463.489	0.532	12.43	Angular	High
43	10+350		Right	4.5	4.00	1457.317	1457.074	-0.243	-6.07	Angular	High
44	10+490	Left		4.7	7.15	1454.078	1452.800	-1.277	-17.88	Perpendicular	High
45	10+820	Left		5.3	7.14	1455.737	1455.851	0.114	1.60	Perpendicular	High
46	11+260	Left		7	7.14	1458.272	1458.764	0.492	6.89	Perpendicular	High
47	11+365	Left		4	7.14	1458.620	1458.990	0.370	5.18	Perpendicular	High
48	11+600	Left		4.25	7.14	1456.792	1458.931	2.139	29.96	Perpendicular	High
49	12+040	Left		3.6	7.14	1456.396	1455.484	-0.912	-12.77	Perpendicular	High
50	12+100	Left		6.6	7.09	1457.018	1455.491	-1.527	-21.55	Angular	High
51	12+240	Left		3.9	10.91	1466.155	1465.314	-0.841	-7.71	Angular	High
52	12+280	Left		4	10.68	1468.744	1469.890	1.146	10.73	Perpendicular	High
53	12+325	Left		4.2	11.87	1471.328	1473.210	1.882	15.86	Angular	High
54	12+650	Left		4.4	9.99	1480.606	1478.063	-2.543	-25.45	Perpendicular	High
55	13+000	Left		4	12.29	1483.098	1485.391	2.293	18.66	Angular	High
56	13+020		Right	5.2	10.80	1483.284	1483.367	0.083	0.77	Angular	High
57	13+380		Right	3	3.55	1496.701	1496.755	0.054	1.52	Angular	High
58	13+700	Left		6.1	18.20	1515.008	1515.116	0.108	0.59	Angular	High
59	13+905	Left		2.8	16.90	1521.706	1530.849	9.143	54.10	Perpendicular	High
60	13+960	Left		2.9	17.33	1522.870	1531.589	8.719	50.32	Perpendicular	High
61	14+280	Left		3.6	15.11	1519.866	1521.017	1.151	7.62	Perpendicular	High
62	14+580	Left		3.8	16.16	1532.796	1536.069	3.273	20.26	Perpendicular	High
63	14+820	Left		5.2	5.00	1541.978	1542.315	0.337	6.74	Angular	High

Left Side	43	Perpendicular				23
Right Side	20	Angular				40
<b>Total</b>	<b>63</b>	<b>Total</b>				<b>63</b>

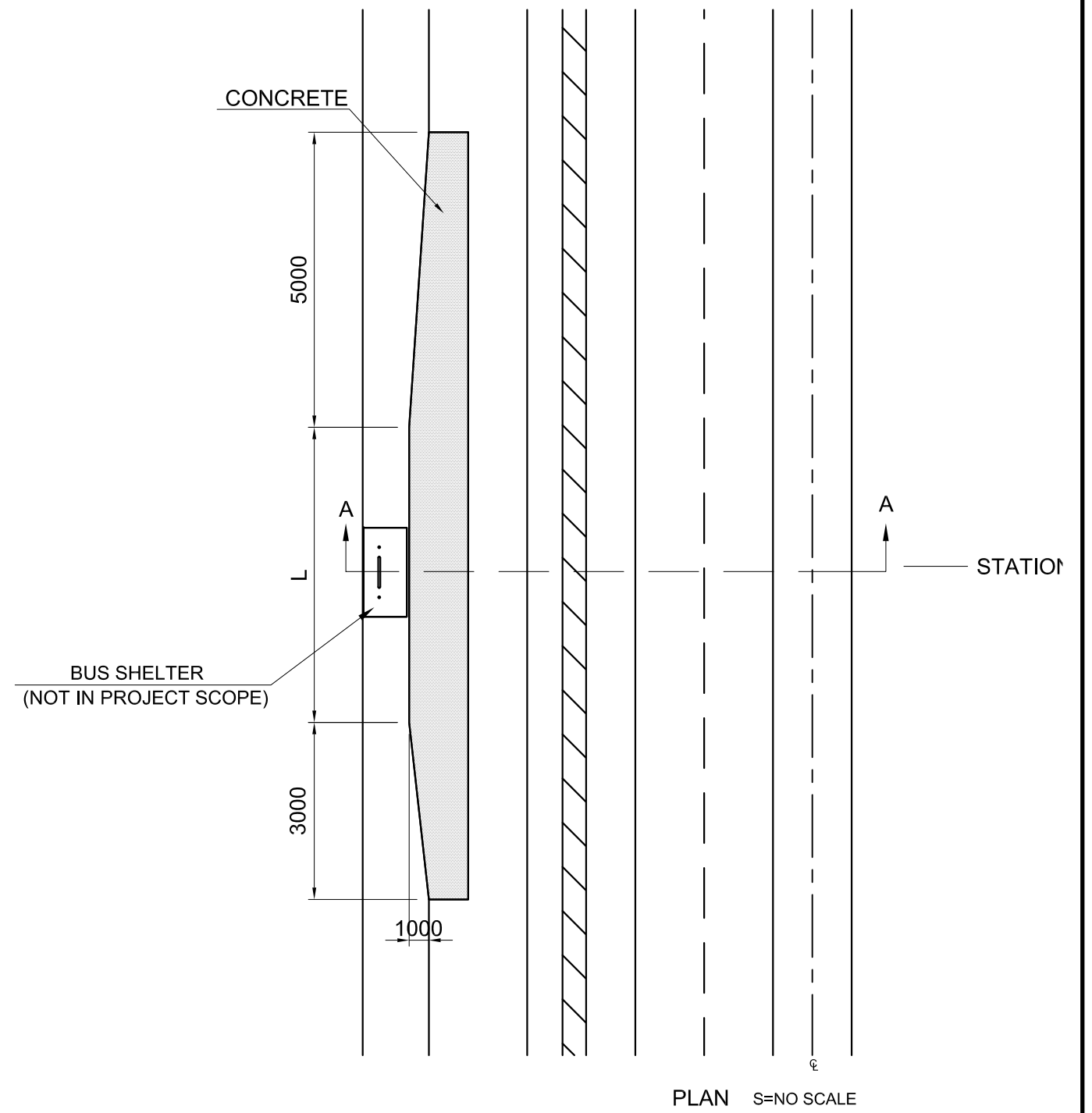
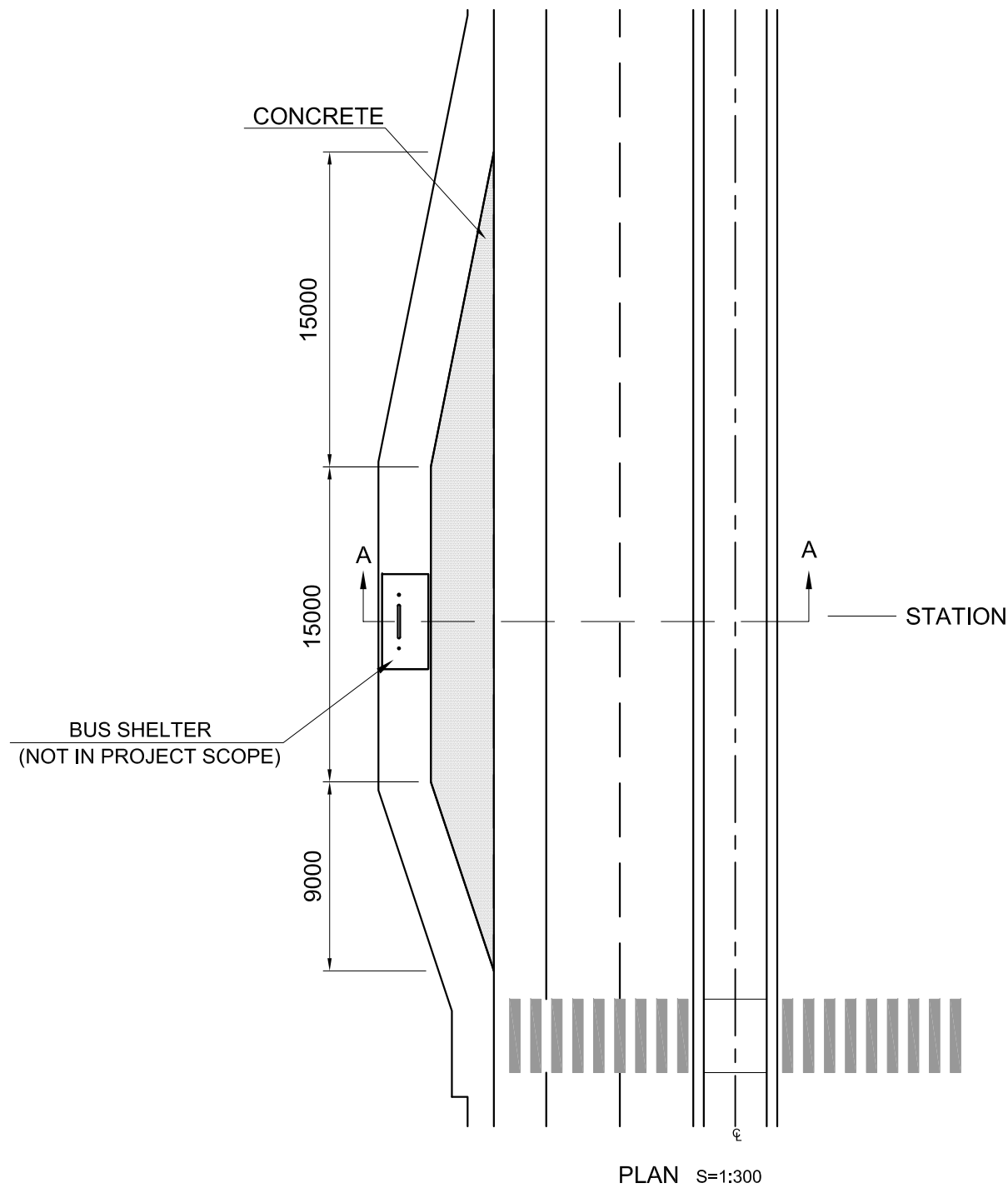

LOCATION OF BUS LAY BY  
(NO SERVICE TRACK)

STATION			
LEFT SIDE		RIGHT SIDE	
1	3+120	1	3+120
2	3+760	2	3+760
3	7+800	3	7+800
4	9+160	4	9+160
5	14+000	5	14+000
6		6	

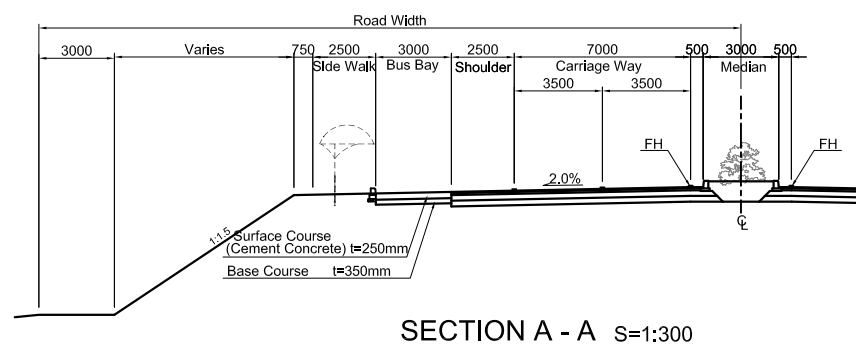

LOCATION OF BUS LAY BY  
(WITH SERVICE TRACK)

STATION					
LEFT SIDE			RIGHT SIDE		
1	1+140	L=30m	1	1+140	L=30m
2	10+200	L=15m	2	10+200	L=15m
3	11+300	L=15m	3	11+900	L=15m
4	11+900	L=15m	4	13+300	L=15m
5	13+300	L=15m			

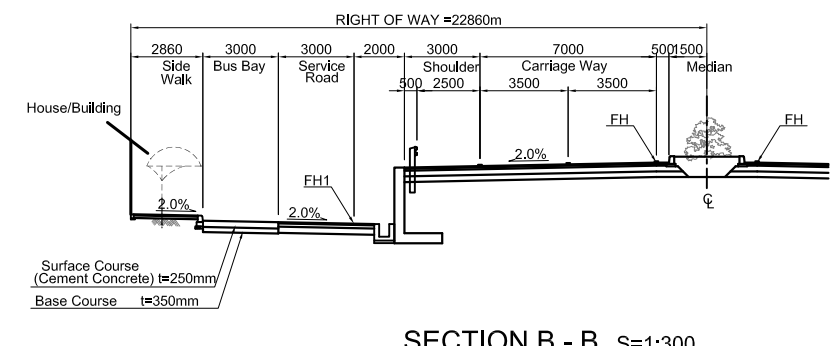



MEDIAN PLAN VIEW (TYPE-D) S=1:100

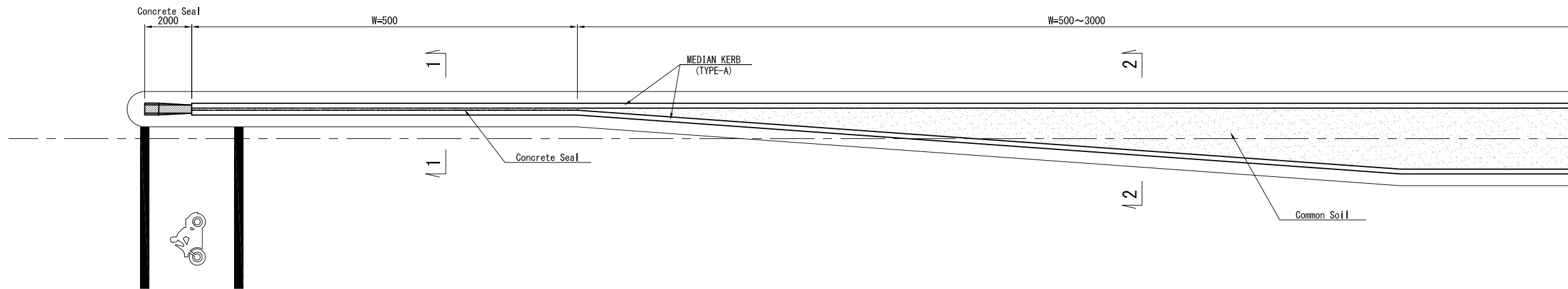

TYPE-D (SECTION 1-1) S=1:20

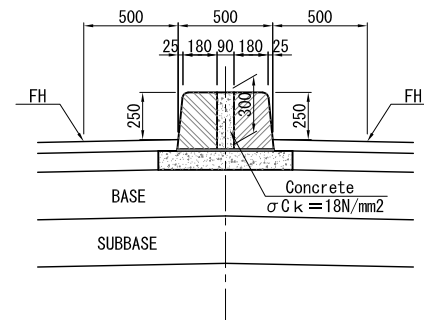

TYPE-E (SECTION 3-3) S=1:20

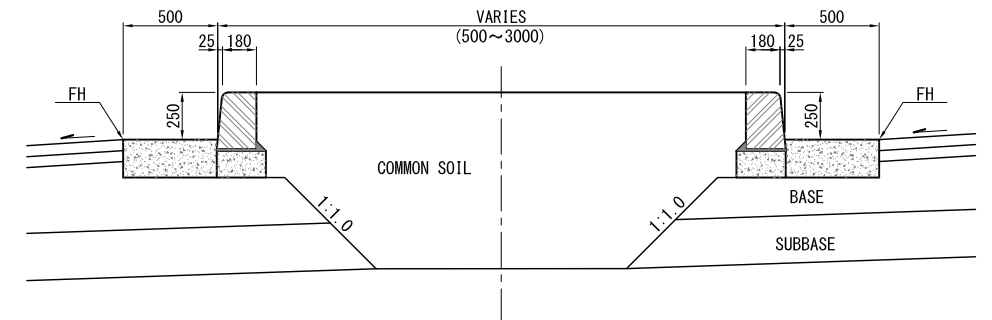

MEDIAN PLAN VIEW (TYPE-E, F) S=1:30

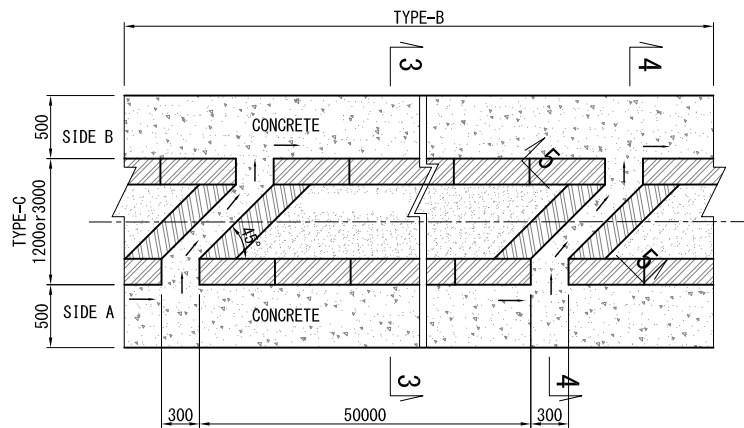

TYPE-D (SECTION 2-2) S=1:20

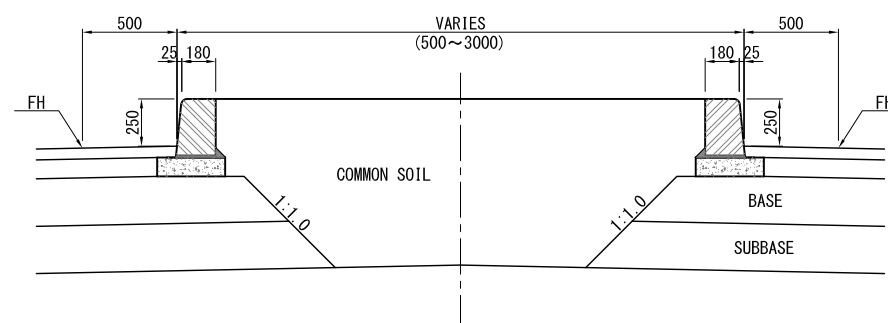

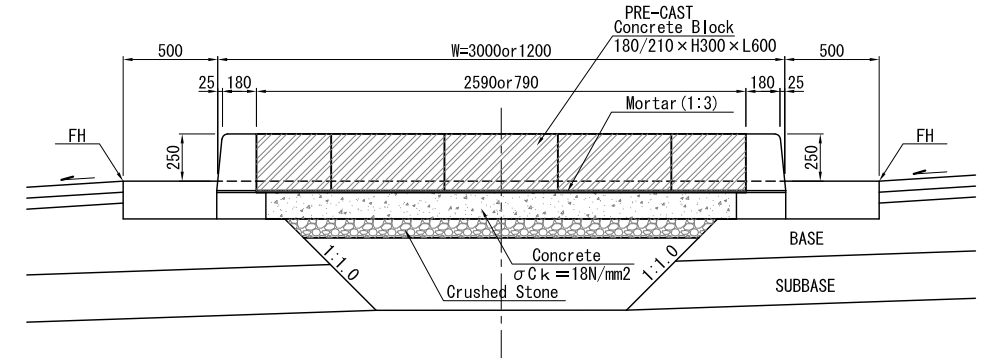

TYPE-F (SECTION 4-4) S=1:20



REMARKS:-

1. ALL DIMENSIONS ARE IN mm.
2. THE FIRST GAPPING OF THE MEDIAN SHALL BE PROVIDED 50m FROM THE BEGINNING OF THE CURVE.
3. THE OPENING WILL HAVE AN ANGLE OF 45°.
4. A-SIDE OF THE OPENING SHALL BE PLACED ON THE HIGHER SIDE IN THE PROFILE DIRECTION

<p>Clients:</p>  Japan International Cooperation Agency	 Department of Roads Ministry of Physical Infrastructure and Transport Federal Democratic Republic of Nepal	<p>Consultants:</p>  CTI Engineering International Co., Ltd. CTI Engineering Co., Ltd.	<p>Project Title:</p> Additional Study of the Suryabinayak-Dhulikhel Road Improvement Project	<p>Sheet Contents:</p> OUTLINE OF ROAD ANCILLARIES OUTLINE OF MEDIAN	<p>Scale: (A1size)</p> AS SHOWN Submission Date March, 2018	<p>SHT. NO.</p> RA-01
--	--	--	---	---	---	-----------------------

SIDEWORK KERB S=1:10

TYPE-A

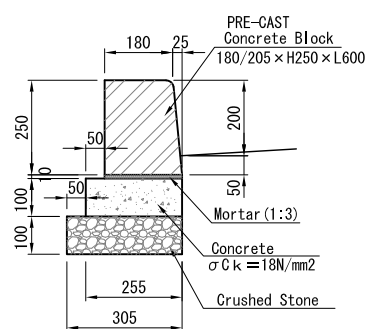

Concrete Block A

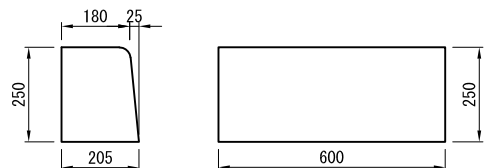

FLUSH KERB S=1:10

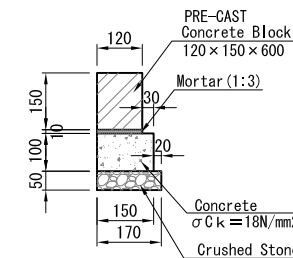

MEDIAN KERB S=1:10

TYPE-D

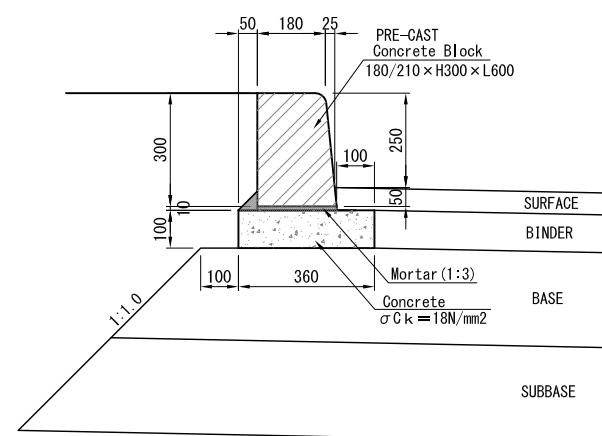

TYPE-F  
(SECTION 5-5)

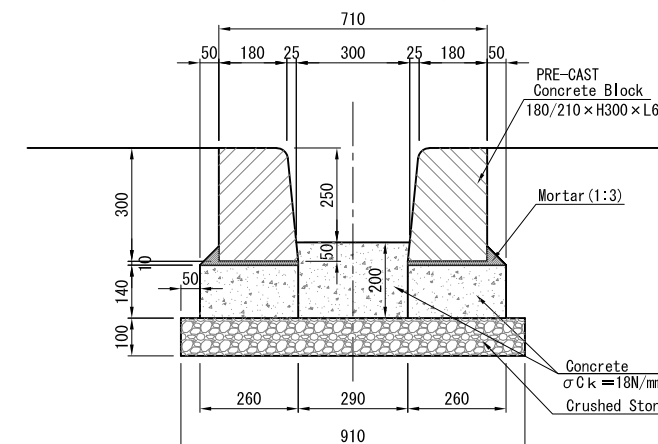

TYPE-B

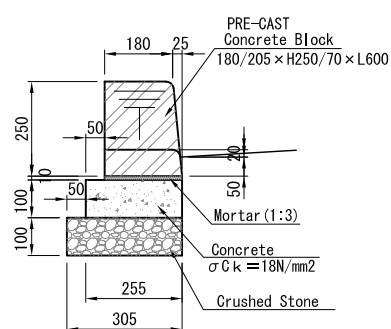

Concrete Block B1

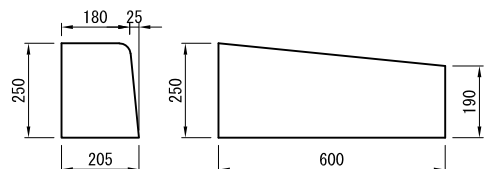

Concrete Block B2

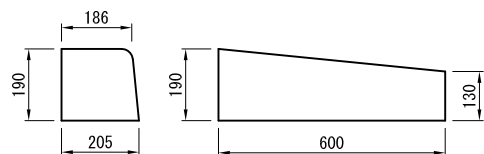

Concrete Block B3

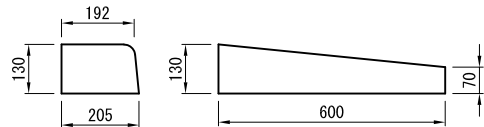

TYPE-C

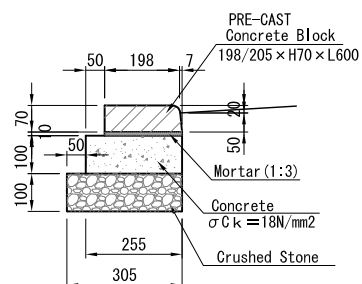

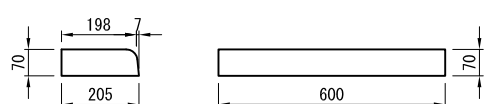

Concrete Block C

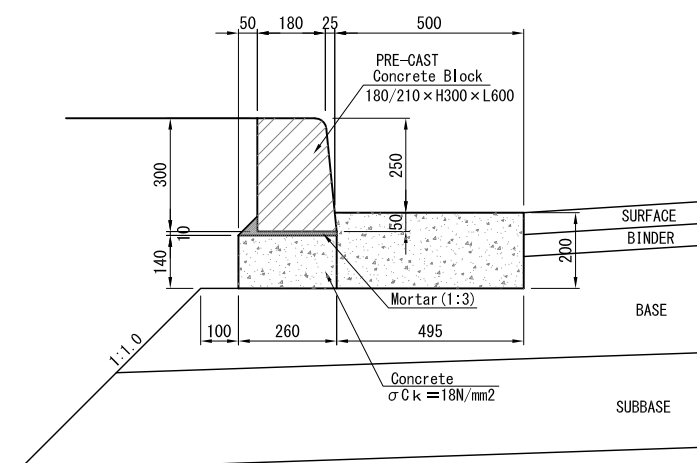

TYPE-E



<p>Clients:</p>  Japan International Cooperation Agency	 Department of Roads Ministry of Physical Infrastructure and Transport Federal Democratic Republic of Nepal	<p>Consultants:</p>  CTI Engineering International Co., Ltd. CTI Engineering Co., Ltd.	<p>Project Title:</p> <p>Additional Study of the Suryabinayak-Dhulikhel Road Improvement Project</p>	<p>Sheet Contents:</p> <p>OUTLINE OF ROAD ANCILLARIES MEDIAN BLOCK, KERB AND EDGE BLOCK (FLUSH KERB)</p>	<p>Scale: (A1size)</p> <p>1:10</p> <p>Submission Date</p> <p>March, 2018</p>	<p>SHT. NO.</p> <p>RA-02</p>
--	--	--	--	--	--	------------------------------





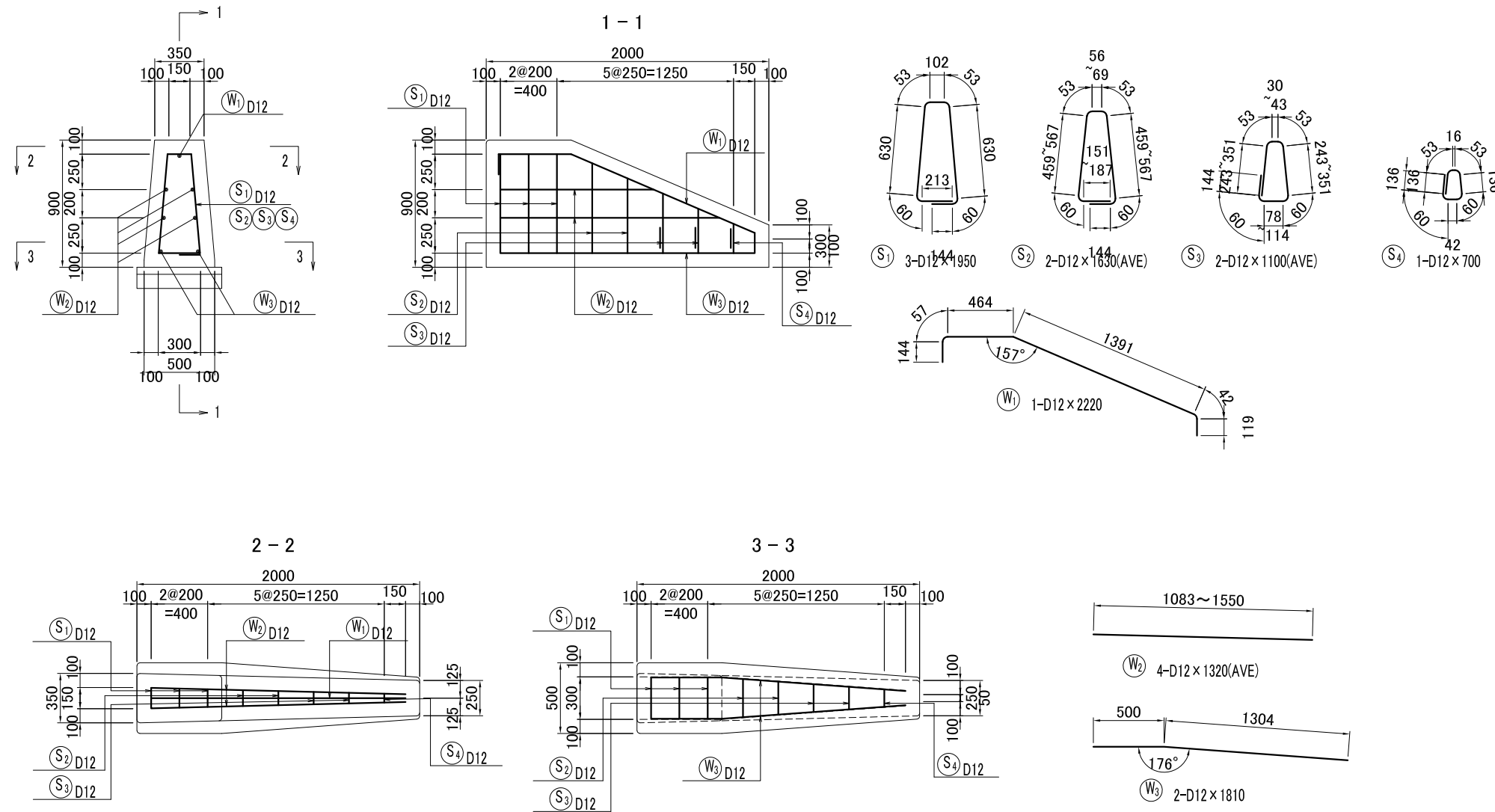

**LIST OF REINFORCEMENT**

MARK	SEC.	LENGTH (mm)	EACH	WEIGHT (kg/m)	WEIGHT/one (kg)	WEIGHT (kg)	REMARKS
S 1	D12	1 950	3	0.888	1.73	5	⏏
S 2	D12	1 630	2	0.888	1.45	3	⏏ (AVE)
S 3	D12	1 100	2	0.888	0.977	2	⏏ (AVE)
S 4	D12	700	1	0.888	0.622	1	⏏
W 1	D12	2 220	1	0.888	1.97	2	⏏
W 2	D12	1 320	4	0.888	1.17	5	⏏
W 3	D12	1 810	2	0.888	1.61	3	⏏
SUB TOTAL						21	
TOTAL						D12	21 Kg

D	a (mm)	b (mm)	c (mm)	R (mm)	L (mm)
D12	57	144	201	36	380

GUARDRAIL S=1:20

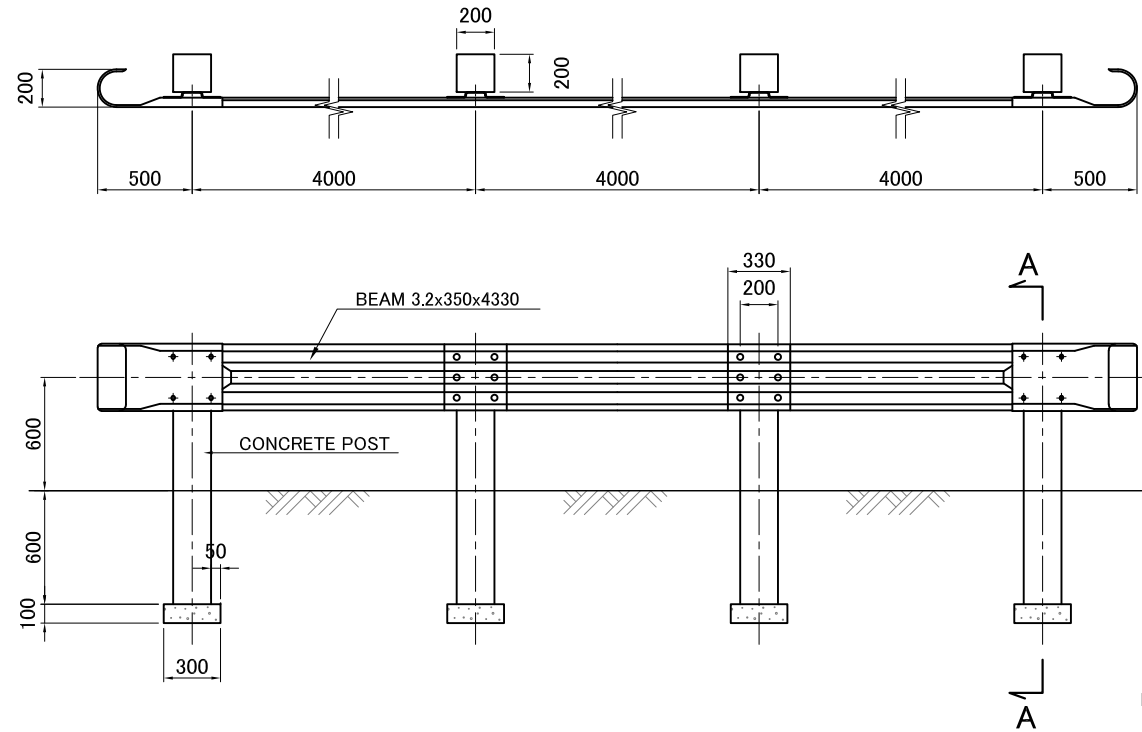

CROSSING PREVENTION FENCE S=1:20

SECTION A-A

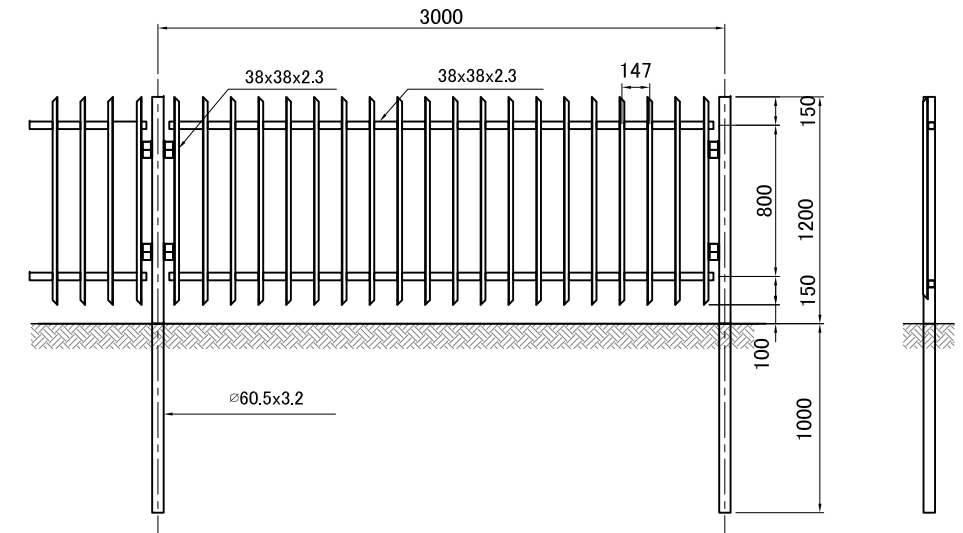
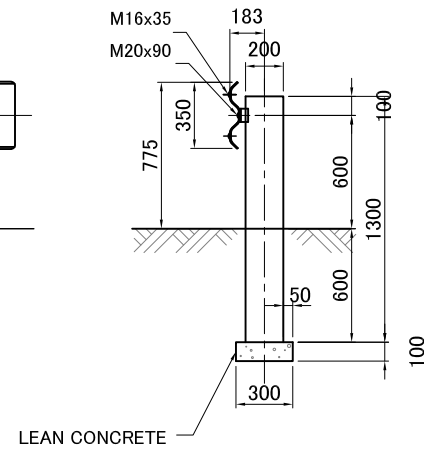

GUARD PIPE S=1:20

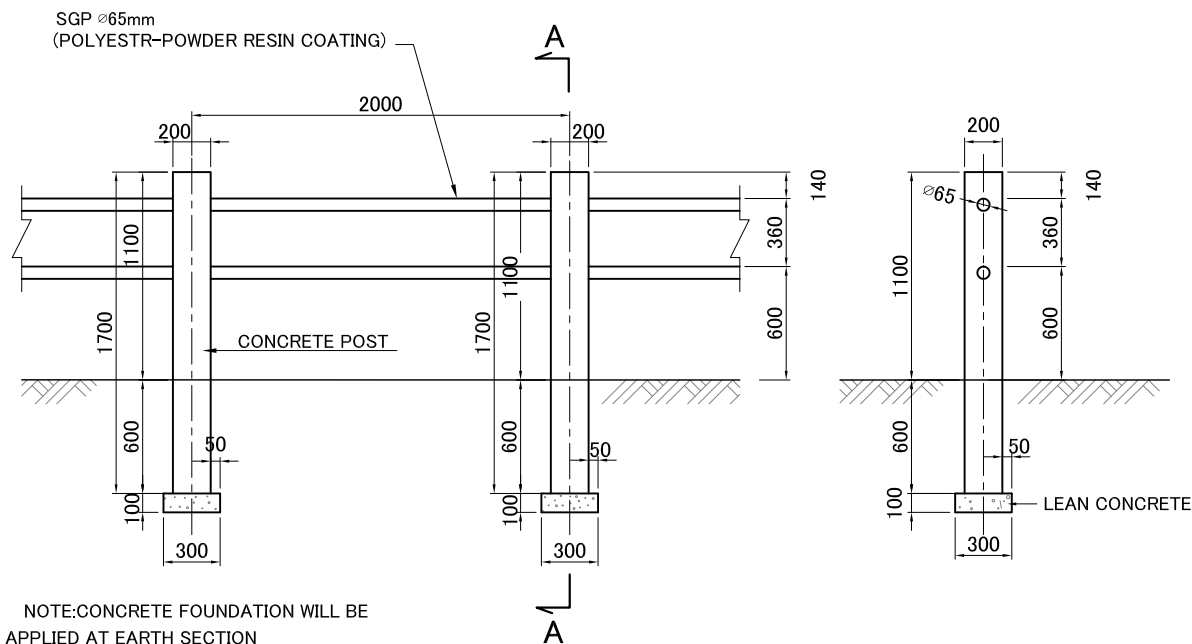

NOTE: CONCRETE FOUNDATION WILL BE APPLIED AT EARTH SECTION

REINFORCEMENT DETAIL OF GUARD RAIL S=1:20

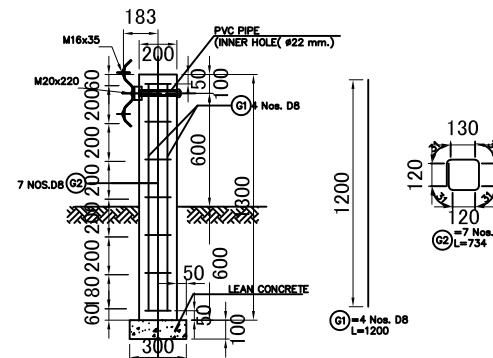

BARBENDING SCHEDULE TABLE OF GUARD RAIL

Sl. No.	MarC	Dia	Nos.	Shape	Length (mm)	Weight (kg/m)	Total Weight (kg)
1.	H1	8	4	□	1200	0.395	1.896
2.	H2	8	7	□	734	0.395	2.029
Grand Total Weight							3.925/1 Pc.

SECTION (GUARD PIPE) S=1:20

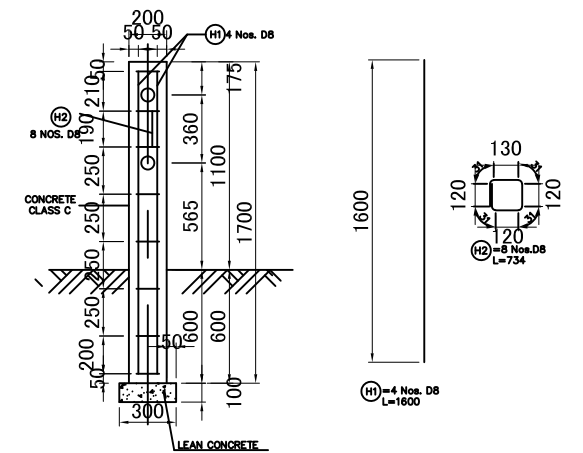

BARBENDING SCHEDULE TABLE (GUARD PIPE)

Sl. No.	MarC	Dia	Nos.	Shape	Length (mm)	Weight (kg/m)	Total Weight (kg)
1.	H1	8	4	□	1600	0.395	2.528
2.	H2	8	8	□	734	0.395	2.319
Grand Total Weight							4.847/1 Pc.

SIGN POST S=1:20

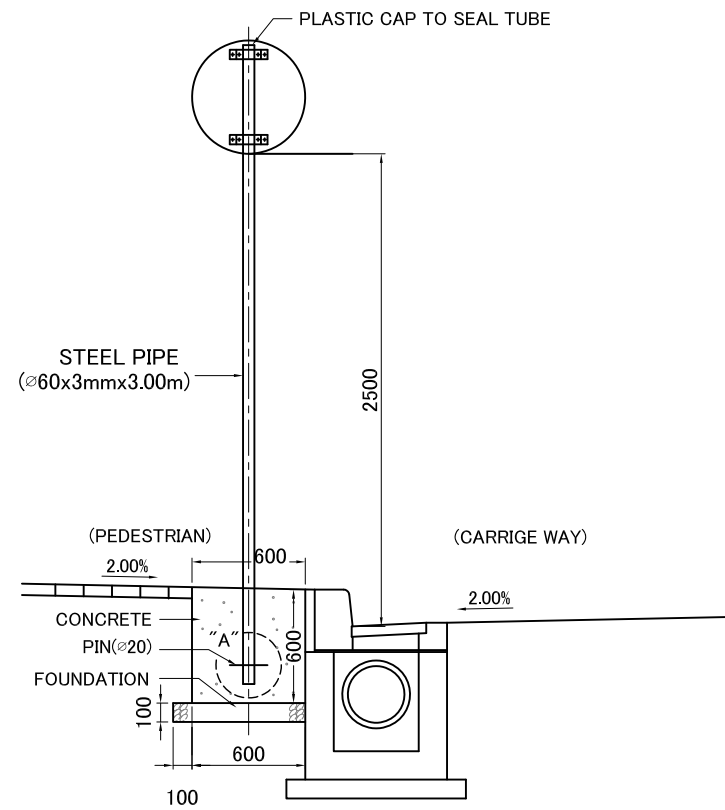

DETAIL OF "A" S=1:5

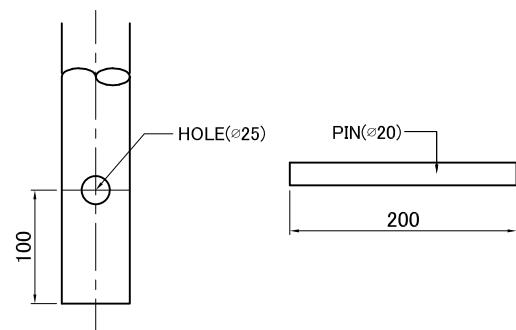

REGULATORY SIGN TYPICAL DETAILS S=1:20

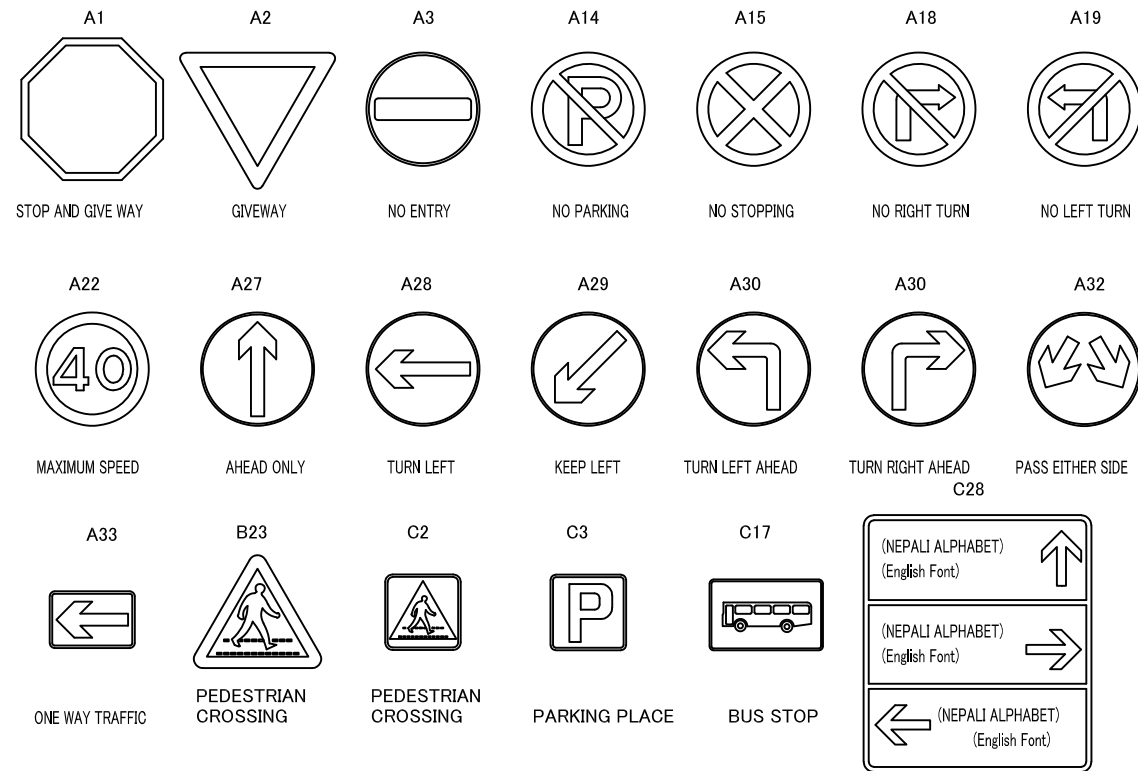

ON APPROACHES TO JUNCTIONS

SIZE OF REGULATORY SIGNS

SIGN TYPE	A	B	C	D	E	F	G
a	600	600	600	600	865	300	600
b	600	865	-	450	600	300	375
REMARKS							
	A1	A2	A3-A32	A33	B23	C2, C3	C17

NOTE: REFER MANUAL, TRAFFIC SIGN MANUAL BY D.O.R.

PEDESTRIAN CROSSING MARKINGS S=1:50

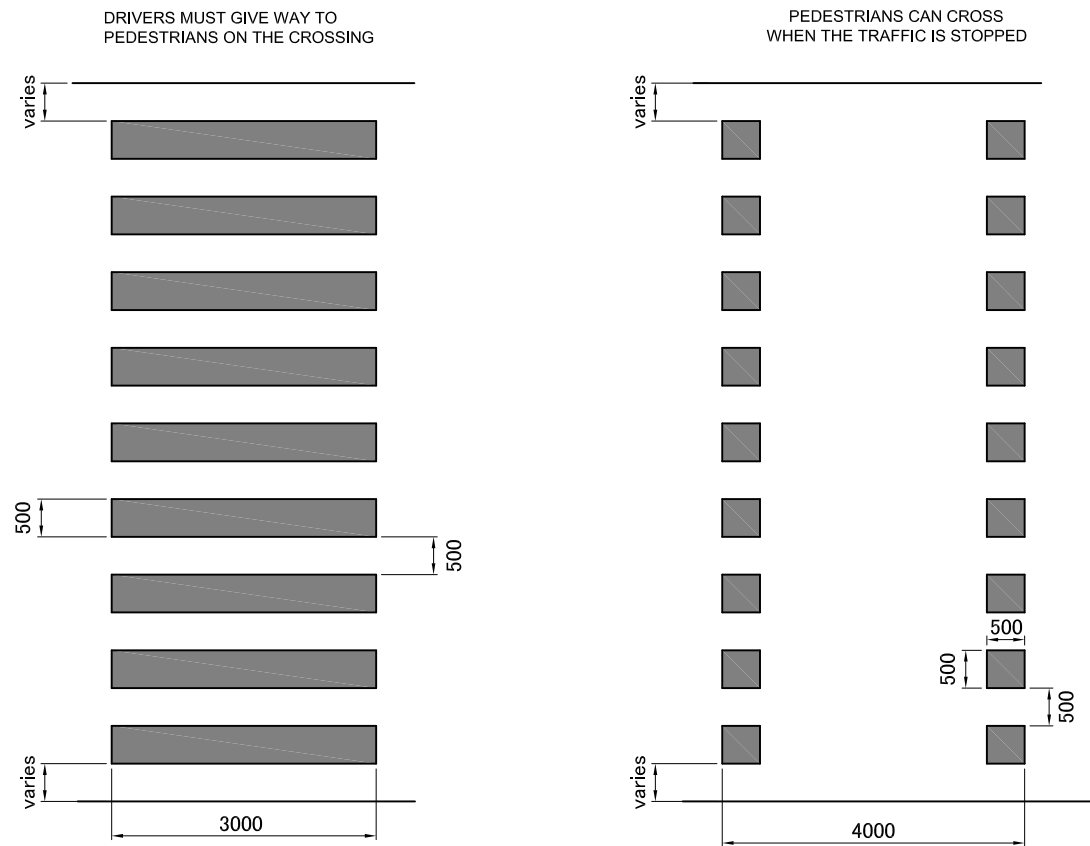

ARROW MARKINGS S=1:50

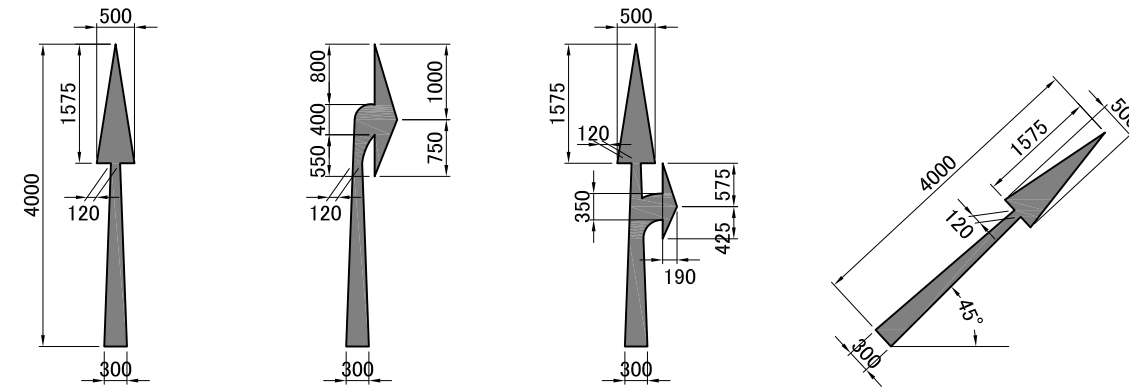

ZEBRA MARKINGS S=1:50

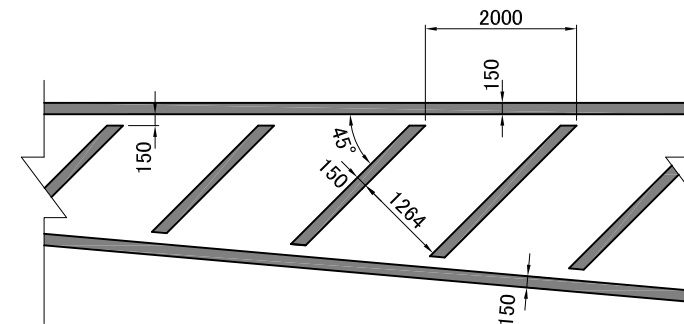

TRAFFIC ISLAND AROUND BENDS

CARRIAGEWAY MARKINGS S=1:50

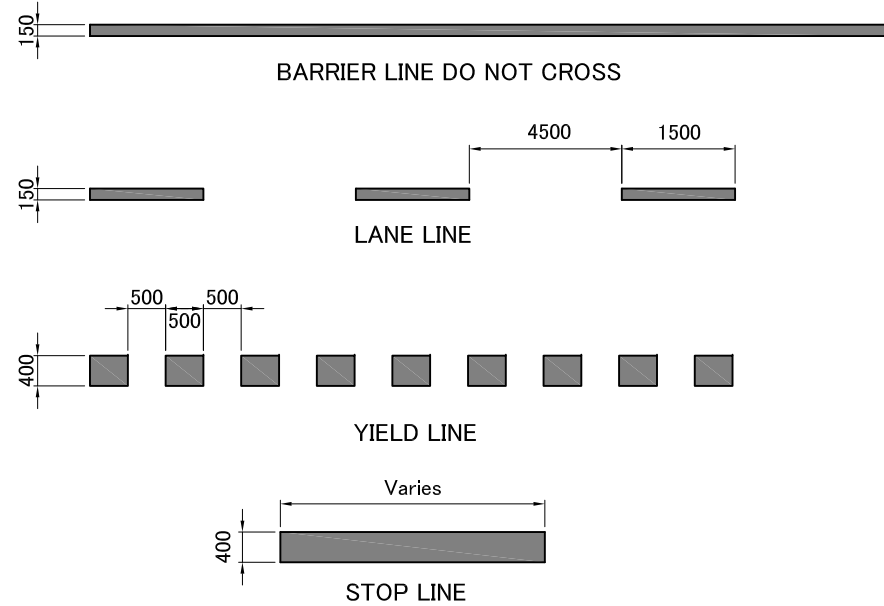



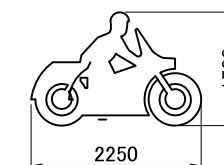

BIKE MARKING S=1:50

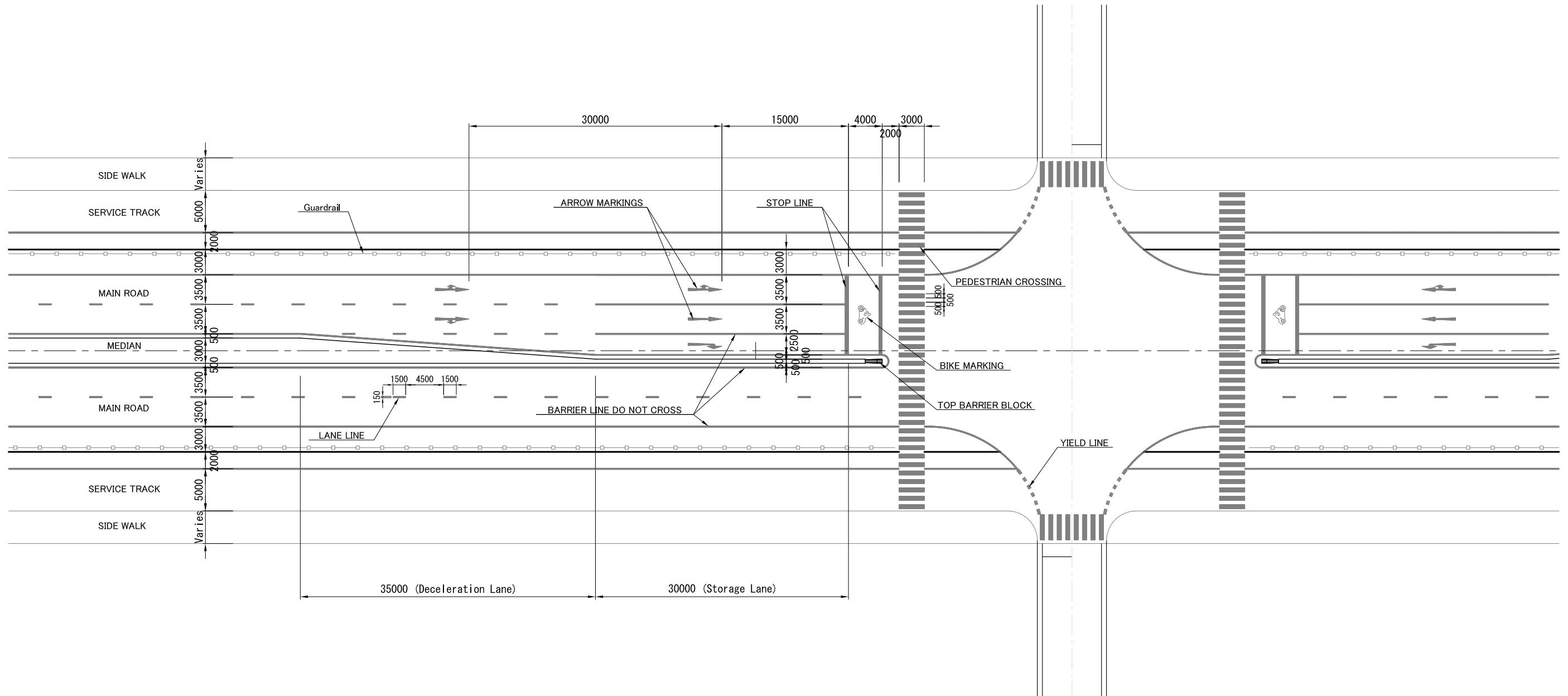

Clients:	Department of Roads Ministry of Physical Infrastructure and Transport Federal Democratic Republic of Nepal	Consultants:	Project Title:	Sheet Contents:	Scale: (A1size)	SHT. NO.
Japan International Cooperation Agency		CTI Engineering International Co., Ltd. CTI Engineering Co., Ltd.	Additional Study of the Suryabinayak-Dhulikhel Road Improvement Project	OUTLINE OF ROAD ANCILLARIES CONDUITS FOR FUTURE INSTALLATION OF TRAFFIC SIGNALS	1:50 Submission Date March, 2018	RA-07

# ROAD MARKINGS S=1:250



Clients:	 Department of Roads Ministry of Physical Infrastructure and Transport Federal Democratic Republic of Nepal	Consultants:	 CTI Engineering International Co., Ltd.  CTI Engineering Co., Ltd.	Project Title:	Scale: (A1size)	SHT. NO.
 Japan International Cooperation Agency			Additional Study of the Suryabinayak-Dhulikhel Road Improvement Project	OUTLINE OF ROAD ANCILLARIES ROAD MARKINGS	1:250 Submission Date March, 2018	RA-08