

Department of Community Territorial Administration and Transport (DATC)
UEMOA Commission
National Development Planning Commission (NDPC)
Ministry of Roads and Highways (MRH)
Ministry of Finance (MoF)
The Republic of Ghana

THE PROJECT ON THE CORRIDOR DEVELOPMENT FOR WEST AFRICA GROWTH RING MASTER PLAN

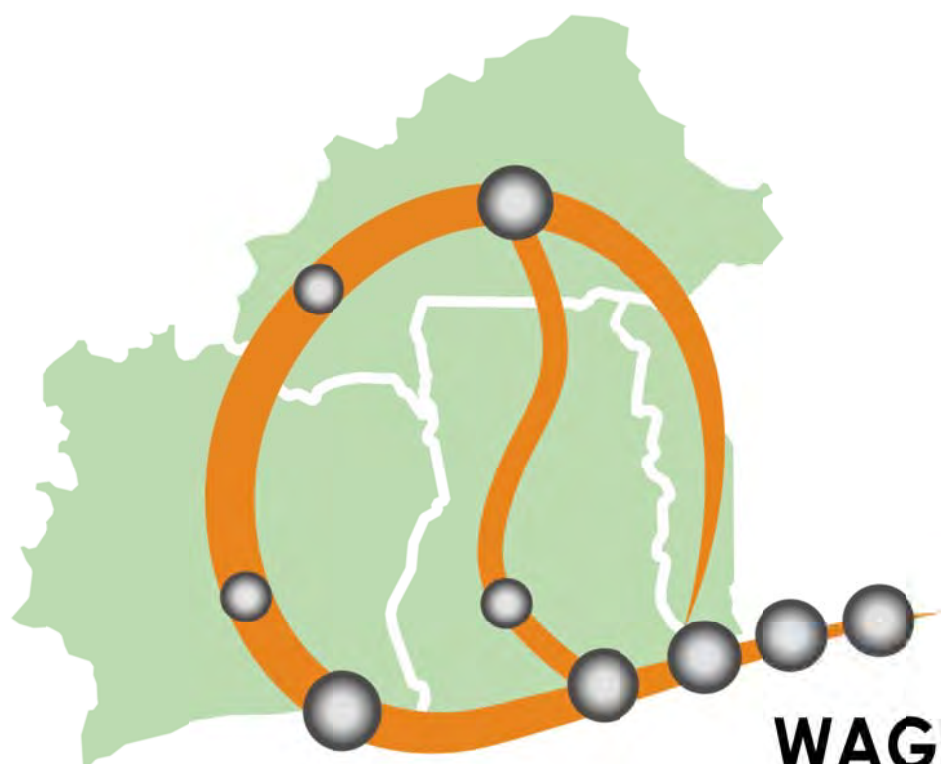

Final Report
Volume 3
Appendices

March 2018

WAGRIC-CACAO

Japan International Cooperation Agency (JICA)

Oriental Consultants Global Co., Ltd.
CTI Engineering International Co., Ltd.
CTI Engineering Co., Ltd.

EI
JR
18-029

Department of Community Territorial Administration and Transport (DATC)
UEMOA Commission
National Development Planning Commission (NDPC)
Ministry of Roads and Highways (MRH)
Ministry of Finance (MoF)
The Republic of Ghana

THE PROJECT ON THE CORRIDOR DEVELOPMENT FOR WEST AFRICA GROWTH RING MASTER PLAN



Final Report
Volume 3
Appendices

March 2018

WAGRIC-CACAO

Japan International Cooperation Agency (JICA)

Oriental Consultants Global Co., Ltd.
CTI Engineering International Co., Ltd.
CTI Engineering Co., Ltd.

Currency Exchange Rates

EUR 1.00 = JPY 118.230
EUR 1.00 = XOF 655.139
EUR 1.00 = GHS 4.47650
USD 1.00 = JPY 108.748
USD 1.00 = XOF 602.333
USD 1.00 = GHS 4.11747
XOF 1.00 = JPY 0.180473
GHS 1.00 = JPY 26.4406

Average during the period between June 2016 and May 2017

The Project on Corridor Development for West Africa Growth Ring Master Plan

Final Report Volume 3

TABLE OF CONTENTS

	<u>Page</u>
Table of Contents	i
List of Figures.....	vii
List of Tables.....	x
List of Abbreviation.....	xiii

APPENDIX

Appendix A	Value Chain for Food and Agriculture Sector.....	A-1
A.1	Rice	A-1
A.1.1	Present Situation of Rice Value Chain	A-1
A.1.2	Main Players and Value Chain	A-4
A.1.3	Issues of Rice Value Chain.....	A-6
A.1.4	Future Prospects of Rice Value Chain.....	A-6
A.1.5	Future Prospects based on Sub-Regional Development Strategies.....	A-8
A.2	Maize.....	A-8
A.2.1	Present Situation of Maize Value Chain.....	A-8
A.2.2	Main Players and Value Chain	A-10
A.2.3	Issues of Maize Value Chain	A-11
A.2.4	Future Prospects of Maize Value Chain	A-11
A.2.5	Future Prospects based on Sub-Regional Development Strategies.....	A-12
A.3	Cashews	A-12
A.3.1	Present Situation of Cashew Value Chain	A-12
A.3.2	Main Players and Value Chain	A-14
A.3.3	Issues of Cashew Value Chain	A-15
A.3.4	Future Prospects of Cashew Value Chain	A-15
A.3.5	Future Prospects based on Sub-Regional Development Strategies.....	A-16
A.4	Mango	A-16
A.4.1	Present Situation of Mango Value Chain	A-16
A.4.2	Main Players and Value Chain in Côte d'Ivoire	A-17
A.4.3	Issues of Mango Value Chain in Côte d'Ivoire	A-20
A.4.4	Future Prospects of Mango Value Chain in Côte d'Ivoire	A-21
A.4.5	Future Prospects based on Sub-Regional Development Strategies.....	A-23
A.4.6	Main Players and Value Chain in Ghana.....	A-23
A.4.7	Issues of Mango Value Chain in Ghana	A-26
A.4.8	Future Prospects of Mango Value Chain in Ghana	A-27

A.4.9	Future Prospects based on Sub-Regional Development Strategies.....	A-28
A.5	Livestock and Poultry.....	A-28
A.5.1	Present Situation of Livestock & Poultry Value Chain	A-28
A.5.2	Main Players and Value Chain	A-31
A.5.3	Issues of Livestock & Poultry Value Chain.....	A-33
A.5.4	Future Prospects of Livestock & Poultry Value Chain.....	A-34
A.5.5	Future Prospects based on Sub-Regional Development Strategies.....	A-35
Appendix B	Traffic Survey and Traffic Data	B-1
B.1	Traffic Survey	B-1
B.1.1	Overview of Traffic Survey.....	B-1
B.1.2	Traffic Volume.....	B-4
B.1.3	Current Traffic Flow Patterns.....	B-10
B.1.4	Trip Characteristics	B-15
B.1.5	Trend of Logistics	B-16
B.1.6	Other Traffic Characteristics	B-30
B.2	Traffic Demand Forecast.....	B-31
B.2.1	Basic Idea	B-31
B.2.2	Socio-Economic Framework	B-32
B.2.3	Traffic Demand Forecast.....	B-34
B.2.4	Analysis of Competitiveness between Corridors.....	B-39
B.3	Supply and Demand Analysis in Corridor Infrastructures by Considering Existing Development Plans for Economic Sectors and Corridor Infrastructures.....	B-42
B.4	Result of Traffic Count Survey	B-46
B.5	Future OD Matrix.....	B-78
Appendix C	Development Potential Maps of Economic Sectors and Information Maps of Corridor Infrastructures.....	C-1
C.1	Development Potential Maps of Economic Sectors	C-1
C.2	Information Maps of Corridor Infrastructures.....	C-18
Appendix D	General Future Land Use for Abidjan-Lagos Corridor	D-1
Appendix E	Planning Study’s Activities.....	E-1
E.1	Phases of the Project	E-1
E.2	Project Activities in Phase 1.....	E-1
E.2.1	Project Kick-Off.....	E-1
E.2.2	Sector Study	E-7
E.2.3	Stakeholder Meetings for Planning and SEA	E-7
E.3	Project Activities in Phase 2.....	E-11
E.3.1	Counterpart Training in Japan (Study Tour in Japan).....	E-11
E.3.2	Approval of the Inception Report.....	E-14
E.3.3	Explanation and Discussion on the Progress Report	E-15
E.3.4	Sector Study	E-19
E.3.5	Discussion on Abidjan-Lagos Corridor.....	E-19

E.4	Project Activities in Phase 3.....	E-22
E.4.1	Explanation and Discussion on the Interim Report	E-22
E.4.2	JTMC-Regional Meeting for Discussion on the Interim Report.....	E-26
E.4.3	Stakeholders Meeting for Planning and SEA	E-27
E.4.4	Sector Study	E-36
E.4.5	Explanation and Discussion on the Draft Final Report.....	E-36
E.4.6	Meeting for Discussion on the Summary Report of the Draft Final Report	E-40
E.5	Project Activities in Phase 4.....	E-41
E.5.1	JTMC-Regional Meeting for Discussion on the Draft Final Report in Lomé.....	E-41
E.5.2	Joint Steering Committee Meeting in Abidjan	E-41
E.5.3	International Seminar in Abidjan	E-42
E.5.4	Final Seminar in Accra.....	E-42
Appendix F	Records of SEA Stakeholder Meetings.....	F-1
F.1	Overall SEA Procedure in Each Country	F-1
F.1.1	SEA Procedure of Burkina Faso.....	F-1
F.1.2	SEA Procedure of Côte d'Ivoire.....	F-1
F.1.3	SEA Procedure of Ghana	F-2
F.1.4	SEA Procedure of Togo	F-3
F.2	Detailed Progress of SEA for Burkina Faso.....	F-3
F.2.1	Activities in Preparation Stage of SEA	F-3
F.2.2	Activities in Scoping Study Stage of SEA	F-4
F.2.3	Activities in Assessment Stage of SEA.....	F-5
F.3	Detailed Progress of SEA for Côte d'Ivoire.....	F-15
F.3.1	Activities in Preparation Stage of SEA	F-15
F.3.2	Activities in Scoping Study Stage of SEA	F-17
F.3.3	Activities in Assessment Stage of SEA.....	F-17
F.4	Detailed Progress of SEA for Ghana.....	F-23
F.4.1	Activities in Preparation Stage of SEA	F-23
F.4.2	Activities in Scoping Study Stage of SEA	F-26
F.4.3	Activities in Assessment Stage of SEA.....	F-28
F.5	Detailed Progress of SEA for Togo.....	F-33
F.5.1	Activities in Preparation Stage of SEA	F-33
F.5.2	Activities in Scoping Stage of SEA.....	F-34
F.5.3	Activities in Assessment Stage of SEA.....	F-35
F.5.4	The Third Stakeholder Meeting for Planning and SEA in Togo	F-38

Final Report Volume 1

Executive Summary

PART I INTRODUCTION

Chapter 1 Introduction

PART II SUB-REGIONAL DEVELOPMENT AND INTEGRATION

Chapter 2 Review of Sub-Regional Development Vision and Review of Strategies for West Africa

PART III SUB-REGIONAL DEVELOPMENT STRATEGIES

Chapter 3 Existing Conditions and Emerging Development Opportunities of WAGRIC Sub-Region

Chapter 4 Sub-Regional Development Strategies for WAGRIC Countries

Chapter 5 Growth Scenarios and Essential Strategies

Chapter 6 Sub-Regional Socioeconomic Framework and Future Spatial Structure of WAGRIC Sub-Region

Chapter 7 Sub-Regional Sector Development Strategies for WAGRIC Countries

Final Report Volume 2

PART IV CORRIDOR DEVELOPMENT PLANS FOR BURKINA FASO

Chapter 8 National Development Strategies for Burkina Faso

Chapter 9 Corridor Development Strategies for Burkina Faso

Chapter 10 Development Strategies for Economic Sectors of Burkina Faso

Chapter 11 Development Strategies for Infrastructure Sectors for Burkina Faso

Chapter 12 Urban Development Strategies for Burkina Faso

Chapter 13 Social Development Strategies for Burkina Faso

PART V CORRIDOR DEVELOPMENT PLANS FOR COTE D'IVOIRE

Chapter 14 National Development Strategies for Côte d'Ivoire

Chapter 15 Corridor Development Strategies for Côte d'Ivoire

Chapter 16 Development Strategies for Economic Sectors of Côte d'Ivoire

Chapter 17 Development Strategies for Infrastructure Sectors for Côte d'Ivoire

Chapter 18 Urban Development Strategies for Côte d'Ivoire

Chapter 19 Social Development Strategies for Côte d'Ivoire

PART VI CORRIDOR DEVELOPMENT PLANS FOR GHANA

Chapter 20 National Development Strategies for Ghana

Chapter 21 Corridor Development Strategies for Ghana

Chapter 22 Development Strategies for Economic Sectors of Ghana

Chapter 23 Development Strategies for Infrastructure Sectors of Ghana

Chapter 24 Urban Development Strategies for Ghana

Chapter 25 Social Development Strategies for Ghana

PART VII CORRIDOR DEVELOPMENT PLANS FOR TOGO

Chapter 26 National Development Strategies for Togo

Chapter 27 Corridor Development Strategies for Togo

Chapter 28 Development Strategies for Economic Sectors of Togo

Chapter 29 Development Strategies for Infrastructure Sectors of Togo

Chapter 30 Urban Development Strategies for Togo

Chapter 31 Social Development Strategies for Togo

PART VIII STRATEGIC ENVIRONMENTAL ASSESSMENT (SEA)

Chapter 32 Strategic Environmental Assessment (SEA) for Burkina Faso

Chapter 33 Strategic Environmental Assessment (SEA) for Côte d'Ivoire

Chapter 34 Strategic Environmental Assessment (SEA) for Ghana

Chapter 35 Strategic Environmental Assessment (SEA) for Togo

LIST OF FIGURES

Appendix A

Figure A.1.1	Production, Import, Export and Processing of Rice in West Africa.....	A-1
Figure A.1.2	Production and Market Flow of Rice in West Africa.....	A-4
Figure A.1.3	Rice Value Chain in West Africa.....	A-5
Figure A.1.4	Plan of Rice Mills Network in Côte d'Ivoire.....	A-7
Figure A.2.1	Production, Import, Export and Processing of Maize in West Africa.....	A-8
Figure A.2.2	Major Maize Producing Countries in West Africa.....	A-9
Figure A.2.3	Flow of Maize and Other Cereals in West Africa.....	A-9
Figure A.2.4	Maize Value Chain in West Africa.....	A-10
Figure A.3.1	Cashew Production in Major Countries in West Africa.....	A-13
Figure A.3.2	Cashew Value Chain in West Africa.....	A-14
Figure A.4.1	Supply Chain of Fresh Mango in Côte d'Ivoire.....	A-18
Figure A.4.2	Supply Chain of Processed Mango in Côte d'Ivoire.....	A-20
Figure A.4.3	Import of Fruits Juice in Côte d'Ivoire.....	A-22
Figure A.4.4	Supply Chain of Fresh Mango in Ghana.....	A-24
Figure A.4.5	Mango Production in Ghana (based 2009-2010 figures).....	A-27
Figure A.5.1	Stock, Export and Import of Livestock in West Africa.....	A-28
Figure A.5.2	Stock of Poultry in West Africa.....	A-30
Figure A.5.3	Production of Chicken Meat and Eggs.....	A-30
Figure A.5.4	Poultry Trade Flows in West Africa.....	A-31
Figure A.5.5	Ruminant Livestock Value Chain of in West Africa.....	A-32
Figure A.5.6	Poultry Value Chain.....	A-32

Appendix B

Figure B.1.1	Locations of Traffic Survey Stations.....	B-2
Figure B.1.2	Traffic Zones.....	B-3
Figure B.1.3	Daily Traffic Volume on National Borders.....	B-5
Figure B.1.4	Daily Traffic Volume in Burkina Faso.....	B-6
Figure B.1.5	Daily Traffic Volume in Côte d'Ivoire.....	B-7
Figure B.1.6	Daily Traffic Volume in Ghana and Togo.....	B-8
Figure B.1.7	Daily Traffic Volume at Dry Port.....	B-9
Figure B.1.8	Daily Traffic Volumes in Sub-Regions in 2015.....	B-10
Figure B.1.9	Current Traffic Flow Patterns - Total of All Vehicles –.....	B-11
Figure B.1.10	Current Traffic Flow Patterns -Passenger Cars-.....	B-11
Figure B.1.11	Current Traffic Flow Patterns -Freight Vehicles-.....	B-12
Figure B.1.12	Current Traffic Flow from/to San-Pedro Port.....	B-12
Figure B.1.13	Current Traffic Flow from/to Abidjan Port.....	B-13
Figure B.1.14	Current Traffic Flow from/to Takoradi Port.....	B-13
Figure B.1.15	Current Traffic Flow from/to Tema Port.....	B-14
Figure B.1.16	Current Traffic Flow from/to Lomé Port.....	B-14
Figure B.1.17	Relationship of Distance and Traffic Volume between the Main City (Abidjan and Accra) and Other Zones.....	B-15

Figure B.1.18	Relationship of Distance and Traffic Volume between the Main City (Lomé and Ouagadougou) and Other Zones.....	B-16
Figure B.1.19	Trend of Export Value.....	B-17
Figure B.1.20	Trend of Export Value by Index (year 1950= 1.0).....	B-17
Figure B.1.21	Trend of Import Value.....	B-18
Figure B.1.22	Trend of Import Value by Index (year 1950= 1.0).....	B-18
Figure B.1.23	Cross-Border Freight Traffic Volume	B-19
Figure B.1.24	Type of Cross-Border Freight Traffic (All cargo).....	B-19
Figure B.1.25	Type of Cross-Border Freight Traffic (Land cargo).....	B-20
Figure B.1.26	Mode Share of Cross-Border Freight Traffic	B-20
Figure B.1.27	Mode Share of Cross-Border Freight Traffic	B-21
Figure B.1.28	Freight Flow, Total.....	B-22
Figure B.1.29	Freight Flow, Total without Oil products.....	B-22
Figure B.1.30	Freight Flow, Agricultural Products (HS1-15).....	B-23
Figure B.1.31	Freight Flow, Foodstuffs (HS16-24).....	B-23
Figure B.1.32	Freight Flow, Mineral Products (HS25-26).....	B-24
Figure B.1.33	Freight Flow, Oil Products (HS27)	B-24
Figure B.1.34	Freight Flow, Chemicals/ Allied Industries (HS28-38).....	B-25
Figure B.1.35	Freight Flow, Plastics / Rubber (HS39-40)	B-25
Figure B.1.36	Freight Flow, Leather (HS41-43).....	B-26
Figure B.1.37	Freight Flow, Wood Products (HS44-49)	B-26
Figure B.1.38	Freight Flow, Textiles (HS50-63)	B-27
Figure B.1.39	Freight Flow, Footwear/Headgear (64-67).....	B-27
Figure B.1.40	Freight Flow, Stone/ Glass (HS68-71)	B-28
Figure B.1.41	Freight Flow, Metals (HS72-83)	B-28
Figure B.1.42	Freight Flow, Machinery /Electrical (HS84-85).....	B-29
Figure B.1.43	Freight Flow, Vehicles and Parts (HS86-89).....	B-29
Figure B.1.44	Freight Flow, Miscellaneous (HS90-97)	B-30
Figure B.2.1	Basic Work Flows for Traffic Demand Forecast.....	B-32
Figure B.2.2	GDP Framework by Country in WAGRIC Countries.....	B-34
Figure B.2.3	GDP per Capita in WAGRIC Countries.....	B-34
Figure B.2.4	Road Development Scenarios for Year 2033	B-37
Figure B.2.5	Road Development Scenarios for Year 2040	B-37
Figure B.2.6	Road Network for Traffic Assignment.....	B-38
Figure B.2.7	Result of Traffic Assignment in Year 2033.....	B-38
Figure B.2.8	Result of Traffic Assignment in Year 2040.....	B-39
Figure B.3.1	Expansion of Transport Areas and Increase of Market Population from Lomé	B-43
Figure B.3.2	Expansion of Transport Areas and Increase of Market Population from Accra.....	B-43
Figure B.3.3	Expansion of Transport Areas and Increase of Market Population from Abidjan.....	B-44
Figure B.3.4	Expansion of 6-hour Transport Areas by Strengthening of North-South Connectivity	B-44

Appendix C

Figure C.1.1	Agricultural Investment Possibility: Agricultural Irrigation Development Projects in Burkina Faso.....	C-2
--------------	--	-----

Figure C.1.2	Local Supply and Consumption of Major Staple Crops by Zone in Burkina Faso (2014/15).....	C-3
Figure C.1.3	Food Balance by Region and Flow in Burkina Faso	C-3
Figure C.1.4	Local Supply and Consumption of Major Staple Crops (Maize and Rice) by Zone in Côte d’Ivoire (2012 Estimated).....	C-4
Figure C.1.5	Local Supply and Consumption of Major Staple Crops (Root Crops and Plantain) by Zone in Côte d’Ivoire (2012 Estimated)	C-5
Figure C.1.6	Agricultural Investment Possibility in Ghana: Irrigation Projects considered as Large Scale Agriculture in SADA Zone of Ghana.....	C-6
Figure C.1.7	Local Supply and Consumption of Major Staple Crops (Maize and Rice) by Zone in Ghana (2014 Estimated).....	C-7
Figure C.1.8	Local Supply and Consumption of Major Staple Crops (Root Crops and Plantain) by Zone in Ghana (2014 Estimated)	C-8
Figure C.1.9	Agricultural Investment Possibility: Situation of Land Use and Planned Areas for Agricultural Development in Togo.....	C-9
Figure C.1.10	Local Supply and Consumption of Major Staple Crops (Cereals and Root Crops) by Zone in Togo (2015 estimated)	C-10
Figure C.1.11	Local Supply and Consumption of Major Staple Crops (Cereals and Root Crops) by Region in Togo (2015 estimated).....	C-11
Figure C.1.12	Synthesis of Cross-Border Trade Flows of Livestock, and Cereals, Roots and Tubers (September 2015).....	C-12
Figure C.1.13	Live Cattle Trading and Flow in Burkina Faso (2014).....	C-12
Figure C.1.14	Major Mineral Deposit of Burkina Faso.....	C-13
Figure C.1.15	Major Mineral Deposit of Côte d’Ivoire.....	C-14
Figure C.1.16	Major Mineral Deposit of Ghana	C-15
Figure C.1.17	Major Mineral Deposit of Togo	C-16
Figure C.1.18	Major Rivers and River Basins and Water Resources Potential in the WAGRIC Countries	C-17
Figure C.2.1	Existing Road Conditions for WAGRIC Countries.....	C-19
Figure C.2.2	Existing Railway Infrastructure in the Sub-region	C-20
Figure C.2.3	Storage and Distribution Network of Multi-products Pipeline in Côte d’Ivoire	C-21
Figure C.2.4	Multi-products Pipeline between Tema and Buipe via Kumasi in Ghana.....	C-21
Figure C.2.5	Locations of Source of Gas Supply and Pipeline in Côte d’Ivoire	C-22
Figure C.2.6	Locations of Source of Gas Supply and Pipeline in Ghana.....	C-22
Figure C.2.7	Power Supply: Peak Load and Generation Capacity in Burkina Faso, Cote d’Ivoire, Ghana and Togo	C-23
Figure C.2.8	Power Grids covering ECOWAS Countries.....	C-24

Appendix D

Figure D.1.1	General Future Land Use for Abidjan-Lagos Corridor	D-2
--------------	--	-----

LIST OF TABLES

Appendix A

Table A.1.1	Major Rice Importing Countries in the World and West Africa	A-2
Table A.1.2	Major Countries Exporting Rice to West Africa (2015)	A-2
Table A.1.3	Production, Import, Export and Processing of Rice1 in Countries in West Africa	A-3
Table A.3.1	Major Cashew Producing Countries in the World and West Africa.....	A-13
Table A.3.2	Major Cashew Exporting Countries in the World	A-14
Table A.4.1	Major Mango Exporting Countries in the World and West Africa	A-17
Table A.4.2	Major Mango Importing Countries in the World and West Africa	A-17
Table A.4.3	Major Importing Countries of Mango Exported by Côte d'Ivoire	A-19
Table A.4.4	Major Importing Countries of Mango Exported by Ghana	A-24
Table A.5.1	Stock, Export and Import of Livestock in Major Countries in West Africa.....	A-29

Appendix B

Table B.1.1	Outline of Traffic Survey	B-1
Table B.1.2	Zone Code	B-3
Table B.1.3	Daily Traffic Volume in 2015	B-4
Table B.1.4	Percentage of Overloaded Vehicles on Corridors	B-30
Table B.2.1	Basic Conditions for Traffic Demand Forecast	B-32
Table B.2.2	Population Framework by Countries.....	B-33
Table B.2.3	Population Framework by Zone (thousand)	B-33
Table B.2.4	Generated Traffic A by Zone	B-35
Table B.2.5	Distribution Model Parameters	B-35
Table B.2.6	Future OD Trip - Passenger Traffic -	B-36
Table B.2.7	Future OD Trip - Freight Traffic -.....	B-36
Table B.2.8	Road Condition for Traffic Assignment.....	B-38
Table B.2.9	Parameter Estimation Results.....	B-41
Table B.2.10	Results of Estimated Value of Time.....	B-41
Table B.2.11	Scale Parameter θ	B-42
Table B.3.1	Reduction of Transport Costs by Road Development	B-45
Table B.5.1	OD Matrix in 2033	B-78
Table B.5.2	OD Matrix in 2040	B-79

Appendix E

Table E.3.1	Schedule of Counterpart Training in Japan	E-12
Table E.4.1	Schedule of Community-level SEA Consultation Meeting in Ghana	E-31

Appendix F

Table F.1.1	Series of Stakeholder Meeting held for SEA in Burkina Faso	F-1
Table F.1.2	Series of Stakeholder Meeting held for SEA in Côte d'Ivoire	F-1
Table F.1.3	Series of SEA Core Team Meeting held for SEA in Ghana.....	F-2
Table F.1.4	Series of Meetings and Workshops held for SEA in Ghana.....	F-3
Table F.1.5	Series of Stakeholder Meeting held for SEA in Togo	F-3

Table F.2.1	Targets for Identification of Impacts in the Second Stakeholder Meeting	F-6
Table F.2.2	Tools for Identification of Impacts in the Second Stakeholder Meeting	F-6
Table F.2.3	Summary of Identified Impacts due to Corridor Development	F-7
Table F.2.4	Targets for Assessment in the Third Stakeholder Meeting and Grouping for Group Work	F-8
Table F.2.5	Environmental Criteria/ Effects.....	F-9
Table F.2.6	Compound Matrix	F-9
Table F.2.7	Compound Matrix – Score Sheet (Result).....	F-11
Table F.2.8	Compound Matrix – Score Sheet (Result by Area).....	F-12
Table F.2.9	Reason for Negative Impact of Projects in Ouagadougou.....	F-12
Table F.2.10	Reason for Negative Impact of Projects in Bobo-Doulasso	F-13
Table F.2.11	Reason for Negative Impact of Projects along Abidjan-Ouagadougou Corridor	F-13
Table F.2.12	Reason for Negative Impact of Projects in and along Tema-Ouagadougou Corridor and in the South	F-14
Table F.2.13	Reason for Negative Impact of Projects along Lome-Ouagadougou Corridor.....	F-14
Table F.2.14	Reason for Negative Impact of Projects between Ouagadougou and Tambao.....	F-15
Table F.3.1	Result of Group Discussions of Group 1.....	F-16
Table F.3.2	Result of Group Discussion of Group 2	F-17
Table F.3.3	Result of Group Discussion of Group 3	F-17
Table F.3.4	Targets for Identification of Impacts in the Second Stakeholder Meeting	F-18
Table F.3.5	Concept of Alternative Scenarios.....	F-18
Table F.3.6	Tools for Identification of Impacts in the Second Stakeholder Meeting	F-19
Table F.3.7	Summary of Identified Impacts due to Corridor Development in the Second Stakeholder Meeting	F-20
Table F.3.8	Targets for Assessment in the Third Stakeholder Meeting and Grouping for Group Work	F-20
Table F.3.9	Environmental Criteria/ Effects.....	F-21
Table F.3.10	Compound Matrix	F-21
Table F.3.11	Compound Matrix – Score Sheet (Result).....	F-22
Table F.3.12	Reasons for Negative Impact of Each Project.....	F-23
Table F.4.1	SEA Meetings between EPA and the Promoter of the Project.....	F-24
Table F.4.2	Action Matrix for the Conduct of the SEA for the Project.....	F-25
Table F.4.3	SEA Activities in Scoping Study Stage.....	F-26
Table F.4.4	Outcomes of Analysis of Stakeholder Issues	F-27
Table F.4.5	Strategies for Development of Each Sector in Ghana and Grouping for Group Work.....	F-28
Table F.4.6	Priority Projects for Ghana and Grouping for Group Work	F-29
Table F.4.7	Matrix for Compatibility Test	F-30
Table F.4.8	Matrix for Risk-Opportunity Assessment.....	F-30
Table F.4.9	Reasons for Incompatibility	F-31
Table F.4.10	Results of Environmental Evaluation	F-32
Table F.5.1	Targets for Identification of Impacts in the Second Stakeholder Meeting	F-36
Table F.5.2	Tools for Identification of Impacts in the Second Stakeholder Meeting	F-37
Table F.5.3	Summary of Identified Impacts due to Corridor Development	F-38

Table F.5.4	Targets for Assessment in the Third Stakeholder Meeting and Grouping for Group Work	F-39
Table F.5.5	Environmental Criteria/ Effects.....	F-40
Table F.5.6	Compound Matrix	F-40
Table F.5.7	Compound Matrix – Score Sheet (Result).....	F-41
Table F.5.8	Reason for Negative Impact of Each Project.....	F-42

LIST OF ABBREVIATION

Abbreviation	English	French
ACA	African Cashew Alliances	-
ACS	Africa Coastal Services	-
ADCI	Agency for Development and Competitiveness of Industries in Côte d'Ivoire	Association des Démobilisés de Côte d'Ivoire
AFD	French Development Agency	Agence Française de Développement
AfDB	African Development Bank	-
AGEDI	Agency for Management and Development of Industrial Infrastructures	Agence pour la Gestion et le Développement des Infrastructures Industrielles
AGEROUTE	Road Management Agency of Côte d'Ivoire	Agence de Gestion des Routes
AGETUR	Executing Agency of Urban Work	Agence d'Execution des Travaux Urbains
AGI	Association of Ghana Industries	-
AI	Avian influenza	-
ANAC	National Agency for Civil Aviation	Agence Nationale de l'Aviation Civile
ANADER	National Agency for Rural Development	Agence Nationale d'Appui au Développement Rural
ANDE	National Environment Agency	Agence Nationale de l'Environnement
ANECEI	National Water Agency of Côte d'Ivoire	Agence Nationale de l'Eau de Côte d'Ivoire
ANGE	National Agency for Environmental Management	Agence Nationale pour la Gestion de l'Environnement
ANPTIC	National Authority for Promotion of ICT	Autorité Nationale pour la Promotion des TIC
ANSUT	National Agency of Telecommunications Universal Service	Agence de Nationale du Service Universel des Telecommunications
APESS	Association for Livestock Promotion in Sahel and Savanna	Association pour la Promotion de l'Elevage au Sahel et en Savane
API-BF	Burkina Faso Investment Promotion Agency	Agence de Promotion des Investissements du Burkina Faso
API-ZF	Agency for Investment promotion and Free Zone	Agence de Promotion des Investissements et des Zones Franches
ARCEP	Regulatory Authority for Electronic Communications and Postal Services	Autorité de Régulation des Communications Electroniques et des Postes
ART&P	Regulation Authority of Telecommunication and Posts	Autorité de Régulation des Télécommunications et des Postes
ASYCUDA++	Automated System for Customs Data	-
ATP	Ashanti Technology Park	-
ATP	Agribusiness and Trade Promotion	-
BADEA	Arab Bank for Economic Development in Africa	Banque Arabe pour le Développement Economique en Afrique
BCEAO	Central Bank of West African States	Banque Centrale des Etats de l'Afrique de l'Ouest
BCF	Billion Cubic Feet	-
BCM	Billion Cubic Meter	-
BOAD	West Africa Development Bank	Banque Ouest Africaine de Développement
BOE	Barrel of Oil Equivalent	-
BOOT	Build–Own–Operate–Transfer	-
bopd	barrels of oil per day	-
BOST	Bulk Oil Storage and Transportation Company Ltd.	-
BOT	Build-Operate-Transfer	-
BPA	Bui Power Authority	-
BPO	Business Process Outsourcing	-
bpsd	barrel per stream day	-

Abbreviation	English	French
BSCF	Billion Standard Cubic Feet	-
BTS	Base Transceiver Station	-
BUMIGEB	Bureau of Mines and Geology of Burkina Faso	Bureau des Mines et Géologie du Burkina Faso
BUNEE	National Office of Environmental Assessment	Bureau National des Evaluations Environnementales
CAADP	Comprehensive African Agriculture Development Programme	-
CACDI	Support Centers on Competitiveness and Industrial Development	Centres d'Appui à la Compétitivité et au Développement Industriel
CBC	Burkina Faso Shippers' Council	Conseil Burkinabé des Chargeurs
CCI	Ivorian Chamber of Commerce and Industry	Chambre de Commerce et d'Industrie ivoirienne
CCI BF	Burkina Faso Chamber of Commerce	Chambre de Commerce d'Industrie et d'Artisanat du Burkina Faso
CDB	China Development Bank	-
CDU	Crude Distillation Unit	-
CEB	Electric Community of Benin	Communauté Électrique du Bénin
CEET	Electric Power Company of Togo	Copagnie Énergie Électrique du Togo
CEFCOD	Education Center for Training and Development Consultancy	Centre d'Étude de la Formation et de Conseil en Développement
CEFORE	Centre for Business Formalities	Centre de Formalités des Entreprises
CEPICI	Investment Promotion Centre in Côte d'Ivoire	Centre de Promotion des Investissements en Côte d'Ivoire
CERT	Cell Fight Against Cybercrime	Renforcer la Cellule de lutte contre la cybercriminalité
CFT	Togo Railways	Chemins de Fer du Togo
CGECI	General Confederation of Enterprises of Côte d'Ivoire	Confederation General des Entreprises de Côte d'Ivoires
CIA	Central Intelligence Agency	-
CIAPOL	Ivorian Anti-Pollution Center	Centre Ivoirien Antipollution
CICs	Community information Centers	-
CIDR	International Development and Research Centre	Alliance Internationale de Développement et de Recherche
CIE	Côte d'Ivoire Electricity Company	Compagnie Ivoirienne d'Electricité
CIP	Common Industrial Policy	Politique Industrielle Commune
CIRAD	Research Center for International Agricultural Development	Centre de coopération Internationale en Recherche Agronomique pour le Développement
CNCT	National Shipper's Council of Togo	Conseil National des Chargeurs du Togo
CNG	Compressed Natural Gas	-
CNR	Canadian Natural Resources Limited	-
COCOBOD	Ghana Cocoa Board	-
COFENABVI	Confederation of National Federation of Meat and Livestock Chain	Confédération des Fédérations Nationales de la Filière Bétail et Viande
CONIWAS	Coalition of NGOs in Water and Sanitation	-
CPO	Crude Palm Oil	-
CPR	Rural Promotion Center	Centre de Promotion Rurale
CRISTO	Social Engineer Research Centre in Togo	Centre de Recherche et Ingénieur Sociaux du Togo
CSIR	Council for Scientific and Industrial Research	-
CSLP	Strategic Framework for Poverty Reduction	Cadre Stratégique de Lutte contre la Pauvreté
CU	UEMOA Community Road Network	Réseau Routier de la Communauté UEMOA
CWIQ	Core Welfare Indicator Questionnaire	-
CWSA	Community Water Supply and Sanitation Agency	-

Abbreviation	English	French
DA	Directorate of Sanitation	Direction de l'Assainissement
DADO	District Agriculture Development Office	Bureau du Développement Agricole des Districts
DAEP	Directorate of Water Supply	Direction de l'Approvisionnement en Eau Potable
DAES	Directorate of Agricultural Extension Services	Direction des Services de Vulgarisation Agricole
DAFP	Directorate of Financial Affairs and Heritage	Direction des Affaires Administratives et Financières
DAHA	Directorate of Hydro-Agricultural Development	Direction des Aménagements Hydro-Agricoles
DAJUCIREP	Directorate of Legal Affairs; International Cooperation and Public Relations	Service des Affaires Juridiques, Coopération Internationale et de la Communication et des Relations Publiques
DANIDA	Danish International Development Agency	-
DAP	Directorate of Aquaculture and Fisheries	Direction de l'Aquaculture et des Pêches
DB	Doing Business	-
DCMTRIP	District Capital and Major Town Roads Improvement Project	-
DCS	Directorate of Crop Services	-
DDO	Diesel Distillate Oil	-
DF2VP	Directorate of Training, Extension, and The Value of Products	Direction de la Formation, de la Vulgarisation et de la Valorisation des Produits
DFA	Directorate of Finance and Administration	-
DFO	Diesel Fuel Oil	-
DFR	Department of Feeder Roads	-
DGADI	General Directorate of Irrigational Development	Direction Générale des Aménagements et du Développement de l'Irrigation
DGDER	General Directorate of Development of Regional Economy, Ministry of State, Ministry of Planning and Development	Direction Générale du Développement Economique Régional, Ministère d'Etat, Ministère du Plan et du Développement CI
DGDRME	General Direction of Rural Development and Irrigation	Directeur Général du Développement Rural et de la Maîtrise de l'Eau dans le domaine agricole
DGESS	General Directorate of Study, Planning and Statistics	Directeurs Généraux des Etudes Statistiques et Sectorielles
DGFOMR	General Directorate of Landholding, Training and Organization of Rural Society	Direction Générale du foncier de la Formation et de l'Organisation du Monde Rural
DGI	General Directorate of Industry	Direction Générale de l'Industrie
DGIHH	General Directorate of Infrastructure of Domestic Water	Direction Generale des Infrastructures de l'Hydraulique Humain
DGIR	General Directorate of Road Infrastructure	Direction Générale de l'Infrastructure Routier
DGMG	General Directorate of Mines and Geology	Direction Générale des Mines et de la Géologie
DGMN	General Directorate of National Meteorology	Direction Generale de Meteorologie Nationale
DGPA	General Directorate of Animal Production	Direction Générale des Productions Animales
DGPER	General Directorate of the Promotion of Rural Economy	Direction Générale de la Promotion de l'Économie Rurale
DGPPS	General Direction of Planning, Project Management and Statistics	Direction Générale de la Panification, du contrôle des Projets et des Statistiques
DGPRES	Directorate of Management and Protection of Water Resources	Direction de la Gestion et de Protection des Ressources en Eau
DGPSA	General Direction of Production and Food Security	Directeur Général des Productions et de la Sécurité Alimentaire
DGPSE	General Directorate of Livestock Prevision Statistics	Direction Générale de la Prévision et des Statistiques de l'Elevage
DGPV	General Directorate of Plant Production	Direction Générale des Productions Végétales
DGR	General Directorate of Roads	Direction Générale des Routes
DGRE	Water Resources Department	Direction Générale des Ressources en Eau

Abbreviation	English	French
DGSA	General Directorate of Animal Health	Direction Générale de la Santé Animale
DMU	Diesel Multiple Unit	Diesel de Multiple Unit
DNAGEP	Directorate of Animal Nutrition and Management of Pastoral Areas	Direction de la Nutrition Animale et de la Gestion de l'Espace Pastoral
DO	Delivery Order	-
DOPAF	Directorate of Professional Organizations and Support Funding	Direction des Organisations Professionnelles et de l'Appui au Financement
DPAEP	Directorate of Personnel Management and Adaptation of the Professional Environment	Direction des Personnels et de l'Adaptation de l'Environnement Professionnel
DPARHASA	Provincial Directorate of Agriculture , Water Resources , Sanitation and Safety of Food	Direction Provinciale de l'Agriculture, des Ressources Hydrauliques, de l'Assainissement et de la Sécurité Alimentaire
DPC	Data Protection Commission	-
DPE	Directorate of Livestock Productions	Direction des Productions d'Elevage
DPFA	Directorate of Promotion of Animal Value Chain	Direction de la Promotion des Filières Animales
DPSP	Directorate of Planning, Statistics and Programs	Direction de la Planification, Statistiques et des Programmes
DRAEP	Regional Directorate of Agriculture, Livestock and Fisheries	Les Directions Régionales de l'Agriculture, de l'Élevage et de la Pêche
DRARHASA	Regional Director of the Ministry of Agriculture, Water Resources , Sanitation and Food Security	Directrice Régionale du ministère de l'Agriculture, des Ressources Hydrauliques, de l'Assainissement et de la Sécurité Alimentaire
DRE	Directorate of Water Resources	Direction des Ressources en Eau
DRH	Human Resources Directorate	Direction des Ressources Humaines
DSA	Directorate of Animal Health	Direction de la Santé Animale
DSV	Directorate of Veterinary Services	Direction des Services Vétérinaires
DUR	Department of Urban Roads	-
EATP	Extended West Africa Agribusiness and Trade Promotion	-
EBID	ECOWAS Bank for Investment and Development	-
EC	Energy Commission (Ghana)	-
EC	Electric Conductivity	-
ECA	Economic Consulting Associates Limited	-
ECG	Electricity Company of Ghana	-
ECOWAP	ECOWAS Agricultural Policy	-
ECOWAS	Economic Community of West African States	-
EDF	European Development Fund	-
EDI	Electronic Data Interchange	-
EDIF	Export Development and Investment Fund	-
EDM	Electronic Document Management	-
E-GOV	Electronic Governance	-
EIA	Environmental Impact Assessment	-
ENP	National Prospective Study	Etude Nationale Prospective
ENV	Household Living Standards Survey	Enquête sur le Niveau de Vie des Ménages
EPA	Environmental Protection Agency	-
EPZ	Export Processing Zone	-
ESATIC	African School of Information Technology and Communication	l'Ecole Supérieure Africaine des Technologies de l'Information et de la Communication
ESOP	Service Companies and Producers Organizations	Entreprises de Service et Organisation de Producteurs

Abbreviation	English	French
ETC	Electronic Toll Collection	-
F/S	Feasibility Study	-
FAIR	Fund Assistance for Regional Integration	Fonds d'Aide à l'intégration Régionale des Etats membres de l'UEMOA
FAO	Food and Agriculture Organization of the United Nations	-
FASDEP	Food and Agriculture Sector Development Policy	-
FC	Forestry Commission	-
FCFA	CFA Franc African Financial Community Franc	Francs de la Communauté Financière Africaine
FDI	Foreign Direct Investment	-
FEDOCI	The Federation Development Cote d'Ivoire NGO	La Fédération des ONG de Développement de Côte d'Ivoire
FER	Road Maintenance Fund	Fonds d'Entretien Routier
FER-B	Road Maintenance Fund of Burkina Faso	Fonds d'Entretien Routier du Burkina Faso
FIDA	Foundation for International Development Africa	-
FIRCA	Inter-professional Fund for Research and Agricultural Council	Fonds Interprofessionnel pour la Recherche et le Conseil Agricoles
FNE	National Water Fund	Fonds National de l'Ea
FONGTO	Federation of Non-Governmental Organization in Togo	Fédération des Organisations Non-Gouvernementales du Togo
FPSO	Floating Production Storage and Offloading	-
FRCI	The Republican Forces of Cote d'Ivoire	Forces Républicaines de Côte d'Ivoire
FREMIN	Restructuring Fund	Fonds de Restructuration
FSRU	Floating Storage and Regasification Unit	-
GACL	Ghana Airport Company Limited	-
GAFSP	Global Agriculture and Food Security Program	-
GAP	Good Agricultural Practices	-
GASIP	Ghana Agriculture Sector Investment Programme	-
GASSCOM	Ghana Association of Software and IT Services Companies	-
GAWMIF	Ghana Agricultural Water Management Investment Framework	-
GCAP	Ghana Commercial Agriculture Project	-
GAMA	Greater Accra Metropolitan Area	-
GCMS	Ghana Customs Management System	-
GCNet	Ghana Community Network Services Limited	-
GDP	Gross Domestic Product	-
GEPA	Ghana Export Promotion Authority	-
GESTOCI	Management Company of the Oil Stocks of Ivory Coast	Société de Gestion des Stocks Pétroliers de Côte d'Ivoire
GFZB	Ghana Free Zones Board	-
GHA	Ghana Highway Authority	-
GHACEM	Ghana Cement Company Ltd.	-
Ghana Gas	Ghana National Gas Company	-
GHS	Ghanaian Cedi	-
GIDA	Ghana Irrigation Development Authority	-
GIPC	Ghana Investment Promotion Centre	-
GIZ	German Corporation for International Cooperation (<i>Deutsche Gesellschaft für Internationale</i>	-

Abbreviation	English	French
	<i>Zusammenarbeit</i>)	
GJT	Golden Jubilee Terminal	-
GLSS6	Ghana Living Standards Survey Round 6	-
GM	General Mortars Locomotive Group	-
GMC	Ghana Manganese Company Limited	-
GMET	Ghana Meteorological Agency	-
GMIC	Ghana Multimedia Incubation Center	-
GMP	Gas Master Plan of Ghana	-
GNAPF	Ghana National Association of Poultry Farmers	-
GNPC	Ghana National Petroleum Corporation	-
GNR	General Nice Resources	-
GoG	Government of Ghana	-
GOIL	Ghana Oil Company Ltd.	-
GOSTIC	Group Operators of the sector of Information Technology in Cote d'Ivoire	Groupment des Operateurs de secteur des Technologies de l'Information de Cote d'Ivoire
GoT	Government of Togo	-
GPHA	Ghana Ports and Harbors Authority	-
GPRS II	Growth and Poverty Reduction Strategy 2006-2009	-
GPS	Global Positioning System	-
GRCL	Ghana Railway Company Limited	-
GRDA	Ghana Railway Development Authority	-
GRDP	Gross Regional Domestic Product	-
GRIDCo	Ghana Grid Company Limited	-
GSA	Ghana Shippers Association	-
GSA	Gas Supply Agreement	-
GSC	Ghana Shippers Council	-
GSGDA	Ghana Shared Growth and Development Agenda	-
GSGDA II	Ghana Shared Growth Development Agenda II 2014-2017	-
GSS	Ghana Statistical Services	-
GWCL	Ghana Water Company Limited	-
HFO	Heavy Fuel Oil	-
HIPC	Heavily Indebted Poor Countries	-
HIV/AIDS	Human Immunodeficiency Virus/Acquired Immuno-Deficiency Syndrome	-
HVA	Improved Rural Water Supply	Hydraulique Villageoise Améliorée
IBP	International Best Practice	-
ICAO	International Civil Aviation Organization	-
ICAT	Institute Council and Technical Support	Institut de Conseil et d'Appui Technique
ICD	Inland Container Deport	Intérieurs de Conteneurs
ICT	Information and Communication Technology	Technologies de l'Information et de la Communication
ICT4D	ICT for Accelerated Development	-
IDB	Islamic Development Bank	-
IFAD	International Fund for Agricultural Development	-
IFG-TG	International Fertilizers Group-Togo	International Fertilizers Group-Togo

Abbreviation	English	French
IMF	International Monetary Fund	-
INERA	Institute of Environment and Agricultural Research	Institut National de l'Environnement et de Recherches Agricoles
INS	National Statistics Office	Institut National de la Statistique
INSD	National Institute of Statistics and Demography	Institut National de la Statistique et de la Demographie
IOC	International Oil Companies	-
IPP	Independent Power Producer	-
ISP	Internet Service Provider	-
ISRT	Inter-State Road Transit	-
ITC	International Trade Centre	-
ITES	IT Enabled Services Secretariat	-
ITFC	Integrated Tamale Fruit Company	-
ITRA	Togolese Institution of Agricultural Research	Institut Togolais de Recherche Agronomique
ITS	Intelligent Transportation Systems	-
ITU	International Telecommunication Union	Union internationale des télécommunications
IWRM	Integrated Water Resources Management	-
JAPTU	Joint Association of Port Transport Union	-
JICA	Japan International Cooperation Agency	Agence Japonaise de Coopération Internationale
KACE	Kofi Annan Centre of Excellence in ICT	-
kV	kilo Volt	kilo Volt
LAN	Local Area Networks	-
LCO	Light Crude Oil	-
LCT	Lomé Container Terminal	Terminal à Conteneurs de Lomé
LNG	Liquefied Natural Gas	-
LOTT	Orientation Law of Terrestrial Transport	Loi d'Orientation des Transports Terrestres
LPG	Liquefied Petroleum Gas	-
M/T	Metric Ton	-
MAE	Mean Annual Potential Evaporation-Transpiration	-
MAEH	Ministry of Agriculture, Livestock and Hydraulics	Ministère de l'Agriculture, de l'Élevage et de l'Hydraulique
MAEP	Ministry of Agriculture, Livestock and Fisheries	Ministère de l'Agriculture de l'Élevage et de la Pêche
MAHRA	Ministry of Agriculture, Hydraulics and Fishery Resources former MARHASA	Ministère de l'Agriculture, de l'Hydraulique et des Ressources Halieutiques former MARHASA
MAP	Mean Annual Precipitation	-
MARHASA	Ministry of Agriculture, Water Resources, Sanitation and Food Security	Ministère de l'Agriculture, des Ressources Hydrauliques, de l'Assainissement et de la Sécurité Alimentaire
MAT	Annual Mean Air Temperature	-
MC	Minerals Commission	-
MCLAU	Ministry of Construction, Housing, Sanitation and Urban Planning	Ministère de la Construction, du Logement de l'Assainissement et de l'Urbanisme
MCM	Million Cubic Meter	-
MCT	Maersk Container Terminal	-
MDA	Ministries Departments and Agencies	-
MDENP	Ministry of development of digital economy and posts	Ministère du Développement de l'Economie Numérique et des Postes
MDG	Millennium Development Goal	-
MEAHV	Ministry of Water, Sanitation and Rural Hydraulic	Ministère de l'Eau, de l'Assainissement et de

Abbreviation	English	French
	(former MAEH)	l'Hydraulique Villageoise (ancien MAEH)
MEBF	Burkina Faso Business Centre	Maison de l'Entreprise du Burkina Faso
MEDD	Ministry of Environment and Sustainable Development	Ministère de l'Environnement et du Développement Durable
MEF	Ministry of Water and Forest	Ministère des Eaux et Forêts
METASIP	Medium Term Agriculture Sector Investment Plan	-
MICA	Minister of Industry, Commerce and Handicrafts	Ministère de l'Industrie, du Commerce et de l'Artisanat
MIDT	Ministry of Infrastructures, Development and Transport	Ministère des Infrastructures, du Désenclavement et des Transports
MIE	Ministry of Economic Infrastructure	Ministère des Infrastructures Economiques
MIM	Ministry of Industry and Mines	Ministère de l'Industrie et des Mines
MINAGRI	Ministry of Agriculture	Ministère de l'Agriculture
MINESUDD	Ministry of Environment, Urban Safety and Sustainable Development	Ministère de l'Environnement, de la Salubrité Urbaine et du Développement Durable
MIRAH	Ministry of Animal and Fishery Resources	Ministère des Ressources Animales et Halieutiques
MIT	Ministry of Infrastructure and Transport	Ministère des Infrastructures et des Transports
MLGRD	Ministry of Local Government and Rural Development	-
mmcf	million cubic feet per day	-
MMDAs	Metropolitan, Municipal and District Assemblies	-
MMDRU	Migration Management Data and Research Unit	-
MME	Ministry of Mines and Energy	Ministère des Mines et de l'Energie
MMET	Ministry of Mines and Energy of Togo	Ministère des Mines et de l'Energie au Togo
MMscfd	Million standard cubic feet per day	-
MOB	Bagré Construction project	Maîtrise d'Ouvrage de Bagré
MOC	Ministry of Communication	-
MOEP	Ministry of Energy and Petroleum	-
MOFA	Ministry of Food and Agriculture	-
MoFEP	Ministry of Finance and Economic Planning	-
MoH	Ministry of Health	-
MOP	Ministry of Power	-
MOPE	Ministry of Petroleum and Energy	-
MoT/MT/MOT	Ministry of Transport	-
MoU	Memorandum of Understanding	-
MPARH	Ministry of Livestock and Fish Resources	Ministère de la Production Animale et des Ressources Halieutiques
MPEN	Ministry of Post and Economy	Ministère de la Poste et de l'Economie Numérique
MPER	Micro and Small Rural Enterprises	Micro et Petites Entreprises Rurales
MPI	Multidimensional Poverty Index	-
MPTIC	Ministry of Posts and ICT	Ministère des Postes et des TIC
MRA	Ministry of Animal Resources	Ministère des Ressources Animales
MRE	Ministry of Rural Equipment (former MAEH)	Ministère de l'Équipement Rural (ancien MAEH)
MRH	Ministry of Roads and Highways	-
MTADP	Medium Term Agricultural Development Programme	-
MW	Mega Watt	-
MWRWH	Ministry of Water Resources, Works and Housing	-
NDA	Northern Development Authority	-

Abbreviation	English	French
NDP	National Development Plan	Plan National de Développement
NDPC	National Development Planning Commission	-
NEDCo	Northern Electric Distribution Company	-
NGO	Non-Governmental Organization	-
NHIS	National Health Insurance Scheme	-
NIE	Note of Impact on Environment	-
NIIT	National Institute of Information and Technology	-
NISD	National Institute of Statistics and Demographics	Institut National de la Statistique et de la Démographie
NITA	National IT Agency	-
NPA	National Petroleum Authority	-
NRS		
NSEZ	Northern Savannah Ecological Zone	-
NTP	National Transport Policy	-
NWP	National Water Policy	-
NWRMP	National Water Resources Master Plan	Plan directeur national des ressources en eau
OFID	Industrial Infrastructure Development Fund	Fonds de Développement des Infrastructures Industrielles
OMC	Oil Marketing Companies	-
ONAD	National Office for Sanitation and Drainage	Bureau National de l'Assainissement et du Drainage
ONATEL	The National Telecommunications Office	Office national des télécommunications
ONDR	National Office for Rice Development	Office National De Développement De La Riziculture
ONEP	National Office of Water Supply	Office of National de l'Eau Potable
OSBP	One Stop Border Point	Postes de Contrôle Juxtaposés
OTRAF	The Organization of Motor Carriers of Burkina	Le l'Organisation des Transporteurs Routiers du Burkina
PAA	Port of Abidjan	Port Autonome d'Abidjan
PACITR	Community Roads of UEMOA infrastructure and Transport Action Program	Programme d'Actions Communautaire des Infrastructures et du Transport Routiers
PADAT	National Agricultural Development Policy of Togo	Projet d'Appui au Développement Agricole du Togo
PAFASP	Agriculture, Forestry and Livestock Value Chains Support Program	Programme d'Appui aux Filières Agro Sylvo Pastorales
PAGIRE	National Action Plan for Integrated Water Resources Management	Plan d' Action National de Gestion Intégrée des Ressources en Eau
PAL	Port Authority of Lomé	Port Automome de Lome
PAM	Pan African Minerals Ltd.	Pan-African Minerals
PANSEA	National Action Plan for the Water Sector and Sanitation	Plan d'Actions National pour le Secteur de l'Eau et de l'Assainissement
PAPAN	Support Program for National Poultry Production	Programme d'Appui à la Production Avicole Nationale
PAPAOM	Project to support the development of a blueprint for a Oriented Agriculture Promotion to the Market	Projet d'Appui à l'élaboration d'un schéma directeur pour la Promotion d'une Agriculture Orientée vers le Marché
PAPISE	Action Plan and Program for Investment of Livestock Sector	Plan d'Action et Programme d'Investissements du Secteur Elevage
PAPSA	Agricultural Productivity and Food Security Project	Projet d'Amélioration de la Productivité agricole et de la Sécurité Alimentaire
PASA	Agricultural Sector Support Project	Projet d'Appui au Secteur Agricole
PAUT	Urban Renovation Project in Togo	Projet d'Aménagement Urbain du Togo
PC	Petroleum Commission	-
PCESA	Agricultural Sector Economic Growth Program	Programme de Croissance Économique dans le Secteur Agricole

Abbreviation	English	French
PDA	Agricultural Development Programme	Programme Développement de l'Agriculture
PDADOH	Master plans on development of hydraulic works	Plans Directeurs d'Aménagement et de Développement des Ouvrages Hydrauliques
PDIS	Integral Development Programme of Samendéni	Programme de Développement Intégré de la vallée de Samendéni
PDRI-Mô	Development Project of Rice in the plain Mô	Projet de Développement Rural Intégré en plain Mô
PEC	Competitive Economic Poles	Pôles Economiques Compétitifs
PERH	Livestock and Fisheries Post	Postes d'Elevage et des Ressources Halieutiques
PETROCI	National Company for Oil Operations in Côte d'Ivoire	Société Nationale d'Opérations Pétrolières de Côte d'Ivoire
PID	Detailed Investment Plan	Plan d'Investissement Détaillé
PLANGIRE	Action Plan of Integrated Water Resources Management	Plan d'Actions National de Gestion Intégrée des Ressources en Eau
PMAG	Pharmaceutical Manufacturers 'Association of Ghana	-
PMI	Small and Medium Industries	Petites et moyennes industries
PND	National Development Plan	Plan National de Développement
PNDEL	National Policy Document Sustainable Livestock Development	Politique Nationale de Développement durable de l'Elevage
PNIA	National Agricultural Investment Program	Programme National d'Investissement Agricole
PNIASA	National Agriculture and Food Security Investment Programme	Programme National d'Investissement Agricole et de Sécurité Alimentaire
PNPER	National Project on Rural Entrepreneurship	Projet National de Promotion de l'Entrepreneuriat Rural
PNRMN	National Programme for Restructuring and Upgrading	Programme National de Restructuration et de Mise à Niveau
PNSR	National Programme for Rural Sector	Programme National du Secteur Rural
POSCIA	Sectoral Policy of Industry, Trade and Handicrafts	Politique Sectorielle du Commerce, de l'Industrie, et de l'Artisanat
PPA	Power Purchase Agreement	-
PPCB	Bagré Growth Pole Project	Projet Pôle de Croissance de Bagré
PPCS	Sahel Growth Pole Project	Projet Pôle de Croissance du Sahel
PPI	Priority Investment Programme	Programme Prioritaire d'Intervention
PPMED	Policy Planning Monitoring and Evaluation Directorate	-
PPP	Purchasing Power Parity	-
PPP	Public-Private Partnership	-
PPPs	Policies, Plans and Programmes	-
PPU	Presidential Emergency Programme	Programme Présidentiel d'Urgence
PRD	Regional Development Plan	Plan Régional de Développement
ProDRA	Program of Rural and Agricultural Development	Programme du Développement Rural Agricole
PROFIL	Project in Support of Agricultural Value Chains	Projet d'appui aux Filières agricoles
PRSP	Poverty Reduction Strategy Paper	Document de Stratégie de Réduction de la Pauvreté
PSDPA	Strategic Plan for Development of Livestock, Fisheries and Aquaculture	Plan Stratégique de Développement de l'Elevage, de la Pêche et de l'Aquaculture
PSRA	Strategic Plan for Revitalization of Poultry	Plan Stratégique de Relance de l'Aviculture
QUIBB	Wellness Questionnaire of Basic Indicators	Questionnaire des Indicateurs de Base du Bien-Etre
RCN	raw cashew nut	
RD	Departmental Road	Routes départementales
RD-PA	Provincial Directorates of Animal Resources	Directions Provençales des Ressources Animales
RD-RA	Regional Departments of Animal Resources	Directions Régionales des Ressources Animales
RF	Road Fund	-

Abbreviation	English	French
RGPH	General Census of Population and Housing	Recensement Général de la Population et de l'Habitat
RN	National Road	Routes National
RR	Regional Road	Routes Régionales
SACS	African Society of Sausages and Meats	-
SADA	Savannah Accelerated Development Authority	-
SAZOF	Management Company of Free Zones	Compagnie de Gestion des Zones Franches
SCADD	Strategy for Accelerated Growth and Sustained Development	Stratégie de Croissance Accélérée et de Développement Durable
SCAPE	Strategy for Accelerated Growth and Promotion of Employment	Stratégie de Croissance Accélérée et de Promotion de l'Emploi
SDAU	Urban Development Master Plan	Schéma Directeur d'Aménagement et d'Urbanisme
SDE	Water Development Fund	Fonds de Développement de l'Eau
SDFA	Strategy for Agriculture Value Chain Development	Stratégie de Développement des Filières Agricoles
SDR	Rural Development Strategy	Stratégie de Développement Rural
SDU	Schematic Urban Master Plan	Schéma Directeur d'Urbanisme
SDUGA	Urban Master Plan for Greater Abidjan	Schéma Directeur d'Urbanisme du Grand Abidjan
SEA	Strategic Environment Assessment	-
SIPF	Ivorian Railway Asset Management Company	Société Ivoirienne de Gestion du Patrimoine Ferroviaire
SIR	Ivorian Refining Company	Société Ivoirienne de Raffinage
SITARAIL	The International Society for African rail transport	La Société internationale de transport africain par rail
SMB	Multinational company Bitumen	Société Multinationale de Bitumes
SME	Small and Medium sized Enterprises	-
SIMs	Small and Medium-sized Industry	-
SMTDP	Sector Medium-Term Development Plan	-
SNAT	National Strategy of Spatial Planning	Stratégie Nationale d'Aménagement du Territoire
SNCT	National Society of the Railways of Togo	Nouvelle Société Cotonnière du Togo
SNDCV	National Development Strategy for Food Crops Other than Rice	Strategie Nationale de Developpement des Cultures Vivrieres Autres Que le Riz
SNDI	Computer Development National Company	Société Nationale de Développement Informatique
SNDR	National Strategy for the Development of Rice Sector	Stratégie Nationale Revisee de Développement de la Filiere Riz
SNPT	State National Phosphate Company	Société National Phosphate Togo
SODECI	Côte d'Ivoire Water Company	Societe de Distribution d'Eau de la Côte d'Ivoire
SODEMI	State Company for Mining Development	Societe pour le Developpement Minier de la Côte d'Ivoire
SODEXAM	-	Societe d'Exploitation de Développement Aeroportuaire Aéronautique Météo
SODIGAZ	Gas Distribution Company in Togo	Société de Distribution de Gaz au Togo
SOFIB	Group of investors of France	Société Financière de Banque
SONABEL	National Company of Burkina electricity	Société Nationale d'électricité du Burkina
SONABHY	Company Burkinabe National Hydrocarbons	Société Nationale Burkinabè d'Hydrocarbures
SOPAFER-B	Trust Company of the Railway Assets of Burkina Faso	Societe de Genstion du Patrimoine Ferroviaire du Burkina
SPE	Society of Petroleum Engineers	-
SP-EAU	Agency for Water and Sanitation in Urban and Semi-Urban Area	Société de Patrimoine Eau et Assainissement en Milieu Urban et Semi-Urban
SPONG	Permanent Secretariat of Non-Governmental Organizations	Secretirat Permanent des Organisations Non Gouvernementales

Abbreviation	English	French
SP-PAGIRE	Permanent Secretariat for the IWRM Action Plan	Secrétariat Permanent du Plan d'Action pour la Gestion Intégrée des Ressources en Eau
SRAT	Regional Spatial Development Plan	Schéma Régional de l'Aménagement du Territoire
ST&I	Science, Technology & Innovation	-
SYDAM	Automated Customs Clearance System of Goods	Système de Dédouanement Automatisé des Marchandises
SYVLIE	Virtual Importing and Exporting Operations Liaison System	Système Virtuel de liaison des opérations d'Importation et d'Exportation
TCF	Trillion cubic feet	-
TdE	Togo Water Company	Societe Togolaise des Eaux
TEN	Tweneboa, Enyenra & Ntomme	-
TEU	Twenty-foot Equivalent Unit	Équivalent vingt pieds
TFP	Technical and Financial Partners	-
TOR	Tema Oil Refinery Limited	-
ToR	Terms of Reference	Termes de Référence
WAEMU (UEMOA)	West African Economic and Monetary Union	Union Economique et Monétaire Africaine
UNDP	United Nations Development Program	-
UNICEF	United Nations Children's Fund	-
USAID	United States Agency for International Development	-
USD	US Dollar	-
VALCO	Volta Aluminum Company	-
VAT	Value Added Tax	-
VITIB	Village for Information Technology and Biotechnology	Village des Technologies de l'Information et de la Biotechnologie
VLTC	Volta Lake Transport Company Ltd.	-
VRA	Volta River Authority	-
WACIP	West African Common Industrial Policy	-
WAGP	West African Gas Pipeline	-
WAIPRO	West African Irrigation Project	-
WAPCo	West African Gas Pipeline Company	-
WAPP	West African Power Pool	-
WARCIP	West African Regional Communications Infrastructure Programme	-
WD	Water Directorate	-
WEF	World Economic Forum	-
WHO	World Health Organization	-
WRC	Water Resources Commission	-
WRI/CSIR	Water Research Institute of the Council for Scientific and Industrial Research	-
WSDBs	Water and Sanitation Development Boards	-
WSSDP	Water Sector Strategic Development Plan	-
WTP	Water Treatment Plant	-
XOF	CFA Franc	Franc CFA
ZAT	Zone of Technical Support	Zone d'Appui Technique

APPENDIX

Appendix A Value Chain for Food and Agriculture Sector

A.1 Rice

A.1.1 Present Situation of Rice Value Chain

Production and Trade

While the production of paddy rice has increased more than 40% from 2005 to 2011 in the West Africa region, it is pointed out that it covers only 40 percent of the rice needs. The region is therefore dependent on the international market for the remainder¹. The import amount of rice is over 80% of the production in 2011.

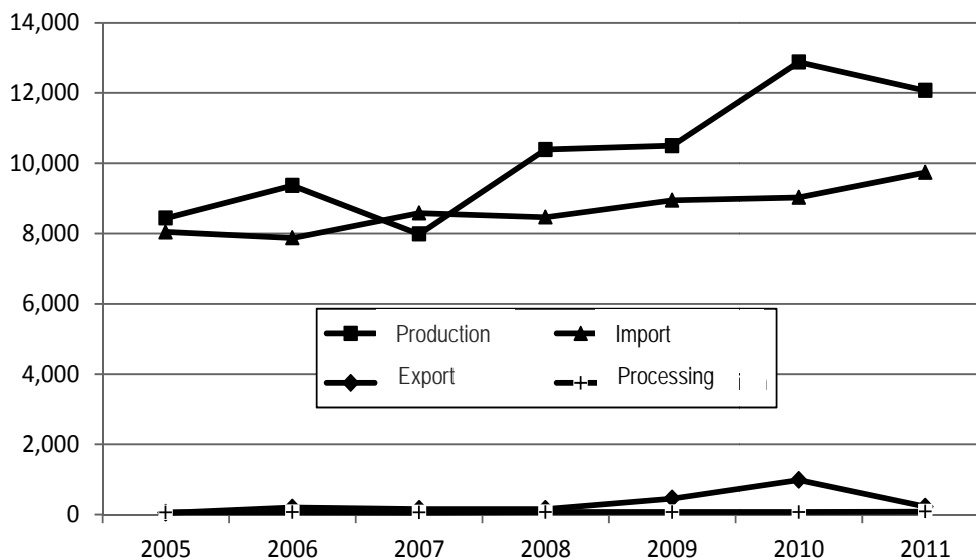

Note 1: Paddy rice equivalent

Note 2: West Africa includes Cape Verde, Benin, Gambia, Ghana, Guinea, Côte d'Ivoire, Liberia, Mali, Mauritania, Niger, Nigeria, Guinea-Bissau, Senegal, Sierra Leone, Togo and Burkina Faso.

Source: FAOSTAT

Figure A.1.1 Production, Import, Export and Processing of Rice¹ in West Africa² (1,000 tons)

The amount of export and processing of rice have also been increasing, but are negligible compared to the major rice producing/exporting countries in the world. Therefore, countries in the West Africa region are large rice importers. Senegal and Côte d'Ivoire rank 3rd and 4th respectively on the global import scale, and other countries like Benin and Nigeria rank within 20th. These countries mainly import from India, Thailand, Pakistan and Brazil.

¹ USAID West Africa Trade Hub, "Trade Hub and African Partners Network: Value Chain Assessment Report: Rice", May 2014.

Table A.1.1 Major Rice Importing Countries in the World and West Africa (1,000 tons)

Ranking (2015)	Importers	2011	2012	2013	2014	2015
	World	33,900	39,775	37,689	40,185	38,571
1	China	578	2,345	2,244	2,557	3,350
2	Saudi Arabia	1,123	1,225	1,272	1,428	1,604
3	Senegal	808	1,041	1,124	1,111	1,159
4	Côte d'Ivoire	935	1,268	803	953	1,130
5	Philippines	710	1,023	405	1,079	1,100
6	Malaysia	1,031	1,006	890	942	1,051
7	United Arab Emirates	0	946	727	889	993
8	Iraq	1,053	1,385	1,320	1,073	991
9	Benin	272	561	1,390	1,398	977
10	Iran, Islamic Republic of	1,187	1,261	2,227	1,144	942
13	Nigeria	441	479	20	752	783
23	Guinea	386	421	523	621	546
32	Niger	161	325	385	363	407
36	Burkina Faso	319	401	440	362	377

Note: Figures include rice in the husk (paddy or rough) and semi-milled or wholly-milled rice (HS1006)
Source: ITC Trade Map-Trade Competitiveness Map

Table A.1.2 Major Countries Exporting Rice to West Africa (2015)

Exporters (rank)	1	2	3	4	5
Senegal	India	Thailand	Pakistan	Brazil	Antigua and Barbuda
Côte d'Ivoire	Thailand	India	Viet Nam	Pakistan	Myanmar
Benin	India	Thailand	United Arab Emirates	Pakistan	Brazil
Nigeria*	Thailand	India	China	Brazil	Australia

* 2014

Source: ITC Trade Map-Trade Competitiveness Map

Within the region, Nigeria is the biggest producer of rice, followed by Mali, Guinea, Sierra Leone and Côte d'Ivoire. These countries have very small amounts of export and processing, except for Côte d'Ivoire. Senegal, Benin and Niger also have substantial amounts of production, export and processing.

Table A.1.3 Production, Import, Export and Processing of Rice¹ in Countries in West Africa (tons)

		Benin				Ghana			
	Production	Import	Export	Processing	Production	Import	Export	Processing	
2005	78,329	564,165	7,511	3,673	287,000	722,321	4	513	
2006	70,972	1,092,464	7,272	9,403	250,000	580,588	3,387	1,209	
2007	74,866	990,138	17,911	4,825	185,340	364,265	12	369	
2008	105,596	1,040,457	43,094	5,625	301,920	303,903	4	1,435	
2009	112,700	1,006,668	209,480	5,257	391,440	583,097	213	704	
2010	124,975	894,552	825,306	5,300	491,603	485,983	10	350	
2011	219,626	548,697	595	6,119	463,975	336,435	102	1,071	
		Côte d'Ivoire				Liberia			
	Production	Import	Export	Processing	Production	Import	Export	Processing	
2005	703,931	1,347,038	19,125	49,093	154,800	230,714	750	1,207	
2006	715,898	1,505,358	10,638	45,414	164,000	324,208	0	997	
2007	606,310	1,348,028	3,064	44,167	231,800	222,732	0	899	
2008	679,969	1,270,346	38,859	51,218	295,150	255,673	0	1,272	
2009	687,721	1,868,506	88,988	56,725	293,000	372,591	0	1,092	
2010	1,206,153	1,433,185	23,469	56,320	296,090	447,789	0	1,598	
2011	873,016	1,612,722	53,999	68,153	298,000	190,392	0	785	
		Mali				Guinea			
	Production	Import	Export	Processing	Production	Import	Export	Processing	
2005	945,823	441,569	369	0	1,272,415	241,855	1,659	n.a.	
2006	1,053,236	285,056	0	0	1,340,313	377,636	30	n.a.	
2007	1,082,384	239,296	0	-1	1,401,592	501,958	0	n.a.	
2008	1,624,246	279,902	0	-1	1,534,088	542,076	66	n.a.	
2009	1,950,805	181,576	0	-1	1,455,932	357,405	66	n.a.	
2010	2,305,612	95,731	0	0	1,498,962	360,483	66	n.a.	
2011	1,741,472	171,575	0	0	1,670,000	224,591	66	n.a.	
		Burkina Faso				Nigeria			
	Production	Import	Export	Processing	Production	Import	Export	Processing	
2005	93,516	317,607	244	1,681	3,567,000	1,777,743	6,568	n.a.	
2006	113,700	293,539	174	5,882	4,042,000	1,466,798	3,755	n.a.	
2007	68,916	229,377	160	1,681	3,186,000	1,369,182	377	n.a.	
2008	195,102	211,338	44	4,202	4,179,000	1,464,167	69	n.a.	
2009	213,584	420,384	789	5,042	3,546,250	1,748,215	2	n.a.	
2010	270,658	387,359	915	5,042	4,472,520	2,333,436	141	n.a.	
2011	240,866	502,082	0	5,882	4,567,320	3,290,235	250	n.a.	
2012	319,390	654,341	27	8,067	4,833,000	2,923,534	0	n.a.	
2013	305,382	724,158	4,559	6,723	4,700,000	3,291,440	0	n.a.	
		Sierra Leone				Niger			
	Production	Import	Export	Processing	Production	Import	Export	Processing	
2005	738,000	124,152	n.a.	154	59,902	455,621	1,572	0	
2006	1,062,320	172,998	n.a.	0	78,377	292,284	24,927	817	
2007	588,004	172,834	n.a.	154	70,000	268,530	25,457	573	
2008	680,097	301,900	n.a.	154	32,475	420,139	43,122	1,063	
2009	888,417	163,621	n.a.	154	20,117	299,789	15,212	571	
2010	1,026,671	167,070	n.a.	645	29,963	233,313	57,457	818	
2011	1,078,005	264,105	n.a.	806	13,324	290,117	9,091	655	
		Senegal				Togo			
	Production	Import	Export	Processing	Production	Import	Export	Processing	
2005	279,080	1,277,965	10,629	3,760	72,858	128,094	179	1,681	
2006	190,493	1,053,635	149,580	3,787	76,284	117,090	45	1,681	
2007	193,379	1,602,102	110,769	4,612	74,843	123,079	2,628	1,681	
2008	408,219	1,512,961	30,378	4,042	85,540	112,670	3,369	1,429	
2009	502,104	1,151,762	140,741	1,206	121,295	129,016	570	420	
2010	604,043	1,056,599	80,554	976	110,109	111,519	180	420	
2011	405,824	1,207,266	163,626	1,142	112,233	159,595	1,024	420	
2012	469,649	1,554,405	143,726	949					
2013	436,153	1,678,850	131,659	863					

Source: FAOSTAT

Although intra-regional trade of rice is very low as mentioned above, there are some patterns in rice trade flows in the West Africa region. First, rice flows throughout every corner of West Africa. Second, almost all of the cross-border rice trade flows are of imported rice, both through formal transit shipments of rice from the main ports and through informal trade. Informal exports of West African rice are mostly from production locations close to the borders. Third, almost all the trade from surplus areas to urban markets remains within the country of production due to sufficient domestic demand, high transport costs and customs formalities². In addition, parboiled rice is mainly subject to intra-regional trade, as this product has developed significant demand in the region, especially in the urban areas.

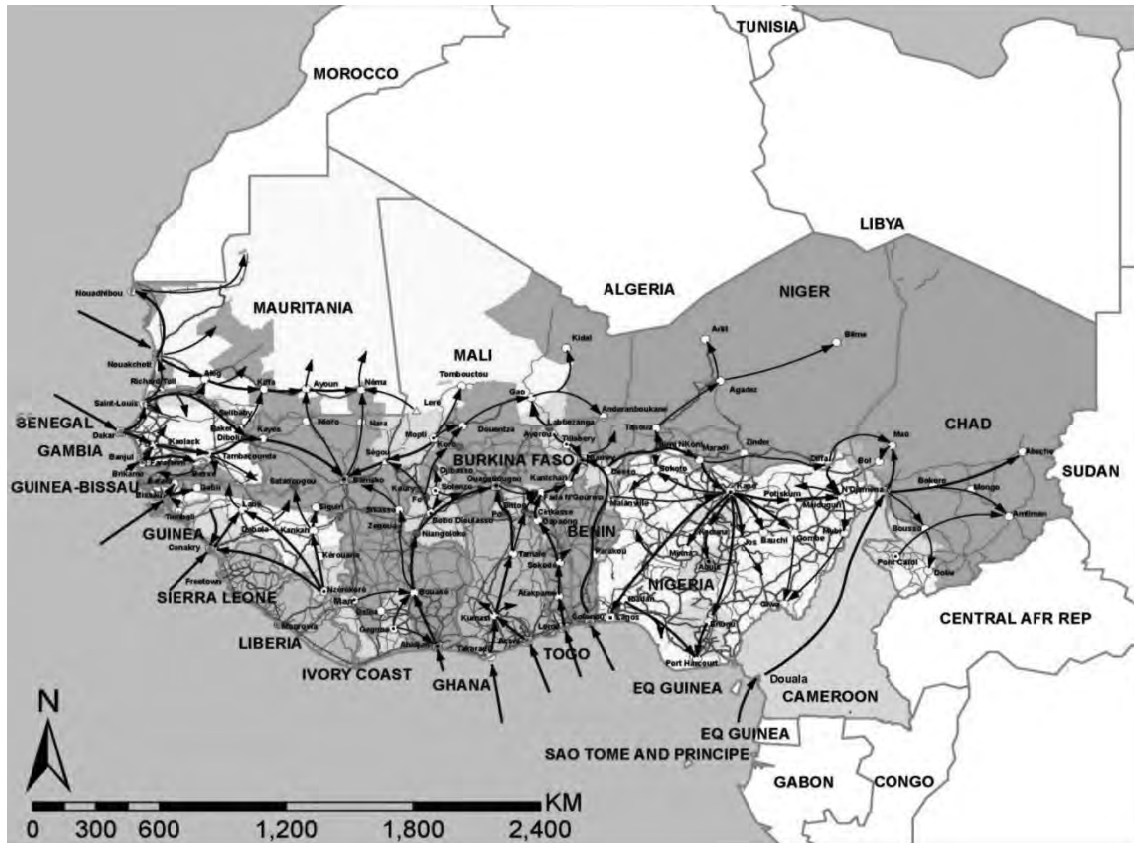

Source: USAID (2009)

Figure A.1.2 Production and Market Flow of Rice in West Africa

A.1.2 Main Players and Value Chain³

Main players in the rice sector in West Africa comprises farmers, aggregators or local buying agents, wholesale dealers, suppliers, urban grain markets, processors, retail sellers, and wholesale end markets. The value chain is also supported by a large number of stakeholders from the public sector, as well as private organizations and donor-supported technical assistance projects.

Seventy percent of rice farmers in West Africa are small, owning less than one hectare. Another 25 percent are medium-scale farmers who own one to three hectares. The remaining 5 percent are large commercial farmers, owning more than three hectares.

The major entities involved in input supply, production, processing, and trading are also micro, small, and medium enterprises. Rice milling is dominated by hammer milling, which produces low-quality rice. Rice is sold in bulk without packaging.

² USAID, "Global Food Security Response: West Africa Rice Value Chain Analysis", October 2009.

³ Based on USAID West Africa, "Trade Hub and African Partners Network: Value Chain Assessment Report: Rice", May 2014.

There are some major and large firms in each value chain phase. In particular, traders have begun to invest vertically downstream in the rice value chain in West Africa. But other firms are also involved in processing and marketing. Examples include Sokimex in Burkina Faso (processing), the Velegda Group in Nigeria (marketing), GADCO (production and processing of rice) and Finatrade (marketing) in Ghana, Louis Dreyfus Commodities (trading) and the Olam and Mimran companies (production) in Côte d'Ivoire.

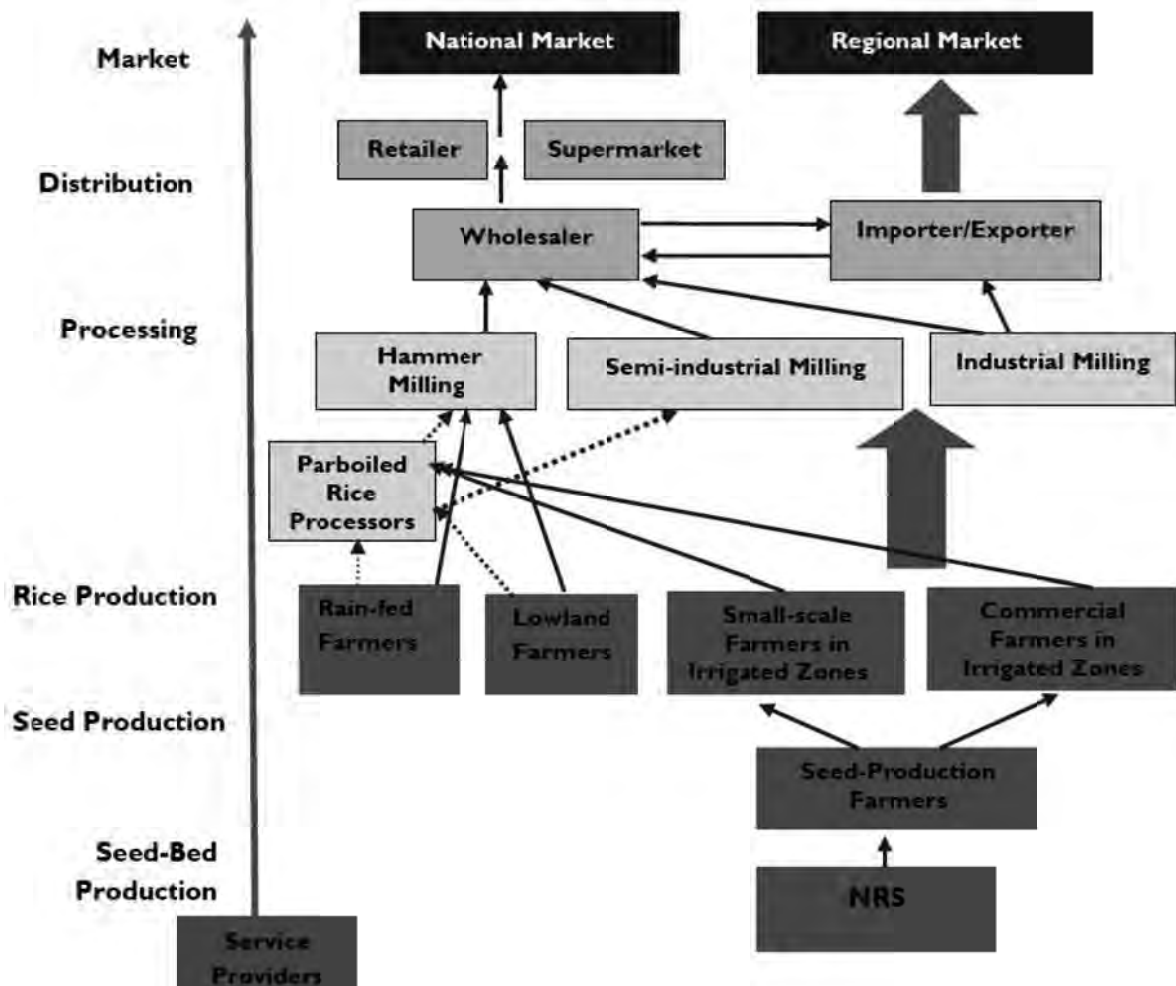

Source: USAID West Africa, May 2014, "Trade Hub and African Partners Network: Value Chain Assessment Report: Rice"

Figure A.1.3 Rice Value Chain in West Africa

Each country has a supply channel of imported rice, one is private and the other one is government. Private importers supply wholesalers, semi-wholesalers, and lead retailers. The government distribution channel is permanent in some countries and sporadic in others, with aims to mitigate soaring prices on local markets.

Most imported rice is either broken or milled rice. Commercial imports of husked brown rice are minimal, limited mainly to Nigeria. Nigeria and Liberia are importers of parboiled rice. Senegal, Gambia, Mauritania and Mali principally import 100 percent broken rice and most of the other countries import white rice. (Côte d'Ivoire and Ghana are the most diverse importers, buying various qualities of white rice)⁴

⁴ USAID (2009)

A.1.3 Issues of Rice Value Chain

The issues of the rice value chain in West Africa are as follows:⁵

- Agricultural inputs are high-cost and difficult to access.
- Market infrastructure (warehousing, docks, phytosanitary facilities, etc.) is inadequate.
- There is limited access to credit (for farmers, storage, traders, and millers).
- West Africa produces only 40 percent of its rice needs; it is dependent on the international market for the rest.
- Poor-quality rice is inappropriate for the transformation process and does not adhere to norms and standards.
- There is a lack of sufficient irrigation and storage facilities.
- The economic environment is very unfavourable; there is a lack of funds for investment and operation.
- Norms and standards are lacking or are not harmonized in the region. Consequently, the quality of grains is weak (there is little concern about grades).
- Market information is limited due to the insufficiency of existing market information systems (MIS).
- Yields are weak.
- There are significant harvest and post-harvest losses.
- There are seasonal bans on grain exports.
- Tariff and non-tariff barriers exist.
- Road and cross-border harassment.

In addition, less attention has been given to post-production activities (processing and marketing), that has resulted in an unbalanced effect of increased production, which shows up in lower producer prices and results in disincentives for continued rice production. A major concern is the low quality of local rice, and the high level of impurities in paddy rice, which persist throughout the processing stages up to the final product, resulting in a discounted price that keeps local rice less competitive. The lack of organizations and market-savvy producer groups is linked to this constraint⁶.

A.1.4 Future Prospects of Rice Value Chain

Rice is among the staple foods most tightly connected with increased urbanization in West Africa, which is a result of its greater reliance on imports and import-easing policies. The accelerated increase in rice consumption over the last few years is principally attributed to income growth and urbanization. Since 60 percent of West Africans are projected to live in urban areas by 2020 and the number of cities with more than 100,000 inhabitants will grow to more than 200 in 2030, demand for imported staples such as rice is likely to increase. This requires a significantly upgraded staple food processing capacity in the region⁷.

West African nations, donors, associations and the private sector are putting a lot of emphasis on Africa's self-sufficiency in rice. Fortunately, there have been some recent gains in the production of paddy rice in some countries such as Côte d'Ivoire. However, the storage, milling, packaging, and distribution of rice remain herculean challenges and offer opportunities for investors in Africa⁸

In this regard, recent efforts by the government of Côte d'Ivoire to organize stakeholders in the rice sector and establish a nation-wide milling facilities network system is worthy to note as follows.

⁵ USAID West Africa, May 2014, "Trade Hub and African Partners Network: Value Chain Assessment Report: Rice"

⁶ FAO and IFAD (2013)

⁷ Aziz ELBEHRI, Jonathan KAMINSKI, Suffyan KOROMA, Massimo IAFRATE, and Marwan BENALI, "West Africa Staple Food Systems: An Overview of Trends and Indicators of Demand, Supply and Trade" in FAO and IFAD, 2013, *Rebuilding West Africa's Food Potential: Policies and Market Incentives for Smallholder-Inclusive Food Value Chains*

⁸ USAID West Africa, March 2015, "Trade Hub and African Partners Network: Feed the Future Finance and Investment Opportunities Report"

【Case of Rice Processing: Strategy for Establishing 3 Layer System of Rice Milling in Côte d’Ivoire】⁹

In Côte d’Ivoire, there are around 2,500 small processing units for rice milling spread over the country and just one large rice mill in Bongouanou operated by a private rice processor, AMC-FC. The small units can process only 2 tons per hour and its processing quality is too low to compete with imported rice. To improve this situation by filling the gap between small units and large mills, of which processing capacity of each is 12 tons per hour, it is planned to install 30 mills each with the processing capacity of 5 tons per hour (25,000 tons per year) in every region, and operate them in PPP scheme. These middle-sized mills will have contracts with producers (farms) and small processors in the same regions. They will also have contracts with the government to ensure the maintenance of an adequate quality and quantity to meet local needs. It is also expected that they will purchase domestic rice at a higher price than is currently being paid and to sell it to the domestic consumers at a lower price than the imported rice.

According to the plan by the National Rice Development Office (ONDR: *Office National de Développement de la Riziculture*), the processing cost of middle-sized mills is estimated at 284.39 CFA/kg, which will enable them to sell at a lower price than imported rice (about 370 CFA/kg) and make a profit of 85.61 CFA/kg. This processing system will also be beneficial to rice producers by providing higher profitability than other crops. ONDR is inviting both domestic and foreign investment for the middle-sized mills¹⁰.

In the longer term, large-sized mills with equivalent capacity to the AMC-FC plant will be installed in 10 locations. These mills will be established and operated by private processors and will export products to the neighbouring countries.

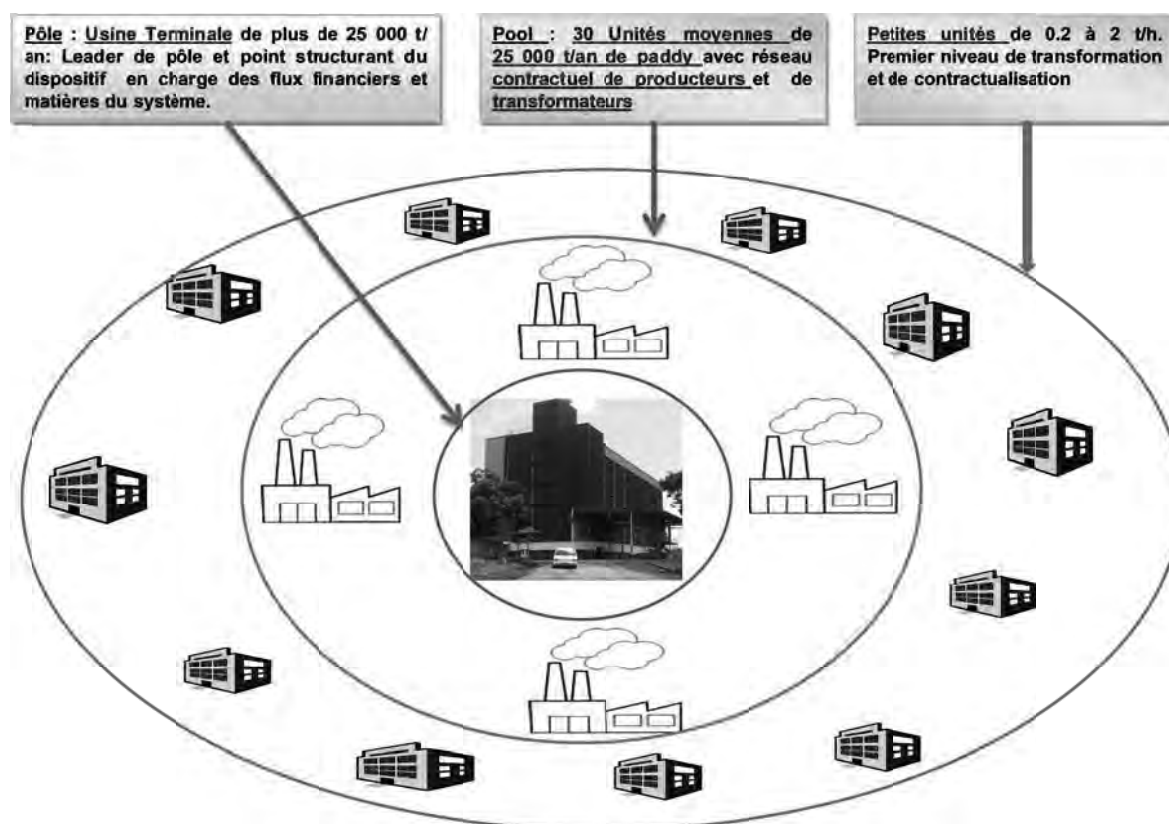

Source: ONDR

Figure A.1.4 Plan of Rice Mills Network in Côte d’Ivoire

⁹ Based on the interview with a director of ONDR in August 2016.

¹⁰ The director mentioned that USD 3 million loans shall be provided by the EXIM bank of India for constructing the mills.

The locations for the 10 large-sized mills will become the regional centres for the rice industry, which include Korhogo, Bouaké and Yamoussoukro along the Abidjan-Ouagadougou Corridor.

A.1.5 Future Prospects based on Sub-Regional Development Strategies

Among the priority projects for the agricultural sector in the targeted countries, the “Programme for Development and Effective Use of Agricultural Infrastructure and Bas-fonds” and “Support for the Agro-industrial Pole of Bélier Region” in Côte d’Ivoire, four “Agricultural Cluster Area Development Programmes” and “Accra Plains Irrigation Development Project” are expected to contribute to strengthen rice value chains in Côte d’Ivoire and Ghana, as these projects have comprehensive approaches to improve the issues mentioned before.

A.2 Maize

A.2.1 Present Situation of Maize Value Chain

Production and Trade

While the production of maize has increased more than 40% from 2005 to 2011 in the West Africa region, the amount of import and export has stayed quite small. Therefore, most of the maize produced in the region is believed to be consumed in each country almost fulfilling their domestic demand. The processed volume is around 1 % of the production.

The biggest producing country of maize in the region is Nigeria, which had 55% of the regional production in 2014. Ghana, Mali and Burkina Faso follow Nigeria, but their respective shares are less than 10% each.

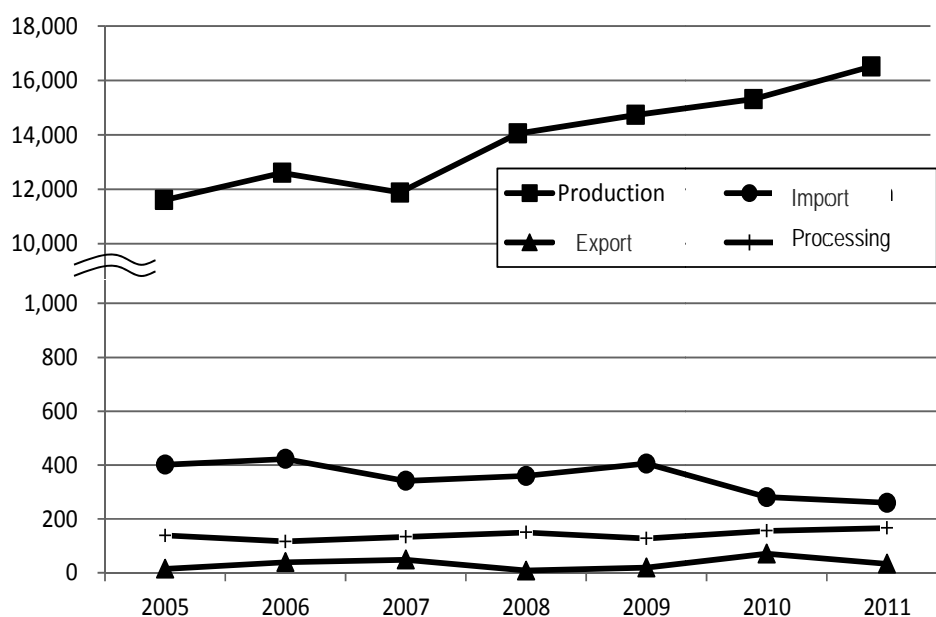

Note 1: Maize and products

Note 2: West Africa includes Cape Verde, Benin, Gambia, Ghana, Guinea, Côte d’Ivoire, Liberia, Mali, Mauritania, Niger, Nigeria, Guinea-Bissau, Senegal, Sierra Leone, Togo and Burkina Faso.

Source: FAOSTAT

Figure A.2.1 Production, Import, Export and Processing of Maize¹ in West Africa² (1,000 tons)

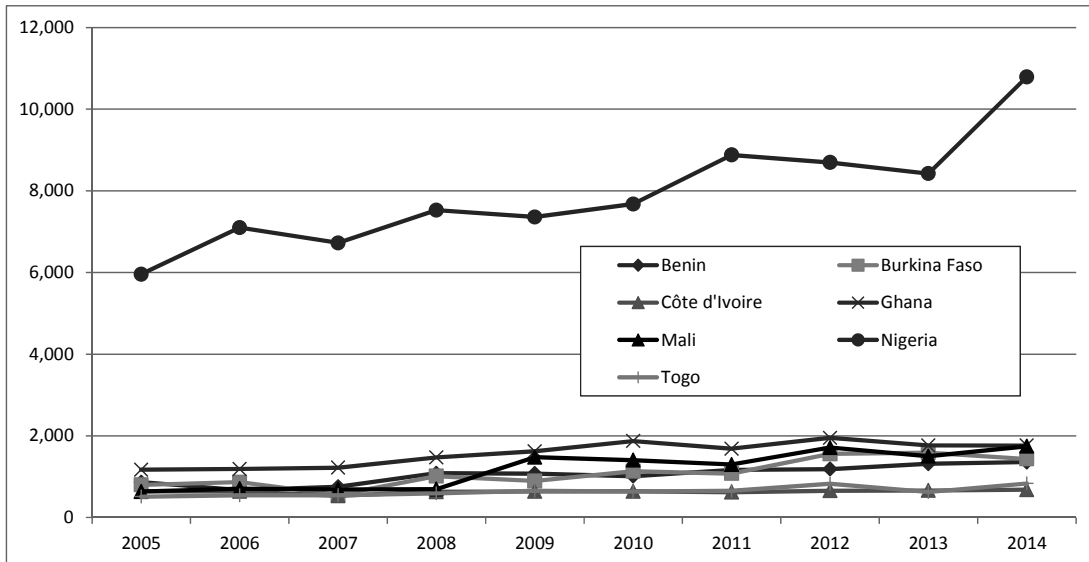

Source: FAOSTAT

Figure A.2.2 Major Maize Producing Countries in West Africa (1,000 tons)

Although only a small percentage of production is traded (around 2~3 %) inside and outside the region, there is a large number of small scale traders that collect and trade maize, mainly along the following transport corridors¹¹.

- Ghana-Burkina Faso (Techiman-Leo-Ouagadougou), along which maize travels in both directions according to the period of the year.
- Côte d'Ivoire-Mali (Bouaké-Bamako)
- Niger-Nigeria (Zinder/Maradi- Kano)
- Burkina Faso-Burkina Faso-Abidjan (Ouagadougou-Bobo Dioulasso-Abidjan)
- Mali-Burkina Faso (Bamako-Ouagadougou)
- Burkina Faso-Niger (Ouagadougou-Niamey).



Source: USAID West Africa, May 2014, "Trade Hub and African Partners Network: Value Chain Assessment Report: Maize Value Chain"

Figure A.2.3 Flow of Maize and Other Cereals in West Africa

¹¹ USAID West Africa, "Trade Hub and African Partners Network: Value Chain Assessment Report: Maize Value Chain", May 2014.

A.2.2 Main Players and Value Chain

The maize value chain in the West Africa region is composed of a marketing network led generally by the wholesalers and semi-wholesalers operating in wholesale markets. Wholesalers determine the nature and quantity of production to purchase and provide indications about prices, given their expectations for marketing prospects. Wholesalers fund collectors who initiate orders on their behalf after having jointly agreed on price offers to make, based on export prices and prices observed on behalf of urban wholesalers and institutional customers. Thus, collectors pay for cereals in the producer's markets to supply them to wholesalers, which in turn supply and market the production to the other stakeholders of the marketing system¹²

Regarding the input supply, governments manage the input supply chain in some countries, offering subsidies to incentivize production increases in the interest of improving food security. In other countries, which employ a more private-sector driven model, agro dealers and their agents are actively involved in input supply, and they provide these items at non-subsidized costs.

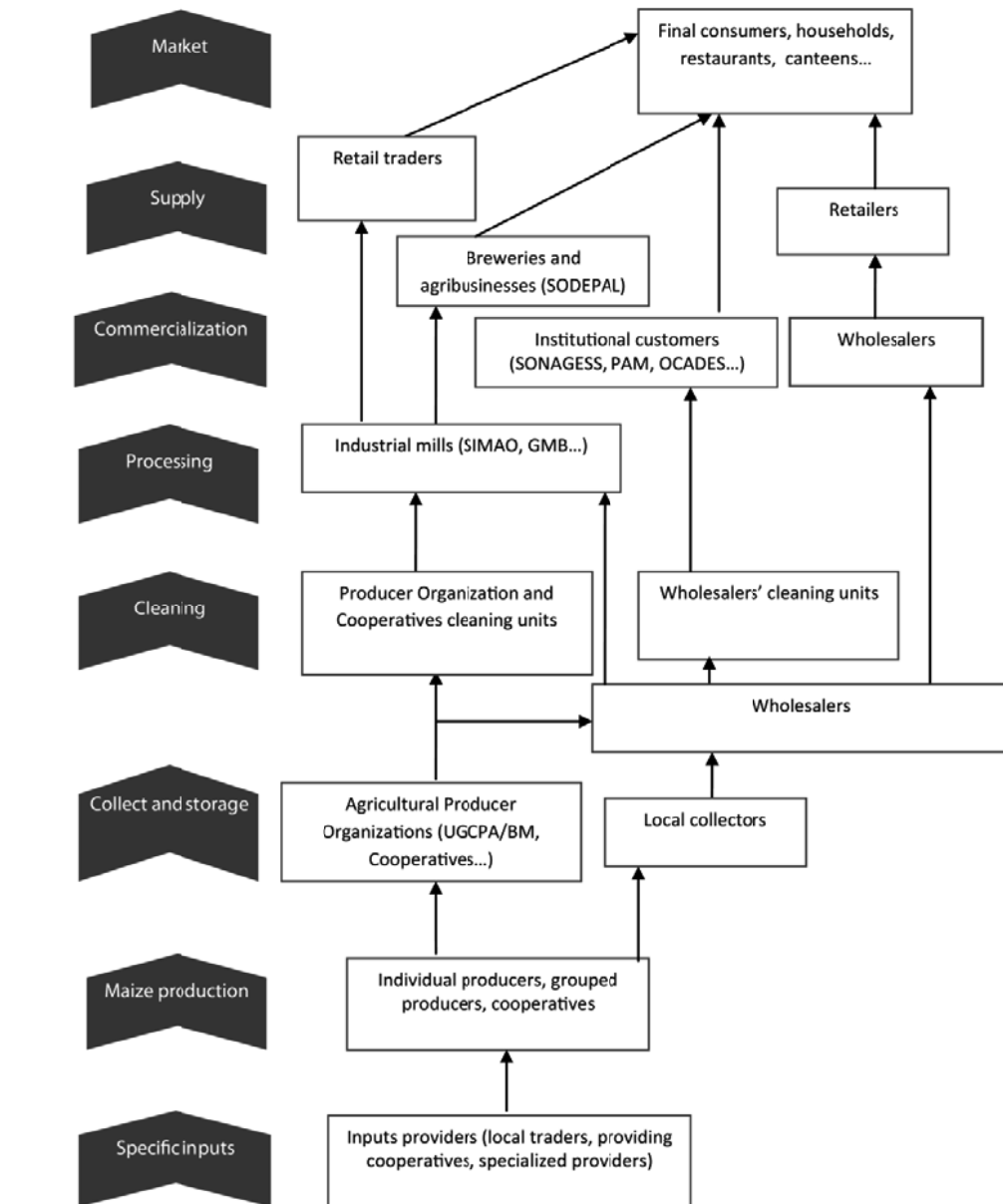

Source: FAO and IFAD, 2013

Figure A.2.4 Maize Value Chain in West Africa

¹² Jonathan Kaminski, Aziz Elbehri and Jean-Baptiste Zoma, "An Analysis of Maize Value Chain and Competitiveness in Burkna Faso: Implications for Smallholder-Inclusive Policies and Initiatives", in FAO and IFAD, *Rebuilding West Africa's Food Potential: Policies and Market Incentives for Smallholder-Inclusive Food Value Chains*, 2013.

At the production phase, more than 85% of maize production is by small scale producers, farmers who operate on farms that are smaller than 3 hectares. Farmers who cultivate more than 3 ha are considered to be commercial maize farmers. Farm yields are typically in the range of 1 to 2 metric tons per hectare, which are lower than the higher performing maize producers in Southern Africa and Northern Africa, mainly due to limited access to agricultural credit, limited and/or inefficient use of fertilizers, high-yielding maize varieties or improved seed, and sub-optimal pest and disease control measures.

As for the processing, local industries that use maize as a critical input include beer, pasta, couscous, and fish, cattle/dairy and poultry production. There are a number of important maize processors in the region: Premium Foods (Ghana), IPRAVI/IVOGRAIN, SIPRA and Nestle' (Côte d'Ivoire), Data Foods (Nigeria), AFEEX (Senegal), breweries (in every country), and many small scale processing firms. Many of them, breweries in particular, purchase maize from outside the region (Argentina, Brazil and elsewhere) as they require good quality, respecting grades, norms and standards¹³.

A.2.3 Issues of Maize Value Chain

The West African maize value chain compares poorly to international goods performers in terms of important measures of competitiveness, such as quality, productivity, percentage of production reaching market, prices, and delivery conditions. The ability of the upgraded value chain to respond reliably to market requirements with competitive quality and cost requires: (i) restructuring value chain relationships, information, and incentives; (ii) the use of best practices at every level of the value chain, especially at the production level, and (iii) access to inputs, to finance, and to the market in a positive enabling commercial environment¹⁴.

The maize processing also faces many constraints: (iv) processing yields from mechanical hulling are rather weak (15% to 25% for several units); (v) low-quality processing of mechanic hulling has had bad effects on the overall quality of end products (taste, nutritional content and conservation attributes); (vi) flour quality is sometimes inadequate as a result of grain size, metallic contamination and other impurities; (vii) handling of the processing machinery may also be inadequate (choice of the machinery or lack of training of processors); (viii) most manual techniques of second-stage processing are painful and lengthy; (ix) packaging is sometimes difficult; and (x) the outputs may be highly perishable¹⁵.

A.2.4 Future Prospects of Maize Value Chain

The strengths and opportunities of/ for the maize value chain in West Africa are as follows¹⁶:

Strengths

- Maize is a strategic commodity for food security at the regional level (ECOWAS Agricultural Policy (ECOWAP) and UEMOA Agricultural Policy (PAU: Politique agricole de l'UEMOA))
- The region still has huge amounts of fertile lands to cultivate for more production
- Maize has a great potential for economic growth and income generation, and it is an important potential source of employment for West Africa.

Opportunities

- Maize is a staple food for most West African countries, especially in rural contexts, where it is consumed in large quantities
- There is large market for maize, both for human consumption and for animal feed
- There are numerous trade opportunities, including The World Food Programme (WFP) and breweries in all the countries of the region

¹³ USAID West Africa, "Trade Hub and African Partners Network: Value Chain Assessment Report: Maize Value Chain", May 2014.

¹⁴ *Ibid*

¹⁵ Jonathan Kaminski, Aziz Elbehri, Jean-Baptiste Zoma (2013)

¹⁶ USAID West Africa, May 2014, "Trade Hub and African Partners Network: Value Chain Assessment Report: Maize Value Chain"

- The ECOWAS regulation on free trade exists, but it remains to be enforced to increase trade across borders.

The poultry sector is one major outlet for maize flour and maize for the feeding sector. In Ghana, due to recent government support for domestic poultry production, yellow maize production, and its scaling up, presents a potentially compelling investment opportunity in the medium term, given the resurgent poultry industry¹⁷. In Burkina Faso, most semi-industrial poultry production is located close to Ouagadougou and Bob-Dioulasso urban centres. This is an emerging dynamic sector which consumes processed food and medicines, but is geared towards egg production. Although there is no fully integrated industrial poultry sector for broilers in Burkina Faso, as income increases in urban dwellings, demand could emerge for more biosafety in broiler production and be conducive to industrialization of that sector, which would increase demand for processed grains¹⁸.

A.2.5 Future Prospects based on Sub-Regional Development Strategies

There are several priority projects in the agricultural sector which aim for production development of cash crops including maize, and they are expected to contribute to strengthen the production capacity of maize and other cereals and promote their processing. Such projects include “irrigation and agribusiness development in Douna and Karfiguéla” (Burkina Faso), “Support for Agro-industrial Pole of Bélier Region” (Côte d’Ivoire), and “Tamale-Mamprusi Agricultural Cluster Area Development Programme” (Ghana).

However, in terms of development and upgrading of maize processing, institutional arrangements and policies to facilitate and encourage more processing to take place within the value chains are also important. For example, industrial poultry production promotion in Côte d’Ivoire and Ghana, and the warehouse receipt system¹⁹ in Ghana are supposed to fall under such categories. Among the priority projects, “development of poultry processing plants with cold storage” and “feed resource development project” in Ghana are also expected to contribute to maize processing promotion.

A.3 Cashews

A.3.1 Present Situation of Cashew Value Chain

Production and Trade

Among the top 10 cashew (shelled cashew nuts, also known as raw cashew nuts (RCN)) producing countries in the world, 4 countries are in West Africa, and another 6 West African countries are included in the top 20. In 2014, the production of these 10 West African countries shared 54% of the world cashew production.

While recent cashew production in the world has been decreasing due to the big drop of Viet Nam’s production, the production in the West Africa region has been steadily increasing, mainly due to the production expansion in Nigeria and Côte d’Ivoire.

¹⁷ USAID West Africa, March 2015, “Trade Hub and African Partners Network: Feed the Future Finance and Investment Opportunities Report”

¹⁸ Jonathan Kaminski, Aziz Elbehri, Jean-Baptiste Zoma (2013)

¹⁹ In warehouse receipt system, licensed warehouse operators issue a document certifying the quantity and quality of a specified grain (maize, rice, soya, etc) placed by a named depositor (farmer, trader, food processor, financial institution, etc.) into a secured storage operated by the warehouse operator to encourage market access and fair returns for smallholder farmers, and to facilitate the formalization of informal agricultural trading activities.

Table A.3.1 Major Cashew Producing Countries in the World and West Africa (1,000 tons)

Ranking (2014)	Producers	2010	2011	2012	2013	2014
1	Nigeria	864	814	839	867	894
2	India	613	675	725	753	753
3	Côte d'Ivoire	380	393	450	488	531
4	Viet Nam	1,242	1,237	1,250	275	245
5	Benin	102	163	163	198	202
6	Philippines	135	133	133	146	171
7	Guinea-Bissau	121	124	117	135	156
8	Indonesia	115	115	117	116	131
9	United Republic of Tanzania	74	121	160	128	130
10	Brazil	104	231	81	110	108
11	Burkina Faso	21	95	60	115	90
12	Mali	3	4	4	39	72
14	Ghana	32	36	40	42	50
18	Guinea	7	8	9	9	9
19	Togo	5	7	7	7	7
20	Senegal	6	7	7	7	7
World Total		4,025	4,371	4,329	3,613	3,714

Note: Cashew means cashew nuts with shell.

Source: FAOSTAT

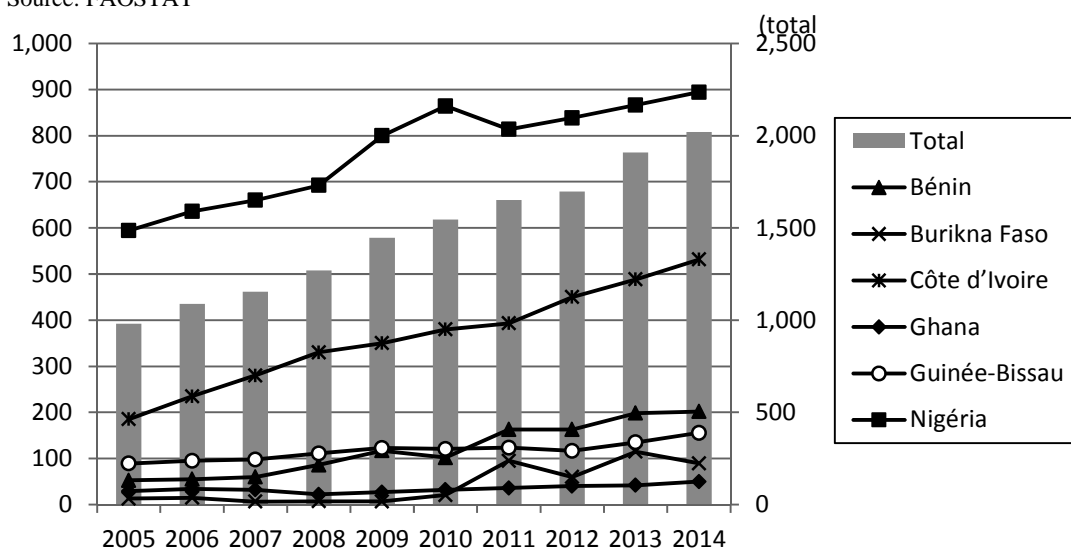

Note: West Africa includes Benin, Gambia, Ghana, Guinea, Côte d'Ivoire, Mali, Guinea-Bissau, Senegal, Togo and Burkina Faso

Source: FAOSTAT

Figure A.3.1 Cashew Production in Major Countries in West Africa (1,000 tons)

Major cashew producing countries in West Africa are also major exporting countries in the world. Côte d'Ivoire, Guinea-Bissau, Burkina Faso and Ghana export most of or more RCN than they domestically produce, procuring some RCN from other countries in the region. On the other hand, the export amount of processed cashew nuts (cashew nuts without shell) is extremely small. It is often pointed out that less than 10 percent of the total RCN production of the region is locally processed, and the export ratio is much lower than that.

Table A.3.2 Major Cashew Exporting Countries in the World (1,000 tons)

【Cashew nuts with shell】						【Cashew nuts without shell】					
	2011	2012	2013	2014	2015		2011	2012	2013	2014	2015
Côte d'Ivoire	278	410	426	532	659	Viet Nam	174	218	255	294	261
Tanzania	99	131	151	196	170	India	133	102	126	117	103
Benin	51	94	116	118	131	Netherlands	25	29	22	26	30
Guinea-Bissau	146	111	196	155	123	Indonesia	4	4	5	8	18
Burkina Faso	81	46	71	72	107	Brazil	26	25	21	17	13
Indonesia	42	59	47	50	84	Germany	4	4	5	8	12
Ghana	132	101	170	144	69	Côte d'Ivoire	1	3	4	6	7
Nigeria	46	79	58	-	46	Belgium	3	3	4	4	5
Gambia	25	38	65	75	17	USA	2	2	2	3	3
Guinea	14	4	10	12	15	Guinea	3	0	2	0	2
World total	1,065	1,099	1,353	-	1,442	World total	428	429	654	532	475

Source: ITC Trade Map-Trade Competitiveness Map

A.3.2 Main Players and Value Chain

The cashew value chain consists of a large number of micro-, small and medium-sized enterprises (MSMEs) and the leading firms in the region engaged in RCN purchases and processing. MSMEs engage in the following activities: aggregators of cashews (local buying agents); transporters; storage facilities maintenance; traders; logistic suppliers; and service providers to cashew processors. In all the cashew-processing countries in the region, there are only a few companies that purchase RCN for export and some that process nuts locally. These companies include: Anatrans (Burkina Faso); Olam and SITA (Côte d'Ivoire); Mim Cashew and Rajkumar (Ghana); and Cajou Espoire (Togo). In addition, seasonal buyers come from India and elsewhere and engage in large-scale buying of RCN, and foreign investors have begun to enter the processing market (e.g. USIBRA Co. from Brazil has constructed a large processing unit with 35,000 ton capacity in Ghana).²⁰

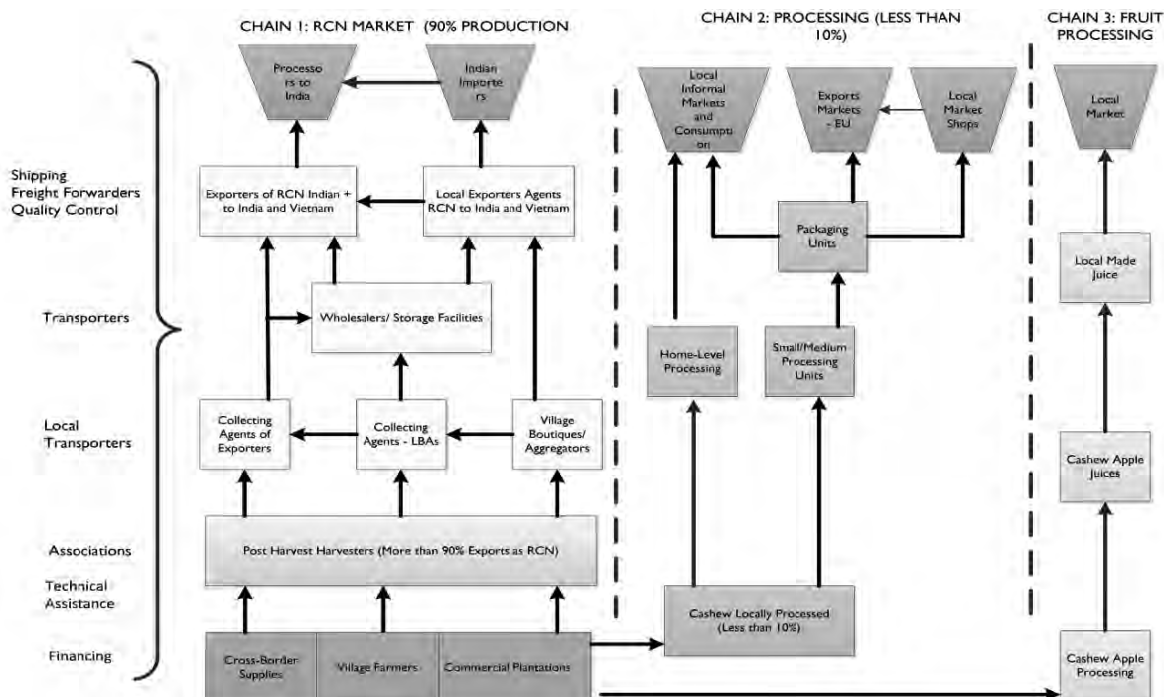

Source: USAID West Africa, May 2014, "Trade Hub and African Partners Network: Value Chain Assessment Report: Cashew Value Chain"

Figure A.3.2 Cashew Value Chain in West Africa

The RCN generally flow from farmers to exporters, either directly from farmers to exporters or through intermediaries, and—in the case of processing—to the processor. Until recently, exporters

²⁰ USAID West Africa, May 2014, "Trade Hub and African Partners Network: Value Chain Assessment Report: Cashew Value Chain"

and processors in Ghana purchased RCN from Côte d'Ivoire, often unofficially. Based on this flow, several local and foreign companies invested in processing units and storage facilities in Ghana. However, due to the recent Ivorian ban on cross-border cashew exports, these Ghana-based investors face difficulties. Similarly, cross-border trade of cashew is significant in West Africa. For example, production from Senegal crosses to Gambia to be exported from the Banjul port²¹.

RCN are currently for export, mainly to India and Vietnam, with only a limited quantity being locally processed. Although locally processed nuts are sold in a variety of local markets, production from organized industries is mainly exported. Cashews are not a traditional part of African diets; therefore the local market for cashews is quite limited²².

A.3.3 Issues of Cashew Value Chain

Some of the issues often mentioned in cashew sector development are briefly discussed below²³.

- **Consistency of the quality of the raw nut supply:** Although there are many improvements in the RCN supply, quality standards and grading will require participation by all players. Currently, farmers sell all the nuts irrespective of quality to seasonal visiting buyers. It is important to have a consensus on the code of practice (quality standards, grading methods) and for it to be accepted and respected by all major players.
- **Access to finance:** Finance is a major issue, mainly for traders and processors. Intermediaries and other operators also have difficulties accessing financing during the harvest season.
- **Slow progress in the processing industry:** Although there are initiatives to promote processing nuts at their origin, other issues need to be addressed. These include the technology for processing, the availability of trained labour, working conditions in processing factories, disposal of shells and other environmental concerns, promotion of export markets, and export market norms and standards.
- **Limited capacity of sector associations:** The African Cashew Alliance (ACA) is a valuable platform for actors for networking, information, and other services. However, national-level sector associations are very weak in terms of resources, technical capacity, and operations

The issues are different from country to country. In Ghana, the ban on cross-border cashew exports by Côte d'Ivoire and overcapacity of the processing companies are serious problems. This situation basically originates from low productivity of processing plants in Ghana that gives processors weak purchasing power for RCN procurement against local buying agents. In order to improve this situation, ACA and the Ghanaian cashew industry have proposed introducing an "export window" that prohibits exporting of cashews for two months out of the whole year to ensure that processing companies get raw materials to process²⁴.

A.3.4 Future Prospects of Cashew Value Chain

The strengths and opportunities of/ for the cashew value chain in West Africa are as follows²⁵:

Strengths

- World's second-largest producer of RCN
- Sustainable production of quality nuts
- Competitive prices, with price competition created by the presence of a large number of buyers in the region

²¹ USAID West Africa, May 2014, "Trade Hub and African Partners Network: Value Chain Assessment Report: Cashew Value Chain" According the African Cashew Alliance (ACA), processors in Ghana purchase RCN from Guinea-Bissau. Similarly, Togo imports RCN from Benin.

²² Ibid

²³ USAID West Africa, May 2014, "Trade Hub and African Partners Network: Value Chain Assessment Report: Cashew Value Chain"

²⁴ Based on the interview with the ACA in Accra in August 2016.

²⁵ USAID West Africa, May 2014, "Trade Hub and African Partners Network: Value Chain Assessment Report: Maize Value Chain"

- Relatively easy access to shipping ports
- Substantial producer awareness of quality requirements

Opportunities

- Increasing export market for RCN
- Possibility of promoting processing of nuts locally; with export especially to EU and U.S. markets
- Possibility of increased production and productivity
- Natural resource management; cashew is a soil protection and reforestation plant
- An effective stakeholder networking platform provided by the ACA

In short, there are further potential opportunities in expanding export of RCN and promoting processing with increasing domestic consumption of RCN. In addition, several levels of value addition to the cashew value chain are expected. One is the value addition to RCN by improving quality, drying, storing, and bagging, all of which substantially increase the prices paid by exporters. Second is the value addition in processing at the producer level, which is implemented through introducing local processing facilities and developing linkage between local processors and local producers such as the “project for acceleration of cashew nuts processing” in Côte d’Ivoire. The third is the value addition in producing by-products from cashew apples, including juices, jams, sweets and pickles.

A.3.5 Future Prospects based on Sub-Regional Development Strategies

Among the various sub-regional priority projects for the agricultural sector, the “Project for Acceleration of Cashew Nuts Processing” in Côte d’Ivoire will give substantive impetus to promotion of cashew nut processing. However, it is concerned about the continued shortage of RCN for Ghanaian processors.

Basically, the above mentioned attempt to promote cashew processing at the regional level is applicable to all the cashew producing countries in West Africa, as long as they would work on the issues mentioned, financial access in particular, and it is expected to strengthen the linkage between producers and processors within the region. At the same time, cross-border trade of cashew should not be restricted, as it seems to be the unique characteristics of the cashew value chain in West Africa which have attracted foreign investors.

A.4 Mango

A.4.1 Present Situation of Mango Value Chain

Production and Trade

Although there are no internationally comparable statistics of mango production, it is reported that the major part of the world production of mango is from Asia. The major African producer countries are Kenya (7% of world production) and Nigeria (2%). In West Africa, 13 countries produced 1.5 million tons in 2012, about 3 to 4% of world production²⁶.

In terms of trade, countries in Asia and Latin America are the major exporters. In West Africa, Côte d’Ivoire is the biggest and has been rapidly expanding its export volume, followed by Senegal. On the contrary, Mali has been decreasing its export. The share of the five countries in West Africa to the world export in 2015 was less than 4%.

The biggest importer of mango in the world is the United States, which had a 25% share of the world import in 2015. Other importers are from Europe, Asia and the Middle East. In West Africa,

²⁶ USAID West Africa, June 2014, “Trade Hub and African Partners Network - Value Chain Assessment Reports: Overview and Recommended Actions” (revised version)

Niger and Ghana have a small amount of imports. The total import volume, or the world demand has an increasing tendency.

Table A.4.1 Major Mango Exporting Countries in the World and West Africa (1,000 tons)

Ranking (2015)	Exporters	2011	2012	2013	2014	2015
	Total	1,682	1,780	1,857	1,779	1,690
1	Mexico	288	297	338	290	331
2	Thailand	152	196	253	247	219
3	India	229	215	231	206	174
4	Brazil	127	127	122	133	157
5	Peru	124	100	127	121	132
12	Côte d'Ivoire	12	19	12	24	30
21	Senegal	7	8	10	14	16
28	Mali	20	22	6	6	9
33	Burkina Faso	7	9	7	7	7
37	Ghana	1	1	1	3	3

Note: Figures include fresh or dried guavas, mangoes and mangosteens (HS080450)

Source: ITC Trade Map-Trade Competitiveness Map

Table A.4.2 Major Mango Importing Countries in the World and West Africa (1,000 tons)

Ranking (2015)	Importers	2011	2012	2013	2014	2015
	World	1,419	1,453	1,583	1,540	1,613
1	United States of America	380	377	436	386	406
2	Netherlands	138	129	131	150	149
3	China	112	129	138	89	113
4	Viet Nam	8	n.a.	34	53	100
5	United Kingdom	50	49	56	60	71
6	Germany	58	52	56	66	71
7	Saudi Arabia	63	70	58	64	65
8	Canada	56	54	60	58	57
9	United Arab Emirates	0	84	104	104	56
10	Malaysia	51	61	51	50	55
32	Niger	3.3	3.7	3.2	2.7	5.6
46	Ghana	0.3	0.1	0.6	6.0	2.4

Note: Figures include fresh or dried guavas, mangoes and mangosteens (HS080450)

Source: ITC Trade Map-Trade Competitiveness Map

A.4.2 Main Players and Value Chain in Côte d'Ivoire²⁷

(1) Fresh Mango

1) Main Players

The fresh mangoes in Côte d'Ivoire are grown by approximately 5,000 producers, grouped in different associations and organizations. In 2009, with the support of the National Agency for Rural Development (ANADER: *Agence Nationale d'Appui au Développement Rural*), the Interprofessional Fund for Agricultural Research and the Council (FIRCA: *Fonds Interprofessionnel pour la Recherche et le Conseil Agricoles*) undertook to organize the sector by creating six cooperatives, of which five are located in the savannah region and one in the Denguelé Region.

Nearly 90% of the national production comes from smallholders, and the balance is from larger operators. The first category (smallholders) is characterized by the combination of factors such as production areas ranging from plantation villages (less than 1-2 hectare(s)) to controlled orchards (between 1 and 50 hectares) of yields below 20 tons, with or without partial control irrigation and

²⁷ This section is based on the analysis of Centre du Commerce International, "Côte d'Ivoire – Etude nationale mangue", April 2012.

phytosanitary treatments. The large farms exceed 50 hectares and are fully irrigated and treated, and the returns can easily exceed 20 tons per hectare, or even reach 30 tons.

Exporting companies are the majority of mango producers and have their own air conditioning units. There are 13 conditioning stations covering large production areas to ensure the quantities to export and are geographically distributed as follows; Korhogo (7), Sinématiali (4), Ferkessédougou (1) and Odienné (1).

Professional and interprofessional structures are involved in mango promotion. The Central Organization includes producers and exporters of Pineapple, Banana and Mango (OCAB: *Organisation Centrale regroupe les producteurs et exportateurs d'ananas, de bananes et de mangues*), which brings together the sector operators of pineapple, banana and mango and organizes the marketing of these products for the benefit of its members. As an Interprofessional structure, the Centre of Fruit and Vegetables (Cifel: *Centre Interprofessionnel des fruits et légumes*) has the mission to improve the income of producers and reduce the use of pesticides in order to meet European standards for residual pesticides.

Fertilizer suppliers, cardboard packaging, nursery growers and the companies responsible for logistics (both national and international) and post-harvest infrastructure management (such as the Agricultural Products Handling Company (SMPA: *Société Manutention des Produits Agricoles*) at the Port of Abidjan, that manages the fruit terminal and boarding operations) also play key roles in the supply chain of Ivorian mangoes.

2) Value Chain

After processing and packaging the mangoes for export, they are transported by sea and shipped from the SDV-SAGA container terminal at Ferkessédougou located about 650 km from the Port of Abidjan on the Abidjan-Ouagadougou corridor. The International Society of African Transport (SITARAIL: *Société Internationale de Transport africain par Rail*) offers two locomotives and four trains with 11 refrigerated containers dedicated to the transport of goods and a fleet of trucks to Abidjan for shipments to Europe (Rotterdam and Antwerp) by sea in about 12 days.

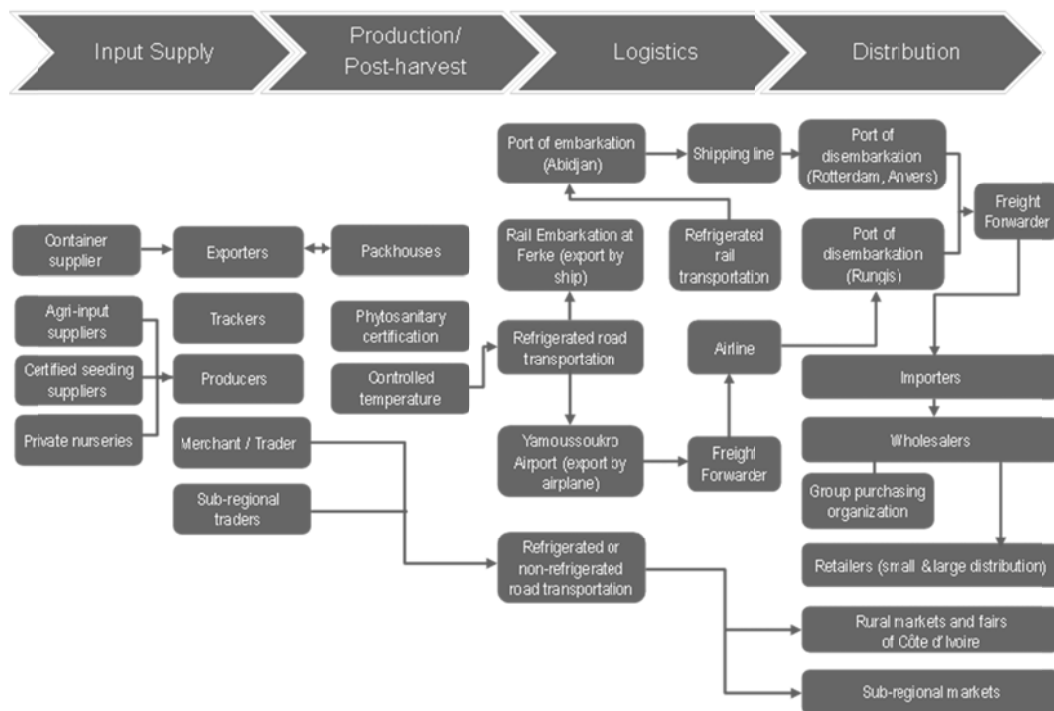

Source: Centre du Commerce International, April 2012, "Côte d'Ivoire – Etude nationale mangue"

Figure A.4.1 Supply Chain of Fresh Mango in Côte d'Ivoire

Whereas the major importing countries are European countries including Belgium, France, United Kingdom and Netherlands, Ghana has almost the same or even greater volume of imports than European countries like Spain and Germany.

Table A.4.3 Major Importing Countries of Mango Exported by Côte d'Ivoire (tons)

Importers	2010	2011	2012	2013	2014
World	12,975	11,603	18,879	12,004	23,967
Belgium	0	8,811	13,186	8,005	15,707
France	1,385	2,222	2,713	1,211	2,874
United Kingdom	167	0	322	195	1,913
Netherlands	465	399	1,727	1,708	1,230
Ghana	545	0	200	191	681
Spain	151	80	333	250	681
Germany	54	37	127	92	601

Note: Figures include fresh or dried guavas, mangoes and mangosteens (HS080450)

Source: ITC Trade Map-Trade Competitiveness Map

(2) Processed Mango

1) Main Players

In Côte d'Ivoire, there are some industrial-type companies that process mango by-products, mainly juice and pulp. One of them is Cotivana which has existed since 1945 and specializes in fruit juice production for the national and international markets. However, there have been barriers to entry into the processing sector, including the investment required in terms of technology and know-how, the lack of political will to support the food processing sector, the complexity of the supply of raw materials and a range of other factors such as issues related to logistics and distribution, that still hamper the development of the fruit processing sector in Côte d'Ivoire.

To encourage and facilitate the processing of fresh mango in agricultural organizations, FIRCA has organized mango producers into cooperatives since 2009 with the support of ANADER and succeeded in establishing six cooperatives.

2) Value Chain

The industrial type of mango processing requires securing the supply of raw material in terms of availability, quality and cost. Indeed, the processing companies have contracts with mango producers (preferably groups) who have to respect a set of specifications detailing the product requirements in terms of quality and production method. Those producers involved in the supply chain of the industrial processors are also trained to maintain mango orchards (particularly in the fight against diseases and pests such as fruit fly) and the strict application of specifications.

On the other hand, there is craft type processing of mango juice. The market of this type of product, whose size could not be estimated, is mainly based on commercialization activity that could be described as "nomadic", that is to say not having fixed sales premises but based on a system of roadside sellers.

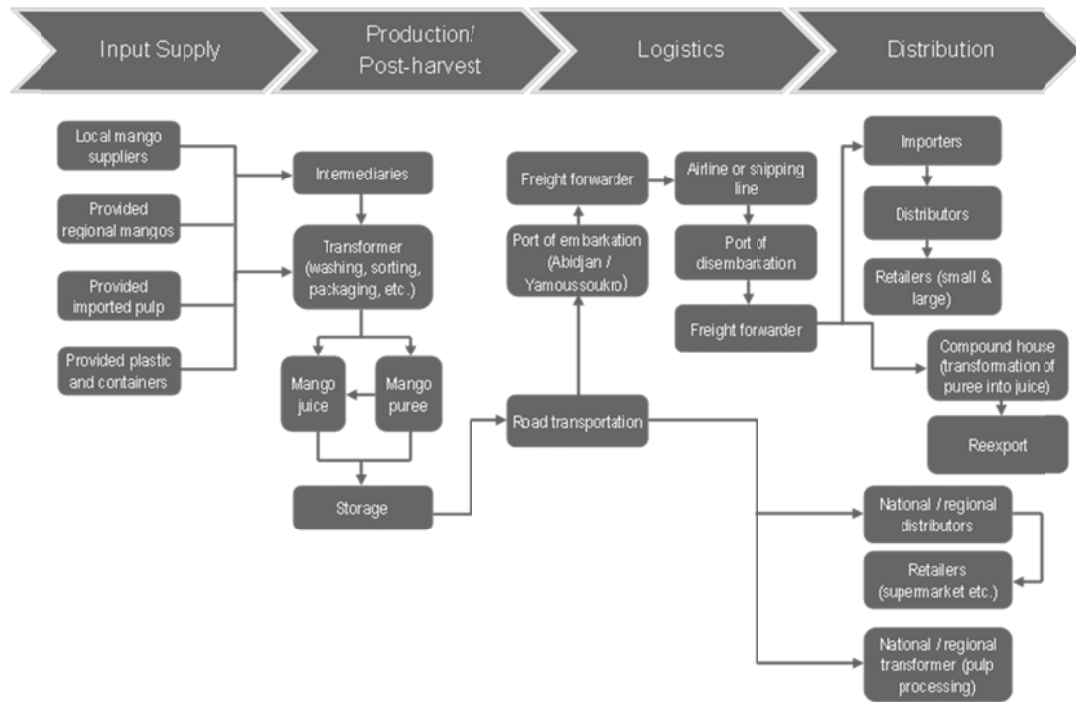

Source: Centre du Commerce International, April 2012, "Côte d'Ivoire – Etude nationale mangue"

Figure A.4.2 Supply Chain of Processed Mango in Côte d'Ivoire

3) Case of Mango Processing: Establishing Mango Processing Units for Cooperatives in Northern Region²⁸

FIRCA installed mango drying units in the six cities in the northern region in Côte d'Ivoire during 2015 to 2016. FIRCA imported drying units from South Africa and provided them to the cooperatives in Korhogo, Boundiali, and Ferkessedougou in 2015 and Sinématiali, Tingréla, and Odienné in 2016. FIRCA has financed the cost for purchasing, transporting and installing the units and provided working capital for one year, as well as providing technical training for operation. The cooperatives also financed some part of the capital expenditure. The cooperatives aim to process 30 % of the mangoes that are lost in the post-harvest phase. The processing unit in Korhogo will produce 1.8 tons of dried mangoes every 18 hours during the season. Products are purchased by a South African firm "Dryer for Africa" and delivered to the world market.

A.4.3 Issues of Mango Value Chain in Côte d'Ivoire²⁹

(1) Fresh Mango

The characteristics and bottlenecks of the fresh mango value chain in Côte d'Ivoire are as follows:

- One of the major constraints is the difficulty of applying good agricultural practice to be able to meet the specifications required from the markets (appropriate use of chemical inputs, irrigation and orchard maintenance, fight against pests and diseases, harvesting techniques and handling, etc.).
- Controlling the cold chain from product harvest to delivery inside the supermarket is one of the most critical operations of the supply chain of fresh mango over long distance. Ivorian mango exporters have a major logistical advantage in this regard because of the presence of a railway adapted for refrigerated transport connecting the north production zone (between Odienné and Ferkessedougou) to the Port of Abidjan.
- The main challenge is to harvest the fruit while unripened in order to arrive at the destination

²⁸ Based on an interview with the program manager of FIRCA and FIRCA website (<http://firca.ci/blog/mangue-sechee-marche-de-20000-tonnes-a-pouvoir-firca/>).

²⁹ Centre du Commerce International, April 2012, "Côte d'Ivoire – Etude nationale mangue"

markets ready for consumption. With regard to shipments by air, it is necessary to obtain a premium or high quality of mango to cover the expensive transportation fee, and to transport the products to the fruit terminal of the Yamoussoukro International airport maintaining the quality and appearance of the products.

- There is no apparent formal criteria for quality standards for the fresh mangoes prior to their admission to the market as required on the international market.
- While domestic consumption is estimated at about 50,000 tons per year, production is above 100,000 tons per year with post-harvest losses estimated between 30,000 tons and 40,000 tons per year. Huge losses recorded after harvest are due to lack of storage facilities or processing of mangoes in the premises or places near production, the high cost and lack of adequate and immediate transfer means to markets and areas of large consumption. Moreover, the absence of passable roads and means of transport necessary for routing of mangoes to the consumer regions are bottlenecks in the supply chain.
- The cost of transportation and high profit margins because of numerous intermediaries and road harassment, are partly responsible for the bad coverage for mangoes in the country. The distribution is so poorly organized and many parts of the country seldom or never consume mangoes from the north because of their excessive prices, except for those in large consumption centres located along the main road from Abidjan to the production areas.

(2) Processed Mango

The characteristics and bottlenecks of the processed mango value chain in Côte d'Ivoire are as follows:

- The quality and availability of packaging are a concern for the actors, as well as material mango availability. There is a lack of quality packaging suppliers who meet the food standards. Glass containers are not easily accessible and orders outside are very expensive and make them uncompetitive.
- There are a number of constraints in production including low mastery of technology and processing methods, deficiencies in terms of food safety, quality assurance, management and marketing, and heterogeneity of the product quality. The acquisition of modern operational units responding to sanitary standards are not within the reach of processors because they require a large investment.
- Marginal consumption of products of mango processing is salient for the juice. The design of product presentation is basic, unattractive and not diversified enough.
- Access to business finance is a key constraint in this sector.

A.4.4 Future Prospects of Mango Value Chain in Côte d'Ivoire

(1) Fresh Mango

Côte d'Ivoire produces about 100,000 tons of mangoes per year, of which 10% to 15% is exported. There are large orchards of traditional mango plantations and some modern types, and these orchards are mainly concentrated in the northern region of the country, especially in areas of Korhogo, Sinématiali and Ferkessédougou with each having an area of 2,000 hectares, Boundiali with an area of 200 hectares, and Odienné with an area of 150 hectares. Bouaké with about 1,500 hectares produced traditional varieties. These areas are very favourable for the cultivation of mango because of the good alternation between dry seasons and wet seasons³⁰.

³⁰ Centre du Commerce International, April 2012, "Côte d'Ivoire – Etude nationale mangue"

Although small village plantations with average 2 to 3 hectares provide more than 90% of the local supply of fresh mango and some producers are abandoning or destroying mango orchards to shift to other more profitable crops such as cashew, most of them are still confident and the industrial-type plantations with over 60 hectares are participating in the national production of mangoes³¹.

With regard to the demand aspect, world import of mango continues to grow and the growing middle class in Côte d'Ivoire and other West African countries in the various urban centres are looking for affordable quality of mangoes.

Therefore, if the fresh mango producers in Côte d'Ivoire could meet the specifications required from the markets and the traders/exporters could reduce the huge volume of post-harvest losses by preparing cold storage, the value chain of the Ivorian fresh mango would be strengthened and add more value.

(2) Processed Mango

The import of fruit and vegetable juice including mango by Côte d'Ivoire has increased nearly six fold during 2005 to 2012.

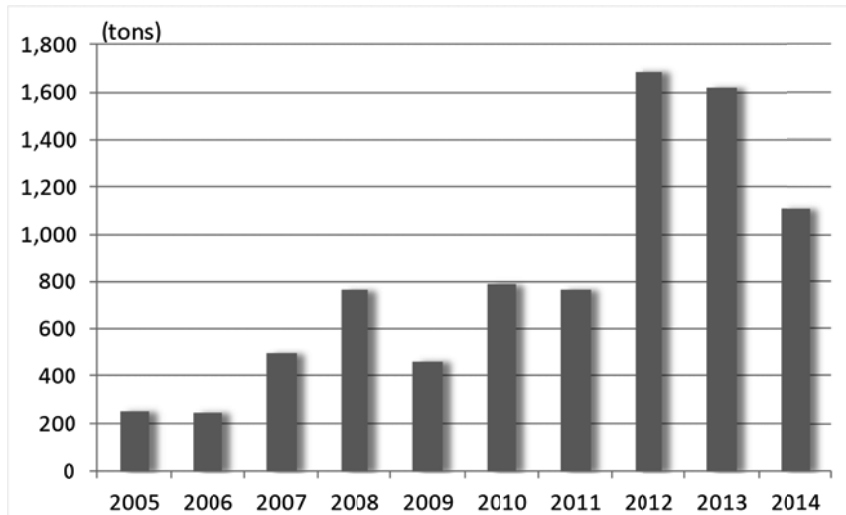

Note: Figures include juice of fruit or vegetables, unfermented, whether or not containing added sugar or other sweetening matter (HS200980)

Source: UN COMTRADE

Figure A.4.3 Import of Fruits Juice in Côte d'Ivoire

According to a study by FIRCA in 2009, on the basis of 400 people accustomed to shop in supermarkets in big cities, 84% of the population consumes mango in its fresh form. This study reveals that the mango jam and mango juice are the products that are most requested by consumers³².

Therefore, there is a good opportunity for the mango industry in Côte d'Ivoire, although it has limited processing capability, to supply such processed mango products to the domestic and regional markets. It could also seek an opportunity to export to the European market when it is developed to the level in which it can take advantage of a good reputation as a fresh mango exporting country. However, it should be noted that, like the fresh mango case, it should meet the specifications required from the markets and should reduce the huge volume of post-harvest losses. In addition, a substantial amount of investment is needed to acquire modern operational facilities, technologies and sales channels, etc. It may take medium to longer term even for the cooperatives that have advantageous positions in the mango processing in Côte d'Ivoire to develop the business.

³¹ *Ibid*

³² Centre du Commerce International, April 2012, "Côte d'Ivoire – Etude nationale mangue"

A.4.5 Future Prospects based on Sub-Regional Development Strategies

Development of the Abidjan-Ouagadougou Corridor with cold chain logistics will contribute to strengthen and add value to the Ivorian fresh mango value chain. The cities with the conditioning stations along the corridor, namely Korhogo, Ferkessédougou and Sinématiali, will be the logistics centres of fresh mango trade even in the short term based on the premise of the above mentioned conditions.

A.4.6 Main Players and Value Chain in Ghana³³

(1) Fresh Mango

1) Main Players

Actors involved in the fresh mango value chain include producers, input suppliers, exporters, logistical service providers and other key stakeholders involved in the distribution of the product to final consumers.

Major fresh mango producers include: Farm Management Services Limited (FMSL) in Somanya in the Eastern Region; Yilo Krobo Mango Farmers Association, whose member farms are scattered around Dodowa, Ssomanya and the surrounding districts; Volta Mango Growers Association (VOMAGA) in the Volta Region, around Juapong and Fojuku, south of the Volta Lake; Papaya and Mango Producers and Exporters Association of Ghana (PAMPEAG), which is an association of privately owned companies specializing in the production of premium fresh papaya and mangoes; Blue Skies Limited-fresh cut, which was established to prepare, pack and export pineapples for the UK market and mangoes were incorporated into its portfolio in the course of its operations; and Integrated Tamale Fruit Company (ITFC) in Gushie, within the Savelugu Nanton District of the Northern Region, with operations in four districts (Savelugu Nanton, Tolon Kunbunu, Karaga and West Mamprusi). ITFC has presently shifted its business portfolio to production of dried mango due to some challenges in exporting fresh mango to the international market³⁴.

Major input suppliers (agri-chemical providers) include Dizengoff Ghana Limited, YARA Ghana Limited, Sidalco Ghana Limited and Wienco Ghana Limited. Among them, Wienco has established ITFC as a subsidiary company to develop organic mango production³⁵.

Public institutions in Ghana have also played important roles in fresh mango production. Ghana Export Promotion Authority (GEPA) has been intervening in the mango sector over the years by reclaiming the area of nursery development and trade promotion activities. The Export Development and Investment Fund (EDIF) provides financial resources for the development and promotion of Ghanaian exporters. In 2009, EDIF embarked on a “National Mango Plantation Development Project” aiming at developing 20,000 acres of mango plantation by 2013 in the savannah and transitional zones of the country i.e Brong Ahafo, Northern, Upper East, Upper West, Ashanti and Volta Regions. As of 2011, a total of 11,400 acres have been supported by the project.

2) Value Chain

Mango is either processed or packed fresh (fresh cut) either for the local or the international market place. If the fruit is to be exported as fresh, it has to go through several steps to ensure that it meets international market standards and access requirements. Harvested fruits are transported to a bulking point and then to pack houses where the fruits are washed, disinfected, waxed, graded, boxed, palletized and then pre-cooled from a temperature of about 32 degrees Celsius to about 9 degrees Celsius. The fruits are then packed in reefer containers at the same temperature of 9 degrees Celsius and taken to Tema Port³⁶. The containers are plugged on the vessel carrying the products to the

³³ This section is based on the analysis of the International Trade Centre, “Ghana – National Mango Study”, April 2012.

³⁴ Based on an interview with the general manager of ITFC in July 2016.

³⁵ Wienco had already withdrawn its capital from ITFC when it was taken over by RMG Concept Ltd, a large agri-chemical provider in the West Africa region.

³⁶ Located in Tema Port and managed by the Federation of Associations of Ghanaian Exporters (FAGE) and Golden Exotics, a leading banana and pineapple producer in Ghana, Shed Nine Fruit Terminal became operational in 2009 to serve as a transit point prior to the shipment of fresh horticultural produce to the destination market.

destination market. If the fruits are to be air freighted, mangoes are harvested at a later period when the fruits are ready to be consumed within the next few days using a more costly air logistic to cater for foreign markets.

Major importing countries of the Ghanaian mangoes are Lebanon and countries in the EU. Among these, Lebanon is obviously an important destination for Ghanaian mangoes. According to industry sources, the majority of mangoes are sent by a single operator within Ghana, and the product is being processed in Lebanon. However, no clear assessment has been conducted in order to understand the Lebanese consumers' tastes and preferences or to determine the possibility of Lebanon to become a market diversification platform for the Ghanaian mangoes.

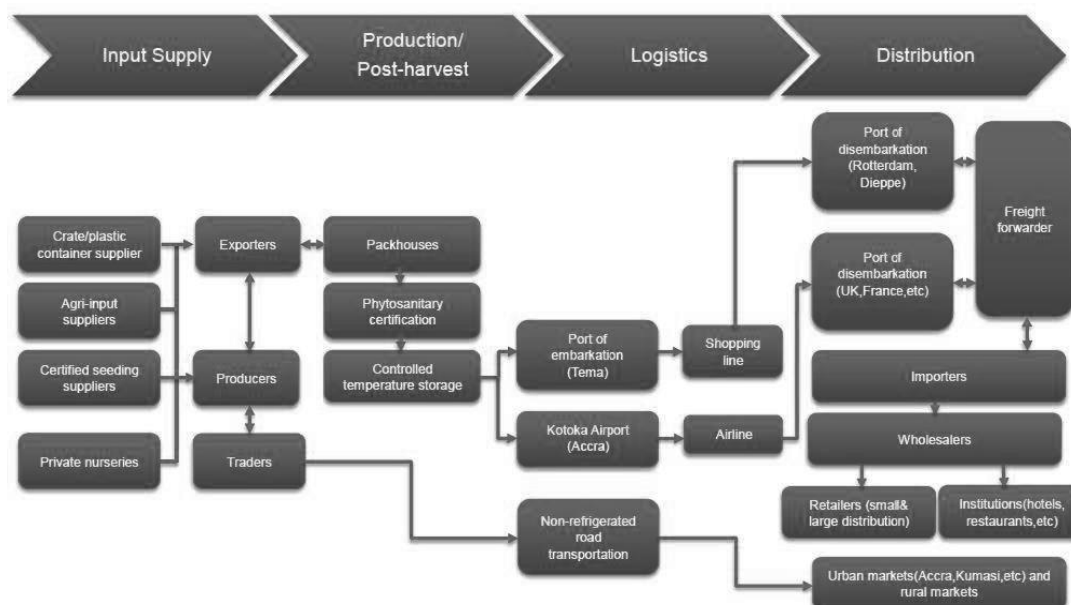

Source: International Trade Centre, April 2012, “Ghana – National Mango Study”

Figure A.4.4 Supply Chain of Fresh Mango in Ghana

Table A.4.4 Major Importing Countries of Mango Exported by Ghana (tons)

Importers	2009	2010	2011	2012	2013
World	332	8	628	826	1,054
Lebanon	0	0	99	431	591
United Kingdom	0	0	78	60	140
Netherlands	20	0	25	122	96
Italy	0	8	32	41	60
Kuwait	0	0	10	12	51
Belgium	53	0	217	55	35
Libya, State of	0	0	2	0	32
Germany	0	0	93	1	22
Saudi Arabia	0	0	0	0	13
Canada	0	0	0	0	7
France	0	0	0	0	4
United Arab Emirates	0	0	44	62	2

Note: Figures include fresh or dried guavas, mangoes and mangosteens (HS080450)

Source: ITC Trade Map-Trade Competitiveness Map

Problems abound at every stage of the mango value chain including production, harvesting, post-harvest handling, distribution and logistics and quality management. Consumers, especially in Europe and North America, are becoming more concerned about the safety of the food that they consume and the very manner in which this food has been produced.

(2) Processed Mango

Main Players and Value Chain

Processed mango products in Ghana mainly consist of mango juice and dried mango. The major players (producers) of these products are as follows.

Mango Juice

- Sunripe Food Processing Company Ltd.

Incorporated in 1994 in Accra, Sunripe Food Processing Company processes freshly harvested local fruits into juice, pulp, puree, smoothies and pineapple cylinders for the local market. The company can process pineapple, mango, watermelon, pawpaw and passion fruits, with a processing capacity of 20 tons of juice per day. The company has PET blowing machines in-house. The bottles are blown directly onto the production line thus minimizing cost and contamination.

- Blue Skies

Blue Skies started its operations in Ghana in 1998, as a subsidiary of Blue Skies Holdings Limited based in the United Kingdom, by setting up a factory in the southern part of Ghana to prepare, pack and export pineapples to the UK. In the course of its operations, the company incorporated mangoes into its portfolio of services and has pioneered the growth of mango farming in the Eastern Region of Ghana. Blue Skies also imports mangoes from various countries including Brazil, Burkina Faso, South Africa and Senegal. It currently supplies 100 percent of its fruit products to some of the biggest supermarket chains in Europe and South Africa.

Dried Mango

- Integrated Tamale Fruits Company Ltd., Ghana (ITFC)³⁷

Since incorporation in 1999, ITFC has been operating in the Savelugu-Nanton District of the Northern region of Ghana. ITFC runs a company farm (about 160 hectares) with approximately 250 employees and works with over 1,300 small scale outgrower mango farmers by providing technical assistance and inputs (seeds, water, fertilizer, etc.) as interest-free loans that are only paid back when the trees begin to bear fruit. Although ITFC has aimed to produce 12,000 to 17,000 tons of organic mangoes per year to export to European markets, it is producing less than this amount and is instead processing dried mangoes for export due to some technical challenges. Mangoes for drying are also obtained from various locations including Burkina Faso.

- Ebenut Company Limited

Since its establishment in 1996 at Weija in the Greater Accra region, Ebenut Company has been known locally for its range of dried fruits and vegetables, notably dried mangoes, pineapple, citrus, coconut and a blend of mango and coconut or a mixture of mango, pineapple and coconut. Having operated in the local market for a while, the company is making efforts to expand its exports into the ECOWAS region. It exports the dried mangoes, originating from Dodowa, Akosombo (Akonadi), to Switzerland and Germany, and usually exports about 20 tons per year.

The mango juice supply chain in Ghana has been virtually established by two processing companies. They buy mangoes from reliable and reputable farmers or farmer groups, especially those that are Global GAP certified. The pre-inspection of the mango orchards by agronomists of the various juice processing entities is conducted to ensure that the mangoes to be harvested are disease / pest-free and they are of good quality. After the product has been harvested, it is conveyed to the factory for sorting and subsequent processing.

The value chain of dried mango is rather simple. Inputs are obtained from producers, after export grade mangoes have been selected, and then transported to the processing enclave where mangoes are sliced and dried using ovens.

³⁷ Based on the UNDP, "Integrated Tamale Fruit Company: Organic Mangoes Improving Livelihoods for the Poor", Case Study, Growing Inclusive Markets, September 2007 and an interview with the general manager of ITFC in July 2016.

A.4.7 Issues of Mango Value Chain in Ghana³⁸

(1) Fresh Mango

The characteristics and bottlenecks of the fresh mango value chain in Ghana are as follows:

- While the European market is divided into various market segments with different price and quality ratios, the Ghanaian growers do not have a strategy that is adapted to suit these markets in terms of diversification or individual cultivation decisions, and in terms of variety selection to be cultivated.
- Exporters are also facing challenges in the area of marketing including:
 - Stringent sanitary and phytosanitary requirements in the market destinations,
 - Change in taste and preferences of the import market,
 - Lack of trust between importers and exporters,
 - No reliable and powerful institution or entity to represent the interests of the exporters in the destination market,
 - Lack of management capacity,
 - Limited knowledge of the segmented nature of the European markets, particularly the organic mango market.
 - The local market is small. Poorly developed local market, particularly with respect to cushioning the effects of overproduction or lack of exports,
 - Poor infrastructure, especially bad nature of the road network, still impacts negatively on the quality of mangoes,
 - Unadapted trucks used in transporting mangoes from farms to pack houses,
 - Lack of refrigeration facilities resulting in losses and inferior product quality,
 - High freight charges due to low export volumes arising from low product quality,
- There are some challenges in the area of cultivation and post-harvest losses (estimated between 20 and 50 %) including:
 - Cost and availability of inputs including fertilizers,
 - Lack of knowledge and timely intervention by extension officers,
 - Cost of seedlings,
 - Farmers rely on natural rainfall due to lack of irrigation equipment,
 - Damages due to road conditions, inadequate transportation material, poor packing into crates, and product mishandling during loading and unloading operations,
 - Cold-chain management does not start immediately after fruit picking,
 - Harvesting methods of small-scale farmers vary greatly.
- Although adequate packaging is essential for exports and to meet the European and United States' norms and dimensions, the quality of local packaging is inferior compared with the packaging imported from South Africa and Europe.

(2) Processed Mango

The major problem encountered by juice processors are:

- Inadequate supply of mangoes as well as quality and reliability of supply of fresh mangoes
High cost of transporting the fruits; high cost of energy and power fluctuation
- The cost and availability of preforms and other packaging materials.

³⁸ International Trade Centre, April 2012, "Ghana – National Mango Study"

On the other hand, the major challenge dryers are facing has to do with the cost of operating the ovens. Cost of energy has been identified as the major cost when it comes to oven operations. Another challenge is related to securing markets for the dried mangoes.

A.4.8 Future Prospects of Mango Value Chain in Ghana

(1) Fresh Mango

Although mango trees can be found all over Ghana, commercial production is mainly found in two distinctive agro-ecological zones: northern Ghana around Tamale and southern Ghana (Greater Accra, Eastern and Volta Regions). Half of the production (close to 20,000 tons) is located within the Eastern Region on more than 5,200 hectares, while Brong-Ahafo and Greater Accra produces respectively 18% and 16% of national mango outputs. It is estimated that of the total mangoes produced in the country, export grade constitutes about 10%, whilst 25% is lost due to post-harvest methods.

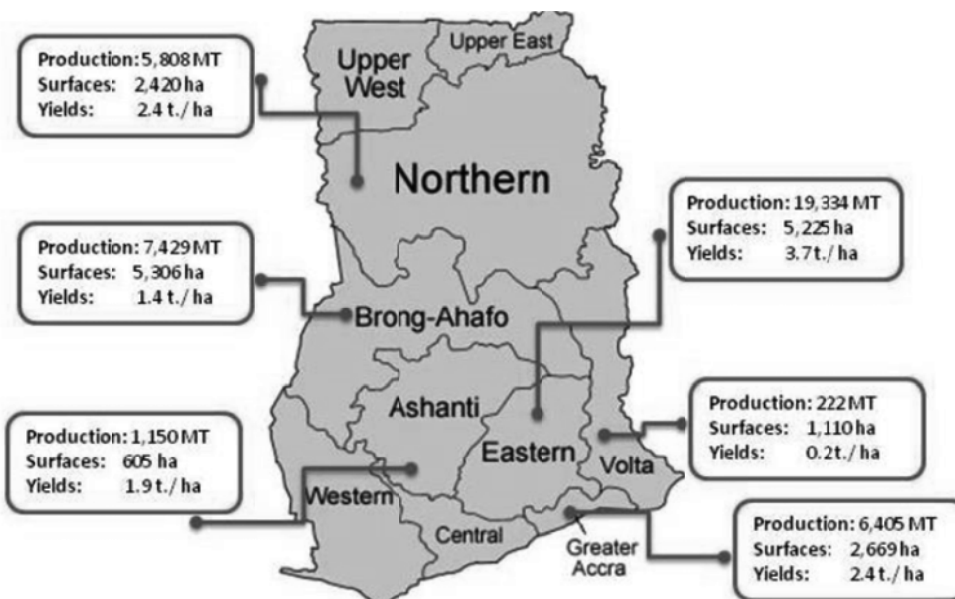

Source: International Trade Centre, April, 2012, "Ghana – National Mango Study"

Figure A.4.5 Mango Production in Ghana (based 2009-2010 figures)

Ghana's unique climate provides two seasons, a short one December to February complement the traditional April to July production period. Whilst volumes peak between June and July, lean periods hover from the end of April / beginning of May and then August and early September. Furthermore, Ghana grows a number of mango varieties, however the vast majority is made up of Keitt (approx. 80% or 24,000 tons) and Kent (approx. 10% or about 3,000 tons), the other fourteen varieties (Palmer, Tommy Atkins, Zill, etc.) amount to very low quantities. These varieties of seasonality and mango provide Ghana with comparative advantage against neighbouring countries, although the production in Ghana used to lag far behind that of those countries.

Mango in Ghana also has some unique comparative advantages over cocoa, palm oil and citrus production. Statistics show that citrus has a break-even point of 7 years, cocoa 8 and palm oil 10, while mango has a break-even point of 5 years. Acknowledging that surfaces and production figures involved can greatly vary, in terms of export earnings, currently, the yield per acre for cocoa stood at more than 1,000 Ghana Cedis; citrus, 1,500 to 2,500 Ghana Cedis but mango ranges between 2,500 and 4,000 Cedis.

Regarding the demand aspect, the major market for Ghana's mango export is EU, whose mango imports are still growing. In addition, urban consumers in West Africa are becoming richer and more conscious of healthy living, and Accra represents an immediate opportunity compared to foreign markets. Moreover, it should be noted that Ghana has been importing a certain amount of fresh mangoes every year in order to meet processing companies' year-round demand.

Considering these strengths and opportunities of/for the Ghanaian fresh mangoes, the value chain would be strengthened and add more value, for when the producers and traders/exporters of fresh mango in Ghana can meet the specifications required from the markets and overcome some of the bottlenecks they are facing.

(2) Processed Mango

The mango juice sector remains modest in Ghana when compared to other African countries such as Nigeria, South Africa or Egypt. While the processing capacity is estimated to be in the order of 20,000 to 30,000 tons of finished product, it is expected that increased market demand in the West Africa region will lead to further expansion of the fruit juice industry in Ghana.

The dried mango segment in Ghana is not yet popular in terms of both consumption and exportation. As the awareness of dried mangoes is created locally, it can be expected that demand will eventually grow and attract more operators in the sector. While export opportunities for dried tropical fruit in Europe are small compared with fresh-cut and juices, supply capacity of dried mango in Ghana is far short of meeting the demand. At the same time, GEPA has embarked on proactive market diversification strategies in the Maghreb and the Middle East, where fruit consumption is high, especially during the month of Ramadan. It is estimated that Ghana has the capacity to produce and export more than 100 tons of dried mangoes yearly.

A.4.9 Future Prospects based on Sub-Regional Development Strategies

Development of the Accra-Ouagadougou corridor with cold chain logistics will contribute to strengthen and add value to the Ghanaian fresh mango value chain. Tamale, Kumasi and Tema will be the logistics centres of the fresh mango trade. It might take, however, middle to long term when the current value chain of Ghanaian mango industry is considered.

A.5 Livestock and Poultry

A.5.1 Present Situation of Livestock & Poultry Value Chain

Production and Trade

While the number of livestock (cattle, goats and sheep) in West Africa has been continuously increasing since the middle of the 2000s and exceeded 300 million, the volume of export and import is quite limited, less than 1% of the stock.

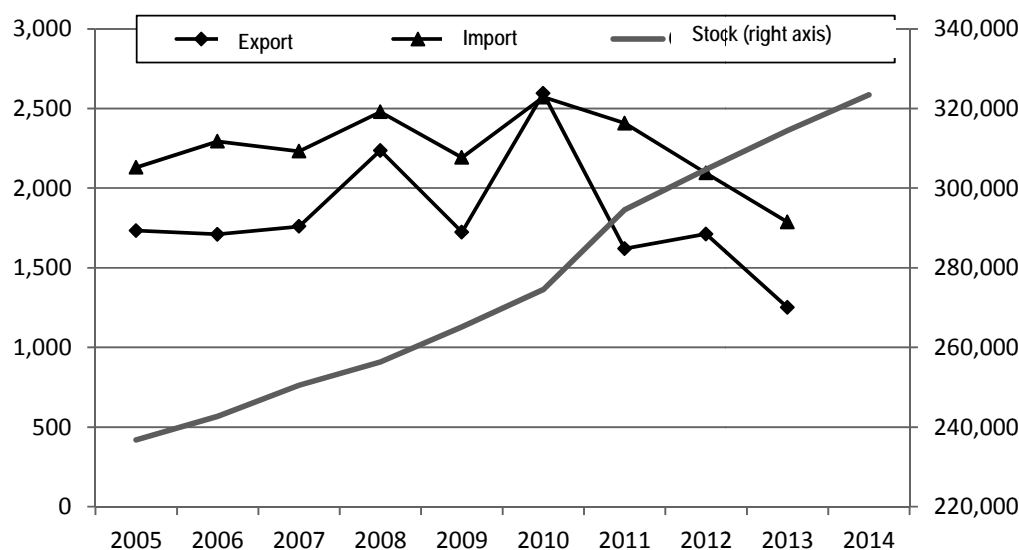

Note: Livestock included cattle, goats and sheep.
Source: FAOSTAT

Figure A.5.1 Stock, Export and Import of Livestock in West Africa (1,000 heads)

The biggest livestock holder in the region is Nigeria, which has more than 1/3 of the regional stock and imports around one million head every year. The followers are Mali, Niger, Burkina Faso, which are the major exporting countries in the region. Ghana has more than 10 million stocks, but is a net importing country as with Côte d'Ivoire and Senegal.

Table A.5.1 Stock, Export and Import of Livestock in Major Countries in West Africa (1,000 heads)

	Burkina Faso			Côte d'Ivoire			Ghana		
	Stock	Export	Import	Stock	Export	Import	Stock	Export	Import
2005	25,364	490	7.9	4,194	0.0	329	8,507	7.7	206
2006	26,049	430	12.7	4,278	0.0	352	8,670	9.2	202
2007	26,753	370	10.5	4,363	0.0	244	8,989	9.1	210
2008	27,476	325	0.3	4,451	0.0	225	9,326	0.4	205
2009	28,220	291	0.0	4,551	0.0	148	9,705	0.5	200
2010	28,984	274	0.1	4,598	0.1	157	10,068	0.8	109
2011	29,770	293	0.1	4,615	0.0	147	10,522	2.1	175
2012	30,577	225	0.7	4,631	0.0	124	10,997	0.0	135
2013	31,407	34	0.1	4,690	0.0	0	11,497	0.0	36
2014	32,259			4,727			12,036		
	Guinea			Mali			Niger		
	Stock	Export	Import	Stock	Export	Import	Stock	Export	Import
2005	6,321	26	3.0	27,853	345	7.0	27,766	534	0.6
2006	6,699	25	4.7	27,940	208	7.0	28,978	718	0.1
2007	7,099	25	10.2	30,398	334	7.0	30,245	617	0.3
2008	7,524	31	15.6	31,496	593	7.0	31,570	1,001	0.1
2009	7,974	31	15.6	32,918	374	7.0	32,957	692	0.1
2010	8,656	30	16.0	35,932	325	7.1	33,457	1,630	0.1
2011	9,175	31	14.3	37,551	260	7.2	32,803	704	0.0
2012	9,725	31	14.6	39,245	565	0.0	34,256	561	0.1
2013	10,309	31	14.6	41,019	529	0.1	35,777	325	0.2
2014	10,525			42,875			37,369		
	Nigeria			Senegal			Togo		
	Stock	Export	Import	Stock	Export	Import	Stock	Export	Import
2005	97,382	0.3	908	12,098	0.1	557	3,850	0.1	16.4
2006	99,527	0.0	1,028	12,397	0.0	569	3,972	0.1	15.1
2007	101,721	0.0	967	12,625	0.0	661	4,033	0.0	16.5
2008	103,968	0.0	1,302	12,938	0.3	580	4,085	0.0	0.4
2009	106,268	0.0	963	13,242	0.0	684	4,232	0.0	0.2
2010	108,622	0.0	1,435	13,639	0.0	710	4,333	0.0	0.6
2011	124,710	0.0	1,074	13,748	0.0	850	4,382	0.2	1.1
2012	127,517	0.0	853	14,304	0.0	830	5,105	0.0	0.3
2013	130,392	0.1	859	14,710	0.0	750	5,371	0.0	0.3
2014	133,336			14,244			5,609		

Note: Livestock included cattle, goats and sheep.

Source: FAOSTAT

The coastal countries of West Africa have a deficit in meat production and depend on imports of live animals from the Sahel region and imported meat from outside of the continent. The West Africa region can be divided into three broad trading areas: the Eastern Trade Corridor (Benin, Chad, Niger, and Nigeria), a Central Trade Corridor (Burkina Faso, Benin, Côte d'Ivoire, Mali, Ghana, and Togo), and the Western Trade Corridor (Mali, Mauritania, Senegal, Gambia, Guinea Bissau, Guinea, Liberia, Sierra Leone, and Cape Verde)³⁹.

The number of poultry (chickens) has also almost steadily increased in West Africa, exceeding 500 million. Nigeria has the largest number, followed by Ghana, Côte d'Ivoire and Senegal. While the production of eggs in the region has been increasing, the production of indigenous chicken meat has failed to increase.

³⁹ USAID West Africa, May 2014, "Trade Hub and African Partners Network: Value Chain Assessment Report: Livestock-Cattle"

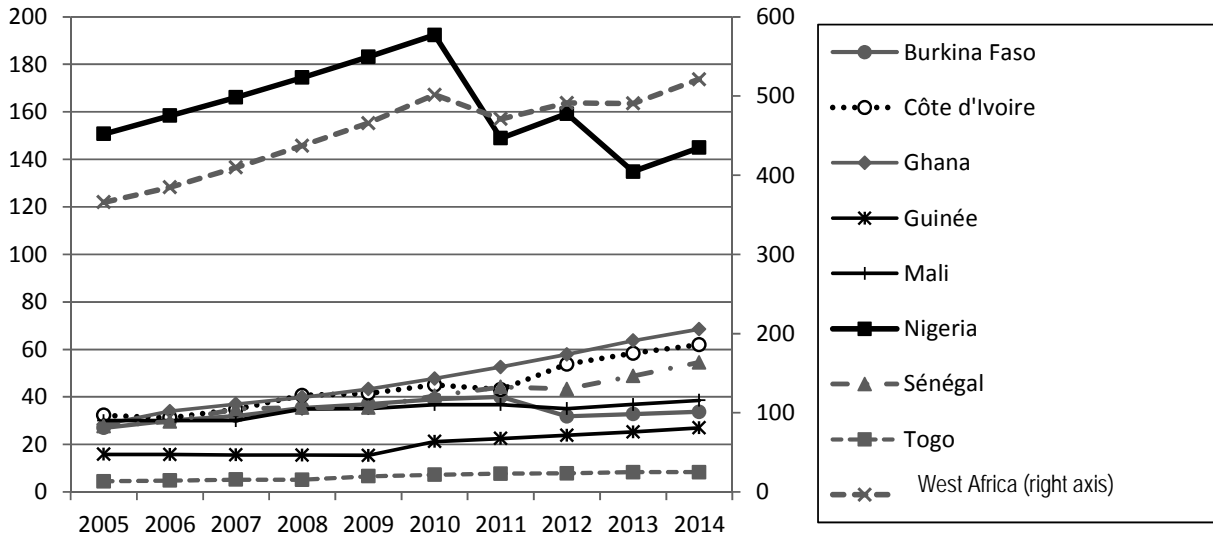

Source: FAOSTAT

Figure A.5.2 Stock of Poultry in West Africa (millions of chickens)

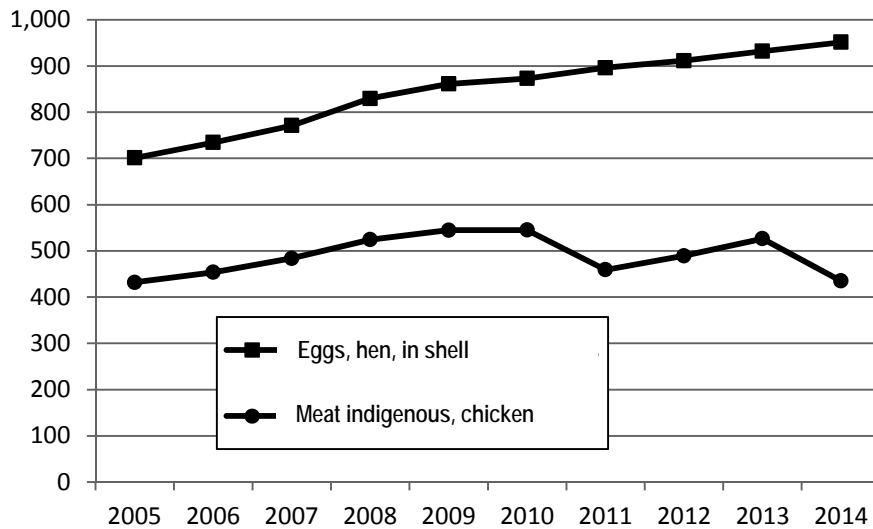

Source: FAOSTAT

Figure A.5.3 Production of Chicken Meat and Eggs (1,000 tons)

Due to the outbreak of avian influenza (AI) in West Africa region 2006-2008, most cross border poultry trade has been officially banned. However, unofficial trade still occurs at a diminished level.⁴⁰

Figure A.5.4 shows the trade flow of poultry in West Africa. In general, day-old chicks tend to move from coastal hatcheries to the Sahel countries while traditionally raised live chickens are exported to coastal nations.

⁴⁰ J.E. Austin Associates. Inc, "Market Opportunities for Poultry Investments in Burkina Faso and Mali", July 2010.

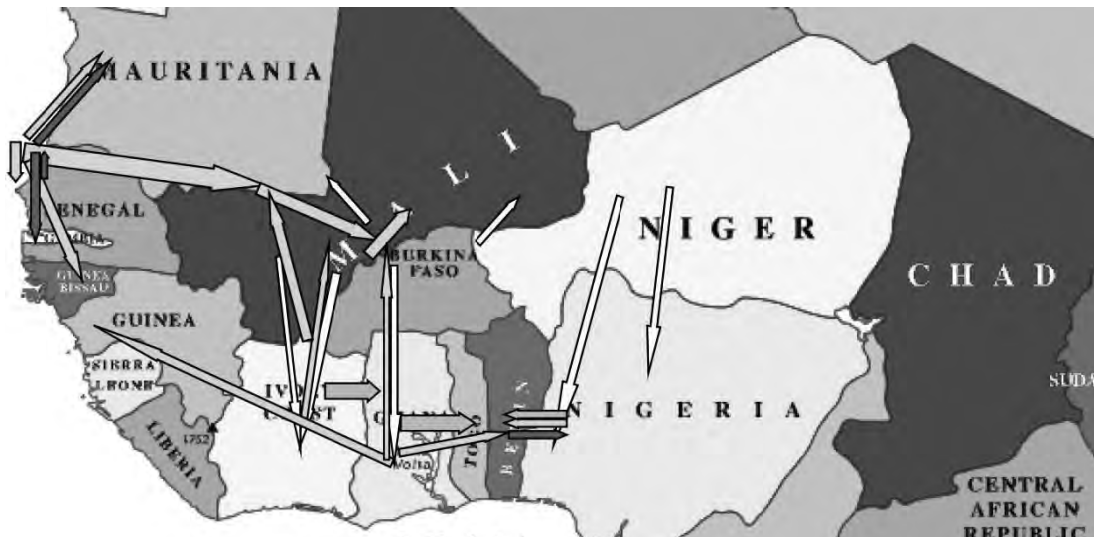

Source: J.E. Austin Associates, Inc (2010)

Figure A.5.4 Poultry Trade Flows in West Africa

A.5.2 Main Players and Value Chain

Main players in the livestock (mainly cattle) value chain and their relationships are as follows:⁴¹

- **Producers:** Generally producers in West Africa are divided into two groups. The traditional producer sells his animals without ever providing them with special feed. A modern producer (or cattle fattener), who is considered a commercial operator, expends a substantial amount of money in order to provide good feed to the animals so as to get a better price.
- **Collectors:** They attend cattle markets to purchase ruminants (cattle,) or their products (hides). They generally work for traders and receive commissions from their ‘employers’, and do not have the financial means to engage in trade on their own account.
- **Traders:** Thousands of major traders are engaged in different aspects of the livestock value chain. A live animal market includes the seller (herder or smaller trader), the broker-dealer (selling on behalf of the seller) and the buyer (larger trader or butcher). Negotiations are based on trust and sealed with a verbal commitment.
- **Middlemen:** These actors ensure transactions, interface between sellers and buyers, host exporters, and save those players time and money when checkpoints proliferate on the Côte d’Ivoire route. The presence of middlemen who operate in the informal sector contributes to increasing prices rather than facilitating trade, because they increase transaction costs of shipping livestock to the coastal countries.
- **Meat Products Wholesalers:** These actors slaughter a number of head a day to sell to retailers, butchers, and restaurateurs
- **Retail-slaughters:** These actors do not have large operations, but they slaughter small quantities every day for direct sale to the market. Some members of this group operate shops where they sell grilled meat (dibiteries) or have traditional roasting ovens.
- **Retail butchers:** These butchers are small meat retailers in markets in large cities and neighbourhoods.
- **Grillers and dibitiers:** These are mainly small economic actors who do not slaughter the animals. They buy sheep and goat carcasses from wholesale butchers in the large urban centres.
- **Hide and skin collectors and processors:** As for hides and skins, processors can be divided into two categories—cottage-type and industrial. Cottage-type is the traditional processor/trader

⁴¹ USAID West Africa, “Trade Hub and African Partners Network: Value Chain Assessment Report: Livestock-Cattle”, May 2014

of shoes or bags made with sub-products in the local market. Industrial types export hides and skins.

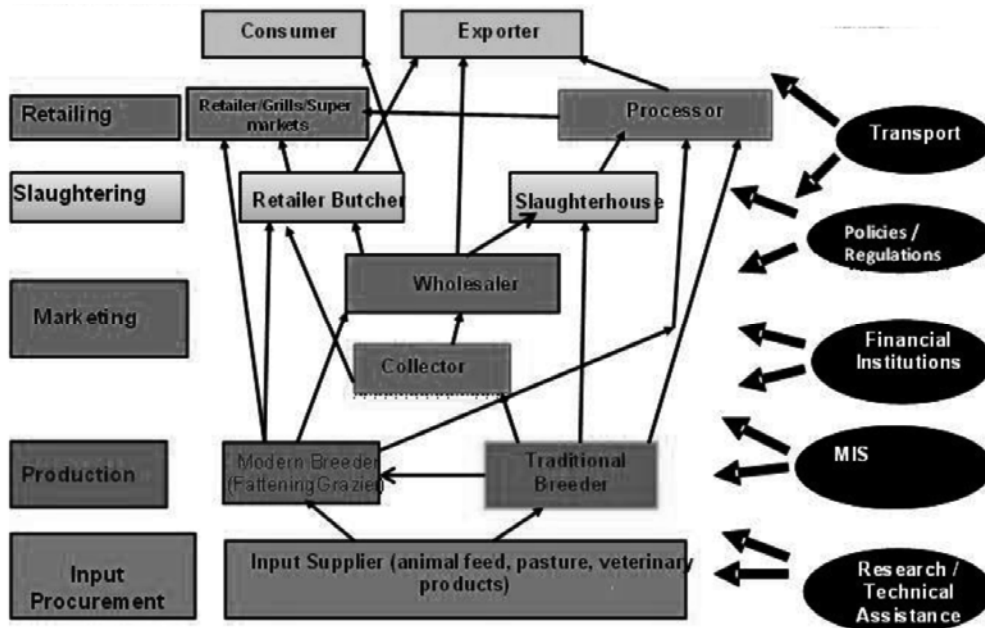

Source: USAID West Africa, May 2014, “Trade Hub and African Partners Network: Value Chain Assessment Report: Livestock-Cattle”

Figure A.5.5 Ruminant Livestock Value Chain of in West Africa

Poultry rearing at the household level plays an important role in income generation and poverty reduction, particularly for poor rural women or where people lack land for crop cultivation or formal skills to participate in income-earning activities. The poultry value chain is affected by (i) reactions to market shocks, or long-term trends in supply and consumer preferences; (ii) price variations (short or longer term); (iii) access to knowledge and emerging technologies; and (iv) lobbies and other groups that can directly influence the dynamics of the value chain.⁴²

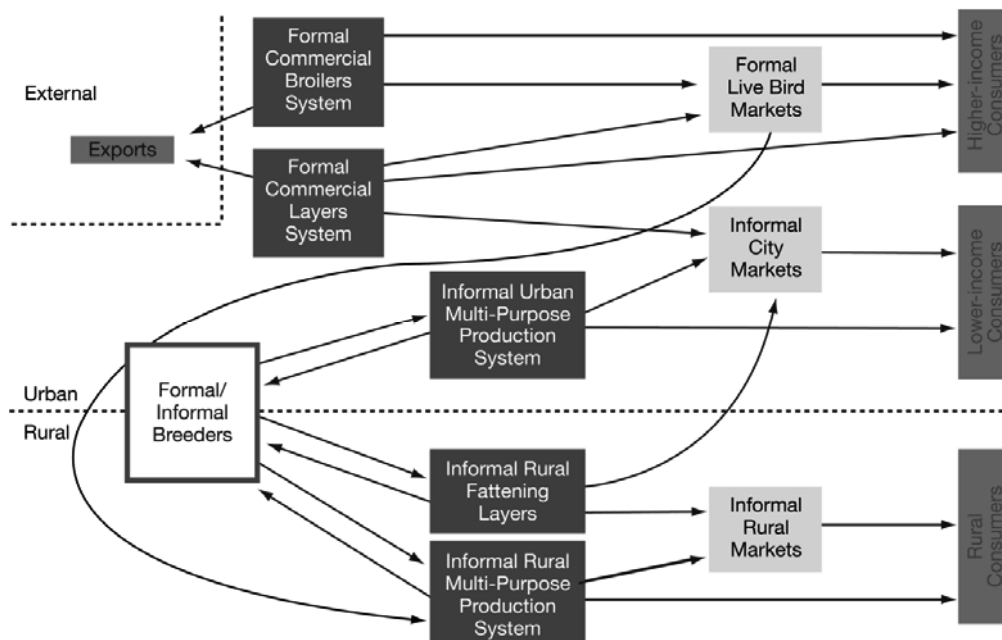

Source: IFAD, 2010

Figure A.5.6 Poultry Value Chain

⁴² IFAD, February 2010, “Value Chains, Linking Producers to the Markets”, Livestock Thematic Papers: Tools for Project Design

A.5.3 Issues of Livestock & Poultry Value Chain

The major constraints that depress the profitability of the marketing of cattle in the region are pointed out as follows:⁴³

- Irregular supply markets, poor infrastructure
- Multiplicity of the number of intermediaries
- Inadequate institutional and regulatory frameworks
- Inadequate marketing facilities and transportation
- Lack of professional dynamism of national operators
- Difficult access to credit
- Lack of reliable information regarding the market
- Gaps in modern business management
- Absence of legislation and standardization of product quality
- Weak efficiency of sub-regional transport of cattle to the market because of lack of means and costs of transport, and lack of professional dynamism of national operators vs. their external competitors.

The following issues are also critical:⁴⁴

- Basic structural factors linked to the informal nature of the region's livestock commercial practices will likely limit the success of a broad-based movement toward formal contracting in the short-term. New and successful business models need to be developed that will modernize the sector and enable it to help drive market-led economic growth for the region.
- Production systems are only loosely linked to market demand. Fundamental limitations on production mean that growing demand is not necessarily sufficient to trigger increased supply.
- Feed resources are limited and are often not found in the same locations as the animals. This constrains efforts to increase exports of quality animals through Sahelian-based feedlot networks.

The restricting issues on the poultry value chain in West Africa are as follows:⁴⁵

- **Inadequate Supply of Day-Old Chicks (DOC) and Eggs-to-Hatch (ETH):** There is significant domestic capacity to produce ETH and DOC in the key coastal producing countries, the Côte d'Ivoire, Ghana and Senegal, but more limited capacity in interior countries (Burkina Faso and Mali). The interior countries import many of their DOC from the EU at high cost; efforts to promote DOC production in Burkina Faso have had mixed results while progress is being made in Mali, which still imports most of its ETH from Brazil via Senegal.
- **Irregular Access to and High Cost of Feed:** Feed is the key cost component in commercial poultry production, along with the investment in broiler or layer chicks. Maize is the principal feed ingredient, although there are some efforts underway to expand tannin-free sorghum production in Mali. Coarse grain prices fluctuate inter-seasonally and inter-annually. As many poultry producers lack access to finance and sufficient storage capacity, they are unable to take advantage of lower post-harvest prices for grain. Other feed ingredients, particularly protein sources such as cottonseed cake, soybean meal, and fish meal, are often expensive and limited in supply or of low quality.
- **Limited Access to Quality Veterinary Products and High Mortality:** Poultry mortality and morbidity are high in West Africa, and there is a long list of diseases that afflict producers. Access to high quality veterinary products (vaccines, drugs) is reportedly uneven, and

⁴³ USAID West Africa, May 2014, "Trade Hub and African Partners Network: Value Chain Assessment Report: Livestock-Cattle"

⁴⁴ USAID West Africa, June 2015, "Trade Hub and African Partners Network: Livestock Value Chain Strategy"

⁴⁵ USAID, November 2011, "Poultry Value Chain Development Plan Updated for FY2012"

biosecurity on smaller commercial farms is often inadequate. Access to veterinary services is also limited, in part a function of privatization of veterinary services that were previously performed by West African governments. Public veterinary services did receive donor support to prevent the spread of AI, but over the past 20 years reduced support and privatization of veterinary services in many African countries has led to a reduction in the numbers of government veterinarians and veterinary service budgets.

- **Limited Access to Finance for Poultry Value Chain Actors:** Many commercial poultry farms in West Africa are entirely self-financed and commercial bank credit is rare. A few farms or firms have tapped into outside sources of funds such as microfinance institutions and grants from donors, but most poultry investments have been funded through income from other sources (such as extended family), and other businesses owned by the poultry farm investors (e.g. construction, transport)
- **Limited Commercial and Hygienic Processing of Poultry:** Nearly all poultry commercialized in West Africa is sold live, in open-air markets. As a live chicken or guinea fowl costs FCFA 1,500 to 3,000, this expenditure represents a significant outlay for many West African consumers, and this limits the opportunities of commercial slaughter in hygienic facilities in cities so that urban consumers can buy whole chickens or chicken parts and offal.
- **Barriers to Intra-regional Trade in Poultry Products:** The main barrier to trade in poultry products is the ban on exports from West African countries that experienced AI outbreaks. Both of these countries and non-AI infected countries have also banned imports. This has led to a significant decline in exports of local breeds of poultry (village chicken and guinea fowl) from Burkina Faso and Mali to coastal countries, although the trade continues in an informal and clandestine way. Trade in DOC and ETH has also been affected, as exports from Ghana and Côte d'Ivoire to Burkina Faso and Mali are not permitted.

A.5.4 Future Prospects of Livestock & Poultry Value Chain

The strengths and opportunities of/ for livestock value chains in West Africa are as follows⁴⁶:

Strengths

- Opportunities for greater efficiency in cattle exporting, if done correctly
- Existence of numerous cattle markets
- Significant levels of Sahelian cattle are sold in the coastal markets.

Opportunities

- Increasingly high demand for cattle meat in local markets
- Opportunities for improving upon sharing the chilled and frozen meat segment market by offering fresher, higher quality Sahel meat
- Governments' commitment and support to increase meat exports
- Individuals engaged in fattening practice
- Farmers' increasing awareness of the number of export abattoirs
- Sub-regional dynamics enable integration to trade in raw products
- A growing enabling environment for the international cattle market

Potential to increase trade is pointed out as follows:⁴⁷

- There are a number of markets throughout the livestock production zones of West Africa; however, the supply chain for cattle is long and inefficient with many participants. Producers

⁴⁶ USAID West Africa, May 2014, "Trade Hub and African Partners Network: Value Chain Assessment Report: Livestock-Cattle"

⁴⁷ USAID article as above and "Trade Hub and African Partners Network: Livestock Value Chain Strategy"

lack the necessary information on standards and prices to make decisions on producing quality livestock. The Livestock Market Information System (LMIS) implemented by the Livestock Climate Change - Cooperative Research Support Program (LCC-CRSP) in Mali generates needed information for traders and improving market linkages between producers in Sahel countries and traders in the terminal markets.

- USAID West Africa is promoting a strategy for increasing trade by working through major livestock associations in the region to strengthen them to play long-term roles in building a favourable business and trade environment for their members. It also works to build and expand opportunities along specific trade corridors (Bamako-Abidjan, Bamako-Dakar and Ouagadougou-Accra Corridors) to facilitate and encourage increases in targeted commerce, through building public-private partnership to improve corridor-specific trade environments.

Opportunities for poultry value chain development corresponding to some of the constraints are as follows:⁴⁸

- There are opportunities for coastal countries to export DOC and ETH to interior countries, as well as to coastal countries with less commercially developed poultry value chains such as Guinea, Liberia, Togo, and Benin to be able to greatly reduce imports of DOC from the EU.
- Commercial banks perceive poultry production as risky, especially in a post-AI outbreak environment. However, alternative sources of funding for selected poultry enterprises could be explored, if they are educated about the opportunities and risks in the poultry value chain, how to analyse investments in poultry enterprises, and how to assess the creditworthiness of particular firms.
- Although consumers prefer fresh poultry meat (over frozen products), there is scope to expand commercial slaughter in hygienic facilities in cities so that urban consumers can buy whole chickens or chicken parts and offal. To this extent, there is a need to invest in upgrading slaughter facilities and cold chains to ensure sanitary poultry products. The cold chain in this context is relatively short given that commercial slaughter is performed close to end use markets, in peri-urban abattoirs specialized in poultry slaughter.

A.5.5 Future Prospects based on Sub-Regional Development Strategies

Most of the priority projects for the livestock sector in the targeted countries are relevant to developing and upgrading the livestock & poultry value chains. These projects are expected to contribute to ease the constraints in the feeding, processing, and marketing phases in the value chain. At the same time, those projects need to be supported mainly by institutional development for modernizing and formalizing business practices, improving access to credit and quality veterinary products /services, and setting and disseminating quality standards for products. In addition, cross-border transhumance management is a critical issue in the region, but it gives an opportunity to establish a common livestock market with well-managed, safe and efficient transport and transaction system for livestock, which will have great comparative advantages over other regions.

⁴⁸ USAID, November 2011, "Poultry Value Chain Development Plan Updated for FY2012"

Appendix B Traffic Survey and Traffic Data

B.1 Traffic Survey

B.1.1 Overview of Traffic Survey

(1) Objective of the Traffic Survey

The JICA Study Team has conducted the traffic survey to understand the traffic volume and characteristics of traffic on the major corridors and border posts as well as the major logistics nodes in the Study area in August and September 2015. The survey consists of a) Traffic Count Survey, b) Roadside OD (Origin-Destination) Survey and c) OD Survey at the Logistics Nodes.

Table B.1.1 shows the outline of the Survey such as the duration, number of survey points, vehicle classification, interview items and so on.

Table B.1.1 Outline of Traffic Survey

Survey Name	Description
Traffic Count Survey	<p><u>Duration</u> : One weekday, for 24 hours</p> <p><u>Survey Points</u>: 32 (10 national borders and 22 traffic zone boundaries)</p> <p><u>Vehicle Classification</u>: 6 types (motorcycle, passenger car, mini bus, bus, light truck, truck with 2 or 3 axles, truck with 4 or more axles, maritime container trailer)</p>
Roadside OD Survey	<p><u>Duration</u> : Same as Traffic Count Survey</p> <p><u>Survey Points</u>: Same as Traffic Count Survey</p> <p><u>Vehicle Classification</u>: Same as Traffic Count Survey</p> <p><u>Interview Item</u>: vehicle registration country, vehicle type, origin and destination of trip, commodity type, packing type, net commodity weight and load capacity, transportation days, trip purpose, driver's residence, number of passengers</p>
OD Survey at the Logistics Nodes	<p><u>Duration</u> : One weekday, operating hours of the facility</p> <p><u>Survey Points</u>: 5 sea ports (Ports of Abidjan, San-Pédro, Tema, Takoradi and Lomé)</p> <p>2 dry ports (Ouaga inter and Bobo inter in Burkina Faso)</p> <p><u>Vehicle Classification</u>: 4 types (light truck, truck with 2 or 3 axles, truck with 4 or more axles, maritime container trailer)</p> <p><u>Interview Item</u>: vehicle registration country, vehicle type, origin and destination of trip, commodity type, packing type, net commodity weight and load capacity, transportation days</p>

Source: JICA Study Team

(2) Traffic Survey Stations and Zoning for Traffic Flow Analysis

Figure B.1.1 shows the traffic survey points at 39 stations composed of 10 national boundaries, 22 traffic zone boundaries, 5 seaports and 2 dry ports. Zoning for the OD survey in the study area (Burkina Faso, Côte d'Ivoire, Ghana, Togo) is divided into 15 zones by national and regional boundaries even though some regions are integrated to be in the same zone in order to analyse the wide-area traffic movements. In addition, international seaports have their individual zones to analyse the traffic movements related to logistics nodes. Figure B.1.2 shows the traffic zone map and Table B.1.2 shows the details of traffic zones.

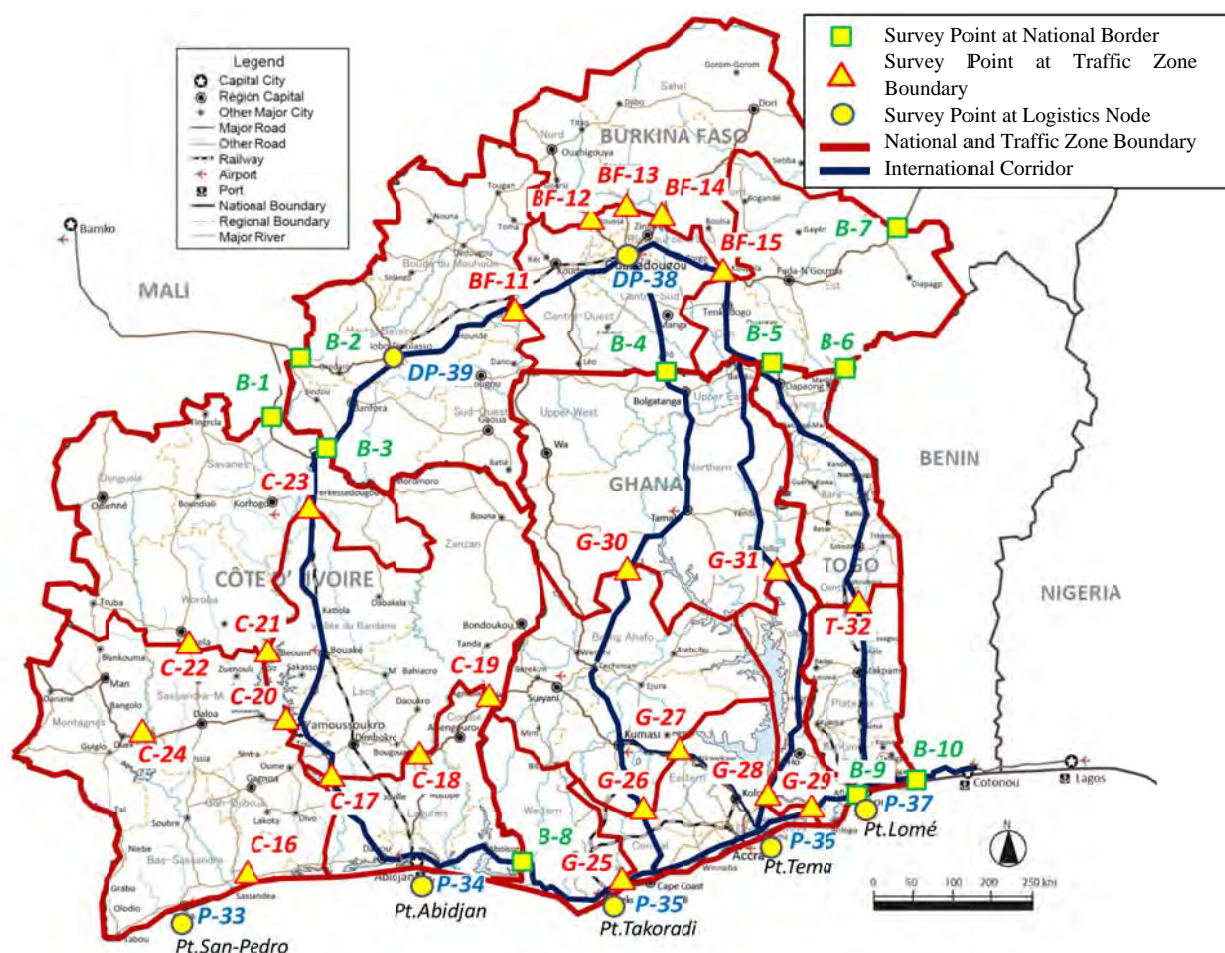

Source: JICA Study Team

Figure B.1.1 Locations of Traffic Survey Stations

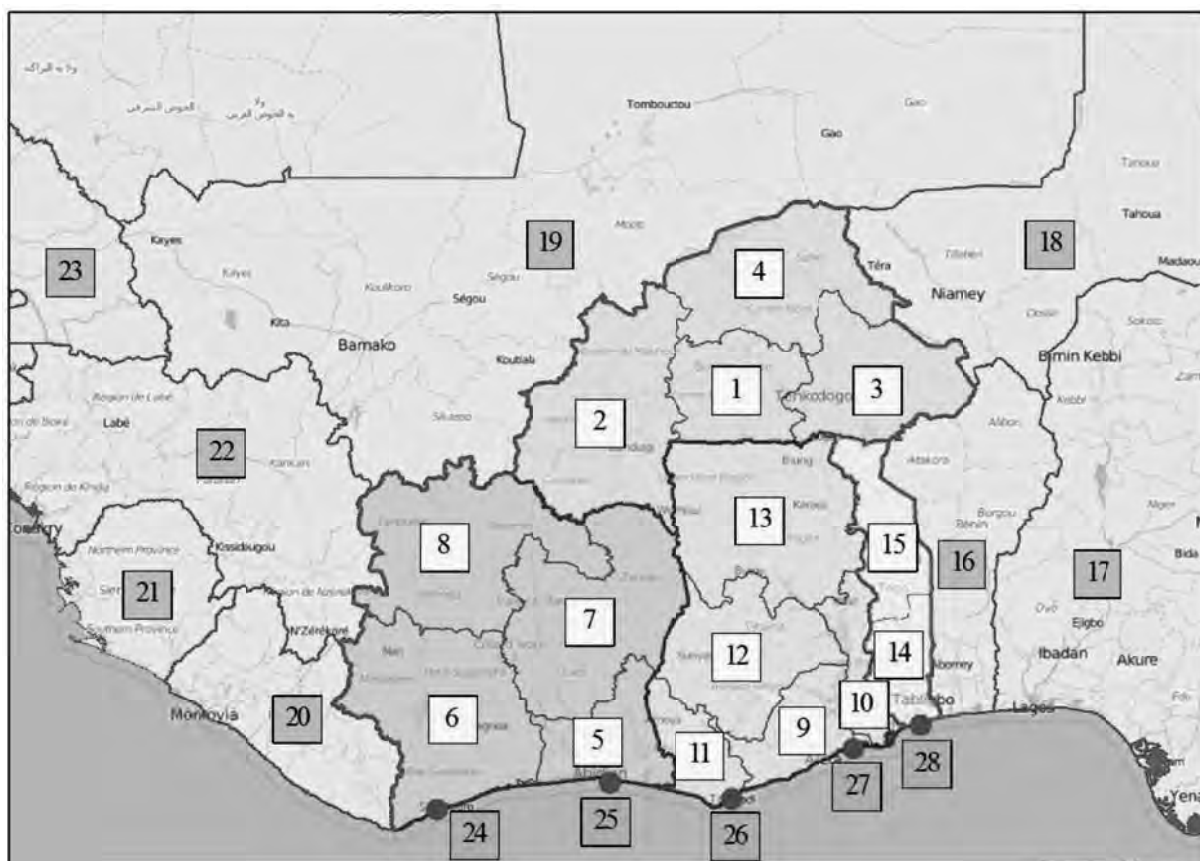

Source: JICA Study Team

Figure B.1.2 Traffic Zones

Table B.1.2 Zone Code

Code	Zone	Code	Zone
1	Burkina Faso-South	16	Benin
2	Burkina Faso -West	17	Nigeria
3	Burkina Faso -East	18	Niger
4	Burkina Faso -North	19	Mali
5	Côte d'Ivoire-South East	20	Liberia
6	Côte d'Ivoire-South West	21	Sierra Leone
7	Côte d'Ivoire-North East	22	Guinea
8	Côte d'Ivoire-North West	23	Senegal
9	Ghana-South	24	Port San-Pédro
10	Ghana-South East	25	Port Abidjan
11	Ghana-South West	26	Port Takoradi
12	Ghana-Central	27	Port Tema
13	Ghana-North	28	Port Lomé
14	Togo-South	29	Other Countries
15	Togo-North		

Source: JICA Study Team

B.1.2 Traffic Volume

(1) Traffic Volume at Survey Station

The annual average daily traffic by survey station is shown in Table B.1.3. The annual average daily traffic is calculated based on the traffic survey results and existing traffic data.

The figures from Figure B.1.3 till Figure B.1.7 show the daily traffic volume by vehicle type and the vehicle composition of traffic volume by each country.

Table B.1.3 Daily Traffic Volume in 2015

Station	Passenger Car	Mini Bus	Large Bus	Light Truck	Truck (2,3 axle)	Truck & Trailer	Container Trailer	Total
BF-NE	49	58	34	9	29	122	65	366
BF-BN	12	4	3	0	42	179	39	279
BF-TG	116	9	47	6	37	395	136	746
BF-GH	51	26	12	21	60	197	98	465
BF-CI	24	88	106	17	34	278	65	612
BF-ML	86	32	34	20	27	91	10	300
ML-CI	108	20	44	9	41	194	68	484
GH-CI	2986	384	77	74	128	51	19	3719
GH-TG	5879	138	50	31	70	234	13	6415
TG-BN	5068	158	48	73	94	120	34	5595
BF-1	576	270	315	180	396	738	387	2862
BF-2	588	246	294	50	101	59	62	1400
BF-3	307	113	113	126	185	185	92	1121
BF-4	852	208	168	152	108	56	28	1572
BF-5	740	612	176	56	160	552	224	2520
C-1	266	211	54	145	78	80	32	866
C-2	2310	494	413	419	272	712	138	4758
C-3	130	2	0	48	14	33	0	227
C-4	707	594	6	220	264	146	28	1965
C-5	1231	327	232	155	190	232	15	2382
C-6	46	56	0	80	50	8	0	240
C-7	164	231	11	67	75	30	3	581
C-8	716	371	400	151	241	415	32	2326
C-9	429	372	161	140	121	206	52	1481
G-1	2460	2094	226	290	455	411	190	6126
G-2	1062	1166	168	137	146	281	35	2995
G-3	1967	3257	1034	1014	1235	1139	1033	10679
G-4	3431	3244	113	472	177	54	9	7500
G-5	2724	2637	184	399	158	416	130	6648
G-6	777	221	249	128	141	317	56	1889
G-7	24	32	18	45	25	4	0	148
T-1	847	476	84	67	144	562	57	2237
Pt. SanPedro	0	0	0	22	3	364	250	639
Pt. Abidjan	0	0	0	1159	634	2101	960	4854
Pt. Takoradi	0	0	0	162	100	536	19	817
Pt. Tema	0	0	0	26	275	1392	966	2659
Pt. Lome	0	0	0	54	232	834	544	1664
Ouaga-Inter	0	0	0	8	48	333	108	497
Bobo-Inter	0	0	0	5	24	257	20	306

Source: JICA Study Team based on traffic survey conducted by JICA Study Team

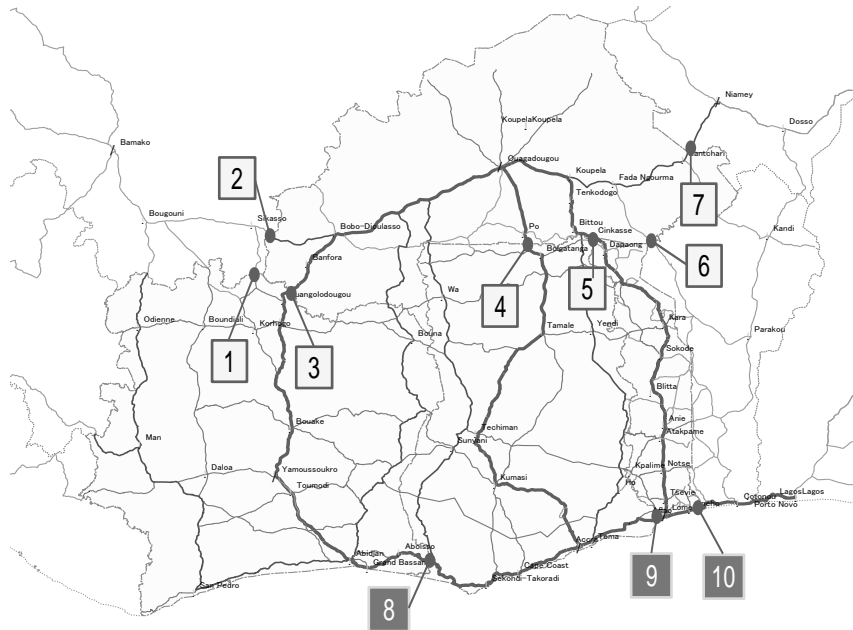

Container Trailer
 Truck & Trailer (over 4 axle)
 Truck (2,3 axle)
 Light Truck
 Large Bus
 Mini Bus
 Passenger Car

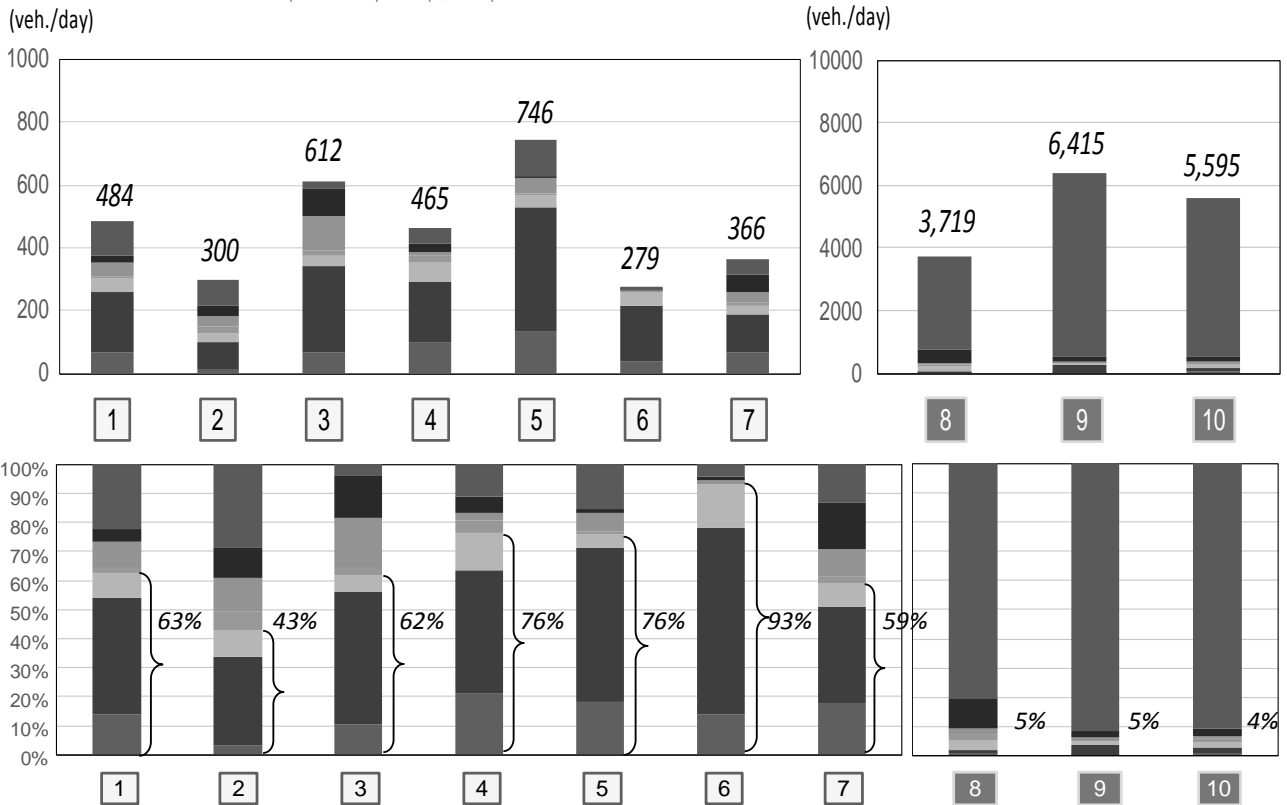

Source : JICA Study Team based on traffic survey result conducted by JICA Study Team in 2015
Figure B.1.3 Daily Traffic Volume on National Borders

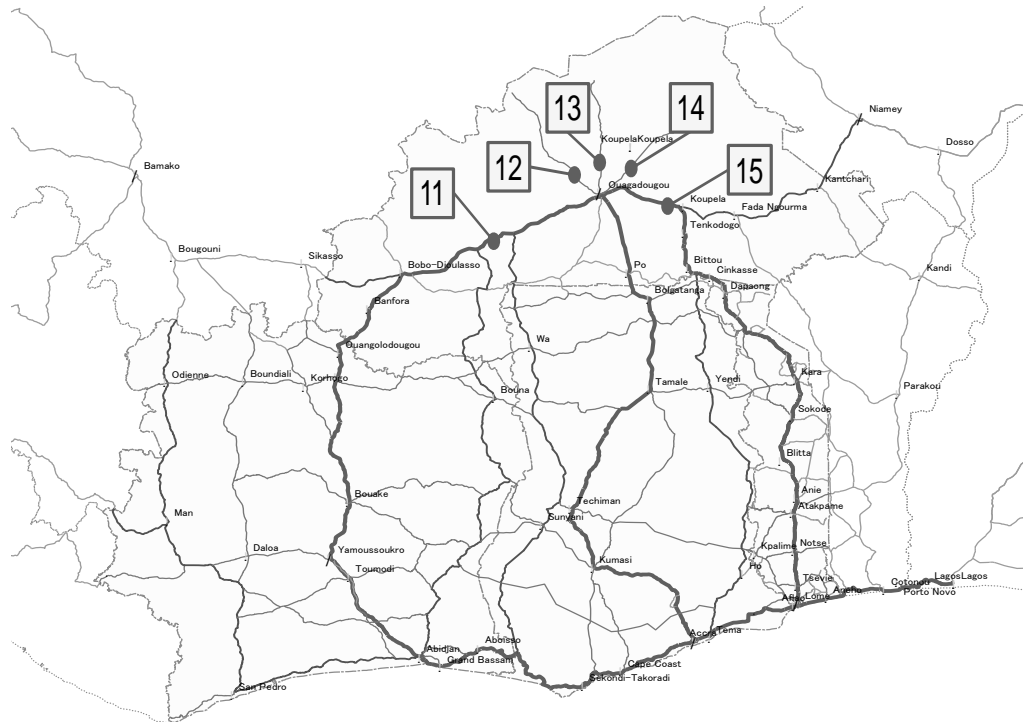

(veh./day) ■ Container Trailer ■ Truck & Trailer (over 4 axle) ■ Truck (2,3 axle) ■ Light Truck ■ Large Bus ■ Mini Bus ■ Passenger Car

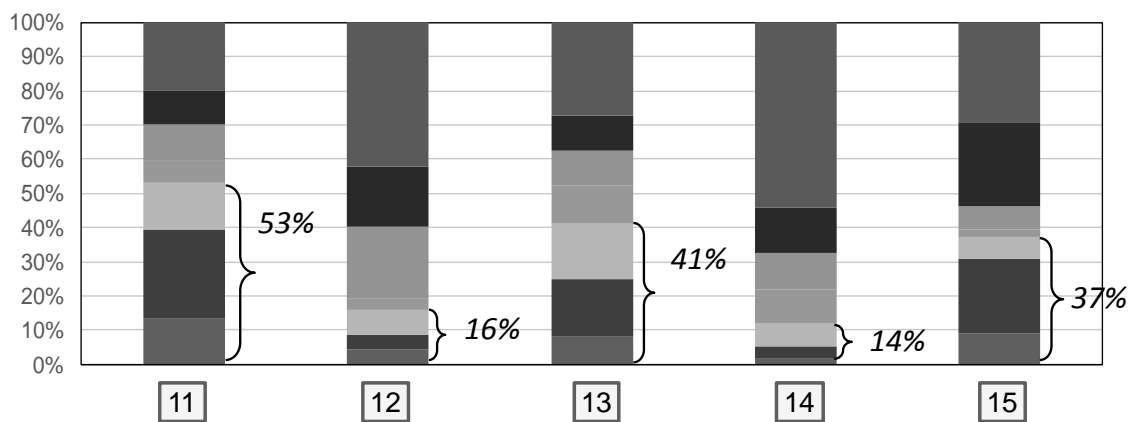
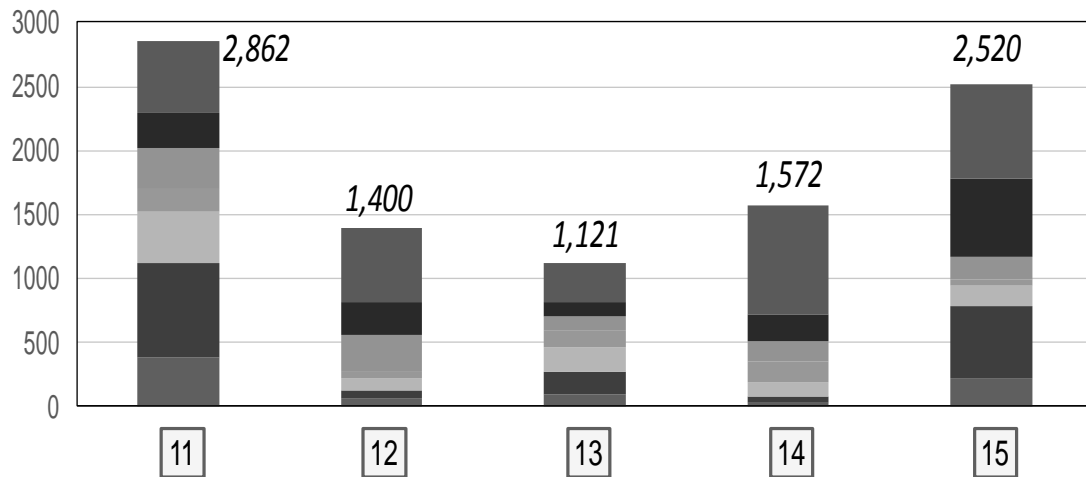

Source : JICA Study Team based on traffic survey result conducted by JICA Study Team in 2015

Figure B.1.4 Daily Traffic Volume in Burkina Faso

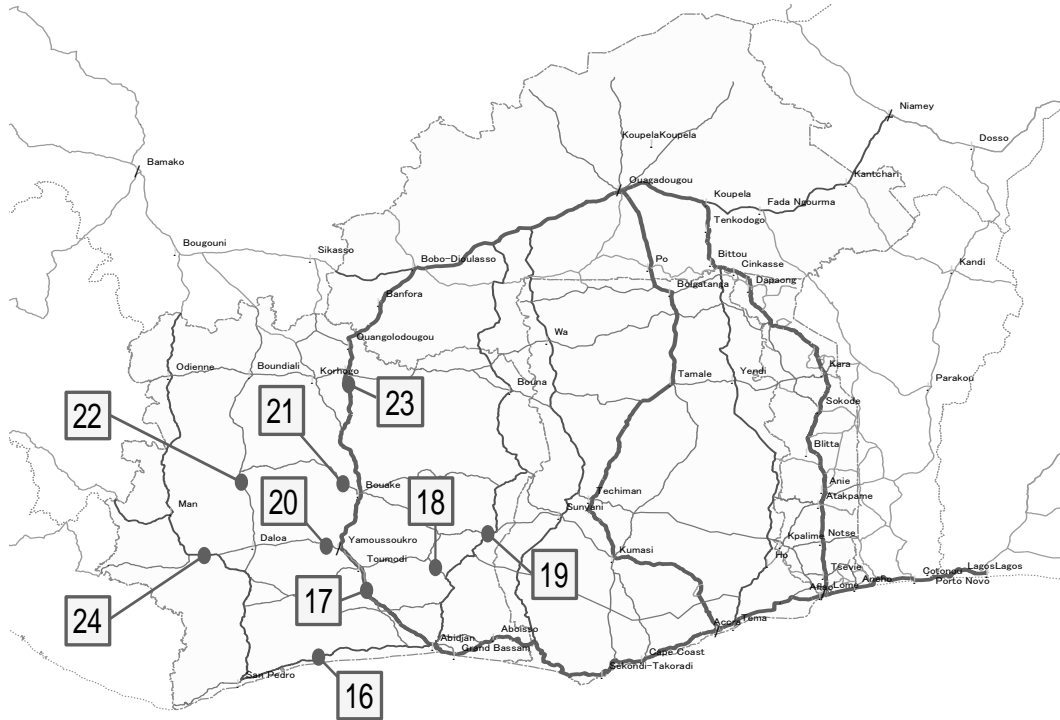

(veh./day) ■ Container Trailer ■ Truck & Trailer (over 4 axle) ■ Truck (2,3 axle) ■ Light Truck ■ Large Bus ■ Mini Bus ■ Passenger Car

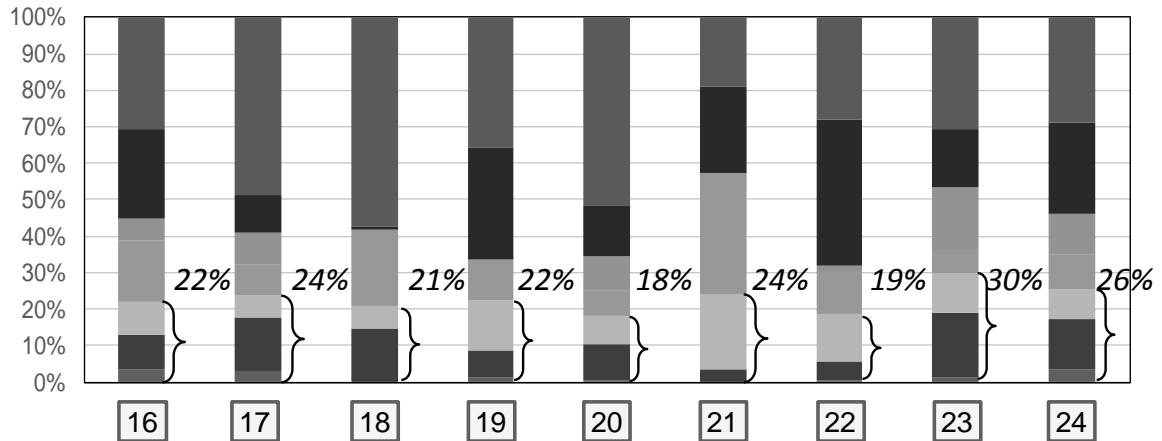
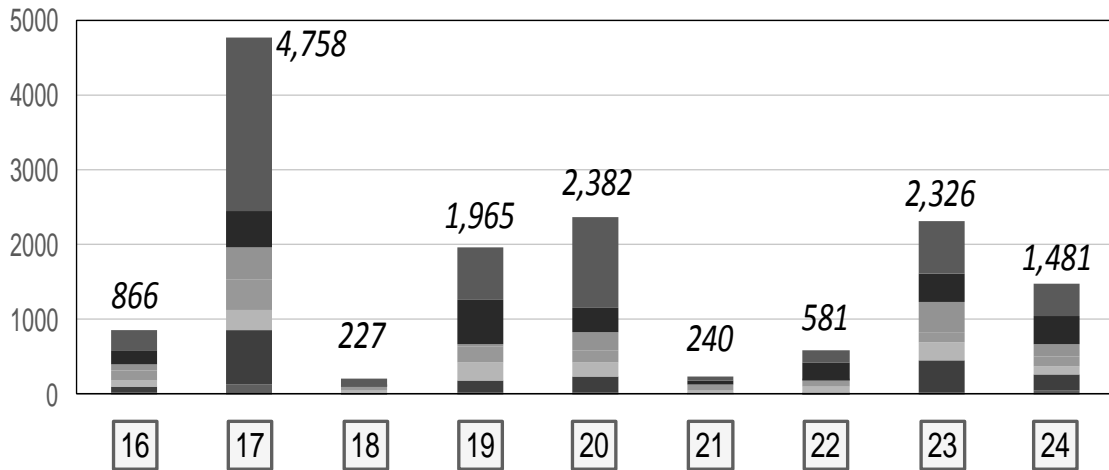

Source : JICA Study Team based on traffic survey result conducted by JICA Study Team in 2015

Figure B.1.5 Daily Traffic Volume in Côte d'Ivoire

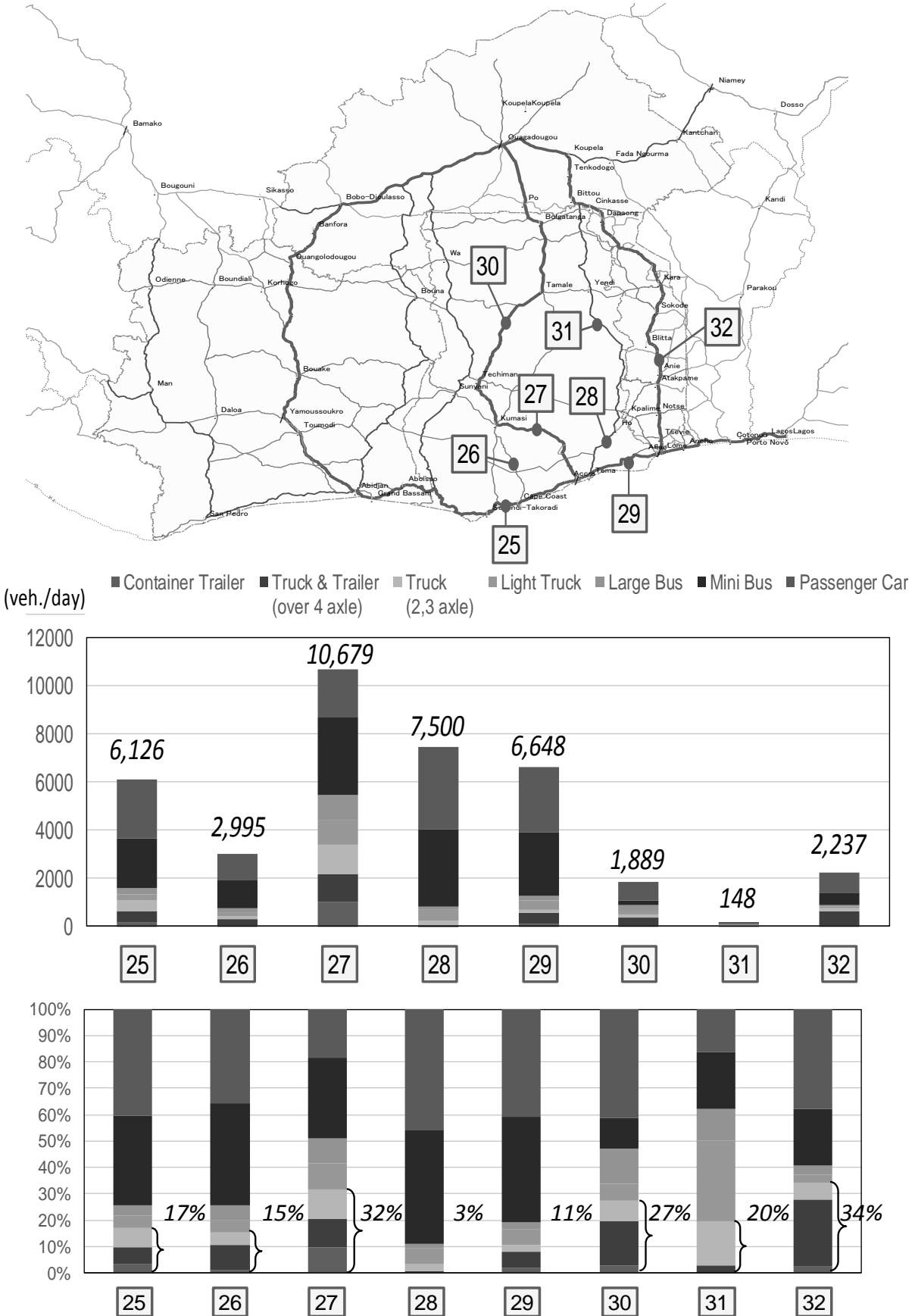

Source : JICA Study Team based on traffic survey result conducted by JICA Study Team in 2015

Figure B.1.6 Daily Traffic Volume in Ghana and Togo

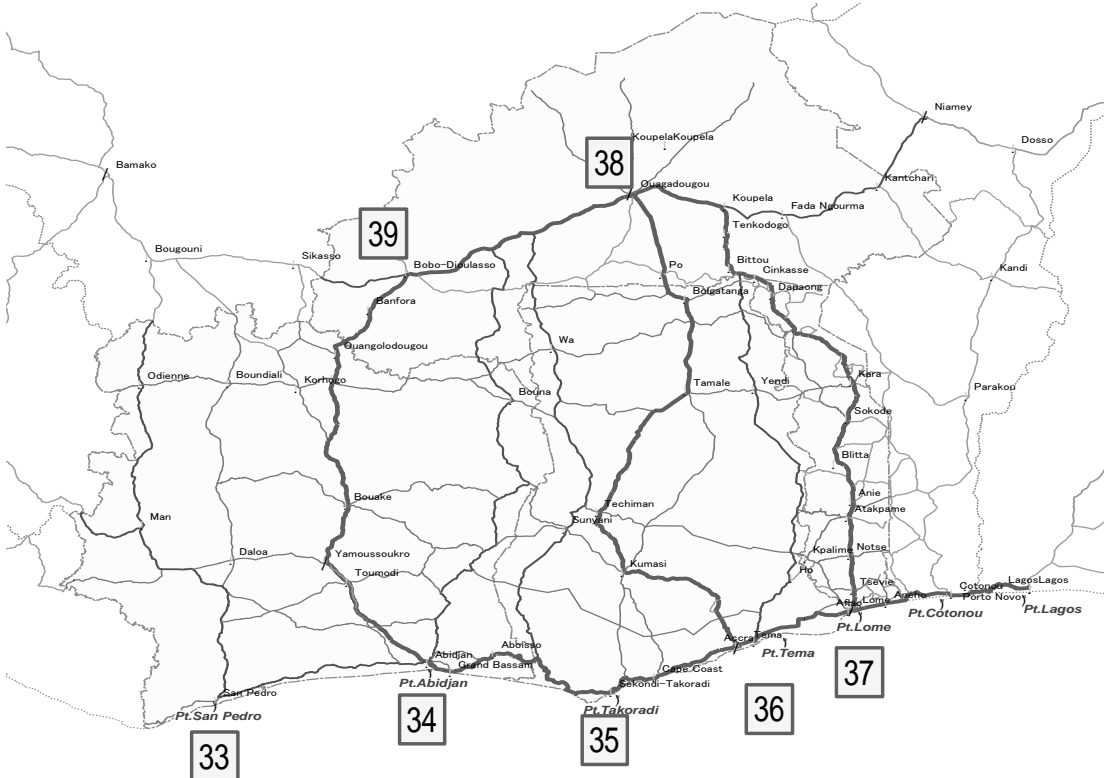

(veh./day) ■ Container Trailer ■ Truck & Trailer (over 4 axle) ■ Truck (2,3 axle) ■ Light Truck ■ Large Bus ■ Mini Bus ■ Passenger Car

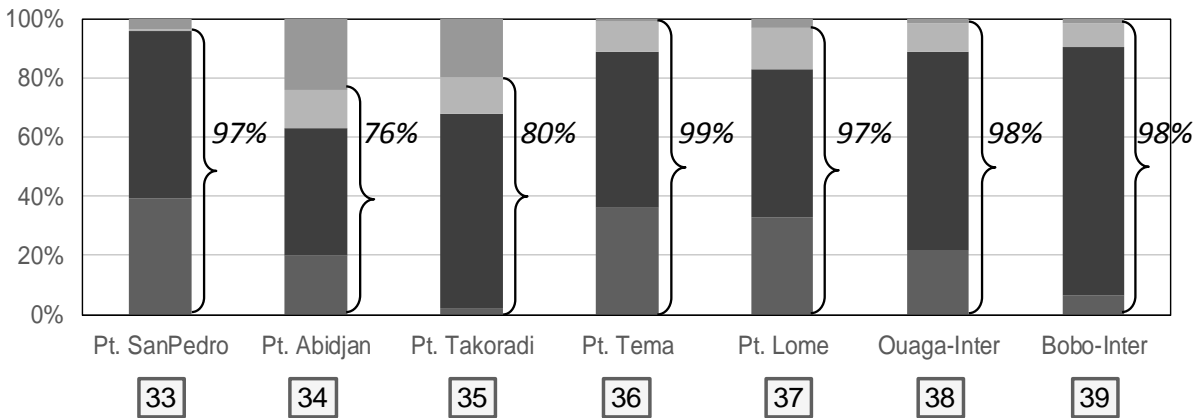
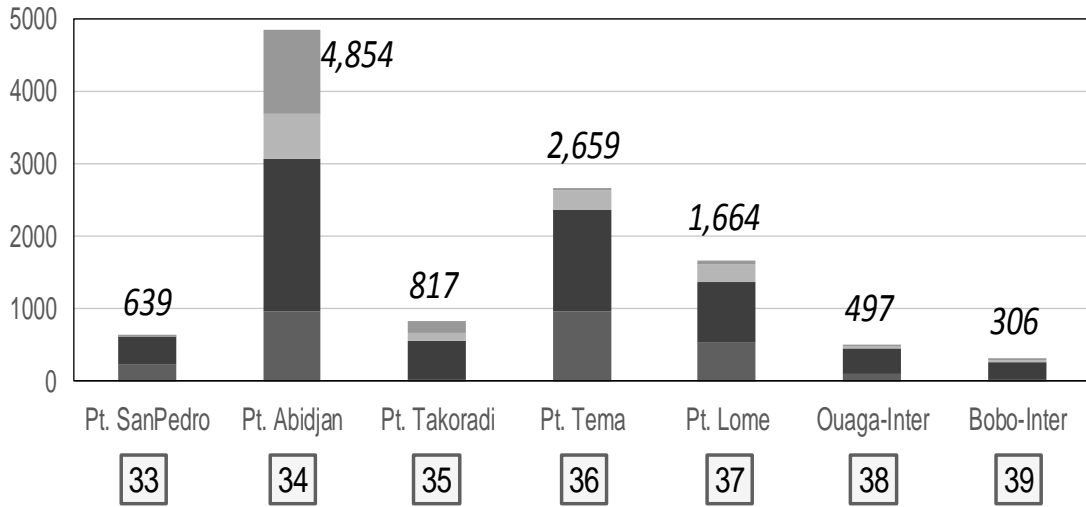

Source : JICA Study Team based on traffic survey result conducted by JICA Study Team in 2015

Figure B.1.7 Daily Traffic Volume at Dry Port

(2) Traffic Volume in Sub-region

Figure B.1.8 shows the daily traffic volumes on the main trunk roads within the region in 2015. This figure was prepared by integrating the results of a traffic survey carried out by the Study Team and existing traffic volume data.

The traffic volumes on the outskirts of Abidjan and Accra cities are in the order of 10,000 vehicles per day. On the other hand the traffic volumes inland are less than 5,000 vehicles per day.

In the case of the traffic volumes at the borders between the coastal countries, the traffic volume at the border between Côte d'Ivoire and Ghana is less than 4,000 vehicles per day, but at the border between Ghana and Togo it exceeds 6,000 vehicles per day.

On the other hand the traffic volume between the coastal countries and the inland country Burkina Faso is less than 1,000 vehicles per day.

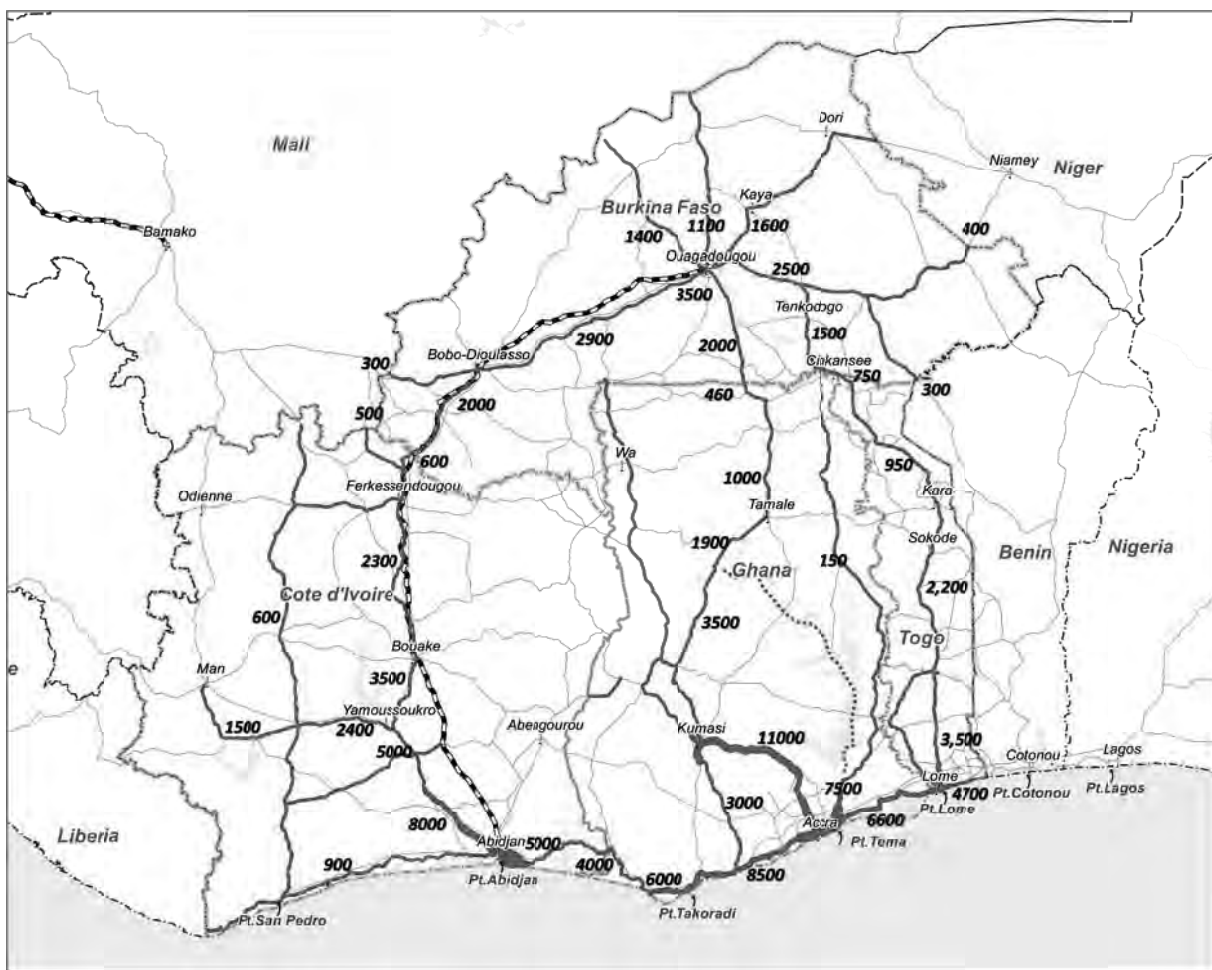

Source: JICA Study Team's survey and existing traffic data

Figure B.1.8 Daily Traffic Volumes in Sub-Regions in 2015

B.1.3 Current Traffic Flow Patterns

(1) Current Traffic Flow Patterns in Sub-regions

The current traffic flow pattern by vehicle type between zones based on roadside OD survey is shown in the figures below. The colour of the line and the thickness of the line indicate the strength of the connection between zones.

From these figures, we can understand the strength of exchange ties between zones.

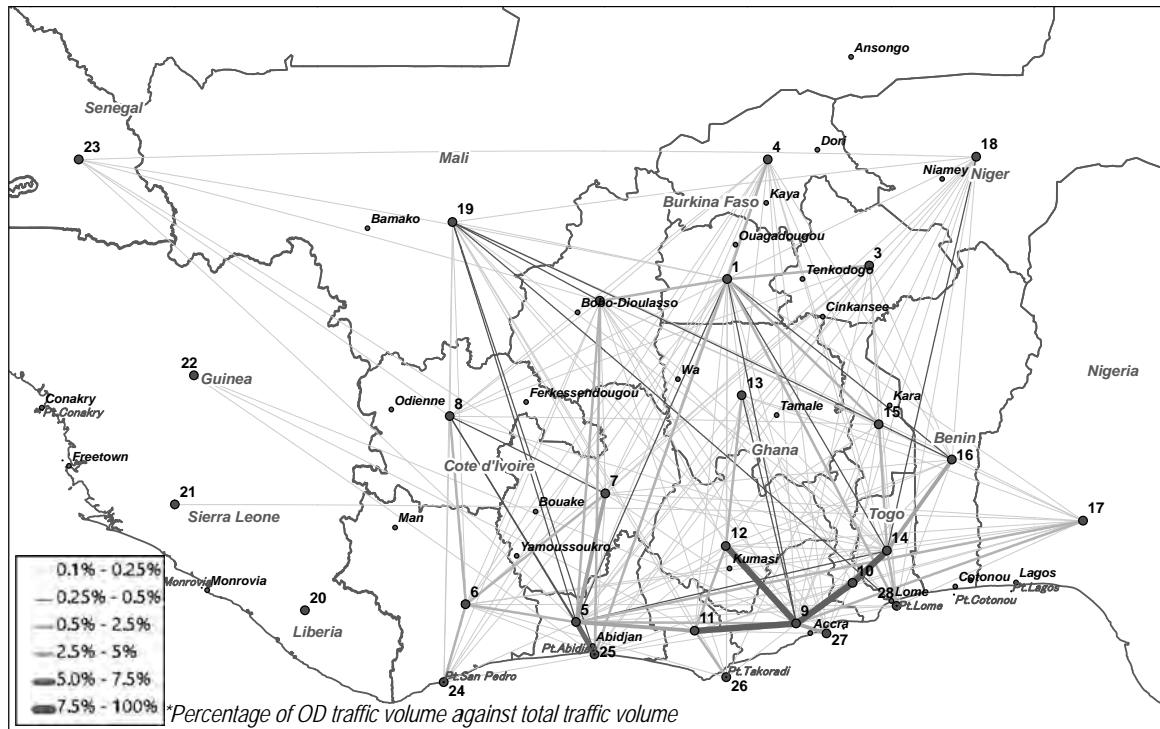

Source : JICA Study Team based on traffic survey result conducted by JICA Study Team in 2015

Figure B.1.9 Current Traffic Flow Patterns - Total of All Vehicles -



Source : JICA Study Team based on traffic survey result conducted by JICA Study Team in 2015

Figure B.1.10 Current Traffic Flow Patterns -Passenger Cars-

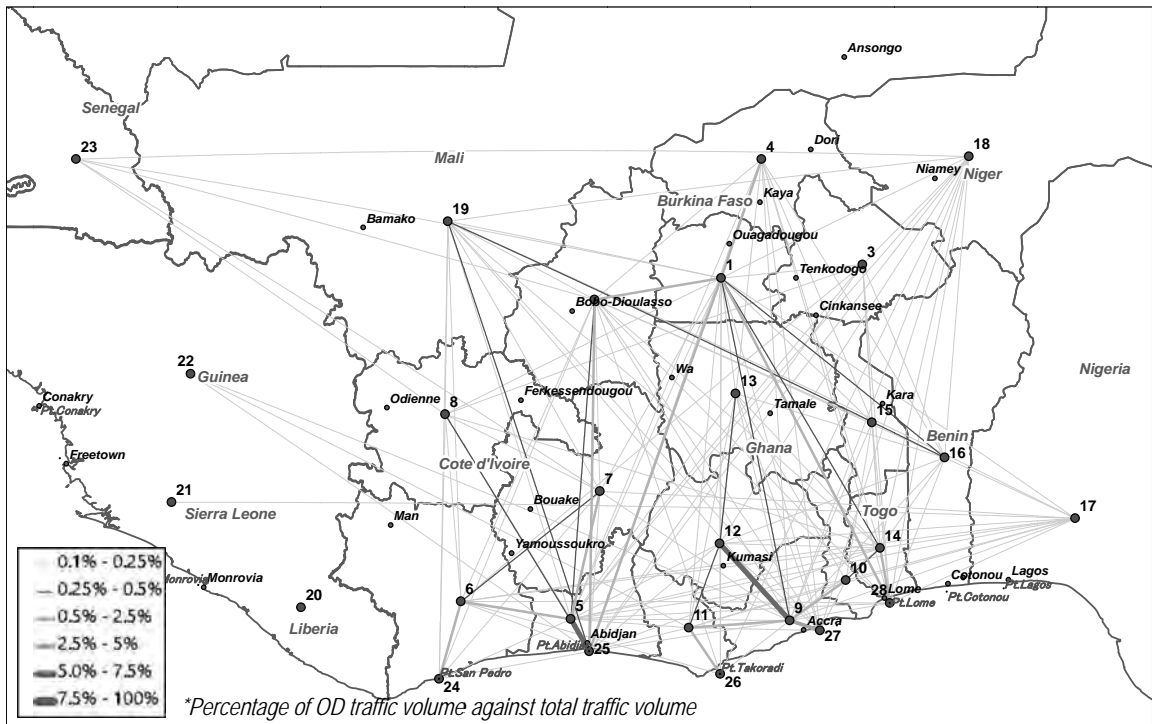

Source: JICA Study Team based on traffic survey result conducted by JICA Study Team in 2015

Figure B.1.11 Current Traffic Flow Patterns -Freight Vehicles-

(2) Current Traffic Flow Pattern Centred on Ports

The current traffic flow pattern between zones centred on five major ports is shown in the figures below. The colour of the line and the thickness of the line indicate the strength of the connection from the perspective of logistics between ports and inland zones.

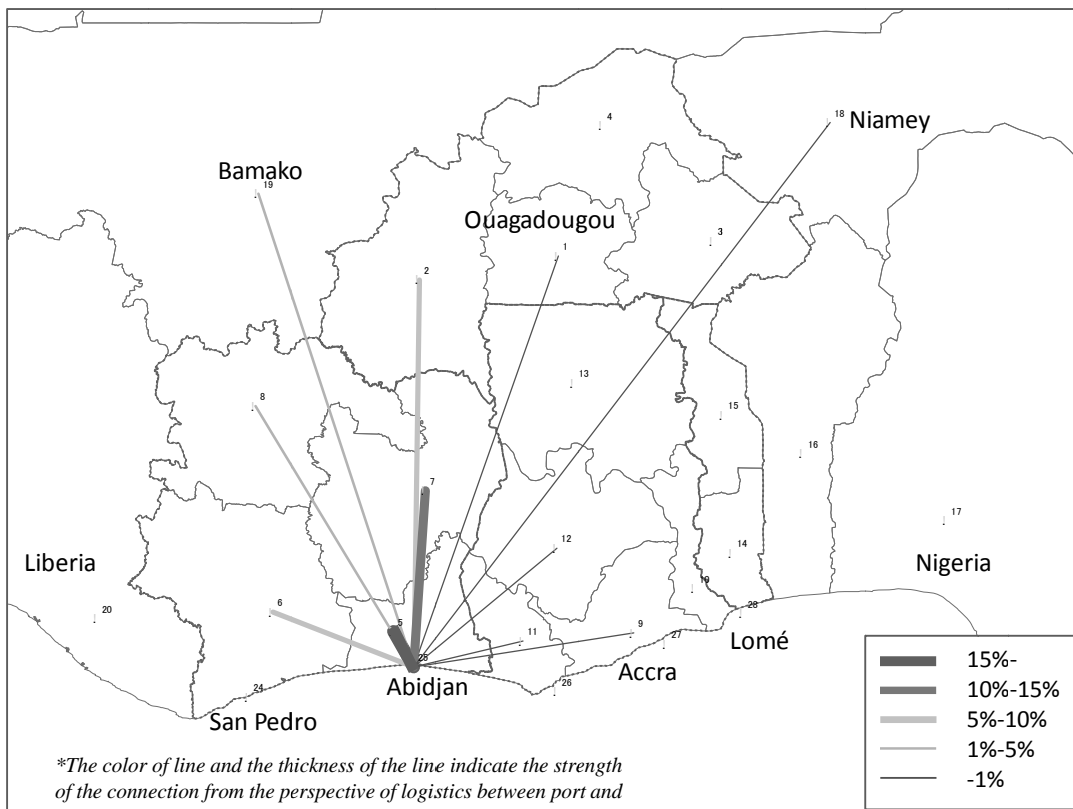

Source: JICA Study Team based on traffic survey result conducted by JICA Study Team in 2015

Figure B.1.12 Current Traffic Flow from/to San-Pedro Port

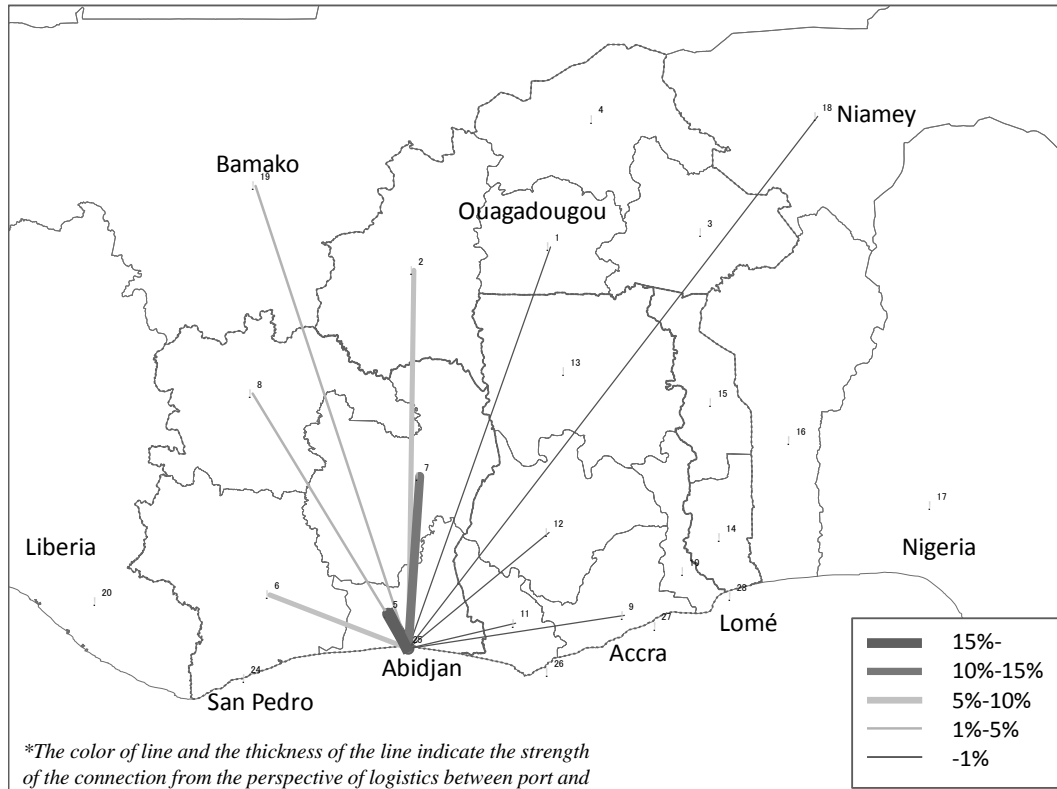

Source: JICA Study Team based on traffic survey result conducted by JICA Study Team in 2015

Figure B.1.13 Current Traffic Flow from/to Abidjan Port

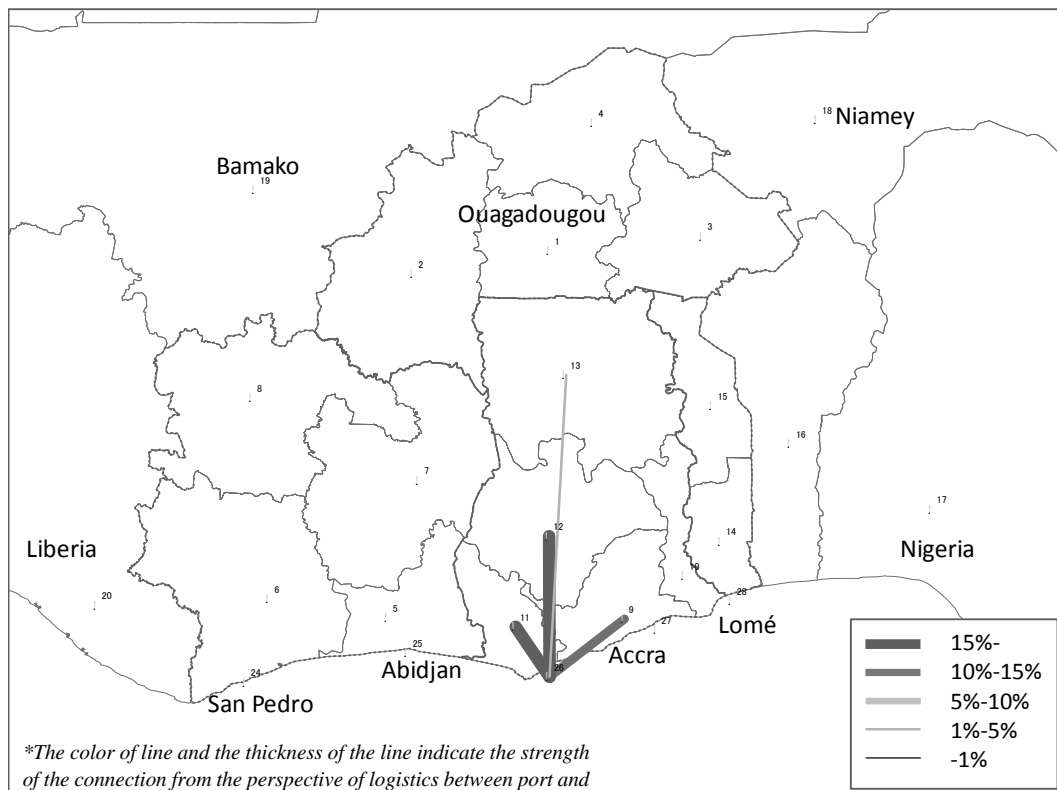

Source: JICA Study Team based on traffic survey result conducted by JICA Study Team in 2015

Figure B.1.14 Current Traffic Flow from/to Takoradi Port

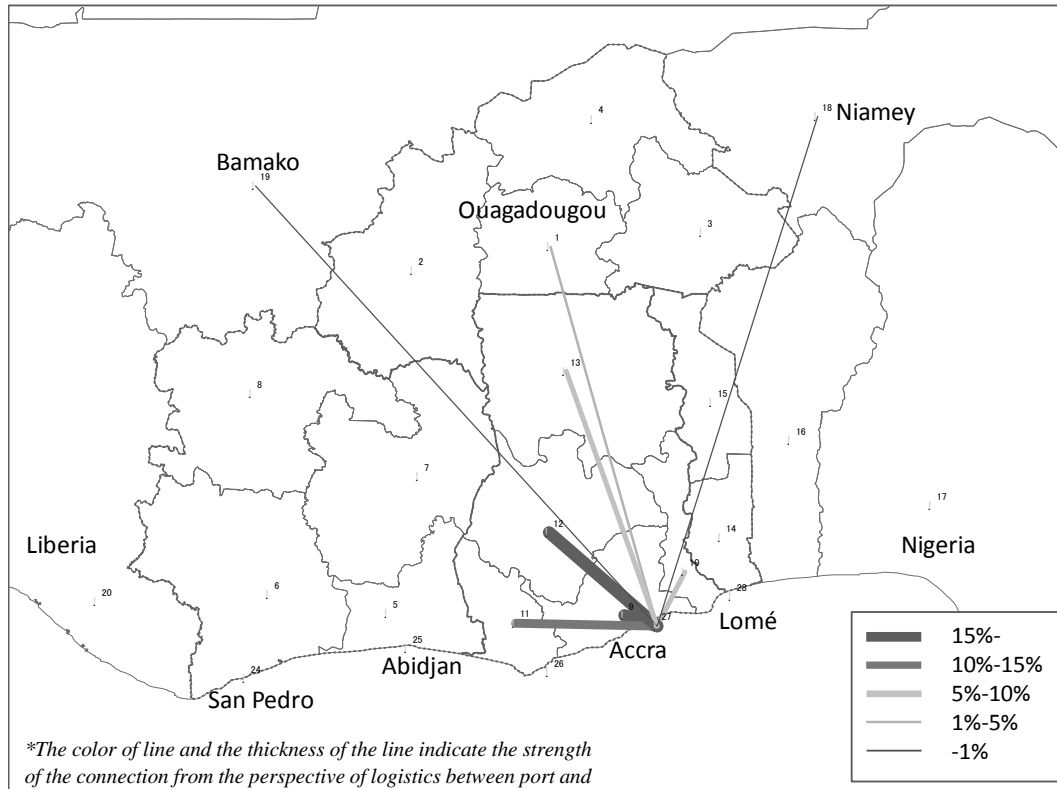

Source : JICA Study Team based on traffic survey result conducted by JICA Study Team in 2015

Figure B.1.15 Current Traffic Flow from/to Tema Port

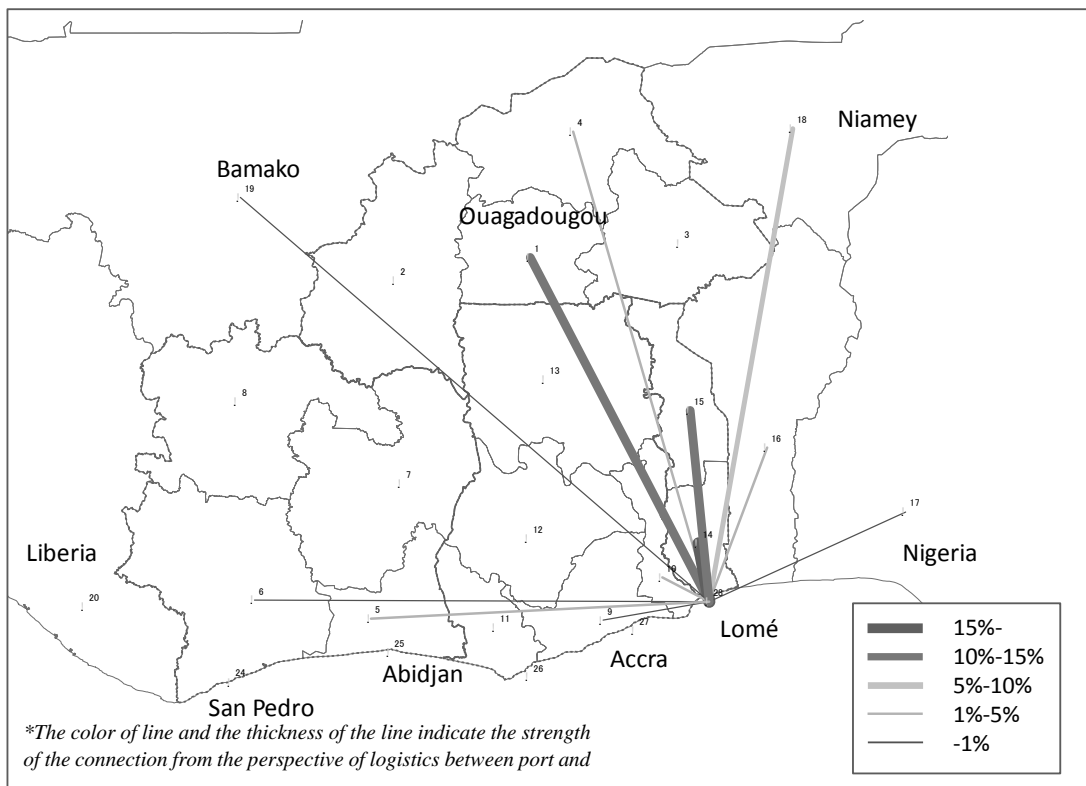

Source : JICA Study Team based on traffic survey result conducted by JICA Study Team in 2015

Figure B.1.16 Current Traffic Flow from/to Lomé Port

B.1.4 Trip Characteristics

The relationship of distance and traffic volume between zones, including the main city and port and other zones, is shown in the figures below.

Overall, the number of trips in the east-west direction crossing borders from the main cities, including the main ports, is rather small, whether the distance is short or long and regardless of the population. In the case of Côte d'Ivoire the traffic between Abidjan and San-Pédro is weak. If free traffic and trade is realized, it is likely that the volume of traffic generated will be several times that of the present.

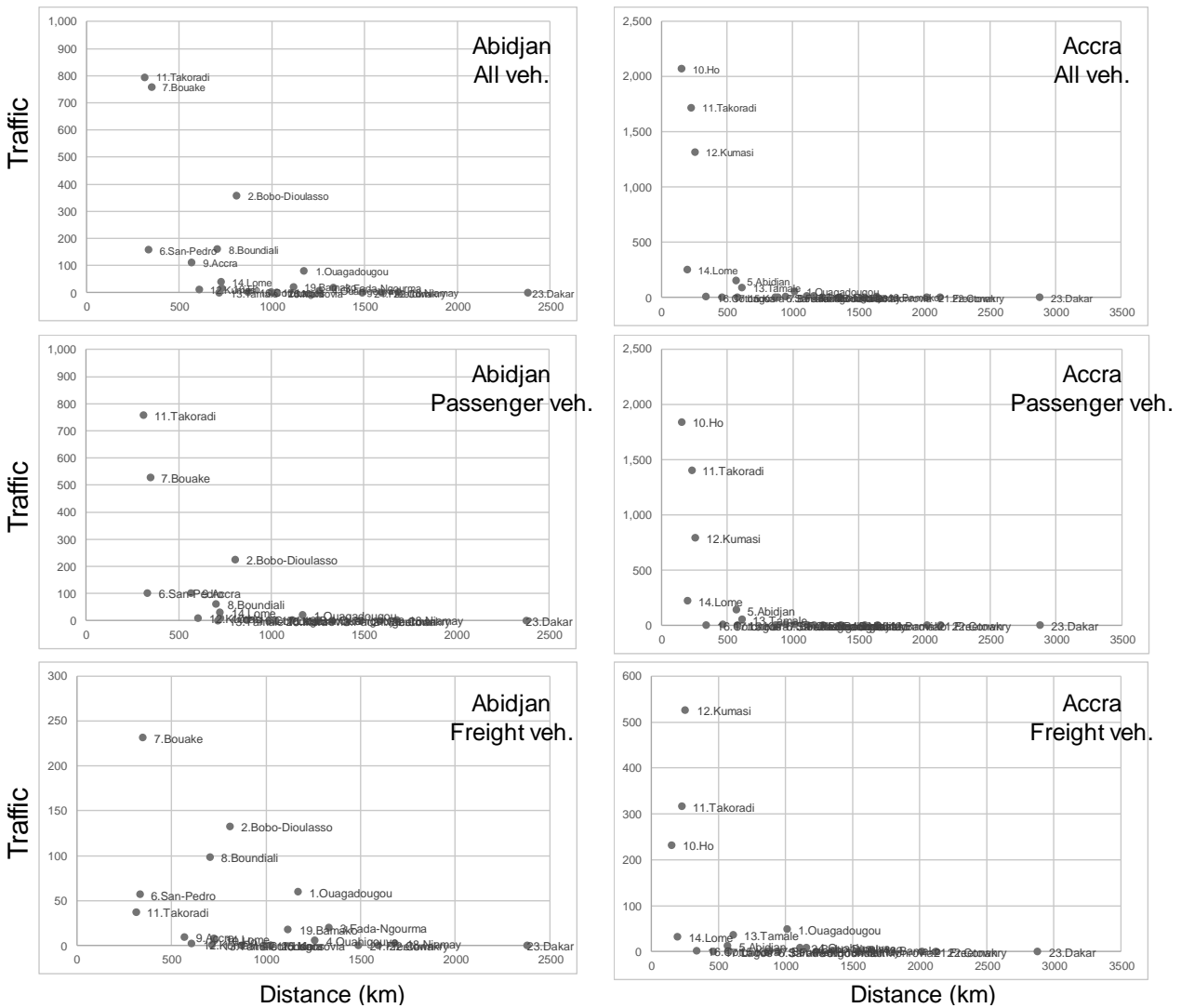

Source : JICA Study Team based on traffic survey result conducted by JICA Study Team in 2015

Figure B.1.17 Relationship of Distance and Traffic Volume between the Main City (Abidjan and Accra) and Other Zones

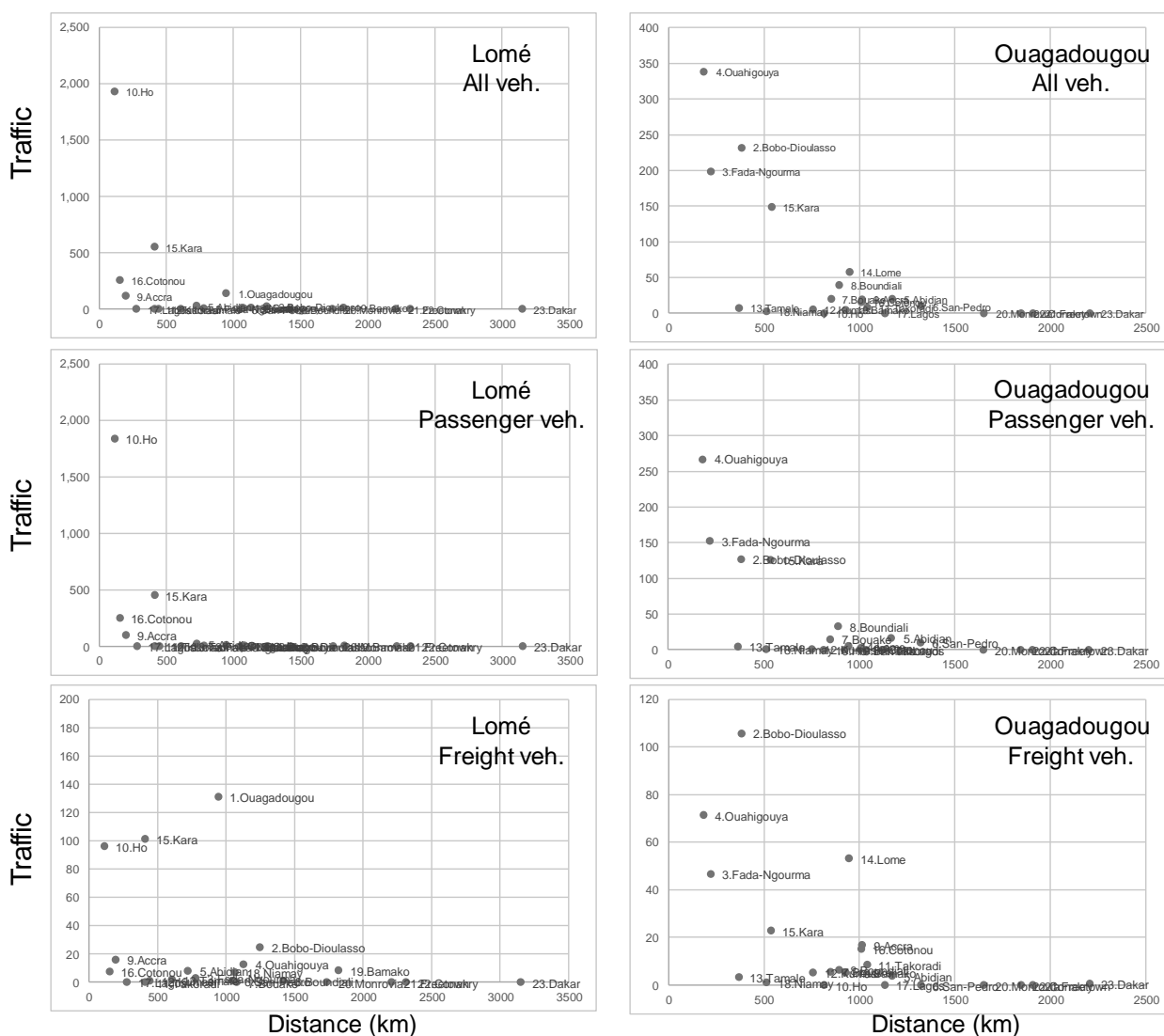

Source : JICA Study Team based on traffic survey result conducted by JICA Study Team in 2015

Figure B.1.18 Relationship of Distance and Traffic Volume between the Main City (Lomé and Ouagadougou) and Other Zones

B.1.5 Trend of Logistics

(1) Overview of the Analysis

An overview of the trends in logistics between countries can be obtained based on analysis of import and export data and customs data for each country. The analysis data is made up of the import and export statistics and the 2015 customs data provided by the customs bureaus of the four target countries. Note that in some cases there are gaps between the import side and the export side data in the customs data between countries. In these cases the average value between the two countries was taken to be the volume of exports between the two countries.

(2) Trends in Value of Trade by Country

1) Trends in Value of Exports

Each country has a trend towards increasing value of exports. In particular, there was a significant increase during the 2000s. This figure shows the value of exports, but it is anticipated that the volume of goods is steadily increasing. In terms of value of exports, the scale of exports from Côte d'Ivoire and Ghana is large. The scale of exports from Côte d'Ivoire was very large up until the first half of the 2000s, but from 2010 onwards the value of trade from Ghana has overtaken

that of Côte d'Ivoire. On the other hand, taking the value of exports in 1950 as an index of 1, it can be seen that the rate of increase in Burkina Faso is extremely high. In recent years the main exports from Burkina Faso have been precious metals. Also, the rate of increase for the inland countries Niger and Mali is also high, so it can be seen that the rate of increase from inland countries is high.

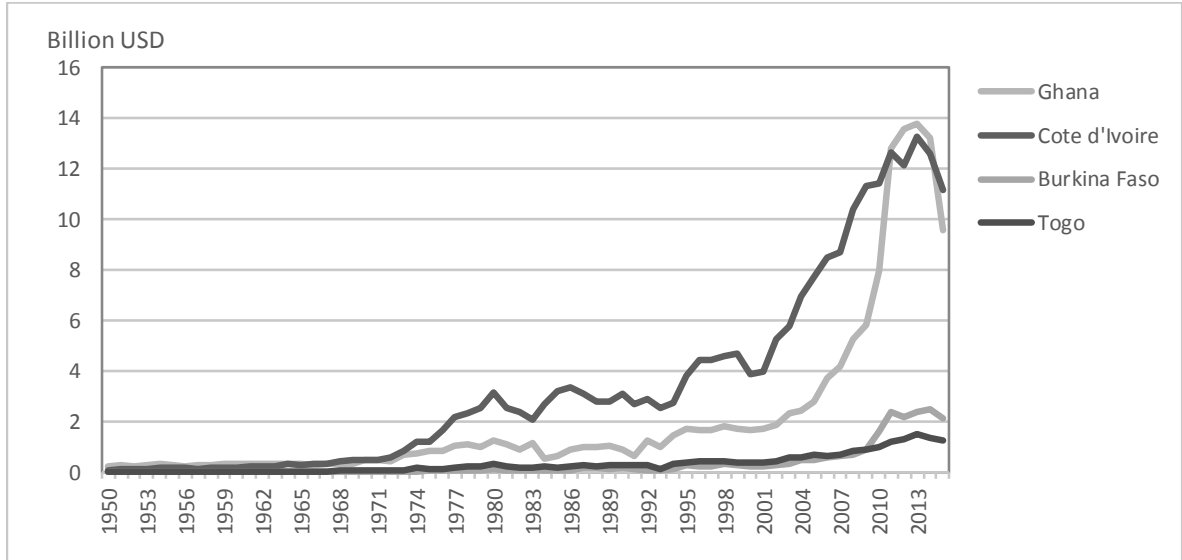

Source: JICA Study Team based on the UN data

Figure B.1.19 Trend of Export Value

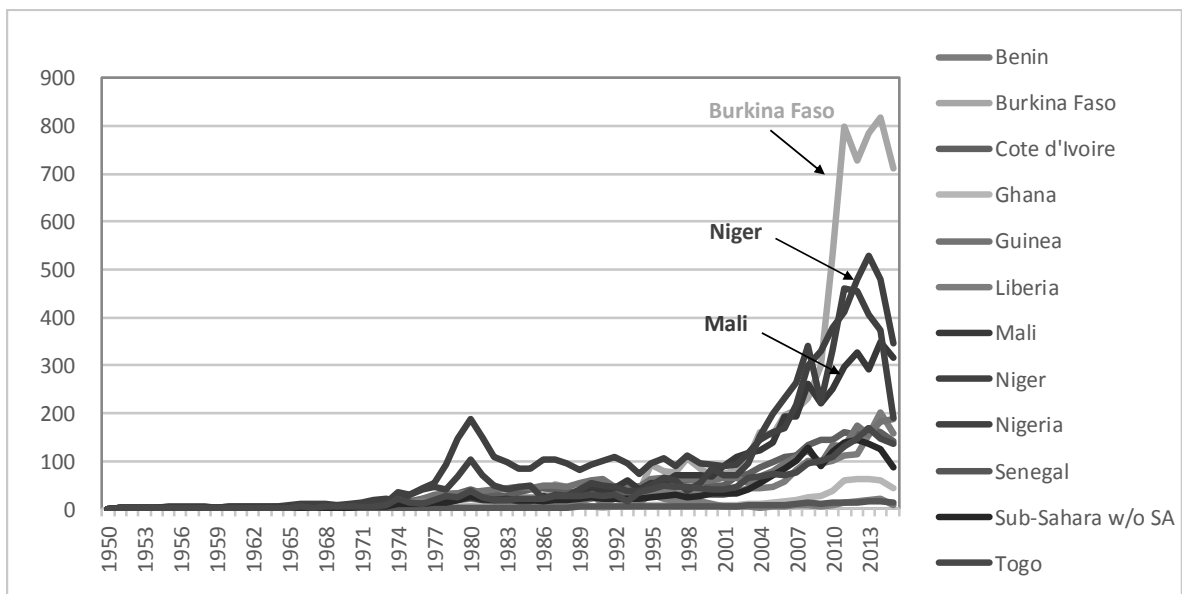

Source: JICA Study Team based on the UN data

Figure B.1.20 Trend of Export Value by Index (year 1950= 1.0)

2) Trends in Value of Imports

In each country the trend is towards an increase in the value of imports. In particular there was significant increase during the 2000s. This figure shows the value of imports, but it is anticipated that the volume of goods is steadily increasing. Of the four countries, the scale is comparatively large for Côte d'Ivoire and Ghana. There is an increasing trend in each country. This figure shows the value of trade (imports), but it is anticipated that the volume of goods will also steadily increase. In particular the rate of increase for Côte d'Ivoire and Ghana is large. Taking the value of imports in 1950 as an index of 1, it can be seen that the rate of increase in Burkina Faso is

extremely high, the same as for exports. In terms of scale, the value of imports for Burkina Faso and Togo is smaller than for Côte d'Ivoire and Ghana, but the rate of increase is extremely high. It can be said that with economic development, imports and exports of fuel and food will increase, and the importance of the north-south corridor for inland transport will increase year-by-year.

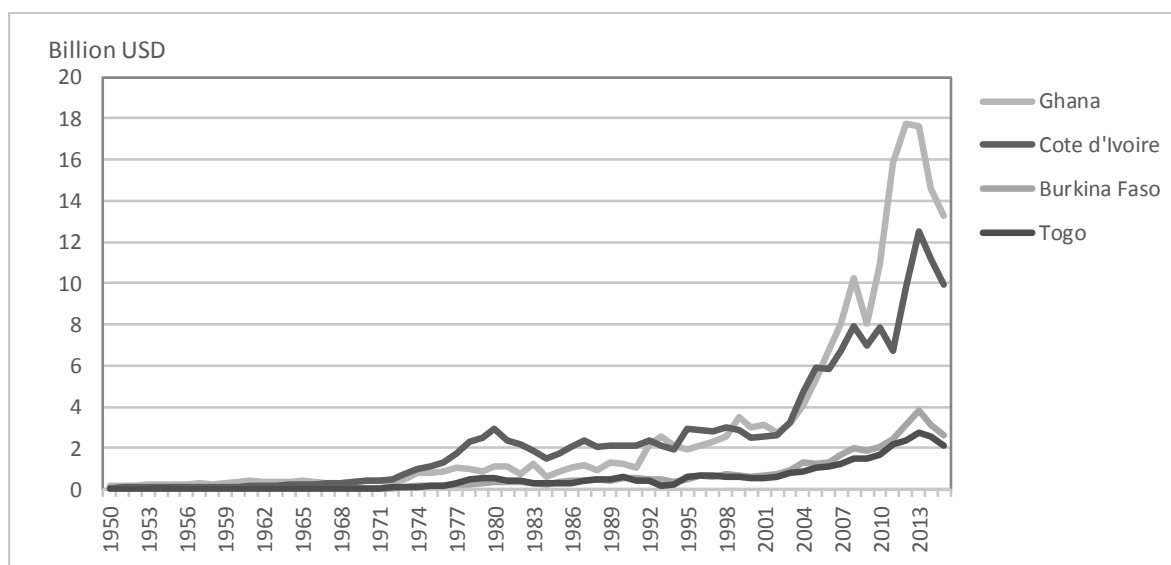

Source: JICA Study Team based on the UN data

Figure B.1.21 Trend of Import Value

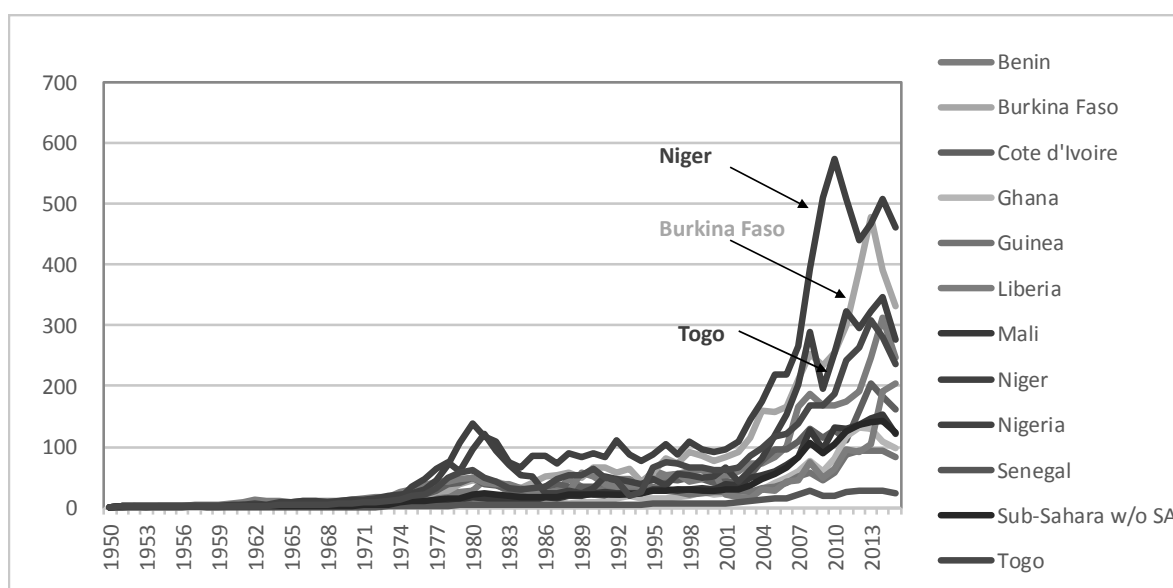

Source: JICA Study Team based on the UN data

Figure B.1.22 Trend of Import Value by Index (year 1950=1.0)

3) Overview of Logistics within the Region

Figure B.1.23 shows the cross-border freight traffic volume for the four countries, based on analysis of the customs data. This data includes not only overseas imports and exports, but also imports and exports between the four countries.

The volume of freight generated annually in the four countries is 54 million tons. Ghana generates the largest volume of freight at 24.8 million tons, or 42% of the total. Next is Côte d'Ivoire with 21.6 million tons, or 37% of the total. Burkina Faso and Togo each account for about 10% of the total.

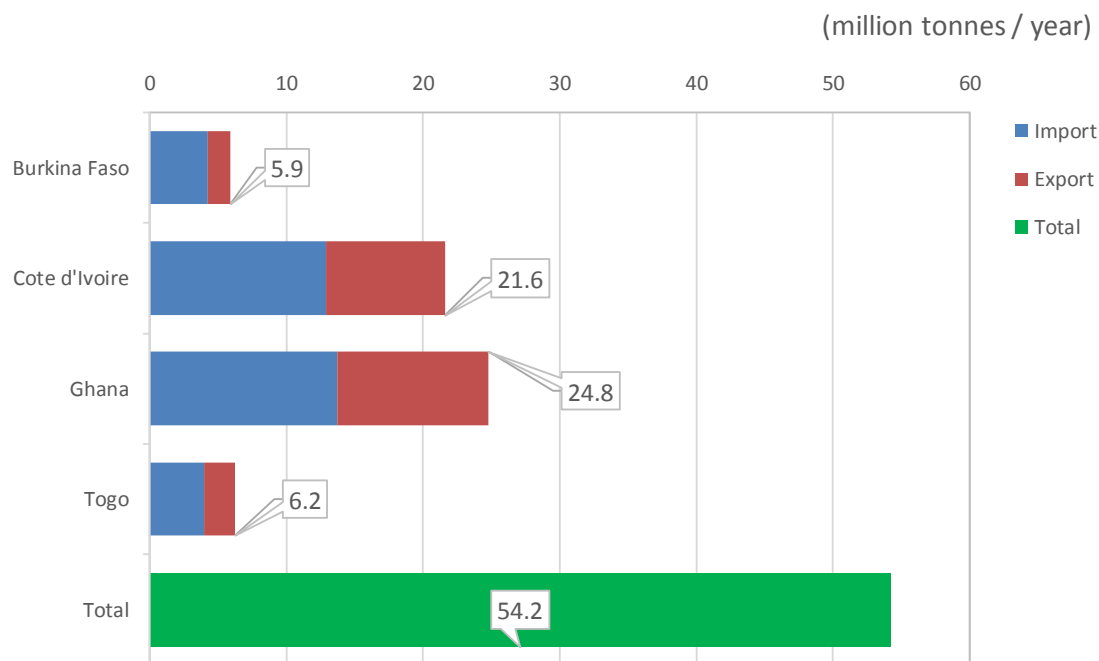

Source: JICA Study Team based on the customs data in 2014

Figure B.1.23 Cross-Border Freight Traffic Volume

Figure B.1.24 shows each item of freight as a percentage of the total volume of freight. From these results it can be seen that fossil fuels account for 32% of the total. Next is mineral products (including building materials such as clinker, etc.) at 21%, third is agricultural products at 14%, and fourth is industrial food processing products at 8%, so food accounts for 22% of the total.

Figure B.1.25 shows each item of freight as a percentage of the total volume of land transport freight. The main freight items are mineral products (mainly building materials such as clinker, cement, etc.), fuel oil, and agricultural products, and in fourth place is textiles. This shows that the essentials of daily life, namely clothing, food, and housing, account for the main products. It is worth noting that agricultural produce freight is increasing in the cross-border freight transported on land. It can be seen that the international transport corridor very much functions as infrastructure for supporting the basic lifestyle.

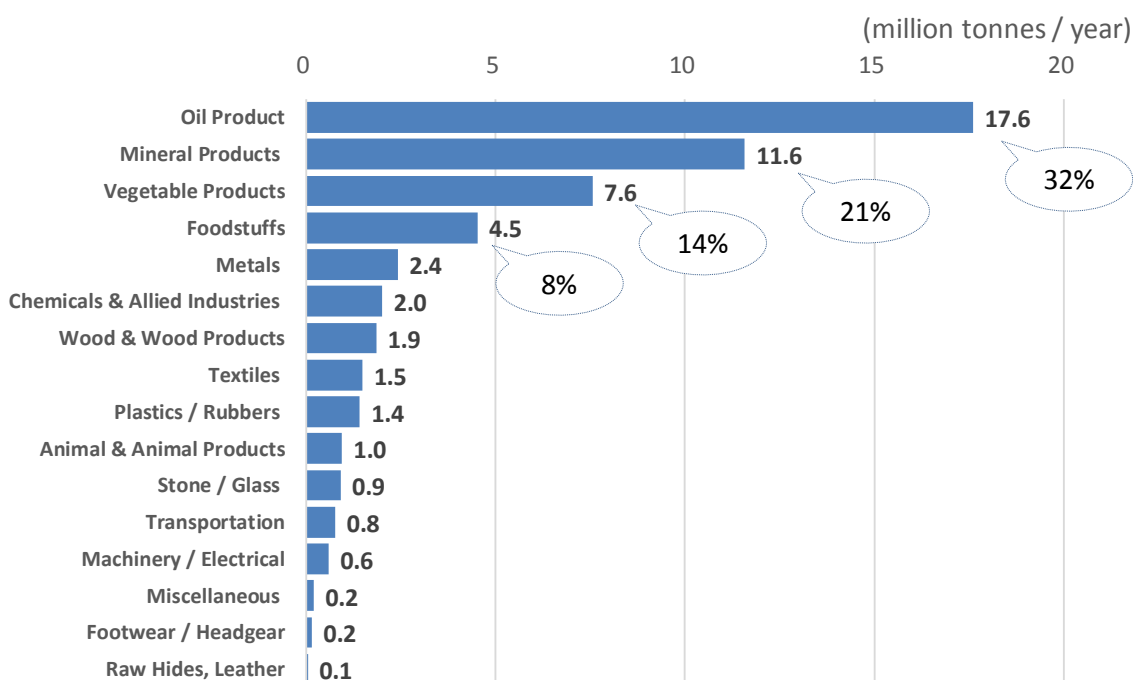

Source: JICA Study Team based on the customs data in 2014

Figure B.1.24 Type of Cross-Border Freight Traffic (All cargo)

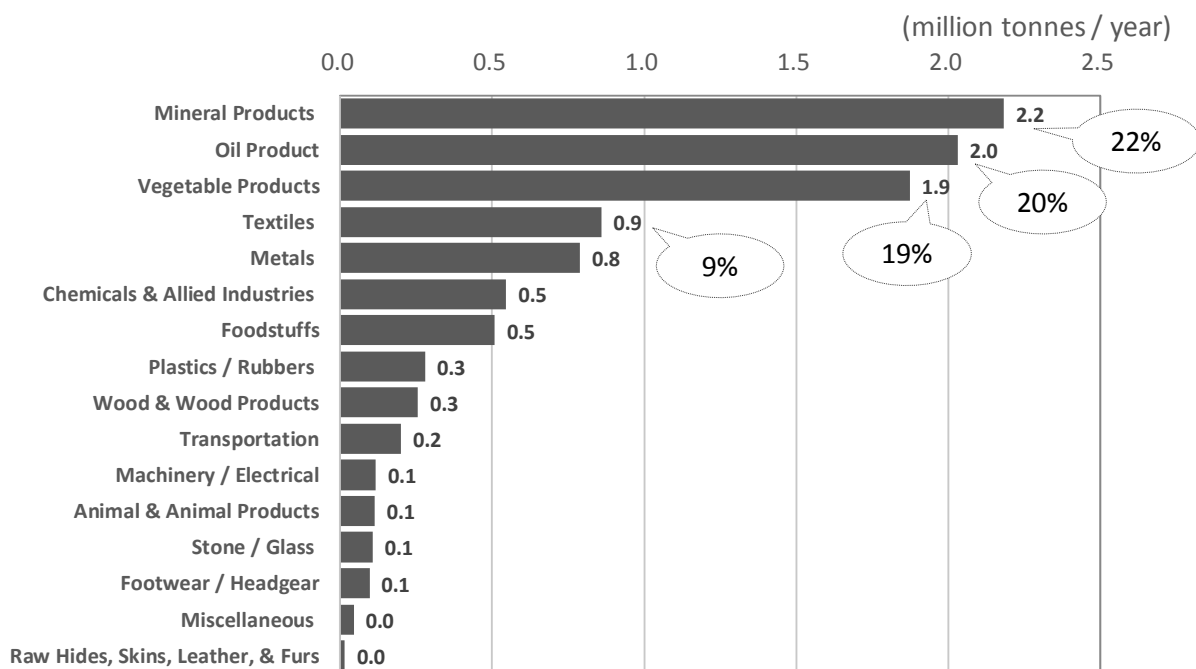

Source: JICA Study Team based on the customs data in 2014

Figure B.1.25 Type of Cross-Border Freight Traffic (Land cargo)

Figure B.1.26 shows the share of cross-border freight traffic (= import and export freight) according to the transport mode by weight for the four countries. The figure on the right shows the share by transport mode of all cargo including international imports and exports. Sea transport accounts for more than 80% of the total. Truck transport accounts for 16%, and rail transport for 2%. The percentage of air transport and internal trade is extremely small. The figure on the left shows the percentage share by transport mode within the region. Within the region refers to transport between the four countries and between ECOWAS. Truck transport accounts for 61%, and rail transport accounts for 7%.

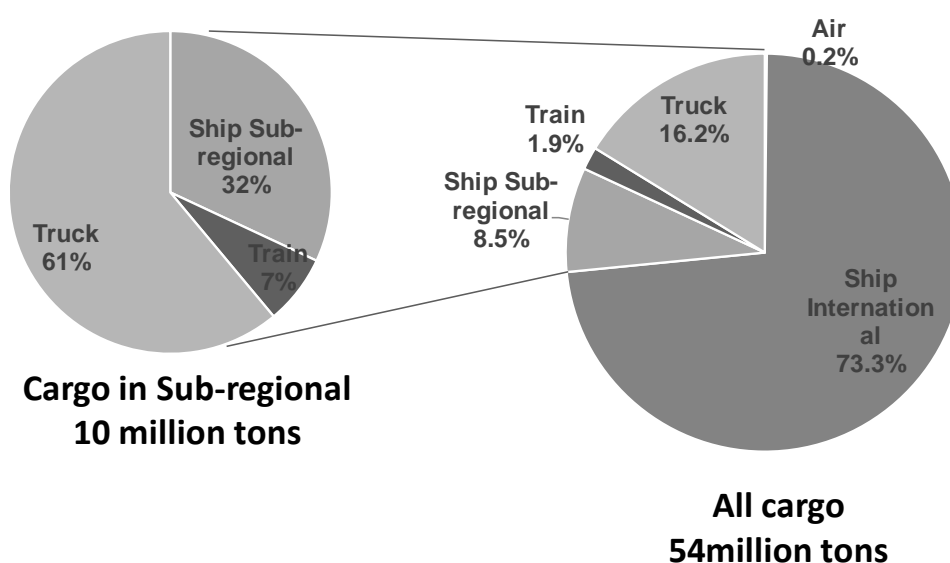

Source : JICA Study Team based on the customs data in 2014

Figure B.1.26 Mode Share of Cross-Border Freight Traffic

Figure B.1.27 shows the shares of each item of land transport according to the transport modes, rail and truck. Truck transport accounts for 90%, but the percentage of rail transport for metals, stone, and agricultural produce is higher than for other items.

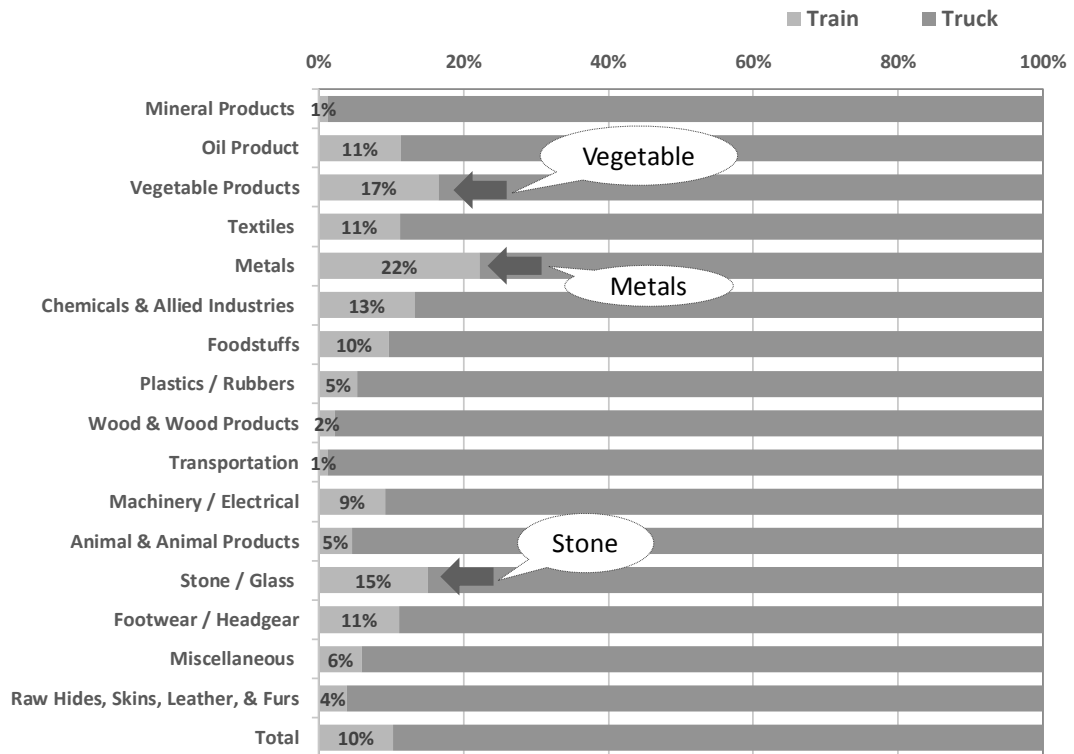

Source: JICA Study Team based on the customs data in 2014

Figure B.1.27 Mode Share of Cross-Border Freight Traffic

(3) Freight Flow Centring on WAGRIC Four Countries

The logistics flow was analysed separately for product items and transport modes, based on customs data. From the analysis results, the status of logistics for each product item can be understood for the various countries of West Africa.

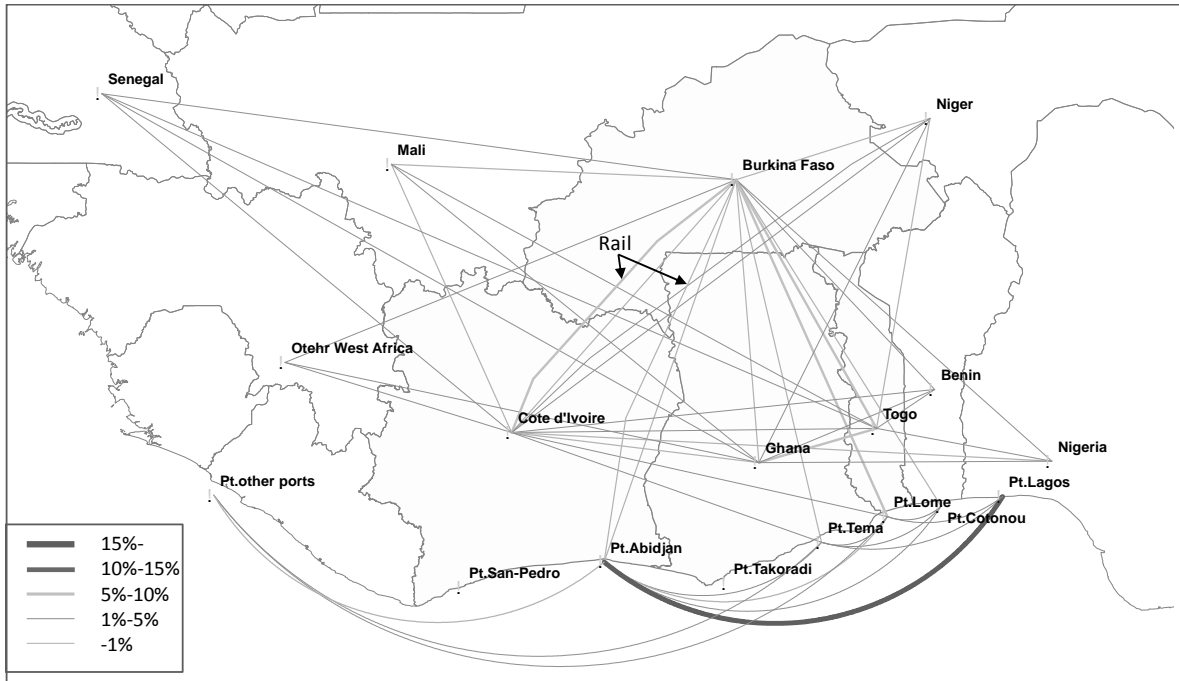

Type of goods: Total volume: 14,465 thousand tons /year

*Cargo to overseas like EU, Air cargo and Transshipment cargo are not included

Source: JICA Study Team based on the customs data in 2014

Figure B.1.28 Freight Flow, Total

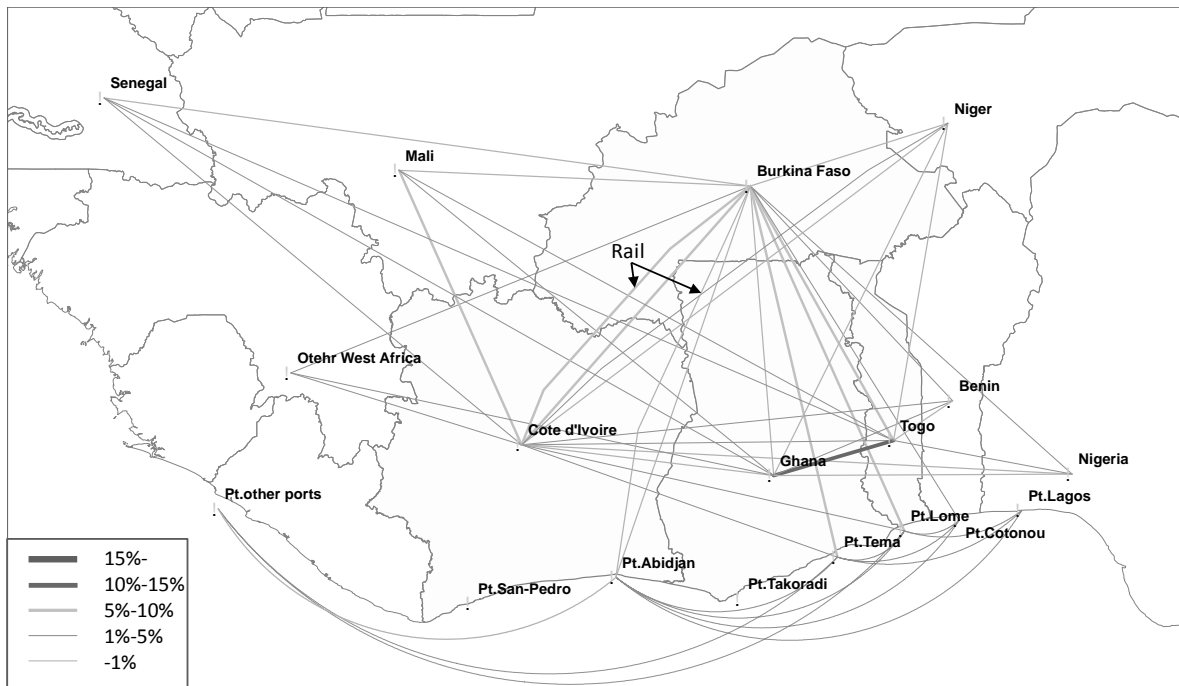

Type of goods: Total without Oil products, Total volume: 8,540 thousand tons /year

*Cargo to overseas like EU, Air cargo and Transshipment cargo are not included

Source: JICA Study Team based on the customs data in 2014

Figure B.1.29 Freight Flow, Total without Oil products

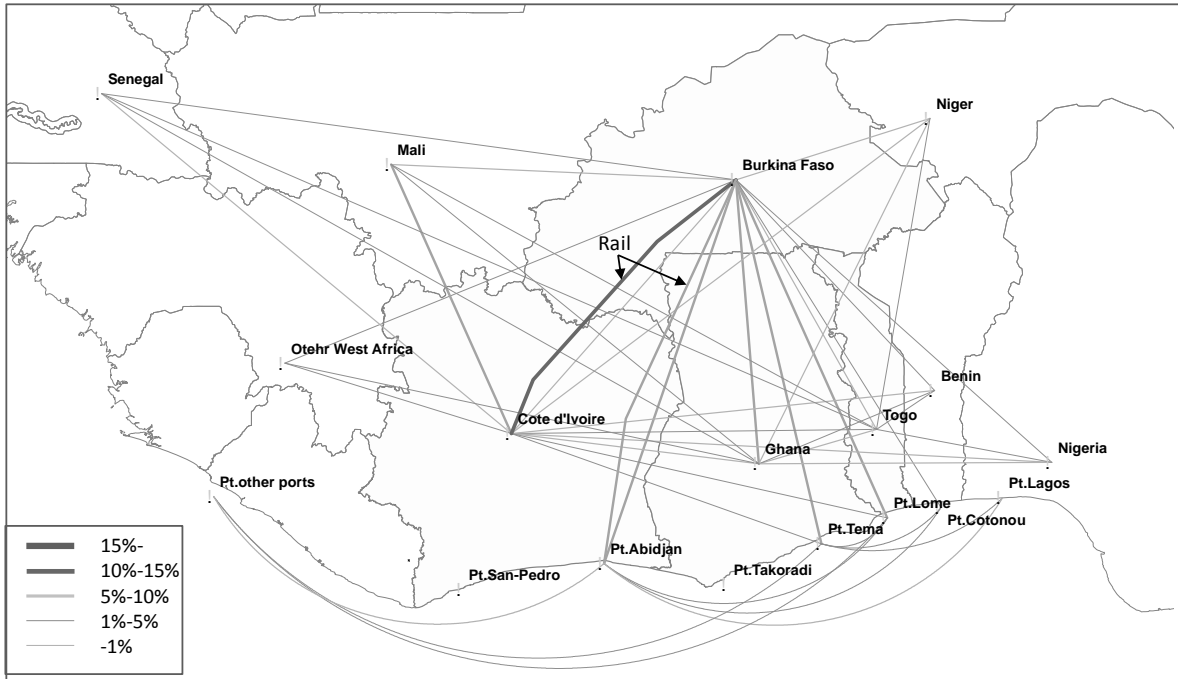

Type of goods: Agricultural products (HS1-15), Total volume: 2,090 thousand tons /year

*Cargo to overseas like EU, Air cargo and Transshipment cargo are not included

Source: JICA Study Team based on the customs data in 2014

Figure B.1.30 Freight Flow, Agricultural Products (HS1-15)

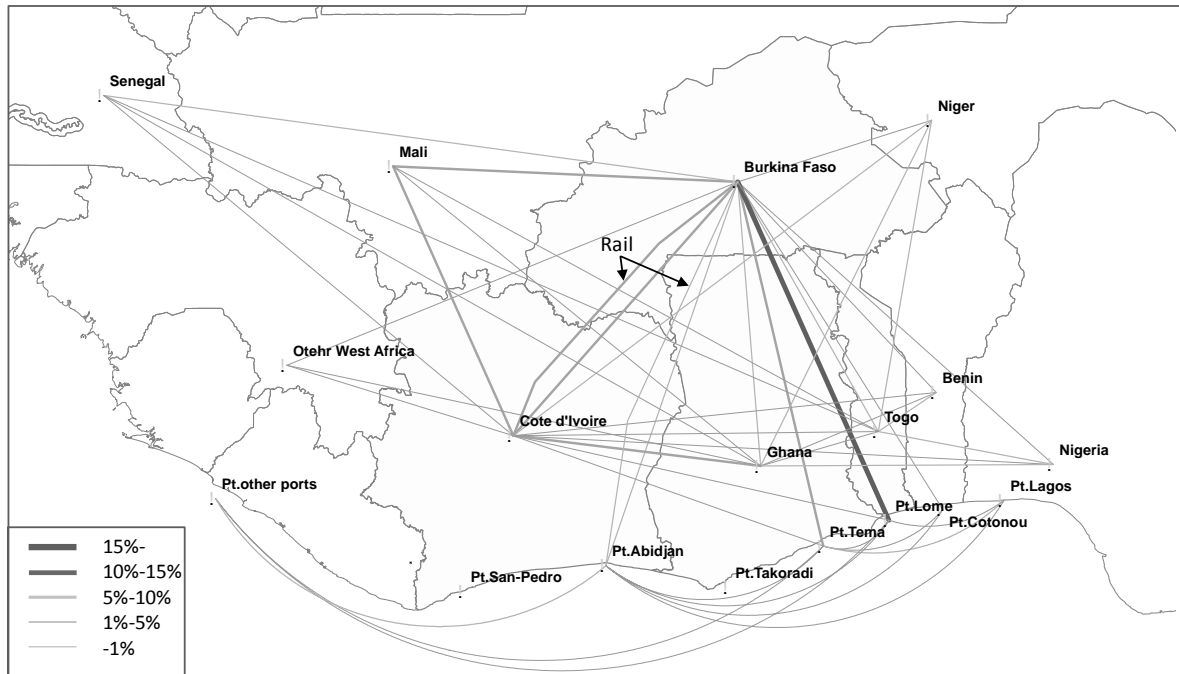

Type of goods: Foodstuffs (HS16-24), Total volume: 540 thousand tons /year

*Cargo to overseas like EU, Air cargo and Transshipment cargo are not included

Source: JICA Study Team based on the customs data in 2014

Figure B.1.31 Freight Flow, Foodstuffs (HS16-24)

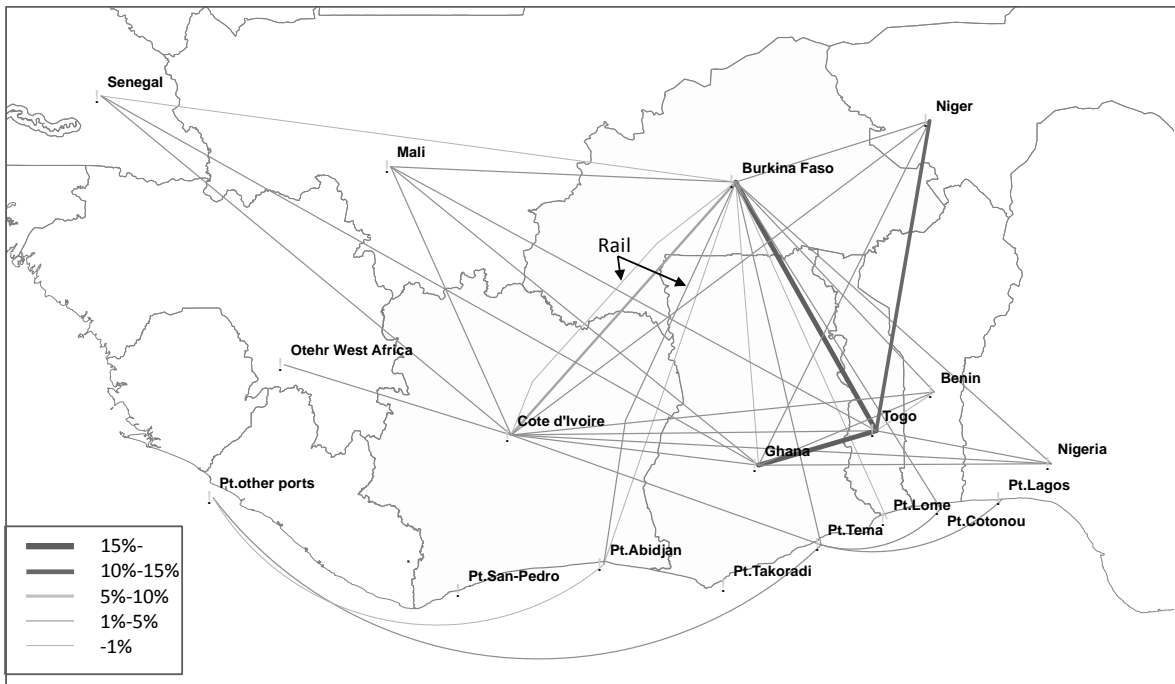

Type of goods: Mineral Products (HS25-26), Total volume: 2,270 thousand tons /year

*Cargo to overseas like EU, Air cargo and Transshipment cargo are not included

Source: JICA Study Team based on the customs data in 2014

Figure B.1.32 Freight Flow, Mineral Products (HS25-26)

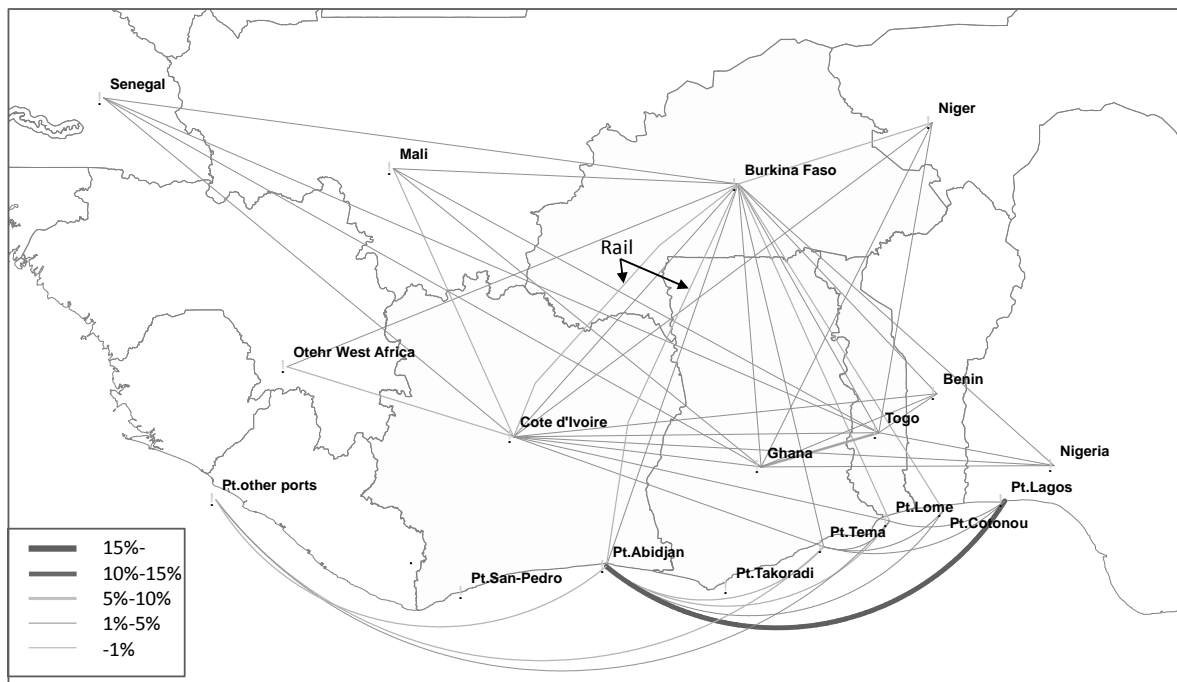

Type of goods: Oil Products (HS27), Total volume: 5,930 thousand tons /year

*Cargo to overseas like EU, Air cargo and Transshipment cargo are not included

Source: JICA Study Team based on the customs data in 2014

Figure B.1.33 Freight Flow, Oil Products (HS27)

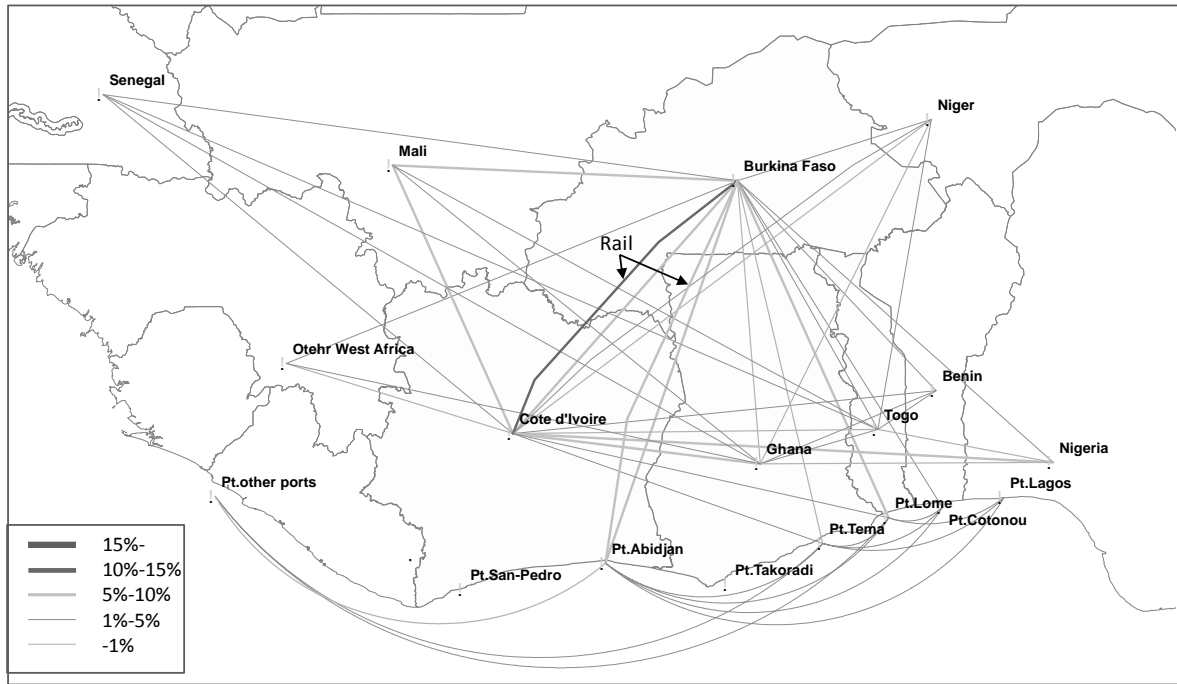

Type of goods: Chemicals/ Allied industries (HS28-38) , Total volume: 580 thousand tons /year

*Cargo to overseas like EU, Air cargo and Transshipment cargo are not included

Source: JICA Study Team based on the customs data in 2014

Figure B.1.34 Freight Flow, Chemicals/ Allied Industries (HS28-38)

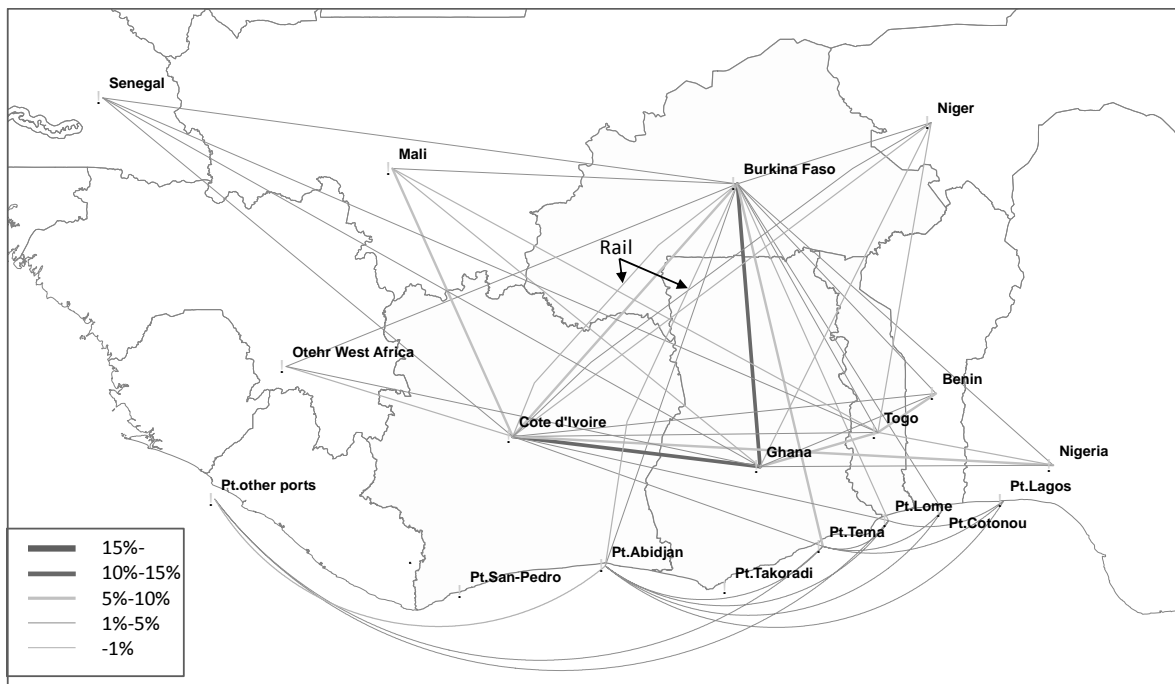

Type of goods: Plastics / Rubber (HS39-40), Total volume: 280 thousand tons /year

*Cargo to overseas like EU, Air cargo and Transshipment cargo are not included

Source: JICA Study Team based on the customs data in 2014

Figure B.1.35 Freight Flow, Plastics / Rubber (HS39-40)

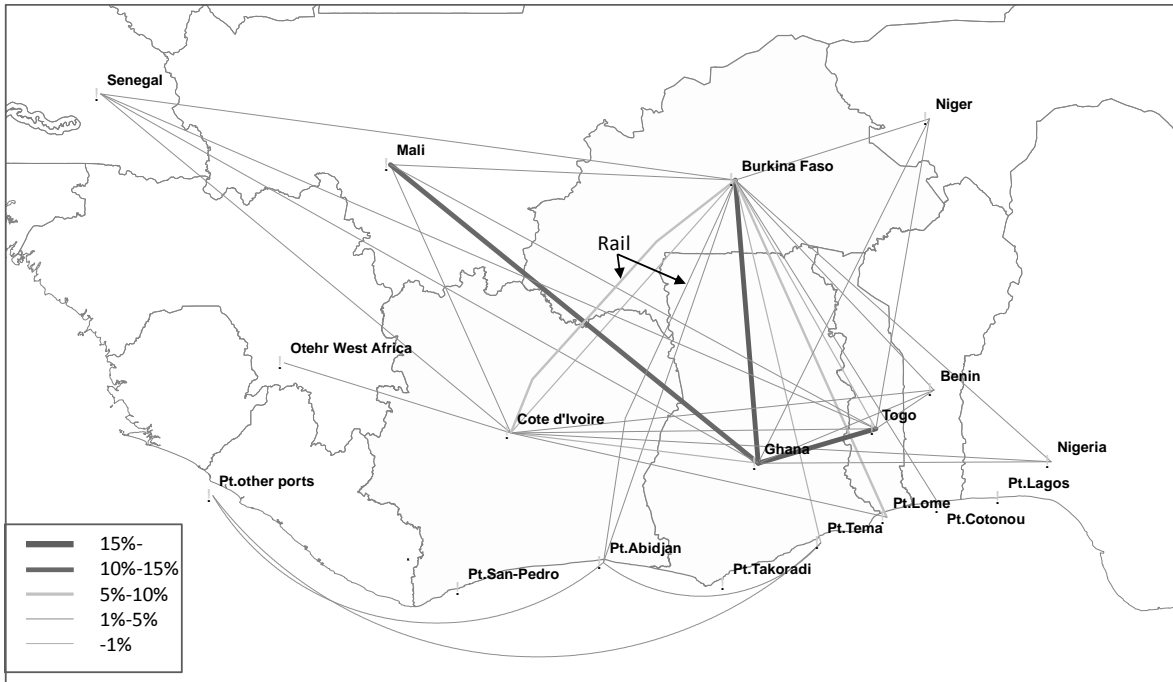

Type of goods: Leather (HS41-43), Total volume: 15 thousand tons /year

*Cargo to overseas like EU, Air cargo and Transshipment cargo are not included

Source: JICA Study Team based on the customs data in 2014

Figure B.1.36 Freight Flow, Leather (HS41-43)

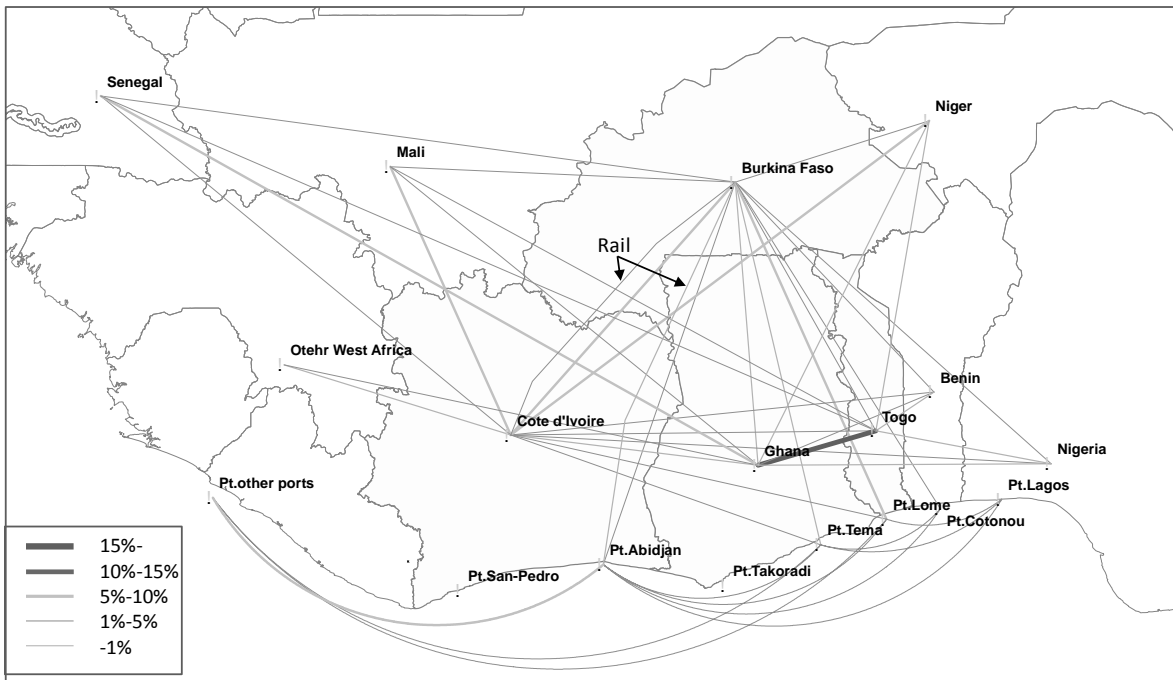

Type of goods: Wood Products (HS44-49), Total volume: 250 thousand tons /year

*Cargo to overseas like EU, Air cargo and Transshipment cargo are not included

Source: JICA Study Team based on the customs data in 2014

Figure B.1.37 Freight Flow, Wood Products (HS44-49)

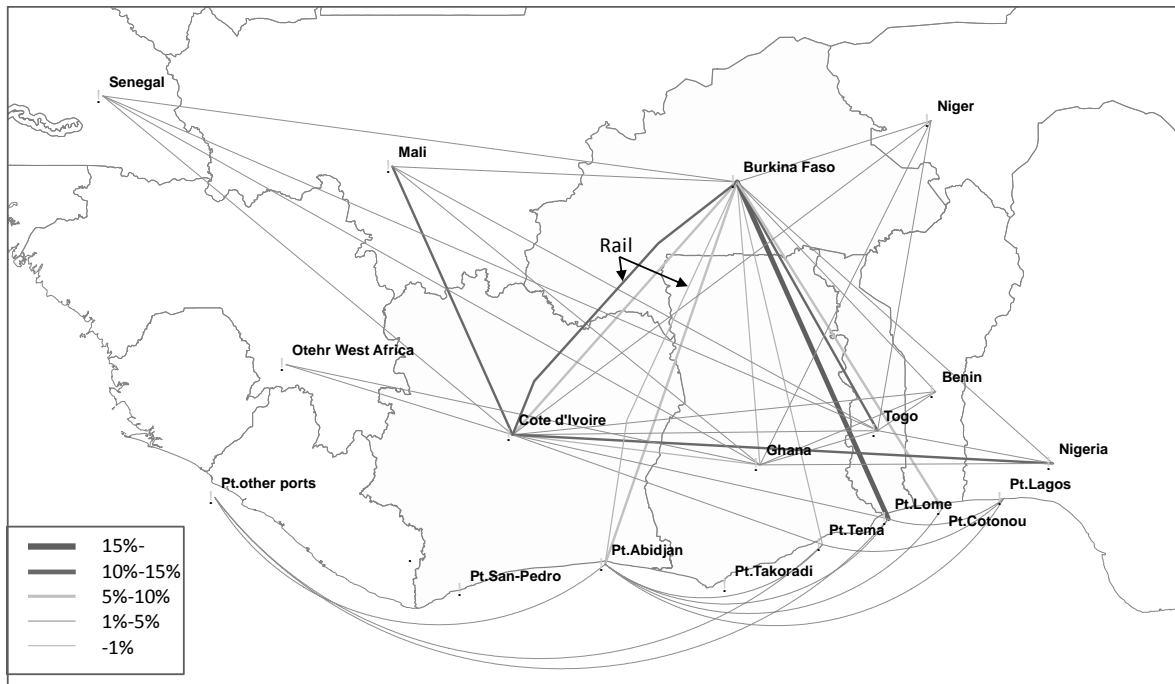

Type of goods: Textiles (HS50-63), Total volume: 910 thousand tons /year

*Cargo to overseas like EU, Air cargo and Transshipment cargo are not included

Source: JICA Study Team based on the customs data in 2014

Figure B.1.38 Freight Flow, Textiles (HS50-63)

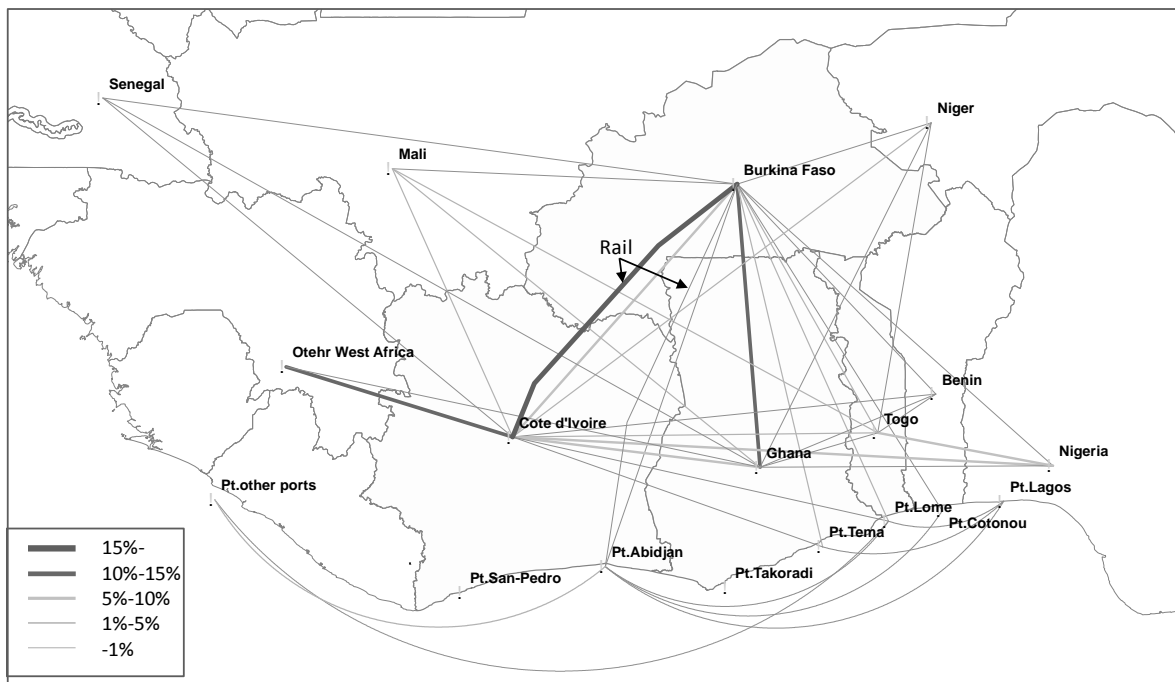

Type of goods: Footwear/Headgear (64-67), Total volume: 110 thousand tons /year

*Cargo to overseas like EU, Air cargo and Transshipment cargo are not included

Source: JICA Study Team based on the customs data in 2014

Figure B.1.39 Freight Flow, Footwear/Headgear (64-67)

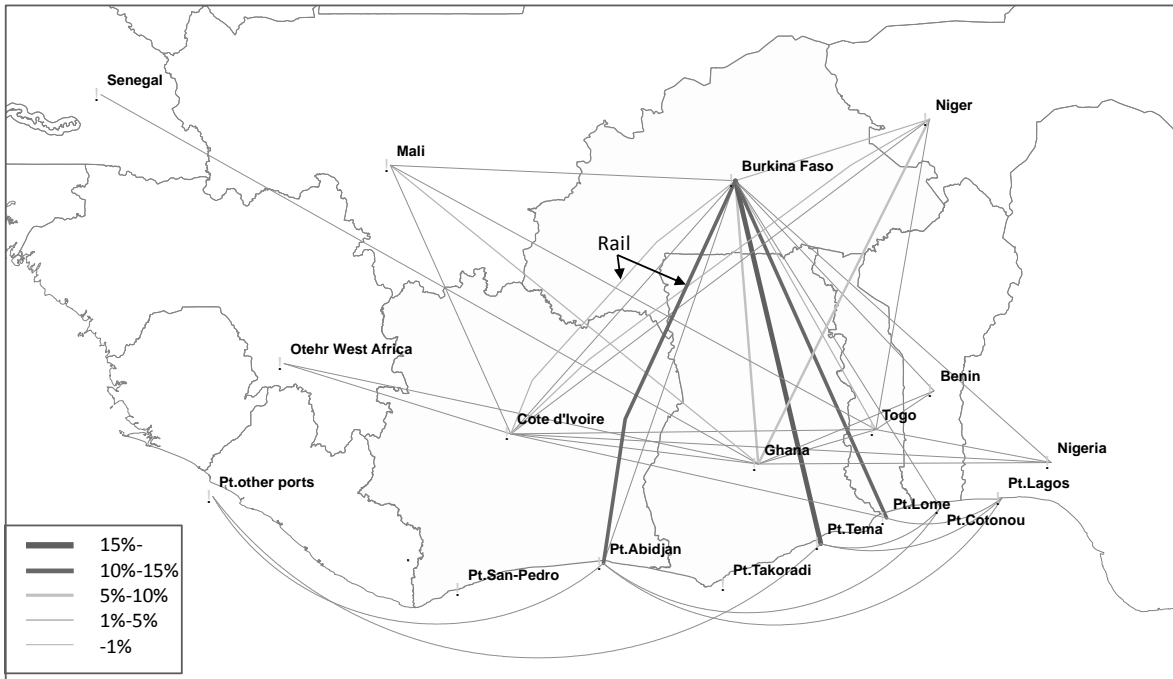

Type of goods: Stone/ Glass (HS68-71), Total volume: 110 thousand tons /year

*Cargo to overseas like EU, Air cargo and Transshipment cargo are not included

Source: JICA Study Team based on the customs data in 2014

Figure B.1.40 Freight Flow, Stone/ Glass (HS68-71)

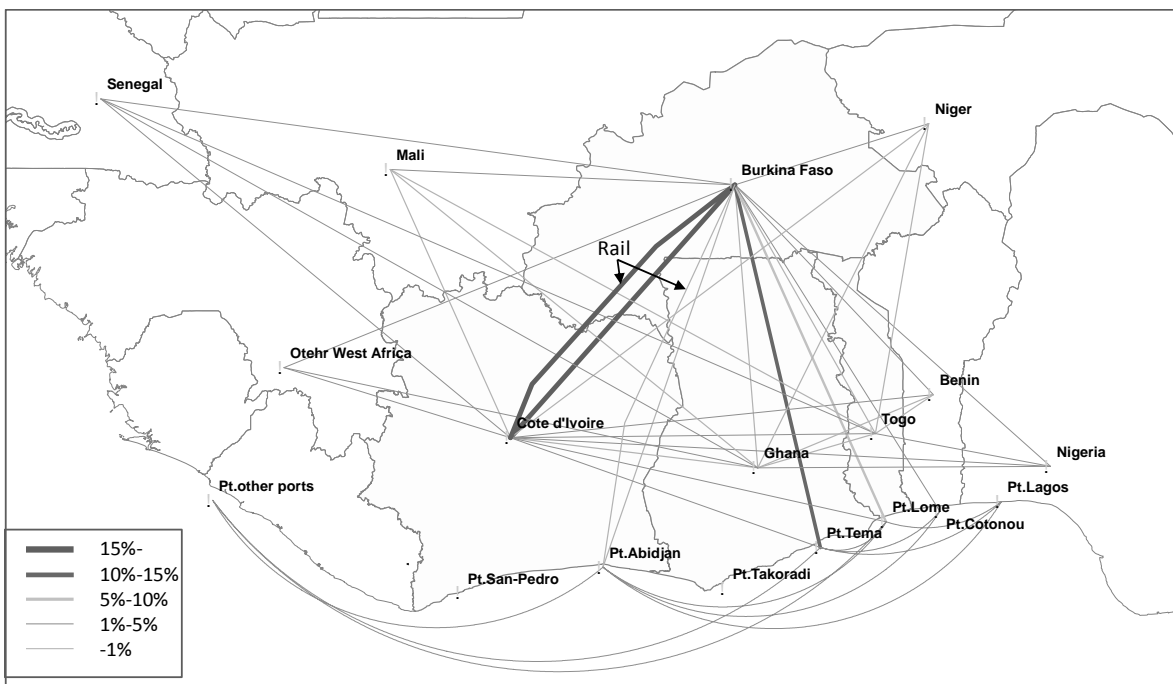

Type of goods: Metals (HS72-83), Total volume: 910 thousand tons /year

*Cargo to overseas like EU, Air cargo and Transshipment cargo are not included

Source: JICA Study Team based on the customs data in 2014

Figure B.1.41 Freight Flow, Metals (HS72-83)

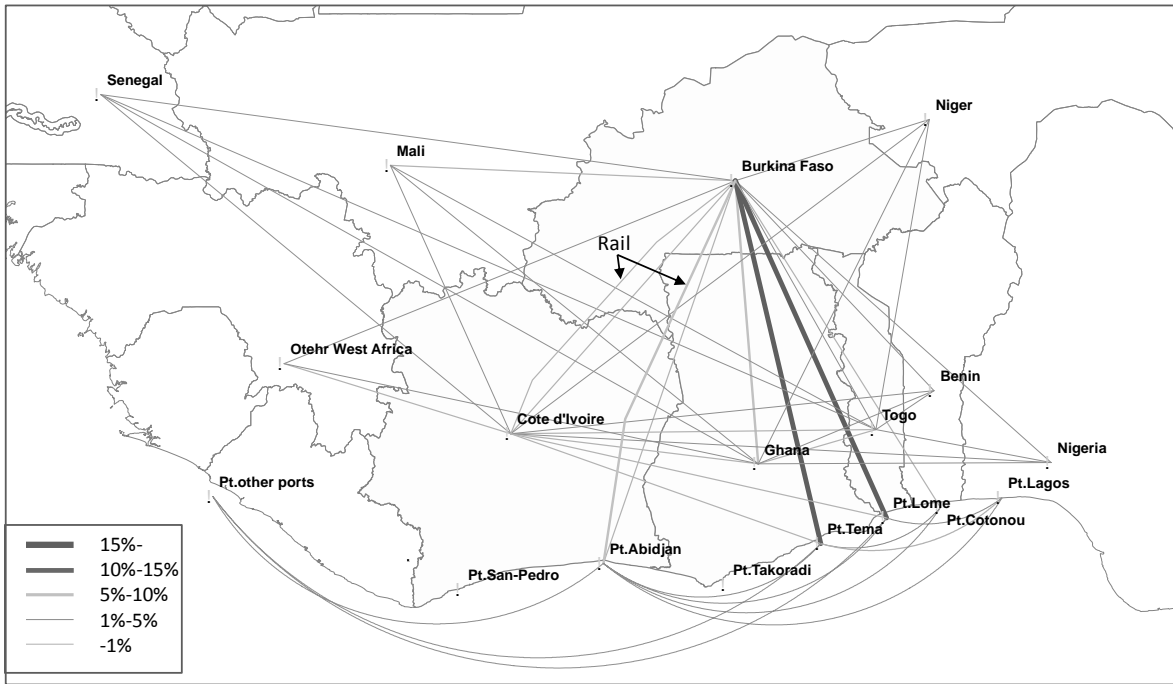

Type of goods: Machinery /Electrical (HS84-85), Total volume: 110 thousand tons /year

*Cargo to overseas like EU, Air cargo and Transshipment cargo are not included

Source: JICA Study Team based on the customs data in 2014

Figure B.1.42 Freight Flow, Machinery /Electrical (HS84-85)

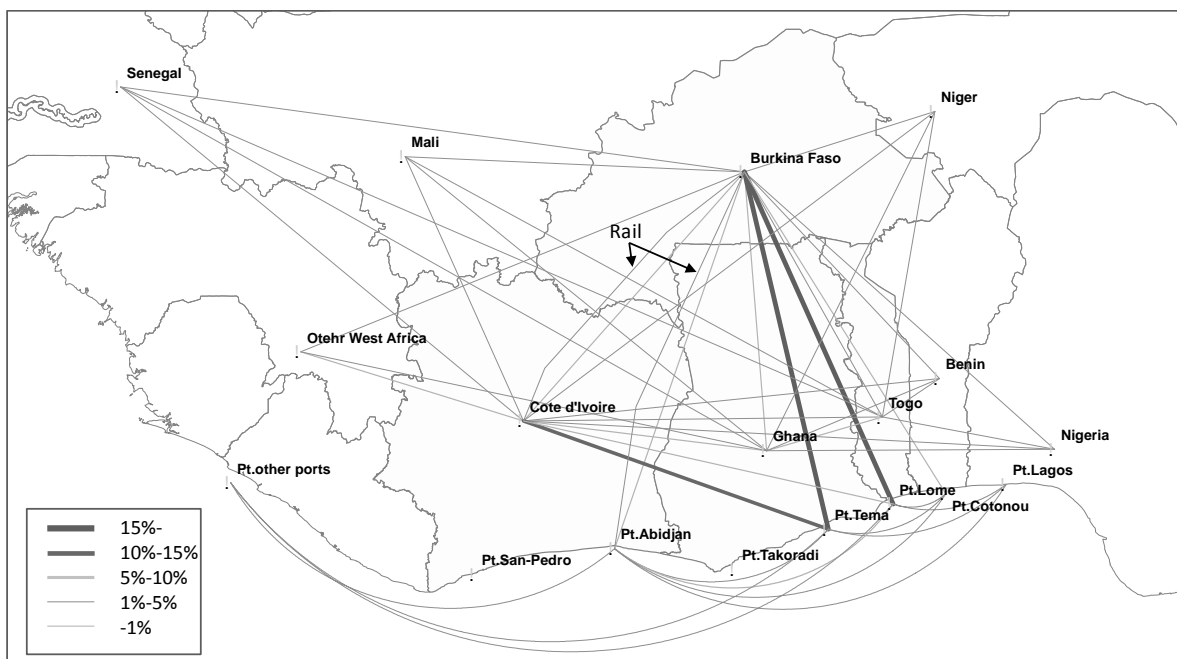

Type of goods: Vehicles and parts (HS86-89), Total volume: 180 thousand tons /year

*Cargo to overseas like EU, Air cargo and Transshipment cargo are not included

Source: JICA Study Team based on the customs data in 2014

Figure B.1.43 Freight Flow, Vehicles and Parts (HS86-89)

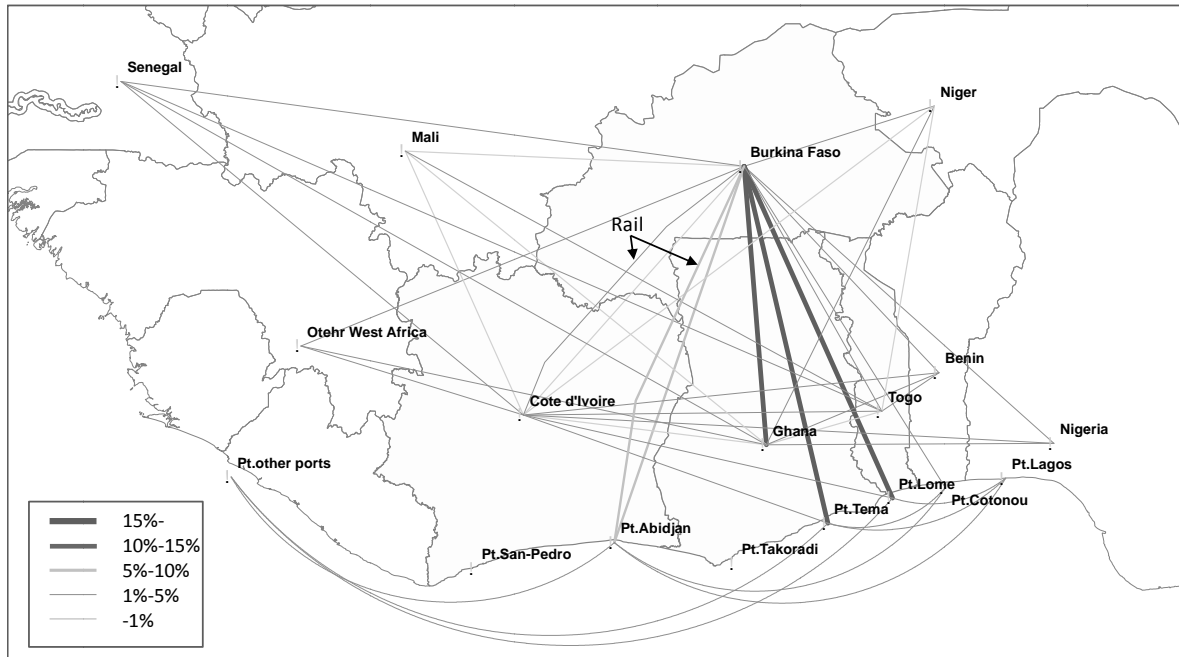

Type of goods: Miscellaneous (HS90-97), Total volume: 40 thousand tons /year

*Cargo to overseas like EU, Air cargo and Transshipment cargo are not included

Source: JICA Study Team based on the customs data in 2014

Figure B.1.44 Freight Flow, Miscellaneous (HS90-97)

B.1.6 Other Traffic Characteristics

(1) Overloaded Vehicles

Overloading in main corridors is shown below. Around 50% of through-traffic is overloaded. A maximum gross weight of more than 100 tons was observed. UEMOA standards differ by vehicle type, but whereas even at the top end of the scale (seven-axle truck: 63 tons, six-axle truck: 51 tons) the maximum gross weight is 63 tons, several vehicles with a gross weight of over 100 tons exist.

Table B.1.4 Percentage of Overloaded Vehicles on Corridors

Corridor	Percentage of overloaded vehicles	Gross weight of maximum loading vehicle (tons)
Abidjan-Ouagadougou	57%	106
Accra/Tema-Ouagadougou	49%	104
Lomé-Ouagadougou	47%	113

(2) Broken-down Trucks

No official statistical data on broken-down trucks exists. When the Study Team visited the site, 20-30 broken-down vehicles were seen in each corridor. According to the Togo National Shippers Council which provides a wrecker service, engine trouble is the major cause of breakdown. In addition, most of the trucks are around 20 years old.

B.2 Traffic Demand Forecast

B.2.1 Basic Idea

The two methodologies that were proposed in the inception report for the demand analysis are shown below. However, the total demand to be generated by the development of economic sectors along transport corridors was not estimated by experts of the related economic sectors. Unfortunately, the available socio-economic indicator data including the future production for each zone was not estimated. Neither does it project estimates of the changes in the future value chain of agriculture and other industries as well. It is difficult to estimate the future volume of freight items with this limited information.

- Methodology 1: Traffic demand to be generated by economic sectors will be estimated and compared with the transport capacity of corridor infrastructures which are existing and/or planned to be rehabilitated or upgraded.
- Methodology 2: Estimation of volumes of transport demand and level of development of economic sectors which enable investment required for development of corridor infrastructures

From the situation of data availability mentioned above, the traffic demand forecast in this study is done based on a simple method.

Basic Condition

Attention will also be paid to the sharing of traffic demand between international corridors and between different modes of transport (mainly road and railway) in the forecast. Table B.2.1 shows the basic condition for the demand forecast. The work flows shown in Figure B.2.1 will be used for future traffic demand forecasts. Demand forecast will be carried out for passenger traffic flow and freight traffic flow. Road traffic volumes will be estimated by combining estimated traffic volumes of passenger vehicles and freight vehicles.

The existing railway is currently being used for some passenger transportation, but it is considered that the modal shift from the road to the railroad in the future would be limited. The reason is that based on an interview with the railroad company, the company has a plan for capital investment in response to the net rise of future railway passengers, but they think that a remarkable modal shift from passenger cars and bus transportation is not realistic. In WAGRIC-CACAO, a motorway plan competing with the existing railway is proposed. Because the competitiveness of highway transport is very high, it would be difficult for a modal shift to railway to occur.

Basically, the construction of new railways will be developed for the mine development. Therefore, the mineral resources to be developed shall be transported by only rail. This new railway would be provided for some freight transport. But, the new railway development depends on mining development, so the planned year is uncertain. Therefore, the traffic demand forecast does not take into consideration the presence or absence of new railway maintenance.

Table B.2.1 Basic Conditions for Traffic Demand Forecast

Item	Study Contents
Target Years for Forecast	Year 2033 for Medium-term year Year 2040 for long-term target year
Forecast Area	Traffic demand for transport corridors in the four countries and their neighbouring countries will be forecast. Influx and efflux traffic to and from sea ports in the Study Areas will be forecast.
Passenger Transport and Freight Traffic Flow to be Forecast	The passenger traffic flow (by passenger vehicles and buses) and the freight traffic flow (by trucks and railways) will be forecast.
Traffic Zones and Transportation Network	The Study Areas are to be divided into fifteen traffic zones. Traffic demand on international corridors, trunk roads (the UEMOA priority roads and national priority roads) and railways will be forecast.
Forecast Method	A standard four-step forecast model will be used for future traffic forecast. The mode choice and route assignment models used in past studies will be examined.

Source: JICA Study Team

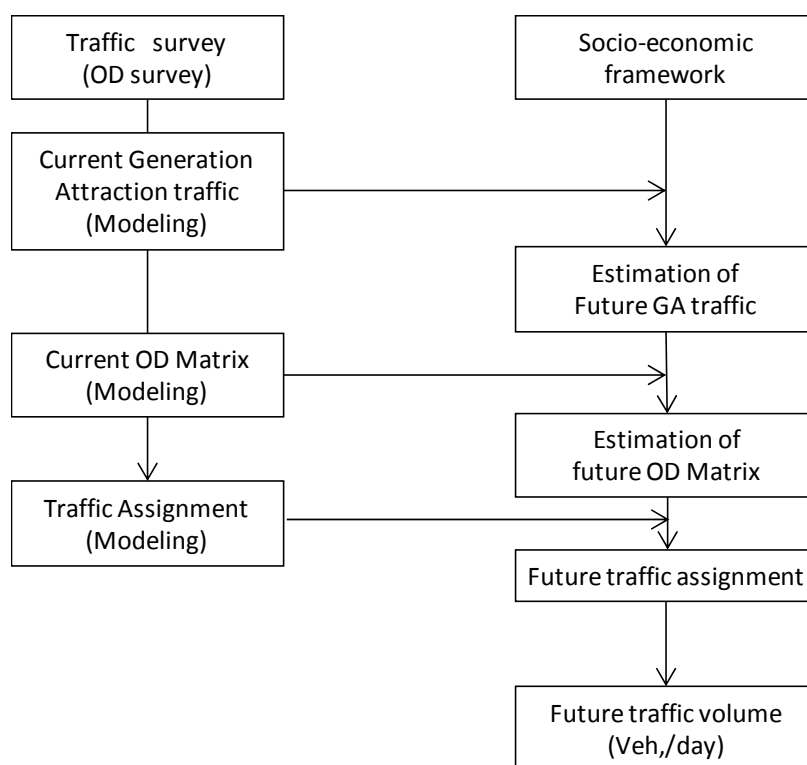

Source: JICA Study Team

Figure B.2.1 Basic Work Flows for Traffic Demand Forecast

B.2.2 Socio-Economic Framework

The only socio-economic indicators calculated in Chapter 5 of this report that can be used are the resident populations by country and GDP by country.

Therefore, these two indicators are used as the explanatory variables for predicting traffic demand. The current population and economic indicators and future framework are shown below.

(1) Population

Table B.2.2 shows the population framework by country described in Chapter 5. The population of the WAGRIC region is expected to increase steadily. The total population of the four countries is expected to reach 150 million by 2040, approximately double that in 2015. The population of the Abidjan and Accra urban areas is forecast to exceed 10 million, creating two megacities in West Africa. The population projection framework by zone was created with the population framework by country as the control total. The population by zone is as shown in Table B.2.3.

Table B.2.2 Population Framework by Countries

Country		2000	2010	2015	2020	2025	2030	2035	2040
Burkina Faso	Population	11,588,542	16,018,720	18,999,897	22,523,602	26,548,027	30,959,506	35,672,198	40,559,751
	Annual Growth Rate		3.29%	3.47%	3.46%	3.34%	3.12%	2.87%	2.60%
Cote d'Ivoire	Population	16,867,089	20,741,611	23,217,271	26,393,493	30,470,452	35,165,668	40,107,210	45,142,028
	Annual Growth Rate		2.09%	2.28%	2.60%	2.91%	2.91%	2.66%	2.39%
Ghana	Population	18,912,038	24,659,120	28,018,147	31,753,831	35,831,244	40,224,659	44,889,236	49,758,219
	Annual Growth Rate		2.69%	2.59%	2.53%	2.45%	2.34%	2.22%	2.08%
Togo	Population	4,633,431	6,190,000	7,150,472	8,247,824	9,493,005	10,897,981	12,473,111	14,222,551
	Annual Growth Rate		2.94%	2.93%	2.90%	2.85%	2.80%	2.74%	2.66%
WAGRIC	Population	52,001,080	67,609,450	77,385,786	88,918,751	102,342,728	117,247,794	133,141,755	149,682,549
	Annual Growth Rate		2.66%	2.74%	2.82%	2.85%	2.76%	2.58%	2.37%

Source: JICA Study Team

Table B.2.3 Population Framework by Zone (thousand)

Zone	Pop 2015	Pop 2033	Pop 2040	
1	Burkina Faso-South	5,938	11,116	13,321
2	Burkina Faso-West	5,460	9,854	11,720
3	Burkina Faso-East	3,181	5,860	6,924
4	Burkina Faso-North	4,421	7,903	9,328
5	Côte d'Ivoire-South East	7,552	11,992	14,212
6	Côte d'Ivoire-South West	8,771	14,618	17,668
7	Côte d'Ivoire-North East	4,069	6,265	7,249
8	Côte d'Ivoire-North West	2,826	5,025	6,913
9	Ghana-South	10,137	16,074	18,126
10	Ghana-South East	2,386	3,544	3,937
11	Ghana-South West	2,756	4,573	5,426
12	Ghana-Central	7,841	12,472	14,183
13	Ghana-North	4,655	6,972	8,087
14	Togo-South	4,611	7,764	9,295
15	Togo-North	2,539	4,1145	4,928
16	Benin	10,543	15,884	17,958
17	Nigeria	178,418	274,146	311,373
18	Niger	23,495	41,735	48,828
19	Mali	17,390	29,589	34,333
20	Liberia	4,260	6,402	7,235
21	Sierra Leone	6,590	9,000	9,937
22	Guinea	10,802	16,594	18,847
23	Senegal	14,347	23,263	26,730

Source: JICA Study Team

(2) GDP

Figure B.2.2 shows the GDP by country mentioned in Chapter 5. Figure B.2.3 shows the GDP per capita. GDP is expected to grow steadily, increasing to over five times its current level by 2040. GDP per capita will reach 3,000 USD by 2035. It is likely that motorisation in Abidjan and Accra urban areas will advance rapidly from around 2025.

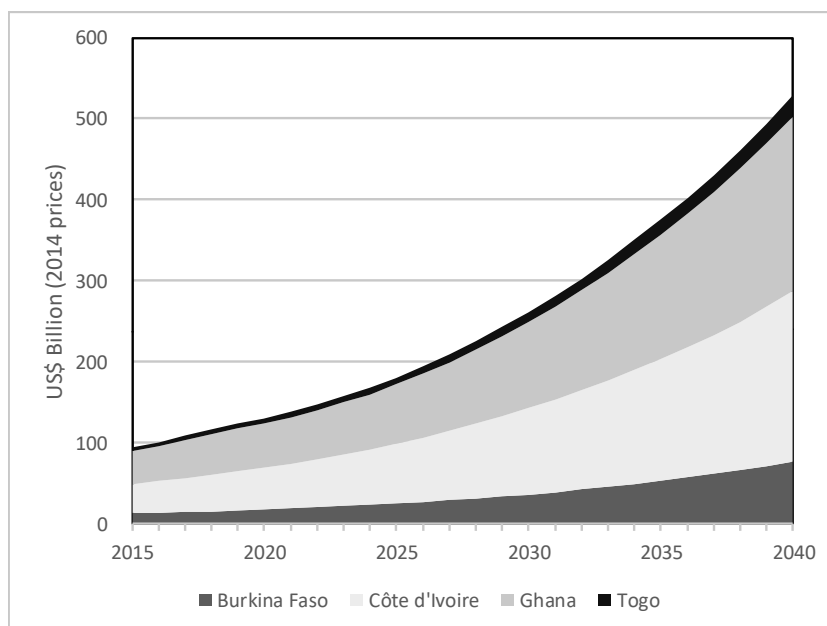

Source: JICA Study Team

Figure B.2.2 GDP Framework by Country in WAGRIC Countries

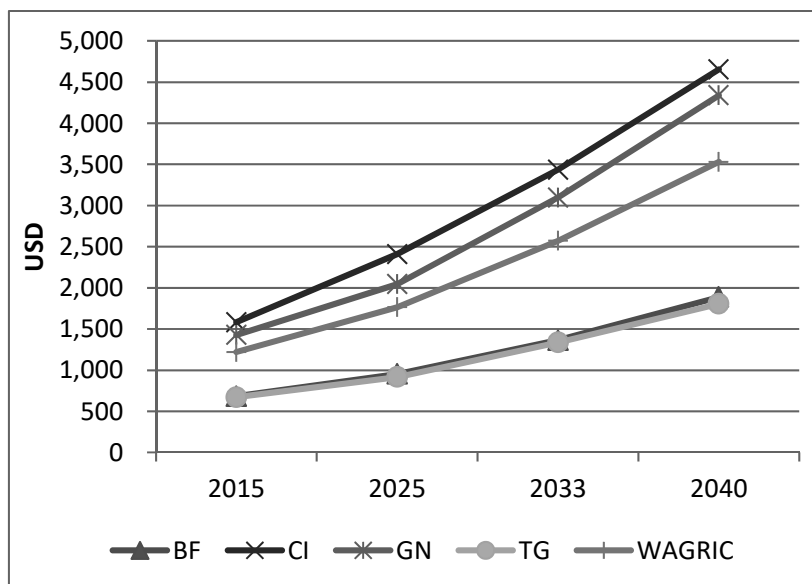

Source: JICA Study Team

Figure B.2.3 GDP per Capita in WAGRIC Countries

B.2.3 Traffic Demand Forecast

(1) Forecasting Generated and Attracted Traffic Volume

Generated and attracted traffic volume was estimated for passengers and for freight. The two years used in the estimation were 2033 and 2040. A generated and attracted traffic volume model was built using the current zone-specific traffic volume, population and GDP. The generated traffic volume approach uses linear regression. As population and GDP are the only future socio-economic indicators that can be used, the model was built with these two variables as the explanatory variables and the generated and attracted traffic volume, composed of arterial traffic across the zones, as the explained variable.

The object of traffic volume calculation for passengers was traffic volume on the basis of persons. The freight volume was calculated on a vehicle basis with trucks as the object. The resulting generated and attracted traffic model is as shown below.

$$\text{Number of passenger trips} = 3555 * \text{Population (million)} - 3199 * \text{GDP (billion)} - 2.48 \quad R^2=0.6$$

$$\text{Number of Freight Vehicles} = 221 * \text{Population (million)} - 323 * \text{GDP (billion)} - 869 \quad R^2=0.87$$

Looking at the growth in traffic volume in the 15 zones of the four countries, the passenger traffic volume in 2033 is forecast to be 3.2 times that in 2015 with a long-term forecast of 4.1 times by 2040. The freight traffic volume in 2033, on the other hand, is forecast to be 4.2 times that in 2015 with a long-term prediction of 5.5 times by 2040.

Table B.2.4 Generated Traffic A by Zone

Unit: Trip-end

Zone	Passenger trip					Freight traffic				
	2015	2033	2033 /2015	2040	2040 /2015	2015	2033	2033 /2015	2040	2040 /2015
1 Burkina Faso-South	28,094	127,348	4.5	162,524	5.8	2,994	10,710	3.6	13,959	4.7
2 Burkina Faso -West	21,358	88,997	4.2	112,716	5.3	1,662	7,008	4.2	9,147	5.5
3 Burkina Faso -East	18,025	37,168	2.1	46,645	2.6	370	2,324	6.3	3,135	8.5
4 Burkina Faso -North	9,347	48,194	5.2	60,092	6.4	512	3,155	6.2	4,160	8.1
5 Côte d'Ivoire-South East	50,649	319,274	6.3	411,075	8.1	6,361	29,986	4.7	38,957	6.1
6 Côte d'Ivoire-South West	24,707	178,710	7.2	228,400	9.2	1,886	15,415	8.2	20,014	10.6
7 Côte d'Ivoire-North East	21,505	97,288	4.5	124,133	5.8	1,351	8,346	6.2	10,921	8.1
8 Côte d'Ivoire-North West	6,923	46,395	6.7	59,232	8.6	513	3,373	6.6	4,533	8.8
9 Ghana-South	137,079	294,614	2.1	372,845	2.7	8,661	26,927	3.1	34,550	4.0
10 Ghana-South East	49,349	63,441	1.3	80,599	1.6	975	5,301	5.4	6,981	7.2
11 Ghana-South West	36,782	93,758	2.5	120,438	3.3	1,824	8,223	4.5	10,801	5.9
12 Ghana-Central	79,504	148,504	1.9	186,113	2.3	4,650	12,660	2.7	16,223	3.5
13 Ghana-North	10,478	75,626	7.2	95,356	9.1	435	6,057	13.9	7,896	18.2
14 Togo-South	36,284	82,211	2.3	104,517	2.9	1,993	6,613	3.3	8,655	4.3
15 Togo-North	9,946	18,597	1.9	23,255	2.3	370	685	1.9	1,048	2.8
total	540,029	1,720,126	3.2	2,187,940	4.1	34,557	146,784	4.2	190,979	5.5

Source: JICA Study Team

(2) Forecasting of Trip Distribution

Future trip distribution in 2033 and 2040 was estimated. The parameters for trip distribution between zones were identified by applying the gravity model, which is the spatial interaction model.

The shortest travel time estimated from the road network conditions was used for the impedance between zones. The generated and attracted traffic volume estimated with the model in the previous section was input to estimate future trip distribution. The trip distribution was then corrected by applying the Frater method to the results with the generated and attracted traffic volume as the control total. The OD trip table for passenger travel on a vehicle basis by vehicle type was created by multiplying by the current ratio of cars, minibuses and buses.

$$T_{ij} = k \cdot \frac{G_i^\alpha A_j^\beta}{d_{ij}^\gamma}$$

where:

T_{ij} = interzonal traffic volume

G_i = generated traffic volume

A_j = attracted traffic volume

d_{ij} = interzonal impedance (time distance)

k, α, β, γ = parameters

Table B.2.5 Distribution Model Parameters

	α	B	Γ	k	R^2
Passenger	0.28	0.37	-1.21	16.39	0.63
Truck	0.33	0.35	-0.59	0.84	0.60

Source: JICA Study Team

(3) Traffic Assignment

Traffic assignment was performed using the created OD trip table and road network by year. The method used was the incremental assignment method. First, the parameters were set while confirming the reproducibility of current conditions using the current OD trip table and road network conditions. Based on the results, future road traffic volume was estimated for 2033 in the medium term and 2040 in the long term. The estimated road network conditions by year were based on the construction scenario shown in Figure B.2.4 and Figure B.2.5. In addition, the basic road conditions by road type were as shown in Table B.2.8. The traffic volume estimated here is the arterial traffic volume between zones and across borders.

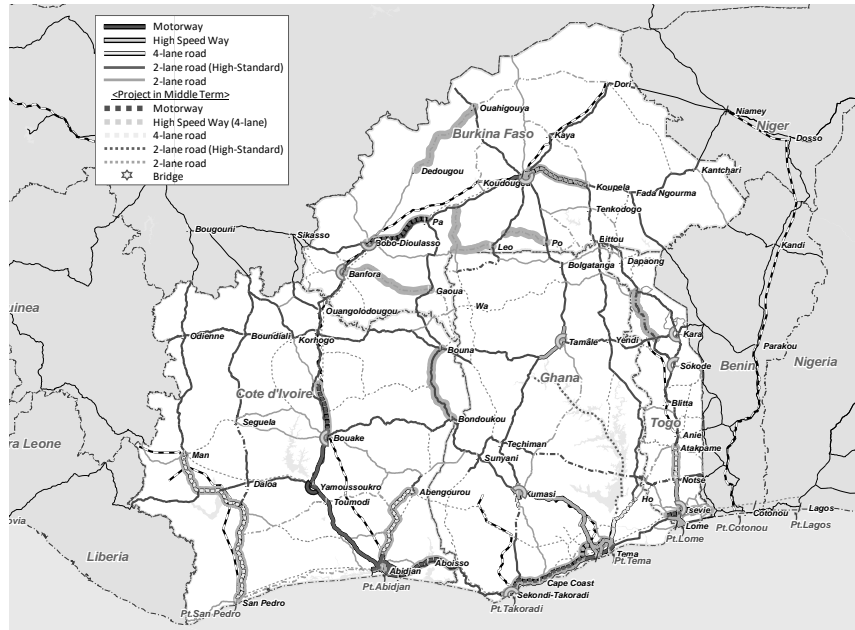

Source: JICA Study Team

Figure B.2.4 Road Development Scenarios for Year 2033

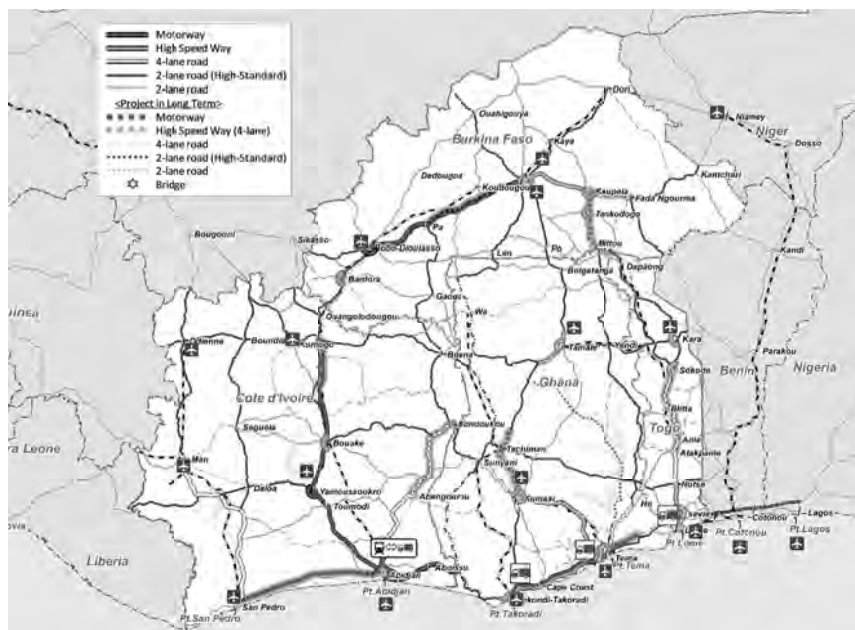

Source: JICA Study Team

Figure B.2.5 Road Development Scenarios for Year 2040

Table B.2.8 Road Condition for Traffic Assignment

Road Category	No. of Lanes	Velocity (km/h)	Traffic capacity (PCU/day)
Motorway	6	120	6,0000
	4	120	4,0000
High speed way	4	100	4,0000
General Road	4	60	4,0000
General Road (Paved)	2	45, 60	1,0000
General Road (Unpaved)	2	30	1,0000

Source: JICA Study Team

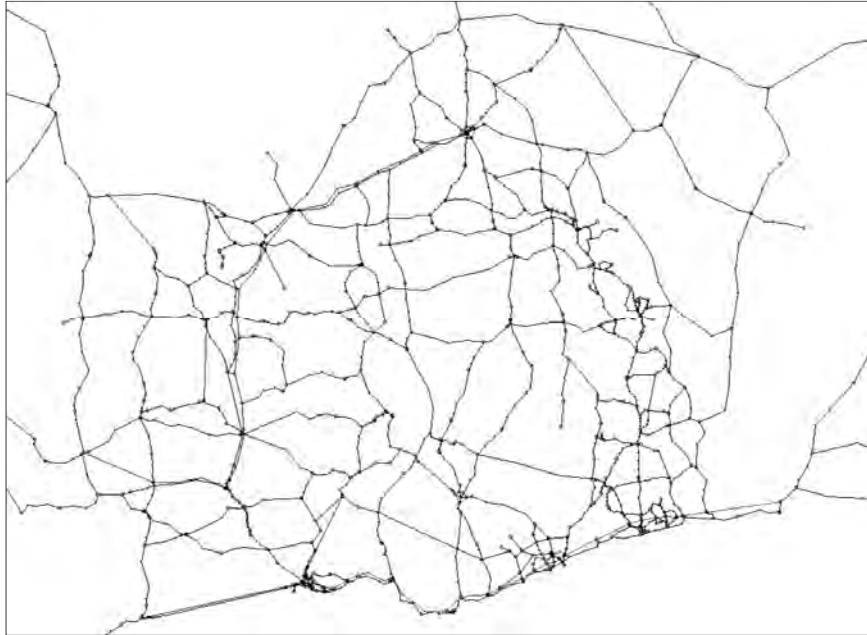

Source: JICA Study Team

Figure B.2.6 Road Network for Traffic Assignment

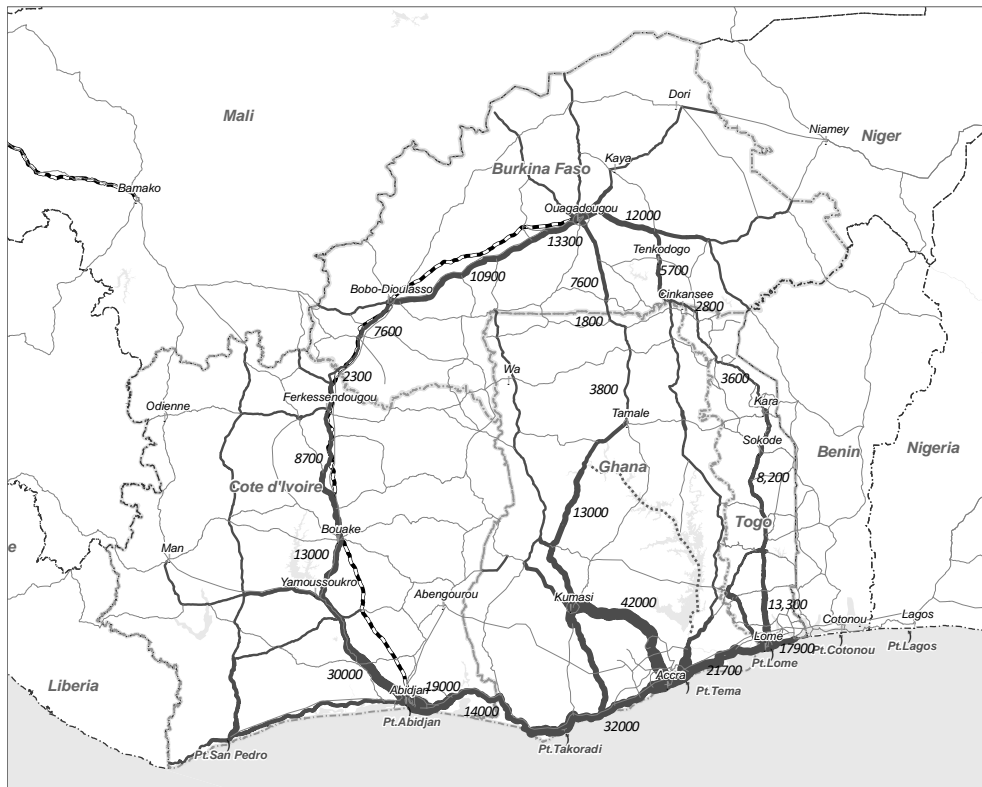

Source: JICA Study Team

Figure B.2.7 Result of Traffic Assignment in Year 2033

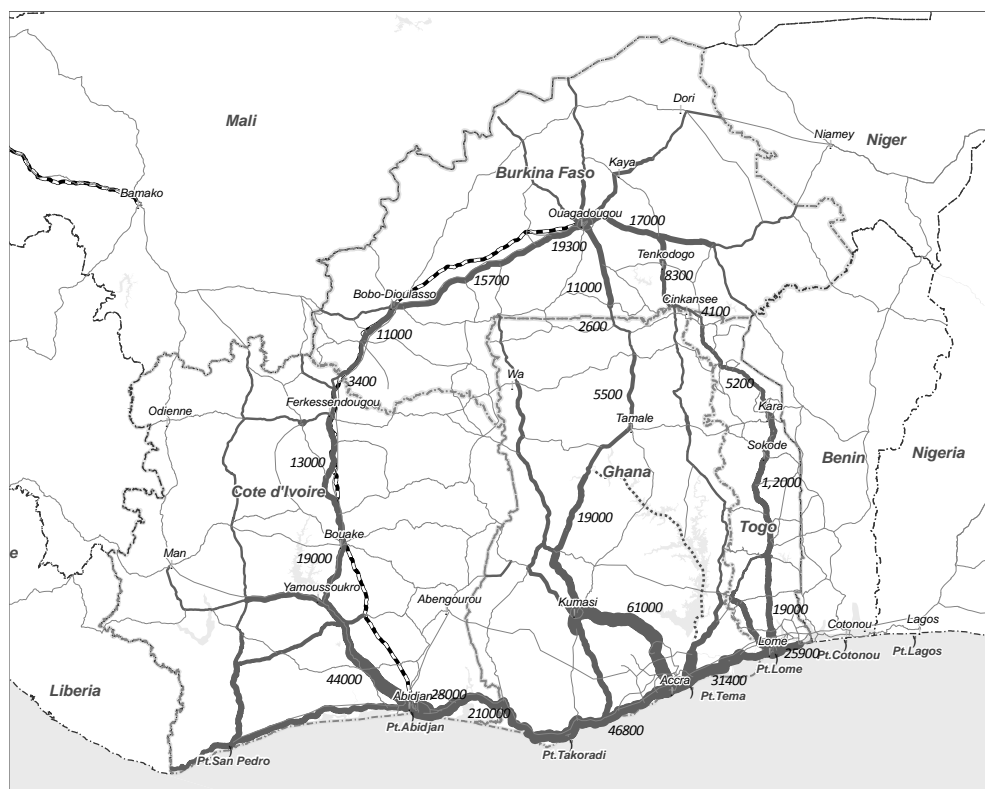

Source: JICA Study Team

Figure B.2.8 Result of Traffic Assignment in Year 2040

B.2.4 Analysis of Competitiveness between Corridors

In addition to the infrastructure status, the logistical origins/destinations, such as a port, and the amount of lead time required to cross the border will greatly affect the choice of freight traffic corridor. A corridor selection model based on a questionnaire survey of logistics service providers was built and the impact of changes in traffic volume due to reduced lead time was analysed. In addition, the time evaluation value was calculated from the analysis results.

(1) Modelling of the Corridor Choice Model

The corridor choice model was developed in order to compare the import transit cargo volume in four different corridors (Abidjan, Tema, Lomé corridor and Cotonou) between their ports and Burkina Faso. It is assumed that the choice of corridor is made by a shipper in Burkina Faso and its trading condition is Cost and Freight (CFR), which means the consignee (importer) of Burkina Faso pays the cost of transport from the port to the final destination in Burkina Faso. The shipper chooses the corridor so as to minimize the generalized cost of import. The relationship with the shipping company is important when selecting a port, but the model assumes that all shipping companies are of the same quality.

Due to the road network, transit transport from each port to Burkina Faso by trucks may use only the respective corridor in each country. In addition, due to transport agreements, transit cargo handled at the port cannot pass through corridors of other countries' corridors. Accordingly, the corridor and port are selected at the same time.

The Logit model is used to analyse the relationship between shippers and corridor choice. Corridor choice probability changes based on the generalized cost recognized by the shipper. Specifically, as shown in Equation (1), the recognized generalized cost \tilde{C}^{rsk} consists of the sum of the generalized cost GC^{rsk} that can be measured and a probability error ε^{rsk} :

$$\tilde{C}^{rsk} = GC^{rsk} + \varepsilon^{rsk} \quad (1)$$

When the Gumbel distribution is assumed for the scale parameter θ with error term ε^{rsk} , the distribution cargo volume q^{rsk} in route k can be expressed by Equation (2) which is the logit model:

$$q^{rsk} = Q^{rs} \frac{\exp[-\theta \cdot GC^{rsk}]}{\sum_{k \in K^{rs}} \exp[-\theta \cdot GC^{rsk}]} \quad (2)$$

where:

q^{rsk} : Cargo volume in Corridor k between O/D pair rs (tons)

Q^{rs} : Cargo between O/D pair rs (tons)

θ : Scale parameter

GC^{rsk} : Generalized cost for corridor k between O/D pair rs (FCFA/20 tons)

k^{rs} : Corridor chosen between O/D pair rs

Scale parameter θ is unknown and cannot be observed. It is estimated as the highest possible value that can reproduce the existing conditions. The generalized cost GC^{rsk} is defined as the generalized cost related to road transport on the corridor, and is obtained by Equation (3). Furthermore, the basic unit of 20 tons is the average load capacity per truck. In addition, the port usage charge depends on the TEU or unit weight of freight.

$$GC^{rsk} = time^{rsk} \cdot VT + USC \cdot D^{rsk} + IP^{rsk} + BC^{rsk} + TC^{rsk} \quad (3)$$

where:

$time^{rsk}$: Average transport time on route k between O/D pair rs (days)

VT : Value of time (FCFA/20 tons-day)

USC : Unit transport cost (FCFA/20 tons-km)

D^{rsk} : Transport distance on route k between O/D pair rs (km)

IP^{rsk} : Illegal payment on route k between O/D pair rs (FCFA/20 tons)

BC^{rsk} : Border crossing cost on route k between O/D pair rs (FCFA/20 tons)

TC^{rsk} : Port usage charges on route k between O/D pair rs (FCFA/TEU or 20 tons)

(2) Parameter Estimation

In order to obtain data on the shippers' preferences for corridors for model estimation, the SP survey, which was conducted in the study (Oikawa, 2013) was used to estimate the multinomial logit model parameter. Cargo was divided into agricultural products (HS codes 1-14) and other general cargo in order to facilitate analysis of item characteristics. Gasoline and other mineral fuels (HS code 27) were treated as strategic items and were designated as being outside the scope of this model.

Because the country and port through which the goods pass were not specified for each alternative in the questionnaire, calculations were performed without any constant parameter. The parameter estimation results are shown in Table B.2.9. Both parameter values are negative and are deemed reasonable. The t value of three parameters shows a statistically significant difference at the 1% level, while the parameter of transport time of agricultural products shows a statistically significant difference at the 5% level. The values of hit ratio and likelihood ratio show a good level of relevance. The results for general cargo have a lower level of relevance compared to agricultural products, which is considered to be due to the wide variety of companies that were surveyed.

The value of time calculated from the estimated parameters is shown in Table B.2.10. The value of time can be interpreted as the opportunity cost of cargoes. The value of time for agricultural

products is FCFA 25,900 (USD 52.0) tons/day, and that for general cargo is FCFA 113,883 (USD 228.7) tons/day, indicating that the value of time of general cargo is 4.4 times that of agricultural products.

Table B.2.9 Parameter Estimation Results

Variable	Agricultural Products	General Cargo
Transport Time (α) day	-0.2271 (-2.28)	-0.4973 (-10.32)
Transport Cost (β) '000FCFA	-0.0088 (-5.82)	-0.0044 (-11.36)
Hit ratio (%)	77.6	59.3
Likelihood ratio ($\bar{\rho}^2$)	0.58	0.25
No. of samples	130	300

Note: () = t Value

Source: JICA Study Team

Table B.2.10 Results of Estimated Value of Time

Value of Time: VT	Estimated Value	
	(FCFA 20 tons-day)	(USD 20 tons-day)
Agricultural products	25,900	52.0
General cargo	113,883	228.7

Note: USD 1 = FCFA 498

Source: JICA Study Team

(3) Estimation of Scale Parameter θ

1) Setting of Input Value to Estimate Generalized Cost

The generalized cost GC^{rsk} indicated in Equation (3) is calculated in order to obtain the scale parameter θ in Equation (2). The value of time (VT) is shown in Table B.2.10. Others are exogenous values, and existing reference materials (World Bank, 2013) were used to determine values considered to be reasonable, which were corroborated with payments or interviews with recipients.

The extraversion values between Ouagadougou and each port are used the values got from interview survey with each port authority, shippers and other related organisations. Furthermore, in order to standardize cost, 20 ft. container handling charges are used as the charges during the port stage, and the charges after devanning consist of the cost per ton or cost per truck. The load capacity per 20 ft. container or per truck is set as 20 tons. In addition to port cost during the port stage of the shipment, items such as port usage charges, container terminal charges, and consignment charges for customs declarations by the customer clearance agent, and various other costs such as payments to shippers' associations and truck associations are included. The road transport cost is the unit transport cost per ton-kilometre after deduction of the illegal payment portion from the freight charge. The illegal payment cost includes the border crossing cost between the port and the final destination.

2) Setting of Transit Cargo Volume in Each Corridor

The actual transit cargo volume in each corridor is estimated from the customs clearance data obtained from the Burkina Faso Customs House. The data of the General Directorate of Customs of Burkina Faso is divided into five respective customs clearance zones. Commodity items are classified into two types: agricultural products (HS1-14) and other general cargo from which gasoline and other mineral fuels (HS27) are excluded.

3) Parameter θ Estimation Results

Scale parameter θ in Equation (2) estimates the best value that can reproduce the current status. The estimation method consists of estimating the minimum value for the squared error of the actual values and estimated values set in b) for the four routes for each k of the five centroid zones used in Equation (2). The scale parameter estimation results are shown in Table B.2.11. The mutual relationship of the actual values and respective estimated model values for agricultural products and general cargo are examined in order to confirm the reproducibility of the current status. A correlation value of 0.9 or more is found, verifying that a certain level of accuracy is maintained. Using the results of the above corridor choice models, it can be applied to various policy simulations.

Table B.2.11 Scale Parameter θ

Zone	Scale Parameter θ	
	Agricultural Products	General Cargo
Ouagadougou ($k=1$)	0.0102	0.0035
Bobo-Dioulasso ($k=2$)	0.0225	0.0013
Sapouy ($k=3$)	0.1052	0.0081
Tenkodogo ($k=4$)	0.0281	0.0265
Fada N'Gourma ($k=5$)	-	0.0107

Source: JICA Study Team

B.3 Supply and Demand Analysis in Corridor Infrastructures by Considering Existing Development Plans for Economic Sectors and Corridor Infrastructures

Distribution Improvement Effect due to Construction of Corridor Infrastructure

Distribution is expected to become more efficient due to construction of the corridor infrastructure consisting of trunk roads, leading to improved industrial competitiveness. For example, construction of the Abidjan-Lagos coastal motorway will greatly reduce the transit time between the coastal countries, thus improving overland distribution.

The development of the Abidjan - Lagos coastal motorway brings about the expansion of the market population from major cities along the motorway. The six-hour market population from Lomé will be 55 million that is around 3 times larger when compared with the case of no motorway. In the case of Accra, the six-hour market population from Accra will be 65 million that is around 5 times larger when compared with the case of no motorway. In the case of Abidjan, the twelve-hour market population from Accra will be 65 million that is around 2.8 times larger when compared with the case of no motorway.



Source: JICA Study Team

Figure B.3.1 Expansion of Transport Areas and Increase of Market Population from Lomé



Source: JICA Study Team

Figure B.3.2 Expansion of Transport Areas and Increase of Market Population from Accra



Source: JICA Study Team

Figure B.3.3 Expansion of Transport Areas and Increase of Market Population from Abidjan

Strengthening of north-south connectivity by constructing motorways or 4-lane high-speed ways could reduce transport time between inland areas and coastal areas as shown below, resulting in improvement of investment attraction.

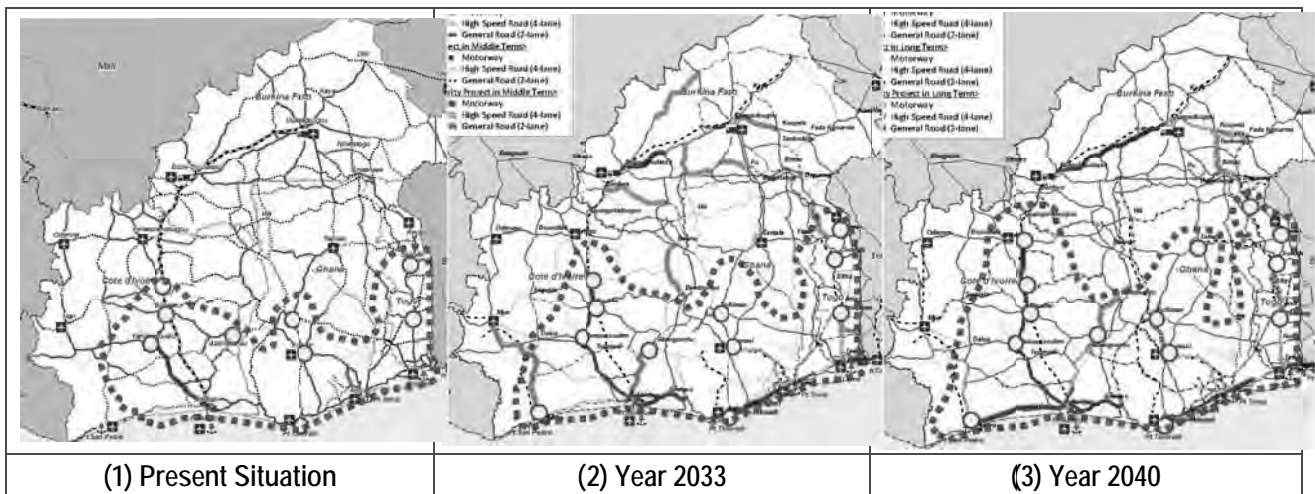

Source: JICA Study Team

Note: 6-hour travel areas mean those areas reachable within 6 hours from the capital city by car. The 6-hour travel areas are attractive for investments to economic sectors.

Figure B.3.4 Expansion of 6-hour Transport Areas by Strengthening of North-South Connectivity

The shorter transit time will contribute to lower transport costs. The effects of reduced transport costs brought about by the road development scenario are outlined in Table B.3.1 The effect of the reduced transport costs here is the travel time savings calculated from the reduced time and time evaluation value in the case of road construction plan and no road construction for each year of the plan, obtained from the results of traffic assignment.

For freight vehicles, if the mid-term plan 2033 could be realized, the transportation cost will be reduced by 31% compared with the case of where the plan is not realized. In the case of the long-term development plan, the transport cost would be reduced by 46%.

Table B.3.1 Reduction of Transport Costs by Road Development

Unit: million USD/year

	Case	2033	2040
All types of Vehicles	With case	6,919	8,242
	Without case	10,011	15,682
	Balance	-3,092	-7,440
	Ratio of cost reduction	-31%	-47%
Freight Vehicles	Case	2033	2040
	With case	4,233	5,121
	Without case	6,106	9,461
	Balance	-1,873	-4,341
	Ratio of cost reduction	-31%	-46%

Source: JICA Study Team

B.4 Result of Traffic Count Survey

Date 9 / 9 / 2015														Guidance Diagram															
Survey Date														To MALI															
Survey Point Name B-1 Border MALI- COTE D'IVOIRE														Direction 1 →															
Direction1 From MALI to COTE D'IVOIRE														← Direction 2															
Direction2 From COTE D'IVOIRE to MALI														To COTE D'IVOIRE															
direction														Direction 1								Direction 2							
Type of Vehicle														Type of Vehicle								Type of Vehicle							
Time	Motorcy cle [veh]	Passen ger Car [veh]	Minibus [veh]	Bus [veh]	Light Truck [veh]	Truck (2,3 axle) [veh]	Truck & Trailer [veh]	Contain er Trailer [veh]	Total *1 [veh]	Comme rcial Vehicle *2 [veh]	Comme rcial Vehicle Ratio *2/*1 [%]	Total /Daily Traffic [%]	Remarks/ Observati ons	Motorcy cle [veh]	Passen ger Car [veh]	Minibus [veh]	Bus [veh]	Light Truck [veh]	Truck (2,3 axle) [veh]	Truck & Trailer [veh]	Contain er Trailer [veh]	Total *1 [veh]	Comme rcial Vehicle *2 [veh]	Comme rcial Vehicle Ratio *2/*1 [%]	Total /Daily Traffic [%]	Remarks/ Observati ons			
07:00-08:00	0	0	0	0	0	3	0	0	3	3	100.0%	0.6%		0	0	0	0	0	0	0	0	0	0	0	-	0.0%			
08:00-09:00	37	2	1	4	1	0	6	0	51	6	11.8%	10.5%		30	3	2	1	1	2	2	0	41	4	9.8%	9.0%				
09:00-10:00	26	2	0	1	0	0	5	0	34	5	14.7%	7.0%		36	2	0	0	0	1	5	0	44	6	13.6%	9.7%				
10:00-11:00	31	1	0	0	0	3	6	1	42	10	23.8%	8.6%		26	0	1	0	0	3	9	0	39	12	30.8%	8.6%				
11:00-12:00	22	1	0	0	0	0	8	2	33	10	30.3%	6.8%		20	2	1	3	0	0	9	3	38	12	31.6%	8.4%				
12:00-13:00	20	5	1	0	0	2	8	3	39	13	33.3%	8.0%		12	0	1	2	0	1	7	2	25	10	40.0%	5.5%				
13:00-14:00	3	2	0	1	1	1	5	1	14	7	50.0%	2.9%		5	1	0	1	0	0	6	4	17	10	58.8%	3.7%				
14:00-15:00	22	4	0	0	0	1	6	2	35	9	25.7%	7.2%		30	1	0	0	0	0	6	2	39	8	20.5%	8.6%				
15:00-16:00	11	2	0	1	1	0	8	6	29	14	48.3%	5.9%		11	7	1	1	1	1	4	3	29	8	27.6%	6.4%				
16:00-17:00	9	2	0	1	0	0	5	3	20	8	40.0%	4.1%		12	3	0	0	0	0	5	5	25	10	40.0%	5.5%				
17:00-18:00	13	1	0	0	0	4	8	2	28	14	50.0%	5.7%		20	0	0	0	0	0	3	2	25	5	20.0%	5.5%				
18:00-19:00	10	3	0	1	0	1	0	2	17	3	17.6%	3.5%		15	5	1	0	1	0	4	1	27	5	18.5%	5.9%				
Daytime Traffic	204	25	2	9	3	15	65	22	345	102	29.6%	70.7%		217	24	7	8	3	8	60	22	349	90	25.8%	76.9%				
19:00-20:00	15	0	2	0	0	0	0	0	17	0	0.0%	3.5%		8	2	0	0	0	0	0	0	10	0	0.0%	2.2%				
20:00-21:00	16	0	0	0	0	0	0	0	16	0	0.0%	3.3%		28	0	0	1	0	0	0	0	29	0	0.0%	6.4%				
21:00-22:00	11	2	0	0	0	0	0	0	13	0	0.0%	2.7%		8	0	0	0	0	0	0	0	8	0	0.0%	1.8%				
22:00-23:00	16	1	0	1	0	0	0	0	18	0	0.0%	3.7%		18	5	0	0	0	0	0	0	23	0	0.0%	5.1%				
23:00-00:00	11	1	0	0	0	0	0	0	12	0	0.0%	2.5%		2	1	0	0	0	0	0	0	3	0	0.0%	0.7%				
00:00-01:00	5	2	0	0	0	0	0	0	7	0	0.0%	1.4%		1	2	1	0	0	0	0	0	4	0	0.0%	0.9%				
01:00-02:00	5	0	0	0	0	1	1	0	7	2	28.6%	1.4%		2	1	0	0	0	0	0	0	3	0	0.0%	0.7%				
02:00-03:00	0	0	0	2	0	0	1	0	3	1	33.3%	0.6%		0	0	0	0	0	0	0	0	0	0	-	0.0%				
03:00-04:00	5	0	0	0	0	1	2	0	8	3	37.5%	1.6%		0	0	0	0	0	0	0	0	0	0	-	0.0%				
04:00-05:00	5	0	1	3	0	0	0	0	9	0	0.0%	1.8%		13	0	0	1	0	0	0	0	14	0	0.0%	3.1%				
05:00-06:00	12	2	0	3	0	1	0	0	18	1	5.6%	3.7%		3	0	0	0	0	0	0	0	3	0	0.0%	0.7%				
06:00-07:00	9	3	0	1	0	1	0	1	15	2	13.3%	3.1%		7	1	0	0	0	0	0	0	8	0	0.0%	1.8%				
Nighttime Traffic	110	11	3	10	0	4	4	1	143	9	6.3%	29.3%		90	12	1	2	0	0	0	0	105	0	0.0%	23.1%				
Daily Traffic	314	36	5	19	3	19	69	23	488	111	22.7%	100.0%		307	36	8	10	3	8	60	22	454	90	19.8%	100.0%				
Ratio of Daily Traffic to Daytime Traffic	1.54	1.44	2.50	2.11	1.00	1.27	1.06	1.05	1.41	1.09	-	-		1.41	1.50	1.14	1.25	1.00	1.00	1.00	1.00	1.30	1.00	-	-				

direction														Total							
Type of Vehicle														Type of Vehicle							
Time	Motorcy cle [veh]	Passen ger Car [veh]	Minibus [veh]	Bus [veh]	Light Truck [veh]	Truck (2,3 axle) [veh]	Truck & Trailer [veh]	Contain er Trailer [veh]	Total *1 [car]	Comme rcial Vehicle *2 [car]	Comme rcial Vehicle Ratio *2/*1 [%]	Total /Daily Traffic [%]	Remarks/ Observati ons								
07:00-08:00	0	0	0	0	0	3	0	0	3	3	100.0%	0.3%									
08:00-09:00	67	5	3	5	2	2	8	0	92	10	10.9%	9.8%									
09:00-10:00	62	4	0	1	0	1	10	0	78	11	14.1%	8.3%									
10:00-11:00	57	1	1	0	0	6	15	1	81	22	27.2%	8.6%									
11:00-12:00	42	3	1	3	0	0	17	5	71	22	31.0%	7.5%									
12:00-13:00	32	5	2	2	0	3	15	5	64	23	35.9%	6.8%									
13:00-14:00	8	3	0	2	1	1	11	5	31	17	54.8%	3.3%									
14:00-15:00	52	5	0	0	0	1	12	4	74	17	23.0%	7.9%									
15:00-16:00	22	9	1	2	2	1	12	9	58	22	37.9%	6.2%									
16:00-17:00	21	5	0	1	0	0	10	8	45	18	40.0%	4.8%									
17:00-18:00	33	1	0	0	0	4	11	4	53	19	35.8%	5.6%									
18:00-19:00	25	8	1	1	1	1	4	3	44	8	18.2%	4.7%									
Daytime Traffic	421	49	9	17	6	23	125	44	694	192	27.7%	73.7%									
19:00-20:00	23	2	2	0	0	0	0	0	27	0	0.0%	2.9%									
20:00-21:00	44	0	0	1	0	0	0	0	45	0	0.0%	4.8%									
21:00-22:00	19	2	0	0	0	0	0	0	21	0	0.0%	2.2%									
22:00-23:00	34	6	0	1	0	0	0	0	41	0	0.0%	4.4%									
23:00-00:00	13	2	0	0	0	0	0	0	15	0	0.0%	1.6%									
00:00-01:00	6	4	1	0	0	0	0	0	11	0	0.0%	1.2%									
01:00-02:00	7	1	0	0	0	1	1	0	10	2	20.0%	1.1%									
02:00-03:00	0	0	0	2	0	0	1	0	3	1	33.3%	0.3%									
03:00-04:00	5	0	0	0	0	1	2	0	8	3	37.5%	0.8%									
04:00-05:00	18	0	1	4	0	0	0	0	23	0	0.0%	2.4%									
05:00-06:00	15	2	0	3	0	1	0	0	21	1	4.8%	2.2%									
06:00-07:00	16	4	0	1	0	1	0	1	23	2	8.7%	2.4%									
Nighttime Traffic	200	23	4	12	0	4	4	1	248	9	3.6%	26.3%									
Daily Traffic	621	72	13	29	6	27	129	45	942	201	21.3%	100.0%									
Ratio of Daily Traffic to Daytime Traffic	1.48	1.47	1.44	1.71	1.00	1.17	1.03	1.02	1.36	1.05	-	-									

Survey Date	Date	3	Month	SEP	Year	2015	Guidance Diagram	
Survey Point Name							To WEST	
Direction1 From							Direction 1 →	
Direction2 From							← Direction 2	
							To EAST	

direction	Direction 1										Direction 2													
	Type of Vehicle										Type of Vehicle													
Time	Motorcycle	Passenger Car	Minibus	Bus	Light Truck	Truck (2,3 axle)	Truck & Trailer	Container Trailer	Total '1	Commercial Vehicle '2	Commercial Vehicle Ratio '2/'1	Total /Daily Traffic	Motorcycle	Passenger Car	Minibus	Bus	Light Truck	Truck (2,3 axle)	Truck & Trailer	Container Trailer	Total '1	Commercial Vehicle '2	Commercial Vehicle Ratio '2/'1	Total /Daily Traffic
07:00-08:00	2	2	0	0	2	0	4	0	10	4	40.0%	6.3%	0	0	0	0	0	0	2	1	3	3	100.0%	2.6%
08:00-09:00	1	2	0	0	0	2	1	0	6	3	50.0%	3.8%	0	0	0	0	0	0	4	0	4	4	100.0%	3.5%
09:00-10:00	0	1	2	0	0	1	0	0	4	1	25.0%	2.5%	0	0	0	0	0	0	3	0	3	3	100.0%	2.6%
10:00-11:00	0	1	2	1	0	2	0	0	6	2	33.3%	3.8%	8	1	0	0	0	0	0	0	9	0	0.0%	7.9%
11:00-12:00	1	2	1	0	0	1	5	0	10	6	60.0%	6.3%	2	2	1	2	0	0	1	0	8	1	12.5%	7.0%
12:00-13:00	7	3	0	1	1	0	9	0	21	9	42.9%	13.3%	6	4	0	0	0	0	1	0	11	1	9.1%	9.6%
13:00-14:00	5	3	0	0	0	0	2	2	12	4	33.3%	7.6%	7	0	0	0	2	0	2	0	11	2	18.2%	9.6%
14:00-15:00	4	2	0	2	0	0	0	0	8	0	0.0%	5.1%	2	3	1	2	0	0	0	0	8	0	0.0%	7.0%
15:00-16:00	9	1	0	1	0	3	0	0	14	3	21.4%	8.9%	0	1	0	2	0	2	0	0	5	2	40.0%	4.4%
16:00-17:00	2	0	1	0	1	0	0	1	5	1	20.0%	3.2%	2	2	2	0	1	0	3	0	10	3	30.0%	8.8%
17:00-18:00	2	0	1	0	0	0	1	0	4	1	25.0%	2.5%	0	1	0	0	0	0	0	0	1	0	0.0%	0.9%
18:00-19:00	6	0	0	0	0	0	5	0	11	5	45.5%	7.0%	0	1	0	1	0	0	0	0	2	0	0.0%	1.8%
Daytime Traffic	39	17	7	5	4	9	27	3	111	39	35.1%	70.3%	27	15	4	7	3	2	16	1	75	19	25.3%	65.8%
19:00-20:00	9	2	1	2	0	1	1	0	16	2	12.5%	10.1%	5	1	3	0	0	1	0	0	10	1	10.0%	8.8%
20:00-21:00	1	3	0	1	1	0	0	1	7	1	14.3%	4.4%	0	1	0	0	0	0	0	0	1	0	0.0%	0.9%
21:00-22:00	0	5	1	1	0	0	0	0	7	0	0.0%	4.4%	0	0	0	2	1	0	1	0	4	1	25.0%	3.5%
22:00-23:00	0	0	0	0	0	0	0	0	0	0	-	0.0%	2	0	0	0	2	0	2	0	6	2	33.3%	5.3%
23:00-00:00	0	0	0	0	0	0	0	0	0	0	-	0.0%	0	0	0	0	0	0	0	0	0	0	-	0.0%
00:00-01:00	0	0	0	0	0	0	0	0	0	0	-	0.0%	0	0	1	0	0	2	0	1	4	3	75.0%	3.5%
01:00-02:00	0	2	0	0	0	0	0	0	2	0	0.0%	1.3%	0	0	0	0	0	0	0	0	0	0	-	0.0%
02:00-03:00	0	0	0	0	0	0	1	0	1	1	100.0%	0.6%	0	0	0	0	0	0	2	0	2	2	100.0%	1.8%
03:00-04:00	0	0	0	0	0	0	0	0	0	0	-	0.0%	0	0	0	0	0	0	4	0	4	4	100.0%	3.5%
04:00-05:00	0	0	0	0	0	0	0	0	0	0	-	0.0%	0	0	0	0	0	0	0	0	0	0	-	0.0%
05:00-06:00	2	0	0	0	0	0	0	0	2	0	0.0%	1.3%	0	0	0	0	0	0	0	0	0	0	-	0.0%
06:00-07:00	7	3	0	2	0	0	0	0	12	0	0.0%	7.6%	2	2	2	0	1	1	0	0	8	1	12.5%	7.0%
Nighttime Traffic	19	15	2	6	1	1	2	1	47	4	8.5%	29.7%	9	4	6	2	4	4	9	1	39	14	35.9%	34.2%
Daily Traffic	58	32	9	11	5	10	29	4	158	43	27.2%	100.0%	36	19	10	9	7	6	25	2	114	33	28.9%	100.0%
Ratio of Daily Traffic to Daytime Traffic	1.49	1.88	1.29	2.20	1.25	1.11	1.07	1.33	1.42	1.10	-	-	1.33	1.27	2.50	1.29	2.33	3.00	1.56	2.00	1.52	1.74	-	-

direction	Total												
	Type of Vehicle										Total '1	Commercial Vehicle '2	Commercial Vehicle Ratio '2/'1
Time	Motorcycle	Passenger Car	Minibus	Bus	Light Truck	Truck (2,3 axle)	Truck & Trailer	Container Trailer	Total '1	Commercial Vehicle '2	Commercial Vehicle Ratio '2/'1	Total /Daily Traffic	
07:00-08:00	2	2	0	0	2	0	6	1	13	7	53.8%	4.8%	
08:00-09:00	1	2	0	0	0	2	5	0	10	7	70.0%	3.7%	
09:00-10:00	0	1	2	0	0	1	3	0	7	4	57.1%	2.6%	
10:00-11:00	8	2	2	1	0	2	0	0	15	2	13.3%	5.5%	
11:00-12:00	3	4	2	2	0	1	6	0	18	7	38.9%	6.6%	
12:00-13:00	13	7	0	1	1	0	10	0	32	10	31.3%	11.8%	
13:00-14:00	12	3	0	0	2	0	4	2	23	6	26.1%	8.5%	
14:00-15:00	6	5	1	4	0	0	0	0	16	0	0.0%	5.9%	
15:00-16:00	9	2	0	3	0	5	0	0	19	5	26.3%	7.0%	
16:00-17:00	4	2	3	0	2	0	3	1	15	4	26.7%	5.5%	
17:00-18:00	2	1	1	0	0	0	1	0	5	1	20.0%	1.8%	
18:00-19:00	6	1	0	1	0	0	5	0	13	5	38.5%	4.8%	
Daytime Traffic	66	32	11	12	7	11	43	4	186	58	31.2%	68.4%	
19:00-20:00	14	3	4	2	0	2	1	0	26	3	11.5%	9.6%	
20:00-21:00	1	4	0	1	1	0	0	1	8	1	12.5%	2.9%	
21:00-22:00	0	5	1	3	1	0	1	0	11	1	9.1%	4.0%	
22:00-23:00	2	0	0	0	2	0	2	0	6	2	33.3%	2.2%	
23:00-00:00	0	0	0	0	0	0	0	0	0	0	-	0.0%	
00:00-01:00	0	0	1	0	0	2	0	1	4	3	75.0%	1.5%	
01:00-02:00	0	2	0	0	0	0	0	0	2	0	0.0%	0.7%	
02:00-03:00	0	0	0	0	0	0	3	0	3	3	100.0%	1.1%	
03:00-04:00	0	0	0	0	0	0	4	0	4	4	100.0%	1.5%	
04:00-05:00	0	0	0	0	0	0	0	0	0	0	-	0.0%	
05:00-06:00	2	0	0	0	0	0	0	0	2	0	0.0%	0.7%	
06:00-07:00	9	5	2	2	1	1	0	0	20	1	5.0%	7.4%	
Nighttime Traffic	28	19	8	8	5	5	11	2	86	18	20.9%	31.6%	
Daily Traffic	94	51	19	20	12	16	54	6	272	76	27.9%	100.0%	
Ratio of Daily Traffic to Daytime Traffic	1.42	1.59	1.73	1.67	1.71	1.45	1.26	1.50	1.46	1.31	-	-	

Survey Date	Date	31	Month	8	Year	2015	Guidance Diagram To NORTH Direction 1 → Direction 2 ← To WEST
Survey Point Name	B-3 BORDER OF COTE D'IVOIRE						
Direction1 From	NORTH	WEST					
Direction2 From	WEST	to			NORTH		

direction	Direction 1												Direction 2																											
	Type of Vehicle											Total '1	Comm ercial Vehid e *2	Comm ercial Vehid e Ratio *2/'1	Total /Daily Traffic	Type of Vehicle											Total '1	Comm ercial Vehid e *2	Comm ercial Vehid e Ratio *2/'1	Total /Daily Traffic										
Time	Motor cycle	Passe nger Car	Minib us	Bus	Light Truck	Truck (2,3 axle)	Truck & Trailer	Contai ner Trailer																																
07:00-08:00	0	1	2	3	0	1	4	1	12	6	50.0%	9.2%	0	0	1	1	0	1	4	0	7	5	71.4%	4.1%																
08:00-09:00	0	1	1	2	1	1	3	0	9	4	44.4%	6.9%	2	0	2	2	1	0	6	1	14	7	50.0%	8.1%																
09:00-10:00	1	0	1	1	1	2	4	2	12	8	66.7%	9.2%	0	1	4	3	0	0	3	0	11	3	27.3%	6.4%																
10:00-11:00	0	0	2	0	0	0	6	1	9	7	77.8%	6.9%	0	0	2	1	1	4	2	10	7	70.0%	5.8%																	
11:00-12:00	2	1	0	0	0	0	1	2	6	3	50.0%	4.6%	2	0	0	4	1	2	6	2	17	10	58.8%	9.9%																
12:00-13:00	0	0	0	1	0	0	2	1	4	3	75.0%	3.1%	1	1	2	2	0	0	2	0	8	2	25.0%	4.7%																
13:00-14:00	0	0	0	0	0	0	0	2	2	2	100.0%	1.5%	1	0	1	1	0	1	4	0	8	5	62.5%	4.7%																
14:00-15:00	0	0	1	0	1	1	5	3	11	9	81.8%	8.5%	0	0	3	2	0	0	4	1	10	5	50.0%	5.8%																
15:00-16:00	0	0	1	0	0	0	6	0	7	6	85.7%	5.4%	0	0	1	3	0	1	6	1	12	8	66.7%	7.0%																
16:00-17:00	0	0	0	0	0	0	1	0	1	1	100.0%	0.8%	1	0	2	4	0	0	8	0	14	8	57.1%	8.1%																
17:00-18:00	1	1	2	0	0	0	6	0	10	6	60.0%	7.7%	0	0	3	1	1	1	4	2	12	7	58.3%	7.0%																
18:00-19:00	0	0	0	2	0	0	0	0	2	0	0.0%	1.5%	0	0	1	1	0	0	2	0	4	2	50.0%	2.3%																
Daytime Traffic	4	4	10	9	3	5	38	12	85	55	64.7%	65.4%	6	2	20	26	4	7	53	9	127	69	54.3%	73.8%																
19:00-20:00	0	0	0	1	0	0	2	0	3	2	66.7%	2.3%	0	0	2	2	0	0	2	0	6	2	33.3%	3.5%																
20:00-21:00	0	0	0	1	0	0	3	2	6	5	83.3%	4.6%	0	0	2	1	0	0	2	3	8	5	62.5%	4.7%																
21:00-22:00	3	0	0	0	0	0	0	0	3	0	0.0%	2.3%	0	0	0	2	0	0	4	0	6	4	66.7%	3.5%																
22:00-23:00	0	0	0	0	0	0	0	0	0	0	-	0.0%	0	0	0	1	0	0	0	1	0	0	0	0.0%	0.6%															
23:00-00:00	0	0	0	0	0	0	0	0	0	0	-	0.0%	0	0	0	0	0	0	3	0	3	3	100.0%	1.7%																
00:00-01:00	0	0	0	0	0	0	0	0	0	0	-	0.0%	0	0	0	0	0	0	1	0	1	1	100.0%	0.6%																
01:00-02:00	0	0	0	0	0	0	0	0	0	0	-	0.0%	0	0	0	0	0	0	2	0	2	2	100.0%	1.2%																
02:00-03:00	0	0	0	0	0	0	2	0	2	2	100.0%	1.5%	0	0	0	0	0	0	1	0	1	1	100.0%	0.6%																
03:00-04:00	0	0	0	1	0	0	2	0	3	2	66.7%	2.3%	0	0	0	0	0	0	1	0	1	1	100.0%	0.6%																
04:00-05:00	0	0	0	1	0	0	0	0	1	0	0.0%	0.8%	0	0	1	0	0	0	2	0	3	2	66.7%	1.7%																
05:00-06:00	1	1	2	1	0	1	5	1	12	7	58.3%	9.2%	0	0	0	0	0	0	1	0	1	1	100.0%	0.6%																
06:00-07:00	2	2	2	2	1	1	3	2	15	6	40.0%	11.5%	2	2	2	1	0	2	2	1	12	5	41.7%	7.0%																
Nighttime Traffic	6	3	4	7	1	2	17	5	45	24	53.3%	34.6%	2	2	7	7	0	2	21	4	45	27	60.0%	26.2%																
Daily Traffic	10	7	14	16	4	7	55	17	130	79	60.8%	100.0%	8	4	27	33	4	9	74	13	172	96	55.8%	100.0%																
Ratio of Daily Traffic to Daytime Traffic	2.50	1.75	1.40	1.78	1.33	1.40	1.45	1.42	1.53	1.44	-	-	1.33	2.00	1.35	1.27	1.00	1.29	1.40	1.44	1.35	1.39	-	-																

direction	Total																						
	Type of Vehicle											Total '1	Comm ercial Vehid e *2	Comm ercial Vehid e Ratio *2/'1	Total /Daily Traffic								
Time	Motor cycle	Passe nger Car	Minib us	Bus	Light Truck	Truck (2,3 axle)	Truck & Trailer	Contai ner Trailer															
07:00-08:00	0	1	3	4	0	2	8	1	19	11	57.9%	6.3%											
08:00-09:00	2	1	3	4	2	1	9	1	23	11	47.8%	7.6%											
09:00-10:00	1	1	5	4	1	2	7	2	23	11	47.8%	7.6%											
10:00-11:00	0	0	2	2	1	1	10	3	19	14	73.7%	6.3%											
11:00-12:00	4	1	0	4	1	2	7	4	23	13	56.5%	7.6%											
12:00-13:00	1	1	2	3	0	0	4	1	12	5	41.7%	4.0%											
13:00-14:00	1	0	1	1	0	1	4	2	10	7	70.0%	3.3%											
14:00-15:00	0	0	4	2	1	1	9	4	21	14	66.7%	7.0%											
15:00-16:00	0	0	2	3	0	1	12	1	19	14	73.7%	6.3%											
16:00-17:00	0	0	2	4	0	0	9	0	15	9	60.0%	5.0%											
17:00-18:00	1	1	5	1	1	1	10	2	22	13	59.1%	7.3%											
18:00-19:00	0	0	1	3	0	0	2	0	6	2	33.3%	2.0%											
Daytime Traffic	10	6	30	35	7	12	91	21	212	124	58.5%	70.2%											
19:00-20:00	0	0	2	3	0	0	4	0	9	4	44.4%	3.0%											
20:00-21:00	0	0	2	2	0	0	5	5	14	10	71.4%	4.6%											
21:00-22:00	3	0	0	2	0	0	4	0	9	4	44.4%	3.0%											
22:00-23:00	0	0	0	1	0	0	0	0	1	0	0.0%	0.3%											
23:00-00:00	0	0	0	0	0	0	3	0	3	3	100.0%	1.0%											
00:00-01:00	0	0	0	0	0	0	1	0	1	1	100.0%	0.3%											
01:00-02:00	0	0	0	0	0	0	2	0	2	2	100.0%	0.7%											
02:00-03:00	0	0	0	0	0	0	3	0	3	3	100.0%	1.0%											
03:00-04:00	0	0	0	1	0	0	3	0	4	3	75.0%	1.3%											
04:00-05:00	0	0	1	1	0	0	2	0	4	2	50.0%	1.3%											
05:00-06:00	1	1	2	1	0	1	6	1	13	8	61.5%	4.3%											
06:00-07:00	4	4	4	3	1	3	5	3	27	11	40.7%	8.9%											
Nighttime Traffic	8	5	11	14	1	4	38	9	90	51	56.7%	29.8%											
Daily Traffic	18	11	41	49	8	16	129	30	302	175	57.9%	100.0%											
Ratio of Daily Traffic to Daytime Traffic	1.80	1.83	1.37	1.40	1.14	1.33	1.42	1.43	1.42	1.41	-	-											

Date											Month											Year											Guidance Diagram																																											
Survey Date																																	20 /											8 /											2015											To SOUTH										
Survey Point Name																																	B-4 BORDER OF GHANA																																											
Direction1 From											SOUTH											to											NORTH											To NORTH																																
Direction2 From											NORTH											to											SOUTH																																											
direction											Direction 1											Direction 2																																																						
Time	Type of Vehicle										Total '1	Comm. Vehic. '2	Comm. Vehic. Ratio '2/'1 [%]	Total /Daily Traffic [%]	Type of Vehicle										Total '1	Comm. Vehic. '2	Comm. Vehic. Ratio '2/'1 [%]	Total /Daily Traffic [%]																																																
	Motorc ycle	Passenger Car	Minibus	Bus	Light Truck	Truck (2,3 axle)	Truck & Trailer	Container Trailer							Motorc ycle	Passenger Car	Minibus	Bus	Light Truck	Truck (2,3 axle)	Truck & Trailer	Container Trailer																																																						
07:00-08:00	7	1	0	1	0	0	3	3	15	6	40.0%	5.6%	6	1	1	0	0	2	8	2	20	12	60.0%	13.7%																																																				
08:00-09:00	9	2	0	0	1	1	9	3	25	13	52.0%	9.3%	4	2	2	0	1	1	6	4	20	11	55.0%	13.7%																																																				
09:00-10:00	10	0	1	1	0	2	4	3	21	9	42.9%	7.8%	1	4	1	0	0	0	5	2	13	7	53.8%	8.9%																																																				
10:00-11:00	9	3	0	1	0	8	3	4	28	15	53.6%	10.4%	2	1	1	1	0	1	1	1	8	3	37.5%	5.5%																																																				
11:00-12:00	11	0	1	1	1	4	8	3	29	15	51.7%	10.8%	3	1	1	0	2	0	2	2	11	4	36.4%	7.5%																																																				
12:00-13:00	10	0	2	0	0	2	4	2	20	8	40.0%	7.4%	1	0	1	1	1	0	6	1	11	7	63.6%	7.5%																																																				
13:00-14:00	12	0	0	0	0	2	3	2	19	7	36.8%	7.1%	0	1	0	0	0	1	2	1	5	4	80.0%	3.4%																																																				
14:00-15:00	13	1	1	0	2	2	1	2	22	5	22.7%	8.2%	0	2	0	0	0	0	1	1	4	2	50.0%	2.7%																																																				
15:00-16:00	11	1	0	1	0	0	2	3	18	5	27.8%	6.7%	1	0	2	0	1	0	6	2	12	8	66.7%	8.2%																																																				
16:00-17:00	11	0	0	0	1	2	5	1	20	8	40.0%	7.4%	0	1	0	0	0	0	1	1	3	2	66.7%	2.1%																																																				
17:00-18:00	6	0	0	0	0	2	3	3	14	8	57.1%	5.2%	0	0	0	0	1	1	2	2	6	5	83.3%	4.1%																																																				
18:00-19:00	6	0	0	0	0	1	0	1	8	2	25.0%	3.0%	2	1	0	0	0	1	4	0	8	5	62.5%	5.5%																																																				
Daytime Traffic	115	8	5	5	5	26	45	30	239	101	42.3%	88.8%	20	14	9	2	6	7	44	19	121	70	57.9%	82.9%																																																				
19:00-20:00	2	0	0	0	0	0	4	0	6	4	66.7%	2.2%	1	0	0	0	0	0	1	1	3	2	66.7%	2.1%																																																				
20:00-21:00	0	0	0	0	0	0	0	0	0	0	-	0.0%	0	0	0	0	0	0	0	0	0	0	-	0.0%																																																				
21:00-22:00	0	1	0	0	0	0	0	0	1	0	0.0%	0.4%	0	0	0	0	0	0	0	0	0	0	-	0.0%																																																				
22:00-23:00	0	0	0	0	0	0	0	0	0	0	-	0.0%	0	0	0	0	0	0	0	0	0	0	-	0.0%																																																				
23:00-00:00	0	0	0	0	0	0	0	0	0	0	-	0.0%	0	0	0	0	0	0	0	0	0	0	-	0.0%																																																				
00:00-01:00	0	0	0	0	0	0	0	0	0	0	-	0.0%	0	0	0	0	0	0	0	0	0	0	-	0.0%																																																				
01:00-02:00	0	0	0	0	0	0	0	0	0	0	-	0.0%	0	0	0	0	0	0	0	0	0	0	-	0.0%																																																				
02:00-03:00	0	0	0	0	0	0	0	0	0	0	-	0.0%	0	0	0	0	0	0	0	0	0	0	-	0.0%																																																				
03:00-04:00	0	0	0	0	0	0	0	0	0	0	-	0.0%	0	0	0	0	0	0	0	0	0	0	-	0.0%																																																				
04:00-05:00	0	0	0	0	0	0	0	0	0	0	-	0.0%	0	0	0	0	0	0	0	0	0	0	-	0.0%																																																				
05:00-06:00	2	1	0	0	0	0	2	0	5	2	40.0%	1.9%	0	1	0	0	1	0	2	2	6	4	66.7%	4.1%																																																				
06:00-07:00	8	2	1	0	0	0	6	1	18	7	38.9%	6.7%	2	2	0	0	0	1	8	3	16	12	75.0%	11.0%																																																				
Nighttime Traffic	12	4	1	0	0	0	12	1	30	13	43.3%	11.2%	3	3	0	0	1	1	11	6	25	18	72.0%	17.1%																																																				
Daily Traffic	127	12	6	5	5	26	57	31	269	114	42.4%	100.0%	23	17	9	2	7	8	55	25	146	88	60.3%	100.0%																																																				
Ratio of Daily Traffic to Daytime Traffic	1.10	1.50	1.20	1.00	1.00	1.00	1.27	1.03	1.13	1.13	-	-	1.15	1.21	1.00	1.00	1.17	1.14	1.25	1.32	1.21	1.26	-	-																																																				

direction											Total										
Time	Type of Vehicle										Total '1	Comm. Vehic. '2	Comm. Vehic. Ratio '2/'1 [%]	Total /Daily Traffic [%]							
	Motorc ycle	Passenger Car	Minibus	Bus	Light Truck	Truck (2,3 axle)	Truck & Trailer	Container Trailer													
07:00-08:00	13	2	1	1	0	2	11	5	35	18	51.4%	8.4%									
08:00-09:00	13	4	2	0	2	2	15	7	45	24	53.3%	10.8%									
09:00-10:00	11	4	2	1	0	2	9	5	34	16	47.1%	8.2%									
10:00-11:00	11	4	1	2	0	9	4	5	36	18	50.0%	8.7%									
11:00-12:00	14	1	2	1	3	4	10	5	40	19	47.5%	9.6%									
12:00-13:00	11	0	3	1	1	2	10	3	31	15	48.4%	7.5%									
13:00-14:00	12	1	0	0	0	3	5	3	24	11	45.8%	5.8%									
14:00-15:00	13	3	1	0	2	2	2	3	26	7	26.9%	6.3%									
15:00-16:00	12	1	2	1	1	0	8	5	30	13	43.3%	7.2%									
16:00-17:00	11	1	0	0	1	2	6	2	23	10	43.5%	5.5%									
17:00-18:00	6	0	0	0	1	3	5	5	20	13	65.0%	4.8%									
18:00-19:00	8	1	0	0	0	2	4	1	16	7	43.8%	3.9%									
Daytime Traffic	135	22	14	7	11	33	89	49	360	171	47.5%	86.7%									
19:00-20:00	3	0	0	0	0	0	5	1	9	6	66.7%	2.2%									
20:00-21:00	0	0	0	0	0	0	0	0	0	0	-	0.0%									
21:00-22:00	0	1	0	0	0	0	0	0	1	0	0.0%	0.2%									
22:00-23:00	0	0	0	0	0	0	0	0	0	0	-	0.0%									
23:00-00:00	0	0	0	0	0	0	0	0	0	0	-	0.0%									
00:00-01:00	0	0	0	0	0	0	0	0	0	0	-	0.0%									
01:00-02:00	0	0	0	0	0	0	0	0	0	0	-	0.0%									
02:00-03:00	0	0	0	0	0	0	0	0	0	0	-	0.0%									
03:00-04:00	0	0	0	0	0	0	0	0	0	0	-	0.0%									
04:00-05:00	0	0	0	0	0	0	0	0	0	0	-	0.0%									
05:00-06:00	2	2	0	0	1	0	4	2	11	6	54.5%	2.7%									
06:00-07:00	10	4	1	0	0	1	14	4	34	19	55.9%	8.2%									
Nighttime Traffic	15	7	1	0	1	1	23	7	55	31	56.4%	13.3%									
Daily Traffic	150	29	15	7	12	34	112	56	415	202	48.7%	100.0%									
Ratio of Daily Traffic to Daytime Traffic	1.11	1.32	1.07	1.00	1.09	1.03	1.26	1.14	1.15	1.18	-	-									

Survey Date: Date <input type="text" value="26"/> / Month <input type="text" value="8"/> / Year <input type="text" value="2015"/>	Guidance Diagram To <input type="text" value="TG"/>
Survey Point Name: <input type="text" value="B-5 BORDER OF TOGO"/>	Direction 1 \longrightarrow Direction 2 \longleftarrow To <input type="text" value="BF"/>
Direction1 From: <input type="text" value="TG"/> to <input type="text" value="BF"/>	
Direction2 From: <input type="text" value="BF"/> to <input type="text" value="TG"/>	

direction	Direction 1											Direction 2															
	Type of Vehicle										Total '1	Comm ercial Vehid e '2	Comm ercial Vehid e Ratio '2/'1	Total /Daily Traffic	Type of Vehicle										Total '1	Comm ercial Vehid e '2	Comm ercial Vehid e Ratio '2/'1
Time	Motocycle	Passenger Car	Minibus	Bus	Light Truck	Truck (2,3 axle)	Truck & Trailer	Container Trailer							Motocycle	Passenger Car	Minibus	Bus	Light Truck	Truck (2,3 axle)	Truck & Trailer	Container Trailer					
07:00-08:00	2	2	0	2	0	0	1	0	7	1	14.3%	2.1%	9	2	0	0	0	0	11	0	0.0%	3.4%					
08:00-09:00	5	0	0	0	0	1	2	2	10	5	50.0%	3.0%	4	2	0	2	0	1	0	9	1	11.1%	2.8%				
09:00-10:00	6	4	2	1	0	0	11	1	25	12	48.0%	7.5%	5	3	0	0	0	6	5	19	11	57.9%	5.8%				
10:00-11:00	5	3	1	2	0	2	12	3	28	17	60.7%	8.4%	6	4	0	0	3	8	2	23	13	56.5%	7.1%				
11:00-12:00	4	2	1	3	1	2	15	7	35	24	68.6%	10.5%	8	3	0	0	0	8	5	24	13	54.2%	7.4%				
12:00-13:00	6	2	0	0	1	2	14	8	33	24	72.7%	9.9%	7	3	0	2	0	9	6	27	15	55.6%	8.3%				
13:00-14:00	7	1	0	0	0	1	12	6	27	19	70.4%	8.1%	5	2	0	0	0	13	6	26	19	73.1%	8.0%				
14:00-15:00	3	2	0	0	0	2	16	5	28	23	82.1%	8.4%	5	1	1	0	0	10	3	20	13	65.0%	6.2%				
15:00-16:00	4	6	0	2	1	2	12	7	34	21	61.8%	10.2%	7	3	0	0	0	11	3	24	14	58.3%	7.4%				
16:00-17:00	5	3	0	3	1	1	12	2	27	15	55.6%	8.1%	8	2	0	0	0	15	4	29	19	65.5%	8.9%				
17:00-18:00	6	4	0	1	0	1	12	0	24	13	54.2%	7.2%	9	8	0	0	3	14	6	40	23	57.5%	12.3%				
18:00-19:00	7	5	0	1	0	2	12	5	32	19	59.4%	9.6%	10	2	1	0	0	12	2	27	14	51.9%	8.3%				
Daytime Traffic	60	34	4	15	4	16	131	46	310	193	62.3%	93.1%	83	35	2	4	7	106	42	279	155	55.6%	85.8%				
19:00-20:00	0	0	0	0	0	0	7	0	7	7	100.0%	2.1%	10	0	0	0	0	7	0	17	7	41.2%	5.2%				
20:00-21:00	0	2	0	1	0	1	2	0	6	3	50.0%	1.8%	11	0	0	0	0	4	0	15	4	26.7%	4.6%				
21:00-22:00	0	0	0	0	0	0	0	0	0	0	-	0.0%	0	0	0	0	0	0	0	0	0	-	0.0%				
22:00-23:00	0	0	0	0	0	0	0	0	0	0	-	0.0%	0	0	0	0	0	0	0	0	0	-	0.0%				
23:00-00:00	0	0	0	0	0	0	0	0	0	0	-	0.0%	0	0	0	0	0	0	0	0	0	-	0.0%				
00:00-01:00	0	0	0	0	0	0	0	0	0	0	-	0.0%	0	0	0	0	0	0	0	0	0	-	0.0%				
01:00-02:00	0	0	0	0	0	0	0	0	0	0	-	0.0%	0	0	0	0	0	0	0	0	0	-	0.0%				
02:00-03:00	0	0	0	0	0	0	0	0	0	0	-	0.0%	0	0	0	0	0	0	0	0	0	-	0.0%				
03:00-04:00	0	0	0	0	0	0	0	0	0	0	-	0.0%	0	0	0	2	0	0	1	3	1	33.3%	0.9%				
04:00-05:00	0	2	0	0	0	0	0	0	2	0	0.0%	0.6%	0	0	0	2	0	0	2	0	0	0.0%	0.6%				
05:00-06:00	2	1	0	0	0	0	0	0	3	0	0.0%	0.9%	0	0	0	3	0	2	5	2	40.0%	1.5%					
06:00-07:00	3	2	0	0	0	0	0	0	5	0	0.0%	1.5%	0	0	0	4	0	0	4	0	0.0%	1.2%					
Nighttime Traffic	5	7	0	1	0	1	9	0	23	10	43.5%	6.9%	21	0	0	11	0	13	1	46	14	30.4%	14.2%				
Daily Traffic	65	41	4	16	4	17	140	46	333	203	61.0%	100.0%	104	35	2	15	7	119	43	325	169	52.0%	100.0%				
Ratio of Daily Traffic to Daytime Traffic	1.08	1.21	1.00	1.07	1.00	1.06	1.07	1.00	1.07	1.05	-	-	1.25	1.00	1.00	3.75	-	1.00	1.12	1.02	1.16	1.09	-	-			

direction	Total												
	Type of Vehicle										Total '1	Comm ercial Vehid e '2	Comm ercial Vehid e Ratio '2/'1
Time	Motocycle	Passenger Car	Minibus	Bus	Light Truck	Truck (2,3 axle)	Truck & Trailer	Container Trailer					
07:00-08:00	11	4	0	2	0	0	1	0	18	1	5.6%	2.7%	
08:00-09:00	9	2	0	2	0	2	2	2	19	6	31.6%	2.9%	
09:00-10:00	11	7	2	1	0	0	17	6	44	23	52.3%	6.7%	
10:00-11:00	11	7	1	2	0	5	20	5	51	30	58.8%	7.8%	
11:00-12:00	12	5	1	3	1	2	23	12	59	37	62.7%	9.0%	
12:00-13:00	13	5	0	2	1	2	23	14	60	39	65.0%	9.1%	
13:00-14:00	12	3	0	0	0	1	25	12	53	38	71.7%	8.1%	
14:00-15:00	8	3	1	0	0	2	26	8	48	36	75.0%	7.3%	
15:00-16:00	11	9	0	2	1	2	23	10	58	35	60.3%	8.8%	
16:00-17:00	13	5	0	3	1	1	27	6	56	34	60.7%	8.5%	
17:00-18:00	15	12	0	1	0	4	26	6	64	36	56.3%	9.7%	
18:00-19:00	17	7	1	1	0	2	24	7	59	33	55.9%	9.0%	
Daytime Traffic	143	69	6	19	4	23	237	88	589	348	59.1%	89.5%	
19:00-20:00	10	0	0	0	0	0	14	0	24	14	58.3%	3.6%	
20:00-21:00	11	2	0	1	0	1	6	0	21	7	33.3%	3.2%	
21:00-22:00	0	0	0	0	0	0	0	0	0	0	-	0.0%	
22:00-23:00	0	0	0	0	0	0	0	0	0	0	-	0.0%	
23:00-00:00	0	0	0	0	0	0	0	0	0	0	-	0.0%	
00:00-01:00	0	0	0	0	0	0	0	0	0	0	-	0.0%	
01:00-02:00	0	0	0	0	0	0	0	0	0	0	-	0.0%	
02:00-03:00	0	0	0	0	0	0	0	0	0	0	-	0.0%	
03:00-04:00	0	0	0	2	0	0	0	1	3	1	33.3%	0.5%	
04:00-05:00	0	2	0	2	0	0	0	0	4	0	0.0%	0.6%	
05:00-06:00	2	1	0	3	0	0	2	0	8	2	25.0%	1.2%	
06:00-07:00	3	2	0	4	0	0	0	0	9	0	0.0%	1.4%	
Nighttime Traffic	26	7	0	12	0	1	22	1	69	24	34.8%	10.5%	
Daily Traffic	169	76	6	31	4	24	259	89	658	372	56.5%	100.0%	
Ratio of Daily Traffic to Daytime Traffic	1.18	1.10	1.00	1.63	1.00	1.04	1.09	1.01	1.12	1.07	-	-	

Survey Date	Date 27 / Month 8 / Year 2015	Guidance Diagram To BE _____ _____ Direction 1 → _____ Direction 2 ← _____ _____ To BF
Survey Point Name	B-6 BORDER OF BENI	
Direction1 From	BE to BF	
Direction2 From	BF to BE	

direction	Direction 1												Direction 2																
	Type of Vehicle											Total '1	Comm. Vehic. '2	Comm. Vehic. Ratio '2/'1 [%]	Total /Daily Traffic	Type of Vehicle											Total '1	Comm. Vehic. '2	Comm. Vehic. Ratio '2/'1 [%]
Time	Motorcycle	Passenger Car	Minibus	Bus	Light Truck	Truck (2,3 axle)	Truck & Trailer	Container Trailer									Motorcycle	Passenger Car	Minibus	Bus	Light Truck	Truck (2,3 axle)	Truck & Trailer	Container Trailer					
07:00-08:00	0	1	0	0	0	2	1	0	4	3	75.0%	2.8%	0	2	0	1	0	2	4	0	9	6	66.7%	6.5%					
08:00-09:00	0	1	0	0	0	1	1	1	4	3	75.0%	2.8%	0	0	1	0	0	2	3	1	7	6	85.7%	5.1%					
09:00-10:00	0	0	0	0	0	1	1	2	4	4	100.0%	2.8%	0	1	0	0	0	3	5	1	10	9	90.0%	7.2%					
10:00-11:00	1	0	0	0	0	2	9	1	13	12	92.3%	9.0%	1	0	0	0	2	4	2	9	8	88.9%	6.5%						
11:00-12:00	0	0	0	0	0	2	10	2	14	14	100.0%	9.7%	0	2	0	0	0	3	6	1	12	10	83.3%	8.7%					
12:00-13:00	0	0	0	0	0	1	11	2	14	14	100.0%	9.7%	0	1	1	0	0	2	13	2	19	17	89.5%	13.8%					
13:00-14:00	1	0	0	0	0	2	13	1	17	16	94.1%	11.7%	0	1	0	1	0	0	10	2	14	12	85.7%	10.1%					
14:00-15:00	0	0	0	0	0	3	10	1	14	14	100.0%	9.7%	0	1	0	0	0	0	11	2	14	13	92.9%	10.1%					
15:00-16:00	0	1	0	0	0	2	13	2	18	17	94.4%	12.4%	1	0	0	0	0	0	9	1	11	10	90.9%	8.0%					
16:00-17:00	0	1	0	0	0	2	14	1	18	17	94.4%	12.4%	0	0	0	0	2	9	1	12	12	100.0%	8.7%						
17:00-18:00	0	0	1	0	0	2	5	1	9	8	88.9%	6.2%	0	0	0	0	0	1	5	1	7	7	100.0%	5.1%					
18:00-19:00	0	0	1	1	0	3	3	1	9	7	77.8%	6.2%	0	0	0	0	0	0	6	1	7	7	100.0%	5.1%					
Daytime Traffic	2	4	2	1	0	23	91	15	138	129	93.5%	95.2%	2	8	2	2	0	17	85	15	131	117	89.3%	94.9%					
19:00-20:00	0	0	0	0	0	0	0	0	0	0	-	0.0%	0	0	0	0	0	0	1	0	1	1	100.0%	0.7%					
20:00-21:00	0	0	0	0	0	0	0	0	0	0	-	0.0%	0	0	0	0	0	0	0	0	0	0	-	0.0%					
21:00-22:00	0	0	0	0	0	0	0	0	0	0	-	0.0%	0	0	0	0	0	0	0	0	0	0	-	0.0%					
22:00-23:00	0	0	0	0	0	0	0	0	0	0	-	0.0%	0	0	0	0	0	0	0	0	0	0	-	0.0%					
23:00-00:00	0	0	0	0	0	0	0	0	0	0	-	0.0%	0	0	0	0	0	0	0	0	0	0	-	0.0%					
00:00-01:00	0	0	0	0	0	0	0	0	0	0	-	0.0%	0	0	0	0	0	0	0	0	0	0	-	0.0%					
01:00-02:00	0	0	0	0	0	0	0	0	0	0	-	0.0%	0	0	0	0	0	0	0	0	0	0	-	0.0%					
02:00-03:00	0	0	0	0	0	0	0	0	0	0	-	0.0%	0	0	0	0	0	0	0	0	0	0	-	0.0%					
03:00-04:00	0	0	0	0	0	0	0	0	0	0	-	0.0%	0	0	0	0	0	0	0	0	0	0	-	0.0%					
04:00-05:00	0	0	0	0	0	0	0	0	0	0	-	0.0%	0	0	0	0	0	0	0	0	0	0	-	0.0%					
05:00-06:00	0	0	0	0	0	0	0	2	2	2	100.0%	1.4%	0	0	0	0	0	0	0	0	0	0	-	0.0%					
06:00-07:00	0	0	0	0	0	1	0	4	5	5	100.0%	3.4%	0	0	0	0	0	1	2	3	6	6	100.0%	4.3%					
Nighttime Traffic	0	0	0	0	0	1	0	6	7	7	100.0%	4.8%	0	0	0	0	0	1	3	3	7	7	100.0%	5.1%					
Daily Traffic	2	4	2	1	0	24	91	21	145	136	93.8%	100.0%	2	8	2	2	0	18	88	18	138	124	89.9%	100.0%					
Ratio of Daily Traffic to Daytime Traffic	1.00	1.00	1.00	1.00	-	1.04	1.00	1.40	1.05	1.05	-	-	1.00	1.00	1.00	1.00	-	1.06	1.04	1.20	1.05	1.06	-	-					

direction	Total																
	Type of Vehicle											Total '1	Comm. Vehic. '2	Comm. Vehic. Ratio '2/'1 [%]	Total /Daily Traffic		
Time	Motorcycle	Passenger Car	Minibus	Bus	Light Truck	Truck (2,3 axle)	Truck & Trailer	Container Trailer									
07:00-08:00	0	3	0	1	0	4	5	0	13	9	69.2%	4.6%					
08:00-09:00	0	1	1	0	0	3	4	2	11	9	81.8%	3.9%					
09:00-10:00	0	1	0	0	0	4	6	3	14	13	92.9%	4.9%					
10:00-11:00	2	0	0	0	0	4	13	3	22	20	90.9%	7.8%					
11:00-12:00	0	2	0	0	0	5	16	3	26	24	92.3%	9.2%					
12:00-13:00	0	1	1	0	0	3	24	4	33	31	93.9%	11.7%					
13:00-14:00	1	1	0	1	0	2	23	3	31	28	90.3%	11.0%					
14:00-15:00	0	1	0	0	0	3	21	3	28	27	96.4%	9.9%					
15:00-16:00	1	1	0	0	0	2	22	3	29	27	93.1%	10.2%					
16:00-17:00	0	1	0	0	0	4	23	2	30	29	96.7%	10.6%					
17:00-18:00	0	0	1	0	0	3	10	2	16	15	93.8%	5.7%					
18:00-19:00	0	0	1	1	0	3	9	2	16	14	87.5%	5.7%					
Daytime Traffic	4	12	4	3	0	40	176	30	269	246	91.4%	95.1%					
19:00-20:00	0	0	0	0	0	0	1	0	1	1	100.0%	0.4%					
20:00-21:00	0	0	0	0	0	0	0	0	0	0	-	0.0%					
21:00-22:00	0	0	0	0	0	0	0	0	0	0	-	0.0%					
22:00-23:00	0	0	0	0	0	0	0	0	0	0	-	0.0%					
23:00-00:00	0	0	0	0	0	0	0	0	0	0	-	0.0%					
00:00-01:00	0	0	0	0	0	0	0	0	0	0	-	0.0%					
01:00-02:00	0	0	0	0	0	0	0	0	0	0	-	0.0%					
02:00-03:00	0	0	0	0	0	0	0	0	0	0	-	0.0%					
03:00-04:00	0	0	0	0	0	0	0	0	0	0	-	0.0%					
04:00-05:00	0	0	0	0	0	0	0	0	0	0	-	0.0%					
05:00-06:00	0	0	0	0	0	0	0	2	2	2	100.0%	0.7%					
06:00-07:00	0	0	0	0	0	2	2	7	11	11	100.0%	3.9%					
Nighttime Traffic	0	0	0	0	0	2	3	9	14	14	100.0%	4.9%					
Daily Traffic	4	12	4	3	0	42	179	39	283	260	91.9%	100.0%					
Ratio of Daily Traffic to Daytime Traffic	1.00	1.00	1.00	1.00	-	1.05	1.02	1.30	1.05	1.06	-	-					

Date		Month		Year	
27		8		2015	
Survey Date					
Survey Point Name B-7 BORDER OF NIGER					
Direction1 From			to		
BF			NE		
Direction2 From			to		
NE			BF		

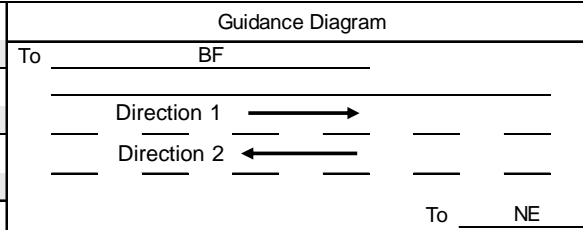

Time	Direction 1											Direction 2																
	Type of Vehicle										Total '1	Comm. Vehic. '2	Comm. Vehic. Ratio '2/'1 [%]	Total /Daily Traffic [%]	Type of Vehicle										Total '1	Comm. Vehic. '2	Comm. Vehic. Ratio '2/'1 [%]	Total /Daily Traffic [%]
	Motorcycle	Passenger Car	Minibus	Bus	Light Truck	Truck (2,3 axle)	Truck & Trailer	Container Trailer							Motorcycle	Passenger Car	Minibus	Bus	Light Truck	Truck (2,3 axle)	Truck & Trailer	Container Trailer						
07:00-08:00	0	4	1	0	0	0	2	2	9	4	44.4%	5.6%	0	3	1	4	0	1	6	5	20	12	60.0%	11.1%				
08:00-09:00	4	1	2	0	0	0	2	1	10	3	30.0%	6.2%	7	4	2	2	1	0	3	3	22	6	27.3%	12.2%				
09:00-10:00	2	1	0	0	0	0	3	2	8	5	62.5%	5.0%	0	0	1	3	1	4	3	0	12	7	58.3%	6.7%				
10:00-11:00	1	2	0	2	0	0	3	3	11	6	54.5%	6.8%	0	2	0	0	1	1	2	0	6	3	50.0%	3.3%				
11:00-12:00	3	1	2	1	2	2	5	2	18	9	50.0%	11.2%	2	2	0	1	0	0	3	1	9	4	44.4%	5.0%				
12:00-13:00	1	0	3	4	0	3	1	2	14	6	42.9%	8.7%	0	1	1	0	0	0	2	3	7	5	71.4%	3.9%				
13:00-14:00	4	0	0	0	0	2	3	2	11	7	63.6%	6.8%	0	0	2	0	0	0	4	0	6	4	66.7%	3.3%				
14:00-15:00	0	4	0	0	0	1	3	3	11	7	63.6%	6.8%	0	1	3	0	0	2	5	2	13	9	69.2%	7.2%				
15:00-16:00	0	2	2	0	0	0	5	2	11	7	63.6%	6.8%	0	0	1	0	0	0	4	0	5	4	80.0%	2.8%				
16:00-17:00	0	0	0	1	0	2	4	1	8	7	87.5%	5.0%	1	1	0	2	0	1	3	0	8	4	50.0%	4.4%				
17:00-18:00	0	0	3	0	0	2	3	2	10	7	70.0%	6.2%	0	0	2	2	0	0	3	3	10	6	60.0%	5.6%				
18:00-19:00	4	0	4	0	0	0	4	1	13	5	38.5%	8.1%	10	3	3	0	0	0	5	3	24	8	33.3%	13.3%				
Daytime Traffic	19	15	17	8	2	12	38	23	134	73	54.5%	83.2%	20	17	16	14	3	9	43	20	142	72	50.7%	78.9%				
19:00-20:00	4	0	2	0	1	0	2	2	11	4	36.4%	6.8%	0	5	1	0	1	0	4	2	13	6	46.2%	7.2%				
20:00-21:00	3	0	0	0	0	0	0	2	5	2	40.0%	3.1%	0	0	2	0	0	0	2	1	5	3	60.0%	2.8%				
21:00-22:00	2	0	0	0	0	0	0	0	2	0	0.0%	1.2%	0	0	1	0	0	0	0	0	1	0	0.0%	0.6%				
22:00-23:00	0	0	0	0	0	0	0	0	0	0	-	0.0%	0	0	0	0	0	0	0	0	0	0	-	0.0%				
23:00-00:00	0	0	0	0	0	0	0	0	0	0	-	0.0%	0	0	0	0	0	0	0	0	0	0	-	0.0%				
00:00-01:00	0	0	0	0	0	0	0	0	0	0	-	0.0%	0	0	0	0	0	0	0	0	0	0	-	0.0%				
01:00-02:00	0	0	0	0	0	0	0	0	0	0	-	0.0%	0	0	0	0	0	0	0	0	0	0	-	0.0%				
02:00-03:00	0	0	0	0	0	0	0	0	0	0	-	0.0%	0	0	0	0	0	0	0	0	0	0	-	0.0%				
03:00-04:00	0	0	0	0	0	0	0	0	0	0	-	0.0%	0	0	0	0	0	0	0	0	0	0	-	0.0%				
04:00-05:00	0	0	0	0	0	0	0	0	0	0	-	0.0%	0	0	0	0	0	0	0	0	0	0	-	0.0%				
05:00-06:00	0	0	0	0	0	0	0	0	0	0	-	0.0%	1	0	1	2	0	0	4	2	10	6	60.0%	5.6%				
06:00-07:00	0	0	5	0	0	2	2	0	9	4	44.4%	5.6%	1	2	1	3	0	0	2	0	9	2	22.2%	5.0%				
Nighttime Traffic	9	0	7	0	1	2	4	4	27	10	37.0%	16.8%	2	7	6	5	1	0	12	5	38	17	44.7%	21.1%				
Daily Traffic	28	15	24	8	3	14	42	27	161	83	51.6%	100.0%	22	24	22	19	4	9	55	25	180	89	49.4%	100.0%				
Ratio of Daily Traffic to Daytime Traffic	1.47	1.00	1.41	1.00	1.50	1.17	1.11	1.17	1.20	1.14	-	-	1.10	1.41	1.38	1.36	1.33	1.00	1.28	1.25	1.27	1.24	-	-				

Time	Total														Total '1	Comm. Vehic. '2	Comm. Vehic. Ratio '2/'1 [%]	Total /Daily Traffic [%]
	Type of Vehicle																	
	Motorcycle	Passenger Car	Minibus	Bus	Light Truck	Truck (2,3 axle)	Truck & Trailer	Container Trailer										
07:00-08:00	0	7	2	4	0	1	8	7	29	16	55.2%	8.5%						
08:00-09:00	11	5	4	2	1	0	5	4	32	9	28.1%	9.4%						
09:00-10:00	2	1	1	3	1	4	6	2	20	12	60.0%	5.9%						
10:00-11:00	1	4	0	2	1	1	5	3	17	9	52.9%	5.0%						
11:00-12:00	5	3	2	2	2	2	8	3	27	13	48.1%	7.9%						
12:00-13:00	1	1	4	4	0	3	3	5	21	11	52.4%	6.2%						
13:00-14:00	4	0	2	0	0	2	7	2	17	11	64.7%	5.0%						
14:00-15:00	0	5	3	0	0	3	8	5	24	16	66.7%	7.0%						
15:00-16:00	0	2	3	0	0	0	9	2	16	11	68.8%	4.7%						
16:00-17:00	1	1	0	3	0	3	7	1	16	11	68.8%	4.7%						
17:00-18:00	0	0	5	2	0	2	6	5	20	13	65.0%	5.9%						
18:00-19:00	14	3	7	0	0	0	9	4	37	13	35.1%	10.9%						
Daytime Traffic	39	32	33	22	5	21	81	43	276	145	52.5%	80.9%						
19:00-20:00	4	5	3	0	2	0	6	4	24	10	41.7%	7.0%						
20:00-21:00	3	0	2	0	0	0	2	3	10	5	50.0%	2.9%						
21:00-22:00	2	0	1	0	0	0	0	0	3	0	0.0%	0.9%						
22:00-23:00	0	0	0	0	0	0	0	0	0	0	-	0.0%						
23:00-00:00	0	0	0	0	0	0	0	0	0	0	-	0.0%						
00:00-01:00	0	0	0	0	0	0	0	0	0	0	-	0.0%						
01:00-02:00	0	0	0	0	0	0	0	0	0	0	-	0.0%						
02:00-03:00	0	0	0	0	0	0	0	0	0	0	-	0.0%						
03:00-04:00	0	0	0	0	0	0	0	0	0	0	-	0.0%						
04:00-05:00	0	0	0	0	0	0	0	0	0	0	-	0.0%						
05:00-06:00	1	0	1	2	0	0	4	2	10	6	60.0%	2.9%						
06:00-07:00	1	2	6	3	0	2	4	0	18	6	33.3%	5.3%						
Nighttime Traffic	11	7	13	5	2	2	16	9	65	27	41.5%	19.1%						
Daily Traffic	50	39	46	27	7	23	97	52	341	172	50.4%	100.0%						
Ratio of Daily Traffic to Daytime Traffic	1.28	1.22	1.39	1.23	1.40	1.10	1.20	1.21	1.24	1.19	-	-						

Survey Date		Date	8	/	Month	9	/	Year	2015	Guidance Diagram														
Survey Point Name										B-8 Elubo Border														
Direction1 From										Accra to Abidjan														
Direction2 From										Abidjan to Accra														
To		Accra																						
Direction 1		→																						
Direction 2		←																						
To		Abidjan																						
Direction	Direction 1											Direction 2												
	Motorcycle	PASSENGER Car	Minibus	Bus	Light Truck	Truck (2,3 axle)	Truck & Trailer (over 4 axle)	Container Trailer	Total '1	Commercial Vehicle '2	Commercial Vehicle Ratio '2/'1	Total /Daily Traffic	Motorcycle	PASSENGER Car	Minibus	Bus	Light Truck	Truck (2,3 axle)	Truck & Trailer (over 4 axle)	Container Trailer	Total '1	Commercial Vehicle '2	Commercial Vehicle Ratio '2/'1	Total /Daily Traffic
Time	[veh]	[veh]	[veh]	[veh]	[veh]	[veh]	[veh]	[veh]	[veh]	[veh]	[%]	[%]	[veh]	[veh]	[veh]	[veh]	[veh]	[veh]	[veh]	[veh]	[veh]	[veh]	[%]	[%]
07:00-08:00	15	115	6	2	0	1	1	0	140	2	1.4%	12.0%	33	50	2	1	0	4	2	0	92	6	6.5%	15.2%
08:00-09:00	55	100	5	2	2	0	0	3	167	3	1.8%	14.3%	30	35	7	0	1	1	0	0	74	1	1.4%	12.2%
09:00-10:00	26	30	0	0	0	0	0	1	57	1	1.8%	4.9%	17	22	7	0	2	0	0	0	48	0	0.0%	7.9%
10:00-11:00	45	54	1	1	1	5	1	0	108	6	5.6%	9.2%	20	32	2	0	1	0	0	0	55	0	0.0%	9.1%
11:00-12:00	50	45	0	0	1	0	0	0	96	0	0.0%	8.2%	9	16	1	0	0	0	0	0	26	0	0.0%	4.3%
12:00-13:00	43	55	7	0	3	3	0	0	111	3	2.7%	9.5%	9	18	2	0	1	1	2	0	33	3	9.1%	5.4%
13:00-14:00	35	53	10	0	0	2	2	0	102	4	3.9%	8.7%	15	22	0	0	1	1	0	1	40	2	5.0%	6.6%
14:00-15:00	25	20	5	2	0	3	0	0	55	3	5.5%	4.7%	11	7	1	2	0	0	0	0	21	0	0.0%	3.5%
15:00-16:00	27	35	6	0	0	3	0	1	72	4	5.6%	6.2%	3	7	4	0	0	0	0	0	14	0	0.0%	2.3%
16:00-17:00	18	22	3	0	0	2	0	0	45	2	4.4%	3.9%	20	51	2	1	0	11	0	0	85	11	12.9%	14.0%
17:00-18:00	20	28	7	0	1	0	0	0	56	0	0.0%	4.8%	6	4	0	0	1	0	4	0	15	4	26.7%	2.5%
18:00-19:00	21	25	0	0	0	0	0	0	46	0	0.0%	3.9%	7	6	2	1	1	0	2	0	19	2	10.5%	3.1%
Daytime Traffic	380	582	50	7	8	19	4	5	1,055	28	2.7%	90.3%	180	270	30	5	8	18	10	1	522	29	5.6%	86.0%
19:00-20:00	3	8	6	2	1	2	0	0	22	2	9.1%	1.9%	5	6	7	6	0	0	0	0	24	0	0.0%	4.0%
20:00-21:00	4	7	2	1	0	0	0	0	14	0	0.0%	1.2%	0	4	2	2	0	0	0	0	8	0	0.0%	1.3%
21:00-22:00	0	0	0	0	0	0	0	0	0	0	-	0.0%	0	0	0	0	0	0	0	0	0	0	-	0.0%
22:00-23:00	0	0	0	0	0	0	0	0	0	0	-	0.0%	0	0	0	0	0	0	0	0	0	0	-	0.0%
23:00-00:00	0	0	0	0	0	0	0	0	0	0	-	0.0%	0	0	0	0	0	0	0	0	0	0	-	0.0%
00:00-01:00	0	0	0	0	0	0	0	0	0	0	-	0.0%	0	0	0	0	0	0	0	0	0	0	-	0.0%
01:00-02:00	0	0	0	0	0	0	0	0	0	0	-	0.0%	0	0	0	0	0	0	0	0	0	0	-	0.0%
02:00-03:00	0	0	0	0	0	0	0	0	0	0	-	0.0%	0	0	0	0	0	0	0	0	0	0	-	0.0%
03:00-04:00	0	0	0	0	0	0	0	0	0	0	-	0.0%	0	0	0	0	0	0	0	0	0	0	-	0.0%
04:00-05:00	0	0	0	0	0	0	0	0	0	0	-	0.0%	0	0	0	0	0	0	0	0	0	0	-	0.0%
05:00-06:00	16	16	12	0	5	1	0	0	50	1	2.0%	4.3%	16	25	8	0	0	0	0	0	49	0	0.0%	8.1%
06:00-07:00	8	12	3	1	1	0	2	0	27	2	7.4%	2.3%	1	3	0	0	0	0	0	0	4	0	0.0%	0.7%
Nighttime Traffic	31	43	23	4	7	3	2	0	113	5	4.4%	9.7%	22	38	17	8	0	0	0	0	85	0	0.0%	14.0%
Daily Traffic	411	625	73	11	15	22	6	5	1,168	33	2.8%	100.0%	202	308	47	13	8	18	10	1	607	29	4.8%	100.0%
Ratio of Daily Traffic to Daytime Traffic	1.08	1.07	1.46	1.57	1.88	1.16	1.50	1.00	1.11	1.18	-	-	1.12	1.14	1.57	2.60	1.00	1.00	1.00	1.16	1.00	-	-	
Direction	Total																							
	Motorcycle	PASSENGER Car	Minibus	Bus	Light Truck	Truck (2,3 axle)	Truck & Trailer (over 4 axle)	Container Trailer	Total '1	Commercial Vehicle '2	Commercial Vehicle Ratio '2/'1	Total /Daily Traffic												
Time	[veh]	[veh]	[veh]	[veh]	[veh]	[veh]	[veh]	[car]	[car]	[%]	[%]													
07:00-08:00	48	165	8	3	0	5	3	0	232	8	3.4%	13.1%												
08:00-09:00	85	135	12	2	3	1	0	3	241	4	1.7%	13.6%												
09:00-10:00	43	52	7	0	2	0	0	1	105	1	1.0%	5.9%												
10:00-11:00	65	86	3	1	2	5	1	0	163	6	3.7%	9.2%												
11:00-12:00	59	61	1	0	1	0	0	0	122	0	0.0%	6.9%												
12:00-13:00	52	73	9	0	4	4	2	0	144	6	4.2%	8.1%												
13:00-14:00	50	75	10	0	1	3	2	1	142	6	4.2%	8.0%												
14:00-15:00	36	27	6	4	0	3	0	0	76	3	3.9%	4.3%												
15:00-16:00	30	42	10	0	0	3	0	1	86	4	4.7%	4.8%												
16:00-17:00	38	73	5	1	0	13	0	0	130	13	10.0%	7.3%												
17:00-18:00	26	32	7	0	2	0	4	0	71	4	5.6%	4.0%												
18:00-19:00	28	31	2	1	1	0	2	0	65	2	3.1%	3.7%												
Daytime Traffic	560	852	80	12	16	37	14	6	1,577	57	3.6%	88.8%												
19:00-20:00	8	14	13	8	1	2	0	0	46	2	4.3%	2.6%												
20:00-21:00	4	11	4	3	0	0	0	0	22	0	0.0%	1.2%												
21:00-22:00	0	0	0	0	0	0	0	0	0	0	-	0.0%												
22:00-23:00	0	0	0	0	0	0	0	0	0	0	-	0.0%												
23:00-00:00	0	0	0	0	0	0	0	0	0	0	-	0.0%												
00:00-01:00	0	0	0	0	0	0	0	0	0	0	-	0.0%												
01:00-02:00	0	0	0	0	0	0	0	0	0	0	-	0.0%												
02:00-03:00	0	0	0	0	0	0	0	0	0	0	-	0.0%												
03:00-04:00	0	0	0	0	0	0	0	0	0	0	-	0.0%												
04:00-05:00	0	0	0	0	0	0	0	0	0	0	-	0.0%												
05:00-06:00	32	41	20	0	5	1	0	0	99	1	1.0%	5.6%												
06:00-07:00	9	15	3	1	1	0	2	0	31	2	6.5%	1.7%												
Nighttime Traffic	53	81	40	12	7	3	2	0	198	5	2.5%	11.2%												
Daily Traffic	613	933	120	24	23	40	16	6	1,775	62	3.5%	100.0%												
Ratio of Daily Traffic to Daytime Traffic	1.09	1.10	1.50	2.00	1.44	1.08	1.14	1.00	1.13	1.09	-	-												

Survey Date	Date	19-20	Month	8	Year	2015	Guidance Diagram	
Survey Point Name	B-9 AFLAO						To	FRONTIERE AFLAO
Direction1 From	FRONTIERE AFLAO to LOME							
Direction2 From	LOME to FRONTIERE AFLAO						To	LOME

direction	Direction 1											Direction 2												
	Type of Vehicle								Total '1	Comm ercial Vehid e '2	Comm ercial Vehid e Ratio '2/'1	Total /Daily Traffic	Type of Vehicle								Total '1	Comm ercial Vehid e '2	Comm ercial Vehid e Ratio '2/'1	Total /Daily Traffic
Motorc ycle	Passe nger Car	Minib us	Bus	Light Truck	Truck (2,3 axle)	Truck & Trailer	Contai ner Trailer	Motorc ycle					Passe nger Car	Minib us	Bus	Light Truck	Truck (2,3 axle)	Truck & Trailer	Contai ner Trailer					
07:00-08:00	240	200	2	2	0	0	1	8	453	9	2.0%	4.4%	700	147	1	0	0	3	9	0	860	12	1.4%	5.6%
08:00-09:00	770	171	3	1	0	1	6	0	952	7	0.7%	9.3%	1,142	228	2	5	5	4	24	0	1,410	28	2.0%	9.2%
09:00-10:00	930	178	4	0	0	3	8	0	1,123	11	1.0%	11.0%	1,068	204	0	3	2	2	8	0	1,287	10	0.8%	8.4%
10:00-11:00	488	105	7	0	0	2	6	0	608	8	1.3%	5.9%	665	156	1	1	1	1	3	0	828	4	0.5%	5.4%
11:00-12:00	529	112	3	3	2	4	5	0	658	9	1.4%	6.4%	590	143	1	2	0	0	3	0	739	3	0.4%	4.8%
12:00-13:00	857	187	5	4	0	3	7	0	1,063	10	0.9%	10.4%	851	223	3	3	1	4	10	0	1,095	14	1.3%	7.1%
13:00-14:00	633	192	4	1	3	5	8	0	846	13	1.5%	8.3%	967	270	6	2	1	5	8	0	1,259	13	1.0%	8.2%
14:00-15:00	460	220	10	1	0	8	19	0	718	27	3.8%	7.0%	905	226	9	0	1	1	5	0	1,147	6	0.5%	7.5%
15:00-16:00	330	160	2	2	1	0	18	0	513	18	3.5%	5.0%	965	205	10	2	3	3	6	0	1,194	9	0.8%	7.8%
16:00-17:00	320	240	8	1	0	1	10	0	580	11	1.9%	5.7%	790	257	10	5	0	3	6	0	1,071	9	0.8%	7.0%
17:00-18:00	360	203	2	0	0	1	8	0	574	9	1.6%	5.6%	860	283	5	4	1	4	1	0	1,158	5	0.4%	7.5%
18:00-19:00	203	200	0	2	0	0	6	0	411	6	1.5%	4.0%	588	214	11	4	0	3	10	0	830	13	1.6%	5.4%
Daytime Traffic	6,120	2,168	50	17	6	28	102	8	8,499	138	1.6%	82.9%	10,091	2,556	59	31	15	33	93	0	12,878	126	1.0%	84.0%
19:00-20:00	160	148	6	0	0	0	0	0	314	0	0.0%	3.1%	401	102	2	0	1	4	6	0	516	10	1.9%	3.4%
20:00-21:00	318	97	3	1	4	1	9	0	433	10	2.3%	4.2%	304	130	2	1	2	1	7	0	447	8	1.8%	2.9%
21:00-22:00	182	59	3	0	3	1	2	0	250	3	1.2%	2.4%	195	61	5	0	0	0	1	0	262	1	0.4%	1.7%
22:00-23:00	82	38	0	0	0	1	0	0	121	1	0.8%	1.2%	86	40	1	0	0	0	0	0	127	0	0.0%	0.8%
23:00-00:00	43	25	0	0	0	0	0	0	68	0	0.0%	0.7%	32	25	0	0	0	0	1	0	58	1	1.7%	0.4%
00:00-01:00	38	12	0	0	0	0	0	0	50	0	0.0%	0.5%	40	16	0	0	0	0	0	0	56	0	0.0%	0.4%
01:00-02:00	22	13	0	0	0	0	0	0	35	0	0.0%	0.3%	5	2	0	0	0	0	0	0	7	0	0.0%	0.0%
02:00-03:00	8	5	0	0	0	0	0	0	13	0	0.0%	0.1%	16	6	0	0	0	0	0	0	22	0	0.0%	0.1%
03:00-04:00	10	4	0	0	0	0	0	0	14	0	0.0%	0.1%	13	14	1	0	0	0	0	0	28	0	0.0%	0.2%
04:00-05:00	19	9	0	0	0	0	0	0	28	0	0.0%	0.3%	25	6	0	0	0	0	0	0	31	0	0.0%	0.2%
05:00-06:00	60	25	0	0	0	0	0	0	85	0	0.0%	0.8%	195	77	2	0	0	0	3	0	277	3	1.1%	1.8%
06:00-07:00	240	90	0	0	0	0	1	5	336	6	1.8%	3.3%	465	151	4	0	0	1	9	0	630	10	1.6%	4.1%
07:00-08:00	0	0	0	0	0	0	0	0	0	0	0.0%	0.0%	0	0	0	0	0	0	0	0	0	0	0.0%	0.0%
Nighttime Traffic	1,182	525	12	1	7	3	12	5	1,747	20	1.1%	17.1%	1,777	630	17	1	3	6	27	0	2,461	33	1.3%	16.0%
Daily Traffic	7,302	2,693	62	18	13	31	114	13	10,246	158	1.5%	100.0%	11,868	3,186	76	32	18	39	120	0	15,339	159	1.0%	100.0%
Ratio of Daily Traffic to Daytime Traffic	1.19	1.24	1.24	1.06	2.17	1.11	1.12	1.63	1.21	1.14	-	-	1.18	1.25	1.29	1.03	1.20	1.18	1.29	-	1.19	1.26	-	-

direction	Total											
	Type of Vehicle								Total '1	Comm ercial Vehid e '2	Comm ercial Vehid e Ratio '2/'1	Total /Daily Traffic
Motorc ycle	Passe nger Car	Minib us	Bus	Light Truck	Truck (2,3 axle)	Truck & Trailer	Contai ner Trailer					
07:00-08:00	940	347	3	2	0	3	10	8	1,313	21	1.6%	5.1%
08:00-09:00	1,912	399	5	6	5	5	30	0	2,362	35	1.5%	9.2%
09:00-10:00	1,998	382	4	3	2	5	16	0	2,410	21	0.9%	9.4%
10:00-11:00	1,153	261	8	1	1	3	9	0	1,436	12	0.8%	5.6%
11:00-12:00	1,119	255	4	5	2	4	8	0	1,397	12	0.9%	5.5%
12:00-13:00	1,708	410	8	7	1	7	17	0	2,158	24	1.1%	8.4%
13:00-14:00	1,600	462	10	3	4	10	16	0	2,105	26	1.2%	8.2%
14:00-15:00	1,365	446	19	1	1	9	24	0	1,865	33	1.8%	7.3%
15:00-16:00	1,295	365	12	4	4	3	24	0	1,707	27	1.6%	6.7%
16:00-17:00	1,110	497	18	6	0	4	16	0	1,651	20	1.2%	6.5%
17:00-18:00	1,220	486	7	4	1	5	9	0	1,732	14	0.8%	6.8%
18:00-19:00	791	414	11	6	0	3	16	0	1,241	19	1.5%	4.9%
Daytime Traffic	16,211	4,724	109	48	21	61	195	8	21,377	264	1.2%	83.6%
19:00-20:00	561	250	8	0	1	4	6	0	830	10	1.2%	3.2%
20:00-21:00	622	227	5	2	6	2	16	0	880	18	2.0%	3.4%
21:00-22:00	377	120	8	0	3	1	3	0	512	4	0.8%	2.0%
22:00-23:00	168	78	1	0	0	1	0	0	248	1	0.4%	1.0%
23:00-00:00	75	50	0	0	0	0	1	0	126	1	0.8%	0.5%
00:00-01:00	78	28	0	0	0	0	0	0	106	0	0.0%	0.4%
01:00-02:00	27	15	0	0	0	0	0	0	42	0	0.0%	0.2%
02:00-03:00	24	11	0	0	0	0	0	0	35	0	0.0%	0.1%
03:00-04:00	23	18	1	0	0	0	0	0	42	0	0.0%	0.2%
04:00-05:00	44	15	0	0	0	0	0	0	59	0	0.0%	0.2%
05:00-06:00	255	102	2	0	0	0	3	0	362	3	0.8%	1.4%
06:00-07:00	705	241	4	0	0	1	10	5	966	16	1.7%	3.8%
07:00-08:00	0	0	0	0	0	0	0	0	0	0	0.0%	0.0%
Nighttime Traffic	2,959	1,155	29	2	10	9	39	5	4,208	53	1.3%	16.4%
Daily Traffic	19,170	5,879	138	50	31	70	234	13	25,585	317	1.2%	100.0%
Ratio of Daily Traffic to Daytime Traffic	1.18	1.24	1.27	1.04	1.48	1.15	1.20	1.63	1.20	1.20	-	-

Date 19-20 / Month 8 / Year 2015 Survey Date	Guidance Diagram To <u>LOME</u> Direction 1 → Direction 2 ← To <u>HILAKONDJI</u>
Survey Point Name <u>B-10 HILAKONDI</u>	
Direction1 From <u>LOME</u> to <u>HILAKONDJI</u>	
Direction2 From <u>HILAKONDJI</u> to <u>LOME</u>	

Time	Direction 1											Direction 2												
	Type of Vehicle							Total '1	Comm. Vehic. '2	Comm. Vehic. Ratio '2/'1 [%]	Total /Daily Traffic [%]	Type of Vehicle							Total '1	Comm. Vehic. '2	Comm. Vehic. Ratio '2/'1 [%]	Total /Daily Traffic [%]		
Motorcycle	Passenger Car	Minibus	Bus	Light Truck	Truck (2,3 axle)	Truck & Trailer (over 4 axle)	Container Trailer					Motorcycle	Passenger Car	Minibus	Bus	Light Truck	Truck (2,3 axle)	Truck & Trailer (over 4 axle)					Container Trailer	
07:00-08:00	391	167	2	0	0	2	2	0	564	4	0.7%	6.8%	435	182	1	0	5	0	6	0	629	6	1.0%	6.5%
08:00-09:00	340	128	5	2	2	0	0	0	477	0	0.0%	5.8%	387	115	3	0	1	12	1	0	519	13	2.5%	5.4%
09:00-10:00	313	140	0	1	1	0	3	2	460	5	1.1%	5.6%	476	146	0	0	7	2	1	0	632	3	0.5%	6.6%
10:00-11:00	275	122	2	0	0	1	1	0	401	2	0.5%	4.9%	426	130	1	0	2	2	2	0	563	4	0.7%	5.8%
11:00-12:00	365	195	1	0	2	2	1	0	566	3	0.5%	6.9%	442	130	2	2	4	2	0	0	582	2	0.3%	6.0%
12:00-13:00	315	110	1	0	0	11	3	0	440	14	3.2%	5.3%	483	145	3	2	3	5	5	2	648	12	1.9%	6.7%
13:00-14:00	289	145	3	5	0	5	15	21	483	41	8.5%	5.9%	392	110	1	0	4	4	0	1	512	5	1.0%	5.3%
14:00-15:00	387	159	6	1	1	3	4	0	561	7	1.2%	6.8%	365	150	7	2	0	0	3	0	527	3	0.6%	5.5%
15:00-16:00	425	169	3	1	3	5	4	0	610	9	1.5%	7.4%	395	170	11	6	0	2	2	0	586	4	0.7%	6.1%
16:00-17:00	297	154	2	1	2	4	9	2	471	15	3.2%	5.7%	445	221	9	4	2	1	4	0	686	5	0.7%	7.1%
17:00-18:00	344	177	5	2	0	3	26	0	557	29	5.2%	6.8%	475	290	5	2	0	3	0	0	775	3	0.4%	8.0%
18:00-19:00	379	145	1	0	1	0	0	0	526	0	0.0%	6.4%	505	215	1	0	1	10	2	0	734	12	1.6%	7.6%
Daytime Traffic	4,120	1,811	31	13	12	36	68	25	6,116	129	2.1%	74.3%	5,226	2,004	44	18	29	43	26	3	7,393	72	1.0%	76.7%
19:00-20:00	264	114	9	0	0	1	0	0	388	1	0.3%	4.7%	360	150	2	1	0	2	1	0	516	3	0.6%	5.4%
20:00-21:00	267	77	0	0	0	0	1	1	346	2	0.6%	4.2%	310	101	2	1	3	0	2	0	419	2	0.5%	4.3%
21:00-22:00	115	56	9	3	0	0	0	4	187	4	2.1%	2.3%	120	60	1	1	3	0	0	0	185	0	0.0%	1.9%
22:00-23:00	97	49	17	0	1	1	2	0	167	3	1.8%	2.0%	92	64	2	2	1	1	3	0	165	4	2.4%	1.7%
23:00-00:00	39	39	10	0	0	0	0	0	88	0	0.0%	1.1%	48	29	2	1	1	0	0	0	81	0	0.0%	0.8%
00:00-01:00	15	25	10	0	0	0	0	0	50	0	0.0%	0.6%	16	13	0	0	0	0	0	0	29	0	0.0%	0.3%
01:00-02:00	5	14	3	0	0	0	2	0	24	2	8.3%	0.3%	12	14	0	1	4	0	0	0	31	0	0.0%	0.3%
02:00-03:00	15	10	0	3	0	0	0	0	28	0	0.0%	0.3%	14	22	5	0	0	0	0	0	41	0	0.0%	0.4%
03:00-04:00	15	10	1	3	0	0	0	0	29	0	0.0%	0.4%	17	12	5	0	0	0	0	0	34	0	0.0%	0.4%
04:00-05:00	110	36	1	0	0	0	0	0	147	0	0.0%	1.8%	115	4	0	0	13	0	0	0	132	0	0.0%	1.4%
05:00-06:00	152	95	1	0	0	0	0	0	248	0	0.0%	3.0%	120	65	0	0	2	5	6	0	198	11	5.6%	2.1%
06:00-07:00	314	99	2	0	1	1	2	0	419	3	0.7%	5.1%	305	95	1	1	3	4	7	1	417	12	2.9%	4.3%
07:00-08:00									0	0	-	0.0%									0	-	0.0%	
Nighttime Traffic	1,408	624	63	9	2	3	7	5	2,121	15	0.7%	25.7%	1,529	629	20	8	30	12	19	1	2,248	32	1.4%	23.3%
Daily Traffic	5,528	2,435	94	22	14	39	75	30	8,237	144	1.7%	100.0%	6,755	2,633	64	26	59	55	45	4	9,641	104	1.1%	100.0%
Ratio of Daily Traffic to Daytime Traffic	1.34	1.34	3.03	1.69	1.17	1.08	1.10	1.20	1.35	1.12	-	-	1.29	1.31	1.45	1.44	2.03	1.28	1.73	1.33	1.30	1.44	-	-

Time	Total													
	Type of Vehicle							Total '1	Comm. Vehic. '2	Comm. Vehic. Ratio '2/'1 [%]	Total /Daily Traffic [%]			
Motorcycle	Passenger Car	Minibus	Bus	Light Truck	Truck (2,3 axle)	Truck & Trailer (over 4 axle)	Container Trailer							
07:00-08:00	826	349	3	0	5	2	8	0	1,193	10	0.8%	6.7%		
08:00-09:00	727	243	8	2	3	12	1	0	996	13	1.3%	5.6%		
09:00-10:00	789	286	0	1	8	2	4	2	1,092	8	0.7%	6.1%		
10:00-11:00	701	252	3	0	2	3	3	0	964	6	0.6%	5.4%		
11:00-12:00	807	325	3	2	6	4	1	0	1,148	5	0.4%	6.4%		
12:00-13:00	798	255	4	2	3	16	8	2	1,088	26	2.4%	6.1%		
13:00-14:00	681	255	4	5	4	9	15	22	995	46	4.6%	5.6%		
14:00-15:00	752	309	13	3	1	3	7	0	1,088	10	0.9%	6.1%		
15:00-16:00	820	339	14	7	3	7	6	0	1,196	13	1.1%	6.7%		
16:00-17:00	742	375	11	5	4	5	13	2	1,157	20	1.7%	6.5%		
17:00-18:00	819	467	10	4	0	6	26	0	1,332	32	2.4%	7.5%		
18:00-19:00	884	360	2	0	2	10	2	0	1,260	12	1.0%	7.0%		
Daytime Traffic	9,346	3,815	75	31	41	79	94	28	13,509	201	1.5%	75.6%		
19:00-20:00	624	264	11	1	0	3	1	0	904	4	0.4%	5.1%		
20:00-21:00	577	178	2	1	3	0	3	1	765	4	0.5%	4.3%		
21:00-22:00	235	116	10	4	3	0	0	4	372	4	1.1%	2.1%		
22:00-23:00	189	113	19	2	2	2	5	0	332	7	2.1%	1.9%		
23:00-00:00	87	68	12	1	1	0	0	0	169	0	0.0%	0.9%		
00:00-01:00	31	38	10	0	0	0	0	0	79	0	0.0%	0.4%		
01:00-02:00	17	28	3	1	4	0	2	0	55	2	3.6%	0.3%		
02:00-03:00	29	32	5	3	0	0	0	0	69	0	0.0%	0.4%		
03:00-04:00	32	22	6	3	0	0	0	0	63	0	0.0%	0.4%		
04:00-05:00	225	40	1	0	13	0	0	0	279	0	0.0%	1.6%		
05:00-06:00	272	160	1	0	2	5	6	0	446	11	2.5%	2.5%		
06:00-07:00	619	194	3	1	4	5	9	1	836	15	1.8%	4.7%		
07:00-08:00	0	0	0	0	0	0	0	0	0	0	-	0.0%		
Nighttime Traffic	2,937	1,253	83	17	32	15	26	6	4,369	47	1.1%	24.4%		
Daily Traffic	12,283	5,068	158	48	73	94	120	34	17,878	248	1.4%	100.0%		
Ratio of Daily Traffic to Daytime Traffic	1.31	1.33	2.11	1.55	1.78	1.19	1.28	1.21	1.32	1.23	-	-		

Survey Date											Guidance Diagram													
Date 31 / Month AUGUST / Year 2015											To WEST													
Survey Point Name BF1 PA - HOUNDE											Direction 1 → Direction 2 ← To EAST													
Direction1 From WEST to EAST																								
Direction2 From EAST to WEST																								
direction	Direction 1										Direction 2													
	Type of Vehicle										Type of Vehicle													
Time	Motorcycle	Passenger Car	Minibus	Bus	Light Truck	Truck (2,3 axle)	Truck & Trailer (over 4 axle)	Container Trailer	Total '1	Commercial Vehicle '2	Commercial Vehicle Ratio '2/'1	Total /Daily Traffic	Motorcycle	Passenger Car	Minibus	Bus	Light Truck	Truck (2,3 axle)	Truck & Trailer (over 4 axle)	Container Trailer	Total '1	Commercial Vehicle '2	Commercial Vehicle Ratio '2/'1	Total /Daily Traffic
07:00-08:00	0	3	2	0	3	2	3	0	13	5	38.5%	6.9%	5	1	0	0	0	1	6	2	15	9	60.0%	7.0%
08:00-09:00	5	1	0	0	1	0	1	0	8	1	12.5%	4.3%	0	0	0	0	0	0	0	0	0	0	-	0.0%
09:00-10:00	4	1	3	0	0	2	3	2	15	7	46.7%	8.0%	4	1	0	3	0	0	5	0	13	5	38.5%	6.0%
10:00-11:00	3	2	0	2	0	2	3	2	14	7	50.0%	7.4%	1	2	2	2	0	3	1	1	12	5	41.7%	5.6%
11:00-12:00	1	0	0	3	0	2	2	1	9	5	55.6%	4.8%	9	0	0	4	0	0	1	0	14	1	7.1%	6.5%
12:00-13:00	2	4	1	1	1	2	1	1	13	4	30.8%	6.9%	0	3	1	1	2	1	2	4	14	7	50.0%	6.5%
13:00-14:00	2	2	0	1	1	0	0	1	7	1	14.3%	3.7%	7	0	0	0	0	3	5	0	15	8	53.3%	7.0%
14:00-15:00	0	3	0	0	0	0	2	0	5	2	40.0%	2.7%	3	0	0	0	1	0	0	0	4	1	25.0%	1.9%
15:00-16:00	0	3	0	0	0	0	0	0	3	0	0.0%	1.6%	4	3	2	3	4	0	0	3	19	3	15.8%	8.8%
16:00-17:00	0	1	4	3	0	0	5	0	13	5	38.5%	6.9%	0	1	0	0	0	3	0	0	4	3	75.0%	1.9%
17:00-18:00	7	0	1	1	0	1	2	2	14	5	35.7%	7.4%	1	3	3	2	0	0	4	2	15	6	40.0%	7.0%
18:00-19:00	3	0	1	0	0	4	3	0	11	7	63.6%	5.9%	0	0	0	0	1	0	3	0	4	3	75.0%	1.9%
Daytime Traffic	27	20	12	11	6	15	25	9	125	49	39.2%	66.5%	34	14	8	15	7	12	27	12	129	51	39.5%	60.0%
19:00-20:00	5	2	0	0	2	1	5	2	17	8	47.1%	9.0%	3	0	0	0	1	0	3	0	7	3	42.9%	3.3%
20:00-21:00	0	2	0	0	0	0	0	0	2	0	0.0%	1.1%	2	0	0	2	0	0	0	0	4	0	0.0%	1.9%
21:00-22:00	2	1	3	0	0	0	3	1	10	4	40.0%	5.3%	0	0	0	3	0	0	8	2	13	10	76.9%	6.0%
22:00-23:00	1	4	1	0	0	0	0	0	6	0	0.0%	3.2%	0	4	0	0	0	2	0	6	2	33.3%	2.8%	
23:00-00:00	0	0	0	0	0	0	0	0	0	0	-	0.0%	0	1	1	0	0	6	2	0	10	8	80.0%	4.7%
00:00-01:00	0	2	0	0	1	1	3	0	7	4	57.1%	3.7%	0	1	0	0	0	0	1	1	3	2	66.7%	1.4%
01:00-02:00	0	3	0	0	1	0	0	0	4	0	0.0%	2.1%	0	2	0	0	0	0	0	0	2	0	0.0%	0.9%
02:00-03:00	0	0	0	0	0	0	0	0	0	0	-	0.0%	0	2	0	2	0	0	0	6	10	60.0%	4.7%	
03:00-04:00	0	0	0	2	0	0	0	0	2	0	0.0%	1.1%	0	0	0	0	2	0	1	3	3	100.0%	1.4%	
04:00-05:00	0	0	0	0	0	0	0	0	0	0	-	0.0%	0	0	0	0	0	0	3	3	3	100.0%	1.4%	
05:00-06:00	3	0	1	0	0	0	0	0	4	0	0.0%	2.1%	0	0	2	0	2	0	0	4	0	0.0%	1.9%	
06:00-07:00	6	2	1	0	0	0	0	2	11	2	18.2%	5.9%	2	4	1	0	0	7	3	4	21	14	66.7%	9.8%
Nighttime Traffic	17	16	6	2	4	2	11	5	63	18	28.6%	33.5%	7	14	4	7	3	15	19	17	86	51	59.3%	40.0%
Daily Traffic	44	36	18	13	10	17	36	14	188	67	35.6%	100.0%	41	28	12	22	10	27	46	29	215	102	47.4%	100.0%
Ratio of Daily Traffic to Daytime Traffic	1.63	1.80	1.50	1.18	1.67	1.13	1.44	1.56	1.50	1.37	-	-	1.21	2.00	1.50	1.47	1.43	2.25	1.70	2.42	1.67	2.00	-	-

direction	Total											
	Type of Vehicle											
Time	Motorcycle	Passenger Car	Minibus	Bus	Light Truck	Truck (2,3 axle)	Truck & Trailer (over 4 axle)	Container Trailer	Total '1	Commercial Vehicle '2	Commercial Vehicle Ratio '2/'1	Total /Daily Traffic
07:00-08:00	5	4	2	0	3	3	9	2	28	14	50.0%	6.9%
08:00-09:00	5	1	0	0	1	0	1	0	8	1	12.5%	2.0%
09:00-10:00	8	2	3	3	0	2	8	2	28	12	42.9%	6.9%
10:00-11:00	4	4	2	4	0	5	4	3	26	12	46.2%	6.5%
11:00-12:00	10	0	0	7	0	2	3	1	23	6	26.1%	5.7%
12:00-13:00	2	7	2	2	3	3	5	27	11	40.7%	6.7%	
13:00-14:00	9	2	0	1	1	3	5	1	22	9	40.9%	5.5%
14:00-15:00	3	3	0	0	0	1	2	0	9	3	33.3%	2.2%
15:00-16:00	4	6	2	3	4	0	3	22	3	13.6%	5.5%	
16:00-17:00	0	2	4	3	0	3	5	0	17	8	47.1%	4.2%
17:00-18:00	8	3	4	3	0	1	6	4	29	11	37.9%	7.2%
18:00-19:00	3	0	1	0	1	4	6	0	15	10	66.7%	3.7%
Daytime Traffic	61	34	20	26	13	27	52	21	254	100	39.4%	63.0%
19:00-20:00	8	2	0	0	3	1	8	2	24	11	45.8%	6.0%
20:00-21:00	2	2	0	2	0	0	0	0	6	0	0.0%	1.5%
21:00-22:00	2	1	3	3	0	0	11	3	23	14	60.9%	5.7%
22:00-23:00	1	8	1	0	0	0	2	0	12	2	16.7%	3.0%
23:00-00:00	0	1	1	0	0	6	2	0	10	8	80.0%	2.5%
00:00-01:00	0	3	0	0	1	1	4	1	10	6	60.0%	2.5%
01:00-02:00	0	5	0	0	1	0	0	0	6	0	0.0%	1.5%
02:00-03:00	0	2	0	2	0	0	0	6	10	6	60.0%	2.5%
03:00-04:00	0	0	0	2	0	2	0	1	5	3	60.0%	1.2%
04:00-05:00	0	0	0	0	0	0	0	3	3	3	100.0%	0.7%
05:00-06:00	3	0	3	0	2	0	0	0	8	0	0.0%	2.0%
06:00-07:00	8	6	2	0	0	7	3	6	32	16	50.0%	7.9%
Nighttime Traffic	24	30	10	9	7	17	30	22	149	69	46.3%	37.0%
Daily Traffic	85	64	30	35	20	44	82	43	403	169	41.9%	100.0%
Ratio of Daily Traffic to Daytime Traffic	1.39	1.88	1.50	1.35	1.54	1.63	1.58	2.05	1.59	1.69	-	-

Survey Date	Date	24	Month	AUGUST	Year	2015	Guidance Diagram
Survey Point Name	BF2 (Boussé-Yako)						To SOUTH
Direction1 From	SOUTH		to	NORTH			
Direction2 From	NORTH		to	SOUTH		To NORTH	

Time	Direction 1											Direction 2																
	Type of Vehicle										Total '1	Comm. Vehic. '2	Comm. Vehic. Ratio '2/'1	Total /Daily Traffic	Type of Vehicle										Total '1	Comm. Vehic. '2	Comm. Vehic. Ratio '2/'1	Total /Daily Traffic
Motorcycle	Passenger Car	Minibus	Bus	Light Truck	Truck (2,3 axle)	Truck & Trailer (over 4 axle)	Container Trailer								Motorcycle	Passenger Car	Minibus	Bus	Light Truck	Truck (2,3 axle)	Truck & Trailer (over 4 axle)	Container Trailer						
07:00-08:00	7	5	1	3	0	0	1	0	17	1	5.9%	4.2%	17	10	4	5	0	1	1	0	38	2	5.3%	8.8%				
08:00-09:00	26	11	4	4	0	1	0	0	46	1	2.2%	11.4%	25	8	7	6	0	0	0	0	46	0	0.0%	10.6%				
09:00-10:00	18	10	6	4	2	0	0	0	40	0	0.0%	9.9%	20	8	5	5	0	1	0	0	39	1	2.6%	9.0%				
10:00-11:00	20	15	2	2	0	1	0	0	40	1	2.5%	9.9%	18	10	14	4	1	1	3	0	51	4	7.8%	11.8%				
11:00-12:00	22	7	0	1	1	1	0	0	32	1	3.1%	7.9%	10	9	3	3	0	1	1	0	27	2	7.4%	6.2%				
12:00-13:00	18	7	1	6	2	1	0	0	35	1	2.9%	8.7%	12	8	4	3	0	0	1	2	30	3	10.0%	6.9%				
13:00-14:00	21	5	0	4	4	2	0	0	36	2	5.6%	8.9%	7	17	1	2	0	2	1	1	31	4	12.9%	7.2%				
14:00-15:00	6	5	0	5	0	1	0	0	17	1	5.9%	4.2%	8	8	3	4	1	1	2	3	30	6	20.0%	6.9%				
15:00-16:00	10	3	4	3	1	0	0	0	21	0	0.0%	5.2%	3	4	2	1	4	5	1	2	22	8	36.4%	5.1%				
16:00-17:00	17	10	7	12	0	2	1	1	50	4	8.0%	12.4%	8	13	1	3	0	1	1	0	27	2	7.4%	6.2%				
17:00-18:00	7	6	3	7	0	0	0	0	23	0	0.0%	5.7%	7	10	6	4	1	2	1	0	31	3	9.7%	7.2%				
18:00-19:00	3	8	4	4	0	0	0	0	19	0	0.0%	4.7%	14	7	3	6	1	4	2	1	38	7	18.4%	8.8%				
Daytime Traffic	175	92	32	55	10	9	2	1	376	12	3.2%	93.3%	149	112	53	46	8	19	14	9	410	42	10.2%	94.7%				
19:00-20:00	0	1	1	2	0	0	0	0	4	0	0.0%	1.0%	0	0	0	0	0	0	0	0	0	0	-	0.0%				
20:00-21:00	0	0	0	0	0	0	0	0	0	0	-	0.0%	0	0	0	0	0	0	0	0	0	0	-	0.0%				
21:00-22:00	0	0	0	0	0	0	0	1	1	1	100.0%	0.2%	0	0	0	0	0	0	0	0	0	0	-	0.0%				
22:00-23:00	0	0	0	0	0	0	1	0	1	1	100.0%	0.2%	0	0	0	0	0	0	0	0	0	0	-	0.0%				
23:00-00:00	0	0	0	0	0	1	0	0	1	1	100.0%	0.2%	0	0	0	0	0	0	0	0	0	0	-	0.0%				
00:00-01:00	0	0	0	0	0	0	0	1	1	1	100.0%	0.2%	0	0	0	0	0	0	0	1	1	1	100.0%	0.2%				
01:00-02:00	0	0	0	0	0	0	0	0	0	0	-	0.0%	0	0	0	0	0	0	0	1	1	1	100.0%	0.2%				
02:00-03:00	0	0	0	0	0	1	0	0	1	1	100.0%	0.2%	0	0	0	0	0	0	0	1	1	1	100.0%	0.2%				
03:00-04:00	0	0	0	0	0	0	0	0	0	0	-	0.0%	1	0	0	0	0	1	0	1	3	2	66.7%	0.7%				
04:00-05:00	0	0	0	0	0	0	0	0	0	0	-	0.0%	1	0	0	0	0	1	1	2	5	4	80.0%	1.2%				
05:00-06:00	2	1	2	0	0	1	0	2	8	3	37.5%	2.0%	1	1	0	1	0	0	2	0	5	2	40.0%	1.2%				
06:00-07:00	5	2	0	0	0	1	1	1	10	3	30.0%	2.5%	2	1	0	1	0	2	0	1	7	3	42.9%	1.6%				
Nighttime Traffic	7	4	3	2	0	4	2	5	27	11	40.7%	6.7%	5	2	0	2	0	4	3	7	23	14	60.9%	5.3%				
Daily Traffic	182	96	35	57	10	13	4	6	403	23	5.7%	100.0%	154	114	53	48	8	23	17	16	433	56	12.9%	100.0%				
Ratio of Daily Traffic to Daytime Traffic	1.04	1.04	1.09	1.04	1.00	1.44	2.00	6.00	1.07	1.92	-	-	1.03	1.02	1.00	1.04	1.00	1.21	1.21	1.78	1.06	1.33	-	-				

Time	Total												
	Type of Vehicle										Total '1	Comm. Vehic. '2	Comm. Vehic. Ratio '2/'1
Motorcycle	Passenger Car	Minibus	Bus	Light Truck	Truck (2,3 axle)	Truck & Trailer (over 4 axle)	Container Trailer						
07:00-08:00	24	15	5	8	0	1	2	0	55	3	5.5%	6.6%	
08:00-09:00	51	19	11	10	0	1	0	0	92	1	1.1%	11.0%	
09:00-10:00	38	18	11	9	2	1	0	0	79	1	1.3%	9.4%	
10:00-11:00	38	25	16	6	1	2	3	0	91	5	5.5%	10.9%	
11:00-12:00	32	16	3	4	1	2	1	0	59	3	5.1%	7.1%	
12:00-13:00	30	15	5	9	2	1	1	2	65	4	6.2%	7.8%	
13:00-14:00	28	22	1	6	4	4	1	1	67	6	9.0%	8.0%	
14:00-15:00	14	13	3	9	1	2	2	3	47	7	14.9%	5.6%	
15:00-16:00	13	7	6	4	5	5	1	2	43	8	18.6%	5.1%	
16:00-17:00	25	23	8	15	0	3	2	1	77	6	7.8%	9.2%	
17:00-18:00	14	16	9	11	1	2	1	0	54	3	5.6%	6.5%	
18:00-19:00	17	15	7	10	1	4	2	1	57	7	12.3%	6.8%	
Daytime Traffic	324	204	85	101	18	28	16	10	786	54	6.9%	94.0%	
19:00-20:00	0	1	1	2	0	0	0	0	4	0	0.0%	0.5%	
20:00-21:00	0	0	0	0	0	0	0	0	0	0	-	0.0%	
21:00-22:00	0	0	0	0	0	0	0	1	1	1	100.0%	0.1%	
22:00-23:00	0	0	0	0	0	0	1	0	1	1	100.0%	0.1%	
23:00-00:00	0	0	0	0	0	1	0	0	1	1	100.0%	0.1%	
00:00-01:00	0	0	0	0	0	0	2	2	2	2	100.0%	0.2%	
01:00-02:00	0	0	0	0	0	0	0	1	1	1	100.0%	0.1%	
02:00-03:00	0	0	0	0	0	1	0	1	2	2	100.0%	0.2%	
03:00-04:00	1	0	0	0	0	1	0	1	3	2	66.7%	0.4%	
04:00-05:00	1	0	0	0	0	1	1	2	5	4	80.0%	0.6%	
05:00-06:00	3	2	2	1	0	1	2	2	13	5	38.5%	1.6%	
06:00-07:00	7	3	0	1	0	3	1	2	17	6	35.3%	2.0%	
Nighttime Traffic	12	6	3	4	0	8	5	12	50	25	50.0%	6.0%	
Daily Traffic	336	210	88	105	18	36	21	22	836	79	9.4%	100.0%	
Ratio of Daily Traffic to Daytime Traffic	1.04	1.03	1.04	1.04	1.00	1.29	1.31	2.20	1.06	1.46	-	-	

Survey Date														Guidance Diagram													
Date 24 / Month AUGUST / Year 2015														To SOUTH													
Survey Point Name BF3 (SAMISSI - BOULPORE)														Direction 1 → Direction 2 ←													
Direction1 From SOUTH to NORTH														To NORTH													
Direction2 From NORTH to SOUTH																											
direction	Direction 1										Direction 2																
	Type of Vehicle										Type of Vehicle																
Motorcycle	Passenger Car	Minibus	Bus	Light Truck	Truck (2,3 axle)	Truck & Trailer (over 4 axle)	Container Trailer	Total '1	Commercial Vehicle '2	Commercial Vehicle Ratio '2/'1	Total /Daily Traffic	Motorcycle	Passenger Car	Minibus	Bus	Light Truck	Truck (2,3 axle)	Truck & Trailer (over 4 axle)	Container Trailer	Total '1	Commercial Vehicle '2	Commercial Vehicle Ratio '2/'1	Total /Daily Traffic				
[veh]	[veh]	[veh]	[veh]	[veh]	[veh]	[veh]	[veh]	[veh]	[veh]	[%]	[%]	[veh]	[veh]	[veh]	[veh]	[veh]	[veh]	[veh]	[veh]	[veh]	[veh]	[%]	[%]				
07:00-08:00	7	3	1	1	0	2	3	1	18	6	33.3%	6.9%	1	1	0	0	2	1	0	5	1	20.0%	2.7%				
08:00-09:00	3	4	1	2	0	0	0	1	11	1	9.1%	4.2%	0	0	0	0	0	0	1	1	100.0%	0.5%					
09:00-10:00	4	5	1	1	0	0	0	1	12	1	8.3%	4.6%	3	4	0	1	1	0	2	11	2	18.2%	6.0%				
10:00-11:00	9	4	0	4	1	0	0	0	18	0	0.0%	6.9%	3	0	4	0	3	0	0	10	0	0.0%	5.5%				
11:00-12:00	12	1	0	0	1	3	1	0	18	4	22.2%	6.9%	3	0	0	0	4	0	0	7	0	0.0%	3.8%				
12:00-13:00	10	0	0	0	1	3	0	4	18	7	38.9%	6.9%	7	9	0	2	0	4	2	24	6	25.0%	13.1%				
13:00-14:00	8	1	0	1	3	0	0	3	16	3	18.8%	6.1%	9	6	0	0	0	2	1	18	3	16.7%	9.8%				
14:00-15:00	7	2	0	1	0	1	1	0	12	2	16.7%	4.6%	0	0	0	2	0	0	0	2	0	0.0%	1.1%				
15:00-16:00	7	2	0	0	0	5	1	0	15	6	40.0%	5.7%	6	7	4	0	0	0	2	19	2	10.5%	10.4%				
16:00-17:00	7	1	0	0	0	0	2	0	10	2	20.0%	3.8%	9	6	0	3	0	0	0	18	0	0.0%	9.8%				
17:00-18:00	2	1	2	0	0	5	0	0	10	5	50.0%	3.8%	1	3	0	0	0	3	3	10	6	60.0%	5.5%				
18:00-19:00	9	1	2	3	0	0	0	0	15	0	0.0%	5.7%	1	3	2	0	0	0	1	7	1	14.3%	3.8%				
Daytime Traffic	85	25	7	13	6	19	8	10	173	37	21.4%	66.0%	43	39	10	8	10	10	9	3	132	22	16.7%	72.1%			
19:00-20:00	9	0	1	1	0	0	0	0	11	0	0.0%	4.2%	0	0	0	1	2	4	1	8	5	62.5%	4.4%				
20:00-21:00	10	0	0	0	0	1	4	0	15	5	33.3%	5.7%	0	0	0	0	2	0	1	4	2	50.0%	2.2%				
21:00-22:00	4	0	0	0	0	0	0	0	4	0	0.0%	1.5%	0	0	0	0	0	0	0	1	1	100.0%	0.5%				
22:00-23:00	4	0	0	0	0	0	0	0	4	0	0.0%	1.5%	0	4	0	0	0	0	0	4	0	0.0%	2.2%				
23:00-00:00	0	0	0	0	0	0	0	0	0	0	-	0.0%	0	0	0	0	0	0	0	0	0	-	0.0%				
00:00-01:00	0	0	0	0	1	0	0	0	1	0	0.0%	0.4%	0	0	0	0	0	1	0	1	1	100.0%	0.5%				
01:00-02:00	0	0	0	0	0	0	0	0	0	0	-	0.0%	0	0	0	0	0	0	0	0	0	-	0.0%				
02:00-03:00	0	0	0	0	0	0	0	0	0	0	-	0.0%	0	0	0	0	0	0	0	1	1	100.0%	0.5%				
03:00-04:00	0	0	0	0	0	0	0	0	0	0	-	0.0%	0	0	0	0	0	0	0	0	0	-	0.0%				
04:00-05:00	0	0	0	0	2	0	1	2	5	3	60.0%	1.9%	0	0	0	0	0	0	0	2	2	100.0%	1.1%				
05:00-06:00	7	0	1	2	4	1	4	1	20	6	30.0%	7.6%	0	2	1	0	2	2	7	14	9	64.3%	7.7%				
06:00-07:00	12	0	2	2	0	5	7	1	29	13	44.8%	11.1%	4	3	5	0	1	1	2	16	3	18.8%	8.7%				
Nighttime Traffic	46	0	4	5	7	7	16	4	89	27	30.3%	34.0%	4	9	6	1	7	8	11	5	51	24	47.1%	27.9%			
Daily Traffic	131	25	11	18	13	26	24	14	262	64	24.4%	100.0%	47	48	16	9	17	18	20	8	183	46	25.1%	100.0%			
Ratio of Daily Traffic to Daytime Traffic	1.54	1.00	1.57	1.38	2.17	1.37	3.00	1.40	1.51	1.73	-	-	1.09	1.23	1.60	1.13	1.70	1.80	2.22	2.67	1.39	2.09	-	-			

direction	Total												
	Type of Vehicle												
Motorcycle	Passenger Car	Minibus	Bus	Light Truck	Truck (2,3 axle)	Truck & Trailer (over 4 axle)	Container Trailer	Total '1	Commercial Vehicle '2	Commercial Vehicle Ratio '2/'1	Total /Daily Traffic		
[veh]	[veh]	[veh]	[veh]	[veh]	[veh]	[veh]	[veh]	[car]	[car]	[%]	[%]		
07:00-08:00	8	4	1	1	2	3	3	1	23	7	30.4%	5.2%	
08:00-09:00	3	4	1	2	0	0	0	2	12	2	16.7%	2.7%	
09:00-10:00	7	9	1	2	1	0	2	1	23	3	13.0%	5.2%	
10:00-11:00	12	4	4	4	4	0	0	0	28	0	0.0%	6.3%	
11:00-12:00	15	1	0	0	5	3	1	0	25	4	16.0%	5.6%	
12:00-13:00	17	9	0	2	1	7	2	4	42	13	31.0%	9.4%	
13:00-14:00	17	7	0	1	3	2	1	3	34	6	17.6%	7.6%	
14:00-15:00	7	2	0	3	0	1	1	0	14	2	14.3%	3.1%	
15:00-16:00	13	9	4	0	0	5	1	2	34	8	23.5%	7.6%	
16:00-17:00	16	7	0	3	0	0	2	0	28	2	7.1%	6.3%	
17:00-18:00	3	4	2	0	0	8	3	0	20	11	55.0%	4.5%	
18:00-19:00	10	4	4	3	0	0	1	0	22	1	4.5%	4.9%	
Daytime Traffic	128	64	17	21	16	29	17	13	305	59	19.3%	68.5%	
19:00-20:00	9	0	1	2	2	4	1	0	19	5	26.3%	4.3%	
20:00-21:00	10	0	0	0	2	1	5	1	19	7	36.8%	4.3%	
21:00-22:00	4	0	0	0	0	0	0	1	5	1	20.0%	1.1%	
22:00-23:00	4	4	0	0	0	0	0	0	8	0	0.0%	1.8%	
23:00-00:00	0	0	0	0	0	0	0	0	0	0	-	0.0%	
00:00-01:00	0	0	0	0	1	1	0	0	2	1	50.0%	0.4%	
01:00-02:00	0	0	0	0	0	0	0	0	0	0	-	0.0%	
02:00-03:00	0	0	0	0	0	0	0	1	1	1	100.0%	0.2%	
03:00-04:00	0	0	0	0	0	0	0	0	0	0	-	0.0%	
04:00-05:00	0	0	0	0	2	0	1	4	7	5	71.4%	1.6%	
05:00-06:00	7	2	2	2	6	3	11	1	34	15	44.1%	7.6%	
06:00-07:00	16	3	7	2	1	6	9	1	45	16	35.6%	10.1%	
Nighttime Traffic	50	9	10	6	14	15	27	9	140	51	36.4%	31.5%	
Daily Traffic	178	73	27	27	30	44	44	22	445	110	24.7%	100.0%	
Ratio of Daily Traffic to Daytime Traffic	1.39	1.14	1.59	1.29	1.88	1.52	2.59	1.69	1.46	1.86	-	-	

Survey Date												Guidance Diagram														
Date		24		/		Month		AUGUST		/		Year		2015		To SOUTH										
Survey Point Name												BF4 ZINIARE - KORSIMORO														
Direction1 From												SOUTH to NORTH														
Direction2 From												NORTH to SOUTH														
Time	Direction 1										Direction 2															
	Motorcycle	Passenger Car	Minibus	Bus	Light Truck	Truck (2,3 axle)	Truck & Trailer (over 4 axle)	Container Trailer	Total '1	Commercial Vehicle '2	Commercial Vehicle Ratio '2/'1	Total /Daily Traffic	Motorcycle	Passenger Car	Minibus	Bus	Light Truck	Truck (2,3 axle)	Truck & Trailer (over 4 axle)	Container Trailer	Total '1	Commercial Vehicle '2	Commercial Vehicle Ratio '2/'1	Total /Daily Traffic		
07:00-08:00	4	0	0	0	0	0	0	0	4	0	0.0%	1.4%	12	4	0	2	0	0	0	0	18	0	0.0%	4.7%		
08:00-09:00	4	0	0	0	1	1	0	0	6	1	16.7%	2.1%	9	1	0	0	0	0	0	0	10	0	0.0%	2.6%		
09:00-10:00	5	1	2	2	1	1	0	0	12	1	8.3%	4.3%	6	8	0	0	0	2	0	0	16	2	12.5%	4.2%		
10:00-11:00	3	1	0	0	1	1	0	1	7	2	28.6%	2.5%	12	6	0	0	0	0	0	0	18	0	0.0%	4.7%		
11:00-12:00	2	2	3	2	0	1	1	0	11	2	18.2%	3.9%	11	10	3	0	0	0	0	0	24	0	0.0%	6.3%		
12:00-13:00	6	7	5	4	1	0	0	0	23	0	0.0%	8.2%	10	7	1	1	2	0	0	0	21	0	0.0%	5.5%		
13:00-14:00	10	8	2	1	0	0	1	0	22	1	4.5%	7.8%	12	11	2	3	1	2	1	0	32	3	9.4%	8.3%		
14:00-15:00	4	12	1	3	1	2	3	0	26	5	19.2%	9.3%	14	23	5	3	5	2	1	0	53	3	5.7%	13.8%		
15:00-16:00	18	9	3	2	2	0	0	1	35	1	2.9%	12.5%	19	12	9	5	4	0	0	0	49	0	0.0%	12.8%		
16:00-17:00	12	14	1	2	1	3	1	0	34	4	11.8%	12.1%	26	22	3	3	4	1	0	0	59	1	1.7%	15.4%		
17:00-18:00	12	10	0	2	1	2	1	1	29	4	13.8%	10.3%	22	15	1	1	3	1	2	1	46	4	8.7%	12.0%		
18:00-19:00	14	1	1	1	1	2	2	0	22	4	18.2%	7.8%	5	5	1	1	2	0	0	0	14	0	0.0%	3.6%		
Daytime Traffic	94	65	18	19	10	13	9	3	231	25	10.8%	82.2%	158	124	25	19	21	8	4	1	360	13	3.6%	93.8%		
19:00-20:00	6	4	1	2	1	2	1	2	19	5	26.3%	6.8%	0	0	1	2	0	0	0	0	3	0	0.0%	0.8%		
20:00-21:00	5	8	0	0	2	1	0	0	16	1	6.3%	5.7%	0	1	1	0	2	2	0	0	6	2	33.3%	1.6%		
21:00-22:00	0	0	0	0	0	0	0	1	1	100.0%	0.4%	0	3	3	0	0	0	0	0	6	0	0.0%	1.6%			
22:00-23:00	0	0	0	0	0	0	0	0	0	0	-	0.0%	0	0	0	0	0	0	0	0	0	0	-	0.0%		
23:00-00:00	0	0	0	0	0	0	0	0	0	0	-	0.0%	0	0	0	0	0	0	0	0	0	0	-	0.0%		
00:00-01:00	0	0	0	0	0	0	0	0	0	0	-	0.0%	0	0	0	0	0	0	0	0	0	0	-	0.0%		
01:00-02:00	0	0	0	0	0	0	0	0	0	0	-	0.0%	0	0	0	0	0	0	0	0	0	0	-	0.0%		
02:00-03:00	0	0	0	0	0	0	0	0	0	0	-	0.0%	0	0	0	0	0	0	0	0	0	0	-	0.0%		
03:00-04:00	0	0	0	0	0	0	0	0	0	0	-	0.0%	0	0	0	0	0	0	0	0	0	0	-	0.0%		
04:00-05:00	0	0	0	0	0	0	0	0	0	0	-	0.0%	0	0	0	0	0	0	0	0	0	0	-	0.0%		
05:00-06:00	2	0	1	0	0	0	0	0	3	0	0.0%	1.1%	2	1	0	0	0	0	0	0	3	0	0.0%	0.8%		
06:00-07:00	4	3	2	0	1	1	0	0	11	1	9.1%	3.9%	1	4	0	0	1	0	0	0	6	0	0.0%	1.6%		
Nighttime Traffic	17	15	4	2	4	4	1	3	50	8	16.0%	17.8%	3	9	5	2	3	2	0	0	24	2	8.3%	6.3%		
Daily Traffic	111	80	22	21	14	17	10	6	281	33	11.7%	100.0%	161	133	30	21	24	10	4	1	384	15	3.9%	100.0%		
Ratio of Daily Traffic to Daytime Traffic	1.18	1.23	1.22	1.11	1.40	1.31	1.11	2.00	1.22	1.32	-	-	1.02	1.07	1.20	1.11	1.14	1.25	1.00	1.00	1.07	1.15	-	-		

Time	Total											
	Motorcycle	Passenger Car	Minibus	Bus	Light Truck	Truck (2,3 axle)	Truck & Trailer (over 4 axle)	Container Trailer	Total '1	Commercial Vehicle '2	Commercial Vehicle Ratio '2/'1	Total /Daily Traffic
07:00-08:00	16	4	0	2	0	0	0	0	22	0	0.0%	3.3%
08:00-09:00	13	1	0	0	1	1	0	0	16	1	6.3%	2.4%
09:00-10:00	11	9	2	2	1	3	0	0	28	3	10.7%	4.2%
10:00-11:00	15	7	0	0	1	1	0	1	25	2	8.0%	3.8%
11:00-12:00	13	12	6	2	0	1	1	0	35	2	5.7%	5.3%
12:00-13:00	16	14	6	5	3	0	0	0	44	0	0.0%	6.6%
13:00-14:00	22	19	4	4	1	2	2	0	54	4	7.4%	8.1%
14:00-15:00	18	35	6	6	6	4	4	0	79	8	10.1%	11.9%
15:00-16:00	37	21	12	7	6	0	0	1	84	1	1.2%	12.6%
16:00-17:00	38	36	4	5	5	4	1	0	93	5	5.4%	14.0%
17:00-18:00	34	25	1	3	4	3	3	2	75	8	10.7%	11.3%
18:00-19:00	19	6	2	2	3	2	2	0	36	4	11.1%	5.4%
Daytime Traffic	252	189	43	38	31	21	13	4	591	38	6.4%	88.9%
19:00-20:00	6	4	2	4	1	2	1	2	22	5	22.7%	3.3%
20:00-21:00	5	9	1	0	4	3	0	0	22	3	13.6%	3.3%
21:00-22:00	0	3	3	0	0	0	0	1	7	1	14.3%	1.1%
22:00-23:00	0	0	0	0	0	0	0	0	0	0	-	0.0%
23:00-00:00	0	0	0	0	0	0	0	0	0	0	-	0.0%
00:00-01:00	0	0	0	0	0	0	0	0	0	0	-	0.0%
01:00-02:00	0	0	0	0	0	0	0	0	0	0	-	0.0%
02:00-03:00	0	0	0	0	0	0	0	0	0	0	-	0.0%
03:00-04:00	0	0	0	0	0	0	0	0	0	0	-	0.0%
04:00-05:00	0	0	0	0	0	0	0	0	0	0	-	0.0%
05:00-06:00	4	1	1	0	0	0	0	0	6	0	0.0%	0.9%
06:00-07:00	5	7	2	0	2	1	0	0	17	1	5.9%	2.6%
Nighttime Traffic	20	24	9	4	7	6	1	3	74	10	13.5%	11.1%
Daily Traffic	272	213	52	42	38	27	14	7	665	48	7.2%	100.0%
Ratio of Daily Traffic to Daytime Traffic	1.08	1.13	1.21	1.11	1.23	1.29	1.08	1.75	1.13	1.26	-	-

Survey Date	Date	24 /	Month	AUGUST /	Year	2015
Survey Point Name	BF-5 TORODO - KOUPELA					
Direction1 From	WEST	to	EAST			
Direction2 From	EAST	to	WEST			

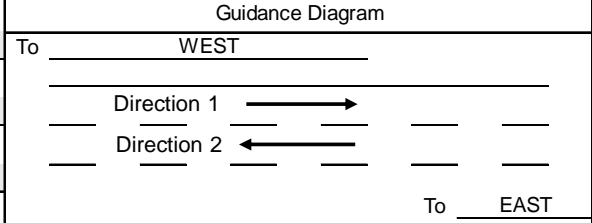

direction	Direction 1												Direction 2																
	Type of Vehicle											Total '1	Comm. Vehic. Ratio '2/'1	Comm. Vehic. Ratio '2/'1	Total /Daily Traffic	Type of Vehicle											Total '1	Comm. Vehic. Ratio '2/'1	Comm. Vehic. Ratio '2/'1
Motorcycle	Passenger Car	Minibus	Bus	Light Truck	Truck (2,3 axle)	Truck & Trailer (over 4 axle)	Container Trailer	Truck & Trailer	Container Trailer	Truck (2,3 axle)	Truck & Trailer (over 4 axle)					Container Trailer	Motorcycle	Passenger Car	Minibus	Bus	Light Truck	Truck (2,3 axle)	Truck & Trailer (over 4 axle)	Container Trailer					
07:00-08:00	7	2	3	1	0	0	0	0	0	13	0	0.0%	2.6%	8	2	2	2	0	0	0	0	14	0	0.0%	3.1%				
08:00-09:00	11	3	5	1	0	1	1	0	0	22	2	9.1%	4.4%	3	2	4	1	0	0	0	1	11	1	9.1%	2.5%				
09:00-10:00	15	8	9	0	0	1	3	1	0	37	5	13.5%	7.4%	7	1	3	4	0	0	2	0	17	2	11.8%	3.8%				
10:00-11:00	17	10	12	2	0	0	3	0	0	44	3	6.8%	8.8%	11	1	10	1	0	3	0	0	26	3	11.5%	5.8%				
11:00-12:00	19	11	8	2	1	1	1	0	0	43	2	4.7%	8.6%	14	2	8	3	0	2	3	0	32	5	15.6%	7.2%				
12:00-13:00	18	8	6	2	1	0	2	0	0	37	2	5.4%	7.4%	16	1	4	2	1	0	1	0	25	1	4.0%	5.6%				
13:00-14:00	15	4	3	2	0	1	7	1	3	33	9	27.3%	6.6%	13	1	8	1	0	0	1	0	24	1	4.2%	5.4%				
14:00-15:00	11	5	3	4	0	0	5	0	28	5	17.9%	5.6%	11	11	6	3	0	0	1	1	33	2	6.1%	7.4%					
15:00-16:00	7	7	4	4	1	1	2	0	26	3	11.5%	5.2%	26	13	2	0	1	2	3	0	47	5	10.6%	10.5%					
16:00-17:00	12	11	7	2	1	2	3	1	39	6	15.4%	7.8%	3	16	1	1	0	0	2	0	23	2	8.7%	5.1%					
17:00-18:00	19	7	3	1	1	0	1	0	32	1	3.1%	6.4%	4	6	8	1	0	1	20	8	48	29	60.4%	10.7%					
18:00-19:00	9	10	3	1	0	2	7	0	32	9	28.1%	6.4%	1	2	5	1	0	5	30	10	54	45	83.3%	12.1%					
Daytime Traffic	160	86	66	22	5	9	35	3	386	47	12.2%	77.5%	117	58	61	20	2	13	63	20	354	96	27.1%	79.2%					
19:00-20:00	5	13	8	0	0	1	4	0	31	5	16.1%	6.2%	1	1	3	0	0	6	15	17	43	38	88.4%	9.6%					
20:00-21:00	3	4	2	0	0	1	2	2	14	5	35.7%	2.8%	0	1	0	0	2	0	3	11	17	14	82.4%	3.8%					
21:00-22:00	2	3	1	0	1	1	1	0	9	2	22.2%	1.8%	0	1	0	0	0	0	2	1	4	3	75.0%	0.9%					
22:00-23:00	1	1	0	0	0	0	1	0	3	1	33.3%	0.6%	0	0	0	0	0	0	1	0	1	1	100.0%	0.2%					
23:00-00:00	0	0	1	0	0	1	0	0	2	1	50.0%	0.4%	0	1	0	0	1	0	1	0	3	1	33.3%	0.7%					
00:00-01:00	1	2	0	0	0	0	0	0	3	0	0.0%	0.6%	0	1	0	0	1	5	1	1	9	7	77.8%	2.0%					
01:00-02:00	1	1	0	0	0	1	0	0	3	1	33.3%	0.6%	0	0	0	0	0	0	0	0	0	0	-	0.0%					
02:00-03:00	0	0	0	0	1	0	0	0	1	0	0.0%	0.2%	0	0	0	0	0	1	0	0	1	1	100.0%	0.2%					
03:00-04:00	0	1	0	0	0	0	0	0	1	0	0.0%	0.2%	0	0	0	0	0	0	0	0	0	0	-	0.0%					
04:00-05:00	0	1	0	0	0	0	0	0	1	0	0.0%	0.2%	0	0	0	0	0	0	0	0	0	0	-	0.0%					
05:00-06:00	9	3	2	0	0	0	1	0	15	1	6.7%	3.0%	0	1	0	1	0	0	3	0	5	3	60.0%	1.1%					
06:00-07:00	11	4	7	1	1	1	3	1	29	5	17.2%	5.8%	4	2	2	0	0	0	2	0	10	2	20.0%	2.2%					
Nighttime Traffic	33	33	21	1	3	6	12	3	112	21	18.8%	22.5%	5	8	5	1	4	12	28	30	93	70	75.3%	20.8%					
Daily Traffic	193	119	87	23	8	15	47	6	498	68	13.7%	100.0%	122	66	66	21	6	25	91	50	447	166	37.1%	100.0%					
Ratio of Daily Traffic to Daytime Traffic	1.21	1.38	1.32	1.05	1.60	1.67	1.34	2.00	1.29	1.45	-	-	1.04	1.14	1.08	1.05	3.00	1.92	1.44	2.50	1.26	1.73	-	-					

direction	Total															
	Type of Vehicle											Total '1	Comm. Vehic. Ratio '2/'1	Comm. Vehic. Ratio '2/'1	Total /Daily Traffic	
Motorcycle	Passenger Car	Minibus	Bus	Light Truck	Truck (2,3 axle)	Truck & Trailer (over 4 axle)	Container Trailer	Truck & Trailer	Container Trailer	Truck (2,3 axle)	Truck & Trailer (over 4 axle)					Container Trailer
07:00-08:00	15	4	5	3	0	0	0	0	27	0	0.0%	2.9%	27	0	0.0%	2.9%
08:00-09:00	14	5	9	2	0	1	1	1	33	3	9.1%	3.5%	33	3	9.1%	3.5%
09:00-10:00	22	9	12	4	0	1	5	1	54	7	13.0%	5.7%	54	7	13.0%	5.7%
10:00-11:00	28	11	22	3	0	3	3	0	70	6	8.6%	7.4%	70	6	8.6%	7.4%
11:00-12:00	33	13	16	5	1	3	4	0	75	7	9.3%	7.9%	75	7	9.3%	7.9%
12:00-13:00	34	9	10	4	2	0	3	0	62	3	4.8%	6.6%	62	3	4.8%	6.6%
13:00-14:00	28	5	11	3	0	1	8	1	57	10	17.5%	6.0%	57	10	17.5%	6.0%
14:00-15:00	22	16	9	7	0	0	6	1	61	7	11.5%	6.5%	61	7	11.5%	6.5%
15:00-16:00	33	20	6	4	2	3	5	0	73	8	11.0%	7.7%	73	8	11.0%	7.7%
16:00-17:00	15	27	8	3	1	2	5	1	62	8	12.9%	6.6%	62	8	12.9%	6.6%
17:00-18:00	23	13	11	2	1	1	21	8	80	30	37.5%	8.5%	80	30	37.5%	8.5%
18:00-19:00	10	12	8	2	0	7	37	10	86	54	62.8%	9.1%	86	54	62.8%	9.1%
Daytime Traffic	277	144	127	42	7	22	98	23	740	143	19.3%	78.3%	740	143	19.3%	78.3%
19:00-20:00	6	14	11	0	0	7	19	17	74	43	58.1%	7.8%	74	43	58.1%	7.8%
20:00-21:00	3	5	2	0	2	1	5	13	31	19	61.3%	3.3%	31	19	61.3%	3.3%
21:00-22:00	2	4	1	0	1	1	3	1	13	5	38.5%	1.4%	13	5	38.5%	1.4%
22:00-23:00	1	1	0	0	0	0	2	0	4	2	50.0%	0.4%	4	2	50.0%	0.4%
23:00-00:00	0	1	1	0	1	1	1	0	5	2	40.0%	0.5%	5	2	40.0%	0.5%
00:00-01:00	1	3	0	0	1	5	1	1	12	7	58.3%	1.3%	12	7	58.3%	1.3%
01:00-02:00	1	1	0	0	0	1	0	0	3	1	33.3%	0.3%	3	1	33.3%	0.3%
02:00-03:00	0	0	0	0	1	1	0	0	2	1	50.0%	0.2%	2	1	50.0%	0.2%
03:00-04:00	0	1	0	0	0	0	0	0	1	0	0.0%	0.1%	1	0	0.0%	0.1%
04:00-05:00	0	1	0	0	0	0	0	0	1	0	0.0%	0.1%	1	0	0.0%	0.1%
05:00-06:00	9	4	2	1	0	0	4	0	20	4	20.0%	2.1%	20	4	20.0%	2.1%
06:00-07:00	15	6	9	1	1	1	5	1	39	7	17.9%	4.1%	39	7	17.9%	4.1%
Nighttime Traffic	38	41	26	2	7	18	40	33	205	91	44.4%	21.7%	205	91	44.4%	21.7%
Daily Traffic	315	185	153	44	14	40	138	56	945	234	24.8%	100.0%	945	234	24.8%	100.0%
Ratio of Daily Traffic to Daytime Traffic	1.14	1.28	1.20	1.05	2.00	1.82	1.41	2.43	1.28	1.64	-	-	1.28	1.64	-	-

Date		Month		Year		Guidance Diagram																		
Survey Date		9		9		2015		To SAN PEDRO																
Survey Point Name								C-1 SASSANDRA-SAN PEDRO																
Direction1 From				SAN PEDRO		to		SASSANDRA																
Direction2 From				SASSANDRA		to		SAN PEDRO																
To SASSANDRA																								
Time	Direction 1									Direction 2														
	Motorcycle	Passenger Car	Minibus	Bus	Light Truck	Truck (2,3 axle)	Truck & Trailer	Container Trailer	Total '1	Commercial Vehicle '2	Commercial Vehicle Ratio '2/'1	Total /Daily Traffic	Motorcycle	Passenger Car	Minibus	Bus	Light Truck	Truck (2,3 axle)	Truck & Trailer	Container Trailer	Total '1	Commercial Vehicle '2	Commercial Vehicle Ratio '2/'1	Total /Daily Traffic
07:00-08:00	9	3	5	3	3	2	2	0	27	4	14.8%	3.9%	14	5	3	0	4	0	2	2	30	4	13.3%	5.1%
08:00-09:00	22	9	5	2	3	1	1	0	43	2	4.7%	6.3%	13	7	3	0	2	2	1	3	31	6	19.4%	5.2%
09:00-10:00	22	7	6	5	3	2	0	0	45	2	4.4%	6.6%	16	5	7	0	1	1	0	0	30	1	3.3%	5.1%
10:00-11:00	14	13	8	2	2	3	2	0	44	5	11.4%	6.4%	9	12	5	0	3	0	1	1	31	2	6.5%	5.2%
11:00-12:00	10	13	6	2	2	1	0	1	35	2	5.7%	5.1%	16	11	5	1	1	2	2	1	39	5	12.8%	6.6%
12:00-13:00	22	5	6	4	10	1	0	0	48	1	2.1%	7.0%	11	10	2	1	4	0	0	1	29	1	3.4%	4.9%
13:00-14:00	14	4	4	0	3	4	2	1	32	7	21.9%	4.7%	14	5	3	1	5	2	0	1	31	3	9.7%	5.2%
14:00-15:00	5	8	3	1	1	0	0	0	18	0	0.0%	2.6%	12	8	3	2	2	2	0	1	30	3	10.0%	5.1%
15:00-16:00	16	8	7	0	1	5	1	2	40	8	20.0%	5.8%	20	5	11	0	2	1	0	1	40	2	5.0%	6.7%
16:00-17:00	13	12	3	1	5	3	2	2	41	7	17.1%	6.0%	13	6	6	2	6	1	1	0	35	2	5.7%	5.9%
17:00-18:00	11	5	4	0	5	6	4	1	36	11	30.6%	5.3%	18	10	3	0	5	1	0	0	37	1	2.7%	6.2%
18:00-19:00	20	9	0	0	3	1	3	4	40	8	20.0%	5.8%	22	8	6	0	6	0	0	0	42	0	0.0%	7.1%
Daytime Traffic	178	96	57	20	41	29	17	11	449	57	12.7%	65.6%	178	92	57	7	41	12	7	11	405	30	7.4%	68.3%
19:00-20:00	18	3	5	0	7	1	5	1	40	7	17.5%	5.8%	17	4	10	5	3	4	0	0	43	4	9.3%	7.3%
20:00-21:00	13	5	3	0	2	1	3	1	28	5	17.9%	4.1%	10	3	6	1	7	1	6	0	34	7	20.6%	5.7%
21:00-22:00	11	3	5	1	2	3	3	2	30	8	26.7%	4.4%	9	1	12	1	3	0	2	0	28	2	7.1%	4.7%
22:00-23:00	2	0	1	0	0	1	0	0	4	1	25.0%	0.6%	4	1	2	0	0	3	1	0	11	4	36.4%	1.9%
23:00-00:00	15	17	6	6	6	5	11	1	67	17	25.4%	9.8%	2	1	1	0	1	0	0	0	5	0	0.0%	0.8%
00:00-01:00	6	7	6	6	6	2	1	0	34	3	8.8%	5.0%	1	0	0	0	5	1	0	0	7	1	14.3%	1.2%
01:00-02:00	0	0	3	0	0	1	2	0	6	3	50.0%	0.9%	0	0	0	1	1	0	1	0	3	1	33.3%	0.5%
02:00-03:00	1	0	0	0	0	0	1	1	3	2	66.7%	0.4%	0	1	2	1	1	0	1	1	7	2	28.6%	1.2%
03:00-04:00	0	0	1	0	0	0	0	0	1	0	0.0%	0.1%	0	0	1	0	0	1	2	0	4	3	75.0%	0.7%
04:00-05:00	0	0	0	0	0	1	0	0	1	1	100.0%	0.1%	1	0	1	0	2	1	1	0	6	2	33.3%	1.0%
05:00-06:00	3	1	3	0	0	0	0	0	7	0	0.0%	1.0%	4	1	3	0	1	2	2	0	13	4	30.8%	2.2%
06:00-07:00	6	4	3	0	0	1	0	0	14	1	7.1%	2.0%	10	2	4	0	3	1	7	0	27	8	29.6%	4.6%
Nighttime Traffic	75	40	36	13	23	16	26	6	235	48	20.4%	34.4%	58	14	42	9	27	14	23	1	188	38	20.2%	31.7%
Daily Traffic	253	136	93	33	64	45	43	17	684	105	15.4%	100.0%	236	106	99	16	68	26	30	12	593	68	11.5%	100.0%
Ratio of Daily Traffic to Daytime Traffic	1.42	1.42	1.63	1.65	1.56	1.55	2.53	1.55	1.52	1.84	-	-	1.33	1.15	1.74	2.29	1.66	2.17	4.29	1.09	1.46	2.27	-	-
Time	Total									Total '1	Commercial Vehicle '2	Commercial Vehicle Ratio '2/'1	Total /Daily Traffic											
	Motorcycle	Passenger Car	Minibus	Bus	Light Truck	Truck (2,3 axle)	Truck & Trailer	Container Trailer	Total '1															
07:00-08:00	23	8	8	3	7	2	4	2	57	8	14.0%	4.5%												
08:00-09:00	35	16	8	2	5	3	2	3	74	8	10.8%	5.8%												
09:00-10:00	38	12	13	5	4	3	0	0	75	3	4.0%	5.9%												
10:00-11:00	23	25	13	2	5	3	3	1	75	7	9.3%	5.9%												
11:00-12:00	26	24	11	3	3	3	2	2	74	7	9.5%	5.8%												
12:00-13:00	33	15	8	5	14	1	0	1	77	2	2.6%	6.0%												
13:00-14:00	28	9	7	1	8	6	2	2	63	10	15.9%	4.9%												
14:00-15:00	17	16	6	3	3	2	0	1	48	3	6.3%	3.8%												
15:00-16:00	36	13	18	0	3	6	1	3	80	10	12.5%	6.3%												
16:00-17:00	26	18	9	3	11	4	3	2	76	9	11.8%	6.0%												
17:00-18:00	29	15	7	0	10	7	4	1	73	12	16.4%	5.7%												
18:00-19:00	42	17	6	0	9	1	3	4	82	8	9.8%	6.4%												
Daytime Traffic	356	188	114	27	82	41	24	22	854	87	10.2%	66.9%												
19:00-20:00	35	7	15	5	10	5	5	1	83	11	13.3%	6.5%												
20:00-21:00	23	8	9	1	9	2	9	1	62	12	19.4%	4.9%												
21:00-22:00	20	4	17	2	5	3	5	2	58	10	17.2%	4.5%												
22:00-23:00	6	1	3	0	0	4	1	0	15	5	33.3%	1.2%												
23:00-00:00	17	18	7	6	7	5	11	1	72	17	23.6%	5.6%												
00:00-01:00	7	7	6	6	11	3	1	0	41	4	9.8%	3.2%												
01:00-02:00	0	0	3	1	1	1	3	0	9	4	44.4%	0.7%												
02:00-03:00	1	1	2	1	1	0	2	2	10	4	40.0%	0.8%												
03:00-04:00	0	0	2	0	0	1	2	0	5	3	60.0%	0.4%												
04:00-05:00	1	0	1	0	2	2	1	0	7	3	42.9%	0.5%												
05:00-06:00	7	2	6	0	1	2	2	0	20	4	20.0%	1.6%												
06:00-07:00	16	6	7	0	3	2	7	0	41	9	22.0%	3.2%												
Nighttime Traffic	133	54	78	22	50	30	49	7	423	86	20.3%	33.1%												
Daily Traffic	489	242	192	49	132	71	73	29	1,277	173	13.5%	100.0%												
Ratio of Daily Traffic to Daytime Traffic	1.37	1.29	1.68	1.81	1.61	1.73	3.04	1.32	1.50	1.99	-	-												

The Project on Corridor Development for West Africa Growth Ring Master Plan
Final Report

Date 9 / 9 / 2015 Survey Point Name C-2(Entrée Yamoussoukro) Direction1 From Yamoussoukro to Pacobo Direction2 From Pacobo to Yamoussoukro	Guidance Diagram To Yamoussoukro Direction 1 → Direction 2 ← To Pacobo
---	--

direction	Direction 1											Direction 2																				
	Type of Vehicle									Total '1	Comm. Vehic/e '2	Comm. Vehic/e Ratio '2/'1 [%]	Total /Daily Traffic	Remarks / Observations	Type of Vehicle									Total '1	Comm. Vehic/e '2	Comm. Vehic/e Ratio '2/'1 [%]	Total /Daily Traffic	Remarks / Observations				
Motorcycle	Passenger Car	Minibus	Bus	Light Truck	Truck (2,3 axle)	Truck & Trailer	Container Trailer	[veh]	[veh]						[veh]	[veh]	[veh]	[veh]	[veh]	[veh]	[veh]	[veh]	[veh]						[veh]	[veh]	[veh]	[veh]
07:00-08:00	12	36	14	4	3	10	10	4	93	24	25.8%	4.3%		13	31	0	1	0	2	27	18	92	47	51.1%	3.7%							
08:00-09:00	17	67	21	5	8	5	9	5	137	19	13.9%	6.3%		14	69	7	7	3	7	7	5	119	19	16.0%	4.7%							
09:00-10:00	12	71	11	7	8	15	8	4	136	27	19.9%	6.2%		10	90	11	7	13	8	7	6	152	21	13.8%	6.1%							
10:00-11:00	16	78	20	8	4	6	8	1	141	15	10.6%	6.5%		10	95	13	42	3	4	15	3	185	22	11.9%	7.4%							
11:00-12:00	7	80	25	11	6	10	9	0	148	19	12.8%	6.8%		13	96	23	25	17	2	9	2	187	13	7.0%	7.5%							
12:00-13:00	16	101	26	20	7	13	10	4	197	27	13.7%	9.0%		18	105	19	27	41	1	19	1	231	21	9.1%	9.2%							
13:00-14:00	6	41	16	17	5	4	9	2	100	15	15.0%	4.6%		22	77	14	14	38	10	5	6	186	21	11.3%	7.4%							
14:00-15:00	10	123	20	13	11	8	10	8	203	26	12.8%	9.3%		18	45	18	14	35	12	6	4	156	22	14.1%	6.2%							
15:00-16:00	19	116	17	15	4	5	18	6	200	29	14.5%	9.2%		16	108	15	10	17	4	10	3	183	17	9.3%	7.3%							
16:00-17:00	21	92	16	15	2	4	19	4	173	27	15.6%	7.9%		1	71	17	16	30	5	10	1	151	16	10.6%	6.0%							
17:00-18:00	12	73	17	6	2	5	26	5	146	36	24.7%	6.7%		7	76	9	6	27	6	13	2	146	21	14.4%	5.8%							
18:00-19:00	11	39	11	6	11	7	22	5	112	34	30.4%	5.1%		19	65	16	7	21	6	8	1	143	15	10.5%	5.7%							
Daytime Traffic	159	917	214	127	71	92	158	48	1,786	298	16.7%	81.9%		161	928	162	180	245	67	136	52	1,931	255	13.2%	76.9%							
19:00-20:00	8	29	10	15	1	1	20	1	85	22	25.9%	3.9%		9	40	9	8	18	4	15	4	107	23	21.5%	4.3%							
20:00-21:00	3	26	6	5	2	3	18	5	68	26	38.2%	3.1%		5	29	6	5	15	7	12	1	80	20	25.0%	3.2%							
21:00-22:00	4	10	2	5	4	6	8	6	45	20	44.4%	2.1%		8	30	10	6	12	7	27	3	103	37	35.9%	4.1%							
22:00-23:00	1	11	1	0	1	1	7	1	23	9	39.1%	1.1%		0	12	3	2	2	6	37	1	63	44	69.8%	2.5%							
23:00-00:00	0	2	1	3	0	3	9	0	18	12	66.7%	0.8%		0	10	2	0	2	5	17	0	36	22	61.1%	1.4%							
00:00-01:00	1	4	3	2	2	9	12	0	33	21	63.6%	1.5%		0	1	2	0	1	10	11	0	25	21	84.0%	1.0%							
01:00-02:00	0	0	1	0	1	4	6	0	12	10	83.3%	0.5%		0	2	0	0	0	5	17	0	24	22	91.7%	1.0%							
02:00-03:00	0	0	2	1	1	2	6	1	13	9	69.2%	0.6%		0	1	0	2	0	2	29	0	34	31	91.2%	1.4%							
03:00-04:00	0	0	1	0	1	0	6	1	9	7	77.8%	0.4%		0	1	0	0	0	1	21	0	23	22	95.7%	0.9%							
04:00-05:00	0	0	1	0	0	1	3	1	6	5	83.3%	0.3%		0	0	0	0	0	2	16	0	18	18	100.0%	0.7%							
05:00-06:00	0	8	2	2	0	5	6	0	23	11	47.8%	1.1%		0	2	0	2	0	0	27	0	31	27	87.1%	1.2%							
06:00-07:00	2	29	11	2	1	4	12	0	61	16	26.2%	2.8%		7	8	0	8	1	0	11	0	35	11	31.4%	1.4%							
Nighttime Traffic	19	119	41	35	14	39	113	16	396	168	42.4%	18.1%		29	136	32	33	51	49	240	9	579	298	51.5%	23.1%							
Daily Traffic	178	1,036	255	162	85	131	271	64	2,182	466	21.4%	100.0%		190	1,064	194	213	296	116	376	61	2,510	553	22.0%	100.0%							
Ratio of Daily Traffic to Daytime Traffic	1.12	1.13	1.19	1.28	1.20	1.42	1.72	1.33	1.22	1.56	-	-		1.18	1.15	1.20	1.18	1.21	1.73	2.76	1.17	1.30	2.17	-	-							

direction	Total																																				
	Type of Vehicle									Total '1	Comm. Vehic/e '2	Comm. Vehic/e Ratio '2/'1 [%]	Total /Daily Traffic	Remarks / Observations																							
Motorcycle	Passenger Car	Minibus	Bus	Light Truck	Truck (2,3 axle)	Truck & Trailer	Container Trailer	[veh]	[car]						[car]	[car]	[car]	[car]																			
07:00-08:00	25	67	14	5	3	12	37	22	185	71	38.4%	3.9%																									
08:00-09:00	31	136	28	12	11	12	16	10	256	38	14.8%	5.5%																									
09:00-10:00	22	161	22	14	21	23	15	10	288	48	16.7%	6.1%																									
10:00-11:00	26	173	33	50	7	10	23	4	326	37	11.3%	6.9%																									
11:00-12:00	20	176	48	36	23	12	18	2	335	32	9.6%	7.1%																									
12:00-13:00	34	206	45	47	48	14	29	5	428	48	11.2%	9.1%																									
13:00-14:00	28	118	30	31	43	14	14	8	286	36	12.6%	6.1%																									
14:00-15:00	28	168	38	31	46	20	16	12	359	48	13.4%	7.7%																									
15:00-16:00	35	224	32	25	21	9	28	9	383	46	12.0%	8.2%																									
16:00-17:00	22	163	33	31	32	9	29	5	324	43	13.3%	6.9%																									
17:00-18:00	19	149	26	12	29	11	39	7	292	57	19.5%	6.2%																									
18:00-19:00	30	104	27	13	32	13	30	6	255	49	19.2%	5.4%																									
Daytime Traffic	320	1,845	376	307	316	159	294	100	3,717	553	14.9%	79.2%																									
19:00-20:00	17	69	19	23	19	5	35	5	192	45	23.4%	4.1%																									
20:00-21:00	8	55	12	10	17	10	30	6	148	46	31.1%	3.2%																									
21:00-22:00	12	40	12	11	16	13	35	9	148	57	38.5%	3.2%																									
22:00-23:00	1	23	4	2	3	7	44	2	86	53	61.6%	1.8%																									
23:00-00:00	0	12	3	3	2	8	26	0	54	34	63.0%	1.2%																									
00:00-01:00	1	5	5	2	3	19	23	0	58	42	72.4%	1.2%																									
01:00-02:00	0	2	1	0	1	9	23	0	36	32	88.9%	0.8%																									
02:00-03:00	0	1	2	3	1	4	35	1	47	40	85.1%	1.0%																									
03:00-04:00	0	1	1	0	1	1	27	1	32	29	90.6%	0.7%																									
04:00-05:00	0	0	1	0	0	3	19	1	24	23	95.8%	0.5%																									
05:00-06:00	0	10	2	4	0	5	33	0	54	38	70.4%	1.2%																									
06:00-07:00	9	37	11	10	2	4	23	0	96	27	28.1%	2.0%																									
Nighttime Traffic	48	255	73	68	65	88	353	25	975	466	47.8%	20.8%																									
Daily Traffic	368	2,100	449	375	381	247	647	125	4,692	1,019	21.7%	100.0%																									
Ratio of Daily Traffic to Daytime Traffic	1.15	1.14	1.19	1.22	1.21	1.55	2.20	1.25	1.26	1.84	-	-																									

Date		Month	Year	Guidance Diagram																				
Survey Date	8 /	9 /	2015	To KOTOBI																				
Survey Point Name	C3 A8-SORTIE AKOUBE			<div style="display: flex; align-items: center;"> <div style="flex: 1; border-bottom: 1px solid black; margin-bottom: 5px;">Direction 1</div> <div style="flex: 1; border-bottom: 1px solid black; margin-bottom: 5px;">Direction 2</div> </div> <p style="text-align: right;">To AKOUBE</p>																				
Direction1 From		KOTOBI	to		AKOUBE																			
Direction2 From		AKOUBE		to			KOTOBI																	
direction	Direction 1									Direction 2														
	Type of Vehicle									Type of Vehicle														
Time	Motocycle [veh]	Passenger Car [veh]	Minibus [veh]	Bus [veh]	Light Truck [veh]	Truck (2,3 axle) [veh]	Truck & Trailer (over 4 axle) [veh]	Container Trailer [veh]	Total *1 [veh]	Commercial Vehicle *2 [veh]	Commercial Vehicle Ratio *2/*1 [%]	Total /Daily Traffic [%]	Motocycle [veh]	Passenger Car [veh]	Minibus [veh]	Bus [veh]	Light Truck [veh]	Truck (2,3 axle) [veh]	Truck & Trailer (over 4 axle) [veh]	Container Trailer [veh]	Total *1 [veh]	Commercial Vehicle *2 [veh]	Commercial Vehicle Ratio *2/*1 [%]	Total /Daily Traffic [%]
07:00-08:00	6	1	0	0	1	0	1	0	9	1	11.1%	3.3%	14	6	0	0	4	1	5	0	30	6	20.0%	11.2%
08:00-09:00	9	6	0	0	5	0	0	0	20	0	0.0%	7.4%	23	6	0	0	0	0	0	0	29	0	0.0%	10.8%
09:00-10:00	11	7	0	0	1	0	1	0	20	1	5.0%	7.4%	16	7	0	0	2	0	0	0	25	0	0.0%	9.3%
10:00-11:00	14	6	0	0	1	0	0	0	21	0	0.0%	7.7%	11	5	0	0	1	0	1	0	18	1	5.6%	6.7%
11:00-12:00	7	7	0	0	2	1	2	0	19	3	15.8%	7.0%	12	4	0	0	2	0	0	0	18	0	0.0%	6.7%
12:00-13:00	10	4	0	0	0	0	1	0	15	1	6.7%	5.5%	6	5	0	0	0	0	0	0	11	0	0.0%	4.1%
13:00-14:00	12	7	0	0	0	0	1	0	20	1	5.0%	7.4%	9	7	0	0	2	0	0	0	18	0	0.0%	6.7%
14:00-15:00	11	3	0	0	2	0	0	0	16	0	0.0%	5.9%	6	2	0	0	0	0	0	0	8	0	0.0%	3.0%
15:00-16:00	10	3	0	0	1	1	2	0	17	3	17.6%	6.3%	8	3	0	0	1	2	1	0	15	3	20.0%	5.6%
16:00-17:00	10	4	0	0	3	0	2	0	19	2	10.5%	7.0%	4	3	0	0	3	1	2	0	13	3	23.1%	4.8%
17:00-18:00	20	4	0	0	4	2	2	0	32	4	12.5%	11.8%	14	0	0	0	2	0	0	0	16	0	0.0%	5.9%
18:00-19:00	21	1	0	0	1	1	0	0	24	1	4.2%	8.9%	12	1	0	0	0	0	0	0	13	0	0.0%	4.8%
Daytime Traffic	141	53	0	0	21	5	12	0	232	17	7.3%	95.6%	135	49	0	0	17	4	9	0	214	13	6.1%	79.6%
19:00-20:00	10	3	2	0	1	1	0	0	17	1	5.9%	6.3%	2	2	0	0	1	0	0	0	5	0	0.0%	1.9%
20:00-21:00	3	0	0	0	0	0	0	0	3	0	0.0%	1.1%	0	0	0	0	0	0	0	0	0	0	-	0.0%
21:00-22:00	5	1	0	0	0	0	0	0	6	0	0.0%	2.2%	2	0	0	0	0	0	0	0	2	0	0.0%	0.7%
22:00-23:00	0	1	0	0	0	0	0	0	1	0	0.0%	0.4%	0	0	0	0	0	0	1	0	1	1	100.0%	0.4%
23:00-00:00	0	0	0	0	0	0	0	0	0	0	-	0.0%	0	0	0	0	3	0	0	0	3	0	0.0%	1.1%
00:00-01:00	0	0	0	0	0	0	0	0	0	0	-	0.0%	0	0	0	0	0	0	0	0	0	0	-	0.0%
01:00-02:00	0	0	0	0	0	0	0	0	0	0	-	0.0%	0	0	0	0	0	0	0	0	0	0	-	0.0%
02:00-03:00	0	0	0	0	0	0	0	0	0	0	-	0.0%	0	0	0	0	0	0	0	0	0	0	-	0.0%
03:00-04:00	0	0	0	0	0	0	0	0	0	0	-	0.0%	0	0	0	0	0	0	0	0	0	0	-	0.0%
04:00-05:00	0	0	0	0	0	0	0	0	0	0	-	0.0%	4	1	0	0	0	0	1	0	6	1	16.7%	2.2%
05:00-06:00	2	3	0	0	0	0	0	0	5	0	0.0%	1.8%	5	2	0	0	0	1	1	0	9	2	22.2%	3.3%
06:00-07:00	5	0	0	0	0	1	1	0	7	2	28.6%	2.6%	19	3	0	0	1	1	5	0	29	6	20.7%	10.8%
Nighttime Traffic	25	8	2	0	1	2	1	0	39	3	7.7%	14.4%	32	8	0	0	5	2	8	0	55	10	18.2%	20.4%
Daily Traffic	166	61	2	0	22	7	13	0	271	20	7.4%	100.0%	167	57	0	0	22	6	17	0	269	23	8.6%	100.0%
Ratio of Daily Traffic to Daytime Traffic	1.18	1.15	-	-	1.05	1.40	1.08	-	1.17	1.18	-	-	1.24	1.16	-	-	1.29	1.50	1.89	-	1.26	1.77	-	-

direction	Total													
	Type of Vehicle								Total *1 [car]	Commercial Vehicle *2 [car]	Commercial Vehicle Ratio *2/*1 [%]	Total /Daily Traffic [%]		
Time	Motocycle [veh]	Passenger Car [veh]	Minibus [veh]	Bus [veh]	Light Truck [veh]	Truck (2,3 axle) [veh]	Truck & Trailer (over 4 axle) [veh]	Container Trailer [veh]						
07:00-08:00	20	7	0	0	5	1	6	0	39	7	17.9%	7.2%		
08:00-09:00	32	12	0	0	5	0	0	0	49	0	0.0%	9.1%		
09:00-10:00	27	14	0	0	3	0	1	0	45	1	2.2%	8.3%		
10:00-11:00	25	11	0	0	2	0	1	0	39	1	2.6%	7.2%		
11:00-12:00	19	11	0	0	4	1	2	0	37	3	8.1%	6.9%		
12:00-13:00	16	9	0	0	0	0	1	0	26	1	3.8%	4.8%		
13:00-14:00	21	14	0	0	2	0	1	0	38	1	2.6%	7.0%		
14:00-15:00	17	5	0	0	2	0	0	0	24	0	0.0%	4.4%		
15:00-16:00	18	6	0	0	2	3	3	0	32	6	18.8%	5.9%		
16:00-17:00	14	7	0	0	6	1	4	0	32	5	15.6%	5.9%		
17:00-18:00	34	4	0	0	6	2	2	0	48	4	8.3%	8.9%		
18:00-19:00	33	2	0	0	1	1	0	0	37	1	2.7%	6.9%		
Daytime Traffic	276	102	0	0	38	9	21	0	446	30	6.7%	82.6%		
19:00-20:00	12	5	2	0	2	1	0	0	22	1	4.5%	4.1%		
20:00-21:00	3	0	0	0	0	0	0	0	3	0	0.0%	0.6%		
21:00-22:00	7	1	0	0	0	0	0	0	8	0	0.0%	1.5%		
22:00-23:00	0	1	0	0	0	0	1	0	2	1	50.0%	0.4%		
23:00-00:00	0	0	0	0	3	0	0	0	3	0	0.0%	0.6%		
00:00-01:00	0	0	0	0	0	0	0	0	0	0	-	0.0%		
01:00-02:00	0	0	0	0	0	0	0	0	0	0	-	0.0%		
02:00-03:00	0	0	0	0	0	0	0	0	0	0	-	0.0%		
03:00-04:00	0	0	0	0	0	0	0	0	0	0	-	0.0%		
04:00-05:00	4	1	0	0	0	0	1	0	6	1	16.7%	1.1%		
05:00-06:00	7	5	0	0	0	1	1	0	14	2	14.3%	2.6%		
06:00-07:00	24	3	0	0	1	2	6	0	36	8	22.2%	6.7%		
Nighttime Traffic	57	16	2	0	6	4	9	0	94	13	13.8%	17.4%		
Daily Traffic	333	118	2	0	44	13	30	0	540	43	8.0%	100.0%		
Ratio of Daily Traffic to Daytime Traffic	1.21	1.16	-	-	1.16	1.44	1.43	-	1.21	1.43	-	-		

Date										Month										Year									
Survey Date										9 / 9										2015									
Survey Point Name										C-4 A1 ENTRÉE AGNIBLEKRO										Guidance Diagram									
Direction1 From										AGNIBLEKRO to NIANDA										To AGNIBLEKRO									
Direction2 From										NIANDA to AGNIBLEKRO										To NIANDA									
direction		Direction 1										Direction 2																	
		Type of Vehicle							Total	Comme	Comme	Total	Type of Vehicle							Total	Comme	Comme	Total						
Time	Motorcy	Passen	Minibus	Bus	Light	Truck	Truck &	Contain	'1	cial	cial	/Daily	Motorcy	Passen	Minibus	Bus	Light	Truck	Truck &	Contain	'1	cial	cial	/Daily					
	[veh]	[veh]	[veh]	[veh]	[veh]	[veh]	[veh]	[veh]	[veh]	[veh]	[veh]	[veh]	[veh]	[veh]	[veh]	[veh]	[veh]	[veh]	[veh]	[veh]	[veh]	[veh]	[veh]	[veh]	[veh]				
07:00-08:00	52	22	21	0	4	4	3	1	107	8	7.5%	7.0%	44	19	18	0	3	4	5	1	94	10	10.6%	6.2%					
08:00-09:00	42	28	18	0	2	9	3	2	104	14	13.5%	6.8%	40	26	16	0	1	7	2	1	93	10	10.8%	6.2%					
09:00-10:00	41	25	18	0	3	8	6	3	104	17	16.3%	6.8%	38	30	21	0	7	6	5	1	108	12	11.1%	7.2%					
10:00-11:00	22	26	25	0	4	5	3	0	85	8	9.4%	5.5%	25	22	19	0	5	4	3	0	78	7	9.0%	5.2%					
11:00-12:00	40	31	16	1	6	3	3	1	101	7	6.9%	6.6%	41	18	14	0	4	3	3	1	84	7	8.3%	5.6%					
12:00-13:00	48	13	9	0	6	2	3	0	81	5	6.2%	5.3%	45	12	15	0	7	1	1	0	81	2	2.5%	5.4%					
13:00-14:00	40	11	10	0	2	4	1	0	68	5	7.4%	4.4%	41	12	6	0	7	3	4	0	73	7	9.6%	4.8%					
14:00-15:00	31	9	16	0	7	6	1	1	71	8	11.3%	4.6%	28	10	13	0	11	4	1	1	68	6	8.8%	4.5%					
15:00-16:00	43	29	21	0	12	5	3	0	113	8	7.1%	7.3%	41	26	21	1	13	5	2	0	109	7	6.4%	7.2%					
16:00-17:00	41	33	21	0	7	4	3	0	109	7	6.4%	7.1%	40	30	22	0	8	4	3	0	107	7	6.5%	7.1%					
17:00-18:00	58	26	24	0	7	11	6	1	133	18	13.5%	8.6%	54	35	13	0	8	10	6	1	127	17	13.4%	8.4%					
18:00-19:00	33	18	11	0	6	9	7	1	85	17	20.0%	5.5%	34	15	9	0	4	5	10	0	77	15	19.5%	5.1%					
Daytime Traffic	491	271	210	1	66	70	42	10	1,161	122	10.5%	75.4%	471	255	187	1	78	56	45	6	1,099	107	9.7%	72.8%					
19:00-20:00	34	13	7	0	6	6	1	0	67	7	10.4%	4.4%	41	12	8	0	6	4	1	0	72	5	6.9%	4.8%					
20:00-21:00	27	9	3	1	4	4	2	2	52	8	15.4%	3.4%	34	8	4	0	5	3	3	0	60	9	15.0%	4.0%					
21:00-22:00	21	4	2	0	4	5	0	0	36	5	13.9%	2.3%	25	4	3	0	4	4	0	1	41	5	12.2%	2.7%					
22:00-23:00	14	3	4	0	2	8	0	0	31	8	25.8%	2.0%	18	3	5	0	3	6	1	0	36	7	19.4%	2.4%					
23:00-00:00	9	6	5	0	2	5	0	0	27	5	18.5%	1.8%	12	5	7	0	2	4	0	1	31	5	16.1%	2.1%					
00:00-01:00	5	2	2	0	1	2	2	0	14	4	28.6%	0.9%	7	1	3	1	1	1	3	0	17	4	23.5%	1.1%					
01:00-02:00	2	3	0	0	3	9	4	0	21	13	61.9%	1.4%	2	2	0	0	4	6	5	0	19	11	57.9%	1.3%					
02:00-03:00	0	6	2	0	0	7	5	0	20	12	60.0%	1.3%	1	5	2	0	0	4	5	0	17	9	52.9%	1.1%					
03:00-04:00	0	1	7	0	0	4	2	1	15	7	46.7%	1.0%	0	1	9	0	0	5	2	1	18	8	44.4%	1.2%					
04:00-05:00	0	2	7	0	0	4	4	0	17	8	47.1%	1.1%	0	1	8	0	0	2	4	0	15	6	40.0%	1.0%					
05:00-06:00	18	4	12	0	0	8	0	0	42	8	19.0%	2.7%	23	3	16	0	0	5	0	0	47	5	10.6%	3.1%					
06:00-07:00	3	10	12	1	4	5	1	0	36	6	16.7%	2.3%	4	9	15	0	5	3	1	0	37	4	10.8%	2.5%					
Nighttime Traffic	133	63	63	2	26	67	21	3	378	91	24.1%	24.6%	167	54	80	1	30	47	25	6	410	78	19.0%	27.2%					
Daily Traffic	624	334	273	3	92	137	63	13	1,539	213	13.8%	100.0%	638	309	267	2	108	103	70	12	1,509	185	12.3%	100.0%					
Ratio of Daily Traffic to Daytime Traffic	1.27	1.23	1.30	3.00	1.39	1.96	1.50	1.30	1.33	1.75	-	-	1.35	1.21	1.43	2.00	1.38	1.84	1.56	2.00	1.37	1.73	-	-					
direction		Total																											
		Type of Vehicle							Total	Comme	Comme	Total																	
Time	Motorcy	Passen	Minibus	Bus	Light	Truck	Truck &	Contain	'1	cial	cial	/Daily																	
	[veh]	[veh]	[veh]	[veh]	[veh]	[veh]	[veh]	[veh]	[car]	[car]	[%	[%																	
07:00-08:00	96	41	39	0	7	8	8	2	201	18	9.0%	6.6%																	
08:00-09:00	82	54	34	0	3	16	5	3	197	24	12.2%	6.5%																	
09:00-10:00	79	55	39	0	10	14	11	4	212	29	13.7%	7.0%																	
10:00-11:00	47	48	44	0	9	9	6	0	163	15	9.2%	5.3%																	
11:00-12:00	81	49	30	1	10	6	6	2	185	14	7.6%	6.1%																	
12:00-13:00	93	25	24	0	13	3	4	0	162	7	4.3%	5.3%																	
13:00-14:00	81	23	16	0	9	7	5	0	141	12	8.5%	4.6%																	
14:00-15:00	59	19	29	0	18	10	2	2	139	14	10.1%	4.6%																	
15:00-16:00	84	55	42	1	25	10	5	0	222	15	6.8%	7.3%																	
16:00-17:00	81	63	43	0	15	8	6	0	216	14	6.5%	7.1%																	
17:00-18:00	112	61	37	0	15	21	12	2	260	35	13.5%	8.5%																	
18:00-19:00	67	33	20	0	10	14	17	1	162	32	19.8%	5.3%																	
Daytime Traffic	962	526	397	2	144	126	87	16	2,260	229	10.1%	74.1%																	
19:00-20:00	75	25	15	0	12	10	2	0	139	12	8.6%	4.6%																	
20:00-21:00	61	17	7	1	9	7	5	5	112	17	15.2%	3.7%																	
21:00-22:00	46	8	5	0	8	9	0	1	77	10	13.0%	2.5%																	
22:00-23:00	32	6	9	0	5	14	1	0	67	15	22.4%	2.2%																	
23:00-00:00	21	11	12	0	4	9	0	1	58	10	17.2%	1.9%																	
00:00-01:00	12	3	5	1	2	3	5	0	31	8	25.8%	1.0%																	
01:00-02:00	4	5	0	0	7	15	9	0	40	24	60.0%	1.3%																	
02:00-03:00	1	11	4	0	0	11	10	0	37	21	56.8%	1.2%																	
03:00-04:00	0	2	16	0	0	9	4	2	33	15	45.5%	1.1%																	
04:00-05:00	0	3	15	0	0	6	8	0	32	14	43.8%	1.0%																	
05:00-06:00	41	7	28	0	0	13	0	0	89	13	14.6%	2.9%																	
06:00-07:00	7	19	27	1	9	8	2	0	73	10	13.7%	2.4%																	
Nighttime Traffic	300	117	143	3	56	114	46	9	788	169	21.4%	25.9%																	
Daily Traffic	1,262	643	540	5	200	240	133	25	3,048	398	13.1%	100.0%																	
Ratio of Daily Traffic to Daytime Traffic	1.31	1.22	1.36	2.50	1.39	1.90	1.53	1.56	1.35	1.74	-	-																	

Date													Month				Year				Guidance Diagram																	
Survey Date													9				/ 9				2015				To Bouafé													
Survey Point Name													C5-Entrée Bouafé								Direction 1 → Direction 2 ←																	
Direction1 From													Bouafé				to Zatta				To Zatta																	
Direction2 From													Zatta				to Bouafé																					
direction													Direction 1							Direction 2																		
Time	Type of Vehicle								Total *1	Comm ercial Vehic le *2	Comm ercial Vehic le *2/ *1 [%]	Total /Daily Traffic [%]	Remarks / Observations	Type of Vehicle								Total *1	Comm ercial Vehic le *2	Comm ercial Vehic le *2/ *1 [%]	Total /Daily Traffic [%]	Remarks / Observations												
	Motorc ycle	Passe nger Car	Minib us	Bus	Light Truck	Truck (2,3 axle)	Truck & Trailer	Contai ner Trailer						Motorc ycle	Passe nger Car	Minib us	Bus	Light Truck	Truck (2,3 axle)	Truck & Trailer	Contai ner Trailer																	
[veh]	[veh]	[veh]	[veh]	[veh]	[veh]	[veh]	[veh]	[veh]	[veh]	[veh]	[veh]	[veh]	[veh]	[veh]	[veh]	[veh]	[veh]	[veh]	[veh]	[veh]	[veh]	[veh]	[veh]	[veh]	[veh]	[veh]	[veh]	[veh]	[veh]	[veh]	[veh]	[veh]	[veh]	[veh]	[veh]			
07:00-08:00	9	20	9	3	2	2	3	0	48	5	10.4%	3.8%		16	19	4	0	2	4	19	1	65	24	36.9%	3.7%													
08:00-09:00	47	37	5	3	4	4	2	0	102	6	5.9%	8.0%		29	41	6	0	6	0	4	0	86	4	4.7%	4.9%													
09:00-10:00	23	40	10	9	0	2	2	0	86	4	4.7%	6.8%		41	37	10	5	2	4	5	0	104	9	8.7%	6.0%													
10:00-11:00	30	51	15	15	0	3	3	1	118	7	5.9%	9.3%		49	57	8	12	5	10	5	0	146	15	10.3%	8.4%													
11:00-12:00	20	50	10	17	3	4	7	0	111	11	9.9%	8.8%		39	45	9	12	3	5	6	0	119	11	9.2%	6.8%													
12:00-13:00	23	42	3	18	1	8	5	0	100	13	13.0%	7.9%		40	56	13	19	8	7	6	1	150	14	9.3%	8.6%													
13:00-14:00	13	43	7	13	3	4	3	0	86	7	8.1%	6.8%		40	50	11	16	15	7	9	0	148	16	10.8%	8.5%													
14:00-15:00	27	52	6	5	1	8	6	0	105	14	13.3%	8.3%		34	55	15	7	0	5	3	0	119	8	6.7%	6.8%													
15:00-16:00	26	44	12	5	10	4	4	0	105	8	7.6%	8.3%		24	36	14	9	4	4	5	0	96	9	9.4%	5.5%													
16:00-17:00	44	19	11	6	13	5	9	0	107	14	13.1%	8.4%		40	46	18	7	7	3	3	0	124	6	4.8%	7.1%													
17:00-18:00	27	34	8	3	6	3	2	1	84	6	7.1%	6.6%		39	48	12	6	8	3	6	0	122	9	7.4%	7.0%													
18:00-19:00	12	14	6	2	4	4	7	0	49	11	22.4%	3.9%		72	43	11	4	9	1	4	0	144	5	3.5%	8.2%													
Daytime Traffic	301	446	102	99	47	51	53	2	1,101	106	9.6%	86.8%		463	533	131	97	69	53	75	21	1,423	130	9.1%	81.5%													
19:00-20:00	2	8	1	0	1	4	5	0	21	9	42.9%	1.7%		30	33	11	5	11	1	10	0	101	11	10.9%	5.8%													
20:00-21:00	3	8	4	0	2	4	2	0	23	6	26.1%	1.8%		7	21	6	2	1	2	6	2	47	10	21.3%	2.7%													
21:00-22:00	1	8	3	2	0	7	6	0	27	13	48.1%	2.1%		11	13	4	4	2	8	5	2	49	15	30.6%	2.8%													
22:00-23:00	0	1	0	0	0	5	1	0	7	6	85.7%	0.6%		2	9	8	2	3	3	5	0	32	8	25.0%	1.8%													
23:00-00:00	0	0	1	0	0	3	0	0	4	3	75.0%	0.3%		0	3	2	0	0	1	8	1	15	10	66.7%	0.9%													
00:00-01:00	0	0	0	0	0	3	0	0	3	3	100.0%	0.2%		0	0	0	0	2	2	2	0	6	4	66.7%	0.3%													
01:00-02:00	0	1	0	0	0	3	0	0	4	3	75.0%	0.3%		1	0	2	0	0	0	4	0	7	4	57.1%	0.4%													
02:00-03:00	0	1	0	0	0	3	0	0	4	3	75.0%	0.3%		0	1	0	0	0	0	9	0	10	9	90.0%	0.6%													
03:00-04:00	0	0	0	0	0	3	0	0	3	3	100.0%	0.2%		0	0	0	0	0	2	4	0	6	6	100.0%	0.3%													
04:00-05:00	1	3	0	0	0	2	0	0	6	2	33.3%	0.5%		0	0	0	0	0	0	1	1	1	1	100.0%	0.1%													
05:00-06:00	4	6	4	0	0	2	0	0	16	2	12.5%	1.3%		1	0	0	0	1	2	3	1	8	6	75.0%	0.5%													
06:00-07:00	10	12	17	0	2	5	3	0	49	8	16.3%	3.9%		11	12	1	0	0	4	10	3	41	17	41.5%	2.3%													
Nighttime Traffic	21	48	30	2	5	44	17	0	167	61	36.5%	13.2%		63	92	34	13	20	25	66	10	323	101	31.3%	18.5%													
Daily Traffic	322	494	132	101	52	95	70	2	1,268	167	13.2%	100.0%		526	625	165	110	89	78	141	12	1,746	231	13.2%	100.0%													
Ratio of Daily Traffic to Daytime Traffic	1.07	1.11	1.29	1.02	1.11	1.86	1.32	1.00	1.15	1.58	-	-		1.14	1.17	1.26	1.13	1.29	1.47	1.88	6.00	1.23	1.78	-	-													
direction													Total																									
Time	Type of Vehicle								Total *1	Comm ercial Vehic le *2	Comm ercial Vehic le *2/ *1 [%]	Total /Daily Traffic [%]	Remarks / Observations																									
	Motorc ycle	Passe nger Car	Minib us	Bus	Light Truck	Truck (2,3 axle)	Truck & Trailer	Contai ner Trailer																														
[veh]	[veh]	[veh]	[veh]	[veh]	[veh]	[veh]	[veh]	[veh]	[car]	[car]	[%]	[%]	[%]																									
07:00-08:00	25	39	13	3	4	6	22	1	113	29	25.7%	3.7%																										
08:00-09:00	76	78	11	3	10	4	6	0	188	10	5.3%	6.2%																										
09:00-10:00	64	77	20	14	2	6	7	0	190	13	6.8%	6.3%																										
10:00-11:00	79	108	23	27	5	13	8	1	264	22	8.3%	8.8%																										
11:00-12:00	59	95	19	29	6	9	13	0	230	22	9.6%	7.6%																										
12:00-13:00	63	98	16	37	9	15	11	1	250	27	10.8%	8.3%																										
13:00-14:00	53	93	18	29	18	11	12	0	234	23	9.8%	7.8%																										
14:00-15:00	61	107	21	12	1	13	9	0	224	22	9.8%	7.4%																										
15:00-16:00	50	80	26	14	14	8	9	0	201	17	8.5%	6.7%																										
16:00-17:00	84	65	29	13	20	8	12	0	231	20	8.7%	7.7%																										
17:00-18:00	66	82	20	9	14	6	8	1	206	15	7.3%	6.8%																										
18:00-19:00	84	57	17	6	13	5	11	0	193	16	8.3%	6.4%																										
Daytime Traffic	764	979	233	196	116	104	128	4	2,524	236	9.4%	83.7%																										
19:00-20:00	32	41	12	5	12	5	15	0	122	20	16.4%	4.0%																										
20:00-21:00	10	29	10	2	3	6	8	2	70	16	22.9%	2.3%																										
21:00-22:00	12	21	7	6	2	15	11	2	76	28	36.8%	2.5%																										
22:00-23:00	2	10	8	2	3	8	6	0	39	14	35.9%	1.3%																										
23:00-00:00	0	3	3	0	0	4	8	1	19	13	68.4%	0.6%																										
00:00-01:00	0	0	0	0	2	5	2	0	9	7	77.8%	0.3%																										
01:00-02:00	1	1	2	0	0	3	4	0	11	7	63.6%	0.4%																										
02:00-03:00	0	2	0	0	0	3	9	0	14	12	85.7%	0.5%																										
03:00-04:00	0	0	0	0	0	5	4	0	9	9	100.0%	0.3%																										
04:00-05:00	1	3	0	0	0	2	0	1	7	3	42.9%	0.2%																										
05:00-06:00	5	6	4	0	1	4	3	1	24	8	33.3%	0.8%																										
06:00-07:00	21	24	18	0	2	9	13	3	90	25	27.8%	3.0%																										
Nighttime Traffic	84	140	64	15	25	69	83	10	490	162	33.1%	16.3%																										
Daily Traffic	848	1,119	297	211	141	173	211	14	3,014	398	13.2%	100.0%																										
Ratio of Daily Traffic to Daytime Traffic	1.11	1.14	1.27	1.08	1.22	1.66	1.65	3.50	1.19	1.69	-	-																										

Survey Date										Guidance Diagram																			
Date					Month					Year					To														
9					9					2015					KONGASSO														
Survey Point Name										C-6 Entrée BEOUMI										Direction 1 →									
Direction1 From										KONGASSO to BEOUMI										Direction 2 ←									
Direction2 From										BEOUMI to KONGASSO										To BEOUMI									
Direction 1										Direction 2																			
Type of Vehicle										Type of Vehicle																			
Motorcycle	Passenger Car	Minibus	Bus	Light Truck	Truck (2,3 axle)	Truck & Trailer	Container Trailer	Total *1	Commercial Vehicle *2	Commercial Vehicle Ratio *2/*1	Total /Daily Traffic	Remarks / Observations	Motorcycle	Passenger Car	Minibus	Bus	Light Truck	Truck (2,3 axle)	Truck & Trailer	Container Trailer	Total *1	Commercial Vehicle *2	Commercial Vehicle Ratio *2/*1	Total /Daily Traffic	Remarks / Observations				
[veh]	[veh]	[veh]	[veh]	[veh]	[veh]	[veh]	[veh]	[veh]	[veh]	[%]	[%]		[veh]	[veh]	[veh]	[veh]	[veh]	[veh]	[veh]	[veh]	[veh]	[veh]	[%]	[%]					
07:00-08:00	9	0	0	0	1	1	1	0	12	2	16.7%	5.3%	5	0	5	0	1	0	2	0	13	2	15.4%	5.4%					
08:00-09:00	11	1	3	0	2	1	0	0	18	1	5.6%	7.9%	10	1	4	0	3	0	0	0	18	0	0.0%	7.4%					
09:00-10:00	10	1	1	0	6	1	0	0	19	1	5.3%	8.3%	4	1	1	0	3	5	0	0	14	5	35.7%	5.8%					
10:00-11:00	16	1	1	0	3	1	0	0	22	1	4.5%	9.6%	14	0	2	0	2	1	0	0	19	1	5.3%	7.9%					
11:00-12:00	13	2	1	0	2	5	1	0	24	6	25.0%	10.5%	13	0	1	0	5	5	0	0	24	5	20.8%	9.9%					
12:00-13:00	16	1	1	0	2	1	0	0	21	1	4.8%	9.2%	18	2	0	0	10	3	0	0	33	3	9.1%	13.6%					
13:00-14:00	10	4	2	0	9	0	0	0	25	0	0.0%	11.0%	15	0	0	0	3	1	0	0	19	1	5.3%	7.9%					
14:00-15:00	9	4	4	0	3	2	0	0	22	2	9.1%	9.6%	11	1	1	0	3	2	0	0	18	2	11.1%	7.4%					
15:00-16:00	14	4	4	0	1	2	1	0	26	3	11.5%	11.4%	13	1	2	0	0	2	1	0	19	3	15.8%	7.9%					
16:00-17:00	7	0	1	0	0	2	0	0	10	2	20.0%	4.4%	6	6	0	0	1	3	1	0	17	4	23.5%	7.0%					
17:00-18:00	11	4	4	0	0	1	0	0	20	1	5.0%	8.8%	4	3	9	0	10	6	0	0	32	6	18.8%	13.2%					
18:00-19:00	1	0	1	0	0	0	0	0	2	0	0.0%	0.9%	2	3	3	0	1	0	0	0	9	0	0.0%	3.7%					
Daytime Traffic	127	22	23	0	29	17	3	0	221	20	9.0%	96.9%	115	18	28	0	42	28	4	0	235	32	13.6%	97.1%					
19:00-20:00	2	0	0	0	0	0	0	0	2	0	0.0%	0.9%	3	1	0	0	1	0	0	0	5	0	0.0%	2.1%					
20:00-21:00	3	1	0	0	0	0	0	0	4	0	0.0%	1.8%	1	0	0	0	1	0	0	0	2	0	0.0%	0.8%					
21:00-22:00	0	0	0	0	0	0	0	0	0	0	-	0.0%	0	0	0	0	0	0	0	0	0	0	-	0.0%					
22:00-23:00	0	0	0	0	0	0	0	0	0	0	-	0.0%	0	0	0	0	0	0	0	0	0	0	-	0.0%					
23:00-00:00	0	0	0	0	0	0	0	0	0	0	-	0.0%	0	0	0	0	0	0	0	0	0	0	-	0.0%					
00:00-01:00	0	0	0	0	0	0	0	0	0	0	-	0.0%	0	0	0	0	0	0	0	0	0	0	-	0.0%					
01:00-02:00	0	0	0	0	0	0	0	0	0	0	-	0.0%	0	0	0	0	0	0	0	0	0	0	-	0.0%					
02:00-03:00	0	0	0	0	0	0	0	0	0	0	-	0.0%	0	0	0	0	0	0	0	0	0	0	-	0.0%					
03:00-04:00	0	0	0	0	0	0	0	0	0	0	-	0.0%	0	0	0	0	0	0	0	0	0	0	-	0.0%					
04:00-05:00	0	0	0	0	0	0	0	0	0	0	-	0.0%	0	0	0	0	0	0	0	0	0	0	-	0.0%					
05:00-06:00	0	0	0	0	0	0	0	0	0	0	-	0.0%	0	0	0	0	0	0	0	0	0	0	-	0.0%					
06:00-07:00	1	0	0	0	0	0	0	0	1	0	0.0%	0.4%	0	0	0	0	0	0	0	0	0	0	-	0.0%					
Nighttime Traffic	6	1	0	0	0	0	0	0	7	0	0.0%	3.1%	4	1	0	0	2	0	0	0	7	0	0.0%	2.9%					
Daily Traffic	133	23	23	0	29	17	3	0	228	20	8.8%	100.0%	119	19	28	0	44	28	4	0	242	32	13.2%	100.0%					
Ratio of Daily Traffic to Daytime Traffic	1.05	1.05	1.00	-	1.00	1.00	-	1.03	1.00	-	-		1.03	1.06	1.00	-	1.05	1.00	1.00	-	1.03	1.00	-	-					

Total												
Type of Vehicle												
Motorcycle	Passenger Car	Minibus	Bus	Light Truck	Truck (2,3 axle)	Truck & Trailer	Container Trailer	Total *1	Commercial Vehicle *2	Commercial Vehicle Ratio *2/*1	Total /Daily Traffic	Remarks / Observations
[veh]	[veh]	[veh]	[veh]	[veh]	[veh]	[veh]	[veh]	[car]	[car]	[%]	[%]	
07:00-08:00	14	0	5	0	2	1	3	0	25	4	16.0%	5.3%
08:00-09:00	21	2	7	0	5	1	0	0	36	1	2.8%	7.7%
09:00-10:00	14	2	2	0	9	6	0	0	33	6	18.2%	7.0%
10:00-11:00	30	1	3	0	5	2	0	0	41	2	4.9%	8.7%
11:00-12:00	26	2	2	0	7	10	1	0	48	11	22.9%	10.2%
12:00-13:00	34	3	1	0	12	4	0	0	54	4	7.4%	11.5%
13:00-14:00	25	4	2	0	12	1	0	0	44	1	2.3%	9.4%
14:00-15:00	20	5	5	0	6	4	0	0	40	4	10.0%	8.5%
15:00-16:00	27	5	6	0	1	4	2	0	45	6	13.3%	9.6%
16:00-17:00	13	6	1	0	1	5	1	0	27	6	22.2%	5.7%
17:00-18:00	15	7	13	0	10	7	0	0	52	7	13.5%	11.1%
18:00-19:00	3	3	4	0	1	0	0	0	11	0	0.0%	2.3%
Daytime Traffic	242	40	51	0	71	45	7	0	456	52	11.4%	97.0%
19:00-20:00	5	1	0	0	1	0	0	0	7	0	0.0%	1.5%
20:00-21:00	4	1	0	0	1	0	0	0	6	0	0.0%	1.3%
21:00-22:00	0	0	0	0	0	0	0	0	0	0	-	0.0%
22:00-23:00	0	0	0	0	0	0	0	0	0	0	-	0.0%
23:00-00:00	0	0	0	0	0	0	0	0	0	0	-	0.0%
00:00-01:00	0	0	0	0	0	0	0	0	0	0	-	0.0%
01:00-02:00	0	0	0	0	0	0	0	0	0	0	-	0.0%
02:00-03:00	0	0	0	0	0	0	0	0	0	0	-	0.0%
03:00-04:00	0	0	0	0	0	0	0	0	0	0	-	0.0%
04:00-05:00	0	0	0	0	0	0	0	0	0	0	-	0.0%
05:00-06:00	0	0	0	0	0	0	0	0	0	0	-	0.0%
06:00-07:00	1	0	0	0	0	0	0	0	1	0	0.0%	0.2%
Nighttime Traffic	10	2	0	0	2	0	0	0	14	0	0.0%	3.0%
Daily Traffic	252	42	51	0	73	45	7	0	470	52	11.1%	100.0%
Ratio of Daily Traffic to Daytime Traffic	1.04	1.05	1.00	-	1.03	1.00	-	1.03	1.00	-	-	

Survey Date										Guidance Diagram																			
Date					Month					Year					To														
9					9					2015					SEGUELA														
Survey Point Name										C-7 VAVOUA																			
Direction1 From					SEGUELA					to					VAVOUA														
Direction2 From					VAVOUA					to					SEGUELA														
direction										Direction 1										Direction 2									
Type of Vehicle										Type of Vehicle										Type of Vehicle									
Motorcycle	Passenger Car	Minibus	Bus	Light Truck	Truck (2,3 axle)	Truck & Trailer	Container Trailer	Total '1	Commercial Vehicle '2	Commercial Vehicle Ratio '2/'1	Total /Daily Traffic	Motorcycle	Passenger Car	Minibus	Bus	Light Truck	Truck (2,3 axle)	Truck & Trailer	Container Trailer	Total '1	Commercial Vehicle '2	Commercial Vehicle Ratio '2/'1	Total /Daily Traffic						
[veh]	[veh]	[veh]	[veh]	[veh]	[veh]	[veh]	[veh]	[veh]	[veh]	[%]	[veh]	[veh]	[veh]	[veh]	[veh]	[veh]	[veh]	[veh]	[veh]	[veh]	[veh]	[%]	[veh]						
07:00-08:00	13	7	6	0	0	1	1	0	28	2	7.1%	4.0%	41	5	8	0	7	3	0	0	64	3	4.7%	9.7%					
08:00-09:00	32	6	10	1	2	0	1	0	52	1	1.9%	7.4%	76	3	4	0	1	2	1	0	87	3	3.4%	13.2%					
09:00-10:00	23	7	13	0	1	2	1	0	47	3	6.4%	6.7%	29	3	8	0	7	3	1	1	52	5	9.6%	7.9%					
10:00-11:00	30	6	11	1	2	6	0	0	56	6	10.7%	7.9%	21	4	12	0	1	3	0	0	41	3	7.3%	6.2%					
11:00-12:00	24	6	7	1	3	3	2	0	46	5	10.9%	6.5%	15	4	8	0	2	1	4	0	34	5	14.7%	5.2%					
12:00-13:00	28	3	8	0	2	3	2	0	46	5	10.9%	6.5%	16	2	7	1	0	0	0	0	26	0	0.0%	3.9%					
13:00-14:00	25	1	8	0	1	2	1	0	38	3	7.9%	5.4%	10	3	5	2	3	3	2	0	28	5	17.9%	4.2%					
14:00-15:00	41	8	8	0	4	3	1	0	65	4	6.2%	9.2%	15	9	6	1	1	5	0	0	37	5	13.5%	5.6%					
15:00-16:00	10	1	3	0	0	1	2	0	17	3	17.6%	2.4%	25	7	10	1	1	0	1	0	45	1	2.2%	6.8%					
16:00-17:00	76	7	3	0	3	3	0	0	92	3	3.3%	13.0%	42	9	8	2	1	0	1	0	63	1	1.6%	9.6%					
17:00-18:00	55	13	5	0	5	5	2	0	85	7	8.2%	12.1%	32	5	8	0	1	0	0	0	46	0	0.0%	7.0%					
18:00-19:00	29	4	6	0	3	3	0	0	45	3	6.7%	6.4%	22	2	9	0	1	1	1	0	36	2	5.6%	5.5%					
Daytime Traffic	386	69	88	3	26	32	13	0	617	45	7.3%	97.5%	344	56	93	7	26	21	11	1	559	33	5.9%	84.8%					
19:00-20:00	31	3	8	0	1	2	1	0	46	3	6.5%	6.5%	13	4	2	0	1	3	0	0	23	3	13.0%	3.5%					
20:00-21:00	6	2	1	0	1	4	0	0	14	4	28.6%	2.0%	3	1	2	0	0	0	0	0	6	0	0.0%	0.9%					
21:00-22:00	2	1	1	0	1	2	0	0	7	2	28.6%	1.0%	3	0	1	0	0	1	0	1	6	2	33.3%	0.9%					
22:00-23:00	3	1	0	0	0	0	0	0	4	0	0.0%	0.6%	4	1	2	0	0	0	0	0	7	0	0.0%	1.1%					
23:00-00:00	1	1	0	0	0	0	0	0	2	0	0.0%	0.3%	0	1	0	0	0	0	0	0	1	0	0.0%	0.2%					
00:00-01:00	1	0	0	0	0	1	0	0	2	1	50.0%	0.3%	1	1	0	0	0	0	0	0	2	0	0.0%	0.3%					
01:00-02:00	0	0	0	0	0	1	0	0	1	1	100.0%	0.1%	0	1	0	0	0	0	0	0	1	0	0.0%	0.2%					
02:00-03:00	0	0	0	0	0	0	0	0	0	0	-	0.0%	0	2	0	0	0	0	0	0	2	0	0.0%	0.3%					
03:00-04:00	1	0	0	0	0	0	0	0	1	0	0.0%	0.1%	1	0	0	0	0	0	0	0	1	0	0.0%	0.2%					
04:00-05:00	0	0	0	0	0	0	0	0	0	0	-	0.0%	0	0	0	0	0	0	0	0	0	0	-	0.0%					
05:00-06:00	0	0	0	0	0	0	0	0	0	0	-	0.0%	2	0	3	0	0	1	1	0	7	2	28.6%	1.1%					
06:00-07:00	7	2	1	0	0	0	0	1	11	1	9.1%	1.6%	27	3	8	0	5	0	1	0	44	1	2.3%	6.7%					
Nighttime Traffic	52	10	11	0	3	10	1	1	88	12	13.6%	12.5%	54	14	18	0	6	5	2	1	100	8	8.0%	15.2%					
Daily Traffic	438	79	99	3	29	42	14	1	705	57	8.1%	100.0%	398	70	111	7	32	26	13	2	659	41	6.2%	100.0%					
Ratio of Daily Traffic to Daytime Traffic	1.13	1.14	1.13	1.00	1.12	1.31	1.08	-	1.14	1.27	-	-	1.16	1.25	1.19	1.00	1.23	1.24	1.18	2.00	1.18	1.24	-	-					

direction										Total														
Type of Vehicle										Type of Vehicle														
Motorcycle	Passenger Car	Minibus	Bus	Light Truck	Truck (2,3 axle)	Truck & Trailer	Container Trailer	Total '1	Commercial Vehicle '2	Commercial Vehicle Ratio '2/'1	Total /Daily Traffic	Motorcycle	Passenger Car	Minibus	Bus	Light Truck	Truck (2,3 axle)	Truck & Trailer	Container Trailer	Total '1	Commercial Vehicle '2	Commercial Vehicle Ratio '2/'1	Total /Daily Traffic	
[veh]	[veh]	[veh]	[veh]	[veh]	[veh]	[veh]	[veh]	[car]	[car]	[%]	[veh]	[veh]	[veh]	[veh]	[veh]	[veh]	[veh]	[veh]	[veh]	[veh]	[car]	[car]	[%]	[veh]
07:00-08:00	54	12	14	0	7	4	1	0	92	5	5.4%	6.7%	108	9	14	1	3	2	2	0	139	4	2.9%	10.2%
08:00-09:00	52	10	21	0	8	5	2	1	99	8	8.1%	7.3%	51	10	23	1	3	9	0	0	97	9	9.3%	7.1%
09:00-10:00	39	10	15	1	5	4	6	0	80	10	12.5%	5.9%	44	5	15	1	2	3	2	0	72	5	6.9%	5.3%
10:00-11:00	35	4	13	2	4	5	3	0	66	8	12.1%	4.8%	56	17	14	1	5	8	1	0	102	9	8.8%	7.5%
11:00-12:00	35	8	13	1	1	1	3	0	62	4	6.5%	4.5%	35	8	13	1	1	1	3	0	62	4	6.5%	4.5%
12:00-13:00	118	16	11	2	4	3	1	0	155	4	2.6%	11.4%	87	18	13	0	6	5	2	0	131	7	5.3%	9.6%
13:00-14:00	51	6	15	0	4	4	1	0	81	5	6.2%	5.9%	51	6	15	0	4	4	1	0	81	5	6.2%	5.9%
Daytime Traffic	730	125	181	10	52	53	24	1	1,176	78	6.6%	86.2%	44	7	10	0	2	5	1	0	69	6	8.7%	5.1%
19:00-20:00	9	3	3	0	1	4	0	0	20	4	20.0%	1.5%	5	1	2	0	1	3	0	1	13	4	30.8%	1.0%
20:00-21:00	7	2	2	0	0	0	0	0	11	0	0.0%	0.8%	1	2	2	0	0	0	0	0	3	0	0.0%	0.2%
21:00-22:00	1	2	0	0	0	0	0	0	4	1	25.0%	0.3%	2	1	0	0	0	0	0	0	2	0	0.0%	0.1%
22:00-23:00	0	1	0	0	0	1	0	0	2	1	50.0%	0.1%	0	2	0	0	0	0	0	0	2	0	0.0%	0.1%
23:00-00:00	0	0	0	0	0	0	0	0	0	0	-	0.0%	0	0	0	0	0	0	0	0	0	0	-	0.0%
00:00-01:00	2	0	3	0	0	1	1	0	7	2	28.6%	0.5%	2	0	3	0	0	1	1	0	7	2	28.6%	0.5%
01:00-02:00	34	5	9	0	5	0	1	1	55	2	3.6%	4.0%	0	0	0	0	0	0	0	0	0	0	-	0.0%
02:00-03:00	106	24	29	0	9	15	3	2	188	20	10.6%	13.8%	106	24	29	0	9	15	3	2	188	20	10.6%	13.8%
03:00-04:00	836	149	210	10	61	68	27	3	1,364	98	7.2%	100.0%	836	149	210	10	61	68	27	3	1,364	98	7.2%	100.0%
Nighttime Traffic	106	24	29	0	9	15	3	2	188	20	10.6%	13.8%	106	24	29	0	9	15	3	2	188	20	10.6%	13.8%
Daily Traffic	836	149	210	10	61	68	27	3	1,364	98	7.2%	100.0%	836	149	210	10	61	68	27	3	1,364	98	7.2%	100.0%
Ratio of Daily Traffic to Daytime Traffic	1.15	1.19	1.16	1.00	1.17	1.28	1.13	3.00	1.16	1.26	-	-	1.15	1.19	1.16	1.00	1.17	1.28	1.13	3.00	1.16	1.26	-	-

Survey Date	Date	8	Month	9	Year	2015	Guidance Diagram						
Survey Point Name							C-8 Entrée Ferké						
Direction1 From							Ferké to Badikaha						
Direction2 From							Badikaha to Ferké						
							To Ferké						
							Direction 1 →						
							Direction 2 ←						
							To Badikaha						

Time	Direction 1										Direction 2															
	Type of Vehicle								Total '1	Comm ercial Vehid e '2	Comm ercial Vehid e Ratio '2/'1 [%]	Total /Daily Traffic [%]	Remarks / Observati ons	Type of Vehicle								Total '1	Comm ercial Vehid e '2	Comm ercial Vehid e Ratio '2/'1 [%]	Total /Daily Traffic [%]	Remarks / Observati ons
	Motorc ycle	Passen ger Car	Minib us	Bus	Light Truck	Truck (2,3 axle)	Truck & Trailer	Contai ner Trailer						Motorc ycle	Passen ger Car	Minib us	Bus	Light Truck	Truck (2,3 axle)	Truck & Trailer	Contai ner Trailer					
07:00-08:00	125	55	10	20	5	25	10	0	250	35	14.0%	8.9%		60	15	9	2	1	1	4	0	92	5	5.4%	5.2%	
08:00-09:00	85	40	40	15	16	27	5	11	239	43	18.0%	8.5%		81	19	4	2	3	2	5	0	116	7	6.0%	6.5%	
09:00-10:00	36	16	6	30	0	1	16	1	106	18	17.0%	3.8%		52	15	17	15	5	5	8	0	117	13	11.1%	6.6%	
10:00-11:00	90	20	20	40	10	20	30	1	231	51	22.1%	8.3%		5	6	10	6	1	0	15	1	44	16	36.4%	2.5%	
11:00-12:00	85	25	10	20	5	5	17	5	172	27	15.7%	6.1%		55	4	10	5	1	1	8	2	86	11	12.8%	4.9%	
12:00-13:00	70	25	30	25	15	15	35	3	218	53	24.3%	7.8%		45	19	30	3	1	0	18	0	116	18	15.5%	6.5%	
13:00-14:00	30	5	10	0	0	10	25	0	80	35	43.8%	2.9%		17	25	5	2	0	0	1	0	50	1	2.0%	2.8%	
14:00-15:00	45	37	30	65	22	23	2	0	224	25	11.2%	8.0%		72	36	15	12	10	6	10	1	162	17	10.5%	9.1%	
15:00-16:00	100	25	5	2	2	1	20	0	155	21	13.5%	5.5%		120	45	10	20	15	10	4	0	224	14	6.3%	12.6%	
16:00-17:00	90	12	10	3	1	4	4	0	124	8	6.5%	4.4%		60	20	5	2	0	0	2	2	91	4	4.4%	5.1%	
17:00-18:00	90	25	7	5	5	13	3	0	148	16	10.8%	5.3%		100	6	2	4	4	1	8	0	125	9	7.2%	7.1%	
18:00-19:00	105	30	13	1	5	5	14	0	173	19	11.0%	6.2%		100	45	10	1	1	5	12	0	174	17	9.8%	9.8%	
Daytime Traffic	951	315	191	226	86	149	181	21	2,120	351	16.6%	75.7%		767	255	127	74	42	31	95	6	1,397	132	9.4%	78.9%	
19:00-20:00	115	9	1	3	0	1	4	0	133	5	3.8%	4.8%		96	15	14	15	0	0	9	2	151	11	7.3%	8.5%	
20:00-21:00	55	4	1	2	0	0	2	0	64	2	3.1%	2.3%		27	10	3	3	4	0	11	0	58	11	19.0%	3.3%	
21:00-22:00	35	3	2	0	0	0	2	0	42	2	4.8%	1.5%		17	6	2	2	0	0	3	0	30	3	10.0%	1.7%	
22:00-23:00	25	5	0	5	0	0	10	0	45	10	22.2%	1.6%		6	1	3	0	0	1	4	0	15	5	33.3%	0.8%	
23:00-00:00	40	0	0	0	0	0	0	0	40	0	0.0%	1.4%		2	0	2	0	0	0	0	0	4	0	0.0%	0.2%	
00:00-01:00	35	0	0	0	0	0	0	0	35	0	0.0%	1.3%		0	0	0	0	0	0	0	0	0	0	-	0.0%	
01:00-02:00	30	0	0	0	0	0	0	0	30	0	0.0%	1.1%		0	0	0	0	0	0	0	0	0	0	-	0.0%	
02:00-03:00	15	0	0	0	0	0	0	0	15	0	0.0%	0.5%		0	0	0	0	0	0	0	0	0	0	-	0.0%	
03:00-04:00	20	0	0	0	0	0	0	0	20	0	0.0%	0.7%		0	0	0	0	0	0	0	0	0	0	-	0.0%	
04:00-05:00	40	0	0	0	0	0	0	0	40	0	0.0%	1.4%		0	0	0	0	0	0	0	0	0	0	-	0.0%	
05:00-06:00	90	10	10	20	5	25	20	0	180	45	25.0%	6.4%		29	7	9	7	0	5	10	0	67	15	22.4%	3.8%	
06:00-07:00	22	3	5	0	0	0	6	0	36	6	16.7%	1.3%		40	8	15	7	0	7	20	0	97	27	27.8%	5.5%	
Nighttime Traffic	522	34	19	30	5	26	44	0	680	70	10.3%	24.3%		217	47		34	4	13	57	2	374	72	19.3%	21.1%	
Daily Traffic	1,473	349	210	256	91	175	225	21	2,800	421	15.0%	100.0%		984	302	127	108	46	44	152	8	1,771	204	11.5%	100.0%	
Ratio of Daily Traffic to Daytime Traffic	1.55	1.11	1.10	1.13	1.06	1.17	1.24	1.00	1.32	1.20	-	-		1.28	1.18	1.00	1.46	1.10	1.42	1.60	1.33	1.27	1.55	-	-	

Time	Total												
	Type of Vehicle								Total '1	Comm ercial Vehid e '2	Comm ercial Vehid e Ratio '2/'1 [%]	Total /Daily Traffic [%]	Remarks / Observati ons
	Motorc ycle	Passen ger Car	Minib us	Bus	Light Truck	Truck (2,3 axle)	Truck & Trailer	Contai ner Trailer					
07:00-08:00	185	70	19	22	6	26	14	0	342	40	11.7%	7.5%	
08:00-09:00	166	59	44	17	19	29	10	11	355	50	14.1%	7.8%	
09:00-10:00	88	31	23	45	5	6	24	1	223	31	13.9%	4.9%	
10:00-11:00	95	26	30	46	11	20	45	2	275	67	24.4%	6.0%	
11:00-12:00	140	29	20	25	6	6	25	7	258	38	14.7%	5.6%	
12:00-13:00	115	44	60	28	16	15	53	3	334	71	21.3%	7.3%	
13:00-14:00	47	30	15	2	0	10	26	0	130	36	27.7%	2.8%	
14:00-15:00	117	73	45	77	32	29	12	1	386	42	10.9%	8.4%	
15:00-16:00	220	70	15	22	17	11	24	0	379	35	9.2%	8.3%	
16:00-17:00	150	32	15	5	1	4	6	2	215	12	5.6%	4.7%	
17:00-18:00	190	31	9	9	9	14	11	0	273	25	9.2%	6.0%	
18:00-19:00	205	75	23	2	6	10	26	0	347	36	10.4%	7.6%	
19:00-20:00	211	24	15	18	0	1	13	2	284	16	5.6%	6.2%	
20:00-21:00	82	14	4	5	4	0	13	0	122	13	10.7%	2.7%	
21:00-22:00	52	9	4	2	0	0	5	0	72	5	6.9%	1.6%	
22:00-23:00	31	6	3	5	0	1	14	0	60	15	25.0%	1.3%	
23:00-00:00	42	0	2	0	0	0	0	0	44	0	0.0%	1.0%	
00:00-01:00	35	0	0	0	0	0	0	0	35	0	0.0%	0.8%	
01:00-02:00	30	0	0	0	0	0	0	0	30	0	0.0%	0.7%	
02:00-03:00	15	0	0	0	0	0	0	0	15	0	0.0%	0.3%	
03:00-04:00	20	0	0	0	0	0	0	0	20	0	0.0%	0.4%	
04:00-05:00	40	0	0	0	0	0	0	0	40	0	0.0%	0.9%	
05:00-06:00	119	17	19	27	5	30	30	0	247	60	24.3%	5.4%	
06:00-07:00	62	11	20	7	0	7	26	0	133	33	24.8%	2.9%	
Nighttime Traffic	739	81	19	64	9	39	101	2	1,054	142	13.5%	23.1%	
Daily Traffic	2,457	651	337	364	137	219	377	29	4,571	625	13.7%	100.0%	
Ratio of Daily Traffic to Daytime Traffic	1.43	1.14	1.06	1.21	1.07	1.22	1.37	1.07	1.30	1.29	-	-	

<p>Date <u>10</u> / Month <u>9</u> / Year <u>2015</u></p> <p>Survey Point Name <u>C-9 Duekoue-Guezon</u></p> <p>Direction1 From <u>DUEKOUÉ</u> to <u>GUEZON</u></p> <p>Direction2 From <u>GUEZON</u> to <u>DUEKOUÉ</u></p>	<p style="text-align: center;">Guidance Diagram</p> <p>To <u>DUEKOUÉ</u></p> <p style="text-align: center;">Direction 1 \longrightarrow</p> <p style="text-align: center;">Direction 2 \longleftarrow</p> <p style="text-align: right;">To <u>GUEZON</u></p>
--	--

Time	Direction 1											Direction 2																		
	Type of Vehicle										Total '1	Comm ercial Vehic le '2	Comm ercial Vehic le Ratio '2/'1 [%]	Total /Daily Traffic	Remarks / Observatio ns	Type of Vehicle										Total '1	Comm ercial Vehic le '2	Comm ercial Vehic le Ratio '2/'1 [%]	Total /Daily Traffic	Remarks / Observatio ns
	Motorc ycle	Passe nger Car	Minib us	Bus	Light Truck	Truck (2,3 axle)	Truck & Trailer (over 4 axle)	Contai ner Trailer	Motorc ycle	Passe nger Car						Minib us	Bus	Light Truck	Truck (2,3 axle)	Truck & Trailer (over 4 axle)	Contai ner Trailer									
07:00-08:00	6	11	16	5	1	1	2	3	45	6	13.3%	5.9%		9	9	12	3	6	3	12	0	54	15	27.8%	6.6%					
08:00-09:00	6	17	17	5	3	1	4	2	55	7	12.7%	7.2%		6	7	10	11	4	5	8	0	51	13	25.5%	6.2%					
09:00-10:00	11	20	11	18	13	6	1	0	80	7	8.8%	10.4%		8	9	6	2	8	4	7	0	44	11	25.0%	5.4%					
10:00-11:00	7	16	12	5	6	3	5	0	54	8	14.8%	7.0%		7	11	0	0	1	1	17	6	43	24	55.8%	5.2%					
11:00-12:00	11	13	21	4	6	3	7	8	73	18	24.7%	9.5%		7	11	10	0	3	4	5	0	40	9	22.5%	4.9%					
12:00-13:00	10	17	18	6	6	3	7	1	68	11	16.2%	8.8%		9	13	8	2	4	5	3	3	47	11	23.4%	5.7%					
13:00-14:00	11	13	3	4	7	5	5	1	49	11	22.4%	6.4%		18	16	12	3	0	5	6	0	60	11	18.3%	7.3%					
14:00-15:00	6	13	11	2	3	3	5	2	45	10	22.2%	5.9%		11	16	7	4	6	6	2	58	14	24.1%	7.1%						
15:00-16:00	11	13	10	0	2	9	4	2	51	15	29.4%	6.6%		12	13	17	6	2	6	6	0	62	12	19.4%	7.6%					
16:00-17:00	7	11	8	2	7	4	7	0	46	11	23.9%	6.0%		16	16	12	6	8	0	10	2	70	12	17.1%	8.5%					
17:00-18:00	11	14	6	3	5	8	1	0	48	9	18.8%	6.2%		11	18	3	0	1	1	1	0	35	2	5.7%	4.3%					
18:00-19:00	4	5	4	0	0	0	2	1	16	3	18.8%	2.1%		1	6	10	4	3	1	0	1	26	2	7.7%	3.2%					
Daytime Traffic	101	163	137	54	59	46	50	20	630	116	18.4%	81.9%		115	145	107	41	46	41	81	14	590	136	23.1%	71.9%					
19:00-20:00	4	8	8	2	0	2	1	0	25	3	12.0%	3.3%		5	9	10	5	5	1	2	0	37	3	8.1%	4.5%					
20:00-21:00	1	5	5	0	2	2	4	2	21	8	38.1%	2.7%		4	8	11	1	2	2	4	1	33	7	21.2%	4.0%					
21:00-22:00	1	1	4	0	0	0	4	1	11	5	45.5%	1.4%		4	5	11	2	1	2	1	0	26	3	11.5%	3.2%					
22:00-23:00	1	0	3	1	0	1	3	0	9	4	44.4%	1.2%		0	9	4	2	2	3	2	2	24	7	29.2%	2.9%					
23:00-00:00	0	3	1	0	3	1	4	0	12	5	41.7%	1.6%		0	6	3	10	2	0	7	0	28	7	25.0%	3.4%					
00:00-01:00	0	0	1	0	0	0	0	0	1	0	0.0%	0.1%		0	5	4	9	0	0	2	0	20	2	10.0%	2.4%					
01:00-02:00	0	0	1	0	0	0	0	0	1	0	0.0%	0.1%		0	0	7	4	1	1	2	0	15	3	20.0%	1.8%					
02:00-03:00	0	0	0	0	0	1	2	0	3	3	100.0%	0.4%		0	0	0	1	0	1	3	0	5	4	80.0%	0.6%					
03:00-04:00	0	0	0	0	1	0	1	1	3	2	66.7%	0.4%		0	0	0	0	1	1	1	0	2	2	100.0%	0.2%					
04:00-05:00	1	0	1	0	0	1	0	0	3	1	33.3%	0.4%		0	1	0	0	2	1	1	0	5	2	40.0%	0.6%					
05:00-06:00	1	0	4	0	0	1	0	0	6	1	16.7%	0.8%		2	1	2	1	0	0	2	0	8	2	25.0%	1.0%					
06:00-07:00	4	17	10	5	1	0	6	1	44	7	15.9%	5.7%		1	4	4	8	0	2	4	5	28	11	39.3%	3.4%					
Nighttime Traffic	13	34	38	8	7	9	25	5	139	39	28.1%	18.1%		16	48	56	43	15	14	31	8	231	53	22.9%	28.1%					
Daily Traffic	114	197	175	62	66	55	75	25	769	155	20.2%	100.0%		131	193	163	84	61	55	112	22	821	189	23.0%	100.0%					
Ratio of Daily Traffic to Daytime Traffic	1.13	1.21	1.28	1.15	1.12	1.20	1.50	1.25	1.22	1.34	-	-		1.14	1.33	1.52	2.05	1.33	1.34	1.38	1.57	1.39	1.39	-	-					

Time	Total											Total '1	Comm ercial Vehic le '2	Comm ercial Vehic le Ratio '2/'1 [%]	Total /Daily Traffic	Remarks / Observatio ns
	Type of Vehicle															
	Motorc ycle	Passe nger Car	Minib us	Bus	Light Truck	Truck (2,3 axle)	Truck & Trailer (over 4 axle)	Contai ner Trailer								
07:00-08:00	15	20	28	8	7	4	14	3	99	21	21.2%	6.2%				
08:00-09:00	12	24	27	16	7	6	12	2	106	20	18.9%	6.7%				
09:00-10:00	19	29	17	20	21	10	8	0	124	18	14.5%	7.8%				
10:00-11:00	14	27	12	5	7	4	22	6	97	32	33.0%	6.1%				
11:00-12:00	18	24	31	4	9	7	12	8	113	27	23.9%	7.1%				
12:00-13:00	19	30	26	8	10	8	10	4	115	22	19.1%	7.2%				
13:00-14:00	29	29	15	7	7	10	11	1	109	22	20.2%	6.9%				
14:00-15:00	17	29	18	6	9	9	11	4	103	24	23.3%	6.5%				
15:00-16:00	23	26	27	6	4	15	10	2	113	27	23.9%	7.1%				
16:00-17:00	23	27	20	8	15	4	17	2	116	23	19.8%	7.3%				
17:00-18:00	22	32	9	3	6	9	2	0	83	11	13.3%	5.2%				
18:00-19:00	5	11	14	4	3	1	2	2	42	5	11.9%	2.6%				
Daytime Traffic	216	308	244	95	105	87	131	34	1,220	252	20.7%	76.7%				
19:00-20:00	9	17	18	7	5	3	3	0	62	6	9.7%	3.9%				
20:00-21:00	5	13	16	1	4	4	8	3	54	15	27.8%	3.4%				
21:00-22:00	5	6	15	2	1	2	5	1	37	8	21.6%	2.3%				
22:00-23:00	1	9	7	3	2	4	5	2	33	11	33.3%	2.1%				
23:00-00:00	0	9	4	10	5	1	11	0	40	12	30.0%	2.5%				
00:00-01:00	0	5	5	9	0	0	2	0	21	2	9.5%	1.3%				
01:00-02:00	0	0	8	4	1	1	2	0	16	3	18.8%	1.0%				
02:00-03:00	0	0	0	1	0	2	5	0	8	7	87.5%	0.5%				
03:00-04:00	0	0	0	0	1	1	2	1	5	4	80.0%	0.3%				
04:00-05:00	1	1	1	0	2	2	1	0	8	3	37.5%	0.5%				
05:00-06:00	3	1	6	1	0	1	2	0	14	3	21.4%	0.9%				
06:00-07:00	5	21	14	13	1	2	10	6	72	18	25.0%	4.5%				
Nighttime Traffic	29	82	94	51	22	23	56	13	370	92	24.9%	23.3%				
Daily Traffic	245	390	338	146	127	110	187	47	1,590	344	21.6%	100.0%				
Ratio of Daily Traffic to Daytime Traffic	1.13	1.27	1.39	1.54	1.21	1.26	1.43	1.38	1.30	1.37	-	-				

<p>Date <u>3</u> / <u>9</u> / <u>2015</u></p> <p>Survey Date</p> <p>Survey Point Name <u>G-1 Kisi Nkwanta</u></p> <p>Direction1 From <u>Takoradi</u> to <u>Accra</u></p> <p>Direction2 From <u>Accra</u> to <u>Takoradi</u></p>	<p>Guidance Diagram</p> <p>To <u>Takoradi</u></p> <p>Direction 1 \longrightarrow</p> <p>Direction 2 \longleftarrow</p> <p>To <u>Accra</u></p>
---	---

direction	Direction 1													Direction 2												
	Type of Vehicle													Type of Vehicle												
Time	Motorcycle	Passenger Car	Minibus	Bus	Light Truck	Truck (2,3 axle)	Truck & Trailer (over 4 axle)	Container Trailer	Total '1	Commercial Vehicle '2	Commercial Vehicle Ratio '2/'1	Total /Daily Traffic	Motorcycle	Passenger Car	Minibus	Bus	Light Truck	Truck (2,3 axle)	Truck & Trailer (over 4 axle)	Container Trailer	Total '1	Commercial Vehicle '2	Commercial Vehicle Ratio '2/'1	Total /Daily Traffic		
07:00-08:00	4	55	37	3	5	6	11	0	121	17	14.0%	4.0%	2	46	43	1	4	11	3	0	110	14	12.7%	4.2%		
08:00-09:00	1	50	35	4	5	4	3	0	102	7	6.9%	3.4%	0	46	48	2	3	10	10	2	121	22	18.2%	4.6%		
09:00-10:00	2	60	67	3	2	14	12	0	160	26	16.3%	5.3%	2	49	56	2	6	8	9	4	136	21	15.4%	5.2%		
10:00-11:00	2	76	62	6	3	12	8	1	170	21	12.4%	5.6%	0	51	56	6	5	1	4	2	125	7	5.6%	4.8%		
11:00-12:00	1	75	71	6	7	9	30	1	200	40	20.0%	6.6%	4	55	47	6	6	8	4	2	132	14	10.6%	5.0%		
12:00-13:00	0	77	55	2	11	3	2	0	150	5	3.3%	5.0%	1	59	49	3	13	2	7	0	134	9	6.7%	5.1%		
13:00-14:00	6	80	63	7	3	14	10	0	183	24	13.1%	6.0%	3	67	60	9	5	6	11	2	163	19	11.7%	6.2%		
14:00-15:00	17	60	55	1	2	14	10	0	159	24	15.1%	5.3%	2	55	63	4	6	1	5	3	139	9	6.5%	5.3%		
15:00-16:00	4	80	55	4	10	12	12	0	177	24	13.6%	5.9%	1	77	57	10	9	7	11	0	172	18	10.5%	6.5%		
16:00-17:00	5	150	15	4	9	10	20	1	214	31	14.5%	7.1%	6	66	58	8	6	6	1	157	13	8.3%	6.0%			
17:00-18:00	2	41	27	4	3	10	13	0	100	23	23.0%	3.3%	3	75	46	5	6	10	10	8	163	28	17.2%	6.2%		
18:00-19:00	2	60	40	2	8	5	17	6	140	28	20.0%	4.6%	4	64	57	9	8	7	8	2	159	17	10.7%	6.0%		
Daytime Traffic	46	864	582	46	68	113	148	9	1,876	270	14.4%	62.0%	28	710	640	65	77	77	88	26	1,711	191	11.2%	65.1%		
19:00-20:00	2	175	110	5	5	55	15	15	382	85	22.3%	12.6%	2	40	24	8	9	4	5	1	93	10	10.8%	3.5%		
20:00-21:00	0	20	15	3	3	30	10	6	87	46	52.9%	2.9%	1	51	40	3	13	5	12	13	138	30	21.7%	5.2%		
21:00-22:00	1	20	15	2	6	14	7	5	70	26	37.1%	2.3%	1	28	25	7	6	2	5	4	78	11	14.1%	3.0%		
22:00-23:00	0	8	14	4	6	5	6	5	48	16	33.3%	1.6%	0	17	17	1	5	6	7	9	62	22	35.5%	2.4%		
23:00-00:00	0	14	10	7	1	10	7	7	56	24	42.9%	1.9%	0	11	13	2	4	3	2	8	43	13	30.2%	1.6%		
00:00-01:00	0	3	7	2	2	2	3	4	23	9	39.1%	0.8%	0	5	18	2	12	5	8	9	59	22	37.3%	2.2%		
01:00-02:00	0	1	5	11	1	4	1	2	25	7	28.0%	0.8%	0	3	13	5	6	16	8	7	58	31	53.4%	2.2%		
02:00-03:00	0	3	11	0	2	3	3	4	26	10	38.5%	0.9%	0	2	18	6	5	19	6	5	61	30	49.2%	2.3%		
03:00-04:00	0	20	21	5	3	2	2	1	54	5	9.3%	1.8%	0	14	12	5	8	3	8	11	61	22	36.1%	2.3%		
04:00-05:00	0	29	20	1	1	2	0	2	55	4	7.3%	1.8%	0	10	20	0	1	8	5	2	46	15	32.6%	1.7%		
05:00-06:00	1	58	70	5	5	2	4	3	148	9	6.1%	4.9%	1	20	31	2	2	8	3	5	72	16	22.2%	2.7%		
06:00-07:00	1	71	79	5	8	3	4	4	175	11	6.3%	5.8%	1	39	74	3	5	13	7	6	148	26	17.6%	5.6%		
Nighttime Traffic	5	422	377	50	43	132	62	58	1,149	252	21.9%	38.0%	6	240	305	44	76	92	76	80	919	248	27.0%	34.9%		
Daily Traffic	51	1,286	959	96	111	245	210	67	3,025	522	17.3%	100.0%	34	950	945	109	153	169	164	106	2,630	439	16.7%	100.0%		
Ratio of Daily Traffic to Daytime Traffic	1.11	1.49	1.65	2.09	1.63	2.17	1.42	7.44	1.61	1.93	-	-	1.21	1.34	1.48	1.68	1.99	2.19	1.86	4.08	1.54	2.30	-	-		

direction	Total												
	Type of Vehicle												
Time	Motorcycle	Passenger Car	Minibus	Bus	Light Truck	Truck (2,3 axle)	Truck & Trailer (over 4 axle)	Container Trailer	Total '1	Commercial Vehicle '2	Commercial Vehicle Ratio '2/'1	Total /Daily Traffic	
07:00-08:00	6	101	80	4	9	17	14	0	231	31	13.4%	4.1%	
08:00-09:00	1	96	83	6	8	14	13	2	223	29	13.0%	3.9%	
09:00-10:00	4	109	123	5	8	22	21	4	296	47	15.9%	5.2%	
10:00-11:00	2	127	118	12	8	13	12	3	295	28	9.5%	5.2%	
11:00-12:00	5	130	118	12	13	17	34	3	332	54	16.3%	5.9%	
12:00-13:00	1	136	104	5	24	5	9	0	284	14	4.9%	5.0%	
13:00-14:00	9	147	123	16	8	20	21	2	346	43	12.4%	6.1%	
14:00-15:00	19	115	118	5	8	15	15	3	298	33	11.1%	5.3%	
15:00-16:00	5	157	112	14	19	19	23	0	349	42	12.0%	6.2%	
16:00-17:00	11	216	73	12	15	16	26	2	371	44	11.9%	6.6%	
17:00-18:00	5	116	73	9	9	20	23	8	263	51	19.4%	4.7%	
18:00-19:00	6	124	97	11	16	12	25	8	299	45	15.1%	5.3%	
Daytime Traffic	74	1,574	1,222	111	145	190	236	35	3,587	461	12.9%	63.4%	
19:00-20:00	4	215	134	13	14	59	20	16	475	95	20.0%	8.4%	
20:00-21:00	1	71	55	6	16	35	22	19	225	76	33.8%	4.0%	
21:00-22:00	2	48	40	9	12	16	12	9	148	37	25.0%	2.6%	
22:00-23:00	0	25	31	5	11	11	13	14	110	38	34.5%	1.9%	
23:00-00:00	0	25	23	9	5	13	9	15	99	37	37.4%	1.8%	
00:00-01:00	0	8	25	4	14	7	11	13	82	31	37.8%	1.5%	
01:00-02:00	0	4	18	16	7	20	9	9	83	38	45.8%	1.5%	
02:00-03:00	0	5	29	6	7	22	9	9	87	40	46.0%	1.5%	
03:00-04:00	0	34	33	10	11	5	10	12	115	27	23.5%	2.0%	
04:00-05:00	0	39	40	1	2	10	5	4	101	19	18.8%	1.8%	
05:00-06:00	2	78	101	7	7	10	7	8	220	25	11.4%	3.9%	
06:00-07:00	2	110	153	8	13	16	11	10	323	37	11.5%	5.7%	
Nighttime Traffic	11	662	682	94	119	224	138	138	2,068	500	24.2%	36.6%	
Daily Traffic	85	2,236	1,904	205	264	414	374	173	5,655	961	17.0%	100.0%	
Ratio of Daily Traffic to Daytime Traffic	1.15	1.42	1.56	1.85	1.82	2.18	1.58	4.94	1.58	2.08	-	-	

Survey Date												Guidance Diagram												
Date						1 / 9			Month			Year			To Accra									
Survey Point Name												Direction 1 → Direction 2 ←												
Direction1 From						Accra			to			Aflao			To Aflao									
Direction2 From						Aflao			to			Accra												
Direction	Direction 1											Direction 2												
	Type of Vehicle											Type of Vehicle												
Time	Motorcycle	Passenger Car	Minibus	Bus	Light Truck	Truck (2,3 axle)	Truck & Trailer (over 4 axle)	Container Trailer	Total '1	Commercial Vehicle '2	Commercial Vehicle Ratio '2/'1	Total /Daily Traffic	Motorcycle	Passenger Car	Minibus	Bus	Light Truck	Truck (2,3 axle)	Truck & Trailer (over 4 axle)	Container Trailer	Total '1	Commercial Vehicle '2	Commercial Vehicle Ratio '2/'1	Total /Daily Traffic
07:00-08:00	184	84	83	0	5	5	6	1	368	12	3.3%	7.6%	150	85	110	2	14	2	7	1	371	10	2.7%	7.1%
08:00-09:00	150	80	69	3	4	0	4	0	310	4	1.3%	6.4%	160	95	70	1	11	2	6	0	345	8	2.3%	6.6%
09:00-10:00	145	84	31	4	9	0	2	0	275	2	0.7%	5.6%	137	85	75	0	20	2	7	6	332	15	4.5%	6.3%
10:00-11:00	120	65	75	6	5	4	6	1	282	11	3.9%	5.8%	145	87	66	2	15	3	3	0	321	6	1.9%	6.1%
11:00-12:00	152	85	77	3	8	3	1	0	329	4	1.2%	6.8%	106	52	59	0	11	4	4	0	236	8	3.4%	4.5%
12:00-13:00	171	80	60	1	0	3	7	0	322	10	3.1%	6.6%	137	80	75	3	19	1	7	1	323	9	2.8%	6.2%
13:00-14:00	123	80	83	3	13	1	7	1	311	9	2.9%	6.4%	124	75	65	4	8	2	4	4	286	10	3.5%	5.5%
14:00-15:00	121	105	70	0	11	6	11	3	327	20	6.1%	6.7%	120	96	78	2	12	2	8	1	319	11	3.4%	6.1%
15:00-16:00	102	100	77	5	12	0	10	16	322	26	8.1%	6.6%	186	100	90	2	15	9	9	3	414	21	5.1%	7.9%
16:00-17:00	155	77	85	5	7	5	5	7	346	17	4.9%	7.1%	91	82	82	2	16	4	16	4	297	24	8.1%	5.7%
17:00-18:00	106	95	105	2	12	1	6	2	329	9	2.7%	6.8%	125	90	80	2	20	5	13	1	336	19	5.7%	6.4%
18:00-19:00	91	63	67	0	10	1	5	3	240	9	3.8%	4.9%	37	27	48	10	10	10	3	2	147	15	10.2%	2.8%
Daytime Traffic	1,620	998	882	32	96	29	70	34	3,761	133	3.5%	77.2%	1,518	954	898	30	171	46	87	23	3,727	156	4.2%	71.0%
19:00-20:00	127	61	56	0	4	4	10	2	264	16	6.1%	5.4%	91	57	60	11	14	5	16	1	255	22	8.6%	4.9%
20:00-21:00	85	41	37	1	6	3	3	3	179	9	5.0%	3.7%	75	51	40	30	6	11	24	5	242	40	16.5%	4.6%
21:00-22:00	56	18	8	0	4	1	6	7	100	14	14.0%	2.1%	36	25	11	16	2	2	27	3	122	32	26.2%	2.3%
22:00-23:00	21	20	10	0	6	4	10	2	73	16	21.9%	1.5%	23	15	9	6	5	0	26	1	85	27	31.8%	1.6%
23:00-00:00	5	3	2	0	3	0	1	3	17	4	23.5%	0.3%	8	5	20	4	2	1	8	1	49	10	20.4%	0.9%
00:00-01:00	4	2	3	0	1	2	0	3	15	5	33.3%	0.3%	7	6	8	3	1	2	27	5	59	34	57.6%	1.1%
01:00-02:00	1	1	2	0	1	5	1	10	21	16	76.2%	0.4%	1	1	5	3	0	3	5	0	18	8	44.4%	0.3%
02:00-03:00	0	1	1	10	0	0	6	1	19	7	36.8%	0.4%	1	2	9	3	1	5	6	0	27	11	40.7%	0.5%
03:00-04:00	1	3	2	4	0	1	3	3	17	7	41.2%	0.3%	3	11	66	1	2	1	6	0	90	7	7.8%	1.7%
04:00-05:00	25	13	14	4	10	3	3	0	72	6	8.3%	1.5%	20	25	48	0	5	3	12	2	115	17	14.8%	2.2%
05:00-06:00	47	25	23	0	6	3	3	5	112	11	9.8%	2.3%	56	32	60	3	3	3	8	1	166	12	7.2%	3.2%
06:00-07:00	129	40	35	0	5	5	4	3	221	12	5.4%	4.5%	115	66	88	6	9	2	6	0	292	8	2.7%	5.6%
Nighttime Traffic	501	228	193	19	46	31	50	42	1,110	123	11.1%	22.8%	436	296	424	86	50	38	171	19	1,520	228	15.0%	29.0%
Daily Traffic	2,121	1,226	1,075	51	142	60	120	76	4,871	256	5.3%	100.0%	1,954	1,250	1,322	116	221	84	258	42	5,247	384	7.3%	100.0%
Ratio of Daily Traffic to Daytime Traffic	1.31	1.23	1.22	1.59	1.48	2.07	1.71	2.24	1.30	1.92	-	-	1.29	1.31	1.47	3.87	1.29	1.83	2.97	1.83	1.41	2.46	-	-

Direction	Total												
	Type of Vehicle												
Time	Motorcycle	Passenger Car	Minibus	Bus	Light Truck	Truck (2,3 axle)	Truck & Trailer (over 4 axle)	Container Trailer	Total '1	Commercial Vehicle '2	Commercial Vehicle Ratio '2/'1	Total /Daily Traffic	
07:00-08:00	334	169	193	2	19	7	13	2	739	22	3.0%	7.3%	
08:00-09:00	310	175	139	4	15	2	10	0	655	12	1.8%	6.5%	
09:00-10:00	282	169	106	4	29	2	9	6	607	17	2.8%	6.0%	
10:00-11:00	265	152	141	8	20	7	9	1	603	17	2.8%	6.0%	
11:00-12:00	258	137	136	3	19	7	5	0	565	12	2.1%	5.6%	
12:00-13:00	308	160	135	4	19	4	14	1	645	19	2.9%	6.4%	
13:00-14:00	247	155	148	7	21	3	11	5	597	19	3.2%	5.9%	
14:00-15:00	241	201	148	2	23	8	19	4	646	31	4.8%	6.4%	
15:00-16:00	288	200	167	7	27	9	19	19	736	47	6.4%	7.3%	
16:00-17:00	246	159	167	7	23	9	21	11	643	41	6.4%	6.4%	
17:00-18:00	231	185	185	4	32	6	19	3	665	28	4.2%	6.6%	
18:00-19:00	128	90	115	10	20	11	8	5	387	24	6.2%	3.8%	
Daytime Traffic	3,138	1,952	1,780	62	267	75	157	57	7,488	289	3.9%	74.0%	
19:00-20:00	218	118	116	11	18	9	26	3	519	38	7.3%	5.1%	
20:00-21:00	160	92	77	31	12	14	27	8	421	49	11.6%	4.2%	
21:00-22:00	92	43	19	16	6	3	33	10	222	46	20.7%	2.2%	
22:00-23:00	44	35	19	6	11	4	36	3	158	43	27.2%	1.6%	
23:00-00:00	13	8	22	4	5	1	9	4	66	14	21.2%	0.7%	
00:00-01:00	11	8	11	3	2	4	27	8	74	39	52.7%	0.7%	
01:00-02:00	2	2	7	3	1	8	6	10	39	24	61.5%	0.4%	
02:00-03:00	1	3	10	13	1	5	12	1	46	18	39.1%	0.5%	
03:00-04:00	4	14	68	5	2	2	9	3	107	14	13.1%	1.1%	
04:00-05:00	45	38	62	4	15	6	15	2	187	23	12.3%	1.8%	
05:00-06:00	103	57	83	3	9	6	11	6	278	23	8.3%	2.7%	
06:00-07:00	244	106	123	6	14	7	10	3	513	20	3.9%	5.1%	
Nighttime Traffic	937	524	617	105	96	69	221	61	2,630	351	13.3%	26.0%	
Daily Traffic	4,075	2,476	2,397	167	363	144	378	118	10,118	640	6.3%	100.0%	
Ratio of Daily Traffic to Daytime Traffic	1.30	1.27	1.35	2.69	1.36	1.92	2.41	2.07	1.35	2.21	-	-	

Survey Date											Guidance Diagram																	
Date			8 /			Month			9 /			Year			2015			To Buipe										
Survey Point Name											G-6 Benkrom Police Post																	
Direction1 From											Buipe to Kportor																	
Direction2 From											Kportor to Buipe																	
Direction											To Kportor																	
Time	Direction 1										Direction 2																	
	Type of Vehicle										Type of Vehicle																	
	Motorcycle	Passenger Car	Minibus	Bus	Light Truck	Truck (2,3 axle)	Truck & Trailer (over 4 axle)	Container Trailer	Total '1	Commercial Vehicle '2	Commercial Vehicle Ratio '2/'1	Total /Daily Traffic		Motorcycle	Passenger Car	Minibus	Bus	Light Truck	Truck (2,3 axle)	Truck & Trailer (over 4 axle)	Container Trailer	Total '1	Commercial Vehicle '2	Commercial Vehicle Ratio '2/'1	Total /Daily Traffic			
	[veh]	[veh]	[veh]	[veh]	[veh]	[veh]	[veh]	[veh]	[veh]	[veh]	[%]	[%]		[veh]	[veh]	[veh]	[veh]	[veh]	[veh]	[veh]	[veh]	[veh]	[veh]	[%]	[%]			
07:00-08:00	14	19	2	0	2	2	5	1	45	8	17.8%	3.8%	22	12	4	1	1	10	5	1	56	16	28.6%	5.2%				
08:00-09:00	33	23	3	3	2	4	3	1	72	8	11.1%	6.2%	19	18	4	1	2	3	4	1	52	8	15.4%	4.8%				
09:00-10:00	32	37	1	2	2	1	5	1	81	7	8.6%	6.9%	15	27	5	5	1	3	5	3	64	11	17.2%	6.0%				
10:00-11:00	31	37	1	3	5	0	8	0	85	8	9.4%	7.3%	18	29	4	1	7	6	6	0	71	12	16.9%	6.6%				
11:00-12:00	22	26	1	2	5	1	6	2	65	9	13.8%	5.6%	19	28	6	9	2	2	7	2	75	11	14.7%	7.0%				
12:00-13:00	13	31	3	7	6	3	3	0	66	6	9.1%	5.6%	13	20	2	4	1	7	7	3	57	17	29.8%	5.3%				
13:00-14:00	20	33	2	6	2	2	10	1	76	13	17.1%	6.5%	17	24	6	2	2	3	4	2	60	9	15.0%	5.6%				
14:00-15:00	13	22	7	6	6	0	9	2	65	11	16.9%	5.6%	14	24	3	3	1	5	7	1	58	13	22.4%	5.4%				
15:00-16:00	12	20	1	1	2	3	9	0	48	12	25.0%	4.1%	9	32	5	6	1	2	5	2	62	9	14.5%	5.8%				
16:00-17:00	19	27	8	3	5	4	5	0	71	9	12.7%	6.1%	12	25	4	1	1	5	6	3	57	14	24.6%	5.3%				
17:00-18:00	24	24	4	6	5	3	9	1	76	13	17.1%	6.5%	11	23	5	3	1	1	6	1	51	8	15.7%	4.8%				
18:00-19:00	11	8	4	8	0	2	5	1	39	8	20.5%	3.3%	5	15	2	4	0	2	2	3	33	7	21.2%	3.1%				
Daytime Traffic	244	307	37	47	42	25	77	10	789	112	14.2%	67.4%	174	277	50	40	20	49	64	22	696	135	19.4%	64.9%				
19:00-20:00	20	3	8	12	4	4	6	3	60	13	21.7%	5.1%	6	17	7	1	4	0	4	1	40	5	12.5%	3.7%				
20:00-21:00	9	12	1	2	1	4	15	1	45	20	44.4%	3.8%	7	3	2	6	2	0	11	0	31	11	35.5%	2.9%				
21:00-22:00	5	5	11	2	3	8	5	3	42	16	38.1%	3.6%	6	5	4	8	2	2	4	1	32	7	21.9%	3.0%				
22:00-23:00	12	1	3	4	3	3	0	1	27	4	14.8%	2.3%	1	1	6	2	1	0	8	0	19	8	42.1%	1.8%				
23:00-00:00	0	2	11	17	1	5	6	0	42	11	26.2%	3.6%	2	4	7	4	1	0	3	2	23	5	21.7%	2.1%				
00:00-01:00	2	0	4	10	0	10	3	2	31	15	48.4%	2.6%	0	4	3	9	1	0	7	0	24	7	29.2%	2.2%				
01:00-02:00	0	0	1	14	1	5	4	0	25	9	36.0%	2.1%	0	2	4	9	4	0	7	0	26	7	26.9%	2.4%				
02:00-03:00	0	0	0	2	1	2	1	0	6	3	50.0%	0.5%	0	5	5	20	7	0	12	0	49	12	24.5%	4.6%				
03:00-04:00	0	0	6	1	2	4	6	0	19	10	52.6%	1.6%	0	1	2	1	3	0	6	1	14	7	50.0%	1.3%				
04:00-05:00	0	2	2	0	0	1	3	0	8	4	50.0%	0.7%	1	2	2	9	3	0	2	0	19	2	10.5%	1.8%				
05:00-06:00	6	10	3	0	0	4	7	2	32	13	40.6%	2.7%	5	8	4	4	4	0	5	1	31	6	19.4%	2.9%				
06:00-07:00	11	12	11	2	0	2	5	1	44	8	18.2%	3.8%	16	23	7	0	6	0	17	0	69	17	24.6%	6.4%				
Nighttime Traffic	65	47	61	66	16	52	61	13	381	126	33.1%	32.6%	44	75	53	73	38	2	86	6	377	94	24.9%	35.1%				
Daily Traffic	309	354	98	113	58	77	138	23	1,170	238	20.3%	100.0%	218	352	103	113	58	51	150	28	1,073	229	21.3%	100.0%				
Ratio of Daily Traffic to Daytime Traffic	1.27	1.15	2.65	2.40	1.38	3.08	1.79	2.30	1.48	2.13	-	-	1.25	1.27	2.06	2.83	2.90	1.04	2.34	1.27	1.54	1.70	-	-				

Time	Total											
	Type of Vehicle											
	Motorcycle	Passenger Car	Minibus	Bus	Light Truck	Truck (2,3 axle)	Truck & Trailer (over 4 axle)	Container Trailer	Total '1	Commercial Vehicle '2	Commercial Vehicle Ratio '2/'1	Total /Daily Traffic
	[veh]	[veh]	[veh]	[veh]	[veh]	[veh]	[veh]	[veh]	[car]	[car]	[%]	[%]
07:00-08:00	36	31	6	1	3	12	10	2	101	24	23.8%	4.5%
08:00-09:00	52	41	7	4	4	7	7	2	124	16	12.9%	5.5%
09:00-10:00	47	64	6	7	3	4	10	4	145	18	12.4%	6.5%
10:00-11:00	49	66	5	4	12	6	14	0	156	20	12.8%	7.0%
11:00-12:00	41	54	7	11	7	3	13	4	140	20	14.3%	6.2%
12:00-13:00	26	51	5	11	7	10	10	3	123	23	18.7%	5.5%
13:00-14:00	37	57	8	8	4	5	14	3	136	22	16.2%	6.1%
14:00-15:00	27	46	10	9	7	5	16	3	123	24	19.5%	5.5%
15:00-16:00	21	52	6	7	3	5	14	2	110	21	19.1%	4.9%
16:00-17:00	31	52	12	4	6	9	11	3	128	23	18.0%	5.7%
17:00-18:00	35	47	9	9	6	4	15	2	127	21	16.5%	5.7%
18:00-19:00	16	23	6	12	0	4	7	4	72	15	20.8%	3.2%
Daytime Traffic	418	584	87	87	62	74	141	32	1,485	247	16.6%	66.2%
19:00-20:00	26	20	15	13	8	4	10	4	100	18	18.0%	4.5%
20:00-21:00	16	15	3	8	3	4	26	1	76	31	40.8%	3.4%
21:00-22:00	11	10	15	10	5	10	9	4	74	23	31.1%	3.3%
22:00-23:00	13	2	9	6	4	3	8	1	46	12	26.1%	2.1%
23:00-00:00	2	6	18	21	2	5	9	2	65	16	24.6%	2.9%
00:00-01:00	2	4	7	19	1	10	10	2	55	22	40.0%	2.5%
01:00-02:00	0	2	5	23	5	5	11	0	51	16	31.4%	2.3%
02:00-03:00	0	5	5	22	8	2	13	0	55	15	27.3%	2.5%
03:00-04:00	0	1	8	2	5	4	12	1	33	17	51.5%	1.5%
04:00-05:00	1	4	4	9	3	1	5	0	27	6	22.2%	1.2%
05:00-06:00	11	18	7	4	4	4	12	3	63	19	30.2%	2.8%
06:00-07:00	27	35	18	2	6	2	22	1	113	25	22.1%	5.0%
Nighttime Traffic	109	122	114	139	54	54	147	19	758	220	29.0%	33.8%
Daily Traffic	527	706	201	226	116	128	288	51	2,243	467	20.8%	100.0%
Ratio of Daily Traffic to Daytime Traffic	1.26	1.21	2.31	2.60	1.87	1.73	2.04	1.59	1.51	1.89	-	-

Survey Date											Guidance Diagram												
Date		2 / 9 / 2015			Month						Year		To Damanko										
Survey Point Name											G-7 Opidjua Police Post												
Direction1 From											Damanko to Nakpayili												
Direction2 From											Nakpayili to Damanko												
Direction 1											Direction 2												
To Nakpayili											To Nakpayili												
Time	Direction 1										Direction 2												
	Motorcycle	Passenger Car	Minibus	Bus	Light Truck	Truck (2,3 axle)	Truck & Trailer (over 4 axle)	Container Trailer	Total '1	Commercial Vehicle '2	Commercial Vehicle Ratio '2/'1	Total /Daily Traffic	Motorcycle	Passenger Car	Minibus	Bus	Light Truck	Truck (2,3 axle)	Truck & Trailer (over 4 axle)	Container Trailer	Total '1	Commercial Vehicle '2	Commercial Vehicle Ratio '2/'1
07:00-08:00	29	2	1	0	3	0	0	35	0	0.0%	6.5%	26	0	0	1	0	0	0	27	0	0.0%	4.7%	
08:00-09:00	30	0	1	0	1	3	3	38	6	15.8%	7.0%	30	0	0	0	0	0	0	30	0	0.0%	5.2%	
09:00-10:00	34	1	0	0	2	0	0	37	0	0.0%	6.9%	35	2	3	1	0	0	0	41	0	0.0%	7.1%	
10:00-11:00	31	1	0	0	1	0	0	33	0	0.0%	6.1%	30	0	1	1	1	0	0	33	0	0.0%	5.7%	
11:00-12:00	32	1	1	0	1	0	0	35	0	0.0%	6.5%	22	0	2	3	3	0	0	30	0	0.0%	5.2%	
12:00-13:00	24	0	2	0	0	1	0	27	1	3.7%	5.0%	25	0	0	1	1	0	0	27	0	0.0%	4.7%	
13:00-14:00	31	0	3	0	0	0	0	34	0	0.0%	6.3%	35	0	5	0	5	0	0	45	0	0.0%	7.8%	
14:00-15:00	25	0	1	2	1	1	0	30	1	3.3%	5.6%	35	0	1	0	0	0	1	37	1	2.7%	6.4%	
15:00-16:00	34	3	1	1	2	0	0	41	0	0.0%	7.6%	40	1	0	0	3	0	0	44	0	0.0%	7.7%	
16:00-17:00	29	2	0	0	0	0	0	31	0	0.0%	5.7%	45	0	1	1	5	5	0	57	5	8.8%	9.9%	
17:00-18:00	30	0	0	1	0	2	0	33	2	6.1%	6.1%	45	0	2	0	1	0	0	48	0	0.0%	8.3%	
18:00-19:00	49	0	0	0	0	0	0	49	0	0.0%	9.1%	47	0	2	0	1	0	0	50	0	0.0%	8.7%	
Daytime Traffic	378	10	10	4	11	7	3	423	10	2.4%	78.3%	415	3	17	8	20	5	1	469	6	1.3%	81.6%	
19:00-20:00	18	0	0	0	0	1	0	19	1	5.3%	3.5%	25	1	0	0	3	2	0	31	2	6.5%	5.4%	
20:00-21:00	15	1	0	0	0	0	0	16	0	0.0%	3.0%	14	0	0	0	0	0	0	14	0	0.0%	2.4%	
21:00-22:00	9	0	0	0	0	1	0	10	1	10.0%	1.9%	9	0	0	0	1	2	0	12	2	16.7%	2.1%	
22:00-23:00	4	0	1	0	0	1	0	6	1	16.7%	1.1%	3	0	0	0	1	0	0	4	0	0.0%	0.7%	
23:00-00:00	8	1	0	0	0	0	0	9	0	0.0%	1.7%	5	0	0	0	0	2	0	7	2	28.6%	1.2%	
00:00-01:00	1	1	0	0	0	0	0	2	0	0.0%	0.4%	2	0	0	1	0	0	0	3	0	0.0%	0.5%	
01:00-02:00	0	0	0	1	0	0	0	1	0	0.0%	0.2%	3	0	0	0	0	0	0	3	0	0.0%	0.5%	
02:00-03:00	0	0	0	0	0	0	0	0	0	-	0.0%	2	0	0	0	0	0	0	2	0	0.0%	0.3%	
03:00-04:00	1	0	0	0	1	0	0	2	0	0.0%	0.4%	1	0	0	0	0	0	0	1	0	0.0%	0.2%	
04:00-05:00	1	0	0	0	0	0	0	1	0	0.0%	0.2%	1	1	0	0	0	0	0	2	0	0.0%	0.3%	
05:00-06:00	16	1	0	2	2	2	0	23	2	8.7%	4.3%	4	0	0	0	0	0	0	4	0	0.0%	0.7%	
06:00-07:00	25	1	1	0	1	0	0	28	0	0.0%	5.2%	20	2	0	0	1	0	0	23	0	0.0%	4.0%	
Nighttime Traffic	98	5	2	3	4	5	0	117	5	4.3%	21.7%	89	4	0	1	6	6	0	106	6	5.7%	18.4%	
Daily Traffic	476	15	12	7	15	12	3	540	15	2.8%	100.0%	504	7	17	9	26	11	1	575	12	2.1%	100.0%	
Ratio of Daily Traffic to Daytime Traffic	1.26	1.50	1.20	1.75	1.36	1.71	1.00	1.28	1.50	-	-	1.21	2.33	1.00	1.13	1.30	2.20	1.00	1.23	2.00	-	-	

Time	Total										Commercial Vehicle '2	Commercial Vehicle Ratio '2/'1	Total /Daily Traffic
	Motorcycle	Passenger Car	Minibus	Bus	Light Truck	Truck (2,3 axle)	Truck & Trailer (over 4 axle)	Container Trailer	Total '1	Commercial Vehicle '2			
07:00-08:00	55	2	1	1	3	0	0	62	0	0.0%	5.6%		
08:00-09:00	60	0	1	0	1	3	3	68	6	8.8%	6.1%		
09:00-10:00	69	3	3	1	2	0	0	78	0	0.0%	7.0%		
10:00-11:00	61	1	1	1	2	0	0	66	0	0.0%	5.9%		
11:00-12:00	54	1	3	3	4	0	0	65	0	0.0%	5.8%		
12:00-13:00	49	0	2	1	1	1	0	54	1	1.9%	4.8%		
13:00-14:00	66	0	8	0	5	0	0	79	0	0.0%	7.1%		
14:00-15:00	60	0	2	2	1	1	1	67	2	3.0%	6.0%		
15:00-16:00	74	4	1	1	5	0	0	85	0	0.0%	7.6%		
16:00-17:00	74	2	1	1	5	5	0	88	5	5.7%	7.9%		
17:00-18:00	75	0	2	1	1	2	0	81	2	2.5%	7.3%		
18:00-19:00	96	0	2	0	1	0	0	99	0	0.0%	8.9%		
Daytime Traffic	793	13	27	12	31	12	4	892	16	1.8%	80.0%		
19:00-20:00	43	1	0	0	3	0	0	50	3	6.0%	4.5%		
20:00-21:00	29	1	0	0	0	0	0	30	0	0.0%	2.7%		
21:00-22:00	18	0	0	0	1	3	0	22	3	13.6%	2.0%		
22:00-23:00	7	0	1	0	1	1	0	10	1	10.0%	0.9%		
23:00-00:00	13	1	0	0	0	2	0	16	2	12.5%	1.4%		
00:00-01:00	3	1	0	1	0	0	0	5	0	0.0%	0.4%		
01:00-02:00	3	0	0	1	0	0	0	4	0	0.0%	0.4%		
02:00-03:00	2	0	0	0	0	0	0	2	0	0.0%	0.2%		
03:00-04:00	2	0	0	0	1	0	0	3	0	0.0%	0.3%		
04:00-05:00	2	1	0	0	0	0	0	3	0	0.0%	0.3%		
05:00-06:00	20	1	0	2	2	2	0	27	2	7.4%	2.4%		
06:00-07:00	45	3	1	0	2	0	0	51	0	0.0%	4.6%		
Nighttime Traffic	187	9	2	4	10	11	0	223	11	4.9%	20.0%		
Daily Traffic	980	22	29	16	41	23	4	1,115	27	2.4%	100.0%		
Ratio of Daily Traffic to Daytime Traffic	1.24	1.69	1.07	1.33	1.32	1.92	1.00	1.25	1.69	-	-		

Date 20-21 / Month 8 / Year 2015 Survey Date	Guidance Diagram To <u>LOME</u> Direction 1 \longrightarrow Direction 2 \longleftarrow To <u>SOKODE</u>
Survey Point Name <u>T-1 NYAMASSILA</u>	
Direction1 From <u>LOME</u> to <u>SOKODE</u>	
Direction2 From <u>SOKODE</u> to <u>LOME</u>	

Time	Direction 1										Direction 2													
	Type of Vehicle								Total '1	Comm ercial Vehid e Ratio '2/'1 [%]	Comm ercial Vehid e Ratio '2/'1 [%]	Total /Daily Traffic [%]	Type of Vehicle								Total '1	Comm ercial Vehid e Ratio '2/'1 [%]	Comm ercial Vehid e Ratio '2/'1 [%]	Total /Daily Traffic [%]
Motor cycle [veh]	Passe nger Car [veh]	Minib us [veh]	Bus [veh]	Light Truck [veh]	Truck (2,3 axle) [veh]	Truck & Trailer [veh]	Contai ner Trailer [veh]	Motor cycle [veh]					Passe nger Car [veh]	Minib us [veh]	Bus [veh]	Light Truck [veh]	Truck (2,3 axle) [veh]	Truck & Trailer [veh]	Contai ner Trailer [veh]	Motor cycle [veh]				
07:00-08:00	45	17	5	0	0	5	9	0	81	14	17.3%	4.8%	30	11	3	0	0	3	14	0	61	17	27.9%	4.4%
08:00-09:00	37	27	9	2	6	3	15	0	99	18	18.2%	5.9%	45	24	11	0	1	3	16	0	100	19	19.0%	7.3%
09:00-10:00	41	21	8	1	6	4	18	2	101	24	23.8%	6.0%	31	17	9	2	0	2	25	0	86	27	31.4%	6.3%
10:00-11:00	41	29	17	2	3	10	20	2	124	32	25.8%	7.4%	31	36	9	6	1	2	10	0	95	12	12.6%	6.9%
11:00-12:00	39	31	13	7	1	4	27	4	126	35	27.8%	7.5%	29	30	15	0	2	3	10	0	89	13	14.6%	6.5%
12:00-13:00	34	31	18	0	5	6	19	2	115	27	23.5%	6.8%	29	29	25	0	5	3	17	1	109	21	19.3%	7.9%
13:00-14:00	34	40	15	0	0	7	8	3	107	18	16.8%	6.4%	39	27	16	1	5	2	10	1	101	13	12.9%	7.3%
14:00-15:00	40	32	16	0	1	8	21	0	118	29	24.6%	7.0%	25	22	12	1	3	0	10	0	73	10	13.7%	5.3%
15:00-16:00	55	40	18	0	0	2	12	3	130	17	13.1%	7.7%	27	25	19	30	3	0	19	0	123	19	15.4%	8.9%
16:00-17:00	51	35	17	0	0	4	27	0	134	31	23.1%	8.0%	26	22	6	3	1	3	18	0	79	21	26.6%	5.7%
17:00-18:00	36	31	16	0	3	6	11	2	105	19	18.1%	6.2%	14	15	11	4	4	3	10	1	62	14	22.6%	4.5%
18:00-19:00	30	28	15	3	0	1	7	7	91	15	16.5%	5.4%	31	14	3	3	3	3	15	1	73	19	26.0%	5.3%
Daytime Traffic	483	362	167	15	25	60	194	25	1,331	279	21.0%	79.0%	357	272	139	50	28	27	174	4	1,051	205	19.5%	76.4%
19:00-20:00	16	17	5	0	0	3	6	0	47	9	19.1%	2.8%	29	5	4	0	2	6	12	3	61	21	34.4%	4.4%
20:00-21:00	14	16	17	3	0	0	11	4	65	15	23.1%	3.9%	16	4	3	4	1	6	3	0	37	9	24.3%	2.7%
21:00-22:00	3	15	10	1	0	0	4	3	36	7	19.4%	2.1%	11	2	0	0	0	0	2	0	15	2	13.3%	1.1%
22:00-23:00	0	10	15	1	0	4	9	1	40	14	35.0%	2.4%	5	4	2	0	1	4	11	0	27	15	55.6%	2.0%
23:00-00:00	0	1	5	0	0	0	2	0	8	2	25.0%	0.5%	2	6	0	0	0	3	8	8	27	19	70.4%	2.0%
00:00-01:00	0	4	10	0	0	0	0	0	14	0	0.0%	0.8%	2	1	6	0	1	2	7	0	19	9	47.4%	1.4%
01:00-02:00	1	4	10	0	0	0	0	0	15	0	0.0%	0.9%	2	0	7	0	0	0	0	0	9	0	0.0%	0.7%
02:00-03:00	0	0	1	0	0	0	0	0	1	0	0.0%	0.1%	0	0	22	2	0	0	4	0	28	4	14.3%	2.0%
03:00-04:00	3	0	0	0	0	0	0	0	3	0	0.0%	0.2%	0	0	0	0	0	0	0	0	0	0	-	0.0%
04:00-05:00	1	5	1	0	0	2	4	0	13	6	46.2%	0.8%	5	0	2	0	0	1	0	0	8	1	12.5%	0.6%
05:00-06:00	5	4	1	0	0	7	20	0	37	27	73.0%	2.2%	8	7	2	0	1	0	16	0	34	16	47.1%	2.5%
06:00-07:00	33	17	2	0	1	5	15	2	75	22	29.3%	4.5%	30	14	2	0	1	1	9	2	59	12	20.3%	4.3%
07:00-08:00	0	0	0	0	0	0	0	0	0	0	-	0.0%	0	0	0	0	0	0	0	0	0	0	-	0.0%
Nighttime Traffic	76	93	77	5	1	21	71	10	354	102	28.8%	21.0%	110	43	50	6	7	23	72	13	324	108	33.3%	23.6%
Daily Traffic	559	455	244	20	26	81	265	35	1,685	381	22.6%	100.0%	467	315	189	56	35	50	246	17	1,375	313	22.8%	100.0%
Ratio of Daily Traffic to Daytime Traffic	1.16	1.26	1.46	1.33	1.04	1.35	1.37	1.40	1.27	1.37	-	-	1.31	1.16	1.36	1.12	1.25	1.85	1.41	4.25	1.31	1.53	-	-

Time	Total																						
	Type of Vehicle								Total '1	Comm ercial Vehid e Ratio '2/'1 [%]	Comm ercial Vehid e Ratio '2/'1 [%]	Total /Daily Traffic [%]											
Motor cycle [veh]	Passe nger Car [veh]	Minib us [veh]	Bus [veh]	Light Truck [veh]	Truck (2,3 axle) [veh]	Truck & Trailer [veh]	Contai ner Trailer [veh]	Motor cycle [veh]					Passe nger Car [veh]	Minib us [veh]	Bus [veh]	Light Truck [veh]	Truck (2,3 axle) [veh]	Truck & Trailer [veh]	Contai ner Trailer [veh]	Motor cycle [veh]	Passe nger Car [veh]	Minib us [veh]	Bus [veh]
07:00-08:00	75	28	8	0	0	8	23	0	142	31	21.8%	4.6%											
08:00-09:00	82	51	20	2	7	6	31	0	199	37	18.6%	6.5%											
09:00-10:00	72	38	17	3	6	6	43	2	187	51	27.3%	6.1%											
10:00-11:00	72	65	26	8	4	12	30	2	219	44	20.1%	7.2%											
11:00-12:00	68	61	28	7	3	7	37	4	215	48	22.3%	7.0%											
12:00-13:00	63	60	43	0	10	9	36	3	224	48	21.4%	7.3%											
13:00-14:00	73	67	31	1	5	9	18	4	208	31	14.9%	6.8%											
14:00-15:00	65	54	28	1	4	8	31	0	191	39	20.4%	6.2%											
15:00-16:00	82	65	37	30	3	2	31	3	253	36	14.2%	8.3%											
16:00-17:00	77	57	23	3	1	7	45	0	213	52	24.4%	7.0%											
17:00-18:00	50	46	27	4	7	9	21	3	167	33	19.8%	5.5%											
18:00-19:00	61	42	18	6	3	4	22	8	164	34	20.7%	5.4%											
Daytime Traffic	840	634	306	65	53	87	368	29	2,382	484	20.3%	77.8%											
19:00-20:00	45	22	9	0	2	9	18	3	108	30	27.8%	3.5%											
20:00-21:00	30	20	20	7	1	6	14	4	102	24	23.5%	3.3%											
21:00-22:00	14	17	10	1	0	0	6	3	51	9	17.6%	1.7%											
22:00-23:00	5	14	17	1	1	8	20	1	67	29	43.3%	2.2%											
23:00-00:00	2	7	5	0	0	3	10	8	35	21	60.0%	1.1%											
00:00-01:00	2	5	16	0	1	2	7	0	33	9	27.3%	1.1%											
01:00-02:00	3	4	17	0	0	0	0	0	24	0	0.0%	0.8%											
02:00-03:00	0	0	23	2	0	0	4	0	29	4	13.8%	0.9%											
03:00-04:00	3	0	0	0	0	0	0	0	3	0	0.0%	0.1%											
04:00-05:00	6	5	3	0	0	3	4	0	21	7	33.3%	0.7%											
05:00-06:00	13	11	3	0	1	7	36	0	71	43	60.6%	2.3%											
06:00-07:00	63	31	4	0	2	6	24	4	134	34	25.4%	4.4%											
07:00-08:00	0	0	0	0	0	0	0	0	0	0	-	0.0%											
Nighttime Traffic	186	136	127	11	8	44	143	23	678	210	31.0%	22.2%											
Daily Traffic	1,026	770	433	76	61	131	511	52	3,060	694	22.7%	100.0%											
Ratio of Daily Traffic to Daytime Traffic	1.22	1.21	1.42	1.17	1.15	1.51	1.39	1.79	1.28	1.43	-	-											

B.5 Future OD Matrix

Table B.5.1 OD Matrix in 2033

Car	1	2	3	4	5	6	7	8	9	10	11	12	13	14	15	16	17	18	19	20	21	22	23	24	25	26	27	28	29	
1	0	546	209	916	257	0	88	151	229	0	0	124	419	80	164	8	0	33	0	0	0	0	0	4	0	0	0	6	0	
2	546	0	0	286	512	0	96	30	938	0	0	0	0	0	0	0	0	0	217	0	0	0	0	0	0	0	0	0	0	
3	210	0	0	0	0	0	0	0	0	0	0	0	0	24	5	77	0	5	0	0	0	0	0	0	0	0	0	2	0	
4	917	287	0	0	0	0	0	0	0	0	0	0	0	0	0	0	0	0	0	0	0	0	0	0	0	0	0	0	0	
5	256	512	0	0	0	2292	3202	213	7247	0	3590	2780	0	368	0	83	665	0	29	0	0	0	2	0	0	0	0	0	0	
6	0	85	0	0	2290	1160	0	80	0	0	0	0	0	1108	0	0	0	0	16	0	0	0	0	0	0	0	0	0	0	
7	88	30	0	0	3197	1160	0	0	0	0	0	0	0	493	0	0	0	29	0	0	0	0	0	0	0	0	0	0	0	
8	151	937	0	0	213	760	80	0	0	0	0	0	0	0	69	0	0	0	337	0	0	0	0	0	0	0	0	0	0	
9	225	0	0	0	7145	0	0	0	724	1069	727	480	4367	0	914	588	0	0	0	0	0	0	0	0	0	0	0	0	0	
10	0	0	0	0	0	0	0	722	0	51	96	48	1381	0	0	197	0	0	0	0	0	0	0	0	0	0	0	0	0	
11	0	0	0	0	3569	0	0	1074	51	0	208	47	0	0	0	0	0	0	0	0	0	0	0	0	0	0	0	0	0	
12	123	0	0	0	2784	0	0	727	94	207	0	261	1520	0	0	0	0	0	0	0	0	0	0	0	0	0	0	0	0	
13	420	0	0	0	0	0	0	487	48	260	0	0	0	0	0	0	0	0	0	0	0	0	0	0	0	0	0	0	0	
14	83	0	26	0	740	1172	526	0	3886	1491	0	1636	0	61	1383	443	99	0	0	0	0	0	0	0	0	0	0	0	0	
15	165	0	5	0	0	0	0	69	0	0	0	0	0	58	0	0	0	0	0	0	0	0	0	0	0	0	0	0	0	
16	6	0	78	0	83	0	0	917	0	0	0	1311	0	0	0	0	0	0	0	0	0	0	0	0	0	0	0	0	0	
17	0	0	0	0	673	0	0	591	195	0	0	0	416	0	0	0	0	0	0	0	0	0	0	0	0	0	0	0	0	
18	33	0	5	0	0	0	0	0	0	0	0	94	0	0	0	0	0	0	0	0	0	0	0	0	0	0	0	0	0	
19	0	217	0	0	28	16	29	337	0	0	0	0	0	0	0	0	0	0	0	0	0	0	0	0	0	0	0	0	0	
20	0	0	0	0	0	0	0	0	0	0	0	0	0	0	0	0	0	0	0	0	0	0	0	0	0	0	0	0	0	
21	0	0	0	0	0	0	0	0	0	0	0	0	0	0	0	0	0	0	0	0	0	0	0	0	0	0	0	0	0	
22	0	0	0	0	0	0	0	0	0	0	0	0	0	0	0	0	0	0	0	0	0	0	0	0	0	0	0	0	0	
23	0	0	0	0	2	0	0	0	0	0	0	0	0	0	0	0	0	0	0	0	0	0	0	0	0	0	0	0	0	
24	4	0	0	0	0	0	0	0	0	0	0	0	0	0	0	0	0	0	0	0	0	0	0	0	0	0	0	0	0	
25	0	0	0	0	0	0	0	0	0	0	0	0	0	0	0	0	0	0	0	0	0	0	0	0	0	0	0	0	0	
26	0	0	0	0	0	0	0	0	0	0	0	0	0	0	0	0	0	0	0	0	0	0	0	0	0	0	0	0	0	
27	0	0	0	0	0	0	0	0	0	0	0	0	0	0	0	0	0	0	0	0	0	0	0	0	0	0	0	0	0	
28	8	0	3	0	9	0	0	0	0	0	0	0	0	0	0	0	0	0	0	0	0	0	0	0	0	0	0	0	0	
29	0	0	0	0	0	0	0	0	0	0	0	0	0	0	0	0	0	0	0	0	0	0	0	0	0	0	0	0	0	
Mini Bus	1	2	3	4	5	6	7	8	9	10	11	12	13	14	15	16	17	18	19	20	21	22	23	24	25	26	27	28	29	
1	0	296	260	199	16	56	108	120	145	0	0	0	0	0	0	0	16	0	0	0	0	1	0	0	0	0	0	0	0	
2	296	0	0	0	233	183	99	0	0	0	0	0	0	0	0	0	0	71	0	0	0	0	1	0	0	0	0	0	0	
3	260	0	0	0	0	34	0	200	0	0	0	0	13	24	0	31	0	0	0	0	0	0	0	0	0	0	0	0	0	
4	199	0	0	0	0	70	59	45	0	0	0	0	0	0	0	0	0	0	0	0	0	1	0	0	0	0	0	0	0	
5	16	233	0	0	0	1262	826	50	907	62	431	0	0	248	0	15	0	9	0	0	0	0	0	0	0	0	0	0	0	
6	56	182	0	69	1260	0	291	384	0	0	0	0	0	0	0	65	0	62	0	0	0	0	0	0	0	0	0	0	0	
7	108	99	34	58	825	292	0	76	0	0	0	0	0	0	0	0	16	0	0	0	0	0	0	0	0	0	0	0	0	
8	120	0	0	45	50	384	76	0	0	0	0	0	0	0	0	0	0	23	0	0	0	0	0	0	0	0	0	0	0	
9	143	0	197	0	895	0	0	0	1273	990	1213	48	324	0	68	40	0	0	0	0	0	0	0	0	0	0	0	0	0	
10	0	0	0	0	64	0	0	1269	0	37	90	48	15	0	0	0	0	0	0	0	0	0	0	0	0	0	0	0	0	
11	0	0	0	0	428	0	0	995	37	0	354	130	0	0	0	42	0	0	0	0	0	0	0	0	0	0	0	0	0	
12	0	0	0	0	0	0	0	1214	89	353	0	94	0	0	0	28	0	0	0	0	0	0	0	0	0	0	0	0	0	
13	0	0	0	0	0	0	0	49	47	131	93	0	0	0	0	44	0	0	0	0	0	0	0	0	0	0	0	0	0	
14	0	0	0	0	263	0	0	289	16	0	0	0	0	37	34	9	0	0	0	0	0	0	0	0	0	0	0	0	0	
15	0	0	14	0	0	0	0	0	0	0	0	34	0	0	0	0	0	0	0	0	0	0	0	0	0	0	0	0	0	
16	0	0	25	0	0	0	0	0	0	0	0	32	0	0	0	0	0	0	0	0	0	0	0	0	0	0	0	0	0	
17	0	0	0	0	16	66	0	68	0	42	28	44	8	0	0	0	0	0	0	0	0	0	0	0	0	0	0	0	0	
18	16	0	31	0	0	0	0	41	0	0	0	0	0	0	0	0	0	0	0	0	0	0	0	0	0	0	0	0	0	
19	0	71	0	0	9	62	16	23	0	0	0	0	0	0	0	0	0	0	0	0	0	0	0	0	0	0	0	0	0	
20	0	0	0	0	0	0	0	0	0	0	0	0	0	0	0	0	0	0	0	0	0	0	0	0	0	0	0	0	0	
21	0	0	0	0	0	0	0	0	0	0	0	0	0	0	0	0	0	0	0	0	0	0	0	0	0	0	0	0	0	
22	0	0	0	0	0	0	0	0	0	0	0	0	0	0	0	0	0	0	0	0	0	0	0	0	0	0	0	0	0	0
23	0	0	0	0	0	0	0	0	0	0	0	0	0	0	0	0	0	0	0	0	0	0	0	0	0	0	0	0	0	0
24	1	1	0	1	0	0	0	0	0	0	0	0	0	0	0	0	0	0	0	0	0	0	0	0	0	0	0	0	0	
25	0	0	0	0	0	0	0	0	0	0	0	0	0	0	0	0	0	0	0	0	0	0	0	0	0	0	0	0	0	
26	0	0	0	0	0	0	0	0	0	0	0	0	0	0	0	0	0	0	0	0	0	0	0	0	0	0	0	0	0	0
27	0	0	0	0	0	0	0	0	0	0	0	0	0	0	0	0	0	0	0	0	0	0	0	0	0	0	0	0	0	0
28	0	0	0	0	0	0	0	0	0	0	0	0	0	0	0	0	0	0	0	0	0	0	0	0	0	0	0	0	0	0
29	0	0	0	0	0	0	0	0	0	0	0	0	0	0	0	0	0	0	0	0	0	0	0	0	0	0	0	0	0	0
Bus	1	2	3	4	5	6	7	8	9	10	11	12	13	14	15	16	17	18	19	20	21	22	23	24	25	26	27	28	29	
1	0	296	260	199	16	56	108	120	145	0	0	0	0	0	0	0	16	0	0	0	0	1	0	0	0	0	0	0	0	
2	296	0	0	0	233	183	99	0	0	0	0	0	0	0	0	0	0	71	0	0	0	0	1	0	0	0	0	0		

Appendix C Development Potential Maps of Economic Sectors and Information Maps of Corridor Infrastructures

C.1 Development Potential Maps of Economic Sectors

The development potential maps covers the following economic sectors related to corridor development in WAGRIC countries:

- Agriculture
- Livestock (Burkina Faso)
- Mineral Resources
- Water Resources

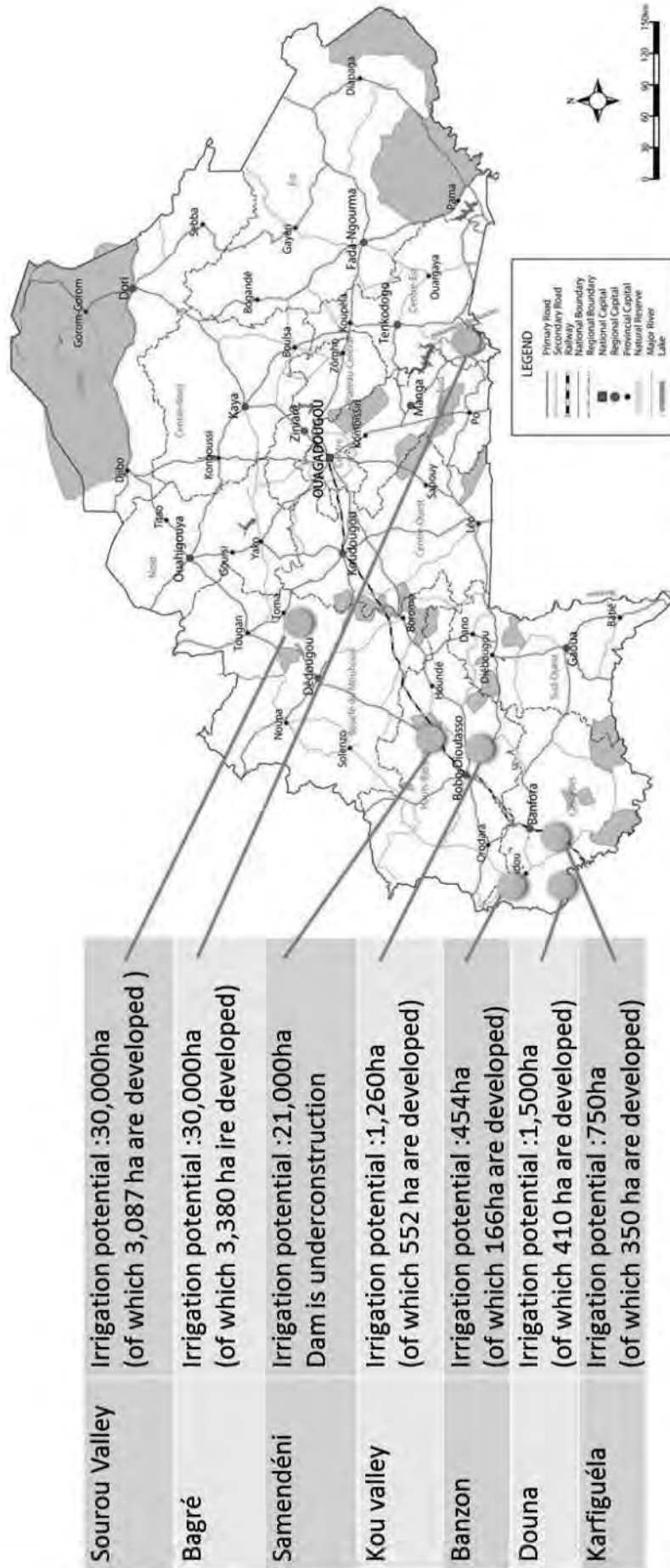

- ✓ The arable land potential of Burkina Faso is approximately 9 million ha of which 3.5 million are not cultivated.
- ✓ Among arable land, 233,000 ha are considered as potential irrigation area including 90,000ha of lowland.

Figure C.1.1 Agricultural Investment Possibility: Agricultural Irrigation Development Projects in Burkina Faso

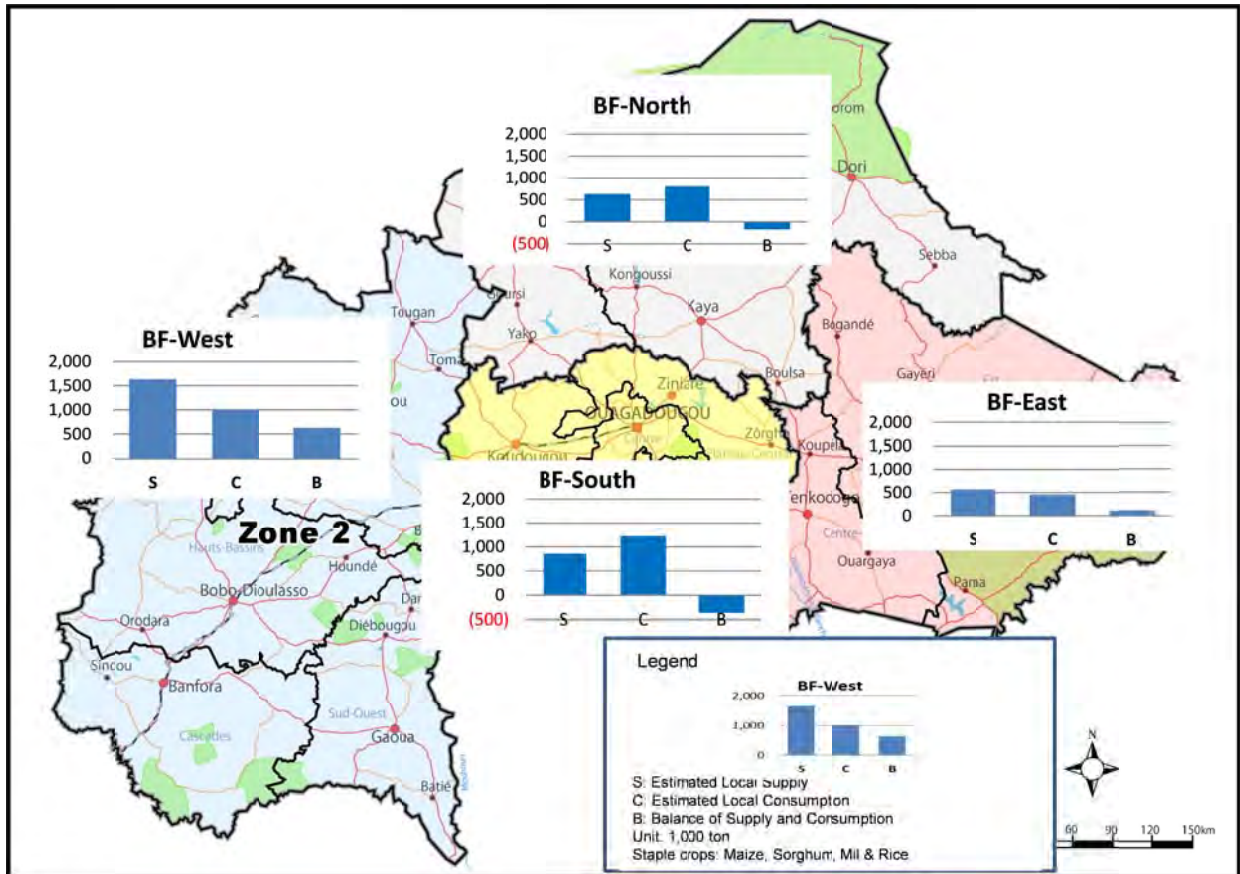

Source: JICA Study Team estimated based on 'RESULTATS DEFINITIFS DE LA CAMPAGNE AGRICOLE 2014/2015 ET PERSPECTIVES DE LA SITUATION ALIMENTAIRE ET NUTRITIONNELLE' by MAAH

Figure C.1.2 Local Supply and Consumption of Major Staple Crops by Zone in Burkina Faso (2014/15)

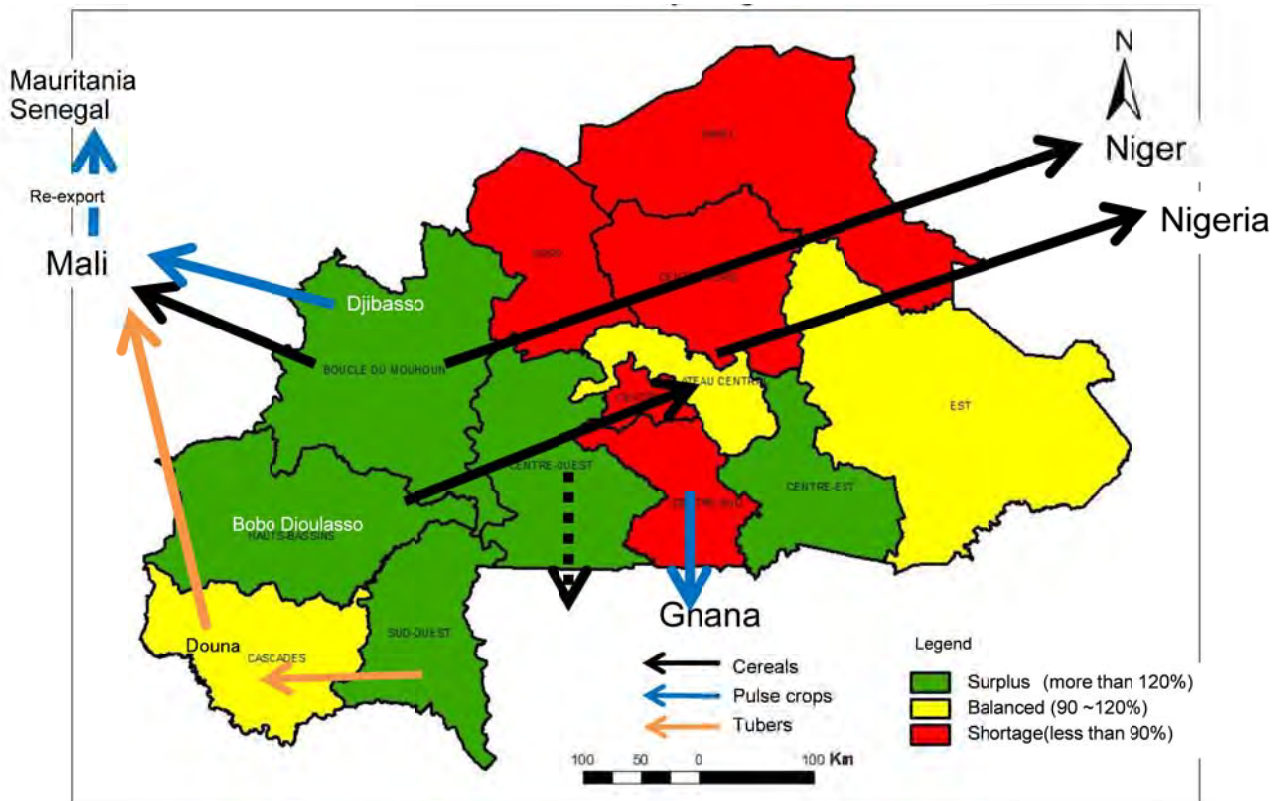

Source: JICA Study Team estimated based on 'RESULTATS DEFINITIFS DE LA CAMPAGNE AGRICOLE 2014/2015 ET PERSPECTIVES DE LA SITUATION ALIMENTAIRE ET NUTRITIONNELLE' by MAAH

Figure C.1.3 Food Balance by Region and Flow in Burkina Faso

Maize

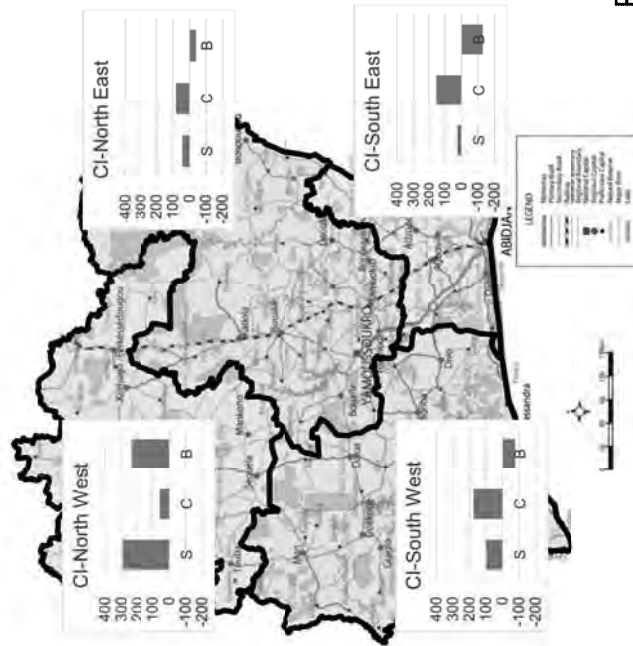

Rice (milled)

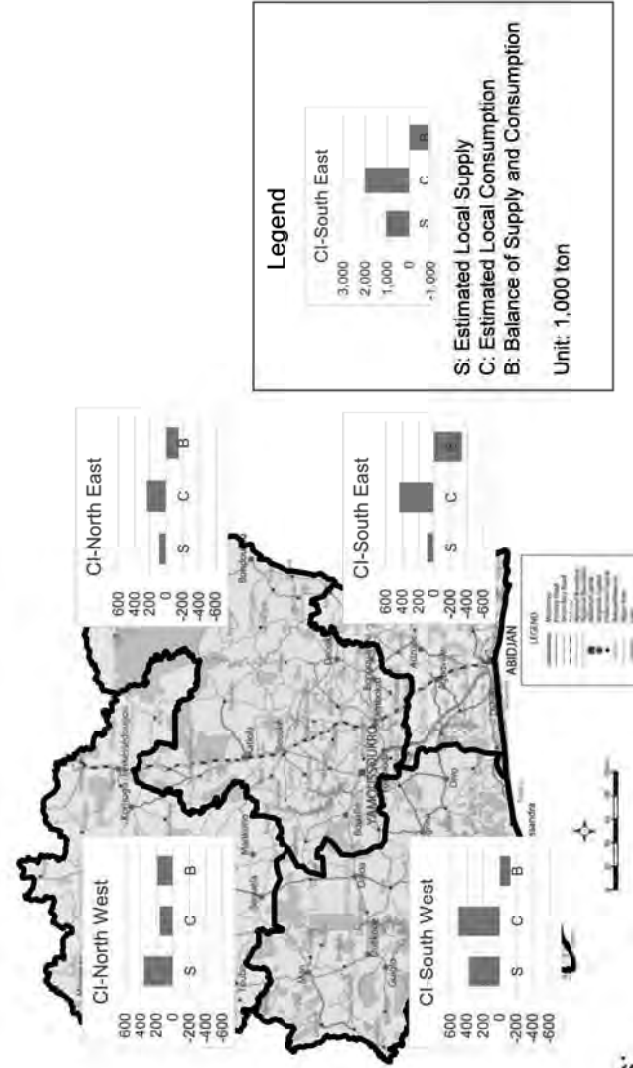

Remarks:

- Local supply amount is estimated considering post harvest loss.
- Local consumption is estimated based on population and average per-capita consumption of food crops.
- Production of each zone is estimated based on the proportional share of regions based RNA 2001.

Source: JICA Study Team estimated based on Annuaire des Statistiques Agricoles 2012, MINAGRI and FAO/STAT

Figure C.1.4 Local Supply and Consumption of Major Staple Crops (Maize and Rice) by Zone in Côte d'Ivoire (2012 Estimated)

Root Crops (Cassava + Yam)

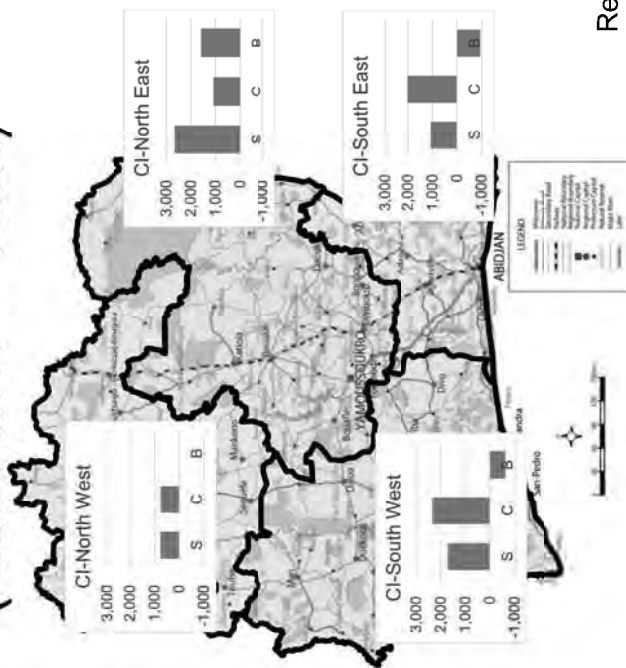

Plantain

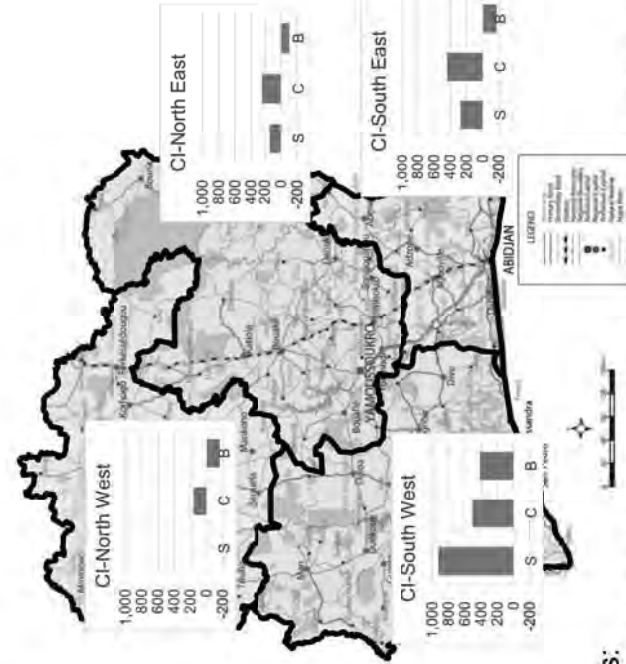

Remarks:

- Local supply amount is estimated considering post harvest loss.
- Local consumption is estimated based on population and average per-capita consumption of food crops.
- Production of each zone is estimated based on the proportional share of regions based RNA 2001.

Source: JICA Study Team estimated based on Annuaire des Statistiques Agricoles 2012, MINAGRI and FAO/STAT

Figure C.1.5 Local Supply and Consumption of Major Staple Crops (Root Crops and Plantain) by Zone in Côte d'Ivoire (2012 Estimated)

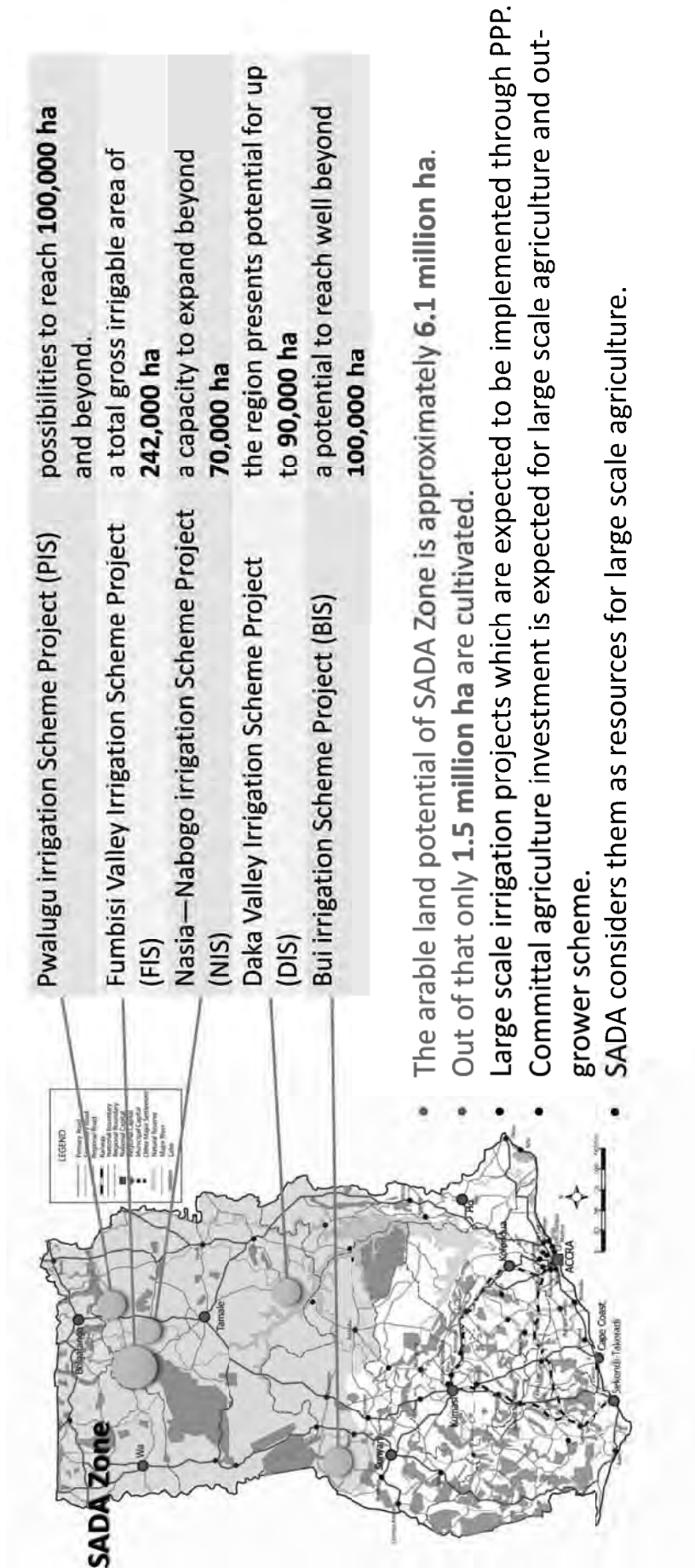

Source: JICA Study Team based on Savannah Zone Master Plan

Figure C.1.6 Agricultural Investment Possibility in Ghana: Irrigation Projects considered as Large Scale Agriculture in SADA Zone of Ghana

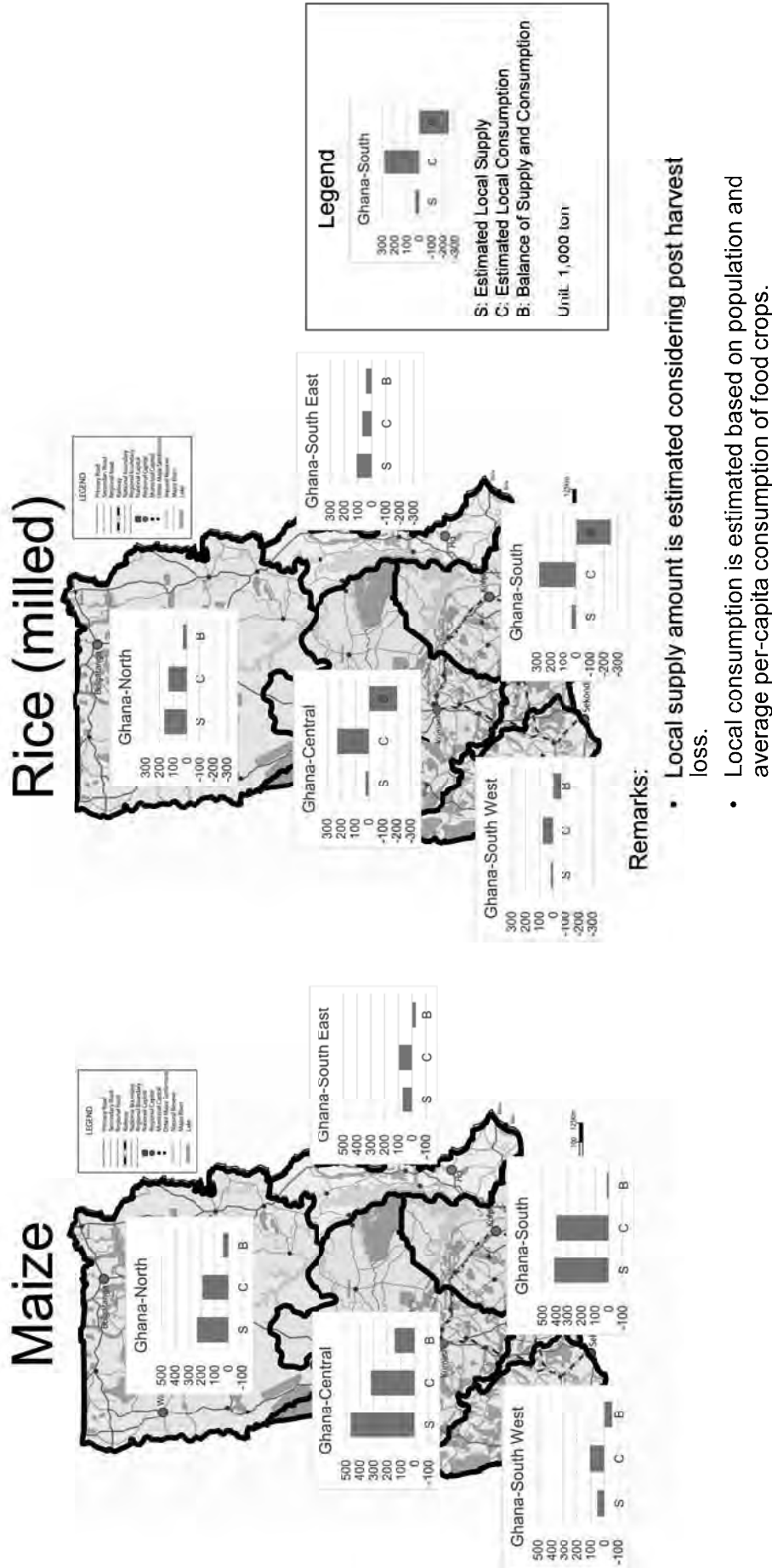

Source: JICA Study Team based on Information provided by SRID, MOFA and Fact and Figures 2014

Figure C.1.7 Local Supply and Consumption of Major Staple Crops (Maize and Rice) by Zone in Ghana (2014 Estimated)

Plantain

Root Crops (Cassava + Yam)

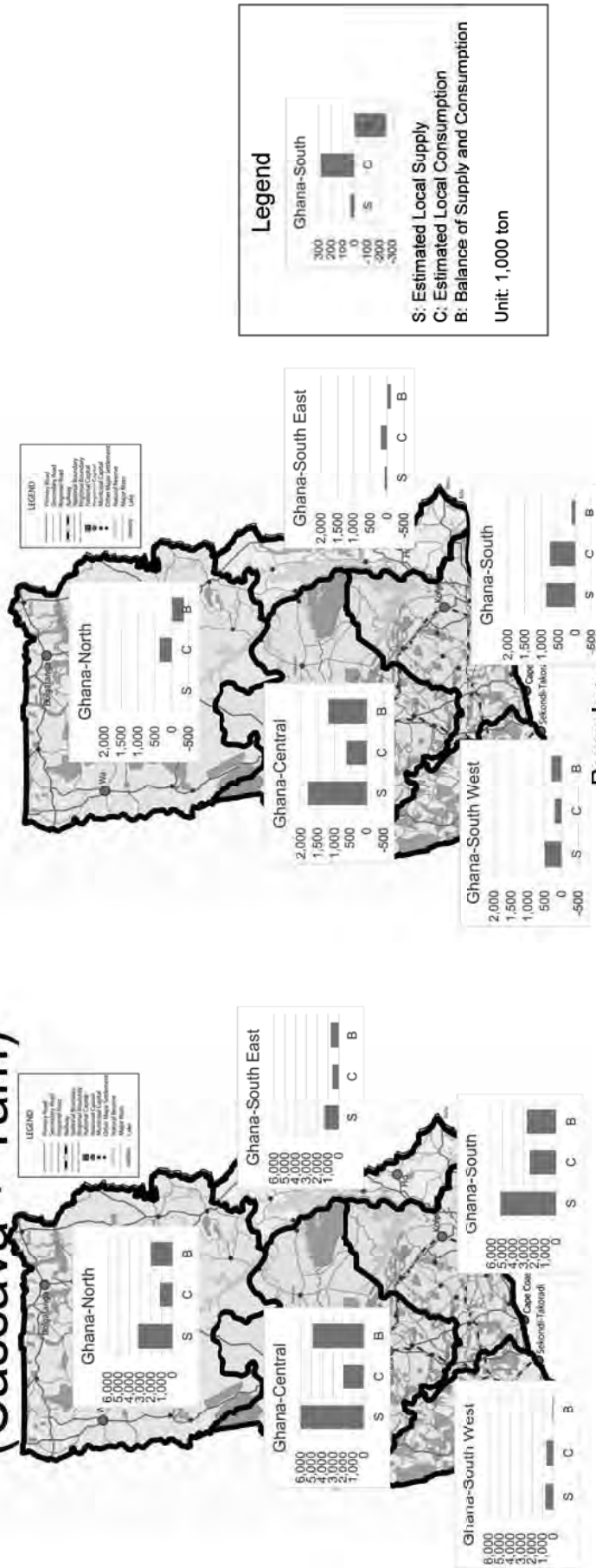

Source: JICA Study Team based on Information provided by SRID, MOFA and Fact and Figures 2014

Figure C.1.8 Local Supply and Consumption of Major Staple Crops (Root Crops and Plantain) by Zone in Ghana (2014 Estimated)

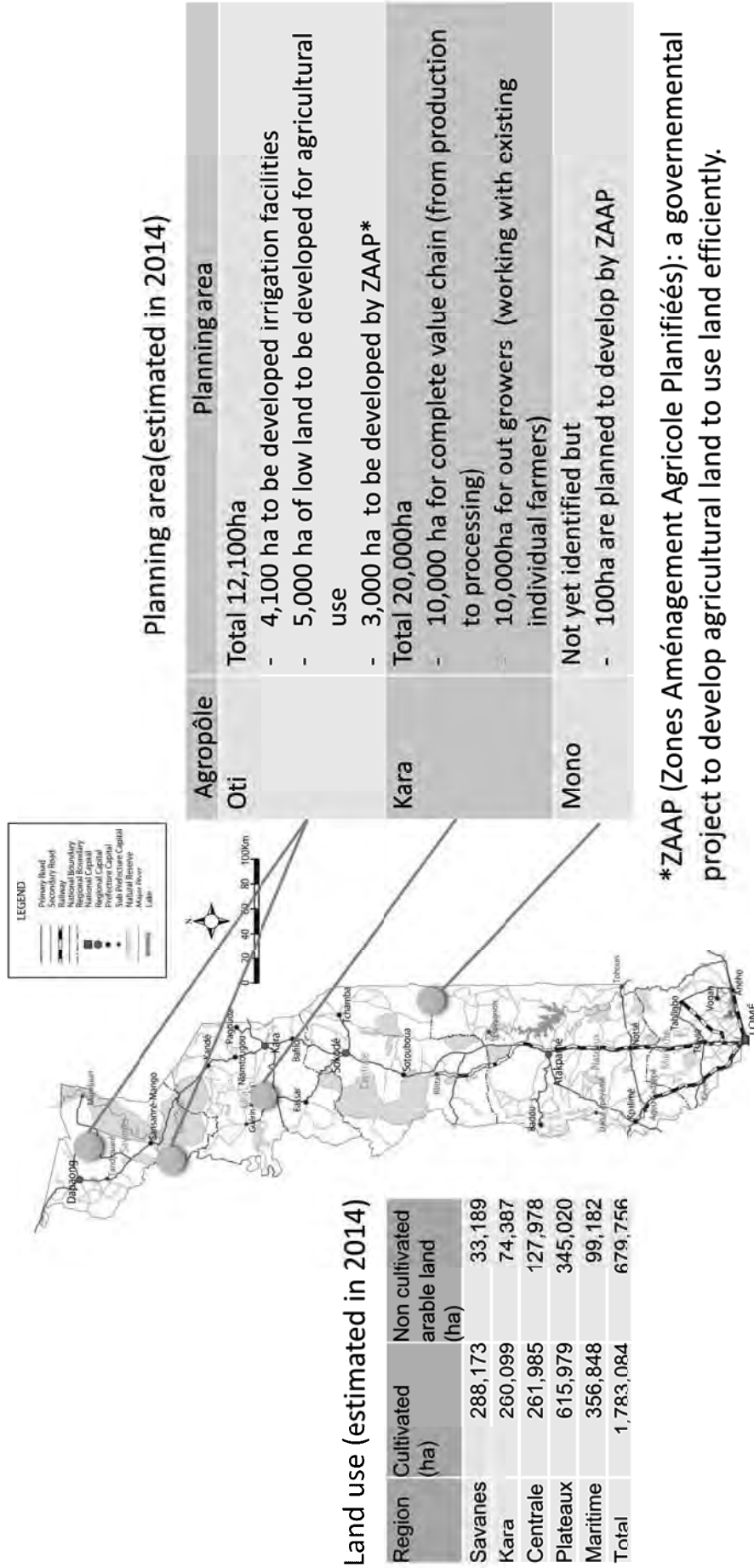
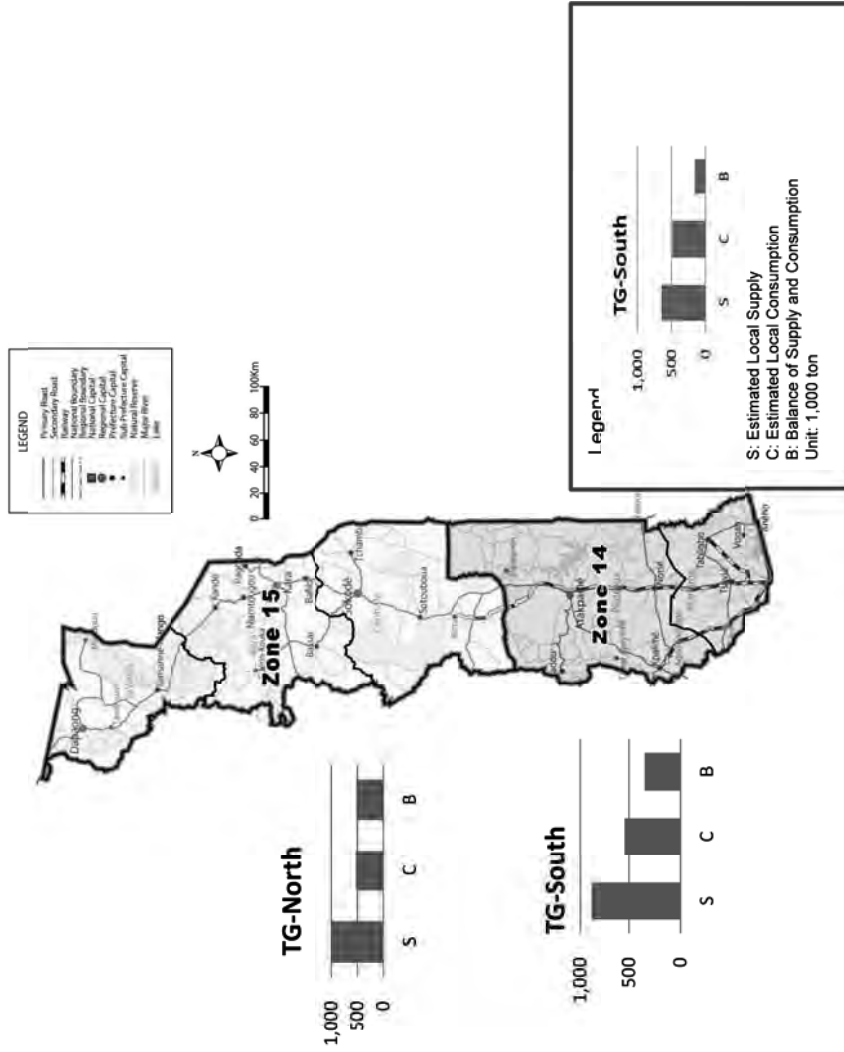
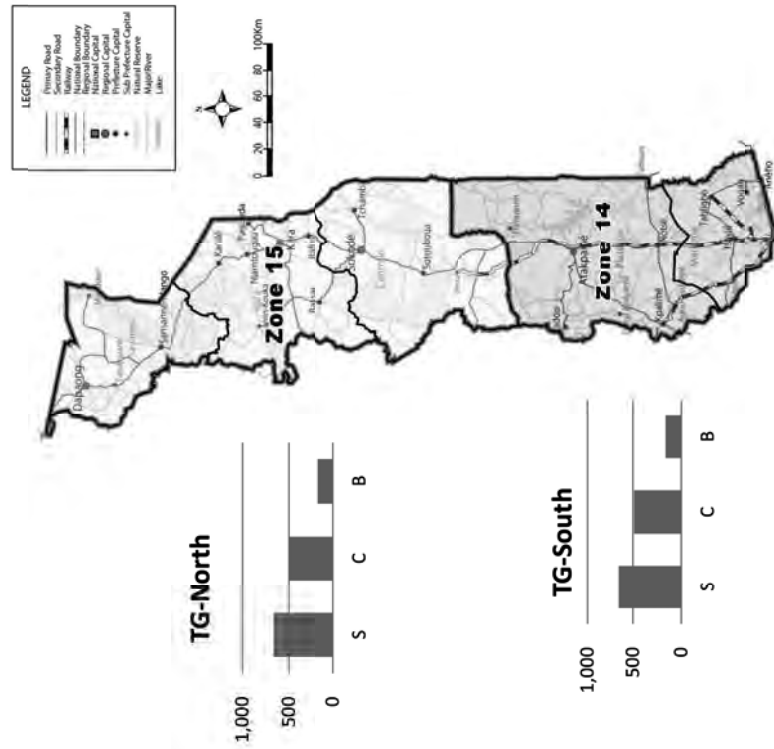

Figure C.1.9 Agricultural Investment Possibility: Situation of Land Use and Planned Areas for Agricultural Development in Togo

Root Crops (Cassava + Yam)



Cereals (Maize, Sorghum, Mil & Rice)



Source: JICA Study Team estimated based on 'EVALUATION A MI-PARCOURS DE LA CAMPAGNE AGRICOLES 2014-2015' by MAEH

Figure C.1.10 Local Supply and Consumption of Major Staple Crops (Cereals and Root Crops) by Zone in Togo (2015 estimated)

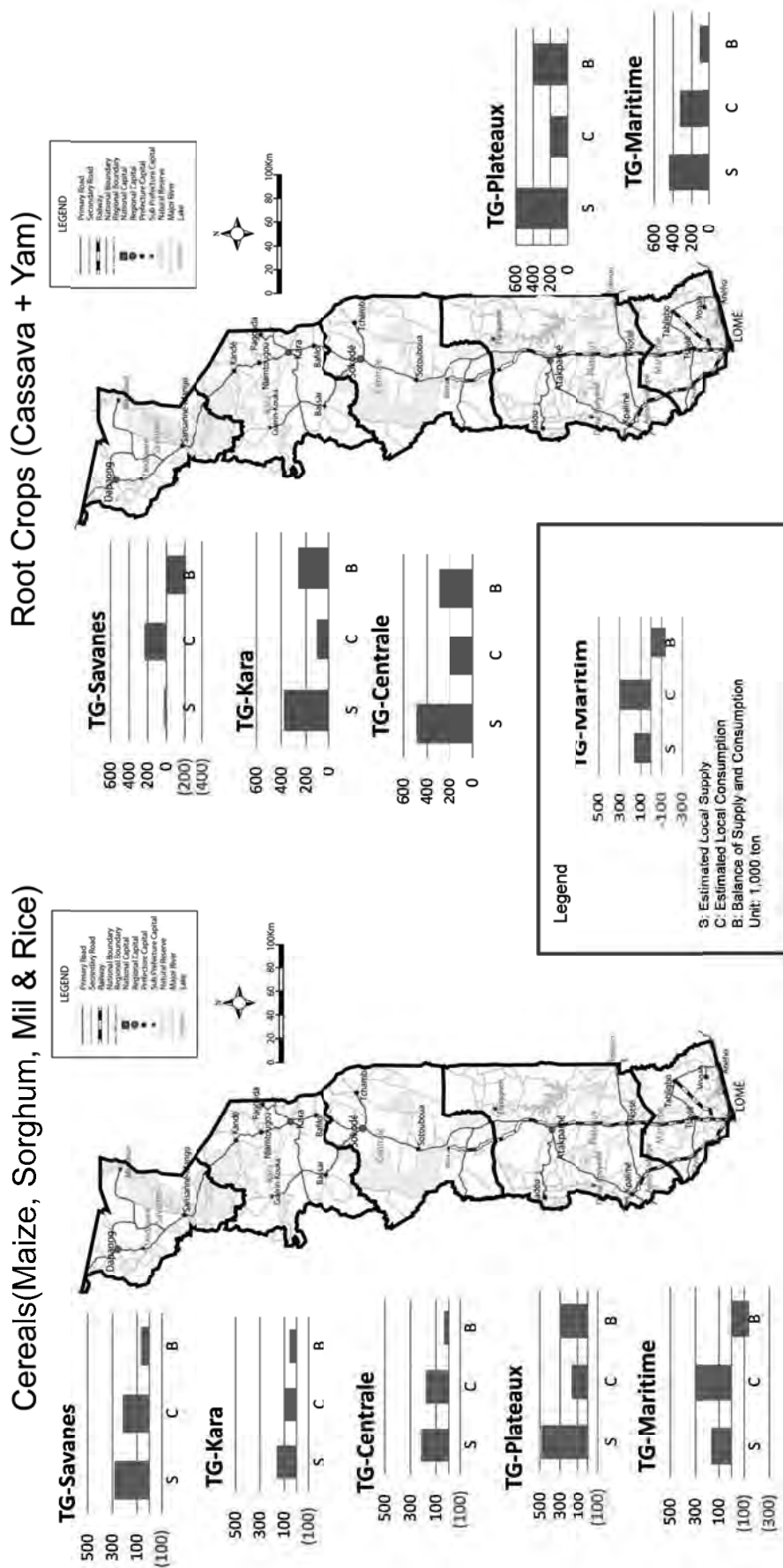

Source: JICA Study Team estimated based on 'EVALUATION A MI-PARCOURS DE LA CAMPAGNE AGRICOLES 2014-2015' by MAEH

Figure C.1.11 Local Supply and Consumption of Major Staple Crops (Cereals and Root Crops) by Region in Togo (2015 estimated)

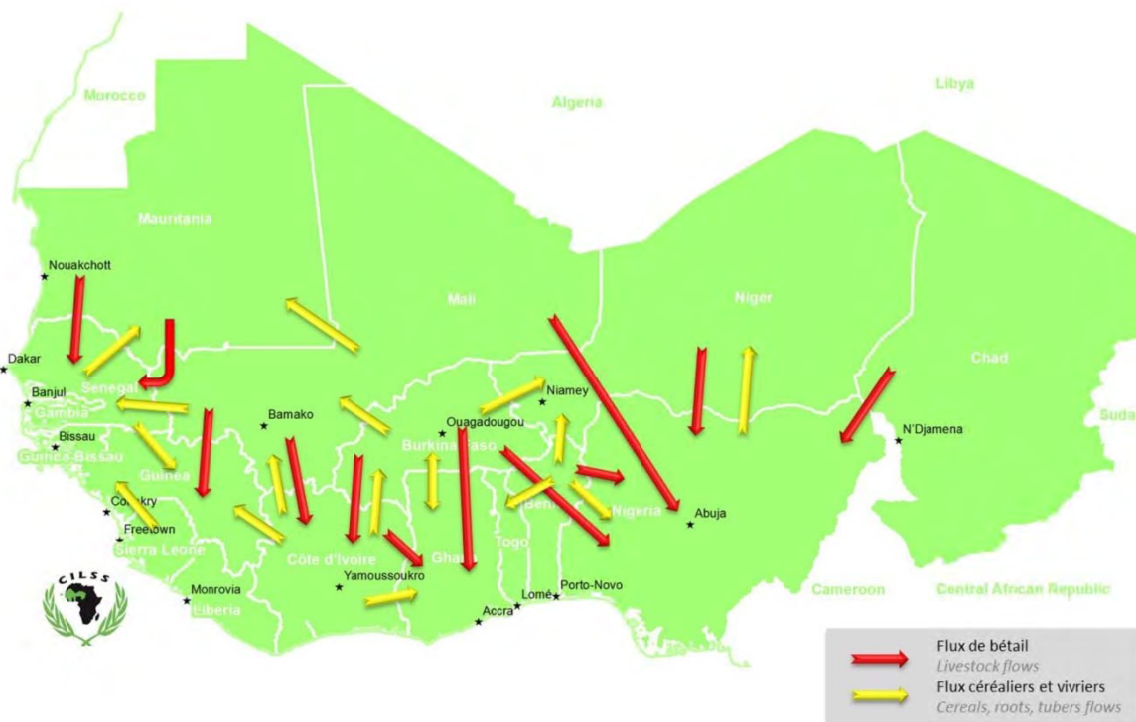

Source: INSTITUT DU SAHEL (INSAH), September 2015, Intra-Regional Trade Flows of Agricultural Products and Livestock in the Sahel and West Africa

Figure C.1.12 Synthesis of Cross-Border Trade Flows of Livestock, and Cereals, Roots and Tubers (September 2015)

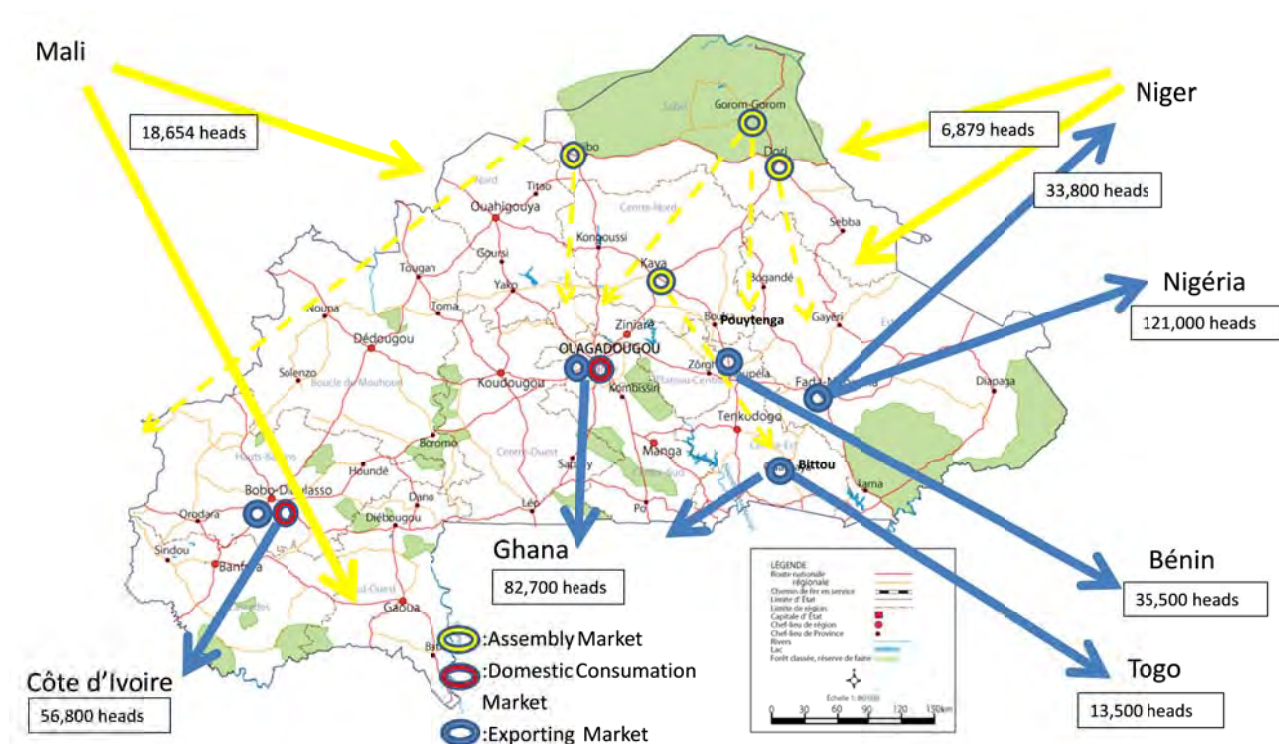

Source: JICA Study Team based on 'ANNUAIRES DES STATISTIQUES DE L'ELEVAGE 2014' by MAAH

Figure C.1.13 Live Cattle Trading and Flow in Burkina Faso (2014)



Ore Deposit	Reserves and Resources	Production forecast
Tambao Mn mine (Suspended)	107million tons measured, indicated and inferred resources*	3 million tons/year full production by 2017*
Perkoa Zn mine (Operating)	4.8 million tons measured and indicated resources 2.3 million tons inferred resources**	Mine closure due to the end of the life of mine which was approximately 5 years**

Source*: Timis Corporation Annual Report

Source**: GLENCORE HP (GLENCORE Resources & Reserves as at 31 December 2015)

Figure C.1.14 Major Mineral Deposit of Burkina Faso

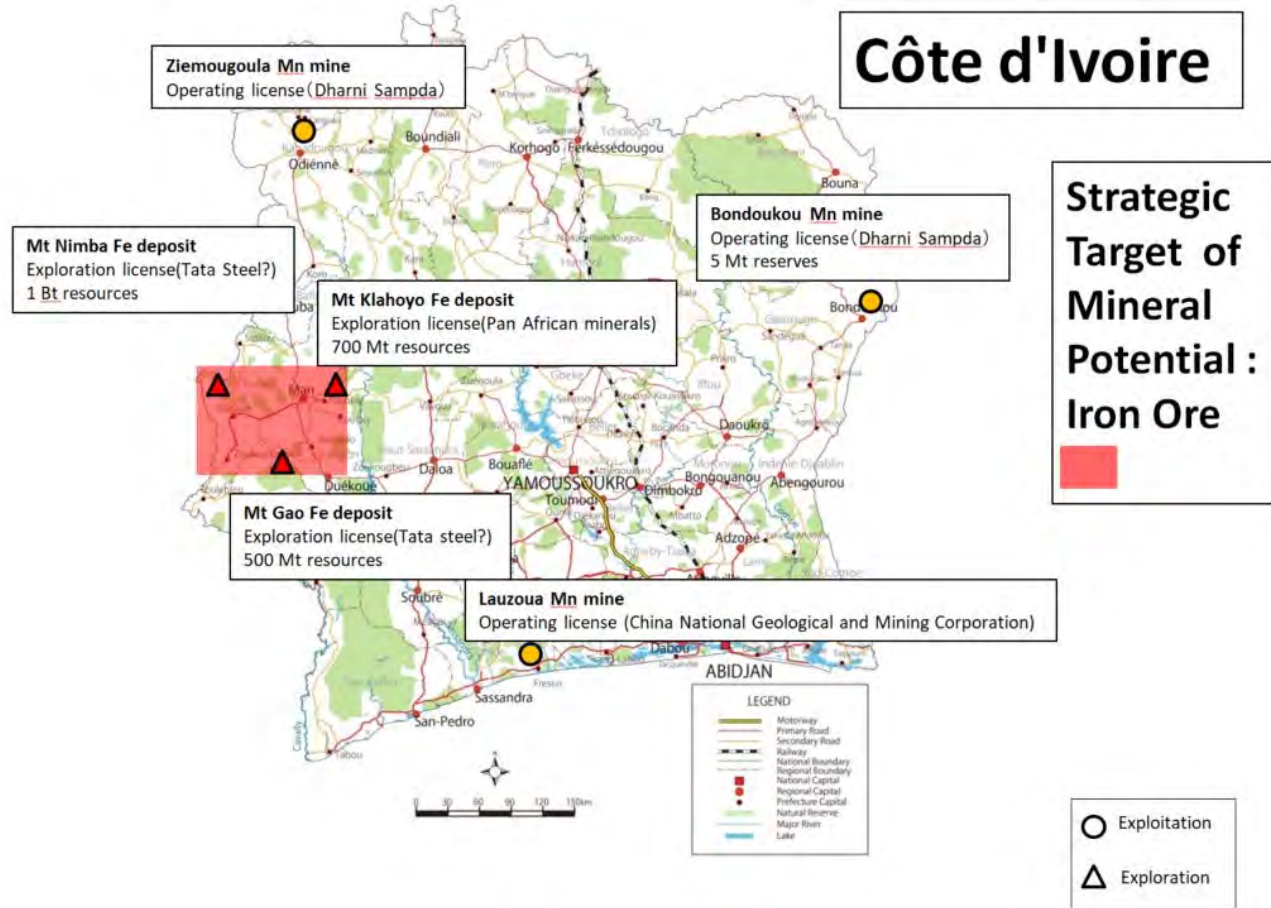

Ore Deposit	Reserves and Resources	Production Forecast
Bondoukou Mn mine (Suspended)	3.2 million tons of proven reserves*	Total 1million tons/ year with three mines in operation at Bondoukou, Ziemougoula, Lauzoua mines within the next 2-3 years**
Ziemougoula Mn mine (Suspended)	3.3 million tons proven reserves with an additional 3 million tons of probable reserves*	
Lauzoua Mn mine (Suspended)	—	2016: 300 thousand tons/ year, 2017: 500 thousand tons/ year**
Mt Nimba Fe deposit (Not developed)	1 billion tons of resources***	—
Mt Gao Fe deposit (Not developed)	500 million tons of resources***	—
Mt Klahoyo Fe deposit (Not developed)	700 million tons of resources	11 million tons/year**

Source*: REUTERS

Source**: SODEMI, 2015

Source***: Ministry of Industry and Mines, 2015

Figure C.1.15 Major Mineral Deposit of Côte d'Ivoire

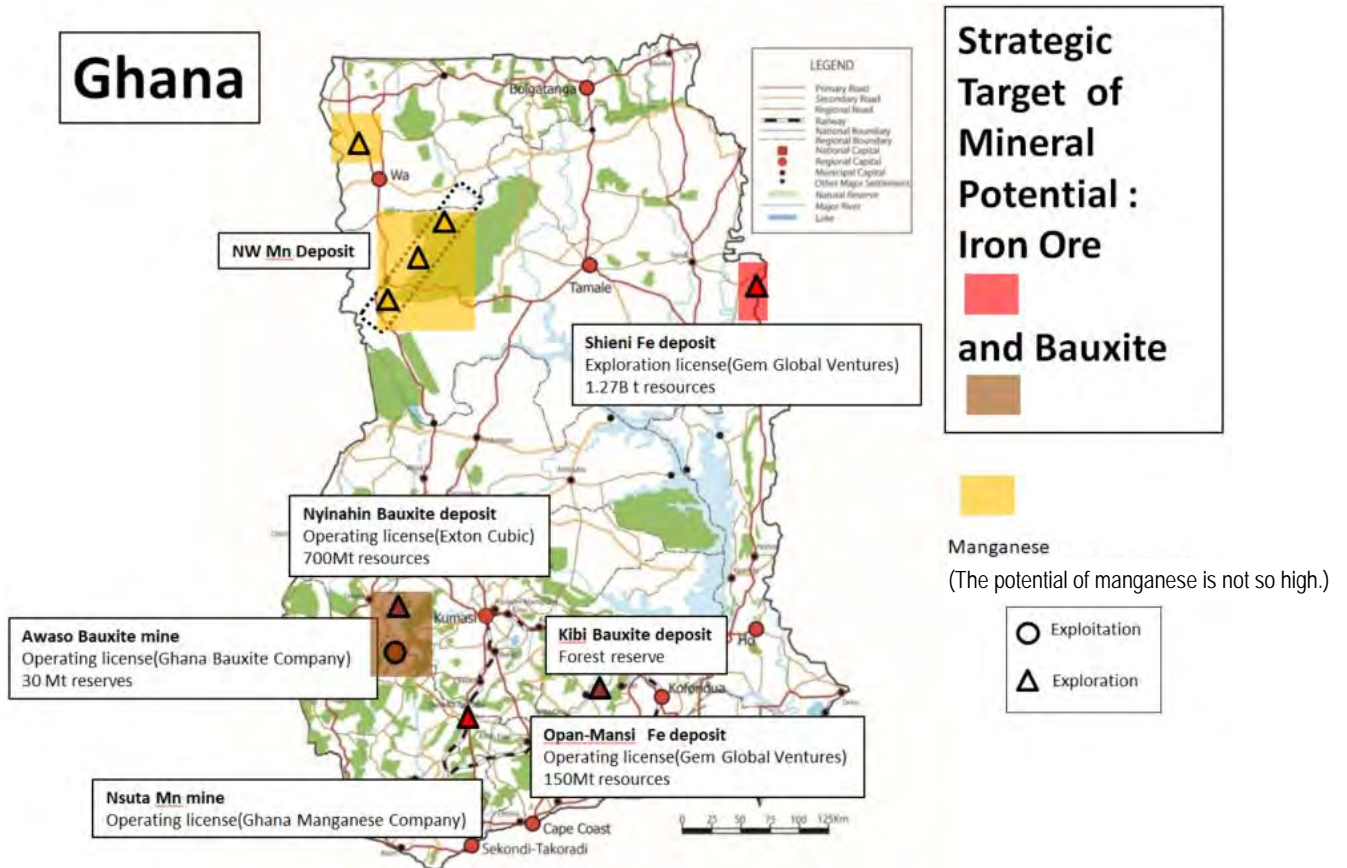

Ore Deposit	Reserves and Resources	Production Forecast
Nsuta Mn Mine (Operating)	—	Production plan is not clear
Awaso Bauxite Mine (Operating)	30 million tons reserve (more than 20million tons produced)	Production plan is not clear.
Nynahin Bauxite Deposit (Not developed)	700 million tons resources*	2017: 3 million tons **
	1billion tons resources **	2018: 12 million tons **
Opan-Mansi Fe Deposit (Not developed)	150 million tons Inferred resources*	—
Shieni Fe Mine (Not developed)	1.27 billion tons Inferred resources*	—

Source*: Minerals Commission, 2015

Source**: Exton Cubic Ltd, 2016

Figure C.1.16 Major Mineral Deposit of Ghana

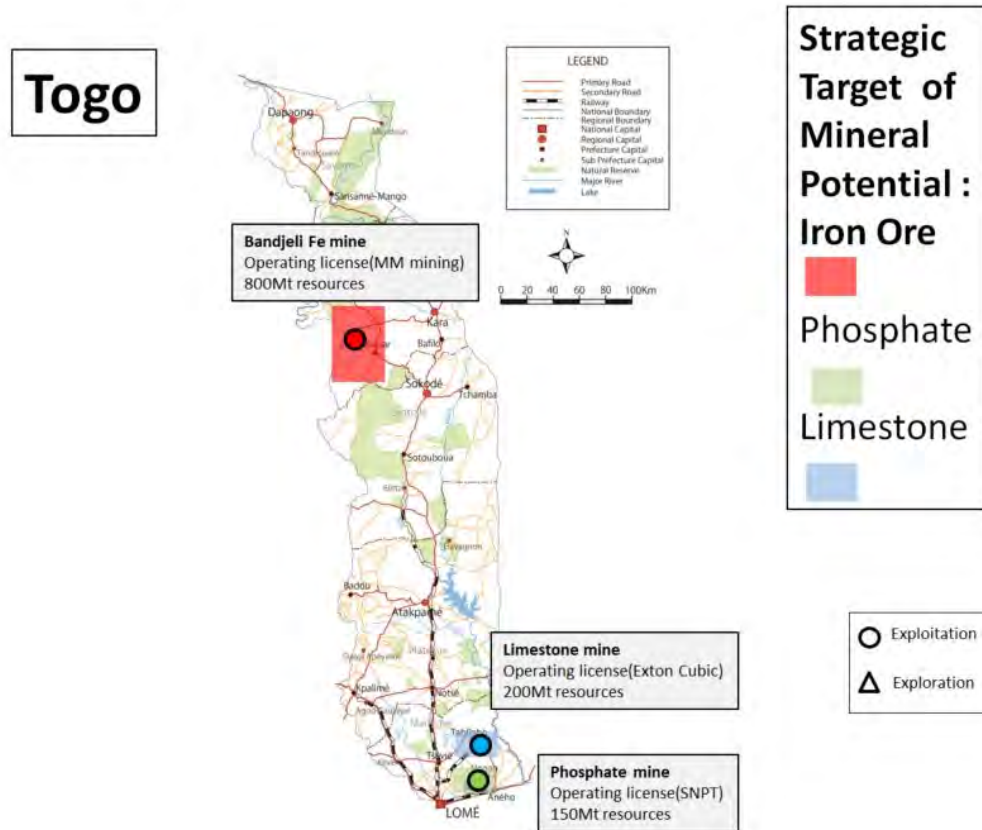

Ore Deposit	Reserves and Resources	Production Forecast
SNPT Phosphate mine (Operating)	150 million tons resources**	3 million tons/year*
Elenilto Phosphate mine (Not developed)		High production rate of 5 million tons/year**
Scantogo Limestone mine (Operating)	200 million tons resources***	2016: 1 million tons/year**** 2017: 2 million tons/year****
Wacem Limestone mine (Operating)		2016: 1 million tons/year*** 2017: 1 million tons/year***
Bandjeli Fe mine (Suspended)	800 million tons resources**	100,000/year

Source*: SNPT, 2016

Source**: Elenilto homepage

Source***: Ministry of Mines and Energy, 2015

Source****: CIMTOGO, 2016

Figure C.1.17 Major Mineral Deposit of Togo

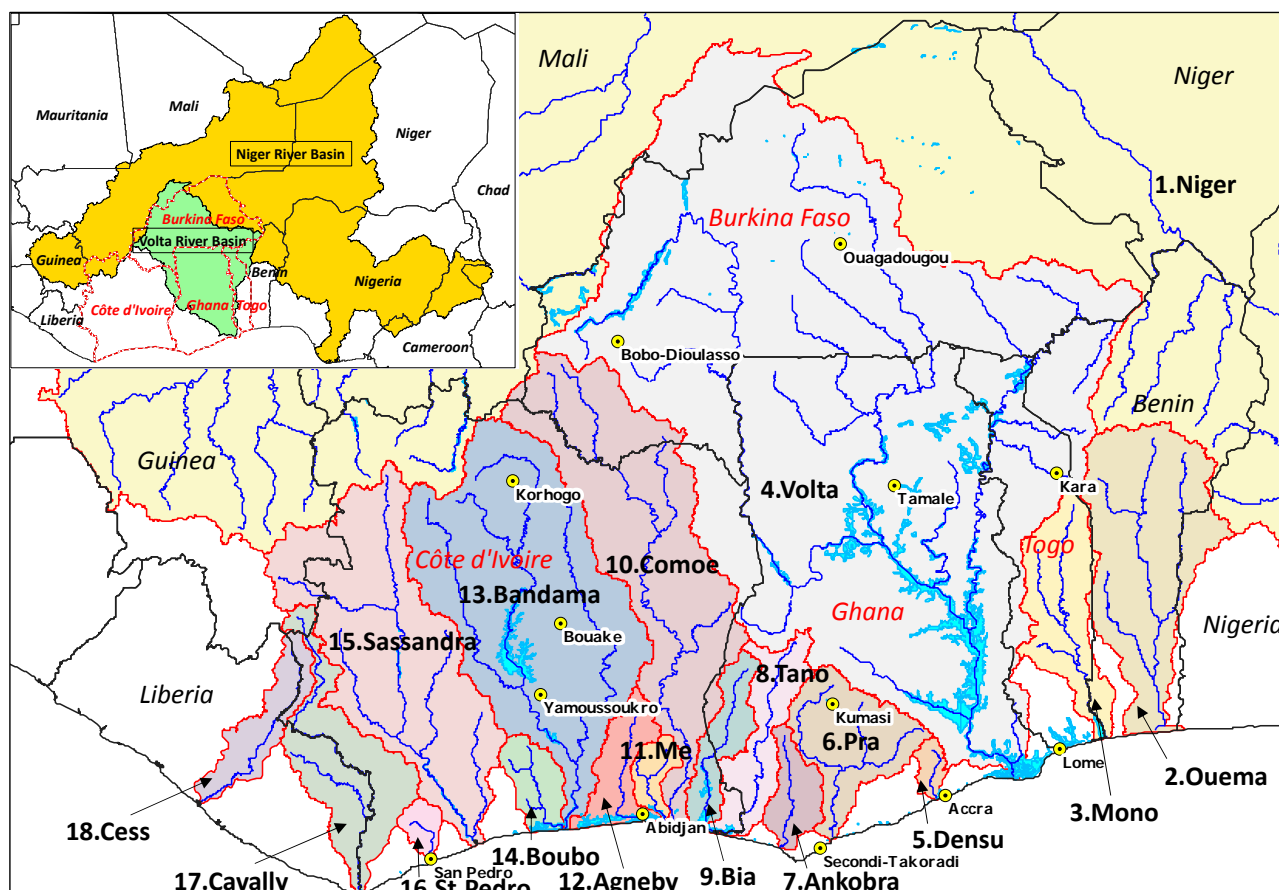

	Burkina Faso		Côte d'Ivoire		Ghana		Togo	
	Annual Volume (BCM/yr)	Share / Ratio (%)	Annual Volume (BCM/yr)	Share / Ratio (%)	Annual Volume (BCM/yr)	Share / Ratio (%)	Annual Volume (BCM/yr)	Share / Ratio (%)
Total Water Resources Potential ¹	13.5	(100.0)	84.1	(100.0)	56.2	(100.0)	14.7	(100.0)
Internal Production	12.5	(92.6)	76.8	(91.3)	30.3	(53.9)	11.5	(78.2)
External Source (Surface Water)	1.0	(7.4)	7.3	(8.7)	25.9	(46.1)	3.2	(21.8)
Water Balance of Internal Production								
Precipitation	205.1	(100.0)	434.7	(100.0)	283.1	(100.0)	66.3	(100.0)
Total Production ²	12.5	(6.1)	76.8	(17.7)	30.3	(10.7)	11.5	(17.3)
Surface Water	8.0	(3.9)	74.0	(17.0)	29.0	(10.2)	10.8	(16.3)
Groundwater	9.5	(4.6)	37.8	(8.7)	26.3	(9.3)	5.7	(8.6)

Note: BCM=Billion Cubic Meter, (*1) Renewable water resources are regarded as water resource potential. (*2) The groundwater that is finally drained as base flow of surface water is not counted as total production, because it has been counted as groundwater potential.

Source: FAO-Aquastat (Hydrobasins_africa, rivers_africa)¹, GADM²

Figure C.1.18 Major Rivers and River Basins and Water Resources Potential in the WAGRIC Countries

¹ FAO: Aquastat, http://www.fao.org/nr/water/aquastat/countries_regions/SEN/index.stm.

² Global Administrative Area (GDM), <http://www.gadm.org/>

C.2 Information Maps of Corridor Infrastructures

The information maps of corridor infrastructure covers the following infrastructure sectors related to corridor development in WAGRIC countries:

- Roads
- Railways
- Pipelines
- Electricity

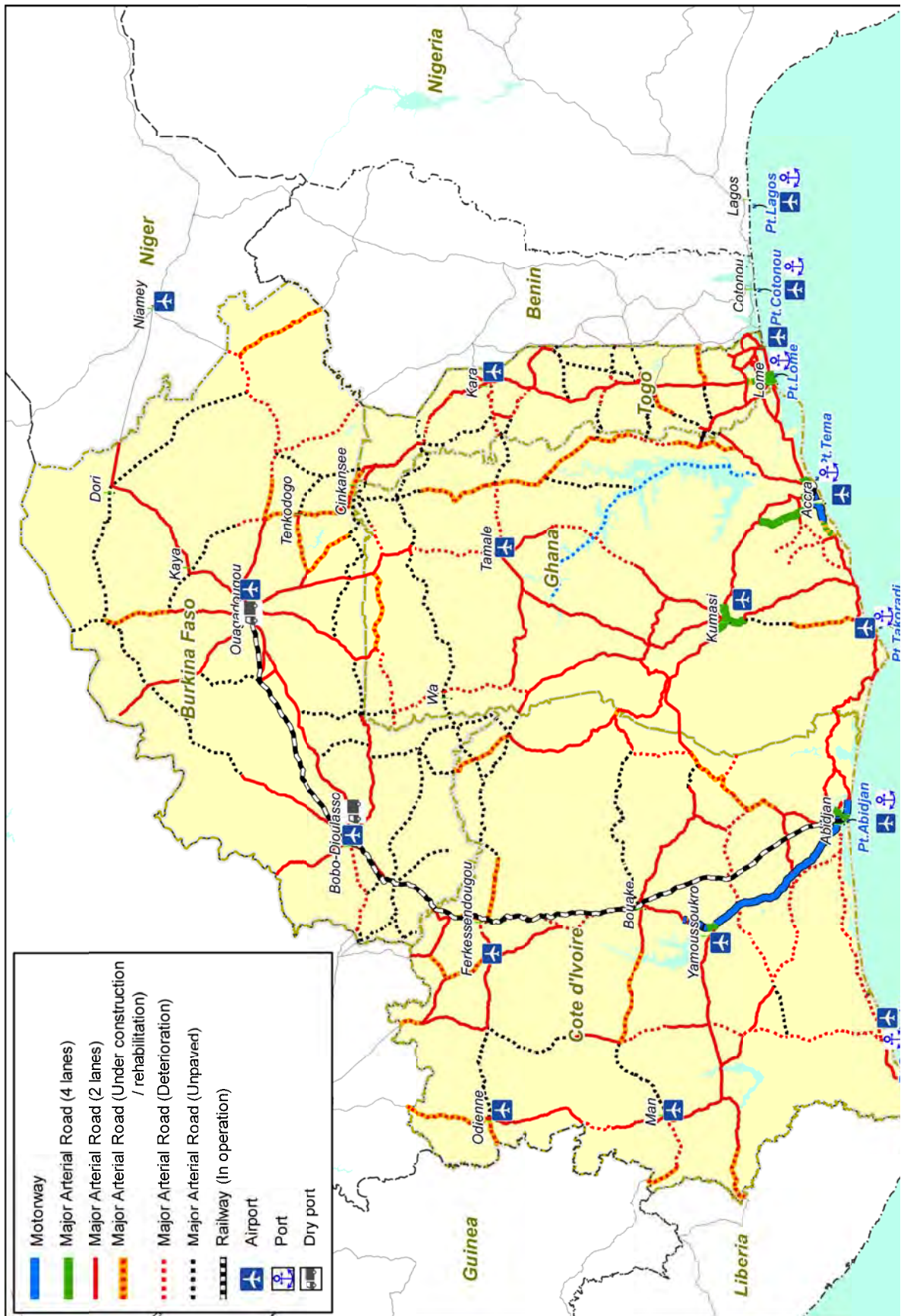

Source: JICA Study Team based on information from road authorities

Figure C.2.1 Existing Road Conditions for WAGRIC Countries

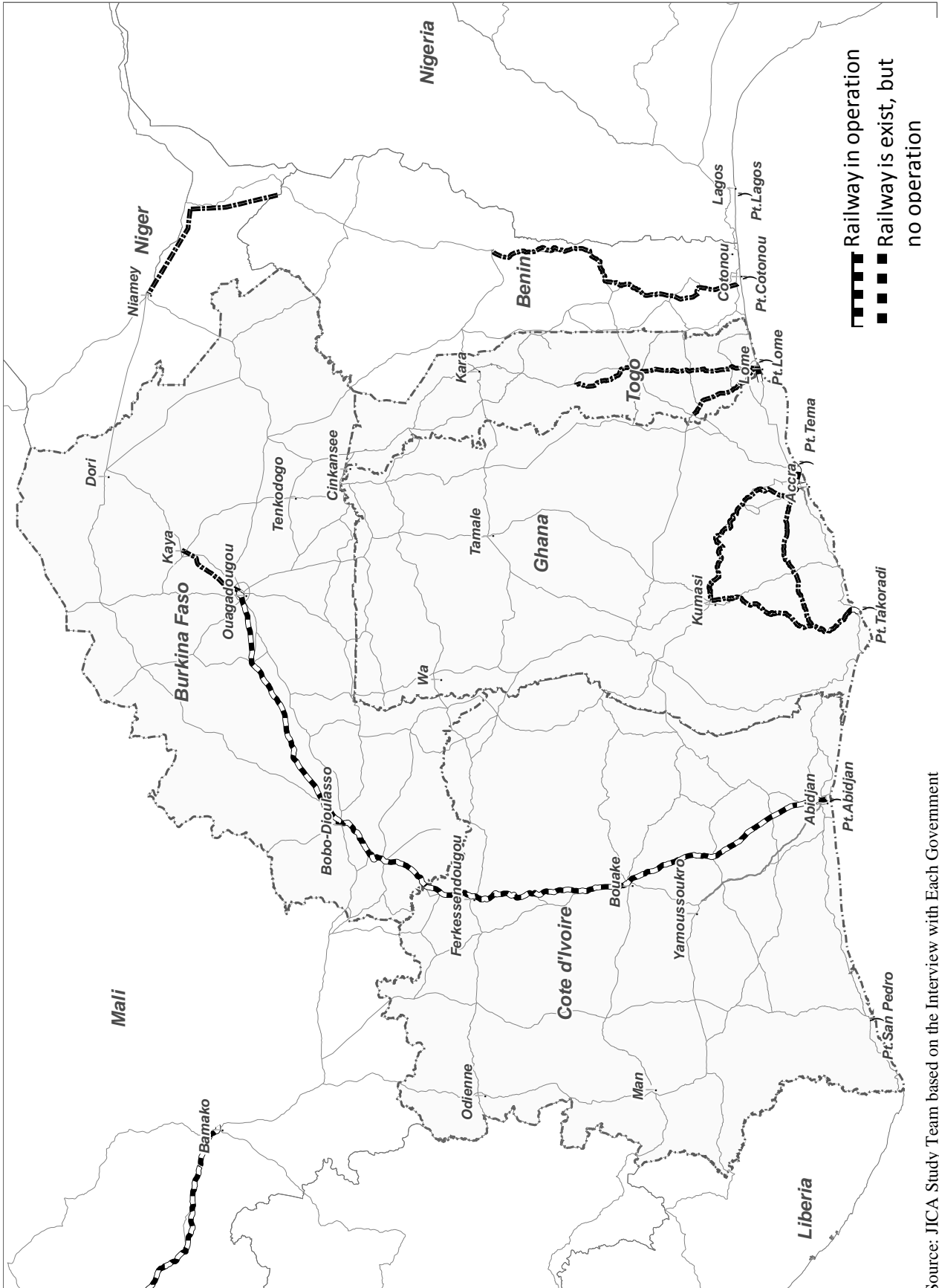

Source: JICA Study Team based on the Interview with Each Government

Figure C.2.2 Existing Railway Infrastructure in the Sub-region

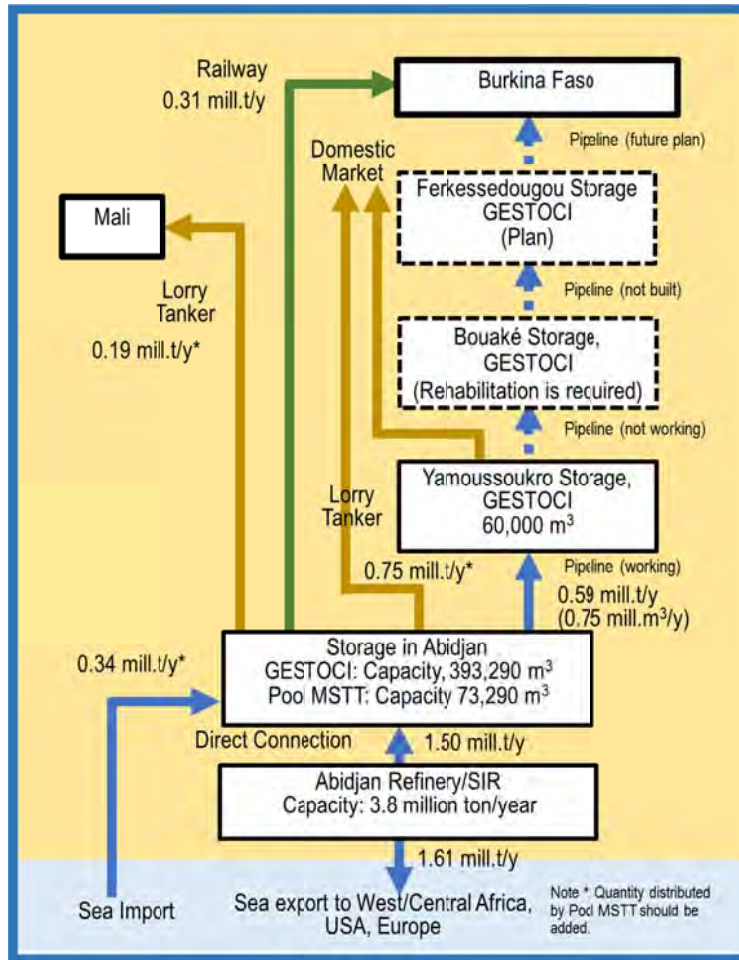

Source: JICA Study Team based on the data in 2012-2014

Figure C.2.3 Storage and Distribution Network of Multi-products Pipeline in Côte d'Ivoire



Source: JICA Study Team

Figure C.2.4 Multi-products Pipeline between Tema and Buipe via Kumasi in Ghana

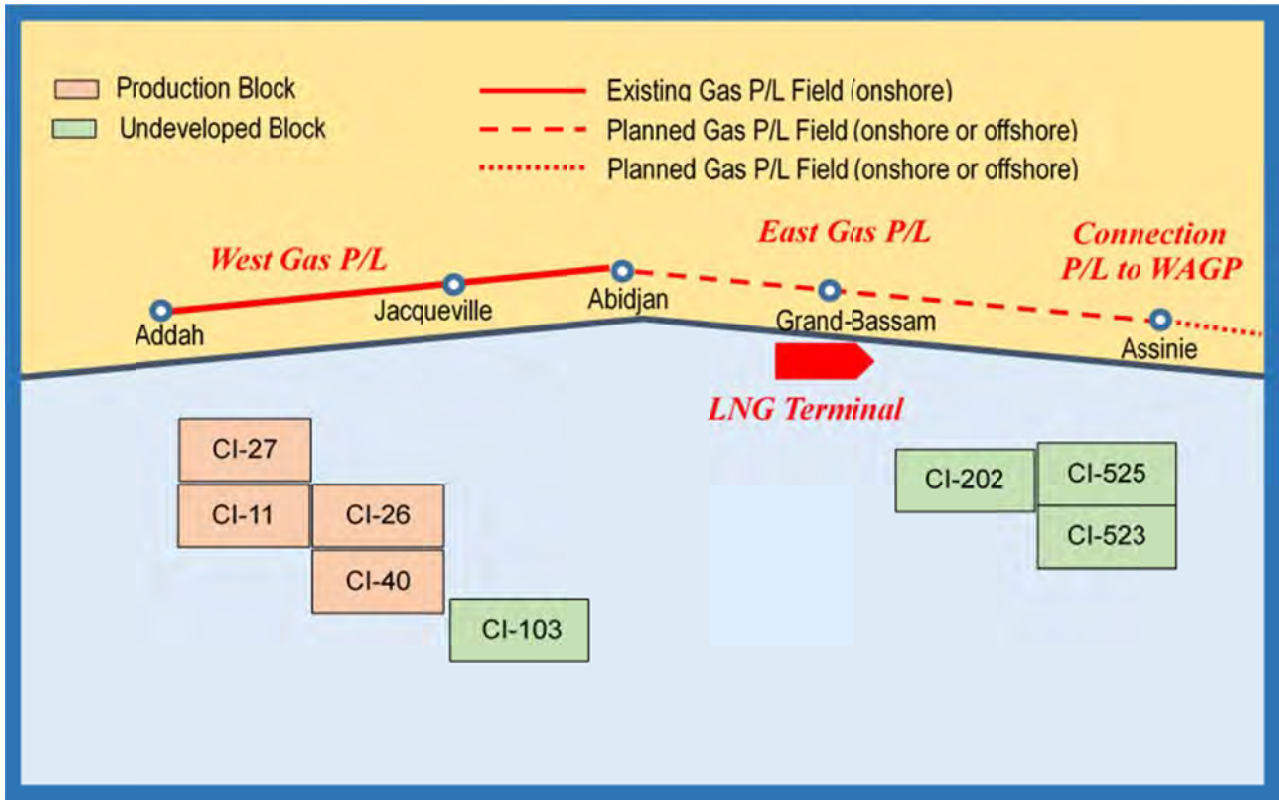

Source: JICA Study Team

Figure C.2.5 Locations of Source of Gas Supply and Pipeline in Côte d'Ivoire

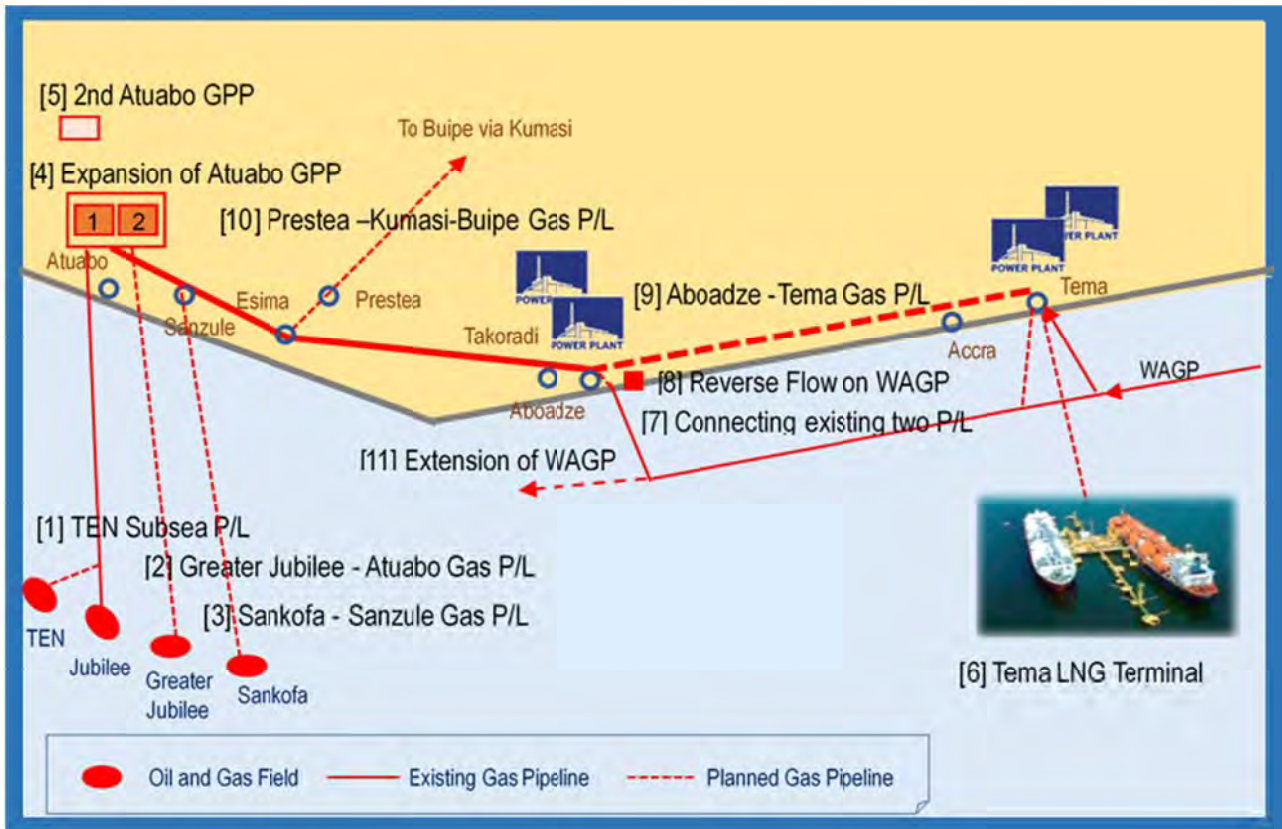

Source: JICA Study Team

Figure C.2.6 Locations of Source of Gas Supply and Pipeline in Ghana

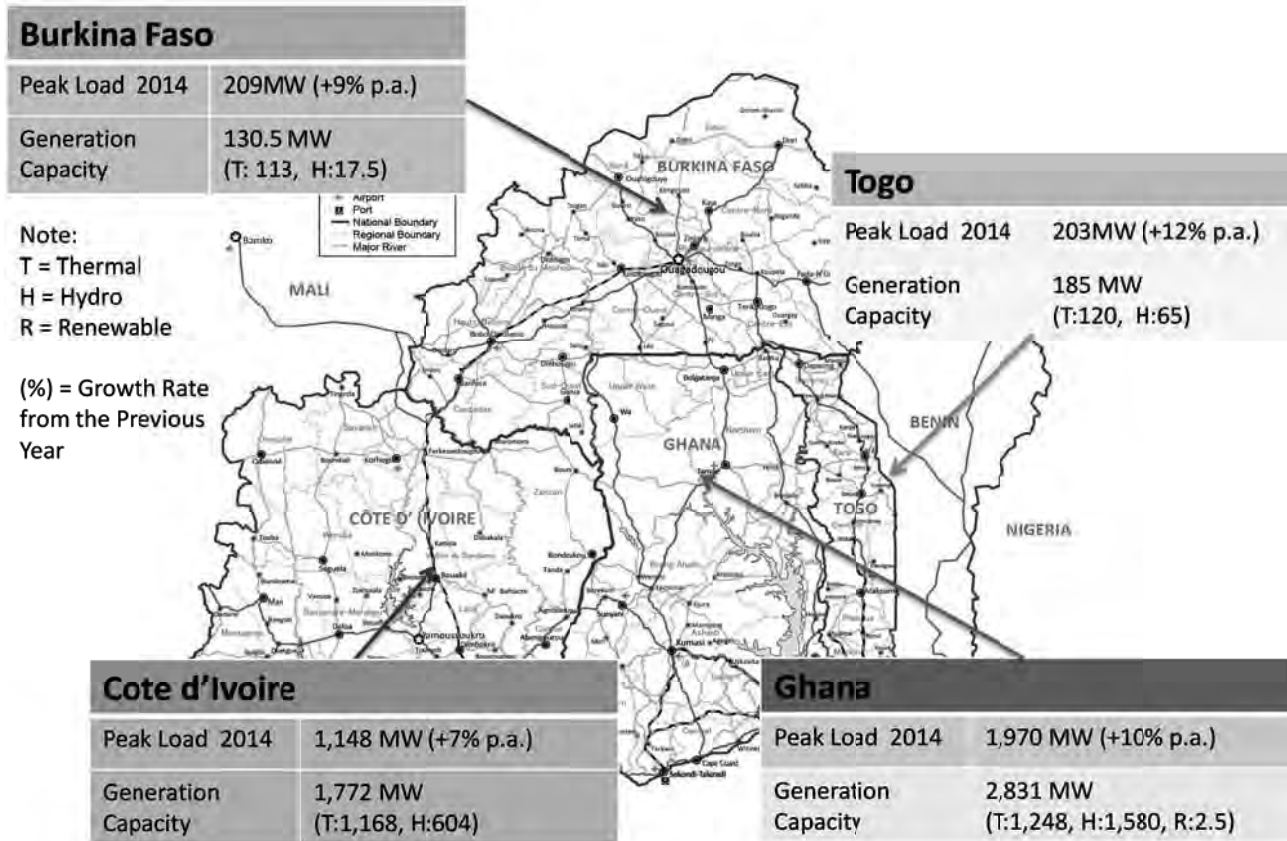

Figure C.2.7 Power Supply: Peak Load and Generation Capacity in Burkina Faso, Cote d'Ivoire, Ghana and Togo

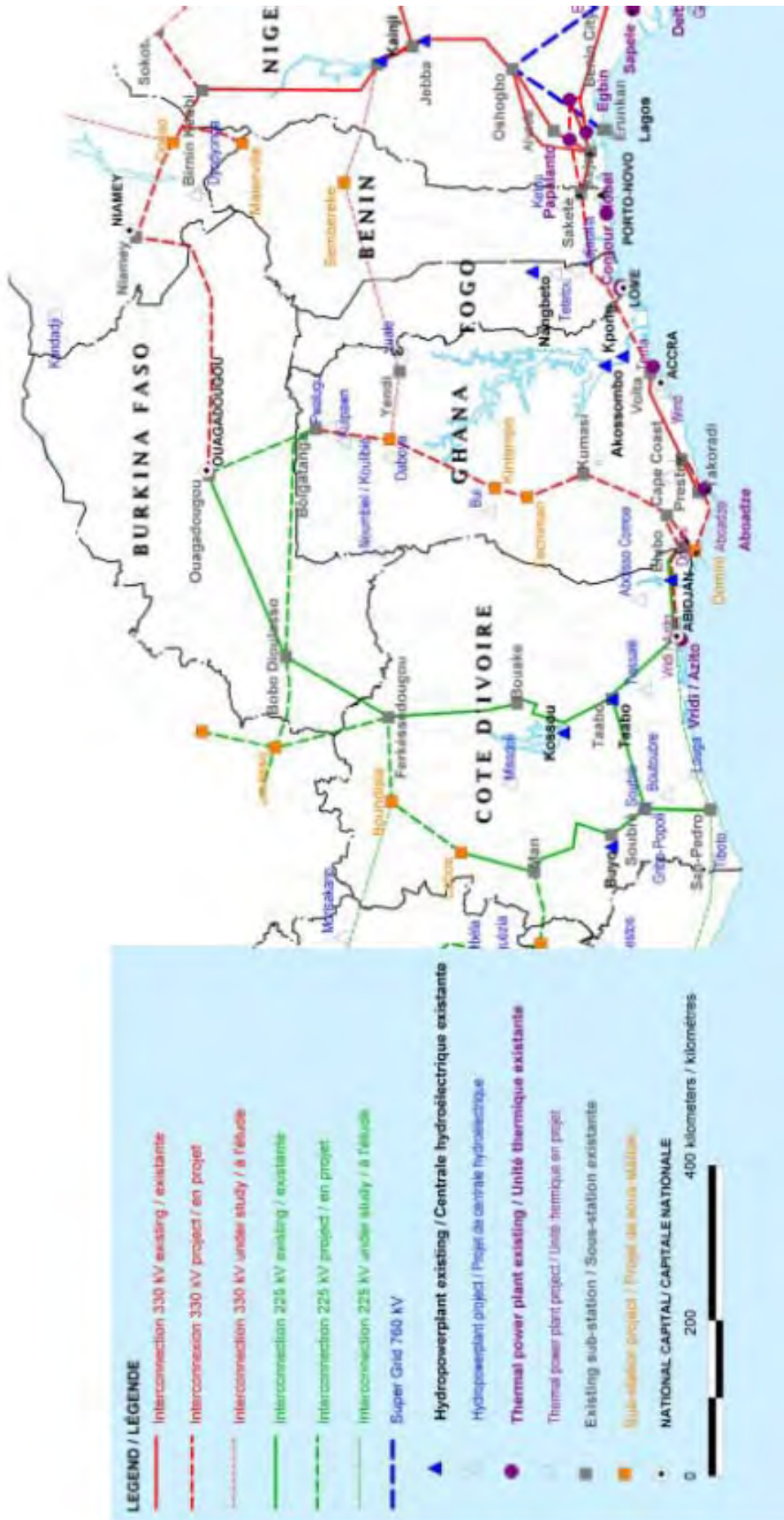

Figure C.2.8 Power Grids covering ECOWAS Countries

Source: WAPP Website

Appendix D General Future Land Use for Abidjan-Lagos Corridor

WAGRIC Project prepared spatial concepts for the coastal metropolitans by conducting preliminary analyses on the following points:

- Where to put an east-west motorway, as part of the Abidjan-Lagos Corridor Motorway, in each coastal metropolitan
- How to secure the connectivity between north-south corridors and coastal corridor within each of the coastal metropolitan
- How to secure a strong access to strategic sea ports which have plans for expansion within coastal metropolitans
- How to get access to new international airports planned within each of the coastal metropolitans
- Where to locate new industrial zones within each of the coastal metropolitans

The future general land use concept for Abidjan-Lagos Corridor was prepared to consider the general route of Abidjan-Lagos Motorway taking in consideration of the major urban centres and the surrounding land use for future development.

Abidjan - Lagos Corridor Spatial Development Concept (Côte d'Ivoire, Ghana, and Togo)



Source: JICA Study Team

Figure D.1.1 General Future Land Use for Abidjan-Lagos Corridor

Appendix E Planning Study's Activities

E.1 Phases of the Project

There are four phases in this Project which are scheduled as follows:

- Phase 1: From mid-June 2015 to mid-January 2016
- Phase 2: From mid-January 2016 to mid-June 2016
- Phase 3: From mid-June 2016 to the end of September 2017
- Phase 4: From the end of September 2017 to the mid-March 2018

In this chapter, major project activities in these four study phases are described.

E.2 Project Activities in Phase 1

The major project activities in the first phase of the Project (Phase 1) are as follows:

- Project Kick-Off in the Four Countries
- Sector Study in the Four Countries
- Stakeholder Meetings and Report Preparation

E.2.1 Project Kick-Off

(1) UEMOA Commission's Project Kick-Off

The JICA Study Team prepared for holding the first coordination meeting with the different departments of the UEMOA Commission together with the DATC of the UEMOA Commission, as well as with the JICA Burkina Faso Office and a JICA Expert for UEMOA Commission.

1) Objectives

- To explain and discuss the Inception Report, including objectives, approaches and scope of the Project, with the counterparts from the UEMOA Commission
- To get feedback on the Inception Report from the counterparts from the UEMOA Commission

2) Date

The first coordination meeting was held on the 1st July, 2015.

3) Venue

The meeting was held in the meeting room of the DATC Office Building of the UEMOA Commission in Ouagadougou.

4) Participants

Eleven officers from various departments of the UEMOA Commission participated in the first coordination meeting. In addition, ten people from the JICA Burkina Faso office, as well as from the JICA Study Team, participated in the meeting.

Participated directions of UEMOA Commission are as follows:

- Department of Community Territorial Administration and Transport (DATC: *Département de l'Aménagement du Territoire Communautaire et des Transports*)
- Department of Business, Energy Development and Tourism (DDET: *Département du Développement de l'Entreprise, de l'Energie et du Tourisme*)
- Department of Regional Markets, Trade, Competition and Cooperation (DMRC: *Département du Marché Régional, du Commerce, de la Concurrence et de la Coopération*)
- Department of Food Security, Agriculture, Mines and Environment (DSAME: *Département de la Sécurité Alimentaire, de l'Agriculture, des Mines et de l'Environnement*)
- Directorate of Legal Affairs (DAJ: *Direction des Affaires Juridiques*)

5) Major Points of Discussion

- Various information on the present situation and on-going studies / projects were provided by the officers of the UEMOA Commission as useful input to the Project.
- Questions on the scope of the Project were raised by the UEMOA Commission side; however, many of them were answered by the JICA Study Team.

(2) Burkina Faso's First Regional-Level Joint Technical and Monitoring Committee Meeting

The JICA Study Team prepared for holding the First National-Level Joint Technical and Monitoring Committee Meeting together with the Direction Générale de la Coopération (DGCOOP) of the Ministry of Economy and Finance (MEF: *Ministère de l'Economie et des Finances*), as well as with the JICA Burkina Faso Office.

1) Objectives

- To establish the National-Level Joint Technical and Monitoring Committee (JTMC-National) for Burkina Faso
- To explain and discuss the Inception Report, including objectives, approaches and scope of the Project, with the counterparts from Burkina Faso
- To get feedback to the Inception Report from the counterparts from Burkina Faso

2) Date

The first National-Level Joint Technical and Monitoring Committee (JTMC-National) was held on the 7th July, 2015.

3) Venue

The meeting was held at the DGCOOP Building of the Ministry of the Economy and Finance in Ouagadougou.

4) Participants

28 officers of JTMC-National participated in the meeting. In addition, eleven people participated from the JICA Burkina Faso office, as well as from the JICA Study Team.

Participated counterpart institutions are as follows:

- Ministry of Economy and Finance (MEF: *Ministère de l'Economie et des Finances*)
- Ministry of Agriculture, Water Resources, Sanitation and Food Security (MARHASA: *Ministère de l'Agriculture, des Ressources Hydriques, de l'Assainissement et de la Sécurité Alimentaire*)
- Ministry of Environment and Fishery Resources (MERH: *Ministère de l'Environnement et des Ressources Halieutiques*)
- Ministry of Industry, Commerce and Handicrafts (MICA: *Ministère de l'Industrie, du Commerce et de l'Artisanat*)

- Ministry of Infrastructure, Improving Access and Transport (MIDT: *Ministère des Infrastructures, du Désenclavement et des Transports*)
- Ministry of Mines and Energy (MME: *Ministère des Mines et de l'Énergie*)
- National Executive Secretariat of Strategy for Accelerated Growth and Sustained Development (SCADD: *Stratégie de croissance accélérée et de développement durable*)
- Burkinabe Shippers Council (*Conseil Burkinabè des Chargeurs*)

5) Major Points of Discussion

In summary, the participants suggested the following points:

- It is necessary to pay attention to social problems in addition to the economic aspects in the Project.
- It is interesting to see the relationship between the increase of consumption potential in the Abidjan-Lagos Corridor and Burkina Faso.
- It is important to review the existing studies and on-going projects in relation to the Project.
- It is important to pay attention to aspects of trade facilitation for the purpose of reducing costs of transportation, in addition to corridor infrastructure and economic sector development.
- The development of highways is not enough. It is necessary to see small agricultural production.
- It is necessary to pay attention to the connection between urban and rural areas.
- Rural roads are important for increasing the contribution of corridor development.
- The importance of national corridors, not only international corridors should be noticed in relation to growth poles in remote areas.

(3) Côte d'Ivoire's First Joint Technical and Monitoring Committee Meeting

The JICA Study Team prepared for holding the First National-Level Joint Technical and Monitoring Committee Meeting together with the Ministry of Economy and Finance, as well as with the JICA Côte d'Ivoire Office.

1) Objectives

- To establish the National-Level Joint Technical and Monitoring Committee (JTMC-National) for Côte d'Ivoire.
- To explain and discuss the Inception Report, including objectives, approaches and scope of the Project, with the counterparts from Côte d'Ivoire.
- To get feedback to the Inception Report from the counterparts from Côte d'Ivoire.

2) Date

The meeting was held on the 16th July, 2015.

3) Venue

The meeting was held at a conference hall of SCIAM in Abidjan.

4) Participants

Seventeen members of the National-Level Joint Technical and Monitoring Committee participated in the meeting. In addition, thirteen people participated from the JICA Côte d'Ivoire office, as well as from the JICA Study Team.

Participated counterpart institutions are as follows:

- Ministry to the Prime Minister, in charge of Economy and Finances (*Ministère auprès du Premier Ministre chargé de l'économie et des finances*)
- Ministry to the Prime Minister, in charge of Budget (*Ministère auprès du Premier Ministre chargé du Budget*)

- Ministry of Animal and Fishery Resources (MIRAH: *Ministere des Ressources Animales et Halieutiques*)
- Ministry of Construction, Housing, Sanitation and Urban Planning (MCLAU: *Ministère de la Construction, du Logement, de l'Assainissement et de l'Urbanisme*)
- Ministry of Economic Infrastructure (MIE: *Ministère des Infrastructures Economiques*)
- Ministry of Petroleum and Energy (MPE: *Ministère du Pétrole et de l'Energie*)
- Ministry of Posts and Information Technology and Communication (MPTIC: *Ministère de la Poste et des Technologies de l'Information et de la Communication*)
- Ministry of State in charge of Planning and Development (*Ministère d'Etat, Ministère du Plan et du Développement*)
- Ministry of Transport (*Ministère des Transports*)
- Autonomous Port of Abidjan (*Port Autonome d'Abidjan*)
- Road Management Agency of Côte d'Ivoire (AGEROUTE: *Agence de Gestion des Routes*)

5) Major Points of Discussion

In summary, participants suggested the following points:

- In addition to the Abidjan-Ouagadougou Corridor, an alternative international corridor between San-Pédro (a port city of south-western part of Côte d'Ivoire), Odienné (a city of north-western part of Côte d'Ivoire) to Bamako (Mali) is important for consideration in the Project.
- At the same time, it is necessary to consider development potentials in the western part of Côte d'Ivoire.
- It is important to pay attention to the sea along the coast (Blue Corridor, 1,000 km) of four of the countries, namely, Côte d'Ivoire, Ghana, Togo and Benin.

(4) Ghana's Project Launching Seminar

In collaboration with the National Development Planning Commission (NDPC) and the Ministry of Roads and Highways (MRH), the JICA Ghana Office prepared for and organized the seminar for launching of the Project by inviting various stakeholders.

1) Objectives

- To announce the commencement of the Project
- To share the scope of the Project with a wide range of stakeholders including various ministries, government agencies, development partners and private sectors at the initial stage of the Project

2) Date

The official launching seminar for the Project was held on the 28th July, 2015.

3) Venue

The seminar was held at Best Western Hotel in Accra.

4) Participants

About 100 persons of government agencies and development partners participated in the seminar.

The Deputy Minister of Roads and Highways and Japanese Acting Ambassador opened the seminar.

5) Major Points of Discussion

- Through many questions and answers, participants showed their understanding of the nature and importance of the Project.
- Participants showed their appreciation of the sharing of information about the Project from the initial stage of the Project.
- Participants agreed to the necessity of continuing information sharing in relation to the Project.

(5) Ghana's First Technical Committee Meeting

The JICA Study Team prepared for holding the First Technical Committee Meeting together with the National Development Planning Commission (NDPC) and the Ministry of Roads and Highways, as well as with the JICA Ghana Office.

1) Objectives

- To establish the Technical Committee (TC) for Ghana
- To explain and discuss the Inception Report, including objectives, approaches and scope of the Project, with the counterparts from Ghana
- To get feedback on the Inception Report from the counterparts from Ghana

2) Date

The meeting was held on the 30th July, 2015.

3) Venue

The meeting was held at a conference room of the NDPC in Accra.

4) Participants

Eighteen members of the Technical Committee participated in the first Technical Committee Meeting. In addition, fifteen people participated from the JICA Ghana Office, as well as from the JICA Study Team.

Participated counterpart institutions are as follows:

- National Development Planning Commission (NDPC)
- Ministry of Roads and Highways (MRH)
- Ministry of Finance (MoF)
- Ministry of Food and Agriculture (MoFA)
- Ministry of Local Government and Rural Development (MLGRD)
- Ministry of Tourism, Culture and Creative Arts (MTCCA)
- Ministry of Transport (MoT)
- Ministry of Trade and Industry (MTI)
- Environmental Protection Agency (EPA)
- Ghana Highways Authority (GHA)
- Lands Commission (LC)
- Town and Country Planning Department (TCPD)

5) Major Points of Discussion

Participants in the meeting expressed and generally agreed upon the following key points:

- Although it is considered that the informal sectors, such as open markets, street vendors and lorry parks, would become a minority in the course of development and modernization, it is necessary to see the impacts on the people working in such informal sectors.
- As for adding of members to the Technical Committee, the participants decided that they will maintain the existing membership of the Technical Committee, and if any needs arise, they will co-opt any persons to the Technical Committee.
- It is necessary to improve local roads in relation to corridor development.
- The Project could be well situated in the context of NDPC's prospective long-term (40-year) development plan.
- It is necessary for the JICA Study Team to be aware of existing collaborations on various sectors between the project countries (the four countries).

- The Technical Committee for the Project will be able to play the role of the Steering Committee for SEA.

(6) Togo's First Joint Technical and Monitoring Committee Meeting

The JICA Study Team prepared for holding the First National-Level Joint Technical and Monitoring Committee (JTMC-National) Meeting together with the Directorate General for Planning, the Ministry of Economy and Finance, as well as with a JICA Expert in charge of Togo.

1) Objectives

- To establish the National-Level Joint Technical and Monitoring Committee (JTMC-National) for Togo
- To explain and discuss the Inception Report, including objectives, approaches and scope of the Project, with counterparts of Togo
- To get feedback to the Inception Report from counterparts of Togo

2) Date

The meeting was held on the 22nd July, 2015.

3) Venue

The first Joint Technical and Monitoring Committee Meeting was held at a conference room at the Ministry of Economy and Finance in Lomé.

4) Participants

33 members of the National-Level Joint Technical and Monitoring Committee participated in the first Technical Committee Meeting. In addition, fourteen people participated from the JICA Côte d'Ivoire Office, the JICA Expert in charge of Togo, as well as the JICA Study Team.

Participated counterpart institutions are as follows:

- Ministry of Economy, Finance and Development Planning (MEFP: *Ministère de l'Economie, des Finance et de la Planification du développement*)
- Ministry of Foreign Affairs, Cooperation and African Integration (MAECIA: *Ministère des Affaires Etrangères, de la Coopèration et de l'Intègration Africaine*)
- Ministry of Agriculture, Livestock and Hydraulics (MAEH: *Ministère de l'Agriculture, de l'Elevage et de l'Hydraulique*)
- Ministry of Infrastructure and Transport (MIT: *Ministère des Infrastructures et des Transports*)
- Ministry of Mines and Energy (MME: *Ministère Mines et de l'Energie*)
- Ministry of Commerce, Industries, Private Sector Promotion and Tourism (MCIPSPT: *Ministère Commerce, de l'Industrie, de la Promotiom du secteur privé et du Tourisme*)
- Ministry of Urban Planning, Habitat and Living Environment (MUHCV: *Ministère de l'Urbanisme, de l'Habitat et du Cadre de vie*)
- Ministry of Post and Digital Economy (MPEN: *Ministère des Postes et de l'Economie Numérique*)
- Ministry of Environment and Forestry Resources (MERF: *Ministère de l'Environnement et des Ressources Forestières*)
- Autonomous Port of Lomé (*Port Autonome de Lomé*)
- Presidential Office of the Republic of Togo (*Présidence de la Republic Togolaise*)
- National Institute of Statistics and Economic and Demographic Studies (INSEED: *Institut National de la Statistique et des Etudes Economiques et Démographiques*)
- Togo Invest Corporation
- Togo Revenue Authority (OTR: *Office Togolais des Recettes*)

5) Major Points of Discussion

- It is necessary to consider not only producing raw materials, but also to process agricultural products in the Project, including bio-energy.
- It is important to integrate the Millennium Development Goals (mostly social development goals) into the Project.
- It is important to pay attention to Benin in sub-regional integration and corridor development.
- If we seek balanced development between coastal and hinterland areas, we also need to consider the integration with the eastern side and western side of Togo.

E.2.2 Sector Study

(1) Sector Study on UEMOA Commission and Burkina Faso

Sector experts of the JICA Study Team intensively conducted sector studies on the UEMOA Commission and Burkina Faso by staying in Burkina Faso from 10th August to 14th August, and 14th September to 16th September, 2015.

(2) Sector Study on Côte d'Ivoire

Sector experts from the JICA Study Team intensively conducted sector studies on Côte d'Ivoire by staying in Côte d'Ivoire from 17th August to 28th August, 2015.

(3) Sector Study on Ghana

Sector experts from the JICA Study Team intensively conducted sector studies on Ghana by staying in Ghana from 31st August to 4th August, 2015.

(4) Sector Study on Togo

Sector experts from the JICA Study Team intensively conducted sector studies on Togo by staying in Togo from 7th September to 11th September, 2015.

E.2.3 Stakeholder Meetings for Planning and SEA

(1) Burkina Faso's First Stakeholder Meeting for Planning and SEA

The JICA Study Team prepared for holding of the First Stakeholder Meeting for Planning and SEA in Burkina Faso, together with the DGCOOP of the Ministry of Economy and Finance.

1) Objectives

- To initiate a series of stakeholder meetings for planning and SEA in Burkina Faso
- To explain and discuss the objectives, approaches and scope of the Project
- To discuss issues on corridor development and environment in Burkina Faso

2) Date

The meeting was held on 16th September, 2015.

3) Venue

The meeting was held at the conference room of Splendid Hotel in Ouagadougou.

4) Participants

The total number of participants: 70 participants

- 11 participants from the following ministries and authorities at the national level:
 - Ministry of Economy and Finance (MEF)
 - Ministry of Agriculture, Water Resources, Sanitation and Food Security (MARHASA)

- Ministry of Environment and Fishery Resources (MERH)
- Ministry of Industry, Commerce and Handicrafts (MICA)
- Ministry of Mines and Energy (MME)
- Ministry of Infrastructure, Improving Access and Transport (MIDT)
- National Environmental Assessment Bureau (BUNEE: *Bureau National des Evaluations Environnementales*)
- National Executive Secretariat of SCADD
- 38 participants from the regional offices of the following regions:
 - Centre Region
 - Centre-Ouest Region
 - Haut-Bassins Region
 - Nord Region
 - Centre-Nord Region
 - Est Region
 - Sud-Ouest Region
 - Centre-Est Region
 - Boucle du Mouhoun Region
 - Centre-Sud Region
 - Cascades Region
 - Sahel Region
 - Plateau Central Region
- 2 participants from the offices of the following communes:
 - Commune of Ouagadougou
 - Commune of Bobo-Dioulasso
- 4 participants from the following NGOs:
 - Green Cross
 - Hunger Project Burkina
 - OXFAM Solidarite Belgique
 - SOS Sahel International
- 2 participants from the following private sector organizations:
 - Burkina Shippers Council (CBC)
 - Chamber of Commerce and Industry of Burkina Faso (CCI-BF: *Chambre de Commerce et d'Industrie du Burkina Faso*)
- Others (including JICA Burkina Faso Office and JICA Study Team):13

(2) Côte d'Ivoire's First Stakeholder Meeting for Planning and SEA

The JICA Study Team prepared for holding of the First Stakeholder Meeting for Planning and SEA in Côte d'Ivoire, together with the Ministry to the Prime Minister, in charge of Economy and Finances.

1) Objectives

- To initiate a series of stakeholder meetings for planning and SEA in Côte d'Ivoire
- To explain and discuss the objectives, approaches and scope of the Project
- To discuss issues on corridor development and environment in Côte d'Ivoire

2) Date

The meeting was held on 2nd October 2015.

3) Venue

The meeting was held at the conference room of Hotel Ivotel in Abidjan.

4) Participants

The total number of participants was 53 participants.

- 24 participants from the following ministries and authorities at the national level:
 - Ministry to the Prime Minister, in charge of Economy and Finances
 - Ministry to the Prime Minister, in charge of Budget
 - Ministry of Construction, Housing, Sanitation and Urban Planning (MCLAU)
 - Ministry of Agriculture (*Ministère de l'Agriculture*)
 - Ministry of Economic Infrastructure (MIE)
 - Ministry of Industry and Mines (*Ministère de l'Industrie et des Mines*)
 - Ministry of Transport
 - Ministry of Petroleum and Energy (MPE)
 - Ministry of State in charge of Planning and Development
 - Autonomous Port of Abidjan
 - Investment Promotion Centre in Côte d'Ivoire (CEPCI: *Centre de Promotion des Investissements en Côte d'Ivoire*)
 - National Agency for Environment (ANDE: *Agence Nationale de l'Environnement*)
 - Road Management Agency of Côte d'Ivoire (AGEROUTE)
- 11 participants from the regional offices of the following regions:
 - Agneby-Tiassa Region (Agboville)
 - Bafing Region (Touba)
 - Bounkani Region (Bouna)
 - Tchologo Region (Ferkessédougou)
 - Guémon Region (Duékoué)
 - Grands Ponts Region (Dabou)
 - Indenie-Djuablin Region (Abengourou)
 - Lagunes Region (Abidjan)
 - Sud-Comoe Region (Aboisso)
- 2 participants from the following communes:
 - Autonomous District of Abidjan
 - Bouake
- 2 participants from the following NGOs:
 - Côte d'Ivoire-Ecologie (CIECO)
 - Federation of the Networks and Associations of Energy, Environment and Sustainable Development (FEREADD: *Fédération des Réseaux et Associations de l'Energie, de l'Environnement et du Développement Durable*)
- 3 participants from the following private sector organizations:
 - Movement of Small and Medium-Sized Enterprises (MPME: *Mouvement des Petites et Moyennes Entreprises de Côte d'Ivoire*)
 - National Federation of Secular Private Training Institutions in Côte d'Ivoire (FENEPLACI: *Fédération Nationale des Etablissements Privés Laïcs d'Enseignement et de Formation de Côte d'Ivoire*)
- Others (including JICA Côte d'Ivoire Office and the JICA Study Team): 12

(3) Ghana's First Stakeholder Meeting for Planning and SEA

In Ghana, the First Stakeholder Meetings for Planning and SEA were held in August and September 2016 in the districts.

(4) Togo's First Stakeholder Meeting for Planning and SEA

The JICA Study Team prepared for holding of the First Stakeholder Meeting for Planning and SEA in Togo, together with the Directorate General of Planning of the Ministry of Economy, Finance and Development Planning.

1) Objectives

- To initiate a series of stakeholder meetings for planning and SEA in Togo
- To explain and discuss the objectives, approaches and scope of the Project
- To discuss issues on corridor development and environment in Togo

2) Date

The meeting was held on 9th September, 2015.

3) Venue

The meeting was held at the conference room of Hotel Ibis Lomé Centre in Lomé.

4) Participants

The total number of participants: 50 participants

- 25 participants from the following ministries and authorities at the national level
 - Ministry of Economy, Finance and Development Planning (MEFP)
 - Ministry of Agriculture, Livestock and Hydraulics (MAEH : *Ministère de l'Agriculture, de l'Élevage et de l'hydraulique*)
 - Ministry of Environment and Forest Resources (MERF)
 - Ministry of Foreign Affairs, Cooperation and African Integration (MAECIA)
 - Ministry of Infrastructure and Transport (MIE)
 - Ministry of Posts and Digital Economy (MPEN)
 - Ministry of Urban Planning, Habitat and Living Environment (MUHCV)
 - National Agency for Environmental Management (ANGE: *Agence Nationale de Gestion de l'Environnement*)
 - National Institute of Statistics and Economic and Demographic Studies (INSEED: *Institut National de la Statistique et des Etudes Economiques et Démographiques*)
- 9 participants from the following regional offices:
 - Savanes Region (Dapaong)
 - Kara Region (Kara)
 - Centrale Region (Sokodé)
 - Plateaux Region (Atakpamé)
 - Maritime Region (Tsevie)
- 7 participants from the following NGOs:
 - Federation of Non-Governmental Organizations of Togo (FONGTO: *Fédération des Organisations Non Gouvernementales au Togo*)
 - Les Amis de la Terre-Togo
 - Togolese Coordination of Farmer Organizations and Agricultural Producers (CTOP: *Coordination Togolaise des Organisations Paysannes et de Producteurs Agricoles*)
 - Union of NGOs of Togo (UONGTO: *Union des ONG du Togo*)
 - Young Volunteers for the Environment (JVE: *Jeunes Volontaires pour l'Environnement*)

- 5 participants from the following private sector organizations:
 - Chamber of Commerce and Industry of Togo (CCIT: *Chambre de Commerce et d'Industrie du Togo*)
 - National Centre for Computer Studies (CENETI: *Centre National d'Etudes et de Traitements Informatiques*)
 - National Council of the Patronage of Togo (CNP-Togo: *Conseil National du Patronat du Togo*)
 - Togo National Shippers Council (CNCT: *Conseil National des Chargeurs du Togo*)
- Others (including JICA Côte d'Ivoire office and JICA Study Team): 4 participants

E.3 Project Activities in Phase 2

The major project activities in the second phase of the Project (Phase 2) were as follows:

- Counterpart Training in Japan
- Approval of the Inception Report
- Explanation and Discussion on the Progress Report (the First Study Report)
- Sector Study in the Four Countries
- Discussion on the Abidjan-Lagos Corridor
- Preparation of the Interim Report (the Second Study Report)

E.3.1 Counterpart Training in Japan (Study Tour in Japan)

The counterpart training was conducted in Japan in January 2016 by inviting 23 counterparts. This was the first time for the main counterparts of the Project to be gathered together.

In the first week the counterparts went on a study tour to gain a better understanding about corridor development. In the second week, several series of meetings were conducted to obtain a common understanding of this corridor development master plan. On the last day of the training, the Yokohama Declaration was adopted by the counterparts.

(1) Objectives

- To observe and understand Japanese experiences of transport corridor development and regional development
- To develop an action plan to be implemented by each of the trainees, based on learning from training in Japan
- To have joint workshops among the four countries, as well as UEMOA Commission

(2) Schedule

The training was from 16th January until 31st January, 2016. The detailed schedule of the training is as shown in Table E.3.1.

Table E.3.1 Schedule of Counterpart Training in Japan

Date	Time	Type of Training	Lectures, Visits and Meetings
1/18 Mon	9:00-12:00	Lecture	AM: Orientation
	13:10-14:40	Lecture	PM1: Overview of Yokohama Port (Yokohama City Port Authority)
	15:15-16:15	Site Visit	PM2: Visit Yokohama Port (Yokohama City Port Authority)
1/19 Tue	9:00-9:30	Lecture	AM1: Overview of Yokohama Port Customs (Yokohama Port Customs)
	9:50-12:00	Site Visit	AM2: Yokohama Port Customs (Yokohama Port Customs)
	14:30-16:00	Site Visit	PM1: Keihin Truck Terminal (Japan Motor Terminal)
	17:00-18:00	Meeting	PM2: Review Session (JICA Study Team)
1/20 Wed	10:00-11:30		AM1: Move by Expressway from Tokyo to Laran Fujioka (Roadside Station) via Tokyo Metropolitan Outer-Outer Ring Road
	11:30-12:30	Lecture	AM2: Laran Fujioka (Roadside Station)
	13:30-14:30	Site Visit	PM1: Laran Fujioka (Roadside Station)
	16:00-17:00	Lecture	PM3: Presentation about Project
1/21 Thu	9:00-12:00	Lecture	AM: Overview of Agriculture and Industry in Nagano Prefecture (Nagano Prefectural Government)
	14:00-14:45	Site Visit	PM: Visit Market (Nagano Prefectural Government)
1/22 Fri	8:30-12:30		AM: Move to Aichi Prefecture from Nagano Prefecture
	14:00-16:00	Site Visit	PM1: Heavy Industry at the Coastal Area (Nippon Steel and Sumitomo Metal)
	17:00-18:00	Meeting	PM2: Review Session
1/23 Sat	9:30-11:00	Site Visit	AM1: Go around and see heavy industrial area in Chubu coastal area
	11:00-12:00	Lecture	AM2: Industrial Development and Urban Environment Management
	14:00-15:30		PM: Move to Tokyo (by Shinkansen)
1/24 Sun			Off Day
1/25 Mon	9:00-14:00	Presentation	AM1: West Africa Growth Ring Master Plan - Country Potential Seminar-
	14:10-15:30	Lecture	PM1: Session by JICA Africa Division
	15:45-17:30	Lecture	PM2: Japan's Post-war Regional Development and Industrial Development (JICA Study Team)
1/26 Tue	9:00-12:00		AM: Courtesy Call
	14:00-16:00	Meeting	PM1: Individual Country Meeting (UEMOA Commission)
	16:00-18:00	or Site Seeing	PM2: Individual Country Meeting (Côte d'Ivoire)
1/27 Wed	10:00-12:00	Meeting	AM: Individual Country Meeting (Burkina Faso)
	13:00-15:00	Meeting	PM1: Individual Country Meeting (Togo)
	15:00-17:30	or Site Seeing	PM2: Individual Country Meeting (Ghana)
1/28 Thu	10:00-12:30	Meeting	AM: Regional-Level JTMC Meeting (3 Countries + UEMOA Commission)
	14:00-16:30	Meeting	PM: 4-Country Joint Workshop together with UEMOA Commission
1/29 Fri	10:00-17:00	Workshop & Presentation	AM&PM: Action Plan Preparation (4-Country Joint Workshop with UEMOA Commission)
	19:00-20:00		Closing Dinner

Source: JICA Study Team

(3) Participants

For this study tour in Japan, the following counterparts from UEMOA Commission and four countries were invited to Japan:

1) Commission of West African Economic and Monetary Union (UEMOA Commission):

- Mr. Emmanuel Gouali YORO: Director of Cabinet, Department of Community Territorial Administration and Transport (DATC), UEMOA
- Mr. Koffi N'GOYET: Technical Advisor, Department of Enterprise, Energy and Tourism, UEMOA Commission
- Mr. Adebayo Samson BALOGOUN: Chief of the Maritime Transport, DATC, UEMOA Commission
- Mr. Christian Emmanuel A. SEGBO: Trade Promotion Expert, Department of Regional Market, Commerce and Cooperation, UEMOA Commission
- Mr. Amevi Edoe APEZOU MON-AGBETIAFA: Water Resources Expert, Department of Food, Agriculture, Mines and Environment, UEMOA Commission

2) Burkina Faso

- Mr. Amidou OUEDRAOGO: Director of Bilateral Cooperation / Directorate General of Cooperation / Ministry of Economy and Finances
- Mr. Moise OUEDRAOGO: General Director / General Direction of Studies and Sectorial Statistics / Ministry of Mines and Energy
- Ms. Kiswendsida Alice OUEDRAOGO: Executive Director / General Direction of Studies and Sectorial Statistics / Ministry of Infrastructure, Improving Access and Transport

3) Côte d'Ivoire

- Mr. Kouassi Jacob AKOUSSI: Energy Senior Advisor / Cabinet of Ministry / Ministry of Petroleum and Energy
- Mr. Kouadio Bernard TANO: Advisor of General Manager / Department of Road Infrastructure / Ministry of Economic Infrastructure
- Mr. Kaladji FADIGA: General Manager / Department of International Trade / Ministry of Commerce
- Mr. Gnominibori Henri OUATTARA: In charge of Projects Evaluation / Asia Department / Ministry to Prime Minister in charge of Economic and Finance
- Mr. Gozia Yves BLESSE: Head of Planning Service / Department of Planning and Finance / Ministry of Agriculture

4) Ghana

- Mr. Nii Moi THOMPSON: Director-General / Office of The Director-General / National Development Planning Commission
- Mr. Edmund OFFEI-ANNOR: Director / Policy & Planning / Ministry of Roads and Highways
- Mr. Otchere BAFFOUR AWUAH: Deputy Director / Plan Coordination / National Development Planning Commission
- Ms. Efua EFFAH: Senior Engineer / Policy and Planning / Ministry of Roads and Highways
- Ms. Matilda Mankosah ANNOR: Economic Officer / External Resource Mobilization / Ministry of Finance and Economic Planning

5) Togo

- Mr. Etsri HOMEVOR: Secretary General / Ministry of Planning and Development
- Mr. Baroma Magolemiena BAMANA: Secretary General / Ministry of Commerce and Industry

- Mr. Raouf GAFO: Study officer / Minister's office / Ministry of Mines and Energy
- Ms. Jamila DAODOU: Regional Director/ Ministry of Infrastructure and Transport

(4) Meetings conducted during the Study Tour in Japan

The technical meetings for explanation and discussion on alternative scenarios of sub-regional corridor development were organized on the following dates in the second week of the study tour in Japan:

- Individual Meeting with UEMOA Commission: 26th January 2016
- Individual Country Meeting with Côte d'Ivoire: 26th January 2016
- Individual Country Meeting with Burkina Faso: 27th January 2016
- Individual Country Meeting with Togo: 27th January 2016
- Individual Country Meeting (Ghana): 27th January 2016
- These individual meetings were followed by regional-level meetings and joint meeting as follows:
- Regional-Level JTMC Meeting (participated in by UEMOA Commission, Burkina Faso, Côte d'Ivoire and Togo): 28th January 2016
- Joint Meeting (participated by UEMOA Commission and 4 Countries): 28th January 2016

(5) Yokohama Declaration

As a result of the discussions on 29th January 2016, the participants agreed on the following principles and wrote them down in a memorandum as the “Yokohama Declaration”:

- To broaden the scope of the four major corridors (Abidjan-Ouagadougou, Lomé-Ouagadougou, Accra-Ouagadougou, and Abidjan- Lagos) to be studied to include new secondary corridors for Master Plan Preparation.
- To formulate One Master Plan for the four Countries
- To adopt the phased approach to the development of the master plan
- To adopt Sub-Regional Scenarios for Corridor Development
- To adopt Process/Steps for Master Plan Preparation and Approval

The delegations from UEMOA Commission and four countries also set their own Action Plans in relation to WAGRIC and attached them to the Yokohama Declaration.

E.3.2 Approval of the Inception Report

(1) UEMOA Commission's First JTMC-Regional

On 24th February 2016, the first JTMC-Regional was conducted by UEMOA Commission through video conference. Prior to the meeting, Burkina Faso, Côte d'Ivoire and Togo submitted the results of discussions on the Inception Report within their own countries to UEMOA Commission.

Counterparts from Côte d'Ivoire were able to attend the meeting through UEMOA Commission's video conference network. JICA Burkina Faso and JICA Côte d'Ivoire also attended the meeting as observers.

(2) Ghana's First Steering Committee

1) Objectives

- To introduce and explain about the Project
- To share the Progress Report
- To present and to have discussions on corridor development alternative scenarios

2) Date

The First Steering Committee Meeting was held on the 9th of March, 2016.

3) Venue

The meeting was held at a conference room of the NDPC in Accra.

4) Participants

11 members of the Steering Committee participated in the First Steering Committee Meeting. In addition, 6 people participated from the JICA Ghana office, as well as from the JICA Study Team.

5) Major Points of Discussion

- It was agreed that the structure of the final report will be one master plan containing individual country sections. The one master plan should be in line with the national development policies and plans of the four countries.
- The discussions on the coastal corridor development should be done among the four countries rather than between ECOWAS and UEMOA.
- The Steering Committee and Joint Steering Committee should meet each other in order to avoid overlapping among national plans, ECOWAS plans, UEMOA plans and private sector plans.
- Having an integrated industry development in the four countries for the sub-region will add value to raw materials and increase productivity and income.

E.3.3 Explanation and Discussion on the Progress Report

(1) Ghana's Second Technical Committee Meeting

1) Objectives

- To explain about the Progress Report and to get feedback regarding the Progress Report
- To present and to discuss sub-regional corridor development alternative scenarios

2) Date

The Second Technical Committee Meeting was held on the 11th February, 2016.

3) Venue

The meeting was held at a conference room of the NDPC in Accra.

4) Participants

27 members of the Technical Committee participated in the Second Technical Committee Meeting. In addition, 10 people participated from the JICA Ghana office, as well as from the JICA Study Team.

Participated counterpart institutions are as follows:

- National Development Planning Commission (NDPC)
- Ministry of Finance (MoF)
- Ministry of Local Government and Rural Development (MLGRD)
- Ministry of Roads and Highways (MRH)
- Ministry of Tourism, Culture and Creative Arts (MTCCA)
- Ministry of Trade and Industry (MTI)
- Ministry of Transport (MoT)
- Town and Country Planning Department (TCPD)
- Environmental Protection Agency (EPA)
- Ghana Highways Authority (GHA)

- Lands Commission (LC)

5) Major Points of Discussion

- As for alternative scenarios, the Technical Committee members of Ghana emphasized the importance of railway in the future. Although Ghana has a railway masterplan, a strategic framework for implementation is lacking. It is required to reconsider implementation strategies for railway development.
- The SEA study and process for Ghana has been stranded for the last 5 months due to different approaches on SEA between EPA and the JICA Study Team. However, after the discussion held in this Technical Committee Meeting, it was decided that organizations concerned about the SEA for the Project should find a common ground.

(2) Togo's Second JTMC-National Meeting

1) Objectives

- To explain about the Progress Report and to get feedback regarding the Progress Report
- To present and to discuss sub-regional corridor development alternative scenarios

2) Date

The Second Technical Committee Meeting was held on the 15th February, 2016.

3) Venue

The meeting was held at conference room at the Ministry of Economy and Finance and Development Planning in Lomé.

4) Participants

40 members of the National-Level Joint Technical and Monitoring Committee participated in the meeting. In addition, 10 people participated including the JICA Expert in charge of Togo, as well as from the JICA Study Team.

Participated counterpart institutions are as follows:

- Ministry of Planning and Development
- Ministry of Agriculture, Livestock and Hydraulics
- Ministry of Commerce, Industry, Private Sector Promotion and Tourism
- Ministry of Infrastructure and Transport
- Ministry of Mines and Energy
- Ministry of Post and Economy
- Ministry of Urban Planning, Habitat and Living Environment
- Autonomous Port of Lomé
- Presidential Office of the Republic of Togo
- Management Company of Free Zones
- Union of Non-Governmental Organizations in Togo
- Chamber of Commerce and Industry of Togo
- Collective of the Civil Society Organizations of the Maritime Region
- National Council of the Togolese Patronage
- Federation of Non-Governmental Organizations of Togo
- National Federation of NGO Regional Networks

5) Major Points of Discussion

- There was a strong request that the tourism sector should be considered as one of the targeted economic sectors in this study.

- It is important to pay attention to both the maritime corridor and the terrestrial corridor in the corridor development.
- At the national level, it is important to carefully look at development of different regions through corridor development in Togo.

(3) Côte d'Ivoire's Second JTMC-National Meeting

1) Objectives

- To explain about the Progress Report and to get feedback to the Progress Report
- To present and to discuss sub-regional corridor development alternative scenarios

2) Date

The meeting was held on the 2nd March, 2016.

3) Venue

The meeting was held at conference room at Hotel Ivotel Annex in Abidjan.

4) Participants

20 members of the National-Level Joint Technical and Monitoring Committee participated in the meeting. In addition, 13 people participated from the JICA Côte d'Ivoire Office, as well as from the JICA Study Team.

Participated counterpart institutions are as follows:

- Ministry to the Prime Minister, in charge of the Budget and the State Portfolio
- Ministry to the Prime Minister, in charge of Economy and Finances
- Ministry of Agriculture and Rural Development
- Ministry of Commerce
- Ministry of Post and Digital Economy
- Ministry of National Entrepreneurship, Crafts and Promotion of SMEs
- Ministry of Industry and Mines
- Ministry of Economic Infrastructure
- Ministry of African Integration and Ivoirians Abroad
- Ministry of Petroleum and Energy
- Ministry of Planning and Development
- Ministry of Animal and Fish Resources
- Ministry of Transport
- Autonomous Port of Abidjan
- Road Management Agency of Côte d'Ivoire
- National Agency for the Environment
- Investment Promotion Centre in Côte d'Ivoire

5) Major Points of Discussion

- The JTMC-National members of Côte d'Ivoire emphasised the importance of the San-Pédro-Lagos Corridor rather than the Abidjan-Lagos Corridor.
- The sub-corridor passing through San-Pédro, Daloa, Seguela, Kani, Tingrela and Bamako needs to be included as a target corridor for the study.
- A group discussion session was held at Côte d'Ivoire's JTMC-National meeting. In the beginning of the discussion, north-south corridor development was actually preferred by quite a few participants. However, at the end of the discussion session, two groups out of three reached

the conclusion that west-east (Abidjan-Lagos) corridor development would give more benefits to the country.

(4) Burkina Faso's Second JTMC-National Meeting

1) Objectives

- To explain about the Progress Report and to get feedback regarding the Progress Report
- To present and to discuss sub-regional corridor development alternative scenarios

2) Date

The second Joint Technical and Monitoring Committee meeting for Burkina Faso was held on the 16th March, 2016.

3) Venue

The meeting was held at conference room at the Building of DGCOOP, the Ministry of Economy and Finance in Ouagadougou

4) Participants

23 members of the National-Level Joint Technical and Monitoring Committee participated in the meeting. In addition, 17 people participated from the JICA Burkina Faso Office, as well as from the JICA Study Team.

Participated counterpart institutions are as follows:

- Ministry of Economy, Finance and Development
- Ministry of Agriculture, Water Resources, Sanitation and Food Security
- Ministry of Development of Digital Economy and Posts
- Ministry of Mines and Energy
- Ministry of Environment of the Green Economy and Climate Change
- Ministry of Environment and Fishery Resources
- Ministry of Industry, Commerce and Handicrafts
- Ministry of Transport, Urban Mobility and Road Safety
- National Office of Environmental Assessment
- Burkina Faso Chamber of Industry and Commerce
- Burkinabe Shippers Council

5) Major Points of Discussion

- Involvement of all actors in the WAGRIC-CACAO Study is necessary.
- Existing projects of UEMOA and ECOWAS should be taken into account in the WAGRIC Study.
- It is important to evaluate scenarios from a perspective of which scenario would not create more imbalanced development among the four countries.
- It is also important to develop the capacities of the actors, especially transportation actors.

(5) UEMOA Commission's Second Monitoring Meeting

1) Objectives

- To explain about the Progress Report and to get feedback regarding the Progress Report
- To present and to discuss sub-regional corridor development alternative scenarios

2) Date

The second Monitoring Committee Meeting was held on the on the 15th of March, 2016.

3) Venue

The Meeting was held at the meeting room at the UEMOA Commission Building in Ouagadougou

4) Participants

16 members from various departments of UEMOA Commission participated in the meeting. In addition, 12 people participated including officers of JICA Burkina Faso Office, and a JICA Expert, as well as members of the JICA Study Team.

Participated directions of UEMOA Commission are as follows:

- Department of Community Territorial Administration and Transport (DATC)
- Department of Business, Energy Development and Tourism (DDET)
- Department of Regional Markets, Trade, Competition and Cooperation (DMRC)
- Department of Food Security, Agriculture, Mines and Environment (DSAME)

5) Major Points of Discussion

- Combination of two scenarios (north-south corridors and Abidjan-Lagos corridor) was generally accepted by the participants. However, it is pointed out that rural roads linking the corridors and production areas are required.
- It is important to pay attention to whether or not UEMOA Commission already has similar plans to proposals of the JICA Study Team. If there are such similar plans, it is important to find common points between them.
- It is important to analyse such links between the corridors and production areas, and integration between different sectors.

E.3.4 Sector Study

(1) Sector Study on Ghana

Sector experts from the JICA Study Team intensively conducted sector studies on Ghana by staying in Ghana from 22nd February to 26th February, 2016.

(2) Sector Study on Côte d'Ivoire

Sector experts from the JICA Study Team intensively conducted sector studies on Côte d'Ivoire by staying in Côte d'Ivoire from 29th February to 4th March, 2016.

(3) Sector Study on Togo

Sector experts from the JICA Study Team intensively conducted sector studies on Togo by staying in Togo from 7th March to 11th March, 2016.

(4) Sector Study on UEMOA Commission and Burkina Faso

Sector experts of the JICA Study Team intensively conducted sector studies on the UEMOA Commission and Burkina Faso by staying in Burkina Faso from 14th March to 18th March, 2016.

E.3.5 Discussion on Abidjan-Lagos Corridor

For three weeks from 4th April till 23rd April, the JICA Study Team conducted site visits and meetings with relevant organizations in the three countries, namely Côte d'Ivoire, Ghana and Togo, along the Abidjan-Lagos Corridor.

The objectives of organizing discussion meetings are to initiate discussions covering the following points:

- To discuss spatial concepts of the Abidjan-Accra-Lomé-Cotonou-Lagos Corridor

- To review existing urban master plans of metropolitan areas in the Abidjan-Accra-Lomé-Cotonou-Lagos Corridor
- To review projects of major roads including Abidjan-Accra-Lomé-Cotonou-Lagos Motorway
- To discuss the spatial structure of each country of Abidjan-Accra-Lomé-Cotonou-Lagos Corridor
- To consider how to situate the Abidjan-Accra-Lomé-Lagos Motorway in metropolitan areas, such as Abidjan, San-Pedro, Accra, Sekondi-Takoradi and Lomé in the Abidjan-Accra-Lomé-Cotonou-Lagos Corridor
- To consider how to connect the Abidjan-Accra-Lomé-Cotonou-Lagos Corridor with north-south corridors
- To consider how to secure the connectivity of major ports (Abidjan, San-Pedro, Accra, Sekondi-Takoradi and Lomé) with north-south corridors and the Abidjan-Accra-Lomé-Cotonou-Lagos Motorway

(1) Discussion Meeting with District Autonome d'Abidjan (DAA) of Côte d'Ivoire

1) Date

The meeting was held on 6th April, 2016

2) Venue

Office of District Autonome d'Abidjan (DAA)

3) Participants

- 11 people from various departments of DAA
- 8 members of the JICA Study Team

(2) Discussion Meeting with Ministry of Construction and Urban Planning (MCU) of Côte d'Ivoire

1) Date

The meeting was held on 7th April, 2016

2) Venue

Office of Ministry of Construction and Urban Planning (MCU)

3) Participants

- 6 officers of Direction de l'Urbanisme, MCU
- 8 members of the JICA Study Team

(3) Discussion Meeting with Ministry of Economic Infrastructure (MIE) of Côte d'Ivoire

1) Date

The meeting was held on the 7th April, 2016

2) Venue

Ministry of Economic Infrastructure (*Ministère des Infrastructures Economiques*, MIE)

3) Participants

- 9 officers of MIE including technical advisors
- 1 officer of AGEROUTE
- 5 members of the JICA Study Team

(4) Discussion Meeting with Ghana

1) Date

The meeting was held on the 15th April, 2016

2) Venue

Conference Room of NDPC

3) Participants

- 9 persons participated from the Ghana side.
 - Ministry of Roads and Highways (MRH)
 - National Development Planning Commission (NDPC)
 - Ministry of Transport (MoT)
- 2 officers of the JICA Ghana Office
- 6 members of the JICA Study Team

(5) Discussion Meeting with MSC Togo

1) Date

The meeting was held on on 20th April, 2016

2) Venue

Office of MSC in Lomé

3) Participants

- 1 director of MSC Togo
- 5 members of the JICA Study Team

(6) Discussion Meeting with Togo

1) Date

On 21st of April, 2016

2) Venue

Conference Room of Ministry of Economy, Finance and Planning of Togo

3) Participants

- 20 persons from various organizations like those shown below participated in the meeting.
 - Ministry of Planning and Development and Territorial Development (*Ministre de la Planification, du Développement et de l'Aménagement du Territoire*)
 - SAZOF (*Société d'Administration des Zones Franches*)
 - Ministry of Urban Planning, Habitat and Living Environment (*Ministre de l'Urbanisme, de l'Habitat et du Cadre de Vie, MUHCV*)
 - Togo Invest Corporation
 - ANAC-Togo (*Agence Nationale de l'Aviation Civile du Togo*)
 - Ministry of Foreign Affairs, Cooperation and African Integration (*Ministère des Affaires Étrangères, de la Coopération et de l'Intégration Africaine, MAECIA*)
 - Ministry of Mines and Energy (*Ministere des Mines et de l'Energie*)
 - MCIPSPT (*Ministère du Commerce, de l'Industrie, de la Promotion du Secteur Privé et du Tourisme*)
 - Ministry of Infrastructure and Transport (*Ministre des Infrastructures et des Transports , MIT*)

➤ *AGETUR (Agence d'Exécution des Travaux Urbains) -Togo*

- 1 JICA Expert
- 7 members of the JICA Study Team

(7) Discussion Meeting with Togo Invest

1) Date

The meeting was held on 22nd April, 2016

2) Venue

Office of Togo Invest in Lomé

3) Participants

- 1 Director and employees from 1 office of Togo Invest in Lomé
- 5 members of the JICA Study Team

E.4 Project Activities in Phase 3

The major project activities in the third phase of the Project (Phase 3) were as follows:

- Explanation and Discussion on the Interim Report (the Second Study Report)
- Sector Study in the Four Countries
- Regional-Level Joint Technical Monitoring Committee (JTMC-R) in Ouagadougou
- Preparation of the Draft Final Report
- Explanation and Discussion on the Draft Final Report (the Third Study Report)
- Sector study on urban water supply in Abidjan

E.4.1 Explanation and Discussion on the Interim Report

(1) Ghana's Third Technical Committee Meeting

1) Objectives

- To explain about the Interim Report and to get feedback to the Interim Report
- To present and to discuss about country corridor development scenarios

2) Date

The meeting was held on the 20th of June, 2016.

3) Venue

The meeting was held at a conference room of the NDPC in Accra.

4) Participants

20 members of the Technical Committee participated in the Third Technical Committee Meeting. In addition, 13 people participated from the JICA Ghana office, as well as from the JICA Study Team.

Participated counterpart institutions are as follows:

- National Development Planning Commission
- Ministry of Foreign Affairs and Regional Integration
- Ministry of Roads and Highways
- Ministry of Petroleum
- Ministry of Trade and Industry
- Ministry of Transport

- UNFPA
- Environmental Protection Agency
- Ghana Highways Authority
- Ghana Revenue Authority
- Lands Commission

(2) Côte d'Ivoire's Third JTMC-National Meeting

1) Objective

- To explain about the Interim Report and to get feedback to the Interim Report
- To present and to discuss about three country corridor development scenarios

2) Date

The meeting was held on the 28th of June, 2016

3) Venue

The meeting was held at the conference room of Hotel Ivotel Annex in Abidjan.

4) Participants

22 members of the National-Level Joint Technical and Monitoring Committee participated in the meeting. In addition, 15 people participated from the JICA Côte d'Ivoire Office, as well as from the JICA Study Team.

Participated counterpart institutions are as follows:

- Ministry to the Prime Minister, in charge of the Budget and the State Portfolio
- Ministry to the Prime Minister, in charge of Economy and Finances
- Ministry of Water and Forests
- Ministry of the Digital Economy and Posts, Spokesman of the Government
- Ministry of National Entrepreneurship, Crafts and Promotion of SMEs
- Ministry of Economic Infrastructure
- Ministry of African Integration and Ivorians Abroad
- Ministry of Petroleum and Energy
- Ministry of Planning and Development
- Observatory of Transport Fluidity
- National Drinking Water Authority
- Office of the Ivorian Chargers
- Road Management Agency of Côte d'Ivoire
- National Agency for the Environment
- Investment Promotion Centre in Côte d'Ivoire
- Abidjan Autonomous District
- Autonomous Port of San Pedro

(3) Togo's Third JTMC-National Meeting

1) Objectives

- To explain about the Interim Report and to get feedback to the Interim Report
- To present and to discuss about three country corridor development scenarios

2) Date

On the 29th of June, 2016

3) Venue

The meeting was held at a conference room at the Ministry of Economy and Finance and Development Planning in Lomé.

4) Participants

43 members of the National-Level Joint Technical and Monitoring Committee participated in the meeting. In addition, 12 people participated including the JICA Expert in charge of Togo, as well as from the JICA Study Team.

Participated counterpart institutions are as follows:

- Ministry of Planning and Development
- Ministry of Infrastructure and Transport
- Ministry of Foreign Affairs, Cooperation and African Integration
- Ministry of Agriculture, Livestock and Hydraulics
- Ministry of Commerce, Industry, Private Sector Promotion and Tourism
- Ministry of Environment and Forest Resources
- Ministry of Mines and Energy
- Ministry of Post and Digital Economy
- Ministry of Urban Planning, Habitat and Living Environment
- United Nations Industrial Development Organization
- Autonomous Port of Lomé
- Presidency of the Republic of Togo
- Management Company of Free Zones
- Togo Invest Corporation
- Union of Non-Governmental Organizations of Togo
- Executing Agency of Urban Work
- Postal and Telecommunications Regulatory Authority
- Chamber of Commerce and Industry of Togo
- National Council of the Togolese Patronage
- National Federation of NGO Regional Networks

(4) Burkina Faso's Third JTMC-National Meeting

1) Objective

- To explain about the Interim Report and to get feedback to the Interim Report
- To present and to discuss about three country corridor development scenarios

2) Date

On the 1st July, 2016

3) Venue

The meeting was held at a conference room in the building of DGCOOP, Ministry of Economy, Finance and Development in Ouagadougou

4) Participants

25 members of the National-Level Joint Technical and Monitoring Committee participated in the meeting. In addition, 12 people participated including the JICA Burkina Faso Office, as well as from the JICA Study Team.

Participated counterpart institutions are as follows:

- Ministry of Economy, Finance and Development

- Ministry of Agriculture and Water Development
- Ministry of Mines and Energy
- Ministry of Environment of the Green Economy and Climate Change
- Ministry of Animal and Fishery Resources
- Ministry of Industry, Commerce and Handicrafts
- Ministry of Transport, Urban Mobility and Road Safety
- National Executive Secretariat for Strategy for Accelerated Growth and Sustained Development
- National Electricity Company of Burkina Faso
- National Office of Environmental Assessment
- Burkinabe Shippers Council

(5) UEMOA Commission's Third Monitoring Meeting

1) Objective

- To explain about the Interim Report and to get feedback to the Interim Report
- To present and to discuss about each country's corridor development scenarios

2) Date

On the 4th July, 2016

3) Venue

The meeting was held at a conference room at the building of UEMOA Commission.

4) Participants

10 members from various departments of UEMOA Commission participated in the meeting. In addition, 14 people participated including officers of JICA Burkina Faso Office, a JICA Expert, as well as members of the JICA Study Team.

Participated directions of UEMOA Commission are as follows:

- Department of Community Territorial Administration and Transport (DATC)
- Department of Business, Energy Development and Tourism (DDET)
- Department of Regional Markets, Trade, Competition and Cooperation (DMRC)
- Department of Food Security, Agriculture, Mines and Environment (DSAME)

(6) Ghana's Fourth Technical Committee Meeting

1) Objectives

- To have a follow-up to the Third Technical Committee Meeting and present revised scenario.
- To present and to discuss about national level corridor development scenarios

2) Date

On the 26th July, 2016.

3) Venue

The meeting was held at a conference room of the NDPC in Accra.

4) Participants

13 members of the Technical Committee participated in the Fourth Technical Committee Meeting. In addition, 9 people participated from the JICA Ghana office, as well as from the JICA Study Team.

Participated counterpart institutions are as follows:

- National Development Planning Commission

- Ministry of Foreign Affairs and Regional Integration
- Ministry of Roads and Highways
- Ministry of Petroleum
- Savannah Accelerated Development Authority
- Town and Country Planning Department
- Ghana Highways Authority
- Ghana Revenue Authority

E.4.2 JTMC-Regional Meeting for Discussion on the Interim Report

1) Objectives

- To examine and validate the Interim Report

2) Date

The Second Regional Level Joint Technical Monitoring Committee (JTMC-R) was held on the 18th to 21st of July, 2016.

3) Venue

Conference room at Royal Beach Hotel in Ouagadougou

4) Participants

Participated counterpart institutions are as follows:

- UEMOA Commission
 - Department of Community Territorial Administration and Transport (DATC)
 - Directorate of Urban Land and Community Land Infrastructure (DATIT)
 - Department of Business, Energy Development and Tourism (DDET)
 - Department of Regional Markets, Trade, Competition and Cooperation (DMRC)
- Burkina Faso
 - Ministry of Agriculture and Water Development
 - Ministry of Commerce, Industry and Handicraft
 - Ministry of Economy, Finance and Development
 - Ministry of Energy of Mines and Quarries
 - Ministry of Infrastructure, Improving Access and Transport
- Côte d'Ivoire
 - Ministry of Agriculture and Rural Development
 - Ministry of Commerce
 - Ministry of Economy and Finance
 - Ministry of Economic Infrastructure
 - Ministry of Petroleum and Energy
- Ghana
 - National Development Planning Commission
 - Ministry of Roads and Highways
 - Ministry of Finance
- Togo
 - Ministry of Planning and Development
 - Ministry of Agriculture, Livestock and Hydraulics
 - Ministry of Commerce, Industry, Private Sector Promotion and Tourism
 - Ministry of Infrastructure and Transport
 - Ministry of Mines and Energy

In addition to the above counterpart institutions, 15 people participated the meeting including JICA Burkina Faso Office, JICA Ghana Office and JICA Study Team between 19th and 21st July 2016.

E.4.3 Stakeholders Meeting for Planning and SEA

(1) Burkina Faso's Second Stakeholder Meeting for Planning and SEA

The JICA Study Team prepared for holding of the Second Stakeholder Meeting for Planning and SEA in Burkina Faso, together with the DGCOOP of the Ministry of Economy and Finance.

1) Objectives

- To explain the corridor development strategies and alternative scenarios for Burkina Faso
- To discuss issues on corridor development in Burkina Faso
- To analyse and assess the social and environmental impact of corridor development strategies using SEA tools.

2) Date

On the 28th of July, 2016

3) Venue

The meeting was held at Hotel des Conferences Ouind Yide in Ouagadougou.

4) Participants

The total number of participants: 72 participants

- 17 participants from the following ministries and authorities at the national level:
 - Ministry of Economy, Finance and Development
 - Ministry of Agriculture and Water Development
 - Ministry of Commerce and Industry
 - Ministry of Mines and Energy
 - Ministry of Environment of the Green Economy and Climate Change
 - Ministry of Transport, Urban Mobility and Road Safety
 - Ministry of Animal and Fishery Resources
 - Ministry of Urban Planning and Housing
 - National Council for the Environment and Sustainable Development
 - National Executive Secretariat of Growth Pole and Support to Decentralization
 - National Executive Secretariat of SCADD
 - Association of the Regions of Burkina Faso (ARBF: *Association des Régions du Burkina Faso*)
- 25 participants from the authorities at the regional level in the following regions:
 - Centre Region
 - Centre-Ouest Region
 - Haut-Bassins Region
 - Nord Region
 - Centre-Nord Region
 - Est Region
 - Sud-Ouest Region
 - Centre-Est Region
 - Boucle du Mouhoun Region
 - Centre-Sud Region
 - Cascades Region

- Plateau Central Region
- Sahel Region
- 2 participants from the following communes:
 - Commune of Ouagadougou
 - Commune of Bobo-Dioulasso
- 4 participants from the following NGO organizations:
 - GREEN CROSS
 - SOS Sahel International
- Private Sectors: 2 participants from the following organization:
 - Chamber of Commerce and Industry of Burkina Faso
 - Burkinabe Shippers Council
- Others: 22 participants from the following organizations:
 - JICA Burkina Faso Office
 - JICA Study Team

(2) Côte d'Ivoire's Second Stakeholder Meeting for Planning and SEA

The JICA Study Team prepared for holding of the Second Stakeholder Meeting for Planning and SEA in Côte d'Ivoire, together with the Ministry of Economy and Finance.

1) Objectives

- To explain the corridor development strategies and alternative scenarios for Côte d'Ivoire
- To assess the social and environmental impact of corridor development strategies using SEA tools.

2) Date

On the 2nd of August, 2016

3) Venue

The meeting was held at the conference room of Hotel Ivotel in Abidjan.

4) Participants

The total number of participants: 62 participants

- 18 participants from the following ministries and authorities at the national level:
 - Ministry to the Prime Minister, in charge of Economy and Finances
 - National Agency for the Environment
 - Investment Promotion Centre in Côte d'Ivoire
 - Ministry of Agriculture and Rural Development
 - Ministry of Commerce
 - Ministry of Industry and Mines
 - Ministry of Economic Infrastructure
 - Ministry of African Integration and Ivorians Abroad
 - Ministry of Transport
 - Ministry of Petroleum and Energy
 - Ministry of Planning and Development
 - Ministry of Animal and Fishery Resources
 - Autonomous Port of Abidjan
 - Autonomous Port of San Pedro
- Authorities at the Regional Level: 13 participants from the following organizations:
 - Assembly of the Regions of Côte d'Ivoire

- Bélier (Toumodi)
- Béré (Mankono)
- Tchologo (Ferkessédougou)
- Guémon (Duékoué)
- Bafing (Touba)
- Kabadougou (Odienné)
- Grands Ponts (Dabou)
- Gbôkle (Sassandra)
- Mé (Adzopé)
- Gontougo (Bondoukou)
- Bounkani (Bouna)
- Commune: 3 participants from the following organizations:
 - Autonomous District of Abidjan
 - Autonomous District of Yamoussoukro
- NGO: 3 participants from the following organizations:
 - Côte d'Ivoire Ecologie
 - FEREADD
- Private Sectors: 1 participant from the following organization:
 - Small and Medium Enterprises Movement
- Others (including JICA Burkina Faso office and JICA Study Team):21 participants

(3) Togo's Second Stakeholder Meeting for Planning and SEA

The JICA Study Team prepared for holding of the Second Stakeholder Meeting for Planning and SEA in Togo, together with the Ministry of Economy and Finance and Development Planning.

1) Objectives

- To initiate a series of stakeholder meetings for planning and SEA in Togo
- To explain and discuss the objectives, approaches and scope of the Project
- To discuss issues on corridor development and environment in Togo

2) Date

On 4th of August, 2016

3) Venue

The meeting was held at the conference room of Ministry of Economy and Finance and Development Planning in Lomé.

4) Participants

The total number of participants: 81 participants

- Ministries and Authorities at the National Level: 45 participants from the following organizations:
 - Ministry of Planning and Development
 - Ministry of Territorial Administration of Decentralization and Local Communities
 - Ministry of Foreign Affairs, Cooperation and African Integration
 - Ministry of Social Action and Promotion of Women and Literacy
 - Ministry of Agriculture, Livestock and Hydraulics
 - Ministry of Defense and Veterans Affairs
 - Ministry of Commerce, Industry, Private Sector Promotion and Tourism
 - Ministry of Communication, Culture, Sports and Civic Training

- Ministry of Development based on Youth Craft and Youth Employment
- Ministry of Environment and Forest Resources
- Ministry of Infrastructure and Transport
- Ministry of Mines and Energy
- Ministry of Post and Economy
- Ministry of Health and Social Protection
- Ministry of Security and Civil Protection
- Ministry of Urban Planning, Habitat and Living Environment
- National Agency of Civil Aviation of Togo
- Togo Revenue Authority
- Autonomours Port of Lomé
- CDS Grand Lomé Project
- Presidential Office of the Republic of Togo
- Technial Secretariat of DRSP
- Togo Free Zone Authority
- Togo Invest Corporation
- Authorities at the Regional Level: 10 participants from the following organizations:
 - Savanes Region
 - Kara Region
 - Centrale Region
 - Plateaux Region
 - Maritime Region
- Commune: 1 participants from the following organization:
 - Commune of Lomé
- NGO: 6 participants from the following organizations:
 - Association of Large Enterprises of Togo
 - Collective of the Civil Society Organizations of the Maritime Region
 - Federation of Non-Governmental Organizations of Togo
 - National Federation of Regional Networks of Togo
 - Young Volunteers for the Environment
 - Union of Non-Governmental Organizations of Togo
- Private Sectors: 2 participants from the following organizations:
 - Chamber of Commerce and Industry of Togo
 - National Council of the Patronage of Togo
- Others (including JICA Burkina Faso office and JICA Study Team):17 participants from the following organizations:
 - ART&P
 - National Institute of Statistics and Economic and Demographic Studies
 - National Union of Road Transporters of Togo
 - University of Lomé

(4) Ghana's Community-level Consultation Meeting for Planning and SEA

In compliance with EPA's SEA process, the SEA Core Team prepared for holding of the Community-level Consultation Meeting in Ghana. SEA Core Team is composed of EPA, NDPC, MRH, Delin Consult (the local consultant) and JICA Study Team.

1) Objectives

- To share information on corridor development initiatives in Ghana, Burkina Faso, Côte d'Ivoire and Togo.
- To discuss issues in relation to such corridor development at the district or community level.

2) Date

The meetings were held from 18th of August to 2nd of September, 2016.

3) Venue

12 selected districts in all the 10 regions of Ghana along the Coastal, Eastern, Central and Western Corridors.

4) Participants

All the participants in each district are invited through Metropolitan, Municipal and District Assemblies (MMDAs).

The date, host assembly and number of participants of each consultation meeting are summarized as follows:

Table E.4.1 Schedule of Community-level SEA Consultation Meeting in Ghana

No	Date	Host Assembly	Number of Participants
1	18th August, 2016	Tema Metropolitan Assembly, Tema, Greater Accra Region	134
2	22nd August, 2016	Dormaa Municipal Assembly, Dormaa Ahenkro, Brong Ahafo Region	48
3	24th August, 2016	Kintampo South District Assembly, Jema, Brong Ahafo Region	89
4	25th August, 2016	Kassena-Nankana District Assembly, Navrongo, Upper East Region	67
5	26th August, 2016	Bawku Municipal Assembly, Bawku, Upper East Region	44
6	26th August, 2016	Sawla-Tuna-Kalba District Assembly, Sawla, Northern Region	69
7	29th August, 2016	Cape Coast Metropolitan Assembly, Cape Coast, Central Region	125
8	30th August, 2016	Hohoe Municipal Assembly, Hohoe, Volta Region	77
9	31st August, 2016	Nkwanta South District Assembly, Nkwanta, Volta Region	86
10	31st August, 2016	Sekondi/Takoradi Metropolitan Assembly, Takoradi, Western Region	92
11	1st September, 2016	Kumasi Metropolitan Assembly, Kumasi, Ashanti Region	50
12	2nd September, 2016	Savelugu/Nanton District Assembly, Savelugu, Northern Region	98

Source: JICA Study Team

(5) Burkina Faso's Third Stakeholder Meeting for SEA

The JICA Study Team prepared for holding of the Third Stakeholder Meeting for SEA in Burkina Faso, together with the DGCOOP of the Ministry of Economy and Finance.

1) Objectives

- To explain corridor development plan for Burkina Faso
- To assess corridor development plan for Burkina Faso

2) Date

From 10th to 11th October, 2016

3) Venue

The meeting was held at Hotel des Conférences Ouind Yide in Ouagadougou.

4) Participants

The total number of participants: 67 participants

- 17 participants from the following ministries and authorities at the national level:
 - Ministry of Agriculture and Water Development
 - Ministry of Commerce and Handicraft
 - Ministry of Economy, Finance and Development
 - Ministry of Mines and Energy
 - Ministry of Forests
 - Ministry of Infrastructure
 - Ministry of Transport, Urban Mobility and Road Safety
 - Ministry of Animal and Fishery Resources
 - Ministry of Urban Planning and Housing
 - Ministry of Environment, Green Economy and Climate Change
 - National Technical Secretariat of the SCADD
 - National Council for Sustainable Development
 - Association of Municipalities of Burkina Faso
- 25 participants from the authorities at the regional level in the following regions:
 - Centre-Ouest Region
 - Haut-Bassins Region
 - Nord Region
 - Centre-Nord Region
 - Est Region
 - Sud-Ouest Region
 - Centre-Est Region
 - Boucle du Mouhoun Region
 - Centre-Sud Region
 - Cascades Region
 - Plateau Central Region
 - Sahel Region
 - Centre Region
 - Sahel Region
 - Haut-Bassins Region
 - Nord Region
- 1 participant from the following commune:
 - Commune of Bobo-Dioulasso
- 1 participant from the following NGO organization:
 - SOS Sahel International
- 2 participant from the following private sectors organization:
 - Chamber of Commerce and Industry of Burkina Faso
 - OBOUF Group (le Groupe Ouédraogo Boureima et Frères)
- Others (including JICA Burkina Faso office and JICA Study Team):18

(6) Côte d'Ivoire's Third Stakeholder Meeting for SEA

The JICA Study Team prepared for holding of the Third Stakeholder Meeting for SEA in Côte d'Ivoire, together with the Ministry of Economy and Finance.

1) Objectives

- To explain corridor development plan for Côte d'Ivoire
- To assess corridor development plan for Côte d'Ivoire

2) Date

On the 13th of October, 2016

3) Venue

The meeting was held at the conference room of Hotel Ivotel in Abidjan.

4) Participants

The total number of participants: 36 participants

- Ministries and Authorities at the National Level: 10
 - Ministry of Commerce
 - Ministry of African Integration and Ivorians Abroad
 - Ministry of Economic Infrastructure
 - Ministry to the Prime Minister, in charge of Economy and Finances
 - Ministry of Transport
 - Autonomous Port of Abidjan
 - Autonomous Port of San Pedro
 - National Agency for the Environment
 - Investment Promotion Centre in Côte d'Ivoire
- 3 participants from the authorities at the regional level in the following regions:
 - Gbéké Region (Bouaké)
 - Worodougou Region (Séguéla)
 - Iffou Region (Daoukro)
- 2 participants from the following communes
 - Autonomous District of Abidjan
 - Bouaké
- NGO: 0
- Private Sectors: 0
- Others (including JICA Burkina Faso office and JICA Study Team): 21

(7) Togo's Third Stakeholder Meeting for SEA

The JICA Study Team prepared for holding of the Third Stakeholder Meeting for SEA in Togo, together with the Ministry of Development Planning.

1) Objectives

- To explain corridor development plan for Togo
- To assess corridor development plan for Togo

2) Date

The meeting was held on 6th of October, 2016

3) Venue

The meeting was held at the conference room of Ministry of Environment in Lomé.

4) Participants

The total number of participants: 76 participants

- Ministries and Authorities at the National Level: 37

- Ministry of Planning and Development
- Ministry of Foreign Affairs, Cooperation and African Integration (MAECIA: *Ministère des Affaires Étrangères, de la Coopération et de l'Intégration Africaine*)
- Ministry of Social Action and Promotion of Women and Literacy (MASPFA: *Ministère de l'Action Sociale, de la Promotion de la Femme et de l'Alphabétisation*)
- Ministry of Agriculture, Livestock and Hydraulics (MAEH)
- Ministry of Commerce, Industry, Private Sector Promotion and Tourism (MCIPSPT)
- Ministry of Communication, Culture, Sports and Civic Education (MCCSFC: *Ministère de la Communication, de la Culture, des Sports et de la Formation Civique*)
- Ministry of Basic Development, Crafts, Youth and Youth Employment (MDBAJEJE: *Ministère du Développement à la Base, de l'Artisanat, de la Jeunesse et de l'Emploi des Jeunes*)
- Ministry of Environment and Forest Resources (MEFR)
- Ministry of Infrastructure and Transport (MIT)
- Ministry of Mines and Energy (MME)
- Ministry of Health and Social Protection
- Ministry of Security and Civil Protection (MSPC: *Ministère de la Sécurité et de la Protection Civile*)
- Ministry of Urban Planning, Habitat and Living Environment (MUHCV)
- Ministry of Territorial Administration, Decentralization and Local Government (MATDCL: *Ministère de l'Administration Territoriale, de la Décentralisation et des Collectivités Locales*)
- National Agency for Environmental Management (ANGE)
- Togo Revenue Authority (OTR)
- Office of Prime Minister (Primature)
- Togo Free Zone Authority (SAZOF)
- Togo Invest Corporation
- National Institute of Statistics and Economic and Demographic Studies (INSEED)
- Secrétariat Technique du DSRP
- Delegation to the Informal Sector Organizations (DOSI: *Délégation à l'Organisation du Secteur Informel*)
- Authorities at the Regional Level: 10
 - Savanes Region
 - Kara Region
 - Centrale Region
 - Plateaux Region
 - Maritime Region
- Commune: 2
 - Commune of Kara
 - Commune of Lomé
- NGO: 6
 - Agence d'Exécution des Travaux Urbains (AGETUR-Togo)
 - Les Amis de la Terre-TOGO
 - Joint Civil Society Organizations of the Maritime Region (COSCREMA: *Collectif des organisations de la Société Civile de la Région Maritime*)
 - Federation of Non-Governmental Organizations of Togo (FONGTO)

- National Federation of Regional networks of NGOs and Development Associations of Togo (FNRR-Togo: *Faîtière nationale des réseaux régionaux d'ONG et d'associations de développement du Togo*)
- Young Volunteers for the Environment (JVE)
- Union of Non-Governmental Organizations of Togo (UONGTO)
- Private Sectors: 7
 - Association of Large Enterprises of Togo (AGET: *Association des Grandes Entreprises du Togo*)
 - Chamber of Commerce and Industry of Togo (CCIT)
 - Togo Shippers Council (CNCT)
 - National Centre for Computer Studies (CENETI)
 - Togolese Institute of Agricultural Research (ITRA: *Institut Togolaise de Recherche Agronomique*)
- Others (including JICA Burkina Faso office and JICA Study Team):16

(8) Ghana's Stakeholder Meeting for SEA

The JICA Study Team prepared for holding of the Third Stakeholder Meeting for SEA in Togo, together with the Ministry of Development Planning.

In compliance with EPA's SEA process, the SEA Core Team prepared for holding of the Stakeholder Meeting in Ghana.

1) Objectives

- To explain corridor development plan for Ghana
- To assess corridor development plan for Ghana

2) Date

The meeting was held on 1st and 2nd of February, 2017

3) Venue

The meeting was held at the conference room of Mensvic Hotel in Accra.

4) Participants

The total number of participants: 51 participants

- Ministries and Authorities at the National Level: 28
 - Environmental Protection Agency
 - National Development Planning Commission
 - Ministry of Roads and Highways
 - Ministry of Food and Agriculture
 - Ministry of Trade and Industry
 - Ministry of Transport
 - Ministry of Environment, Science, Technology and Innovation
 - Town and Country Planning Department
 - Water Resources Commission
 - Ghana Railway Development Authority
 - Ghana Free Zone Board
- Authorities at the Regional Level: 2
 - Greater Accra Region
 - Western Region
- MMDAs: 13

- Accra Metropolitan Assembly
- Kumasi Metropolitan Assembly
- Sekondi-Takoradi Metropolitan Assembly
- Tema Municipal Assembly
- Yendi Municipal Assembly
- Techiman Municipal Assembly
- Savelugu District Assembly
- Jaman Fanh District Assembly
- Hohoe District Assembly
- Ekumfi District Assembly
- Nkoranza South District Assembly
- Jasikan District Assembly
- Ningo-Prampram District Assembly
- NGO: 1
 - Friends of Earth
- Others (including JICA Burkina Faso office and JICA Study Team):7

E.4.4 Sector Study

(1) Sector Study on Ghana

Sector experts from the JICA Study Team intensively conducted sector studies on Ghana by staying in Ghana from 11th July to 15th July and 6th August to 16th August 2016.

(2) Sector Study on Côte d'Ivoire

Sector experts from the JICA Study Team intensively conducted sector studies on Côte d'Ivoire by staying in Côte d'Ivoire from 18th July to 22nd July, 25th September to 2nd October and 12th October to 15th October, 2016.

(3) Sector Study on UEMOA Commission and Burkina Faso

Sector experts from the JICA Study Team intensively conducted sector studies on the UEMOA Commission and Burkina Faso by staying in Burkina Faso from 25th July to 29th July and 7th October to 11th October, 2016.

(4) Sector Study on Togo

Sector experts of the JICA Study Team intensively conducted sector studies on Togo in Togo from 1st August to 5th August, 2016 and 3rd October to 6th October, 2016.

(5) Sector Study on Urban Water Supply in Abidjan

Sector experts of the JICA Study Team intensively conducted sector studies on urban water supply in Abidjan from 23rd January to 31st March, 2017.

E.4.5 Explanation and Discussion on the Draft Final Report

(1) Burkina Faso's Fourth JTMC-National Meeting

1) Objective

- To explain about the Draft Final Report and to get feedback to the Draft Final Report
- To present and to discuss about sub-regional corridor development plan, county's corridor development plan, and priority projects.

2) Date

The meeting was held on the 7th of February, 2017

3) Venue

The meeting was held at a conference room in the building of DGCOOP, Ministry of Economy, Finance and Development in Ouagadougou.

4) Participants

17 members of the National-Level Joint Technical and Monitoring Committee participated in the meeting. In addition, 13 people participated including the JICA Burkina Faso Office, as well as from the JICA Study Team.

Participated counterpart institutions are as follows:

- Ministry of Economy, Finance and Development
- Ministry of Agriculture and Water Development
- Ministry of Development of Digital Economy and Posts
- Ministry of Environment of the Green Economy and Climate Change
- Ministry of Animal and Fishery Resources
- Ministry of Industry, Commerce and Handicrafts
- Ministry of Infrastructure, Improving Access and Transport
- Ministry of Transport, Urban Mobility and Road Safety
- National Executive Secretariat of Growth Pole and Support to Decentralization
- National Executive Secretariat of the SCADD
- Chamber of Commerce and Industry of Burkina Faso
- Burkinabe Shippers Council

(2) Ghana's Fifth Technical Committee Meeting

1) Objective

- To explain about the Draft Final Report and to get feedback to the Draft Final Report
- To present and to discuss about sub-regional corridor development plan, county's corridor development plan, and priority projects.

2) Date

The meeting was held on the 14th of February, 2017.

3) Venue

The meeting was held at a conference room of the NDPC in Accra.

4) Participants

26 members of the Technical Committee participated in the Fourth Technical Committee Meeting. In addition, 13 people participated from the JICA Ghana office, as well as from the JICA Study Team.

Participated counterpart institutions are as follows:

- National Development Planning Commission
- Ministry of Energy
- Ministry of Finance
- Ministry of Food and Agriculture
- Ministry of Health
- Ministry of Local Government and Rural Development

- Ministry of Roads and Highways
- Association of Ghana Industries
- Bulk Oil Storage and Transportation Co. Ltd.
- Environmental Protection Agency
- Ghana Highways Authority
- Ghana Ports & Harbours Authority
- Ghana Railway Development Authority
- Institute for Infrastructure Development
- Savannah Accelerated Development Authority
- Town and Country Planning Department

(3) Côte d'Ivoire's Fourth JTMC-National Meeting

1) Objective

- To explain about the Draft Final Report and to get feedback to the Draft Final Report
- To present and to discuss about sub-regional corridor development plan, county's corridor development plan, and priority projects.

2) Date

The meeting was held on the 15th of February, 2017.

3) Venue

The meeting was held at conference room at Hotel Ivotel Annex in Abidjan.

4) Participants

28 members of the National-Level Joint Technical and Monitoring Committee participated in the meeting. In addition, 15 people participated from the JICA Côte d'Ivoire Office, as well as from the JICA Study Team.

Participated counterpart institutions are as follows:

- Ministry of the Budget and the State Portfolio
- Ministry of Economy and Finances
- Ministry of Agriculture and Rural Development
- Ministry of Commerce
- Ministry of Construction and Urbanism
- Ministry of Water and Forests
- Ministry of the Digital Economy and the Post Office, Spokesman of the Government
- Ministry of Economic Infrastructure
- Ministry of Industry and Mines
- Ministry of African Integration and Ivorians Abroad
- Ministry of Petroleum, Energy and Renewable Energy
- Ministry of Planning and Development
- Ministry of Animal and Fish Resources
- Investment Promotion Centre in Côte d'Ivoire
- Autonomous District of Abidjan
- Office of the Ivorian Chargers
- Road Management Agency of Côte d'Ivoire
- National Agency for the Environment
- National Trade Facilitation Committees
- Autonomous Port of Abidjan

- Autonomous Port of San Pédro

(4) Togo's Fourth JTMC-National Meeting

1) Objective

- To explain about the Draft Final Report and to get feedback to the Draft Final Report
- To present and to discuss about sub-regional corridor development plan, county's corridor development plan, and priority projects.

2) Date

The meeting was held on the 16th of February, 2017.

3) Venue

The meeting was held at the conference room of Ministry of Environment in Lomé.

4) Participants

61 members of the National-Level Joint Technical and Monitoring Committee participated in the meeting. In addition, 12 people participated including the JICA Expert in charge of Togo, as well as from the JICA Study Team.

Participated counterpart institutions are as follows:

- Ministry of Planning and Development
- Ministry of Economy and Finance
- Ministry of Territorial Administration of Decentralization and Local Communities
- Ministry of Foreign Affairs, Cooperation and African Integration
- Ministry of Social Action and Promotion of Women and Literacy
- Ministry of Agriculture, Livestock and Hydraulics
- Ministry of Defense and Veterans Affairs
- Ministry of Commerce, Industry, Private Sector Promotion and Tourism
- Ministry of Communication, Culture, Sports and Civic Training
- Ministry of Development based on Youth Craft and Youth Employment
- Ministry of Environment and Forest Resources
- Ministry of Infrastructure and Transport
- Ministry of Mines and Energy
- Ministry of Post and Digital Economy
- Ministry of Health and Social Protection
- Ministry of Security and Civil Protection
- Ministry of Urban Planning, Habitat and Living Environment
- National Agency for Environmental Management
- Executing Agency of Urban Work
- National Assembly of Togo
- National Council of the Togolese Patronage
- Delegation to the Informal Sector Organizations
- Federation of Non-Governmental Organizations of Togo
- Young Volunteers for the Environment
- Togo Revenue Authority
- Les Amis de la Terre-TOGO
- Presidency of the Republic of Togo
- Togo Free Zone Authority
- Togo Invest Corporation

- Union of Non-Governmental Organizations of Togo
- National Union of Carriers in Togo

(5) UEMOA Commission's Fourth Monitoring Meeting

1) Objective

- To explain about the Draft Final Report and to get feedback to the Draft Final Report
- To present and to discuss about sub-regional corridor development plan, and high priority projects of sub-regional level.

2) Date

The meeting was held on the 17th of February, 2017.

3) Venue

The meeting was held at a conference room at the building of UEMOA Commission.

4) Participants

14 members from various departments of UEMOA Commission participated in the meeting. In addition, 15 people participated including officers of JICA Headquarters, JICA Burkina Faso Office, a JICA Expert, as well as members of the JICA Study Team.

Participated directions of UEMOA Commission are as follows:

- Department of Community Territorial Administration and Transport (DATC)
- Directorate of Urban Land and Community Land Infrastructure (DATIT)
- Department of Business, Energy Development and Tourism (DDET)
- Department of Regional Markets, Trade, Competition and Cooperation (DMRC)
- Department of Food Security, Agriculture, Mines and Environment (DSAME)

E.4.6 Meeting for Discussion on the Summary Report of the Draft Final Report

(1) UEMOA Commission's Fifth Monitoring Meeting

1) Objective

- To explain about the Summary Report of the Draft Final Report and to get feedback
- To present and to discuss about sub-regional corridor development plan, necessary actions and priority projects

2) Date

The meeting was held on the 21st of July, 2017.

3) Venue

The meeting was held at a conference room at the building of UEMOA Commission.

(2) Ghana's Second Steering Committee Meeting

1) Objective

- To explain about the major changes made in the Summary Report of the Draft Final Report and to get general approval of the plan
- To present and to discuss about sub-regional corridor development plan, county's corridor development plan, necessary actions and priority projects

2) Date

The meeting was held on the 24th of August, 2017.

3) Venue

The meeting was held at the conference room of the NDPC in Accra.

4) Participants

- Members of Ghana's Steering Committee for the WAGRIC Project

E.5 Project Activities in Phase 4

The major project activities in the fourth phase of the Project (Phase 4) were as follows:

- Holding of Regional Level Joint Technical and Monitoring Committee Meeting in Lomé
- Approving the Master Plan
- Holding the International Seminar in Abidjan
- Holding the Final Seminar in Accra
- Preparation of the Final Report

E.5.1 JTMC-Regional Meeting for Discussion on the Draft Final Report in Lomé

1) Objectives

- To examine and validate the Draft Final Report

2) Date

The Third Regional Level Joint Technical Monitoring Committee (JTMC-R) was held on the 17th to 19th of October, 2017.

3) Venue

The meeting was held at the conference room of Hotel 2 Fevrier in Lomé.

4) Participants

- Seven JTMC-Regional Committee members each from individual countries (Burkina Faso, Côte d'Ivoire and Togo)
- Ghana's delegation participated the meeting as observers

5) Results of the Meeting

The Regional Joint Technical and Monitoring Committee members validated the Draft Final Report and decided to organize a Joint Steering Committee Meeting in December 2017 or January 2018 in Abidjan.

E.5.2 Joint Steering Committee Meeting in Abidjan

1) Objectives

- To validate the Draft Final Report for the WAGRIC Master Plan
- To discuss and agree on the Implementation Framework for the WAGRIC Master Plan
- To approve the WAGRIC Master Plan.

2) Date

Joint Steering Committee Meeting was held on the 23rd of January, 2018.

3) Venue

The meeting was held at the conference room of Sofitel Hotel in Abidjan.

4) Participants

Representatives of seven ministries from each country participated the meeting. Seven ministers participated the meeting. Regional-Level Joint Technical and Monitoring Committee members (seven members each from each country) also participated the meeting as observers.

In total, about 70 persons participated the meeting.

5) Results

By having validate the Draft Final Report, the Joint Steering Committee approved the WAGRIC Master Plan and the Implementation Framework for the WAGRIC Master Plan.

E.5.3 International Seminar in Abidjan

1) Objectives

- To share the approved WAGRIC Master Plan with development partners and private sectors
- To present individual countries' ways of adoption and incorporation of the WAGRIC Master Plan into their national development plans and other plans (presentation by representatives of individual countries)
- To present individual countries' selected high priority projects for implementation (presentation by representatives of individual countries)
- To share the information of the sub-regional corridors related projects currently underway by major development partners

2) Date

International Seminar was held on the 24th of January, 2018.

3) Venue

The meeting was held at the conference room of Radisson Blue in Abidjan.

4) Participants

- About 120 persons in tota
- International development partners (WB, AfDB, EU, AFD, BOAD, NEPAD Agency, DBSA, Borderless Alliance etc.)
- Private sectors
- Joint Steering Committee Members for the WAGRIC Project
- Regional-Level Joint Technical and Monitoring Committee Members for the WAGRIC Project

5) Results of the Seminar

The approved WAGRIC Master Plan was presented and discussed for implementation by the participants.

JICA expressed its intention to provide support for implementing projects in accordance with the WAGRIC Master Plan.

E.5.4 Final Seminar in Accra

1) Objectives

- To disseminate the approved WAGRIC Master Plan

2) Date

Final Seminar was held on the 14th of March, 2018.

3) Venue

The meeting was held at the conference room of Best Western Premier Hotel in Accra.

4) Participants

142 persons including high-level officials and media participated the Final Seminar.

- Ministries, departments and Agencies (MDAs) – majority of the participants
- Selected Metropolitan, Municipal and District Assemblies
- Professional Bodies
- Ghanaian Private Sector
- Development Partners
- Associations
- Japanese Private sector in Ghana
- Media - about 18 media houses covered the events.

Appendix F Records of SEA Stakeholder Meetings

F.1 Overall SEA Procedure in Each Country

F.1.1 SEA Procedure of Burkina Faso

In Burkina Faso, a Strategic Environmental Assessment (SEA) is carried out following the requirements described by the Environmental Code in Burkina Faso (Law No. 006-2013).

Series of stakeholder meeting held for SEA in Burkina Faso is shown in Table below.

Table F.1.1 Series of Stakeholder Meeting held for SEA in Burkina Faso

Meeting	Date	Objective
The 1 st Stakeholder Meeting	16 September 2015	-To explain and discuss the objectives, approaches and scope of the Project -To discuss issues on corridor development and the environment in Burkina Faso
The 2 nd Stakeholder Meeting	28 July 2016	-To identify social and environmental impacts that corridor development strategies might generate
The 3 rd Stakeholder Meeting	10-11 October 2016	-To analyse and assess impacts of implementing corridor development strategies.

Source: JICA Study Team

F.1.2 SEA Procedure of Côte d'Ivoire

Considering the environmental legal frameworks for Côte d'Ivoire, the Environmental Code (Law No.96-766, 1996) is considered as the principal law next to the constitution. Under the Environmental Code, the presidential decree No. 2013-41 of 30 January 2013 on “Strategic environmental assessment (SEA) for Policies, Plans, and Programmes” was enforced in Côte d'Ivoire. Although the detailed requirements and guidelines for such activities shall be set in the future, the decree No.2013-41 principally sets the requirement of SEA for any policy, plan, or programme development by authorities except for some exceptions such as national security matters after the date of enforcement.

Series of stakeholder meeting held for planning and SEA in Côte d'Ivoire is shown in Table below.

Table F.1.2 Series of Stakeholder Meeting held for SEA in Côte d'Ivoire

Meeting	Date	Objective
The 1 st Stakeholder Meeting	2 October 2015	-To explain and discuss the objectives, approaches and scope of the Project -To discuss issues on corridor development and the environment in Côte d'Ivoire
The 2 nd Stakeholder Meeting	2 August 2016	-To identify social and environmental impacts that corridor development strategies might generate
The 3 rd Stakeholder Meeting	13 October 2016	-To analyse and assess impacts of implementing corridor development strategies.

Source: JICA Study Team

F.1.3 SEA Procedure of Ghana

In Ghana, a Strategic Environmental Assessment (SEA) is being carried out based on the requirements of three acts, namely, National Development Planning Commission Act (1994, Act 479), National Development Planning (System) Act (1994, Act 480) and Environmental Protection Agency Act (1994, Act 490).

Series of meetings was held between the promoter side of the Project (NDPC, MRH, JICA, the JICA Study Team and the local consultant) and the competent authorities of SEA in Ghana (EPA and NDPC) prior to preparation of the TOR for SEA.

Table F.1.3 Series of SEA Core Team Meeting held for SEA in Ghana

Meeting	Date	Objective/Topics
The 1 st Preparatory Meeting	15 October 2015	- TOR for the SEA study - SEA methodology and approach
The 2 nd Preparatory Meeting	22 December 2015	- Payment policies of JICA - SEA process (ideal process and adopted process) - Role of each organization
The 1 st SEA Core Team Meeting	6 January 2016	- Preparation of TOR for the SEA study
The 2 nd SEA Core Team Meeting	18 January 2016	-Preparation of TOR for the SEA study - Scope for the SEA study
Second Technical Committee Meeting	11 February, 2016	-The SEA process for the Project
The 3 rd SEA Core Team Meeting	16 February 2016	- Proposed options for activities of the SEA study - Proposed budget for the SEA study - Procurement of SEA local consultant
The 4 th SEA Core Team Meeting	19 February 2016	- Budget prepared by EPA - Budget prepared by the JICA Study Team
The 5 th SEA Core Team Meeting	15th August, 2016	-Presentation and discussion on the draft institutional analysis for the conduct of the SEA of the Project -Themes and methodology for the community consultation meetings -Draft programme outline for the community consultation meetings - Draft consultation schedule
The 6 th SEA Core Team Meeting	12th October, 2016	- Review of consultation findings - List of stakeholders - Action matrix
The 7 th SEA Core Team Meeting	12th December, 2016	- Draft scoping report - Way forward

Source: JICA Study Team

Series of meetings workshops held for SEA in are shown in Table below.

Table F.1.4 Series of Meetings and Workshops held for SEA in Ghana

Meeting	Date	Objective/Topics
Stakeholder Consultation Meetings (Tema, Dormaa Ahenkro, Jema, Navrongo, Bawku, Sawla, Cape Coast, Hohoe, Nkwanta, Takoradi, Kumasi and Savelugu)	18th August to 2 nd September 2016	Consultation – group discussions on four pillars
SEA Scoping Workshop	19th-21st October, 2016	- Baseline information for SEA report - Institutional analysis for SEA report - Three basic scenarios - Matrix of key issues
SEA Assessment Workshop	1-2 February, 2017	To assess the proposed strategies and programs by the project

Source: JICA Study Team

F.1.4 SEA Procedure of Togo

Currently, Togo has not established any laws, regulations or guidelines for SEA. As a result, SEA in Togo should be carried out in line with Togo's Framework Law on the Environment (Law No. 2008-005) and the National Environmental Policy adopted on 23rd of December, 1998.

Table F.1.5 Series of Stakeholder Meeting held for SEA in Togo

Meeting	Date	Objective
The 1 st Stakeholder Meeting	9 September 2015	-To explain and discuss the objectives, approaches and scope of the Project -To discuss issues on corridor development and the environment in Togo
The 2 nd Stakeholder Meeting	4 August 2016	-To identify social and environmental impacts that corridor development strategies might generate
The 3 rd Stakeholder Meeting	6 October 2016	-To analyse and assess impacts of implementing corridor development strategies.

Source: JICA Study Team

F.2 Detailed Progress of SEA for Burkina Faso

F.2.1 Activities in Preparation Stage of SEA

There was the following progress in SEA for Burkina Faso after the initiation of the Project.

(1) The First Stakeholder Meeting for Planning and SEA in Burkina Faso

The First Stakeholder Meeting for Planning and SEA was held in Burkina Faso on 16th September, 2015, jointly by the JICA Study Team and the DGCOOP of the Ministry of Economy and Finance. The objectives were to explain and discuss the objectives, approaches and scope of the Project and to discuss issues on corridor development and the environment in Burkina Faso

(2) Procurement of Local Consultant

In order to carry out a SEA study, the JICA Study Team made a sub-consulting agreement on the SEA study in Burkina Faso with a national consulting firm, BGB Méridien SARL on 30th September, 2015, BGB Méridien.

(3) Finalization of TOR of SEA

Based on several consultations with the National Office of Environmental Evaluation (BUNEE: *Bureau National des Evaluations Environnementales*), a conference on a Terms of Reference (TOR) of SEA for the Project was held at the office of BUNEE on 15th October, 2015, attended by BUNEE, the DGCOOP of the Ministry of Economy and Finance, the JICA Study Team and JICA Burkina Faso Office.

BUNEE transmitted observations on the draft TOR that the JICA Study Team made after the conference. Major comments are listed below.

- To observe the national regulations in addition to good international practices in SEA
- To make SEA for PAPSAP (Project to Support Productivity and Food Security) a reference
- To consider the national development plan of Burkina Faso
- To extend the study area beyond 50 km from both sides of the corridors to take into account any significant points outside the study area
- To consider infrastructure projects (roads, energy and fibre optics, etc.) being developed as part of the SEA;
- To examine the cumulative impacts of different types of projects under the Project
- To take into account any significant concern not raised at the scoping and which would be revealed in the field
- To consider the security actors (police, gendarmerie), the Ministries in charge of social action and local communities in the actions of stakeholder meetings for SEA

The TOR as revised by the JICA Study Team based on the BUNEE's observations was acknowledged to conform to the current regulations.

(4) The Second Joint Technical and Monitoring Committee Meeting

The JICA Study Team gave a presentation on alternative scenarios for sub-regional corridor development at the Second National-Level Joint Technical and Monitoring Committee Meeting held on 16th March, 2016. The concerns raised at the meeting were as follows:

- Necessity of involving all actors
- Necessity to take into account existing projects of UEMOA and ECOWAS
- Selection of a best case scenario so as not to create an imbalance in development among the countries.

F.2.2 Activities in Scoping Study Stage of SEA

(1) Result of Scoping for SEA

The scoping study touches on the main components of the environment that need to be considered i.e. potential impacts which have to be analysed along the following lines:

- Rivers and lakes (type of substrate, quality and uses);
- Shorelines, wetlands and floodplains;
- Hydrodynamic conditions;
- Hydrogeological context (classification and physicochemical quality of groundwater, identification of aquifers);
- Soil and surface deposits and their physicochemical quality and their current or past use, slopes, mining areas, areas prone to erosion, agricultural potential;
- Topography, subsurface drainage and surface hydrogeology (depth and quality of groundwater, groundwater movements);
- The sound environment (sensitive points), contaminant concentrations etc.;
- Vegetation cover of aquatic, riparian and terrestrial lands, indicating the presence of fragile or

- exceptional strands;
- Wildlife and plant species (terrestrial and aquatic) and habitats of these species (annual cycles, migration patterns, phenology), paying special attention to those that are threatened or vulnerable or those likely to be;
 - The use and planned use of the territory where the project is located on public land, with reference to planning tools related to public land and resort development; and
 - The current and planned land use with reference to policies, development plans and local and regional regulations of development and planning.
 - Urbanization perimeters, concentrations of housing, urban areas,
 - Commercial, industrial and other development projects,
 - Agricultural areas, agricultural activities (buildings, crops, structures, etc.), drainage for monitoring the water table, the cadastral structure
 - The forest environment
 - Resort areas, attractions, activities, existing equipment and planned recreational or tourist attractions (controlled zones, theme parks, campgrounds, bike paths, tours listed, etc.)
 - Natural areas dedicated to protection or preservation, or of interest for their recreational, aesthetic, historical and educational value
 - Transport infrastructure, telecommunications and public services (roads, railways, airports, cable, telecommunication towers, power lines, aqueducts, sewers, canals, pipelines, landfills etc.), community and institutional (hospitals, schools, nurseries, etc.)
 - The sources of drinking water, including private wells, municipal wells and any other works for catchment of ground and surface water
 - Protection areas (immediate, near, far in the future) around groundwater catchment works and surface

The archaeological and cultural heritage: known archaeological sites, areas of archaeological potential and other heritage interest protected or not by the Cultural Property Act (Aboriginal burials in biophysical environment, historic districts, buildings, etc.)

F.2.3 Activities in Assessment Stage of SEA

(1) The Second Stakeholder Meeting for Planning and SEA in Burkina Faso

The Second Stakeholder Meeting for Planning and SEA was held in Burkina Faso on 28th July, 2016. The objective of this meeting was to identify social and environmental impacts that corridor development strategies might generate.





1) Targets for Identification of Impacts

The targets for identification of impacts in the Second Stakeholder Meeting were scheduled as follows:

- Objectives for corridor development in Burkina Faso
- Alternative scenarios for corridor development in Burkina Faso
- Strategies for economic sectors and infrastructure sectors of Burkina Faso

As a result, due to the lack of time for group work in the Second Stakeholder Meeting, the discussion of participants focused on the alternative scenarios. A summary of the alternative scenarios is presented in Table F.2.1, while their detailed description is contained in other chapters of this Main Report.

Table F.2.1 Targets for Identification of Impacts in the Second Stakeholder Meeting

<p>AB-1-1</p>  <ul style="list-style-type: none"> • Economic sectors targeting at export to overseas are to be mainly promoted • Development of corridor transport infrastructure to support the export to overseas • Especially to Abidjan Port and to Lomé Port 	<p>AB-1-2</p>  <ul style="list-style-type: none"> • Economic sectors targeting at export to overseas are to be mainly promoted • Development of corridor transport infrastructure to support the export to overseas • Especially to Abidjan Port and to Lomé Port • Transport corridors not only to the south, but also to the north for providing access to economic sectors' potential areas in the north
<p>AB-2-1</p>  <ul style="list-style-type: none"> • Economic sectors targeting at sales to neighbouring large cities are to be promoted • Development of corridor transport infrastructure to support the sales (export) to neighbouring large cities' markets • Various transport corridors connecting Burkina Faso with Côte d'Ivoire, Ghana, Togo and Benin • In the southern part of Burkina Faso, east-west corridors connecting Primary Corridors to sea ports for providing access to agricultural potential areas 	<p>AB-2-2</p>  <ul style="list-style-type: none"> • Economic sectors targeting at sales to neighbouring large cities are to be promoted • Development of corridor transport infrastructure to support the sales (export) to neighbouring large cities' markets • Various transport corridors connecting Burkina Faso with Côte d'Ivoire, Ghana, Togo and Benin • Transport corridors not only to the south, but also to the north for providing access to economic sectors' potential areas in the north • In the southern part of Burkina Faso, east-west corridors connecting Primary Corridors to sea ports for providing access to agricultural potential areas

Source: JICA Study Team

2) Tools for Identification of Impacts

The alternative scenarios for corridor development in Burkina Faso were evaluated by using a risk and opportunity matrix (see Table F.2.2) during the group work of the Second Stakeholder Meeting.

Table F.2.2 Tools for Identification of Impacts in the Second Stakeholder Meeting

Plan Interventions	Anticipated Risks/ Opportunities	Proposed Mitigation Measures	Responsible Institution(s)
Scenario AB-1-1	<u>Risks</u> <u>Opportunities</u>		
Scenario AB-1-1	<u>Risks</u> <u>Opportunities</u>		
Scenario AB-1-1	<u>Risks</u> <u>Opportunities</u>		
Scenario AB-1-1	<u>Risks</u> <u>Opportunities</u>		

Source: JICA Study Team

3) Result of Group Work

Scenario AB-2-2 attracted participants' attention as being the one that can interest Burkina Faso and it falls within the new referential document on socio-economic development in Burkina Faso, that is to say the PNDES where road facilities are an essential component. Participants determined the risks and opportunities of Scenario AB-2-2 as follows:

Risks:

- Insufficiency of funds for implementation of projects,
- Socio-political crises,
- Non-compliance with free flow of people and goods, and
- Weak quality of infrastructures

Opportunities:

- Development of cities,
- Existence of a port with large storage capacities for storing and drainage of cargo flows,
- Promotion of industries, and
- Inter and intra-regional exchanges.

Table F.2.3 Summary of Identified Impacts due to Corridor Development

1. Natural Resources/ Environment <ul style="list-style-type: none"> • Deforestation/ Loss of Biodiversity • Loss of land/ Land take • Protected Areas • Pollution of Water, Air and Soil e.g. Noise Nuisance, Drop of Sanitation & Hygiene Standards • Climatic Risks (floods and drought) 	3. Economic Environment <ul style="list-style-type: none"> • Employment Generation • Investments • Revenue Generation
2. Socio-Cultural Environment <ul style="list-style-type: none"> • Risk of Contagious Diseases • Urban Migration- increased population density of urban areas • Increased Traffic • Loss of Historic/ Cultural Heritage 	4. Institutional Environment <ul style="list-style-type: none"> • Institutional Role Play • Standards/ Guidelines • Law Enforcement

Source: JICA Study Team

(2) The Third Stakeholder Meeting for Planning and SEA in Burkina Faso

The Third Stakeholder Meeting for Planning and SEA was held in Burkina Faso on the 10th and 11th of October 2016. The objective was to analyse and assess impacts of implementing corridor development strategies.

1) Targets for analysis and assessment

The targets for analysis and assessment in the Third Stakeholder Meeting were a total of 34 priority projects for Burkina Faso. A list of the priority projects is presented in Table F.2.4, while their detailed description is contained in other chapters of this Main Report.

Table F.2.4 Targets for Assessment in the Third Stakeholder Meeting and Grouping for Group Work

Plan Interventions (Priority Projects for Corridor Development for Burkina Faso)	Group Responsible
<p>Economic Sectors Development</p> <ol style="list-style-type: none"> 1) Expansion of Mining Operation of Tambao Manganese Mine by Rehabilitation and Construction of Railway between Tambao and Ouagadougou through Dori and Kaya 2) Expansion of Production and Export of Cattle 3) Promotion of Investment and Development for Bagrépole in Agriculture, Aquaculture and Agro-Processing 4) Promotion of Investment and Development of Irrigated Agriculture in Karfiguéla 5) Promotion of Investment and Development of Irrigated Agriculture in Douna 6) Promotion of Investment for Other Agropoles 7) Development of Specialized Crops Targeting at Middle-Income Consumers of Sub-Regional Markets 8) Promotion of Investment and Development for Manufacturing in Ouagadougou 9) Promotion of Investment and Development for Manufacturing in Bobo-Dioulasso 	Group A
<p>Transport Corridor Infrastructure</p> <ol style="list-style-type: none"> 10) Replacement and Rehabilitation of Old Road Bridges and Improvement of Road Pavement for Strengthening of Primary Transport Corridors 11) Construction of Southern and Eastern Sections (between N1 and N3) for Ouagadougou Outer Ring Road 12) Construction of Motorway between Ouagadougou and Bodo-Dioulasso 13) Construction and Operation of Multi-Modal Dry Port for Ouagadougou including Construction of Access Road from N1 to Ouagadougou Multi-Modal Dry Port 14) Expansion and Strengthening of Operation of Bobo-Dioulasso Multi-Modal Dry Port 15) Construction of Southern Section (between N1 and N8) of Bobo-Dioulasso Outer Ring Road 16) Improvement of Road from N1 toward Ghana's Wa through Hamile 17) Upgrading of Road between Ouagadougou and Cinkassé to 4-Lane Dualized Road 18) Upgrading of Road between Koupéla and Fada-Genourna to 4-Lane Dualized Road 	Group B
<p>Transport Corridor Infrastructure</p> <ol style="list-style-type: none"> 19) Construction of Bypass Road for Fada-Ngrouma 20) Development of Inter-Modal Dry Port of Cinkassé 21) Upgrading of Bobo-Dioulasso International Airport for Accommodating More Frequent Sub-Regional and Domestic Flights 22) Replacement and Rehabilitation of Old Railway Bridges and Improvement of Track of Existing of Railway Line 23) Rehabilitation of the Track of Kaya and Ouagadougou Railway Line and Construction of Railway between Tambao and Kaya through Dori 24) Development of Loading and Off-Loading Facilities for Cattle at the following railway stations together with Cattle Waiting Pens (Railway Station in a Suburban Area of Ouagadougou, Railway Station in a Suburban Area of Bobo-Dioulasso, Railway Station in Kaya, Railway Station in Cinkassé) 	Group C
<p>Other Corridor Infrastructure</p> <ol style="list-style-type: none"> 25) Establishment and Operation of Data Centre located in Ouagadougou 26) Nationwide 5,000km Optic Fibre Cabling Project 	
<p>Basic Infrastructure for Economic Sector Development</p> <ol style="list-style-type: none"> 27) Electricity Interconnection Line (Kompienga-Porga [Benin]) Development Project 28) Project for Irrigation Development in Karfiguéla 29) Project for Irrigation Development in Douna 30) Integrated Development Project of Gounghin and Kossodo Industrial Zones in Ouagadougou (Expansion of Kossodo Industrial Area, Relocation of industries from Gounghin Industrial Area in the centre of Ouagadougou to Kossodo Industrial Area, Rehabilitation of Gounghin Industrial Area) 31) Construction and Operation of New Industrial Park along an Outer Ring Road in Bobo-Dioulasso 32) Project on Water Supply to Ouagadougou from Ziga Dam (Ziga II) 33) Expansion of Water Supply System based on Boreholes in Bobo-Dioulasso 34) Projects for Improvement of National and Regional Roads for Providing Better Access to Potential Agriculture Areas (Improvement of Road (N20) connecting N5 and N12, Rehabilitation of Road between Bobo-Dioulasso and Ouahigouya through Tougan for Sourou Agricultural Potential Area, Improvement of Road between Banfora-Douna) 	Group D

Source: JICA Study Team

2) Tools for Analysis and Assessment

The priority projects for Burkina Faso were evaluated by using a compound matrix (see Table F.2.6) during the group work of the Second Stakeholder Meeting. The compound matrix is used, principally to evaluate individual plan interventions against a range of environmental criteria/ effects, which serve as indicators of the existing environmental conditions. These criteria relate to the four

pillars of sustainability, namely, natural resources, socio-cultural, economic and institutional. See Table F.2.5.

The way in which the Plan Intervention (Priority Project) interacts with each criterion in the matrix was discussed by the groups and a view was taken as to whether or not the plan intervention is likely to eliminate the environmental effect or worsen it or be largely neutral. The following symbols were used to record evaluation results as follows:

- Conditions are likely to be positive “+”
- Conditions are likely to be negative “-”
- Conditions are likely to be neutral “0”

Table F.2.5 Environmental Criteria/ Effects

Sustainability Pillars	Environmental Criteria/ Effects
1. Natural resources	1-1 Deforestation/ Loss of biodiversity 1-2 Loss of land/ Land take 1-3 Protected areas 1-4 Pollution of water, air and soil e.g. noise nuisance, drop of sanitation & hygiene standards 1-5 Climatic risks (floods and drought)
2. Socio-cultural	2-1 Risk of Contagious diseases 2-2 Urban migration- increased population density of urban areas 2-3 Increased traffic 2-4 Loss of historic/ cultural heritage
3. Economic	3-1 Employment generation 3-2 Investments 3-3 Revenue generation
4. Institutional	4-1 Institutional role play 4-2 Standards/ Guidelines 4-3 Law enforcement

Source: JICA Study Team

Table F.2.6 Compound Matrix

[Score Sheet]

Plan Interventions	Environmental Criteria/ Effects														
	1. Natural resources					2. Socio-cultural				3. Economic			4. Institutional		
	1-1	1-2	1-3	1-4	1-5	2-1	2-2	2-3	2-4	3-1	3-2	3-3	4-1	4-2	4-3
Priority Projects 1 to 34															

[Reason Sheet : Description of Plan Intervention: Priority Project No. 1]

Sustainability Pillars	Environmental Criteria/Effects	Reasons	Score*
1. Natural resources	1-1		

Note*: positive->+, negative->-, Neutral->0

Source: JICA Study Team

3) Result of Group Work

Results of the evaluation using a compound matrix by group work are as shown in Table F.2.7. Due to the lack of time for group work in the Third Stakeholder Meeting, participants could not finish evaluating some priority projects.

When it comes to evaluation results of individual projects, the following projects are evaluated to have relatively high environmental impact as shown below:

Projects assessed as having a great impact on criteria of natural resources

- No. 1: Expansion of Mining Operation of Tambao Manganese Mine by Rehabilitation and Construction of Railway between Tambao and Ouagadougou through Dori and Kaya
- No. 4: Promotion of Investment and Development of Irrigated Agriculture in Karfiguéla
- No. 5: Promotion of Investment and Development of Irrigated Agriculture in Douna
- No. 17: Upgrading of Road between Ouagadougou and Cinkassé to 4-Lane Dualized Road
- No. 19: Construction of Bypass Road for Fada-Ngrouma
- No. 23: Rehabilitation of the Track of Kaya and Ouagadougou Railway Line and Construction of Railway between Tambao and Kaya through Dori
- No. 30: Integrated Development Project of Gounghin and Kossodo Industrial Zones in Ouagadougou (Expansion of Kossodo Industrial Area, Relocation of industries from Gounghin Industrial Area in the centre of Ouagadougou to Kossodo Industrial Area, Rehabilitation of Gounghin Industrial Area)
- No. 31: Construction and Operation of New Industrial Park along an Outer Ring Road in Bobo-Dioulasso
- No. 34: Projects for Improvement of National and Regional Roads for Providing Better Access to Potential Agriculture Areas (Improvement of Road (N20) connecting N5 and N12, Rehabilitation of Road between Bobo-Dioulasso and Ouahigouya through Tougan for Sourou Agricultural Potential Area, Improvement of Road between Banfora-Douna)

Projects assessed as having a great impact on socio-cultural criteria

- No. 8: Promotion of Investment and Development for Manufacturing in Ouagadougou

Especially, the industrial development projects in Ouagadougou (No. 8 and No. 30) were evaluated as having a great impact on both natural resources and socio-cultural criteria. Participants suggested that many mitigation measures are necessary for the industrial development in Ouagadougou.

Table F.2.7 Compound Matrix – Score Sheet (Result)

Plan Interventions		Environmental Criteria/ Effects														
		1. Natural resources					2. Socio-cultural				3. Economic			4. Institutional		
		1-1	1-2	1-3	1-4	1-5	2-1	2-2	2-3	2-4	3-1	3-2	3-3	4-1	4-2	4-3
Economic Sectors Development	1	-	-	-	-	-	-	+	+	-	+	+	+	+	+	+
	2													+	+	+
	3	-	-	+	-	-	-	+	+	-	+	+	+	+	+	
	4	-	-	-	-	-	-	+	+	0	+	+	+			
	5	-	-	-	-	-	-	-		-	+			+	+	+
	6	-	-		-	-	-		-	-	+	+	+			
	7															
	8	+	-	+	-	-	-	-	-	-						
	9															
Transport Corridor Infrastructure	10	-	-	-	-	0	-	+	+	0	+	+	+	+	0	0
	11	-	-	-	-	0	-	+	+	0	+	+	+	0	0	0
	12	-	-	-	-	0	-	+	+	-	+	+	+	+	+	+
	13	-	-	0	-	-	-	+	+	0	+	+	+	+	0	0
	14	-	-	0	-	0	-	+	+	0	+	+	+	0	0	0
	15	-	-	0	-	-	-	+	+	-	+	+	+	+	0	0
	16	-	-	-	-	0	-	0	+	0	+	+	+	0	0	0
	17	-	-	-	-	-	-	0	+	0	+	+	+	+	0	0
	18	-	-	0	-	-	-	0	+	-	+	+	+	+	0	0
	19	-	-	-	-	-	-	0	+	0	+	+	+	0	0	0
	20	-	-	-	-	0	0	-	-	0	+	+	+	0	0	0
	21	0	0	0	-	0	0	0	+	0	+	+	+	+	0	0
	22	-	0	0	-	0	-	0	-	0	+	0	+	0	0	0
	23	-	-	-	-	-	-	-	+	0	+	+	+	0	0	0
	24															
Other Corridor Infrastructure	25															
	26															
Basic Infrastructure for Economic Sector Development	27	-	-	-	-	0	-	0	-	-	+	+	+	0	0	0
	28	-	+	0	-	0	-	0	+	-	+	+	+	0	+	0
	29	-	+	0	-	0	-	0	+	-	+	+	+	0	+	0
	30	-	-	-	-	-	-	-	+	-	+	+	+	0	+	0
	31	-	-	-	-	-	-	-	+	-	+	+	+	0	+	0
	32	-	0	0	-	0	0	0	0	0	+	+	+	0	+	0
	33	-	-	-	-	0	0	0	0	-	+	+	+	0	+	0
	34	-	-	-	-	-	-	0	+	-	+	+	+	0	+	0

Source: JICA Study Team

Table F.2.8 shows the evaluation results after grouping the priority projects in several areas. Projects not included in these areas and not limited to areas are excluded by the group work. The reasons for negative results in evaluation of projects by area and by group work are as shown in

Table F.2.9 to Table F.2.14.

Table F.2.8 Compound Matrix – Score Sheet (Result by Area)

Plan Interventions		Environmental Criteria/ Effects														
		1. Natural resources					2. Socio-cultural				3. Economic			4. Institutional		
		1-1	1-2	1-3	1-4	1-5	2-1	2-2	2-3	2-4	3-1	3-2	3-3	4-1	4-2	4-3
Projects in Ouagadougou	8	+	-	+	-	-	-	-	-							
	11	-	-	-	-	0	-	+	+	0	+	+	+	0	0	0
	13	-	-	0	-	-	-	+	+	0	+	+	+	+	0	0
	30	-	-	-	-	-	-	-	+	-	+	+	+	0	+	0
	32	-	0	0	-	0	0	0	0	0	+	+	+	0	+	0
Projects in Bobo-Dioulasso	14	-	-	0	-	0	-	+	+	0	+	+	+	0	0	0
	15	-	-	0	-	-	-	+	+	-	+	+	+	+	0	0
	21	0	0	0	-	0	0	0	+	0	+	+	+	+	0	0
	31	-	-	-	-	-	-	-	+	-	+	+	+	0	+	0
Projects along Abidjan-Ouagadougou Corridor	33	-	-	-	-	0	0	0	0	-	+	+	+	0	+	0
	4	-	-	-	-	-	-	+	+	0	+	+	+			
	5	-	-	-	-	-	-	-	-		+			+	+	+
	10	-	-	-	-	0	-	+	+	0	+	+	+	+	0	0
	12	-	-	-	-	0	-	+	+	-	+	+	+	+	+	+
	22	-	0	0	-	0	-	0	-	0	+	0	+	0	0	0
	28	-	+	0	-	0	-	0	+	-	+	+	+	0	+	0
Projects along Tema-Ouagadougou Corridor and in the south	29	-	+	0	-	0	-	0	+	-	+	+	+	0	+	0
	34	-	-	-	-	-	-	0	+	-	+	+	+	0	+	0
	3	-	-	+	-	-	-	+	+	-	+	+	+	+	+	
	16	-	-	-	-	0	-	0	+	0	+	+	+	0	0	0
Projects along Lome-Ouagadougou Corridor	34	-	-	-	-	-	-	0	+	-	+	+	+	0	+	0
	3	-	-	+	-	-	-	+	+	-	+	+	+	+	+	
	17	-	-	-	-	-	-	0	+	0	+	+	+	+	0	0
	18	-	-	0	-	-	-	0	+	-	+	+	+	+	0	0
	19	-	-	-	-	-	-	0	+	0	+	+	+	0	0	0
Projects between Ouagadougou and Tambao	20	-	-	-	-	0	0	-	-	0	+	+	+	0	0	0
	27	-	-	-	-	0	-	0	-	-	+	+	+	0	0	0
Projects between Ouagadougou and Tambao	1	-	-	-	-	-	-	+	+	-	+	+	+	+	+	+
	23	-	-	-	-	-	-	-	+	0	+	+	+	0	0	0

Source: JICA Study Team

Table F.2.9 Reason for Negative Impact of Projects in Ouagadougou

Sustainability Pillars	Environmental Criteria/ Effects	Reasons
Natural resources	Deforestation/ Loss of biodiversity	- Destruction of vegetation cover (30, 32)
	Loss of land/ Land take	- Movement of populations for the establishment of enterprises/ factories and access routes to the site (8) - Destruction of vegetation cover (30)
	Protected areas	- Possible crossing of the forest of Gampella (11) - Existence of green belt (30)
	Pollution of water, air and soil e.g. noise nuisance, drop of sanitation & hygiene standards	- Discharge of residues of manufactured products, whirring machines (8) - Dust, gas emissions, noise (11, 13) - Pollution during construction and operation phases (30) - Dust raising, machine noise (32)
	Climatic risks (floods and drought)	- Elevation of roads, shrinkage of streams by roads and buildings (8) - Emissions of greenhouse gases (CO ₂) (13) - Production of greenhouse gases (30)
Socio-cultural	Contagious diseases	- Pollution of water, air, chemical discharges, dust, noise and acoustic nuisance (8) - STI / HIV AIDS, meningitis, infectious diseases (13) - Respiratory diseases, population mixing (30)
	Urban migration- increased population density of urban areas	- Displacement of populations, search for employment in industrial areas (8) - Creation of the buffer zone, spontaneous habitat (30)
	Increased traffic	- Population increase in the city, transport of goods (8)
	Loss of historic/ cultural heritage	- Displacement of populations, reduction of spaces due to overcrowding (8) - Relocation of habitat and sacred place (30)

Source: JICA Study Team

Table F.2.10 Reason for Negative Impact of Projects in Bobo-Doulasso

Sustainability Pillars	Environmental Criteria/ Effects	Reasons
Natural resources	Deforestation/ Loss of biodiversity	- Destruction of vegetation cover (31, 33)
	Loss of land/ Land take	- Destruction of vegetation cover (31) - Land acquisition by ONEA (33)
	Protected areas	- Existence of classified forest of Kua (31) - Encroachment of protected areas (33)
	Pollution of water, air and soil e.g. noise nuisance, drop of sanitation & hygiene standards	- Risk of increase in noise pollution (21) - Pollution during construction and operation phases (31) - Dust raising, machine noise, soil pollution by machine oils (33)
	Climatic risks (floods and drought)	- Risk of flooding in suburbs (15) - Production of greenhouse gases (31)
Socio-cultural	Contagious diseases	- STI / HIV AIDS, meningitis, infectious diseases (15) - Respiratory diseases, population mixing (31)
	Urban migration- increased population density of urban areas	- Creation of the buffer zone, spontaneous habitat (31)
	Loss of historic/ cultural heritage	- Risk of impact on some cultural sites (15) - Disturbance of habitat and sacred place (31, 33)

Source: JICA Study Team

Table F.2.11 Reason for Negative Impact of Projects along Abidjan-Ouagadougou Corridor

Sustainability Pillars	Environmental Criteria/ Effects	Reasons
Natural resources	Deforestation/ Loss of biodiversity	- Clearing and stumping trees (4, 5) - Opening of quarries, creation of diversions, road widening, withdrawal of water (10, 12) - Loss of biodiversity (22) - Destruction of vegetation cover (28, 29) - Massive destruction of trees (34)
	Loss of land/ Land take	- Disposal of land (4, 5) - Opening of quarries, creation of diversions, road widening, withdrawal of water (10, 12) - Destruction of land and widening of the right-of-way of roads (34)
	Protected areas	- Clearing and stumping trees (4) - Disappearance of plants and animal species (5) - Creation of diversions, road widening, withdrawal of water (10, 12) - Encroachment of protected areas (including Nazinga Reserve and elephant corridor) (34)
	Pollution of water, air and soil e.g. noise nuisance, drop of sanitation & hygiene standards	- Disposal of land (4) - Use of pesticides and chemical fertilizers (5) - Water sampling, noise of construction equipment, emissions of gases and dust (10, 12) - Noise, pollution of air, water and soil, regularly control of water (22) - Pollution during construction and operation phases (28, 29) - Dust raising, machine noise, soil pollution by machine oils (34)
	Climatic risks (floods and drought)	- Clearing and stumping trees (4) - Levelling and reclamation of land (5) - Risk of flooding due to lack of or poor drainage of water (34)
Socio-cultural	Contagious diseases	- Development of irrigation canals will favour the multiplication of mosquitoes inducing malaria. (4) - Non-organic products, genetically modified organisms and pesticides (5) - Sexually transmitted infections and HIV / AIDS (10, 12) - Arrival of temporary labour (22) - Mixing of populations (workers and local population) (28, 34)
	Urban migration- increased population density of urban areas	- Expropriation of land, non-integration of young people into projects (5)
	Increased traffic	- Reduction of rail traffic (22)
	Loss of historic/ cultural heritage	- Destruction of sacred sites (altars, tombs, etc.) (5) - New layout (100 m of right-of-way) (12) - Cultural remains may be affected (construction phase) (28) - Disturbance of habitat and sacred places (34)

Source: JICA Study Team

Table F.2.12 Reason for Negative Impact of Projects in and along Tema-Ouagadougou Corridor and in the South

Sustainability Pillars	Environmental Criteria/ Effects	Reasons
Natural resources	Deforestation/ Loss of biodiversity	- Sowing the areas, installation of ponds and industrial units (3) - Massive destruction of trees (34)
	Loss of land/ Land take	- Cultural practices, use of chemical fertilizers (3) - Destruction of land and widening of the right-of-way of the road (34)
	Protected areas	- Encroachment of protected areas (including Nazinga Reserve and elephant corridor) (34)
	Pollution of water, air and soil e.g. noise nuisance, drop of sanitation & hygiene standards	- Use of large equipment, fertilizers and improved seeds (3) - Dust raising, machine noise, soil pollution by machine oil (34)
	Climatic risks (floods and drought)	- Creation of desert roads, obstruction of watercourses (3) - Risk of flooding due to lack or poor drainage of water (34)
Socio-cultural	Contagious diseases	- Inter-country movement and transhumance (3) - Mixing of populations (workers and local population) (34)
	Loss of historic/ cultural heritage	- Cultural interpenetration (3) - Disturbance of habitat and sacred places (34)

Source: JICA Study Team

Table F.2.13 Reason for Negative Impact of Projects along Lome-Ouagadougou Corridor

Sustainability Pillars	Environmental Criteria/ Effects	Reasons
Natural resources	Deforestation/ Loss of biodiversity	- Sowing the areas, installation of ponds and industrial units (3) - Existence of forests or trees (20,27)
	Loss of land/ Land take	- Cultural practices, use of chemical fertilizers (3) - Existence of fields (19,20) - Existence of dwellings (19,20) - Existence of private plantation (20) - Expropriations of landowners (27)
	Protected areas	- Existence of classified forest of Gonsée (17) - Existence of communal forest of Fada (19) - Existence of classified areas (20) - Destruction of vegetation cover (27)
	Pollution of water, air and soil e.g. noise nuisance, drop of sanitation & hygiene standards	- Use of large equipment, fertilizers and improved seeds (3) - Existence of dams to be protected (19) - Dust generation, soil pollution by work-related oils (Construction phase) (27)
	Climatic risks (floods and drought)	- Creation of desert roads, obstruction of watercourses (3) - Tree felling (17) - Risk of flooding by rainwater (19)
Socio-cultural	Risk of Contagious diseases	- Inter-country movement and transhumants (3) - Sexually transmitted infection and HIV / AIDS (17) - Arrival of temporary labour (19) - Mixing between the workers and the local population (27)
	Increased traffic	- Development of social evils, loss of certain socio-cultural values (20) - Risk of traffic accidents (20) - Number of vehicles used during construction (27)
	Loss of historic/ cultural heritage	- Cultural interpenetration (3) - Moving graves (18) - Risk of disruption of cultural heritage (27)

Source: JICA Study Team

Table F.2.14 Reason for Negative Impact of Projects between Ouagadougou and Tambao

Sustainability Pillars	Environmental Criteria/ Effects	Reasons
Natural resources	Deforestation/ Loss of biodiversity	- Alignment and laying the rails - Existence of forests - Occupation of land by rail tracks, displacement of populations, creation of new fields by displaced populations
	Loss of land/ Land take	- Alignment and laying the rails - Existence of fields - Existence of dwellings - Occupation of land by rail tracks, displacement of populations, creation of new fields by displaced populations
	Protected areas	- Existence of classified forests - Existence of the agro-forestry-pastoral reserve - Habitat disturbance and even destruction of wildlife habitat (concession of hunting areas in Sanmatenga and Oudalan) - Crossing of rivers
	Pollution of water, air and soil e.g. noise nuisance, drop of sanitation & hygiene standards	- Existence of plants and watercourses - Release of materials (iron, cement, oil, etc.) - Whirring machines - Dust raised by machines - Diseases caused pollution of water, air and soil (soil, cement, smoke)
	Climatic risks (floods and drought)	- Obstruction of waterways - Erosion due to water flows - Destruction of watercourses - Risk of flooding by rainwater
Socio-cultural	Contagious diseases	- Arrival of temporary labour

Source: JICA Study Team

F.3 Detailed Progress of SEA for Côte d'Ivoire

F.3.1 Activities in Preparation Stage of SEA

There was the following progress in SEA for Côte d'Ivoire after the initiation of the Project.

(1) The First Stakeholder Meeting for Planning and SEA in Côte d'Ivoire

The First Stakeholder Meeting for Planning and SEA was held in Abidjan on 2nd October, 2015, jointly by the JICA Study Team and the Ministry to the Prime Minister in Charge of Economy and Finance. The objectives were to explain and discuss the objectives, approaches and scope of the Project and to discuss issues on corridor development and the environment in Côte d'Ivoire.

(2) Procurement of Local Consultant

In order to carry out a SEA study, the JICA Study Team made a sub-consulting agreement on the SEA study in Côte d'Ivoire with a national consulting firm, NEXON Consulting on 12th October, 2015.

(3) Finalization of TOR of SEA

Based on several discussions between the JICA Study Team and ANDE, ANDE prepared and transmitted a Terms of Reference (TOR) of SEA for the Project on 19th August, 2015 according to the national regulation. ANDE delivered the revised TOR to the JICA Study Team on 20th January, 2016, as a result of several exchanges of information and views. The following expected results of SEA were incorporated into the original TOR:

Expected Results of SEA

The SEA should provide more specifically the following results:

- The plan is conform to the norms of democratic governance reflected in national commitments and multilateral agreements;

- All the right holders equally enjoy the benefits of the plan;
- The plan contributes in the long term to security of conditions and living conditions of local communities and increases their welfare, with special attention to the most vulnerable people;
- The plan contributes to a larger sustainable development, abides by human rights, rights as per national legislation, customary rights and collective rights and national development goals;
- The plan maintains and increases services for the biodiversity and ecosystems;
- All the stakeholders have access to specific information and take part fully and efficiently in the plan.

These results will lead to:

1. Selection of acceptable strategies;
2. Adjustments in some strategies so as to reduce negative impacts;
3. Development of a social and environmental management framework (SEMF).

This SEMF can be accompanied by other tools for social and environmental safeguards based on issues related to the plan.

(4) The Second Joint Technical and Monitoring Committee Meeting

The JICA Study Team gave a presentation on alternative scenarios for sub-regional corridor development at the Second National-Level Joint Technical and Monitoring Committee Meeting held on 2nd March, 2016. After the presentation and questions and answers, participants were divided into three groups and held group discussions on the two development scenarios. The results of the group discussions are described below.

Overview of the Group Discussions on Alternative Scenarios (Côte d’Ivoire)

The participants compared and discussed two major alternative corridor development scenarios at the sub-regional level, namely, Scenario A: Strengthening of the Coastal Corridor First¹, and Scenario B: Strengthening of the North-South Corridors First. Each group was requested to compare these scenarios having a different aim; the first group -integration of the sub-region, the second group -development of economic sectors in Côte d’Ivoire, and the third group could choose their aim. The three groups concluded as described below.

Table F.3.1 Result of Group Discussions of Group 1

Question 1	Which scenarios are more effective and efficient, scenario A or B, for integration of the sub-region?
Answer 1	Scenario B
Question 2	Why?
Answer 2	Scenario B will help to easily reach some countries, such as NIGER and MALI. It will also make agricultural products easy to flow towards ports for exportation (commercialization).
Question 3	Besides Scenarios A and B, are there any other alternative scenarios which are more effective and efficient for integration of the sub-region?
Answer 3	The group proposed a scenario which combines the following corridors: Corridor 1: San Pedro-Man-Odiéné-Ouangolodougou-Ouagadougou Corridor 2: San Pedro-Abidjan-Accra-Lomé Corridor 3: Ouagadougou-Accra Corridor 4: Abidjan-Divo-Yamoussoukro-Bouaké-Ouagadougou

Source: JICA Study Team

¹ Scenario A was renamed the "Stronger Coastal Corridor Development." Scenario B was also renamed the "Stronger North-South Corridor Development."

Table F.3.2 Result of Group Discussion of Group 2

Question 1	Which scenarios are more effective and efficient, scenario A or B, for development of economic sectors in Côte d'Ivoire?
Answer 1	Basically Scenario A, but Scenario B is also very important for development of the country
Question 2	Why?
Answer 2	Côte d'Ivoire promotes the development of the South-North corridors, mainly the western corridor that connects to Mali and other neighbouring countries. And the development in inland regions lags behind.
Question 3	Besides Scenarios A and B, are there any other alternative scenarios which are more effective and efficient for development of the economic sectors in Côte d'Ivoire?
Answer 3	Integrated Scenario of both ideas is recommended

Source: JICA Study Team

Table F.3.3 Result of Group Discussion of Group 3

Question 1	Which scenario is more effective and efficient, Scenario A or Scenario B, for integration of the sub-region? Please choose and specify where you stand or for what you are arguing or for whom you are arguing?
Answer 1	The standing point of the discussion was for the development of Côte d'Ivoire in general.
Question 2	Which scenario is more effective and efficient, Scenario A or Scenario B?
Answer 2	Scenario A
Question 3	Why?
Answer 3	Scenario A is selected because the economic power of Côte d'Ivoire will grow faster through the development of Abidjan-Lagos Corridor. WB is also already starting to develop this corridor. However, since the coastal corridor includes many countries, there is a risk that other countries along the coast might not agree to this scenario. It is also important to think about the social impact of the development of the coastal corridor which might cause more concentration on Abidjan. General development is also important for the country. Therefore, if possible, a combination of both scenario A and B might be a better solution.

Source: JICA Study Team

F.3.2 Activities in Scoping Study Stage of SEA

There are several priority projects in the agricultural sector which aim for production development of cash crops including maize, and they are expected to contribute to strengthen the production capacity of maize and other cereals and promote their processing. Such projects include “irrigation and agribusiness development in Douna and Karfiguéla” (Burkina Faso), “Support for Agro-industrial Pole of Bélier Region” (Côte d'Ivoire), and “Tamale-Mamprusi Agricultural Cluster Area Development Programme” (Ghana).

However, in terms of development and upgrading of maize processing, institutional arrangements and policies to facilitate and encourage more processing to take place within the value chains are also important. For example, industrial poultry production promotion in Côte d'Ivoire and Ghana, and the warehouse receipt system (WRS)² in Ghana are supposed to fall under such categories. Among the priority projects, “development of poultry processing plants with cold storage” and “feed resource development project” in Ghana are also expected to contribute to maize processing promotion.

F.3.3 Activities in Assessment Stage of SEA

(1) The Second Stakeholder Meeting for Planning and SEA in Côte d'Ivoire

² In WRS, licensed warehouse operators issue a document certifying the quantity and quality of a specified grain (maize, rice, soya, etc) placed by a named depositor (farmer, trader, food processor, financial institution, etc.) into a secured storage operated by the warehouse operator to encourage market access and fair returns for smallholder farmers, and to facilitate the formalization of informal agricultural trading activities.

The Second Stakeholder Meeting for Planning and SEA was held in Côte d'Ivoire on 2nd August, 2016. The objective of this meeting was to identify social and environmental impacts that corridor development strategies might generate.

1) Targets for identification of impacts

The targets for identification of impacts in the Second Stakeholder Meeting were alternative scenarios for corridor development in Côte d'Ivoire. A summary of the alternative scenarios is presented in Table F.3.4, while their detailed description is contained in other chapters of this Main Report.

Table F.3.4 Targets for Identification of Impacts in the Second Stakeholder Meeting

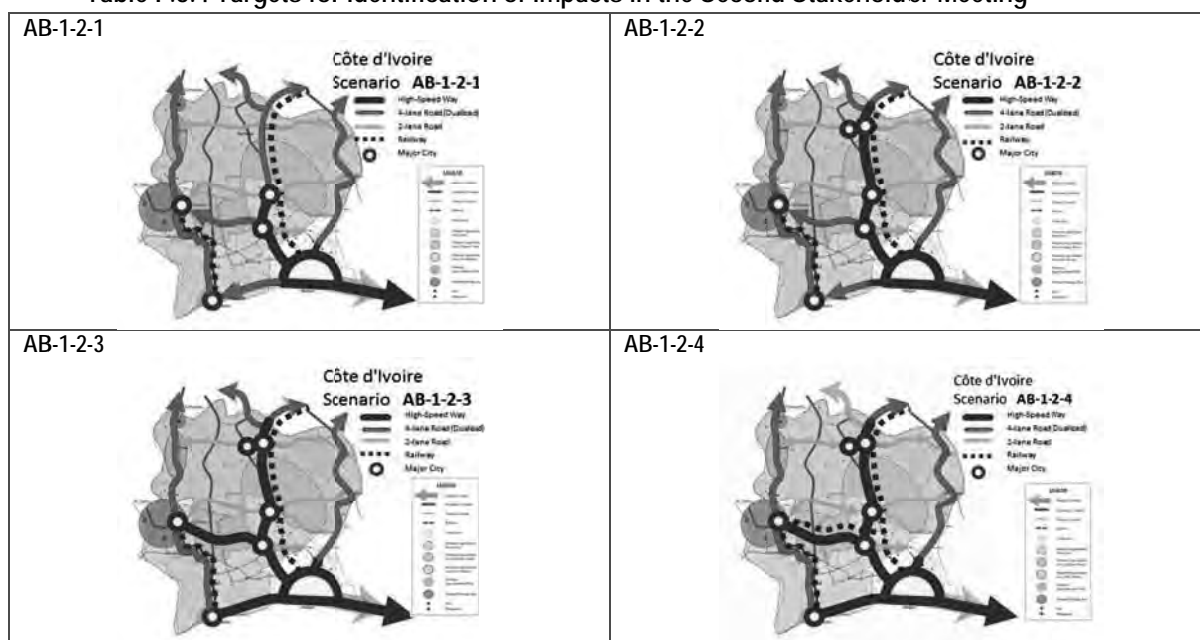

Source: JICA Study Team

Table F.3.5 Concept of Alternative Scenarios

Major types of agricultural sectors to be promoted in the central and northern part of Côte d'Ivoire	AB-1-2-1 AB-1-2-2 AB-1-2-3 AB-1-2-4	Not only medium and large scale agriculture and agriculture related sectors based on foreign and domestic investment, but also small scale agriculture
Major economic sectors to be promoted for regional cities along the Central Corridor in central and northern part of Côte d'Ivoire	AB-1-2-1	Manufacturing industries and ICT & BPO industries in addition to commerce in Bouaké, Yamoussoukro and Man
	AB-1-2-2 AB-1-2-3 AB-1-2-4	Manufacturing industries and ICT & BPO industries in addition to commerce in Bouaké, Yamoussoukro, Korhogo, Ferkessédougou and Man
Major economic sectors to be promoted for Greater Abidjan	AB-1-2-1 AB-1-2-2 AB-1-2-3 AB-1-2-4	Not only manufacturing industries and ICT & BPO, but also advanced services sectors
Development of San-Pédro	AB-1-2-1 AB-1-2-2	
	AB-1-2-3 AB-1-2-4	To promote development of San-Pédro by attracting manufacturing industries and ICT & BPO industries, in addition to existing commerce/services and government administration function
Speed of development of inland areas	AB-1-2-1	Low
	AB-1-2-2 AB-1-2-3 AB-1-2-4	High

Source: JICA Study Team

2) Tools for identification of impacts

The alternative scenarios for corridor development in Côte d'Ivoire were evaluated by using an impact assessment matrix (see Table F.3.6) during the group work of the Second Stakeholder Meeting.

Table F.3.6 Tools for Identification of Impacts in the Second Stakeholder Meeting

			Scenario AB-1-2-1	Scenario AB-1-2-2	Scenario AB-1-2-3	Scenario B-1-2-4
Benefits (Positive Impacts)	Economic	<ul style="list-style-type: none"> ➤ Investment in economic sectors ➤ Possibility of the improvement of value-chains for agriculture ➤ Employment creation, Income generation ➤ Revenue generation 				
	Spatial	<ul style="list-style-type: none"> ➤ Investment in infrastructure and urban facilities ➤ Geographical concentration of economic development ➤ Getting access to transport services 				
	Other	<ul style="list-style-type: none"> ➤ Skills acquisition 				
Impacts (Negative Impacts)	Economic					
	Spatial					
	Environmental	<ul style="list-style-type: none"> ➤ Air pollution, Water pollution, Noise pollution ➤ Land degradation, Forest depletion, Erosion 				
	Social	<ul style="list-style-type: none"> ➤ Migration, Employment, Child labour, Community ➤ Land litigation, Health, Education, Gender 				
	Institutional	<ul style="list-style-type: none"> ➤ Conflict among institutions ➤ Non-compliance with planning schemes ➤ Weak enforcement of planning Laws ➤ Development of unauthorised structures 				
	Other					
Synthetic Evaluation						

Source: JICA Study Team

3) Result of group work

After considering the different criteria mentioned for the analysis and assessment, as a whole all the groups selected Scenario AB-1-2-4. The synthetic evaluation by each group is shown below. According to some attendees, some adjustments need to be made on the selected scenario AB-1-2-4 to integrate railways, roads and highways.

Group A:

Scenario AB-1-2-4 is the ideal one with the consideration of creating development poles in the East and North-West. Nevertheless, this scenario generates more impact on the environment. It is important to formulate measures for the protection of forest reserve and cultural heritage and management of inter-community conflicts.

Group B:

Scenario AB-1-2-4 has more advantage and promotes equitable development of Côte d'Ivoire but it should take into account some observations:

- Provision of a railway linking Man to Odienné to develop the mineral resources in the northeast of Côte d'Ivoire and at the border with Guinea
- Development of industrial centres in the east (Abengourou and Bondoukou)
- Consideration of territorial development plans of the concerned regions
- Consideration of health and tourism infrastructure
- Creation of new economic and industrial cities around Abidjan
- Consideration of environmental issues

Group C:

Proposed scenario is AB-1-2-4. The observations are as follows:

- Creation of a railway near 4 lane roads (2 x 2 lanes) connecting the existing railway to cope with the overexploitation of roads that could be triggered by the development of socioeconomic activities
Example: the link Anoumaba-Bongouanou-Bondoukou -Bouna
- Consideration of territorial development plans
- Development of hotels and other establishments to meet the needs of the tourism market

Table F.3.7 Summary of Identified Impacts due to Corridor Development in the Second Stakeholder Meeting

1. Natural Resources/ Environment <ul style="list-style-type: none"> • Protected Areas/ Deforestation/ Loss of Biodiversity • Loss of land/ Land take • Protected Areas • Pollution of Water, Air and Soil e.g. Noise Nuisance, Drop of Sanitation & Hygiene Standards • Climatic Risks (floods and drought) 	3. Economic Environment <ul style="list-style-type: none"> • Employment Generation • Investments • Revenue Generation
2. Socio-Cultural Environment <ul style="list-style-type: none"> • Urban Migration- increased population density of urban areas • Increased Traffic • Loss of Historic/ Cultural Heritage 	4. Institutional Environment <ul style="list-style-type: none"> • Institutional Role Play • Law Enforcement/ Standards/ Guidelines

Source: JICA Study Team

(2) The Third Stakeholder Meeting for Planning and SEA in Côte d'Ivoire

The Third Stakeholder Meeting for Planning and SEA was held in Côte d'Ivoire on the 13th of October 2016. The objective was to analyse and assess impacts of implementing corridor development strategies.

1) Targets for analysis and assessment

A total of 20 priority projects for Côte d'Ivoire were narrowed down for the group as the targets for analysis and assessment in the Third Stakeholder Meeting. As a result, due to the lack of time and insufficient number of participants for group work, six priority projects were assessed by two groups. A list of the priority projects is presented in Table F.3.8, while their detailed description is contained in other chapters of this Main Report.

Table F.3.8 Targets for Assessment in the Third Stakeholder Meeting and Grouping for Group Work

Plan Interventions (Priority Projects for Corridor Development for Côte d'Ivoire)	
Economic Sectors Development	
1) Project for Acceleration of Cashew Nuts Processing (14 regions - Bafing, Eirb Hambol, Worodougou, Boukani, Gontougo, Bagoue, Kabadougou, Marahoué, Poro, Folon, Tchologo, Iffou, Hauto Sassandra)	Group B
2) Construction of Slaughterhouses in the Country (Yamoussoukro, Daloa, Bouaké, Ferkessedougou, Korhogo)	Group A
Transport Corridor Infrastructure	
3) Construction of 4- lane Motorway; the east exit line Cocody-Bonoua	Group A
4) Construction of western section for Bouake Outer Ring Road	Group A
5) Construction of 4- lane road between Anyama and Bondoukou	Group B
6) Construction of New Port in Ile Boulay	Group A

Source: JICA Study Team

2) Tools for analysis and assessment

The priority projects for Côte d'Ivoire were evaluated by using a compound matrix (see Table F.3.10) during the group work of the Second Stakeholder Meeting. The compound matrix is used, principally to evaluate individual plan interventions against a range of environmental criteria/ effects, which serve as indicators of the existing environmental conditions. These criteria relate to the four pillars of sustainability, namely, natural resources, socio-cultural, economic and institutional. See Table F.3.9.

The way in which the Plan Intervention (Priority Project) interacts with each criterion in the matrix was discussed by the groups and views were taken as to whether or not the plan intervention is likely to eliminate the environmental effect or worsen it or be largely neutral. The following symbols were used to record evaluation results as follows:

- Conditions are likely to be positive “+”
- Conditions are likely to be negative “_”
- Conditions are likely to be neutral “0”

Table F.3.9 Environmental Criteria/ Effects

Sustainability Pillars	Environmental Criteria/ Effects
1. Natural resources	1-1 Protected areas/ Deforestation/ Loss of biodiversity 1-2 Loss of land/ Land take 1-3 Pollution of water, air and soil e.g. noise nuisance, drop of sanitation & hygiene standards 1-4 Climatic risks (floods and drought)
2. Socio-cultural	2-1 Urban migration- increased population density of urban areas 2-2 Increased traffic 2-3 Loss of historic/ cultural heritage
3. Economic	3-1 Employment generation 3-2 Investments 3-3 Revenue generation
4. Institutional	4-1 Institutional role play 4-2 Law enforcement/ Standards/ Guidelines

Source: JICA Study Team

Table F.3.10 Compound Matrix

[Score Sheet]

Plan Interventions	Environmental Criteria/ Effects											
	1. Natural resources				2. Socio-cultural			3. Economic			4. Institutional	
	1-1	1-2	1-3	1-4	2-1	2-2	2-3	3-1	3-2	3-3	4-1	4-2
Priority Projects 1 to 6												

[Reason Sheet : Description of Plan Intervention: Priority Project No. 1]

Sustainability Pillars	Environmental Criteria/Effects	Reasons	Score*
1. Natural resources	1-1		

Note*: positive->+, negative->-, Neutral->0

Source: JICA Study Team

3) Result of group work

Results of the evaluation using a compound matrix by group work are as shown in Table F.3.11.

When it comes to evaluation results of individual projects³, the following projects are evaluated to have relatively high environmental impact as shown below:

Projects assessed as having a great impact on criteria of natural resources

- No. 4: Construction of western section for Bouaké Outer Ring Road

Projects assessed as having a great impact on socio-cultural criteria

- No. 6: Construction of New Port in Île Boulay of Greater Abidjan

The reasons for negative results in evaluation of projects and proposed mitigation measures by group work are as shown in Table F.3.12

Table F.3.11 Compound Matrix – Score Sheet (Result)

Plan Interventions		Environmental Criteria/ Effects											
		1. Natural resources				2. Socio-cultural			3. Economic			4. Institutional	
		1-1	1-2	1-3	1-4	2-1	2-2	2-3	3-1	3-2	3-3	4-1	4-2
Economic Sectors Development	1	0	-	-	0	0	+	0	+	+	+	0	0
	2	0	0	-	0	-	-	0	+	+	+	+	+
Transport Corridor Infrastructure	3	-	-	-	0	-	+	-	+	+	+	+	+
	4	-	-	-	0	-	+	-	+	+	+	0	0
	5	-	-	-	0	0	-	-	+	+	+	0	0
	6	-	-	-	0	-	-	-					

Source: JICA Study Team

³ Corridor development strategies formulated by the JICA Study Team are composed of a variety of projects. Therefore, it is possible to review or evaluate corridor development strategies by evaluating individual projects which compose the corridor development strategies.

Table F.3.12 Reasons for Negative Impact of Each Project

Sustainability Pillars	Environmental Criteria/ Effects	Project	Reasons	
Natural resources	Protected areas/ Deforestation/ Loss of biodiversity	No. 3.4	Marshy area – mangroves Measures: avoiding any needless destruction since there is no forest in this area	
		No. 5	The protected areas can be affected (classified forests) Measures: take into account the environmental impact surveys in the context of studies	
		No. 6	Deforestation – loss of biodiversity Measures: compensation	
	Loss of land/ Land take	No. 1	Local population might be subjected to land expropriation. Measures: payment for customary rights	
		No. 3.4	Loss of crops and undeveloped lots Measures: identify and compensate people that are likely to be affected in line with the regulation, before and after the works	
		No. 5	Local population might be subjected to land expropriation. Measures: compensation to the population and for the affected properties	
		No. 6	Loss of land Measures: compensation and relocation	
	Pollution of water, air and soil e.g. noise nuisance, drop of sanitation & hygiene standards	No. 1	Environmental pollution (water, air, soil, noise) Measures: use good management of industrial waste, use innovative technology	
		No. 2	Water pollution due to the slaughtering of animals Health hazards related to water pollution Measures: management of the waste (waste water) derived from animal slaughtering; respecting health and sanitation standards	
		No. 3.4	During preparatory works - construction – operation Measures: spray roads before the start of works – maintain vehicle engines and use new vehicles – renew vehicle fleet	
		No. 5	Environmental pollution (water, air, soil, noise) Measures: use sound management of the waste on the work site; use an innovative technology	
		No. 6	Air pollution, water pollution and noise nuisance Measures: waste and noise management	
	Socio-cultural	Urban migration- increased population density of urban areas	No. 2	Activities zone that is likely to generate employment Measures: need to plan some butcher shops to avoid any urban concentration
			No. 3, 4	The road passes through the villages. Measures: connecting neighbouring communities with local roads – creating feeder roads
			No. 6	Measures: planning residential areas
Increased traffic		No. 2	Traffic congestion Measures: need to plan bypass roads	
		No. 5	The construction of roads will allow an increase in traffic, population movements and risks of accidents. Measures: take into account road safety measures	
Loss of historic/ cultural heritage		No. 3, 4	The road passes through the villages – risk of population displacement – destruction of sacred sites Measures: population relocation and compensation payment	
		No. 5	Possibility of cultural heritage destruction (cemeteries) Measures: payment for traditional and customary rights	
		No. 6	Existence of populations Measures: compensation and relocation	

Source: JICA Study Team

F.4 Detailed Progress of SEA for Ghana

F.4.1 Activities in Preparation Stage of SEA

There was the following progress in SEA for Ghana after the initiation of the Project.

(1) The First Technical Committee Meeting

In the First Technical Committee Meeting held on 30th July 2015, the following matters on SEA were discussed and agreed:

- SEA Study and Process should be done in accordance with Ghana's SEA procedure and methodology.

- The Steering Committee for WAGRIC-CACAO should play the function of the SEA Steering Committee for WAGRIC-CACAO.
- The Technical Committee for WAGRIC-CACAO should report on SEA matters and progress to the Steering Committee for WAGRIC-CACAO.
- The JICA Study Team should proceed to preparation and submission of a proposed TOR for the SEA Study to EPA.

(2) SEA Meetings between EPA and the Promoter of the Project

The JICA Study Team prepared a proposed Terms of Reference (TOR) for SEA for WAGRIC-CACAO and submitted it to Environmental Protection Agency (EPA) for review and approval. However, the TOR was not reviewed and accepted by EPA because EPA considered that discussions between the promoter side of the Project (NDPC, MRH, JICA, the JICA Study Team and the local consultant) and the competent authorities of SEA in Ghana (EPA and NDPC) should be done prior to any preparation of the TOR for SEA.

The promoter side of the Project and the competent authorities of SEA in Ghana have been having a series of meetings including four SEA Core Team Meetings as shown in Table F.4.1.

Table F.4.1 SEA Meetings between EPA and the Promoter of the Project

Date	Attending Organizations	Main Topics
15 th October, 2015	SEA Unit of EPA / NDPC / MRH / JICA Ghana Office / JICA Study Team	- TOR for the SEA study - SEA methodology and approach
22 nd December, 2015	SEA Unit of EPA / NDPC / MRH / JICA Ghana Office / JICA Study Team	- Payment policies of JICA - SEA process (ideal process and adopted process) - Role of each organization
6 th January, 2016	SEA Unit of EPA / NDPC / MRH / JICA Ghana Office / JICA Study Team	<u>First SEA Core Team Meeting</u> - Preparation of TOR for the SEA study
18 th January, 2016	SEA Unit of EPA / NDPC / MRH / JICA Study Team	<u>Second SEA Core Team Meeting</u> - Preparation of TOR for the SEA study - Scope for the SEA study
11 th February, 2016	Technical Committee Members	(Second Technical Committee Meeting)
16 th February, 2016	SEA Unit of EPA / NDPC / MRH / JICA Ghana Office / JICA Study Team	<u>Third SEA Core Team Meeting</u> - Proposed options for activities of the SEA study - Proposed budget for the SEA study - Procurement of SEA local consultant
19 th February, 2016	SEA Unit of EPA / NDPC / MRH / JICA Ghana Office / JICA Study Team	<u>Fourth SEA Core Team Meeting</u> - Budget prepared by EPA - Budget prepared by the JICA Study Team

Source: JICA Study Team

The TOR was prepared as the result of these meetings and a set of steps and activities to be conducted for SEA for the Project were agreed upon, as shown in Table F.4.2. In line with these steps and activities for the conduct of SEA for the Project, a budget for the SEA activities was estimated in detail.

Table F.4.2 Action Matrix for the Conduct of the SEA for the Project

No.	Steps/Contents	Activities
1	Preparatory meetings and discussions with the JICA	
2	Development of a Terms of Reference for the conduct of the SEA of the Corridor Development for the West Africa Growth Ring Master Plan	
3	Procurement of a local consultant	
4	Preparation of a Road map with budget and timelines for the conduct of the SEA of the Corridor Development for the West Africa Growth Ring Master Plan i.e. number of consultation Workshops	Meeting (1 day)
5	Carry out an Institutional analysis for the implementation of the Plan International and local consultant to do an institutional mapping and present to the SEA Core Team	Meeting (1 day)
5	Report preparation (Draft)	Meeting (1 day)
6	Identification and analysis of Stakeholders for the conduct of the SEA of the Corridor Development for the West Africa Growth Ring Master Plan	Meeting (2 days)
7	Development and discussions on proposed scenarios and Tools for the conduct of the SEA	
8	Pre-scoping stakeholders' workshop i.e. issues identified presented under the pillars of sustainability, etc.	1 day meeting for pre-scoping (1 mtg) 3 days meeting for SEA Core Team (known issues to inform the scenario development & tools)
9	Report on Workshop	Meeting (to discuss a draft report)
10	Consultation Meetings with various stakeholders who will be affected by the plan i.e. community level, district, opinion leaders, groups, etc. who will be affected directly or indirectly by the plan	3 communities (100 people) & consultations per corridor 2 days travel time & 1 day for consultation
11	Report on Consultations Issues and concerns discussed at these consultations are captured in the report The issues will inform the proposed scenarios and the SEA Tools to be used	Meeting (To discuss an draft report)
12	Assessment through a workshop and the application of the SEA Tools by stakeholders	55 key stakeholders 4 days/5 nights workshop
13	SEA Report Preparation (Executive Summary, Content, Process Reports)	5 days/6 nights meeting

Source: JICA Study Team

(3) The Second Technical Committee Meeting

The Second Technical Committee Meeting was held on 11th February. The SEA process for the Project was discussed in the meeting, and the following conclusions were reached.

- The JICA Study Team and the SEA Core Team will start the SEA process on the same understanding, using a Ghanaian system and tools of SEA provided by the SEA Unit of EPA.
- The JICA Study Team and the SEA Core Team will decide on the details for the procurement of a local consultant at the meeting set in the next week, based on the TOR prepared through the meetings between the SEA Unit of EPA and the JICA Study Team.
- The JICA Study Team and the SEA Core Team will submit minutes of the meeting and the final TOR to the Technical committee.
- Since JICA cannot cover all the items of the necessary budget for SEA, a division of cost bearing between the Ghanaian Side and the JICA Side should be considered and determined for implementation of the SEA study for the Project.

(4) Procurement of Local Consultant for SEA

The JICA Study Team made a sub-consulting agreement for the SEA study in Ghana with a national consulting firm, DELIN Consult Limited on 30th May, 2016, Delin Consult, so that the local consulting firm could carry out a SEA study in accordance with the TOR for the SEA for the Project.

F.4.2 Activities in Scoping Study Stage of SEA

(1) Activities in Scoping Study Stage of SEA

After the local consultant procurement, while receiving advice from the SEA Team, institutional analysis, stakeholder analysis and a scoping study have been carried out by the local consultant. In parallel with this, a series of community level consultation meetings were held at all 12 locations in Ghana, and the results were reflected in the scoping study.

The activities of SEA in the scoping study stage are as shown in Table F.4.3.

Table F.4.3 SEA Activities in Scoping Study Stage

Date	Attending Organizations	Main Topics
25 th July, 2016	SEA Unit of EPA / NDPC / JICA Study Team / Local Consultant	- Schedule of immediate activities of the SEA study - Budget prepared by the JICA Study Team
15 th August, 2016	SEA Unit of EPA / NDPC / MRH / JICA Ghana Office / JICA Study Team / Local Consultant	Fifth SEA Core Team Meeting - Presentation and discussion on the draft institutional analysis for the conduct of the SEA of the Project - Themes and methodology for the community consultation meetings - Draft programme outline for the community consultation meetings - Draft consultation schedule
18 th August, 2016	SEA Unit of EPA / NDPC / MRH / JICA Ghana Office / JICA Study Team / Local Consultant	Stakeholder Consultation Meeting in Tema - Consultation – group discussions on four pillars
19 th August, 2016	SEA Unit of EPA / NDPC / MRH / JICA Study Team / Local Consultant	- Review of the consultation meeting in Tema - Schedule and mobilization plan
22 nd August to 2 nd September, 2016	SEA Unit of EPA / NDPC / MRH / JICA Study Team / Local Consultant	Stakeholder Consultation Meeting in Dormaa Ahenkro, Jema, Navrongo, Bawku, Sawla, Cape Coast, Hohoe, Nkwanta, Takoradi, Kumasi and Savelugu - Consultation – group discussions on four pillars
19 th September, 2016	SEA Unit of EPA / NDPC / MRH / JICA Study Team / Local Consultant	- Review of consultation findings (key issues emerging from the consultation meetings)
22 nd September, 2016	SEA Unit of EPA / NDPC / MRH / JICA Study Team / Local Consultant	- Review of consultation findings (key issues emerging from the consultation meetings) - Action matrix
12 th October, 2016	SEA Unit of EPA / NDPC / MRH / JICA Study Team / Local Consultant	Sixth SEA Core Team Meeting - Review of consultation findings - List of stakeholders - Action matrix
19 th -21 st October, 2016	SEA Unit of EPA / NDPC / MRH / JICA Study Team / Local Consultant	SEA Scoping Workshop - Baseline information for SEA report - Institutional analysis for SEA report - Three basic scenarios - Matrix of key issues
12 th December, 2016	SEA Unit of EPA / NDPC / MRH / JICA Study Team / Local Consultant	Seventh SEA Core Team Meeting - Draft scoping report - Way forward

Source: JICA Study Team

(2) Stakeholder Consultation Meetings in 12 Selected Districts

In compliance with the SEA process shown in Table F.4.2 the SEA team conducted stakeholder consultation meetings in the 12 selected districts in all the 10 regions of Ghana from 18th August to 2nd September, 2016. At each of the selected districts the SEA team took the opportunity to inform stakeholders about the outline of the West Africa Growth Ring Corridor Master Planning Project (WAGRIC-CACAO). This was followed by the presentation on possible corridor development in Ghana and furthermore followed by the explanation about SEA. These presentations were intended to enable them to understand what corridor development is about and what SEA is about.

After these presentations, group discussions were conducted so as to enable participants to express their opinions and views on issues concerning anticipated impacts of corridor development. The impacts were conveniently grouped under the four pillars of sustainable development, namely, institutional, economic, socio-cultural and natural resources.

It was notable that the stakeholder consultation meetings were characterized by participatory engagement and their willingness to be involved in document formulation.

(3) Result of Scoping for SEA

After the community-level stakeholder engagement, the issues which came out of the group discussions were summarized and presented in the order of frequency of occurrence during the stakeholder meetings. Below are the results of the analysis of key issues in relation to the four pillars. Issues indicated in bold in the table are those with high occurrence frequency at the stakeholder consultation meetings.

Table F.4.4 Outcomes of Analysis of Stakeholder Issues

Environmental Component	Potentially Significant Effect, if unmitigated (Most Relevant)
Institutional	<ul style="list-style-type: none"> • Ineffective Institutional collaboration • Ineffective land use management • Poor stakeholder engagement • Boundary/Jurisdictional challenges • External and internal interferences on functions and mandates of institution • Ineffective monitoring, reporting and verification processes • Disparities in traffic signage among member countries • Accidents and low emergency preparedness • Adherence to local content law challenges • Poor enforcement and compliance to laws and regulations <p><u>Less Relevant</u></p> <ul style="list-style-type: none"> • Budgeting and financial constraints for institutions • Inadequately skilled human resources personnel • High cost of capital for businesses • Bureaucracy • Development of unauthorized structures • Waste management challenges
Economic	<ul style="list-style-type: none"> • Opportunities for job creation and employment of local workers • Government revenue and income mobilization • Regional integration challenges • Challenges in Immigration and customs regulations • Threat to local businesses • Unreliable power supply • Disruption of access to farmlands (economic space) as a result of new road or increased traffic <p><u>Less Relevant</u></p> <ul style="list-style-type: none"> • Non-uniform investment opportunities • Promotion of street and highway vending • Lack of access roads to link main road corridors • Gentrification effect
Socio-cultural	<ul style="list-style-type: none"> • Disruption of community cultural property (i.e. sites and structures of historical, religious, cultural or aesthetic value) • Inadequate provision for Compensation and rehabilitation of affected persons, including livelihood restoration • Dislocation and compulsory resettlement of people living on the right-of-way • In-migration • Health impacts (spread of diseases including HIV/AIDS) safety and security • Language barrier • Potential destruction of arable/farmlands • Land tenure challenges • Provision of road user-friendly structures (footbridges, underpasses) for all pedestrians <p><u>Less Relevant</u></p> <ul style="list-style-type: none"> • The split of community (as a result of new road construction and significant widening) • Traffic impacts/management issues • Urban Sprawl and development of slums • Housing/ accommodation challenges in urban centres

Environmental Component	Potentially Significant Effect, if unmitigated (Most Relevant)
Natural Resources	<ul style="list-style-type: none"> • Air pollution from dust and other particulate matter • Climate change effects from emission of GHG • Disruption to biodiversity and other protected/sensitive areas • Noise pollution and vibrations • Surface and ground water contamination by oil, grease and other chemicals • Destruction of wetlands and aquatic habitat damage • Sand mining for construction • Landscape deformation from excavation and borrow pits • Improper reclamation/ restoration process <p><u>Less Relevant</u></p> <ul style="list-style-type: none"> • Contamination of soil and potential erosion from uncontrolled clearing • Increased potential for flooding

Source: JICA Study Team

F.4.3 Activities in Assessment Stage of SEA

(1) SEA Assessment Workshop

The SEA Assessment Workshop was held in Accra, Ghana on the 1st and 2nd of February, 2017. The objective of this workshop was to assess the proposed strategies and programmes by the Project to ensure the sustainability of corridor development in Ghana.

1) Targets for Assessment

The targets for assessment in the SEA Assessment Workshop were scheduled as follows:

- Strategies for development of each sector in Ghana (See Table F.4.5)
- A total of 59 priority projects for Ghana (See Table F.4.6)

Table F.4.5 Strategies for Development of Each Sector in Ghana and Grouping for Group Work

Strategies for Development of Each Sector in Ghana	Group Responsible
Strategies for Agricultural Sector in Ghana Strategies for Development of Roads and Highways in Ghana Strategies for Development of Tema Port	Group A
Strategies for Railways Development in Ghana Strategies for Development of Takoradi Port Strategies for Logistics Infrastructure in Ghana Strategies for Inland Water Transport in Ghana	Group B
Strategies for Agricultural Sector in Ghana Strategies for the Livestock Sector in Ghana Strategies for the Fisheries Sector in Ghana	Group C
Strategies for Mining Sector in Ghana Strategies for Manufacturing Sector in Ghana Strategies for ICT Industry in Ghana Strategies for Oil Sector in Ghana Strategies for Gas Sector in Ghana Strategies for Investment Promotion in Ghana	Group D

Source: JICA Study Team

Table F.4.6 Priority Projects for Ghana and Grouping for Group Work

Priority Projects for Corridor Development for Ghana	Group Responsible
<p>Road transport</p> <ol style="list-style-type: none"> 1) Improvement of National Road No.9 between Tamale and Yendi 2) Improvement of East-West Roads for Access to Potential Agricultural Areas from Central Corridor 3) Improvement of Road between Yendi and the National Boarder with Togo 4) Continuation of Widening of Accra - Kumasi Road (Central Corridor) 5) Widening of Tema Roundabout - Atimpoku Road (Eastern Corridor) 6) Greater Kumasi Outer Ring Road North-East Section (Central Corridor) 7) Widening of National Road No.1 between Tamale Yaipé and Tamale Savelugu (Central Corridor) 8) Completion of North East Section of Inner Ring Road in Tamale 9) Replacement of Buipe Bridge (Central Corridor) 10) Replacement of Yapei Bridge (Central Corridor) 11) Replacement of Ankobra Bridge (Coastal Corridor) 12) Replacement of Iture Bridge (Coastal Corridor) 13) Widening of Accra – Tema Motorway to 6 Lanes (Abidjan – Lagos Corridor) 14) Construction of Bypass Road for Tamale (Central Corridor) 15) Construction of Outer Ring Road for Greater Accra (Coastal Corridor) 16) Construction of Outer Ring Road for Sekondi Takoradi (Coastal Corridor) 17) Construction of Abidjan Lagos Motorway Section between Cape Coast – Sekondi Takoradi (Coastal Corridor) 18) Construction of Motorway between Kumasi and Kimtampo 19) Construction of Abidjan Lagos Motorway between Prampram – Sogakope (Coastal Corridor) 20) Construction of Motorway between Accra and Kumasi 	Group A
<p>Railway and inland water transport</p> <ol style="list-style-type: none"> 1) Strengthening and Reform of Regulatory Function of Railway Sector 2) Rehabilitation of Takoradi-Awaso Section of Western Railway Line 3) Upgrading of Tema-Accra Railway 4) Construction of Railway from Tema Port to Akosombo Port (Eastern Corridor) 5) Construction of Ashaiman Truck Terminal along Accra Tema Motorway 6) Operationalization of One Stop Border Post in Noépé (at the National Border with Togo) 7) Establishment of One Stop Border Post in Elubo Noé (at the National Border with Côte d'Ivoire) 8) Establishment of One Stop Border Post in Paga (at the National Border with Burkina Faso) 9) Dredging Volta Lake for Access to Buipe Port 10) Upgrading Akosombo Port at Volta Lake 11) Rehabilitation of Tema Port – Boankra Section of Eastern Railway 12) Establishment of Boankra Multi Modal Dry Port 13) Construction of Railway between Nyinahin and Wa 14) Rehabilitation of Boankra – Kumasi Section of Eastern Railway 	Group B
<p>Agriculture, livestock and fisheries sectors</p> <ol style="list-style-type: none"> 1) Tamale Mamprusi Agricultural Cluster Area Development Programme 2) Atebubu East Gonja Agricultural Cluster Area Development Programme Phase 1 (including Daka Valley Irrigation Project) 3) Gonja Kintampo and Bole Tain Agricultural Cluster Area Development Programme Phase 1 (including Bui Irrigation Scheme Project) 4) Accra Plains Irrigation Development Project 5) Feed Resource Development Project 6) Improvement of Livestock Stations of Pong Tamale Livestock Breeding Station, Babile Pig Breeding Station and Amrahia Dairy Farm 7) Development of Poultry Processing Plants with Cold Storage Phase 1 and Phase 2 (2026-2033) 8) Formulating National Plan for Transhumance Management 9) Programme for Aquaculture Development on the Volta Lake 	Group C
<p>Manufacturing, mining, ICT, investment, oil and gas sectors</p> <ol style="list-style-type: none"> 1) Construction of Aboadze Tema Gas Pipeline 2) Tema ICT Park Expansion Project 3) Construction of Community Information Centre in Tema 4) Development of ICT Park at Cape Coast 5) Investment Promotion for ICT BOP Industries in Greater Kumasi 6) Investment Promotion for Manufacturing Industries in Sekondi- Takoradi 7) Replacement of Multi Products Pipeline between Tema and Akosombo 8) Extension of Multi Products Pipeline from Buipe to Debre 9) Construction of Multi Products Pipeline between Tema and Kumasi 10) Development of Nyinahin Bauxite Mine with Construction of Railway between Awaso and Nyinahin 	Group D

Priority Projects for Corridor Development for Ghana	Group Responsible
11) Development of Shieni Iron Mine 12) Investment Promotion for Manufacturing Industries in Greater Kumasi 13) Investment Promotion for ICT BPO Industries in Tema, Cape Coast and Greater Kumasi 14) Construction of Multi Products Pipeline between Kumasi and Buipe 15) Development of Manganese Mine in the North Western Part of Ghana with Construction of Railway between Nyinahin and Wa 16) Construction of Multi Products Pipeline between Bolgatanga and Bingo	

Source: JICA Study Team

2) Tools for Assessment

The strategies formulated for development of each sector in Ghana were evaluated using a compatibility test tool (see Table F.4.7) and the priority projects for Ghana were evaluated using a risk-opportunity assessment tool (see Table F.4.8) during the group work of the SEA Assessment Workshop.

Table F.4.7 Matrix for Compatibility Test

No	Strategies for development of each sector					
		1	2	3	4	5
1						
2						
3						
4						
5						

Source: JICA Study Team

Table F.4.8 Matrix for Risk-Opportunity Assessment

No.	Priority Projects	Environmental Evaluation			Reason for Evaluation	Proposed Mitigation Measures
		Opportunities	Risk	Neutral		
1		NR <input type="checkbox"/>	NR <input type="checkbox"/>	NR <input type="checkbox"/>		
		SC <input type="checkbox"/>	SC <input type="checkbox"/>	SC <input type="checkbox"/>		
		EC <input type="checkbox"/>	EC <input type="checkbox"/>	EC <input type="checkbox"/>		
		INS <input type="checkbox"/>	INS <input type="checkbox"/>	INS <input type="checkbox"/>		
2		NR <input type="checkbox"/>	NR <input type="checkbox"/>	NR <input type="checkbox"/>		
		SC <input type="checkbox"/>	SC <input type="checkbox"/>	SC <input type="checkbox"/>		
		EC <input type="checkbox"/>	EC <input type="checkbox"/>	EC <input type="checkbox"/>		
		INS <input type="checkbox"/>	INS <input type="checkbox"/>	INS <input type="checkbox"/>		
3		NR <input type="checkbox"/>	NR <input type="checkbox"/>	NR <input type="checkbox"/>		
		SC <input type="checkbox"/>	SC <input type="checkbox"/>	SC <input type="checkbox"/>		
		EC <input type="checkbox"/>	EC <input type="checkbox"/>	EC <input type="checkbox"/>		
		INS <input type="checkbox"/>	INS <input type="checkbox"/>	INS <input type="checkbox"/>		
4		NR <input type="checkbox"/>	NR <input type="checkbox"/>	NR <input type="checkbox"/>		
		SC <input type="checkbox"/>	SC <input type="checkbox"/>	SC <input type="checkbox"/>		
		EC <input type="checkbox"/>	EC <input type="checkbox"/>	EC <input type="checkbox"/>		
		INS <input type="checkbox"/>	INS <input type="checkbox"/>	INS <input type="checkbox"/>		
5		NR <input type="checkbox"/>	NR <input type="checkbox"/>	NR <input type="checkbox"/>		
		SC <input type="checkbox"/>	SC <input type="checkbox"/>	SC <input type="checkbox"/>		
		EC <input type="checkbox"/>	EC <input type="checkbox"/>	EC <input type="checkbox"/>		
		INS <input type="checkbox"/>	INS <input type="checkbox"/>	INS <input type="checkbox"/>		

Source: JICA Study Team

Note: NR: Natural Resources, SC: Socio-cultural, EC: Economic, and INS: Institutional.

3) Result of group work

The result of the evaluation using a compatibility test tool by the group work was that there is no incompatible strategy except for the strategies of the livestock sector. Reasons for incompatibility for the strategies of livestock sector are as shown in Table F.4.9.

Table F.4.9 Reasons for Incompatibility

Policy No. (Column)	Policy No. (Row)	Reasons for Incompatibility
1. Research into large scale breeding and production of guinea fowls, cattle, sheep, and goats, especially in the northern regions	11. Development of transhumance routes for cattle	Counter productive
3. Intensify disease control and surveillance, especially for zoonotic and scheduled diseases	10. Promote integrated crop-livestock farming	Disease control of Plants incompatible with livestock farming because of insects
4. Promotion of out grower farms among proven selected farmers in various communities for the supply of breeding stock to commercial and small scale farmers	5. Organizing and strengthening livestock farmers' associations	Difficulty in selecting out grower farmers against the livestock farmers' association (Conflict of interest between the promoting organization and the livestock farmers' association)
4. Promotion of out grower farms among proven selected farmers in various communities for the supply of breeding stock to commercial and small scale farmers	6. Organizing and strengthening livestock farmers' associations	Same as row 4, column 5
9. Support large scale cultivation of maize and soya beans for the formulation of animal feed	10. Promote integrated crop-livestock farming	Competition for use of land

Source: JICA Study Team

Results of the evaluation using a risk-opportunity assessment tool by the group work are as shown in Table F.4.10. The following projects are evaluated to have relatively high environmental risk as shown below:

- Railway and inland water transport No. 2: Rehabilitation of Takoradi-Awaso Section of Western Railway Line
- Railway and inland water transport No. 3: Upgrading of Tema-Accra Railway
- Railway and inland water transport No. 4: Construction of Railway from Tema Port to Akosombo Port (Eastern Corridor)
- Railway and inland water transport No. 5: Construction of Ashaiman Truck Terminal along Accra-Tema Motorway
- Railway and inland water transport No. 7: Establishment of One Stop Border Post in Elubo-Noé (at the National Border with Côte d'Ivoire)
- Railway and inland water transport No. 8: Establishment of One Stop Border Post in Paga (at the National Border with Burkina Faso)
- Railway and inland water transport No. 11: Rehabilitation of Tema Port – Boankra Section of Eastern Railway
- Railway and inland water transport No. 12: Establishment of Boankra Multi-Modal Dry Port
- Railway and inland water transport No. 13: Construction of Railway between Nyinahin-Wa
- Railway and inland water transport No. 14: Rehabilitation of Boankra - Kumasi Section of Eastern Railway

F.5 Detailed Progress of SEA for Togo

F.5.1 Activities in Preparation Stage of SEA

The Project WAGRIC-CACAO made the following progress in the SEA for Togo after the initiation of the Project

(1) The First Stakeholder Meeting for Planning and SEA in Togo

The First Stakeholder Meeting for Planning and SEA was held in Lomé on 9th September, 2015, jointly by the JICA Study Team and the Ministry of the Economy, Finance and Development Planning. The objectives were to explain and discuss the objectives, approaches and scope of the Project and to discuss issues on corridor development and the environment in Togo.

(2) Procurement of Local Consultant

In order to carry out a SEA study for the Project, the JICA Study Team entered into a sub-consulting agreement on a SEA study in Togo with a national consulting firm, Design and Control - Ingénieurs Conseils (DECO-IC) on 9th September, 2015.

(3) The Second National-Level Joint Technical and Monitoring Committee Meeting

The JICA Study Team gave a presentation on development of alternative scenarios (Scenario A and Scenario B described in Chapter 5) for sub-regional level corridor development at the Second National-Level Joint Technical and Monitoring Committee Meeting held on 15th February, 2016. After the presentation, participants discussed two scenarios in a comparative manner. The following points were raised and an overview of the discussions is given below.

Points Raised during the Discussion on Alternative Scenarios on Sub-Regional Level Corridor Development (from Togo's perspectives)

The results of the discussions are summarized as follows:

- Since, except for Burkina Faso, the three other countries have sea ports, we should observe carefully and add new options in our ways of defining priorities. We need to consider the economic capacities of the various countries and populations.
- We should consider the total costs of both options and other available information which will help us to decide.
- Regarding both scenarios, we need to consider the future situation and come up with what (future scenarios) we find best for the sub-region.
- We should think about the combination of both scenarios.
- The level of development of our economy and infrastructures must help support attainment of our goals but most of the projects seem not to look in that direction. On the poverty and social issues, strategies based on defended policies by the countries must also be focusing on the possibility of satisfying the local demand, not only production for export.
- We won't succeed in integrating the development of the populations beyond our borders.
- Though Togo Invest has put in place scenarios just like JICA did, the implementation costs are too high. In trying to develop the San-Pédro-Abidjan-Lagos corridor, the population's needs, concerns and status should be taken into account in the planning of that project or things have to be done just for the sake of doing them.
- We should think about complementary characteristics between railways and roads, and learn lessons from the Bolloré's railway project experiences and see what to add to the current approach for it so as to make it efficient.
- We should thoroughly look at the available documents regarding on-going projects in order to make sure past mistakes are not repeated over the years.

- The maritime corridor and air transport corridor should be considered. There is a framework of the maritime corridors of a project called “SEA-LINK”, which is based in Nigeria. Air transport in the sub-region is important for the transport of easily perishable products, such as fruits and vegetables.
- It is necessary to think about the inland east-west corridors connecting Togo and the northern part of Ghana and Côte d’Ivoire.
- Also logistics infrastructures to transform, conserve and transport products should be taken into account.

F.5.2 Activities in Scoping Stage of SEA

(1) Result of Scoping for SEA

The scoping report touches on major aspects of the environment to consider i.e. on potential impacts which have to be analysed along the following lines:

- Rivers and lakes (type of substrate, quality and uses);
- Shorelines, wetlands and floodplains;
- Hydrodynamic conditions;
- Hydrogeological context (classification and physicochemical quality of groundwater, identification of aquifers);
- Soil and surface deposits and their physicochemical quality and their current or past use, slopes, mining areas, areas prone to erosion, and agricultural potential;
- Topography, subsurface drainage and surface hydrogeology (depth and quality of groundwater, groundwater movements);
- The sound environment (sensitive points), contaminant concentrations etc.;
- Vegetation cover of aquatic, riparian and terrestrial areas, indicating the presence of fragile or exceptional strands;
- Wildlife and plant species (terrestrial and aquatic) and habitats of these species (annual cycles, migration patterns, phenology), paying special attention to threatened or vulnerable people or those likely to be;
- The use and planned use of the area where the project is located on public land, with reference to planning tools related to public land and resort development; and
- The current and planned land use with reference to policies, development plans and local and regional regulations of development and planning.
 - Urbanization perimeters, concentrations of housing, urban areas,
 - Commercial, industrial and other development projects,
 - Agricultural areas, agricultural activities (buildings, crops, structures, etc.), drainage for monitoring the water table, and the cadastral structure
 - The forest environment and forestry areas including tree resin
 - Resort areas, attractions, activities, existing equipment and planned recreational or tourist entertainment (controlled zones, theme parks, campgrounds, bike paths, tours listed, etc.)
 - Natural areas dedicated to the protection or preservation of flora and fauna, or of interest for their recreational, aesthetic, historical or educational importance
 - Transport infrastructure, telecommunications and public services (roads, railways, airports, cable, telecommunication towers, power lines, aqueducts, sewers, canals, pipelines, landfills etc.), community and institutional services (hospitals, schools, nurseries, etc.)
 - The sources of drinking water, including private wells, municipal wells and any other works of catchment of groundwater and surface water

- Protection areas (immediate, near, far) around groundwater catchment works and surface water
- The archaeological and cultural heritage: known archaeological sites, areas of archaeological potential and other heritage interests, protected or not, as identified by the Cultural Property Act (Aboriginal burials in biophysical environment, historic districts, buildings, etc.)

F.5.3 Activities in Assessment Stage of SEA



(1) The Second Stakeholder Meeting for Planning and SEA in Togo

The Second Stakeholder Meeting for Planning and SEA was held in Togo on 4th August, 2016. The objective of this meeting was to identify social and environmental impacts that corridor development strategies might generate.

1) Targets for identification of impacts

The targets for identification of impacts in the Second Stakeholder Meeting were alternative scenarios for corridor development in Togo. A summary of the alternative scenarios is presented in Table F.5.1, while their detailed description is contained in other chapters of this Main Report.

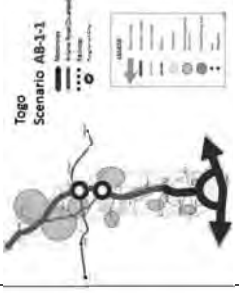
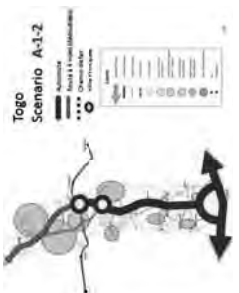
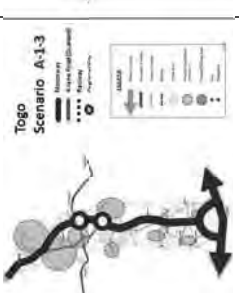
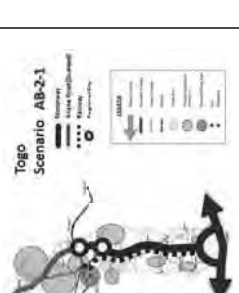
Table F.5.1 Targets for Identification of Impacts in the Second Stakeholder Meeting

	Scenario AB-1-1	Scenario AB-1-2	Scenario AB-1-3	Scenario AB-2-1	Scenario AB-2-2
					
	Togo's Scenario AB-1 Inland Agriculture, Regional Cities' Industries and Greater Lomé's Advanced Services	Togo's Scenario AB-1 Inland Agriculture, Regional Cities' Industries and Greater Lomé's Manufacturing Industries and Advanced Services	Togo's Scenario AB-2 Inland Agriculture, Regional Cities' Industries, Iron Ore Mining and Greater Lomé's Advanced Services		
Major types of agricultural sectors in the central and northern part of	Not only medium and large-scale agriculture and agriculture-related sectors based on foreign and domestic investment, but also small-scale agriculture				
Major types of economic sectors in the central and northern part of	Manufacturing industries and ICT & BPO industries in addition to commerce and service sectors in well-targeted regional cities, namely Kara and Sokodé along the Lomé-Ouagadougou Corridor in the northern part of Togo				
Major economic sectors for coastal metropolitan areas of Greater Lomé	Not only manufacturing industries and ICT & BPO industries targeting at sub-regional markets, but also sub-regional business functions, advanced financial services and international recreational services, in addition to existing commerce and services				
Speed of development of	High				
Characteristics of spatial development	<ul style="list-style-type: none"> Development of a motorway (high-speed highway) between Lomé and Atakpamé by 2040 No north-south railway Strengthening of north-south transmission line (Lomé-Kara-Dapaong) 	<ul style="list-style-type: none"> Development of a motorway (high-speed highway) between Lomé and Kara by 2040 No north-south railway 	<ul style="list-style-type: none"> Development of a motorway (high-speed highway) between Lomé and Cinkassé by 2040 No north-south railway Strengthening of north-south transmission line (Lomé-Kara-Dapaong) 	<ul style="list-style-type: none"> Development of a motorway (high-speed highway) between Lomé and Kara by 2040 Development of the railway between Lomé and Kabou (near Bandjeli) Strengthening of north-south transmission line (Lomé-Kara-Dapaong) Multi-modal dry port in Kabou 	<ul style="list-style-type: none"> Development of a motorway (high-speed highway) between Lomé and Kara by 2040 Development of the railway between Lomé and Cinkassé Strengthening of north-south transmission line (Lomé-Kara-Dapaong) Multi-modal dry port in Kabou
Cost performance of motorway development	lower than AB-1-2, but higher than AB-1-3	higher than AB-1-1 and AB-1-3	lower than AB-1-2	higher than AB-1-1 and AB-1-3	higher than AB-1-1 and AB-1-3
Cost performance of railway development				medium because multi-modal dry port in Kabou cannot attract much truck transport	not good because the volume of container traffic related to inland countries is not large enough to make this railway extension feasible

Source: JICA Study Team

2) Tools for Identification of Impacts

The alternative scenarios for corridor development in Togo were evaluated using an impact assessment matrix (see Table F.5.2) during the group work of the Second Stakeholder Meeting.

Table F.5.2 Tools for Identification of Impacts in the Second Stakeholder Meeting

		Scenario AB-1-1	Scenario AB-1-2	Scenario AB-1-3	Scenario AB-2-1	Scenario AB-2-2
Benefits (Positive Impacts)	Economic					
	Spatial					
	Other					
Impacts (Negative Impacts)	Economic					
	Spatial					
	Environmental					
	Social					
	Institutional					
	Other					
Synthetic Evaluation						

Source: JICA Study Team

3) Result of group work

After considering the different criteria mentioned for analysis and assessment, as a whole all groups worked separately but came out with the proposal of the last scenario which is the AB-2-2.

In response to the question from the JICA Study Team “When do you think that the selected scenario will be realized?” most participants answered the deadline 2040. The discussions revealed that the country has to attract investors to the Banjeli iron ore and the agricultural opportunities.

The synthetic evaluation by each group is shown below.

Group A:

Scenarios other than AB-2-2 have more disadvantages than advantageous from the point of view of sustainable development. Scenario AB-2-2 is the best for a sustainable and integral development of the country. It is desirable that for this scenario, the motorway should go to Cinkassé.

Group B:

Scenario AB-2-2 is the best scenario. Our recommendation is to extend the railway and motorway to the north in the long term.

Group C:

- Scenario AB-1-1 is less costly but not sustainable. Notation: 1 (not very interesting)
- Scenario AB-1-2 2 (interesting)
- Scenario AB-1-3 3 (quite interesting)
- Scenario AB-2-1 4 (very interesting)
- Scenario AB-2-2 5 (excellent)

At the end of the evaluation, it is known that scenario AB-2-2 is desirable.

Table F.5.3 Summary of Identified Impacts due to Corridor Development

<p>1. Natural Resources/ Environment</p> <ul style="list-style-type: none"> • Deforestation/ loss of biodiversity • Loss of land/ land take • Protected areas • Pollution of water, air and soil e.g. noise nuisance, drop of sanitation & hygiene standards • Climatic risks (floods and drought) 	<p>3. Economic Environment</p> <ul style="list-style-type: none"> • Employment generation • Investments • Revenue generation
<p>2. Socio-Cultural Environment</p> <ul style="list-style-type: none"> • Risk of contagious diseases • Urban migration- increased population density of urban areas • Increased traffic • Depravity of moral values/ prostitution and juvenile delinquency • Loss of historic/ cultural heritage 	<p>4. Institutional Environment</p> <ul style="list-style-type: none"> • Institutions' playing/effecting their roles and responsibilities • Standards/ guidelines • Law enforcement

Source: JICA Study Team

F.5.4 The Third Stakeholder Meeting for Planning and SEA in Togo

The Third Stakeholder Meeting for Planning and SEA was held in Togo on the 6th of October 2016. The objective was to analyse and assess impacts of implementing corridor development strategies.

1) Targets for Analysis and Assessment

The targets for analysis and assessment in the Third Stakeholder Meeting were a total of 38 priority projects for Togo. A list of the priority projects is presented in Table F.5.4, while their detailed description is contained in other chapters of this Main Report.

Table F.5.4 Targets for Assessment in the Third Stakeholder Meeting and Grouping for Group Work

Plan Interventions (Priority Projects for Corridor Development for Togo)	Group Responsible
<p>Urban Infrastructure Base and Better Public Service Provision</p> <p>1) Upgrading Kara University 2) Upgrading the University Hospital of Kara and Sokode hospital, etc.</p> <p>Economic Sectors Development</p> <p>3) Investment Promotion for Development of Agropoles in inland areas (Kara) 4) Investment Promotion for Development of Agropoles in inland areas (Oti) 5) Investment Promotion for Development of Agropoles in inland areas (Haunt Mono) 6) Investment Promotion of Manufacturing and Logistics Industries in Greater Lomé 7) Investment Promotion for Manufacturing Industries in Sokodé and Kara 8) Investment Promotion for Aquaculture at Adjarala Dam 9) Investment Promotion for Reactivating Bandjeli Iron Mine</p> <p>Transport Corridor Infrastructure Development</p> <p>10) Functionalization of Kara regional airport (Lomé- Kara line) 11) Functionalization of Cinkassé OSBP 12) Construction of Fibre Optic Cable from Lomé to Cinkassé</p>	Group A
<p>Transport Corridor Infrastructure Development</p> <p>13) Promotion of land use restructuring of terminal and waterfront areas surrounding Lomé Port for effective port operation and for attracting enterprises from the logistics industry and processing industry 14) Promotion of reduction of port charges at Lomé Port 15) Construction of logistic platforms (truck terminals) in a hinterland area of Lomé Port 16) Construction of Greater Lomé Sections of Abidjan-Lagos Motorway 17) Construction of 4-Lane Road (Dualized) between Lomé and Sokodé 18) Construction of 4-Lane Road (Dualized) from Sokodé up to Kara 19) Construction of 4-Lane Road (Dualized) from Kara up to Cinkassé 20) Construction of High-Speed Way from Lomé to Notsé 21) Construction of High-Speed Way from Notsé to Atakpamé 22) Construction of Tsevié Bypass Road 23) Construction of Sokodé Bypass Road 24) Construction of Bypass Road for Kara 25) Improvement of East-West Road connecting Kara with east side national border and west side national boarder</p>	Group B
<p>Transport Corridor Infrastructure Development</p> <p>26) Construction of Railway from Lomé to Blitta 27) Construction of Railway from Blitta to Kabou 28) Construction of Railway from Kabou to Cinkassé 29) Construction and Operation of Multi-Modal Dry Port in Blitta 30) Construction and Operation of Multi-Modal Dry Port in Kabou 31) Construction and Operation of Multi-Modal Dry Port in Cinkassé</p> <p>Basic Infrastructure Development for Economic Sector</p> <p>32) Improvement of Roads for Access to Agricultural Potential Areas 33) Construction of Industrial Free Zone in Sokodé 34) Construction of Connecting Line between Togo's National Power Grid and Ghana's National Power Grid 35) Expansion of Kozah Hydro Power Plant 36) Construction of Hydro Power Dam and Power Generation Plant in Adjarala 37) Construction of Industrial Free Zone in Kara 38) Implementation of New Water Source Development for Kara</p>	Group C

Source: JICA Study Team

2) Tools for Analysis and Assessment

The priority projects for Togo were evaluated using a compound matrix (see

Table F.5.6) during the group work of the Second Stakeholder Meeting. A compound matrix was used, principally to evaluate individual plan interventions against a range of environmental criteria/effects, which serve as indicators of the existing environmental conditions. These criteria relate to the four pillars of sustainability, namely, natural resources, socio-cultural, economic and institutional. See Table F.5.5.

The way in which the Plan Intervention (Priority Project) interacts with each criterion in the matrix was discussed by the groups and a view was taken as to whether or not the plan intervention is likely to eliminate the environmental effect or worsen it or be largely neutral. The following symbols were used to record evaluation results as follows:

- Conditions are likely to be positive “+”
- Conditions are likely to be negative “-”
- Conditions are likely to be neutral “0”

Table F.5.5 Environmental Criteria/ Effects

Sustainability Pillars	Environmental Criteria/ Effects
1. Natural resources	1-1 Deforestation/ Loss of biodiversity 1-2 Loss of land/ Land take 1-3 Protected areas 1-4 Pollution of water, air and soil e.g. noise nuisance, drop of sanitation & hygiene standards 1-5 Climatic risks (floods and drought)
2. Socio-cultural	2-1 Contagious diseases 2-2 Urban migration- increased population density of urban areas 2-3 Increased traffic 2-4 Depravity of moral values/ prostitution and juvenile delinquency 2-5 Loss of historic/ cultural heritage
3. Economic	3-1 Employment generation 3-2 Investments 3-3 Revenue generation
4. Institutional	4-1 Institutions' playing/effecting their roles and responsibilities 4-2 Standards/ Guidelines 4-3 Law enforcement

Source: JICA Study Team

Table F.5.6 Compound Matrix

[Score Sheet]

Plan Interventions	Environmental Criteria/ Effects															
	1. Natural resources					2. Socio-cultural					3. Economic			4. Institutional		
	1-1	1-2	1-3	1-4	1-5	2-1	2-2	2-3	2-4	2-5	3-1	3-2	3-3	4-1	4-2	4-3
Priority Projects 1 to 38																

[Reason Sheet : Description of Plan Intervention: Priority Project No. 1]

Sustainability Pillars	Environmental Criteria/Effects	Reasons	Score*
1. Natural resources	1-1		

Note*: positive->+, negative->-, Neutral->0

Source: JICA Study Team

3) Result of Group Work

Results of the evaluation using a compound matrix in the group work session are as shown in Table F.5.7. Due to the lack of time for group work in the Third Stakeholder Meeting, participants could not finish evaluating some priority projects.

When it comes to evaluation results of individual projects, the following projects are evaluated to have relatively high environmental impact as shown below:

Projects assessed as having a great impact on criteria of natural resources

- No.32: Improvement of Roads for Access to Areas with Agricultural Potential
- No. 33: Construction of Industrial Free Zone in Sokodé

- No. 36: Construction of Hydro Power Dam and Power Generation Plant in Adjarala

Projects assessed as having a great impact on socio-cultural criteria

- No. 1: Upgrading Kara University
- No. 36: Construction of Hydro Power Dam and Power Generation Plant in Adjarala

The reasons for negative results in evaluation of projects and proposed mitigation measures by group work are as shown in Table F.5.8.

Table F.5.7 Compound Matrix – Score Sheet (Result)

Plan Interventions	Environmental Criteria/ Effects															
	1. Natural resources					2. Socio-cultural					3. Economic			4. Institutional		
	1-1	1-2	1-3	1-4	1-5	2-1	2-2	2-3	2-4	2-5	3-1	3-2	3-3	4-1	4-2	4-3
1	-	-	0	-	0	-	-	-	-	-	+	+	+	+	+	+
2	-	-	0	-	0	-	0	-	-	-	+	+	+	+	+	+
3	-	-	-	-	0	-	+	+	-	-	+	+	+	+	+	+
4	-	-	-	-	-	-	+	+	-	-	+	+	+	+	+	+
5	-	-	-	-	-	-	+	+	-	-	+	+	+	+	+	+
6	-	-	0	-	-	-	-	-	-	-	+	+	+	+	+	+
7	-	-	0	-	-	-	-	-	-	-	+	+	+	+	+	+
8																
9																
10																
11																
12																
13	0	-	0	-	-	-	-	-	-	0	+	+	+	+	+	+
14	0	0	0	0	0	-	-	-	-	0	+	+	+	+	+	+
15	-	-	-	-	-	-	-	-	-	-	+	+	+	+	+	+
16																
17																
18																
19																
20																
21																
22																
23																
24																
25																
26					0		+	+			+	+	+	+	+	+
27					0		+	+			+	+	+	+	+	+
28					0		+	+			+	+	+	+	+	+
29			0		0		+	+			+	+	+	+	+	+
30			0		0		++	+			+		+	+	+	+
31			0		0		+	+			+	+	++	+	+	+
32								+			+	+		+	+	+
33							+	+	0	0	+	+	+	+	+	+
34				0	0	0	0	0	0	0	++	+	++	+	+	++
35	0		0		0	0	0	0	0	0	+	+	+	+	+	+
36											+	+	+	+	+	+
37			0	0	0					0	+	+	++	+	+	+
38					0	0	0	0	0	0	+	+			+	+

Source: JICA Study Team

Table F.5.8 Reason for Negative Impact of Each Project

Sustainability Pillars	Environmental Criteria/ Effects	Project	Reasons	
1. Natural resources	1-1. Deforestation/ loss of biodiversity	No. 1, No. 2	The impact will be negative, because some plant and animal species will disappear.	
		No. 3, No. 4 No. 5, No. 6 No. 7	The impact will be negative, because of deforestation.	
		No. 26	The impact will be negative, because vegetation will be destroyed, loss of biodiversity	
	1-2. Loss of land/ land take	No. 1, No. 2	Some owners will no longer have access to their land	
		No. 3, No. 4 No. 5, No. 6 No. 7	Development will result in land loss and / or depreciation	
		No. 13	Relocation of the population, infrastructure	
		No. 15	Occupation of domains	
		No. 26	Loss of arable land due to occupation of right-of-way	
	1-3. Protected areas	No. 3	This may lead to the degradation of some protected areas	
		No. 26	Destruction of protected areas in the case of a new construction	
	1-4. Pollution of water, air and soil e.g. noise nuisance, drop of sanitation & hygiene standards	No. 1	Yes, by production of liquid, solid and gaseous wastes	
		No. 2	Yes, by production of liquid, solid waste ...	
		No. 3, No. 4 No. 5	Use of pesticides, soil depletion ...	
		No. 6, No. 7	Pollution of water, emission of greenhouse gases ...	
		No. 13	Degradation of air, water, soil ...	
	1-5. Climatic risks (floods and drought)	No. 26	Pollution because of the right of way running through inhabitable areas, streams, wetlands	
		No. 6, No. 7	Climatic risks (flooding ...)	
		No. 13	At risk areas	
	2. Socio-cultural	2-1. Contagious diseases	No. 15	Possibility of deviation of rainwater, sources of flood
			No. 1	Risk of transmission of diseases (HIV, tuberculosis, chicken pox ...)
No. 2			Risk of transmission of diseases (HIV, tuberculosis, varicella ...)	
No. 3, No. 4 No. 5, No. 7			Yes, risk of avian flu, and swine flu...	
No. 6			Yes, risk of STIs / HIV, respiratory diseases ...	
No. 13			Insalubrity, proliferation of larval habitats, risk of STI / HIV transmission	
No. 14			Prostitution, delinquency, rape, homosexuality,	
2-2. Urban migration-increased population density of urban areas		No. 15	Population growth,	
		No. 26	Mobility of labour	
		No. 1	Neutral, low probability of impact of migratory flow	
2-3. Increased traffic		No. 13	Rural exodus, de-schooling, slum creation, insecurity,	
		No. 14	Prostitution, delinquency, rape, homosexuality,	
		No. 1, No. 2	Yes, risk of increased accidents	
		No. 6, No. 7	Rural disenfranchisement	
		No. 13	Noise pollution, risk of traffic accidents, air pollution	
2-4. Depravity of moral values/ prostitution and juvenile delinquency		No. 14	Increase in vehicle fleet, risk of accidents	
		No. 15	Risk of accident,	
		No. 1, No. 2	Yes, violation of prohibitions, non-compliance with customs and traditions	
		No. 3, No. 4 No. 5, No. 6, No. 7	Depravation of customs and customs	
		No. 13	Rape, homosexuality, increase in sexually transmitted diseases,	
	No. 14	Destruction of tourist sites,		
2-5. Loss of historic/ cultural heritage	No. 15	Prostitution, delinquency ...		
	No. 26	Negative consequence of development of inland areas by railway development		
	No. 1, No. 2	The depravity of manners leads to the loss of cultural heritage		
	No. 3, No. 4 No. 5, No. 6 No. 7	Transformation of traditional structures in the central area		
	No. 26	Disappearance of tourist sites, idols etc.		

Source: JICA Study Team