

添付資料 4.15

2017 年秋期研修「O&M of Sewer and Storm Water Drainage」の教材



In the name of Allah, the most Gracious and ever Merciful



Introduction

Welcome To Al-Jazari Academy

2/20



Introduction

3/20



Welcome To All Stakeholders

Introduction

4/20

Course Team



Mr. Ryuta Kudo
JICA Expert



Mr. Muhammad Irfan
Course Leader



Mr. Rizwan Qazi
JICA Coordinator



Mr. Syed Fahad Hussain
Young Professional

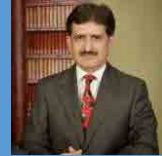

Course Reviewer
Prof. Dr. Sajjad Haider (UET),
Lahore

Operation and Maintenance (O&M) of Sewerage and Drainage System including Safety Precautions

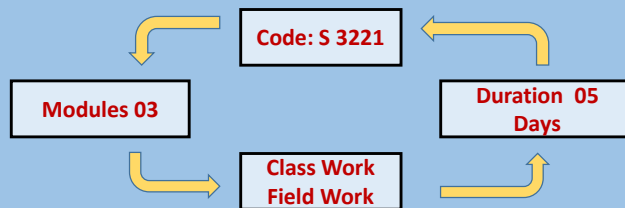

Modules



- Module 1**
 - Safety Control and Measures for Sewerage and Drainage Works
 - 01 Days
- Module 2**
 - Operation and Maintenance (O&M) of Storm Water Drainage System
 - 01 Days
- Module 3**
 - Operation and Maintenance (O&M) of Sewerage System
 - 02 Days + Action Plans

Introduction

7/20

HOW WE WILL PROCEED . . .



- Module Introduction
- Expected Learning Outcomes
- Lectures
- Tea Break
- Field Work
- Lunch Break
- Presentation by Participants
- Comments by Participants
- Day Work Conclusion

1



2



3



4



5



6



Sign off

Introduction

8/20

WHAT WILL ANIMATE THE TRAINING SESSION. . .



Course Evaluation Criteria

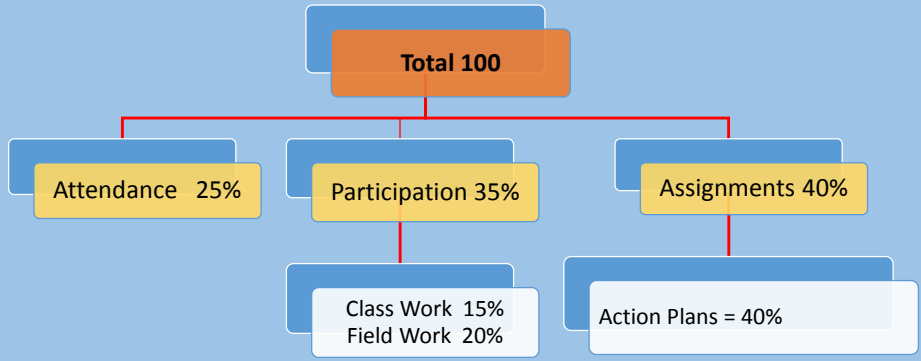

Please Note:
 Participants with active participation, maintaining 80% attendance and passing their exam with at least 70% score will be awarded certificates

Reference Material

Book : Operation & Maintenance of Wastewater Collection Systems (Vol. 01)
By: Kenneth D. Kerri & John Brady (California State University, USA)

O&M Manual : Water Born Sanitation Operations and Maintenance Guide
By: S J van Vuuren & M van Dijk (University of Pretoria, South Africa)

Operation Manuals : (1) Portable Gas Monitor (GX-8000)
RIKEN KEIKI Co., Ltd. Japan

(2) Valve Box Locator M130
SEWERIN, UK



WHY O&M TRAINING IS ESSENTIAL . . .

Open Drain



Open Drain is Silted Badly

1. Solid waste
2. Bushes & weed growth

Covered Drain



Covered Drain is Choked

1. Root growth
2. Solid waste



Pump Replacement Operation at Disposal Station

1. Metallic boom contacting electricity conductors
2. No traffic management exercised



WHY O&M TRAINING IS ESSENTIAL . . .



Manhole Lid Missing

1. Tree branch is used as replacement (Self help)



Uncovering Manhole

1. Non-standard method applied



Kerb Grating Missing

1. Solid waste entry is evident

Introduction

13/20



WHY TRAINING IS MANDATORY . . .



1. Poor screening may cause damage to pump internal parts.



Un-Safe Sludge Handling

1. Non-hygienic conditions
2. PPE no-where



No Compliance with SOP

1. Unsafe working (without PPE).

Introduction

14/20



WHY TRAINING IS MANDATORY . . .



1. Proper care & maintenance is ignored

Non-Functional Bucket Machine (Winch Machine)

WHY TRAINING IS MANDATORY . . .



O&M Training is Essential Every Where



ADVANTAGES OF AN EFFICIENT (O&M) SYSTEM

- Full use of the system over its intended design life will be achieved.
- It will result in high reliability of equipment and facilities as designed.
- It will ensure that facilities and equipment are available as intended.
- It will maintain the value of the infrastructure investment.
- There will be a collection of accurate information and data on which the operation and maintenance can be planned and budgeted for.
- It will reduce costs since planned maintenance and repairs are much more cost-effective than late-night emergency repairs.





In the name of Allah, the most Gracious and ever Merciful

Operation and Maintenance of Sewer & Storm Water Drainage System including Safety Precautions
S 3221

Module 01
Safety Control and Measures for Sewerage and Drainage Works

01 Days

Module 02
O&M of Storm Water Drainage System

01 Days

Module 03
O&M of Sewer System

02 Days

Module 01 (An Overview)

Safety Control and Measures for Sewerage and Drainage Works



DAY 01	<input type="checkbox"/> Risks and hazards associated with sewers & drains	<input type="checkbox"/> Risks and hazards	Theory
		<input type="checkbox"/> Control measures	Theory
	<input type="checkbox"/> Safety practices for sewers & drain O&M	<input type="checkbox"/> Current safety practices in WASA & Visit to WASA Training Center	OST
	<input type="checkbox"/> Use of safety gears	<input type="checkbox"/> Concept of PPEs	Theory
	<input type="checkbox"/> Best safety practices	<input type="checkbox"/> Working in confined spaces	OST
		<input type="checkbox"/> Tests for hazardous gases	
	<input type="checkbox"/> First aid	<input type="checkbox"/> Arrangements for medical treatment	Theory
<input type="checkbox"/> Traffic control practice	<input type="checkbox"/> Identification of a specific manhole	OST	
	<input type="checkbox"/> Traffic control plan		

3/15

Module 01

Safety Control and Measures for Sewerage and Drainage Works



Lecture Breakdown	Duration
Objectives	15 Min.
Important Definitions	
Hazards & Risks related to Sewer & Drainage Works	
Risk Assessment	
Summary	
Q&A	



Module-1 Lecture-1 Risks and Hazards

4/15

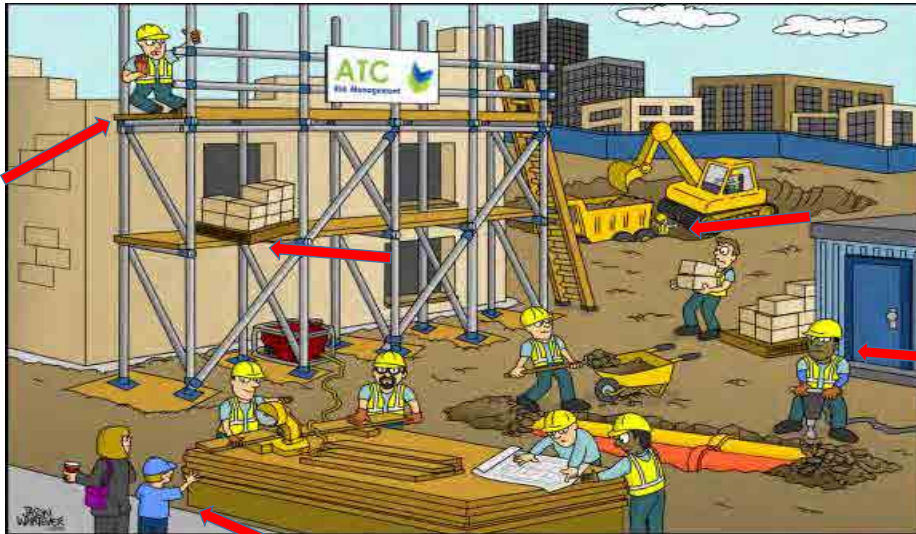

Target	Steps
Determine Risk	1
Decide if the Risk is Tolerable	2
Review the Risk	3
Develop Control Measures	4



Likelihood of Harm	Severity of Harm		
	Slight Harm	Moderate Harm	Extreme Harm
Very unlikely	Very low risk	Very low risk	High risk
Unlikely	Very low risk	Medium risk	Very high risk
Likely	Low risk	High risk	Very high risk
Very likely	Low risk	Very high risk	Very high risk





Manhole De-Silting Operation (Night)
-near Ferozpur Road, Lahore

Summary:

Hazards are always present at & around WASA work sites

Risk Assessment is no doubt utmost **necessary** before commencing O&M works

O&M Works can be done **safely** if best practices & **Control Measures** are adopted





In the name of Allah, the most Gracious and ever Merciful

Safety Control and Measures for Sewerage and Drainage Works



Lecture Breakdown	Duration
Objectives	15 Min.
Important Definitions	
Various Control Measures	
Brainstorming Session	
Summary	
Q&A	





Objectives:

To aware participants about various control measures to be adopted to avoid risks during O&M



Important Definitions



- **Control Measures** Actions that reduce the potential of exposure to hazard
- **Elimination** Remove hazard from the workplace
- **Substitution** Replace hazardous materials or machines with less hazardous ones
- **Engineering** Design modifications to reduce the hazard
- **Administration** Procedure changes, employee training, signs, labels & exercise breaks
- **PPE** Protective clothing, helmets, goggles & equipment etc.



Control Measures during O&M:

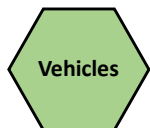

Routing Traffic around Job Site

- Advance Warning Area
- Transition Area
- Buffer Space
- Work Area
- Termination Area

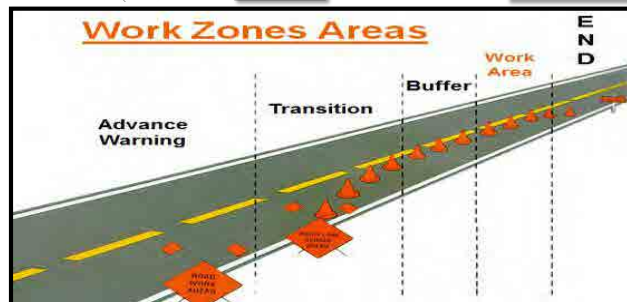

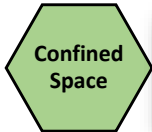

Atmospheric Hazards:

Explosive	Toxic	Deficiency
Methane - CH ₃	Hydrogen Sulfide - H ₂ S Carbon Monoxide - CO	Oxygen - O ₂

Any space where:

- Existing ventilation is insufficient
- Oxygen is deficient
- Access is difficult
- Getting out is difficult
- Not designed for permanent dwelling

Control Measures:

- Use gas detector/monitor
- Continuous Ventilation
- Continuous Testing
- Self Contained Breathing Apparatus (SCBA)



Risks:

- Strained Muscles
- Torn Skin
- Abrasion
- Swelling
- Puncture
- Fracture



Hazards:

- Uneven Footing
- Poor Balance
- Awkward Position
- Ladder Drop
- Weak Manhole Rungs
- Dropping Tool
- Sharp Objects

Control Measures:

- Correct Position/Orientation
- Correct SOP
- Light Weight Ladder
- Avoid Tool Drop & Throw/Toss
- PPE (Helmet + Goggles + Gloves + Safety Shoes)



Infections & Diseases



Hazards:

- Parasite
- Virus
- Infection
- Illness
- Urine & Feces of Rat

Risks:

- Fever
- Headaches
- Nausea
- Muscular Pain
- Tetanus
- Polio
- Typhoid



Control Measures:

- Personal Cleanliness
- Keep & Wash Cloths Separately
- No Eating/Drinking at Job Site
- Disinfect the Manhole
- Prevent Infectious Discharge Entry
- PPE (Goggles + Gloves + Wader+ Safety Shoes)



Insects- Bugs- Rodents



Hazards:

- Black Widow Spider
- Violin Spider
- Scorpions
- Rat
- Mosquito
- Cockroaches

Risks:

- Allergy & Fever
- Infections
- Poisoning
- Rat Bite
- Rabies
- Malaria



Control Measures:

- Spray Insecticide
- Ventilate Manhole
- Wash Manhole
- PPE (Gloves + Wader)
- Get Medical Attention



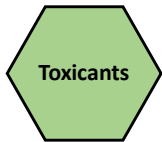

Risks:

- Inhalation
- Dermal Contact (Absorption)
- Ingestion
- Splash

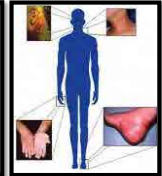

Hazards:

- Acids
- Bases
- Poisons
- Hazardous Liquids
- Solid Chemicals

Control Measures:

- Avoid Accidental Spill
- Avoid Deliberate Action
- Implement Law
- PPE (Gloves + Gums)
- Get Medical Attention

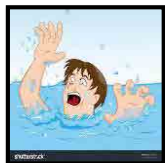
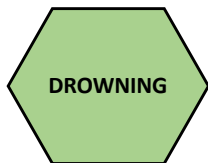

Risks:

- Drowning
- Injury
- Death

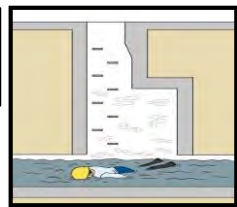

Hazards:

- Large Sewage Flow
- Accidental Slip
- Fall
- Uneven Base
- Weak Eyesight

Control Measures:

- Watch Your Steps
- Wear Life Jackets
- Use Life Line
- Get Medical Attention



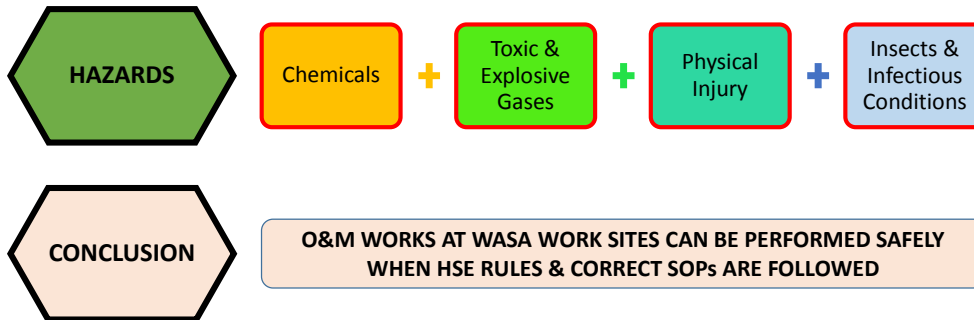

- Q. 01:**
How can you protect yourself from diseases when working at WASA work sites?
- Q. 02:**
How can you protect yourself from insects when working in a manhole?
- Q. 03:**
How can you protect yourself from drowning when working in a manhole?



In the name of Allah, the most Gracious and ever Merciful

Module 01

Safety Control and Measures for Sewerage and Drainage Works



Lecture Breakdown	Duration
OJT	15 Min. 
OJT Cycle for WASA Site	
OJT Success at WASA Site	
Current Safety Practices in WASA	
Pictorial...	
Q&A	



OJT...Dates Back

1	Training where the “Trainer” instructs the new “Trainees” on the skills needed to perform his/her new job effectively
2	Either the Trainee performs the job while the Trainer instructs Or
3	The Trainer performs the job while the Trainee observes.
4	On-the-Job training should take place mostly in the field ; however, some classroom training is also permissible.



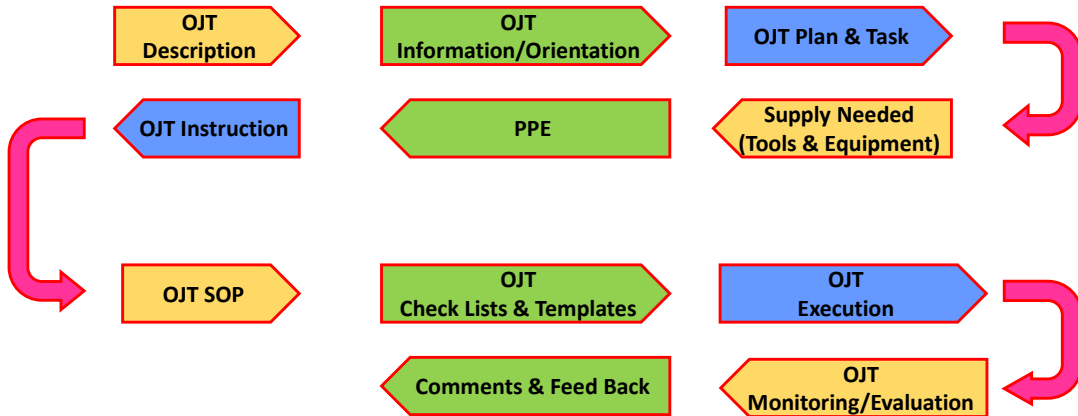

OJT Instruction



- 1) Understand the need of OJT
- 2) Comprehend the aim & plan
- 3) Read through the templates (for filling in the observations during OJT)
- 4) Travel towards WASA work site
- 5) Get the orientation
- 6) Wear the requisite PPE
- 7) Chose safe position for observation
- 8) Remain as close to the normal working position as possible
- 9) Follow the directions of Trainer
- 10) While performing OJT keep in mind the WASA policies and local rules
- 11) Use the accompanying equipment & tools with care
- 12) Fill in the templates with accurate data
- 13) Write a concise report after return

IMPORTANT: TRAINER WILL EVALUATE THE TRAINEES' PERFORMANCE DURING OJT

OJT Description

Current Safety Practices in WASA

OJT Plan & Task

- To visit various WASA work sites where O&M works are in progress
- To observe that up to which level the HSE standards are being adopted during O&M works

OJT Information

De-silting & Cleaning operation at a Manhole affected by Chronical Blockages WASA Lahore (Green Town Sub-Division)

Supply Needed

HSE related check lists

PPE



Outcomes

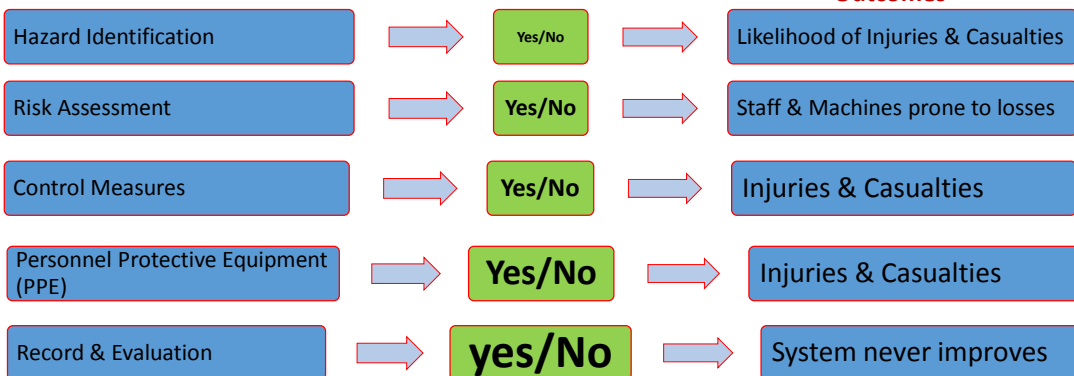

➤ Current Safety Practices in WASA

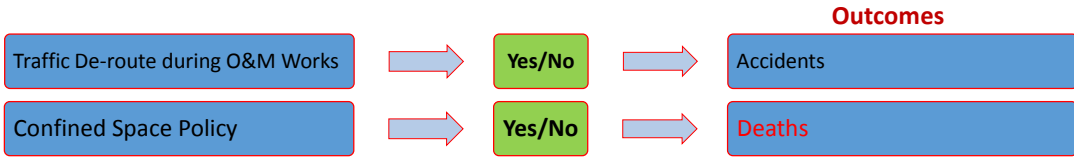

Q. 01:

How you assess the implementation of HSE rules in **WASA** during various O&M jobs?

Q. 02:

What are the reasons behind non-implementation of HSE practices at WASA work sites?

Q. 03:

What are your suggestions to improve & implement the HSE policies during O&M jobs?

WASA Training Directorate Gulshan-e-Ravi LAHORE

OBJECTIVE:

- To observe training facilities & infrastructure at the directorate
- Preparation of visit report on return

Remember: PPE are necessary

Road Map

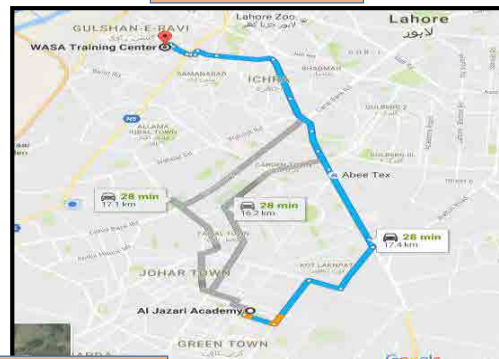

17 Km – 30 Min.

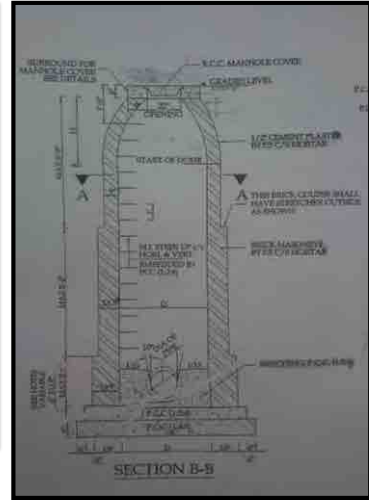

Manhole Structural Details

13/16



Trunk Sewers

14/16



Cardiopulmonary Resuscitation (CPR)



01/07



A view of Training on CPR at **RESCUE 1122 H/O (Lahore)**



02/07



Students learning how to perform mouth-to-mouth breathing, an artificial respiration technique and component of cardiopulmonary resuscitation (CPR)

03/07



D = DANGER
R = RESPONSE
S = SHOUT FOR HELP
A = AIRWAY
B = BREATHING
C = CIRCULATION
D = DEFIBRILLATION

TASK

- ✓ Artificial Respiration
- ✓ Artificial Blood Circulation

04/07



Cardiopulmonary Resuscitation (CPR) (00:03:52)



05/07



Cardiopulmonary Resuscitation (CPR) (00:01:13)



ProTrainings.com

06/07



Thank You



In the name of Allah, the most Gracious and ever Merciful







Module 01

Safety Control and Measures for Sewerage and Drainage Works



Lecture Breakdown	Duration
Purpose of PPE	20 Min.
Selection of PPE	
PPE in Details	
Care & Maintenance	
Q&A	



PPE	Protective <u>clothing, helmets, goggles</u> , or other garments or equipment designed to protect the wearer's body from injury or infection.
Purpose of PPE	When controlling measures e.g. elimination, engineering, work practice and administrative controls do not provide sufficient protection against the HAZARDS & RISKS, personal protective equipment (PPE) must be used as a last resort.
Selection of PPE	The selection of appropriate PPE is based upon the <u>hazard assessment</u> and many other factors.
Care & Maintenance	<u>Clean and properly maintained PPE</u> is important to ensure the effectiveness and proper functioning of PPE and to prevent transmitting infections.
	     

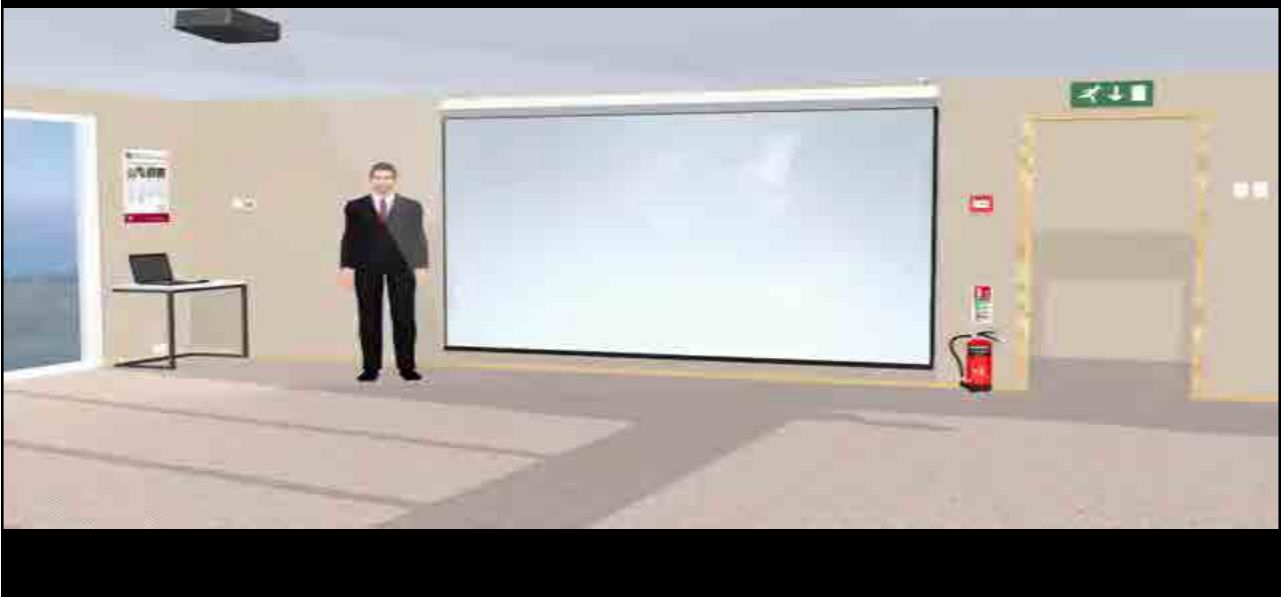

PPE Selection Criteria

	Identify the Potential Hazards
	Impact + Penetration + Compression + Chemical + Heat/Cold + Harmful Dust + Light + Radiation
	Determine the Types of Protective Equipment Available for the Present Hazards
	Evaluate the Effectiveness of the PPE
	Select Appropriate Protective Equipment
	Provide a Variety of Sizes to Properly Fit all Users
	Select Equipment that is Compatible with other PPE

VARIOUS HAZARDS AT WORK SITE



PPE Selection Criteria

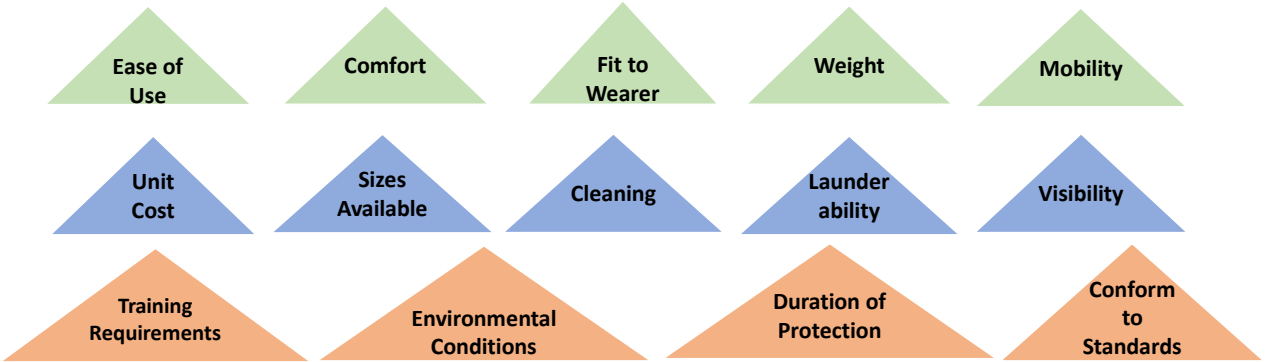

REMEMBER : PPE IS LAST LINE OF DEFENCE AGAINST ACCIDENTS & INJURIES

PPE EXAMPLES



PPE EXAMPLES

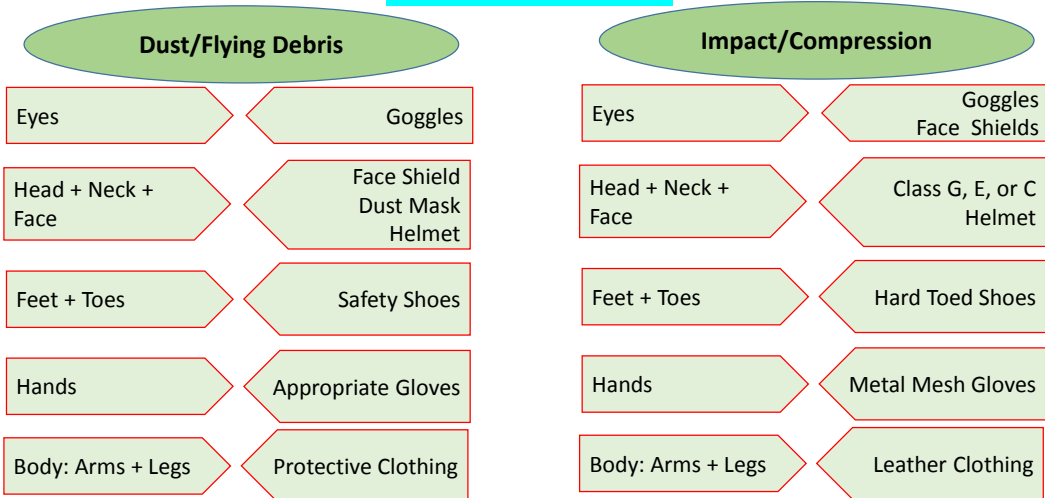

PPE EXAMPLES

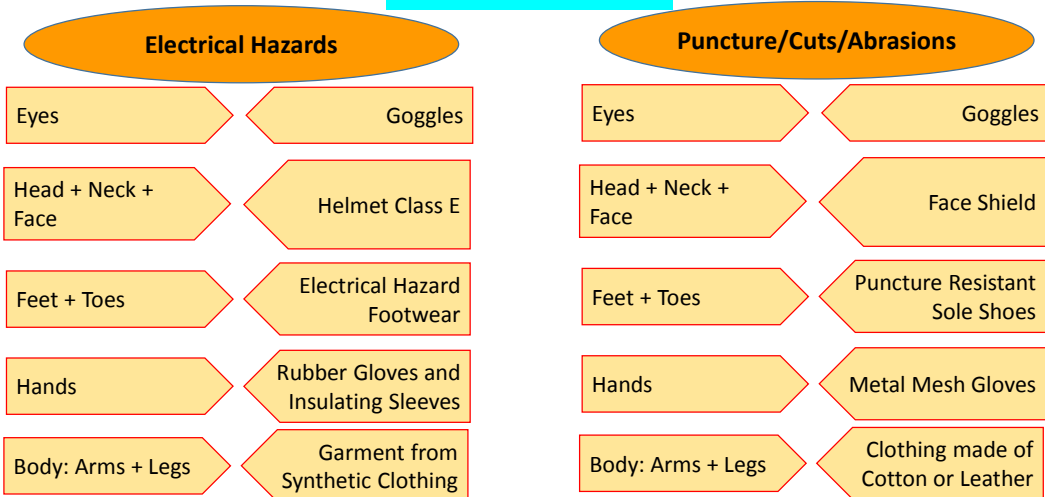

PPE SELECTION ON THE BASIS OF HAZARD ASSESSMENT

Work Site: _____
 Sub-Division: _____
 Foreman: _____
 Date: _____

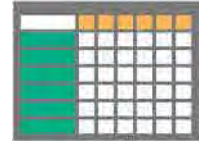

SR. NO.	JOB	HAZARDS	PPE REQUIRED

Employees Training in PPE Use

Employers are required to train each employee who must use PPE



- When PPE is necessary?
- How to properly put on, take off, adjust and wear the PPE?
- The limitations of the PPE
- Proper Care, Maintenance, Useful Life and Safe Disposal of PPE

PPE Care & Maintenance

Clean and Properly Maintained PPE is Important to Ensure the Effectiveness of PPE



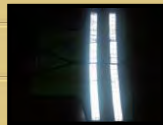

Care & Maintenance Includes....

Cleaning of PPE + Storage of PPE + Examination + Testing

Repair + Replacement of Worn Components + Safe Disposal



PPE Care & Maintenance

Helmet	Clean hard hats regularly Store head protection out of the sun Check the headband Replace a hard hat if it is cracked or dented	
Goggles	Clean safety glasses and goggles regularly Store eye protection preferably in a clean dust-proof case Replace safety glasses if frames are bent	
Respirators	Clean and disinfect Check for holes & cracks Store in a safe location which is protected from dust	
Gloves	Keep gloves clean and dry Have a backup pair in case gloves get wet Replace worn or damaged gloves right away	
Safety Shoes	Wipe wet or soiled shoes with a clean cloth Have worn or damaged shoes repaired, or replace them	



Observations

Module-1 OST-1

Day/Date:

Name:

Visit Location:

Designation:

Observations

- 1.
- 2.
- 3.
- 4.
- 5.
- 6.

Suggestions for Improving the Training Directorate Facilities



In the name of Allah, the most Gracious and ever Merciful

Module 01

Safety Control and Measures for Sewerage and Drainage Works



Lecture Breakdown	Duration
Safety Equipment & Procedures	20 Min.
Precautions before Manhole Entry	
Procedure during Manhole Entry	
While Operator is in Manhole	
Special Problems relates with Manhole O&M	
After Leaving the Manhole	
Q&A	



Manhole – A Confined Space

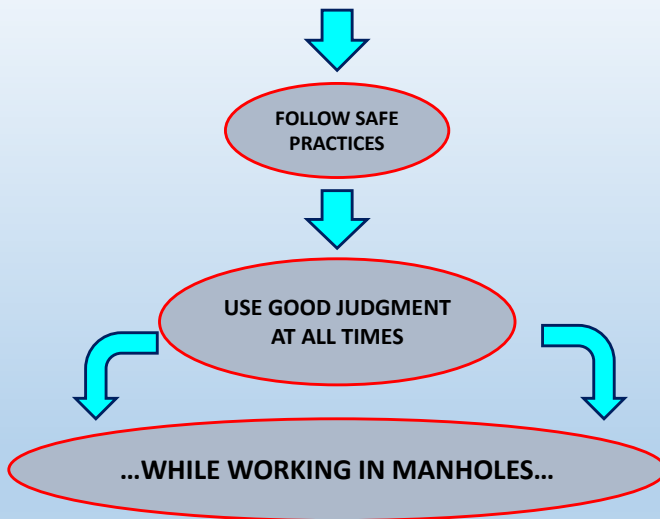

Safety Equipment & Procedures

Self-Contained Breathing Apparatus (SCBA)



Ventilation Blower with Hose



Tripod



Manhole Enclosure



Portable Atmospheric Alarm Unit (Gas Monitor)







Safety Harness with Lifeline



Safety Equipment & Procedures

Winch		Hard Hats (Safety Helmet) with Removable Torch	 
Ladders		Protective Clothing	
Ropes & Buckets		Cones + Barricades + High-Level Flags	

Safety Equipment & Procedures

First Aid Kit		Clean Clothes	
Fresh Water		RESCUE NO. 1122	
Soap			

Module-1 Lecture-5 Working in Confined Space



3/14

Precautions before Manhole Entry

Health Conditions of Operator:

- ✓ Be in good health
- ✓ Be in sound physical condition
- ✓ Be free from alcohol or drugs



Required Tools + Materials + Equipment:

- ✓ Examine the condition of all required tools
- ✓ Arrange tools & equip. so that work must be accomplished with single entry & exit



Foreman or Crew Leader should Hold Briefing

- ✓ To explain about HSE rules
- ✓ To explain the work sequence
- ✓ To explain SOP



Module-1 Lecture-5 Working in Confined Space

8/17

Manhole Entry Form

Date:	Structure Entering:	Location:
Person Entering:		
Supervisor:		
	Not Applicable	Complete
1. Unit Pumped Out		
2. Unit Ventilated		
3. Explosive Vapors Less Than 20% Of LEL		
4. Oxygen Content 19.5% Minimum		
5. H ₂ S Less Than 10 Ppm		
6. PPE and Rescue Devices		
a. Harness on Person Entering		
b. Lifeline Attached to Harness		
c. SCBA on Employee Entering		
7. Emergency Procedure Explained and Understood		
Send Original To Supervisor		Send Copy To Safety Officer

Procedure during Manhole Entry

Following procedure shall be adhered to:

- A confined space entry form shall be used to review the necessary precautions
- All traffic control measures shall be taken
- All valves or power sources shall be locked out
- An initial test of the atmosphere must be performed
- All persons who enter a confined space shall be instructed about hazards
- All persons entering a confined space shall wear a rescue harness with attached lifeline
- No smoking shall be permitted inside or within ten feet (10 ft.) of a confined space
- At least one person shall remain outside the confined space while it is occupied
- Atmospheric testing shall continue while the confined space is occupied
- All persons in a confined space shall vacate immediately if the warning alarm is activated
- A hard hat shall be worn at all times in a confined space

Operation of Manhole Entry

Following procedure shall be adhered to:

- Place the manhole safety enclosure around the manhole
- Calibrate** the portable atmospheric monitor **BEFORE** removing the manhole cover
- Test** the manhole from top to bottom for oxygen deficiency, explosive and toxic (hydrogen sulfide) gases
- Never use hands to remove the manhole cover**
- Open manholes** upstream and downstream from the work area
- Sweep the area** before removing the manhole cover
- Before entering the manhole start the ventilation blower
- Once the operator going into the hole confirm safety harness and lifeline is attached**
- Continue** to use the atmospheric monitoring system

While Operator is in Manhole

Following procedure shall be adhered to:

- The end of the lifeline must be secured outside of the confined space
- Whenever an operator is in a manhole continuously test the atmosphere**
- The operator in the manhole must be observed continuously
- If there are any indications of trouble immediately remove the operator**



Special Problems of Manhole Work

Following problems may occur during working in manhole:

- Sharp odor or prolonged breathing of an odorous atmosphere will cause the sense of smell to be temporarily lost
- NEVER allow anyone to enter a manhole until the oxygen content tests greater than 19.5 percent oxygen**
- Victims suffering from a lack of oxygen may require artificial respiration if the case is severe

DANGER

OXYGEN DEFICIENT
CONFINED SPACE

After Leaving the Manhole

Following steps should be taken after operation inside manhole:

1. Take hot shower.
2. **Put on clean clothes.**
3. Don't wear the clothing worn in manhole, at home.
4. **Never expose your family to any object which was in contact with your clothing.**
5. No clothing should be washed with the family laundry.







In the name of Allah, the most Gracious and ever Merciful

Module 01

Safety Control and Measures for Sewerage and Drainage Works



Lecture Breakdown	Duration
Objectives	20 Min.
Purpose of First Aid	
Phases of First Aid	
First Aid Rules	
Various Emergencies around Job Site	
Q&A	



Objectives

The objective of this lecture is to improve capacity of participants to render first aid in emergency situations

FIRST AID :

First aid is the assistance given to any person suffering a sudden illness or injury, with care provided to preserve life, prevent the condition from worsening, and/or promote recovery.

Purposes of First Aid

1. Prevent further injury
2. Preserve life
3. Promote recovery

Phases of First Aid

1. Self-aid
2. Assistance from a companion
3. Emergency treatment
4. Initial surgery

First Aid Rules



1. Do not get excited
2. Do not move injured victim unless it is necessary
3. Keep the victim lying down
4. Keep the victim warm and comfortable
5. Examine the victim gently
6. Avoid allowing the victim to see his own injury
7. Do not try to give any solid or liquid substance by mouth
8. Do not touch open wounds or burns with fingers or other objects
9. Seek medical attention immediately

Various Emergencies around Job Site

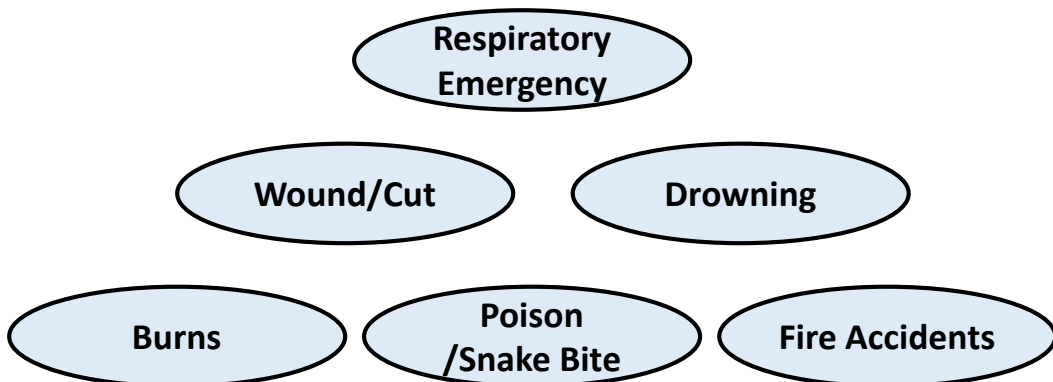

Respiratory Emergency

- Common Causes
- Signs & Symptoms
- First Aid Measures

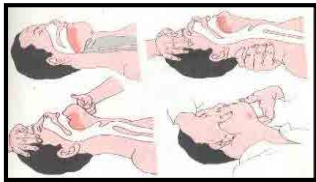

Snake Bite

- Signs & Symptoms
- First Aid Measures



Drowning

- First Aid Measures

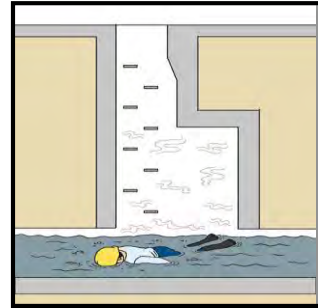

Wound

- Common Causes
- First Aid Measures



Burns

- First Aid Measures



Fire Accidents

- Fire & Causes
- Fire Suppression
- Fire Extinguisher

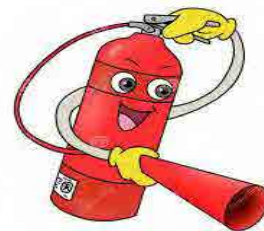



In the name of Allah, the most Gracious and ever Merciful

Module 01

Safety Control and Measures for Sewerage and Drainage Works



Lecture Breakdown	Duration
Objectives	30 Min. 
General Conditions	
Traffic Control Criteria	
Areas of Traffic Control	
Traffic Control Devices	
Q&A	



Traffic Routing Layout

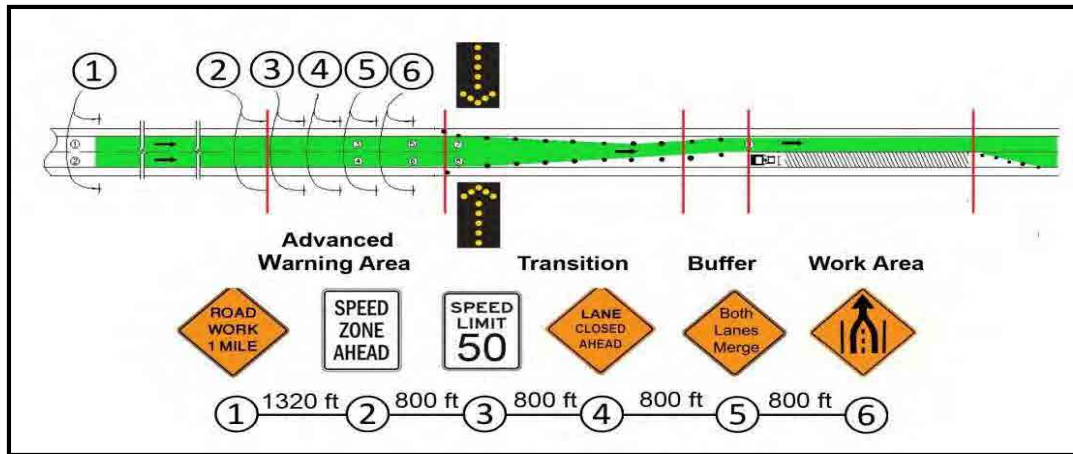

Objectives of Routing Traffic Around Job Site

To Create a Safe zone for WASA Staff + Machinery + Tools & Equipment :

Who are busy at or near the roads in operation and maintenance works e.g.

- ✓ Manhole de-silting,
- ✓ Drain dredging,
- ✓ Replacement of sewer pipe

Routing Traffic Criteria

Answers to several questions will determine traffic control criteria around the WASA work site:

- Is traffic moving at a low speed (0-60 Km/Hr.) or a high speed (60-90 Km/Hr.)?
- Is the road two-lane, one-way or two-way?
- Is it undivided four-lane?
- Is it multi-lane one-way?
- Are pedestrian walkways affected?
- Is it in a residential area?
- Will a lane closure be required?
- Will more than one lane be closed?
- Will traffic control be required during peak traffic periods or at night?

Areas of Traffic Control

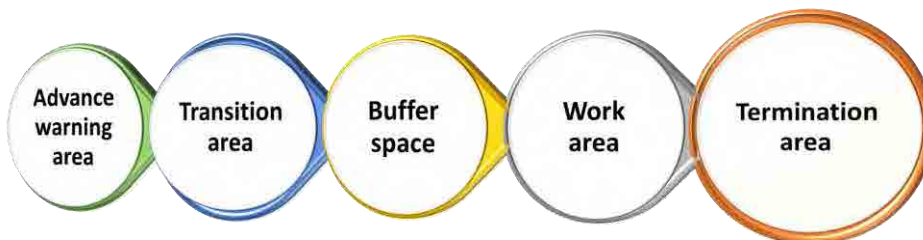

1 - Advance Warning Area

- The purpose of this area is to **alert drivers** to activity ahead.
- Allow them enough time to alter their driving patterns prior to reaching the work area.

2 – Transition Area

- Traffic is channeled** from the normal traffic lane to the path required to move it around the work area

3 – Buffer Space

- This zone provides an **additional margin** of safety for both traffic and working operators

4 – Work Area

- Work area is that portion of the road which contains the **work activity** and equipment, is closed to the traffic

5 – Termination Area

- This area provides a short distance for traffic to **get clear of the work area** and to return to the normal traffic lanes

Pictorial Views of Traffic Routing

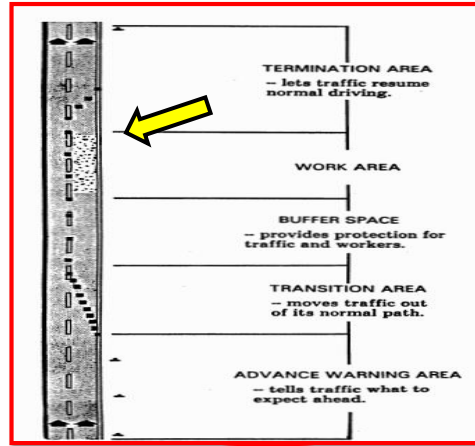

Module-1 Lecture-7 Traffic Control Plan

General Layout

9/16

Pictorial Views of Traffic Routing

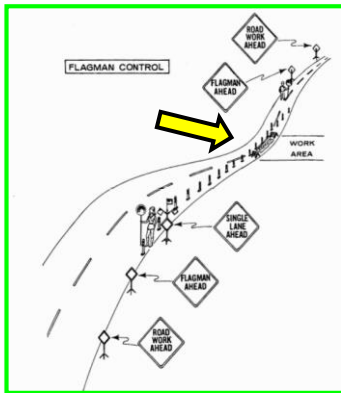

Flagman Control

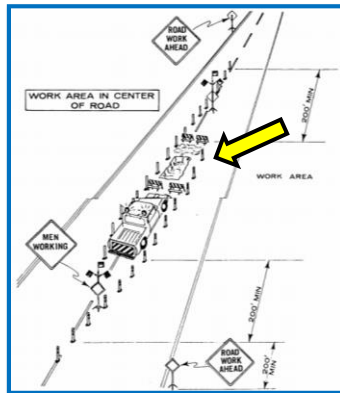

Work Area in Center of Road

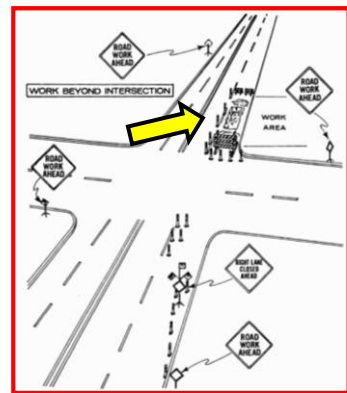

Work Beyond Intersection

Module-1 Lecture-7 Traffic Control Plan

10/16

Pictorial Views of Traffic Routing

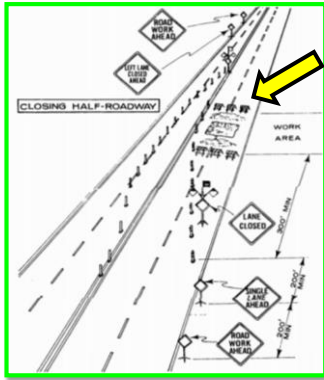

Closing Half-Roadway

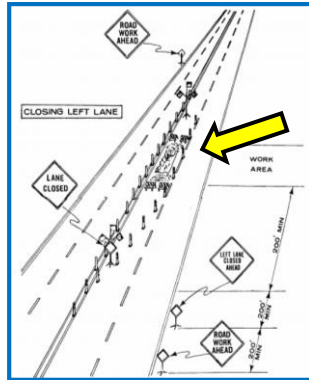

Closing Left Lane

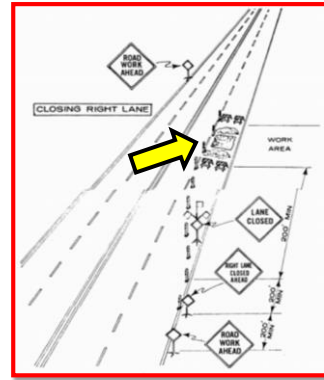

Closing Right Lane

Traffic Control Devices

Traffic control devices are **markers, signs** and **signal devices** used to inform, guide and control traffic, including pedestrians, motor vehicle drivers and bicyclists

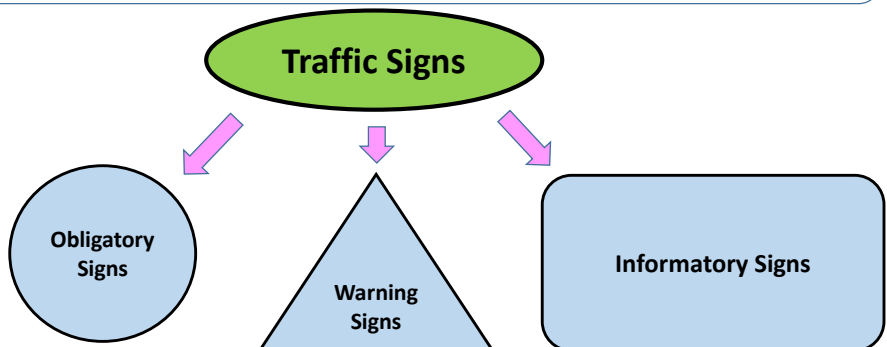

Traffic Control Devices



Questions & Answer Session:

Q. 01:

Who should be **contacted** before setting up a work site at a Road?

Q. 02:

How can **traffic be warned** of your presence at a road?

Q. 03:

How can motorists be **safely routed** around a job site?



HSE Action Plan Module 01

ACTION PLAN

A	DESCRIPTION OF PROBLEM						
1	Description of Problem						
	Date						
2	Type / Rating of Hazard		Major		Probable Outcomes		
			Moderate				
			Minor				
3	Hazard Discovered Through		Inspection	Near Miss	Accident	Any Other	

B		IMMEDIATE ACTION			
1	Take Immediate Action	Remove Hazard	How?		
		Isolate Hazard	How?		
	Date of Response	Restrict the Access	How?		
		Erect Signage	How?		
		Any Other	How?		
2	Finding Root Cause	Apply "5Whys" Methodology			
3	Contributing Reasons / Causes	Lack of Training	Un-Safe O&M Method	Ignorance	
		No Use of PPE	Lack of Proper Tools	Willful Misconduct	
		Improper House Keeping	Improper Maintenance	Any Other	

C - Action Plan Template



Sr. No.	WHAT TO DO?	HOW TO DO?	WHEN TO DO?	WHO TO DO?		DO WITH WHAT?		CHECK DONE?	WHO TO CHECK?
	Preventive Action	(Follow SOP)	(Frequency)	(Carried out By)		Materials	Tools/ Equip.	How to Check?	Effectiveness to be Checked By?
				Class of Work	Worker				

C- Action Plan Template

Sr. No.	Due Date	Date Complete	Date Verified	Any New Risk / Hazard Developed	

D- SIGNATURES			
Implementer Name		Signature	
Authority Title		Signature	

O&M of Drainage System



O&M of Drainage System

- Components
- O&M Objectives

Strategy for Improvement

- Sensitizing Senior Decision Makers
- Assessing the Existing Facilities
- Identification of Factors affecting Quality of Maintenance
- Snags in Management
- Immediate Action Plan
- Long term Action Plan



Course

Operation and Maintenance (O&M) of Sewer & Storm Water Drainage System including Safety Precautions

Module 2

O&M of Storm Water Drainage System

Lecture 1

Need for O&M of Storm Water Drainage System

1. Storm Water Drainage System and its Components
2. Current Issues
3. Sediment Deposition
4. Need for O&M
5. Maintenance of Drains



➤ Receives runoff from inlets and conveys the runoff to some point where it is then discharged into a channel, water body, or piped system

➤ It may be a

- closed-conduit
- Open channel

➤ "Storm sewer" replaced with the term "storm drain" to differentiate between sanitary sewers and storm drains

- ❑ A **drainage pipe** used to convey a stream through a road or embankment
- ❑ It may carry a stream for a long distance underground to a surface discharge location
- ❑ **Short in length** and **open at both ends** and often must withstand substantial traffic loads



Ditch

- ❑ Ditches are constructed to convey water from storm runoff to an adequate outlet.
- ❑ A good ditch is shaped and lined and does not cause flooding, erosion, or sedimentation.



Gutter



- ❑ That portion of the roadway section adjacent to the curb which is utilized to convey storm water runoff.



A location where storm water runoff from an open area enters the storm drain system.



Drop inlets are usually part of the public drainage system, but can sometimes be considered private.

A structure in the form of a chamber which is provided along with the sewer line to admit clear rain Water free from silt, grit, debris, etc, into the combined sewer

Allows rainwater runoff to be safely collected to prevent road and property flooding

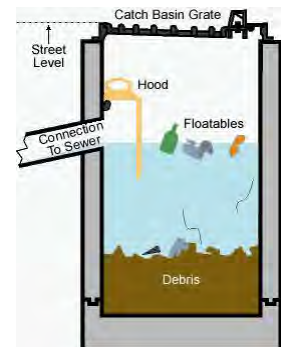



Encroachment of drains



Silting of drains due to constant blockages



Stability of drainage cross-sections dislocated and damaged old lining of the drains



Unpleasant odor of dirty water flowing in the drains

Absence of comprehensive data on storm-water drainage network

Inadequate attention to cleaning of natural drains and clearance of excess floral growth on the drains

Free access to dispose wastewater from nearby habitation

Due to the sediment deposition the problems occurred in the **open channel** includes:

- Encourages prolific weed growth
- Cause flooding of various degrees of magnitude
- Ponding of water creates breeding grounds for some disease causing agents
- Silted roadside drains produce ponding on roads



In the case of **buried or completely covered** storm channels, problems occurred are:

- Silting + Weed Growth + Bushes
- Release & accumulation of gases (that can be highly corrosive to the channel material)



Lack of regular maintenance cause the accumulation of the sediment and garbage in the drain

Extensive, regular sediment removal is a difficult and expensive process

Routine inspection and preventive maintenance are the best ways to prevent blockages and deterioration of drains

Departments should devise maintenance procedures including:

- Frequency of inspection
- Programme for dredging
- Necessary repair works
- Documentation for maintenance records





Course

Operation and Maintenance of Sewer & Storm Water Drainage System Including Safety Practices

Module 2

Operation and Maintenance of Storm Water Drainage System

Lecture-2

Tools and Equipment for Drain Dredging Operations

Module-2 Lecture-2

3/15

Contents

- Hydraulic Excavator
 - Excavation Buckets
 - Variations of Excavators

- Silt Pusher Boat
- Cutter Suction Dredger
- Dredge Pump



Module-2 Lecture-2

4/15

- Excavators (Hydraulic Excavators) are heavy construction equipment consisting of a boom, dipper (or stick), bucket and cab on a rotating platform known as the "house"
- All movement and functions of a hydraulic excavator are accomplished through the use of **hydraulic fluid**, with hydraulic cylinders and hydraulic motors



Digging Bucket

- Excavates materials using a pulling movement
- It is often implemented to remove thin layers of silt



Dredging Bucket

- Slightly different from standard buckets
- Characterized by holes that retain silt while allowing water to escape



Visor Bucket

- Traditional excavation bucket
- Excavate thin and very dense layers with low water content



Excavation Buckets



Clamshell

- Operates using a gripping movement
- Excavate thick layers of silt and for transferring materials
- Layer thickness must be at least 0.5 m in order to achieve reasonable productivity



Environmental Grab Bucket

- An alternative type of grab bucket
- Enables an almost horizontal closing movement
- The maximum opening is circa 80% larger than a traditional grab bucket
- Relatively thin layers can also be excavated efficiently

Module-2 Lecture-2

7/15



Excavation Buckets



Backhoe

- It has emerged as a suitable workhorse for soils:
 - glacial tills
 - fragmented or softish, crumbly rock
 - variety of non-rock types of soils that have stones
- May be used for dredging relatively small quantities of material that are at varying depths
- Often used for bulk dredging of a variety of sediments



Module-2 Lecture-2

8/15

A wide range of variations have been developed for hydraulic excavators over the years due to:

- Height restrictions
- Propulsion issues
- Insufficient access to the water bottom

The following variations can be encountered:

- Excavator boat
- Amphibious Excavators
- Tractor with Side-Arm



Excavator Boat



Amphibious Excavator



Tractor with Side-Arm

- ❑ A silt push boat is like a floating bulldozer, which has been developed especially for cleaning ponds, lakes and small waterways
- ❑ The machine is primarily used in situations where it is difficult to work from the water's bank

Range of Applications

- Primarily suitable for soft water bottoms (silt, clay, turf, mud, etc.)
- Effective on relatively long, straight waterways
- It can also be used for thicker layers.
- Only effective in relatively shallow waters.
- Depending on the dimensions of the machine, it is possible to work in **Depths of up to 2 m**
- Machine becomes unsuitable when depths exceed 3 m





Cutter Suction Dredger



- ❑ A cutter suction dredger is a dredging machine that is used in continuous excavation processes and is positioned using spud poles or winch cables



Range of Applications

- Generally only suitable for silt, clay and sand.
- Depending on the dredger design, be used up to **6 m deep**
- The soil type and project conditions must be known for each project
- For **harder bottoms** (i.e. sand), a cutter with larger cutting sections must be selected in order to penetrate the layer of sand

Module-2 Lecture-2

11/15



Dredge Pump



- ❑ Used to suck dredging materials from the water bottom
- ❑ The pump's suction opening is guided through the center of ditches to maximize contact with dredged materials
- ❑ Dredge pumps can be mounted to a tractor or crane, or can also be placed on a boat



Range of Applications

- Only suitable for soft water bottoms (silt, turf, etc.)
- Suited to waterways with non-polluted silt
- **Cutter** can also be attached for dredging more solid water bottoms
- Dredge pumps are **susceptible to stones** and **branches**, which could block the opening
- Less suited to dredging activities in urban settings

Module-2 Lecture-2

12/15



Dredge Pump



Observations

Module-2 Lecture-2

13/15



Module-2 Field Visit-01 (Observation of De-Silting Machinery)



Date:

Name:

Day:

Designation:

Field Visit Site:

WASA/TMA:

Temp.

Sr. No.	Machinery					Attachment(s)		Remarks
	Name/Type	Nos.	Manufacturer /Year	Capacity (Tons)	Fuel Consumption (Liters/day)	Name/Type	Capacity (Tons)	
1.								
2.								
3.								
4.								
5.								
6.								
7.								

Module-2 Lecture-2

14/15

Observations



Module-2 Field Visit-01 (Observation of De-Silting Machinery)



Date:

Name:

Day:

Designation:

Field Visit Site:

WASA/TMA:

Temp.

Sr. No.	Machinery					Attachment		Remarks
	Name/Type	Nos.	Manufacturer /Year	Capacity (Tons)	Fuel Consumption (Liters/day)	Name/Type	Capacity (Tons)	
1.								
2.								
3.								
4.								
5.								
6.								
7.								



In the name of Allah, the most Gracious and ever Merciful



Course

Operation and Maintenance of Sewer & Storm Water
Drainage System including Safety Practices

Module 2

Operation and Maintenance of Storm Water Drainage
System

Lecture 3

Measurement of Sludge Quantity in Drains

Class Work
Field Work

Documents
Equipment & Tools
PPE

- Presentation + Discussion on Current Practices
- Estimation of Deposited Sludge
(at Maulana Shaukat Ali Drain, Akbar Chowk, Township)
- Drain map of area + Templates
- Ranging Rod + Aluminum Staff + Distance Meter+ Road Signs + Traffic Cones etc.
- Helmet + Goggles + Hand Gloves + Safety Shoes + Gum Boots



Module-2 Lecture-3 (Measurement of Sludge Quantity in Drains)

3/19

- Need of Measurement of Sludge Quantity in Drains
- Equipment
- Procedure
- Sludge Volume Calculations
- Observations

Module-2 Lecture-3 (Measurement of Sludge Quantity in Drains)

4/19

- To **prevent** excessive sediment built-up
- No **standard method** of measuring the sediment build-up
- A **regular monitoring** programme and measurement tools will ensure that the depth of accumulated sludge is accurately measured
- Inconsistent and **inaccurate readings** of sediment accumulation could result in too frequent maintenance

1- Staff with Disc

- Consists of a rod with a flat disc (welded to its base)
- The depth of sludge is measured off the graduations on the rod
- This will then be used to find the actual sediment depth



Advantages

- Portable and cheap
- Need minor maintenance
- Can be used in any type of drain



2- Ranging Rod

- Ranging Rod (6 feet Height)
- Colour Coded
- Each Segment is 01 Foot Long
- Metal Conical Tip for Penetration in Sludge



3-Distance Meter (Surveyor's Wheel) & Use



Step 01



Before Measurement
(Reading 0-0)



Lo = 119 m

Step 02



Li = 115 m

Step 03

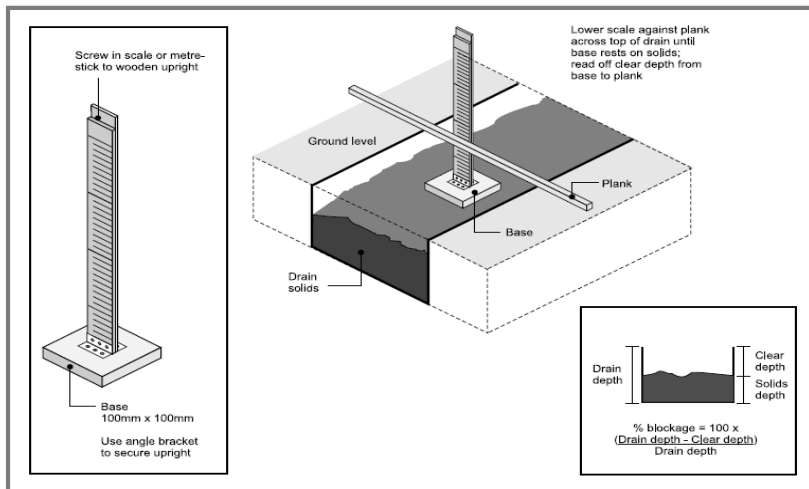
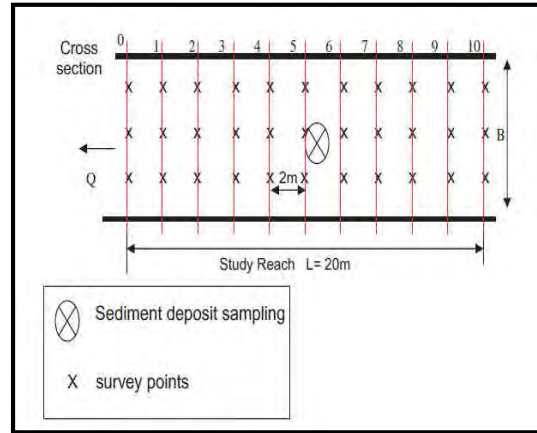
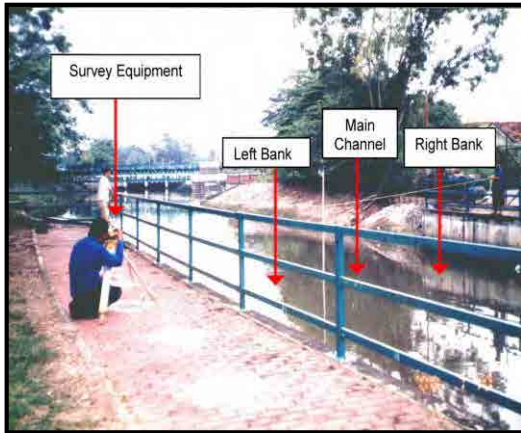

1. First **select the venue** where you have to do dredging or sediment thickness measurement
2. Select some **culvert or bridge**
3. Properly apply **traffic control plan**
4. Ensure that each worker has worn the proper **safety gadgets**
5. Find out the **dimensions** of the drain i.e. Length Width and Depth
6. **Mark** the stations on the drain

7. Two persons at both banks of the drain are required
8. **Find the depth** by using staff having graduations on it
9. Find out the **capacity of dump truck** for transporting sludge
10. **Calculate the number of trips** by dumper from dredging to disposal site
11. Also calculate the **time required by the dumper per trip** and total time for overall operation
12. If the **cleaning along the road** is required because of spillage of waste then clean that



Road Map for Sludge Measurement Site

Maulana Shaukat Ali Road (Near Shauk Chowk)

Distance: 4.0 Km
Travel Time: 10 Min.

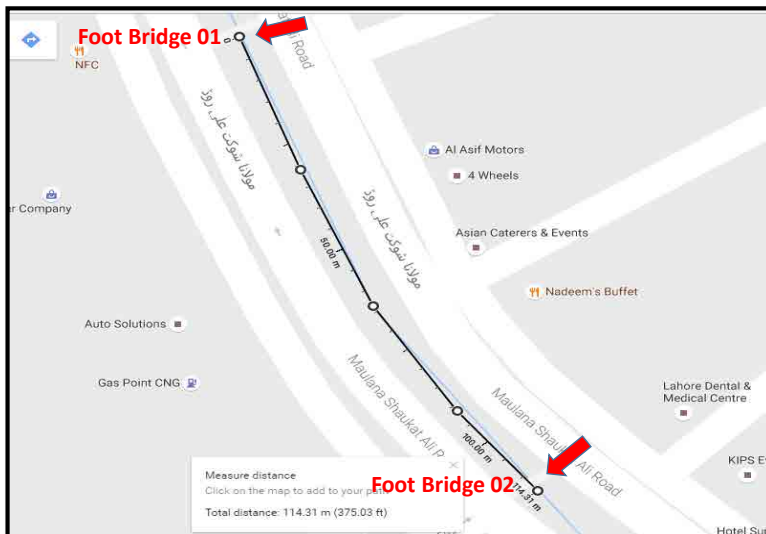

Top View of Field Work Area (Sludge Measurement Site)

Maulana Shaukat Ali Road (Near Shauk Chowk)

Foot Bridge 01



Foot Bridge 02



Maulana Shaukat Ali Drain (Secondary Type)

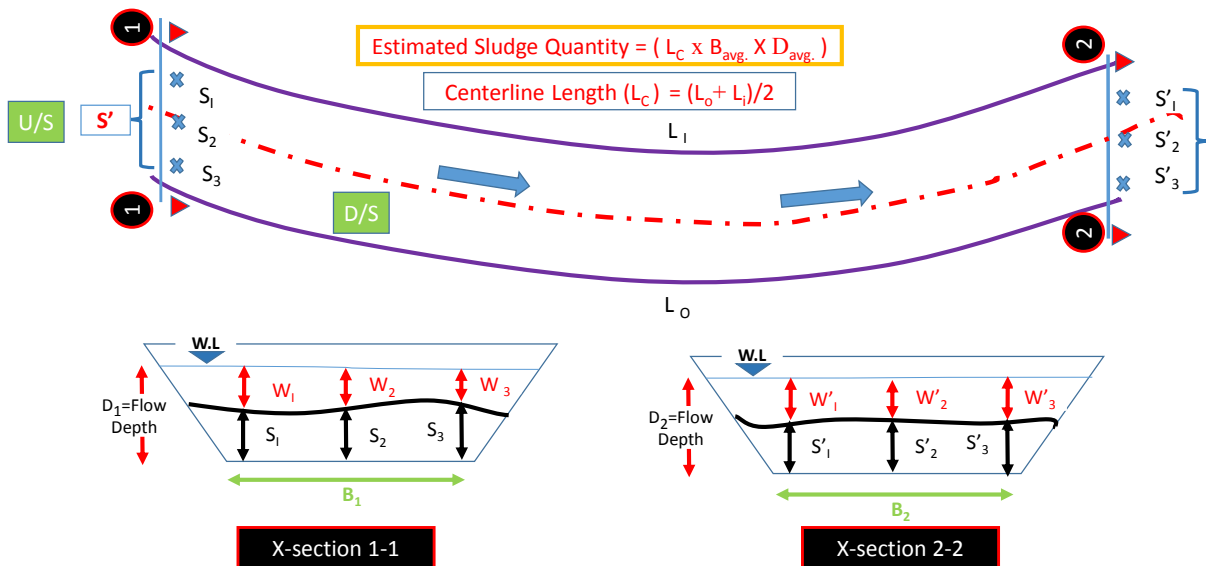

Depth at Foot 1 $S_n = (D - W_n)$	Avg. Depth at Foot 1 S_{avg}	Depth at Foot 2 $S_n = (D - W_n)$	Avg. Depth at Foot 2 S'_{avg}	Overall Avg. Depth D_{avg}	Width at Foot 1 B_1	Width at Foot 2 B_2	Avg. Width B_{avg}	Length Inner L_i	Length Outer L_o	L_c	Sludge Volume V
S_1		S'_1									
S_2		S'_2									
S_3		S'_3									

$D_1 =$	<p style="color: red; text-align: center;">Estimated Sludge Quantity (Vol.)</p> <p style="text-align: center;">$= (L_c \times B_{avg.} \times D_{avg.})$</p> <p style="text-align: right; font-size: small;">CUM or CFT</p>	<p>$L_c = (L_o + L_i) / 2$ (if drain stretch is curved)</p> <p>$S' = (S_1 + S_2 + S_3 + \dots) / n$</p> <p>$S'' = (S'_1 + S'_2 + S'_3 + \dots) / n$</p> <p>$D_{avg.} = (S' + S'' + S''' + \dots) / n$</p> <p>$B_{avg.} = (B_1 + B_2 + B_3 + \dots) / n$</p>
$D_2 =$		
	<p style="color: red; text-align: center;">Estimated Sludge Quantity (Vol.)</p> <p style="text-align: center;">$= (\quad \times \quad \times \quad)$</p> <p style="text-align: right; font-size: small;">CUM or CFT</p>	

Sr. No.	Observations	Remarks
1.	Type of de-silted material	
2.	Flow conditions before the dredging	
3.	Flow conditions after the dredging	





Course

Operation and Maintenance of Sewer & Storm Water
Drainage System Including Safety Practices

Module 2

Operation and Maintenance of Storm Water Drainage System

Lecture 4

Dredging and Desilting Operations

1. Small Scale Dredging

2. Critical Processes in Small Scale Dredging

3. Dredging Process

4. Dredging Techniques & Case Study

5. Selection Criteria for Dredging Techniques

6. Workplace Worksheet and Traffic Control

Small-scale dredging projects generally involve drainage channels and modified rivers in areas with artificial (pumped) drainage and smaller urban and suburban waterways, which are not used for shipping activities



- ❑ **Accessibility** along and in channels and lakes
- ❑ Logistics and transport of material in populated areas (traffic)
- ❑ **Limited space** for disposal of sediment and waste
- ❑ Sensitive project environment:
 - hinder to surroundings
 - highly visible
 - public opinion and interest
- ❑ (Old) embankments, low bridges, etc.
- ❑ **Household waste & objects**



Excavation

Process involves the:
Dislodgement;
Removal of sediments
(soils) and/or rocks

Dredger – is used to excavate the material either:

- Mechanically
- Hydraulically
- By combined action

Transportation

Transportation of dredged material is achieved by:

- In self-contained hoppers of the dredgers;
 - In barges;
- Rarely used transport methods are:
- Truck
 - Conveyor belt

Utilization or Disposal

- In **construction projects**, dredging is driven by the demand for dredged material.
- In **navigation and remediation dredging**, the project is driven by the objective of removing the material from its original place

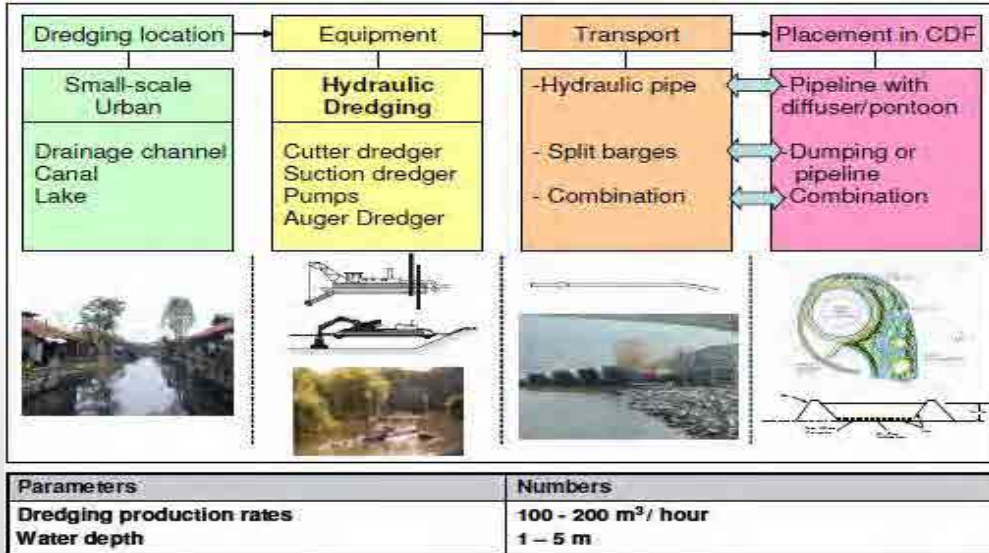

Hydraulic Dredging

- Used for maintenance dredging projects
- Removal of loosely compacted materials by cutter heads, dustpans, hoppers, hydraulic pipeline, plain suction, and side casters



Cutter Head

Mechanical Dredging

- Used either for maintenance or new-work projects
- Removal of loose or hard compacted materials by clamshell, dipper, or ladder dredges



Clamshell

While selection of dredging technique, the following factors must be taken into consideration:

- Composition of dredged materials
- Type and level of pollution
- Size of project
- Acceptable opacification and spillage
- Required accuracy
- Side-effects
- Ecological considerations



Work Report No: Date:

District:

Zone: Road No:

Section: From km to km

Location (s):

WORK ACHIEVED:

.....

.....

MANPOWER USED:

Name..... Grade..... Hour Worked.....

Name..... Grade..... Hour Worked.....

Name..... Grade..... Hour Worked.....

EQUIPMENT USED: DIESEL USED

Hrs..... Liters

Hrs..... Liters

MATERIALS USED:

.....



Course



Operation and Maintenance of Sewer & Storm Water Drainage System Including Safety Practices





Module 2

Operation and Maintenance of Storm Water Drainage System



Lecture 5

Maintenance of Storm Water Drainage System

 **Contents** 

-  O & M Plan
-  Maintenance Activities for Road Drainage
-  BMPs for Storm Water Drainage System
-  BMPs for Dredging

Module-2 Lecture-5 **3/22**

 

O & M Plan

Module-2 Lecture-5 **4/22**



Requirement of O & M Plan



- Define the Area to be Covered
- Identify Problem Areas
- Set an Inspection Schedule
- Assign Responsibility for Inspection
- Define What Categories of Work will be Performed Under this Program
- Identify Parties Responsible for Debris Removal
- Keep Records
- Budget



Module-2 Lecture-5

5/22





O & M Plan for Open Drains





Storm water system feature	Are any of these conditions present?	Problem	Recommendation
General	Dumped yard wastes or no degradable materials (glass, plastic, Styrofoam, etc.) are present in pond	Accumulation of trash and debris	Remove trash and debris and dispose of properly.
	Undesirable vegetation is invading the pond	Nuisance, poisonous, or noxious weeds	Seek advice from the Dept. of Agriculture before applying pesticides. Certain pesticides should not be used near waterbodies.

Module-2 Lecture-5

6/22

		<h2 style="text-align: center;">O & M Plan for Open Drains</h2>		
Storm water system feature	Are any of these conditions present?	Problem	Recommendation	
General	Grass is taller than 10"m	Overgrown vegetation	Mow grass regularly. Grass should be mowed to a height of 4-9" for best storm water control. Avoid over-applying fertilizers. Excessive fertilizer application may compound water quality problems.	
	Offensive color, odor, or sludge is present	Unknown or uncharacteristic substances	Remove substance and eliminate its source. If you don't know if the substance is hazardous, either take a sample or contact a qualified hazardous waste consultant for more information.	
	Excessive mosquito population is present	Mosquitos	Install predacious bird and bat nesting boxes to control insects	
Module-2 Lecture-5			7/22	

		<h2 style="text-align: center;">O & M Plan for Open Drains</h2>		
Storm water system feature	Are any of these conditions present?	Problem	Recommendation	
General	Water flows through holes in dam or berm; holes are present around pond	Rodents	Destroy rodents and repair dam or berm.	
	Large trees interfere with maintenance activities	Overgrown trees	Remove trees that interfere with access or maintenance activities. Preserve trees that are not a problem	
	Accumulated sediment exceeds 10% of the designed pond depth	Excessive sediment	Clean out sediment to original shape and depth of the pond. Re-seed pond, if necessary, to control erosion.	
Module-2 Lecture-5			8/22	



O & M Plan for Storm Sewers



Storm water system feature	Are any of these conditions present?	Problem	Recommendation
General	Accumulated sediment or trash exceeds 20% of the diameter of the pipe	Excess accumulation of sediment or trash	Clean out sediment and trash from pipe. You can use a high pressure hose, vacuum suction, or other appropriate cleaning method.
	Vegetation is impeding water flow	Overgrown vegetation	
	Pipe is rusted; protected coating is damaged	Corroded pipe	Replace or repair pipe to original design specifications.
	Dent in pipe has reduced the pipe diameter by 20%; water flow is impeded; pipe is broken	Defective pipe	
	Water is leaking from pipe	Cracked pipe	

Module-2 Lecture-5

9/22



Maintenance Activities for Road Drainage



Module-2 Lecture-5

10/22

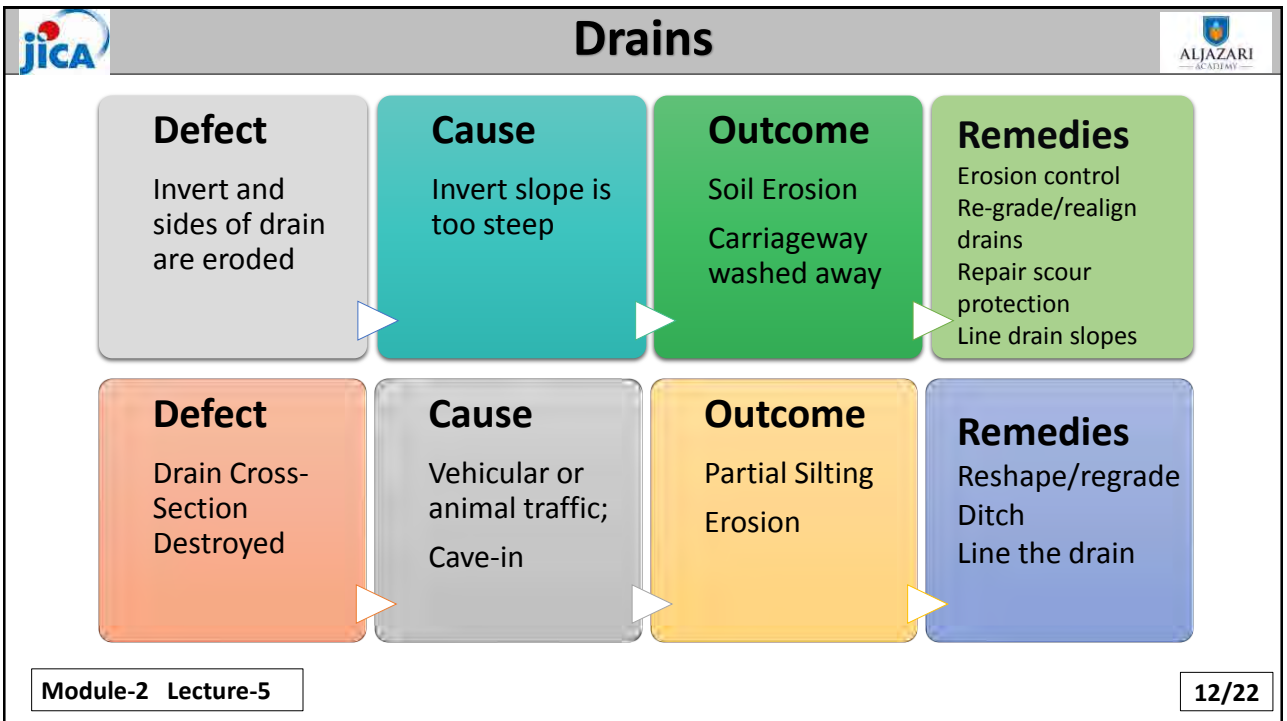
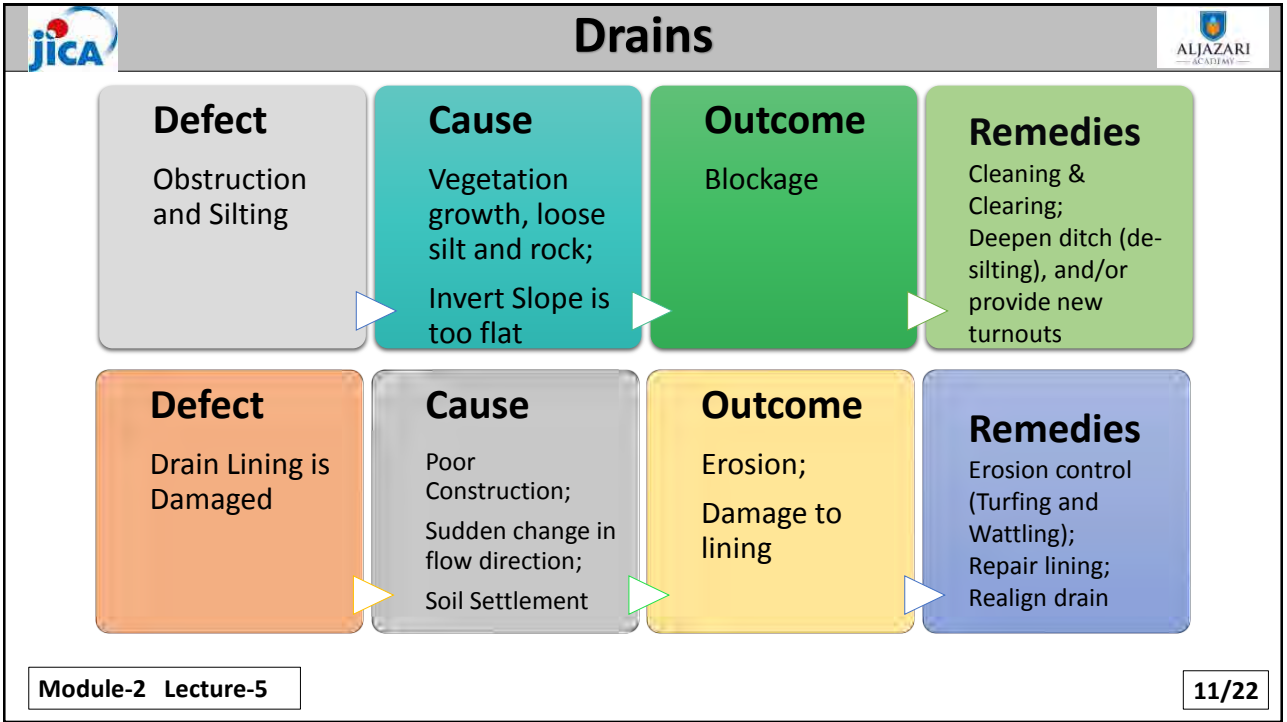

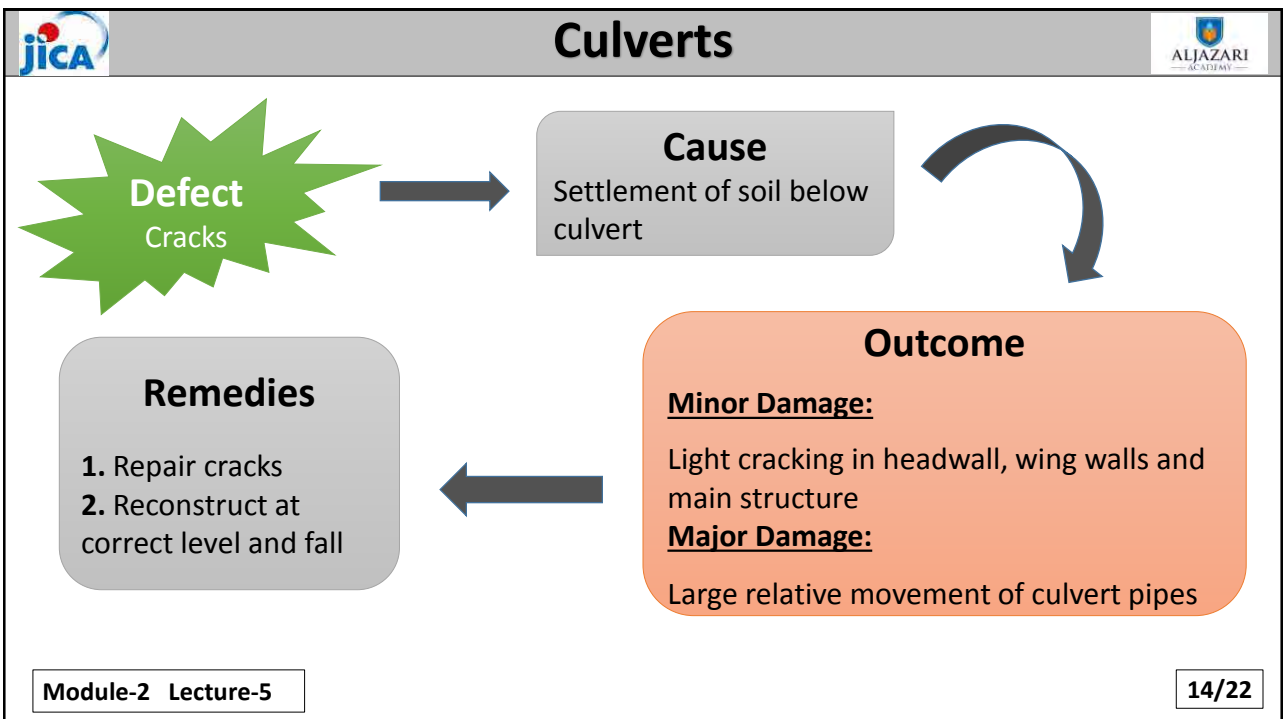
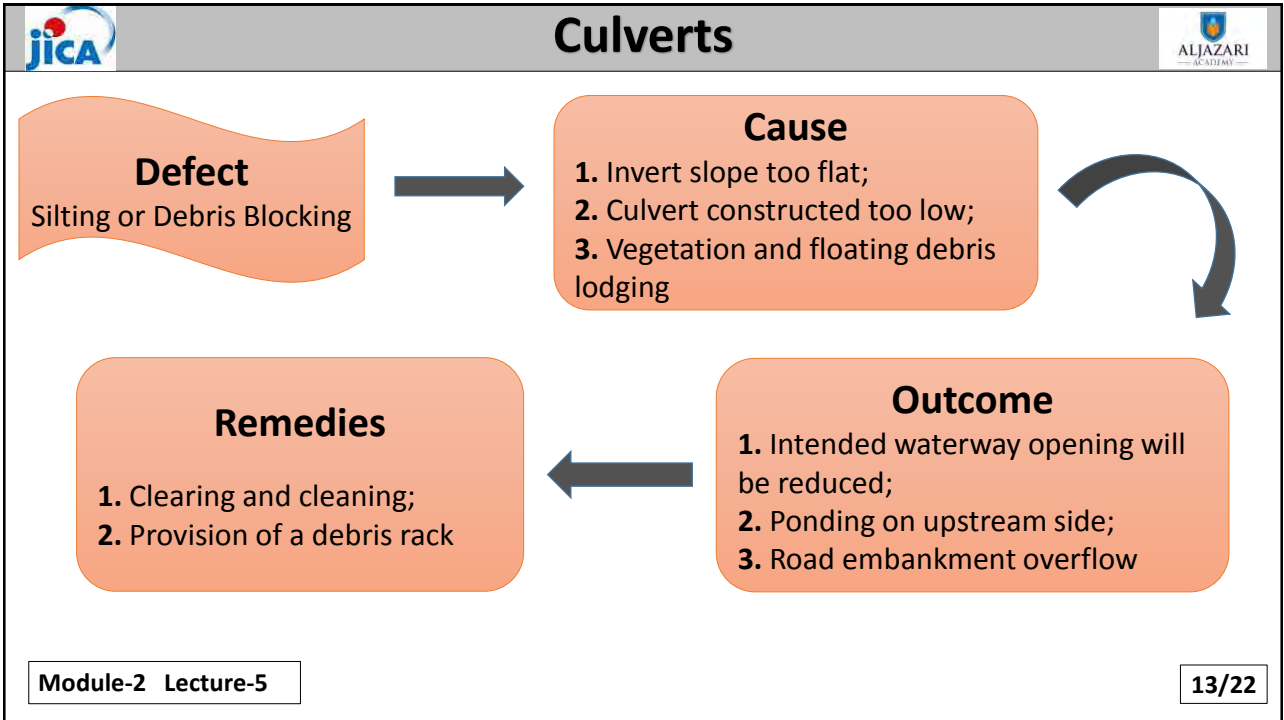

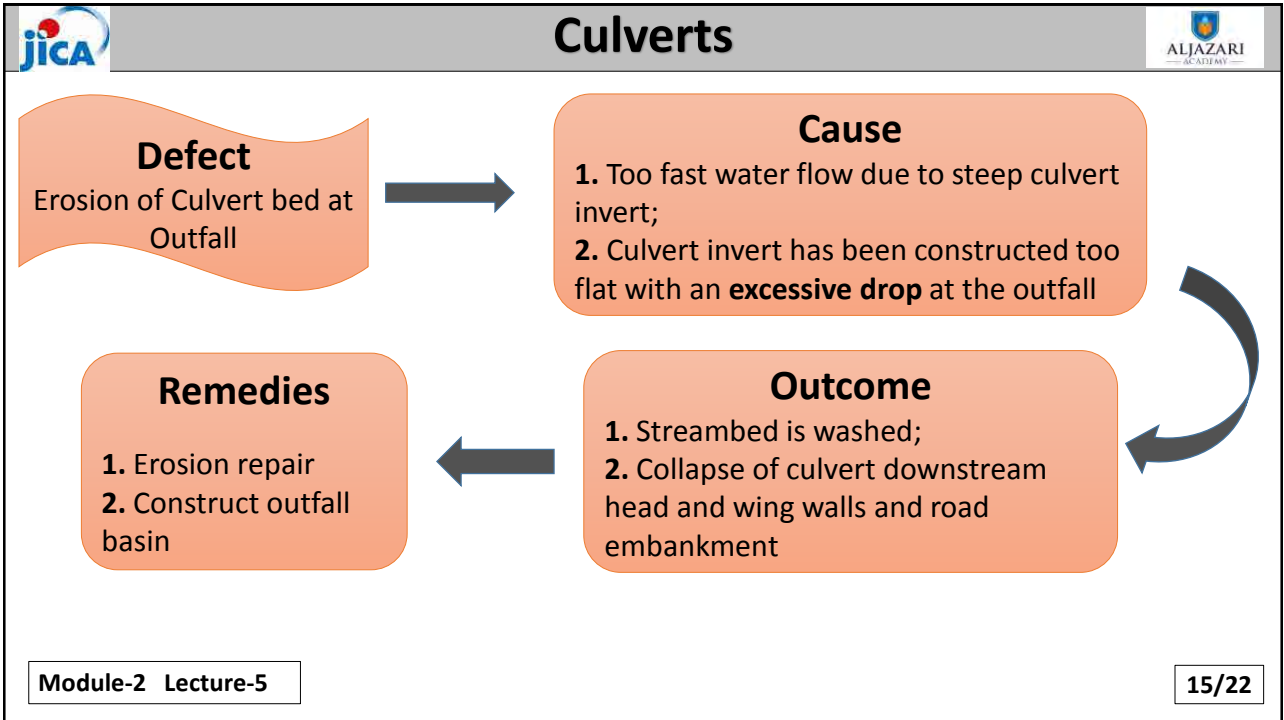

BMPs for Storm Water Drainage System

BEST PRACTICE
STRAIGHT AHEAD

Module-2 Lecture-5 16/22

Municipal staff should regularly inspect facilities to ensure the following:

- Immediate repair** of any deterioration
- Cleaning before the sump is **40% full**
- Clean structures in **high pollutant load areas** just before the wet season
- Keep **accurate logs** of the number of catch basins cleaned
- Record** the amount of waste collected
- Store wastes** in appropriate containers or temporary storage sites



Module-2 Lecture-5

17/22

- ❖ Consider modification of storm channel characteristics to:
 - Improve channel hydraulics,
 - Increase pollutant removals, and
 - Enhance channel/creek aesthetic and habitat value.
- ❖ Conduct channel modification/improvement in accordance with existing laws.



Module-2 Lecture-5

18/22



Illegal Dumping



- ❑ Regularly inspect and clean up hot spots
- ❑ Establish a system for **tracking incidents**. The system should be designed to identify the following:
 - Illegal dumping hot spots
 - Types and quantities (in some cases) of wastes
 - Patterns in time of occurrence
 - Mode of dumping
 - Responsible parties
- ❑ Post **"No Dumping"** signs in problem areas with a phone number for reporting



Module-2 Lecture-5

19/22



BMPs for Dredging

Module-2 Lecture-5

20/22



BMPs for Dredging



- ❑ Installation of **temporary silt fence**
- ❑ Fence shall remain in place for the duration of the maintenance dredging activity
- ❑ Stop the activity if watercourse flows are encountered
- ❑ **Accumulated silt** shall be removed to the greatest extent possible
- ❑ Dredging shall be conducted with hand tools and/or a tracked equipment



Module-2 Lecture-5

21/22



BMPs for Dredging



- ❑ Dredging shall be held to the absolute minimum necessary to achieve the target channel width, depth and gradient
- ❑ The channel banks shall be sloped such that the resulting channel banks are stable
- ❑ Maintenance dredging shall not straighten or shorten the existing channel alignment
- ❑ Woody material embedded in the channel bank shall be left undisturbed and intact



Module-2 Lecture-5

22/22



Course

Operation and Maintenance of Sewer & Storm Water Drainage System Including Safety Practices

Module 2

Operation and Maintenance of Storm Water Drainage System

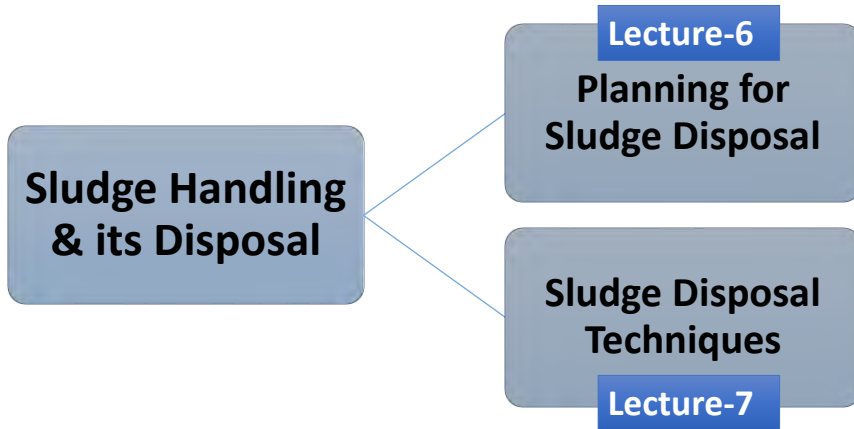

Contents

- Importance of Site Selection
- Early Considerations
- Requirements for Site Selection
- Screening Process for Site Selection
- Site Selection Criteria
- Factors to be considered for Criteria



- ❑ Minimizes the future impact on public health
- ❑ Reduces the cost of:
 - Design and Construction
 - Operation
 - Maintenance

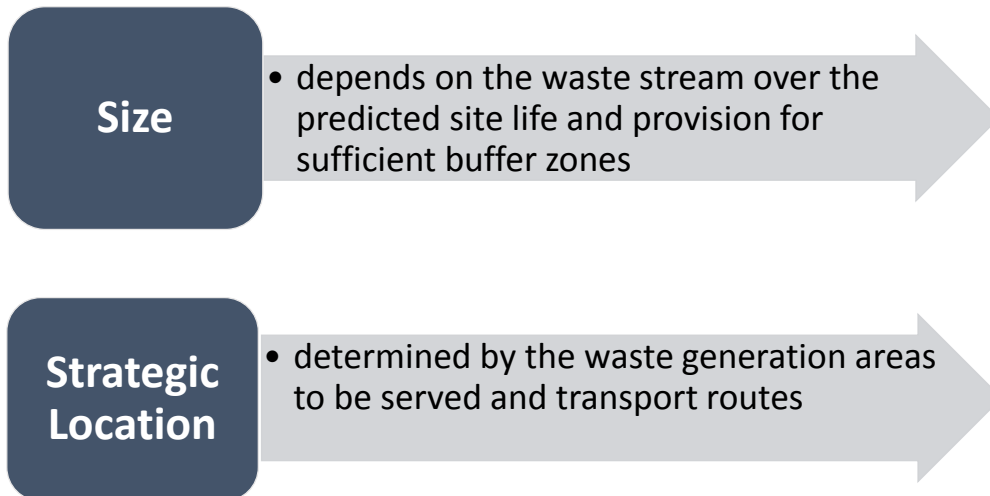

- Spatial and urban planning requirements
- Spatial and regional requirements
- Required land area
- Transportation distances
- Local site conditions
- Topography
- Climate conditions
- Hydrogeological conditions
- Geological conditions
- Geo-mechanical conditions
- Environmental protection

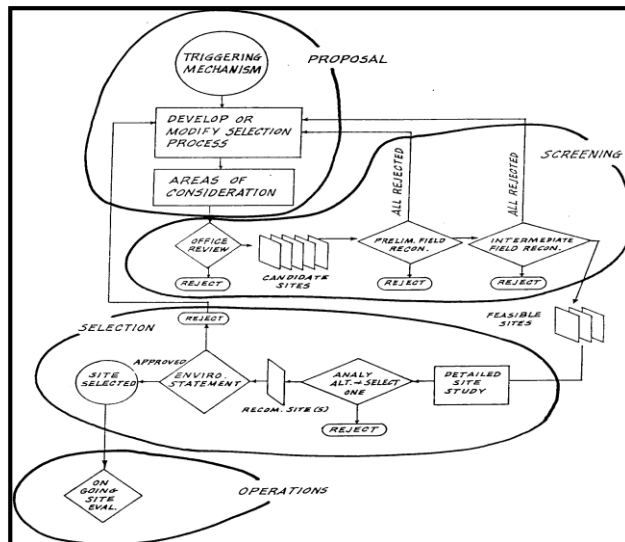

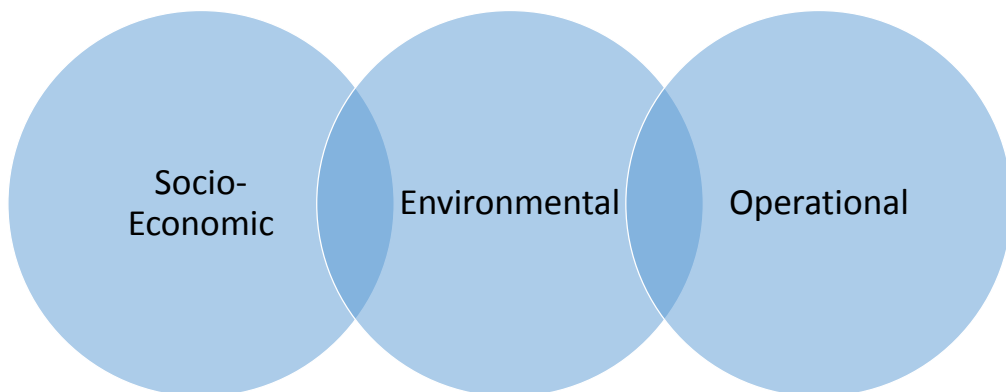
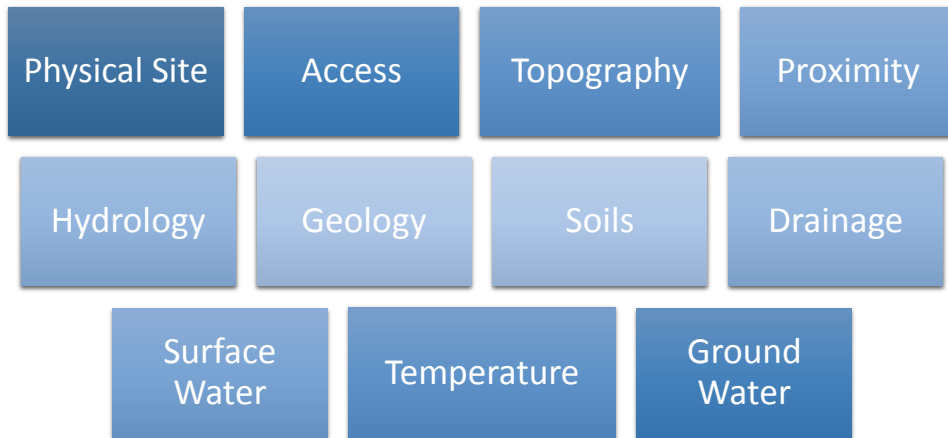

Contents

- ❑ Introduction
- ❑ Controlled Dumping
 - Important Considerations for Controlled Dumping
- ❑ Landfilling
 - How it Works
 - Sludge Disposal at a MSW Landfill
 - Sludge/Solid Waste Mixture
 - Sludge/Soil Mixture

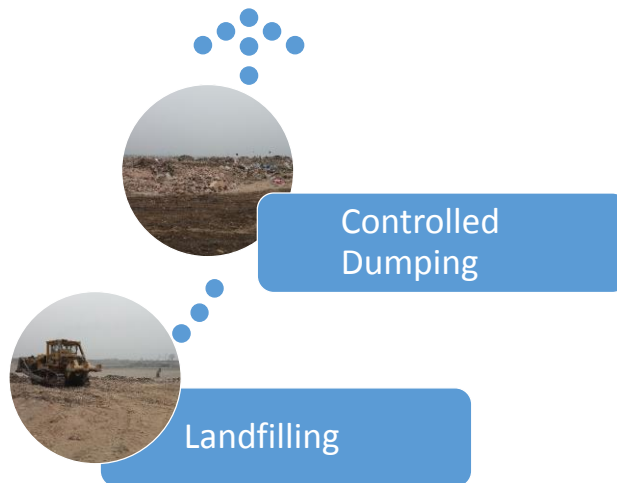

- ❑ Essential burial of waste in earth on a daily basis, in an isolated and demarcated site
- ❑ An established system for rotational and organized deposit of waste
- ❑ To prepare the site to retain its waste more effectively



- ❑ Minimize its chances of contact with **humans and animals**
- ❑ Waste should be covered with a soil layer **10-15cm** deep
- ❑ If coverage with soil is not possible, **lime** may be deposited over the waste
- ❑ **Access** to these dedicated disposal areas should be **restricted**
- ❑ It would require **supervision by staff**
- ❑ Prevent scavenging



- ❑ Landfill is the site where waste is isolated from environment until it is safe
(Until completely degraded biologically, chemically and physically)



- ❑ In landfill operation, Sludge is spread and compacted in thin layers within a small area
- ❑ To allow for proper compaction, the **cell depth** should not exceed about **2 meters**
- ❑ The cell is then covered with a **layer of soil** which is spread uniformly and then compacted
- ❑ To provide an adequate **seal the cover** should normally be at least 20 cm thick

- ❑ When a number of cells reach the final desired elevation, a **final cover of about one meter** of earth is placed and it is again compacted
- ❑ Landfill must be provided with **Liners** to prevent the migration of waste out of landfill to adjacent surface soil or ground water or surface water during anytime

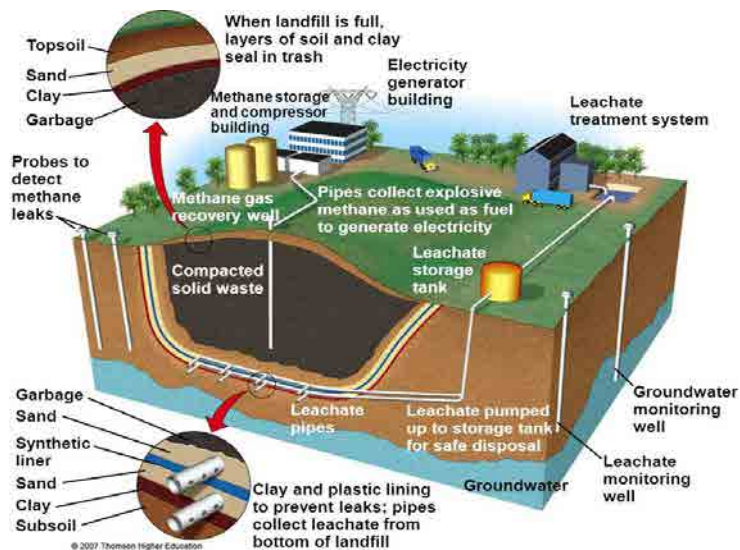

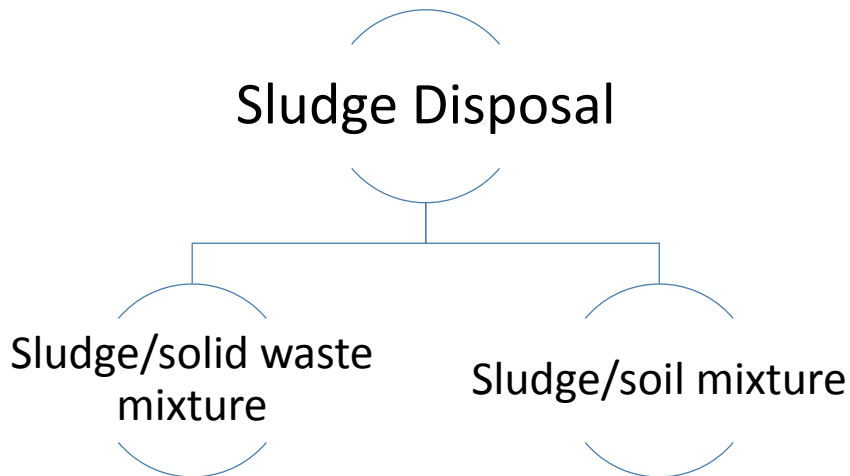

- Sludge is deposited atop solid waste and mixed as thoroughly as possible with the solid waste
- The mixture is then spread, compacted, and covered in the usual manner used at MSW landfills
- The minimum sludge solids content is approximately 20 percent
- The sludge is usually spread by conventional landfill operating equipment

- ❑ To provide adequate workability of the sludge/solid waste mixture, the bulking ratio for a 20 percent solids sludge should be **4 mg of solid waste to 1 wet mg of sludge**
- ❑ **Sludge application rates** for sludge/solid waste mixtures compare favorably with rates for other types of sludge disposal methods
- ❑ **Disposal rates** generally range from 500 to 4,200 yd³ of sludge per acre (900 to 7,900 m³ of sludge per ha)

- ❑ Sludge is mixed with soil and applied as intermediate or final cover over completed areas of the MSW landfill
- ❑ This is not strictly a sludge landfilling method from an engineering standpoint, because the sludge is not buried



But it is a viable and proven option for disposal of sludge at MSW landfills

Storm Water Drains

Action Plan for Desilting Operation (Example)

1. Purpose of the plan

One of the problems that WASA faces at present is the deposition of sludge in the drainages and ultimately the flow rate of the drainage system is decreased, which is causing overflowing and flooded conditions. For avoiding the flood, proper drainage cleaning plan should be made.

2. Human resources

Organization of staff is followings. The plan should be performed within staff member.

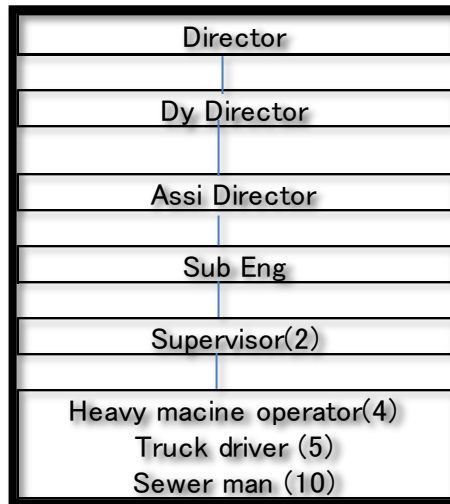

3. Equipment

We have and can use following equipment in WASA

Equipment	Quantity
Truck (8t)	1
Truck (4t)	2
Truck (2t)	3
Back Hoe (0.25m ³)	3
Back Hoe (0.40m ³)	4
Clam shell (0.4m ³)	2
Clam shell (0.7m ³)	2

4- Implementation

The plan includes following implementations

- Survey of sludge deposit quantities
- Flow rate calculation
- To make plan of the cleanings
- Implementation of the cleanings

(1) Survey of sludge deposit quantities

At first sludge deposit in drainages should be measured for making the cleaning plan.

Methodology

Same as study in the training method

Equipment

Map, Digital camera, Measuring stuff, Survey pole

Team

Two supervisors

Productivity

Visiting and surveying one place per hour per team

(2) Flow rate calculation

Methodology

From result of the survey of sludge deposit quantities, we calculate water flow rate in the all drainages, and they compare original flow rate of the drainages.

Equipment

Computers

Team

Engineers

Productivity

All calculation within a week

(3) To make plan of the cleanings

Methodology

At first, priority of cleaning place should be decided by the results of the calculation and comparison of original flow. And we make the cleaning plan considering staff and equipment.

Equipment

Computers

Team

Engineers

ACTION PLAN FOR DRAIN DE-SILTING

A - Purpose of the plan

- ✓ To avoid Over Flowing & Flooded Conditions in Storm Water Drains

B - Human resources

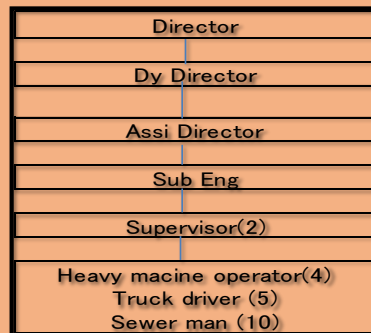

ACTION PLAN FOR DRAIN DE-SILTING

C - Equipment

Equipment	Nos.
Truck (8t)	1
Truck (4t)	2
Truck (2t)	3
Back Hoe (0.25m ³)	3
Back Hoe (0.40m ³)	4
Clam shell (0.4m ³)	2
Clam shell (0.7m ³)	2

ACTION PLAN FOR DRAIN DE-SILTING

D - Implementation

The plan includes following implementations:

- Survey of sludge deposit quantities
- Flow rate calculation
- To make plan of the cleanings
- Implementation of the cleanings

SCHEDULES

Working items	2016		2017										Remarks	
	Nov	Dec	Jan	Feb	Mar	Apr	May	Jun	Jul	Aug	Sep	Oct		
Survey of sludge deposit quantities	■													240places survey
Flow rate calculation			■											
To make plan of the cleanings				■										
Implementation of the cleanings				■										

SCHEDULES

DESILTING SCHEDULE OF DRAINAGE SUB DIVISION CENTRAL MONTH OF 15 NOVEMBER-2016 TO 31 DECEMBER-2016

Sr.No	Date	Name of Drain	Reach		Total Length to be desilted per day		Machinery
			From	To	Rft	Size (ftxft)	
Schedule of Heavy Machinery							
1	15-11-2016 to 30-11-2016	Cantt Drain	Shadman Bidge	Shama Bridge	100	60 x12	01 Long boom + 05 Dump Trucks
2	15-11-2016 to 30-11-2016	Kharak Drain	Liaqat Tokay Walli Pully	WAPDA God Station	90	14 x7	01 Ex. + 05 Dump Trucks
3	15-11-2016 to 20-11-2016	Birdwood Drain	Jail Road	LOS Ferozepur Road	120	15 x 8	01 Clamshell + 05 Dump Trucks
6	01-12-2016 to 15-12-2016	Cantt Drain	Shera Kot	Old Babu Saou	100	90x11	01 Long boom + 05 Dump Trucks
8	01-12-2016 to 10-12-2016	Gulberg Drain-I	Railway Line	Main Boulevard Gulberg	105	30x07	01 Clamshell + 05 Dump Trucks
14	16-12-2016 to 31-12-2016	Cantt Drain	Shera Kot	Gulshan-e-Ravi	100	90x11	01 Ex. + 05 Dump Trucks

Note:- Heavy Machinery schedule for only removal of silt.

Back Hoe, Trolley and Wheel Loader as per requirement of Site Supervisor / Sub Engineer.

Schedule Subject to availability of PDL.

During the Desilting for the purpose of Blockage/Daka and floating material removal, Machinery will be shifted when and where required.

615 187

SCHEDULES

Monthly Desilting Schedule with Labour for the Month of April-2016

Drainage Sub Division (Central) WASA, LDA, Lahore.

Date	Name of Drain	Locations	Total Length (Rft)	Length to be Desilted (Rft)	Labour Deployed	Name of Sub Engineer	Name of Supervisor	Remarks
01-04-2016 to 30-04-2016	Nagra Drain	Ghugian Nagra	3000	1100	8	Mirza Kashif	Hanida	3rd Shift
01-04-2016 to 30-04-2016	Abu Bakar Saddique Colony	In Colony	2500	1000	8	Ayaz Hanif	Ashiq	1st Shift
01-04-2016 to 30-04-2016	Open Nagra Drain, G-Block Sabzazar & Line-B Sabzazar	-----	2500	1200	8	Mirza Kashif	Ishaque	1st Shift
01-04-2016 to 30-04-2016	Cantt Drain	Shama Bridge	250	250	12	Umair Raza	Khusbi	1st Shift
	Sub Engineer-I	Sub Engineer-II	Sub Engineer-III			SDO Drainage Central		



O&M of Drainage System

Module 02

Action Plan Template



Sr. No	WHAT TO DO?	HOW TO DO?	WHEN TO DO?	WHO TO DO?		DO WITH WHAT?		CHECK DONE?	WHO TO CHECK?
	(Define O&M Task)	(Follow SOP Ref.#)	(Frequency)	(Carried out By)		Materials	Tools/ Equip.	How to Check?	To be Checked By?
			Class of Work	Worker					

Thanks indeed for your valuable time

• GOOD BYE

Have a Safe Journey



In the name of Allah, the most Gracious and ever Merciful

WELCOME BACK TO AL-JAZARI ACADEMY





3rd Module Training

Operation and Maintenance of Sewerage System

Introduction

3/25

3rd Module

Operation and Maintenance of Sewerage System

Start Date	Closing Date	Duration (Days)	Participants
04 October, 2017 (Wednesday)	05 October, 2017 (Thursday)	02	<ul style="list-style-type: none"> ▪ Engineers ▪ Sub-Engineers



Introduction

4/25

Module 03 (An Overview)

Operation and Maintenance of Sewerage System

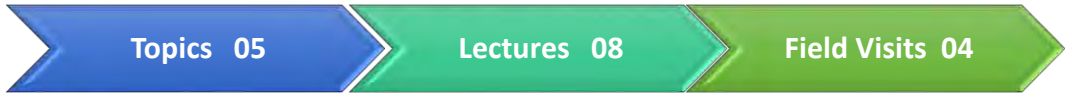

DAY 01	<input type="checkbox"/> Inspection & Testing of Sewers & Manholes	<input type="checkbox"/> Inspection of Manholes & Sewer Lines <input type="checkbox"/> Testing Techniques	02 Lectures + 01 Field Visit
DAY 02	<input type="checkbox"/> Machinery, Tools & Equipment for Cleaning Sewer Lines & Manholes	<input type="checkbox"/> Machinery, Tools & Equipment <input type="checkbox"/> Cleaning Techniques	02 Lectures + 01 Field Visit
DAY 03	<input type="checkbox"/> O&M of Disposal Station	<input type="checkbox"/> Disposal Station Introduction & O&M	01 Lecture + 02 Field Visits
DAY 04	<input type="checkbox"/> Maintenance & Rehabilitation <input type="checkbox"/> Emergency Response Planning	<input type="checkbox"/> Repair & Rehabilitation <input type="checkbox"/> Emergency Planning for Rainy Season	02 Lecture + 01 Action Plan

Introduction

5/25

Course Team



Mr. Ryuta Kudo
JICA Expert



Mr. Muhammad Irfan
Course Leader



Mr. Rizwan Qazi
JICA Coordinator



Mr. Syed Fahad Hussain
Young Professional



Course Reviewer
Prof. Dr. Sajjad Haider (UET),
Lahore

Introduction

6/25

WHAT WILL ANIMATE THE TRAINING SESSION. . .



Introduction

7/25

Module Evaluation Criteria

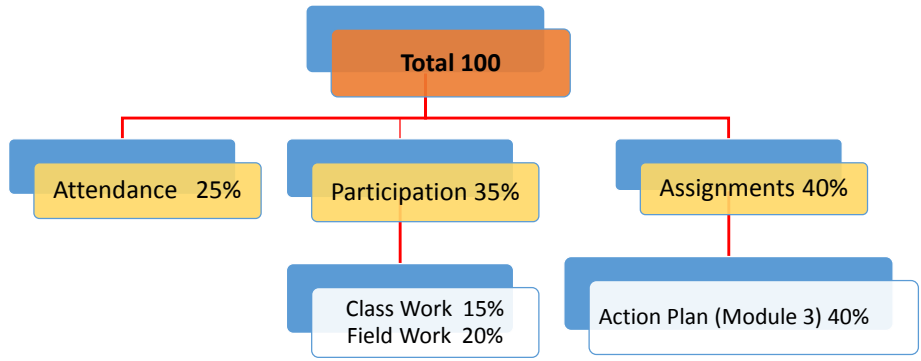

Please Note:

Participants with active participation, maintaining 80% attendance and passing their exam with at least 70% score will be awarded certificates.

Introduction

8/25



Introduction

9/25



Definitions

Sewerage System

- ✓ An underground infrastructure that conveys liquid waste.
- ✓ It is the system of pipes, manholes and disposal stations etc.

Sewage

- ✓ Its liquid waste originating from homes, commercial buildings and industrial establishments.

Sewer

- ✓ An underground conduit through which sewage is carried to a point of discharge or disposal.

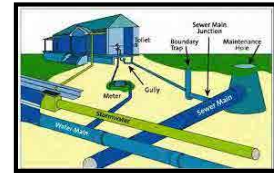

1 - Combined Sewerage System

2 - Separate Sewerage System

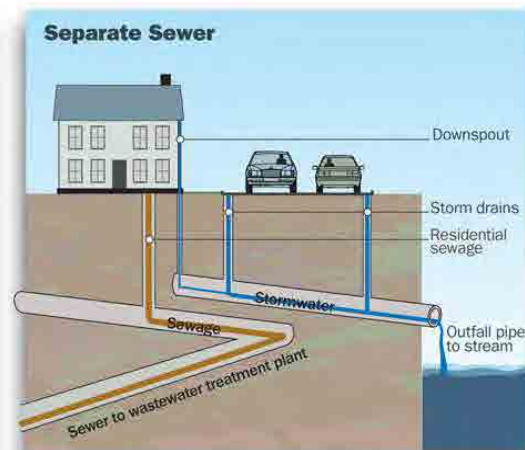
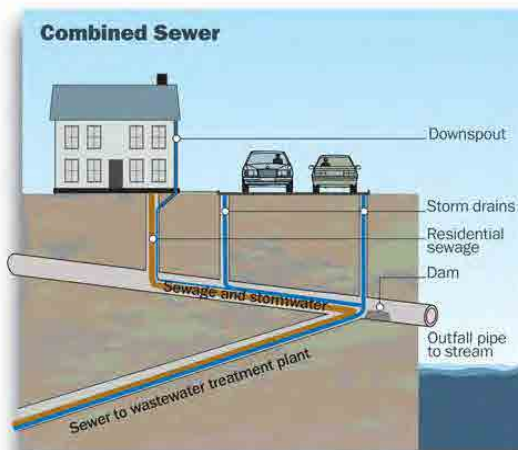

3 - Effluent Sewerage System

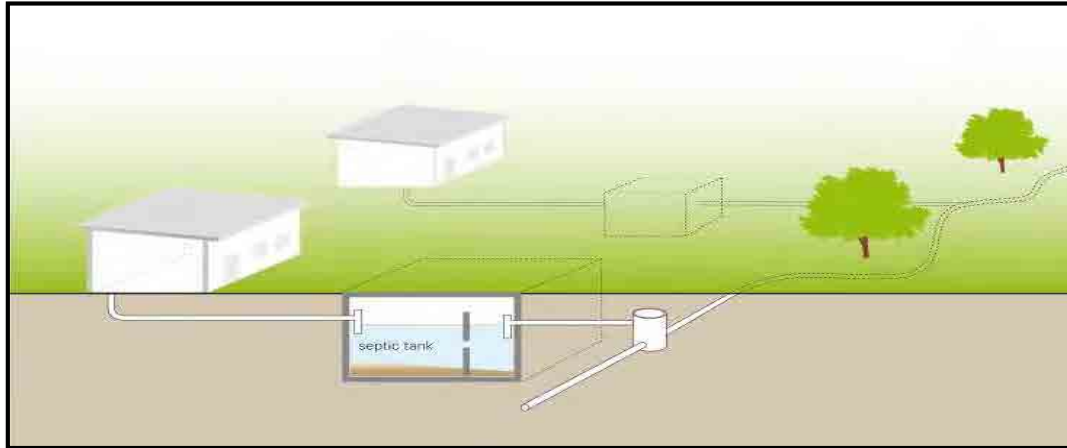

Introduction

13/25

- 1) Components
- 2) O&M Objectives

Strategy for Improvement

- 1) Sensitizing Senior Decision Makers
- 2) Assessing the Existing Facilities
- 3) Identification of Factors affecting Quality of Maintenance
- 7) Snags in Management
- 8) Immediate Action Plan
- 9) Long term Action Plan

Introduction

14/25

Components of Sewerage System

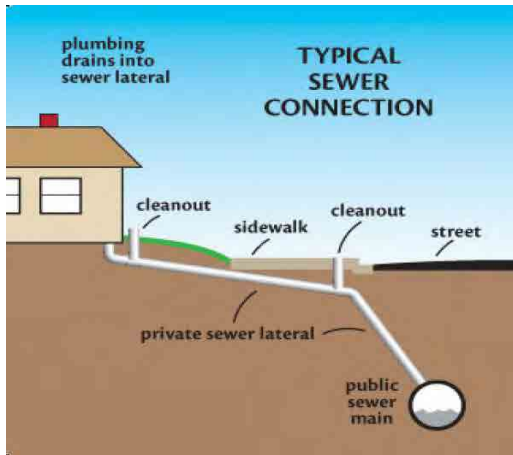

Introduction

15/25

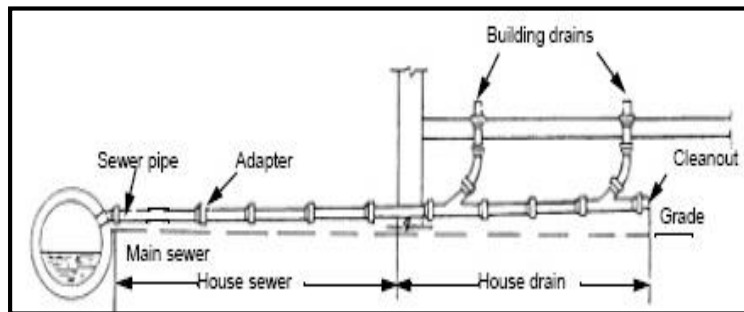

Sewerage System (Profile View)

Introduction

16/25

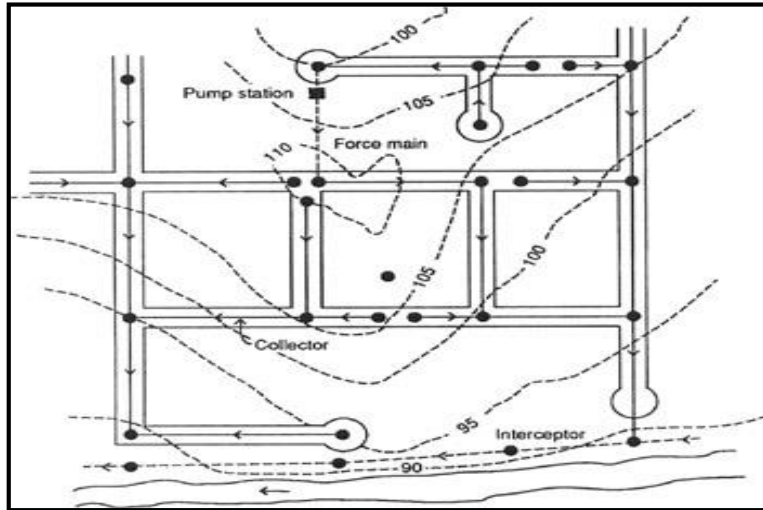

Sewerage System Layout - 1

Introduction

17/25

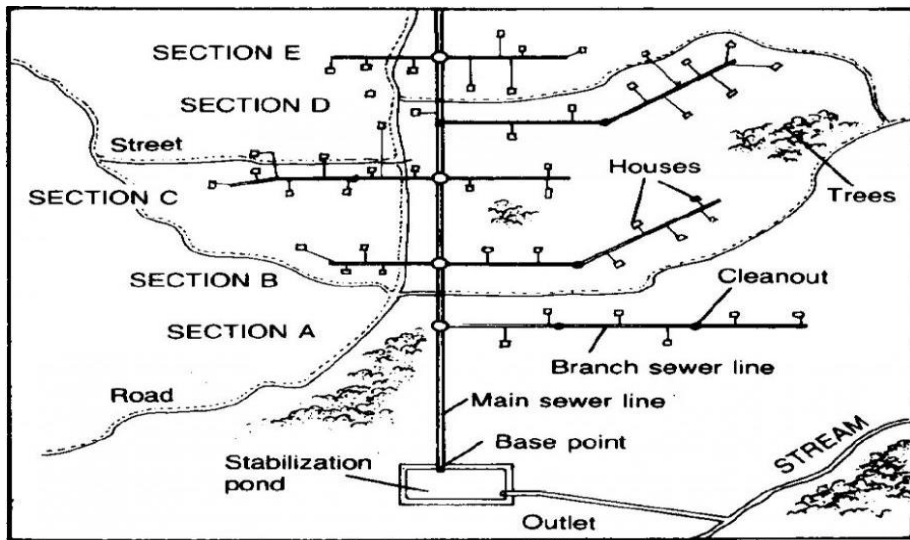

Sewerage System Layout - 2

Introduction

18/25



1. Disposal Station
2. Lift Station
3. Sewer Lines
4. Manholes

Sewerage System Layout - 3

Components of Sewerage System

1. Lateral Sewer
2. Sub-Main Sewer
3. Main Sewer
4. Trunk Sewer
5. Sullage Carrier or Outfall Sewer
6. Pumping Station (Disposal/Lift Station)



RCC SEWERS

Dia. Ranges

6" 9" 12" 15" 18" 24" 30" 36" 42" 48" 54" 60" 66" 68" 72"



Sewer Pipe Joining Works

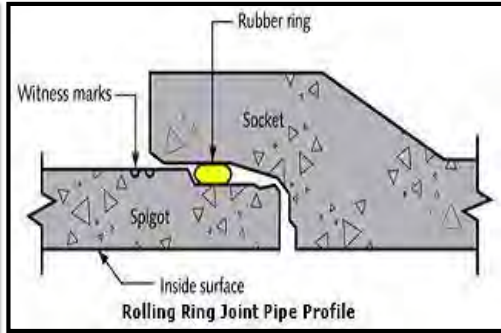

RCC Sewer Pipe Joint
(X-Section)

Introduction

21/25

Components of Sewerage System

SEWER APPURTENANCES

1. Manhole
2. Catch Basin
3. Clean out
4. Lamp hole
5. Inlets
6. Traps
7. Vent Shaft
8. Flushing Tanks
9. Inverted Siphon

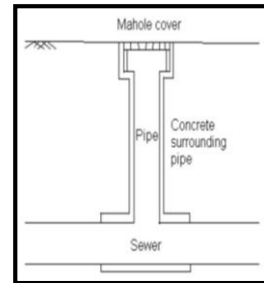
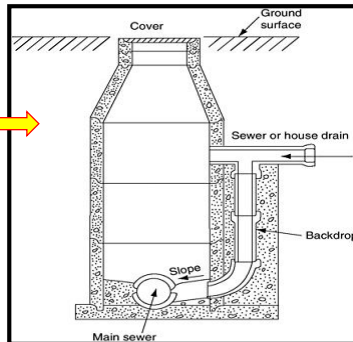

Introduction

22/25

Now What are your...



About Module & Training

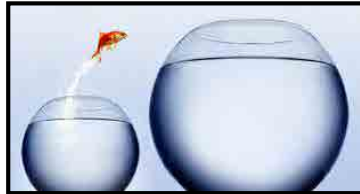

Introduction

23/25





In the name of Allah, the most Gracious and ever Merciful

Module 03

Safety Control and Measures for Sewerage and Drainage Works



Lecture Breakdown	Duration
Objectives	1 Hour
Reasons for Identifying a Specific Manhole	
Early Metal Locator	
Manhole Cover Locator	
Parts with Labels	
Working Principle	



Objectives

The objectives of this lecture are:

- To understand the need of locating a buried manhole
- To comprehend the working principle of metal locator device
- To identify the buried manhole with the help of metal locator

Reasons for Identifying a Specific Manhole

The reasons are:

- To conduct an inspection survey against the sewer system related complaint
- To initiate operation and maintenance work at the rightly identified manhole for redressing the complaint received

Early Metal Locator

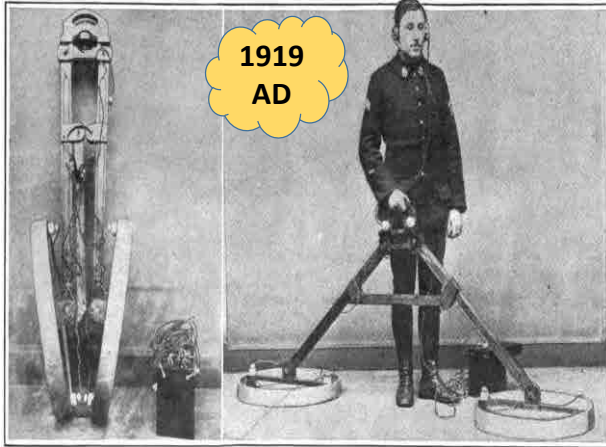

1919
AD

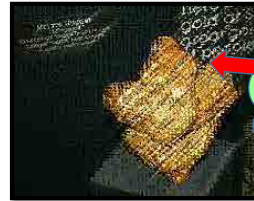

4.9 Kg
Gold
Found in
California



Manhole Cover Locator



Manhole Cover Locator (Parts with Labels)

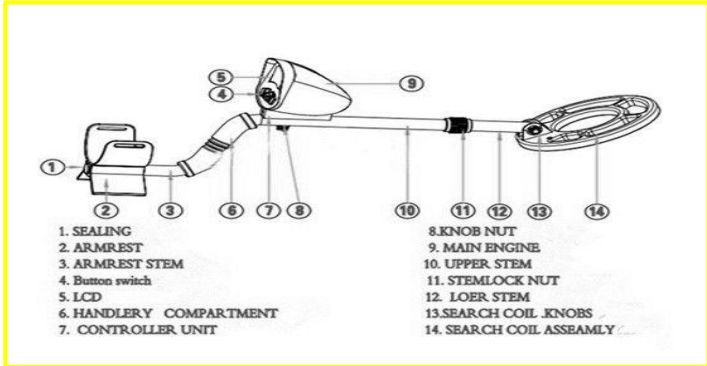

Module-3 Lecture-1 Identification of a Specific Manhole

7/12

Working Principle of Manhole Cover Locator (Al-Jazari Apparatus)

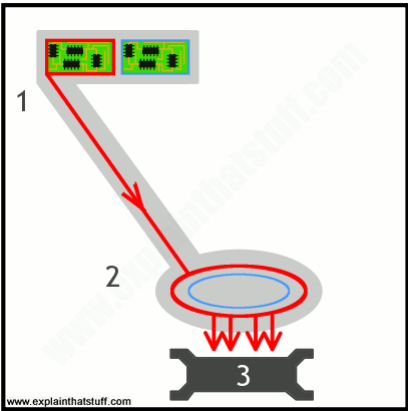

Module-3 Lecture-1 Identification of a Specific Manhole

8/12

Working Principle of Manhole Cover Detector

1. A battery in the top of the metal detector activates the **transmitter circuit** (red) that passes electricity to the **transmitter coil**
2. When electricity flows through the transmitter coil, it creates a **magnetic field** all around it.
3. If you sweep the detector above a **metal object** electric current flow inside the metal object.
4. This flowing electric current creates a loudspeaker buzz and alerting you you've found something.





In the name of Allah, the most Gracious and ever Merciful

Module 03

Safety Control and Measures for Sewerage and Drainage Works

Standard Safety Practices
during Sewer and Manhole
Operations

Lecture No. 02
Test for Hazardous
Gases

OJT

Lecture Breakdown	Duration
Various Gas Monitors	 1 Hour
Purpose of Use	
Portable Gas Monitor GX-8000	
Names & Functions for Each Part	
Start the Gas Monitor	
LCD Display, Features & Cautions	
Q&A	



Gas Monitoring at Manhole

Module-3 Lecture-2 Test for Hazardous Gases

2/17

Various Gas Monitors



Module-3 Lecture-2 Test for Hazardous Gases

3/17

Purpose of Use

Gas monitor enables simultaneous monitoring of the following four types of gases in Manholes:

- | | | | |
|---------------------|--------|---|-----------------|
| 1- Oxygen | O_2 | } | COMBUSTIBLE GAS |
| 2- Methane | CH_4 | | |
| 3- Carbon Monoxide | CO | } | TOXIC GASES |
| 4- Hydrogen Sulfide | H_2S | | |



Module-3 Lecture-2 Test for Hazardous Gases

4/17

Al-Jazari Apparatus

**Portable Gas
Monitor
GX-8000**



Make:
**RIKEN KEIKI
Co. Ltd Tokyo
Japan**

Accessories:

1. Li-ion battery unit
2. AC powered charger
3. Shoulder strap
4. Gas sampling probe

Module-3 Lecture-2 Test for Hazardous Gases

5/17

Portable Gas Monitor GX-8000 - Accessories

<Main Unit>

GX-8000
main unit



Battery unit: Li-ion or dry

<Standard Accessories>

- AC powered charger: 1
OR
AA alkaline battery: 3
- Gas sampling probe and
gas sampling hose: 1
- Shoulder strap: 1
- Operating manual
- Product warranty



Module-3 Lecture-2 Test for Hazardous Gases

6/17

Names & Functions for Each Part (Various Views)

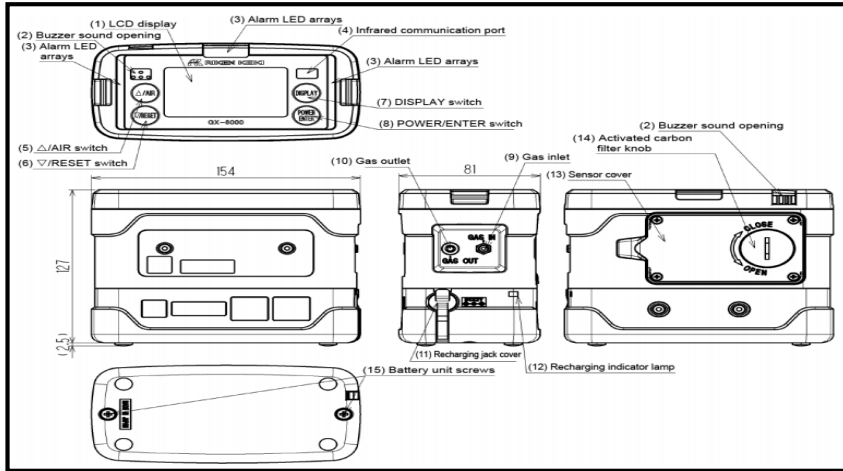

Module-3 Lecture-2 Test for Hazardous Gases

7/17

Starting 'Gas Monitor'

<<Start-up Procedure>>
 Keep the POWER switch pressed for three seconds or more.

1

All LCDs light up.

Date/Time Display

Battery Voltage Display

LCD

Alarm lamp lights up. Buzzer sounds once. (Beep)

2

Gas Name Display

Full Scale Display

First Alarm Setpoint Display

Module-3 Lecture-2 Test for Hazardous Gases

8/17

Starting 'Gas Monitor'

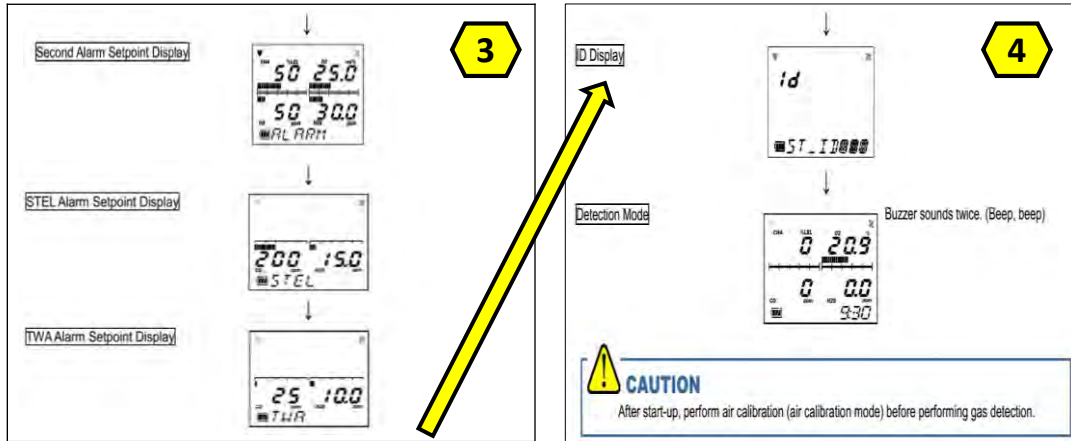

LCD Display

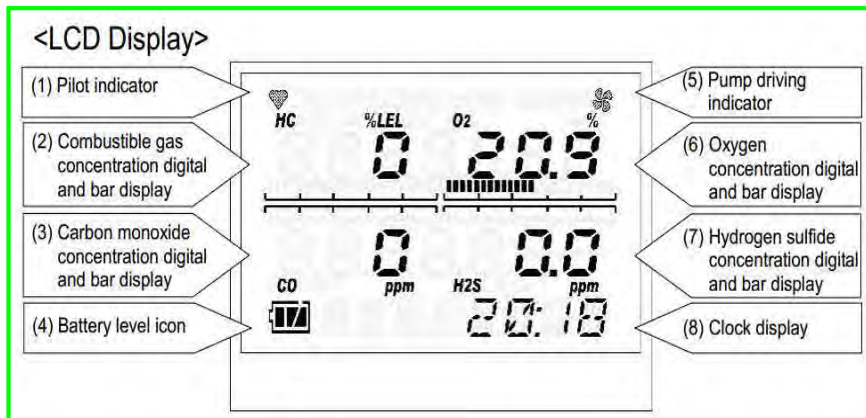

Features of Portable Gas Monitor GX-8000

- Portable and battery operated
- Continuously and simultaneously monitor for toxic and flammable gases
- Audible and visible **ALARMS**
- Small enough and light enough to be worn by an operator
- Over 10 hours of continuous operation on one full battery charge
- Automatic audible and visible low battery alarm
- Remote sample hose

Basic Functions & Operation (5:23)

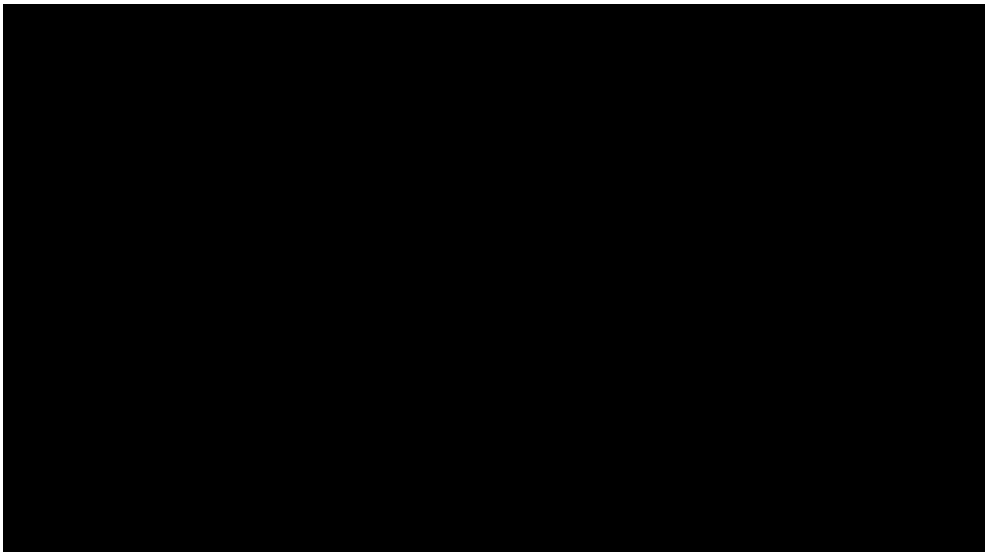

Physical Appearance of Gases in Manhole

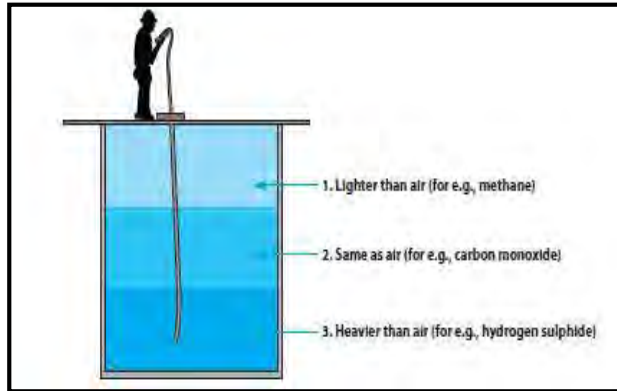
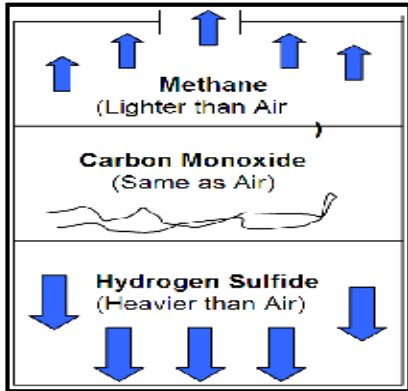

Module-3 Lecture-2 Test for Hazardous Gases

13/17

Cautions regarding Gas Monitor

- Do not drop or give shock to the gas monitor.
- Pressing buttons unnecessarily may change the settings.
- Do not use the gas monitor in a place where the temperature drops below -20°C or rises over 50°C .
- Do not use the gas monitor where it is exposed to oil, chemicals, etc.
- Verify that the pump driving indicator is rotating before using the gas monitor.
- Do not forget to perform a regular maintenance.

Module-3 Lecture-2 Test for Hazardous Gases

14/17



**Thank
You!!!**



Module 3
Operation and Maintenance of Sewerage System

Topic 1
Inspection and Testing of Sewers and Manholes

Lecture 3
Inspection Techniques

Inspection of Sewers & Manholes

- Objectives of Inspection
- Types of Manholes
- X-Sections & Profiles
- Inspection Methods
- Inspection & Report Forms



- To identify existing or potential problems in Manhole
- To examine structural integrity of the manhole
- To observe functional capacity of manhole
- To generate concise and meaningful reports

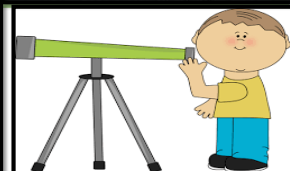

Types Manholes (Shallow + Medium + Deep)



Concentric Manhole



Eccentric Manhole

Module-3 Lecture-3 Inspection Techniques

5 / 28

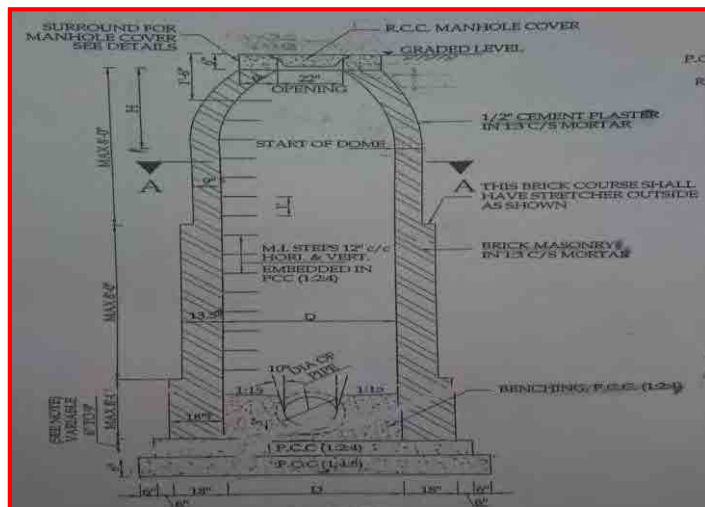

X-Section of Manhole

Module-3 Lecture-3 Inspection Techniques

6 / 28

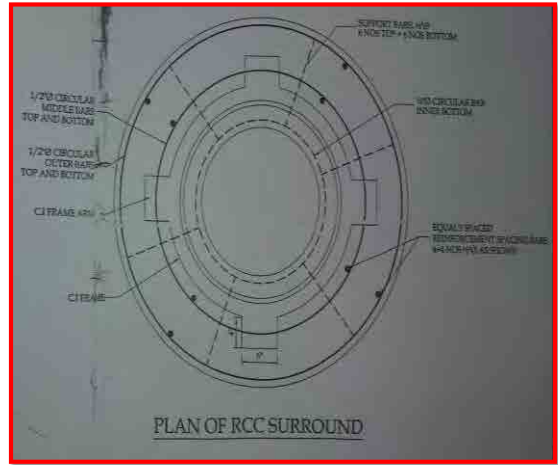
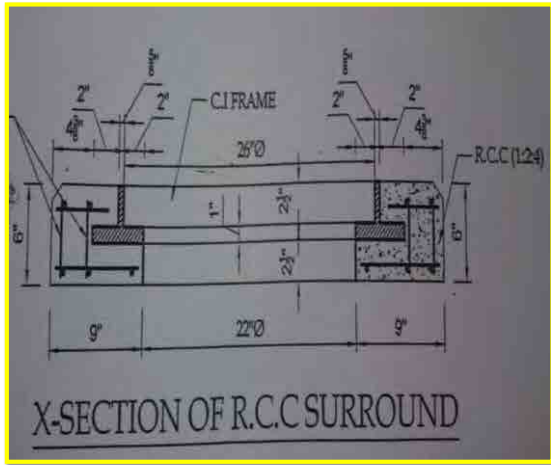

X-Section of Manhole R.C.C Surround

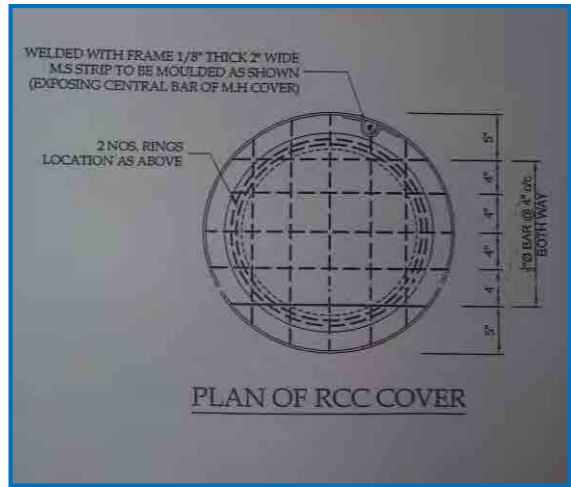
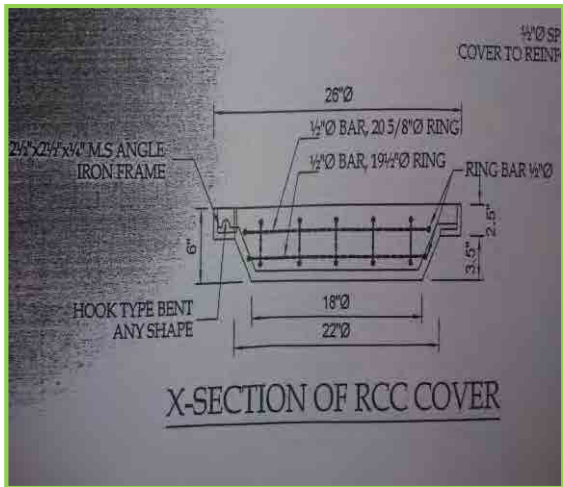

X-Section of Manhole Cover / Lid

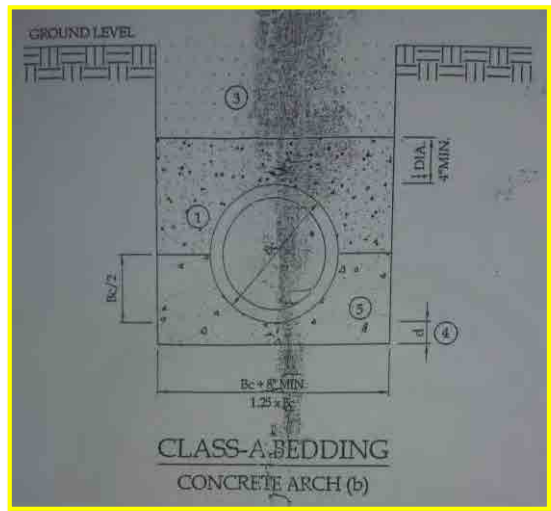
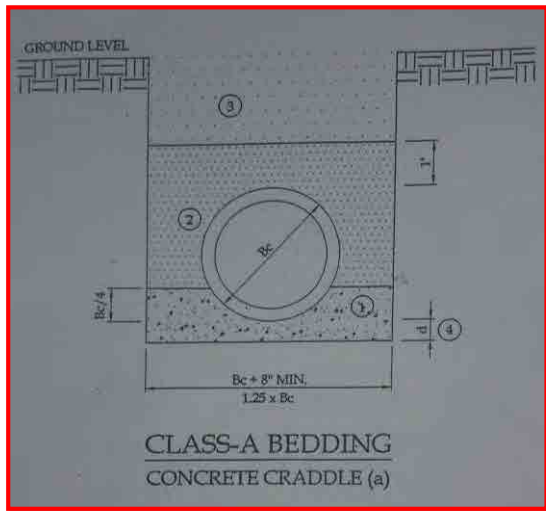

X-Section of Sewer in Trench

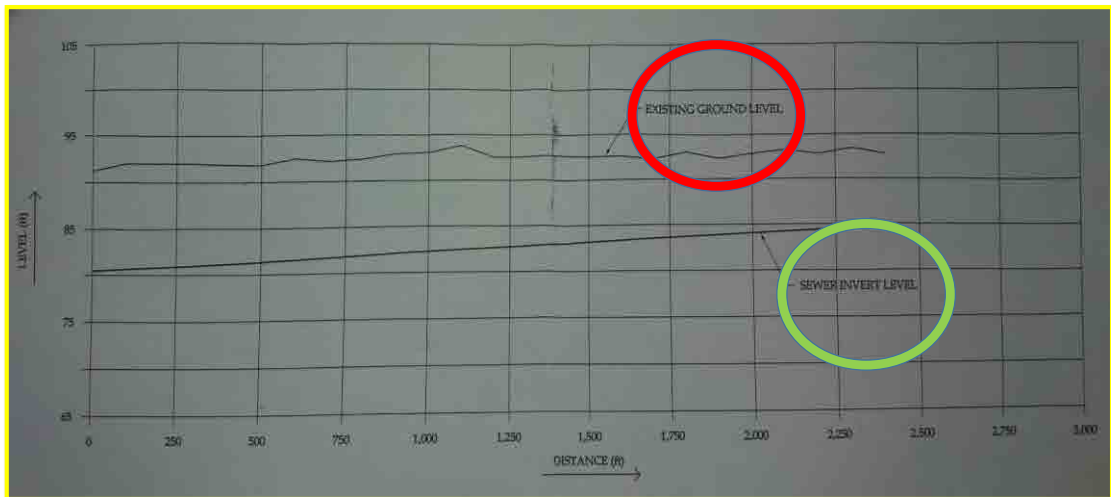

Profile of Sewer Line

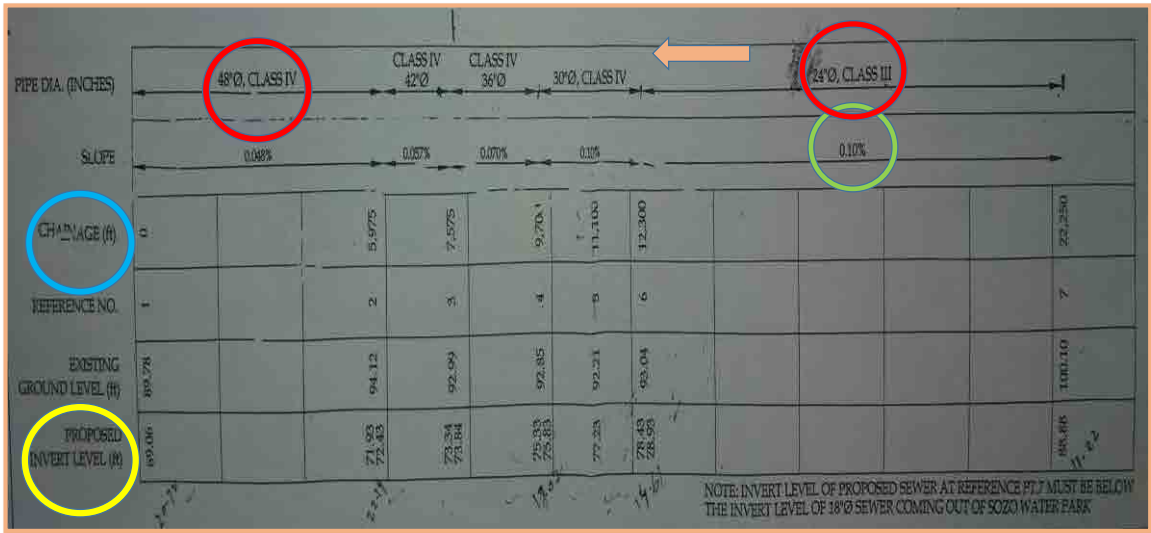

Profile Details of Sewer Line

INSPECTION METHODS

▪ Visual

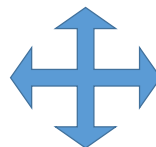

▪ CCTV

▪ Pole-Mounted TV Camera

Arrangements before Inspection:

<ul style="list-style-type: none"> Map of the Collection System 	<ul style="list-style-type: none"> Scrapers and Wire Brushes for Cleaning the Manhole Ring
<ul style="list-style-type: none"> Metal Detector 	<ul style="list-style-type: none"> Powerful Flashlight
<ul style="list-style-type: none"> Warning Devices, Safety Cones and Traffic Safety Devices 	<ul style="list-style-type: none"> Gas Detection Devices
<ul style="list-style-type: none"> Manhole Lid Removal Device 	<ul style="list-style-type: none"> Blower and Hose for Ventilating Manhole
<ul style="list-style-type: none"> Leather Gloves 	



- Sewer Man
- Operator
- Helper
- Flag Man

Procedure

- Locate the Manhole
- Test Atmospheric Conditions (Use Gas Monitor)
- Remove the Cover
- Use Flash Light
- Inspect Manhole Cover & Chamber Carefully
- Fill in the Inspection Form & Prepare Report

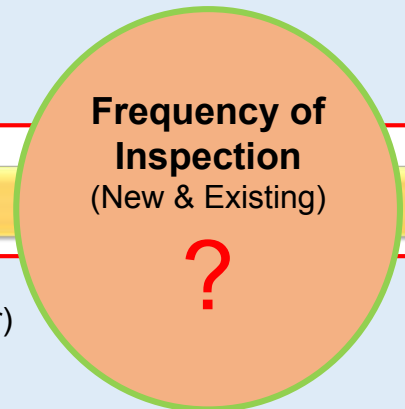



Categories of Visual Inspection...

Initial Inspection

- Location
- Manhole Cover
- Ring & Frame
- Manhole Material
- Sizes

Structural Inspection

- Steps
- Cone
- Riser
- Shelf
- Channel

Hydraulic Inspection

- Inflow
- Clarity
- Flow
- Flow Depth
- Vermin



Recognize better one among all . . .

Manholes in the streets of Yokohama Japan



Manholes in the streets of Yokohama Japan



SANITARY SEWER MANHOLE INSPECTION FORM			
M.H. DEPTH:	FORM:	M.H. #:	DATE:
I. INITIAL INSPECTION		II. STRUCTURAL INSPECTION	
A. LOCATION: 1. Roadway <input type="checkbox"/> 2. Gutter <input type="checkbox"/> 3. Paved Alley <input type="checkbox"/> 4. Unpaved Alley <input type="checkbox"/> 5. Easement <input type="checkbox"/> 6. Other <input type="checkbox"/> B. MANHOLE COVER: 1. Serviceable <input type="checkbox"/> 2. Damaged <input type="checkbox"/> 3. Displaced <input type="checkbox"/> 4. Missing Grout <input type="checkbox"/> 5. Needs Raising <input type="checkbox"/> 6. Needs Lowering <input type="checkbox"/> C. RING & FRAME: 1. Serviceable <input type="checkbox"/> 2. Loose <input type="checkbox"/> 3. Displaced <input type="checkbox"/> 4. Missing Grout <input type="checkbox"/> 5. Needs Raising <input type="checkbox"/> 6. Needs Lowering <input type="checkbox"/> D. MANHOLE MATERIAL: 1. Brick <input type="checkbox"/> 2. Concrete <input type="checkbox"/> E. SIZE M.H. COVER: 1. 24 Inch <input type="checkbox"/> 2. 30 Inch <input type="checkbox"/> F. MANHOLE SIZE: 1. 4 foot <input type="checkbox"/> 2. 5 foot <input type="checkbox"/>		A. STEPS: 1. Serviceable <input type="checkbox"/> 2. Unsafe <input type="checkbox"/> 3. Missing (No.) <input type="checkbox"/> 4. Corroded <input type="checkbox"/> B. CONE: 1. Serviceable <input type="checkbox"/> 2. Broken <input type="checkbox"/> 3. Sulfided <input type="checkbox"/> 4. Misaligned <input type="checkbox"/> 5. Leaking/Bad Joints <input type="checkbox"/> C. RISER: 1. Serviceable <input type="checkbox"/> 2. Broken <input type="checkbox"/> 3. Sulfided <input type="checkbox"/> 4. Misaligned <input type="checkbox"/> 5. Leaking/Bad Joints <input type="checkbox"/> D. SHELF: 1. Serviceable <input type="checkbox"/> 2. Broken <input type="checkbox"/> 3. Dirty <input type="checkbox"/> 4. Sulfided <input type="checkbox"/> 5. Bad Base Joint <input type="checkbox"/> E. CHANNEL: 1. Serviceable <input type="checkbox"/> 2. Obstructed <input type="checkbox"/> 3. Sulfided <input type="checkbox"/> 4. Bad Pipe Joint <input type="checkbox"/> 5. Silt <input type="checkbox"/> 6. Poor Struct. Cond. <input type="checkbox"/>	
III. HYDRAULIC INSPECTION			
A. INFLOW INDICATIONS: 1. Debris on Sides/ Shelf <input type="checkbox"/> B. SURCHARGE INDICATIONS: 1. Grosse/Debris on Sides & Shelf <input type="checkbox"/> C. CLARITY OF FLOW: 1. Turbid Appearance <input type="checkbox"/> 2. Clear Appearance <input type="checkbox"/> D. FLOW: 1. Steady <input type="checkbox"/> 2. Pulsing <input type="checkbox"/> 3. Turbulent <input type="checkbox"/> 4. Surcharging <input type="checkbox"/> 5. Sluggish <input type="checkbox"/> E. FLOW DEPTH COMPARED TO ADJACENT MANHOLES: 1. Same <input type="checkbox"/> 2. Lower <input type="checkbox"/> 3. Higher <input type="checkbox"/> F. FLOW DEPTH: _____ Inches Time _____ AM/PM			
IV. VERMIN			
1. Rosches <input type="checkbox"/> 2. Rats <input type="checkbox"/> 3. Other <input type="checkbox"/>			
OBSERVATION SUMMARY:			

Manhole Inspection Form

MANHOLE INSPECTION REPORT			
MH NO. _____	DATE _____	TIME _____	INSPECTOR _____
ELEVATION _____	DEPTH TO INVERT _____	CLEANLINESS _____	
TYPE CONSTRUCTION _____		STREET REFERENCES _____	
DEFECTS: (Cover, frame, grout, steps, shelf, pipes, or channels)			
1. _____			
2. _____			
3. _____			
4. _____			
5. _____			
6. _____			
7. _____			
8. _____			
(USE REVERSE SIDE FOR ADDITIONAL DEFECTS TO BE NOTED.)			
PIPE SIZE	LENGTH TO MH	EST. FLOW	TYPE FLOW
A- _____	_____	_____	_____
B- _____	_____	_____	_____
C- _____	_____	_____	_____
D- _____	_____	_____	_____
REMARKS: (Include need for repairs)			

MANHOLE INSPECTION REPORT			

Manhole Inspection Report

Closed Circuit Television Inspections (CCTV)



Objectives of CCTV Inspection

- To look for damages / breaks in sewer line
- To locate root intrusion
- To find unrecorded connection
- To locate protruding laterals
- To locate cracks / inflow sources
- To search lost / buried manholes
- To verify alignment

- Television Camera
- Camera Light
- Television Picture Monitor
- Power Source





Module 3

Operation and Maintenance of Sewerage System

Topic 1

Inspection and Testing of Sewers and Manholes

Lecture 4

Testing of Sewers

Testing of Sewers

- Objectives of Testing
- Types of Testing
- Equipment Required for Testing
- Methods



Objectives

- Find out leaks in sewers joints and manholes
- Locate and determine the inflow, infiltration and exfiltration problems
- Effectively use tools & equipment

- Smoke Testing
- Dye Testing
- Lamp Test



Objectives

Smoke testing is a quick method of detecting:

- Sources of inflow in sewer systems
- The location of illegal connections
- The location of broken sewers



Equipment Required

Smoke Blower Units

Smoke Bombs

Sand Bags or Plugs

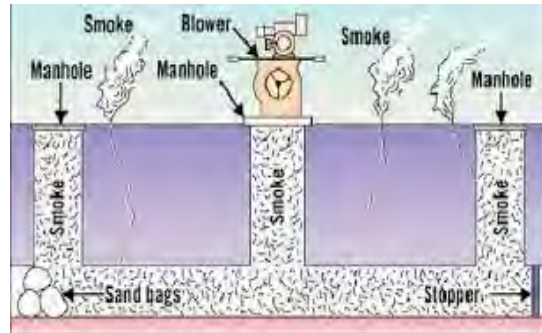

Objectives

The typical application of dye testing includes the following:

- To identify illegal connections
- To reveal interconnection between sanitary & storm sewer
- Testing for infiltration and exfiltration
- Flow velocity measurement



Equipment Required

Dye Powder

Sand Bags / Plugs

Water Source





Objectives

- To confirm the straightness of sewer
- To verify that the sewer is not block
- To permit an sewer inspector to visually examine conditions of pipe



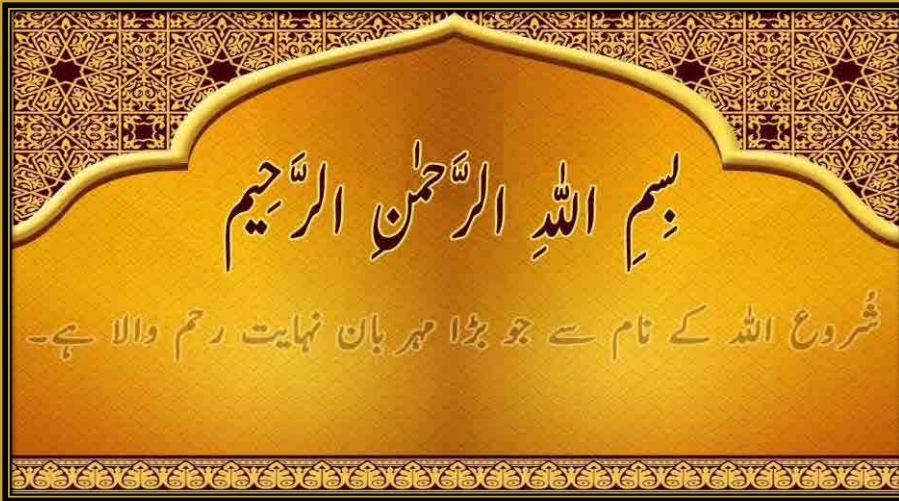

Operation and Maintenance of Sewerage System



Lecture 05

▪ Machinery, Tools & Equipment for Sewer & Manhole Cleaning

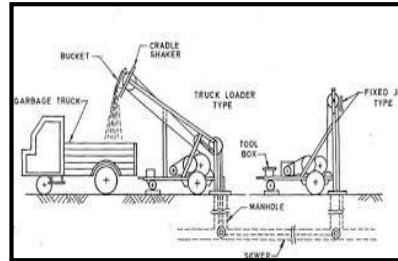

Lecture Breakdown

- Objectives
- Sewer Cleaning Equipment
- Advantages & Limitations
- Effectiveness of Solution
- Cleaning Equipment Maintenance
- Responsibility of Maintenance
- General Maintenance of Equipment Engines
- Maintenance Procedure



Objectives

- To build understanding of equipment required for removing sewer blockages
- To make a selection criteria for choosing the right machine and equipment
- To develop a maintenance program for sewer cleaning equipment



Sewer Cleaning Equipment

1. Split Bamboo Cane
2. Steel Rod
3. Power Rodder
4. Sewer Ball or Tire
5. High Pressure Water Jetting Machine

6. Bucket Machine (Winch Machine)
7. Flushing
8. Scooter
9. Kite

1 - Split Bamboo Cane

Hand Rodding



- ✓ Oldest Method
- ✓ Torque by Hand

2 - Steel Rod

Hand Rodding



Torque by Hand



3 - Power Rodder

Torque by Engine

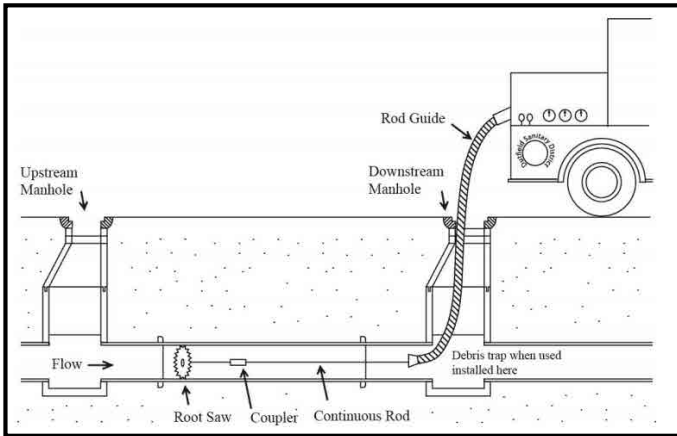

3 - Power Rodder

Advantages

- To cut roots
- Scrape, dislocate and remove certain material
- Effective in removing emergency stoppages

Limitations

- Ineffective for removing sand and grit, but may loosen material
- Rods have a tendency to coil and bend

4 - Sewer Ball or Tire

Cleaning Ball Application



1. Install Plug to isolate manhole.



2. Attach Ball to tag line and inflate.



3. Introduce water into manhole and slowly release Ball down the line.



4 - Sewer Plug Set Up





Sewer Ball

Advantages

- Hydraulic action of spinning ball and velocity of water **dislodge** debris and move debris downstream.
- Very effective in removing sand, grit and grease from sewers.

Limitations

- Cannot be used when sewers have protruding service connections.





Courtesy – WASA Mustafa Town Sub-Division

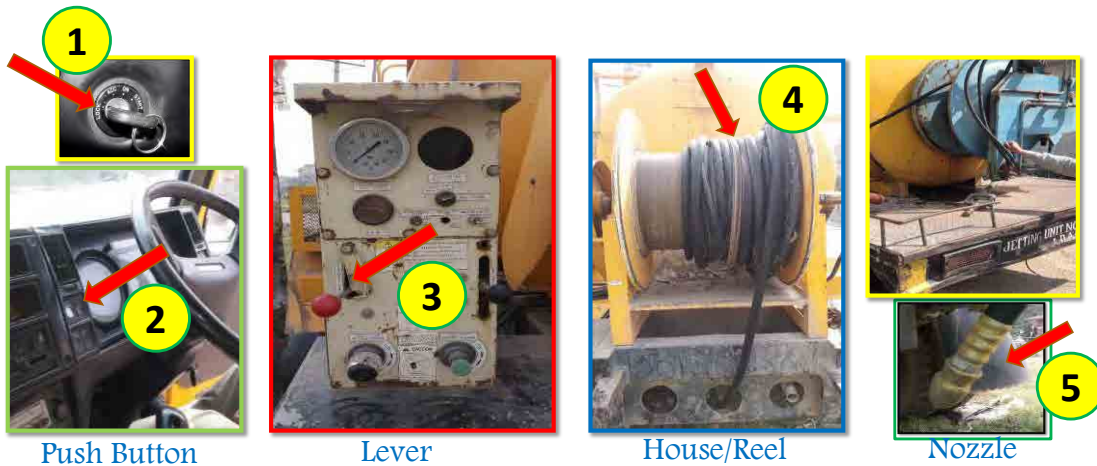

Push Button

Lever

House/Reel

Nozzle

Courtesy – WASA Mustafa Town Sub-Division



High Pressure Water Jetting Machine

Advantages

- Very effective in cleaning flat, slow flowing sewers
- Efficient in removing grease, sand, gravel and debris
- Can be used to remove emergency stoppages

Limitations

- Effectiveness in take out debris from larger diameter lines decrease as the cross-sectional area of the pipe is increased





Courtesy – WASA Green Town Sub-Division



Courtesy – WASA Mustafa Town Sub-Division

6 -Bucket Machine (Winch Machine)

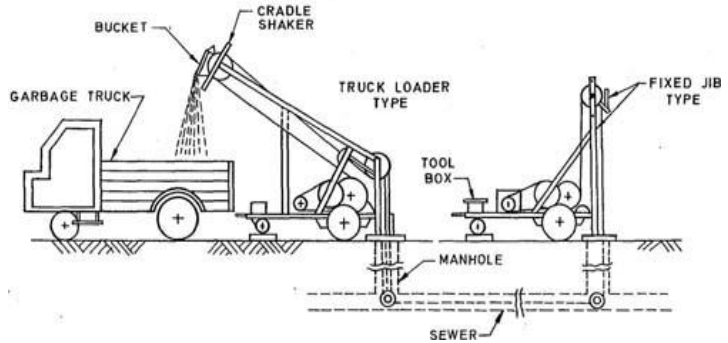

Bucket Machine (Winch Machine)



Bucket Machine



Advantages

- Efficient in removing sand, gravel, and debris

Limitations

- Can damage pipe line internally
- Setting up equipment is time taking activity

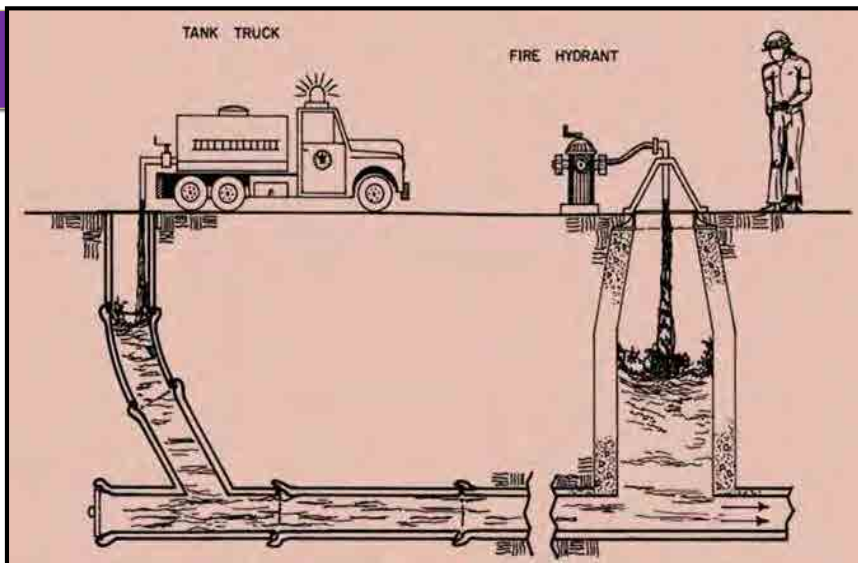

7- Flushing

Flushing

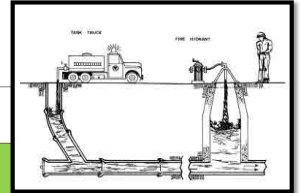

- Advantages**
- Supplies a surge of water to move light matter downstream in slowly flowing sewers

- Limitations**
- Flushing does not remedy the cause of the problem
 - This method does not move heavy debris and grit

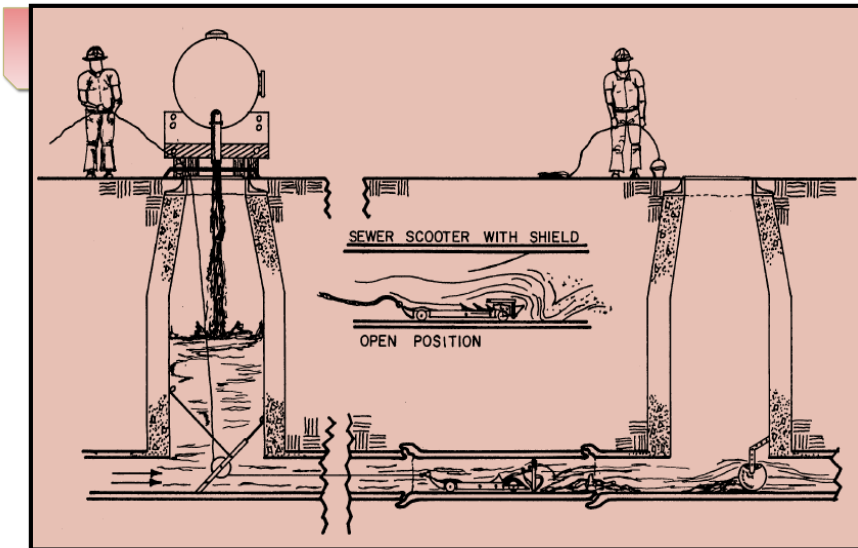

8- Scooter

9- Kite

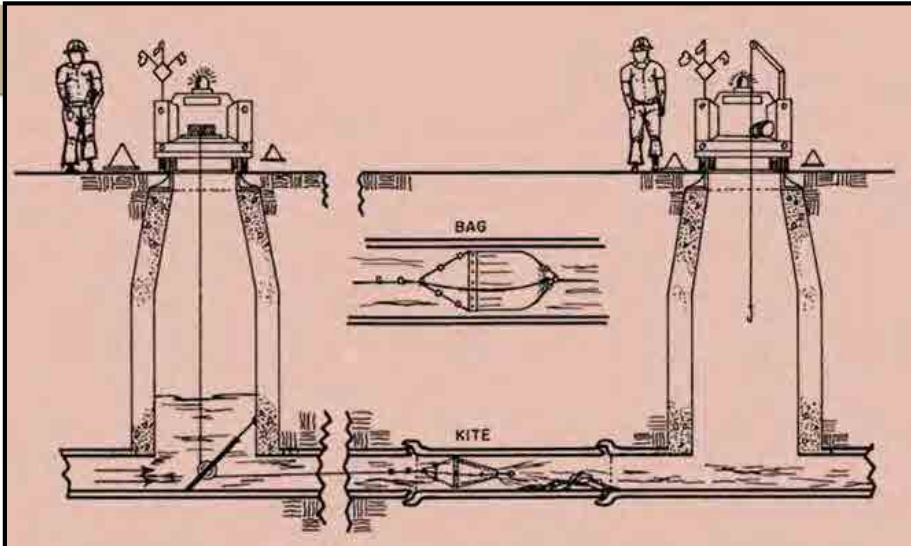

Effectiveness of Solution

Sr. No.	Solution to Problem	Type of Problem				
		Emergency Blockages	Grease	Roots	Sand, Grit & Debris	Odor
1.	Flushing					•
2.	Hand Rod	■	•	•		
3.	Power Rodder	■	•	•		
4.	High Velocity Cleaner	•	■		■	•
5.	Bucket Machine				■	
6.	Balling		•		■	■

Care & Maintenance of Equipment

Objectives

To keep equipment in good condition to help prevent equipment failure on the job

To prolong the lifespan of the equipment

To enhance the efficiency and safety at maintenance jobs

Responsibility of Maintenance

The main responsibility goes to the following team members of WASA

Responsibility of Maintenance

Crew Forman

Equipment Operator

Examine the Worn Part

Change the Broken Part

Report the Lost Part

General Maintenance of Equipment Engines

1. Always be sure **oil and water levels** are in proper range.
2. Use a fresh supply of the proper grade of **clean diesel**.
3. Change **oil and air filters** according to manufacturer's recommendations.
4. Exercise **(operate)** equipment weekly.
5. Use **proper type of oil** in engines, transmission and for lubrication.
6. Keep **battery terminals** clean and battery charged, especially during winter.

Maintenance Procedure of High Velocity Cleaner

Daily Maintenance Steps

Sr. No.	Description	Sr. No.	Description	Sr. No.	Description
1.	<ul style="list-style-type: none"> Keep all equipment and accessories clean. 	2.	<ul style="list-style-type: none"> Hold Tank 	3.	<ul style="list-style-type: none"> Oil Levels
	<ul style="list-style-type: none"> a) Tool compartments b) Engine compartment 		<ul style="list-style-type: none"> a) Drain to prevent 		<ul style="list-style-type: none"> a) Engine b) Pressure pump Hydraulic oil tank
	<ul style="list-style-type: none"> ✓ Wipe up oil and grease ✓ Paint rust spots 		<ul style="list-style-type: none"> ✓ Rust ✓ Sand or dirt deposits ✓ Clean tank strainers 		
4.	<ul style="list-style-type: none"> Tape splits in hose, or replace as necessary 	5.	<ul style="list-style-type: none"> Look for worn or plugged orifices in nozzle. 		

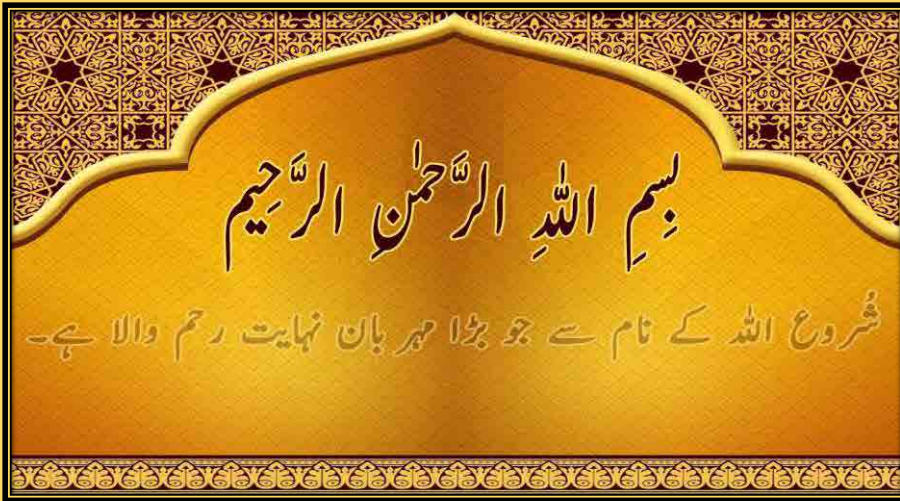

Operation & Maintenance of Sewerage System

Topic 2
Machinery, Tools and
Equipment for Cleaning Sewer
& Manhole

Lecture 06
Cleaning Techniques

Contents

1. Objectives
2. Sewer Blockages & its Types
3. Reasons of Cleaning
4. Methods of Cleaning
5. Record of Cleaning Operation



To Determine Equipment & Staffing Requirements

To Set up Sewer Cleaning Equipment

To Operate & Maintain Equipment

To Record the Necessary Data & Information

1 - Sewer Blockage

Any barrier which causes the sewer system plugged and in the result flow backs up

2 -Types of Sewer Blockage

Grease	Roots	Sand	Lost Rods
Debris	Rags	Silt	Plugs
Broken Pipe	Plastic Bags	Ruble	Wooden Posts
Joint Failure	Broken Pipes	Steel Rebar	Barbed Wire
Detergents	Brick	Large Metal	Tree Limbs
Sticks	Rock	Plastic Buckets	Dead Animals

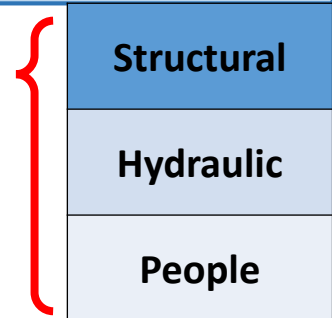

Roots

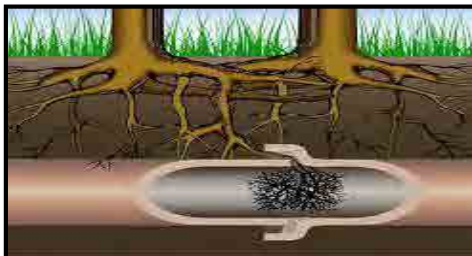

Grease
Debris



Reasons for Cleaning Sewer & Manhole

1. To remove the obstruction
2. To reduce the complaints regarding the bad odor
3. To minimize the overflow and ponding of sewage

Methods for Sewer & Manhole Cleaning

- 1) **Manual**
- 2) **Mechanical**
- 3) **Hydraulic**
- 4) **Chemical**

Manual Method

Hand Rodding

Long strips from bamboo stem are taken and tailored to use as sewer cleaning rod between two consecutive manholes

Crew

If a crew is essentially doing only hand rodding, at least two operators are recommended:

1. Maintenance man I
2. Maintenance man II.



1. **Ventilate** the manhole and test for toxic gases, explosive gases, and oxygen level
2. Determine the **depth** of the manhole
3. **Assemble sufficient rod** portion to firmly rest in the sewer and leave enough protruding above the street level to allow for working conditions, usually about 18 to 24 inches

Power Rodding

- Power rodding machines use a steel rod to push or pull various clearing tools through sewers.
- These machines are of various designs and are equipped with a rod in a reel having lengths up to approximately 1,000 feet.
- This reel can be rotated to give turning action as the rod is pushed in or removed.

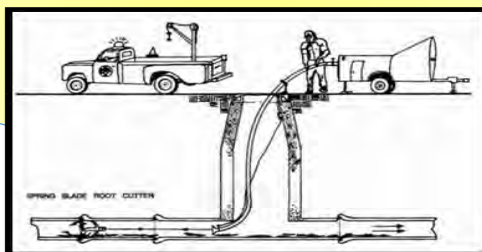



Equipment Set up

- 1) Position the two machines over the respective manholes
- 2) Place the pads under the stabilizer feet of the machine and jack them down. The lower manhole roller is lowered into the manhole.

Equipment Set up

- 4) To thread the sewer, a synthetic rope can be used
- 5) To this rope attach a nylon parachute designed for such use and allow this parachute to float downstream to the working manhole

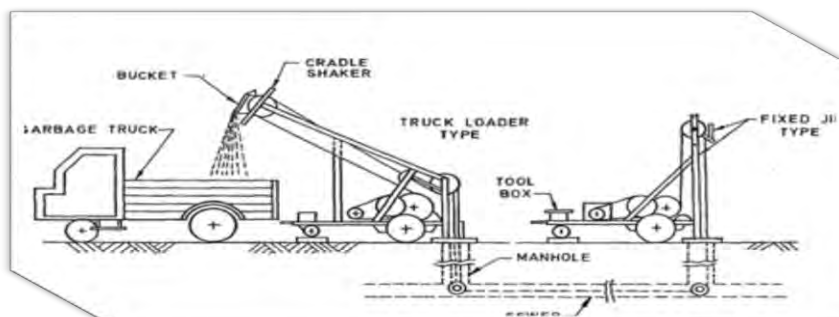

Equipment Set up

- 6) The clearing bucket is now ready to be attached to the cable
- 7) As the bucket is pulled upstream into the material deposited in the sewer, a definite resistance can be noticed when the bucket is full
- 8) When the bucket is full, pull the loaded bucket back out of the sewer
- 9) Final cleanup is performed with special care given to washing down and completely cleaning the entire area

1 - Flushing

1. Start operation at the **upstream end**
2. Place the water line over the manhole
3. **Clean** the manhole first
4. Dumped some of the water
5. Observe any evidence of **water backing up**
6. Look for signs of grease & roots etc.
7. Close the manhole and **go to downstream** manhole
8. Repeat from **manhole to manhole**

The use of hydraulic pressure to de-silt sewers dates back to the early 1900s; however, this method has been developed with the passage of time by using high velocity cleaning machines

High velocity cleaning machines are confidently used to:

- Open Stoppages
- Remove Grease
- Clean lines of Debris
- Wash Manholes and Wet Wells

Sr. No.	Set up and working
1	Fill the water tank from a fire hydrant close to the area where you will do the cleaning
2	Start at the top or highest point in the collection system
3	Select the appropriate nozzle for the size of pipe to be cleaned
4	Install the proper size sand or debris trap in the downstream manhole
5	Turn the reel directional control to "Out" and lower the hose and cleaning nozzle into the manhole
6	Turn the water valve on and start the high pressure pump

Sr. No.	Set up and working
7	First try 50 feet to check the situation in the sewer
8	By increasing pressure you may be able to go farther
9	Retest the manhole atmosphere for sewer gases to be sure the ventilation procedures are effective
10	Allow an operator properly equipped with a safety harness to enter the manhole and shovel the debris into a bucket which in turn is pulled to the surface with a hand line
11	During all this jetting operation sucking machine will suck all the dislodged silt and debris from the same manhole by a 4 inch hose
12	Sucker will be emptied at drain or some other purpose built area

Section 01			
Division		Subdivision	
Foreman		Time of cleaning started	
Date		Time of cleaning finished	
Temperature		Duration	
Street no.		Line size (dia.)	
Block / Mohallah		Manhole number	
Section 02			
Details of cleaning operation			
a) Condition of flow before cleaning		b) Machines used	
c) Condition of flow after cleaning		d) Tools and equipment	
e) Kind of materials removed			
Remarks:			



jica **ALJAZARI ACADEMY**

Operation & Maintenance of Sewer & Drainage system (S 3221)

Module 3

Topic 5 :
Emergency Response Plans for Rainy Season

Lecture 7:
Emergency Planning

Duration :
45 Min.

Module-3 Lecture-7 2/25

Emergency Planning

Module-3 Lecture-7 (Emergency Planning)

3/25

Contents

- ❖ Introduction
- ❖ Emergency Management Process
- ❖ Objective
- ❖ Assessment of Existing situation
- ❖ Special Arrangements for Rainy Season
- ❖ Monitoring System
- ❖ Reporting mechanism
- ❖ Alarm System

Module-3 Lecture-7 (Emergency Planning)

4/25

Introduction

What is an Emergency Response Plan?

It is an action plan to organize all resources during workplace emergencies.

Well developed emergency plans and proper employee training will result in fewer injuries and less structural damage to the facility during emergencies



Emergency Management Process

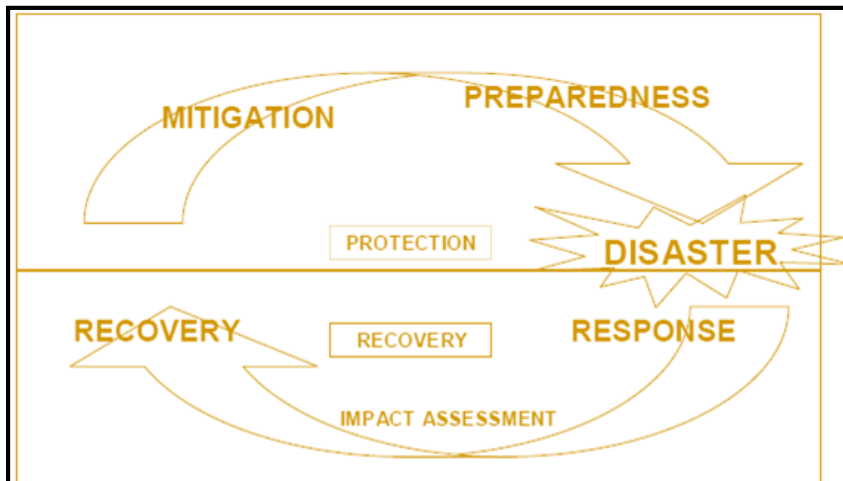

Emergency Management Process

Preparedness Phase

Consists of activities carry out in advance before an emergency strike to improve response to emergency

E.g. hazard or risk analyses, training, drills and exercises, emergency plans and procedures, emergency communications, joint cooperation consensus, warning systems procedures and response planning.

Emergency Management Process

Response Phase

Consists of the immediate response to emergency by the ERT

It is aim at containing the disaster so as to minimize loss of life and destruction to property.

Includes measures such as: notification, implementation of emergency plans, activation of emergency operation centers, mobilization of resources, issuance of warnings and directions, provisions of medical and social services assistance, announcement of emergencies or disasters by the management.

Emergency Management Process

Recovery Phase

It refers to those measures undertaken following a disaster that will return all systems to normal levels of service.

Includes measures such as: physical restoration and reconstruction, cleaning up contaminated areas, eliminating and/or reducing any known hazards restoring businesses

Emergency Management Process

Mitigation Phase

It is the continuous ongoing endeavor to avert or reduce the impact that a hazardous materials incident will have on people, property, and the environment

Examples of mitigation activities would include the following: Hazard Identification, Risk Analysis , Evaluation, Research , Education

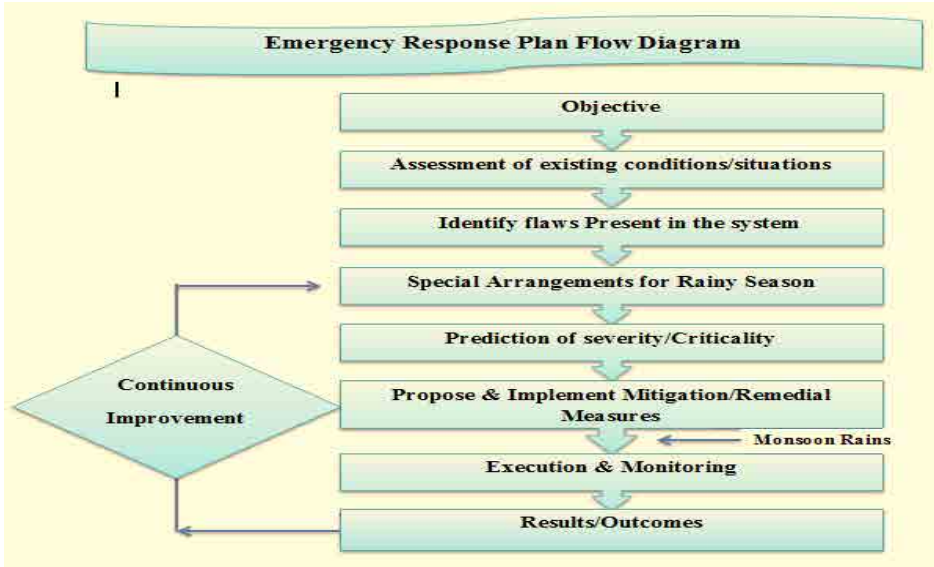

Life threatening condition which requires the administration of life-saving measures.

(German Red Cross)

When there is an unexpected condition requiring specific action plans to normalize

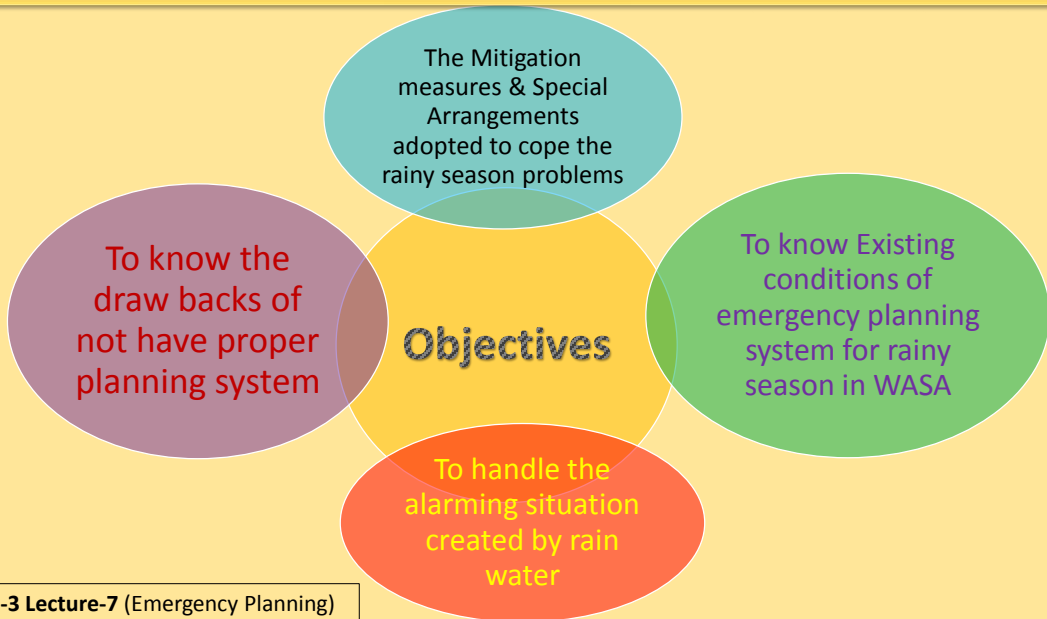

Assessment of Existing Situation/Condition

- ♣ Poor drainage system
- ♣ No separate storm water drainage system is present
- ♣ Accumulation or trapping of solid waste & Plastic material in sewers (Choking of sewer system)



Special Arrangements for Rainy Season

Cleaning & Desilting of

- ✓ Sewer lines
- ✓ Disposal stations
- ✓ Storm water channels

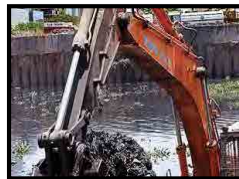

Module-3 Lecture-7 (Emergency Planning)

15/25

Special Arrangements for Rainy Season

- Strengthening of katcha drains/channels
- Repair of pacca channels
- Closure schedule of factories



Proper & effective CMS should be established



Module-3 Lecture-7 (Emergency Planning)

16/25

Special Arrangements for Rainy Season

- Maintenance and utilization of dewatering sets
- Installation of Mobile Dewatering Sets



- Stockage of material for repair of channels
- Repair of pumping machinery
- Repair of heavy mobile machinery



Module-3 Lecture-7 (Emergency Planning)

17/25

Special Arrangements for Rainy Season

- Arrangements for low lying areas
- Duties of emergency duty staff
- Response of O & M official during emergency
- Duties of O & M staff during rain
- Identification of Major Low lying areas of the city



- Availability of Double Feeder System
- Report of rain water after rain
- Enhancement of generation capacity of Disposal Station



Module-3 Lecture 7 (Emergency Planning)

18/25

Special Arrangements for Rainy Season

Emergency Camps

Replacement of Outlived Sewer lines

Identification of Major Low lying areas of the city

Construction of Outlets and Small Drains

Dewatering Plan of Ponding Areas should be made

Mitigation Measures

The District Government assisted by the other relevant Departments agencies and even Army in acute emergency should execute relief measures and rescue operations

For cleaning of chocked sewers due to heavy raining in monsoon, WASA should have jetting & sucker machines, all should be in working condition and available for emergency at any time.

Mitigation Measures

- Staff should be put on high alert and WASA should utilize all available resources in the rainy season.
- Arrangements should be made to drain rainwater and de-silt sewerage system to flush out the rainwater from the low-lying areas.
- Mobility of machinery and response time should be monitored.

Performance of staff should be monitored in their areas to ensure prompt redress.

Disposal pumps should be provided to mobile teams so they can work round the clock in shifts in their respective areas.

Monitoring System

All work operation should be properly monitored by high authority. There should be a proper monitoring system established.

Monitoring Teams supervised by listed officers, along with subordinate officers shall be in place to feed back the actual position of the city during rain fall.

Directors shall once daily check the functionality and operation of disposal/lift stations through their teams

Focal Person should be selected

Central Control Office should be established at Head Office for co-ordination with all Field Complaints Centers and Emergency Control Room

Immediate and remedial actions on reporting of emergency including power failure, machinery break down etc.

Action plan and status of Disposal Stations should be submitted to focal person immediately after rainfall

Alarm systems with a backup power source shall be provided for pumping stations. The alarm shall be activated in cases of power failure, dry well sump and wet well high water levels, pump failure, unauthorized entry, or any other cause of pump station malfunction. Pumping station alarms including identification of the alarm condition shall be transmitted to a municipal facility that is staffed 24 hours a day. If such a facility is not available and a 24-hour holding capacity is not provided, the alarm shall be transmitted to municipal offices during normal working hours and to the home of the responsible person(s) in charge of the lift station during off-duty hours. Audio-visual alarm systems may be acceptable in some cases in lieu of a transmitting system depending upon location, station holding capacity and inspection frequency.

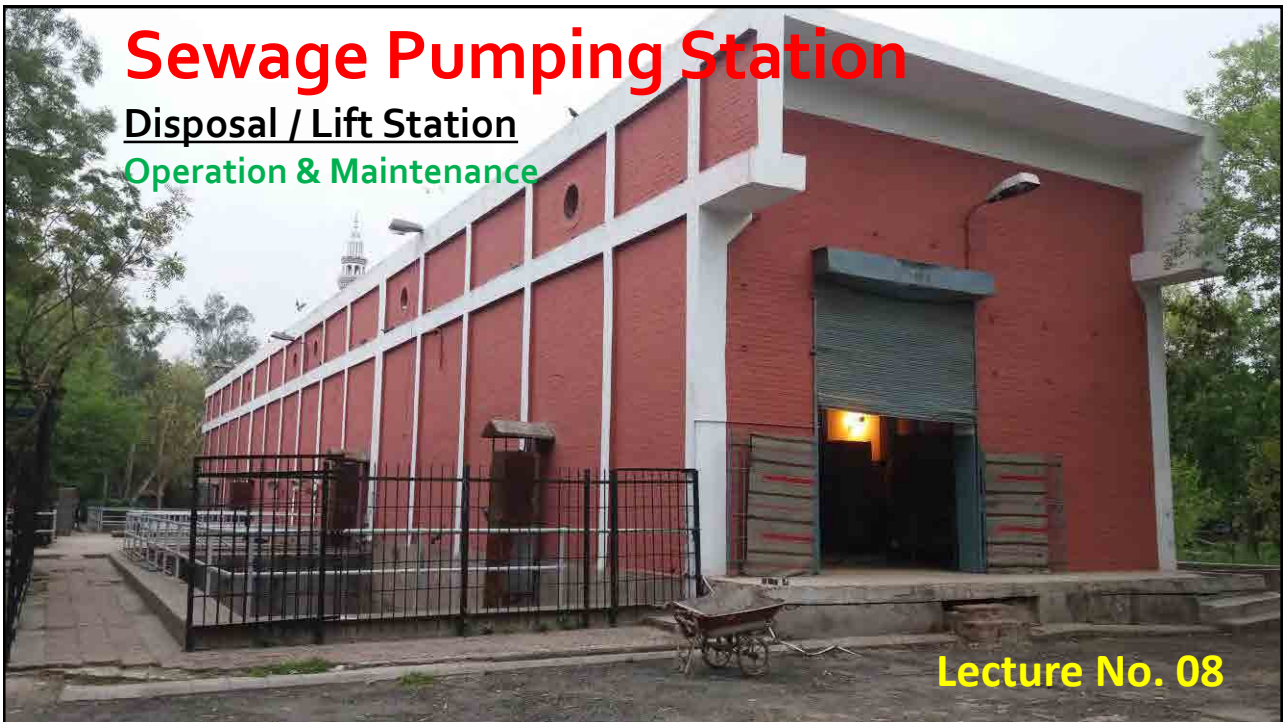

PURPOSE

Pumping stations are used to move sewage to higher elevations.

❑ Disposal Station

❑ Lift Station

COMPONENTS

1. Collection Chamber (Screening Area)
2. Wet Well(s)
3. Dry Pit (Pump Room)
4. Force Main



Pumping station - Netherlands

Working Principle

- 1- Raw sewage is received from **underground sewers**.
- 2- **Screening** is performed.
- 3- Sewage is stored in an underground pit (**a wet well**).
(Wet well is equipped with **electrical instrumentations**)
- 4- Electrical instrumentations detect the **level of sewage**.
- 5- As sewage level rises to a point, **pump starts**.
- 6- Pump **lifts** the sewage upward.
- 7- Sewage is discharged into some **other channel/sewer**.
(**Cycle repeats until the sewage reaches its fixed/lowest point in wet well**)

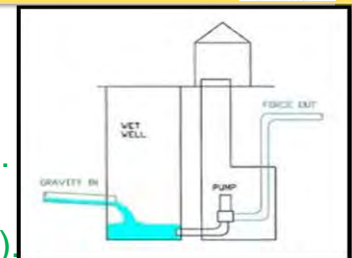



Sewage Route (Simplified)



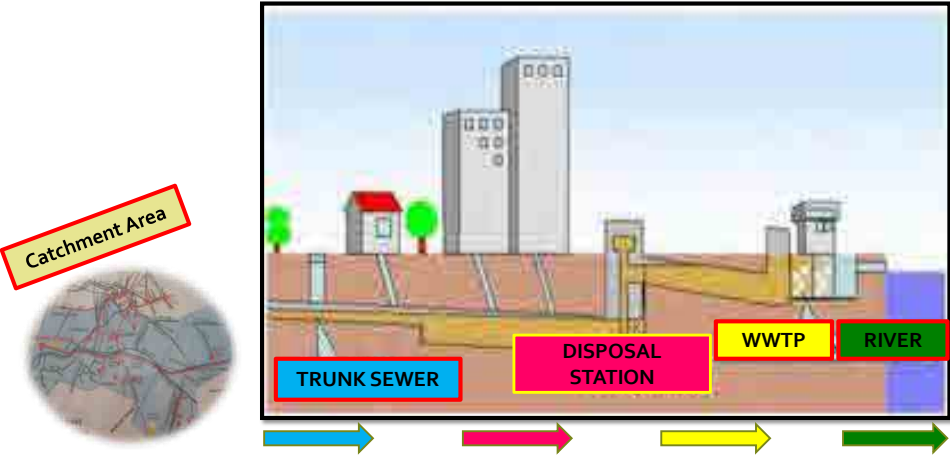



The diagram illustrates a cross-section of the ground showing the path of sewage. It starts at a 'Catchment Area' (indicated by a red box and a circular inset map), flows through a 'TRUNK SEWER' (blue box), passes through a 'DISPOSAL STATION' (pink box), then to a 'WWTP' (yellow box), and finally discharges into a 'RIVER' (green box). Arrows below the ground line indicate the direction of flow from left to right.

Module 3 Lecture 8 Sewage Pumping Station

05/31



Sewage Route (Detailed)



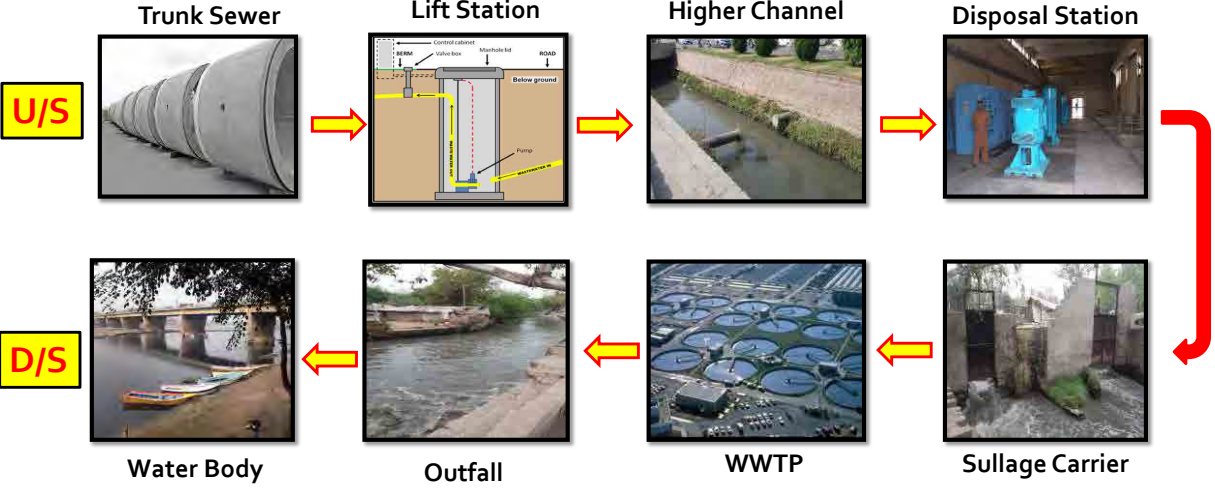

The detailed diagram shows the following stages from left to right:

- Trunk Sewer** (U/S): A large pipe with a yellow arrow pointing right.
- Lift Station**: A cross-section diagram showing a pump lifting sewage from below ground to above ground. A yellow arrow points right.
- Higher Channel**: A concrete-lined channel with a yellow arrow pointing right.
- Disposal Station**: An indoor facility with a yellow arrow pointing right.
- Sullage Carrier**: A narrow, covered channel with a red arrow pointing left.
- WWTP**: Aerial view of circular treatment tanks with a yellow arrow pointing left.
- Outfall**: A river with a yellow arrow pointing left.
- Water Body** (D/S): A lake or reservoir with a yellow arrow pointing left.

Module 3 Lecture 8 Sewage Pumping Station

06/31

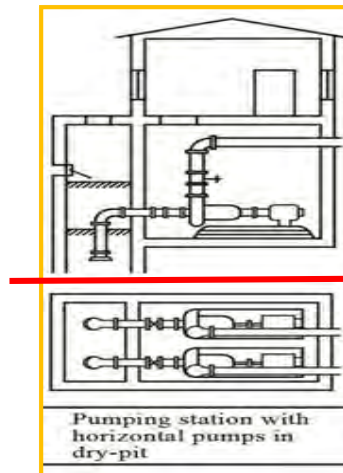
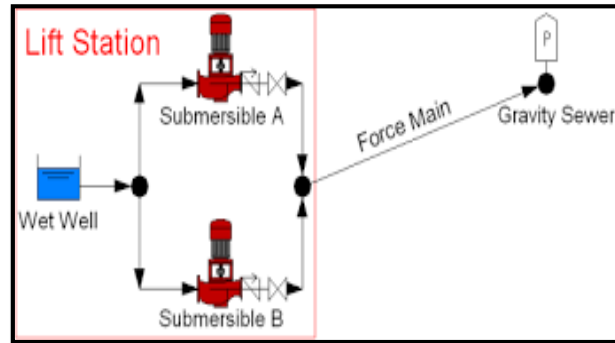

Vertical Pump in Dry Pit

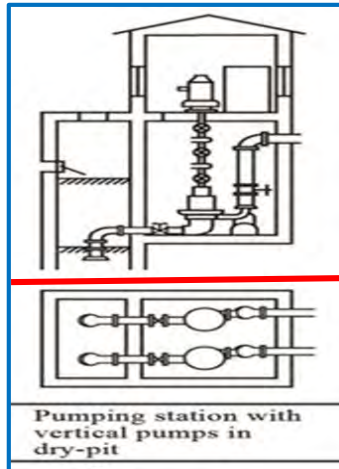

Module 3 Lecture 8 Sewage Pumping Station

09/31

Vertical Pump in Wet Pit

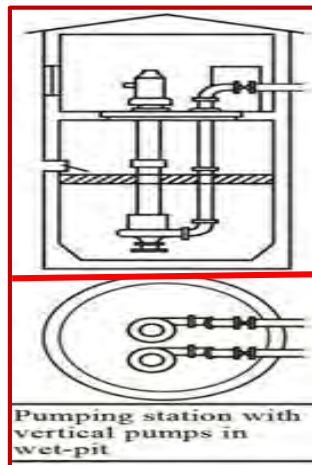

Module 3 Lecture 8 Sewage Pumping Station

10/31

Submersible Pump in Wet Pit

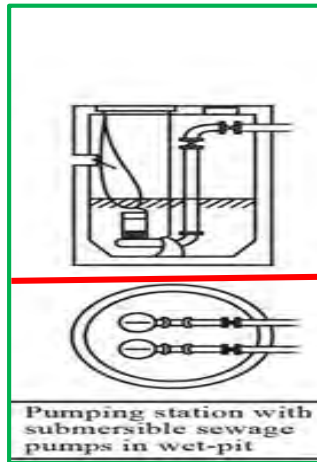

Module 3 Lecture 7 Sewage Pumping Station

11/31

Various Pump Arrangements for Disposal Station

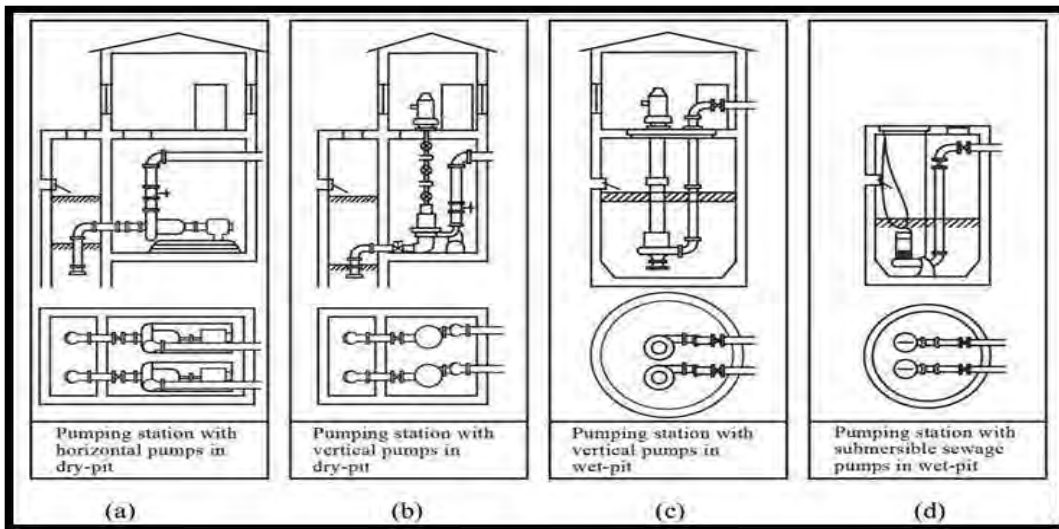

Module 3 Lecture 8 Sewage Pumping Station

12/31



Plan - 01

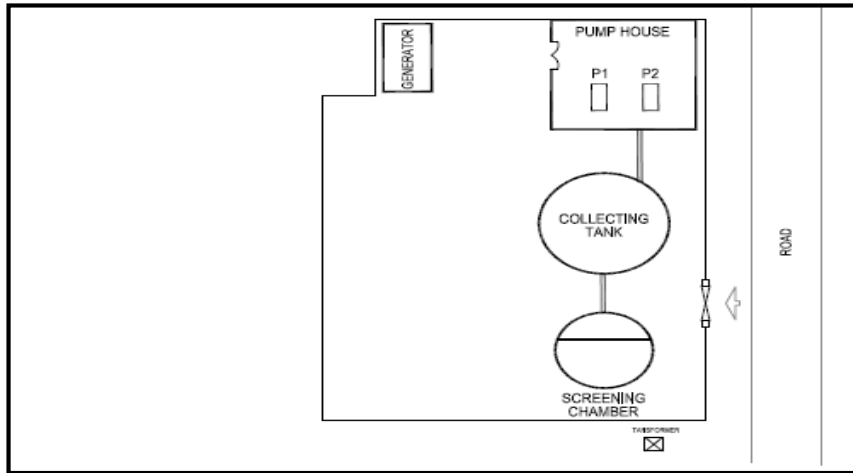

Module 3 Lecture 8 Sewage Pumping Station

13/31



Cross-Section 01

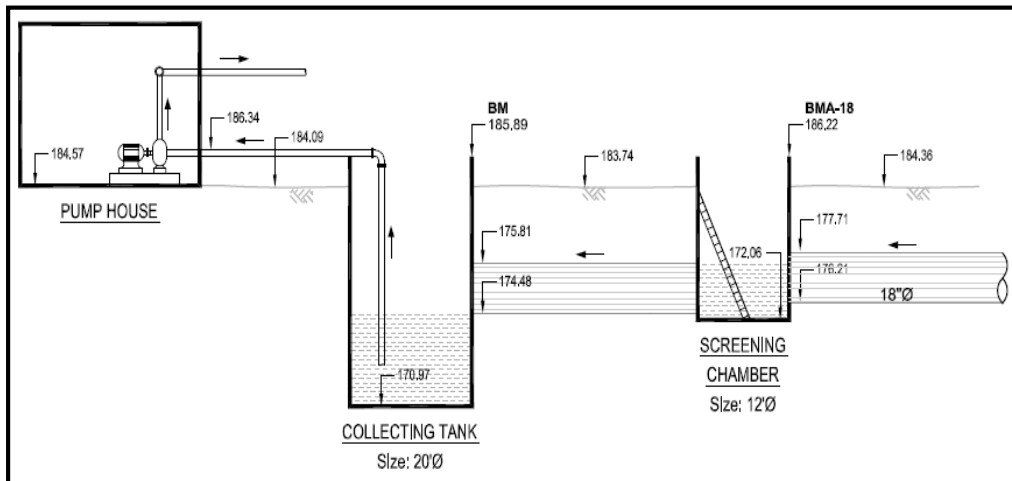

Module 3 Lecture 8 Sewage Pumping Station

14/31



Plan - 02

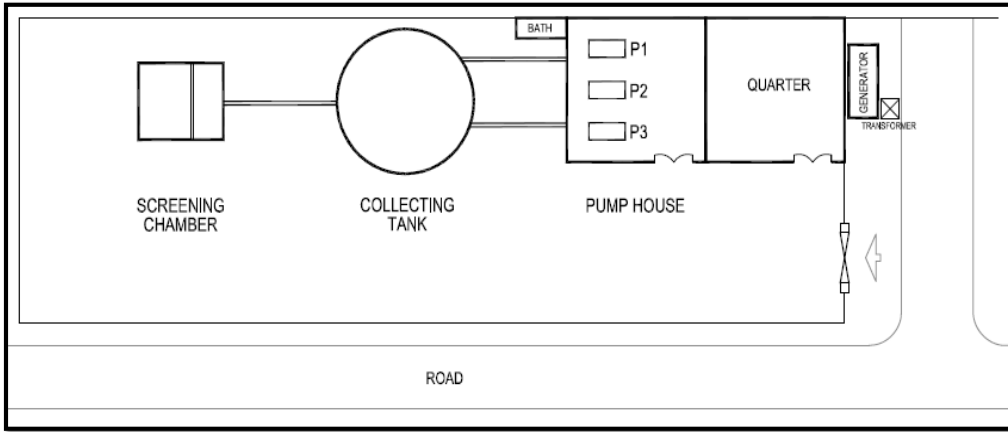

Module 3 Lecture 8 Sewage Pumping Station

15/31



Cross-Section 02

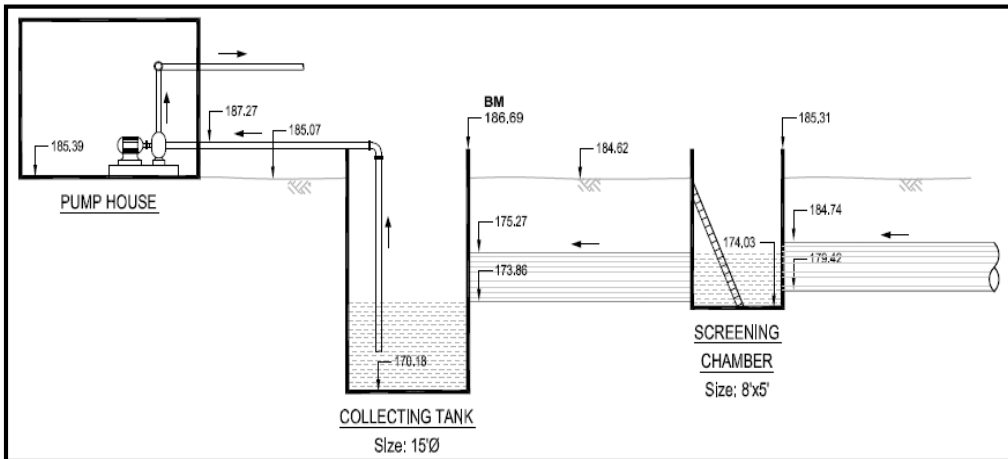

Module 3 Lecture 8 Sewage Pumping Station

16/31

Modern Pumping Station

- Do not require a **dry well** or pump house.
- Only consisting of a **wet well**.
- **Submersible pumps** with motors are mounted in the wet well.
- For maintenance or replacement, submersible pumps are raised by a chain pulley system.
- Reinstalling the pumps simply reverses this process.
- No above ground structures are required.
- Except electrical switchgear and control systems.

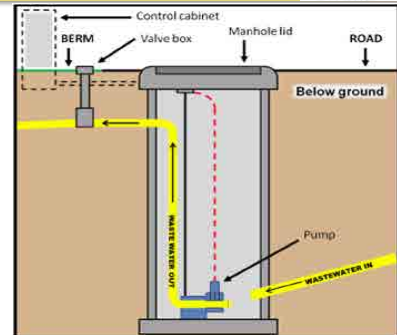

Module 3 Lecture 8 Sewage Pumping Station

17/31

Sewage Pumping Station (Basic HSE Considerations)

1. The interior of a sewage pump station is a very dangerous place.
2. Gases, such as **methane** and **hydrogen sulfide**, can accumulate in the wet well.
3. Entry into the wet well requires **confined space** entry method.



Module 3 Lecture 8 Sewage Pumping Station

18/31



Safety Considerations



The design of the pumping station shall give due regard to safety for the protection of maintenance personnel and visitors from hazards:

- a) Handrails and guards are to be installed around tanks, trenches, pits, stairwells and other hazardous areas.
- b) Gratings are to be installed over areas where access for maintenance is required.
- c) Gas detection and monitoring equipment where required.
- d) Adequate ventilation in pumping chambers.

Module 3 Lecture 8 Sewage Pumping Station

19/31



- e) Portable lighting equipment intrinsically safe, where required.
- f) Provisions for lockout and tag-out of mechanical and electrical equipment.
- g) Eyewash fountains and safety showers were required.
- h) Fire extinguishers and emergency lighting.
- i) Appropriately placed warning signs for slippery areas, non-potable water fixtures, low head clearance, open service maintenance holes, hazardous material storage areas, flammable fuel storage areas, etc.

Module 3 Lecture 8 Sewage Pumping Station

20/31



Maintenance of Pumping Station



- Quarterly inspection of submersible pumps, impellers, and floats allows for clearance of debris and grease.
- Half yearly inspection of check valves ensures proper valve function that restricts backflow from the force main to the wet well.
- Wet well cleaning is done at least twice a year.
- The electrical motor equipment has to be inspected twice a year to identify poor connections and replace worn out parts.
- Light and alarm system need to be inspected every week.

Module 3 Lecture 8 Sewage Pumping Station

21/31



Maintenance of Pumping Station



The routine inspection and maintenance activities include the following:

- Visually inspect the station for vandalism or damage.
- Clean up any trash or debris found on the site.
- Record pump run time hours for each pump.
- Record kilowatt-hour meter reading for the pump station.
- Run each pump by hand (manual control) to ensure pumps/motors are operating properly.

Module 3 Lecture 8 Sewage Pumping Station

22/31



Maintenance of Pumping Station



The routine inspection and maintenance activities include the following:

- Inspect wet well to determine need for cleaning.
- Test panel lights and change as needed to ensure proper operation.
- Complete any scheduled PM Work Orders.
- Place pump controls back in auto position prior to leaving station.
- Lock up station, including exterior power panels if required, prior to leaving.

Module 3 Lecture 8 Sewage Pumping Station

23/31



Emergency



- Any lift station failure must be responded to immediately with an appropriate back-up plan.
- The alarm system should be in working order to immediately alert the authorities to problems.
- The log book is referenced for the maintenance dates and appropriate action is taken.
- Generator back-up for power outage during storms or usage of engine-driven pumps ensure unhindered sewage water treatment and processing.

Module 3 Lecture 8 Sewage Pumping Station

24/31

O&M OF DISPOSAL STATION

Field Work Exercise

Module 3 Lecture 8 Sewage Pumping Station

25/31

Disposal Station (General Data Sheet)

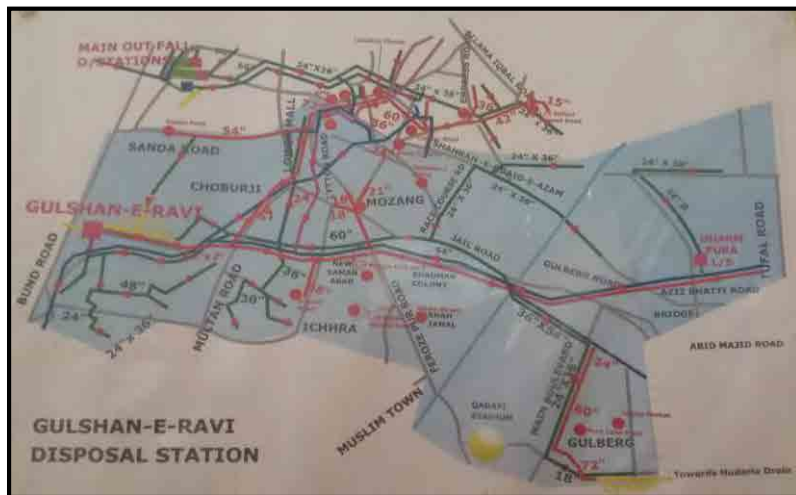

Module 3 Lecture 8 Sewage Pumping Station

26/31

Disposal Station (General Data Sheet)

Disposal Station	
Catchment Area (Sq. Km)	
Screening Chamber(s)	
Size	
Incoming Sewer Dia. (Inch)	
Depth of Sewer Invert (Feet)	
Depth to Bottom (Feet)	
Collecting Tank(s)	
Numbers	
Size (Length x Breadth x Height)	
Depth of Pipe (Feet)	
Depth to Bottom (Feet)	
Discharge Point (Location)	
Miscellaneous Information	

Module 3 Lecture 8 Sewage Pumping Station

27/31

Infrastructure Condition at Disposal Station

Structure	Existence	If Yes Then	
	Yes/No	Satisfactory	Damaged/ Unsatisfactory
Pump House			
Electric Wiring			
Incoming Sewer Dia. (Inch)			
Doors & Windows			
Screening Chamber(s)			
Wet Well(s)			
Wet Well Number(s)			
Generator Room			
Boundary Wall			
Gate			

Module 3 Lecture 8 Sewage Pumping Station

28/31

Pump(s) at Disposal Station

Pump No.	Suction / Delivery	Make / Type	Year of Install	Capacity (cfs)	Head (feet)	Driven By		Working Hours in a Day	Condition
						Elec. (BHP)	Diesel (BHP)		

Module 3 Lecture 8 Sewage Pumping Station

29/31

Generator(s) at Disposal Station

Type	Make	Year	Capacity	Condition
Generator(s)				
1)				
2)				
3)				
Force Main				

Module 3 Lecture 8 Sewage Pumping Station

30/31

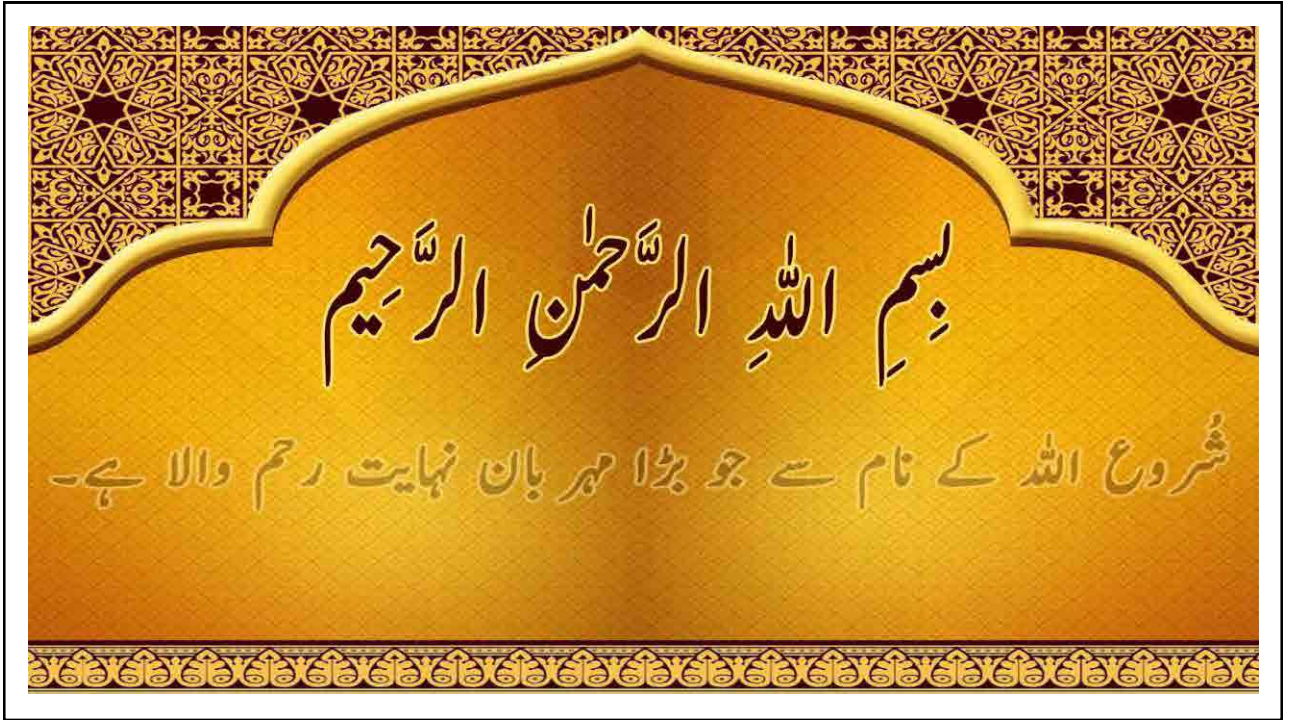

Operation & Maintenance of Sewer and Drainage System

Operation & Maintenance of Sewer & Drainage system (S 3221)

Module 3

Topic 4:

Maintenance and
Rehabilitation of Sewer
Line & Manhole

Lecture 8:

Repair and
Rehabilitation

Duration :
20 Min.

Module-3, Lecture-8 (Repair & Rehabilitation)

3/34

- Objective
- Benefits of Rehabilitation
- Failures in System
- Solutions of Failures
- Renovation Material
- Repair Methods
 - Repair
 - Renovation
 - Replacement
- Rehabilitation Techniques
- Case Study

Lecture Breakdown



Module-3, Lecture-8 (Repair & Rehabilitation)

4/34

Repair & Rehabilitation

Objective

To maintain the overall
viability of a conveyance
system.

Factors affecting Selection Method

The choice of methods will depend on following factors:

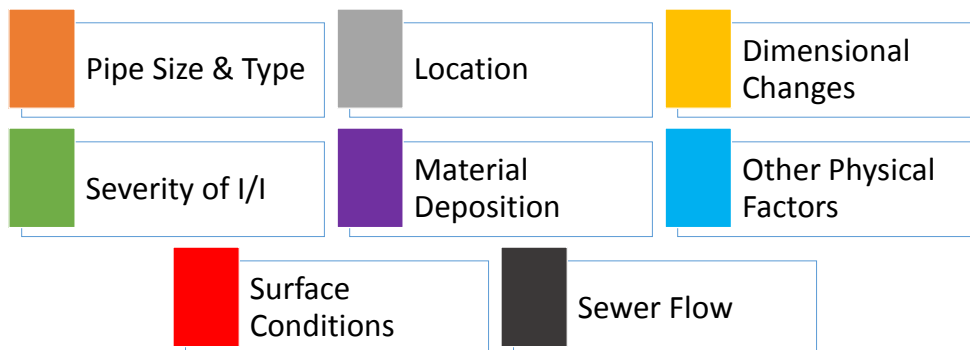

Outcomes of Rehabilitation

Minimize Sanitary Sewer Overflows

Improving the Hydraulic Capacity of the Sewer System

Eliminate or Reduce the Occurrence of Infiltration and Inflows

Failures in Sewer System & Manholes

Problems in Sewer System

- Old and Deteriorated Main and Lateral Pipes
- Cracked Sewer Pipe
- Misaligned and Open Pipe Joints
- Undersized Sewer Pipe
- Defective Manholes
- Missing and/or Unrecorded Sewer Pipes and Manholes



Module-3, Lecture-8 (Repair & Rehabilitation)

9/34

Sewer Systems are subject to several stresses which may be caused by:

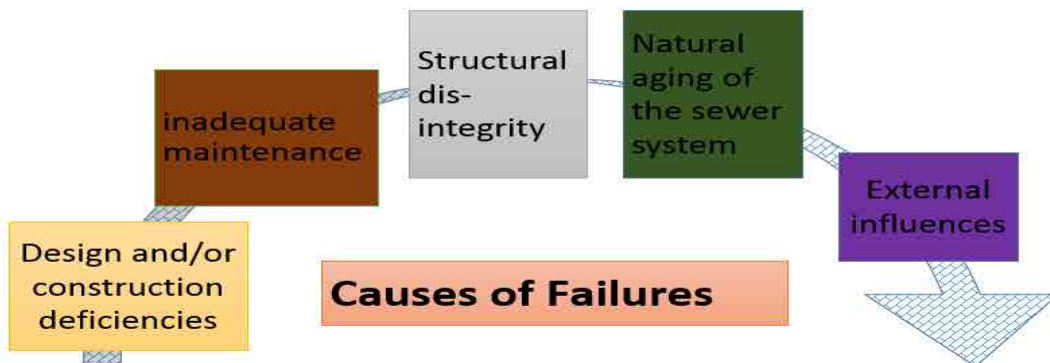

Module-3, Lecture-8 (Repair & Rehabilitation)

10/34

Manhole Failures

Common failures of manholes are:



Leaks & Deterioration

- Cracks, Holes & Joints
- Root Penetration
- H₂S Corrosion
- Traffic Loading
- Cover
- Mortar Erosion
- Structural Failure

Manholes Failures

Infiltration – inflow and exfiltration.

Surround ground settlements.

Hydrogen sulfide (H₂S) release may attack concrete manholes.

Corrosion of cast-in-place rungs can be an important safety issue.

Structural problems.

Solutions of Manholes Failures

- Grouting
- Concrete Patching
- Re-build Upper portion of Manhole
- Manhole Liner
- Corrosion Protection
- Build a Manhole within a Manhole



Module-3, Lecture-8 (Repair & Rehabilitation)

13/34

Renovation Material

- ✓ Chemical Grout
 - Acrylic
 - Acrylate Based Grout
 - Urethane Based Grout
- ✓ Cementitious Material
- ✓ Urethane Resin
- ✓ Rapid Setting Cements



Module-3, Lecture-8 (Repair & Rehabilitation)

14/34

Renovation Material

- ✓ Mono Crystalline Quartz Aggregates
- ✓ Various Accelerating Agents
- ✓ Liner materials shall be
 - Cement Based
 - Poly fiber Reinforced
 - Shrinkage Compensated
 - Siliceous Aggregates



Renovation
Leads to
New
Condition

Renovation Material

- ✓ Polyvinyl chloride (PVC) protective sheet liners
- ✓ High density polyethylene (HDPE)
- ✓ HDPE, PVC, EPP
- ✓ Rubber, brick, block, cement or poured concrete
- ✓ Oakum Water Plugs to prevent leakages
- ✓ Manhole frame adjustments shall be HDPE, PVC, EPP, rubber, brick, block, cement or poured concrete

Rehabilitation Methods

Module-3, Lecture-8 (Repair & Rehabilitation)

17/34

Rehabilitation Methods

Sewer rehabilitation methods include:

- ❖ **Repair**
- ❖ **Renovation**
- ❖ **Replacement**



Module-3, Lecture-8 (Repair & Rehabilitation)

18/34

Repair

Repairs may be temporary or permanent depending on the methods and technologies.



Types of Repairs

There are usually two types of repairs

- ❖ Structural Repairs
- ❖ Non-Structural Repairs



Methods of Repairs

- ❖ Point and Replacement Repairs
- ❖ Joint Testing and Grouting
- ❖ Sewer Lining



BEFORE



AFTER

Spot Repair

The following techniques are available for spot repairs of short deficient sections of a pipeline which is otherwise in a generally good condition:

- ❖ Open Cut Repair/Replacement
- ❖ CIPP
- ❖ Internal Grouting
- ❖ External Grouting
- ❖ Rubber Seals with Stainless Mechanical Bands

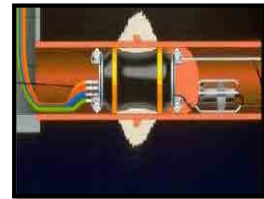
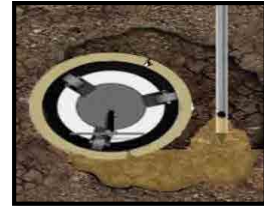

Module-3, Lecture-8 (Repair & Rehabilitation)

21/34

Renovation

- Renew the Structural Integrity of the Sewer
- Use the Existing Pipe Structure to “build” a New Pipe or Support a New Lining
- Coating and Lining

Replacement

- The classic Method
- Cheaper than Lining Technologies
- Requires more Construction Time

Module-3, Lecture-8 (Repair & Rehabilitation)

22/34

Rehabilitation Techniques

Module-3, Lecture-8 (Repair & Rehabilitation)

23/34

Sewer Line Rehabilitation

Slip Lining

- ❖ Used to rehabilitate damaged sewer pipes by placing a smaller diameter conduit inside the damaged section
- ❖ This method is commonly used where the new, smaller diameter sewer pipe, and the resulting lower friction coefficient for the new pipe, is sufficient for the system capacity needs

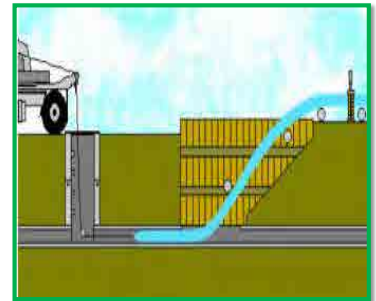

Module-3, Lecture-8 (Repair & Rehabilitation)

24/34

Sewer Line Rehabilitation

Cured-In-Place-Pipe (CIPP)

- Used for both structural and semi-structural rehabilitation of sewer lines.
- The CIPP liner consists of a tubular felt like material saturated with an epoxy resin that after curing turns into a rigid liner for the pipe.
- Before the process is initiated, pipes must be thoroughly cleaned and dried.

Module-3, Lecture-8 (Repair & Rehabilitation)

25/34

Sewer Line Rehabilitation

Fold and Form

Fold & form is a technology for rehabilitation of sewer lines by inserting a folded liner into the existing pipe and expanding it through pressure, heat or mechanical means to restore its original circular shape

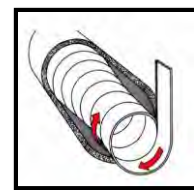
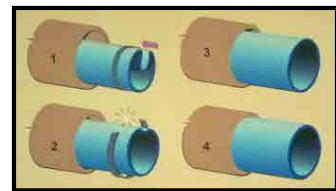

Module-3, Lecture-8 (Repair & Rehabilitation)

26/34

Sewer Line Rehabilitation



Spirally Wound Pipe

- This technique is based on forming a pipe in-situ by using PVC-ribbed profiles with interlocking edges. The ribs enhance the hoop strength of the liner.
- This method is applicable to sewer lines smaller than 30 inches in diameter.
- The process involves the fabrication of the liner in the manhole by helically winding a continuous PVC fabric.

Module-3, Lecture-6 (Repair & Rehabilitation)

27/34

Manhole Rehabilitation

Manhole rehabilitation is done for to minimize sewer service downtime, disturbance to the surrounding environment, traffic flow, business and community activities, and avoid a large volume of debris to be disposed of.

Module-3, Lecture-8 (Repair & Rehabilitation)

28/34

Manhole Rehabilitation

The following methods are available for manhole rehabilitation:

- Chemical Grouting
- Coating Systems
- Structural Linings
- **Frame, Cover & Chimney Rehabilitation**
 - Full depth Lining
 - Frame and cover casting adjustment, including replacement or resetting
 - Manhole Replacement
 - Grouting

Module-3, Lecture-8 (Repair & Rehabilitation)

29/34

Manhole Rehabilitation

Open Cut Replacement

- ✓ If a manhole is severely deteriorated, open cut replacement may become a preferred option
- ✓ Open cut may also be utilized if manhole relocation is dictated by hydraulic or access requirements.

Module-3, Lecture-8 (Repair & Rehabilitation)

30/34

Manhole Rehabilitation

Chemical Grouting

- Chemical grouting is used to reduce I/I in manhole structures.
- Grouts give best results in cohesive soils.
- They may be used to fill voids and stabilize soils behind manhole walls.
- Grouts are normally applied under pressure through grout holes drilled into the manhole walls



Module-3, Lecture-8 (Repair & Rehabilitation)

31/34

Manhole Rehabilitation

Coating Systems

- Coating systems may be used as a corrosion protection barrier and/or to enhance structural integrity of manhole structures.
- Coatings can be applied by spraying, or hand applied. When using coating system, it is essential that the surfaces be properly cleaned and prepared.



Module-3, Lecture-8 (Repair & Rehabilitation)

32/34



O&M of Sewerage System

Module 03



Dated: _____

Action Plan Template (Module 03)

Name: _____

Department: _____

Designation: _____



Sr. No.	WHAT TO DO?	HOW TO DO?	WHEN TO DO?	WHO TO DO?		DO WITH WHAT?		CHECK DONE?	WHO TO CHECK?
	(Define O&M Task)	(Follow SOP Ref.#)	(Frequency)	(Carried out By)		Materials	Tools/ Equip.	How to Check?	To be Checked By?
			Class of Work	Worker					

Thanks indeed for your valuable time

• GOOD BYE

Have a Safe Journey