



Course

Operation and Maintenance (O&M) of Sewer & Storm Water Drainage System including Safety Precautions

Module 2

O&M of Storm Water Drainage System

Lecture 1

Need for O & M of Storm Water Drainage System

1. Storm Water Drainage System and its Components
2. Current Issues
3. Sediment Deposition
4. Need for O&M
5. Maintenance of Drains



➤ Receives runoff from inlets and conveys the runoff to some point where it is then discharged into a channel, water body, or piped system

➤ It may be a

- closed-conduit
- Open channel

➤ “Storm sewer” replaced with the term “storm drain” to differentiate between sanitary sewers and storm drains

- ❑ A **drainage pipe** used to convey a stream through a road or embankment
- ❑ It may carry a stream for a long distance underground to a surface discharge location
- ❑ **Short in length** and **open at both ends** and often must withstand substantial traffic loads



Ditch

- ❑ Ditches are constructed to convey water from storm runoff to an adequate outlet.
- ❑ A good ditch is shaped and lined and does not cause flooding, erosion, or sedimentation.



Gutter



- ❑ That portion of the roadway section adjacent to the curb which is utilized to convey storm water runoff.



A location where storm water runoff from an open area enters the storm drain system.



Drop inlets are usually part of the public drainage system, but can sometimes be considered private.

A structure in the form of a chamber which is provided along with the sewer line to admit clear rain Water free from silt, grit, debris, etc, into the combined sewer

Allows rainwater runoff to be safely collected to prevent road and property flooding

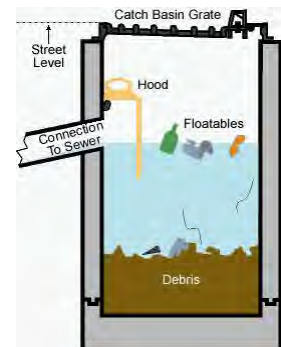



Encroachment of drains



Silting of drains due to constant blockages



Stability of drainage cross-sections dislocated and damaged old lining of the drains



Unpleasant odor of dirty water flowing in the drains

Absence of comprehensive data on storm-water drainage network

Inadequate attention to cleaning of natural drains and clearance of excess floral growth on the drains

Free access to dispose wastewater from nearby habitation

Due to the sediment deposition the problems occurred in the **open channel** includes:

- Encourages prolific weed growth
- Cause flooding of various degrees of magnitude
- Ponding of water creates breeding grounds for some disease causing agents
- Silted roadside drains produce ponding on roads

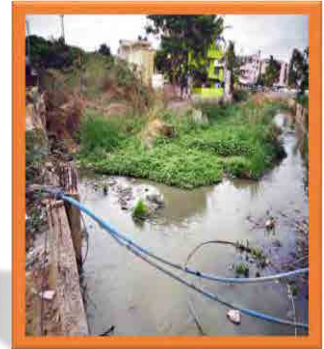

In the case of **buried or completely covered** storm channels, problems occurred are:

- Silting + Weed Growth + Bushes
- Release & accumulation of gases (that can be highly corrosive to the channel material)



Lack of regular maintenance cause the accumulation of the sediment and garbage in the drain

Extensive, regular sediment removal is a difficult and expensive process

Routine inspection and preventive maintenance are the best ways to prevent blockages and deterioration of drains

Departments should devise maintenance procedures including:

- Frequency of inspection
- Programme for dredging
- Necessary repair works
- Documentation for maintenance records





Course

Operation and Maintenance of Sewer & Storm Water Drainage System Including Safety Practices

Module 2

Operation and Maintenance of Storm Water Drainage System

Lecture 5

Maintenance of Storm Water Drainage System

- O & M Plan
- Maintenance Activities for Road Drainage
- BMPs for Storm Water Drainage System
- BMPs for Dredging

O & M Plan

- Define the Area to be Covered
- Identify Problem Areas
- Set an Inspection Schedule
- Assign Responsibility for Inspection
- Define What Categories of Work will be Performed Under this Program
- Identify Parties Responsible for Debris Removal
- Keep Records
- Budget



Storm water system feature	Are any of these conditions present?	Problem	Recommendation
General	Dumped yard wastes or no degradable materials (glass, plastic, Styrofoam, etc.) are present in pond	Accumulation of trash and debris	Remove trash and debris and dispose of properly.
	Undesirable vegetation is invading the pond	Nuisance, poisonous, or noxious weeds	Seek advice from the Dept. of Agriculture before applying pesticides. Certain pesticides should not be used near waterbodies.



O & M Plan for Open Drains



Storm water system feature	Are any of these conditions present?	Problem	Recommendation
General	Grass is taller than 10"m	Overgrown vegetation	Mow grass regularly. Grass should be mowed to a height of 4-9" for best storm water control. Avoid over-applying fertilizers. Excessive fertilizer application may compound water quality problems.
	Offensive color, odor, or sludge is present	Unknown or uncharacteristic substances	Remove substance and eliminate its source. If you don't know if the substance is hazardous, either take a sample or contact a qualified hazardous waste consultant for more information.
	Excessive mosquito population is present	Mosquitos	Install predacious bird and bat nesting boxes to control insects

Module-2 Lecture-5

7/22



O & M Plan for Open Drains



Storm water system feature	Are any of these conditions present?	Problem	Recommendation
General	Water flows through holes in dam or berm; holes are present around pond	Rodents	Destroy rodents and repair dam or berm.
	Large trees interfere with maintenance activities	Overgrown trees	Remove trees that interfere with access or maintenance activities. Preserve trees that are not a problem
	Accumulated sediment exceeds 10% of the designed pond depth	Excessive sediment	Clean out sediment to original shape and depth of the pond. Re-seed pond, if necessary, to control erosion.

Module-2 Lecture-5

8/22

Storm water system feature	Are any of these conditions present?	Problem	Recommendation
General	Accumulated sediment or trash exceeds 20% of the diameter of the pipe	Excess accumulation of sediment or trash	Clean out sediment and trash from pipe. You can use a high pressure hose, vacuum suction, or other appropriate cleaning method.
	Vegetation is impeding water flow	Overgrown vegetation	
	Pipe is rusted; protected coating is damaged	Corroded pipe	Replace or repair pipe to original design specifications.
	Dent in pipe has reduced the pipe diameter by 20%; water flow is impeded; pipe is broken	Defective pipe	
	Water is leaking from pipe	Cracked pipe	

Maintenance Activities for Road Drainage



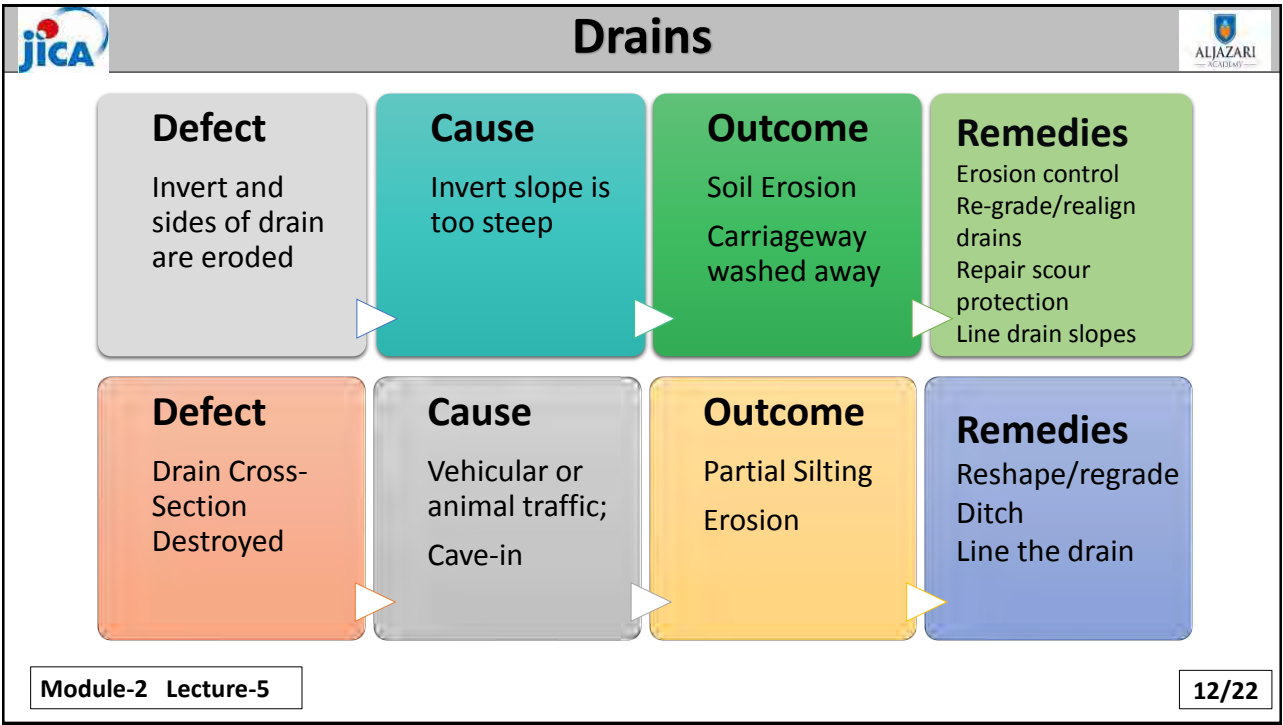
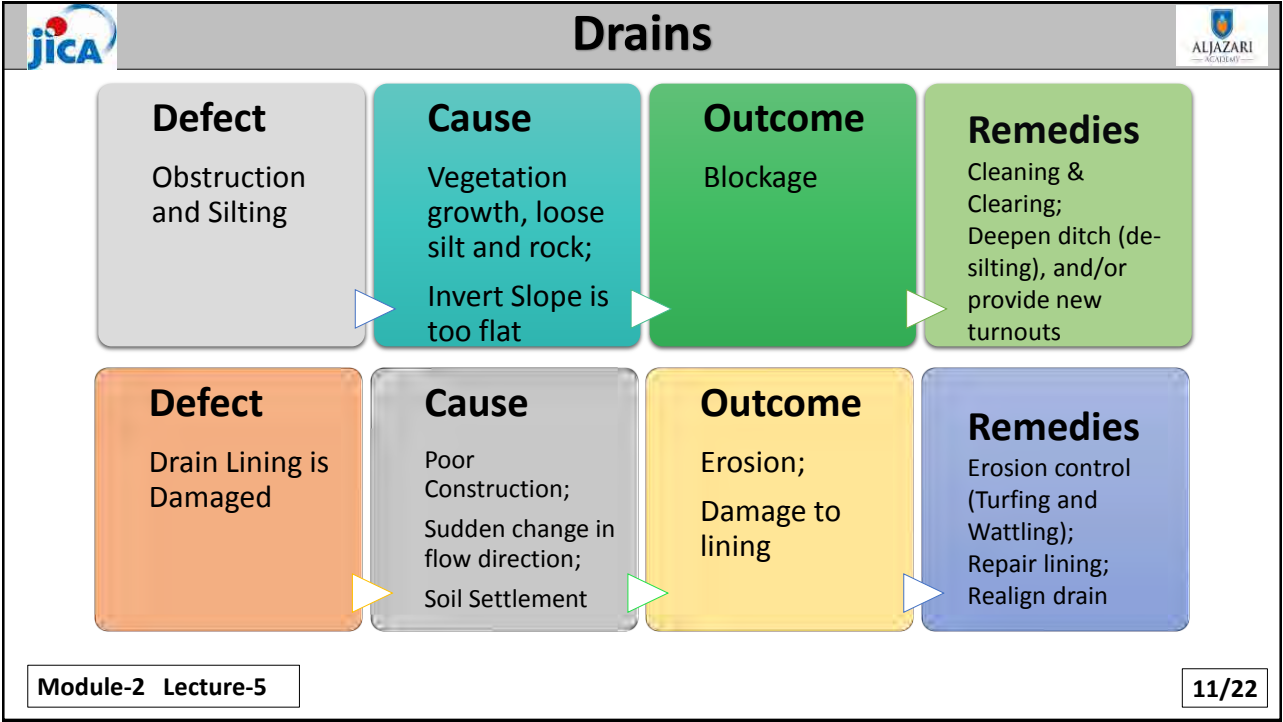

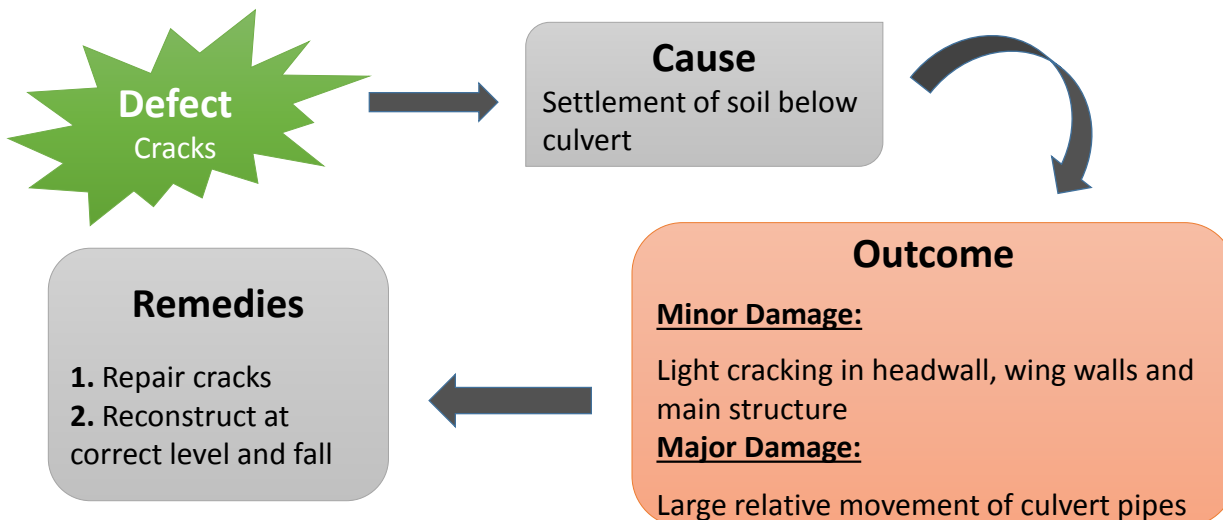
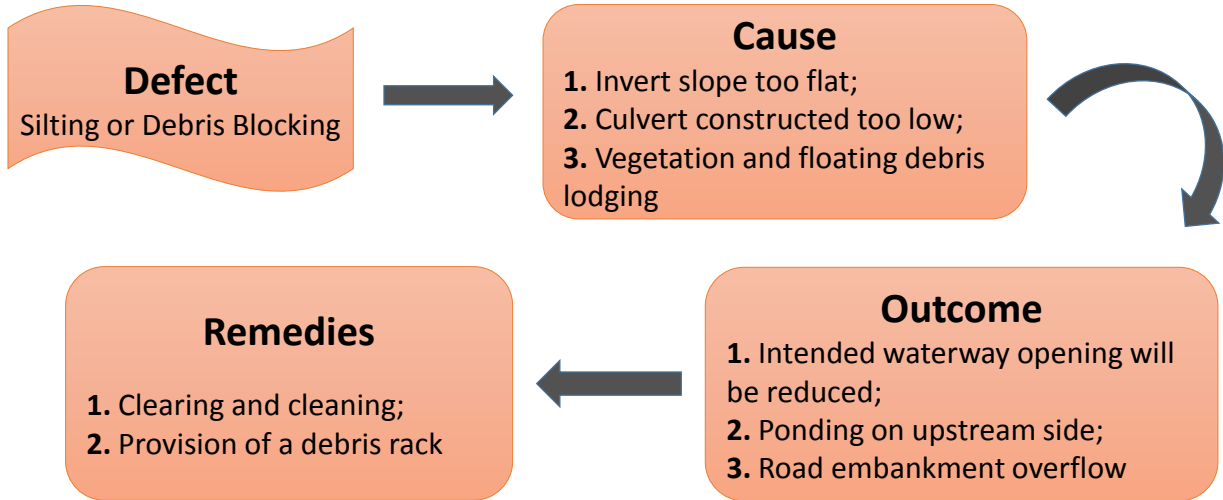

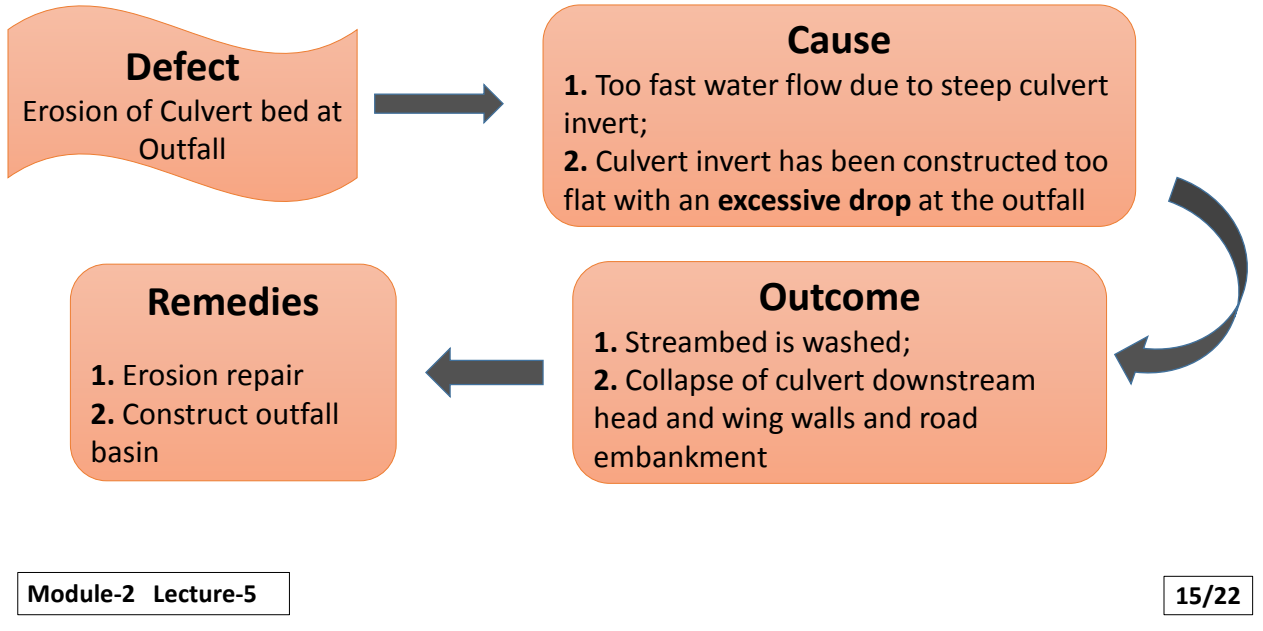

BMPs for Storm Water Drainage System

Municipal staff should regularly inspect facilities to ensure the following:

- Immediate repair** of any deterioration
- Cleaning before the sump is **40% full**
- Clean structures in **high pollutant load areas** just before the wet season
- Keep **accurate logs** of the number of catch basins cleaned
- Record** the amount of waste collected
- Store wastes** in appropriate containers or temporary storage sites



- ❖ Consider modification of storm channel characteristics to:
 - Improve channel hydraulics,
 - Increase pollutant removals, and
 - Enhance channel/creek aesthetic and habitat value.
- ❖ Conduct channel modification/improvement in accordance with existing laws.



- ❑ Regularly inspect and clean up hot spots
- ❑ Establish a system for **tracking incidents**. The system should be designed to identify the following:
 - Illegal dumping hot spots
 - Types and quantities (in some cases) of wastes
 - Patterns in time of occurrence
 - Mode of dumping
 - Responsible parties
- ❑ Post **“No Dumping”** signs in problem areas with a phone number for reporting



BMPs for Dredging

- ❑ Installation of **temporary silt fence**
- ❑ Fence shall remain in place for the duration of the maintenance dredging activity
- ❑ Stop the activity if watercourse flows are encountered
- ❑ **Accumulated silt** shall be removed to the greatest extent possible
- ❑ Dredging shall be conducted with hand tools and/or a tracked equipment



- ❑ Dredging shall be held to the absolute minimum necessary to achieve the target channel width, depth and gradient
- ❑ The channel banks shall be sloped such that the resulting channel banks are stable
- ❑ Maintenance dredging shall not straighten or shorten the existing channel alignment
- ❑ Woody material embedded in the channel bank shall be left undisturbed and intact





Course

Operation and Maintenance of Sewer & Storm Water
Drainage System Including Safety Practices

Module 2

Operation and Maintenance of Storm Water Drainage System

Lecture 4

Dredging and Desilting Operations

1. Small Scale Dredging

2. Critical Processes in Small Scale Dredging

3. Dredging Process

4. Dredging Techniques & Case Study

5. Selection Criteria for Dredging Techniques

6. Workplace Worksheet and Traffic Control

Small-scale dredging projects generally involve drainage channels and modified rivers in areas with artificial (pumped) drainage and smaller urban and suburban waterways, which are not used for shipping activities



- ❑ **Accessibility** along and in channels and lakes
- ❑ Logistics and transport of material in populated areas (traffic)
- ❑ **Limited space** for disposal of sediment and waste
- ❑ Sensitive project environment:
 - hinder to surroundings
 - highly visible
 - public opinion and interest
- ❑ (Old) embankments, low bridges, etc.
- ❑ **Household waste & objects**



Excavation

Process involves the:
Dislodgement;
Removal of sediments
(soils) and/or rocks

Dredger – is used to excavate the material either:

- Mechanically
- Hydraulically
- By combined action

Transportation

Transportation of dredged material is achieved by:

- In self-contained hoppers of the dredgers;
 - In barges;
- Rarely used transport methods are:
- Truck
 - Conveyor belt

Utilization or Disposal

- In **construction projects**, dredging is driven by the demand for dredged material.
- In **navigation and remediation dredging**, the project is driven by the objective of removing the material from its original place

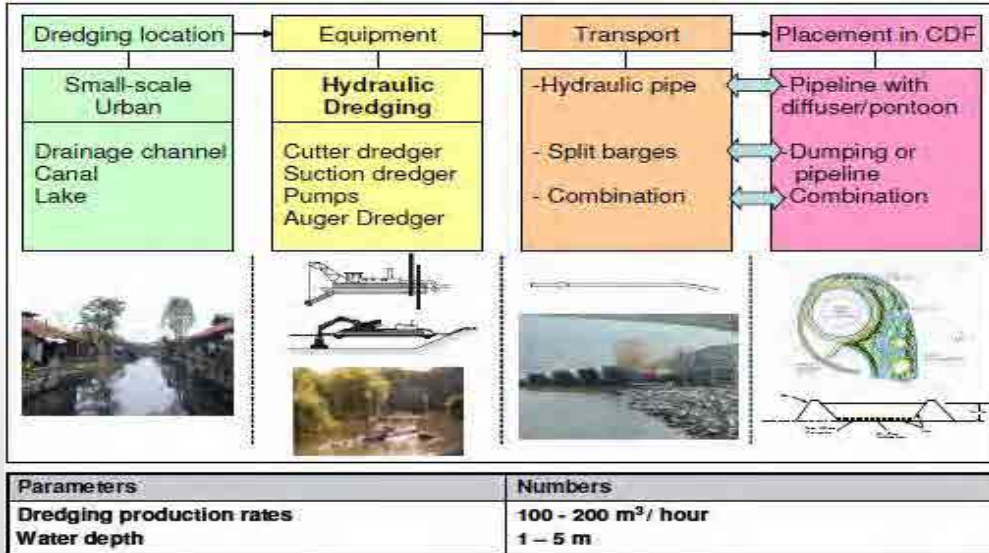

Hydraulic Dredging

- Used for maintenance dredging projects
- Removal of loosely compacted materials by cutter heads, dustpans, hoppers, hydraulic pipeline, plain suction, and side casters



Cutter Head

Mechanical Dredging

- Used either for maintenance or new-work projects
- Removal of loose or hard compacted materials by clamshell, dipper, or ladder dredges



Clamshell

While selection of dredging technique, the following factors must be taken into consideration:

- Composition of dredged materials
- Type and level of pollution
- Specific circumstances
- Size of project
- Acceptable opacification and spillage
- Required accuracy
- Side-effects
- Ecological considerations



Work Report No: Date:

District:

Zone: Road No:

Section: From km to km

Location (s):

WORK ACHIEVED:

.....

.....

MANPOWER USED:

Name..... Grade..... Hour Worked.....

Name..... Grade..... Hour Worked.....

Name..... Grade..... Hour Worked.....

EQUIPMENT USED: DIESEL USED

Hrs..... Liters

Hrs..... Liters

MATERIALS USED:

.....



Course

Operation and Maintenance of Sewer & Storm Water Drainage System Including Safety Practices

Module 2

Operation and Maintenance of Storm Water Drainage System

Lecture-3

Tools and Equipment for Drain Cleaning Operations

Module-2 Lecture-3

3/15

Contents

- Hydraulic Excavator
 - Excavation Buckets
 - Variations of Excavators

- Silt Pusher Boat
- Cutter Suction Dredger
- Dredge Pump



Module-2 Lecture-3

4/15

- Excavators (Hydraulic Excavators) are heavy construction equipment consisting of a boom, dipper (or stick), bucket and cab on a rotating platform known as the "house"
- All movement and functions of a hydraulic excavator are accomplished through the use of **hydraulic fluid**, with hydraulic cylinders and hydraulic motors



Digging Bucket

- Excavates materials using a pulling movement
- It is often implemented to remove thin layers of silt



Dredging Bucket

- Slightly different from standard buckets
- Characterized by holes that retain silt while allowing water to escape



Visor Bucket

- Traditional excavation bucket
- Excavate thin and very dense layers with low water content

Clamshell

- Operates using a gripping movement
- Excavate thick layers of silt and for transferring materials
- Layer thickness must be at least 0.5 m in order to achieve reasonable productivity



Environmental Grab Bucket

- An alternative type of grab bucket
- Enables an almost horizontal closing movement
- The maximum opening is circa 80% larger than a traditional grab bucket
- Relatively thin layers can also be excavated efficiently

Backhoe

- It has emerged as a suitable workhorse for soils:
 - glacial tills
 - fragmented or softish, crumbly rock
 - variety of non-rock types of soils that have stones
- May be used for dredging relatively small quantities of material that are at varying depths
- Often used for bulk dredging of a variety of sediments



A wide range of variations have been developed for hydraulic excavators over the years due to:

- Height restrictions
- Propulsion issues
- Insufficient access to the water bottom

The following variations can be encountered:

- Excavator boat
- Amphibious Excavators
- Tractor with Side-Arm



Excavator Boat



Amphibious Excavator



Tractor with Side-Arm

- ❑ A silt push boat is like a floating bulldozer, which has been developed especially for cleaning ponds, lakes and small waterways
- ❑ The machine is primarily used in situations where it is difficult to work from the water's bank

Range of Applications

- Primarily suitable for soft water bottoms (silt, clay, turf, mud, etc.)
- Effective on relatively long, straight waterways
- It can also be used for thicker layers.
- Only effective in relatively shallow waters.
- Depending on the dimensions of the machine, it is possible to work in **Depths of up to 2 m**
- Machine becomes unsuitable when depths exceed 3 m



- ❑ A cutter suction dredger is a dredging machine that is used in continuous excavation processes and is positioned using spud poles or winch cables



Range of Applications

- Generally only suitable for silt, clay and sand.
- Depending on the dredger design, be used up to **6 m deep**
- The soil type and project conditions must be known for each project
- For **harder bottoms** (i.e. sand), a cutter with larger cutting sections must be selected in order to penetrate the layer of sand

- ❑ Used to suck dredging materials from the water bottom
- ❑ The pump's suction opening is guided through the center of ditches to maximize contact with dredged materials
- ❑ Dredge pumps can be mounted to a tractor or crane, or can also be placed on a boat



Range of Applications

- Only suitable for soft water bottoms (silt, turf, etc.)
- Suited to waterways with non-polluted silt
- **Cutter** can also be attached for dredging more solid water bottoms
- Dredge pumps are **susceptible to stones** and **branches**, which could block the opening
- Less suited to dredging activities in urban settings



Dredge Pump



Observations

Module-2 Lecture-3

13/15



Module-2 Field Visit-01 (Observation of De-Silting Machinery)



Date:

Name:

Day:

Designation:

Field Visit Site:

WASA/TMA:

Temp.

Sr. No.	Machinery					Attachment(s)		Remarks
	Name/Type	Nos.	Manufacturer /Year	Capacity (Tons)	Fuel Consumption (Liters/day)	Name/Type	Capacity (Tons)	
1.								
2.								
3.								
4.								
5.								
6.								
7.								

Module-2 Lecture-3

14/15



Course

Operation and Maintenance of Sewer & Storm Water
Drainage System Including Safety Practices

Module 2

Operation and Maintenance of Storm Water Drainage System
Lecture 06 & 07

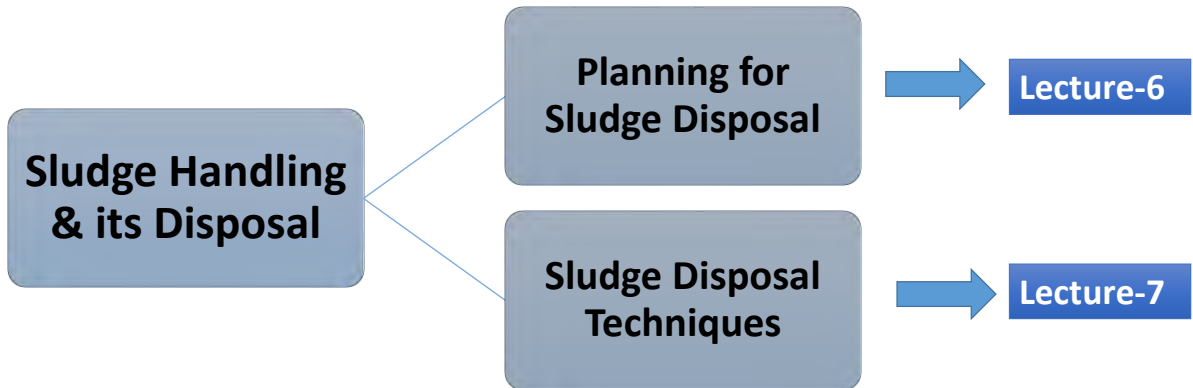

Contents

- Importance of Site Selection
- Early Considerations
- Requirements for Site Selection
- Screening Process for Site Selection
- Site Selection Criteria
- Factors to be considered for Criteria



- ❑ Minimizes the future impact on public health
- ❑ Reduces the cost of:
 - Design and Construction
 - Operation
 - Maintenance

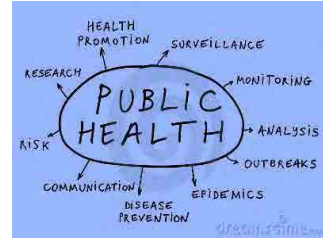

Size

- depends on the waste stream over the predicted site life and provision for sufficient buffer zones

Strategic Location

- determined by the waste generation areas to be served and transport routes

- Spatial and urban planning requirements
- Spatial and regional requirements
- Required land area
- Transportation distances
- Local site conditions
- Topography
- Climate conditions
- Hydrogeological conditions
- Geological conditions
- Geo-mechanical conditions
- Environmental protection

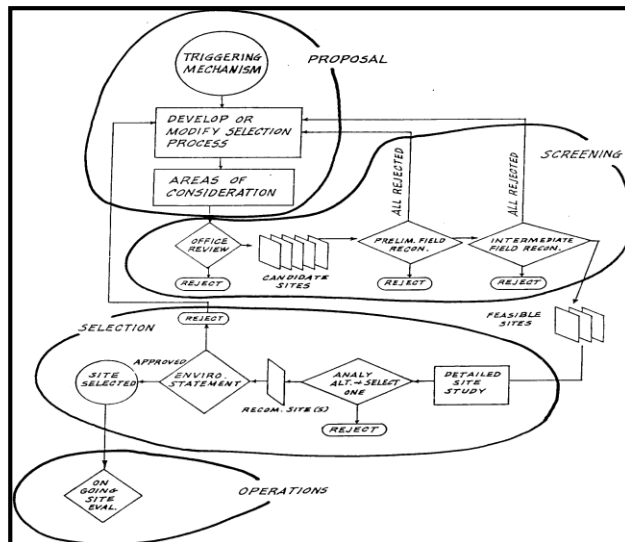

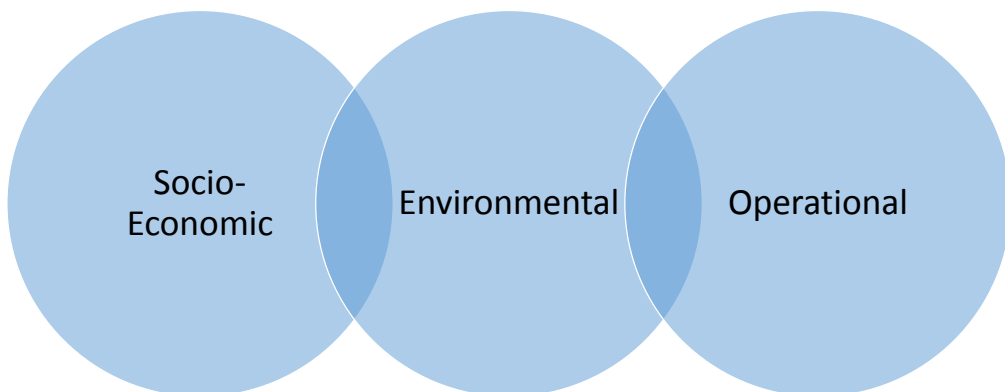
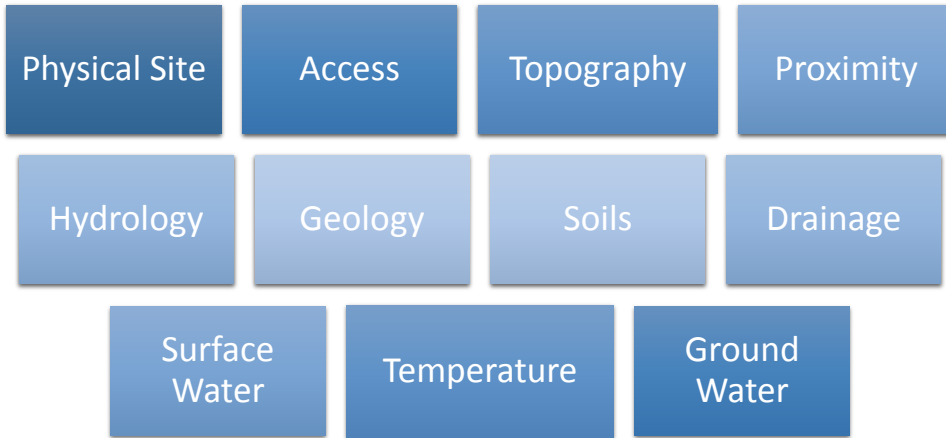

Contents

- ❑ Introduction
- ❑ Controlled Dumping
 - Important Considerations for Controlled Dumping
- ❑ Landfilling
 - How it Works
 - Sludge Disposal at a MSW Landfill
 - Sludge/Solid Waste Mixture
 - Sludge/Soil Mixture

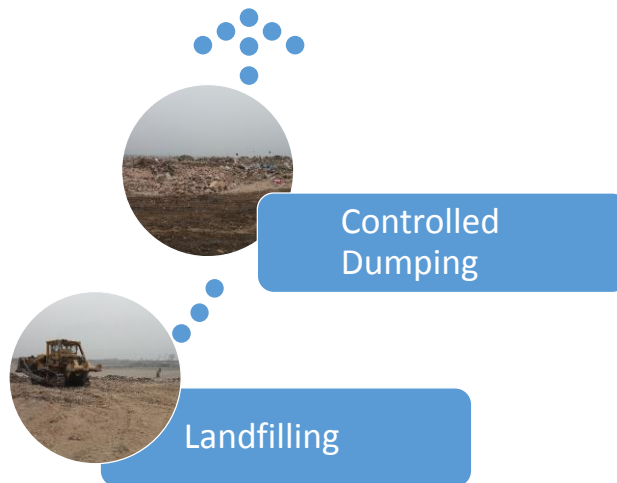

- ❑ Essential burial of waste in earth on a daily basis, in an isolated and demarcated site
- ❑ An established system for rotational and organized deposit of waste
- ❑ To prepare the site to retain its waste more effectively



- ❑ Minimize its chances of contact with **humans and animals**
- ❑ Waste should be covered with a soil layer **10-15cm** deep
- ❑ If coverage with soil is not possible, **lime** may be deposited over the waste
- ❑ **Access** to these dedicated disposal areas should be **restricted**
- ❑ It would require **supervision by staff**
- ❑ Prevent scavenging



- ❑ Landfill is the site where waste is isolated from environment until it is safe
(Until completely degraded biologically, chemically and physically)



- ❑ In landfill operation, Sludge is spread and compacted in thin layers within a small area
- ❑ To allow for proper compaction, the **cell depth** should not exceed about **2 meters**
- ❑ The cell is then covered with a **layer of soil** which is spread uniformly and then compacted
- ❑ To provide an adequate **seal the cover** should normally be at least 20 cm thick

- ❑ When a number of cells reach the final desired elevation, a **final cover of about one meter** of earth is placed and it is again compacted
- ❑ Landfill must be provided with **Liners** to prevent the migration of waste out of landfill to adjacent surface soil or ground water or surface water during anytime

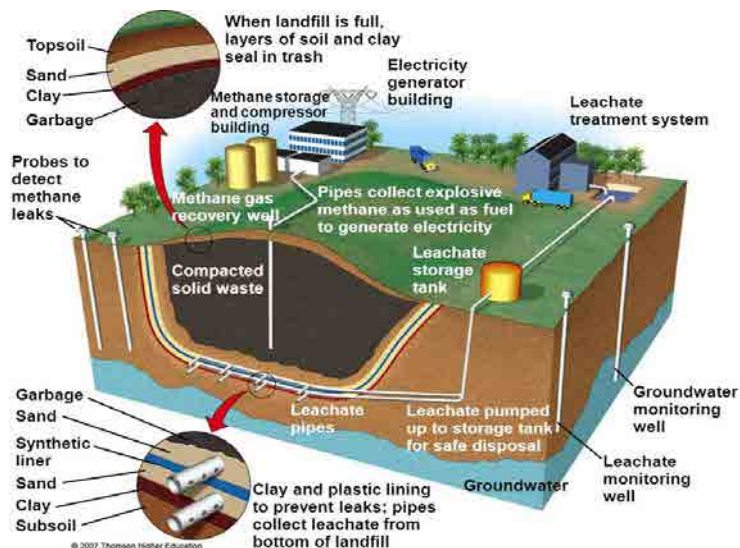

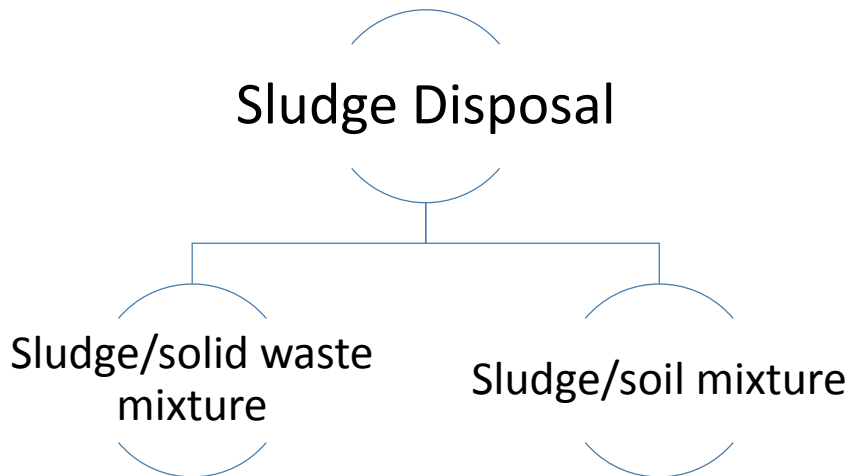

- Sludge is deposited atop solid waste and mixed as thoroughly as possible with the solid waste
- The mixture is then spread, compacted, and covered in the usual manner used at MSW landfills
- The minimum sludge solids content is approximately 20 percent
- The sludge is usually spread by conventional landfill operating equipment

- ❑ To provide adequate workability of the sludge/solid waste mixture, the bulking ratio for a 20 percent solids sludge should be **4 mg of solid waste to 1 wet mg of sludge**
- ❑ **Sludge application rates** for sludge/solid waste mixtures compare favorably with rates for other types of sludge disposal methods
- ❑ **Disposal rates** generally range from 500 to 4,200 yd³ of sludge per acre (900 to 7,900 m³ of sludge per ha)

- ❑ Sludge is mixed with soil and applied as intermediate or final cover over completed areas of the MSW landfill
- ❑ This is not strictly a sludge landfilling method from an engineering standpoint, because the sludge is not buried



But it is a viable and proven option for disposal of sludge at MSW landfills



O&M of Sewerage & Drainage System including Safety Precautions Module 02

Action Plan Template



Sr. No	WHAT TO DO?	HOW TO DO?	WHEN TO DO?	WHO TO DO?		DO WITH WHAT?		CHECK DONE?	WHO TO CHECK?
	(Define O&M Task)	(Follow SOP Ref.#)	(Frequency)	(Carried out By)		Materials	Tools/ Equip.	How to Check?	To be Checked By?
			Class of Work	Worker					

Thanks indeed for your valuable time

• GOOD BYE

Have a Safe Journey



 

Operation and Maintenance of Sewer and Drainage System



The slide has a light gray background with a white diagonal line. The title is centered in a bold, black, sans-serif font. The image of the pipes is on the right side, showing two large, grey concrete pipes lying on a bed of gravel. The slide includes logos for JICA and Al-Jazari University in the top corners, and a footer with the text "Module-3 Lecture-1 & 2" and "2 / 25" in the bottom corners.

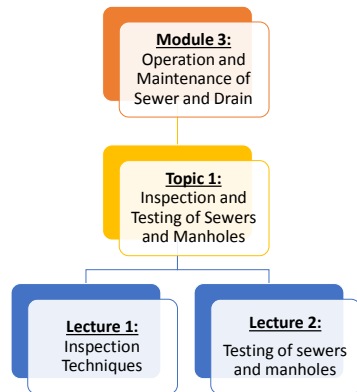

jica **Lecture Contents** 

Lec 1:
Inspection of Sewers & Manholes

- Objective
- Equipment
- Inspection Methods
- Failures & their prevention

Lec 2:
Testing of Sewers & Manholes

- Types of testing
- Equipment
- Method



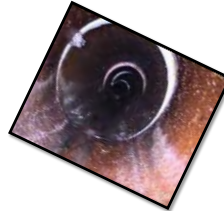

- To identify existing or potential problem in the collection system
- To determine the proper elevations or grades around the lid to be sure the lid isn't buried
- To examine structural integrity (look for cracks) of the manhole and its functional capacity
- To generate clear, concise, and meaningful reports to supervisors regarding problems







<ul style="list-style-type: none"> Powerful flashlight 	<ul style="list-style-type: none"> Warning devices, safety cones and other traffic safety devices
<ul style="list-style-type: none"> Map of the collection system to reference manhole 	<ul style="list-style-type: none"> Metal detector
<ul style="list-style-type: none"> Manhole lid removal device 	<ul style="list-style-type: none"> Gas detection devices
<ul style="list-style-type: none"> Scrapers and wire brushes for cleaning the manhole ring 	<ul style="list-style-type: none"> A blower and hose for ventilating manhole
<ul style="list-style-type: none"> Leather gloves 	<ul style="list-style-type: none"> A pick and shovel

jica Inspection Methods **ALJAZARI**

Visual
CCTV
Lamping
Camera Inspection
Sonar

Module-3 Lecture-1 & 2 9 / 25

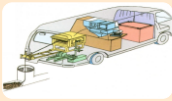
jica Limitations of Inspection Techniques **ALJAZARI**

			
<p>In smaller sewers, the scope of problems detected is minimal.</p> <p>Any definitive information on cracks or other structural problems is unlikely.</p>	<p>The video camera does not fit into the pipe and during the inspection it remains only in the maintenance hole</p> <p>Only the first 10 feet of the pipe can be viewed or inspected</p>	<p>Requires late night.</p> <p>TV operators are vulnerable to lapses in concentration.</p> <p>Quite expensive.</p> <p>Time consuming.</p>	<p>Photographs are taken haphazardly.</p> <p>The photographs tend to be less comprehensive.</p>

Module-3 Lecture-1 & 2 10 / 25

- Visual inspections are vital in fully understanding the condition of a sewer system.
- Visual inspections of manholes and pipelines are comprised of surface and internal inspections.

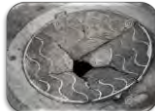

Manhole identification number and location

Cracks or breaks

Offsets or misalignments

Atmospheric hazard measurements

Evidence of surcharge

Condition of the frame

Inflow or Infiltration

Accumulations of grease, debris, or grit

Presence of corrosion

Wastewater flow characteristics

Sr. No	Defects	Sr. No	Defects
1.	Cracks or breaks in the walls or bottom	7.	Gravel or debris accumulations in invert
2.	Infiltration at any place	8.	Concrete or grout in the invert or pipe causing flow turbulence
3.	Joints in a manhole should be tight.	9.	Deterioration of the grout bed of frame
4.	There should not be any visible cracks	10.	Grease accumulations inside of sewers entering and leaving manhole
5.	Offsets or misalignment of any parts	11.	Sluggish flow or wastewater backing up into the manhole
6.	Root intrusions	12.	Corrosion

- Build-up of grease & debris
- Tree root intrusion
- Old and deteriorated sewer pipes
- Illegal pipe connections





Preventing Stoppages



Sr. No.	Stoppages	Remedial Actions
1	General Causes of Stoppages	<ul style="list-style-type: none"> Building awareness among general public about the prevention of blockade Provision of manhole lid if not provided Construction of sewer appurtenances (like catch basin) if absent
2	Joint failures	<ul style="list-style-type: none"> Repairing of the joint or replacement the pipe
3	Tree roots intrusion	<ul style="list-style-type: none"> Plantation of trees should be avoided along side the sewerage network Roots should be removed from pipe and repair the cracks
4	Improper Hydraulic Design	<ul style="list-style-type: none"> Redesign the problematic stretch to avoid the repeated stoppages

Module-3 Lecture-1 & 2

15 / 25

MANHOLE INSPECTION REPORT

MH NO. _____ DATE _____ TIME _____ INSPECTOR _____
 ELEVATION _____ DEPTH TO INVERT _____ CLEANLINESS _____
 TYPE CONSTRUCTION _____ STREET REFERENCES _____

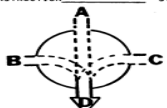
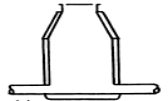
DEFECTS: (Cover, frame, grout, steps, shelf, pipes, or channels)

- _____
- _____
- _____
- _____
- _____
- _____
- _____

8. (USE REVERSE SIDE FOR ADDITIONAL DEFECTS TO BE NOTED.)

PIPE SIZE	LENGTH TO MH	EST. FLOW	TYPE FLOW
A- _____	_____	_____	_____
B- _____	_____	_____	_____
C- _____	_____	_____	_____
D- _____	_____	_____	_____

REMARKS:
(Include need for repairs)

MANHOLE INSPECTION REPORT

Module-3 Lecture-1 & 2

16 / 25

Manhole Visual Inspection Report

SANTARY SEWER MANHOLE INSPECTION FORM			
V. SEC. #:		M.H. #:	
M.H. DEPTH:		DATE:	
I. INITIAL INSPECTION		II. STRUCTURAL INSPECTION	
A. LOCATION: 1. Roadway <input type="checkbox"/> 2. Gutter <input type="checkbox"/> 3. Paved Alley <input type="checkbox"/> 4. Unpaved Alley <input type="checkbox"/> 5. Easement <input type="checkbox"/> 6. Other <input type="checkbox"/>		A. STEPS: 1. Serviceable <input type="checkbox"/> 2. Unsafe <input type="checkbox"/> 3. Missing (No.) <input type="checkbox"/> 4. Corroded <input type="checkbox"/>	
B. MANHOLE COVER: 1. Serviceable <input type="checkbox"/> 2. Damaged <input type="checkbox"/> 3. Displaced <input type="checkbox"/> 4. Missing Grout <input type="checkbox"/> 5. Needs Raising <input type="checkbox"/> 6. Needs Lowering <input type="checkbox"/>		B. CONE: 1. Serviceable <input type="checkbox"/> 2. Broken <input type="checkbox"/> 3. Sulfided <input type="checkbox"/> 4. Misaligned <input type="checkbox"/> 5. Leaking/Bad Joints <input type="checkbox"/>	
C. RING & FRAME: 1. Serviceable <input type="checkbox"/> 2. Loose <input type="checkbox"/> 3. Displaced <input type="checkbox"/> 4. Missing Grout <input type="checkbox"/> 5. Needs Raising <input type="checkbox"/> 6. Needs Lowering <input type="checkbox"/>		C. RISE/F: 1. Serviceable <input type="checkbox"/> 2. Broken <input type="checkbox"/> 3. Sulfided <input type="checkbox"/> 4. Misaligned <input type="checkbox"/> 5. Leaking/Bad Joints <input type="checkbox"/>	
D. MANHOLE MATERIAL: 1. Brick <input type="checkbox"/> 2. Concrete <input type="checkbox"/>		D. SHELF: 1. Serviceable <input type="checkbox"/> 2. Broken <input type="checkbox"/> 3. Dirty <input type="checkbox"/> 4. Sulfided <input type="checkbox"/> 5. Bad Base Joint <input type="checkbox"/>	
E. SIZE M.H. COVER: 1. 24 inch <input type="checkbox"/> 2. 30 inch <input type="checkbox"/>		E. CHANNEL: 1. Serviceable <input type="checkbox"/> 2. Obstructed <input type="checkbox"/> 3. Sulfided <input type="checkbox"/> 4. Bad Pipe Joint <input type="checkbox"/> 5. Sit <input type="checkbox"/> 6. Poor Struct. Cond. <input type="checkbox"/>	
F. MANHOLE SIZE: 1. 4 foot <input type="checkbox"/> 2. 5 foot <input type="checkbox"/>		F. FLOW DEPTH: _____ Inches Time _____ AMPM	
IV. VERMIN: 1. Roaches <input type="checkbox"/> 2. Rats <input type="checkbox"/> 3. Other <input type="checkbox"/>			
OBSERVATION SUMMARY:			

Manhole Inspection Form

17 / 25

Module-3 Lecture-1 & 2

Testing of Sewers & Manholes

Objectives

- Find out leaks in sewers joints and manholes
- Locate and determine the inflow, infiltration and exfiltration problems
- Effectively use tools and equipment and procedures

Module-3 Lecture-1 & 2

18 / 25

- Smoke Testing
- Dye Testing
- Water Flooding Test
 - Sprinkler test
 - Exfiltration test



Objectives

Smoke testing is a relatively inexpensive and quick method of detecting:

- Sources of inflow in sewer systems, such as down spouts, or driveway and yard drains
- The location of illegal connections into the collection system
- The location of broken sewers due to foundation settlement, manholes and other structures

Equipment Required

Air Blowers

Camera and Film

Smoke Bombs

Sand Bags and/or Plugs

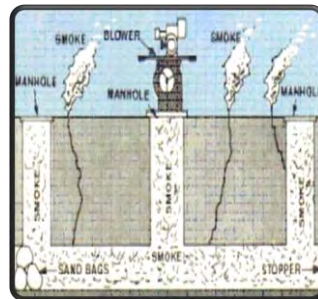

21 / 25

The typical application of dye testing includes the following:

- Where a storm water drain is suspected of being linked into the building sewer or later sewer;
- Testing for infiltration and exfiltration; and
- Flow velocity measurement.



22 / 25

Equipment Required

Fire Hydrants

Fluorescent Dye

Sand Bags

Water Tankers

Sprinkler Test

Determine the quantity of infiltration being experienced in sewer lines under unpaved areas, particularly service connections, during wet weather conditions.

The rainfall is simulated by sprinkling the areas above the sewer lines to be tested with water.

Exfiltration Test

Check the sewer lines and manholes for possible leakages.

The results from exfiltration tests can also be compared with the infiltration rates determined by the sprinkler tests in a given area.



**Thank
You!!!**

25/25

بِسْمِ اللّٰهِ الرَّحْمٰنِ الرَّحِیْمِ

شروع اللہ کے نام سے جو بڑا مہربان نہایت رحم والا ہے۔



Operation and Maintenance of Sewer and Drainage System





Module3:

Operation and Maintenance of Sewer and Drain



Topic 2:

Machinery, Tools and Equipment for Cleaning Sewer Line, Manhole and Disposal Station along with Standard Cleaning Techniques



Lecture 1:
Machinery, Tools and Equipment Requirement & Maintenance



Lecture 2:
Cleaning Techniques

Machinery, Tools and Equipment

- Requirement
- Maintenance



Lecture Breakdown

- Objective
- Sewer Cleaning Equipment
- Advantages & Limitations
- Effectiveness of Solution
- Cleaning Equipment Maintenance
- Responsibility of Maintenance
- General Maintenance of Equipment Engines
- Maintenance Procedure



Objectives

- To make a selection criteria for choosing the right machine and equipment for cleaning job
- To make a preventive maintenance program for sewer clearing and cleaning equipment



Sewer Cleaning Equipment

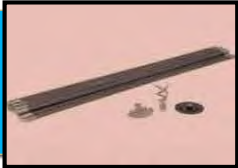

Rodding



Sewer Ball



High Velocity Cleaner



Bucket Machine

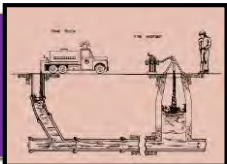

Flushing

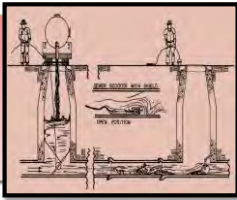

Scooter

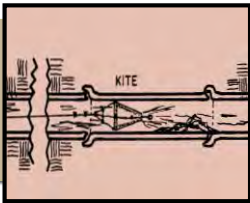

Kite

Rodding



Advantages

- To cut roots
- Scrape, dislocate and remove certain material
- Very effective in removing emergency stoppages

Limitations

- Ineffective for removing sand and grit, but may loosen material
- Rods have a tendency to coil and bend

Sewer Ball



Advantages

- Hydraulic action of spinning ball and high
- Velocity of water dislodge debris and move debris downstream
- Very effective in removing heavy concentrations of sand,
- Grit and grease from sewers

Limitations

- Dangerous to use in steep-grade hill areas
- Cannot be used effectively when sewers have protruding service connections because ball will not be able to do an effective cleaning job

High Velocity Cleaner (Jetting and Sucking Machine)



Advantages

- Very effective in cleaning flat, slow flowing sewers
- Efficient in removing grease, sand, gravel, and debris
- Can be used to remove emergency stoppages

Limitations

- Effectiveness in take out debris from larger diameter lines decrease as the cross-sectional area of the pipe is increased

Bucket Machine



Advantages

- Efficient in removing sand, gravel, and debris

Limitations

- Can damage pipe line internally
- Setting up equipment is time taking activity

Flushing

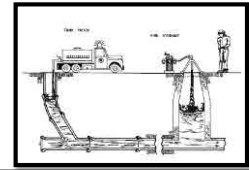

Advantages

- Supplies a surge of water to move light, decaying organic matter downstream in slowly flowing sewers

Limitations

- Must use with care in steep-grade hill areas
- Causes a temporary movement of debris
- Flushing does not remedy the cause of the problem
- This method does not move heavy debris and grit

Scooter

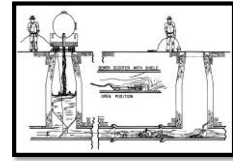

Advantages

- Very effective in removing in heavy debris due to scouring action
- Capable of removing grease

Limitations

- Must use with care in steep-grade hill areas
- When cleaning large diameter sewers, the manholes must be designed to a bigger size to receive and retrieve this equipment

Kite

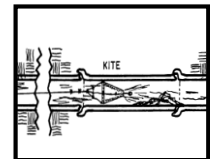

Advantages

- Efficient in removing debris
- Capable of washing ahead of it a full pipe of deposits
- Root removal

Limitations

- Must use with care in steep-grade hill areas

Effectiveness of Solution

Sr. no.	Solution to problem	Type of problem				
		Emergency stoppages	Grease	Roots	Sand, grit and debris	Odor
1.	Flushing					▪
2.	Hand rod	▪	▪	▪		
3.	Power rodder	▪	▪	▪		
4.	High velocity cleaner	▪	▪		▪	▪
5.	Bucket machine				▪	
6.	Balling		▪		▪	▪
7.	Scooters		▪		▪	

Cleaning Equipment Maintenance

Objectives

To keep equipment in good repair to help prevent equipment failure on the job

To prolong the lifespan of the equipment

To enhance the efficiency and safety of maintenance jobs

Responsibility of Maintenance

The main responsibility goes to the following team members of WASA

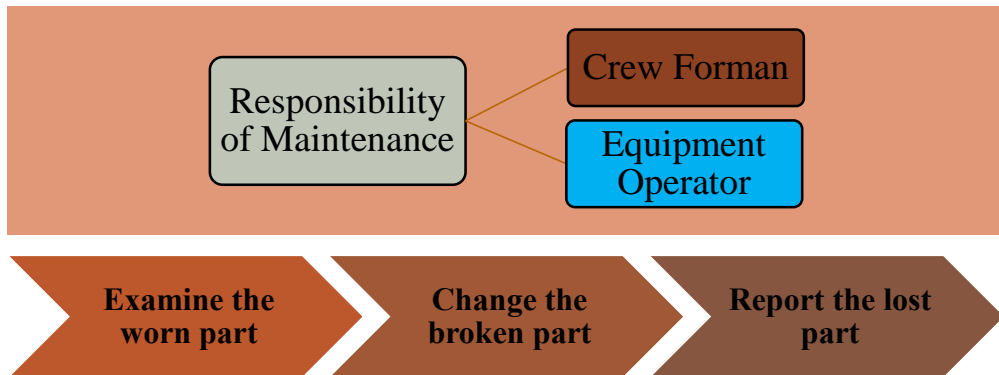

General Maintenance of Equipment Engines

- Always be sure oil and water levels are in proper range before starting unit
- Use a fresh supply of the proper grade of clean gasoline
- Change oil and air filters according to manufacturer's recommendations
- Exercise (operate) equipment weekly
- Use proper type of oil in engines, transmission and for lubrication
- Keep battery terminals clean and battery charged for engines with electric starters, especially during winter months

Maintenance Procedure of High Velocity Cleaner

Daily Maintenance Steps

Sr. No.	Description	Sr. No.	Description	Sr. No.	Description
1	<ul style="list-style-type: none"> Keep all equipment and accessories clean. 	2	<ul style="list-style-type: none"> Hold Tank 	3	<ul style="list-style-type: none"> Oil Levels
	<ul style="list-style-type: none"> a) Tool compartments b) Engine compartment 		<ul style="list-style-type: none"> a) Drain to prevent 		<ul style="list-style-type: none"> a) Engine b) Pressure pump Hydraulic oil tank
	<ul style="list-style-type: none"> ✓ Wipe up oil and grease ✓ Paint rust spots 		<ul style="list-style-type: none"> ✓ Rust ✓ Sand or dirt deposits 		
			<ul style="list-style-type: none"> a) Clean tank strainers 		
4.	<ul style="list-style-type: none"> Tape splits in hose, or replace as necessary 	5.	<ul style="list-style-type: none"> Look for worn or plugged orifices in nozzle. 		



**Thank
You!!!**

بِسْمِ اللّٰهِ الرَّحْمٰنِ الرَّحِیْمِ

شروع اللہ کے نام سے جو بڑا مہربان نہایت رحم والا ہے۔

Operation & Maintenance of Sewer & Drainage system (S 3221)

Module 3

Topic 2 :

Machinery, Tools and Equipment for Cleaning Sewer Line

Lecture 2:

Cleaning Techniques

Duration :

05 hrs

Cleaning Techniques

Module-3 Lecture-4

3/28

Contents

- Objectives
- Reasons of Cleaning
- Methods of Cleaning
 - Manual
 - Mechanical
 - Hydraulic
 - Setup & Procedures
 - Safety & Precautions
- Record of Cleaning Operation



Module-3 Lecture-4

4/28

Objectives

To Determine Equipment & Staffing requirements for various Sewer Clearing & Cleaning Methods

To Set up Sewer Clearing & Cleaning Equipment Carefully & Appropriately

To Operate & Maintain Sewer Clearing & Cleaning Equipment without harm & Effectively

To Record the Necessary Data & Information pertaining to Clearing & Cleaning Operations

Module-3 Lecture-4

5/28

Reasons for Cleaning Sewer and Manhole

To remove the Stoppages and Obstruction



To Reduce the Complaints regarding the Bad Odor

Odor Control

To Minimize the Overflow and Ponding of Sewage



Module-3 Lecture-4

6/28

Factors to be Considered for Proper Cleaning

For proper Cleaning, following Factors must be Considered:

- Access Condition of Manholes
- Depth of Sewer
- Size of Pipe
- Depth & Type of Solid material to be Removed
- Degree of Root Intrusion
- Amount of Flow
- Structural Integrity of Pipes
- Degree of Cleanliness



Module-3 Lecture-4

7/28

Adverse Outcomes of Not Cleaning

If debris is allowed to accumulate,

- Reduction of capacity of the pipe
- Blockage
- Overflows
- Physical damage to sewers

Module-3 Lecture-4

8/28

Methods for Clearing and Cleaning

- 1) Manual
- 2) Mechanical
- 3) Hydraulic
- 4) Chemical

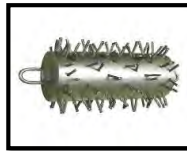
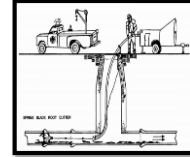

Module-3 Lecture-4

9/28

Manual Method

Hand Rod

Long strips from bamboo stem are taken and tailored to use as sewer cleaning rod between two consecutive manholes

Crew

If a crew is essentially doing only hand rodding, at least two operators are recommended:

1. Maintenance man I, and
2. Maintenance man II.



Module-3 Lecture-4

10/28

Set Up and Procedure

1. Ventilate the manhole and test for toxic gases, explosive gases, and oxygen level
2. Determine the depth of the manhole
3. Assemble sufficient rod portion to firmly rest in the sewer and leave enough protruding above the street level to allow for working conditions, usually about 18 to 24 inches

Module-2 Lecture-4

11/28

Precautions and Safety

- While rodding operation starts in the sewer line, the trapped hazardous gasses may erupt out and cause serious problems for the operator near the manhole opening. So care must be taken to handle such emergency situation
- Gas monitor must be used to test the concentration of hazardous gas.
- Wait for the proper ventilation before restarting the work otherwise causality may occur.



Module-3 Lecture-4

12/28

Mechanical Method

1) Power Rodder

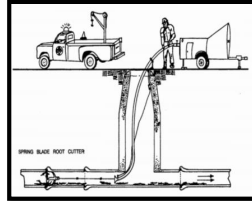

2) Bucket Machine (Winch Machine)



Module-3 Lecture-4

13/28

1. Power Rodder

- ❑ Power rodding machines use a steel rod to push or pull various clearing tools through sewers.
- ❑ These machines are of various designs and are equipped with a rod in a reel having lengths up to approximately 1,000 feet.
- ❑ This reel can be rotated to give turning action as the rod is pushed in or removed.

Module-3 Lecture-4

14/28

Uses of Power Rodder

1. Routine preventive maintenance
2. Scheduled clearing of:
 - a. Grease deposits
 - b. Roots
 - c. Debris accumulations in flat lines
3. Threading cable for:
 - a. Balling equipment
 - b. TV inspection
 - c. Bucket machines
4. Emergency use for clearing stoppages

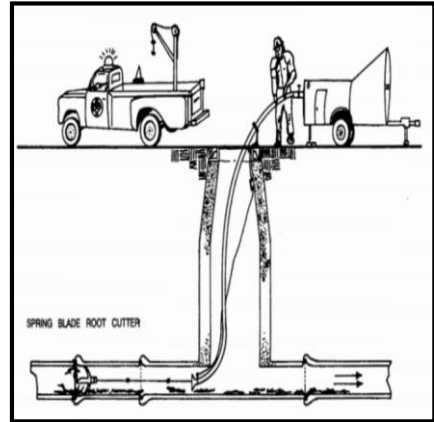

15/28

Module-3 Lecture-4

Rodding Operation

- Using the proper controls of the Rodder, push the rod and clearing tool into the line a few feet and slowly start rotating the rod in a clockwise direction
- Do not jam the rod into an obstruction
- Do not rotate the rod in one position for extended periods

Module-3 Lecture-4

16/28

Rodding Operation

- ❑ Clean the dislodged material out of the channel
- ❑ With the bucket, remove the material from the manhole and clean up around the working area

Module-3 Lecture-4

17/28

2. Bucket Machine (Winch Machine)

Equipment Set up

- 1) Position the two machines over the respective manholes
- 2) Place the pads under the stabilizer feet of the machine and jack them down so that the weight of the machine holds the pads in place
- 3) The lower manhole roller is lowered into the manhole
- 4) To thread the sewer, a synthetic rope can be used
- 5) To this rope attach a nylon parachute designed for such use and allow this parachute to float downstream to the working manhole

Module-3 Lecture-4

18/28

Operation

- 6) The clearing bucket is now ready to be attached to the cable
- 7) As the bucket is pulled upstream into the material deposited in the sewer, a definite resistance can be noticed when the bucket is full
- 8) When the bucket is full, pull the loaded bucket back out of the sewer.
- 9) Final cleanup is performed with special care given to washing down and completely cleaning the entire area

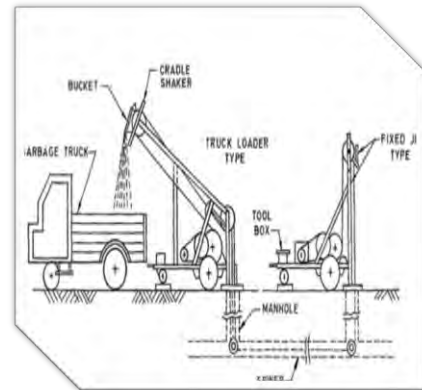

Module-3 Lecture-4

19/28

Precautions and Safety

- Regularly inspect cable clamps, clevis and swivels, bucket condition, cable condition, and condition of accessories
- If a bucket becomes lodged, don't try to force your way through
- Be careful when lowering the bucket into the working manhole
- Personal safety must be stressed when using cable-operated equipment



Module-3 Lecture-4

20/28

Hydraulic Methods

High water velocities can effectively remove grease, sand and other debris.

1. **Flushing**
2. **Jetting & Sucking**



Module-3 Lecture-4

21/28

1. Flushing

Flushing method of hydraulic cleaning is occasionally used at the beginning of the collection system where low or sluggish flows permit the deposition of solids.

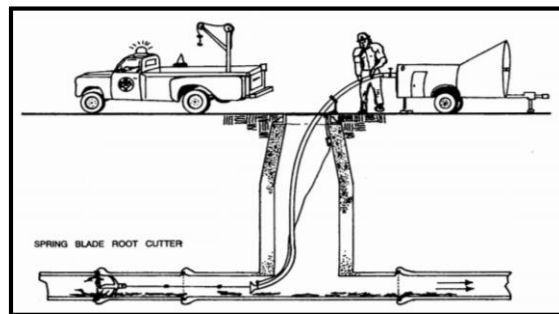

Module-3 Lecture-4

22/28

Set up and Operation

1. Start the flushing operation at the extreme upstream end
2. Place the water line over the manhole
3. Clean the manhole first
4. After you have dumped some of the water, observe if there is any evidence of the water backing up
5. Observe the water flowing in the downstream manholes and look for signs of grease, roots, or other debris that are creating the restriction
6. Close the manhole and go to the next downstream manhole
7. This operation will be repeated from manhole to manhole

Module-3 Lecture-4

23/28

Safety and Precautions

- Safety measures need to be followed carefully at all times
- PPE must be worn by all the personnel involved in working
- Gas must be monitored with gas detector periodically
- Working area must be highlighted with road safety cones



Module-3 Lecture-4

24/28

2. Jetting and Sucking

The use of hydraulic pressure to de-silt sewers dates back to the early 1900s; however, this method has been developed with the passage of time by using high velocity cleaning machines

- High velocity cleaning machines are confidently used to:
 - Open Stoppages
 - Remove Grease
 - Clean lines of Debris
 - Wash Manholes and Wet Wells

Module-3 Lecture-4

25/28

Equipment Set up and Operation

Sr. No.	Set up and working	Sr. No.	Set up and working
1.	Fill the water tank from a fire hydrant close to the area where you will do the cleaning	7	First try 50 feet to check the situation in the sewer
2	Start at the top or highest point in the collection system	8	By increasing pressure you may be able to go farther
3	Select the appropriate nozzle for the size of pipe to be cleaned	9	Retest the manhole atmosphere for sewer gases to be sure the ventilation procedures are effective
4	Install the proper size sand or debris trap in the downstream manhole	10	Allow an operator properly equipped with a safety harness to enter the manhole and shovel the debris into a bucket which in turn is pulled to the surface with a hand line
5	Turn the reel directional control to "Out" and lower the hose and cleaning nozzle into the manhole	11	During all this jetting operation sucking machine will suck all the dislodged silt and debris from the same manhole by a 4 inch hose
6	Turn the water valve on and start the high pressure pump	12	Sucker will be emptied at drain or some other purpose built area

Module-3 Lecture-4

26/28

Record of Cleaning Operation

Section 01			
Division		Subdivision	
Foreman		Time of cleaning started	
Date		Time of cleaning finished	
Temperature		Duration	
Street no.		Line size (dia.)	
Block / Mohallah		Manhole number	

Section 02			
Details of cleaning operation			
a) Condition of flow before cleaning		b) Machines used	
c) Condition of flow after cleaning		d) Tools and equipment	
e) Kind of materials removed			

Remarks:

Module-3 Lecture-4

27/28



28/28

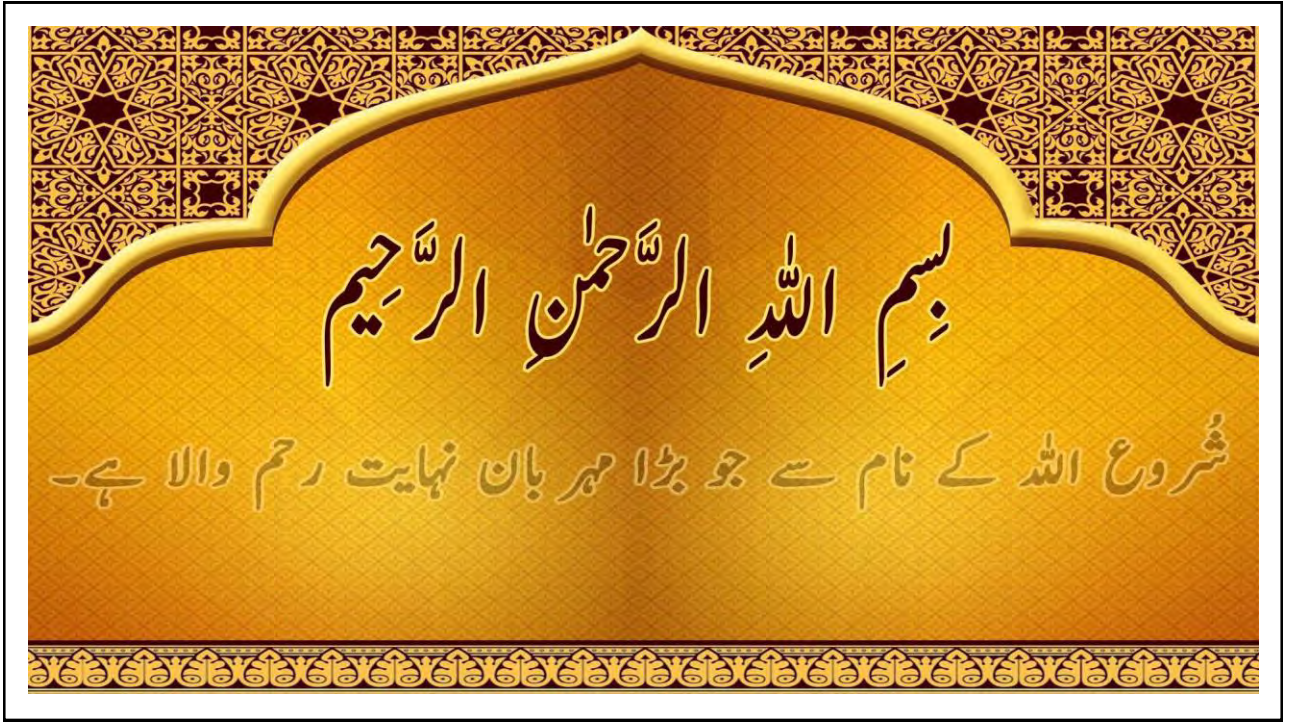

Operation & Maintenance of Sewer and Drainage System

Operation & Maintenance of Sewer & Drainage system (S 3221)

Module 3

Topic 3:

Maintenance and Rehabilitation of Sewer Line & Manhole

Lecture 1:

Repair and Rehabilitation

Duration :

03 hrs

Module-3 Lecture-5

3/34

- Objective
- Benefits of Rehabilitation
- Failures in System
- Solutions of Failures
- Renovation Material
- Repair Methods
 - Repair
 - Renovation
 - Replacement
- Rehabilitation Techniques
- Case Study

Lecture Breakdown



Module-3 Lecture-5

4/34

Repair & Rehabilitation

Objective

To maintain the overall viability of a conveyance system.

Module-3 Lecture-5

5/34

Factors affecting Selection Method

The choice of methods will depend on following factors:

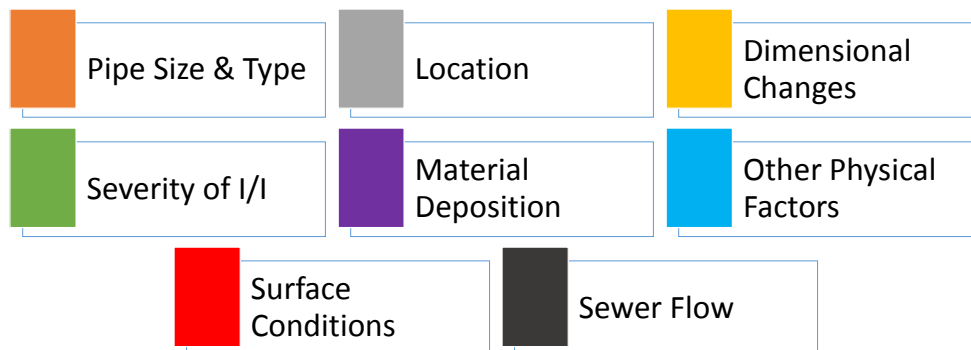

Module-3 Lecture-5

6/34

Outcomes of Rehabilitation

Minimize Sanitary Sewer Overflows

Improving the Hydraulic Capacity of the Sewer System

Eliminate or Reduce the Occurrence of Infiltration and Inflows

Failures in Sewer System & Manholes

Manhole Failures

Common failures of manholes are (ASCE, 1997):



Leaks & Deterioration

- Cracks, Holes & Joints
- Root Penetration
- H₂S Corrosion
- Traffic Loading
- Cover
- Mortar Erosion
- Structural Failure

Module-3 Lecture-5

11/34

Manholes Failures

Infiltration – inflow and exfiltration.

Surround ground settlements.

Hydrogen sulfide (H₂S) release may attack concrete manholes.

Corrosion of cast-in-place rungs can be an important safety issue.

Structural problems.

Module-3 Lecture-5

12/34

Solutions of Manholes Failures

- Grouting
- Concrete Patching
- Re-build Upper portion of Manhole
- Manhole Liner
- Corrosion Protection
- Build a Manhole within a Manhole



Module-3 Lecture-5

13/34

Renovation Material

- ✓ Chemical Grout
 - Acrylic
 - Acrylate Based Grout
 - Urethane Based Grout
- ✓ Cementitious Material
- ✓ Urethane Resin
- ✓ Rapid Setting Cements



Module-3 Lecture-5

14/34

Renovation Material

- ✓ Mono Crystalline Quartz Aggregates
- ✓ Various Accelerating Agents
- ✓ Liner materials shall be
 - Cement Based
 - Poly fiber Reinforced
 - Shrinkage Compensated
 - Siliceous Aggregates



Renovation
Leads to
New
Condition

Module-3 Lecture-5

15/34

Renovation Material

- ✓ Polyvinyl chloride (PVC) protective sheet liners
- ✓ High density polyethylene (HDPE)
- ✓ HDPE, PVC, EPP
- ✓ Rubber, brick, block, cement or poured concrete
- ✓ Oakum Water Plugs to prevent leakages
- ✓ Manhole frame adjustments shall be HDPE, PVC, EPP, rubber, brick, block, cement or poured concrete

Module-3 Lecture-5

16/34

Rehabilitation Methods

Module-3 Lecture-5

17/34

Rehabilitation Methods

Sewer rehabilitation methods include:

- ❖ **Repair**
- ❖ **Renovation**
- ❖ **Replacement**



Module-3 Lecture-5

18/34

Repair

Repairs may be temporary or permanent depending on the methods and technologies.

Types of Repairs

There are usually two types of repairs

- ❖ Structural Repairs
- ❖ Non-Structural Repairs



Module-3 Lecture-5

19/34

Methods of Repairs

- ❖ Point and Replacement Repairs
- ❖ Joint Testing and Grouting
- ❖ Sewer Lining



BEFORE



AFTER

Module-3 Lecture-5

20/34

Spot Repair

The following techniques are available for spot repairs of short deficient sections of a pipeline which is otherwise in a generally good condition:

- ❖ Open Cut Repair/Replacement
- ❖ CIPP
- ❖ Internal Grouting
- ❖ External Grouting
- ❖ Rubber Seals with Stainless Mechanical Bands

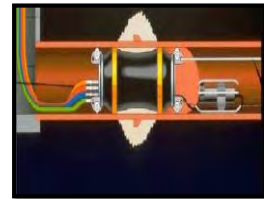
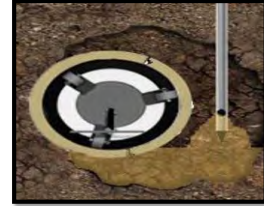

Module-3 Lecture-5

21/34

Renovation

- Renew the Structural Integrity of the Sewer
- Use the Existing Pipe Structure to “build” a New Pipe or Support a New Lining
- Coating and Lining

Replacement

- The classic Method
- Cheaper than Lining Technologies
- Requires more Construction Time

Module-3 Lecture-5

22/34

Rehabilitation Techniques

Module-3 Lecture-5

23/34

Sewer Line Rehabilitation

Slip Lining

- ❖ Used to rehabilitate damaged sewer pipes by placing a smaller diameter conduit inside the damaged section
- ❖ This method is commonly used where the new, smaller diameter sewer pipe, and the resulting lower friction coefficient for the new pipe, is sufficient for the system capacity needs

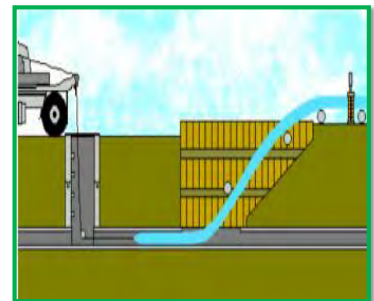

Module-3 Lecture-5

24/34

Sewer Line Rehabilitation

Cured-In-Place-Pipe (CIPP)

- Used for both structural and semi-structural rehabilitation of sewer lines.
- The CIPP liner consists of a tubular felt like material saturated with an epoxy resin that after curing turns into a rigid liner for the pipe.
- Before the process is initiated, pipes must be thoroughly cleaned and dried.

Module-3 Lecture-5

25/34

Sewer Line Rehabilitation

Fold and Form

Fold & form is a technology for rehabilitation of sewer lines by inserting a folded liner into the existing pipe and expanding it through pressure, heat or mechanical means to restore its original circular shape

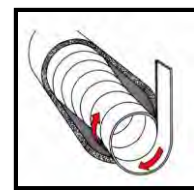
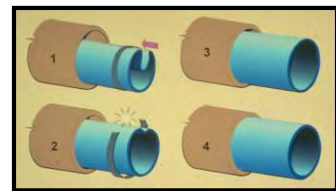

Module-3 Lecture-5

26/34

Sewer Line Rehabilitation



Spirally Wound Pipe

- This technique is based on forming a pipe in-situ by using PVC-ribbed profiles with interlocking edges. The ribs enhance the hoop strength of the liner.
- This method is applicable to sewer lines smaller than 30 inches in diameter.
- The process involves the fabrication of the liner in the manhole by helically winding a continuous PVC fabric.

Module-3 Lecture-5

27/34

Manhole Rehabilitation

Manhole rehabilitation is done for to minimize sewer service downtime, disturbance to the surrounding environment, traffic flow, business and community activities, and avoid a large volume of debris to be disposed of.

Module-3 Lecture-5

28/34

Manhole Rehabilitation

The following methods are available for manhole rehabilitation:

- Chemical Grouting
- Coating Systems
- Structural Linings
- **Frame, Cover & Chimney Rehabilitation**
 - Full depth Lining
 - Frame and cover casting adjustment, including replacement or resetting
 - Manhole Replacement
 - Grouting

Module-3 Lecture-5

29/34

Manhole Rehabilitation

Open Cut Replacement

- ✓ If a manhole is severely deteriorated, open cut replacement may become a preferred option
- ✓ Open cut may also be utilized if manhole relocation is dictated by hydraulic or access requirements.

Module-3 Lecture-5

30/34

Manhole Rehabilitation

Chemical Grouting

- Chemical grouting is used to reduce I/I in manhole structures.
- Grouts give best results in cohesive soils.
- They may be used to fill voids and stabilize soils behind manhole walls.
- Grouts are normally applied under pressure through grout holes drilled into the manhole walls



Module-3 Lecture-5

31/34

Manhole Rehabilitation

Coating Systems

- Coating systems may be used as a corrosion protection barrier and/or to enhance structural integrity of manhole structures.
- Coatings can be applied by spraying, or hand applied. When using coating system, it is essential that the surfaces be properly cleaned and prepared.



Module-3 Lecture-5

32/34

Case Study (Concrete Sewer Manhole Repair)

Project Scope:

Water infiltration, where brick tops join poured concrete, due to freeze/thaw and vibration. Standard repair materials failed over time.



Solution:

Fortress carbon was designed to make three monolithic to resist separation movement, thereby increasing life of the polyurethane grout and cementitious coatings.

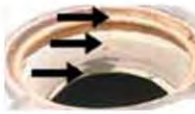

Observations:

Sewer installs performed as designed, increasing the traditional water stop life.

Module-3 Lecture-5

33/34



Thank you!

34/34



Operation & Maintenance of Sewer & Drainage system (S 3221)

Module 3

Topic 4 :

Emergency Response Plans for Rainy Season

Lecture 1:

Emergency Planning

Duration :

03 hrs

Module-3 Lecture-6

2/25

Emergency Planning

Module-3 Lecture-6

3/25

Contents

- ❖ Introduction
- ❖ Emergency Management Process
- ❖ Objective
- ❖ Assessment of Existing situation
- ❖ Special Arrangements for Rainy Season
- ❖ Monitoring System
- ❖ Reporting mechanism
- ❖ Alarm System

Module-3 Lecture-6

4/25

Introduction

What is an Emergency Response Plan?

It is an action plan to organize and employee actions during workplace emergencies.

Well developed emergency plans and proper employee training will result in fewer injuries and less structural damage to the facility during emergencies



Module-3 Lecture-6

5/25

Emergency Management Process

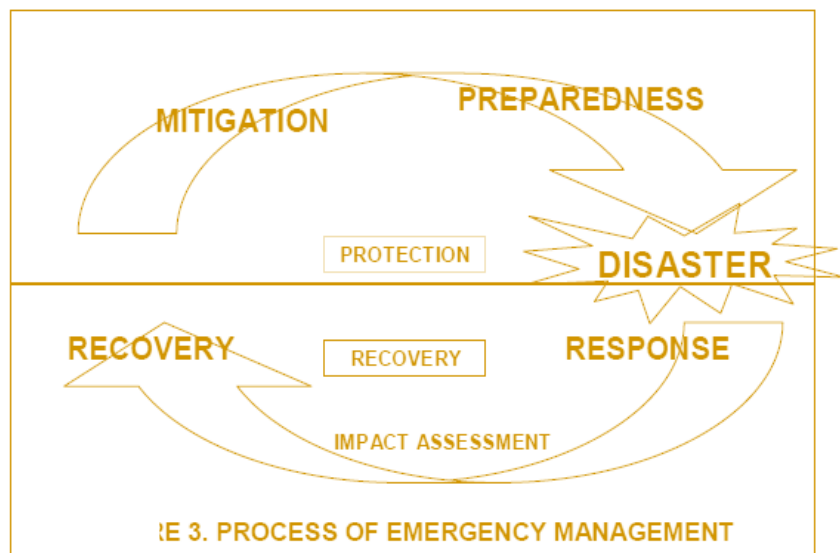

Module-3 Lecture-6

6/25

Emergency Management Process

Preparedness Phase

Consists of activities carry out in advance before an emergency strike to improve response to emergency

E.g. hazard or risk analyses, training, drills and exercises, emergency plans and procedures, emergency communications, joint cooperation consensus, warning systems procedures and response planning.

Module-3 Lecture-6

7/25

Emergency Management Process

Response Phase

Consists of the immediate response to emergency by the ERT

It is aim at containing the disaster so as to minimize loss of life and destruction to property.

Includes measures such as: notification, implementation of emergency plans, activation of emergency operation centers, mobilization of resources, issuance of warnings and directions, provisions of medical and social services assistance, announcement of emergencies or disasters by the management.

Module-3 Lecture-6

8/25

Emergency Management Process

Recovery Phase

It refers to those measures undertaken following a disaster that will return all systems to normal levels of service.

Includes measures such as: physical restoration and reconstruction, cleaning up contaminated areas, eliminating and/or reducing any known hazards restoring businesses

Module-3 Lecture-6

9/25

Emergency Management Process

Mitigation Phase

It is the continuous ongoing endeavor to avert or reduce the impact that a hazardous materials incident will have on people, property, and the environment

Examples of mitigation activities would include the following: Hazard Identification, Risk Analysis , Evaluation, Research , Education

Module-3 Lecture-6

10/25

Emergency Response Plan Flow Diagram

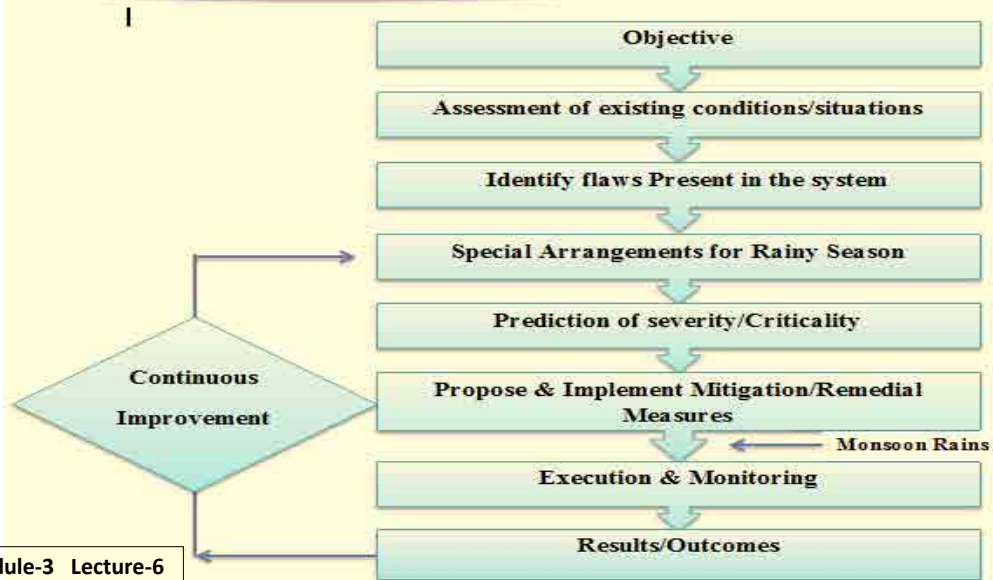

Module-3 Lecture-6

11/25

Introduction

Emergency

Life threatening condition which requires the administration of life-saving measures.

(German Red Cross)

When there is an unexpected condition requiring specific action plans to normalize

Module-3 Lecture-6

12/25

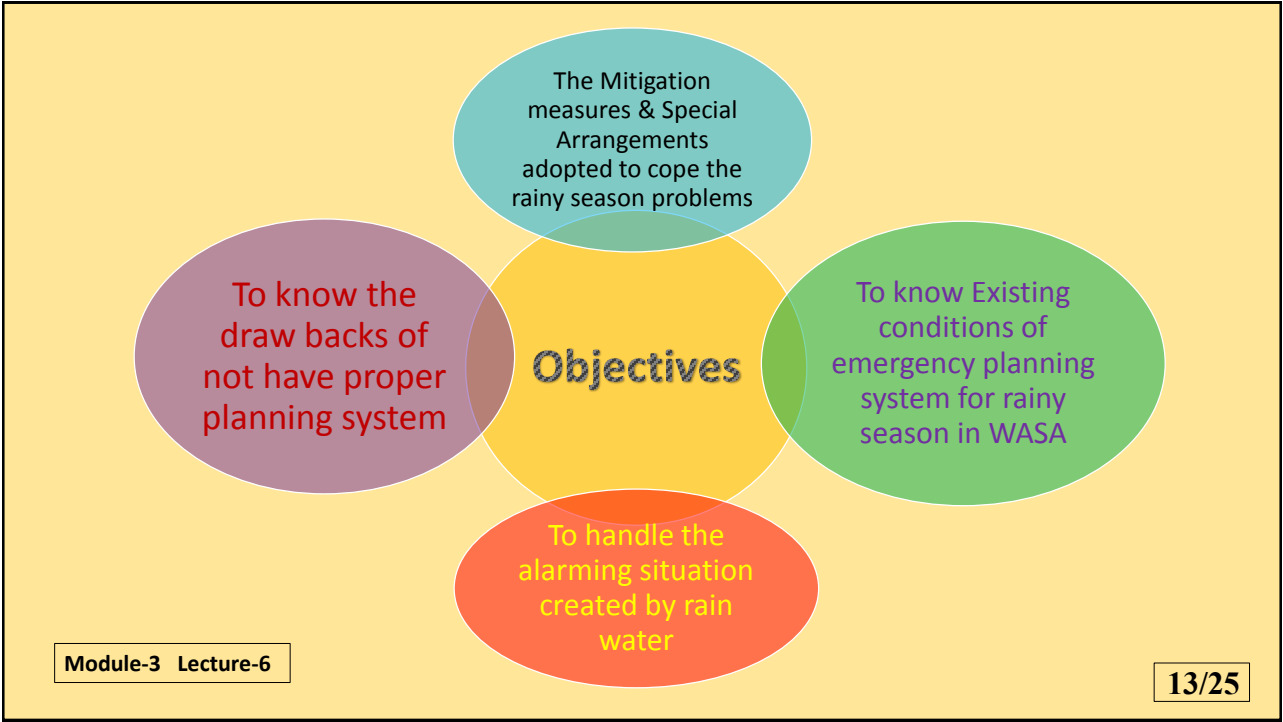

Assessment of Existing Situation/Condition

- ♣ Poor drainage system
- ♣ No separate storm water drainage system is present
- ♣ Accumulation or trapping of solid waste & Plastic material in sewers (Choking of sewer system)

Module-3 Lecture-6

14/25

Special Arrangements for Rainy Season

Cleaning & Desilting of

- ✓ Sewer lines
- ✓ Disposal stations
- ✓ Storm water channels



Module-3 Lecture-6

15/25

Special Arrangements for Rainy Season

- Strengthening of katcha drains/channels
- Repair of pacca channels
- Closure schedule of factories



- Proper & effective CMS should be established



Module-3 Lecture-6

16/25

Special Arrangements for Rainy Season

- Maintenance and utilization of dewatering sets
- Installation of Mobile Dewatering Sets



- Stockage of material for repair of channels
- Repair of pumping machinery
- Repair of heavy mobile machinery



Module-3 Lecture-6

17/25

Special Arrangements for Rainy Season

- Arrangements for low lying areas
- Duties of emergency duty staff
- Response of O & M official during emergency
- Duties of O & M staff during rain
- Identification of Major Low lying areas of the city



- Availability of Double Feeder System
- Report of rain water after rain
- Enhancement of generation capacity of Disposal Station



Module-3 Lecture-6

18/25

Special Arrangements for Rainy Season

Emergency Camps

Replacement of Outlived Sewer lines

Identification of Major Low lying areas of the city

Construction of Outlets and Small Drains

Dewatering Plan of Ponding Areas should be made

Mitigation Measures

The District Government assisted by the other relevant Departments agencies and even Army in acute emergency should execute relief measures and rescue operations

For cleaning of chocked sewers due to heavy raining in monsoon, WASA should have jetting & sucker machines, all should be in working condition and available for emergency at any time.

Mitigation Measures

- Staff should be put on high alert and WASA should utilize all available resources in the rainy season.
- Arrangements should be made to drain rainwater and de-silt sewerage system to flush out the rainwater from the low-lying areas.
- Mobility of machinery and response time should be monitored.

Performance of staff should be monitored in their areas to ensure prompt redress.

Disposal pumps should be provided to mobile teams so they can work round the clock in shifts in their respective areas.

Monitoring System

All work operation should be properly monitored by high authority. There should be a proper monitoring system established.

Monitoring Teams supervised by listed officers, along with subordinate officers shall be in place to feed back the actual position of the city during rain fall.

Directors shall once daily check the functionality and operation of disposal/lift stations through their teams

Reporting Mechanism

Focal Person should be selected

Central Control Office should be established at Head Office for co-ordination with all Field Complaints Centers and Emergency Control Room

Immediate and remedial actions on reporting of emergency including power failure, machinery break down etc.

Action plan and status of Disposal Stations should be submitted to focal person immediately after rainfall

23/25

Alarm Systems

Alarm systems with a backup power source shall be provided for pumping stations. The alarm shall be activated in cases of power failure, dry well sump and wet well high water levels, pump failure, unauthorized entry, or any other cause of pump station malfunction. Pumping station alarms including identification of the alarm condition shall be transmitted to a municipal facility that is staffed 24 hours a day. If such a facility is not available and a 24-hour holding capacity is not provided, the alarm shall be transmitted to municipal offices during normal working hours and to the home of the responsible person(s) in charge of the lift station during off-duty hours. Audio-visual alarm systems may be acceptable in some cases in lieu of a transmitting system depending upon location, station holding capacity and inspection frequency.

Module-3 Lecture-6

24/25



25/25



ALJAZARI
— ACADEMY —

Course Code: 3221

Module 1
**Safety Control and Measures for Sewer
and Drainage Works**

Participant Lecture Notes

Lecture 1
Risks and Hazards

2016



1 Lecture information

Topic: Risks and hazards associated with sewer, drain and disposal station operation and maintenance	Lecture duration (hrs.): 01 • Lecture (hrs.) : 1.0
Lecture topics: Risks and hazards	Training delivery mode: Theory
Lecture date: TBD	Day: One

2 Objectives

The objectives of this lecture are:

- Give an overview of job related risks and hazards
- Introduce various types of risks and hazards
- Assessment of risks at WASA work sites during operation and maintenance

3 Definitions

3.1 Hazard

A Hazard is a potential source of harm or adverse health effect on a person or persons [1].



Figure 1



3.2 Risks

Risk is the likelihood that a person may be harmed or suffer adverse health effects if exposed to a hazard. [1]

4 Types of Hazards



The sanitation workers, who are engaged in operation and maintenance of sewerage system are exposed to different types of hazards like injuries caused by physical actions and chemicals contacts, infections caused by pathogenic organisms in sewage and dangers inherent with oxygen deficiency, hydrogen sulphide, and combustible gases. On the other hand, since the sewerage system handles insanitary objects, physical, mental and aesthetically negative impacts on the surrounding environment are unavoidable. Hazards of sewerage system are categorized as:

- Occupational Hazards
- Environmental Hazards [3].



4.1 Occupational Hazard

Various occupation hazard, and their effects are listed in Table 1.

Table 1: Occupational Hazards and Their Effects

Sr. No.	Type	Effects
1.	Accidental 	<ul style="list-style-type: none"> • Confined space hazards (Oxygen deficiency / Hydrogen sulphide poisoning / combustible gas) • Chlorine poisoning • Fall and Slip • Electric shock caused by contact with faulty electrical equipment, • Fire and explosions due to the formation and release of flammable gases during processing (e.g., methane, hydrogen)
2.	Physical 	Exposure to excessive noise levels and adverse weather



3.	<p>Chemical</p> 	<ul style="list-style-type: none"> • Dermatoses caused by exposure of the skin to waste waters • Latex allergy caused by the use of latex gloves • Irritation of mucous membranes (in particular of the respiratory tract) by aerosols and hydrogen sulfide
4.	<p>Biological</p> 	<p>Diseases caused by infectious agents (bacteria, viruses, protozoa, helminths and fungi)</p>
5.	<p>Ergonomic</p> 	<ul style="list-style-type: none"> • Musculoskeletal injuries by awkward working postures (including frequent bending), etc. • Discomfort and psychological problems related to prolonged wear of protective clothing

Possible hazards at wastewater quality test laboratory include toxic substances, alkalis /acids and glass appliances. [5]

4.2 Environmental Hazards

- Surface and Ground Water Pollution
- Odor
- Soil Contamination [3]
- Ecological Damage
- Economic Loss

5 Risk Assessment

Risk assessment is the process where you:

- Identify hazards.
- Analyze or evaluate the risk associated with that hazard.
- Determine appropriate ways to eliminate or control the hazard.

5.1 How to do Assessment

Assessments should be done by a competent team of individuals who have a good working knowledge of the workplace. Supervisors and workers involved should be those who work with the process under review, as they are the most familiar with the operation.

In general, to do an assessment, you should:

- Identify hazards.
- Evaluate the likelihood of an injury or illness occurring, and its severity.



- Consider normal operational situations as well as non-standard events such as shutdowns, power outages, emergencies, etc.
- Review all available health and safety information about the hazard such as MSDSs, manufacturer's literature, and information from reputable organizations, results of testing, etc.
- Identify actions necessary to eliminate or control the risk.
- Monitor and evaluate to confirm the risk is controlled.
- Keep any documentation or records that may be necessary. Documentation may include detailing the process used to assess the risk, outlining any evaluations, or detailing how conclusions were made.

When doing an assessment, you must take into account:

- The methods and procedures used in the work, handling or storage of the substance used in the work, etc.
- The actual and the potential exposure of workers.
- The measures and procedures necessary to control such exposure by means of engineering controls, work practices, and hygiene practices and facilities.

By determining the level of risk associated with the hazard, the employer and the joint health and safety committee can decide whether a control program is required.

It is important to remember that the assessment must take into account not only the current state of the workplace but any potential situations as well. [2]

5.2 Prioritization of Risks

The risk involved, in a work, is evaluated by the likelihood of any harm during performing that task and extent of damage done, if that harm occurs. Table 2 explain this in bit details.

Table 2: Risk Assessment by British Standard Organization

Likelihood of Harm	Severity of Harm		
	Slight Harm	Moderate Harm	Extreme Harm
Very unlikely	Very low risk	Very low risk	High risk
Unlikely	Very low risk	Medium risk	Very high risk
Likely	Low risk	High risk	Very high risk
Very likely	Low risk	Very high risk	Very high risk



6 Glossary

Key Word	Definition
Aesthetic	set of principles governing the idea of beauty at a given time and place
MSDS	Material Safety Data Sheet
Shut downs	a closure of a factory or system, typically a temporary closure due to a fault or for maintenance
Dermatoses	a disease of the skin, especially one that does not cause inflammation
Workplace	physical location where someone works

7 References

1. <http://www.hsa.ie/eng/Topics/Hazards/>
2. http://www.ccohs.ca/oshanswers/hsprograms/risk_assessment.html
3. www.pseau.org/.../moud_manual_on_sewerage_and_sewage_treatment
4. <http://water.wuk1.emsystem.co.uk/home/policy/publications/archive/health-and-safety/exposure-to-sewage-ogn/exposure-to-sewage-ogn.pdf>
5. ILO Encyclopaedia of Occupational Health and Safety, 3d Edition. Parmeggiani, L, Editor. Vol. 1, pp. 744-5 (1983)





ALJAZARI
— ACADEMY —

Course Code: 3221

Module 1
Safety Control and Measures for Sewer and
Drainage Works

Participant Lecture Notes

Lecture 2
Control Measures

2016



1 Lecture Information

Topic:	Risks and hazards associated with sewer, drain and disposal station operation and maintenance	Lecture duration (hrs.): 1.0 • Brainstorming (hrs.) : 1.0
Lecture topics:	Control measures	Training delivery mode: Theory
Lecture date:	TBD	Day: One

2 Objectives

The objective of this lecture are:

- To apprise the participants about the risks and hazards associated with the works related to O&M activities in WASA.
- Various control measures to be adopted to avoid those risks

3 Control Measures for Occupational Hazards

The basic concept of safety controls, while at work is shown in Figure-1. It is most preferred that we eliminate the risk altogether. If it is not possible, then one may substitute the method of work with the one that is safe. If that is also not feasible, then we may isolate the point of hazard. Isolation would reduce the chances of contact with the risky point with the workers at that place.

The next less preferred approach may be to apply engineering controls to reduce the risk. If engineering control is not possible then administrative measures should be taken to reduce the risk. And finally, if that is not even possible, then personal protective equipment be used. But this is the least preferred approach. The selection of approach depends upon the situation. It is not always possible to use the most preferred approach.



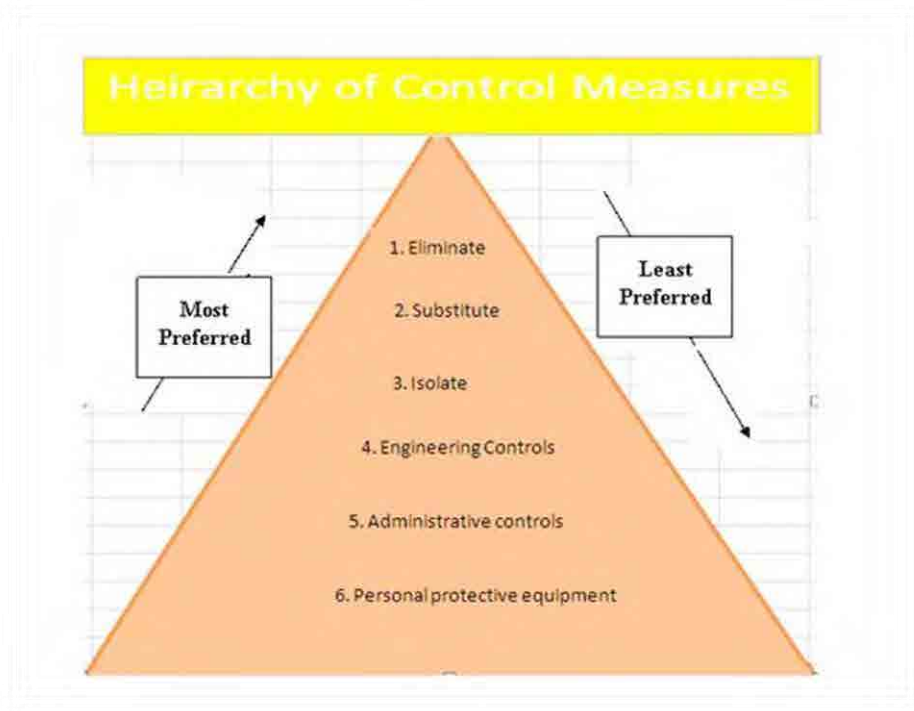

Figure 1: Hierarchy of Control Measures

Various safety measures that may be adopted, during sewerage works, are briefly discussed in the following sections.

3.1 Elimination

The first consideration in controlling the hazards associated with sewage and its by-products should be, in all cases, to consider the possibility of eliminating the need for contact, or working in close proximity to, sewage and its by-products.

Risk Assessments for work of this kind should always consider if there is a reasonably practicable way to avoid the need for contact with sewage. Possible means to avoiding contact could include the use of:

- CCTV systems (Figure 2)
- Robot moles for clearing blockages in sewers (Figure 3)





Figure 2: CCTV System

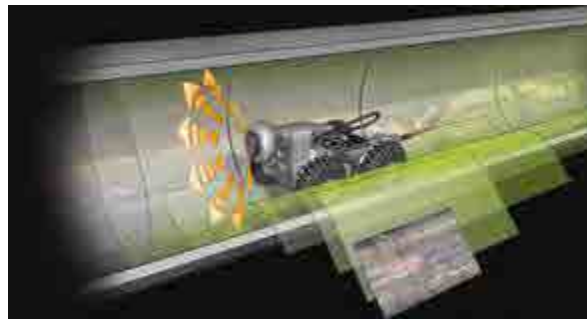

Figure 3: Robot Moles

- Hand tools for handling or lifting objects contaminated by sewage
- Local Exhaust Ventilation systems etc.

In addition, the need to eliminate the hazards associated with sewage at source, e.g. through the use of **etc**, should always be assessed and implemented where reasonably practicable.

3.2 Administrative Controls

Where work that involves contact with sewage is unavoidable, the best control measure available is good personal hygiene practice on the part of the individuals involved in that work.



3.2.1 Personal Hygiene

- All persons that come into contact with sewage must have access to a means of cleansing exposed skin areas.
- Adequate washing facilities should be available either on site or within a reasonable travelling distance.
- Showers or access to running water should be provided where there is a risk of gross contamination occurring.
- Waterproof clothing, rubber or safety boots, which have become contaminated with sewage, should be hosed, scrubbed clean and dried as soon as possible.
- Disposable gloves should be for single use only and disposed after each use.
- If cuts or grazes occur they should be washed immediately with clean running water or sterile cleansing wipes and a sterile waterproof dressing applied.[4]

3.2.2 Hazard-Specific Preventive Measures

The work supervisor should make the following arrangements:

- Inspect protective gear before start of work and ensure that they are ready for use at all times. Repair or replace gear and equipment that are defective.
- Keep ready breathing apparatus, ladder, rope, safety belt and other equipment for use in evacuating or rescuing workers in the event of an emergency.



Figure 4: Use of Tripod Stand and Proper Ladder for Manhole Entry





Figure 5: Hand Washing after Task Completion

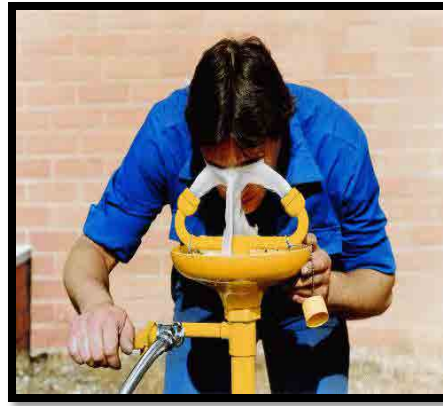

Figure 6: Eye Washer in-case of Emergency

- Non-spark tools should be used in confined spaces.
- The safety guard should check access to the workplace of the workers engaged in the work.
- Ensure that nobody falls from ladders (including metal rungs) and that tools are not dropped from ground level.
- Check that the ladder to the manhole is not corroded or worn out.
- Special anti-skid shoes with metal cladding over the “fingers” portion should be provided by the employer for the workers.
- Keep floor of workplaces dry and free from grease or oil.
- Methods for safe handling of electric equipment should be drilled into the workers and inspection and maintenance methods for electric equipment should be established.
- Special precautions should be taken to prevent electric shocks at locations where water is likely to accumulate (pumping room and in pipe gallery).
- Rubber-soled sports shoes may be used to prevent electric shocks.
- Do not place combustible items near exposed wiring and electric equipment.
- Install fire extinguishers at easily visible locations such that they can be used immediately in the event of a fire.
- Periodically inspect and store disconnecting switches, operating rods, insulating plates, etc., at their specified positions.
- Regulate the use, storage and disposal of all combustible materials/substances.
- Routinely inspect fire doors to ensure proper operation and unobstructed access.



3.2.3 Workplace-Specific Preventive Measures

Good design and the use of safety equipment will not prevent physical injuries in sewerage works unless safety practices are understood by the entire crew and are enforced. Safety preventive measures specific for the workplace are described here.

a) On-site

- When oxygen concentration is less than 19.5% and hydrogen sulphide concentration is more than 10 ppm, use forced ventilation to ventilate the tank before entering it.
- Wear rubber gloves to prevent wounds from infection.

b) Traffic Hazards

- Before starting any job in a street or other traffic area, study the work area and plan your work.
- Traffic cones, signs, or barricades arranged around the work, or a flagger are applicable to direct traffic.
- Use fluorescent jacket while working along roads.



Figure 7: Barricading and Usage of Safety Signs for Traffic Control

c) Manhole

- Before entering the manhole, follow safety entry procedure.
- Use forced ventilation to ventilate the tank before entering it.
- Manhole work usually requires job site protection by barricades and warning devices.
- Never use your fingers or hands to remove a manhole lid. Always use a tool specifically designed for this purpose.



- Tools and equipment should be lowered into a manhole by means of a bucket or a basket.

d) Pumping Station

- Do not work on electrical systems or controls unless you are qualified and authorized to do so.
- Guards over couplings and shafts should be provided and should be in place at all times.
- If stairs are installed in a pumping station, they should have hand rails and non-slip treads.
- Fire extinguishers should be provided in the station, properly located and maintained. The use of liquid-type fire extinguishers should be avoided.
- Good housekeeping is a necessity in a pumping station to prevent slip and fall accidents.
- Properly secure and lock up an unattended pumping station when you leave so as to prevent injury to a neighborhood child and possible vandalism to the station.



e) Sewage Treatment Plant

- Obey all safety-instructions regarding the storage, transport, handling or pouring of chemicals
- Check electrical equipment for safety before use
- Wear safety goggles in all cases where the eyes may be exposed to dust, flying particles, or splashes of harmful liquids
- Take extreme care when handling highly corrosive agents such as liquid or gaseous chlorine, concentrated acids or alkalis, or when toxic gases may be emitted from the reagents, etc.
- Obey all safety instructions concerning entry into confined spaces
- All workers should undergo periodic examinations by occupational physician to reveal early symptoms of possible chronic effects or allergies.
- Learn and use safe lifting and moving techniques for heavy or awkward loads such as containers of chemicals; use mechanical aids to assist in lifting.
- Do not smoke, eat or drink in areas where chemical or biological contamination may be expected





Figure 8: Use of Warning Signs

3.3 Personal Protective Devices

3.3.1 Head Protection

- All personnel working in any areas where there may be danger from falling, flying tools or other objects must wear approved hard hats.
- Specially insulated hard hats must be worn when working around high voltage to protect from electrical shock.



3.3.2 Face and Eye Protection

- Impact Goggles must be worn to protect against flying objects.
- Frames must be corrosion resistant and simple in design for cleaning and disinfection.
- Cup goggles should have cups large enough to protect the eye socket and to distribute impact over a wide area of facial bones.
- Chemical goggles and acid hoods should be used for protection against splashes of corrosive chemicals.
- Face shields can be used against light impact.



3.3.3 Hands and Lower Arms

- Protective sleeves, gloves and finger pads are used for different types of hazards and jobs.



- Linemen and electricians working on energized or high voltage electrical equipment require specially made and tested rubber gloves.

3.3.4 Body Protection

- A good quality diver suit should be provided to the diver whose services are very necessary while plugging the sewer line or removal of some hard blockage due to stone etc. at the mouth of the pipe in the manholes. Depending upon the site condition, suit should have provision to connect an air line with compressor or oxygen cylinder.
- Always use rubber aprons when working with chemicals.



3.3.5 Legs and Feet

- Leggings are provided where leg protection is necessary and are in the same category as coats, frocks and aprons. Kneepads made of cloth, padding, rubber, cork are used on jobs where kneeling is required.
- Ordinary work shoes are acceptable for many jobs. They should have non-skid soles to prevent slips.
- Safety shoes are required where there is danger of dropping tools or materials on the feet.
- For working on electrical equipment suitable safety shoes must be used.



3.3.6 Gas Mask

Gas masks are used for respiratory protection from low and moderately high concentrations of all types of toxic gases and vapors present in the atmosphere in which there is sufficient oxygen to support life.



3.3.7 Safety Belt

When you work on ladders or scaffolding, use extreme caution to prevent falls. Safety belt should be used to prevent falls.[3]



4 Control Measures for Environmental Hazards

- ✓ Appropriate distance between water supply pipes and sewer pipes shall be maintained.
- ✓ Sometimes, sewage overflows. In such a case, check whether the flow rate to the facility is greater than the design flow rate.
- ✓ Necessary precautions should be taken to prevent water supply contamination due to leakage from sewers.
- ✓ It is good to maintain a record of the Total Dissolve Solids of ground water in the well waters of households so that questions of sewage seeping into ground water and polluting the well waters can be verified.
- ✓ Prevent corrosion in the collection well of the facility by blowing air through the facility.
- ✓ Wash down all spills and grease coatings.
- ✓ If the sewage is septic, add chemicals in the collection system or at the plant, as appropriate, to reduce sulphide.
- ✓ Deodorization equipment is effective in controlling ammonia, similar to H₂S. However, care is necessary since there is selectivity depending on the substance.
- ✓ Avoid draining untreated sewage directly at sea, rivers or water bodies.
- ✓ Use biodegradable soaps and detergents without phosphates.
- ✓ Maintaining an aerobic environment also inhibits the anaerobic degradation process contributing to the generation of hydrogen sulphide.
- ✓ Remove sand and grit deposited in house service connection or sewer immediately.
- ✓ Thoroughly clean each facility and the areas surrounding the facility.

5 Glossary

Key Word	Definition
Proximity	The state of being near
CCTV	Closed Circuit Television
Chronic	Chronic effect is the effect of a pollutant if one is exposed to it for a very long period of time. Like intake of high concentration of Arsenic, in drinking water, results in skin cancer, if the water is used for a period of 10 to 15 years. Whereas acute effect of a pollutant appears immediately, after the intake of pollutant.
Sterile	Free from bacteria or other living microorganisms; totally clean
Biodegradable	Disintegration of materials by bacteria, fungi, or other biological means



Aerobic	In the Presence of Oxygen
H₂S Gas	Hydrogen Sulphide Gas
Deodorize	Remove or conceal an unpleasant smell
Non-Skid Shoes	Designed to prevent sliding or skidding

6 References

1. <http://www.hsa.ie/eng/Topics/Hazards/>
2. http://www.ccohs.ca/oshanswers/hsprograms/risk_assessment.html
3. www.pseau.org/.../moud_manual_on_sewerage_and_sewage_treatment
4. <http://water.wuk1.emsystem.co.uk/home/policy/publications/archive/health-and-safety/exposure-to-sewage-ogn/exposure-to-sewage-ogn.pdf>
5. ILO Encyclopaedia of Occupational Health and Safety, 3rd Edition. Parmeggiani, L, Editor. Vol. 1, pp. 744-5 (1983)





Course Code: 3221

Module 1
**Safety Control and Measures for Sewer
and Drainage Works**

Participant Lecture Notes
Lecture 3-Current Safety Practices in WASA

2016



1 Lecture Information

Topic: Safety practices for sewer and drainage system operation and maintenance	Lecture duration (hrs.): 04 • Classroom briefing (hrs.): 0.5 • OJT (Hrs.): 3.5
Lecture topics: Current safety practices in WASA in comparison with HSE standards	• Training delivery mode: OJT
Lecture date: TBD	Day: One

2 Objectives

The objectives of this lecture are introduce following concepts to the participants:

- Fundamentals of HSE
- General safety rules
- Current safety practices in WASA
- Conclusions and recommendations

3 Fundamentals of HSE

3.1 Introduction

- HSE stands for Health Safety and Environment. The first formal HSE management approach was introduced in 1985 by the chemical industry as a reaction to several catastrophic accidents.
- Now a days the HSE standards are opted in most of the organizations and companies around the world.

3.2 Regulatory Agencies

There are various regulatory agencies in the world who are engaged in the formulation of regulations on the basis of observations, experiments, experiences and profound research. Few of the leading agencies are as under:

- Occupational Safety & Health Administration (OSHA)
- National Examination Board in Occupational Safety and Health (NEBOSH)



- The Institution of Occupational Safety and Health (IOSH)



3.3 Scope of HSE at Job Sites

The goal and scope of Health, Safety and Environment (HSE), at job site is to protect employees, the public, the environment and to comply with applicable laws and protect the Company's reputation. HSE departments, of some companies are responsible for environmental protection, occupational health and safety at work as well.

3.4 Responsibilities

Management

To avoid the fatalities, casualties and injuries, the management of a company is under the utmost responsibility and that is to appoint only competent personnel as supervisors, who shall be responsible for the safety of those under his or her supervision.

Supervisors

The supervisors, at all the times, would be responsible for the execution of the work in a safe manner. They will be held accountable for all accidents and employee actions unless investigation indicates the actions were due to conditions beyond the supervisor's control. They shall instruct all new employees on the reporting of all accidents and the prompt receipt of first aid.

General duties of Employees

It is not the supervisor only. Everybody at work, has a part to play. A part in ensuring that work is done in a healthy and safe way. While employers have duties to ensure a safe working environment for employees, employees also have a role in ensuring their own health and safety, and that of people around them. Following are the few of general duties of employees:

- Ensure their own health and safety
- Ensure that nothing they do, which harms any other person.
- To ensure use of protective equipment
- Avoid undertaking work which involves unsafe practices



- Make unsafe work situations safe or, if they cannot, inform supervisor or manager
- Report any work-related hazard, accidents, near miss, illnesses and injuries
- Comply with any improvement and prohibition notices issued for their workplace.

4 General Safety Rules

Location of Safety Manual

Every employee should have access to the safety manual, prepared for use by the company. Preferably, each employee should have a copy of this manual.

Safety Meetings

Safety meetings should be held on a weekly basis. It may be held on the first day of each week. During these meetings, the company should keep employees updated on any current regulations or changes that may have occurred since the last meeting.

Personal Conduct While on Company Business

The use of intoxicating liquor during working hours, including lunch hour, should be strictly prohibited. Strict disciplinary action be taken in case of any violation.

Taking Chances

Before commencing any work that may involve some safety risks, complete procedure to perform it must be laid down. This procedure should ensure the safety of workers involved. Where more than one employee is engaged in the same job, all employees must be given awareness on hazards involved. They should be adequately trained as well. Under no circumstances shall safety be sacrificed for speed.

Guards

No guard shall be removed from any machine or piece of equipment except to perform required maintenance.

Protecting the Public

When an employee needs additional light while working on the premises of a customer, he should always use a battery powered flashlight, or an approved properly guarded electrical extension light. An open flame light such as a match, or cigarette lighter shall not be used.



Housekeeping

Materials and supplies, used at a working site, should be stored in a neat and orderly manner. This would avoid interfering with free movement. In addition, their falling on moving equipment or personnel could also be avoided.

Spare parts used in the operation of a wastewater treatment plant should be kept in a neat and orderly manner with the item labeled to indicate on what piece of equipment the spare part is used.

Reporting Hazardous Conditions

When an employee observes a hazardous condition that may cause injury or property damage, the employee shall report it promptly to a proper authority and when necessary, guard it^[1]

5 Standard HSE Practices

5.1 Performing Job Hazard Analysis (JHA):

A job hazard analysis is a technique that focuses on job tasks as a way to identify hazards before they occur. By applying the Job Hazard Analysis various types of losses can be avoided.

5.2 Use of PPE

Definition and advantages

Personal Protective Equipment or PPE are the equipment and clothing worn on the body that protects a worker from exposure to a work hazard.

Types of PPE

PPEs include face shields, safety glasses, hard hats, a variety of devices and garments such as goggles, coveralls, gloves, vests, earplugs, and respirators (Figure 1).





Figure 1: Different types of PPE

5.3 Work Zone Traffic Safety

Highest number of fatal work injuries result from moving vehicles and moving equipment at the work site. Therefore, traffic movement must be planned very carefully. Traffic must move in an approved manner. For this a Traffic Management Plan must be prepared. Proper road signage, caution signs, cones, barriers and flaggers must be in placed to avoid accidents.





Traffic Control Devices and Road Signage

Standard traffic control devices, signals and signs will instruct drivers to follow a path away from where site work is under progress. Some of these signs are shown in Table 1.

Table 1: Road Signs

Direction	Road Sign	Direction	Road Sign
Stop		Work in Progress	



Direction	Road Sign	Direction	Road Sign
Reduce Speed Ahead		Detour	
Road Closed		Speed Limit	

Flagging

Flaggers (Figure 2) may also be used for traffic movement control. Flaggers should wear high visibility clothing with a background of fluorescent orange-red or yellow-green and retro reflective material of orange, yellow, white, silver, or yellow-green.

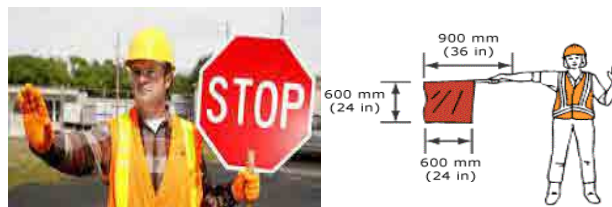

Figure 2: Flaggers

Figure 3 shows a complete layout of a traffic control zone during work on a busy road. The basic concept of traffic diversion, signage and safety of workplace may be used by WASA officials while working on a manhole on a busy road.



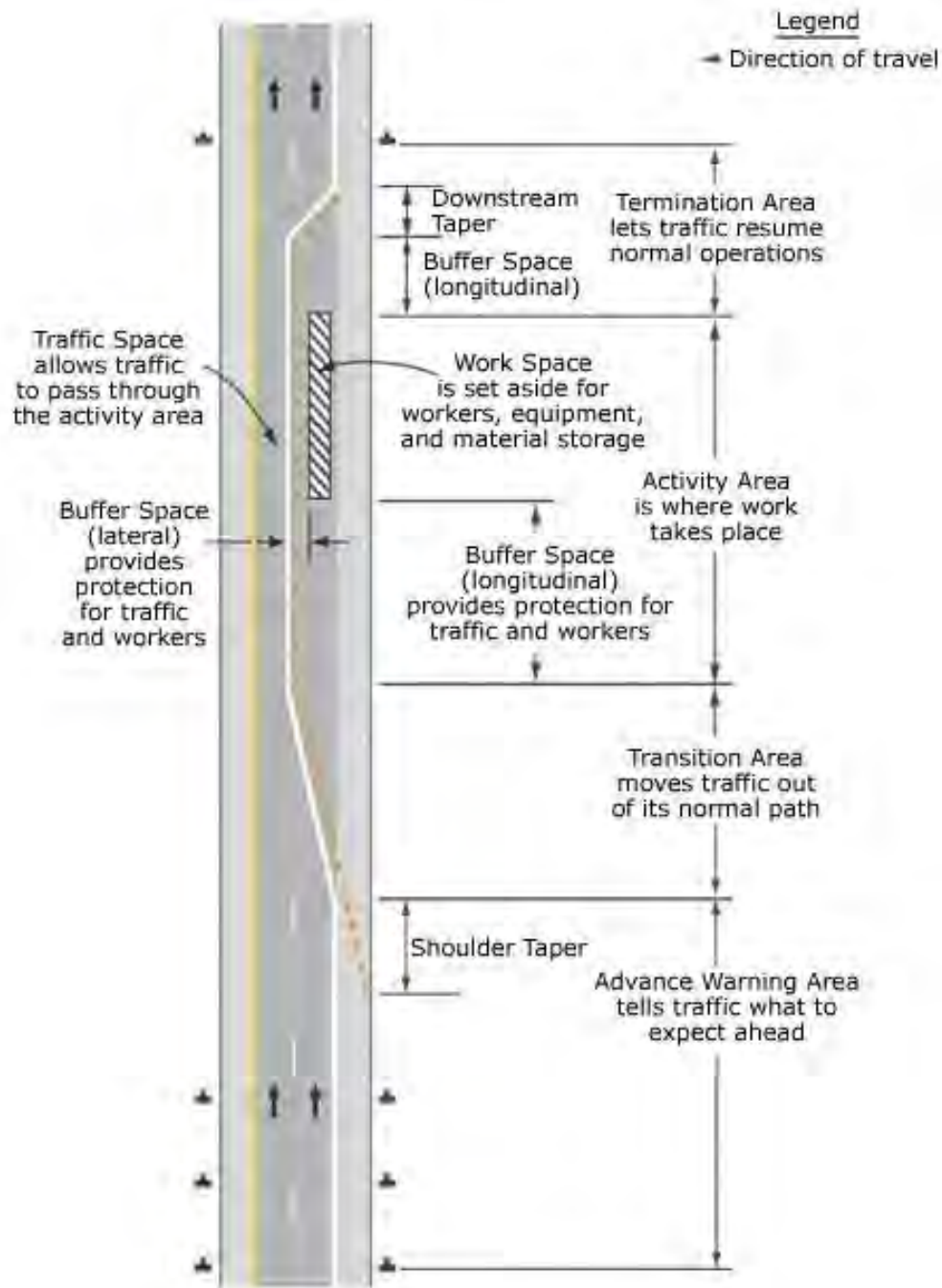

Figure 3: Component parts of a traffic control zone



6 Current Safety Practices in WASAS

Table 2 shows that current status of safety measures prevailing in WASAs during the maintenance and operation works. The possible adverse effects of low level priority given to safety issues, are also shown.

Table 2: Current status of safety levels during O&M in WASAs

Sr. No.	Activities	Status within WASAs	Probable Adverse Outcomes
1.	Trainings	Not Regular	Fatalities, Injuries and Property Loss
2.	First Aid Guide Lines	Partially Followed	Wound/injury become more severe.. Permanent Disability
3.	Firefighting Drills	No	Loss of Property & Equipment. Panic conditions will be developed
4.	Hazard Identification	No	More likelihood of injuries & casualties
5.	HSE Surveys & Questionnaires	No	Unawareness of hazards
6.	Work Permits	No	Fatalities and Injuries
7.	Traffic Zone Management	No	Traffic Jam and hindrance in work
8.	Hazard Assessment	No	More likelihood of injuries & casualties
9.	Identification of PPE's according to Job	No	Loss of life, Injuries and Casualties
10	Proper Maintenance of Machines	Yes	Machines and Equipment are in order
11	Medical Practitioner	No	Wound/injury become more severe
12	Reporting of Accidents or Incidents	Partially Performed	No Data is Available





Sr. No.	Activities	Status within WASAs	Probable Adverse Outcomes
13	Reporting of Accidents or Incidents	Partially Performed	No Data is Available
14	Workplace Supervision	Yes	Job/Work is performed smoothly
15	Communication procedure	Poor	Confined Space Casualties
16	Proper job description	Partially Defined	Employees are working at too many jobs



6.1 Comparison between Current Safety Practices and Global Standards

A comparison between current WASA practices and global standards is shown in Table 3. It may be observed that there is a lot of room for improvement. Safety of workers is of prime importance and in no way be overlooked.

Table 3: Comparison of current WASA practices Vs standard procedures

WASA Current Methodology	HSE Standards
	
Sanitary Worker without Safety Helmet and Protective Clothing	Standard Entry Procedure in Manhole



WASA Current Methodology	HSE Standards
	
<p>Sucking Machine Operator without Safety Helmet, Safety Gums and Gloves</p>	<p>Sucking Machine Operator with Safety Helmet, Vest and other gears</p>
	
<p>De-Silted Materials is left exposed to Environment</p>	<p>De-Silted Materials is promptly being shifted to dumping site</p>

6.2 Decrease in Injuries after Application of HSE Rules in UK

Figure 4 shows the record of fatal injuries, at workplace, in UK from 1995 to 2014-15. It may be seen in the figure that as better safety measures were adopted, at workplace, the no of fatal injuries reduced. The number of total fatal injuries to workers, reduced from 350 in 1995 to 150 in 2014-15. This clearly shows the significance of adopting proper safety measures at the workplace.



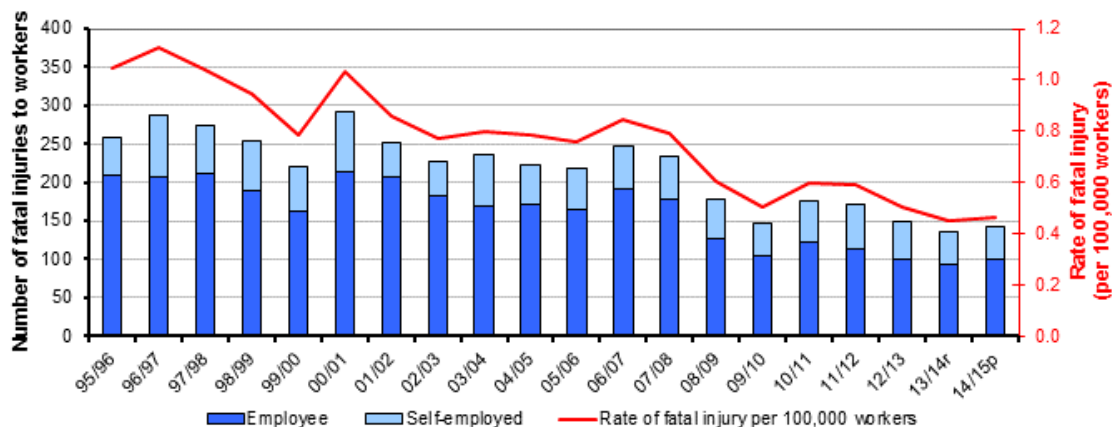

Figure 4: Safety measures and reduction in fatal injuries in UK

7 Glossary

Keyword	Definition
HSE	Health Safety and Environment
OHS	Occupational Health and Safety
OSHA	Occupational Health and Safety Administration
NEBOSH	National Examination Board in Occupational Safety and Health
IOSH	Institution of Occupational Safety and Health
Hazard	It is a situation that poses a level of threat to life, health, property, or environment
Risk	Chance that any hazard will actually cause somebody harm
Near Miss	An unplanned event that did not result in injury, illness, or damage but had the potential to do so
Fatality	A death caused by an accident or disease
Causality	An injury due to accident or disease
PPE	Personal Protective Equipment
Work Permits	A document which specifies the work to be done and the precautions to be taken
Safety Gears	Garments or equipment designed to protect the wearer's body from injury or infection during the job work



Keyword	Definition
Road Signs	Informatory and warning signs which are displayed at the job site
Manual	A guide book which describes the operation and maintenance rules of a machine or equipment
Confined Space	A manhole, vessel or container having narrow entry and not designed for continuous occupancy

8 References

https://www.waternz.org.nz/Attachment?Action=Download&Attachment_id=121

National Guidelines for Occupational Health and Safety in the NZ Water Industry
Second Edition .June 2001.Retrieved April 13, 2016, from

https://www.waternz.org.nz/Attachment?Action=Download&Attachment_id=12





Course Code: 3221

Module 1
**Safety Control and Measures for Sewer
and Drainage Works**

Participant Lecture Notes
Lecture 4- Concept of PPE

2016



1 Lecture Information

Topic: Use of safety gears during operation and maintenance of sewer and drainage works	Lecture duration (hrs.): 01 • Demonstration (hrs.) : 1.0
Lecture topics: Concept of PPE	• Training delivery mode: OJT
Lecture date: TBD	Day: Two

2 Objectives

The objectives of this lecture are:

- Orientation on fundamentals of PPE
- Enable participants to assess suitable PPE related to their job
- Factors influencing PPE Selection
- Usage of various PPE as per the job site requirement

3 Introduction

Hazards exist in every workplace. These may be in many different forms: sharp edges, falling objects, flying sparks, chemicals, noise and a myriad of other potentially dangerous situations. The N.C Department of Labor's (NCDOL) Occupational Safety and Health Division requires that employers protect their employees from workplace hazards that can cause injury.

When work practices and administrative controls are not feasible or do not provide sufficient protection, employers must provide **personal protective equipment** to their employees and ensure its use.

3.1 What is PPE?

PPE is equipment that will protect the user against health or safety risks at work. These include items such as safety helmets and hard hats, gloves, eye protection, high-visibility clothing, safety footwear and safety harnesses.

3.2 The Requirement for Personal Protective Equipment

To ensure the greatest possible protection for employees in the workplace, the mutual efforts of both employers and employees will help in establishing and maintaining a safe and healthful work environment.



In General, Employers are Responsible for:

- Performing a “hazard assessment” of the workplace to identify and control physical and health hazards.
- Identifying and providing appropriate PPE for employees.
- Training employees in the use and care of the PPE.
- Maintaining PPE, including replacing worn or damaged PPE.
- Periodically reviewing, updating and evaluating the effectiveness of the PPE program.
- Paying for PPE.

In General, Employees should:

- Properly wear PPE.
- Attend training sessions on PPE.
- Care for, clean and maintain PPE.
- Inform a supervisor of the need to repair or replace PPE.^[1]

3.3 Selection of Suitable PPEs

To make sure the right type of PPE is chosen, consider the possible hazards in the workplace. Identify the PPE that will provide adequate protection against them; this may be different for each job.

Ask your supplier for advice on the types of PPE available and their suitability for different tasks. In some cases, you may need to get advice from specialists or from the PPE manufacturer, Health and Safety Executive etc.

Consider the Following When Assessing Suitability:

- Does the PPE protect the wearer from the risks and take account of the environmental conditions where the task is taking place? For example eye protection designed to protect against agricultural pesticides may not offer adequate protection when using an angle grinder to cut steel or stone.
- Does using PPE increase the overall level of risk or add new risks, e.g. by making communication more difficult?
- Can it be adjusted to fit the wearer correctly?
- Assess job needs and requirements placed on the worker while at job? For example, the length of time the PPE needs to be worn Vs the physical effort required to do the job or the requirements for visibility and communication.
- If someone wears more than one item of PPE, are they compatible? For example, does using a respirator make it difficult to fit eye protection properly?

4 Points kept in mind while selecting PPE

- All PPE clothing and equipment must be of safe design and construction and should be maintained in a clean and reliable fashion.



- Employers should take the fit and comfort of PPE into consideration when selecting appropriate items for their workplace. PPE that fits well and is comfortable to wear will encourage employee to use PPE.
- Most protective devices are available in multiple sizes, and care must be taken to select the proper size for each employee
- If several different types of PPE are worn together, make sure they are compatible.
- If PPE does not fit properly, it can make the difference between being safely covered or dangerously exposed. It may not provide the level of protection desired and may discourage its use by the employee
- Instruct and train people how to use it
- Tell them why it is needed, when to use it and what its limitations are.^[2]

4.1 Factors Influencing PPE Selection

- Type of exposure anticipated
 - Splash/spray versus touch
 - Category of isolation precautions
- Durability and appropriateness for the task
- Fit

5 Training

- Make sure anyone using PPE is aware of why it is needed, when to use, repair or replace it, how to report a fault, and limitations of PPE.
- Train and instruct people how to use PPE properly and make sure they are doing this.
- Include managers and supervisors in the training, they may not need to use the equipment personally, but they do need to ensure their staff is using it correctly.
- It is important that users wear PPE all the time they are exposed to the risk.
- Check regularly that PPE is being used and investigate incidents where it is not.
- Safety signs can be useful reminders to wear PPE. Make sure that staff understand these signs, what they mean and where they can get PPEs e.g. for visitors or contractors^[1]

6 Maintenance

Make sure:

- Equipment is well looked after and properly stored when it is not being used, e.g. in a dry, clean cupboard, or for smaller items in a box or case;



- Equipment is kept clean and in good condition – follow the manufacturer’s maintenance schedule (including recommended replacement periods and shelf lives);
- Simple maintenance can be carried out by the trained wearer, but more intricate repairs should only be done by specialists;
- Replacement parts match the original, e.g. respirator filters;
- You identify who is responsible for maintenance and how to do it;
- Employees make proper use of PPE and report its loss or destruction or any fault in it.
- Make sure suitable replacement of PPE is always readily available. It may be useful to have a supply of disposable PPE, e.g. for visitors who need protective clothing^[2].

7 Types of PPE

7.1 Hands Protection

7.1.1 Gloves

- **Purpose** – protect hands during work
- **Glove material:**

Vinyl, latex, nitrile, other

Sterile or non-sterile

One or two pair

Single use or reusable



Figure 1 Gloves

7.1.2 Do’s and Don’ts of Glove Use

- Work from “clean to dirty”
 - Limit opportunities for “touch contamination” - protect yourself, others, and the environment
- Don’t touch your face or adjust PPE with contaminated gloves
- Don’t touch environmental surfaces except as necessary while using gloves



- Change gloves
- During use if torn and when heavily soiled
 - Discard in appropriate receptacle
- Never wash or reuse disposable gloves

8 Chemical-Resistant Gloves

Corrosive chemicals such as acids and bases may damage hands. Chemical-resistant work gloves are provided under such circumstances. Chemical-resistant gloves are formulated to resist chemical degradation thereby protecting your workers hands. These work gloves can be made from nitrile, latex, neoprene, vinyl, PVC or rubber. Be sure to perform a hazard assessment as gloves made from different materials have different properties and chemical resistance.^[3]



Figure 2 Chemical Resistant Gloves

9 Instructions for the Safe Removal of Contaminated Gloves

1. Pull one glove near your wrist towards your fingertips until the glove folds over.



2. Carefully grab the fold and pull towards your fingertips. As you pull you are turning the inside of the glove outwards.



3. Pull the fold until the glove is almost off



4. To avoid contamination of your environment, continue to hold the removed glove. Completely remove your hand from the glove.



5. Slide your finger from your hand, which is free from the glove, under the glove worn on the other hand. Continue to slide your finger towards your fingertips until almost half of your finger is under the glove.





6. Turn your finger 180 degrees and pull the glove outwards and towards your fingertips. As you do this, the first glove will be encased in the second glove. The inside of the second glove will also be turned outwards.



7. Grab the gloves firmly, by the uncontaminated surface (the side that was originally touching your hand). Release your grasp of the first glove, you removed. Pull your second hand free from its glove. Dispose of the gloves properly^[4]



9.1 Body Protection

9.1.1 Gowns or Aprons

- Material –
 - Natural or man-made
 - Reusable or disposable
 - Resistance to fluid penetration
- Clean or sterile

Aprons are single-use items and must be worn when in close contact with materials or equipment that poses a risk of contamination with sewage or sludge. Fluid-repellent gowns must be worn when there is an extensive risk of the splashing of sewage or sludge.



Figure 3 Gowns

Staff should Ensure that Aprons/Gowns are:

- Changed when visibly soiled - although it takes some time for fluid to seep through fluid-repellent gowns (strike through), they are not waterproof;
- Non-disposable PPE should be sent for appropriate decontamination

9.1.2 Factors Affecting Selection of Gown:

There are three factors that influence the selection of a gown or apron as PPE.

First is the purpose of use. Isolation gowns are generally the preferred PPE for clothing but aprons occasionally are used where limited contamination is anticipated. If contamination of the arms can be anticipated, a gown should be selected. Gowns should fully cover the torso, fit comfortably over the body, and have long sleeves that fit snugly at the wrist.

Second are the material properties of the gown. Isolation gowns are made either of cotton or a spun synthetic material that dictate whether they can be laundered and reused or must be disposed. Cotton and spun synthetic isolation gowns vary in their degree of fluid resistance,



another factor that must be considered in the selection of this garb. If fluid penetration is likely, a fluid resistant gown should be used.

10 Flame-Resistant Jackets

Protect yourself from heat and fire with flame resistant jackets

Flame-resistant jackets protect one from too much heat that may come from the work place. Stylish enough for off-duty wear, these jackets keep you from burning yourself when doing heat intensive tasks such as welding and more. Some jackets provide additional pockets or have leather reinforced sections to provide even more functionality to your jacket. So go and check out our selection and grab the right jacket for you!



Figure 4 Flame Resistant Jackets

Cool-V™ Hi-Vis Work Shirts

High-visibility clothing that combines moisture-wicking and cooling properties to keep the body dry, and more importantly, cool all shift long.

It pulls moisture away from workers' skin and absorbs it into the Cool-V fibers, as the moisture evaporates it creates a cooling effect to keep workers more comfortable and drier in warm weather. The Cool-V fabric will feel noticeably cooler and can cool the skin by at least 2°



Figure 5 Cool-V™ Hi-Vis Work Shirts



10.1 Face Protection

10.1.1 Masks

- protect nose and mouth
- Should fully cover nose and mouth and prevent fluid penetration

Masks should fully cover the nose and mouth and prevent fluid penetration. Masks should fit snugly over the nose and mouth. For this reason, masks that have a flexible nose piece and can be secured to the head with string ties or elastic are preferable.

10.1.2 Goggles

- protect eyes
- Should fit snugly over and around eyes
- Personal glasses not a substitute for goggles
- Anti fog feature improves clarity

Goggles provide barrier protection for the eyes; personal prescription lenses do not provide optimal eye protection and should not be used as a substitute for goggles. Goggles should fit snugly over and around the eyes or personal prescription lenses. Goggles with anti-fog features will help maintain clarity of vision.

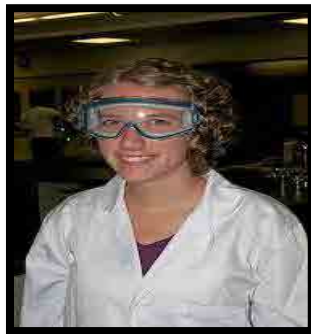

Figure 6 Goggles

10.1.3 Face Shields

- protect face, nose, mouth, and eyes
- Should cover forehead, extend below chin and wrap around side of face

When skin protection, in addition to mouth, nose, and eye protection, is needed or desired, a face shield can be used as a substitute to wearing a mask or goggles. The face shield should cover the forehead, extend below the chin, and wrap around the side of the face.





Figure 7 Face Shield

10.2 Head Protection

Hard hats, bump caps, or helmets are types of protection that should be considered if there is a hazard of head injury. Head injuries can occur under various circumstances: slip or fall, working with unpredictable animals, working in confined areas or where there are low ceilings or where there may be falling objects



Figure 8 Hat

10.3 Foot Protection

Foot protection is usually in the form of steel-toed work boots, with a steel shank to protect the bottom of the foot from puncture wounds.

In wet environments, steel-toed boots that are waterproof and slip-resistant may be necessary. The hazards that workers are exposed to will determine what type of foot protection is most appropriate for the job.





Figure 9 Safety Boots

10.4 Hearing Protection

- Hearing protection should be worn in work environments where noise levels exceed 85 decibels.
- In limited circumstances, a worker may be exposed to noise levels above 85 decibels without wearing hearing protection, but the acceptable duration of such an exposure will vary depending upon the noise level (in decibels).
- There are many types of hearing protection, including earplugs or muffs. Hearing protection that is suitable for the work environment and provides adequate noise reduction should be chosen.^[3]



Figure 10 Ear Plugs

10.5 Respiratory Protection

There are many types of respirators available to protect against a variety of atmospheric hazards. It is important that the respirator being used for a particular job protects against the hazard in question. Using the wrong respirator can be as dangerous as not wearing one at all. All respirators must fit well and provide a proper seal with the wearer's face in order to provide adequate protection.



1. Disposable respirators should be used where dusts, mists and fumes may be present. They must not be used in oxygen deficient atmospheres.
2. Chemical cartridge respirators should be used to filter out gases and organic vapors. These respirators are hazard-specific, meaning that a cartridge designed to filter out a particular gas will not protect a worker from exposure to a different gas. They must not be used in oxygen deficient atmospheres.
3. Gas masks should be used for high concentrations of specific gases. They usually have a full face piece and canister attached. They must not be used in oxygen deficient atmospheres.
4. Supplied air respirators should be used in highly toxic and oxygen deficient atmospheres. Users should be well trained. Such equipment:
 - comes with the air supply in a tank
 - comes with a small emergency bottle
 - has positive pressure for use in toxic atmospheres
 - should never be used alone
 - Should be used according to confined space entry procedures.

10.6 Types of Respirators:

10.6.1 Air-Purifying Respirator (APR), Disposable

Key Features

- Usually half mask, negative-pressure particulate respirator
- Inspiratory effort of wearer draws air through filter
- Filter comprises all or a significant portion of the face piece
- Airborne particles removed as inspired air passes through filter

Advantages

- Light weight
- Does not restrict mobility
- Low cost (compared to other respirators)

Disadvantages

- Does not supply oxygen (cannot be used in low oxygen environments)
- May only be used when air contaminant level is below the concentration limits of the filter
- Fit testing required
- Some contaminated air will leak into face piece



- Half mask models do not provide adequate eye protection
- Full face piece models may fog up during use
- Communication can be difficult



Figure 11 APR

10.6.2 Air-Purifying Respirator (APR), Reusable

Key Features

- Elastic face piece worn over mouth and nose
- Inspiratory effort of wearer draws ambient air through filter(s) before air is inhaled
- Provides increased protection when used with filters, cartridges, or canisters that remove specific contaminants

Advantages

- Comparatively light weight
- Does not restrict mobility
- Relatively low cost (compared to other respirators)

Disadvantages

- Does not supply oxygen (cannot be used in low oxygen environments)
- May only be used when air contaminant level is below the concentration limits of the filter(s)
- Fit testing required
- Some contaminated air can leak into face piece
- Half mask models do not provide adequate eye protection
- Communication can be difficult





Figure 12 (APR), reusable

10.6.3 Powered Air-Purifying Respirator (PAPR)

Key Features

- Battery powered blower forces contaminated ambient air through air-purifying filters
- Purified air delivered under positive-pressure to face piece mask, helmet, or hood
- Worn when disposable and reusable half mask negative-pressure air-purifying respirators do not provide adequate protection

Advantages

- Provides greater protection than non-powered negative-pressure air-purifying respirators
- More comfortable to wear and to breathe compared to non-powered negative-pressure air-purifying respirators
- Air delivery to face piece mask, helmet, or hood ensures that leakage of contaminated air is usually outward
- Fit testing not required
- Various chemical cartridges or canisters available to eliminate chemicals including organic vapors and acid gases
- Provides both respiratory and eye protection

Disadvantages

- Bulky and noisy
- Battery dependent
- Is not a true positive-pressure device (i.e., some leakage of contaminated air into face piece mask, helmet, or hood can occur)
- Communication can be difficult



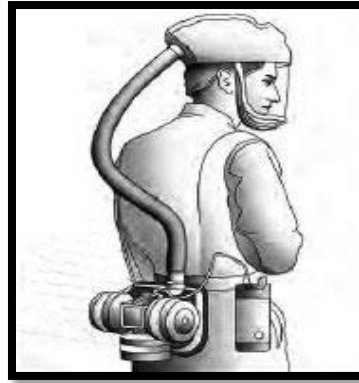

Figure 13 PAPR

10.6.4 Supplied-Air Respirator (SAR)

Key Features

- Compressed air delivered from a stationary source (located away from contaminated area) to a half or full face piece mask via a hose
- Worn when negative-pressure and powered air-purifying respirators do not provide adequate protection

Advantages

- Provides high level respiratory protection
- Provides positive pressure to mask so almost all leakage is outward
- Less bulky and can be used for longer periods than self-contained breathing apparatus
- Provides both respiratory and eye protection

Disadvantages

- Length of air hose may limit mobility
- Air hose may be a trip hazard
- Clean source of breathing air required
- Fit testing required
- Immediately operable emergency escape respirator, escape hood, or escape mask is required
- Communication can be difficult





Figure 14 SAR

10.6.5 Auxiliary Escape Respirator, Escape Hood, or Escape Mask

Key Features

- Carried or worn *in case of SAR failure*
- Protects wearer from breathing harmful gases, vapors, fumes, and dusts for a limited amount of time in emergency situations
- Can be designed as an air-purifying escape respirator (APER) or a self-contained breathing apparatus (SCBA) type respirator
- APERs have a filter canister mounted on a hood to filter contaminants before air is inhaled
- SCBA type escape respirators have an attached source of breathing air and a hood that provides a barrier against contaminated outside air

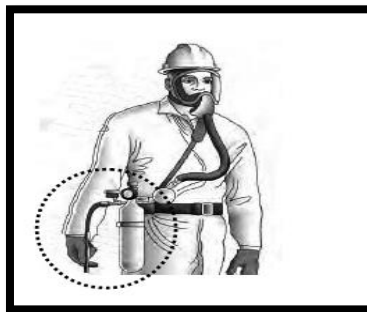

Figure 15 Auxiliary escape Respirator

10.6.6 Self-Contained Breathing Apparatus (SCBA)

Key Features

- Provides very pure, dry compressed air to full face piece mask via a hose
- Air is exhaled to environment



- By law, must be worn whenever entering environments immediately dangerous to life and health (IDLH) or when information is inadequate to rule out IDLH atmosphere

Advantages

- Provides highest level of respiratory protection
- Several different types available depending on need
- Improved mobility over Supplied-Air Respirators
- Provides both respiratory and eye protection

Disadvantages

- Heavy to wear
- Limited oxygen supply limits duration of use
- Fit testing required
- Communication can be difficult



Figure 16 SCBA

When should a Respirator be used?

Workers should use respirators if other hazard control methods are not practical or possible under the circumstances. Respirators should not be the first choice for respiratory protection in workplaces. They should only be used:

- When following the "hierarchy of control" is not possible (elimination, substitution, engineering or administrative controls)
- While engineering controls are being installed or repaired
- When emergencies or other temporary situations arise (e.g., maintenance operations)

How should you Control Respiratory Hazards?

Respiratory hazards can include airborne contaminants such as biological contaminants, dusts, mists, fumes, and gases, or oxygen-deficient atmospheres. Note that more than one respiratory hazard can be present at the same time. After elimination and substitution, well designed and



maintained engineering controls are the preferred methods of controlling worker exposure to hazardous contaminants in the air. These control methods include:

- Mechanical ventilation
- Enclosure isolation of the process or work equipment
- Popper control and use of process equipment, and
- Process modifications including substitution of less hazardous materials where possible.

Administrative controls may be used in addition to engineering controls. Administrative controls limit workers' exposures by scheduling reduced work times in contaminant areas or by implementing other such work rules. These control measures have many limitations because the hazard is not removed. Administrative controls are not generally favored because they can be difficult to implement, maintain and are not reliable.^[5]

11 Checklist for PPE

General Requirements	Please Circle
1. Has a hazard assessment been conducted in the workplace to identify possible hazards that would require the use of PPE?	Y N N/A
2. Is there a written certification of hazard assessment which identifies the workplace evaluated, the person certifying that the evaluation has been performed, and the date(s) of the hazard assessment?	Y N N/A
3. Based on the hazards identified, has PPE been selected for all appropriate individuals?	Y N N/A
4. Have individuals involved been informed of the PPE selection decisions?	Y N N/A
5. If PPE is necessary to prevent injury or impairment by exposure to chemical hazards, radiological hazards, or mechanical irritants through absorption, inhalation or physical contact, is it provided?	Y N N/A
6. Has the selected PPE been fitted to appropriate individuals?	Y N N/A
7. Is PPE maintained in a sanitary and reliable condition?	Y N N/A
8. Do appropriate individuals use the PPE selected?	Y N N/A
9. Is defective or damaged PPE removed from service immediately? (shall not be used)	Y N N/A
Training	
10. Has each individual who is required to use PPE been provided with training?	Y N N/A
11. Has training on PPE included all of the following elements: when PPE is necessary; what PPE is necessary; how to properly put on,	Y N N/A



General Requirements	Please Circle
off, adjust, and wear PPE; the limitations of the PPE; and the proper care, maintenance, useful life and disposal of the PPE.	
12. Have the trained individuals demonstrated an understanding of the training and the ability to use PPE properly before being allowed to perform work requiring the use of PPE?	Y N N/A
13. Are individuals re-trained when there is reason to believe that they do not have the understanding or skill to use PPE properly?	Y N N/A
14. Is re-training conducted whenever changes in the workplace or changes in types of PPE make previous training obsolete?	Y N N/A
15. Is there written certification for each person who has received PPE training that includes the following: a statement indicating the person understood the training; the name of the person trained; the date(s) of the training; and the subject of the certification?	Y N N/A
Head, Foot, and Hand Protection	
16. Are protective helmets used wherever there is the possible danger of head injury from impact, or from falling or flying objects, or from electrical shock and burns?	Y N N/A
17. Do protective helmets meet the American National Standard Safety Requirements for Industrial Head Protection	Y N N/A
18. Is protective footwear used wherever there is the danger of foot injuries due to falling or rolling objects, or objects piercing the sole, and where feet are exposed to electrical hazards?	Y N N/A
19. Are appropriate protective gloves used wherever there is the danger to hands of exposure to hazards such as those from skin absorption of harmful substances, severe cuts or lacerations, severe abrasions, punctures, chemical burns, thermal burns, and harmful temperature extremes?	Y N N/A
Eye and Face Protection	
20. Are individuals issued and required to wear appropriate eye protective devices while participating or observing activities which present a potential eye safety hazard? Note: Eye potential hazards include: caustic or explosive chemicals or materials, hot liquids or solids, molten materials, welding operations of any type, repairing or servicing of vehicles, heat treatment or tempering of metals, the shaping of solid materials and laser device operation and experimentation.	Y N N/A
Posting Requirements	
21. Are all lab or shop entrances, areas and equipment requiring the use of PPE devices posted with a sign indicating this requirement?	Y N N/A



12 Glossary:

Keyword	Definition
OSHA	Occupational Safety and Health Administration
HAZARDS	A hazard is any source of potential damage, harm or adverse health effects on something or someone under certain conditions at work
PPE	Personnel Protective Equipment
Sterile	free from bacteria or other living microorganisms; totally clean
hazard assessment	A hazard assessment is an evaluation of a work place, or work situation, as to the potential for hazards that an employee may encounter while performing the job.
Splashing	Cause (liquid) to strike or fall on something in irregular drops.
SAR	Supplied-Air Respirator
Administrative controls	Administrative controls (or work practice controls) are changes in work procedures such as written safety policies, rules, supervision, schedules, and training with the goal of reducing the duration, frequency, and severity of exposure to hazardous chemicals or situations
Cartridge	any small container for powder, liquid, or gas, made for ready insertion into some device or mechanism
IDLH	immediately dangerous to life or health

13 References

1. <https://www.osha.gov/Publications/osha3151.pdf>
Occupational Safety and Health Administration. 2004. U.S. Department of Labor: Personal Protective Equipment. OSHA 3151-12R.
2. www.hse.gov.uk/pubns/indg174.pdf
Health and Safety Executive. INDG174(rev2), June 2013. Personal protective Equipment (PPE) at work. Retrieved April 21, 2016, from www.hse.gov.uk/pubns/indg174.pdf
3. www.cdc.gov/HAI/pdfs/ppe/PPEslides6-29-04.pdf
PPE Use in Health care Settings. (n.d). Guidance for the Selection and Use of Personal Protective Equipment (PPE) in Healthcare



Settings. Retrieved April 21, 2016 from www.cdc.gov/HAI/pdfs/ppe/PPEslides6-29-04.pdf

4. <http://www.des.umd.edu/os/ppe/glove/>
Department of Environmental Safety, Sustainability & Risk (n.d). University of Maryland. Retrieved April 21, 2016, from <http://www.des.umd.edu/os/ppe/glove/>
5. https://www.remm.nlm.gov/respiratory_ppe.htm
U.S.Department of Health & Human Services. Jan 13, 2016. PPE Image Gallery: Respiratory Protective Equipment. Retrieved April 21, 2016, from https://www.remm.nlm.gov/respiratory_ppe.htm





Course Code: 3221

Module 1

**Safety Control and Measures for Sewer
and Drainage Works**

Participant Lecture Notes

Lecture 5

Working in Confined Spaces

2016



1 Lecture Information

Topic: Standard safety practices for performing sewer and manhole inspection	Lecture duration (hrs.): 5.0 • OJT (hrs.): 5.0
Lecture topics: Working in confined space	Training delivery mode: OJT
Lecture date: TBD	Day: Two

2 Objectives

After the completion of this OJT the participants will be able to understand the followings:

- Concept of confined space
- Implementing the SOPs for working in confined space
- Creating and implementing check lists pertaining to confined space

3 What is Confined Space?

A confined space means any place in which, by virtue of its enclosed nature, there arises a reasonably foreseeable specified risk of:

- Fire or explosion;
- Loss of consciousness of any person due to an increase in body temperature;
- Loss of consciousness or oxygen deficiency of any person due to gas, fume, vapor or lack of oxygen;
- Drowning of any person due to an increase in the level of liquid; or
- Oxygen deficiency to any person who is trapped by a flowing solid.

Confined spaces include any chamber, tank, vat, pit, well, sewer, tunnel, pipe, flue, boiler, pressure receiver, hatch, caisson, shaft or silo.(Figure 1) [1].



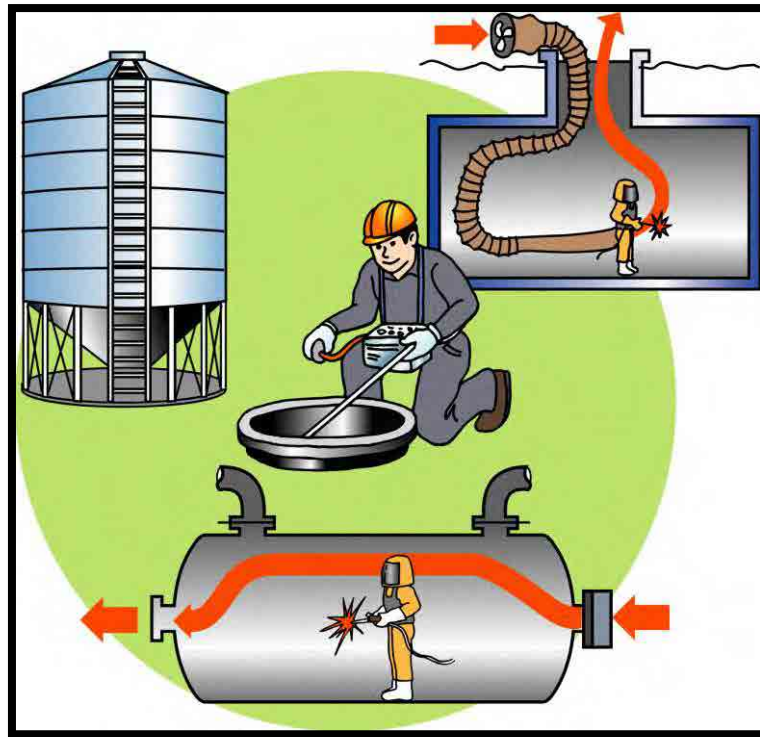

Figure 1: Confined Space

4 Definitions

4.1 Competent Person

A “competent person” refers to a person who has sufficient experience and training to perform the work required to be carried out.[2]

4.2 Certified Person

Certified person is the one who:

- Observe instructions and attend training.
- Comply with all safety working procedures formulated.
- Make full and proper use of any safety equipment or emergency facilities and report any fault or defect in such equipment or facilities immediately [1].

4.3 Entrant

A person required to enter confined spaces to carry out inspections or work [2].



5 Introduction

5.1 Why Working in Confined Spaces is Hazardous?

Working in confined spaces is more hazardous than working in other workplaces because:

- The entrances/exits of confined spaces might not allow the entrant to evacuate effectively if there is a flood of free-flowing material or collapse of the confined structure;
- Self-rescue by entrant is more difficult;
- Rescue of the victim is more difficult. The interior configuration of a confined space often restricts the movement of people or equipment within it;
- Natural ventilation alone is often not sufficient to maintain breathable quality air because the interior configuration of some confined spaces does not allow air to circulate;
- Conditions can change very quickly;
- The space outside the confined place may have impact on the conditions inside it and vice versa; or
- Work activities inside confine place may introduce hazards not present, initially.

5.2 Why Entry into a Confined Space is Needed?

People enter a confined space for:

- Cleaning;
- Inspection;
- Maintenance and repair;
- Construction; or
- Rescue, etc.[2]

6 Hazard Assessment

6.1 Key Elements of Risk Assessment for Confined Spaces

Risk, while working in a confined place, could be significantly reduced. It could be done through proper and detailed risk assessments prior to entry. Everyone, from employer to worker, must work together to ensure that the risk assessment process identifies all expected risks. And that all measures are taken to make the entry as safe as possible. What is important is, that the risk assessment is conducted by knowledgeable and experience personnel.



6.1.1 Assess Need for Entry into a Confined Space

Before attempting to enter or work in a confined space, it is important to consider the possibility of using alternatives and other methods to do the job. Entry into or work in a confined space should only be a last resort.

6.1.2 Identification and Evaluation of Confined Spaces

All confined spaces shall be clearly identified, documented and labelled. It includes any equipment that is installed in a confined space. The document should contain the particulars of the types of confined spaces and their services. It is critical to identify and evaluate each confined space to determine whether it has chemical or physical hazards. It is advisable to never assume that a confined space is hazard-free. Different chemical and physical hazards may be introduced through various work activities inside the confined space.

6.2 Communication

It is important to communicate the risks involved to all workers who have to enter into a confined space. It is necessary for managers/supervisors to inform the workers of:

- The confined space work activities to be carried out;
- Associated safety and health hazards affecting them and nature of the risks involved;
- Types of control measures implemented to protect them;
- Any changes to the work conditions and risks control measures.

Their responsibilities and expectations to comply with all work requirements including:

- a) Obeying general safety rules and regulations;
- b) The use of personal and respiratory protective equipment;
- c) Complying with safe work procedures; and
- d) Instructions as required under the Permit to Work system.

6.3 Periodic Risk Assessment

It is essential to review or revise the confined space risk assessment at least once every 3 years. It is also necessary to review the risk assessment when the following events happen:

- When there is significant change to work practices or procedures including implementation of additional risk control measures; or
- After an incident arising from work in confined spaces.

Various important elements involved in risk assessment are shown in Figure 2.



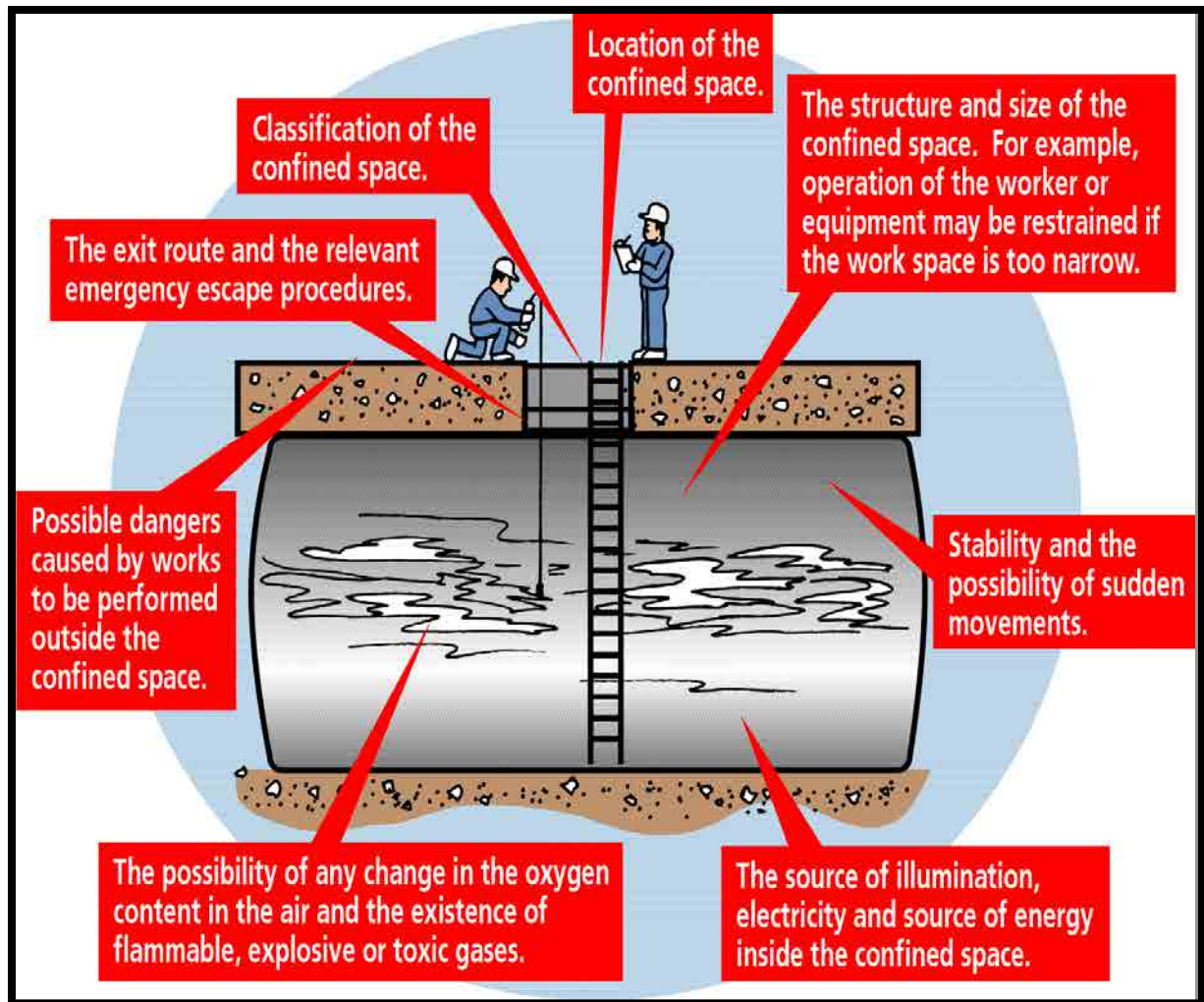

Figure 2: Risk Assessment

6.4 Documentation

Documentation of the risk assessment process is of prime importance. The document must contain the following information:

- The findings of risk assessments exercise (detail of risk involved);
- Risk control measures to be taken within an agreed time frame; and
- Any safe work procedures [2].

7 Hazards of Confined Space

Dangers can arise in confined spaces because of:

- Fire or explosion, e.g. from flammable vapors, combustible gases, etc. Such a hazard is represented by Figure 3.



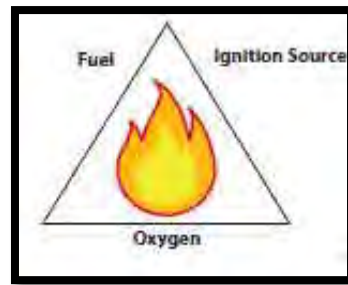

Figure 3: Fire Triangle

- Liquids and solids which can suddenly release hazardous gases, fumes or vapors when disturbed.
- A lack of oxygen. This can occur:
 - ✓ Where there is a reaction between the soils and the oxygen in the atmosphere, resulting in the consumption of oxygen in the confined space.
 - ✓ Inside steel tanks and vessels when rust forms.[3]

Changes of the oxygen content in air that is breathed in, can cause the following adverse physical reactions to the human body as shown in Figure 4 [1].

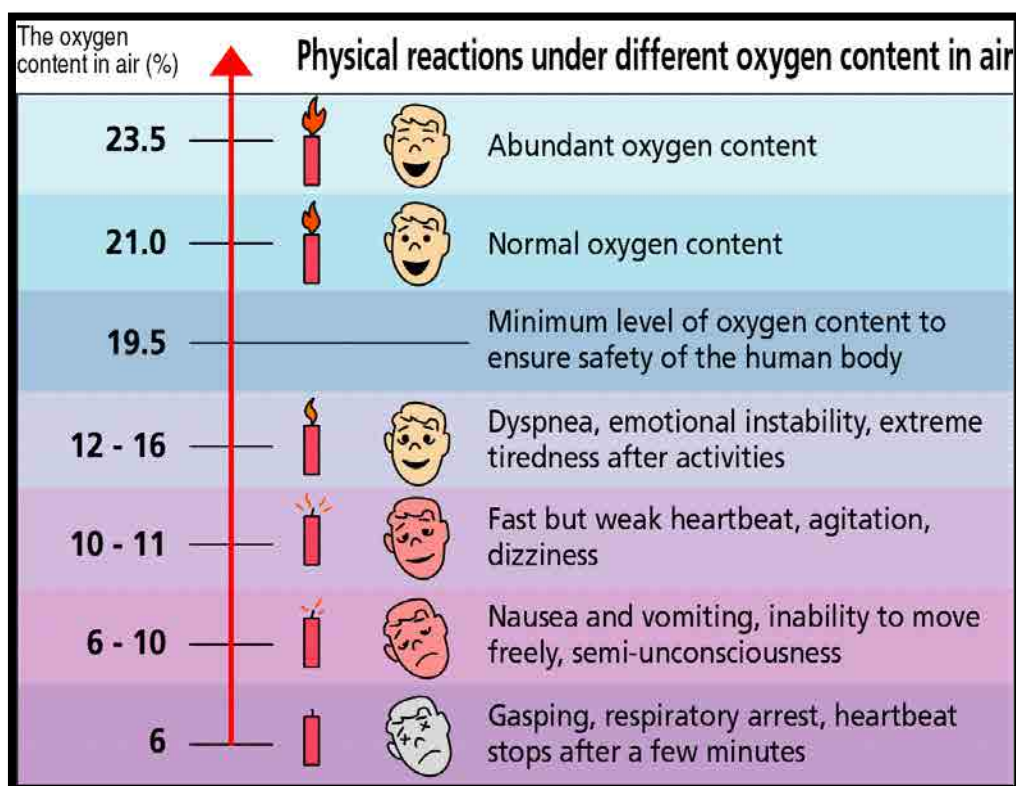

Figure 4: Physical Reactions under Different O₂ Content in Air

- If access to the space is through a restricted entrance, such as a manhole, escape or rescue in an emergency will be more difficult [4].



- The use of personal protective equipment may also increase the difficulty of performing manual operations [1].
- Workers may be infected with different varieties of bacteria and viruses and even threatened by biological hazards produced by insects and snakes [1].
- Poisonous gases, fumes or vapors, the exposure limit of which is shown in Figure 5. These can:
 - ✓ Build up in sewers and manholes and in pits connected to the system;
 - ✓ Enter tanks or vessels from connecting pipes;
 - ✓ Leak into trenches and pits in contaminated land, such as old refuse tips and old gas works [3].

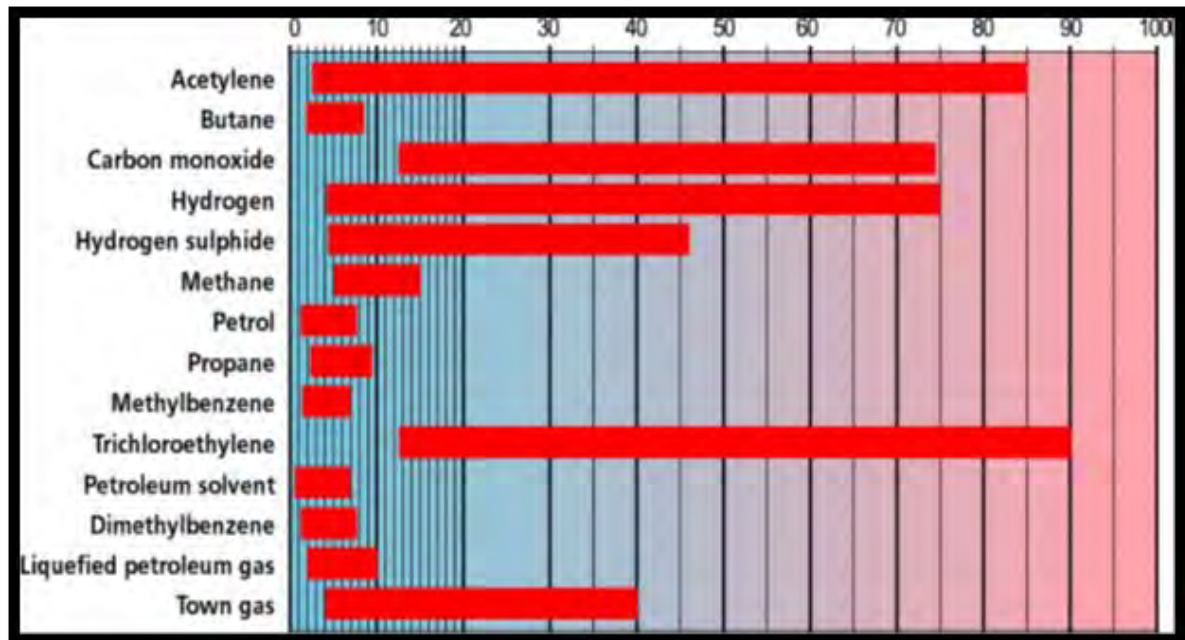

Figure 5: Explosive Limits of Poisonous Gases

Drowning of workers arising from an increase in the level of liquid [3].



Figure 6: Drowning

The environmental conditions are more likely to pose danger in confined spaces like extremely high or low temperature, dampness and wet spaces [1].



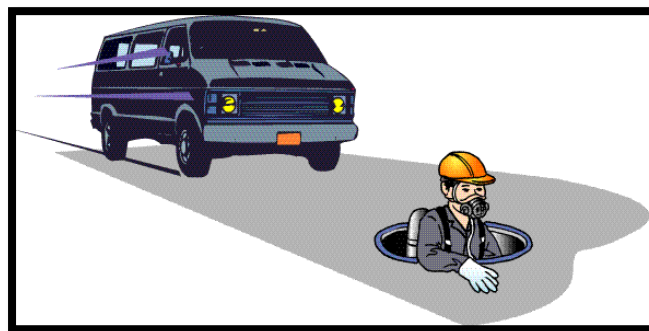

Figure 7: Effect of Temperature



Figure 8: Risk of Falling Down

Since the entrance and exit of some confined spaces, such as sewers, are situated on pavements or roads, workers will have the risk of being knocked down by vehicles passing by. There is also risk of people falling down into the confined spaces [1].



7.1 Chemical Substances

The workers may come in contact with hazardous chemicals by inhaling them through respiration, through skin absorption or by eating them, by mistake (Figure 9). The effects brought by chemical substances upon the human body may be chronic (effect that appear after a long exposure time) or acute (effect that immediately appear after contact), depending on:



- The period of contact,
- The intensity of the hazards during contact and
- The impact of such hazards on health, for example, corrosive, toxic or harmful.

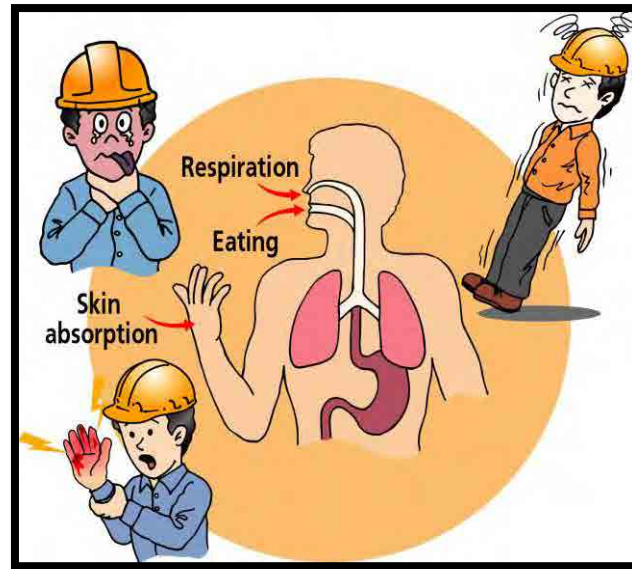

Figure 9: Effect of Chemical Substances

Some poisonous gases emit a particular odor. Like hydrogen sulphide gas has a smell of rotten egg. While carbon monoxide, on the other hand is odorless. Hydrogen sulphide is likely to anaesthetize one's sense of smell soon after contact so that one may no longer sense its existence. Therefore, only the use of scientific equipment is reliable to measure the existence of poisonous gases [1].

8 Safety Precautions for Confined Space Work

If your assessment identifies risks of serious injury from work in confined spaces, such as the dangers highlighted above, the Confined Spaces Regulations 1997 apply. These regulations contain the following key duties [4].

- ✓ Avoid entry to confined spaces, e.g. by doing the work from outside;
- ✓ If entry to a confined space is unavoidable, follow a safe system of work; and
- ✓ Devise an appropriate emergency plan before the work starts [3].

These duties, and how to carry them out are described in the sections below.

8.1 Avoid Entering Confined Spaces

In the first instance, it must be checked whether any means exist that the desired work could be performed without entering the confined space. Better work planning or a different approach of performing the work may reduce the need for entering the confined space

Ask yourself if the intended work is really necessary, or if you could:



- Modify the confined space itself or other plant to eliminate the confined space;
- Have the work done from outside, for example:
 - ✓ Inspection, sampling and cleaning operations can be done from outside the space using appropriate equipment and tools; and
 - ✓ Remote control monitors can be used for internal inspection of sewers [3].

8.2 Safe System of Work

If entry to a confined space is unavoidable, a safe system for working inside the space should be developed. A “competent person” should be appointed to carry out a risk assessment of the conditions and the work and activities, and identify the necessary safety precautions to be taken to avoid posing hazards to workers.

Make sure that the safe system of work, including the precautions identified, is developed and put into practice. Everyone involved will need to be properly trained and instructed to make sure they know what to do and how to do it safely.

8.2.1 Appoint Suitable Persons for the Work



Suitable workers should meet the following requirements:

- Have received training to become “certified workers”;
- Have sufficient experience in the type of work to be carried out;
- Have a suitable build for the work if the risk assessment highlights exceptional constraints as a result of the physical layout;
- Be fit to wear breathing apparatus if the work requires the use of such apparatus, and there is no medical advice against an individual’s suitability to work in a confined space [3].



8.2.2 Isolation



The proprietor or contractor should, before allowing workers to enter a confined space, ensure that the confined space has been securely and completely isolated and separated from all the other connecting parts so as to prevent any materials which are liable to create a hazard from entering a confined space.

- Ensure that the dangerous materials will not go into the confined space whilst the workers are working in it. [5]
- All pipelines connected to a confined space should be completely shut off or blanked off as appropriate.
- Openings in a confined space (e.g. drain holes) should be sealed off if there is any possibility of hazardous gases or vapors backing up from another area and contaminating it.
- Effective steps should be taken to prevent an ingress to the confined space of hazardous gas, vapor, dust or fume, or in-rush of mud, water or other free flowing liquids and solids [5].

8.2.3 Purging

Confined space should be adequately purged by suitable method, such as inert gas purging, forced ventilation, etc. to remove all the hazardous substances contained in the confined space.

- To avoid the formation of an explosive mixture with air when a confined space containing flammable gas or vapor is opened up, the confined space may be purged by an inert gas (e.g. nitrogen, carbon dioxide).
- If persons have to enter or approach a confined space which has been purged by an inert gas, the confined space should be purged again by fresh air so as to provide adequate oxygen into the confined space to support life [5].



8.2.4 Check the Size of the Entrance



Ensure that the entrance to a confined place is big enough. It must allow workers wearing all the necessary equipment to get in and out easily, and provide safe access and egress in an emergency. For example, if the entrance is narrow, air-line breathing apparatus should be used instead of self-contained breathing apparatus which is more bulky and therefore restricts passage [4].

8.2.5 Ventilation

It is unsafe to enter any confined space when adequate ventilation is absent. Adequate and effective ventilation is required throughout the validity period of the entry permit (Figure 10). As such, it is important to provide an adequate and effective ventilation to always maintain the contaminants concentration level as low as possible, and the level of oxygen within safe range [2].

Provision of ventilation can be achieved by:

- Increasing the number of openings and therefore improve ventilation.
- Mechanical ventilation may be necessary to ensure an adequate supply of fresh air [3].



Figure 10: Exhaust Ventilation System

Effective steps to prevent an ingress to the confined space, particular attention has to be paid to any possible ingress, inrush, spillage or leakage of the substances through the ingress, egress or openings of the confined space from areas or places surrounded [5].



8.2.6 Testing the Air

This is necessary in order to check that the air is free from both toxic and flammable gases, and that there is no deficiency in oxygen and the air is fit to breathe. Testing should be carried out by a competent person using a suitable gas detector which is correctly calibrated. Where the risk assessment indicates that conditions may change in the course of work, or as a further precaution, continuous air monitoring as advised by the competent person is required [4].



8.2.7 Provision of Tools and Lighting

Adequate and suitable lighting shall be provided for entry and work in a confined space.

- Access and passage into a confined space shall be provided with illumination of not less than 50 lux.
- All portable hand-held lightings provided in confined spaces shall be operated at a voltage not exceeding alternative current (AC) 55 volts between the conductor and earth or direct current (DC) 110 volts.
- Temporary lights shall be equipped with guards to prevent accidental contact with the bulb, except when the construction of the reflector is such that the bulb is deeply recessed
- Temporary lights shall be equipped with heavy-duty electric cords with connections and insulation maintained in safe condition. [2]



8.2.8 Communications

An effective and reliable means of communication among entrants inside the confined space, and between entrants and attendants outside, is required. When choosing a means of communication, it is advisable to give careful consideration to all anticipated conditions inside the confined space (e.g., visibility, possibility of a flammable atmosphere, and noise levels) and to the personal protective equipment in use (e.g., ear muffs and breathing apparatus).



The communication system used can be based on speech, hand signals, telephone, radio, and so on. Whatever system is used, it is important that all messages can be communicated easily, rapidly and unambiguously between relevant people [2].

8.2.9 Openings of Confined Spaces

After opening a confined space for access, cover is removed. Any known unsafe conditions shall be eliminated. When entrance covers are removed, the opening shall be promptly guarded by a railing, temporary cover, or other temporary barrier. This will prevent anyone from falling in. The barrier or cover shall prevent foreign objects from entering the space and protect each employee working in it. If it is in a traffic flow area, adequate barriers shall be erected to divert the traffic [2].



8.2.10 Barricade

It is essential to use safety barriers to separate workers from hazards that cannot be reasonably eliminated by other engineering controls. Selection of suitable barriers will depend on the nature of the hazard and the size of the area or equipment to be cordoned off. The supervisor must determine if safety barriers will be needed for the confined space entry prior to any workers entering the confined space [2].

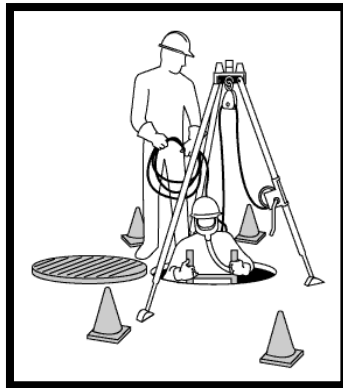

8.2.11 Provision of Breathing Apparatus

It is essential that any person working in the confined space is wearing an approved breathing apparatus. It should be of a type that gives appropriate protection given the nature of the confined space.[3]

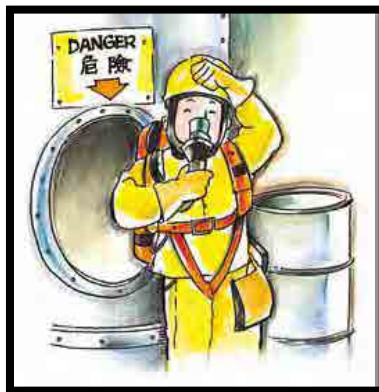

8.2.12 Provision of Safety Harness

Ensure that person is wearing a suitable safety harness, which is connected to a lifeline that is strong enough to enable him to be pulled out, and that the free end is held by a person staying outside the confined space. The person should have sufficient physical strength to be capable of pulling the worker out of the confined space in an emergency. That person must remain in situ throughout the course of work [3].



8.2.13 Warning Signs

Warning sign/s can be used to inform workers about the confined spaces. It is critical for the workers to know the location of the confined space, its hazards, and the required safe work procedures and permit to enter the confined space [2].



8.2.14 Standby Persons

For every confined space entry, a worker must be assigned as a standby person. His job is the well-being of workers inside the space. He keeps the workers observing, either visually or using another method of checking. The standby person also summons help in the event of an emergency. Workers inside the space must be able to contact the standby person at any time, either through voice or visual contact. The standby person must be stationed outside the confined space, never inside [7].

8.2.15 Issuance of Permit-to-Work

A permit-to-work ensures a formal check is undertaken to make sure all the elements of a safe system of work are in place before people are allowed to enter or work in the confined space. It is also a means of communication between site management, supervisors, and those carrying out the hazardous work. Essential features of a permit-to-work are [4]:

- The length of time the permit is valid for.
- The name(s) of the worker(s) that are authorized to enter the confined space.
- The name(s) of the attendant(s) (safety watch) and/or supervisor.
- The location and description of the confined space.
- The work that is to be done in the confined space.
- Possible hazards that may be encountered inside and outside the space.
- Possible hazards that may develop during the work activity.
- The date and time of entry into the confined space and the anticipated time of exit.
- The details of any atmospheric testing done of the confined space - when, where, results, date monitoring equipment was last calibrated. Ideally, calibration would be done just before each use. If this is not possible, follow the equipment manufacturer's guidelines for frequency of calibration.



- Hazard control measures, including the use of mechanical ventilation and other protective equipment needed and any other precautions that will be followed by every worker who is going to enter the confined space.
- Means of communication between the persons working in the confined space and the attendant.
- Emergency plan, and the protective equipment and emergency equipment to be used by any person who takes part in a rescue or responds to other emergency situations in the confined space
- A signature of a worker who did the confined space air testing. The signature on the permit would indicate that adequate precautions are being taken to control the anticipated hazards.
- Authorization signature by the supervisor certifying that the space has been properly evaluated, prepared, and it is safe for entry and work.
- The entry permit should be posted at the confined space and remain so until the work is completed. The employer should keep a copy of the completed permit in file [6].



Figure 11: Permit-to-Work

8.3 Emergency Plan

To deal with any serious and imminent danger to workers inside a confined space, appropriate emergency procedures should be formulated and implemented according to the nature of the confined space, the risks involved and the nature of an emergency rescue. Provide, and keep readily available in a satisfactory condition a sufficient supply of:

- Approved breathing apparatus;
- Suitable reviving apparatus;
- Vessels containing oxygen or air;
- Safety harness and ropes;
- An audio and visual alarm for alerting others outside the confined space.



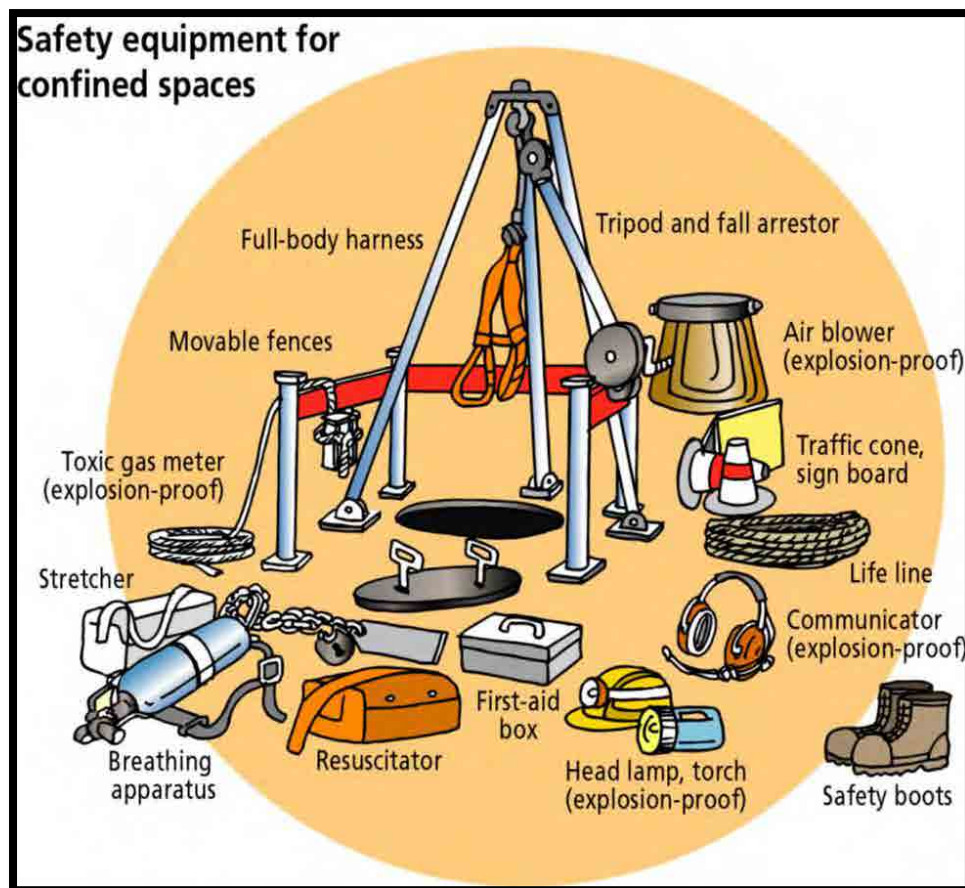

Figure 12: Provision of Safety Equipment for Confined Space

8.3.1 Liaison and Rescue

When work is being carried out in a confined space, another person should be assigned to station outside the confined space to maintain communication with the worker inside. Sufficient number of rescue personnel should also be made available outside the confined space. These persons need to be properly trained in rescues, physically fit and readily available to carry out rescue tasks, and capable of using any rescue equipment provided, e.g. breathing apparatus, reviving apparatus, lifelines and firefighting equipment. They should also be adequately protected against any harm [3].

8.3.2 First-aid Procedures

Qualified first-aiders need to be available to make proper use of any necessary first-aid equipment provided.

8.3.3 Drills

Drills for the rescue should be conducted periodically for gaining practical experience and making sure that the rescue personnel understand and are familiar with the necessary rescue procedures.



8.3.4 Emergency Services

Procedures to notify emergency services departments (e.g. Fire Services Department) in case of an emergency should be formulated in advance. Preparation should also be made to provide these emergency services departments with relevant information on their arrival to help them understand the dangers in the confined space [3].

9 Checklists

9.1 Confined Space Plan Checklist

Workplace Name:			
Workplace No.:		Date:	
Elements of Confined Space	Yes	No	Remarks
1. Responsibilities of Personnel			
i. Have the key personnel who are involved in confined space entry or work been appointed?			
ii. Are the duties and responsibilities of all employees (including key personnel) clearly stipulated?			
2. Confined Space Identification			
i. Do you keep a record of all identified confined spaces?			
ii. Have all affected employees been informed of the existence of these confined spaces and warned of the possible hazards?			
3. Risk Assessment			
i. Has a risk assessment been conducted to identify, evaluate and control all risks arising from entry or work in confined spaces?			
ii. Are the risk control measures selected based on the hierarchy of control for management of confined space hazards?			
iii. Are confined space hazards re-evaluated when new operations or work procedures are introduced or when current operations or work procedures are altered?			
4. Safe Work Procedures and Entry Permit			
i. Have safe work procedures been established for all confined space works?			
ii. Is the evaluation of the need to enter or carry out work in the confined space is done?			
iii. Does the worker has a confined space entry permit?			



Workplace Name:			
Workplace No.:		Date:	
Elements of Confined Space	Yes	No	Remarks
iv. Which types of atmospheric testing required and the interpretation of results of the tests is done?			
v. Are the safety and health precautions taken during entry into the confined space and during an emergency situation?			
vi. Is there proper provision and safe use of safety equipment and PPE?			
vii. Are the warning signs are displayed to prevent unauthorized entry into the confined space?			
viii. Is a copy of the confined space entry permit and a sketch of work area displayed prominently at the entrance to the confined space?			
ix. Are the entry permits kept for a minimum of 2 years from the date of approval?			
x. Is adequate ventilation provided and maintained at all times in the confined space during the validity of the confined space entry permit?			
xi. Is the air supply for the ventilation system from a source or area which is free of contaminants?			
xii. Are all confined space openings barricaded or guarded properly after opening?			
xiii. Are all confined space openings covered effectively to prevent objects from falling through?			
xiv. Is there sufficient and suitable lighting provided for entry into and work in confined space?			
5. Emergency Preparedness and Rescue			
i. Are appropriate emergency procedures are developed and implemented?			
ii. Are trained rescue personnel are available at the confined space for emergency?			
iii. Are the provisions for first aid and emergency services available?			
iv. Are periodic drills conducted for rescue personnel?			



9.2 Confined Space Entry Checklist

Process	Yes	No	Remarks
1. Isolate the Space from all hazards			
i. Remove unauthorized personnel and materials from the site of entry			
ii. Remove the connected pipelines			
iii. Sealed the openings in confined space			
iv. Prevention of ingress of hazardous gases, vapors etc.			
2. Purging and Ventilation			
i. Purged the air with inert gas for adequate oxygen supply			
ii. Proper ventilate the confined space to remove hazardous gases			
3. Fill Entry Permit			
i. Is the entry permit filled properly?			
ii. Are all the requirements of entry permit fulfilled?			
4. Test the Atmosphere			
i. Enter atmosphere readings on the permit			
ii. Place the completed permit on or near the task			
5. Enter the Space and Proceed With Work			
i. Is Supervisor available?			
ii. Attendant at the entry site			
iii. Harness			
iv. Required PPE			
v. Retest atmosphere as needed / required			
6. When the Job is Done:			
i. Remove all personnel, tools and debris from the space.			
ii. Close the space			
iii. Cancel the permit			
iv. Review the job with the employer (hazards, problems, etc.)			
7. Closure			
File the completed and closed permit			



Confined space entry procedure is shown in Figure 13

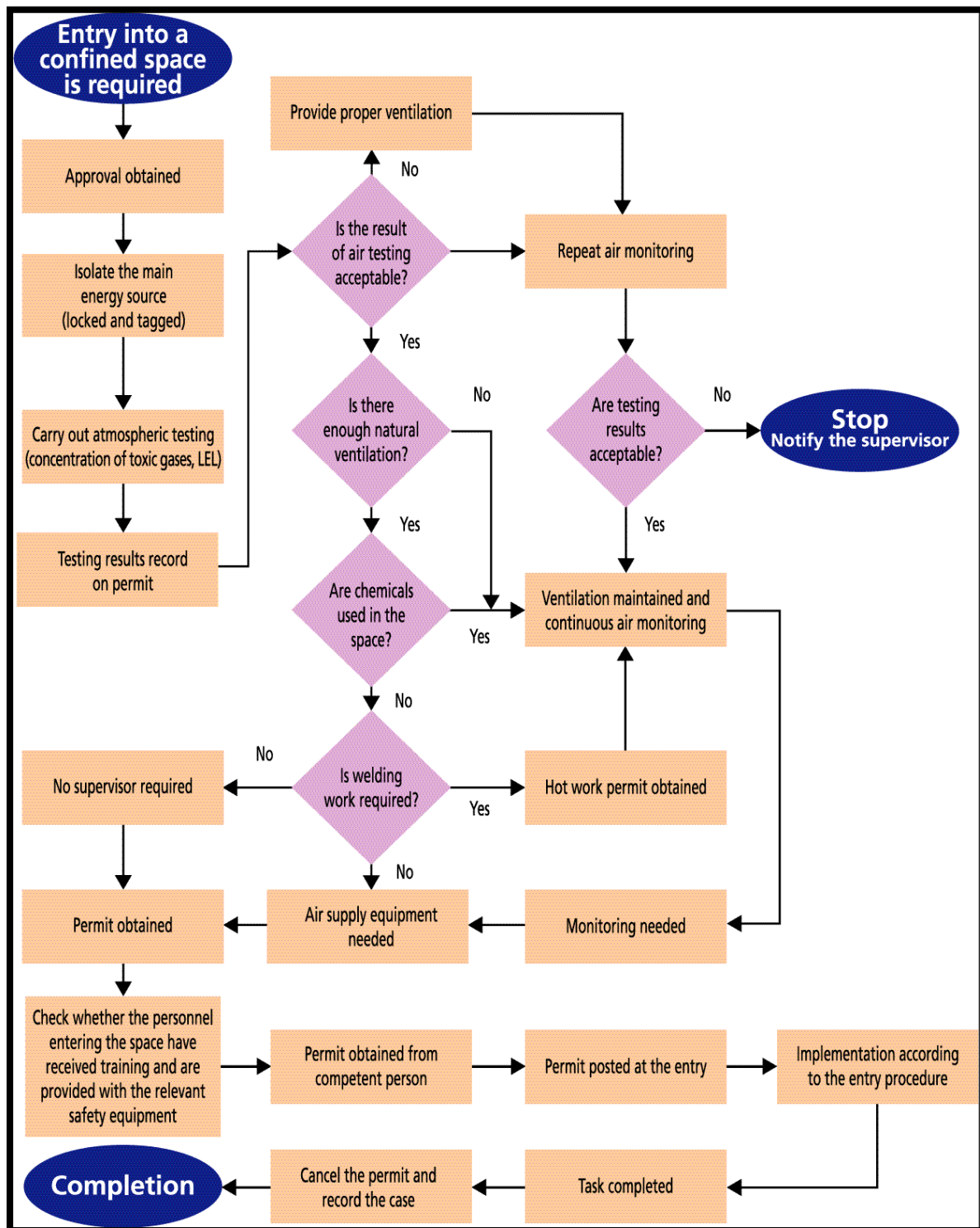

Figure 13: Confined Space Entry Procedure



10 Glossary

Key Word	Definition
Asphyxiation	Condition of severely deficient supply of oxygen to the body that arises from abnormal breathing
Flammable	Easily ignited and capable of burning rapidly
Biological Hazard	Biological substances that pose a threat to the health of living organisms, primarily that of humans
Trench	A long, narrow ditch
Anaesthetize	Deprive of feeling or awareness
Chronic	(of an illness) persisting for a long time or constantly recurring
Acute	(of an unpleasant or unwelcome situation or phenomenon) present or experienced to a severe or intense degree
Liaison	Communication or cooperation which facilitates a close working relationship between people or organizations

11 Reference

1. <http://www.oshc.org.hk/others/bookshelf/CB985E.pdf>
2. <https://www.wshc.sg/files/wshc/upload/cms/file/2014/cs2.pdf>
3. http://www.labour.gov.hk/eng/public/os/D/Safe_Work_in_Confined_Spaces.pdf
4. <http://www.hse.gov.uk/pubns/indg258.pdf>
5. <http://www.labour.gov.hk/eng/public/os/B/space.pdf>
6. https://www.ccohs.ca/oshanswers/hsprograms/confinedspace_program.html
7. http://www.worksafebc.com/publications/health_and_safety/by_topic/assets/pdf/confined_space_entry_bk84.pdf
8. https://www.osha.gov/dte/grant_materials/fy10/sh-21000-10/CS_Entry_Procedure_Checklist.pdf





ALJAZARI
— ACADEMY —

Course Code: 3221

Module 1
Safety Control and Measures for Sewer and
Drainage Works

Participant Lecture Notes
Lecture 6
Test for Hazardous Gases

2016



1 Lecture information

Topic: Standard safety practices for performing sewer and manhole inspection	Lecture duration (hrs.): 5.0 • OJT (hrs.) : 5.0
Lecture topics: Tests for hazardous gases	Training delivery mode: OJT
Lecture date: TBD	Day: Two

2 Objectives

The objectives of this lecture are:

- Sensitize the participants on hazardous gases released from manhole and sewer system
- Introduce testing methods and equipment used for detecting the hazardous gases during operation and maintenance works, especially in confined spaces (CS)

3 Introduction

Testing of the atmosphere within a confined space (CS) may be needed prior to entry. The purpose is to ensure that the quality of the air is satisfactory. [1] It is also important to continuously monitor, after entry, to ensure that the atmosphere is safe. [2]

Atmospheric testing is required for two distinct purposes:

- Evaluation of the hazards of the permit space;
- Verification that acceptable conditions exist for human entry into that space.[3]

No person shall enter a confined space until it is tested to be free from any gas hazards. If entry is required, the authorized entrant must be equipped with an appropriate supplied air respirator and other PPE as per defined by hazard analysis.

It is crucial to carry out the initial testing from outside the confined space. It is done by drawing the air sample from the confined space using suitable sampling devices. [2] Testing will also be needed where the atmosphere was purged to remove gases or vapors, so as to check the result. [1]

4 What to Test and What are the Acceptable Limits

It is the responsibility of the site supervisor or sub engineering incharge, to know and establish what atmospheric hazards may be present in the confined space. Once the atmospheric hazards are



known, the correct gas testing equipment and their corresponding alarm concentrations on the equipment must be pre-set.

The pre-set would provide a warning on the dangerous level according to the limit values for the substance of concern. As a minimum, the following shall be tested: oxygen reading, flammable gases and vapors reading, and toxic gases and vapors reading.

The acceptable limits are:

- Oxygen reading: ≥ 19.5 % Vol. to ≤ 23.5 % Vol.
- Flammable gases and vapors reading: $\leq 10\%$ LEL
- Toxic gases and vapors reading: \leq PEL values[2]

5 Types of Testing Methods/Equipments

Right gas detection equipment, are required for the detection of gases of concern. It is also important to know that not all the gas hazards identified may be measured with an electronic gas detection instrument. [2] The choice of testing equipment will depend on the circumstances of the work, the conditions of the workplace and knowledge of possible contaminants. [1]

Due to the different physical and chemical properties of the gases, different detection principles may be used to ascertain that the atmosphere is safe. There are various types of portable electronic gas testing instruments, which may be used for the detection of the gas hazards found in confined space. [2]. Table 1 shows different gas hazards and their measuring principles.



Table 1: Types of gas hazards and their measurement principles

Sr. No.	Types of Gas Hazards	Example	Gas Measurement Principles		
			Catalytic Sensor	Electrochemical Sensor	Colorimetric Tubes
1.	Toxic	<ul style="list-style-type: none"> • Ammonia • Hydrogen Sulphide 		X	X
2.	Toxic and Flammable	Carbon Monoxide	X	X	X
3.	Oxygen deficiency	Nitrogen		X	

These instruments may be available either as a single gas monitoring instrument for just one gas or contaminant, or a multi-gas monitoring instrument that will typically measure oxygen, flammable gases and toxic gases. Using either diffusion or active sampling via manual or electrical pump will warn the users when concentration levels in the confined space are unsafe.

It is important that training on the use of these instruments include instrument calibration, equipment maintenance and the proper interpretation of the instrument readings and warning alarms. When in doubt, it is advisable for the competent person to check with the instrument manufacturers for more details.

As mentioned, not all gases can be measured with an electronic gas detection instrument. The colorimetric tubes are still a common method used by many gas testers. These tubes are impregnated with chemicals that will react in the presence of a specific gas or vapor. The reaction will produce a color change and from the length of the color change or the intensity of the color change, the concentration of this gas or vapor can be determined.[2]

6 Procedures

6.1 Evaluation

Initial evaluation of the atmosphere of a confined space should be made with an Environment Health & Safety Centre approved instrument that is sensitive enough and designed to evaluate any hazardous atmospheres that may exist or arise. The results of the atmospheric testing will have a direct impact on the:

- Development of the entry procedure,
- Selection of PPE,
- Duration of worker exposure, or



- Whether an entry will be made at all.

The Environmental Health and Safety Center should be called for assistance with the evaluation and interpretation of the data, and the development of the entry procedure.

6.2 Verification

Prior to entry, a CS that is likely to have hazardous gases may be tested using suitable equipment. Residues of all potential dangerous gases are recorded. Later these are added to the entry permit. And compared to the safe levels for human entry.

If testing reveals oxygen deficiency or the presence of toxic gases or vapors, the space must be ventilated or purged and retested before entry. The atmosphere shall be tested continuously during entry operations.

6.3 Measurement Duration

The measurement of each atmospheric parameter shall be made for at least the minimum response time of the test instrument specified by the manufacturer. It is recommended that the measurement be made for twice (2x) the response time.

6.4 Stratified Atmospheres

In a confined space (e.g. a manhole, big diameter sewers), the density of gases and vapors will cause them to stack one above the other as given below (Figure 1):

- Hydrogen sulfide: heavier than air, and settle to the bottom of a space
- Methane: lighter than air, and concentrate at the top of the space
- Carbon monoxide: same as air, and accumulate in the center

When some workers enter into a confined space (manhole or big diameter sewer) the space should be tested every four feet (4 ft.) as shown in Figure 1, in the direction of travel and to each side. The entrant's speed of movement be slowed to allow for sampling and detector response.



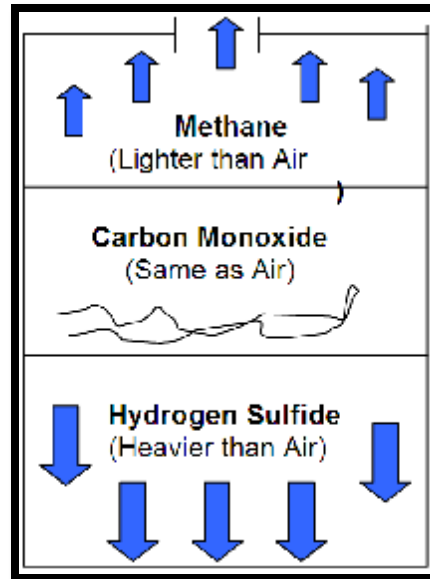

Figure 1: Stratified Atmosphere in a confined space (e.g. manhole)

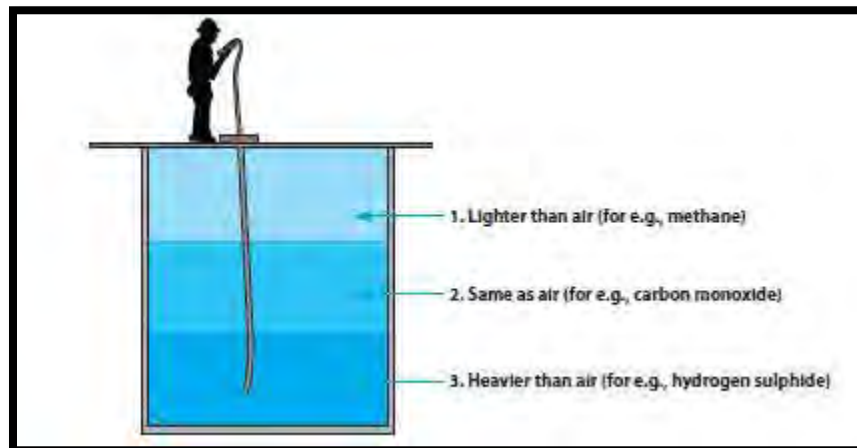

Figure 2: Test air at 3 or more elevations: top, mid-point and bottom

6.5 Order of Testing

When using an atmospheric testing instrument that requires the manual selection of test parameters, the order of testing **MUST** be:

- **Oxygen** - most combustible gas meters require a specific amount of oxygen, (min 20.8%), to be present in order to give a correct reading for flammable / explosive gases.
- **Flammable / Explosive gases** - are tested next because they represent more of an immediate and life threatening hazard, in most cases, than toxic gases or vapors.



- **Toxic gases or vapors** [4]

7 Testing Procedures and Considerations

A competent person shall be appointed to test the atmosphere of a confined space before entry by any person. Steps to be taken before and when gas testing is conducted:

- ✓ Determine equipment type for the atmospheric testing;
- ✓ Check to see if the atmosphere can be tested from outside. Determine if the atmosphere can be tested at all depths before entry;
- ✓ Ensure that the gas testing instrument is calibrated;
- ✓ Ensure that the right and necessary accessories are used;
- ✓ Brief all persons concerned on the hazards to be expected, their upper limit values and action needed when instrument alarm comes on;
- ✓ Brief all persons concerned on the emergency procedure, key contacts and assembly point;
- ✓ Use suitable accessories such as water and dust filter and float probe when sampling from confined space with liquid. The sampling hose or sensor may come into contact with the liquid. This could result in contamination of the hose and saturation of sensor filters thereby blocking the gas entry to the instrument;
- ✓ Ensure all depths are tested in the following sequence; start with oxygen, followed by flammable gases and vapors and finally toxic gases and vapors;
- ✓ Record all results and update this information on the entry permit document;
- ✓ Evaluate and determine the frequency of re-tests and notify all concerned; and
- ✓ Evacuate everyone in the confined space immediately whenever an atmospheric hazard is detected during entry, while working or when re-tests are done. Re-evaluate the space thoroughly to determine if the dynamics in it has changed drastically. It is important to take all required measures before any re-entry is to take place.[2]

8 Glossary

Key Word	Definition
LEL	Lower Explosive Limit
Stratification	The division of the Earth's atmosphere into different layers
CS	Confined Space
Diffusion	Process by which molecules intermingle as a result of their kinetic energy of random motion
Impregnate	Soak or saturate (something) with a substance
Countermeasure	A measure or action taken to counter or offset another one



9 Reference

1. http://www.hsa.ie/eng/Publications_and_Forms/Publications/Codes_of_Practice/COP_Confined_Space_Document.pdf
2. <https://www.wshc.sg/files/wshc/upload/cms/file/2014/cs2.pdf>
3. https://www.osha.gov/OshDoc/data/Hurricane_Facts/atmospheric_test_confined.pdf
4. <https://www.ncsu.edu/ehs/www99/right/handsMan/confined/Appx-G.pdf>





ALJAZARI
— ACADEMY —

Course Code: 3221

Module 1
Safety Control and Measures for Sewer and
Drainage Works

Participant Lecture Notes

Lecture 7
Arrangement for medical treatment

2016



1 Lecture Information

Topic: First aid in emergency situations	Lecture duration (hrs.): 01 • Group activity with demonstration (hrs.) : 1.0
Lecture topics: Arrangements for medical treatment	Training delivery mode: Theory
Lecture date: TBD	Day: Three

2 Objectives

The objective of this lecture is to build capacity of participants to render first aid in emergency situations. Along with this they will be able to understand the followings:

- Purpose of first aid
- Providing first aid in the following cases:
 1. Suffocation
 2. Injury
 3. Drowning
 4. Fire Accident

3 Introduction

3.1 Definition

First aid is the immediate care given to a person who gets an injury during work or suddenly taken ill. It includes home care if medical assistance is not available or delayed. It also includes well selected words of encouragement, evidence of willingness to help, and promotion of confidence by demonstration of competence (American red cross, 1998) [1].

3.2 Purpose of First Aid

The key guiding principles and purpose of first aid, is often given in the mnemonic "3 Ps". These three points govern all the actions undertaken by a first aider.

- Prevent further injury
- Preserve life`



- Promote recovery[6]

3.3 Phases of First Aid

- Self-aid
- Assistance from a companion
- Emergency treatment
- Initial surgery [2]

3.4 First Aid Rules

- i. Do not get excited. First, check for danger and then check for responsiveness. Determine whether the victim is conscious. If the victim is conscious, ask him what happened and what is wrong now. If the victim is unconscious, proceed to check the airway, breathing and circulation. Commence resuscitation as appropriate.
- ii. Do not move injured victim unless it is necessary. If necessary to move a casualty, seek assistance if possible and handle gently.
- iii. Keep the victim lying down with his head level with his feet while being examined.
- iv. Keep the victim warm and comfortable. Remove enough clothing to get a clear idea about the extent of the injury.
- v. Examined the victim gently. Treat the most urgent injuries first and then treat the other injuries to the best of your ability.
- vi. Avoid allowing the victim to see his own injury. Assure him that his condition is understood and that he will receive good care.
- vii. Do not try to give any solid or liquid substance by mouth to an unconscious victim nor to a victim who has sustained an injury.
- viii. Do not touch open wounds or burns with fingers or other objects except when sterile compresses or bandages are not available and it is absolutely necessary to stop bleeding.
- ix. Do not try to arouse an unconscious person.
- x. Seek medical attention immediately.[2]

4 Respiratory Emergency

Respiratory emergency is one in which normal breathing stops or in which breathing is reduced so that oxygen intake is insufficient to support life [1].

4.1 Common Causes

- Choking from food, blood, vomit or broken teeth



- May also occur in unconscious victim when the tongue falls to the back of the throat
- Chest compression or collapsed lung, from road accidents or any penetrating injury to the chest
- Drowning or near drowning
- Gas poisoning
 - ✓ Carbon monoxide poisoning from home appliances releasing fumes or released by car exhaust or other toxic fumes
 - ✓ Strangulation
 - ✓ Suffocation
 - ✓ Others
- Severe asthma attack or bronchitis
- Whooping cough [4]

4.2 Signs and Symptoms

- Unable to breath
- Loss of consciousness
- General pallor (paleness)
- Difficulty in breathing
- May be no visible breathing [3]

4.3 First Aid Measures

- i. Shout for help (depend on the condition).
- ii. Determine the consciousness of the causality by tapping the victim on the shoulder and asking loudly “Are you okay!” [3].
- iii. All doors and windows should be opened [5].
- iv. Assess and ensure that patient air way is clear [3].
- v. Move the victim out of the area with the gas, but only if this can be done without endangering the first aid providers.
- vi. If the victim is unconscious, maintain a patent airway and perform rescue breathing if needed [5].
 - i. Place the patient flat on his back with the head turned to one side Kneel beside the patient’s head. Place one hand under his neck and the other hand under his lower Jaw extend his head and neck gently back ward. This prevents the tongue from falling back in to the throat.
 - ii. Remove any thing which is preventing the taking in of air (Remove constraints from the neck).



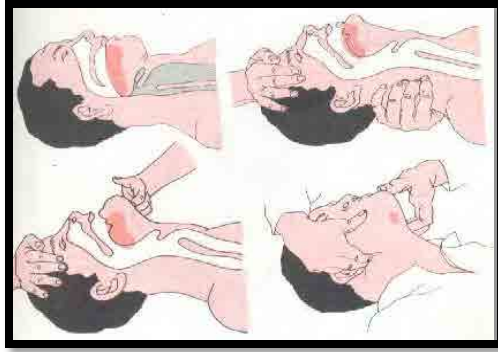

Figure 1: Respiratory emergency

- iii. Remove any thing which is preventing the taking in of air (Remove constraints from the neck) (Figure 1).
- iv. Kneel beside the patient's head. Place one hand under his neck and the other hand under his lower Jaw extend his head and neck gently back ward. This prevents the tongue from falling back in to the throat (Figure 1, 2 and 3).



Figure 2: Air way blocked by Tongue

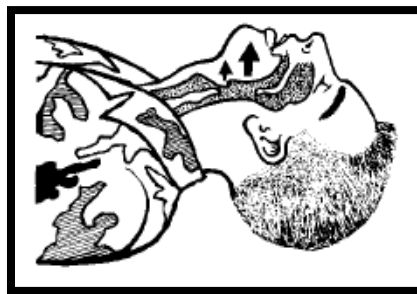

Figure 3: Airway Opened by Extending Neck

- v. Place your cheek and ear close to the victim's mouth and Nose. Look at the victim's chest to see if it rises, falls, and listen and feel for air to be exhaled for about 5 seconds.
- vi. If there is no breathing pinch the victim's nostrils shut with thumb and index finger of your hand that is pressing on the victim's forehead. This action prevents leakage of air when the lungs are inflated through the mouth If there is no breathing pinch the victim's nostrils shut with thumb and index finger of your hand that is pressing on the victim's forehead. This action prevents leakage of air when the lungs are inflated through the mouth.
- vii. Take very deep breath and hold it.
- viii. Fit your mouth tightly over the patient's open mouth and forcibly in to the lungs (Figure 4).
- ix. Take very deep breath and hold it.



- x. Fit your mouth tightly over the patient's open mouth and forcibly in to the lungs (Figure 4).



Figure 4: Rescue Breathing (Mouth-to-Mouth)

- xi. While carrying out respiration, check the patient's pulse every 2 or 3 minutes to ensure the heart has not stopped.
- xii. Continue the breathing procedure at the rate 12 to 18 breaths per minute until the chest is seen to rise and the patient is breathing for himself.

Once the patient can breathe by himself/herself place him/her in what is called the recovery position [3].

5 Drowning

Death caused by water reaching the lungs and either causing lung tissue damage or spasms of the air way that prevents the inhalation of air.

Drowning can happen in many different places, Lake, swamp and manholes, water tanks etc (Figure 5).

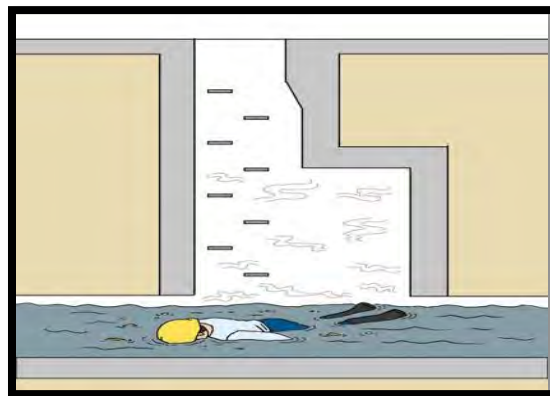

Figure 5: Drowning in Manhole due to Presence of Toxic Gases



5.1 First Aid Management

- You should begin artificial respiration as soon as possible
- Airway management skills must be included in first aid training for drowning process, rescue and resuscitation.
- Drowning process resuscitation must have as the priority upper airway management and early rescue breathing.
- For unconscious or recovering victims, or during transport of drowning victims, the victim may be in as near a true lateral position as possible, with the head dependent to allow free drainage of fluids.
- Routine oropharyngeal suctioning should not be done in the drowning process resuscitation.
- In a submersion victim, suction and manual methods should be used when the oropharynx is blocked by vomitus or debris that is preventing ventilation.
- Supplemental oxygen for the drowning process resuscitation can be used, but doing so should not delay resuscitation, including opening the airway and providing ventilation and compressions as needed [5].
- Do not wait to get water out of the patient's chest first.
- If you cannot get air into his/her lungs, quickly turn the patient on his/her side, putting his head lower than the leg and push the body.
- Then give mouth-to-mouth artificial respiration.
- If the condition of the victim is not improving refer the victim to the next health facility [3].

6 Wound

A wound is a break in the continuity of the tissue of the body either internal or external.

6.1 Common Causes of Wounds

Wounds usually result from external physical forces. The most common accidents resulting in open wounds are accidental falls and handling of sharp objects, tools, machinery and weapons.

6.2 First Aid Measures

- Place a clean cloth on the wound and apply pressure with the palm of your hand until the bleeding stops.
- You should also elevate the wound above the victim's heart, if possible, to slow down the bleeding at the wound site.



- Once the bleeding stops, do not try to remove the cloth that is against the open wound as it could disturb the blood clotting and restart the bleeding.
- If the bleeding is very serious, apply pressure to the nearest major pressure point, located either on the inside of the upper arm between the shoulder and elbow, or in the groin area where the leg joins the body.
- Direct pressure is better than a pressure point or a tourniquet because direct pressure stops blood circulation only at the wound.
- Only use the pressure points if elevation and direct pressure haven't controlled the bleeding.
- Never use a tourniquet (a device, such as a bandage twisted tight with a stick, to control the flow of blood) except in response to an extreme emergency, such as a severed arm or leg. Tourniquets can damage nerves and blood vessels and can cause the victim to lose an arm or leg [7].
 - If direct pressure and elevation does not stop severe bleeding from an open wound of the arm or leg, the pressure point technique may be required. This technique involves applying pressure at a specific point on the arm or leg. There is one recommended pressure point on each arm and leg.
 - This technique should not be used unless the bleeding can't be stopped by the direct pressure method.
 - Do not use a pressure point in conjunction with direct pressure and elevation any longer than is necessary to stop the bleeding [8].

7 Bites and Stings

Bites and stings that could require first aid care can occur from a wide variety of sources. Mostly these cause only minor discomfort and can easily be treated by a first aid provider. However bites and stings from venomous snakes, insects or animals can cause intense pain and swelling. Bites from humans and animals such as dogs, cats, bats etc. can cause severe injury and infection, including tetanus and rabies.

Some people have severe allergic reactions to bites or stings that can be life threatening. In these cases, the most important first aid measure is rapid access to advance emergency medical care [9].

7.1 Snake Bite

7.1.1 Signs and Symptoms

- Disturbed vision
- Feel nauseated or vomiting



- One or two small puncture wounds with sharp pain and local swelling
- Symptoms and sign of shock
- Sweating and salivation in advanced stages of venom reaction

7.1.2 First Aid Management

- Lay the victim down and advise not to move
- Calm the victim
- Immobilized the affected part and keep it below the level of the heart
- Wipe the wound of venom
- Apply firm cord just above the bite
- This must be removed in 15 minutes if you are sure that anti venom has been injected and you cannot get the victim to hospital in time.

If there is no anti-venom do the following:

- Tie a cord tightly around the limb just above the bite
- Using a razor blade or a clean knife make a cut 1 cm deep
- Suck the liquid which is coming out of the wound
- Continue to suck and dispose for 5-10 minutes
- Loosen the cord around the patient's limb
- Disinfect the wound
- Refer to hospital for anti- venom injection [3].

8 Burns

Burn, is injury to the skin and deeper tissues caused by hot liquids, flames, radiant heat, and direct contact with hot solids, caustic chemicals, electricity, or electromagnetic (nuclear) radiation. Skin exposed to temperatures as low as 120°F is burned after about 5 minutes [1].

8.1 First Aid Measures

8.1.1 General

A. Eliminate the Source of Burn:

Quickly remove the casualty from danger and cover the thermal burn with any large non-synthetic material, such as a field jacket. If casualty's clothing is still on fire, roll the casualty on the ground to smother (put out) the flames.





Figure 6: Casualty Covered and Rolled on Ground

B. Expose the Burn:

Cut and gently lift away any clothing covering the burned area, without pulling clothing over the burns. Leave in place any clothing that is stuck to the burn. If the casualty's hands or wrists have been burned, remove jewelry if possible without causing further injury (rings, watches, and so forth) and place in his pockets. This prevents the necessity to cut off jewelry since swelling usually occurs as a result of a burn.

C. Apply a Field Dressing to the Burn.

D. Take the Following Precautions:

- DO NOT place the dressing over the face or genital area.
- DO NOT break the blisters.
- DO NOT apply grease or ointments to the burns.
- For electrical burns, check for both an entry and exit burn from the passage of electricity through the body. Exit burns may appear on any area of the body despite location of entry burn.
- For burns caused by wet or dry chemicals, flush the burns with large amounts of water and cover with a dry dressing.
- If the casualty is conscious and not nauseated, give him small amounts of water.

E. Seek Medical Assistance:

Notify medical personnel [11].

9 Fire Accidents

9.1 Fire

Fire is a self-sustaining, chemical chain reaction with varying degrees of light and heat. Fire is made up of three components:



- Fuel
- Oxygen
- Heat

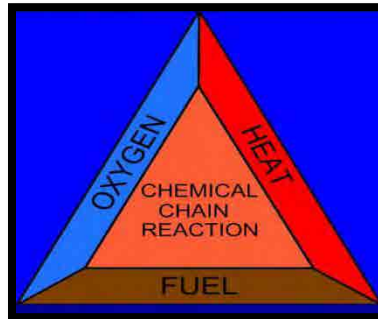

Figure 7: Fire Triangle

By removing one of these four components the fire will go out [12]. Different types of fires are divided into CLASSES. Each class has its fuel source and extinguisher type which best suits to extinguish it, as shown in Figure 8.



Fuel Sources	Class of Fire	Type of Extinguisher (Extinguishing Agent)
Ordinary combustibles (e.g., trash, wood, paper, cloth)	A	Water; chemical foam; dry chemical ¹
Flammable liquids (e.g., oils, grease, tar, gasoline, paints, thinners)	B	Carbon dioxide (CO ₂); halon ² ; dry chemical; aqueous film forming foam (AFFF)
Electricity (e.g., live electrical equipment)	C	CO ₂ ; halon; dry chemical
Combustible metals (e.g., magnesium, titanium)	D	Dry powder (suitable for the specific combustible metal involved)

1. Dry chemicals, CO₂ and halon can be used on Class A fires, but may not be effective on their own. They need to be supplemented with water.

2. Halon extinguishers are no longer made, but some may still be in use. Dangerous gases are formed when halon is used to put out fires. Wear proper respiratory equipment, particularly in enclosed spaces. After use, do not allow anyone to enter the area until it has been well ventilated.

Figure 8: Matching Classes of Fire and Type of Extinguishers [16]

9.2 Fire Suppression Systems

- Fire suppression is achieved by cooling the combustible material to below its ignition temperature or by preventing oxygen from reacting with the combustible material.
- Fire suppression system must be designed by considering the class of fire and the type of building occupancy.
- Fire suppression system may be classified in several ways.
 - ✓ According to the fire suppression medium– water, foam, chemical, gas, etc.
 - ✓ According to the action of the device – a portable extinguisher, standpipe and hose, automatic sprinkler etc automatic sprinkler, etc.
 - ✓ According to the method of operation of the device – manual or automatic.[17]



9.2.1 Portable Fire Extinguishers

- Portable fire extinguishers are used as the first line of fire protection (Figure 9).
- They are normally pre-charged with water or chemicals and are hand-operated.



Figure 9: Portable Fire Extinguisher

9.2.2 Standpipe and Hose Systems (Standpipe Systems)

Standpipe systems consist of piping, valves, hose connections, and nozzles to provide streams of water for fire suppression.

a. Wet system:

- A "wet" standpipe is filled with water and is pressurized at all times (Figure 10).
- Whenever the system is activated, water will charge into the connected hose immediately.
- Wet standpipes can be used by building occupants.



Figure 10: Wet System



b. Dry system:

- A “Dry” standpipe is NOT filled with water.
- The intakes of dry standpipes are usually located near a road or driveway so that a fire engine can supply water to the system. These are normally referred as Fire Hydrants (Figure 11).
- This system can be used only by firefighters.



Figure 11: Fire Hydrant

9.2.3 Dry Chemicals

- Dry chemicals are used especially for Class D fires caused by combustible metals.
- The use of water should be avoided on burning metals since hot metal extracts oxygen from water, promotes combustion, and at the same time liberates hydrogen, which ignites readily.

9.2.4 Automatic Sprinkler Systems

- Automatic sprinkler systems are integrated fire suppression systems consisting of a water supply and a network of pipes, sprinkler heads, and other components to provide automatic fire suppression in areas of a building.
- This system is the most effective for suppressing a Class A fires in buildings containing ordinary combustible materials, such as wood, paper, and plastics.[17].



9.3 How to use Portable Fire Extinguisher

Use the acronym PASS to remember how to use a fire extinguisher [12].

- i. P: Pull the Pin.



- ii. A: Aim the extinguisher nozzle at the base of the flames.



- iii. S: Squeeze trigger while holding the extinguisher upright.



- iv. S: Sweep the extinguisher from side to side, covering the area of the fire with the extinguishing agent [7].



9.4 Risk of Fire in Confined Spaces

The risk of fire or explosion in an enclosed space is extremely high whenever there is a buildup of any flammable gas and vapors. If the gas or vapors are colorless and odorless, the build-up cannot be detected unless a gas detection instrument is used.

For these gases and vapors to ignite and result in a fire or explosion, the following conditions must be met:

- A SOURCE OF IGNITION is present, the temperature of which is equal to or higher than the IGNITION TEMPERATURE of the flammable substance in question. There are many processes which can be sources of ignition. Some examples include:
 - i. Hot work like welding or gas cutting;
 - ii. Pyrophoric materials (e.g., iron sulphide);
 - iii. Sparks from internal combustion engines, (e.g., compressor, drilling and non-flame cutting); or
 - iv. Flows of certain materials like non-conductive liquids and combustible powders which can generate static charges thus providing a source of ignition of the flammable liquid or combustible powder itself.
 - v. Use of cigarette etc.
- The concentration of the flammable substance is in the range between the LOWER EXPLOSIVE LIMIT (LEL) and the UPPER EXPLOSIVE LIMIT (UEL). In the case of a flammable liquid, a flammable vapor/air mixture can only be generated if the temperature of the surroundings is equal or higher than the FLASH POINT of the liquid. Examples of LEL and UEL values for a few flammable substances are given in Table 1.
- A sufficient amount of oxygen is present [13].

Table 1: LEL and UEL of Hazardous Gases [18]

Substance	UEL % Vol.	LEL % Vol.	PEL % Vol.	Flash Point °C	Auto ignition temperature °C
Carbon monoxide	74	12.5	25	NA	607
Hydrogen Sulfide	44	4.3	10	NA	260
Methane	15	5	NA	-187	537



9.5 Fire Safety Procedure

The following steps should be taken in the event that a fire is discovered by an employee:

9.5.1 Call Fire Department

- i. Use telephone in the building if possible.
- ii. Use the nearest communication device available.
- iii. If calling away from the location of the fire, stay there to direct Emergency Services called.

9.5.2 Assisting People with Special Needs

- i. Make face to face contact and correspond in a calm manner
- ii. Use designated fire exits as shown in the fire evacuation plan. Seek alternate route for those unable to use the fire exit.
- iii. Avoid using outdoor areas that are muddy, sandy, or covered by thick grass to meet.
- iv. After evacuating, maintain a distance of at least 100 yards from the accident area.
- v. Appreciate that even normal amounts of background noise may prevent a person with a hearing impairment from understanding spoken instructions and directions.

10 Glossary

Key Word	Definition
Resuscitation	Process of correcting physiological disorders in an acutely unwell patient
Commence	Start
Victim	A person harmed, injured, accident, or other event or action
Oropharynx	Middle part of the pharynx (throat) behind the mouth
Strangulation	Type of asphyxiation “characterized by a closure of blood vessels and/or air passages of the neck as a result of external pressure
Blisters	A small bubble on the skin filled with serum and caused by friction, burning, or other damage

11 Reference

1. http://www.cartercenter.org/resources/pdfs/health/ephti/library/lecture_notes/health_extension_trainees/FirstAid_AccidentPrevention.pdf
2. <http://www.dlsu.edu.ph/offices/sps/rotc/pdf/ms1/first-aid.pdf>



3. http://www.cartercenter.org/resources/pdfs/health/ephti/library/lecture_notes/health_extension_trainees/LN_HEW_First_Aid_Mgmt_final.pdf
4. <http://firstaidandcprcourses.ca/asphyxia-causes-signs-and-symptoms-complications-and-first-aid-management/>
5. <http://www.ifrc.org/PageFiles/53459/IFRCInternational-first-aid-and-resuscitation-guideline-2011.pdf>
6. http://neuron.mefst.hr/docs/katedre/klinicke_vjestine/Dr-Lojpur-FIRST-AID-TO-THE-INJURED.pdf
7. <http://www.cocaa.org/doc/Training-and-Safety.pdf>
8. http://www.sfasu.edu/safety/documents/Accident_Reporting.pdf
9. <http://www.ehs.iastate.edu/sites/default/files/uploads/publications/miscdocs/emergency-firstaid-orientation.pdf>
10. <http://www.tripleonecare.co.nz/sites/default/files/images/TOC%20FA%20Book%20November%202014%20V2%203.pdf>
11. <https://www.coursehero.com/file/9498089/FM-4-2511-First-Aid/>
12. <http://emergency.yale.edu/sites/default/files/files/TMS-Fire-Extinguisher-Training.pdf>
13. <https://www.wshc.sg/files/wshc/upload/cms/file/2014/cs2.pdf>
14. http://amerex-fire.com/wp-content/uploads/2011/12/Fire_and_Fire_Extinguishment.pdf
15. http://tuscolaagriculture.weebly.com/uploads/8/3/8/9/8389114/fire_extinguishers.pdf
16. http://www.iapa.ca/pdf/freedownloads8_fireext.pdf
17. [http://aesl.hanyang.ac.kr/class/are1024/PDF-ENG/ARE1024\(ENG\)-CH10.pdf](http://aesl.hanyang.ac.kr/class/are1024/PDF-ENG/ARE1024(ENG)-CH10.pdf)
18. <http://www.pge.com/includes/docs/pdfs/shared/environment/pge/cleanair/methane1033.pdf>





Course Code: 3221

Module 1
Safety Control and Measures for Sewer and
Drainage Works

Participant Lecture Notes

Lecture 8 - Identification of specific manhole

2016



1 Lecture Information

Topic: Traffic control practice during sewer, manhole and drain cleaning operations	Lecture duration (hrs.): 5.0 • OJT (hrs.) : 5.0
Lecture: Identification of a specific manhole	Training delivery mode: OJT
Lecture date: TBD	Lecture timing: 09 am – 04pm

2 Objectives

The objective of this lecture are:

- To locate the desired manhole for operation and maintenance purposes
- To identify the buried manhole with the help of metal detector
- To read, understand and use the sewer system map for quick complaint redressed

3 Reasons for Identification of a Specific Manhole

- To conduct an inspection survey against the sewer system related complaint
- To initiate operation and maintenance work at the rightly identified manhole for redressing the complaint received

4 Sewer Complaints

Information received from a citizen reporting a sewer complaint must be recorded on the Sewer Complaint Report (Figure 1). All information listed on the form will be collected by the City staff person taking the complaint.

Response to a sewer complaint may require that immediate corrective or emergency maintenance be conducted to correct the situation. If such maintenance is conducted, the Sewer Line Maintenance Repair Report will be completed.

The location of every complaint received by the City will be inspected after any necessary maintenance activities are completed to alleviate the complaint situation.

Inspections will be conducted as appropriate for the location. In addition to the inspection worksheet(s), the Sewer Response Report will be completed [2].



- Avoid heavy lifting while wearing a rucksack or tool bag [3].

6 Identification of Manholes:

6.1 Finding Buried Inspection Chambers

There are several methods for locating buried chambers. They are as follows;

- Firstly, if you have a look at neighboring properties, it may be of similar construction as yours. They are often a mirror image. If they have a chamber on the front boundary line or adjacent to the soil vent pipe, then chances are yours will too. Especially, if this is echoed on two or more houses and the covers seem original to the style of the property.



Figure 2 manhole identification

- If, however, the properties are similar but chambers are at different locations, with newer covers, this would tend to indicate that the chambers have been added to the system at a later date.
- Most concealed covers are literally inches below the surface and often it's the depth of the flag or the thickness of the tar-mac that is covering it. Therefore, if you have an idea of where the cover may be, a metal detector could be an easy and relatively cheap method of locating it. Most metal detectors can be affective to a depth of 300 mm. If it is a stone flag, covering the chamber, instead of a metal cover, you may not get a signal at all.
- The modern version of the metal detector is the ground penetrating radar which can be used to locate drainage runs, culverts, manholes and chambers, it's a high tech bit of kit and the cost would be prohibitive for a single domestic chamber however on large site investigations it's a useful tool.
- A very low tech piece of kit is a road pin which is basically a 4ft spike, we use these when looking for manholes in soft landscaped areas such as flower beds and lawns. Again you



need to have an idea of where you think the cover is and you push the spike into the ground and hopefully hit whatever is covering it. Common sense should be used. Don't go driving any spikes into the ground with a dirty great lump hammer just in case you come across a gas, water or electric service pipe.

- A drain camera inspection survey will find any concealed chambers or traps. we may then use a sonar drain tracer to locate it at ground level, you will of course need access into the system in the first place whether that be via a rodding point, an excavation or another chamber [4].

6.2 Mapping

The first step in the process of locating and repairing sources of inflow and infiltration (I&I) is to ensure that an accurate map of the collection system is available. The map will be used to identify manholes, lift stations, and service main locations. The City map, having GPS coordinates of the collection system manholes may be used. Using an accurate map, the City may be divide into different zones. Categorization of these zones may be done based on known problem that usually arise in each zones. Based on this information, a schedule to inspect the lines in a designated zone, may be prepared. Sewer lines that were installed within the last fifteen years may be excluded from the plan unless there is a reason to believe they are a major source of I&I. The City has updated its sewage collection system maps with GPS coordinates, as well as unique manhole identification numbers. Pipe segments are updated on the map as they are installed [2].

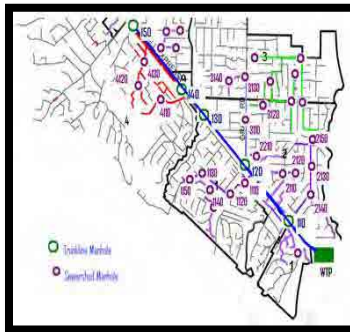

Figure 3 Mapping



6.3 Identification of Buried Manhole

We can find out buried manholes with the help of metal locators or metal pipe locator

6.3.1 Metal Detector

A metal detector is an electronic instrument which detects the presence of metal nearby. Metal detectors are useful for finding metal portions hidden within an objects, or metal objects buried underground. They often consist of a handheld unit with a sensor probe which can be swept over the ground or other objects. If the sensor comes near a piece of metal this is indicated by a changing tone in earphones, or a needle moving on an indicator. Usually the device gives some indication of distance; the closer the metal is, the higher the tone in the earphone or the higher the needle moves.



Figure 4 Metal Detector

6.3.2 Hand Held Metal Detector

- Detects objects up to 36" deep
- Designed for locating valve lids, manhole covers, junction boxes and more.
- Downward directed metal detection field
- 2.4 lbs., 38" long, search head 8" dia.

7 Identifying Leaky Manholes

Manhole leaks can be identified through

- Dyed water testing
- Flow monitoring



- Smoke testing
- Routine inspections
- Inspections during or after a rain event
- Physical evidence.

Additional investigation may be carried out, if manhole is located on a road. In case, there is major leak, you would see a

- Crack in the manhole
- Circular depression around the manhole
- Depression in the asphalt

In soil areas, you are going to see a depressed area in the soil. Inside the manhole, in the bench area, you're probably going to see silt, and in worse cases, you're going to see grass.

The grass doesn't grow in the manhole. It is usually infiltrated into it.

Flow meter measurements during and after rain events can reveal correlations between the event and wastewater treatment flows that point to infiltration. Defects can also show up **as broken or cracked frames, cracked pavement, and street damage**, where infiltration into a manhole washes away the soil, causing significant damage to the pavement.

These cracks are caused by the following reasons

- Frosts lifts
- Pavement expanding and contracting due to fluctuating temperature
- Traffic loads where vehicles are driving over the casting
- Ground movement (referring to soil not seismic)
- Poor construction methods or materials [6].



Figure 5 Leaky manhole



8 Developing a Manhole Numbering System

8.1 A Systematic Approach for Electronic Data Storage and Linkage

The operating agencies (mostly WASAs) has a huge infrastructure of sewer pipes and several manholes. To manage such huge and spread out infrastructure is an uphill task. Its efficient management is not possible without a proper inventory. In addition, information gathered during maintenance works, inspection may also be added in the inventory and may be used to formulate future procurement/replacement plans.

Manhole structures are one of the basic building blocks of sanitary sewer collection systems. These are used to link the underground sewer pipes. In combined sewer systems and storm water sewer systems, catch basins also serve as connection points. Most electronic asset inventories identify underground pipes based on the manholes (and/or catch basins). A systematic method for identifying manholes and catch basins can set the foundation for developing an inventory of all the system's components.

There's no 'right' or 'wrong' way to identify system components. Certain approaches, however, present advantages that may make it easier to use asset information, particularly when it is stored electronically. These tips have been developed from the recommendations of those with experience in manhole identification and include practical considerations for assigning identifiers when building an electronic information management system.

8.1.1 Electronic Data Storage

Many collection systems have begun the data collection process by entering information into a spreadsheet. Others have made use of Geographic Information Systems (GIS) technology to help with the data management. A GIS can be particularly useful because it links information about each system component (e.g., sewer line, storm sewer, open drain, catch basin, manhole, inlet, discharge point, etc.) to its map location. This is similar to Internet mapping programs that allow you to click on a point on a map to access specific information. Connecting database information about a specific component to a graphical map requires an identification system that can uniquely connect each component to its actual location (e.g., latitude and longitude). If no identifier (ID) is specified, a GIS program will automatically generate a unique, but random, ID for each component and an opportunity to assign meaningful and descriptive name that may be used if the identifiers is lost.



Unique IDs are particularly important for manholes and catch basins because it is the ID field in the database that links to the other databases that contain the specific information (such as age, size, condition, etc.) about the system components. In addition, since a GIS considers the manholes, catch basins, and outfalls as "Point Structures" and their associated pipelines and ditches to be "Linear Structures," by uniquely identifying the point structures the system is also identifying the linear structures that link to them. IDs also allow you to easily sort the database information [8].

9 Case Studies

9.1 Finding Faults by Installation of Cured-In-Place Pipe Liners

As the world's infrastructure continues to age, municipal agencies and engineers are working harder than ever to preserve, repair and rehabilitate sewer systems.

The most cost-effective and efficient way to repair sewer main is by inserting a cured-in-place pipe (CIPP) liner into the existing problematic pipe. When properly installed, CIPP liners can be the answer to aging buried infrastructure, but studies show that they are often improperly installed.

For example, US Environmental Protection Agency conducted a study in January 2012 titled "A Retrospective Evaluation of Cured-In-Place-Pipe Used in Municipal Gravity Sewers,". The results of the above studies revealed that defects missed during closed-circuit television (CCTV) inspections in poorly installed CIPP liners later became the cause of infiltration and root intrusion. Much of the pipe inspected during the study was not expected to last the estimated useful life. Proper certification of newly installed CIPP liners is essential for eliminating infiltration, reducing maintenance costs, estimating useful life and ensuring responsible capital spending. The following should serve as a guide to using CIPP liner certification based on defect flow results from Electro Scan, a technology that locates and measures defect size and flow in gallons per minute.



Figure 6 CIPP

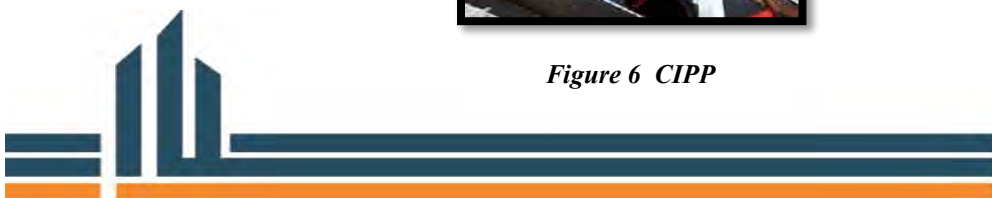

9.1.1 Locating Defects

The technology simulates the performance of sewer main in wet-weather conditions, when pipe is full of water. It releases a focused, low-voltage, high-frequency electrical current of 40 mA to locate and quantify all defects in non-conductive (e.g., CIPP, asbestos, vitrified clay, etc.) pipe. Non-conductive materials naturally prevent electricity from passing through, or along, the wall of a pipe. As a result, no electrical current should ever be able to “leak” or escape from the inside of a pipe unless there is a crack or break present.

The technology’s testing is carried out by pulling an electrically charged probe through a pipe. Measuring the variation of electric current that escapes the pipe wall, finds soil and then makes its way to an electrode on the surface—a metal stake serving as grounding. Given a constantly applied voltage and monitored by the system, the larger the defect, the greater the electric current reading, and the greater the defect flow as documented in the field of geophysics and described in ASTM F2550-13 [1].

9.2 Preliminary Study of Radio Frequency Identification on Underground Manhole's Surveys

9.2.1 Abstract

To provide certain level of serviceability, road authorities need to perform appropriate and timely maintenance and rehabilitation (M&R) activities. Manholes on roads are the most persecution for the evenness of pavements. Lowering manholes into road structures is a good approach to keep the serviceability of pavement. However, a vast expanse of road systems greatly increases the complexity of manhole identifications. Therefore, an emerging method to find the manholes beneath pavements is needed.

In this study, radio frequency identification (RFID) technology was used to identify manholes. RFID tags stuck on the metal were buried in asphalt concrete at different depths and then were identified from laboratory experiments. On the other hand, location-based service (LBS) has been applied to mobile devices with mobile positioning functions to provide users with location-specific services for several years. Augmented reality (AR) can support users in manipulating virtual objects in real environments. In this study, a mobile manholes monitoring system (MMS) and a web-based MMS based on LBS and AR were developed. The RFID adhered to manholes covers, beneath pavements, can be easily monitored by the mobile MMS. The location and information of neighboring manholes will be transmitted from the web-based MMS and be shown on the mobile MMS based on the AR technology. By using RFID and AR technologies, the time and



costs of manhole identifications can be significantly decreased and the pavement maintenance activities can also be timely processed [7].

10 Precautions before Lifting Cover of Manhole

- Ensure you have the appropriate clothing including your PPE and regularly check that it is in good condition.
- Ensure you have the appropriate tools. Regularly check that your tools are in good condition
- Store tools within easy reach to minimize twisting and stooping when retrieving them.
- Assess the lift and ensure that it is within your capability.
- Consider other persons in the work area may also cause an obstruction?

Gauge the weight of the cover and minimize the force or effort required to lift the cover by-

- 1) Establish which equipment is best suited to the lift e.g. which lifting keys you will need.
- 2) Check the condition of the cover, especially the lifting point e.g. is the keyway excessively worn?
- 3) Plan how you will move and where you will put the meter cover down. Never prop up a cover, always place it safely on the ground.

11 Point of Work Risk Assessment

Apply the point of work risk assessment process and verify that the conditions you are presented with are adequately understood:

Refer to the guidance on frequent lifting, application of your training, potential hazard information and recommended control measures

Below is a basic summary particular to individual cover lifts.



1.	Assess the situation	<ul style="list-style-type: none"> ▪ Can I get Hurt – How? – What can I do about it? ▪ How heavy is the cover- What effort is needed to conduct the ▪ Where is the cover – Is it in a safe location? ▪ Is the cover free to lift – are the lifting points in good condition? ▪ Can anybody else get hurt- How? – What can I do about it? ▪ Is the task one that I can undertake following my RISK ASSESSMENT?
2.	Apply control Measures	<ul style="list-style-type: none"> ▪ Do I have the correct tools – are they in good condition? ▪ Do I have the necessary PPE – is it in good condition? ▪ Do I need to erect signs and barriers? ▪ Is the environment in which I am working safe?
3.	Conduct the lift safely or Do not lift the cover	<ul style="list-style-type: none"> ▪ Continue to monitor and review ▪ Consult your team leader if you have any concerns over the assessment you have made or the application of the control measures.

12 Composite Manhole Cover

Composite manhole covers are becoming very popular alternatives to cast iron manhole covers in wastewater collection systems, sewer systems, storm water systems, utilities and industrial applications (Figure 9).

- Composite manhole covers have zero scrap value and eliminate manhole lid theft.



Figure 7: Composite manhole covers

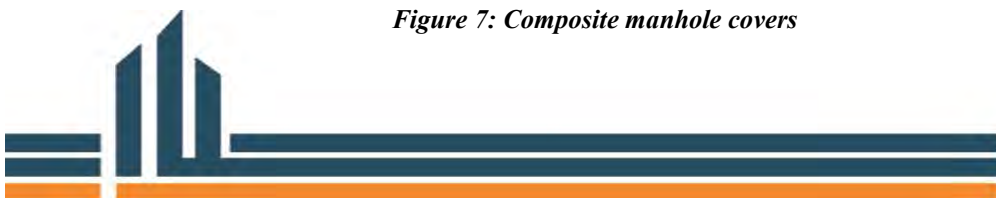

- Reduced weight = reduced worker injuries
- Stay where they should be – locked into place
- Are fully traffic rated
- Can reduce inflow & infiltration in sewers
- Are ideal for corrosive environments
- Can reduce odors
- Are ideal for nonconductive applications
- Allow amr and radio signals to pass through
- Reduce operation costs and save energy [5].

13 Manhole Inspection Worksheet

A sample manhole inspection sheet is shown in Figure 10. This sheet may be used by WASA by making minor modifications.

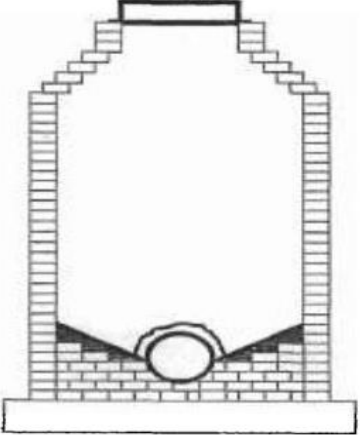
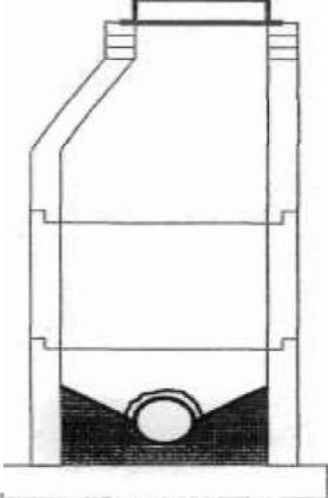

Manhole Inspection Worksheet

Manhole Number: _____
 Inspection Date: _____
 Inspection By: _____
 Rim Elevation: _____
 Downstream Manhole: _____
 Distance: _____

Construction Material
 Brick = B Precast = P
 Cast-in-Place Concrete = CIPC
 Block Masonry = BM Other = O

Pipe Data

	Diameter	Material	Depth from Rim
Outlet			
Inlet 1			
Inlet 2			
Inlet 3			
Inlet 4			

Location
 Field Lawn Wooded
 Gravel Pavement Other

Subject to stream flooding?
 Unlikely Frequent Occasionally

Subject to Ponding?
 Unlikely Frequent Occasionally
 _____ Depth (inches)
 _____ Area (Sq. Ft.)

Estimated Inflow & Infiltration
 _____ Flow, gpm
 _____ Visual estimate, measured

Rehab Required: (Rate by number)

Base & Pipe Connections
 _____ Cut protruding pipes
 _____ Grout pipe connections
 _____ Seal wall/base joint
 _____ Pour new bench
 _____ Repair/smooth bench

Walls
 _____ Repair cracks/holes
 _____ Seal interior walls
 _____ Install new steps
 _____ Replace joint gaskets

Frame & Cover (F&C)
 _____ Replace standard F&C
 _____ Replace waterproof F&C
 _____ Seal frame to riser
 _____ Raise F&C, add risers
 _____ Seal pickholes

Other
 _____ Reconstruct Manhole

Rehabilitation Rating Key

- 1 No work required.
- 2 No visible I & I, but future work required.
- 3 Visible or potential I & I, but not severe. Future work required.
- 4 Visible or potential I & I significant, schedule for repairs.
- 5 Visible or potential I & I severe, immediate repair required.

Label & number inlets.

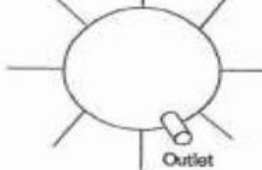

Outlet

Figure 8 Manhole Inspection Worksheet



14 Glossary

Keyword	Definition
Corrective maintenance	Corrective maintenance is a maintenance task performed to identify, isolate, and rectify a fault so that the failed equipment, machine, or system can be restored to an operational condition within the tolerances or limits established for in-service operations.
Depression on road	A depression in geology is a landform sunken or depressed below the surrounding area.
GPS	Global Positioning system
Inventory	An itemized catalog
CCTV	closed-circuit television
RFID	radio frequency identification
Alleviate	to make easier to endure
Radar	a system for detecting the presence, direction, distance, and speed of aircraft, ships, and other objects, by sending out pulses of radio waves which are reflected off the object back to the source.

15 References

1. <http://www.wwdmag.com/pipe-distribution/finding-faults>
 Grabowski, M, Boudwin, C, Feb 2015. Water & Waste Digest. Finding Faults. Retrieved April 28, 2016, from <http://www.wwdmag.com/pipe-distribution/finding-faults>
2. www.cameron-mo.com/DocumentView.aspx?DID=857
 Sanitary sewer inspection and maintenance program. February, 2010. City of Cameron. Retrieved April 28, 2016, from www.cameron-mo.com/DocumentView.aspx?DID=857
3. <https://www.yumpu.com/en/document/view/9026418/manhole-and-meter-pit-cover-booklet>
 Knight.D.Thames water.2016.Manhole and meter pit cover booklet.Retrieved April 28, 2016, from <https://www.yumpu.com/en/document/view/9026418/manhole-and-meter-pit-cover-booklet>



4. <http://www.draindomain.com/manholes.html>
National Association Drainage Contractors. August 2014, Manholes & Inspection Chambers. Retrieved April 28, 2016, from <http://www.draindomain.com/manholes.html>
5. <https://www.aquatechnologygroup.com/category/applications/plastic-manhole-covers/> Aqua technology group, april 21, 2016. Plastic manhole covers. Retrieved April 28.2016, from <https://www.aquatechnologygroup.com/category/applications/plastic-manhole-covers/>
6. <http://www.canadianundergroundinfrastructure.com/article/20489/identifying-problems-and-solutions-to-leaky-manholes>
7. Topf, A. March 16, 2015. Identifying Problems and Solutions to Leaky Manholes, Retrieved April 28, 2016, from <http://www.canadianundergroundinfrastructure.com/article/20489/identifying-problems-and-solutions-to-leaky-manholes>
8. <http://www.scientific.net/AMR.723.877>

Chang, J, Yang, S, Lin. K, August 2013. Innovation and Sustainable Technology in Road and Airfield Pavement. Preliminary Study of Radio Frequency Identification on Underground Manhole's Surveys. 877-884. 10.4028/www.scientific.net/AMR.723.877
9. <https://www3.epa.gov/region1/sso/manhole-id.html>

United State Environmental Protection Agency. Feb 14, 2016. Eliminating Sanitary Sewer Overflows in New England: Developing a Manhole or Catch Basin Numbering System. Retrieved April 28. 2016, from 1. <https://www3.epa.gov/region1/sso/manhole-id.html>





Course Code:3221

Module 1
**Safety Control and Measures for Sewer and
Drainage Works**

Participant Lecture Notes
Lecture 9-Traffic Control Plan

2016



1 Lecture Information

Topic: Traffic control practice during sewer, manhole and drain cleaning operations	Lecture duration (hrs.): 5.0 OJT (hrs.): 5.0
Lecture: Traffic control plan & traffic control devices	Training delivery mode: OJT
Lecture date: TBD	Lecture timing: 09 am – 04pm

2 Objectives

The objective of this lectures are train participants:

- In managing the traffic around roadside where operation and maintenance work is to be carried out
- Erection of road signs along the road side for intimating the drivers about the work in progress
- Minimize the chances of road and traffic related hazards and accidents around work site

3 Reasons for Traffic Control Plan

- Working on a roadway represents a significant danger to sewer maintenance staff, pedestrians and drivers plying on the road

4 Necessary Steps before Routing Traffic

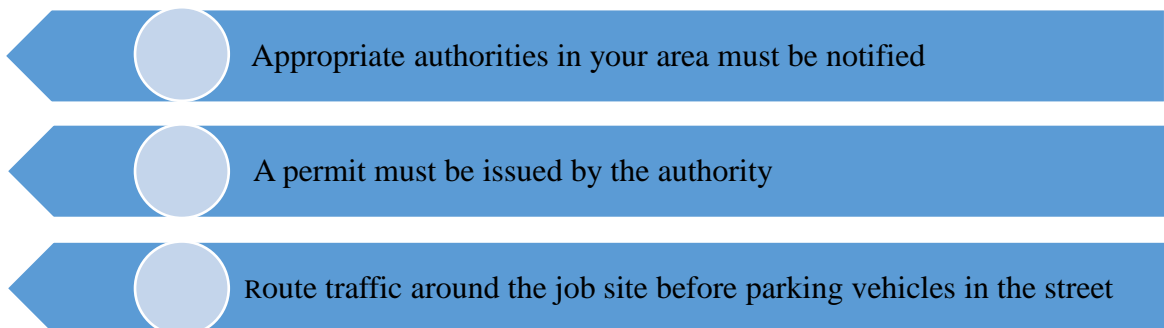

5 General points about Traffic Routing

The points to be kept in mind while doing making traffic routing plan during a maintenance work is shown in Tab3 1.

Table 1: Main considerations while routing traffic during sewer maintenance work

Sr. no.	Steps during traffic routing
1	Traffic must be warned about your existence in the street
2	"PEOPLE WORKING" and "CAUTION, CONSTRUCTION WORK" signs are vital for traffic control
3	Signs with flags, vehicle-mounted traffic guides are appropriate tools
4	Use flagmen to alert drivers and to direct traffic around the job site
5	Warning signs and flagmen must be positioned far enough in advance of the work area
6	If effectively placed, barricades and traffic cones can effectively channel traffic from one lane to another around the job site

6 Information Required for Traffic Routing Plan (Questions)

Answers to numerous questions will govern how traffic control should be accomplished

- Is traffic moving at a low speed or a high speed?
- Is the street two-lane, one-way or two-way?
- Is it undivided four-lane?
- Is it multi-lane one-way?
- Is it in a residential area?
- Will a lane closure be required?
- Will more than one lane be closed?
- Will traffic control be required during peak traffic periods or at night?
- Will a lane closure be required?

7 Areas of Traffic Control

Operation and maintenance staff at sewer or manhole or drain cleaning site must deal with five different areas of traffic control



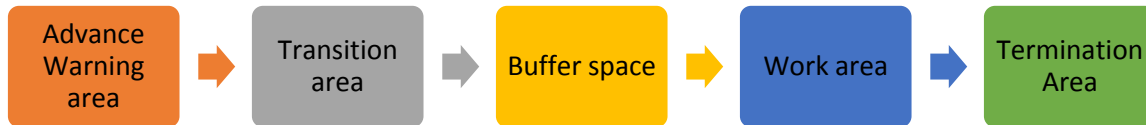

7.1 Advance Warning Area

The purpose of this area is to alert drivers about activity ahead and allow them sufficient time to alter their driving patterns prior to reaching the work area.

7.2 Transition Area

In the transition area, traffic is channeled from the normal traffic lane to the path required to move it around the work area. The transition area generally forms a taper by means of a series of pavement markings and/or channeling devices

7.3 Buffer Space

This open or unoccupied space between the transition and work areas provides an additional margin of safety for both traffic and working operators

7.4 Work Area

Work area is that portion of the road which contains the work activity and equipment. It is closed for traffic and is set aside for exclusive use by operators, equipment, and construction materials.

7.5 Termination Area

This area provides a short distance for traffic to get clear of the work area and to return to the normal traffic lanes. A taper may be installed to channel the traffic back into the normal traffic lanes [2].

The Figure 1, graphically shows these areas.



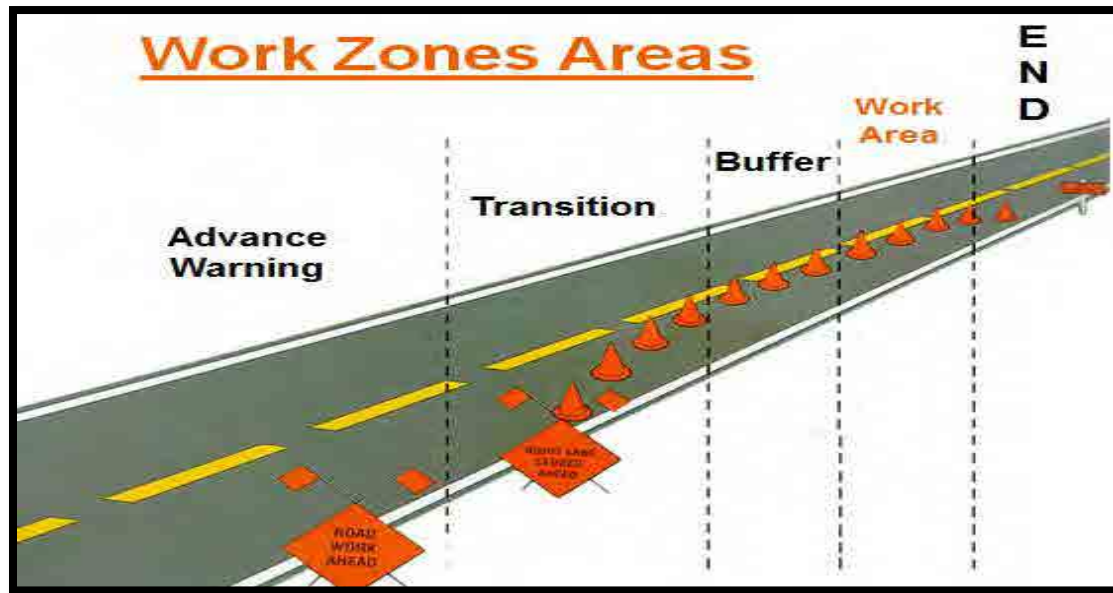

Figure 1: Different areas in a traffic route planned for sewer maintenance

8 Location of Work Area

The position of hi flags, signs, and cones for flagman control and work, may vary under five typical conditions:

1. Work area in center of road,
2. Work beyond intersection,
3. Closing left lane,
4. Closing half-roadway, and
5. Closing right lane.



8.1 Work Area in Center of Road

A graphical representation of this situation is shown in Figure 2.

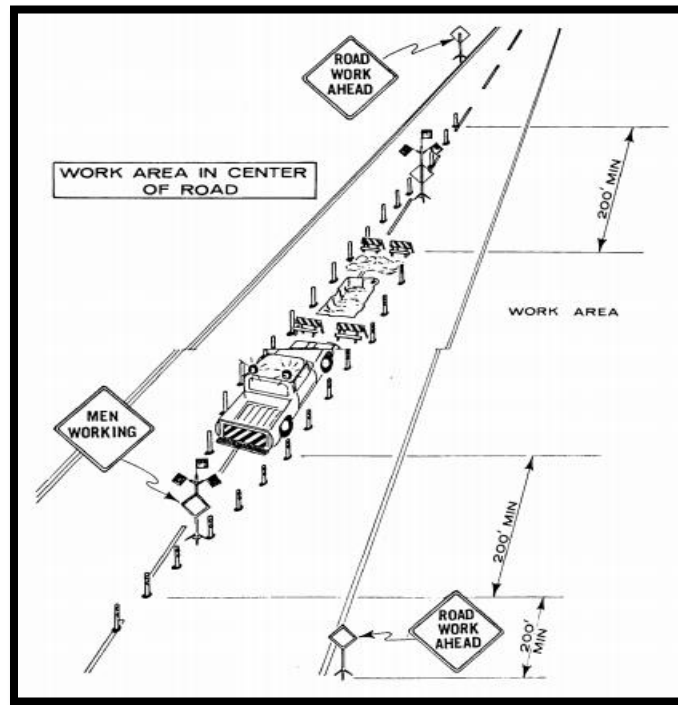

Figure 2: Work area in the center of road

8.2 Closing Left Lane

The above situation is shown in Figure 3.

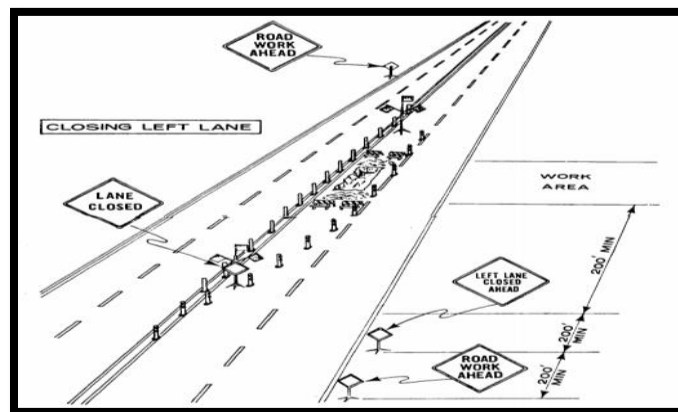

Figure 3



8.3 Closing Half-Roadway

This situation is shown in Figure 4.

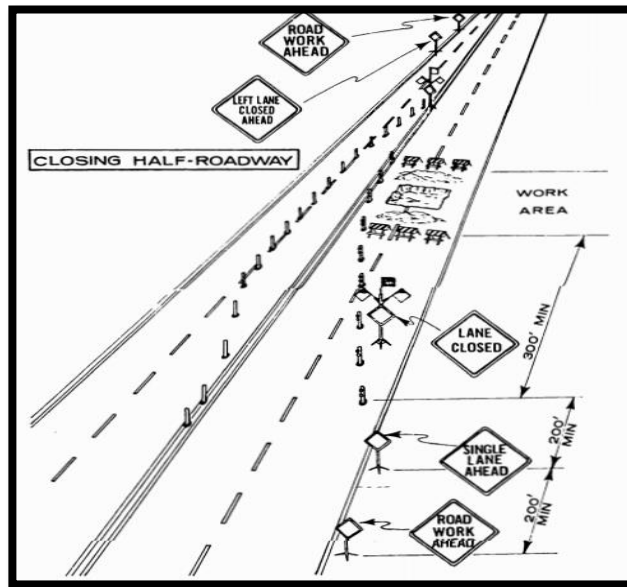

Figure 4

8.4 Closing Right Lane

This situation is shown in Figure 5.

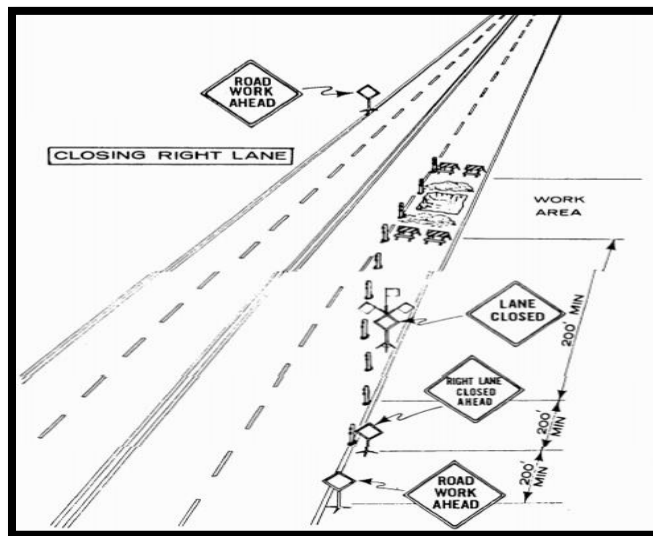

Figure 5



9 How can Traffic Hazards in the Workplace be Managed?

As an employer, you have a duty to eliminate, isolate, or minimize hazards to your employees. To manage traffic hazards at the workplace consider three main areas:

- Safe site
- Safe vehicle
- Safe driver

9.1 Safe Site

The layout and traffic flow of a workplace is important in keeping people and machinery safe. Consider:

- One way systems.
- Well marked road/pedestrian areas.
- Training and inductions for staff and visitors on pedestrian areas and traffic flows.
- Mirrors on blind spots.
- Designated crossing points.
- Sufficient lighting.
- Speed management (bumps, signage).

9.2 Safe Vehicle

Vehicles used in a workplace must be safe for the intended use.

Consider

- The design specification of the vehicle
- The loading/capacity of the vehicle.
- Safe means of access and egress from vehicle cab or trailer unit.
- Fuel source – for example, if used inside, an electric fork lift may be safer than an LPG fueled fork lift.
- Visibility – for example, rotating lights, running lights, mirrors, reversing alarms/cameras.
- Protective structures – for example, falling object protection, roll protection.
- Seat belts – for example, older fork lifts may need to have a seat belt retro-fitted.



9.3 Safe Driver

Drivers of vehicles must be trained and competent to operate the vehicle safely.

Drivers with less experience need to be supervised and monitored to ensure they are operating the vehicle safely. Consider:

- Initial and refresher training for drivers by competent persons/providers.
- Driving observations, with feedback on driving habits.
- Motion sensors/equipment monitors that log driver behavior.
- Guidance material on specific vehicle training
- Training records for each driver.
- Medical checks to ensure drivers are fit to operate vehicles (being aware of medical issues).
- Drug and alcohol policy and checks [1].

10 Traffic Management Plans

If you have a large workplace with a high volume of traffic, a traffic management plan is essential. It can significantly reduce the risks involved due to traffic movement.

A traffic management plan may include details of:

- The desired flow of pedestrian and vehicle movements
- The expected frequency of interaction of vehicles and pedestrians
- Illustrations of the layout of barriers, walkways, signs and general arrangements to warn and guide traffic around, past, or through a work site or temporary hazard
- How short term, mobile work and complex traffic situations will be managed.

A traffic management plan could also set out:

- Responsibilities of people managing traffic in the workplace
- Responsibilities of people expected to interact with traffic in the workplace, and
- Instructions or procedures for controlling traffic including in an emergency.



11 Traffic Control Devices

11.1 Temporary Road Signs and Devices

11.1.1 Types of Road Signs

Different types of road warning signage, used during sewer maintenance works is shown below



12 Glossary

Keyword	Definition
Erection	The action of erecting a structure or object.
Intimating	State or make known
Permit	An official document giving someone authorization to do something.
Blind spots	An area where a person's view is obstructed
Traffic management Plan	A traffic management plan (TMP) is a site-specific plan that covers the design, implementation, maintenance and removal of temporary traffic management (TTM) measures while work or activity is carried out in the road corridor (road, footpath or berm).
Traffic zone	An area that is different from other areas in a particular way that traffic is moving in that area

13 References

1. <http://www.business.govt.nz/worksafe/information-guidance/all-guidance-items/workplace-traffic-management>
Work Safe Newzealand.September 2015.Workplace traffic management.retrieved April 25,2016 from <http://www.business.govt.nz/worksafe/information-guidance/all-guidance-items/workplace-traffic-management>
2. www.wsdot.wa.gov/publications/manuals/fulltext/M51-01/Chapter2.pdf
WSDOT Maintenance Manual. August 2013. Chapter 2: Work Zone Traffic Control and Safety. Retrieved April 25, 2016, from www.wsdot.wa.gov/publications/manuals/fulltext/M51-01/Chapter2.pdf





Course Code: 3221

Module 2

Operation and Maintenance of Sewer System

Participant Lecture Notes

Lecture 1

2016



1 Lecture Information

Topics:	Inspection and testing of sewers and manholes	Lecture Duration (Hrs.):	0.5
Lecture:	Inspection techniques	• Classroom Briefing (Hrs.) :	0.5
Day:	One	Training Delivery Mode:	OJT
Lecture Date:	TBD	Lecture timing:	09 am – 04pm

2 Objectives

The objectives of this lecture are to enable the participants to:

- Inspect existing sewers for the purposes of operation and maintenance
- Inspect new sewers and replacement sewers
- Generate reports after completion of inspection work
- Effectively use tools and equipment and follow procedures

3 Reasons for Inspection

- To identify existing or potential problem areas in the collection system
- To locate the position of problems
- To generate clear, concise, and meaningful reports for supervisors regarding problems

4 Inspection of Manholes and Sewers

Manhole and sewer line inspections are conducted:

- To determine the proper elevations or grades around the lid to be sure the lid isn't buried
- To examine structural integrity (look for cracks) of the manhole and its functional capacity



5 Inspection Methods

There are two methods for the inspection of a manhole and sewer line (Table 1):





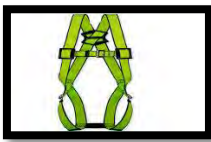

Table 1: Inspection Methods

Sr. No.	Methods
1	Visual inspection
2	CCTV inspection

6 Safety & PPE Requirements

How traffic routing would be done around the job site, for it, please consult the module 1. However, following PPE will be required for the inspection purposes of sewer and manhole (Table 2).

Table 2: PPE Required For Inspection of manhole and sewers

Sr. No.	Personal Protective Equipment (PPE)			
1	Safety helmet		Safety goggles	
2	Rubber gloves		Wader	
3	Safety harness		Safety gum	



7 Equipment Required for Inspection

Following equipment will be required for the inspection of manhole and sewers (Table 3).

Table 3: Equipment Required for Inspection of sewers and manholes

• Powerful flashlight	• Warning devices, safety cones and other traffic safety devices
• Map of the collection system to reference manhole	• Metal detector and
• Manhole lid removal device	• Gas detection devices
• Scrapers and wire brushes for cleaning the manhole ring	• A blower and hose for ventilating manhole
• Leather gloves	• A pick and shovel

8 Staffing Requirements

Staffing requirement will vary according to the type of inspections and tests. However, a typical requirement is given in Table 4.

Table 4: Typical Staff Requirement for Sewer or Manhole Inspection

Sr. No.	Staff or Cadre	Sr. No.	Staff or Cadre
1	Forman	4	Sanitary Worker
2	Operator	5	Flagmen
3	Technician	6	Helper

9 Visual Inspection Procedure

Visual inspection could be broken down into following steps:

Step 1

Locate the manhole and check the area around it.

Step 2

Test atmospheric conditions in the manhole by inserting the probe of a gas detection device through an opening in the manhole cover.



Step 3

While inspection operation, keenly observe the following defects (Table 5):

Table 5: List of Possible Defects in the Manhole

Sr. No.	Defects	Sr. No.	Defects
1.	Cracks or breaks in the walls or bottom	2.	Gravel or debris accumulations in invert
3.	Infiltration at any place	4.	Concrete or grout in the invert or pipe causing flow turbulence
5.	Joints in a manhole should be tight.	6.	Deterioration of the grout bed of frame
7.	There should not be any visible cracks	8.	Condition of steps or rungs (if provided)
9.	Offsets or misalignment of any parts	10.	Sluggish flow or wastewater backing up into the manhole
11.	Root intrusions	12.	Corrosion
13.	Grease accumulations inside of sewers entering and leaving manhole		

Step 4

- With a wire brush and scraper, clean the ledge of the manhole ring
- Inspect carefully for any cracks in the metal parts
- If a crack is observed, the manhole should be barricaded and the ring should be replaced immediately

Step 5

- Look for evidence of a misfit lid by standing at various positions around the lid
- Where traffic passes over a lid with a rattle, the noise and rattle will increase with time
- Make certain that the ring is clean and does not have a pebble or other object preventing proper fit.
- Gaskets may be used to reduce rattles, but gaskets have to be replaced periodically



10 Manhole Visual Inspection Report

A blank sample form (Figure 1) shows how to record data from a manhole inspection. Each participant or group will fill the necessary data after the keen observation at WASA work site so that a comprehensive report could be ready for further action.

MANHOLE INSPECTION REPORT

MH NO. _____ DATE _____ TIME _____ INSPECTOR _____

ELEVATION _____ DEPTH TO INVERT _____ CLEANLINESS _____

TYPE CONSTRUCTION _____ STREET REFERENCES _____

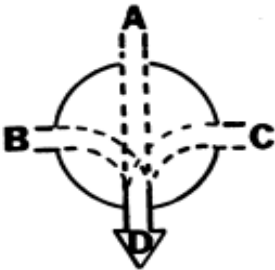
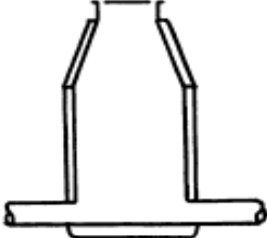
DEFECTS:
(Cover, frame, grout, steps, shelf, pipes, or channels)

1. _____
2. _____
3. _____
4. _____
5. _____
6. _____
7. _____
8. _____

(USE REVERSE SIDE FOR ADDITIONAL DEFECTS TO BE NOTED.)

	PIPE SIZE	LENGTH TO MH#	EST. FLOW	TYPE FLOW
A-	_____	_____	_____	_____
B-	_____	_____	_____	_____
C-	_____	_____	_____	_____
D-	_____	_____	_____	_____

REMARKS:
(Include need for repairs)

MANHOLE INSPECTION REPORT

Figure 1: Manhole Inspection Report



11 Manhole Visual Inspection Form

Figure 2, shows the checklist or inspection form for the evaluation of real-time structural and hydraulic functional capacity of a manhole. This form should be filled with due care for the preparation of a reliable manhole inspection report.

SANITARY SEWER MANHOLE INSPECTION FORM			
W. SEC. #:	FORM:	M.H. #:	DATE:
M.H. DEPTH:			
I. INITIAL INSPECTION		II. STRUCTURAL INSPECTION	
A. LOCATION:		A. STEPS:	
1. Roadway	<input type="checkbox"/>	1. Serviceable	<input type="checkbox"/>
2. Gutter	<input type="checkbox"/>	2. Unsafe	<input type="checkbox"/>
3. Paved Alley	<input type="checkbox"/>	3. Missing (No.)	<input type="checkbox"/>
4. Unpaved Alley	<input type="checkbox"/>	4. Corroded	<input type="checkbox"/>
5. Easement	<input type="checkbox"/>		
6. Other	<input type="checkbox"/>		
B. MANHOLE COVER:		B. CONE:	
1. Serviceable	<input type="checkbox"/>	1. Serviceable	<input type="checkbox"/>
2. Damaged	<input type="checkbox"/>	2. Broken	<input type="checkbox"/>
3. Displaced	<input type="checkbox"/>	3. Sulfided	<input type="checkbox"/>
4. Missing Grout	<input type="checkbox"/>	4. Misaligned	<input type="checkbox"/>
5. Needs Raising	<input type="checkbox"/>	5. Leaking/Bad Joints	<input type="checkbox"/>
6. Needs Lowering	<input type="checkbox"/>		
C. RING & FRAME:		C. RISER:	
1. Serviceable	<input type="checkbox"/>	1. Serviceable	<input type="checkbox"/>
2. Loose	<input type="checkbox"/>	2. Broken	<input type="checkbox"/>
3. Displaced	<input type="checkbox"/>	3. Sulfided	<input type="checkbox"/>
4. Missing Grout	<input type="checkbox"/>	4. Misaligned	<input type="checkbox"/>
5. Needs Raising	<input type="checkbox"/>	5. Leaking/Bad Joints	<input type="checkbox"/>
6. Needs Lowering	<input type="checkbox"/>		
D. MANHOLE MATERIAL:		D. SHELF:	
1. Brick	<input type="checkbox"/>	1. Serviceable	<input type="checkbox"/>
2. Concrete	<input type="checkbox"/>	2. Broken	<input type="checkbox"/>
		3. Dirty	<input type="checkbox"/>
		4. Sulfided	<input type="checkbox"/>
		5. Bad Base Joint	<input type="checkbox"/>
E. SIZE M.H. COVER:		E. CHANNEL:	
1. 24 Inch	<input type="checkbox"/>	1. Serviceable	<input type="checkbox"/>
2. 30 Inch	<input type="checkbox"/>	2. Obstructed	<input type="checkbox"/>
		3. Sulfided	<input type="checkbox"/>
		4. Bad Pipe Joint	<input type="checkbox"/>
		5. Silt	<input type="checkbox"/>
		6. Poor Struct. Cond.	<input type="checkbox"/>
F. MANHOLE SIZE:			
1. 4 foot	<input type="checkbox"/>		
2. 5 foot	<input type="checkbox"/>		
III. HYDRAULIC INSPECTION			
A. INFLOW INDICATIONS:			
1. Debris on Sides/ Shelf <input type="checkbox"/>			
B. SURCHARGE INDICATIONS:			
1. Grease/Debris on Sides & Shelf <input type="checkbox"/>			
C. CLARITY OF FLOW:			
1. Turbid Appearance <input type="checkbox"/>			
2. Clear Appearance <input type="checkbox"/>			
D. FLOW:			
1. Steady <input type="checkbox"/>			
2. Pulsing <input type="checkbox"/>			
3. Turbulent <input type="checkbox"/>			
4. Surcharging <input type="checkbox"/>			
5. Sluggish <input type="checkbox"/>			
E. FLOW DEPTH COMPARED TO ADJACENT MANHOLES:			
1. Same <input type="checkbox"/>			
2. Lower <input type="checkbox"/>			
3. Higher <input type="checkbox"/>			
F. FLOW DEPTH:			
_____ Inches			
Time _____ AM/PM			
IV. VERMIN			
1. Roaches <input type="checkbox"/>			
2. Rats <input type="checkbox"/>			
3. Other <input type="checkbox"/>			
OBSERVATION SUMMARY:			
FOREMAN II RECOMMENDATIONS:			
SUPERVISOR I APPROVAL & COMMENTS:			

Figure 2: Manhole Inspection Form



12 Closed Circuit Television Inspection (CCTV)

Purpose of CCTV inspection is to:

- Inspect conditions and determine location of problem areas for example pipe or joint separations, drops, ruptures, leaks, service connections, obstructions, corrosion, pipe alignment, and root intrusion
- Look for damage to sewers
- Search for unrecorded connections
- Locate inflow or infiltration sources
- Locate buried or lost manholes

12.1 Equipment and Components Required for CCTV Inspection

Essential components for CCTV inspection are listed in Table 6.

Table 6: Components of CCTV Setup

Sr. No.	Component	Sr. No.	Component
1.	Television camera	2.	Portable power source
3.	Camera light	4.	Camera carrying skids
5.	Power cable reel and video unit	6.	Camera pulling winch
7.	Television picture monitor	8.	Camera return winch



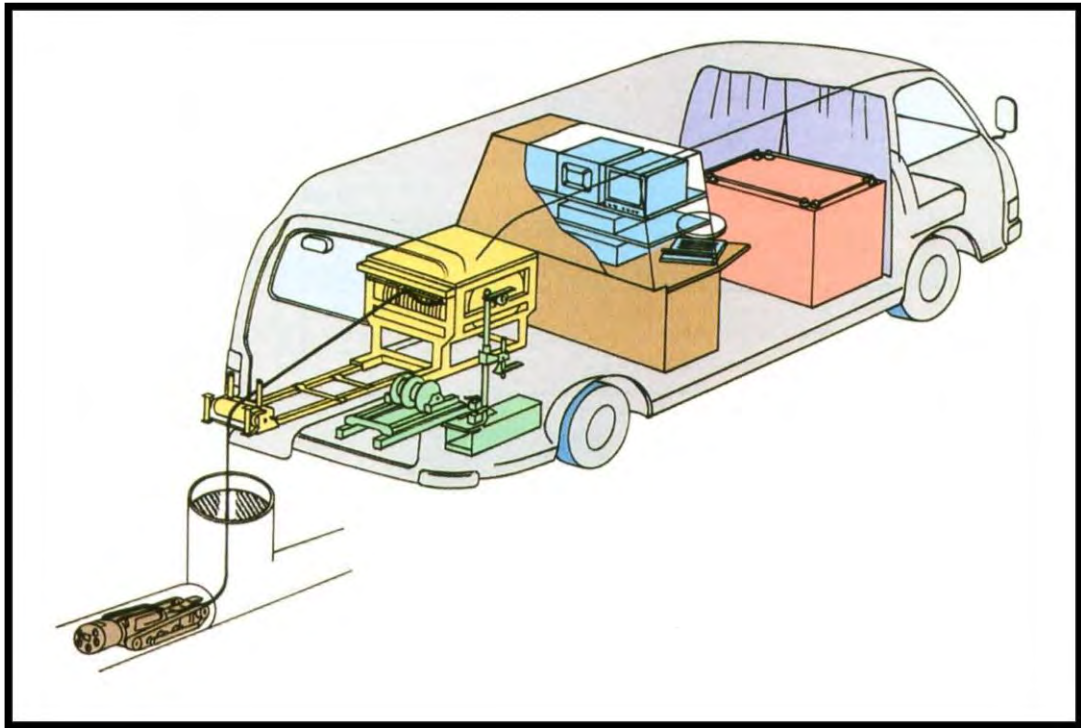

Figure 3: CCTV Camera Van

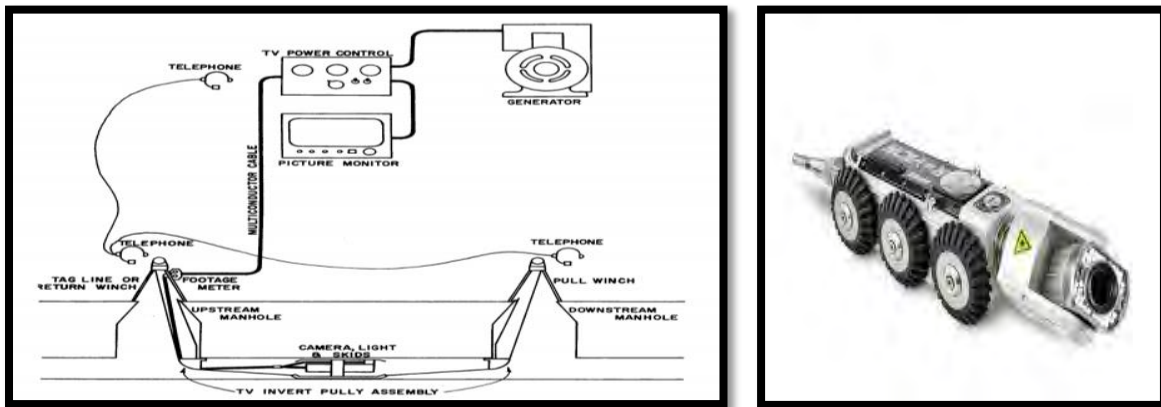

Figure 4: Schematic Diagram for CCTV Setup



13 Inspection Analysis

Table 7 clearly describes the various inspection methods and their results:

Table 7: Inspection Methods & their Results

Inspection Method	Where it should be used?	What it will find?
<ul style="list-style-type: none"> Physical inspections of manholes and sewer pipes 	Manholes and above-ground sewer pipes	<ul style="list-style-type: none"> Manholes Frame & cover defects Structural defects Flow surcharging Root intrusion Sewer pipes Signs of leakage and blockages Exterior structural defects
<ul style="list-style-type: none"> Smoke testing 	Manholes and sewer pipes	<ul style="list-style-type: none"> Sources of I/I Location of illegal connections Location of broken sewers Location of buried manholes
<ul style="list-style-type: none"> Dye-water testing 	Sewer pipes	<ul style="list-style-type: none"> Sources of Exfiltration Proof of building connection to sewer system Location of illegal connections Estimating flow velocity
<ul style="list-style-type: none"> Closed circuit television inspection (CCTV) 	Sewer pipes	<ul style="list-style-type: none"> Structural defects Maintenance Needs Sources of I/I at joints, breaks, connections Cross connections or illegal connections



14 Glossary

Key Word	Definition
Corrosion	The gradual disintegration or damage of a material due to chemical action
Dye	Color powder or tablet
Lamping	Using reflected sunlight or a powerful light beam to inspect a sewer between two adjacent manholes
Subsidence	The dropping or lowering of the sewer pipe or manhole
Infiltration	Entering of water into sewer pipe
Exfiltration	Gradual leakage of sewage from pipe
Pneumatic Plug	A synthetic rubber plug used for blocking the flow of pipe





Course Code: 3221

Module 2
Operation and Maintenance of Sewer
System

Participant Lecture Notes

Lecture 2
OJT 1

2016



1 Lecture Information

Topics: Inspection and testing of sewers and manholes	Lecture Duration (Hrs.): 5.5 OJT (Hrs.): 5.5
Lecture: Testing of sewer and manholes	Training Delivery Mode: OJT
Day: One	Lecture timing: 09 am – 04pm
Lecture Date: TBD	

2 Objectives

This is not a class room lecture. It is an on the job. The objective is to enable the participants to:

- Test for leaks in sewers joints and manholes
- Locate and determine the inflow, infiltration and exfiltration problems
- Effectively use tools and equipment and procedures

3 Reasons for Testing

- To identify existing or potential problem areas in the collection system
- To locate the position of problems
- To generate clear, concise, and meaningful reports to supervisors regarding problems





4 Safety & PPE Requirements

How to rout traffic around the job site (manhole or sewer line), please consult the module. PPE required for the testing purposes of sewer and manhole are shown in Table 1.

Table 1: PPE required for testing

Sr. No.	Personal Protective Equipment (PPE)	
1	Safety helmet 	Safety goggles 



Sr. No.	Personal Protective Equipment (PPE)	
2	Rubber gloves 	Wader 
3	Safety harness 	Safety gum 

5 Equipment Required for Inspection

Typical PPE required for the job are shown in Table 2

Table 2: Equipment required for inspection of Manhole and Sewers

▪ Powerful flashlight	▪ Warning devices, safety cones and other traffic safety devices
▪ Map of the collection system to reference manhole	▪ Metal detector and
▪ Manhole lid removal device	▪ Gas detection devices
▪ A pick and shovel	▪ A blower and hose for ventilating manhole

6 Staffing Requirements

Staffing requirement may vary according to the type of tests underway. However, typical staff requirement is shown as under:

Sr. No.	Staff or Cadre	Sr. No.	Staff or Cadre
1	Forman	4	Sanitary Worker
2	Operator	5	Flagmen
3	Technician	6	Helper



7 Types of Testing

There are various types of tests regarding the sewer and manhole in order to:

Identify existing or potential problem areas
Locate the position of problems
To analyzing and evaluate the structural integrity, stability and hydraulic functionality

7.1 Smoke Testing

7.1.1 Purpose

Smoke testing for wastewater collection systems (Table 3) is used to determine:

Table 3: Purpose of smoke testing

<ul style="list-style-type: none"> ▪ To find the the sources of entry of surface water into the collection system o ▪ To get positive proof that buildings are connected to a wastewater collection system ▪ To locate illegal connections to a wastewater collection system ▪ To locate broken sewers due to settling of foundations and manholes ▪ To locate lost manholes

7.1.2 Equipments

All of the following pieces of equipment are used for smoke test:



Figure 1: Smoke Blower Unit and Pipe Plugs



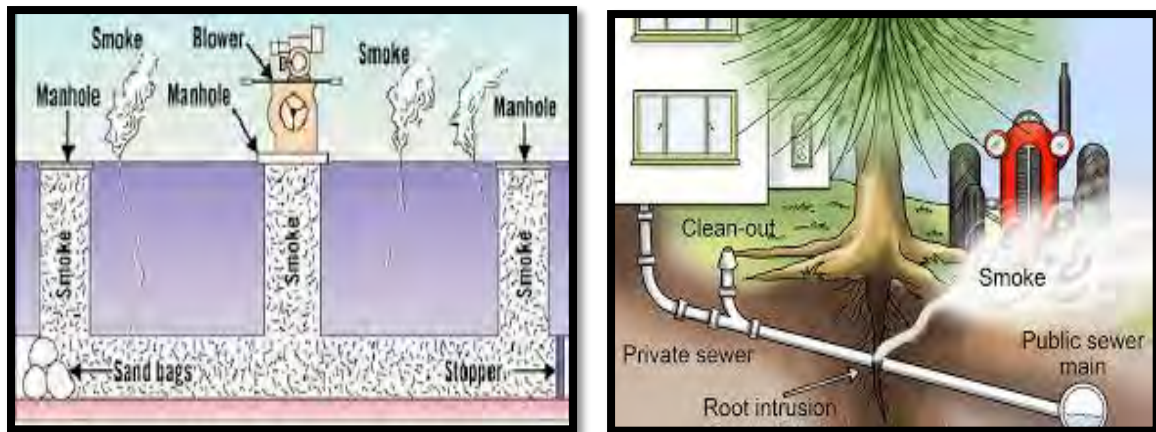

Figure 2: Smoke Testing

7.2 Dye Testing

7.2.1 Purpose

Table 4 shows two things; (1) purpose of dye testing for wastewater collection systems and (2) some examples of typical situations where dye tests would be appropriate.

Table 4: Purpose of dye testing and some examples

Purpose
<ul style="list-style-type: none"> ▪ To find illegal connections ▪ To identify the overflowing or leaking sewer ▪ To reveal interconnections between sanitary and storm sewers
Examples
<ul style="list-style-type: none"> ▪ Buildings that may not show smoke at vents during smoke tests ▪ Any suspected situation of inflow or surface drainage may be checked out by using a dye ▪ Estimating the velocity of flow ▪ Testing for infiltration and exfiltration

7.2.2 Equipment

Following items will be necessary for conducting a dye test in sewer pipes:

- Bucket or container for pouring colored water
- Dye or color

Two types of safe and harmless but effective dyes are available for testing:

1. Powder in cans or containers
2. Tablets of dye





Figure 1: Dye Buckets



Figure 2: Dye Pouring in Manhole



Figure 3: Observation of colored water at manhole and sewer



7.3 Lamping Test

7.3.1 Purpose

The purpose of lamping is to establish that a section of sewer pipe is straight and open or not. Actually lamping test permits an inspector to visually examine conditions in a pipe. Larger sewers are easier to lamp than small sewers.

7.3.2 Equipment

Following items will be necessary for conducting a lamping test in sewer pipes:

- | | |
|------------------------------------|------------------------|
| 1. Bright source of light or Torch | 2. Two or more mirrors |
|------------------------------------|------------------------|

7.3.3 Staffing Requirement

Four (04) persons are usually needed for conducting the pipeline lamping test.

7.3.4 Test Operation

Following is the simple procedure to conduct the lamping test:

- | |
|--|
| ▪ Be sure manhole is safe to enter |
| ▪ One worker enters the manhole |
| ▪ Second operator enters in to the next manhole and shines a bright light towards the first operator |
| ▪ If the first operator can see the light the sewer line is open and straight |

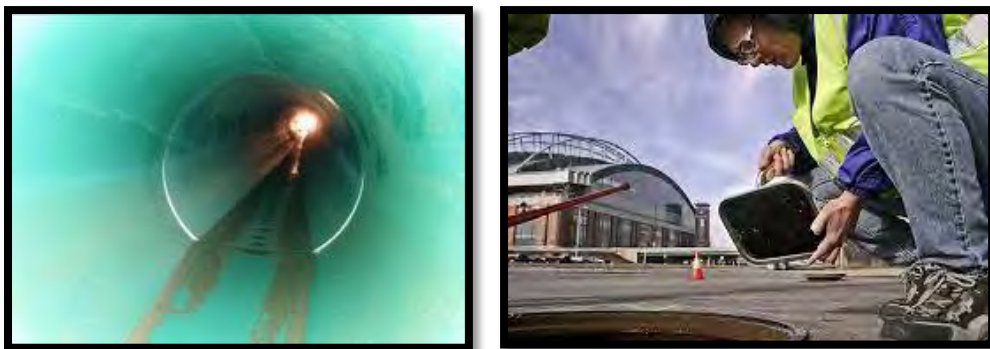

Figure 4: Lamping Test Operation



8 Sewer Stoppages



8.1 Definition

A sewer stoppage happens when a sewer system becomes plugged and the flow backs up.



8.2 Causes of Stoppages

There are several causes for stoppages and obstruction that occur in sewer lines and the Table 5 explains each category of obstruction:

Table 5: Causes of Stoppages

Sr. No.	General causes	Due to the force of nature	Due to improper hydraulic design
1	Throwing of debris, asphalt and concrete rubble, plastic bags, cane and rags in manholes and sewer	Tree or plant roots intrusion 	Sewers not designed for future potential growth
2	 Deposition of Grease, Grit, sand and silt	Ground movement by earthquake	Occurrence of hydraulic flow problems when small diameter pipe connects with the invert of large diameter sewer



Sr. No.	General causes	Due to the force of nature	Due to improper hydraulic design
3	Joint failure between two sewer pipes 	Soil settlement	
4	Misaligned sewers 	-	-
5	Deterioration of other underground utility lines	-	-

8.3 Preventing Stoppages

Numerous prevention measures can be taken to avoid the obstruction in sewerage network (Table 6)

Table 6: Methods for preventing stoppages

Sr. No.	Stoppages	Remedial Actions
1	General Causes of Stoppages	• Raising awareness among general public about the prevention of blockade
		• Provision of manhole lid if not provided
		• Construction of sewer appurtenances (like catch basin) if absent
2	Joint failures	• Repairing of the joint or replacement the pipe
3	Tree roots intrusion	• Plantation of trees should be avoided alongside the sewerage network



Sr. No.	Stoppages	Remedial Actions
		<ul style="list-style-type: none"> • Roots should be removed from pipe and repair the cracks
4	Improper Hydraulic Design	<ul style="list-style-type: none"> • Redesign the problematic stretch to avoid the repeated stoppages

9 Glossary

Key Word	Definition
Corrosion	The gradual disintegration or damage of a material due to chemical action
Dye	Color powder or tablet
Lamping	Using reflected sunlight or a powerful light beam to inspect a sewer between two adjacent manholes
Subsidence	The dropping or lowering of the sewer pipe or manhole
Infiltration	Entering of water into sewer pipe
Exfiltration	Gradual leakage of sewage from pipe
Pneumatic Plug	A synthetic rubber plug used for blocking the flow of pipe





Course Code: 3221

**Module 2
Operation and Maintenance of Sewer
System**

**Participant Lecture Notes
Lecture 3**

2016



1 Lecture Information

Topic: Machinery, Tools and Equipment for cleaning Sewer line, Manhole and Disposal Station along with standard Cleaning Techniques	Lecture duration (hrs.): 1.0 • Classroom Briefing (Hrs.): 1.0
Lecture: Machinery, Tools and Equipment	Training delivery mode: OJT
Lecture date: TBD	Lecture timing: 09 am – 04pm

2 Objectives

The objectives of this lecture is to impart knowledge to the participants related to the following items:

- To be fully acquainted with the traditional and state of the art machinery being used for sewer and manhole cleaning purposes
- To make a selection criteria for choosing the right machine and equipment for cleaning job
- To study comparative effectiveness of the following equipment
- To make a preventive maintenance program for sewer clearing and cleaning equipment

1. Balling	2. Bucket machines	3. Sewer scooters
4. High velocity cleaners	5. Power rods	6. Hand rods
7. Flushing		



3 Cleaning and Maintenance Problems and Solution

Figure 1, is a useful guide for effective and efficient collection system maintenance:

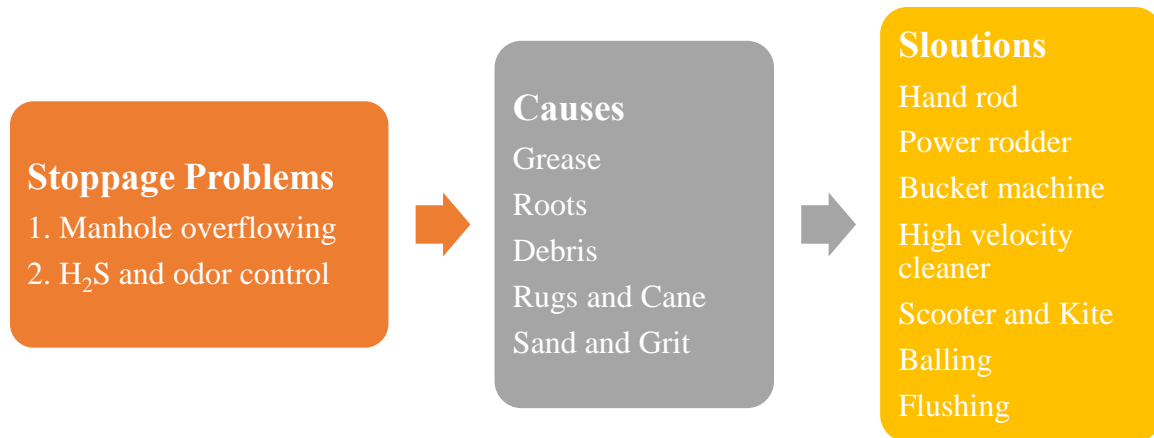



Figure 1: Problems, causes and solutions

4 Equipment Required for De-Silting Sewer (A Selection Criteria)

Following is a list of the basic types of equipment used to identify and remove stoppages and clean sewers

4.1 Rodding

Sr. no.	Equipment Name	Advantages	Limitations
1	Power Rodder machine a) Truck mounted b) Hand rod 	<ul style="list-style-type: none"> To cut roots Scrape, dislocate and remove certain material Very effective in removing emergency stoppages 	<ul style="list-style-type: none"> Ineffective for removing sand and grit, but may loosen material Rods have a tendency to coil and bend

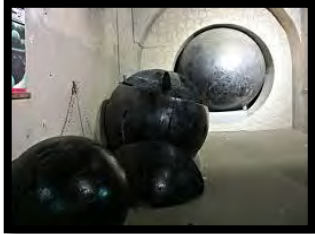

4.2 Sewer Ball or Tire

Sr. no.	Equipment Name with accessories	Advantages	Limitations
1	Ball Tire Cable Reel Water tank Dump truck 	<ul style="list-style-type: none"> Hydraulic action of spinning ball and high velocity of water dislodge debris and move debris downstream Very effective in removing heavy concentrations of sand, Grit and grease from sewers 	<ul style="list-style-type: none"> Dangerous to use in steep-grade hill areas Cannot be used effectively when sewers have protruding service connections because ball will not be able to do an effective cleaning job

4.3 High Velocity Cleaner (Jetting and Sucking Machine)

Sr. no.	Equipment Name with accessories	Advantages	Limitations
1	a) Jetting machine b) Sucking machine 	<ul style="list-style-type: none"> Very effective in cleaning flat, slow flowing sewers Efficient in removing grease, sand, gravel, and debris Can be used to remove emergency stoppages 	<ul style="list-style-type: none"> Effectiveness in taking out debris from larger diameter lines decrease as the cross-sectional area of the pipe is increased



4.4 Bucket Machine

Sr. no.	Equipment Name with accessories	Advantages	Limitations
1	a) Power bucket machine b) Power bucket loader c) Dump truck	<ul style="list-style-type: none"> ▪ Efficient in removing sand, gravel, and debris 	<ul style="list-style-type: none"> ▪ Can damage pipe line internally ▪ Setting up equipment is time taking activity

4.5 Kite or Bag

Sr. no.	Equipment Name with accessories	Advantages	Limitations
1	a) Water Tank truck b) Dump truck c) Winch machine	<ul style="list-style-type: none"> ▪ Efficient in removing debris ▪ Capable of washing ahead of it a full pipe of deposits ▪ Root removal 	<ul style="list-style-type: none"> ▪ Must use with care in steep-grade hill areas

4.6 Scooter

Sr. no.	Equipment Name with accessories	Advantages	Limitations
1	a) Water Tank truck b) Dump truck c) Tag line d) Winch machine e) Water from hydrant	<ul style="list-style-type: none"> ▪ Very effective in removing heavy debris due to scouring action ▪ Capable of removing grease 	<ul style="list-style-type: none"> ▪ Must use with care in steep-grade hill areas ▪ When cleaning large diameter sewers, the manholes must be designed to a bigger size to receive and retrieve this equipment



4.7 Flushing

Sr. no.	Equipment Name with accessories	Advantages	Limitations
1	a) Water tank b) Fire hose	<ul style="list-style-type: none"> Supplies a surge of water to move light, decaying organic matter downstream in slowly flowing sewers 	<ul style="list-style-type: none"> Must use with care in steep-grade hill areas Causes a temporary movement of debris Flushing does not remedy the cause of the problem This method does not move heavy debris and grit

5 Effectiveness of Solutions

Table 1 shows the comparative effectiveness of the possible solutions to diverse problems: (Size of the solid bullet shows the effectiveness of each method)

Table 1: Effectiveness of solution

Sr. no.	Solution to problem	Type of problem				
		Emergency stoppages	Grease	Roots	Sand, grit and debris	Odor
1.	Flushing					▪
2.	Hand rod	■	▪	▪		
3.	Power Rodder	■	▪	▪		
4.	High velocity cleaner	▪	■		■	▪
5.	Bucket machine				▪	
6.	Balling		■		■	■
7.	Scooters		▪		▪	



6 Maintenance of Cleaning Equipment

6.1 Need for Cleaning Equipment Maintenance

- To effectively perform the operation and maintenance jobs, all the tools and equipment must be properly maintained and repaired.
- As the moisture content and dust are the two most dangerous factors which affect the mechanical equipment, so maintenance of all the tools and equipment is highly necessary

6.2 Objectives of Cleaning Equipment Maintenance

The major objectives are as follows:

Sr. No.	Major objectives
1	To keep equipment in good condition to help prevent equipment failure on the job
2	To prolong the lifespan of the equipment
3	To enhance the efficiency and safety of maintenance jobs

6.3 Responsibility of Maintenance

The main responsibility goes to the following team members of WASA (Figure 2)

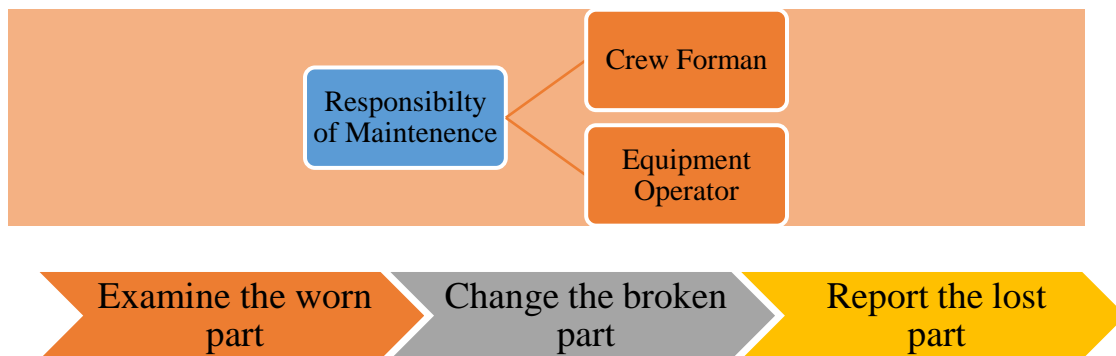

Figure 2 : Responsibility and basics of maintenance



7 Maintenance of Bucket Machine

7.1 Tools for Maintenance

The maintenance tools are shown in Table 2.

Table 2: List of tools for maintenance

Sr. no.	Tool name	Sr. no.	Tool name	Sr. no.	Tool name
1.	Pipe wrenches	2.	Allen wrenches	3.	Cable cutter
4.	Crescent wrenches	5.	Hack saw	6.	Extra oil squirt can
7.	Pliers	8.	Chisel	9.	Grease gun
10.	Screwdrivers	11.	Hammer	12.	Wire brush
13.	Extra cable clamps	14.	Clevis	15.	Wiping rags

7.2 Maintenance Procedure

- Keep oil or grease cups full and chains lubed
- Inspect belt tension, chain tension, and gear clearance
- Watch for loose cable clamps and frayed cable
- Look for loose rivets on buckets
- Return these to the shop for hard-facing and repair
- Keep pipe threads clean and oiled on extension pipes
- Keep extra couplings on exposed pipe thread
- Keep stabilizer legs in good operating condition
- Keep legs locked up" when traveling"



8 Maintenance of Rodding Machine

8.1 Tools for Maintenance



Maintenance tools are shown in Table 3

Table 3: List of tools for maintenance

Sr. no.	Tool name	Sr. no.	Tool name	Sr. no.	Tool name
1.	Assembly wrenches	2.	3.	4.	Allen wrenches
5.	Crescent wrenches	6.	7.	8.	Extra oil squirt can
9.	Pliers	10.	11.	12.	Hack saw
					Grease gun
					Wiping rags

8.2 Maintenance Procedure

- Inspect tension of drive head chain
- Inspect belt tension and wear
- Speed control
- Drive chains
- Oil level (machine oil only as specified by manufacturer)
- Periodically inspect all rod couplings
- Brake band or disc brake blocks. Inspect for wear
- Look for and repair leaky fittings and hoses
- Keep oil filter clean
- Maintain proper hydraulic oil level
- Replace cracked, chafed, or worn hoses



9 Maintenance of High Velocity Cleaner

9.1 Tools for Maintenance



Maintenance tools are shown in Table 4

Table 4 List of tools for maintenance

Sr. no.	Tool name	Sr. no.	Tool name	Sr. no.	Tool name
1.	Pipe wrench	2.	Allen wrenches	3.	Wiping rags
4.	Crescent wrench	5.	Screwdrivers	6.	Tool box
7.	Plastic tape	8.	Grease gun		

9.2 Maintenance Procedure



9.2.1 Daily Maintenance

Daily maintenance is shown in Table 5.

Table 5: Daily Maintenance steps

Sr. no.	Description	Sr. no.	Description	Sr. no.	Description
1	<ul style="list-style-type: none"> • Keep all equipment and accessories clean. 	2	<ul style="list-style-type: none"> • Hold Tank 	3	<ul style="list-style-type: none"> • Oil Levels
	<ul style="list-style-type: none"> a) Tool compartments b) Engine compartment 		<ul style="list-style-type: none"> a) Drain to prevent 		<ul style="list-style-type: none"> a) Engine b) Pressure pump Hydraulic oil tank
	<ul style="list-style-type: none"> ✓ Wipe up oil and grease ✓ Paint rust spots 		<ul style="list-style-type: none"> ✓ Rust ✓ Sand or dirt deposits 		
			<ul style="list-style-type: none"> b) Clean tank strainers 		



Sr. no.	Description	Sr. no.	Description	Sr. no.	Description
4.	• Tape splits in hose, or replace as necessary	5.	• Look for worn or plugged orifices in nozzle.		

10 General Maintenance of Equipment Engines

- Always be sure oil and water levels are in proper range before starting unit
- Use a fresh supply of the proper grade of clean gasoline
- Change oil and air filters according to manufacturer's recommendations
- Exercise (operate) equipment weekly
- Use proper type of oil in engines, transmission and for lubrication
- Keep battery terminals clean and battery charged for engines with electric starters, especially during winter months



11 Glossary

Key Word	Definition
Balling	A technique used to clean the sewer pipe
Scooters	An equipment used to clean the sewer pipe
Grit	Deposit of sand in sewer pipe
Surge	Increase in level of sewage during cleaning operation
Steep-grade	Sewer laid at higher slope





Course Code: 3221

Module 2
Operation and Maintenance of Sewer
System

Participant Lecture Notes
Lecture 5

2016



1 Lecture Information

Topic: Maintenance and rehabilitation of sewer line and manhole	Lecture Duration (hrs.): 3.0
Lecture: Repair and rehabilitation	Training Delivery Mode: Theory
Lecture Date: TBD	Lecture Timing: 09 am – 04pm

2 Introduction

2.1 Objectives

The objective of this lecture is to enable the participants understand:

1. The need for sewer rehabilitation
2. Different methods of sewer and manhole repairs

2.2 Need

- The deterioration of the physical condition of the aging sewer systems
- The increasing regulatory control of wet weather overflows from sewer systems

2.3 Ways of Sewer Rehabilitation

Sewer rehabilitation may be done in four ways

- By ensuring its structural integrity
- Limiting the loss of conveyance and wastewater treatment capacity through reducing infiltration and inflow
- Limiting the potential for groundwater contamination through controlling exfiltration from the wastewater collection system
- Limiting the potential for sewer backups and overflows by maintaining pipeline integrity

2.4 Factors Affecting Selection of Method

There are many rehabilitation methods. The choice of methods will depend on following factors: pipe size, type, location, dimensional changes, sewer flow, material deposition, surface conditions, severity of I/I and other physical factors



2.5 Outcomes of Rehabilitation

- Minimize sanitary sewer overflows
- Improving the hydraulic capacity of the sewer system
- Eliminate or reduce the occurrence of infiltration and inflows [4].

3 Causes of Failures

3.1 Typical Problems in Sewer System

- **Old and deteriorated main and lateral pipes**

Sewers range in age from 30 to 100 years with an average age of 50 years.

- **Misaligned and open pipe joints**

Most of the mortar used to seal the joints between sections of the pipe has deteriorated.

- **Undersized sewer pipe**

The existing sewer system is overloaded due to new sewer hookups, underground water infiltration, and illegal roof and/or yard drain connections.

- **Defective manholes**

Old manholes are made of bricks. Typical problems associated with brick manholes are loose bricks, missing bricks, and misaligned manholes.

- **Missing and/or unrecorded sewer pipes and manholes**

This problem is typical in the easement or backline sewer. Sewer pipe locations shown on the sewer record map are different from the actual sewer location.

- **Sewer main under houses and other improvements**

Complaints of sewer main alignment crossing the house and other improvements. A solution to this problem requires an agreement with the property owner for a new sewer easement at a relocated line.



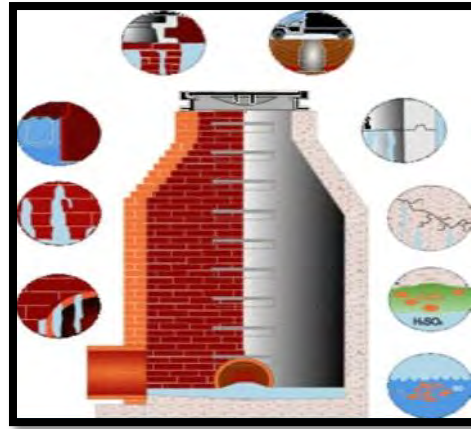

Figure 1: Failures in manhole

3.2 Why do Sewer Systems Keep Failing?

Sewer systems are subject to several (i.e., physical, chemical, etc.) stresses which may be caused by:

- i. Design and/or construction deficiencies
- ii. Structural dis integrity
- iii. Lack of maintenance or inadequate maintenance
- iv. Natural aging of the sewer system
- v. External influences, such as uncontrolled storm water connections, traffic loads, etc [5]

3.3 Manholes Failures

A manhole is the most accessible component of the gravity sewer system and is typically the only element to be routinely exposed at the surface. Due to the fact that it is exposed, a manhole offers significant potential for infiltration and inflow to the sewer system. Common failures of manholes are (ASCE, 1997):

- Leaks & Deterioration
 - Cracks, holes & joints
 - Root penetration
 - H₂S corrosion
 - Traffic Loading
 - Cover
 - Mortar Eroded
 - Structural Failure
- Infiltration – inflow and exfiltration.
- Surround ground settlements.
- Hydrogen sulfide release may attack concrete manholes.



- Corrosion of cast-in-place rungs can be an important safety issue.
- Structural problems

3.3.1 Solutions

- Grouting
- Concrete Patching
- Re build Upper portion of manhole
- Manholes Liner
- Corrosion Protection
- Build a manhole within a Manhole [1]

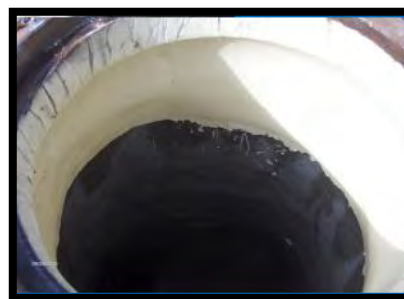

Figure 2: Solutions of different failures



3.4 Failure in Sewer System [5]

Different forms of failure that occur in sewerage system and their possible causes are enumerated below.

Failure	Causes
Deformations	<ul style="list-style-type: none"> • Design and/or construction deficiencies • Material deficiencies in laying and/or bedding • Effects of temperature • Overloading
Cracks, breaks, pipe collapse	<ul style="list-style-type: none"> • Design and/or construction deficiencies • Damages during transport, storage and installation • An effect of wear • Overloading of the sewer pipe
Flow obstacles	<ul style="list-style-type: none"> • Stoppages • Design and/or construction deficiencies • Lack of maintenance or inadequate maintenance • Root intrusion • As effect of inflow–infiltration
Abrasion – corrosion	<ul style="list-style-type: none"> • Emission of Hazardous Gases like CH₄ • Design deficiencies • Wastewater with special components like uncontrolled industrial discharges • Improper materials selection.
Positional deviations	<ul style="list-style-type: none"> • Settling and earthquakes. • Hydro-geological changes. • Design and/or construction deficiencies. • Load changes • As a result of leaks
Infiltration – inflow and exfiltration	<ul style="list-style-type: none"> • Design and/or construction deficiencies • High water table and high permeability ground. • Uncontrolled storm water connections. • Materials ageing • Other failures



4 Renovation Material

- ✓ Chemical Grout
 - Acrylic
 - Acrylate Based Grout
 - Urethane Based Grout
- ✓ Cementitious Material
- ✓ Urethane resin
- ✓ Rapid setting cements
- ✓ Mono crystalline quartz aggregates
- ✓ Various accelerating agents
- ✓ Liner materials shall be
 - Cement based
 - Poly fiber reinforced
 - Shrinkage compensated
 - Siliceous aggregates.
- ✓ Polyvinyl chloride (PVC) protective sheet liners
- ✓ High density polyethylene (HDPE)
- ✓ HDPE, PVC, EPP
- ✓ Rubber, brick, block, cement or poured concrete
- ✓ Oakum Water Plugs to prevent leakages
- ✓ Manhole frame adjustments shall be HDPE, PVC, EPP, rubber, brick, block, cement or poured concrete

5 Rehabilitation Methods

Sewer rehabilitation methods include:

- Repair
- Renovation
- Replacement

5.1 Repair

Repairs typically address maintenance issues (i.e., cleaning) and leakage (i.e., water tightness). Repairs may be temporary or permanent depending on the methods and technologies.



5.1.1 Types of Repairs

There are usually two types of repairs

- Structural Repairs
- Non Structural Repairs

Non-structural Repairs typically involve the sealing of leaking joints in otherwise sound pipe and manholes. Pull-through packer systems are used to test (using air pressure), inject a variety of chemical grouts into leaking joints, and then retest sealed joints, all without excavation. Elastomer sealing rings may also be placed (typically in larger pipes) to seal joints.

Specialized equipment is also used to seal leaking joints in service laterals and at the point of connection of those laterals to the sewer main as well as in manhole joints and around covers and frames.

Structural Repairs involve either the replacement of all or a portion of a sewer line, or the lining of the sewer.

5.1.2 Methods of Repairs

Point and Replacement Repairs

Point repairs consist of repairing cracked, corroded, or broken gravity sewers and force mains. This work typically includes excavation to the location of the break, removal of the broken pipe section(s) and replacement with new pipe.

Joint Testing and Grouting

Joint testing and grouting are done on sewer line sections with leaking joints but no structural defects. This work can be done in conjunction with the routine televising of lines. Grouting has a limited life and must be repeated every 5-10 years.

Sewer Lining

Sewer lining is a technique which returns pipe to new condition. Many of the current systems can be used where pipe is structurally deficient. Due to the limited excavation required for these techniques, they are good choices where surface construction would cause much disruption.

5.2 Renovation

Renovation is more comprehensive than repair and describes rehabilitation techniques that renew the structural integrity of the sewer. Pipeline renovation systems use the existing pipe structure to “build” a new pipe or support a new lining. The systems used for carrying this out are coating and lining.



5.3 Replacement

The classic method to rehabilitate sewers is to replace them. Many problems such as structural, grade, etc. may be too severe for renewal techniques. Replacement is often cheaper than lining technologies, but requires more construction time and needs open trenches.

5.3.1 Traditional Open-Cut Pipeline Replacement Techniques

These repairs can be carried out by **excavating** (common for repairs limited to one or two pipe segments; these are known as point repairs)

5.3.2 Trenchless Technologies

Repair is carried out via existing manholes or a limited number of access excavations. These include

- Slip lining
- Cured-in-place-pipe,
- Fold and form lining,
- Spirally wound pipe,
- Segmental lining, and
- On-line replacement

5.3.2.1 Benefits of Trenchless Technologies over Traditional Open-Cut Pipeline Replacement Techniques

- Generally, more cost-effective than open cut
- Avoidance of many surface constraints,
- Disruption of other services minimized (e.g., power lines)
- Surface reinstatement needs minimized
- Surface disruption including traffic disruption kept to a minimum
- Reduced surface settlement, particularly important in sensitive areas, such as under railways, motor ways, services and adjacent to buildings
- Environmental disturbance minimized, and
- Installation of services at greater depths than would normally be considered cost effective for trenching [2]



6 Rehabilitation Techniques

6.1 Sewer Line Rehabilitation

6.1.1 Slip Lining (Figure 3)

- Used to rehabilitate damaged sewer pipes by placing a smaller diameter conduit inside the damaged section
- This method is commonly used where the new, smaller diameter sewer pipe, and the resulting lower friction coefficient for the new pipe, is sufficient for the system capacity needs
- With slip lining, the liner is inserted into the existing pipe at an access pit location and is then pulled through the existing pipe by a winch or similar equipment. The inserted pipe is not deformed or cured.
- The existing line must be cleaned, if necessary, to insert the new line.

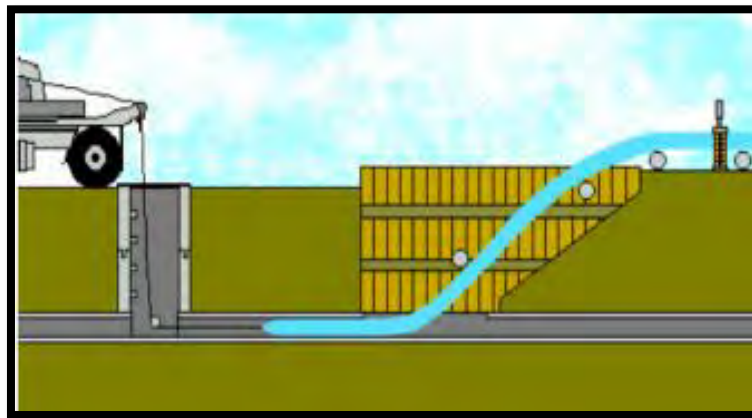

Figure 3: Slip lining

6.1.2 Cured-In-Place-Pipe (CIPP)

- Used for both structural and semi-structural rehabilitation of sewer lines.
- The CIPP liner consists of a tubular felt like material saturated with an epoxy resin that after curing turns into a rigid liner for the pipe.
- Before the process is initiated, pipes must be thoroughly cleaned and dried.

6.1.3 Fold and Form

- Fold & form is a technology for rehabilitation of sewer lines by inserting a folded liner into the existing pipe and expanding it through pressure, heat or mechanical means to restore its original circular shape



- Before the liner is installed, the pipe must be brushed or scraped and cleaned of all debris and build-up, so that the liner can fit tightly against the pipe wall. After the folded liner is pulled into the pipe, it is heated, expanded and reformed to fit against the pipe wall. The installed liner is cooled using circulated air that stiffens the liner.

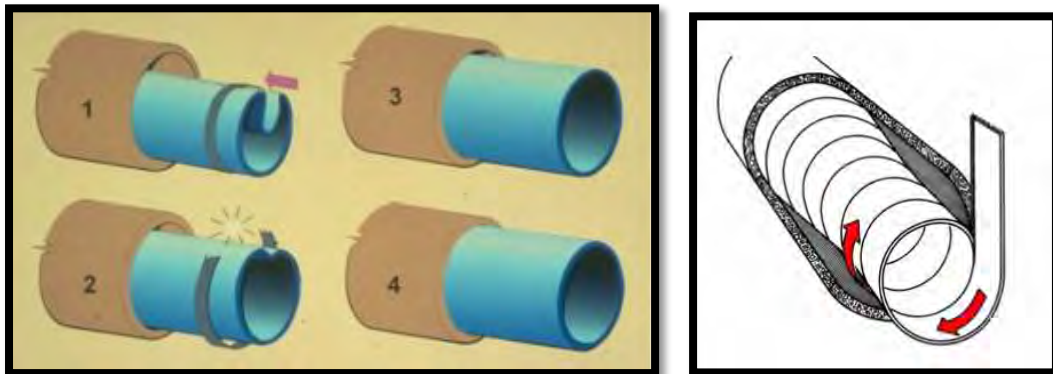

Figure 4: Fold & Form

6.2 Spirally Wound Pipe

- This technique is based on forming a pipe in-situ by using PVC-ribbed profiles with interlocking edges. The ribs enhance the hoop strength of the liner.
- This method is applicable to sewer lines smaller than 30 inches in diameter.
- The process involves the fabrication of the liner in the manhole by helically winding a continuous PVC fabric.
- One option to provide structural strength is to inject grout behind the spirally wound pipe. Another option is to include steel reinforcing in the spirally wound pipe.
- The rehabilitation of sewer lines by this method increases the hydraulic capacity.
- Although the cross-sectional area decreases slightly, the relatively smooth surface of PVC liner reduces the friction to flow and more than offsets the effect of diameter reduction



Figure 5: Spirally wound pipe



6.2.1 On-line Replacement

- On-line replacement is ideally matched to applications with in-situ needs for additional capacity for new development or wet-weather flows, this technology is also a viable alternative for small diameter sewers.
- Structural problems and extensive root infestations may also provide a basis for recommending this renovation technique.
- Principal is crushing or bursting of the host pipe to increase the envelope to receive the larger diameter pipe.
- The ideal sewer for on-line replacement does not have any sewer house connections/taps. Although some on-line replacement technologies can be applied from existing access points such as manholes, the primary launching point for the larger diameter pipe is from an excavation.

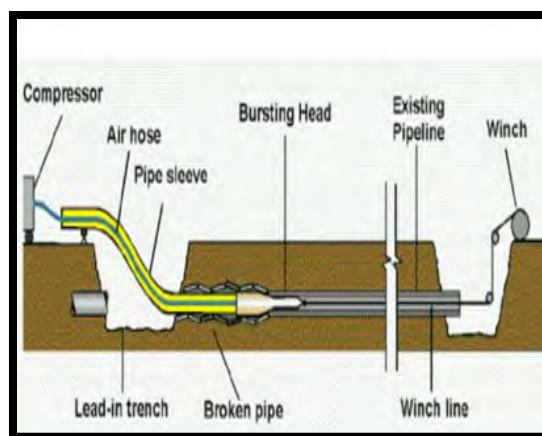

Figure 6 :Online Replacement

6.3 Manhole Rehabilitation

Manhole rehabilitation is done to minimize sewer service downtime, disturbance to the surrounding environment, traffic flow, business and community activities, and avoid a large volume of debris to be disposed of.

The following methods are available for manhole rehabilitation:

- Chemical grouting
- Coating systems
- Structural linings
- Frame, cover & chimney rehabilitation
- Full depth lining
- Partial depth lining
- Install inflow pan



- Elastomeric frame seal
- Frame and cover casting adjustment, including replacement or resetting
- Manhole replacement
- Grouting

Experience shows that 95% of manhole rehabilitation failures are due to weak specifications, improper application, and inexperienced installers. If these three factors are addressed, most manhole rehabilitation projects would be successful

6.3.1 Open Cut Replacement

- If a manhole is severely deteriorated, open cut replacement may become a preferred option
- Open cut may also be utilized if manhole relocation is dictated by hydraulic or access requirements.

6.3.2 Chemical Grouting

- Chemical grouting is used to reduce I/I in manhole structures.
- Since chemical grouts do not add to the structural integrity of manholes, they only should be used when the overall structural integrity of the manhole is sound.
- Grouts give best results in cohesive soils.
- They may be used to fill voids and stabilize soils behind manhole walls.
- Grouts are normally applied under pressure through grout holes drilled into the manhole walls.



Figure 7 : Chemical Grouting

6.3.3 Coating Systems

- Coating systems may be used as a corrosion protection barrier and/or to enhance structural integrity of manhole structures.



- Coatings can be applied by spraying, or hand applied. When using coating system, it is essential that the surfaces be properly cleaned and prepared.
- High pressure water blasting of 2,000 to 5,000 psi may be used to remove loose mortar, grease and oil residues, and prepare the surface to ensure that reliable mechanical bonding occurs when the coating system is applied.
- The key to achieving effective coating systems are proper surface preparation, adequate inspection, and thorough specifications.



Figure 8 Coating

6.4 Spot Repair

- Spot repairs may be used to correct isolated or severe problems in a pipeline segment.
- They are most commonly used to correct individual defects within a pipeline segment, and can be an initial step in the use of other rehabilitation methods.
- Spot repairs are usually limited to the rehabilitation or replacement of only a short portion of the sewer line.

The following techniques are available for spot repairs of short deficient sections of a pipeline which is otherwise in a generally good condition:

- ✓ Open cut repair/replacement
- ✓ CIPP
- ✓ Internal grouting
- ✓ External grouting
- ✓ Rubber Seals with stainless mechanical bands^[3]



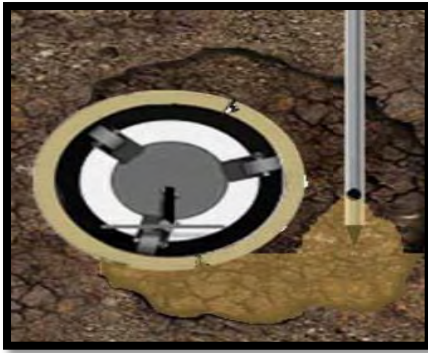

Figure 9: External Grouting

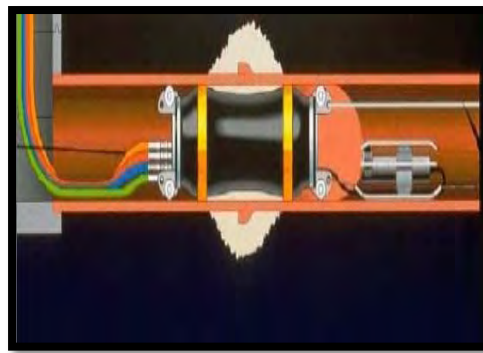

Figure 10: Internal Grouting

7 Case Study

7.1 Concrete Sewer Manhole Repair

Manhole and sewer cover failure is rarely caused by metal failure but rather results from a support or installation failure from the way in which manhole covers, drains, weather, and modern road traffic conditions interplay. Such failures can create serious risk to motorists and the public and need to be addressed. Conventional methods can be expensive, require stopping or detouring traffic during lengthy repairs, and may not always be effective. In this case, Fortress carbon was designed to make three monolithic to resist separation movement and resolve the problem [6]

Water infiltration, where brick tops join poured concrete, due to freeze/thaw and vibration. Standard repair materials failed over time.



Solution:

Fortress carbon was designed to make three monolithic to resist separation movement, thereby increasing life of the polyurethane grout and cementitious coatings.

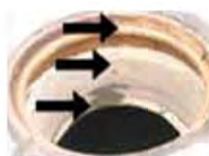

Observations:

Sewer installs performed as designed, increasing the traditional water stop life



8 Glossary

Keyword	Definition
Repair	Restore (something damaged, faulty, or worn) to a good condition
Renovation	To restore to good condition; make new or as if new again
Rehabilitation	Rehabilitation is the act of restoring something to its original state
Grouting	To put a thin line of mortar in the spaces between tiles
CIPP	Cured In place Piping
Detouring	A deviation from a direct course or the usual procedure
PVC	Poly vinyl chloride
Reinstatement	The action of giving someone back a position they have lost

9 References

1. <https://www.wwoa.org/files/publishedpapers/2010/kalahari/Sacha%20TelzoffWWOA%202010%20MH%20presentation%20final.pdf>
2. www.kennedytwp.com/wp-content/uploads/Sewer-OP-Manuel-2012.pdf
3. https://www3.epa.gov/npdes/pubs/sso_solutions_final_report.pdf
4. www.neiwpcc.org/neiwpcc_docs/WEBOM&R.CH7.pdf
5. www.ewra.net/wuj/pdf/WUJ_2014_08_02.pdf
6. <http://www.fortressstabilization.com/cases.php?caseid=3>





Course Code: 3221

**Module 2
Operation and Maintenance of Sewer
System**

**Participant Lecture Notes
Lecture 6**

2016



1 Lecture Information

Lecture Topics: Emergency planning in rainy season	Lecture Duration (Hrs.): 3.0 Mini lecture with brainstorming
Day: Four	Training Delivery Mode: Theory
Lecture Date: TBD	Lecture Timing: 09 am – 04pm

2 Objectives

The objectives of this lecture are to enable the participants understand and learn:

- Existing conditions of emergency planning system for rainy season in WASA
- The mitigation measures and special arrangements adopted to cope with the ponding problem in rainy season
- The draw backs of not having a proper planning system

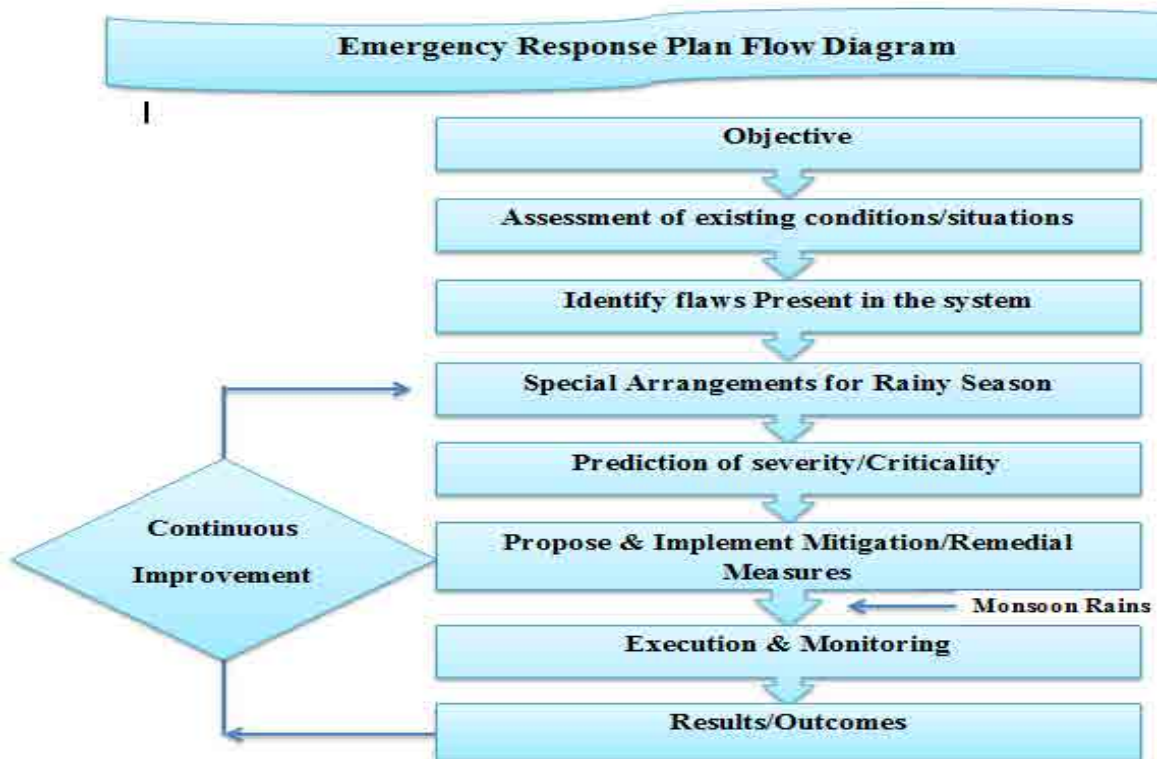

Figure 1 Emergency Response Plan Flowchart



3 Introduction

Monsoon season brings a lot of problems for the inhabitants of urban areas. The current capacity of sewerage and drainage system is unable to take the load of peak rainfalls. Thus temporary ponding occurs in many areas. The problem is further compounded, due to lack of maintenance of sewerage and drainage system. People are habitual of throwing plastic bags and other solid waste into sewers and drains. Thus their capacity is seriously compromised due to this wrong practice. Resultantly, whenever a peak showers comes, in monsoon, many areas are flooded. This creates problems for people, particularly pedestrians, bike-riders and motorists. Water enters into the houses at certain places and result in monetary losses.

By routine cleaning of sewers and drains, the problem of flooding of water in streets and roads in the city could be significantly reduced. In addition, proper and effective planning could also help further minimize it.

4 Special Arrangements for Rainy Season

Following special arrangement may be taken to reduce ponding problems in the cities

- The cleaning and de-silting of sewer lines, lateral sewers and drains should be completed before monsoon season.
- Installation of mobile dewatering sets:
WASA should have mobile diesel driven dewatering sets which should be in working condition with operators, and will be installed in critical locations as and when required.
- Proper and effective CMS should be established
- More complaint centers should be established with essential tools and in low-lying areas of the city in order to cope with any emergency situation during rainy season.
- Number of crews, ready for any kind of emergency, should always be available.
- Every year all stake holders along with WASA should plan an emergency or mitigation plan for monsoon.
- Construction of outlets and small drains will be required at certain points for smooth flow of water during rains. It would end accumulation of water in streets and roads. If the government of Punjab allocates funds in this regard, WASA would certainly work on this project to reduce ponding time during monsoon season. It would certainly relieve the people from nuisance and hardships during heavy rains.
- More disposal pumps should be installed.
- Dewatering plan of ponding areas should be made.



- Replacement and locations of dewatering sets should be done according to the requirements and need.
- Outlived sewer lines should be replaced
- Mobile teams should be made for monsoon season.
- Major low lying areas of the city should be identified where heavy machinery can be deployed for prompt drainage of rain water
- More generators and pumps should be installed at major disposal stations and sensitive lift stations to keep pumping sets at lift stations operational to cope with the problems.
- Double feeder system should be present at every disposal station. In addition, diesel generating sets may also be provided at sensitive disposal station. These may be employed in case of major power breakdowns.
- The alert system should be there to inform the departments concerned two hours before rain and would order them to be ready to cope with any emergency situation.
- Generation capacity of major disposal stations should be enhanced to drain out rainwater shortly

5 Mitigation Measures

Following mitigation measures should be taken to avoid problems:

- The District Government, assisted by the other relevant departments and agencies and even Army, in acute emergency should execute relief measures and rescue operations.
- All drains should be cleaned regularly under the supervision of XENs and SDOs.
- Deployment of Sucker / Jetting Machines
For cleaning of choked sewers due to heavy rain in monsoon, WASA should have jetting & sucker machines, all should be in working condition and available for emergency at any time.
- Performance of staff should be monitored in their areas to ensure prompt redress.
- Disposal pumps should be provided to mobile teams so they can work round the clock in shifts in their respective areas.
- Lahore Waste Management Company and the Town Municipal Administration staff should work alongside WASA in case of an emergency
- Staff should be put on high alert and WASA should utilize all available resources in the rainy season.
- Arrangements should be made to drain rainwater and de-silt sewerage system to flush out the rainwater from the low-lying areas.
- Mobility of machinery and response time should be monitored.



- Emergency Relief camps should be installed in a number of populated and commercial areas and important roads of the city
- Special steps should be taken to deal with the inundation of certain localities in the city.
- Communication/messaging alerts to high ups regarding weather prediction, functioning of disposal station and reporting of stagnation of rainy water as well as coordination with other departments through wireless system especially during monsoon should be there.
- Standard Operating Procedure should be followed for de-silting of drains.

5.1 Standard Operating Procedure (SOP) for De-silting Work [2]

SOPs for de-silting of sewers and drains are presented in Table 1.

Table 1: SOP for De-silting Operation

Action	Description
Attendance of field staff for de-silting operations	Attendance of workers will be done at UC office/ designated place and then workers will move to work areas according to schedule. Android pictures (with date & time) of sanitary workers will also be taken at time of attendance that will verify the number of workers present.
Drain de-silting Work	De-silting work program will be completed according to schedule. Day time (08 am – 04 pm) will strictly be observed.
Record of de-silting work	De-silting work will be done according to schedule and record will be maintained in form of photographs with date and time (before and after work). Hard and soft copy of work done will also be maintained on daily basis.
Removal of de-silted material	The de-silted material will be directly loaded/ stored in garbage bags/specially designed handcarts. De-silted material will be removed regularly during the operations in day shift.



Action	Description
Gully grating	Cleanliness of gully grating along main roads will be done by sanitary workers during routine work of sweeping.
Uniform of sanitary workers	All sanitary workers should wear uniform with safety gadgets.
1134 complaint cell	De-silting related complaints received will be resolve within 2 hours on priority basis
Record of De-silting related complaints	It will be maintained by Planning Section of WASA on daily basis.
Weekly report on de-silting progress	Generated by concerned AMs and shared by Planning Section of WASA.
Public Awareness Campaign	Media and public awareness campaign will be launched, on a large scale, by communication department in coordination with operations department

6 Monitoring System

- All work operation should be properly monitored by higher management of WASA. A proper monitoring system must be established.
- Monitoring Teams supervised by listed officers, along with subordinate officers shall be in place to provide feedback regarding the actual position of the city during rain fall.
- Directors shall once daily check the functionality and operation of disposal / lift stations through their teams.

7 Reporting Mechanism

- Focal Person should be selected
- Central Control Office should be established at Head Office for co-ordination with all Field Complaints Centers and Emergency Control Room
- Immediate and remedial actions on reporting of emergency including power failure, machinery break down etc.
- Action plan and status of disposal stations should be submitted to focal person immediately after rainfall



8 Impacts of Sewage Overflow

Sewage overflows exert physical, chemical and biological effects on the receiving environment. This may result in human health issues, environmental and aesthetic impacts, which can be both acute and cumulative. Such impacts are dependent on the characteristics of the discharge and receiving environment.

8.1 Potential Human Health Impacts

As sewer overflows may contain raw sewage, they can carry pathogens. These include bacteria, viruses, protozoa (parasitic organisms), helminths and inhaled moulds and fungi. The diseases they may cause range in severity from mild gastroenteritis to potentially life-threatening ailments such as cholera, dysentery, infectious hepatitis, and severe gastroenteritis.

Human health impacts can be dependent on the duration of exposure to, and the levels of pollutants in the overflow.

Humans can be exposed to pathogens through:

- Overflows of sewage into drinking water sources
- Direct contact with sewage in public areas such as parks, streets, or to swimming or boating waters
- The consumption of shellfish harvested from areas contaminated by sewage
- Inhalation and skin absorption

8.2 Potential Environmental Impacts

Sewage can contain a range of pollutants. These include: sediment and turbidity; nutrients, particularly nitrogen and phosphorus; toxicants, including metals, pesticides and other chemicals; substances creating a biochemical oxygen demand; and gross pollutants, including plastic and paper products.

Pollutant	Potential impacts include
Suspended solids	Deposited sediment affects aquatic insect habitats
Turbidity	Reduces water clarity, resulting in impact on fish and aquatic plants
Phosphorus and nitrogen	Stimulates growth of algae and undesirable aquatic plants, micro-organisms, and invertebrates (e.g., mosquitoes)



Pollutant	Potential impacts include
Ammonia, metals and pesticides	Toxic to fish and aquatic insects at high levels
Organic matter/Biochemical oxygen demand	Reduces dissolved oxygen levels, affecting fish, oxygen demand insects, and micro-organisms productivity
Gross pollutants/litter	Visual intrusion

8.3 Potential Aesthetic Impact

Sewage overflows can cause unpleasant sights, even if human health and environmental impacts are successfully managed. They can be perceived as offensive, and undermine the confidence of the community in the effectiveness of sewerage authorities [1].

9 Alarm Systems

Alarm systems with a backup power source shall be provided for pumping stations. The alarm shall be activated in cases of power failure, dry well sump and wet well high water levels, pump failure, unauthorized entry, or any other cause of pump station malfunction. Pumping station alarms including identification of the alarm condition shall be transmitted to a municipal facility that is staffed 24 hours a day. If such a facility is not available and a 24-hour holding capacity is not provided, the alarm shall be transmitted to municipal offices during normal working hours and to the home of the responsible person(s) in charge of the lift station during off-duty hours. Audio-visual alarm systems may be acceptable in some cases in lieu of a transmitting system depending upon location, station holding capacity and inspection frequency.

10 Emergency Operation

10.1 Objective

The objective of emergency operation is to prevent the discharge of raw wastewater to any waters and to protect public health by preventing back-up of wastewater and subsequent discharge to basements, streets, and other public and private property.



10.2 Emergency Pumping Capability

Emergency pumping capability is required unless on-system overflow prevention is provided by adequate storage capacity. Emergency pumping capability shall be accomplished by connection of the station to at least two independent utility substations, or by provision of portable or in-place internal combustion engine equipment which will generate electrical or mechanical energy, or by the provision of portable pumping equipment. Such emergency standby systems shall have sufficient capacity to start up and maintain the total rated running capacity of the station. Regardless of the type of emergency standby system provided, a portable pump connection to the force main with rapid connection capabilities and appropriate valving shall be provided outside the dry well and wet well.

10.3 Emergency High Level Overflows

For use during possible periods of extensive power outages, mandatory power reductions, or uncontrollable emergency conditions, consideration should be given to providing a controlled, high-level wet well overflow. It will prevent backup of wastewater into basements, or other discharges which may cause severe adverse impacts on public interests, including public health and property damage.

Where a high level overflow is utilized, consideration shall also be given to the installation of storage/detention tanks, or basins, which shall be made to drain to the station wet well. Where such overflows affect public water supplies or other critical water uses, the regulatory agency shall be contacted for the necessary treatment or storage requirements.

11 Glossary:

Keyword	Definition
mitigation measures	the act of lessening the force or intensity of something unpleasant, in extreme circumstances
Dewatering	Dewatering is the removal of water from solid material
CMS	Compliant monitoring system
Crew	A crew is a body or a class of people who work at a common activity
Gully	A narrow, steep-sided channel formed in loose earth by running water



Keyword	Definition
Turbidity	Turbidity is the cloudiness or haziness of a fluid caused by large numbers of individual particles that are generally invisible to the naked eye, similar to smoke in air.

12 References

1. <https://www.environment.gov.au/.../sewerage-systems-overflows-paper15.pdf>
2. <http://www.lwmc.com.pk/uploads/UC%20Plans/Desilting%20Plan%20-26%20March%202015%20Final.pdf>





ALJAZARI
— ACADEMY —

Course Code: 3221

**Operation and Maintenance of Storm Water
Drainage System**

Module 3

Participant Lecture Notes

**Need for Operation and Maintenance of Drains
Lecture 1**

2016



1 Lecture Information

Topics:	Objectives of operation and maintenance of storm water drains	Lecture duration (hrs.): 1.0 • Group discussion (hrs.) : 1.0
Lecture:	Need for operation and maintenance of drain	Training delivery mode: Theory
Lecture date:	2 nd November, 2016	Lecture timing: 09 am – 10am

2 Objectives

The objectives of the lecture are presented as under:

- Why it becomes necessary to conduct the operation and maintenance works related to storm water drainage system
- Critical issues regarding sediment deposition

3 Need for Operation and Maintenance of Drains

Sewer system receives no treatment before sewage travels through a series of canals to the nearest waterway. This means that whatever enters the storm inlets on the side of roads during rain events or from illegal dumping, is that ends up directly in the nearest canal, river, or other watershed.

The area required to be maintained as right of way for the drains is increasingly being utilized for water pipe lines, electric cables, telecommunication cables etc. The drains are **increasingly being used** for sewage and industrial effluent discharge, especially from unauthorized colonies where an adequate sewer conveyance system is not in place.[1]

The Storm water drainage system comprises of drains that collect the sewage and industrial wastewater of the entire city and its surrounding towns. These drains join together and dispose the collected sewage and industrial wastewater into the River through various pumping and disposal stations. The quantity of wastewater in these drains is subject to seasonal variation and mostly depends upon the weather conditions.

Sediment entered from urban and pre-urban areas, often gets deposited in storm water drains. This constitutes a major factor to the poor performance of urban drainage systems [2]. Most of the WASA drains are **encroached** and disposal of solid waste from the surrounding human



settlements is a common practice. This further reduces their carrying capacity. In routine, the maintenance of the storm drains does not fall in the priority. It only catches attention, when there is serious damage to the drain. Lack of awareness of the people that solid waste is not meant to be dumped in drains is a major issue that needs to be addressed, if these drains are to meet their intended purposes.

The common issues which are seriously undermining storm water drains are listed as under. [1]

1. Encroachment around drains
2. Silting of drains
3. Unpleasant odor of dirty water flowing in the drains
4. Choking of drains due to disposal of debris and garbage
5. Stability of drainage cross-sections
6. Damaged old lining of the drains
7. Free access to storm drains, from nearby habitation
8. Inadequate attention to desilting of WASA drains
9. Clearance of excess floral growth on the drains
10. Unplanned laying of service pipes along the drains by other departments and agencies
11. Absence of comprehensive data on storm-water drainage network

Lack of in-time O & M along with administrative and professional commitment to combat the above stated issues have resulted in non-efficient storm water drainage system. [1]



Figure 1: Encroachment around Drains

4 Critical Issues Regarding Sediment Deposition

1. When the sediment deposition continues for a long time without desilting, the channels get choked. This reduces their carrying capacity. The result is **flooding of various degrees** of magnitude.



2. It **encourages prolific weed growth** in it when soil moisture conditions are favorable. The vegetation increases the roughness factor in the channel, decreases the effective flow area of the channel, hence, reducing the ability of the channel to carry designed storm water.
3. When the sediments are concentrated at sections (e.g. entrance to culverts) and acute curves or sharp 90° turns, **ponding of water** often occurs upstream.
4. Silted roadside drains may create ponding on roads because of their **inability to contain the large quantities of water** flowing into them. When this happens **vehicular traffic is impeded** too.
5. Some **localized floods** are caused by heavily silted channels whose carrying capacities have been drastically reduced.

5 Critical Issues in Buried or Covered Storm Drains

In the case of buried or completely covered storm channels:

- The deposited sediment has the ability to act as a **pollutant store** or generator. These pollutants are usually flushed out under flood flow conditions, and often cause **foul conditions at the outfall points**.
- **Biochemical changes** in the bed of sediment can result in **septic conditions**, releasing **gases** that can be **highly corrosive** to the channel's material of construction.[2]

Knowing that silting will occur in underground channels after their construction, it is always recommended by drainage engineers to undertake regular maintenance activities such as desilting & dredging, etc., in the channels. Experience has however shown that this is easier said than done. Lack of regular maintenance during the previous years has caused the accumulation of the sediment and garbage in WASA drain. Extensive, regular sediment removal from covered drains is a difficult and expensive process [2].

6 Summary

The proper maintenance of storm water drainage systems (covered & uncovered) is essential in order to ensure that the systems are functioning to their designed capacity. This will include **routine inspection** of the systems, and carrying out necessary cleansing, repair and desilting works. WASA should devise **maintenance procedures** including:

- Frequency of inspection
- Programme for cleansing
- Desilting
- Necessary repair works
- Documentation for maintenance records and reporting



Routine inspection and preventive maintenance are the best ways to prevent:

- Excessive silting
- Blockages
- Deterioration of storm water drainage systems

Hence by employing maintenance, risk of flooding is minimized. [3]

7 Glossary

Key Word	Definition
Sediment	Naturally occurring material that is broken down by processes of weathering i.e. grit, silt, stone, pebbles, fruit peel off etc.
Encroachment	Temporary or permanent construction/obstruction along both sides of drain beyond acceptable limits
Biochemical Changes	Changes in the biological (living or dead) substances and their transformation to different forms.
Roughness Factor	Resistance to flow of a surface such as the bed or bank of a stream
Septic Conditions	Anaerobic bacterial environment that develops in the drain which decomposes or mineralizes the waste discharged

8 References

1. <http://www.watertoday.org/Article%20Archieve/Tata%202020.pdf>
2. <http://ir.knust.edu.gh/bitstream/123456789/1350/1/Minimizing%20Sediment%20Deposition%20in%20Urban%20Drainage.pdf>
3. <http://www.devb.gov.hk/filemanager/technicalcirculars/en/upload/64/1/c-2004-14-2004.pdf>





ALJAZARI
— ACADEMY —

Course Code: 3221

**Operation and Maintenance of Storm
Water Drainage System**

Module 3

Participant Lecture Notes

**Tools and Equipments for Drain Cleaning
Operations**

Lecture 2

2016



1 Lecture Information

Topics:	Objectives of operation and maintenance of storm water drains	Lecture duration (hrs.): 1.5 <ul style="list-style-type: none"> • Classroom Briefing (hrs.) : 0.5 • OJT (hrs.): 1.0
Lecture:	Tools and equipment for drain cleaning operations	Training delivery mode: OJT
Lecture date:	2 nd November, 2016	Lecture timing: 09 am – 10am

2 Objectives

The objectives of this lecture are:

- Introduction of participants with the fundamentals of tools and equipment for drain cleaning operations
- Know about selection criteria and working of machines
- Introduce them to a variety of the dredging machinery

3 Hydraulic Excavator

Excavators are heavy equipment consisting of a boom, dipper (or stick), bucket and cab on a rotating platform known as the "house" (Figure 1). The house sits atop an undercarriage with tracks or wheels. All movement and functions of a hydraulic excavator are accomplished through the use of hydraulic fluid, with hydraulic cylinders and hydraulic motors.





Figure 1: Excavator

3.1 Working

This commonly used piece of equipment is a discontinuous excavator, where excavation takes place using single buckets in consecutive cycles. The full bucket is brought to the surface and emptied into a truck or barge, or placed on the bank.

The under-water surface is excavated in a circular pattern, where the bucket is lifted by the excavator when it reaches a certain depth. The next circle will be started once one circular section has been completed, and this process will continue until the whole drain has been excavated. The excavator will then be moved, thus allowing another zone to be excavated or dredged.

3.2 Precaution

The bucket must be carefully positioned after each cycle so it is not easy to perform two consecutive excavation cycles under water without an accurate and reliable system for determining the excavation position.

Water Depth and Working Area

There are two ways of implementing excavator:

- Work carried out from the water's edge,
- Work carried out from a pontoon featuring anchors or spud poles.

The eventual choice will be determined by project-specific circumstances. Depending on the selected method and the size of the excavator, it is possible to achieve water depths up to **10 m** or more. Material above the waterline can also be excavated if the location is accessible to the excavation bucket and the means of transport.



3.3 Excavation Buckets

3.3.1 Digging Bucket

- Excavates materials using a pulling movement
- It is often implemented to remove thin layers of silt



Figure 2: Digging Bucket

3.3.2 Dredging Bucket

- Slightly different from standard buckets
- Characterized by holes that retain silt while allowing water to escape



Figure 3: Dredging Bucket

3.3.3 Visor Bucket

The visor bucket (Figure 4) is a traditional excavation bucket featuring a revolving valve (visor), which can be used to close the top of the bucket. The visor is closed once the bucket is



full, so dredged materials are enclosed in the bucket while being raised to the surface. This avoids or drastically minimizes dredged material mixing with the water column.

- This bucket can be used to excavate thin and very dense layers with low water content.
- Layer thickness of around 0.5 m is needed in order to collect enough material.



Figure 4: Visor Bucket

3.3.4 Clamshell

- A clamshell or “**grab bucket**” operates using a gripping movement (Figure 5).
- Used to excavate thick layers of silt and for transferring materials.
- A traditional clamshell is open at the top, which means excavated materials are exposed to the water column when it is being raised to the surface.
- The top of closed clamshells can be sealed off, so exposure between excavated materials and the water column is avoided when it is being raised to the surface.
- Excavation cannot be done with a high level of accuracy due to the circular closing movement of both clam sections. It is thus difficult to achieve a horizontal surface using this piece of equipment.
- Layer thickness must be at least 0.5 m in order to achieve reasonable productivity.



Figure 5: Clamshell



Environmental Grab Bucket

- An alternative type of grab bucket
- Enables an almost horizontal closing movement
- The maximum opening is circa 80% larger than a traditional grab bucket
- Relatively thin layers can also be excavated efficiently

3.4 Variations

A wide range of variations have been developed for hydraulic excavators over the years due to:

- Height restrictions
- Propulsion issues
- Insufficient access to the water bottom

The following variations can be encountered:

3.4.1 Excavator Boat

On excavator boats, an excavator arm has been mounted directly to the pontoon and the power source and cabin have been incorporated into the pontoon (Figure 6). Such excavator pontoons normally feature 3 or 4 supporting legs, which can be used to stabilize the machine while work is being carried out. Because they feature their own means of propulsion, excavator boats are generally very flexible and help to reduce mobilization time and costs.



Figure 6: Excavator Boat



3.4.2 Amphibious Excavators

These modified excavators have had their standard caterpillar track replaced by a floating caterpillar track system, which allows the machine to also operate in **wet** and **swampy areas** (Figure 7). The arms of standard excavators need to be extended in order to work beyond the dimensions of large caterpillar pontoons.

Such a machine fitted with side pontoons with spud poles, it is possible to work in water up to **5 meters deep**.



Figure 7: Amphibious Excavator

3.4.3 Tractor with Side-Arm

This is a 2-part hydraulic arm that has been assembled to a tractor, and is used to clean drains using a mowing bucket or a dredging pump (Figure 8).



Figure 8: Tractor with Side-Arm



3.5 Selection Criteria

3.5.1 Suitability of Technique

When used as a mechanical digger during maintenance-related dredging, hydraulic excavators can be very useful. In principle, the presence of pollutants is not a significant factor for hydraulic excavators. However, if silt is polluted, then it would be wise to use a **closed excavation bucket** to reduce opacification and the spread of pollutants.

Presence of gross solids:

Hydraulic excavators only experience minor problems if they encounter gross solids.

3.5.2 Environmental Effects

Opacification

When using traditional excavation buckets, opacification may be encountered as buckets are being raised to the surface. This can be **limited by using closed buckets**. However, the level of care taken by the excavator operator has a major impact, and also directly influences productivity.

Spillage

The **visor bucket** and **environmental grab bucket** help to minimize spillage during normal operations. Once again, spillage can also be reduced if work is carried out carefully (Figure 9).



Figure 9: Spillage Loss

Damage to Banks

- In the presence of **high vegetation** (bushes, trees, forests, etc.), vegetation must be fully removed from at least one of the banks. This will often be unacceptable from an environmental perspective.
- In case of **low vegetation** (grass, reeds, etc.), damage can sometimes be limited by using extra-wide caterpillar tracks or driving plates.



- When using **excavators on a pontoon** together with a transport ship/barge, damage to the banks can be restricted to one or only a few zones.



Figure 10: Damage to the Bank

4 Silt Push Boats

A silt push boat or silt pusher is like a floating bulldozer, which has been developed especially for cleaning ponds, lakes and small waterways. The machine is primarily used in situations where it is difficult to work from the drain's bank.



Figure 11: Silt Pusher

4.1 Working

Silt pushers are characterized by an adjustable dozer blade, which can be set to a pre-set working depth. The dozer blades can be adjusted to the required depth and width. The silt pushers pull itself using a winch system and uses the dozer blade to push silt towards a collection point. This often involves an excavator being placed at a strategic location on the bank or pontoon, and using it to transfer silt from the water into the means of transport.



4.2 Selection Criteria

4.2.1 Range of Applications

- Primarily suitable for soft water bottoms (silt, clay, sludge etc.)
- Effective on relatively long, straight waterways. This allows the winch cables to be anchored far away, whereby time needed for set-up is reduced.
- Extremely effective when dredging thin layers of materials and silt, spread across a large surface area
- It can also be used for thicker layers
- Only effective in relatively shallow waters
- Depending on the dimensions of the machine, it is possible to work in **depths** of up to **2 m**. Special modifications need to be made when working in depths up to 3 m.
- Machine becomes unsuitable when depths exceed 3 m.

Pollution Level and Susceptibility

- In principle, the level of pollution **does not have an impact** on silt pushers
- For instance, even **large pollutants** like bricks, bikes, shopping trolleys, etc. **do not restrict** the **workings** and efficiency of silt pushers

4.2.2 Environmental Effects

Opacification

- Due to the **high level of opacification**, the machine is **less effective** when dredging highly polluted water bottoms, unless specific measures have been taken to limit dispersion.
- Dispersion of opacification can be restricted by using **floating screens**. However, they are unnecessary in most cases.

Accuracy

Silt pushers allow a vertical accuracy of 0.1 m to be realized

Spillage

- In principle, there is **no spillage** because scraped materials are pushed forwards.
- If **too much material builds up** in front of the dozer blade, or if the boat is pulled over excessive distances, there will be loss via the sides, which will subsequently cause spillage.
- This can be **limited** by working in short distances and by overlapping dredged areas.



Damage to Banks

Damage to the banks can be reduced significantly because hydraulic excavators are mostly used to transfer materials, damage will be limited to transfer points that are located every **100 to 200 meters**. Therefore, **collection points** must primarily be chosen at the least valuable locations along the bank.

5 Cutter Suction Dredger

A cutter suction dredger is a dredging machine that is used in continuous excavation processes and is positioned using spud poles or winch cables.

5.1 Working

The cutter revolves around a pivot, which could be a spud pole or another anchor point. In dredgers with swivel ladders, which are often used for small-scale dredging activities, the only thing that moves back and forth (from side to side) is the construction (ladder) to which the cutter has been mounted. Once the swivel movement has been completed, the suction device shifts further using the spud pole or winch cables, after which a new cycle is started.

The cutter features a suction opening that has been connected to a dredging pump. The cutter cuts away the soil and mixes it with water. The mixture is then pumped to a (drainage) depot or processing installation via a discharge pipe. A large amount of water is needed to pump the mix. For organic silt, the best mix ratio is 1:3; for sand, the ideal mix ratio is 6 parts water for 1 part sand.



Figure 12: Cutter Suction Dredger



5.2 Selection Criteria

5.2.1 Range of Applications

- Generally only suitable for silt, clay and sand.
- Depending on the dredger design, be used up to **6 m deep**.
- The soil type and project conditions must be known for each project, so the most appropriate type of cutter can be selected.
- For **harder bottoms** (i.e. sand), a cutter with larger cutting sections must be selected in order to penetrate the layer of sand.
- When doing so, it must be kept in mind that there is more wear and tear on the cutter and in transport pipes.
- Wear and tear is a less significant factor in cohesive clay bottoms, but the **clay could block** the cutter or balls of clay could be formed during hydraulic transport, which means extra pumping capacity will be needed.



Figure 13: Cutters for Sand and Silt

Pollution Level and Susceptibility

Cutter suction dredgers are not vulnerable to chemical/organic pollutants, but are vulnerable to gross solids and larger objects that could block the cutter and the pipes. Therefore, if possible, it would be wise to remove all gross solids from the waterway before dredging activities are started.

5.2.2 Environmental Effects

Opacification

- The revolving movement of the cutter will cause fairly intensive dispersion of extracted particles in the area around the cutter, and will also result in opacification.
- But this **effect** can also be **managed** by effectively adjusting the speed.



Spillage

- Although the suction mouth is located inside the cutter, **some spillage** can be **expected** because the silt is partly dispersed due to the revolving movement of the cutter.
- If the cutter rotates too fast, there will be more spillage.
- The layer which is formed by settled spillage can be limited by careful operation. Often a clean-up run is carried out.

Damage to Banks

- Cutter suction dredgers will **not damage banks** because the dredging process takes place on the water.
- At places where anchors have been placed on the banks and where floating pipelines cross over from water to land (limited) damage may occur.

Accuracy

Cutter suction dredgers permit a very **high degree** of accuracy.

6 Dredge Pump

Dredge pumps are used to suck dredging materials from the water bottom. The pump's suction opening, which is sometimes extended using a suction pipe, is guided through the center of ditches to maximize contact with dredged materials.

However, dredge pumps can be mounted to a tractor or crane, or can also be placed on a boat. The production capacity of a dredging pump is determined by the dimensions of the pump and the capacity of the carrying vehicle.



Figure 14: Dredge Pump on Mowing Boat



6.1 Selection Criteria

6.1.1 Range of Applications

- Only suitable for soft water bottoms (silt, turf, etc.) because silt is attracted automatically.
- This technique is primarily suited to waterways with non-polluted silt, whereby extracted dredged materials can be sprayed directly on to adjoining land.
- Dredge pumps allow activities to be performed at depths of up to circa **2 meters**.
- In the same way as a cutter suction dredger, a cutter can also be attached for dredging more solid water bottoms.

Pollution Level and Susceptibility

- Many dredge pumps feature a blade at the opening of the pump, which chops up plants, reed and small branches which are sucked into the pump intake.
- Dredge pumps are susceptible to stones and branches, which could block the opening.
- Due to the large amounts of waste that can be expected in waterways, dredge pumps are less suited to dredging activities in urban settings.

6.1.2 Environmental Effects

Accuracy

- Dredging pumps allow a vertical accuracy of 0.1 m to be realized.
- When dredging pumps are used to clean waterways, some sludge often has to be left behind for ecological purposes.
- This approach does not disturb the banks because only the center of the waterway is cleaned.

Opacification

This approach results in **very little** opacification.

Spillage

Spillage is **not encountered** when dredging pumps are used.

Damage to Bank

The dredging pump only has to be moved in the deepest part of the ditch. This means the banks of waterways do not have to be disturbed.



7 Glossary

Key Word	Definition
Water Column	Conceptual column of water from the surface of a storm water drain to the bottom sediments
Propulsion	A means of creating force leading to movement
Pontoon	Flotation device with buoyancy sufficient to float itself as well as a heavy load
Swampy area	A lowland region saturated with water
Spillage	An occurrence in which something is spilled accidentally
Susceptibility	The state or fact of being likely or liable to be influenced or harmed by a particular thing
Gross Solids	Gross solids are trash, litter, debris, and coarse sediments that are conveyed by storm water runoff or otherwise captured by storm water systems

8 References

1. http://www.mastenbroek.com/assets/downloads/Small_Scale_Dredging-an_introduction.pdf
2. <https://en.wikipedia.org/wiki/Excavator>





ALJAZARI
— ACADEMY —

Course Code: 3221

**Operation and Maintenance of Storm
Water Drainage System**

Module 3

Participant Lecture Notes

**Planning for Sludge Disposal
Lecture 3**

2016



1 Lecture Information

Topics:	Sludge handling and its disposal	Lecture duration (hrs.): 0.5 • Classroom Briefing (hrs.) : 0.5
Lecture:	Planning for sludge disposal	Training delivery mode: OJT
Lecture date:	2 nd November, 2016	Lecture timing: 10 am – 11 am

2 Objectives

The objectives of this lecture are:

- Capacity building of participants on fundamentals of planning for waste disposal
- Selection of a safe site for sewage disposal

3 Site Selection

Site selection, for sludge resulting during cleaning of storm drains, is a difficult and complex process. It requires evaluation of the proposed site on different criteria such as social, environmental and economic. The location must comply with the requirements of governmental regulations and must minimize economic, environmental and social costs. Therefore, available information should be efficiently used to ensure an acceptable outcome by most stakeholders.

Following considerations must be evaluated, for disposal site selection, to ensure that the facility meets the disposal needs:

- **Size** (land area): depends on the waste quantity arriving at the disposal site in the foreseeable future. That sufficient buffer zones are available to avoid any environmental objection from surrounding settlements.
- **Strategic location of the proposed site:** is determined by the waste generation areas to be served and transport routes.

It is economically sound practice to establish the proposed facility as close to the generation areas as possible, with a view to minimizing transport costs.



It is necessary to consider the following requirements for site:

- Spatial and urban planning requirements
- Spatial and regional requirements
- Required land area
- Transportation distances
- Local site conditions
- Topography
- Climate conditions
- Hydrogeological conditions
- Geological conditions
- Environmental protection

Various steps involved, in screening process, for the selection of sludge disposal sites are shown in the form of a flow diagram in Figure 1.



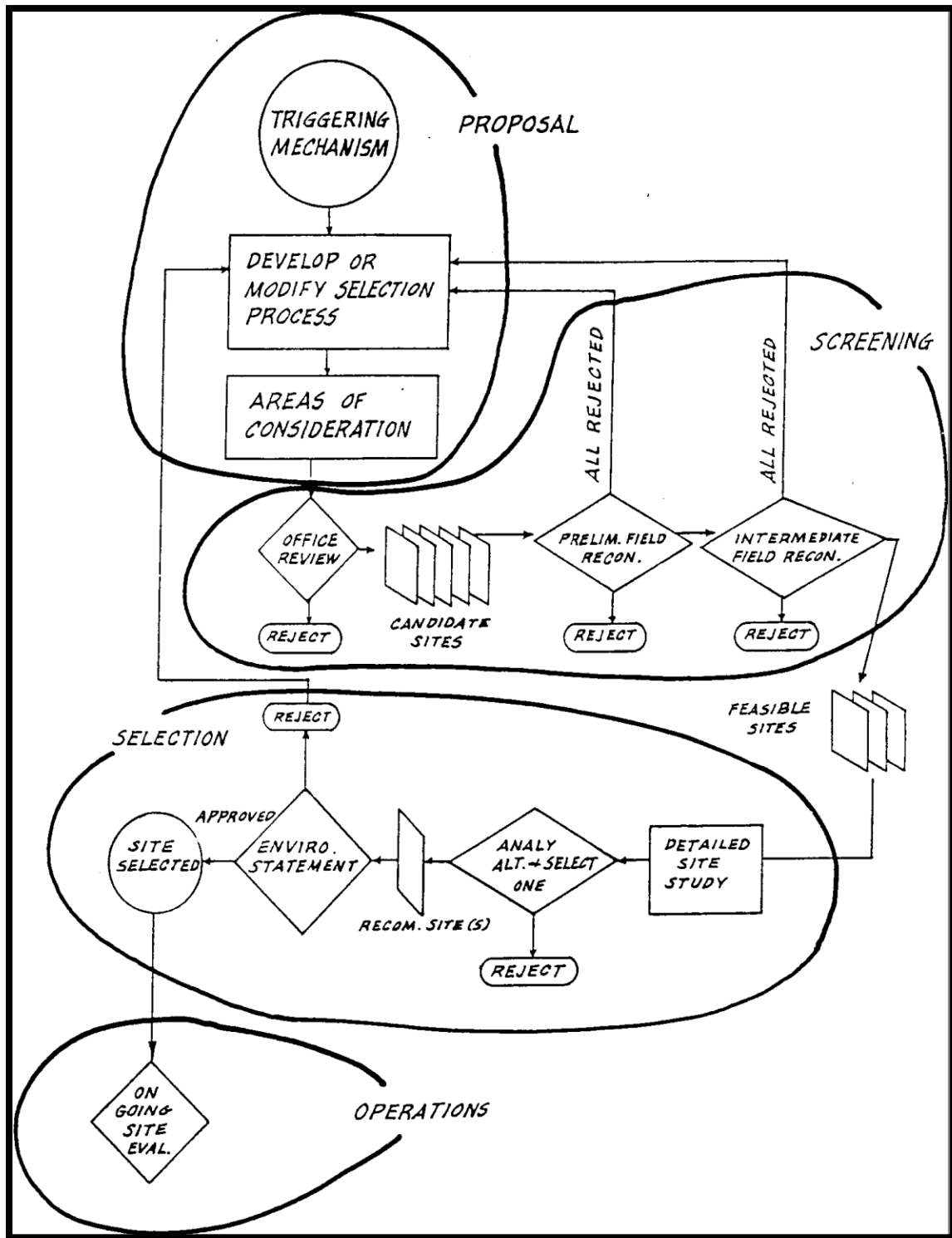

Figure 1: Flow of screening process for site selection (U.S. EPA, 1985)



3.1 Selection Criteria

The criteria used, for the selection of surface disposal site, is exhibited in Box-1

Physical Site:	Should be large enough to accommodate waste for life of production facility.
Proximity:	Locate as close as possible to production facility to minimize handling and reduce transport cost. Locate away from water supply (suggested minimum 1 km) and property line (suggested minimum 250 m).
Access:	Should be all-weather, have adequate width and load capacity, with minimum traffic congestion. Easy access to major highways and railway transport.
Topography:	Should minimize earth-moving, take advantage of natural conditions. Avoid natural depression and valleys where water contamination is likely unless good control of surface water can be assured (suggested site slope of less than 5%).
Geology:	Avoid areas with earthquakes, slides, faults, underlying mines, sinkholes and solution cavities.
Hydrology:	Areas with low rainfall and high evapotranspiration and not affected by tidal water movements and seasonal high water table.
Soils:	Should have a natural clay base, or clay available for liner, and final cover material available; stable soil/rock structure. Avoid sites with thin soil above groundwater, highly permeable soil above shallow groundwater and soils with extreme erosion potential.
Drainage:	Areas with good surface drainage and easy control of runoff.
Surface Water:	Protection of the site against floods. Avoid wetlands or other areas with high watertables.
Groundwater:	No contact with groundwater. Base of fill must be above high groundwater table. Avoid sites above sole-source aquifers and areas of groundwater recharge.
Temperature:	Not within area of recurring temperature inversions.

Box-1: Surface Disposal Site Selection Criteria



Some of the exclusion criteria can be classified into a group of the following indicators:

- Distance from natural elements of space (watercourses, water sources, protected natural resources, etc.)
- Distance from anthropogenic elements of space (infrastructure facilities, settlements, protected cultural structures, etc.)
- Terrain morphology
- Hydrological and geological characteristics of space
- Recommendations of local authorities in the form of inter-municipal corporation agreements, etc.

Site evaluation criteria are mainly classified into several basic groups. Commonly, there are three basic groups of criteria whose definition varies from author to author:

- Ecological or environmental criteria,
- Socio-economic or social or spatial criteria,
- Technical and operational criteria (which usually also involve certain economic, spatial and ecological criteria).

Any variation of groups of basic indicators is possible. Regardless of the formulation of basic groups of criteria, they include approximately either the same or almost the same number of indicators and criteria that are analyzed and compared in the process of selection of the most suitable site.

4 Sludge Disposal Planning

4.1 Collection of Sludge

Sludge is dredged from the drain by using excavator as shown in the figure 2.



Figure 2: Collection of Sludge



4.2 Loading

Once the sludge is dredged it is loaded into dump trucks as shown in the figure 3.

4.3 Transportation

After loading in the trucks sludge is transported to near dumping site for final disposal.

4.4 Off-Loading

At disposal site, sludge is dumped there and covered by the soil cover.

Precautions:

- While transporting sludge, the waste should not litter off.
- Sludge should be properly covered.

5 Glossary

Key Word	Definition
Social Factor	Things that affect lifestyle, such as religion, family or wealth
Economic Factor	Relate to changes such as costs and prices of services, interest rates, wage rates, machine and T & P costs etc.
Environmental Factor	Any factor, abiotic or biotic, that influences living organisms
Strategic Location	It is determined by the waste generation areas to be served and transport routes.
Hydrogeology	Area of geology that deals with the distribution and movement of groundwater in the soil and rocks of the Earth's crust
Spatial	Relating to size, shape and positions of the topographical features
Regional	relating to or characteristic of a region
Topography	Map of the surface features of land. It includes the mountains, hills, creeks, and other bumps and lumps on a particular area of earth



6 References

1. nepis.epa.gov/Exe/zypurl.cgi?dockey=30004oig.txt
2. Solid Waste Management Manual





Course Code: 3221

**Operation and Maintenance of Storm water
Drainage System**

Module 3

Participant Lecture Notes

**Disposal Techniques
Lecture 4**

2016



1 Lecture Information

Topics: Sludge handling and its disposal	Lecture duration (hrs.): 3.0 • OJT (hrs.) : 3.0
Lecture : Disposal techniques	Training delivery mode: OJT
Lecture date: 2 nd November, 2016	Lecture timing: 10 am – 11 am

2 Objectives

The objectives of this lecture are:

- Learn about control dumping methodology
- Impart knowledge about sanitary landfill methodology

3 Disposal Techniques

Various techniques, for the disposal of sludge, are mentioned in the following sections:

3.1 Controlled Dumping

Since engineered sanitary landfill sites are hardly available in Pakistan, an acceptable alternative is a controlled dumpsite.

- ✓ The controlled dumpsite is essential burial of waste in earth on a daily basis, in an isolated and demarcated site, away from the population. However, dumpsite must be prepared before it starts receiving the sludge.
- ✓ An established system for rotational and organized deposit of waste
- ✓ Some engineering works, to prepare the site to retain its waste more effectively
- ✓ Rapid burial of the waste to minimize its chances of contact with humans and animals
- ✓ After each waste load, the waste should be covered with a soil layer 10-15cm thick. If soil cover is not possible, lime may be deposited over the waste
- ✓ Access to these dedicated disposal areas should be restricted, for the purpose of public safety
- ✓ It would require supervision by staff to prevent scavenging activity at the site



3.2 Sanitary Landfill

Sanitary landfills are well-engineered facilities that are located, designed, operated, and monitored to ensure compliance with environmental regulations. Solid waste landfills must be designed to protect the environment from contaminants which may be present in the waste stream.

Sanitary Landfills are designed to greatly reduce or eliminate the risks that waste disposal may pose to the public health and environmental quality. They are usually placed in areas where land features act as natural buffers between the landfill and the environment (Figure 1 and 2).



Figure 1: Gujjar Colony Waste Disposal Ditch



Figure 2: Mahmood Booti Dumping Site

3.2.1 Methodology

Landfills are dug lands, where liners are spread as a base. Preferably, this base would be a clay soil. Clays have physical properties which inhibit the movement of water. This is useful in a landfill, as the water percolating through the waste can carry contaminants into groundwater supplies. Geo-membrane (impermeable membrane liner) is placed on top of the bedrock. This protection is also used to limit the flow of leachate out of the landfill. A layer of sand or gravel and a leachate collection system (network of pipes that pump leachate out of the landfill) are laid above the impermeable layer. Groundwater monitoring wells and methane gas monitoring equipment are inserted into the landfill before waste is added. Water samples are taken, while the site is empty, as a benchmark of groundwater quality; future samples are compared with initial sample.

Waste is dumped daily in the form of a cell. Each cell is compacted to reduce volume and a daily clay cover is spread onto it. Compaction is done using heavy equipment, such as packer tractor. Daily cover keeps odors, pests and contamination to a minimum. When landfill is filled to its full capacity, a top cover is placed above the last rows of cells to seal the site. The site



can be reclaimed using horticulture techniques. Gas and leachate are the two major problems landfills generate. Landfill gas is roughly 50% carbon dioxide and 50% methane. It is the methane that poses the greatest danger; the gas becomes explosive when mixed with oxygen. Without proper control, methane can seep into pipes and buildings. Homes built near old, improperly constructed landfills have been known to have exploded due to methane leaks.

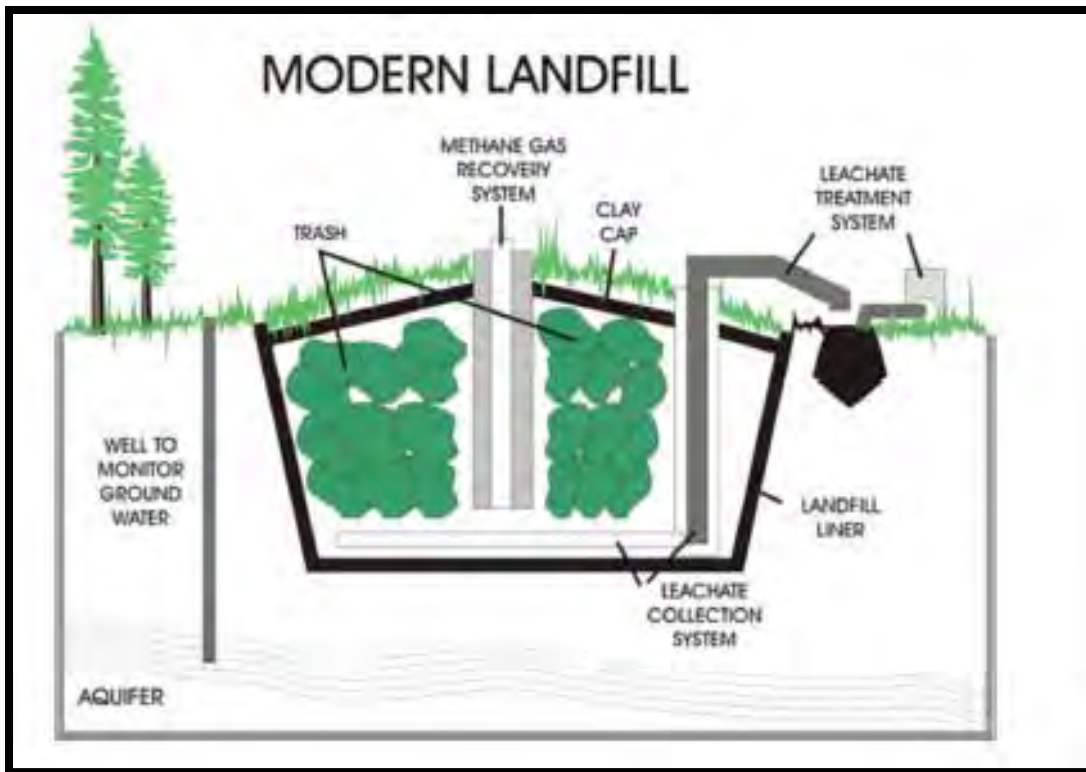

Figure 3: Layout of Sanitary Landfill

3.2.2 Disposal at a Municipal Solid Waste Landfill

Sludge can be disposed with household waste (solid waste) at an MSW landfill. There are two basic types of disposal methods:

- Sludge/solid waste mixture
- Sludge/soil mixture

Sludge/Solid Waste Mixture

In a sludge/solid waste mixture operation, sludge is deposited atop solid waste at the working face of the landfill and mixed as thoroughly as possible with the solid waste. The mixture is then spread, compacted, and covered in the usual manner used at MSW landfills.

Sewage sludge placed on a MSW landfill must pass the “paint filter test”, therefore the minimum sludge solids content for this option is approximately 20 percent. The sludge is



usually spread by conventional landfill operating equipment, such as bulldozers and landfill compactors.

To provide adequate workability of the sludge/solid waste mixture, the bulking ratio for a 20 percent solids sludge should be at least 4 tons of solid waste to 1 wet ton of sludge (4 mg of solid waste to 1 wet mg of sludge).

Sludge application rates for sludge/solid waste mixtures compare favorably with rates for other types of sludge disposal methods, despite the fact that sludge is not the only waste being disposed on the land. Disposal rates generally range from 500 to 4,200 yd³ of sludge per acre (900 to 7,900 m³ of sludge per ha).

Sludge/Soil Mixture

In a sludge/soil mixture operation, sludge is mixed with soil and applied as intermediate or final cover over completed areas of the MSW landfill. This is not strictly a sludge landfilling method from an engineering standpoint, because the sludge is not buried, but it is a viable and proven option for disposal of sludge at MSW landfills.

Advantages

- It removes sludge from the working face of the landfill where it may cause operational problems including equipment slipping or becoming stuck in sludge, or sludge being tracked around the site by equipment and haul vehicles.
- Sludge/soil cover promotes vegetation over completed fill areas, reduces the need for fertilizer, and minimizes siltation and erosion.

Disadvantages

- Generally, requires more manpower and equipment.
- Odors may be more severe than for sludge/solid waste mixtures because the sludge is not completely buried. For this reason, only well-stabilized sludge are recommended for use in sludge/soil mixture operations.

4 Glossary

Key Word	Definition
Scavenging	To search through waste, junk, etc., for something that can be saved or used
Natural Buffer	A low sloping area of maintained grassy or woody vegetation located between a pollutant source and a waterbody
Leachate	Liquid that drains or 'leaches' from a landfill



Geomembrane	Very low permeability synthetic membrane liner or barrier used with any geotechnical engineering related material so as to control fluid (or gas) migration in a human-made project, structure, or system
Horticulture	Branch of agriculture that deals with the art, science, technology, and business of growing plants
MSW	Municipal Solid Waste
Haul	A distance to be covered in a journey
Compaction	The process by which the porosity of a given form of sediment is decreased as a result of its mineral grains being squeezed together by the weight of overlying sediment or by mechanical means

5 References

1. <http://nepis.epa.gov/Exe/zypurl.cgi?dockey=30004oig.txt>
2. Solid Waste Management Manual





ALJAZARI
— ACADEMY —

Course Code: 3221

**Operation and Maintenance of Storm
Water Drainage System
Module 3**

Participant Lecture Notes

**Dredging and Desilting Operation
Lecture 5**

2016



1 Lecture Information

Topics: Operation and maintenance works for storm water drains	Lecture duration (hrs.): 6.0 • Classroom briefing (hrs.) : 1.0
Lecture : Dredging and desilting operations	Training delivery mode: OJT
Lecture date: 3 rd November, 2016	Lecture timing: 09 am – 10pm

2 Objectives

The objectives of this lecture are to introduce following concepts to the participants:

- Fundamentals of storm water drain dredging
- Various dredging processes and techniques
- Machinery involved in dredging
- Traffic control and management for operation and maintenance activity along the drain

3 Dredging and Desilting Operations

3.1 Dredging

The word dredging probably originates from the old English word “Dragan”, or to draw. Dredged materials normally comprising of a layer of soft matter, which is formed when plants, waste, soil material and sludge cling to the bottom of storm water drains.

Dredging is carried out for a variety of reasons. However, in most cases, dredging is done for maintenance purposes and to ensure sufficient sewage flow.

3.2 Small Scale Dredging

Small-scale dredging projects generally involve drainage channels in areas with artificial (pumped) drainage [1].





Figure 1: Drain

3.2.1 Critical Factors in Small-Scale Dredging

- Accessibility along and in drains (Figure 2)
- Logistics and transport of material in populated areas (traffic)
- Limited space for disposal of sediment and sludge
- Sensitive project environment: hinderance to surroundings, highly visible, public opinion and interest
- (Old) embankments, low bridges, etc. [3]



Figure 2: Hinder for Dredging

3.2.2 Mitigation Measures for Hindrances

- Work during restricted hours and seasons
- Create nearby temporary disposal sites and transport at night
- Confer with residents and stakeholders
- Communication (explain necessity) and create positive project image [3]



4 Dredging Process

Capital (or new) dredging projects can be both extensive and expensive. Maintenance dredging is often a regular, perhaps annual ongoing, long-term activity. In either case, the dredging process consists of the following three elements:

4.1 Excavation

This process involves the dislodgement and removal of sludge from the bed of the drain. A special machine - the dredger – is used to excavate the material either mechanically, hydraulically or by combined action.

4.2 Transportation of Excavated Sludge

Transporting of materials from the dredging area to the site of utilization, disposal or intermediate treatment, is generally achieved by one of the following methods:

- a) Dump trucks
- b) In self-contained hoppers of the dredgers;
- c) In barges;
- d) Pumping through pipelines; and

Other, rarely used transport methods are truck and conveyor belt transport. The method of transport is generally linked to the type of dredger being used.

4.3 Utilization or Disposal of Dredged Material

- In navigation and remediation dredging, the project is driven by the objective of removing the material from its original place.

The question of “what to do with the removed material?” arises. As a result of growing environmental pressure, finding an answer to this question has become increasingly difficult, especially when the material is contaminated [4].



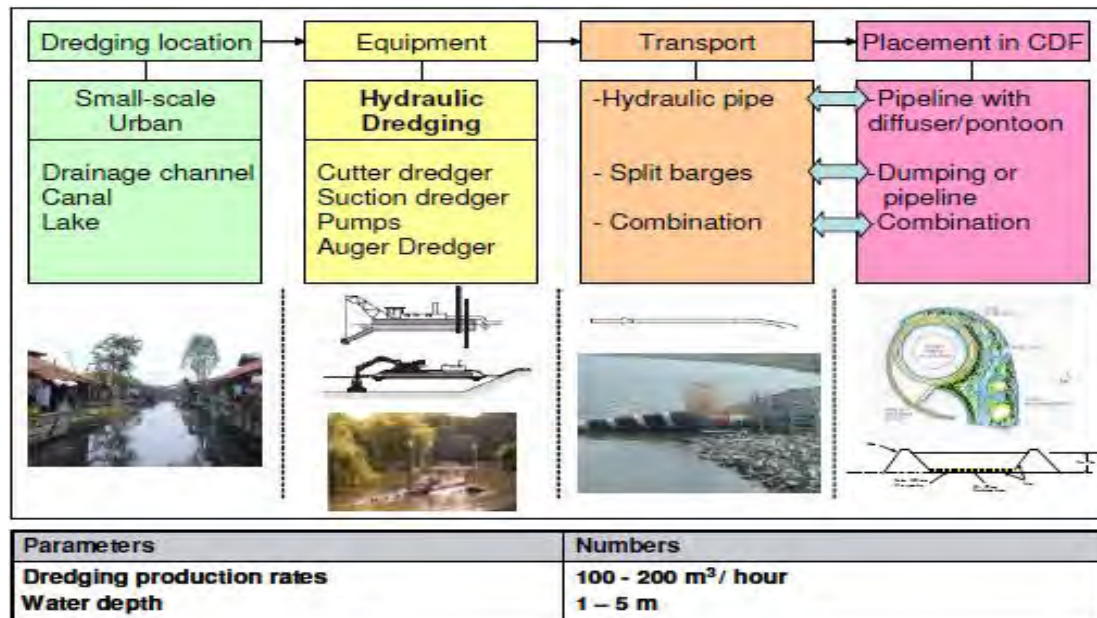

Figure 3: Work plan for dredging process

5 Dredging Techniques

Dredging is accomplished basically by only two mechanisms:

- **Hydraulic dredging** - Removal of sludge by cutter heads, dustpans, hoppers, hydraulic pipeline, plain suction, and side casters, usually for maintenance dredging projects.
- **Mechanical dredging** — Removal of sludge by clamshell, backhoe & fronthoe for maintenance work.

5.1 Hydraulic Dredgers

5.1.1 Working

Hydraulic dredgers remove and transport sludge in liquid slurry form. They are usually barge-mounted and carry diesel or electric-powered centrifugal pumps with discharge pipes ranging in diameter from 6 to 48 inches. The pump produces a vacuum on its intake side, which forces water and sludge through the suction pipe. The slurry is transported by pipeline to a disposal area.

Hydraulic dredging can virtually eliminate disturbance and resuspension of sediments at the dredging site, and is often the first choice when dredging occurs in enclosed waterbodies or in locations near aquatic resources that would be especially sensitive to temporary increases in suspended solids or turbidity. However, because hydraulic dredging typically entrains



additional water that is many times the volume of sediment removed, water management and water quality must be controlled at the disposal site.

5.2 Mechanical Dredges

Mechanical dredgers remove deposited sludge through the direct application of mechanical force to dislodge and excavate the material at almost in situ densities. Types of mechanical dredges are:

- Backhoe/fronthoe



Figure 3: Excavator (Back hoe)

- Bucket (such as clamshell, orange-peel, and dragline)



Figure 4: Clamshell

Sludge excavated with a mechanical dredge are generally placed into a dump truck for transport to the disposal site.

Mechanical dredging creates little additional water management concern at the disposal site because little additional water is entrained by mechanical dredging equipment; therefore mechanical dredging is usually the first choice when disposal site capacity limitations are a primary concern. However, typical mechanical equipment often creates more disturbance and resuspension of sludge at the dredging site. [2]



6 Criteria for Selecting Dredging Technique

A variety of dredging techniques have been developed over the years. When preparing for dredging activities, a decision must be made of which dredging technique is best suited to the activities in question. When doing so, the following factors must be taken into consideration:

- Composition of dredged materials
- Type and level of pollution
- Specific circumstances
- Size of project
- Acceptable opacification and spillage
- Required accuracy
- Side-effects
- Ecological considerations

6.1 Composition of Dredged Materials

The choice of dredging technique is also determined by the physical composition of the materials that must be dredged. For instance, different techniques must be used when dredging sludge than when dredging well consolidated sludge.

6.2 Type and Level of Pollution

Another factor which determines the choice of dredging technique is the presence of gross solids, like household and construction waste. Gross solids on the water bottom can reduce the effectiveness of certain dredging techniques.

The level of pollution on the water bottom is generally not a decisive factor when deciding which dredging technique is going to be used. However, special dredging equipment has been developed to, for example, reduce unwanted dispersion and opacification during dredging activities. This equipment can be damaged by gross solids on the water bottom and cannot be used in all circumstances. The quality of (or level of pollution in) dredged materials determines whether materials can be placed at the water's edge or needs to be transported.

6.3 Specific Circumstances

The choice of dredging technique is primarily determined by:

- Accessibility
- Water depth in drain
- Current speed of sewage flow
- Dimensions of the storm water drain in question.



In urban areas, physical objects like lamp posts and parked cars are major obstacles for equipment operated from the banks of the drain. This also applies to the width of waterways or the height of bridges when floating equipment is used.

6.4 Size of Project

It may be necessary to dredge each stretch of drain extracting sludge and maintaining it for long time. Project size is often expressed as “m³ in situ”.

This refers to the volume of dredged material that must be removed. In addition, the surface area across which materials are spread, thus the layer thickness, also determines the capacity and cost of the deployed dredging technique.

6.5 Acceptable Opacification and Spillage

Sludge is removed under water during the dredging process. Material released by a dredging technique, which is not subsequently disposed of via the transport system, is referred to as 'spillage'. Spillage is often manifested via a loose top layer, possibly featuring chunks of sediment. Spillage also results in a loose top layer when suspended particles (opacification) are subject to sedimentation.

However, polluted spillage is often encountered when dredging polluted water bottoms.

6.6 Accuracy

There are two facets to the accuracy of a drain dredging technique. On the one hand, it involves the accuracy with which dredging takes place and, on the other hand, how accurately these newly dredged areas match the required profile. Accuracy is a criterion that can be clearly measured and checked. In general, it is assumed that opacification and spillage can be minimized if strict accuracy-related benchmarks are implemented.

6.7 Side-Effects

In general, it is impossible to avoid unintentional effects of dredging activities, like opacification in the water column. However, contractors can take measures to reduce such effects, which includes installing silt screens. Other unintentional effects, like destruction of tow paths and noise-related nuisance, cause techniques with such side-effects to be avoided when working in vulnerable (natural) areas. These techniques will only be used if there are no viable alternatives, although the environment must be given maximum priority at all times.



6.8 Ecological Considerations

There is an inter-woven relationship between ecology and dredging. Legislation relating to plants and wildlife imposes additional restrictions on available methods and available periods of the year. Therefore, ecological considerations must always be taken into account when performing dredging activities [1].

7 Typical Worksheet for Drainage Works

Give below is a typical worksheet indicating location, extent of the work to be carried out, the time, equipment and personnel required for the job.

Work Report No: Date: District: Sub-division: Road No: Section: From km..... to km..... Location (s): WORK ACHIEVED: MANPOWER USED: Name..... Grade..... Hour Worked..... Name..... Grade..... Hour Worked..... Name..... Grade..... Hour Worked..... EQUIPMENT USED: DIESEL USED Hrs..... Liters Hrs..... Liters MATERIALS USED: COMMENTS:
--



8 Traffic Control for Maintenance Activity

8.1 Preliminary Tasks

Before setting out to start the job, a check should be made to ensure that everything needed is ready. Complete traffic management plan must be prepared to avoid inconvenience to the public (Figure 5).

- ✓ The dump truck, tractor and trailer, or other plant must be fueled, checked mechanically and water and oil levels are checked.
- ✓ Traffic signs, barriers and cones must be obtained and loaded onto the truck or trailer, if work is required on the carriageway or shoulders.
- ✓ Tools, small equipment and materials, must be obtained and loaded onto the truck or trailer [6].

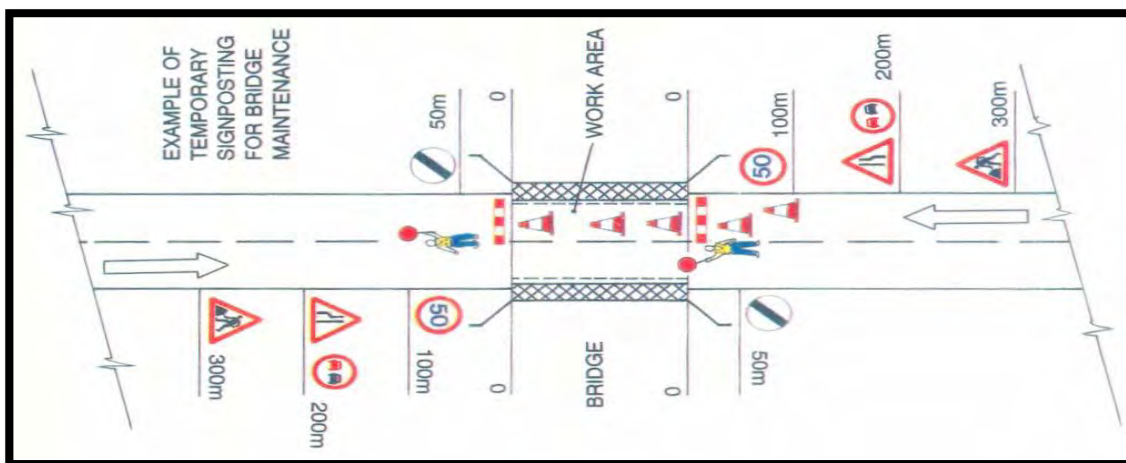

Figure 5: Traffic management for Storm water drain dredging process

8.2 Completion and Removal of Temporary Signs

- ✓ Load tools, equipment and unused materials back onto the truck or trailer.
- ✓ Where used, remove the signs, cones and barriers and load them onto the truck or trailer in the following order:
 - a) "End of Restriction" signs,
 - b) Traffic cones,
 - c) "Speed Limit" signs,
 - d) Barriers,
 - e) "Road Narrows" signs,
 - f) "Men working" signs.
- ✓ Ensure that the site is left clean and tidy with no stockpiles of sludge left behind.
- ✓ Inspect traffic signs and clean if necessary



- ✓ Move onto the next job [5].

9 Glossary

Key Word	Definition
Dredging	The removal of silt, sediments and debris from the bottom of a storm drain
Embankments	Earthen bank of storm water drain
Backhoe	A mechanical excavator which draws towards itself a bucket attached to its hinged boom
Clamshell	A dredging bucket opening at the bottom, consisting of two similar pieces hinged together at the top

10 References

1. www.mastenbroek.com/.../small_scale_dredging-an_introduction.pdf
2. www.bcdc.ca.gov/pdf/dredging/eis_eir/chpt3.pdf
3. http://www.dredging.org/media/ceda/org/documents/presentations/ceda_seminars_workshops/cdp2009_eco_p-3-2-rijks.pdf
4. <https://www.iadc-dredging.com/ul/cms/fck-uploaded/documents/pdf%20publications/dredging-literature-dredging-the-facts.pdf>
5. <http://www.metschies.com/downloads/021-road-maintenance-1-roadside-areas-drainage.pdf>
6. https://www.michigan.gov/documents/zonecontrol_112912_7.pdf





Course Code: 3221

**Operation and Maintenance of Storm
Water Drainage System**

Module 3

Participant Lecture Notes

Maintenance of Drainage System

Lecture 6

2016



1 Lecture Information

Topics:	Operation and maintenance works for storm water drains	Lecture duration (hrs.): 0.5 • Mini Lecture (hrs.) : 0.5
Lecture :	Maintenance of drainage system	Training delivery mode: OJT
Lecture date:	3 rd November, 2016	Lecture timing: 10 am -11 am

2 Objectives

The objectives of this lecture are to train participants on the following aspects of storm water drains maintenance aspects:

- Fundamentals of storm water drain maintenance
- Identify problem areas
- Generating a drain maintenance plan
- Various maintenance techniques for drain
- Traffic control and management for operation and maintenance activity along the drain

3 Developing an Operation and Maintenance (O&M) Plan

An O&M plan would help WASA staff to coordinate inspection and maintenance activities for storm water drain and track problems that you may have observed when performing inspection and maintenance. [1]

3.1 Requirement of O & M Plan

3.1.1 Define the Area to be Covered

A drainage system consists of all watercourses and storage areas that handle storm water from where it hits the ground to where it leaves the community. This includes:

- Primary Drains
- Secondary Drains
- Tertiary Drains
- Storm Sewers



- Ditches

Not all of these areas need to be included in a drainage system maintenance plan. At a minimum, the plan should address open channels on both public and private property.

3.1.2 Identify Problem Areas

Make a list of the sites that require regular inspection, i.e.

- Culverts
- Bridges
- Detention or retention basins
- Other sites where gravel and debris naturally accumulate.

For each site identified as a problem area, and record:

- Nature of the problem
- Size of the site
- Description of the area affected by problems at the site (private homes, roads, critical facilities, etc.).

A baseline photograph of each site is also useful.

3.1.3 Set an Inspection Schedule

Regular inspection of drains is of prime importance. It plays major role in timely removal of accumulated debris and hence avoid major ponding problems. In developed areas, inspection frequency should be at least two times a year. It may be conducted in spring and fall. Some communities may wish to inspect problem areas, more frequently, while the entire drainage system on a less frequent basis. Sites that commonly flood, should be inspected during or after all major storms.

3.1.4 Assign Responsibility for Inspection

Identify the people or offices responsible for inspection. In most cases, these are WASA employees, who on receiving a complaint from the community, visit and inspect the issue.

3.1.5 Define what Categories of Work will be performed under this Program

Typical problems found in open drains include trash, tires, plastic containers, branches, and logjams. Trash and objects that obstruct flow should be removed from all drains.

- ✓ Minor accumulations of “naturally” occurring organic matter and vegetation can often be left in natural channels as long as it does not cause a flood problem.

Commented [DSH1]: I am not sure if community itself has employees for this purpose. Mostly, it is done by WASA employees on receiving complaint from a specific area.



- ✓ Human-made channels and structures may have additional maintenance requirements (mowing, pump repair, etc.).
- ✓ If gravel removal is to be performed as part of this program, this should be specified and time allowed for the permitting process.
- ✓ Some bank erosion problems will be reduced by removing debris that obstructs flow in the channel, but additional measures may be desired in many areas.

3.1.6 Identify Parties Responsible for Solid Waste Removal

Drainage system maintenance will only be effective if there are adequate arrangement for the removal of solid waste. Mostly, in the absence of an adequate system, the solid waste lands into open drainage channels and cause choking. Hence WASA must have close coordination with the relevant department of municipality, responsible for solid waste removal. Especially before monsoon season, a rigorous campaign for solid waste removal be launched with close coordination of WASA and concerned municipal department. Community awareness campaign, for proper disposal of solid waste could help a lot.

3.1.7 Keep Records

Start a log to record inspection dates, problems identified, and re-inspection after problems are corrected. Citizen complaints and their resolution should be recorded. Photographs be taken before and after any maintenance/blockage removal work is carried out. Proper record keeping and pictorial evidence, would also help to reduce fictitious progress reports given to the higher ups.

3.1.8 Budget

The budget for implementation of a drainage system maintenance plan should include the cost of:

- ✓ Equipment
- ✓ Operators
- ✓ Disposal of material



Disposal options that may be considered include:

- ✓ Hauling
- ✓ Burying
- ✓ Chipping



Scope of the drainage system maintenance program must be clearly laid down. It must mention the detailed description of problem areas. Cost estimates for the maintenance work be prepared from the above information. This would help to prepare annual maintenance budgets. A proposed maintenance plan is shown in Table 1 [2].



Table 1: O & M Plan for Open Drains [1]

Storm water system feature	Are any of these conditions present?	Problem	Recommendation
General	Dumped yard wastes or no degradable materials (glass, plastic, Styrofoam, etc.) are present in pond 	Accumulation of trash and debris	Remove trash and debris and dispose of properly.
	Undesirable vegetation is invading the pond 	Nuisance, poisonous, or noxious weeds	Remove the weeds/bushes right before the start of monsoon rains
	Offensive color, odor, or sludge is present 	Unknown or uncharacteristic substance	Remove substance and eliminate its source.



Storm water system feature	Are any of these conditions present?	Problem	Recommendation
	<p>Excessive mosquito population is present</p> 	<p>Mosquitos, stagnant wastewater, & uncovered drains</p>	<p>Plan and manage covering drains near residential areas</p>
	<p>Water flows through holes in dam or berm; holes are present around pond</p>	<p>Rodents</p>	<p>Destroy rodents and repair dam or berm.</p>
	<p>Large trees interfere with maintenance activities</p> 	<p>Overgrown trees</p>	<p>Remove trees that interfere with access or maintenance activities. Preserve trees that are not a problem.</p>



Storm water system feature	Are any of these conditions present?	Problem	Recommendation
	Accumulated sediment exceeds 10% of the designed pond depth 	Excessive sediment	Clean out sediment to original shape and depth of the drain. Re-seed drain, if necessary, to control erosion.

A proposed plan for maintenance of storm sewer is exhibited in Table 2.

Table 2: O & M Plan for Storm Sewers [1]

Storm water system feature	Are any of these conditions present?	Problem	Recommendation
General	Accumulated sediment or trash exceeds 20% of the diameter of the pipe	Excess accumulation of sediment or trash	Clean out sediment and trash from pipe. You can use a high pressure hose, vacuum suction, or other appropriate cleaning method.
	Vegetation is impeding water flow	Overgrown vegetation	
	Pipe is rusted; protective coating is damaged	Corroded pipe	Replace or repair pipe to original design specifications.
	Dent in pipe has reduced the pipe diameter by 20%; water flow is impeded; pipe is broken	Defective pipe	
	Water is leaking from pipe	Cracked pipe	



4 Maintenance Activities for Road Drainage

4.1 Drains

a. Defect: Obstructions

Main Causes: Vegetation growth, bushes, fallen trees, debris, loose silt, loose rocks

If neglected: Blockage of ditch

Remedies: Clearing and cleaning



Figure 1: Vegetation Growth

b. Defect: Silting

Main Causes: Invert slope is too flat; the water cannot flow at sufficient speed

If neglected: Ditch blockage

Remedies:

- Deepen ditch (de-silting), and/or provide new turnouts
- Where deepening or turnouts are not possible because of topography, the construction of a new culvert with a drop-inlet may be possible, in order to discharge water onto the other side of the road.

c. Defect: Ponding in Drains and on Shoulders

Main Causes: The ditch cross-section is too small; the ditch gradient is too flat

If neglected:

- The shoulder material becomes soft and can easily erode
- The pavement can also be flooded and thereby weakened



Remedies:

- Deepen ditch
- Provide new turnout

d. Defect: Drain Cross-Section Destroyed (Unlined Drain)

Main Causes: Vehicular or animal traffic; cave-in

If neglected:

- Partial silting will result if the ditch sides have collapsed
- Erosion can start where water flow passes the blocked section

Remedies: Reshape/re-grade ditch, line drain

e. Defect: Invert and Sides of Drains are Eroded

Main Causes: Invert slope is too steep.

If neglected: The water flows at high speed and starts eroding the soil. The ditch becomes deeper (ravine). The sides then cave-in, the road shoulder and even part of the carriageway can be washed away.

Remedies:

- Erosion control (Turfig and Wattling)
- Re-grade/realign drains
- Provide repair scour protection
- Line drain slopes and invert

f. Defect: Drain Lining is Damaged**Main Causes:**

- Poor construction workmanship
- Soil settlement, erosion of soil under ditch lining
- Poor alignment or sudden change in flow direction

If neglected:

- When flowing water reaches the soil protected by the lining, erosion starts
- The amount of soil washed away increases; the lining is further damaged by loss of support, leading to complete destruction of the lining

Remedies:

- Erosion control (Turfig and Wattling)
- Repair lining



- Realign drain

g. Defect: At Drain Outfall

Main Causes:

- Flow too fast
- Flow too concentrated for the soil at the outfall to resist

If neglected:

- Erosion will continue back into the ditch and increase in the area of the outfall
- The erosion may eventually threaten the road as well as the surrounding land

Remedies:

- Reduce water flow and speed:
 - Realign drain to flatter gradient
 - Provide new turnout drain, upstream from existing
- Reduce impact at outfall:
 - Construct flow spreader
- Erosion control for the soil
 - Turfing and Wattling

4.2 Maintenance of Culverts and Bridges

a. Defect: Silting or Debris Blocking (Figure 2)

Main Causes:

- Invert slope too flat
- Culvert constructed too low, so that material from the stream bed becomes deposited in the culvert



Figure 2: Blockage of Culvert, Vegetation and floating debris carried by water has become lodged in the culvert



If neglected:

The intended waterway opening will be reduced so that floodwater cannot flow. It will back-up or pond on the upstream side of the culvert and may eventually overflow the road embankment (Figure 3). The road is then in danger of being washed away.



Figure 3: Ponding on the Road

Remedies:

- Clearing and cleaning
- If floating debris is a problem, the provision of a debris rack should be considered

b. Defect: Cracks

Main Causes: Settlement of soil below culvert

If neglected:

- **Minor damage:** If the settlement is minor, only light cracking will result in headwalls, wing walls and the main structure. This will hardly affect the functioning of the structure.
- **Major damage:** If the settlement is severe, it will cause large relative movement of culvert pipes so that embankment soil will enter through the cracks and block the culvert, or the culvert may collapse. The culvert must then be reconstructed.

Remedies:

- Repair cracks
- Reconstruct at correct level and fall

c. Defect: Erosion of Culvert Bed at Outlet (Figure 4)**Main Causes:**

- The culvert invert has been constructed too steep so that the water flows too fast



- The culvert invert has been constructed too flat with an excessive drop at the outfall (these are design or construction faults)

If neglected: The streambed is washed. The culvert downstream head and wing walls and even a section of the culvert and road embankment can collapse

Remedies:

- Erosion repair
- Construct outfall basin[3]



Figure 4: Erosion of Culvert Bed

5 Best Management Practices (BMPs) for Storm Water Drainage System

5.1 Catch Basins/Inlet Structures

- WASA staff should regularly inspect facilities to ensure the following:
 - Immediate repair of any deterioration threatening structural integrity.
 - Cleaning before the sump is 40% full. Catch basins should be cleaned as frequently as needed.
- Clean catch basins, storm drain inlets, and other conveyance structures just before the monsoon season to remove sediments and debris accumulated during the summer.
- Conduct inspections, more frequently, during the monsoon season for problem areas where sediment or trash accumulates more often. Cleaning and repair as needed.
- Keep accurate logs of the number of catch basins cleaned.
- Record the amount of waste collected.
- Store wastes collected from cleaning activities of the drainage system in appropriate containers or temporary storage sites. Otherwise, it may get again lodged in storm drain.



- Except for small communities with relatively few catch basins that may be cleaned manually, most municipalities will require mechanical cleaners such as vacuums, or bucket loaders.



Figure 5: Curb Inlets

5.2 Open Drains

- Consider modification of storm channel characteristics to improve channel hydraulics, to increase pollutant removals, and to enhance channel/creek aesthetic and habitat value.
- Conduct channel modification/improvement in accordance with existing laws.



Figure 6: Road-side Open Drain



5.3 Illicit Connections and Discharges

- During routine maintenance of conveyance system and drainage structures field staff should look for evidence of illegal discharges or illicit connections:
 - Is there evidence of spills such as paints, discoloring, etc.
 - Are there any odors associated with the drainage system
 - Record locations of apparent illegal discharges/illicit connections
 - Track flows back to potential dischargers and conduct aboveground inspections. This can be done through visual inspection of up gradient manholes or alternate techniques including zinc chloride, smoke testing, fluorometric dye testing, physical inspection testing, or television camera inspection.
 - Once the origin of flow is established, stop illicit discharger to eliminate the discharge.
- Storm drain inlets should public awareness message like “ Do not dump Waste into Drains” to warn against ignorant or intentional dumping of solid waste into the storm drainage system.

5.4 Illegal Dumping

- Regularly inspect and clean up hot spots and other storm drainage areas where illegal dumping and disposal occurs.
- Establish a system for tracking incidents. The system should be designed to identify the following:
 - Illegal dumping hot spots
 - Types and quantities (in some cases) of wastes
 - Patterns in time of occurrence (time of day/night, month, or year)
 - Mode of dumping (abandoned containers, “midnight dumping” from moving vehicles, direct dumping of materials, accidents/spills)
 - Responsible parties
- Post “No Dumping” signs in problem areas with a phone number for reporting [4].

Activities	BMPs do apply	BMPs do not apply	If BMPs do not apply, explain:
Solid Waste Best Management Practices			
Debris Removal			
Debris Capture Systems			
Containment and Storage			
Waste Dewatering			



6 BMPs for Dredging

Maintaining drainage by dredging is a common and proven method to remove nuisance vegetation and accumulated sediments.

- Prior to initiating maintenance dredging activities, a temporary silt fence shall be installed immediately downstream of the watercourse reach to be dredged (Figure 7). The temporary silt fence shall be installed across the drain and perpendicular to the sewage flow.



Figure 7: Temporary Silt Fence

- The temporary silt fence shall remain in place for the duration of the maintenance dredging activity.
- If watercourse flows are encountered that exceed the design capacity of the silt fence, the maintenance dredging activity shall stop until the watercourse flows subside.
- Prior to the removal of the temporary silt fence from the watercourse, silt that has accumulated behind the silt fence shall be removed to the greatest extent possible.
- The temporary silt fence shall be removed within 2 days of completing the maintenance dredging activity.
- Dredging shall be conducted with hand tools and/ or a tracked excavator equipped with a clam shell or lidded bucket to minimize fallback.[5]





Figure 8: Lidded Bucket on tracked Excavator

- Procedure to minimize the creation and dispersal of suspended sediments when using a clamshell dredge:
 - ✓ Maximizing the size of the "bite" taken by the clamshell. This also results in a minimization of the number of "bites" needed to dredge a particular volume of sediment;
 - ✓ Slowly withdrawing the clamshell through the water column.
- Each pass with the excavator bucket in the channel shall be complete.
- Dredging shall be held to the absolute minimum necessary to achieve the target channel width, depth and gradient.
- The channel banks shall be sloped such that the resulting channel banks are stable.
- Maintenance dredging shall not straighten or shorten the existing channel alignment.
- Existing large woody material embedded in the channel bank or streambed shall be left undisturbed and intact.[5]

7 Glossary

Key Word	Definition
Culvert	Structure that allows water to flow under a road, railroad, trail, or similar obstruction from one side to the other side.
Vegetation	Plants, Grasses, Bushes, Weeds
Impede	Delay or prevent (someone or something) by obstructing them; hinder
Invert level	Measurement or depth of the drainage pipe from ground level to the base of the pipe as it enters the inlet
Lining	Material that covers the inner surface of something



Key Word	Definition
Erosion	Degradation of material surface due to mechanical action, often abrasion, particles suspended in fast flowing liquid or gas, bubbles or droplets, cavitation, etc.
Turfing	Cover (the ground) with a surface layer of grass or grass roots to stope erosion
Wattling	Rows of fence of live cuttings across the slope; a mesh of branches, or straws used to stabilize slopes and avoid erosion.

8 References

1. http://www.partnersforcleanwater.org/media/174222/10104_oandmhandbook1.pdf
2. http://www.stcplanning.org/usr/Program_Areas/Flood_Mitigation/DrainSystMaintenance.pdf
3. <https://asiafoundation.org/resources/pdfs/07RoadandDrainageMaintenance.pdf>
4. http://ehs.ucr.edu/environmentalprograms/CASQA_Source_Control_BMP_Fact_Sheets/SC-74%20Drainage%20System%20Maintenance.pdf
5. www.whatcomcd.org/sites/default/.../07-MaintenanceDredgingBMPs.pdf





ALJAZARI
— ACADEMY —

Course Code: 3221

**Operation and Maintenance of Storm
Water Drainage System**

Module 3

Participant Lecture Notes

**Measurement of Sludge Quantity Deposited in
Storm Water Drains**

Lecture 7

2016



1 Lecture Information

Topics: Survey for Sludge Deposition	Lecture Duration (Hrs.): <ul style="list-style-type: none"> • Classroom Briefing (Hrs.) : • OJT (Hrs.) :
Lecture: Measurement of Sludge Quantity Deposited in Storm Water Drains	Training Delivery Mode: OJT
Lecture Date: 3 rd November, 2016	Lecture timing: 09 am – 04pm

2 Objective

WASAs currently have a number of open drains. These drains need regular sludge depth monitoring along with maintenance, to prevent them from becoming ineffective over time due to excessive sludge built-up. Currently there is no standard method of measuring the sludge build-up in storm water drains.

A regular monitoring programme and standard monitoring and measurement tools will help ensure that the depth of accumulated sludge in storm water drain is being accurately measured. This minimizes the risk of excessive sludge built-up. This would help in timely removal of sludge. Hence maintaining adequate capacity to take storm water and reduce ponding issues in buildup areas, especially during monsoon season.

3 Sludge Measurement

When the Operators go to a storm water drain to monitor/maintain, they undertake a range of other activities. Sludge Accumulation monitoring is only a very small part.

3.1 Staff with Disc

This device is being currently used around the world (Figure 1). The design is simple. It involves a rod with a flat disc welded to its end. The depth of sludge is measured with the help of graduations on the rod. This will then be used to find the actual sludge depth by subtracting the measured depth from the actual rain depth (water level to drain bed).



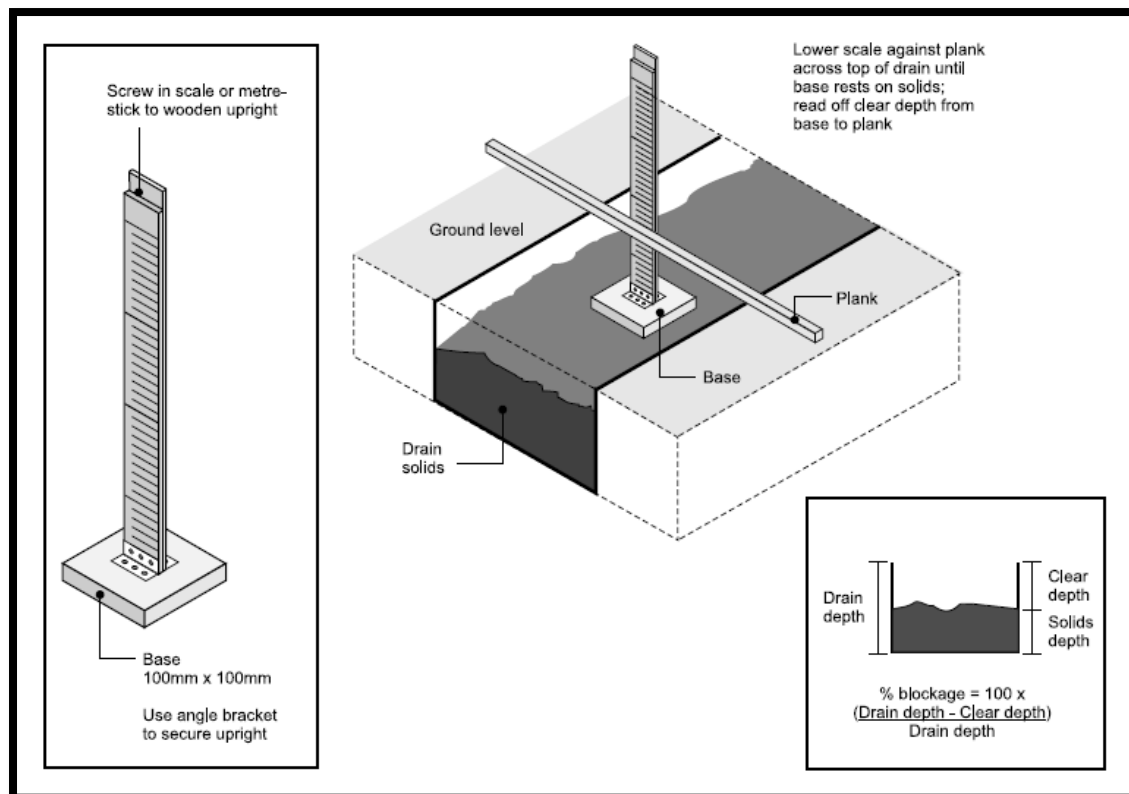

Figure 1: Scale for Measuring Depth of Solids in Open Drain

3.1.1 Benefits

- It is portable
- It is economical and easily available in market.
- It will only need minor maintenance
- Device can be used in any type of drain without getting into the drain if it is small

3.1.2 % Blockage

The following equation is used to calculate the percentage blockage in the drain:

$$\% \text{ Blockage} = 100 * \frac{(\text{Drain Depth} - \text{Clear Depth})}{\text{Drain Depth}}$$

Where:

Drain depth: is the total depth of the cross section

Clear depth: the depth above the deposited sludge



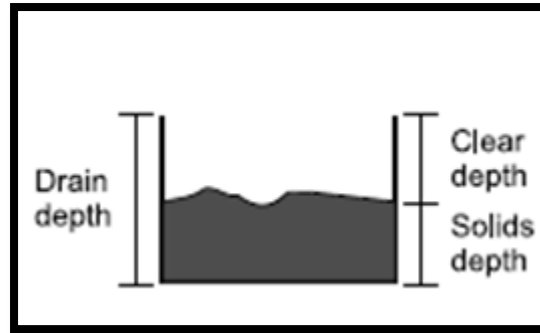

3.1.3 Disadvantage

This device and technique uses water surface level to calculate the sludge depth. Errors could be introduced if the water level is different to the design water level due to evaporation or leakages. If the water level in drain is lower than the design level, the reading on the staff will be higher suggesting higher than actual sludge build-up. This might trigger an un-necessary cleanup of the sludge leading to increase in the maintenance costs.

3.2 Procedure

The main lengths of the drainage system take the form of trapezoidal/ rectangular, open channel sections.

- ✓ First select the venue where you have to do dredging or sludge thickness measurement.
- ✓ Select some culvert or bridge where you have to take measurements.
- ✓ Properly apply traffic control plan i.e. usage of road signs and de-routing.
- ✓ Ensure that each worker has worn the proper safety gadgets.
- ✓ Find out the dimensions of the drain i.e. length width and depth.
- ✓ Mark the stations on the drain where you have to find the thickness of the sludge.
- ✓ Two persons at both banks of the drain are required to hold the survey staff vertical via a rope throughout the measurement.
- ✓ Find the depth by using staff having graduations on it.
- ✓ Calculate sludge quantity by multiplying length, breadth and depth of sludge.
- ✓ Find out the capacity of dump truck for transporting sludge to disposal site.
- ✓ Calculate the number of trips by dumper from dredging to disposal site.
- ✓ Also calculate the time required by the dumper per trip and total time for overall operation.
- ✓ If the cleaning along the road is required because of spillage of waste then clean that.



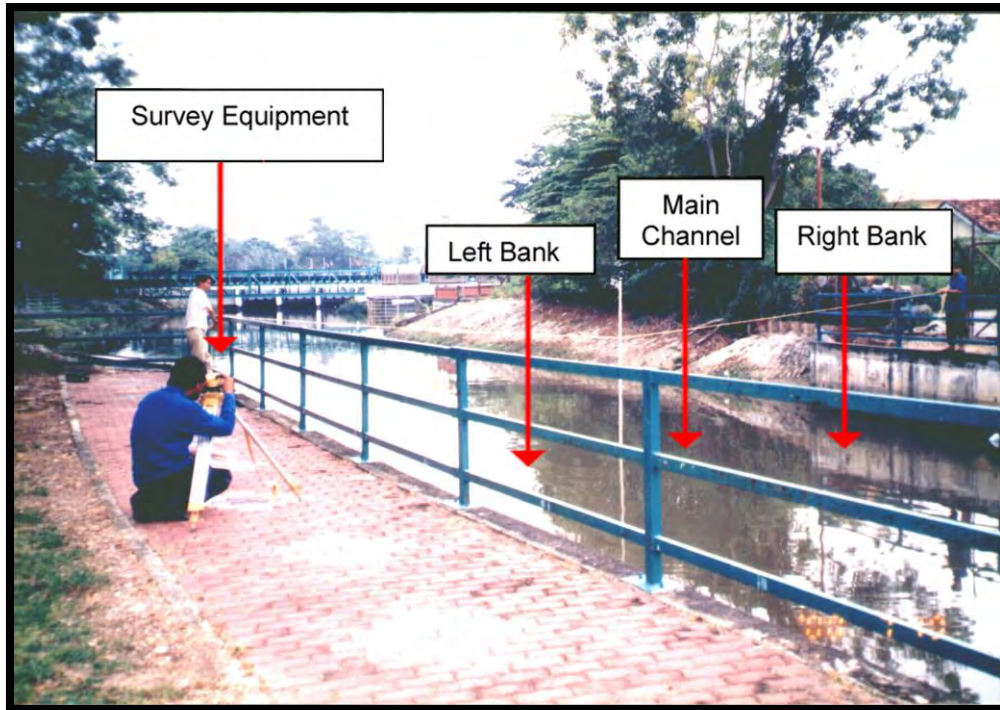

Figure 2: Sediment deposit thickness survey at station

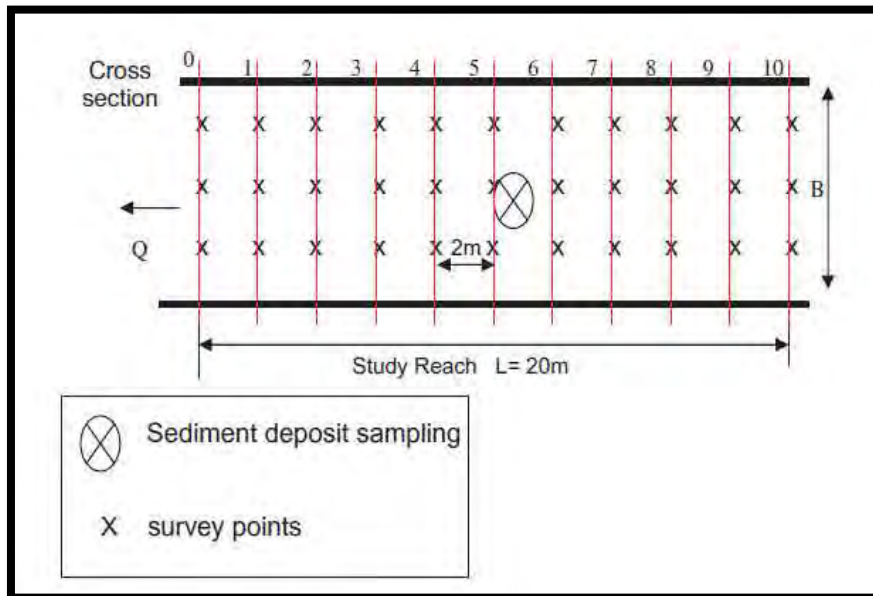

Figure 3: Measurement points at a station



Sludge volume may be calculated by using Table 1.

Table 1: Sludge Volume Calculation

Sr. No.	Drain			Sludge Deposit			Sludge Volume (m ³)	Sludge per Dumper (m ³)	No. of Trips	Haulage Distance (m)	Time duration for operation (hr)
	L (m)	B (m)	H (m)	L (m)	B (m)	Thickness (m)					



Figure 4: Sediment Deposit Sampling

3.3 Observations



Sr. No.	Observations	Remarks
1.	Type of material of Sludge	
2.	Flow condition before the dredging	
3.	Flow condition after the dredging	

4 Glossary

Key Word	Definition
Sediment	Naturally occurring material that is broken down by processes of weathering and erosion, and is subsequently transported by the action of wind, water, or ice, and/or by the force of gravity acting on the particles
Staff	Graduated wooden or aluminum rod, used with a levelling instrument to determine the difference in height between points or heights of points above a datum surface
Sediment Survey	To determine the volume and weight of sediment accumulated between surveys, or during the recorded period of storage
Portable	Able to be easily carried or moved, especially because being of a lighter and smaller version than usual

5 Reference

1. http://redac.eng.usm.my/html/publish/2006_03.pdf
2. <https://www.nzta.govt.nz/assets/resources/stormwater-management/docs/ama-sediment-measurement-final-report-2010.pdf>



