

付録 A 講義及びセミナー資料

A-6 風洞実験セミナー

# Wind Tunnel Test for the Main Girder of Bago Bridge in Under Construction Stage and in After Completion Stage

Hiromichi SHIRATO

Professor, Dr. Eng., shirato.hiromichi.8u@kyoto-u.ac.jp

Bridge Engineering Laboratory,

Department of Civil and Earth Resources Engineering, Kyoto University

Head of Unit for Engineering Enhancement of Higher Education in Myanmar

1

## Contents of the Final Report

1.	Overview of Bago Cable-Stayed Bridge	1
2.	Wind Tunnel	8
3.	Similarity rules	21
4.	Equivalent mass	23
5.	Items of wind tunnel tests	25
6.	Wind tunnel tests of Bago Cable-stayed Bridge	52
7.	Statistical analysis of wind speed record	145
8.	Recommendations to cable vibration	151
9.	Conclusion	152
	References	157

2

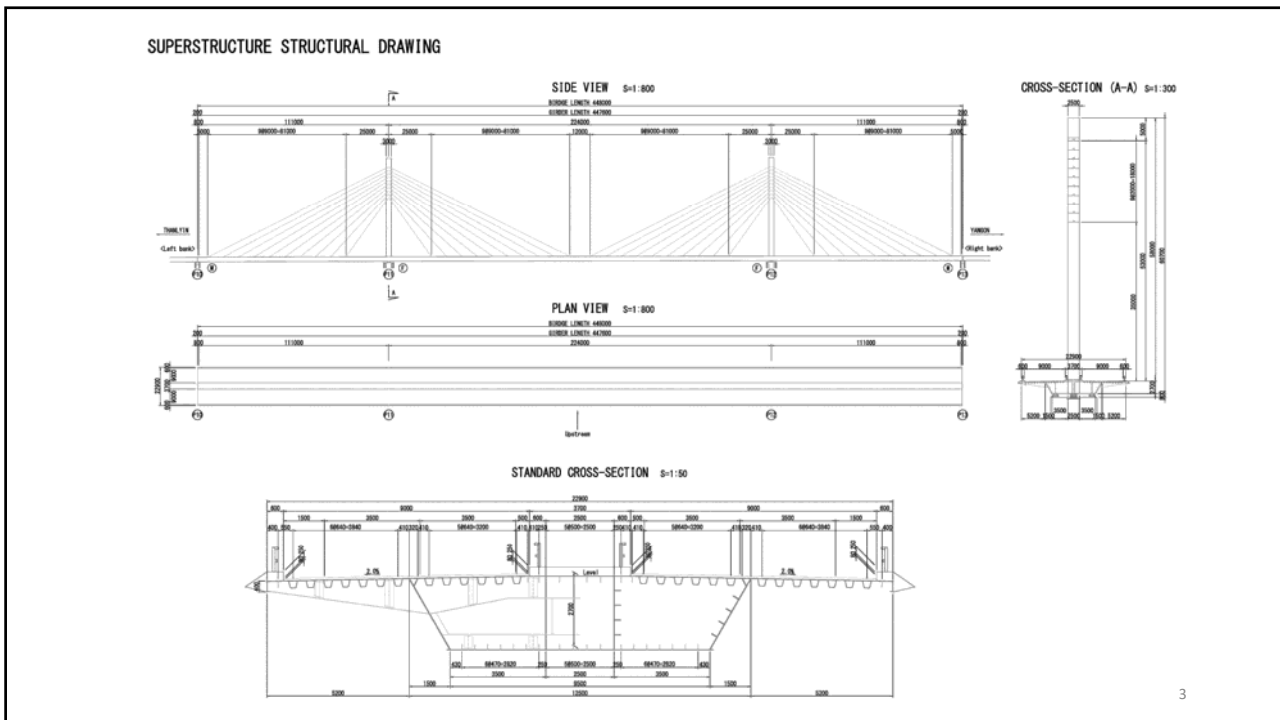

### Basic Condition to Evaluate Aerodynamic Stability

# Elevation of main girder **17.645 m**  
from the average water level (M.W.L.) to the upper surface level of the main girder

# Girder width ( $B$ ) **22.9 m**

# Girder depth ( $D$ ) **2.70 m ( $B/D = 8.48$ )**

# Category of surface roughness: **II**

# Power exponent of vertical profile of wind speed **0.16**

# (Longitudinal) intensity of turbulence: **17 %** At the elevation of the main girder

#### For after completion stage

# Basic wind speed ( $U_{10}$ ) **30 m/s** 10 minute mean wind speed at 10m elevation

# Design wind speed ( $U_d$ ) **32.7 m/s**

At the girder elevation, the design wind speed  $U_d$  is  $U_d = U_{10} \times E_1 = 30 \times 1.09 = 32.7$

#### For under construction stage

# Basic wind speed ( $U_{10E}$ ) **22.1 m/s**  
non-exceeding prob. 0.6, construction period 3 yrs.

# Design wind speed ( $U_{dE}$ ) **24.1 m/s**

At the girder elevation ( $22.1 \times E_1 = 24.1$ ).

### Wind tunnel in Kyoto University



Subject	Direction	Value
Wind Tunnel Type	-	Eiffel Type
Section Size	Width	1,000 (mm)
	Height	1,800 (mm)
	Length	6,550 (mm)
Wind Speed	Streamwise	0 ~ 25 (m/s)
Turbulence Intensity (in smooth flow)	Streamwise	< 0.5 (%)

5

### Wind tunnel in Kyoto University

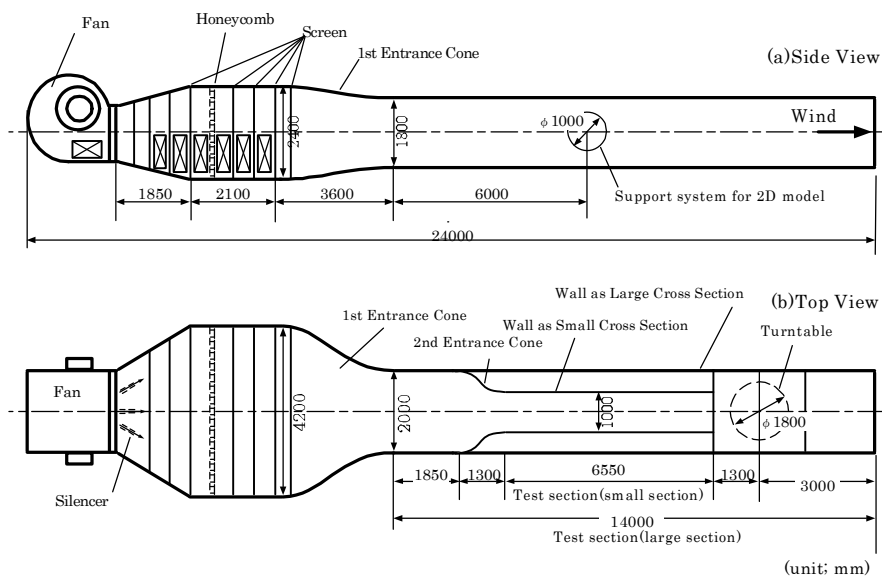

6

models

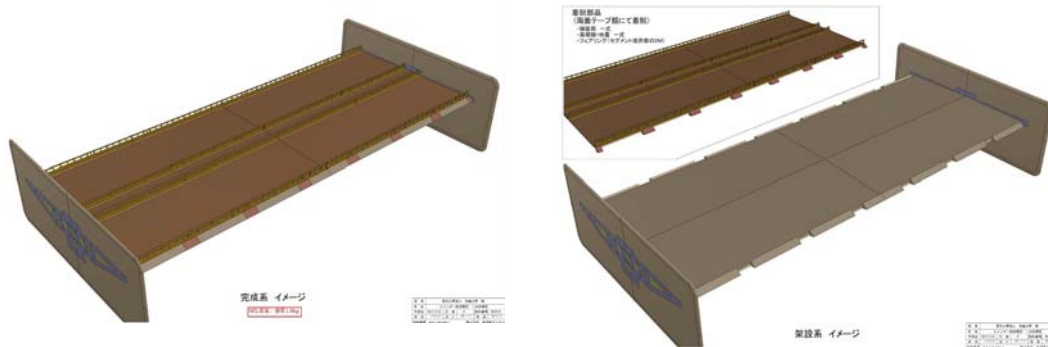

7

models

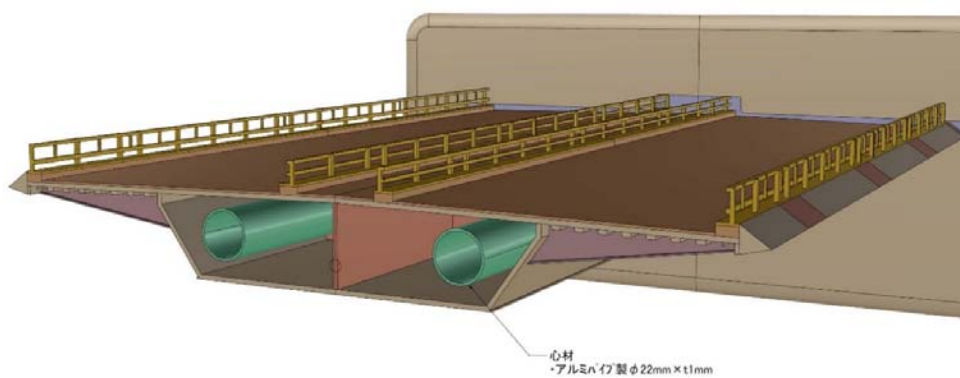

8

models

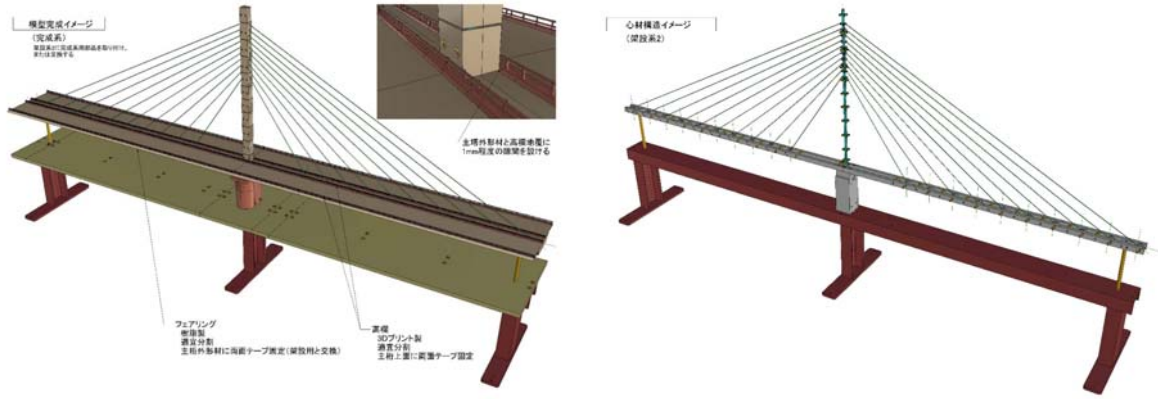

9

models

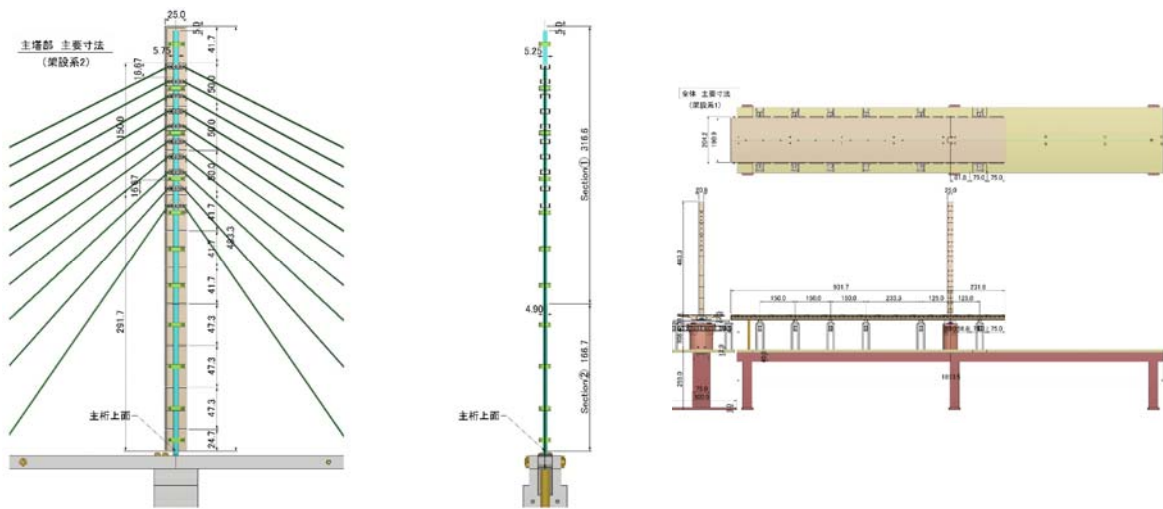

10

## Similarity rules

$$1) \text{ Wind velocity: } \frac{U_p}{f_p L_p} = \frac{U_m}{f_m L_m} \quad (3.1)$$

$$2) \text{ Dynamic sensitivity (Scruton number): } \frac{2m_p \delta_p}{\rho L_p^2} = \frac{2m_m \delta_m}{\rho L_m^2} \quad (3.2)$$

$$\frac{2I_p \delta_p}{\rho L_p^4} = \frac{2I_m \delta_m}{\rho L_m^4} \quad (3.3)$$

where,  $U$  : wind velocity ( $m/s$ ),

$f$  : natural frequency ( $Hz$ ),

$L$  : reference length ( $m$ ),

$m$  : mass per unit span length for heaving mode ( $kg/m$ ),

$I$  : moment of inertia per unit span length for torsional mode ( $kg \cdot m^2/m$ ),

$\delta$  : logarithmic decrement of structural damping (-),

$\rho$  : air density ( $kg/m^3$ ),

$( )_p$  : for real structure,

$( )_m$  : for model

Note: Since the wind tunnel test was conducted in air,  $\rho_p = \rho_m$ .

11

## Similarity rules

item	unit	symbol		scale ratio	note
		real structure	model		
length	$m$	$L_p$	$L_m$	$n$	$L_p = nL_m$
time	$sec$	$t_p$	$t_m$	-	$\frac{U_p t_p}{L_p} = \frac{U_m t_m}{L_m}$ , ( $t_p = t_m$ )
wind velocity	$m/sec$	$U_p$	$U_m$	-	$\frac{U_p}{f_p L_p} = \frac{U_m}{f_m L_m}$
mass per unit span length	$kg/m$	$m_p$	$m_m$	$n^2$	$\frac{2m_p \delta_p}{\rho L_p^2} = \frac{2m_m \delta_m}{\rho L_m^2}$
moment of inertia per unit span length	$kgm^2/m$	$I_p$	$I_m$	$n^4$	$\frac{2I_p \delta_p}{\rho L_p^4} = \frac{2I_m \delta_m}{\rho L_m^4}$
natural frequency	$Hz$	$f_p$	$f_m$	-	-
logarithmic decrement of structural damping	-	$\delta_p$	$\delta_m$	1	$\delta_p = \delta_m$

12

## Equivalent mass

$$m_{eqz} = \frac{\int_{str} \{m(s)[\phi_x^2(s) + \phi_y^2(s) + \phi_z^2(s)] + I_{rx}(s)\phi_{rx}^2(s) + I_{ry}(s)\phi_{ry}^2(s) + I_{rz}(s)\phi_{rz}^2(s)\} ds}{\int_{girder} \phi_z^2(x) dx} \quad (4.1)$$

$$I_{eqx} = \frac{\int_{str} \{m(s)[\phi_x^2(s) + \phi_y^2(s) + \phi_z^2(s)] + I_{rx}(s)\phi_{rx}^2(s) + I_{ry}(s)\phi_{ry}^2(s) + I_{rz}(s)\phi_{rz}^2(s)\} ds}{\int_{girder} \phi_{rx}^2(x) dx} \quad (4.2)$$

13

## Equivalent mass

where.  $\int_{str} \{ \} ds$ : integral along each structural member axis (s).

$\int_{girder} \{ \} dx$ : integral along girder axis (x).

$m(s)$ : mass per unit span length (kg/m).

$I_{rx}(s)$ ,  $I_{ry}(s)$ ,  $I_{rz}(s)$ : moment of inertia per unit span length around local x, y, z coordinates (kgm<sup>2</sup>/m).

$\phi_x(s)$ ,  $\phi_y(s)$ ,  $\phi_z(s)$ : displacement component of mode vector for local x, y, z coordinates.

$\phi_{rx}(s)$ ,  $\phi_{ry}(s)$ ,  $\phi_{rz}(s)$ : rotational displacement component of mode vector for local x, y, z coordinates

14



## Target stage

For the under construction stage, the following 2 stages were focused:

- Before the lowest cable being installed and just after the first segment of the main girder was installed. (Heaving 1 DOF, This condition was abbreviated as **UC1**, hereafter.)
- Just before the last segment of the main girder in the main span is installed. (Heaving and torsional 2 DOF, **UC2**)

For after completion stage, the following modes combination was set to the model:

- (Heaving and torsional 2 DOF, **AC**)

15

## Target modes (UC1, Main girder)

Table 5.1.1 Dynamic properties of each mode (UC1, For main girder).

mode	natural frequency	equivalent mass $m_{eqz}$	equivalent moment of inertia $I_{eqx}$	mode shape
unit	Hz	kg/m	kg · m <sup>2</sup> /m	-
1 and 2	0.655			tower bending (normal to cable plane) 1st
3 and 4	0.754			tower bending (along cable plane) 1st
5 and 6	2.594		5.875E+05	torsional (side span) 1st
7 and 8	3.977	1.171E+04		heaving (main span) 1st
9 and 10	4.199			tower bending (normal to cable plane) 2nd
11 and 12	4.810			tower bending (along cable plane) 2nd
13 and 14	5.197			torsional (side span) 2nd
15 and 16	5.826			torsional (main span) 1st
17 and 18	7.594			torsional (side span) 3rd
19 and 20	9.837			torsional (side span) 4th

Note:  $m_{eqz}$  is given by eq. (4.1) and  $I_{eqx}$  by eq. (4.2)

The shaded mode is the target mode.

16

## Target modes (UC1, Main girder)

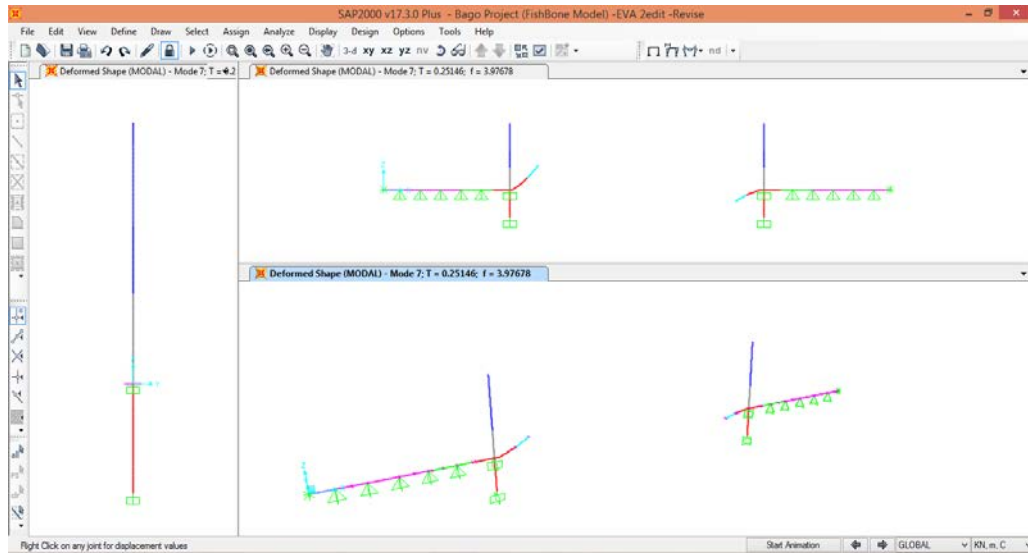

17

## Target modes (UC2, Main girder)

Table 5.1.2 Dynamic properties of each mode (UC2, For main girder).

mode	natural frequency	equivalent mass $m_{eqz}$	equivalent moment of inertia $I_{eqx}$	mode shape
	Hz	kg/m	kg · m <sup>2</sup> /m	
1 and 2	0.439	2.065E+04		heaving 1st
3 and 4	0.509			tower bending (normal to cable plane) 1st
5 and 6	0.822			heaving ?
7 and 8	0.944		8.855E+05	torsional (main span) 1st
9 and 10	1.000			heaving 2nd
11	1.137			torsional (side span) 1st
12 and 13	1.421			heaving 3rd
14	1.841			torsional (side span) 2nd
15 and 16	2.374			heaving 4th
17 and 18	2.816			torsional (main span) 2nd
19 and 20	2.859			heaving 5th

18

## Target modes (UC2, Main girder)

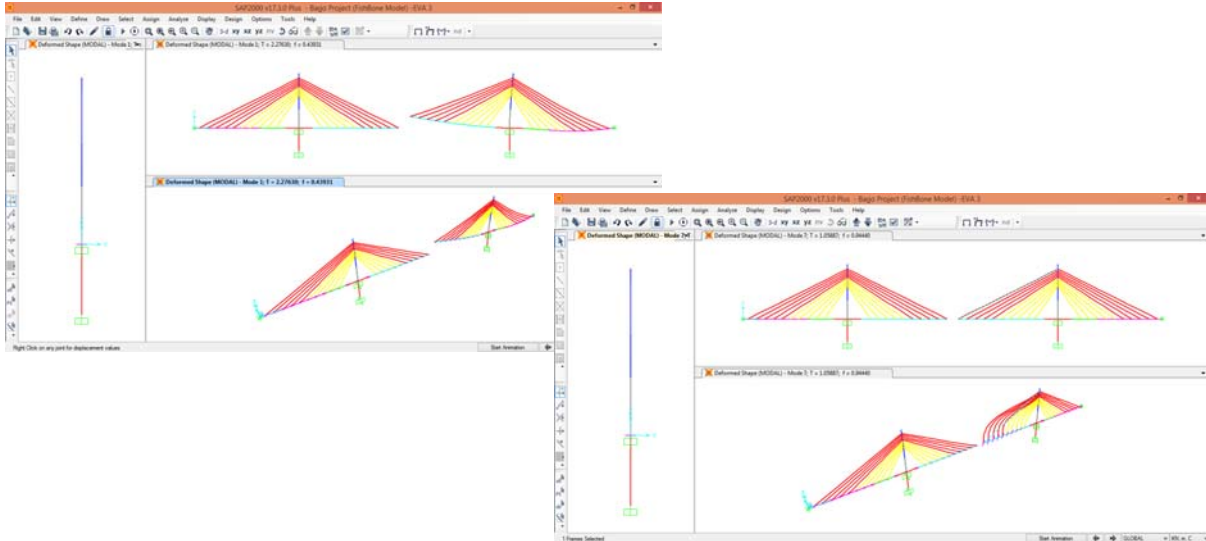

19

## Target modes (AC, Main girder)

Table 5.1.3 Dynamic properties of each mode (AC, For main girder).

mode	natural frequency	equivalent mass $m_{eqz}$	equivalent moment of inertia $I_{eqx}$	mode shape
	Hz	kg/m	$\text{kg} \cdot \text{m}^2/\text{m}$	
1	0.446	2.044E+04		heaving 1st
2	0.509			tower bending (normal to cable plane) 1 <sup>st</sup> (in-phase)
3	0.509			tower bending (normal to cable lane) 1 <sup>st</sup> (out-phase)
4	0.740			heaving 2nd
5	0.895		8.749E+05	torsional (main span) 1st
6	0.984			sway 1st
7	1.014			heaving 3rd
8	1.137			torsional (side span) 1st
9	1.177			heaving 4th
10	1.583			heaving 5th

20

## Target modes (AC, Main girder)

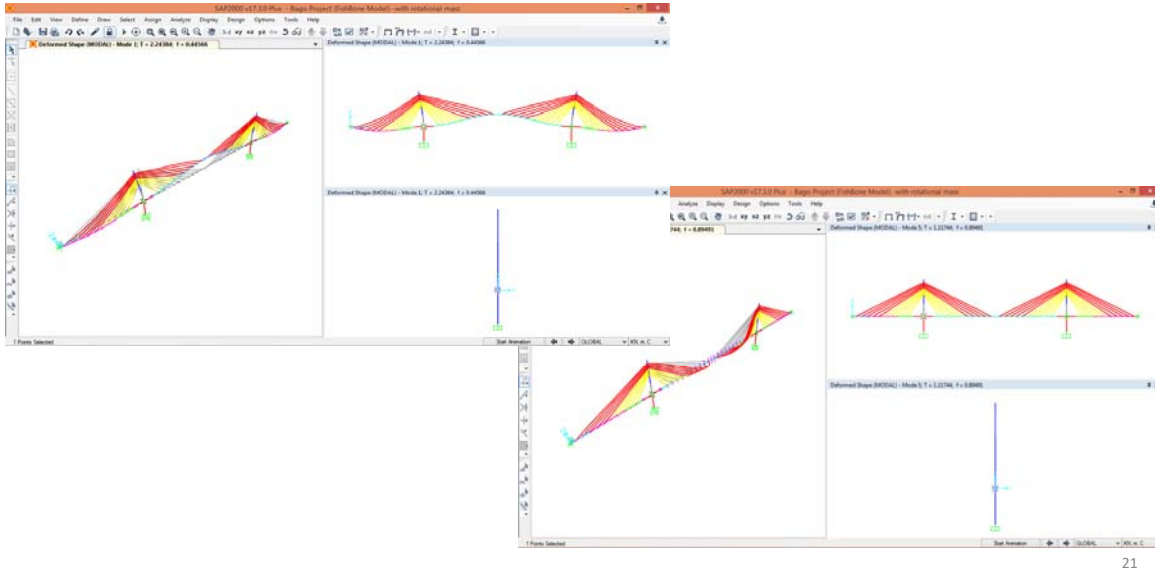

21

## Target modes (UC1, Tower)

Table 5.2.1 Dynamic properties of each mode (UC1, For tower).

mode	natural frequency	equivalent mass $m_{eqx}$	equivalent mass $m_{eqy}$	mode shape
unit	Hz	kg/m	kg/m	-
1	0.234			
2	0.634			
3 and 4	0.655		1.224E+04	tower bending (normal to cable plane) 1st
5 and 6	0.680			girder heaving (side span) 1st
7 and 8	0.754	6.217E+03		tower bending (along cable plane) 1st

22

## Target modes (UC1, Tower)

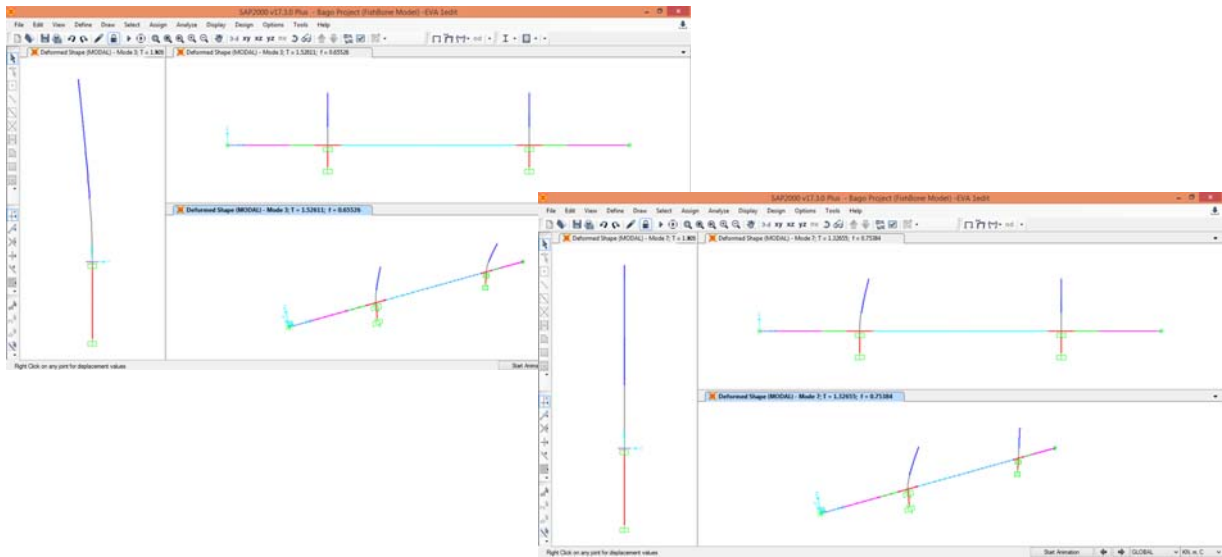

23

## Target modes (AC, Tower)

Table 5.2.2 Dynamic properties of each mode (AC, For tower).

mode	natural frequency	equivalent mass $m_{eqx}$	equivalent mass $m_{eqy}$	mode shape
unit	Hz	kg/m	kg/m	-
1	0.446	7.393E+05		tower bending and girder heaving (along cable plane) 1st
2	0.509		1.949E+04	tower bending (normal to cable plane) 1st (in-phase)
3	0.509		1.949E+04	tower bending (normal to cable plane) 1st (out-phase)
4	0.740			tower bending and girder heaving (along cable plane) 2nd
5	0.895			girder torsional 1st
6	0.984			girder sway 1st

24

### Target modes (AC, Tower)

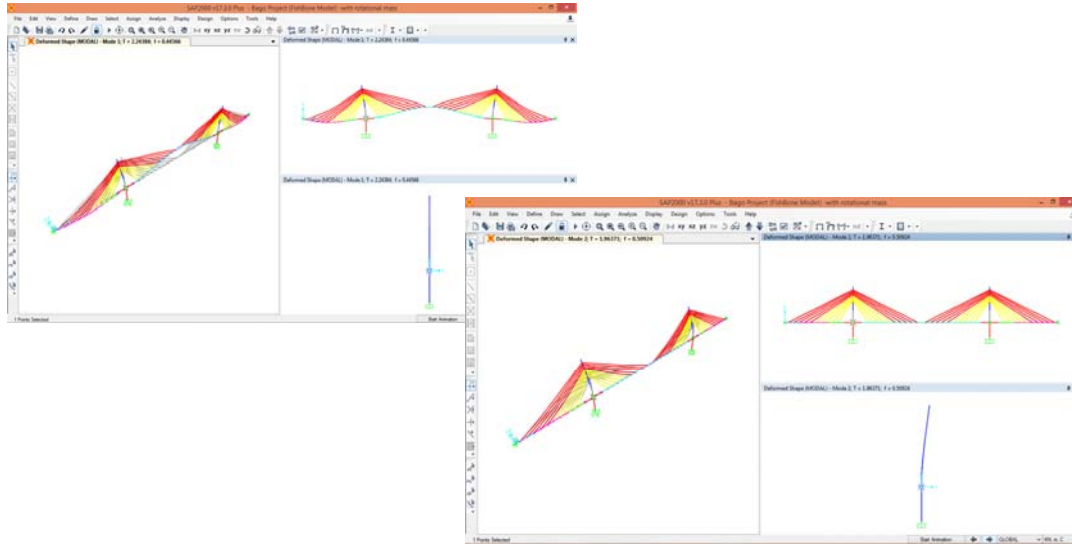

25

### Test setup (Vibrational response measurement)

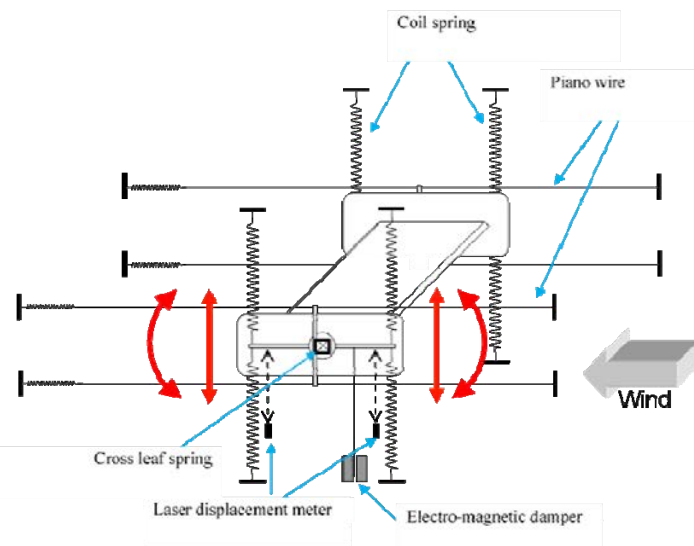

26

## Test setup (Aerodynamic force measurement)



27

## Free vibration test of main girder (UC1)

**Table 6.2.1** Aerodynamic response of the main girder in UC1 (Heaving 1 DOF)

Flow condition	Vertical incidence angle of wind [deg]	Vortex-induced vibration	Flutter	Corresponding figure
Smooth	0	o	o	Fig.6.2.1
	+3	o	o	Fig.6.2.2
	-3	o	o	Fig.6.2.3
Turbulent	0	o	o	Fig.6.2.4
	+3	o	o	Fig.6.2.5
	-3	o	o	Fig.6.2.6

“o” : The corresponding response was not observed.

28

## Free vibration test of main girder (UC2)

**Table 6.2.2** Aerodynamic response of the main girder in UC2 (Heaving/torsional 2 DOF)

Flow condition	Vertical incidence angle of wind [deg]	Vortex-induced vibration	Flutter	Corresponding figure
Smooth	0	o	o	Fig.6.2.7
	+3	o	o	Fig.6.2.8
	-3	o	o	Fig.6.2.9
Turbulent	0	o	o	Fig.6.2.10
	+3	o	o	Fig.6.2.11
	-3	o	o	Fig.6.2.12

“o” : The corresponding response was not observed.

29

## Free vibration test of main girder (AC)

**Table 6.2.3** Aerodynamic response of the main girder in AC (Heaving/torsional 2 DOF)

Flow condition	Vertical incidence angle of wind [deg]	Vortex-induced vibration	Flutter	Corresponding figure
Smooth	0	× Torsional (at around 21.6 [m/s])	o	Fig.6.2.13
	+3	× Torsional (15.4 - 17.9 [m/s]) (22.8 - 25.2 [m/s])	o	Fig.6.2.14
	-3	× Torsional (15.4 - 17.9 [m/s]) (20.3 - 24.0 [m/s])	o	Fig.6.2.15
Turbulent	0	o	o	Fig.6.2.16
	+3	o	o	Fig.6.2.17
	-3	o	o	Fig.6.2.18

“o” : The corresponding response was not observed.

“×” : The corresponding response occurred.

30



### Free vibration test of main girder (AC)

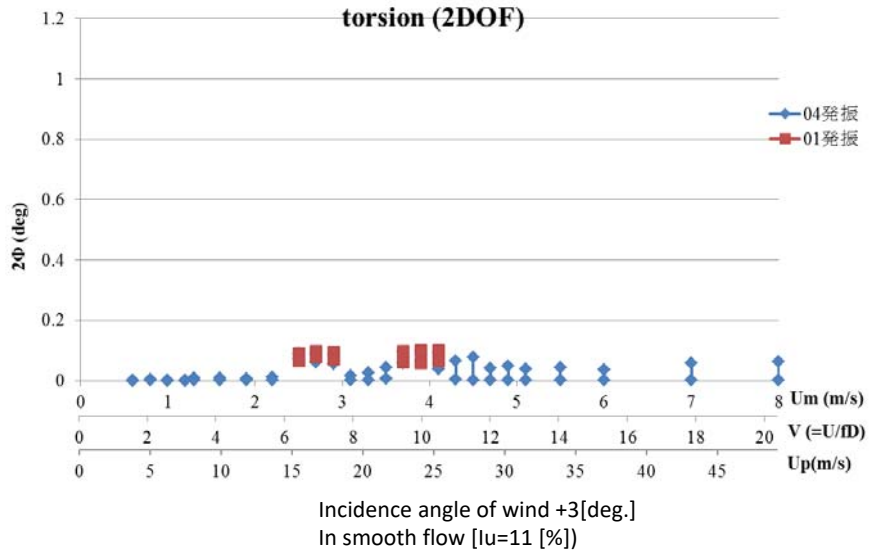

31

### Free vibration test of main girder (AC)

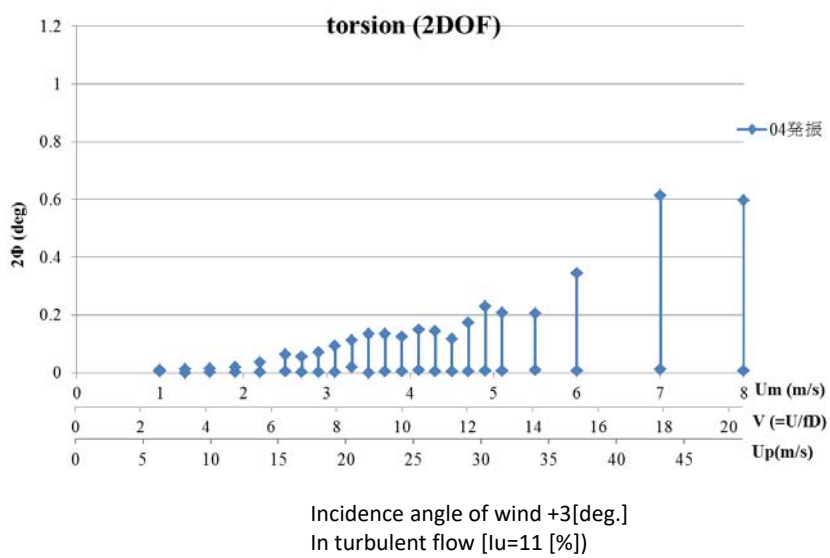

32

### Grid to produce turbulent flow in wind tunnel

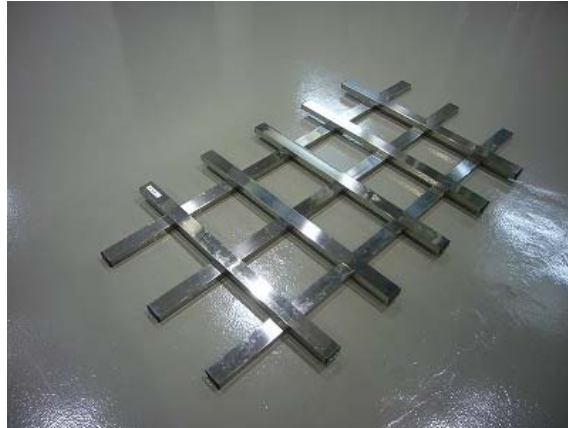

33

### Free vibration test of main girder (AC)

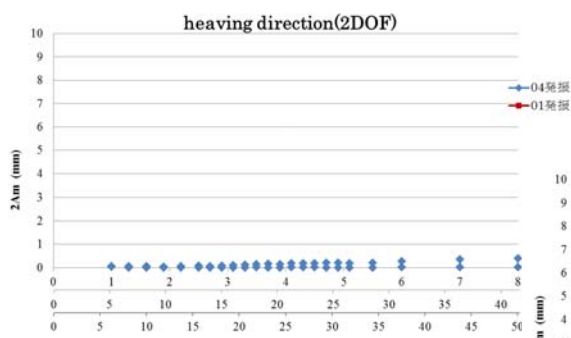

Incidence angle of wind 0[deg.]  
In smooth flow

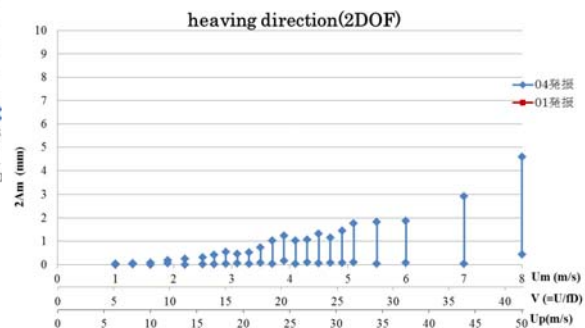

Incidence angle of wind 0[deg.]  
In turbulent flow [ $\text{Iu}=11$  %]

34

## Free vibration test of tower



Yawing angle: 90[deg.]  
In turbulent boundary layer

35

## Free vibration test of tower (UC1)

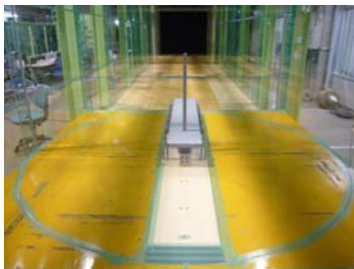

**Table 6.3.1** Under construction 1 (UC1, Original tower configuration (without aerodynamic device))

Flow condition	Yawing angle [deg]	Vortex-induced vibration	Galloping	Corresponding figure
Smooth	0	× in y-direction (16.5m/s~18.6m/s)	o	Fig.6.3.2
	5	× in y-direction (16.5m/s~18.6m/s)	× in y-direction (60.0m/s~)	Fig.6.3.3
	22.5	o	o	Fig.6.3.4
	45	o	o	Fig.6.3.5
	67.5	o	o	Fig.6.3.6
	80	× in x-direction (14.2m/s~22.3m/s)	× in x-direction (58.7m/s~)	Fig.6.3.7
	85	× in x-direction (14.2m/s~20.3m/s)	o	Fig.6.3.8
	90	× in x-direction (16.2m/s~22.3m/s)	× in x-direction (43.6m/s~)	Fig.6.3.9

“o” : The corresponding response was not observed.

“×” : The corresponding response occurred.

36

## Free vibration test of tower (UC1)

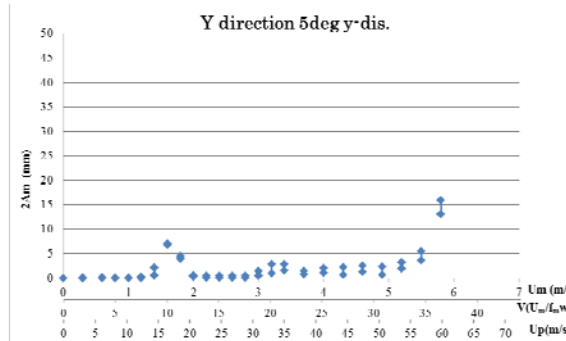

Y direction: normal to cable plane  
In smooth flow

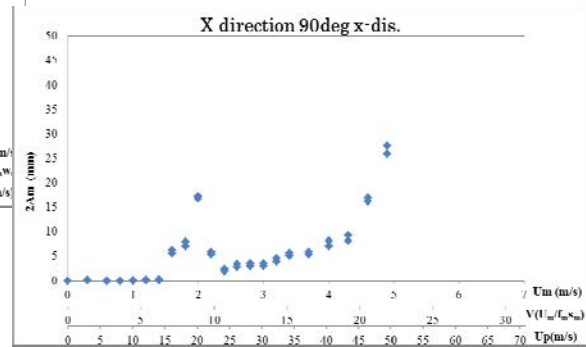

X direction: along cable plane  
In smooth flow

37

## Free vibration test of tower (UC1)

(with L-shaped aerodynamic device, length: 91.7mm (11.0m in real bridge))

Table 6.3.2 Under construction 1 (UC1, With L-shaped aerodynamic device)

(Length of aerodynamic device: 91.7mm (= 11.0m for real bridge) from the top of the tower)

Flow condition	Yawing angle [deg]	Vortex-induced vibration	Galloping	Corresponding figure
Smooth	0	× in y-direction (12.6m/s~14.7m/s)	o	Fig.6.3.11
	90	× in x-direction (18.5m/s~20.6m/s)	o	Fig.6.3.12
Turbulent	80	o	o	Fig.6.3.13
	85	o	o	Fig.6.3.14
	90	o	o	Fig.6.3.15
	180	o	o	Fig.6.3.16

“o” : The corresponding response was not observed.

“×” : The corresponding response occurred.

38

### Free vibration test of tower (UC1)

### L-shaped aerodynamic device

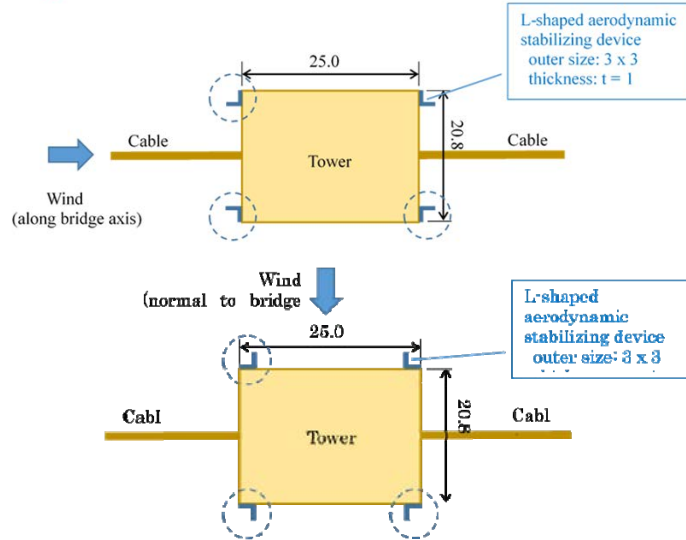

39

### Free vibration test of tower (UC1), L-shaped aerodynamic device

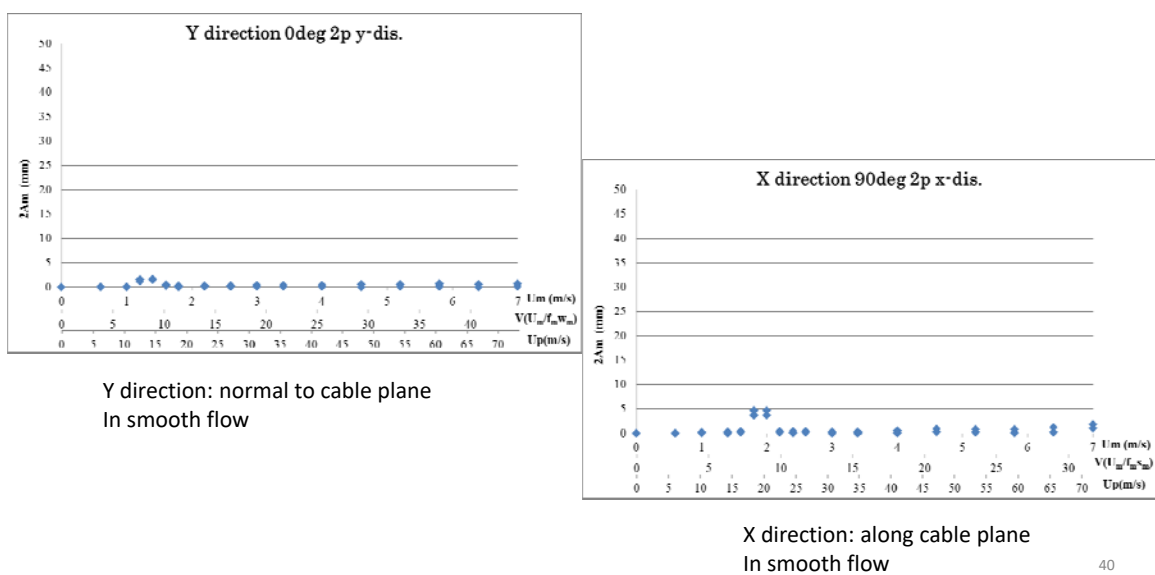

40

## Free vibration test of tower (UC2), L-shaped aerodynamic device

**Table 6.3.3** Under construction 2 (UC2, With L-shaped aerodynamic device)

(Length of aerodynamic device: 91.7mm (= 11.0m for real bridge) from the top of the tower))

Flow condition	Yawing angle [deg]	Vortex-induced vibration	Gallop	Corresponding figure
Smooth	0	× in y-direction (11.1m/s~29.5m/s) (34.2m/s~34.2m/s)	o	Fig.6.3.17
	5	o	o	Fig.6.3.18
Turbulent	0	o	o	Fig.6.3.19
	5	o	o	Fig.6.3.20

“o” : The corresponding response was not observed.

“×” : The corresponding response occurred.

41

## Free vibration test of tower (AC), Original configuration

**Table 6.3.4** After completion (AC, Original tower configuration)

Flow condition	Yawing angle [deg]	Vortex-induced vibration	Gallop	Corresponding figure
Smooth	0	× in y-direction (10.7m/s~30.4m/s)	o	Fig.6.3.21
	5	× in y-direction (10.7m/s~19.7m/s)	× in y-direction (28.6m/s~)	Fig.6.3.22
	10	o	o	Fig.6.3.23
	22.5	o	o	Fig.6.3.24
	45	o	o	Fig.6.3.25
	67.5	o	o	Fig.6.3.26
	90	o	o	Fig.6.3.27
Turbulent	0	× in y-direction (17.9m/s~19.7m/s)	× in y-direction (23.3m/s~)	Fig.6.3.28
	5	o	o	Fig.6.3.29
	10	o	o	Fig.6.3.30
	22.5	o	o	Fig.6.3.31
	45	o	o	Fig.6.3.32
	67.5	o	o	Fig.6.3.33
	90	o	o	Fig.6.3.34

“o” : The corresponding response was not observed.

“×” : The corresponding response occurred.

42

### Free vibration test of tower (AC)

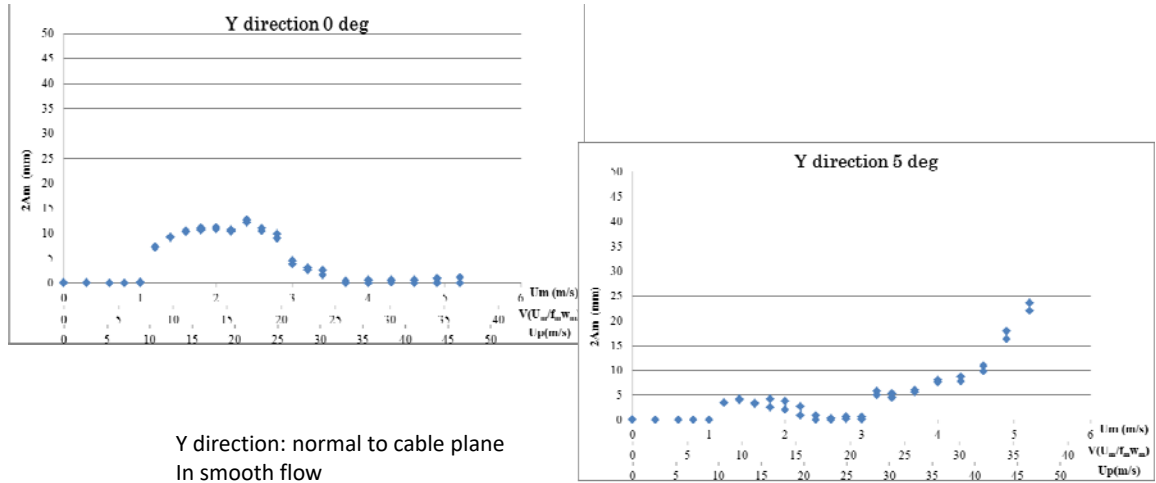

Y direction: normal to cable plane  
In smooth flow

43

### Free vibration test of tower (AC)

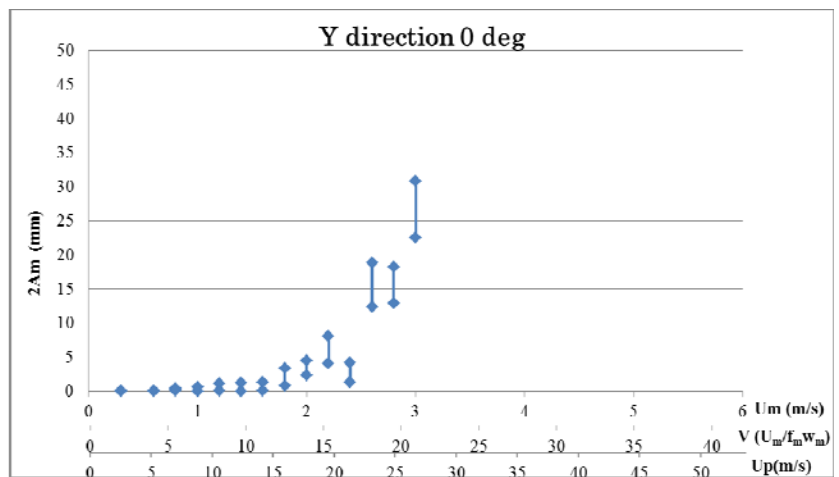

Y direction: normal to cable plane  
In turbulent boundary layer

44

## Free vibration test of tower (AC),

### L-shaped aerodynamic device, length: 91.7mm (11.0m in real bridge)

**Table 6.3.5** After completion (AC, With L-shaped aerodynamic device)

(Length of aerodynamic device: 91.7mm (= 11.0m for real bridge) from the top of the tower)

Flow condition	Yawing angle [deg]	Vortex-induced vibration	Galopping	Corresponding figure
Smooth	0	× in y-direction (22.1m/s~25.8m/s)	o	Fig.6.3.35
	5	o	o	Fig.6.3.36
Turbulent	0	o	o	Fig.6.3.37
	5	o	o	Fig.6.3.38

“o” : The corresponding response was not observed.

“×” : The corresponding response occurred.

45

## Free vibration test of tower (AC),

### L-shaped aerodynamic device, length: variable

**Table 6.3.6** After completion (AC, With L-shaped aerodynamic device)

Flow condition	Yawing angle [deg]	Length of aerodynamic device [mm]	Vortex-induced vibration	Galopping	Corresponding figure
Smooth	0	141.7	× in y-direction (15.0m/s~40.0m/s)	o	Fig.6.3.39
	5	141.7	o	o	Fig.6.3.40
Turbulent	0	41.7	o	o	Fig.6.3.41
		141.7	o	o	Fig.6.3.42
		191.7	o	o	Fig.6.3.43
		233.4	o	o	Fig.6.3.44
	5	41.7	o	o	Fig.6.3.45
		141.7	o	o	Fig.6.3.46
		191.7	o	o	Fig.6.3.47
		233.4	o	o	Fig.6.3.48

“o” : The corresponding response was not observed.

“×” : The corresponding response occurred.

46



## Aerodynamic derivatives

For a body moving in heaving/torsional 2DOF under the approaching wind speed  $U$ , the motion-induced lift force and pitching moment is expressed as:

$$\begin{aligned} L &= \frac{1}{2} \rho (2b) U^2 \left\{ k H_1^* \frac{\dot{\eta}}{U} + k H_2^* \frac{b \dot{\phi}}{U} + k^2 H_3^* \phi + k^2 H_4^* \frac{\eta}{b} \right\} \\ M &= \frac{1}{2} \rho (2b^2) U^2 \left\{ k A_1^* \frac{\dot{\eta}}{U} + k A_2^* \frac{b \dot{\phi}}{U} + k^2 A_3^* \phi + k^2 A_4^* \frac{\eta}{b} \right\} \end{aligned} \quad (6.4.1)$$

Where,  $b$ : half chord length [m] ( $b=B/2$ ),  $\eta$ : heaving displacement [m] (positive downward),  $\phi$ : torsional displacement [rad] (positive nose-up),  $k$ : reduced frequency ( $k = b\omega/U$ ),  $\omega$ : circular frequency of the motion,  $H_i^*$ ,  $A_i^*$ , ( $i = 1, \dots, 4$ ): aerodynamic derivatives.

47

## Aerodynamic derivatives of Main girder

Incidence of wind: 0[deg.]  
In smooth flow

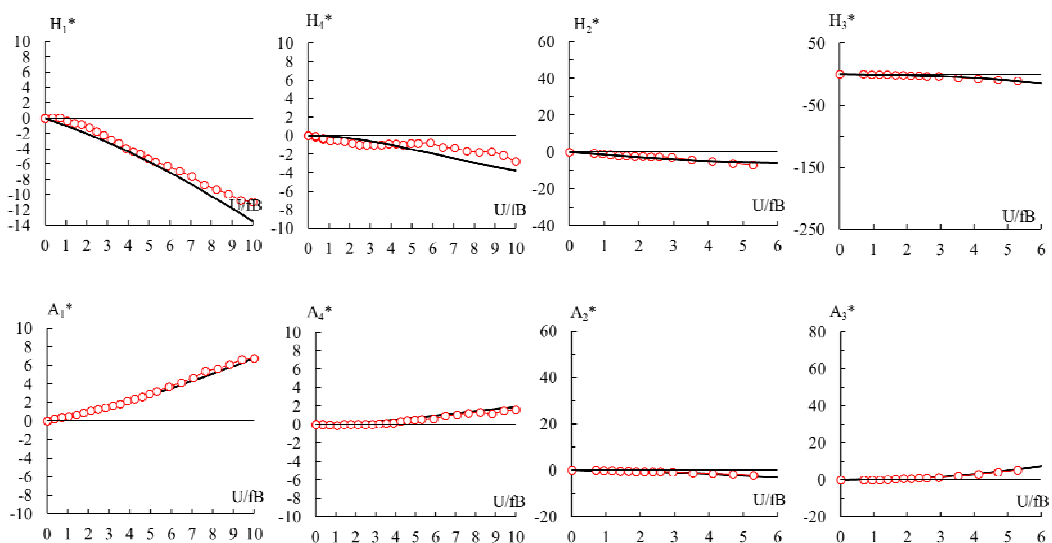

48

## Aero-static force components of Main girder

Drag force coefficient:

$$C_D = \frac{\text{drag force}}{\frac{1}{2}\rho U^2 DL} \quad (6.5.1)$$

Lift force coefficient:

$$C_L = \frac{\text{lift force}}{\frac{1}{2}\rho U^2 BL} \quad (6.5.2)$$

Pitching moment:

$$C_M = \frac{\text{pitching moment}}{\frac{1}{2}\rho U^2 B^2 L} \quad (6.5.3)$$

49

## Aero-static force components of Main girder (UC) (In smooth flow)

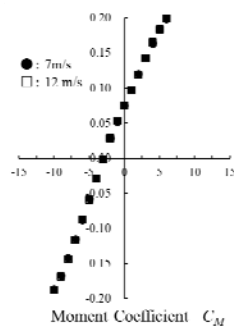
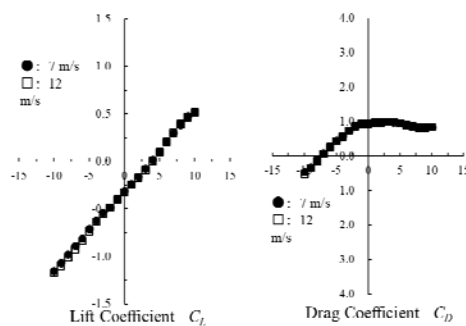

50

Aero-static force components  
of Main girder (UC)  
(In turbulent flow)

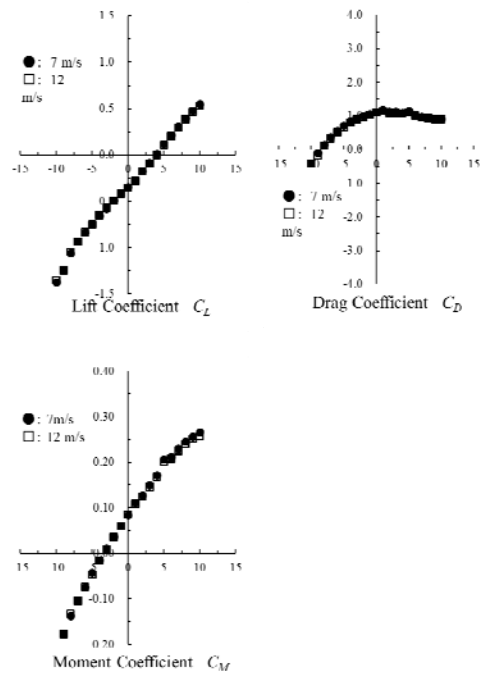

51

Aero-static force components  
of Main girder (AC)  
(In smooth flow)

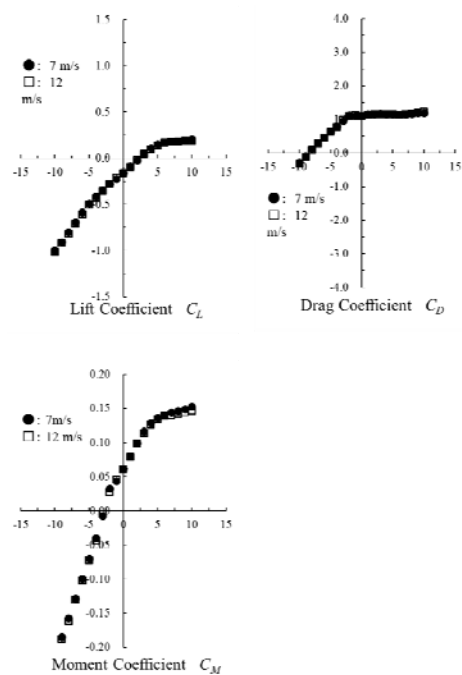

52

## Aero-static force components of Main girder (AC) (In turbulent flow)

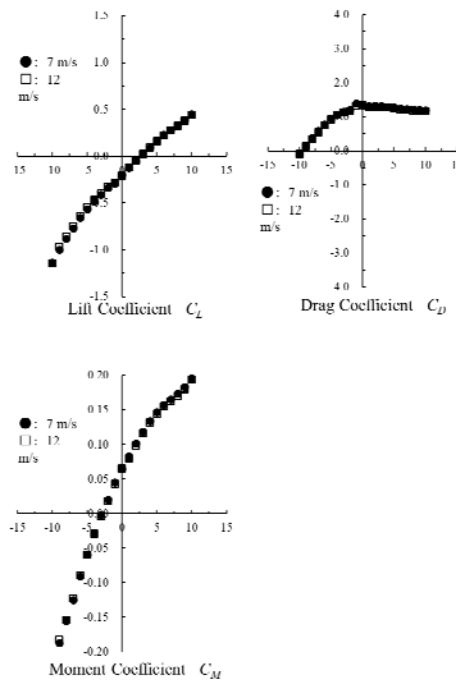

## Statistical analysis of wind speed record

The non-exceeding probability of yearly maximum value of 10-minutes mean wind speed  $x$  is described as:

$$\Pr[x_{\max}|_{\text{year}} < x^*] = \{P(x^*)\}^N \quad (7.1)$$

where,  $x_{\max}|_{\text{year}}$ : yearly maximum of  $x$ ,  $P(x)$ : non-exceeding probability of the wind speed

$x$  that is observed with a certain interval (Probability density function of  $P(x)$ ,  $p(x) = \frac{dP(x)}{dx}$ ,

is sometimes called as mother distribution.),  $N$ : number of observation in a year (If the interval is one hour,  $N=24*365=8760$ ).

## Statistical analysis of wind speed record

Fischer-Tippet type I (Gumbel distribution):

$$\Pr[x_{\max|year} < x^*] = \exp[-\exp\{a(x_{\max|year} - b)\}] \equiv F_I(x_{\max|year}) \quad (7.2)$$

The upper tail is expressed as:

$$P(x) = 1 - \exp\{-g(x)\} \quad (7.3)$$

In general, the non-exceeding probability of the extrema (yearly maximum) of the 10 minutes mean wind speed in Japan is well expressed by the Gumbel distribution as shown in eq.(7.2).

The parameters  $a$  and  $b$  are determined by the following formula:

$$a = \frac{\pi}{\sqrt{6}\sigma_x} = \frac{1}{0.780\sigma_x} \quad (7.10)$$

$$b = \bar{x} - 0.450\sigma_x \quad (7.11)$$

where,  $\sigma_x$ : standard deviation of  $x$ ,  $\bar{x}$ : average of  $x$ .

55

## Statistical analysis of wind speed record

The expected maximum wind speed for a given return period  $R$  is determined as follows:

By taking logarithm of times to both sides in eq.(7.2),

$$\ln[-\ln\{\Pr[x_{\max|year} < x^*]\}] = -a[x_{\max|year} - b] \quad (7.12)$$

The value of  $\Pr[x_{\max|year} < x^*]$  is related to  $R$  as shown below:

$$R = \{1 - \Pr[x_{\max|year} < x^*]\}^{-1} \quad (7.13)$$

56

## Statistical analysis of wind speed record (at Yangon Int. Airport, May, 2014 to April, 2016)

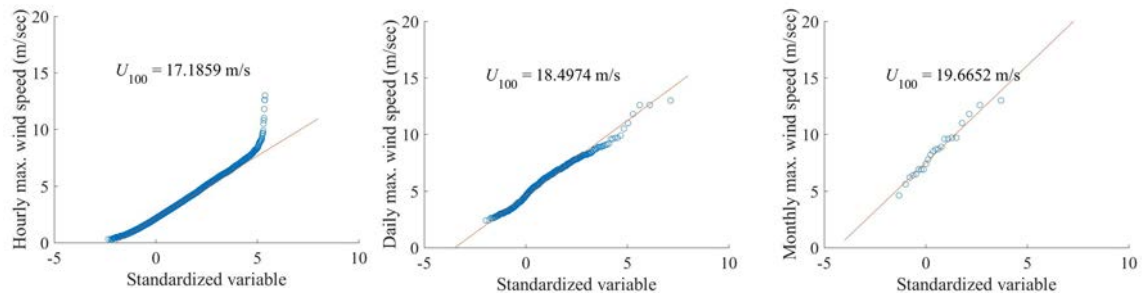

57

## Statistical analysis of wind speed record (at Power plant in Thilawa, August, 2015 to May, 2016)

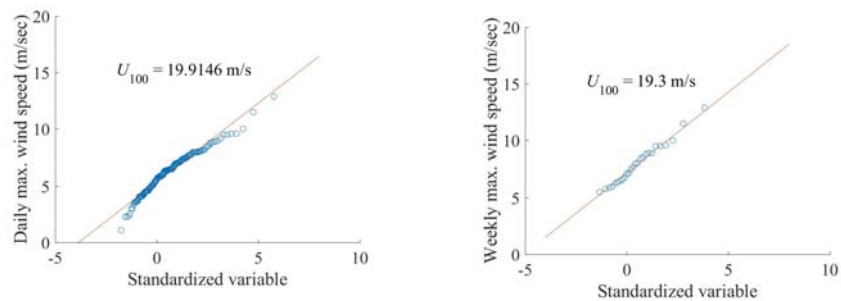

58

## Recommendation to Cable vibration

The cable of the bridge may suffer from aerodynamic vibration such as rain wind induced vibration. According to the Wind resistant design handbook [1], cables are estimated to be stable for wind if their Scruton number  $Sc$  ( $Sc=2m\delta/\rho D^2$ ,  $m$ : mass of a cable per unit length,  $\delta$ : logarithmic damping decrement,  $\rho$ : air density [ $\text{kg}/\text{m}^3$ ] and  $D$ : cable diameter [m]) is 140 to 200, which corresponds to  $d =$  about 0.02 to 0.03.

Cable vibration is one of the academic research subjects and there is still discussion on its generation mechanism and the effect of wind turbulence. Therefore, it should be conservative to recommend to install a rubber damper in order to achieve the above damping.

To install pedestals on the deck is also recommended. This enables to install a conventional damper if cable vibration will become a major concern after completion.

2<sup>nd</sup> semester, 2017  
Earthquake and Wind resistance of Structures,  
and Related Structural Design Principles

## Wind Resistance on Structures (Wind Engineering)

Hikomichi Shirato  
Professor, Bridge Engineering Lab.  
Dep't. of Civil and Earth Resources Eng.

- 1) Aerodynamics of structures (Bluff body aerodynamics)  
17 and 19, Jan., 2018
- 2) Characteristics of natural wind and Design wind load  
23, Jan., 2018
- 3) Wind resistant design  
26, Jan., 2018

1

2<sup>nd</sup> semester, 2016  
Earthquake and Wind resistance of Structures,  
and Related Structural Design Principles

## 1) Aerodynamics of structures

-Bluff body aerodynamics-

2



Flow around a circular cylinder in perfect fluid  
( $Re \rightarrow \infty$ )

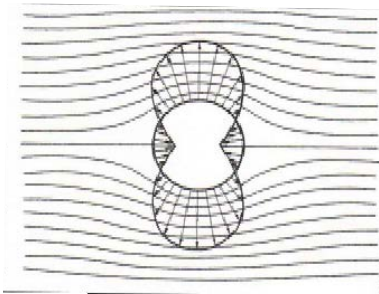

D'Alembert's paradox

3

Pressure distribution on surface of a circular cylinder  
in real flow

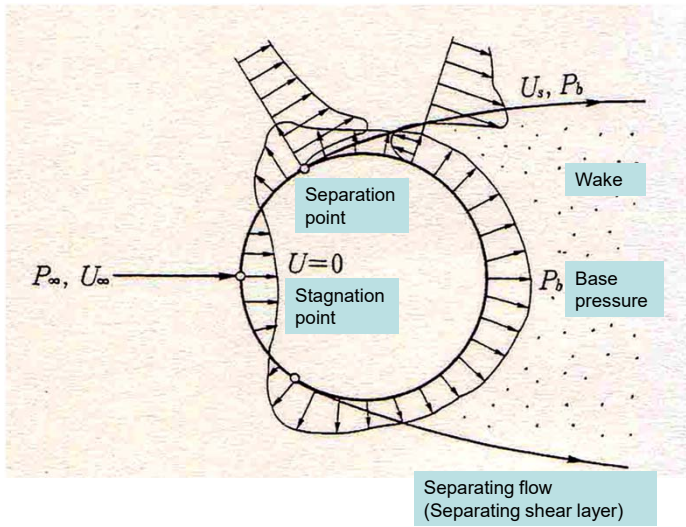

4

### Boundary layer on surface of a circular cylinder and flow separation

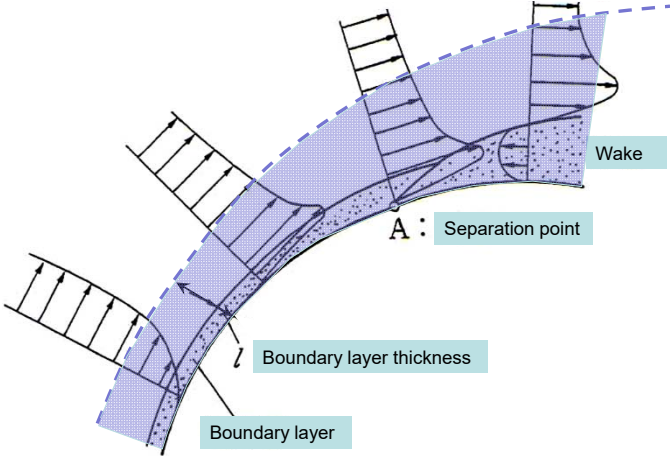

5

### Turbulence transition near the critical Reynolds number

Subcritical  
( $Re=260\sim 2.8 \times 10^5$ )

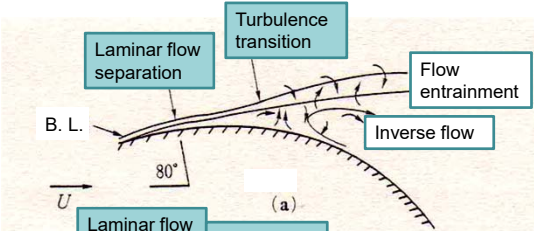

Critical  
( $Re=2.8\sim 3.5 \times 10^5$ )

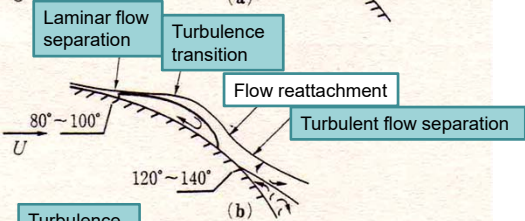

Supercritical  
( $Re=3.5\sim 15 \times 10^5$ )

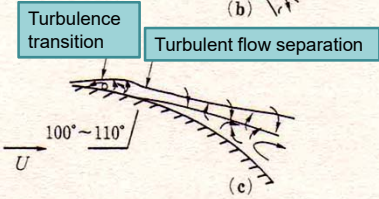

Hypercritical  
( $Re>1 \times 10^6$ )

6

Flow pattern around a circular cylinder and its aerodynamic characteristics with Reynolds number

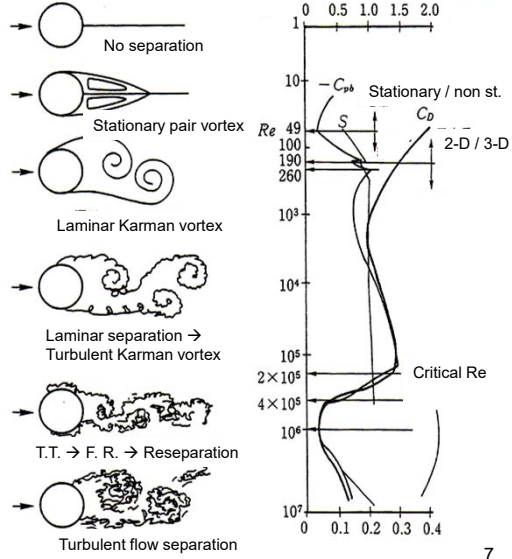

Effect of turbulence on  $C_D$  of a circular cylinder

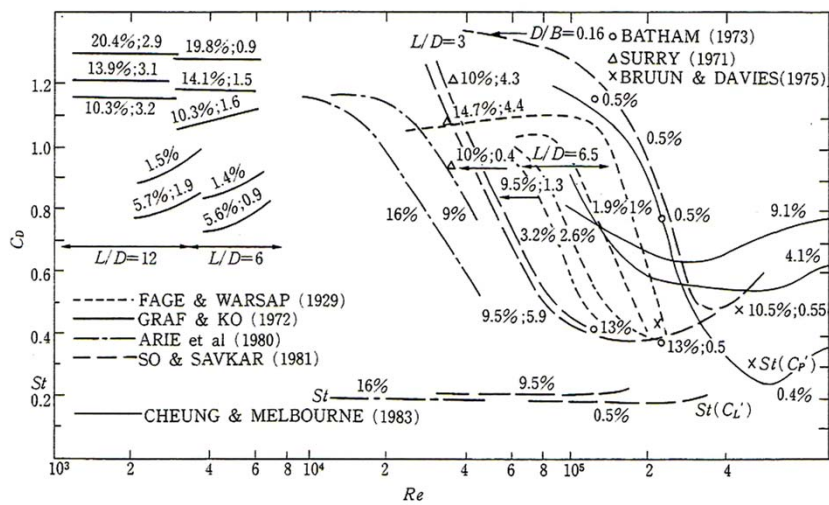

### Effect of surface roughness on $C_D$ of a circular cylinder

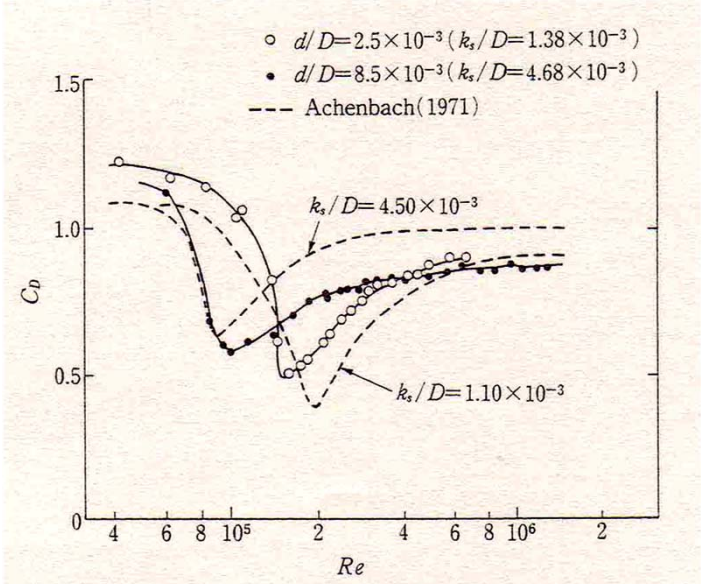

9

### Surface pressure distribution and time integrated flow pattern around a rectangular prism ( $b/d=1.0$ )

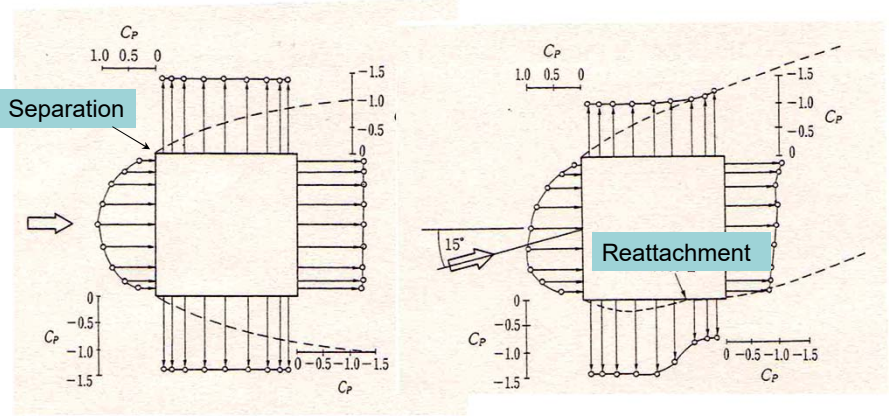

10

### Surface pressure distribution and time integrated flow pattern around a rectangular prism ( $b/d > 2.8$ )

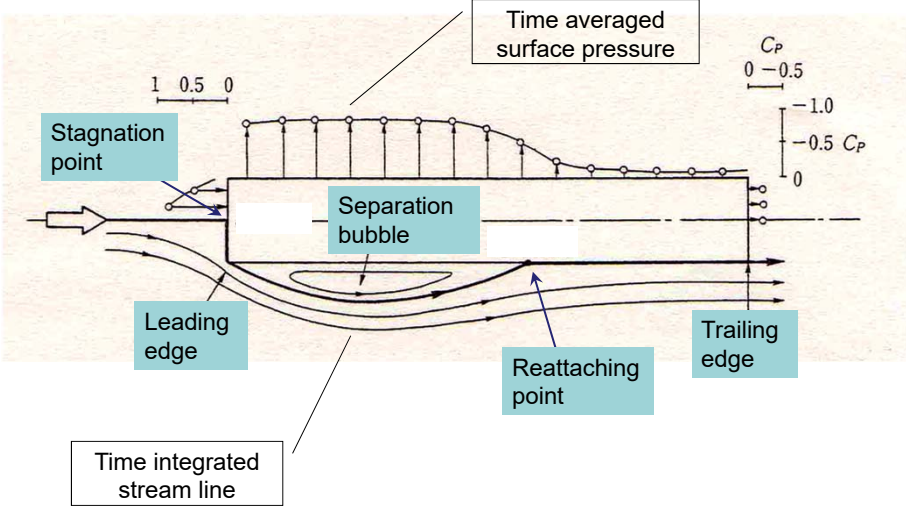

11

### Dependence of aerodynamic characteristics on slenderness ratio ( $b/d$ ) of a rectangular prism

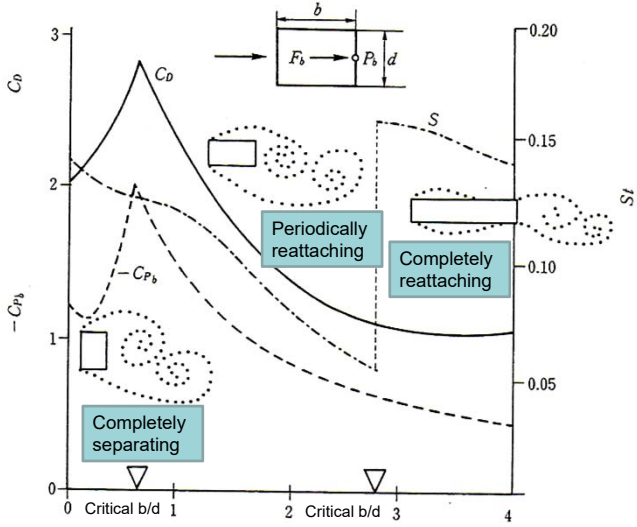

12

Conical vortex and surface pressure on roof of a flat-roof building

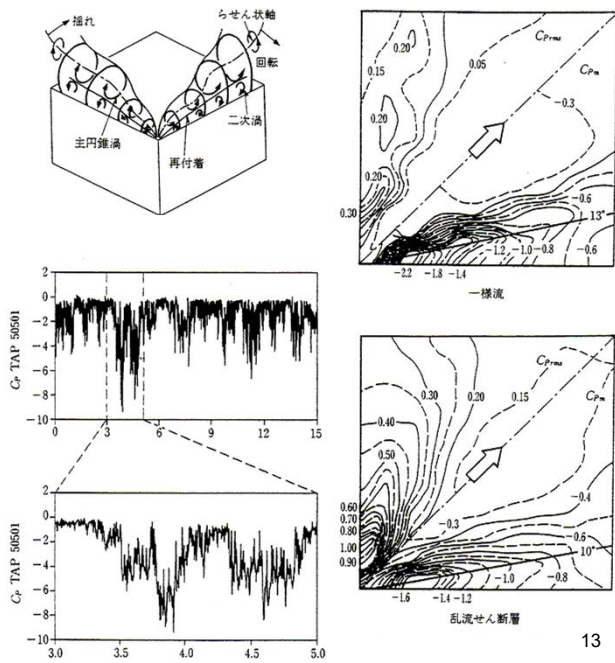

13

Effect of turbulence on  $C_D$  of a rectangular prism

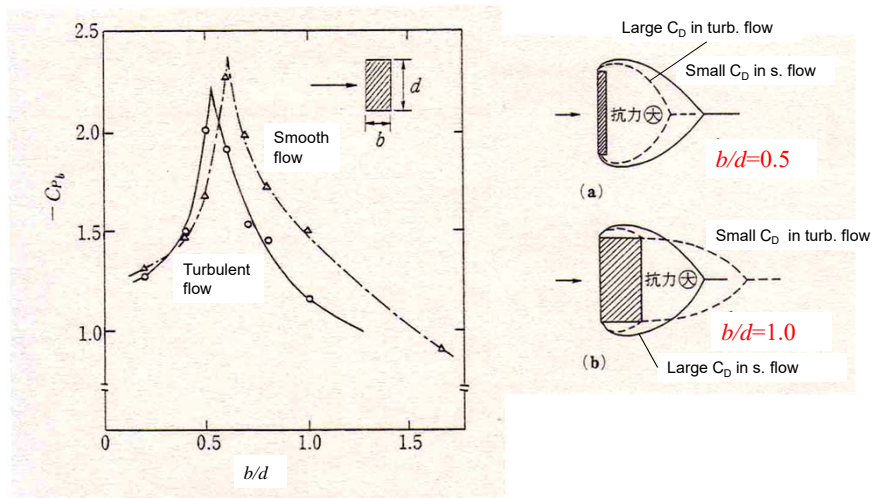

14

## Dependence of $C_D$ on turbulence intensity

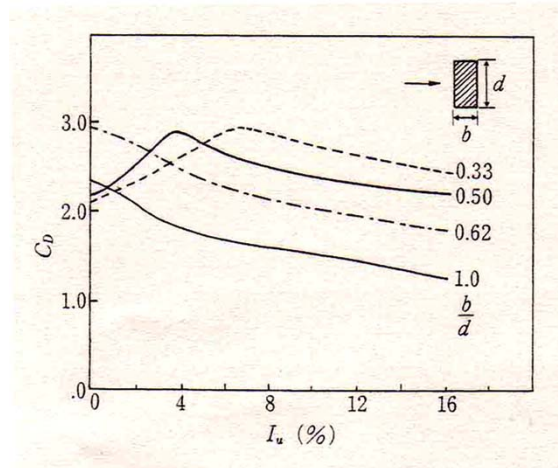

15

## Aerodynamic phenomena

- Vortex-induced vibration
- Galloping
- Flutter
- Gust response, Buffeting
- Cable vibration

Wake galloping

Rain-wind-induced vibration

Dry state galloping

16

- Vortex-Induced Vibration, VIV

An aerodynamic vibration phenomenon due to **synchronization** of Karman vortex shedding frequency and natural frequency of structure (Karman vortex type VIV, KV)

An aerodynamic vibration phenomenon due to the **separation vortex** at the leading edge which is generated by the motion of structure itself and its growth up by amalgamating with another separation vortex at the trailing edge (Movement-induced type VIV, MIV)

VIV appears as an harmonic vibration with limited amplitude under constant wind velocity

VIV occurs in heaving mode (transverse, cross wind direction to approaching wind), in torsional mode (twisting mode around the member axis of structure) and in in-line mode (longitudinal mode)

VIV occurs only in limited wind velocity region

The formula to predict the onset wind velocity of VIV is proposed.

KV	$U_{KVh} = \frac{1}{St} \cdot f_n \cdot D$ (for heaving), $U_{KVt} = \frac{1}{St} \cdot f_i \cdot D$ (for torsional)	St : Strouhal number B : Width of cross section [m]
MIV	$U_{MIVh} = 1.67 \cdot B \cdot f_n$ (for heaving), $U_{MIVt} = 1.11 \cdot B \cdot f_i$ (for torsional)	D : Depth of cross section [m] $f_n$ : Natural frequency of heaving mode [Hz] $f_i$ : Natural frequency of torsional mode [Hz]

- Galloping

An aerodynamic vibration phenomenon which occurs when the direction of the quasi-steady lift force(\*) corresponding to the relative incidence angle of wind(\*\*) is identical to the direction of heaving vibration.

\* Time averaged lift force for a still cross section for the relative incidence angle of wind

\*\* The vertical angle of the relative wind velocity being composed by the horizontal approaching wind  $U$  and the velocity of heaving displacement  $dy/dt$

Galloping appears as an harmonic vibration with diverging heaving amplitude .

Galloping occurs if the approaching wind velocity is beyond the critical wind velocity.

Analytical formula to predict the critical wind velocity of Galloping is proposed. (Den Hartog's criteria)

The system is unstable for Galloping, if  $\frac{dC_L}{d\alpha} < 0$  .

$C_L$  : lift force coefficient with respect to structural axis



- **Flutter**

An aerodynamic vibration phenomenon induced by the time-dependent aerodynamic forces generated by self-induced motion of structure (self-induced aerodynamic forces).

Self-induced aerodynamic forces can be measured in wind tunnel or be evaluated by the help of CFD for general cross section geometry of structures.

Self-induced aerodynamic lift and pitching moment can be obtained analytically for a thin flat plate and a thin airfoil.

Flutter appears as an harmonic vibration with diverging amplitude with torsional 1dof (torsional flutter) or with heaving and torsional 2dof (coupled flutter).

Flutter occurs if the approaching wind velocity is beyond the critical wind velocity.

Flutter analysis should be conducted to predict the critical wind velocity.

19

- **Buffeting, Gust Response**

Buffeting or gust response is random vibration due to wind turbulence.

Wind tunnel experiment should be conducted to evaluate aerodynamic gust forces with enough precision.

Buffeting response analysis proposed by Davenport in 1961 is applied to evaluate not only buffeting response but also to determine wind load for wind resistant design.

Buffeting can be appeared in any wind velocity, but its amplitude is proportional to the square of wind velocity.

20

# Vortex-Induced Vibration, Galloping, Flutter

## Karman VIV, KV

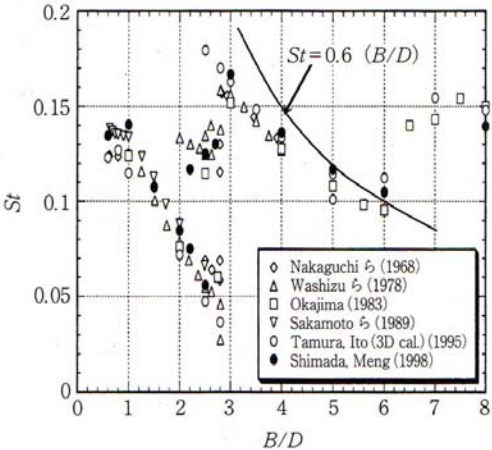

Strouhal Number

$$St = \frac{f_s D}{U}$$

- $f_s$  : vortex shedding frequency [Hz]
- $D$  : depth of cross section [m]
- $U$  : wind velocity [m/s]

KV occurs at  $U=U_{cr}$  where  $f_s$  is equal to natural freq.

Strouhal number of a rectangular prism

VIV (movement-induced type), MIV

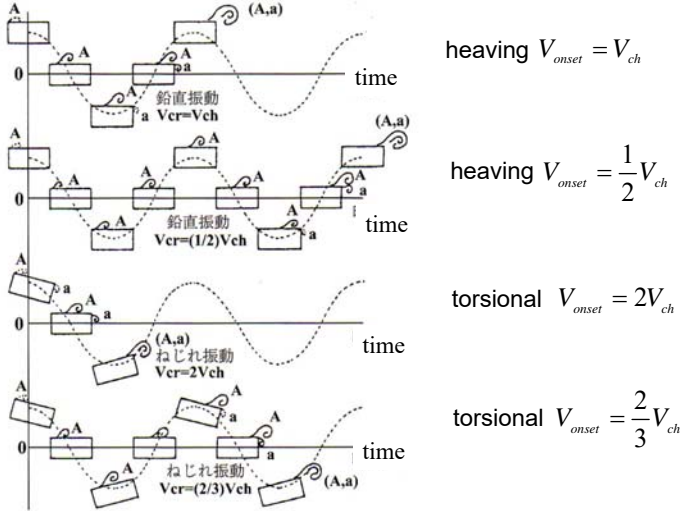

23

Time for one separation vortex travelling along the side surface of cross section and reach to the trailing edge,  $t_{travel}$

$$t_{travel} = \frac{B}{0.6U} = \begin{cases} T_h = \frac{1}{f_h} \\ 2T_h = \frac{2}{f_h} \\ 0.5T_t = \frac{1}{2f_t} \\ 1.5T_t = \frac{3}{2f_t} \end{cases}$$

$f_h$  : natural frequency for heaving mode [Hz]  
 $f_t$  : natural frequency for torsional mode [Hz]

$$V_{ch} = \frac{U}{f_h D} = \frac{1}{0.6} \frac{B}{D} \cong 1.67 \frac{B}{D}$$

24

# Aerodynamic countermeasure

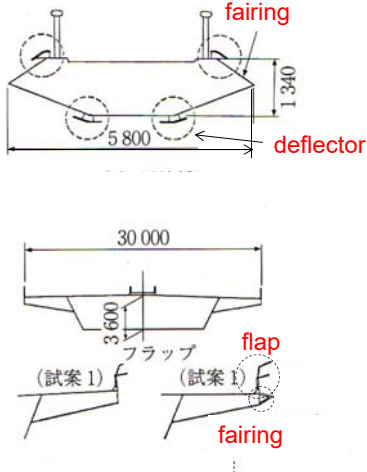

# Galloping, Flutter

# Galloping

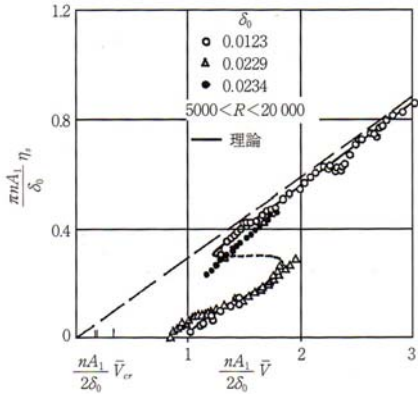
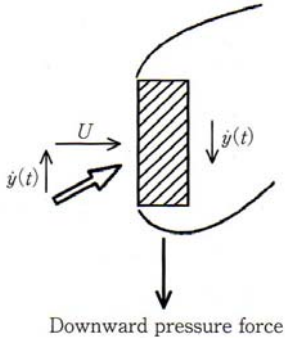

27

$$m\{\ddot{y} + 2\zeta\omega\dot{y} + \omega^2 y\} = -\frac{1}{2}\rho U^2 D l C_L(\alpha) \quad C_L = \frac{\text{Lift}}{\frac{1}{2}\rho U^2 D l}$$

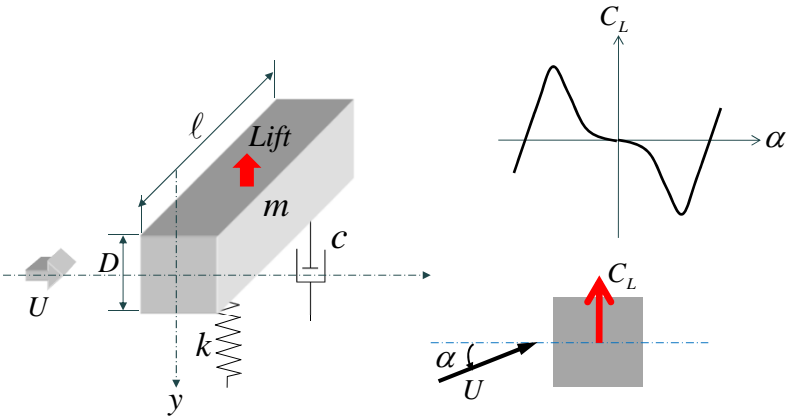

28

$$C_L(\alpha) = C_L(0) + \frac{dC_L}{d\alpha} \alpha - \frac{d^3 C_L}{d\alpha^3} \alpha^3 + \dots$$

$$\alpha = \tan^{-1}\left(\frac{\dot{y}}{U}\right) \cong \frac{\dot{y}}{U}, \quad C_L(0) = 0$$

$$\therefore C_L\left(\frac{\dot{y}}{U}\right) = \frac{dC_L}{d\alpha} \frac{\dot{y}}{U}$$

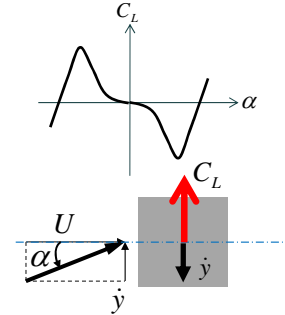

$$m\{\ddot{y} + 2\zeta\omega\dot{y} + \omega^2 y\} = -\frac{1}{2}\rho U^2 D\ell \frac{dC_L}{d\alpha} \frac{\dot{y}}{U}$$

29

### Linear equation of motion

$$m\{\ddot{y} + 2\zeta\omega\dot{y} + \omega^2 y\} = -\frac{1}{2}\rho U^2 D\ell \frac{dC_L}{d\alpha} \frac{\dot{y}}{U}$$

*damping term*

$$2\omega\left(\zeta + \frac{\rho U D \ell}{4m\omega} \frac{dC_L}{d\alpha}\right)\dot{y} \quad \text{If } \frac{dC_L}{d\alpha} < 0, \text{ the system will be unstable when}$$

$$U > \frac{4m\zeta\omega}{\rho D \ell |a_1|}$$

*Den Hartog's criteria*<sub>30</sub>

## Flutter --- self-induced vibration due to motion-induced aerodynamic forces

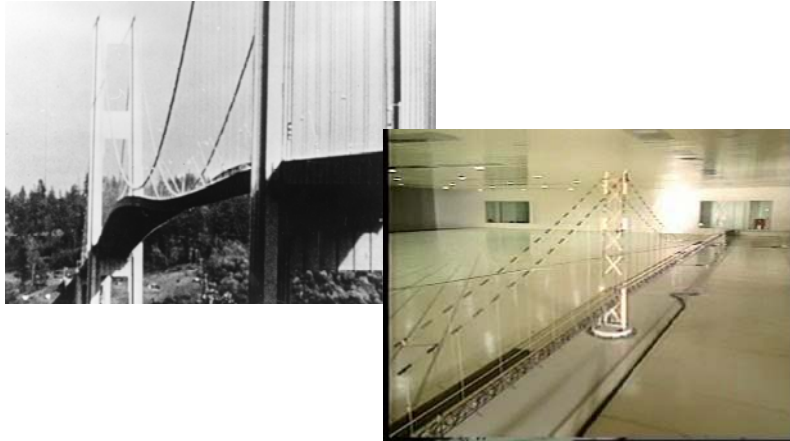

31

## Motion-induced Aerodynamic Force

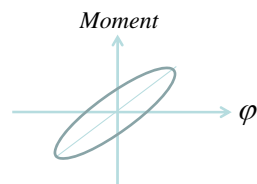

$$\begin{aligned} \varphi &= \varphi_0 \cos \omega t \\ M &= M_0 \cos(\omega t - \theta) \\ &= M_0 \cos \omega t \cos \theta + \sin \omega t \sin \theta \\ &= M_0 \left( \frac{\varphi}{\varphi_0} \cos \theta - \frac{\dot{\varphi}}{\varphi_0 \omega} \sin \theta \right) \end{aligned}$$

$$\left[ \begin{aligned} W &= \oint M d\varphi \\ &= \int_0^{2\pi/\omega} M \dot{\varphi} dt \\ &= -\pi M_0 \varphi_0 \sin \theta \end{aligned} \right. \quad \text{negative workdone for positive } \theta$$

32

Linear system of 2 dof

$$L = \frac{1}{2} \rho (2b) U^2 \left( kH_1^* \frac{\dot{\eta}}{U} + kH_2^* \frac{b\dot{\phi}}{U} + k^2 H_3^* \varphi + k^2 H_4^* \frac{\eta}{b} \right)$$

$$M = \frac{1}{2} \rho (2b^2) U^2 \left( kA_1^* \frac{\dot{\eta}}{U} + kA_2^* \frac{b\dot{\phi}}{U} + k^2 A_3^* \varphi + k^2 A_4^* \frac{\eta}{b} \right)$$

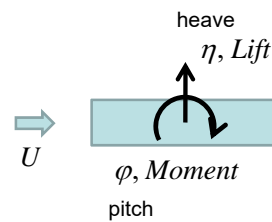

33

$$[M]\{\ddot{Z}\} + [C]\{\dot{Z}\} + [K]\{Z\} = [A]\{\dot{Z}\} + [B]\{Z\}$$

$$\{Z\} = \begin{Bmatrix} \eta_0 \\ \varphi_0 \end{Bmatrix} e^{\lambda t} = \{Z_0\} e^{\lambda t}$$

$$[M] = \begin{bmatrix} m & 0 \\ 0 & I \end{bmatrix}, [C] = \begin{bmatrix} C_\eta & 0 \\ 0 & C_\varphi \end{bmatrix} = \begin{bmatrix} 2m\zeta_\eta \omega_\eta & 0 \\ 0 & 2I\zeta_\varphi \omega_\varphi \end{bmatrix}$$

$$[K] = \begin{bmatrix} k_\eta & 0 \\ 0 & k_\varphi \end{bmatrix} = \begin{bmatrix} m\omega_\eta^2 & 0 \\ 0 & I\omega_\varphi^2 \end{bmatrix}$$

$$[A] = \begin{bmatrix} \rho b^2 \omega H_1^* & \rho b^3 \omega H_2^* \\ \rho b^3 \omega A_1^* & \rho b^4 \omega A_2^* \end{bmatrix}, [B] = \begin{bmatrix} \rho b^2 \omega^2 H_4^* & \rho b^3 \omega^2 H_3^* \\ \rho b^3 \omega^2 A_4^* & \rho b^4 \omega^2 A_3^* \end{bmatrix}$$

State vector  $\{Y\} = \begin{Bmatrix} \lambda[Z] \\ [Z] \end{Bmatrix}$

$$[A^*]\{Y\} = \lambda[\mu]\{Y\} \quad \text{Eigen value problem}$$

$$[A^*] = \begin{bmatrix} -([C]-[A]) & -([K]-[B]) \\ [M] & [0] \end{bmatrix}, [\mu] = \begin{bmatrix} [M] & [0] \\ [0] & [M] \end{bmatrix}$$

34



Eigen equation

$$[[A^*] - \lambda[\mu]] = 0$$

Eigen value

$$\lambda_j = (-\zeta_j + i)\omega_j \quad (j = 1,2)$$

$\zeta_j$  : critical damping ratio for  $j$ -th mode

$\omega_j$  : natural circular frequency for  $j$ -th mode

$$\{Z\} = \begin{Bmatrix} \eta_0 \\ \phi_0 \end{Bmatrix} e^{i\omega t} = \{Z_0\} e^{i\omega t}$$

Amplitude vector for  $j$ -th mode

$$\{Z_{0j}\} = \begin{Bmatrix} \eta_{0j} \\ \phi_{0j} \end{Bmatrix}$$

Amplitude ratio, phase for  $j$ -th mode

$$R_j = \frac{|\eta_{0j}|}{|\phi_{0j}|}, \quad \Psi_j = \tan^{-1} \frac{C_{Ij}}{C_{Rj}} \quad \left( C_{Rj} + iC_{Ij} = \frac{\eta_{0j}}{\phi_{0j}} \right)$$

35

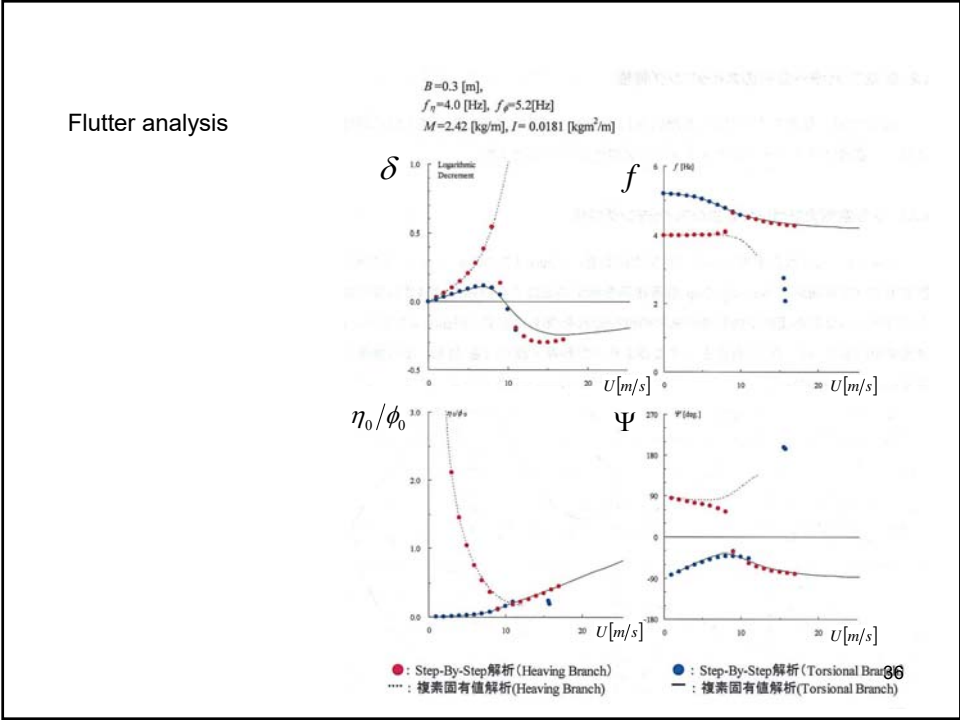

### Torsional flutter

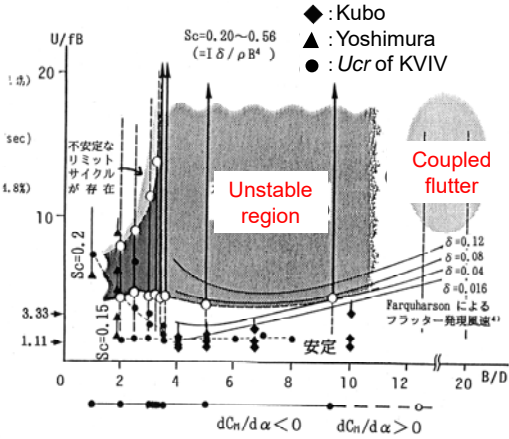

Aerodynamically unstable region for torsional flutter on a 2-D H-shaped section model (in smooth flow, for  $2A_1=1$  [deg])

### Buffeting

## Buffeting (Gust Response)

- Structural response due to sudden change of wind velocity (“gust”, “gusty wind”)
- Structural response due to **turbulence**
- **Random vibration**
- Maximum wind vel., turbulence, structural dynamics, max. displ./stress
- Important from design point of view

39

Equation of motion for along wind displacement of a girder  $y(x,t)$

$$m(x)\ddot{y}(x,t) + c(x)\dot{y}(x,t) + (EI(x)y'')' = p(x,t)$$

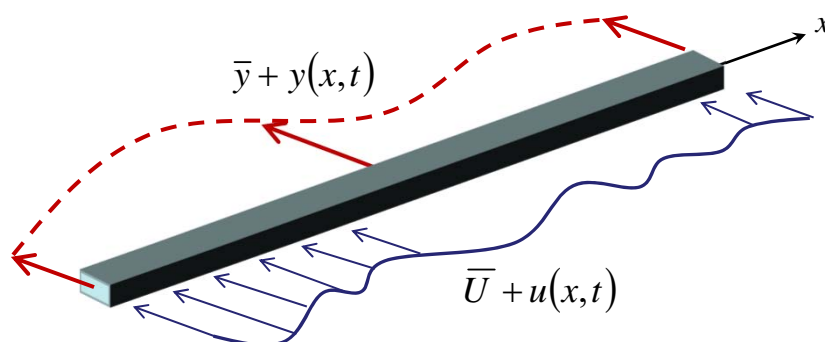

40

**Power spectral density (PSD)** of along wind displacement  $S_y(x; f)$   
 $y(x, t)$  of a bridge girder element at location  $x$  along bridge axis

$$S_y(x; f) = \sum_j S_{q_{y_j}}(f) \phi_j^2(x)$$

$$S_{q_{y_j}}(f) = \frac{4\bar{P}^2 \left\{ \int_L \phi_j^2(x) dx \right\}^2}{\bar{U}^2 \omega_j^4 \left\{ \int_L m(x) \phi_j^2(x) dx \right\}^2} \left| \chi_{d_j}(f) \right|^2 \left| \chi_A(f) \right|^2 \left| J_j(f) \right|^2 S_u(f)$$

$S_{q_{y_j}}(f)$  : **PSD** of generalized coordinate for  $j$ -th mode of  $q_{y_j}(t)$

$\phi_j(x)$  :  $j$ -th modal function (mode vector)

$\bar{P} = \frac{1}{2} \rho \bar{U}^2 C_D(0) D$      $\bar{P}$  : time averaged drag force per unit span length  
 (drag force due to average wind speed)

$\rho$  : air density [kg/m<sup>3</sup>]     $\bar{U}$  : average wind speed [m/s]

$C_D(0)$  : drag force coefficient     $D$  : girder height [m]

**PSD: one-sided spectrum** 41

**Power spectral density (PSD)** of along wind displacement  $S_y(x; f)$   
 $y(x, t)$  of a bridge girder element at location  $x$  along bridge axis

$$S_y(x; f) = \sum_j S_{q_{y_j}}(f) \phi_j^2(x)$$

$$S_{q_{y_j}}(f) = \frac{4\bar{P}^2 \left\{ \int_L \phi_j^2(x) dx \right\}^2}{\bar{U}^2 \omega_j^2 \left\{ \int_L m(x) \phi_j^2(x) dx \right\}^2} \left| \chi_{d_j}(f) \right|^2 \left| \chi_A(f) \right|^2 \left| J_j(f) \right|^2 S_u(f)$$

$\left| \chi_{d_j}(f) \right|^2$  : **dynamic magnification** for  $j$ -th mode

$\left| \chi_A(f) \right|^2$  : **aerodynamic admittance**

$\left| J_j(f) \right|^2$  : **joint mode acceptance**

$S_u(f)$  : PSD of wind speed fluctuation  $u(t)$  [m<sup>2</sup>/s<sup>2</sup>/Hz]

**PSD: one-sided spectrum** 42

### Expected maximum value for displacement and sectional force

$$\text{displacement: } S_y(x; f) = \sum_j S_{q_{y_j}}(f) \phi_j^2(x)$$

$$\text{bending moment: } S_M(x; f) = \{EI(x)\}^2 \sum_j S_{q_{y_j}}(f) \{\phi''(x)\}^2$$

$$\text{shear force: } S_Q(x; f) = \sum_j S_{q_{y_j}}(f) \{EI(x)\phi''(x)\}^2$$

$$\bar{y}_{\max} = G\bar{y} = \bar{y} \left\{ 1 + g(vT) \frac{\sigma_x}{\bar{y}} \right\} \quad G: \text{ gust factor}$$

$$g(vT) = \sqrt{2 \ln vT} + \frac{\alpha}{\sqrt{2 \ln vT}} \quad g(vT) : \text{ peak gust factor}$$

$$\alpha = 1, 0.5772$$

$$v = \left\{ \frac{\int_0^\infty f^2 S_y(f) df}{\int_0^\infty S_y(f) df} \right\}^{\frac{1}{2}} \quad v : \text{ peak response factor}$$

$$T = 600[s]$$

43

## Cable vibration

44

## Design of Cable-Stayed Bridge

- Stay-cables are vibrating on many bridges in all over the world.
- Mechanisms of wind-induced instabilities have not totally clarified yet.
- Mitigation of wind-induced cable vibration is still one of the most important issue on the design of cable-stayed bridges.



## Rain-Wind Induced Vibration





### Galloping??

August 21, 2001 12:21 - 12:41  
Typhoon Pabuk (T0111)

**Mean Wind Velocity:**  
13.2m/s (20 min.)

**Mean Wind Direction:**  
126 deg. (ESE-SE)

**Maximum Wind Speed:**  
35.3m/s

**Rainfall:**  
37mm/h

N  
Tower  
W · · · · · E  
Ground  
S

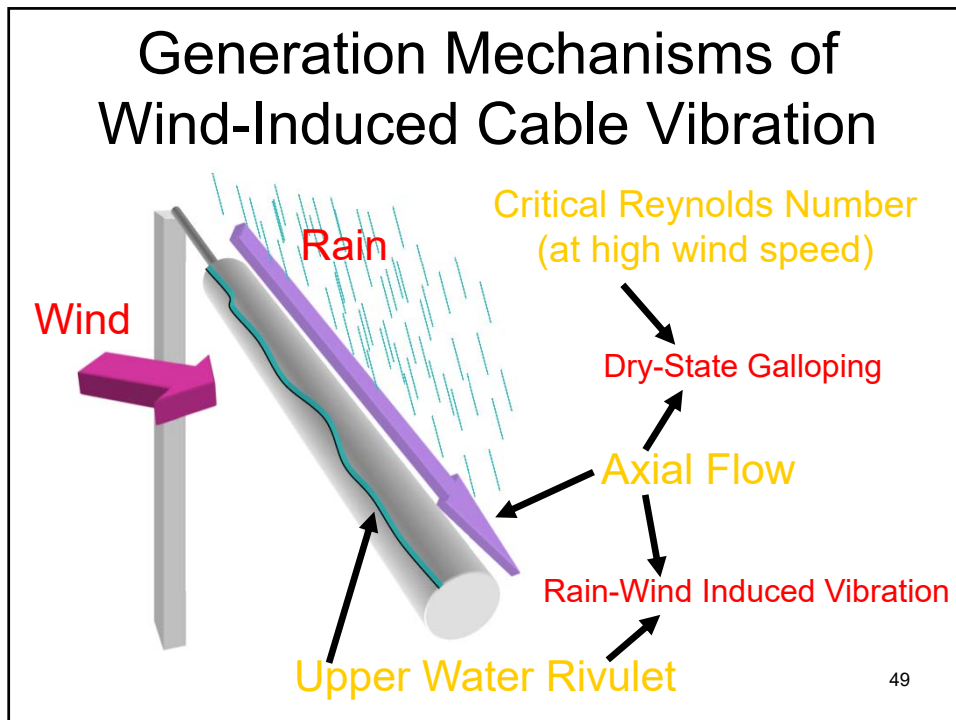

## Cable Aerodynamics of **Single Cable**

- Vortex-induced vibration (with/without rain)
  - Strouhal number:  $St = fsD/U = 0.2$  (circular cylinder)
  - $St = fsD/U = 0.1-0.2$  (inclined circular cylinder)
  - Onset wind velocity:  $U/fD = 5$  (circular cylinder)
  - $U/fD = 5-10$  (inclined circular cylinder)
- Rain-wind induced vibration (**with rain**)
  - Water rivulet
  - Axial flow
  - etc.
- Dry-state galloping (**without rain**)
  - Axial flow
  - Critical Reynolds number
  - etc.



# Cable Aerodynamics of **Parallel** Cables

- Aerodynamics of single cable
- Wake galloping
  - Cable separation < 5 or 6D
  - Onset wind velocity  $U/fD > 20$
  - 1<sup>st</sup> mode vibration
  - Sub-span vibrations (with spacers)
- Wake-induced flutter
  - Cable separation = 8 or 10 - 20D
  - Parallel hanger ropes of Akashi Kaikyo Bridge



## High-speed VIV

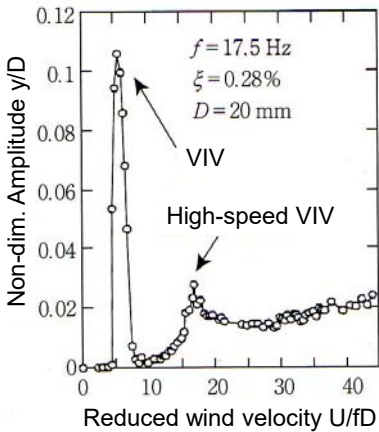

VIV for cylindrical tower

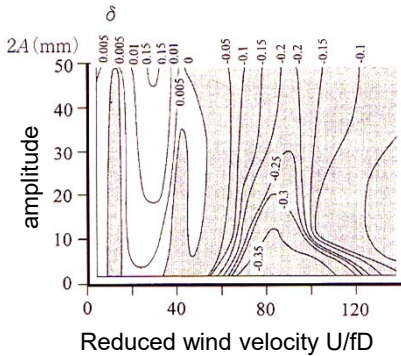

VIV, Galloping and High-speed VIV for an inclined circular cylinder

### Symmetrical vortex



53

### High-speed galloping and low-speed galloping

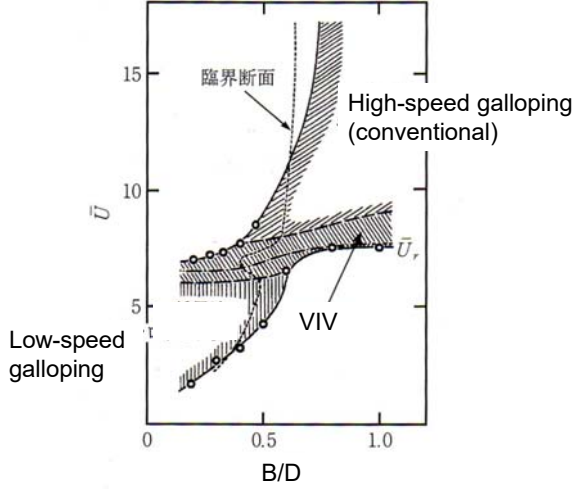

54

Time integrated streamline and wake stagnation point

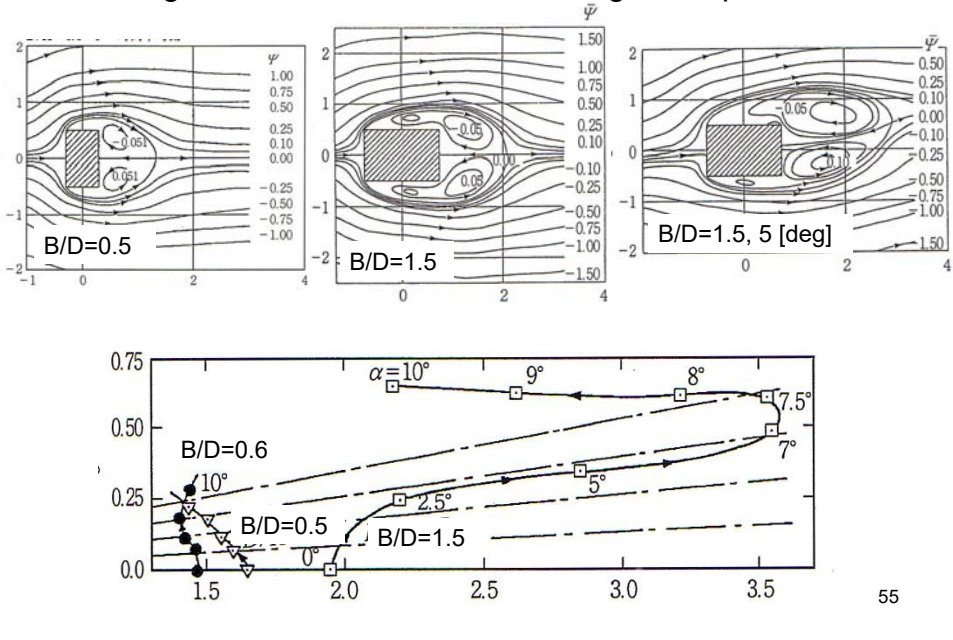

55

Motion-induced Aerodynamic Force

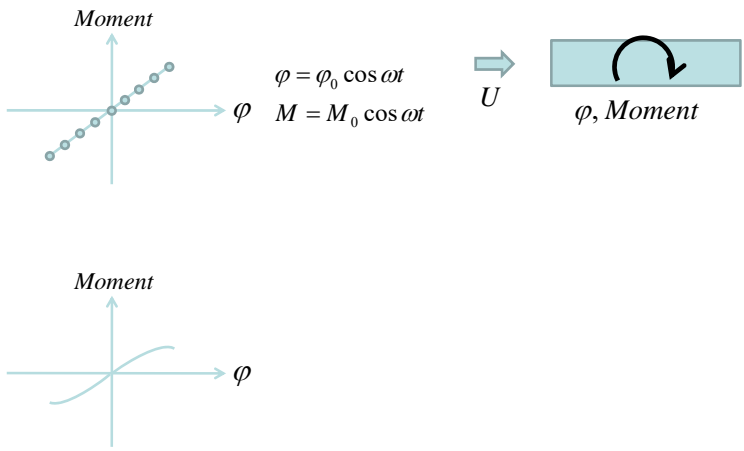

56

Linear system of multi-degree of freedom  
 --Flutter equation--

$$m(\ddot{\eta} + 2\zeta_{\eta 0}\omega_{\eta 0}\dot{\eta} + \omega_{\eta 0}^2\eta) = \frac{1}{4}\rho U^2 B \left( kH_1^* \frac{\dot{\eta}}{U} + kH_2^* \frac{B\dot{\phi}}{U} + k^2 H_3^* \varphi + k^2 H_4^* \frac{\eta}{U} + kH_5^* \frac{\dot{p}}{U} + k^2 H_6^* \frac{p}{B} \right)$$

$$m(\ddot{p} + 2\zeta_{p 0}\omega_{p 0}\dot{p} + \omega_{p 0}^2 p) = \frac{1}{4}\rho U^2 B \left( kP_1^* \frac{\dot{\eta}}{U} + kP_2^* \frac{B\dot{\phi}}{U} + k^2 P_3^* \varphi + k^2 P_4^* \frac{\eta}{U} + kP_5^* \frac{\dot{p}}{U} + k^2 P_6^* \frac{p}{B} \right)$$

$$I(\ddot{\phi} + 2\zeta_{\phi 0}\omega_{\phi 0}\dot{\phi} + \omega_{\phi 0}^2 \phi) = \frac{1}{4}\rho U^2 B^2 \left( kA_1^* \frac{\dot{\eta}}{U} + kA_2^* \frac{B\dot{\phi}}{U} + k^2 A_3^* \varphi + k^2 A_4^* \frac{\eta}{U} + kA_5^* \frac{\dot{p}}{U} + k^2 A_6^* \frac{p}{B} \right)$$

The aerodynamic derivatives,

$$H_i^*, P_i^*, A_i^* (i = 1, 2, 3, 4, 5, 6)$$

are functions of  $k \left( = \frac{b\omega}{U} \right)$ .

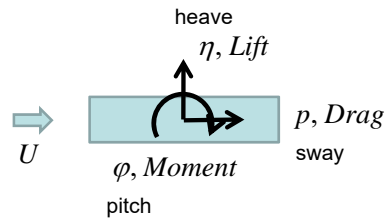

57

Spectral density

Frequency distribution of  $x(t)$

A sample function is generally,

- 1) non-periodic → Fourier analysis cannot be applied.
- 2) infinite data → The condition of  $\int_{-\infty}^{\infty} |x(t)| dt < \infty$  is not satisfied, and therefore Fourier's transform cannot be applied.



Auto correlation function  $R_x(\tau)$ , instead of  $x(t)$

$x(t)$  and  $x(t+\tau)$  are in phase:  $R_x(\tau)=1$  (fully correlated)

$x(t)$  and  $x(t+\tau)$  are out of phase:  $R_x(\tau)=-1$  (fully anti-correlated)

→ Frequency dist. of  $R_x(\tau)$  represents those of  $x(t)$ .

58

### Fourier analysis

Arbitrary periodic function

$$x(t) = a_0 + a_1 \cos \frac{2\pi t}{T} + a_2 \cos \frac{4\pi t}{T} + \dots + b_1 \sin \frac{2\pi t}{T} + b_2 \sin \frac{4\pi t}{T} + \dots$$

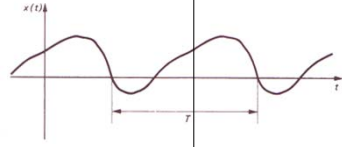
$$= a_0 + \sum_{k=1}^{\infty} \left( a_k \cos \frac{2\pi kt}{T} + b_k \sin \frac{2\pi kt}{T} \right)$$

$a_0 = \frac{1}{T} \int_{-T/2}^{T/2} x(t) dt$   
 $a_k = \frac{2}{T} \int_{-T/2}^{T/2} x(t) \cos \frac{2\pi kt}{T} dt$   
 $b_k = \frac{2}{T} \int_{-T/2}^{T/2} x(t) \sin \frac{2\pi kt}{T} dt$

$\omega_k = \frac{2\pi k}{T}$     k-th frequency  
 $\Delta\omega = \frac{2\pi}{T}$     Frequency interval

### Fourier integral

Non-periodic function ( $T \rightarrow \infty$ )

$$a_0 = 0$$

$$a_k = \frac{2}{T} \int_{-T/2}^{T/2} x(t) \cos \frac{2\pi kt}{T} dt = \frac{\Delta\omega}{\pi} \int_{-T/2}^{T/2} x(t) \cos \omega_k t dt$$

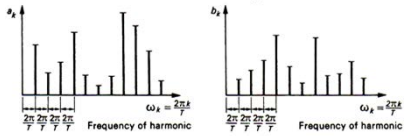
$$b_k = \frac{2}{T} \int_{-T/2}^{T/2} x(t) \sin \frac{2\pi kt}{T} dt = \frac{\Delta\omega}{\pi} \int_{-T/2}^{T/2} x(t) \sin \omega_k t dt$$

$\rightarrow \begin{cases} \alpha(\omega) d\omega = \frac{d\omega}{\pi} \int_{-\infty}^{\infty} x(t) \cos \omega t dt \\ \beta(\omega) d\omega = \frac{d\omega}{\pi} \int_{-\infty}^{\infty} x(t) \sin \omega t dt \end{cases} \quad (\omega \geq 0)$

$\begin{cases} A(\omega) d\omega = \frac{1}{2\pi} \int_{-\infty}^{\infty} x(t) \cos \omega t dt \\ B(\omega) d\omega = \frac{1}{2\pi} \int_{-\infty}^{\infty} x(t) \sin \omega t dt \end{cases} \quad (-\infty < \omega < \infty)$

Necessary and sufficient condition for the integral to be finite

$$\int_{-\infty}^{\infty} |x(t)| dt < \infty$$

$x(t)$  should approach to 0 at  $t \rightarrow |\infty|$

$$x(t) = 2 \int_0^{\infty} A(\omega) \cos \omega t d\omega + 2 \int_0^{\infty} B(\omega) \sin \omega t d\omega$$

### Autocorrelation function

$$R_x(\tau) = \lim_{T \rightarrow \infty} \frac{1}{T} \int_0^T x(t)x(t+\tau)dt$$

random process  $\rightarrow$  function of  $\tau$  (not  $t$ )

$$E[x(t)x(t+\tau)] = f(\tau) \equiv R_x(\tau)$$

$$\rho_{x(t)x(t+\tau)} = \frac{E[\{x(t)-m\}\{x(t+\tau)-m\}]}{\sigma_x^2} = \frac{R_x(\tau) - m^2}{\sigma_x^2}$$

$$\therefore R_x(\tau) = \sigma_x^2 \rho + m^2$$

$$-\sigma_x^2 + m^2 \leq R_x(\tau) \leq \sigma_x^2 + m^2 \quad (= E[x^2])$$

$$R_x(\infty) \rightarrow m^2$$

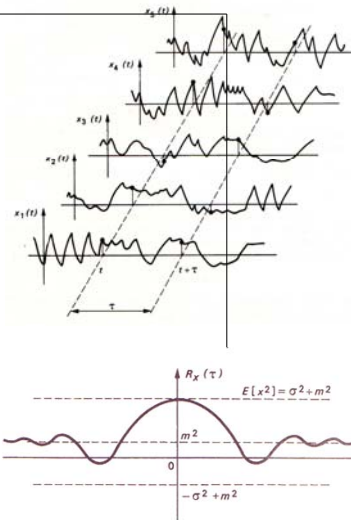

61

### Cross-correlation function

$$R_{xy}(\tau) = E[x(t)y(t+\tau)] \quad R_{yx}(\tau) = E[y(t)x(t+\tau)]$$

$$\bullet R_{xy}(-\tau) = E[x(t)y(t-\tau)] = R_{yx}(\tau)$$

$$\bullet R_{yx}(-\tau) = E[y(t)x(t-\tau)] = R_{xy}(\tau)$$

$$\bullet R_{xy}(\tau) = \sigma_x \sigma_y \rho_{xy}(\tau) + m_x m_y$$

$$\bullet R_{yx}(\tau) = \sigma_y \sigma_x \rho_{yx}(\tau) + m_y m_x$$

$$\bullet -\sigma_x \sigma_y + m_x m_y \leq R_{xy}(\tau) \leq \sigma_x \sigma_y + m_x m_y$$

$$\bullet R_{xy}(\infty) \rightarrow m_x m_y$$

$$\bullet R_{yx}(\infty) \rightarrow m_y m_x$$

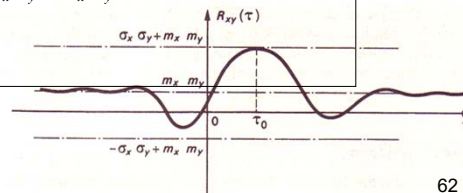

62

### Fourier transform

$$e^{i\theta} = \cos\theta + i\sin\theta$$

$$X(\omega) \equiv A(\omega) - iB(\omega)$$

$$= \frac{1}{2\pi} \int_{-\infty}^{\infty} x(t)(\cos\omega t - i\sin\omega t)dt$$

$$= \frac{1}{2\pi} \int_{-\infty}^{\infty} x(t)e^{-i\omega t} dt \quad \leftarrow \text{Fourier transform of } x(t)$$

$$x(t) = \int_{-\infty}^{\infty} A(\omega)\cos\omega t d\omega + \int_{-\infty}^{\infty} B(\omega)\sin\omega t d\omega$$

$$+ i \int_{-\infty}^{\infty} A(\omega)\sin\omega t d\omega - \int_{-\infty}^{\infty} B(\omega)\cos\omega t d\omega$$

$$= \int_{-\infty}^{\infty} \{A(\omega) - iB(\omega)\} \{\cos\omega t + i\sin\omega t\} d\omega$$

$$= \int_{-\infty}^{\infty} X(\omega)e^{i\omega t} d\omega \quad \leftarrow \text{Inverse Fourier transform of } X(\omega)$$

63

### Spectral density

$$m = E[x] = 0 \quad \rightarrow \quad R_x(\infty) \rightarrow 0$$

$$\therefore \int_{-\infty}^{\infty} |R_x(\tau)| d\tau < \infty \quad \text{is satisfied.}$$

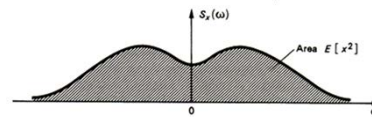

$$S_x(\omega) \equiv \frac{1}{2\pi} \int_{-\infty}^{\infty} R_x(\tau)e^{-i\omega\tau} d\tau \quad \leftarrow S_x(\omega) \text{ is a spectral density of } x(t)$$

$$R_x(\tau) = \int_{-\infty}^{\infty} S_x(\omega)e^{i\omega\tau} d\omega$$

$S_x(\omega)$  and  $R_x(\tau)$  are  
pair of Fourier transform.

- $R_x(0) = \int_{-\infty}^{\infty} S_x(\omega) d\omega = E[x^2]$

- $S_x(\omega)$ : real function ( $\because R_x(-\tau) = R_x(\tau)$ )

- $S_x(\omega) = \lim_{T \rightarrow \infty} \frac{2\pi X(\omega)X^*(\omega)}{T}$

64

## Cross-spectral density

$$S_{xy}(\omega) = \frac{1}{2\pi} \int_{-\infty}^{\infty} R_{xy}(\tau) e^{-i\omega\tau} d\tau = C_{xy}(\omega) - iQ_{xy}(\omega)$$

$$R_{xy}(\tau) = \int_{-\infty}^{\infty} S_{xy}(\omega) e^{i\omega\tau} d\omega$$

$$\int_{-\infty}^{\infty} |R_{xy}(\tau)| d\tau < \infty \quad \leftarrow \quad m_x \text{ or } m_y = 0$$

- $S_{yx}(\omega) = \overline{S_{xy}(\omega)} = C_{xy}(\omega) + iQ_{xy}(\omega)$

65

## One-sided, Two-sided spectral density

$$E[x^2] = \int_{-\infty}^{\infty} S_x(\omega) d\omega$$

$$E[x^2] = \int_0^{\infty} W_x(f) df \quad \text{Equivalent one-sided spectral density}$$

$$2S_x(\omega) d\omega = W_x(f) df = W_x(f) \frac{d\omega}{2\pi}$$

$$\therefore W_x(f) = 4\pi S_x(\omega)$$

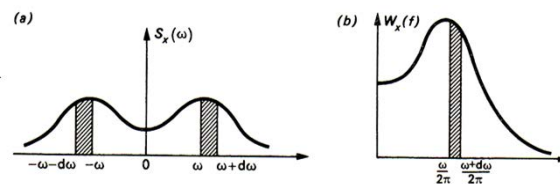

66



Equation of motion for along wind displacement of a girder  $y(x,t)$

$$m(x)\ddot{y}(x,t) + c(x)\dot{y}(x,t) + (EI(x)y'')' = p(x,t)$$

$$y(x,t) = \sum_j q_{y_j}(t)\phi_j(x) \quad \phi_j(x) : j\text{-th modal function (mode vector)}$$

$$p(x,t) = \sum_j q_{p_j}(t)\phi_j(x) \quad \int_L \phi_i(x)\phi_j(x)dx = \delta_{ij} = \begin{cases} 1 & i = j \\ 0 & i \neq j \end{cases}$$

$$\int_L m(x)\ddot{y}(x,t)\phi_j(x)dx = \int_L m(x)\sum_i \ddot{q}_{y_i}(t)\phi_i(x)\phi_j(x)dx = \int_L m(x)\phi_j^2(x)dx \cdot \ddot{q}_{y_j}(t)$$

$$\ddot{q}_{y_j} + 2\zeta_j\omega_j\dot{q}_{y_j} + \omega_j^2 q_{y_j} = \frac{\int_L p(x,t)\phi_j(x)dx}{\int_L m(x)\phi_j^2(x)dx} = \frac{q_{p_j}(t)\int_L \phi_j^2(x)dx}{\int_L m(x)\phi_j^2(x)dx}$$

67

Fourier transform  $\hat{q}_{y_j}(\omega) = \mathcal{F}[q_{y_j}(t)] = \frac{1}{2\pi} \int_{-\infty}^{\infty} q_{y_j}(t)e^{-i\omega t} dt$

$$\left(-\omega^2 + i2\zeta_j\omega_j\omega + \omega_j^2\right)\hat{q}_{y_j}(\omega) = \frac{\hat{q}_{p_j}(\omega) \int_L \phi_j^2(x)dx}{\int_L m(x)\phi_j^2(x)dx} = \frac{1}{m_{eq-j}}$$

equivalent mass for  $j$ -th mode

$$S_{q_{y_j}}(\omega) = \lim_{T \rightarrow \infty} \frac{2\pi \cdot \hat{q}_{y_j}(\omega)\overline{\hat{q}_{y_j}(\omega)}}{T} \quad S_{q_{y_j}}(\omega) = 2S_{q_{p_j}}(\omega) \quad 0 < \omega < \infty$$

$$S_{q_{y_j}}(f) = \left\{ \frac{\int_L \phi_j^2(x)dx}{\omega_j^2 \int_L m(x)\phi_j^2(x)dx} \right\}^2 \frac{1}{\left\{ 1 - \left(\frac{f}{f_j}\right)^2 \right\}^2 + \left(\frac{\delta_j}{\pi}\right)^2 \left(\frac{f}{f_j}\right)^2} S_{q_{p_j}}(f)$$

68

PSD of generalized force  $q_{pj}$  for  $j$ -th mode

$$q_{p_j}(t) = \frac{\int_L p(t, x) \phi_j(x) dx}{\int_L \phi_j^2(x) dx}$$

$$\begin{aligned} S_{q_{p_j}}(f) &= \frac{1}{\int_L \phi_j^2(x) dx} \iint_L S_p(x, x'; f) \phi_j(x) \phi_j(x') dx dx' \\ &= \frac{1}{\int_L \phi_j^2(x) dx} \iint_L S_p(f) R_p(x, x'; f) \phi_j(x) \phi_j(x') dx dx' \\ &= \underline{|J_j(f)|^2 S_p(f)} \end{aligned}$$

69

$$\begin{aligned} p(z, t) &= \frac{1}{2} \rho (\bar{U} + u(z, t))^2 C_D D \\ &= \frac{1}{2} \rho \bar{U}^2 C_D(0) D + \rho \bar{U} u(z, t) C_D(f) D \\ &= \bar{P} + 2\bar{P} \frac{C_D(f)}{C_D(0)} \frac{u(z, t)}{\bar{U}} \end{aligned}$$

$$p_{ref}(t) = \frac{\int_D p(z, t) dz}{D}$$

$$\underline{S_p(f)} = S_{p_{ref}}(f) = \frac{\iint_D S_p(z, z'; f) dz dz'}{D^2}$$

$$= \frac{4\bar{P}^2}{D^2 \bar{U}^2} \left\{ \frac{C_D(f)}{C_D(0)} \right\}^2 \iint_D R_u(z, z'; f) dz dz' S_u(f)$$

$$= \underline{\frac{4\bar{P}^2}{\bar{U}^2} |X_A(f)|^2 S_u(f)}$$

$$\therefore S_{q_{p_j}}(f) = |X_A(f)|^2 |J_j(f)|^2 S_u(f) \frac{4\bar{P}^2}{\bar{U}^2}$$

70

(continued)

$$S_{q_{y_j}}(f) = \frac{4\bar{P}^2 \left\{ \int_L \phi_j^2(x) dx \right\}^2}{\bar{U}^2 \omega_j^2 \left\{ \int_L m(x) \phi_j^2(x) dx \right\}^2} \left| \chi_{d_j}(f) \right|^2 \left| \chi_A(f) \right|^2 \left| J_j(f) \right|^2 S_u(f)$$

$\omega_j$  : natural circular frequency of  $j$ -th mode [rad/s]

$m(x)$  : mass per unit span length of a girder element [kg/m]

$\left| \chi_{d_j}(f) \right|^2$  : **dynamic magnification** for  $j$ -th mode

$$\left| \chi_{d_j}(f) \right|^2 = \frac{1}{\left\{ 1 - \left( \frac{f}{f_j} \right)^2 \right\}^2 + \left( \frac{\delta_j}{\pi} \right)^2 \left( \frac{f}{f_j} \right)^2} \quad \text{--- } \star$$

$f_j$  : natural frequency of  $j$ -th mode [Hz]

$\delta_j$  : structural + aerod. Damping for  $j$ -th mode (logarithmic damping decrement)

71

(continued 2)

$$S_{q_{y_j}}(f) = \frac{4\bar{P}^2 \left\{ \int_L \phi_j^2(x) dx \right\}^2}{\bar{U}^2 \omega_j^2 \left\{ \int_L m(x) \phi_j^2(x) dx \right\}^2} \left| \chi_{d_j}(f) \right|^2 \left| \chi_A(f) \right|^2 \left| J_j(f) \right|^2 S_u(f)$$

$\left| \chi_A(f) \right|^2$  : **aerodynamic admittance**  $\left| \chi_A(f) \right|^2 = \frac{2}{(k\xi)^2} \{ k\xi - 1 + \exp(-k\xi) \}$  ---  $\star$

$$\xi = \frac{fD}{U}$$

$$\left| \chi_A(f) \right|^2 = \frac{1}{D^2} \left\{ \frac{C_D(f)}{C_D(0)} \right\}^2 \iint_D R_u(z, z'; f) dz dz'$$

$$R_u(z, z'; f) = \exp\left( -k \frac{f|z-z'|}{U} \right)$$

**Coherence of wind speed fluctuation component  $u(x, z, t)$  along  $z$  direction**

$k$  : decay factor  $k = 7$

$$\left\{ \frac{C_D(f)}{C_D(0)} \right\} = 1$$

72

(continued 3)

$$S_{q_{y_j}}(f) = \frac{4\bar{P}^2 \left\{ \int_L \phi_j^2(x) dx \right\}^2}{\bar{U}^2 \omega_j^2 \left\{ \int_L m(x) \phi_j^2(x) dx \right\}^2} \left| \chi_{d_j}(f) \right|^2 \left| \chi_A(f) \right|^2 \left| J_j(f) \right|^2 S_u(f)$$

$|J_j(f)|^2$  : joint mode acceptance

$$\left| J_j(f) \right|^2 = \frac{1}{\int_L \phi_j^2(x) dx} \iint_L R_p(x, x'; f) \phi_j(x) \phi_j(x') dx dx' \quad \text{— } \star$$

73

(continued 4)

$$S_{q_{y_j}}(f) = \frac{4\bar{P}^2 \left\{ \int_L \phi_j^2(x) dx \right\}^2}{\bar{U}^2 \omega_j^2 \left\{ \int_L m(x) \phi_j^2(x) dx \right\}^2} \left| \chi_{d_j}(f) \right|^2 \left| \chi_A(f) \right|^2 \left| J_j(f) \right|^2 S_u(f)$$

$S_u(f)$  : PSD of wind speed fluctuation  $u(t)$  [ $\text{m}^2/\text{s}^2/\text{Hz}$ ]

$$S_u(f) = \frac{2K_r U_{10}^2}{f} \frac{X_D^2}{(1 + X_D^2)^{4/3}} \quad \text{(Davenport's formula) — } \star$$

$$X_D = \frac{1200f}{U_{10}} \quad K_r : \text{surface roughness coefficient}$$

ice, sea	0.003
grass	0.005
open area	0.008
trees, bush	0.015

$U_{10}$  : average wind speed at 10m height [ $\text{m/s}$ ]

74

## 2) Characteristics of natural wind and Design wind load

1

### Frictionless wind balance

◆ Pressure gradient force  $\frac{1}{\rho} \frac{\partial p}{\partial n}$  --(a)

◆ Coriolis force  $2\omega V \sin \phi$  --(b)

◆ Centrifugal force  $\frac{V^2}{r}$  --(c)

$\rho$  : air density [kg/m<sup>3</sup>]

$\omega$  : angular velocity of the earth [rad/sec]

$V$  : wind speed [m/s]

$\phi$  : the latitude of the point [rad]

Per unit mass

2

## Frictionless wind balance

Geostrophic wind: (a) = (b)  
(地衡風)

$$\frac{1}{\rho} \frac{\partial p}{\partial n} = 2\omega V_{gs} \sin \phi \quad \therefore V_{gs} = \frac{\frac{\partial p}{\partial n}}{2\rho\omega \sin \phi}$$

Gradient wind: (a) = (b) + (c)  
(傾度風)

$$\frac{1}{\rho} \frac{\partial p}{\partial n} = 2\omega V_{gr} \sin \phi + \frac{V_{gr}^2}{r}$$

$$\therefore V_{gr} = -r\omega \sin \phi + \left[ \frac{r}{\rho} \frac{\partial p}{\partial n} + (r\omega \sin \phi)^2 \right]^{\frac{1}{2}}$$

in the Northern Hemisphere for cyclonic wind

3

## Ekman spiral in atmospheric boundary layer

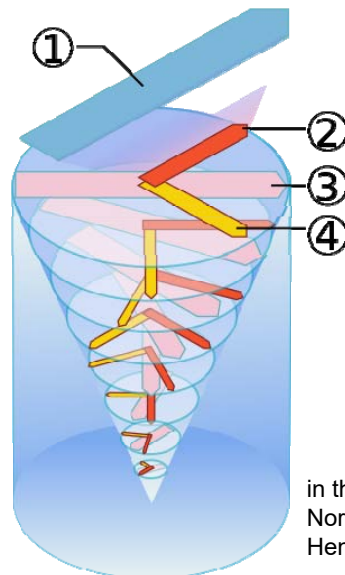

①Wind, ②Shear force from above layer, ③Effective direction of the current, ④Coriolis effect

in the Northern Hemisphere

4

## Natural winds

- Normal wind
- Monsoon
- Typhoon (26.7 annually, 2.6 strike, 10.8 close)
- Tornado (18.7 annually, offshore)
- Local wind



5

## Weibull distribution

- Normal wind velocity (10 min. mean)

$$P(V^*) = \Pr[V > V^*] = \exp\left\{-\left(\frac{V^*}{c}\right)^k\right\} \quad \text{Exceeding prob.}$$

$c$  : scale parameter [m/s]

$k$  : shape parameter

6

## Annual maximum wind speed

- $N$  sample of size  $n$  from a mother dist.  
( $n=8 \times 365=2,920$ )
- Order the sample as  $x_1 \leq x_2 \leq \dots \leq x_i \dots \leq x_n$
- The extrema ( $x_1$  or  $x_n$ ) will approach to the particular distribution, if  $n$  and  $N$  are large enough.

→ Fisher Tippet I, II, III

7

## Fisher-Tippet I, II, III type distribution

- Depends on the mother distribution

$$G_Y(y) = [F_x(y)]^n$$

$G_Y(y)$  Non-exceeding prob.

$$G_Y(y) = \int_{-\infty}^y g_Y(\xi) d\xi, \quad g_Y(y) = \frac{dG_Y(y)}{dy}$$

$$g_Y(y) = \frac{dG_Y(y)}{dy} = n[F_x(y)]^{n-1} f_x(y)$$

A probability distribution  $G_Y(y)$  of the extrema  $Y$  depends only on the upper tail of  $F_x(x)$ , not on the entire distribution of  $F_x(x)$ .

8





$$G_Y(y) = [F_x(y)]^n$$

$G_Y(y)$ : Non-exceeding prob. of the extrema  
(annual maximum wind speed)  $\Pr[x_n \leq y]$

$F_x(y)$ : Non-exceeding prob. of the normal wind  
(every 3 hours wind speed record,  $n=8 \times 365=2,920$ )  
 $\Pr[x_i \leq y]$  ( $i$ : any of  $n$ )

$$F_x(y) = 1 - P(y) = \Pr[V \leq y] = 1 - \exp\left\{-\left(\frac{y}{c}\right)^k\right\}$$

(1-Weibull dist.) 

Probability :  
"none of  $n$  data doesn't exceed the maxima,  $x_n$ " 

## Fisher Tippet I (Gumbel)

➤ Exponential type

$$F_x(x) = 1 - \exp\{-g(x)\}$$

$$G_Y(y) = \exp\{-\exp(-\alpha(y-u))\} \quad -\infty \leq y \leq \infty$$

$u$ : mode,  $\alpha$ : shape parameter

$$m_Y = u + \frac{\gamma}{\alpha}$$

$$\sigma_Y = \frac{\pi}{\sqrt{6}\alpha} \approx \frac{1.2825}{\alpha}$$

$\gamma$ : Euler constant  
 $\gamma = 0.5772$

## Fisher Tippet II (Frechet)

➤ Polynomial type

$$F_x(x) = 1 - \beta \left( \frac{1}{x} \right)^k \quad u: \text{mode}, k: \text{shape parameter}$$

$$G_Y(y) = \exp \left\{ - \left( \frac{u}{y} \right)^k \right\} \quad y \geq 0$$

$$m_Y = u \Gamma \left( 1 - \frac{1}{k} \right) \quad k > 1 \quad \sigma_Y^2 = u^2 \left[ \Gamma \left( 1 - \frac{2}{k} \right) - \Gamma^2 \left( 1 - \frac{1}{k} \right) \right] \quad k > 2$$

11

## Fisher Tippet III (Weibull)

➤ Minima

$$F_x(x) = a(x - \varepsilon)^k$$

$$G_Y(y) = 1 - \exp \left[ - \left( \frac{y - \varepsilon}{u - \varepsilon} \right)^k \right] \quad y \geq \varepsilon$$

$$m_Y = \varepsilon + (u - \varepsilon) \Gamma \left( 1 + \frac{1}{k} \right) \quad \sigma_Y^2 = (u - \varepsilon)^2 \left[ \Gamma \left( 1 + \frac{2}{k} \right) - \Gamma^2 \left( 1 + \frac{1}{k} \right) \right]$$

12

## Which type will fit the observed annual maximum wind speed data best?

- Exceeding probability for each sample (**empirical formula** of exceeding probability)
- Plot on the double exponential probability sheet

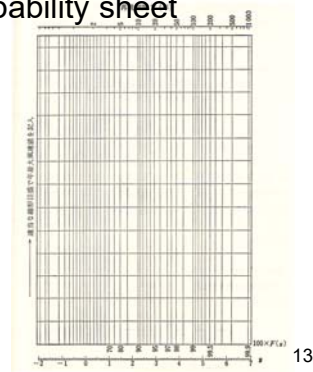

## Empirical formula

$$P_j = \frac{j}{N}$$

$$P_j = \frac{j}{N+1} \quad (\text{Gumbel}) \quad \text{underestimate}$$

$$P_j = \frac{j-1}{N} \quad \rightarrow \text{overestimate}$$

$$P_j = \frac{2j-1}{2N} \quad (\text{Hazen}) \quad \rightarrow \text{most practical}$$

$$P_j = \frac{j-a}{N+1-2a} \quad (\text{Gringorten}) \quad a \doteq 0.44 \text{ for } N \geq 20$$

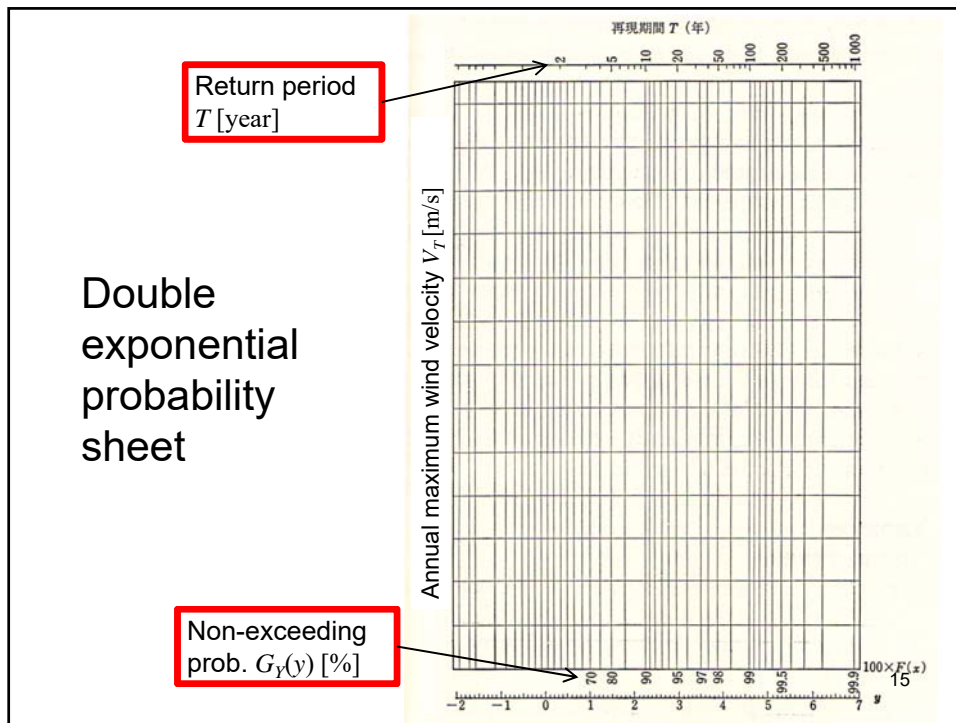

## Annual maximum wind speed and return period

$$T = \frac{1}{1-q} = \frac{1}{1-G_Y(V_T)}$$

$T$ : return period of wind speed  $V_T$ (year)

$q$ : non-exceeding probability

$$V_T = u + \frac{1}{a} \ln T \quad \text{For } T > 5$$

# Strong wind evaluation

$$G_Y(V) = \exp[-\exp\{-\alpha(V - u)\}]$$

① determine distribution function (determine  $\alpha, u$ )

$$G_Y(V) = 1 - \frac{1}{T}$$

② Determine return period  $T$   
(for road bridge:  $T=100$  (yr))

③ value of  $V$  can be determined ( $V=40\text{m/s}$ )

Design manual of wind resistant design for road bridges, 2005  
(道路橋耐風設計便覧)  
Japan road association  
(日本道路協会)



Recommendations for  
loads on buildings  
Chap.6 Wind loading  
(2004, AIJ)

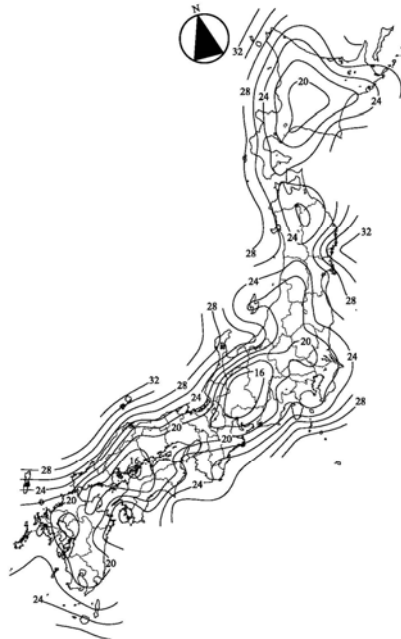

Figure A6.1.5 100-year-recurrence 10-minutes mean wind speed at 10m above ground over a flat and open terrain in winter (m/s)

19

An example to determine design wind speed  
- fitting to Gumbel dist. -

$$G_Y(y) = \exp\{-\exp(-\alpha(y-u))\}$$

20

## Annual maximum wind speed data

Year No.	Annual maximum wind speed (m/s)	Year No.	Annual maximum wind speed (m/s)
1	8.1	11	11.7
2	7.3	12	10.3
3	10.0	13	9.0
4	9.4	14	8.0
5	7.8	15	11.1
6	10.2	16	8.4
7	7.9	17	8.2
8	9.4	18	10.2
9	7.4	19	11.5
10	8.8	20	8.3

21

## Fisher Tippet I (Gumbel)

➤ Exponential type

$$G_Y(y) = \exp\{-\exp(-\alpha(y-u))\} \quad -\infty \leq y \leq \infty$$

$u$ : mode,  $\alpha$ : shape parameter

$$m_Y = u + \frac{\gamma}{\alpha} = 9.15 \text{ [m/s]} \quad \sigma_Y = \frac{\pi}{\sqrt{6}\alpha} \approx \frac{1.2825}{\alpha} = 1.32 \text{ [m/s]}$$

$$\therefore \alpha = 0.97, u = 8.56$$

$$G_Y(y) = \exp\{-\exp(-0.97(y-8.56))\} \quad \longleftrightarrow \quad G_Y(y) = 1 - \frac{1}{T(y)}$$

$y=13.29 \text{ [m/s]}$  for 100yr.,  $y=15.66 \text{ [m/s]}$  for 1000yr. 22

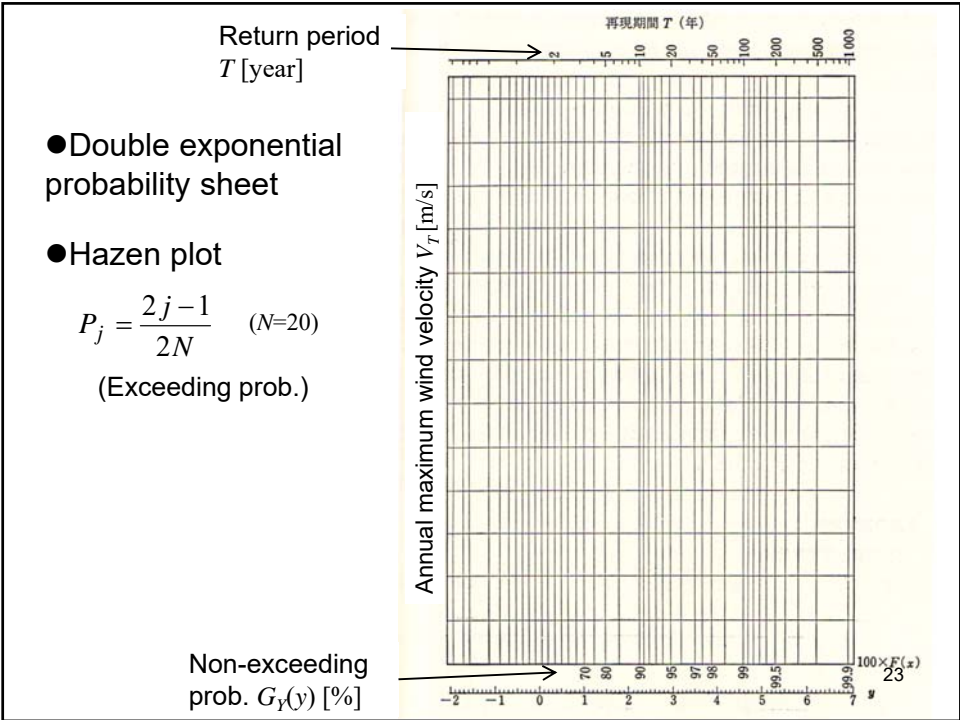

Annual maximum wind speed data -ordering,  $P_j$

$$P_j = \frac{2j-1}{2N}$$

Data No. $j$	Annual maximum wind speed (m/s)	$P_j$	Data No. $j$	Annual maximum wind speed (m/s)	$P_j$
1	11.7	0.025	11	8.8	0.525
2	11.5	0.075	12	8.4	0.575
3	11.1	0.125	13	8.3	0.625
4	10.3	0.175	14	8.2	0.675
5	10.2	0.225	15	8.1	0.725
6	10.2	0.275	16	8.0	0.775
7	10.0	0.325	17	7.9	0.825
8	9.4	0.375	18	7.8	0.875
9	9.4	0.425	19	7.4	0.925
10	9.0	0.475	20	7.3	0.975



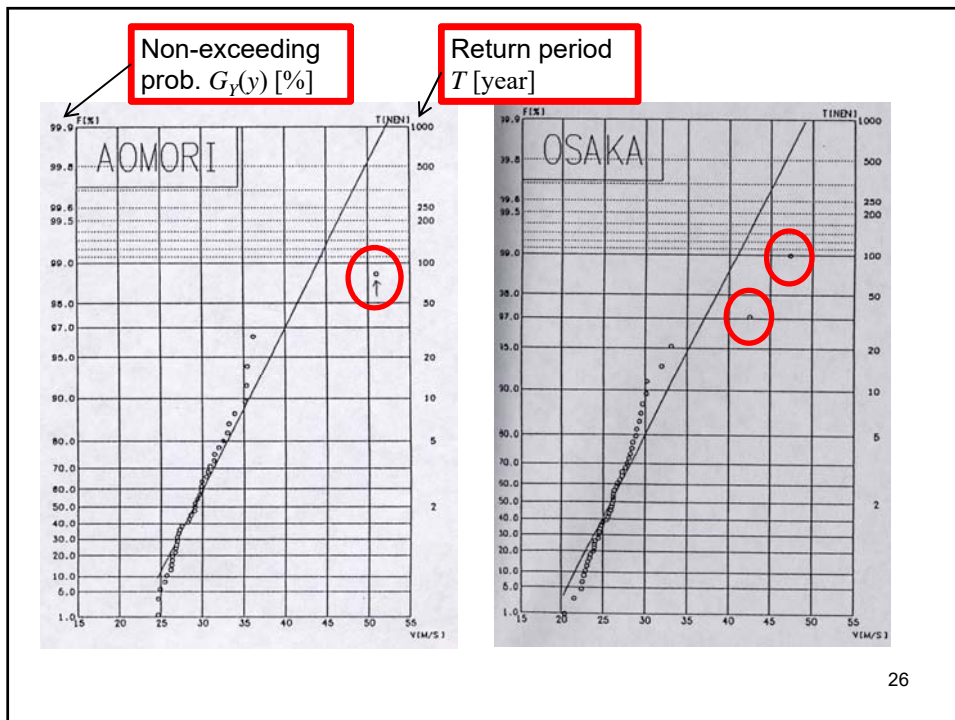
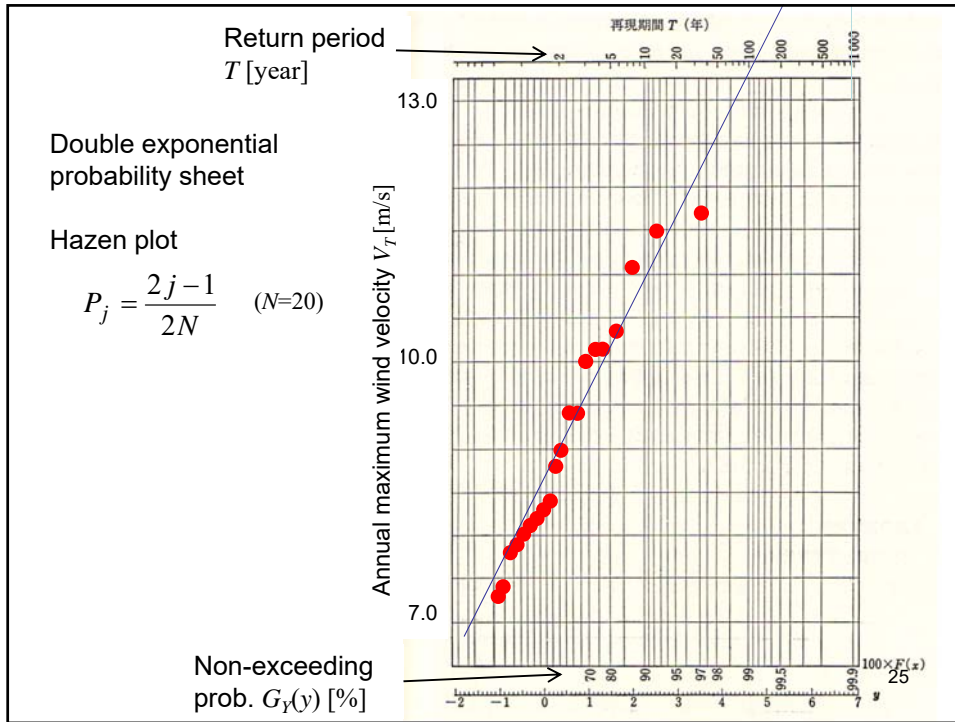

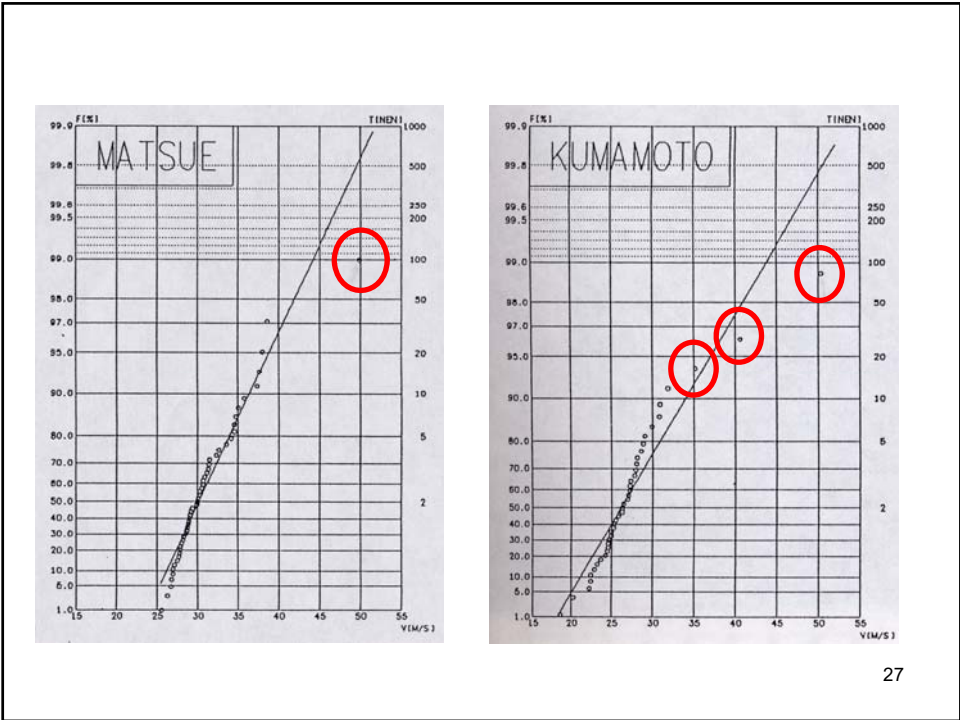

27

Design wind load  
for road bridges

28

Gust Factor

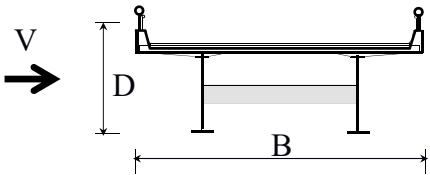

$$P = \frac{1}{2} \rho V^2 C_D G A_n$$

The ratio of the maxima to the average of wind load due to wind turbulence and buffeting response,  $G=1.9$

$P$  Wind load [N/m]  
 $\rho$  Air density [kg/m<sup>3</sup>]  
 $V$  Design wind speed [m/s],  $V=40\text{m/s}$   
 $C_d$  Drag force coefficient  
 $G$  Gust response factor  
 $A_n$  Effective project area [m<sup>2</sup>/m]

Design code for Road bridges, 2012 (道路用示方書)  
 Japan Road Association (日本道路協会)

29

Gust Factor

Wind speed [m/s]

$$U(t) = \bar{U} + u(t)$$

$$U(t)_{\max} \cong \bar{U} + 3\sigma_u = \bar{U} \left( 1 + \frac{3\sigma_u}{\bar{U}} \right), \quad Iu \equiv \frac{\sigma_u}{\bar{U}}$$

$$\Leftrightarrow G_U \equiv \frac{U(t)_{\max}}{\bar{U}} = 1 + 3Iu$$

Wind load [N/m]

$$P(t) = \bar{P} + p(t), \quad P \propto U^2 \quad \Leftrightarrow \quad G = G_U^2$$

$$G \equiv \frac{P(t)_{\max}}{\bar{P}} = 1.9 \quad \Leftrightarrow \quad G_U = \sqrt{1.9} = 1.378 \quad \therefore Iu = 0.126$$

At 10m elevation on the sea, open terrain 30

Drag force coefficient

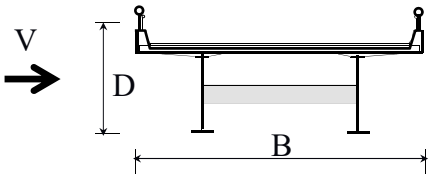

$$P = \frac{1}{2} \rho V^2 C_D G A_n$$

Depends on structural geometry of cross section

$P$  Wind load [N/m]  
 $\rho$  Air density [kg/m<sup>3</sup>]  
 $V$  Design wind speed [m/s],  $V=40\text{m/s}$   
 $C_d$  Drag force coefficient  
 $G$  Gust response factor  
 $A_n$  Effective project area [m<sup>2</sup>/m]

Design code for Road bridges, 2012 (道路用示方書)  
 Japan Road Association (日本道路協会)

31

Drag force coefficient      Design code for Road bridges(日本道路協会)

Steel girder

$$C_d = \begin{cases} 2.1 - 0.1(B/D) & \dots\dots (1 \leq B/D < 8) \\ 1.3 & \dots\dots (8 \leq B/D) \end{cases}$$

2 plane truss

$$C_d = \begin{cases} 1.35/\sqrt{\phi} & (0.1 \leq \phi \leq 0.6) & \text{for truss} \\ 1.6 & & \text{for deck} \end{cases} \quad \phi : \text{solidity ratio}$$

Arch (angular member)      Arch (pipe member)

$$C_d = \begin{cases} 1.6 & \text{for windward} \\ 0.8 & \text{for leeward} \end{cases} \quad C_d = 0.8$$

Suspension, Cable-stayed (steel girder, 2 plane truss)

$C_d$ (see above)	(tower)	(cable)
	$C_d = \begin{cases} 1.6 & \text{for wind ward} \\ 0.8 & \text{for leeward} \end{cases}$	$C_d = 0.8$

32

# Hurricane simulation

*Journal of Wind Engineering and Industrial Aerodynamics*, 13 (1983) 139-152  
 Elsevier Science Publishers B.V., Amsterdam - Printed in The Netherlands

139

**DESIGN WIND SPEEDS IN REGIONS DOMINATED BY TROPICAL CYCLONES**

P. N. Georgiou, A. G. Davenport and B. J. Vickery  
 Boundary Layer Wind Tunnel Laboratory, The University of Western Ontario,  
 London, Ontario, Canada

**SUMMARY**

In recent years computer simulation methods predicting extreme wind speeds in regions dominated by tropical cyclones have been developed and shown to give reasonable estimates of long-term risk levels arising from these winds. In this paper, refinements of the model are presented with the emphasis on improvements to the statistical distribution functions describing tropical cyclone characteristics used in the simulation. In particular the relationships chosen for the two parameters which influence wind speeds the most, the central pressure difference and the decay rate after landfall, represent significant changes from previous models. The application of the simulation to specific oceanic regions is discussed and the results of a case study conducted along the Gulf and Atlantic Coasts of the United States presented.

**NOTATION**

### 3.2 Occurrence - Spatial Domain

Several methods exist for locating tropical cyclone paths with respect to any geographical point. The one chosen for the present simulation is shown in Figure 1. Tracks are simulated as straight line paths, defined by their approach angle,  $\theta$ , taken clockwise positive from North, and their minimum approach distance,  $d_{min}$ . When a track passes to the left of a station of interest  $d_{min}$  is taken to be positive. In practice tropical cyclone tracks are never straight. There is however no way to model the erratic upper-level atmospheric conditions upon which the real curvature of observed paths depends. Moreover by limiting simulation circles

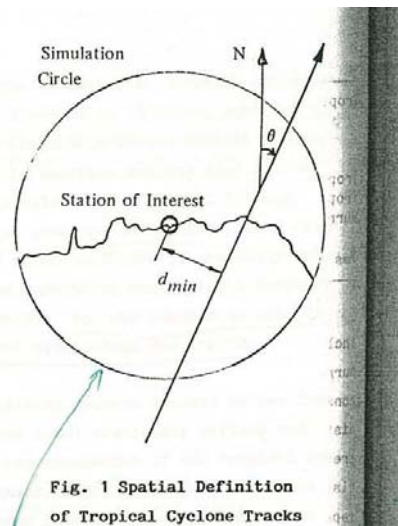

**Fig. 1 Spatial Definition of Tropical Cyclone Tracks**

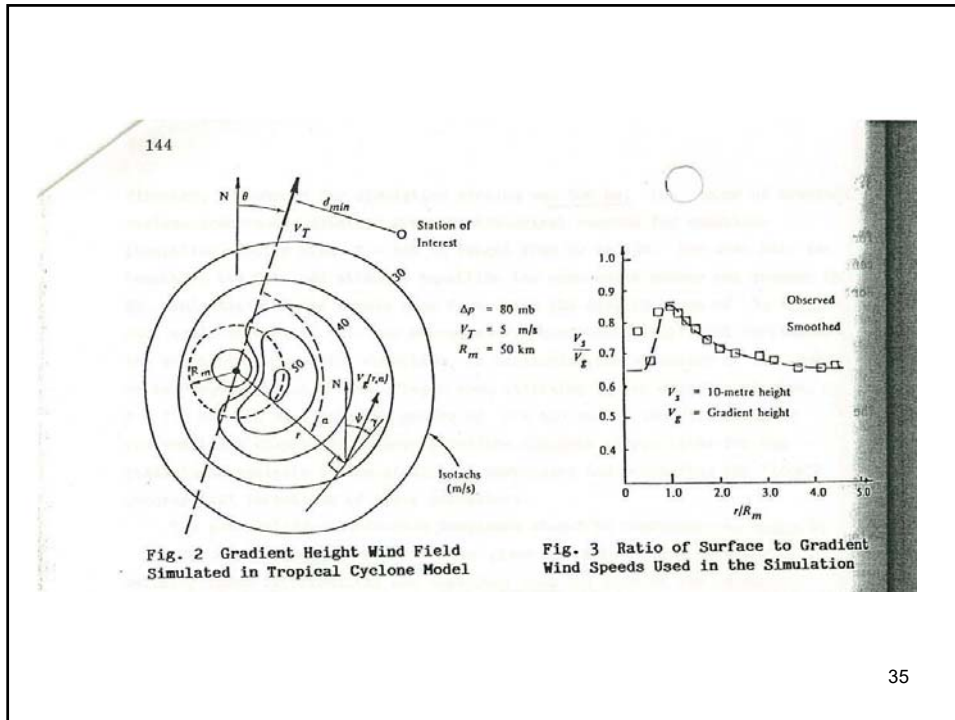

35

TABLE 2

Parameter	Probability Distribution Function Representation Used in the Simulation
$\lambda$ = Annual Occurrence Rate	Poisson
$d_{min}$ = Minimum Approach Distance	Polynomial
$\theta$ = Approach Angle	von Mises
$\Delta p$ = Central Pressure Difference	Weibull
$R_m$ = Radius of Maximum Winds	Log-normal
$V_T$ = Translation Velocity	Log-normal
	conditionally dependent upon $\Delta p$

36

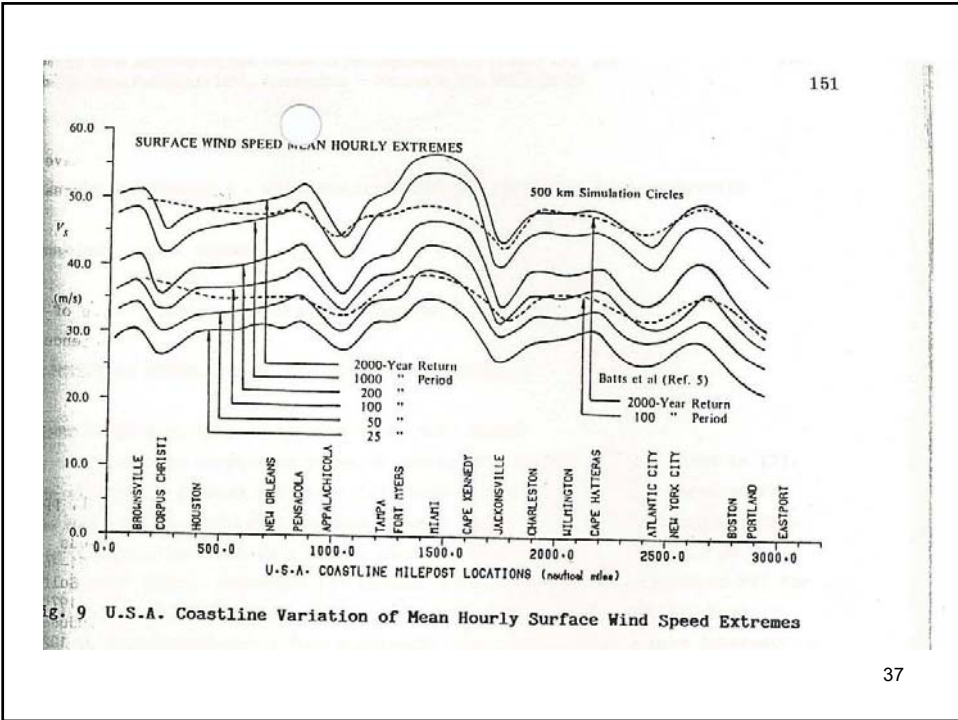

# Extreme winds

(Tornadoes, downburst, gust front)

## Extreme winds (Tornadoes, downburst, gust front)



39

## Annual number of tornado

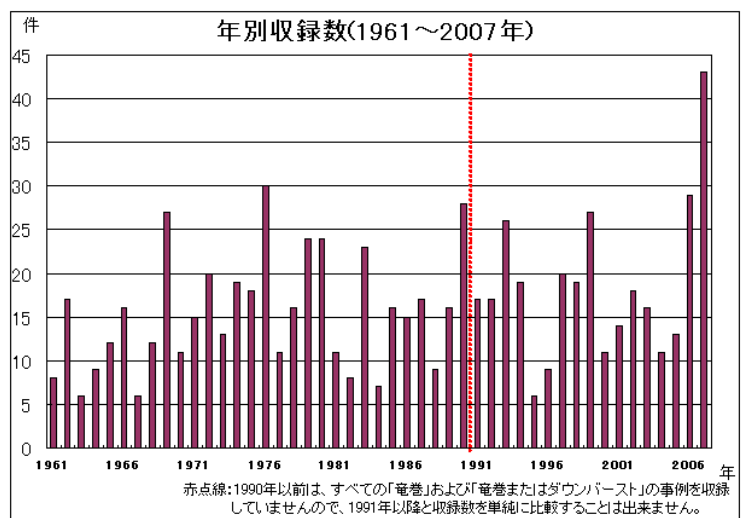

40



## Extreme winds (Tornadoes, downburst, gust front)

- 18.66 annually (leads to disaster)
- Up to F3 (less than 90 m/s)  
(JMA statistics)
- 1.4 annually per 10<sup>4</sup> km<sup>2</sup>  
(comparable with in Alabama and Missouri) (Niino et al., 1997)
- 8 tornadoes annually may cross railway tracks anywhere in Japan (Tamura, 2007)
  
- Wind loads, flying debris
- Safety level for high hazardous facilities, mass-, high-speed transports
  
- Hard to be predicted

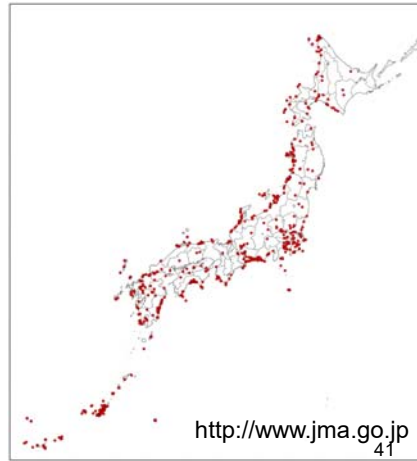

## Recent big tornadoes in Japan

表 11 FPP で整理した主な竜巻の比較

竜巻	茂原 1990.12.11	豊橋 1999.09.24	佐賀 2004.06.27	延岡 2006.09.17	佐呂間 2006.11.07
Life time (min)	7	25	7	5	3?
F scale	F3	F3	F2	F2	F3
P scale (length)	P2 6.5km	P3 19 km	P2 8 km	P2 7.5 km	P1? 1.5 km
P scale (width)	P3 500 m	P3 550 m	P2 200 m	P2 250 m	P2? 300 m

Tornado disaster  
6, May, 2012 in Tsukuba



<https://www.city.tsukuba.ibaraki.jp/1330/010537.htm>

### Fujita scale

Maximum wind speed

F scale	Description	Wind speed (m/s)	Damage to wooden living houses
F0	Mild	17-32	Light, local
F1	Weak	33-49	Roof tiles will be flying away.
F2	Strong	50-69	Roofs will be teared off.
F3	Severe	70-92	Houses will be collapsed.
F4	Violent	93-116	Houses will be totally dismantled.
F5	Unimaginable	117-142	Houses will dissappear.

# Design-basis tornado

(U.S. Nuclear Regulatory Commission. 2007. "Regulatory Guide 1.76")

Table 1. Design-Basis Tornado Characteristics

Region	Maximum wind speed m/s (mph)	Translational speed m/s (mph)	Maximum rotational speed m/s (mph)	Radius of maximum rotational speed m (ft)	Pressure drop mb (psi)	Rate of pressure drop mb/s (psi/s)
I	103 (230)	21 (46)	82 (184)	45.7 (150)	83 (1.2)	37 (0.5)
II	89 (200)	18 (40)	72 (160)	45.7 (150)	63 (0.9)	25 (0.4)
III	72 (160)	14 (32)	57 (128)	45.7 (150)	40 (0.6)	13 (0.2)

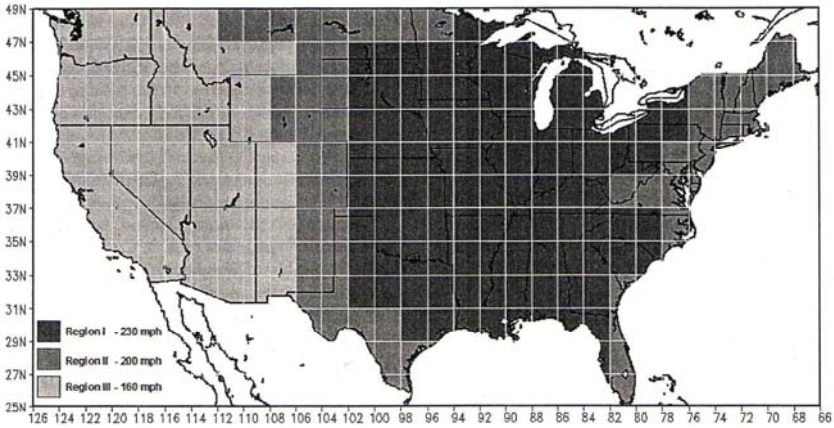

Figure 1. Tornado intensity regions for the contiguous United States for exceedance probabilities of  $10^{-7}$  per year

Flying debris

Table 2. Design-Basis Tornado Missile Spectrum and Maximum Horizontal Speeds

Missile Type		Schedule 40 Pipe	Automobile	Solid Steel Sphere
Dimensions		0.168 m dia × 4.58 m long (6.625 in. dia × 15 ft long)	<u>Region I and II</u> 5 m × 2 m × 1.3 m (16.4 ft × 6.6 ft × 4.3 ft)	2.54 cm dia (1 in. dia)
			<u>Region III</u> 4.5 m × 1.7 m × 1.5 m (14.9 ft × 5.6 ft × 4.9 ft)	
Mass		130 kg (287 lb)	<u>Region I and II</u> 1810 kg (4000 lb)	0.0669 kg (0.147 lb)
			<u>Region III</u> 1178 kg (2595 lb)	
C <sub>D</sub> A/m		0.0043 m <sup>2</sup> /kg (0.0212 ft <sup>2</sup> /lb)	<u>Region I and II</u> 0.0070 m <sup>2</sup> /kg (0.0343 ft <sup>2</sup> /lb)	0.0034 m <sup>2</sup> /kg (0.0166 ft <sup>2</sup> /lb)
			<u>Region III</u> 0.0095 m <sup>2</sup> /kg (0.0464 ft <sup>2</sup> /lb)	
V <sub>MB</sub> <sup>max</sup>	Region I	41 m/s (135 ft/s)	41 m/s (135 ft/s)	8 m/s (26 ft/s)
	Region II	34 m/s (112 ft/s)	34 m/s (112 ft/s)	7 m/s (23 ft/s)
	Region III	24 m/s (79 ft/s)	24 m/s (79 ft/s)	6 m/s (20 ft/s)

47

Recent research topics  
(Aerodynamics under gusty wind condition)

48

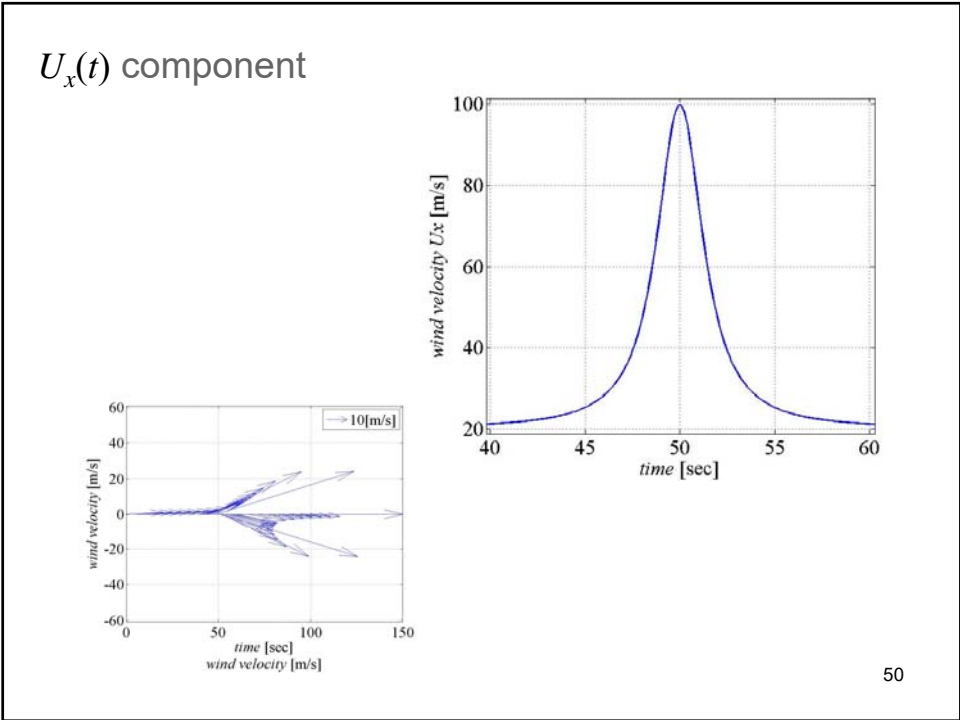
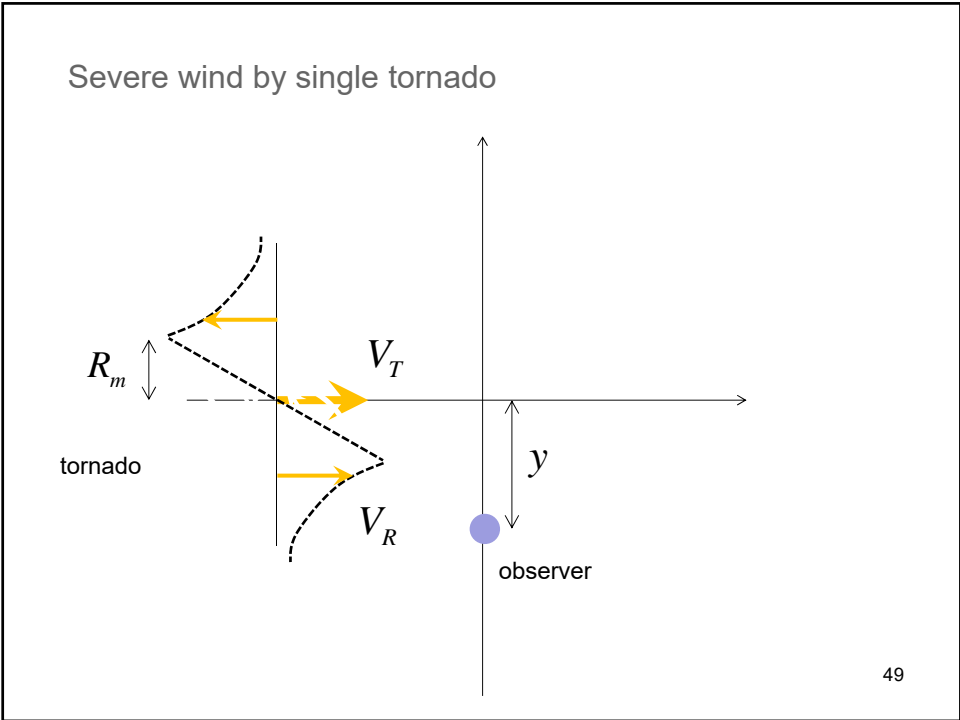

## Gust, strong wind by tornado passage

- Velocity increase in short time duration  
→ like a step function

$$U(t) \approx U_0 \cdot 1(t) + U_{init}$$

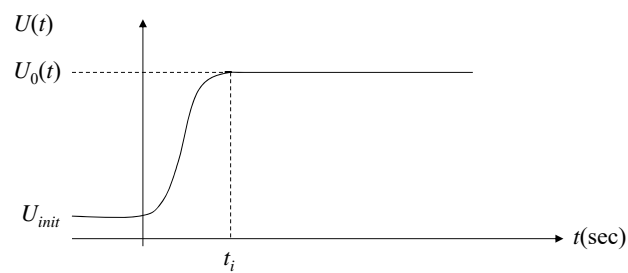

51

## Wind tunnel for short-time velocity increase

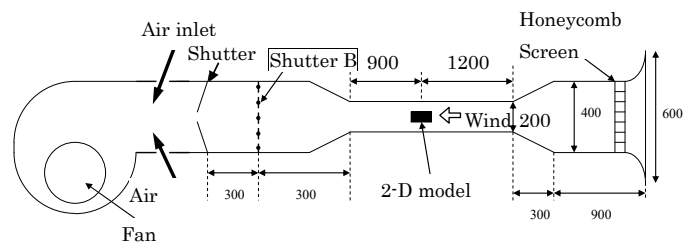
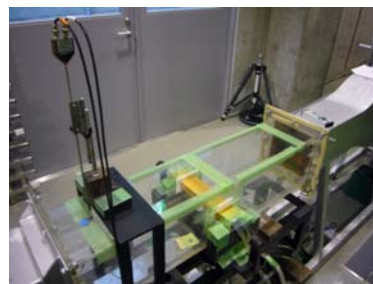

52

A square prism with incidence angle  $\alpha=10$  [deg]

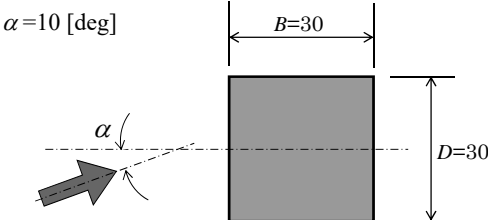

$U=3.0\text{m/s}$  to  $7.0\text{m/s}$ ,  $Re= 6.0\times 10^3$  to  $1.4\times 10^4$

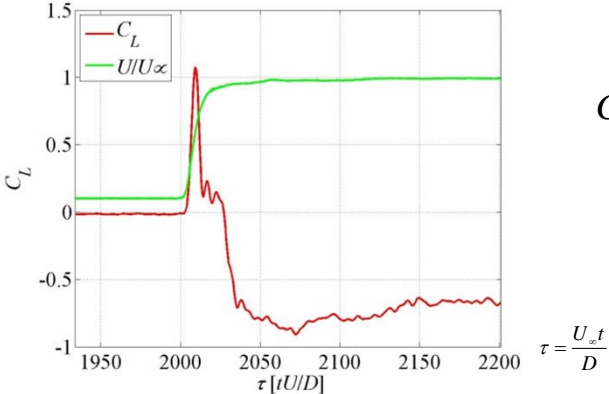
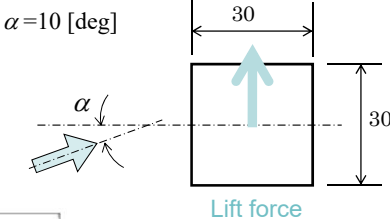

$$C_L = \frac{\text{Lift force}}{\frac{1}{2} \rho U_\infty^2 D l}$$

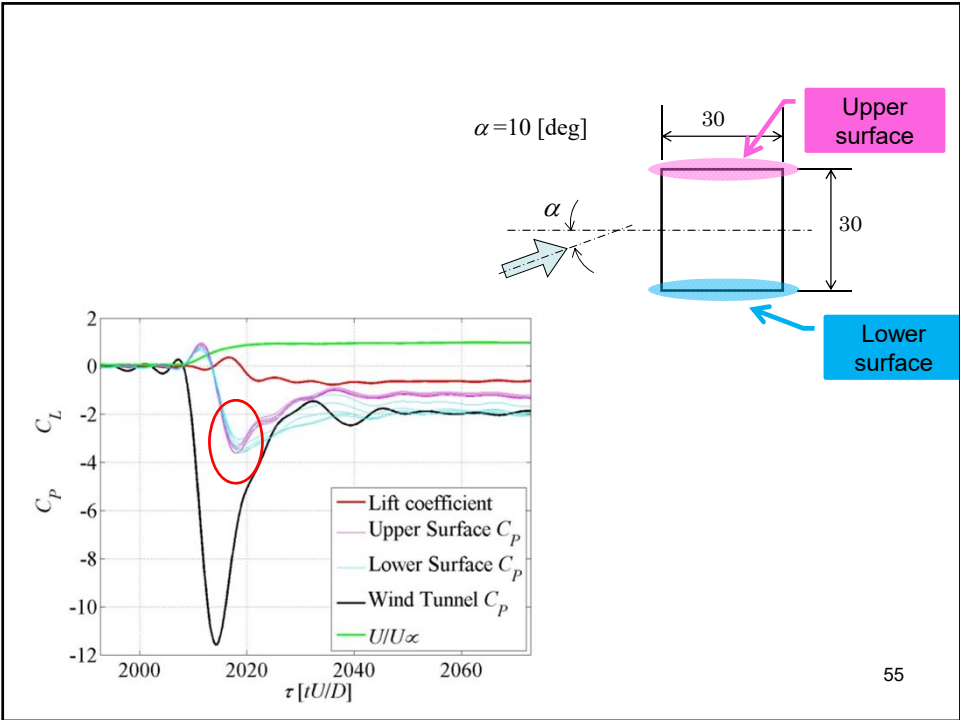

55

### Flow visualization

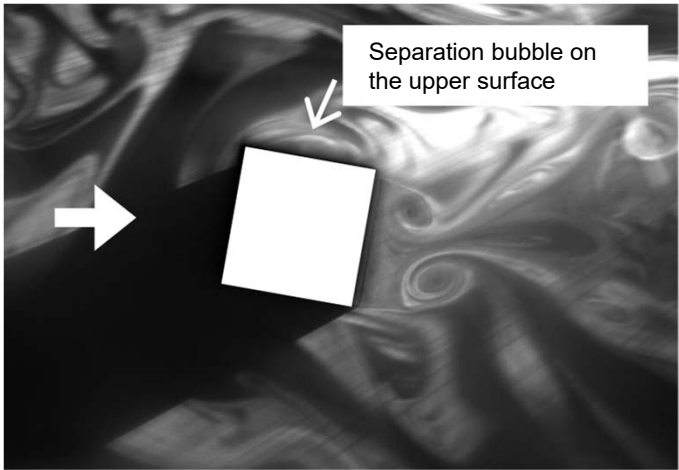

56



### Flow visualization

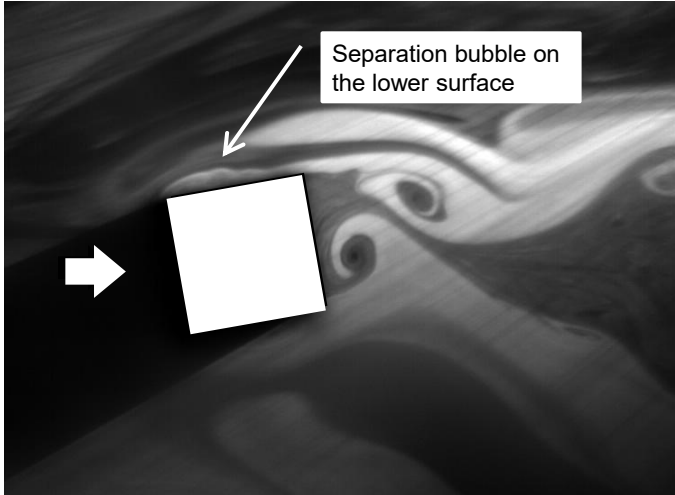

57

Drag force peak  
Lift force peak

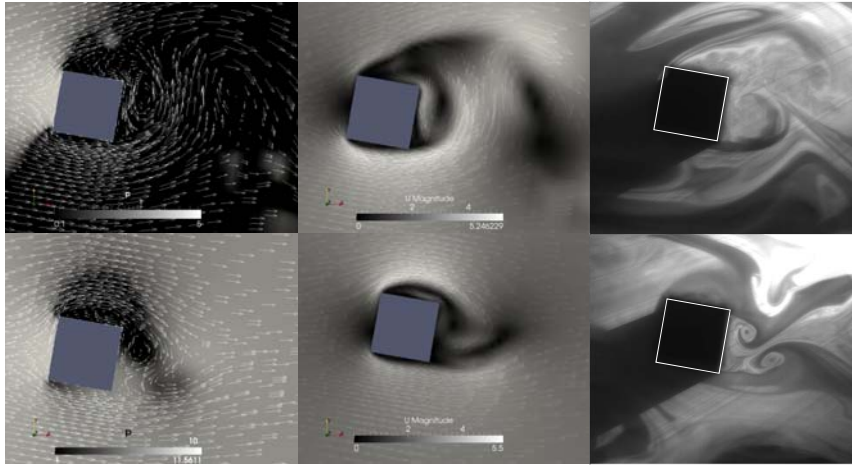

CFD (with pressure contour)

CFD (velocity contour)

Experiment

58

Rectangular prism with B/D=0.5

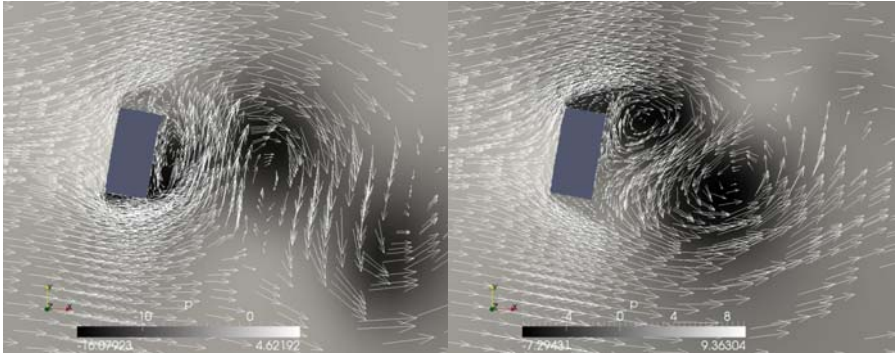

at drag peak (with pressure contour) at lift peak (with pressure contour)

If  $t_r$  is relatively short, the peak value  $C_{L peak}$  may exceed its steady state value ( $U=U_\infty$ )

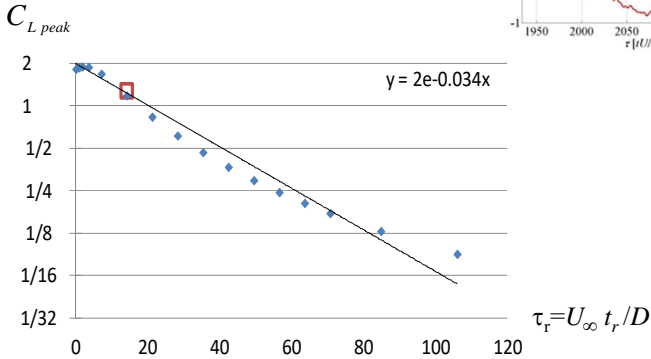
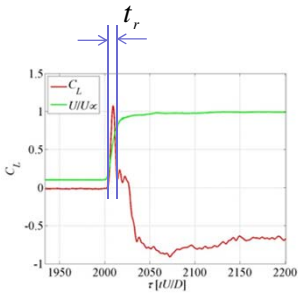



Feb.28, 1978 Tozai line

[http://www.ne.jp/asahi/aluminium/mania/al\\_train/t\\_eidan\\_clash2.htm](http://www.ne.jp/asahi/aluminium/mania/al_train/t_eidan_clash2.htm)

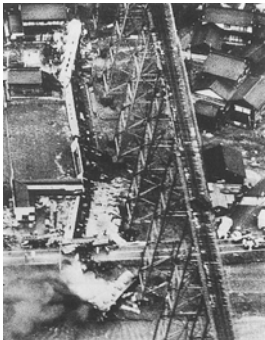

28 Dec., 1986 San-in main line

<http://www.sydrose.com/creativedesigengine/HTML/bb4-01213/bb4-01213.html>



3 Apr., 2012 Niigata pref.

<http://livedoor.blogimg.jp/joetsufj/imgs/3/8/3811c96a.jpg>



<http://minkara.carview.co.jp/userid/143276/blog/25999634/>

Vehicles overturning phenomenon due to lateral wind

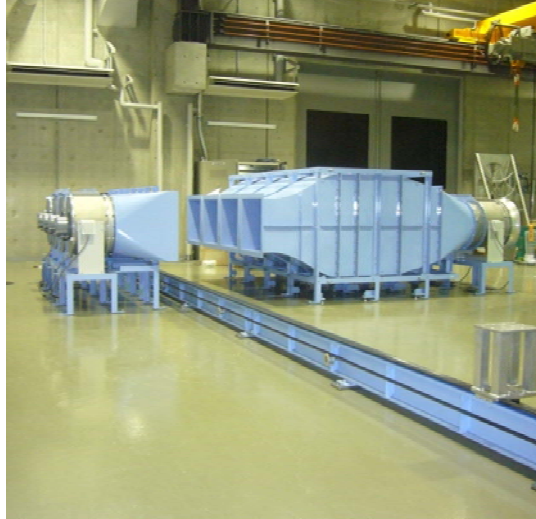

63

### 3) Wind resistance design codes

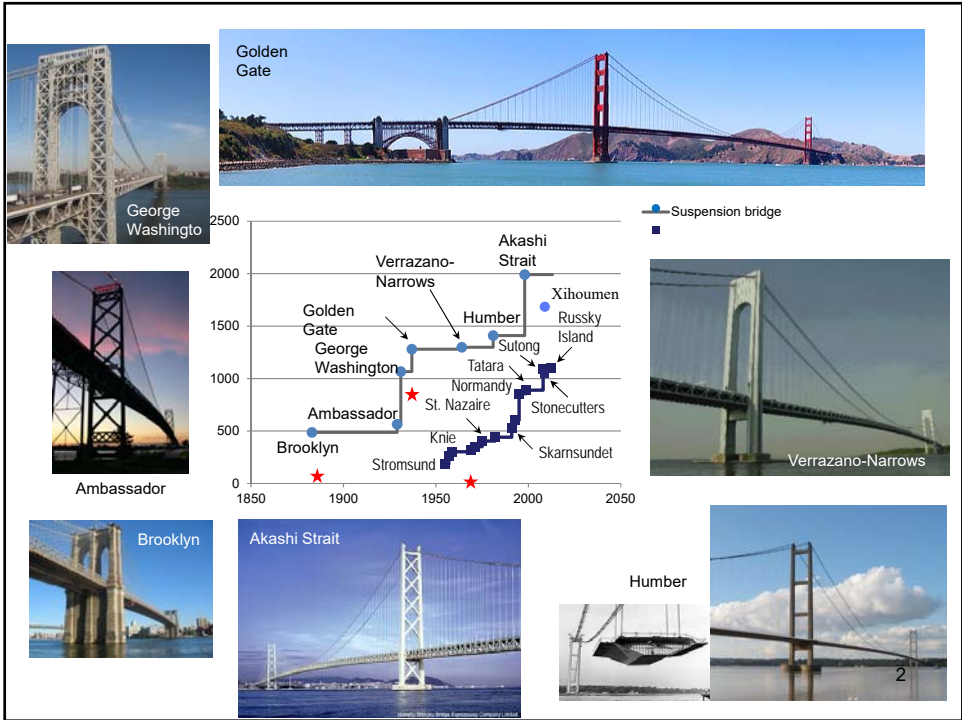

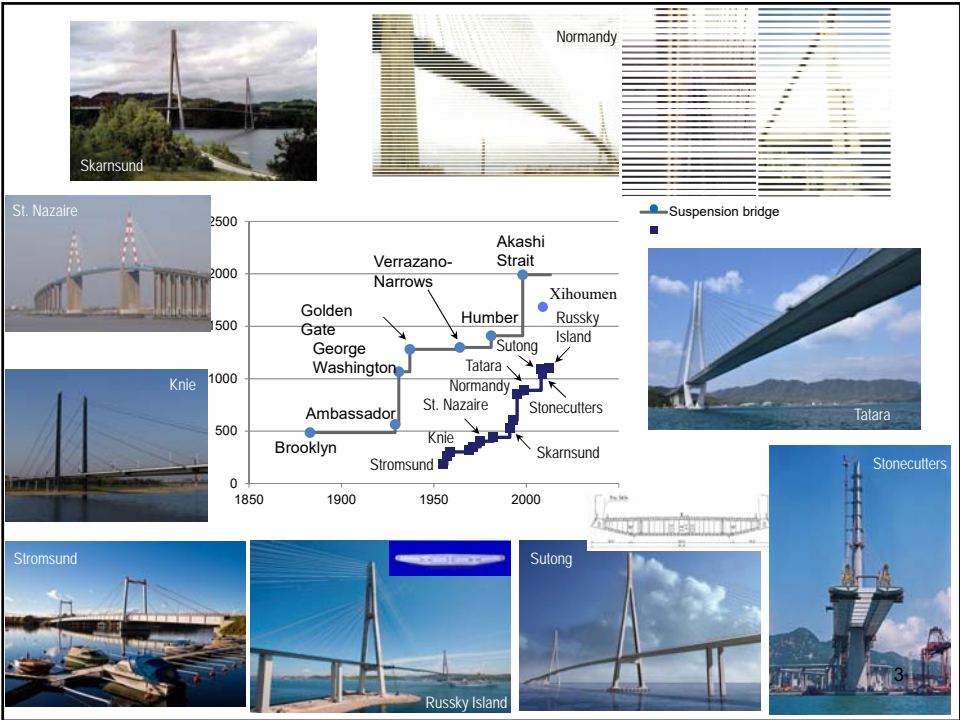

# Tay Bridge (1879)

Learned by wind  
Pioneers' footprint

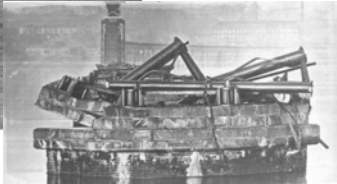
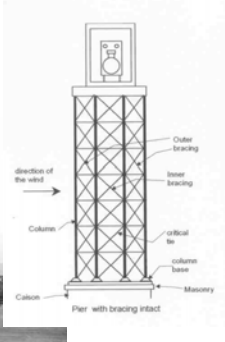

<http://taybridgedisaster.co.uk/index/wind-theory>

Learned by wind  
Pioneers' footprint

## Old Tacoma Narrows Bridge (1940)

"On the morning of  
November 7th the frequency  
was 36 cycles per minute  
with the wind blowing  
at 42 miles per hour."

5

Learned by wind  
Pioneers' footprint

## Ferrybridge Cooling Tower (1965)



Learned by wind  
Pioneers' footprint

# Wind resistant design codes

本州四国道路橋  
耐風設計基準  
(2001)・解説

20010222

本州四国道路橋

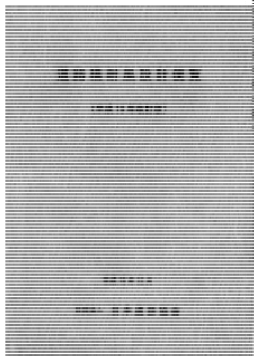

建築物荷重指針・解説  
(2004)

Recommendations for  
Loads on Buildings (2004)

日本建築学会

Learned by wind  
Pioneers' footprint

# Wind tunnel tests





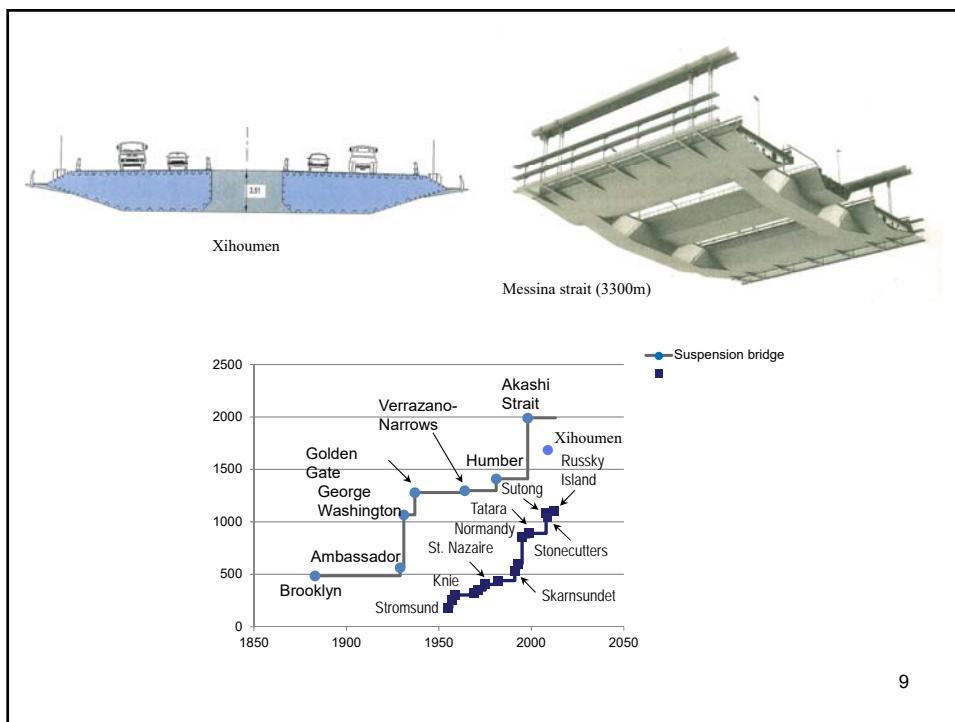

9

### Major codes in Japan for wind resistant design and wind loading

- Design code for Road bridges in Japan, 2012  
(道路橋示方書・同解説) *Japan road association, JRA1*
- Wind resistant design standard, 2001  
(本州四国連絡橋耐風設計基準) *Honshu-Shikoku Bridge Authority*
- Design manual of wind resistant design for road bridges, 2005  
(道路橋耐風設計便覧) *Japan road association, JRA2*

10

(JRA1)

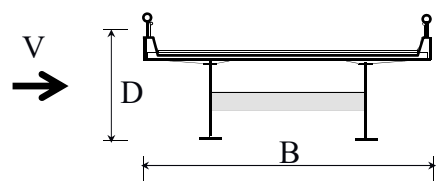

$$P = \frac{1}{2} \rho V^2 C_d G A_n$$

$P$  Wind load [N/m]  
 $\rho$  Air density [kg/m<sup>3</sup>]  
 $V$  Design wind speed [m/s]  
 $C_d$  Drag force coefficient  
 $G$  Gust response factor  
 $A_n$  Effective project area [m<sup>2</sup>/m]

The ratio of the maxima to the average of wind load due to wind turbulence and buffeting response

Depends on structural geometry of cross section

11

Drag force coefficient (JRA1)

Steel girder

$$C_d = \begin{cases} 2.1 - 0.1(B/D) & \dots\dots (1 \leq B/D < 8) \\ 1.3 & \dots\dots (8 \leq B/D) \end{cases}$$

2 plane truss

$$C_d = \begin{cases} 1.35/\sqrt{\phi} & (0.1 \leq \phi \leq 0.6) & \text{for truss} \\ 1.6 & & \text{for deck} \end{cases} \quad \phi : \text{solidity ratio}$$

Arch (angular member)      Arch (pipe member)

$$C_d = \begin{cases} 1.6 & \text{for windward} \\ 0.8 & \text{for leeward} \end{cases} \quad C_d = 0.8$$

Suspension, Cable-stayed (steel girder, 2 plane truss)

$C_d$ (see above)	(tower)	(cable)
	$C_d = \begin{cases} 1.6 & \text{for wind ward} \\ 0.8 & \text{for leeward} \end{cases}$	$C_d = 0.8$

12

Modification factor of Drag force coefficient due to closely spaced arrangements (JRA1)

表-3.9 風洞試験による並列橋の抗力の修正係数<sup>注)</sup>

水平距離	2D	D	0	-D	-2D
前面距離	0.94	1.25	1.14	1.12	0.96
D	0.94	1.04	1.09	0.96	0.96
0	0.97	1.14	-	-0.16	0.14
-D	0.95	1.10	1.05	0.94	0.91
-2D	0.93	1.07	1.08	1.14	0.94

注) 修正係数=並列橋としての抗力/単独橋としての抗力  
この修正係数は迎角が-3°から+3°の範囲の最大値である。



図-3.10 並列橋の位置関係

Wind resistant design procedure (HonShi)

- 1) Static design.
- 2) Wind tunnel test using a spring support section model to find aerodynamically stable geometry of a girder. Wind tunnel test using a full elastic model to find aerodynamically stable geometry of a tower.
- 3) Safety check for instability due to static wind load.
- 4) Safety check for divergent vibration, buffeting, vortex-induced vibration by wind tunnel test (full elastic model), flutter analysis and buffeting analysis.

Static effect

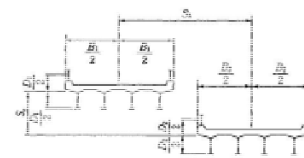
- Deformation, stress due to static wind load
- instability (lateral buckling, divergence)

Dynamic effect

- Divergent vibration (Galopping, Flutter)
- Buffeting
- Vortex-induced vibration
- Cable vibration

Aerodynamic phenomena and structural elements to be assured its safety  
(HonShi)

		Girder	Tower/ Pylon	Main cable	Hanger	Cable for c.s.b.	
Static effect	Deformation, stress	○	○	○	○	○	
	instability	Lateral buckling	○	—	—	—	—
		divergence	○	—	—	—	—
Dynamic effect	Divergent vibration	○	○	—	—	—	
	Buffeting	○	△	—	—	—	
	Vortex-induced vibration	○	○	—	△	○	
	Cable vibration	—	—	—	△	○	

15

Wind-resistant design procedure for Akashi strait and Kurushima strait Bridges (HonShi)

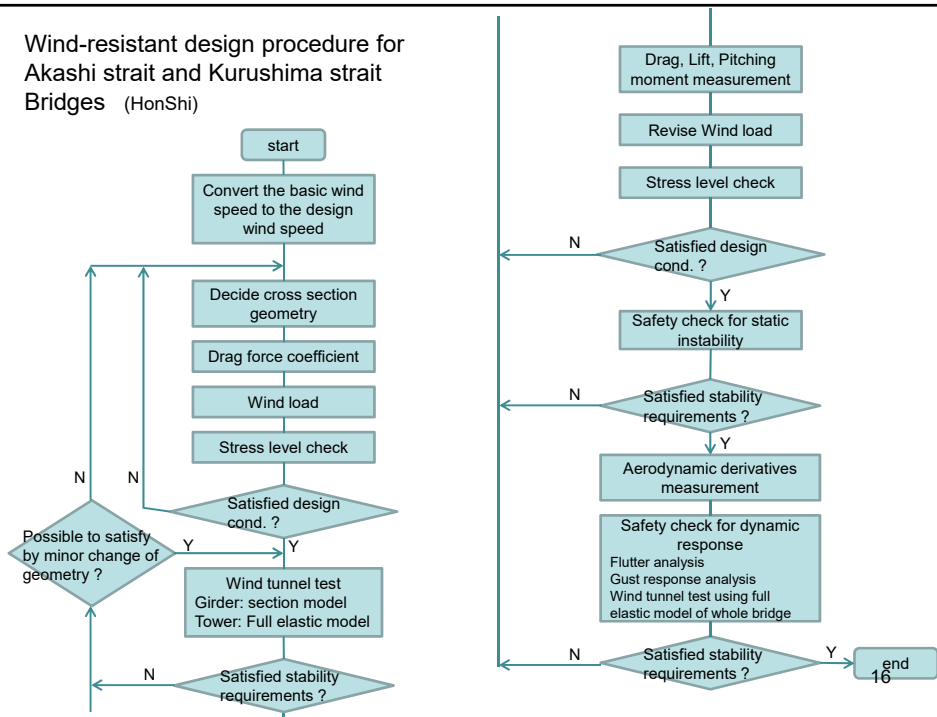

Basic wind speed  $\bar{U}_{10}$  (HonShi)

Bridge name	Basic wind speed (m/s)
Akashi strait	46
Kurushima 1 <sup>st</sup> , 2 <sup>nd</sup> , 3 <sup>rd</sup>	40
Tatara	37

History of the BSW for Akashi strait Bridge

- Wind observation at Tarumi obs. Tower (H=80m)
- 49.4m/s for 150 year return priod
- Bad fit to Gumbel dist. (Maximum ever recorded and 2<sup>nd</sup> maximum)
- 49.4 × 1.1=54.3m/s
- Wind velocity ratio of at Tarumi and at Akashi strait = 1:1.1 (by topographic model)
- Vertical profile 54.3 × 1.1 × (10/80)<sup>1/8</sup>=45.9m/s

※ power  $\alpha$   
 : 1/8 (Akashi st. br.)  
 : 1/7 (Tatara br., Kurishima st. br.)

$$\bar{U}_z = \bar{U}_{10} \cdot \left(\frac{z}{10}\right)^\alpha$$

17

Gust response factor  $\mu_2, \mu_3$  (HonShi)

Girder, cable, hanger, Suspended structures

$$P_D = \mu_2 \frac{\rho \bar{U}_z^2}{2} C_D A_n$$

Air density

$$\rho = 1.2 \text{ [kg/m}^3\text{]}$$

Tower/pylon

$$P_D = \mu_3 \frac{\rho \bar{U}_z^2}{2} C_D A_n$$

Structural element to design			girder		tower	
			Normal to bridge axis	Along bridge axis	Normal to bridge axis	Along bridge axis
Akashi strait	Main cable	$\mu_2$	1.55	--	1.35	--
	Hanger rope Suspended girder	$\mu_2$	1.55	1.25	1.35	1.25
	Tower	$\mu_3$	--	--	1.55	1.50 (top fixed) 1.75 (top free)
Kurushima 1 <sup>st</sup> , 2 <sup>nd</sup> , 3 <sup>rd</sup>	Main cable Hanger rope Suspended girder	$\mu_2$	2.0	1.3	1.7	1.3
	Tower	$\mu_3$	--	--	1.4	1.55 (top fixed) 1.75 (top free)
Tatara	Cable Main girder	$\mu_2$	1.9	1.35	1.65	1.35
	Pylon	$\mu_3$	1.9	1.5	1.65	1.5 (top fixed) 1.8 (top free)

18

Gust response factor (HonShi)

$$\mu_2, \mu_3$$

$$= G \text{ (JRA1)}$$

depends on

- Spanwise correlation of wind velocity fluctuation
- Dynamic properties (Nat. freq., Damping, Vib. modes, etc.)

19

Drag force coefficient (HonShi)

Structural element		Normal to bridge axis		Along bridge axis	
		$C_D$	remarks	$C_D$	remarks
girder	Truss structure	By wind tunnel test using similar geometry of cross section		60% to the value for normal to bridge axis	
	Box	By wind tunnel test using similar geometry of cross section		30% to the value for normal to bridge axis	
Tower		1.8	Per one column with rectangular cross section	1.8	Per column with rectangular cross section
		or by wind tunnel test using similar geometry of cross section		or by wind tunnel test using similar geometry of cross section	
Main cable for suspension bridge		0.7		–	
Hanger rope for suspension bridge		0.7		0.7/√2 0.7	For truss
Cable for cable-stayed bridge		0.7		0.7	

20

Projected area  $A_n$  (HonShi)

Structural element	Normal to bridge axis	Along bridge axis
Girder	Windward area of girder, handrail and parapet	Same as left
Tower	Windward and leeward area of columns	Windward and leeward area of columns and bracing
Main cable for suspension bridge	Windward and leeward cables	--
Hanger rope for suspension bridge	Windward and leeward hanger ropes	Same as left
Cable for cable-stayed bridge	Windward and leeward cables	Same as left

21

Basic wind speed during construction (HonShi)

Bridge name	Basic wind speed during construction (m/s)
Akashi strait	37
Kurushima 1 <sup>st</sup> , 2 <sup>nd</sup> , 3 <sup>rd</sup>	31
Tatara	29

(Akashi) Durable period ( $R$ ) = 5(yr.), Non-exceeding prob. ( $q$ ) = 0.8  
 → Return period ( $T$ ) = 23(yr.)

(Kurushima, Tatara)  
 $R=4, q=0.8 \rightarrow T=18$

$$q = \left(1 - \frac{1}{T}\right)^R$$

22

Structural damping (Wind tunnel test, Flutter and buffeting analysis) (HonShi)

Structural part		Logarithmic damping decrement	
		Heaving vibration	Torsional vibration
Girder dominant mode	Truss stiffened girder	0.03	0.02 0.03 for main span length being 500 to 600m
	Box girder	0.02	0.02
Tower dominant mode	Tower, cable, girder system	0.02	0.02
	Isolated tower	0.01	0.01
Cable dominating mode for cable-stayed bridge		0.003	--
Hanger dominating mode for suspension bridge		0.003	--

23

Vertical inclination of wind incidence angle (HonShi)

- Smooth flow  $-3^{\circ} \sim +3^{\circ}$
- Turbulent flow  $0^{\circ}$

Maximum expected angle during the time duration being required for growth up of divergent vibration

24



Safety assurance for divergent vibration (HonShi)

For the critical wind velocity of divergent vibration  $U_F$ , the following criteria must be satisfied:

$$U_F \geq 1.2 \cdot \mu_F \cdot \bar{U}_z$$

Where,  $\mu_F$  is a correction factor with regard to wind velocity fluctuation and  $\bar{U}_z$  is the basic design wind speed.

Bridge name	$\mu_F$
Akashi strait	1.08
Kurushima 1 <sup>st</sup> , 2 <sup>nd</sup> , 3 <sup>rd</sup>	1.1
tatara	1.1

$\mu_F$ : The ration of the maximum expected wind speed in the duration of 5 times of natural period of divergent vibration

Examination of Aerodynamic stability (JRA2)

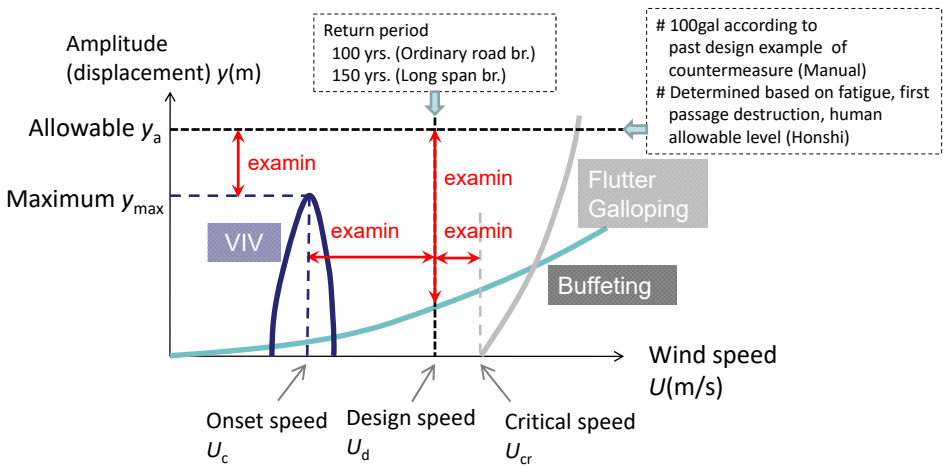

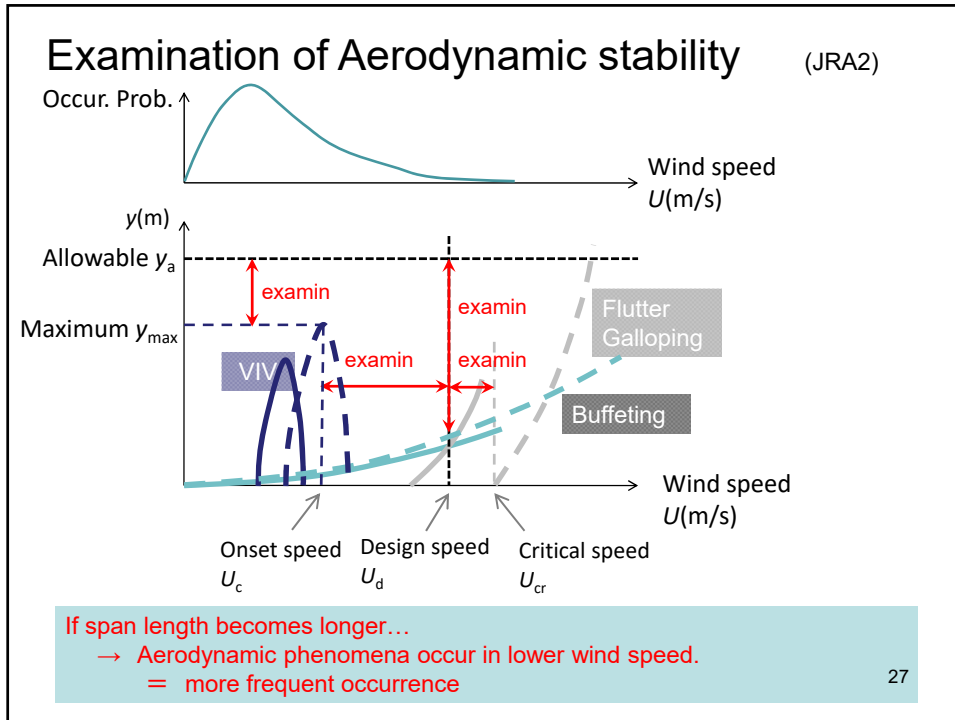

### Criteria for aerodynamic phenomena (JRA2)

● flutter

$$U_{cf} > U_{rf}$$

$$U_{cf} = 2.5f_{\theta}B \dots$$

$$U_{rf} = 1.2E_{r1}U_d$$

Based on wind tunnel test

smooth flow :  $U_{rf} = 1.2E_{r1}U_d$

full model in turbulent flow :  $U_{rf} = 1.2U_d$

$U_{cf}$  : Critical wind speed (m/s)  
 $f_{\theta}$  : Natural freq. (1<sup>st</sup> torsional) (Hz)  
 $B$  : Bridge deck width (m)  
 $d$  : Bridge deck height (m)  
 $U_{rf}$  : Examining wind speed (m/s)  
 $E_{r1}$  : Correction factor due to wind fluctuation  
 $U_d$  : Basic design wind speed (m/s)

Surface roughness category	$E_{r1}$
0	1.10
I	1.10
II	1.15
III	1.20
IV	1.25

28

● flutter

$$\begin{aligned}
 &U_{cf} > U_{rf} \\
 &U_{cf} = 2.5 f_{\theta} B \quad \dots \\
 &U_{rf} = 1.2 E_{r1} U_d
 \end{aligned}$$

← for suspension br. and cable-stayed br. with box girder, or truss girder

for steel I-shaped girder br.

$$U_{cf} = \begin{cases} (6.0 - B/d) \cdot f_{\theta} \cdot B & (1.9 \leq B/d < 3.5) \\ 2.5 \cdot f_{\theta} \cdot B & (3.5 \leq B/d < 4.5) \\ 2.1 \cdot f_{\theta} \cdot B & (3.5 \leq B/d < 4.5) \end{cases}$$

← And to be constructed above sea in low turbulence intensity

● flutter

$$\begin{aligned}
 &U_{cf} > U_{rf} \\
 &U_{cf} = 2.5 f_{\theta} B \quad \dots \\
 &U_{rf} = 1.2 E_{r1} U_d
 \end{aligned}$$

If stability against flutter is examined by wind tunnel test,

- In case of section model test in uniform flow: the test should be done under the condition of incidence angle of wind,  $-3 \text{ (deg)} \leq \alpha \leq +3 \text{ (deg)}$
- In case of full bridge model in turbulent boundary layer in which the wind condition on bridge site is simulated:

$$U_{rf} = 1.2 U_d$$

Bridge type	Susp. Truss g.	Susp. Box g.	Cable-st. Truss g.	Cable-st. Box g.	Girder St. sup.	Girder Rub. Sup.
Log. Damp.	0.03	0.02	0.03	0.02	$\frac{0.75}{\sqrt{L}}$	$\frac{0.75}{\sqrt{L}}$

● galloping

$$U_{cg} > U_{rg}$$

$$U_{cg} = 8f_h B \dots$$

$$U_{rg} = 1.2U_d$$

$U_{cg}$  : Critical wind speed (m/s)  
 $U_{rg}$  : Examining wind speed (m/s)  
 $f_h$  : Natural freq. (heaving 1<sup>st</sup>) (Hz)

● VIV

$$U_{cvh} > U_{rvh} \quad \text{or} \quad h_c < h_a$$

$$U_{cv\theta} > U_{rv\theta} \quad \text{or} \quad \theta_c < \theta_a$$

$U_{cvh}$  : Onset wind speed for heav. (m/s)  
 $U_{rvh}$  : Examining wind speed for heav. (m/s)  
 $h_c$  : Maximum amp. for heav. (m)  
 $h_a$  : Allowable amp. for heav.(m)  
 $U_{cv\theta}$  : Onset wind speed for tors. (m/s)  
 $U_{rv\theta}$  : Examining wind speed for tors. (m/s)  
 $\theta_c$  : Maximum amp. for tors. (deg.)  
 $\theta_a$  : Allowable amp. for tors.(deg.)

● galloping

$$U_{cg} > U_{rg}$$

$$U_{cg} = 8f_h B \dots$$

$$U_{rg} = 1.2U_d$$

for **suspension br. and cable-stayed br.**  
 with box girder, or truss girder  
 and to be constructed above flat terrain and  
 expected almost horizontal wind such as  
 above sea  
 and with **steel supporting member**

$U_{cg} = 4.5 \cdot f_h \cdot B$  for **suspension br. and cable-stayed br.**  
 with box girder, or truss girder  
 and to be constructed above flat terrain and  
 expected almost horizontal wind such as above sea  
 and with **rubber supporting member**

$U_{cg} = 4 \cdot f_h \cdot B$  for **suspension br. and cable-stayed br.**  
 with box girder, or truss girder  
 and to be constructed where a ridge, or a cape locates  
 behind and is running in parallel to the bridge axis

$U_{cg} = 3.5 \cdot f_h \cdot B$  for **steel I-shaped girder br.**

● VIV

$$U_{cvh} > U_{rvh} \quad \text{or} \quad h_c < h_a$$

$$U_{cv\theta} > U_{rv\theta} \quad \text{or} \quad \theta_c < \theta_a$$

- $U_{cvh}$ : Onset wind speed for heav. (m/s)
- $U_{rvh}$ : Examining wind speed for heav. (m/s)
- $h_c$ : Maximum amp. for heav. (m)
- $h_a$ : Allowable amp. for heav.(m)
- $U_{cv\theta}$ : Onset wind speed for tors. (m/s)
- $U_{rv\theta}$ : Examining wind speed for tors. (m/s)
- $\theta_c$ : Maximum amp. for tors. (deg.)
- $\theta_a$ : Allowable amp. for tors.(deg.)

$$U_{rvh} = U_d$$

For heaving response

- For **suspension br. and cable-stayed br.** with box girder

$$U_{cvh} = 2.0 \cdot f_h \cdot B$$

- For **steel I-shaped girder**

$$U_{cvh} = 2.0 \cdot f_h \cdot B \quad (1.9 \leq B/d < 4.5)$$

$$h_c = h_e \cdot E_{ms} \cdot E_{th}$$

$$h_e = \frac{\beta_h}{m_r \delta_h} \cdot B$$

$h_e$ : Heaving VIV amplitude in smooth flow at vibration mode =1.0

$\beta_h$ : Heaving VIV amplitude equivalence factor  
For suspension br. and cable-stayed br.  
with box girder:  $\beta_h = 0.05(B/d)^{-1} \cdot \beta_{ds}$

For steel I-shaped girder:

$$\beta_h = 0.04 \quad (1.9 \leq B/d < 3.5)$$

$$\beta_h = 0.14(B/d)^{-1} \quad (3.5 \leq B/d < 4.5)$$

$\beta_{ds}$ : Correction factor related with cross section geometry of box girder

33

$m_r$ : Non-dimensional mass

$\delta_h$ : Logarithmic structural damping decrement for heaving mode

$E_{ms}$ : Correction factor related to vibration mode:

$E_{th}$ : Reduction factor due to wind turbulence:

$$E_{th} = 1 - 15 \cdot \beta_t \cdot (B/d)^{1/2} \cdot I_u^2$$

34

Recommendations for loads on buildings  
 Chap.6 Wind loading  
 (2004, AIJ)

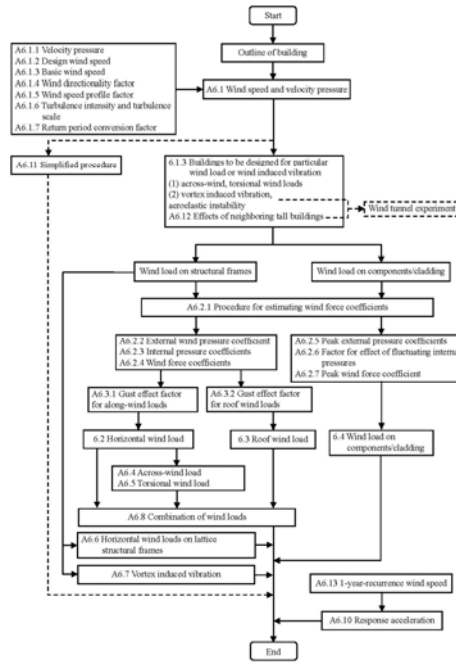

Figure 6.1.4 Flow chart for estimation of wind load

35

Recommendations for loads on buildings  
 Chap.6 Wind loading  
 (2004, AIJ)

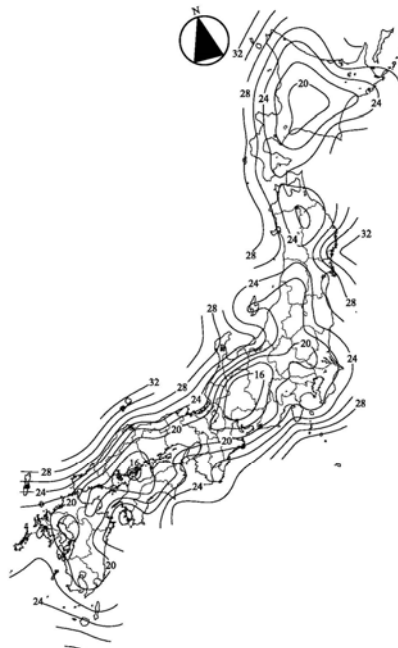

Figure A6.1.5 100-year-recurrence 10-minute mean wind speed at 10m above ground over a flat and open terrain in winter (m/s)

36

付録 A 講義及びセミナー資料

A-7 積算セミナー

1

# Seminar for Cost Estimate

## 2017/10/31 – 11/1

JICA Survey Team

Takuya KURAMOCHI  
Cost Estimate in Bago River BridgeD/D  
Nippon Koei

JICA Survey Team 2

▶ Objective  
To enhance understanding and importance of cost estimate from the view point of the employer

▶ Contents

- 1. Cost Estimate**
  - Purpose/Meaning
  - Japanese standard
  - Myanmar standard
- 2. Cost Estimate Method**
- 3. Cost Breakdown**  
Structure of Contract Amount in JP standard
- 4. Cost Breakdown**
- 5. Exercise: PC-I girder (On-ramp of Bago Bridge)**  
\*Trainee have start exercise from considering work items
  - A\_Superstructure
  - B\_Substructure
  - C\_Foundation



JICA Survey Team 3

## Infrastructure

### ► Characteristics

Infrastructure has important role to support citizens daily activity. Government has responsibility to build and maintain infrastructures.

Infrastructure characteristics are followings

- Financed by government (from citizens taxation)
- Only one in particular conditions
- Not only one way of construction to accomplish a project

Because of those characteristics, clear **justification(Fairness)** and **explanation** of project cost are required for public.

For this sake, specified cost estimate standards are important. In addition cost estimate standards dedicate to **keep infrastructure quality** and **continuous improvement of construction industry**.

JICA Survey Team 4

## About "Cost Estimate"

### ► Estimate an appropriate cost

All activities are converted into money

For employer,  
To confirm expected project cost  
\*for bidding to have appropriate contract

For contractor,  
To estimate bidding contract amount



Difference is whether a cost estimator should define project condition or not, as following 3 factor.

- 1\_ Preparing "Bidding Document"
- 2\_ Setting "Construction Conditions"
- 3\_ Setting "Cost Estimate Conditions"

These are Employers obligations

JICA Survey Team 5

▶ 2 steps of “Cost Estimate” as an employer

1st Step,  
Definition of project condition

2nd Step  
Estimation of “Contract amount”, especially  
“construction cost” composed by required resources  
*\*Contractors consider only this step. Project conditions are provided in a contract doc.*

▶ Purpose of Cost Estimate

**For Public**

- Fairness/Justification / Clear Explanation
- Minimization of Cost
- Quality Control

= infrastructure should be commenced “Fairly / with reasonable price / better quality”  
⇒ Ordinary **“Trade off relation ship”**  
⇒ Fair cost estimate is necessary for everyone, employer and contractor, public

JICA Survey Team 6

▶ International Bidding

“Lump Sum Contract and Unit Price Agreement Method”.

\*An international bidding based on FIDIC pink book\* applies this contract

For international bidding, estimated cost is defined as “Engineer Estimation(Engineer cost)” In FIDIC.

“Engineer Estimation” is reference cost of bidding document.  
To keep quality of infrastructure, evaluation of bidding price is important procedure.

```

graph TD
    Employer[The employer] --- Method([Lump Sum Contract and Unit Price Agreement Method])
    Engineer[The engineer] --- Method
    Engineer --- Estimation[Engineer's Estimation]
    Estimation --- Summation[Summation method]
    UnitRate[Unit Rate] --- Summation
    Summation --- Contractor[The Contractor]
  
```

In Bago bridge detailed design,  
“Summation method” is applied by Japanese standards

\*Pink book :  
Multilateral Development Bank(MDB) Harmonised Edition  
June 2010

JICA Survey Team 7

## Japanese Standard, Guideline, Manual

▶ Applied Japanese Standards for Bago Bridge DD

Japan International Cooperation Agency (JICA)

- Preparatory Survey for Grant Aid / Design and Cost Estimate Manual (Civil Engineering), 2016
- Preparatory Survey for Grant Aid / Design and Cost Estimate Manual (Equipment Procurement), 2016
- Preliminary Project Cost Estimate Guideline, 2008

Construction Research Institute

- Cost Estimate Standard for Civil Works (MLIT), 2016, 2013, 2012, 2011
- Cost Estimate Standard for Civil Works (MOC), 2000, 1999, 1993, 1992
- Cost Estimate Standard for Port Civil Works (MLIT), 2016
- Standard Specification of Cost Estimate for Civil Works (MLIT), 2016
- Construction Material Cost, April, 2017

Japan Construction Machinery and Construction Association

- Construction Equipment Depreciation Calculation, 2016
- Bridge Erection Works Cost Estimation, 2016

JICA Survey Team 8

## Several Methods of Cost Estimate in Japan

- 1\_ Summation Method
- 2\_ Market Unit Price Method
- 3\_ Work Package Price Method

\*appropriate English name is not sure

▶ Position of Every Method

```

graph LR
    Employer[The employer] --- LumpSum(Lump Sum contract)
    LumpSum --- Contractor[The Contractor]
    Contractor --- MarketUnit[Market Unit Price method]
    MarketUnit --- Subcontractor[Subcontractor]
    LumpSum --- WorkPackage[Work Package Price Method]
    Contractor --- Summation[Summation method]
    Subcontractor --- UnitRate[Unit Rate]
    UnitRate --> Summation
    
```

\*Agreement of Work Package Price

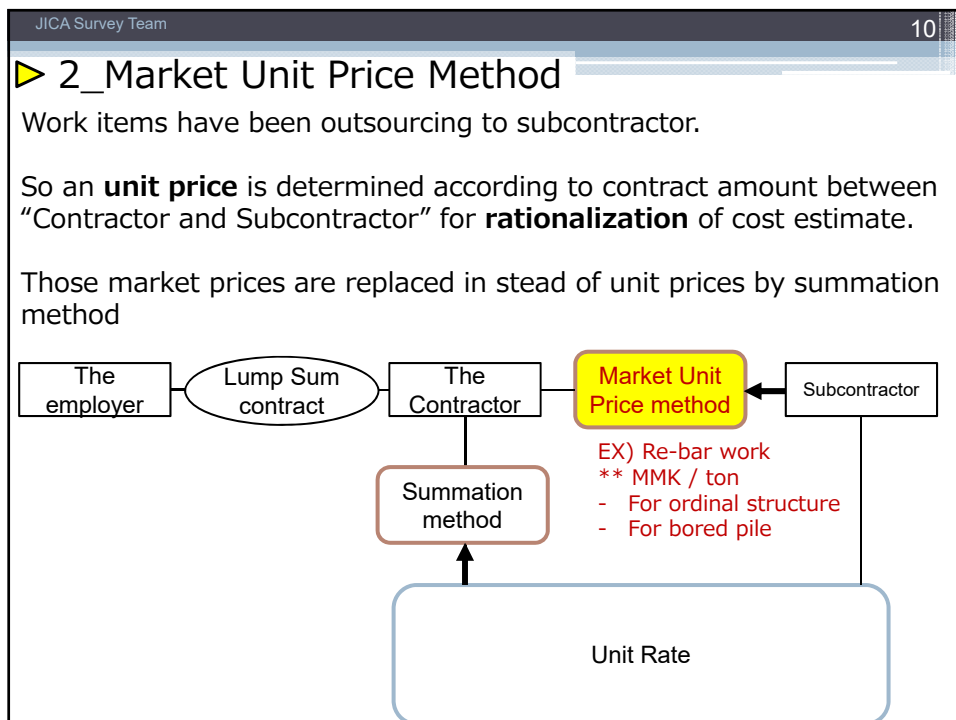
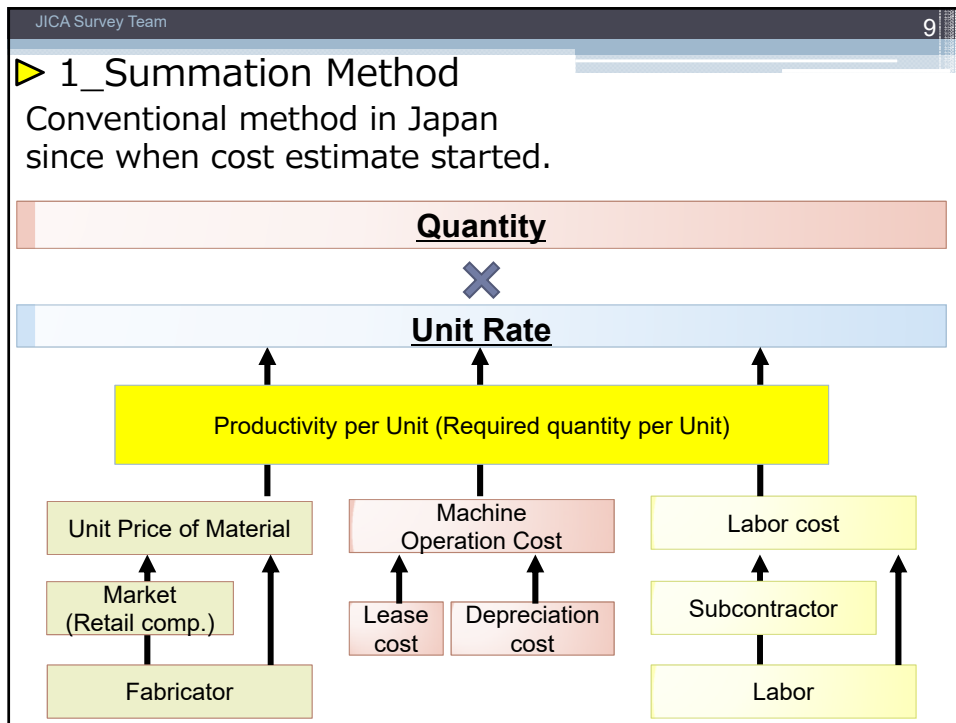

JICA Survey Team 11

### ▶ 3\_ Work Package Price Method

This method is applied for "Lump Sum Contract and Unit Price Agreement Method".  
 \*An international bidding based on FIDIC pink book applies this contract

A **package price** is already continuously published by government for **rationalization** and **justification** of cost estimate.  
 Focusing on structure, like AS con. pavement, concrete pier,,,

```

    graph LR
      Employer[The employer] --- LS[Lump Sum contract] --- Contractor[The Contractor]
      Contractor --- MUP[Market Unit Price method] --- Subcontractor[Subcontractor]
      Contractor --- WPPM[Work Package Price Method]
      Contractor --- Summation[Summation method]
      UnitRate[Unit Rate] --- Summation
      Subcontractor --- UnitRate
    
```

EX) AS con. Pavement  
 \*\* MMK / m2  
 - Thickness: 45-55 mm  
 - Width: B<1.4 m  
 - AC 20

JICA Survey Team 12

### ▶ Ex) 1,000m2 form work

Method \ Procedure	1_Estimation of Work productivity (per day)	2_Work productivity (per day)	3_Setting Unit Rate	4_Calculation of Cost
0_Summation Method (from estimation of work productivity) Condition: 1,000m2 should be done in (33d)	Form worker: <b>3 person/30m2</b> Unskilled labor: <b>1 person/30m2</b>	Form worker: <b>0.1 person/m2</b> Unskilled labor: <b>0.03person/m2</b>	@20,000MMK/pers on* <b>0.1 person/m2 =2,000MMK/m2</b> @13,000MMK/pers on* <b>0.033 person/m2 =429 MMK/m2</b>	(2,000+429) MMK/m2*1,000m2= 2,429,000 MMK
1_Summation Method		Form worker: <b>0.1 person/m2</b> Unskilled labor: <b>0.03 person/m2</b>	@20,000MMK/pers on* <b>0.1 person/m2 =2,000MMK/m2</b> @13,000MMK/pers on* <b>0.033 person/m2 =429 MMK/m2</b>	(2,000+429) MMK/m2*1,000m2= 2,429,000 MMK
2_Market Unit Price Method			Form work unit rate: <b>2,000MMK/m2+500 MMK/m2 = 2,500 MMK/m2</b>	@2,500MMK * 1,000m2 = 2,500,000 MMK
3_Work Package Price Method				Form work 2,500/m2*1,000m2 = 2,500,000 MMK

JICA Survey Team  
"Standard Data for working out Rates Per Unit Quantity of Items of Work-contd. Book" and the price from "Material & Labour Price Book" 13

## Myanmar Cost Estimate Standard

▶ Standard

"Standard Data for working out Rates Per Unit Quantity of Items of Work-contd. Book"  
"Material & Labour Price Book"

\*Like "Market Unit Price Method" in Japan(in my understanding)

▶ Indirect Construction Cost

- Miscellaneous Amount  
Maximum 10% of Total Material and Labour Amount
- Transportation Amount  
Maximum 5% of Total Material Amount

JICA Survey Team  
Miscellaneous Amount (maximum 10% of Total Material and Labour Amount and Transportation Amount ( maximum 5% of Total Material Amount) 14

## Structure of Contract Amount in JP standard

```

graph LR
    CA[Contract amount] --- CP[Construction price]
    CA --- TE[Tax etc.]
    CP --- CC[Construction cost]
    CP --- OC[Overhead cost]
    CC --- DCC[Direct construction cost]
    CC --- ICC[Indirect construction cost]
    DCC -.-> NCC[Net construction cost]
    ICC --- GTWC[General temporary work cost]
    ICC --- SMC[Site management cost]
  
```

- Physical contingency
- Price escalation
- Consultant fee
- Land acquisition etc. (The employer obligation)

are out of this structure

JICA Survey Team  
Miscellaneous Amount (maximum 10% of Total Material and Labour Amount and Transportation Amount ( maximum 5% of Total Material Amount) 15

### ► Overhead Cost

```

graph LR
    CA[Contract amount] --> CP[Construction price]
    CA --> TE[Tax etc.]
    CP --> CC[Construction cost]
    CP --> OC[Overhead cost]
    CC --> DCC[Direct construction cost]
    CC --> ICC[Indirect construction cost]
    ICC --> GTWC[General temporary work cost]
    ICC --> SMC[Site management cost]
    DCC -.-> NCC[Net construction cost]
  
```

“Overhead Cost” is cost for

- Contractor’s head office expense
- Cost for experiment to improve their technology
- Appropriate profit as public work

In Japanese standards, “Overhead Cost” is calculated as rate calculation depending on contract amount of “Construction cost”

JICA Survey Team  
Miscellaneous Amount (maximum 10% of Total Material and Labour Amount and Transportation Amount ( maximum 5% of Total Material Amount) 16

### ► Indirect Construction Cost

```

graph LR
    CA[Contract amount] --> CP[Construction price]
    CA --> TE[Tax etc.]
    CP --> CC[Construction cost]
    CP --> OC[Overhead cost]
    CC --> DCC[Direct construction cost]
    CC --> ICC[Indirect construction cost]
    ICC --> GTWC[General temporary work cost]
    ICC --> SMC[Site management cost]
    DCC -.-> NCC[Net construction cost]
  
```

“Indirect Construction Cost” is cost for “not particular object”.  
In other word, general cost shared by all work items of direct construction cost.

Mainly Indirect construction cost is classified into 2 parts.

- General temporary work cost
- Site management cost

JICA Survey Team  
Miscellaneous Amount (maximum 10% of Total Material and Labour Amount and Transportation Amount ( maximum 5% of Total Material Amount) 17

### ► General Temporary Work Cost

```

graph LR
    CA[Contract amount] --> CP[Construction price]
    CA --> TE[Tax etc.]
    CP --> CC[Construction cost]
    CP --> OC[Overhead cost]
    CC --> DCC[Direct construction cost]
    CC --> ICC[Indirect construction cost]
    ICC --> GTWC[General temporary work cost]
    ICC --> SMC[Site management cost]
    DCC -.-> NCC[Net construction cost]
    GTWC -.-> NCC
  
```

“General temporary work cost” is cost for “General works for all work items of direct construction cost”.

EX) temporary road, temporary jetty, and management of site office etc. are for any kind of works in site

In Japanese standards, “General temporary work cost” is composed by **2 portions** “Rate calculation portion” and “Summation portion”  
Rate calculation portion is determined by rate and correction coefficient depending on “**Type of civil work**” and “**Amount of direct construction cost**”

JICA Survey Team  
Miscellaneous Amount (maximum 10% of Total Material and Labour Amount and Transportation Amount ( maximum 5% of Total Material Amount) 18

### ► Site Management Cost

```

graph LR
    CA[Contract amount] --> CP[Construction price]
    CA --> TE[Tax etc.]
    CP --> CC[Construction cost]
    CP --> OC[Overhead cost]
    CC --> DCC[Direct construction cost]
    CC --> ICC[Indirect construction cost]
    ICC --> GTWC[General temporary work cost]
    ICC --> SMC[Site management cost]
    DCC -.-> NCC[Net construction cost]
    GTWC -.-> NCC
  
```

“Site management cost” is cost for “Management of site”.

In Japanese standards, “Site management cost” is calculated as rate calculation.

Ratio and Correction coefficient in calculation are depending on “**Amount of net construction cost**”



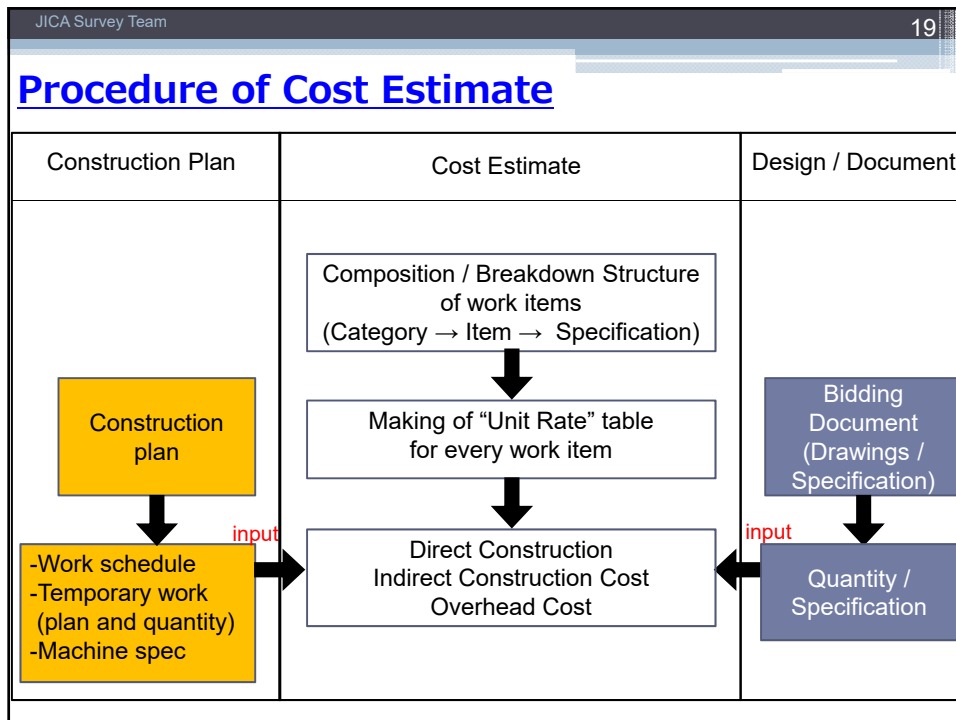

JICA Survey Team 20

### Exercise 1

▶ Breakdown Structure of Direct Construction cost

Let's try making breakdown structure of direct construction cost of "PC-I girder"!!

In Bago bridge DD, PC-I girder is applied for On-ramp and F.O. in PKG3

Major Category (On-ramp)

## Exercise 2

### ▶ Making of "Unit Rate" table for "Foundation"

Let's try making Unit Rate table of "Foundation"!!

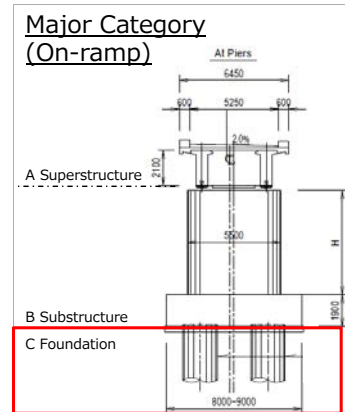

### ▶ Expense of Equipment

Mainly 2 ways

#### 1\_Lease cost

##### 1.1\_All equipment except for cranes

$$\text{Lease cost} = \text{Market price} * \text{lease days}$$

##### 1.2\_Cranes

$$\text{Lease cost} = \text{Market price} * \text{operation days / months}$$

#### 2\_Depreciation cost

Next page

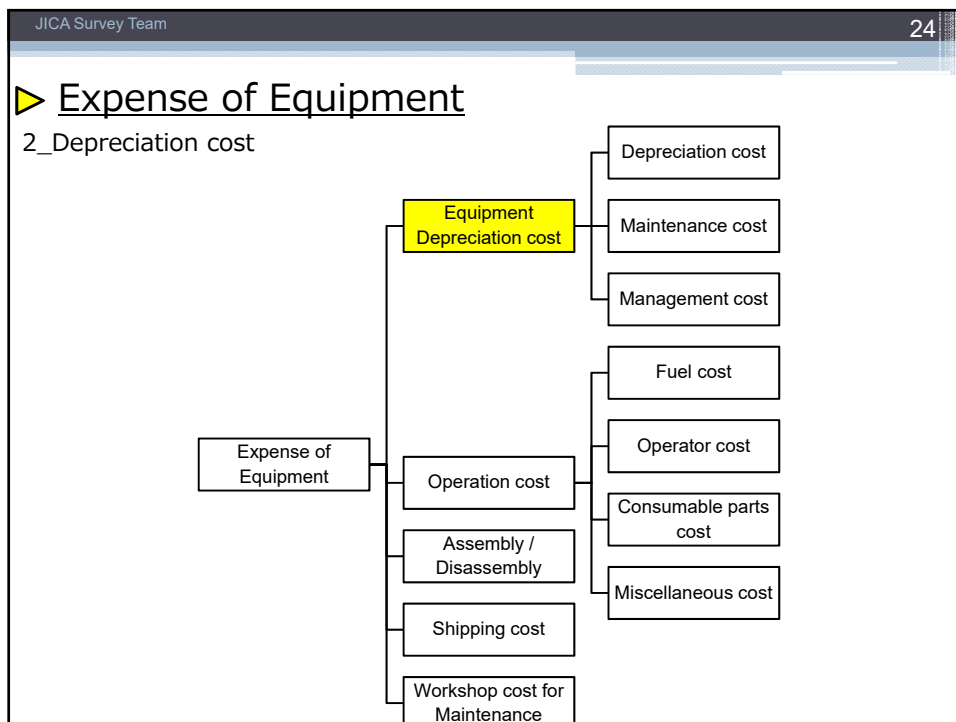
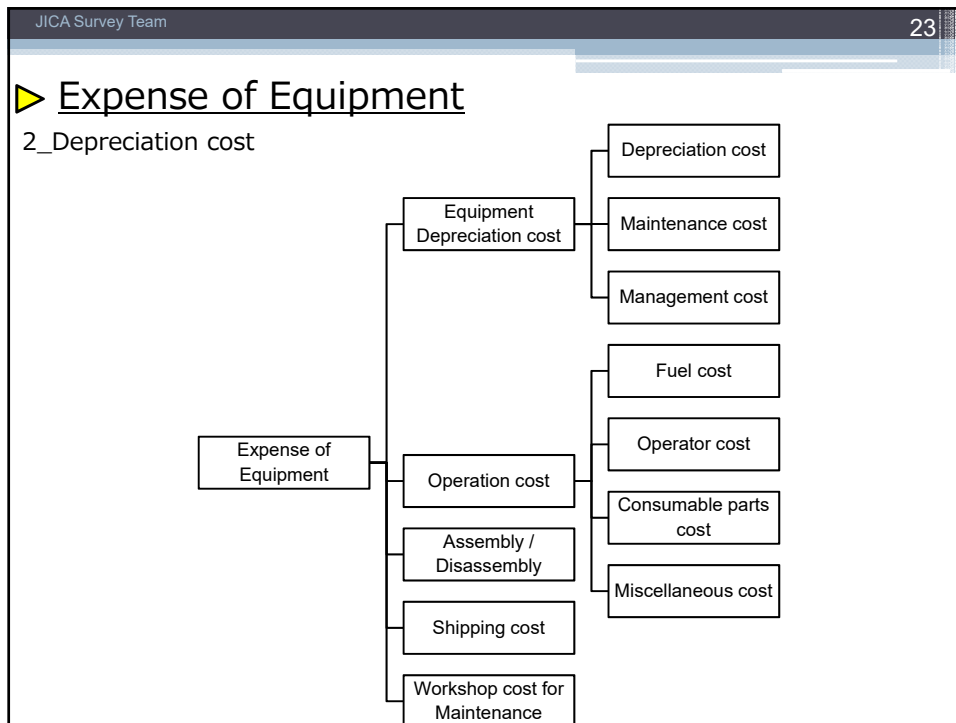

JICA Survey Team 25

### ► Equipment Depreciation cost

OPE- 2 Backhoe Crawler type Full bucket@ 5m3 Source:

No.	Item Conditions	Category	Item	Specification	Unit	Quantity	Unit Price		Subtotal		Total Yen cons.
							Local(MMK)	Foreign(JPY)	Local(MMK)	Foreign(JPY)	
OPE-2			Backhoe Crawler type Full bucket@ 5		day	1			316.684		26,348
OPE-2			Backhoe Crawler type Full bucket@ 5		day	1	316.684		316.684		26,348
No.	Item Conditions	Category	Item	Specification	Unit	Quantity	Unit Price		Subtotal		Total
Lab-12			Equipment Operator		person	1	18,220		18,220		1,420
			Machine depreciation / rental cost		day	1.28	200,000		256,000		21,299
			Diesel		L	61.47	690		42,414		3,529

**Note**

- Construction Equipment Rental Table/2016 P02-7
- Standard Operating Hours Per Year: a = 690 h / Standard Operating Days Per Year: b = 110 days
- Fuel Consumption Per Hour: c = 9.8 l/h
- Fuel Consumption Per Day: d = a / b \* c = 690 / 110 \* 9.8 = 61.47 l
- Equipment Operation Unit Cost Per Hour
- Hours Operating Per Day = a / b = 690 / 110 = 6.27 h

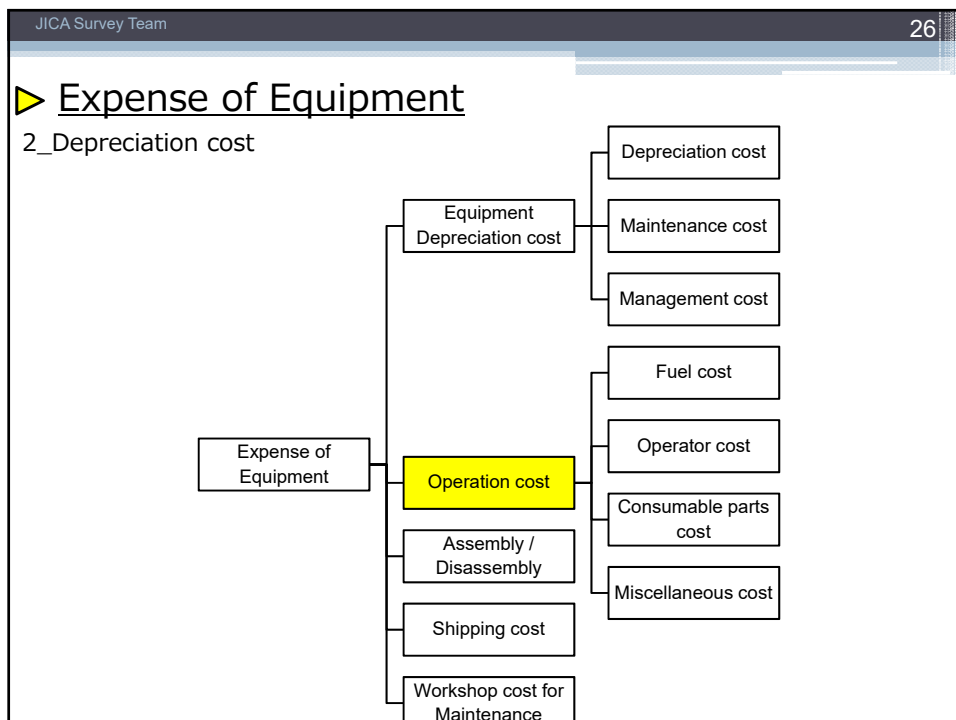

JICA Survey Team 27

### ▶ Operation Cost

OPE- 2 Backhoe Crawler type Full bucketØ 5m3 Source:

No.	Item Conditions	Category	Item	Specification	Unit	Quantity	Unit Price		Subtotal		Total Yen cons.
							Local(MMK)	Foreign(JPY)	Local(MMK)	Foreign(JPY)	
	OPE-2		Backhoe Crawler type Full bucketØ 5		day	1			316.684		26,348
	OPE-2		Backhoe Crawler type Full bucketØ 5		day	1		316.684		316.684	26,348
	Lab-12		Equipment Operator		person	1	18.270		18.270		1,520
			Machine depreciation / rental cost		day	1.28	200.000		256.000		21,299
			Diesel		L	61.47	690		42,414		3,529

**Note**

- Construction Equipment Rental Table/2016 P02-7
- Standard Operating Hours Per Year: a = 690 h / Standard Operating Days Per Year: b = 110 days
- Fuel Consumption Per Hour: c = 9.8 l/h
- Fuel Consumption Per Day: d = a / b \* c = 690/110 \* 9.8 = 61.47 l
- Equipment Operation Unit Cost Per Hour
- Hours Operating Per Day = a / b = 690/110 = 6.27 h

JICA Survey Team 28

### Exercise 3

#### ▶ Making of "Unit Rate" table for "Substructure"

Let's try making Unit Rate table of "Substructure"!!

**Major Category (On-ramp)**

A Superstructure

B Substructure

C Foundation

## Exercise 4

### ▶ Making of "Unit Rate" table for "Superstructure"

Let's try making Unit Rate table of "Superstructure"!!

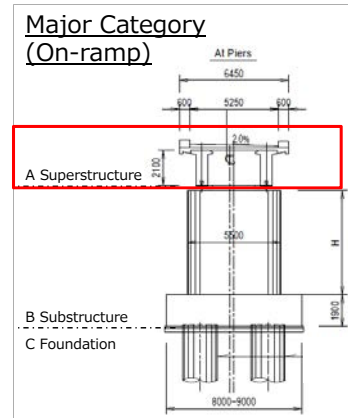

付録 A 講義及びセミナー資料

A-8 鋼斜張橋の設計演習

Date		No.	Contents	
1st	Mon			
2nd	Tue			
3rd	Wed			
4th	Thu			
5th	Fri			
6th	Sat			
7th	Sun			
8th	Mon	1	Introduction	CSB at Bago Bridge
9th	Tue	2	Modeling	Material Properties
10th	Wed	3		Section Properties
11th	Thu	4		Design Load
12th	Fri	5		Boundary Conditions
13th	Sat			
14th	Sun			
15th	Mon	6	Parametric Analysis	Cable Pre-stress
16th	Tue	7		Cable Number
17th	Wed	8		Cable Arrangement
18th	Thu	9		Girder Height
19th	Fri	10		Tower Height
20th	Sat			
21st	Sun			
22nd	Mon	11	Section Calculation	Section Calculation Sheet 1
23rd	Tue	12		Section Calculation Sheet 2
24th	Wed	13		Section Calculation Sheet 3
25th	Thu	14		Design Check by JSHB 1
26th	Fri	15		Design Check by JSHB 2
27th	Sat			
28th	Sun			
29th	Mon	16		Design Check by JSHB 3
30th	Tue	17		Design Check by JSHB 4
31st	Wed	18		Design Check by JSHB 5

Date		No.	Contents	
1st	Thu	19	Re-Analysis	Re-modeling
2nd	Fri	20		Re-calculation
3rd	Sat			
4th	Sun			
5th	Mon	21		Re-Design Check 1
6th	Tue	22		Re-Design Check 2
7th	Wed	23		Re-Design Check 3
8th	Thu	24	Seismic Design	Seismic Design by JSHB
9th	Fri	25		Support Condition
10th	Sat			
11th	Sun			
12th	Mon			
13th	Tue	26	Design Exercise	Introduction
14th	Wed	27		Modeling
15th	Thu	28		Material, Section Properties
16th	Fri	29		Load Conditions
17th	Sat			
18th	Sun			
19th	Mon	30		Cable Pre-stress
20th	Tue	31		Section Calculation 1
21st	Wed	32		Re-analysis
22nd	Thu	33		Section Calculation 2
23rd	Fri	34	Presentation	Presentation Preparation 1
24th	Sat			
25th	Sun			
26th	Mon	35		Presentation Preparation 2
27th	Tue	36		Presentation Preparation 3
28th	Wed	37	Closing	Presentation by Trainee

Extra Step	Construction Stage	Construction Step
	Analysis	Modeling
		Analysis
		Design Check



# GENERAL VIEW OF BAGO RIVER BRIDGE (4)

## LONGITUDINAL SECTION

S=1:1000

BAGO RIVER BRIDGE L=2031000

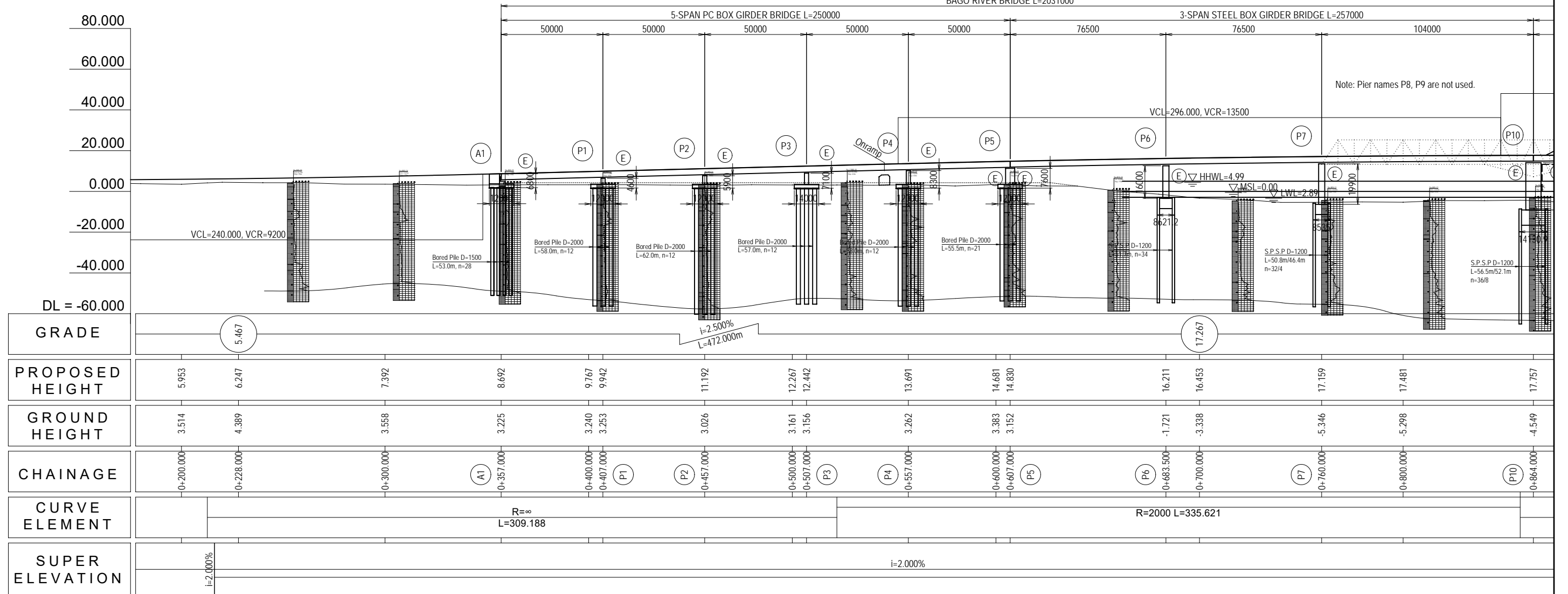

## PLAN VIEW

S=1:1000

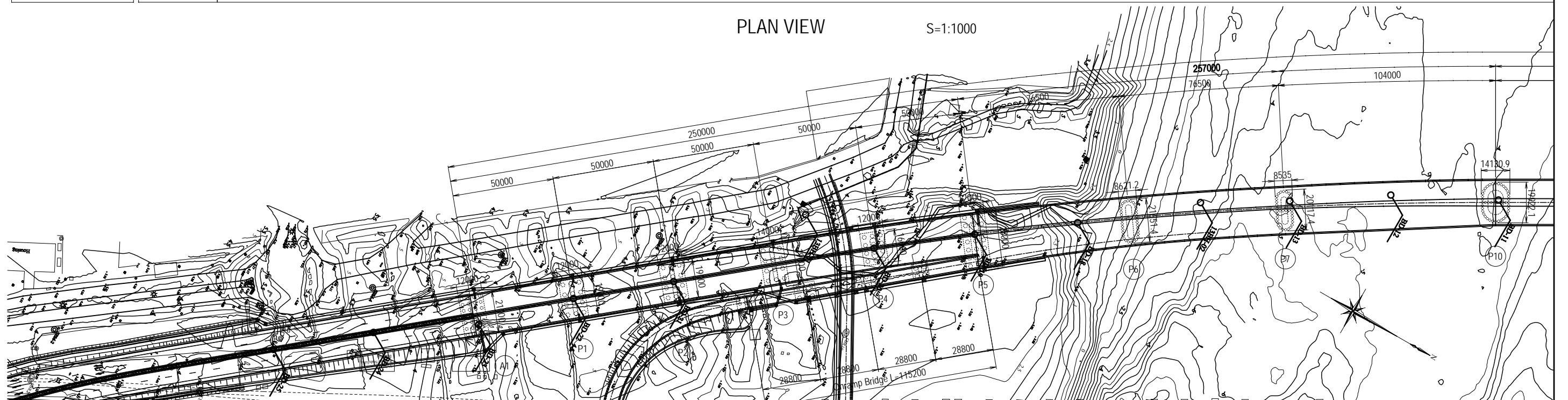

Elevation represents above MSL unless otherwise indicated.

PROJECT NAME DETAILED DESIGN ON BAGO RIVER BRIDGE CONSTRUCTION PROJECT	FINANCED BY JAPAN INTERNATIONAL COOPERATION AGENCY	COUNTERPART REPUBLIC OF THE UNION OF MYANMAR MINISTRY OF CONSTRUCTION DEPARTMENT OF BRIDGE	JICA STUDY TEAM NIPPON KOEI CO., LTD. ORIENTAL CONSULTANTS GLOBAL CO., LTD. METROPOLITAN EXPRESSWAY COMPANY LIMITED CHODAI CO., LTD. NIPPON ENGINEERING CONSULTANTS CO., LTD.	NAME	SIGNATURE	DATE	DRAWING TITLE	PACKAGE	
				PREPARED BY	T. HAYAKAWA				27 Nov. 2017
				CHECKED BY	T. HAYAKAWA				28 Nov. 2017
				APPROVED BY	Y. SANO				29 Nov. 2017
							GENERAL VIEW OF BAGO RIVER BRIDGE (4)	1	
								DWG No.	
								P1-GE-0005	

# GENERAL VIEW OF BAGO RIVER BRIDGE (5)

LONGITUDINAL SECTION S=1:1000

BAGO RIVER BRIDGE L=2031000

3-SPAN STEEL CABLE STAYED BRIDGE L=448000

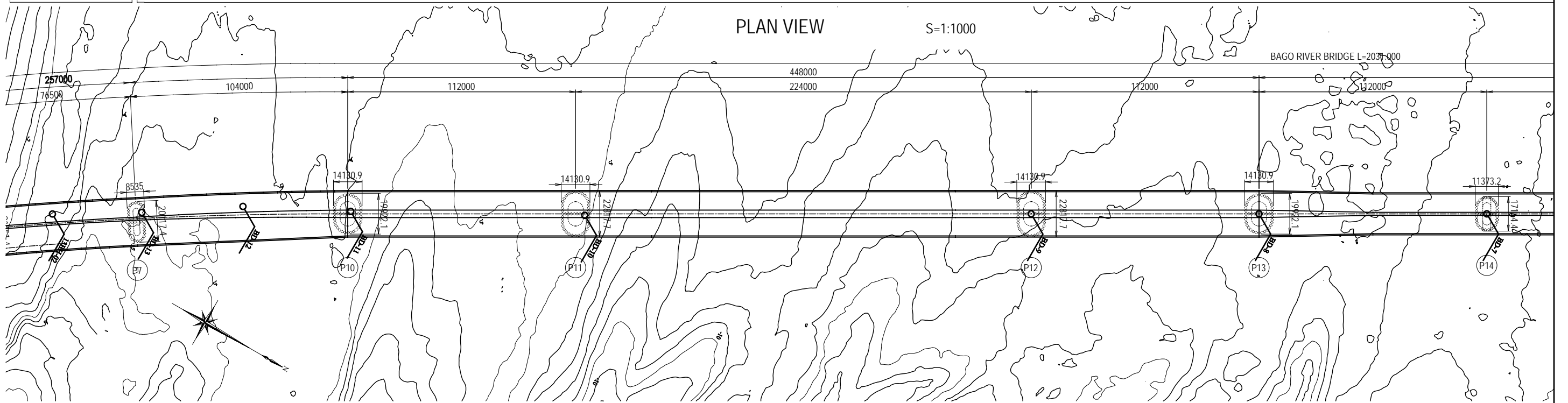
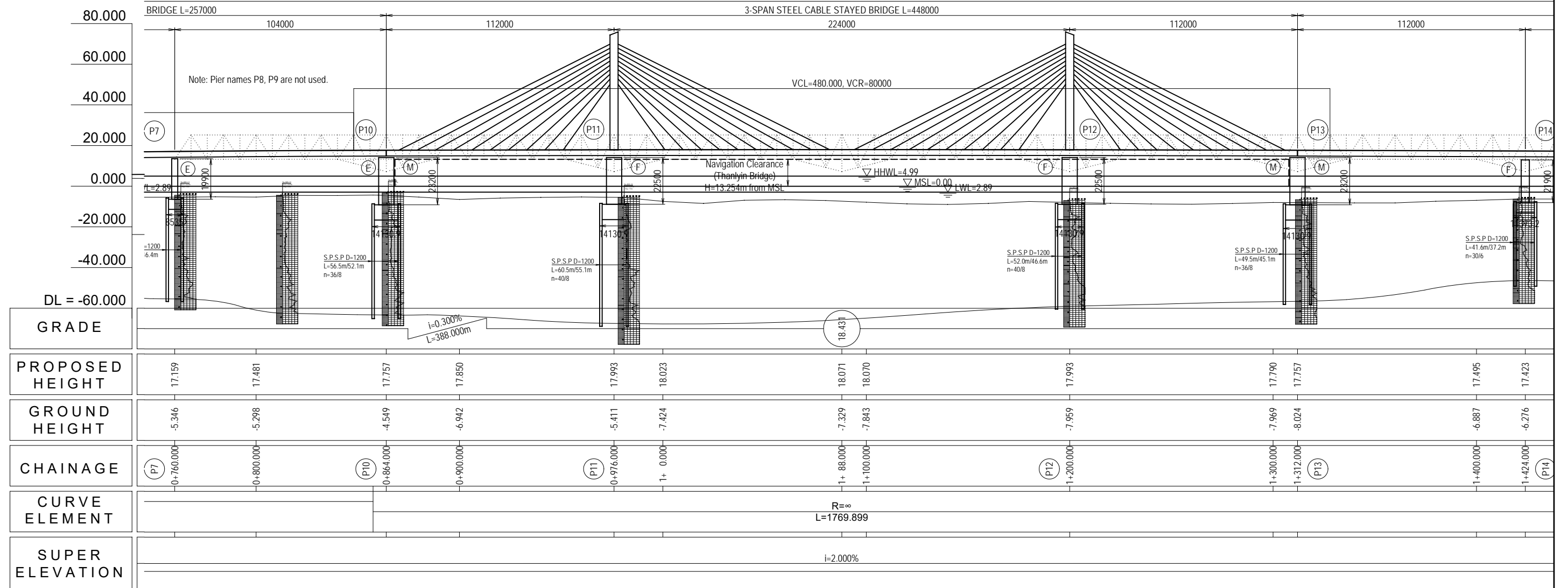

Elevation represents above MSL unless otherwise indicated.

PROJECT NAME	FINANCED BY	COUNTERPART	JICA STUDY TEAM	NAME	SIGNATURE	DATE	DRAWING TITLE	PACKAGE
DETAILED DESIGN ON BAGO RIVER BRIDGE CONSTRUCTION PROJECT	JICA JAPAN INTERNATIONAL COOPERATION AGENCY	REPUBLIC OF THE UNION OF MYANMAR MINISTRY OF CONSTRUCTION DEPARTMENT OF BRIDGE	NIPPON KOEI CO., LTD. ORIENTAL CONSULTANTS GLOBAL CO., LTD. METROPOLITAN EXPRESSWAY COMPANY LIMITED CHODAI CO., LTD. NIPPON ENGINEERING CONSULTANTS CO., LTD.	T. HAYAKAWA		27 Nov. 2017	GENERAL VIEW OF BAGO RIVER BRIDGE (5)	1
				T. HAYAKAWA		28 Nov. 2017		DWG No.
				Y. SANO		29 Nov. 2017		P1-GE-0006

# GENERAL VIEW OF BAGO RIVER BRIDGE (6)

LONGITUDINAL SECTION S=1:1000

BAGO RIVER BRIDGE L=2031000  
7-SPAN STEEL BOX GIRDER BRIDGE L=776000

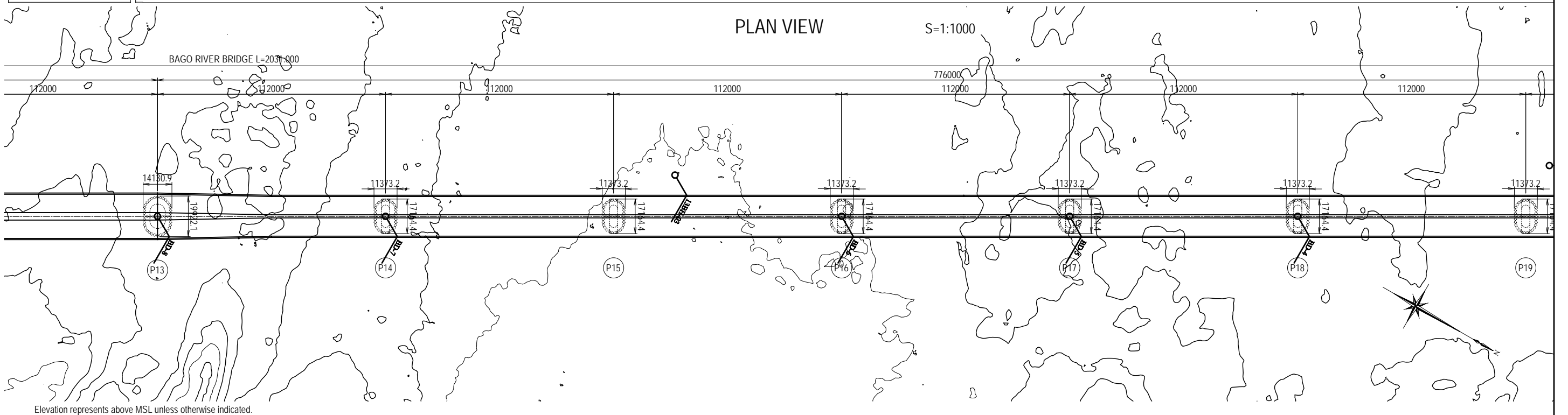
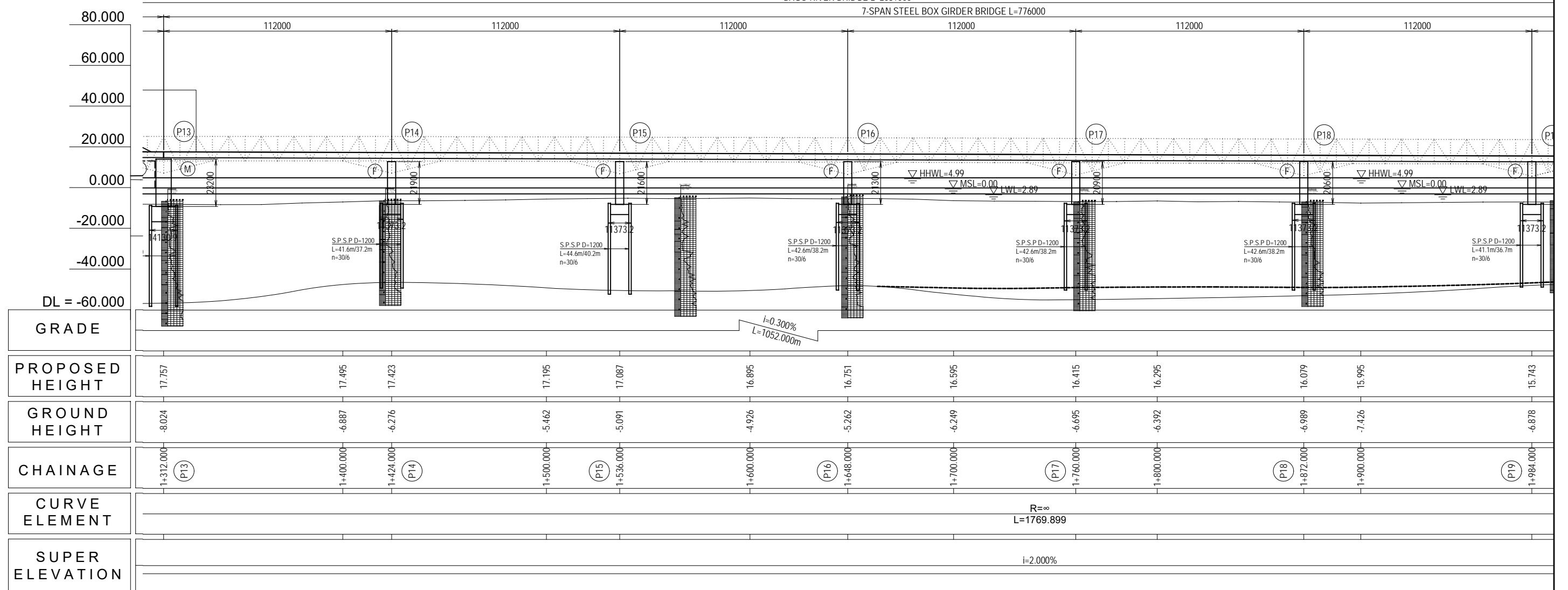

Elevation represents above MSL unless otherwise indicated.

PROJECT NAME DETAILED DESIGN ON BAGO RIVER BRIDGE CONSTRUCTION PROJECT	FINANCED BY JAPAN INTERNATIONAL COOPERATION AGENCY	COUNTERPART REPUBLIC OF THE UNION OF MYANMAR MINISTRY OF CONSTRUCTION DEPARTMENT OF BRIDGE	JICA STUDY TEAM NIPPON KOEI CO., LTD. ORIENTAL CONSULTANTS GLOBAL CO., LTD. METROPOLITAN EXPRESSWAY COMPANY LIMITED CHODAI CO., LTD. NIPPON ENGINEERING CONSULTANTS CO., LTD.	NAME	SIGNATURE	DATE	DRAWING TITLE GENERAL VIEW OF BAGO RIVER BRIDGE (6)	PACKAGE	
				PREPARED BY	T. HAYAKAWA			27 Nov. 2017	1
				CHECKED BY	T. HAYAKAWA			28 Nov. 2017	DWG No.
				APPROVED BY	Y. SANO			29 Nov. 2017	P1-GE-0007

# GENERAL VIEW OF BAGO RIVER BRIDGE (7) LONGITUDINAL SECTION

S=1:1000

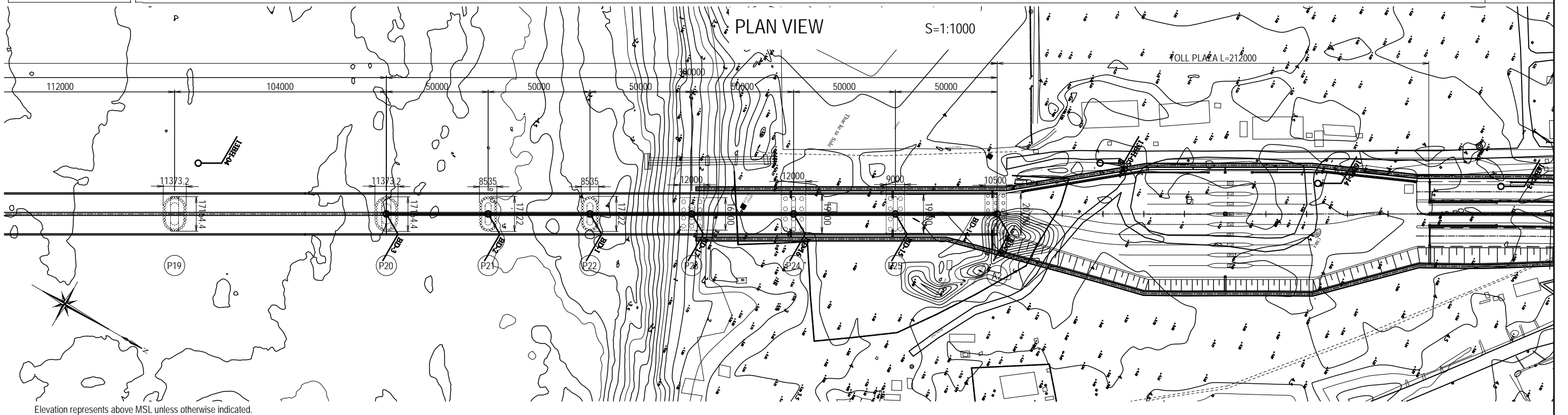
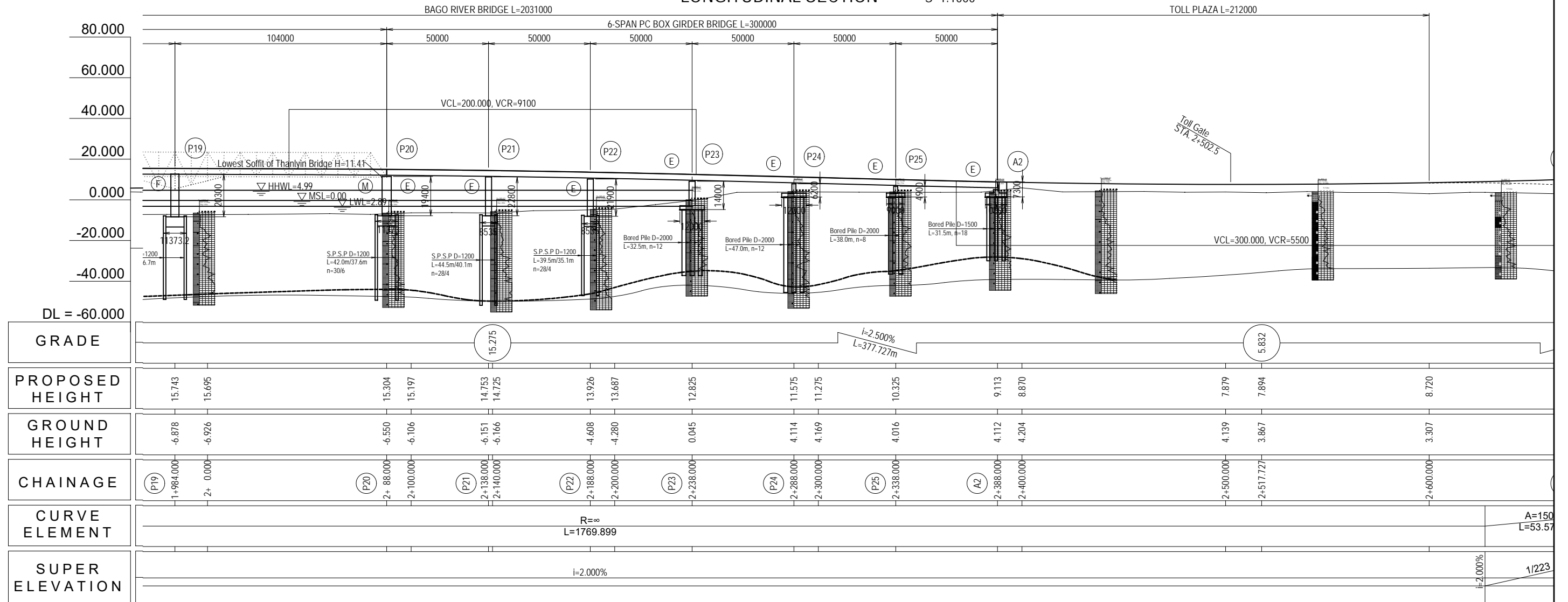

PROJECT NAME DETAILED DESIGN ON BAGO RIVER BRIDGE CONSTRUCTION PROJECT	FINANCED BY JAPAN INTERNATIONAL COOPERATION AGENCY	COUNTERPART REPUBLIC OF THE UNION OF MYANMAR MINISTRY OF CONSTRUCTION DEPARTMENT OF BRIDGE	JICA STUDY TEAM NIPPON KOEI CO., LTD. ORIENTAL CONSULTANTS GLOBAL CO., LTD. METROPOLITAN EXPRESSWAY COMPANY LIMITED CHODAI CO., LTD. NIPPON ENGINEERING CONSULTANTS CO., LTD.	<table border="1" style="width: 100%; border-collapse: collapse;"> <thead> <tr> <th></th> <th>NAME</th> <th>SIGNATURE</th> <th>DATE</th> </tr> </thead> <tbody> <tr> <td>PREPARED BY</td> <td>T. HAYAKAWA</td> <td></td> <td>27 Nov. 2017</td> </tr> <tr> <td>CHECKED BY</td> <td>T. HAYAKAWA</td> <td></td> <td>28 Nov. 2017</td> </tr> <tr> <td>APPROVED BY</td> <td>Y. SANO</td> <td></td> <td>29 Nov. 2017</td> </tr> </tbody> </table>		NAME	SIGNATURE	DATE	PREPARED BY	T. HAYAKAWA		27 Nov. 2017	CHECKED BY	T. HAYAKAWA		28 Nov. 2017	APPROVED BY	Y. SANO		29 Nov. 2017	DRAWING TITLE GENERAL VIEW OF BAGO RIVER BRIDGE (7)	PACKAGE 1 DWG No. P1-GE-0008
	NAME	SIGNATURE	DATE																			
PREPARED BY	T. HAYAKAWA		27 Nov. 2017																			
CHECKED BY	T. HAYAKAWA		28 Nov. 2017																			
APPROVED BY	Y. SANO		29 Nov. 2017																			

# GENERAL VIEW OF STEEL CABLE STAYED BRIDGE (1)

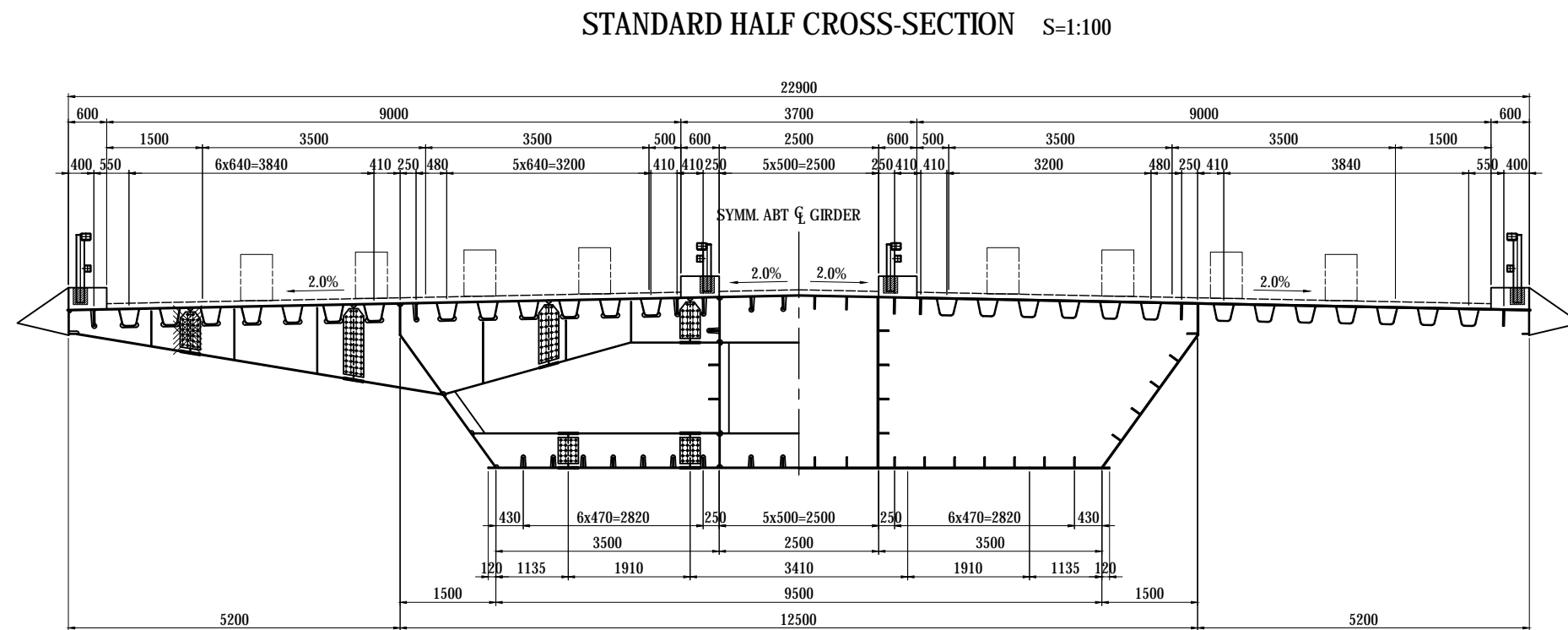
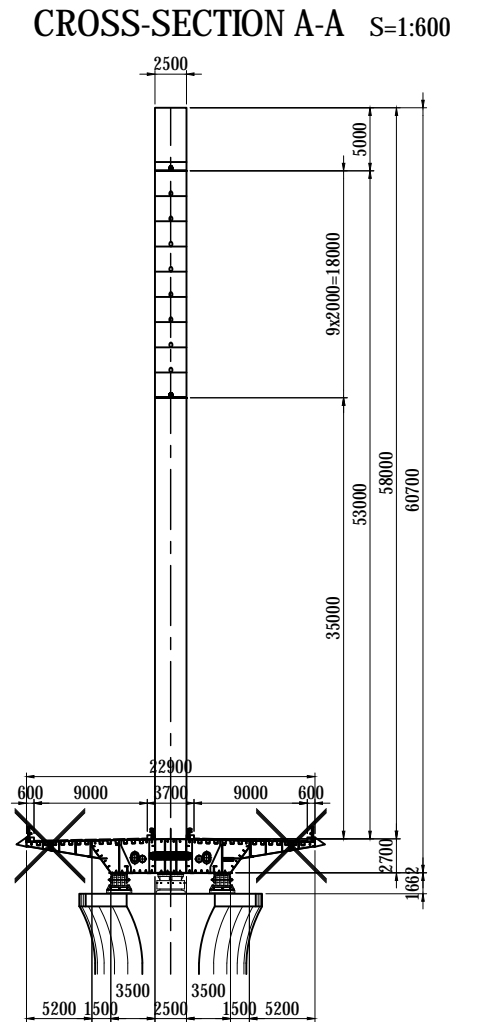
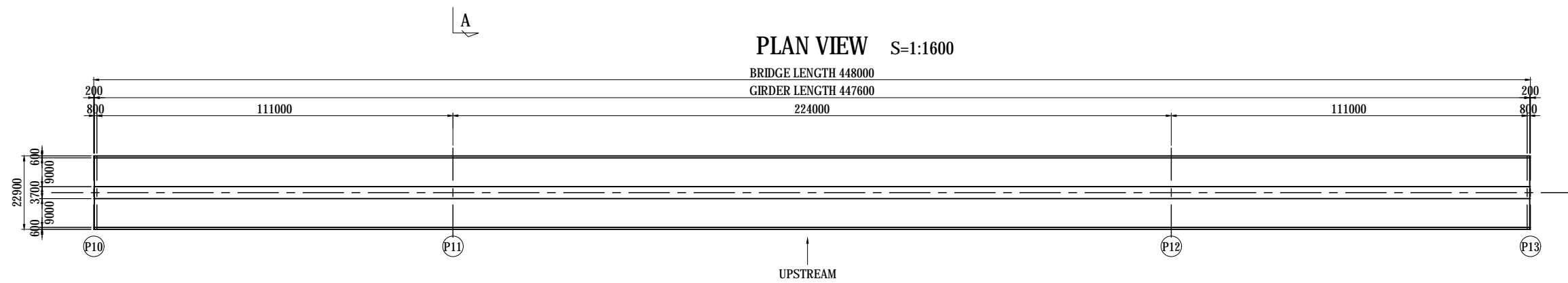
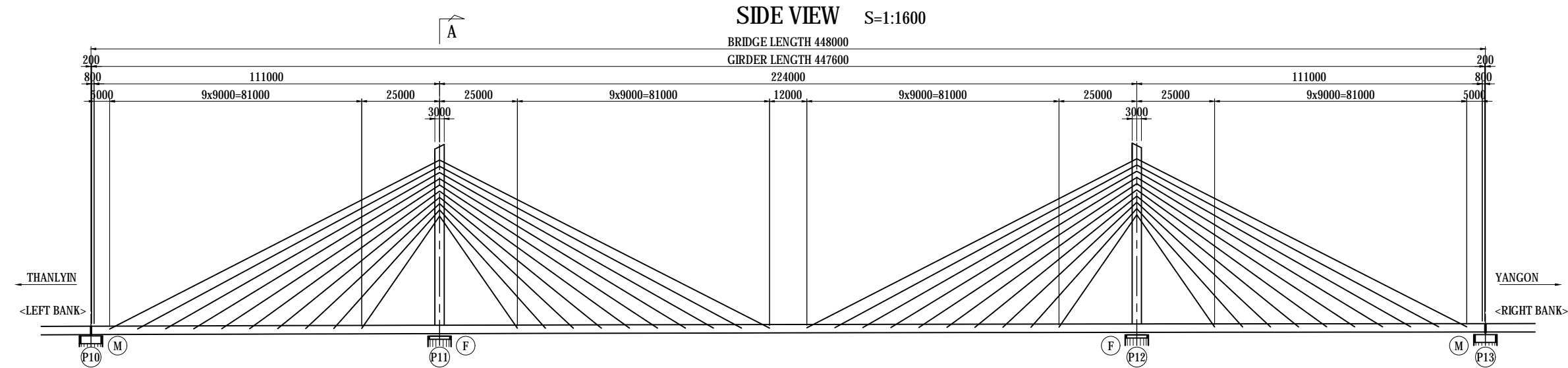

PROJECT NAME DETAILED DESIGN ON BAGO RIVER BRIDGE CONSTRUCTION PROJECT	FINANCED BY JAPAN INTERNATIONAL COOPERATION AGENCY	COUNTERPART REPUBLIC OF THE UNION OF MYANMAR MINISTRY OF CONSTRUCTION DEPARTMENT OF BRIDGE	JICA STUDY TEAM NIPPON KOEI CO., LTD. ORIENTAL CONSULTANTS GLOBAL CO., LTD. METROPOLITAN EXPRESSWAY COMPANY LIMITED CHODAI CO., LTD. NIPPON ENGINEERING CONSULTANTS CO., LTD.	NAME	SIGNATURE	DATE	DRAWING TITLE	PACKAGE	
				PREPARED BY	T.TOMODA				27. Nov.2017
				CHECKED BY	T. HAYAKAWA				28. Nov.2017
				APPROVED BY	Y. SANO				29. Nov.2017
GENERAL VIEW OF STEEL CABLE STAYED BRIDGE (1)							1	DWG No.	
								P1-CS-0001	

# GENERAL VIEW OF STEEL CABLE STAYED BRIDGE (2)

## SIDE VIEW

BRIDGE LENGTH 448000  
GIRDER LENGTH 447600

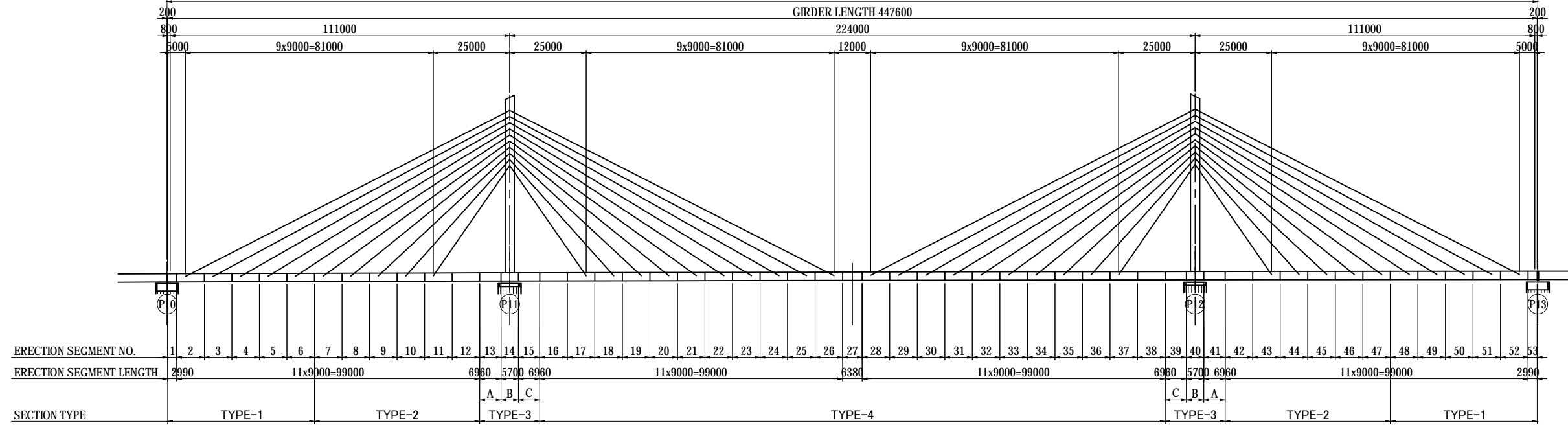

UNIT: mm

DECK PL	THK	16	16	16	16	16	16	16				
	STEEL GRADE	SM400	SM400	a	b	a	SM400	a	b	a	SM400	SM400
	TROUGH	320 x 240 x 8	320 x 240 x 8	320 x 240 x 8	320 x 240 x 8	320 x 240 x 8	320 x 240 x 8	320 x 240 x 8	320 x 240 x 8	320 x 240 x 8	320 x 240 x 8	320 x 240 x 8
	LONGIT. RIB A	250 x 24	250 x 24	250 x 24	250 x 24	250 x 24	250 x 24	250 x 24	250 x 24	250 x 24	250 x 24	250 x 24
OUTER WEB	LONGIT. RIB B	200 x 20	200 x 20	200x20	200 x 20	200 x 20	200 x 20	200x20	200 x 20	200 x 20	200 x 20	200 x 20
	THK	14	14	17	14	14	14	17	14	14	14	14
INNER WEB	STEEL GRADE	SM490Y	SM490Y	SM490Y	SM490Y	SM490Y	SM490Y	SM490Y	SM490Y	SM490Y	SM490Y	SM490Y
	THK	14	14	18	35	18	14	18	35	18	14	14
	STEEL GRADE	SM490Y	SM490Y	SM490Y	SM490Y	SM490Y	SM490Y	SM490Y	SM490Y	SM490Y	SM490Y	SM490Y
BOTTOM FLANGE	LONGIT. RIB	160 x 16	160 x 16	200 x 20	160 x 16	160 x 16	160 x 16	200 x 20	160 x 16	160 x 16	160 x 16	160 x 16
	THK	14	11	15	14	14	11	15	14	14	14	14
	STEEL GRADE	SM490Y	SM490Y	SM490Y	SM490Y	SM490Y	SM490Y	SM490Y	SM490Y	SM490Y	SM490Y	SM490Y
	LONGIT. RIB	160 x 16	160 x 16	200 x 20	160 x 16	160 x 16	160 x 16	200 x 20	160 x 16	160 x 16	160 x 16	160 x 16

a : SM400A  
b : SM490Y

PROJECT NAME DETAILED DESIGN ON BAGO RIVER BRIDGE CONSTRUCTION PROJECT	FINANCED BY JAPAN INTERNATIONAL COOPERATION AGENCY	COUNTERPART REPUBLIC OF THE UNION OF MYANMAR MINISTRY OF CONSTRUCTION DEPARTMENT OF BRIDGE	JICA STUDY TEAM NIPPON KOEI CO., LTD. ORIENTAL CONSULTANTS GLOBAL CO., LTD. METROPOLITAN EXPRESSWAY COMPANY LIMITED CHODAI CO., LTD. NIPPON ENGINEERING CONSULTANTS CO., LTD.	NAME	SIGNATURE	DATE	DRAWING TITLE	PACKAGE	
				PREPARED BY	T.TOMODA				27. Nov.2017
				CHECKED BY	T. HAYAKAWA				28. Nov.2017
				APPROVED BY	Y. SANO				29. Nov.2017
							GENERAL VIEW OF STEEL CABLE STAYED BRIDGE (2)	1	
								DWG No.	
								P1-CS-002	

# GENERAL VIEW OF STEEL CABLE STAYED BRIDGE (3)

SIDE VIEW S=1:400

SECTION A-A

SECTION B-B

UNIT: mm

STEEL GRADE	SM490Y
FLANGE THK	2420x40
LONGIT. RIB	2-280x27
WEB THK	3000x40
LONGIT. RIB	5-250x25

STEEL GRADE	SM490Y
FLANGE THK	2430x35
LONGIT. RIB	2-280x25
WEB THK	3000x35
LONGIT. RIB	5-250x25

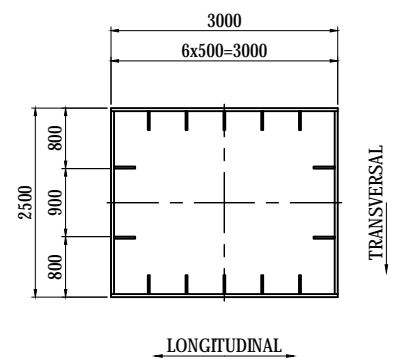
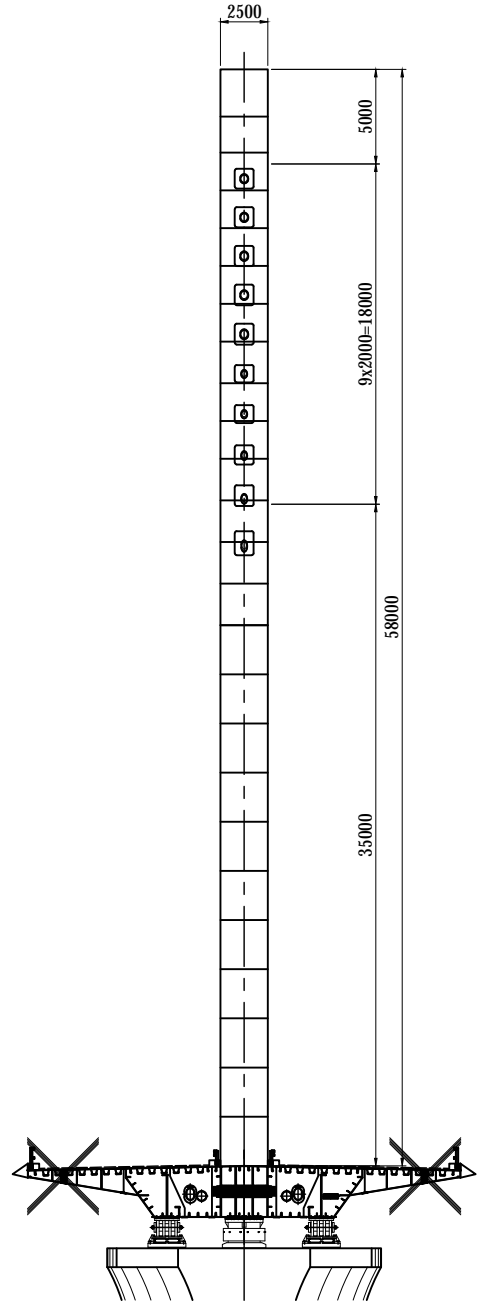
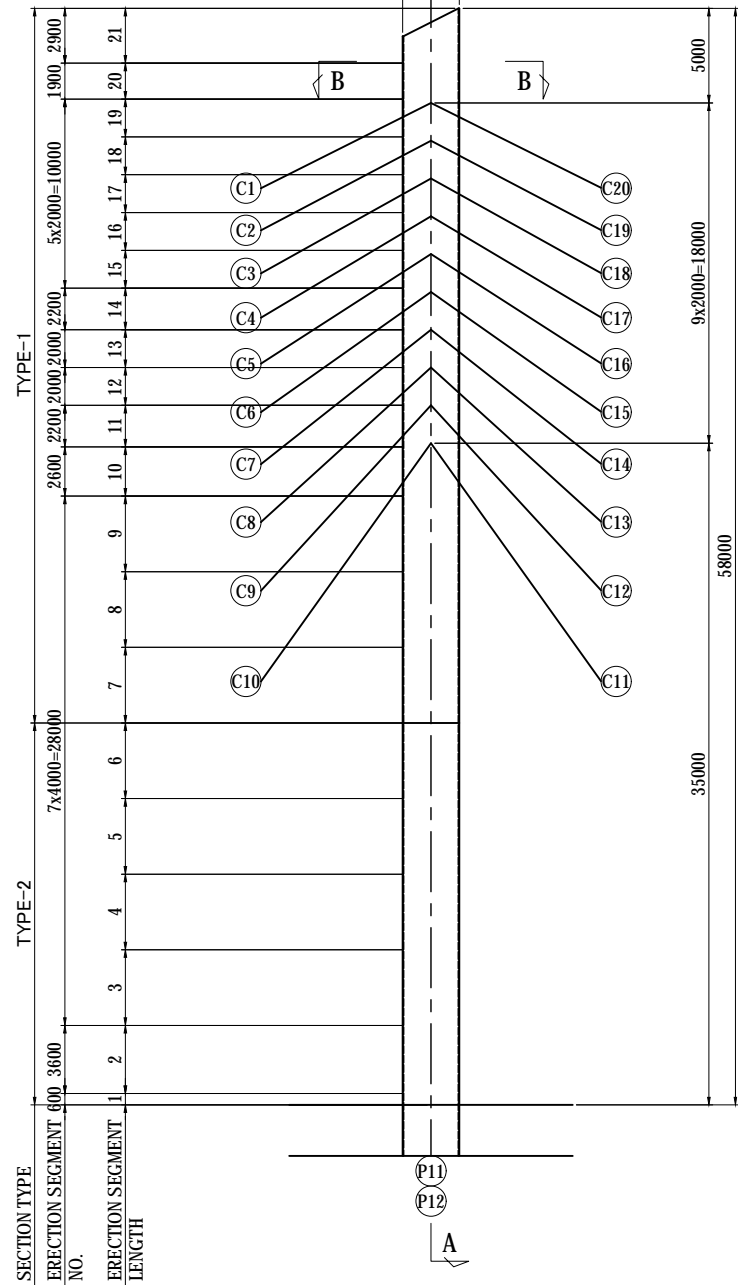

STAY CABLE NO.	NOS.	TYPE
C1	2	FUT-H ( 15φ-70)
C2	2	
C3	2	
C4	2	
C5	2	FUT-H ( 15φ-37)
C6	2	
C7	2	
C8	2	
C9	2	FUT-H ( 15φ-37)
C10	2	
C11	2	
C12	2	
C13	2	FUT-H ( 15φ-70)
C14	2	
C15	2	
C16	2	
C17	2	FUT-H ( 15φ-70)
C18	2	
C19	2	
C20	2	

ANCHORAGE TYPE	37H	70H
CABLE CROSS SECTION		
NOM.AREA	5420 mm <sup>2</sup>	10255 mm <sup>2</sup>
TENSILE STRENGTH	9657 kN	18270 kN
ELASTIC MODULUS	190 kN/mm <sup>2</sup>	190 kN/mm <sup>2</sup>
UNIT WEIGHT (STRANDS+HDPE DUCT)	50.8 kg/m (37x1.288+3.1)	96.0 kg/m (70x1.288+5.8)

LAYOUT DRAWING S=1:1600

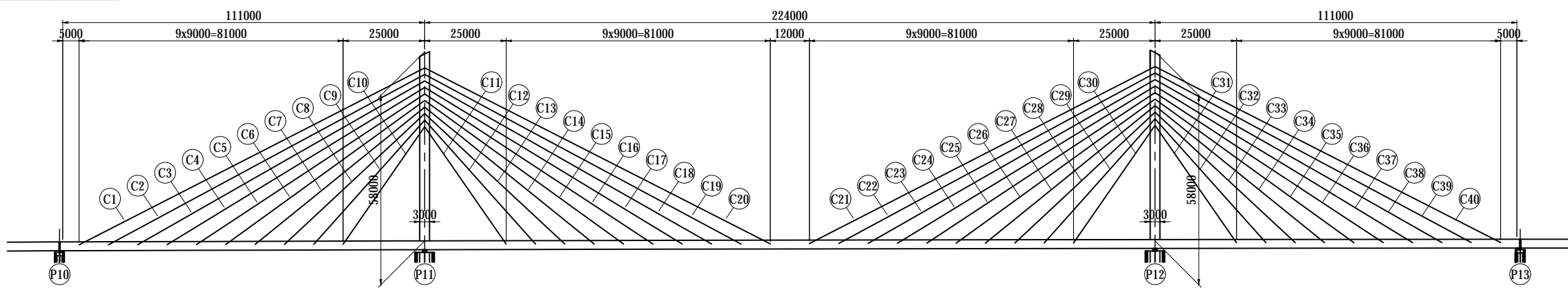

# GENERAL VIEW OF MAIN GIRDER (1) S=1:800

## ELEVATION

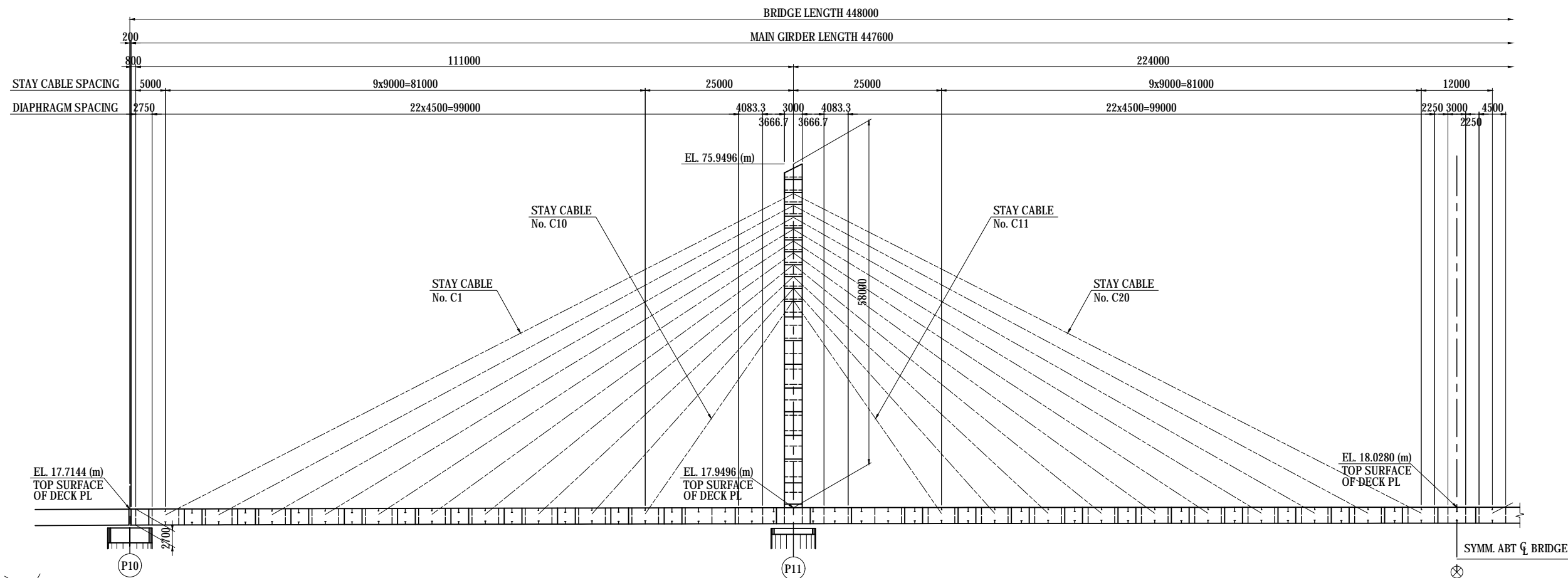

## PLAN

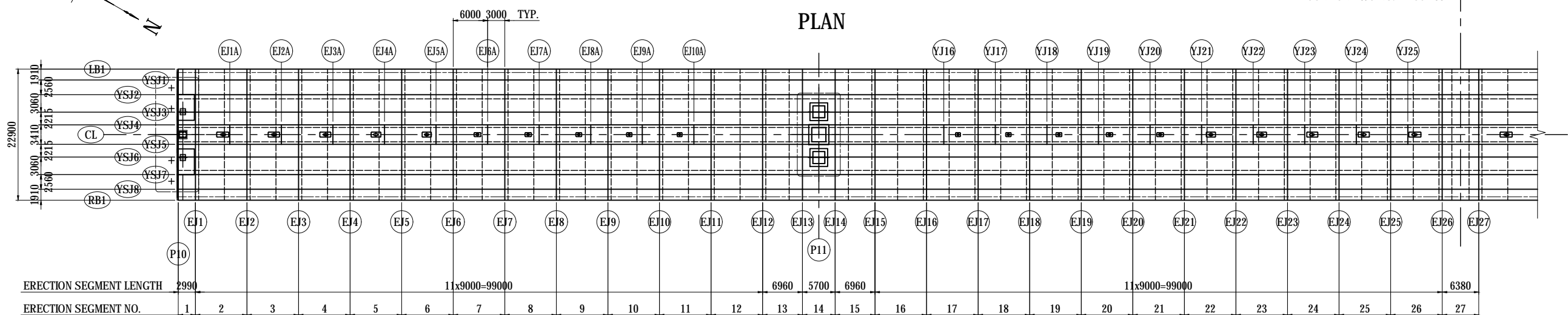

## KEY PLAN

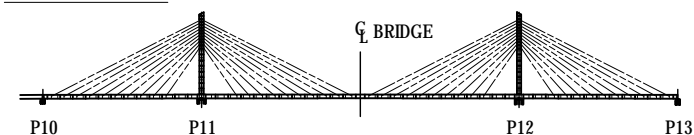

PROJECT NAME DETAILED DESIGN ON BAGO RIVER BRIDGE CONSTRUCTION PROJECT	FINANCED BY JAPAN INTERNATIONAL COOPERATION AGENCY	COUNTERPART REPUBLIC OF THE UNION OF MYANMAR MINISTRY OF CONSTRUCTION DEPARTMENT OF BRIDGE	JICA STUDY TEAM NIPPON KOEI CO., LTD. ORIENTAL CONSULTANTS GLOBAL CO., LTD. METROPOLITAN EXPRESSWAY COMPANY LIMITED CHODAI CO., LTD. NIPPON ENGINEERING CONSULTANTS CO., LTD.	NAME	SIGNATURE	DATE	DRAWING TITLE <b>GENERAL VIEW OF MAIN GIRDER (1)</b>	PACKAGE	
				PREPARED BY	T.TOMODA			27. Nov.2017	1
				CHECKED BY	T. HAYAKAWA			28. Nov.2017	DWG No.
				APPROVED BY	Y. SANO			29. Nov.2017	P1-CS-1001



# GENERAL VIEW OF MAIN GIRDER (2) S=1:800

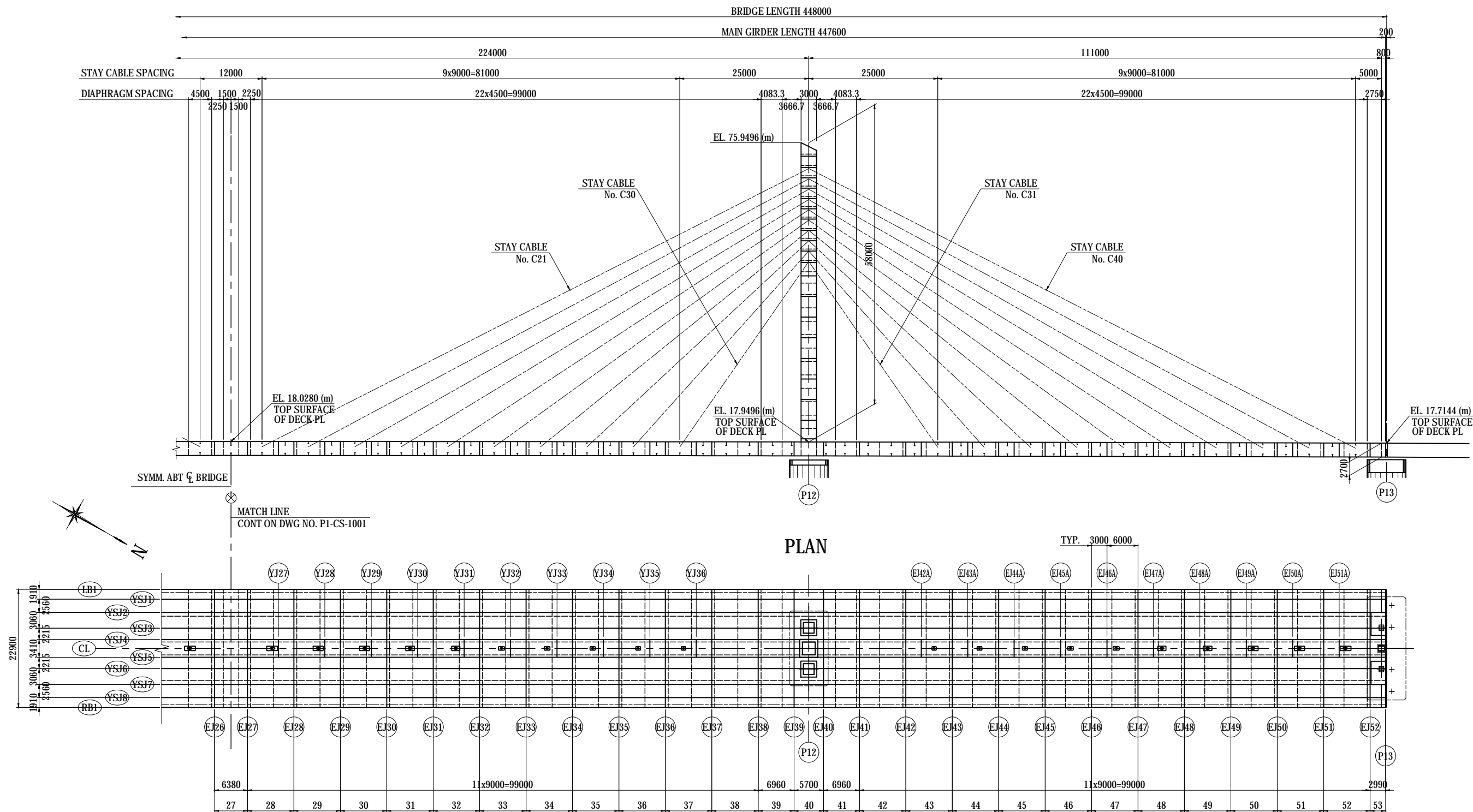

PROJECT NAME DETAILED DESIGN ON BAGO RIVER BRIDGE CONSTRUCTION PROJECT	FINANCED BY JAPAN INTERNATIONAL COOPERATION AGENCY	COUNTERPART REPUBLIC OF THE UNION OF MYANMAR MINISTRY OF CONSTRUCTION DEPARTMENT OF BRIDGE	JICA STUDY TEAM NIPPON KOEI CO., LTD. ORIENTAL CONSULTANTS GLOBAL CO., LTD. METROPOLITAN EXPRESSWAY COMPANY LIMITED CHODAI CO., LTD. NIPPON ENGINEERING CONSULTANTS CO., LTD.	NAME	SIGNATURE	DATE	DRAWING TITLE <b>GENERAL VIEW OF MAIN GIRDER (2)</b>	PACKAGE	
				PREPARED BY	T.TOMODA			27. Nov.2017	1
				CHECKED BY	T. HAYAKAWA			28. Nov.2017	DWG No.
				APPROVED BY	Y. SANO			29. Nov.2017	P1-CS-1002

# GENERAL VIEW OF MAIN GIRDER (8)

ELEVATION N.T.S.

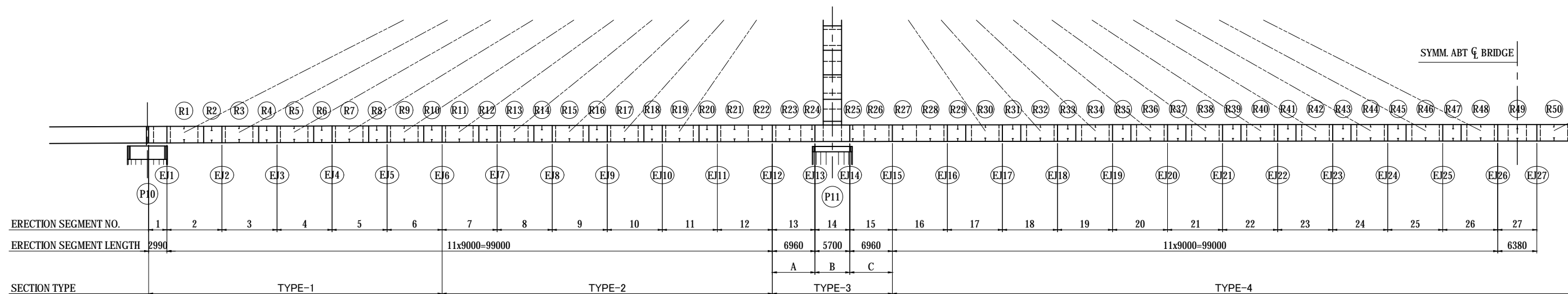

UNIT: mm

DECK PL	THK	16	16	16			16
	STEEL GRADE	SM400	SM400	SM400	SM490Y	SM400	SM400
	TROUGH	320 x 240 x 8	320 x 240 x 8	320 x 240 x 8			320 x 240 x 8
	LONGIT. RIB A	250 x 24	250 x 24	250 x 24			250 x 24
LONGIT. RIB B	200 x 20	200 x 20	200x20			200 x 20	
OUTER WEB	THK	14	14	17			14
	STEEL GRADE	SM490Y	SM490Y	SM490Y			SM490Y
	HORIZ. STIFF.	160 x 16	160 x 16	200 x 20			160 x 16
INNER WEB	THK	14	14	18	35	18	14
	STEEL GRADE	SM490Y	SM490Y	SM490Y			SM490Y
	LONGIT. RIB	160 x 16	160 x 16	200 x 20			160 x 16
BOTTOM FLANGE	THK	14	11	15			11
	STEEL GRADE	SM490Y	SM490Y	SM490Y			SM490Y
	LONGIT. RIB	160 x 16	160 x 16	200 x 20			160 x 16

TYPICAL SECTION N.T.S.

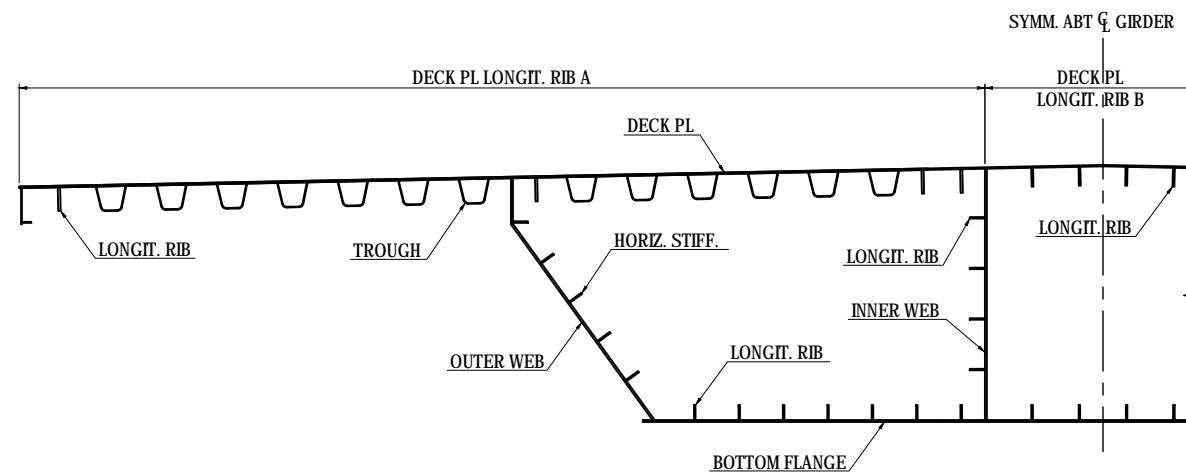

PROJECT NAME DETAILED DESIGN ON BAGO RIVER BRIDGE CONSTRUCTION PROJECT	FINANCED BY JAPAN INTERNATIONAL COOPERATION AGENCY	COUNTERPART REPUBLIC OF THE UNION OF MYANMAR MINISTRY OF CONSTRUCTION DEPARTMENT OF BRIDGE	JICA STUDY TEAM NIPPON KOEI CO., LTD. ORIENTAL CONSULTANTS GLOBAL CO., LTD. METROPOLITAN EXPRESSWAY COMPANY LIMITED CHODAI CO., LTD. NIPPON ENGINEERING CONSULTANTS CO., LTD.	NAME	SIGNATURE	DATE	DRAWING TITLE <b>GENERAL VIEW OF MAIN GIRDER (8)</b>	PACKAGE	
				PREPARED BY	T.TOMODA			27. Nov.2017	1
				CHECKED BY	T. HAYAKAWA			28. Nov.2017	DWG No.
				APPROVED BY	Y. SANO			29. Nov.2017	P1-CS-1008

# GENERAL VIEW OF MAIN GIRDER (9) S=1:40

## SECTION OUTLINES TYPICAL SECTION

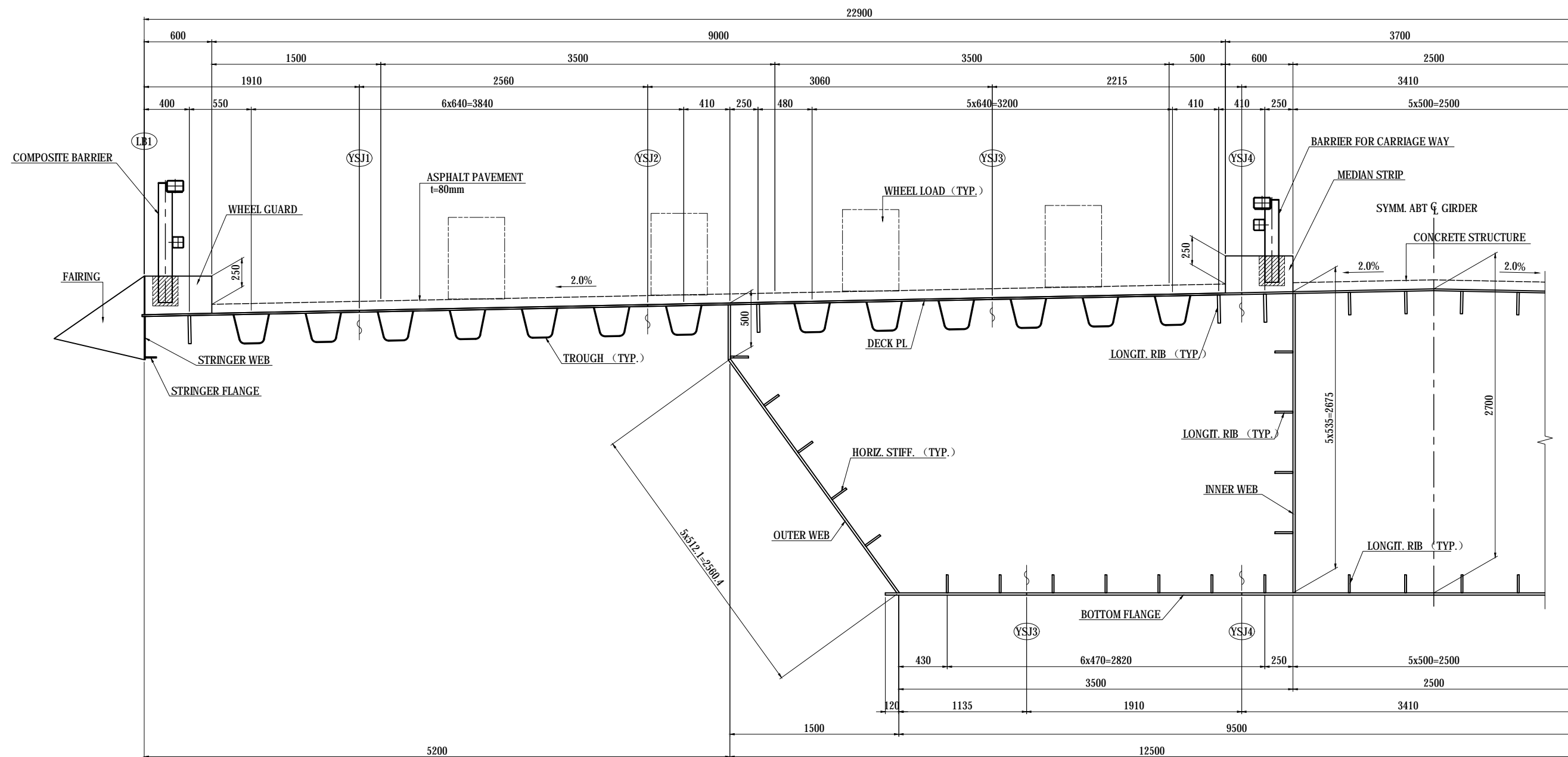

PROJECT NAME  
DETAILED DESIGN ON  
BAGO RIVER BRIDGE  
CONSTRUCTION PROJECT

FINANCED BY  
 JAPAN INTERNATIONAL  
COOPERATION AGENCY

COUNTERPART  
 REPUBLIC OF THE UNION OF MYANMAR  
MINISTRY OF CONSTRUCTION  
DEPARTMENT OF BRIDGE

JICA STUDY TEAM  
 NIPPON KOEI CO., LTD.  
ORIENTAL CONSULTANTS GLOBAL CO., LTD.  
METROPOLITAN EXPRESSWAY COMPANY LIMITED  
CHODAI CO., LTD.  
NIPPON ENGINEERING CONSULTANTS CO., LTD.

	NAME	SIGNATURE	DATE
PREPARED BY	T.TOMODA		27. Nov.2017
CHECKED BY	T. HAYAKAWA		28. Nov.2017
APPROVED BY	Y. SANO		29. Nov.2017

DRAWING TITLE  
GENERAL VIEW OF MAIN GIRDER (9)

PACKAGE  
1  
DWG No.  
P1-CS-1009

# GENERAL VIEW OF MAIN GIRDER (10) S=1:60

## SECTION OUTLINES

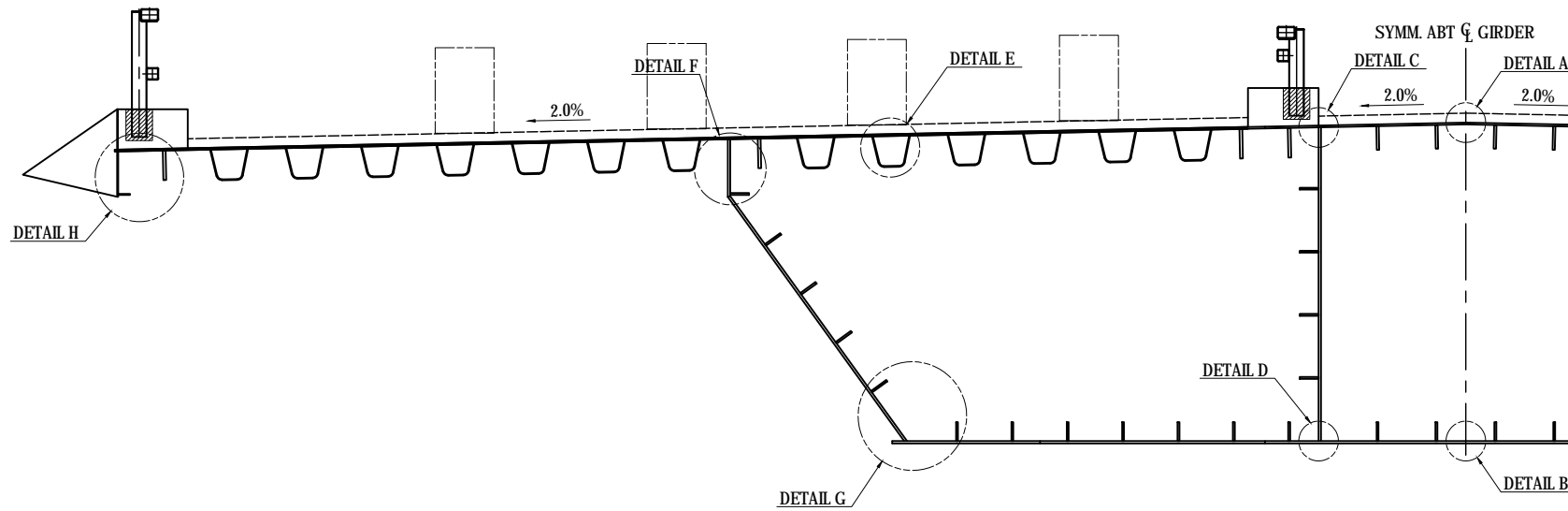

DETAIL H N.T.S.

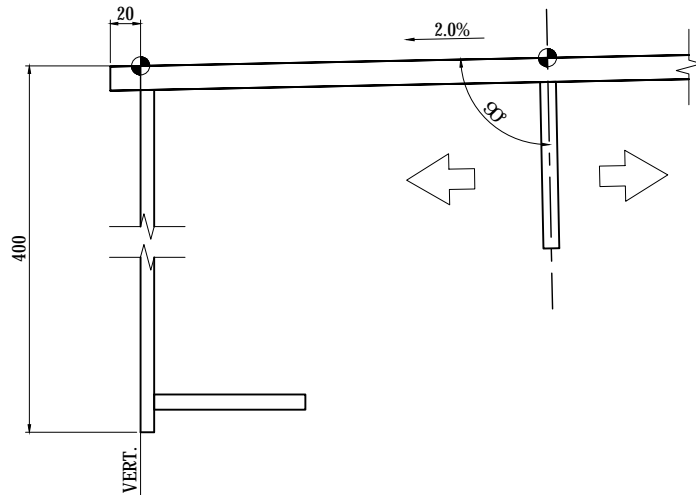

DETAIL F N.T.S.

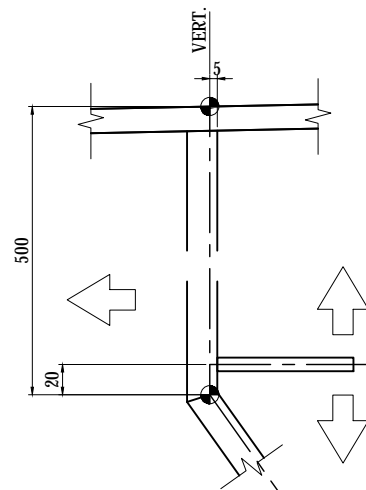

DETAIL E N.T.S.

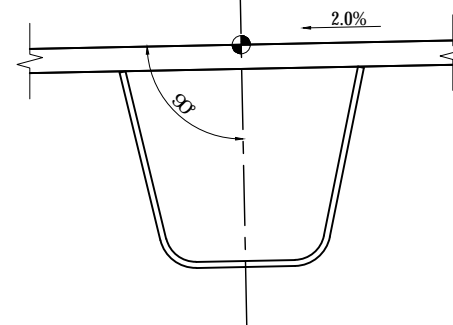

DETAIL C S=1:5

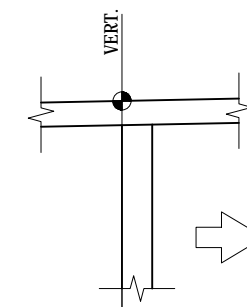

DETAIL A S=1:5

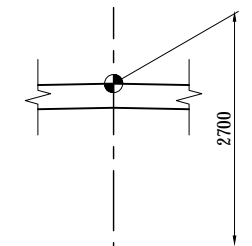

DETAIL G N.T.S.

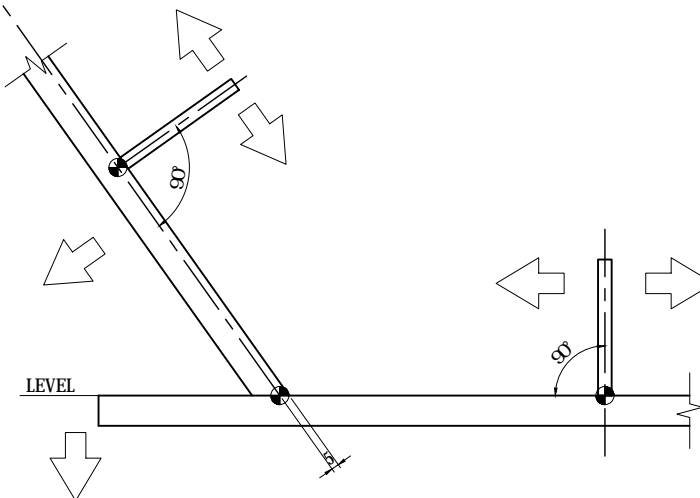

DETAIL D N.T.S.

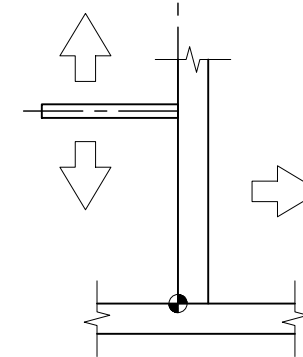

DETAIL B S=1:5

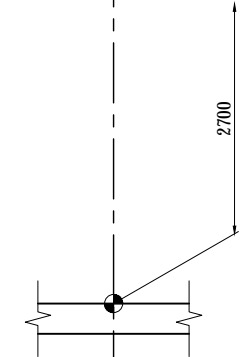

**NOTES:**  
1 - ⇄ DIRECTION

PROJECT NAME	FINANCED BY	COUNTERPART	JICA STUDY TEAM	NAME	SIGNATURE	DATE	DRAWING TITLE	PACKAGE
DETAILED DESIGN ON BAGO RIVER BRIDGE CONSTRUCTION PROJECT	JICA JAPAN INTERNATIONAL COOPERATION AGENCY	REPUBLIC OF THE UNION OF MYANMAR MINISTRY OF CONSTRUCTION DEPARTMENT OF BRIDGE	NIPPON KOEI CO., LTD. ORIENTAL CONSULTANTS GLOBAL CO., LTD. METROPOLITAN EXPRESSWAY COMPANY LIMITED CHODAI CO., LTD. NIPPON ENGINEERING CONSULTANTS CO., LTD.	PREPARED BY T.TOMODA	友田 隆雄	27. Nov.2017	GENERAL VIEW OF MAIN GIRDER (10)	1
				CHECKED BY T. HAYAKAWA	平川 知平	28. Nov.2017		DWG No.
				APPROVED BY Y. SANO	佐野 祐一	29. Nov.2017		P1-CS-1010

JICA Survey Team 1

# Cable Stayed Bridge

## Basic Design-1



*Cable Stayed Bridge (P9-12)*

JICA Survey Team 2

### Contents for Cable Stayed Bridge

1. B/D Results and Revised Points from F/S
2. Review of F/S Design (Bridge Type)
3. Flow Chart of B/D for Cable Stayed Bridge
4. Selection of Structure Type

*Cable Stayed Bridge (P9-12)*

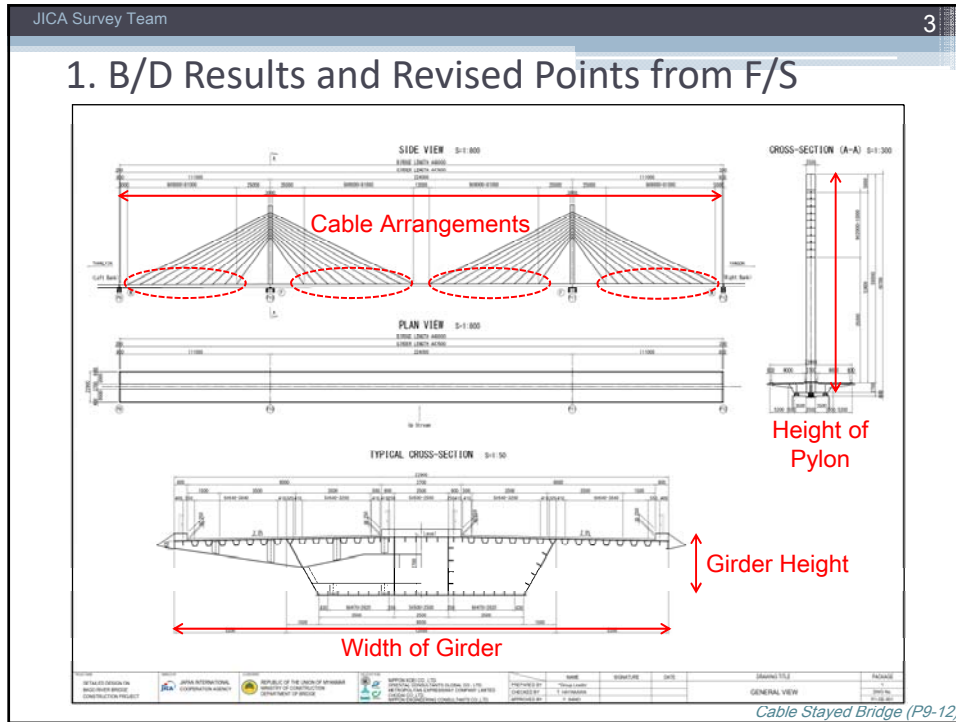

JICA Survey Team 4

### 1. B/D Results and Revised Points from F/S

Items	F/S Design	B/D Results
<b>Main Girder</b>		
Width	24.0m	22.0m
Height	3.0m	2.7m
<b>Main Tower</b>		
Height	57.0m (3m+31.5m+9@2m+4.5m)	60.7m (2.7m+35m+9@2m+5m)
Width	2.4m	2.5m
<b>Cable Arrangements</b>		
Side Span	12.5m+9@8m+27.5m	5m+9@9m+25m
Center Span	27.5m+9@8m+12.5m(CL)	25m+9@9m+6m(CL)
<b>Substructure</b>		
Shape of Pier, Arrangement of Pile, Dimension, etc. were revised.		

*Cable Stayed Bridge (P9-12)*

JICA Survey Team 5

## 2. Review of F/S Design (Bridge Type)

In case of Main Span length  $L=224m$ , following type of bridges can be applied. However, because of the reasons below, **only a Cable Stayed Bridge can be applied** in this Project.

- Truss Bridge : Gerber Truss should be used and not good at maintenance and cost.
- Arch Bridge : There are no applicable construction methods in this Project.
- Suspension Bridge : Anchorage can't be constructed in the river.

Bridge Type	Span Length (m)	Typical Cross Section	Span Length (m)																								
			10	20	30	40	50	60	70	80	90	100	110	120	130	140	150	160	170	180	190	200	224	250	500	1000	2000
Truss	Continuous Truss Bridge (Gerber Truss)																										
Arch	Nielsen Lohse																										
Cable Stayed Bridge																											
Suspension Bridge																											

*Cable Stayed Bridge (P9-12)*

JICA Survey Team 6

## 3. Flow Chart of B/D for Cable Stayed Bridge

In the B/D for Cable Stayed Bridge, **9 Important Items were studied** as shown in the flow chart.

At each step, basically 3-alternatives were compared and the best type was selected.

```

    graph TD
      Start([Start]) --> Step1[Step 1: Height of Main Tower]
      Step1 --> Step2[Step 2: Typical Girder Cross Section]
      Step2 --> Step3[Step 3: Type of Main Tower]
      Step3 --> Step4[Step 4: Cable Stayed Arrangement]
      Step4 --> Step5[Step 5: Number of Cables]
      Step5 --> Step6[Step 6: Cable Type]
      Step6 --> Step7[Step 7: Support Condition]
      Step7 --> Step8[Step 8: Shape of Pier Column]
      Step8 --> Step9[Step 9: Shape of Foundation]
      Step9 --> Finish([Finish])
    
```

*Cable Stayed Bridge (P9-12)*

JICA Survey Team 7

### 4. Selection of Structure Type

Step1: Height of Main Tower

Generally, most economical gradient of top cable at cable stayed bridge is **1:2**.

Considering side span length, the gradient of top cable and working space at top of tower, height of main tower was decided as **58m** in this Project.

*Cable Stayed Bridge (P9-12)*

JICA Survey Team 8

### Step2: Typical Girder Cross Section

Comparison of typical girder cross section is shown as follows.  
**“Conventional Box Cross Section”** was selected as the best one.

Type	① : Wide Box Cross Section	② : Conventional Box Cross Section	③ : Narrow Box Cross Section
Figure			
Characteristics	<ul style="list-style-type: none"> <li>- Web is not located under the wheel load, therefore this type is <b>good at fatigue resistance</b>.</li> <li>- Due to the wide box cross section, the number of parts of the girder will be increased, and <b>increasing assembly time at Site</b>.</li> </ul>	<ul style="list-style-type: none"> <li>- Web is not located under the wheel load, therefore this type is <b>good at fatigue resistance</b>.</li> <li>- Steel weight is lower than other types, therefore this cross section is the <b>most economical</b>.</li> </ul>	<ul style="list-style-type: none"> <li>- Web is located under the wheel load, therefore this type is <b>not good at fatigue resistance</b>.</li> <li>- Overhang length is large, therefore this type is <b>not good at deflection and fatigue resistance</b>.</li> </ul>
Cost Ratio	1.01	1.00	1.01
Evaluation		○	

(In the F/S Stage, “Conventional Box Cross Section” was selected same with the B/D. [at the F/S Stage, overhang length is 5400mm])

*Cable Stayed Bridge (P9-12)*



JICA Survey Team 9

### Step3: Type of Main Tower

Comparison of type of main tower is shown as follows.  
**“Single Tower”** was selected as the best one.

Type	① : Single Tower	② : A-Shape Tower	③ : Twin Tower
Figure			
Characteristics	- This type has 1 straight pylon, and it's a <b>simple structure</b> rather than others.	- Column of main tower is located at both sides of girder, therefore <b>pier width will be wider</b> .	- Column of main tower is located at both sides, therefore compared to type-1, <b>pier width will be wider</b> .
Cost Ratio*	<b>1.00</b>	<b>1.23</b>	<b>1.17</b>
Evaluation	○		

\* This total cost ratio includes cost of superstructure and substructure.  
 (In the F/S Stage, “Single Tower” was selected same with the B/D) *Cable Stayed Bridge (P9-12)*

JICA Survey Team 10

### Step4: Cable Stayed Arrangement

Comparison of cable stayed arrangement is shown as follows.  
**“Semi Fan Arrangement”** was selected as the best one.

Type	① : Harp Arrangement	② : Fan Arrangement	③ : Semi Fan arrangement
Figure			
Characteristics	- From structural point of view, the <b>lower cables are not so efficient</b> due to the gradient .  - From aesthetic point of view, it has a good appearance and it's <b>more attractive than other arrangement types</b> .	- All cables are attached to single point at the top of the pylon, <b>making difficult to attach the cables</b> to one point, therefore this type is <b>not applied in long span</b> cable stayed bridges.	- From structural point of view, gradient of the lower cables are bigger than Harp Arrangement, therefore <b>structural efficiency is higher</b> .  - From aesthetic point of view, cables are arranged by a single plane, giving also <b>good appearance</b> .
Cost Ratio	<b>1.05</b>	<b>1.01</b>	<b>1.00</b>
Evaluation			○

(In the F/S Stage, “Semi Fan Arrangement” was selected same with the B/D) *Cable Stayed Bridge (P9-12)*

JICA Survey Team 11

### Step5: Number of Cables

Comparison of number of cables is shown as follows.  
**“10 Cables”** was selected as the best one.

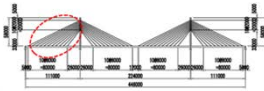
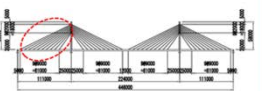
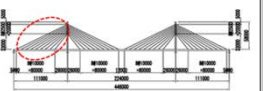
Type	① : 11 Cables	② : 10 Cables	③ : 9 Cables
Figure	 11 cables at one-side, total 44 cables	 10 cables at one-side, total 40 cables	 9 cables at one-side, total 36 cables
Characteristics	- For each cable installed, the stiffening girder and the pylon need to be strengthened locally in order to be able to receive the stayed forces. Therefore, increasing the cables also <b>increases the parts that require local strengthening.</b>	- This cable arrangement is <b>more economical</b> , due to the <b>lower weight of the total cables</b> compared to the 9 cables arrangement.	- Due to the increase of space between cables, the length and weight of the blocks increases, making <b>necessary a bigger crane for the erection work.</b>
Cost Ratio	1.01	1.00	1.02
Evaluation		○	

(In the F/S Stage, “10 Cables” was selected same with the B/D)

*Cable Stayed Bridge (P9-12)*

JICA Survey Team 12

### Step6: Type of Cables

Comparison of type of cables is shown as follows.  
**“FUT-H strand cables”** was selected as the best one.

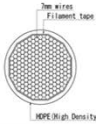
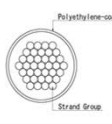
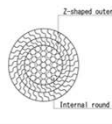
Type	① : NPWS(New Parallel Wire Strand)	② : FUT-H strand cables	③ : Locked Coil Rope
Figure	 7 wires Filament layer HDPE (High Density Polyethylene)	 Polyethylene-coated Strand Group	 Z-shaped outer Wires Internal round Wires
Young's modulus	$1.95 \times 10^5 \text{ N/mm}^2$	$1.90 \times 10^5 \text{ N/mm}^2$	$1.55 \times 10^5 \text{ N/mm}^2$
Characteristics	- NPWS cables are prefabricated at factory, <b>reducing the erection time</b> of the cables in site.  - In order to install this type of cable it's necessary <b>heavy machinery, such as big cranes and jacks.</b>	- FUT-H cables are formed in site by tensioning each stranded wire one by one, <b>slightly increasing the time of erection.</b>  - During installation it's necessary <b>a small crane, jacks and other small machines</b> , avoiding the use of big cranes and vast loads on the girder during erection.	- LCR cables are prefabricated at factory, but in order to apply this type of cable in this design there where <b>necessary 3 cables per section, increasing the time of erection and fabrication.</b>
Cost Ratio	1.25	1.00	1.05
Evaluation		○	

(In the F/S Stage, Type-1 “NPWS” was selected)

*Cable Stayed Bridge (P9-12)*

JICA Survey Team 13

### Step7: Support Condition

Comparison of support condition is shown as follows.  
**“M-F-F-M” support condition** was selected as the best one.

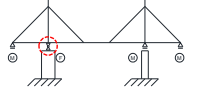
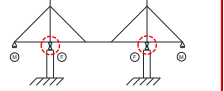
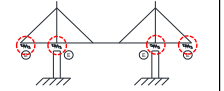
Type	① : M-F-M-M	② : M-F-F-M	③ : E-E-E-E
Figure			
Characteristics	Pin bearing is used at 1-main pier - Horizontal displacement is resisted by pin bearing at 1 main tower, therefore horizontal displacement of main girder due to temperature change and earthquake becomes slightly large. - In order to fix horizontal movement of girder, temporary pin bearing supports should be installed at M-supported pier at main tower during erection works.	Pin bearing is used at 2-main piers - Rigidity of overall structure is high, and horizontal movement is fixed by pin bearing to the main tower. - Horizontal displacement under earthquakes is small, therefore gap at girder ends and expansion joints become compact.	Rubber bearing is used at all of pier - Horizontal displacement is resisted by rubber bearing at the 2 main towers and the 2 side piers at both ends, therefore horizontal displacement of main girder due to earthquake becomes large. - Horizontal force caused by earthquake is dispersed throughout the piers, therefore this type is efficient for seismic design.
Displacement	Temperature : -60mm~+40mm Earthquake : 150mm	Temperature : -40mm~+30mm Earthquake : 70mm	Temperature : -40mm~+30mm Earthquake : 650mm
Cost Ratio*	1.02	1.00	1.02
Evaluation		○	

\* This total cost ratio includes cost of superstructure and substructure.  
 (In the F/S Stage, Type-3 “E-E-E-E” support condition was selected) Cable Stayed Bridge (P9-12)

JICA Survey Team 14

### Step8: Shape of Pier Column (P10, P11)

Comparison of shape of pier column is shown as follows.  
**“Oval Shape”** was selected as the best one.

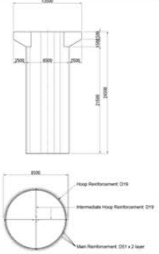
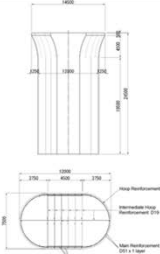
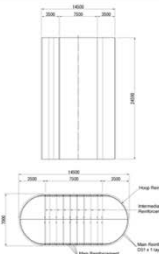
	① Round Shape	② Oval Shape	③ Oval Shape (w/o overhang)
Cross Section			
Characteristics	- Width of column at transverse direction is wider than other types, therefore impediment ratio of river flow become big.	- From aesthetic point of view, since this type has same shape with other spans, it has a good appearance.	- Because of the big cross section, concrete volume become large.
Cost Ratio	0.87	1.00	1.01
Evaluation	×(Pier column at river should be oval shape)	○	

(In the F/S Stage, Type-3 “Oval Shape (w/o over hang)” was selected) Cable Stayed Bridge (P9-12)

JICA Survey Team 15

### Step9: Shape of Foundation (P10, P11)

Comparison of shape of foundation is shown as follows.  
**“Oval Shape”** was selected as the best one.

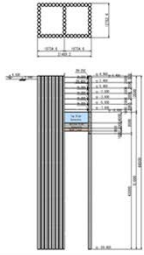
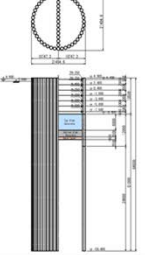
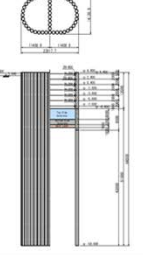
	① Rectangle Shape	② Round Shape	③ Oval Shape
Cross Section			
Characteristics	- From structural point of view, this rectangle shape is <b>unfavorable to water flow</b> and <b>many support should be installed</b> during construction work.	- Pier shape was decided as "Oval Shape", therefore this type has <b>too much needless space</b> .	- Pier shape was decided as "Oval Shape" and this foundation has <b>same shape</b> , therefore this type is the <b>most reasonable</b> .
Cost Ratio	1.06	1.12	1.00
Evaluation			○

(In the F/S Stage, “Oval Shape” was selected same with the B/D) Cable Stayed Bridge (P9-12)

JICA Survey Team 16

## Cable Stayed Bridge

### Basic Design-2



Cable Stayed Bridge (P9-12)

JICA Survey Team		17
<u>Contents for Cable Stayed Bridge</u>		
1. Summary of B/D Results		
1) Superstructure		
2) Substructure at Side Pier		
3) Substructure at Intermediate Pier		
2. Items to be Studied at D/D Stage		
<i>Cable Stayed Bridge (P9-12)</i>		

JICA Survey Team		18
1. Summary of B/D Results		
(1) Superstructure		
Items	F/S Results	B/D Results
<b>Main Girder</b>		
Width	24.0m	22.9m
Height	3.0m	2.7m
<b>Main Tower</b>		
Height	54.0m	58.0m
Cross Section	2.4m x 3.0m	2.5m x 3.0m
<b>Cable</b>		
Type	New PWS	FUT-H Type
Cross Section	---	Φ15.6 x 44, 70
Side Span	12.5m+9@8m+27.5m	5m+9@9m+25m
Center Span	27.5m+9@8m+12.5m(CL)	25m+9@9m+6m(CL)
<i>Cable Stayed Bridge (P9-12)</i>		



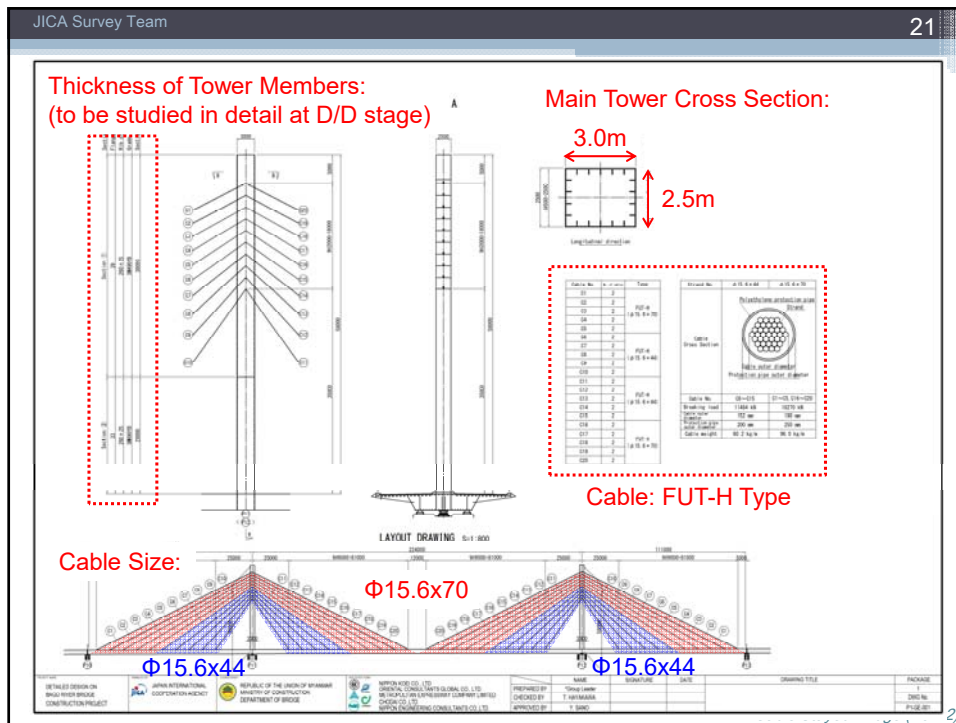

JICA Survey Team 22

### 1. Summary of BD Results

#### (2) Substructure at Side Pier (P10, P13)

Items	F/S Results	B/D Results
<b>Side Pier (P10, P13)</b>		
<b>Pier Column</b>		
Shape	Oval Shape	Oval Shape
Cross Section		
Bottom	4.5m x 14.0m	7.0m x 12.0m
Pier Head	4.5m x 20.0m	7.0m x 18.0m
<b>SPSP Foundation</b>		
Pile Diameter	1.0m	1.2m
Shape	Oval Shape	Oval Shape
Cross Section	9.768 x 19.750 (m)	14.131 x 19.922 (m)

*Cable Stayed Bridge (P9-12)*

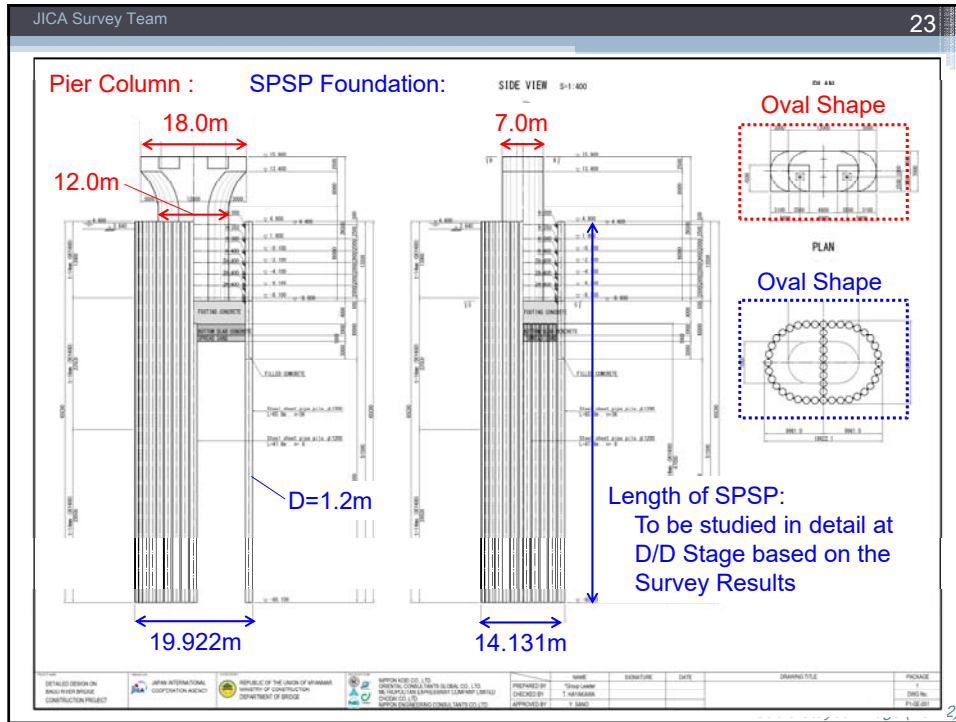

JICA Survey Team 24

### 1. Summary of BD Results

#### (3) Substructure at Intermediate Pier (P11, P12)

Items	F/S Results	B/D Results
<b>Intermediate Pier (P11, P12)</b>		
<b>Pier Column</b>		
Shape	Oval Shape (w/o overhang)	Oval Shape
Cross Section		
Bottom	8.0m x 11.0m	7.5m x 12.0m
Pier Head	8.0m x 11.0m	7.5m x 14.5m
<b>SPSP Foundation</b>		
Pile Diameter	1.0m	1.2m
Shape	Oval Shape	Oval Shape
Cross Section	13.730 x 16.226 (m)	14.131 x 22.818 (m)

*Cable Stayed Bridge (P9-12)*



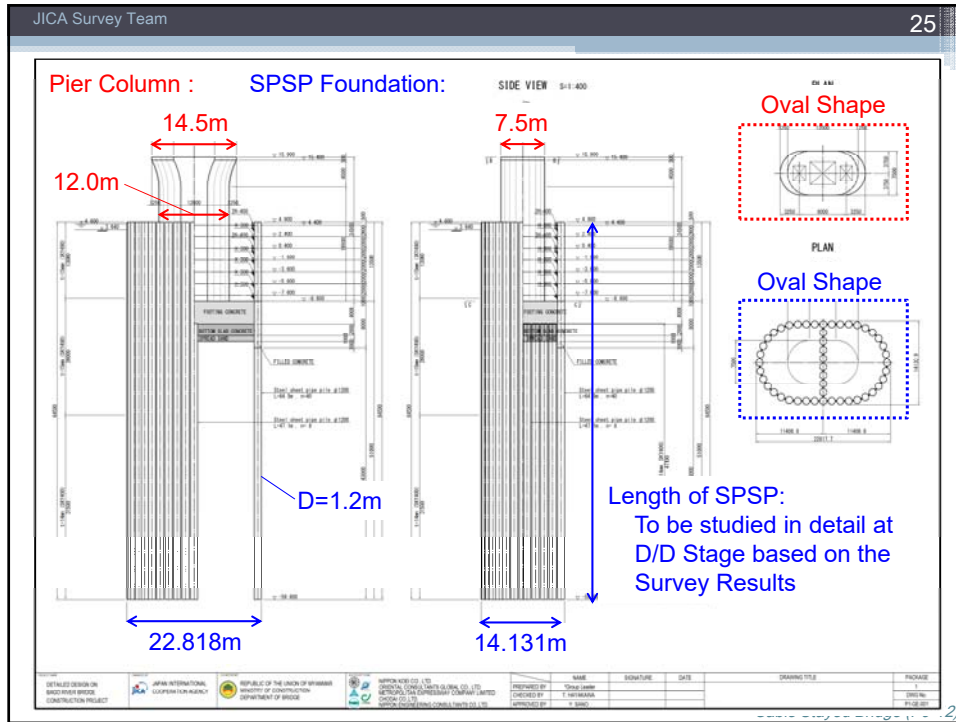

JICA Survey Team 26

## 2. Items to be Studied at D/D Stage

Items	Descriptions
Election Calculation	Verify the safety and deformation state during election works.
Load-bearing Capacity	Consider the non-linear behavior of section force at cable stayed bridge, analyze by [1.7 x design load] and compare with yield stress.
Cable Anchor	3D-FEM Analysis will be conducted in order to check local stress.
Seismic Design	Apply seismic waveforms and analyze time-history response.
Soil Parameter	Update soil parameter based on the Survey results.
River Bed Height	Update river bed height and footing level based on the Survey results.

*Cable Stayed Bridge (P9-12)*

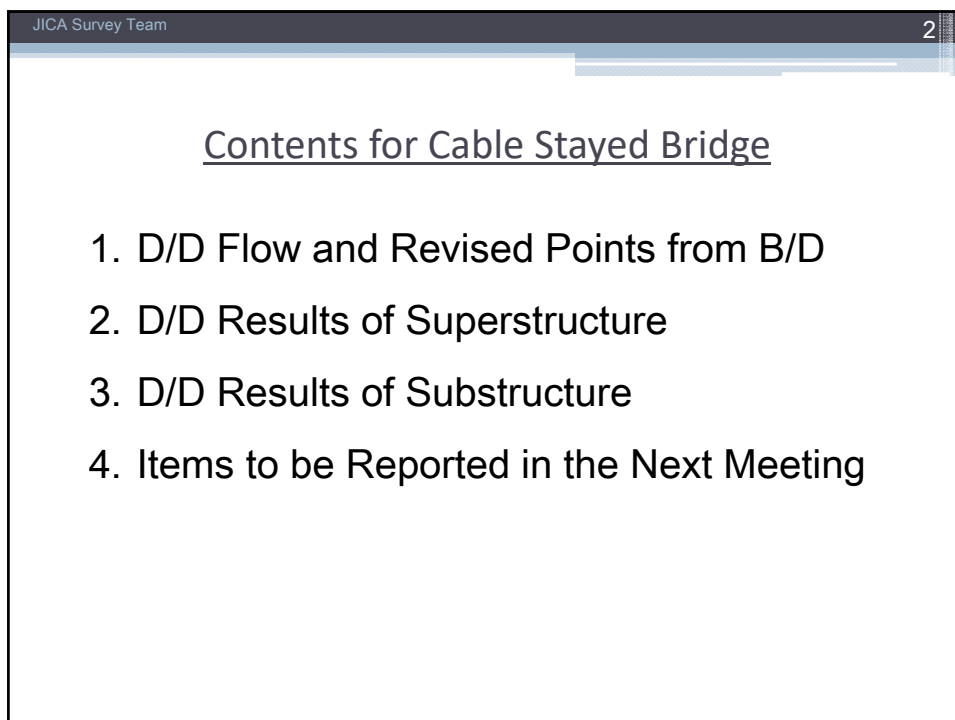

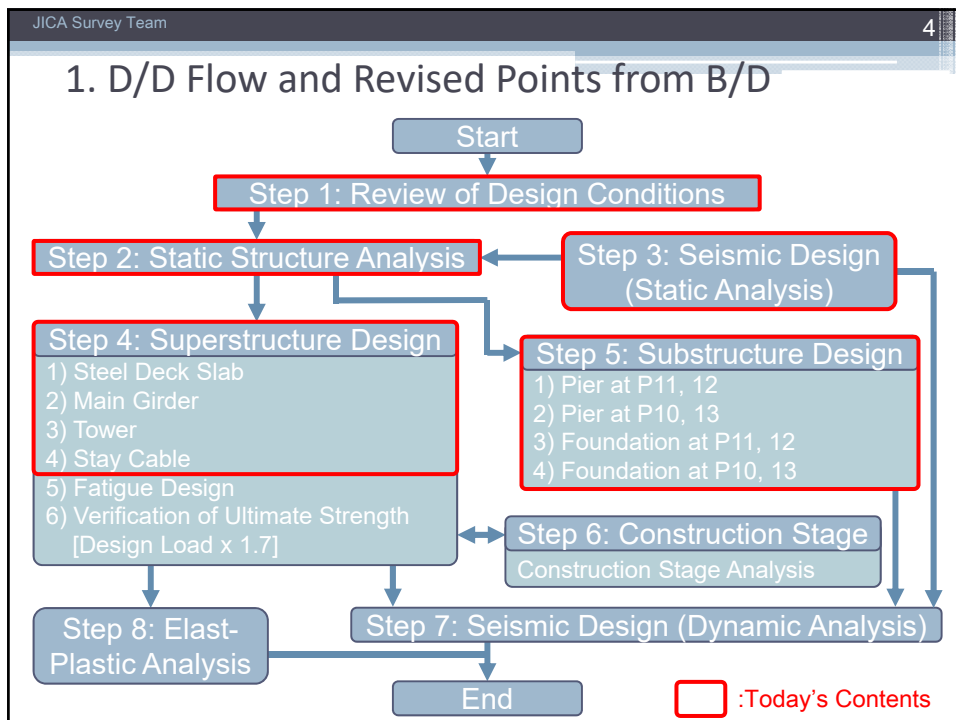
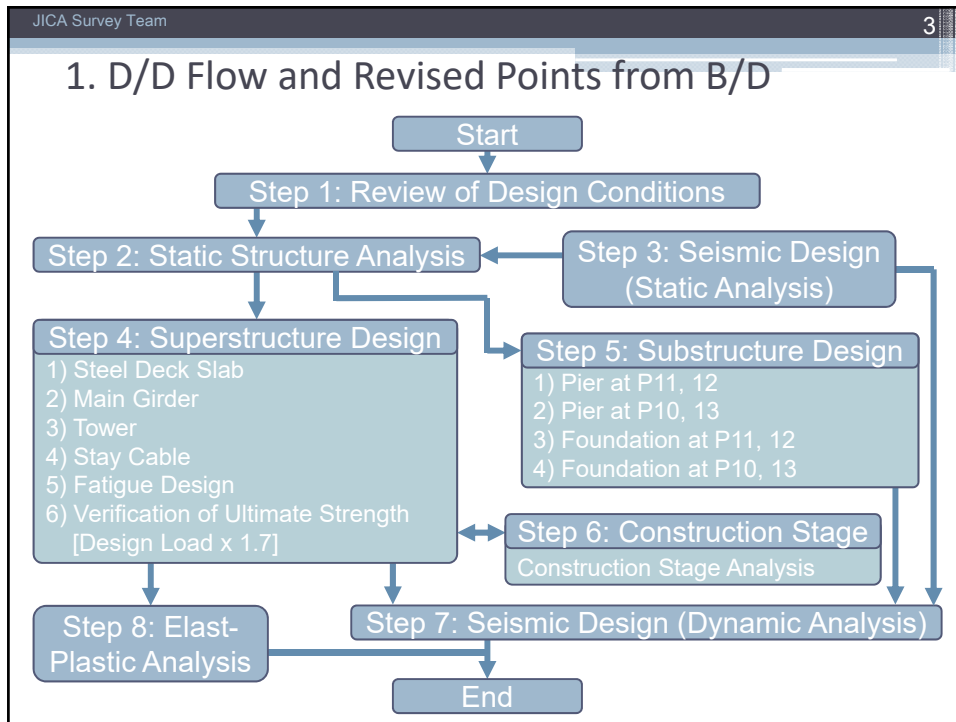

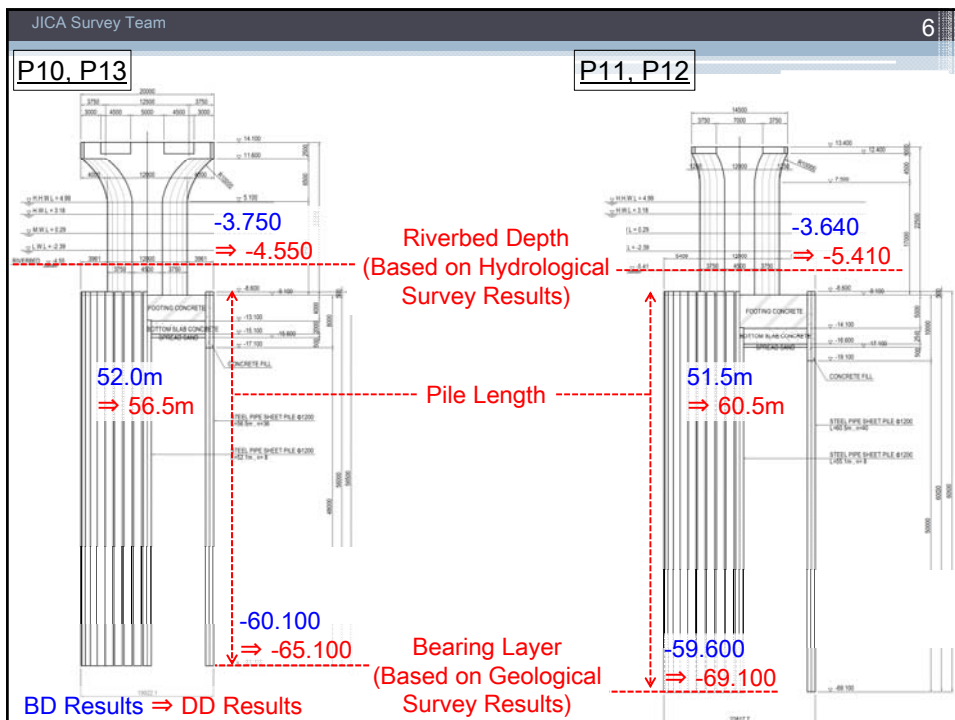
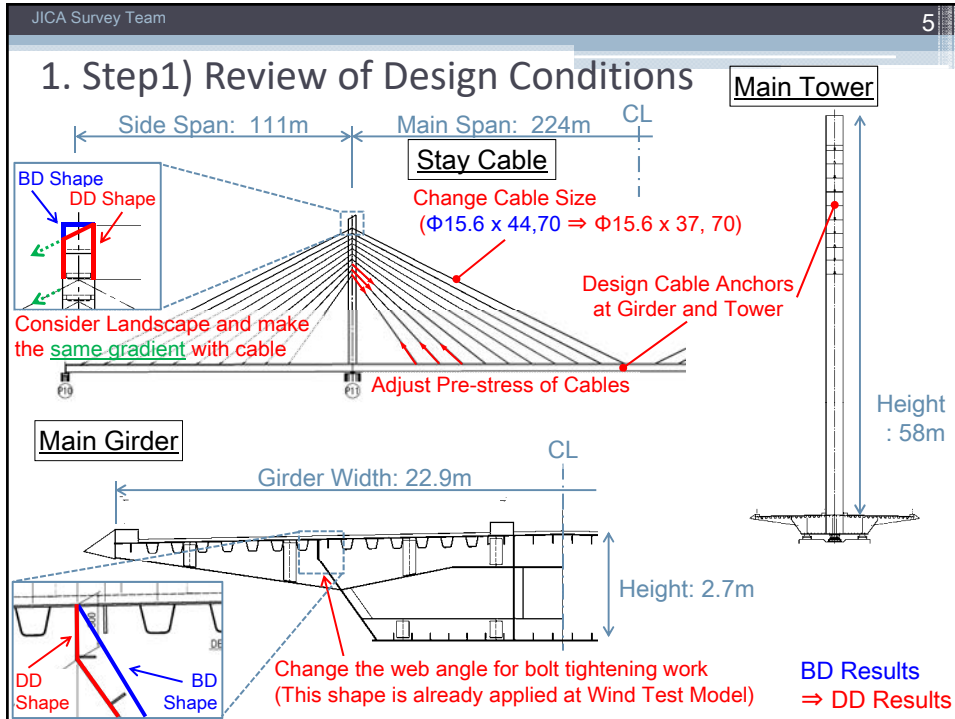

JICA Survey Team 7

## 2. Step2,3,4) D/D Results of Superstructure

### 1) Cable Pre-stress

- “How to decide Cable Pre-stress” is the most essential issue for Cable Stayed Bridge Design.
- In this Project, Cable Pre-stress was decided based on following conditions at construction completed state;
  - 1) Leveling of Moment at Girder
  - 2) Moment at Tower Base  $\approx 0$

**Theory of Cable Pre-stress**

**Step1 [Dead Load]**

Moment at Girder

**Step2**

**[Dead Load + Cable Pre-stress]**

Reduction of Maximum Moment and Leveling of Moment

Axial Force at Girder

Axial Force (compression) is occurred

**[Cable Pre-stress]**

Pre-stress

Vertical Force

Axial Force

JICA Survey Team 8

## 2) Moment Diagram at Dead Load and Pre-stress conditions

**Step1: [Dead Load]**

Large moment is occurred at center of main span

Mainly, moment is distributed at main span

**Step2: [Dead Load + Cable Pre-stress]**

Maximum moment was reduced at center of main span

Moment is leveled and distributed at whole section of bridge

JICA Survey Team 9

### 3) Static Structure Analysis

- Modeling the Bridge by Beam/Truss (Cable) Elements.
- Apply all Design Loads (Dead Load, Live Load, Wind, Seismic and etc.) to the Model and start static analysis.
- Output "Stress Resultants" of each elements.

#### Analysis Model

#### Stress Resultants

Item	Point	Load Case	Axial	Shear_Y	Shear_Z	Torsion	Moment_Y	Moment_Z
			[kN]	[kN]	[kN]	[kN·m]	[kN·m]	[kN·m]
Main Girder	A	D+L (max)	-18330.7	464.4	17.0	7934.2	42914.0	741.5
		D+ELG (max)	-10341.7	-599.8	0.6	-5.9	4954.8	-33.8
	B	D+L (max)	-22667.2	-3421.8	15.0	23709.3	-24637.1	1685.3
		D+ELG (max)	-13246.1	2570.3	0.6	-5.8	715.0	-74.2
	C	D+L (max)	4088.7	1346.4	13.8	11009.8	32766.5	435.3
		D+ELG (max)	1574.5	82.3	-0.4	-0.1	1567.1	-26.5
Cable	D	D+PS	4511	---	---	---	---	---
		D+PS+L (max)	5794	---	---	---	---	---
	E	D+PS	2721	---	---	---	---	---
		D+PS+L (max)	3527	---	---	---	---	---

JICA Survey Team 10

### 3) Design Results of Main Girder and Moment Diagram

#### Moment Diagram

#### Section-A

Item	Material	Plate Thickness	Stress		
			Load Case	$\sigma$ or $\tau$	Allowable Value
Deck	SM400	16mm	D+L+T	52.3	140
Web	SM490Y	14mm	D+L	25.8	120
Bottom Flange	SM490Y	14mm	D+L+T	-94.5	146

#### Section-B

Item	Material	Plate Thickness	Stress		
			Load Case	$\sigma$ or $\tau$	Allowable Value
Deck	SM400	16mm	D+ETR	45.6	140
Web	SM490Y	14mm	D+L	31.4	120
Bottom Flange	SM490Y	11mm	D+ETR	-86.7	102

Deck PL is determined based on fatigue and Web PL is by Cable anchor.

JICA Survey Team 11

### 4) Design Results of Main Tower and Buckling

- Bending moment and Axial force affect Tower Design and Tower has slender shape, therefore "Global Buckling" should be prevented.
- Check buckling mode shape by buckling analysis.

Buckling Analysis

Effective Buckling Length

53.9m

37.7m

Primary mode [Trans. Direction]

3rd mode [Longi. Direction]

(These Effective Buckling Length were used for design of Tower)

Results and Moment Diagram

Moment Diagram

[SM490Y]  
Flange, Web: 40mm  
Flange Rib: 280x27mm  
Web Rib: 250x25mm

37.8m

[SM490Y]  
Flange, Web: 35mm  
Flange Rib: 260x25mm  
Web Rib: 250x25mm

20.2m

D+L (Max)

D+L (Min)

JICA Survey Team 12

### 5) FEM Analysis for Cable Anchor

- Cable is supported by Cable Anchor at girder and tower.
- Cable Anchor receive Cable Tension and transmit the tension to girder and tower.
- Cable Anchor Area will become complicated.

➔ 1) Verify stress concentration by FEM around Cable Anchor  
2) Apply a necessary reinforcement.

FEM Analysis@Girder

- Modeling by FEM and apply cable tension
- Check stress and deformation

Modeling Area

Cable Anchor (General design)

Deformation at Anchor

FEM Results (Deformation)

Extend Diaphragm

Add Steel Plate  
Add Reinforcement

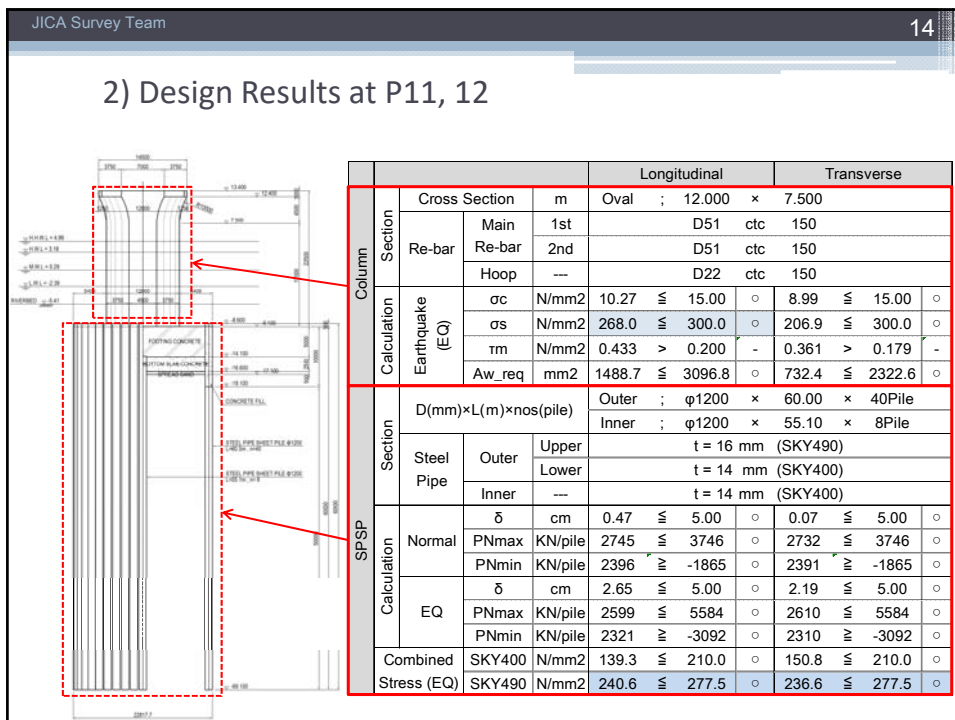
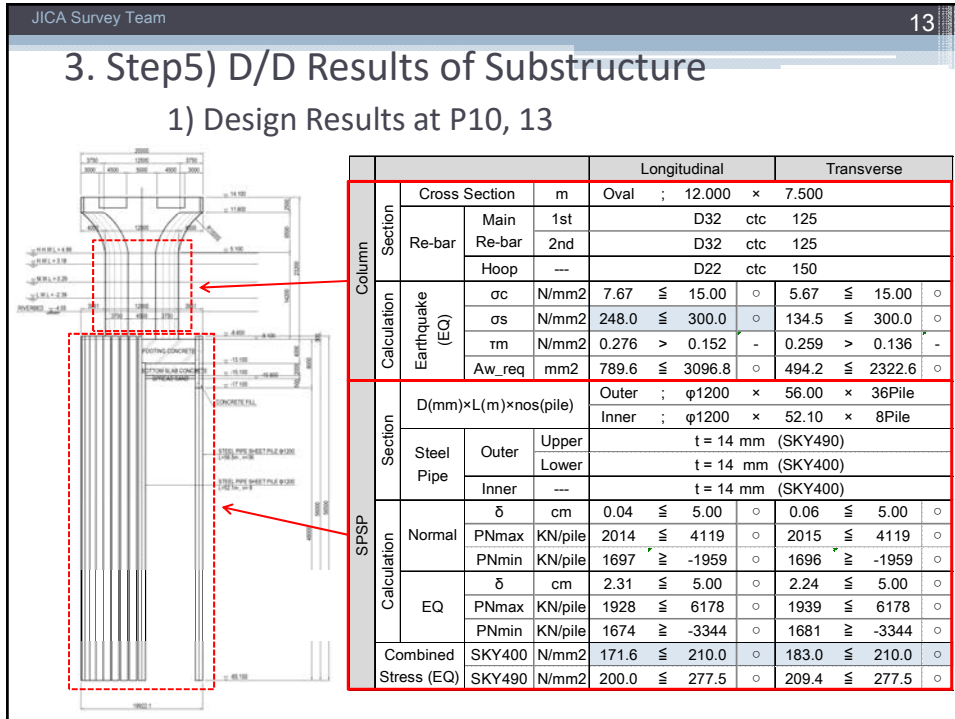



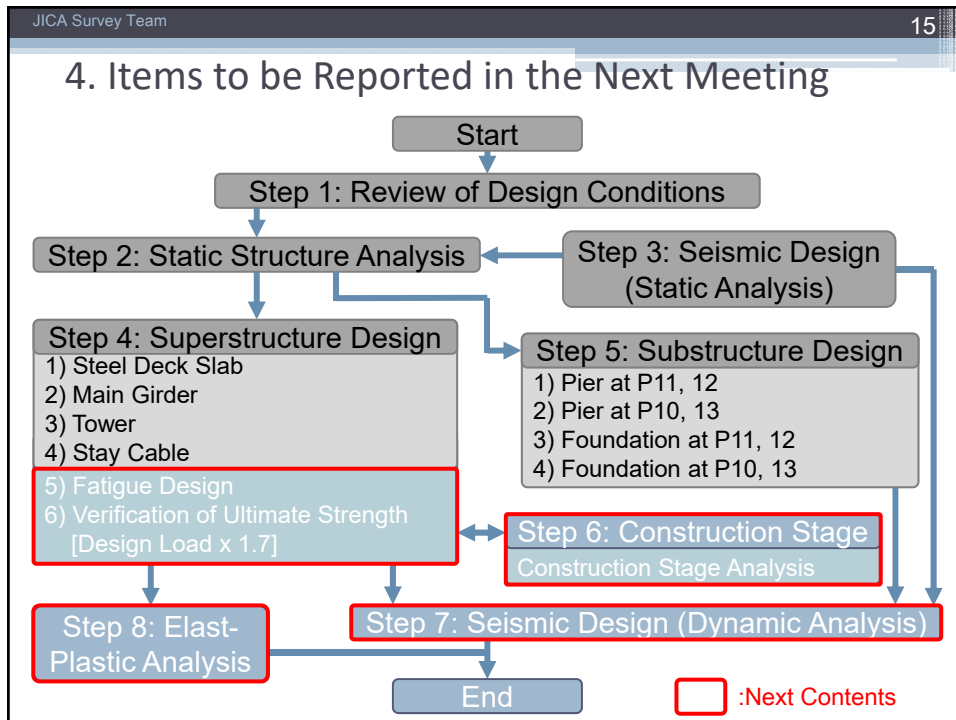

JICA Survey Team 17

### Contents for Cable Stayed Bridge

1. Fatigue Design
2. Verification of Ultimate Strength
3. Construction Stage Analysis
4. Seismic Design (Dynamic Analysis)
5. Elasto-plastic Analysis

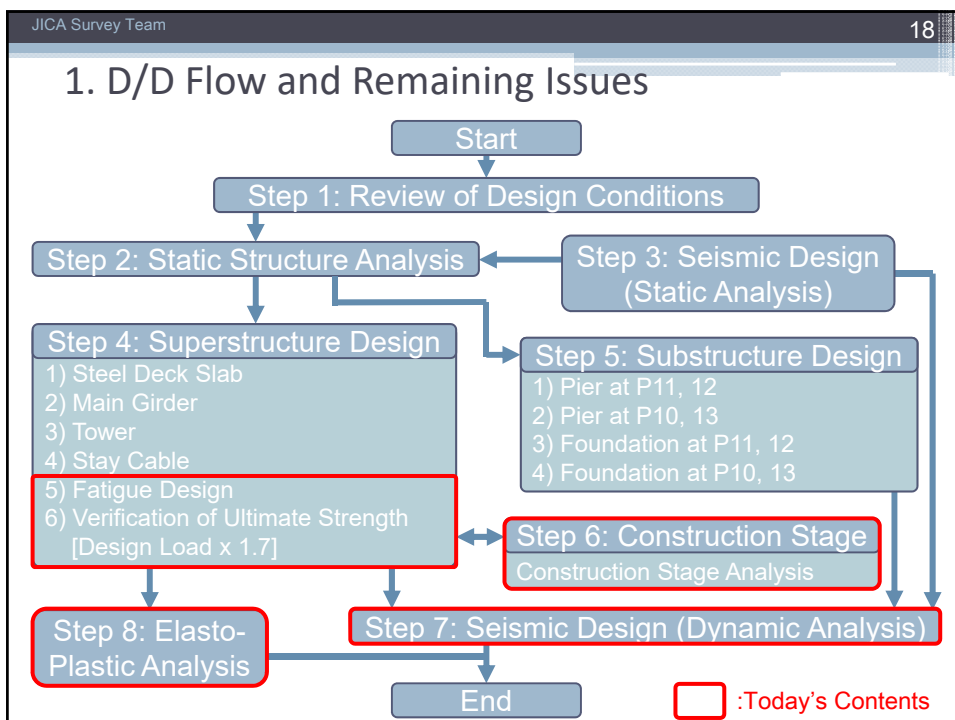

JICA Survey Team 19

- Description for Today's Contents -

[Step 4-5]  
Fatigue Design  
(Steel Deck Panels)

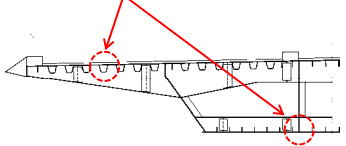

[Step 4-6]  
Verification of Ultimate Strength  
(Non-linear Analysis)

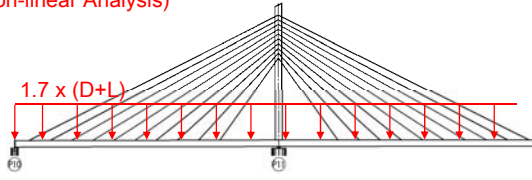

[Step 6]  
Construction Stage Analysis

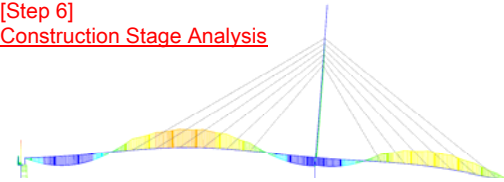

[Step 7]  
Seismic Design [Dynamic Analysis]

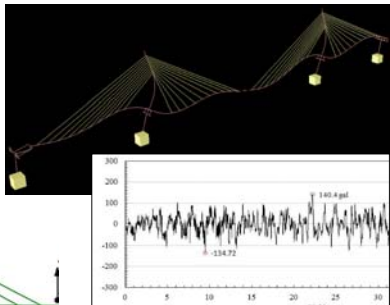

[Step 8]  
Elasto-plastic Analysis

Yield Section

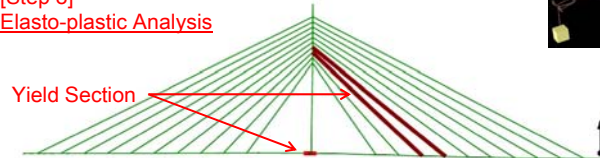



JICA Survey Team 20

## 2. Step4-5) Fatigue Design

### 1) Steel Deck Plate

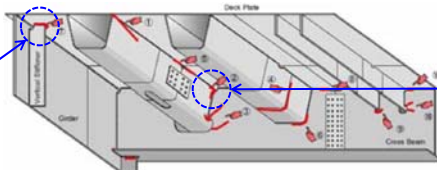
- Due to a cyclic live load, "Fatigue Crack" was occurred at Steel Deck Slab in Japanese Road in the past.

- In order to prevent such cracks, rib arrangement and deck plate thickness are decided by "Fatigue Design Recommendations for Steel Structure (Japan Road Association)".

- ⇒ It can be considered that the Steel Deck Slab has enough durability for Fatigue.
- ⇒ Thickness of deck plate was decided by the Fatigue Design.

Item	Material	Plate Thickness	Load Case	Stress	
				Resultants ( $\sigma$ or $\tau$ )	Allowable Value
Deck	SM400	16mm	D+ETR	45.60	140.00

Deck Plate  
t = 12mm → **16mm**

Stress is less than fatigue allowance

JICA Survey Team 21

## 2) Welding at Web and Flange

- Welding at web and flange should be checked by the **Fatigue Design** based on the Japanese Bridge Design Specifications.
- Compare girder stress and fatigue allowance (fatigue allowance depend on welding type and plate thickness).

Check Points

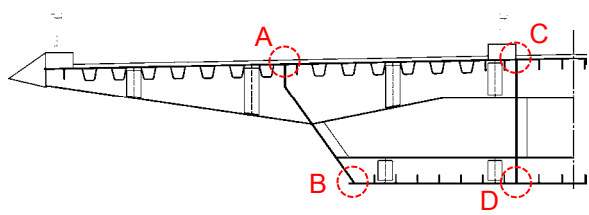

Section	Description of Welding	Stress	Allowable Value for Fatigue
A	Steel Deck and Outer Web	4 N/mm <sup>2</sup>	109 N/mm <sup>2</sup>
B	Bottom Flange and Outer Web	54 N/mm <sup>2</sup>	92 N/mm <sup>2</sup>
C	Steel Deck and Inner Web	2 N/mm <sup>2</sup>	109 N/mm <sup>2</sup>
D	Bottom Flange and Inner Web	54 N/mm <sup>2</sup>	92 N/mm <sup>2</sup>

JICA Survey Team 22

## 3. Step4-6) Verification of Ultimate Strength

### 1) Theory of Non-Linear Characteristics

Non-linear Characteristics

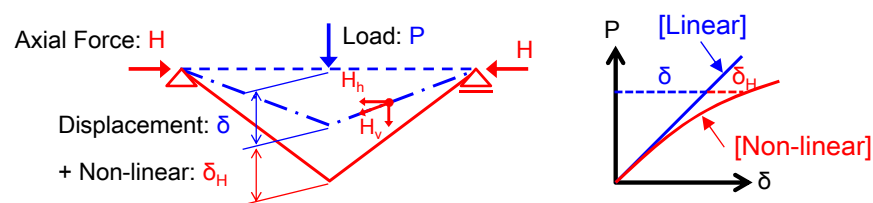

- In the Linear analysis, effect of axial force “H” is neglected at calculation for vertical displacement. However, in the Non-linear analysis, the axial force cause vertical displacement and **displacement become slightly larger**.
- Cable stayed bridge has axial force at girder and tower and shows **Non-linear characteristics**. Therefore, it should be studied whether the structure has necessary safety ratio (Steel:1.7) or not.

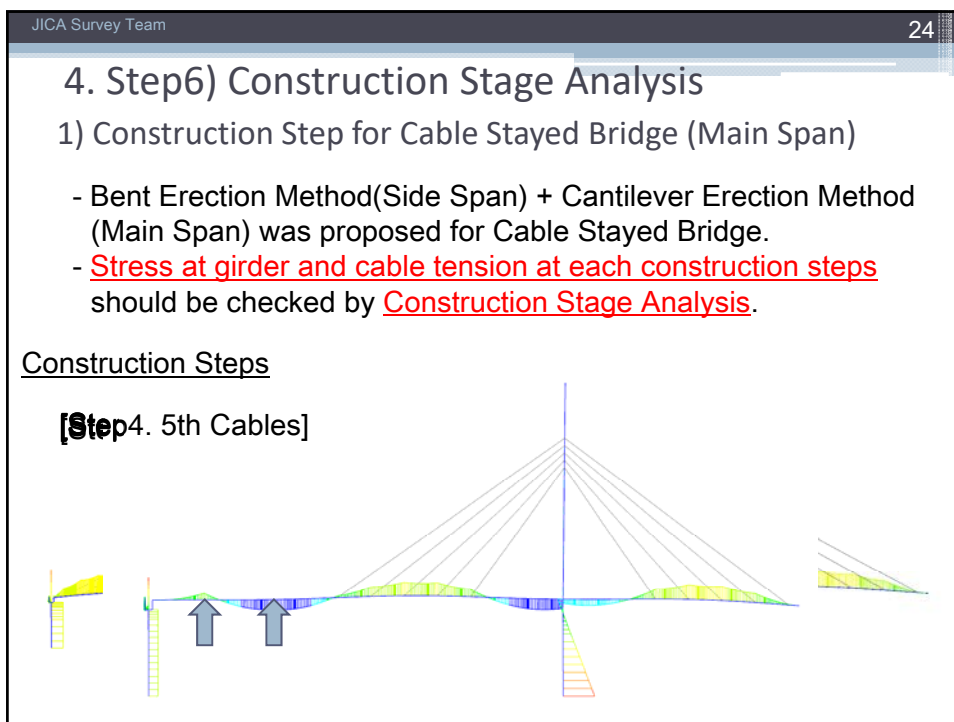
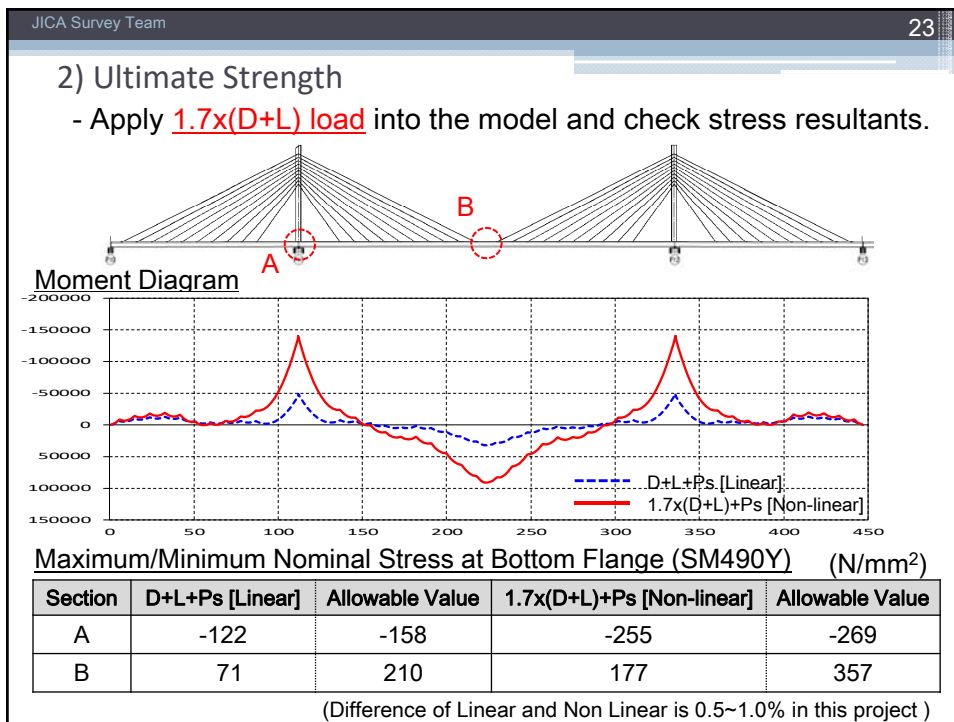

JICA Survey Team 25

### 2) Girder Stress and Cable Tension at Construction Stage

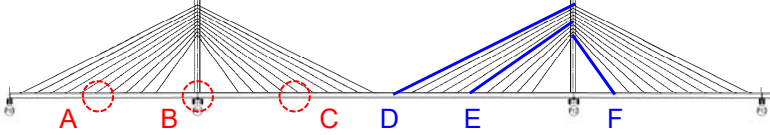

**Maximum/Minimum Nominal Stress and Cable Tension**

Section		Girder Stress/Cable Tension		Allowable Value
Girder [Max/Min Stress]	A	Max	35 N/mm <sup>2</sup>	263 N/mm <sup>2</sup>
		Min	-106 N/mm <sup>2</sup>	-130 N/mm <sup>2</sup>
	B	Max	39 N/mm <sup>2</sup>	263 N/mm <sup>2</sup>
		Min	-50 N/mm <sup>2</sup>	-198 N/mm <sup>2</sup>
	C	Max	5 N/mm <sup>2</sup>	263 N/mm <sup>2</sup>
		Min	-76 N/mm <sup>2</sup>	-128 N/mm <sup>2</sup>
Cable [Tension]	D	4359 kN		9135 kN
	E	3365 kN		4828 kN
	F	3110 kN		4828 kN

JICA Survey Team 26

### 5. Step7) Seismic Design (Dynamic Analysis)

#### 1) Dynamic Analysis

- Cable Stayed Bridge is complex structure, therefore **safety performance should be verified by Dynamic Analysis.**
- Apply standard seismic wave in Japanese Design Specifications. (Max: 140.4gai, Min:-134.72gal, Time: 50 sec) (=  $k_h=0.30$ )
- Analysis was conducted in **longitudinal direction** and **transverse direction.**

**Analysis Model**

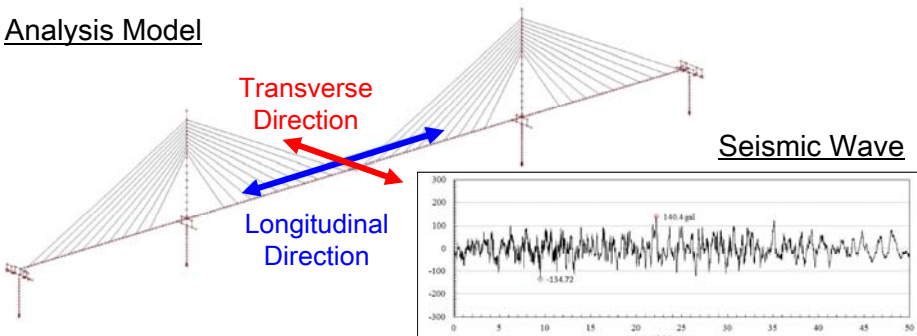

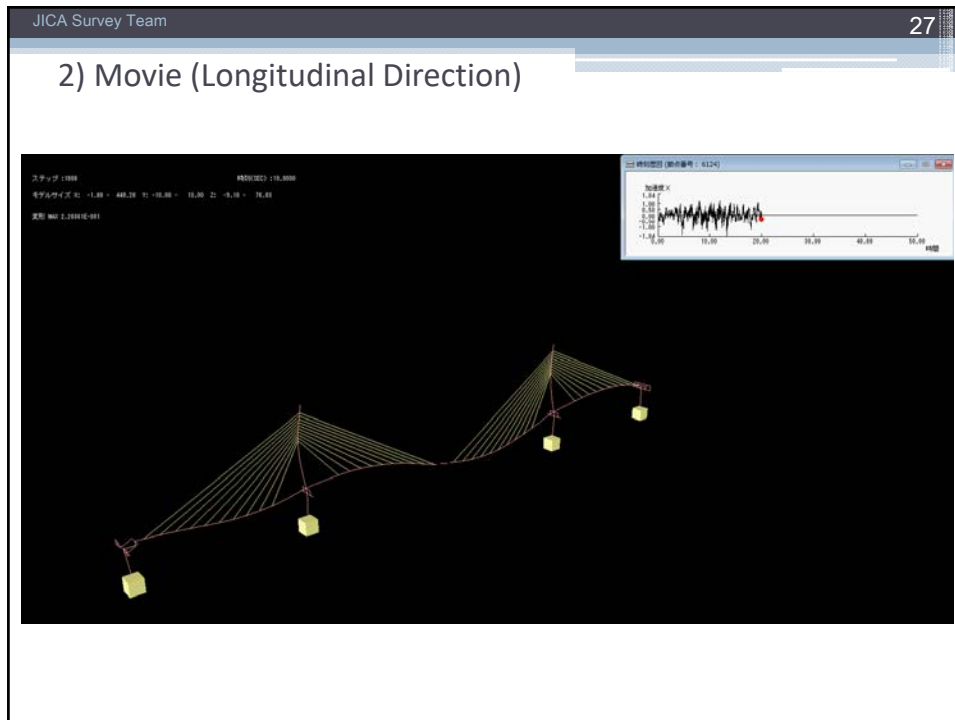

JICA Survey Team 28

### 3) Dynamic Analysis Results

- Stress Resultants at Girder and Tower were less than the allowable value.
- Stress at RC column in transverse direction was over the allowable value. ⇒ **1) Increase re-bar amount**
- Horizontal force (transverse) at horizontal bearing became bigger than the design force in static analysis  
⇒ **2) Re-design the horizontal bearing**

2) Re-design the horizontal bearing  
(Design Force 2400kN ⇒ 6700kN)

1) Increase re-bar amount at RC Column  
(D32 x 0.5 layer ⇒ D32 x 1.0 layer)

JICA Survey Team 29

## 6. Step8) Elasto-plastic Analysis

### 1) Elasto-plastic Analysis

- Cable Stayed Bridge is complex structure and it is difficult to estimate ultimate strength and collapse mode.
- In order to verify safety performance of the structure at ultimate state, Elasto-plastic Analysis was conducted.  
(Plastic buckling of girder/tower and plastic behavior of cable can be evaluated appropriately by the elasto-plastic analysis.)

Analysis Method

Check the "α" when the structure is yielded

JICA Survey Team 30

### 2) Movie (Yielding Step)



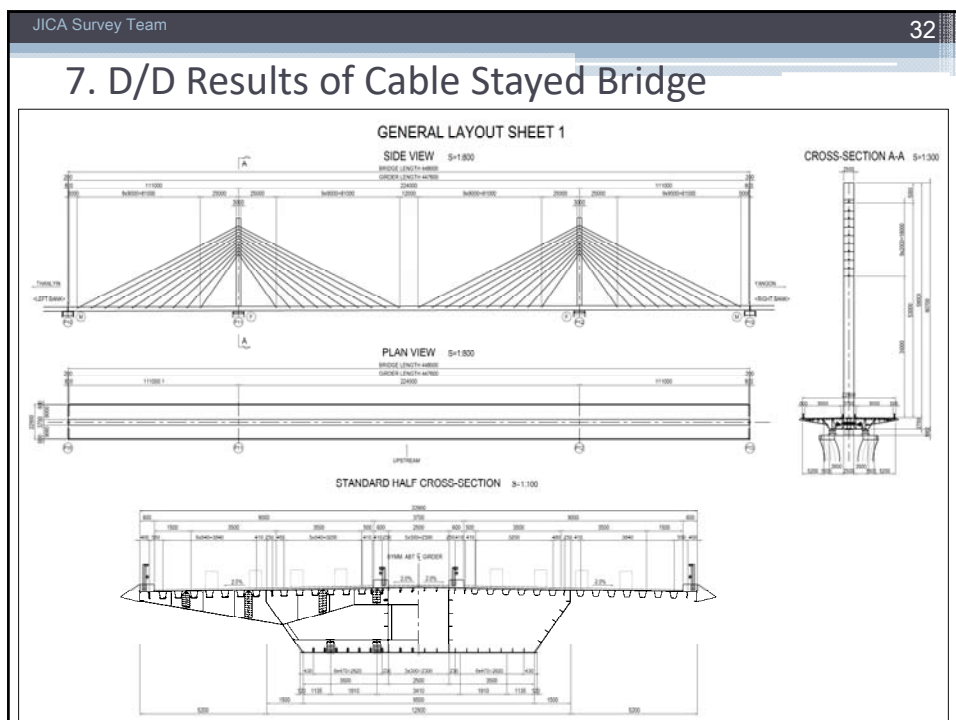
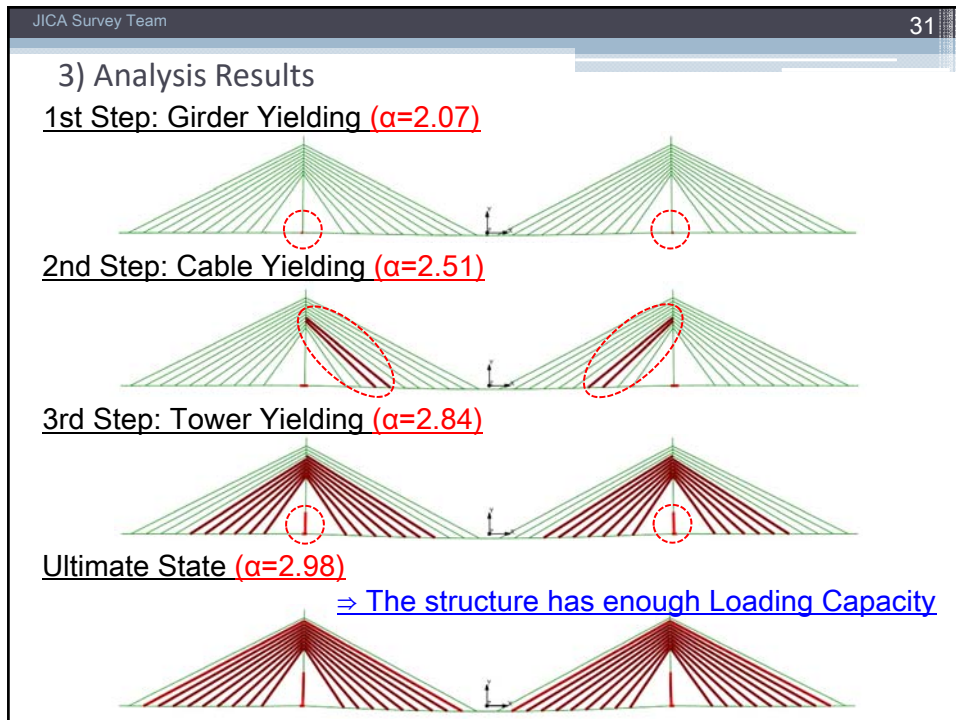

# Applicable Span of Steel Bridge

Bridge Type	Span Length (m)	Typical Cross Section	Span Length (m)																									
			10	20	30	40	50	60	70	80	90	100	110	120	130	140	150	160	170	180	190	200	224	250	500	1000	2000	
Plate Girder Bridge	Simple Composite H-Girder		█	█	█																							
	Simple Non-composite I-Girder			█	█	█	○	64																				
	Simple Composite I-Girder			█	█	█			69																			
	Simple Non-composite Box Girder			█	█	█				92																		
	Simple Composite Box Girder			█	█	█			75																			
	Continuous Non-composite I-Girder			█	█	█				89																		
	Continuous Non-composite Box Girder			█	█	█										147												
	Steel Plate Deck I-Girder			█	█	█				80																		
	Steel Plate Deck Box Girder			█	█	█																				250		
	Simple I-Girder (PC/Composite Slab)			█	█	█																						
	Continuous I-Girder (PC/Composite Slab)			█	█	█				79.5																		
	Narrow Box Girder (PC/Composite Slab)																											
	Open Box Girder																											
	Rigid Frame	Rigid Frame ( $\pi$ -Shape)																										
Rigid Frame (V-Shape)																												
Continuous Rigid Frame																												
Truss	Simple Truss Bridge																											
	Continuous Truss Bridge (Gerber Truss)																											
	Truss Bridge (PC/Composite Slab)																											
Arch	Langer																											
	Deck Langer																											
	Lohse																											
	Deck Lohse																											
	Langered truss																											
	Trussed Langer																											
	Nielsen Lohse																											
	Unstiffened Arch																											
Cable Stayed Bridge																												
Suspension Bridge																												

█ Ordinary Applicable Range    █ Applicable Range    ○ Maximum Span in Japan

1

# Detailed Design on Bago River Bridge Construction Project

Design Technology Transfer  
Lecture : Detailed Practice\_Cable-stayed Bridge

27<sup>th</sup> Oct 2017

JICA Study Team 2

## 1. Modeling

- Node
- Element
- Node Number: Girder: 1~ (1, 0, 15)  
Cable: 401~  
Tower: 501~, 601~
- Material: Girder, Tower, Cable
- Element: Girder, Tower: Beam  
Cable: Truss
- Element Number: Girder: 1~  
Cable: 401~  
Tower: 501~, 601~

# GENERAL VIEW OF STEEL CABLE STAYED BRIDGE (1)

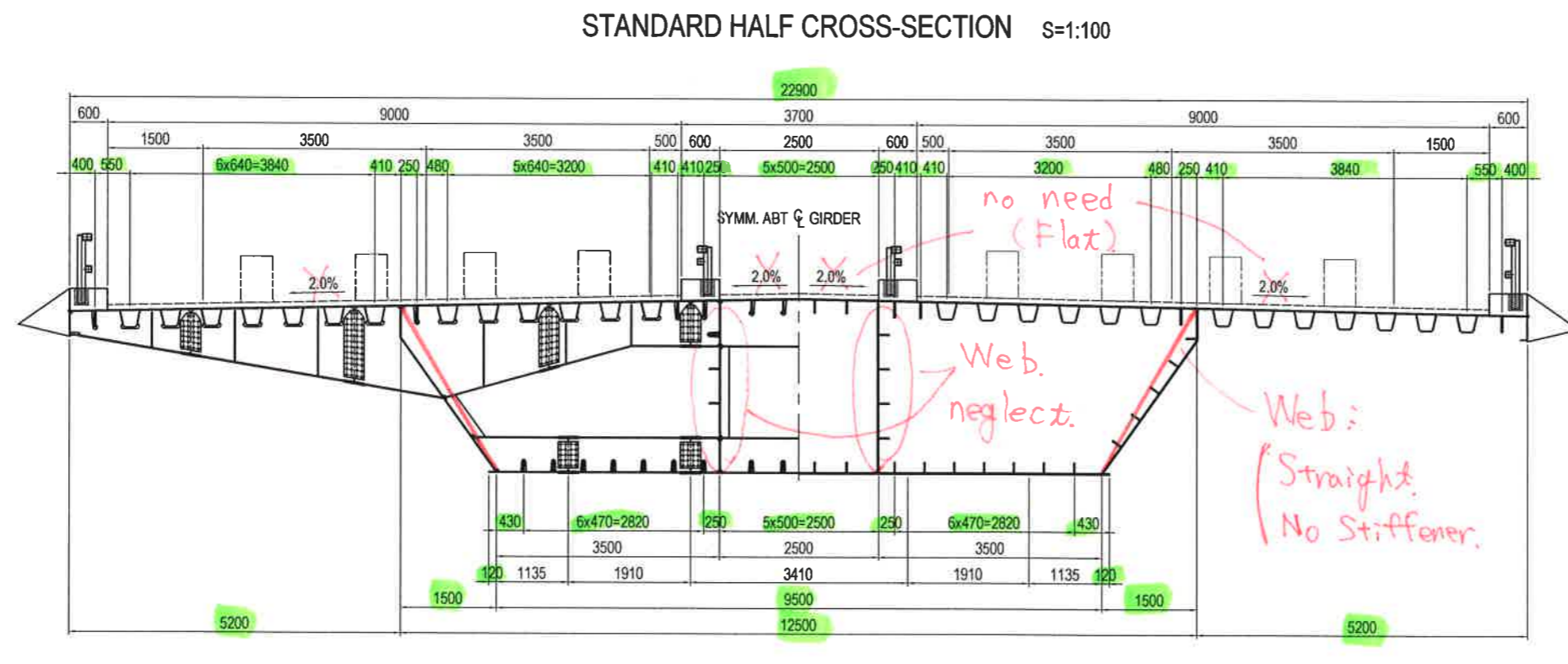
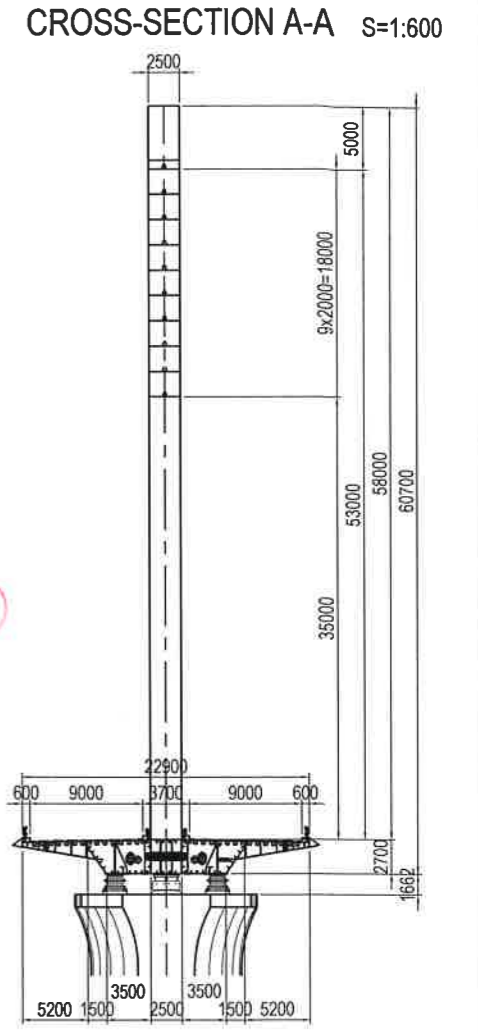
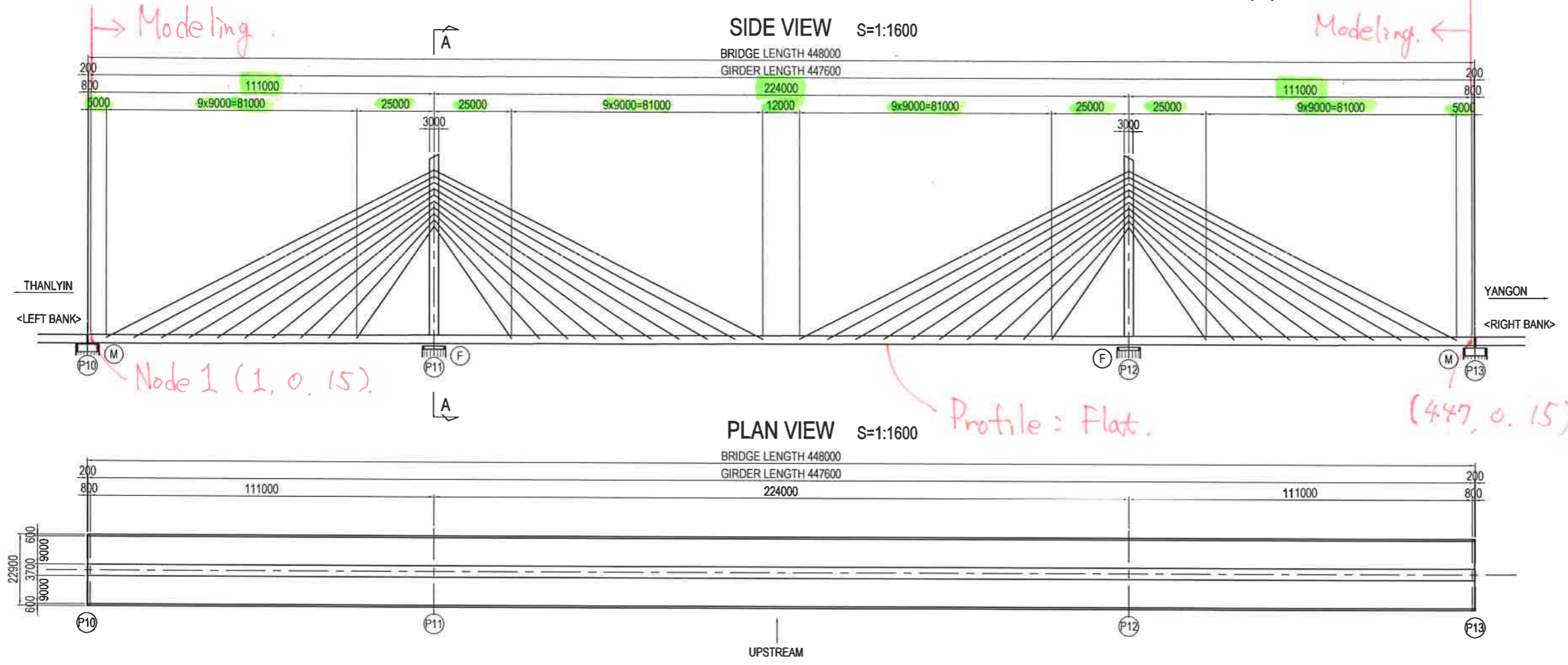

Height {  
 16mm : Deck.  
 +  
 2670mm : Web  
 +  
 14mm : Bottom Flange  
 Total: 2700mm

PROJECT NAME DETAILED DESIGN ON BAGO RIVER BRIDGE CONSTRUCTION PROJECT	FINANCED BY JAPAN INTERNATIONAL COOPERATION AGENCY	COOPERATION REPUBLIC OF THE UNION OF MYANMAR MINISTRY OF CONSTRUCTION DEPARTMENT OF BRIDGE	JICA STUDY TEAM NIPPON KOEI CO., LTD. ORIENTAL CONSULTANTS GLOBAL CO., LTD. METROPOLITAN EXPRESSWAY COMPANY LIMITED CHODAI CO., LTD. NIPPON ENGINEERING CONSULTANTS CO., LTD.	PREPARED BY	NAME	SIGNATURE	DATE	DRAWING TITLE GENERAL VIEW OF STEEL CABLE STAYED BRIDGE (1)	PACKAGE
				CHECKED BY	T.TOMODA				1
				APPROVED BY	T. HAYAKAWA				DWG No.
					Y. SANO				P1-CS-0005

# GENERAL VIEW OF MAIN GIRDER (8)

ELEVATION N.T.S.

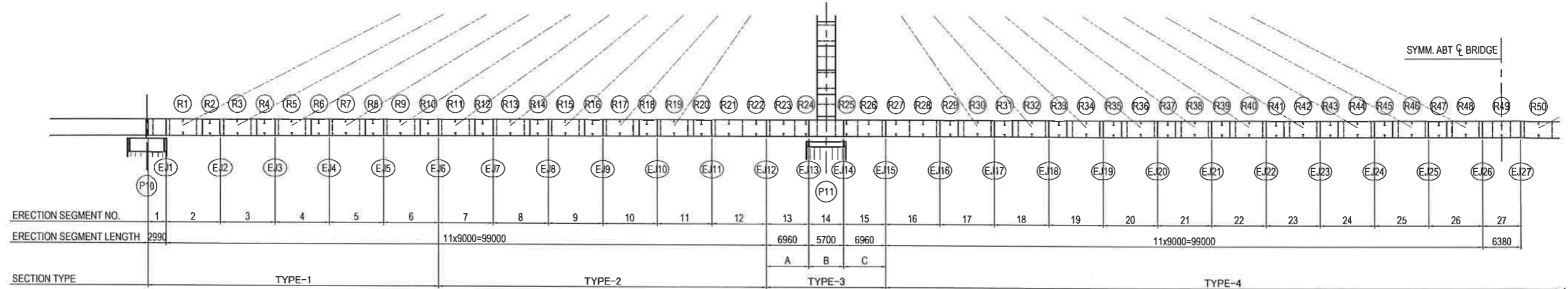

UNIT: mm

DECK PL	THK	16	16	16			16
	STEEL GRADE	SM400	SM400	SM400	SM490Y	SM400	SM400
	TROUGH	320 x 240 x 8	320 x 240 x 8	320 x 240 x 8			320 x 240 x 8
	LONGIT. RIB A	250 x 24	250 x 24	250 x 24			250 x 24
OUTER WEB	LONGIT. RIB B	200 x 20	200 x 20	200x20			200 x 20
	THK	14	14	17			14
	STEEL GRADE	SM490Y	SM490Y	SM490Y			SM490Y
INNER WEB	HORIZ. STIFF.	160 x 16	160 x 16	200 x 20			160 x 16
	THK	14	14	18	35	18	14
	STEEL GRADE	SM490Y	SM490Y	SM490Y			SM490Y
BOTTOM FLANGE	LONGIT. RIB	160 x 16	160 x 16	200 x 20			160 x 16
	THK	14	11	15			11
	STEEL GRADE	SM490Y	SM490Y	SM490Y			SM490Y
	LONGIT. RIB	160 x 16	160 x 16	200 x 20			160 x 16

*Modeling Section.*

TYPICAL SECTION N.T.S.

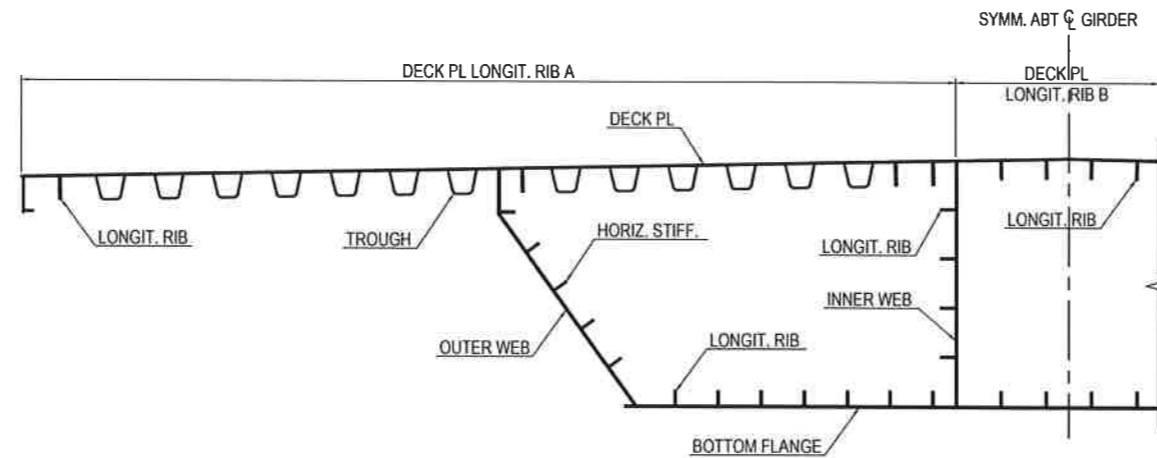

PROJECT NAME DETAILED DESIGN ON BAGO RIVER BRIDGE CONSTRUCTION PROJECT	FINANCED BY JAPAN INTERNATIONAL COOPERATION AGENCY	COUNTERPART REPUBLIC OF THE UNION OF MYANMAR MINISTRY OF CONSTRUCTION DEPARTMENT OF BRIDGE	JICA STUDY TEAM NIPPON KOEI CO., LTD. ORIENTAL CONSULTANTS GLOBAL CO., LTD. METROPOLITAN EXPRESSWAY COMPANY LIMITED CHODAI CO., LTD. NIPPON ENGINEERING CONSULTANTS CO., LTD.	NAME	SIGNATURE	DATE	DRAWING TITLE GENERAL VIEW OF MAIN GIRDER (8)	PACKAGE	
				PREPARED BY	T.TOMODA			27. Nov.2017	1
				CHECKED BY	T. HAYAKAWA			28. Nov.2017	DWG No.
				APPROVED BY	Y. SANO			29. Nov.2017	P1-CS-1008

# GENERAL VIEW OF STEEL CABLE STAYED BRIDGE (3)

SIDE VIEW S=1:400

SECTION A-A

SECTION B-B

UNIT : mm

STEEL GRADE	SM490Y	SM490Y	SM490Y	SM490Y
THK	2420x40	2430x35	2420x40	2430x35
LONGIT. RIB	2-280x27	2-260x25	2-280x27	2-260x25
STEEL GRADE	SM490Y	SM490Y	SM490Y	SM490Y
THK	3000x40	3000x35	3000x40	3000x35
LONGIT. RIB	5-250x25	5-250x25	5-250x25	5-250x25
FLANGE				
WEB				

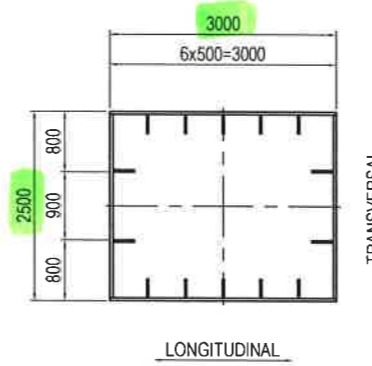
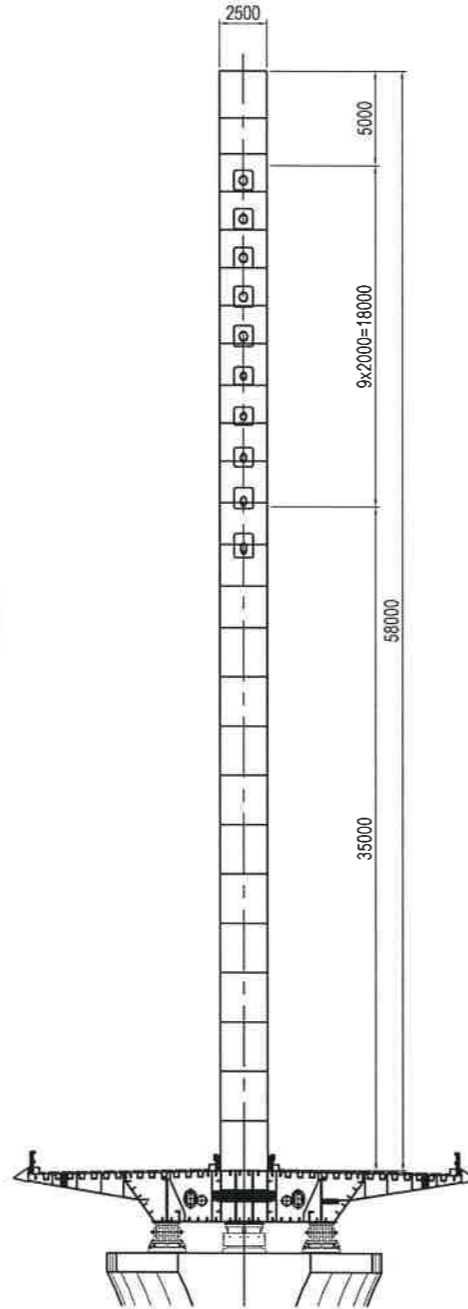
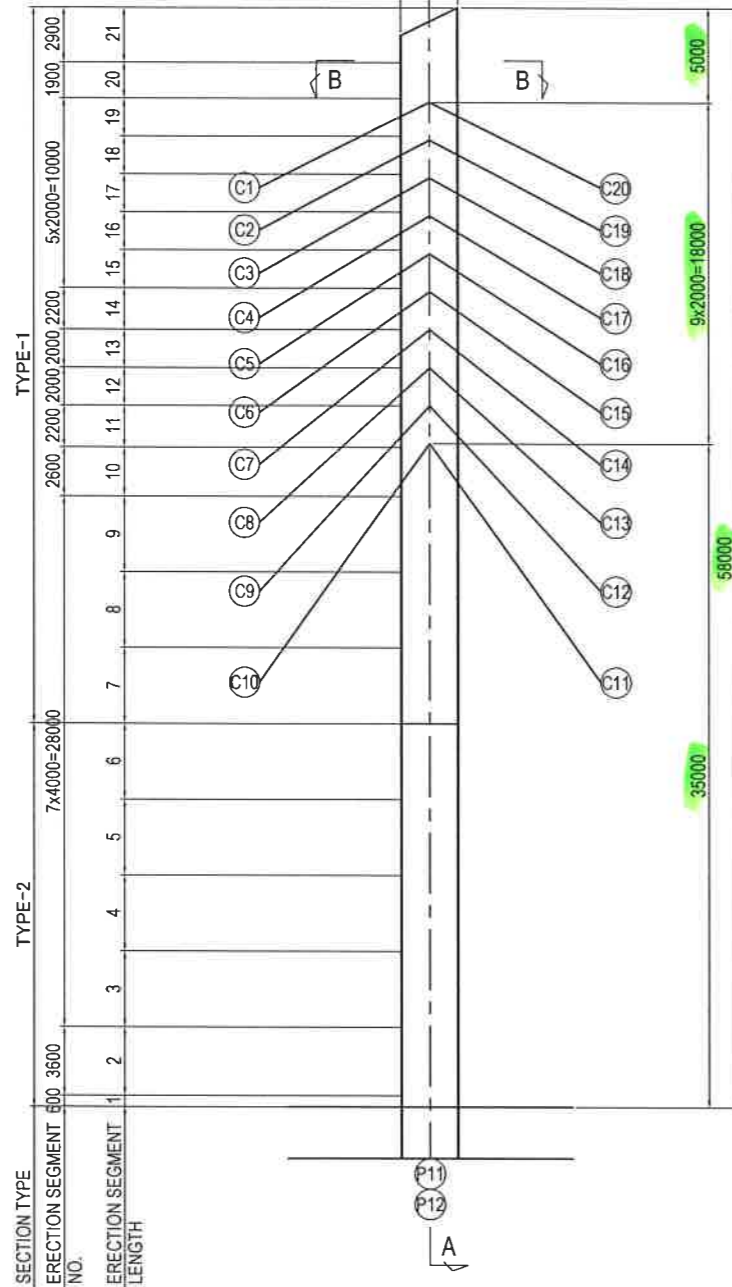

STAY CABLE NO.	NOS.	TYPE
C1	2	FUT-H (Φ15.6×70)
C2	2	
C3	2	
C4	2	
C5	2	FUT-H (Φ15.6×37)
C6	2	
C7	2	
C8	2	
C9	2	FUT-H (Φ15.6×37)
C10	2	
C11	2	
C12	2	
C13	2	FUT-H (Φ15.6×70)
C14	2	
C15	2	
C16	2	
C17	2	FUT-H (Φ15.6×70)
C18	2	
C19	2	
C20	2	

ANCHORAGE TYPE	37H	70H
CABLE CROSS SECTION		
NOM.AREA	5420 mm <sup>2</sup>	10255 mm <sup>2</sup>
TENSILE STRENGTH	9657 kN	18270 kN
ELASTIC MODULUS	190 kN/mm <sup>2</sup>	190 kN/mm <sup>2</sup>
UNIT WEIGHT (STRANDS+HDPE DUCT)	50.8 kg/m (37×1.288+3.1)	96.0 kg/m (70×1.288+5.8)

Cable.

44H.

Area. 7178 mm<sup>2</sup>

Diameter 200 mm

LAYOUT DRAWING S=1:1600

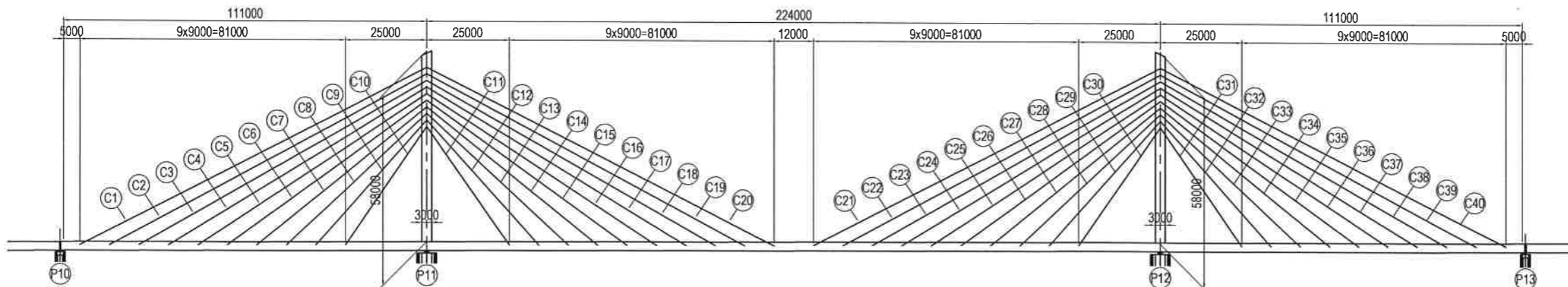

### Material Data

**General**

Material ID:  Name:

**Elasticity Data**

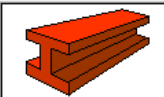
Type of Design:  

Steel

Standard:  DB:

Concrete

Standard:  Code:  DB:

Type of Material

Isotropic  Orthotropic

**Steel**

Modulus of Elasticity :  N/mm2

Poisson's Ratio :

Thermal Coefficient :  1/[F]

Weight Density :  N/mm3

Use Mass Density:  N/mm3/g

**Concrete**

Modulus of Elasticity :  N/mm2

Poisson's Ratio :

Thermal Coefficient :  1/[F]

Weight Density :  N/mm3

Use Mass Density:  N/mm3/g

**Plasticity Data**

Plastic Material Name:

**Thermal Transfer**

Specific Heat :  Btu/N\*[F]

Heat Conduction :  Btu/mm\*hr\*[F]

Damping Ratio :

OK Cancel Apply

### Material Data

**General**

Material ID:  Name:

**Elasticity Data**

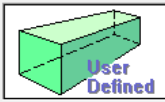
Type of Design:  

User Defined

Standard:  DB:

Concrete

Standard:  Code:  DB:

Type of Material

Isotropic  Orthotropic

**User Defined**

Modulus of Elasticity :  N/mm2

Poisson's Ratio :

Thermal Coefficient :  1/[F]

Weight Density :  N/mm3

Use Mass Density:  N/mm3/g

**Concrete**

Modulus of Elasticity :  N/mm2

Poisson's Ratio :

Thermal Coefficient :  1/[F]

Weight Density :  N/mm3

Use Mass Density:  N/mm3/g

**Plasticity Data**

Plastic Material Name:

**Thermal Transfer**

Specific Heat :  Btu/N\*[F]

Heat Conduction :  Btu/mm\*hr\*[F]

Damping Ratio :

OK Cancel Apply

JICA Study Team 5

## 1. Modeling

- Section: Girder: Steel Girder\_Box  
Tower: DB\_Box with Stiffener  
Cable: Value\_Solid Round
- Assign Section: Girder, Tower, Cable
- Assign Material: Girder, Tower, Cable
- Boundary: P10, 13: Move (y,z,rx fix)  
P11, 12: Fix (x,y,z,rx fix)

JICA Study Team 6

## 2. Loading

- Dead Load: Before Closing: Da  
Girder + Cable Anchor  
Tower + Cable Anchor  
Fairing, Attachments,  
Inspection rail, Cable
- After Closing: Db  
Pavement, Curb, Median,  
Railing, Over Lay

⇒ Affect to Cable Pre-stressing



JICA Study Team 7

## 2. Loading

- Cable Pre-stress: PS
  - 1) **Smoothen girder moment** at completion state  
⇒ Check at [Da + Db + PS]
  - 2) Bending moment at **Tower = 0**  
at completion state  
⇒ Check at [Da + Db + PS]
  - 3) Bending Moment at **Joint = 0 at girder closing**  
⇒ Check at **[Da + PS]**

JICA Study Team 8

- **Dead Load**

Items	Unit Weight	Width	Length	Nos	Total Load (kN/m)
[Before Closing]					
Girder	105.00 kN/m	---	---	---	
Girder Cable Anchor	35.28 kN/nos.	---	81	10	
Tower	43.00 kN/m	---	---	---	
Tower Cable Anchor	50.96 kN/nos.	---	18	10	
Fairing	5.00 kN/m	---	---	2	
Attachments	6.00 kN/m	---	---	1	
Inspection Rail	1.50 kN/m	---	---	2	
Cable	Refer "Cable Weight"				
[After Closing]					
Pavement	22.50 kN/m <sup>3</sup>	9	0.08	2	
Curb	24.50 kN/m <sup>3</sup>	0.6	0.336	2	
Median_Curb	24.50 kN/m <sup>3</sup>	0.6	0.324	2	
Median_Concrete Pavement	23.00 kN/m <sup>3</sup>	2.5	0.08	---	
railing	0.60 kN/m	---	---	2	
Over Lay	0.70 kN/m <sup>2</sup>	22.9	---	---	

JICA Study Team 9

• Cable Weight

Elem. No	Node No.		Type	Total Cable Weight				
	Girder	Tower		Cable	Girder Anchor	Tower Anchor	Girder Total	Tower Total
				(kN)	(kN)	(kN)	(kN)	(kN)
401	2	510	49	36.7	2.3	2.1	39.0	38.8
402	3	509	49	33.9	2.3	2.1	36.2	36.0
403	4	508	49	31.2	2.3	2.1	33.5	33.3
404	5	507	49	28.4	2.3	2.1	30.7	30.5
405	6	506	49	25.8	2.3	2.1	28.1	27.9

JICA Study Team 10

### 3. Analysis

- Check moment of girder by [Da+Db]
- Input cable force at [Pre-stress]
- Check moment of girder by [Da+Db+PS]
- Check force at Truss by [Da+Db+PS], [PS]

Cable seems to **resist to the Pre-stress force**  
 ⇒ Change section property by  
 “Section Manager”

#### 4. Change Cable Property

- Make boundary group for Pre-stress
- Make boundary for Pre-stress
- Use “Section Manager”
  - Cable dose no resist to the Pre-stress force
- Boundary Change Assignment
  - Pre-stress: used as PS
  - Other Load: Normal
- Re-calculate
- Check [Pre-stress]
- Check [Da+Db+PS]

JICA Study Team 11

## 5. Live Load

- Moving Load Coad: AASHTO LRFD
- Traffic Line Lanes: Lane 1~6
  - 1) Eccentricity: Lane1: -9.35m  
Lane2~6: Pls Calculate
  - 2) Wheel Spacing: 1.8m
  - 3) Vehicular Load Distribution: Lane Element
  - 4) Moving Direction: Both
  - 5) Selected by 2 points (All Section of Girder)

JICA Study Team 12

## 5. Live Load

- Vehicles
  - 1) HL-93 TDM
  - 2) HL-93 TRK
- Vehicle Class
  - 1) HL-93: Select HL-93TDM and HL-93TRK
- Moving Load Cases
  - 1) Load Case: HL-93, Truck, Tandem
  - 2) Loading Effect: Combined
  - 3) Add - Vehicle Class: HL-93  
Min Lane: 0 Max Lane: 6  
Select All Lanes

## 5. Live Load

- Impact  
Load Combination "L-impact",  
HL-93, factor = 1.073  
Impact for Girder:  $i = 20/(50+L)$  [JSHB]  
Impact for Tower:  $i = 0.15$  [from other projects]  
Impact for Cable:  $i = 0.2$  [from other projects]
- \* In actually, we need to make 5 models  
impact for side span, impact for main span,  
impact for intermediate pier, impact for cable  
impact for tower

## 6. Temperature Effect

- Temperature Range  
 $10^{\circ} \sim 40^{\circ}$  ( $25^{\circ} \pm 15^{\circ}$ )  
Load Case: Temp+15, Temp-15  
Temp./Pre-stress, Element Temp.  
(Add to all of element)
- Load Combination  
Make "Temp", [Type: Envelope]  
Select "Temp+15" and "Temp-15"

## 7. Wind Load

- Wind Speed
  - JSHB: U10 (10 minutes Average Wind Speed)
  - MNBC: 3 sec Gust Wind Speed
  - ⇒ Convert from 3 sec gust wind speed to U10
- Wind Load
  - Based on JSHB, Guideline for Wind Resistance Design and other project.
  - (1) Wind Load for Girder and Tower [kN/m]
    - ⇒ Input by Element Beam Load
  - (2) Wind Load for Cable [kN]
    - ⇒ Input by Nodal Load

## 7. Wind Load

- Wind Load for Live Load: w
  - Ud: 32.3m/s (same with Girder)
  - Cd: 1.6 (from JSHB)
  - G: 1.9 (from JSHB)
  - $pd = \frac{1}{2} \times \rho \times Ud^2 \times Cd \times G$  [kN/m<sup>2</sup>]
  - $w = \frac{1}{2} \times pd \times 1.0 \text{ m}^2/\text{m}$  [kN/m]
- Loading Height
  - From loading position to Bridge Surface: 1.5m
  - Pavement: 0.08m
  - From Deck to Center of G: 0.75m
  - Total Height:            m ⇒            m

## 7. Wind Load

- Wind Load for Girder and Tower  
Element Beam Load  
[Global Y direction]
- Wind Load for Cable  
Nodal Load  
[FY direction]
- Wind Load for Live Load  
Element Beam Load  
[Global Y direction, Eccen. Global Z 2.5m]

## 8. Load Combination

- Load Combination at JSHB

- 1) D+L    2) D+L+T    3) D+Wg    4) D+L+Wg  
 5) D+Wt    6) D+L+Wt    7) D+Wg+T  
 8) D+L+Wg+T    9) D+Wt+T    10) D+L+Wt+T

Table 3.1.1 Increase factor of allowable stress

Combination of loads	Increase coefficient
1) Principal loads ( $P$ ) + Special loads corresponding to “principal load” ( $PP$ )	1.00
2) Principal loads ( $P$ ) + Special loads corresponding to “principal load” ( $PP$ ) + Effects of temperature changes ( $T$ )	1.15
3) Principal loads ( $P$ ) + Special loads corresponding to “principal load” ( $PP$ ) + Wind load ( $W$ )	1.25
4) Principal loads ( $P$ ) + Special loads corresponding to “principal load” ( $PP$ ) + Effects of temperature changes ( $T$ ) + Wind load ( $W$ )	1.35
5) Principal loads ( $P$ ) + Special loads corresponding to “principal load” ( $PP$ ) + Braking load ( $BK$ )	1.25
6) Principal loads ( $P$ ) + Special loads corresponding to “principal load” ( $PP$ ) + Collision load ( $CO$ )	
For a steel member	1.70
For a reinforced concrete member	1.50
7) Principal loads other than live load and impact + Effects of earthquakes ( $EQ$ )	1.50
8) Wind load ( $W$ )	1.20
9) Braking load ( $BK$ )	1.20
10) Erection load ( $ER$ )	1.25



Items	Unit Weight	Width	Length	Nos	Total Load (kN/m)
[Before Closing]					
Girder	105.00 kN/m	---	---	---	
Girder Cable Anchor	35.28 kN/nos.	---	81	10	
Tower	43.00 kN/m	---	---	---	
Tower Cable Anchor	50.96 kN/nos.	---	18	10	
Fairing	5.00 kN/m	---	---	2	
Attachments	6.00 kN/m	---	---	1	
Inspection Rail	1.50 kN/m	---	---	2	
Cable	Refer "Cable Weight"				
[After Closing]					
Pavement	22.50 kN/m3	9	0.08	2	
Curb	24.50 kN/m3	0.6	0.336	2	
Median_Curb	24.50 kN/m3	0.6	0.324	2	
Median_Concrete Pavement	23.00 kN/m3	2.5	0.08	1	
Railing	0.60 kN/m	---	---	4	
Over Lay	0.70 kN/m2	22.9	---	---	



[Basic Wind Speed]

Wind Speed U10 30 m/s

[Basic Height]

Girder

Ave. Height 15 m

Tower 58 m

65% of the tower 37.7 m

---

Total Height 52.7 m

Tower Section (m)	
Longi.	Trans.
3	2.5

Cable

Top of Tower 73 m

Ave. of Girder 15 m

---

Height for Cable 44 m

[Basic Design Wind Speed]

$$U_d = \mu_1 \times U_{10}$$

$$\mu_1 = (Z/10)^{(1/8)}$$

Items	Basic Height	$\mu_1$	U10 (m/s)	Ud (m/s)
Girder	15	1.052	30	31.6
Tower	52.7	1.231	30	36.9
Cable	44	1.203	30	36.1

[Total Height of Girder]

Railing 0.40 m

Curb 0.25 m

Pavement 0.08 m

Girder 2.70 m

---

Total: D 3.43 m  $\Rightarrow$  3.50 m

[Loading Height of Wind]

Total of Girder/2 1.75 m

Girder -2.70 m

From CoG to Deck 0.75 m

---

Total -0.20 m  $\Rightarrow$  0.00 m

[Total Width of Girder]

Width: B 22.9 m

[Drag Coefficient]

B/D 6.54

CD for Girder	$1 \leq B/D \leq 8$	$2.1 - 0.1(B/D)$
	$8 < B/D$	1.3

Items	CD
-------	----

Girder	1.45	
Tower	1.80	from other projects
Cable	0.70	from other projects

[Projected Area]

Items	Area (m2)
Girder	1561.0
Tower	173.0

[Modification Factor]

Design Object	Girder	Tower
Direction	Trans.	Trans.
Girder $\mu 2$	1.90	1.65
Tower $\mu 3$	1.90	1.65
Cable $\mu 2$	1.90	1.65

from other projects

[Wind Load] (kN/m2)

(From Other Project)

Girder, Cable  $PD = 1/2 \cdot \rho \cdot Ud^2 \cdot \mu 2 \cdot CD$

Tower  $PD = 1/2 \cdot \rho \cdot Ud^2 \cdot \mu 3 \cdot CD$

$\rho$  : Air Density(1.23kg/m3)

Design Object	Girder	Tower
Direction	Trans.	Trans.
Girder	1.68	1.46
Tower	2.87	2.49
Cable	1.07	0.93

[Wind Load] (kN/m)

(From Other Project)

Girder, Cable  $PD = 1/2 \cdot \rho \cdot Ud^2 \cdot \mu 2 \cdot CD \cdot h$

Tower  $PD = 1/2 \cdot \rho \cdot Ud^2 \cdot \mu 3 \cdot CD \cdot h$

$\rho$  : Air Density(1.23kg/m3)

Design Object		Girder	Tower
Direction		Trans.	Trans.
Girder	h	3.50	3.50
	PD	5.90	5.10
Tower	h	3.00	3.00
	PD	8.60	7.50

1

# Detailed Design on Bago River Bridge Construction Project

Design Technology Transfer  
Lecture : Detailed Practice\_Cable-stayed Bridge

15<sup>th</sup> Jan 2018

JICA Study Team 2

## 1. Parametric Analysis

- In order to decide the best structure type and grasp the characteristics of cable-stayed bridge, parametric analysis should be conducted.
- Items to be studied;
  - (1) Girder Rigidity
  - (2) Tower Height
  - (3) Cable Arrangement
  - (4) Cable Number
- Load Case: Dead Load + Pre-stress  
Dead Load + Pre-stress + Live Load

JICA Study Team 3

## 1. Parametric Analysis

- (1) Girder Rigidity  
Change Girder Rigidity  
(Height, Dimension, Value, etc.)
- (2) Tower Height  
Change Tower Height (Low, Middle, High, etc.)
- (3) Cable Arrangement  
Fan Type, Semi-fan Type, Radial Type
- (4) Cable Number  
Change Cable Number

JICA Study Team 4

## 1. Parametric Analysis

- Analysis Case  
Please try to analyze 3~5 cases for each Items
- Check Points
  - Displacement (D+PS, D+PS+L)
  - Stress Resultants (N, M, Q) and Diagram
  - Reaction Force at Bearing, etc.
- Report
  - Prepare “Conclusion Report” (ppt, excel, word)
- Period: 15<sup>th</sup> of Jan. ~ 26<sup>th</sup> of Jan.

1

# Detailed Design on Bago River Bridge Construction Project

Design Technology Transfer  
Lecture : Detailed Practice\_Cable-stayed Bridge

26<sup>th</sup> Jan 2018

JICA Study Team 2

## 1. Section Design

- In order to decide the detail of section (Plate thickness, Cable size, etc.), stress, displacement, tension force should be checked.
- Items to be studied;
  - (1) Load Combination (Increase Coefficient)
  - (2) Allowable Stress (Axial, Bending, Shear)
  - (3) Allowable Cable Tension (Safety Factor=2.5)
  - (4) Stress Resultants  $\Rightarrow$  Stress
  - (5) Stress Check based on JSHB
  - (6) Displacement Check under Live Load

## 1. Section Design\_(1) Load Combination

- Load Combination and Increase Coefficient
  - “Chapter 2 Loads”
  - Load Combination: 1) DL+PS+LL  
2) DL+PS+LL+T
- Increase Coefficient
  - “Chapter3 Allowable Stress” Table3.1.1

## 1. Section Design\_(2)(3) Allowable Value

- Calculation of Allowable Stress
  - [Tensile]  
Axial Stress, Bending Stress : Table 3.2.1
  - [Compressive]  
Axial Stress : Table 3.2.2  
Bending Stress : Table 3.2.3
  - Shear Stress: Table 3.2.4
- Calculation of Allowable Cable Tension
  - Safety Factor: Table 16.5.1



## 1. Section Design\_(2)(3) Allowable Value

- Effective Buckling Length
  - Girder: Distance between 2 cables or distance from cable to support point
  - Tower: In-plane: 0.7h  
Out-plane: 1.0h

## 1. Section Design\_(4) Stress

- Calculation of Stress
  - Axial Force  $\Rightarrow$  Axial Stress ( $\sigma = N/A$ )
  - Bending Moment  $\Rightarrow$  Bending Stress ( $\sigma = M/I \times y$ )
  - Shear Force  $\Rightarrow$  Shear Stress ( $\tau = Q/A_{Web}$ )  
(Torsion, Shear Stress of Flange, Effective Width: Neglect)
- Stress Resultants
  - Use only 3 components  
(Axial, Moment at Y axis, Shear in Z direction)

## 1. Section Design\_(5) Stress Check

- Check by Each Stress
  - Axial Stress vs Allowable Axial Stress
  - Bending Stress vs Allowable Bending Stress
  - Shear Stress vs Allowable Shear Stress
- Check by Combination of Stress
  - Combination of Axial and Bending  
Refer “Chapter 4.3”
  - Combination of Bending and Shear  
Refer “Chapter 10.2.5”

## 1. Section Design\_(6) Displacement Check

- Displacement Check under Live Load w/o impact
  - Refer “Chapter 2.3”

JICA Study Team 9

## 2. Others

- Design Points:  
At least, please try to calculate 3 points for Girder,  
2 points for tower and 2 cables.
- Stress:  
For Flange: Axial and Bending Stress  
For Web: Axial, Bending and Shear Stress

1

# Detailed Design on Bago River Bridge Construction Project

Design Technology Transfer  
Lecture : Detailed Practice\_Cable-stayed Bridge

8<sup>th</sup> Feb 2018

JICA Study Team 2

## 1. Seismic Design by JSHB

- Seismic design of bridges based on JSHB is relation of;

Seismic Level for Design [2 levels]  
x  
Importance Category of Bridge [2 Categories]  
↓  
Required Performance [3 performances]

JICA Study Team 3

## 1. Seismic Design by JSHB

### 1) Seismic Level for Design

[Level 1 Earthquake]  
Corresponds to an earthquake with high probability of occurrence during the bridge service life (100 years).

[Level 2 Earthquake]  
Corresponds to an earthquake with less probability of occurrence during the bridge service life.

In the Level 2, there are 2 types of seismic wave;  
Type1: Plate boundary type  
Type2: Inland direct strike type

JICA Study Team 4

## 1. Seismic Design by JSHB

### 2) Importance Category of Bridge

[Class A]  
The bridges of standard importance.  
(Other than the Class B)

[Class B]  
The bridges of high importance.  
(National Expressways, Urban Highways,  
Highway Viaducts, Rail/Road Over Bridges, etc.)

JICA Study Team 5

## 1. Seismic Design by JSHB

### 3) Required Seismic Performance

[Performance Level 1]  
 Bridge keeping its sound functions during earthquake.

[Performance Level 2]  
 Bridge sustaining limited damages during an earthquake and capable of recovery within a short period.

[Performance Level 3]  
 Bridge sustaining no critical damages during an earthquake

JICA Study Team 6

**Table C-2.2.1 Seismic Performance of Bridges**

Seismic Performance	Seismic Safety Design	Seismic Serviceability Design	Seismic Repairability Design	
			Emergency Repairability	Permanent Repairability
Seismic Performance Level 1: Keeping the sound functions of bridges	To ensure the safety against girder unseating	To ensure the normal functions of bridges	No repair work is needed to recover the functions	Only easy repair works are needed
Seismic Performance Level 2: Limited damages and recovery	Same as above	Capable of recovering functions within a short period after the event	Capable of recovering functions by emergency repair works	Capable of easily undertaking permanent repair works
Seismic Performance Level 3: No critical damages	Same as above			

⇒ Refer Chapter 5

JICA Study Team 7

## 1. Seismic Design by JSHB

### 4) Relation of these items

Seismic Level		Class A Bridges	Class B Bridges
Level 1 Earthquake		Seismic Performance 1	
Level2 Earthquake	Type 1	Seismic Performance 3	Seismic Performance 2
	Type 2		

JICA Study Team 8

## 2. Verification of Seismic Performance

### 1) Design Steps

[Level 1 Earthquake]

- Static Analysis or Dynamic Analysis
- Compare with Allowable stress

↓

[Level 2 Earthquake]

- Static Analysis or Dynamic Analysis
- Compare with Ultimate Strength or Displacement
- Consider plastic behavior

## 2. Verification of Seismic Performance

### 2) Static Analysis or Dynamic Analysis

- Depend on seismic performance
- Depend on bridge type

### 3) Static Analysis Method

- Design Force  
 $H = kh \times W$  (kh: Horizontal Seismic Coefficient)
- Apply the force into longi. and trans. direction
- kh: depend on the period, soil type, area

## 2. Verification of Seismic Performance

### 4) Dynamic Analysis Method

- Input design seismic wave
- Seismic wave: Actual recorded wave
- Depend on soil type



### 3. Design Seismic Load

#### 1) Horizontal Force

- $kh = 0.3$
- Horizontal Force  $H = 0.3 \times W$
- W: All dead load
  - Girder and Tower: Element Beam Load
  - Cable: Nodal Load

#### 2) Load Case

- Seismic Load for Longitudinal Direction
- Seismic Load for Transverse Direction

#### 3) Load Combination

- D + PS + EQ (Increase Factor: 1.5)

### 4. Difference of Support Conditions

#### 1) M-F-F-M

Move - Fix - Fix - Move

#### 2) M-F-M-M

Move - Fix - Move - Move

#### 3) E-E-E-E

Elastic - Elastic - Elastic - Elastic

※ Point Spring Support:  $SD_x = 10000\text{kN/m}$

$SD_y = 10000\text{kN/m}$

$SD_z = 4000000\text{kN/m}$

Check Reaction Force and Displacement under  
Temperature Load and Seismic Load

1

# Detailed Design on Bago River Bridge Construction Project

Design Technology Transfer  
Lecture : Detailed Practice\_Cable-stayed Bridge

14<sup>th</sup> Feb 2018

JICA Study Team 2

## 1. Design Exercise

### Design Conditions 1

Bridge Type: 3-span cable-stayed Bridge  
Span Length: 150m + 300m + 150m  
Structure: Steel Girder, Steel Tower, Cable  
Girder and Tower Section:  
Basic shape is same with previous model, but you can change shape, height, etc. as you want.  
(Top Flange: 16mm)  
Cable Section: Decide by yourself

JICA Study Team 3

## 1. Design Exercise

### Design Conditions 2

Tower Height: Decide by yourself  
(1:2, L/6 ~ L/4, etc.)

Cable Number: Decide by yourself

Cable Arrangement: Select different arrangement  
(Harp or Semi-fan)

Pre-stress: Decide by yourself

Boundary Conditions: M-F-F-M

JICA Study Team 4

## 1. Design Exercise

### Design Conditions 3

Design Load : Dead Load, Pre-stress  
Live Load with impact  
Temperature Effect ( $25 \pm 15^\circ\text{C}$ )  
~~(Wind and Seismic)~~

(Girder and Tower:  $DL = 1.4 \times \text{Area} \times \text{Density}$ )  
(Cable Anchor: Same with previous model)  
(Other: Same with previous model)

Load Case: DL+PS+LL, DL+PS+LL+T  
~~(DL+PS+LL+W, DL+PS+EQ)~~

JICA Study Team 5

## 1. Design Exercise

### Design Conditions 4

Section Type: Side Span 2~3 Type  
Center Span 2~3 Type  
Tower 1~2 Type

Effective Buckling Length  
Girder: Cable or Support Distance  
Tower: 1.0h or 0.7h

Check Items:  $\sigma_b$ ,  $\sigma_a$ ,  $\tau$ ,  $\sigma_b + \sigma_a$ ,  $\sigma_b + \tau$ , LL\_disp

JICA Study Team 6

## 1. Design Exercise

### Design Conditions 5

Conclusion:

- Design Conditions
- Diagram: DL, DL+PS, DL+PS+LL
- Section Summary of Girder, Tower, Cable
- Section Calculation Results
- ~~(- Comparison of structure type)~~

Prepare design report (Word, Excel, etc.) including these contents.