

## **APPENDIX 5.7**

# **Outline Design for Ancillary Civil Structures**

### Appendix 5.7.1 Outline Design for Ancillary Civil Structures

Design Item	Same as YM-D/D(1)	Structures and Methods for YM Phase II	Remark
<b>CVL1. Level Crossing</b>			
1.1 Code, Standards and References	Yes	AREMA 2014 and other relevant ones	
1.2 Number and Type of Level Crossing	Yes	Number and type will be decided tentatively based on the site	
1.3 Level Crossing Structures	Yes	See Sketch-1.	To be finalized at D/D stage
1.4 Level Crossing Protection Device Foundation	Yes	See Photo-1	
1.5 Approach Road to Level Crossing	Yes	almost level 10m before and after a level crossing	
1.6 Drainage	Yes	Surface and Subsurface Drainage	
1.7 Traffic control of the Level Crossing during Construction	Yes	referring to a Japanese example (Road Construction Ordinance)	To be studied at D/D stage
<b>CVL2. Trespass Prevention Fence</b>	<b>NO</b>	<b>Follow MR's Design</b>	<b>MR's Scope</b>
<b>CVL3. Drainage Structures across the Track</b>	Yes	Basically no reconstruction for Masonry arches and reconstruction for Rail Openings, but need site survey and detailed checking at D/D stage	To ensure actual
<b>CVL4. Distance Posts</b>	Yes	The main kilometrage posts are to be every 1km, the middle-kilometrage posts every 500m and the sub-kilometrage posts every 100m.	locations at D/D stage.

Appendix 5.7-1

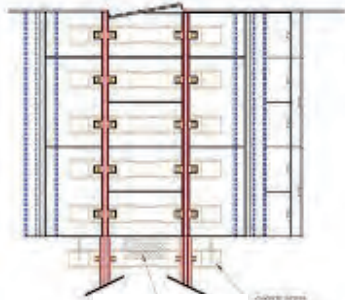
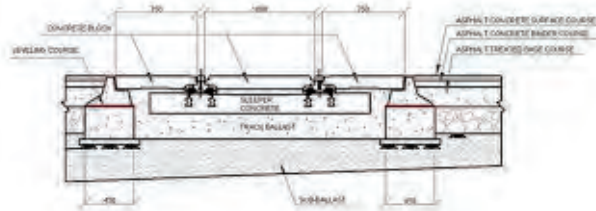

Sketch-1

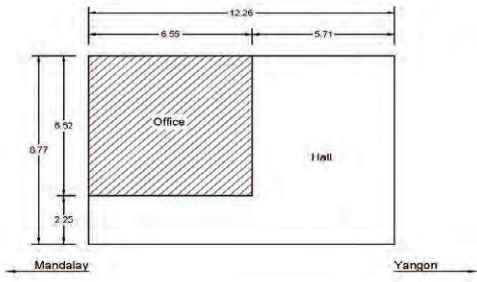



Photo-1

## **APPENDIX 5.9**



### **Existing station Building Conditions**

## Investigation of Station Building

Station No.	39	Line Name	Yangon – Mandalay Line	Date of Survey	5/7/2017		
Station Name	KYEDAW						
Existing Station Building	Kilopost	276.5	Mileage	171.75			
	Access Road	<input checked="" type="radio"/> Yes <input type="radio"/> No	Age of Building	Over 50 years			
	Story of Building	( 1 ) Story Building	Total Floor Area	About 109 m <sup>2</sup>			
	Type of Main Structure (Check <input type="radio"/> )	<input checked="" type="radio"/> Brick with RC • Wood • Other(    )	Finish Material	Roof	<input checked="" type="radio"/> Corrugated Steel sheet • Roof Tiles • RC • Asbestos Fibre Cement		
	Other Structure	Wall		<input checked="" type="radio"/> Brick <input type="radio"/> Wood	Wall	<input checked="" type="radio"/> Paint	
		Column		<input checked="" type="radio"/> Brick <input type="radio"/> Wood	Column	<input checked="" type="radio"/> Paint	
		Beam		Wood <input checked="" type="radio"/> RC <input type="radio"/> Steel	Floor	<input checked="" type="radio"/> Concrete    • Wood	
	Electric system (Check <input type="radio"/> )	<input checked="" type="radio"/> Retract from outside • Solar System • Generator	Water Supply (Check <input type="radio"/> )	<input checked="" type="radio"/> Water Well (    ) • Waterwork • None			
	Condition of Main Structure	Main Damage Type & Rank*		Condition of Finish Material	Main Damage Type & Rank*		
		D	<input checked="" type="radio"/> Crack (10 mm) • Settlement • Inclination		D	<input checked="" type="radio"/> Water Leak <input checked="" type="radio"/> Peel Off (Roof, Ceiling, Wall, Colum )	
General Evaluation	• Usual <input checked="" type="radio"/> Poor • Severe		Remarks	No passenger and freight. No toilet. 1 cable room and 1 generator room.			
Photograph							
							

\*Damage Rank C;Slight (Repair) D;Heavy (Repair and Reinforcement) F; Fatal (Reconstruction)

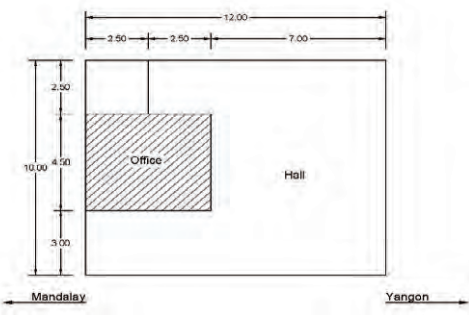
## Investigation of Station Building

Station No.	40	Line Name	Yangon – Mandalay Line	Date of Survy	17/5/2017		
Station Name	KYUNGON						
Existing Station Building	Kilopost	282.5	Mileage	175.5			
	Access Road	<input checked="" type="radio"/> Yes <input type="radio"/> No	Age of Building	Over 100 years			
	Story of Building	( 1 ) Story Building	Total Floor Area	About 120 m <sup>2</sup>			
	Type of Main Structure (Check <input type="radio"/> )	<input checked="" type="radio"/> Brick with RC • Wood • Other(    )	Finish Material	Roof	<ul style="list-style-type: none"> <li>• Corrugated Steel sheet</li> <li>• Roof Tiles</li> <li><input checked="" type="radio"/> RC</li> <li>• Asbestos Fibre Cement</li> </ul>		
	Other Structure	Wall		<input checked="" type="radio"/> Brick <input type="radio"/> Wood	Wall	<input checked="" type="radio"/> Paint	
		Column		<input checked="" type="radio"/> Brick <input type="radio"/> Wood	Column	<input checked="" type="radio"/> Paint	
		Beam		Wood <input checked="" type="radio"/> RC <input type="radio"/> Steel	Floor	<input checked="" type="radio"/> Concrete with Brick    • Wood	
	Electric system (Check <input type="radio"/> )	<input checked="" type="radio"/> Retract from outside • Solar System • Generator	Water Supply (Check <input type="radio"/> )	<ul style="list-style-type: none"> <li>• Water Well (    )</li> <li>• Waterwork</li> <li><input checked="" type="radio"/> None</li> </ul>			
	Condition of Main Structure	Main Damage Type & Rank*		Condition of Finish Material	Main Damage Type & Rank*		
		D	<input checked="" type="radio"/> Crack (5 mm) • Settlement • Inclination		D	<input checked="" type="radio"/> Water Leak <input checked="" type="radio"/> Peel Off (Roof, Ceiling, Wall, Colum )	
General Evaluation	<ul style="list-style-type: none"> <li>• Usual</li> <li><input checked="" type="radio"/> Poor</li> <li>• Severe</li> </ul>		Remarks	No passenger and freight. No toilet and tube well. 1 cable room and 1 generator room.			
Photograph	 						

\*Damage Rank C;Slight (Repair) D;Heavy (Repair and Reinforcement) F; Fatal (Reconstruction)

## Investigation of Station Building

Station No.	41	Line Name	Yangon – Mandalay Line	Date of Survey	17/5/2017		
Station Name	KAYTUMADI						
Existing Station Building	Kilopost	290.5		Mileage	180.5		
	Access Road	Yes	No	Age of Building			
	Story of Building	( ) Story Building		Total Floor Area	About m <sup>2</sup>		
	Type of Main Structure (Check <input type="checkbox"/> )	<ul style="list-style-type: none"> <li>▪ Brick with RC</li> <li>▪ Wood</li> <li>▪ Other( )</li> </ul>		Finish Material	Roof	<ul style="list-style-type: none"> <li>▪ Corrugated Steel sheet</li> <li>▪ Roof Tiles</li> <li>▪ RC</li> <li>▪ Asbestos Fibre Cement</li> </ul>	
	Other Structure	Wall	Brick		Wood	Wall	▪ Paint
		Column	Brick		Wood	Column	▪ Paint
		Beam	Wood		RC	Steel	Floor
	Electric system (Check <input type="checkbox"/> )	<ul style="list-style-type: none"> <li>▪ Retract from outside</li> <li>▪ Solar System</li> <li>▪ Generator</li> </ul>		Water Supply (Check <input type="checkbox"/> )	<ul style="list-style-type: none"> <li>▪ Water Well ( )</li> <li>▪ Waterwork</li> <li>▪ None</li> </ul>		
	Condition of Main Structure	Main Damage Type & Rank*		Condition of Finish Material	Main Damage Type & Rank*		
			<ul style="list-style-type: none"> <li>▪ Crack ( mm)</li> <li>▪ Settlement</li> <li>▪ Inclination</li> </ul>			<ul style="list-style-type: none"> <li>▪ Water Leak</li> <li>▪ Peel Off (Roof, Ceiling, Wall, Colum )</li> </ul>	
General Evaluation	<ul style="list-style-type: none"> <li>▪ Usual</li> <li>▪ Poor</li> <li>▪ Severe</li> </ul>		Remarks	Dismantled in 1994.			
Photograph							

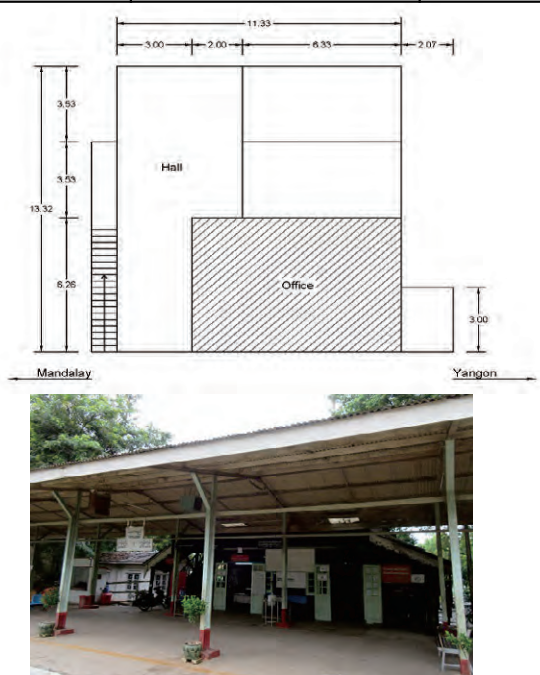

\*Damage Rank C;Slight (Repair) D;Heavy (Repair and Reinforcement) F; Fatal (Reconstruction)

## Investigation of Station Building

Station No.	42	Line Name	Yangon – Mandalay Line	Date of Survey	5/7/2017		
Station Name	YEDASHE						
Existing Station Building	Kilopost	295		Mileage	183.25		
	Access Road	<input checked="" type="radio"/> Yes <input type="radio"/> No		Age of Building	Over 100 years		
	Story of Building	( 2 ) Story Building		Total Floor Area	About 147 m <sup>2</sup>		
	Type of Main Structure (Check <input type="radio"/> )	<input type="radio"/> Brick with RC <input checked="" type="radio"/> Wood <input type="radio"/> Other(    )		Finish Material	Roof	<input checked="" type="radio"/> Corrugated Steel sheet <input type="radio"/> Roof Tiles <input type="radio"/> RC <input type="radio"/> Asbestos Fibre Cement	
		Other Structure	Wall		Brick <input checked="" type="radio"/> Wood	Wall	<input type="radio"/> Paint
			Column		Brick <input checked="" type="radio"/> Wood	Column	<input type="radio"/> Paint
			Beam		<input checked="" type="radio"/> Wood    RC    Steel	Floor	<input type="radio"/> Concrete <input checked="" type="radio"/> Wood
	Electric system (Check <input type="radio"/> )	<input checked="" type="radio"/> Retract from outside <input type="radio"/> Solar System <input type="radio"/> Generator		Water Supply (Check <input type="radio"/> )	<input type="radio"/> Water Well (    ) <input type="radio"/> Waterwork <input checked="" type="radio"/> None		
	Condition of Main Structure	Main Damage Type & Rank*		Condition of Finish Material	Main Damage Type & Rank*		
		D	<input type="radio"/> Crack (    mm) <input type="radio"/> Settlement <input type="radio"/> Inclination		D	<input checked="" type="radio"/> Water Leak <input checked="" type="radio"/> Peel Off (Roof, Ceiling, Wall, Colum )	
General Evaluation	<input type="radio"/> Usual <input checked="" type="radio"/> Poor <input type="radio"/> Severe		Remarks	About 70 passengers/day and no freight.No toilet and tube well.1 cable rm, 1 generator rm and 1 store rm.			
Photograph							

\*Damage Rank C;Slight (Repair) D;Heavy (Repair and Reinforcement) F; Fatal (Reconstruction)

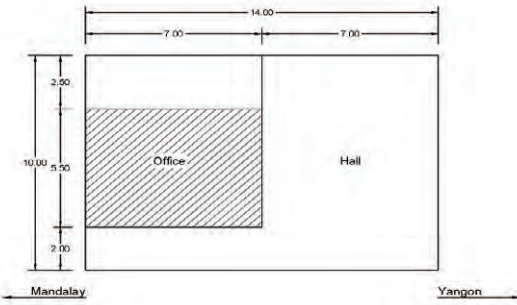

## Investigation of Station Building

Station No.	43	Line Name	Yangon – Mandalay Line	Date of Survey	18/5/2017	
Station Name	KONGYI					
Existing Station Building	Kilopost	301.5		Mileage	187.25	
	Access Road	<input checked="" type="radio"/> Yes    No		Age of Building	Over 100 years	
	Story of Building	( 1 ) Story Building		Total Floor Area	About 120 m <sup>2</sup>	
	Type of Main Structure (Check <input type="radio"/> )	<input checked="" type="radio"/> Brick with RC • Wood • Other(    )		Finish Material	Roof	<input checked="" type="radio"/> Corrugated Steel sheet • Roof Tiles • RC • Asbestos Fibre Cement
	Other Structure	Wall	<input checked="" type="radio"/> Brick    Wood		Wall	<input checked="" type="radio"/> Paint
		Column	<input checked="" type="radio"/> Brick    Wood		Column	<input checked="" type="radio"/> Paint
		Beam	Wood <input checked="" type="radio"/> RC    Steel		Floor	<input checked="" type="radio"/> Concrete    • Wood
	Electric system (Check <input type="radio"/> )	• Retract from outside <input checked="" type="radio"/> Solar System • Generator		Water Supply (Check <input type="radio"/> )	• Water Well (    ) • Waterwork <input checked="" type="radio"/> None	
	Condition of Main Structure	Main Damage Type & Rank*		Condition of Finish Material	Main Damage Type & Rank*	
		F	<input checked="" type="radio"/> Crack ( 10mm) • Settlement • Inclination		D	<input checked="" type="radio"/> Water Leak <input checked="" type="radio"/> Peel Off (Roof, Ceiling, Wall, Colum )
General Evaluation	• Usual • Poor <input checked="" type="radio"/> Severe		Remarks	No toilet room.1 cable room and 1 generator room.Tube well for staff.Train: Upline 1stop/day Dline 1stop/day.		
Photograph						
						

\*Damage Rank C;Slight (Repair) D;Heavy (Repair and Reinforcement) F; Fatal (Reconstruction)



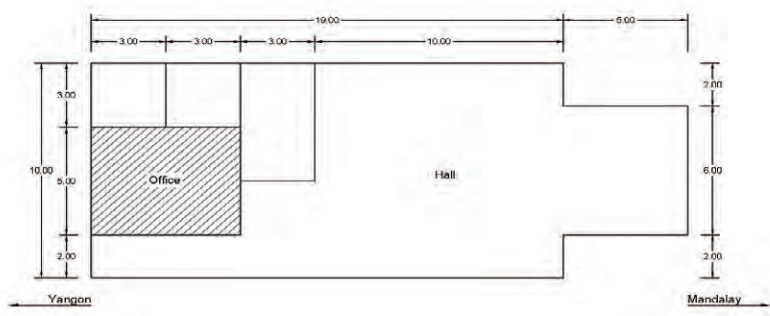

## Investigation of Station Building

Station No.	44	Line Name	Yangon – Mandalay Line	Date of Survey	16/5/2017		
Station Name	SWA						
Existing Station Building	Kilopost	308.5		Mileage	191.5		
	Access Road	<input checked="" type="radio"/> Yes <input type="radio"/> No		Age of Building	Over 100 years		
	Story of Building	( 1 ) Story Building		Total Floor Area	About 190 m <sup>2</sup>		
	Type of Main Structure (Check <input type="radio"/> )	<input type="radio"/> Brick with RC <input checked="" type="radio"/> Wood <input type="radio"/> Other(    )		Finish Material	Roof	<input checked="" type="radio"/> Corrugated Steel sheet <input type="radio"/> Roof Tiles <input type="radio"/> RC <input type="radio"/> Asbestos Fibre Cement	
	Other Structure	Wall	Brick		<input checked="" type="radio"/> Wood	Wall	• Paint
		Column	Brick		<input checked="" type="radio"/> Wood	Column	• Paint
		Beam	<input checked="" type="radio"/> Wood		<input type="radio"/> RC <input type="radio"/> Steel	Floor	<input checked="" type="radio"/> Concrete <input type="radio"/> Wood
	Electric system (Check <input type="radio"/> )	<input checked="" type="radio"/> Retract from outside <input type="radio"/> Solar System <input type="radio"/> Generator		Water Supply (Check <input type="radio"/> )	<input type="radio"/> Water Well (    ) <input type="radio"/> Waterwork <input checked="" type="radio"/> None		
	Condition of Main Structure	Main Damage Type & Rank*			Condition of Finish Material	Main Damage Type & Rank*	
		D	<input type="radio"/> Crack ( mm) <input type="radio"/> Settlement <input type="radio"/> Inclination <input checked="" type="radio"/> Break column			B	<input type="radio"/> Water Leak <input type="radio"/> Peel Off (Roof, Ceiling, Wall, Colum )
General Evaluation	<input type="radio"/> Usual <input checked="" type="radio"/> Poor <input type="radio"/> Severe		Remarks		No toilet room.		
Photograph							
							

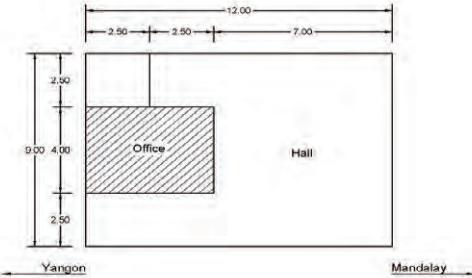

\*Damage Rank C;Slight (Repair) D;Heavy (Repair and Reinforcement) F; Fatal (Reconstruction)

## Investigation of Station Building

Station No.	45	Line Name	Yangon – Mandalay Line	Date of Survy	16/5/2017		
Station Name	THARGAYA						
Existing Station Building	Kilopost	314.5		Mileage	195.25		
	Access Road	<input checked="" type="radio"/> Yes    No		Age of Building	Over 100 years		
	Story of Building	( 1 ) Story Building		Total Floor Area	About 108 m <sup>2</sup>		
	Type of Main Structure (Check <input type="radio"/> )	<input type="radio"/> Brick with RC <input checked="" type="radio"/> Wood <input type="radio"/> Other(    )		Finish Material	Roof	<input checked="" type="radio"/> Corrugated Steel sheet <input type="radio"/> Roof Tiles <input type="radio"/> RC <input type="radio"/> Asbestos Fibre Cement	
	Other Structure	Wall	Brick		<input checked="" type="radio"/> Wood	Wall	• Paint
		Column	Brick		<input checked="" type="radio"/> Wood	Column	• Paint
		Beam	<input checked="" type="radio"/> Wood		RC    Steel	Floor	<input checked="" type="radio"/> Concrete    •Wood
	Electric system (Check <input type="radio"/> )	<input checked="" type="radio"/> Retract from outside <input type="radio"/> Solar System <input type="radio"/> Generator		Water Supply (Check <input type="radio"/> )	<input type="radio"/> Water Well (    ) <input type="radio"/> Waterwork <input type="radio"/> None		
	Condition of Main Structure	Main Damage Type & Rank*		Condition of Finish Material	Main Damage Type & Rank*		
		<b>B</b>	<input type="checkbox"/> Crack (    mm) <input type="checkbox"/> Settlement <input type="checkbox"/> Inclination		<b>B</b>	<input type="checkbox"/> Water Leak <input type="checkbox"/> Peel Off (Roof, Ceiling, Wall, Colum )	
General Evaluation	<input checked="" type="radio"/> Usual <input type="radio"/> Poor <input type="radio"/> Severe		Remarks	No toilet room.			
Photograph	 						

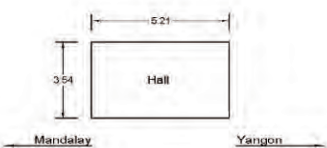

\*Damage Rank C;Slight (Repair) D;Heavy (Repair and Reinforcement) F; Fatal (Reconstruction)

## Investigation of Station Building

Station No.	46	Line Name	Yangon – Mandalay Line	Date of Survey	5/7/2017		
Station Name	THARYARGON						
Existing Station Building	Kilopost	318.5		Mileage	197		
	Access Road	Yes <input type="radio"/> No <input checked="" type="radio"/>		Age of Building	Over 100 years		
	Story of Building	( 1 ) Story Building		Total Floor Area	About 19 m <sup>2</sup>		
	Type of Main Structure (Check <input type="radio"/> )	<input type="checkbox"/> Brick with RC <input checked="" type="checkbox"/> Wood <input type="checkbox"/> Other(     )		Finish Material	Roof	<input checked="" type="checkbox"/> Corrugated Steel sheet <input type="checkbox"/> Roof Tiles <input type="checkbox"/> RC <input type="checkbox"/> Asbestos Fibre Cement	
		Other Structure	Wall		Brick    Wood	Wall	<input type="checkbox"/> Paint
			Column		Brick <input checked="" type="radio"/> Wood	Column	<input type="checkbox"/> Paint
			Beam		<input checked="" type="radio"/> Wood    RC    Steel	Floor	<input type="checkbox"/> Concrete <input type="checkbox"/> Wood
	Electric system (Check <input type="radio"/> )	<input type="checkbox"/> Retract from outside <input type="checkbox"/> Solar System <input type="checkbox"/> Generator		Water Supply (Check <input type="radio"/> )	<input type="checkbox"/> Water Well (     ) <input type="checkbox"/> Waterwork <input checked="" type="radio"/> None		
	Condition of Main Structure	Main Damage Type & Rank*		Condition of Finish Material	Main Damage Type & Rank*		
		C	<input type="checkbox"/> Crack (     mm) <input type="checkbox"/> Settlement <input type="checkbox"/> Inclination		C	<input type="checkbox"/> Water Leak <input type="checkbox"/> Peel Off (Roof, Ceiling, Wall, Colum )	
General Evaluation	<input checked="" type="radio"/> Usual <input type="checkbox"/> Poor <input type="checkbox"/> Severe		Remarks				
Photograph	 						

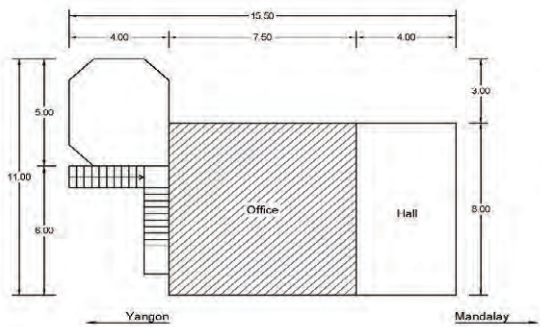

\*Damage Rank C;Slight (Repair) D;Heavy (Repair and Reinforcement) F; Fatal (Reconstruction)

## Investigation of Station Building

Station No.	47	Line Name	Yangon – Mandalay Line	Date of Survey	16/5/2017		
Station Name	MYOHLA						
Existing Station Building	Kilopost	324		Mileage	201.25		
	Access Road	<input checked="" type="radio"/> Yes    No		Age of Building	Over 100 years		
	Story of Building	( 2 ) Story Building		Total Floor Area	About 150 m <sup>2</sup>		
	Type of Main Structure (Check <input type="radio"/> )	<input checked="" type="radio"/> Brick with RC • Wood • Other(    )		Finish Material	Roof	<input checked="" type="radio"/> Corrugated Steel sheet • Roof Tiles • RC • Asbestos Fibre Cement	
	Other Structure	Wall	<input checked="" type="radio"/> Brick    Wood		Wall	<input checked="" type="radio"/> Paint	
		Column	<input checked="" type="radio"/> Brick    Wood		Column	<input checked="" type="radio"/> Paint	
		Beam	<input checked="" type="radio"/> Wood    RC    Steel		Floor	<input checked="" type="radio"/> Concrete    • Wood	
	Electric system (Check <input type="radio"/> )	<input checked="" type="radio"/> Retract from outside • Solar System • Generator		Water Supply (Check <input type="radio"/> )	• Water Well (    ) • Waterwork <input checked="" type="radio"/> None		
	Condition of Main Structure	Main Damage Type & Rank*			Condition of Finish Material	Main Damage Type & Rank*	
		D	• Crack (    mm) • Settlement • Inclination			D	<input checked="" type="radio"/> Water Leak <input checked="" type="radio"/> Peel Off (Roof, Ceiling, Wall, Colum )
General Evaluation	• Usual <input checked="" type="radio"/> Poor • Severe		Remarks		No toilet room(Only staff).		
Photograph							
							

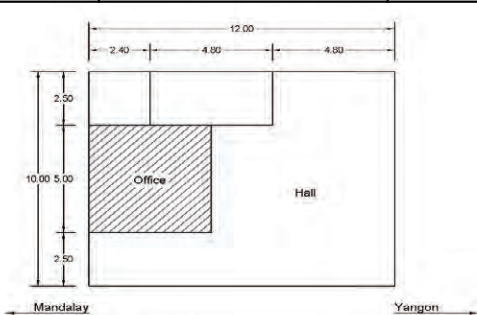

\*Damage Rank C;Slight (Repair) D;Heavy (Repair and Reinforcement) F; Fatal (Reconstruction)

## Investigation of Station Building

Station No.	48	Line Name	Yangon – Mandalay Line	Date of Survy	16/5/2017		
Station Name	YENI						
Existing Station Building	Kilopost	332.5		Mileage	206.5		
	Access Road	<input checked="" type="radio"/> Yes <input type="radio"/> No		Age of Building	Over 100 years		
	Story of Building	( 1 ) Story Building		Total Floor Area	About 120 m <sup>2</sup>		
	Type of Main Structure (Check <input type="radio"/> )	<input type="radio"/> Brick with RC <input checked="" type="radio"/> Wood <input type="radio"/> Other(    )		Finish Material	Roof	<input type="radio"/> Corrugated Steel sheet <input checked="" type="radio"/> Roof Tiles <input type="radio"/> RC <input type="radio"/> Asbestos Fibre Cement	
	Other Structure	Wall	Brick		<input checked="" type="radio"/> Wood	Wall	• Paint
		Column	Brick		<input checked="" type="radio"/> Wood	Column	• Paint
		Beam	<input checked="" type="radio"/> Wood		<input type="radio"/> RC <input type="radio"/> Steel	Floor	<input checked="" type="radio"/> Concrete    •Wood
	Electric system (Check <input type="radio"/> )	<input checked="" type="radio"/> Retract from outside <input type="radio"/> Solar System <input type="radio"/> Generator		Water Supply (Check <input type="radio"/> )	<input type="radio"/> Water Well (    ) <input type="radio"/> Waterwork <input checked="" type="radio"/> None		
	Condition of Main Structure	Main Damage Type & Rank*		Condition of Finish Material	Main Damage Type & Rank*		
		F	<input checked="" type="radio"/> Crack (30mm) <input type="radio"/> Settlement <input type="radio"/> Inclination		C	<input checked="" type="radio"/> Water Leak <input type="radio"/> Peel Off (Roof, Ceiling, Wall, Colum )	
General Evaluation	<input type="radio"/> Usual <input type="radio"/> Poor <input checked="" type="radio"/> Severe		Remarks	No toilet room.			
Photograph	 						

\*Damage Rank C;Slight (Repair) D;Heavy (Repair and Reinforcement) F; Fatal (Reconstruction)

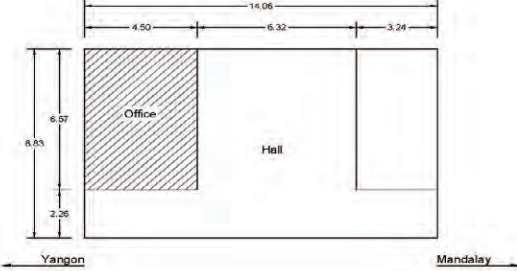
## Investigation of Station Building

Station No.	49	Line Name	Yangon – Mandalay Line	Date of Survey	5/7/2017		
Station Name	TAWUTI						
Existing Station Building	Kilopost	338		Mileage	210		
	Access Road	<input checked="" type="radio"/> Yes <input type="radio"/> No		Age of Building	Over 100 years		
	Story of Building	( 1 ) Story Building		Total Floor Area	About 126 m <sup>2</sup>		
	Type of Main Structure (Check <input type="radio"/> )	<ul style="list-style-type: none"> <li>▪ Brick with RC</li> <li><input checked="" type="radio"/> Wood</li> <li>▪ Other(       )</li> </ul>		Finish Material	Roof	<ul style="list-style-type: none"> <li>▪ Corrugated Steel sheet</li> <li><input checked="" type="radio"/> Roof Tiles</li> <li>▪ RC</li> <li>▪ Asbestos Fibre Cement</li> </ul>	
	Other Structure	Wall	Brick		<input checked="" type="radio"/> Wood	Wall	▪ Paint
		Column	Brick		<input checked="" type="radio"/> Wood	Column	▪ Paint
		Beam	<input checked="" type="radio"/> Wood		RC    Steel	Floor	<input checked="" type="radio"/> Concrete    ▪ Wood
	Electric system (Check <input type="radio"/> )	<ul style="list-style-type: none"> <li><input checked="" type="radio"/> Retract from outside</li> <li>▪ Solar System</li> <li>▪ Generator</li> </ul>		Water Supply (Check <input type="radio"/> )	<ul style="list-style-type: none"> <li><input checked="" type="radio"/> Water Well ( Mortar )</li> <li>▪ Waterwork</li> <li>▪ None</li> </ul>		
	Condition of Main Structure	Main Damage Type & Rank*		Condition of Finish Material	Main Damage Type & Rank*		
		F	<ul style="list-style-type: none"> <li><input checked="" type="radio"/> Crack (10mm)</li> <li><input type="radio"/> Settlement</li> <li><input type="radio"/> Inclination</li> </ul>		C	<ul style="list-style-type: none"> <li><input checked="" type="radio"/> Water Leak</li> <li><input checked="" type="radio"/> Peel Off (Roof, Ceiling, Wall, Colum )</li> </ul>	
General Evaluation	<ul style="list-style-type: none"> <li>▪ Usual</li> <li>▪ Poor</li> <li><input checked="" type="radio"/> Severe</li> </ul>		Remarks	No toilet room. About 7 passengers/day and a little freight(sometime).			
Photograph	 						



\*Damage Rank C;Slight (Repair) D;Heavy (Repair and Reinforcement) F; Fatal (Reconstruction)

## Investigation of Station Building

Station No.	50	Line Name	Yangon – Mandalay Line	Date of Survey	16/5/2017		
Station Name	HTEININN						
Existing Station Building	Kilopost	344.5		Mileage	214		
	Access Road	Yes	No	Age of Building			
	Story of Building	( ) Story Building		Total Floor Area	About m <sup>2</sup>		
	Type of Main Structure (Check O)	<ul style="list-style-type: none"> <li>▪ Brick with RC</li> <li>▪ Wood</li> <li>▪ Other( )</li> </ul>		Finish Material	Roof	<ul style="list-style-type: none"> <li>▪ Corrugated Steel sheet</li> <li>▪ Roof Tiles</li> <li>▪ RC</li> <li>▪ Asbestos Fibre Cement</li> </ul>	
		Other Structure	Wall		Brick	Wood	▪ Paint
			Column		Brick	Wood	▪ Paint
			Beam		Wood	RC	Steel
	Electric system (Check O)	<ul style="list-style-type: none"> <li>▪ Retract from outside</li> <li>▪ Solar System</li> <li>▪ Generator</li> </ul>		Water Supply (Check O)	<ul style="list-style-type: none"> <li>▪ Water Well ( )</li> <li>▪ Waterwork</li> <li>▪ None</li> </ul>		
	Condition of Main Structure	Main Damage Type & Rank*		Condition of Finish Material	Main Damage Type & Rank*		
			<ul style="list-style-type: none"> <li>▪ Crack ( mm)</li> <li>▪ Settlement</li> <li>▪ Inclination</li> </ul>			<ul style="list-style-type: none"> <li>▪ Water Leak</li> <li>▪ Peel Off (Roof, Ceiling, Wall, Colum )</li> </ul>	
General Evaluation	<ul style="list-style-type: none"> <li>▪ Usual</li> <li>▪ Poor</li> <li>▪ Severe</li> </ul>		Remarks	Dismantled.			
Photograph							

\*Damage Rank C;Slight (Repair) D;Heavy (Repair and Reinforcement) F; Fatal (Reconstruction)

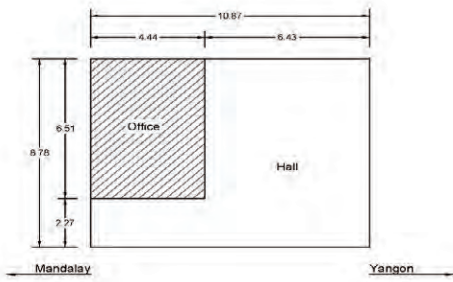

## Investigation of Station Building

Station No.	51	Line Name	Yangon – Mandalay Line	Date of Survey	5/7/2017		
Station Name	ELA						
Existing Station Building	Kilopost	349		Mileage	216.75		
	Access Road	<input checked="" type="radio"/> Yes    No		Age of Building	Over 100 years		
	Story of Building	( 1 ) Story Building		Total Floor Area	About 96 m <sup>2</sup>		
	Type of Main Structure (Check <input type="radio"/> )	<ul style="list-style-type: none"> <li>• Brick with RC</li> <li><input checked="" type="radio"/> Wood</li> <li>• Other(    )</li> </ul>		Finish Material	Roof	<ul style="list-style-type: none"> <li>• Corrugated Steel sheet</li> <li><input checked="" type="radio"/> Roof Tiles</li> <li>• RC</li> <li>• Asbestos Fibre Cement</li> </ul>	
	Other Structure	Wall	<input checked="" type="radio"/> Brick    Wood		Wall	<input checked="" type="radio"/> Paint	
		Column	Brick <input checked="" type="radio"/> Wood		Column	<input checked="" type="radio"/> Paint	
		Beam	<input checked="" type="radio"/> Wood    RC    Steel		Floor	<input checked="" type="radio"/> Concrete    • Wood	
	Electric system (Check <input type="radio"/> )	<ul style="list-style-type: none"> <li><input checked="" type="radio"/> Retract from outside</li> <li>• Solar System</li> <li>• Generator</li> </ul>		Water Supply (Check <input type="radio"/> )	<ul style="list-style-type: none"> <li><input checked="" type="radio"/> Water Well ( Mortar )</li> <li>• Waterwork</li> <li>• None</li> </ul>		
	Condition of Main Structure	Main Damage Type & Rank*			Condition of Finish Material	Main Damage Type & Rank*	
		D	<ul style="list-style-type: none"> <li><input checked="" type="radio"/> Crack (10mm)</li> <li>• Settlement</li> <li>• Inclination</li> </ul>			D	<ul style="list-style-type: none"> <li><input checked="" type="radio"/> Water Leak</li> <li><input checked="" type="radio"/> Peel Off (Roof, Ceiling, Wall, Colum )</li> </ul>
General Evaluation	<ul style="list-style-type: none"> <li>• Usual</li> <li><input checked="" type="radio"/> Poor</li> <li>• Severe</li> </ul>		Remarks	No toilet room. About 70 passengers/day and a little freight(sometime). 1 cable and 1 generator			
Photograph							
							

\*Damage Rank C;Slight (Repair) D;Heavy (Repair and Reinforcement) F; Fatal (Reconstruction)

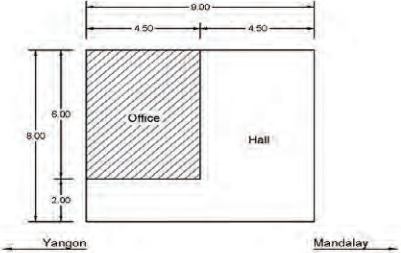

## Investigation of Station Building

Station No.	52	Line Name	Yangon – Mandalay Line	Date of Survey	16/5/2017		
Station Name	PYAYWUN						
Existing Station Building	Kilopost	353.5		Mileage	219.17		
	Access Road	<input checked="" type="radio"/> Yes    No		Age of Building	Over 100 years		
	Story of Building	( 1 ) Story Building		Total Floor Area	About 120 m <sup>2</sup>		
	Type of Main Structure (Check <input type="radio"/> )	<input checked="" type="radio"/> Brick with RC • Wood • Other(    )		Finish Material	Roof	<input checked="" type="radio"/> Corrugated Steel sheet • Roof Tiles • RC • Asbestos Fibre Cement	
	Other Structure	Wall	<input checked="" type="radio"/> Brick    Wood		Wall	<input checked="" type="radio"/> Paint	
		Column	<input checked="" type="radio"/> Brick    Wood		Column	<input checked="" type="radio"/> Paint	
		Beam	Wood		<input checked="" type="radio"/> RC    Steel	Floor	<input checked="" type="radio"/> Concrete    • Wood
	Electric system (Check <input type="radio"/> )	<input checked="" type="radio"/> Retract from outside • Solar System • Generator		Water Supply (Check <input type="radio"/> )	<input checked="" type="radio"/> Water Well (    ) • Waterwork • None		
	Condition of Main Structure	Main Damage Type & Rank*		Condition of Finish Material	Main Damage Type & Rank*		
		F	<input checked="" type="radio"/> Crack (10mm) <input checked="" type="radio"/> Settlement • Inclination		D	<input checked="" type="radio"/> Water Leak <input checked="" type="radio"/> Peel Off (Roof, Ceiling, Wall, Colum )	
General Evaluation	• Usual • Poor <input checked="" type="radio"/> Severe		Remarks	No toilet room.			
Photograph							
							



\*Damage Rank C;Slight (Repair) D;Heavy (Repair and Reinforcement) F; Fatal (Reconstruction)

## Investigation of Station Building

Station No.	53	Line Name	Yangon – Mandalay Line	Date of Survey	16/5/2017		
Station Name	PYINMANA						
Existing Station Building	Kilopost	362		Mileage	225		
	Access Road	<input checked="" type="radio"/> Yes <input type="radio"/> No		Age of Building	Over 100 years		
	Story of Building	( 1 ) Story Building		Total Floor Area	About 450 m <sup>2</sup>		
	Type of Main Structure (Check <input type="radio"/> )	<input type="radio"/> Brick with RC <input type="radio"/> Wood <input checked="" type="radio"/> Other( RC )		Finish Material	Roof	<input checked="" type="radio"/> Corrugated Steel sheet <input type="radio"/> Roof Tiles <input type="radio"/> RC <input type="radio"/> Asbestos Fibre Cement	
	Other Structure	Wall	<input checked="" type="radio"/> Brick <input type="radio"/> Wood		Wall	<input checked="" type="radio"/> Paint	
		Column	Brick    Wood <input checked="" type="radio"/> RC		Column	<input checked="" type="radio"/> Paint	
		Beam	Wood <input checked="" type="radio"/> RC    Steel		Floor	<input checked="" type="radio"/> Concrete <input type="radio"/> Wood	
	Electric system (Check <input type="radio"/> )	<input checked="" type="radio"/> Retract from outside <input type="radio"/> Solar System <input type="radio"/> Generator		Water Supply (Check <input type="radio"/> )	<input checked="" type="radio"/> Water Well (         ) <input type="radio"/> Waterwork <input type="radio"/> None		
	Condition of Main Structure	Main Damage Type & Rank*			Condition of Finish Material	Main Damage Type & Rank*	
		D	<input checked="" type="radio"/> Crack (5mm) <input type="radio"/> Settlement <input type="radio"/> Inclination			D	<input checked="" type="radio"/> Water Leak <input checked="" type="radio"/> Peel Off (Roof, Ceiling, Wall, Colum )
General Evaluation	<input type="radio"/> Usual <input checked="" type="radio"/> Poor <input type="radio"/> Severe		Remarks	Front of station plaza.			
Photograph							

\*Damage Rank C;Slight (Repair) D;Heavy (Repair and Reinforcement) F; Fatal (Reconstruction)

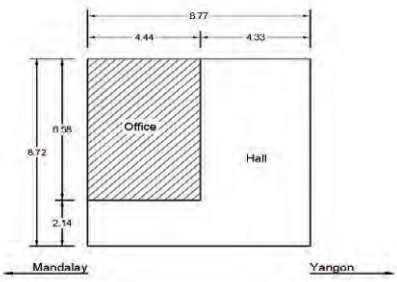
## Investigation of Station Building

Station No.	54	Line Name	Yangon – Mandalay Line	Date of Survey	5/7/2017		
Station Name	YWADAW						
Existing Station Building	Kilopost	370		Mileage	230		
	Access Road	<input checked="" type="radio"/> Yes    No		Age of Building	Over 100 years		
	Story of Building	( 1 ) Story Building		Total Floor Area	About 78 m <sup>2</sup>		
	Type of Main Structure (Check <input type="radio"/> )	<input type="radio"/> Brick with RC <input checked="" type="radio"/> Wood <input type="radio"/> Other(    )		Finish Material	Roof	<input checked="" type="radio"/> Corrugated Steel sheet <input type="radio"/> Roof Tiles <input type="radio"/> RC <input type="radio"/> Asbestos Fibre Cement	
		Other Structure	Wall		<input checked="" type="radio"/> Brick    Wood	Wall	<input checked="" type="radio"/> Paint
			Column		Brick <input checked="" type="radio"/> Wood    RC	Column	<input checked="" type="radio"/> Paint
			Beam		<input checked="" type="radio"/> Wood    RC    Steel	Floor	<input checked="" type="radio"/> Concrete <input type="radio"/> Wood
	Electric system (Check <input type="radio"/> )	<input checked="" type="radio"/> Retract from outside <input type="radio"/> Solar System <input type="radio"/> Generator		Water Supply (Check <input type="radio"/> )	<input checked="" type="radio"/> Water Well ( Tube ) <input type="radio"/> Waterwork <input type="radio"/> None		
	Condition of Main Structure	Main Damage Type & Rank*		Condition of Finish Material	Main Damage Type & Rank*		
		C	<input checked="" type="radio"/> Crack (6mm) <input checked="" type="radio"/> Settlement <input type="radio"/> Inclination		B	<input type="radio"/> Water Leak <input type="radio"/> Peel Off (Roof, Ceiling, Wall, Colum )	
General Evaluation	<input checked="" type="radio"/> Usual <input type="radio"/> Poor <input type="radio"/> Severe		Remarks	About 5 passengers/day and 2times freight/month. 1 toilet and 1 cable room.			
Photograph							
							



\*Damage Rank C;Slight (Repair) D;Heavy (Repair and Reinforcement) F; Fatal (Reconstruction)

## Investigation of Station Building

Station No.	55	Line Name	Yangon – Mandalay Line	Date of Survey	16/5/2017		
Station Name	NAYPYITAW						
Existing Station Building	Kilopost	375		Mileage	232		
	Access Road	<input checked="" type="radio"/> Yes <input type="radio"/> No		Age of Building	Over 8 years		
	Story of Building	( 2 ) Story Building		Total Floor Area	About 2500 m <sup>2</sup>		
	Type of Main Structure (Check <input type="radio"/> )	<input type="radio"/> Brick with RC <input type="radio"/> Wood <input checked="" type="radio"/> Other( RC )		Finish Material	Roof	<input checked="" type="radio"/> Corrugated Steel sheet <input type="radio"/> Roof Tiles <input type="radio"/> RC <input type="radio"/> Asbestos Fibre Cement	
	Other Structure	Wall	<input checked="" type="radio"/> Brick <input type="radio"/> Wood		Wall	<input checked="" type="radio"/> Paint	
		Column	Brick		Wood	<input checked="" type="radio"/> RC	<input checked="" type="radio"/> Paint
		Beam	Wood		<input checked="" type="radio"/> RC	Steel	<input checked="" type="radio"/> Concrete with stone tile
	Electric system (Check <input type="radio"/> )	<input checked="" type="radio"/> Retract from outside <input type="radio"/> Solar System <input type="radio"/> Generator		Water Supply (Check <input type="radio"/> )	<input type="radio"/> Water Well (         ) <input type="radio"/> Waterwork <input type="radio"/> None		
	Condition of Main Structure	Main Damage Type & Rank*			Condition of Finish Material	Main Damage Type & Rank*	
		<b>B</b>	<input type="radio"/> Crack (     mm) <input type="radio"/> Settlement <input type="radio"/> Inclination			<b>B</b>	<input type="radio"/> Water Leak <input checked="" type="radio"/> Peel Off (Roof, Ceiling, Wall, Colum )
General Evaluation	<input checked="" type="radio"/> Usual <input type="radio"/> Poor <input type="radio"/> Severe		Remarks	About 5 passengers/day and 2times freight/month. 1 toilet and 1 cable room.			
Photograph							

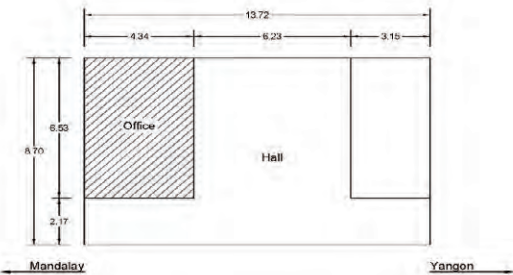

\*Damage Rank C;Slight (Repair) D;Heavy (Repair and Reinforcement) F; Fatal (Reconstruction)

## Investigation of Station Building

Station No.	56	Line Name	Yangon – Mandalay Line	Date of Survy	5/7/2017		
Station Name	KYIDAUNGKAN						
Existing Station Building	Kilopost	378.5	Mileage	235-1/4			
	Access Road	<input checked="" type="radio"/> Yes <input type="radio"/> No	Age of Building	Over 100 years			
	Story of Building	( 1 ) Story Building	Total Floor Area	About 120 m <sup>2</sup>			
	Type of Main Structure (Check <input type="radio"/> )	<input type="radio"/> Brick with RC <input checked="" type="radio"/> Wood <input type="radio"/> Other(    )	Finish Material	Roof	<input checked="" type="radio"/> Corrugated Steel sheet <input type="radio"/> Roof Tiles <input type="radio"/> RC <input type="radio"/> Asbestos Fibre Cement		
	Other Structure	Wall		<input checked="" type="radio"/> Brick <input type="radio"/> Wood	Wall	<input checked="" type="radio"/> Paint	
		Column		Brick <input checked="" type="radio"/> Wood <input type="radio"/> RC	Column	<input checked="" type="radio"/> Paint	
		Beam		<input checked="" type="radio"/> Wood <input type="radio"/> RC <input type="radio"/> Steel	Floor	<input checked="" type="radio"/> Concrete <input type="radio"/> Wood	
	Electric system (Check <input type="radio"/> )	<input checked="" type="radio"/> Retract from outside <input type="radio"/> Solar System <input type="radio"/> Generator	Water Supply (Check <input type="radio"/> )	<input checked="" type="radio"/> Water Well ( Tube ) <input type="radio"/> Waterwork <input type="radio"/> None			
	Condition of Main Structure	Main Damage Type & Rank*		Condition of Finish Material	Main Damage Type & Rank*		
		D	<input checked="" type="radio"/> Crack (6mm) <input checked="" type="radio"/> Settlement <input type="radio"/> Inclination		C	<input checked="" type="radio"/> Water Leak <input type="radio"/> Peel Off (Roof, Ceiling, Wall, Colum )	
General Evaluation	<input type="radio"/> Usual <input checked="" type="radio"/> Poor <input type="radio"/> Severe	Remarks	About 100 passengers/day and freight(sometime). No toilet. 1 cable room and 1 store				
Photograph							
							

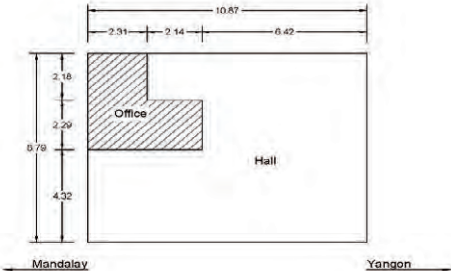

\*Damage Rank C;Slight (Repair) D;Heavy (Repair and Reinforcement) F; Fatal (Reconstruction)

## Investigation of Station Building

Station No.	57	Line Name	Yangon – Mandalay Line	Date of Survey	5/7/2017		
Station Name	PYOKKWE						
Existing Station Building	Kilopost	387	Mileage	240-1/2			
	Access Road	Yes <input type="radio"/> No <input checked="" type="radio"/>	Age of Building	Over 100 years			
	Story of Building	( 1 ) Story Building	Total Floor Area	About 96 m <sup>2</sup>			
	Type of Main Structure (Check <input type="radio"/> )	<ul style="list-style-type: none"> <li>• Brick with RC</li> <li><input checked="" type="radio"/> Wood</li> <li>• Other( )</li> </ul>	Finish Material	Roof	<ul style="list-style-type: none"> <li>• Corrugated Steel sheet</li> <li><input checked="" type="radio"/> Roof Tiles</li> <li>• RC</li> <li>• Asbestos Fibre Cement</li> </ul>		
	Other Structure	Wall		<input checked="" type="radio"/> Brick <input type="radio"/> Wood	Wall	<input checked="" type="radio"/> Paint	
		Column		Brick <input checked="" type="radio"/> Wood <input type="radio"/> RC	Column	<input checked="" type="radio"/> Paint	
		Beam		<input checked="" type="radio"/> Wood <input type="radio"/> RC <input type="radio"/> Steel	Floor	<input checked="" type="radio"/> Concrete <input type="radio"/> Wood	
	Electric system (Check <input type="radio"/> )	<ul style="list-style-type: none"> <li><input checked="" type="radio"/> Retract from outside</li> <li>• Solar System</li> <li>• Generator</li> </ul>	Water Supply (Check <input type="radio"/> )	<ul style="list-style-type: none"> <li>• Water Well ( )</li> <li>• Waterwork</li> <li><input checked="" type="radio"/> None</li> </ul>			
	Condition of Main Structure	Main Damage Type & Rank*		Condition of Finish Material	Main Damage Type & Rank*		
		F	<ul style="list-style-type: none"> <li><input checked="" type="radio"/> Crack (10mm)</li> <li><input checked="" type="radio"/> Settlement</li> <li><input checked="" type="radio"/> Inclination 5°</li> </ul>		D	<ul style="list-style-type: none"> <li><input checked="" type="radio"/> Water Leak</li> <li><input checked="" type="radio"/> Peel Off (Roof, Ceiling, Wall, Colum )</li> </ul>	
General Evaluation	<ul style="list-style-type: none"> <li>• Usual</li> <li>• Poor</li> <li><input checked="" type="radio"/> Severe</li> </ul>	Remarks	About 40 passengers/day and no freight. No toilet. 1 cable and 1 generator				
Photograph							
							

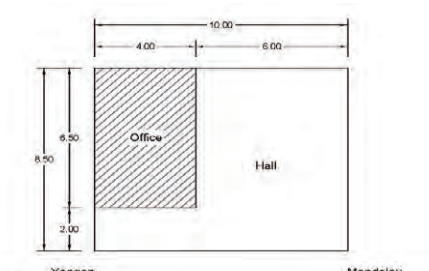

\*Damage Rank C;Slight (Repair) D;Heavy (Repair and Reinforcement) F; Fatal (Reconstruction)

## Investigation of Station Building

Station No.	58	Line Name	Yangon – Mandalay Line	Date of Survey	15/5/2017		
Station Name	SINBYUGYUN						
Existing Station Building	Kilopost	392	Mileage	243-1/2			
	Access Road	<input checked="" type="radio"/> Yes <input type="radio"/> No	Age of Building	Over 100 years			
	Story of Building	( 1 ) Story Building	Total Floor Area	About 120 m <sup>2</sup>			
	Type of Main Structure (Check <input type="radio"/> )	<input checked="" type="radio"/> Brick with RC • Wood • Other(    )	Finish Material	Roof	<input checked="" type="radio"/> Corrugated Steel sheet • Roof Tiles • RC • Asbestos Fibre Cement		
	Other Structure	Wall		<input checked="" type="radio"/> Brick <input type="radio"/> Wood	Wall	<input checked="" type="radio"/> Paint	
		Column		<input checked="" type="radio"/> Brick <input type="radio"/> Wood <input type="radio"/> RC	Column	<input checked="" type="radio"/> Paint	
		Beam		Wood <input checked="" type="radio"/> RC <input type="radio"/> Steel	Floor	<input checked="" type="radio"/> Concrete    • Wood	
	Electric system (Check <input type="radio"/> )	• Retract from outside <input checked="" type="radio"/> Solar System • Generator	Water Supply (Check <input type="radio"/> )	• Water Well (    ) • Waterwork <input checked="" type="radio"/> None			
	Condition of Main Structure	Main Damage Type & Rank*		Condition of Finish Material	Main Damage Type & Rank*		
		F	<input checked="" type="radio"/> Crack (10mm) • Settlement • Inclination		D	<input checked="" type="radio"/> Water Leak <input checked="" type="radio"/> Peel Off (Roof, Ceiling, Wall, Colum )	
General Evaluation	• Usual • Poor <input checked="" type="radio"/> Severe		Remarks	No toilet.			
Photograph	 						

\*Damage Rank C;Slight (Repair) D;Heavy (Repair and Reinforcement) F; Fatal (Reconstruction)

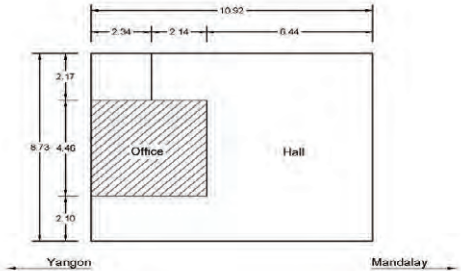

## Investigation of Station Building

Station No.	59	Line Name	Yangon – Mandalay Line	Date of Survey	6/7/2017		
Station Name	SHWEMYO						
Existing Station Building	Kilopost	397		Mileage	246-3/4		
	Access Road	<input checked="" type="radio"/> Yes <input type="radio"/> No		Age of Building	Over 100 years		
	Story of Building	( 1 ) Story Building		Total Floor Area	About 97 m <sup>2</sup>		
	Type of Main Structure (Check <input type="radio"/> )	<input type="radio"/> Brick with RC <input checked="" type="radio"/> Wood <input type="radio"/> Other(    )		Finish Material	Roof	<input type="radio"/> Corrugated Steel sheet <input type="radio"/> Roof Tiles <input type="radio"/> RC <input checked="" type="radio"/> Asbestos Fibre Cement	
		Other Structure	Wall		Brick <input checked="" type="radio"/> Wood	Wall	<input checked="" type="radio"/> Paint
			Column		Brick <input checked="" type="radio"/> Wood    RC	Column	<input checked="" type="radio"/> Paint
			Beam		<input checked="" type="radio"/> Wood    RC    Steel	Floor	<input checked="" type="radio"/> Concrete <input type="radio"/> Wood
	Electric system (Check <input type="radio"/> )	<input checked="" type="radio"/> Retract from outside <input type="radio"/> Solar System <input type="radio"/> Generator		Water Supply (Check <input type="radio"/> )	<input checked="" type="radio"/> Water Well ( Tube ) <input type="radio"/> Waterwork <input type="radio"/> None		
	Condition of Main Structure	Main Damage Type & Rank*		Condition of Finish Material	Main Damage Type & Rank*		
		D	<input checked="" type="radio"/> Crack (10mm) <input checked="" type="radio"/> Settlement <input checked="" type="radio"/> Inclination 3°		C	<input checked="" type="radio"/> Water Leak <input type="radio"/> Peel Off (Roof, Ceiling, Wall, Colum )	
General Evaluation	<input type="radio"/> Usual <input checked="" type="radio"/> Poor <input type="radio"/> Severe		Remarks	No toilet.About 70-80passengers/day and no freight.1 cable rm,1 generator rm and 1 wireless rm.			
Photograph	 						

\*Damage Rank C;Slight (Repair) D;Heavy (Repair and Reinforcement) F; Fatal (Reconstruction)



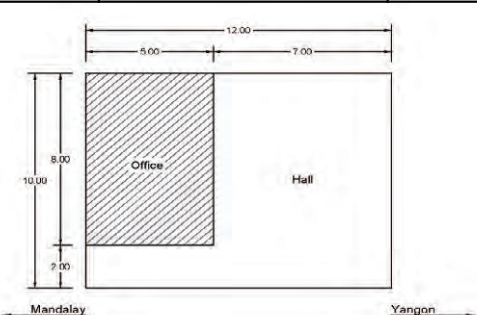

## Investigation of Station Building

Station No.	60	Line Name	Yangon – Mandalay Line	Date of Survey	15/5/2017		
Station Name	SINTHE						
Existing Station Building	Kilopost	404		Mileage	251		
	Access Road	<input checked="" type="radio"/> Yes <input type="radio"/> No		Age of Building	Over 100 years		
	Story of Building	( 1 ) Story Building		Total Floor Area	About 150 m <sup>2</sup>		
	Type of Main Structure (Check <input type="radio"/> )	<input type="radio"/> Brick with RC <input checked="" type="radio"/> Wood <input type="radio"/> Other(    )		Finish Material	Roof	<input checked="" type="radio"/> Corrugated Steel sheet <input type="radio"/> Roof Tiles <input type="radio"/> RC <input type="radio"/> Asbestos Fibre Cement	
		Other Structure	Wall		Brick <input checked="" type="radio"/> Wood	Wall	<input checked="" type="radio"/> Paint
			Column		Brick <input checked="" type="radio"/> Wood    RC	Column	<input checked="" type="radio"/> Paint
			Beam		<input checked="" type="radio"/> Wood    RC    Steel	Floor	<input checked="" type="radio"/> Concrete <input type="radio"/> Wood
	Electric system (Check <input type="radio"/> )	<input checked="" type="radio"/> Retract from outside <input type="radio"/> Solar System <input type="radio"/> Generator		Water Supply (Check <input type="radio"/> )	<input checked="" type="radio"/> Water Well (    ) <input type="radio"/> Waterwork <input type="radio"/> None		
	Condition of Main Structure	Main Damage Type & Rank*		Condition of Finish Material	Main Damage Type & Rank*		
		<b>B</b>	<input type="radio"/> Crack (    mm) <input type="radio"/> Settlement <input type="radio"/> Inclination		<b>B</b>	<input type="radio"/> Water Leak <input type="radio"/> Peel Off (Roof, Ceiling, Wall, Colum )	
General Evaluation	<input checked="" type="radio"/> Usual <input type="radio"/> Poor <input type="radio"/> Severe		Remarks	No toilet.			
Photograph	 						

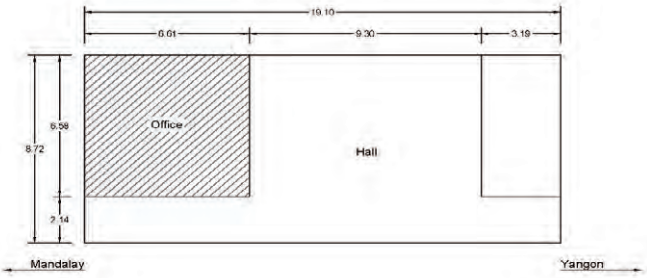

\*Damage Rank C;Slight (Repair) D;Heavy (Repair and Reinforcement) F; Fatal (Reconstruction)

## Investigation of Station Building

Station No.	61	Line Name	Yangon – Mandalay Line	Date of Survey	6/7/2017		
Station Name	TATKON						
Existing Station Building	Kilopost	407.5	Mileage	253-1/2			
	Access Road	<input checked="" type="radio"/> Yes    No	Age of Building	Over 100 years			
	Story of Building	( 1 ) Story Building		Total Floor Area	About 169 m <sup>2</sup>		
	Type of Main Structure (Check <input type="radio"/> )	<input type="radio"/> Brick with RC <input checked="" type="radio"/> Wood <input type="radio"/> Other(    )		Finish Material	Roof	<input checked="" type="radio"/> Corrugated Steel sheet <input type="radio"/> Roof Tiles <input type="radio"/> RC <input type="radio"/> Asbestos Fibre Cement	
	Other Structure	Wall	<input checked="" type="radio"/> Brick    Wood		Wall	<input checked="" type="radio"/> Paint	
		Column	Brick		<input checked="" type="radio"/> Wood    RC	Column	<input checked="" type="radio"/> Paint
		Beam	<input checked="" type="radio"/> Wood    RC    Steel		Floor	<input checked="" type="radio"/> Concrete <input type="radio"/> Wood	
	Electric system (Check <input type="radio"/> )	<input checked="" type="radio"/> Retract from outside <input type="radio"/> Solar System <input type="radio"/> Generator		Water Supply (Check <input type="radio"/> )	<input checked="" type="radio"/> Water Well ( Mortar ) <input type="radio"/> Waterwork <input type="radio"/> None		
	Condition of Main Structure	Main Damage Type & Rank*		Condition of Finish Material	Main Damage Type & Rank*		
		C	<input checked="" type="radio"/> Crack ( 8mm ) <input type="radio"/> Settlement <input type="radio"/> Inclination		B	<input type="radio"/> Water Leak <input type="radio"/> Peel Off (Roof, Ceiling, Wall, Colum )	
General Evaluation	<input checked="" type="radio"/> Usual <input type="radio"/> Poor <input type="radio"/> Severe		Remarks	No toilet. About 350passengers/day and 4ton/day freight. 1 cable rm and 1generator			
Photograph	 						

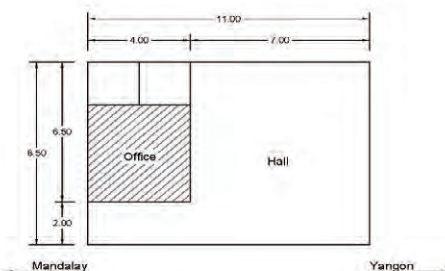

\*Damage Rank C;Slight (Repair) D;Heavy (Repair and Reinforcement) F; Fatal (Reconstruction)

## Investigation of Station Building

Station No.	62	Line Name	Yangon – Mandalay Line	Date of Survey	15/5/2017			
Station Name	MAGYIBIN							
Existing Station Building	Kilopost	414		Mileage	257-1/2			
	Access Road	<input checked="" type="radio"/> Yes <input type="radio"/> No		Age of Building	Over 100 years			
	Story of Building	( 1 ) Story Building		Total Floor Area	About 120 m <sup>2</sup>			
	Type of Main Structure (Check <input type="radio"/> )	<input checked="" type="radio"/> Brick with RC • Wood • Other(    )		Finish Material	Roof	<input checked="" type="radio"/> Corrugated Steel sheet • Roof Tiles • RC • Asbestos Fibre Cement		
	Other Structure	Wall	<input checked="" type="radio"/> Brick <input type="radio"/> Wood		Wall	<input checked="" type="radio"/> Paint		
		Column	<input checked="" type="radio"/> Brick		<input type="radio"/> Wood	<input type="radio"/> RC	Column	<input checked="" type="radio"/> Paint
		Beam	<input type="radio"/> Wood		<input checked="" type="radio"/> RC	<input type="radio"/> Steel	Floor	<input checked="" type="radio"/> Concrete    • Wood
	Electric system (Check <input type="radio"/> )	<input checked="" type="radio"/> Retract from outside • Solar System • Generator		Water Supply (Check <input type="radio"/> )	<input checked="" type="radio"/> Water Well (    ) • Waterwork • None			
	Condition of Main Structure	Main Damage Type & Rank*			Condition of Finish Material	Main Damage Type & Rank*		
		D	• Crack (    mm ) • Settlement • Inclination			C	<input checked="" type="radio"/> Water Leak • Peel Off (Roof, Ceiling, Wall, Colum )	
General Evaluation	• Usual <input checked="" type="radio"/> Poor • Severe		Remarks		No toilet.			
Photograph								
								

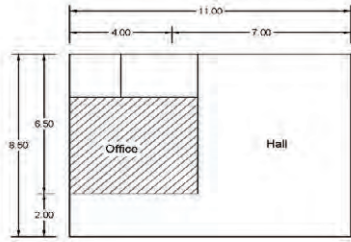

\*Damage Rank C;Slight (Repair) D;Heavy (Repair and Reinforcement) F; Fatal (Reconstruction)

## Investigation of Station Building

Station No.	63	Line Name	Yangon – Mandalay Line	Date of Survy	15/5/2017		
Station Name	NYAUNGLUN						
Existing Station Building	Kilopost	420.5	Mileage	261-1/2			
	Access Road	<input checked="" type="radio"/> Yes    No	Age of Building	Over 100 years			
	Story of Building	( 1 ) Story Building	Total Floor Area	About 120 m <sup>2</sup>			
	Type of Main Structure (Check <input type="radio"/> )	<input checked="" type="radio"/> Brick with RC • Wood • Other(    )	Finish Material	Roof	<input checked="" type="radio"/> Corrugated Steel sheet • Roof Tiles • RC • Asbestos Fibre Cement		
	Other Structure	Wall		<input checked="" type="radio"/> Brick    Wood	Wall	<input checked="" type="radio"/> Paint	
		Column		<input checked="" type="radio"/> Brick    Wood    RC	Column	<input checked="" type="radio"/> Paint	
		Beam		Wood <input checked="" type="radio"/> RC    Steel	Floor	<input checked="" type="radio"/> Concrete    • Wood	
	Electric system (Check <input type="radio"/> )	<input checked="" type="radio"/> Retract from outside • Solar System • Generator	Water Supply (Check <input type="radio"/> )	<input checked="" type="radio"/> Water Well (    ) • Waterwork • None			
	Condition of Main Structure	Main Damage Type & Rank*		Condition of Finish Material	Main Damage Type & Rank*		
		F	<input checked="" type="radio"/> Crack ( 50mm) • Settlement • Inclination		C	<input checked="" type="radio"/> Water Leak • Peel Off (Roof, Ceiling, Wall, Colum )	
General Evaluation	• Usual • Poor <input checked="" type="radio"/> Severe		Remarks	No toilet.			
Photograph	 						

\*Damage Rank C;Slight (Repair) D;Heavy (Repair and Reinforcement) F; Fatal (Reconstruction)

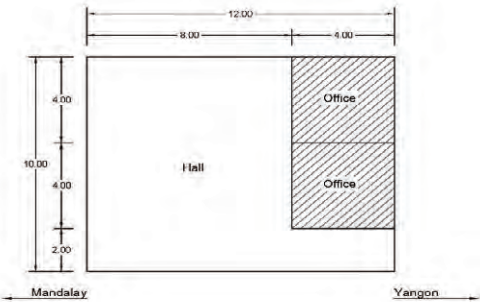
## Investigation of Station Building

Station No.	64	Line Name	Yangon – Mandalay Line	Date of Survey	15/5/2017		
Station Name	HNGETTHAIK						
Existing Station Building	Kilopost	431		Mileage	268		
	Access Road	<input checked="" type="radio"/> Yes    No		Age of Building	Over 100 years		
	Story of Building	( 1 ) Story Building		Total Floor Area	About 120 m <sup>2</sup>		
	Type of Main Structure (Check <input type="radio"/> )	<input type="radio"/> Brick with RC <input checked="" type="radio"/> Wood <input type="radio"/> Other(    )		Finish Material	Roof	<input checked="" type="radio"/> Corrugated Steel sheet <input type="radio"/> Roof Tiles <input type="radio"/> RC <input type="radio"/> Asbestos Fibre Cement	
		Other Structure	Wall		Brick <input checked="" type="radio"/> Wood	Wall	<input checked="" type="radio"/> Paint
			Column		Brick <input checked="" type="radio"/> Wood    RC	Column	<input checked="" type="radio"/> Paint
			Beam		<input checked="" type="radio"/> Wood    RC    Steel	Floor	<input checked="" type="radio"/> Concrete <input type="radio"/> Wood
	Electric system (Check <input type="radio"/> )	<input checked="" type="radio"/> Retract from outside <input type="radio"/> Solar System <input type="radio"/> Generator		Water Supply (Check <input type="radio"/> )	<input type="radio"/> Water Well (    ) <input type="radio"/> Waterwork <input checked="" type="radio"/> None		
	Condition of Main Structure	Main Damage Type & Rank*		Condition of Finish Material	Main Damage Type & Rank*		
		<b>B</b>	<input type="radio"/> Crack (    mm) <input type="radio"/> Settlement <input type="radio"/> Inclination		<b>B</b>	<input type="radio"/> Water Leak <input type="radio"/> Peel Off (Roof, Ceiling, Wall, Colum )	
General Evaluation	<input checked="" type="radio"/> Usual <input type="radio"/> Poor <input type="radio"/> Severe		Remarks	No toilet.			
Photograph	 						

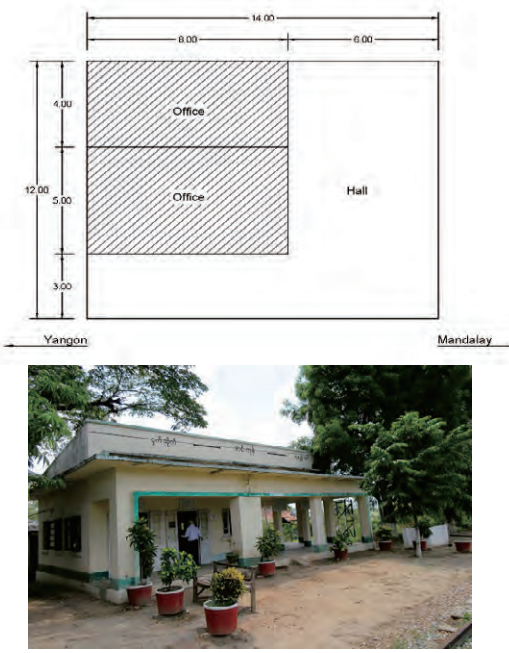

\*Damage Rank C;Slight (Repair) D;Heavy (Repair and Reinforcement) F; Fatal (Reconstruction)

## Investigation of Station Building

Station No.	65	Line Name	Yangon – Mandalay Line	Date of Survey	15/5/2017		
Station Name	INGON						
Existing Station Building	Kilopost	435.5	Mileage	270–3/4			
	Access Road	<input checked="" type="radio"/> Yes <input type="radio"/> No	Age of Building	Over 100 years			
	Story of Building	( 1 ) Story Building	Total Floor Area	About 120 m <sup>2</sup>			
	Type of Main Structure (Check <input type="radio"/> )	<input checked="" type="radio"/> Brick with RC • Wood • Other(    )	Finish Material	Roof	<input checked="" type="radio"/> Corrugated Steel sheet • Roof Tiles • RC • Asbestos Fibre Cement		
	Other Structure	Wall		<input checked="" type="radio"/> Brick <input type="radio"/> Wood	Wall	<input checked="" type="radio"/> Paint	
		Column		<input checked="" type="radio"/> Brick <input type="radio"/> Wood <input type="radio"/> RC	Column	<input checked="" type="radio"/> Paint	
		Beam		Wood <input checked="" type="radio"/> RC <input type="radio"/> Steel	Floor	<input checked="" type="radio"/> Concrete    • Wood	
	Electric system (Check <input type="radio"/> )	• Retract from outside <input checked="" type="radio"/> Solar System • Generator	Water Supply (Check <input type="radio"/> )	<input checked="" type="radio"/> Water Well (    ) • Waterwork • None			
	Condition of Main Structure	Main Damage Type & Rank*		Condition of Finish Material	Main Damage Type & Rank*		
		F	<input checked="" type="radio"/> Crack (10 mm) <input checked="" type="radio"/> Settlement • Inclination		D	<input checked="" type="radio"/> Water Leak <input checked="" type="radio"/> Peel Off (Roof, Ceiling, Wall, Colum )	
General Evaluation	• Usual • Poor <input checked="" type="radio"/> Severe	Remarks	No toilet.				
Photograph							

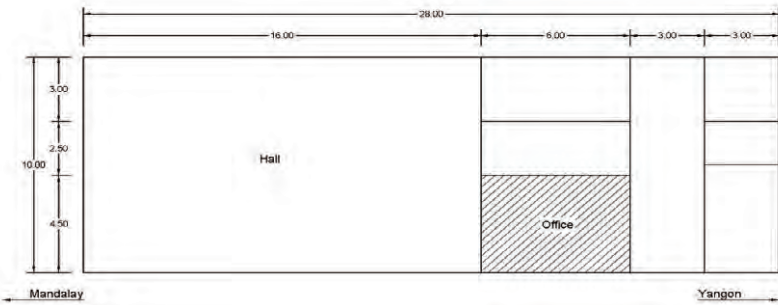

\*Damage Rank C;Slight (Repair) D;Heavy (Repair and Reinforcement) F; Fatal (Reconstruction)

## Investigation of Station Building

Station No.	66	Line Name	Yangon – Mandalay Line	Date of Survy	15/5/2017		
Station Name	YAMETHIN						
Existing Station Building	Kilopost	441.5		Mileage	274-1/2		
	Access Road	<input checked="" type="radio"/> Yes    No		Age of Building	Over 100 years		
	Story of Building	( 2 ) Story Building		Total Floor Area	About 280 m <sup>2</sup>		
	Type of Main Structure (Check <input type="radio"/> )	<input type="radio"/> Brick with RC <input type="radio"/> Wood <input checked="" type="radio"/> Other( RC )		Finish Material	Roof	<input checked="" type="radio"/> Corrugated Steel sheet <input type="radio"/> Roof Tiles <input type="radio"/> RC <input type="radio"/> Asbestos Fibre Cement	
	Other Structure	Wall	<input checked="" type="radio"/> Brick    Wood		Wall	<input checked="" type="radio"/> Paint	
		Column	Brick		Wood	<input checked="" type="radio"/> RC	<input checked="" type="radio"/> Paint
		Beam	Wood		<input checked="" type="radio"/> RC    Steel		Floor
	Electric system (Check <input type="radio"/> )	<input checked="" type="radio"/> Retract from outside <input type="radio"/> Solar System <input type="radio"/> Generator		Water Supply (Check <input type="radio"/> )	<input checked="" type="radio"/> Water Well (Breaking Pump) <input type="radio"/> Waterwork <input type="radio"/> None		
	Condition of Main Structure	Main Damage Type & Rank*		Condition of Finish Material	Main Damage Type & Rank*		
		C	<input type="radio"/> Crack ( mm) <input type="radio"/> Settlement <input type="radio"/> Inclination		D	<input checked="" type="radio"/> Water Leak <input checked="" type="radio"/> Peel Off (Roof, Ceiling, Wall, Colum )	
General Evaluation	<input type="radio"/> Usual <input checked="" type="radio"/> Poor <input type="radio"/> Severe		Remarks				
Photograph							
							

\*Damage Rank C;Slight (Repair) D;Heavy (Repair and Reinforcement) F; Fatal (Reconstruction)

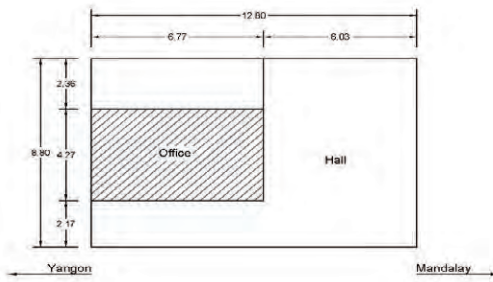

## Investigation of Station Building

Station No.	67	Line Name	Yangon – Mandalay Line	Date of Survey	6/7/2017		
Station Name	INGYINKAN						
Existing Station Building	Kilopost	448	Mileage	278-1/2			
	Access Road	<input checked="" type="radio"/> Yes <input type="radio"/> No	Age of Building	Over 100 years			
	Story of Building	( 1 ) Story Building	Total Floor Area	About 113 m <sup>2</sup>			
	Type of Main Structure (Check <input type="radio"/> )	<input checked="" type="radio"/> Brick with RC • Wood • Other(    )	Finish Material	Roof	• Corrugated Steel sheet • Roof Tiles • RC <input checked="" type="radio"/> Asbestos Fibre Cement		
	Other Structure	Wall		<input checked="" type="radio"/> Brick <input type="radio"/> Wood	Wall	<input checked="" type="radio"/> Paint	
		Column		<input checked="" type="radio"/> Brick <input type="radio"/> Wood <input type="radio"/> RC	Column	<input checked="" type="radio"/> Paint	
		Beam		Wood <input checked="" type="radio"/> RC <input type="radio"/> Steel	Floor	<input checked="" type="radio"/> Concrete    • Wood	
	Electric system (Check <input type="radio"/> )	• Retract from outside <input checked="" type="radio"/> Solar System • Generator	Water Supply (Check <input type="radio"/> )	<input checked="" type="radio"/> Water Well ( Mortar ) • Waterwork • None			
	Condition of Main Structure	Main Damage Type & Rank*		Condition of Finish Material	Main Damage Type & Rank*		
		F	<input checked="" type="radio"/> Crack ( 10mm ) <input checked="" type="radio"/> Settlement • Inclination		D	<input checked="" type="radio"/> Water Leak <input checked="" type="radio"/> Peel Off (Roof, Ceiling, Wall, Colum )	
General Evaluation	• Usual • Poor <input checked="" type="radio"/> Severe	Remarks	No toilet. No passenger and freight. 1 cable rm and 1 generator rm.				
Photograph							
							

\*Damage Rank C;Slight (Repair) D;Heavy (Repair and Reinforcement) F; Fatal (Reconstruction)



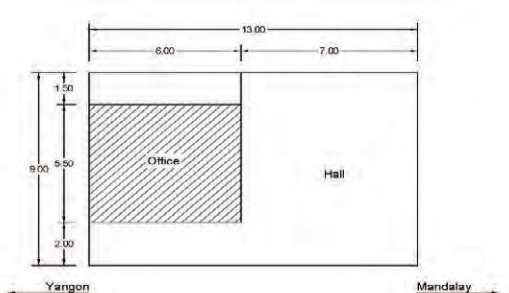

## Investigation of Station Building

Station No.	68	Line Name	Yangon – Mandalay Line	Date of Survey	18/5/2017		
Station Name	SHWEDA						
Existing Station Building	Kilopost	454	Mileage	282-1/2			
	Access Road	<input checked="" type="radio"/> Yes <input type="radio"/> No	Age of Building	Over 100 years			
	Story of Building	( 1 ) Story Building	Total Floor Area	About 120 m <sup>2</sup>			
	Type of Main Structure (Check <input type="radio"/> )	<input checked="" type="radio"/> Brick with RC • Wood • Other(    )	Finish Material	Roof	<input checked="" type="radio"/> Corrugated Steel sheet • Roof Tiles • RC • Asbestos Fibre Cement		
	Other Structure	Wall		<input checked="" type="radio"/> Brick <input type="radio"/> Wood	Wall	<input checked="" type="radio"/> Paint	
		Column		<input checked="" type="radio"/> Brick <input type="radio"/> Wood <input type="radio"/> RC	Column	<input checked="" type="radio"/> Paint	
		Beam		Wood <input checked="" type="radio"/> RC <input type="radio"/> Steel	Floor	<input checked="" type="radio"/> Concrete    • Wood	
	Electric system (Check <input type="radio"/> )	<input checked="" type="radio"/> Retract from outside • Solar System • Generator	Water Supply (Check <input type="radio"/> )	<input checked="" type="radio"/> Water Well ( Pump ) • Waterwork • None			
	Condition of Main Structure	Main Damage Type & Rank*		Condition of Finish Material	Main Damage Type & Rank*		
		F	<input checked="" type="radio"/> Crack ( 15mm ) <input checked="" type="radio"/> Settlement • Inclination		D	<input checked="" type="radio"/> Water Leak <input checked="" type="radio"/> Peel Off ( Roof, Ceiling, Wall, Colum )	
General Evaluation	• Usual • Poor <input checked="" type="radio"/> Severe		Remarks				
Photograph							
							

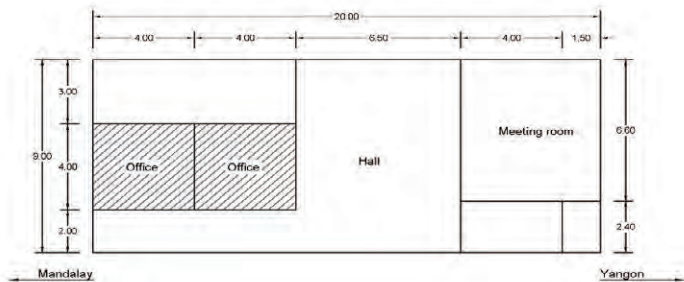

\*Damage Rank C;Slight (Repair) D;Heavy (Repair and Reinforcement) F; Fatal (Reconstruction)

## Investigation of Station Building

Station No.	69	Line Name	Yangon – Mandalay Line	Date of Survy	18/5/2017		
Station Name	PYAWBWE						
Existing Station Building	Kilopost	462.5		Mileage	287-1/2		
	Access Road	<input checked="" type="radio"/> Yes    No		Age of Building	Over 100 years		
	Story of Building	( 1 ) Story Building		Total Floor Area	About 200 m <sup>2</sup>		
	Type of Main Structure (Check <input type="radio"/> )	<input type="radio"/> Brick with RC <input type="radio"/> Wood <input checked="" type="radio"/> Other( RC )		Finish Material	Roof	<input type="radio"/> Corrugated Steel sheet <input type="radio"/> Roof Tiles <input checked="" type="radio"/> RC <input type="radio"/> Asbestos Fibre Cement	
		Other Structure	Wall		<input checked="" type="radio"/> Brick    Wood	Wall	<input checked="" type="radio"/> Paint
			Column		Brick    Wood <input checked="" type="radio"/> RC	Column	<input checked="" type="radio"/> Paint
			Beam		Wood <input checked="" type="radio"/> RC    Steel	Floor	<input checked="" type="radio"/> Concrete <input type="radio"/> Wood
	Electric system (Check <input type="radio"/> )	<input checked="" type="radio"/> Retract from outside <input type="radio"/> Solar System <input type="radio"/> Generator		Water Supply (Check <input type="radio"/> )	<input checked="" type="radio"/> Water Well (        ) <input type="radio"/> Waterwork <input type="radio"/> None		
	Condition of Main Structure	Main Damage Type & Rank*		Condition of Finish Material	Main Damage Type & Rank*		
		C	<input checked="" type="radio"/> Crack ( 5 mm ) <input type="radio"/> Settlement <input type="radio"/> Inclination		C	<input checked="" type="radio"/> Water Leak <input type="radio"/> Peel Off (Roof, Ceiling, Wall, Colum )	
General Evaluation	<input checked="" type="radio"/> Usual <input type="radio"/> Poor <input type="radio"/> Severe		Remarks	Public toilet pay 100MMK.			
Photograph							
							

\*Damage Rank C;Slight (Repair) D;Heavy (Repair and Reinforcement) F; Fatal (Reconstruction)

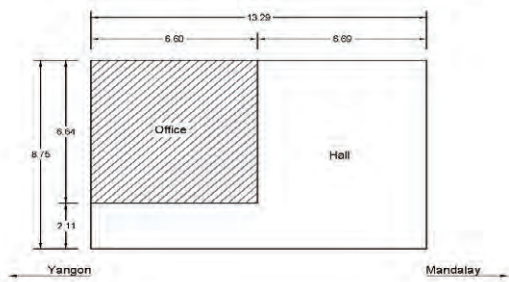
## Investigation of Station Building

Station No.	70	Line Name	Yangon – Mandalay Line	Date of Survey	6/7/2017		
Station Name	SHANYWA						
Existing Station Building	Kilopost	471	Mileage	292-3/4			
	Access Road	<input checked="" type="radio"/> Yes    No	Age of Building	Over 100 years			
	Story of Building	( 1 ) Story Building	Total Floor Area	About 118 m <sup>2</sup>			
	Type of Main Structure (Check <input type="radio"/> )	<input checked="" type="radio"/> Brick with RC • Wood • Other( RC )	Finish Material	Roof	• Corrugated Steel sheet • Roof Tiles • RC <input checked="" type="radio"/> Asbestos Fibre Cement		
	Other Structure	Wall		<input checked="" type="radio"/> Brick    Wood	Wall	<input checked="" type="radio"/> Paint	
		Column		<input checked="" type="radio"/> Brick    Wood    RC	Column	<input checked="" type="radio"/> Paint	
		Beam		Wood <input checked="" type="radio"/> RC    Steel	Floor	<input checked="" type="radio"/> Concrete    • Wood	
	Electric system (Check <input type="radio"/> )	• Retract from outside <input checked="" type="radio"/> Solar System • Generator	Water Supply (Check <input type="radio"/> )	<input checked="" type="radio"/> Water Well ( Mortar ) • Waterwork • None			
	Condition of Main Structure	Main Damage Type & Rank*		Condition of Finish Material	Main Damage Type & Rank*		
		F	<input checked="" type="radio"/> Crack ( 5 mm ) • Settlement • Inclination		C	<input checked="" type="radio"/> Water Leak • Peel Off (Roof, Ceiling, Wall, Colum )	
General Evaluation	• Usual • Poor <input checked="" type="radio"/> Severe	Remarks	No toilet. About 15passengers/day and no freight. 1 cable rm and 1 generator				
Photograph							
							

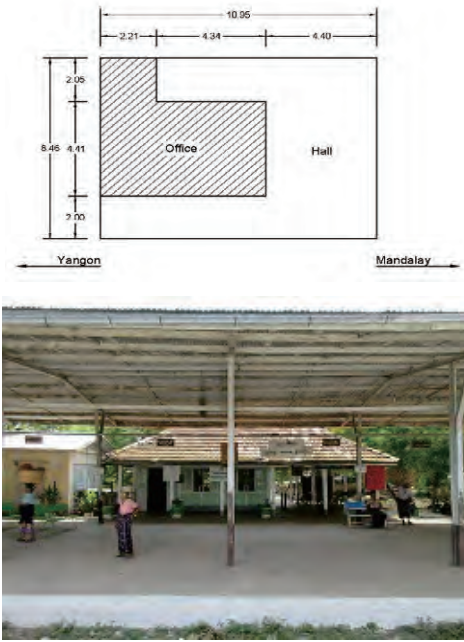

\*Damage Rank C;Slight (Repair) D;Heavy (Repair and Reinforcement) F; Fatal (Reconstruction)

## Investigation of Station Building

Station No.	71	Line Name	Yangon – Mandalay Line	Date of Survey	6/7/2017		
Station Name	NYAUNGYAN						
Existing Station Building	Kilopost	481		Mileage	299-1/4		
	Access Road	<input checked="" type="radio"/> Yes <input type="radio"/> No		Age of Building	Over 100 years		
	Story of Building	( 1 ) Story Building		Total Floor Area	About 98 m <sup>2</sup>		
	Type of Main Structure (Check <input type="radio"/> )	<input type="radio"/> Brick with RC <input checked="" type="radio"/> Wood <input type="radio"/> Other( RC )		Finish Material	Roof	<input type="radio"/> Corrugated Steel sheet <input checked="" type="radio"/> Roof Tiles <input type="radio"/> RC <input type="radio"/> Asbestos Fibre Cement	
		Other Structure	Wall		<input checked="" type="radio"/> Brick <input type="radio"/> Wood	Wall	<input checked="" type="radio"/> Paint
			Column		Brick <input checked="" type="radio"/> Wood <input type="radio"/> RC	Column	<input checked="" type="radio"/> Paint
			Beam		<input checked="" type="radio"/> Wood <input type="radio"/> RC <input type="radio"/> Steel	Floor	<input checked="" type="radio"/> Concrete <input type="radio"/> Wood
	Electric system (Check <input type="radio"/> )	<input checked="" type="radio"/> Retract from outside <input type="radio"/> Solar System <input type="radio"/> Generator		Water Supply (Check <input type="radio"/> )	<input checked="" type="radio"/> Water Well ( Pump ) <input type="radio"/> Waterwork <input type="radio"/> None		
	Condition of Main Structure	Main Damage Type & Rank*		Condition of Finish Material	Main Damage Type & Rank*		
		D	<input checked="" type="radio"/> Crack ( 5 mm ) <input type="radio"/> Settlement <input checked="" type="radio"/> Inclination 2°		D	<input checked="" type="radio"/> Water Leak <input checked="" type="radio"/> Peel Off (Roof, Ceiling, Wall, Colum )	
General Evaluation	<input type="radio"/> Usual <input checked="" type="radio"/> Poor <input type="radio"/> Severe		Remarks	No toilet. About 90passengers/day and 200viss/day freight. 1 cable rm and 1 generator			
Photograph							

\*Damage Rank C;Slight (Repair) D;Heavy (Repair and Reinforcement) F; Fatal (Reconstruction)

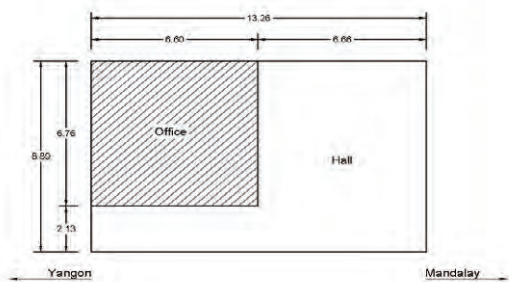
## Investigation of Station Building

Station No.	72	Line Name	Yangon – Mandalay Line	Date of Survey	6/7/2017		
Station Name	NWATO						
Existing Station Building	Kilopost	486	Mileage	302-1/4			
	Access Road	Yes <input type="radio"/> No <input checked="" type="radio"/>	Age of Building	Over 100 years			
	Story of Building	( 1 ) Story Building	Total Floor Area	About 118 m <sup>2</sup>			
	Type of Main Structure (Check <input type="radio"/> )	<input checked="" type="radio"/> Brick with RC <input type="radio"/> Wood <input type="radio"/> Other(    )	Finish Material	Roof	<input checked="" type="radio"/> Corrugated Steel sheet <input type="radio"/> Roof Tiles <input type="radio"/> RC <input type="radio"/> Asbestos Fibre Cement		
	Other Structure	Wall		<input checked="" type="radio"/> Brick <input type="radio"/> Wood	Wall	<input checked="" type="radio"/> Paint	
		Column		<input checked="" type="radio"/> Brick <input type="radio"/> Wood <input type="radio"/> RC	Column	<input checked="" type="radio"/> Paint	
		Beam		Wood <input checked="" type="radio"/> RC <input type="radio"/> Steel	Floor	<input checked="" type="radio"/> Concrete <input type="radio"/> Wood	
	Electric system (Check <input type="radio"/> )	<input type="radio"/> Retract from outside <input type="radio"/> Solar System <input checked="" type="radio"/> Generator	Water Supply (Check <input type="radio"/> )	<input type="radio"/> Water Well (    ) <input type="radio"/> Waterwork <input checked="" type="radio"/> None			
	Condition of Main Structure	Main Damage Type & Rank*		Condition of Finish Material	Main Damage Type & Rank*		
		F	<input checked="" type="radio"/> Crack ( 7mm ) <input type="radio"/> Settlement <input type="radio"/> Inclination		F	<input checked="" type="radio"/> Water Leak <input checked="" type="radio"/> Peel Off (Roof, Ceiling, Wall, Colum )	
General Evaluation	<input type="radio"/> Usual <input type="radio"/> Poor <input checked="" type="radio"/> Severe		Remarks	About 15passengers/day and no freight. 1 toilet, 1 cable rm and 1 generator rm.			
Photograph	 						



\*Damage Rank C;Slight (Repair) D;Heavy (Repair and Reinforcement) F; Fatal (Reconstruction)

## Investigation of Station Building

Station No.	73	Line Name	Yangon – Mandalay Line	Date of Survey	19/5/2017		
Station Name	THAZI						
Existing Station Building	Kilopost	492.5	Mileage	306			
	Access Road	<input checked="" type="radio"/> Yes <input type="radio"/> No	Age of Building	Over 100 years			
	Story of Building	( 2 ) Story Building	Total Floor Area	About 1350m <sup>2</sup>			
	Type of Main Structure (Check <input type="radio"/> )	<input checked="" type="radio"/> Brick with RC <input type="radio"/> Wood <input type="radio"/> Other( Steel Frame )	Finish Material	Roof	<input type="radio"/> Corrugated Steel sheet <input checked="" type="radio"/> Roof Tiles <input type="radio"/> RC <input type="radio"/> Asbestos Fibre Cement		
	Other Structure	Wall		<input checked="" type="radio"/> Brick <input type="radio"/> Wood	Wall	<input checked="" type="radio"/> Paint	
		Column		<input checked="" type="radio"/> Brick <input type="radio"/> Wood <input checked="" type="radio"/> RC	Column	<input checked="" type="radio"/> Paint	
		Beam		<input checked="" type="radio"/> Wood <input type="radio"/> RC <input checked="" type="radio"/> Steel	Floor	<input checked="" type="radio"/> Concrete <input type="radio"/> Wood	
	Electric system (Check <input type="radio"/> )	<input checked="" type="radio"/> Retract from outside <input type="radio"/> Solar System <input type="radio"/> Generator	Water Supply (Check <input type="radio"/> )	<input checked="" type="radio"/> Water Well (            ) <input type="radio"/> Waterwork <input type="radio"/> None			
	Condition of Main Structure	Main Damage Type & Rank*		Condition of Finish Material	Main Damage Type & Rank*		
		F	<input checked="" type="radio"/> Crack ( 10mm) <input type="radio"/> Settlement <input type="radio"/> Inclination		C	<input checked="" type="radio"/> Water Leak <input type="radio"/> Peel Off (Roof, Ceiling, Wall, Colum )	
General Evaluation	<input type="radio"/> Usual <input type="radio"/> Poor <input checked="" type="radio"/> Severe		Remarks				
Photograph							

\*Damage Rank C;Slight (Repair) D;Heavy (Repair and Reinforcement) F; Fatal (Reconstruction)

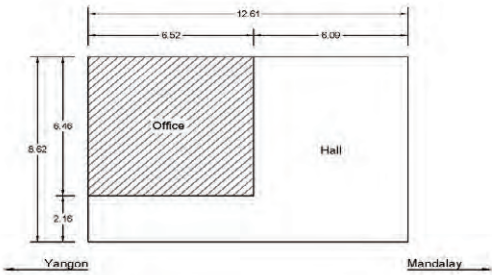
## Investigation of Station Building

Station No.	74	Line Name	Yangon – Mandalay Line	Date of Survey	6/7/2017		
Station Name	YWAPALE						
Existing Station Building	Kilopost	499.5	Mileage	310-1/2			
	Access Road	<input checked="" type="radio"/> Yes <input type="radio"/> No	Age of Building	Over 100 years			
	Story of Building	( 1 ) Story Building	Total Floor Area	About 111 m <sup>2</sup>			
	Type of Main Structure (Check <input type="radio"/> )	<input checked="" type="radio"/> Brick with RC • Wood • Other(    )	Finish Material	Roof	<input checked="" type="radio"/> Corrugated Steel sheet • Roof Tiles • RC • Asbestos Fibre Cement		
	Other Structure	Wall		<input checked="" type="radio"/> Brick <input type="radio"/> Wood	Wall	<input checked="" type="radio"/> Paint	
		Column		<input checked="" type="radio"/> Brick <input type="radio"/> Wood <input type="radio"/> RC	Column	<input checked="" type="radio"/> Paint	
		Beam		<input checked="" type="radio"/> Wood <input type="radio"/> RC <input type="radio"/> Steel	Floor	<input checked="" type="radio"/> Concrete    • Wood	
	Electric system (Check <input type="radio"/> )	• Retract from outside <input checked="" type="radio"/> Solar System • Generator	Water Supply (Check <input type="radio"/> )	• Water Well (    ) • Waterwork <input checked="" type="radio"/> None			
	Condition of Main Structure	Main Damage Type & Rank*		Condition of Finish Material	Main Damage Type & Rank*		
		C	<input checked="" type="radio"/> Crack ( 6mm) • Settlement • Inclination		B	• Water Leak • Peel Off (Roof, Ceiling, Wall, Colum )	
General Evaluation	<input checked="" type="radio"/> Usual • Poor • Severe	Remarks	About 2passengers/day and no freight. No toilet. 1 cable rm.				
Photograph							
							

\*Damage Rank C;Slight (Repair) D;Heavy (Repair and Reinforcement) F; Fatal (Reconstruction)

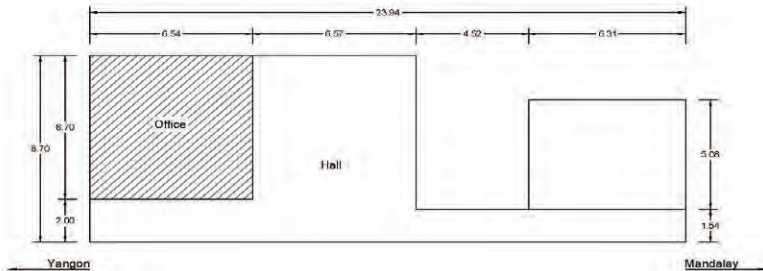

## Investigation of Station Building

Station No.	75	Line Name	Yangon – Mandalay Line	Date of Survey	6/7/2017		
Station Name	HANZA						
Existing Station Building	Kilopost	507.5		Mileage	315-1/2		
	Access Road	<input checked="" type="radio"/> Yes    No		Age of Building	Over 100 years		
	Story of Building	( 1 ) Story Building		Total Floor Area	About 230 m <sup>2</sup>		
	Type of Main Structure (Check <input type="radio"/> )	<input checked="" type="radio"/> Brick with RC • Wood • Other(    )		Finish Material	Roof	• Corrugated Steel sheet • Roof Tiles • RC <input checked="" type="radio"/> Asbestos Fibre Cement	
		Other Structure	Wall		<input checked="" type="radio"/> Brick    Wood	Wall	<input checked="" type="radio"/> Paint
			Column		<input checked="" type="radio"/> Brick    Wood    RC	Column	<input checked="" type="radio"/> Paint
			Beam		Wood <input checked="" type="radio"/> RC    Steel	Floor	<input checked="" type="radio"/> Concrete    • Wood
	Electric system (Check <input type="radio"/> )	<input checked="" type="radio"/> Retract from outside • Solar System • Generator		Water Supply (Check <input type="radio"/> )	• Water Well (    ) • Waterwork <input checked="" type="radio"/> None		
	Condition of Main Structure	Main Damage Type & Rank*		Condition of Finish Material	Main Damage Type & Rank*		
		F	<input checked="" type="radio"/> Crack ( 6mm) • Settlement • Inclination		D	<input checked="" type="radio"/> Water Leak <input checked="" type="radio"/> Peel Off (Roof, Ceiling, Wall, Colum )	
General Evaluation	• Usual • Poor <input checked="" type="radio"/> Severe		Remarks	About 30passengers/day and a little freight.No toilet. 1 cable rm,1 generator rm and 2shop rm.			
Photograph							

\*Damage Rank C;Slight (Repair) D;Heavy (Repair and Reinforcement) F; Fatal (Reconstruction)



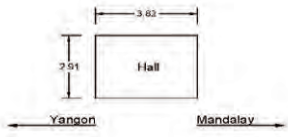

## Investigation of Station Building

Station No.	76	Line Name	Yangon – Mandalay Line	Date of Survey	6/7/2017		
Station Name	DAHATTAW						
Existing Station Building	Kilopost	512	Mileage	318-1/4			
	Access Road	Yes <input type="radio"/> No <input checked="" type="radio"/>	Age of Building	Over 100 years			
	Story of Building	( 1 ) Story Building	Total Floor Area	About 12 m <sup>2</sup>			
	Type of Main Structure (Check <input type="radio"/> )	<input checked="" type="radio"/> Brick with RC • Wood • Other( )	Finish Material	Roof	• Corrugated Steel sheet • Roof Tiles <input checked="" type="radio"/> RC • Asbestos Fibre Cement		
	Other Structure	Wall		<input checked="" type="radio"/> Brick Wood	Wall	<input checked="" type="radio"/> Paint	
		Column		Brick Wood <input checked="" type="radio"/> RC	Column	<input checked="" type="radio"/> Paint	
		Beam		Wood <input checked="" type="radio"/> RC Steel	Floor	<input checked="" type="radio"/> Concrete • Wood	
	Electric system (Check <input type="radio"/> )	• Retract from outside • Solar System • Generator	Water Supply (Check <input type="radio"/> )	• Water Well ( ) • Waterwork <input checked="" type="radio"/> None			
	Condition of Main Structure	Main Damage Type & Rank*		Condition of Finish Material	Main Damage Type & Rank*		
		<b>B</b>	• Crack ( mm) • Settlement • Inclination		<b>B</b>	• Water Leak • Peel Off (Roof, Ceiling, Wall, Colum )	
General Evaluation	<input checked="" type="radio"/> Usual • Poor • Severe		Remarks				
Photograph	 						

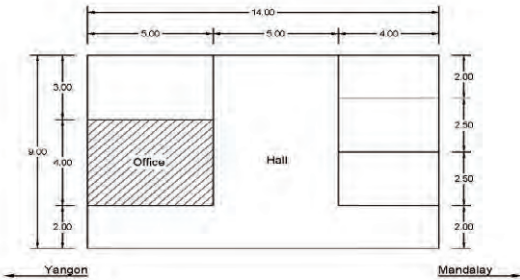

\*Damage Rank C;Slight (Repair) D;Heavy (Repair and Reinforcement) F; Fatal (Reconstruction)

## Investigation of Station Building

Station No.	77	Line Name	Yangon – Mandalay Line	Date of Survey	19/5/2017		
Station Name	THEDAW						
Existing Station Building	Kilopost	517		Mileage	322-1/4		
	Access Road	<input checked="" type="radio"/> Yes    No		Age of Building	Over 100 years		
	Story of Building	( 1 ) Story Building		Total Floor Area	About 126 m <sup>2</sup>		
	Type of Main Structure (Check <input type="radio"/> )	<input type="radio"/> Brick with RC <input checked="" type="radio"/> Wood <input type="radio"/> Other(    )		Finish Material	Roof	<input checked="" type="radio"/> Corrugated Steel sheet <input type="radio"/> Roof Tiles <input type="radio"/> RC <input type="radio"/> Asbestos Fibre Cement	
	Other Structure	Wall	<input checked="" type="radio"/> Brick    Wood		Wall	<input checked="" type="radio"/> Paint	
		Column	Brick		<input checked="" type="radio"/> Wood    RC	Column	<input checked="" type="radio"/> Paint
		Beam	<input checked="" type="radio"/> Wood    RC    Steel		Floor	<input checked="" type="radio"/> Concrete    •Wood	
	Electric system (Check <input type="radio"/> )	<input checked="" type="radio"/> Retract from outside <input type="radio"/> Solar System <input type="radio"/> Generator		Water Supply (Check <input type="radio"/> )	<input checked="" type="radio"/> Water Well (    ) <input type="radio"/> Waterwork <input type="radio"/> None		
	Condition of Main Structure	Main Damage Type & Rank*		Condition of Finish Material	Main Damage Type & Rank*		
		<b>B</b>	<input type="radio"/> Crack (    mm) <input type="radio"/> Settlement <input type="radio"/> Inclination		<b>B</b>	<input type="radio"/> Water Leak <input type="radio"/> Peel Off (Roof, Ceiling, Wall, Colum )	
General Evaluation	<input checked="" type="radio"/> Usual <input type="radio"/> Poor <input type="radio"/> Severe		Remarks	Public toilet.			
Photograph	 						

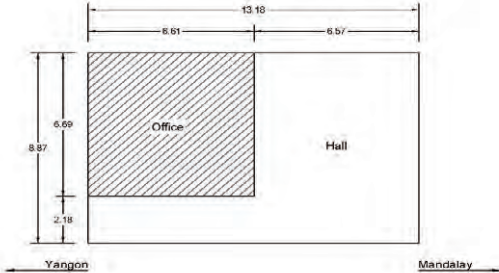

\*Damage Rank C;Slight (Repair) D;Heavy (Repair and Reinforcement) F; Fatal (Reconstruction)

## Investigation of Station Building

Station No.	78	Line Name	Yangon – Mandalay Line	Date of Survey	7/7/2017		
Station Name	KHINBAN						
Existing Station Building	Kilopost	523.5	Mileage	325–3/4			
	Access Road	Yes <input type="radio"/> No <input checked="" type="radio"/>	Age of Building	Over 50 years			
	Story of Building	( 1 ) Story Building	Total Floor Area	About 118 m <sup>2</sup>			
	Type of Main Structure (Check <input type="radio"/> )	<input checked="" type="radio"/> Brick with RC • Wood • Other( )	Finish Material	Roof	<ul style="list-style-type: none"> <li>• Corrugated Steel sheet</li> <li>• Roof Tiles</li> <li>• RC</li> <li><input checked="" type="radio"/> Asbestos Fibre Cement</li> </ul>		
	Other Structure	Wall		<input checked="" type="radio"/> Brick Wood	Wall	<input checked="" type="radio"/> Paint	
		Column		<input checked="" type="radio"/> Brick Wood RC	Column	<input checked="" type="radio"/> Paint	
		Beam		Wood <input checked="" type="radio"/> RC Steel	Floor	<input checked="" type="radio"/> Concrete • Wood	
	Electric system (Check <input type="radio"/> )	<input checked="" type="radio"/> Retract from outside • Solar System • Generator	Water Supply (Check <input type="radio"/> )	<ul style="list-style-type: none"> <li>• Water Well ( )</li> <li>• Waterwork</li> <li><input checked="" type="radio"/> None</li> </ul>			
	Condition of Main Structure	Main Damage Type & Rank*		Condition of Finish Material	Main Damage Type & Rank*		
		F	<ul style="list-style-type: none"> <li><input checked="" type="radio"/> Crack ( 10mm)</li> <li><input checked="" type="radio"/> Settlement</li> <li><input checked="" type="radio"/> Inclination</li> </ul>		D	<ul style="list-style-type: none"> <li><input checked="" type="radio"/> Water Leak</li> <li><input checked="" type="radio"/> Peel Off (Roof, Ceiling, Wall, Colum )</li> </ul>	
General Evaluation	<ul style="list-style-type: none"> <li>• Usual</li> <li>• Poor</li> <li><input checked="" type="radio"/> Severe</li> </ul>	Remarks	About 15passengers/day and 5–10boxes/day freight. No toilet. No cable rm.				
Photograph							
							

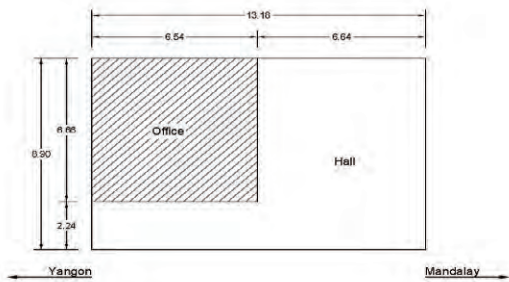

\*Damage Rank C;Slight (Repair) D;Heavy (Repair and Reinforcement) F; Fatal (Reconstruction)

## Investigation of Station Building

Station No.	79	Line Name	Yangon – Mandalay Line	Date of Survey	7/7/2017		
Station Name	SAMON						
Existing Station Building	Kilopost	530	Mileage	329			
	Access Road	Yes <input type="radio"/> No <input checked="" type="radio"/>	Age of Building	Over 100 years			
	Story of Building	( 1 ) Story Building	Total Floor Area	About 118 m <sup>2</sup>			
	Type of Main Structure (Check <input type="radio"/> )	<input checked="" type="radio"/> Brick with RC • Wood • Other( )	Finish Material	Roof	<input checked="" type="radio"/> Corrugated Steel sheet • Roof Tiles • RC • Asbestos Fibre Cement		
	Other Structure	Wall		<input checked="" type="radio"/> Brick Wood	Wall	<input checked="" type="radio"/> Paint	
		Column		<input checked="" type="radio"/> Brick Wood RC	Column	<input checked="" type="radio"/> Paint	
		Beam		Wood <input checked="" type="radio"/> RC Steel	Floor	<input checked="" type="radio"/> Concrete • Wood	
	Electric system (Check <input type="radio"/> )	<input checked="" type="radio"/> Retract from outside • Solar System • Generator	Water Supply (Check <input type="radio"/> )	<input checked="" type="radio"/> Water Well ( Mortar ) • Waterwork • None			
	Condition of Main Structure	Main Damage Type & Rank*		Condition of Finish Material	Main Damage Type & Rank*		
		F	<input checked="" type="radio"/> Crack ( 6mm ) • Settlement • Inclination		C	<input checked="" type="radio"/> Water Leak • Peel Off (Roof, Ceiling, Wall, Colum )	
General Evaluation	• Usual • Poor <input checked="" type="radio"/> Severe	Remarks	About 40passengers/day and 400viss/day freight. No toilet. 1 cable rm and 1 generator				
Photograph							
							

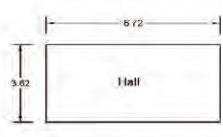

\*Damage Rank C;Slight (Repair) D;Heavy (Repair and Reinforcement) F; Fatal (Reconstruction)

## Investigation of Station Building

Station No.	80	Line Name	Yangon – Mandalay Line	Date of Survey	7/7/2017		
Station Name	ODOKKON						
Existing Station Building	Kilopost	534.5	Mileage	332-1/2			
	Access Road	Yes <input type="radio"/> No <input checked="" type="radio"/>	Age of Building	Over 100 years			
	Story of Building	( 1 ) Story Building	Total Floor Area	About 25 m <sup>2</sup>			
	Type of Main Structure (Check <input type="radio"/> )	<ul style="list-style-type: none"> <li>▪ Brick with RC</li> <li><input checked="" type="radio"/> Wood</li> <li>▪ Other(    )</li> </ul>	Finish Material	Roof	<input checked="" type="radio"/> Corrugated Steel sheet <ul style="list-style-type: none"> <li>▪ Roof Tiles</li> <li>▪ RC</li> <li>▪ Asbestos Fibre Cement</li> </ul>		
	Other Structure	Wall		<input checked="" type="radio"/> Brick    Wood	Wall	<input checked="" type="radio"/> Paint	
		Column		Brick <input checked="" type="radio"/> Wood    RC	Column	▪ Paint	
		Beam		<input checked="" type="radio"/> Wood    RC    Steel	Floor	<input checked="" type="radio"/> Concrete    ▪ Wood	
	Electric system (Check <input type="radio"/> )	<ul style="list-style-type: none"> <li>▪ Retract from outside</li> <li>▪ Solar System</li> <li>▪ Generator</li> </ul>	Water Supply (Check <input type="radio"/> )	<ul style="list-style-type: none"> <li>▪ Water Well (            )</li> <li>▪ Waterwork</li> <li><input checked="" type="radio"/> None</li> </ul>			
	Condition of Main Structure	Main Damage Type & Rank*		Condition of Finish Material	Main Damage Type & Rank*		
		<b>B</b>	<ul style="list-style-type: none"> <li>▪ Crack (    mm)</li> <li>▪ Settlement</li> <li>▪ Inclination</li> </ul>		<b>B</b>	<ul style="list-style-type: none"> <li>▪ Water Leak</li> <li>▪ Peel Off (Roof, Ceiling, Wall, Colum )</li> </ul>	
General Evaluation	<ul style="list-style-type: none"> <li><input checked="" type="radio"/> Usual</li> <li>▪ Poor</li> <li>▪ Severe</li> </ul>		Remarks				
Photograph	<div style="display: flex; justify-content: center; align-items: center; gap: 20px;"> <div style="text-align: center;">  <p style="font-size: 0.8em;">6.72 3.02 Hall</p> </div> <div style="text-align: center;">  </div> </div>						

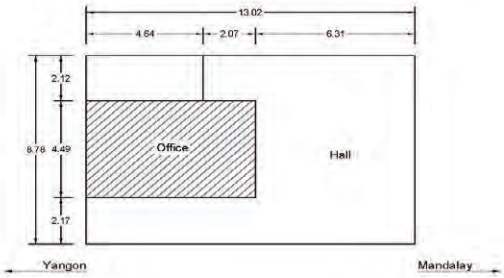

\*Damage Rank C;Slight (Repair) D;Heavy (Repair and Reinforcement) F; Fatal (Reconstruction)

## Investigation of Station Building

Station No.	81	Line Name	Yangon – Mandalay Line	Date of Survey	7/7/2017		
Station Name	THABYETAUNG						
Existing Station Building	Kilopost	541		Mileage	336-1/4		
	Access Road	<input checked="" type="radio"/> Yes    No		Age of Building	Over 100 years		
	Story of Building	( 1 ) Story Building		Total Floor Area	About 115 m <sup>2</sup>		
	Type of Main Structure (Check <input type="radio"/> )	<input checked="" type="radio"/> Brick with RC • Wood • Other(    )		Finish Material	Roof	• Corrugated Steel sheet • Roof Tiles • RC <input checked="" type="radio"/> Asbestos Fibre Cement	
	Other Structure	Wall	<input checked="" type="radio"/> Brick    Wood		Wall	<input checked="" type="radio"/> Paint	
		Column	<input checked="" type="radio"/> Brick		Wood    RC	Column	<input checked="" type="radio"/> Paint
		Beam	Wood		<input checked="" type="radio"/> RC    Steel	Floor	<input checked="" type="radio"/> Concrete    • Wood
	Electric system (Check <input type="radio"/> )	• Retract from outside <input checked="" type="radio"/> Solar System • Generator		Water Supply (Check <input type="radio"/> )	<input checked="" type="radio"/> Water Well ( Tube    ) • Waterwork • None		
	Condition of Main Structure	Main Damage Type & Rank*		Condition of Finish Material	Main Damage Type & Rank*		
		<b>B</b>	• Crack (    mm) • Settlement • Inclination		<b>C</b>	<input checked="" type="radio"/> Water Leak • Peel Off (Roof, Ceiling, Wall, Colum )	
General Evaluation	<input checked="" type="radio"/> Usual • Poor • Severe		Remarks	About 20passengers/day and no freight. 1 toilet rm,1 cable rm and 1 generator rm.			
Photograph	 						

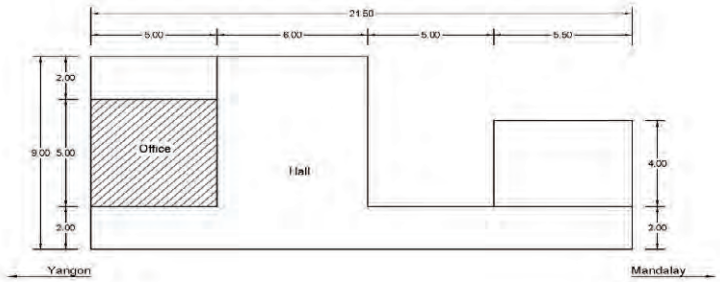

\*Damage Rank C;Slight (Repair) D;Heavy (Repair and Reinforcement) F; Fatal (Reconstruction)

## Investigation of Station Building

Station No.	82	Line Name	Yangon – Mandalay Line	Date of Survey	19/5/2017		
Station Name	KUME LAN						
Existing Station Building	Kilopost	549.5	Mileage	341-1/2			
	Access Road	<input checked="" type="radio"/> Yes <input type="radio"/> No	Age of Building	Over 100 years			
	Story of Building	( 1 ) Story Building	Total Floor Area	About 230 m <sup>2</sup>			
	Type of Main Structure (Check <input type="radio"/> )	<input checked="" type="radio"/> Brick with RC • Wood • Other(    )	Finish Material	Roof	<input checked="" type="radio"/> Corrugated Steel sheet • Roof Tiles • RC • Asbestos Fibre Cement		
	Other Structure	Wall		<input checked="" type="radio"/> Brick    Wood	Wall	<input checked="" type="radio"/> Paint	
		Column		<input checked="" type="radio"/> Brick    Wood    RC	Column	<input checked="" type="radio"/> Paint	
		Beam		Wood <input checked="" type="radio"/> RC    Steel	Floor	<input checked="" type="radio"/> Concrete    • Wood	
	Electric system (Check <input type="radio"/> )	<input checked="" type="radio"/> Retract from outside • Solar System • Generator	Water Supply (Check <input type="radio"/> )	• Water Well (    ) • Waterwork <input checked="" type="radio"/> None			
	Condition of Main Structure	Main Damage Type & Rank*		Condition of Finish Material	Main Damage Type & Rank*		
		F	<input checked="" type="radio"/> Crack (15mm) • Settlement • Inclination		C	<input checked="" type="radio"/> Water Leak • Peel Off (Roof, Ceiling, Wall, Colum )	
General Evaluation	• Usual • Poor <input checked="" type="radio"/> Severe		Remarks	No toilet.			
Photograph							
							

\*Damage Rank C;Slight (Repair) D;Heavy (Repair and Reinforcement) F; Fatal (Reconstruction)

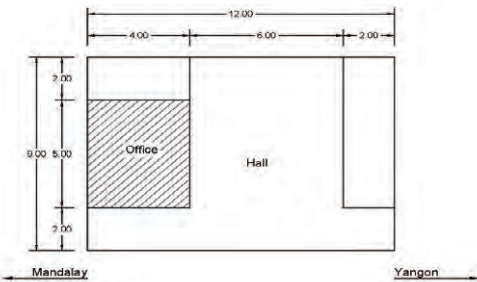

## Investigation of Station Building

Station No.	83	Line Name	Yangon – Mandalay Line	Date of Survy	19/5/2017		
Station Name	MYITTHAR						
Existing Station Building	Kilopost	558.5		Mileage	347		
	Access Road	<input checked="" type="radio"/> Yes    No		Age of Building	Over 100 years		
	Story of Building	( 1 ) Story Building		Total Floor Area	About 108 m <sup>2</sup>		
	Type of Main Structure (Check <input type="radio"/> )	<input type="radio"/> Brick with RC <input checked="" type="radio"/> Wood <input type="radio"/> Other(    )		Finish Material	Roof	<input checked="" type="radio"/> Corrugated Steel sheet <input type="radio"/> Roof Tiles <input type="radio"/> RC <input type="radio"/> Asbestos Fibre Cement	
	Other Structure	Wall	<input checked="" type="radio"/> Brick    Wood		Wall	<input checked="" type="radio"/> Paint	
		Column	Brick		<input checked="" type="radio"/> Wood    RC	Column	<input checked="" type="radio"/> Paint
		Beam	<input checked="" type="radio"/> Wood    RC    Steel		Floor	<input checked="" type="radio"/> Concrete <input type="radio"/> Wood	
	Electric system (Check <input type="radio"/> )	<input checked="" type="radio"/> Retract from outside <input type="radio"/> Solar System <input type="radio"/> Generator		Water Supply (Check <input type="radio"/> )	<input checked="" type="radio"/> Water Well ( Pump ) <input type="radio"/> Waterwork <input type="radio"/> None		
	Condition of Main Structure	Main Damage Type & Rank*			Main Damage Type & Rank*		
		D	<input checked="" type="radio"/> Crack ( 10mm ) <input type="radio"/> Settlement <input type="radio"/> Inclination		B	<input type="radio"/> Water Leak <input type="radio"/> Peel Off (Roof, Ceiling, Wall, Colum )	
General Evaluation	<input type="radio"/> Usual <input checked="" type="radio"/> Poor <input type="radio"/> Severe		Remarks	No toilet.			
Photograph	 						

\*Damage Rank C;Slight (Repair) D;Heavy (Repair and Reinforcement) F; Fatal (Reconstruction)



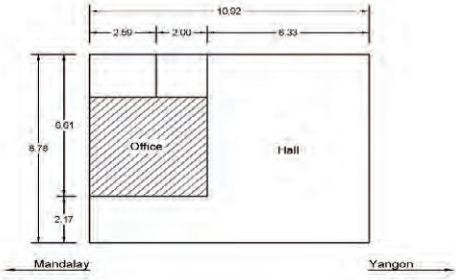

## Investigation of Station Building

Station No.	84	Line Name	Yangon – Mandalay Line	Date of Survey	7/7/2017		
Station Name	MINZU						
Existing Station Building	Kilopost	567		Mileage	352-1/2		
	Access Road	<input checked="" type="radio"/> Yes <input type="radio"/> No		Age of Building	Over 100 years		
	Story of Building	( 1 ) Story Building		Total Floor Area	About 97 m <sup>2</sup>		
	Type of Main Structure (Check <input type="radio"/> )	<input checked="" type="radio"/> Brick with RC • Wood • Other(    )		Finish Material	Roof	<input checked="" type="radio"/> Corrugated Steel sheet • Roof Tiles • RC • Asbestos Fibre Cement	
		Other Structure	Wall		<input checked="" type="radio"/> Brick <input type="radio"/> Wood	Wall	<input checked="" type="radio"/> Paint
			Column		<input checked="" type="radio"/> Brick <input type="radio"/> Wood <input type="radio"/> RC	Column	<input checked="" type="radio"/> Paint
			Beam		Wood <input checked="" type="radio"/> RC <input type="radio"/> Steel	Floor	<input checked="" type="radio"/> Concrete    • Wood
	Electric system (Check <input type="radio"/> )	<input checked="" type="radio"/> Retract from outside • Solar System • Generator		Water Supply (Check <input type="radio"/> )	• Water Well (    ) <input type="radio"/> Waterwork • None		
	Condition of Main Structure	Main Damage Type & Rank*		Condition of Finish Material	Main Damage Type & Rank*		
		F	<input checked="" type="radio"/> Crack ( 5 mm ) • Settlement • Inclination		F	<input checked="" type="radio"/> Water Leak <input checked="" type="radio"/> Peel Off (Roof, Ceiling, Wall, Colum )	
General Evaluation	• Usual • Poor <input checked="" type="radio"/> Severe		Remarks	No toilet. About 10passengers/day and a little freight sometime. 1 cable rm and 1 generator			
Photograph							
							

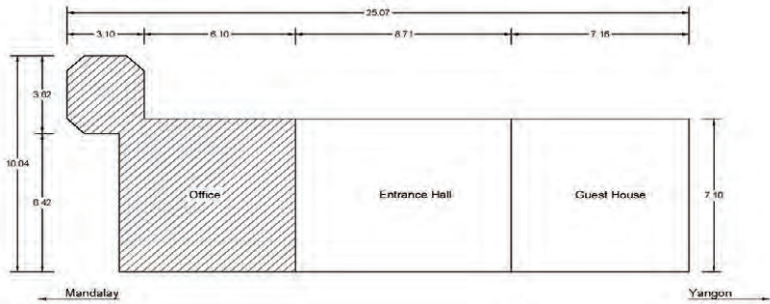

\*Damage Rank C;Slight (Repair) D;Heavy (Repair and Reinforcement) F; Fatal (Reconstruction)

## Investigation of Station Building

Station No.	85	Line Name	Yangon – Mandalay Line	Date of Survey	7/7/2017		
Station Name	KYAUKSE						
Existing Station Building	Kilopost	578		Mileage	359-1/4		
	Access Road	<input checked="" type="radio"/> Yes    No		Age of Building	Over 100 years		
	Story of Building	( 2 ) Story Building		Total Floor Area	About 174 m <sup>2</sup>		
	Type of Main Structure (Check <input type="radio"/> )	<input type="radio"/> Brick with RC <input checked="" type="radio"/> Wood <input type="radio"/> Other(    )		Finish Material	Roof	<input checked="" type="radio"/> Corrugated Steel sheet <input type="radio"/> Roof Tiles <input type="radio"/> RC <input type="radio"/> Asbestos Fibre Cement	
	Other Structure	Wall	<input checked="" type="radio"/> Brick    Wood		Wall	<input checked="" type="radio"/> Paint	
		Column	Brick		<input checked="" type="radio"/> Wood    RC	Column	<input checked="" type="radio"/> Paint
		Beam	<input checked="" type="radio"/> Wood    RC    Steel		Floor	<input checked="" type="radio"/> Concrete    •Wood	
	Electric system (Check <input type="radio"/> )	<input checked="" type="radio"/> Retract from outside <input type="radio"/> Solar System <input type="radio"/> Generator		Water Supply (Check <input type="radio"/> )	<input type="radio"/> Water Well (    ) <input checked="" type="radio"/> Waterwork <input type="radio"/> None		
	Condition of Main Structure	Main Damage Type & Rank*			Main Damage Type & Rank*		
		C	<input checked="" type="radio"/> Crack ( 5mm) <input type="radio"/> Settlement <input type="radio"/> Inclination	Condition of Finish Material	B	<input type="radio"/> Water Leak <input type="radio"/> Peel Off (Roof, Ceiling, Wall, Colum )	
General Evaluation	<input checked="" type="radio"/> Usual <input type="radio"/> Poor <input type="radio"/> Severe		Remarks	About 130passengers/day and 2600viss/day freight. 6 toilet rm,1 cable rm,2 generator rm and 1 guest rm.			
Photograph							
							

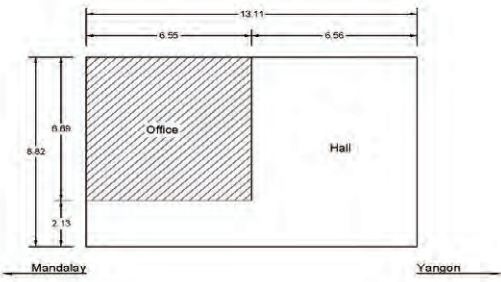

\*Damage Rank C;Slight (Repair) D;Heavy (Repair and Reinforcement) F; Fatal (Reconstruction)

## Investigation of Station Building

Station No.	86	Line Name	Yangon – Mandalay Line	Date of Survey	7/7/2017		
Station Name	BELIN						
Existing Station Building	Kilopost	585		Mileage	363-1/2		
	Access Road	<input checked="" type="radio"/> Yes    No		Age of Building	Over 100 years		
	Story of Building	( 1 ) Story Building		Total Floor Area	About 118m <sup>2</sup>		
	Type of Main Structure (Check <input type="radio"/> )	<input checked="" type="radio"/> Brick with RC • Wood • Other(    )		Finish Material	Roof	<input checked="" type="radio"/> Corrugated Steel sheet • Roof Tiles • RC • Asbestos Fibre Cement	
		Other Structure	Wall		<input checked="" type="radio"/> Brick    Wood	Wall	<input checked="" type="radio"/> Paint
			Column		<input checked="" type="radio"/> Brick    Wood    RC	Column	<input checked="" type="radio"/> Paint
			Beam		Wood <input checked="" type="radio"/> RC    Steel	Floor	<input checked="" type="radio"/> Concrete    • Wood
	Electric system (Check <input type="radio"/> )	<input checked="" type="radio"/> Retract from outside • Solar System • Generator		Water Supply (Check <input type="radio"/> )	<input checked="" type="radio"/> Water Well ( Mortar ) • Waterwork • None		
	Condition of Main Structure	Main Damage Type & Rank*		Condition of Finish Material	Main Damage Type & Rank*		
		D	<input checked="" type="radio"/> Crack ( 8mm) • Settlement • Inclination		B	• Water Leak • Peel Off (Roof, Ceiling, Wall, Colum )	
General Evaluation	• Usual <input checked="" type="radio"/> Poor • Severe		Remarks	About 10passengers/day and stone & cement freight. 1 toilet rm,1 cable rm and 1 generator rm.			
Photograph	 						

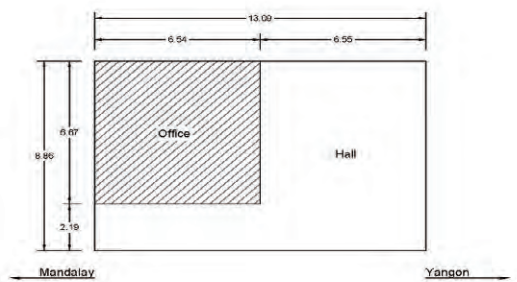

\*Damage Rank C;Slight (Repair) D;Heavy (Repair and Reinforcement) F; Fatal (Reconstruction)

## Investigation of Station Building

Station No.	87	Line Name	Yangon – Mandalay Line	Date of Survey	7/7/2017		
Station Name	SINGAING						
Existing Station Building	Kilopost	594	Mileage	369			
	Access Road	<input checked="" type="radio"/> Yes <input type="radio"/> No	Age of Building	Over 50 years			
	Story of Building	( 1 ) Story Building	Total Floor Area	About 118 m <sup>2</sup>			
	Type of Main Structure (Check <input type="radio"/> )	<input checked="" type="radio"/> Brick with RC • Wood • Other(    )	Finish Material	Roof	<input type="radio"/> Corrugated Steel sheet <input type="radio"/> Roof Tiles <input type="radio"/> RC <input checked="" type="radio"/> Asbestos Fibre Cement		
	Other Structure	Wall		<input checked="" type="radio"/> Brick <input type="radio"/> Wood	Wall	<input checked="" type="radio"/> Paint	
		Column		<input checked="" type="radio"/> Brick <input type="radio"/> Wood <input type="radio"/> RC	Column	<input checked="" type="radio"/> Paint	
		Beam		Wood <input checked="" type="radio"/> RC <input type="radio"/> Steel	Floor	<input checked="" type="radio"/> Concrete    • Wood	
	Electric system (Check <input type="radio"/> )	<input checked="" type="radio"/> Retract from outside • Solar System • Generator	Water Supply (Check <input type="radio"/> )	<input checked="" type="radio"/> Water Well ( Mortar ) <input type="radio"/> Waterwork <input type="radio"/> None			
	Condition of Main Structure	Main Damage Type & Rank*		Condition of Finish Material	Main Damage Type & Rank*		
		F	<input checked="" type="radio"/> Crack (4 mm) <input type="radio"/> Settlement <input type="radio"/> Inclination		B	<input type="radio"/> Water Leak <input type="radio"/> Peel Off (Roof, Ceiling, Wall, Colum )	
General Evaluation	<input type="radio"/> Usual <input type="radio"/> Poor <input checked="" type="radio"/> Severe		Remarks	About 3passengers/day and no freight. 1 toilet rm,1 cable rm and 1 generator rm.			
Photograph	 						

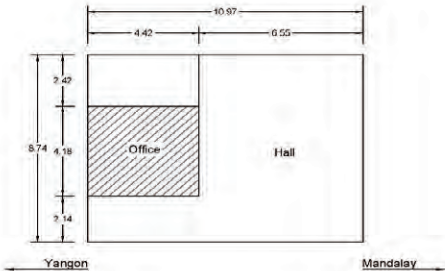

\*Damage Rank C;Slight (Repair) D;Heavy (Repair and Reinforcement) F; Fatal (Reconstruction)

## Investigation of Station Building

Station No.	88	Line Name	Yangon – Mandalay Line	Date of Survey	7/7/2017		
Station Name	PALEIK						
Existing Station Building	Kilopost	602		Mileage	374-1/4		
	Access Road	<input checked="" type="radio"/> Yes    No		Age of Building	Over 100 years		
	Story of Building	( 1 ) Story Building		Total Floor Area	About 97 m <sup>2</sup>		
	Type of Main Structure (Check <input type="radio"/> )	<input type="radio"/> Brick with RC <input checked="" type="radio"/> Wood <input type="radio"/> Other(    )		Finish Material	Roof	<input checked="" type="radio"/> Corrugated Steel sheet <input type="radio"/> Roof Tiles <input type="radio"/> RC <input type="radio"/> Asbestos Fibre Cement	
	Other Structure	Wall	<input checked="" type="radio"/> Brick    Wood		Wall	<input checked="" type="radio"/> Paint	
		Column	Brick		<input checked="" type="radio"/> Wood    RC	Column	<input checked="" type="radio"/> Paint
		Beam	<input checked="" type="radio"/> Wood    RC    Steel		Floor	<input checked="" type="radio"/> Concrete <input type="radio"/> Wood	
	Electric system (Check <input type="radio"/> )	<input checked="" type="radio"/> Retract from outside <input type="radio"/> Solar System <input type="radio"/> Generator		Water Supply (Check <input type="radio"/> )	<input checked="" type="radio"/> Water Well ( Mortar ) <input type="radio"/> Waterwork <input type="radio"/> None		
	Condition of Main Structure	Main Damage Type & Rank*			Condition of Finish Material	Main Damage Type & Rank*	
		B	<input checked="" type="radio"/> Crack ( 5mm) <input type="radio"/> Settlement <input type="radio"/> Inclination			B	<input type="radio"/> Water Leak <input type="radio"/> Peel Off (Roof, Ceiling, Wall, Colum )
General Evaluation	<input checked="" type="radio"/> Usual <input type="radio"/> Poor <input type="radio"/> Severe		Remarks	About 30passengers/day and 200viss/day freight. 1 toilet rm and 1 cable rm.			
Photograph							
							

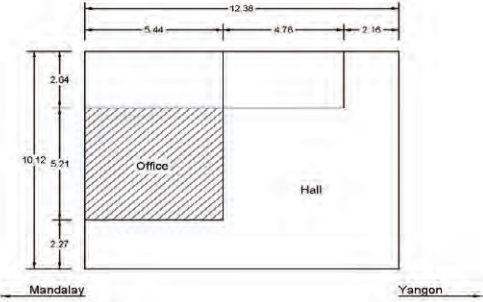

\*Damage Rank C;Slight (Repair) D;Heavy (Repair and Reinforcement) F; Fatal (Reconstruction)

## Investigation of Station Building

Station No.	89	Line Name	Yangon – Mandalay Line	Date of Survey	7/7/2017		
Station Name	MYITNGE						
Existing Station Building	Kilopost	607		Mileage	377-3/4		
	Access Road	<input checked="" type="radio"/> Yes    No		Age of Building	Over 50 years		
	Story of Building	( 1 ) Story Building		Total Floor Area	About 126 m <sup>2</sup>		
	Type of Main Structure (Check <input type="radio"/> )	<input type="radio"/> Brick with RC <input checked="" type="radio"/> Wood <input type="radio"/> Other(    )		Finish Material	Roof	<input checked="" type="radio"/> Corrugated Steel sheet <input type="radio"/> Roof Tiles <input type="radio"/> RC <input type="radio"/> Asbestos Fibre Cement	
		Other Structure	Wall		<input checked="" type="radio"/> Brick    Wood	Wall	<input checked="" type="radio"/> Paint
			Column		Brick <input checked="" type="radio"/> Wood    RC	Column	<input checked="" type="radio"/> Paint
			Beam		<input checked="" type="radio"/> Wood    RC    Steel	Floor	<input checked="" type="radio"/> Concrete <input type="radio"/> Wood
	Electric system (Check <input type="radio"/> )	<input checked="" type="radio"/> Retract from outside <input checked="" type="radio"/> Solar System <input type="radio"/> Generator		Water Supply (Check <input type="radio"/> )	<input type="radio"/> Water Well ( Mortar ) <input checked="" type="radio"/> Waterwork <input type="radio"/> None		
	Condition of Main Structure	Main Damage Type & Rank*		Condition of Finish Material	Main Damage Type & Rank*		
		B	<input checked="" type="radio"/> Crack ( 5mm ) <input type="radio"/> Settlement <input type="radio"/> Inclination		B	<input type="radio"/> Water Leak <input type="radio"/> Peel Off (Roof, Ceiling, Wall, Colum )	
General Evaluation	<input checked="" type="radio"/> Usual <input type="radio"/> Poor <input type="radio"/> Severe		Remarks	About 20passengers/day and 200viss/day freight. 1 toilet rm and 1 cable rm.			
Photograph							
							

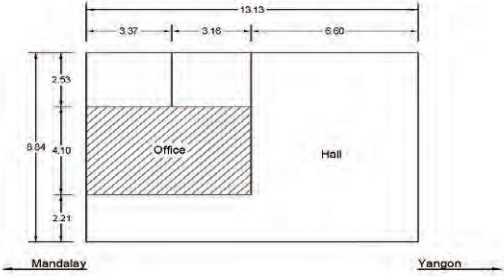

\*Damage Rank C;Slight (Repair) D;Heavy (Repair and Reinforcement) F; Fatal (Reconstruction)

## Investigation of Station Building

Station No.	90	Line Name	Yangon – Mandalay Line	Date of Survey	7/7/2017		
Station Name	TAGUNDAING						
Existing Station Building	Kilopost	611.5		Mileage	380-1/2		
	Access Road	<input checked="" type="radio"/> Yes    No		Age of Building	Over 100 years		
	Story of Building	( 1 ) Story Building		Total Floor Area	About 117 m <sup>2</sup>		
	Type of Main Structure (Check <input type="radio"/> )	<input checked="" type="radio"/> Brick with RC • Wood • Other(    )		Finish Material	Roof	<input checked="" type="radio"/> Corrugated Steel sheet • Roof Tiles • RC • Asbestos Fibre Cement	
	Other Structure	Wall	<input checked="" type="radio"/> Brick    Wood		Wall	<input checked="" type="radio"/> Paint	
		Column	<input checked="" type="radio"/> Brick		Wood	RC	<input checked="" type="radio"/> Paint
		Beam	Wood		<input checked="" type="radio"/> RC	Steel	<input checked="" type="radio"/> Concrete    • Wood
	Electric system (Check <input type="radio"/> )	<input checked="" type="radio"/> Retract from outside • Solar System • Generator		Water Supply (Check <input type="radio"/> )	<input checked="" type="radio"/> Water Well ( Tube    ) • Waterwork • None		
	Condition of Main Structure	Main Damage Type & Rank*		Condition of Finish Material	Main Damage Type & Rank*		
		F	<input checked="" type="radio"/> Crack ( 10mm) • Settlement • Inclination		C	<input checked="" type="radio"/> Water Leak • Peel Off (Roof, Ceiling, Wall, Colum )	
General Evaluation	• Usual • Poor <input checked="" type="radio"/> Severe		Remarks	About 20passengers/day and 12viss/day freight. No toilet rm and 1 cable rm.			
Photograph	 						

\*Damage Rank C;Slight (Repair) D;Heavy (Repair and Reinforcement) F; Fatal (Reconstruction)

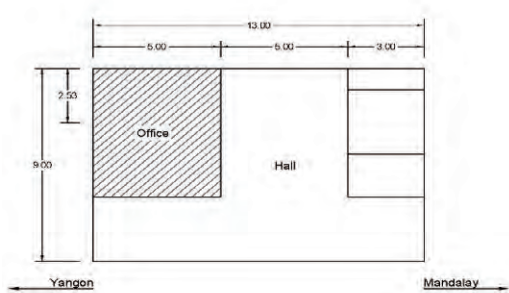

## Investigation of Station Building

Station No.	91	Line Name	Yangon – Mandalay Line	Date of Survey	22/5/2017		
Station Name	MYOHAUNG						
Existing Station Building	Kilopost	616		Mileage	382-3/4		
	Access Road	<input checked="" type="radio"/> Yes    No		Age of Building	Over 100 years		
	Story of Building	( 1 ) Story Building		Total Floor Area	About 120 m <sup>2</sup>		
	Type of Main Structure (Check <input type="radio"/> )	<input type="radio"/> Brick with RC <input checked="" type="radio"/> Wood <input type="radio"/> Other(    )		Finish Material	Roof	<input checked="" type="radio"/> Corrugated Steel sheet <input type="radio"/> Roof Tiles <input type="radio"/> RC <input type="radio"/> Asbestos Fibre Cement	
	Other Structure	Wall	<input checked="" type="radio"/> Brick    Wood		Wall	<input checked="" type="radio"/> Paint	
		Column	Brick		<input checked="" type="radio"/> Wood	RC	<input checked="" type="radio"/> Paint
		Beam	<input checked="" type="radio"/> Wood		RC	Steel	<input checked="" type="radio"/> Concrete <input type="radio"/> Wood
	Electric system (Check <input type="radio"/> )	<input checked="" type="radio"/> Retract from outside <input type="radio"/> Solar System <input type="radio"/> Generator		Water Supply (Check <input type="radio"/> )	<input checked="" type="radio"/> Water Well ( Pump ) <input type="radio"/> Waterwork <input type="radio"/> None		
	Condition of Main Structure	Main Damage Type & Rank*			Condition of Finish Material	Main Damage Type & Rank*	
		<b>B</b>	<input type="radio"/> Crack (    mm) <input type="radio"/> Settlement <input type="radio"/> Inclination			<b>B</b>	<input type="radio"/> Water Leak <input type="radio"/> Peel Off (Roof, Ceiling, Wall, Colum )
General Evaluation	<input checked="" type="radio"/> Usual <input type="radio"/> Poor <input type="radio"/> Severe		Remarks	Toilet for staff.			
Photograph	 						

\*Damage Rank C;Slight (Repair) D;Heavy (Repair and Reinforcement) F; Fatal (Reconstruction)

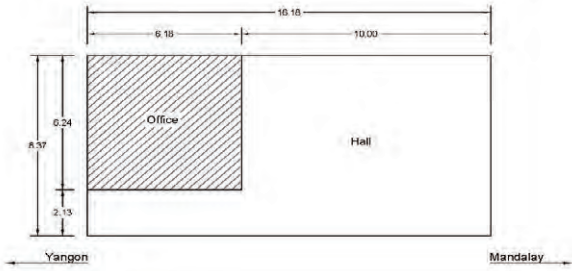

## Investigation of Station Building

Station No.	92	Line Name	Yangon – Mandalay Line	Date of Survey	7/7/2017		
Station Name	SHANZU						
Existing Station Building	Kilopost	617.5	Mileage	384			
	Access Road	<input checked="" type="radio"/> Yes    No	Age of Building	Over 50 years			
	Story of Building	( 1 ) Story Building	Total Floor Area	About 136 m <sup>2</sup>			
	Type of Main Structure (Check <input type="radio"/> )	<input checked="" type="radio"/> Brick with RC • Wood • Other(    )	Finish Material	Roof	<input checked="" type="radio"/> Corrugated Steel sheet • Roof Tiles • RC • Asbestos Fibre Cement		
	Other Structure	Wall		<input checked="" type="radio"/> Brick    Wood	Wall	<input checked="" type="radio"/> Paint	
		Column		Brick <input checked="" type="radio"/> Wood    RC	Column	<input checked="" type="radio"/> Paint	
		Beam		<input checked="" type="radio"/> Wood    RC    Steel	Floor	<input checked="" type="radio"/> Concrete    • Wood	
	Electric system (Check <input type="radio"/> )	<input checked="" type="radio"/> Retract from outside • Solar System • Generator	Water Supply (Check <input type="radio"/> )	• Water Well (    ) • Waterwork <input checked="" type="radio"/> None			
	Condition of Main Structure	Main Damage Type & Rank*		Condition of Finish Material	Main Damage Type & Rank*		
		D	<input checked="" type="radio"/> Crack ( 6mm) • Settlement • Inclination		C	<input checked="" type="radio"/> Water Leak • Peel Off (Roof, Ceiling, Wall, Colum )	
General Evaluation	• Usual <input checked="" type="radio"/> Poor • Severe	Remarks	No toilet. About 10–15passengers/day.				
Photograph	 						

\*Damage Rank C;Slight (Repair) D;Heavy (Repair and Reinforcement) F; Fatal (Reconstruction)

## Investigation of Station Building

Station No.	93	Line Name	Yangon – Mandalay Line	Date of Survey	22/5/2017		
Station Name	MANDALAY						
Existing Station Building	Kilopost	620.5		Mileage	385-1/2		
	Access Road	<input checked="" type="radio"/> Yes    No		Age of Building	Since 2001		
	Story of Building	( 7 ) Story Building		Total Floor Area	About 15000 m <sup>2</sup>		
	Type of Main Structure (Check <input type="radio"/> )	<input checked="" type="radio"/> Brick with RC • Wood • Other(    )		Finish Material	Roof	<input checked="" type="radio"/> Corrugated Steel sheet • Roof Tiles • RC • Asbestos Fibre Cement	
	Other Structure	Wall	<input checked="" type="radio"/> Brick    Wood		Wall	<input checked="" type="radio"/> Paint	
		Column	Brick    Wood <input checked="" type="radio"/> RC		Column	<input checked="" type="radio"/> Paint	
		Beam	Wood <input checked="" type="radio"/> RC    Steel		Floor	<input checked="" type="radio"/> Concrete    • Wood	
	Electric system (Check <input type="radio"/> )	<input checked="" type="radio"/> Retract from outside • Solar System • Generator		Water Supply (Check <input type="radio"/> )	<input checked="" type="radio"/> Water Well ( Pump ) • Waterwork • None		
	Condition of Main Structure	Main Damage Type & Rank*			Condition of Finish Material	Main Damage Type & Rank*	
		B	• Crack (    mm) • Settlement • Inclination			C	<input checked="" type="radio"/> Water Leak • Peel Off (Roof, Ceiling, Wall, Colum )
General Evaluation	<input checked="" type="radio"/> Usual • Poor • Severe		Remarks				
Photograph							

\*Damage Rank C;Slight (Repair) D;Heavy (Repair and Reinforcement) F; Fatal (Reconstruction)

## **APPENDIX 5.16.1**

### **Location of Power Supply Equipment**

Level Crossing No.6 (5)  
(Pan Chi Ta Ga Level Crossing)

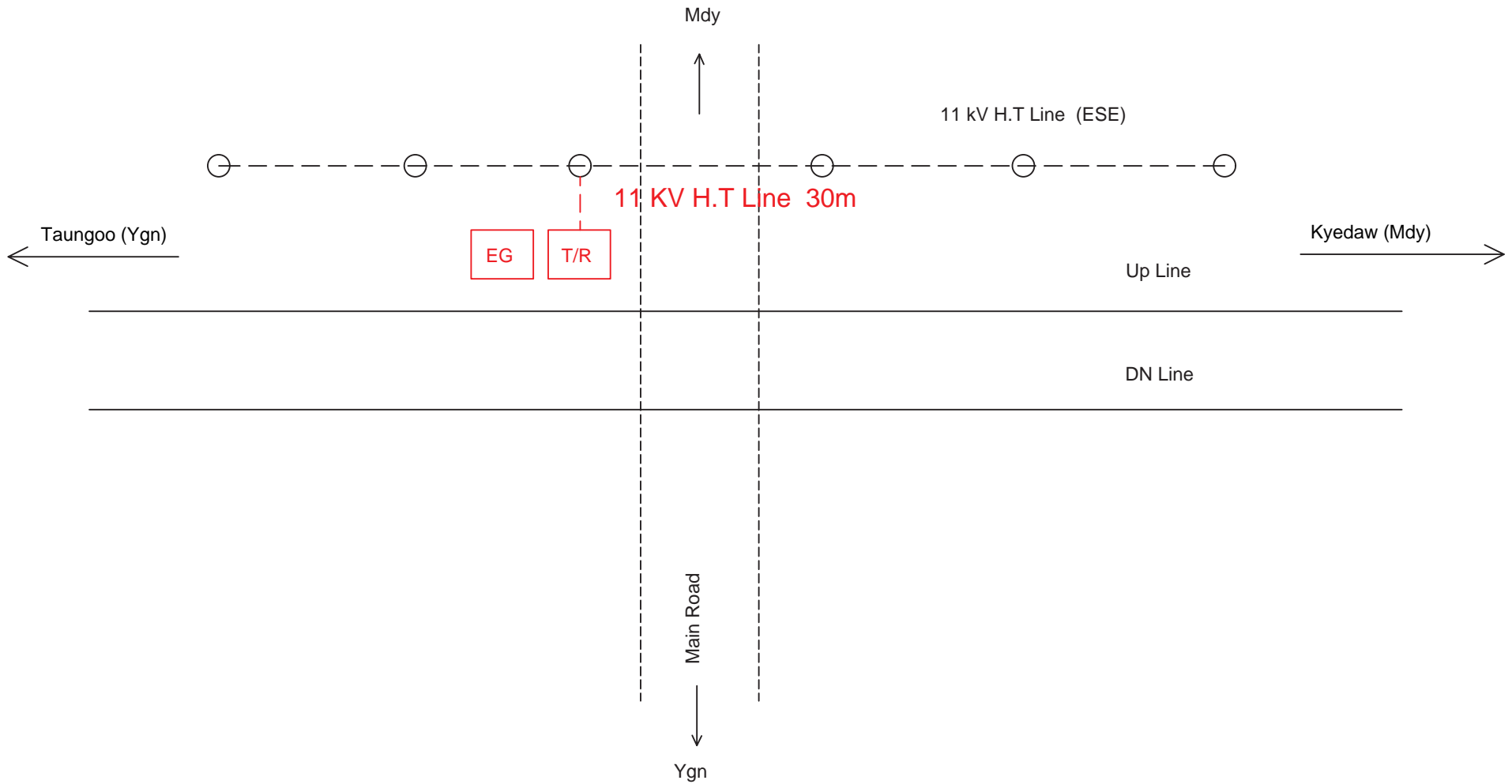

Appendix 5.16.1-1

Level Crossing No.7 (5)  
(Ba Yint Naung Level Crossing)

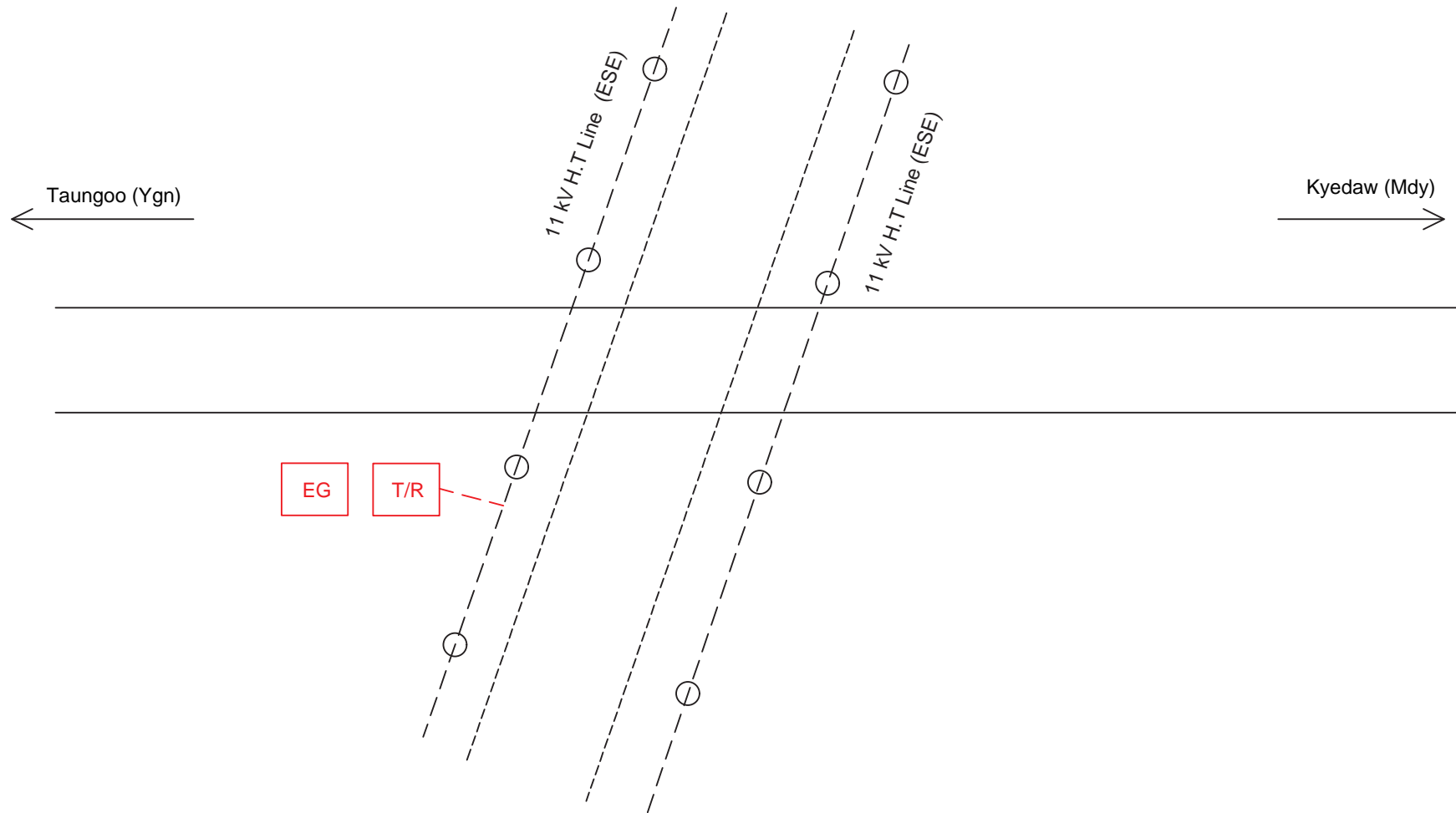

Appendix 5.16.1-2

# Kyedaw Station

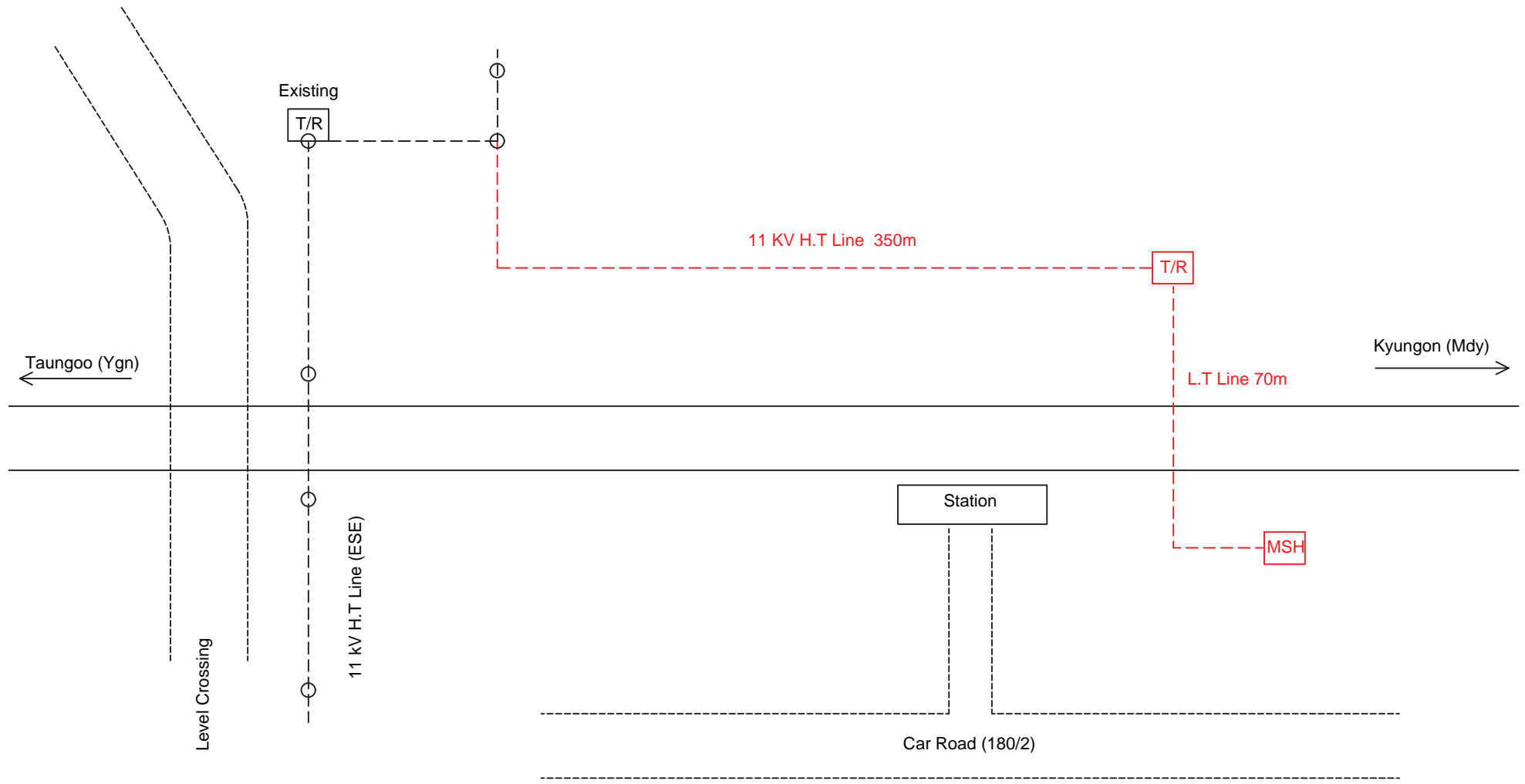

Appendix 5.16.1-3

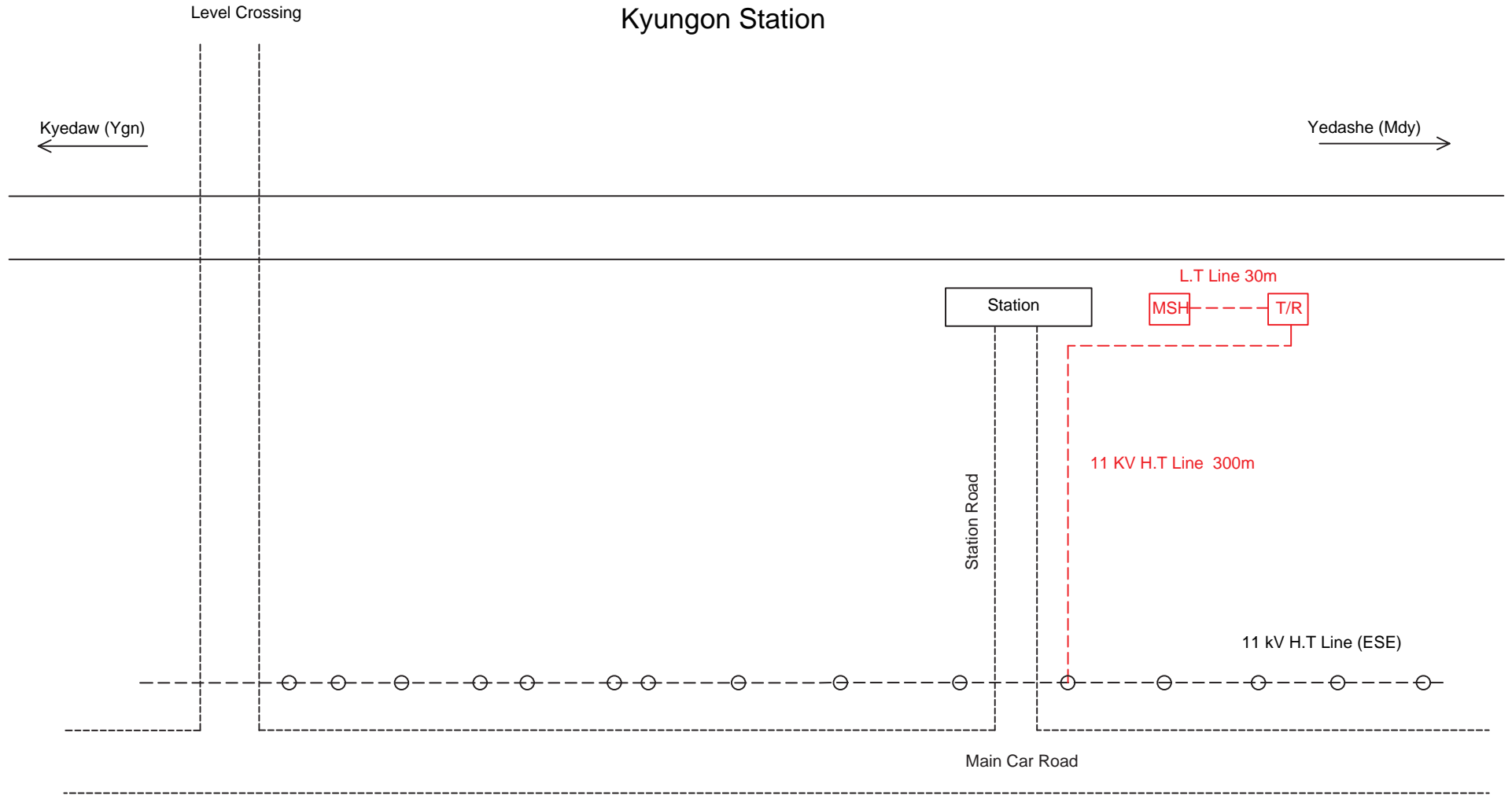

# Yedashe Station

Kyungon (Ygn) ←

→ Kongyi (Mdy)

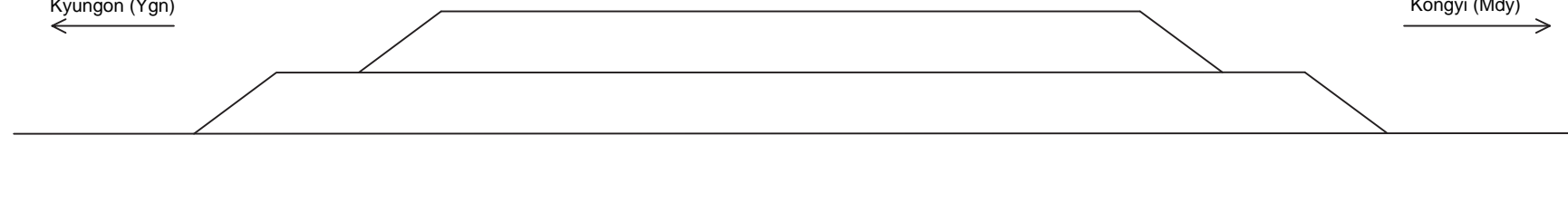

L.T Line 30m

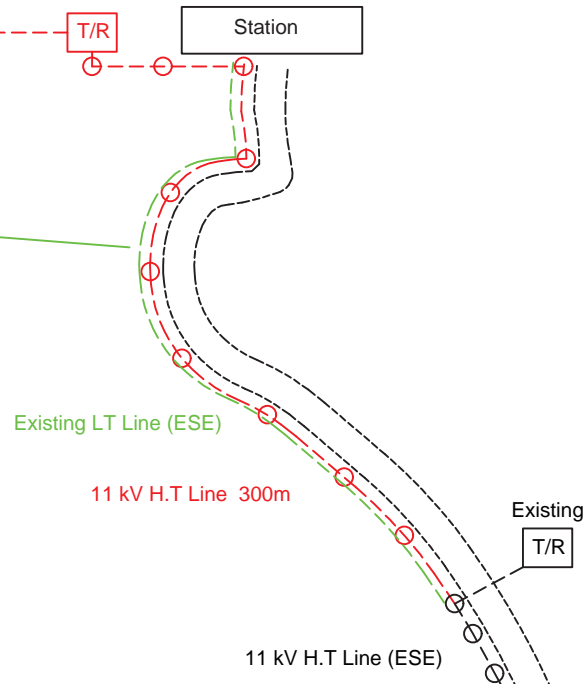
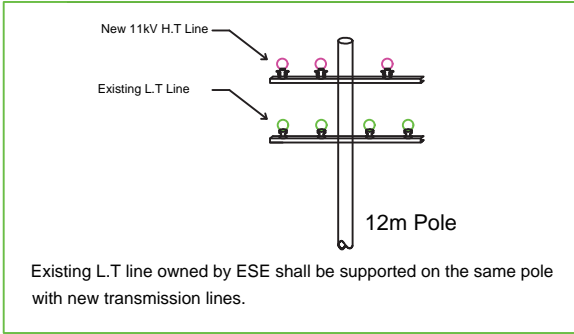
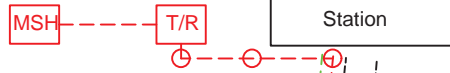

Appendix 5.16.1-5



Level Crossing No.16 (5)  
(Nyaung Pin Gaing Level Crossing)

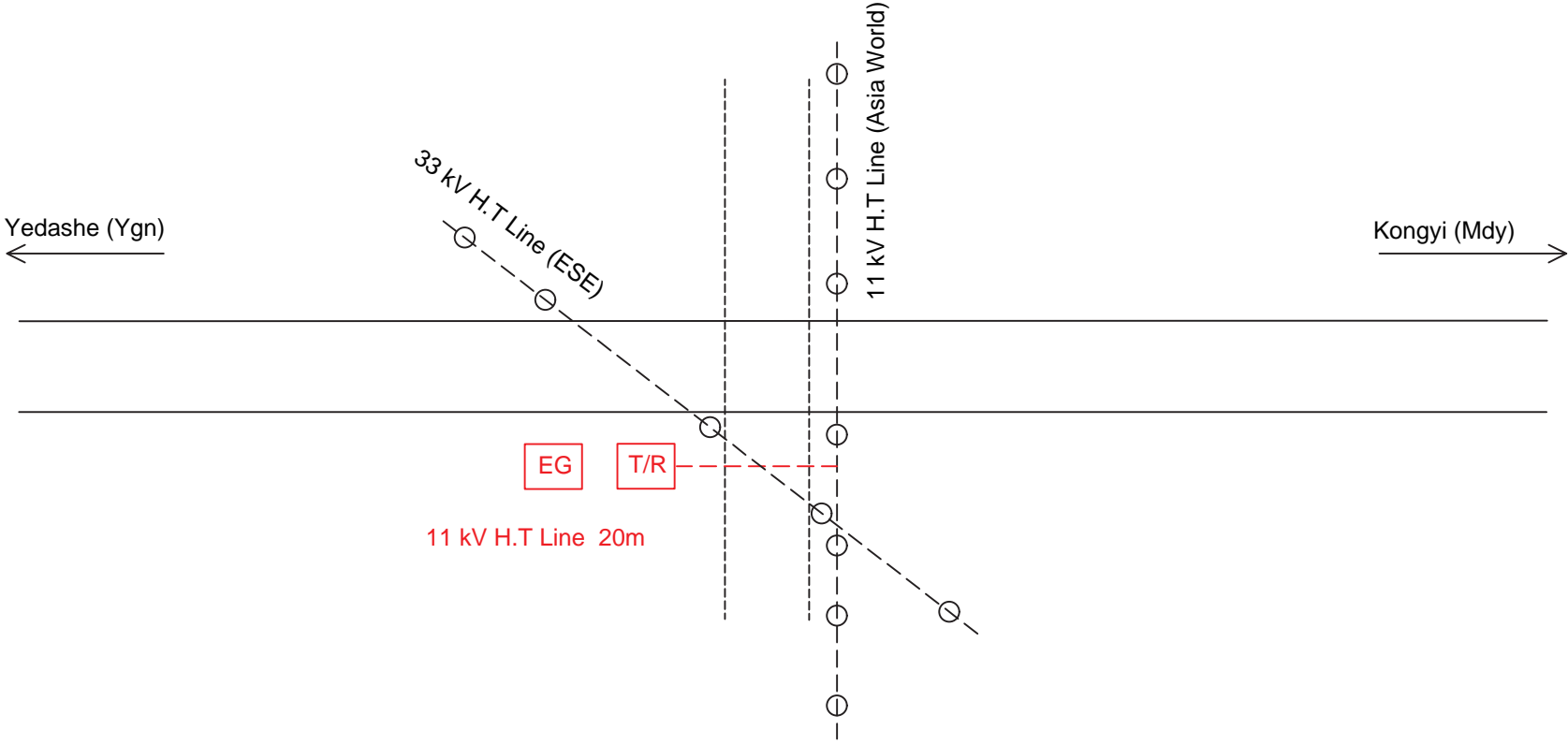

Appendix 5.16.1-6

# Swa Station

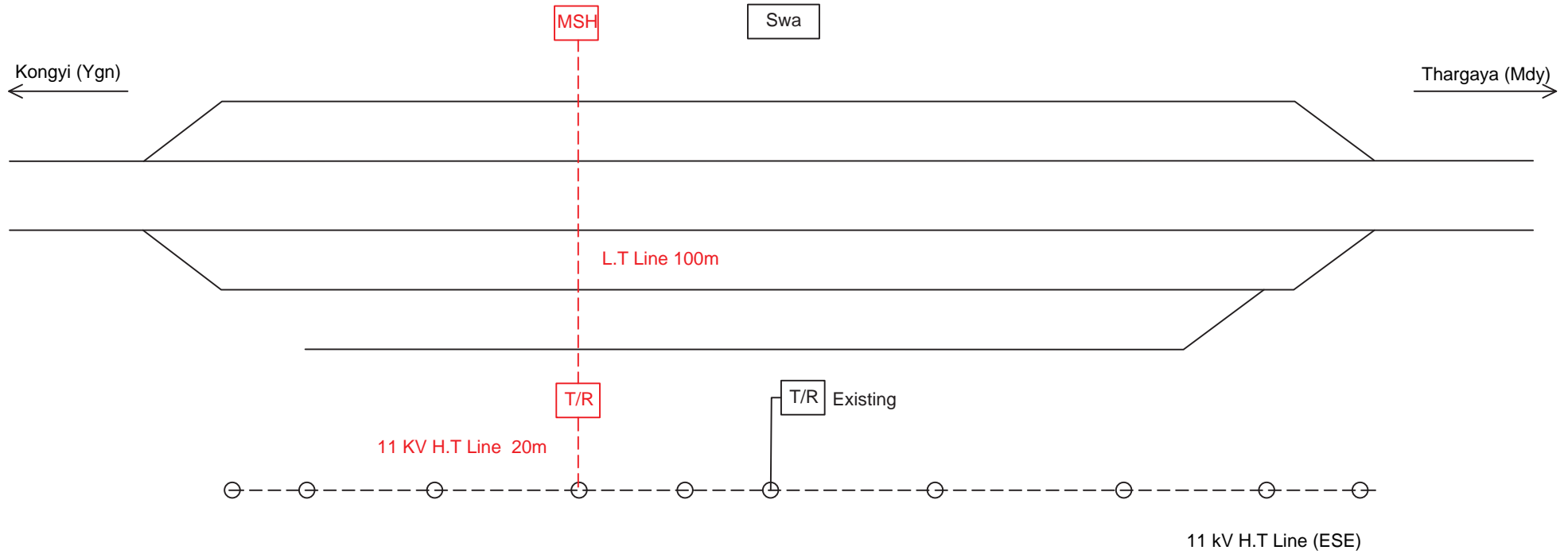

Appendix 5.16.1-7

# Kongyi Station

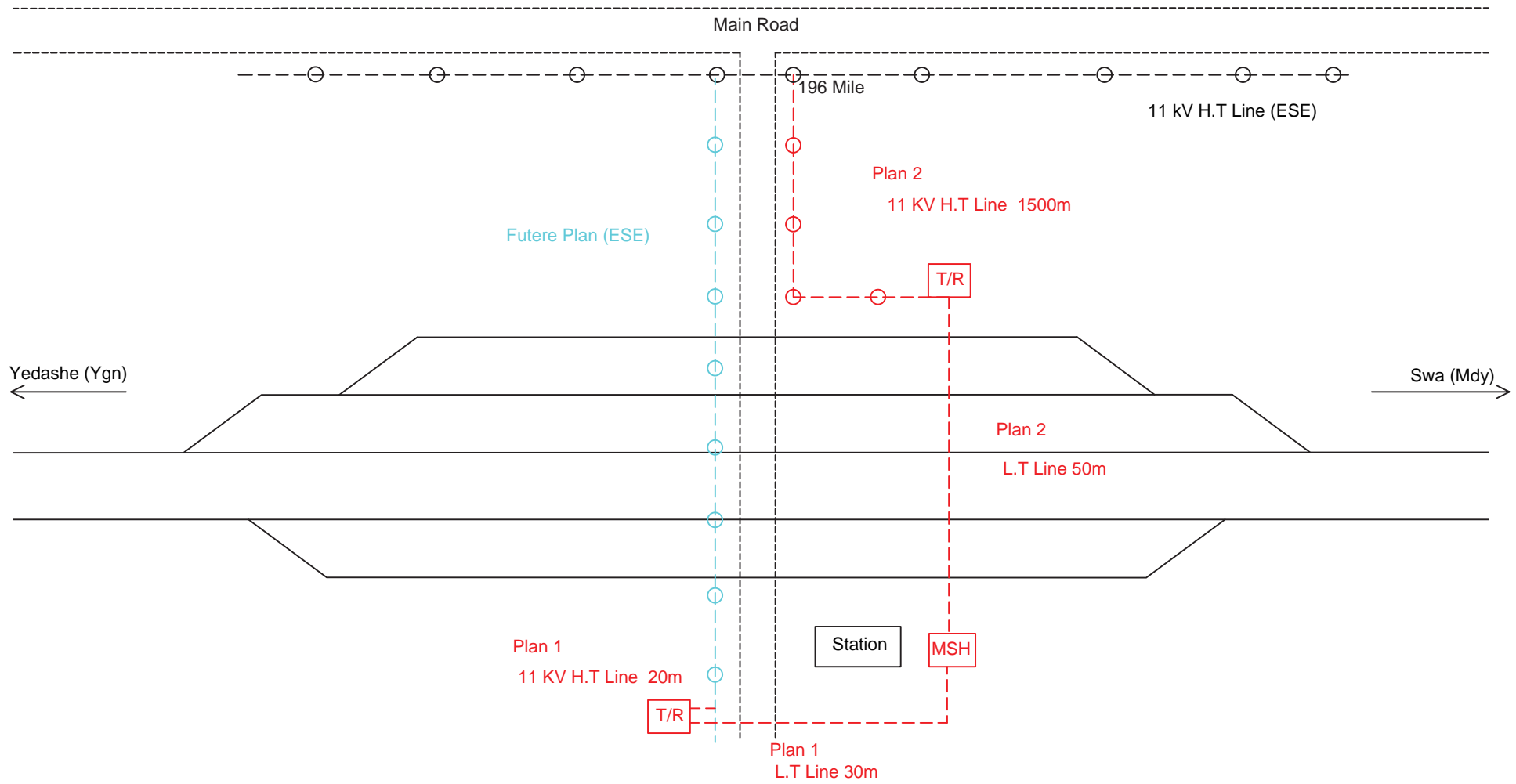

Appendix 5.16.1-8

### Thargaya Station

Level Crossing

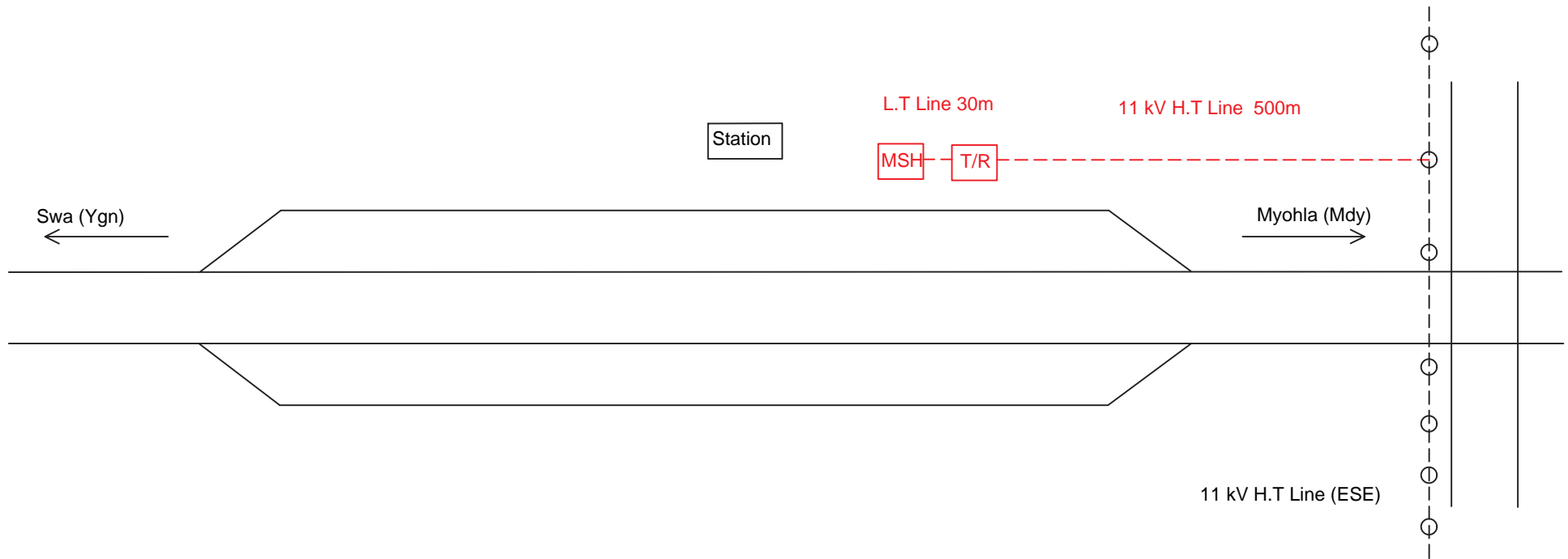

Myohla Station

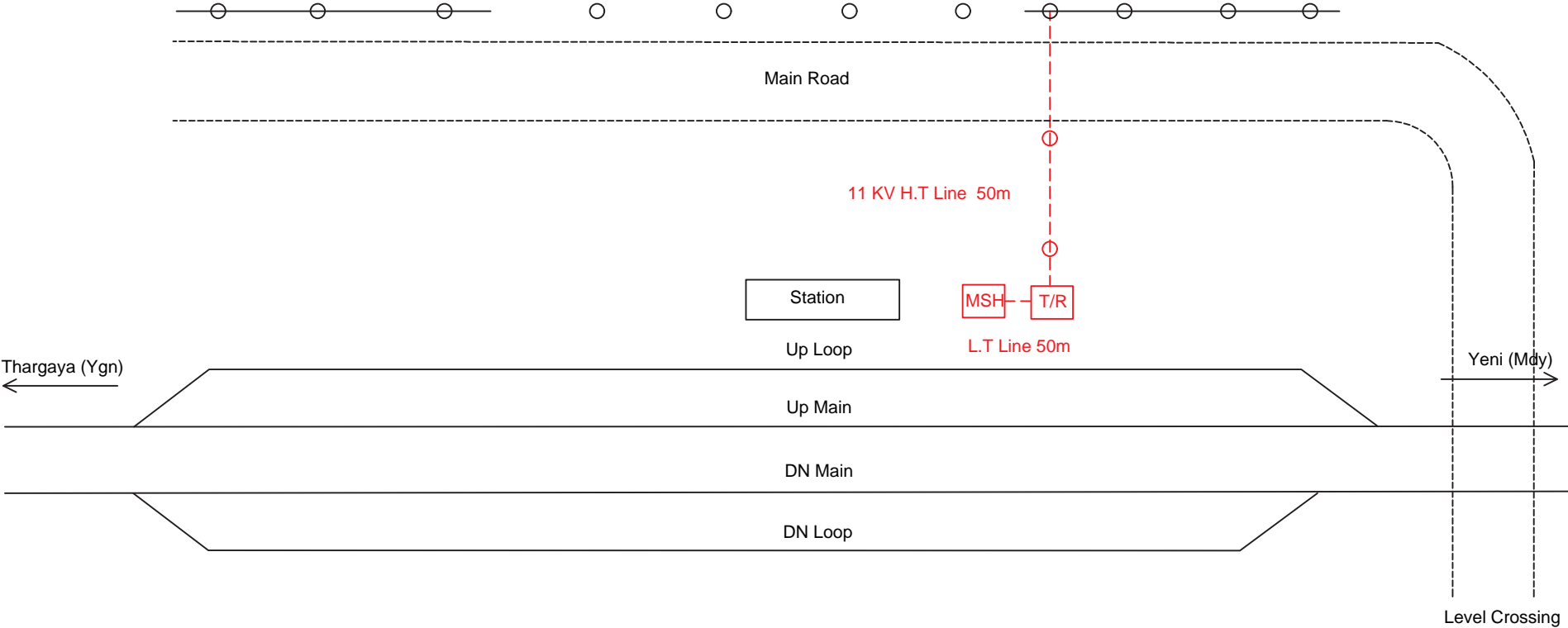

Appendix 5.16.1-10

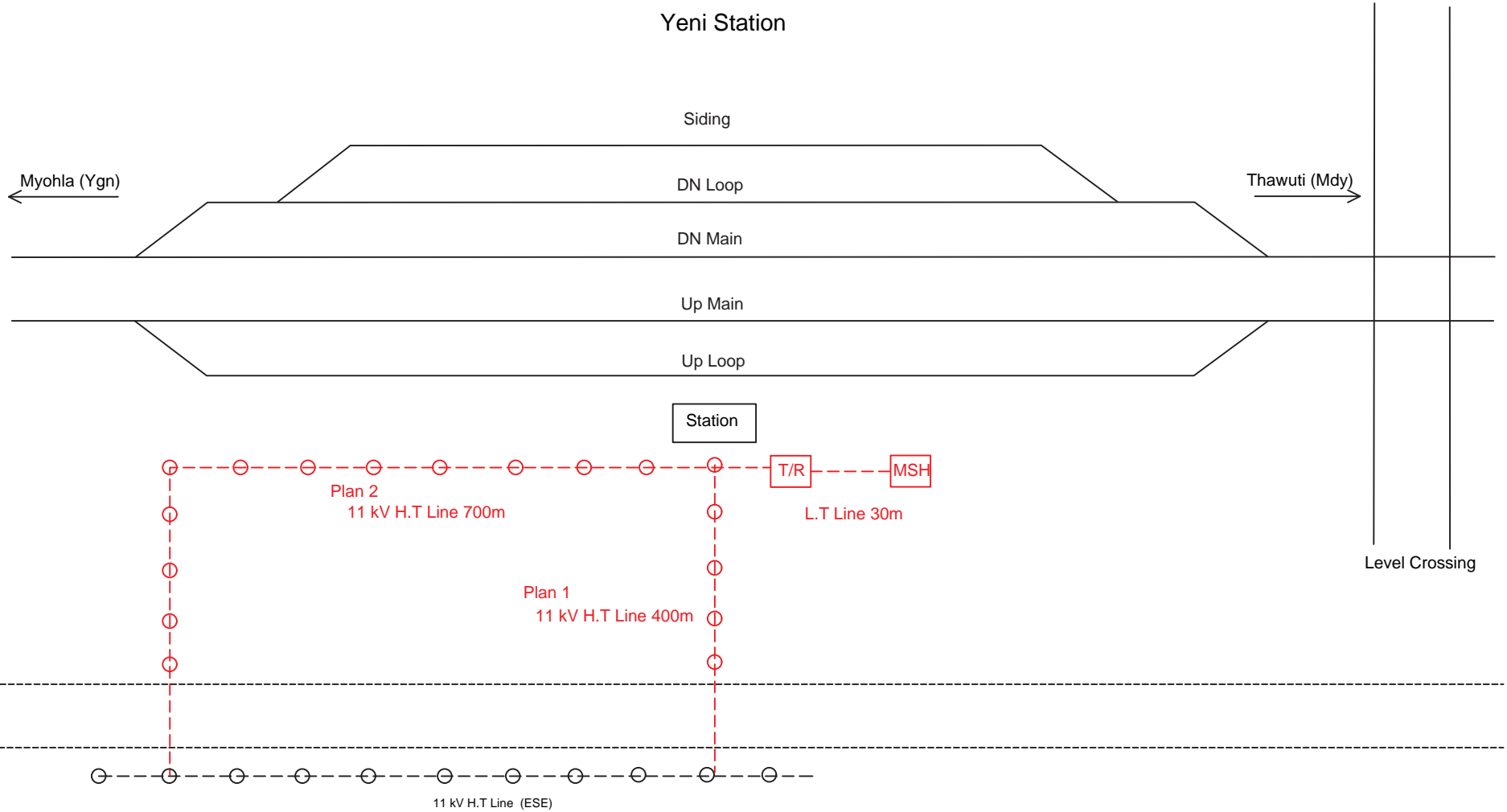

### Thawuti Station

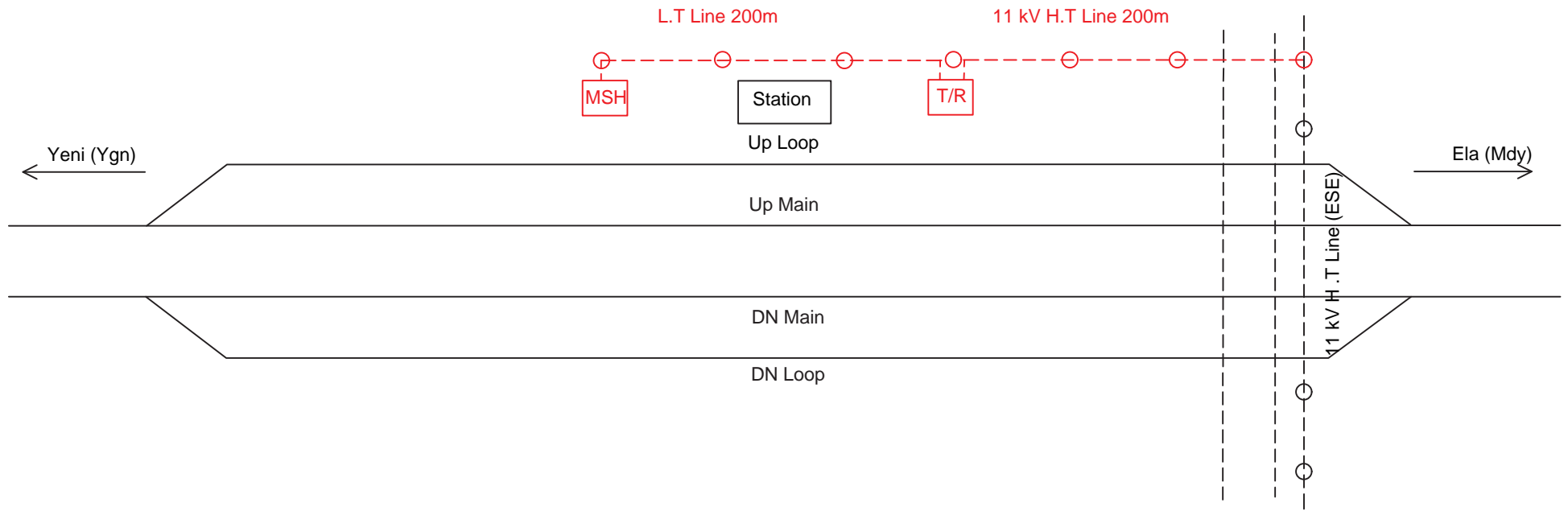

Level Crossing No.26 (5)  
(Ya Thae' Taung Level Crossing)

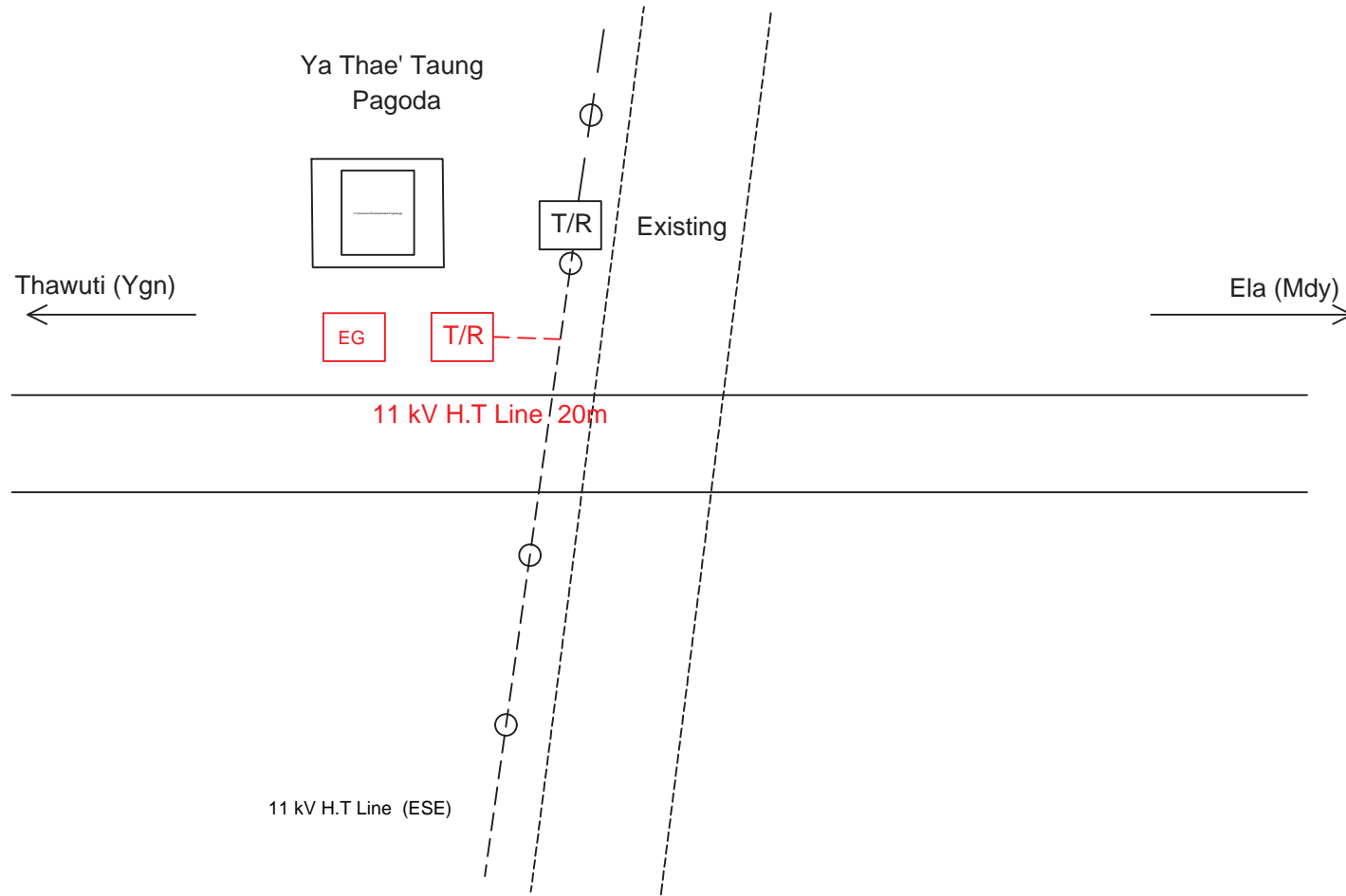

Appendix 5.16.1-13



# Level Crossing No.28 (5) (Ela Level Crossing)

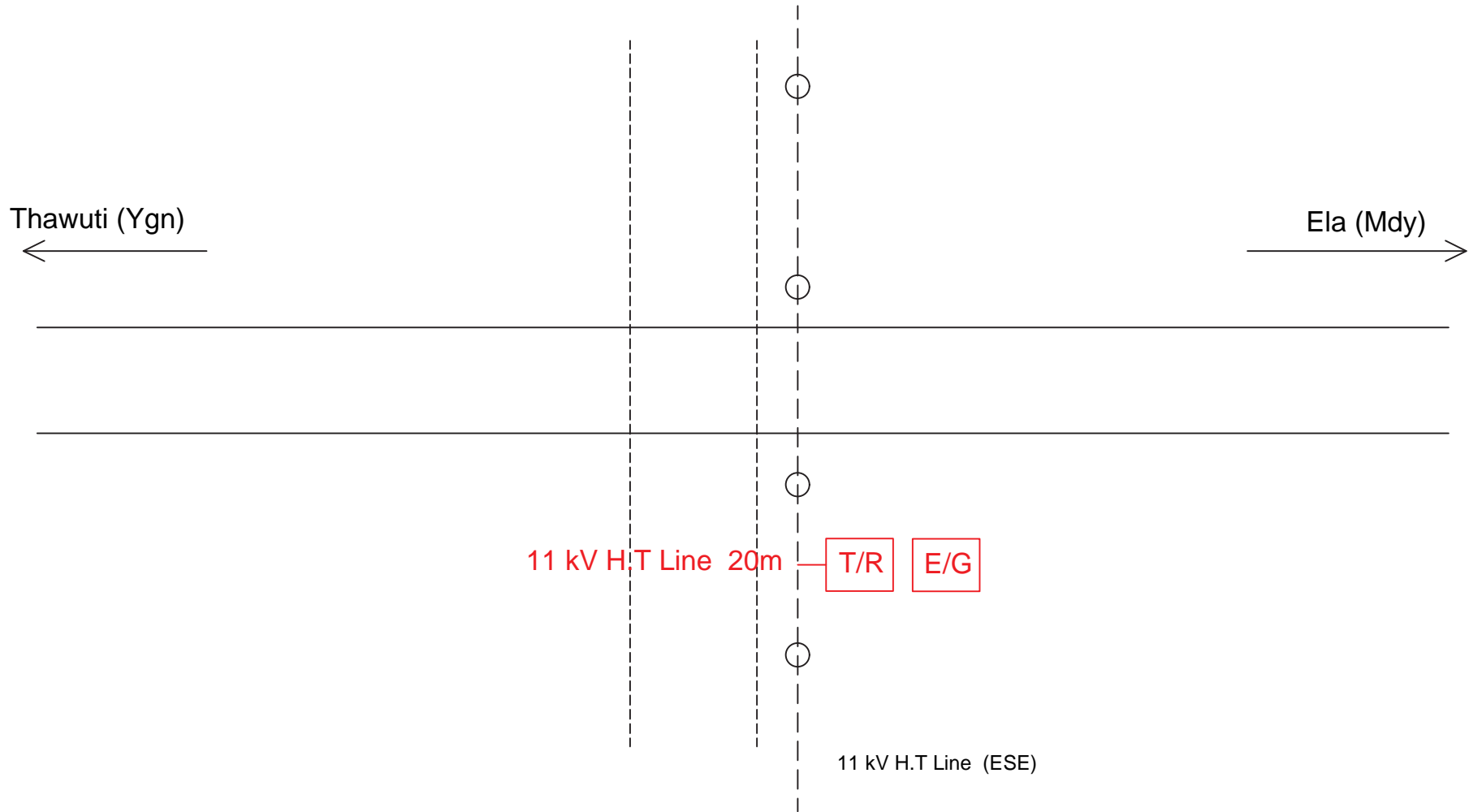

Appendix 5.16.1-14

# Ela Station

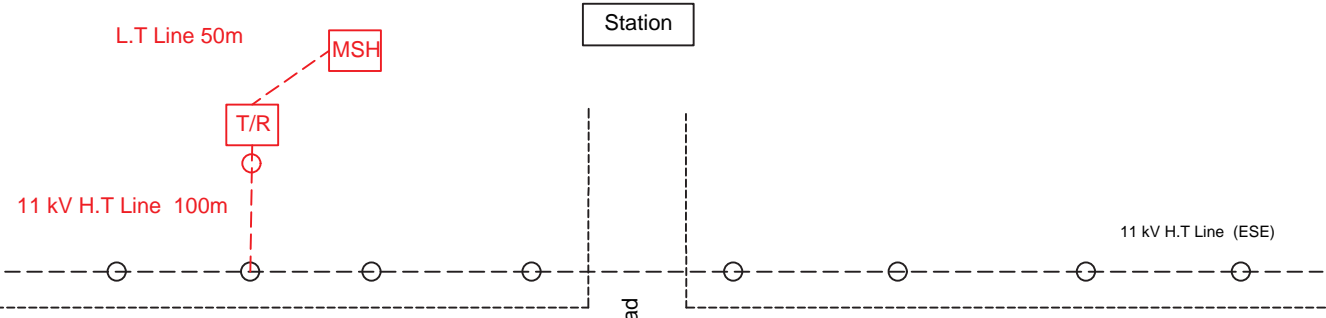
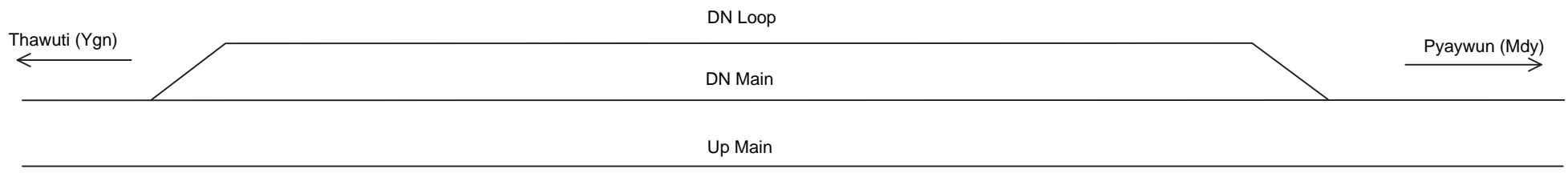

# Pyaywun Station

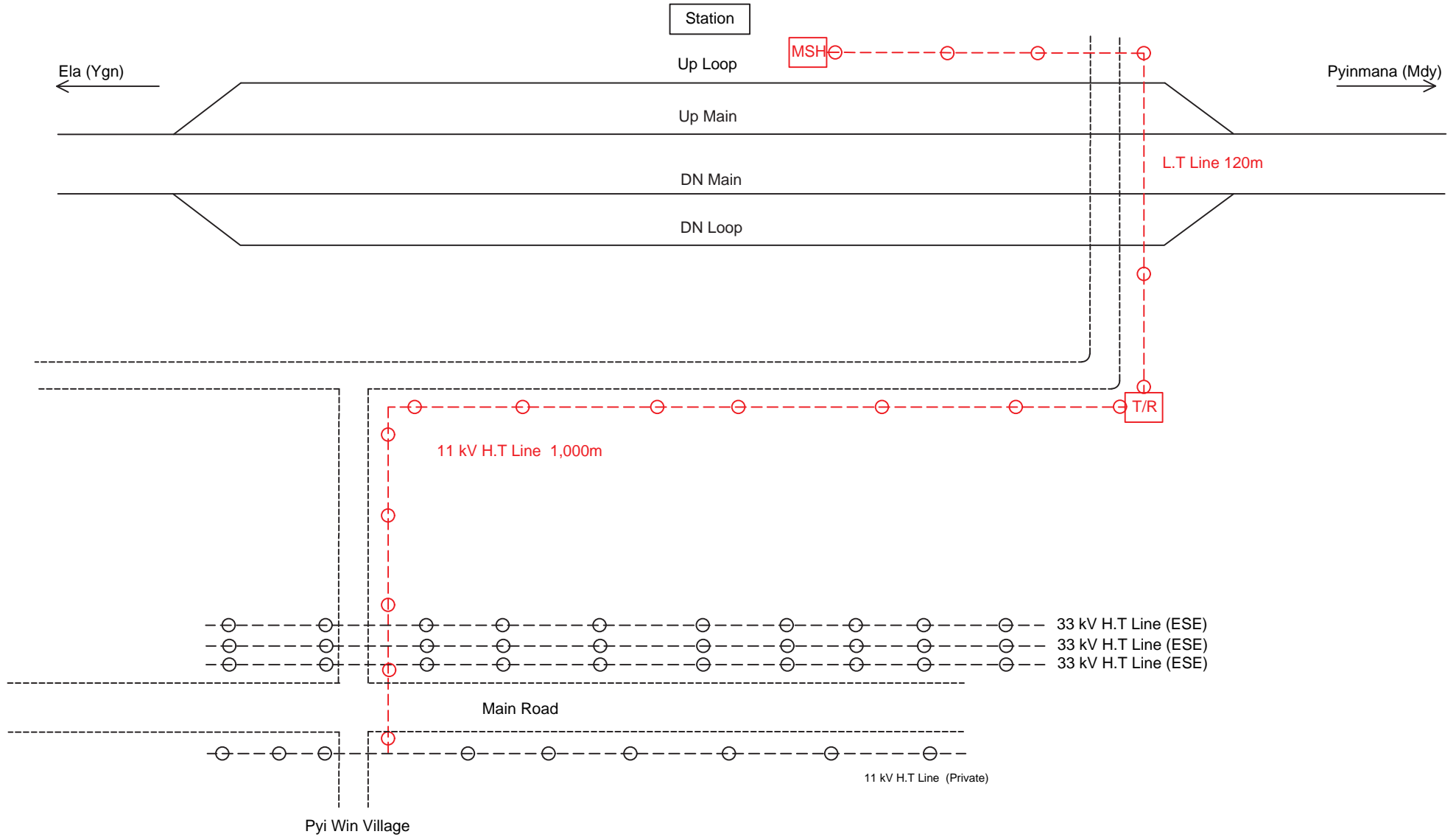

Appendix 5.16.1-16

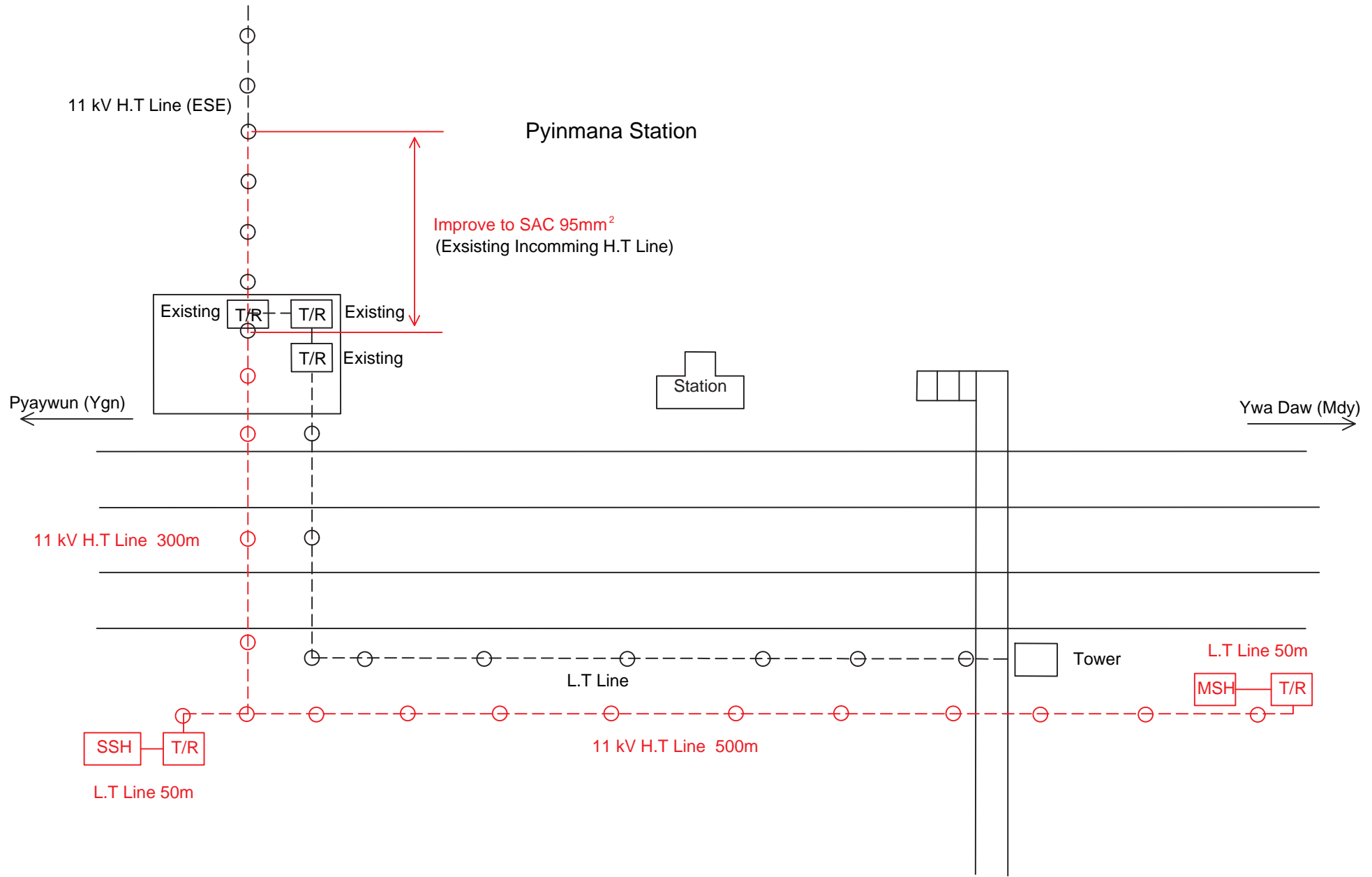

### Level Crossing No. 38 (5) (Pagoda Gate Level Crossing)

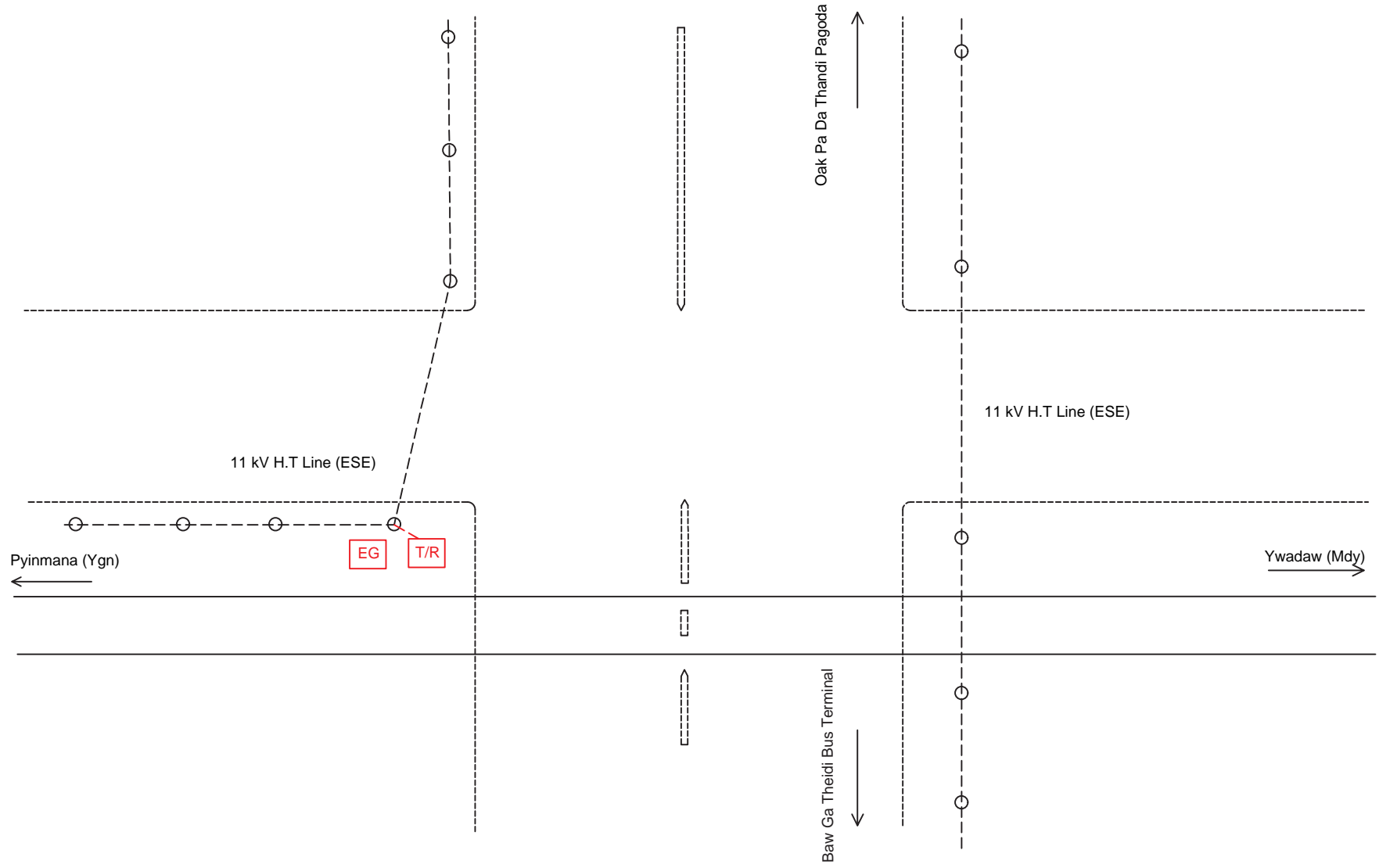

Level Crossing No.36 (5)  
(Army Level Crossing)

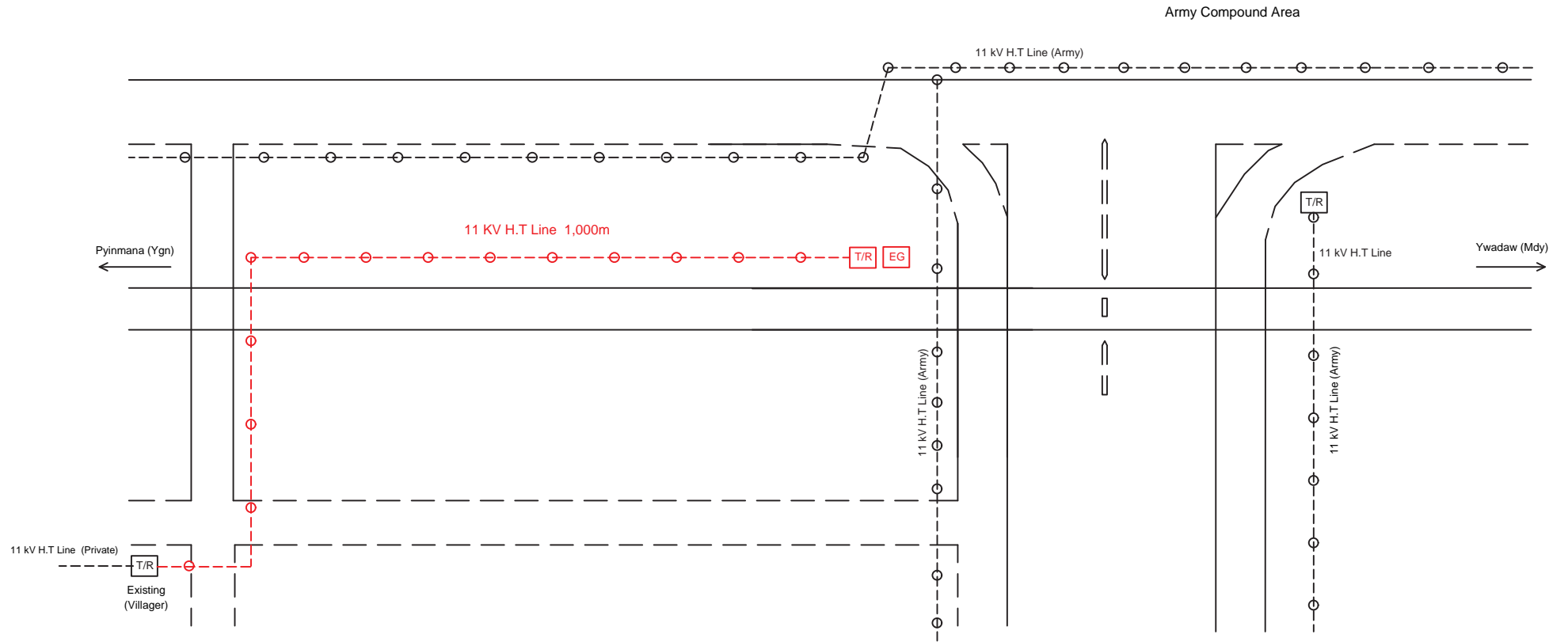

Appendix 5.16.1-19

# Ywadow Station

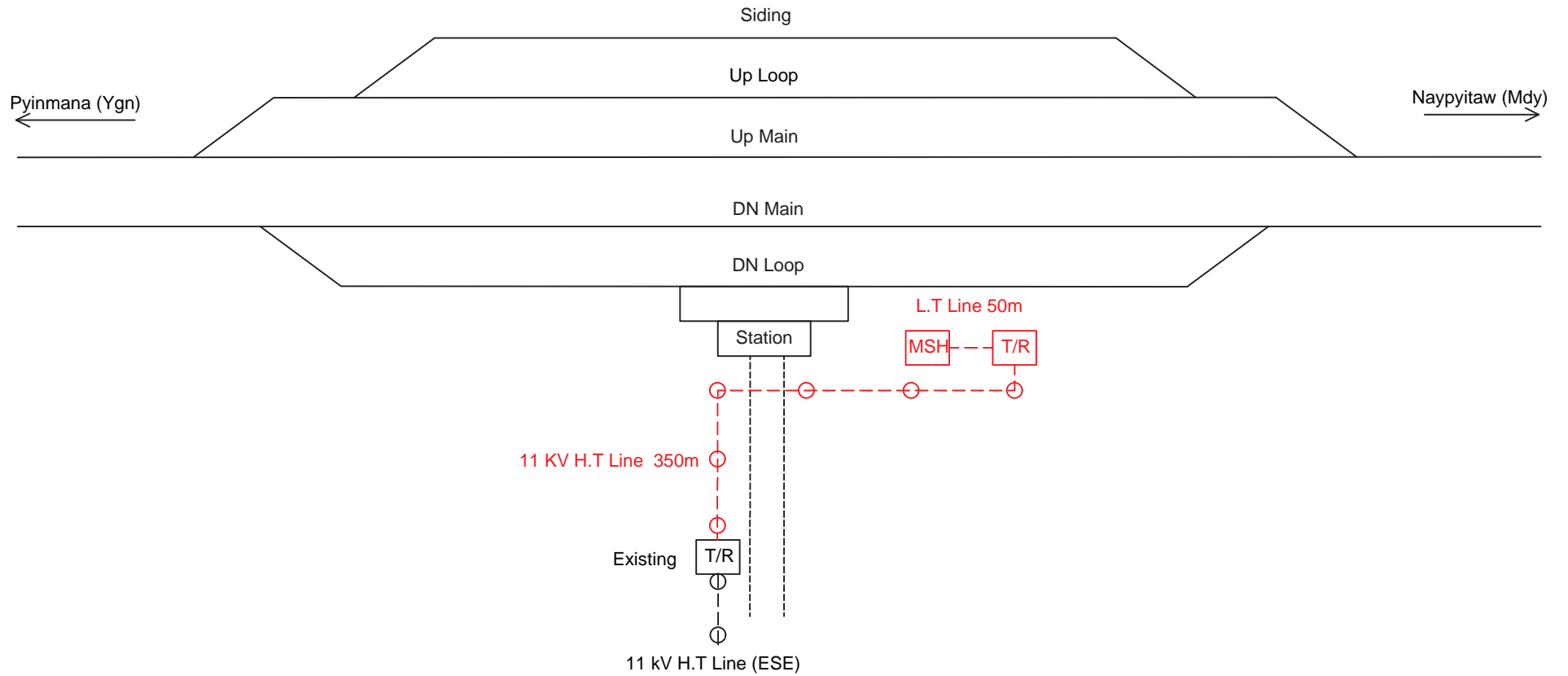

Appendix 5.16.1-20





# Kyidaungkan Station

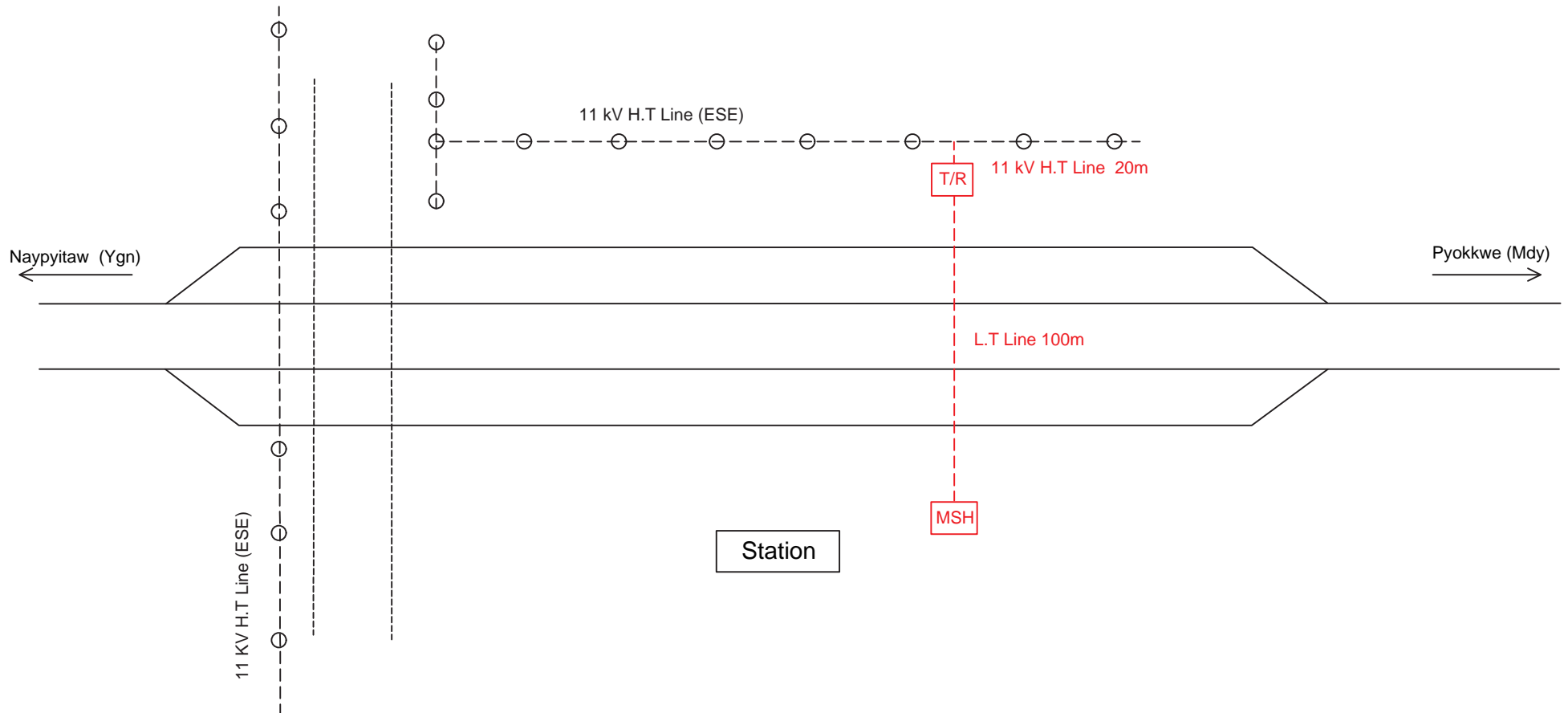

Level Crossing No.43 (5)  
(Neik Ban Level Crossing)

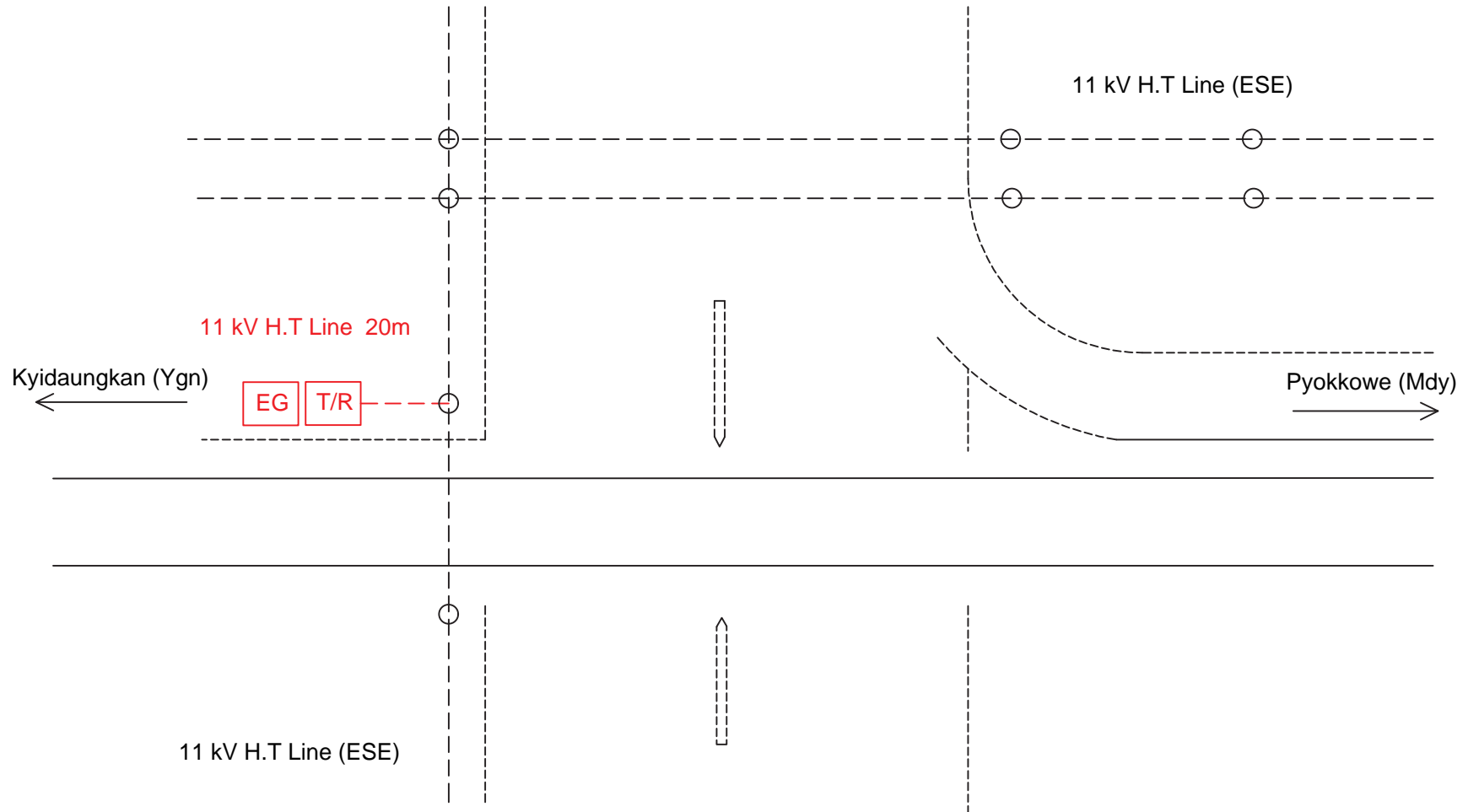

Appendix 5.16.1-23

# Pyokkwe Station

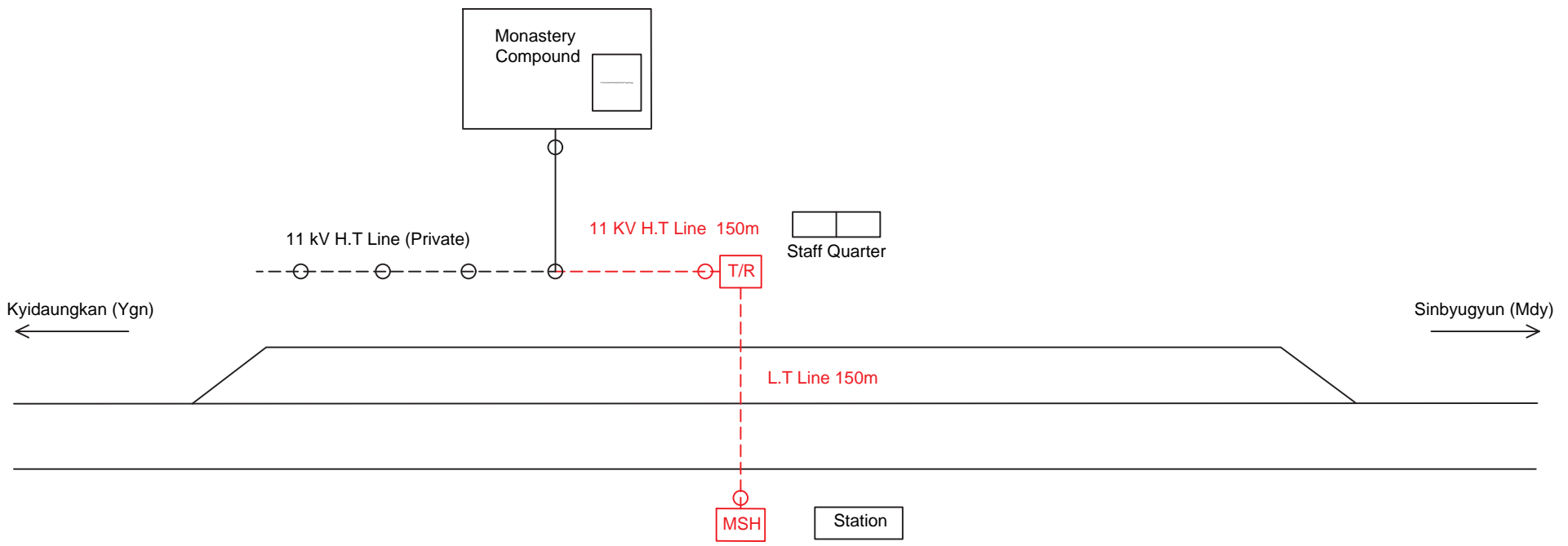

Appendix 5.16.1-24

Sinbyugyun Station

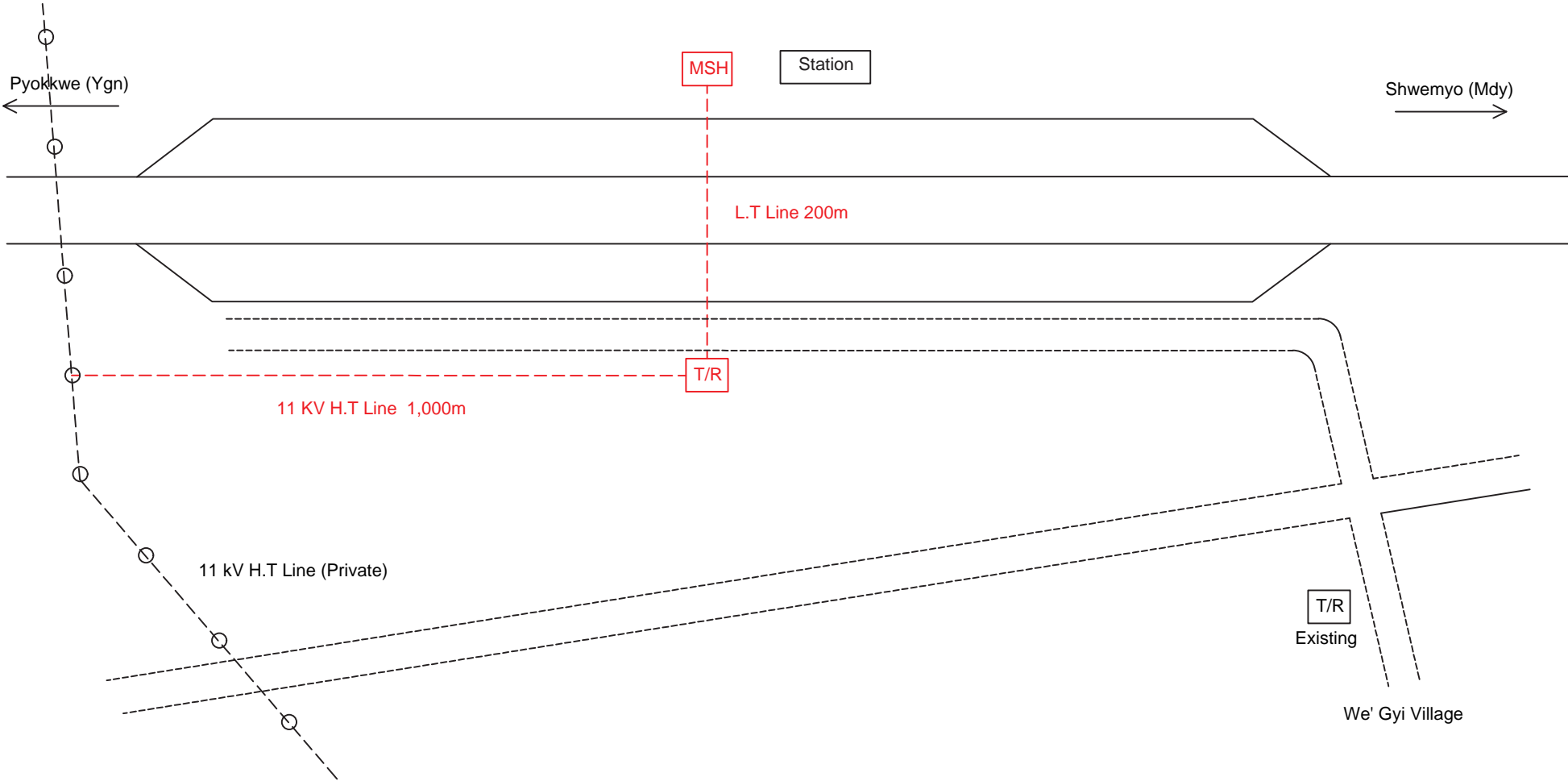

Appendix 5.16.1-25

# Shwemyo Station

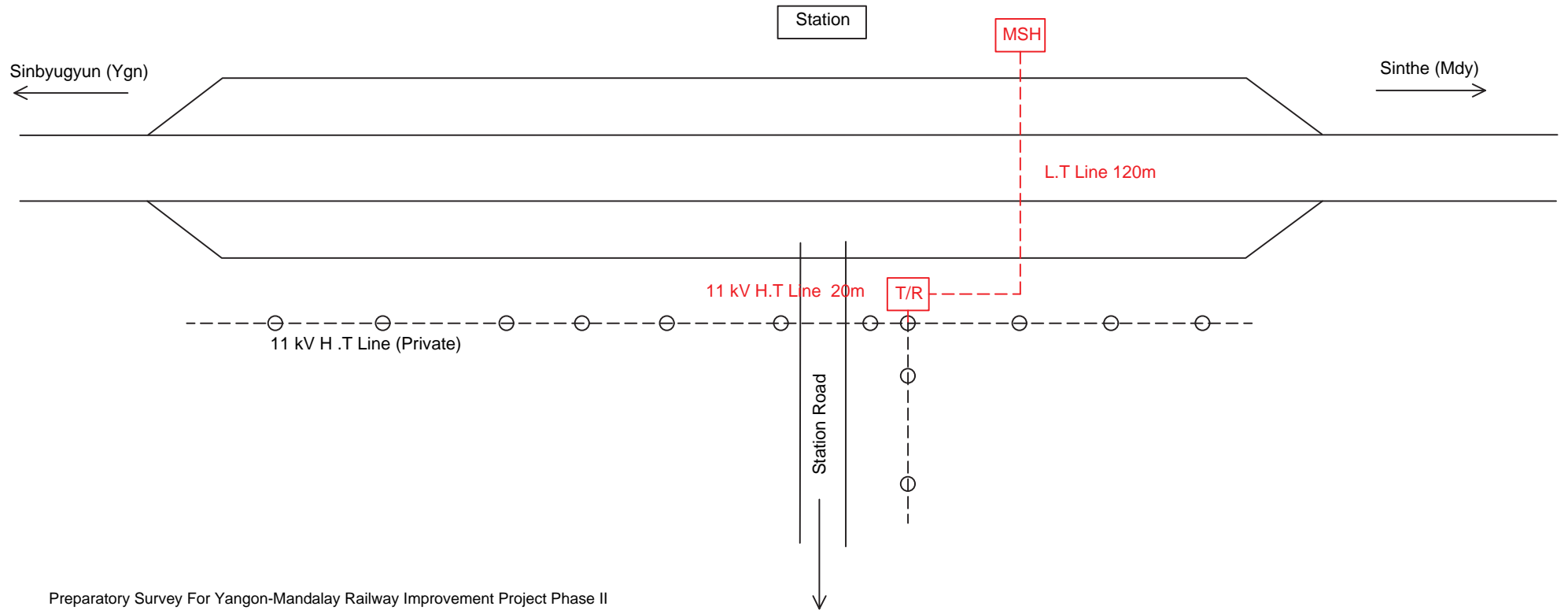

Appendix 5.16.1-26

# Sinthe Station

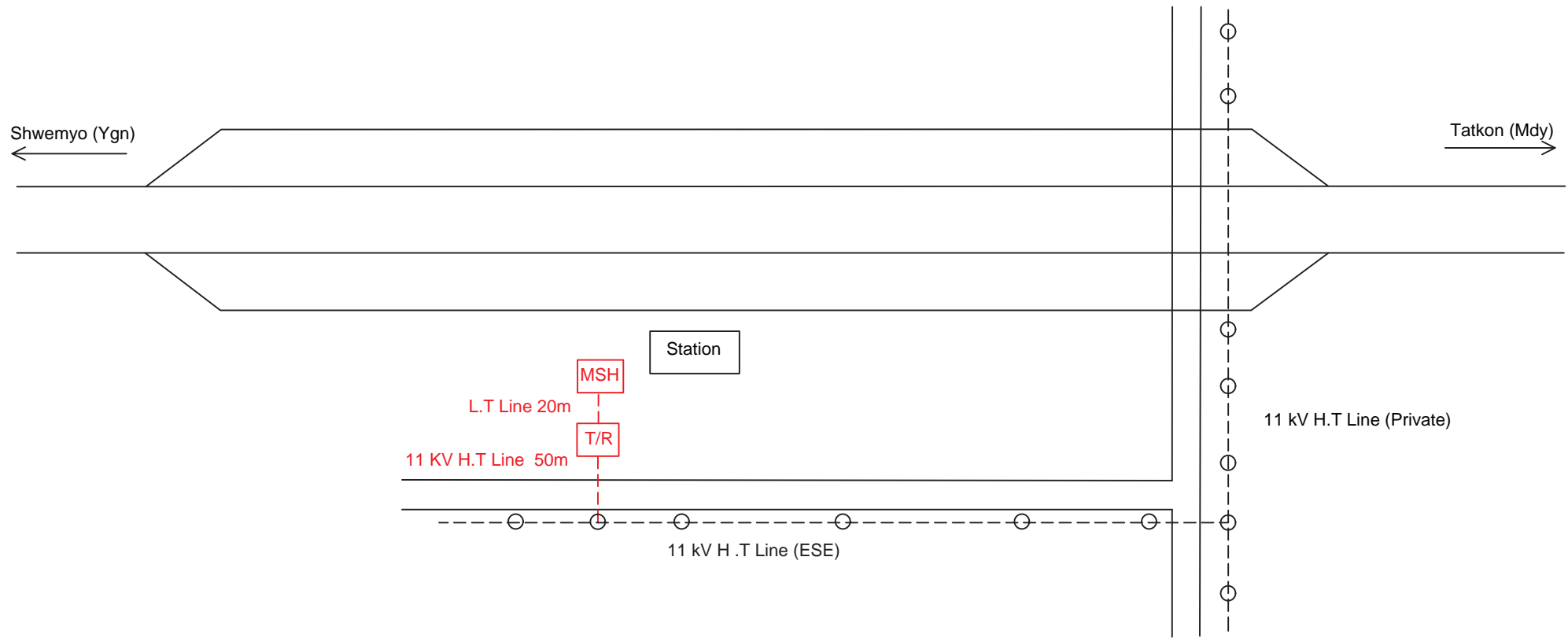

Appendix 5.16.1-27

Tatkon Station

Sinthe (Ygn)

Magyibin (Mdy)

Appendix 5.16.1-28

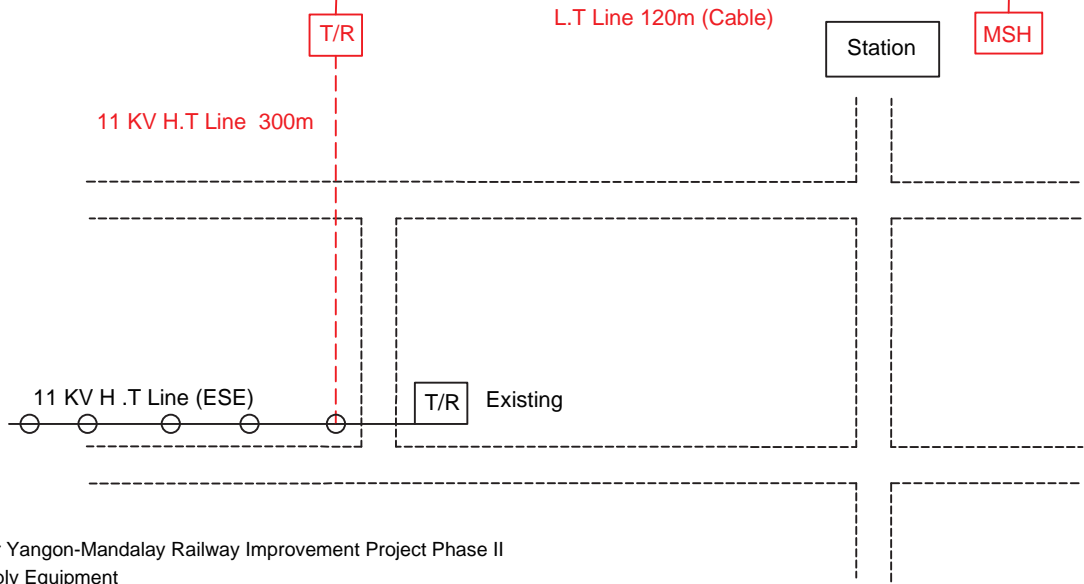

Preparatory Survey For Yangon-Mandalay Railway Improvement Project Phase II  
Location of Power Supply Equipment

Magyibin Station

Tatkon (Ygn)

Nyaunglun (Mdy)

11 kV H.T Line (Private)

Plan 3  
11 KV H.T Line 1,000m

T/R

Station

Plan 1, 2  
L.T Line 50m

T/R

MSH

Plan 3  
L.T Line 100m

Plan 1 11KV H.T Line 100m

Plan 2 33KV H.T Line 1,000m

Car Main road

11 kV H.T Line (ESE) (Future Plan)

33 kV H.T Line (ESE)

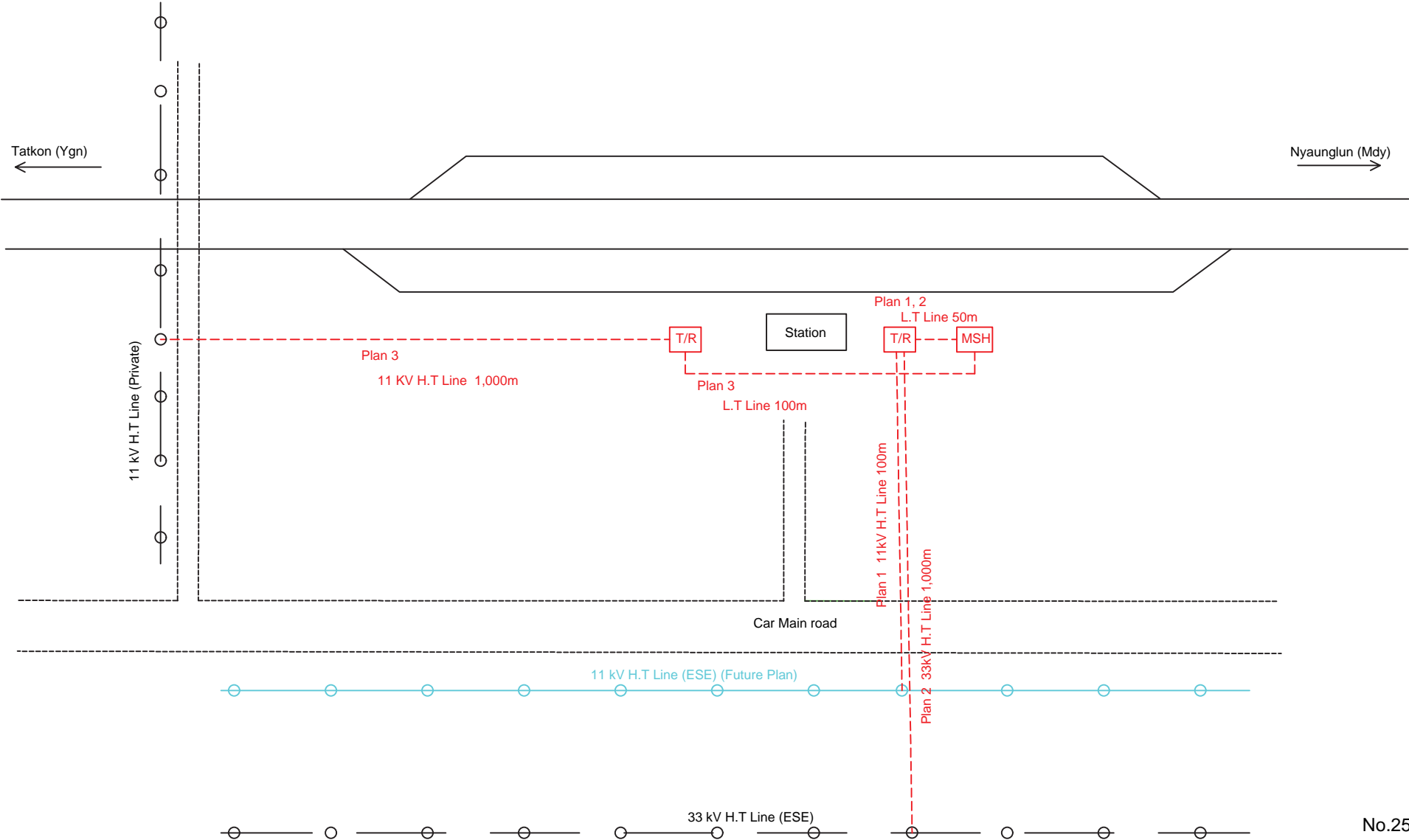



Level Crossing No.54 (5)  
Nyaung Car Pin Level Crossing

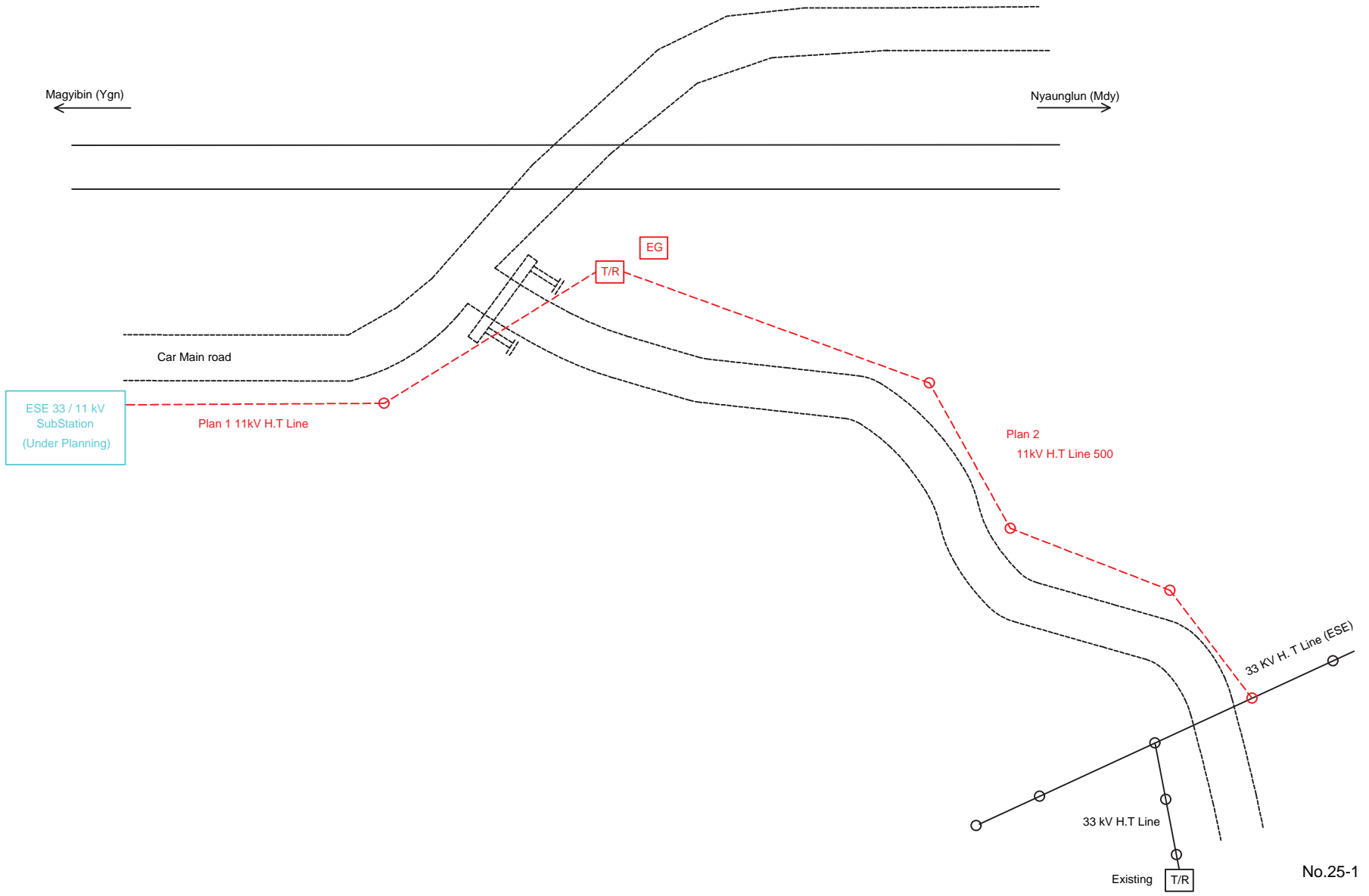

Appendix 5.16.1-30

Nyaung Lun Station

Magyibin (Ygn)

Hngetthaik (Mdy)

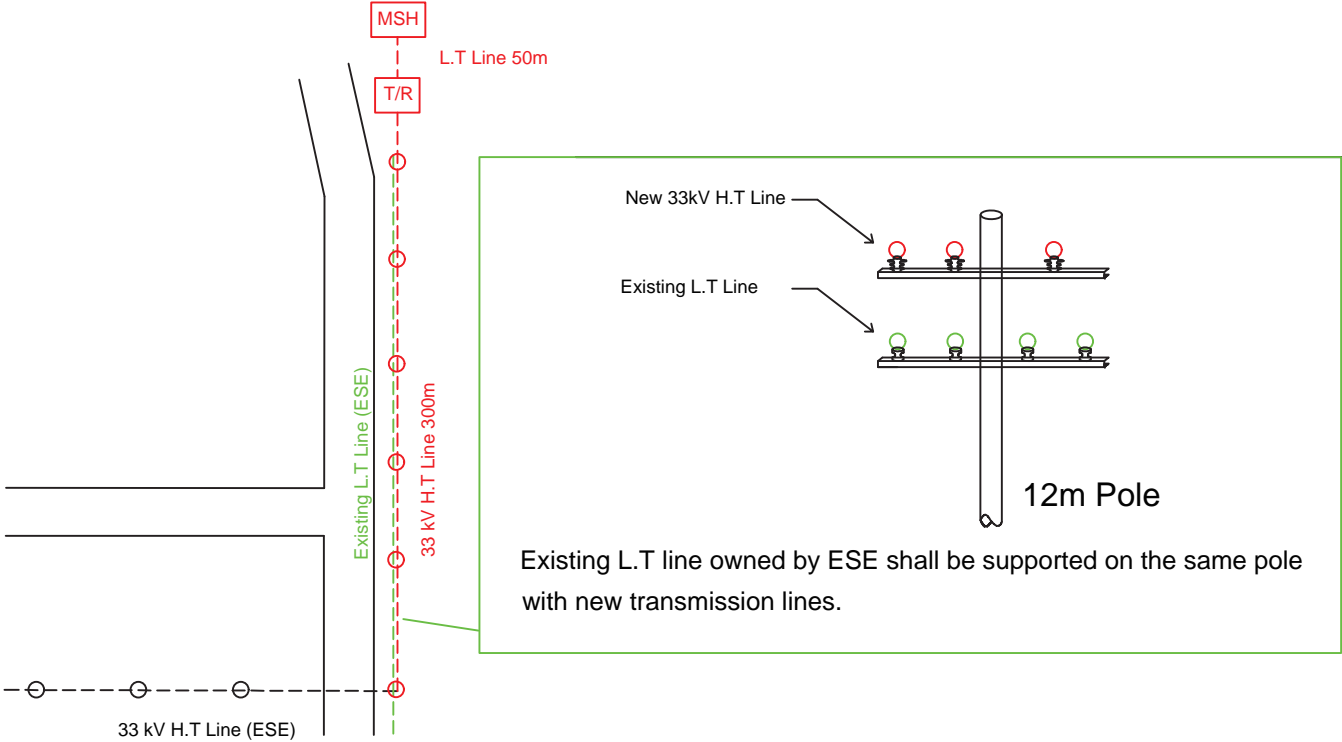

Preparatory Survey For Yangon-Mandalay Railway Improvement Project Phase II  
 Location of Power Supply Equipment

11 kV H . T Line (MESC) (Under Construction)

### Hnggetthaik Station

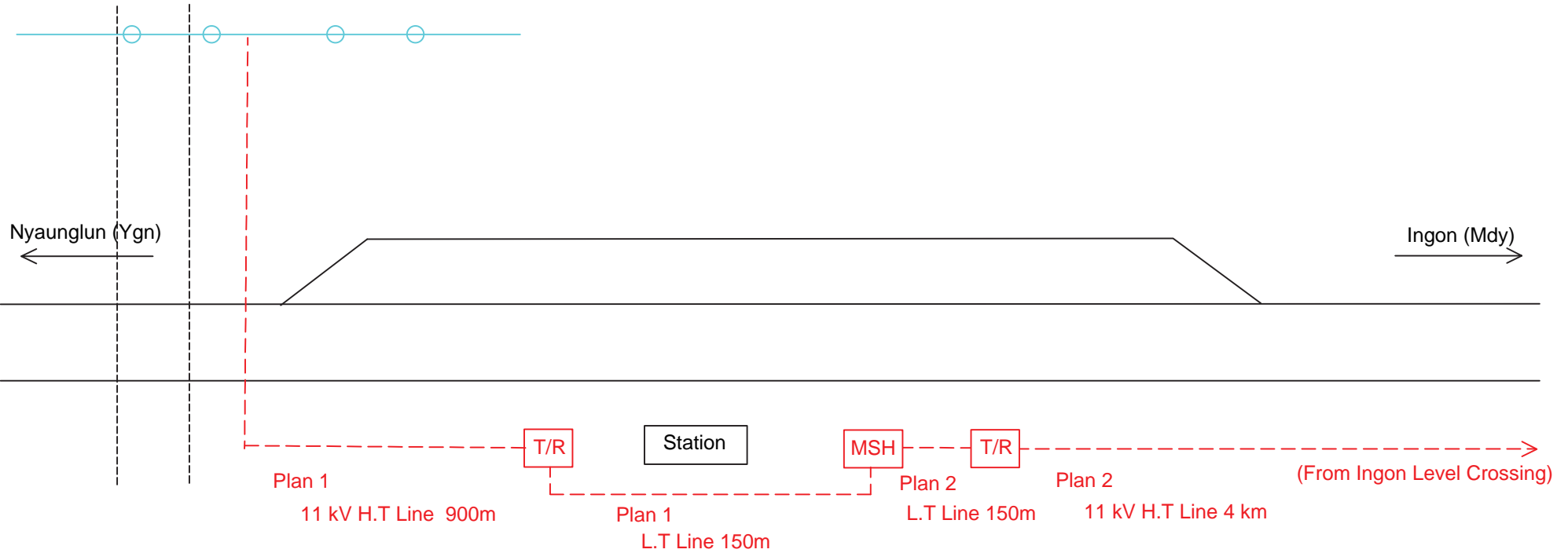

Ingon Station

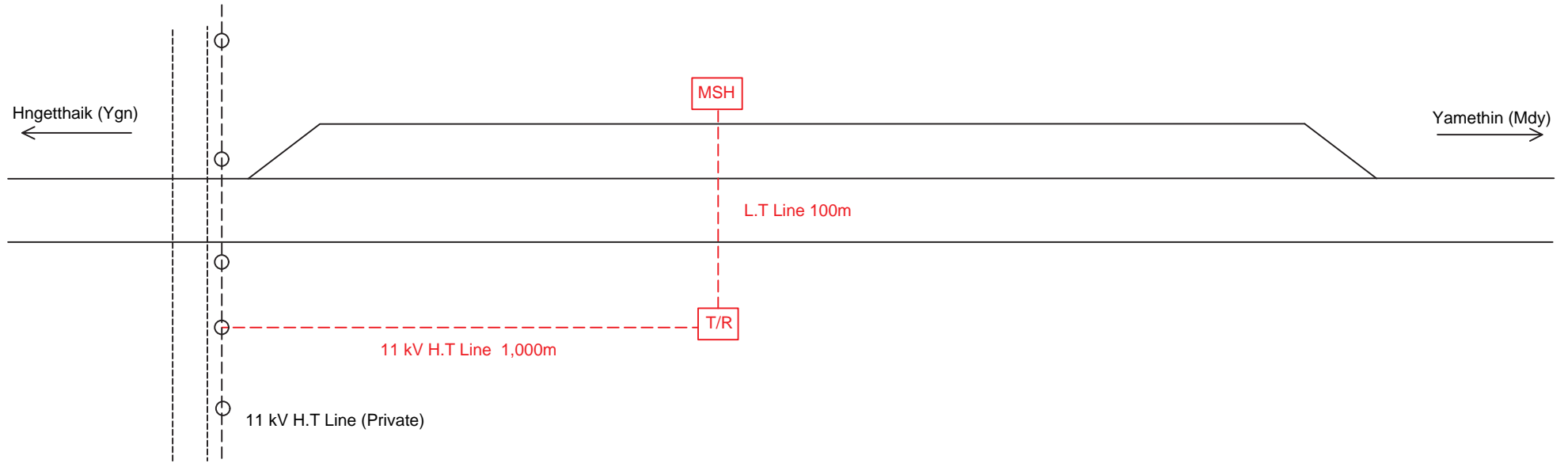

Appendix 5.16.1-33

### Yamethin Station

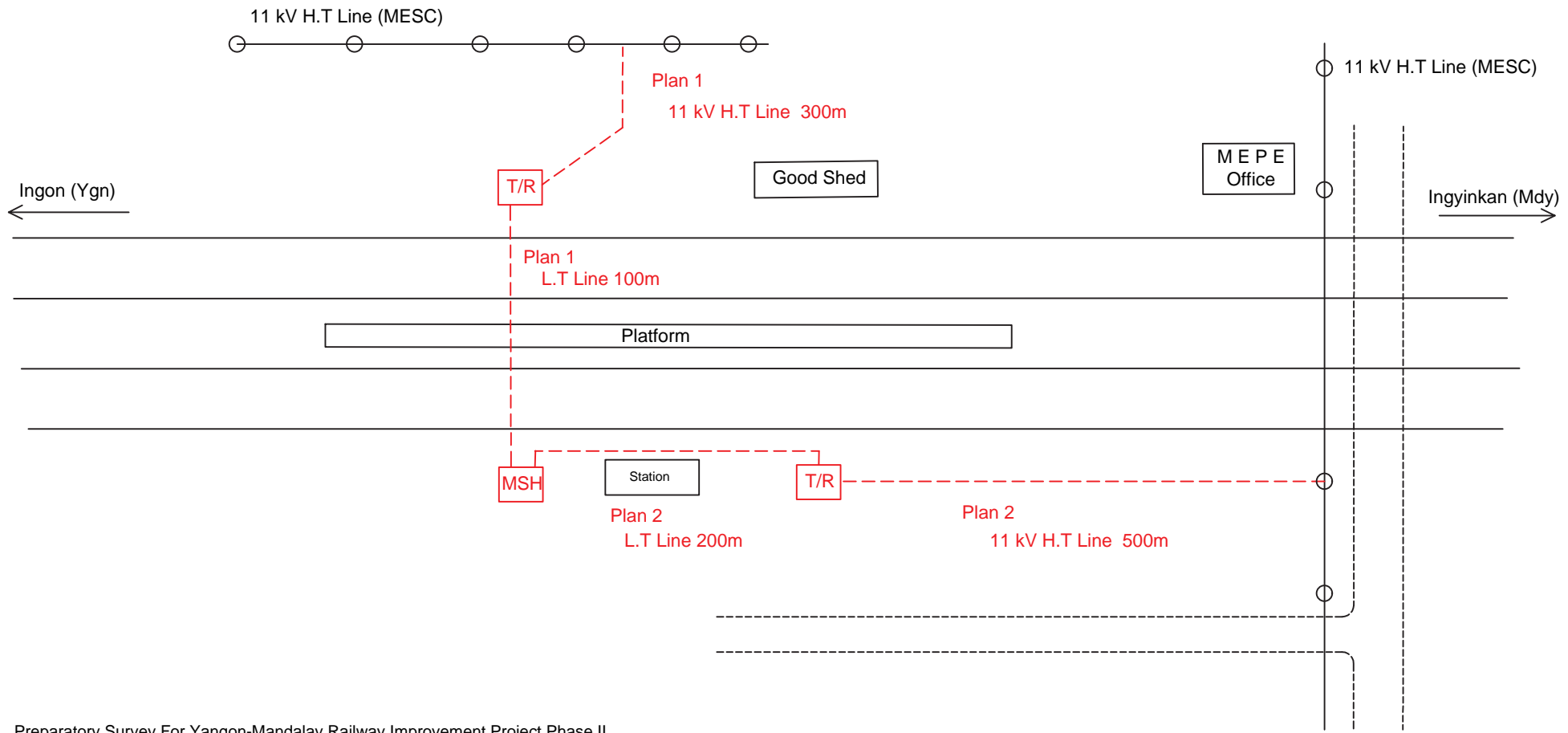

Level Crossing No. 6 (5)  
(Tha Zin Level Crossing)

Yamethin (Ygn)  
←

→  
Ingyinkan (Mdy)

EG

T/R

11 kV H.T Line 2,000m (Supply to Ingyinkan Station)

11 KV H.T Line 1,000m

Petrol Station  
Tha Zin

11 KV H . T Line (Private)

Appendix 5.16.1-35

### Ingyinkan Station

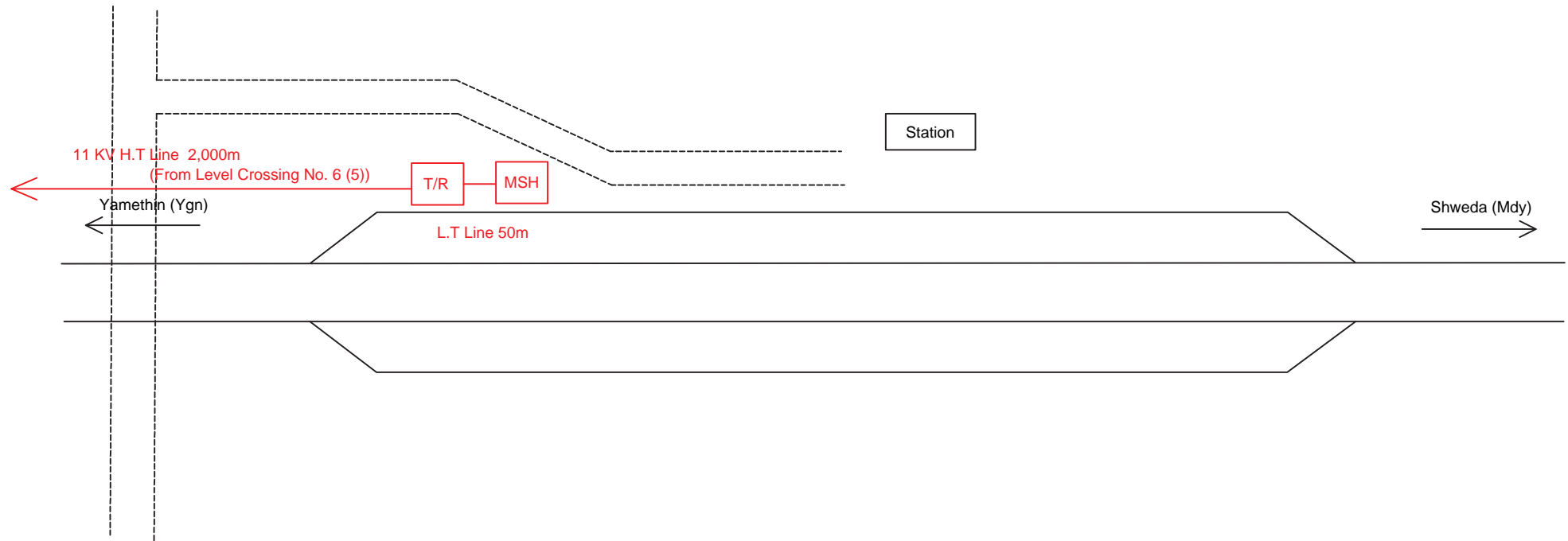

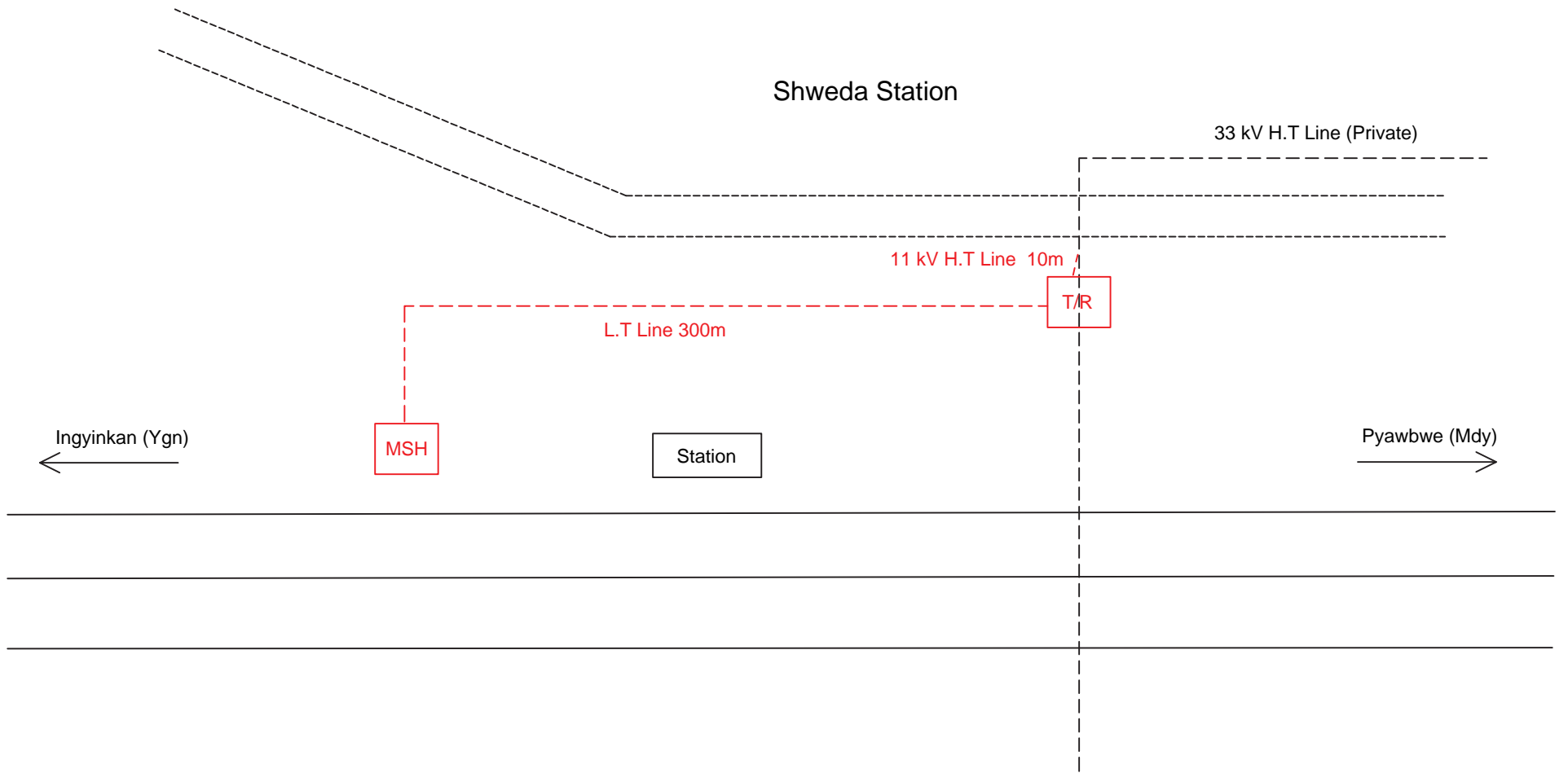



Level Crossing No.62 (5)  
(Pay Kone Level Crossing)

Shweda (Ygn)  
←

Pyawbwe (Mdy)  
→

T/R

EG

11 kV H.T Line 600m

Agricultural Department



Appendix 5.16.1-38

# Pyawbwe Station

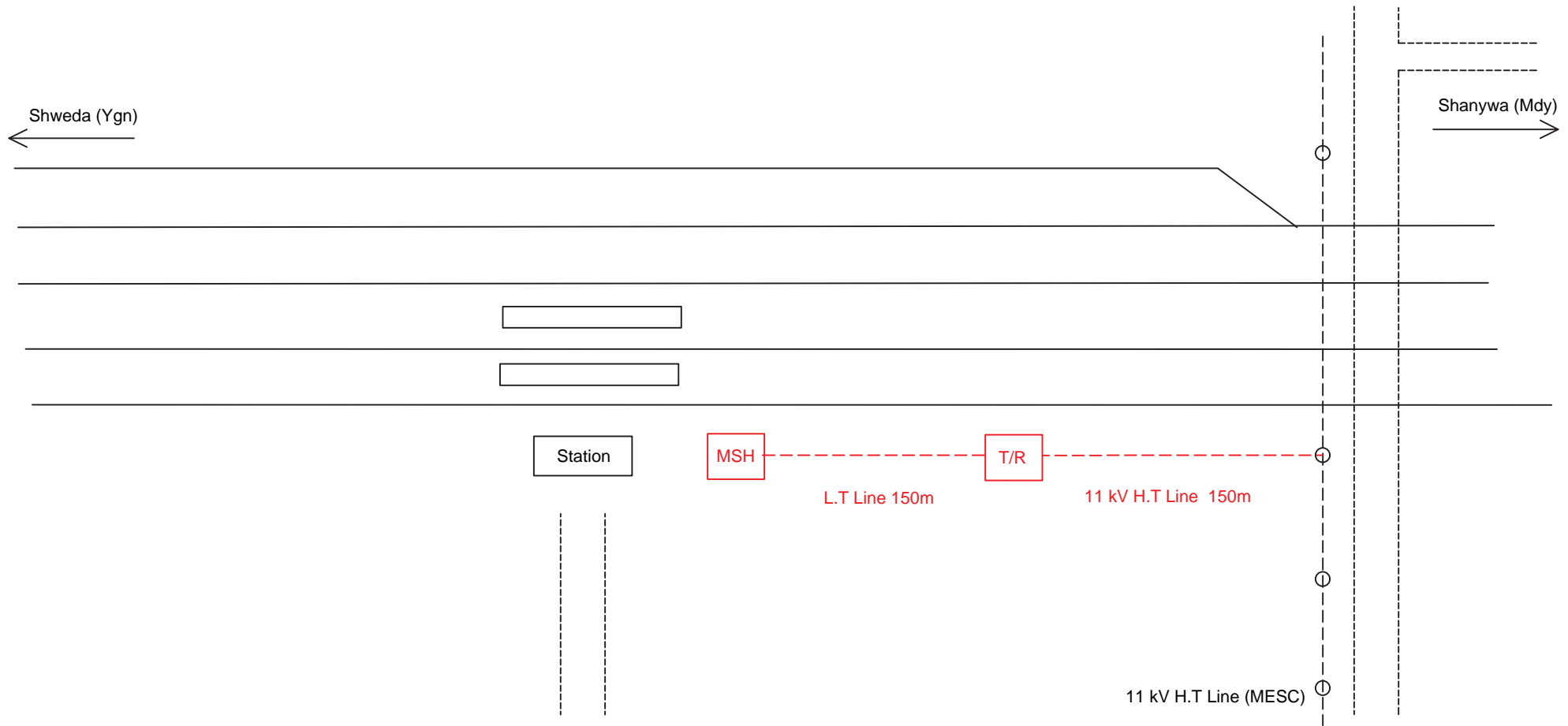

Appendix 5.16.1-39

# Shanywa Station

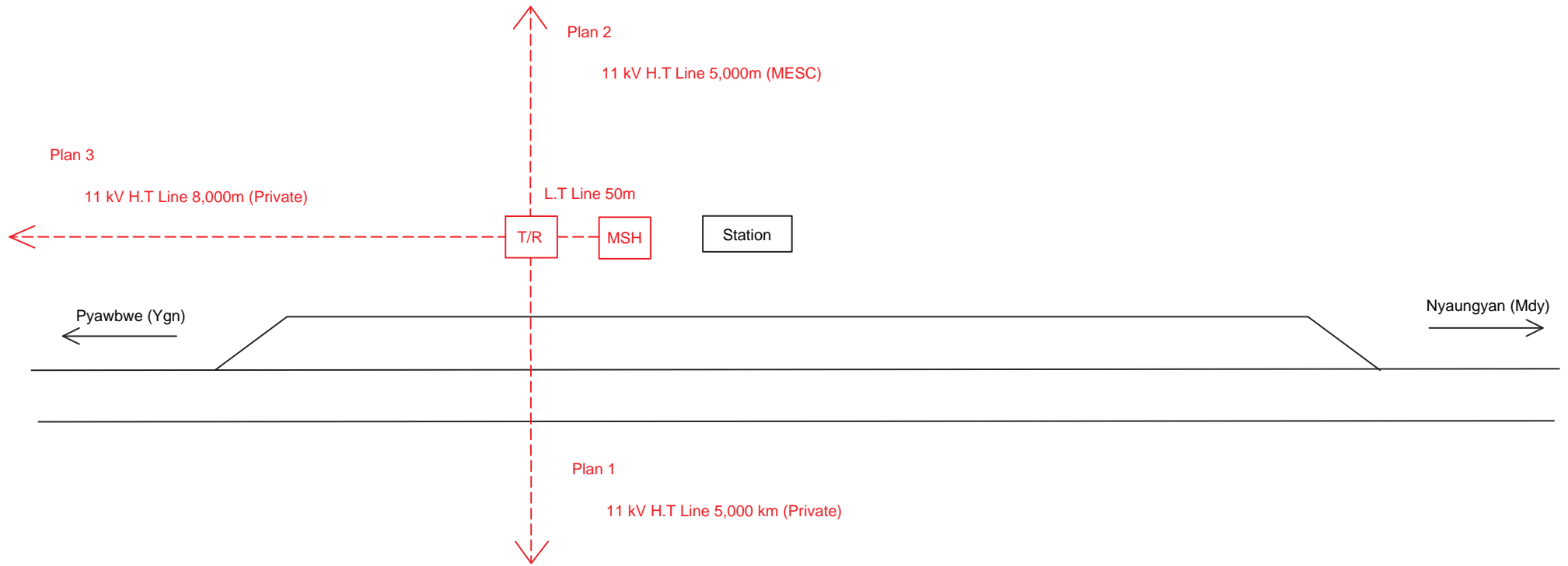

Appendix 5.16.1-40

# Nyaungyan Station

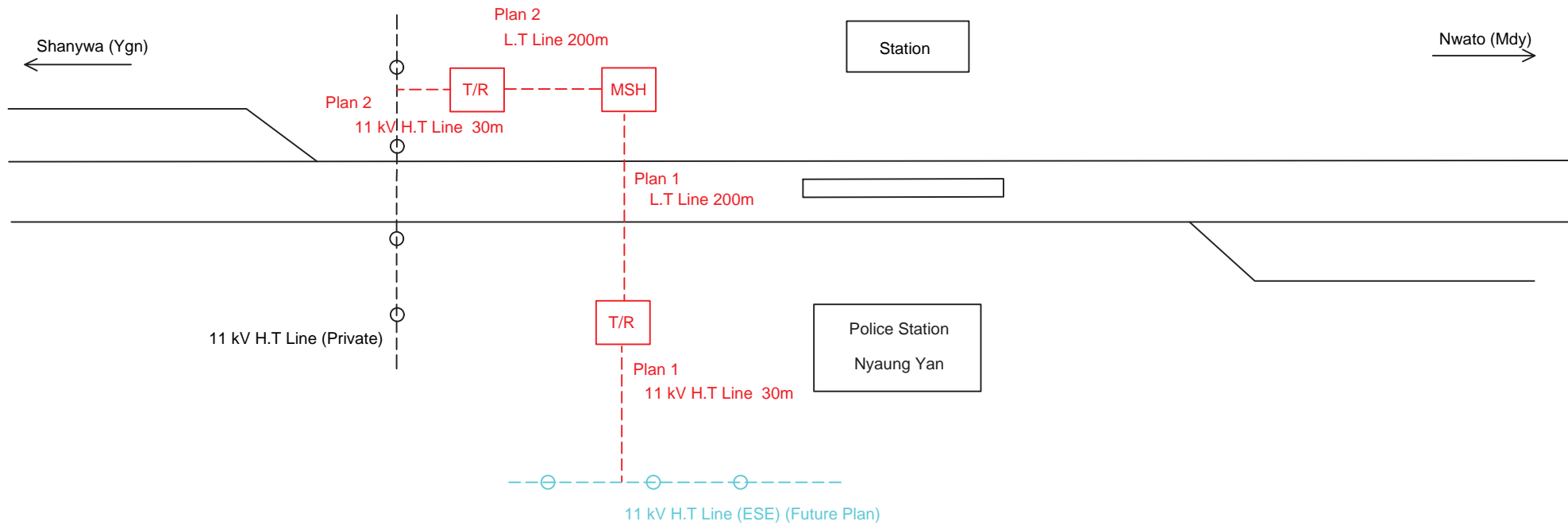

Appendix 5.16.1-41

Nwato Station

Nyaungyan (Ygn) ←

→ Thazi (Mdy)

11 KV H.T Line 5,000km  
(Future Plan)

L.T Line 50m



T/R

MSH

Station



Appendix 5.16.1.42

### Thazi Station

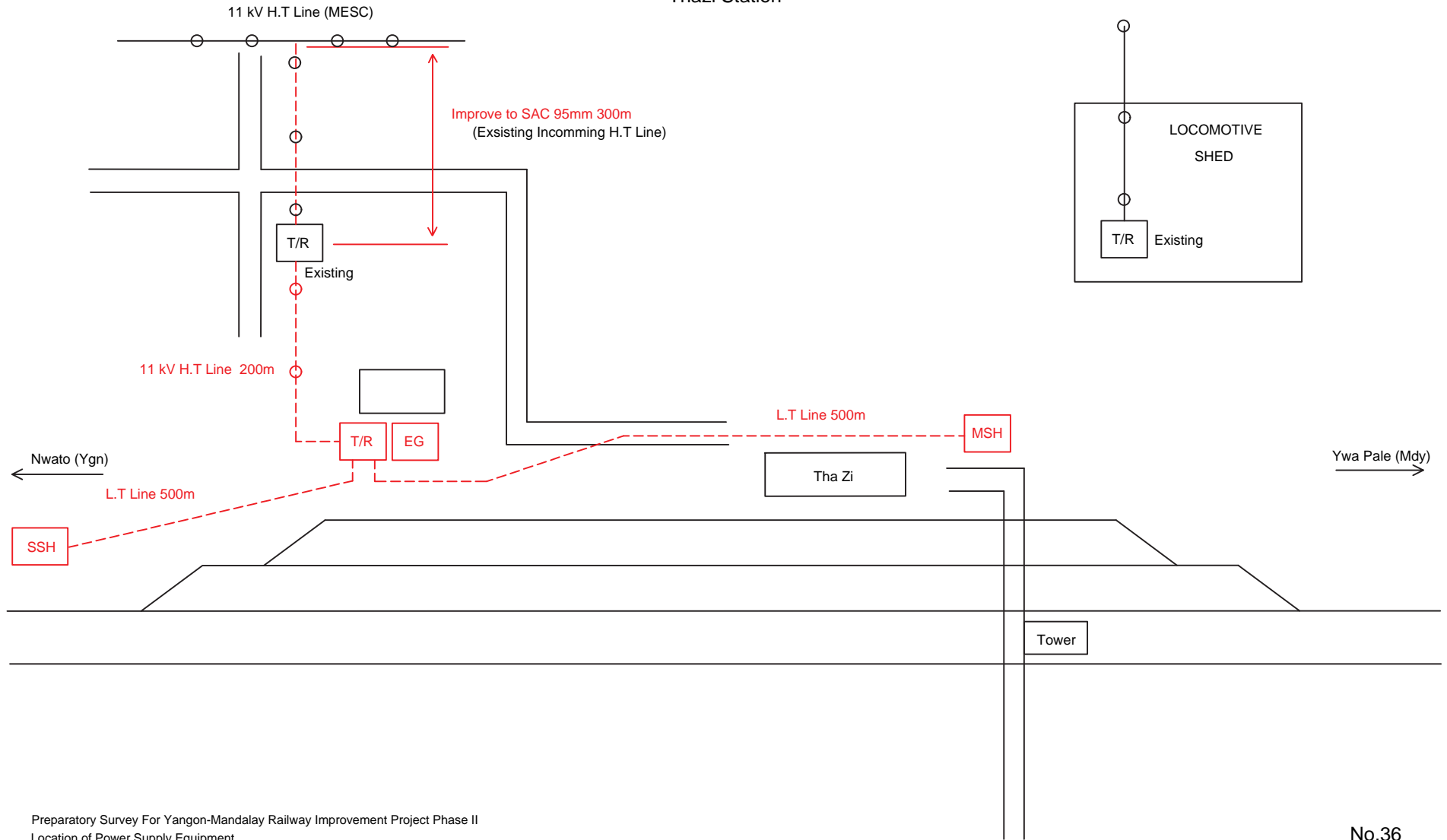

### Ywapale Station

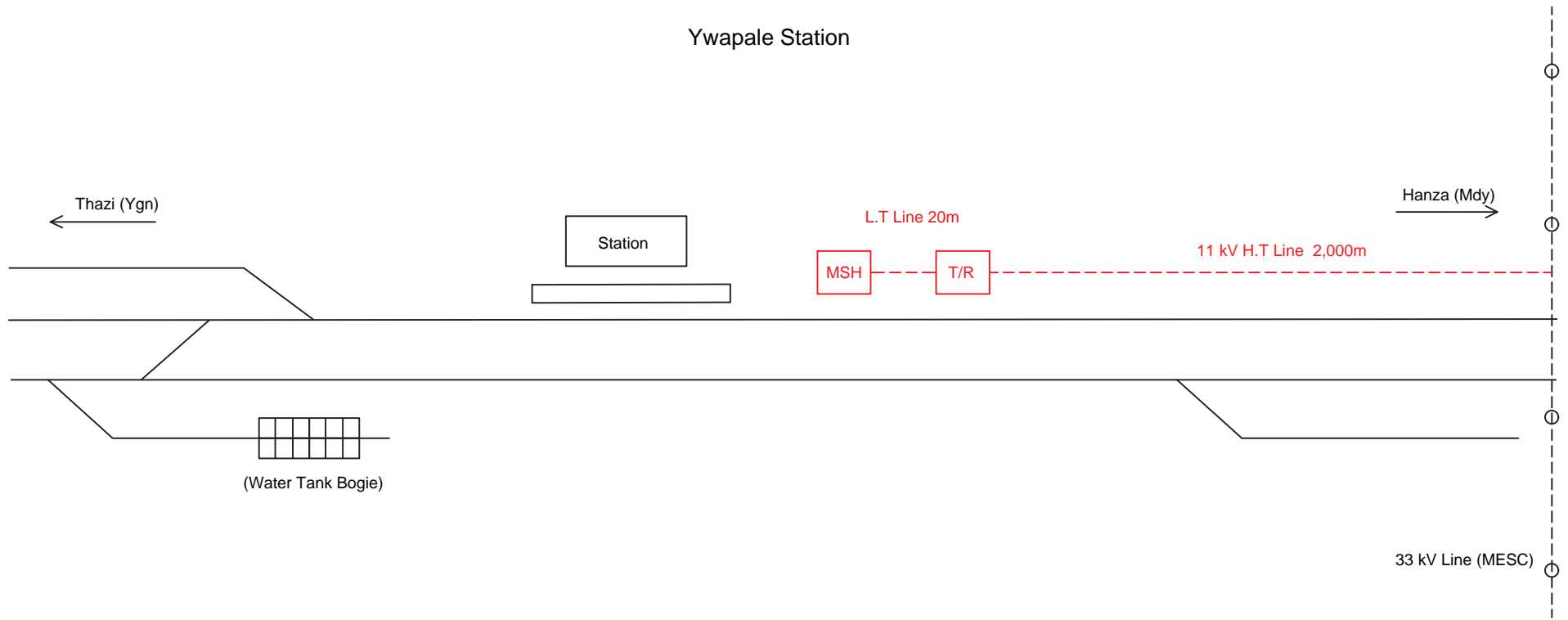

### Hanza Station

Police Station

11 kV H.T Line 250m

11 KV H.T Line (MESCO)

This transmission line is now full loaded.  
ESE is planning to improve the substation.  
The improvement shall be finished  
before connecting the new transformer.

L.T Line 100m

T/R

MSH

Station

Thedaw (Mdy)

Ywapale (Ygn)

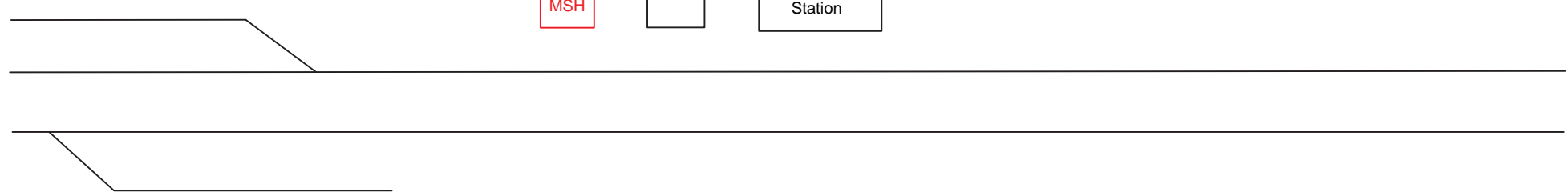



### Thedaw Station

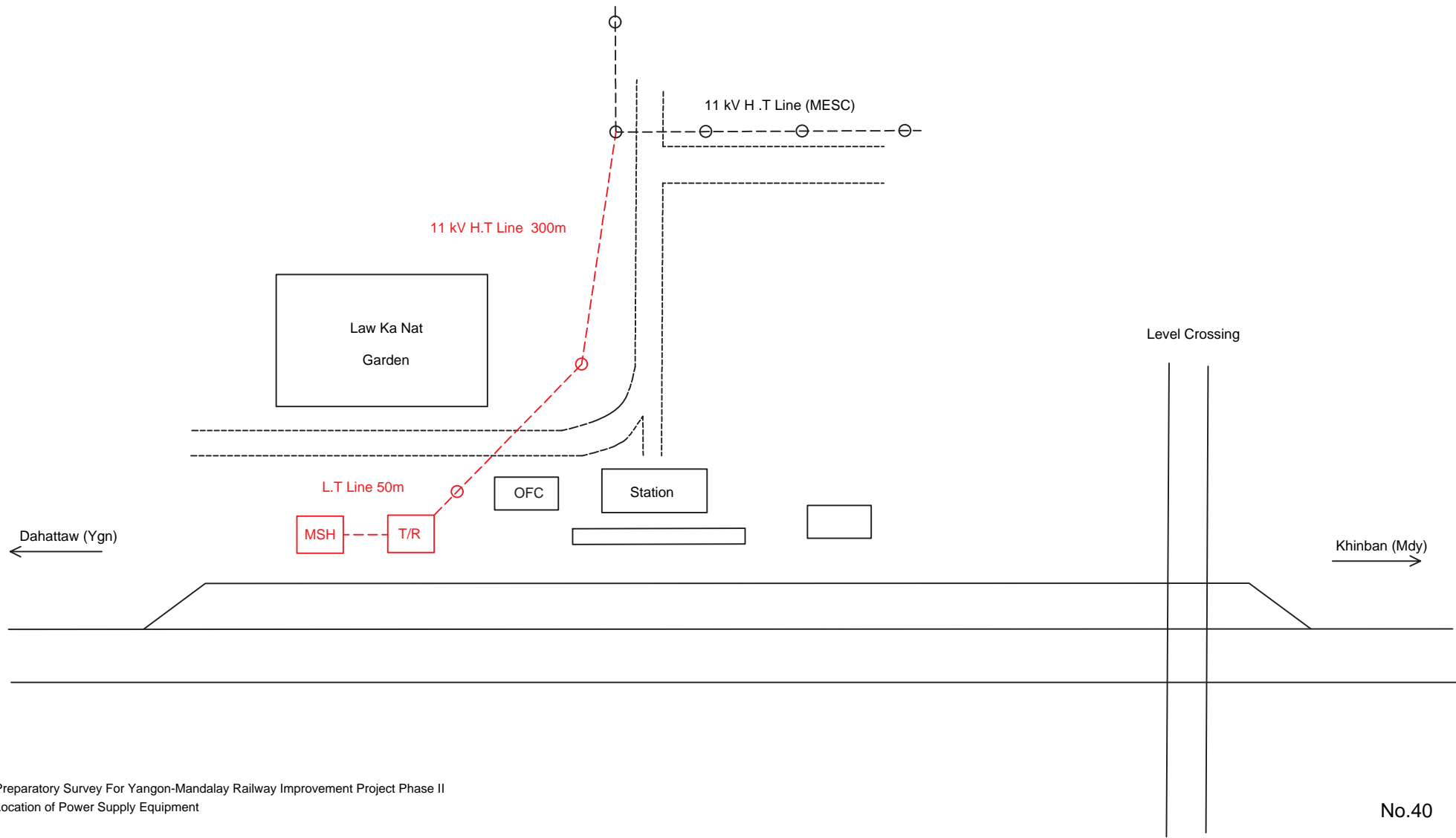

### Khinban Station

Existing



11 kV H.T Line (Private)

11 kV H.T Line 500m

L.T Line 200m

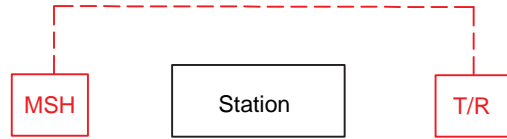

MSH



T/R

← Thedaw (Ygn)

→ Samon (Mdy)

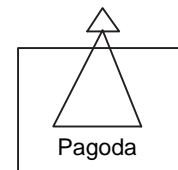

Pagoda

# Samon Station

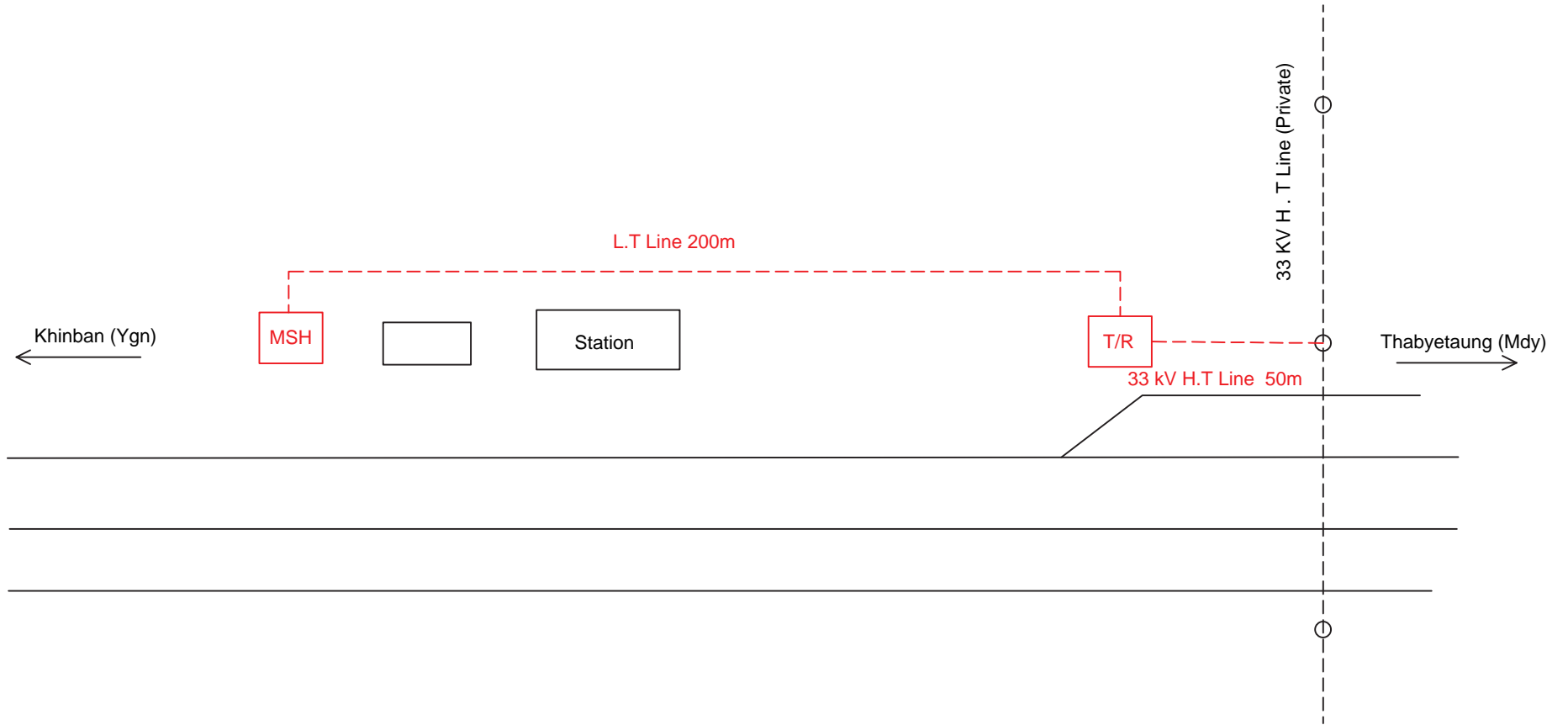

Appendix 5.16.1.48

Thabyetaung Station

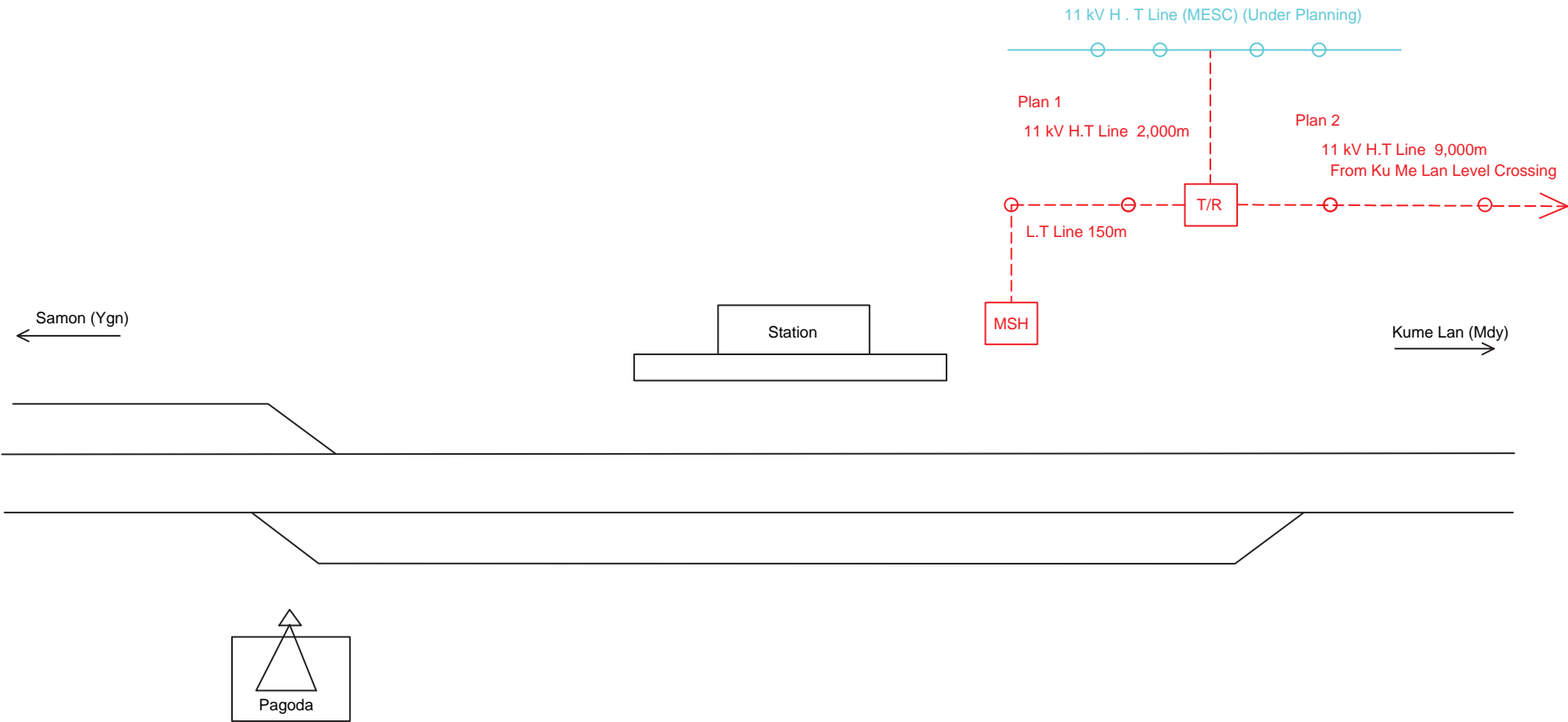

Appendix 5.16.1.49

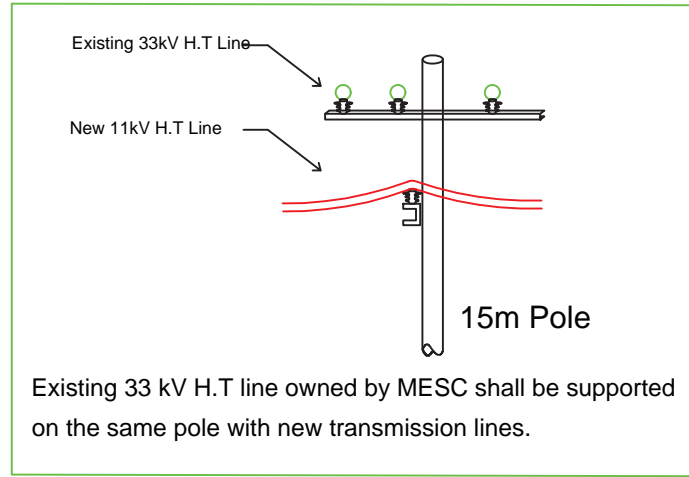

Kume Lan Station

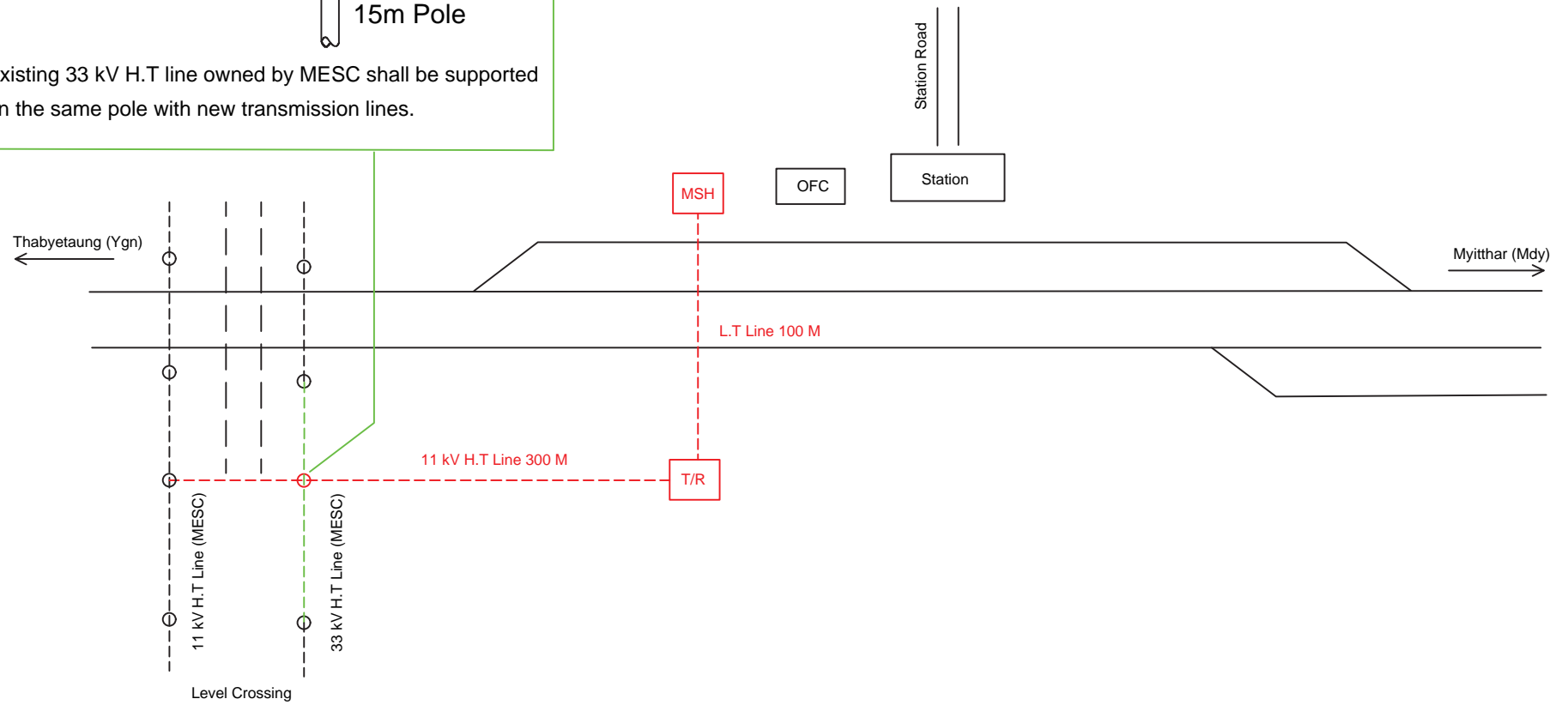

# Myitthar Station

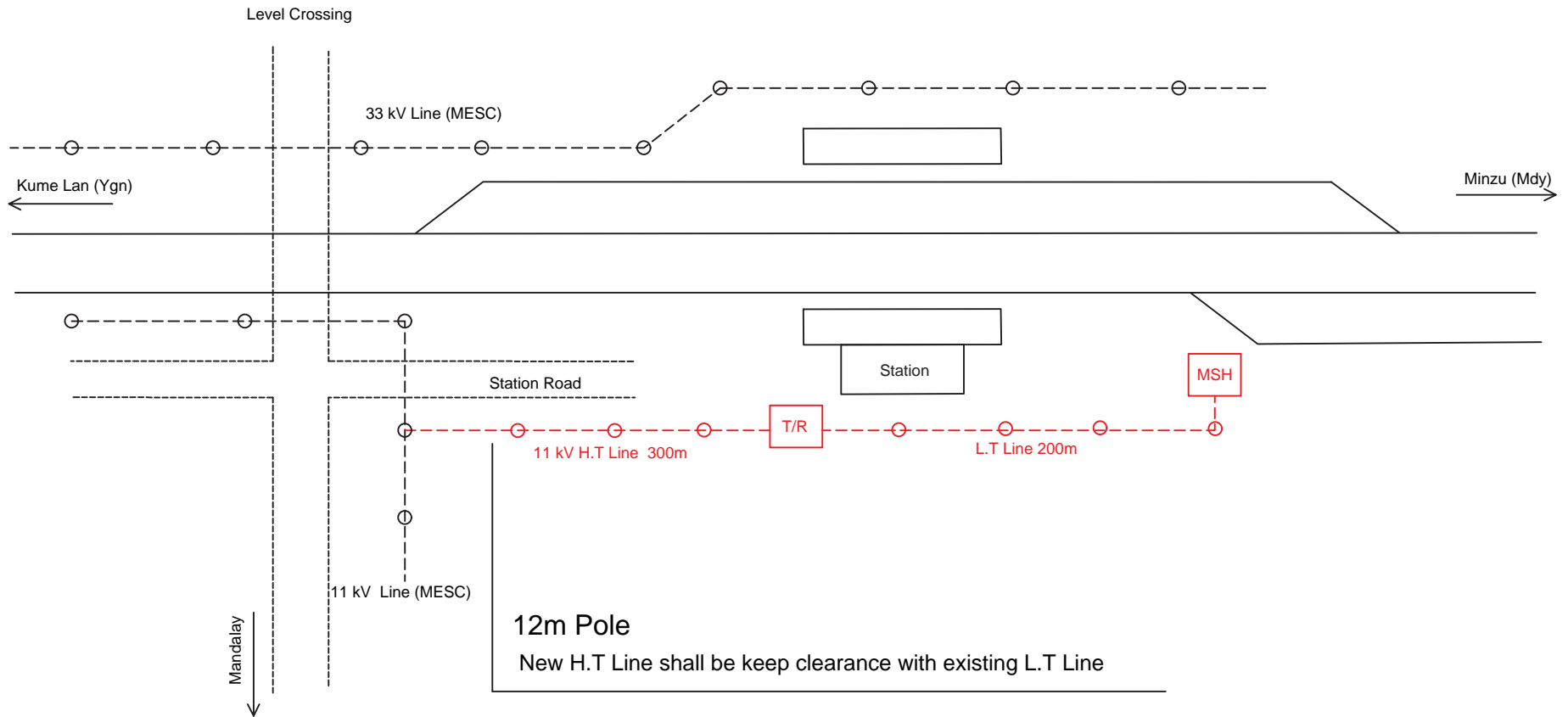

Appendix 5.16.1-51

# Minzu Station

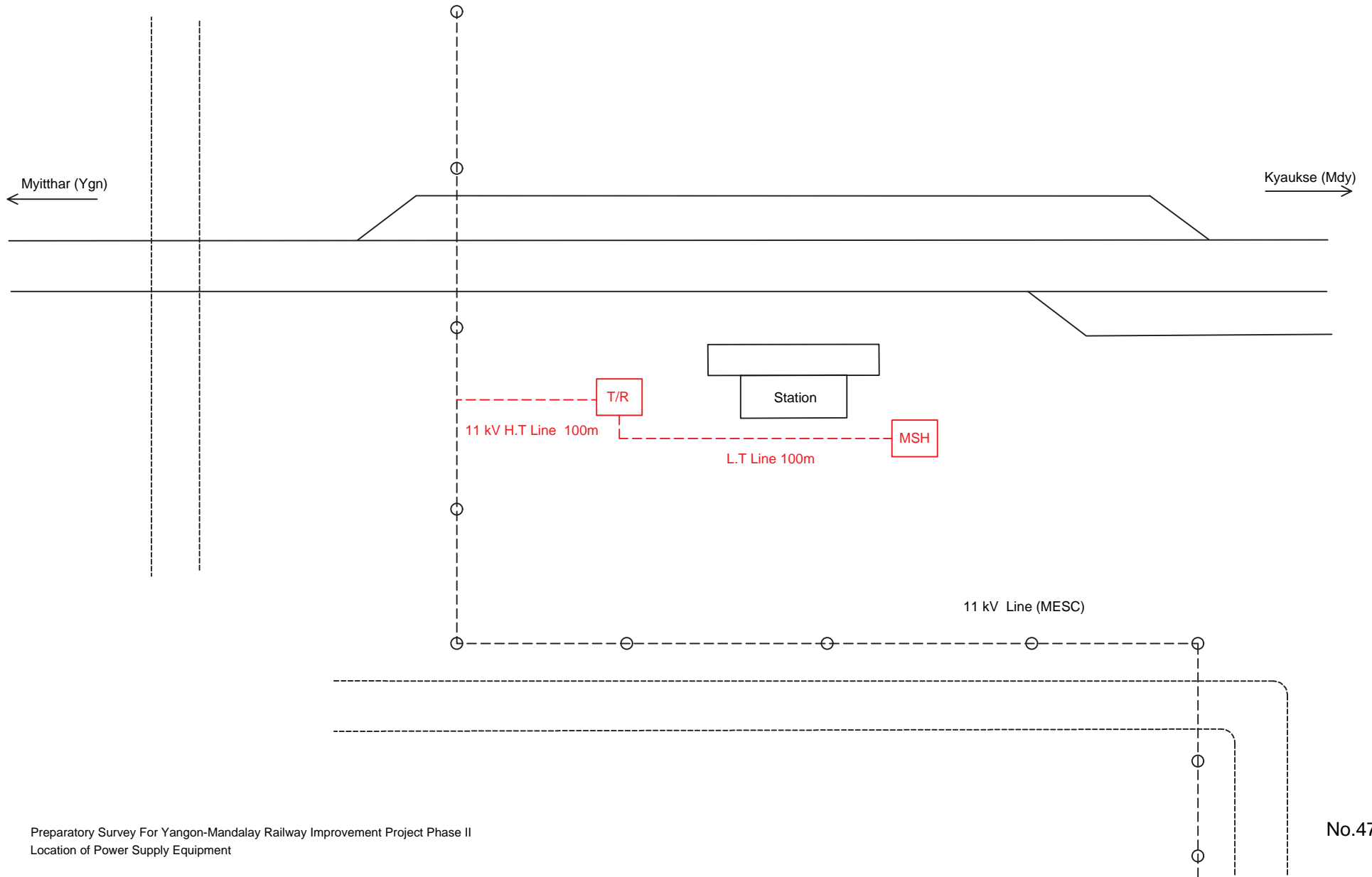

Appendix 5.16.1-52

# Kyause Station

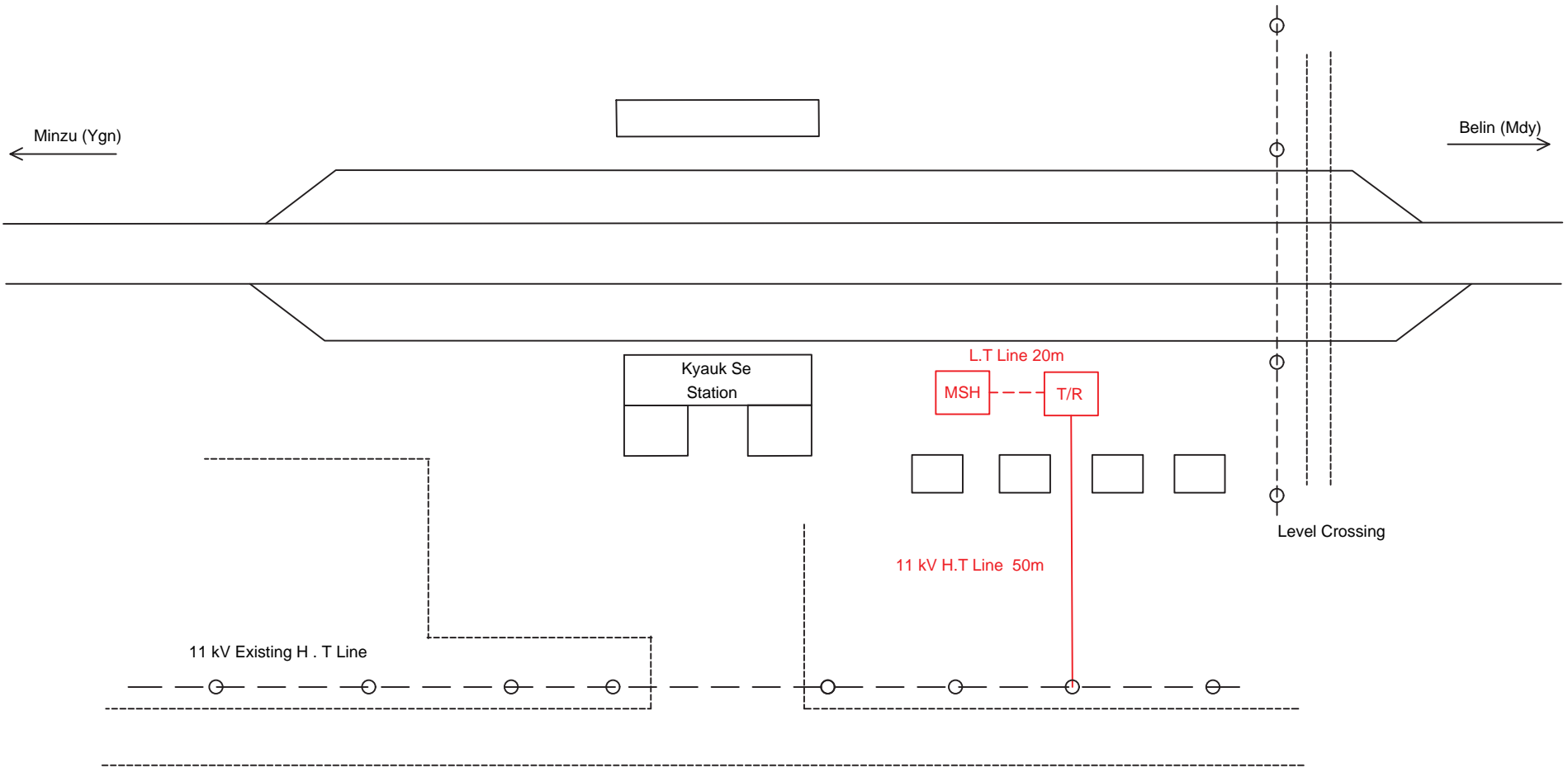

Appendix 5.16.1-53



### Belin Station

Kyaukse (Ygn) ←

→ Singaing (Mdy)

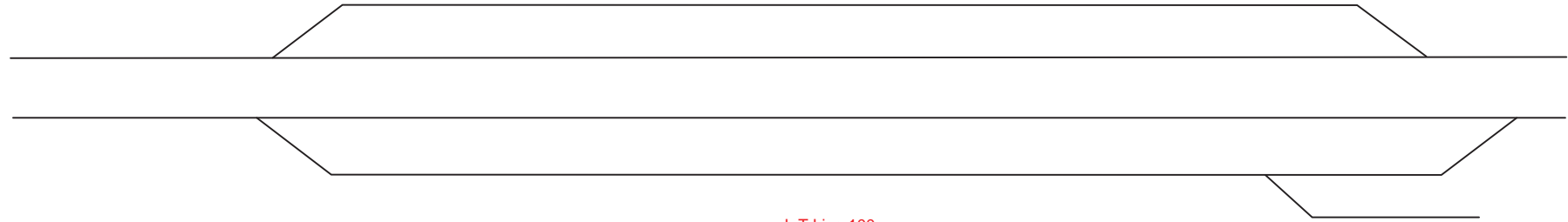

Station

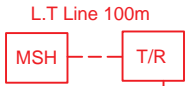

11 kV H.T Line 250m

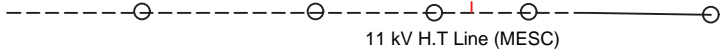

# Singaing Station

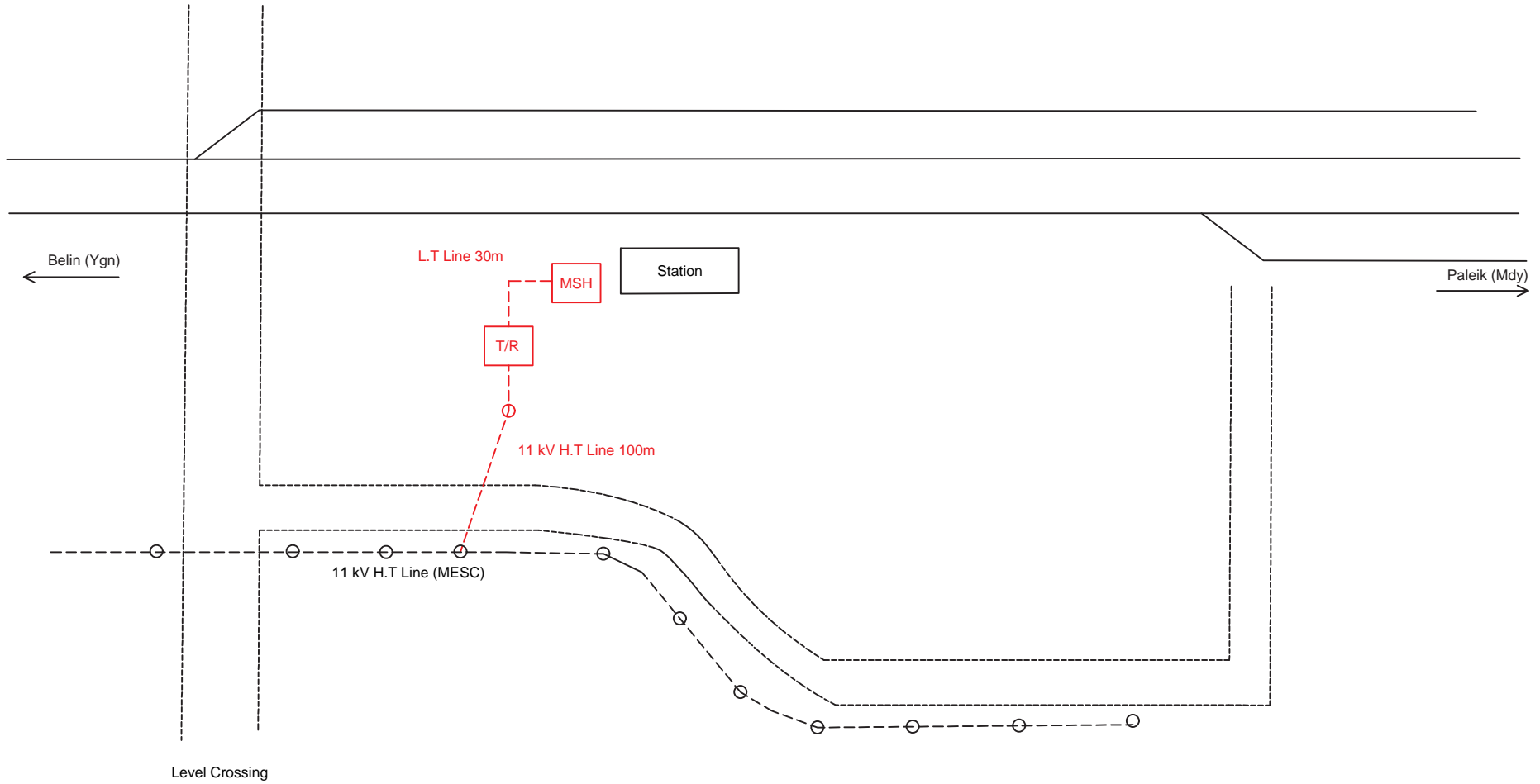

Appendix 5.16.1-55

Level Crossing No.23 (3)  
(Hnit Saung Pyaing Level Crossing)

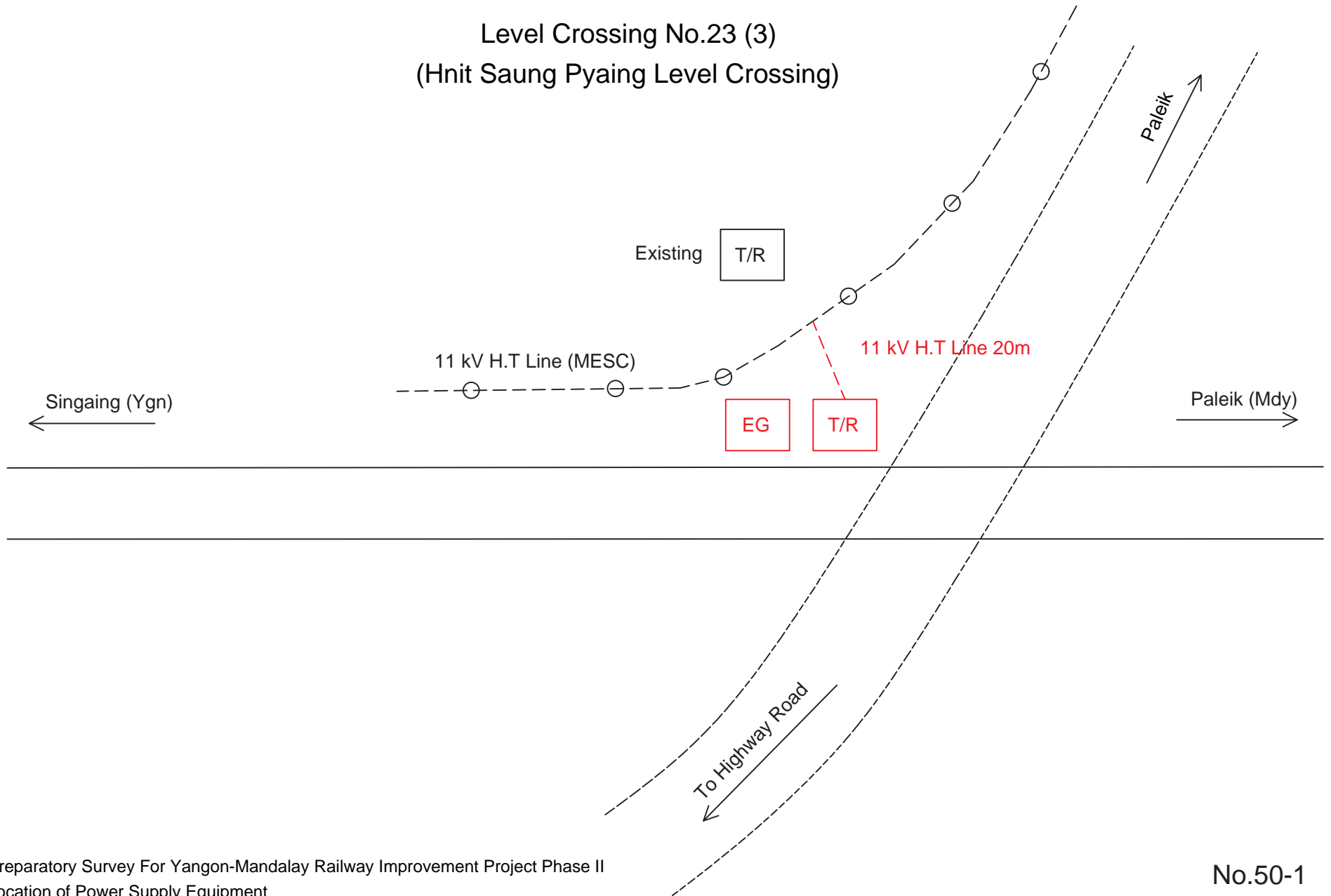

Appendix 5.16.1-56

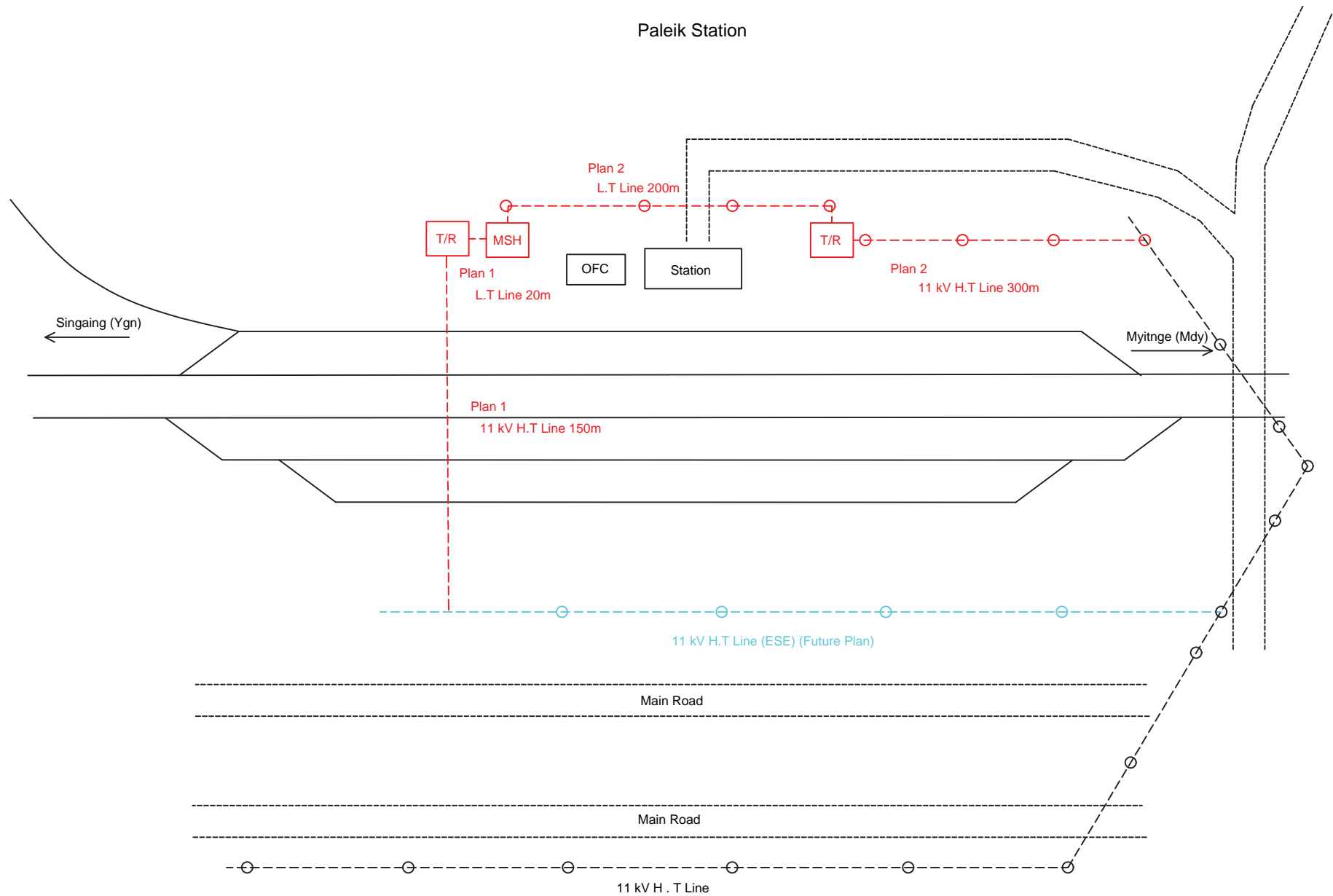

# Myitnge Station

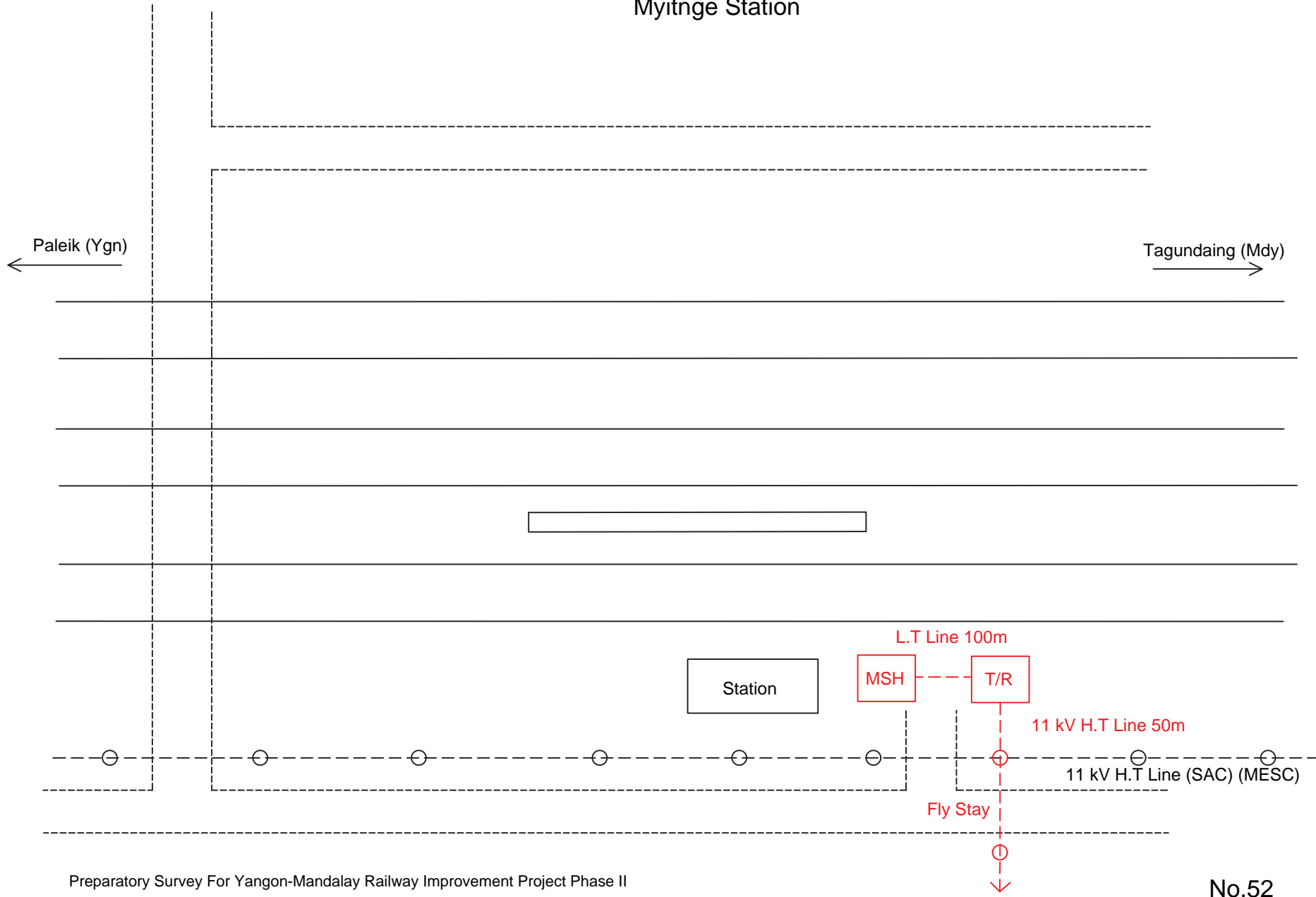

Appendix 5.16.1-58

### Tagundaing Station

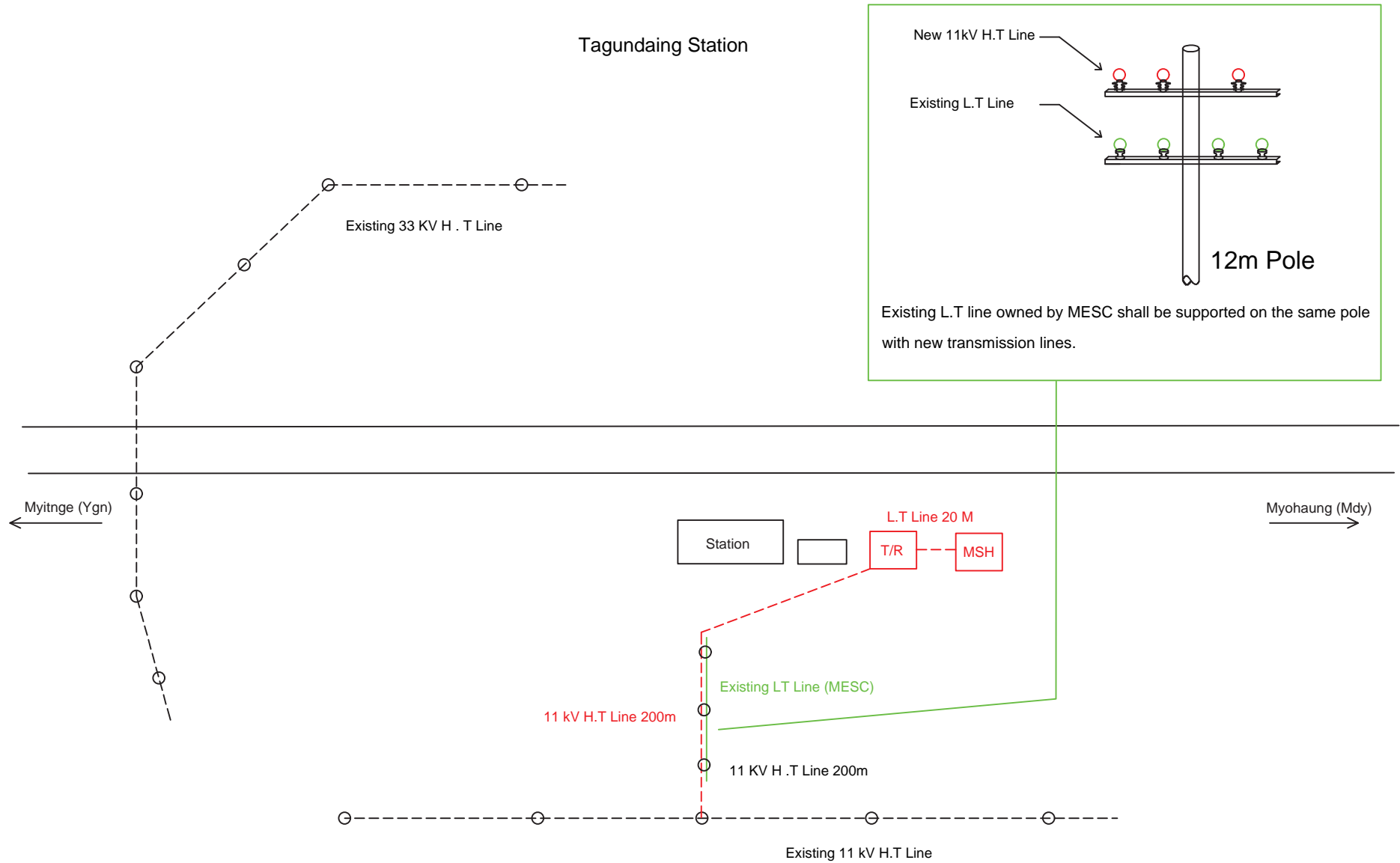

# Level Crossing No.28 (3) (Ta Mar Tan Level Crossing)

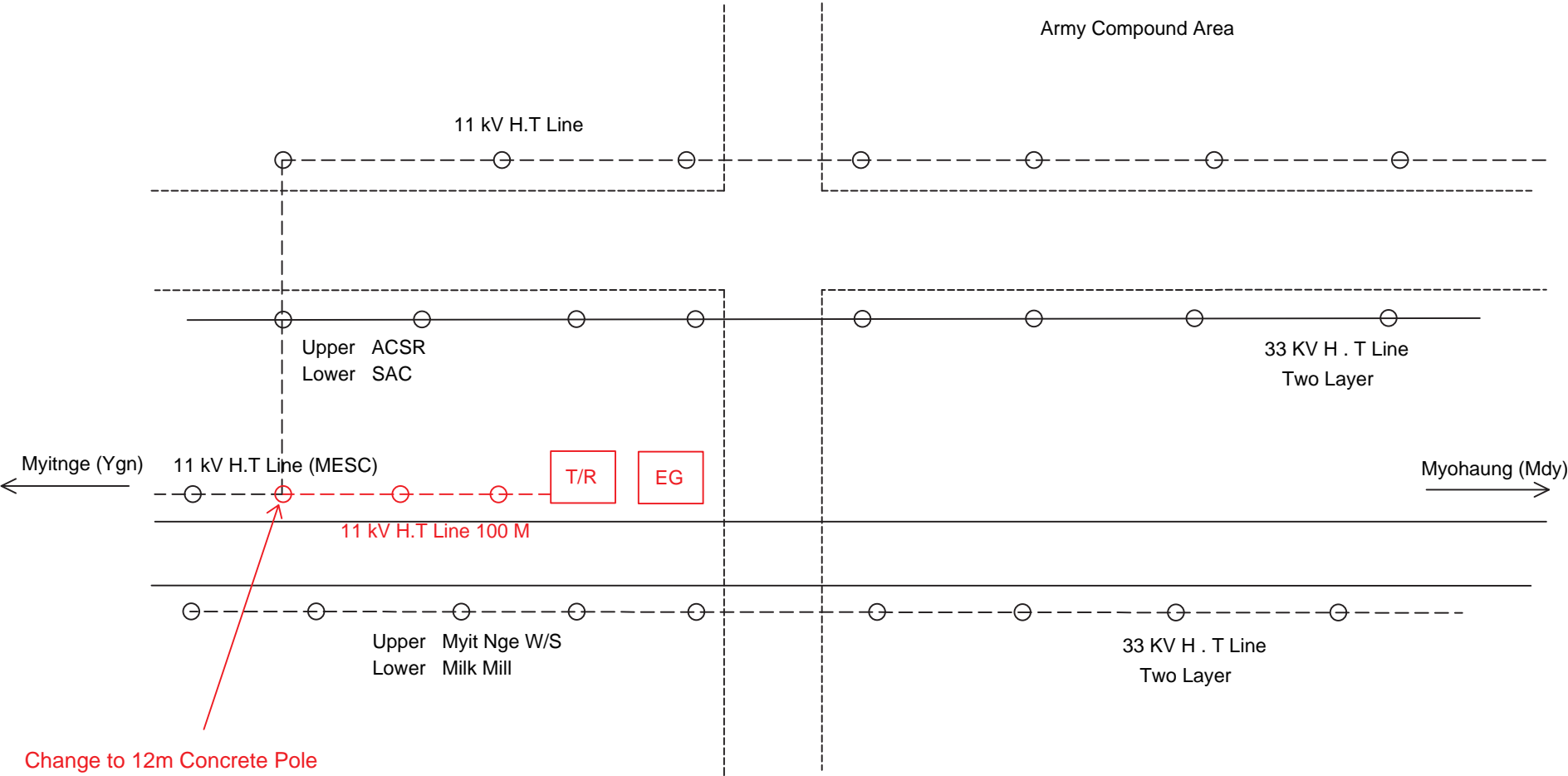

Appendix 5.16.1-60

### Myohaung Station

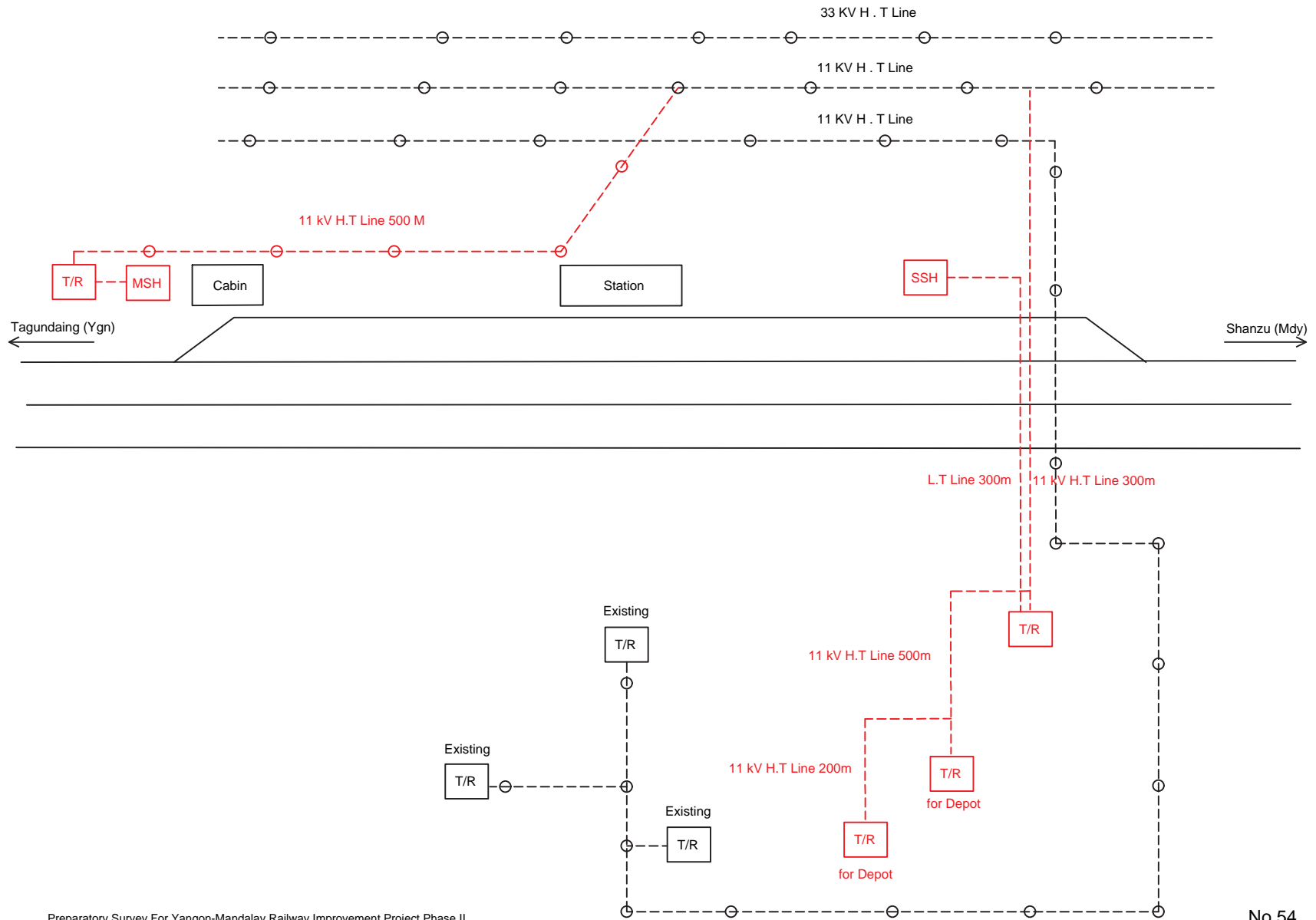



### Shanzu Station

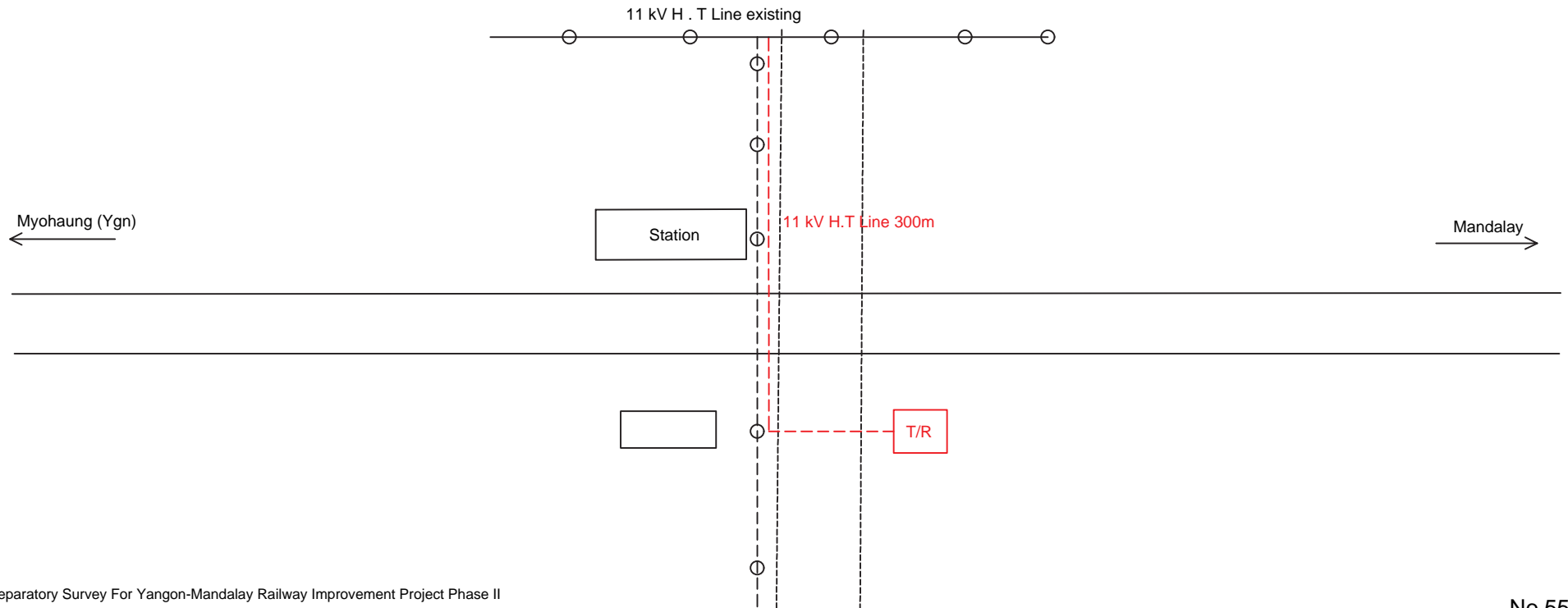
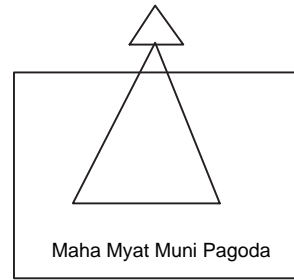

Level Crossing No. 35 (3)  
(39th Street)

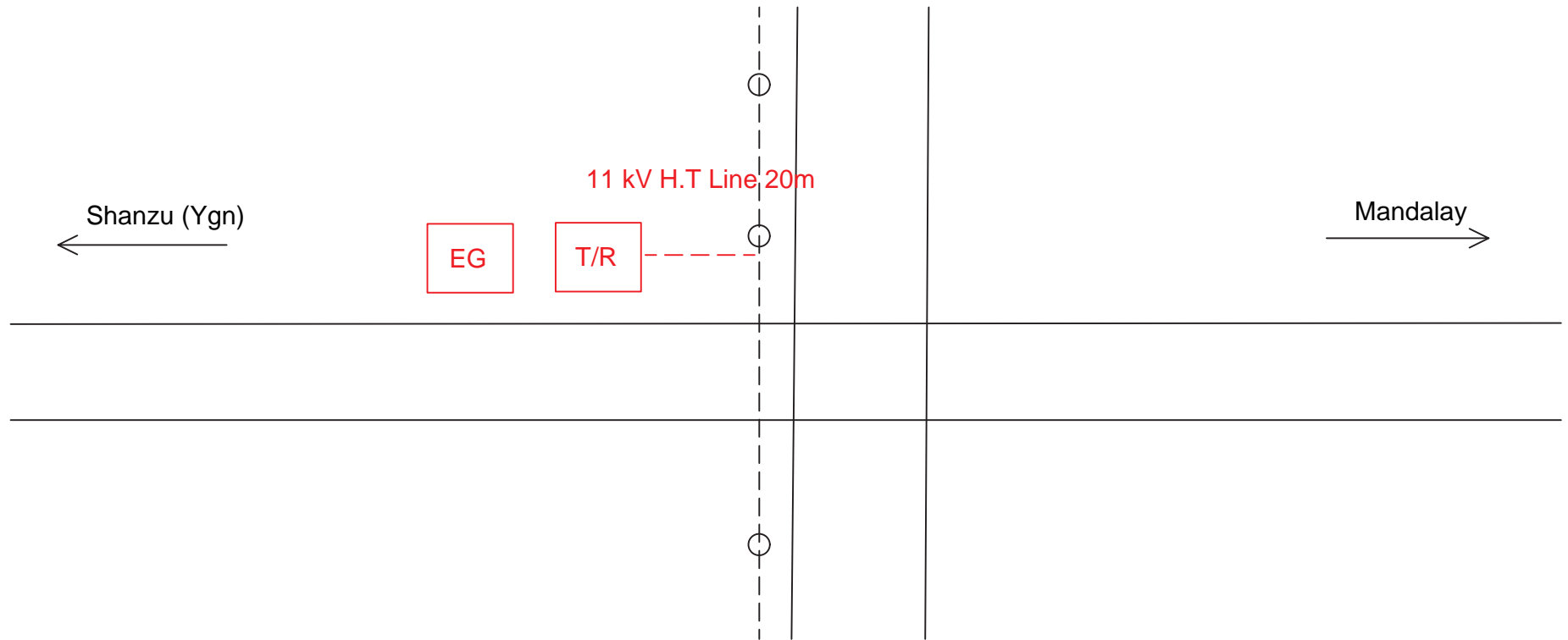

Appendix 5.16.1-63

### Mandalay Station

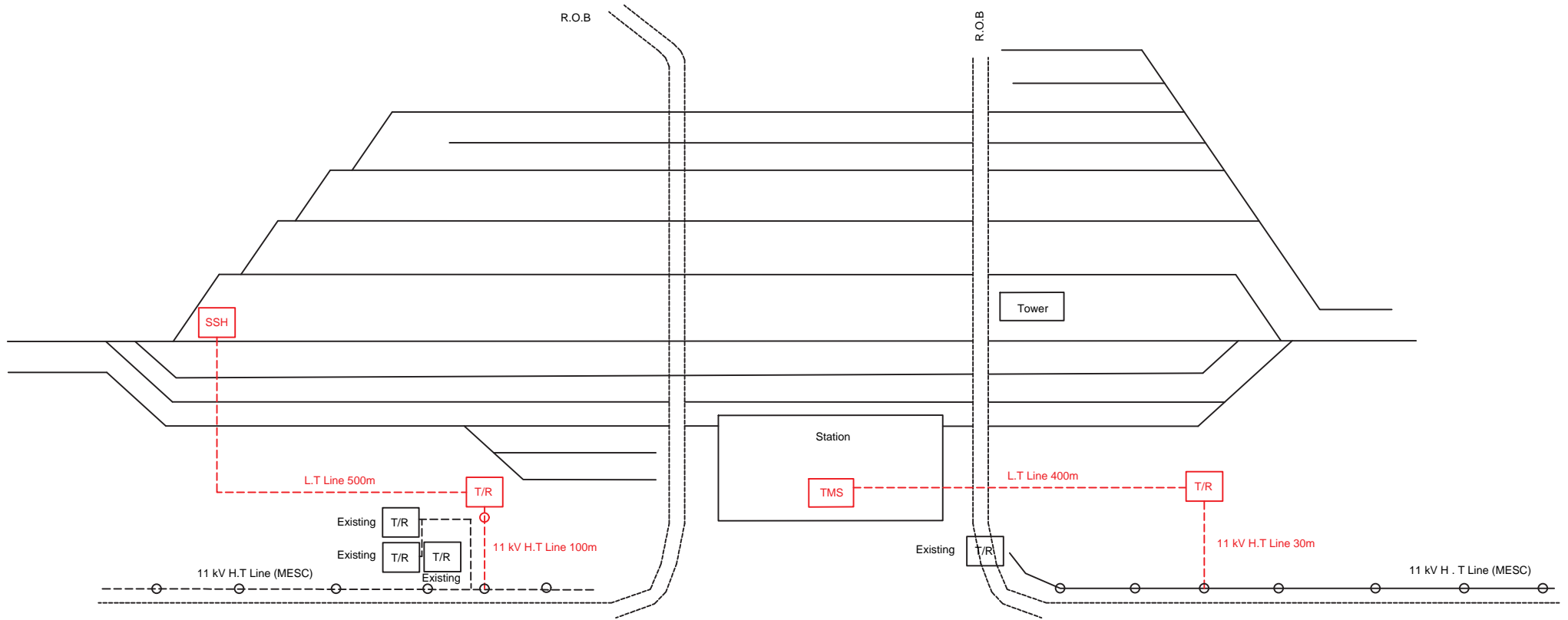

## **APPENDIX 5.16.2**

### **Diagram of Power Supply System**

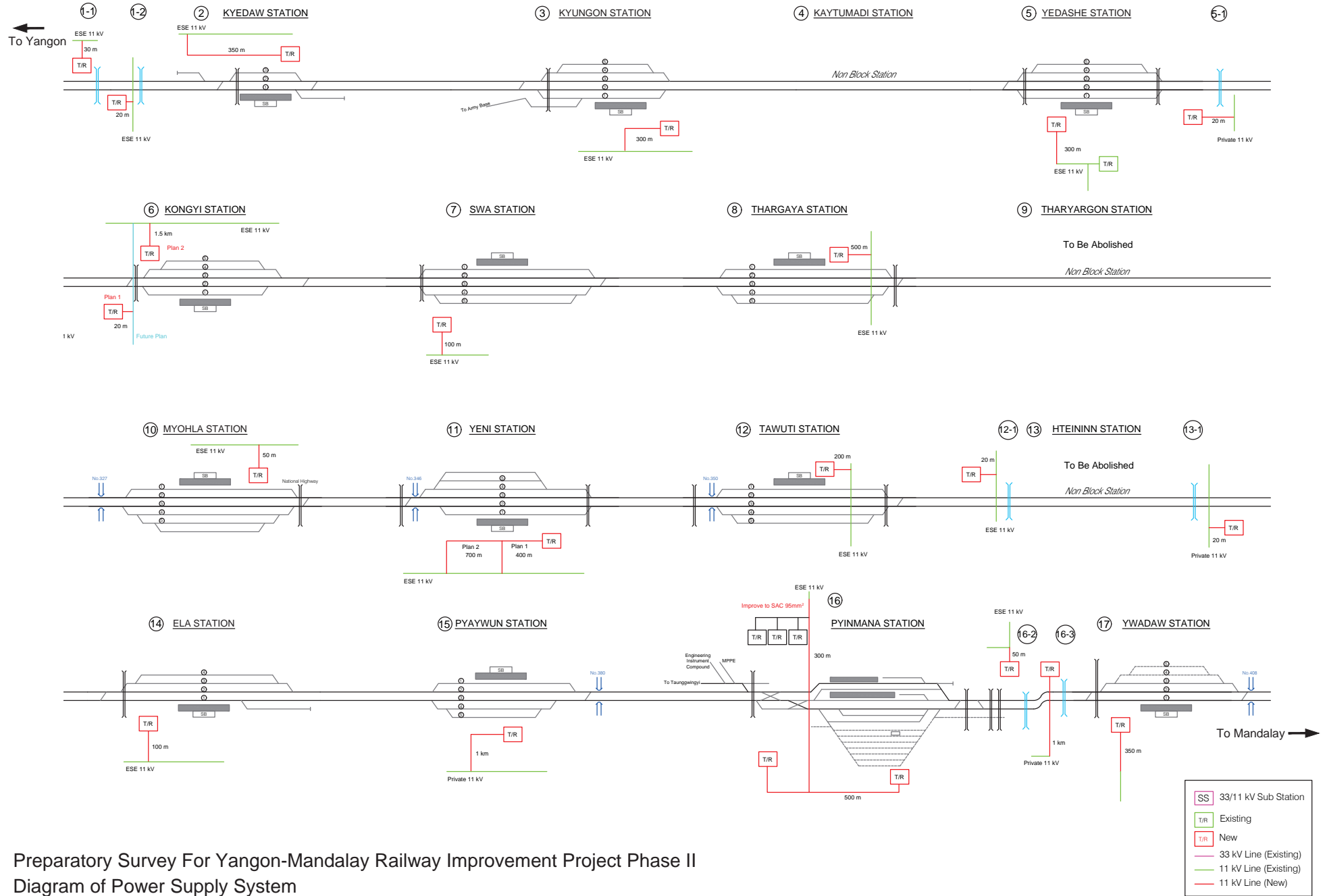

Preparatory Survey For Yangon-Mandalay Railway Improvement Project Phase II  
Diagram of Power Supply System

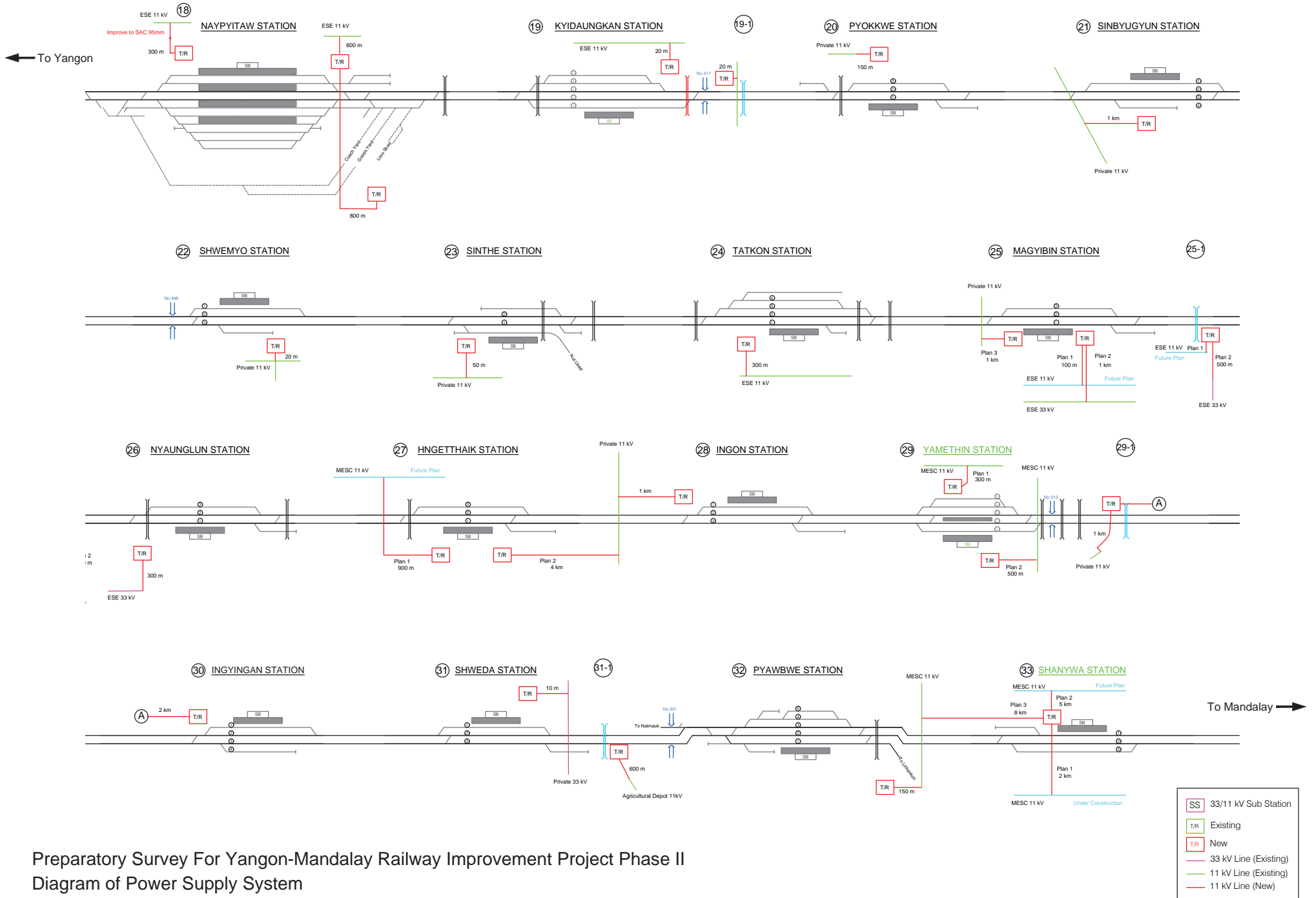

Preparatory Survey For Yangon-Mandalay Railway Improvement Project Phase II  
 Diagram of Power Supply System

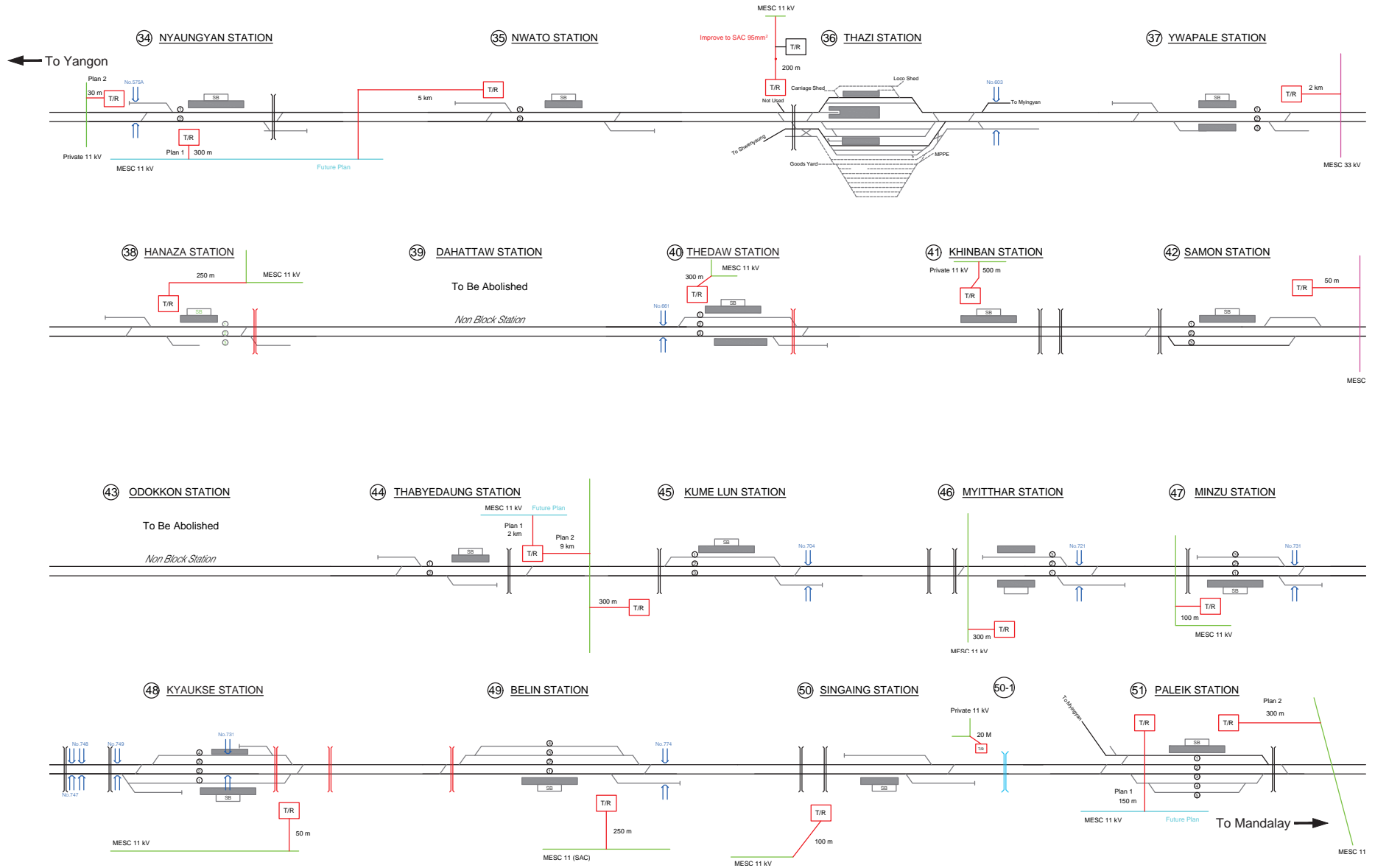

SS	33/11 kV Sub Station
T/R	Existing
T/R	New
—	33 kV Line (Existing)
—	11 kV Line (Existing)
—	11 kV Line (New)

Preparatory Survey For Yangon-Mandalay Railway Improvement Project Phase II  
Diagram of Power Supply System

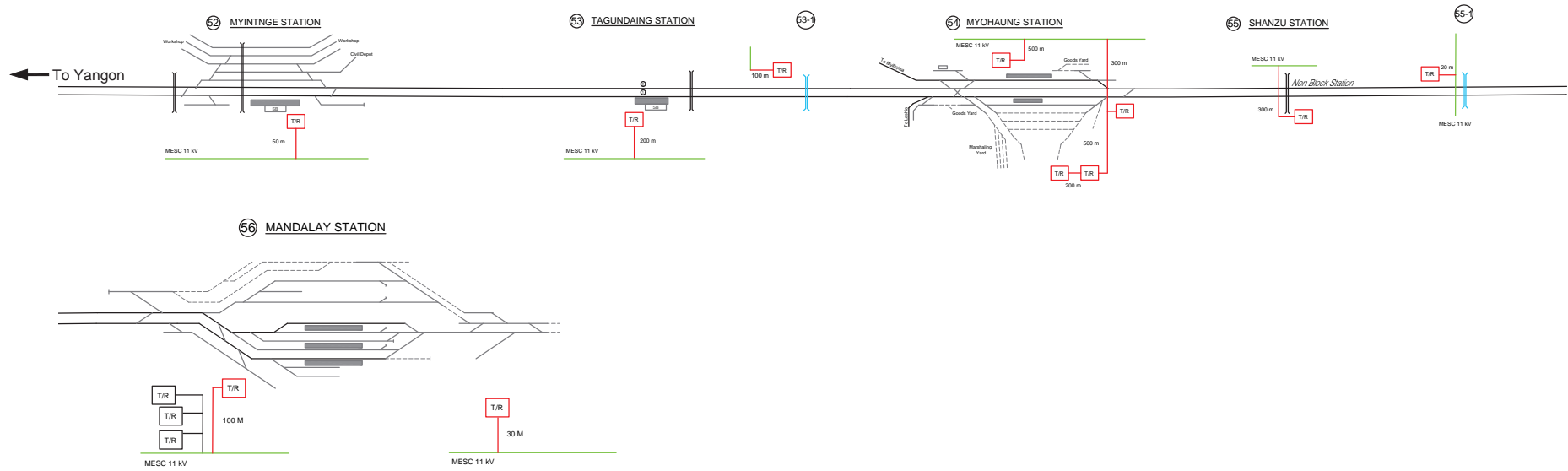

Preparatory Survey For Yangon-Mandalay Railway Improvement Project Phase II  
Diagram of Power Supply System

SS	33/11 kV Sub Station
T/R	Existing
T/R	New
—	33 kV Line (Existing)
—	11 kV Line (Existing)
—	11 kV Line (New)



## **APPENDIX 5.17**

# **Proposal of Urban Development Plan for Regional Cities, Mandalay Patheingyi and Mawlamyine.**

“ Proposal of Urban Development Plan for Regional Cities -Mandalay, Patheingyi and Mawlamyine-, 2016, JICA”

- Disused Line in Royal Palace

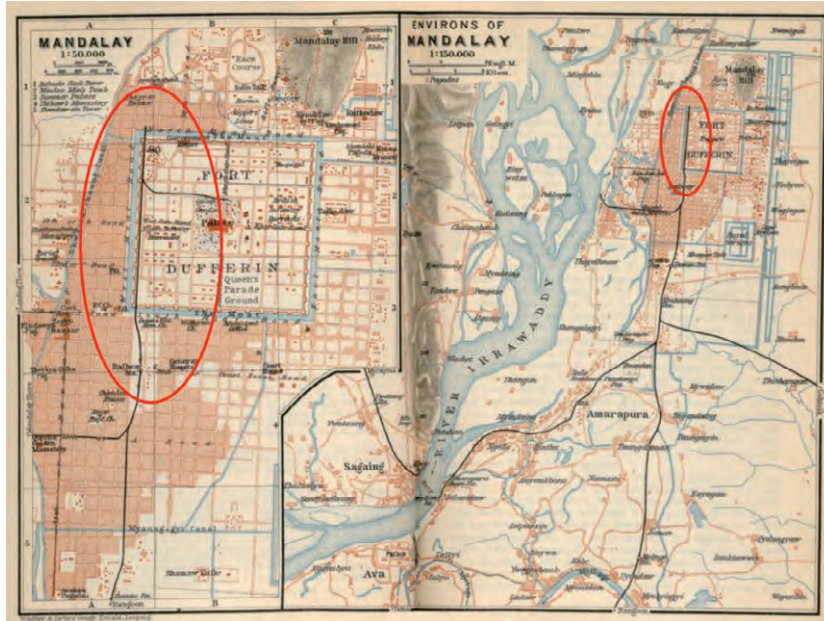

- BRT Plan

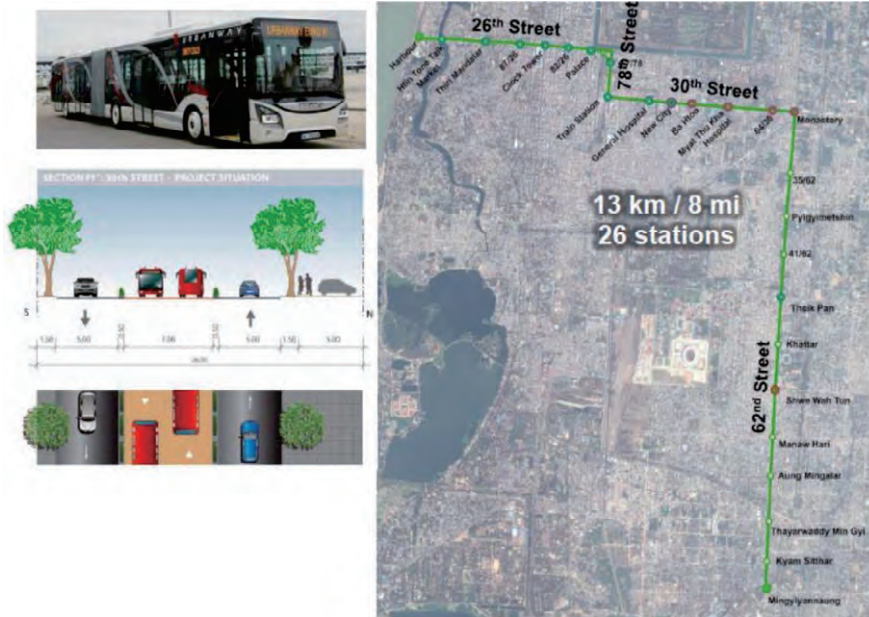

- Future Urban Transport Plan

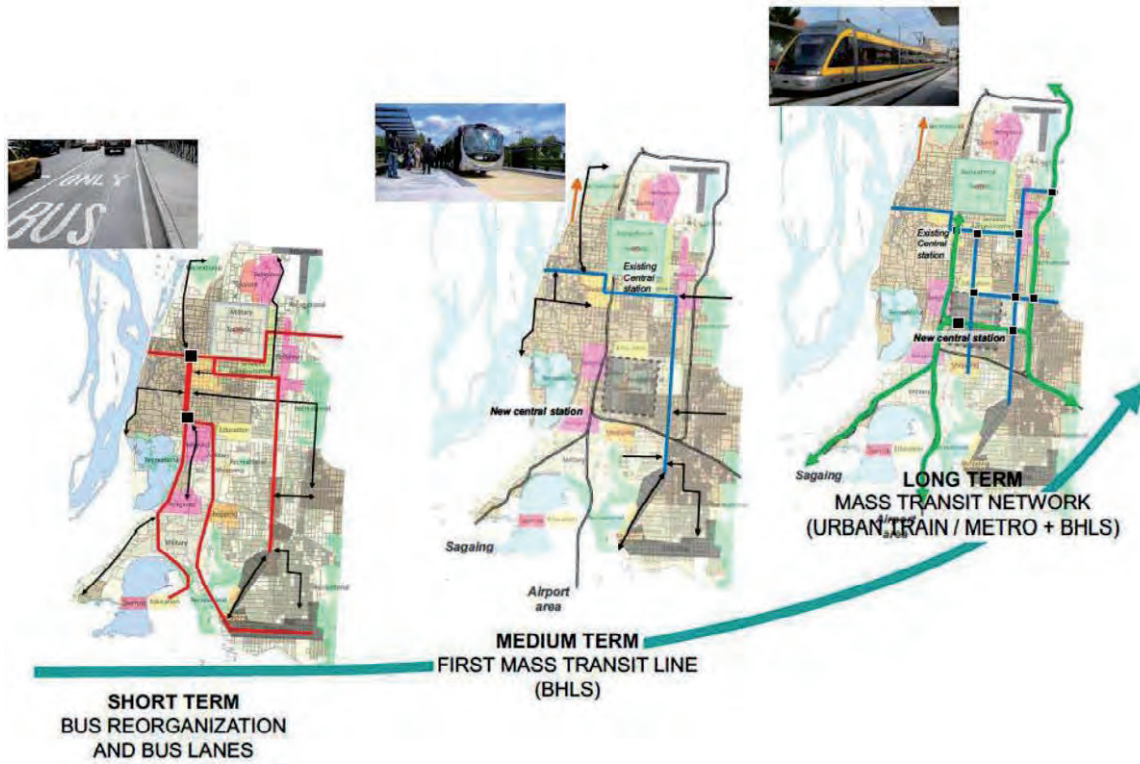

➤ Commuter Railway Development Plan

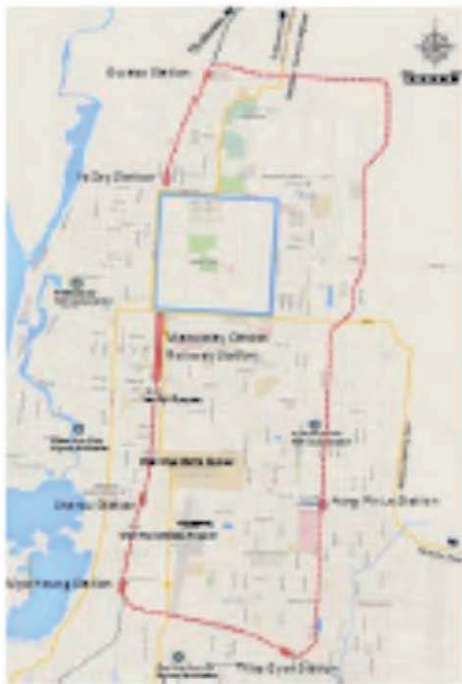

(Urban Railway Track in Mandalay)



(Current Condition: Railway Track and Station)



(Image of LRT: LRT in Sapporo City)

➤ Existing Bus Terminals

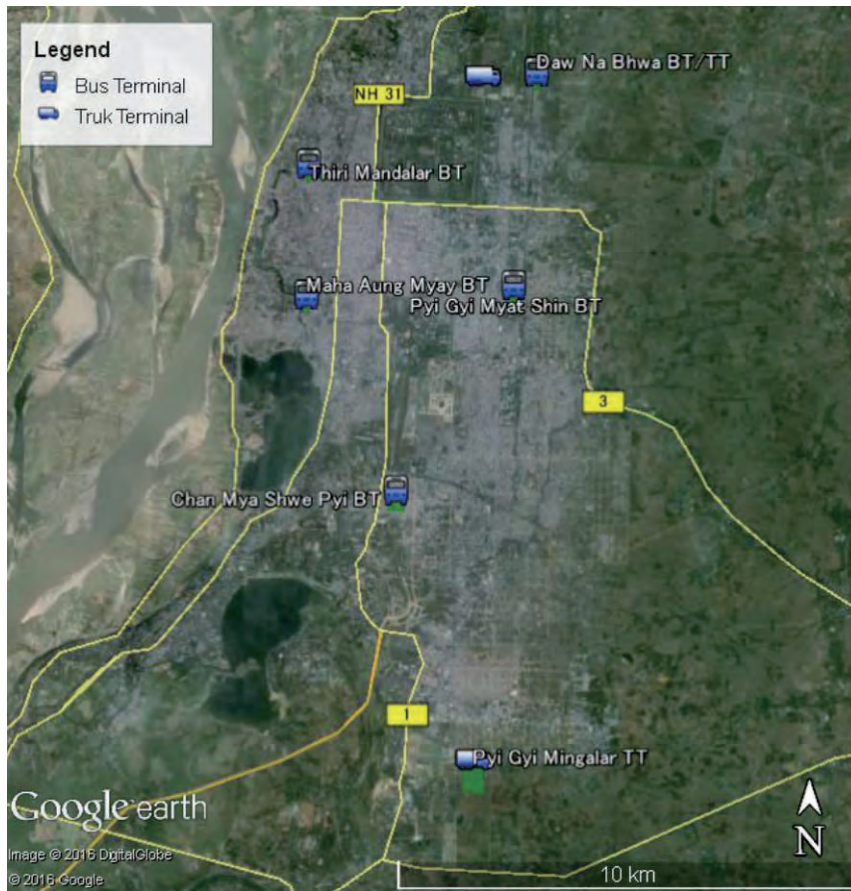

➤ Estimated Bus Routes



➤ New CBD Development Project

**1. New CBD Development Project**

**Table 6.2.2 New CBD Development Project**

Current Status and Issues	The site of the old airport in Mandalay City is currently dysfunctional and underutilized. The site occupies a prime location in the center of Mandalay City in close proximity to the lakes, the Mahamuni Paya, the University of Mandalay as well as the IT University. The city lacks an organized and modern CBD. There is no space where the citizens of Mandalay City can go for leisure, shopping, or cultural activity. This site has the potential to be developed as a modern and well planned CBD which is well serviced by the future railway station. The old railway depot can be a future extension of this CBD.
Purpose	To develop the old airport site into a CBD, culture and leisure destination.
Main Scope	<ul style="list-style-type: none"> <li>- Development of a central CBD and a leisure space for citizens</li> <li>- To create a central park surrounded by malls, hotels, office towers, cultural spaces, and new cultural landmarks like art museums, libraries, and interpretation centers.</li> <li>- Strengthening the tourist potential of Mandalay City by creating a zone of hotels, outdoor eating streets, cafes, and other tourist facilities.</li> </ul>

Source: JICA Study Team

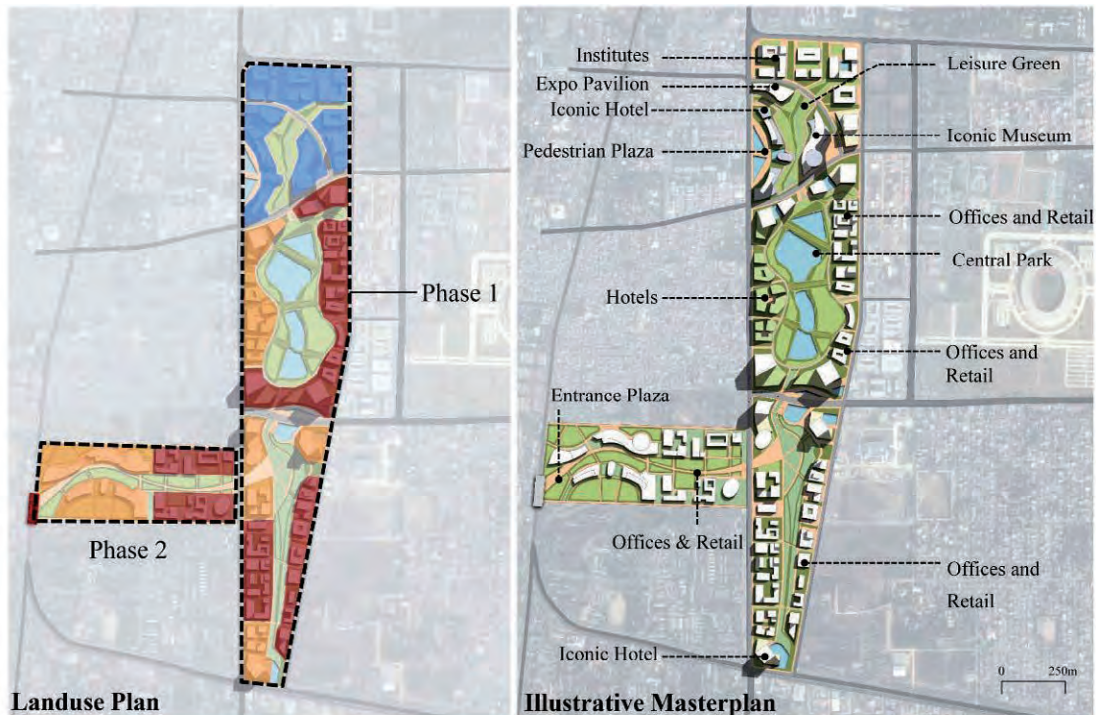

**Landuse Plan**

**Illustrative Masterplan**

- Cultural Zone** (Museums, Art Galleries, Institutes)
- Recreation Zone** (Hotels, Restaurants, Banquet Halls)
- Business Zone** (Offices, Retail)



**Illustrative View**