

**REPUBLIC OF THE UNION OF MYANMAR
MINISTRY OF CONSTRUCTION
DEPARTMENT OF BRIDGE**

**DETAILED DESIGN STUDY ON
THE BAGO RIVER BRIDGE
CONSTRUCTION PROJECT**

FINAL REPORT ATTACHMENTS

VOLUME V DRAFT TENDER DOCUMENT

PACKAGE 3

Volume - IV

DRAWINGS

DECEMBER 2017

JAPAN INTERNATIONAL COOPERATION AGENCY (JICA)

NIPPON KOEI CO., LTD.

ORIENTAL CONSULTANTS GLOBAL CO., LTD.

METROPOLITAN EXPRESSWAY COMPANY LIMITED.

CHODAI CO., LTD.

NIPPON ENGINEERING CONSULTANTS CO., LTD.

EI
CR(3)
17-136

**REPUBLIC OF THE UNION OF MYANMAR
MINISTRY OF CONSTRUCTION
DEPARTMENT OF BRIDGE**

**DETAILED DESIGN STUDY ON
THE BAGO RIVER BRIDGE
CONSTRUCTION PROJECT**

FINAL REPORT ATTACHMENTS

VOLUME V DRAFT TENDER DOCUMENT

PACKAGE 3

Volume - IV

DRAWINGS

DECEMBER 2017

JAPAN INTERNATIONAL COOPERATION AGENCY (JICA)

NIPPON KOEI CO., LTD.

ORIENTAL CONSULTANTS GLOBAL CO., LTD.

METROPOLITAN EXPRESSWAY COMPANY LIMITED.

CHODAI CO., LTD.

NIPPON ENGINEERING CONSULTANTS CO., LTD.

CONTENTS OF DRAWINGS

A. GENERAL					
		LOCATION MAP	P3-GE -0001		
		GENERAL VIEW OF BAGO RIVER BRIDGE (1)-(7)	P3-GE -0002 ~ 0008		
		GENERAL NOTES (1)-(4)	P3-GE-1001 ~ 1004		
		ALIGNMENT LAYOUT AND GEOMETRIC DATA	P3-GE-2001		
B. ROAD DESIGN					
	PLAN & PROFILE	PLAN & PROFILE (1)-(3)	P3-RD-0100 ~ 0120		
	TYPICAL CROSS SECTION	TYPICAL CROSS SECTION (1)-(2)	P3-RD-0200 ~ 0210		
	PAVEMENT	DETAIL OF ASPHALT CONCRETE PAVEMENT	P3-RD-0300		
		PLAN FOR PAVEMENT TYPE (1)-(3)	P3-RD-0310 ~ 0330		
	CROSS SECTION	CROSS SECTION (1)-(16)	P3-RD-0400 ~ 0550		
	INTERSECTION	INTERSECTION PLAN,PROFILE AND SECTION(SHUKHINTHAR INTERSECTION STA.2+830)	P3-RD-2000		
		INTERSECTION PLAN,PROFILE AND SECTION(YADANAR INTERSECTION STA.3+160)	P3-RD-2010		
	DRAINAGE	DRAINAGE SYSTEM PLANS AND OUTLETS (RIGHT RIVER BANK)	P3-RD-3000		
		DRAINAGE SYSTEM PLAN (1)-(3)	P3-RD-3010 ~ 3030		
		DETAIL OF CONCRETE PIPE CULVERT ϕ 300 (CON. 360°) TYPE B	P3-RD-3040		
		DETAIL OF CATCH PIT 500x500x500	P3-RD-3050		
		DETAIL OF CATCH PIT (C-DITCH) TYPE A	P3-RD-3060		
		DETAIL OF SIDE DITCH (1)	P3-RD-3070		
	MECHANICALLY STABILISED EARTWALL AND RETAINING	GENERAL PLAN OF MECHANICALLY-STABILISED EARTH WALL (1)-(2)	P3-RD-4000 ~ 4010		
		ARRANGEMENT OF CONCRETE SKIN PLATE OF MECHANICALLY STABILISED EARTH WALL (1)-(4)	P3-RD-4020 ~ 4050		
		CROSS SECTION (1)-(6)	P3-RD-4060 ~ 4110		
		DETAIL OF MECHANICALLY-STABILISED EARTH WALL (1)-(4)	P3-RD-4120 ~ 4150		
		DETAIL OF CONCRETE BARRIER ON MECHANICALLY-STABILISED EARTH WALL (1)-(2)	P3-RD-4160 ~ 4170		
		DETAIL OF L TYPE RETAINING WALL (1)-(4)	P3-RD-4180 ~ 4210		
		BAR ARRANGEMENT OF L TYPE RETAINING WALL (1)-(18)	P3-RD-4220 ~ 4390		
		DETAIL OF LIGHTING FOUNDATION	P3-RD-4400		
	SOFT SOIL TREATMENT	SOFT SOIL IMPROVEMENT MEASURES (1)-(2)	P3-RD-5000 ~ 5010		
		CROSS SECTION OF DEEP MIXING METHOD (1)-(2)	P3-RD-5020 ~ 5030		
	MISCELLANEOUS	DETAILS OF KERB	P3-RD-6000		
		DETAILS OF CONCRETE SEAL	P3-RD-6010		
		DETAIL OF BOUNDARY FENCE (1)-(2)	P3-RD-6020 ~ 6030		
		DETAIL OF BOX BEAM (1)-(3)	P3-RD-6040 ~ 6060		
		DETAIL OF INFOMATORY SIGNBOARD-TYPE A FOUNDATION AND POST (1)-(2)	P3-RD-6070 ~ 6080		
		DETAIL OF INFOMATORY SIGNBOARD-TYPE B FOUNDATION AND POST (1)-(2)	P3-RD-6090 ~ 6100		
		DETAIL OF INFOMATORY SIGNBOARD	P3-RD-6110		
		SCHEDULE OF INFOMATORY SIGNBOARD	P3-RD-6120		
		ROAD MARKINGS DETAILS (1)-(2)	P3-RD-6130 ~ 6140		
		PLAN FOR ROAD MARKINGS (1)-(3)	P3-RD-6150 ~ 6170		
		REFERENCE DRAWING	QUANTITY TABLE OF ROAD (REFERENCE DRAWING)	P3-RD-7000	
C. FLYOVER BRIDGE					
	GENERAL	GENERAL VIEW OF FLYOVER BRIDGE (1)-(5)	P3-FO-0001 ~ 0005		
SUPERSTRUCTURE	PC-I GIRDER (AF1-PF2)	SUPERSTRUCTURE COORDINATES (AF1-PF2) (1)-(2)	P3-FO-1001 ~ 1002		
		GENERAL VIEW OF SUPERSTRUCTURE (AF1-PF2) (1)-(3)	P3-FO-1003 ~ 1005		
		PC STRAND ARRANGEMENT OF MAIN GIRDER (AF1-PF2) (1)-(2)	P3-FO-1006 ~ 1007		
		BAR ARRANGEMENT OF MAIN GIRDER (AF1-PF2) (1)-(6)	P3-FO-1008 ~ 1013		
		BAR ARRANGEMENT OF CROSSBEAM (AF1-PF2) (1)-(2)	P3-FO-1014 ~ 1015		
		DETAIL OF PC PLATE FOR DECK SLAB (AF1-PF2)	P3-FO-1016		
		BAR ARRANGEMENT OF DECK SLAB (AF1-PF2) (1)-(2)	P3-FO-1017 ~ 1018		
		DETAIL OF CONCRETE CURB, BARRIER AND MEDIUM (AF1-PF2) (1)-(3)	P3-FO-1019 ~ 1021		
		DETAIL OF LIGHTING FOUNDATION (AF1-PF2)	P3-FO-1022		
		DETAIL OF RUBBER BEARING (AF1-PF2) (1)-(2)	P3-FO-1023 ~ 1024		
		DETAIL OF EXPANSION JOINT (AF1-PF2) (1)-(2)	P3-FO-1025 ~ 1026		
			REFERENCE DRAWING	QUANTITY TABLE OF ROAD (REFERENCE DRAWING)	P3-FO-7000
			SUPERSTRUCTURE	SUPERSTRUCTURE COORDINATES (PF5-PF7) (1)-(2)	P3-FO-1101 ~ 1102
				GENERAL VIEW OF SUPERSTRUCTURE (PF5-PF7) (1)-(3)	P3-FO-1103 ~ 1105
				PC STRAND ARRANGEMENT OF MAIN GIRDER (PF5-PF7) (1)-(2)	P3-FO-1106 ~ 1107
				BAR ARRANGEMENT OF MAIN GIRDER (PF5-PF7) (1)-(6)	P3-FO-1108 ~ 1113
		BAR ARRANGEMENT OF CROSSBEAM (PF5-PF7) (1)-(2)	P3-FO-1114 ~ 1115		
		DETAIL OF PC PLATE FOR DECK SLAB (PF5-PF7)	P3-FO-1116		
		BAR ARRANGEMENT OF DECK SLAB (PF5-PF7) (1)-(2)	P3-FO-1117 ~ 1118		
		DETAIL OF CONCRETE CURB, BARRIER AND MEDIUM (PF5-PF7) (1)-(3)	P3-FO-1119 ~ 1121		
		DETAIL OF LIGHTING FOUNDATION (PF5-PF7)	P3-FO-1122		
		DETAIL OF RUBBER BEARING (PF5-PF7) (1)-(2)	P3-FO-1123 ~ 1124		
		DETAIL OF EXPANSION JOINT (PF5-PF7) (1)-(2)	P3-FO-1125 ~ 1126		
	PC-I GIRDER (PF7-PF11)	SUPERSTRUCTURE COORDINATES (PF7-PF11) (1)-(3)	P3-FO-1201 ~ 1203		
		GENERAL VIEW OF SUPERSTRUCTURE (PF7-PF11) (1)-(3)	P3-FO-1204 ~ 1206		
		PC STRAND ARRANGEMENT OF MAIN GIRDER (PF7-PF11) (1)-(3)	P3-FO-1207 ~ 1209		
		BAR ARRANGEMENT OF MAIN GIRDER (PF7-PF11) (1)-(4)	P3-FO-1210 ~ 1213		
		BAR ARRANGEMENT OF CROSSBEAM (PF7-PF11) (1)-(2)	P3-FO-1214 ~ 1215		
		DETAIL OF PC PLATE FOR DECK SLAB (PF7-PF11)	P3-FO-1216		
		BAR ARRANGEMENT OF DECK SLAB (PF7-PF11) (1)-(2)	P3-FO-1217 ~ 1218		
		DETAIL OF CONCRETE CURB, BARRIER AND MEDIUM (PF7-PF11) (1)-(3)	P3-FO-1219 ~ 1221		
		DETAIL OF LIGHTING FOUNDATION (PF7-PF11)	P3-FO-1222		
		DETAIL OF RUBBER BEARING (PF7-PF11) (1)-(3)	P3-FO-1223 ~ 1225		
		DETAIL OF EXPANSION JOINT (PF7-PF11) (1)-(2)	P3-FO-1226 ~ 1227		
	PC-I GIRDER (PF14-AF2)	SUPERSTRUCTURE COORDINATES (PF14-AF2) (1)-(2)	P3-FO-1301 ~ 1302		
		GENERAL VIEW OF SUPERSTRUCTURE (PF14-AF2) (1)-(2)	P3-FO-1303 ~ 1304		
		PC STRAND ARRANGEMENT OF MAIN GIRDER (PF14-AF2) (1)-(2)	P3-FO-1305 ~ 1306		
		BAR ARRANGEMENT OF MAIN GIRDER (PF14-AF2) (1)-(4)	P3-FO-1307 ~ 1310		
		BAR ARRANGEMENT OF CROSSBEAM (PF14-AF2) (1)-(2)	P3-FO-1311 ~ 1312		
		DETAIL OF PC PLATE FOR DECK SLAB (PF14-AF2)	P3-FO-1313		
		BAR ARRANGEMENT OF DECK SLAB (PF14-AF2) (1)-(2)	P3-FO-1314 ~ 1315		
		DETAIL OF CONCRETE CURB, BARRIER AND MEDIUM (PF14-AF2) (1)-(2)	P3-FO-1316 ~ 1317		
		DETAIL OF LIGHTING FOUNDATION (PF14-AF2)	P3-FO-1318 ~		
		DETAIL OF RUBBER BEARING (PF14-AF2) (1)-(2)	P3-FO-1319 ~ 1320		
		DETAIL OF EXPANSION JOINT (PF14-AF2) (1)-(2)	P3-FO-1321 ~ 1322		
	REFERENCE DRAWING	QUANTITY TABLE OF SUPERSTRUCTURE (PC-I GIRDER) (REFERENCE DRAWING)	P3-FO-1323		
	STEEL BOX GIRDER (PF2-PF5)	SUPERSTRUCTURE COORDINATES (PF2-PF5) (1)-(2)	P3-FO-1401 ~ 1402		
			GENERAL VIEW OF SUPERSTRUCTURE (PF2-PF5)	P3-FO-1403	
			STRESS DIAGRAM OF MAIN GIRDER (PF2-PF5) (1)-(2)	P3-FO-1404 ~ 1405	
			COMMON DETAIL (PF2-PF5) (1)-(4)	P3-FO-1406 ~ 1409	
			DETAIL OF MAIN GIRDER G1 (PF2-PF5) (1)-(23)	P3-FO-1410 ~ 1432	
			DETAIL OF MAIN GIRDER G2 (PF2-PF5) (1)-(23)	P3-FO-1433 ~ 1455	
			DETAIL OF CROSSBEAM (PF2-PF5) (1)-(4)	P3-FO-1456 ~ 1459	
			DETAIL OF LATERAL RIB (PF2-PF5) (1)-(2)	P3-FO-1460 ~ 1461	
			DETAIL OF OUTSIDE STRINGER (PF2-PF5) (1)-(8)	P3-FO-1462 ~ 1469	
			DETAIL OF INSIDE STRINGER (PF2-PF5)	P3-FO-1470	
			DETAIL OF DECK SLAB (PF2-PF5) (1)-(3)	P3-FO-1471 ~ 1473	
			DETAIL OF CONCRETE CURB, BARRIER AND MEDIUM (PF2-PF5) (1)-(3)	P3-FO-1474 ~ 1476	
			DETAIL OF LIGHTING FOUNDATION (PF2-PF5)	P3-FO-1477	
		DETAIL OF RUBBER BEARING (PF2-PF5) (1)-(2)	P3-FO-1478 ~ 1479		
		DETAIL OF PAINTING SYSTEM (1)-(2)	P3-FO-1480 ~ 1481		
	REFERENCE DRAWING	QUANTITY TABLE OF SUPERSTRUCTURE (STEEL BOX GIRDER) (REFERENCE DRAWING)	P3-FO-1482		

CONTENTS OF DRAWINGS

C. FLYOVER BRIDGE

SUPERSTRUCTURE	STEEL-I GIRDER (PF11-PF14)	SUPERSTRUCTURE COORDINATES (PF11-PF14) (1)-(2)	P3-FO-1501 ~ 1502
		GENERAL VIEW OF SUPERSTRUCTURE (PF11-PF14)	P3-FO-1503
		STRESS DIAGRAM OF MAIN GIRDER (PF11-PF14) (1)-(5)	P3-FO-1504 ~ 1508
		COMMON DETAIL (PF11-PF14) (1)-(2)	P3-FO-1509 ~ 1510
		DETAIL OF MAIN GIRDER G1 (PF11-PF14) (1)-(7)	P3-FO-1511 ~ 1517
		DETAIL OF MAIN GIRDER G2 (PF11-PF14) (1)-(7)	P3-FO-1518 ~ 1524
		DETAIL OF MAIN GIRDER G3 (PF11-PF14) (1)-(7)	P3-FO-1525 ~ 1531
		DETAIL OF MAIN GIRDER G4 (PF11-PF14) (1)-(7)	P3-FO-1532 ~ 1538
		DETAIL OF MAIN GIRDER G5 (PF11-PF14) (1)-(7)	P3-FO-1539 ~ 1545
		DETAIL OF LATERAL (PF11-PF14) (1)-(3)	P3-FO-1546 ~ 1548
		DETAIL OF CROSSBEAM (PF11-PF14) (1)-(4)	P3-FO-1549 ~ 1552
		DETAIL OF DECK SLAB (PF11-PF14) (1)-(3)	P3-FO-1553 ~ 1555
		DETAIL OF CONCRETE CURB, BARRIER AND MEDIAN (PF11-PF14) (1)-(3)	P3-FO-1556 ~ 1558
		DETAIL OF LIGHTING FOUNDATION (PF11-PF14)	P3-FO-1559
		DETAIL OF RUBBER BEARING (PF11-PF14) (1)-(2)	P3-FO-1560 ~ 1561
		DETAIL OF PAINTING SYSTEM (1)-(2)	P3-FO-1562 ~ 1563
	REFERENCE DRAWING	QUANTITY TABLE OF SUPERSTRUCTURE (STEEL-I GIRDER) (REFERENCE DRAWING)	P3-FO-1564
SUBSTRUCTURE AND FOUNDATION		COORDINATES OF SUBSTRUCTURE (AF1-AF2)	P3-FO-2001
		GENERAL VIEW OF SUBSTRUCTURE AND FOUNDATION (1)-(12)	P3-FO-2002 ~ 2013
		BAR ARRANGEMENT OF AF1 ABUTMENT (1)-(12)	P3-FO-2014 ~ 2025
		BAR ARRANGEMENT OF PF1 PIER (1)-(6)	P3-FO-2026 ~ 2031
		BAR ARRANGEMENT OF PF2 PIER (1)-(7)	P3-FO-2032 ~ 2038
		BAR ARRANGEMENT OF PF3 PIER (1)-(6)	P3-FO-2039 ~ 2044
		BAR ARRANGEMENT OF PF4 PIER (1)-(6)	P3-FO-2045 ~ 2050
		BAR ARRANGEMENT OF PF5 PIER (1)-(7)	P3-FO-2051 ~ 2057
		BAR ARRANGEMENT OF PF6 PIER (1)-(6)	P3-FO-2058 ~ 2063
		BAR ARRANGEMENT OF PF7 PIER (1)-(7)	P3-FO-2064 ~ 2070
		BAR ARRANGEMENT OF PF8 PIER (1)-(6)	P3-FO-2071 ~ 2076
		BAR ARRANGEMENT OF PF9 PIER (1)-(6)	P3-FO-2077 ~ 2082
		BAR ARRANGEMENT OF PF10 PIER (1)-(6)	P3-FO-2083 ~ 2088
		BAR ARRANGEMENT OF PF11 PIER (1)-(7)	P3-FO-2089 ~ 2095
		BAR ARRANGEMENT OF PF12 PIER (1)-(6)	P3-FO-2096 ~ 2101
		BAR ARRANGEMENT OF PF13 PIER (1)-(6)	P3-FO-2102 ~ 2107
		BAR ARRANGEMENT OF PF14 PIER (1)-(7)	P3-FO-2108 ~ 2114
		BAR ARRANGEMENT OF PF15 PIER (1)-(6)	P3-FO-2115 ~ 2120
		BAR ARRANGEMENT OF AF2 ABUTMENT (1)-(12)	P3-FO-2121 ~ 2132
		BAR ARRANGEMENT OF CAST IN PLACE PILE (1)-(12)	P3-FO-2133 ~ 2144
	REFERENCE DRAWING	QUANTITY TABLE OF SUBSTRUCTURE (1)-(2) (REFERENCE DRAWING)	P3-FO-2145 ~ 2146
BRIDGE ACCESSORIES	DRAINAGE	BRIDGE DRAINAGE LAYOUT (AF1-PF2) (1)-(2)	P3-FO-3001 ~ 3002
		BRIDGE DRAINAGE LAYOUT (PF2-PF5) (1)-(3)	P3-FO-3003 ~ 3005
		BRIDGE DRAINAGE LAYOUT (PF5-PF7) (1)-(2)	P3-FO-3006 ~ 3007
		BRIDGE DRAINAGE LAYOUT (PF7-PF11) (1)-(4)	P3-FO-3008 ~ 3011
		BRIDGE DRAINAGE LAYOUT (PF11-PF14) (1)-(2)	P3-FO-3012 ~ 3013
		BRIDGE DRAINAGE LAYOUT (PF14-AF2) (1)-(2)	P3-FO-3014 ~ 3015
		BRIDGE DRAINAGE DETAIL (1)-(6)	P3-FO-3016 ~ 3021
		BRIDGE DRAINAGE LAYOUT OF SUBSTRUCTURE (1)-(3)	P3-FO-3022 ~ 3024
		BRIDGE DRAINAGE DETAIL OF SUBSTRUCTURE	P3-FO-3025

D. LIGHTING

		TYPICAL POWER DISTRIBUTION PLAN	P3-EL-0001
		TYPICAL WIRING PLAN FOR FLYOVER BRIDGE	P3-EL-0002
		(REFERENCE) INCOMING POWER RECEIVING FOR ROAD LIGHTING	P3-EL-0003
		TYPICAL MV SITE SUBSTATION	P3-EL-0004
		TYPICAL ELECTRIC POLE ASSEMBLING (11 kv USE)	P3-EL-0005
		TYPICAL LIGHTING PLAN FOR FLYOVER BRIDGE	P3-EL-0006
		(REFERENCE) SINGLE LINE DIAGRAM FOR PANELS	P3-EL-0007
		TYPICAL LED LUMINAIR AND POLE	P3-EL-0008
		TYPICAL FOUNDATION DETAILS FOR LIGHTING POLE	P3-EL-0009
		(REFERENCE) INSTALLATION DETAIL FOR FLEXIBLE PIPE	P3-EL-0010
		(REFERENCE) OUTLINE OF ELECTRIC PANELS	P3-EL-0011
		TYPICAL TRAFFIC SIGNAL CONTROL SYSTEM PLAN AND WIRING PLAN FOR SHUKHINTHAR INTERSECTION	P3-EL-0012
		TYPICAL TRAFFIC SIGNAL CONTROL SYSTEM PLAN FOR SHUKHINTHAR INTERSECTION	P3-EL-0013
		TYPICAL UNDERGROUND WIRING PLAN FOR SHUKHINTHAR INTERSECTION	P3-EL-0014
		(REFERENCE) TRAFFIC SIGNAL HEAD AND POLES	P3-EL-0015
		(REFERENCE) OUTLINE OF TRAFFIC SIGNAL CONTROLLER AND JUNCTION BOX	P3-EL-0016
	REFERENCE DRAWING	QUANTITY TABLE OF LIGHTING AND ELECTRICAL WORKS (REFERENCE DRAWING)	P3-EL-0017

E. REFERENCE DRAWING

		(REFERENCE) ERECTION PLAN FOR PC-I GIRDER (AF1-PF2) (1)-(2)	P3-REF-0001 ~ 0002
		(REFERENCE) ERECTION PLAN FOR PC-I GIRDER (PF5-PF7) (1)-(2)	P3-REF-0003 ~ 0004
		(REFERENCE) ERECTION PLAN FOR PC-I GIRDER (PF7-PF11) (1)-(4)	P3-REF-0005 ~ 0008
		(REFERENCE) ERECTION PLAN FOR PC-I GIRDER (PF14-AF2) (1)-(2)	P3-REF-0009 ~ 0010
		(REFERENCE) ERECTION PLAN OF CROSS SECTION FOR PC-I GIRDER	P3-REF-0011
		(REFERENCE) ERECTION PLAN FOR STEEL BOX GIRDER (PF2-PF5)	P3-REF-0012
		(REFERENCE) ERECTION PLAN FOR STEEL-I GIRDER (PF11-PF14)	P3-REF-0013
		(REFERENCE) CAMBER ARRANGEMENT OF MAIN GIRDER (PF2-PF5)	P3-REF-0014
		(REFERENCE) CAMBER ARRANGEMENT OF MAIN GIRDER (PF11-PF14)	P3-REF-0015
		(REFERENCE) DETAIL OF TEMPORARY RETAINING WALL FOR BRIDGE FOUNDATION	P3-REF-0016
		(REFERENCE) EXISTING UNDERGROUND UTILITIES LAYOUT (1)-(3)	P3-REF-0017 ~ 0019
		(REFERENCE) RIGHT OF WAY PLAN (1)-(3)	P3-REF-0020 ~ 0022
		(REFERENCE) SITE CLEARING	P3-REF-0023
		(REFERENCE) DEMOLITION AND REMOVAL	P3-REF-0024
		(REFERENCE) MONUMENT AND BRIDGE RECORD	P3-REF-0025
		(REFERENCE) NETWORK PLAN	P3-REF-0026
		(REFERENCE) GENERAL LAYOUT OF CONSTRUCTION YARD	P3-REF-0027
		(REFERENCE) QUARRY SITE LOCATION	P3-REF-1001
		(REFERENCE) LAND TRANSPORTATION ROUTE TO WASTE DISPOSAL SITE IN THILAWA SEZ	P3-REF-1002
		(REFERENCE) LAND TRANSPORTATION ROUTE FROM LANDING PORT	P3-REF-1003

CONTENTS OF DRAWINGS

F. REFERENCE DRAWING (MOC PORTION)			
PLAN & PROFILE	PLAN & PROFILE (1)-(3)	P0-RD-0100 ~ 0120	
TYPICAL CROSS SECTION	TYPICAL CROSS SECTION (1)-(3)	P0-RD-0200 ~ 0220	
PAVEMENT	DETAIL OF ASPHALT CONCRETE PAVEMENT	P0-RD-0300	
	PLAN FOR PAVEMENT TYPE (1)-(3)	P0-RD-0310 ~ 0330	
CROSS SECTION	CROSS SECTION (1)-(16)	P0-RD-0400 ~ 0550	
INTERSECTION	INTERSECTION PLAN,PROFILE AND SECTION(SHUKHINTHAR INTERSECTION STA.2+830)	P0-RD-2000	
	INTERSECTION PLAN,PROFILE AND SECTION(YADANAR INTERSECTION STA.3+160)	P0-RD-2010	
DRAINAGE	DRAINAGE SYSTEM PLAN AND OUTLETS (RIGHT RIVER BANK)	P0-RD-3000	
	DRAINAGE SYSTEM PLAN (1)-(3)	P0-RD-3010 ~ 3030	
	DETAIL OF BOX CULVERT TYPE 1000 x 1000	P0-RD-3040	
	DETAIL OF BOX CULVERT TYPE 1500 x 1000	P0-RD-3050	
	DETAIL OF BOX CULVERT TYPE 1500 x 1500	P0-RD-3060	
	GENERAL VIEW OF BOX CULVERT (1) SHUKHINTHAR(LEFT SIDE)	P0-RD-3070	
	GENERAL VIEW OF BOX CULVERT (2) SHUKHINTHAR(RIGHT SIDE)	P0-RD-3080	
	GENERAL VIEW OF BOX CULVERT (3) YADANAR(LEFT SIDE)	P0-RD-3090	
	GENERAL VIEW OF BOX CULVERT (4) YADANAR(RIGHT SIDE)	P0-RD-3100	
	DETAIL OF CONCRETE PIPE CULVERT φ300 (CON. 360°) TYPE A	P0-RD-3110	
	DETAIL OF CONCRETE PIPE CULVERT φ900 (CON. 360°)	P0-RD-3120	
	GENERAL VIEW OF CONCRETE PIPE CULVERT φ300 (CON. 360°) TYPE A	P0-RD-3130	
	DETAIL OF CATCH PIT 500x500x1200	P0-RD-3140	
	DETAIL OF CATCH PIT (C-DITCH) TYPE B	P3-RD-3150	
	DETAIL OF U-DITCH TYPE A	P0-RD-3160	
	DETAIL OF U-DITCH TYPE B	P0-RD-3170	
	DETAIL OF U-DITCH TYPE C	P0-RD-3180	
DETAIL OF SIDE DITCH (1)-(3)	P0-RD-3190 ~ 3210		
MISCELLANEOUS	DETAILS OF KERB	P0-RD-6000	
	DETAIL OF GUARD FENCE	P0-RD-6010	
	DETAIL OF SIGNBOARD FOUNDATION AND POST	P0-RD-6020	
	DETAIL OF SIGNBOARD	P0-RD-6030	
	SCHEDULE OF SIGNBOARD	P0-RD-6040	
	ROAD MARKINGS DETAILS (1)-(2)	P0-RD-6050 ~ 6060	
	PLAN FOR ROAD MARKINGS (1)-(3)	P0-RD-6070 ~ 6090	
	DETAIL OF TEMPORARY WORKS	P0-RD-6100	
	QUANTITY TABLE OF ROAD (REFERENCE DRAWING)	P0-RD-7000	

F. REFERENCE DRAWING (MOC PORTION)			
LIGHTING	TYPICAL POWER DISTRIBUTION PLAN	P0-EL-0001	
	TYPICAL WIRING PLAN FOR FLYOVER BRIDGE AND PUBLIC ROAD	P0-EL-0002	
	TYPICAL MV SITE SUBSTATION	P0-EL-0003	
	TYPICAL ELECTRIC POLE ASSEMBLING (11KV USE)	P0-EL-0004	
	TYPICAL LIGHTING PLAN FOR THANLYIN CHIN KAT ROAD	P0-EL-0005	
	(REFERENCE) SINGLE LINE DIAGRAM FOR PANELS	P0-EL-0006	
	TYPICAL LED LUMINAIR AND POLE	P0-EL-0007	
	TYPICAL FOUNDATION DETAILS FOR LIGHTING POLE	P0-EL-0008	
	(REFERENCE) OUTLINE OF ELECTRIC PANELS	P0-EL-0009	
	TYPICAL TRAFFIC SIGNAL CONTROL SYSTEM PLAN FOR INTERSECTIONS (MOC'S CONSTRUCTION)	P0-EL-0010	
	TYPICAL WIRING PLAN FOR INTERSECTION (MOC'S CONSTRUCTION)	P0-EL-0011	
	(REFERENCE) TYPICAL OVERHEAD WIRING PLAN	P0-EL-0012	
	TYPICAL TRAFFIC SIGNAL CONTROL SYSTEM DIAGRAM	P0-EL-0013	
	(REFERENCE) TRAFFIC SIGNAL HEAD AND POLES	P0-EL-0014	
	(REFERENCE) OUTLINE OF TRAFFIC SIGNAL CONTROLLER AND JUNCTION BOX	P0-EL-0015	
	QUANTITY TABLE OF LIGHTING AND ELECTRICAL WORKS FOR MOC'S CONSTRUCTION (REFERENCE DRAWING)	P0-EL-0016	
REFERENCE DRAWING	(REFERENCE) EXISTING UNDERGROUND UTILITIES LAYOUT (1)-(3)	P0-REF-0001 ~ 0003	
	(REFERENCE) RIGHT OF WAY PLAN (1)-(3)	P0-REF-0004 ~ 0006	
	(REFERENCE) NETWORK PLAN	P0-REF-0007	
	(REFERENCE) SITE CLEARING	P0-REF-0008	
	(REFERENCE) DEMOLITION AND REMOVAL	P0-REF-0009	

A. GENERAL



LOCATION MAP

S=1:100,000

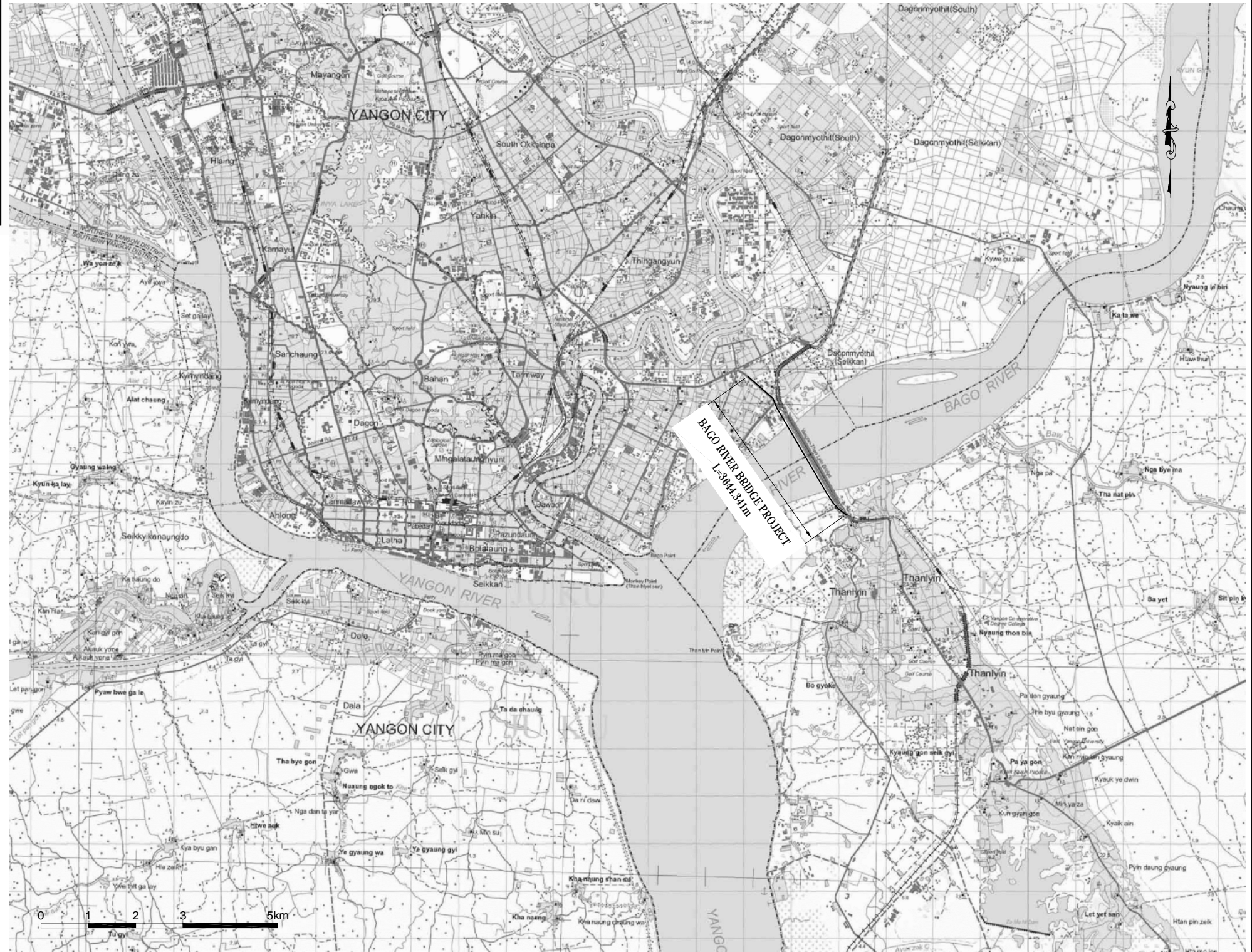

<p>PROJECT NAME DETAILED DESIGN ON BAGO RIVER BRIDGE CONSTRUCTION PROJECT</p>	<p>FINANCED BY JAPAN INTERNATIONAL COOPERATION AGENCY</p>	<p>COUNTERPART REPUBLIC OF THE UNION OF MYANMAR MINISTRY OF CONSTRUCTION DEPARTMENT OF BRIDGE</p>	<p>JICA STUDY TEAM NIPPON KOEI CO., LTD. ORIENTAL CONSULTANTS GLOBAL CO., LTD. METROPOLITAN EXPRESSWAY COMPANY LIMITED CHODAI CO., LTD. NIPPON ENGINEERING CONSULTANTS CO., LTD.</p>	<table border="1"> <thead> <tr> <th></th> <th>NAME</th> <th>SIGNATURE</th> <th>DATE</th> </tr> </thead> <tbody> <tr> <td>PREPARED BY</td> <td>T. HAYAKAWA</td> <td></td> <td>15 Sep.2017</td> </tr> <tr> <td>CHECKED BY</td> <td>T. HAYAKAWA</td> <td></td> <td>22 Sep.2017</td> </tr> <tr> <td>APPROVED BY</td> <td>Y. SANO</td> <td></td> <td>29 Sep.2017</td> </tr> </tbody> </table>		NAME	SIGNATURE	DATE	PREPARED BY	T. HAYAKAWA		15 Sep.2017	CHECKED BY	T. HAYAKAWA		22 Sep.2017	APPROVED BY	Y. SANO		29 Sep.2017	<p>DRAWING TITLE LOCATION MAP</p>	<p>PACKAGE 3 DWG No. P3-GE-001</p>
	NAME	SIGNATURE	DATE																			
PREPARED BY	T. HAYAKAWA		15 Sep.2017																			
CHECKED BY	T. HAYAKAWA		22 Sep.2017																			
APPROVED BY	Y. SANO		29 Sep.2017																			

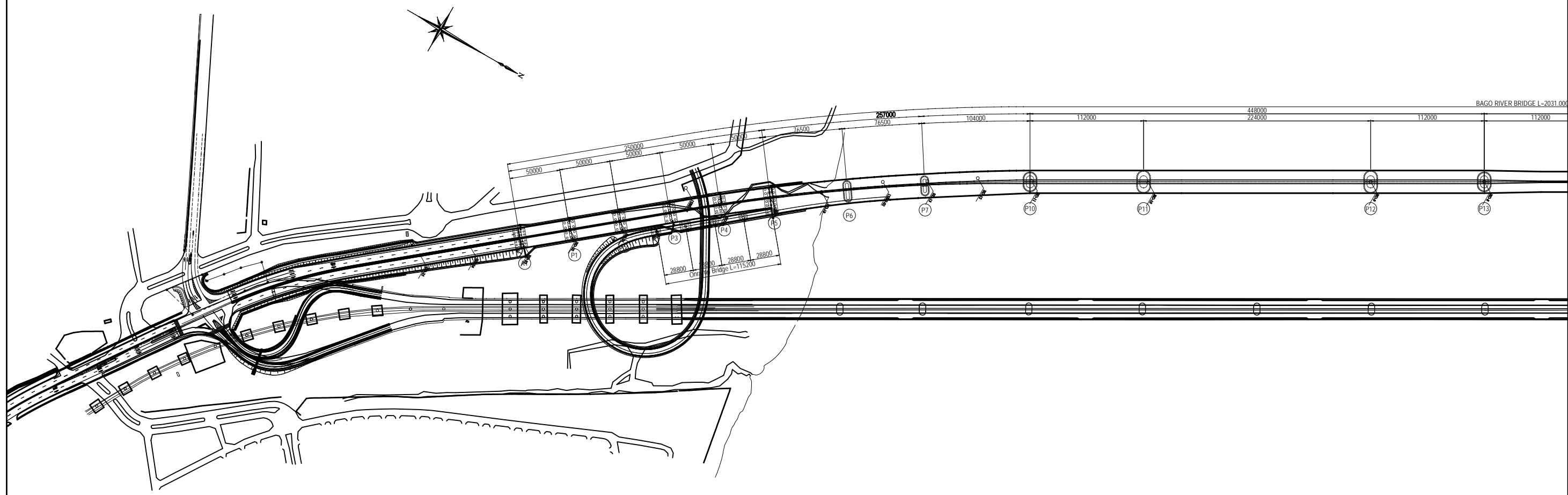
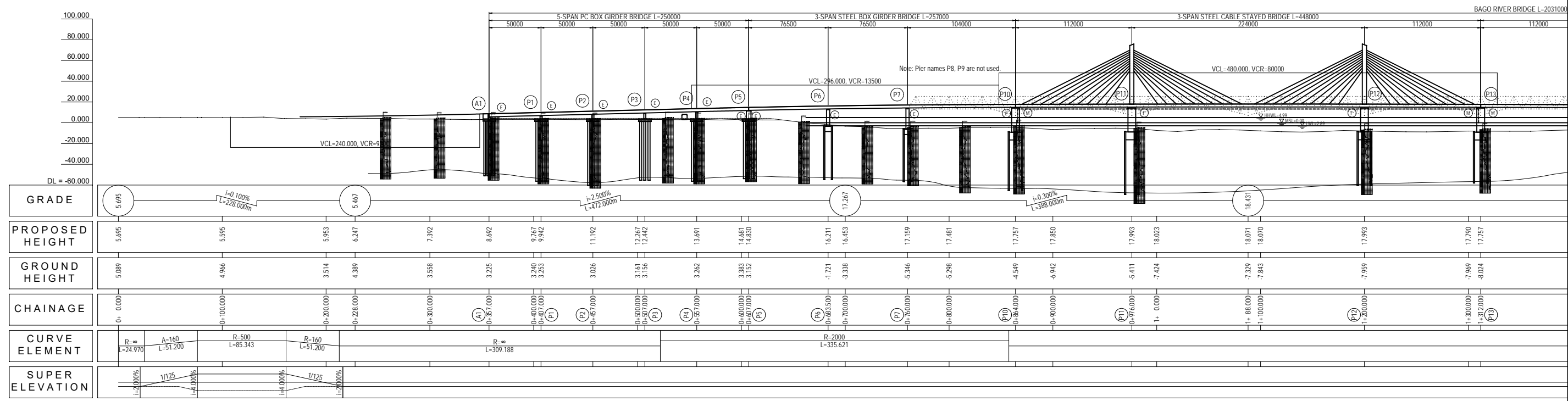

Elevation represents above MSL unless otherwise indicated.

PROJECT NAME DETAILED DESIGN ON BAGO RIVER BRIDGE CONSTRUCTION PROJECT	FINANCED BY JAPAN INTERNATIONAL COOPERATION AGENCY	COUNTERPART REPUBLIC OF THE UNION OF MYANMAR MINISTRY OF CONSTRUCTION DEPARTMENT OF BRIDGE	JICA STUDY TEAM NIPPON KOEI CO., LTD. ORIENTAL CONSULTANTS GLOBAL CO., LTD. METROPOLITAN EXPRESSWAY COMPANY LIMITED CHODAI CO., LTD. NIPPON ENGINEERING CONSULTANTS CO., LTD.	NAME	SIGNATURE	DATE	DRAWING TITLE GENERAL VIEW OF BAGO RIVER BRIDGE (1)	PACKAGE 3 DWG No. P3-GE-0002	
				PREPARED BY	T. HAYAKAWA				27 Nov. 2017
				CHECKED BY	T. HAYAKAWA				28 Nov. 2017
				APPROVED BY	Y. SANO				29 Nov. 2017

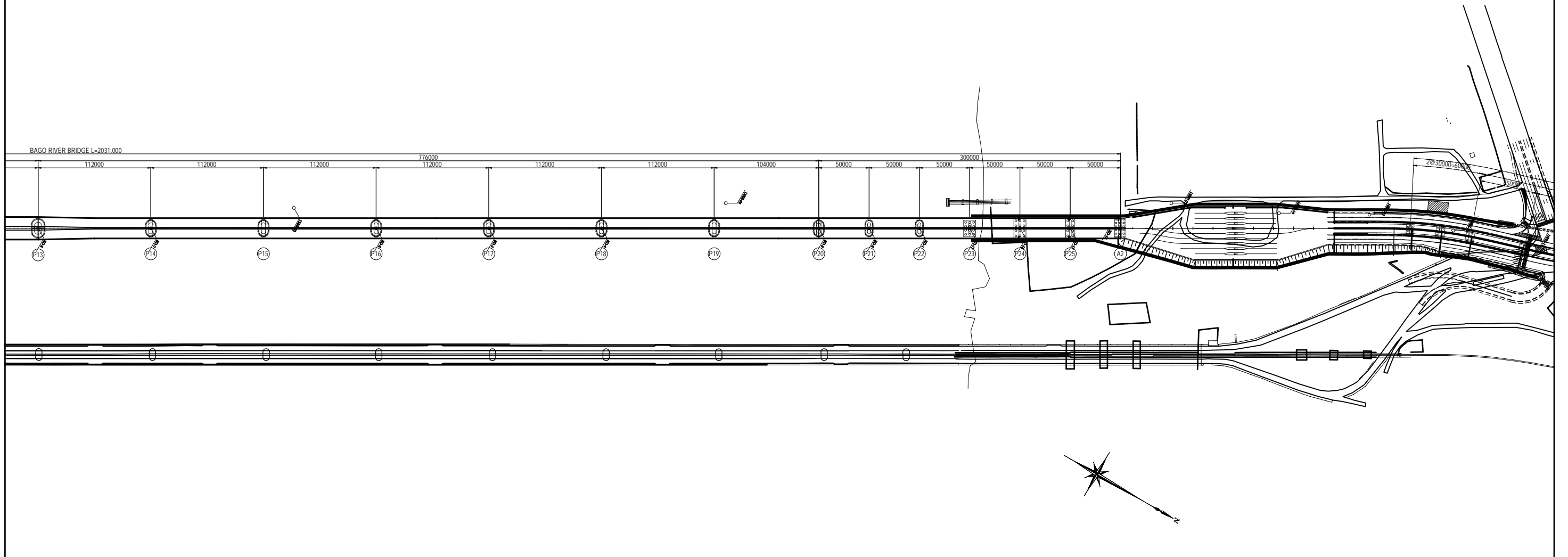
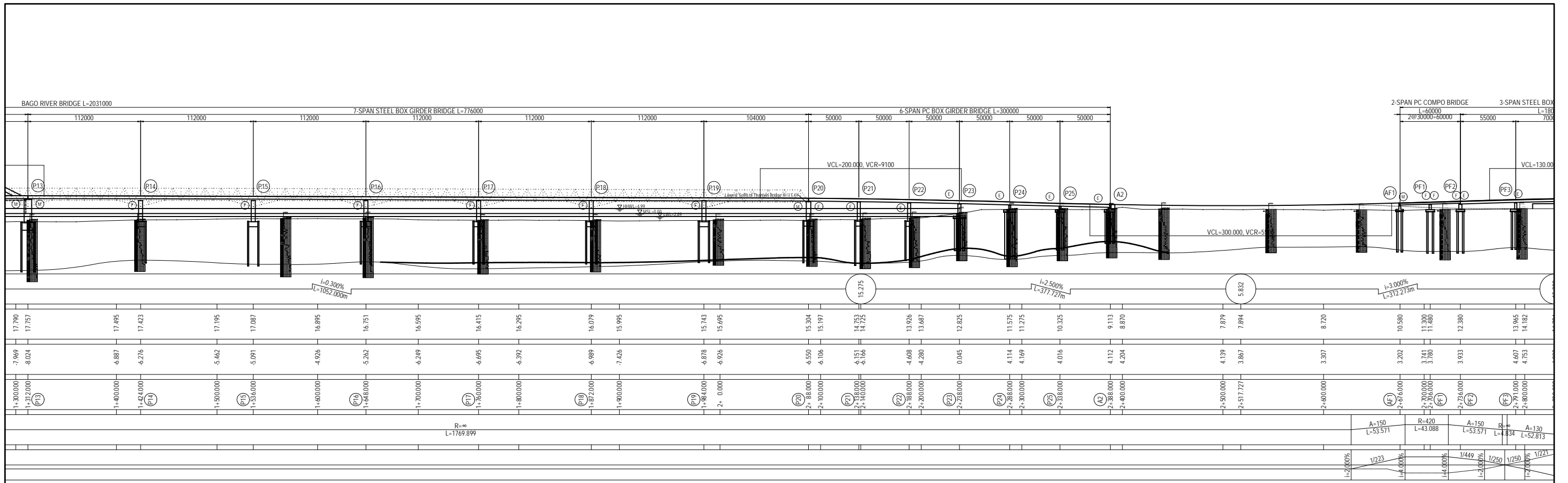

Elevation represents above MSL unless otherwise indicated.

PROJECT NAME DETAILED DESIGN ON BAGO RIVER BRIDGE CONSTRUCTION PROJECT	FINANCED BY JAPAN INTERNATIONAL COOPERATION AGENCY	COUNTERPART REPUBLIC OF THE UNION OF MYANMAR MINISTRY OF CONSTRUCTION DEPARTMENT OF BRIDGE	JICA STUDY TEAM NIPPON KOEI CO., LTD. ORIENTAL CONSULTANTS GLOBAL CO., LTD. METROPOLITAN EXPRESSWAY COMPANY LIMITED CHODAI CO., LTD. NIPPON ENGINEERING CONSULTANTS CO., LTD.	NAME	SIGNATURE	DATE	DRAWING TITLE GENERAL VIEW OF BAGO RIVER BRIDGE (2)	PACKAGE	
				PREPARED BY	T. HAYAKAWA			27 Nov. 2017	3
				CHECKED BY	T. HAYAKAWA			28 Nov. 2017	DWG No.
				APPROVED BY	Y. SANO			29 Nov. 2017	P3-GE-0003

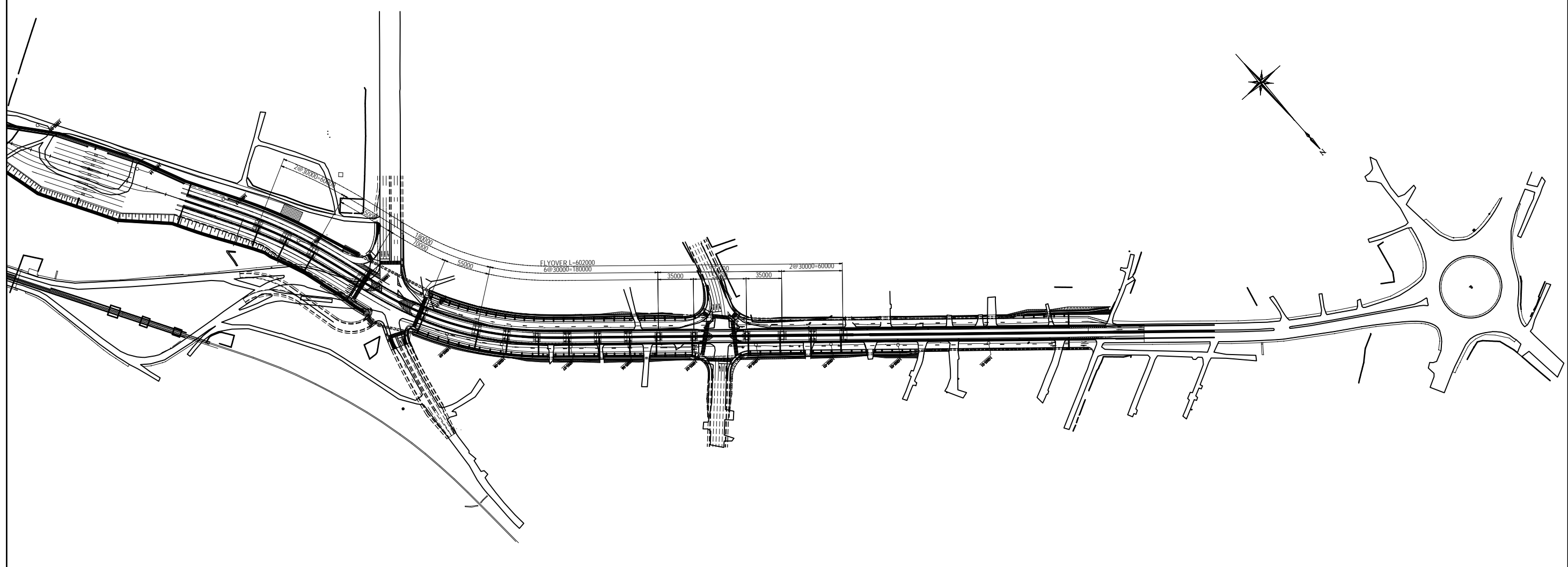
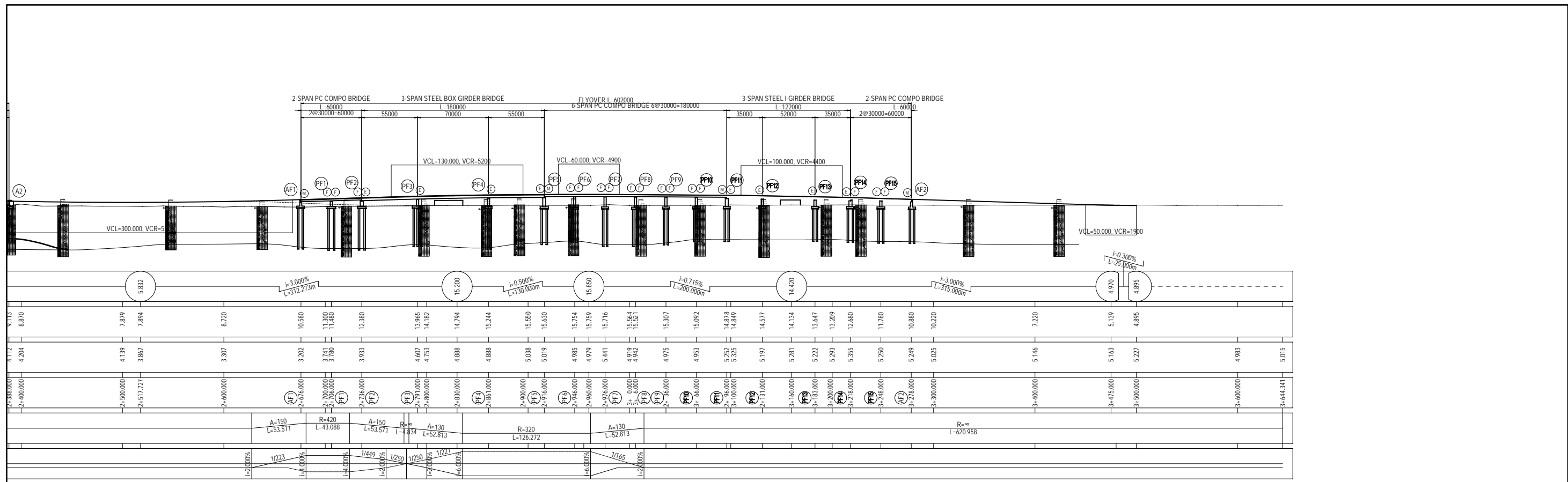

Elevation represents above MSL unless otherwise indicated.

PROJECT NAME DETAILED DESIGN ON BAGO RIVER BRIDGE CONSTRUCTION PROJECT	FINANCED BY JAPAN INTERNATIONAL COOPERATION AGENCY	COUNTERPART REPUBLIC OF THE UNION OF MYANMAR MINISTRY OF CONSTRUCTION DEPARTMENT OF BRIDGE	JICA STUDY TEAM NIPPON KOEI CO., LTD. ORIENTAL CONSULTANTS GLOBAL CO., LTD. METROPOLITAN EXPRESSWAY COMPANY LIMITED CHODAI CO., LTD. NIPPON ENGINEERING CONSULTANTS CO., LTD.	NAME	SIGNATURE	DATE	DRAWING TITLE GENERAL VIEW OF BAGO RIVER BRIDGE (3)	PACKAGE 3 DWG No. P3-GE-0004	
				PREPARED BY	T. HAYAKAWA				27 Nov. 2017
				CHECKED BY	T. HAYAKAWA				28 Nov. 2017
				APPROVED BY	Y. SANO				29 Nov. 2017

GENERAL VIEW OF BAGO RIVER BRIDGE (4)

LONGITUDINAL SECTION

S=1:1000

BAGO RIVER BRIDGE L=2031000

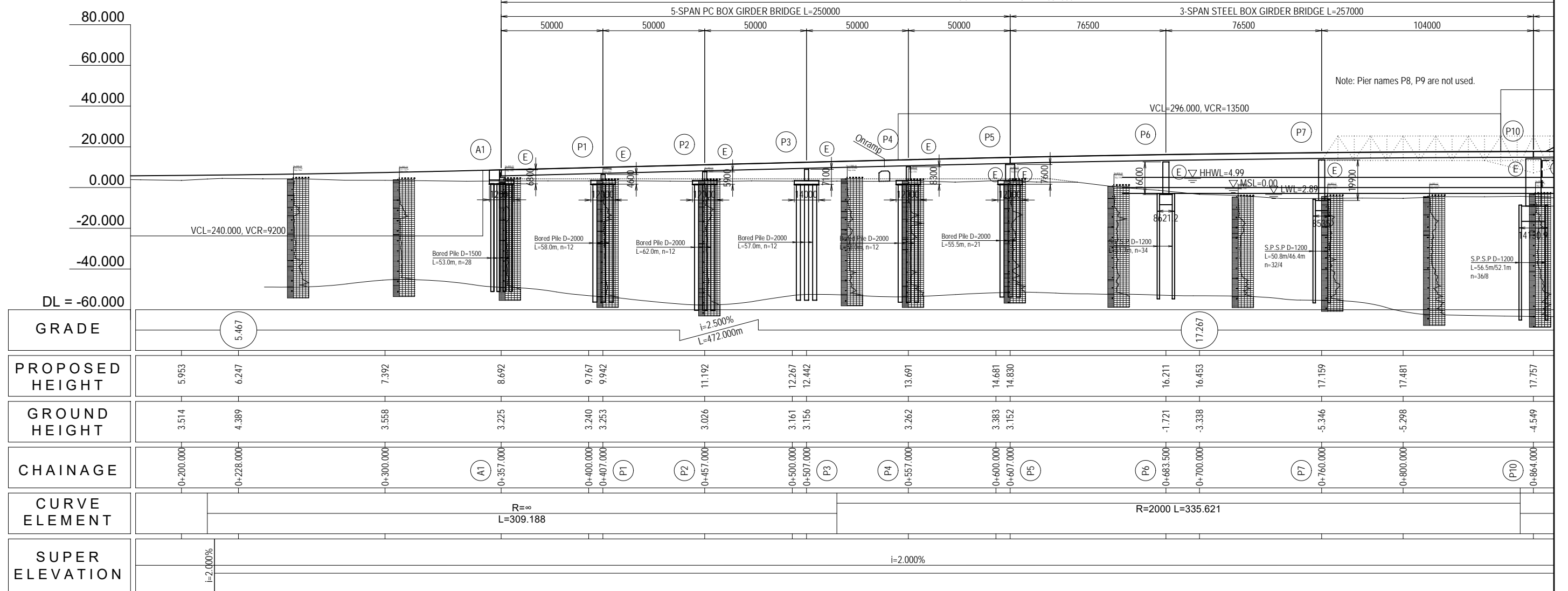

PLAN VIEW

S=1:1000

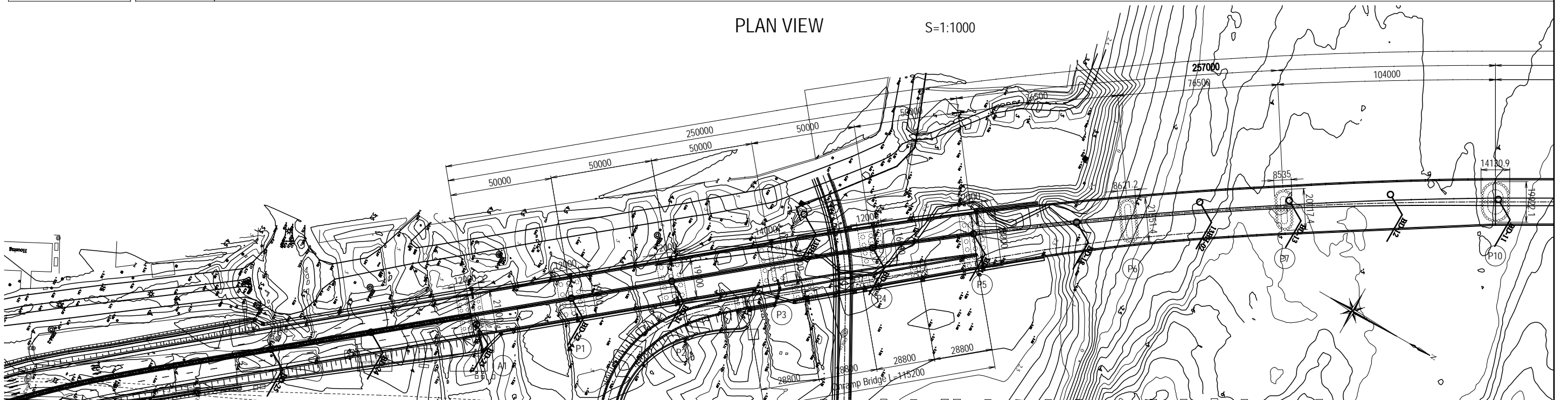

Elevation represents above MSL unless otherwise indicated.

PROJECT NAME DETAILED DESIGN ON BAGO RIVER BRIDGE CONSTRUCTION PROJECT	FINANCED BY JAPAN INTERNATIONAL COOPERATION AGENCY	COUNTERPART REPUBLIC OF THE UNION OF MYANMAR MINISTRY OF CONSTRUCTION DEPARTMENT OF BRIDGE	JICA STUDY TEAM NIPPON KOEI CO., LTD. ORIENTAL CONSULTANTS GLOBAL CO., LTD. METROPOLITAN EXPRESSWAY COMPANY LIMITED CHODAI CO., LTD. NIPPON ENGINEERING CONSULTANTS CO., LTD.	NAME	SIGNATURE	DATE	DRAWING TITLE GENERAL VIEW OF BAGO RIVER BRIDGE (4)	PACKAGE 3 DWG No. P3-GE-0005	
				PREPARED BY	T. HAYAKAWA				27 Nov. 2017
				CHECKED BY	T. HAYAKAWA				28 Nov. 2017
				APPROVED BY	Y. SANO				29 Nov. 2017

GENERAL VIEW OF BAGO RIVER BRIDGE (5)

LONGITUDINAL SECTION S=1:1000

BAGO RIVER BRIDGE L=2031000

3-SPAN STEEL CABLE STAYED BRIDGE L=448000

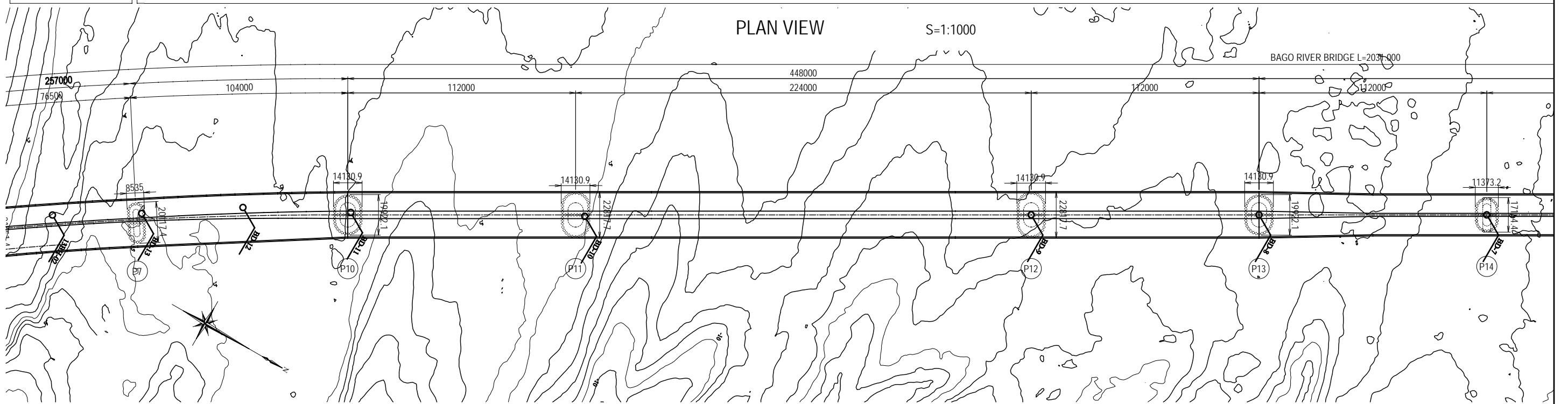
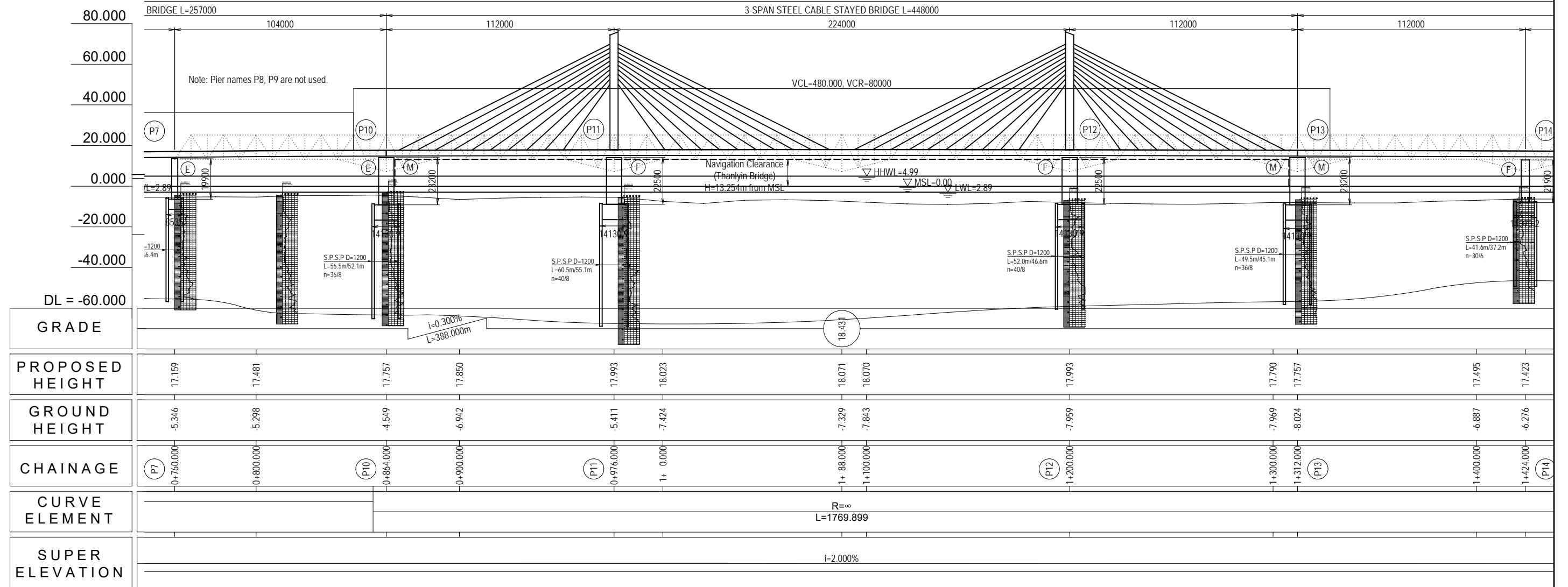

Elevation represents above MSL unless otherwise indicated.

PROJECT NAME DETAILED DESIGN ON BAGO RIVER BRIDGE CONSTRUCTION PROJECT	FINANCED BY JAPAN INTERNATIONAL COOPERATION AGENCY	COUNTERPART REPUBLIC OF THE UNION OF MYANMAR MINISTRY OF CONSTRUCTION DEPARTMENT OF BRIDGE	JICA STUDY TEAM NIPPON KOEI CO., LTD. ORIENTAL CONSULTANTS GLOBAL CO., LTD. METROPOLITAN EXPRESSWAY COMPANY LIMITED CHODAI CO., LTD. NIPPON ENGINEERING CONSULTANTS CO., LTD.	NAME	SIGNATURE	DATE	DRAWING TITLE GENERAL VIEW OF BAGO RIVER BRIDGE (5)	PACKAGE 3 DWG No. P3-GE-0006	
				PREPARED BY	T. HAYAKAWA				27 Nov. 2017
				CHECKED BY	T. HAYAKAWA				28 Nov. 2017
				APPROVED BY	Y. SANO				29 Nov. 2017

GENERAL VIEW OF BAGO RIVER BRIDGE (6)

LONGITUDINAL SECTION S=1:1000

BAGO RIVER BRIDGE L=2031000
7-SPAN STEEL BOX GIRDER BRIDGE L=776000

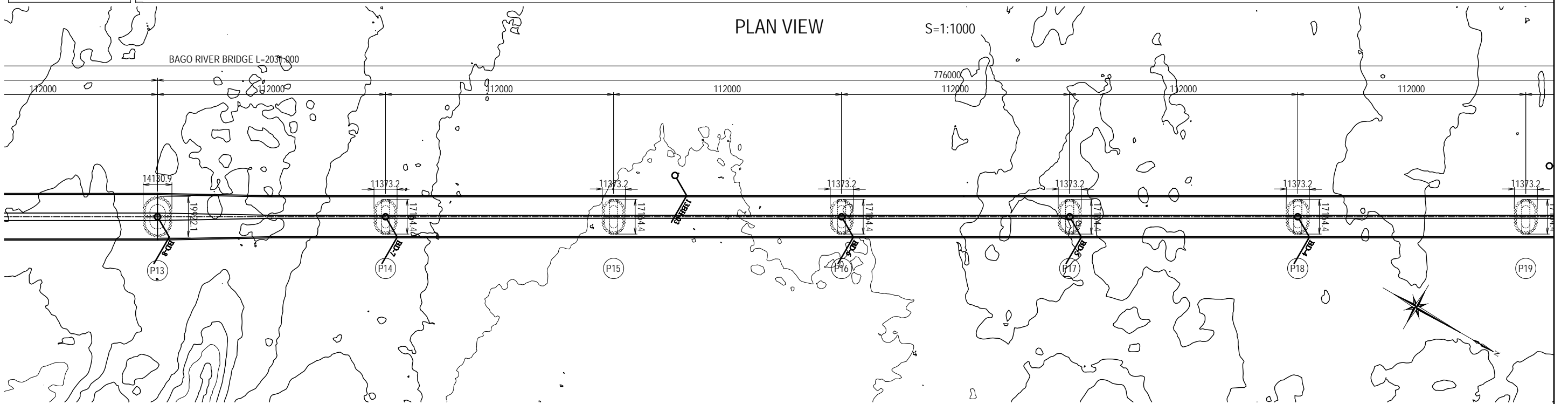
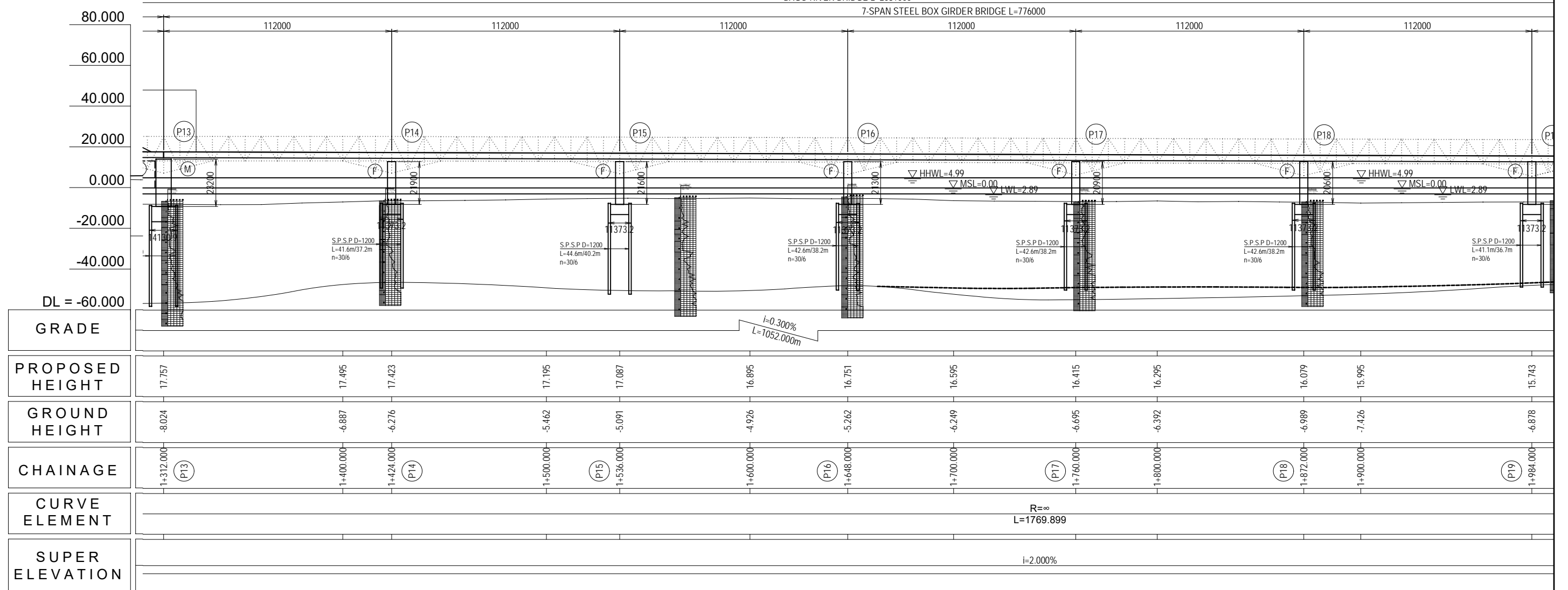

Elevation represents above MSL unless otherwise indicated.

PROJECT NAME DETAILED DESIGN ON BAGO RIVER BRIDGE CONSTRUCTION PROJECT	FINANCED BY JAPAN INTERNATIONAL COOPERATION AGENCY	COUNTERPART REPUBLIC OF THE UNION OF MYANMAR MINISTRY OF CONSTRUCTION DEPARTMENT OF BRIDGE	JICA STUDY TEAM NIPPON KOEI CO., LTD. ORIENTAL CONSULTANTS GLOBAL CO., LTD. METROPOLITAN EXPRESSWAY COMPANY LIMITED CHODAI CO., LTD. NIPPON ENGINEERING CONSULTANTS CO., LTD.	NAME	SIGNATURE	DATE	DRAWING TITLE GENERAL VIEW OF BAGO RIVER BRIDGE (6)	PACKAGE 3 DWG No. P3-GE-0007	
				PREPARED BY	T. HAYAKAWA				27 Nov. 2017
				CHECKED BY	T. HAYAKAWA				28 Nov. 2017
				APPROVED BY	Y. SANO				29 Nov. 2017

GENERAL VIEW OF BAGO RIVER BRIDGE (7) LONGITUDINAL SECTION

S=1:1000

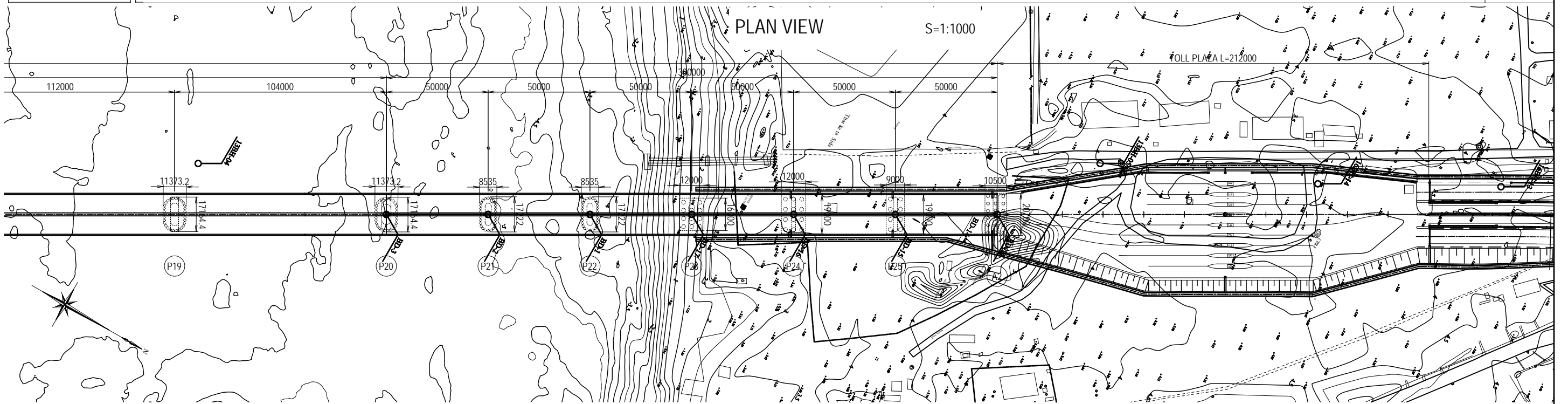
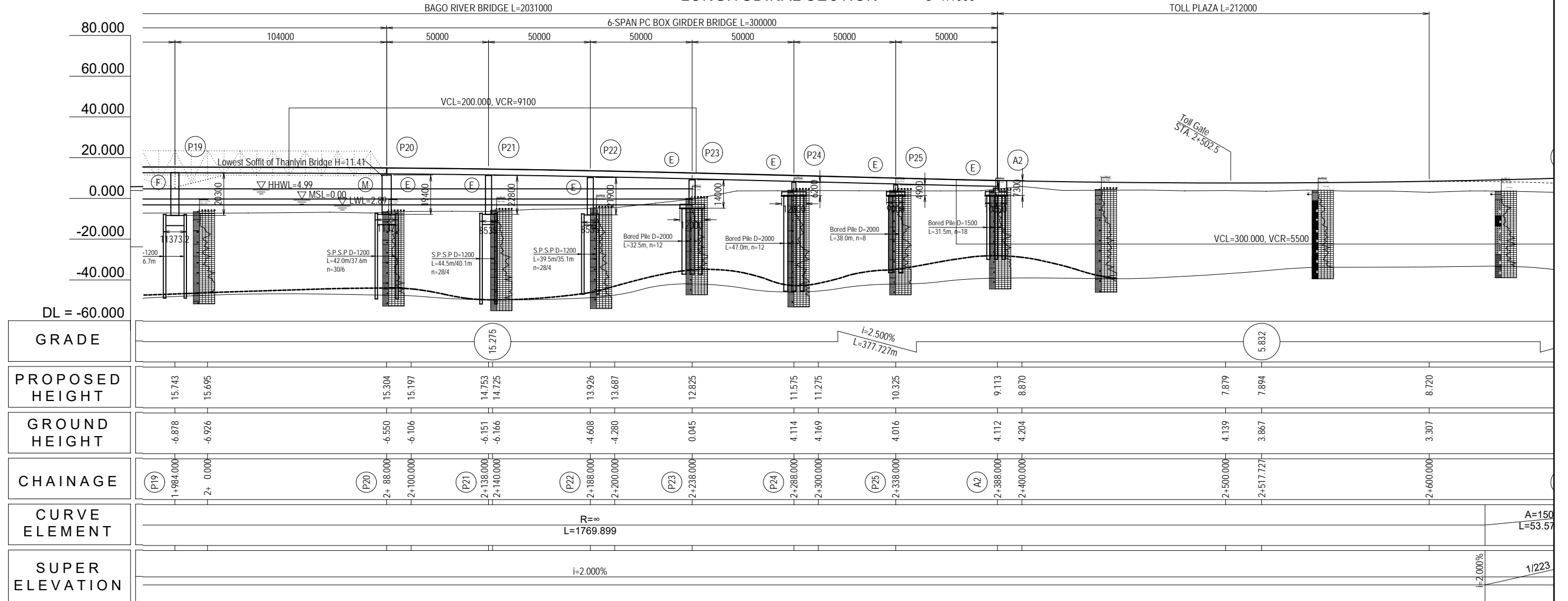

Elevation represents above MSL unless otherwise indicated.

PROJECT NAME DETAILED DESIGN ON BAGO RIVER BRIDGE CONSTRUCTION PROJECT	FINANCED BY JAPAN INTERNATIONAL COOPERATION AGENCY	COUNTERPART REPUBLIC OF THE UNION OF MYANMAR MINISTRY OF CONSTRUCTION DEPARTMENT OF BRIDGE	JICA STUDY TEAM NIPPON KOEI CO., LTD. ORIENTAL CONSULTANTS GLOBAL CO., LTD. METROPOLITAN EXPRESSWAY COMPANY LIMITED CHODAI CO., LTD. NIPPON ENGINEERING CONSULTANTS CO., LTD.	<table border="1" style="width: 100%; border-collapse: collapse;"> <thead> <tr> <th>NAME</th> <th>SIGNATURE</th> <th>DATE</th> </tr> </thead> <tbody> <tr> <td>PREPARED BY T. HAYAKAWA</td> <td></td> <td>27 Nov. 2017</td> </tr> <tr> <td>CHECKED BY T. HAYAKAWA</td> <td></td> <td>28 Nov. 2017</td> </tr> <tr> <td>APPROVED BY Y. SANO</td> <td></td> <td>29 Nov. 2017</td> </tr> </tbody> </table>	NAME	SIGNATURE	DATE	PREPARED BY T. HAYAKAWA		27 Nov. 2017	CHECKED BY T. HAYAKAWA		28 Nov. 2017	APPROVED BY Y. SANO		29 Nov. 2017	DRAWING TITLE GENERAL VIEW OF BAGO RIVER BRIDGE (7)	PACKAGE 3 DWG No. P3-GE-0008
NAME	SIGNATURE	DATE																
PREPARED BY T. HAYAKAWA		27 Nov. 2017																
CHECKED BY T. HAYAKAWA		28 Nov. 2017																
APPROVED BY Y. SANO		29 Nov. 2017																

GENERAL NOTES (1)

HIGHWAY / CIVIL AND DRAINAGE

1.0 SPECIFICATIONS

- 1.1 ALL WORKS SHALL COMPLY WITH THE AASHTO STANDARD SPECIFICATIONS FOR ROADS AND BRIDGES, AND WITH THE SPECIAL PROVISIONS & SUPPLEMENTAL SPECIFICATIONS PERTAINING TO THIS PROJECT.

2.0 DIMENSIONS

- 2.1 DISTANCES AND ELEVATIONS SHOWN ON THE PLANS ARE IN METERS (m) UNLESS OTHERWISE SPECIFIED.
 2.2 DIMENSIONS OF CULVERTS, BRIDGES AND OTHER STRUCTURES ARE MEASURED AND EXPRESSED IN MILLIMETERS UNLESS OTHERWISE SPECIFIED.

3.0 STATIONING

- 3.1 STATIONING OF ROAD, BRIDGE, ELEMENTS OF CURVE FOR BOTH HORIZONTAL AND VERTICAL ALIGNMENTS ARE RECKONED FROM THE ROAD CENTERLINE.
 3.2 STATION TICK MARKS ARE SHOWN AT 20m INTERVAL AND STATION LABELS AT 100m INTERVAL. STATIONS ARE SHOWN ALSO AT LOCATIONS OF HORIZONTAL AND VERTICAL GEOMETRY.

4.0 HORIZONTAL AND VERTICAL ALIGNMENT

- 4.1 NO ALTERATION/CHANGE IN ALIGNMENT SHALL BE MADE UNLESS EXISTING FIELD CONDITIONS SO WARRANT AND ONLY UPON APPROVAL OF THE ENGINEER.
 4.2 FINISHED GRADE ELEVATIONS SHOWN ON THE PLAN AND PROFILE SHEET REFER TO THE FINISHED GRADE LEVEL AT ROAD CENTERLINE SHOWN ON THE TYPICAL ROADWAY SECTIONS. MODIFICATIONS CAN BE DONE ON DESIGN GRADES AND ELEVATIONS ONLY UPON APPROVAL OF THE ENGINEER.
 4.3 GROUND LEVEL SHOWN ON THE PLAN AND PROFILE SHEET REFERS TO THE ELEVATION OF THE ORIGINAL GROUND ALONG THE DESIGN ROAD CENTERLINE.

5.0 ROAD CONNECTIONS AND SHOULDER IMPROVEMENT

- 5.1 ROAD CONNECTIONS SHALL BE CONSTRUCTED BY THE CONTRACTOR AS SHOWN ON THE PLAN OR AS DIRECTED BY THE ENGINEER IN SUCH MANNER AS TO ENSURE SMOOTH CONNECTION AND GOOD RIDING QUALITY.
 5.2 THE SHOULDER STRUCTURE IS ASPHALT CONCRETE WITH VARYING WIDTHS. THE WIDTH MAY BE ADJUSTED DURING CONSTRUCTION TO SUIT EXISTING FIELD CONDITION UPON APPROVAL OF THE ENGINEER.

6.0 REMOVAL OF EXISTING UTILITIES, STRUCTURES AND OBSTRUCTIONS

- 6.1 ALL WORKS SHALL COMPLY WITH THE REQUIREMENTS AND CONDITIONS OF CONTRACT OF THE MINISTRY OF CONSTRUCTION.
 6.2 EXTREME PRECAUTION SHALL BE EXERCISED BY THE CONTRACTOR NOT TO DAMAGE ANY PORTION OF EXISTING UTILITIES DURING CONSTRUCTION. ANY DAMAGE THEREOF SHALL BE REPAIRED OR COMPENSATED ON THE ACCOUNT OF THE CONTRACTOR.

7.0 DRAINAGE STRUCTURES

- 7.1 EXACT LOCATIONS, SLOPES, OUTFALLS, AND INVERT ELEVATIONS OF DRAINAGE STRUCTURES SHALL BE CHECKED IN THE FIELD BY THE CONTRACTOR BEFORE MAKING ANY REMOVAL OR IMPROVEMENT. MINOR ADJUSTMENTS MAY BE MADE TO SUIT ACTUAL FIELD CONDITIONS UPON APPROVAL OF THE ENGINEER.
 7.2 EXISTING DRAINAGE STRUCTURES THAT ARE FAULTY, BROKEN DOWN, OR NOT IN GOOD WORKING CONDITION SHALL BE DETERMINED IN THE FIELD. RECONSTRUCTION, REPAIR AND/OR REPLACEMENT OF SAME SHALL BE DIRECTED BY THE ENGINEER, AND SHALL CONFORM TO THE STANDARDS SHOWN IN THE DRAWINGS.
 7.3 EXISTING DRAINAGE STRUCTURES OR PARTS THEREOF REMOVED BY THE CONTRACTOR THAT ARE STILL SERVICEABLE SHALL BE TURNED OVER TO THE GOVERNMENT AND SHALL BE DEPOSITED AT A PLACE DESIGNATED BY THE ENGINEER WITHOUT ANY EXTRA COMPENSATION. EXTREME PRECAUTIONS SHALL BE EXERCISED BY THE CONTRACTOR NOT TO DAMAGE THESE MATERIALS DURING THE REMOVAL AND HANDLING OPERATION.
 7.4 PRIOR TO INSTALLATION OF PIPE CULVERTS AND OTHER DRAINAGE STRUCTURES, ALL MATERIALS SHALL BE TESTED TO CHECK ANY DEFECT AND CONFORMITY WITH TECHNICAL SPECIFICATIONS.
 7.5 THE CONTRACTOR SHALL BE RESPONSIBLE FOR THE REPLACEMENT OF MATERIALS INSTALLED AND FOUND TO BE DEFICIENT IN WORKMANSHIP AND QUALITY.
 7.6 INLETS AND OUTLETS OF NEW AND OPERATIONAL EXISTING CULVERTS SHALL BE CHANNELIZED AND CLEARED OF DEBRIS AND OBSTRUCTIONS. THIS SHALL BE CONSIDERED AS SUBSIDIARY WORK OF OTHER DRAINAGE PAY ITEMS.
 7.7 ANY REVISION, REMOVAL, CLEANING, UNCLOGGING AND/OR RE-LAYING OF DRAINAGE STRUCTURES AS DIRECTED BY THE ENGINEER TO SUIT EXISTING FIELD CONDITION SHALL BE CONSIDERED AS SUBSIDIARY WORK PERTAINING TO OTHER CONTRACT ITEMS. NO DIRECT PAYMENT SHALL BE MADE FOR THIS WORK UNLESS OTHERWISE SPECIFICALLY IDENTIFIED FOR PAYMENT IN THE BID SCHEDULE.

8.0 OPEN DITCHES (LINED CANAL AND EARTH DITCH)

- 8.1 ALL DITCHES SHALL COMPLY WITH THE REQUIRED STANDARDS.
 8.2 INVERT ELEVATIONS AND EXACT LOCATION AND DIMENSION OF OPEN DITCHES MAYBE ADJUSTED IN THE FIELD AS DIRECTED BY THE ENGINEER.

9.0 MISCELLANEOUS STRUCTURES

- 9.1 LOCATION AND LENGTH OF GUARDRAILS, SLOPE PROTECTIONS SUCH AS GROUTED RIPRAP, STONE MASONRY RETAINING WALLS AND OTHER STRUCTURES ARE SUBJECT TO ADJUSTMENT TO SUIT EXISTING FIELD CONDITIONS UPON APPROVAL OF THE ENGINEER.
 9.2 GROUTED RIPRAP AND/OR RIPRAP, STONE MASONRY SHOULD BE WELL CONSTRUCTED AS SPECIFIED IN THE STANDARD SPECIFICATION FOR THE SAID ITEM.
 9.3 CUT SLOPE CONSTRUCTION SHALL BE DONE AT PACE WITH EMBANKMENT CONSTRUCTION TO AVOID SLIDING OF FILL MATERIALS.

10.0 OTHERS

- 10.1 ALL SCHEDULES/LISTINGS FOR GUARDRAILS, SLOPE PROTECTION STRUCTURES, PAVEMENT MARKINGS, ROAD SIGNS AND ALL OTHER RELATED SCHEDULES/LISTINGS SHOWN ON THE PLANS ARE SUBJECT TO ADJUSTMENT/MODIFICATION TO SUIT ACTUAL FIELD CONDITION. THE ENGINEER MAY ORDER IN WRITING THE CONSTRUCTION/INSTALLATION OF NEW STRUCTURES/OR MISCELLANEOUS ITEMS IF IN HIS OPINION IS DEEMED NECESSARY IN ADDITION TO THE APPROVED SCHEDULES AND LISTINGS.
 10.2 ADEQUATE ROAD SIGNAGE AND SAFETY PRECAUTION SHALL BE PROVIDED TO INFORM, WARN AND ALERT MOTORISTS DURING CONSTRUCTION.

PROJECT NAME DETAILED DESIGN ON BAGO RIVER BRIDGE CONSTRUCTION PROJECT	FINANCED BY JAPAN INTERNATIONAL COOPERATION AGENCY	COUNTERPART REPUBLIC OF THE UNION OF MYANMAR MINISTRY OF CONSTRUCTION DEPARTMENT OF BRIDGE	JICA STUDY TEAM NIPPON KOEI CO., LTD. ORIENTAL CONSULTANTS GLOBAL CO., LTD. METROPOLITAN EXPRESSWAY COMPANY LIMITED CHODAI CO., LTD. NIPPON ENGINEERING CONSULTANTS CO., LTD.		NAME T. HAYAKAWA T. HAYAKAWA Y. SANO	SIGNATURE 	DATE 14 Jul. 2017 20 Jul. 2017 25 Jul. 2017	DRAWING TITLE GENERAL NOTES (1)	PACKAGE 3 DWG No. P3-GE-1001
---	--	---	--	--	---	-----------------------	--	------------------------------------	---------------------------------------

GENERAL NOTES (2)

BRIDGE (1)

GENERAL

ALL DRAWINGS SHALL BE READ IN CONJUNCTION WITH THE SPECIFICATION
 ALL DIMENSIONS ARE IN MILLIMETER EXCEPT ELEVATIONS OR OTHERWISE INDICATED
 ALL DIMENSIONS SHALL BE CHECKED BY THE CONTRACTOR PRIOR TO CONSTRUCTION

DESIGN STANDARD

THE LATEST VERSION OF:
 AASHTO LRFD BRIDGE DESIGN (AMERICAN ASSOCIATION OF STATE HIGHWAY AND TRANSPORTATION OFFICIALS)
 SPECIFICATIONS FOR HIGHWAY BRIDGES (JAPAN ROAD ASSOCIATION)
 SPECIFICATIONS FOR PC-I GIRDER BRIDGE WITH COMPOSITE DECK (JAPAN PRESTRESSED CONCRETE CONSTRUCTIONS ASSOCIATION)

DESIGN LOAD

DEAD LOAD	SPECIFICATIONS FOR HIGHWAY BRIDGES	
	MATERIALS	UNIT WEIGHT kN/m ³
	STEEL	77.0
	PLAIN CONCRETE	23.0
	REINFORCED CONCRETE	24.5
	PRE-STRESSED CONCRETE	24.5
	ASPHALT PAVEMENT	22.5

LIVE LOAD AASHTO HL-93
TEMPERATURE REFERENCE TEMPERATURE 30 degrees Celsius
 EFFECTIVE TEMPERATURE RANGE FOR STEEL BRIDGE IS FROM 5 TO 55.
 EFFECTIVE TEMPERATURE RANGE FOR CONCRETE BRIDGE IS FROM 15 TO 45.

WIND BASIC WIND SPEED IS 44.7m/s

MATERIALS

CONCRETE :
 CONCRETE SHALL HAVE THE FOLLOWING 28 DAYS MINIMUM CUBE COMPRESSIVE STRENGTH IN MPa, AS FOLLOWS :

STRUCTURAL ELEMENT	CUBE STRENGTH (MPa)
Precast Concrete Deck Plate in Composite Deck Slab Main Girder of PC-I Girder Bridge	40
RC Deck Slab in Composite Deck Slab Cross Beam Coupling Concrete of Main Girder Cast-in-place Pile	30
RC Deck Slab of Steel Bridge Pier Column, Abutment, Pilecap Approach Slab Cast-in-place RC Deck Slab in Composite Deck Slab, Earth Wall, L-Type Wall, Gravity Retaining Wall Concrete Kerb, Concrete Barrier, Median, Foundation of Lighting Pole	24
Leveling Concrete on Deck Slab Lean Concrete on Pilecap and Approach Slab	18

ALL CONCRETE ADMIXTURES TO BE USED SHALL BE ACCORDING TO THE SPECIFICATION AND APPROVED BY THE ENGINEER.

REINFORCEMENT BAR :
 GRADE SD345 IN ACCORDANCE WITH JIS G 3112

PRESTRESSING STEEL STRAND :
 PRESTRESSING STEEL STRAND SHALL CONFORM TO JIS STANDARD AS FOLLOWS :

TYPE OF PRESTRESSING STEEL STRAND	BREAKING STRESS	YIELD STRESS
SWPR7AL	9.3mm	88.8kN
SWPR7BL	15.2mm	261kN

STRUCTURAL STEEL :
 STRUCTURAL STEEL SHALL COMFORM TO JIS STANDARD AS FOLLOWS :

JIS G3101 FOR NON-WELDED STEEL	SS400	SM400	SM490	SM490Y
THICKNESS (mm)	40 or less	more than 40	40 or less	more than 40
MINIMUM TENSILE STRENGTH Fu (Mpa)	400	490	490	490
SPECIFIED MINIMUM YIELD STRENGTH Fy(Mpa)	235	315	295	355

GENERAL :
 -STRUCTURAL STEEL GRADE SM400 U.N.O. , FOR TRANSVERSE WEB STIFFNERS , AND INTERMEDIATE DIAPHRAGMS
 SM490
 -STRUCTURAL STEEL GRADE SM490 FOR SOLE PLATE
 SM400A :
 -STRUCTURAL STEEL GRADE SM400A FOR TRANSVERSE WEB STIFFNERS, T-STIFFENERS, AND INTERMEDIATE DIAPHRAGMS OF ALL BRIDGE GIRDERS.
 SS400 :
 -STRUCTURAL STEEL GRADE SS400A FOR SECONDARY MEMBERS, SHAPE STEEL*
 *WHEN THE SHAPE STEELS OF SS400 WHICH USED FOR SECONDARY MEMBERS ARE TO BE WELDED, SHALL BE USED AFTER VERIFYING BY EXAMINING THEIR CHEMICAL CONSTITUENTS BEFOREHAND OR A WELDING TEST.

BOLTS :
 HIGH TENSIONING BOLTS SHALL CONFORM TO JIS B1186 HIGH TENSIONING HEXANGULAR BOLTS, NUTS AND WASHERS FOR SLIP CRITICAL CONNECTION, DESIGNATED AS F10T.
 TORQUE SHEAR TYPE HIGH TENSION HEXAGONAL BOLTS, NUTS AND WASHERS DESIGNATED AS S10T by JAPAN ROAD ASSOCIATION.

DESIGNATION (NOMINAL BOLT DIAMETER)	F10T/S10T ALLOWABLE FORCE	DESIGN TENSION (kN)
M22	54 *	205

CONTACT SURFACES IN BOLTED JOINTS SHALL BE PAINTED BY SYSTEM NO. J AS SPECIFIED IN PAINTING OF THE SPECIFICATIONS.

PAINTING ASSIGNMENT

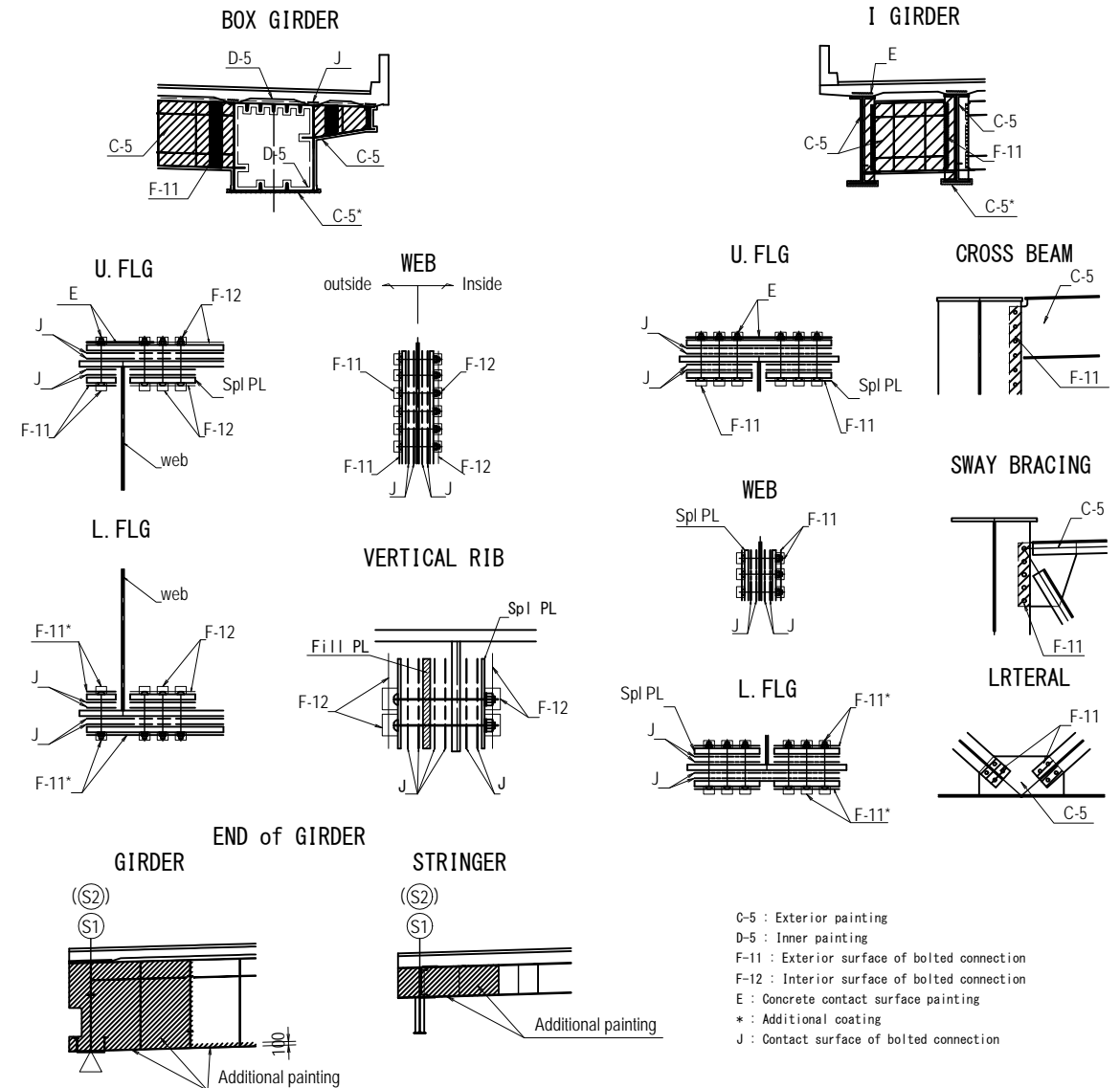

C-5 : Exterior painting
 D-5 : Inner painting
 F-11 : Exterior surface of bolted connection
 F-12 : Interior surface of bolted connection
 E : Concrete contact surface painting
 * : Additional coating
 J : Contact surface of bolted connection

PROJECT NAME	FINANCED BY	COUNTERPART	JICA STUDY TEAM	NAME	SIGNATURE	DATE	DRAWING TITLE	PACKAGE
DETAILED DESIGN ON BAGO RIVER BRIDGE CONSTRUCTION PROJECT	JICA JAPAN INTERNATIONAL COOPERATION AGENCY	REPUBLIC OF THE UNION OF MYANMAR MINISTRY OF CONSTRUCTION DEPARTMENT OF BRIDGE	NIPPON KOEI CO., LTD. ORIENTAL CONSULTANTS GLOBAL CO., LTD. METROPOLITAN EXPRESSWAY COMPANY LIMITED CHODAI CO.,LTD. NIPPON ENGINEERING CONSULTANTS CO.,LTD.	T. HAYAKAWA	平川 知寿	14 Jul. 2017	GENERAL NOTES (2)	3
				T. HAYAKAWA	平川 知寿	20 Jul. 2017		DWG No.
				Y. SANO	佐野 祐一	25 Jul. 2017		P3-GE-1002

GENERAL NOTES (3)

BRIDGE (2)

STEEL MATERIAL SHAPE NAME

PL	Plate
CHPL	Applied plate
DECK	Deck plate
EX	Expanded metal
L	equilateral/unequal angle steel
LL	Unequal angle steel with unequal thickness
CT	CT-shaped steel
CH	Channel-shaped steel
H	H-shaped steel
I	I-shaped steel
U	U-shaped steel(The dimensions are names)
BULB	Bulb plate
FB	Flat bar
RB	Round bar
DB	Deformed bar
HRB	Half-round bar
SB	Square bar
6B	Hexagonal bar
LC	Light channel-shaped steel
LZ	Light Z-shaped steel
LA	Light angle steel
LRC	Lip channel-shaped steel
LRZ	Lip Z-shaped steel
LH	Hat steel
LSP	Square steel pipe
STK	Ordinary structural carbon steel pipe
STPY	Arc welding carbon steel pipe for piping
SGP	Carbon steel pipe for piping(The dimensions are names)
PIPE	Steel pipe for piping
SP5	Stainless steel pipe for piping(5S)
SP10	Stainless steel pipe for piping(10S)
HTB	Hexagon head bolt for high-strength structural bolting
TCB	Torshear type high strength bolt
HTBF	Driving high strength bolt(flat head)
HTBR	Driving high strength bol(round head)
B. N	Normal hexagon headed bolt set (1-nut, 1-bolt)
B. UN	Hexagon headed bolt and lock nut set (1-lock nut, 1-bolt)
BLT	Normal hexagon headed bolt
W	Washer
SW	Spring-washer
TW	Taper washer
RH	Roundhead rivet
WPIN	Split pin(The dimensions are names)
NUT	Hexagon nut (1 type)
NUT3	Hexagon nut (3 type)
UNUT	U nut
HLN	Hardlock nut
UBA	U bolt (TYPE-A)
UBB	U bolt (TYPE-B)
UBC	U bolt (TYPE-C)
STUD	Stud dowel
STUG	Cast-in-place stud dowel
TAP	Tap bolt (machine screw)
A. N	Driving anchor bolt (Sleeve driving type)
A. N2	Driving anchor bolt (Bolt driving type)
S. BT	Stud bolt
PIN	Pin
CHAN	Chain
MASU	Drainage basin
LL45	Steel pipe elbow 4 5° long
LS90	Steel pipe elbow 9 0° short
LL90	Steel pipe elbow 9 0° long
RC	Reducer
FJ10	Flange joint S=10K
FJ5	Flange joint S=5K
HNUT	Nut for high strength bolt
S. N	Machine screw
PBT	Flat head bolt
T-NT	High nut
ST. 2	Stud dowel(with screw)
SP10	Stainless steel pipe for piping(10S)

REINFORCEMENT

ANCHORAGE LENGTH :

- THE ANCHORAGE LENGTH OF STRAIGHT BARS SHALL BE AT LEAST 40 BAR DIAMETERS FOR A SINGLE BAR AND 50 BAR DIAMETERS FOR 2 BARS IN A BUNDLE IF NOT OTHERWISE SHOWN ON THE DRAWINGS.

SPLICING

- REINFORCEMENT BARS SHALL BE SPLICED BY LAPS.
- LAP LENGTH SHALL BE EQUAL TO THE ANCHORAGE LENGTH OF THE SMALLER BAR IF NOT OTHERWISE SHOWN ON THE DRAWINGS.
- SPLICING OF BARS NOT INCLUDED ON THE DRAWINGS SHALL BE APPROVED BY THE ENGINEER.
- BARS DRAWN IN FULL LENGTH (ALSO CALLED CONTINUOUS BARS) SHALL HAVE AS FEW SPLICES AS POSSIBLE.

HOOKS AND BENDS

- HOOKS AND BENDS OF BARS SHALL BE IN ACCORDANCE WITH JRA's Specifications INCLUDING MINIMUM RADIUS, MINIMUM END DIMENSION ETC.
- STIRRUPS AND COLUMN TIE BARS SHALL ALWAYS HAVE ANOTHER BAR OF AT LEAST ITS OWN SIZE INSIDE THE HOOK.

SPACING

- CLEAR HORIZONTAL AND VERTICAL DISTANCE BETWEEN BARS OR PAIR OF BARS SHOULD NOT BE LESS THAN Hagg+5mm.
- CLEAR HORIZONTAL AND VERTICAL DISTANCE BETWEEN BUNDLED BARS SHOULD NOT BE LESS THAN Hagg+15mm, WHERE Hagg IS MAX SIZE OF COARSE AGGREGATE.
- CLEAR HORIZONTAL AND VERTICAL DISTANCE BETWEEN PRESTRESSING STEEL STRAND SHOULD BE MIN 90 mm BUT NOT LESS THAN THE INTERNAL DIAMETER OF THE DUCT.

CONCRETE COVER

THE MINIMUM COVER SHALL BE AS FOLLOWS :

- DECK SLAB 30 mm
- SUPERSTRUCTURE EXCEPT DECK SLAB 35 mm
- BEAM OF PIER 35 mm
- ABUTMENT, PIER, PILECAP 70 mm
- CAST-IN-PLACE PILE 120 mm

OR AS SHOWN ON THE DRAWINGS

TOLERANCE SHALL BE IN ACCORDANCE WITH THE SPECIFICATION.

CONCRETE WORK

- CONSTRUCTION JOINTS SHALL BE LOCATED AS SHOWN ON THE DRAWINGS, AS DESCRIBED IN THE SPECIFICATION OR AS PROPOSED BY THE CONTRACTOR, TO BE APPROVED BY THE ENGINEER.
- ALL FORMWORK SHALL BE FABRICATED AS DESCRIBED IN THE SPECIFICATION
- 20x20 mm CHAMFERS SHALL BE PROVIDED ON ALL EXTERNAL CORNERS UNLESS LARGER VALUES GIVEN ON THE DRAWINGS
- A LAYER OF MIN 100 mm LEAN CONCRETE SHALL BE PLACED UNDER ALL PILECAP LOCATED DIRECTLY ON GROUND
- SURFACE FINISH SHALL BE IN ACCORDANCE WITH THE SPECIFICATIONS

INTERNAL PRESTRESSING WORK

- DUCT DIAMETERS, MATERIALS AND WALL THICKNESSES SHALL BE AS DESCRIBED IN THE SPECIFICATIONS.
- ASSUMED PRESTRESSING LOSS PARAMETERS ARE GIVEN AS FOLLOWS.
FRICTIONAL COEFFICIENT $\mu = 0.30 /rad$
WOBBLE COEFFICIENT $k = 0.004 rad/m$
WEDGE DRAW-IN 5mm
RELAXATION 1.5%
- PRESTRESSING STEEL STRAND TENSIONING LOADS AND STRESSING SEQUENCE FOR MULTIPLE TENDONS ARE GIVEN ON RELEVANT DRAWINGS
- EXTENSIONS PRIOR TO "LOCK OFF" SHALL BE CALCULATED BY THE CONTRACTOR TO THE APPROVAL OF THE ENGINEER
- GROUTING OF TENDONS SHALL COMPLY WITH REQUIREMENTS IN THE SPECIFICATION

STEEL WORK

- ALL STEEL WORK SHALL HAVE CORROSION PROTECTION IN ACCORDANCE WITH THE SPECIFICATION
- ALL FABRICATIONS SHALL BE IN ACCORDANCE WITH THE SPECIFICATION UNLESS OTHERWISE INDICATED
- ALL WELDS SHALL BE CONTINUOUS UNLESS OTHERWISE INDICATED
- TEMPORARY WELDED ATTACHMENTS SHALL BE SUBJECT TO ENGINEER'S APPROVAL
- SHAPES AND DIMENSIONS FOR PARTIAL JOINT PENETRATION OF GROVE WELDING OR "TYP" SHOWN IN THE TAIL OF WELDING SYMBOL SHALL BE SUBJECT TO THE ENGINEER'S APPROVAL.

PILE WORK

- TIP ELEVATION OF PILES SHOWN IN THE DRAWINGS IS DETERMINED WITH BOREHOLE DATA.
- THE CONTRACTOR MAY PROPOSE THE CHANGE OF TIP ELEVATION IN CASE THE ACTUAL ROCK PENETRATION SPEED IS SMALLER INDICATING BEARING STRENGTH IS SUFFICIENT FOR THE DESIGN.
- WHEN APPROVED BY THE ENGINEER, THE TIP ELEVATION MAY BE CHANGED.

OTHERS

















- WATERPROOFING SHALL BE APPLIED ON BRIDGE DECK SURFACE IN ACCORDANCE WITH THE SPECIFICATIONS.

PROJECT NAME DETAILED DESIGN ON BAGO RIVER BRIDGE CONSTRUCTION PROJECT	FINANCED BY  JAPAN INTERNATIONAL COOPERATION AGENCY	COUNTERPART  REPUBLIC OF THE UNION OF MYANMAR MINISTRY OF CONSTRUCTION DEPARTMENT OF BRIDGE	JICA STUDY TEAM  NIPPON KOEI CO., LTD.  ORIENTAL CONSULTANTS GLOBAL CO., LTD.  METROPOLITAN EXPRESSWAY COMPANY LIMITED  CHODAI CO., LTD.  NIPPON ENGINEERING CONSULTANTS CO., LTD.	NAME	SIGNATURE	DATE	DRAWING TITLE GENERAL NOTES (3)	PACKAGE	
				PREPARED BY	T. HAYAKAWA			14 Jul. 2017	3
				CHECKED BY	T. HAYAKAWA			20 Jul. 2017	DWG No.
				APPROVED BY	Y. SANO			25 Jul. 2017	P3-GE-1003

GENERAL NOTES (4)

LIGHTING

LEGEND



























-  : Concrete pole
-  : Steel pole
-  : Traffic signal controller
-  : Vehicle traffic signal
-  : Arrow sign traffic signal
-  : Pedestrian signal
-  : Push-button switch
-  : Junction box
-  : Power supply box
-  : Pull box
-  : Hand hole
-  : Raising underground pipe
-  : Base mounted pole signal head pole (with arm)
-  : Pedestrian signal head pole (with push-button)
-  : Underground piping
-  : Underground wiring
- SVV : Control -use vinyl insulated vinyl sheathed cable
- IV : Indoor PVC
- E : Grounding
- G : Vehicle traffic signal : Green light
- Y : Vehicle traffic signal : Yellow light
- R : Vehicle traffic signal : Red light
- A : Arrow traffic signal : Green light
- PG : Pedestrian signal lamp : Green light
- PR : Pedestrian signal lamp : Red light
- COM : Common for all indication

GENERAL NOTES

1. THE ELECTRICAL WORKS SHALL BE DONE UNDER THE DIRECT SUPERVISION OF THE DUTY REGISTERED ELECTRICAL ENGINEER.
2. THE CONTRACTOR SHALL SECURE ALL PERMITS AND PAY ALL FEES REQUIRED FOR ELECTRICAL INSTALLATION WORKS AND FURNISH THE OWNER, THROUGH THE ENGINEER, THE FINAL CERTIFICATE OF ELECTRICAL INSPECTION AND APPROVAL FROM PROPER GOVERNMENT AUTHORITIES FOR THE COMPLETE ELECTRICAL WORKS.
3. ALL ELECTRICAL MATERIALS TO BE USED SHALL BE BRAND NEW AND APPROVED TYPES.
4. ALL UNDERGROUND CONDUIT PIPES AND CONDUIT RUN EMBEDDED IN CONCRETE SHALL BE HIGH-DENSITY POLYETHYLENE (HDPE)..
5. UNPROTECTED CONDUIT RISERS AND EXPOSED CONDUIT SHALL BE GAS PIPE(GP).
6. ALL CONDUIT RUN SHALL BE PROVIDED WITH A 14mm² BARE COPPER GROUND WIRE AND SHALL BE TERMINATED AT MAIN DISTRIBUTION PANEL BOARD, ALL EQUIPMENT, METALLIC PARTS AND SURFACES SHALL BE EFFECTIVELY GROUNDED.
7. ALL STREET LUMINAIRE ASSEMBLIES INCLUDING POLES SHALL WITHSTAND UP TO 180 Kph GUSTING WINDS WITHOUT PERMANENT DEFORMATION.
8. THE ELECTRICAL SERVICE VOLTAGE FOR THAKETA SIDE SHALL BE 11KV/240V SECONDARY, 3-PHASE 4 WIRE, 50 HERTZ AC.
9. THE ELECTRICAL SERVICE VOLTAGE FOR THANLYIN SIDE SHALL BE 6.6KV/240V SECONDARY, 3-PHASE 4 WIRE, 50 HERTZ AC.
10. THE CONTRACTOR SHALL EXERCISE EXTREME CARE IN REMOVING EXISTING INSTALLATIONS, APPROPRIATE TOOLS AND EQUIPMENT SHALL BE UTILIZED TO MINIMIZED DAMAGE.
11. ALL FEEDER LINES AND BRANCH CIRCUITS SHALL BE INSTALLED AS INDICATED ON PLANS, INDIVIDUAL FEEDER AND BRANCH CIRCUIT AND HOMERUNS SHALL NOT BE COMBINED IN THE SAME RACEWAY UNLESS SPECIFIED.
12. LOCATIONS OF ELECTRICAL EQUIPMENT AND DEVICES INCLUDING CONDUIT ROUTINGS SHOWN IN THE DRAWINGS ARE APPROXIMATE LOCATION ONLY. CONTRACTOR SHALL ALLOW FOR NECESSARY FIELD ADJUSTMENTS TO SUIT ACTUAL CONDITION AT SITE.
13. SUBMIT COMPLETE TECHNICAL TECHNICAL SPECIFICATIONS OF MATERIALS/EQUIPMENTS AND SHOP DRAWINGS FOR APPROVAL BY THE ENGINEER PRIOR TO START OF INSTALLATION.

ABBREVIATIONS:

- A : AMPERE
- AC : ALTERNATING CURRENT
- AF : AMPERE FRAME
- AT : AMPERE TRIP
- BCW : BARE COPPER WIRE
- C : CONDUIT
- CB : CIRCUIT BREAKER
- CHH : COMMUNICATION HANDHOLE
- CT : CURRENT TRANSFORMER
- DF : DEMAND FACTOR
- DIA : DIAMETER
- ECB : ENCLOSED CIRCUIT BREAKER
- EHH : ELECTRICAL HANDHOLE
- EL : ELEVATION
- (GND) : GROUND
- ATS : AUTOMATIC TRANSFER SWICH
- HID : HIGH INTENSITY DISCHARGE LAMP
- HZ : HERTZ
- IMC : INTERMEDIATE METAL CONDUIT
- IND'L : INDUSTRIAL
- KVA : KILOVOLT AMPERE
- KW : KILOWATT
- KWHR : KILOWATT HOUR
- KAIC : KILOAMPERE INTERRUPTIG CAPACITY
- LED : LIGHT EMITTING DIODE
- LP : LIGHTING PANEL BOARD
- LTG : LIGHTING
- MDP : MAIN DISTRIBUTION PANEL BOARD
- MTD : MOUNTED
- P,Ø : POLE, PHASE
- PVC : POLYVINYL CHLORIDE
- uPVC : UNPLASTICIZED POLYVINYL CHLORIDE
- ROW : RIGHT OF WAY
- STA : STATION
- SDBC : SOFT DRAWN BARE COPPER WIRE
- TW : THERMOPLASTIC MOISTURE RESISTANT
- TYP : TYPICAL
- THW : THERMOPLASTIC HEAT AND MOISTURE RESISTANT
- V : VOLT / VOLTAGE
- VA : VOLT - AMPERE
- W : WATT
- XLPE : CORSS-LINKED POLYETHYLENE INSULATED CABLES
- TEI : TARLAC ELECTRIC INCORPORATED

-  : MOLD-CASE CIRCUIT BREAKER
-  : EXITER
-  : LIGHTING PANEL
-  : AMPERE TRIPPING
-  : AMPERE METER
-  : KILOWATT HR.METER
-  : GROUNDING
-  : VOLTAGE METER
-  : POWER TRANSFORMER
-  : CONTACTOR
-  : FREQUENCY METER
-  : PRIMARY CUTOUT (PE) WITH POWER FUSE (PF)
-  : VOLTMETER CHANGE OVER SWITCH
-  : BATTERY
-  : LIGHTING ARRESTER (LA)
-  : AMMETER CHANGOVER SWITCH
-  : AUTOMATIC VOLTAGE LEGULATOR
-  : CURRENT FUSE
-  : CURRENT TRANSFORMER
-  : LOW VOLTAGE RELAY
-  : MAIN DISTRIBUTION PANEL
-  : DIESEL ENGINE
-  : OVER VOLTAGE
-  : POWER FUSE
-  : GENERATOR
-  : OVERCURRENT RELAY

PROJECT NAME DETAILED DESIGN ON BAGO RIVER BRIDGE CONSTRUCTION PROJECT	FINANCED BY  JAPAN INTERNATIONAL COOPERATION AGENCY	COUNTERPART  REPUBLIC OF THE UNION OF MYANMAR MINISTRY OF CONSTRUCTION DEPARTMENT OF BRIDGE	JICA STUDY TEAM  NIPPON KOEI CO., LTD. ORIENTAL CONSULTANTS GLOBAL CO., LTD. METROPOLITAN EXPRESSWAY COMPANY LIMITED CHODAI CO.,LTD. NIPPON ENGINEERING CONSULTANTS CO.,LTD.	NAME T. HAYAKAWA T. HAYAKAWA Y. SANO	SIGNATURE   	DATE 14 Jul. 2017 20 Jul. 2017 25 Jul. 2017	DRAWING TITLE GENERAL NOTES (4)	PACKAGE 3 DWG No. P3-GE-1004
---	--	---	--	---	--	--	------------------------------------	---------------------------------------

DESIGN ELEMENTS OF HORIZONTAL ALIGNMENT

1. MAIN HIGHWAY

POINT NAME	STATION	NORTHING X-COORDINATE	EASTING Y-COORDINATE	ELEMENT	AZIMUTH ANGLE	ELEMENT LENGTH	ACCUMULATED DISTANCE
BP	0+000.000000	1857219.291051	205789.549518				0.000000
KE 1-1	0+024.969805	1857233.508737	205769.022741	STRAIGHT LINE	304° 42' 29.009669"	24.969805	24.969805
KA 1-1	0+076.169805	1857263.372323	205727.441550	CLOTHOID A=160	307° 38' 29.767749"	51.200000	76.169805
KA 1-2	0+161.512727	1857320.993624	205664.628061	CIRCLE R=500	317° 25' 16.250510"	85.342923	161.512727
KE 1-2	0+212.712727	1857359.850350	205631.296633	CLOTHOID A=160	320° 21' 17.008590"	51.200000	212.712727
BC 2	0+521.900231	1857597.927606	205434.024909	STRAIGHT LINE	320° 21' 17.008590"	309.187504	521.900231
EC 2	0+857.521703	1857873.073202	205242.524037	CIRCLE R=2000	329° 58' 10.457547"	335.621472	857.521703
KA 3-1	2+627.420376	1859405.380223	204356.760802	STRAIGHT LINE	329° 58' 10.457547"	1769.898673	2627.420376
KE 3-1	2+680.991804	1859452.311131	204330.947038	CLOTHOID A=150	333° 37' 25.100803"	53.571429	2680.991804
KE 3-2	2+724.079800	1859491.826837	204313.816465	CIRCLE R=420	339° 30' 5.903241"	43.087995	2724.079800
KA 3-2	2+777.651228	1859542.749064	204297.209619	CLOTHOID A=150	343° 9' 20.546495"	53.571429	2777.651228
KA 4-1	2+782.485673	1859547.376091	204295.808734	STRAIGHT LINE	343° 9' 20.546495"	4.834445	2782.485673
KE 4-1	2+835.298173	1859597.467560	204279.125895	CLOTHOID A=130	338° 25' 39.671372"	52.812500	2835.298173
KE 4-2	2+961.570619	1859702.829467	204211.024695	CIRCLE R=320	315° 49' 7.291643"	126.272446	2961.570619
KA 4-2	3+014.383119	1859738.611303	204172.202890	CLOTHOID A=130	311° 5' 26.416517"	52.812500	3014.383119
EP	3+575.000000	1860107.078174	203749.682533	STRAIGHT LINE	311° 5' 26.416517"	560.616881	3575.000000

2. ACCESS ROAD FROM STAR CITY TO THE PROJECT HIGHWAY

POINT NAME	STATION	NORTHING X-COORDINATE	EASTING Y-COORDINATE	ELEMENT	AZIMUTH ANGLE	ELEMENT LENGTH	ACCUMULATED DISTANCE
BP	0+000.000000	1857586.250773	205393.281977				0.000000
BC-1	0+004.471511	1857589.735828	205396.083549	STRAIGHT LINE	38° 47' 42.593542"	4.471511	4.471511
EC-1	0+058.044963	1857624.134584	205436.728193	CIRCLE R=140	60° 43' 13.433109"	53.573451	58.044963
KA 2-1	0+105.007058	1857647.102428	205477.690573	STRAIGHT LINE	60° 43' 13.433109"	46.962095	105.007058
KE 2-1	0+148.110506	1857663.282883	205517.356898	CLOTHOID A=50	82° 0' 37.609033"	43.103448	148.110506
KE 2-2	0+367.483423	1857554.981013	205497.547926	CIRCLE R=58	298° 43' 11.268296"	219.372917	367.483423
KA 2-2	0+410.586871	1857584.154535	205466.177078	CLOTHOID A=50	320° 0' 35.444221"	43.103448	410.586871
BC-3	0+535.778322	1857680.070576	205385.722045	STRAIGHT LINE	320° 0' 35.444221"	125.191450	535.778322
EP	0+643.083345	1857765.821505	205321.300759	CIRCLE R=1000	326° 9' 28.675974"	107.305023	643.083345

3. ACCESS ROAD FROM TOLL PLAZA TO SHUKHINTHAR MAYOPAT ROAD

POINT NAME	STATION	NORTHING X-COORDINATE	EASTING Y-COORDINATE	ELEMENT	AZIMUTH ANGLE	ELEMENT LENGTH	ACCUMULATED DISTANCE
BP	0+000.000000	1859387.083266	204379.898737				0.000000
KA 1-1	0+027.420376	1859410.822724	204366.175940	STRAIGHT LINE	329° 58' 10.457547"	27.420376	27.420376
KE 1-1	0+080.298246	1859457.142519	204340.689898	CLOTHOID A=147.083849	333° 40' 19.933366"	52.877870	80.298246
KE 1-2	0+122.270570	1859495.635051	204324.002884	CIRCLE R=409.125000	339° 33' 0.735807"	41.972324	122.270570
KA 1-2	0+175.148440	1859545.900332	204307.618036	CLOTHOID A=147.083849	343° 9' 20.546495"	52.877870	175.148440
KA 2-1	0+179.982885	1859550.527359	204306.217150	STRAIGHT LINE	343° 9' 20.546495"	4.834445	179.982885
EP	0+228.545623	1859596.665312	204291.095464	CLOTHOID A=132.996909	341° 1' 10.050264"	48.562738	228.545623

4. ACCESS ROAD FROM SHUKHINTHAR MAYOPAT ROAD TO TOLL PLAZA

POINT NAME	STATION	NORTHING X-COORDINATE	EASTING Y-COORDINATE	ELEMENT	AZIMUTH ANGLE	ELEMENT LENGTH	ACCUMULATED DISTANCE
BP	0+000.000000	1859376.198265	204361.068463				0.000000
KA 1-1	0+027.420376	1859399.937722	204347.345665	STRAIGHT LINE	329° 58' 10.457547"	27.420376	27.420376
KE 1-1	0+081.685363	1859447.479743	204321.204179	CLOTHOID A=152.909864	333° 34' 39.093555"	54.264987	81.685363
KE 1-2	0+125.889030	1859488.018623	204303.630046	CIRCLE R=430.875000	339° 27' 19.895993"	44.203667	125.889030
KA 1-2	0+180.154017	1859539.597796	204286.801203	CLOTHOID A=152.909864	343° 9' 20.546495"	54.264987	180.154017
KA 2-1	0+184.988462	1859544.224823	204285.400317	STRAIGHT LINE	343° 9' 20.546495"	4.834445	184.988462
EP	0+219.973050	1859577.579400	204274.853056	CLOTHOID A=127.777631	341° 0' 29.487429"	34.984588	219.973050

5. RELOCATION ROAD BETWEEN SHUKHINTHAR MAYOPAT ROAD AND YANGON - THANLYIN BRIDGE

POINT NAME	STATION	NORTHING X-COORDINATE	EASTING Y-COORDINATE	ELEMENT	AZIMUTH ANGLE	ELEMENT LENGTH	ACCUMULATED DISTANCE
BP	0+000.000000	1859592.452945	204287.866125				0.000000
BC 1	0+024.306092	1859591.810075	204312.163713	STRAIGHT LINE	91° 30' 56.114217"	24.306092	24.306092
EC-1	0+063.975512	1859568.426887	204340.633817	CIRCLE R=30	167° 16' 42.957166"	39.669420	63.975512
TO YANGON-THANLYIN BRIDGE							
BC-2	0+115.859871	1859517.816166	204352.059301	STRAIGHT LINE	167° 16' 42.957166"	51.884359	115.859871
EP	0+168.655834	1859474.391353	204380.139144	CIRCLE R=75	126° 56' 43.638429"	52.795963	168.655834
FROM YANGON-THANLYIN BRIDGE							
BC-2	0+102.399065	1859530.946541	204349.095089	STRAIGHT LINE	167° 16' 42.957166"	38.423553	102.399065
EP	0+164.083776	1859492.287742	204392.126807	CIRCLE R=50	96° 35' 35.259250"	61.684711	164.083776

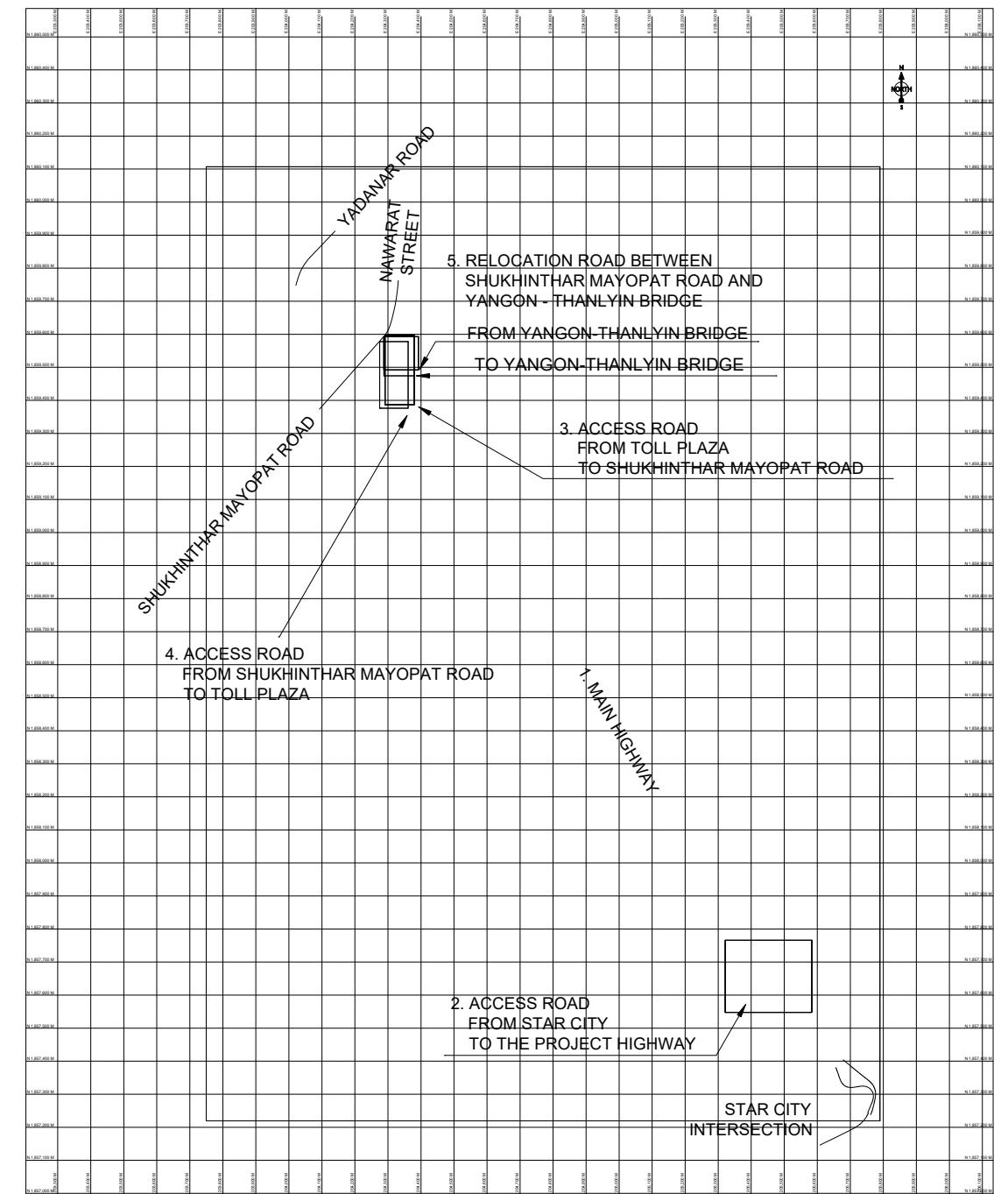

ALIGNMENT DIAGRAM SCALE = 1:20,000

NOTE: 1. STAR CITY INTERSECTION CONSISTS OF FOUR (4) ROADS, I.E., MAIN HIGHWAY, YANGON ACCESS LINE, THILAWA ACCESS LINE AND STAR CITY ACCESS LINE. SEE STAR CITY INTERSECTION DRAWINGS FOR THE HORIZONTAL ALIGNMENT DATA OF YANGON ACCESS LINE, THILAWA ACCESS LINE AND STAR CITY ACCESS LINE.
 2. SEE THE DESIGN DATA OF HORIZONTAL ALIGNMENT OF SHUKHINTHAR MAYOPAT ROAD AND NAWARAT STREET IN THE DRAWING INCLUDED IN PACKAGE 3 DRAWINGS.
 3. SEE THE DESIGN DATA OF HORIZONTAL ALIGNMENT OF YADANAR ROAD IN THE DRAWING INCLUDED IN PACKAGE 3 DRAWINGS.

PROJECT NAME	FINANCED BY	COUNTERPART	JICA STUDY TEAM	NAME	SIGNATURE	DATE	DRAWING TITLE	PACKAGE
DETAILED DESIGN ON BAGO RIVER BRIDGE CONSTRUCTION PROJECT	JICA JAPAN INTERNATIONAL COOPERATION AGENCY	REPUBLIC OF THE UNION OF MYANMAR MINISTRY OF CONSTRUCTION DEPARTMENT OF BRIDGE	NIPPON KOEI CO., LTD. ORIENTAL CONSULTANTS GLOBAL CO., LTD. METROPOLITAN EXPRESSWAY COMPANY LIMITED CHODAI CO., LTD. NIPPON ENGINEERING CONSULTANTS CO., LTD.	T. HAYAKAWA	<i>T. Hayakawa</i>	15 Jun.2017	ALIGNMENT LAYOUT AND GEOMETRIC DATA	3
				T. HAYAKAWA	<i>T. Hayakawa</i>	20 Jun.2017		DWG No.
				Y. SANO	<i>Y. Sano</i>	21 Jun.2017		P3-GE-2001

B. ROAD DESIGN

PLAN&PROFILE(1)

V= 1: 250
H= 1:1000

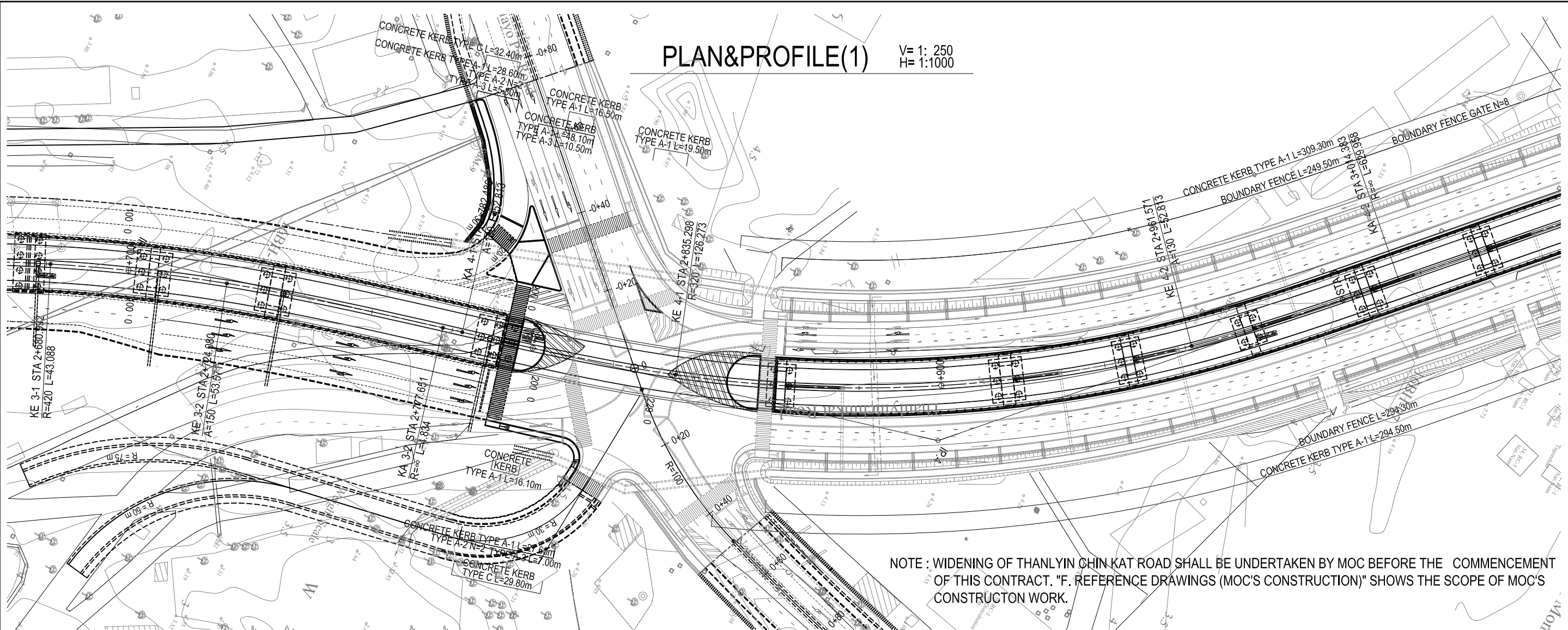

NOTE : WIDENING OF THANLYIN CHIN KAT ROAD SHALL BE UNDERTAKEN BY MOC BEFORE THE COMMENCEMENT OF THIS CONTRACT. "F. REFERENCE DRAWINGS (MOC'S CONSTRUCTION)" SHOWS THE SCOPE OF MOC'S CONSTRUCTION WORK.

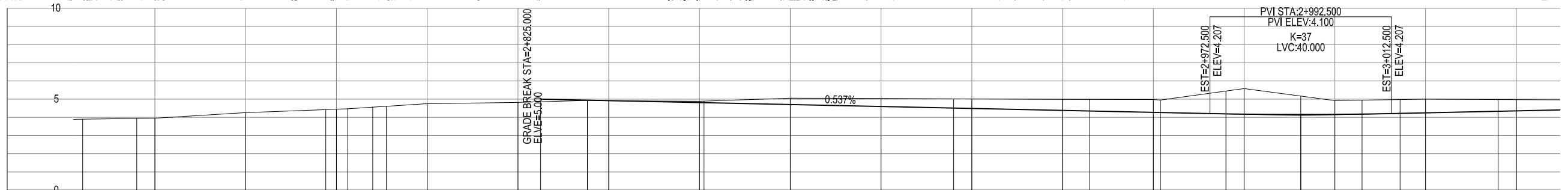
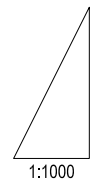

GRADE	PROPOSED HEIGHT	EXISTING HEIGHT	STATION	SUPER ELEVATION	CURVE ELEMENTS
		3.90	-KE 3-2		L=53.571 A=150.000
		3.94	+736.000		
		3.95	+740.000		R=∞
		4.26	+760.000		
		4.42	KA 3-2		L=4.834
		4.45	+780.000		
		4.47	KA 4-1		A=130.000 L=52.813
		4.56	+788.000		
		4.61	+791.000		R=∞
		4.75	+800.000		
		4.82	+820.000		2.0%
		4.86	+825.000		
		4.93	-KE 4-1		IP = IP.4 IA = 32-03-54 CL = 231.898 R=320.000 L=126.273
		4.91	+840.000		
		4.88	+860.000		A=130.000 L=52.813
		4.89	+861.000		
		5.05	+880.000		L=167.500 I=0.537%
		5.04	+900.000		
		5.02	+916.000		A=130.000 L=52.813
		5.01	+920.000		
		4.99	+940.000		EST STA: +2+972.500 EST ELEV: 4.207
		4.99	+946.000		
		4.98	+960.000		PVI STA: +2+992.500 PVI ELEV: 4.100 K=37 LVC: 40.000
		4.95	-KE 4-2		
		5.44	+976.000		EST STA: +3+012.500 EST ELEV: 4.207
		5.58	+990.000		
		5.17	+992.500		A=130.000 L=52.813
		4.92	STA3		
		4.95	+6.000		A=130.000 L=52.813
		4.98	KA 4-2		
		5.00	+20.000		A=130.000 L=52.813
		4.98	+36.000		
		4.97	+40.000		

PLAN&PROFILE(2)

V= 1: 250
H= 1:1000

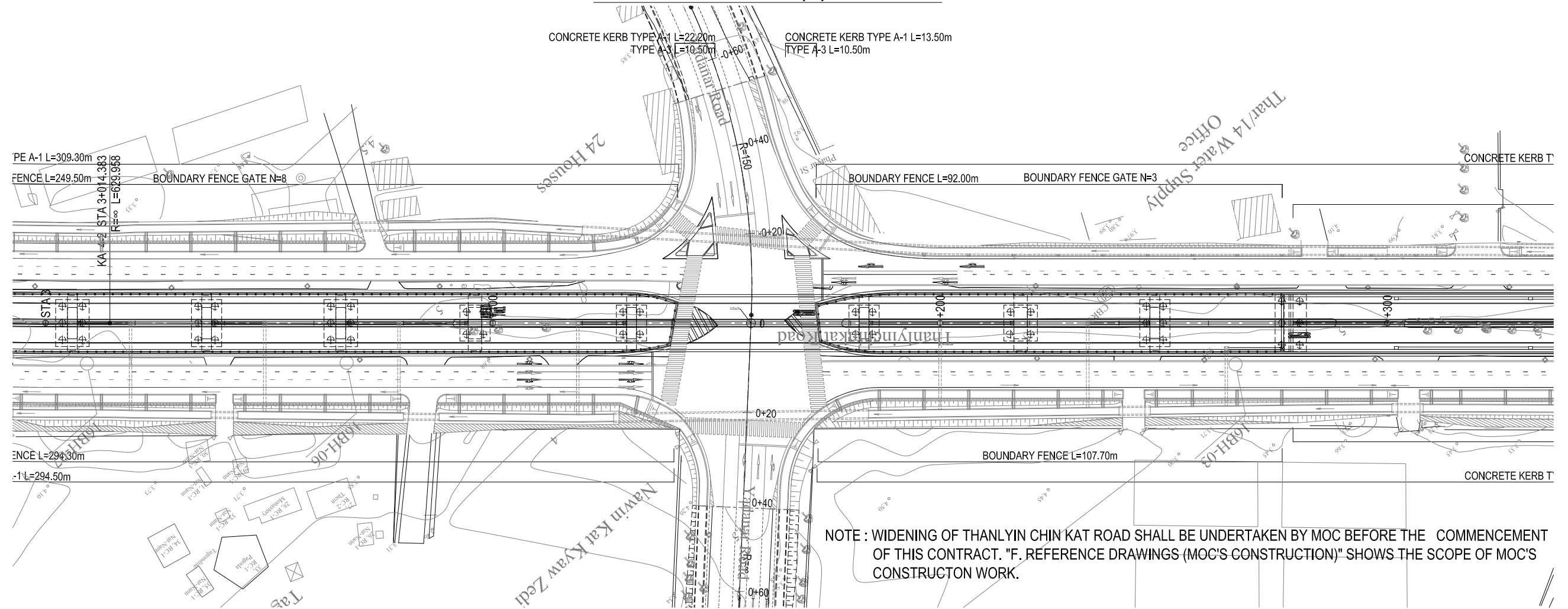

NOTE : WIDENING OF THANLYIN CHIN KAT ROAD SHALL BE UNDERTAKEN BY MOC BEFORE THE COMMENCEMENT OF THIS CONTRACT. "F. REFERENCE DRAWINGS (MOC'S CONSTRUCTION)" SHOWS THE SCOPE OF MOC'S CONSTRUCTION WORK.

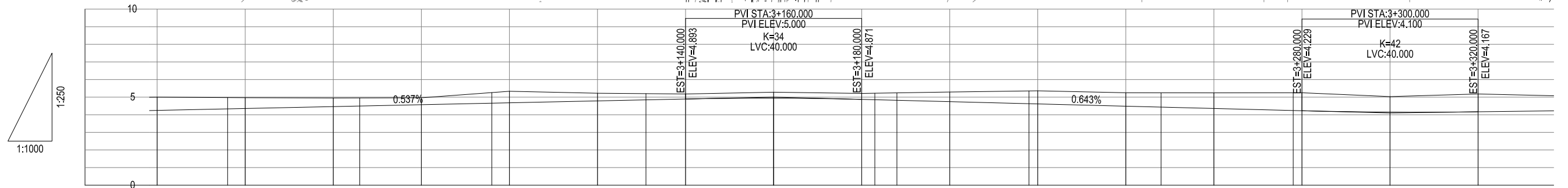

GRADE	i=0.537% L=167.500										i=0.643% L=140.000													
PROPOSED HEIGHT	4.248	4.334	4.355	4.463	4.495	4.570	4.656	4.678	4.785	4.844	4.893	4.941	4.871	4.852	4.820	4.743	4.486	4.434	4.357	4.241	4.229	4.149	4.167	
EXISTING HEIGHT	5.00	4.98	4.97	4.95	4.95	4.96	5.26	5.33	5.22	5.20	5.18	5.28	5.21	5.22	5.24	5.29	5.25	5.25	5.24	5.25	5.25	5.03	5.18	
STATION	+20.000	+36.000	+40.000	+60.000	+66.000	+80.000	+96.000	+100.000	+120.000	+131.000	+140.000	+160.000	+180.000	+183.000	+188.000	+200.000	+240.000	+248.000	+260.000	+278.000	+280.000	+300.000	+320.000	
SUPER ELEVATION	-----																							
CURVE ELEMENTS	-----																							

PLAN&PROFILE(3)

V= 1: 250
H= 1:1000

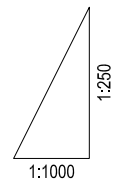
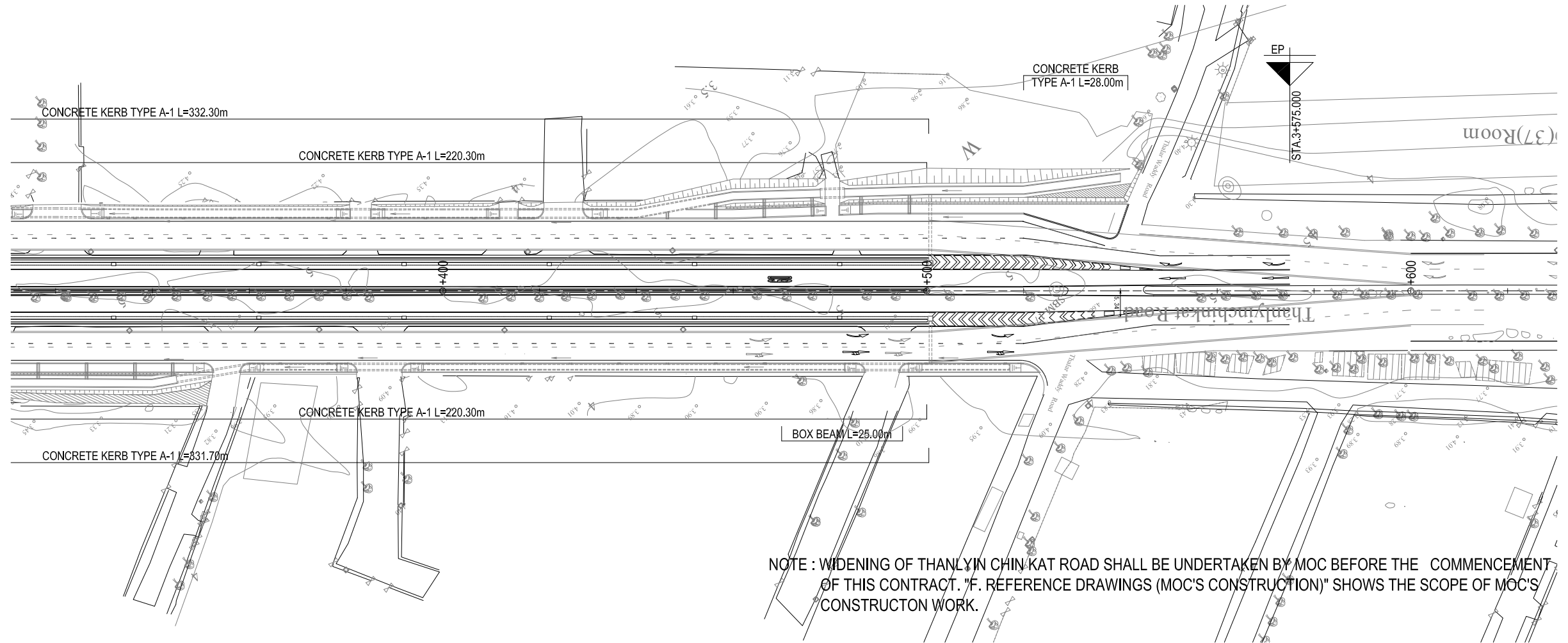

GRADE																	
PROPOSED HEIGHT	4.167	4.233	4.300	4.366	4.433	4.499	4.566	4.632	4.699	4.765	4.765	5.16	4.87	5.10	5.08	4.98	5.01
EXISTING HEIGHT	5.18	5.06	5.20	5.13	5.15	5.12	5.19	5.11	5.16	5.23	5.16	4.87	5.10	5.08	4.98	5.01	
STATION	+320.000	+340.000	+360.000	+380.000	+400.000	+420.000	+440.000	+460.000	+480.000	+500.000	+520.000	+540.000	+560.000	+580.000	+600.000	+620.000	
SUPER ELEVATION	-----																
CURVE ELEMENTS	$R = \infty$ $L = 629.958$																

TYPICAL CROSS SECTION (1) S=1:200

℄

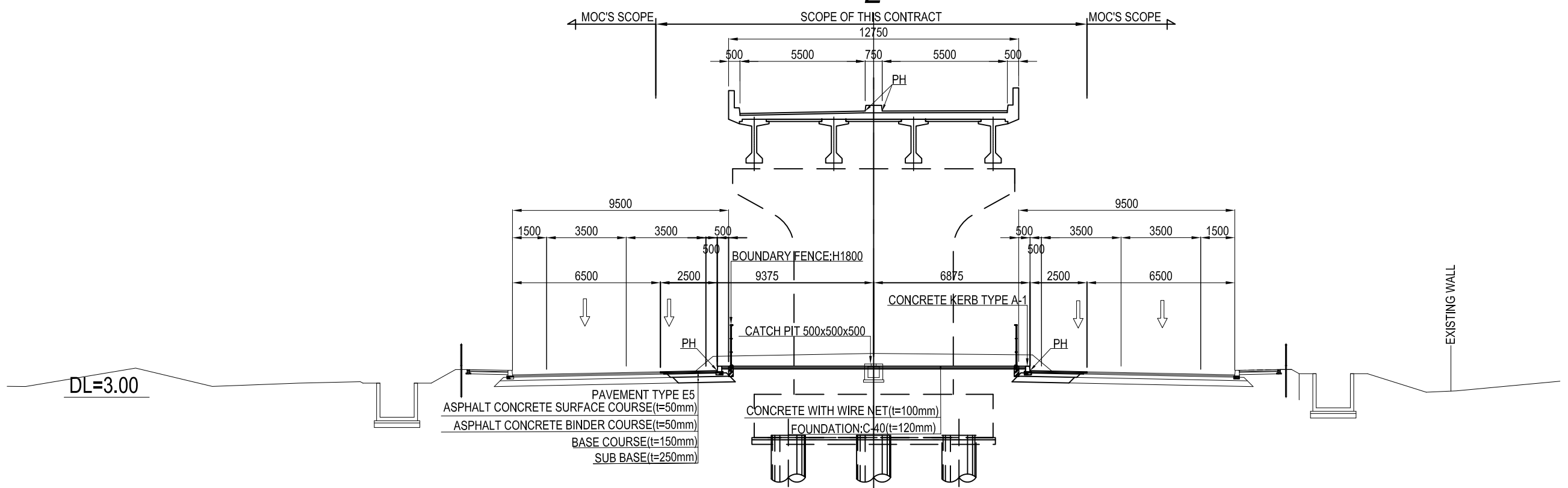

"SHUKHINTHAR INTERSECTION - YADANAR INTERSECTION" SECTION

℄

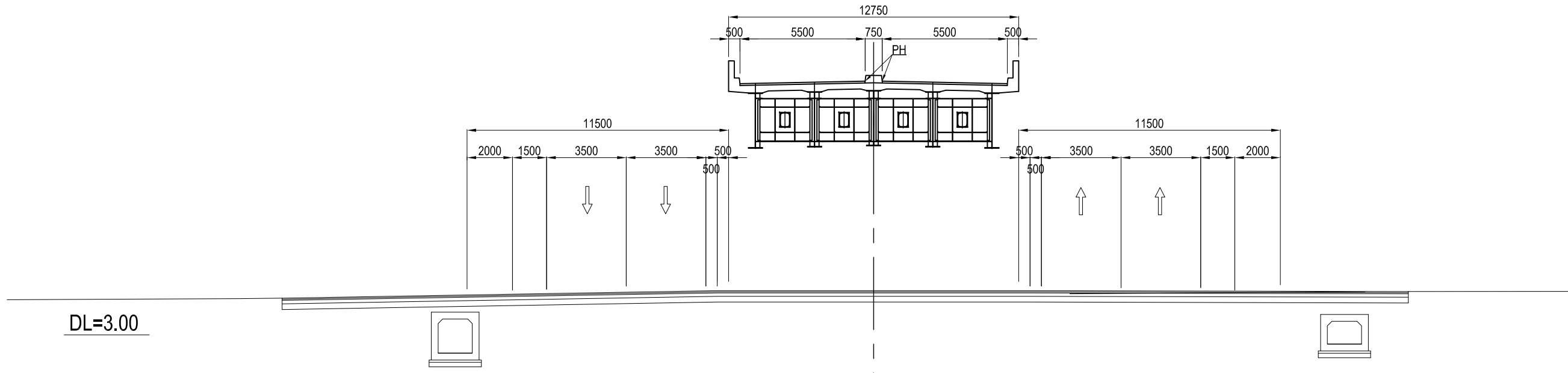

INTERSECTION

PROJECT NAME DETAILED DESIGN ON BAGO RIVER BRIDGE CONSTRUCTION PROJECT	FINANCED BY JAPAN INTERNATIONAL COOPERATION AGENCY	COUNTERPART REPUBLIC OF THE UNION OF MYANMAR MINISTRY OF CONSTRUCTION DEPARTMENT OF BRIDGE	JICA STUDY TEAM NIPPON KOEI CO., LTD. ORIENTAL CONSULTANTS GLOBAL CO., LTD. METROPOLITAN EXPRESSWAY COMPANY LIMITED CHODAI CO., LTD. NIPPON ENGINEERING CONSULTANTS CO.,LTD.	NAME	SIGNATURE	DATE	DRAWING TITLE TYPICAL CROSS SECTION (1) S=1:200	PACKAGE	
				PREPARED BY	K. TACHIBANA			29 Sep. 2017	3
				CHECKED BY	T. HAYAKAWA			3 Oct. 2017	DWG No.
				APPROVED BY	Y. SANO			6 Oct. 2017	P3-RD-0200

TYPICAL CROSS SECTION (2) S=1:200

DL=3.00

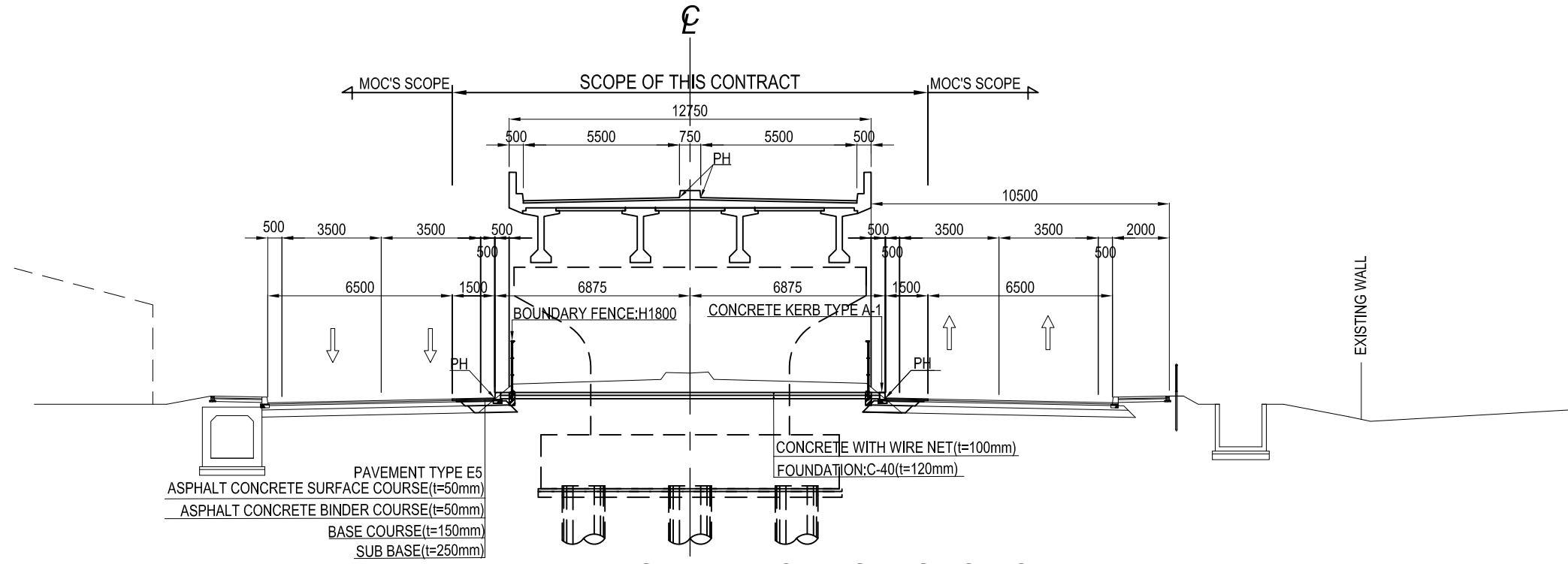

"NEAR THE WATER SUPPLY OFFICE" SECTION

DL=3.00

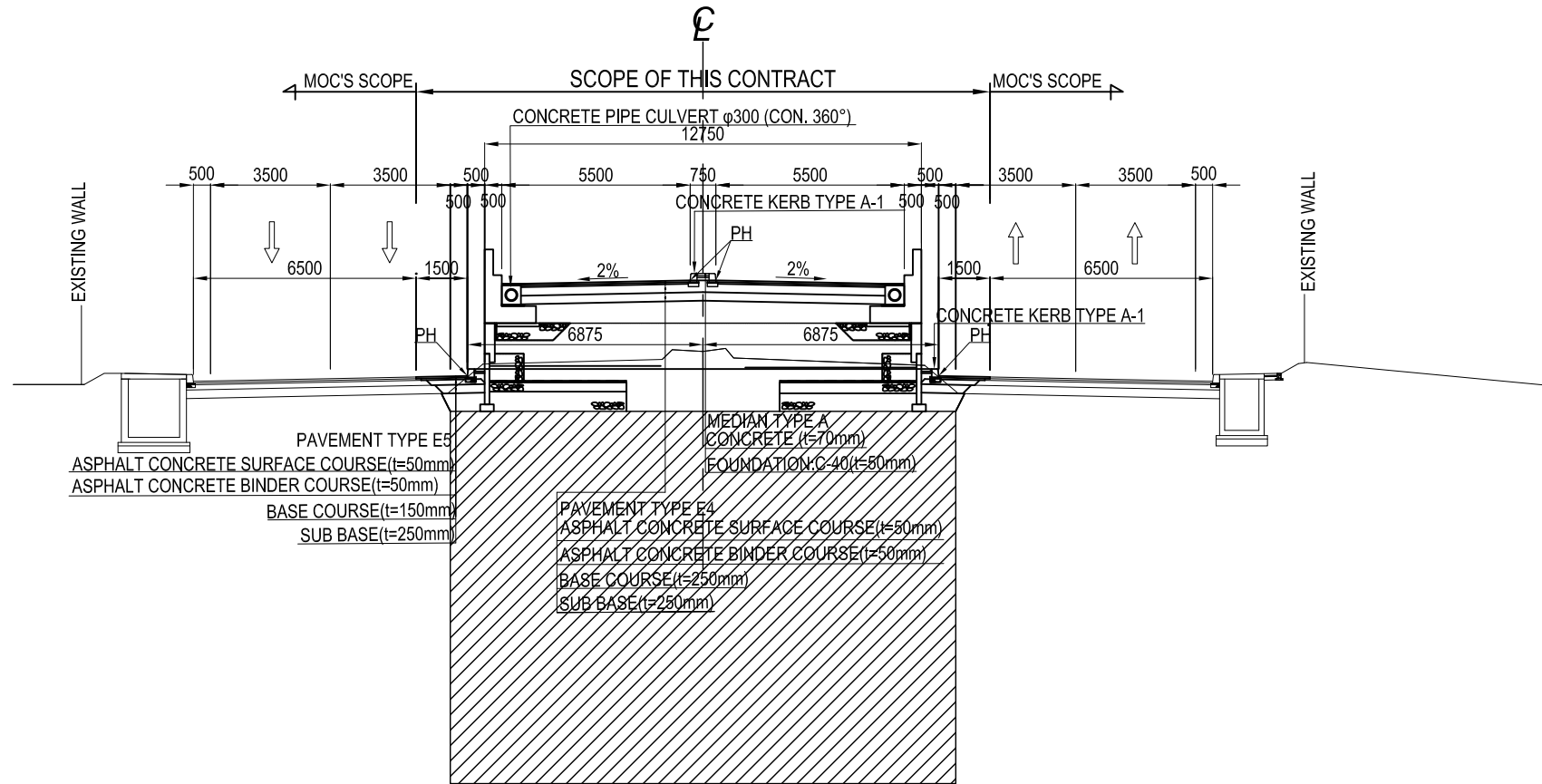

"MECHANICALLY-STABILISED EARTH WALL" SECTION

PROJECT NAME DETAILED DESIGN ON BAGO RIVER BRIDGE CONSTRUCTION PROJECT	FINANCED BY JAPAN INTERNATIONAL COOPERATION AGENCY	COUNTERPART REPUBLIC OF THE UNION OF MYANMAR MINISTRY OF CONSTRUCTION DEPARTMENT OF BRIDGE	JICA STUDY TEAM NIPPON KOEI CO., LTD. ORIENTAL CONSULTANTS GLOBAL CO., LTD. METROPOLITAN EXPRESSWAY COMPANY LIMITED CHODAI CO., LTD. NIPPON ENGINEERING CONSULTANTS CO., LTD.	NAME	SIGNATURE	DATE	DRAWING TITLE TYPICAL CROSS SECTION (2) S=1:200	PACKAGE 3 DWG No. P3-RD-0210	
				PREPARED BY	K. TACHIBANA				29 Sep. 2017
				CHECKED BY	T. HAYAKAWA				3 Oct. 2017
				APPROVED BY	Y. SANO				6 Oct. 2017

DETAIL OF ASPHALT CONCRETE PAVEMENT S=1:30

Type E1

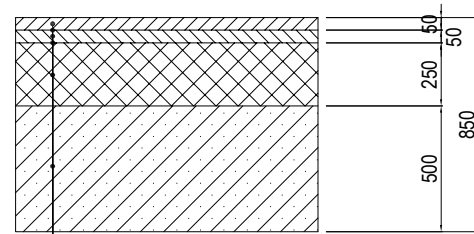

AC SURFACE COURSE (t=50mm)
TACK COAT 0.4 l/m²
AC SURFACE BASE (t=50mm)
PRIME COAT 0.4 l/m²
BASE COURSE (t=250mm)
SUB BASE (t=500mm)

Type E2

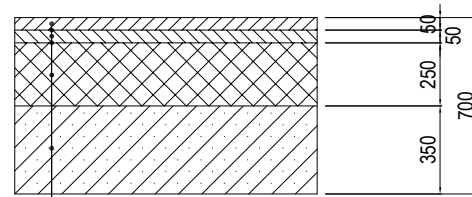

AC SURFACE COURSE (t=50mm)
TACK COAT 0.4 l/m²
AC SURFACE BASE (t=50mm)
PRIME COAT 0.4 l/m²
BASE COURSE (t=250mm)
SUB BASE (t=350mm)

Type E3

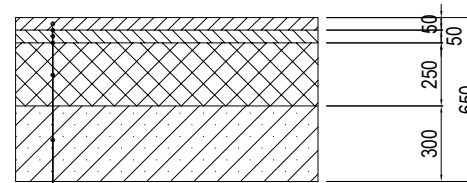

AC SURFACE COURSE (t=50mm)
TACK COAT 0.4 l/m²
AC SURFACE BASE (t=50mm)
PRIME COAT 0.4 l/m²
BASE COURSE (t=250mm)
SUB BASE (t=300mm)

Type E4

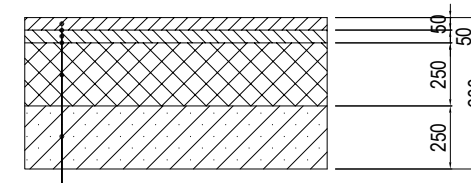

AC SURFACE COURSE (t=50mm)
TACK COAT 0.4 l/m²
AC SURFACE BASE (t=50mm)
PRIME COAT 0.4 l/m²
BASE COURSE (t=250mm)
SUB BASE (t=250mm)

Type E5

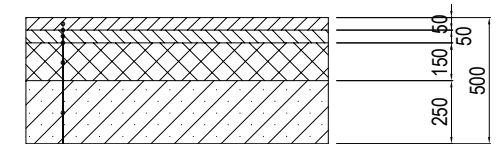

AC SURFACE COURSE (t=50mm)
TACK COAT 0.4 l/m²
AC SURFACE BASE (t=50mm)
PRIME COAT 0.4 l/m²
BASE COURSE (t=150mm)
SUB BASE (t=250mm)

Type E6

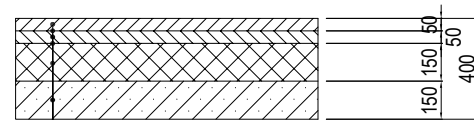

AC SURFACE COURSE (t=50mm)
TACK COAT 0.4 l/m²
AC SURFACE BASE (t=50mm)
PRIME COAT 0.4 l/m²
BASE COURSE (t=150mm)
SUB BASE (t=150mm)

Type C

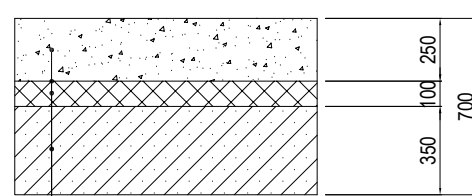

CONCRETE (t=250mm)
PRIME COAT 0.4 l/m²
BASE COURSE (t=100mm)
SUB BASE (t=350mm)

**Type B1
(FOR CONCRETE DECK)**

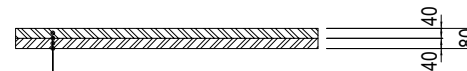

AC SURFACE COURSE (t=40mm)
TACK COAT 0.4 l/m²
AC SURFACE COURSE (t=40mm)
WATERPROOFING
BONDING COAT

**Type B2
(FOR STEEL DECK)**

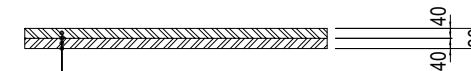

POLYMER-MODIFIED ASPHALT II (t=40mm)
TACK COAT 0.4 l/m²
POLYMER-MODIFIED ASPHALT III-WF (t=40mm)
WATERPROOFING
BONDING COAT

Side Walk



PRECAST CONCRETE PAVING BLOCK (300x300mm x t=60mm)
SAND (t=30mm)
SOIL AGGREGATE: C-30 (t=100mm)

<small>PROJECT NAME</small> DETAILED DESIGN ON BAGO RIVER BRIDGE CONSTRUCTION PROJECT	<small>FINANCED BY</small> JAPAN INTERNATIONAL COOPERATION AGENCY	<small>COUNTERPART</small> REPUBLIC OF THE UNION OF MYANMAR MINISTRY OF CONSTRUCTION DEPARTMENT OF BRIDGE	<small>JICA STUDY TEAM</small> NIPPON KOEI CO., LTD. ORIENTAL CONSULTANTS GLOBAL CO., LTD. METROPOLITAN EXPRESSWAY COMPANY LIMITED CHODAI CO., LTD. NIPPON ENGINEERING CONSULTANTS CO., LTD.	<table border="1" style="width: 100%; border-collapse: collapse;"> <tr> <th style="text-align: left;">NAME</th> <th style="text-align: left;">SIGNATURE</th> <th style="text-align: left;">DATE</th> </tr> <tr> <td>PREPARED BY K. TACHIBANA</td> <td></td> <td>29 Sep. 2017</td> </tr> <tr> <td>CHECKED BY T. HAYAKAWA</td> <td></td> <td>3 Oct. 2017</td> </tr> <tr> <td>APPROVED BY Y. SANO</td> <td></td> <td>6 Oct. 2017</td> </tr> </table>	NAME	SIGNATURE	DATE	PREPARED BY K. TACHIBANA		29 Sep. 2017	CHECKED BY T. HAYAKAWA		3 Oct. 2017	APPROVED BY Y. SANO		6 Oct. 2017	<small>DRAWING TITLE</small> DETAIL OF ASPHALT CONCRETE PAVEMENT S=1:30	<small>PACKAGE</small> 3 DWG No. P3-RD-0300
NAME	SIGNATURE	DATE																
PREPARED BY K. TACHIBANA		29 Sep. 2017																
CHECKED BY T. HAYAKAWA		3 Oct. 2017																
APPROVED BY Y. SANO		6 Oct. 2017																

PLAN FOR PAVEMENT TYPE(1) S= 1:1000

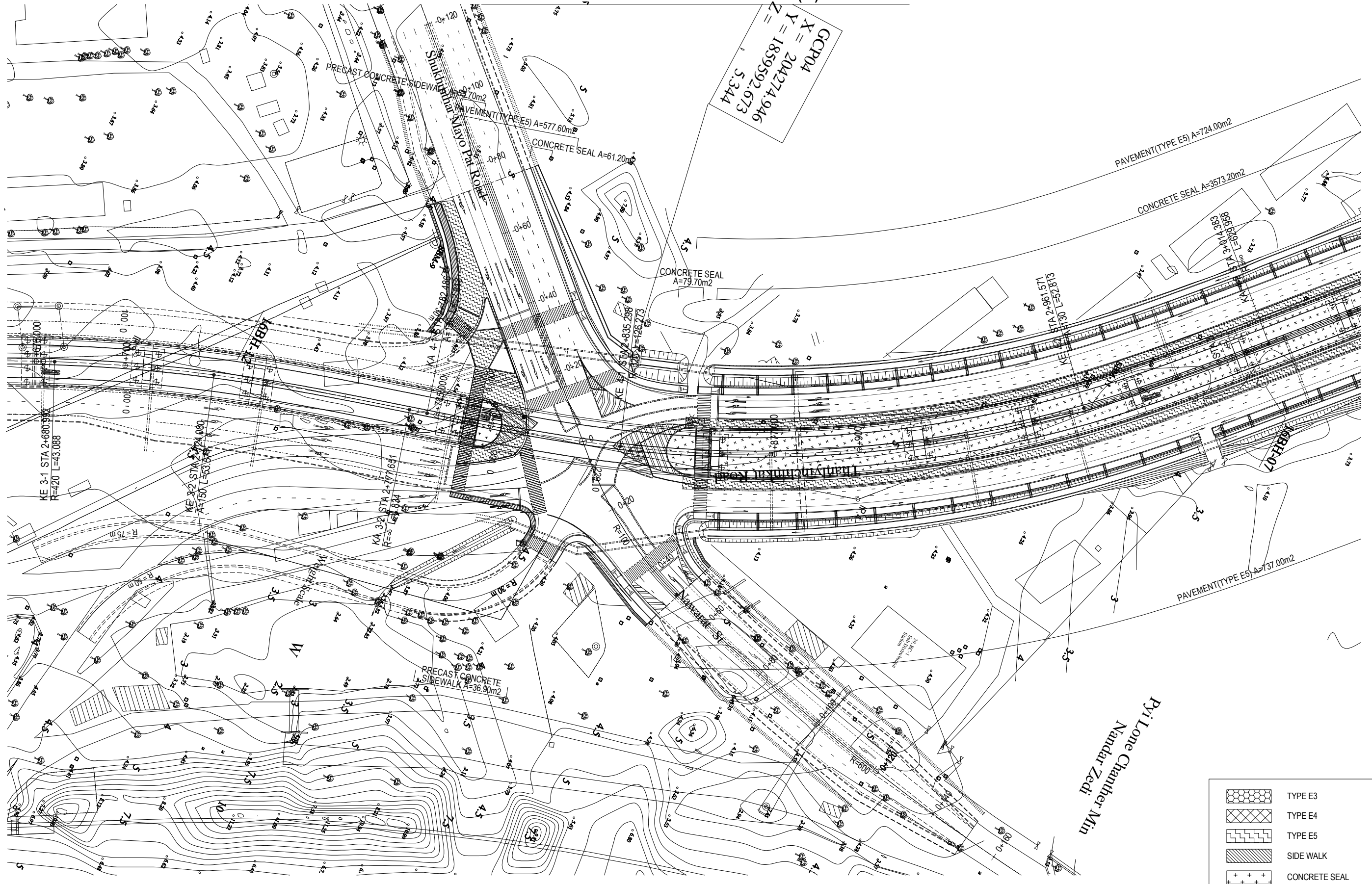

	TYPE E3
	TYPE E4
	TYPE E5
	SIDE WALK
	CONCRETE SEAL

Pyi Lone Chantler Min
Nandar Zedi

PROJECT NAME DETAILED DESIGN ON BAGO RIVER BRIDGE CONSTRUCTION PROJECT	FINANCED BY JAPAN INTERNATIONAL COOPERATION AGENCY	COUNTERPART REPUBLIC OF THE UNION OF MYANMAR MINISTRY OF CONSTRUCTION DEPARTMENT OF BRIDGE	JICA STUDY TEAM NIPPON KOEI CO., LTD. ORIENTAL CONSULTANTS GLOBAL CO., LTD. METROPOLITAN EXPRESSWAY COMPANY LIMITED CHODAI CO. LTD. NIPPON ENGINEERING CONSULTANTS CO., LTD.	NAME	SIGNATURE	DATE	DRAWING TITLE PLAN FOR PAVEMENT TYPE(1) S=1:1000	PACKAGE 3 DWG No. P3-RD-0310	
				PREPARED BY	K. TACHIBANA				29 Sep.2017
				CHECKED BY	T. HAYAKAWA				3 Oct.2017
				APPROVED BY	Y. SANO				6 Oct.2017

PLAN FOR PAVEMENT TYPE(2) S= 1:1000

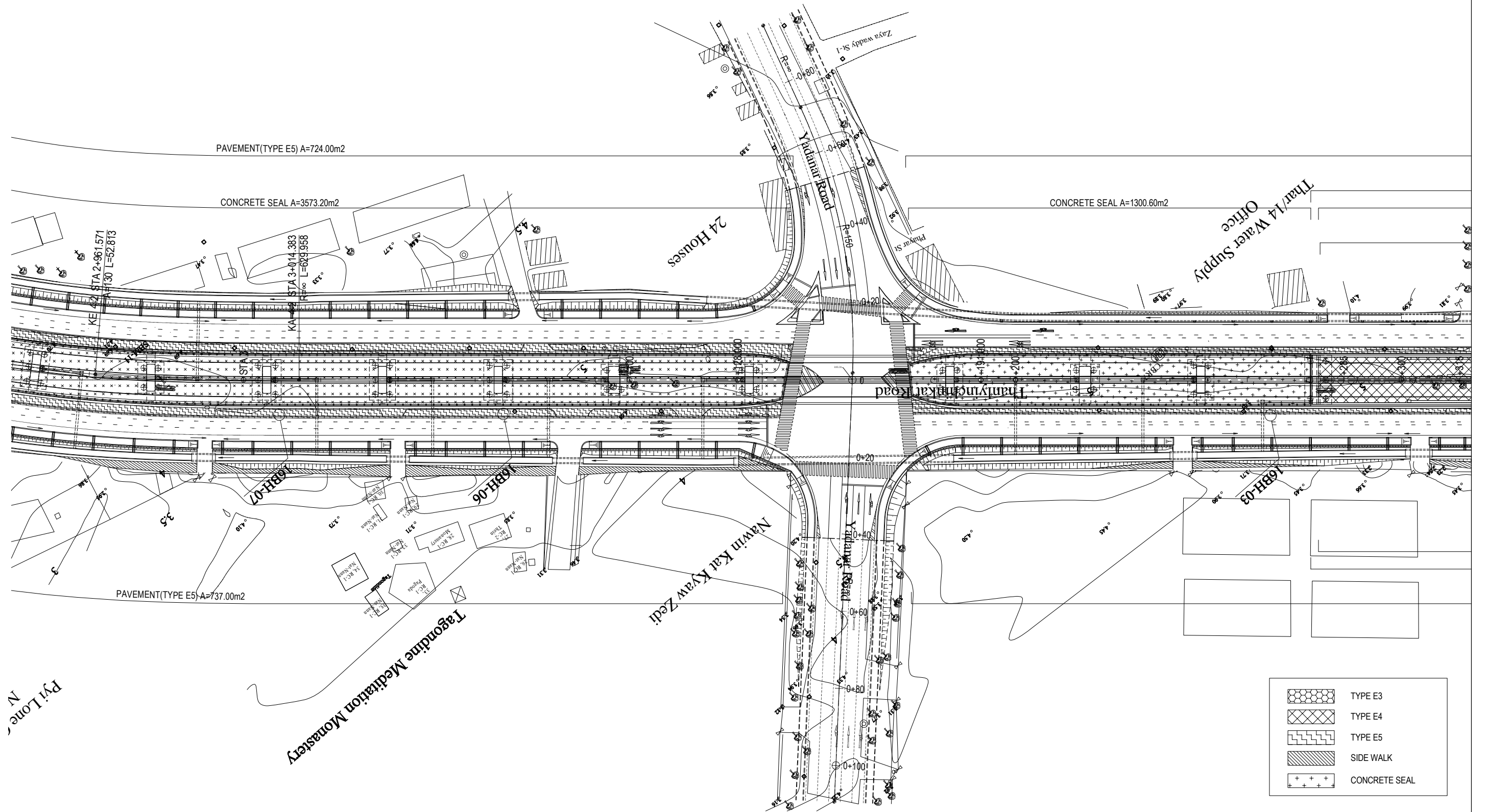

PROJECT NAME DETAILED DESIGN ON BAGO RIVER BRIDGE CONSTRUCTION PROJECT	FINANCED BY JAPAN INTERNATIONAL COOPERATION AGENCY	COUNTERPART REPUBLIC OF THE UNION OF MYANMAR MINISTRY OF CONSTRUCTION DEPARTMENT OF BRIDGE	JICA STUDY TEAM NIPPON KOEI CO., LTD. ORIENTAL CONSULTANTS GLOBAL CO., LTD. METROPOLITAN EXPRESSWAY COMPANY LIMITED CHODAI CO. LTD. NIPPON ENGINEERING CONSULTANTS CO., LTD.	NAME	SIGNATURE	DATE	DRAWING TITLE PLAN FOR PAVEMENT TYPE(2) S=1:1000	PACKAGE 3 DWG No. P3-RD-0320	
				PREPARED BY	K. TACHIBANA				29 Sep.2017
				CHECKED BY	T. HAYAKAWA				3 Oct.2017
				APPROVED BY	Y. SANO				6 Oct.2017

PLAN FOR PAVEMENT TYPE(3) S= 1:1000

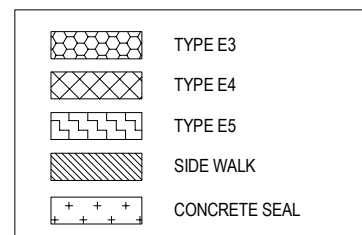
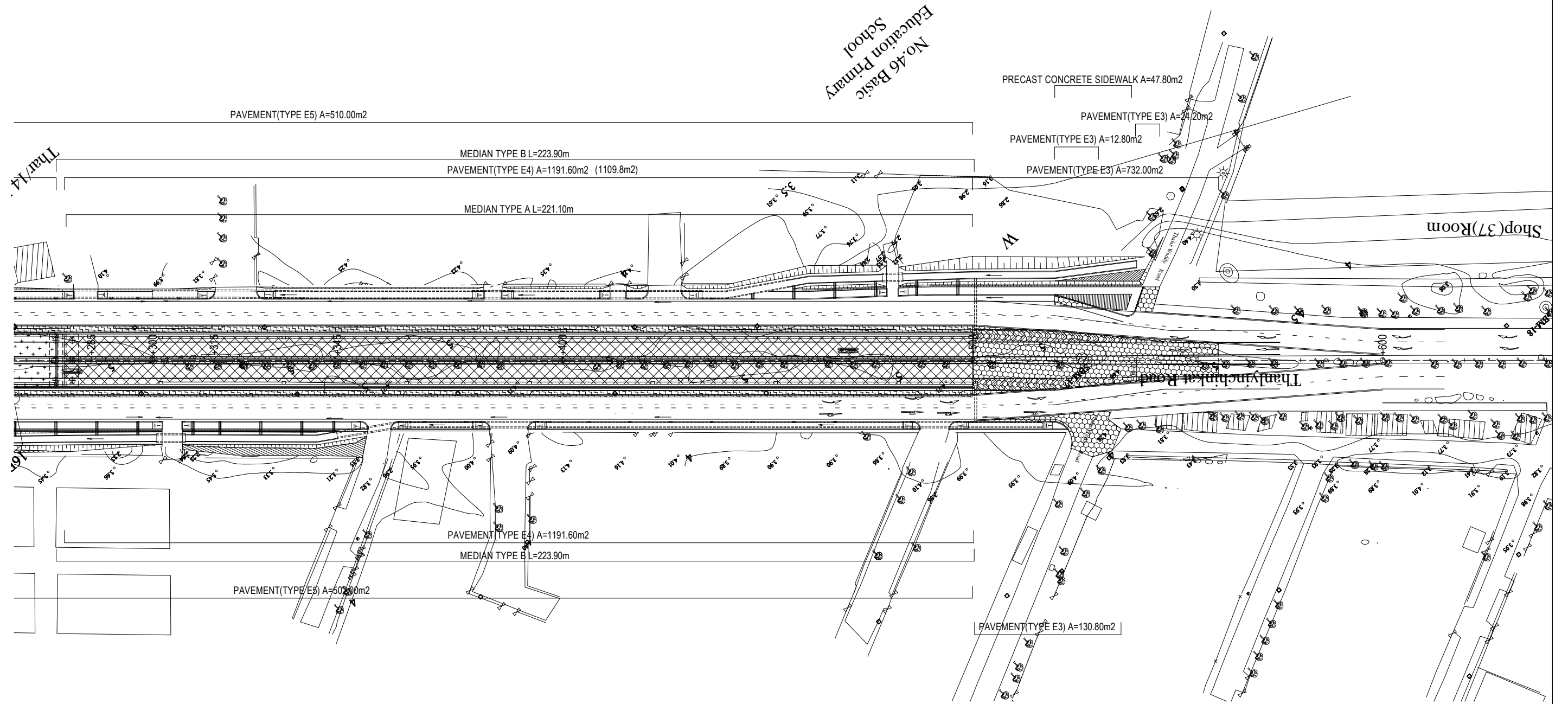

PROJECT NAME DETAILED DESIGN ON BAGO RIVER BRIDGE CONSTRUCTION PROJECT	FINANCED BY JAPAN INTERNATIONAL COOPERATION AGENCY	COUNTERPART REPUBLIC OF THE UNION OF MYANMAR MINISTRY OF CONSTRUCTION DEPARTMENT OF BRIDGE	JICA STUDY TEAM NIPPON KOEI CO., LTD. ORIENTAL CONSULTANTS GLOBAL CO., LTD. METROPOLITAN EXPRESSWAY COMPANY LIMITED CHODAI CO., LTD. NIPPON ENGINEERING CONSULTANTS CO., LTD.	NAME	SIGNATURE	DATE	DRAWING TITLE PLAN FOR PAVEMENT TYPE(3) S=1:1000	PACKAGE	
				PREPARED BY	K. TACHIBANA			29 Sep.2017	3
				CHECKED BY	T. HAYAKAWA			3 Oct.2017	DWG No.
				APPROVED BY	Y. SANO			6 Oct.2017	P3-RD-0330

CROSS SECTION(1) S= 1:400

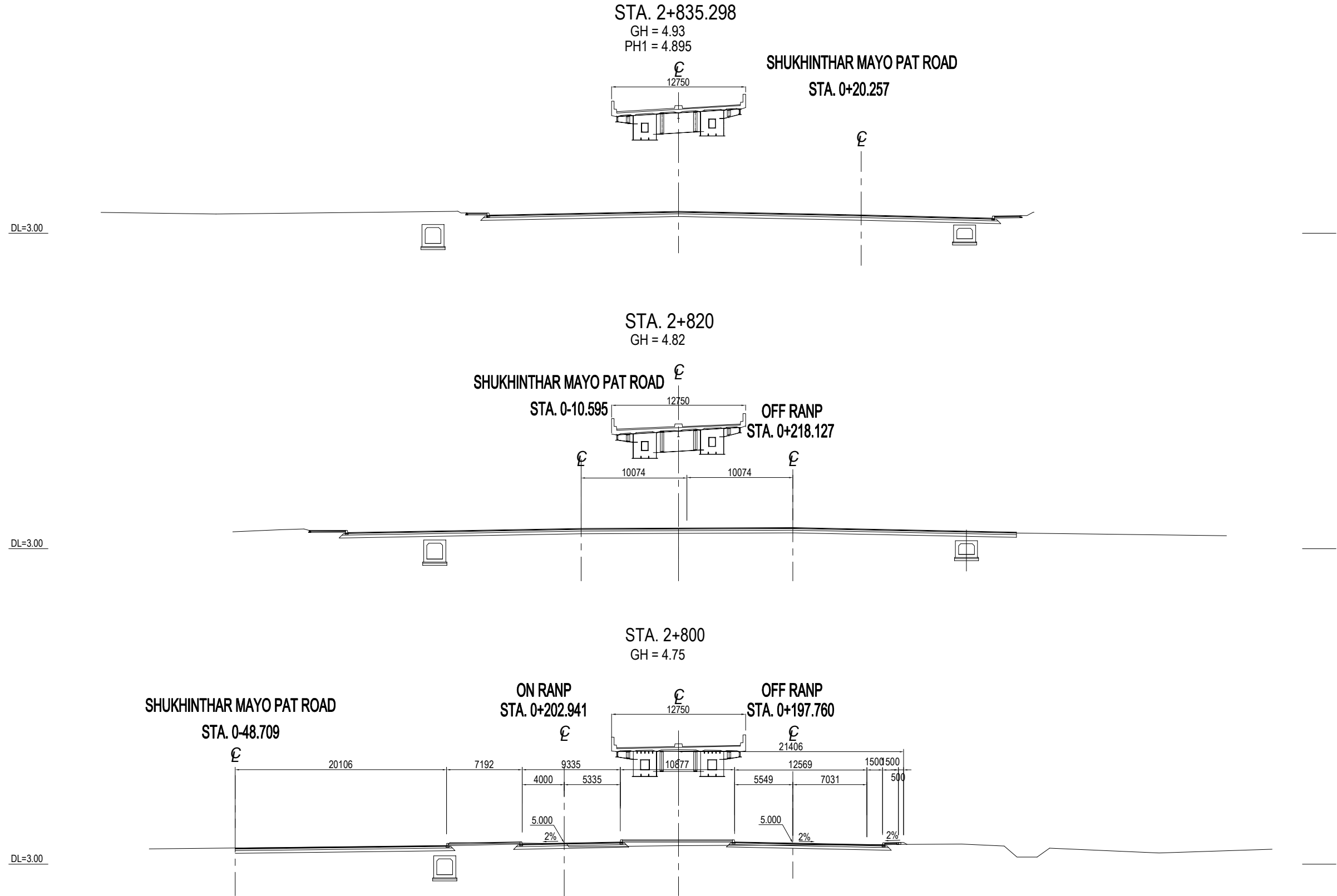

Note: Elevation of each cross section is based on Mean Sea Level (MSL).

PROJECT NAME	FINANCED BY	COUNTERPART	JICA STUDY TEAM	NAME	SIGNATURE	DATE	DRAWING TITLE	PACKAGE
DETAILED DESIGN ON BAGO RIVER BRIDGE CONSTRUCTION PROJECT	JICA JAPAN INTERNATIONAL COOPERATION AGENCY	REPUBLIC OF THE UNION OF MYANMAR MINISTRY OF CONSTRUCTION DEPARTMENT OF BRIDGE	NIPPON KOEI CO., LTD. ORIENTAL CONSULTANTS GLOBAL CO., LTD. METROPOLITAN EXPRESSWAY COMPANY LIMITED CHODAI CO., LTD. NIPPON ENGINEERING CONSULTANTS CO., LTD.	K. TACHIBANA		29 Sep.2017	CROSS SECTION(1) S= 1:400	3
				T. HAYAKAWA		3 Oct.2017		DWG No.
				Y. SANO		6 Oct.2017		P3-RD-0400

CROSS SECTION(2) S= 1:400

STA. 2+880
GH = 4.98
PH1 = 4.654

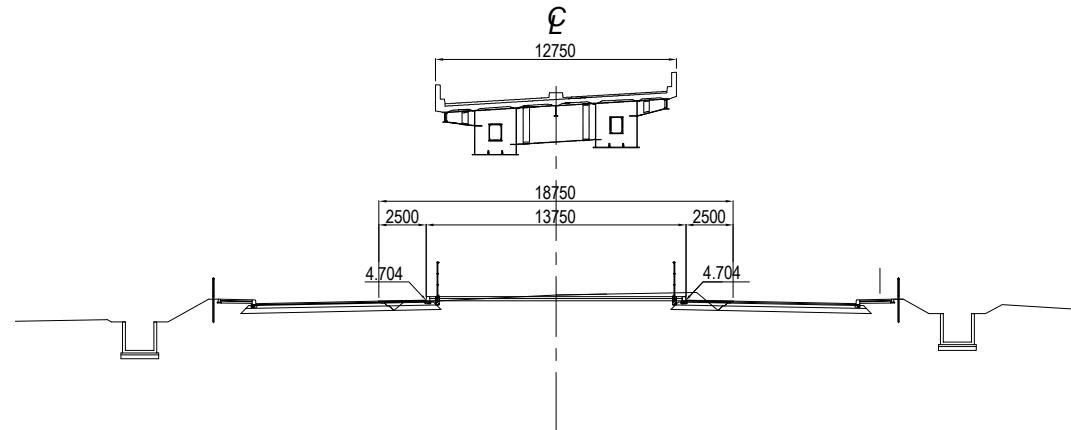

STA. 2+860
GH = 4.88
PH1 = 4.762

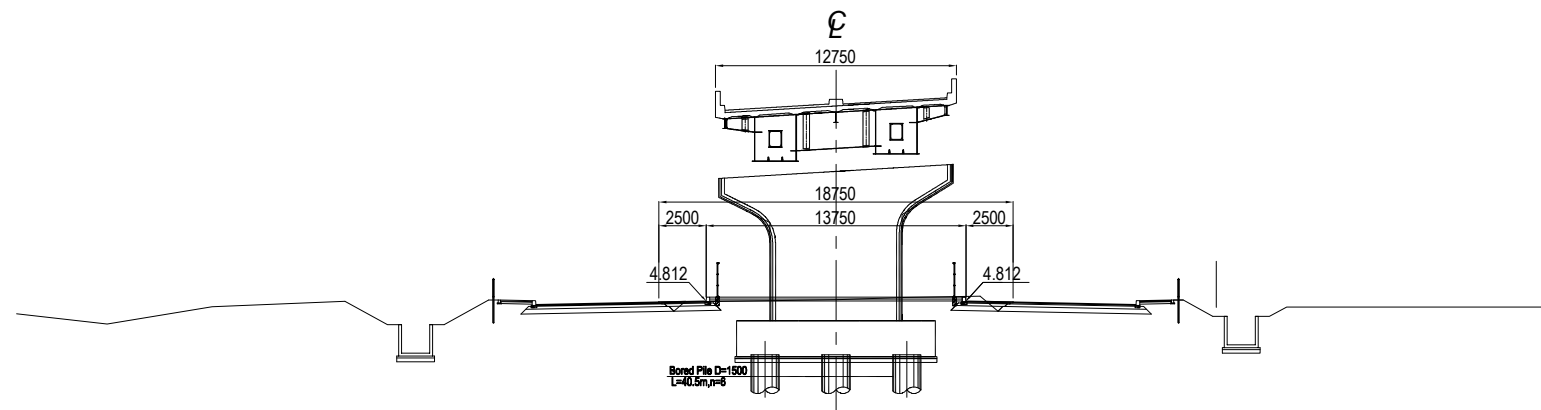

STA. 2+840
GH = 4.91
PH1 = 4.869

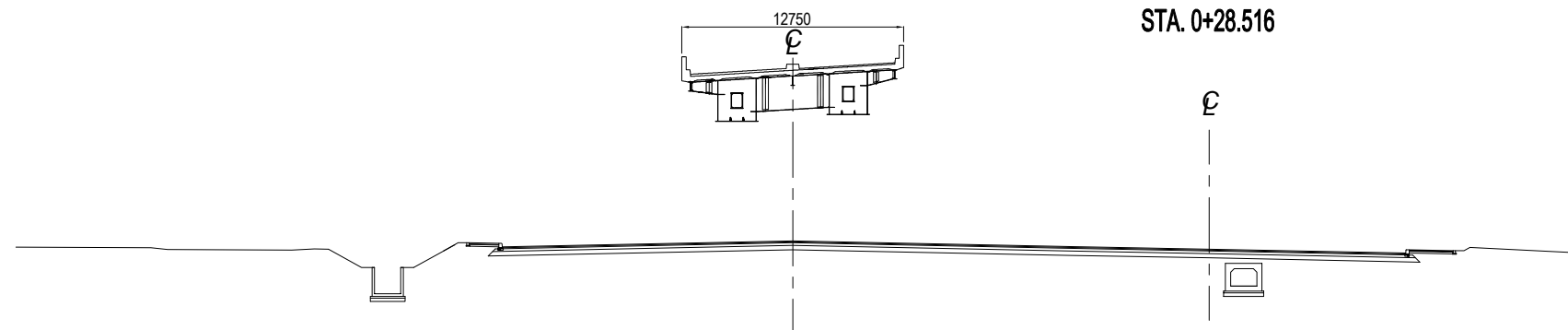

SHUKHINTHAR MAYO PAT ROAD
STA. 0+28.516

Note: Elevation of each cross section is based on Mean Sea Level (MSL).

PROJECT NAME DETAILED DESIGN ON BAGO RIVER BRIDGE CONSTRUCTION PROJECT	FINANCED BY JAPAN INTERNATIONAL COOPERATION AGENCY	COUNTERPART REPUBLIC OF THE UNION OF MYANMAR MINISTRY OF CONSTRUCTION DEPARTMENT OF BRIDGE	JICA STUDY TEAM NIPPON KOEI CO., LTD. ORIENTAL CONSULTANTS GLOBAL CO., LTD. METROPOLITAN EXPRESSWAY COMPANY LIMITED CHODAI CO., LTD. NIPPON ENGINEERING CONSULTANTS CO., LTD.	NAME	SIGNATURE	DATE	DRAWING TITLE CROSS SECTION(2) S= 1:400	PACKAGE 3 DWG No. P0-RD-0410	
				PREPARED BY	K. TACHIBANA				29 Sep.2017
				CHECKED BY	T. HAYAKAWA				3 Oct.2017
				APPROVED BY	Y. SANO				6 Oct.2017

CROSS SECTION(3) S= 1:400

STA. 2+940
GH = 4.99
PH 1= 4.332

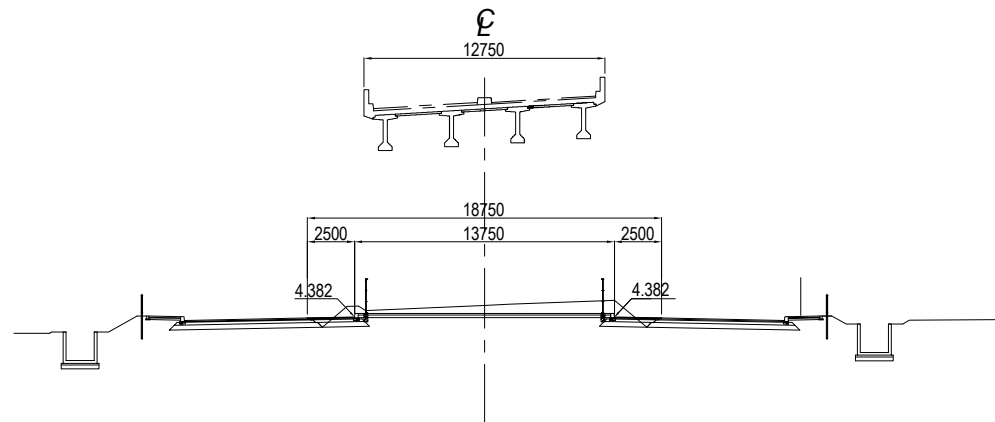

DL=3.00

STA. 2+920
GH = 5.01
PH1 = 4.440

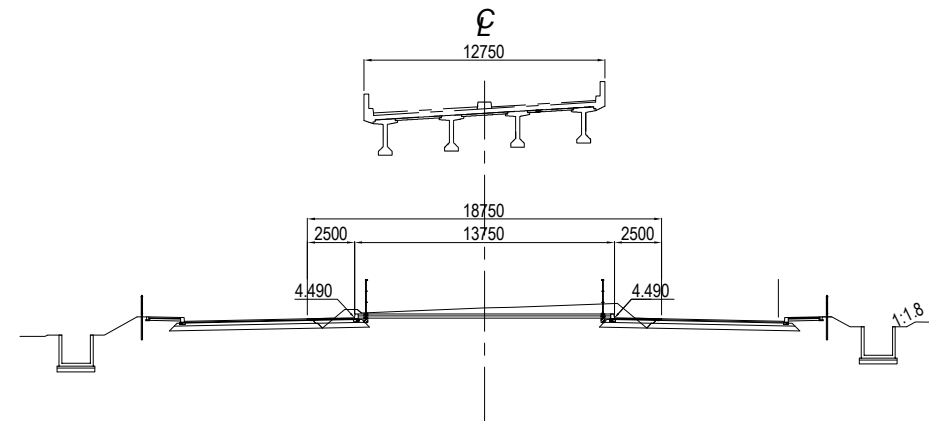

DL=3.00

STA. 2+900
GH = 5.04
PH 1= 4.547

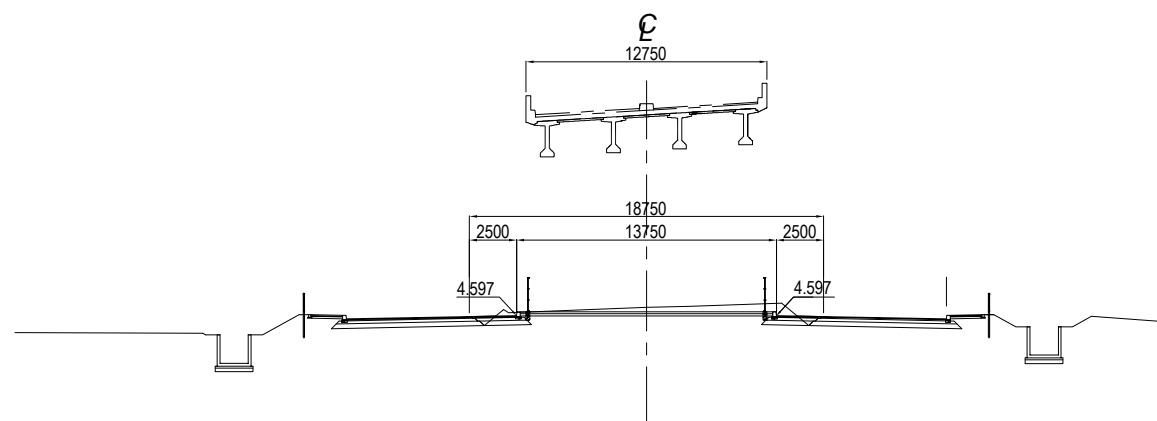

DL=3.00

Note: Elevation of each cross section is based on Mean Sea Level (MSL).

PROJECT NAME	FINANCED BY	COUNTERPART	JICA STUDY TEAM	NAME	SIGNATURE	DATE	DRAWING TITLE	PACKAGE
DETAILED DESIGN ON BAGO RIVER BRIDGE CONSTRUCTION PROJECT	JICA JAPAN INTERNATIONAL COOPERATION AGENCY	REPUBLIC OF THE UNION OF MYANMAR MINISTRY OF CONSTRUCTION DEPARTMENT OF BRIDGE	NIPPON KOEI CO., LTD. ORIENTAL CONSULTANTS GLOBAL CO., LTD. METROPOLITAN EXPRESSWAY COMPANY LIMITED CHODAI CO., LTD. NIPPON ENGINEERING CONSULTANTS CO., LTD.	PREPARED BY CHECKED BY APPROVED BY	K. TACHIBANA T. HAYAKAWA Y. SANO	29 Sep.2017 3 Oct.2017 6 Oct.2017	CROSS SECTION(3) S= 1:400	3 DWG No. P3-RD-0420

CROSS SECTION(4) S= 1:400

STA. 2+980
GH = 5.58
PH1 = 4.125

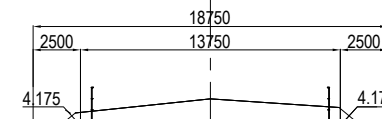
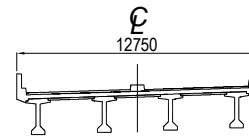

DL=3.00

STA. 2+961.571
GH = 4.95
PH1 = 4.216

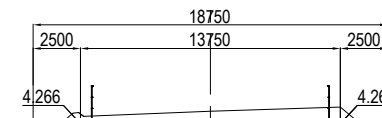
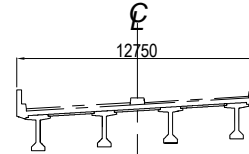

DL=3.00

STA. 2+960
GH = 4.97
PH1=4.225

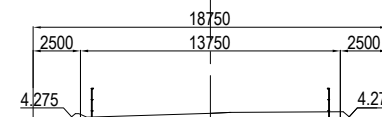
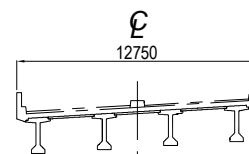

DL=3.00

Note: Elevation of each cross section is based on Mean Sea Level (MSL).

PROJECT NAME DETAILED DESIGN ON BAGO RIVER BRIDGE CONSTRUCTION PROJECT	FINANCED BY JAPAN INTERNATIONAL COOPERATION AGENCY	COUNTERPART REPUBLIC OF THE UNION OF MYANMAR MINISTRY OF CONSTRUCTION DEPARTMENT OF BRIDGE	JICA STUDY TEAM NIPPON KOEI CO., LTD. ORIENTAL CONSULTANTS GLOBAL CO., LTD. METROPOLITAN EXPRESSWAY COMPANY LIMITED CHODAI CO., LTD. NIPPON ENGINEERING CONSULTANTS CO., LTD.	NAME	SIGNATURE	DATE	DRAWING TITLE CROSS SECTION(4) S= 1:400	PACKAGE	
				PREPARED BY	K. TACHIBANA			29 Sep.2017	3
				CHECKED BY	T. HAYAKAWA			3 Oct.2017	DWG No.
				APPROVED BY	Y. SANO			6 Oct.2017	P3-RD-0430

CROSS SECTION(5) S= 1:400

STA. 3+020
GH = 4.99
PH1 = 4.198

DL=3.00

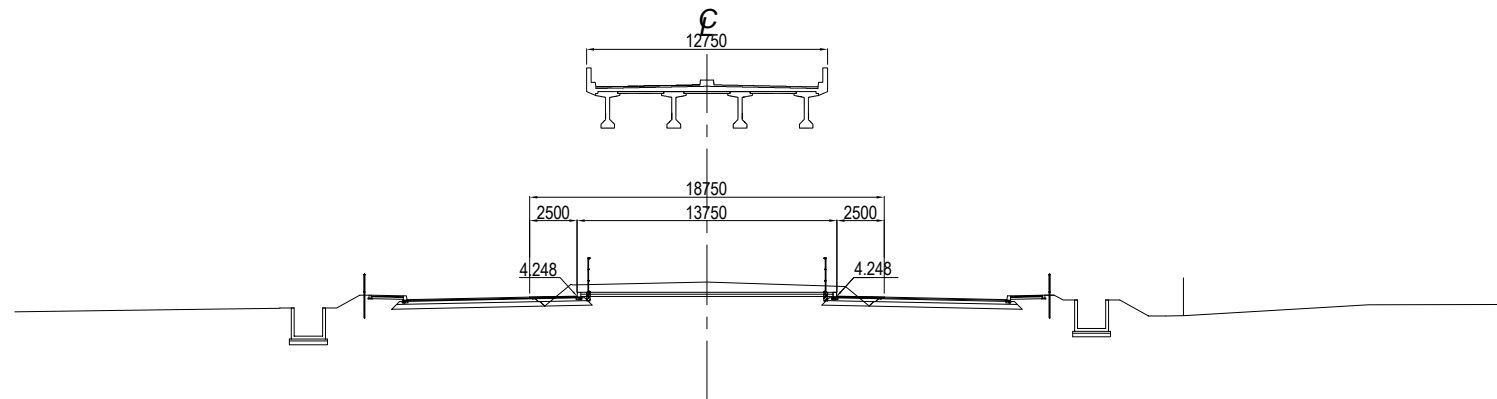

STA. 3+014.383
GH = 4.98
PH1 = 4.168

DL=3.00

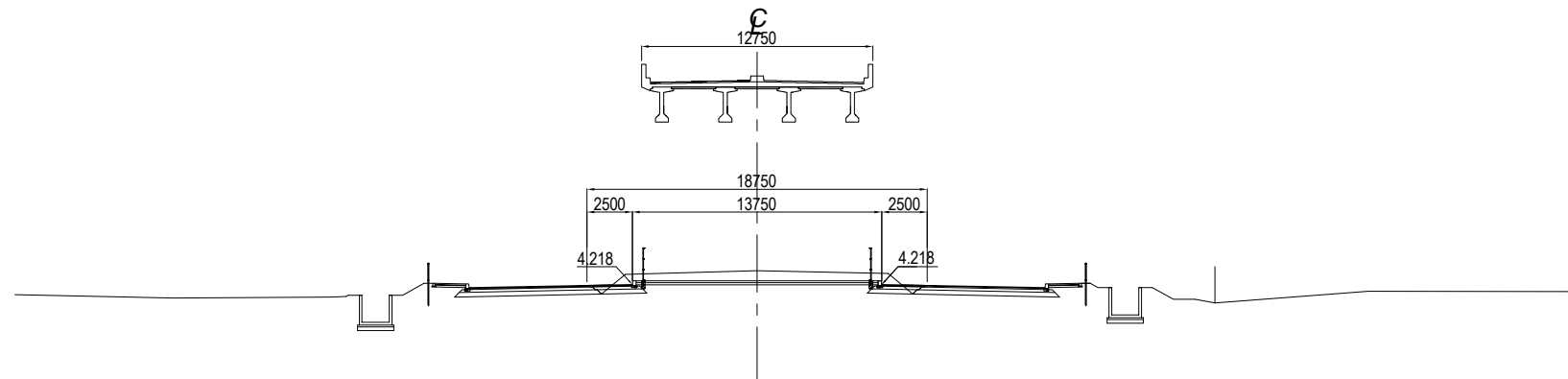

STA. 3+0.0
GH = 4.92
PH1 = 4.111

DL=3.00

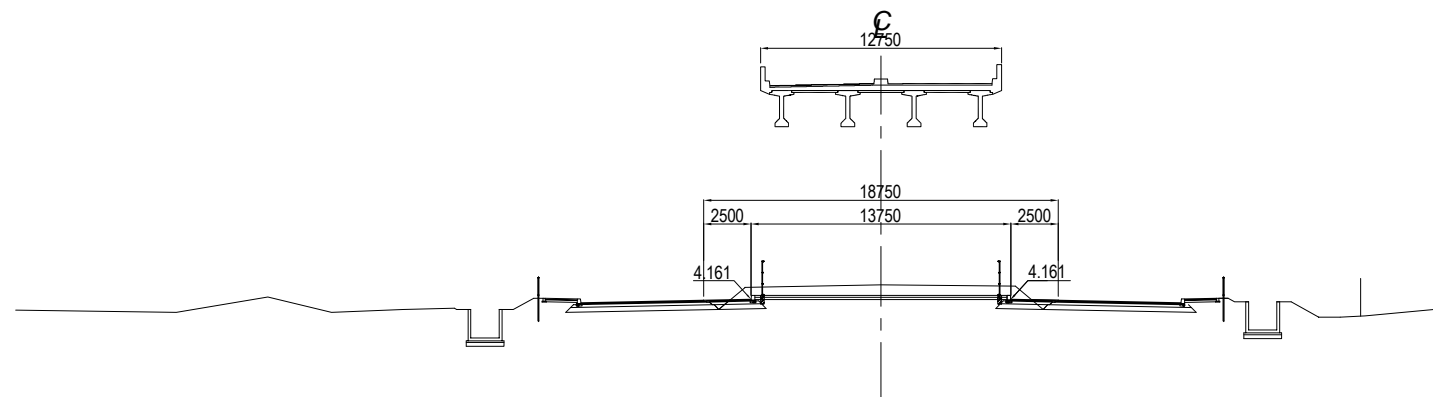

Note: Elevation of each cross section is based on Mean Sea Level (MSL).

PROJECT NAME DETAILED DESIGN ON BAGO RIVER BRIDGE CONSTRUCTION PROJECT	FINANCED BY JAPAN INTERNATIONAL COOPERATION AGENCY	COUNTERPART REPUBLIC OF THE UNION OF MYANMAR MINISTRY OF CONSTRUCTION DEPARTMENT OF BRIDGE	JICA STUDY TEAM NIPPON KOEI CO., LTD. ORIENTAL CONSULTANTS GLOBAL CO., LTD. METROPOLITAN EXPRESSWAY COMPANY LIMITED CHODAI CO., LTD. NIPPON ENGINEERING CONSULTANTS CO., LTD.	NAME	SIGNATURE	DATE	DRAWING TITLE CROSS SECTION(5) S= 1:400	PACKAGE 3 DWG No. P3-RD-0440	
				PREPARED BY	K. TACHIBANA				29 Sep.2017
				CHECKED BY	T. HAYAKAWA				3 Oct.2017
				APPROVED BY	Y. SANO				6 Oct.2017

CROSS SECTION(6) S= 1:400

STA. 3+080
GH = 4.96
PH1 = 4.520

DL=3.00

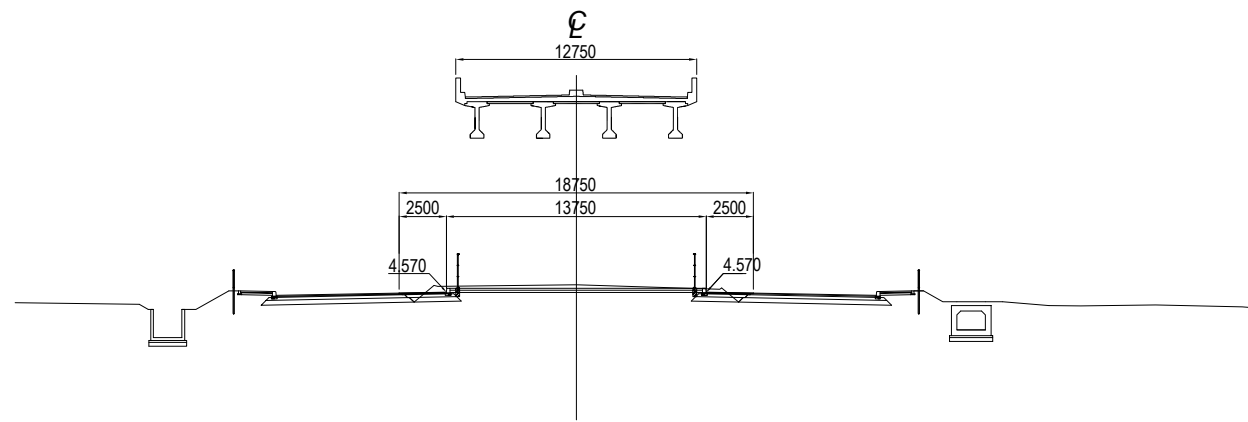

STA. 3+060
GH = 4.95
PH1 = 4.413

DL=3.00

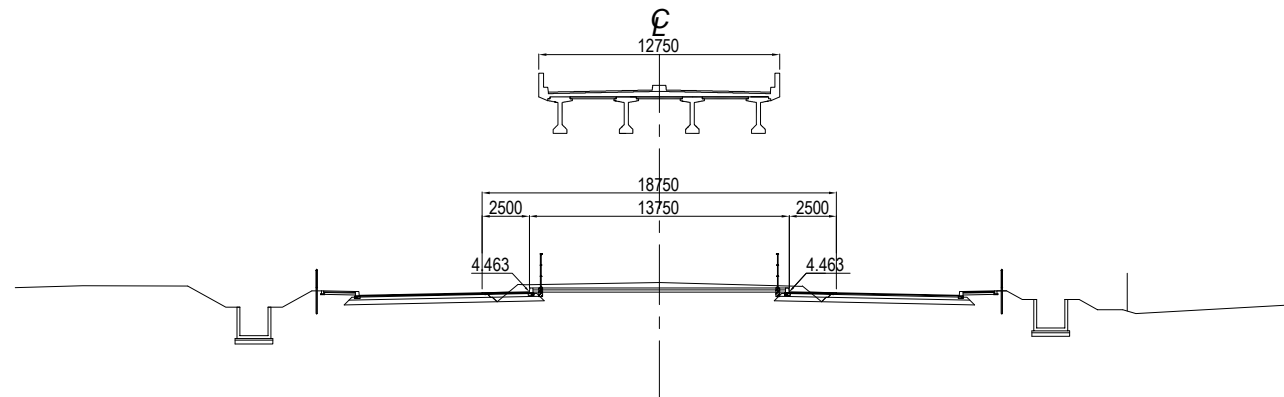

STA. 3+040
GH = 4.97
PH1 = 4.305

DL=3.00

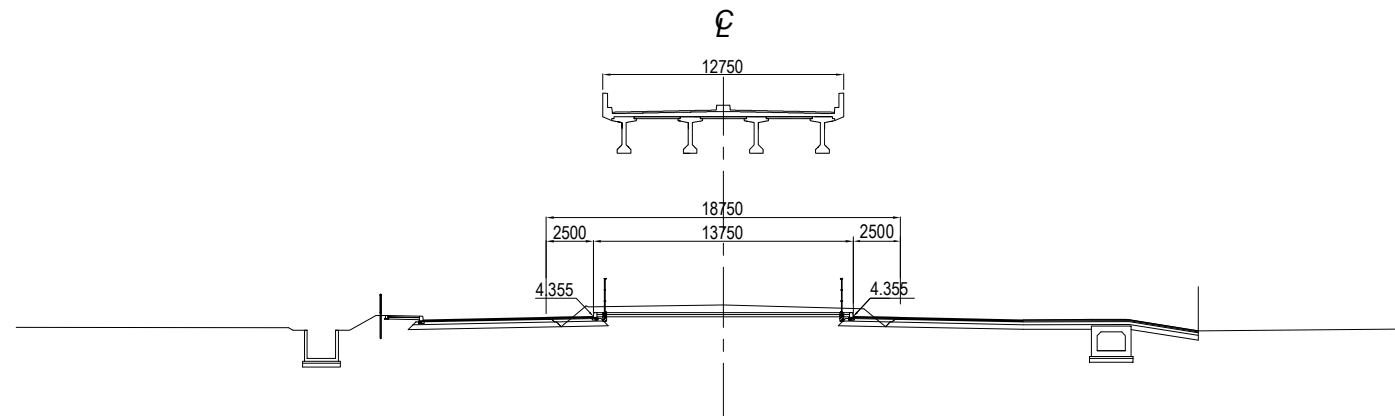

Note: Elevation of each cross section is based on Mean Sea Level (MSL).

PROJECT NAME DETAILED DESIGN ON BAGO RIVER BRIDGE CONSTRUCTION PROJECT	FINANCED BY JAPAN INTERNATIONAL COOPERATION AGENCY	COUNTERPART REPUBLIC OF THE UNION OF MYANMAR MINISTRY OF CONSTRUCTION DEPARTMENT OF BRIDGE	JICA STUDY TEAM NIPPON KOEI CO., LTD. ORIENTAL CONSULTANTS GLOBAL CO., LTD. METROPOLITAN EXPRESSWAY COMPANY LIMITED CHODAI CO., LTD. NIPPON ENGINEERING CONSULTANTS CO., LTD.	NAME	SIGNATURE	DATE	DRAWING TITLE CROSS SECTION(6) S= 1:400	PACKAGE 3 DWG No. P3-RD-0450	
				PREPARED BY	K. TACHIBANA				29 Sep.2017
				CHECKED BY	T. HAYAKAWA				3 Oct.2017
				APPROVED BY	Y. SANO				6 Oct.2017

CROSS SECTION(7) S= 1:400

STA. 3+140
GH = 5.22
PH1 = 4.843

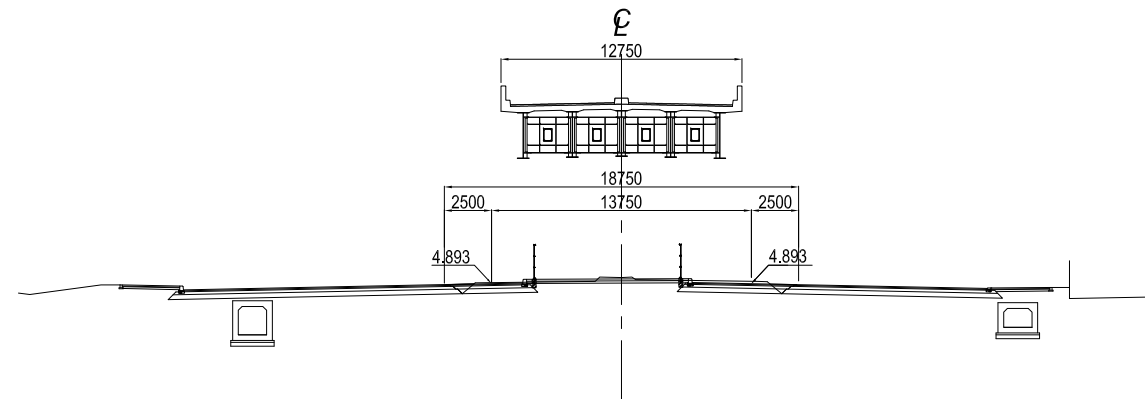

DL=3.00

STA. 3+120
GH = 5.22
PH1 = 4.735

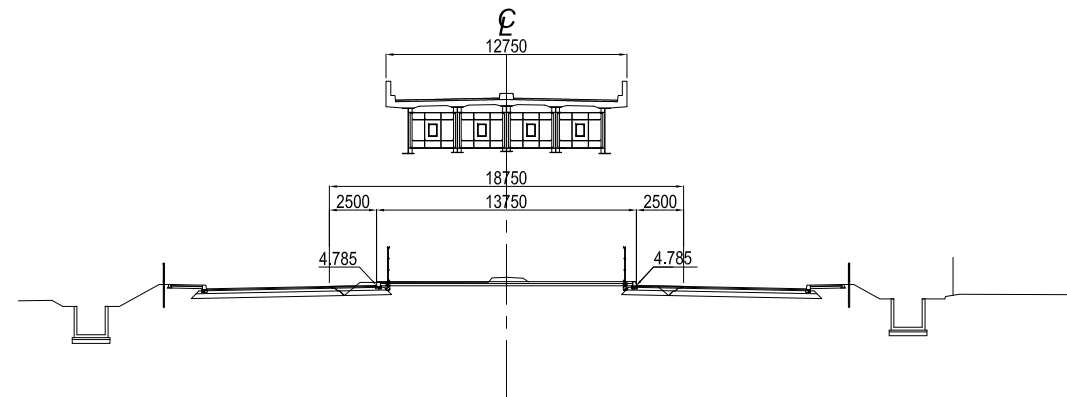

DL=3.00

STA. 3+100
GH = 5.30
PH1 = 4.628

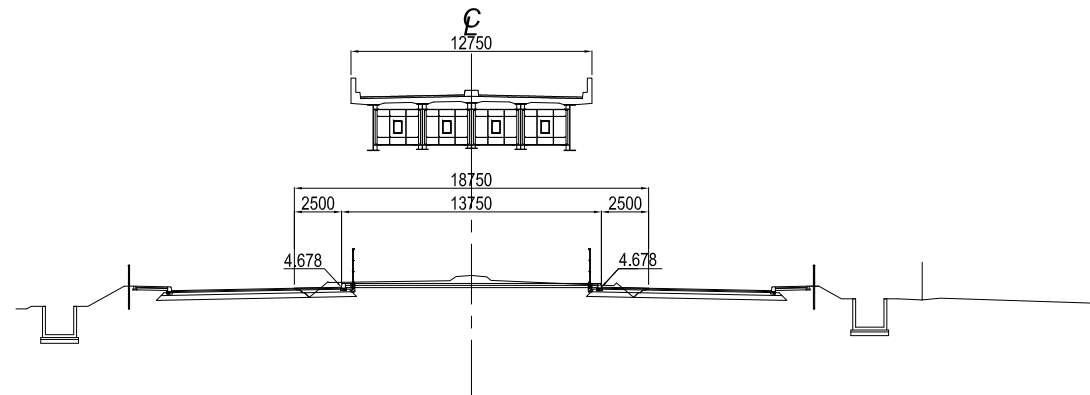

DL=3.00

Note: Elevation of each cross section is based on Mean Sea Level (MSL).

PROJECT NAME	FINANCED BY	COUNTERPART	JICA STUDY TEAM	NAME	SIGNATURE	DATE	DRAWING TITLE	PACKAGE
DETAILED DESIGN ON BAGO RIVER BRIDGE CONSTRUCTION PROJECT	JICA JAPAN INTERNATIONAL COOPERATION AGENCY	REPUBLIC OF THE UNION OF MYANMAR MINISTRY OF CONSTRUCTION DEPARTMENT OF BRIDGE	NIPPON KOEI CO., LTD. ORIENTAL CONSULTANTS GLOBAL CO., LTD. METROPOLITAN EXPRESSWAY COMPANY LIMITED CHODAI CO., LTD. NIPPON ENGINEERING CONSULTANTS CO., LTD.	PREPARED BY CHECKED BY APPROVED BY	K. TACHIBANA T. HAYAKAWA Y. SANO	29 Sep. 2017 3 Oct. 2017 6 Oct. 2017	CROSS SECTION(7) S= 1:400	3 DWG No. P3-RD-0460

CROSS SECTION(8) S= 1:400

STA. 3+200
GH = 5.29
PH2 = 4.713

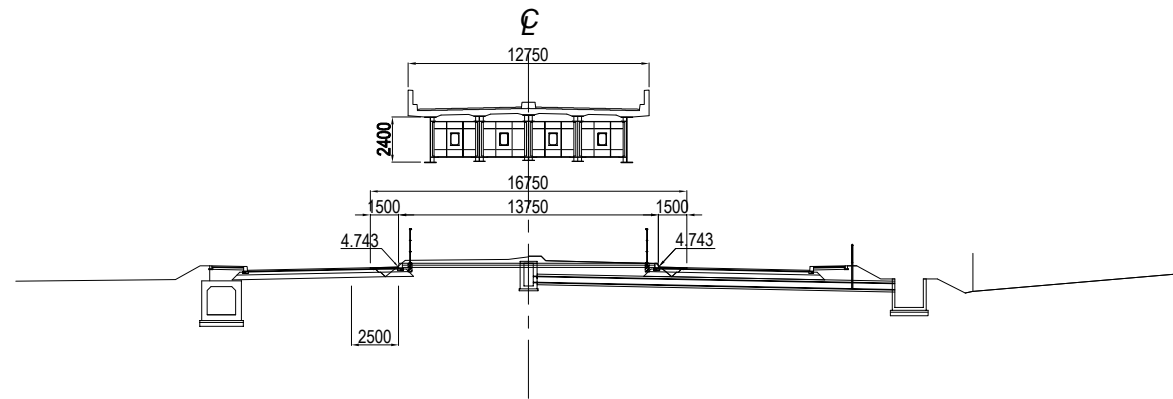

STA. 3+180
GH = 5.21
PH2 = 4.841

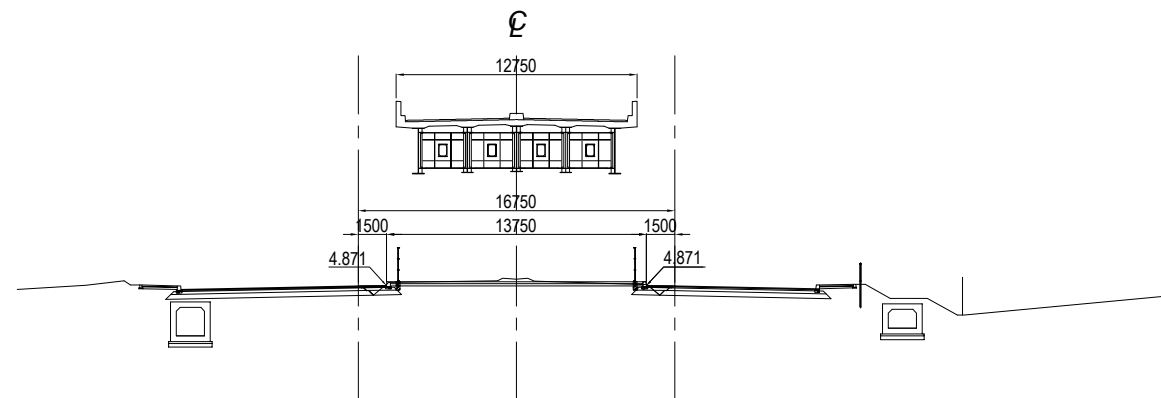

STA. 3+160
GH = 5.26
PH1 = 4.891 PH2 = 4.911

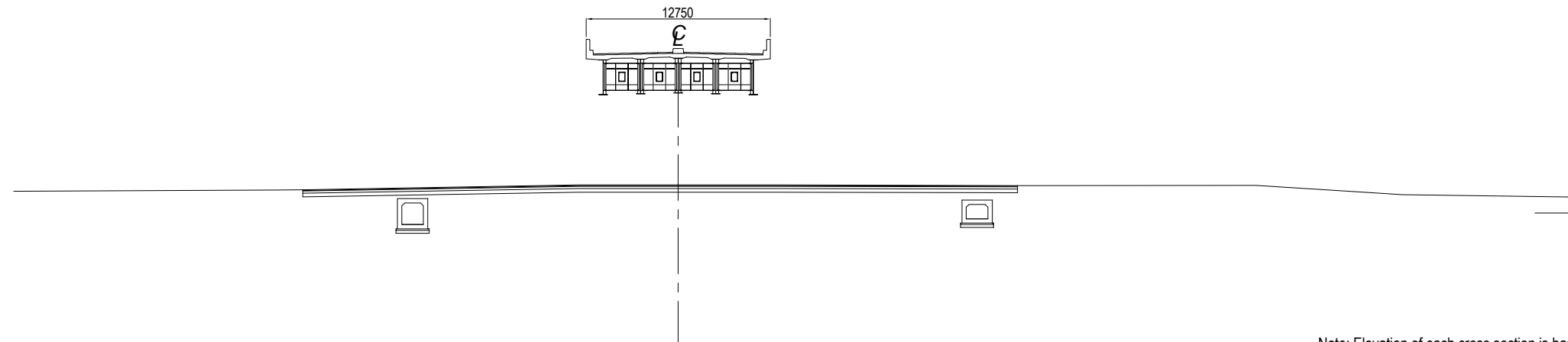

Note: Elevation of each cross section is based on Mean Sea Level (MSL).

PROJECT NAME DETAILED DESIGN ON BAGO RIVER BRIDGE CONSTRUCTION PROJECT	FINANCED BY JAPAN INTERNATIONAL COOPERATION AGENCY	COUNTERPART REPUBLIC OF THE UNION OF MYANMAR MINISTRY OF CONSTRUCTION DEPARTMENT OF BRIDGE	JICA STUDY TEAM NIPPON KOEI CO., LTD. ORIENTAL CONSULTANTS GLOBAL CO., LTD. METROPOLITAN EXPRESSWAY COMPANY LIMITED CHODAI CO., LTD. NIPPON ENGINEERING CONSULTANTS CO., LTD.	NAME	SIGNATURE	DATE	DRAWING TITLE CROSS SECTION(8) S= 1:400	PACKAGE	
				PREPARED BY	K. TACHIBANA			29 Sep.2017	3
				CHECKED BY	T. HAYAKAWA			3 Oct.2017	DWG No.
				APPROVED BY	Y. SANO			6 Oct.2017	P3-RD-0470

CROSS SECTION(9) S= 1:400

STA. 3+260
GH = 5.24
PH2 = 4.327

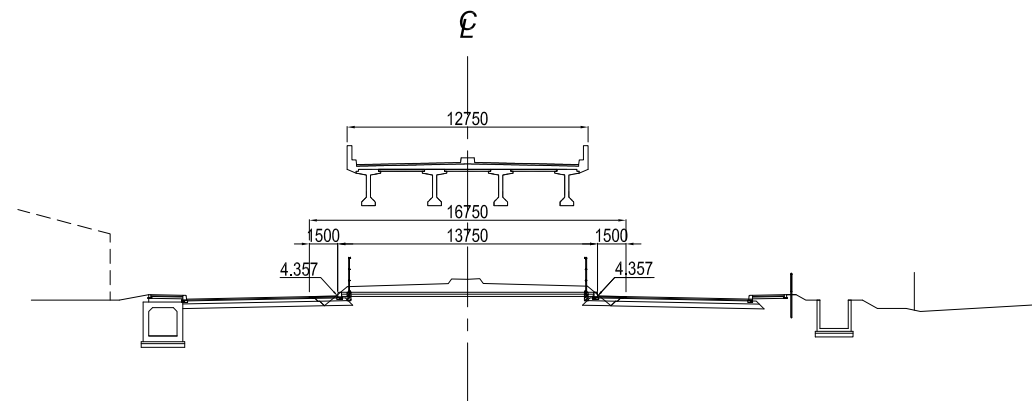

DL=3.00

STA. 3+240
GH = 5.25
PH2 = 4.456

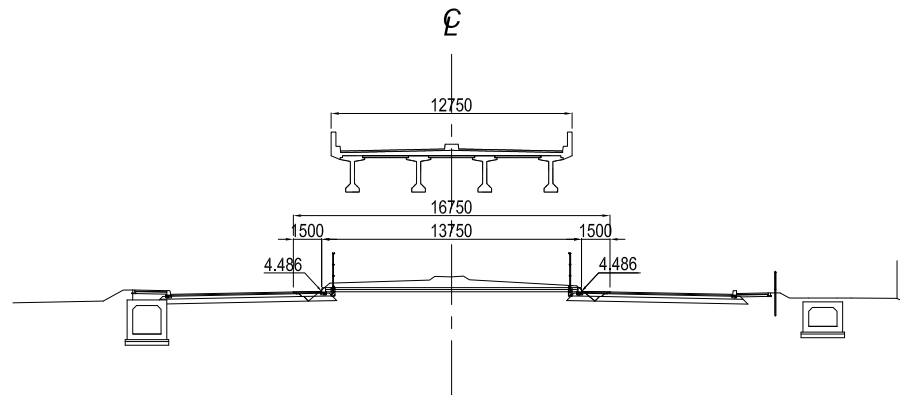

DL=3.00

STA. 3+220
GH = 5.36
PH2 = 4.584

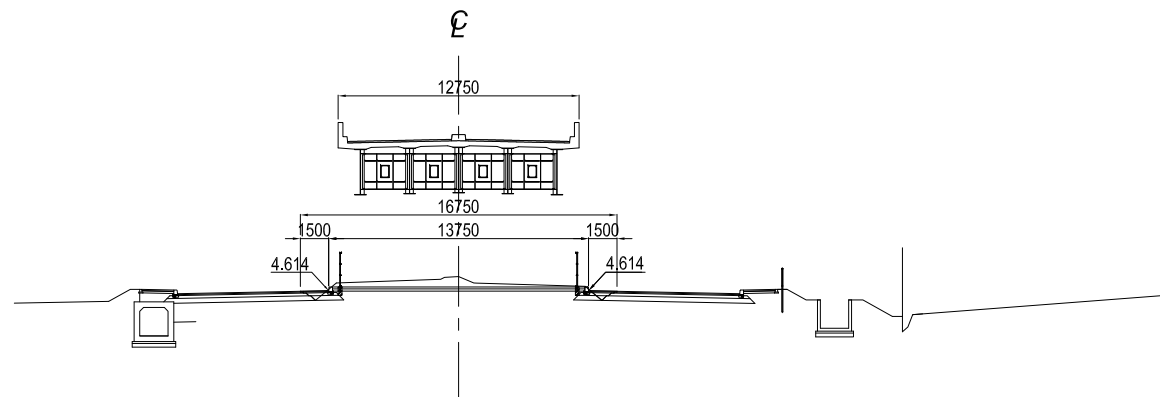

DL=3.00

Note: Elevation of each cross section is based on Mean Sea Level (MSL).

PROJECT NAME	FINANCED BY	COUNTERPART	JICA STUDY TEAM	NAME	SIGNATURE	DATE	DRAWING TITLE	PACKAGE
DETAILED DESIGN ON BAGO RIVER BRIDGE CONSTRUCTION PROJECT	JICA JAPAN INTERNATIONAL COOPERATION AGENCY	REPUBLIC OF THE UNION OF MYANMAR MINISTRY OF CONSTRUCTION DEPARTMENT OF BRIDGE	NIPPON KOEI CO., LTD. ORIENTAL CONSULTANTS GLOBAL CO., LTD. METROPOLITAN EXPRESSWAY COMPANY LIMITED CHODAI CO., LTD. NIPPON ENGINEERING CONSULTANTS CO., LTD.	PREPARED BY CHECKED BY APPROVED BY	K. TACHIBANA T. HAYAKAWA Y. SANO	29 Sep. 2017 3 Oct. 2017 6 Oct. 2017	CROSS SECTION(9) S= 1:400	3 DWG No. P3-RD-0480

CROSS SECTION(10) S= 1:400

STA. 3+300
GH = 5.03
PH2 = 4.119

℄

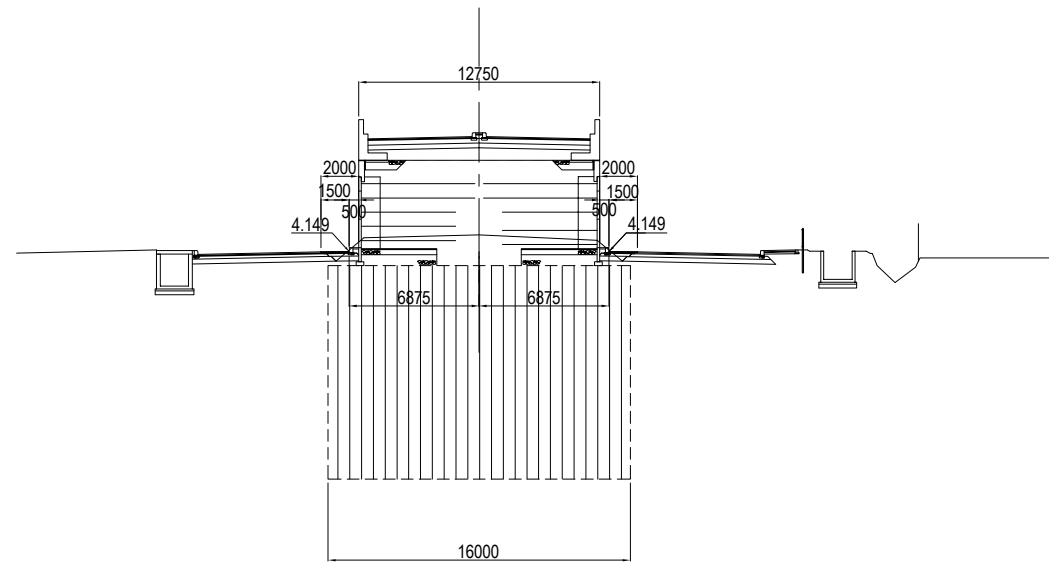

DL=3.00

STA. 3+280
GH = 5.25
PH2 = 4.199

℄

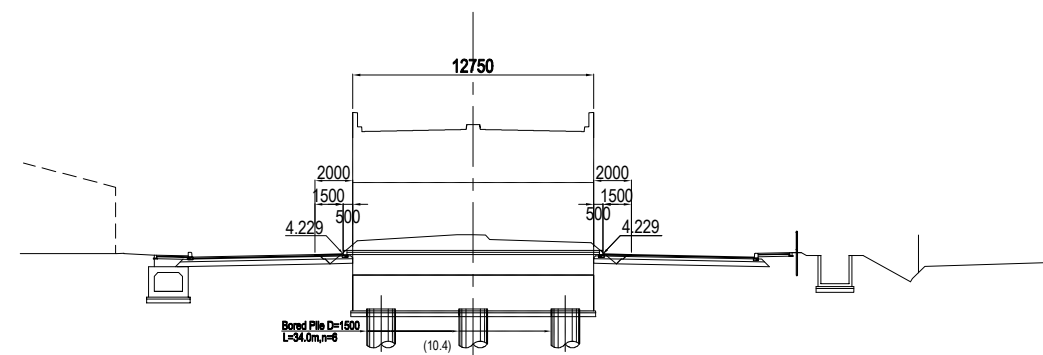

DL=3.00

Note: Elevation of each cross section is based on Mean Sea Level (MSL).

PROJECT NAME	FINANCED BY	COUNTERPART	JICA STUDY TEAM	NAME	SIGNATURE	DATE	DRAWING TITLE	PACKAGE
DETAILED DESIGN ON BAGO RIVER BRIDGE CONSTRUCTION PROJECT	JICA JAPAN INTERNATIONAL COOPERATION AGENCY	REPUBLIC OF THE UNION OF MYANMAR MINISTRY OF CONSTRUCTION DEPARTMENT OF BRIDGE	NIPPON KOEI CO., LTD. ORIENTAL CONSULTANTS GLOBAL CO., LTD. METROPOLITAN EXPRESSWAY COMPANY LIMITED CHODAI CO., LTD. NIPPON ENGINEERING CONSULTANTS CO., LTD.	K. TACHIBANA		29 Sep.2017	CROSS SECTION(10) S= 1:400	3
				T. HAYAKAWA		3 Oct.2017		DWG No.
				Y. SANO		6 Oct.2017		P3-RD-0490

CROSS SECTION(11) S= 1:400

STA. 3+340
GH = 5.06
PH2 = 4.203

℄

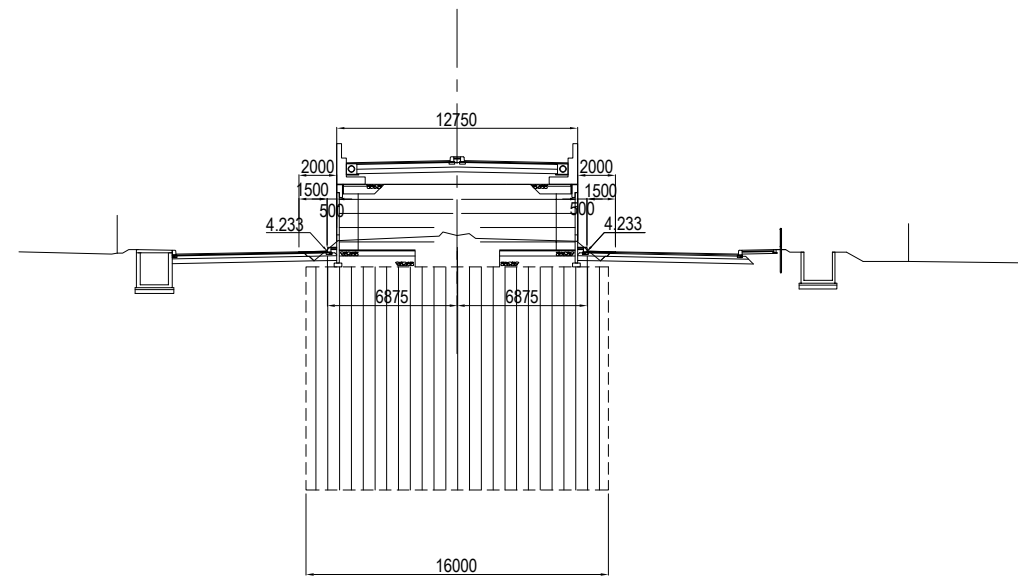

STA. 3+320
GH = 5.18
PH2 = 4.137

℄

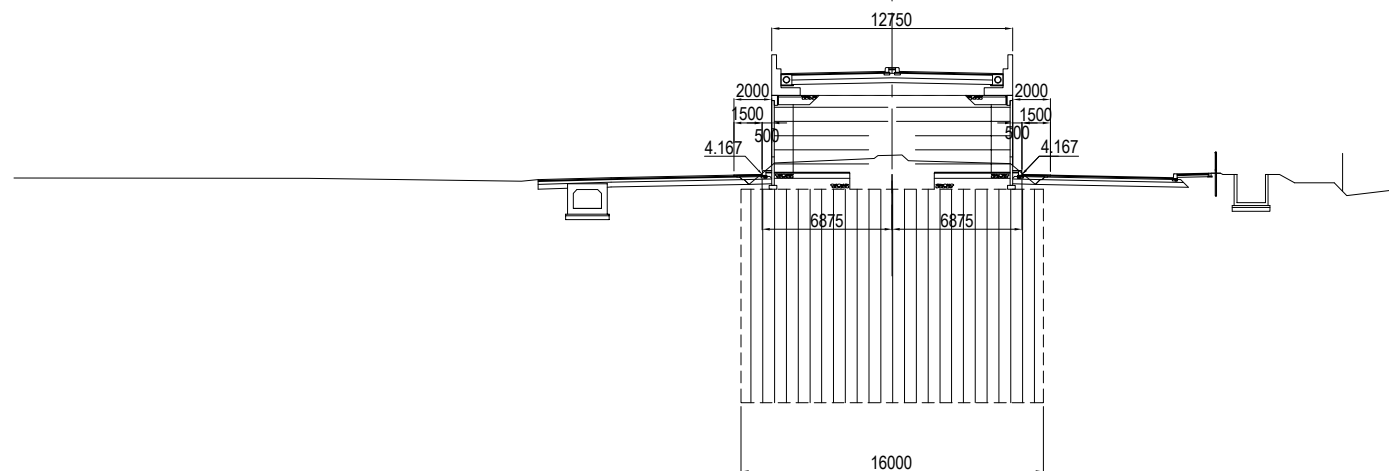

Note: Elevation of each cross section is based on Mean Sea Level (MSL).

PROJECT NAME	FINANCED BY	COUNTERPART	JICA STUDY TEAM	NAME	SIGNATURE	DATE	DRAWING TITLE	PACKAGE
DETAILED DESIGN ON BAGO RIVER BRIDGE CONSTRUCTION PROJECT	JAPAN INTERNATIONAL COOPERATION AGENCY	REPUBLIC OF THE UNION OF MYANMAR MINISTRY OF CONSTRUCTION DEPARTMENT OF BRIDGE	NIPPON KOEI CO., LTD. ORIENTAL CONSULTANTS GLOBAL CO., LTD. METROPOLITAN EXPRESSWAY COMPANY LIMITED CHODAI CO., LTD. NIPPON ENGINEERING CONSULTANTS CO., LTD.	PREPARED BY	K. TACHIBANA	29 Sep.2017	CROSS SECTION(11) S= 1:400	3
				CHECKED BY	T. HAYAKAWA	3 Oct.2017		DWG No.
				APPROVED BY	Y. SANO	6 Oct.2017		P3-RD-0500

CROSS SECTION(12) S= 1:400

STA. 3+380
GH = 5.13
PH2 = 4.336

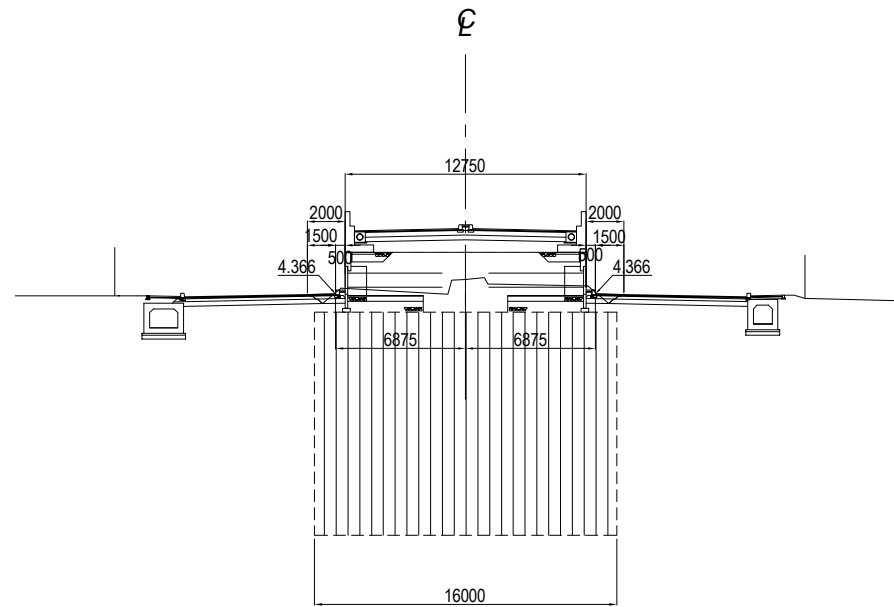

DL=3.00

STA. 3+360
GH = 5.20
PH2 = 4.270

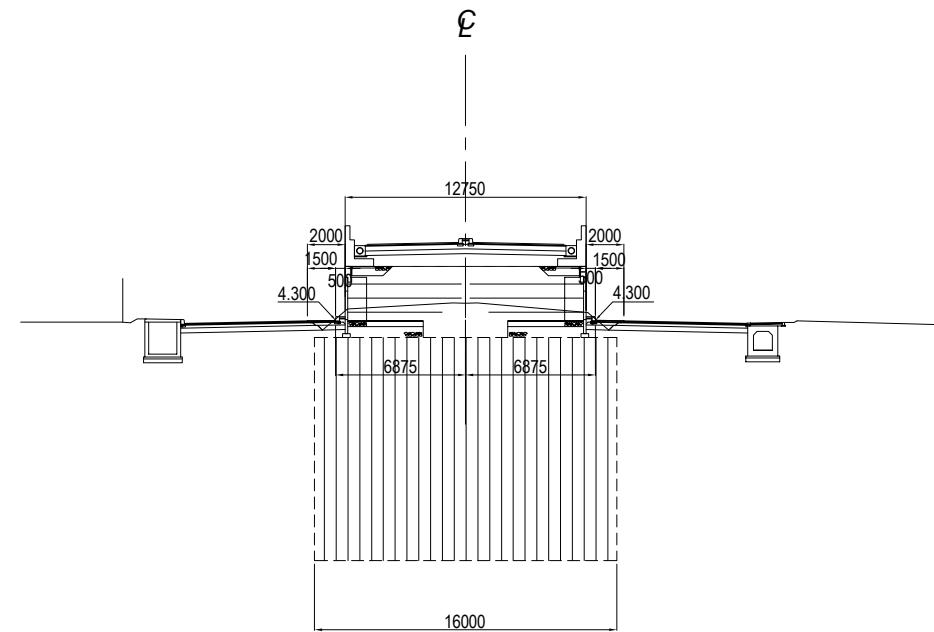

DL=3.00

Note: Elevation of each cross section is based on Mean Sea Level (MSL).

PROJECT NAME	FINANCED BY	COUNTERPART	JICA STUDY TEAM	NAME	SIGNATURE	DATE	DRAWING TITLE	PACKAGE
DETAILED DESIGN ON BAGO RIVER BRIDGE CONSTRUCTION PROJECT	JAPAN INTERNATIONAL COOPERATION AGENCY	REPUBLIC OF THE UNION OF MYANMAR MINISTRY OF CONSTRUCTION DEPARTMENT OF BRIDGE	NIPPON KOEI CO., LTD. ORIENTAL CONSULTANTS GLOBAL CO., LTD. METROPOLITAN EXPRESSWAY COMPANY LIMITED CHODAI CO., LTD. NIPPON ENGINEERING CONSULTANTS CO., LTD.	PREPARED BY	K. TACHIBANA	29 Sep.2017	CROSS SECTION(12) S= 1:400	3
				CHECKED BY	T. HAYAKAWA	3 Oct.2017		DWG No.
				APPROVED BY	Y. SANO	6 Oct.2017		P3-RD-0510

CROSS SECTION(13) S= 1:400

STA. 3+420
GH = 5.12
PH2 = 4.469

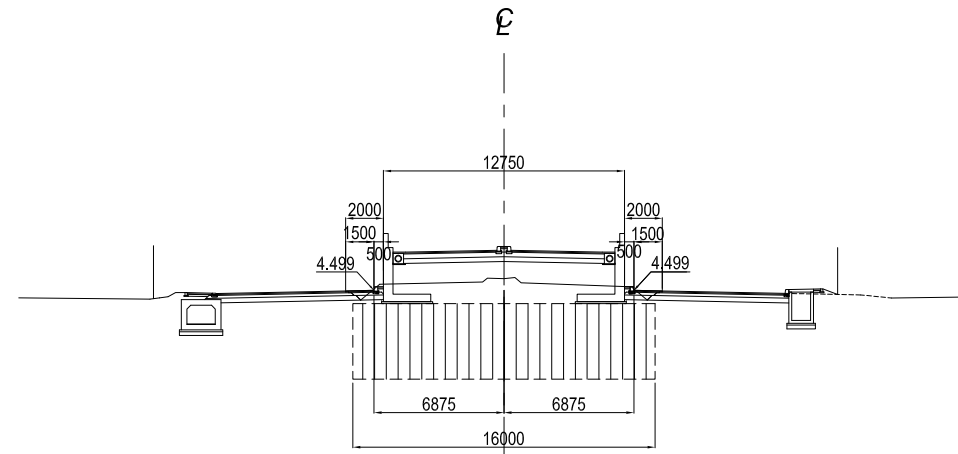

DL=3.00

STA. 3+400
GH = 5.15
PH2 = 4.403

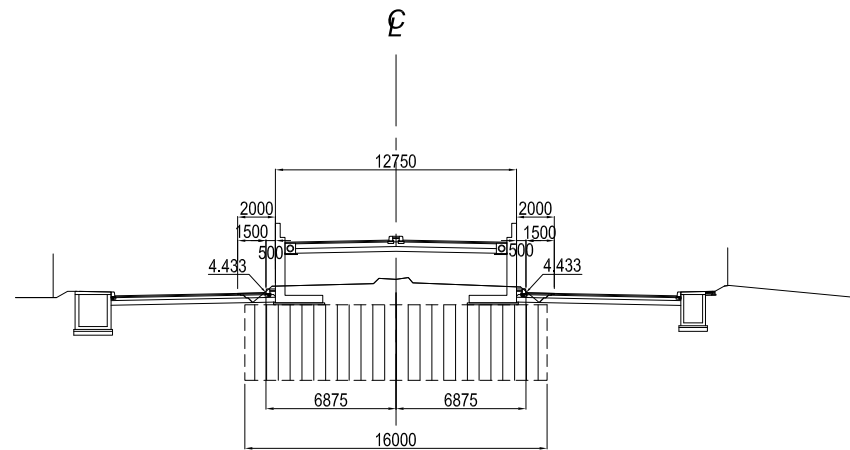

DL=3.00

Note: Elevation of each cross section is based on Mean Sea Level (MSL).

PROJECT NAME	FINANCED BY	COUNTERPART	JICA STUDY TEAM	NAME	SIGNATURE	DATE	DRAWING TITLE	PACKAGE
DETAILED DESIGN ON BAGO RIVER BRIDGE CONSTRUCTION PROJECT	JICA JAPAN INTERNATIONAL COOPERATION AGENCY	REPUBLIC OF THE UNION OF MYANMAR MINISTRY OF CONSTRUCTION DEPARTMENT OF BRIDGE	NIPPON KOEI CO., LTD. ORIENTAL CONSULTANTS GLOBAL CO., LTD. METROPOLITAN EXPRESSWAY COMPANY LIMITED CHODAI CO., LTD. NIPPON ENGINEERING CONSULTANTS CO., LTD.	PREPARED BY CHECKED BY APPROVED BY	K. TACHIBANA T. HAYAKAWA Y. SANO	29 Sep. 2017 3 Oct. 2017 6 Oct. 2017	CROSS SECTION(13) S= 1:400	3 DWG No. P3-RD-0520

CROSS SECTION(14) S= 1:400

STA. 3+460
GH = 5.11
PH2 = 4.602

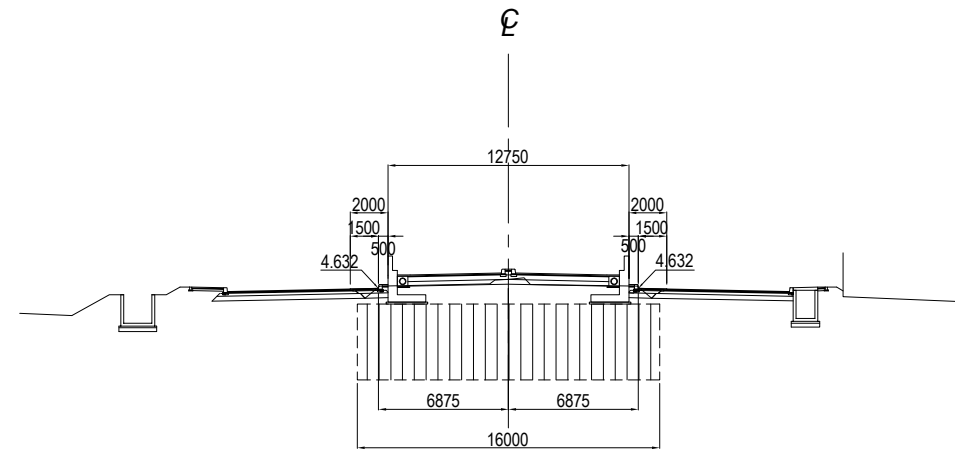

STA. 3+440
GH = 5.19
PH2 = 4.536

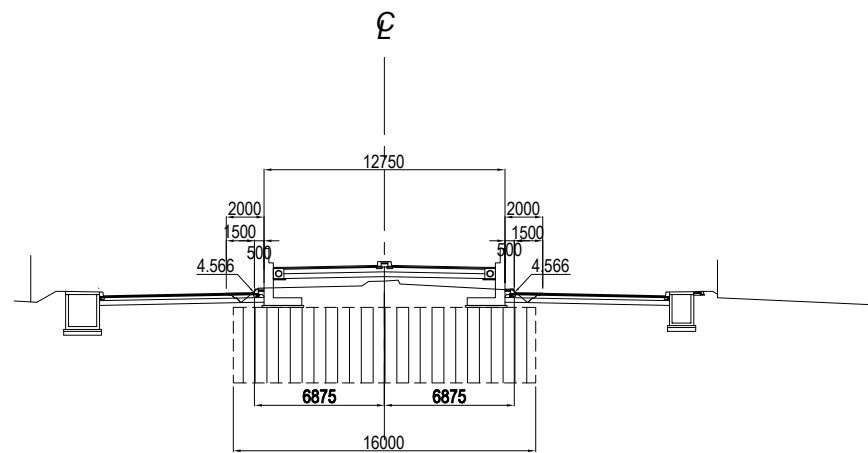

Note: Elevation of each cross section is based on Mean Sea Level (MSL).

PROJECT NAME DETAILED DESIGN ON BAGO RIVER BRIDGE CONSTRUCTION PROJECT	FINANCED BY JAPAN INTERNATIONAL COOPERATION AGENCY	COUNTERPART REPUBLIC OF THE UNION OF MYANMAR MINISTRY OF CONSTRUCTION DEPARTMENT OF BRIDGE	JICA STUDY TEAM NIPPON KOEI CO., LTD. ORIENTAL CONSULTANTS GLOBAL CO., LTD. METROPOLITAN EXPRESSWAY COMPANY LIMITED CHODAI CO., LTD. NIPPON ENGINEERING CONSULTANTS CO., LTD.	NAME	SIGNATURE	DATE	DRAWING TITLE CROSS SECTION(14) S= 1:400	PACKAGE	
				PREPARED BY	K. TACHIBANA			29 Sep.2017	3
				CHECKED BY	T. HAYAKAWA			3 Oct.2017	DWG No.
				APPROVED BY	Y. SANO			6 Oct.2017	P3-RD-0530

CROSS SECTION(15) S= 1:400

STA. 3+500
GH = 5.23
PH2 = 4.735

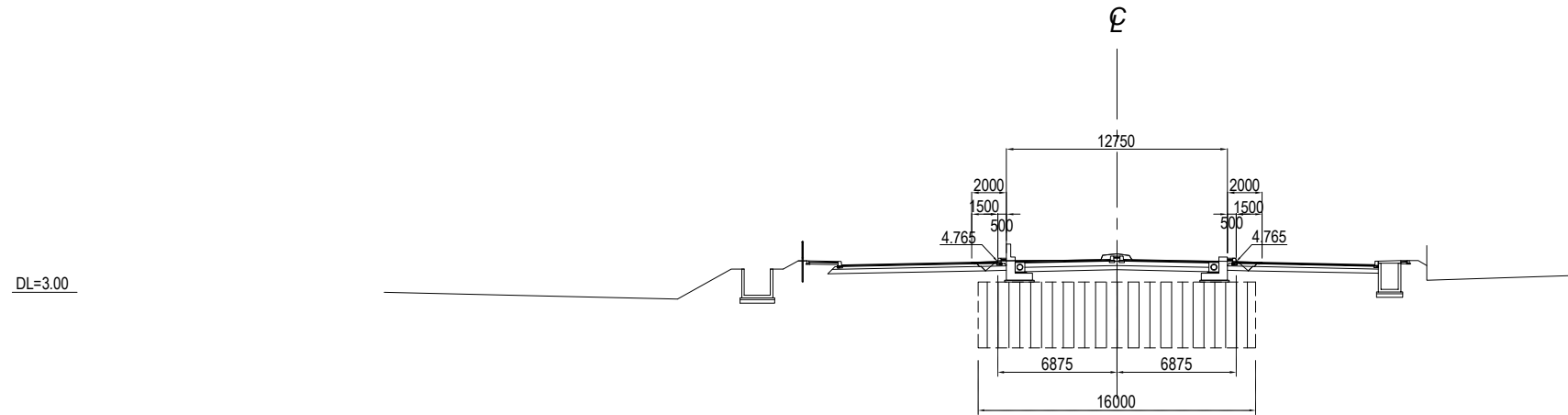

STA. 3+480
GH = 5.16
PH2 = 4.669

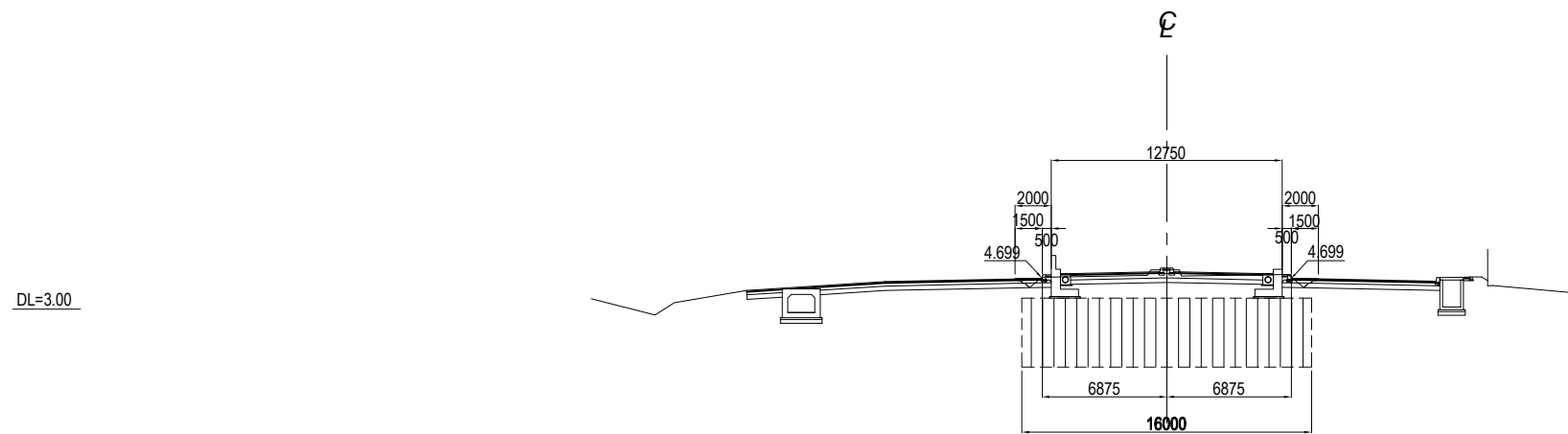

Note: Elevation of each cross section is based on Mean Sea Level (MSL).

PROJECT NAME	FINANCED BY	COUNTERPART	JICA STUDY TEAM	NAME	SIGNATURE	DATE	DRAWING TITLE	PACKAGE
DETAILED DESIGN ON BAGO RIVER BRIDGE CONSTRUCTION PROJECT	JAPAN INTERNATIONAL COOPERATION AGENCY	REPUBLIC OF THE UNION OF MYANMAR MINISTRY OF CONSTRUCTION DEPARTMENT OF BRIDGE	NIPPON KOEI CO., LTD. ORIENTAL CONSULTANTS GLOBAL CO., LTD. METROPOLITAN EXPRESSWAY COMPANY LIMITED CHODAI CO., LTD. NIPPON ENGINEERING CONSULTANTS CO., LTD.	PREPARED BY	K. TACHIBANA	29 Sep.2017	CROSS SECTION(15) S= 1:400	3
				CHECKED BY	T. HAYAKAWA	3 Oct.2017		DWG No.
				APPROVED BY	Y. SANO	6 Oct.2017		P3-RD-0540

CROSS SECTION(16) S= 1:400

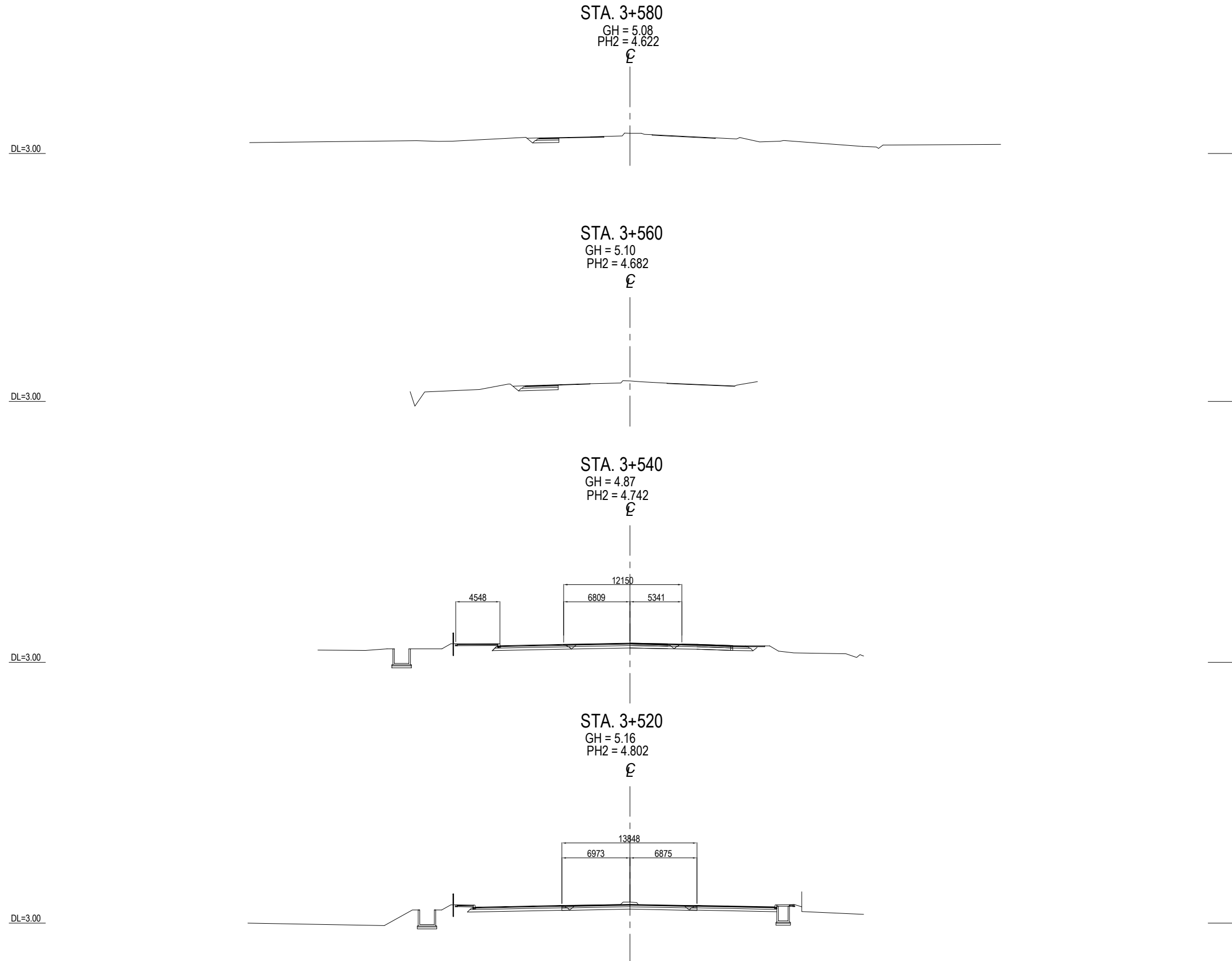

STA. 3+580
GH = 5.08
PH2 = 4.622

STA. 3+560
GH = 5.10
PH2 = 4.682

STA. 3+540
GH = 4.87
PH2 = 4.742

STA. 3+520
GH = 5.16
PH2 = 4.802

Note: Elevation of each cross section is based on Mean Sea Level (MSL).

PROJECT NAME DETAILED DESIGN ON BAGO RIVER BRIDGE CONSTRUCTION PROJECT	FINANCED BY JAPAN INTERNATIONAL COOPERATION AGENCY	COUNTERPART REPUBLIC OF THE UNION OF MYANMAR MINISTRY OF CONSTRUCTION DEPARTMENT OF BRIDGE	JICA STUDY TEAM NIPPON KOEI CO., LTD. ORIENTAL CONSULTANTS GLOBAL CO., LTD. METROPOLITAN EXPRESSWAY COMPANY LIMITED CHODAI CO., LTD. NIPPON ENGINEERING CONSULTANTS CO., LTD.	NAME	SIGNATURE	DATE	DRAWING TITLE CROSS SECTION(16) S= 1:400	PACKAGE	
				PREPARED BY	K. TACHIBANA			29 Sep.2017	3
				CHECKED BY	T. HAYAKAWA			3 Oct.2017	DWG No.
				APPROVED BY	Y. SANO			6 Oct.2017	P3-RD-0550

INTERSECTION PLAN, PROFILE AND SECTION (SHUKHINTHAR INTERSECTION STA.2+830)

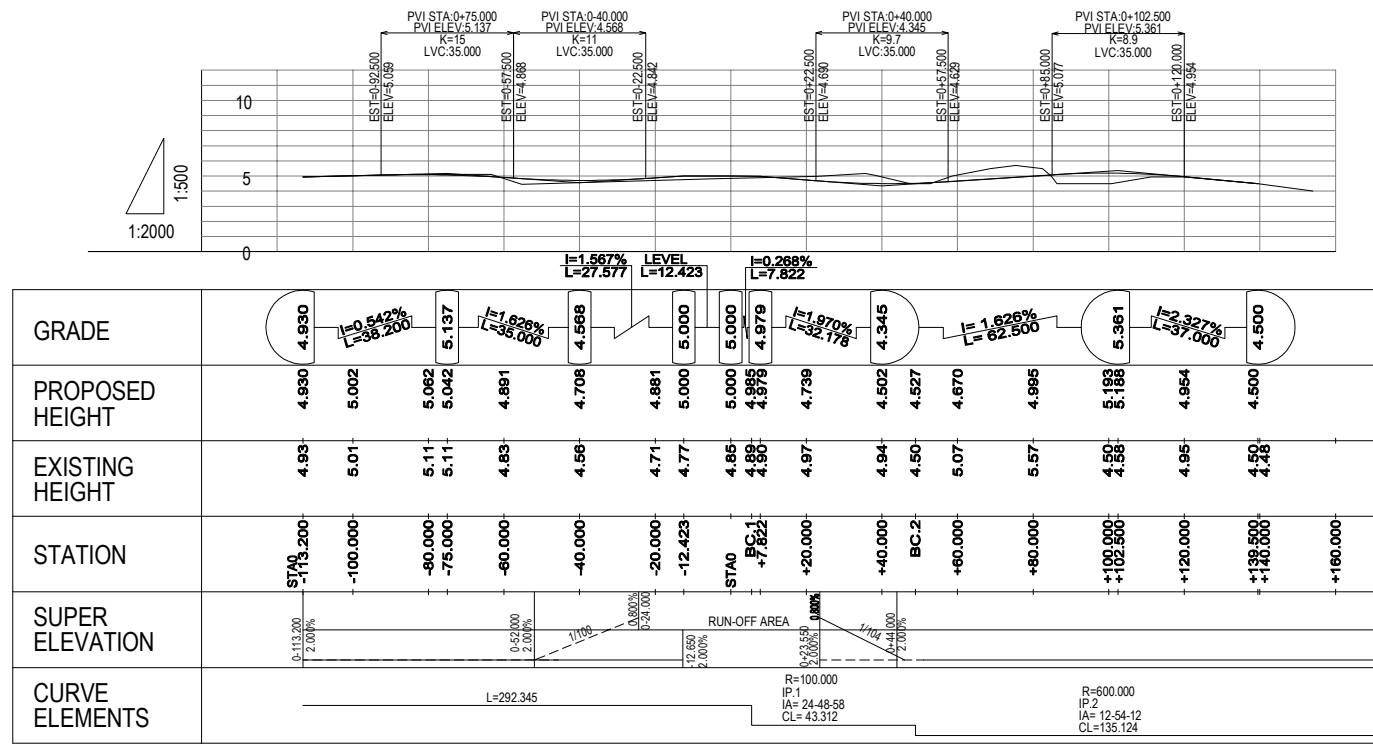

PROFILE OF SUBROAD
SCALE-1:2000,V-1:500

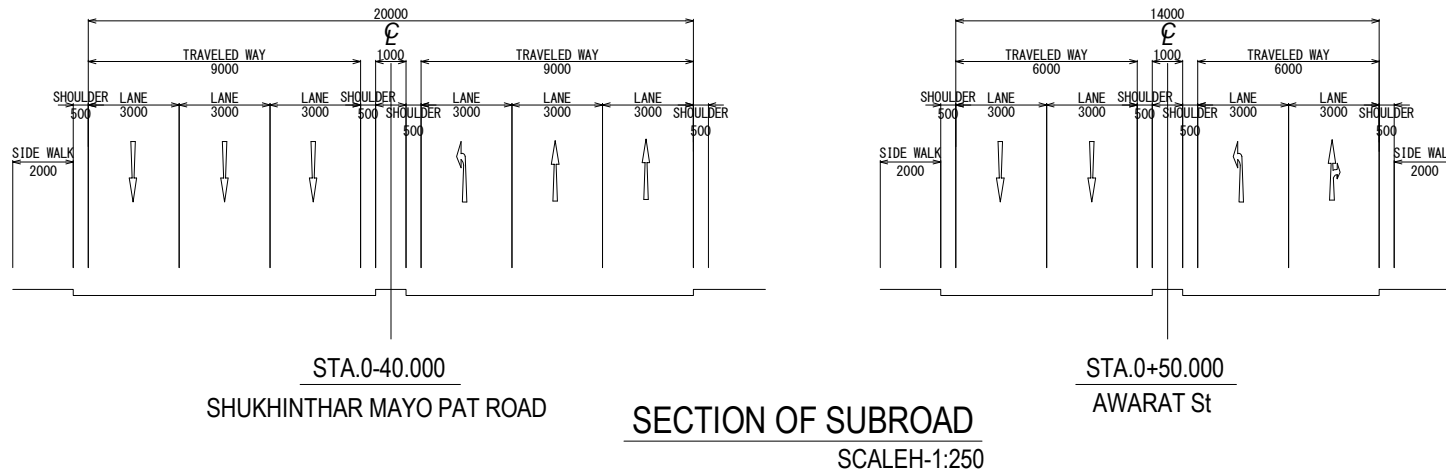

SHUKHINTHAR MAYO PAT ROAD	STA	NAWARAT St	EASTING	NORTHING	ELEMENT	DIRECTION	BR	P	ER	L
BP	0+286.8224		204092.659200	1859373.180867	S	L				292.345
BC.1	0+5.5228		204286.365525	1859592.141060	R	L	100.000			43.312
BC.2	0+48.8349		204307.258946	1859629.694478	R	L	600.000			135.124
EP	0+183.9593		204331.207129	1859762.389763	E					

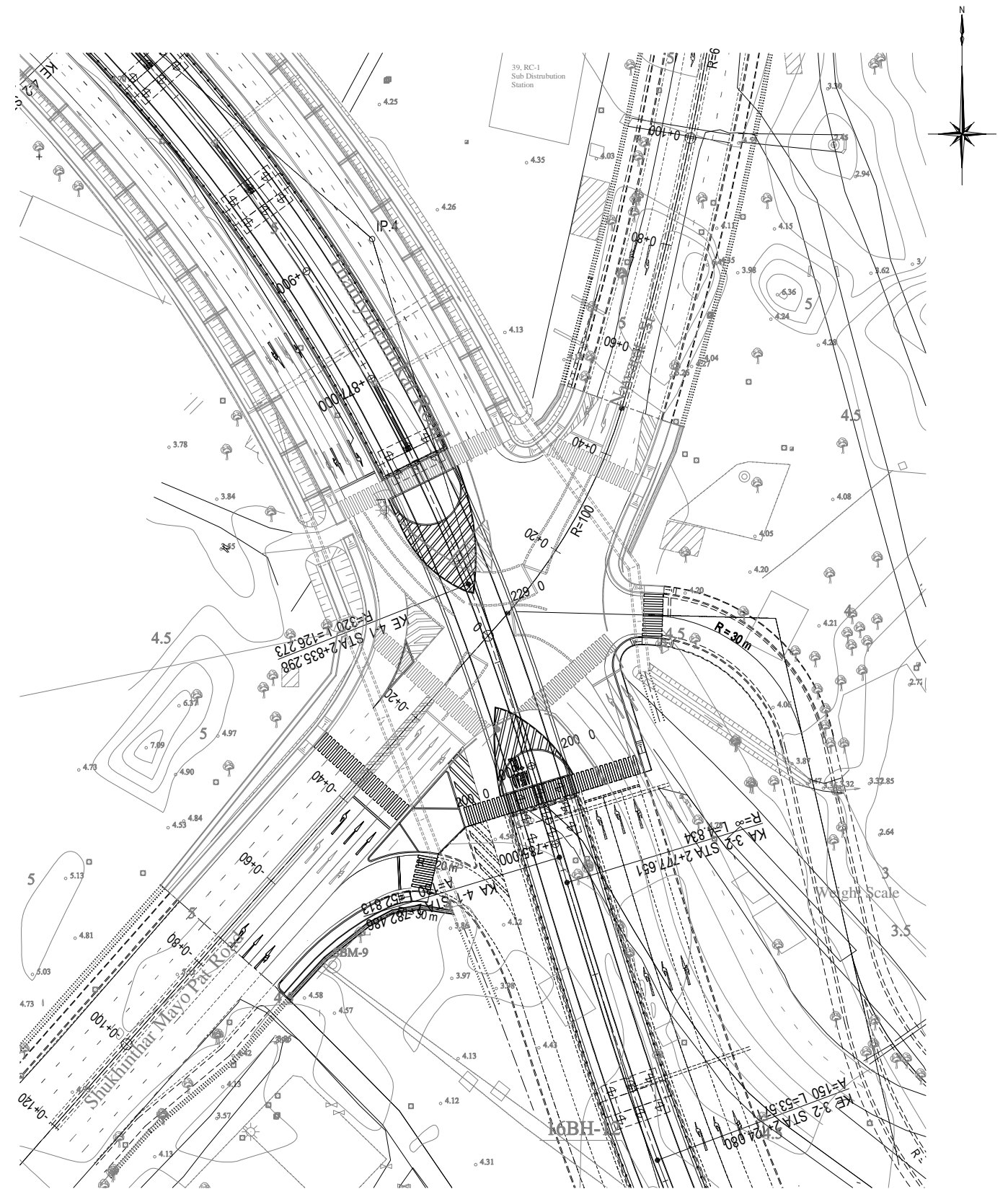

INTERSECTION PLAN
SCALE-1:1000

PROJECT NAME DETAILED DESIGN ON BAGO RIVER BRIDGE CONSTRUCTION PROJECT	FINANCED BY JAPAN INTERNATIONAL COOPERATION AGENCY	COUNTERPART REPUBLIC OF THE UNION OF MYANMAR MINISTRY OF CONSTRUCTION DEPARTMENT OF BRIDGE	JICA STUDY TEAM NIPPON KOEI CO., LTD. ORIENTAL CONSULTANTS GLOBAL CO., LTD. METROPOLITAN EXPRESSWAY COMPANY LIMITED CHODAI CO., LTD. NIPPON ENGINEERING CONSULTANTS CO., LTD.	NAME	SIGNATURE	DATE	DRAWING TITLE INTERSECTION PLAN, PROFILE AND SECTION (SHUKHINTHAR INTERSECTION STA.2+830)	PACKAGE 3 DWG No. P3-RD-2000	
				PREPARED BY	K. TACHIBANA				29 Sep.2017
				CHECKED BY	T. HAYAKAWA				3 Oct.2017
				APPROVED BY	Y. SANO				6 Oct.2017

INTERSECTION PLAN, PROFILE AND SECTION (YADANAR INTERSECTION STA.3+160)

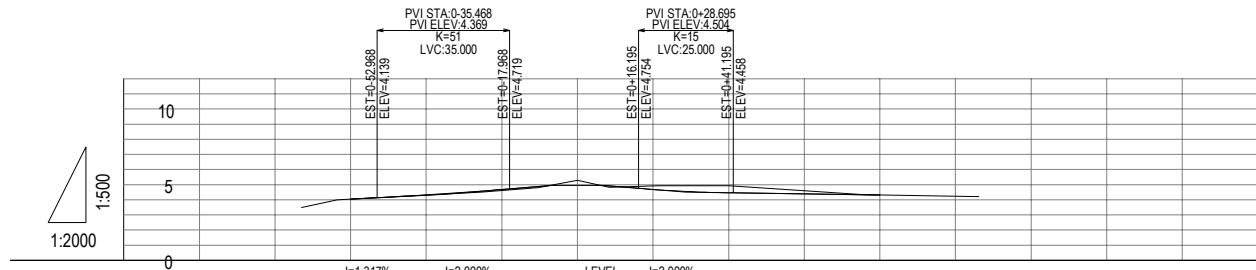

GRADE		4.046	4.326	4.369	4.679	4.941	4.941	4.683	4.555	4.464	4.389	4.315				
PROPOSED HEIGHT		4.046	4.326	4.369	4.679	4.941	4.941	4.683	4.555	4.464	4.389	4.315				
EXISTING HEIGHT		3.62	4.05	4.31	4.37	4.81	4.96	4.91	4.92	4.89	4.60	4.31	4.24			
STATION	BP	-80.000	-60.000	-40.000	-35.468	-20.000	-8.875	EC.1	STA.0	+20.000	+28.695	+40.000	+60.000	+80.000	+100.000	EP
SUPER ELEVATION			0-60.000 2.00%	0-60.000 2.00%	0-60.000 2.00%	0-60.000 2.00%	0-60.000 2.00%	0-60.000 2.00%	0-60.000 2.00%	0-60.000 2.00%	0-60.000 2.00%	0-60.000 2.00%	0-60.000 2.00%	0-60.000 2.00%	0-60.000 2.00%	0-60.000 2.00%
CURVE ELEMENTS			L=23.316	R=150.000 IP.1 HW=2.133 CL=70.754												L=111.190

PROFILE OF SUBROAD
SCALEH-1:2000,V-1:500

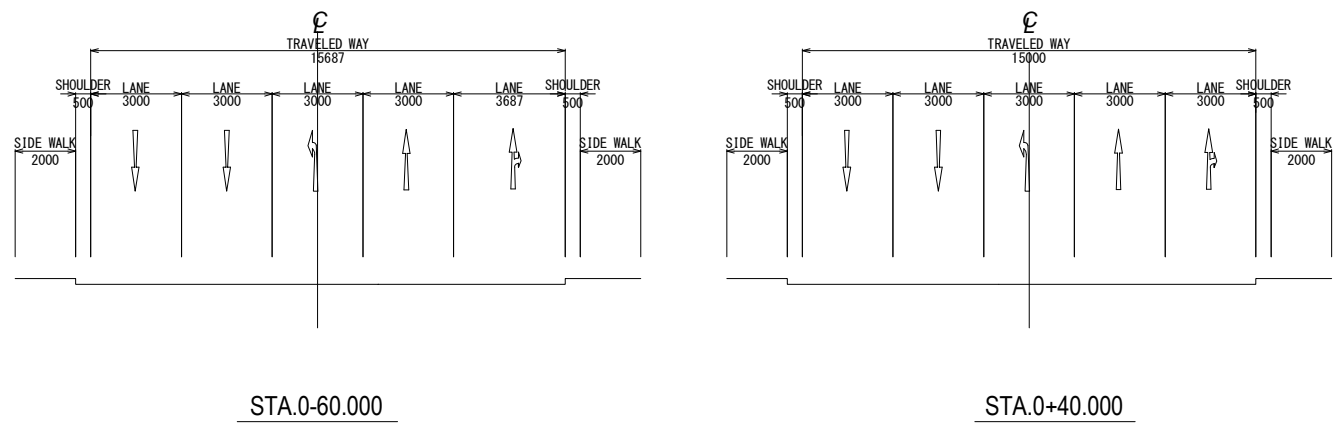

SECTION OF SUBROAD
SCALEH-1:250

YADANAR ROAD									
	STA	EASTING	NORTHING	ELEMENT	DIRECTION	BR	P	ER	L
BP	0-95.8649	204021.251900	1859748.460679	S	L				23.316
BC.1	0-72.5487	204027.875452	1859770.816336	R	R	150.000			70.754
EC.1	0-1.7949	204062.942775	1859831.514307	S	L				111.190
EP	0+109.3947	204139.522025	1859912.129132	E					

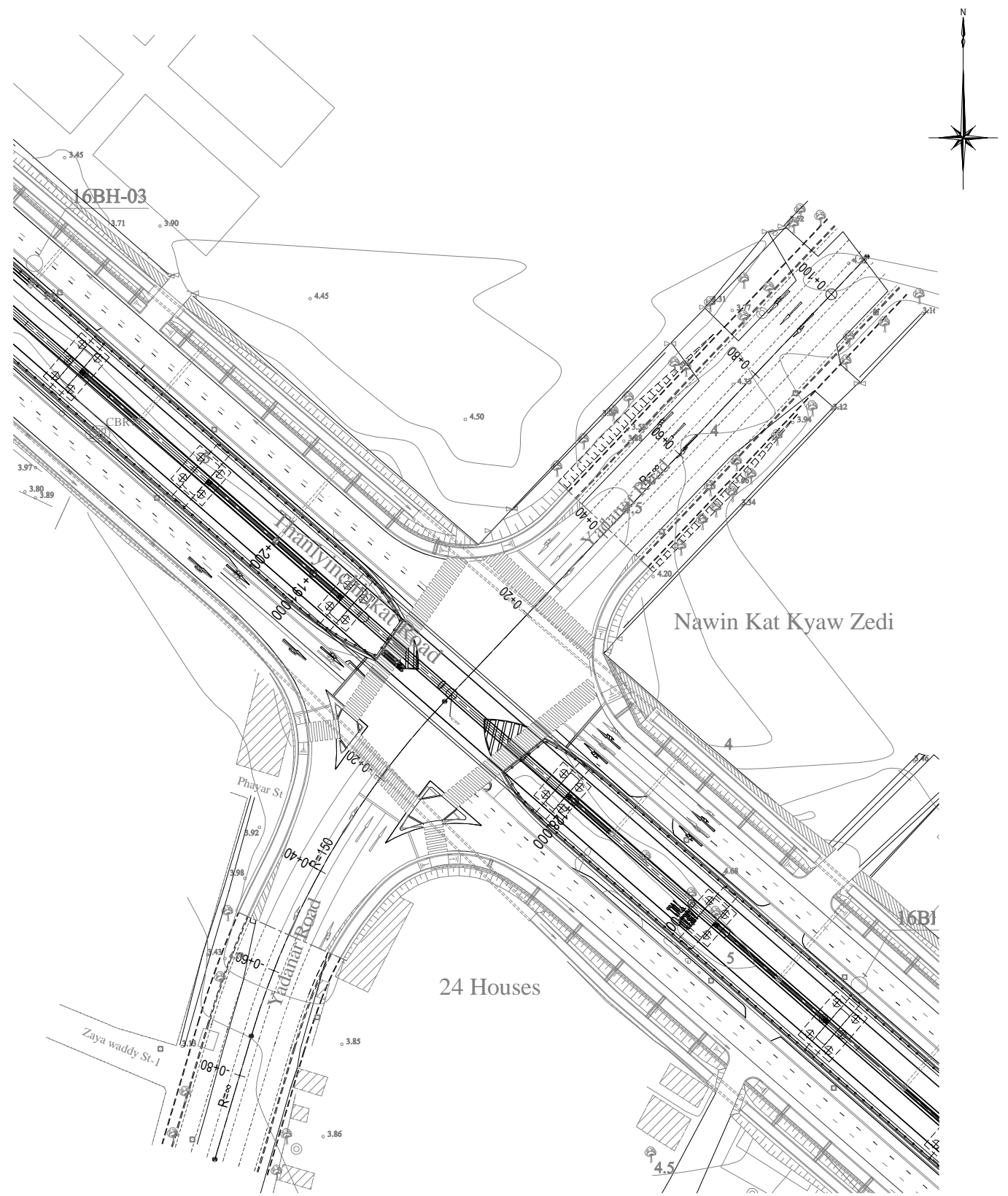

INTERSECTION PLAN
SCALEH-1:1000

DRAINAGE SYSTEM PLAN AND OUTLETS (RIGHT RIVER BANK)

S= 1:5000

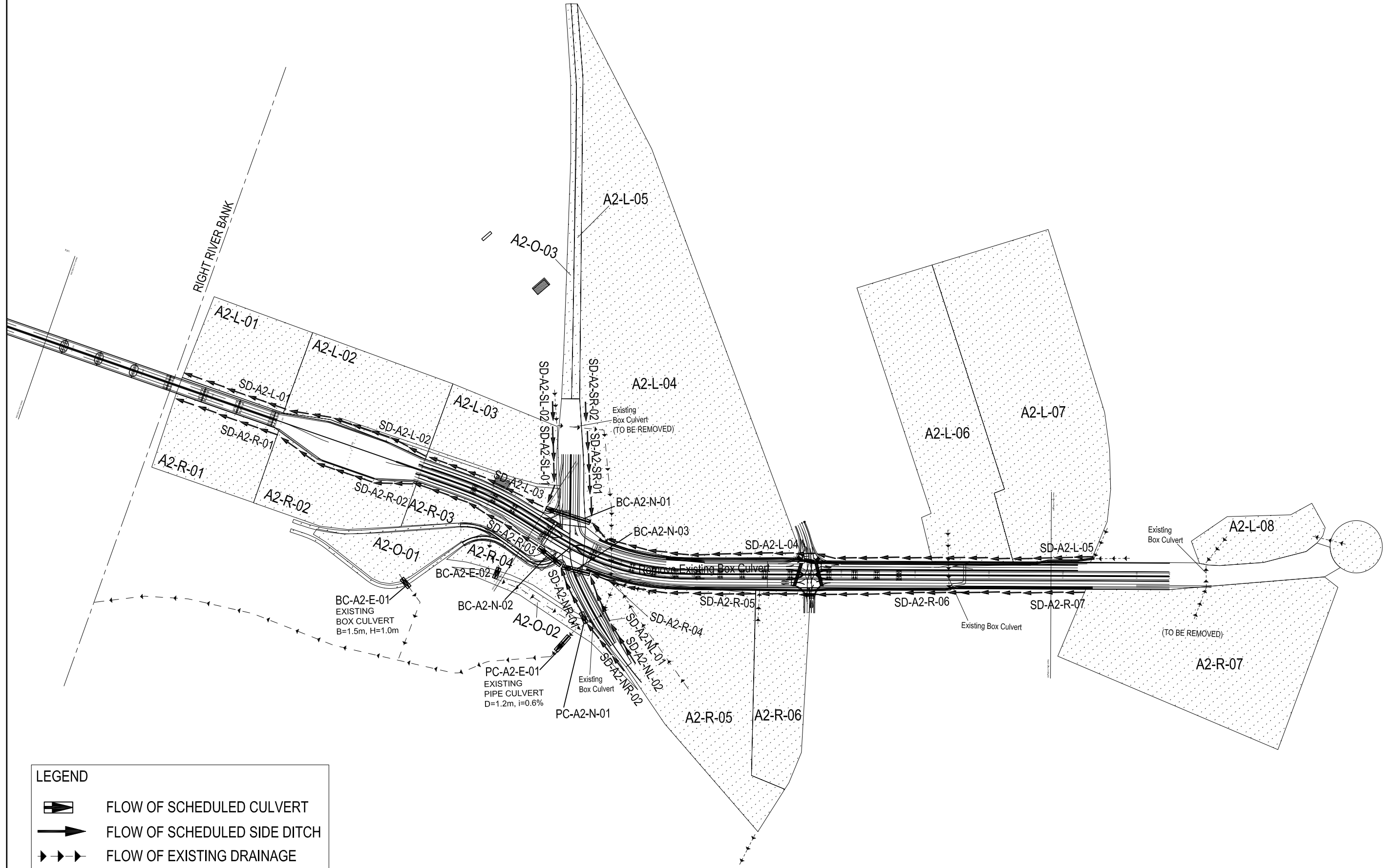

LEGEND

- FLOW OF SCHEDULED CULVERT
- FLOW OF SCHEDULED SIDE DITCH
- FLOW OF EXISTING DRAINAGE
- CATCHMENT AREA

PROJECT NAME DETAILED DESIGN ON BAGO RIVER BRIDGE CONSTRUCTION PROJECT	FINANCED BY JAPAN INTERNATIONAL COOPERATION AGENCY	COUNTERPART REPUBLIC OF THE UNION OF MYANMAR MINISTRY OF CONSTRUCTION DEPARTMENT OF BRIDGE	JICA STUDY TEAM NIPPON KOEI CO., LTD. ORIENTAL CONSULTANTS GLOBAL CO., LTD. METROPOLITAN EXPRESSWAY COMPANY LIMITED CHODAI CO., LTD. NIPPON ENGINEERING CONSULTANTS CO., LTD.	NAME	SIGNATURE	DATE	DRAWING TITLE	PACKAGE			
				PREPARED BY	K. TACHIBANA				29 Sep. 2017	DRAINAGE SYSTEM PLAN AND OUTLETS(RIGHT RIVER BANK)	3
				CHECKED BY	T. HAYAKAWA				3 Oct. 2017		DWG No.
				APPROVED BY	Y. SANO				6 Oct. 2017		P3-RD-3000

DRAINAGE SYSTEM PLAN(1) H= 1:1000

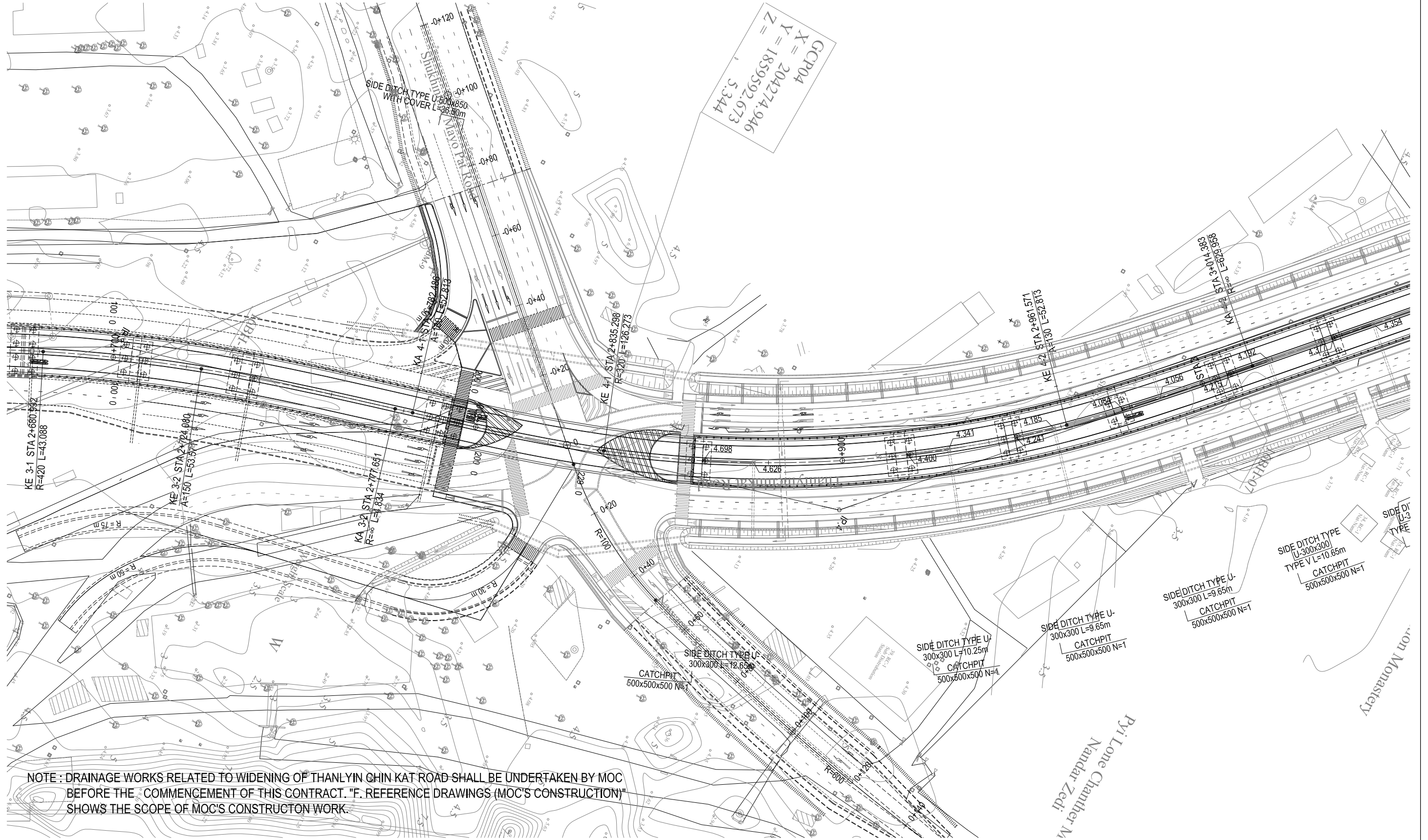

NOTE : DRAINAGE WORKS RELATED TO WIDENING OF THANLYIN CHIN KAT ROAD SHALL BE UNDERTAKEN BY MOC BEFORE THE COMMENCEMENT OF THIS CONTRACT. "F. REFERENCE DRAWINGS (MOC'S CONSTRUCTION)" SHOWS THE SCOPE OF MOC'S CONSTRUCTION WORK.

PROJECT NAME DETAILED DESIGN ON BAGO RIVER BRIDGE CONSTRUCTION PROJECT	FINANCED BY JAPAN INTERNATIONAL COOPERATION AGENCY	COUNTERPART REPUBLIC OF THE UNION OF MYANMAR MINISTRY OF CONSTRUCTION DEPARTMENT OF BRIDGE	JICA STUDY TEAM NIPPON KOEI CO., LTD. ORIENTAL CONSULTANTS GLOBAL CO., LTD. METROPOLITAN EXPRESSWAY COMPANY LIMITED CHODAI CO., LTD. NIPPON ENGINEERING CONSULTANTS CO., LTD.	<table border="1"> <thead> <tr> <th>NAME</th> <th>SIGNATURE</th> <th>DATE</th> </tr> </thead> <tbody> <tr> <td>PREPARED BY K. TACHIBANA</td> <td></td> <td>29 Sep. 2017</td> </tr> <tr> <td>CHECKED BY T. HAYAKAWA</td> <td></td> <td>3 Oct. 2017</td> </tr> <tr> <td>APPROVED BY Y. SANO</td> <td></td> <td>6 Oct. 2017</td> </tr> </tbody> </table>	NAME	SIGNATURE	DATE	PREPARED BY K. TACHIBANA		29 Sep. 2017	CHECKED BY T. HAYAKAWA		3 Oct. 2017	APPROVED BY Y. SANO		6 Oct. 2017	DRAWING TITLE DRAINAGE SYSTEM PLAN(1) S=1:1000	PACKAGE 3 DWG No. P3-RD-3010
NAME	SIGNATURE	DATE																
PREPARED BY K. TACHIBANA		29 Sep. 2017																
CHECKED BY T. HAYAKAWA		3 Oct. 2017																
APPROVED BY Y. SANO		6 Oct. 2017																

DRAINAGE SYSTEM PLAN(2) H= 1:1000

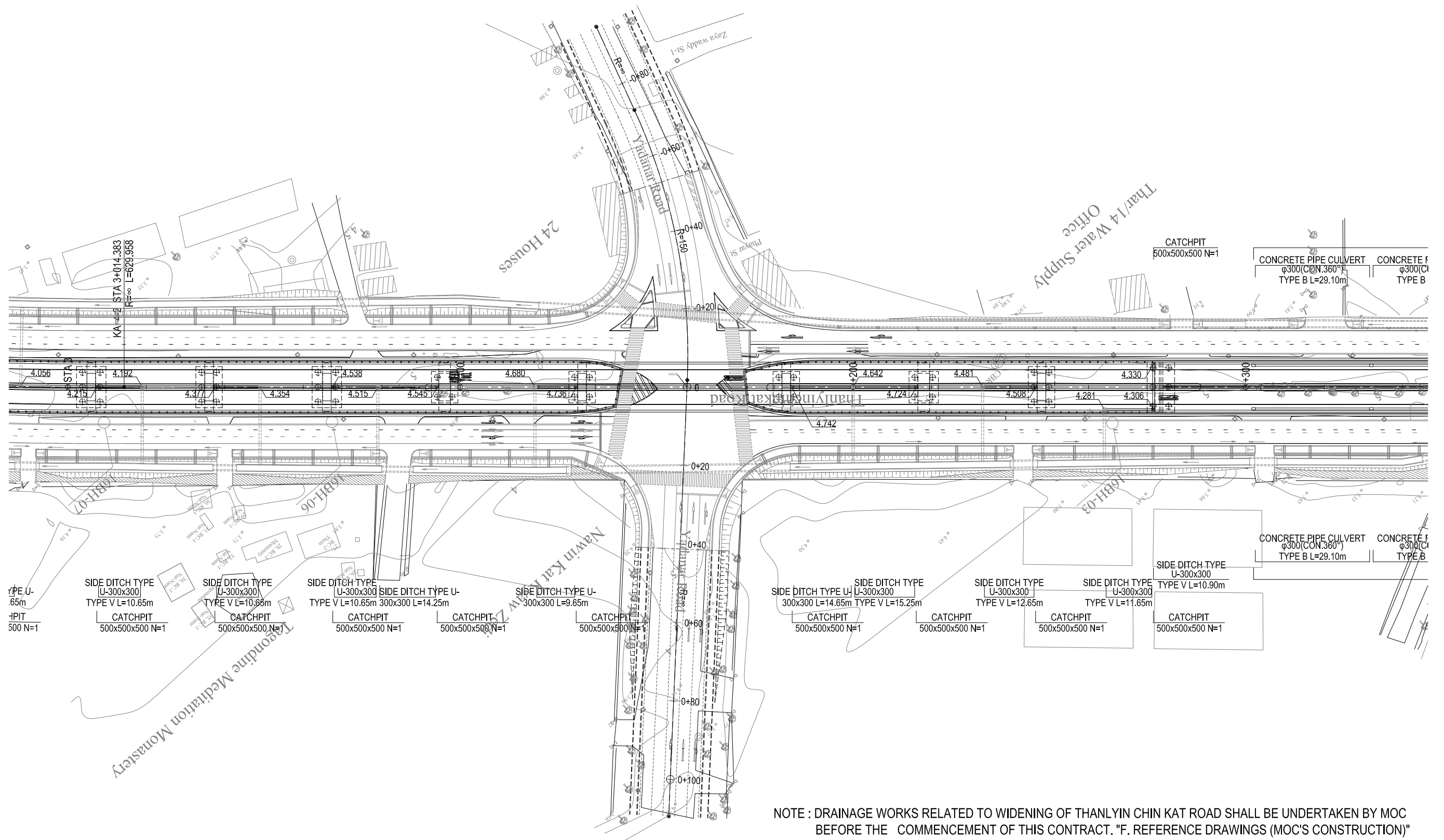

NOTE : DRAINAGE WORKS RELATED TO WIDENING OF THANLYIN CHIN KAT ROAD SHALL BE UNDERTAKEN BY MOC BEFORE THE COMMENCEMENT OF THIS CONTRACT. "F. REFERENCE DRAWINGS (MOC'S CONSTRUCTION)" SHOWS THE SCOPE OF MOC'S CONSTRUCTION WORK.

<small>PROJECT NAME</small> DETAILED DESIGN ON BAGO RIVER BRIDGE CONSTRUCTION PROJECT	<small>FINANCED BY</small> JAPAN INTERNATIONAL COOPERATION AGENCY	<small>COUNTERPART</small> REPUBLIC OF THE UNION OF MYANMAR MINISTRY OF CONSTRUCTION DEPARTMENT OF BRIDGE	<small>JICA STUDY TEAM</small> NIPPON KOEI CO., LTD. ORIENTAL CONSULTANTS GLOBAL CO., LTD. METROPOLITAN EXPRESSWAY COMPANY LIMITED CHODAI CO., LTD. NIPPON ENGINEERING CONSULTANTS CO., LTD.	<table border="1" style="width: 100%; border-collapse: collapse;"> <thead> <tr> <th style="text-align: left;">NAME</th> <th style="text-align: left;">SIGNATURE</th> <th style="text-align: left;">DATE</th> </tr> </thead> <tbody> <tr> <td>PREPARED BY K. TACHIBANA</td> <td></td> <td>29 Sep. 2017</td> </tr> <tr> <td>CHECKED BY T. HAYAKAWA</td> <td></td> <td>3 Oct. 2017</td> </tr> <tr> <td>APPROVED BY Y. SANO</td> <td></td> <td>6 Oct. 2017</td> </tr> </tbody> </table>	NAME	SIGNATURE	DATE	PREPARED BY K. TACHIBANA		29 Sep. 2017	CHECKED BY T. HAYAKAWA		3 Oct. 2017	APPROVED BY Y. SANO		6 Oct. 2017	<small>DRAWING TITLE</small> DRAINAGE SYSTEM PLAN(2) S=1:1000	<small>PACKAGE</small> 3 <small>DWG No.</small> P3-RD-3020
NAME	SIGNATURE	DATE																
PREPARED BY K. TACHIBANA		29 Sep. 2017																
CHECKED BY T. HAYAKAWA		3 Oct. 2017																
APPROVED BY Y. SANO		6 Oct. 2017																

DRAINAGE SYSTEM PLAN(3) H= 1:1000

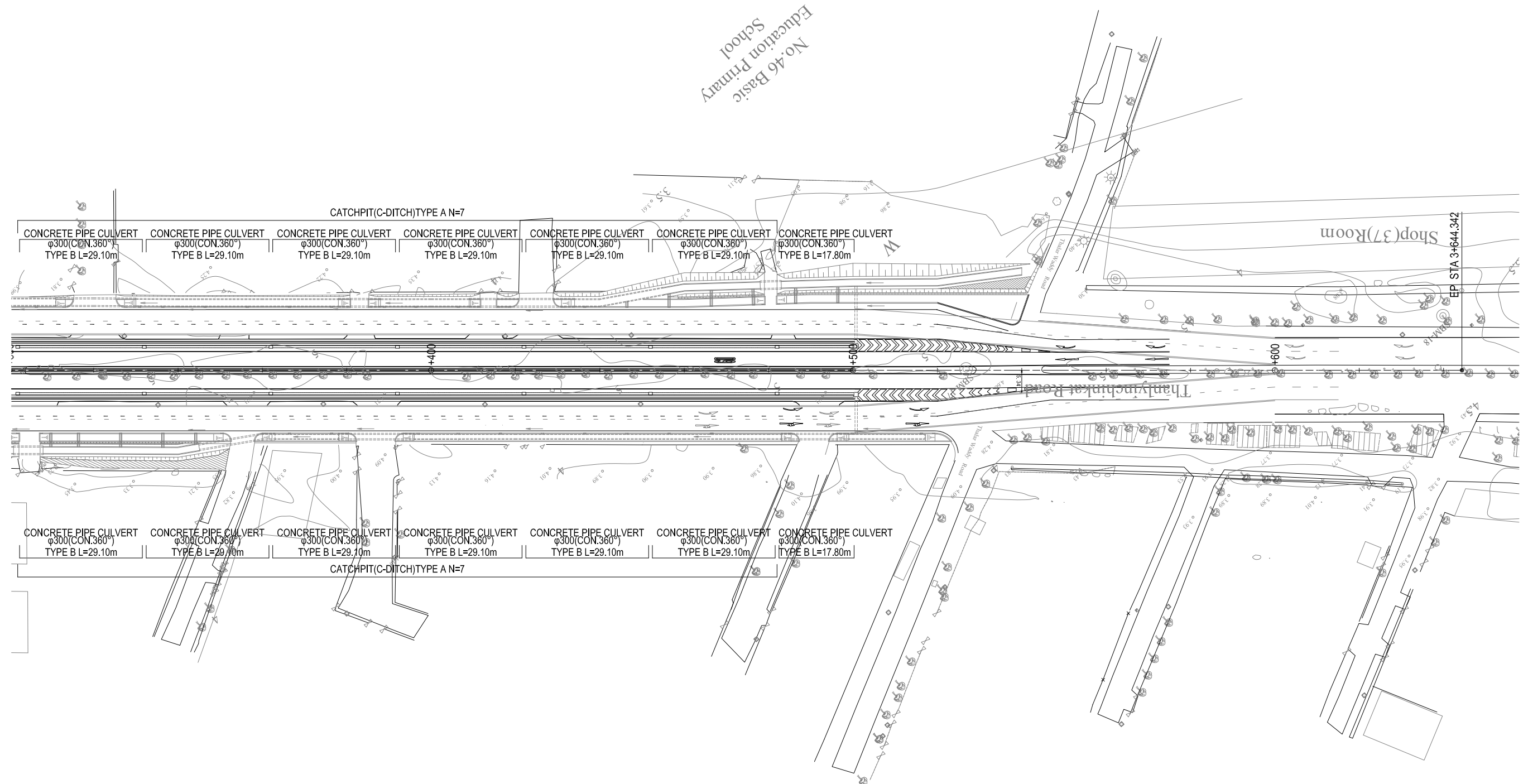

NOTE : DRAINAGE WORKS RELATED TO WIDENING OF THANLYIN CHIN KAT ROAD SHALL BE UNDERTAKEN BY MOC BEFORE THE COMMENCEMENT OF THIS CONTRACT. "F. REFERENCE DRAWINGS (MOC'S CONSTRUCTION)" SHOWS THE SCOPE OF MOC'S CONSTRUCTION WORK.

<small>PROJECT NAME</small> DETAILED DESIGN ON BAGO RIVER BRIDGE CONSTRUCTION PROJECT	<small>FINANCED BY</small> JAPAN INTERNATIONAL COOPERATION AGENCY	<small>COUNTERPART</small> REPUBLIC OF THE UNION OF MYANMAR MINISTRY OF CONSTRUCTION DEPARTMENT OF BRIDGE	<small>JICA STUDY TEAM</small> NIPPON KOEI CO., LTD. ORIENTAL CONSULTANTS GLOBAL CO., LTD. METROPOLITAN EXPRESSWAY COMPANY LIMITED CHODAI CO., LTD. NIPPON ENGINEERING CONSULTANTS CO.,LTD.	<table border="1" style="width: 100%; border-collapse: collapse;"> <tr> <th style="text-align: left;">NAME</th> <th style="text-align: left;">SIGNATURE</th> <th style="text-align: left;">DATE</th> </tr> <tr> <td>PREPARED BY K. TACHIBANA</td> <td></td> <td>29 Sep. 2017</td> </tr> <tr> <td>CHECKED BY T. HAYAKAWA</td> <td></td> <td>3 Oct. 2017</td> </tr> <tr> <td>APPROVED BY Y. SANO</td> <td></td> <td>6 Oct. 2017</td> </tr> </table>	NAME	SIGNATURE	DATE	PREPARED BY K. TACHIBANA		29 Sep. 2017	CHECKED BY T. HAYAKAWA		3 Oct. 2017	APPROVED BY Y. SANO		6 Oct. 2017	<small>DRAWING TITLE</small> DRAINAGE SYSTEM PLAN(3) S=1:1000	<small>PACKAGE</small> 3 DWG No. P3-RD-3030
NAME	SIGNATURE	DATE																
PREPARED BY K. TACHIBANA		29 Sep. 2017																
CHECKED BY T. HAYAKAWA		3 Oct. 2017																
APPROVED BY Y. SANO		6 Oct. 2017																

DETAIL OF CONCRETE PIPE CULVERT $\Phi 300$ (CON.360°) TYPE B S= 1:15

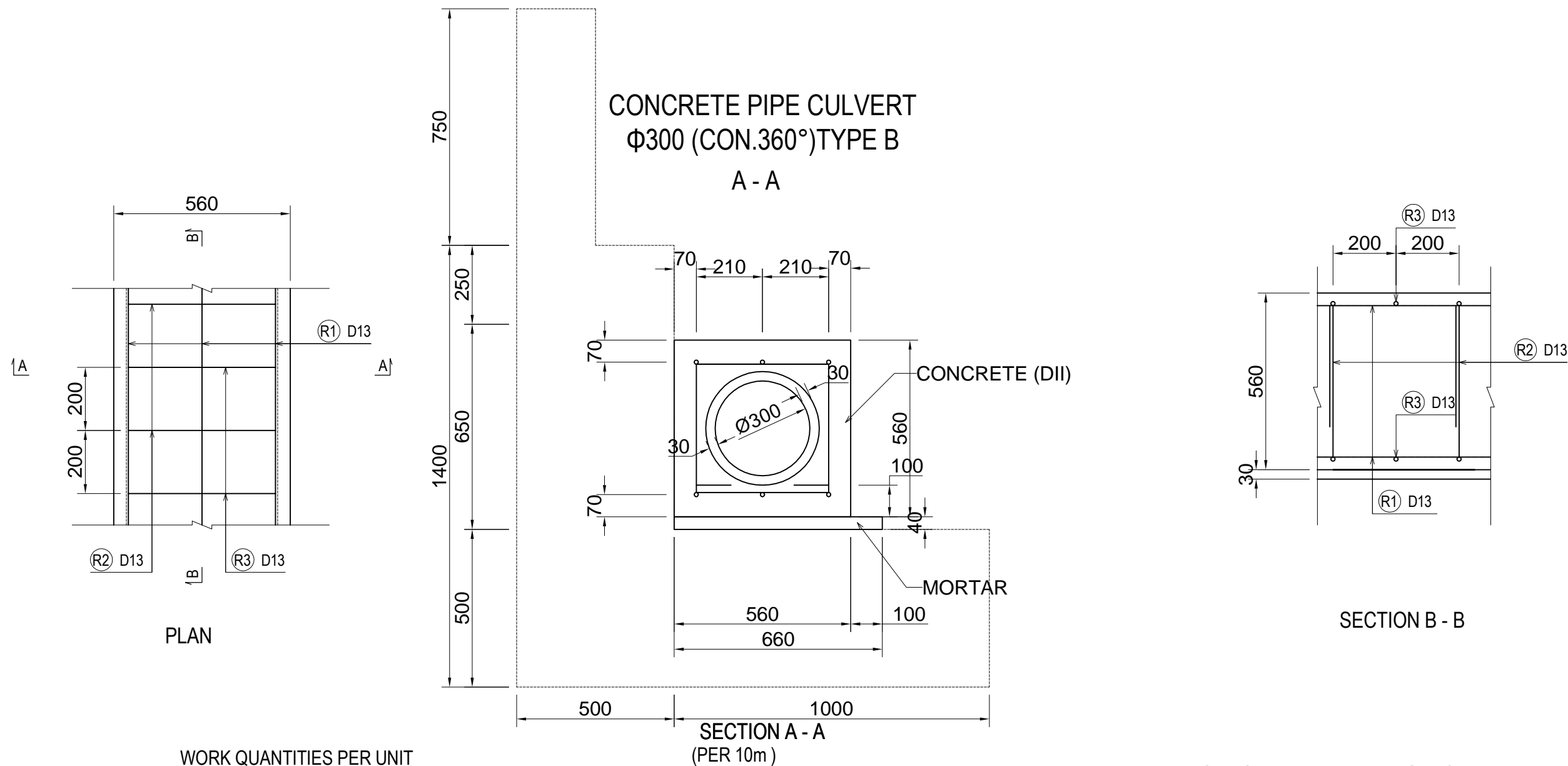

WORK QUANTITIES PER UNIT (PER 10m)

ITEM	UNIT	QUANTITY	REMARKS
R.C.PIPE $\Phi 300$	m	10.000	JIS A 5303 CLASS 1
CONCRETE (DII)	m ³	2.118	28 days = 240 kg/cm ²
MORTAR	m ²	0.264	
FORM	m ²	11.200	

WORK QUANTITIES PER UNIT FOR REINFORCEMENT BAR (PER 1.0m)

Dia	Nos	Length (mm/nos)	Unit Weight (kg/m)	Weight (kg)	Remarks
D13	6	1,000	0.995	5.970	(R1) / SD345
D13	5	420	0.995	2.090	(R2) / SD345
D13	5	1,310	0.995	6.517	(R3) / SD345
TOTAL				14.557	

DETAIL OF STEEL REINFORCEMENT

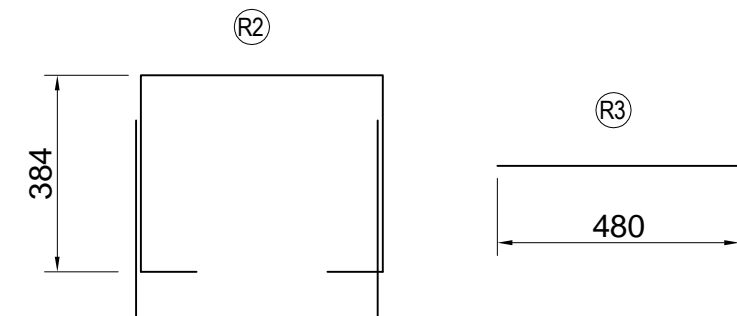

Note: Precast R.C. Pipe $\Phi 300$, Reinforced Spun and Centrifugal Reinforced Concrete Pipes shall be Selected.

PROJECT NAME DETAILED DESIGN ON BAGO RIVER BRIDGE CONSTRUCTION PROJECT	FINANCED BY JAPAN INTERNATIONAL COOPERATION AGENCY	COUNTERPART REPUBLIC OF THE UNION OF MYANMAR MINISTRY OF CONSTRUCTION DEPARTMENT OF BRIDGE	JICA STUDY TEAM NIPPON KOEI CO., LTD. ORIENTAL CONSULTANTS GLOBAL CO., LTD. METROPOLITAN EXPRESSWAY COMPANY LIMITED CHODAI CO. LTD. NIPPON ENGINEERING CONSULTANTS CO., LTD.	NAME PREPARED BY K. TACHIBANA CHECKED BY T. HAYAKAWA APPROVED BY Y. SANO	SIGNATURE 	DATE 29 Sep.2017 3 Oct.2017 6 Oct.2017	DRAWING TITLE DETAIL OF CONCRETE PIPE CULVERT $\Phi 300$ (CON.360°) TYPE B S=1:15	PACKAGE 3 DWG No. P3-RD-3040
---	--	---	---	---	-----------------------	---	---	---------------------------------------

DETAIL OF CATCH PIT 500x500x500

S=1:20

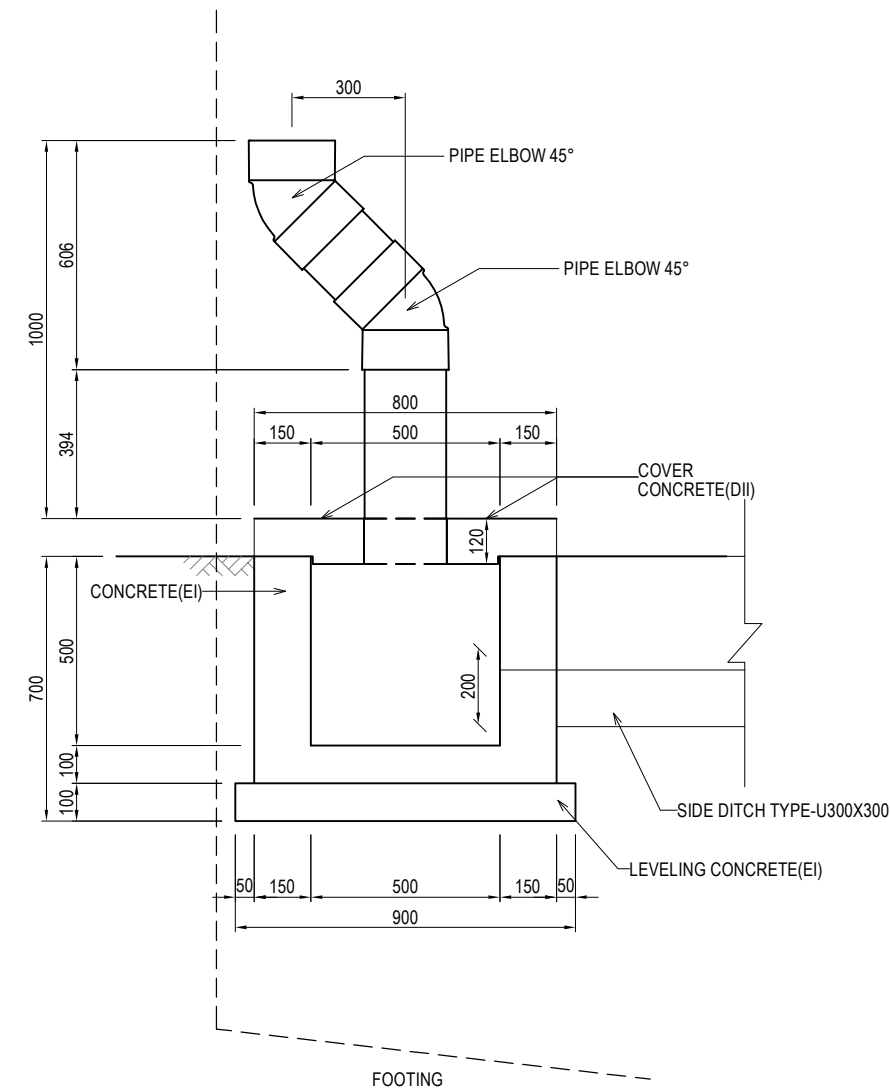
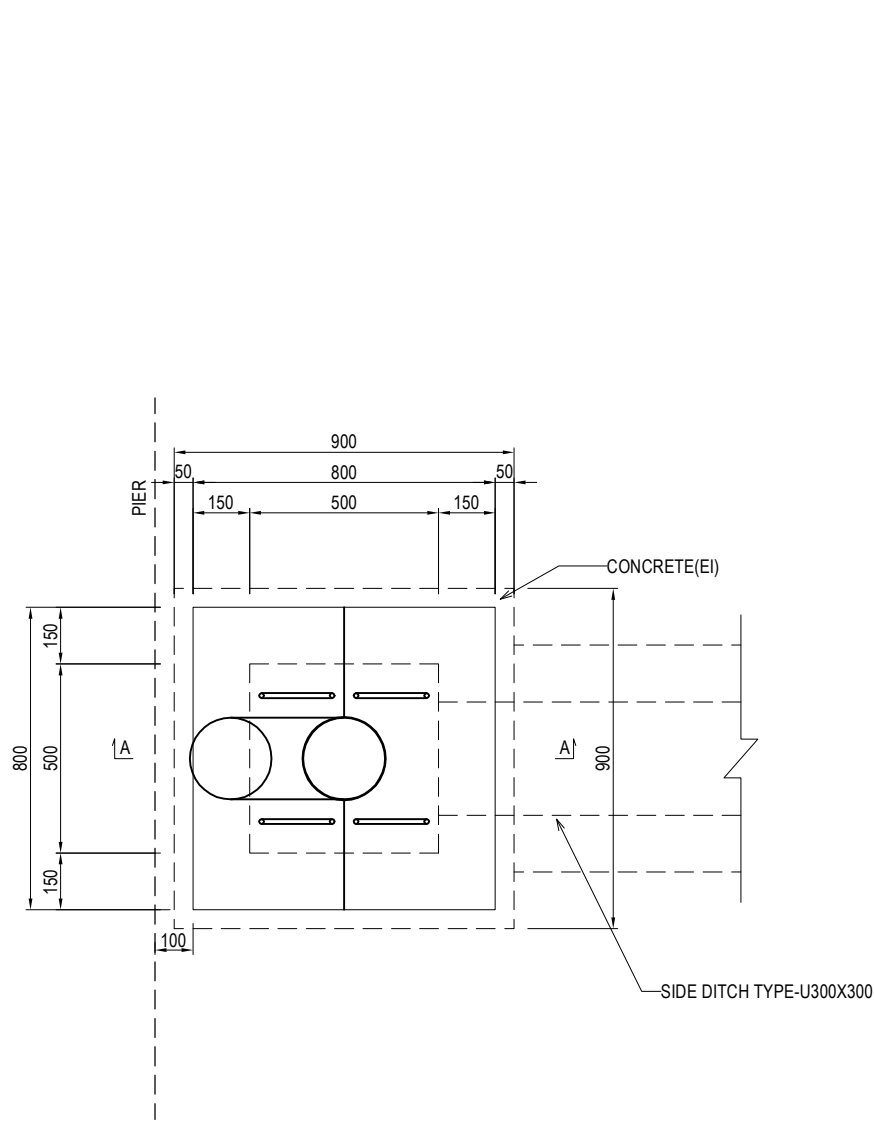

DETAIL OF HOOKS

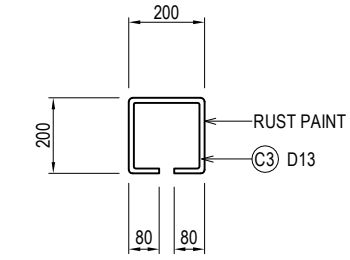

DETAIL OF COVER SECTION A - A

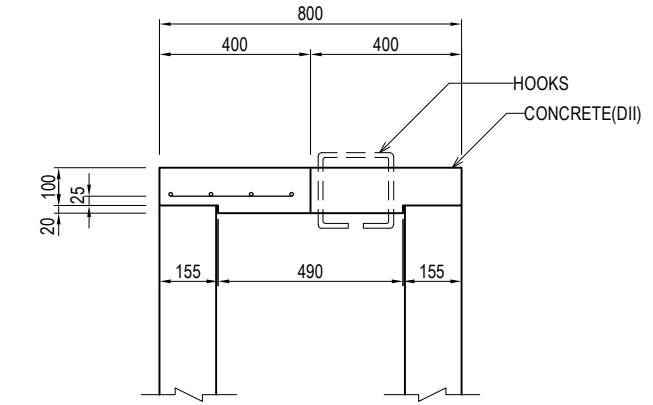

PLAN

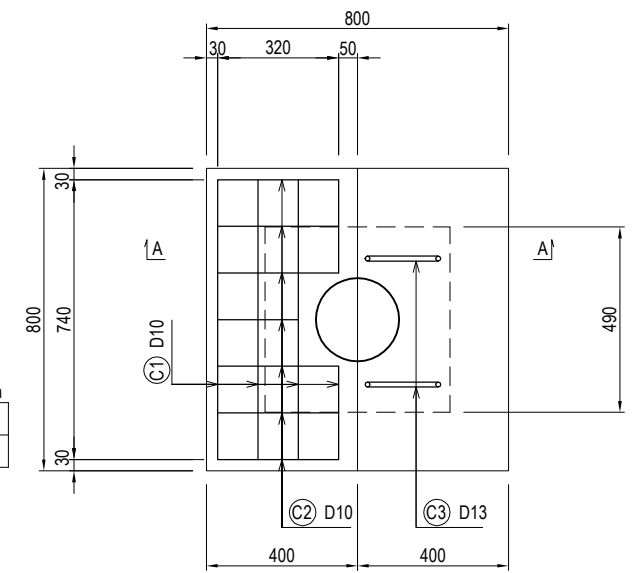

QUANTITY Per 10 each

Title	Specification	Quantity
Body		
Concrete	EI	2.46 m3
Form		32.35 m2
Leveling Concrete	t=100	8.10 m2
Cover		
Concrete	DII	0.64 m3
Reinforcing bar	D10	54.32 kg
	D13	31.68 kg
Form		6.35 m2
Pipe	VPφ200	9.00 m
Pipe Elbow	45°	20 each

BAR LIST Per 10 each		
C1	C2	C3
4-D10-740	7-D10-320	2-φ13-760

- Note
1. Specification of Plain Concrete should be CLASS EI
 2. Specification of Reinforced Concrete should be CLASS DII
 3. Specification of Steel reinforcement bar should be SD345

DETAIL OF CATCH PIT (C-DITCH) TYPE A S=1:20

Note
1. Specification of Plain Concrete should be CLASS EI

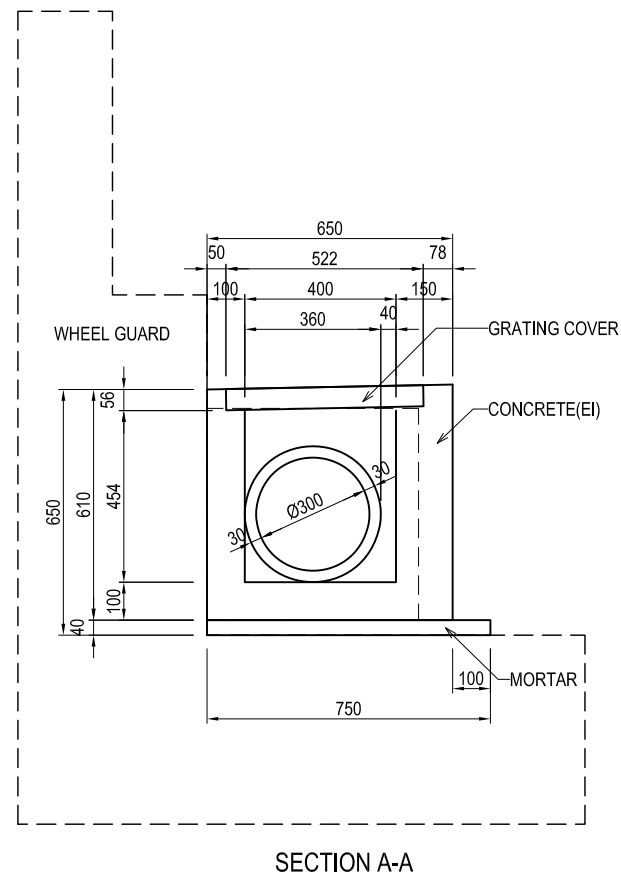
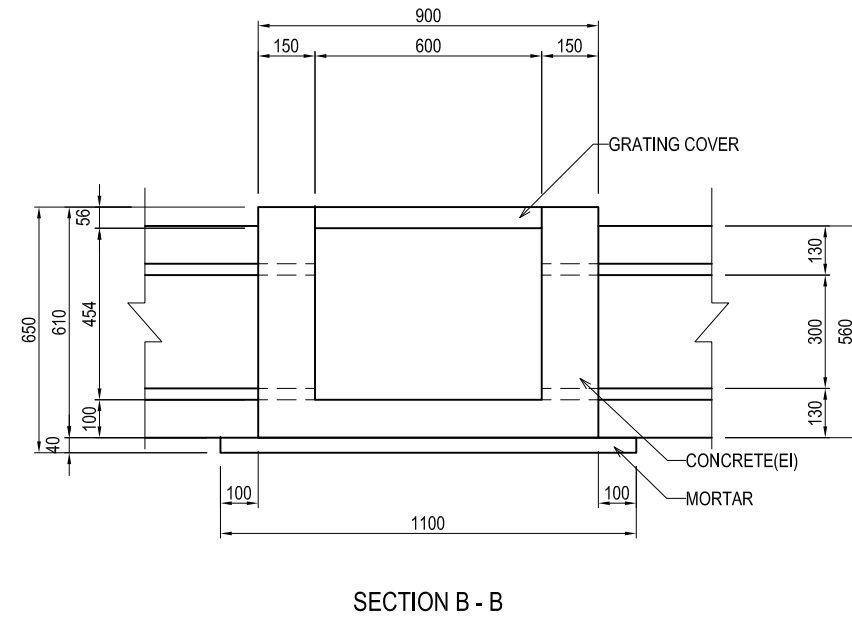
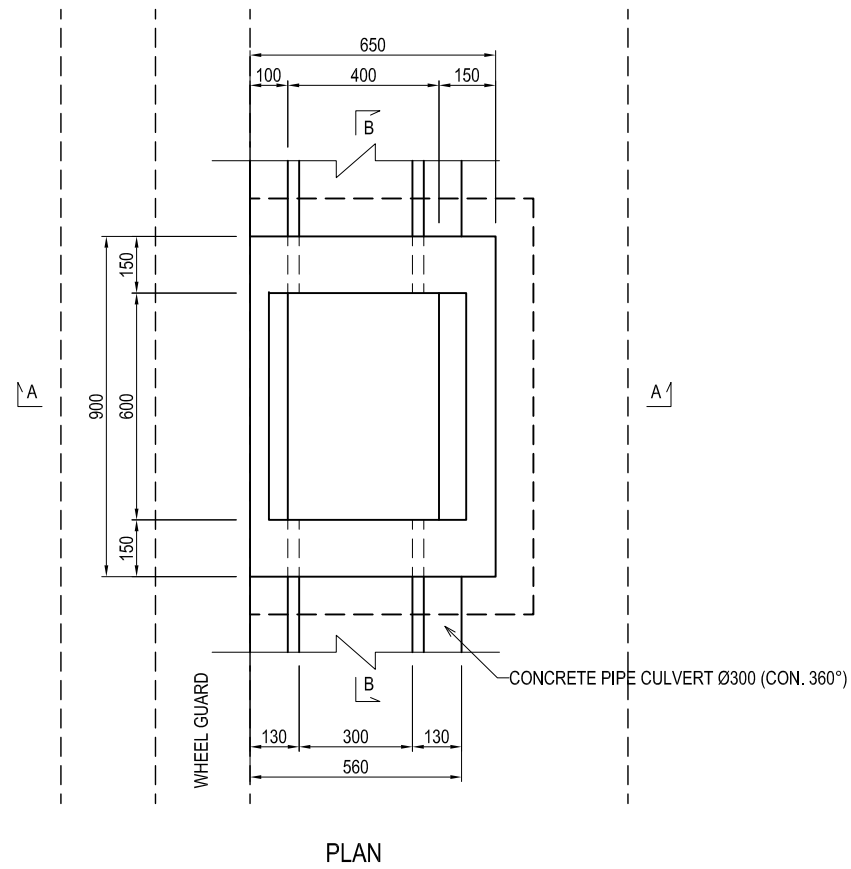

DETAIL OF GRATING COVER FOR CATCH PIT

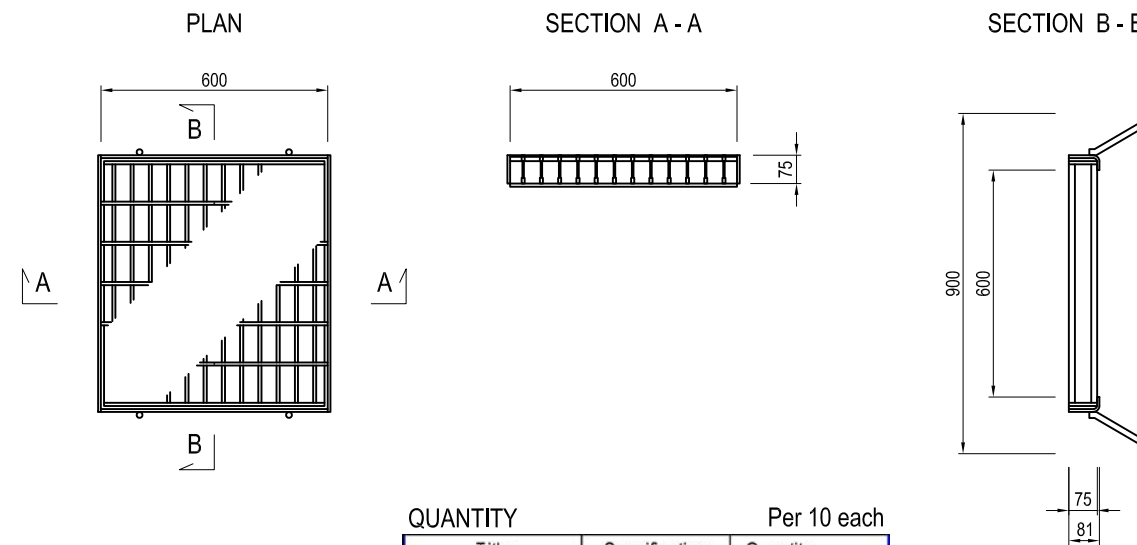

QUANTITY		Per 10 each	
Title	Specification	Quantity	
Body			
Concrete	EI	2.23	m ³
Form		31.83	m ²
Mortar	≒40	8.25	m ²
Cover			
Grating Cover	520x600	10	each

DETAIL OF SIDE DITCH (1)

S=1:50

NOTES:

1. Concrete Class DII (240 kg/cm²)
2. Steel Reinforcement SD345
3. Pit of Steel Reinforcement is 200mm

SIDE DITCH TYPE U-300×300

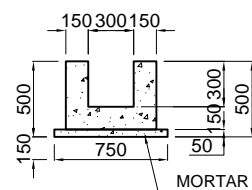

SIDE DITCH TYPE U-300×300 TYPE V

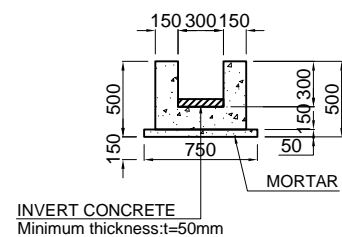

SIDE DITCH TYPE U-500×500

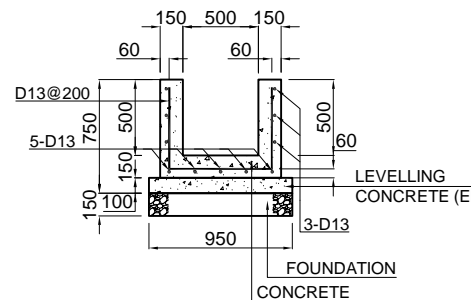

SIDE DITCH TYPE U-800×800

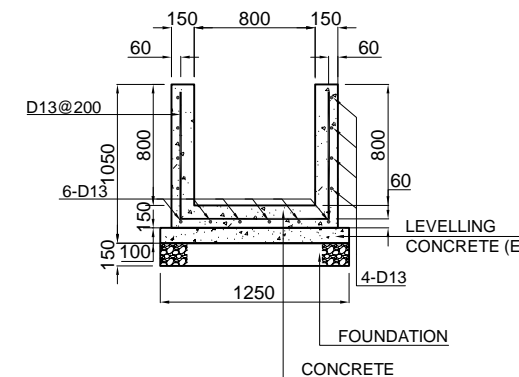

SIDE DITCH TYPE U-1000×1000

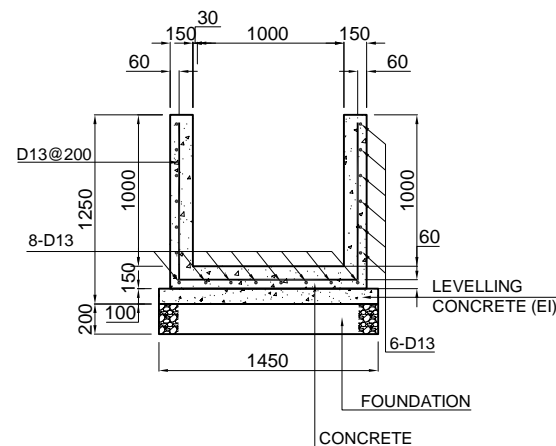

SIDE DITCH TYPE U-1500×1500

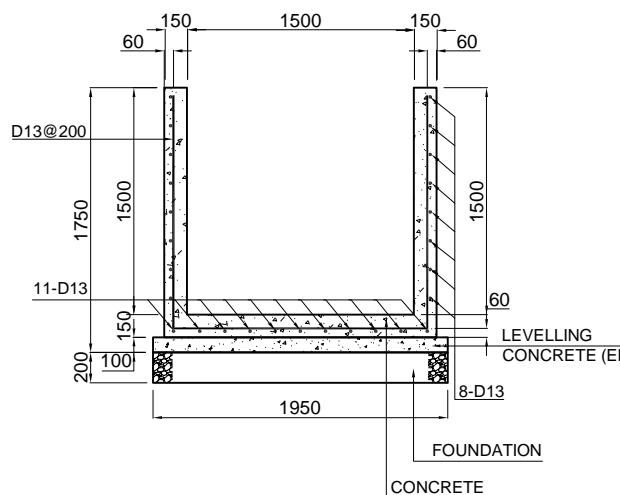

SIDE DITCH TYPE U-1500x1700

S=1:50

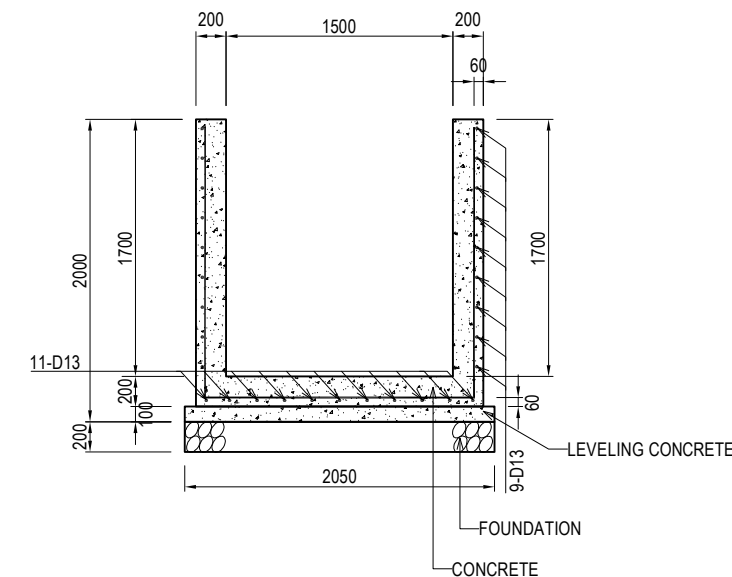

PROJECT NAME	FINANCED BY	COUNTERPART	JICA STUDY TEAM	NAME	SIGNATURE	DATE	DRAWING TITLE	PACKAGE
DETAILED DESIGN ON BAGO RIVER BRIDGE CONSTRUCTION PROJECT	JICA JAPAN INTERNATIONAL COOPERATION AGENCY	REPUBLIC OF THE UNION OF MYANMAR MINISTRY OF CONSTRUCTION DEPARTMENT OF BRIDGE	NIPPON KOEI CO., LTD. ORIENTAL CONSULTANTS GLOBAL CO., LTD. METROPOLITAN EXPRESSWAY COMPANY LIMITED CHODAI CO., LTD. NIPPON ENGINEERING CONSULTANTS CO., LTD.	K. TACHIBANA		29 Sep.2017	DETAIL OF SIDE DITCH (1) S=1:50	3
				T. HAYAKAWA		3 Oct.2017		DWG No.
				Y. SANO		6 Oct.2017		P3-RD-3070