

GENERAL PLAN OF MECHANICALLY-STABILISED EARTH WALL(1)

LEFT SIDE (DEVELOP FROM BACK SIDE) S=1:800

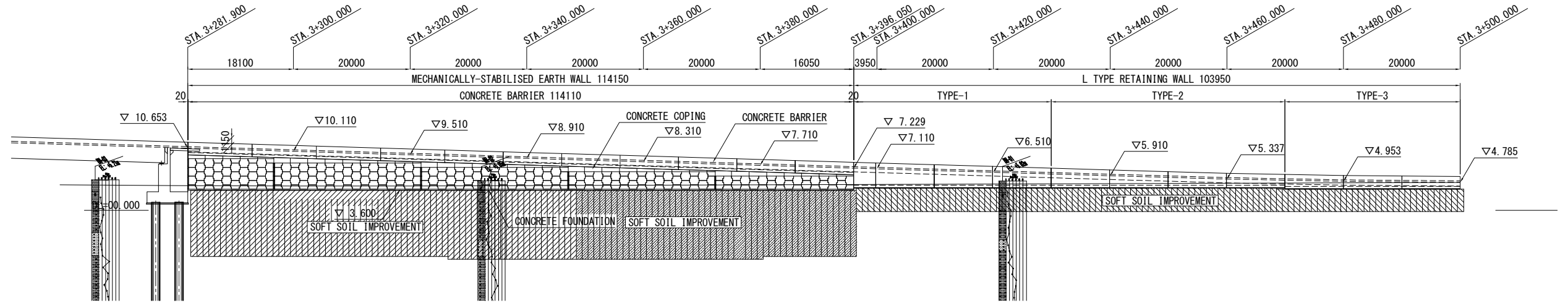

RIGHT SIDE S=1:800

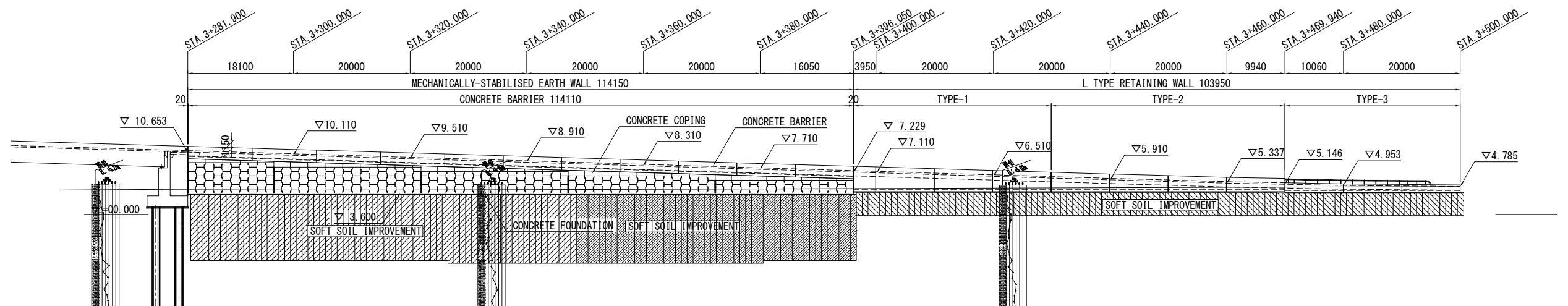

PLAN S=1:800

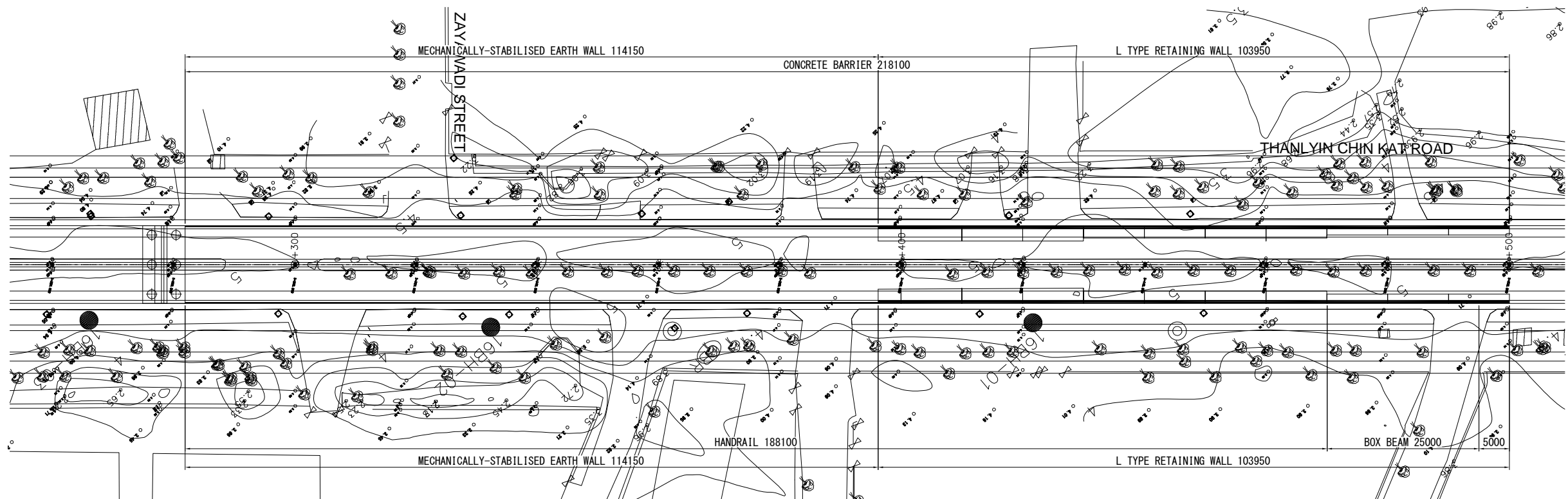

PROJECT NAME
DETAILED DESIGN ON
BAGO RIVER BRIDGE
CONSTRUCTION PROJECT

FINANCED BY
JICA JAPAN INTERNATIONAL
COOPERATION AGENCY

COUNTERPART
 REPUBLIC OF THE UNION OF MYANMAR
MINISTRY OF CONSTRUCTION
DEPARTMENT OF BRIDGE

JICA STUDY TEAM
 NIPPON KOEI CO., LTD.
ORIENTAL CONSULTANTS GLOBAL CO., LTD.
METROPOLITAN EXPRESSWAY COMPANY LIMITED
CHODAI CO., LTD.
NIPPON ENGINEERING CONSULTANTS CO., LTD.

	NAME	SIGNATURE	DATE
PREPARED BY	K. TACHIBANA		29 Sep.2017
CHECKED BY	T. HAYAKAWA		3 Oct.2017
APPROVED BY	Y. SANO		6 Oct.2017

DRAWING TITLE
**GENERAL PLAN
OF MECHANICALLY-STABILISED EARTH WALL(1)**

PACKAGE
3
DWG No.
P3-RD-4000

GENERAL PLAN OF MECHANICALLY-STABILISED EARTH WALL(2)

TYPICAL CROSS SECTION S=1:200

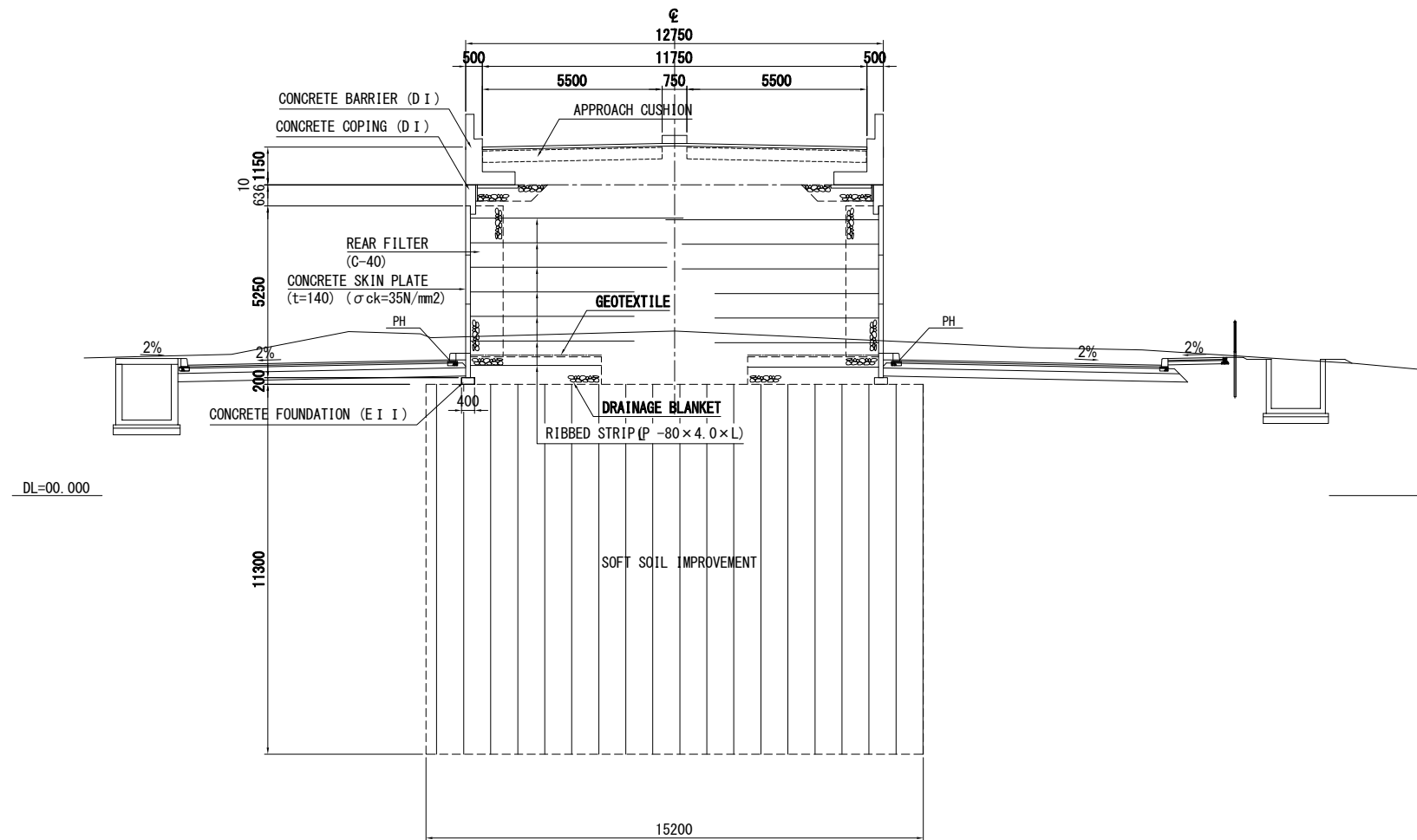

PROJECT NAME
DETAILED DESIGN ON
BAGO RIVER BRIDGE
CONSTRUCTION PROJECT

FINANCED BY
 JAPAN INTERNATIONAL
COOPERATION AGENCY

COUNTERPART
 REPUBLIC OF THE UNION OF MYANMAR
MINISTRY OF CONSTRUCTION
DEPARTMENT OF BRIDGE

JICA STUDY TEAM
 NIPPON KOEI CO., LTD.
 ORIENTAL CONSULTANTS GLOBAL CO., LTD.
 METROPOLITAN EXPRESSWAY COMPANY LIMITED
 CHODAI CO., LTD.
 NIPPON ENGINEERING CONSULTANTS CO., LTD.

	NAME	SIGNATURE	DATE
PREPARED BY	K. TACHIBANA		29 Sep.2017
CHECKED BY	T. HAYAKAWA		3 Oct.2017
APPROVED BY	Y. SANO		6 Oct.2017

DRAWING TITLE
GENERAL PLAN
OF MECHANICALLY-STABILISED EARTH WALL(2)

PACKAGE
3
DWG No.
P3-RD-4010

ARRANGEMENT OF CONCRETE SKIN PLATE OF MECHANICALLY-STABILISED EARTH WALL(1)

LEFT SIDE (DEVELOP FROM BACK SIDE) S=1:800

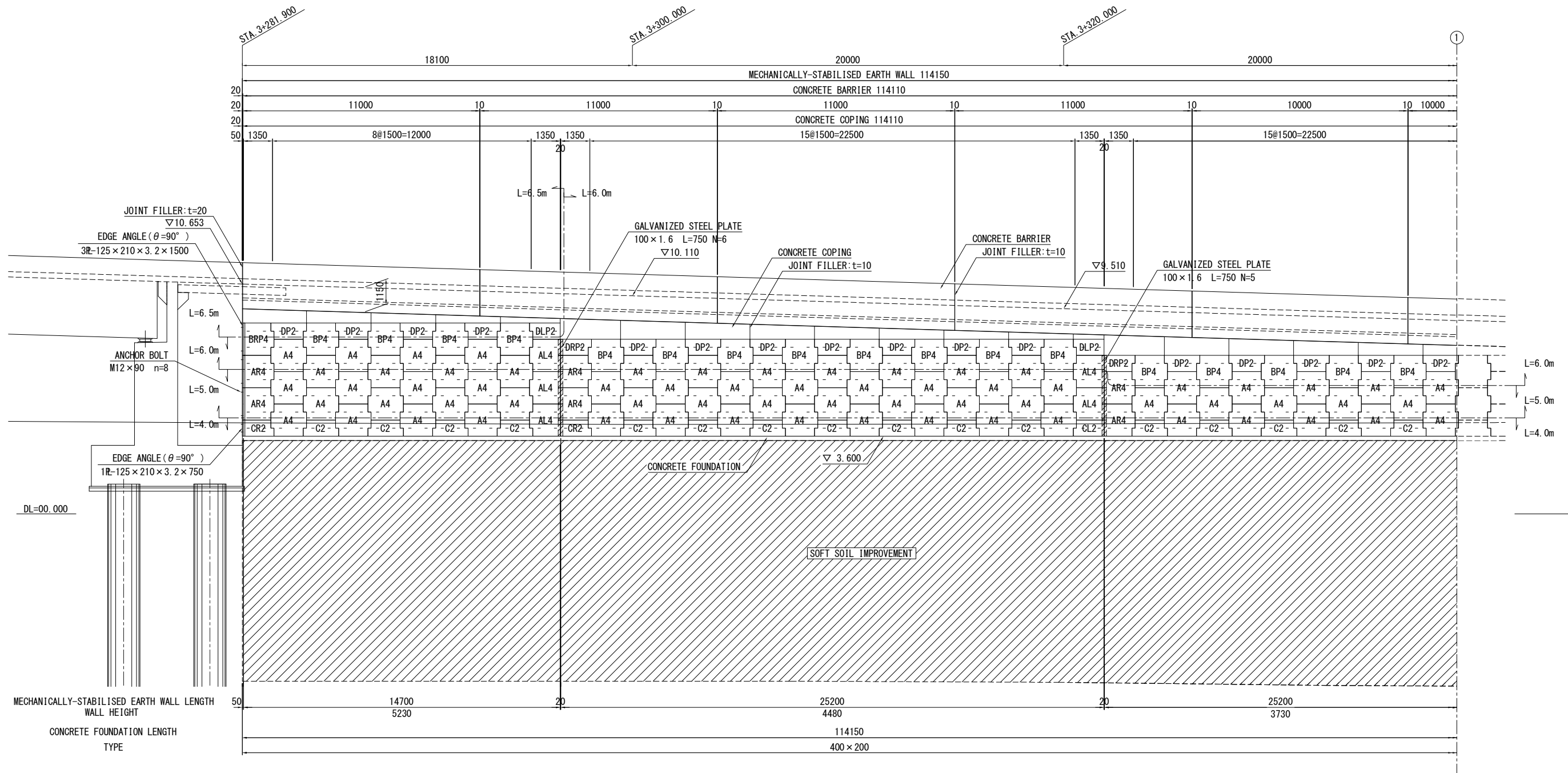

EDGE DETAIL DRAWING S=1:40

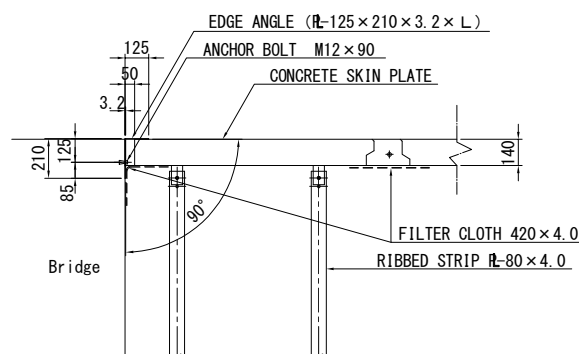

NOTE)

- 1) The mark "L" indicates the length of steel strip determined by the stability calculation.
- 2) Wall length indicates the length of wall surface.

PROJECT NAME DETAILED DESIGN ON BAGO RIVER BRIDGE CONSTRUCTION PROJECT	FINANCED BY JAPAN INTERNATIONAL COOPERATION AGENCY	COUNTERPART REPUBLIC OF THE UNION OF MYANMAR MINISTRY OF CONSTRUCTION DEPARTMENT OF BRIDGE	JICA STUDY TEAM NIPPON KOEI CO., LTD. ORIENTAL CONSULTANTS GLOBAL CO., LTD. METROPOLITAN EXPRESSWAY COMPANY LIMITED CHODAI CO., LTD. NIPPON ENGINEERING CONSULTANTS CO., LTD.	NAME K. TACHIBANA T. HAYAKAWA Y. SANO	SIGNATURE 	DATE 29 Sep.2017 3 Oct.2017 6 Oct.2017	DRAWING TITLE ARRANGEMENT OF CONCRETE SKIN PLATE OF MECHANICALLY-STABILISED EARTH WALL(1)	PACKAGE 3 DWG No. P3-RD-4020
---	--	---	--	--	-----------------------	---	---	---------------------------------------

ARRANGEMENT OF CONCRETE SKIN PLATE OF MECHANICALLY-STABILISED EARTH WALL(2)

LEFT SIDE (DEVELOP FROM BACK SIDE) S=1:800

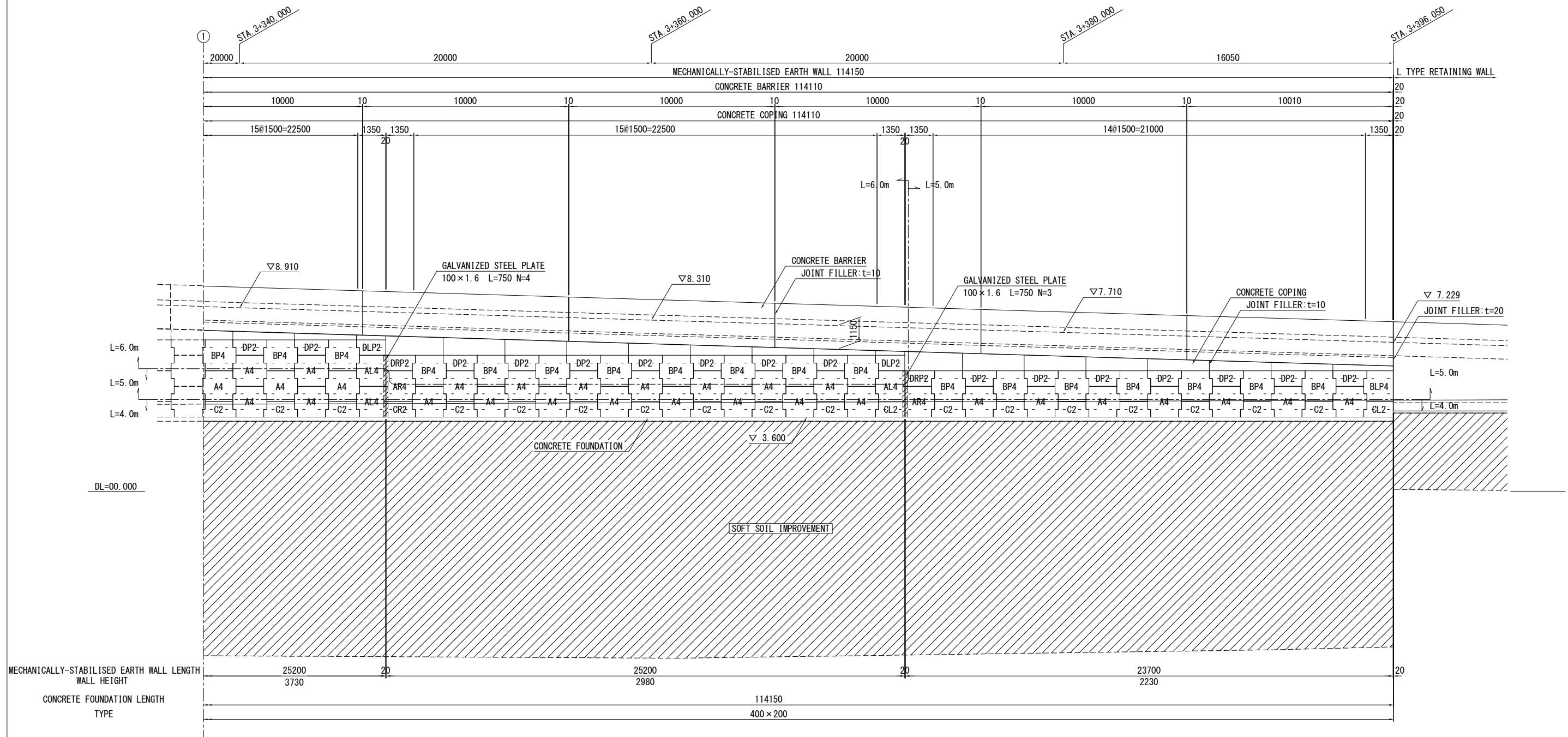

NOTE)

- 1) The mark "L" indicates the length of steel strip determined by the stability calculation.
- 2) Wall length indicates the length of wall surface.

PROJECT NAME DETAILED DESIGN ON BAGO RIVER BRIDGE CONSTRUCTION PROJECT	FINANCED BY JAPAN INTERNATIONAL COOPERATION AGENCY	COUNTERPART REPUBLIC OF THE UNION OF MYANMAR MINISTRY OF CONSTRUCTION DEPARTMENT OF BRIDGE	JICA STUDY TEAM NIPPON KOEI CO., LTD. ORIENTAL CONSULTANTS GLOBAL CO., LTD. METROPOLITAN EXPRESSWAY COMPANY LIMITED CHODAI CO., LTD. NIPPON ENGINEERING CONSULTANTS CO., LTD.	NAME	SIGNATURE	DATE	DRAWING TITLE	PACKAGE	
				PREPARED BY	K. TACHIBANA				29 Sep.2017
				CHECKED BY	T. HAYAKAWA				3 Oct.2017
				APPROVED BY	Y. SANO				6 Oct.2017
ARRANGEMENT OF CONCRETE SKIN PLATE OF MECHANICALLY-STABILISED EARTH WALL(2)							3	DWG No.	
								P3-RD-4030	

ARRANGEMENT OF CONCRETE SKIN PLATE OF MECHANICALLY-STABILISED EARTH WALL(3)

RIGHT SIDE S=1:800

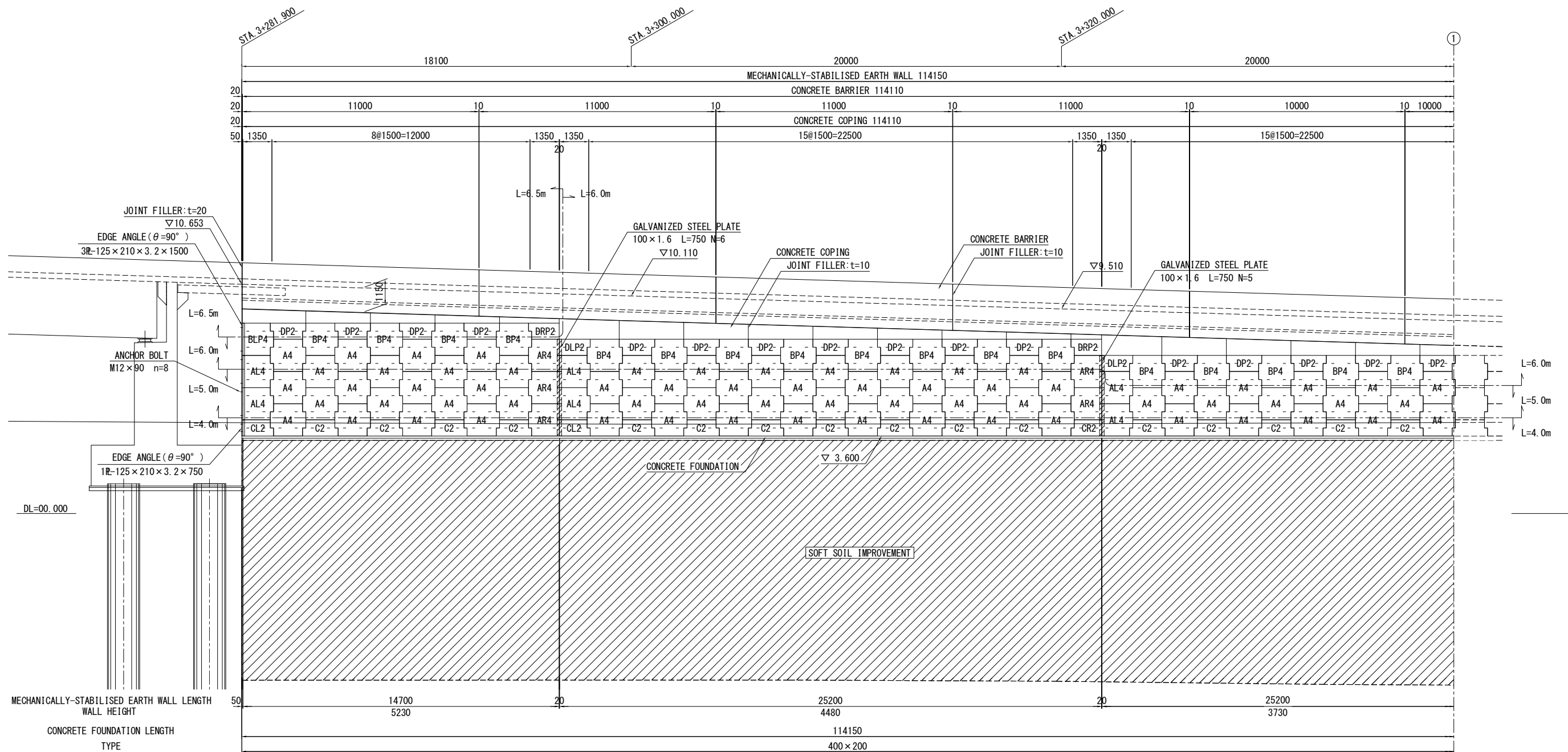

EDGE DETAIL DRAWING S=1:40

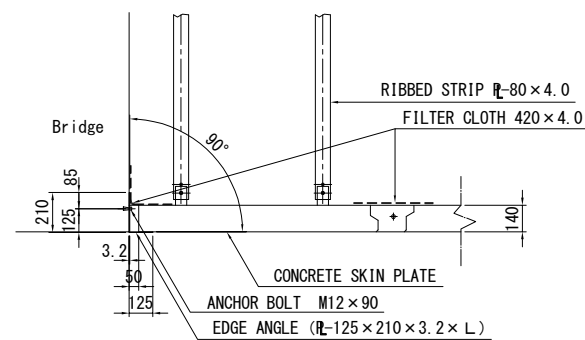

NOTE)

- 1) The mark "L" indicates the length of steel strip determined by the stability calculation.
- 2) Wall length indicates the length of wall surface.

PROJECT NAME DETAILED DESIGN ON BAGO RIVER BRIDGE CONSTRUCTION PROJECT	FINANCED BY JAPAN INTERNATIONAL COOPERATION AGENCY	COUNTERPART REPUBLIC OF THE UNION OF MYANMAR MINISTRY OF CONSTRUCTION DEPARTMENT OF BRIDGE	JICA STUDY TEAM NIPPON KOEI CO., LTD. ORIENTAL CONSULTANTS GLOBAL CO., LTD. METROPOLITAN EXPRESSWAY COMPANY LIMITED CHODAI CO., LTD. NIPPON ENGINEERING CONSULTANTS CO., LTD.	NAME K. TACHIBANA T. HAYAKAWA Y. SANO	SIGNATURE 	DATE 29 Sep.2017 3 Oct.2017 6 Oct.2017	DRAWING TITLE ARRANGEMENT OF CONCRETE SKIN PLATE OF MECHANICALLY-STABILISED EARTH WALL(3)	PACKAGE 3 DWG No. P3-RD-4040
---	--	---	--	--	-----------------------	---	---	---------------------------------------

ARRANGEMENT OF CONCRETE SKIN PLATE OF MECHANICALLY-STABILISED EARTH WALL(4)

RIGHT SIDE S=1:800

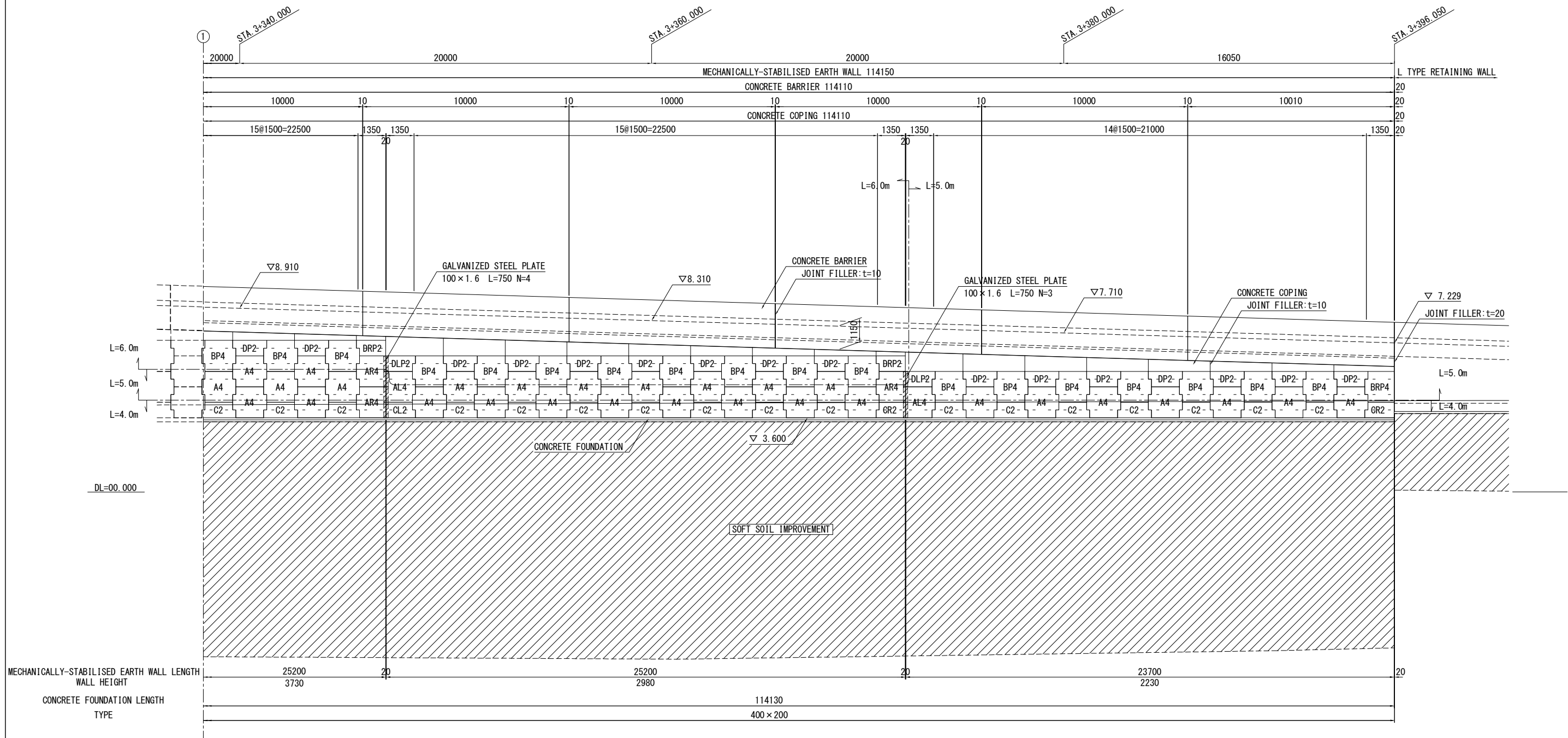

- NOTE)
- 1) The mark "L" indicates the length of steel strip determined by the stability calculation.
 - 2) Wall length indicates the length of wall surface.

PROJECT NAME DETAILED DESIGN ON BAGO RIVER BRIDGE CONSTRUCTION PROJECT	FINANCED BY JAPAN INTERNATIONAL COOPERATION AGENCY	COUNTERPART REPUBLIC OF THE UNION OF MYANMAR MINISTRY OF CONSTRUCTION DEPARTMENT OF BRIDGE	JICA STUDY TEAM NIPPON KOEI CO., LTD. ORIENTAL CONSULTANTS GLOBAL CO., LTD. METROPOLITAN EXPRESSWAY COMPANY LIMITED CHODAI CO., LTD. NIPPON ENGINEERING CONSULTANTS CO., LTD.	NAME	SIGNATURE	DATE	DRAWING TITLE ARRANGEMENT OF CONCRETE SKIN PLATE OF MECHANICALLY-STABILISED EARTH WALL(4)	PACKAGE	
				PREPARED BY	K. TACHIBANA			29 Sep.2017	3
				CHECKED BY	T. HAYAKAWA			3 Oct.2017	DWG No.
				APPROVED BY	Y. SANO			6 Oct.2017	P3-RD-4050

CROSS SECTION(1) S=1:400

STA. 3+300

GH = 5.03
PH = 4.149

℄

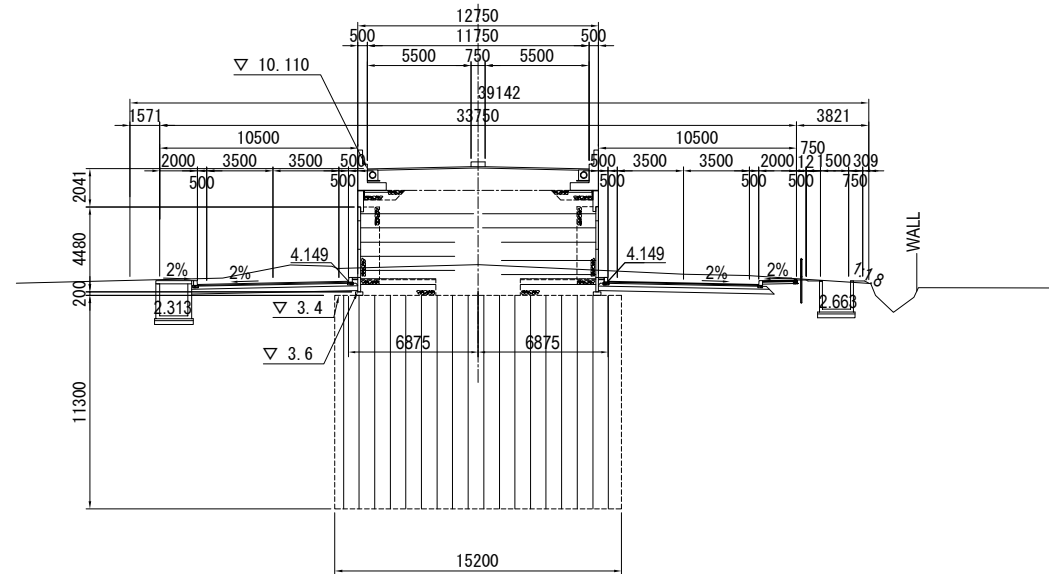

DL=3.00

STA. 3+280

GH = 5.25
PH = 4.229

℄

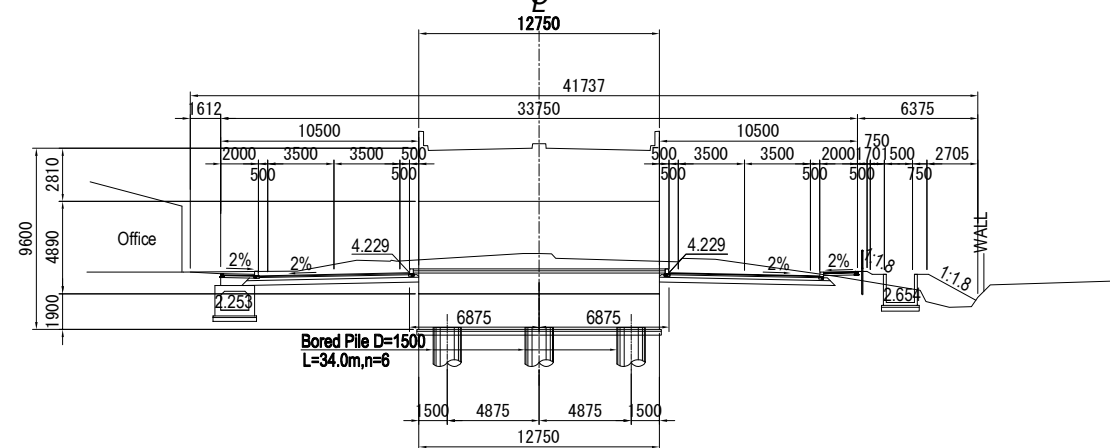

DL=3.00

PROJECT NAME	FINANCED BY	COUNTERPART	JICA STUDY TEAM	NAME	SIGNATURE	DATE	DRAWING TITLE	PACKAGE
DETAILED DESIGN ON BAGO RIVER BRIDGE CONSTRUCTION PROJECT	JICA JAPAN INTERNATIONAL COOPERATION AGENCY	REPUBLIC OF THE UNION OF MYANMAR MINISTRY OF CONSTRUCTION DEPARTMENT OF BRIDGE	NIPPON KOEI CO., LTD. ORIENTAL CONSULTANTS GLOBAL CO., LTD. METROPOLITAN EXPRESSWAY COMPANY LIMITED CHODAI CO., LTD. NIPPON ENGINEERING CONSULTANTS CO., LTD.	K. TACHIBANA		29 Sep.2017	CROSS SECTION(1)	3
				T. HAYAKAWA		3 Oct.2017		DWG No.
				Y. SANO		6 Oct.2017		P3-RD-4060

CROSS SECTION(2) S=1:400

STA. 3+340

GH = 5.06
PH = 4.233

℄

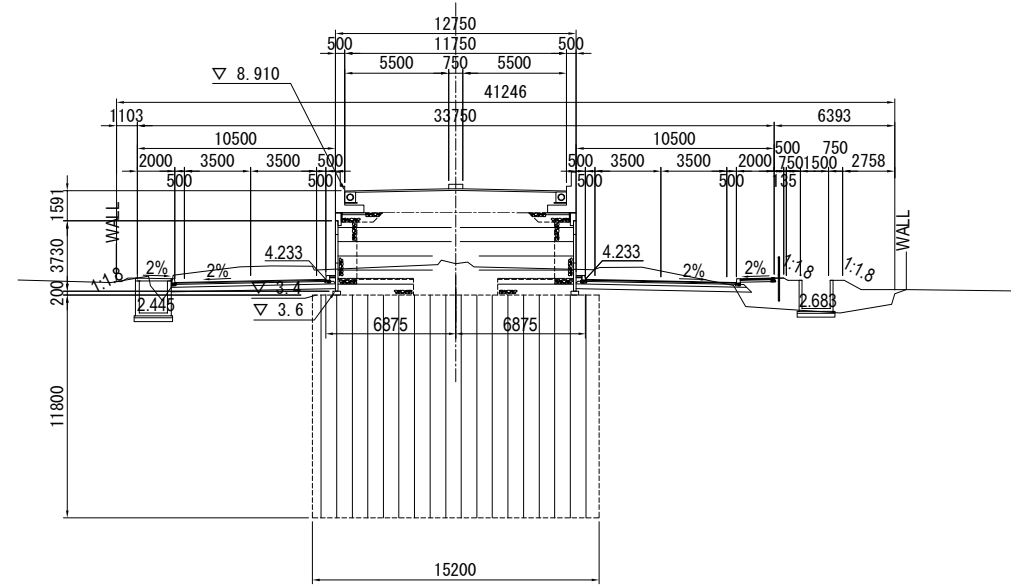

DL=3.00

STA. 3+320

GH = 5.18
PH = 4.167

℄

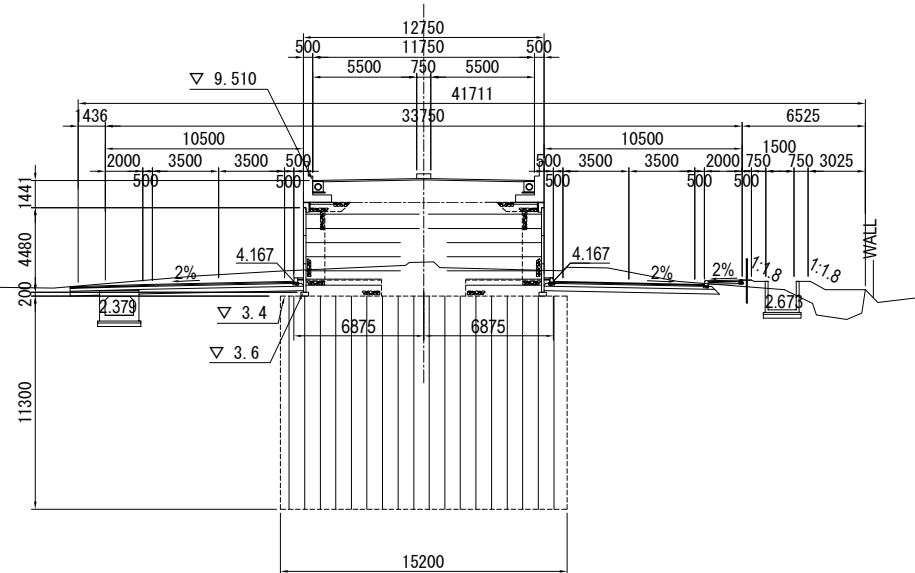

DL=3.00

PROJECT NAME	FINANCED BY	COUNTERPART	JICA STUDY TEAM	NAME	SIGNATURE	DATE	DRAWING TITLE	PACKAGE
DETAILED DESIGN ON BAGO RIVER BRIDGE CONSTRUCTION PROJECT	JAPAN INTERNATIONAL COOPERATION AGENCY	REPUBLIC OF THE UNION OF MYANMAR MINISTRY OF CONSTRUCTION DEPARTMENT OF BRIDGE	NIPPON KOEI CO., LTD. METROPOLITAN EXPRESSWAY COMPANY LIMITED CHODAI CO., LTD. NIPPON ENGINEERING CONSULTANTS CO.,LTD.	PREPARED BY CHECKED BY APPROVED BY	K. TACHIBANA T. HAYAKAWA Y. SANO	 	29 Sep.2017 3 Oct.2017 6 Oct.2017	CROSS SECTION(2)
								3 DWG No. P3-RD-4070

CROSS SECTION(3) S=1:400

STA. 3+380

GH = 5.13
PH = 4.366

℄

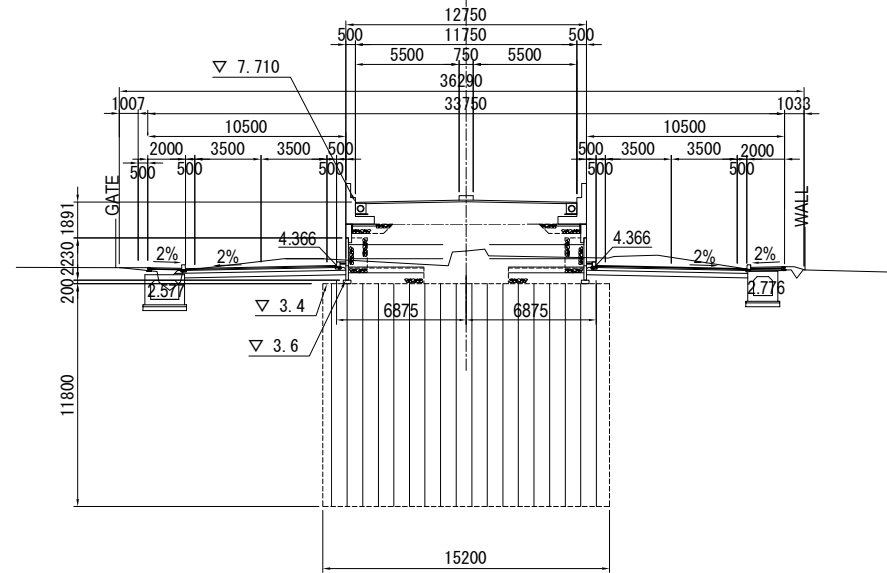

DL=3.00

STA. 3+360

GH = 5.20
PH = 4.300

℄

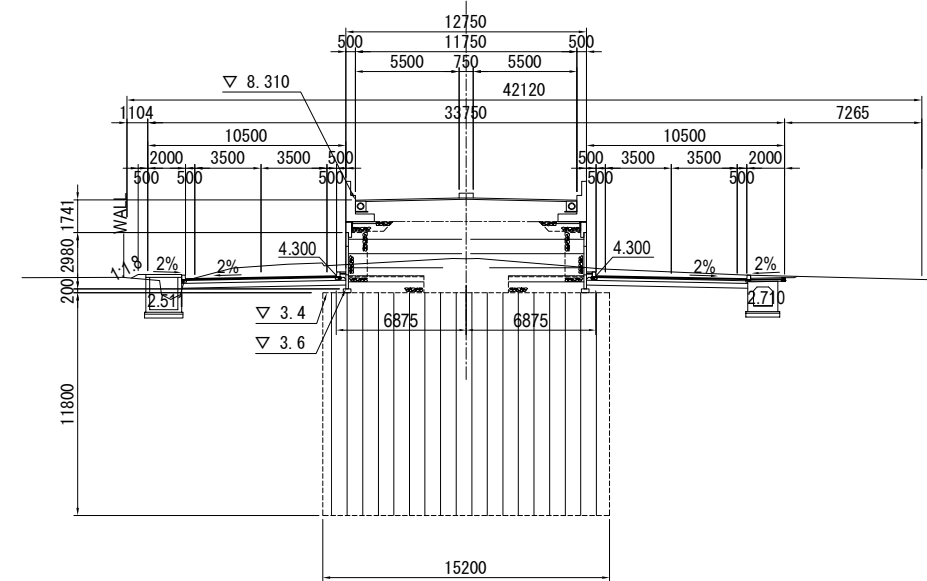

DL=3.00

PROJECT NAME	FINANCED BY	COUNTERPART	JICA STUDY TEAM	NAME	SIGNATURE	DATE	DRAWING TITLE	PACKAGE
DETAILED DESIGN ON BAGO RIVER BRIDGE CONSTRUCTION PROJECT	JICA JAPAN INTERNATIONAL COOPERATION AGENCY	REPUBLIC OF THE UNION OF MYANMAR MINISTRY OF CONSTRUCTION DEPARTMENT OF BRIDGE	NIPPON KOEI CO., LTD. ORIENTAL CONSULTANTS GLOBAL CO., LTD. METROPOLITAN EXPRESSWAY COMPANY LIMITED CHODAI CO., LTD. NIPPON ENGINEERING CONSULTANTS CO., LTD.	PREPARED BY K. TACHIBANA	[Signature]	29 Sep.2017	CROSS SECTION(3)	3
				CHECKED BY T. HAYAKAWA	[Signature]	3 Oct.2017		DWG No.
				APPROVED BY Y. SANO	[Signature]	6 Oct.2017		P3-RD-4080

CROSS SECTION(4) S=1:400

STA. 3+420

GH = 5.12
PH = 4.499

⌀

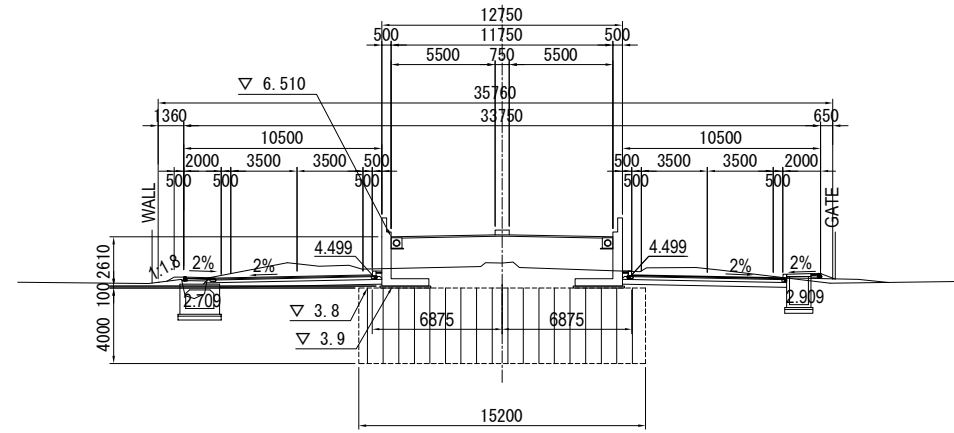

DL=3.00

STA. 3+400

GH = 5.15
PH = 4.433

⌀

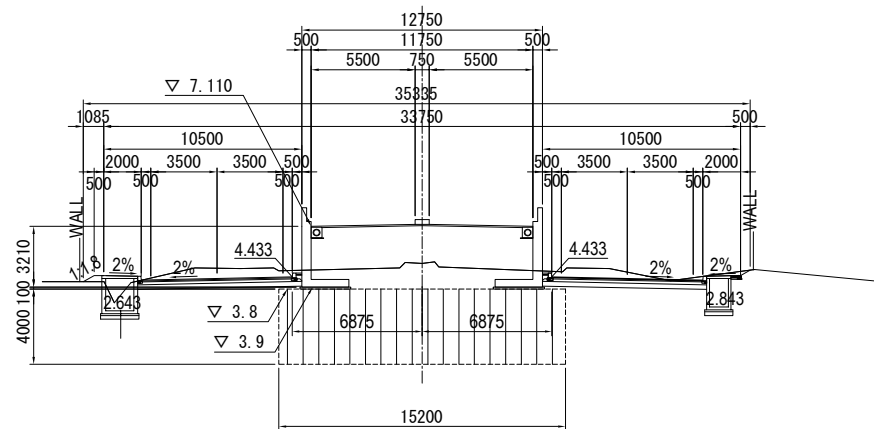

DL=3.00

PROJECT NAME	FINANCED BY	COUNTERPART	JICA STUDY TEAM	NAME	SIGNATURE	DATE	DRAWING TITLE	PACKAGE
DETAILED DESIGN ON BAGO RIVER BRIDGE CONSTRUCTION PROJECT	JAPAN INTERNATIONAL COOPERATION AGENCY	REPUBLIC OF THE UNION OF MYANMAR MINISTRY OF CONSTRUCTION DEPARTMENT OF BRIDGE	NIPPON KOEI CO., LTD. ORIENTAL CONSULTANTS GLOBAL CO., LTD. METROPOLITAN EXPRESSWAY COMPANY LIMITED CHODAI CO., LTD. NIPPON ENGINEERING CONSULTANTS CO.,LTD.	PREPARED BY	K. TACHIBANA		29 Sep.2017	CROSS SECTION(4)
			CHECKED BY	T. HAYAKAWA		3 Oct.2017	DWG No.	
			APPROVED BY	Y. SANO		6 Oct.2017	P3-RD-4090	

CROSS SECTION(5) S=1:400

STA. 3+460

GH = 5.11
PH = 4.632

℄

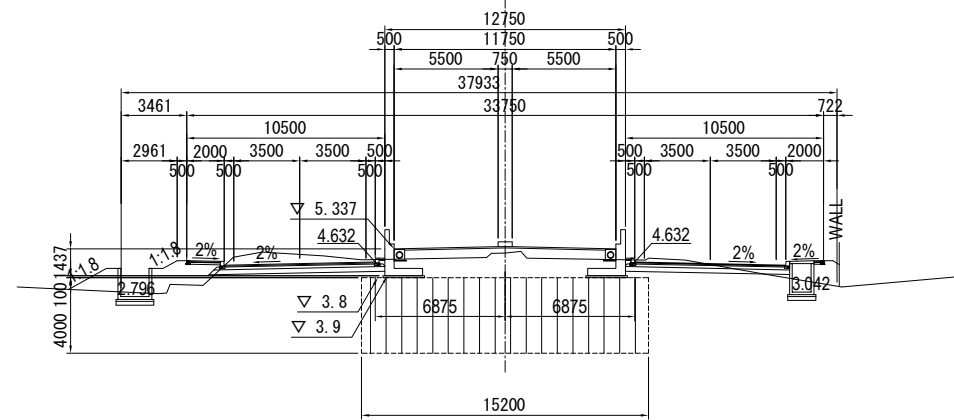

DL=3.00

STA. 3+440

GH = 5.19
PH = 4.566

℄

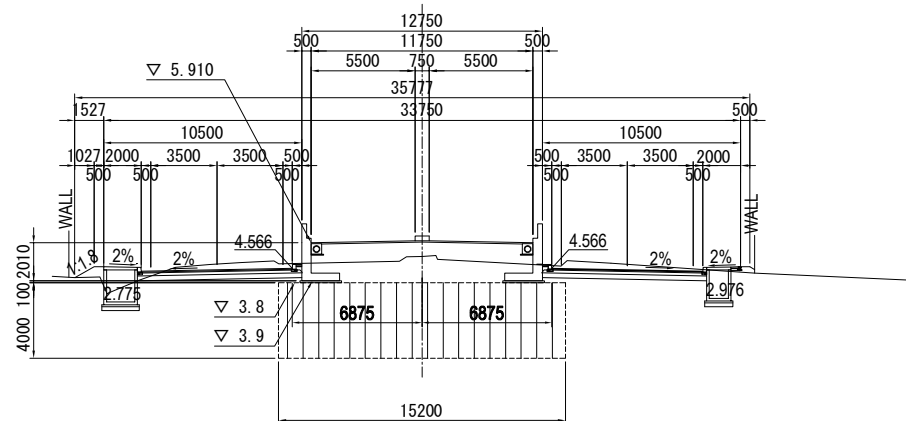

DL=3.00

PROJECT NAME	FINANCED BY	COUNTERPART	JICA STUDY TEAM	NAME	SIGNATURE	DATE	DRAWING TITLE	PACKAGE
DETAILED DESIGN ON BAGO RIVER BRIDGE CONSTRUCTION PROJECT	JAPAN INTERNATIONAL COOPERATION AGENCY	REPUBLIC OF THE UNION OF MYANMAR MINISTRY OF CONSTRUCTION DEPARTMENT OF BRIDGE	NIPPON KOEI CO., LTD. ORIENTAL CONSULTANTS GLOBAL CO., LTD. METROPOLITAN EXPRESSWAY COMPANY LIMITED CHODAI CO., LTD. NIPPON ENGINEERING CONSULTANTS CO., LTD.	PREPARED BY	K. TACHIBANA	29 Sep.2017	CROSS SECTION(5)	3
				CHECKED BY	T. HAYAKAWA	3 Oct.2017		DWG No.
				APPROVED BY	Y. SANO	6 Oct.2017		P3-RD-4100

CROSS SECTION(6) S=1:400

STA. 3+500

GH = 5.23
PH = 4.765

℄

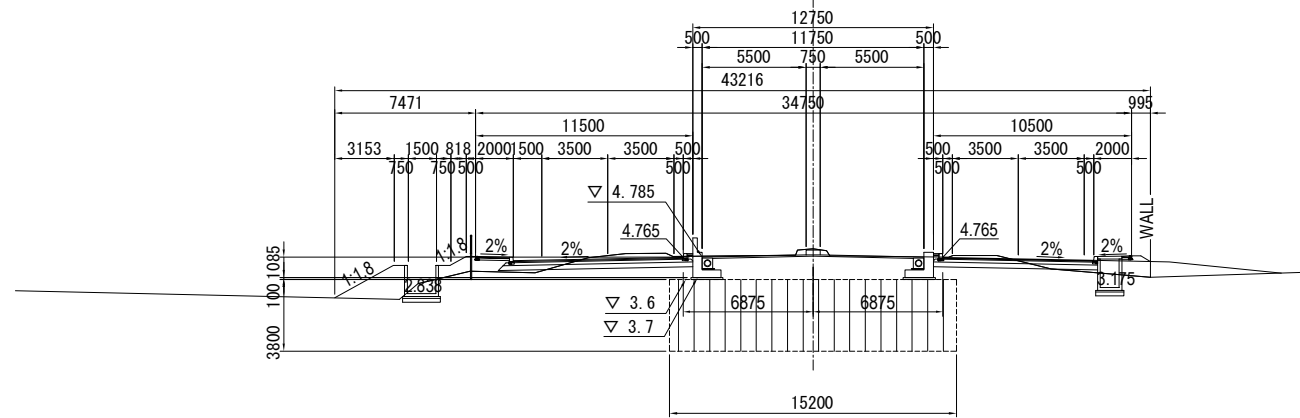

DL=3.00

STA. 3+480

GH = 5.16
PH = 4.699

℄

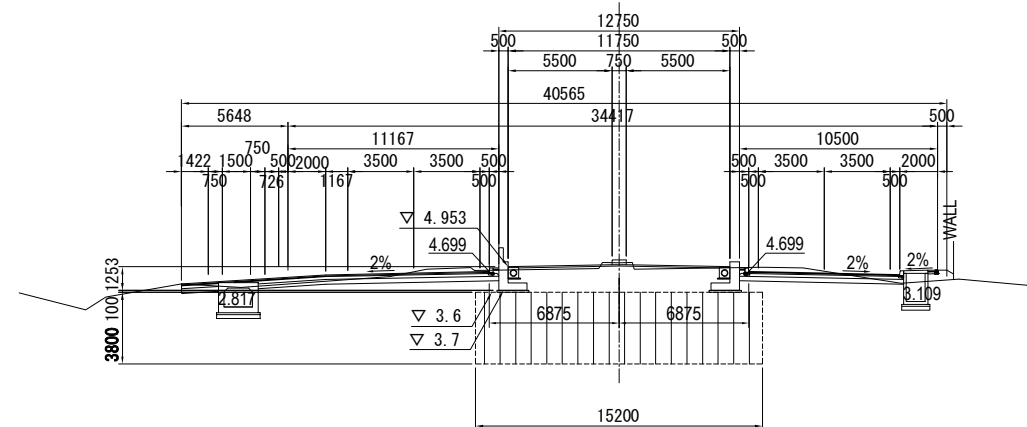

DL=3.00

PROJECT NAME	FINANCED BY	COUNTERPART	JICA STUDY TEAM	NAME	SIGNATURE	DATE	DRAWING TITLE	PACKAGE
DETAILED DESIGN ON BAGO RIVER BRIDGE CONSTRUCTION PROJECT	JICA JAPAN INTERNATIONAL COOPERATION AGENCY	REPUBLIC OF THE UNION OF MYANMAR MINISTRY OF CONSTRUCTION DEPARTMENT OF BRIDGE	NIPPON KOEI CO., LTD. ORIENTAL CONSULTANTS GLOBAL CO., LTD. METROPOLITAN EXPRESSWAY COMPANY LIMITED CHODAI CO., LTD. NIPPON ENGINEERING CONSULTANTS CO., LTD.	PREPARED BY CHECKED BY APPROVED BY	K. TACHIBANA T. HAYAKAWA Y. SANO	29 Sep.2017 3 Oct.2017 6 Oct.2017	CROSS SECTION(6)	3 DWG No. P3-RD-4110

DETAIL OF MECHANICALLY-STABILISED EARTH WALL(1)

SKIN ARRANGEMENT S=1:60

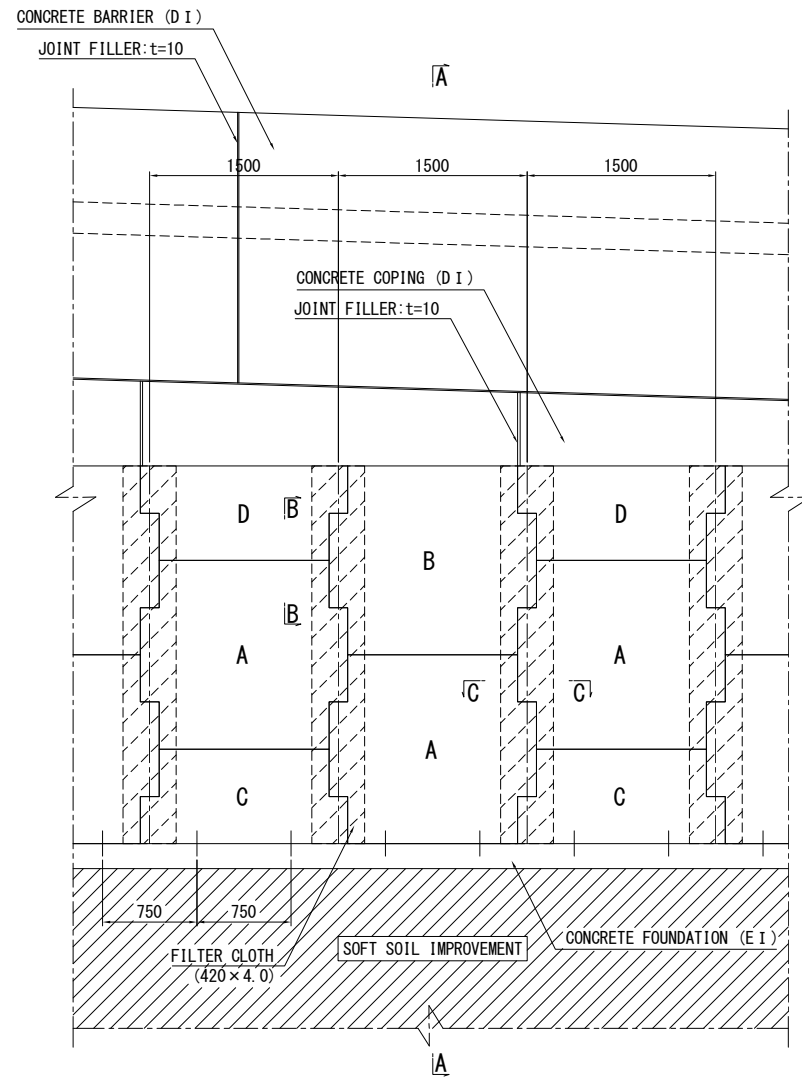

A-A CROSS SECTION S=1:60

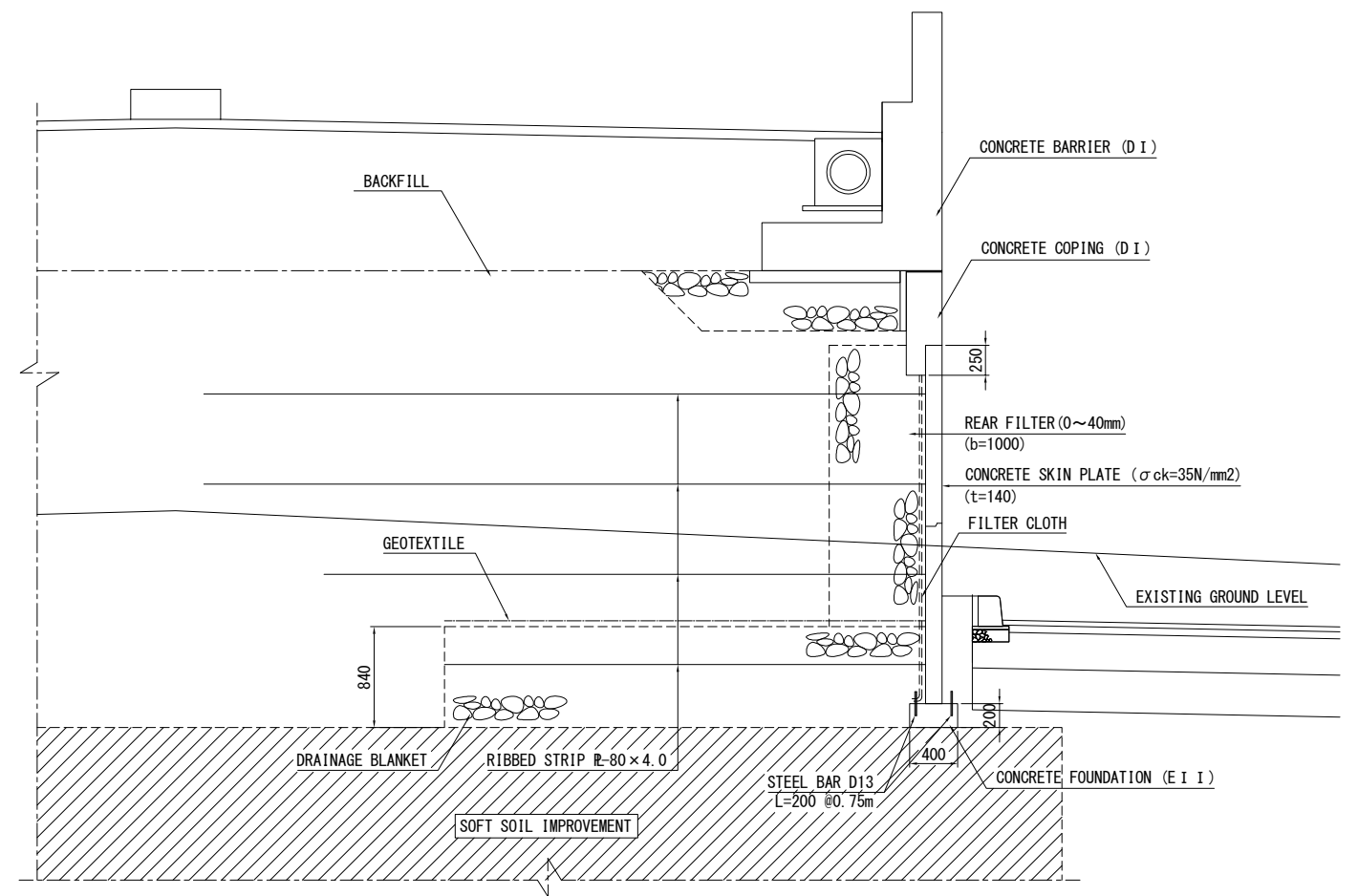

B-B CROSS SECTION S=1:40

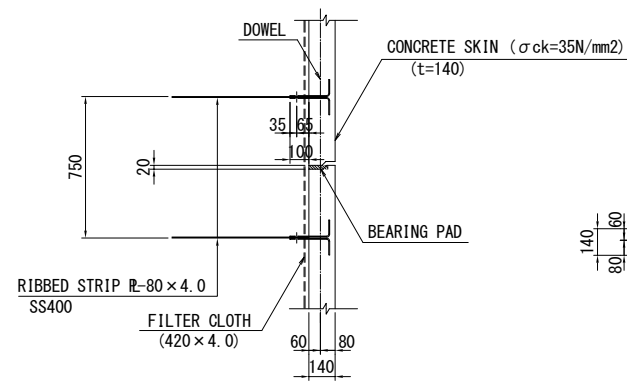

C-C CROSS SECTION S=1:40

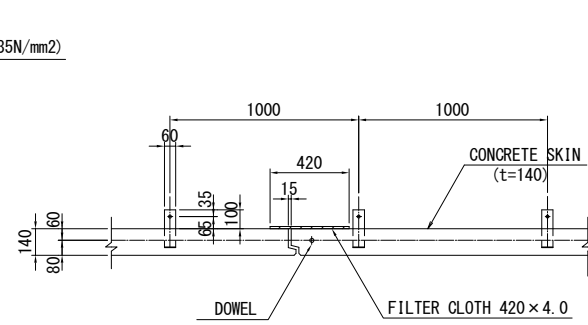

FILTER CLOTH S=1:40

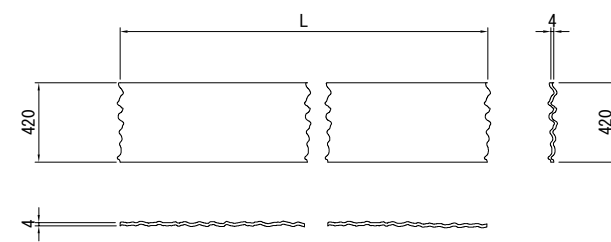

BEARING PAD S=1:20

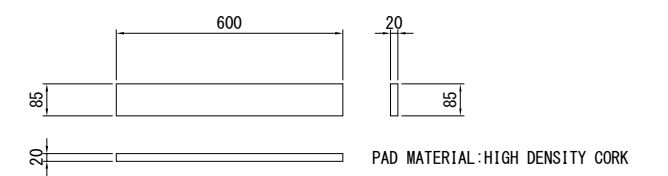

PROJECT NAME
DETAILED DESIGN ON
BAGO RIVER BRIDGE
CONSTRUCTION PROJECT

FINANCED BY
JICA JAPAN INTERNATIONAL
COOPERATION AGENCY

COUNTERPART
REPUBLIC OF THE UNION OF MYANMAR
MINISTRY OF CONSTRUCTION
DEPARTMENT OF BRIDGE

JICA STUDY TEAM
NIPPON KOEI CO., LTD.
ORIENTAL CONSULTANTS GLOBAL CO., LTD.
METROPOLITAN EXPRESSWAY COMPANY LIMITED
CHODAI CO., LTD.
NIPPON ENGINEERING CONSULTANTS CO., LTD.

	NAME	SIGNATURE	DATE
PREPARED BY	K. TACHIBANA	<i>[Signature]</i>	29 Sep.2017
CHECKED BY	T. HAYAKAWA	<i>[Signature]</i>	3 Oct.2017
APPROVED BY	Y. SANO	<i>[Signature]</i>	6 Oct.2017

DRAWING TITLE
DETAIL OF MECHANICALLY-STABILISED EARTH WALL(1)

PACKAGE
3
DWG No.
P3-RD-4120

DETAIL OF MECHANICALLY-STABILISED EARTH WALL(2)

TYPE OF CONCRETE SKIN S=1:40

COPING REINFORCEMENT S=1:60

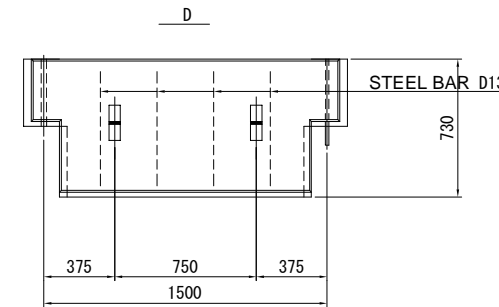
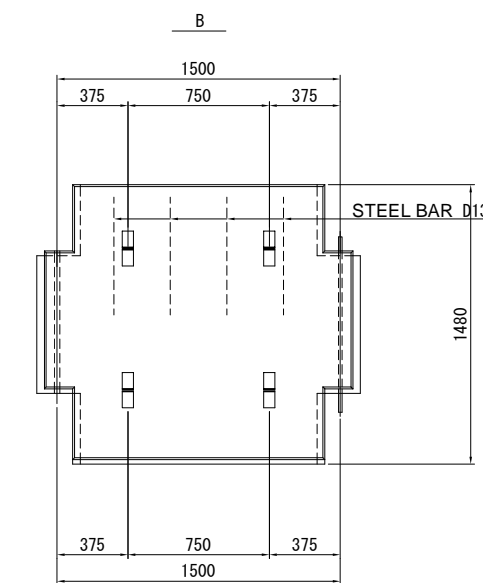
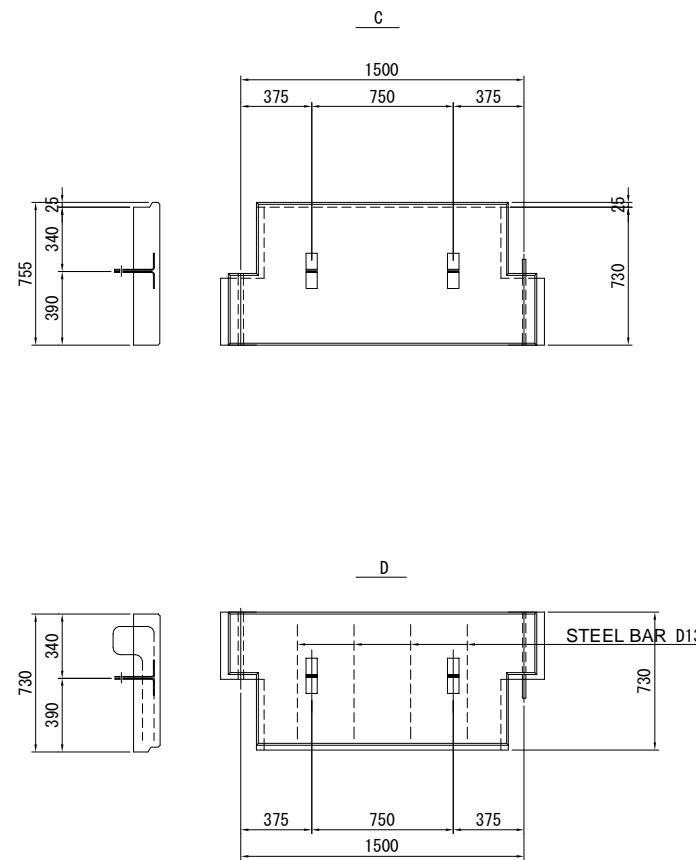
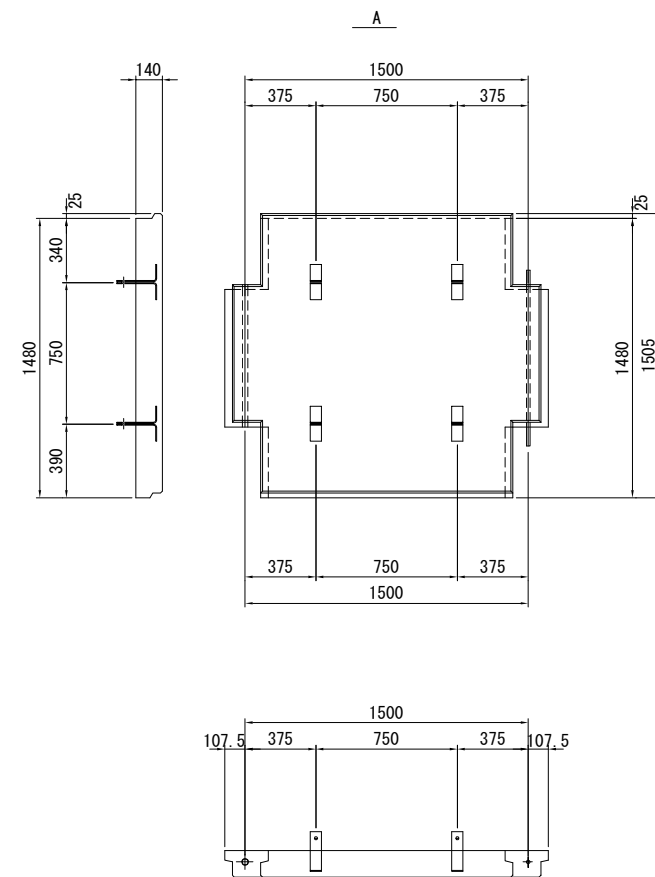

BOLT NUT (M12 x 40) S=1:4

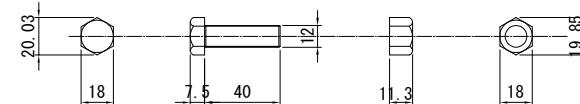

RIBBED STRIP S=1:20

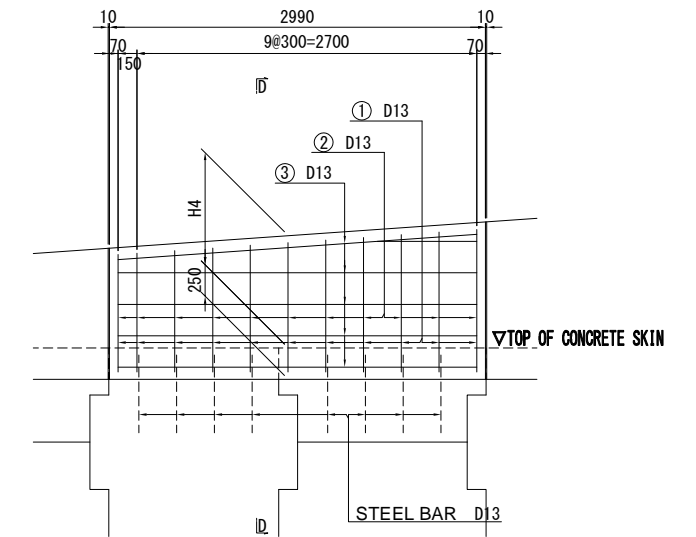
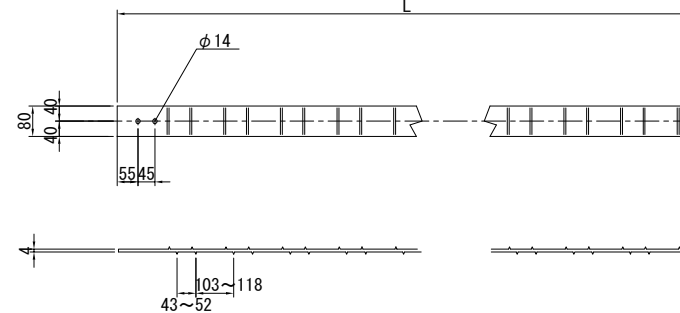

D-D CROSSSECTION

BAR SCHEDULING

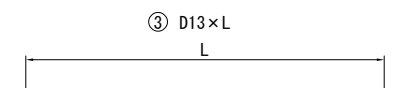
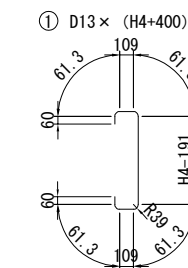
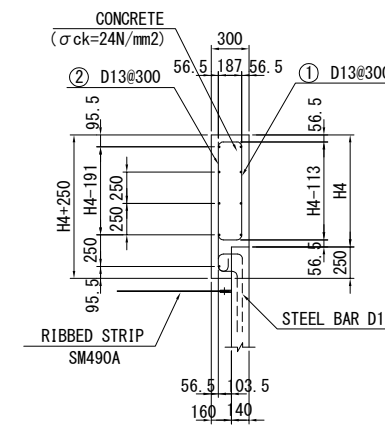

NOTE) L SHOWS THE CENTER OF BAR

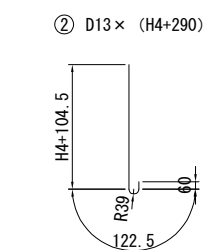

NOTE) "H4" IS THE HIGH OF COPING REINFORCEMENT

PROJECT NAME DETAILED DESIGN ON BAGO RIVER BRIDGE CONSTRUCTION PROJECT	FINANCED BY JICA JAPAN INTERNATIONAL COOPERATION AGENCY	COUNTERPART REPUBLIC OF THE UNION OF MYANMAR MINISTRY OF CONSTRUCTION DEPARTMENT OF BRIDGE	JICA STUDY TEAM NIPPON KOEI CO., LTD. ORIENTAL CONSULTANTS GLOBAL CO., LTD. METROPOLITAN EXPRESSWAY COMPANY LIMITED CHODAI CO., LTD. NIPPON ENGINEERING CONSULTANTS CO., LTD.	NAME K. TACHIBANA T. HAYAKAWA Y. SANO	SIGNATURE <i>[Signature]</i> <i>[Signature]</i> <i>[Signature]</i>	DATE 29 Sep.2017 3 Oct.2017 6 Oct.2017	DRAWING TITLE DETAIL OF MECHANICALLY-STABILISED EARTH WALL(2)	PACKAGE 3 DWG No. P3-RD-4130
---	--	---	--	--	---	---	--	---------------------------------------

DETAIL OF MECHANICALLY-STABILISED EARTH WALL(3)

CONCRETE FOUNDATION DRAWING S=1:40

FRONT VIEW DRAWING

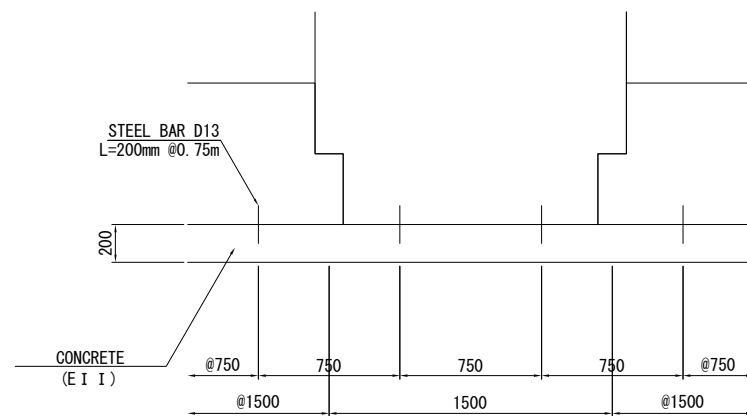

NOTE) 1. FOUNDATION WORK OF TOP FINISH:TROWEL FINISH

CROSS SECTION

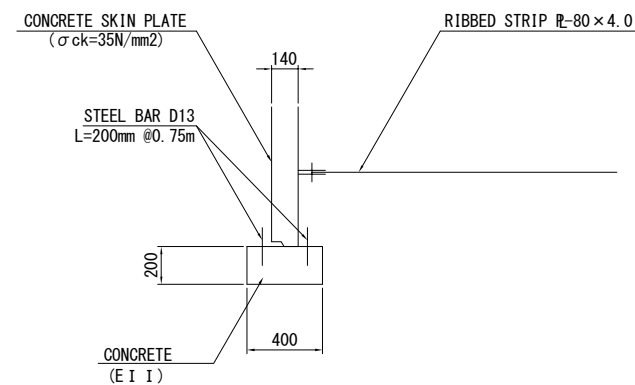

JOINT DETAIL DRAWING S=1:40

CROSS SECTION

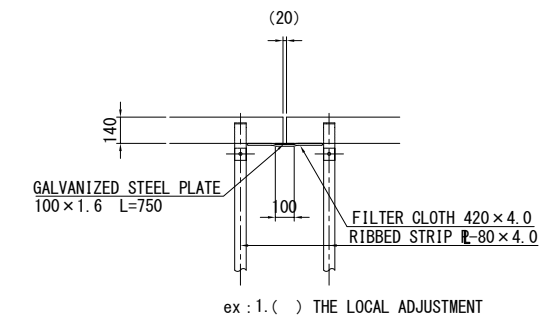

GALVANIZED STEEL PLATE S=1:40

FRONT VIEW DRAWING CROSS SECTION

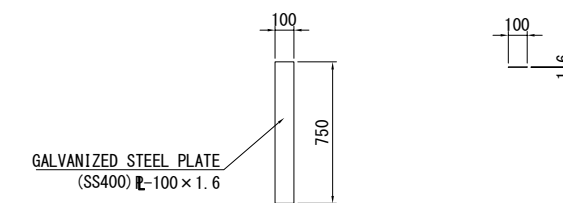

EDGE DETAIL DRAWING

CROSS SECTION S=1:6

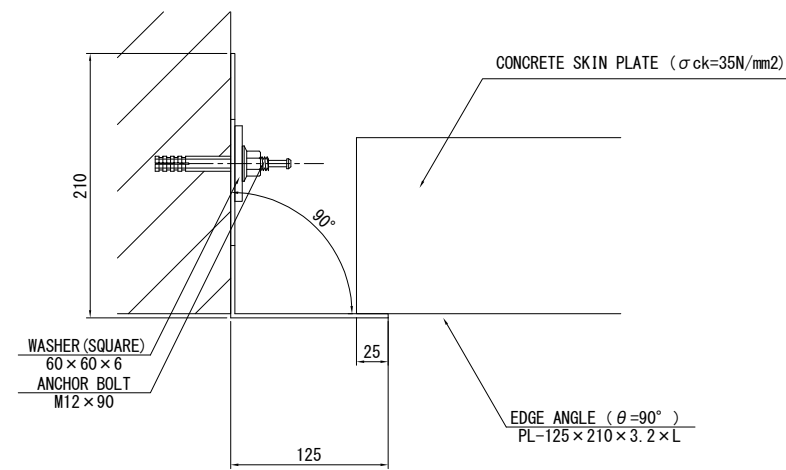

NOTE) 1. BOLT IT IS USED TWO PER ONE EDGE ANGLE

EDGE ANGLE BRACKET S=1:20

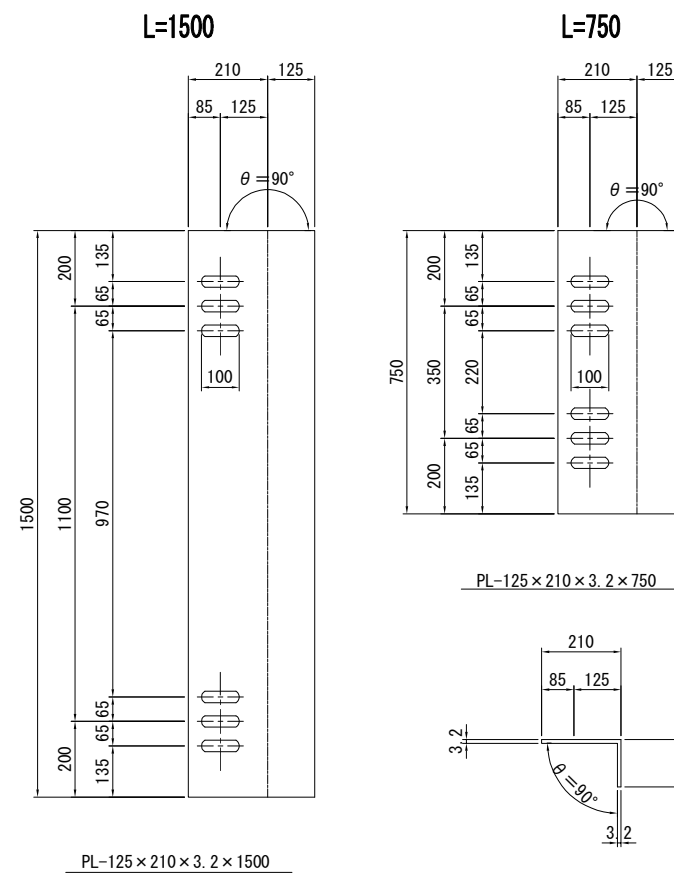

PROJECT NAME	FINANCED BY	COUNTERPART	JICA STUDY TEAM	NAME	SIGNATURE	DATE	DRAWING TITLE	PACKAGE
DETAILED DESIGN ON BAGO RIVER BRIDGE CONSTRUCTION PROJECT	JICA JAPAN INTERNATIONAL COOPERATION AGENCY	REPUBLIC OF THE UNION OF MYANMAR MINISTRY OF CONSTRUCTION DEPARTMENT OF BRIDGE	NIPPON KOEI CO., LTD. ORIENTAL CONSULTANTS GLOBAL CO., LTD. METROPOLITAN EXPRESSWAY COMPANY LIMITED CHODAI CO., LTD. NIPPON ENGINEERING CONSULTANTS CO., LTD.	K. TACHIBANA		29 Sep.2017	DETAIL OF MECHANICALLY-STABILISED EARTH WALL(3)	3
				T. HAYAKAWA		3 Oct.2017		DWG No.
				Y. SANO		6 Oct.2017		P3-RD-4140

DETAIL OF MECHANICALLY-STABILISED EARTH WALL(4)

CONCRETE COPING

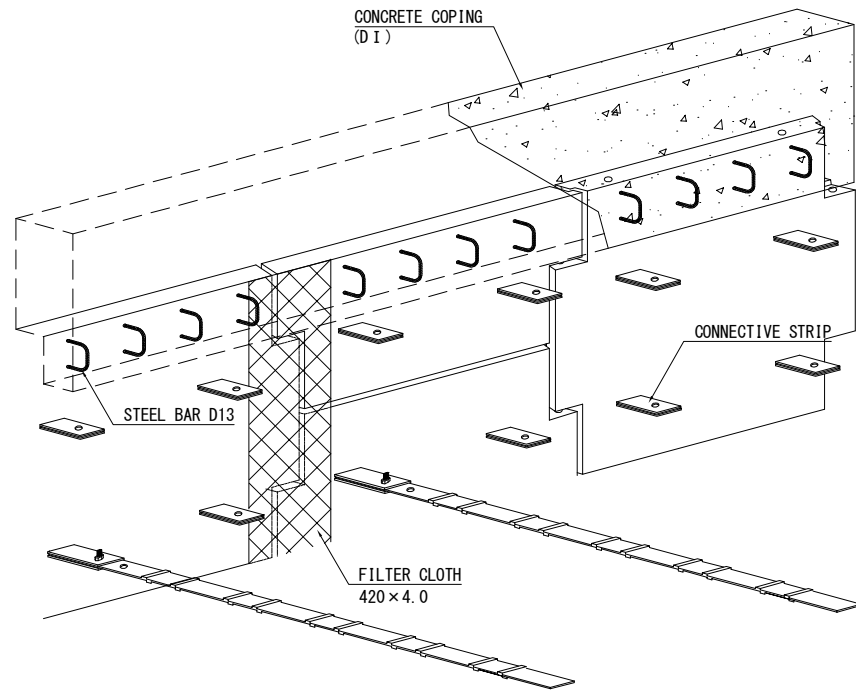

BIRD'S EYE VIEW

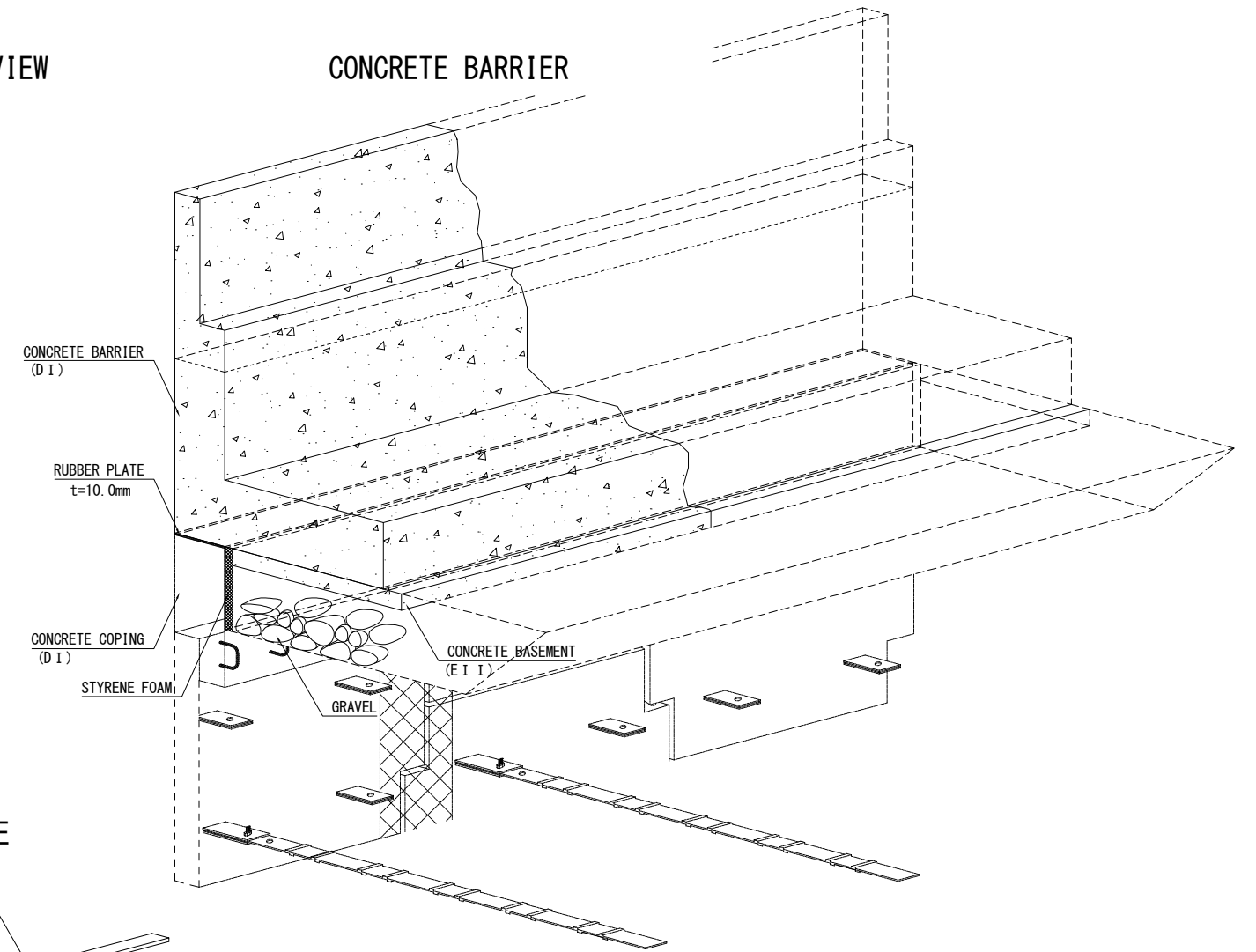

CONCRETE BARRIER

CONCRETE SKIN PLATE

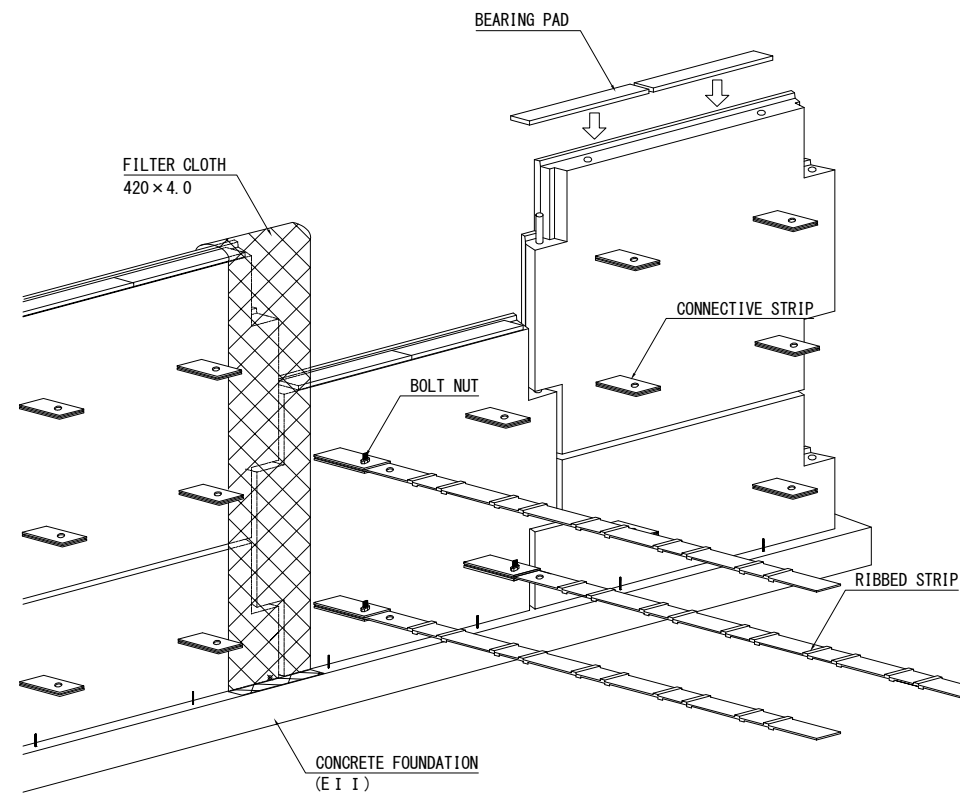

PROJECT NAME	FINANCED BY	COUNTERPART	JICA STUDY TEAM	NAME	SIGNATURE	DATE	DRAWING TITLE	PACKAGE
DETAILED DESIGN ON BAGO RIVER BRIDGE CONSTRUCTION PROJECT	JICA JAPAN INTERNATIONAL COOPERATION AGENCY	REPUBLIC OF THE UNION OF MYANMAR MINISTRY OF CONSTRUCTION DEPARTMENT OF BRIDGE	NIPPON KOEI CO., LTD. ORIENTAL CONSULTANTS GLOBAL CO., LTD. METROPOLITAN EXPRESSWAY COMPANY LIMITED CHODAI CO., LTD. NIPPON ENGINEERING CONSULTANTS CO., LTD.	K. TACHIBANA		29 Sep.2017	DETAIL OF MECHANICALLY-STABILISED EARTH WALL(4)	3
				T. HAYAKAWA		3 Oct.2017		DWG No.
				Y. SANO		6 Oct.2017		P3-RD-4150

DETAIL OF CONCRETE BARRIER ON MECHANICALLY-STABILISED EARTH WALL(1) S=1:40

SECTION

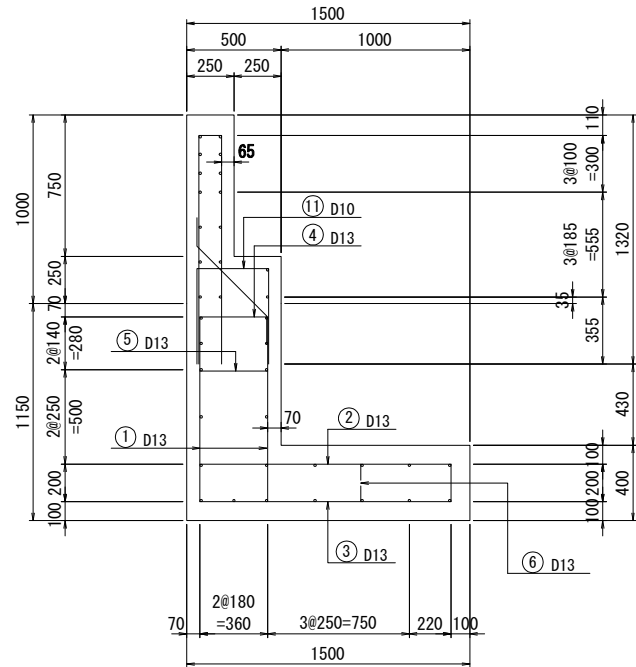

BREST WALL

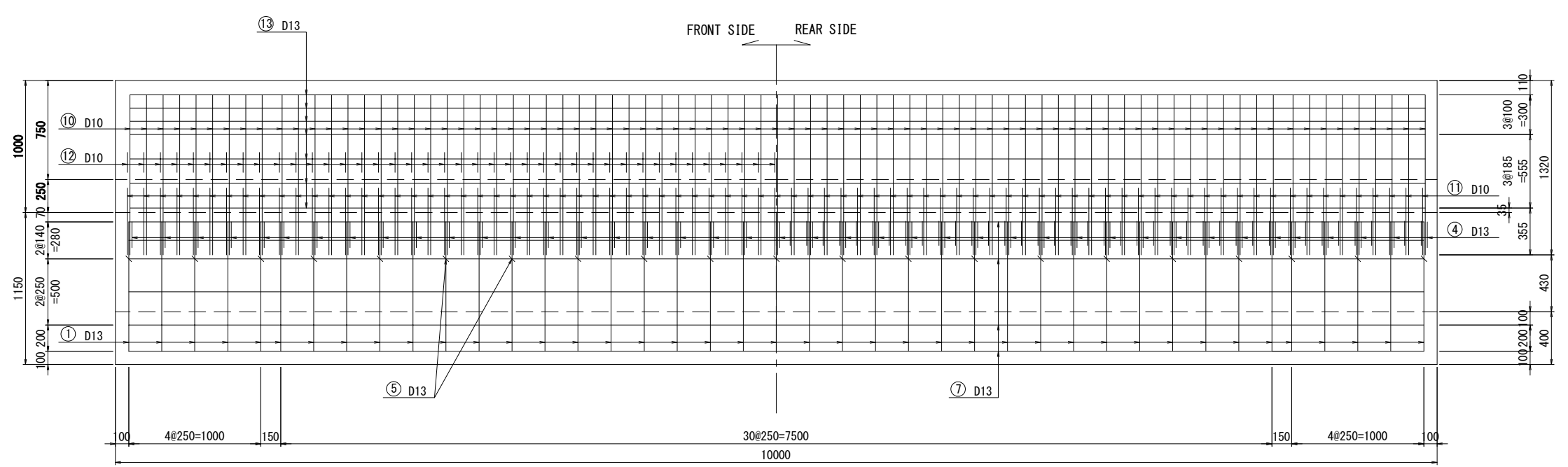

BOTTOM SLAB

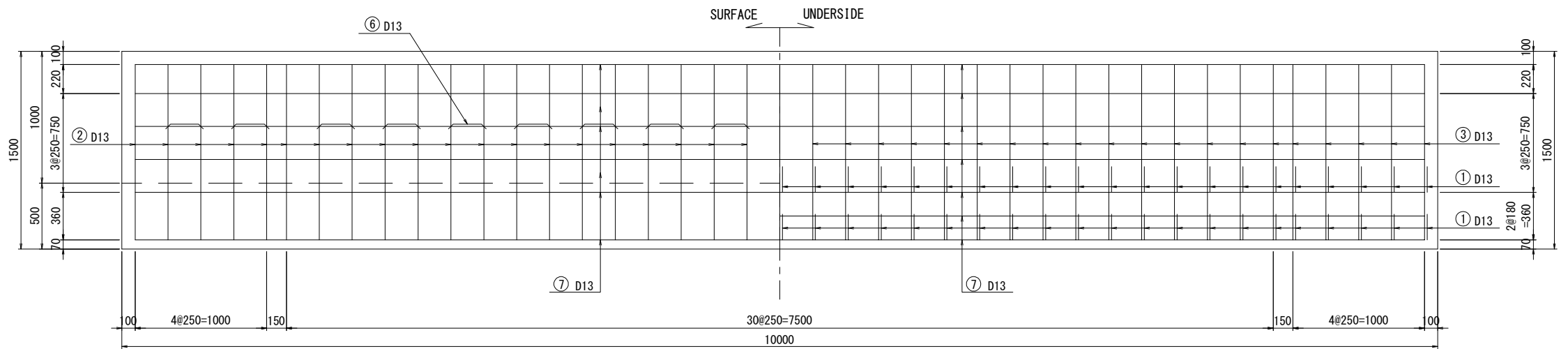

SETTING

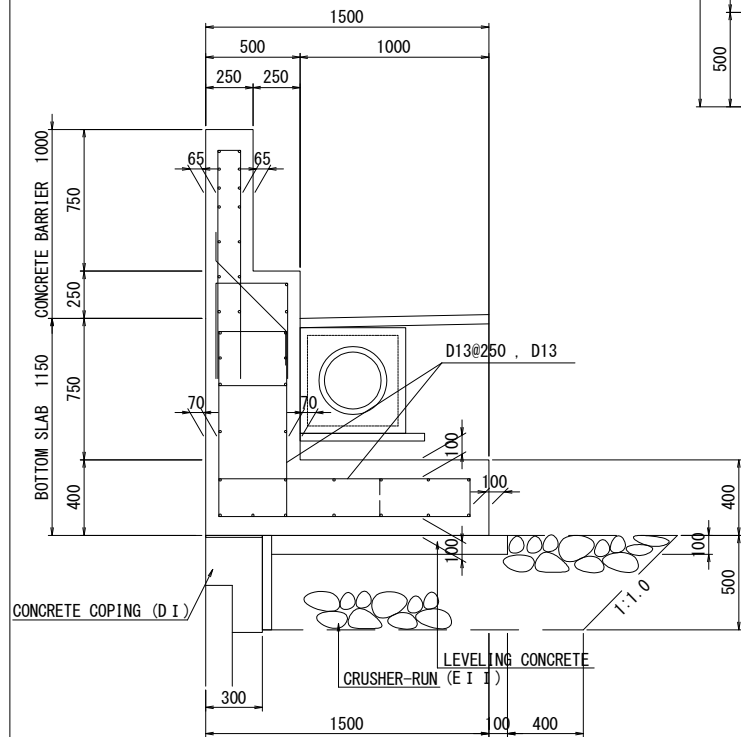

BAR ASSEMBLING

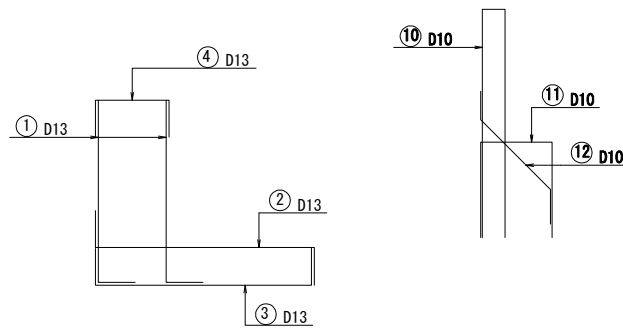

PROJECT NAME DETAILED DESIGN ON BAGO RIVER BRIDGE CONSTRUCTION PROJECT	FINANCED BY JAPAN INTERNATIONAL COOPERATION AGENCY	COUNTERPART REPUBLIC OF THE UNION OF MYANMAR MINISTRY OF CONSTRUCTION DEPARTMENT OF BRIDGE	JICA STUDY TEAM NIPPON KOEI CO., LTD. ORIENTAL CONSULTANTS GLOBAL CO., LTD. METROPOLITAN EXPRESSWAY COMPANY LIMITED CHODAI CO., LTD. NIPPON ENGINEERING CONSULTANTS CO., LTD.	NAME K. TACHIBANA T. HAYAKAWA Y. SANO	SIGNATURE 	DATE 29 Sep.2017 3 Oct.2017 6 Oct.2017	DRAWING TITLE DETAIL OF CONCRETE BARRIER ON MECHANICALLY-STABILISED EARTH WALL(1)	PACKAGE 3 DWG No. P3-RD-4160
---	--	---	--	--	-----------------------	---	---	---------------------------------------

DETAIL OF CONCRETE BARRIER ON MECHANICALLY-STABILISED EARTH WALL(2)

BAR SCHEDULING

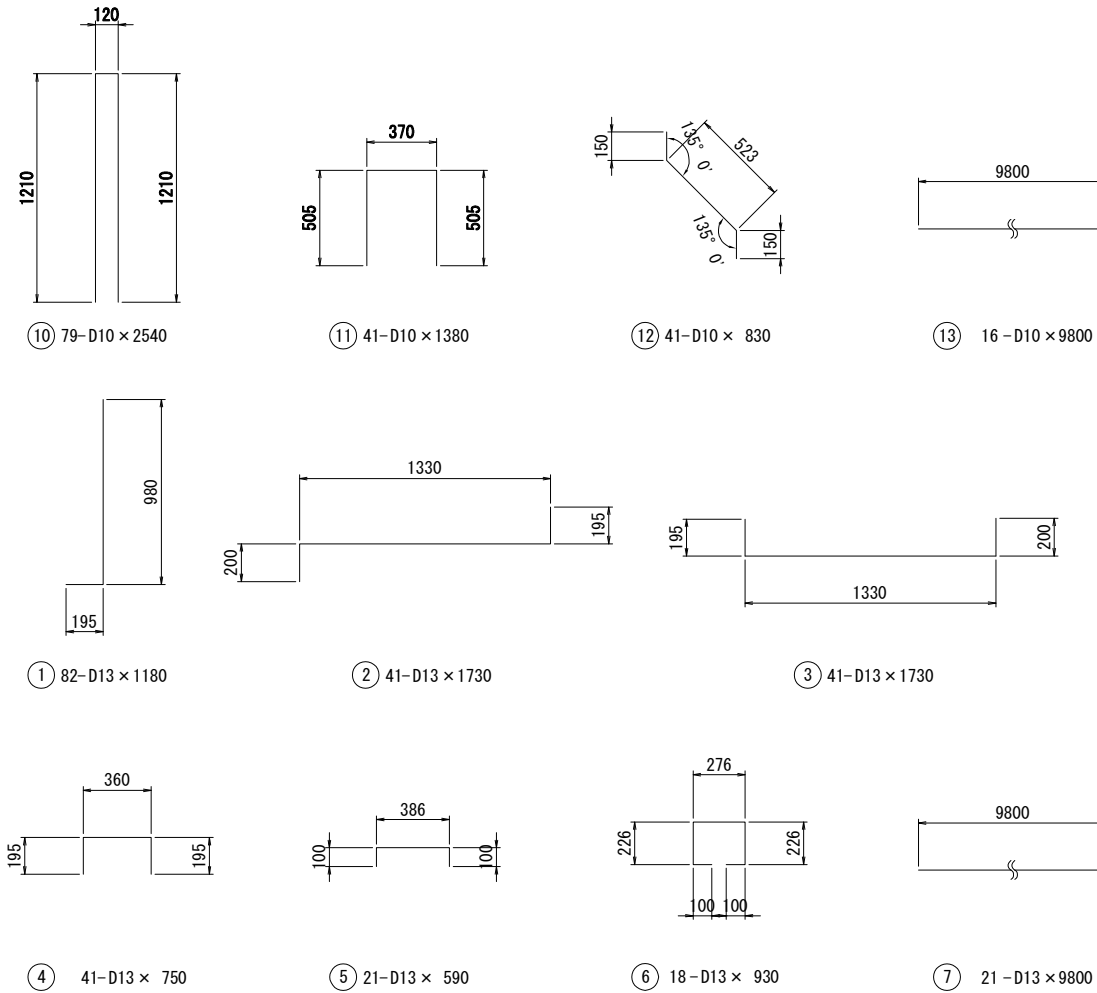

LIST OF REINFORCEMENT (per 10.0m)

NAME	DIAMETER	LENGTH (mm)	NUMBER	UNIT WEIGHT (kg/m)	WEIGHT/BAR (kg)	WEIGHT (kg)	REMARKS
HANDRAIL							
10	D10	2540	79	0.560	1.42	112	□
11	D10	1380	41	0.560	0.77	32	□
12	D10	830	41	0.560	0.46	19	□
13	D10	9800	16	0.560	5.49	88	□
BOTTOM SLAB							
1	D13	1180	82	0.995	1.17	96	□
2	D13	1730	41	0.995	1.72	71	□
3	D13	1730	41	0.995	1.72	71	□
4	D13	750	41	0.995	0.75	31	□
5	D13	590	21	0.995	0.59	12	□
6	D13	930	18	0.995	0.93	17	□
7	D13	9800	21	0.995	9.75	205	□
						D10	251 kg
						D13	503 kg
total						754 kg	

DETAIL OF L TYPE RETAINING WALL(1)

LEFT SIDE (DEVELOP FROM BACK SIDE) S=1:200

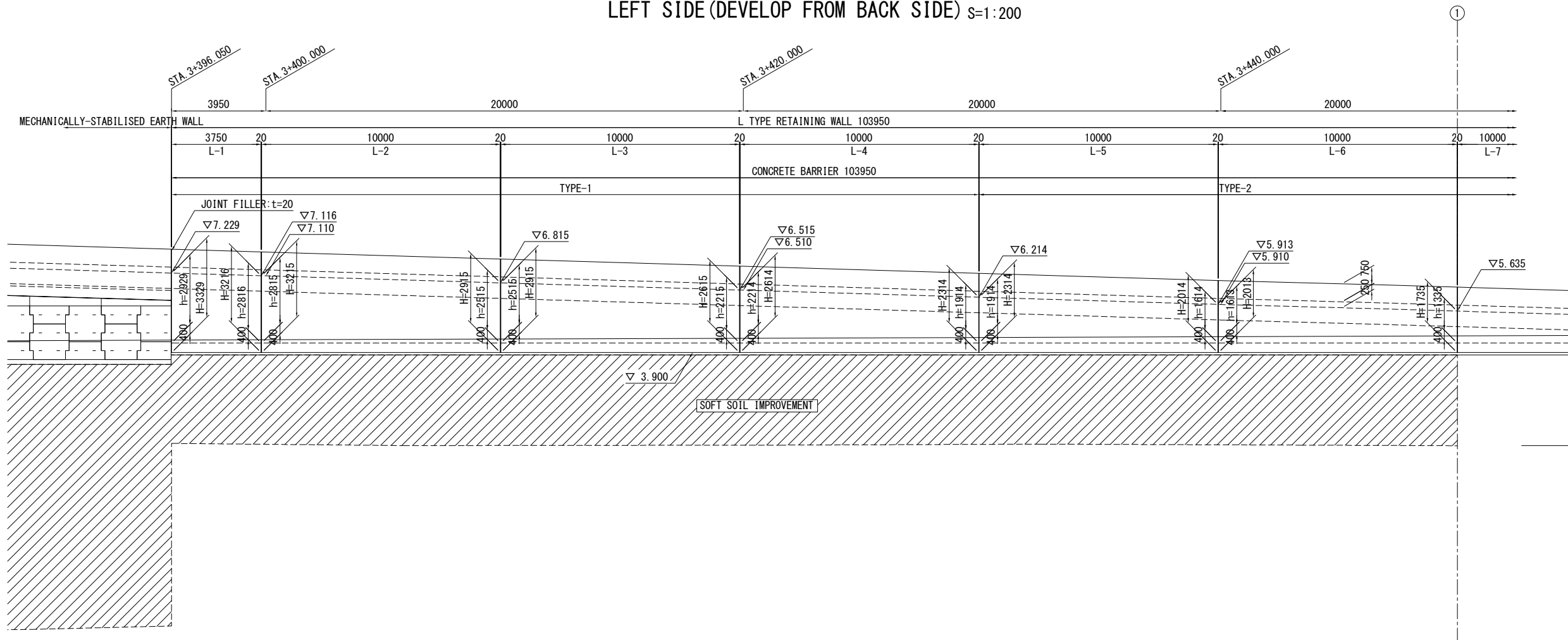

(TYPE-1)

CROSS SECTION S=1:200 (TYPE-2)

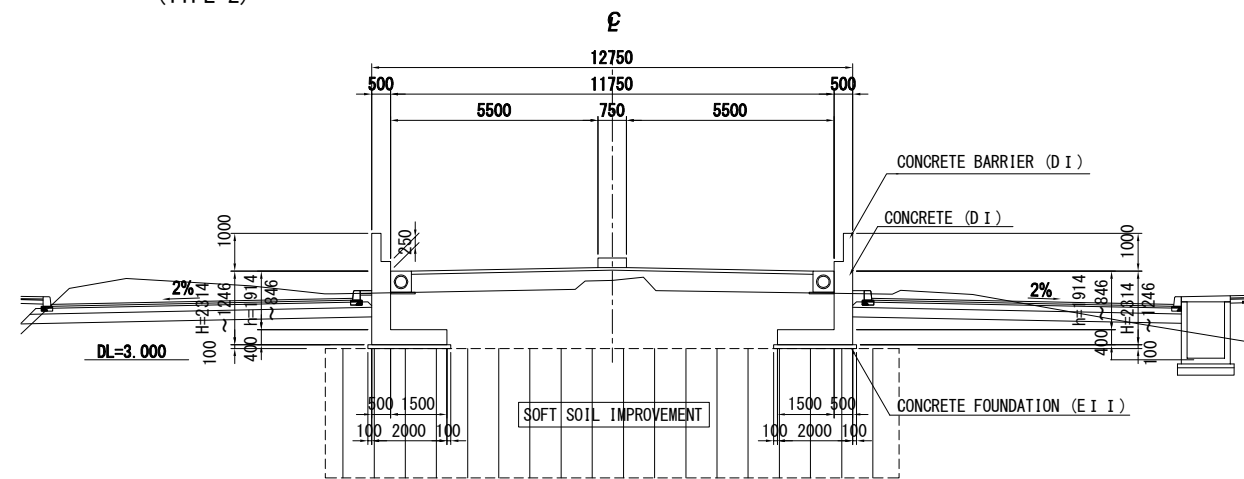
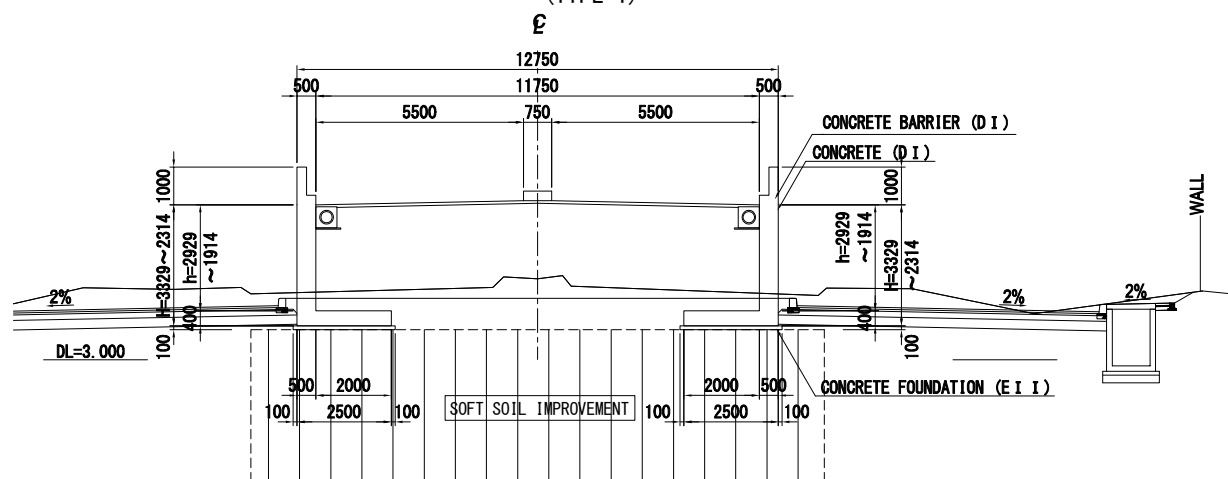

PROJECT NAME
DETAILED DESIGN ON
BAGO RIVER BRIDGE
CONSTRUCTION PROJECT

FINANCED BY
JICA
JAPAN INTERNATIONAL
COOPERATION AGENCY

COUNTERPART
REPUBLIC OF THE UNION OF MYANMAR
MINISTRY OF CONSTRUCTION
DEPARTMENT OF BRIDGE

JICA STUDY TEAM
NIPON KOEI CO., LTD.
ORIENTAL CONSULTANTS GLOBAL CO., LTD.
METROPOLITAN EXPRESSWAY COMPANY LIMITED
CHODAI CO., LTD.
NIPPON ENGINEERING CONSULTANTS CO., LTD.

	NAME	SIGNATURE	DATE
PREPARED BY	K. TACHIBANA		29 Sep.2017
CHECKED BY	T. HAYAKAWA		3 Oct.2017
APPROVED BY	Y. SANO		6 Oct.2017

DRAWING TITLE
DETAIL OF L TYPE RETAINING WALL(1)

PACKAGE
3
DWG No.
P3-RD-4180

DETAIL OF L TYPE RETAINING WALL(2)

LEFT SIDE (DEVELOP FROM BACK SIDE) S=1:200

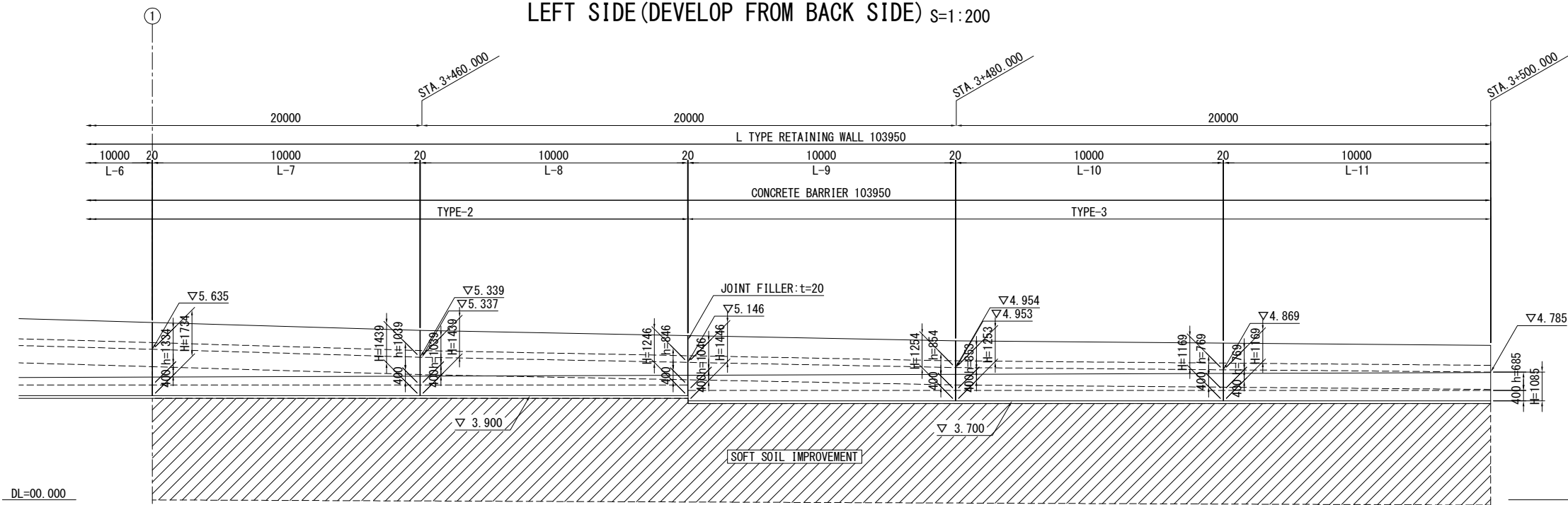

CROSS SECTION S=1:200

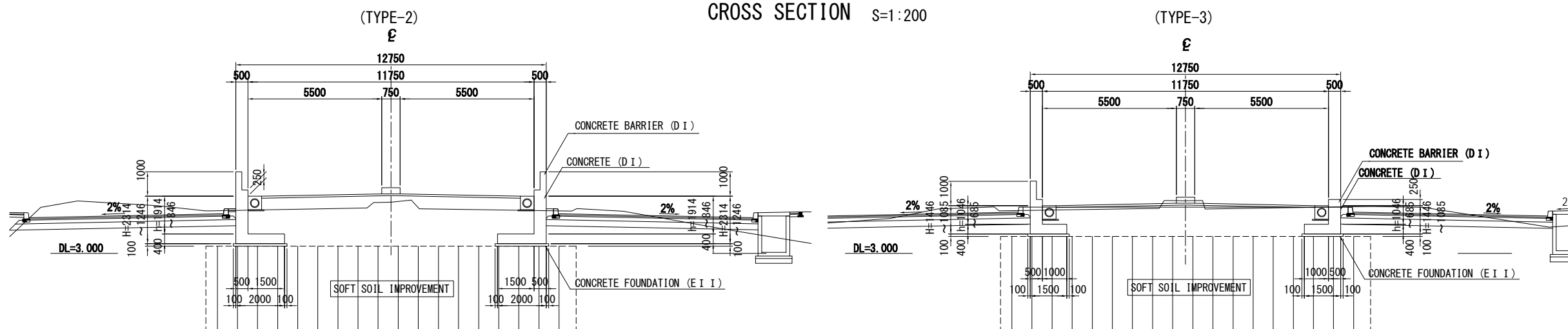

PROJECT NAME
DETAILED DESIGN ON
BAGO RIVER BRIDGE
CONSTRUCTION PROJECT

FINANCED BY
JICA JAPAN INTERNATIONAL
COOPERATION AGENCY

COUNTERPART
 REPUBLIC OF THE UNION OF MYANMAR
MINISTRY OF CONSTRUCTION
DEPARTMENT OF BRIDGE

JICA STUDY TEAM
 NIPPON KOEI CO., LTD.
 ORIENTAL CONSULTANTS GLOBAL CO., LTD.
 METROPOLITAN EXPRESSWAY COMPANY LIMITED
 CHODAI CO., LTD.
 NIPPON ENGINEERING CONSULTANTS CO., LTD.

	NAME	SIGNATURE	DATE
PREPARED BY	K. TACHIBANA		29 Sep.2017
CHECKED BY	T. HAYAKAWA		3 Oct.2017
APPROVED BY	Y. SANO		6 Oct.2017

DRAWING TITLE
DETAIL OF L TYPE RETAINING WALL(2)

PACKAGE
3
DWG No.
P3-RD-4190

DETAIL OF L TYPE RETAINING WALL(3)

RIGHT SIDE S=1:200

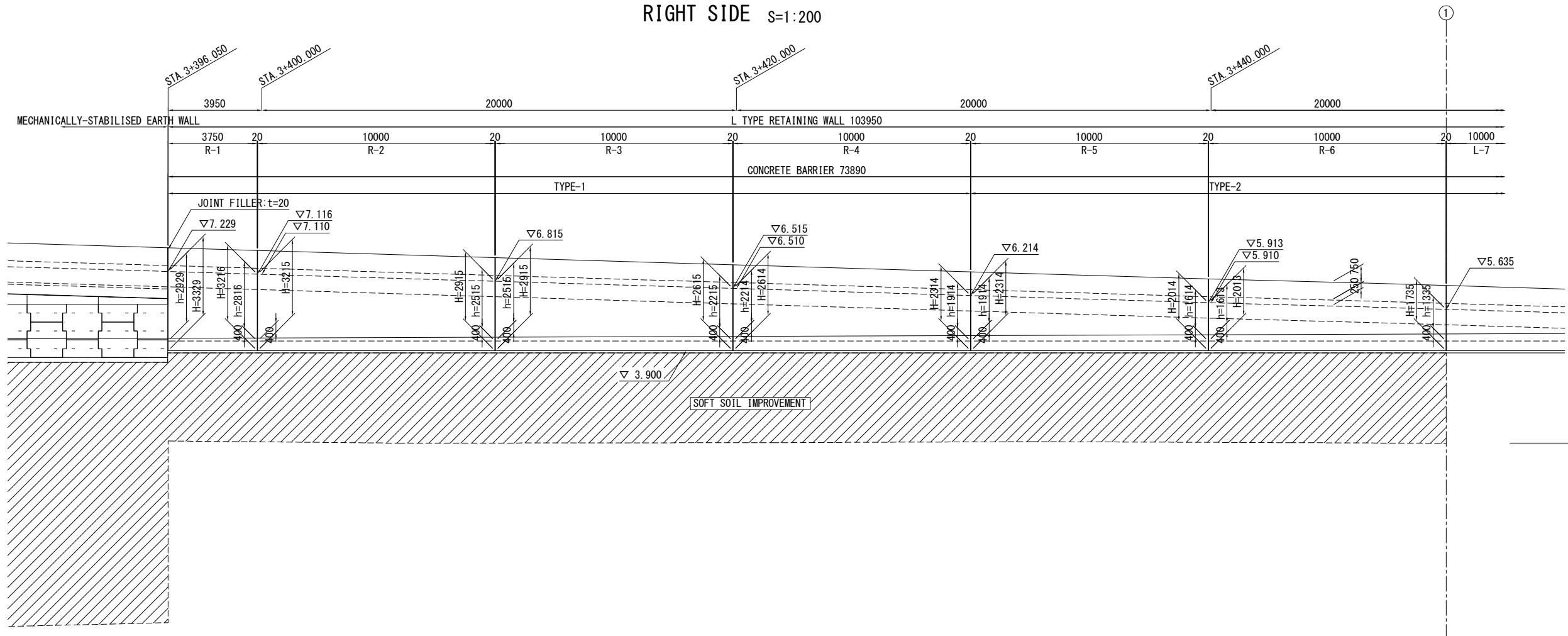

CROSS SECTION S=1:200

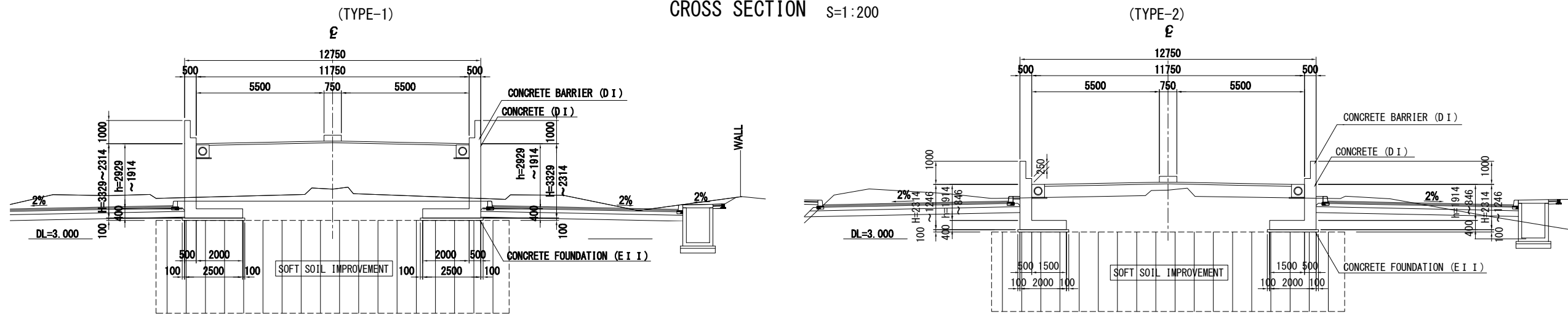

PROJECT NAME
DETAILED DESIGN ON
BAGO RIVER BRIDGE
CONSTRUCTION PROJECT

FINANCED BY
JICA JAPAN INTERNATIONAL
COOPERATION AGENCY

COUNTERPART
 REPUBLIC OF THE UNION OF MYANMAR
MINISTRY OF CONSTRUCTION
DEPARTMENT OF BRIDGE

JICA STUDY TEAM

NIPPON KOEI CO., LTD.
ORIENTAL CONSULTANTS GLOBAL CO., LTD.
METROPOLITAN EXPRESSWAY COMPANY LIMITED
CHODAI CO., LTD.
NIPPON ENGINEERING CONSULTANTS CO., LTD.

	NAME	SIGNATURE	DATE
PREPARED BY	K. TACHIBANA		29 Sep.2017
CHECKED BY	T. HAYAKAWA		3 Oct.2017
APPROVED BY	Y. SANO		6 Oct.2017

DRAWING TITLE
DETAIL OF L TYPE RETAINING WALL(3)

PACKAGE
3
DWG No.
P3-RD-4200

DETAIL OF L TYPE RETAINING WALL(4)

RIGHT SIDE S=1:200

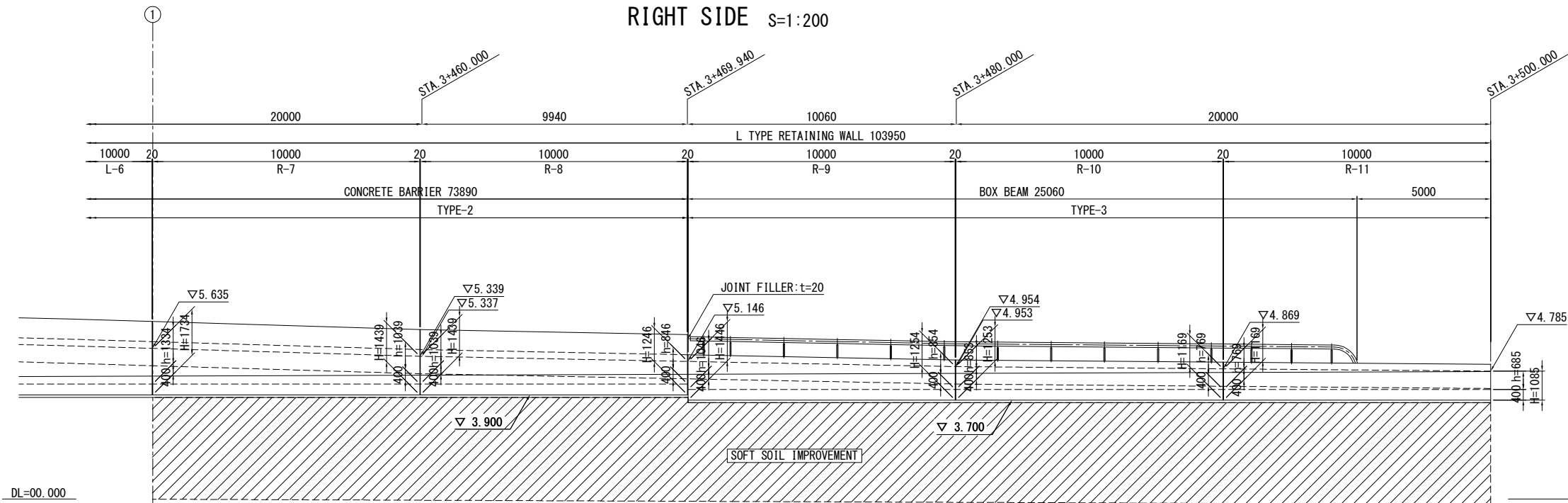

CROSS SECTION S=1:200

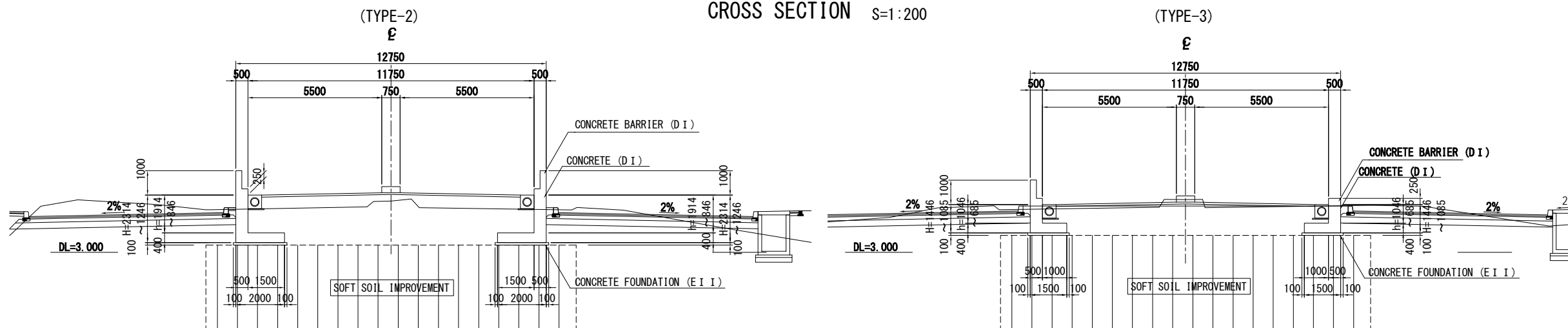

PROJECT NAME
DETAILED DESIGN ON
BAGO RIVER BRIDGE
CONSTRUCTION PROJECT

FINANCED BY
JICA JAPAN INTERNATIONAL
COOPERATION AGENCY

COUNTERPART
 REPUBLIC OF THE UNION OF MYANMAR
MINISTRY OF CONSTRUCTION
DEPARTMENT OF BRIDGE

JICA STUDY TEAM
 NIPPON KOEI CO., LTD.
ORIENTAL CONSULTANTS GLOBAL CO., LTD.
METROPOLITAN EXPRESSWAY COMPANY LIMITED
CHODAI CO., LTD.
NIPPON ENGINEERING CONSULTANTS CO., LTD.

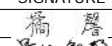
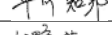
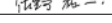
	NAME	SIGNATURE	DATE
PREPARED BY	K. TACHIBANA		29 Sep.2017
CHECKED BY	T. HAYAKAWA		3 Oct.2017
APPROVED BY	Y. SANO		6 Oct.2017

DRAWING TITLE
DETAIL OF L TYPE RETAINING WALL(4)

PACKAGE
3
DWG No.
P3-RD-4210

BAR ARRANGEMENT OF L TYPE RETAINING WALL(1) S=1:40

CONCRETE BARRIER(1) L-1 · R-1

SECTION

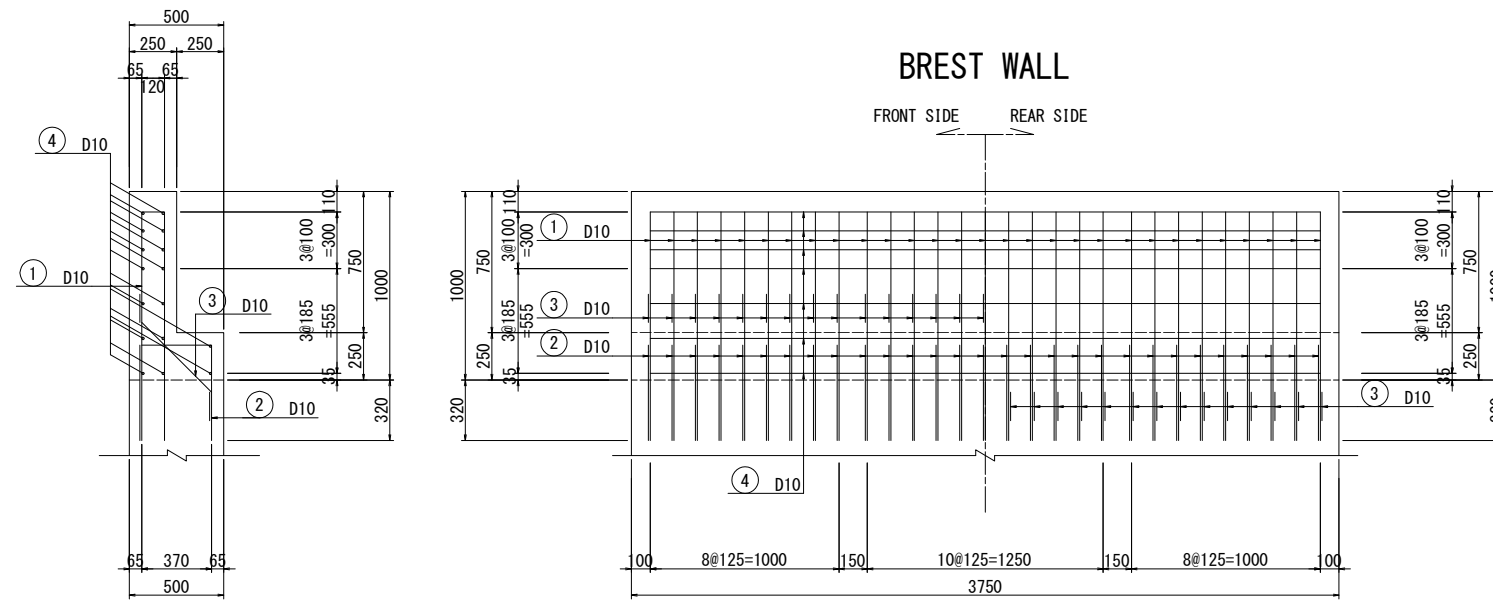

BAR SCHEDULING

BAR ASSEMBLING

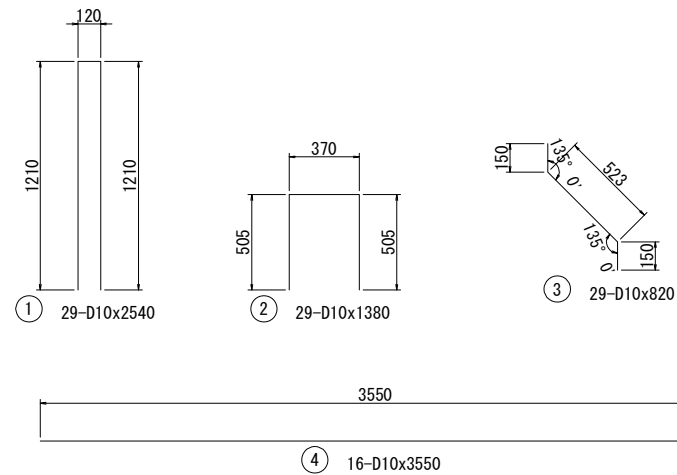
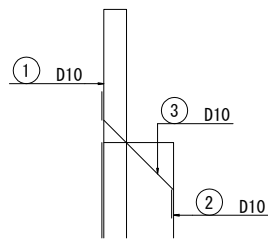

LIST OF REINFORCEMENT

NAME	DIAMETER	LENGTH (mm)	NUMBER	UNIT WEIGHT (kg/m)	WEIGHT/BAR (kg)	WEIGHT (kg)	REMARKS
1	D10	2540	29	0.56	1.42	41	
2	D10	1380	29	0.56	0.77	22	
3	D10	820	29	0.56	0.46	13	
4	D10	3550	16	0.56	1.99	32	
						108	
						D10	108 kg
						total	108 kg

KEY PLAN

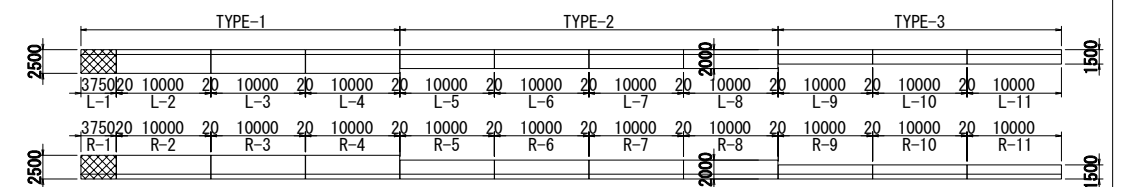

BAR ARRANGEMENT OF L TYPE RETAINING WALL(2) S=1:40

CONCRETE BARRIER (2) L2~11 · R2~8

SECTION

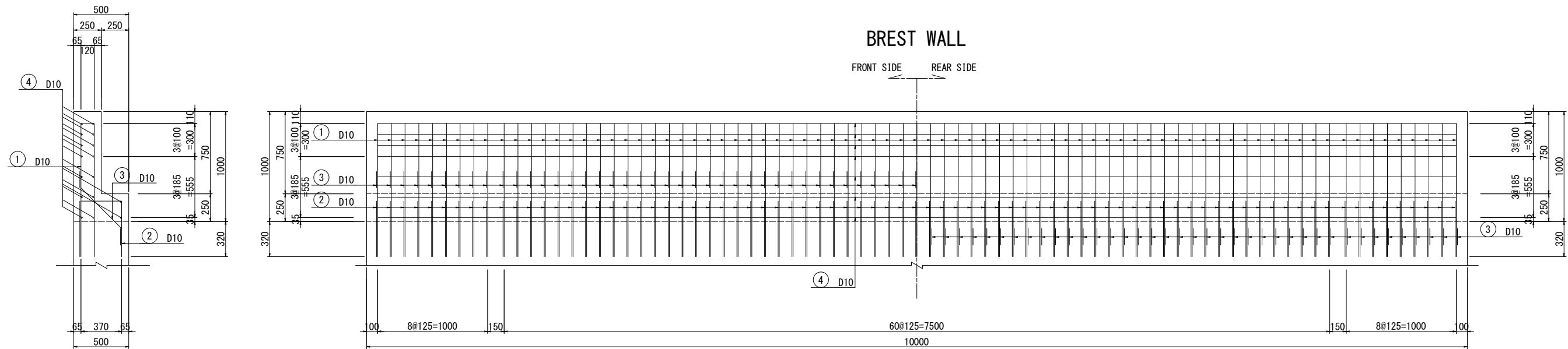

BAR SCHEDULING

BAR ASSEMBLING

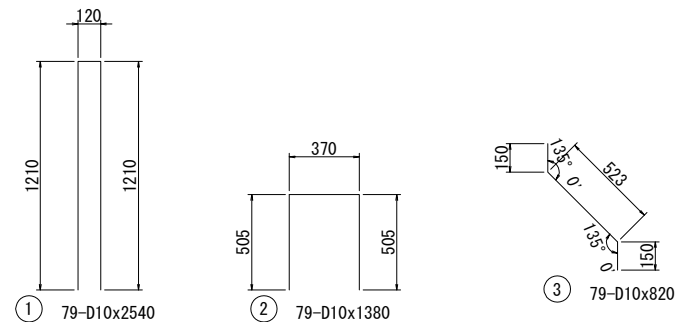
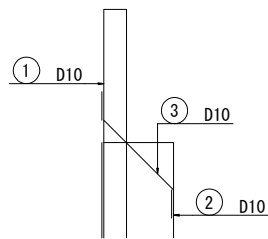

9800

④ 16-D10x9800

LIST OF REINFORCEMENT

NAME	DIAMETER	LENGTH (mm)	NUMBER	UNIT WEIGHT (kg/m)	WEIGHT/BAR (kg)	WEIGHT (kg)	REMARKS
1	D10	2540	79	0.56	1.42	112	
2	D10	1380	79	0.56	0.77	61	
3	D10	820	79	0.56	0.46	36	
4	D10	9800	16	0.56	5.49	88	
						297	
						D10	297 kg
						total	297 kg

KEY PLAN

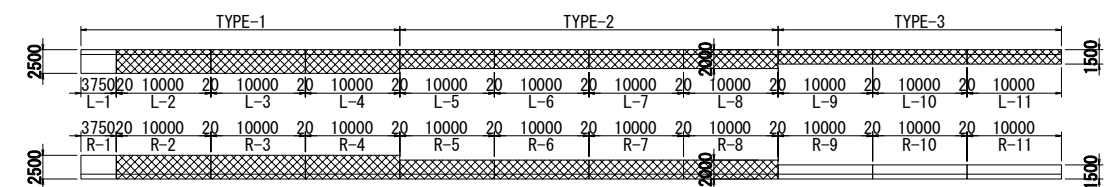

PROJECT NAME
DETAILED DESIGN ON
BAGO RIVER BRIDGE
CONSTRUCTION PROJECT

FINANCED BY
JICA
JAPAN INTERNATIONAL
COOPERATION AGENCY

COUNTERPART
REPUBLIC OF THE UNION OF MYANMAR
MINISTRY OF CONSTRUCTION
DEPARTMENT OF BRIDGE

JICA STUDY TEAM
NIPPON KOEI CO., LTD.
ORIENTAL CONSULTANTS GLOBAL CO., LTD.
METROPOLITAN EXPRESSWAY COMPANY LIMITED
CHODAI CO., LTD.
NIPPON ENGINEERING CONSULTANTS CO., LTD.

	NAME	SIGNATURE	DATE
PREPARED BY	K. TACHIBANA		29 Sep.2017
CHECKED BY	T. HAYAKAWA		3 Oct.2017
APPROVED BY	Y. SANO		6 Oct.2017

DRAWING TITLE
BAR ARRANGEMENT OF L TYPE RETAINING WALL(2)

PACKAGE
3
DWG No.
P3-RD-4230

BAR ARRANGEMENT OF L TYPE RETAINING WALL(3) S=1:40

CONCRETE BARRIER (3) R-9~11

SECTION

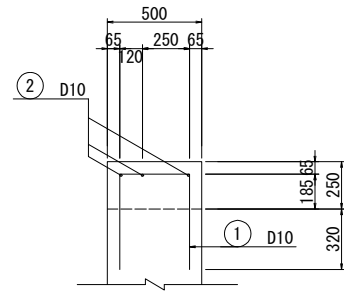

BREST WALL

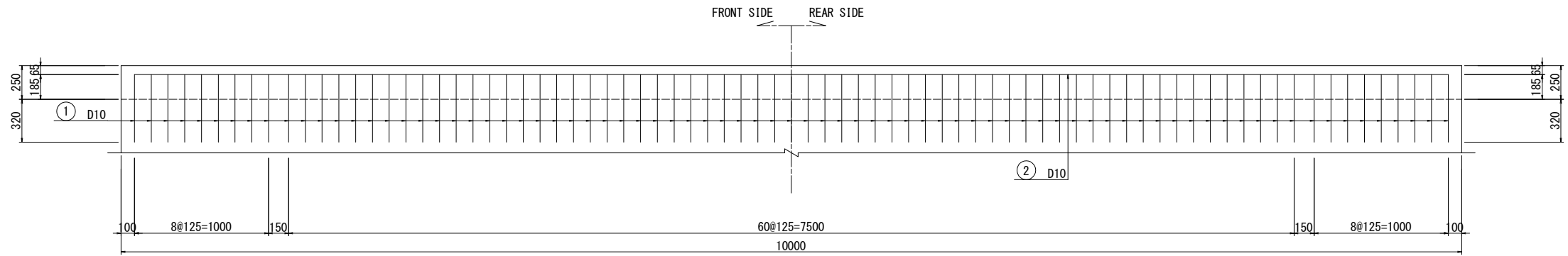

BAR SCHEDULING

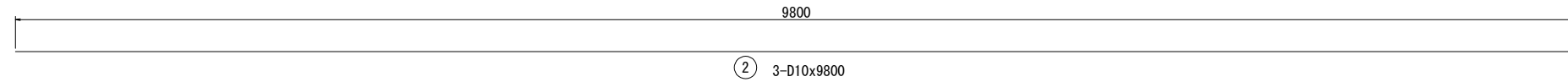
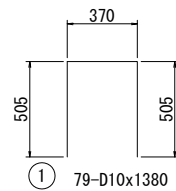

LIST OF REINFORCEMENT

NAME	DIAMETER	LENGTH (mm)	NUMBER	UNIT WEIGHT (kg/m)	WEIGHT/BAR (kg)	WEIGHT (kg)	REMARKS
1	D10	1380	79	0.56	0.77	61	□
2	D10	9800	3	0.56	5.49	16	—
						77	
						D10	77 kg
						total	77 kg

KEY PLAN

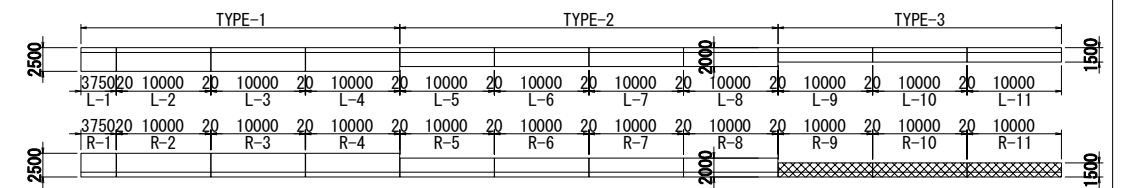

PROJECT NAME DETAILED DESIGN ON BAGO RIVER BRIDGE CONSTRUCTION PROJECT	FINANCED BY JAPAN INTERNATIONAL COOPERATION AGENCY	COUNTERPART REPUBLIC OF THE UNION OF MYANMAR MINISTRY OF CONSTRUCTION DEPARTMENT OF BRIDGE	JICA STUDY TEAM NIPPON KOEI CO., LTD. ORIENTAL CONSULTANTS GLOBAL CO., LTD. METROPOLITAN EXPRESSWAY COMPANY LIMITED CHODAI CO., LTD. NIPPON ENGINEERING CONSULTANTS CO., LTD.	NAME	SIGNATURE	DATE	DRAWING TITLE BAR ARRANGEMENT OF L TYPE RETAINING WALL(3)	PACKAGE	
				PREPARED BY	K. TACHIBANA			29 Sep.2017	3
				CHECKED BY	T. HAYAKAWA			3 Oct.2017	DWG No.
				APPROVED BY	Y. SANO			6 Oct.2017	P3-RD-4240

BAR ARRANGEMENT OF L TYPE RETAINING WALL(4) S=1:40

WALL (1) L-1 · R-1

BREST WALL

FRONT SIDE REAR SIDE

SECTION

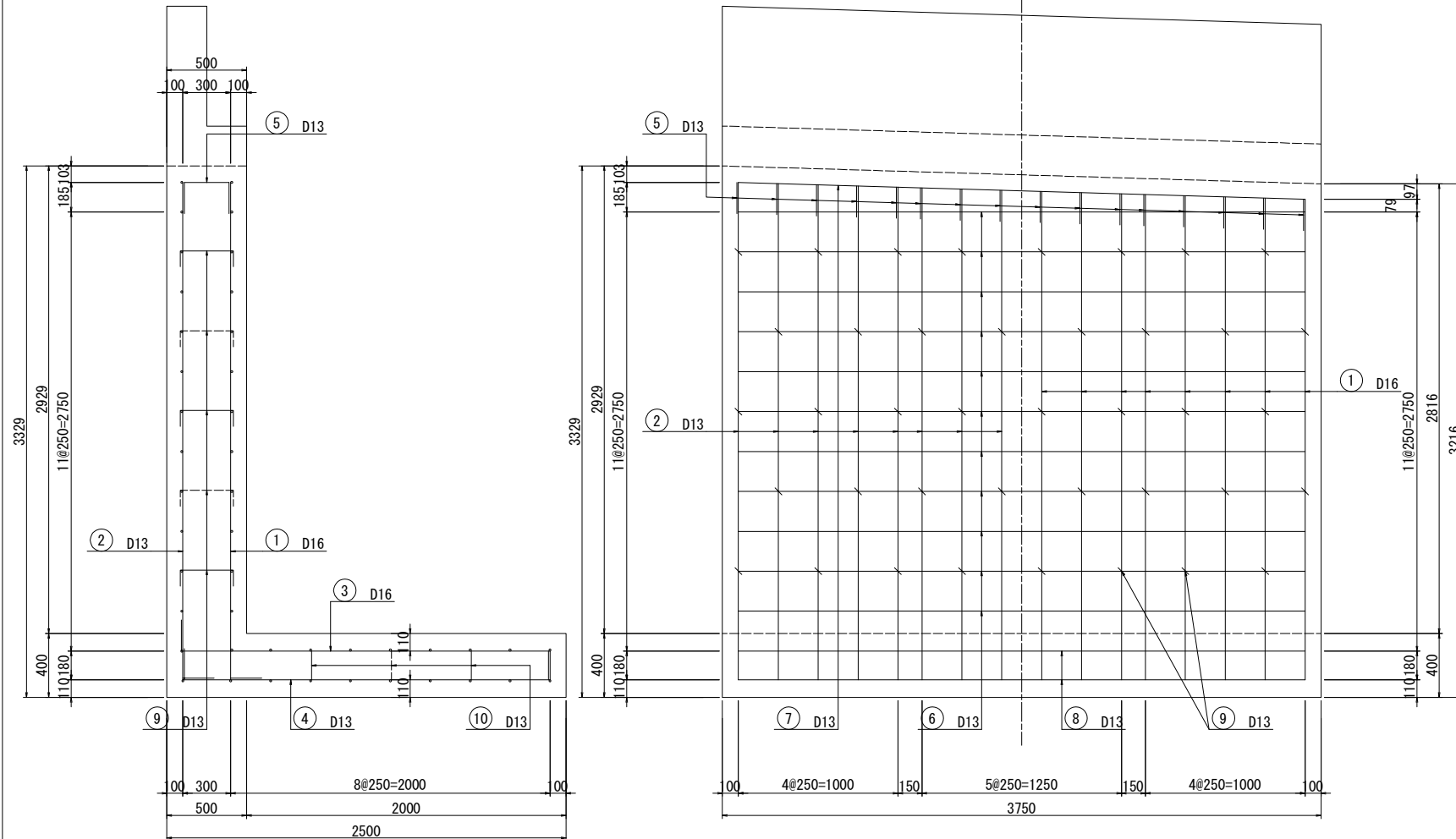

BAR ASSEMBLING

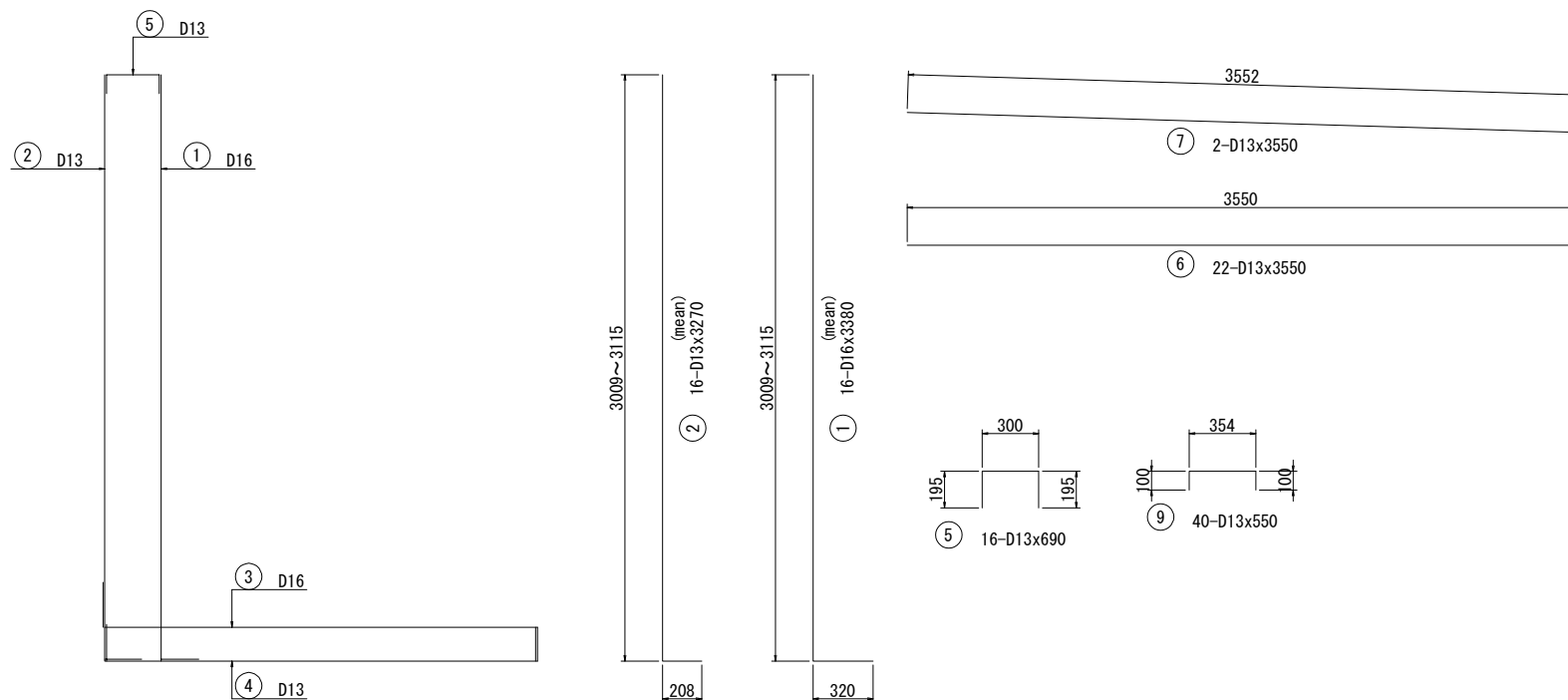

LIST OF REINFORCEMENT

NAME	DIAMETER	LENGTH (mm)	NUMBER	UNIT WEIGHT (kg/m)	WEIGHT/BAR (kg)	WEIGHT (kg)	REMARKS
1	D16	3380	16	1.56	5.27	84	L (mean)
2	D13	3270	16	0.995	3.25	52	L (mean)
3	D16	2720	16	1.56	4.24	68	L
4	D13	2680	16	0.995	2.67	43	L
5	D13	690	16	0.995	0.69	11	L
6	D13	3550	22	0.995	3.53	78	—
7	D13	3550	2	0.995	3.53	7	—
8	D13	3550	20	0.995	3.53	71	—
9	D13	550	40	0.995	0.55	22	L
10	D13	1150	11	0.995	1.14	13	L
						449	
						D13	297 kg
						D16	152 kg
						total	449 kg

KEY PLAN

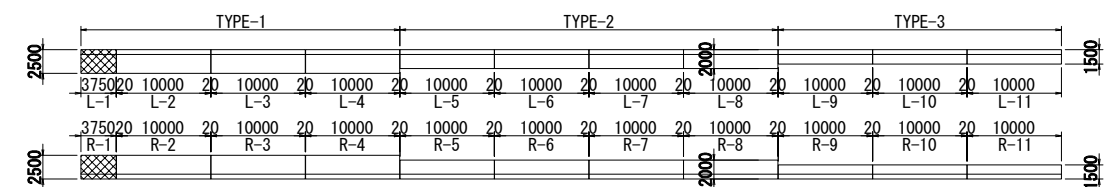

BAR ARRANGEMENT OF L TYPE RETAINING WALL(5) S=1:40

WALL (2) L-2 · R-2

BREAST WALL

FRONT SIDE REAR SIDE

SECTION

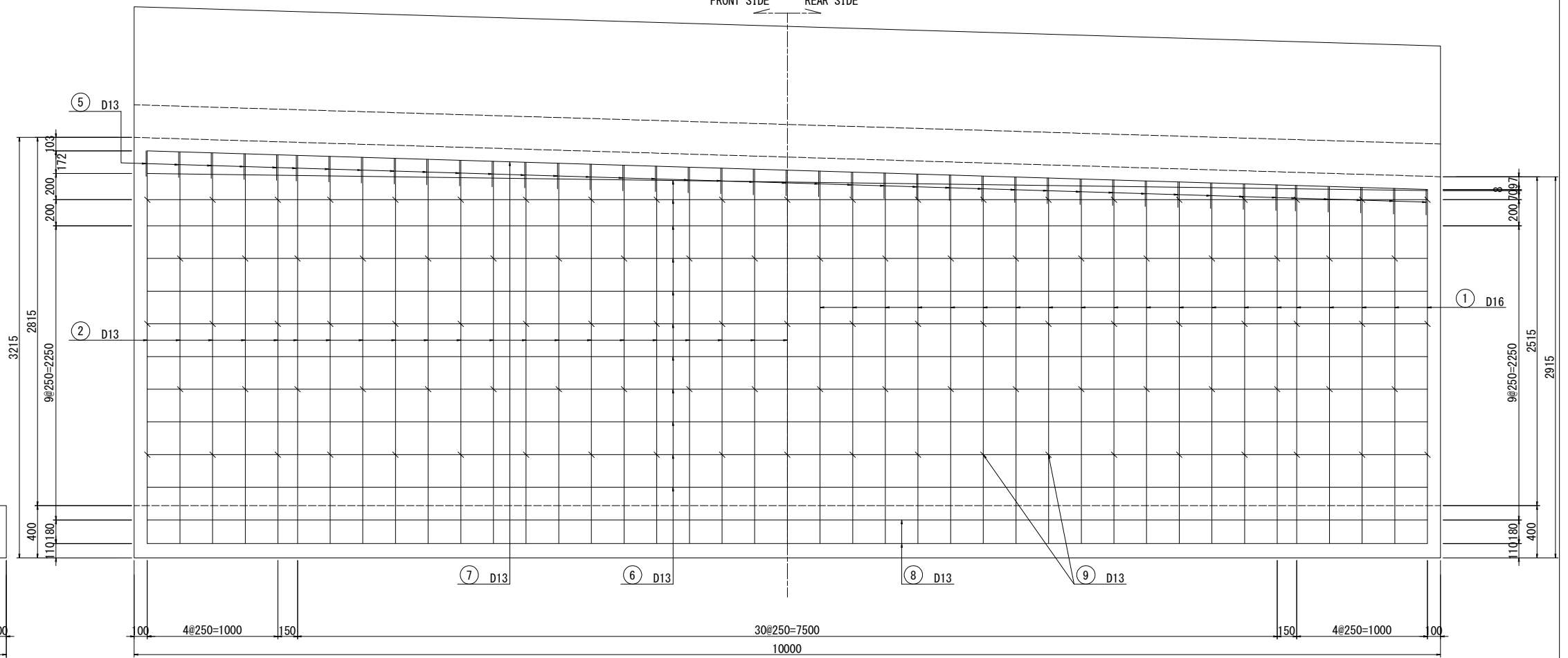
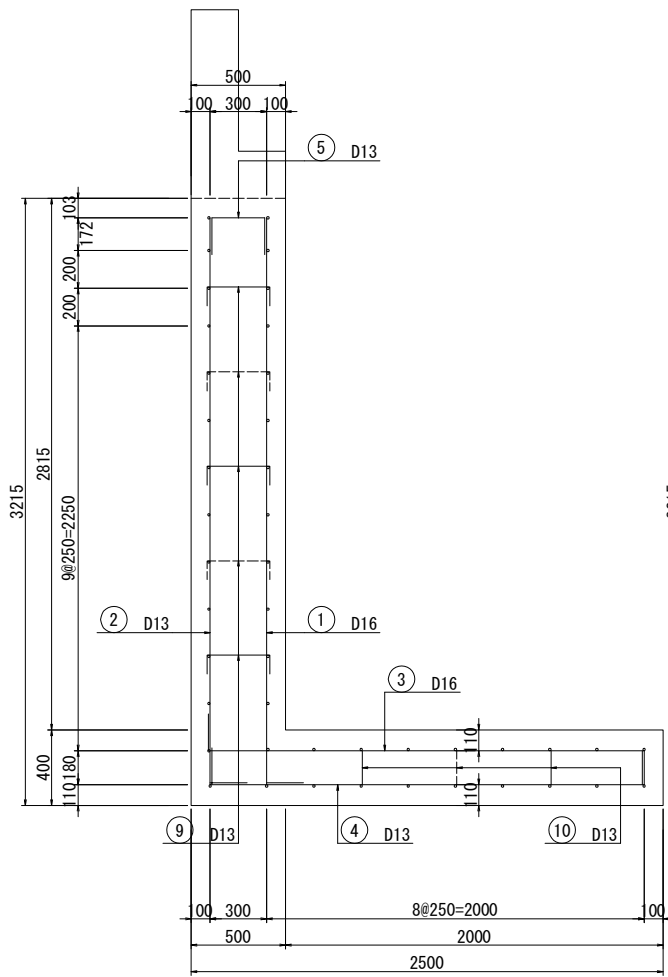

BAR ASSEMBLING

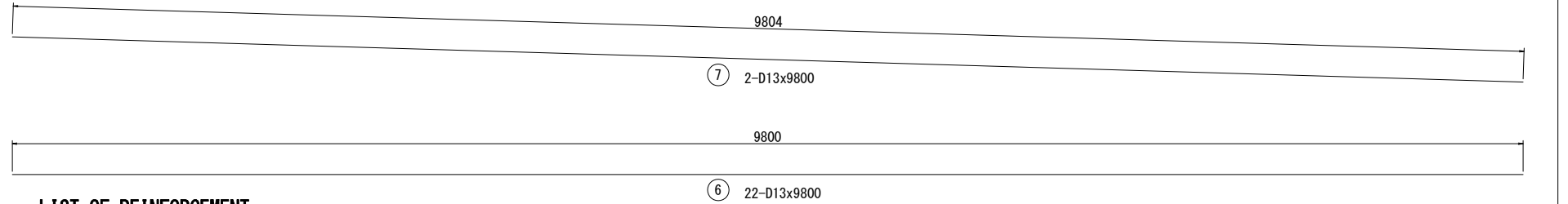
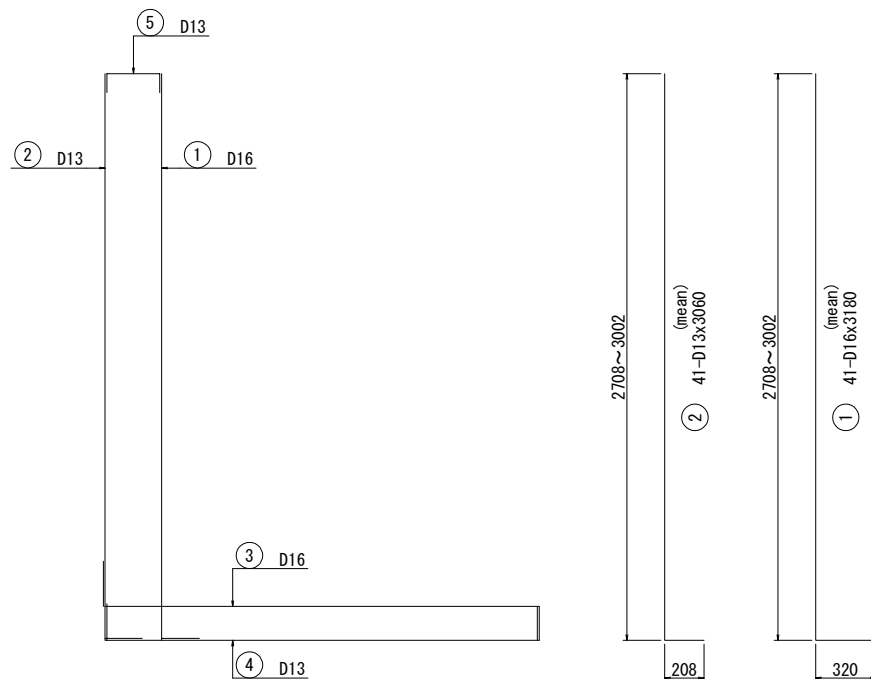

LIST OF REINFORCEMENT

NAME	DIAMETER	LENGTH (mm)	NUMBER	UNIT WEIGHT (kg/m)	WEIGHT/BAR (kg)	WEIGHT (kg)	REMARKS
1	D16	3180	41	1.56	4.96	203	L (mean)
2	D13	3060	41	0.995	3.04	125	L (mean)
3	D16	2720	41	1.56	4.24	174	L
4	D13	2680	41	0.995	2.67	109	L
5	D13	690	41	0.995	0.69	28	L
6	D13	9800	22	0.995	9.75	215	L
7	D13	9800	2	0.995	9.75	20	L
8	D13	9800	20	0.995	9.75	195	L
9	D13	550	103	0.995	0.55	57	L
10	D13	1150	30	0.995	1.14	34	L
						1160	
						D13	783 kg
						D16	377 kg
						total	1160 kg

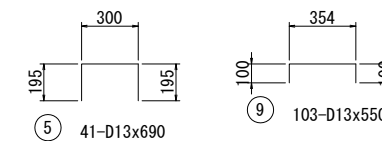

KEY PLAN

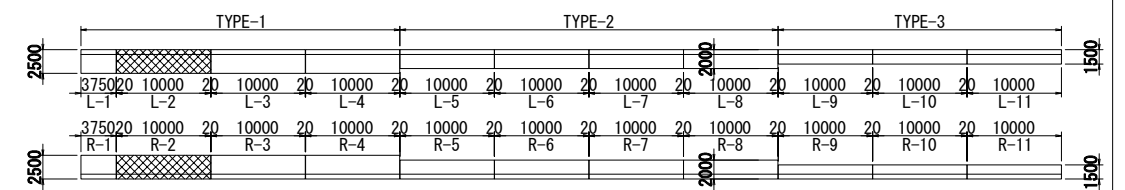

PROJECT NAME
DETAILED DESIGN ON
BAGO RIVER BRIDGE
CONSTRUCTION PROJECT

FINANCED BY
JICA
JAPAN INTERNATIONAL
COOPERATION AGENCY

COUNTERPART
REPUBLIC OF THE UNION OF MYANMAR
MINISTRY OF CONSTRUCTION
DEPARTMENT OF BRIDGE

JICA STUDY TEAM
NIPPON KOEI CO., LTD.
ORIENTAL CONSULTANTS GLOBAL CO., LTD.
METROPOLITAN EXPRESSWAY COMPANY LIMITED
CHODAI CO., LTD.
NIPPON ENGINEERING CONSULTANTS CO., LTD.

	NAME	SIGNATURE	DATE
PREPARED BY	K. TACHIBANA	橋 馨	29 Sep.2017
CHECKED BY	T. HAYAKAWA	平川 知子	3 Oct.2017
APPROVED BY	Y. SANO	佐野 祐一	6 Oct.2017

DRAWING TITLE	PACKAGE
BAR ARRANGEMENT OF L TYPE RETAINING WALL(5)	3
	DWG No.
	P3-RD-4260

BAR ARRANGEMENT OF L TYPE RETAINING WALL(6) S=1:40

WALL (3) L-3 · R-3

BREST WALL

FRONT SIDE REAR SIDE

SECTION

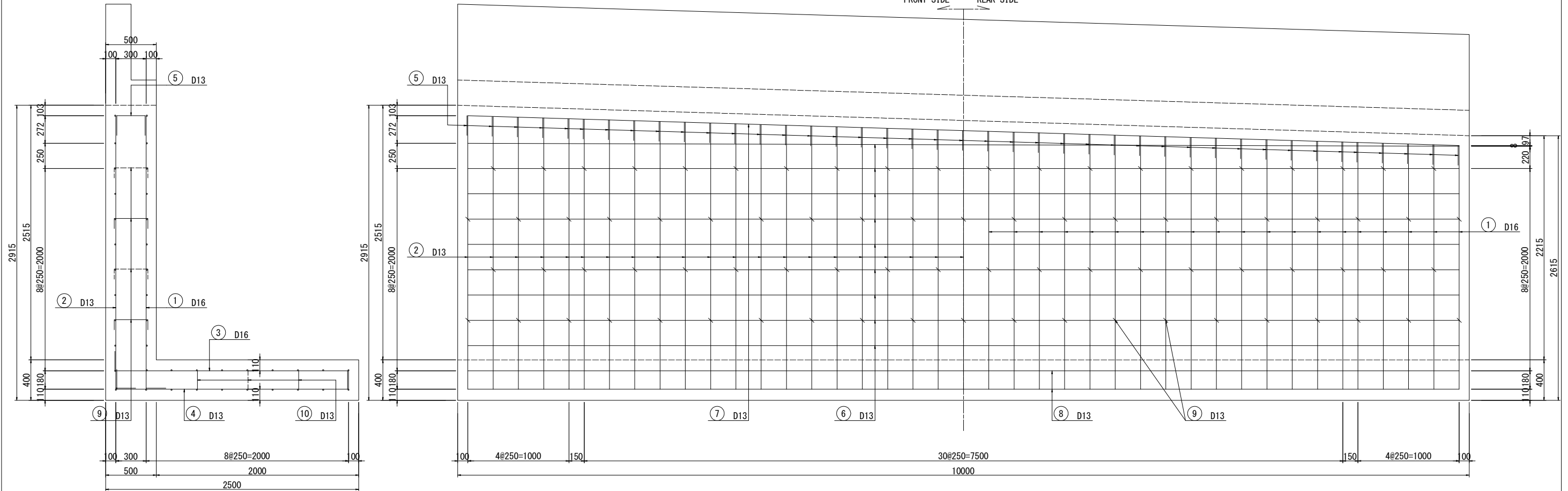

BAR ASSEMBLING

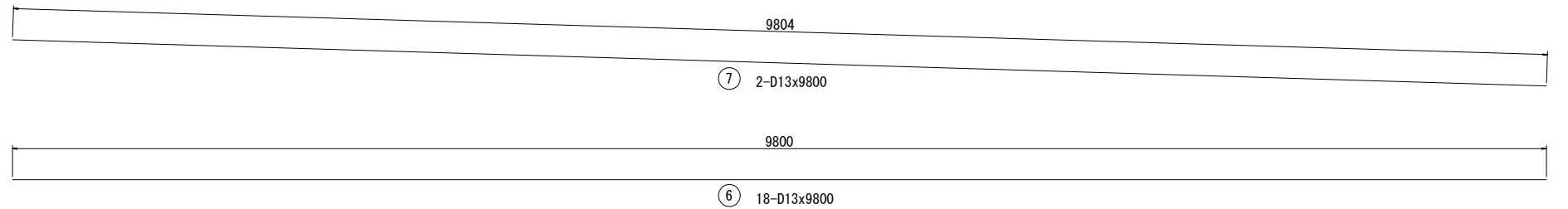
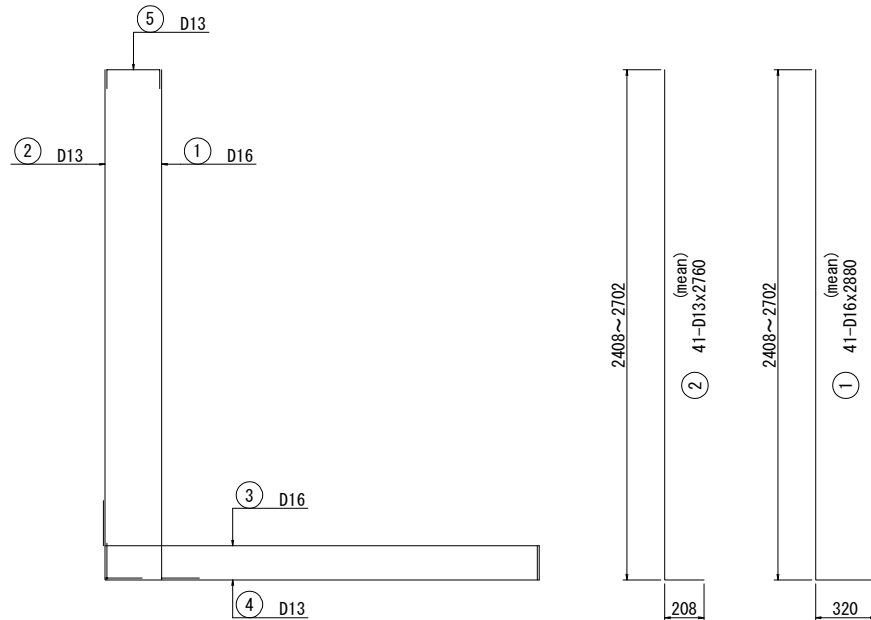

LIST OF REINFORCEMENT

NAME	DIAMETER	LENGTH (mm)	NUMBER	UNIT WEIGHT (kg/m)	WEIGHT/BAR (kg)	WEIGHT (kg)	REMARKS
1	D16	2880	41	1.56	4.49	184	L (mean)
2	D13	2760	41	0.995	2.75	113	L (mean)
3	D16	2720	41	1.56	4.24	174	L
4	D13	2680	41	0.995	2.67	109	L
5	D13	690	41	0.995	0.69	28	L
6	D13	9800	18	0.995	9.75	176	L
7	D13	9800	2	0.995	9.75	20	L
8	D13	9800	20	0.995	9.75	195	L
9	D13	550	82	0.995	0.55	45	L
10	D13	1150	30	0.995	1.14	34	L
						1078	
						D13	720 kg
						D16	358 kg
						total	1078 kg

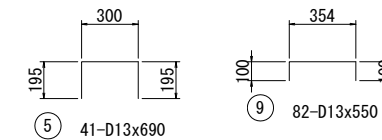

KEY PLAN

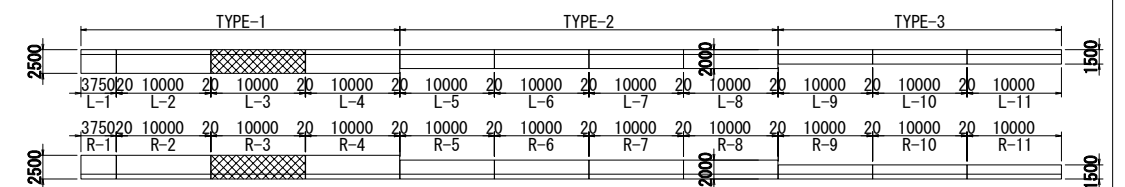

PROJECT NAME
DETAILED DESIGN ON
BAGO RIVER BRIDGE
CONSTRUCTION PROJECT

FINANCED BY
JICA JAPAN INTERNATIONAL
COOPERATION AGENCY

COUNTERPART
REPUBLIC OF THE UNION OF MYANMAR
MINISTRY OF CONSTRUCTION
DEPARTMENT OF BRIDGE

JICA STUDY TEAM
NIPPON KOEI CO., LTD.
ORIENTAL CONSULTANTS GLOBAL CO., LTD.
METROPOLITAN EXPRESSWAY COMPANY LIMITED
CHODAI CO., LTD.
NIPPON ENGINEERING CONSULTANTS CO., LTD.

	NAME	SIGNATURE	DATE
PREPARED BY	K. TACHIBANA	橋 馨	29 Sep.2017
CHECKED BY	T. HAYAKAWA	平川 知平	3 Oct.2017
APPROVED BY	Y. SANO	佐野 祐一	6 Oct.2017

DRAWING TITLE	PACKAGE
BAR ARRANGEMENT OF L TYPE RETAINING WALL(6)	3
	DWG No.
	P3-RD-4270

BAR ARRANGEMENT OF L TYPE RETAINING WALL(7) S=1:40

WALL (4) L-4 · R-4

BREST WALL

FRONT SIDE REAR SIDE

SECTION

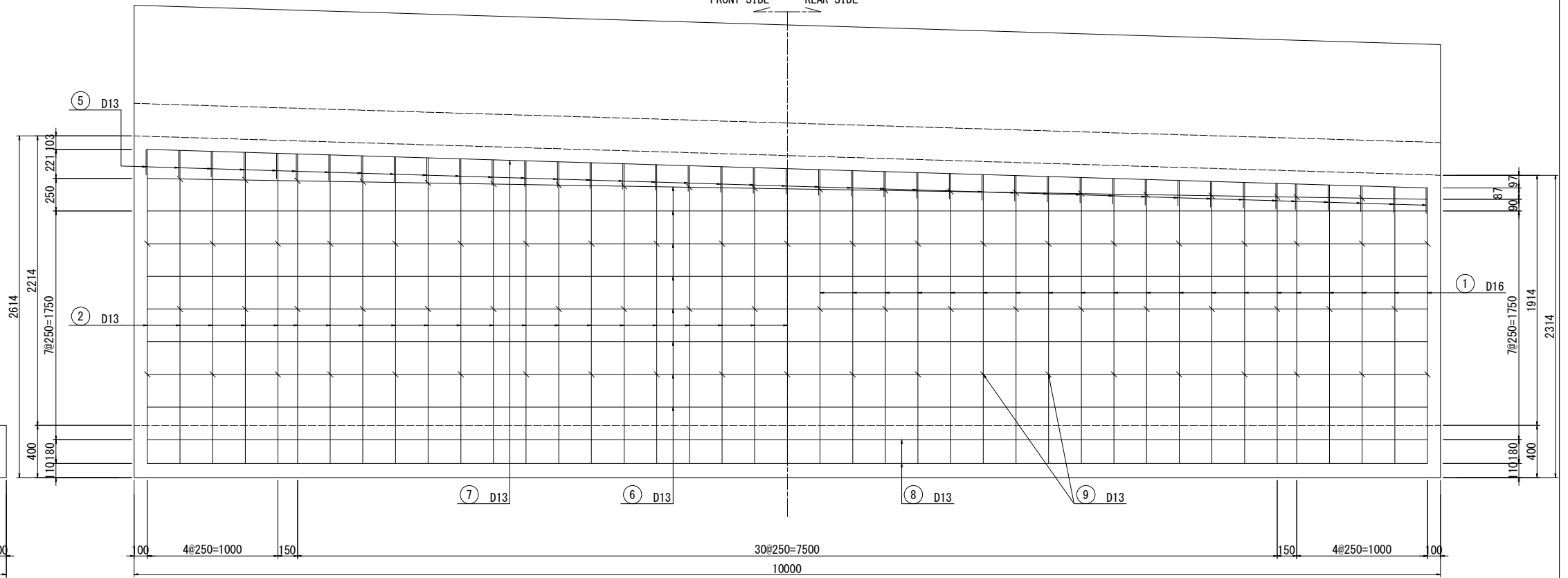
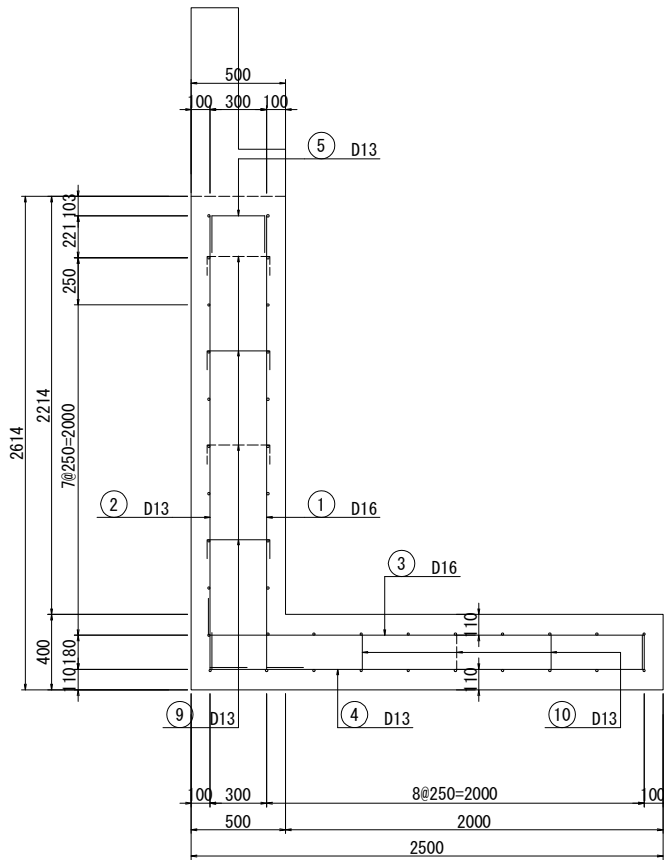

BAR ASSEMBLING

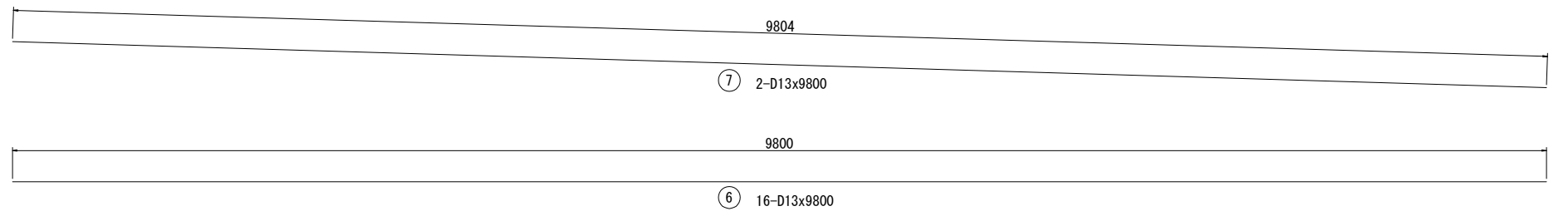
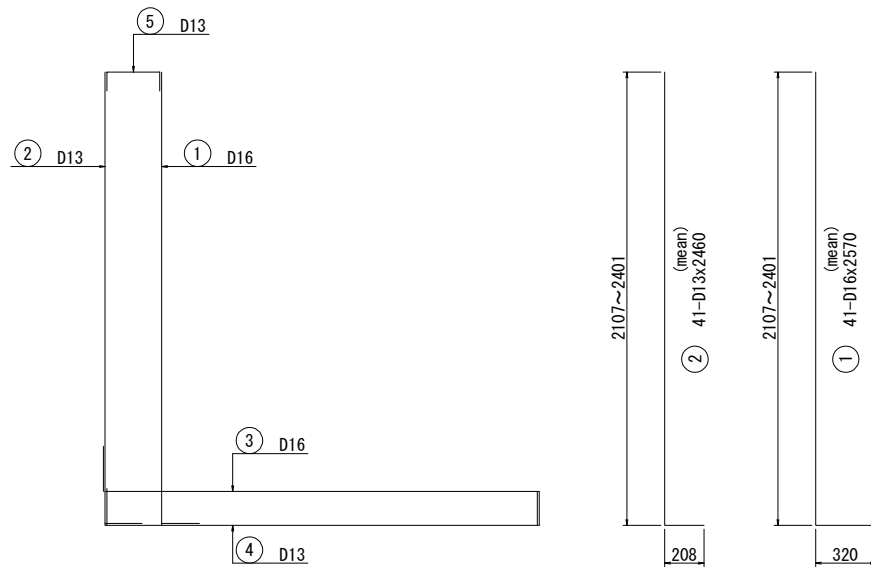

LIST OF REINFORCEMENT

NAME	DIAMETER	LENGTH (mm)	NUMBER	UNIT WEIGHT (kg/m)	WEIGHT/BAR (kg)	WEIGHT (kg)	REMARKS
1	D16	2570	41	1.56	4.01	164	L (mean)
2	D13	2460	41	0.995	2.45	100	L (mean)
3	D16	2720	41	1.56	4.24	174	L
4	D13	2680	41	0.995	2.67	109	L
5	D13	690	41	0.995	0.69	28	L
6	D13	9800	16	0.995	9.75	156	L
7	D13	9800	2	0.995	9.75	20	L
8	D13	9800	20	0.995	9.75	195	L
9	D13	550	82	0.995	0.55	45	L
10	D13	1150	30	0.995	1.14	34	L
						1025	
						D13	687 kg
						D16	338 kg
						total	1025 kg

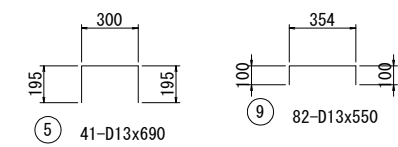

KEY PLAN

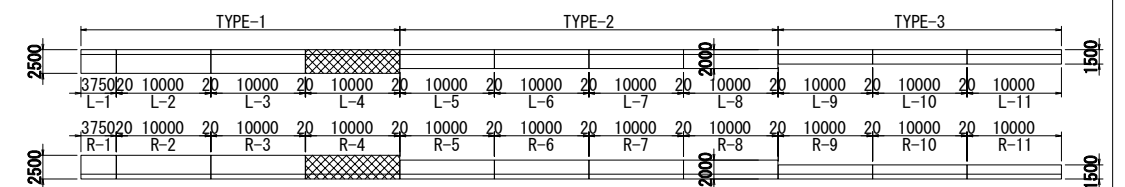

BAR ARRANGEMENT OF L TYPE RETAINING WALL(8) S=1:40

WALL (5) L-5 · R-5

BREST WALL

FRONT SIDE REAR SIDE

SECTION

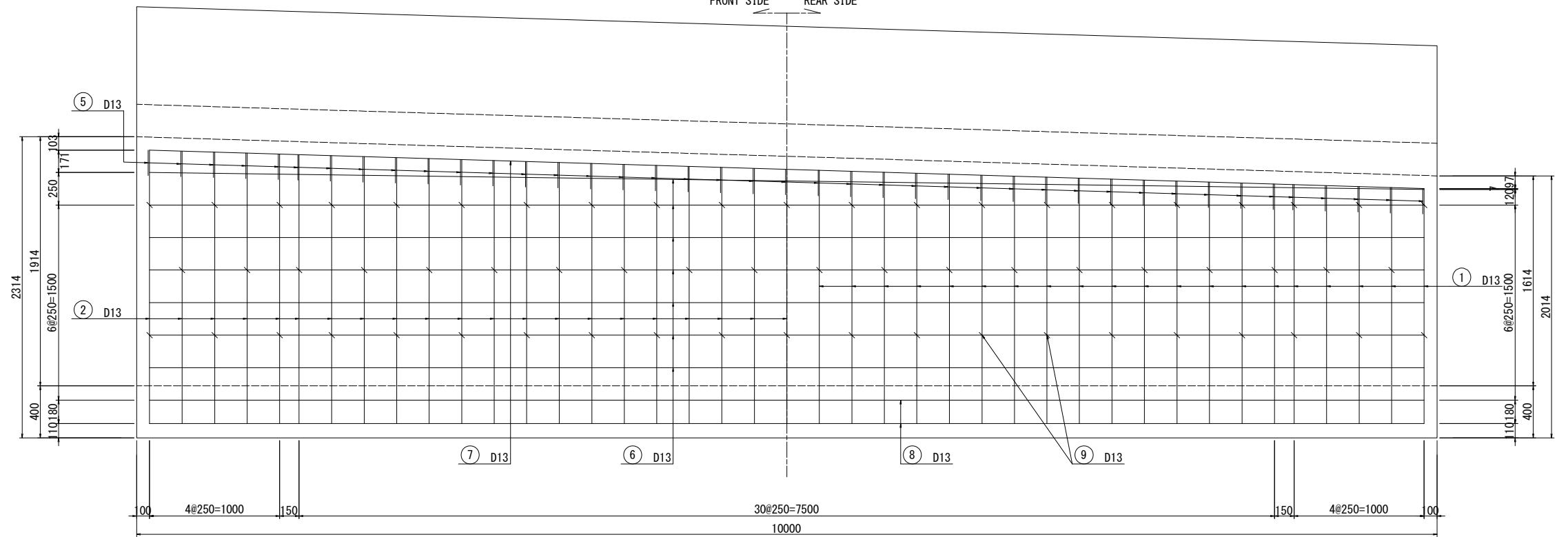
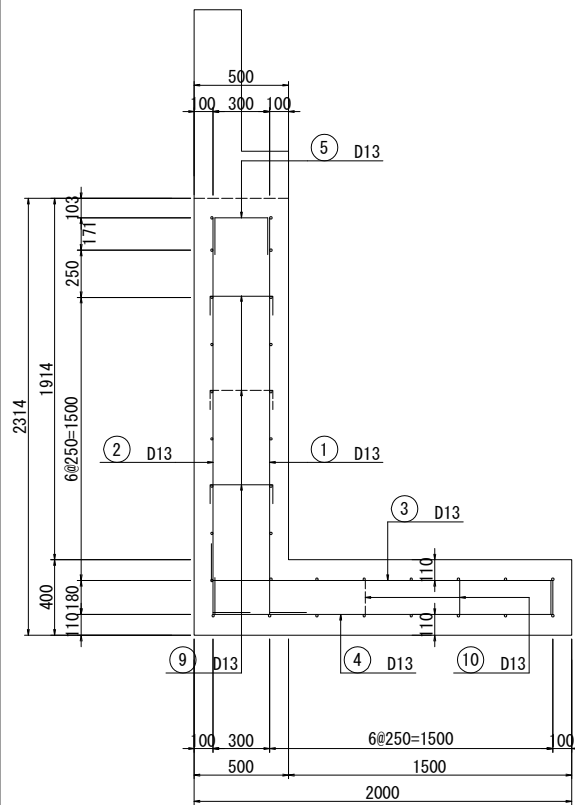

BAR ASSEMBLING

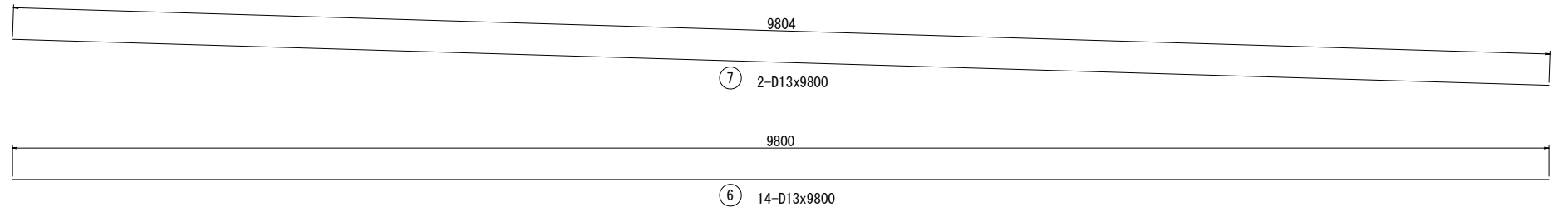
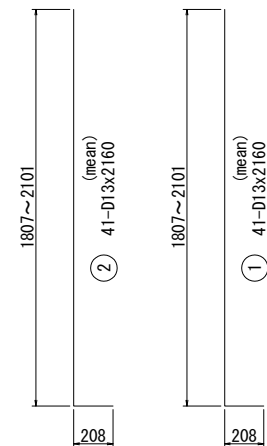
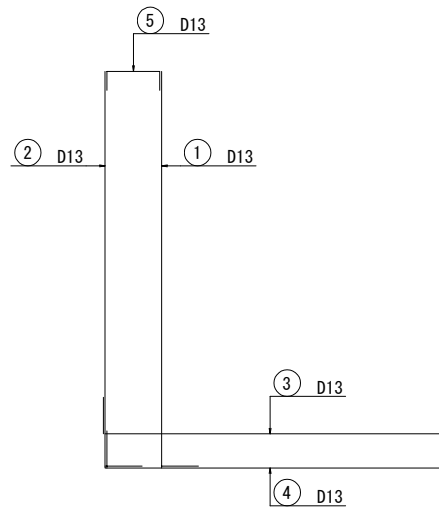

LIST OF REINFORCEMENT

NAME	DIAMETER	LENGTH (mm)	NUMBER	UNIT WEIGHT (kg/m)	WEIGHT/BAR (kg)	WEIGHT (kg)	REMARKS
1	D13	2160	41	0.995	2.15	88	L (mean)
2	D13	2160	41	0.995	2.15	88	L (mean)
3	D13	2180	41	0.995	2.17	89	L
4	D13	2180	41	0.995	2.17	89	L
5	D13	690	41	0.995	0.69	28	L
6	D13	9800	14	0.995	9.75	137	L
7	D13	9800	2	0.995	9.75	20	L
8	D13	9800	16	0.995	9.75	156	L
9	D13	550	62	0.995	0.55	34	L
10	D13	1140	20	0.995	1.13	23	L
						752	
						D13	752 kg
						total	752 kg

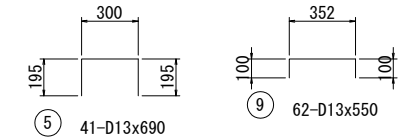

KEY PLAN

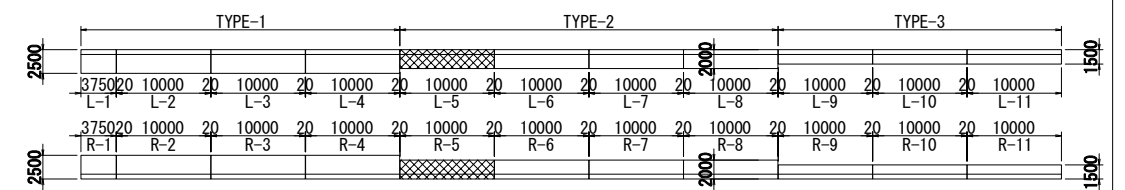

BAR ARRANGEMENT OF L TYPE RETAINING WALL(9) S=1:40

WALL (6) L-6 · R-6

BREST WALL

FRONT SIDE REAR SIDE

SECTION

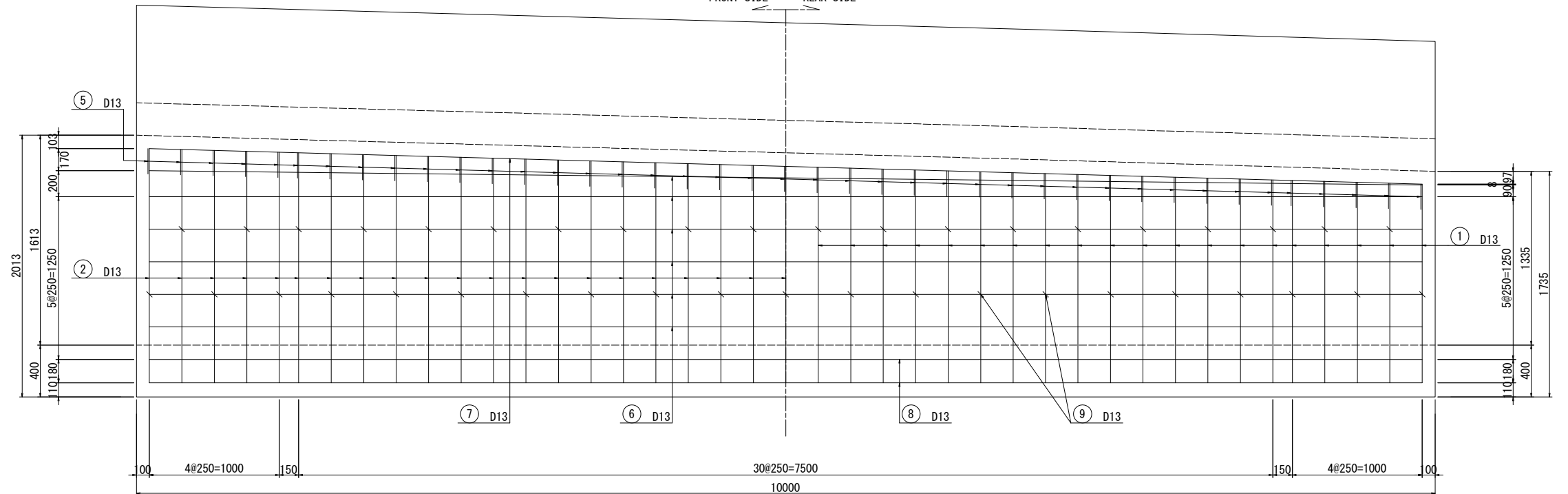
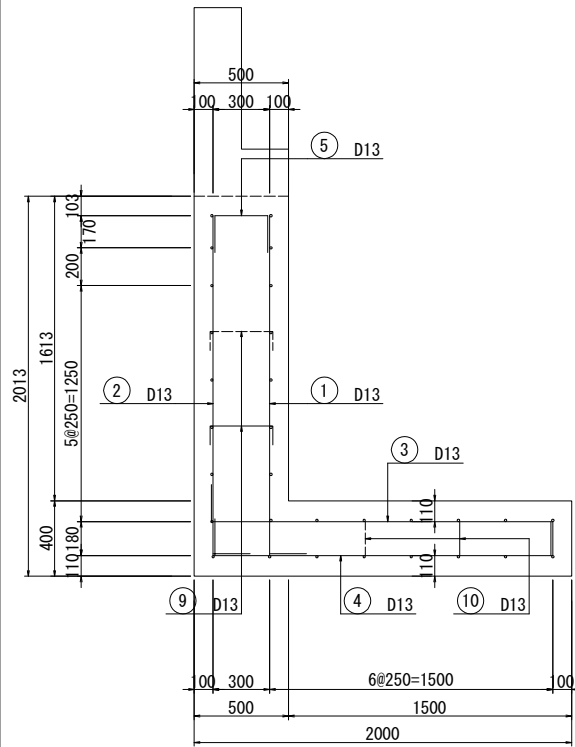

BAR ASSEMBLING

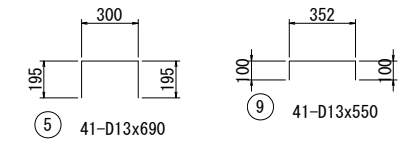
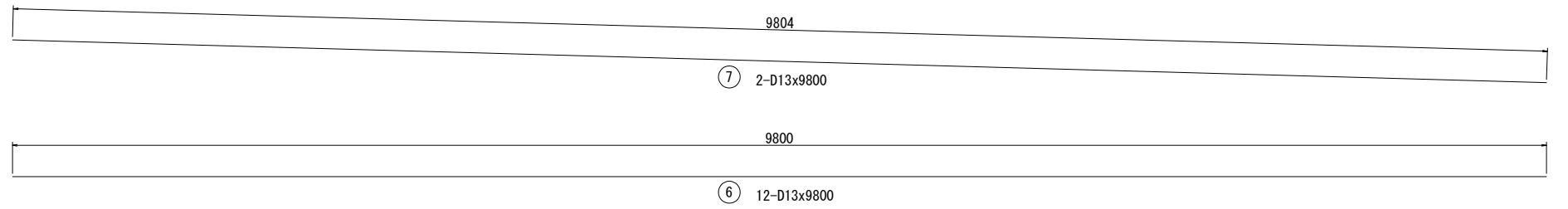
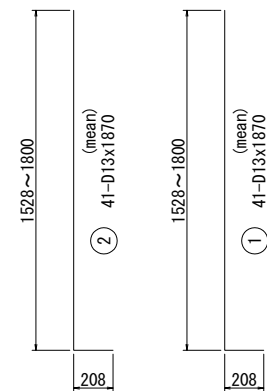
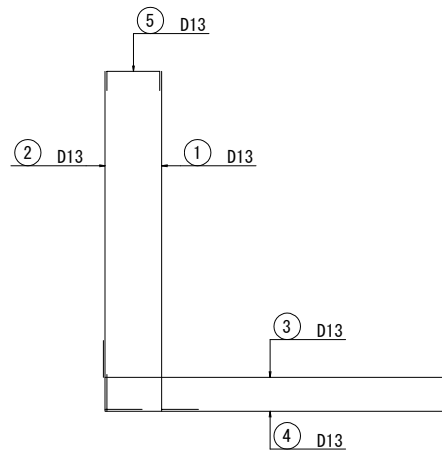

LIST OF REINFORCEMENT

NAME	PIANETER	LENGTH (mm)	NUMBER	UNIT WEIGHT (kg/m)	WEIGHT/BAR (kg)	WEIGHT (kg)	REMARKS
1	D13	1870	41	0.995	1.86	76	L (mean)
2	D13	1870	41	0.995	1.86	76	L (mean)
3	D13	2180	41	0.995	2.17	89	L
4	D13	2180	41	0.995	2.17	89	L
5	D13	690	41	0.995	0.69	28	L
6	D13	9800	12	0.995	9.75	117	L
7	D13	9800	2	0.995	9.75	20	L
8	D13	9800	16	0.995	9.75	156	L
9	D13	550	41	0.995	0.55	23	L
10	D13	1140	20	0.995	1.13	23	L
						697	
						D13	697 kg
						total	697 kg

KEY PLAN

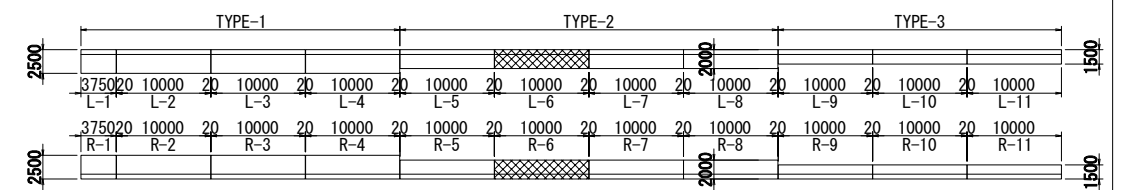

BAR ARRANGEMENT OF L TYPE RETAINING WALL(10) S=1:40

WALL (7) L-7 · R-7

BREST WALL

FRONT SIDE REAR SIDE

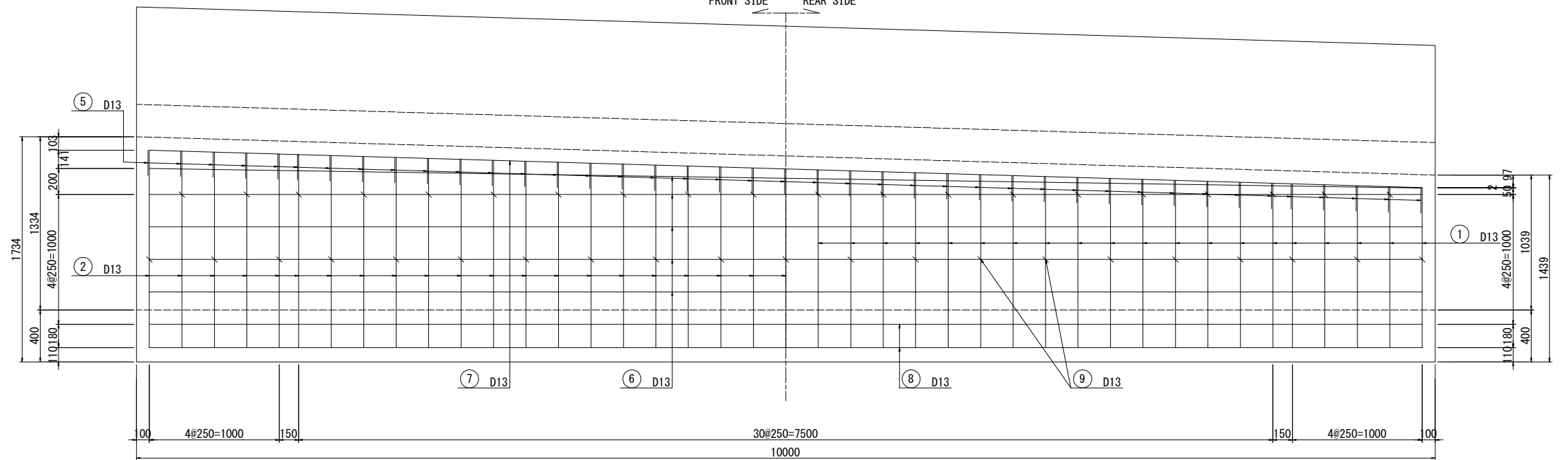
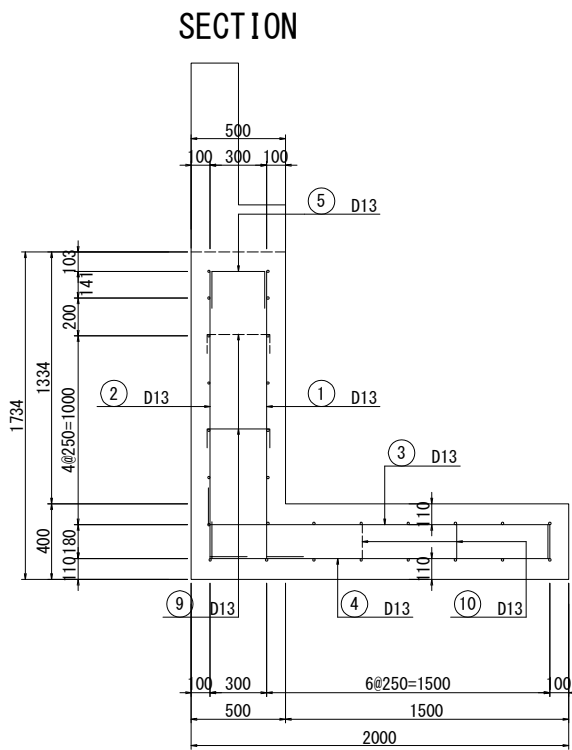

BAR ASSEMBLING

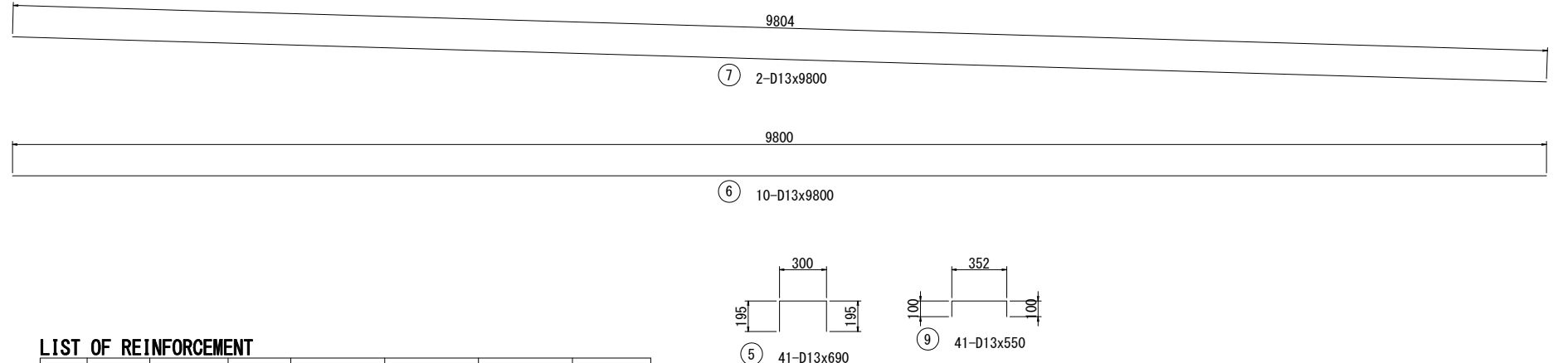
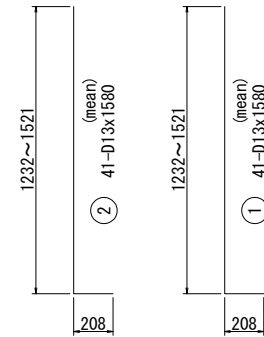
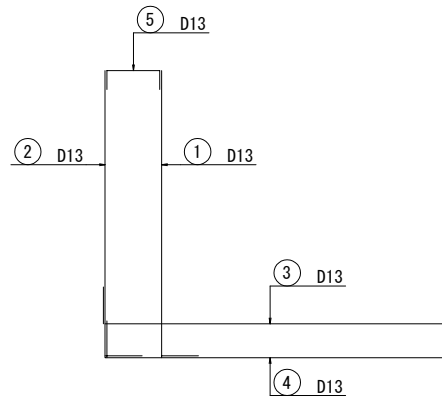

LIST OF REINFORCEMENT

NAME	DIAMETER	LENGTH (mm)	NUMBER	UNIT WEIGHT (kg/m)	WEIGHT/BAR (kg)	WEIGHT (kg)	REMARKS
1	D13	1580	41	0.995	1.57	64	(mean)
2	D13	1580	41	0.995	1.57	64	(mean)
3	D13	2180	41	0.995	2.17	89	
4	D13	2180	41	0.995	2.17	89	
5	D13	690	41	0.995	0.69	28	
6	D13	9800	10	0.995	9.75	98	
7	D13	9800	2	0.995	9.75	20	
8	D13	9800	16	0.995	9.75	156	
9	D13	550	41	0.995	0.55	23	
10	D13	1140	20	0.995	1.13	23	
						654	
						D13	654 kg
						total	654 kg

KEY PLAN

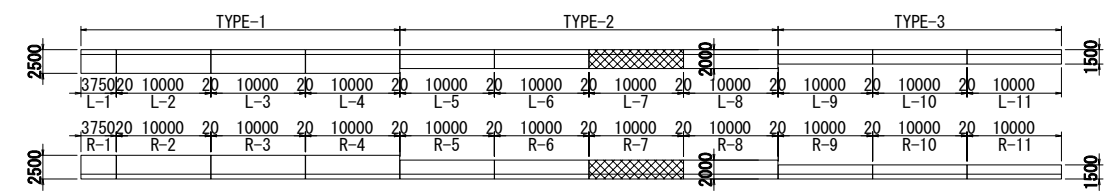

BAR ARRANGEMENT OF L TYPE RETAINING WALL(11) S=1:40

WALL (8) L-8 · R-8

BREST WALL

FRONT SIDE REAR SIDE

SECTION

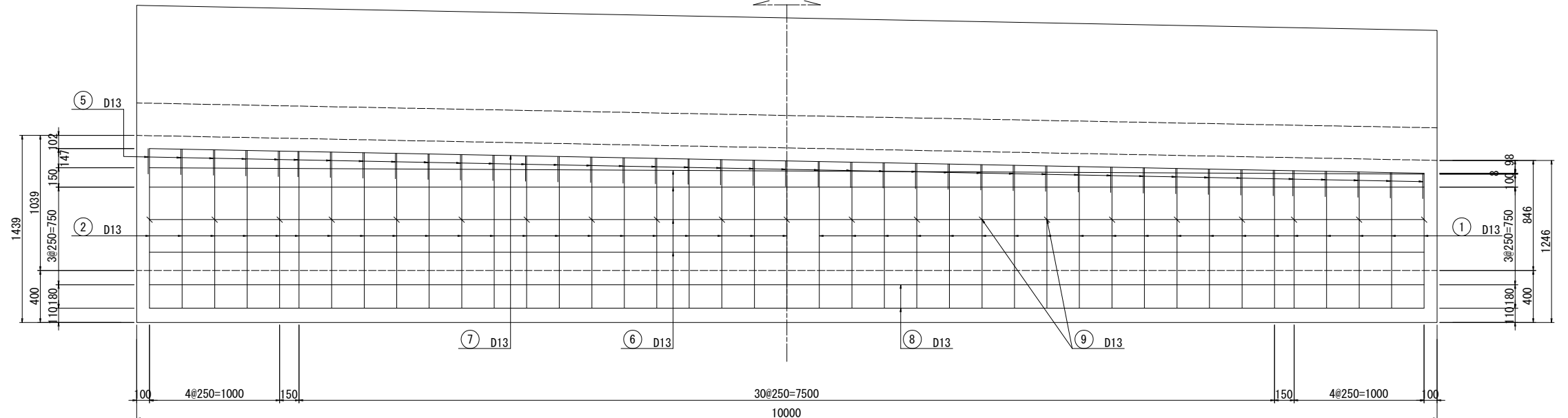
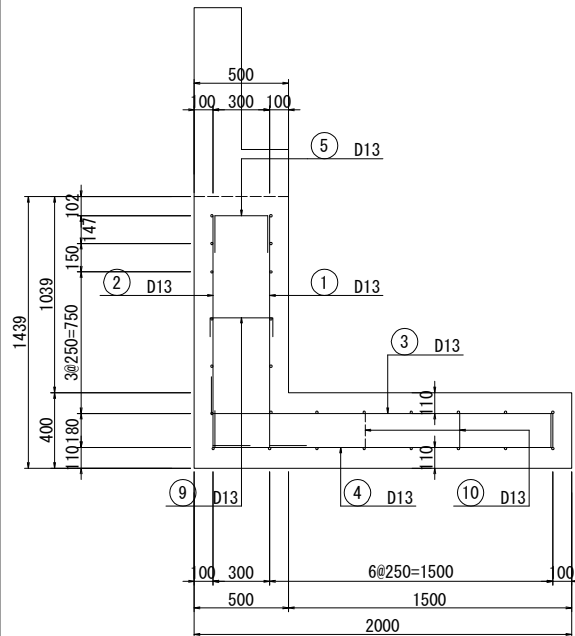

BAR ASSEMBLING

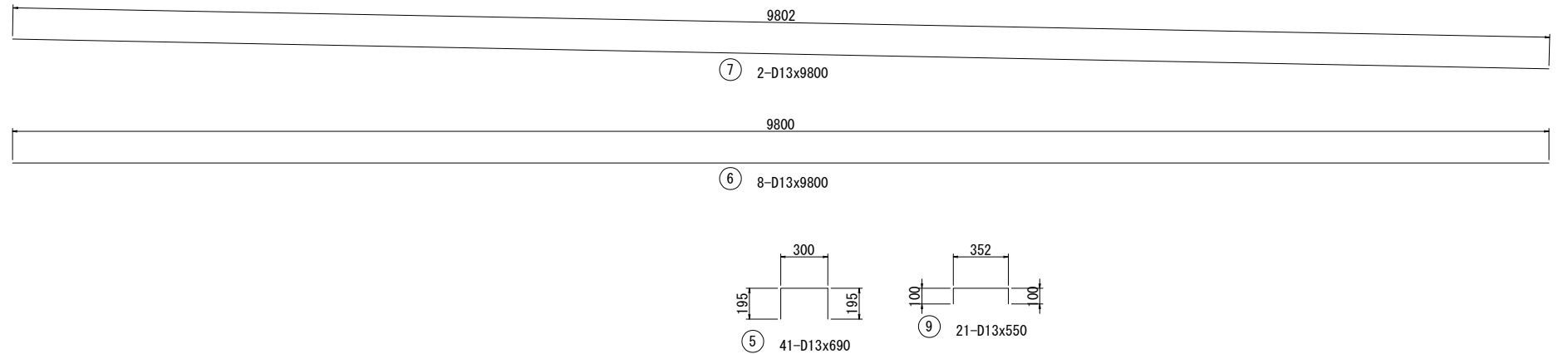
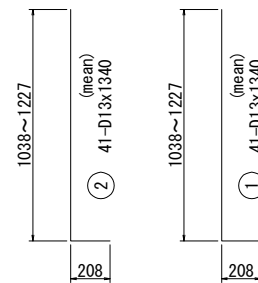
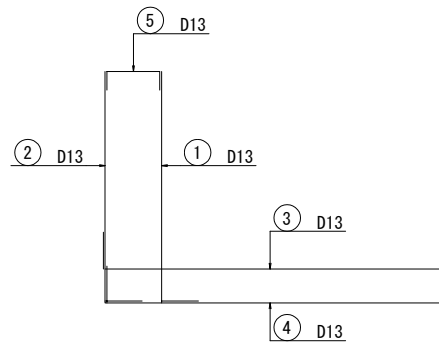

LIST OF REINFORCEMENT

NAME	PIANETER	LENGTH (mm)	NUMBER	UNIT WEIGHT (kg/m)	WEIGHT/BAR (kg)	WEIGHT (kg)	REMARKS
1	D13	1340	41	0.995	1.33	55	L (mean)
2	D13	1340	41	0.995	1.33	55	L (mean)
3	D13	2180	41	0.995	2.17	89	L
4	D13	2180	41	0.995	2.17	89	L
5	D13	690	41	0.995	0.69	28	L
6	D13	9800	8	0.995	9.75	78	L
7	D13	9800	2	0.995	9.75	20	L
8	D13	9800	16	0.995	9.75	156	L
9	D13	550	21	0.995	0.55	12	L
10	D13	1140	20	0.995	1.13	23	L
						605	
						D13	605 kg
						total	605 kg

KEY PLAN

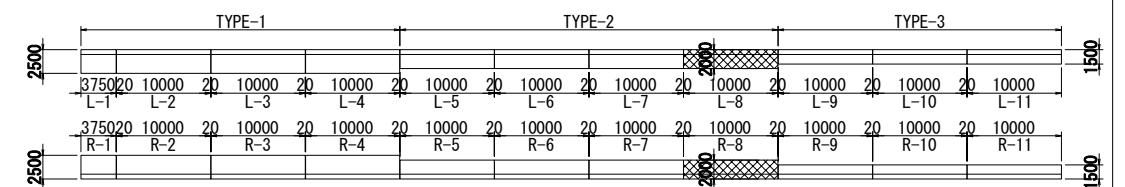

PROJECT NAME
DETAILED DESIGN ON
BAGO RIVER BRIDGE
CONSTRUCTION PROJECT

FINANCED BY
JICA
JAPAN INTERNATIONAL
COOPERATION AGENCY

COUNTERPART
REPUBLIC OF THE UNION OF MYANMAR
MINISTRY OF CONSTRUCTION
DEPARTMENT OF BRIDGE

JICA STUDY TEAM
NIPPON KOEI CO., LTD.
ORIENTAL CONSULTANTS GLOBAL CO., LTD.
METROPOLITAN EXPRESSWAY COMPANY LIMITED
CHODAI CO., LTD.
NIPPON ENGINEERING CONSULTANTS CO., LTD.

	NAME	SIGNATURE	DATE
PREPARED BY	K. TACHIBANA	橋 馨	29 Sep.2017
CHECKED BY	T. HAYAKAWA	平川 知平	3 Oct.2017
APPROVED BY	Y. SANO	佐野 祐一	6 Oct.2017

DRAWING TITLE	PACKAGE
BAR ARRANGEMENT OF L TYPE RETAINING WALL(11)	3
	DWG No.
	P3-RD-4320

BAR ARRANGEMENT OF L TYPE RETAINING WALL(12) S=1:40

WALL (9) L-9 · R-9

BREST WALL

FRONT SIDE REAR SIDE

SECTION

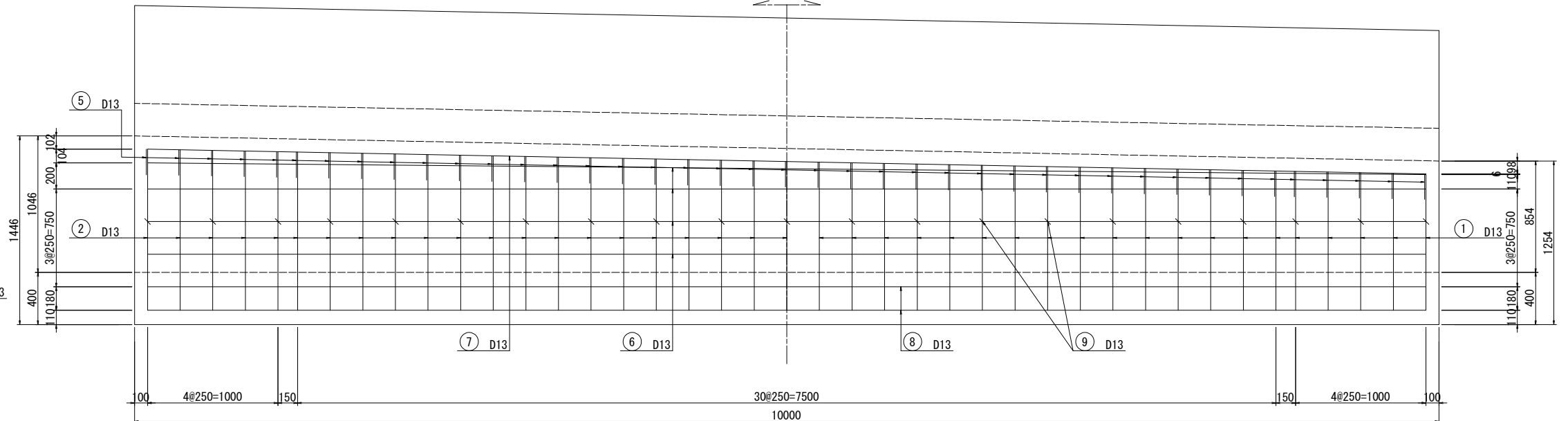
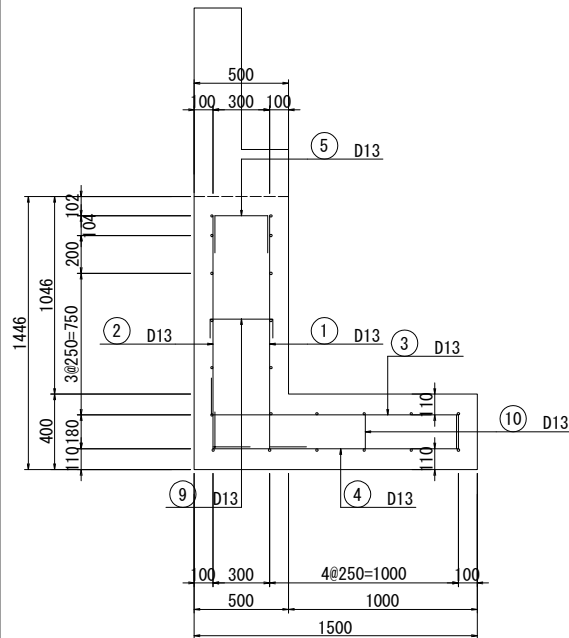

BAR ASSEMBLING

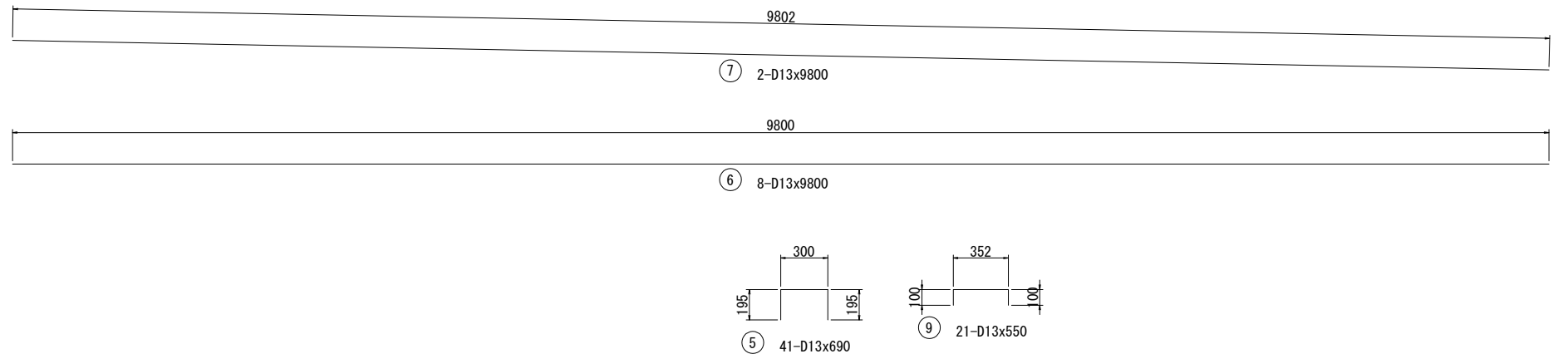
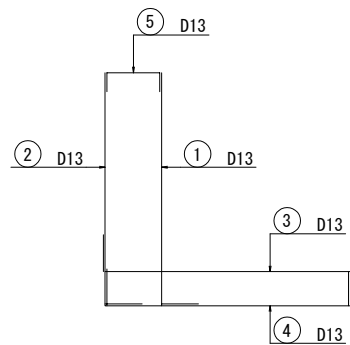

LIST OF REINFORCEMENT

NAME	DIAMETER	LENGTH (mm)	NUMBER	UNIT WEIGHT (kg/m)	WEIGHT/BAR (kg)	WEIGHT (kg)	REMARKS
1	D13	1350	41	0.995	1.34	55	L (mean)
2	D13	1350	41	0.995	1.34	55	L (mean)
3	D13	1680	41	0.995	1.67	68	L
4	D13	1680	41	0.995	1.67	68	L
5	D13	690	41	0.995	0.69	28	L
6	D13	9800	8	0.995	9.75	78	—
7	D13	9800	2	0.995	9.75	20	—
8	D13	8800	12	0.995	8.76	105	—
9	D13	550	21	0.995	0.55	12	—
10	D13	1140	10	0.995	1.13	11	—
						500	
						D13	500 kg
						total	500 kg

KEY PLAN

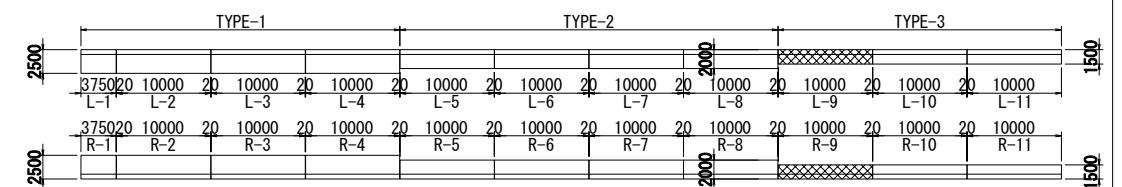

BAR ARRANGEMENT OF L TYPE RETAINING WALL(13) S=1:40

WALL (10) L-10 · R-10

BREST WALL

FRONT SIDE REAR SIDE

SECTION

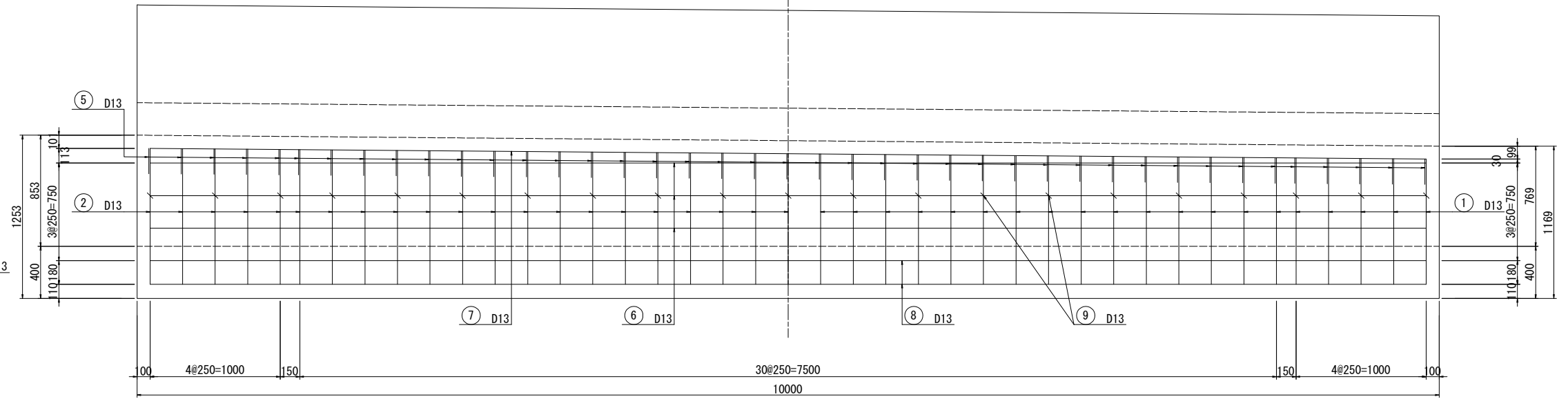
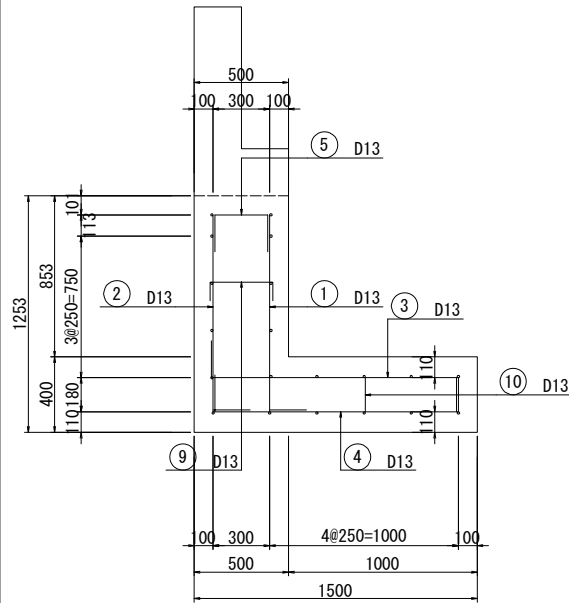

BAR ASSEMBLING

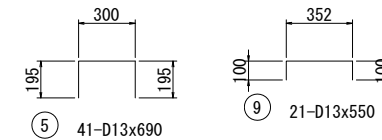
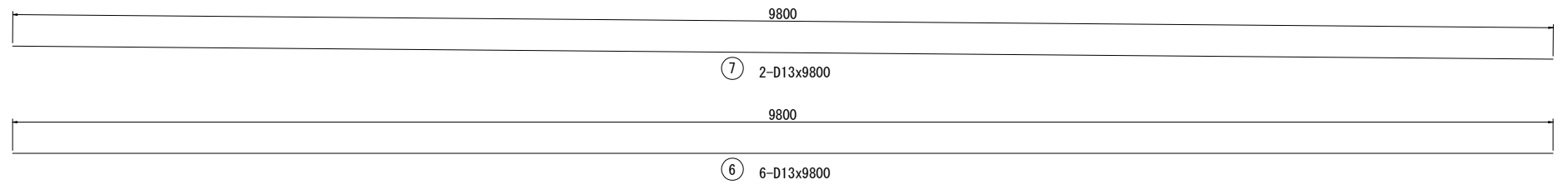
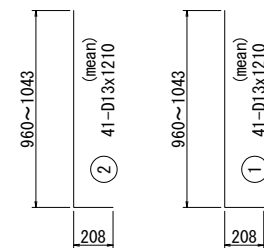
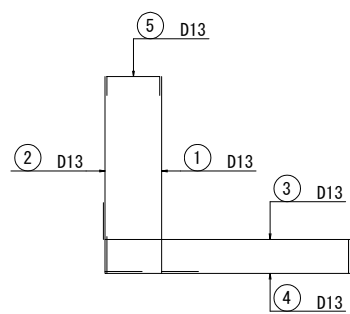

LIST OF REINFORCEMENT

NAME	DIAMETER	LENGTH (mm)	NUMBER	UNIT WEIGHT (kg/m)	WEIGHT/BAR (kg)	WEIGHT (kg)	REMARKS
1	D13	1210	41	0.995	1.20	49	L (mean)
2	D13	1210	41	0.995	1.20	49	L (mean)
3	D13	1680	41	0.995	1.67	68	L
4	D13	1680	41	0.995	1.67	68	L
5	D13	690	41	0.995	0.69	28	L
6	D13	9800	6	0.995	9.75	59	L
7	D13	9800	2	0.995	9.75	20	L
8	D13	8800	12	0.995	8.76	105	L
9	D13	550	21	0.995	0.55	12	L
10	D13	1140	10	0.995	1.13	11	L
						469	
						D13	469 kg
						total	469 kg

KEY PLAN

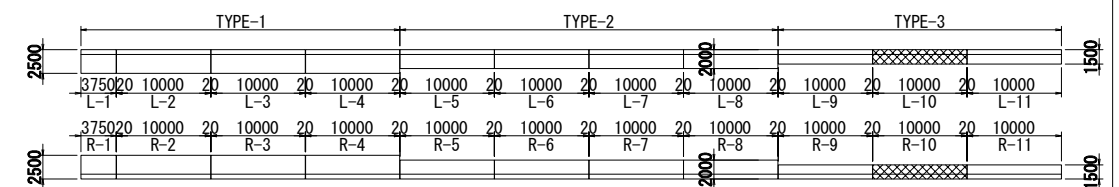

BAR ARRANGEMENT OF L TYPE RETAINING WALL(14) S=1:40

WALL (11) L-11 · R-11

BREST WALL

FRONT SIDE REAR SIDE

SECTION

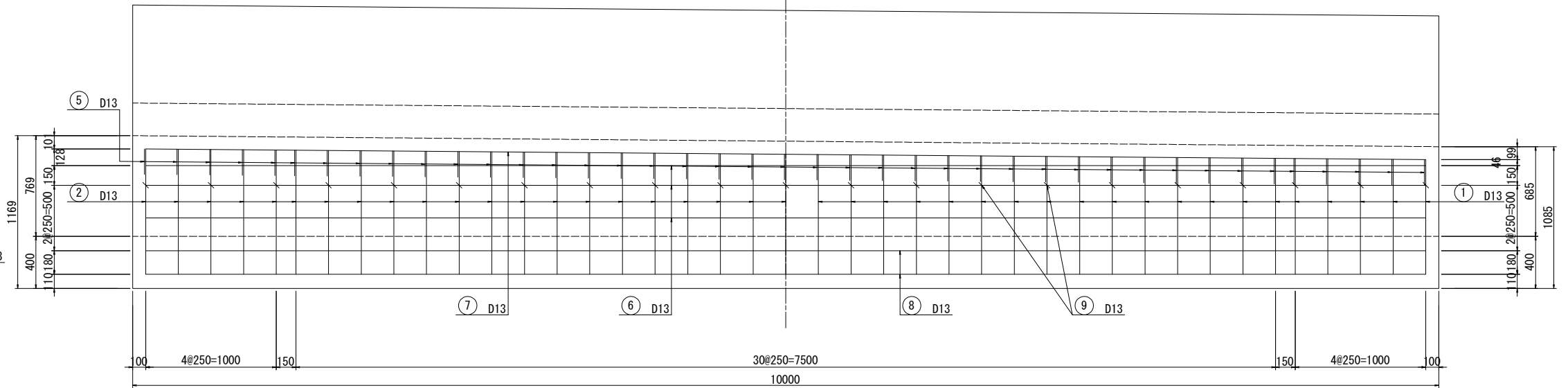
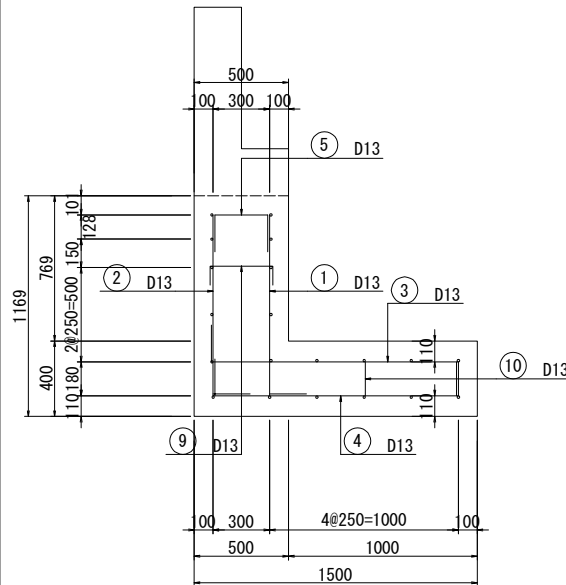

BAR ASSEMBLING

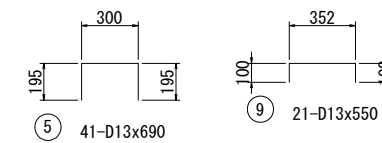
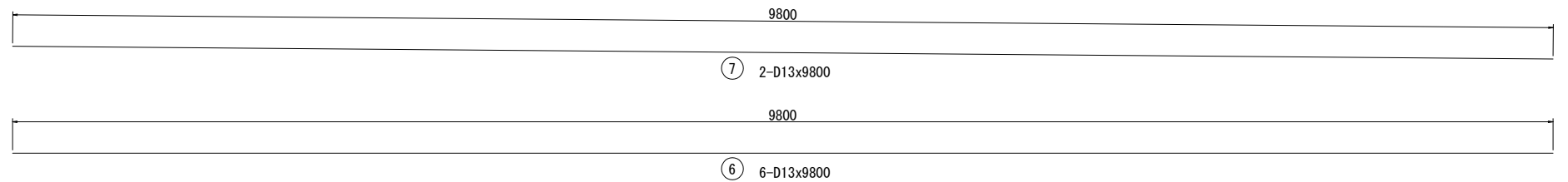
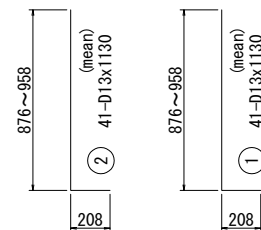
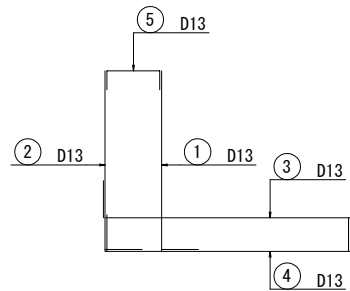

LIST OF REINFORCEMENT

NAME	PIANETER	LENGTH (mm)	NUMBER	UNIT WEIGHT (kg/m)	WEIGHT/BAR (kg)	WEIGHT (kg)	REMARKS
1	D13	1130	41	0.995	1.12	46	L (mean)
2	D13	1130	41	0.995	1.12	46	L (mean)
3	D13	1680	41	0.995	1.67	68	L
4	D13	1680	41	0.995	1.67	68	L
5	D13	690	41	0.995	0.69	28	L
6	D13	9800	6	0.995	9.75	59	L
7	D13	9800	2	0.995	9.75	20	L
8	D13	8800	12	0.995	8.76	105	L
9	D13	550	21	0.995	0.55	12	L
10	D13	1140	10	0.995	1.13	11	L
						463	
						D13	463 kg
						total	463 kg

KEY PLAN

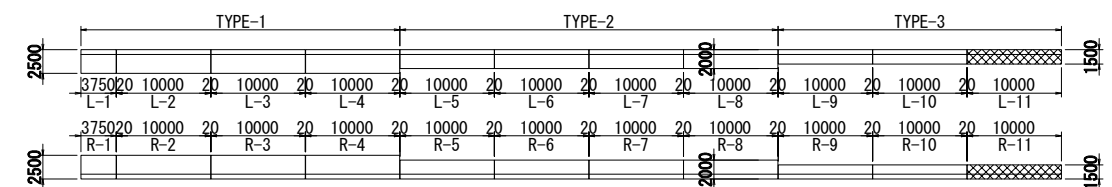

PROJECT NAME
DETAILED DESIGN ON
BAGO RIVER BRIDGE
CONSTRUCTION PROJECT

FINANCED BY
JICA
JAPAN INTERNATIONAL
COOPERATION AGENCY

COUNTERPART
REPUBLIC OF THE UNION OF MYANMAR
MINISTRY OF CONSTRUCTION
DEPARTMENT OF BRIDGE

JICA STUDY TEAM
NIPPON KOEI CO., LTD.
ORIENTAL CONSULTANTS GLOBAL CO., LTD.
METROPOLITAN EXPRESSWAY COMPANY LIMITED
CHODAI CO., LTD.
NIPPON ENGINEERING CONSULTANTS CO., LTD.

	NAME	SIGNATURE	DATE
PREPARED BY	K. TACHIBANA	橋 馨	29 Sep.2017
CHECKED BY	T. HAYAKAWA	平川 知平	3 Oct.2017
APPROVED BY	Y. SANO	佐野 祐一	6 Oct.2017

DRAWING TITLE	PACKAGE
BAR ARRANGEMENT OF L TYPE RETAINING WALL(14)	3
	DWG No.
	P3-RD-4350

BAR ARRANGEMENT OF L TYPE RETAINING WALL(15) S=1:40

BOTTOM SLAB(1) L-1 · R-1

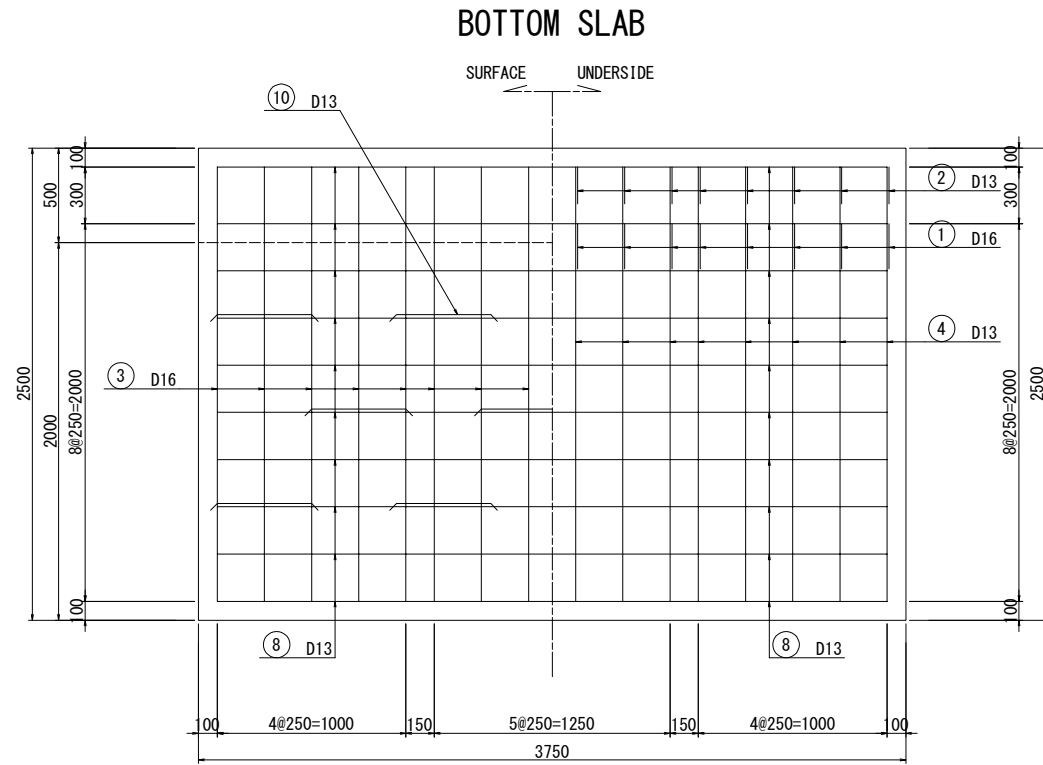

BAR SCHEDULING

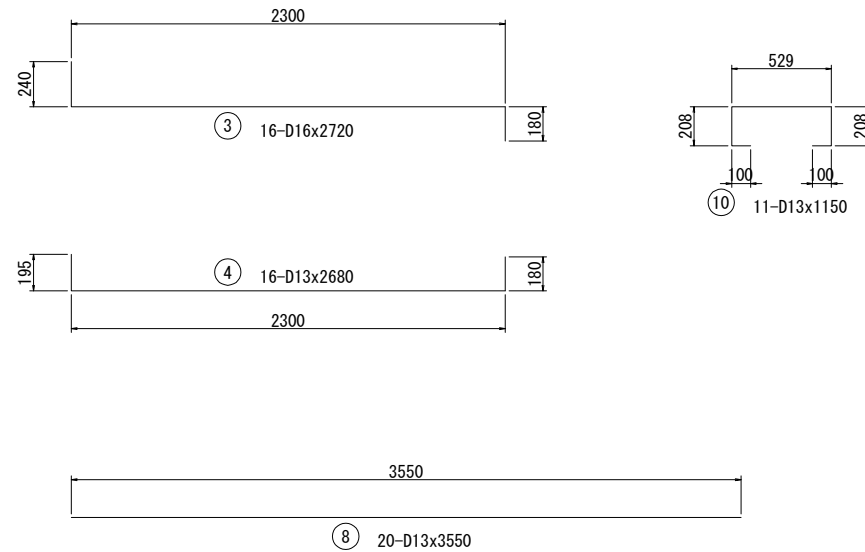

KEY PLAN

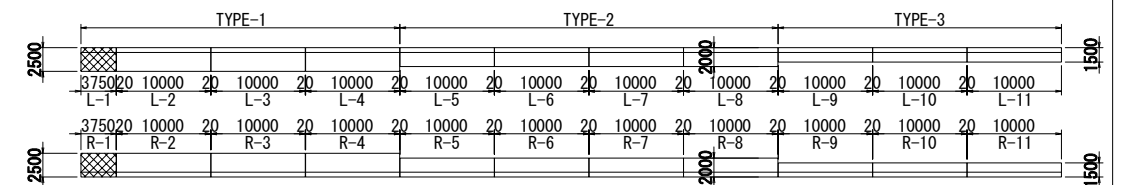

PROJECT NAME DETAILED DESIGN ON BAGO RIVER BRIDGE CONSTRUCTION PROJECT	FINANCED BY JAPAN INTERNATIONAL COOPERATION AGENCY	COUNTERPART REPUBLIC OF THE UNION OF MYANMAR MINISTRY OF CONSTRUCTION DEPARTMENT OF BRIDGE	JICA STUDY TEAM NIPPON KOEI CO., LTD. ORIENTAL CONSULTANTS GLOBAL CO., LTD. METROPOLITAN EXPRESSWAY COMPANY LIMITED CHODAI CO.,LTD. NIPPON ENGINEERING CONSULTANTS CO.,LTD.	NAME K. TACHIBANA T. HAYAKAWA Y. SANO	SIGNATURE 	DATE 29 Sep.2017 3 Oct.2017 6 Oct.2017	DRAWING TITLE BAR ARRANGEMENT OF L TYPE RETAINING WALL(15)	PACKAGE 3 DWG No. P3-RD-4360
---	--	---	--	--	-----------------------	---	---	---------------------------------------

BAR ARRANGEMENT OF L TYPE RETAINING WALL(16) S=1:40

BOTTOM SLAB (2) L-2~4 · R-2~4

BOTTOM SLAB

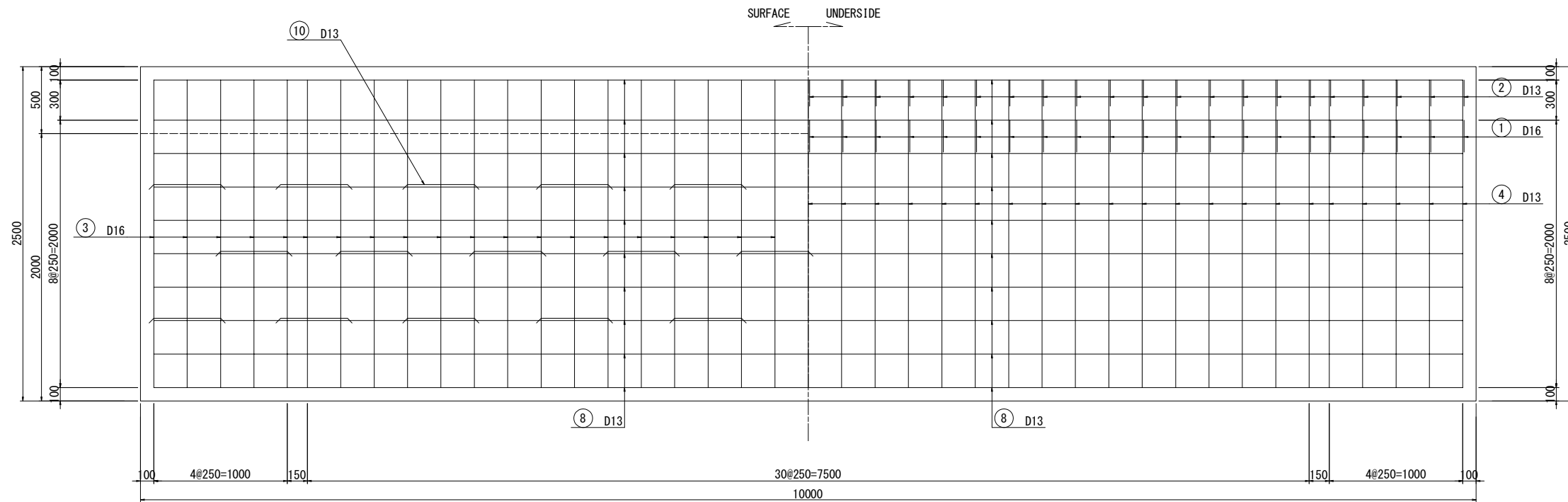

BAR SCHEDULING

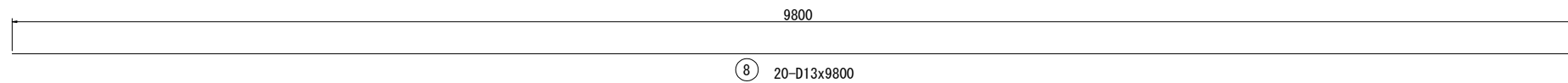
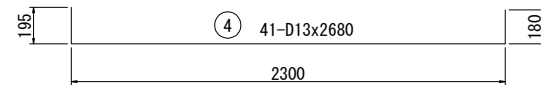
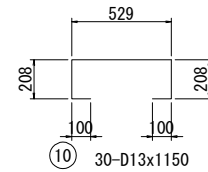
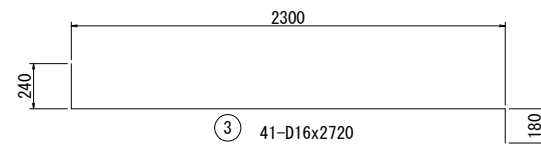

KEY PLAN

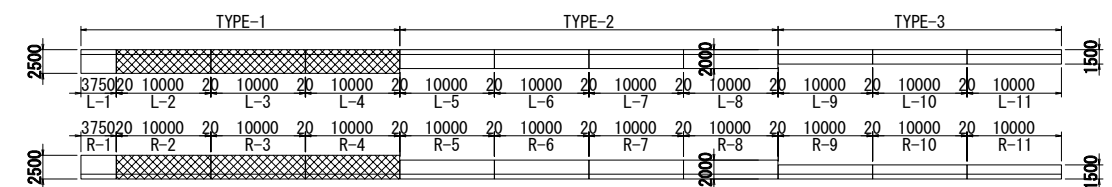

PROJECT NAME
DETAILED DESIGN ON
BAGO RIVER BRIDGE
CONSTRUCTION PROJECT

FINANCED BY
jica JAPAN INTERNATIONAL
COOPERATION AGENCY

COUNTERPART
 REPUBLIC OF THE UNION OF MYANMAR
MINISTRY OF CONSTRUCTION
DEPARTMENT OF BRIDGE

JICA STUDY TEAM
 NIPPON KOEI CO., LTD.
ORIENTAL CONSULTANTS GLOBAL CO., LTD.
METROPOLITAN EXPRESSWAY COMPANY LIMITED
CHODAI CO., LTD.
NIPPON ENGINEERING CONSULTANTS CO., LTD.

	NAME	SIGNATURE	DATE
PREPARED BY	K. TACHIBANA		29 Sep.2017
CHECKED BY	T. HAYAKAWA		3 Oct.2017
APPROVED BY	Y. SANO		6 Oct.2017

DRAWING TITLE
BAR ARRANGEMENT OF L TYPE RETAINING WALL(16)

PACKAGE
3
DWG No.
P3-RD-4370

BAR ARRANGEMENT OF L TYPE RETAINING WALL(17) S=1:40

BOTTOM SLAB (3) L-5~8 · R-5~8

BOTTOM SLAB

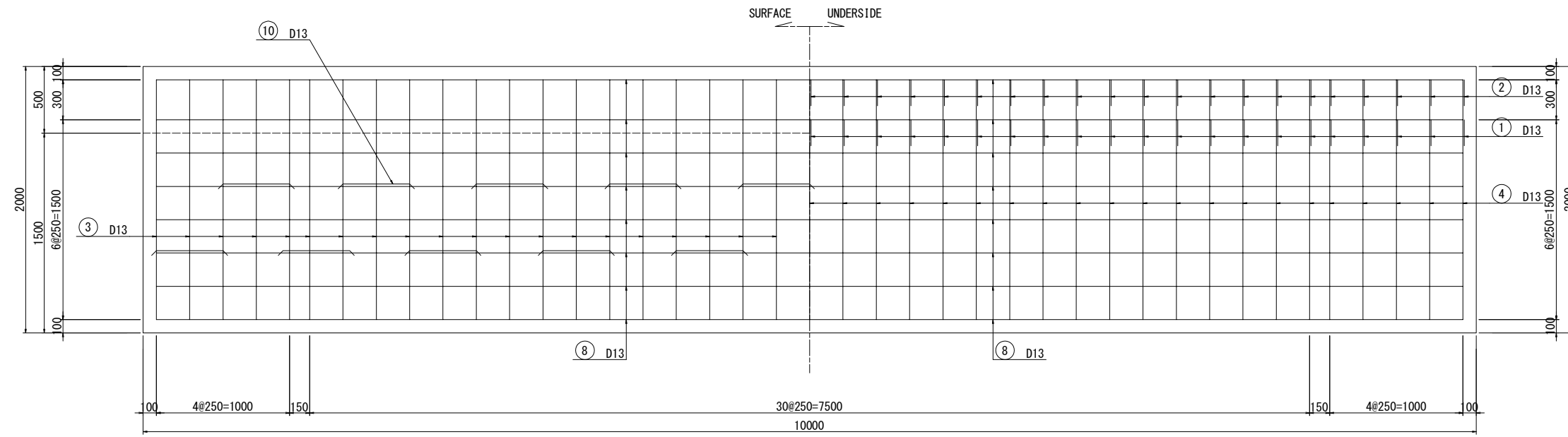

BAR SCHEDULING

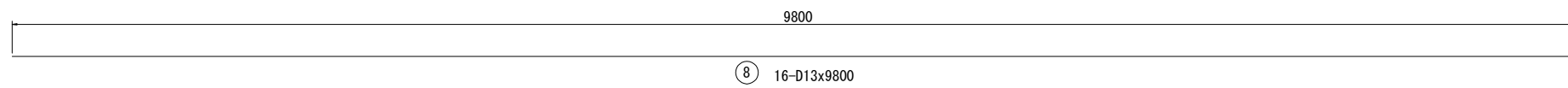
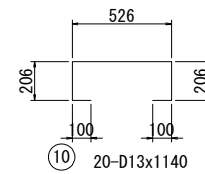
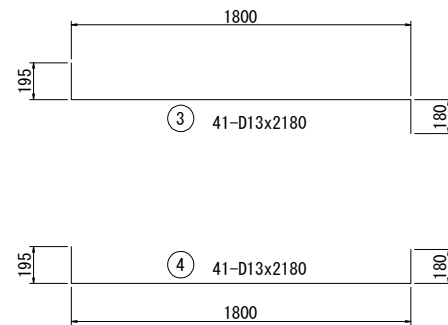

KEY PLAN

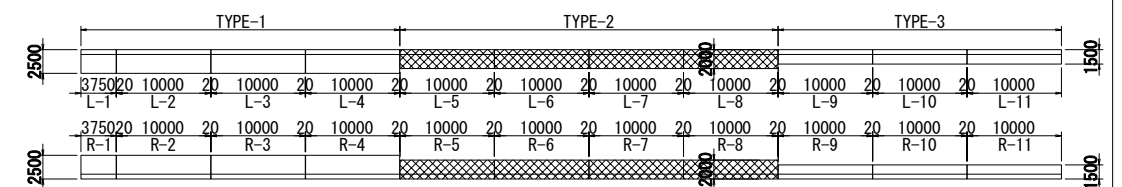

PROJECT NAME DETAILED DESIGN ON BAGO RIVER BRIDGE CONSTRUCTION PROJECT	FINANCED BY JAPAN INTERNATIONAL COOPERATION AGENCY	COUNTERPART REPUBLIC OF THE UNION OF MYANMAR MINISTRY OF CONSTRUCTION DEPARTMENT OF BRIDGE	JICA STUDY TEAM NIPPON KOEI CO., LTD. ORIENTAL CONSULTANTS GLOBAL CO., LTD. METROPOLITAN EXPRESSWAY COMPANY LIMITED CHODAI CO., LTD. NIPPON ENGINEERING CONSULTANTS CO., LTD.	NAME PREPARED BY CHECKED BY APPROVED BY	K. TACHIBANA T. HAYAKAWA Y. SANO	SIGNATURE 	DATE 29 Sep.2017 3 Oct.2017 6 Oct.2017	DRAWING TITLE BAR ARRANGEMENT OF L TYPE RETAINING WALL(17)	PACKAGE 3 DWG No. P3-RD-4380
---	--	---	--	--	--	---------------	---	---	---------------------------------------

BAR ARRANGEMENT OF L TYPE RETAINING WALL(18) S=1:40

BOTTOM SLAB(4) L-9~11 · R-9~11

BOTTOM SLAB

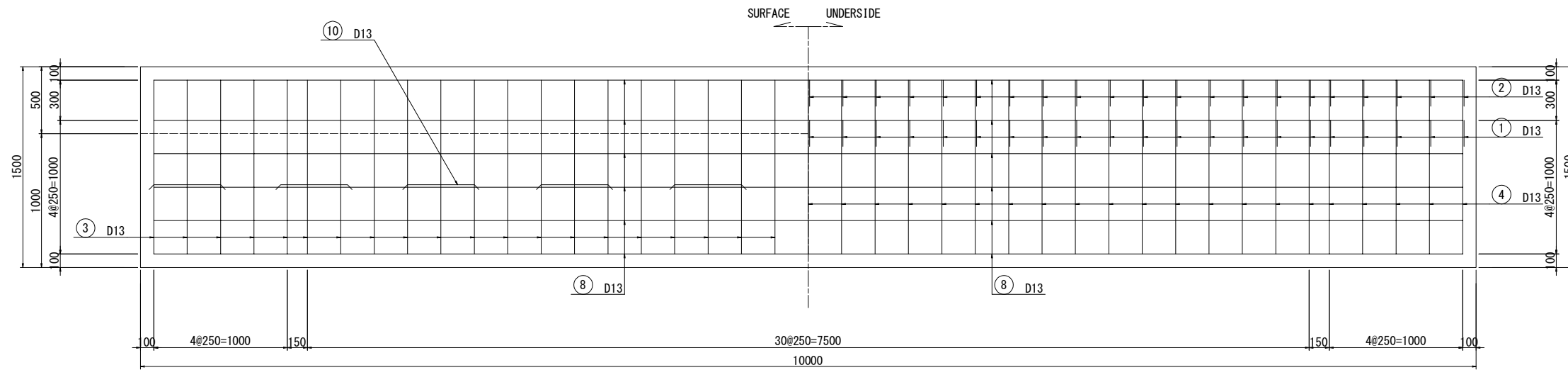

BAR SCHEDULING

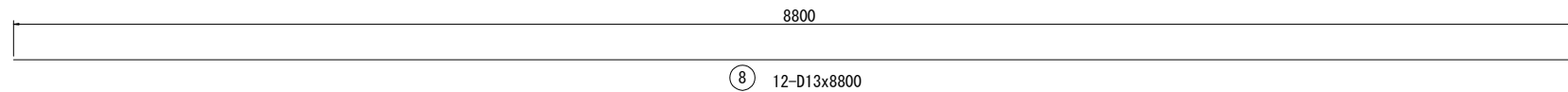
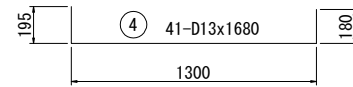
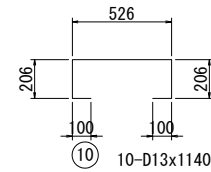
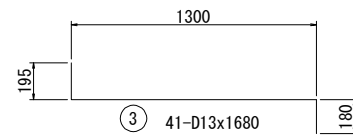

KEY PLAN

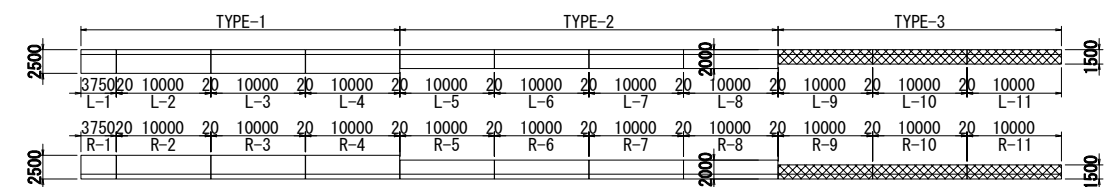

PROJECT NAME
DETAILED DESIGN ON
BAGO RIVER BRIDGE
CONSTRUCTION PROJECT

FINANCED BY
JICA JAPAN INTERNATIONAL
COOPERATION AGENCY

COUNTERPART
 REPUBLIC OF THE UNION OF MYANMAR
MINISTRY OF CONSTRUCTION
DEPARTMENT OF BRIDGE

JICA STUDY TEAM
 NIPPON KOEI CO., LTD.
ORIENTAL CONSULTANTS GLOBAL CO., LTD.
METROPOLITAN EXPRESSWAY COMPANY LIMITED
CHODAI CO., LTD.
NIPPON ENGINEERING CONSULTANTS CO., LTD.

	NAME	SIGNATURE	DATE
PREPARED BY	K. TACHIBANA		29 Sep.2017
CHECKED BY	T. HAYAKAWA		3 Oct.2017
APPROVED BY	Y. SANO		6 Oct.2017

DRAWING TITLE
BAR ARRANGEMENT OF L TYPE RETAINING WALL(18)

PACKAGE
3
DWG No.
P3-RD-4390

DETAIL OF LIGHTING FOUNDATION S=1:40

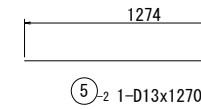
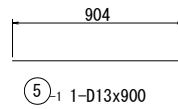
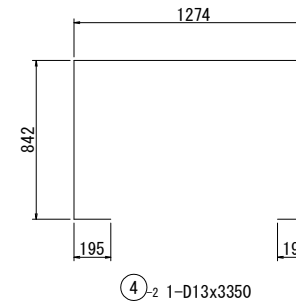
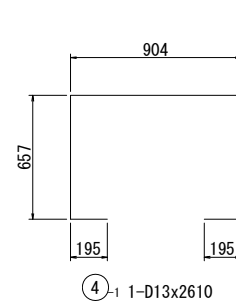
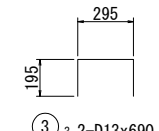
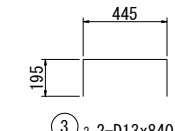
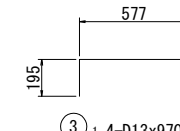
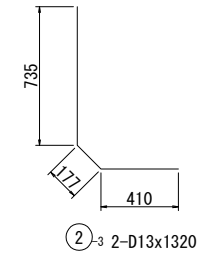
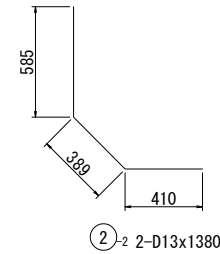
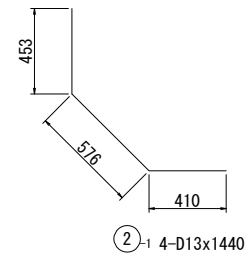
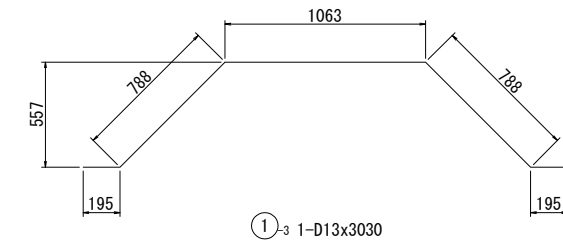
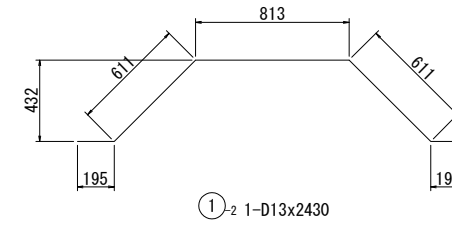
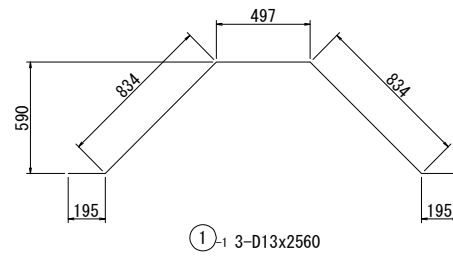
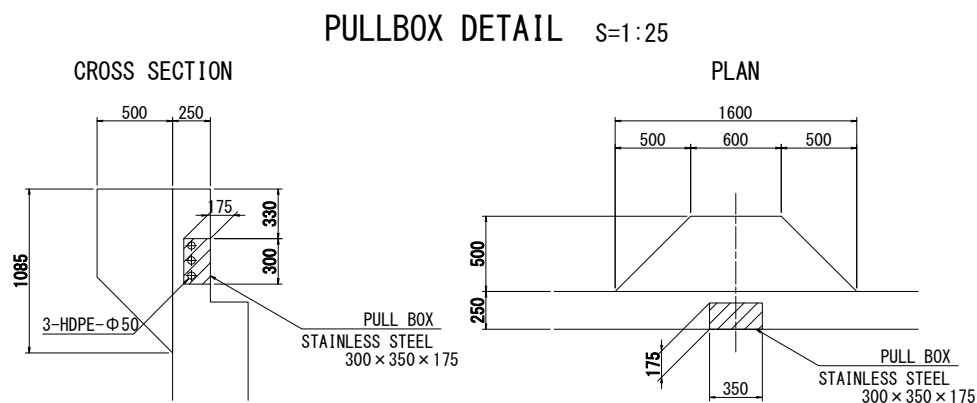
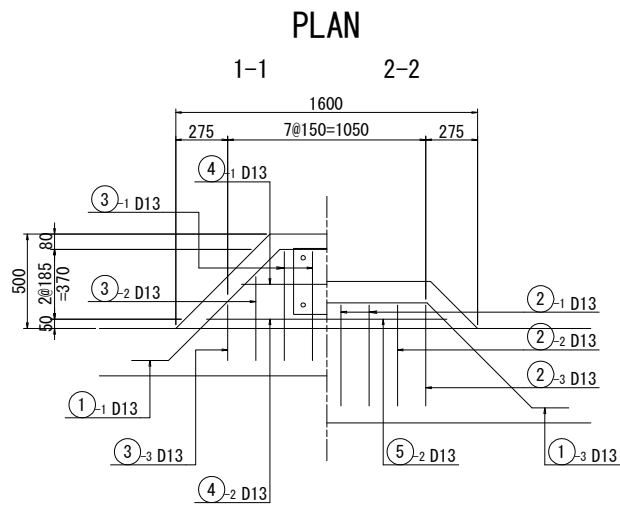
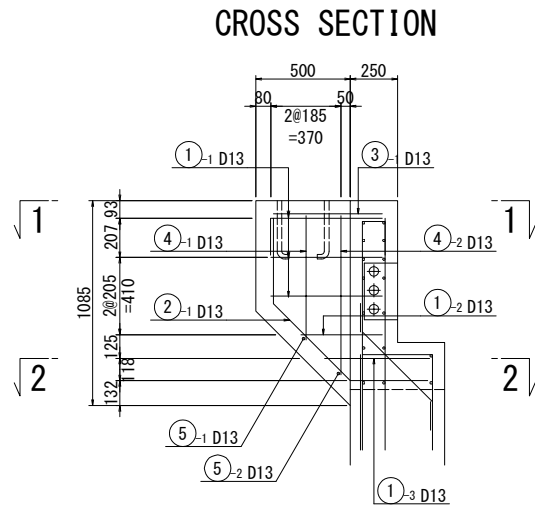

LIST OF REINFORCEMENT

NAME	PIANETER	LENGTH (mm)	NUMBER	UNIT WEIGHT (kg/m)	WEIGHT/BAR (kg)	WEIGHT (kg)	REMARKS
1-1	D13	2560	3	0.995	2.55	8	~
1-2	D13	2430	1	0.995	2.42	2	~
1-3	D13	3030	1	0.995	3.01	3	~
2-1	D13	1440	4	0.995	1.43	6	~
2-2	D13	1380	2	0.995	1.37	3	~
2-3	D13	1320	2	0.995	1.31	3	~
3-1	D13	970	4	0.995	0.97	4	~
3-2	D13	840	2	0.995	0.84	2	~
3-3	D13	690	2	0.995	0.69	1	~
4-1	D13	2610	1	0.995	2.60	3	~
4-2	D13	3350	1	0.995	3.33	3	~
5-1	D13	900	1	0.995	0.90	1	~
5-2	D13	1270	1	0.995	1.26	1	~
						40	
						D13	40 kg
						total	40 kg

PROJECT NAME
DETAILED DESIGN ON
BAGO RIVER BRIDGE
CONSTRUCTION PROJECT

FINANCED BY
JICA JAPAN INTERNATIONAL
COOPERATION AGENCY

COUNTERPART
REPUBLIC OF THE UNION OF MYANMAR
MINISTRY OF CONSTRUCTION
DEPARTMENT OF BRIDGE

JICA STUDY TEAM
NIPPON KOEI CO., LTD.
ORIENTAL CONSULTANTS GLOBAL CO., LTD.
METROPOLITAN EXPRESSWAY COMPANY LIMITED
CHODAI CO., LTD.
NIPPON ENGINEERING CONSULTANTS CO., LTD.

	NAME	SIGNATURE	DATE
PREPARED BY	K. TACHIBANA	<i>[Signature]</i>	29 Sep.2017
CHECKED BY	T. HAYAKAWA	<i>[Signature]</i>	3 Oct.2017
APPROVED BY	Y. SANO	<i>[Signature]</i>	6 Oct.2017

DRAWING TITLE
DETAIL OF LIGHTING FOUNDATION

PACKAGE
3
DWG No.
P3-RD-4400

SOFT SOIL IMPROVEMENT MEASURES(1)

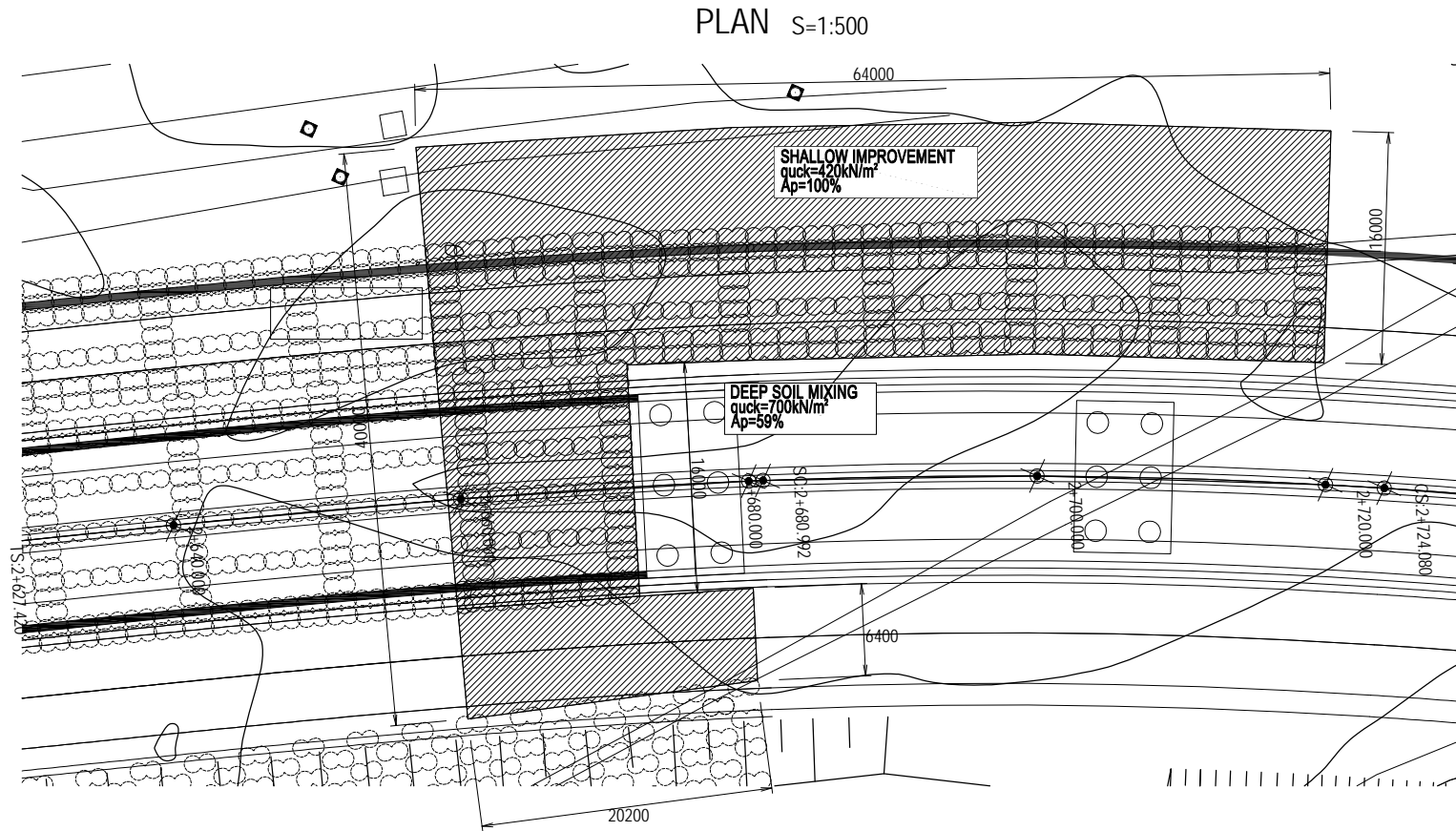

PROFILE
LEFT SIDE(DEVELOP FROM BACK SIDE)
MAIN LOAD(STA.2+660~2+672.686)
S=1:400

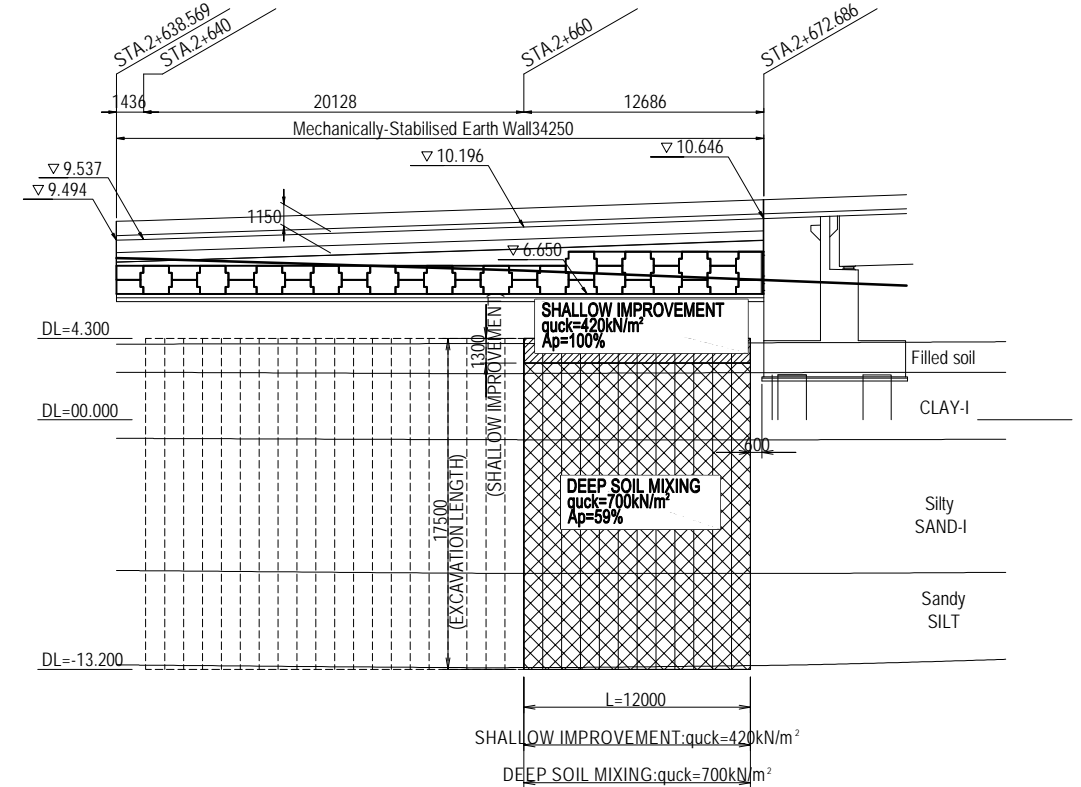

LEFT SIDE(DEVELOP FROM BACK SIDE)
APPROACH ROAD(STA.2+600~2+710)
S=1:400

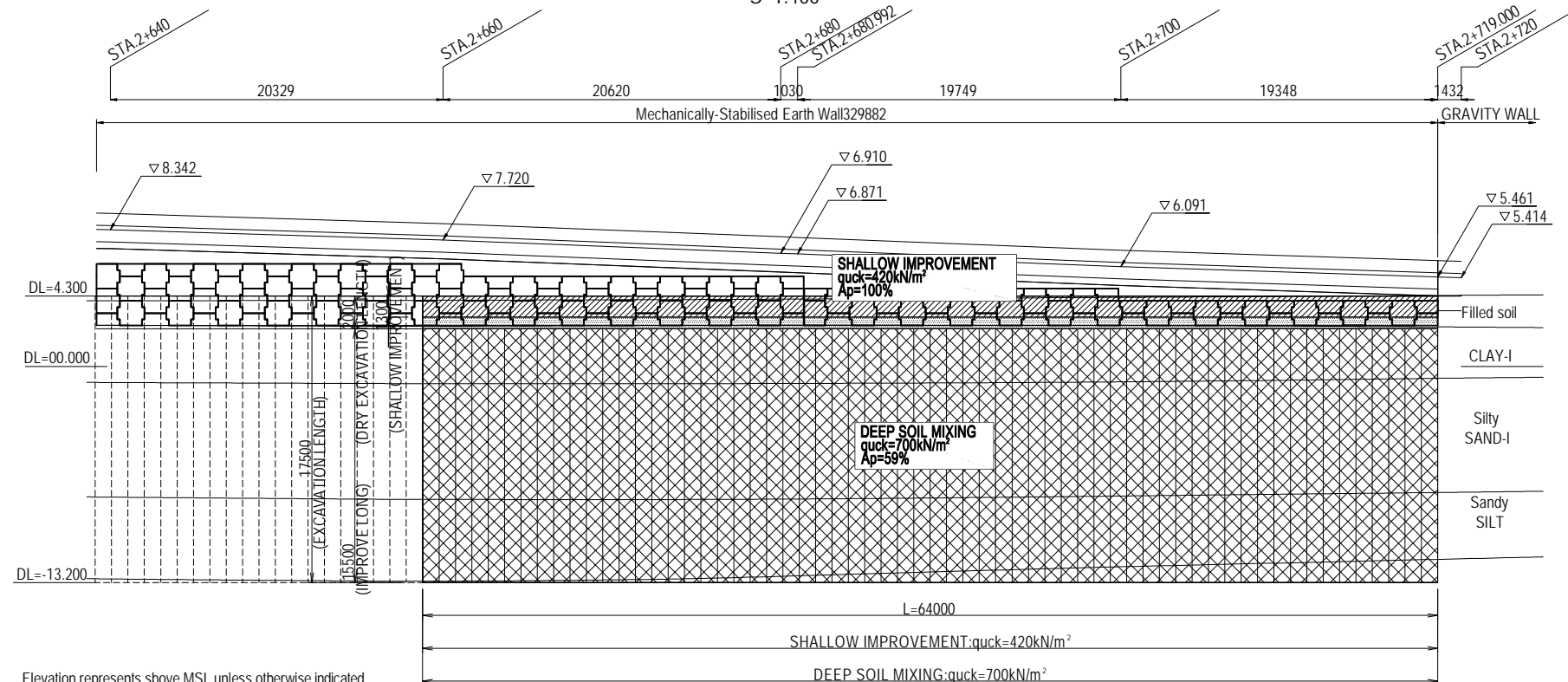

RIGHT SIDE
MAIN ROAD(STA.2+660~2+672.314)
S=1:400

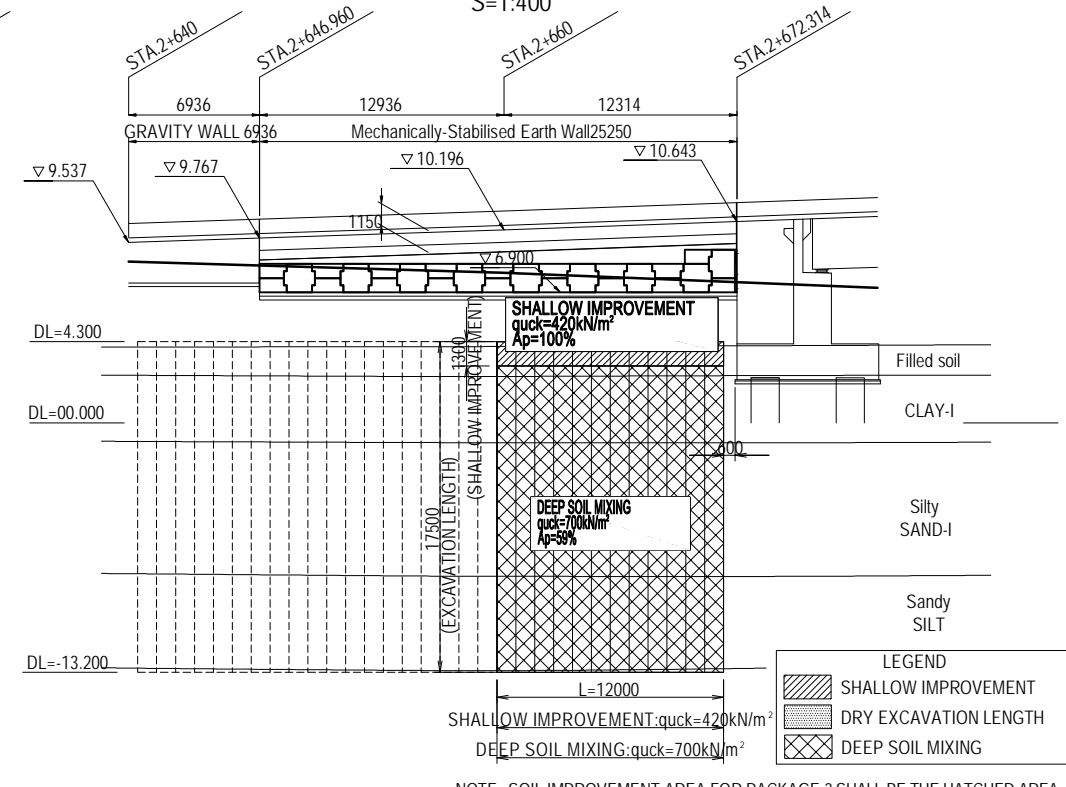

Elevation represents above MSL unless otherwise indicated.

NOTE: SOIL IMPROVEMENT AREA FOR PACKAGE 3 SHALL BE THE HATCHED AREA IN THE DRAWING ONLY, UNLESS OTHERWISE DIRECTED BY THE ENGINEER.

PROJECT NAME DETAILED DESIGN ON BAGO RIVER BRIDGE CONSTRUCTION PROJECT	FINANCED BY JICA JAPAN INTERNATIONAL COOPERATION AGENCY	COUNTERPART REPUBLIC OF THE UNION OF MYANMAR MINISTRY OF CONSTRUCTION DEPARTMENT OF BRIDGE	JICA STUDY TEAM NIPPON KOEI CO., LTD. ORIENTAL CONSULTANTS GLOBAL CO., LTD. METROPOLITAN EXPRESSWAY COMPANY LIMITED CHODAI CO., LTD. NIPPON ENGINEERING CONSULTANTS CO., LTD.	NAME K. TACHIBANA T. HAYAKAWA Y. SANO	SIGNATURE 	DATE 29 Sep. 2017 3 Oct. 2017 6 Oct. 2017	DRAWING TITLE SOFT SOIL IMPROVEMENT MEASURES(1)	PACKAGE 3 DWG No. P3-RD-5000
---	--	---	--	--	-----------------------	--	--	---------------------------------------

SOFT SOIL IMPROVEMENT MEASURES(2)

PROFILE S=1:800

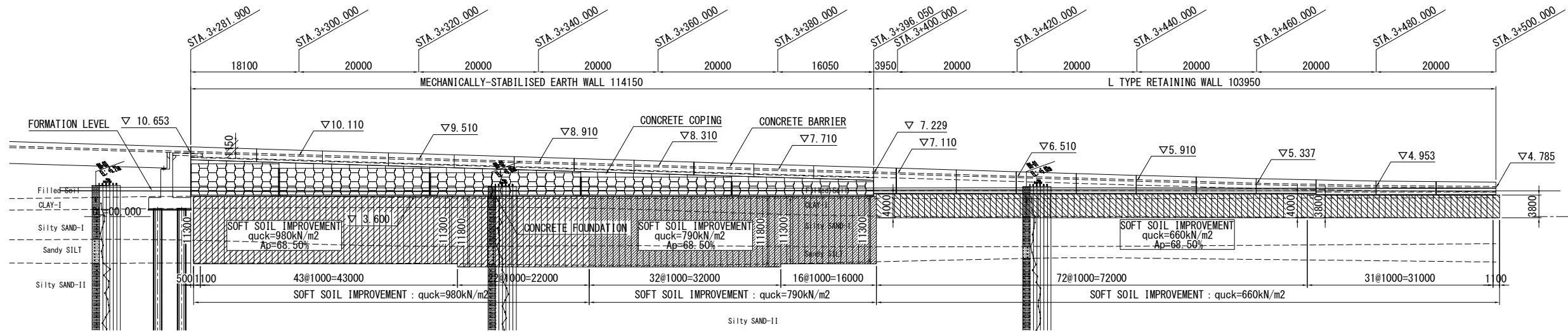

PLAN S=1:800

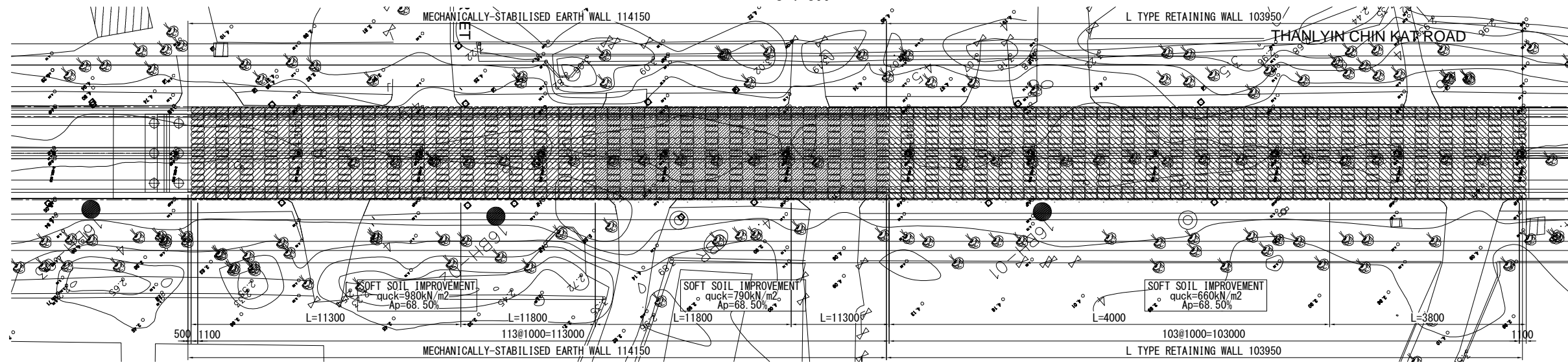

as=41.64m²/60.8m² × 100=68.50%

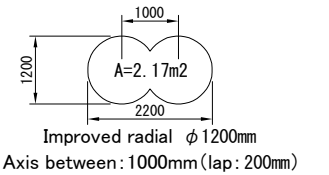
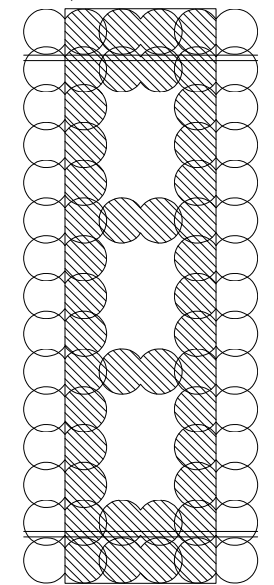

CROSS SECTION S=1:400

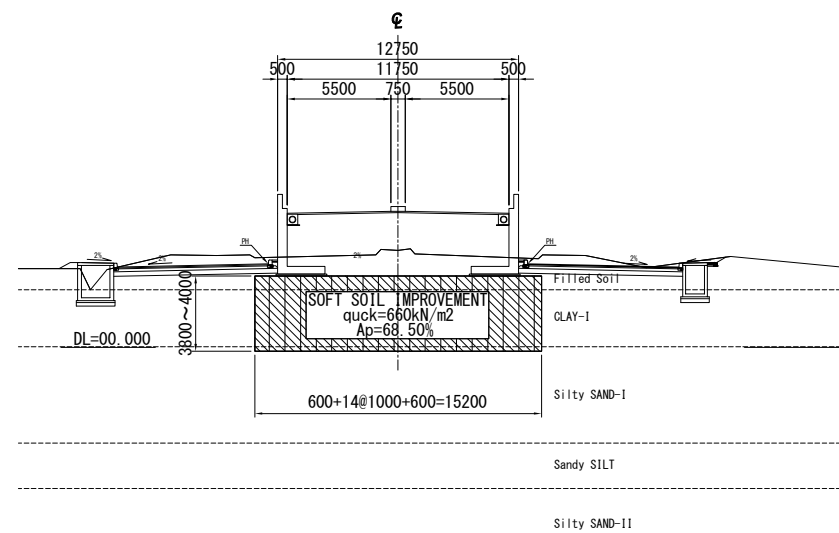
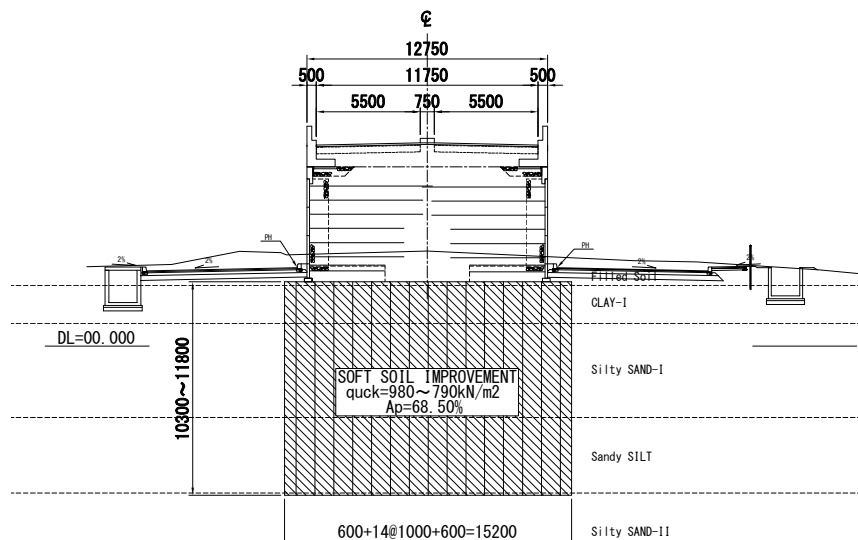

SOFT SOIL IMPROVEMENT

MECHANICALLY-STABILISED EARTH WALL AREA (quack=980kN/m ² , 790kN/m ²)												
Quack (kN/m ²)	AREA	Improved radial	Section(m ²)	Excavation length(m)	Dry excavation length(m)	Improve long(m)	sets	Total excavation long(m)	Total dry excavation length(m)	Total improve long(m)	Total improve area(m ³)	
980	A(L=11800)	1200mm@1000 2-axis	2.17	12.50	0.70	11.80	231	2887.50	161.70	2725.80	5914.99	
	B(L=11300)	1200mm@1000 2-axis	2.17	12.00	0.70	11.30	120	1440.00	84.00	1356.00	2942.52	
Subtotal							351	4327.50	245.70	4081.80	8857.51	
790	C(L=11800)	1200mm@1000 2-axis	2.17	12.50	0.70	11.80	168	2100.00	117.60	1982.40	4301.81	
	D(L=11300)	1200mm@1000 2-axis	2.17	12.00	0.70	11.30	111	1332.00	77.70	1254.30	2721.83	
Subtotal							252	3108.00	176.40	2931.60	6361.57	
L TYPE RETAINING WALL AREA (quack=660kN/m ²)												
660	E(L=4000)	1200mm@1000 2-axis	2.17	4.60	0.60	4.00	378	1738.80	226.80	1512.00	3281.04	
	F(L=3800)	1200mm@1000 2-axis	2.17	4.40	0.60	3.80	168	739.20	100.80	638.40	1385.33	
Subtotal							546	2478.00	327.60	2150.40	4666.37	
Total							1149	9913.50	749.70	9163.80	19885.45	

PROJECT NAME
DETAILED DESIGN ON
BAGO RIVER BRIDGE
CONSTRUCTION PROJECT

FINANCED BY
JICA
JAPAN INTERNATIONAL
COOPERATION AGENCY

COUNTERPART
REPUBLIC OF THE UNION OF MYANMAR
MINISTRY OF CONSTRUCTION
DEPARTMENT OF BRIDGE

JICA STUDY TEAM
NIPPON KOEI CO., LTD.
ORIENTAL CONSULTANTS GLOBAL CO., LTD.
METROPOLITAN EXPRESSWAY COMPANY LIMITED
CHODAI CO., LTD.
NIPPON ENGINEERING CONSULTANTS CO., LTD.

	NAME	SIGNATURE	DATE
PREPARED BY	K. TACHIBANA		29 Sep.2017
CHECKED BY	T. HAYAKAWA		3 Oct.2017
APPROVED BY	Y. SANO		6 Oct.2017

DRAWING TITLE
SOFT SOIL IMPROVEMENT MEASURES(2)

PACKAGE
3
DWG No.
P3-RD-5010

CROSS SECTION OF DEEP MIXING METHOD(1) S=1:400

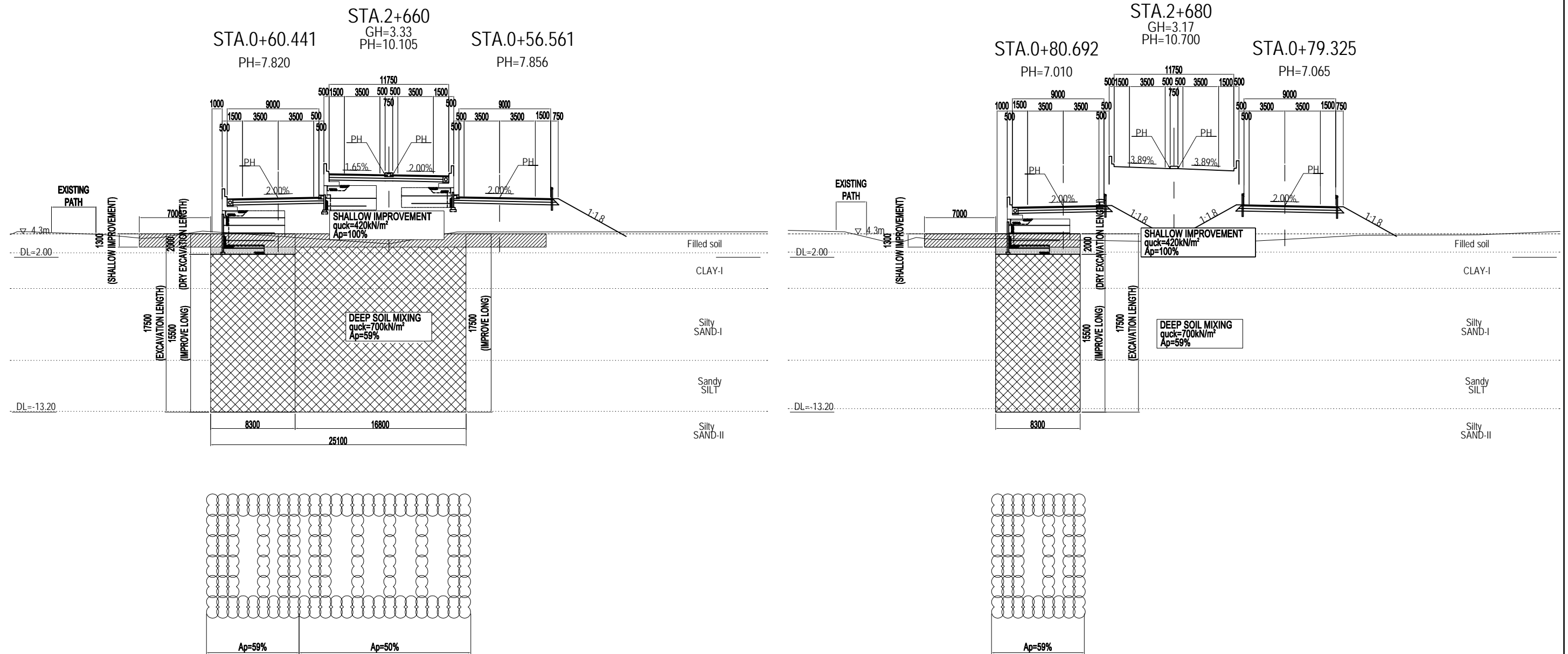

Elevation represents above MSL unless otherwise indicated.

LEGEND	
	SHALLOW IMPROVEMENT
	DRY EXCAVATION LENGTH
	DEEP SOIL MIXING

PROJECT NAME DETAILED DESIGN ON BAGO RIVER BRIDGE CONSTRUCTION PROJECT	FINANCED BY JAPAN INTERNATIONAL COOPERATION AGENCY	COUNTERPART REPUBLIC OF THE UNION OF MYANMAR MINISTRY OF CONSTRUCTION DEPARTMENT OF BRIDGE	JICA STUDY TEAM NIPPON KOEI CO., LTD. ORIENTAL CONSULTANTS GLOBAL CO., LTD. METROPOLITAN EXPRESSWAY COMPANY LIMITED CHODAI CO., LTD. NIPPON ENGINEERING CONSULTANTS CO., LTD.	NAME	SIGNATURE	DATE	DRAWING TITLE CROSS SECTION OF DEEP MIXING METHOD(1)	PACKAGE	
				PREPARED BY	K. TACHIBANA			29 Sep.2017	3
				CHECKED BY	T. HAYAKAWA			3 Oct.2017	DWG No.
				APPROVED BY	Y. SANO			6 Oct.2017	P3-RD-5020

CROSS SECTION OF DEEP MIXING METHOD(2) S=1:400

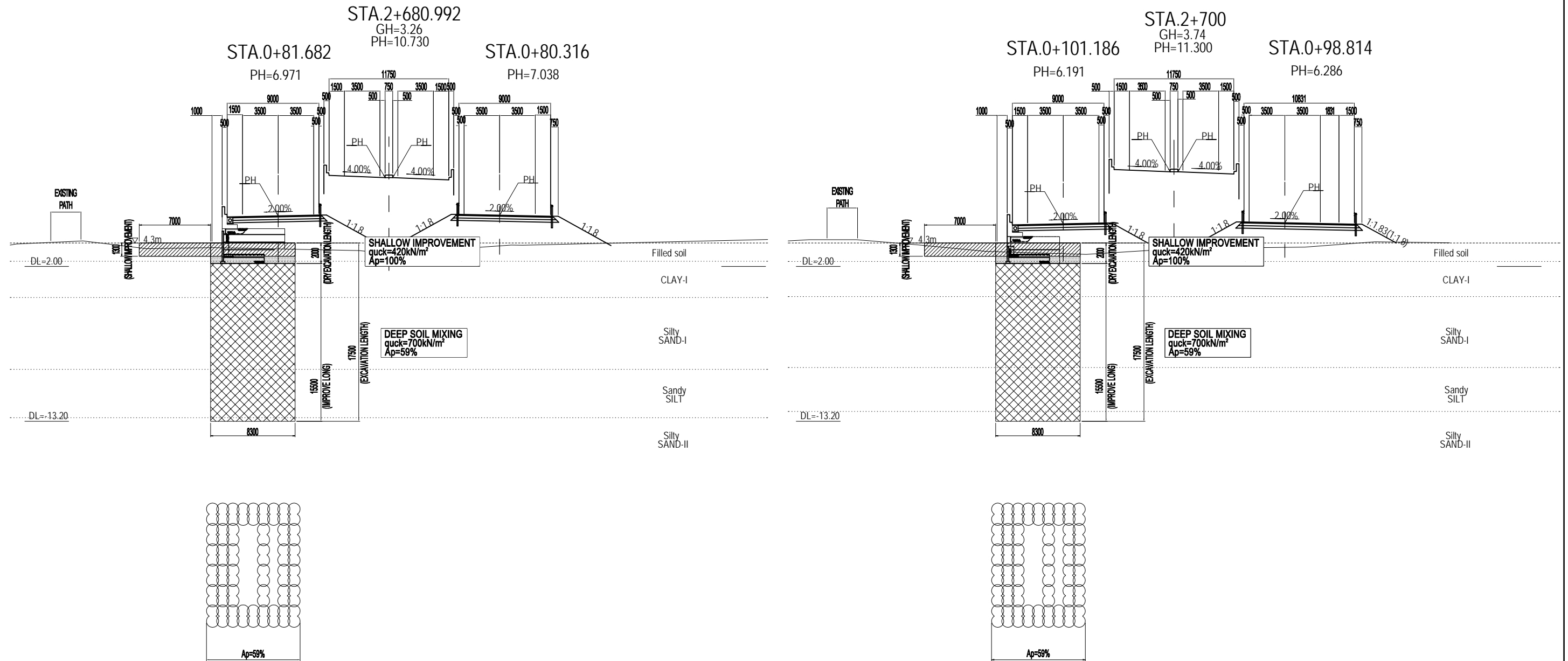

Elevation represents above MSL unless otherwise indicated.

LEGEND	
	SHALLOW IMPROVEMENT
	DRY EXCAVATION LENGTH
	DEEP SOIL MIXING

PROJECT NAME DETAILED DESIGN ON BAGO RIVER BRIDGE CONSTRUCTION PROJECT	FINANCED BY JAPAN INTERNATIONAL COOPERATION AGENCY	COUNTERPART REPUBLIC OF THE UNION OF MYANMAR MINISTRY OF CONSTRUCTION DEPARTMENT OF BRIDGE	JICA STUDY TEAM NIPPON KOEI CO., LTD. ORIENTAL CONSULTANTS GLOBAL CO., LTD. METROPOLITAN EXPRESSWAY COMPANY LIMITED CHODAI CO., LTD. NIPPON ENGINEERING CONSULTANTS CO., LTD.	NAME	SIGNATURE	DATE	DRAWING TITLE CROSS SECTION OF DEEP MIXING METHOD(2)	PACKAGE 3 DWG No. P3-RD-5030	
				PREPARED BY	K. TACHIBANA				29 Sep.2017
				CHECKED BY	T. HAYAKAWA				3 Oct.2017
				APPROVED BY	Y. SANO				6 Oct.2017

DETAILS OF KERB SCALE = 1:20

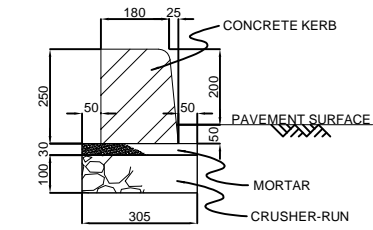

CONCRETE KERB TYPE A-1

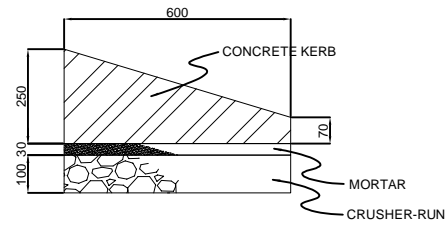

CONCRETE KERB TYPE A-2
TRANSITION BLOCK BETWEEN
TYPE A-1 AND TYPE A-3

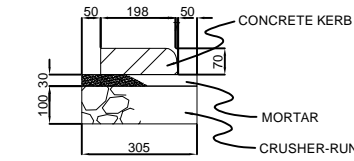

CONCRETE KERB TYPE A-3

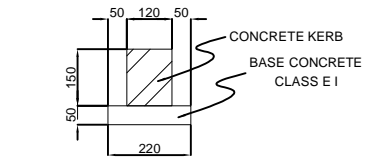

CONCRETE KERB TYPE C

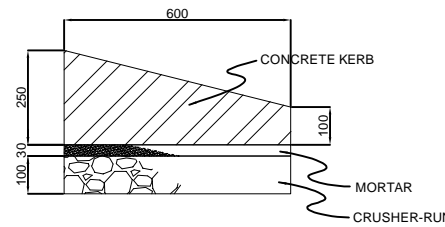

CONCRETE KERB TYPE A-4
TRANSITION BLOCK BETWEEN
TYPE A-1 AND TYPE A-5

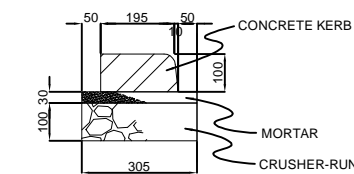

CONCRETE KERB TYPE A-5

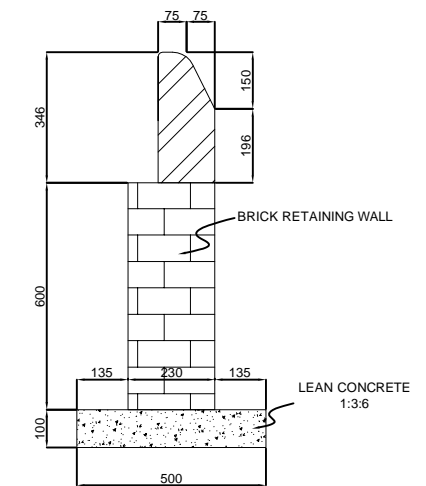

CONCRETE KERB TYPE D

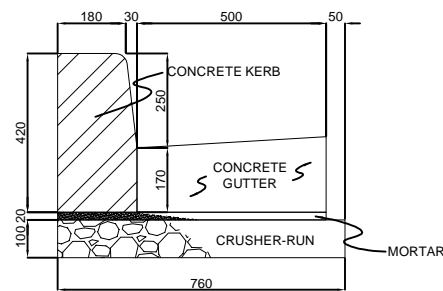

CONCRETE KERB TYPE B-1

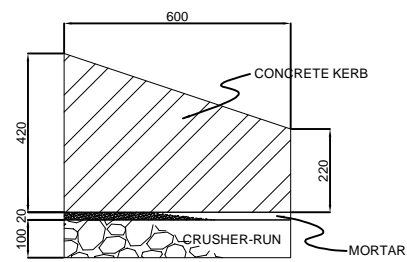

CONCRETE KERB TYPE B-2
TRANSITION BLOCK BETWEEN
TYPE B-1 AND TYPE B-3

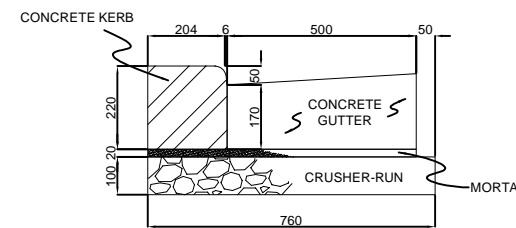

CONCRETE KERB TYPE B-3

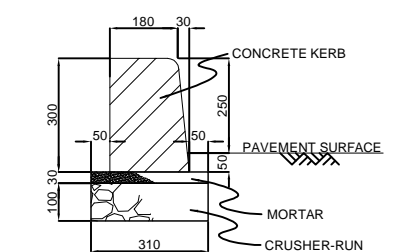

CONCRETE KERB TYPE E

MATERIAL LIST (QUANTITIES PER 10 M)

TYPE	A-1	A-2	A-3	A-4	A-5	B-1	B-2	B-3
DIMENSION	180/205×H250×L600	180/205×H250×L600 198/205×H70	198/205×H70×L600	180/205×H250×L600 195/205×H100	195/205×H100×L600	180/210×H420×L600	180/210×H420×L600 204/210×H220	204/210×H220×L600
CONCRETE	CLASS E I	CLASS E I	CLASS E I	CLASS E I	CLASS E I	CLASS E I	CLASS E I	CLASS E I
MORTAR (1:3)	0.0915 m ³	0.0915 m ³	0.0915 m ³	0.0915 m ³	0.0915 m ³	0.142 m ³	0.142 m ³	0.142 m ³
CRUSHER-RUN	0.305 m ³	0.305 m ³	0.305 m ³	0.305 m ³	0.305 m ³	0.760 m ³	0.760 m ³	0.760 m ³
GUTTER CONCRETE	-	-	-	-	-	0.925 m ³	0.925 m ³	0.925 m ³

MATERIAL LIST (QUANTITIES PER 10 M)

TYPE	C	D	E
DIMENSION	120×H150×L600	75/150×H346×L600	180/210×H300×L600
CONCRETE	CLASS E I	CLASS E I	CLASS E I
MORTAR (1:3)	-	-	-
CRUSHER-RUN	-	-	0.093 m ³
BASE CONCRETE	0.110 m ³	-	0.310 m ³
LEAN CONCRETE	-	0.500 m ³	-
BRICK	-	1.380 m ³	-

PROJECT NAME
DETAILED DESIGN ON
BAGO RIVER BRIDGE
CONSTRUCTION PROJECT

FINANCED BY
JICA
JAPAN INTERNATIONAL
COOPERATION AGENCY

COUNTERPART
REPUBLIC OF THE UNION OF MYANMAR
MINISTRY OF CONSTRUCTION
DEPARTMENT OF BRIDGE

JICA STUDY TEAM
NIPPON KOEI CO., LTD.
ORIENTAL CONSULTANTS GLOBAL CO., LTD.
METROPOLITAN EXPRESSWAY COMPANY LIMITED
CHODAI CO. LTD.
NIPPON ENGINEERING CONSULTANTS CO. LTD.

	NAME	SIGNATURE	DATE
PREPARED BY	K. TACHIBANA		29 Sep.2017
CHECKED BY	T. HAYAKAWA		3 Oct.2017
APPROVED BY	Y. SANO		6 Oct.2017

DRAWING TITLE
DETAILS OF KERB

PACKAGE
3
DWG No.
P3-RD-6000

DETAILS OF CONCRETE SEAL S=1:10

Note
1. Specification of Plain Concrete should be CLASS E1

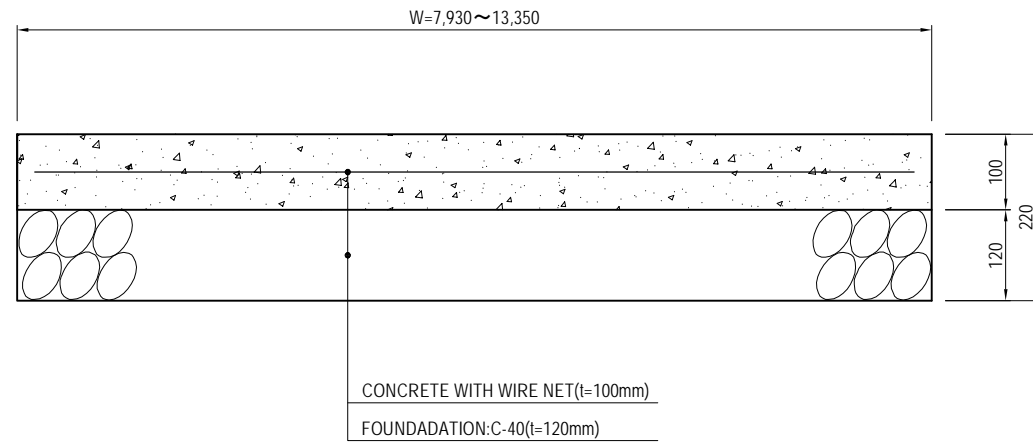

QUANTITY		Per 100 m ²	
Title	Specification	Quantity	
Concrete	18N/mm ² , t=100	100.00	m ²
Wire net		100.00	m ²
Foundation	t=120	100.00	m ²

CONCRETE SEAL (t=100mm)
("UNDER FLYOVER" SECTION)

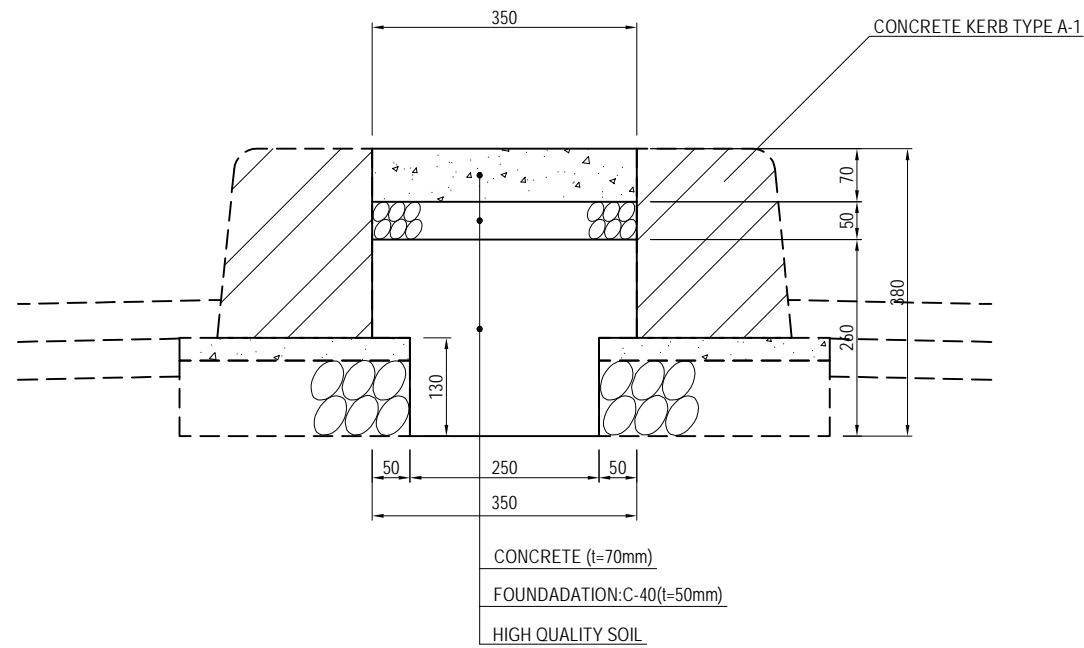

MEDIAN TYPE A (t=70mm)
("MECHANICALLY STABILISED EARTH WALL" SECTION)

QUANTITY		Per 100 m	
Title	Specification	Quantity	
Concrete	18N/mm ² , t=70	2.45	m ³
Foundation	t=50	35.00	m ²
High Quality Soil		7.80	m ³

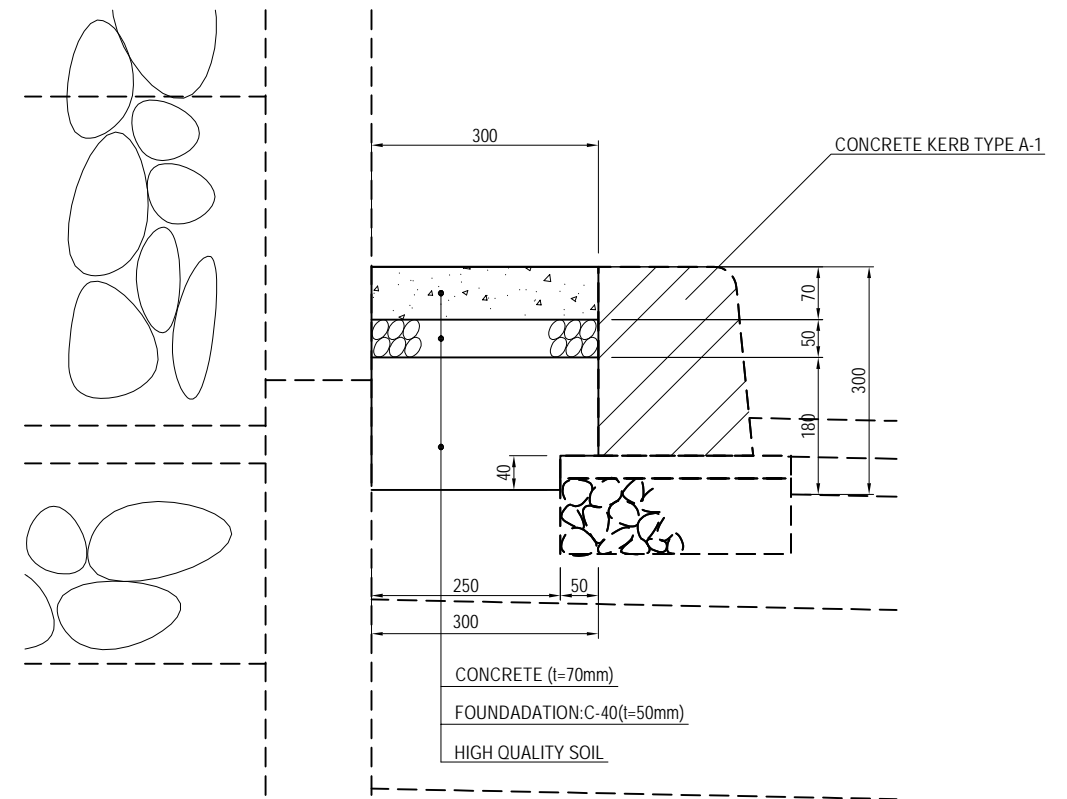

MEDIAN TYPE B (t=70mm)
("MECHANICALLY STABILISED EARTH WALL" SECTION)

QUANTITY		Per 100 m	
Title	Specification	Quantity	
Concrete	18N/mm ² , t=70	2.10	m ³
Foundation	t=50	30.00	m ²
High Quality Soil		5.20	m ³

DETAIL OF BOUNDARY FENCE (1)

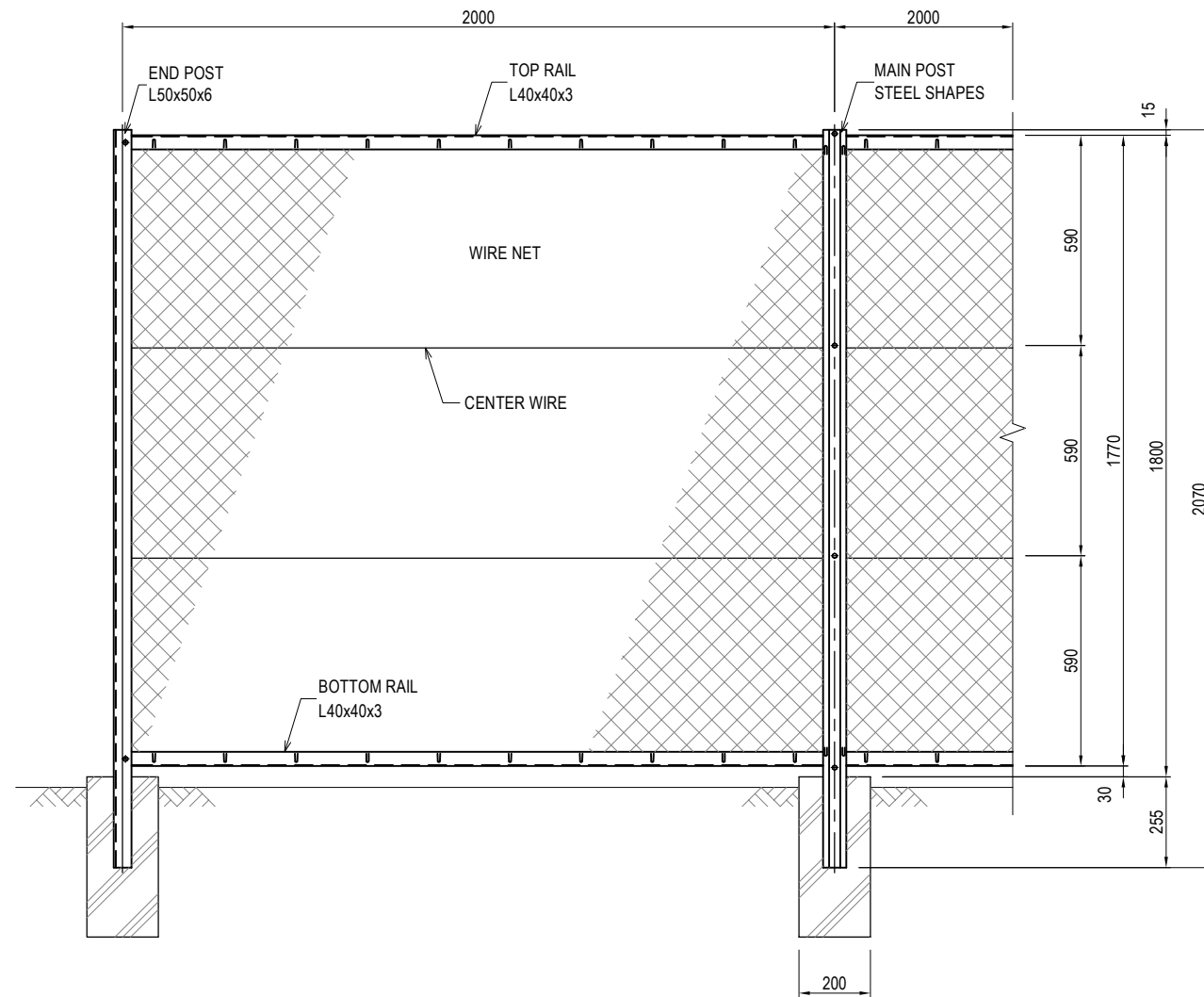

FRONT VIEW
S=1:20

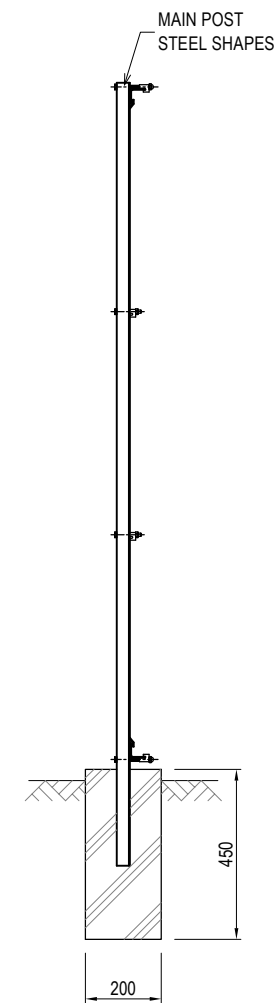

SIDE VIEW
S=1:20

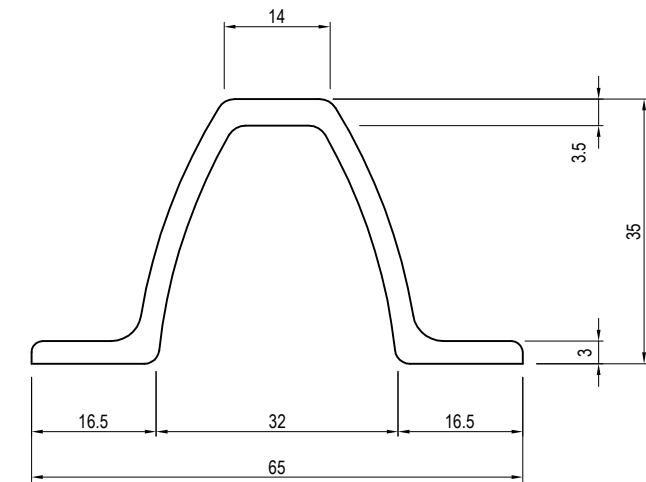

MAIN POST DETAIL
S=1:1

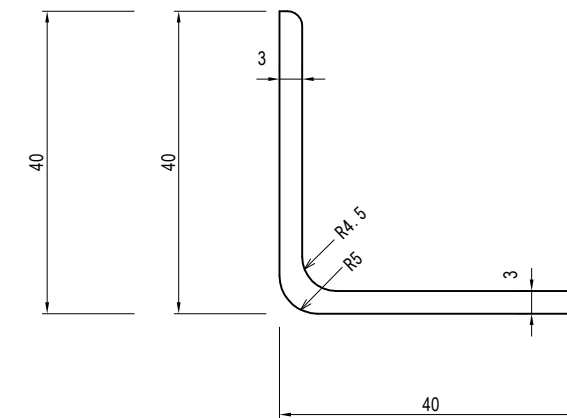

RAIL SECTION(L40x40x3)
S=1:1

QUANTITY PER 10m

Title	Specification	Quantity	Description
Main Post	t=3,L=2070	4 each	Coating specification
End Post	L-50x50x6,L=2070	(2) each	Coating specification
Rail	L-40x40x3,L=10m	2 each	Coating specification
Wire Net	φ3.2-50x50,L=1800	10 m	
Concrete	E I	0.09 m3	
Form		1.8 m2	

PROJECT NAME
DETAILED DESIGN ON
BAGO RIVER BRIDGE
CONSTRUCTION PROJECT

FINANCED BY
 JAPAN INTERNATIONAL
COOPERATION AGENCY

COUNTERPART
 REPUBLIC OF THE UNION OF MYANMAR
MINISTRY OF CONSTRUCTION
DEPARTMENT OF BRIDGE

JICA STUDY TEAM
 NIPPON KOEI CO., LTD.
 ORIENTAL CONSULTANTS GLOBAL CO., LTD.
 METROPOLITAN EXPRESSWAY COMPANY LIMITED
 CHODAI CO. LTD.
 NIPPON ENGINEERING CONSULTANTS CO. LTD.

	NAME	SIGNATURE	DATE
PREPARED BY	K. TACHIBANA		29 Sep.2017
CHECKED BY	T. HAYAKAWA		3 Oct.2017
APPROVED BY	Y. SANO		6 Oct.2017

DRAWING TITLE
DETAIL OF BOUNDARY FENCE (1)

PACKAGE
3
DWG No.
P3-RD-6020

DETAIL OF BOUNDARY FENCE (2)

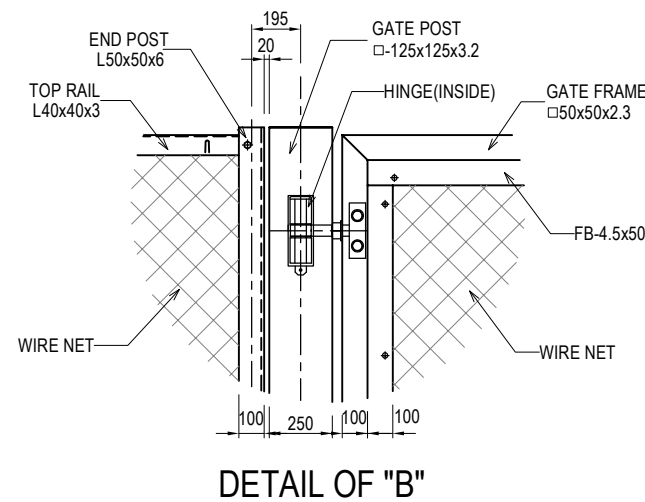
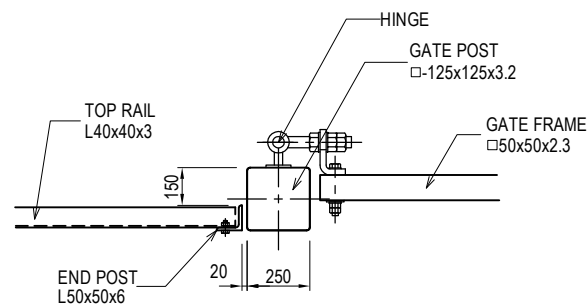
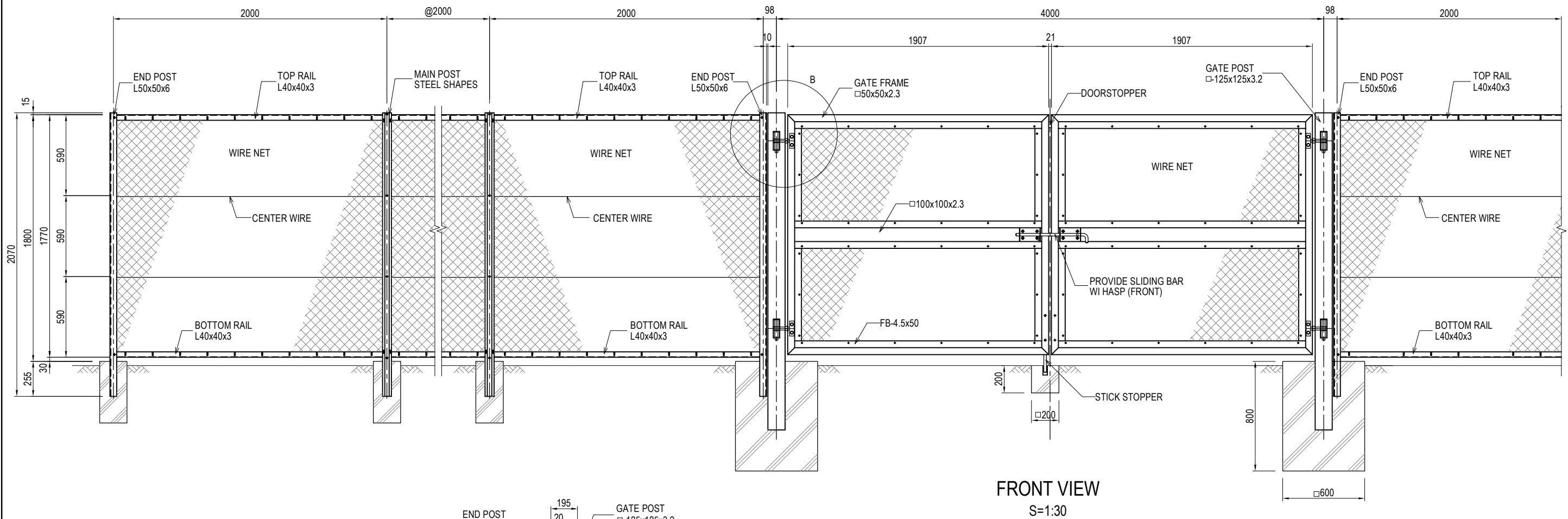
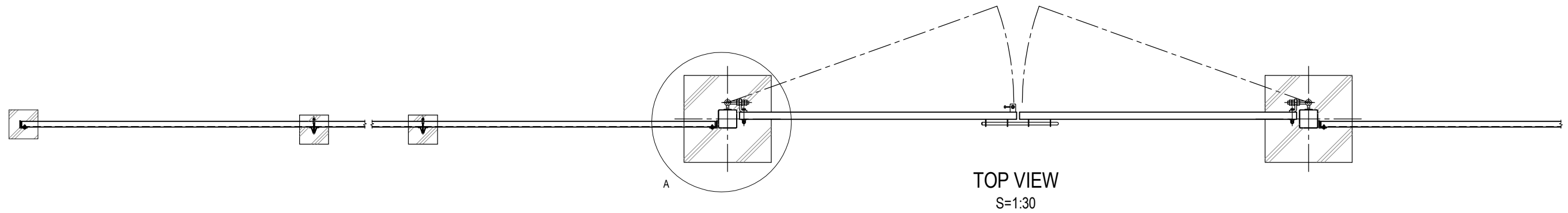

QUANTITY			PER 1each
Title	Specification	Quantity	Description
Gate	W=4.0m,H=1.8m	1 set	Coating specification
Concrete	E 1	0.58 m3	
Form		4.0 m2	

PROJECT NAME
DETAILED DESIGN ON
BAGO RIVER BRIDGE
CONSTRUCTION PROJECT

FINANCED BY
 JAPAN INTERNATIONAL
COOPERATION AGENCY

COUNTERPART
 REPUBLIC OF THE UNION OF MYANMAR
MINISTRY OF CONSTRUCTION
DEPARTMENT OF BRIDGE

JICA STUDY TEAM
 NIPPON KOEI CO., LTD.
 ORIENTAL CONSULTANTS GLOBAL CO., LTD.
 METROPOLITAN EXPRESSWAY COMPANY LIMITED
 CHODAI CO. LTD.
 NIPPON ENGINEERING CONSULTANTS CO. LTD.

	NAME	SIGNATURE	DATE
PREPARED BY	K. TACHIBANA		29 Sep.2017
CHECKED BY	T. HAYAKAWA		3 Oct.2017
APPROVED BY	Y. SANO		6 Oct.2017

DRAWING TITLE
DETAIL OF BOUNDARY FENCE (2)

PACKAGE
3
DWG No.
P3-RD-6030

DETAIL OF BOX BEAM (1)

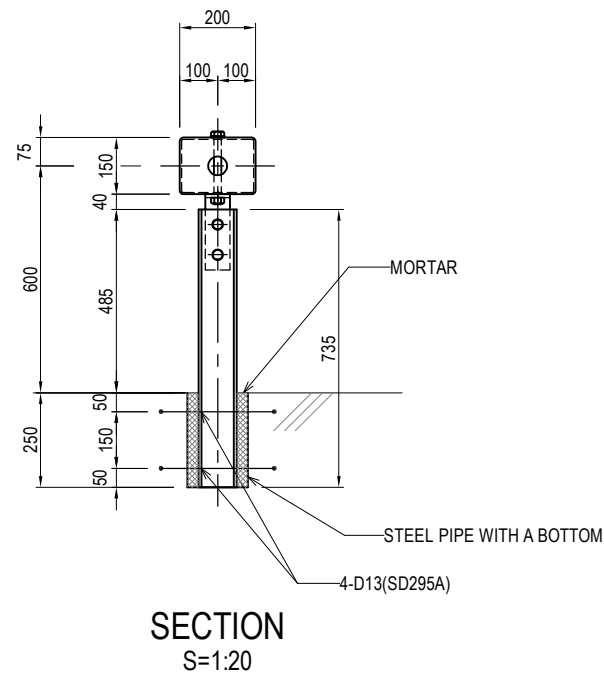
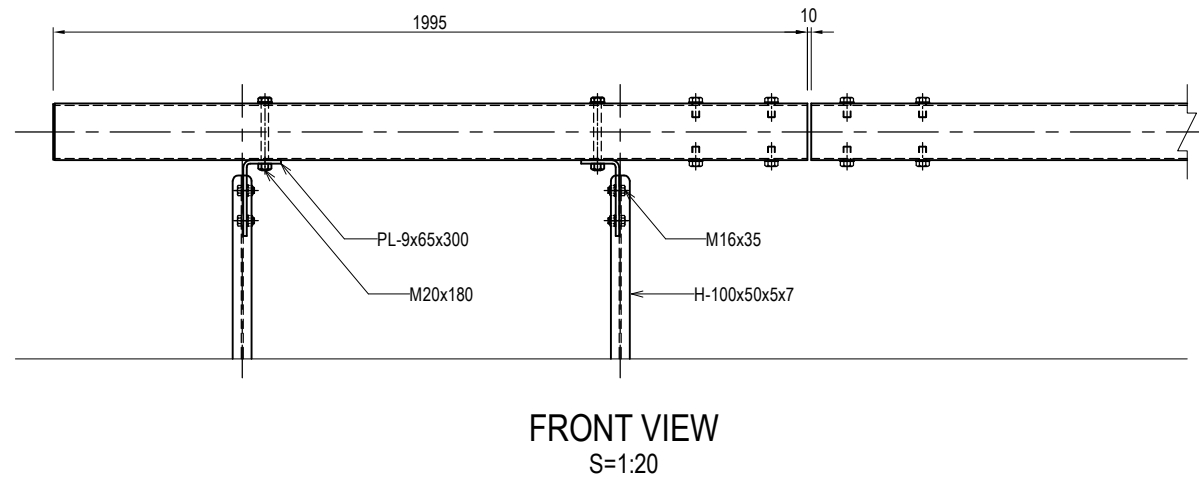
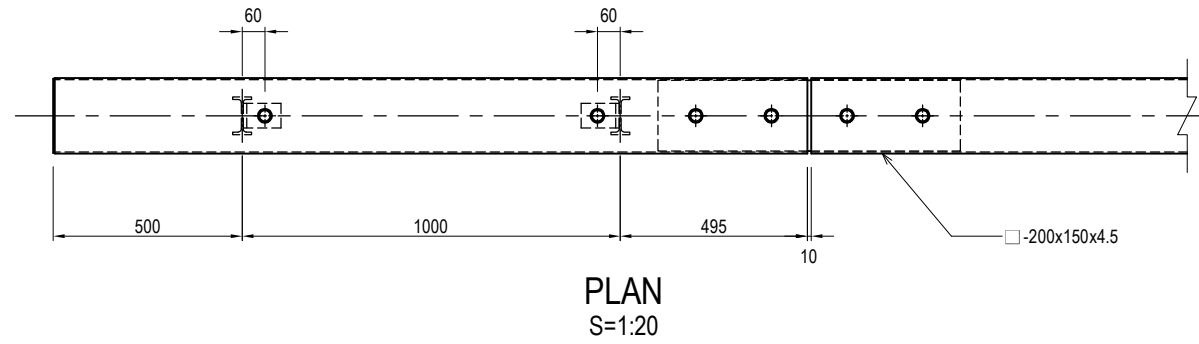

DETAIL OF BRACKET S=1:10

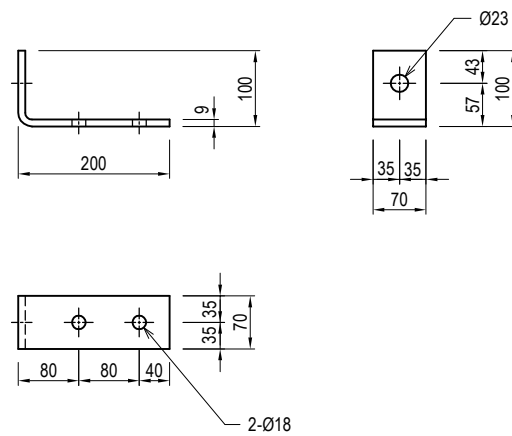

DETAIL OF CONNECTION BOLT S=1:5

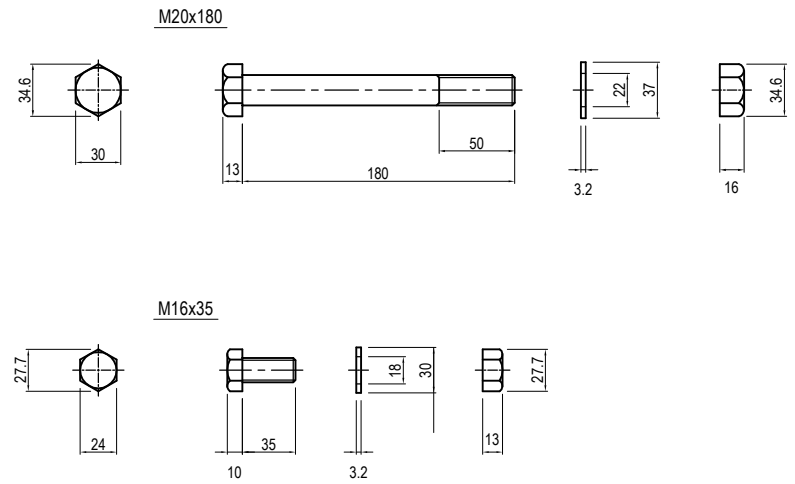

QUANTITY PER 1each

Title	Specification	Quantity	Description
Post	H-100 x 50 x 5 x 7 L=735	2 each	HDZ 55
Box beam (Edge)	□-200 x 150 x 4.5 L=1995	1 each	HDZ 55

PROJECT NAME
DETAILED DESIGN ON
BAGO RIVER BRIDGE
CONSTRUCTION PROJECT

FINANCED BY
JICA
JAPAN INTERNATIONAL
COOPERATION AGENCY

COUNTERPART
REPUBLIC OF THE UNION OF MYANMAR
MINISTRY OF CONSTRUCTION
DEPARTMENT OF BRIDGE

JICA STUDY TEAM
NIPPON KOEI CO., LTD.
ORIENTAL CONSULTANTS GLOBAL CO., LTD.
METROPOLITAN EXPRESSWAY COMPANY LIMITED
CHODAI CO. LTD.
NIPPON ENGINEERING CONSULTANTS CO., LTD.

	NAME	SIGNATURE	DATE
PREPARED BY	K. TACHIBANA		29 Sep.2017
CHECKED BY	T. HAYAKAWA		3 Oct.2017
APPROVED BY	Y. SANO		6 Oct.2017

DRAWING TITLE
DETAIL OF BOX BEAM (1)

PACKAGE
3
DWG No.
P3-RD-6040

DETAIL OF BOX BEAM (2)

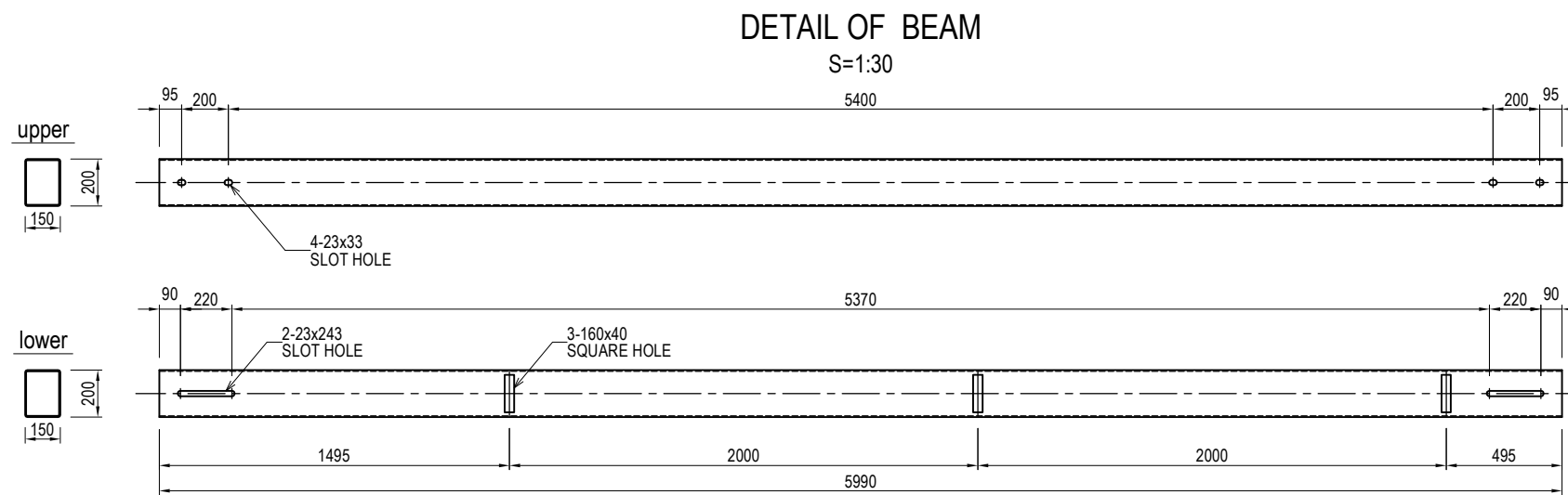
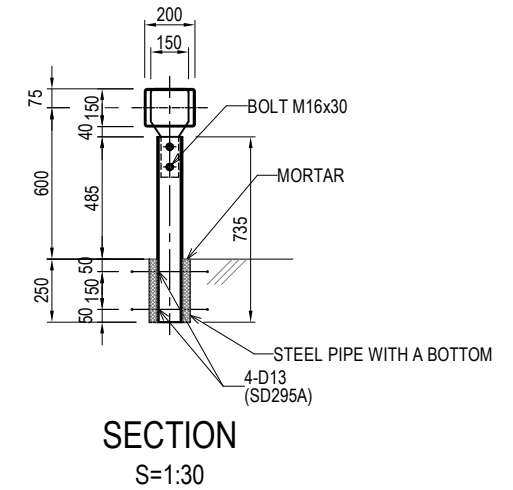
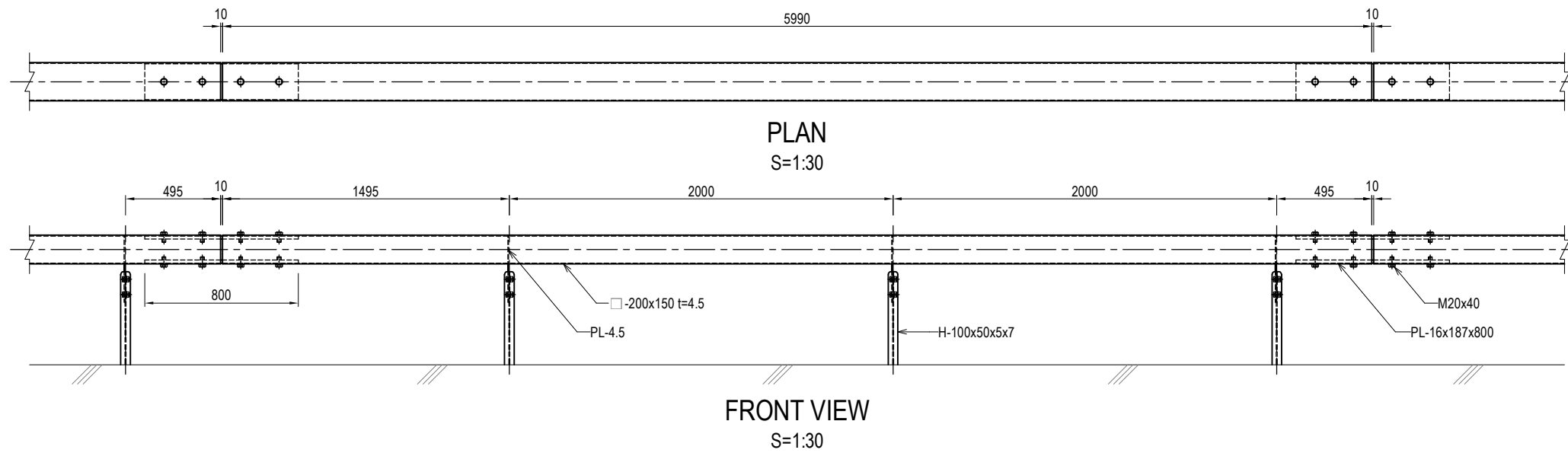

DETAIL OF REINFORCING BAR

S=1:20

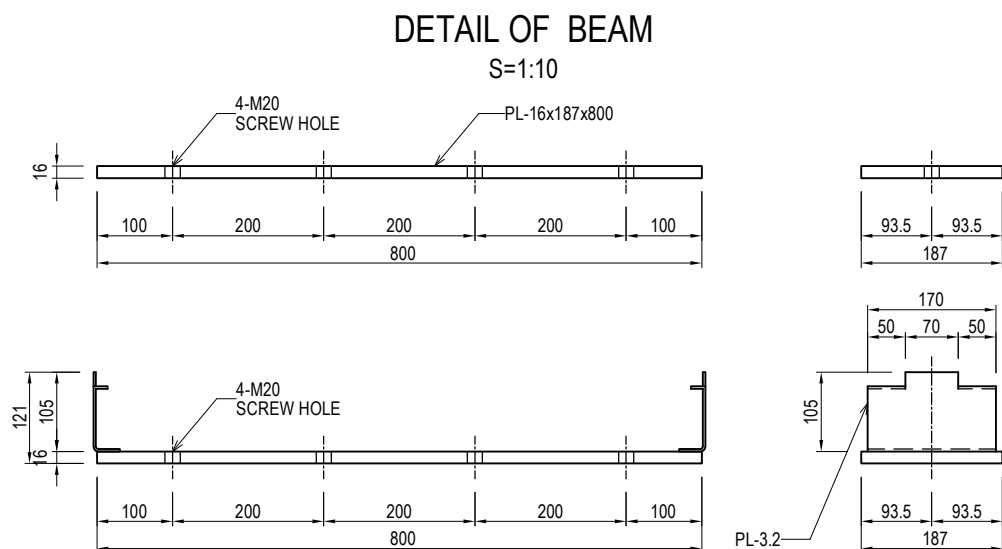
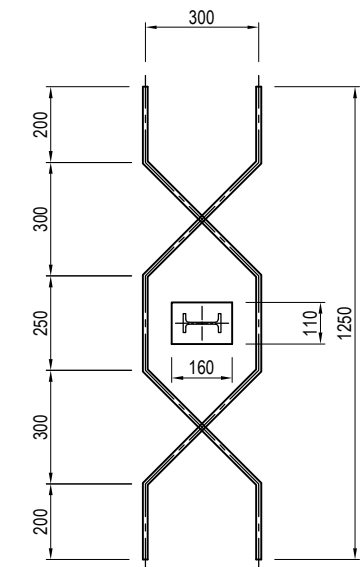

DETAIL OF PADDLE

S=1:10

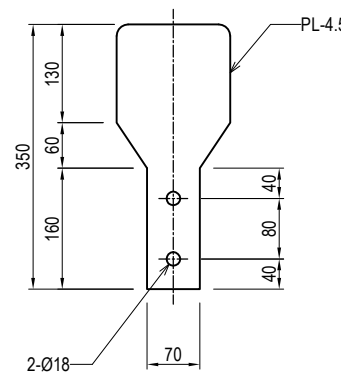

DETAIL OF CONNECTION BOLT

S=1:5

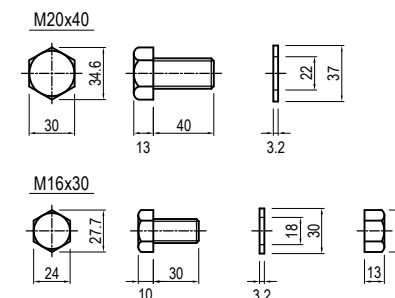

QUANTITY			PER 10m
Title	Specification	Quantity	Description
Post	H-100 x 50 x 5 x 7 L=735	5 each	HDZ 55
Box beam	□-200 x 150 x 4.5 L=2000	5 each	HDZ 55

DETAIL OF BOX BEAM (3)

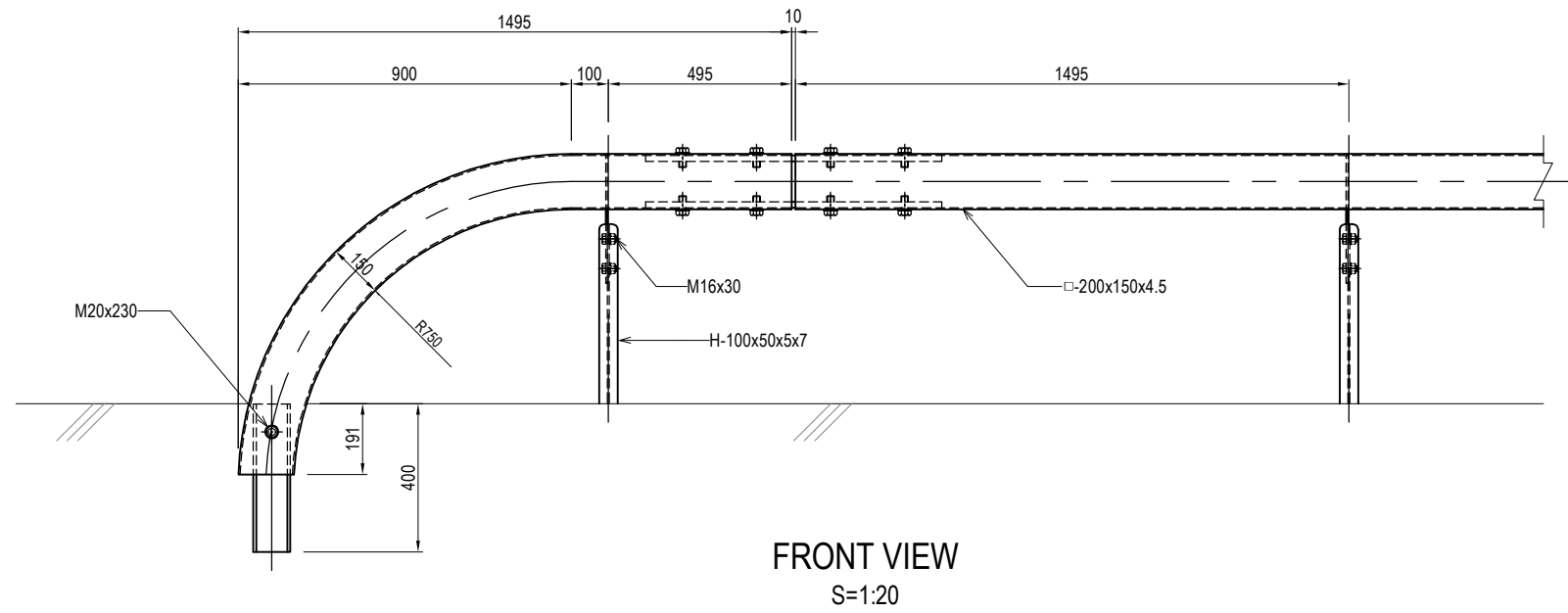
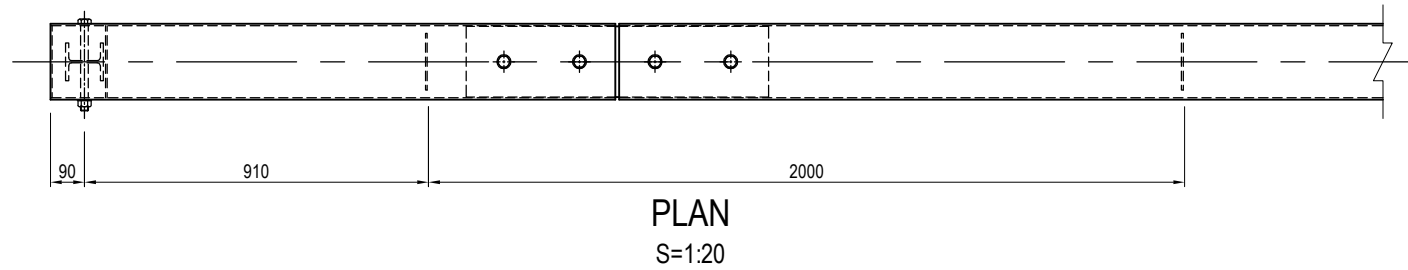

DETAIL OF ANCHOR POST S=1:10

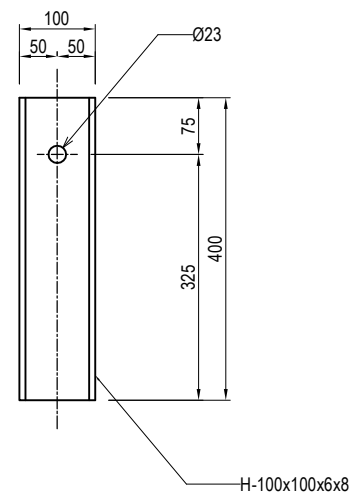

DETAIL OF CONNECTION BOLT S=1:5

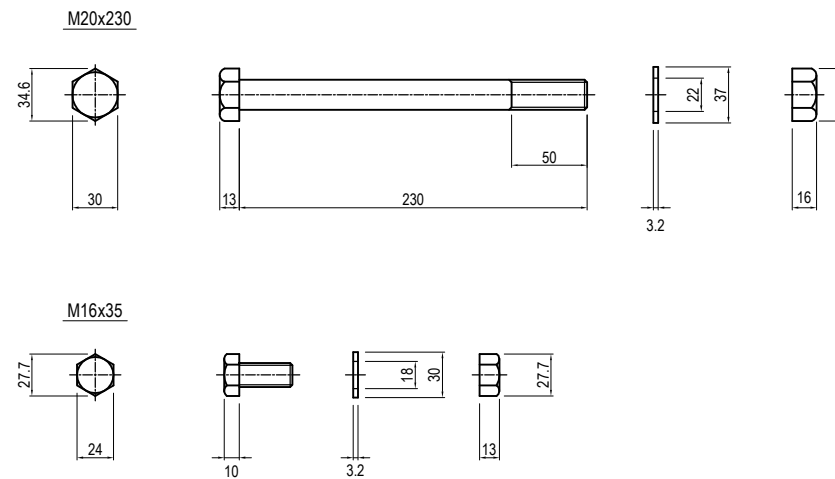

QUANTITY			PER 1each
Title	Specification	Quantity	Description
Post	H-100 x 50 x 5 x 7 L=735	2 each	HDZ 55
Anchor post	H-100 x 100 x 6 x 8 L=400	1 each	HDZ 55
Box beam (Edge)	□-200 x 150 x 4.5 L=1495	1 each	HDZ 55
Box beam (Edge)	□-200 x 150 x 4.5 R=750	1 each	HDZ 55

PROJECT NAME
DETAILED DESIGN ON
BAGO RIVER BRIDGE
CONSTRUCTION PROJECT

FINANCED BY
JICA
JAPAN INTERNATIONAL
COOPERATION AGENCY

COUNTERPART
REPUBLIC OF THE UNION OF MYANMAR
MINISTRY OF CONSTRUCTION
DEPARTMENT OF BRIDGE

JICA STUDY TEAM
NIPPON KOEI CO., LTD.
ORIENTAL CONSULTANTS GLOBAL CO., LTD.
METROPOLITAN EXPRESSWAY COMPANY LIMITED
CHODAI CO. LTD.
NIPPON ENGINEERING CONSULTANTS CO., LTD.

	NAME	SIGNATURE	DATE
PREPARED BY	K. TACHIBANA		29 Sep.2017
CHECKED BY	T. HAYAKAWA		3 Oct.2017
APPROVED BY	Y. SANO		6 Oct.2017

DRAWING TITLE
DETAIL OF BOX BEAM (3)

PACKAGE
3
DWG No.
P3-RD-6060

DETAIL OF INFORMATORY SIGNBOARD-TYPE A FOUNDATION AND POST (1)

GENERAL VIEW S = 1:40

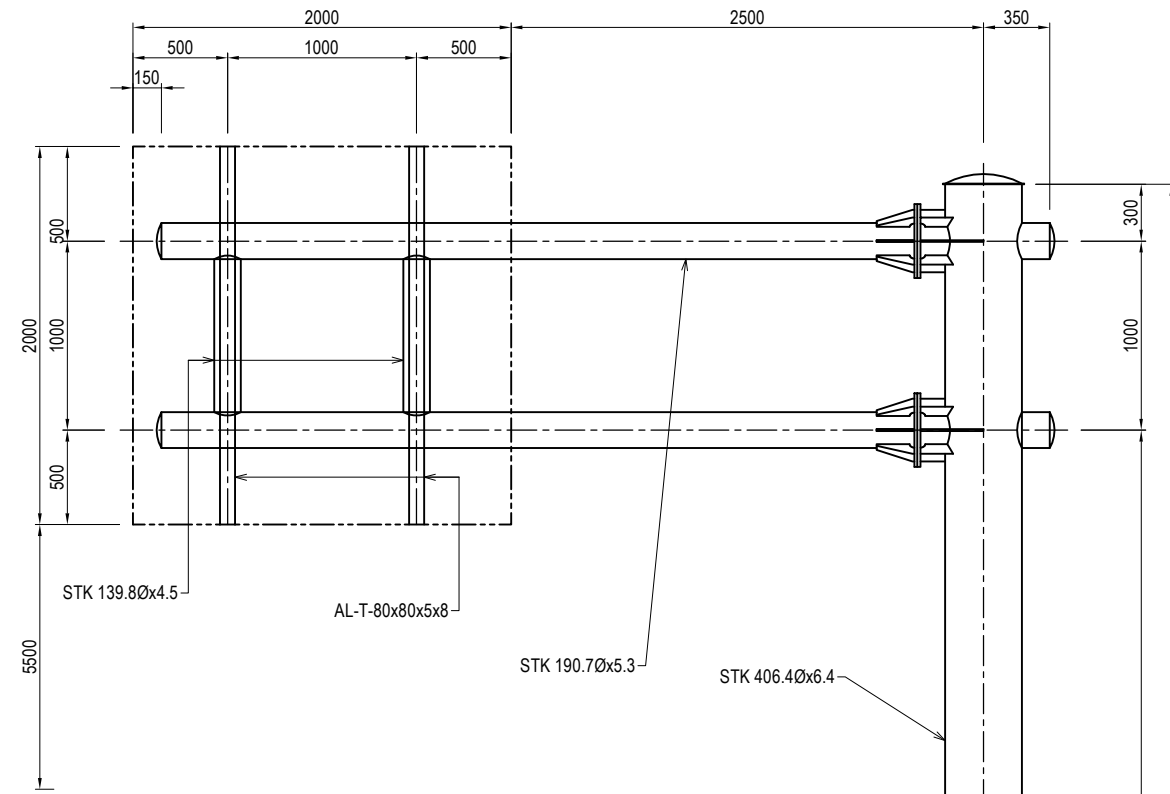

SECTION OF PANEL S = 1:40

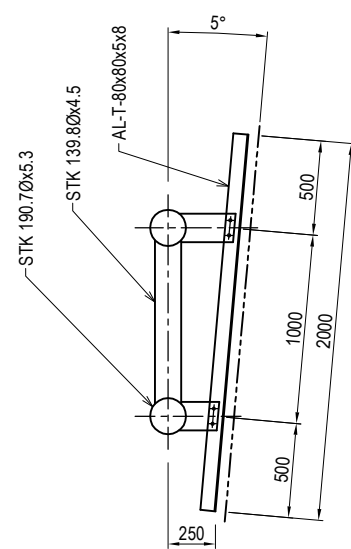

DETAIL OF MOUNTING BRACKET

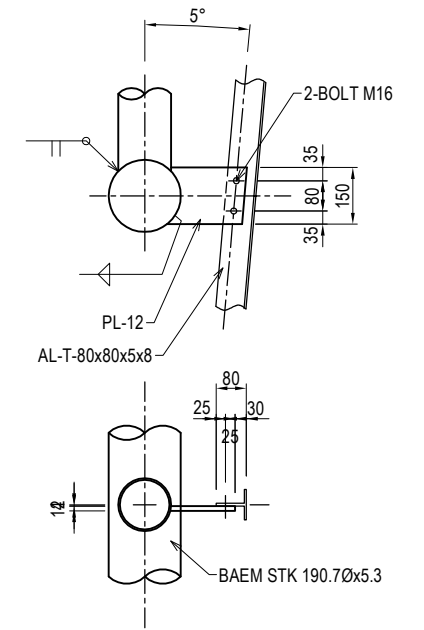

DETAIL OF INTERACTION BETWEEN BEAM AND PILLAR S = 1:20

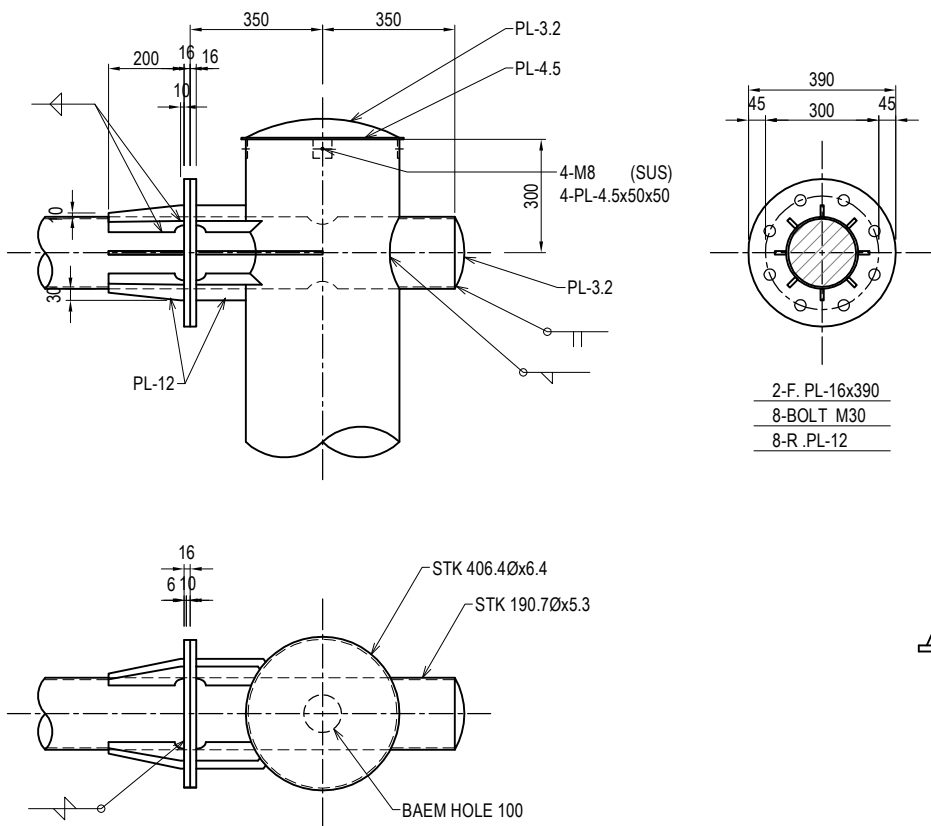

DETAIL OF COLUMN BASE S = 1:20 DETAIL OF ANCHOR BOLT S = 1:20

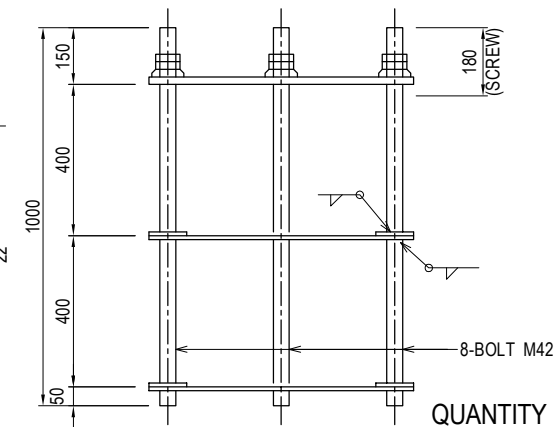
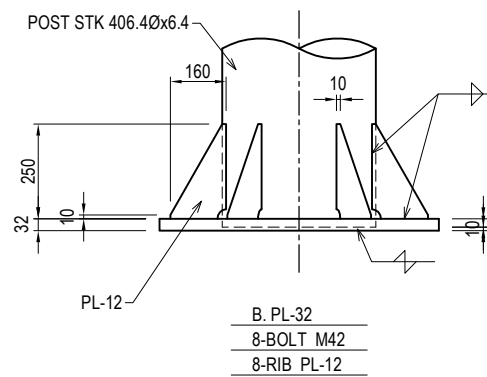
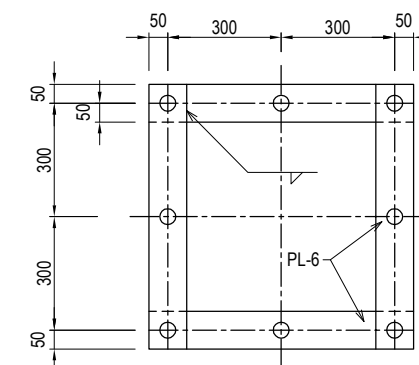
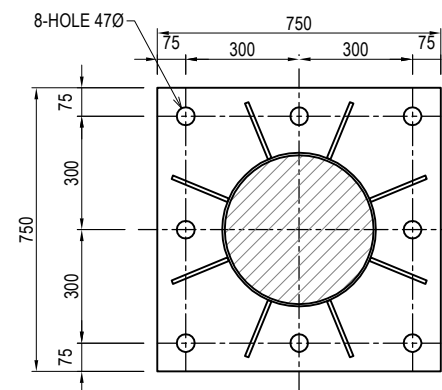

QUANTITY		PER 1each	
Title	Specification	Quantity	Description
Signboard	aluminium:t=2.0	1 each	Encapsulated lens type
Post	φ406.4 x 7300 x 6.4	460.63 kg	HDZ 55
Beam	φ190.7 x 4700 x 5.3	227.48 kg	HDZ 55
Post jointing	φ139.8 x 1000 x 4.5	30.00 kg	HDZ 55
Stiffener		333.58 kg	
Anchor bolt	M42 x 1000	99.12 kg	HDZ 55
Anchor bolt fixed frame	PL-100 x 700 x 6	28.40 kg	HDZ 55

PROJECT NAME
DETAILED DESIGN ON
BAGO RIVER BRIDGE
CONSTRUCTION PROJECT

FINANCED BY
 JAPAN INTERNATIONAL
COOPERATION AGENCY

COUNTERPART
 REPUBLIC OF THE UNION OF MYANMAR
MINISTRY OF CONSTRUCTION
DEPARTMENT OF BRIDGE

JICA STUDY TEAM
 NIPPON KOEI CO., LTD.
ORIENTAL CONSULTANTS GLOBAL CO., LTD.
METROPOLITAN EXPRESSWAY COMPANY LIMITED
CHODAI CO. LTD.
NIPPON ENGINEERING CONSULTANTS CO., LTD.

	NAME	SIGNATURE	DATE
PREPARED BY	K. TACHIBANA		29 Sep.2017
CHECKED BY	T. HAYAKAWA		3 Oct.2017
APPROVED BY	Y. SANO		6 Oct.2017

DRAWING TITLE
**DETAIL OF INFORMATORY SIGNBOARD-TYPE A
FOUNDATION AND POST (1)**

PACKAGE
3
DWG No.
P3-RD-6070

DETAIL OF INFORMATORY SIGNBOARD-TYPE A FOUNDATION AND POST (2) S=1:30

FRONT VIEW OF BASEMENT

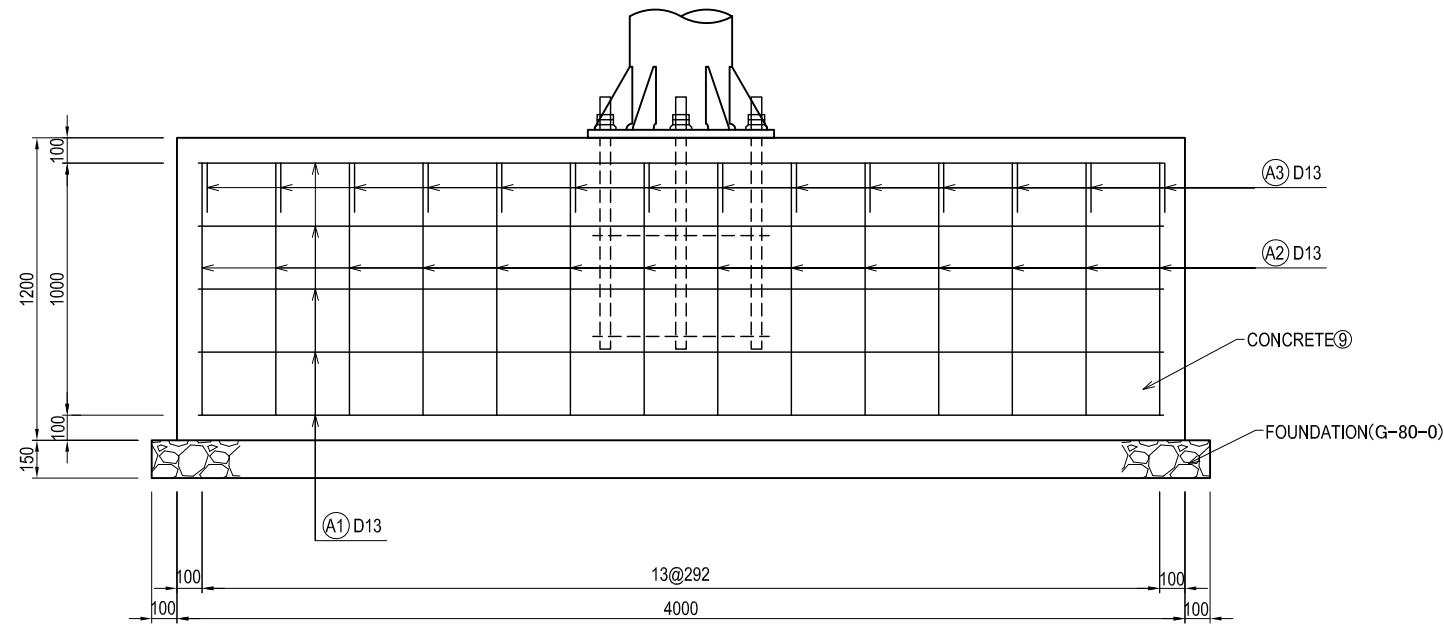

SIDE VIEW OF BASEMENT

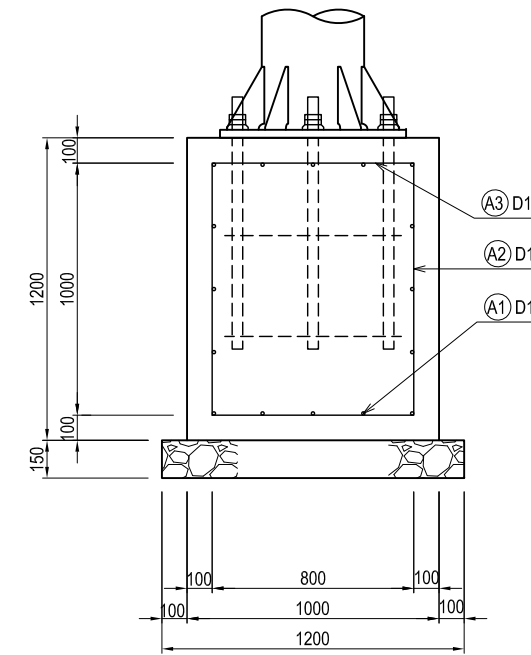

Note
 1. Specification of Reinforced Concrete should be CLASS DII
 2. Specification of Steel reinforcement bar should be SD345

PLAN VIEW OF BASEMENT

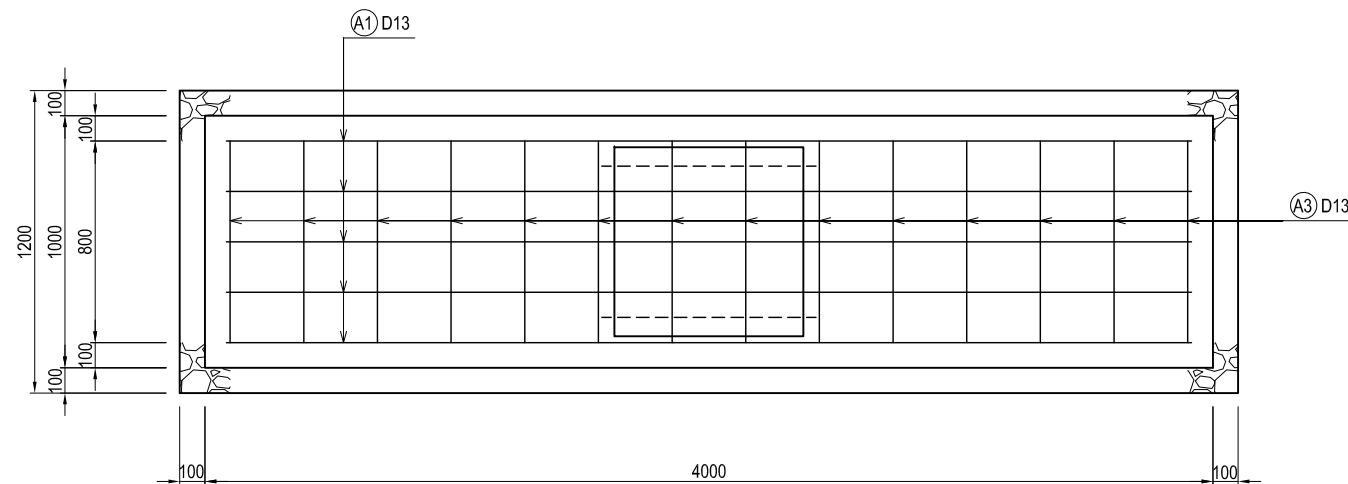

REBAR PROCESSING DRAWING

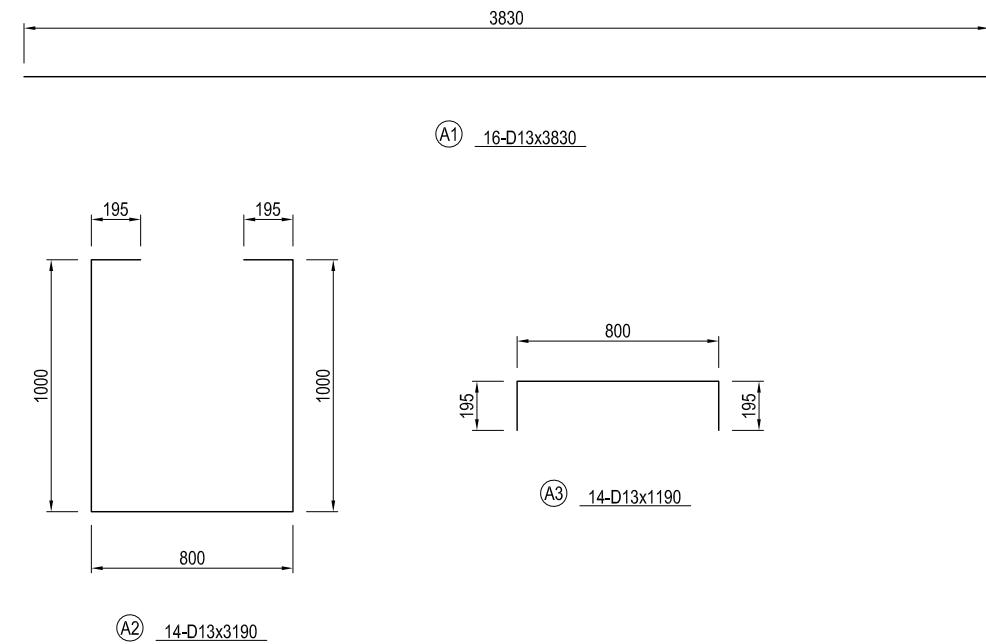

QUANTITY PER 1each

Title	Specification	Quantity	Description
Concrete	D II	4.80 m3	
Reinforcing bar	D 13	121.99 kg	
Foundation	t=150	5.04 m2	
Form		12.00 m2	

PROJECT NAME
 DETAILED DESIGN ON
 BAGO RIVER BRIDGE
 CONSTRUCTION PROJECT

FINANCED BY
 JAPAN INTERNATIONAL
 COOPERATION AGENCY

COUNTERPART
 REPUBLIC OF THE UNION OF MYANMAR
 MINISTRY OF CONSTRUCTION
 DEPARTMENT OF BRIDGE

JICA STUDY TEAM
 NIPPON KOEI CO., LTD.
 ORIENTAL CONSULTANTS GLOBAL CO., LTD.
 METROPOLITAN EXPRESSWAY COMPANY LIMITED
 CHODAI CO., LTD.
 NIPPON ENGINEERING CONSULTANTS CO., LTD.

NAME	SIGNATURE	DATE
PREPARED BY K. TACHIBANA		29 Sep. 2017
CHECKED BY T. HAYAKAWA		3 Oct. 2017
APPROVED BY Y. SANO		6 Oct. 2017

DRAWING TITLE
 DETAIL OF INFORMATORY SIGNBOARD-TYPE A
 FOUNDATION AND POST (2) S=1:30

PACKAGE
 3
 DWG No.
 P3-RD-6080

DETAIL OF INFORMATORY SIGNBOARD-TYPE B FOUNDATION AND POST (1)

GENERAL VIEW S = 1:40

SECTION OF PANEL S = 1:40

DETAIL OF MOUNTING BRACKET S = 1:20

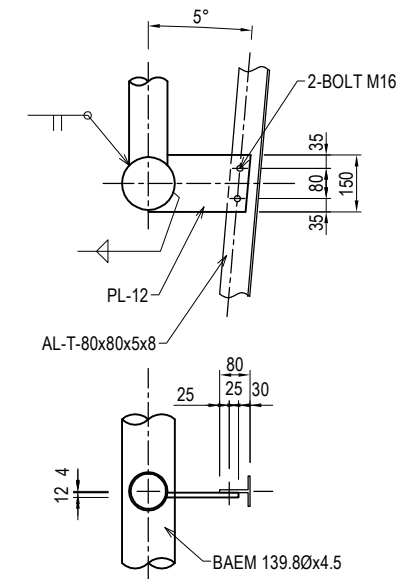
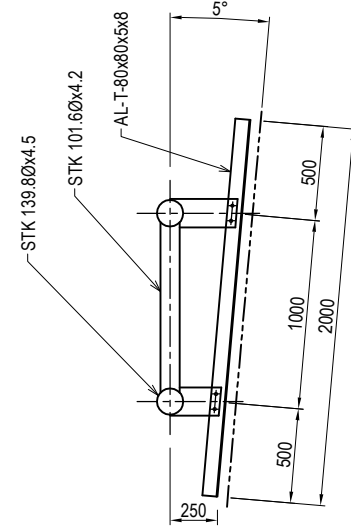
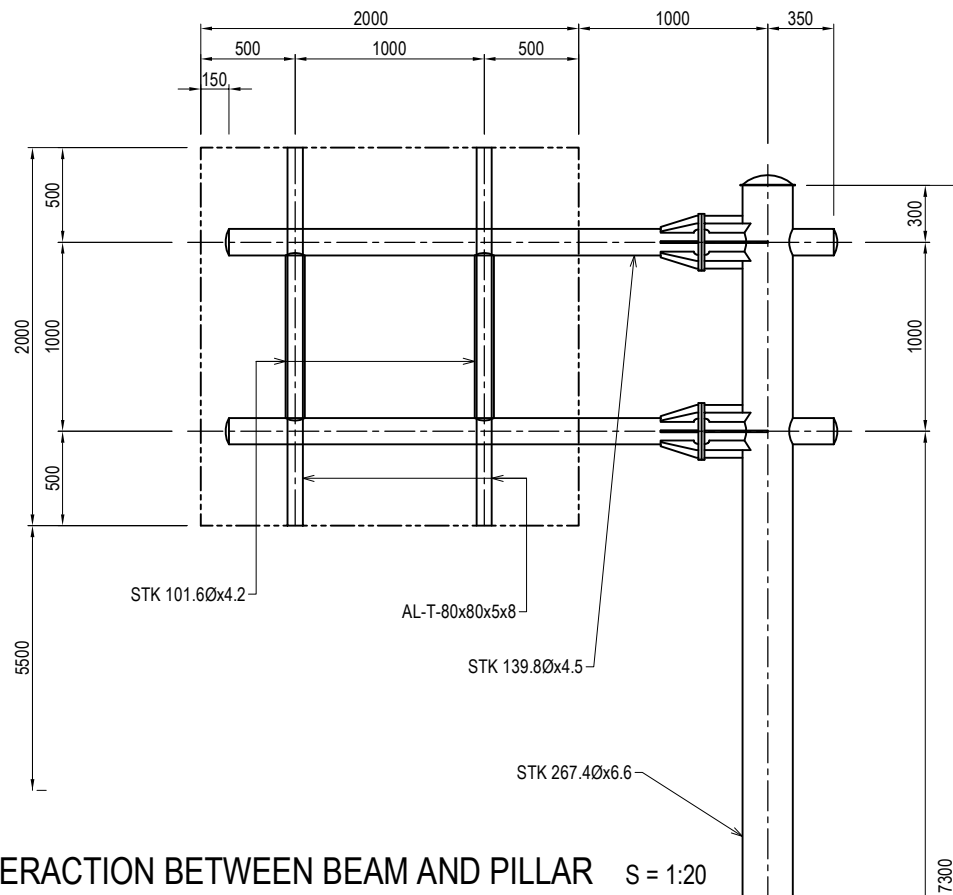

DETAIL OF INTERACTION BETWEEN BEAM AND PILLAR S = 1:20

DETAIL OF COLUMN BASE S = 1:20

DETAIL OF ANCHOR BOLT S = 1:20

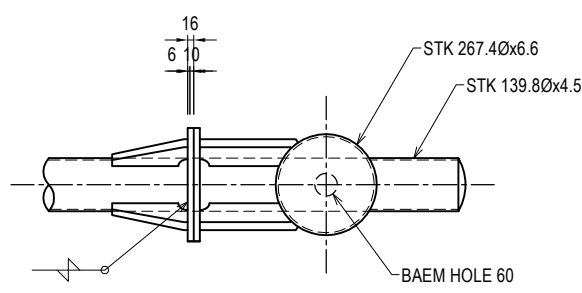
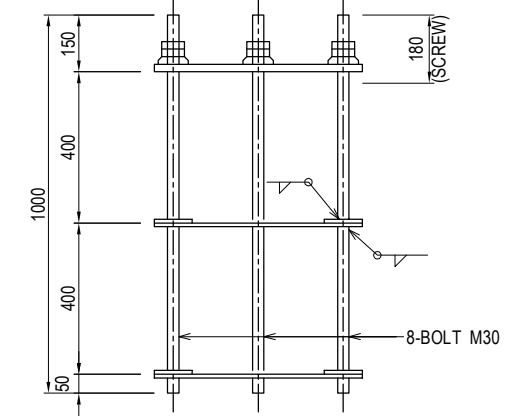
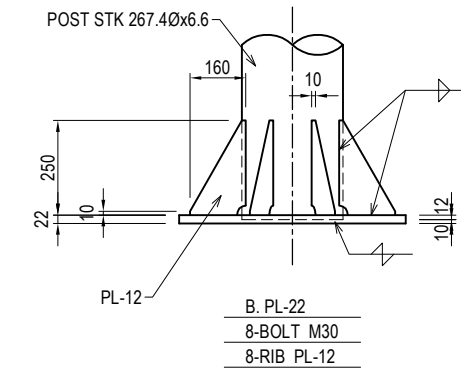
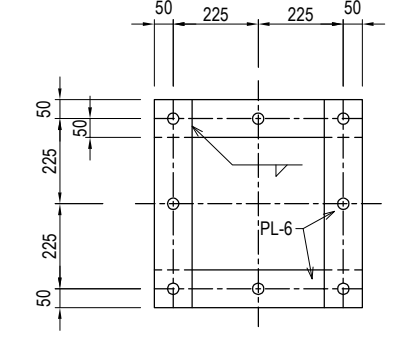
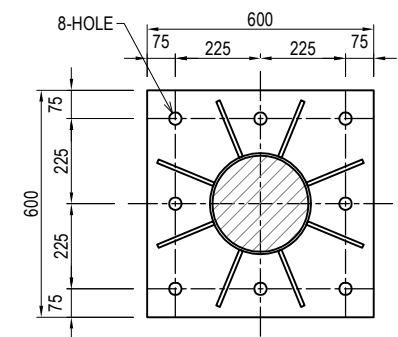
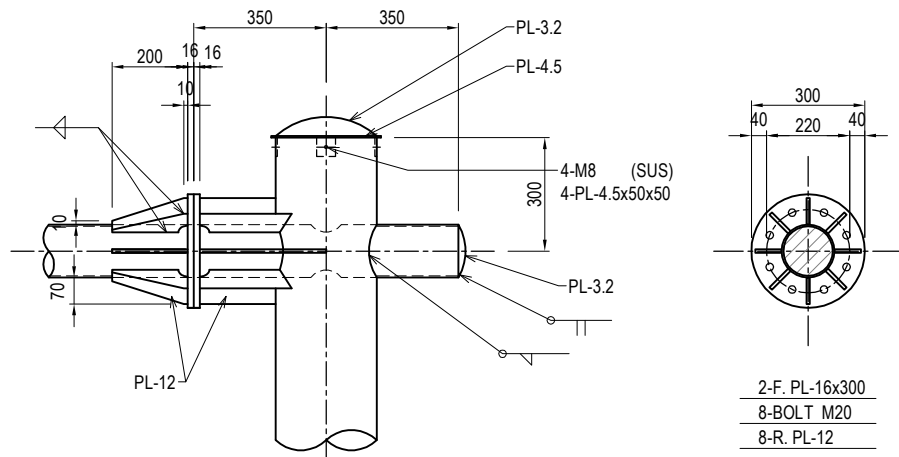

QUANTITY PER 1each

Title	Specification	Quantity	Description
Signboard	aluminium:t=2.0	1 each	Encapsulated lens type
Post	φ406.4 x 7300 x 6.4	309.52 kg	HDZ 55
Beam	φ190.7 x 4700 x 5.3	96.00 kg	HDZ 55
Post jointing	φ139.8 x 1000 x 4.5	20.20 kg	HDZ 55
Stiffener		209.92 kg	
Anchor bolt	M42 x 1000	48.40 kg	HDZ 55
Anchor bolt fixed frame	PL-100 x 700 x 6	20.72 kg	HDZ 55

DETAIL OF INFORMATORY SIGNBOARD-TYPE B FOUNDATION AND POST (2) S=1:30

FRONT VIEW OF BASEMENT

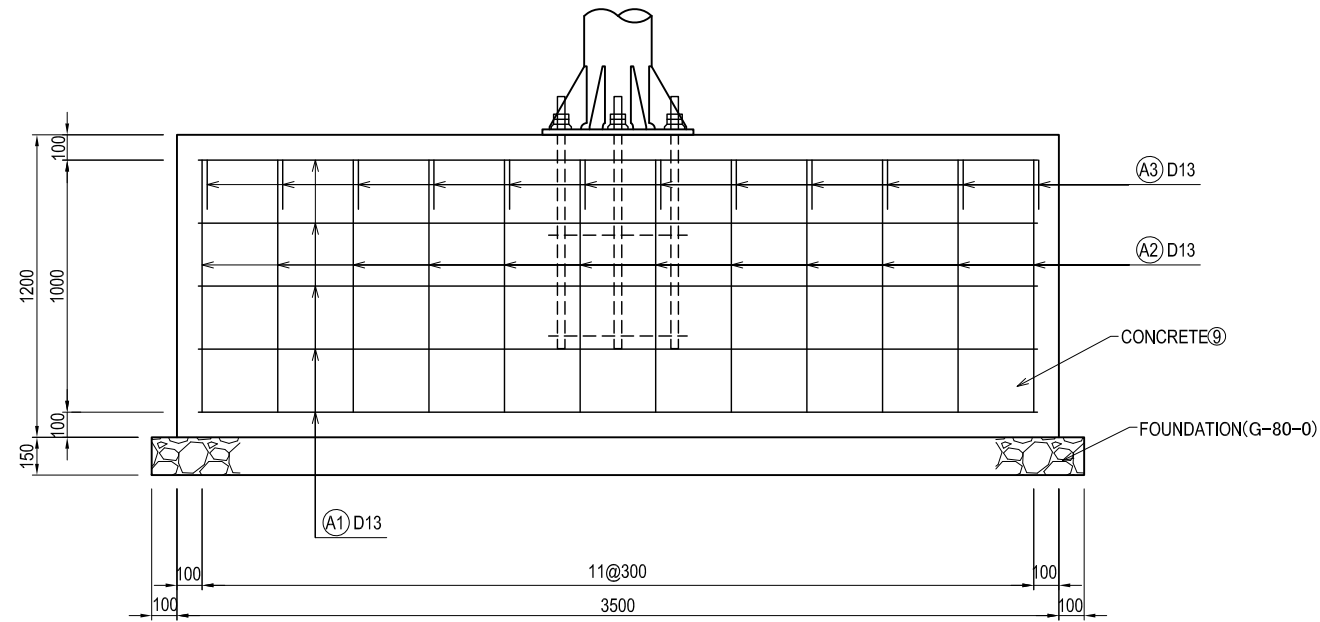

SIDE VIEW OF BASEMENT

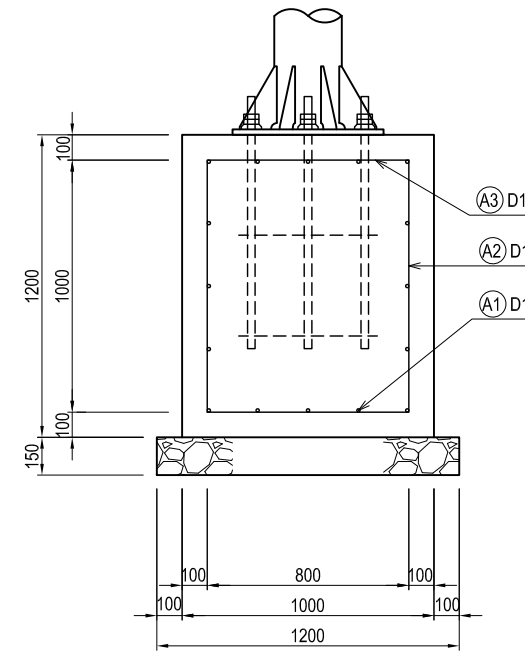

Note
 1. Specification of Reinforced Concrete should be CLASS DII
 2. Specification of Steel reinforcement bar should be SD345

PLAN VIEW OF BASEMENT

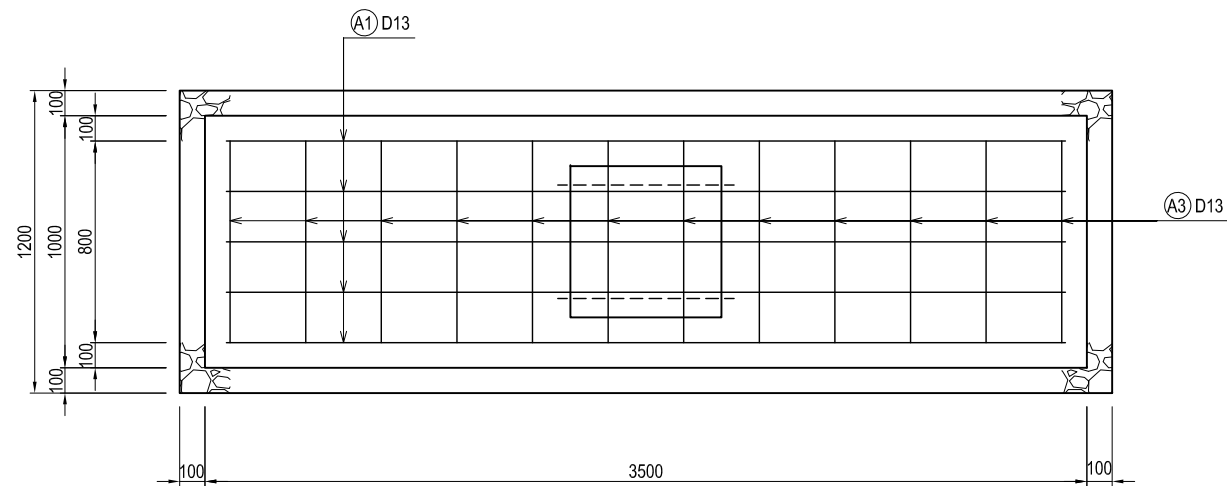

REBAR PROCESSING DRAWING

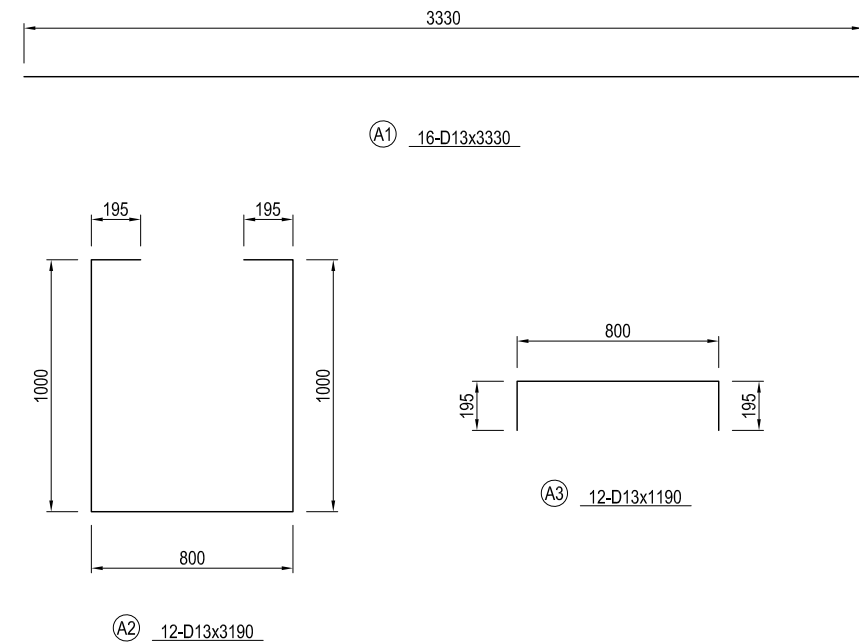

QUANTITY			PER 1each
Title	Specification	Quantity	Description
Concrete	D II	4.20 m3	
Reinforcing bar	D 13	105.31 kg	
Foundation	t=150	4.44 m2	
Form		10.80 m2	

DETAIL OF INFORMATORY SIGNBOARD

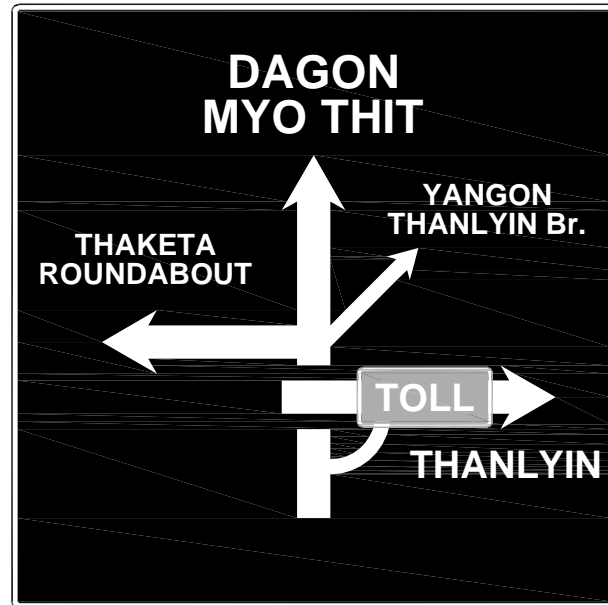

TYPE GS-5

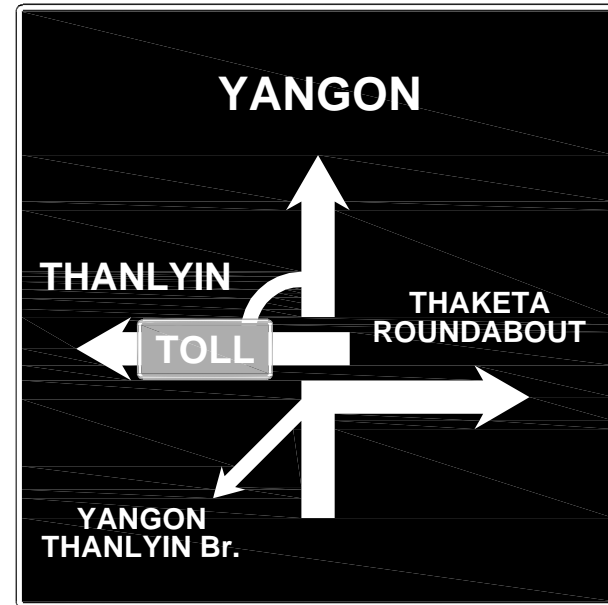

TYPE GS-6

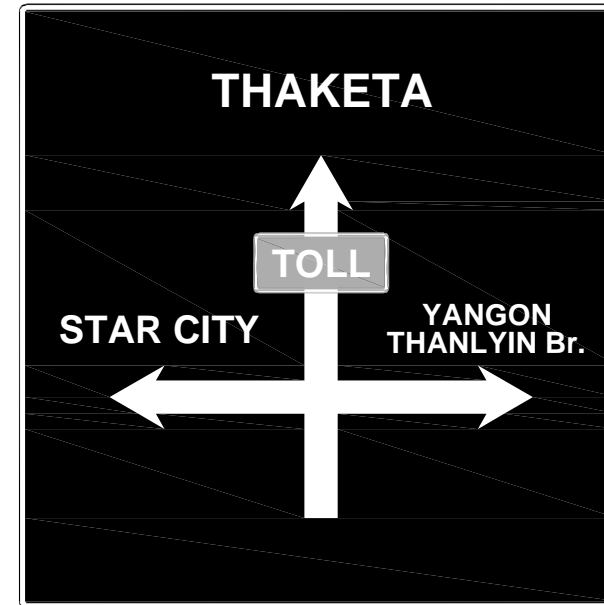

TYPE GS-7

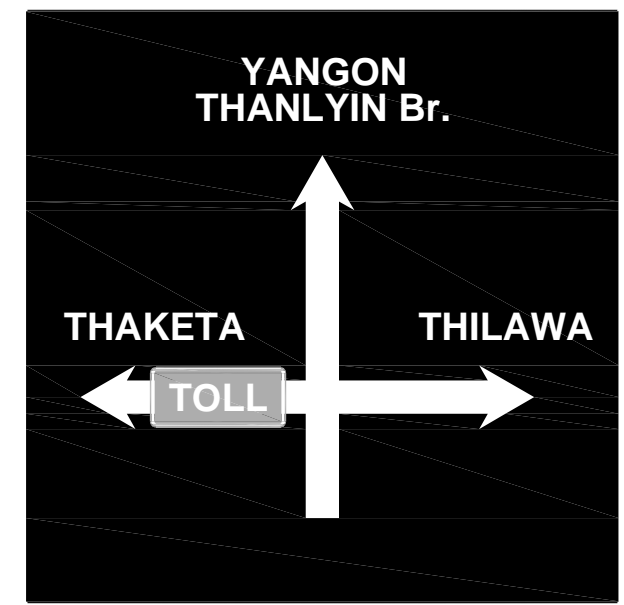

TYPE GS-8

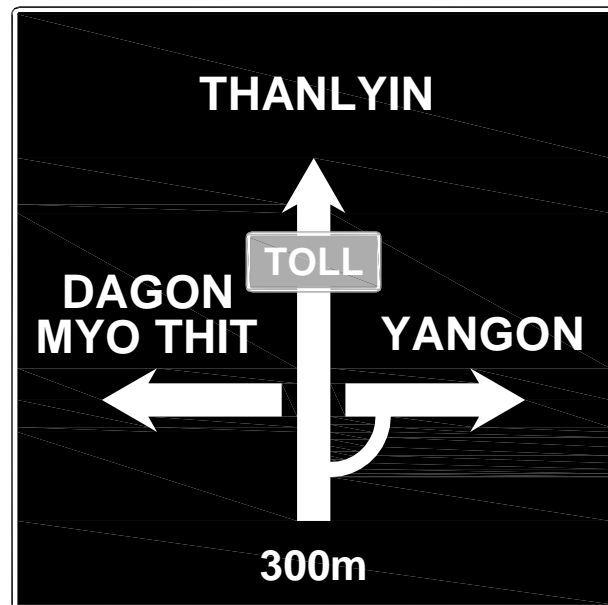

TYPE GS-1

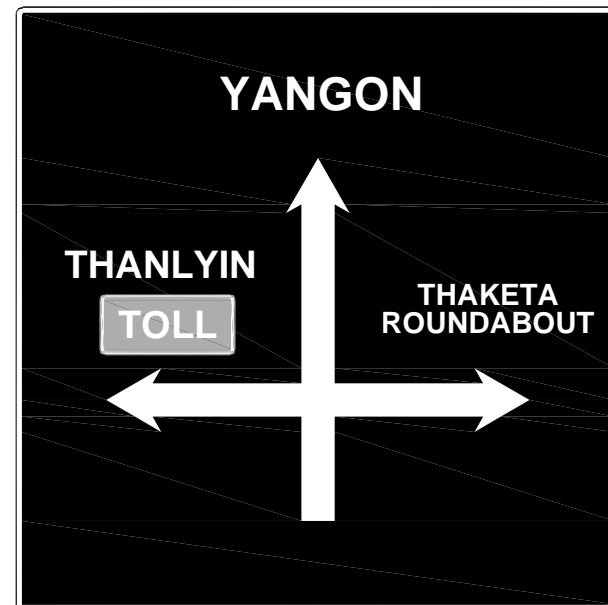

TYPE GS-2

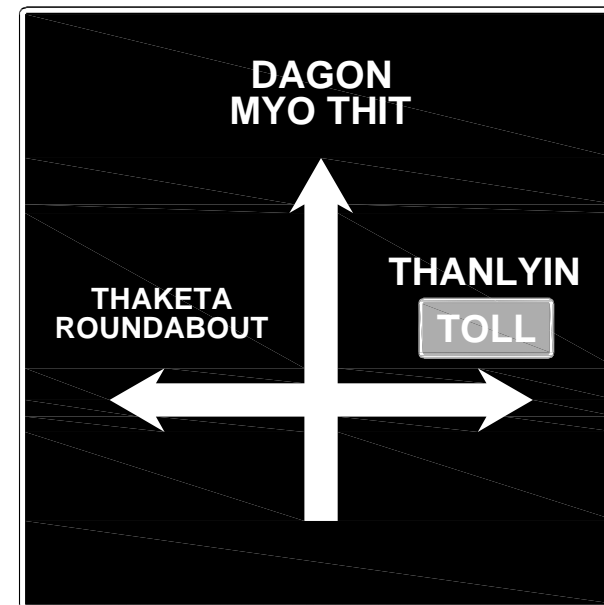



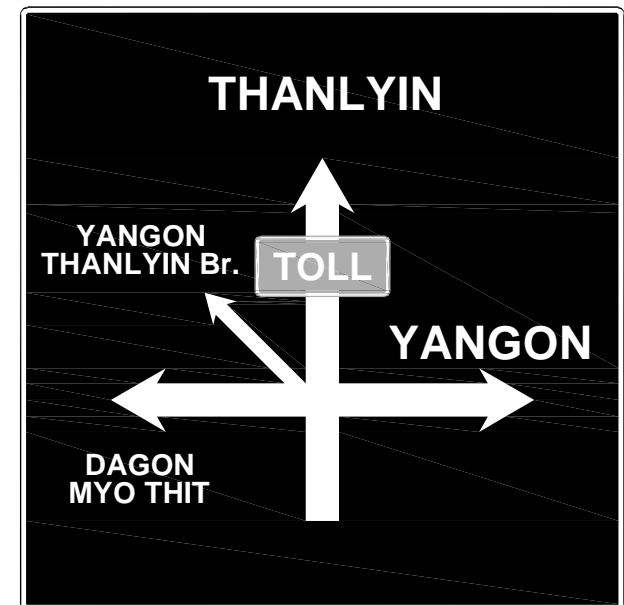

TYPE GS-3

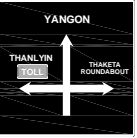

TYPE GS-4

COLORS: WHITE BLUE GREEN

SCHEDULE OF INFORMATORY SIGNBOARD

ROAD SIGN		1		2		3		4		5		6		TOTAL QUANTITY OF SAME ITEM	FOUNDATION AND POST
		0+000 to -0+080		0+000 to 0+060		2+860 to 2+900		0+000 to -0+060		0+000 to 0+060		3+500 to 3+575			
		L	R	L	R	L	R	L	R	L	R	L	R		
ROAD		SHUKHINTHAR MAYO PAT ROAD		NAWARAT St		MAIN ROAD		YADANAR ROAD				MAIN ROAD			
SIGN		TYPE GS-1											1	1	TYPE A
		TYPE GS-2									1			1	TYPE B
		TYPE GS-3								1				1	TYPE B
		TYPE GS-4					1							1	TYPE A
		TYPE GS-5		1										1	TYPE B
		TYPE GS-6						1						1	TYPE B

ROAD MARKINGS DETAILS(1)

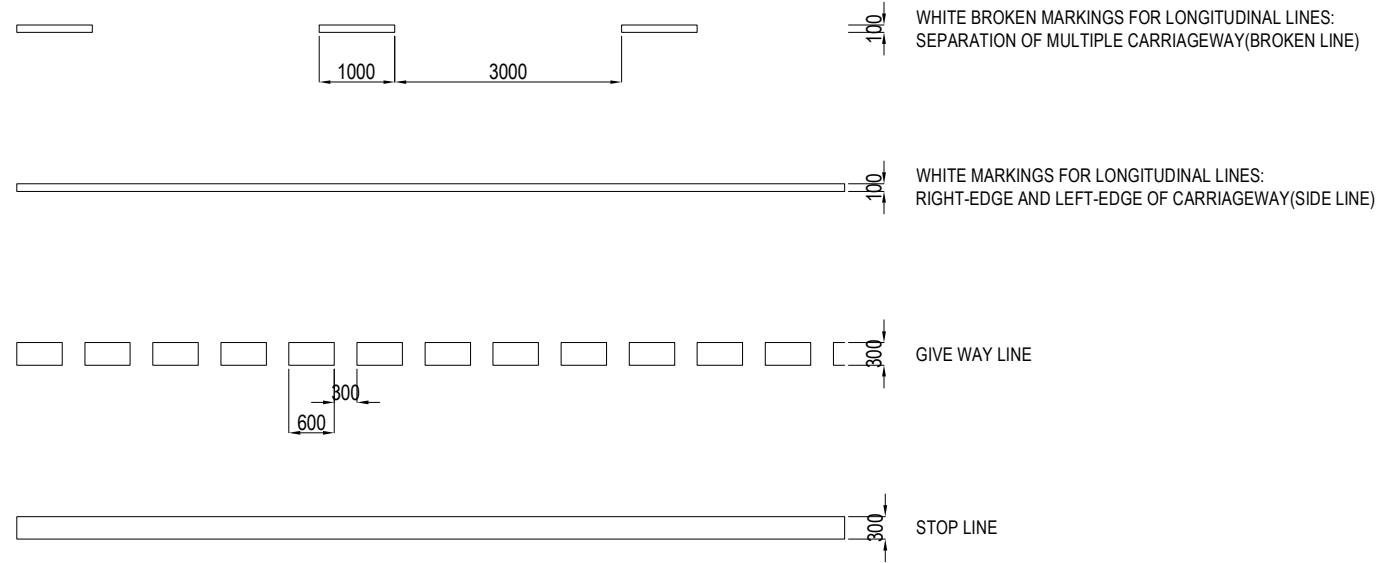

LINE MARKINGS SCALE = 1:100

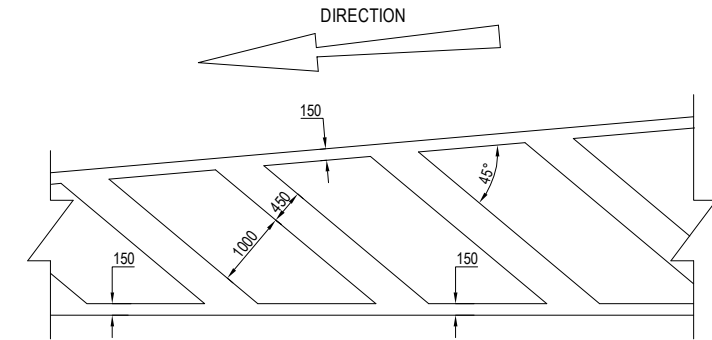

SCALE = 1:100

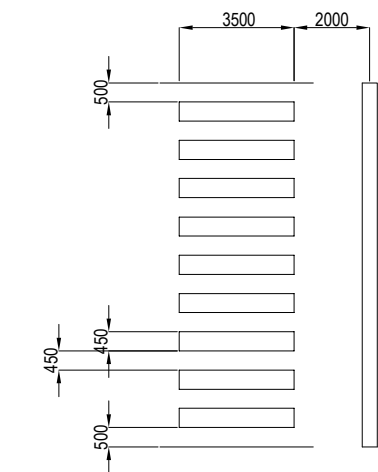

SCALE = 1:200

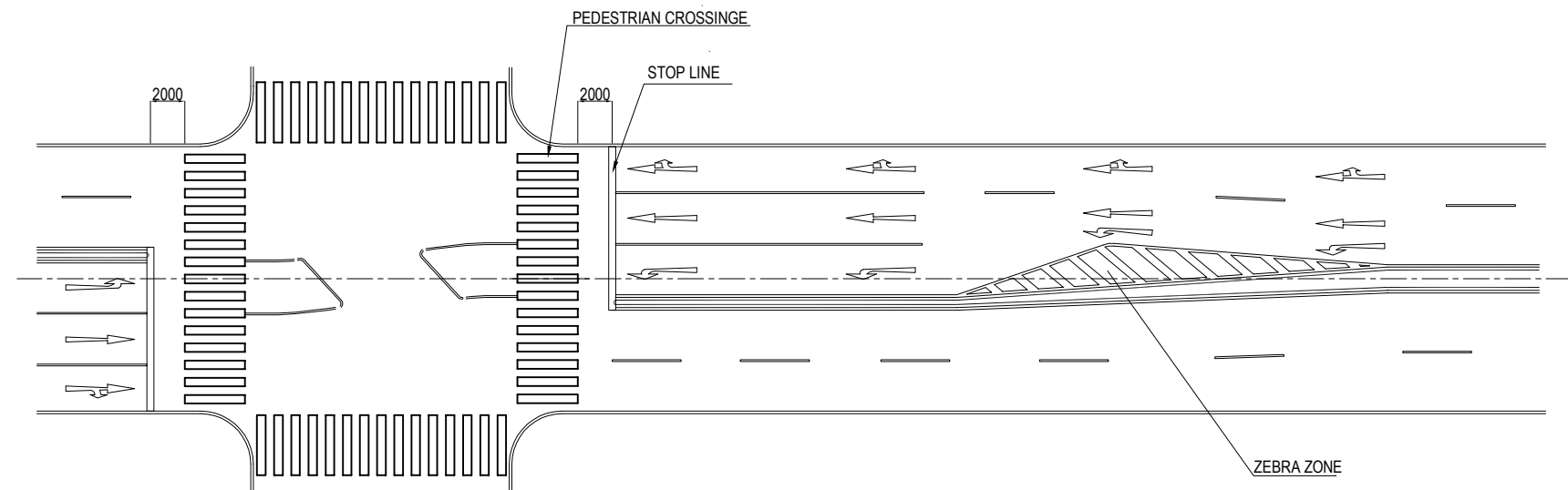

PAVEMENT MARKINGS AT CROSS ROAD

NO SCALE

PROJECT NAME DETAILED DESIGN ON BAGO RIVER BRIDGE CONSTRUCTION PROJECT	FINANCED BY JICA JAPAN INTERNATIONAL COOPERATION AGENCY	COUNTERPART REPUBLIC OF THE UNION OF MYANMAR MINISTRY OF CONSTRUCTION DEPARTMENT OF BRIDGE	JICA STUDY TEAM NIPPON KOEI CO., LTD. ORIENTAL CONSULTANTS GLOBAL CO., LTD. METROPOLITAN EXPRESSWAY COMPANY LIMITED CHODAI CO., LTD. NIPPON ENGINEERING CONSULTANTS CO., LTD.	NAME	SIGNATURE	DATE	DRAWING TITLE ROAD MARKINGS DETAILS(1)	PACKAGE
				PREPARED BY	K. TACHIBANA	29 Sep.2017		3
				CHECKED BY	T. HAYAKAWA	3 Oct.2017		DWG No.
				APPROVED BY	Y. SANO	6 Oct.2017		P0-RD-6130

ROAD MARKINGS DETAILS(2)



PM-1 SPEED LIMIT 30 KM/H PM-2 SPEED LIMIT 40 KM/H PM-3 SPEED LIMIT 60 KM/H

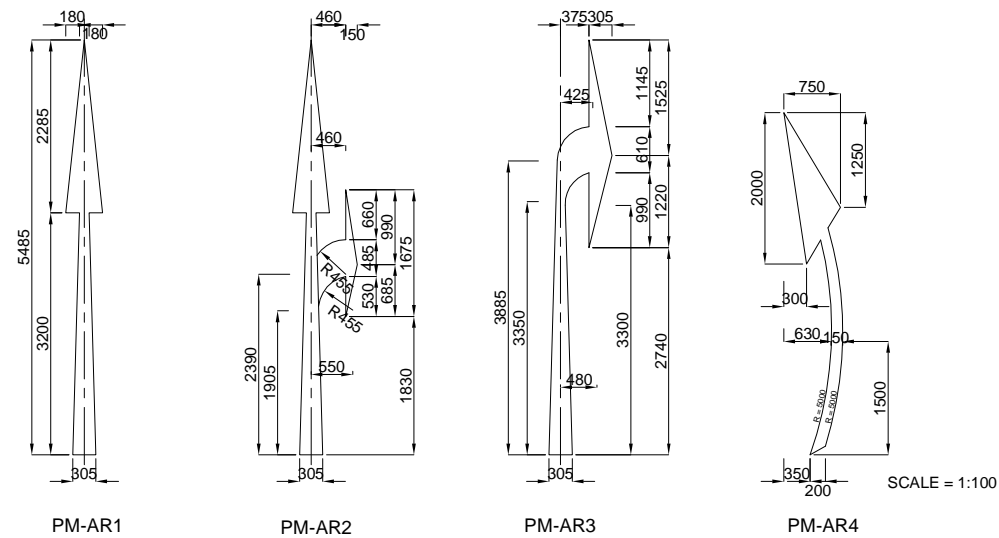

ARROW MARKS
REFERENCE SHALL BE MADE TO
DRAWING NO. PWD(RD)/SD91/8-2
ROAD AND TRANSPORTATION DIVISION,
PUBLIC WORKS DEPARTMENT

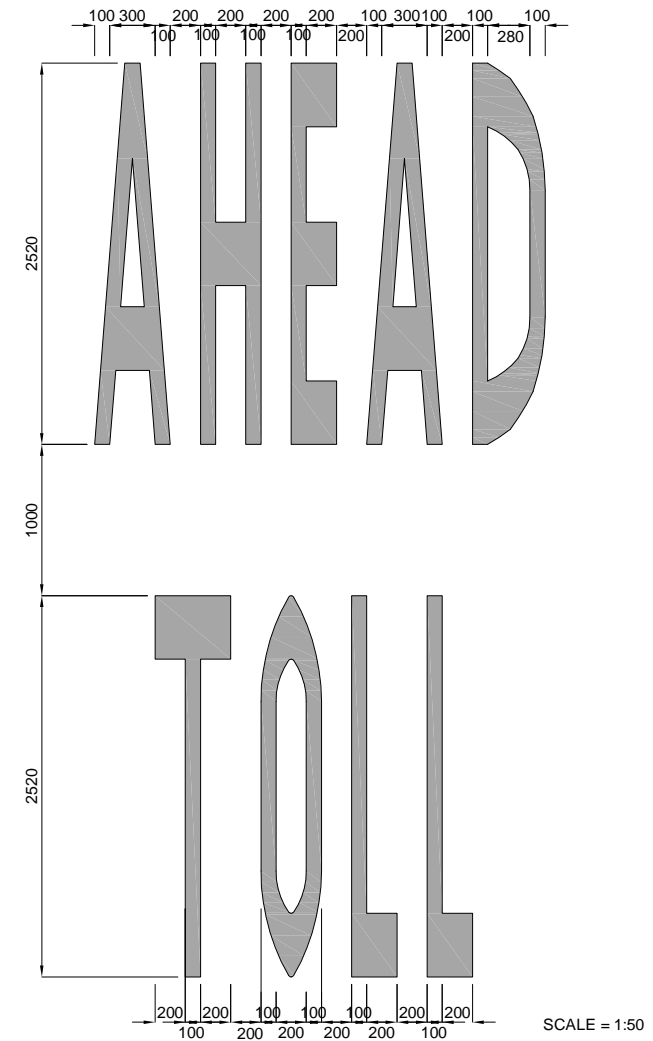

PM-4
TOLL AHEAD
REFERENCE SHALL BE MADE TO
DRAWING NO. PWD(RD)/SD91/20-1,
ROAD AND TRANSPORTATION DIVISION,
PUBLIC WORKS DEPARTMENT

COLORS: WHITE ORANGE

PROJECT NAME DETAILED DESIGN ON BAGO RIVER BRIDGE CONSTRUCTION PROJECT	FINANCED BY JAPAN INTERNATIONAL COOPERATION AGENCY	COUNTERPART REPUBLIC OF THE UNION OF MYANMAR MINISTRY OF CONSTRUCTION DEPARTMENT OF BRIDGE	JICA STUDY TEAM NIPPON KOEI CO., LTD. ORIENTAL CONSULTANTS GLOBAL CO., LTD. METROPOLITAN EXPRESSWAY COMPANY LIMITED CHODAI CO. LTD. NIPPON ENGINEERING CONSULTANTS CO., LTD.	NAME	SIGNATURE	DATE	DRAWING TITLE ROAD MARKING DETAILS (2)	PACKAGE	
				PREPARED BY	K. TACHIBANA			29 Sep.2017	3
				CHECKED BY	T. HAYAKAWA			3 Oct.2017	DWG No.
				APPROVED BY	Y. SANO			6 Oct.2017	P0-RD-6140

PLAN FOR ROAD MARKINGS(1) S= 1:1000

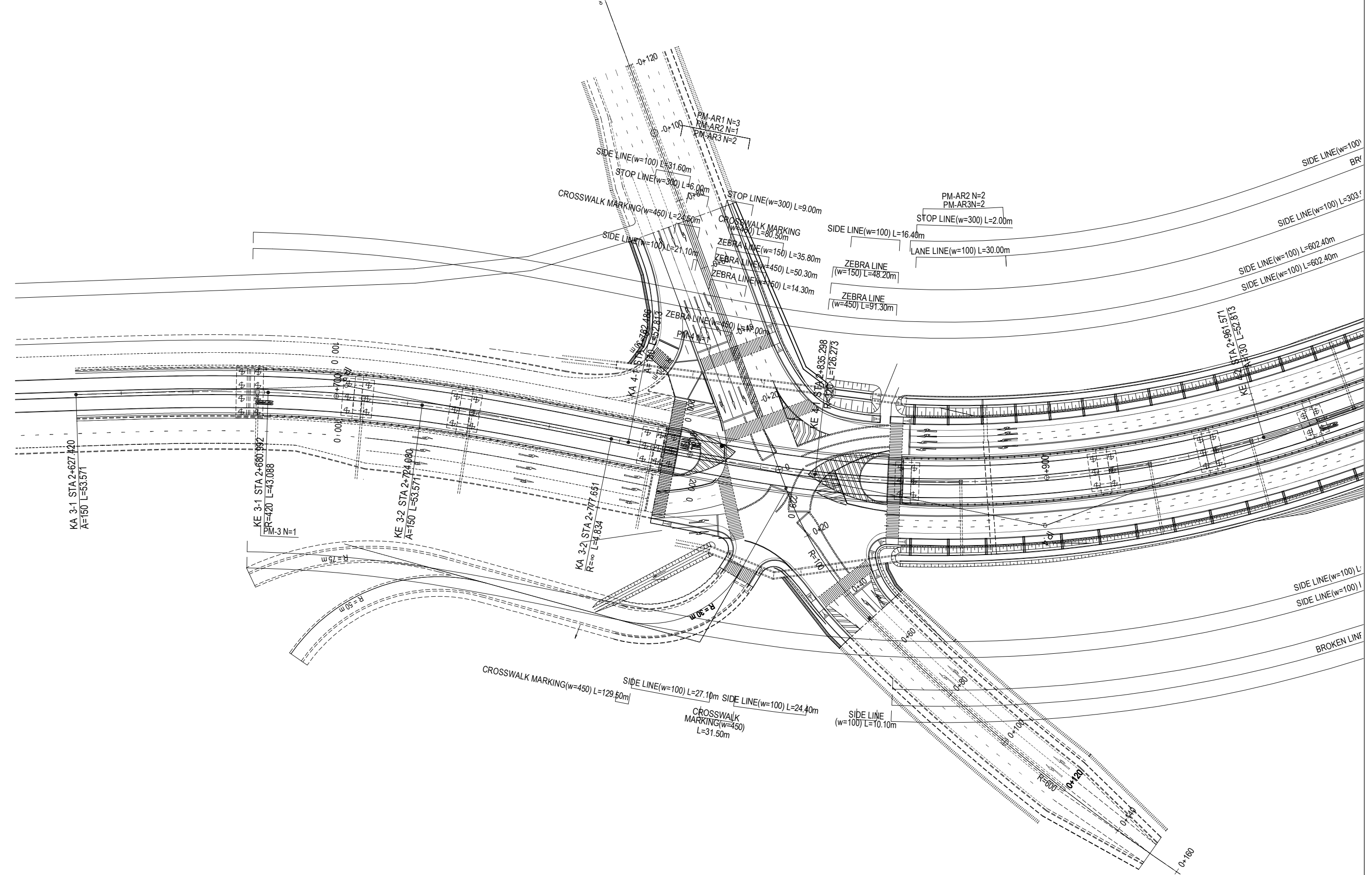

PROJECT NAME DETAILED DESIGN ON BAGO RIVER BRIDGE CONSTRUCTION PROJECT	FINANCED BY JAPAN INTERNATIONAL COOPERATION AGENCY	COUNTERPART REPUBLIC OF THE UNION OF MYANMAR MINISTRY OF CONSTRUCTION DEPARTMENT OF BRIDGE	JICA STUDY TEAM NIPPON KOEI CO., LTD. ORIENTAL CONSULTANTS GLOBAL CO., LTD. METROPOLITAN EXPRESSWAY COMPANY LIMITED CHODAI CO., LTD. NIPPON ENGINEERING CONSULTANTS CO., LTD.	NAME	SIGNATURE	DATE	DRAWING TITLE PLAN FOR ROAD MARKINGS(1) S=1:1000	PACKAGE 3 DWG No. P3-RD-6150	
				PREPARED BY	K. TACHIBANA				29 Sep.2017
				CHECKED BY	T. HAYAKAWA				3 Oct.2017
				APPROVED BY	Y. SANO				6 Oct.2017

PLAN FOR ROAD MARKINGS(2) S= 1:1000

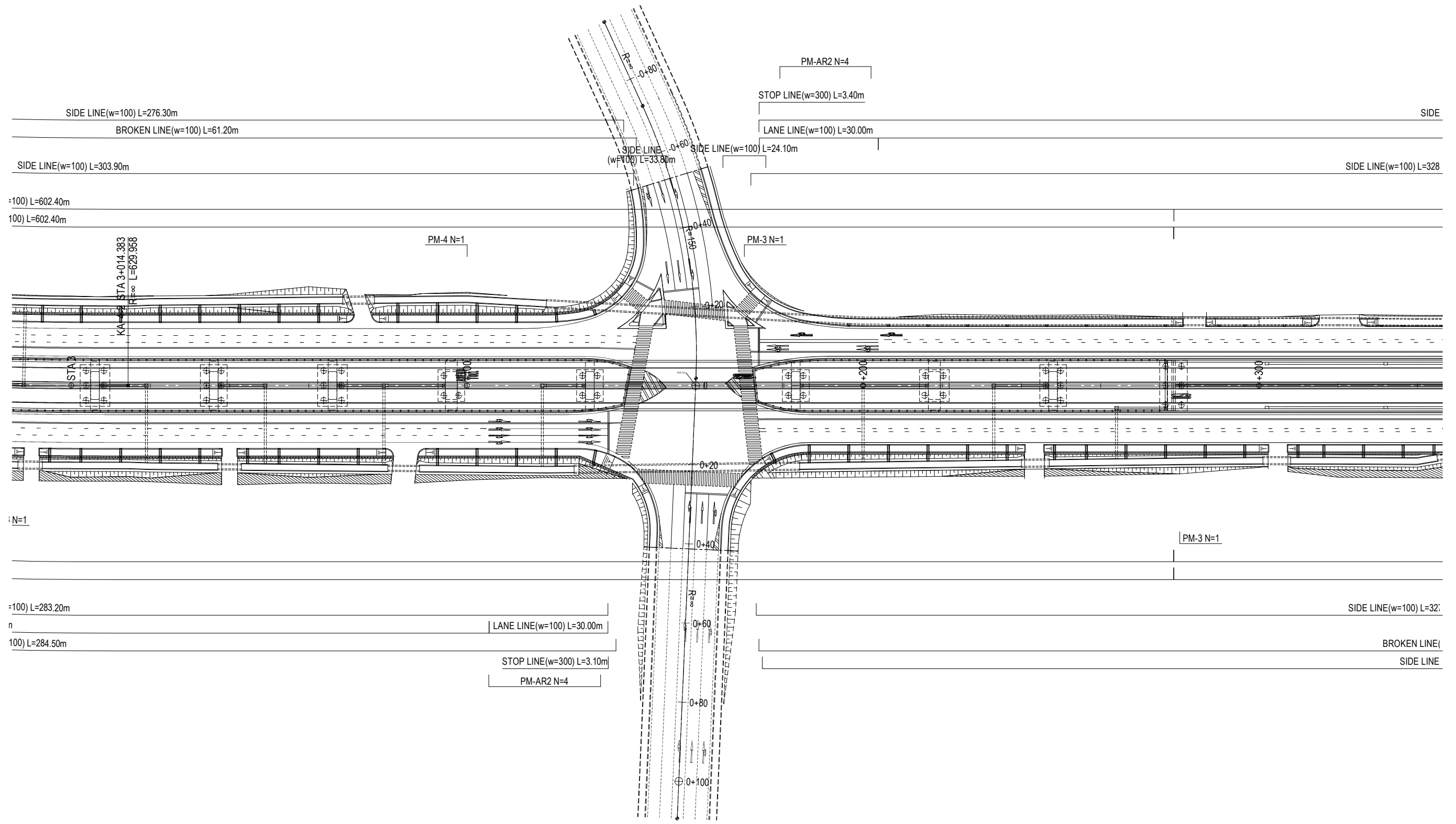

PROJECT NAME
 DETAILED DESIGN ON
 BAGO RIVER BRIDGE
 CONSTRUCTION PROJECT

FINANCED BY
 JAPAN INTERNATIONAL
 COOPERATION AGENCY

COUNTERPART
 REPUBLIC OF THE UNION OF MYANMAR
 MINISTRY OF CONSTRUCTION
 DEPARTMENT OF BRIDGE

JICA STUDY TEAM
 NIPPON KOEI CO., LTD.
 ORIENTAL CONSULTANTS GLOBAL CO., LTD.
 METROPOLITAN EXPRESSWAY COMPANY LIMITED
 CHODAI CO., LTD.
 NIPPON ENGINEERING CONSULTANTS CO., LTD.

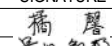
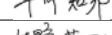
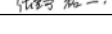
	NAME	SIGNATURE	DATE
PREPARED BY	K. TACHIBANA		29 Sep.2017
CHECKED BY	T. HAYAKAWA		3 Oct.2017
APPROVED BY	Y. SANO		6 Oct.2017

DRAWING TITLE
 PLAN FOR ROAD MARKINGS(2)
 S=1:1000

PACKAGE
 3
 DWG No.
 P3-RD-6160

PLAN FOR ROAD MARKINGS(3) S= 1:1000

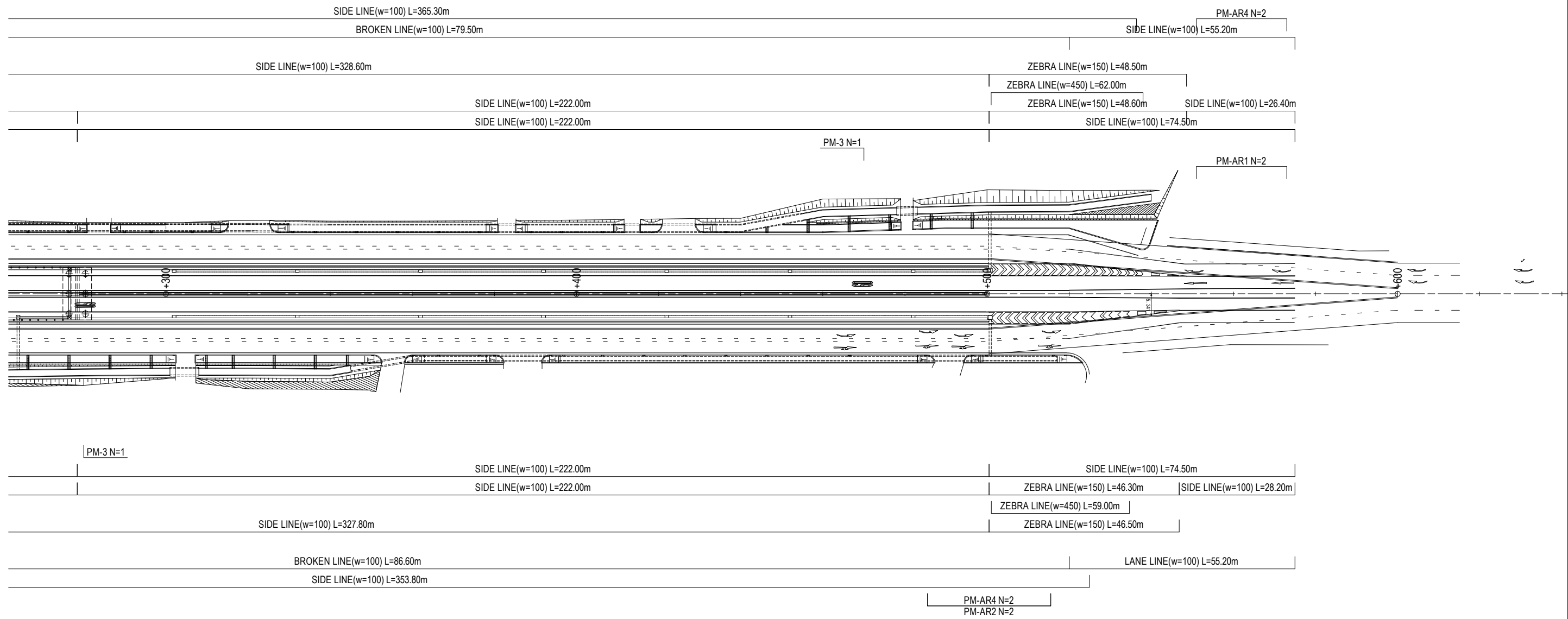

PROJECT NAME	FINANCED BY	COUNTERPART	JICA STUDY TEAM	NAME	SIGNATURE	DATE	DRAWING TITLE	PACKAGE
DETAILED DESIGN ON BAGO RIVER BRIDGE CONSTRUCTION PROJECT	JICA JAPAN INTERNATIONAL COOPERATION AGENCY	REPUBLIC OF THE UNION OF MYANMAR MINISTRY OF CONSTRUCTION DEPARTMENT OF BRIDGE	NIPPON KOEI CO., LTD. ORIENTAL CONSULTANTS GLOBAL CO., LTD. METROPOLITAN EXPRESSWAY COMPANY LIMITED CHODAI CO., LTD. NIPPON ENGINEERING CONSULTANTS CO., LTD.	K. TACHIBANA		29 Sep.2017	PLAN FOR ROAD MARKINGS(3) S=1:1000	3
				T. HAYAKAWA		3 Oct.2017		DWG No.
				Y. SANO		6 Oct.2017		P3-RD-6170

QUANTITY TABLE OF ROAD (REFERENCE DRAWING)

Construction type	Classification	standard	UNIT	Quantity			Remark	
				BREAK DOWN				Total
				Side Road	Approach Road	Fly Over		
DIVISION 02 SITE WORKS								
	Demolition of Existing Concrete Structure (Unreinforced concrete)		m3	218			218	
	Demolition of Existing Concrete Structure Asphalt Pavement		m3	1,068			1,068	
	Clearing and Grubbing		m2	427			427	
DIVISION 03 EARTH WORKS								
	ROAD EARTH WORK							
	Excavation - Type 1 (Open Cut for Road)		m3	3,604			3,604	
	Backfill for Filled-up ground		m3	34			34	
	Gravel Removal		m3	396			396	
	Excavation - Type 1 (Open Cut for Road Structure)		m3		3,893		3,893	
	Backfill		m3		6,180		6,180	
DIVISION 04 WATERWAY WORKS								
	SIDE DITCH TYPE U-500x850 with Cover		m	37			37	
	SIDE DITCH TYPE U-300x300		m			81	81	
	SIDE DITCH TYPE U-300x300 TYPE V		m			82	82	
	CATCH PIT 500x500x500		each			14	14	
	CATCH PIT (C-DITCH) TYPE A		each		14		14	
	CONCRETE PIPE CULVERT φ300 (CON. 360°) TYPE B		m		385		385	
DIVISION 05 PAVEMENTS								
	Prime Coat		m2	3,951	2,383		6,334	
	Tack Coat		m2	3,951	2,220		6,171	
	Normal A/C Surface Course, thickness 5cm		m2	3,951	2,383		6,334	
	Normal A/C Subbase Course, thickness 5cm		m2	3,951	2,220		6,171	
	Aggregate Base thickness 15cm		m2	3,051			3,051	
	Aggregate Base thickness 25cm		m2		2,220		2,220	
	Aggregate Subbase thickness 25cm		m2	3,051	2,220		5,271	
	Aggregate Subbase thickness 30cm		m2	900			900	
	Concrete Plate for Sidewalk		m2	140			140	
	Sand(Side walk)		m2	140			140	
	Aggregate Base thickness 10cm(Sidewalk)		m2	140			140	
	Concrete Seal		m2	5,015			5,015	
	Median type A		m		221		221	
	Median type B		m	448			448	

Construction type	Classification	standard	UNIT	Quantity			Remark	
				BREAK DOWN				Total
				Side Road	Approach Road	Fly Over		
DIVISION 08 MISCELLANEOUS								
	CONCRETE KERB TYPE A-1		m	1,929			1,929	
	CONCRETE KERB TYPE A-2		each	4			4	
	CONCRETE KERB TYPE A-3		m	44			44	
	CONCRETE KERB TYPE C		m	62			62	
	INFORMATORY SIGN BOARD -TypeA(Arm2.5m)		each	2			2	
	INFORMATORY SIGN BOARD -TypeB(Arm1.0m)		each	4			4	
	Boundary Fence		m			744	744	
	Fence Gate		each			11	11	
	Box Beam		m		25		25	
	LANE LINE(w=100)		m	145			145	
	SIDE LINE(w=100)		m	2,970	888	2,410	6,268	
	BROKEN LINE(w=100)		m	290			290	
	STOP LINE(w=300)		m	24			24	
	CROSSWALK ARKING(w=450)		m	266			266	
	ZEBRA LINE(w=150)		m	288			288	
	ZEBRA LINE(w=450)		m	280			280	
	ARROW		each	26			26	
			each		2	3	6	
			m2		7	11	18	
			each			2	2	
			m2			9	9	

C. FLYOVER BRIDGE

GENERAL VIEW OF FLYOVER BRIDGE (1)

LONGITUDINAL SECTION S=1:1000

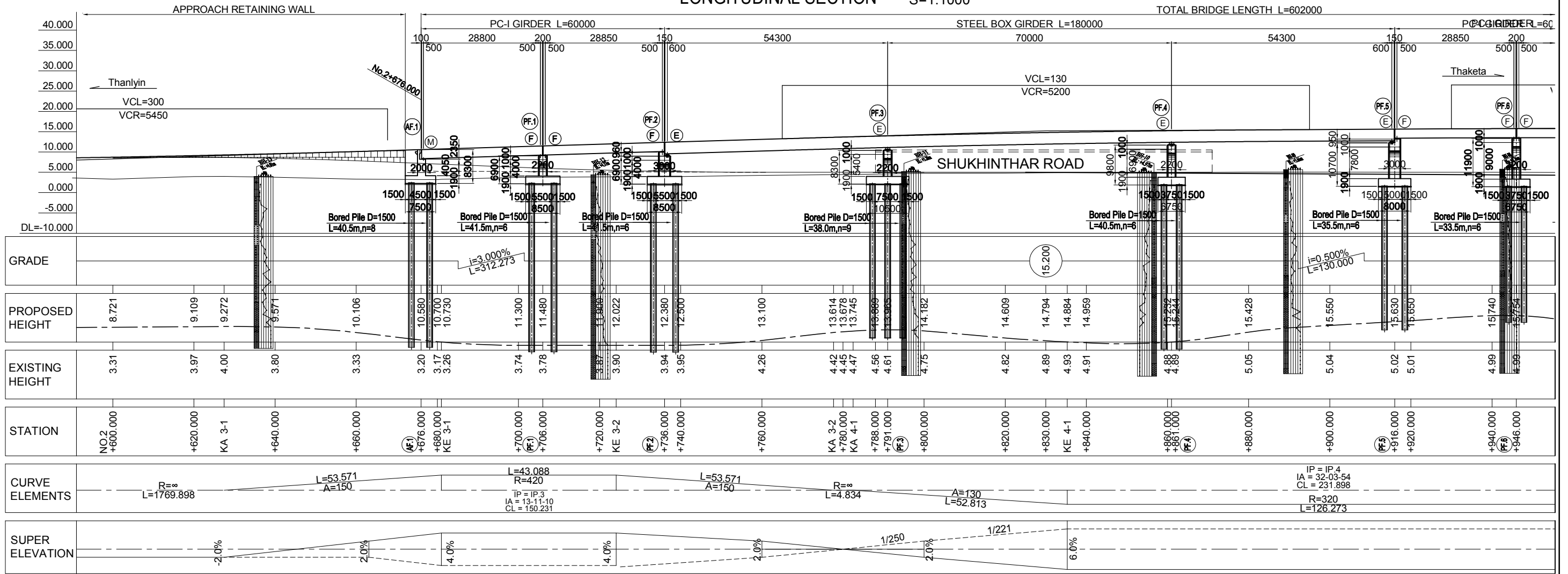

PLAN VIEW S=1:1000

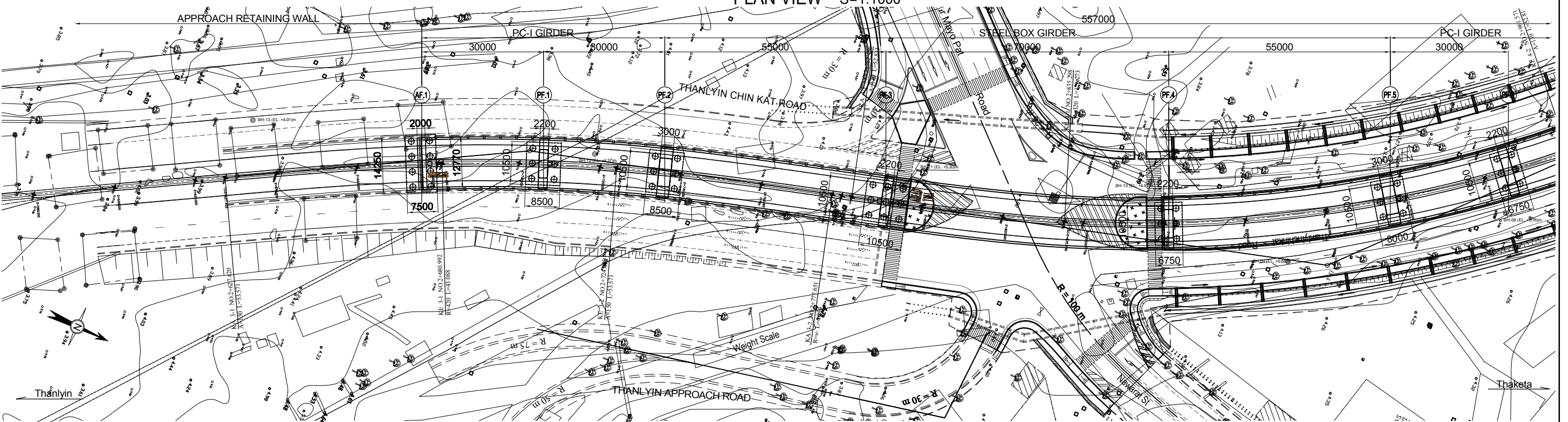

PROJECT NAME DETAILED DESIGN ON BAGO RIVER BRIDGE CONSTRUCTION PROJECT	FINANCED BY JAPAN INTERNATIONAL COOPERATION AGENCY	COUNTERPART REPUBLIC OF THE UNION OF MYANMAR MINISTRY OF CONSTRUCTION DEPARTMENT OF BRIDGE	JICA STUDY TEAM NIPPON KOEI CO., LTD. ORIENTAL CONSULTANTS GLOBAL CO., LTD. METROPOLITAN EXPRESSWAY COMPANY LIMITED CHODAI CO., LTD. NIPPON ENGINEERING CONSULTANTS CO., LTD.	NAME	SIGNATURE	DATE	DRAWING TITLE	PACKAGE	
				PREPARED BY	Y. SUZUKI				29 Sep. 2017
				CHECKED BY	T. HAYAKAWA				3 Oct. 2017
	APPROVED BY	Y. SANO		6 Oct. 2017			GENERAL VIEW OF FLYOVER BRIDGE (1)	3 DWG No. P3-F0-0001	

GENERAL VIEW OF FLYOVER BRIDGE (2)

LONGITUDINAL SECTION S=1:1000

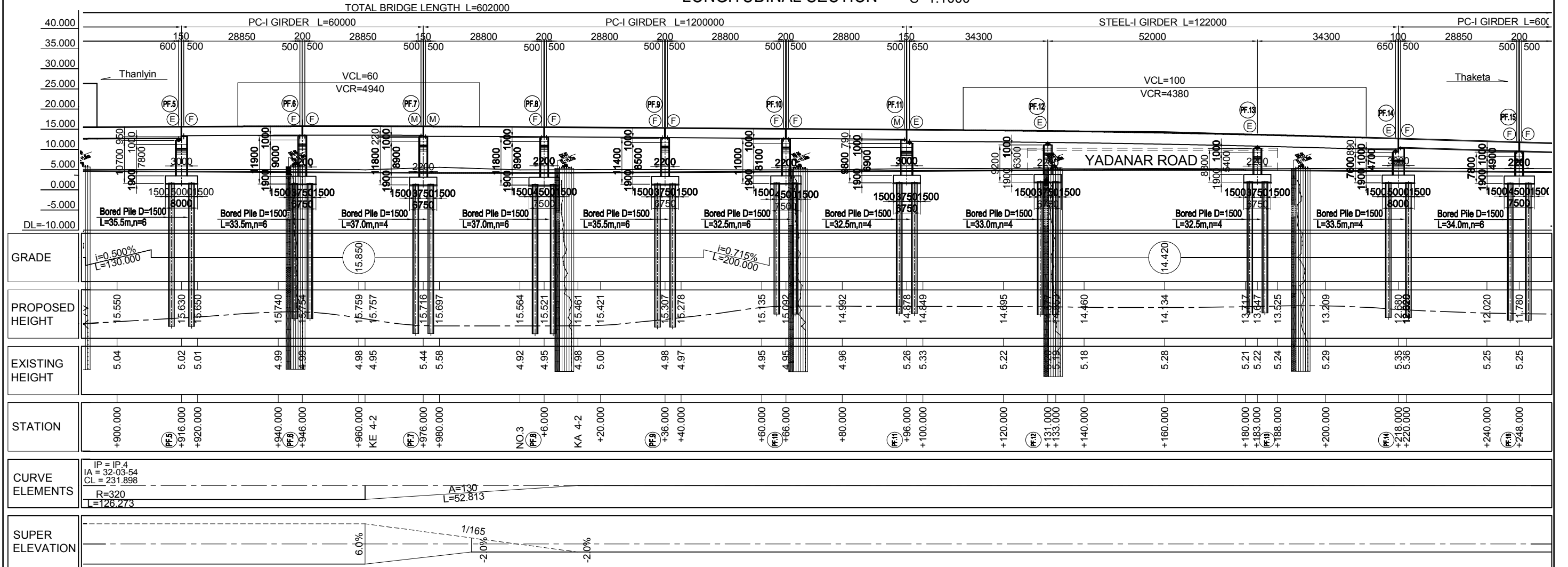

PLAN VIEW S=1:1000

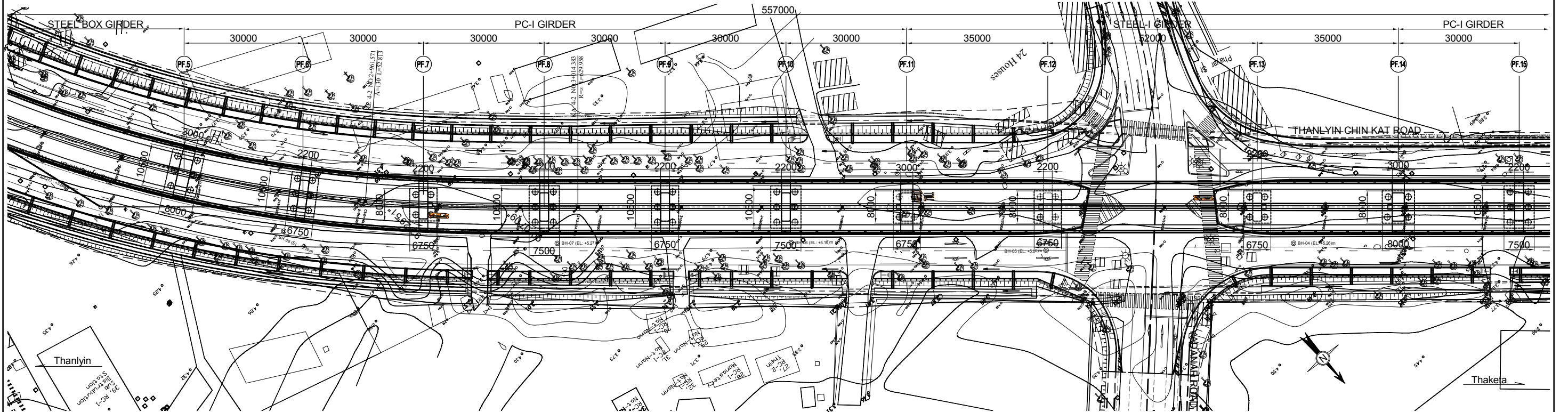

PROJECT NAME DETAILED DESIGN ON BAGO RIVER BRIDGE CONSTRUCTION PROJECT	FINANCED BY JAPAN INTERNATIONAL COOPERATION AGENCY	COUNTERPART REPUBLIC OF THE UNION OF MYANMAR MINISTRY OF CONSTRUCTION DEPARTMENT OF BRIDGE	JICA STUDY TEAM NIPPON KOEI CO., LTD. ORIENTAL CONSULTANTS GLOBAL CO., LTD. METROPOLITAN EXPRESSWAY COMPANY LIMITED CHODAI CO., LTD. NIPPON ENGINEERING CONSULTANTS CO., LTD.	<table border="1" style="width: 100%; border-collapse: collapse;"> <thead> <tr> <th>NAME</th> <th>SIGNATURE</th> <th>DATE</th> </tr> </thead> <tbody> <tr> <td>PREPARED BY Y. SUZUKI</td> <td></td> <td>29 Sep. 2017</td> </tr> <tr> <td>CHECKED BY T. HAYAKAWA</td> <td></td> <td>3 Oct. 2017</td> </tr> <tr> <td>APPROVED BY Y. SANO</td> <td></td> <td>6 Oct. 2017</td> </tr> </tbody> </table>	NAME	SIGNATURE	DATE	PREPARED BY Y. SUZUKI		29 Sep. 2017	CHECKED BY T. HAYAKAWA		3 Oct. 2017	APPROVED BY Y. SANO		6 Oct. 2017	DRAWING TITLE GENERAL VIEW OF FLYOVER BRIDGE (2)	PACKAGE 3 DWG No. P3-FO-0002
NAME	SIGNATURE	DATE																
PREPARED BY Y. SUZUKI		29 Sep. 2017																
CHECKED BY T. HAYAKAWA		3 Oct. 2017																
APPROVED BY Y. SANO		6 Oct. 2017																

GENERAL VIEW OF FLYOVER BRIDGE (3)

LONGITUDINAL SECTION S=1:1000

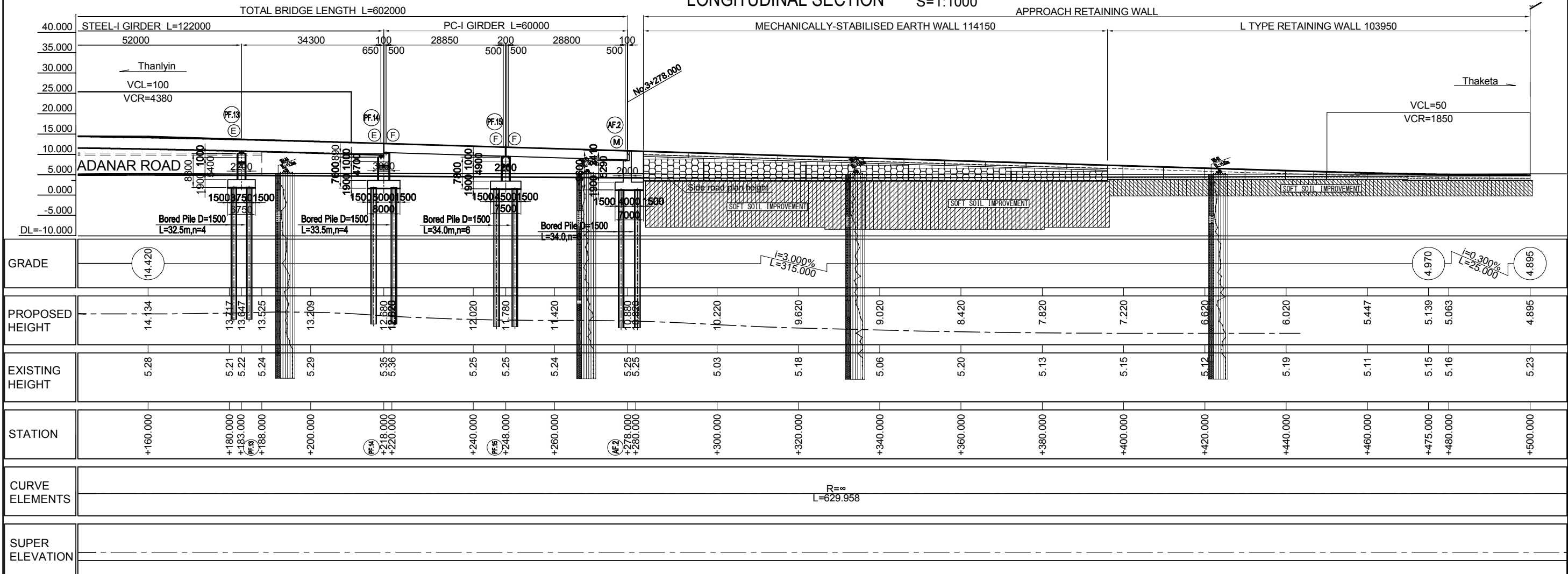

PLAN VIEW S=1:1000

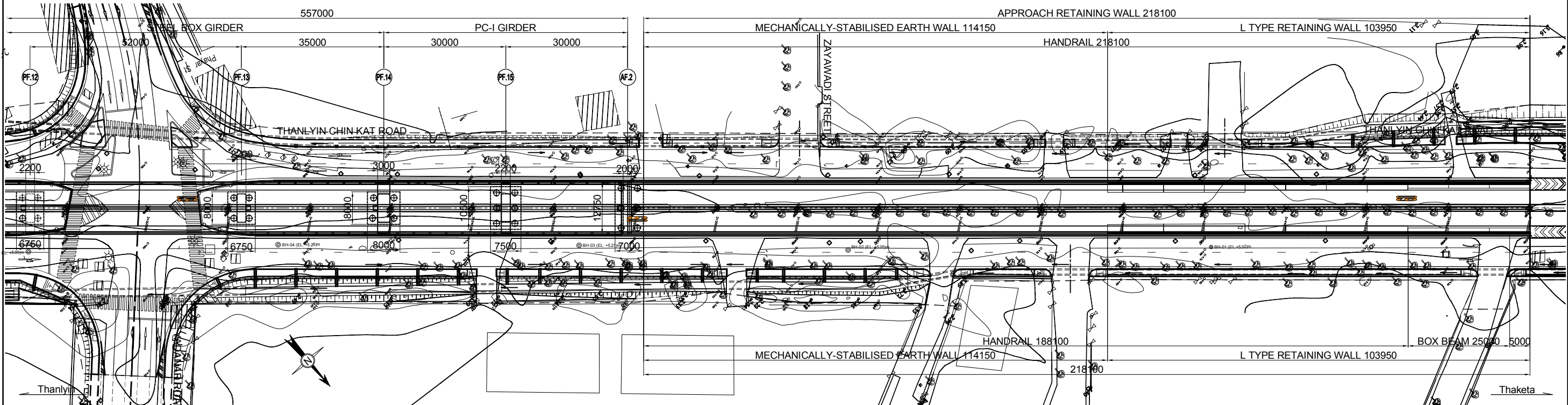

PROJECT NAME DETAILED DESIGN ON BAGO RIVER BRIDGE CONSTRUCTION PROJECT	FINANCED BY JAPAN INTERNATIONAL COOPERATION AGENCY	COUNTERPART REPUBLIC OF THE UNION OF MYANMAR MINISTRY OF CONSTRUCTION DEPARTMENT OF BRIDGE	JICA STUDY TEAM NIPPON KOEI CO., LTD. ORIENTAL CONSULTANTS GLOBAL CO., LTD. METROPOLITAN EXPRESSWAY COMPANY LIMITED CHODAI CO., LTD. NIPPON ENGINEERING CONSULTANTS CO., LTD.	NAME	SIGNATURE	DATE	DRAWING TITLE GENERAL VIEW OF FLYOVER BRIDGE (3)	PACKAGE	
				PREPARED BY	Y. SUZUKI			29 Sep. 2017	3
				CHECKED BY	T. HAYAKAWA			3 Oct. 2017	DWG No.
				APPROVED BY	Y. SANO			6 Oct. 2017	P3-FO-0003

GENERAL VIEW OF FLYOVER BRIDGE (4)

CROSS SECTION FOR SUBSTRUCTURE S=1:250

CROSS SECTION FOR SUPERSTRUCTURE S=1:200

STEEL-I GIRDER

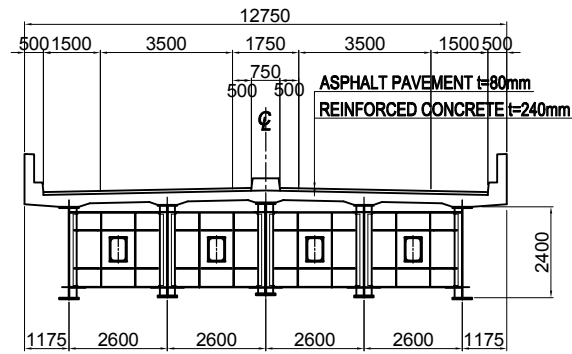

STEEL-BOX GIRDER

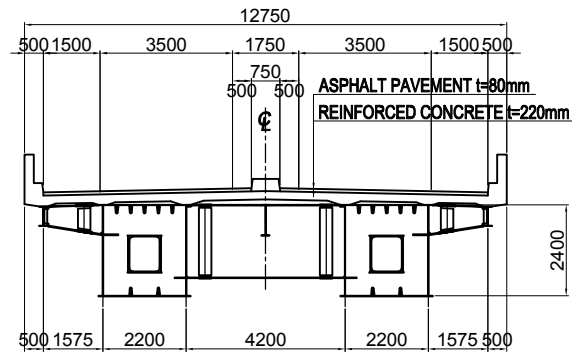

PC-I GIRDER

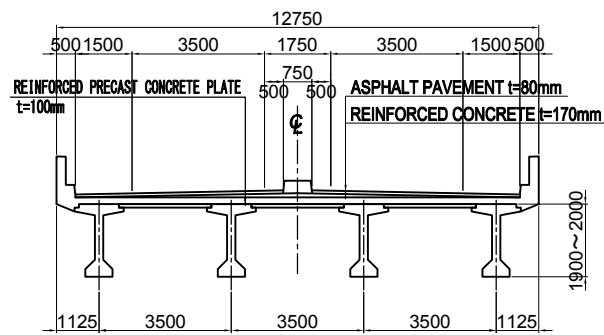

AF1

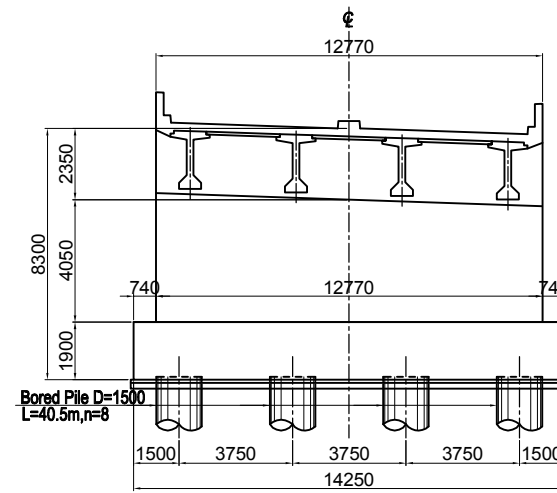

AF2

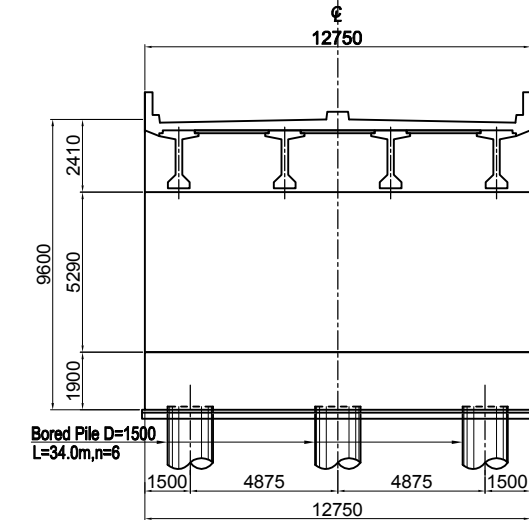

PF1

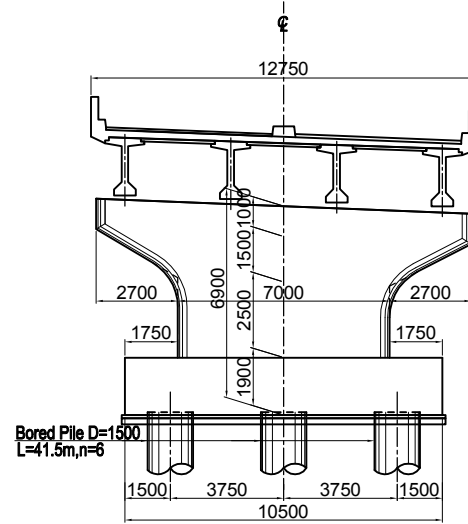

PF2

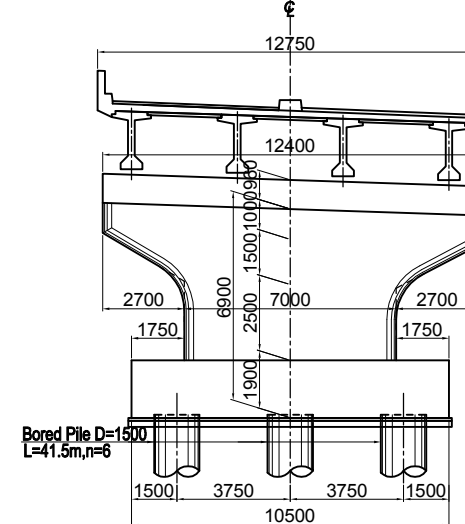

PF3

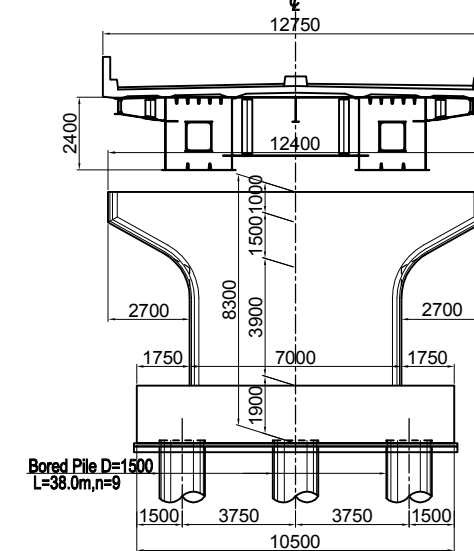

PF4

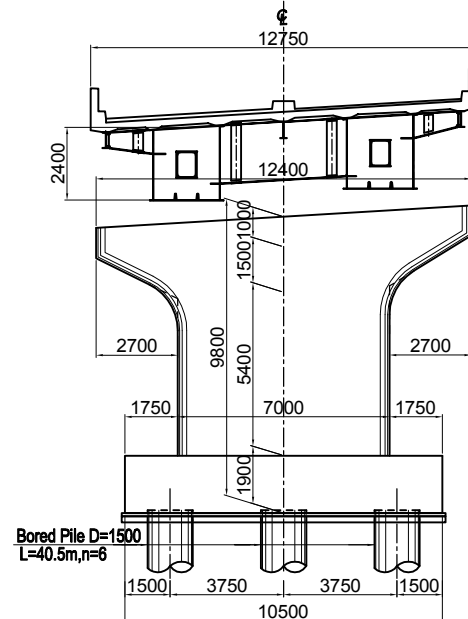

PF5

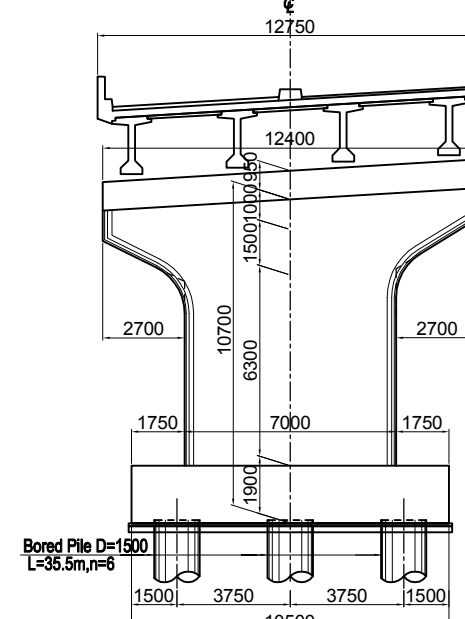

PF6

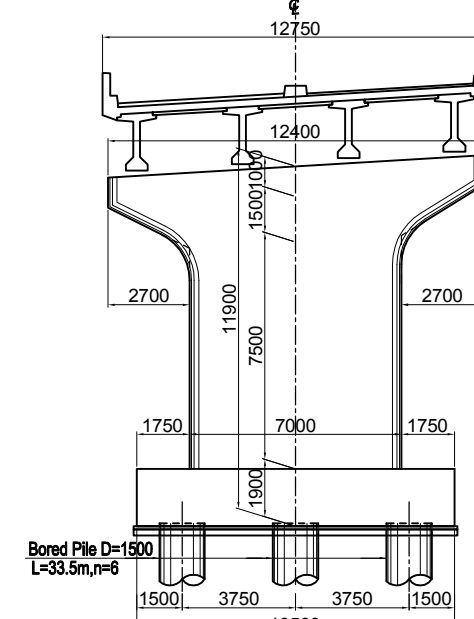

PROJECT NAME		FINANCED BY		COUNTERPART		JICA STUDY TEAM		NAME	SIGNATURE	DATE	DRAWING TITLE	PACKAGE
DETAILED DESIGN ON BAGO RIVER BRIDGE CONSTRUCTION PROJECT		JAPAN INTERNATIONAL COOPERATION AGENCY		REPUBLIC OF THE UNION OF MYANMAR MINISTRY OF CONSTRUCTION DEPARTMENT OF BRIDGE		NIPPON KOEI CO., LTD. ORIENTAL CONSULTANTS GLOBAL CO., LTD. METROPOLITAN EXPRESSWAY COMPANY LIMITED CHODAI CO., LTD. NIPPON ENGINEERING CONSULTANTS CO., LTD.		PREPARED BY	Y. SUZUKI	29 Sep. 2017	GENERAL VIEW OF FLYOVER BRIDGE (4)	3
								CHECKED BY	T. HAYAKAWA	3 Oct. 2017		DWG No.
								APPROVED BY	Y. SANO	6 Oct. 2017		P3-FO-004

GENERAL VIEW OF FLYOVER BRIDGE (5)

CROSS SECTION FOR SUBSTRUCTURE S=1:250

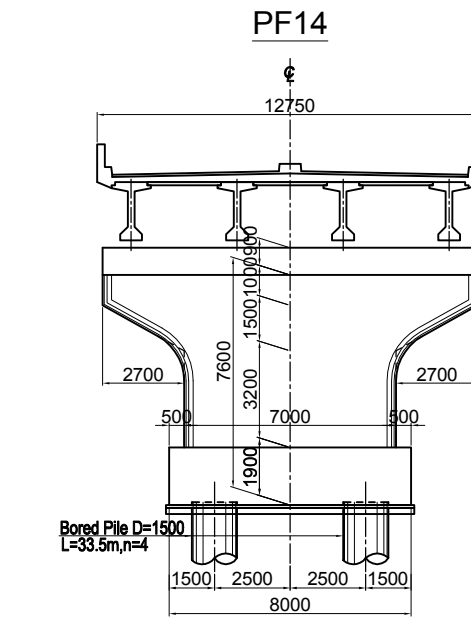
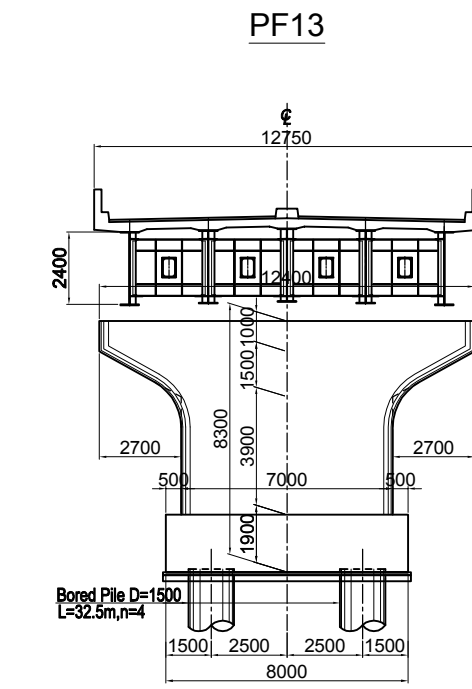
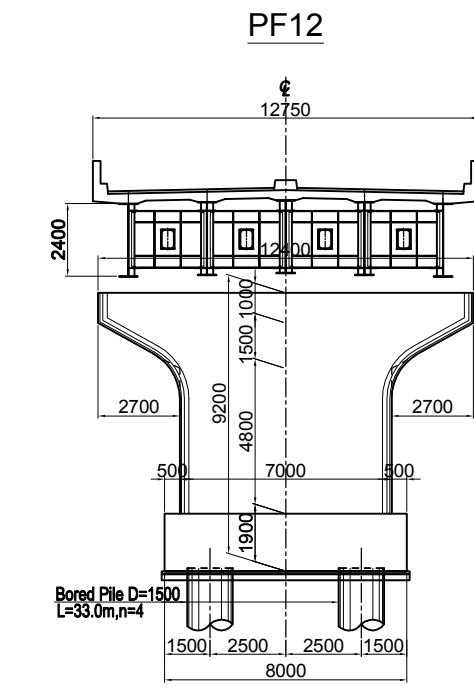
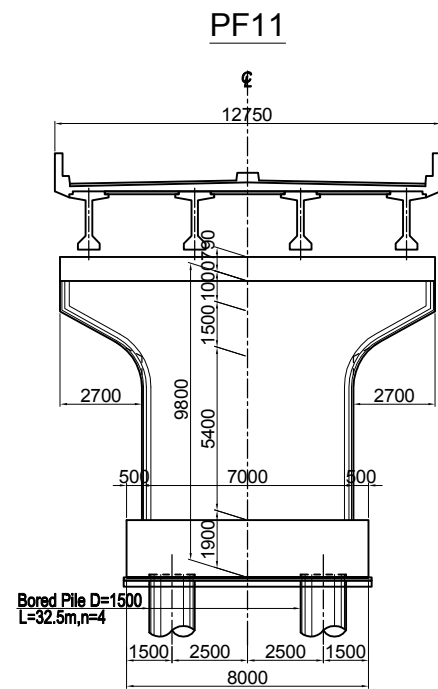
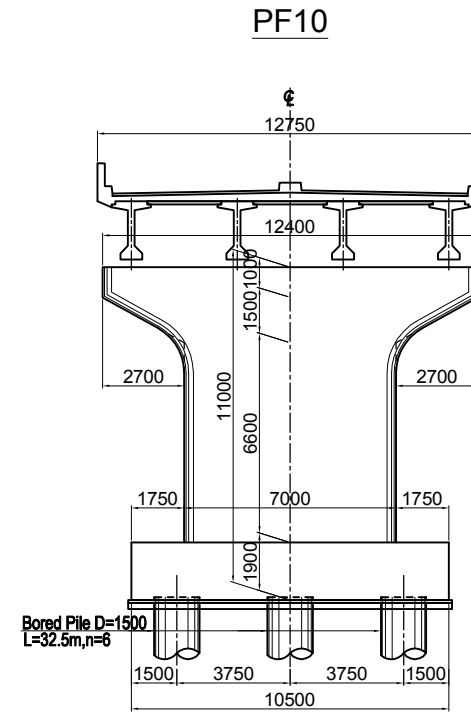
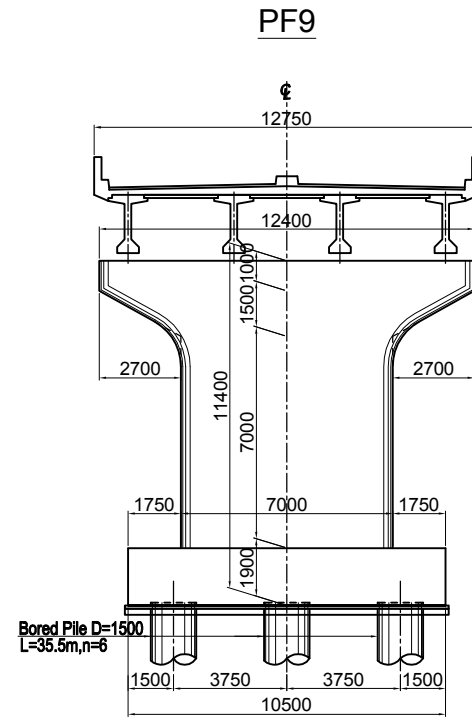
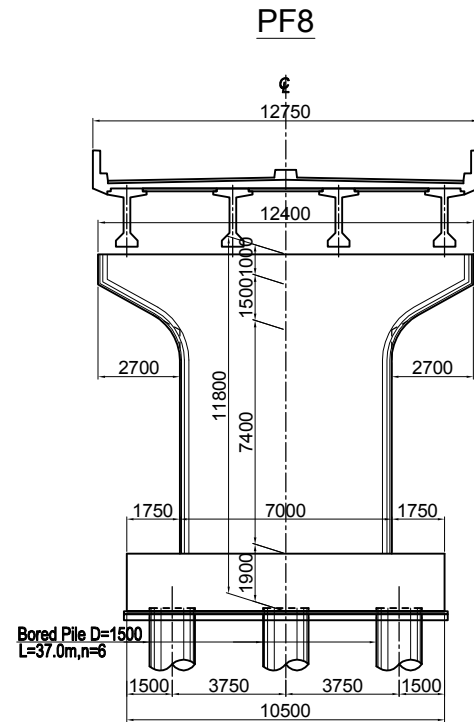
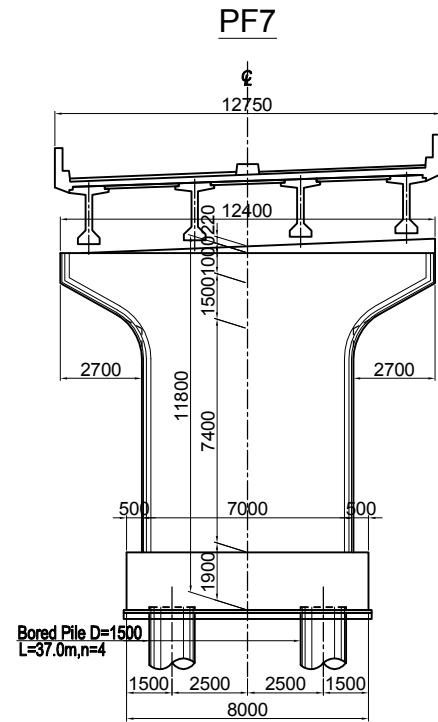

DESIGN CRITERIA

TOTAL BRIDGE LENGTH	L=602.000m
WIDTH	TOTAL 12.750 m
BRIDGE TYPE	(1) 2 SPAN CONTINUOUS PC-I GIRDER BRIDGE (2) 3 SPAN CONTINUOUS STEEL BOX GIRDER BRIDGE (3) 2 SPAN CONTINUOUS PC-I GIRDER BRIDGE (4) 4 SPAN CONTINUOUS PC-I GIRDER BRIDGE (5) 3 SPAN CONTINUOUS STEEL-I GIRDER BRIDGE (6) 2 SPAN CONTINUOUS PC-I GIRDER BRIDGE
BRIDGE LENGTH	(1) L=60.00m(30.00m+30.00m) (2) L=180.00m(55.00m+70.00m+55.00m) (3) L=60.00m(30.00m+30.00m) (4) L=120.00m(4×30.00m) (5) L=122.00m(35.00m+52.00m+35.00m) (6) L=60.00m(30.00m+30.00m)
GIDER LENGTH	(1) L=29.80m+29.85m (2) L=54.90m+70.00m+54.90m (3) L=29.85m+29.85m (4) L=4×29.80m (5) L=34.95m+52.00m+34.95m (6) L=29.85m+29.80m
LIVE-LOAD	AASHTO HL-93
SUBSTRUCTURE	INVERTED T-SHAPED ABUTMENT T-SHAPED PIER
FOUNDATION	BORED PILE FOUNDATION(P=1500mm)
ANGLE OF SKEW	PF7: 92°29'51" PF8: 90°07'09" ANOTHER: 90°00'00"
RADIUS OF CURVATUPE	R=420m~A=150m, A=130m~R=320m~A=130
SECTION SLOPE	LEFT: +4.000% ~ -6.000% RIGHT: -4.000% ~ +6.000%
LONGITUDINAL SLOPE	i=3.000%~0.500% i=0.715%~3.000%

MATERIALS

CONCRETE	PC I GIRDER	σ _{ck} =40.0 N/mm ²
	PC PLATE	σ _{ck} =40.0 N/mm ²
	RC DECK SLAB	σ _{ck} =30.0 N/mm ²
	SUBSTRUCTURE	σ _{ck} =24.0 N/mm ²
PC CABLE	PC I GIRDER	SWPR7BL 7S15.2
	CROSS BEAM	SWPR7BL 4S15.2
	PC PLATE	SWPR7AL 1S9.3
STEEL	STEEL GIRDER	SS400, SM400, SM490, SM570, S10T
DEFORMED BAR	SUPERSTRUCTURE	SD345
	SUBSTRUCTURE	SD345

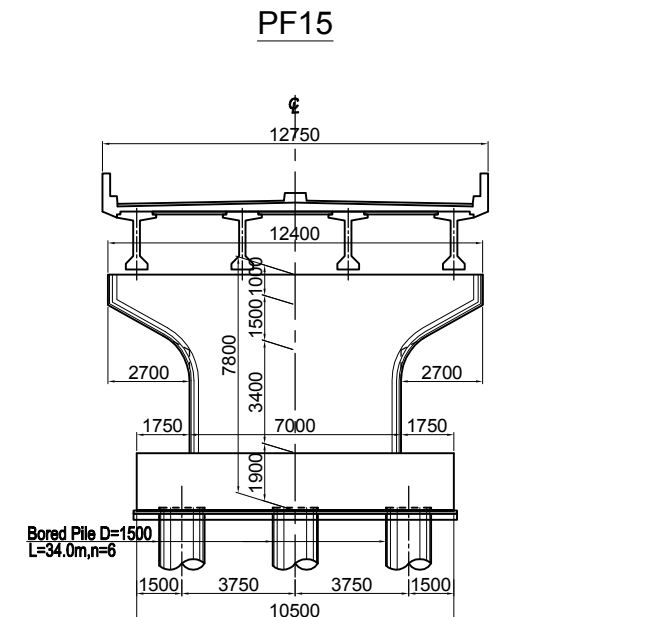

SUPERSTRUCTURE COORDINATES (AF1-PF2) (1)

PLAN S=1:250

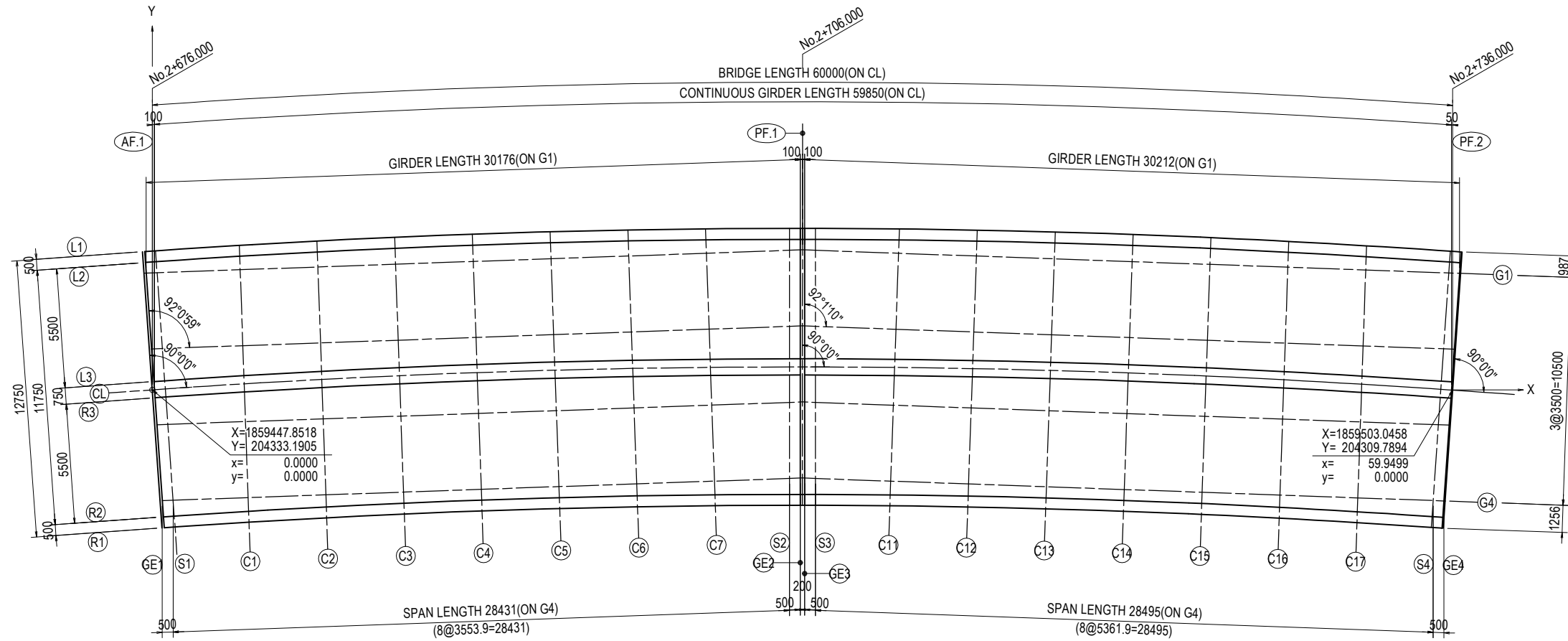

How to set the small coordinates
X coordinate : Starting point is intersection of AF1 and CL
Ending point is intersection of PF2 and CL
Y coordinate : Perpendicular to X line

TYPICAL CROSS SECTION S=1:150

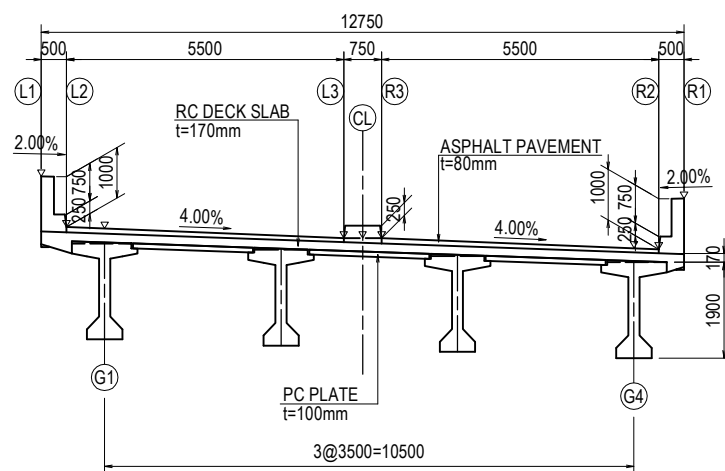

GRADE FOR LONGITUDINAL

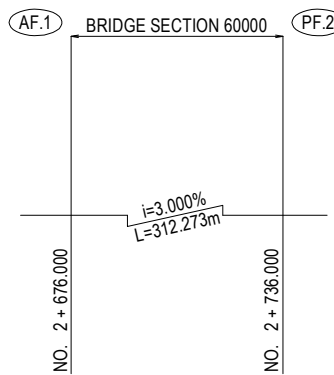

SUPER ELEVATION

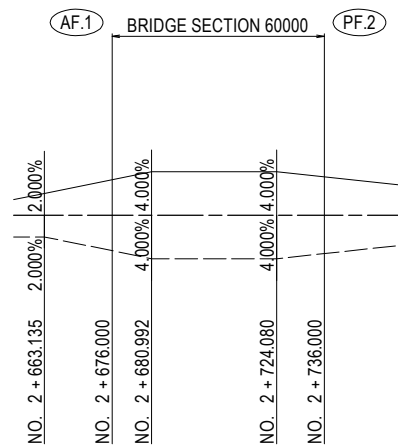

CURB ELEMENTS

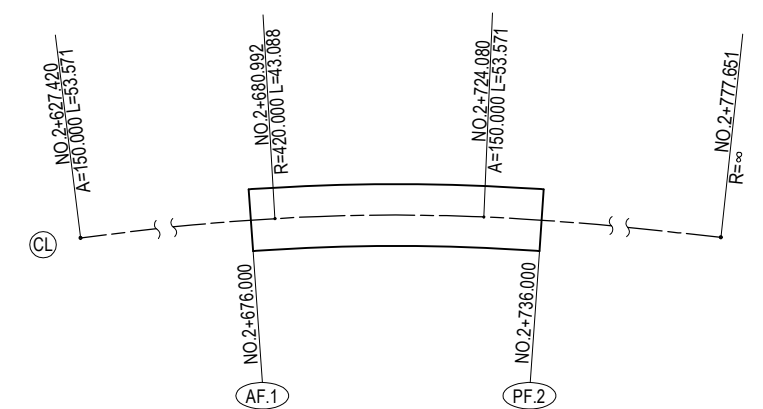

CHANGING POINT	STATION POINT	X COORDINATE	Y COORDINATE	ELEMENT
	2+627.420	1859405.3802	204356.7608	A= 150.000
	2+680.992	1859452.3111	204330.9470	R= 420.000
	2+724.080	1859491.8268	204313.8165	A= 150.000
	2+777.651	1859542.7491	204297.2096	

GENERAL VIEW OF SUPERSTRUCTURE (AF1-PF2) (1)

SIDE VIEW S=1:250

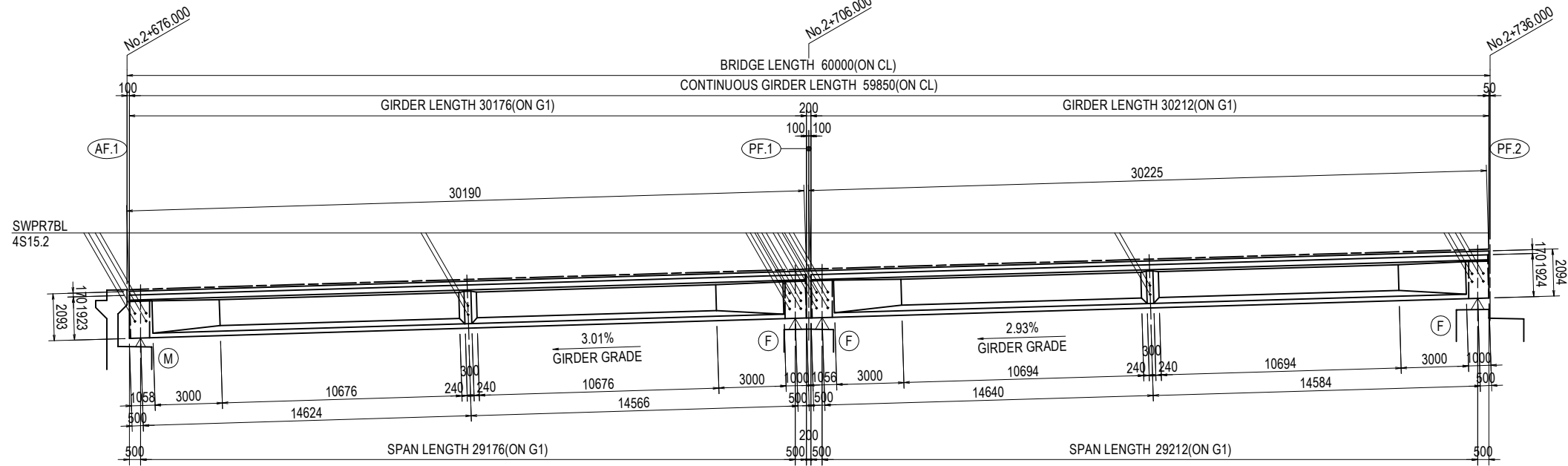

PLAN S=1:250

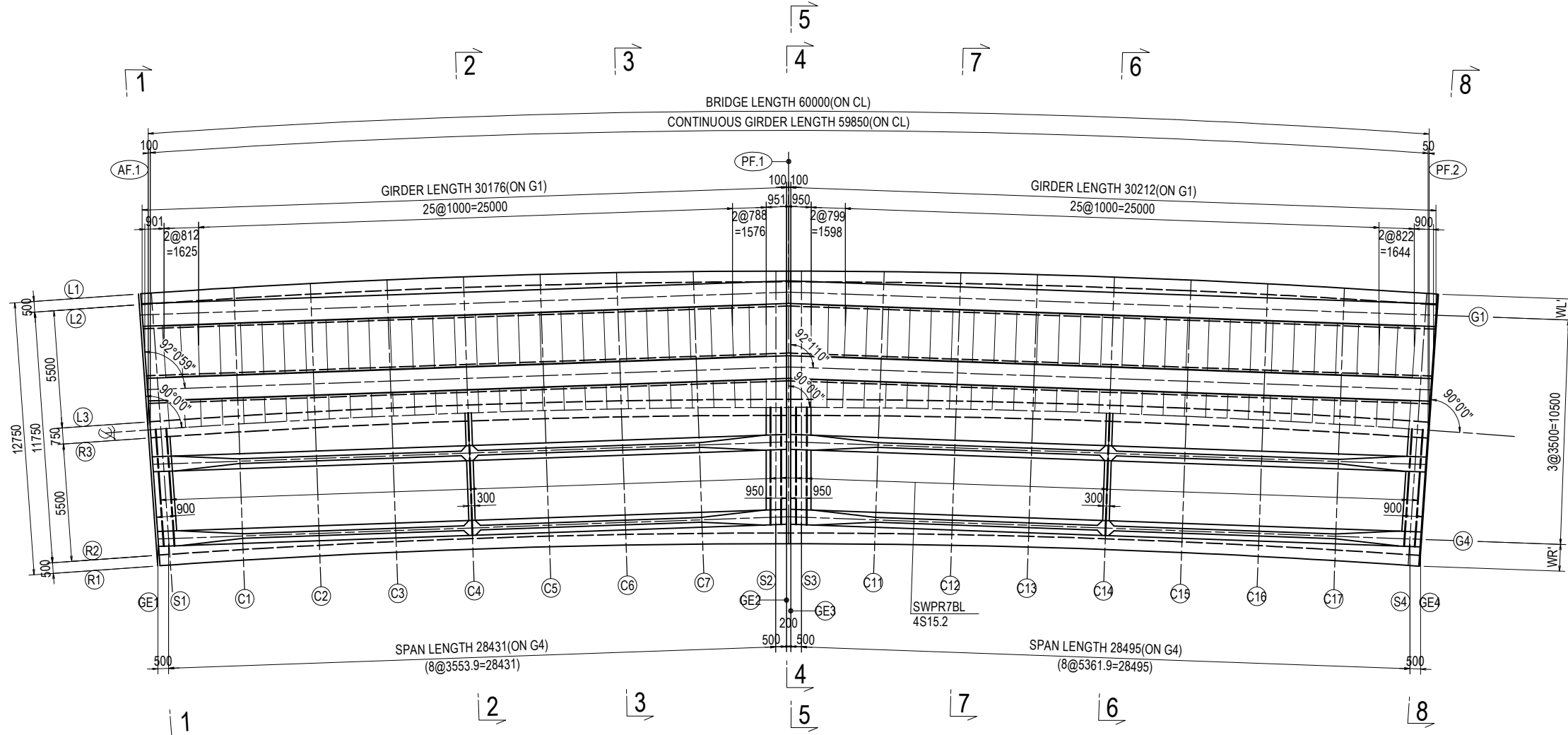

PROJECT NAME DETAILED DESIGN ON BAGO RIVER BRIDGE CONSTRUCTION PROJECT	FINANCED BY JAPAN INTERNATIONAL COOPERATION AGENCY	COUNTERPART REPUBLIC OF THE UNION OF MYANMAR MINISTRY OF CONSTRUCTION DEPARTMENT OF BRIDGE	JICA STUDY TEAM NIPPON KOEI CO., LTD. ORIENTAL CONSULTANTS GLOBAL CO., LTD. METROPOLITAN EXPRESSWAY COMPANY LIMITED CHODAI CO., LTD. NIPPON ENGINEERING CONSULTANTS CO., LTD.	NAME	SIGNATURE	DATE	DRAWING TITLE GENERAL VIEW OF SUPERSTRUCTURE (AF1-PF2) (1)	PACKAGE 3 DWG No. P3-FO-1003	
				PREPARED BY	Y. SUZUKI				14 Jul. 2017
				CHECKED BY	T. HAYAKAWA				20 Jul. 2017
				APPROVED BY	Y. SANO				25 Jul. 2017

GENERAL VIEW OF SUPERSTRUCTURE (AF1-PF2) (2)

CROSS SECTION S=1:150

AF1-PF1

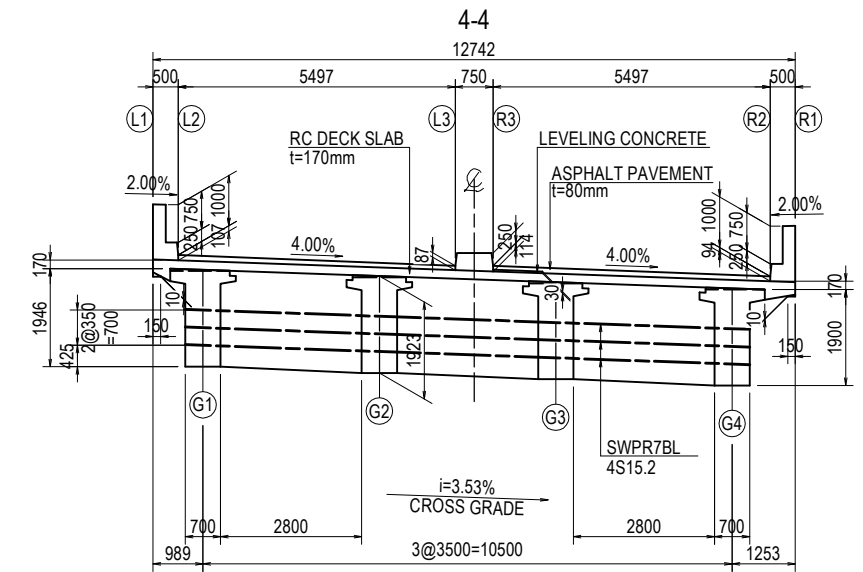
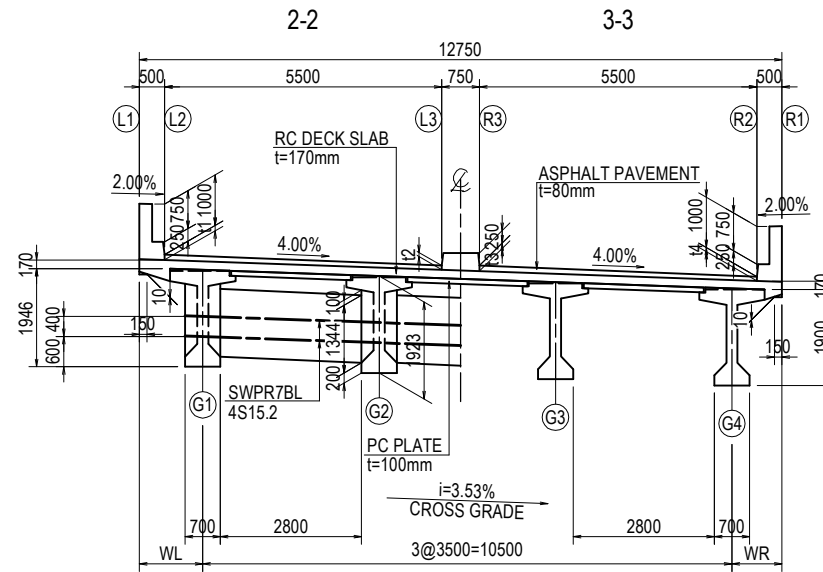
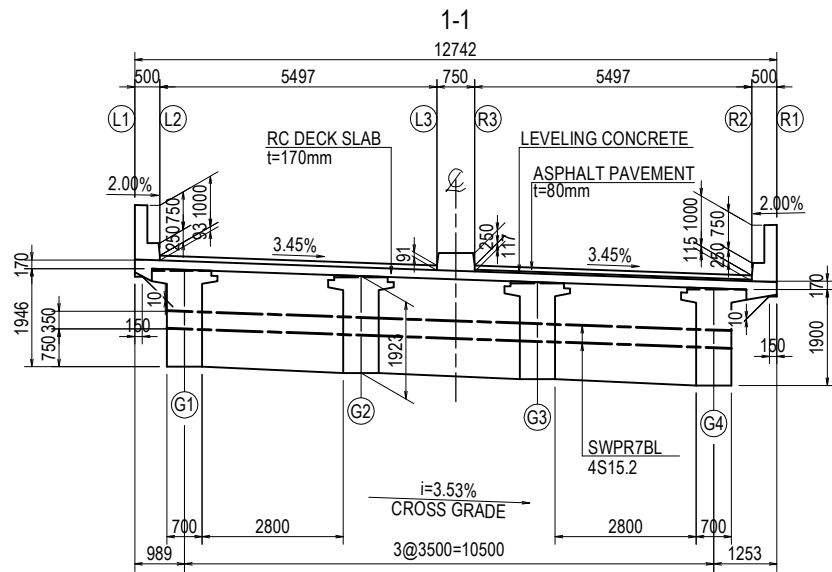

PF1-PF2

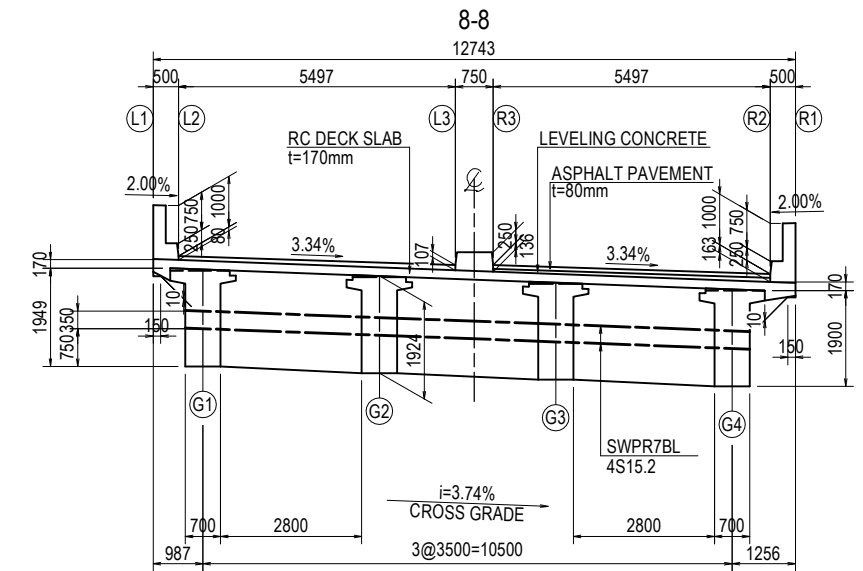
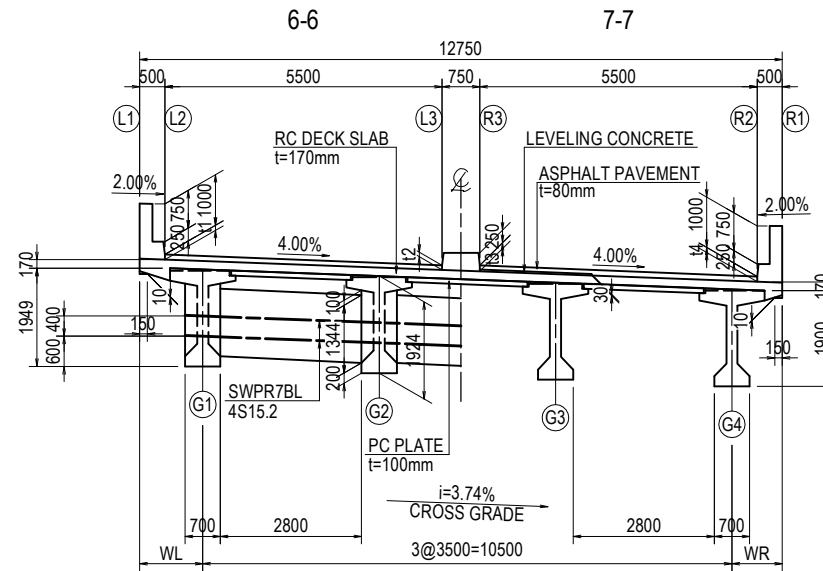
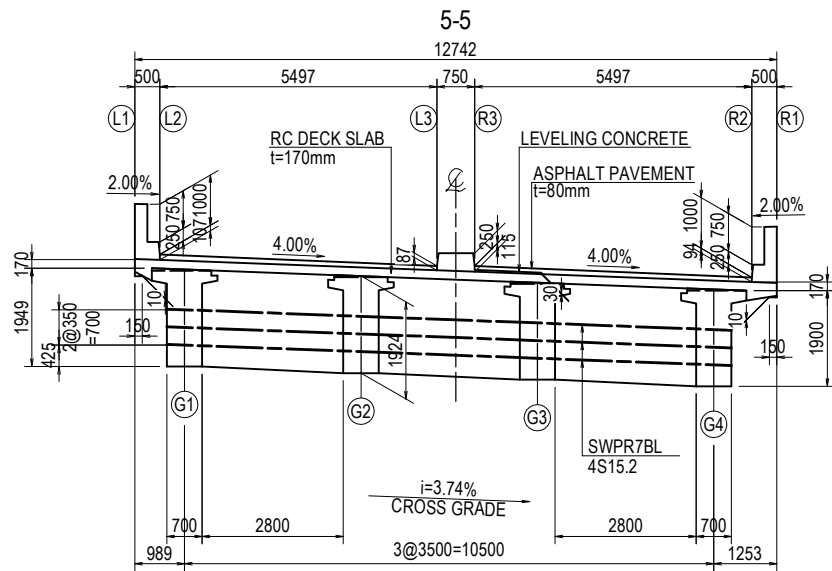

Note: Dimension of crosssection at end of girder is based on the actual angle of girder end.

LIST OF PAVEMENT THICKNESS (mm)

	GE1	S1	C1	C2	C3	C4	C5	C6	C7	S2	GE2	PF1
t1	93	95	113	112	108	106	105	104	105	107	107	107
t2	91	91	86	83	81	80	80	81	83	87	87	87
t3	117	117	112	109	107	107	107	108	110	114	114	115
t4	115	112	88	81	80	81	82	85	89	94	94	94

	PF1	GE3	S3	C11	C12	C13	C14	C15	C16	C17	S4	GE4
t1	107	107	107	104	102	101	102	102	94	87	81	80
t2	87	87	87	85	85	86	88	91	95	100	106	107
t3	115	115	114	113	113	114	116	119	123	129	135	136
t4	94	94	94	94	96	98	101	108	125	143	161	163

LIST OF WL/WR LENGTH (mm)

	GE1	S1	C1	C2	C3	C4	C5	C6	C7	S2	GE2	PF1
WL	989	1006	1121	1196	1242	1257	1242	1197	1121	1006	989	985
WR	1253	1236	1134	1056	1009	993	1009	1055	1133	1236	1253	1257

	PF1	GE3	S3	C11	C12	C13	C14	C15	C16	C17	S4	GE4
WL	985	989	1006	1120	1194	1237	1251	1234	1188	1113	1004	987
WR	1257	1253	1236	1134	1058	1013	999	1017	1065	1141	1239	1256

GENERAL VIEW OF SUPERSTRUCTURE (AF1-PF2) (3)

CROSS SECTION OF MAIN GIRDER S=1:50

DESIGN CONDITION

ROAD GRADE	Equivalent to CLASS 4-1
BRIDGE TYPE	2 span continuous PC-I girder bridge with composite deck(PC plate and RC deck)
BRIDGE LENGTH	L = 60.000 m
SPAN LENGTH	L = 28.801 + 28.851 m
WIDTH OF THE ROAD	TOTAL : 12.750 m L = 0.500 + 5.500 + 0.750 + 5.500 + 0.500 m
HORIZONTAL ALIGNMENT	A=150~R=420~A=150
LONGITUDINAL SLOPE	3.000%
SECTION SLOPE	LEFT : 3.45%~4.00%~3.34% RIGHT : 3.45%~4.00%~3.34%
ANGLE OF SKEW	AF.1,PF.1,PF.2 : 90°00'00"
PAVEMENT	ASPHALT PAVEMENT t = 80 mm
SLAB	RC DECK SLAB t = 170 mm
PLATE	PC PLATE t = 100 mm
LIVE ROAD	AASHTO HL-93
DESIGN STANDARD	AASHTO LRFD BRIDGE DESIGN 2014(LIVE ROAD) Specifications for highway bridges(Japan Road Association) 1 Common matters,3 Concrete bridges,5 seismic design (April 2012)

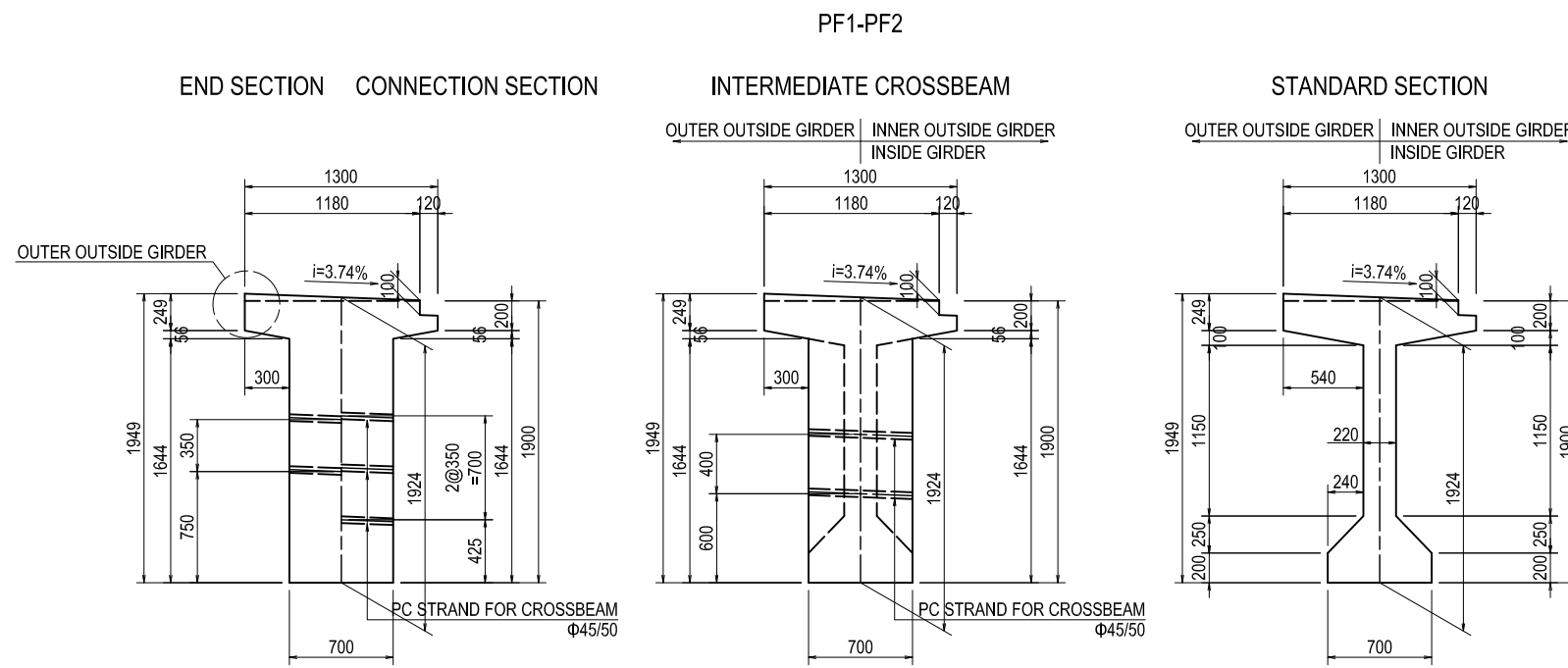
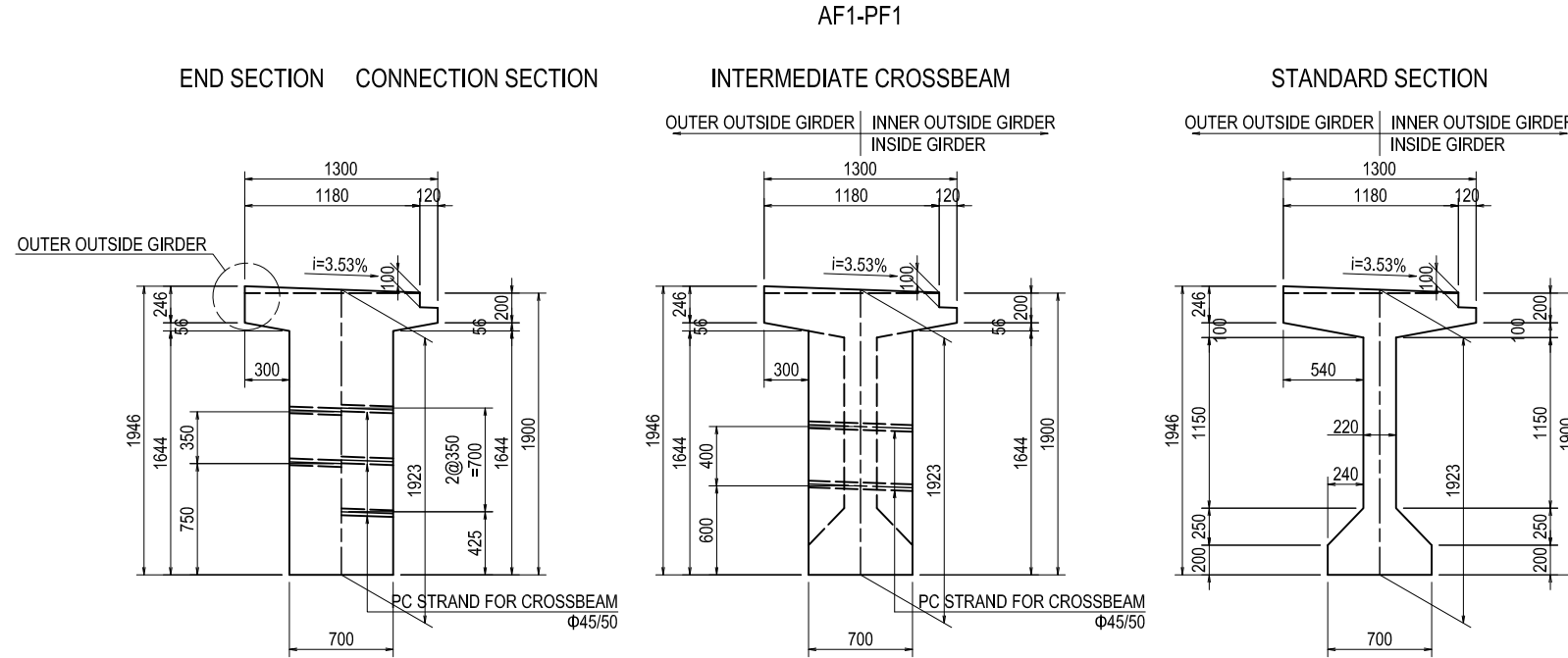

MATERIALS STRENGTH

CONCRETE		(N/mm ²)				
		MAIN GIRDER	CROSS BEAM	PC PLATE	RC SLAB	COUPLING CONCRETE
DESIGN STANDARD STRENGTH OF CONCRETE		40.0	30.0	40.0	30.0	30.0
BENDING COMPRESSIVE STRESS	IMMEDIATELY AFTER PRESTRESSING	19.0	14.0	19.0	—	—
	OTHERS	14.0	11.0	15.0	10.0	10.0
BENDING TENSILE STRESS	IMMEDIATELY AFTER PRESTRESSING	-1.5	-1.2	-1.5	—	—
	DEAD LOAD	0.0	0.0	—	—	—
	OTHERS	-1.5	-1.2	0.0	—	—
MEAN SHEAR STRESS CONCRETE CAN CARRY		0.55	0.45	—	—	—
MAXIMUM MEAN CONCRETE SHEAR STRESS		IN CASE WHERE ONLY SHEAR FORCES				
ALLOWABLE DIAGONEL TENSILE STRESS (DEAD LOAD)	IN CASE WHERE ONLY SHEAR FORCES	-1.0	-0.8	—	—	—
ALLOWABLE DIAGONEL TENSILE STRESS (LIVE LOAD)	IN CASE WHERE ONLY SHEAR FORCES	-2.0	-1.7	—	—	—

PC STRAND		(N/mm ²)		
		SWPR7BL 7S15.2mm	SWPR7BL 4S15.2mm	SWPR7AL 1S9.3mm
TENSILE STRENGTH		1850	1850	1700
YIELD POINT		1600	1600	1450
ALLOWABLE TENSILE STRESS	DURING PRESTRESSING	1440	1440	1305
	IMMEDIATELY AFTER PRESTRESSING	1295	1295	1190
	UNDER DESIGN LOAD	1110	1110	1020

REINFORCING STEEL		(N/mm ²)			
		MAIN GIRDER	CROSS BEAM	RC SLAB	COUPLING CONCRETE
STEEL TYPE		SD345	SD345	SD345	SD345
YIELD POINT		345	345	345	345
ALLOWABLE TENSILE STRESS	DEAD LOAD	—	—	100	100
	DESIGN LOAD	180	180	140	160
	EARTHQUAKE LOAD	—	200	—	—

LAYER S=1:30

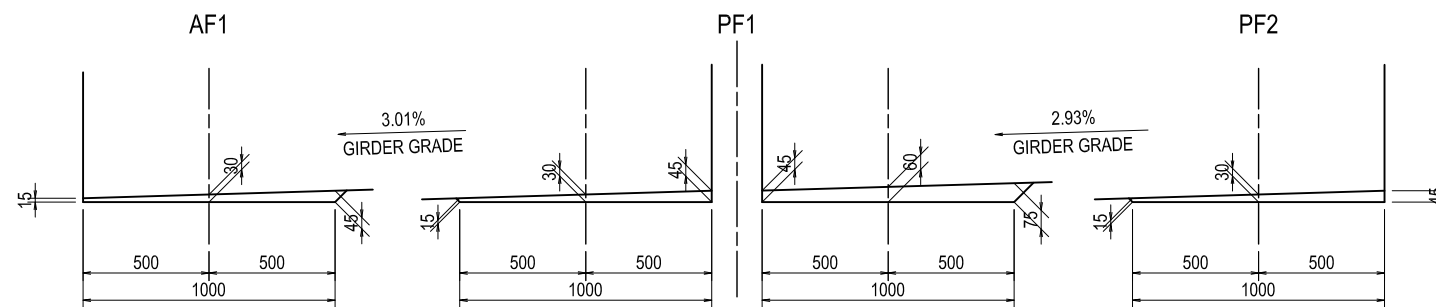

PC STRAND ARRANGEMENT OF MAIN GIRDER (AF1-PF2) (1)

SIDE VIEW S=1:100

AF.1-PF.1
30190 (G1)

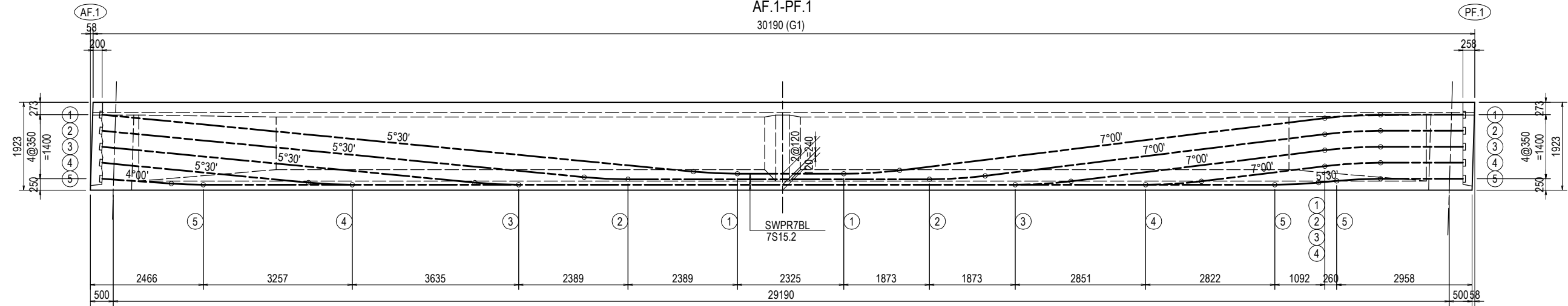

PC STRAND LENGTH & ELEVATION

7S15.2
w=7.707 kg/m
R=10.000m

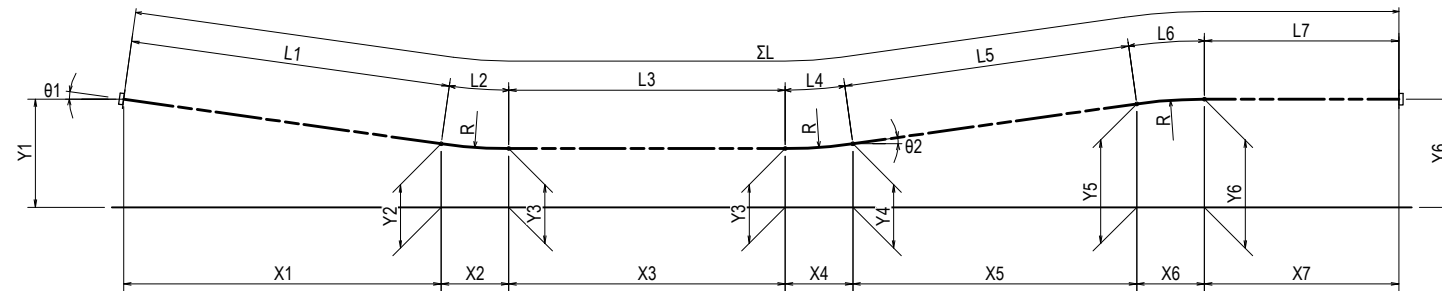

AF.1-PF.1

PC STRAND No	θ1	θ2	Y1	Y2	Y3	Y4	Y5	Y6	X1	X2	X3				X4	X5	X6	X7	
											G1	G2	G3	G4					
1	5°30'	7°00'	1650	406	360	435	1576	1650	12919	959	2325	2076	1828	1580	1218	9292	1219	1800	
2	5°30'	7°00'	1300	286	240	315	1226	1300	10530	959	6587	6338	6090	5842	1218	7419	1219	1800	
3	5°30'	7°00'	950	166	120	195	876	950	8142	958	10848	10599	10353	10103	1219	5545	1219	1800	
4	5°30'	7°00'	600	166	120	195	526	600	4507	958	17334	17085	16837	16589	1218	2695	1219	1800	
5	4°00'	5°30'	250	144	120	166	204	250	1511	697	23413	23164	22916	22668	959	394	958	1800	
												ΣL (UNIT:mm)				WEIGHT (UNIT:kg)			
PC STRAND No	L1	L2	L3				L4	L5	L6	L7	G1	G2	G3	G4	G1	G2	G3	G4	
			G1	G2	G3	G4													
1	12979	960	2325	2076	1828	1580	1222	9362	1222	1800	29870	29621	29373	29125	230.20	228.29	226.38	224.47	
2	10579	960	6587	6338	6090	5842	1222	7475	1222	1800	29845	29596	29348	29100	230.02	228.10	226.19	224.27	
3	8179	960	10848	10599	10353	10103	1222	5587	1222	1800	29818	29569	29323	29073	229.81	227.89	225.99	224.07	
4	4528	960	17334	17085	16837	16589	1222	2715	1222	1800	29781	29532	29284	29036	229.52	227.60	225.69	223.78	
5	1514	698	23413	23164	22916	22668	960	396	960	1800	29741	29492	29244	28996	229.21	227.29	225.38	223.47	
TOTAL											149055	147810	146572	145330	1148.8	1139.2	1129.6	1120.1	

CROSS SECTION OF MAIN GIRDER S=1:50

END SECTION

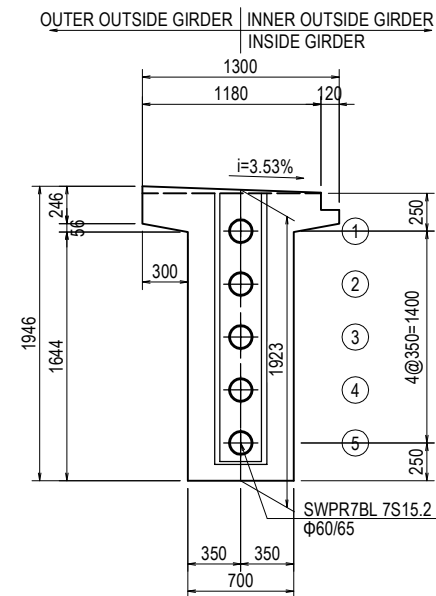

INTERMEDIATE CROSSBEAM

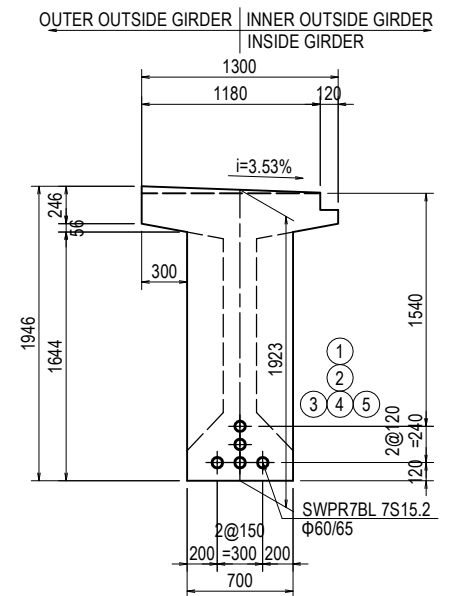

PC STRAND ARRANGEMENT OF MAIN GIRDER (AF1-PF2) (2)

SIDE VIEW S=1:100

PF.1-PF.2
30225 (G1)

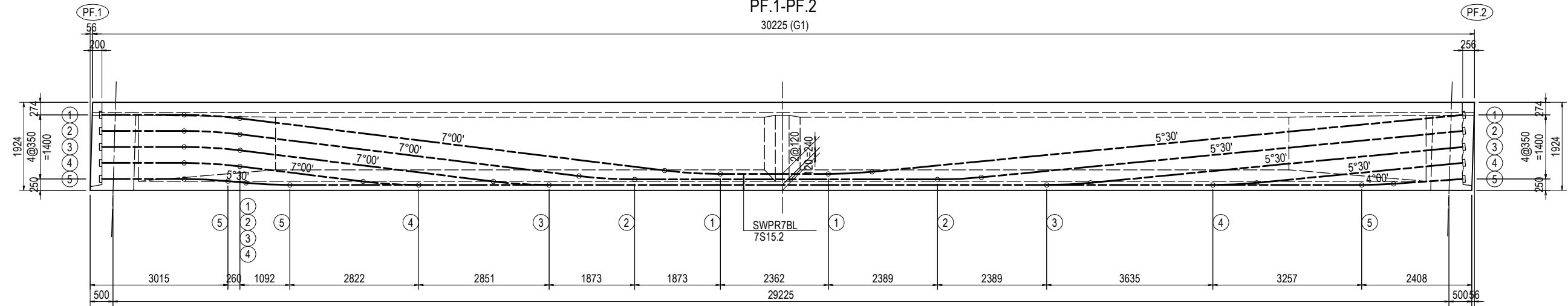

PC STRAND LENGTH & ELEVATION

7S15.2
w=7.707 kg/m
R=10.000m

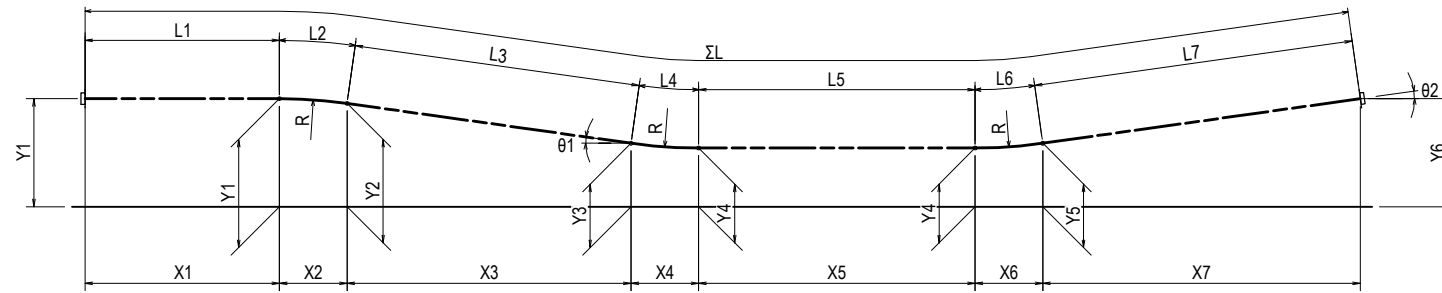

PF.1-PF.2

PC STRAND No	θ1	θ2	Y1	Y2	Y3	Y4	Y5	Y6	X1	X2	X3	X4	X5				X6	X7
													G1	G2	G3	G4		
1	7°00'	5°30'	1650	1576	435	360	406	1650	1800	1219	9292	1219	2361	2122	1883	1644	958	12919
2	7°00'	5°30'	1300	1226	315	240	286	1300	1800	1219	7419	1218	6623	6384	6145	5906	959	10530
3	7°00'	5°30'	950	876	195	120	166	950	1800	1219	5545	1219	10885	10646	10407	10168	958	8142
4	7°00'	5°30'	600	526	195	120	166	600	1800	1219	2695	1219	17371	17132	16893	16654	958	4507
5	5°30'	4°00'	250	204	166	120	144	250	1800	959	393	959	23450	23211	22972	22733	697	1511

PC STRAND No	L1	L2	L3	L4	L5				L6	L7	ΣL (UNIT:mm)				WEIGHT (UNIT:kg)			
					G1	G2	G3	G4			G1	G2	G3	G4	G1	G2	G3	G4
1	1800	1222	9362	1222	2361	2122	1883	1644	960	12979	29906	29667	29428	29189	230.49	228.64	226.80	224.96
2	1800	1222	7475	1222	6623	6384	6145	5906	960	10579	29881	29642	29403	29164	230.29	228.45	226.61	224.77
3	1800	1222	5587	1222	10885	10646	10407	10168	960	8179	29855	29616	29377	29138	230.09	228.25	226.41	224.57
4	1800	1222	2715	1222	17371	17132	16893	16654	960	4528	29818	29579	29340	29101	229.81	227.97	226.12	224.28
5	1800	960	396	960	23450	23211	22972	22733	698	1514	29778	29539	29300	29061	229.50	227.66	225.82	223.97
TOTAL											149238	148043	146848	145653	1150.2	1141.0	1131.8	1122.6

CROSS SECTION OF MAIN GIRDER S=1:50

END SECTION

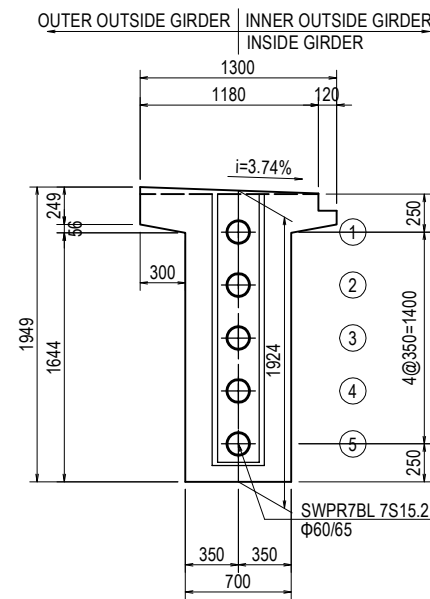

INTERMEDIATE CROSSBEAM

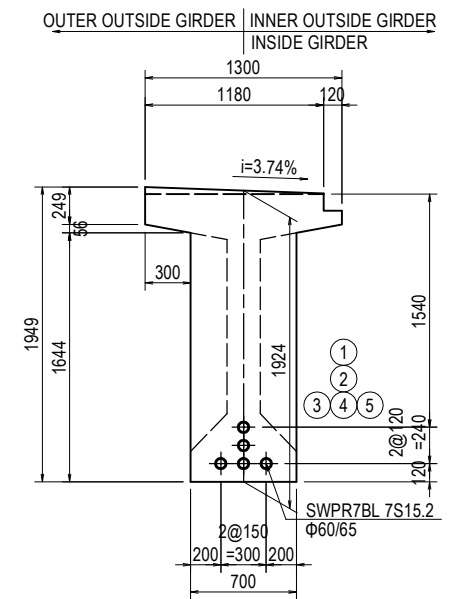

BAR ARRANGEMENT OF MAIN GIRDER (AF1-PF2) (1)

SIDE VIEW S=1:100

AF.1-PF.1

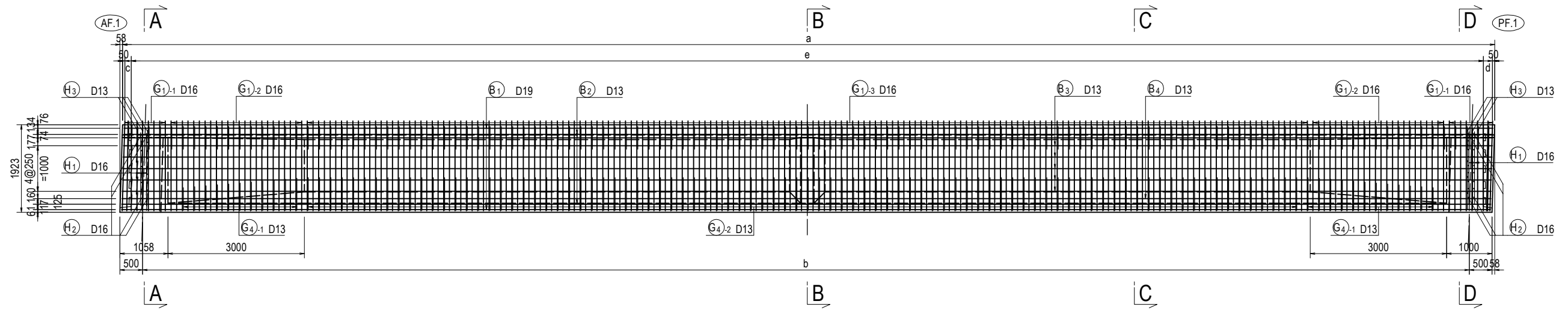

PLAN S=1:100

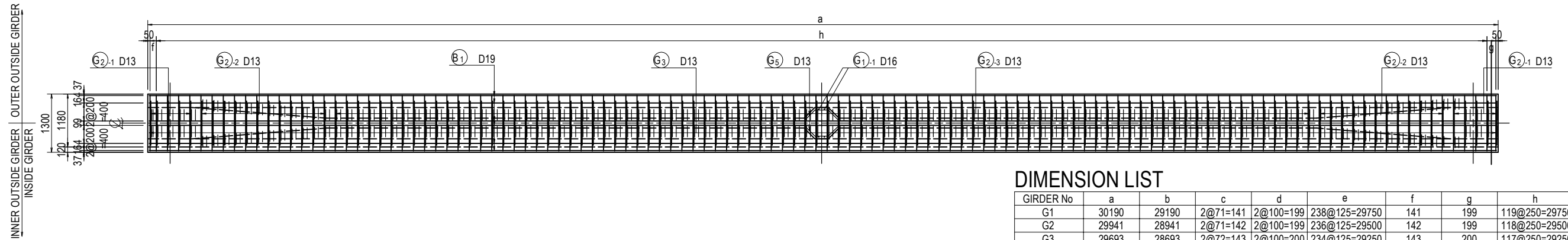

DIMENSION LIST

GIRDER No	a	b	c	d	e	f	g	h
G1	30190	29190	2@71=141	2@100=199	238@125=29750	141	199	119@250=29750
G2	29941	28941	2@71=142	2@100=199	236@125=29500	142	199	118@250=29500
G3	29693	28693	2@72=143	2@100=200	234@125=29250	143	200	117@250=29250
G4	29444	28444	2@72=143	2@101=201	232@125=29000	143	201	116@250=29000

CROSS SECTION OF MAIN GIRDER S=1:50

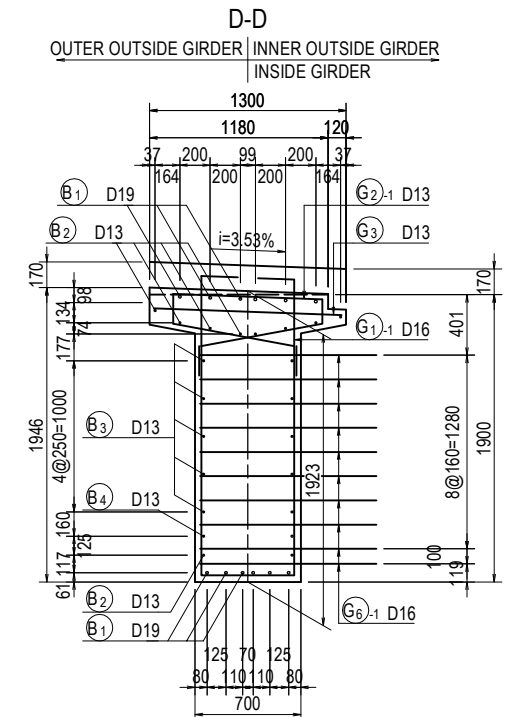
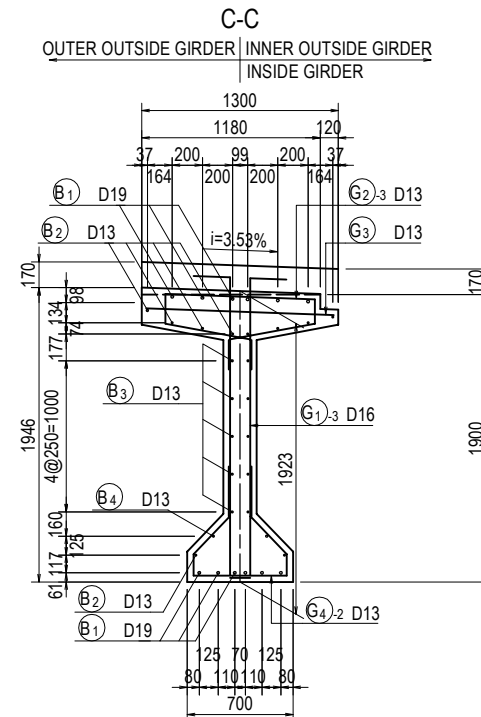
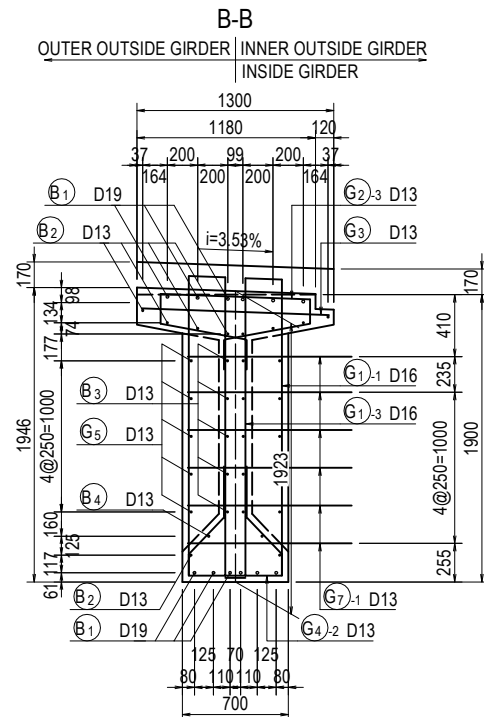
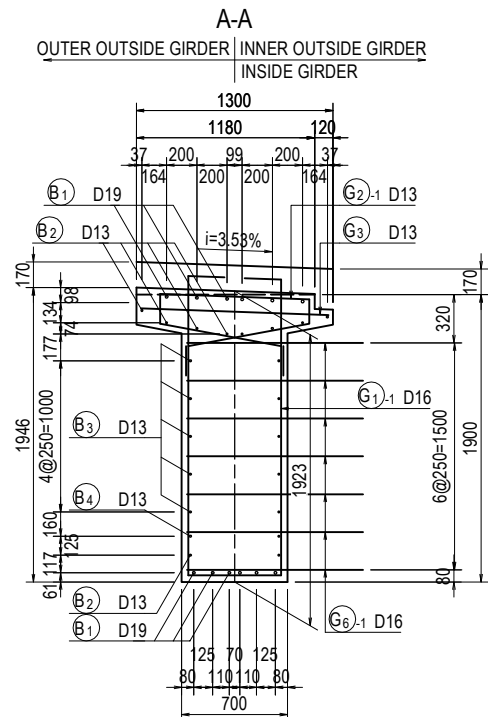

PROJECT NAME DETAILED DESIGN ON BAGO RIVER BRIDGE CONSTRUCTION PROJECT	FINANCED BY JAPAN INTERNATIONAL COOPERATION AGENCY	COUNTERPART REPUBLIC OF THE UNION OF MYANMAR MINISTRY OF CONSTRUCTION DEPARTMENT OF BRIDGE	JICA STUDY TEAM NIPPON KOEI CO., LTD. ORIENTAL CONSULTANTS GLOBAL CO., LTD. METROPOLITAN EXPRESSWAY COMPANY LIMITED CHODAI CO., LTD. NIPPON ENGINEERING CONSULTANTS CO., LTD.	NAME	SIGNATURE	DATE	DRAWING TITLE	PACKAGE	
				PREPARED BY	Y. SUZUKI				14 Jul. 2017
				CHECKED BY	T. HAYAKAWA				20 Jul. 2017
				APPROVED BY	Y. SANO				25 Jul. 2017
							BAR ARRANGEMENT OF MAIN GIRDER (AF1-PF2) (1)	3	
								DWG No.	
								P3-FO-1008	

BAR ARRANGEMENT OF MAIN GIRDER (AF1-PF2) (2)

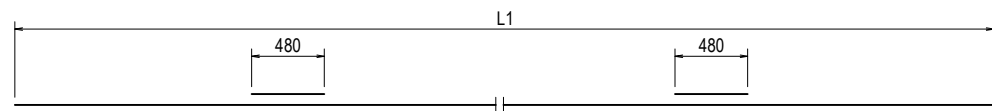

⊖1 12-D19xL

	B1	
	L1	L
G1	30120	31080
G2	29871	30840
G3	29623	30590
G4	29374	30340

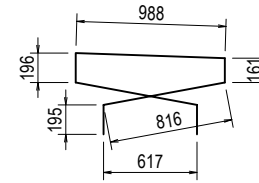

⊖2-1 10-D13x3370

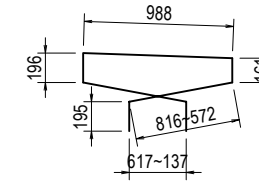

⊖2-2 24-D13x3130 (AVE)

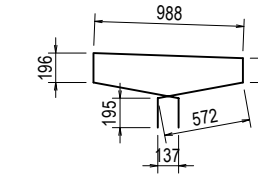

⊖2-3 N-D13x2880

	N(number)
	G2-3
G1	88
G2	87
G3	86
G4	85

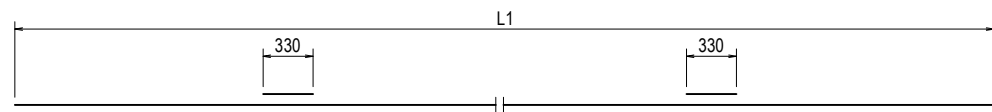

⊖2 10-D13xL

	B2	
	L1	L
G1	30120	30780
G2	29871	30540
G3	29623	30290
G4	29374	30040

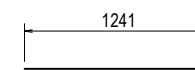

⊖3 N-D13x1250

	N(number)
	G3
G1	122
G2	121
G3	120
G4	119

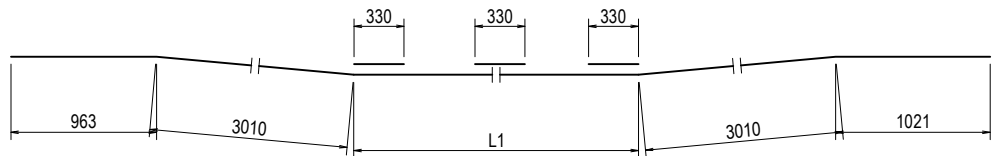

⊖3 10-D13xL

	B3	
	L1	L
G1	22136	31130
G2	21888	30890
G3	21640	30640
G4	21391	30390

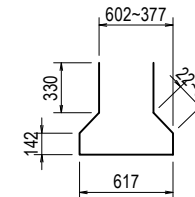

⊖4-1 22-D13x1930 (AVE)

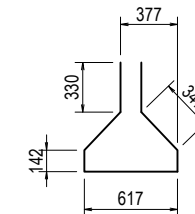

⊖4-2 N-D13x2260

	N(number)
	G4-2
G1	88
G2	87
G3	86
G4	85

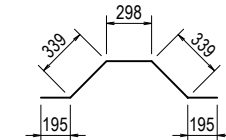

⊖5 10-D13x1370

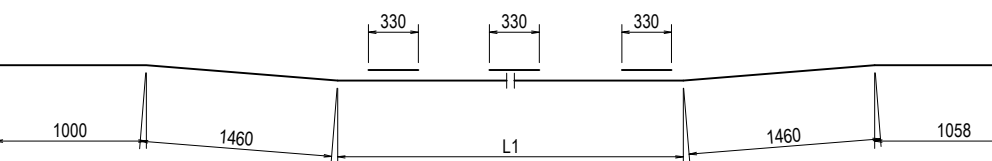

⊖4 2-D13xL

	B4	
	L1	L
G1	25150	31120
G2	24901	30870
G3	24653	30630
G4	24404	30380

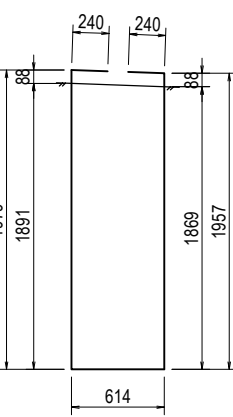

⊖1-1 20-D16x5030

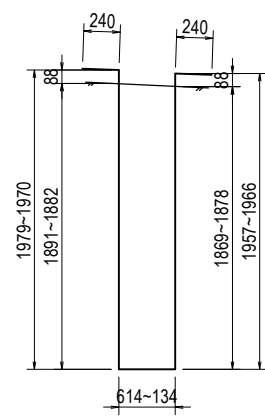

⊖1-2 48-D16x4800 (AVE)

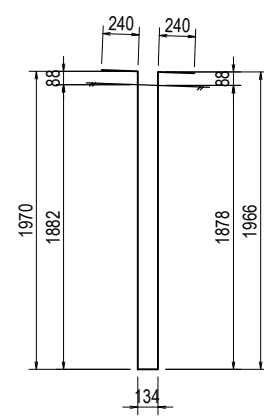

⊖1-3 N-D16x4550

	N(number)
	G1-3
G1	177
G2	175
G3	173
G4	171

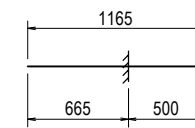

⊖6-1 54-D16x1170 (OUTSIDE GIRDER)

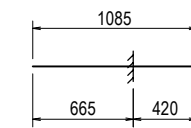

⊖7-1 12-D13x1090 (OUTSIDE GIRDER)

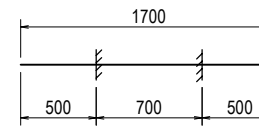

⊖6-2 54-D16x1700 (INSIDE GIRDER)

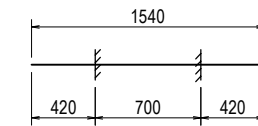

⊖7-2 12-D13x1540 (INSIDE GIRDER)

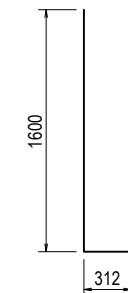

⊖1 8-D16x3520

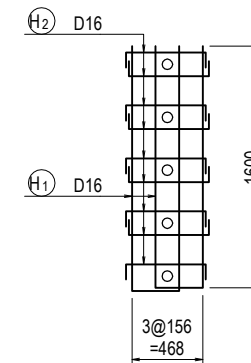

⊖2 36-D16x670

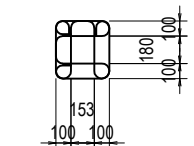

⊖3 30-D13x4020

BAR ARRANGEMENT OF MAIN GIRDER (AF1-PF2) (3)

(G1)BAR LIST

REBAR NO.	DIA (mm)	LENGHT (mm)	NUMBER	UNIT WEIGHT (kg/m)	WEIGHT/ONE (kg)	WEIGHT (kg)	REMARKS
B 1	D19	31080	12	2.25	69.93	839	
B 2	D13	30780	10	0.995	30.63	306	
B 3	D13	31130	10	0.995	30.97	310	
B 4	D13	31120	2	0.995	30.96	62	
G 1 -1	D16	5030	20	1.56	7.85	157	
G 1 -2	D16	4800	48	1.56	7.49	360	AVERAGE
G 1 -3	D16	4550	177	1.56	7.10	1257	
G 2 -1	D13	3370	10	0.995	3.35	34	
G 2 -2	D13	3130	24	0.995	3.11	75	AVERAGE
G 2 -3	D13	2880	88	0.995	2.87	253	
G 3	D13	1250	122	0.995	1.24	151	
G 4 -1	D13	1930	22	0.995	1.92	42	AVERAGE
G 4 -2	D13	2260	88	0.995	2.25	198	
G 5	D13	1370	10	0.995	1.36	14	
G 6 -1	D16	1170	54	1.56	1.83	99	OUTSIDE GIRDER
G 7 -1	D13	1090	12	0.995	1.08	13	OUTSIDE GIRDER
H 1	D16	3520	8	1.56	5.49	44	
H 2	D16	670	36	1.56	1.05	38	
H 3	D13	4020	30	0.995	4.00	120	
						D19	839 kg
						D16	1955 kg
						D13	1578 kg
						TOTAL	4372 kg

(G3)BAR LIST

REBAR NO.	DIA (mm)	LENGHT (mm)	NUMBER	UNIT WEIGHT (kg/m)	WEIGHT/ONE (kg)	WEIGHT (kg)	REMARKS
B 1	D19	30590	12	2.25	68.83	826	
B 2	D13	30290	10	0.995	30.14	301	
B 3	D13	30640	10	0.995	30.49	305	
B 4	D13	30630	2	0.995	30.48	61	
G 1 -1	D16	5030	20	1.56	7.85	157	
G 1 -2	D16	4800	48	1.56	7.49	360	AVERAGE
G 1 -3	D16	4550	173	1.56	7.10	1228	
G 2 -1	D13	3370	10	0.995	3.35	34	
G 2 -2	D13	3130	24	0.995	3.11	75	AVERAGE
G 2 -3	D13	2880	86	0.995	2.87	247	
G 3	D13	1250	120	0.995	1.24	149	
G 4 -1	D13	1930	22	0.995	1.92	42	AVERAGE
G 4 -2	D13	2260	86	0.995	2.25	194	
G 5	D13	1370	10	0.995	1.36	14	
G 6 -2	D16	1700	54	1.56	2.65	143	INSIDE GIRDER
G 7 -2	D13	1540	12	0.995	1.53	18	INSIDE GIRDER
H 1	D16	3520	8	1.56	5.49	44	
H 2	D16	670	36	1.56	1.05	38	
H 3	D13	4020	30	0.995	4.00	120	
						D19	826 kg
						D16	1970 kg
						D13	1560 kg
						TOTAL	4356 kg

(G2)BAR LIST

REBAR NO.	DIA (mm)	LENGHT (mm)	NUMBER	UNIT WEIGHT (kg/m)	WEIGHT/ONE (kg)	WEIGHT (kg)	REMARKS
B 1	D19	30840	12	2.25	69.39	833	
B 2	D13	30540	10	0.995	30.39	304	
B 3	D13	30890	10	0.995	30.74	307	
B 4	D13	30870	2	0.995	30.72	61	
G 1 -1	D16	5030	20	1.56	7.85	157	
G 1 -2	D16	4800	48	1.56	7.49	360	AVERAGE
G 1 -3	D16	4550	175	1.56	7.10	1243	
G 2 -1	D13	3370	10	0.995	3.35	34	
G 2 -2	D13	3130	24	0.995	3.11	75	AVERAGE
G 2 -3	D13	2880	87	0.995	2.87	250	
G 3	D13	1250	121	0.995	1.24	150	
G 4 -1	D13	1930	22	0.995	1.92	42	AVERAGE
G 4 -2	D13	2260	87	0.995	2.25	196	
G 5	D13	1370	10	0.995	1.36	14	
G 6 -2	D16	1700	54	1.56	2.65	143	INSIDE GIRDER
G 7 -2	D13	1540	12	0.995	1.53	18	INSIDE GIRDER
H 1	D16	3520	8	1.56	5.49	44	
H 2	D16	670	36	1.56	1.05	38	
H 3	D13	4020	30	0.995	4.00	120	
						D19	833 kg
						D16	1985 kg
						D13	1571 kg
						TOTAL	4389 kg

(G4)BAR LIST

REBAR NO.	DIA (mm)	LENGHT (mm)	NUMBER	UNIT WEIGHT (kg/m)	WEIGHT/ONE (kg)	WEIGHT (kg)	REMARKS
B 1	D19	30340	12	2.25	68.27	819	
B 2	D13	30040	10	0.995	29.89	299	
B 3	D13	30390	10	0.995	30.24	302	
B 4	D13	30380	2	0.995	30.23	60	
G 1 -1	D16	5030	20	1.56	7.85	157	
G 1 -2	D16	4800	48	1.56	7.49	360	AVERAGE
G 1 -3	D16	4550	171	1.56	7.10	1214	
G 2 -1	D13	3370	10	0.995	3.35	34	
G 2 -2	D13	3130	24	0.995	3.11	75	AVERAGE
G 2 -3	D13	2880	85	0.995	2.87	244	
G 3	D13	1250	119	0.995	1.24	148	
G 4 -1	D13	1930	22	0.995	1.92	42	AVERAGE
G 4 -2	D13	2260	85	0.995	2.25	191	
G 5	D13	1370	10	0.995	1.36	14	
G 6 -1	D16	1170	54	1.56	1.83	99	OUTSIDE GIRDER
G 7 -1	D13	1090	12	0.995	1.08	13	OUTSIDE GIRDER
H 1	D16	3520	8	1.56	5.49	44	
H 2	D16	670	36	1.56	1.05	38	
H 3	D13	4020	30	0.995	4.00	120	
						D19	819 kg
						D16	1912 kg
						D13	1542 kg
						TOTAL	4273 kg

BAR ARRANGEMENT OF MAIN GIRDER (AF1-PF2) (4)

SIDE VIEW S=1:100
PF.1-PF.2

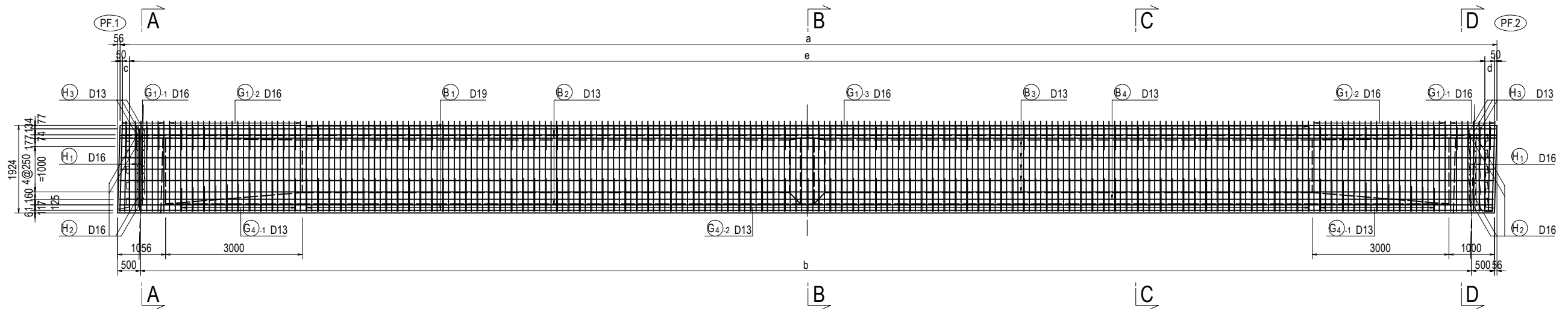

PLAN S=1:100

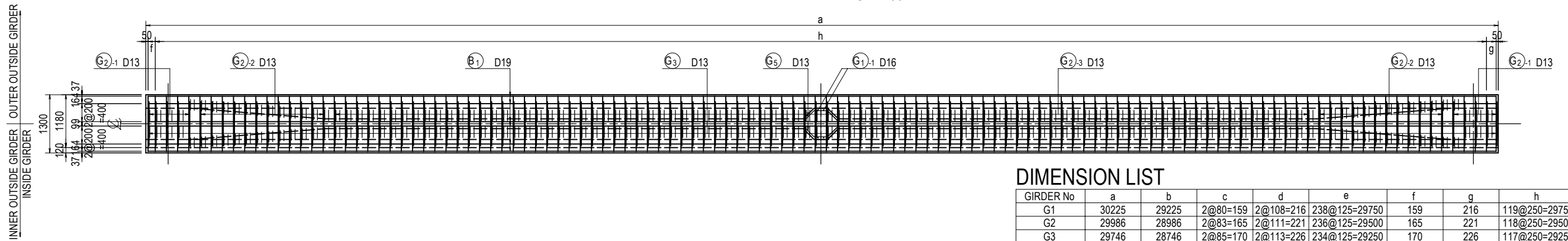

DIMENSION LIST

GIRDER No	a	b	c	d	e	f	g	h
G1	30225	29225	2@80=159	2@108=216	238@125=29750	159	216	119@250=29750
G2	29986	28986	2@83=166	2@111=222	236@125=29500	165	221	118@250=29500
G3	29746	28746	2@85=170	2@113=226	234@125=29250	170	226	117@250=29250
G4	29507	28507	2@88=176	2@116=232	232@125=29000	175	232	116@250=29000

CROSS SECTION OF MAIN GIRDER S=1:50

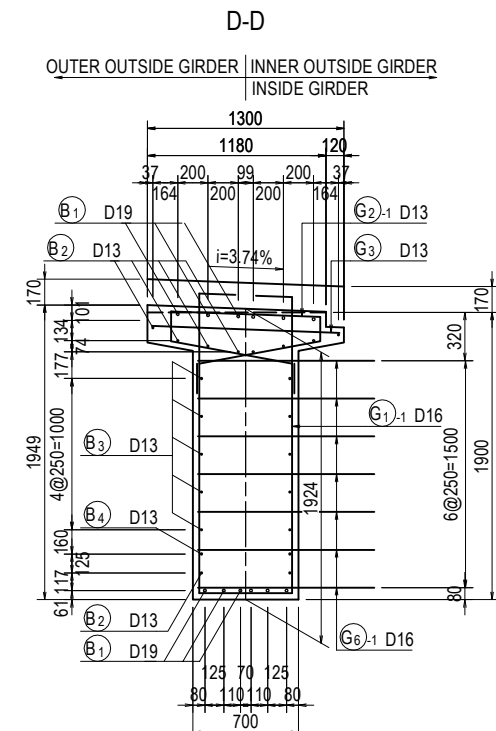
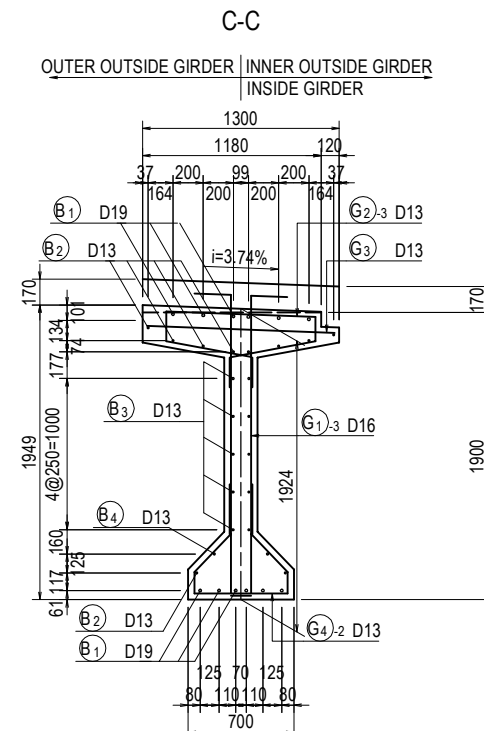
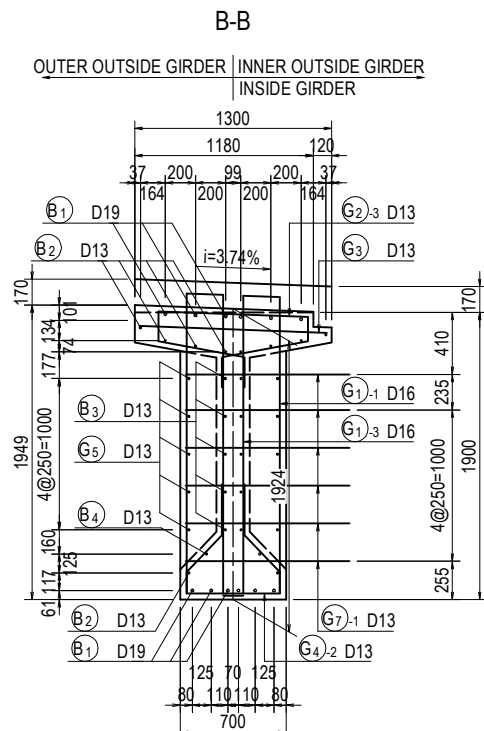
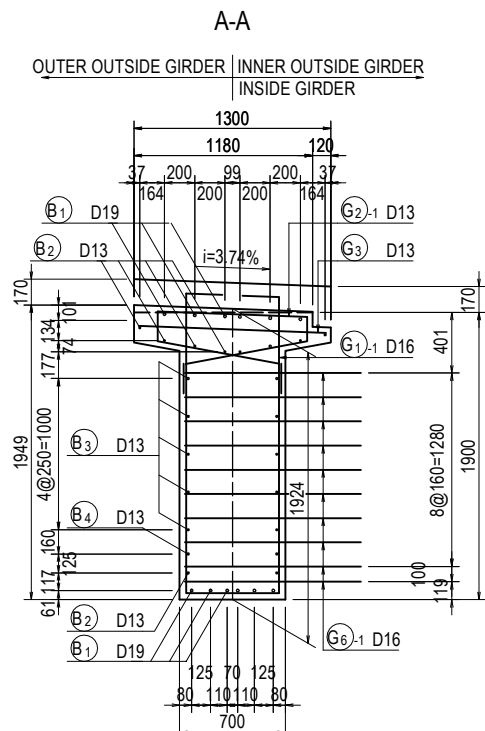

PROJECT NAME
DETAILED DESIGN ON
BAGO RIVER BRIDGE
CONSTRUCTION PROJECT

FINANCED BY
 JAPAN INTERNATIONAL
COOPERATION AGENCY

COUNTERPART
 REPUBLIC OF THE UNION OF MYANMAR
MINISTRY OF CONSTRUCTION
DEPARTMENT OF BRIDGE

JICA STUDY TEAM
 NIPPON KOEI CO., LTD.
ORIENTAL CONSULTANTS GLOBAL CO., LTD.
METROPOLITAN EXPRESSWAY COMPANY LIMITED
CHODAI CO., LTD.
NIPPON ENGINEERING CONSULTANTS CO., LTD.

	NAME	SIGNATURE	DATE
PREPARED BY	Y. SUZUKI		14 Jul. 2017
CHECKED BY	T. HAYAKAWA		20 Jul. 2017
APPROVED BY	Y. SANO		25 Jul. 2017

DRAWING TITLE
BAR ARRANGEMENT OF MAIN GIRDER (AF1-PF2) (4)

PACKAGE
3
DWG No.
P3-FO-1011

BAR ARRANGEMENT OF MAIN GIRDER (AF1-PF2) (5)

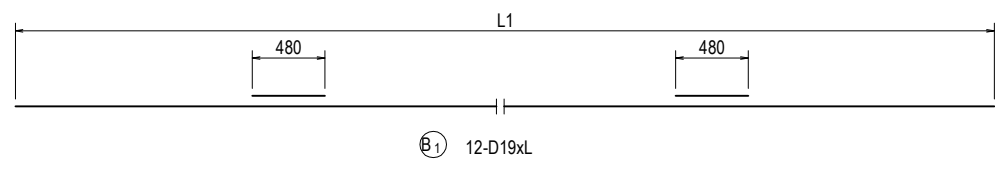

	B1	
	L1	L
G1	30155	31120
G2	29916	30880
G3	29676	30640
G4	29437	30400

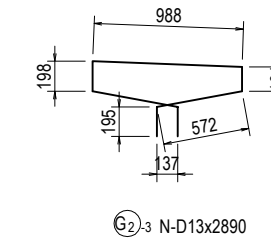
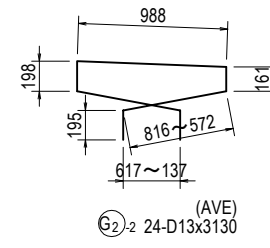
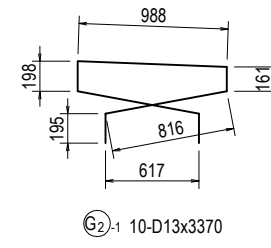

	N(number)	
	G2-3	N
G1	88	
G2	87	
G3	86	
G4	85	

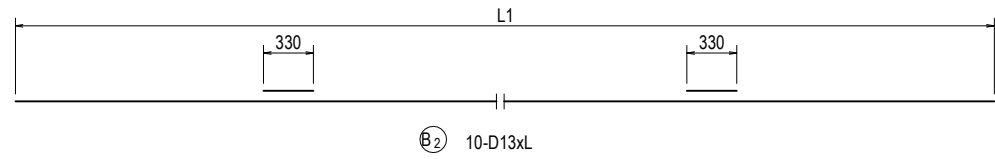

	B2	
	L1	L
G1	30155	30820
G2	29916	30580
G3	29676	30340
G4	29437	30100

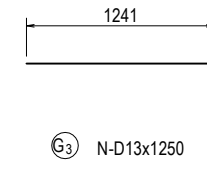

	N(number)	
	G3	N
G1	122	
G2	121	
G3	120	
G4	119	

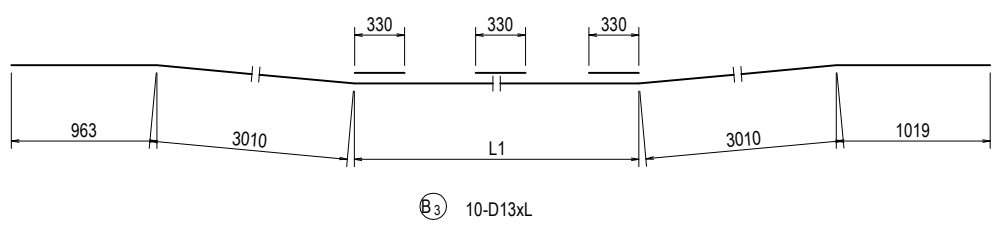

	B3	
	L1	L
G1	22173	31170
G2	21934	30930
G3	21694	30690
G4	21455	30450

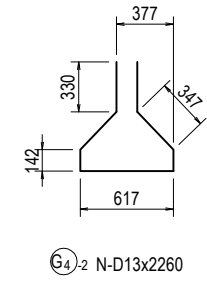
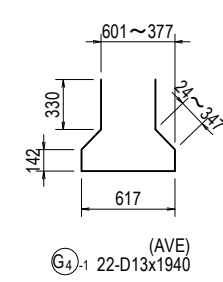

	N(number)	
	G4-2	N
G1	88	
G2	87	
G3	86	
G4	85	

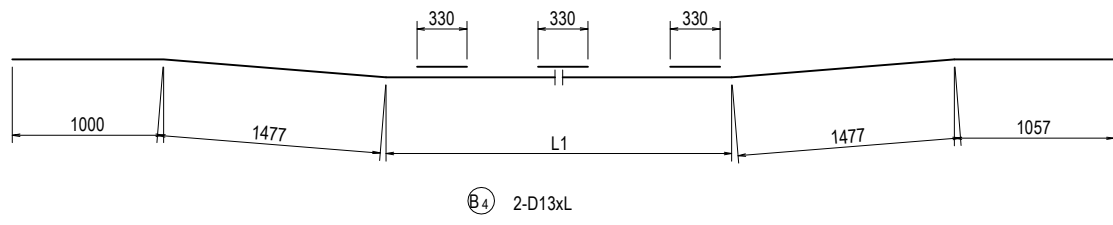
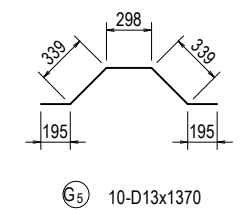

	B4	
	L1	L
G1	25153	31160
G2	24914	30920
G3	24674	30680
G4	24435	30440

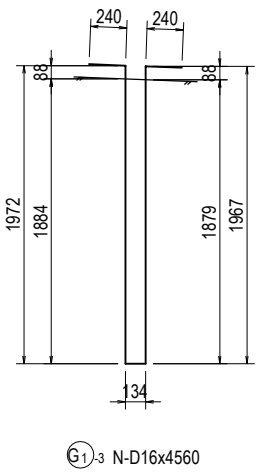
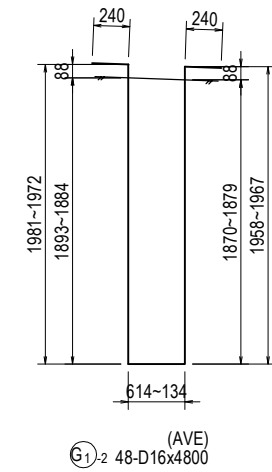
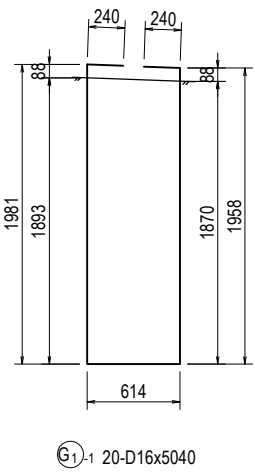
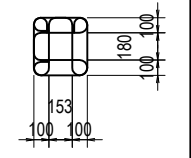
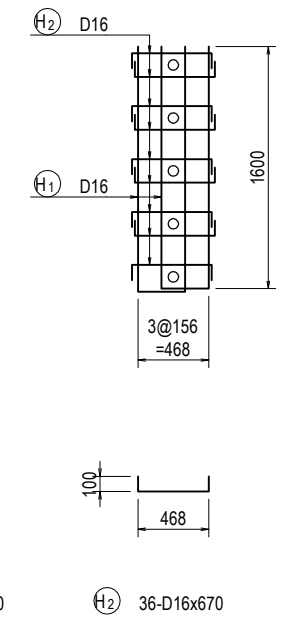
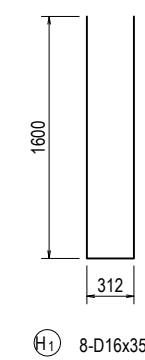
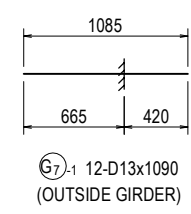
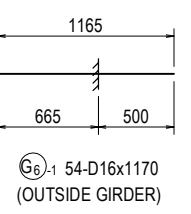

	N(number)	
	G1-3	N
G1	177	
G2	175	
G3	173	
G4	171	

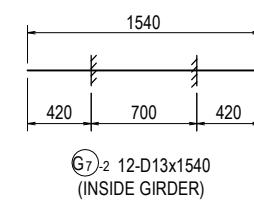
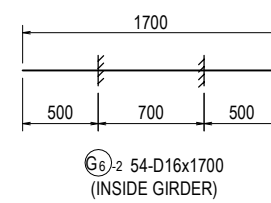

BAR ARRANGEMENT OF MAIN GIRDER (AF1-PF2) (6)

(G1)BAR LIST

REBAR NO.	DIA (mm)	LENGHT (mm)	NUMBER	UNIT WEIGHT (kg/m)	WEIGHT/ONE (kg)	WEIGHT (kg)	REMARKS
B 1	D19	31120	12	2.25	70.02	840	
B 2	D13	30820	10	0.995	30.67	307	
B 3	D13	31170	10	0.995	31.01	310	
B 4	D13	31160	2	0.995	31.00	62	
G 1 -1	D16	5040	20	1.56	7.86	157	
G 1 -2	D16	4800	48	1.56	7.49	360	AVERAGE
G 1 -3	D16	4560	177	1.56	7.11	1258	
G 2 -1	D13	3370	10	0.995	3.35	34	
G 2 -2	D13	3130	24	0.995	3.11	75	AVERAGE
G 2 -3	D13	2890	88	0.995	2.88	253	
G 3	D13	1250	122	0.995	1.24	151	
G 4 -1	D13	1940	22	0.995	1.93	42	AVERAGE
G 4 -2	D13	2260	88	0.995	2.25	198	
G 5	D13	1370	10	0.995	1.36	14	
G 6 -1	D16	1170	54	1.56	1.83	99	OUTSIDE GIRDER
G 7 -1	D13	1090	12	0.995	1.08	13	OUTSIDE GIRDER
H 1	D16	3520	8	1.56	5.49	44	
H 2	D16	670	36	1.56	1.05	38	
H 3	D13	4020	30	0.995	4.00	120	
						D19	840 kg
						D16	1956 kg
						D13	1579 kg
						TOTAL	4375 kg

(G3)BAR LIST

REBAR NO.	DIA (mm)	LENGHT (mm)	NUMBER	UNIT WEIGHT (kg/m)	WEIGHT/ONE (kg)	WEIGHT (kg)	REMARKS
B 1	D19	30640	12	2.25	68.94	827	
B 2	D13	30340	10	0.995	30.19	302	
B 3	D13	30690	10	0.995	30.54	305	
B 4	D13	30680	2	0.995	30.53	61	
G 1 -1	D16	5040	20	1.56	7.86	157	
G 1 -2	D16	4800	48	1.56	7.49	360	AVERAGE
G 1 -3	D16	4560	173	1.56	7.11	1230	
G 2 -1	D13	3370	10	0.995	3.35	34	
G 2 -2	D13	3130	24	0.995	3.11	75	AVERAGE
G 2 -3	D13	2890	86	0.995	2.88	248	
G 3	D13	1250	120	0.995	1.24	149	
G 4 -1	D13	1940	22	0.995	1.93	42	AVERAGE
G 4 -2	D13	2260	86	0.995	2.25	194	
G 5	D13	1370	10	0.995	1.36	14	
G 6 -2	D16	1700	54	1.56	2.65	143	INSIDE GIRDER
G 7 -2	D13	1540	12	0.995	1.53	18	INSIDE GIRDER
H 1	D16	3520	8	1.56	5.49	44	
H 2	D16	670	36	1.56	1.05	38	
H 3	D13	4020	30	0.995	4.00	120	
						D19	827 kg
						D16	1972 kg
						D13	1562 kg
						TOTAL	4361 kg

(G2)BAR LIST

REBAR NO.	DIA (mm)	LENGHT (mm)	NUMBER	UNIT WEIGHT (kg/m)	WEIGHT/ONE (kg)	WEIGHT (kg)	REMARKS
B 1	D19	30880	12	2.25	69.48	834	
B 2	D13	30580	10	0.995	30.43	304	
B 3	D13	30930	10	0.995	30.78	308	
B 4	D13	30920	2	0.995	30.77	62	
G 1 -1	D16	5040	20	1.56	7.86	157	
G 1 -2	D16	4800	48	1.56	7.49	360	AVERAGE
G 1 -3	D16	4560	175	1.56	7.11	1244	
G 2 -1	D13	3370	10	0.995	3.35	34	
G 2 -2	D13	3130	24	0.995	3.11	75	AVERAGE
G 2 -3	D13	2890	87	0.995	2.88	251	
G 3	D13	1250	121	0.995	1.24	150	
G 4 -1	D13	1940	22	0.995	1.93	42	AVERAGE
G 4 -2	D13	2260	87	0.995	2.25	196	
G 5	D13	1370	10	0.995	1.36	14	
G 6 -2	D16	1700	54	1.56	2.65	143	INSIDE GIRDER
G 7 -2	D13	1540	12	0.995	1.53	18	INSIDE GIRDER
H 1	D16	3520	8	1.56	5.49	44	
H 2	D16	670	36	1.56	1.05	38	
H 3	D13	4020	30	0.995	4.00	120	
						D19	834 kg
						D16	1986 kg
						D13	1574 kg
						TOTAL	4394 kg

(G4)BAR LIST

REBAR NO.	DIA (mm)	LENGHT (mm)	NUMBER	UNIT WEIGHT (kg/m)	WEIGHT/ONE (kg)	WEIGHT (kg)	REMARKS
B 1	D19	30400	12	2.25	68.40	821	
B 2	D13	30100	10	0.995	29.95	300	
B 3	D13	30450	10	0.995	30.30	303	
B 4	D13	30440	2	0.995	30.29	61	
G 1 -1	D16	5040	20	1.56	7.86	157	
G 1 -2	D16	4800	48	1.56	7.49	360	AVERAGE
G 1 -3	D16	4560	171	1.56	7.11	1216	
G 2 -1	D13	3370	10	0.995	3.35	34	
G 2 -2	D13	3130	24	0.995	3.11	75	AVERAGE
G 2 -3	D13	2890	85	0.995	2.88	245	
G 3	D13	1250	119	0.995	1.24	148	
G 4 -1	D13	1940	22	0.995	1.93	42	AVERAGE
G 4 -2	D13	2260	85	0.995	2.25	191	
G 5	D13	1370	10	0.995	1.36	14	
G 6 -1	D16	1170	54	1.56	1.83	99	OUTSIDE GIRDER
G 7 -1	D13	1090	12	0.995	1.08	13	OUTSIDE GIRDER
H 1	D16	3520	8	1.56	5.49	44	
H 2	D16	670	36	1.56	1.05	38	
H 3	D13	4020	30	0.995	4.00	120	
						D19	821 kg
						D16	1914 kg
						D13	1546 kg
						TOTAL	4281 kg

BAR ARRANGEMENT OF CROSSBEAM (AF1-PF2) (1)

CROSS SECTION S=1:60

SIDE VIEW S=1:60

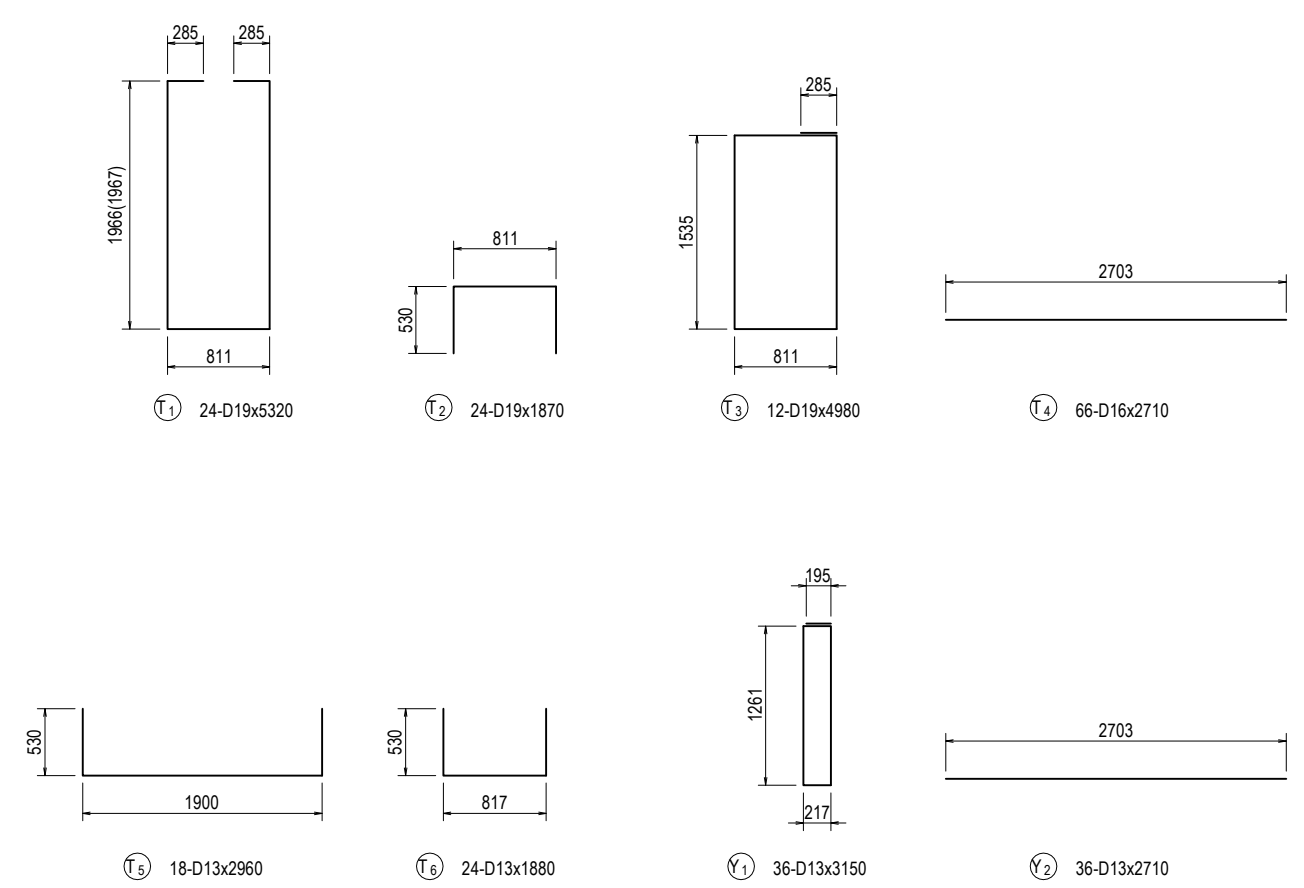
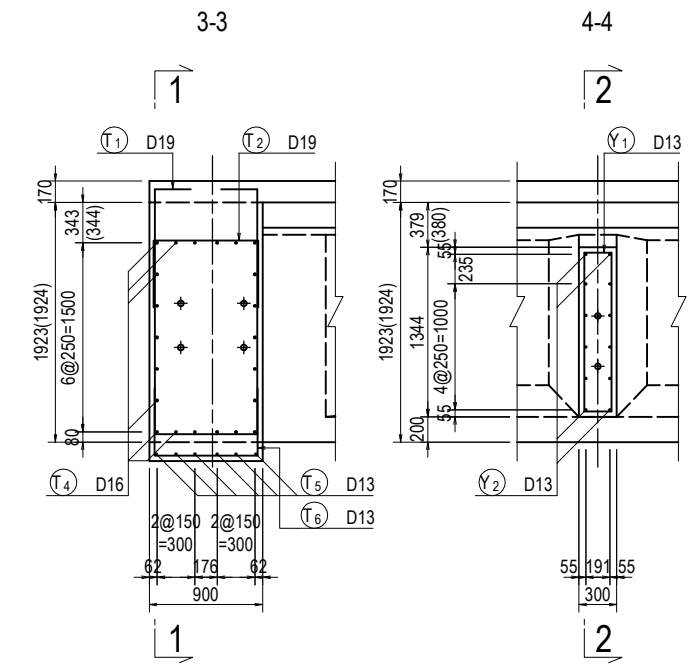
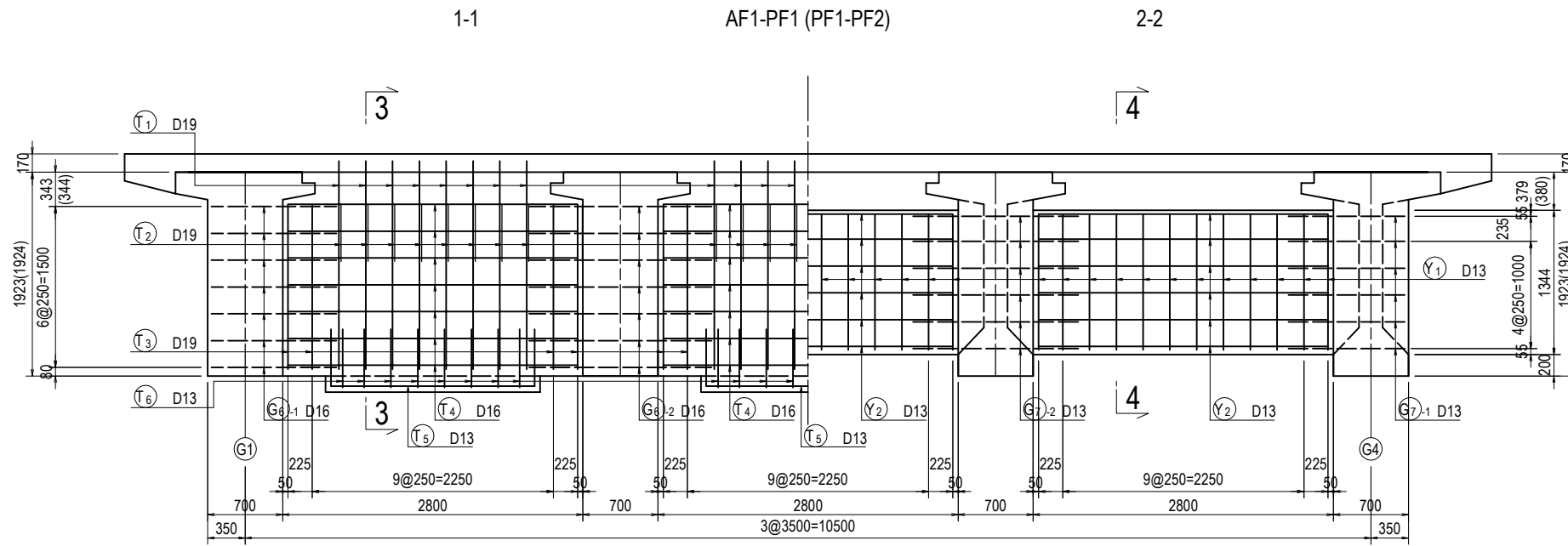

PC STRAND LIST

	TYPE	LENGTH (mm)	NUMBER	UNIT WEIGHT (kg/m)	WEIGHT/ONE (kg)	WEIGHT (kg)	REMARKS
	CROSSBEAM AT END OF MAIN GIRDER(AF1)	11207	4	4.404	49.356	197.4	
	CROSSBEAM AT END OF MAIN GIRDER(PF2)	11206	4	4.404	49.351	197.4	
	INTERMEDIATE CROSSBEAM	11200	4	4.404	49.325	197.3	
					TOTAL LENGTH	ΣL= 134.452 m	
					TOTAL WEIGHT	ΣW= 592.1 kg	

BAR LIST

REBAR NO.	DIA (mm)	LENGTH (mm)	NUMBER	UNIT WEIGHT (kg/m)	WEIGHT/ONE (kg)	WEIGHT (kg)	REMARKS
T1	D19	5320	24	2.25	11.97	287	
T2	D19	1870	24	2.25	4.21	101	
T3	D19	4980	12	2.25	11.21	135	
T4	D16	2710	66	1.56	4.23	279	
T5	D13	2960	18	0.995	2.95	53	
T6	D13	1880	24	0.995	1.87	45	
Y1	D13	3150	36	0.995	3.13	113	
Y2	D13	2710	36	0.995	2.70	97	
				D19	523 kg	×2 = 1046 kg	
				D16	279 kg	×2 = 558 kg	
				D13	308 kg	×2 = 616 kg	
				TOTAL	1110 kg	×2 = 2220 kg	

BAR ARRANGEMENT OF CROSSBEAM (AF1-PF2) (2)

CROSS SECTION S=1:60

SIDE VIEW S=1:60

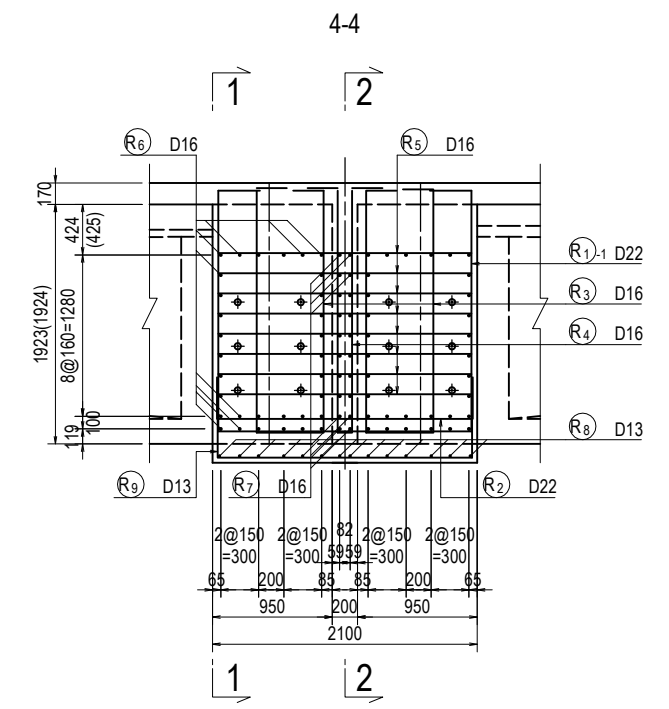
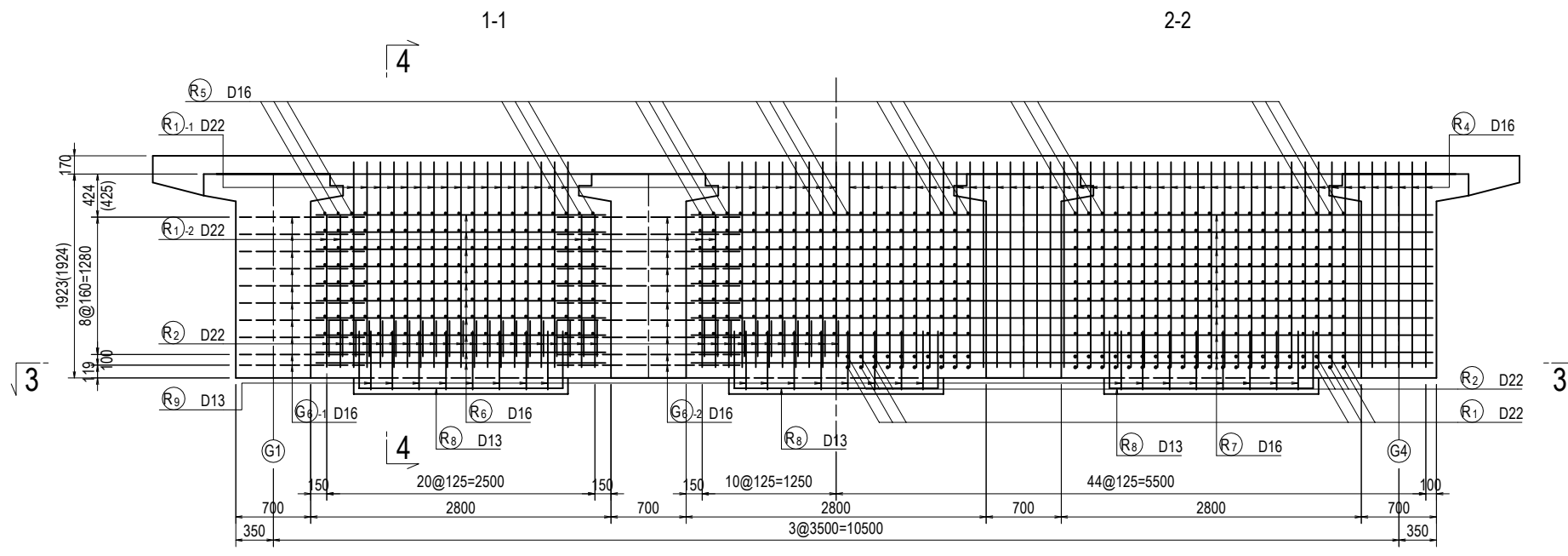

PLAN S=1:60

PC STRAND LIST

	TYPE	LENGTH (mm)	NUMBER	UNIT WEIGHT (kg/m)	WEIGHT/ONE (kg)	WEIGHT (kg)	REMARKS
	CONNECTING CROSSBEAM	SWPR7BL 4S15.2	11207	12	4.404	49.356	
						TOTAL LENGTH	ΣL= 134.484 m
						TOTAL WEIGHT	ΣW= 592.3 kg

BAR LIST

REBAR NO.	DIA (mm)	LENGTH (mm)	NUMBER	UNIT WEIGHT (kg/m)	WEIGHT/ONE (kg)	WEIGHT (kg)	REMARKS
R 1 -1	D22	6540	51	3.04	19.88	1014	
R 1 -2	D22	5510	12	3.04	16.75	201	
R 2	D22	2670	63	3.04	8.12	512	
R 3 -1	D16	4880	102	1.56	7.61	776	
R 3 -2	D16	3850	24	1.56	6.01	144	
R 4	D16	4470	89	1.56	6.97	620	
R 5	D16	2030	504	1.56	3.17	1598	
R 6	D16	2710	192	1.56	4.23	812	
R 7	D16	11140	20	1.56	17.38	348	
R 8	D13	2960	42	0.995	2.95	124	
R 9	D13	3080	24	0.995	3.06	73	
						D22	1727 kg
						D16	4298 kg
						D13	197 kg
						TOTAL	6222 kg

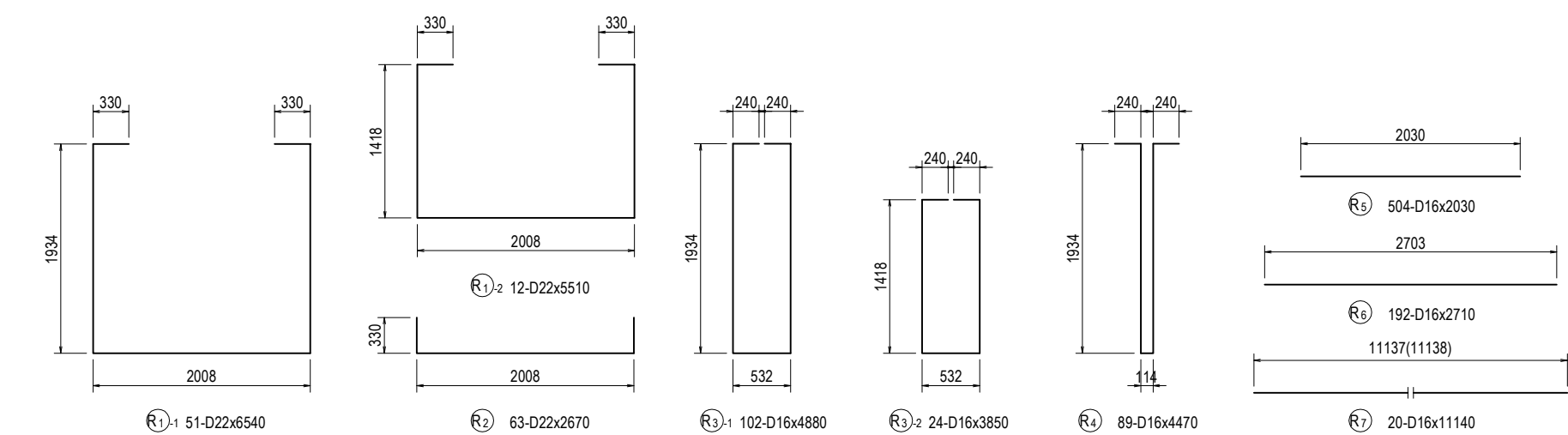
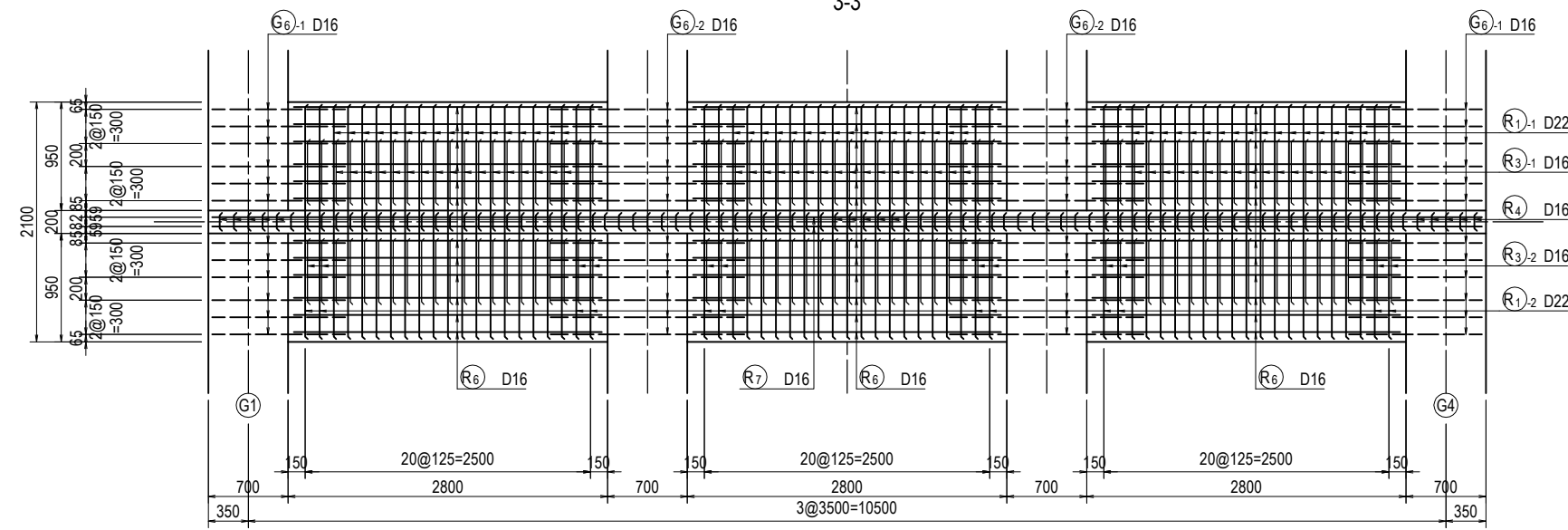

DETAIL OF PC PLATE FOR DECK SLAB (AF1-PF2)

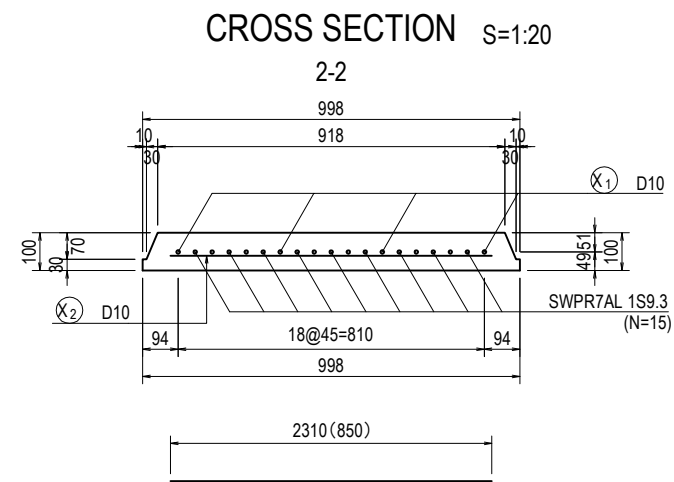
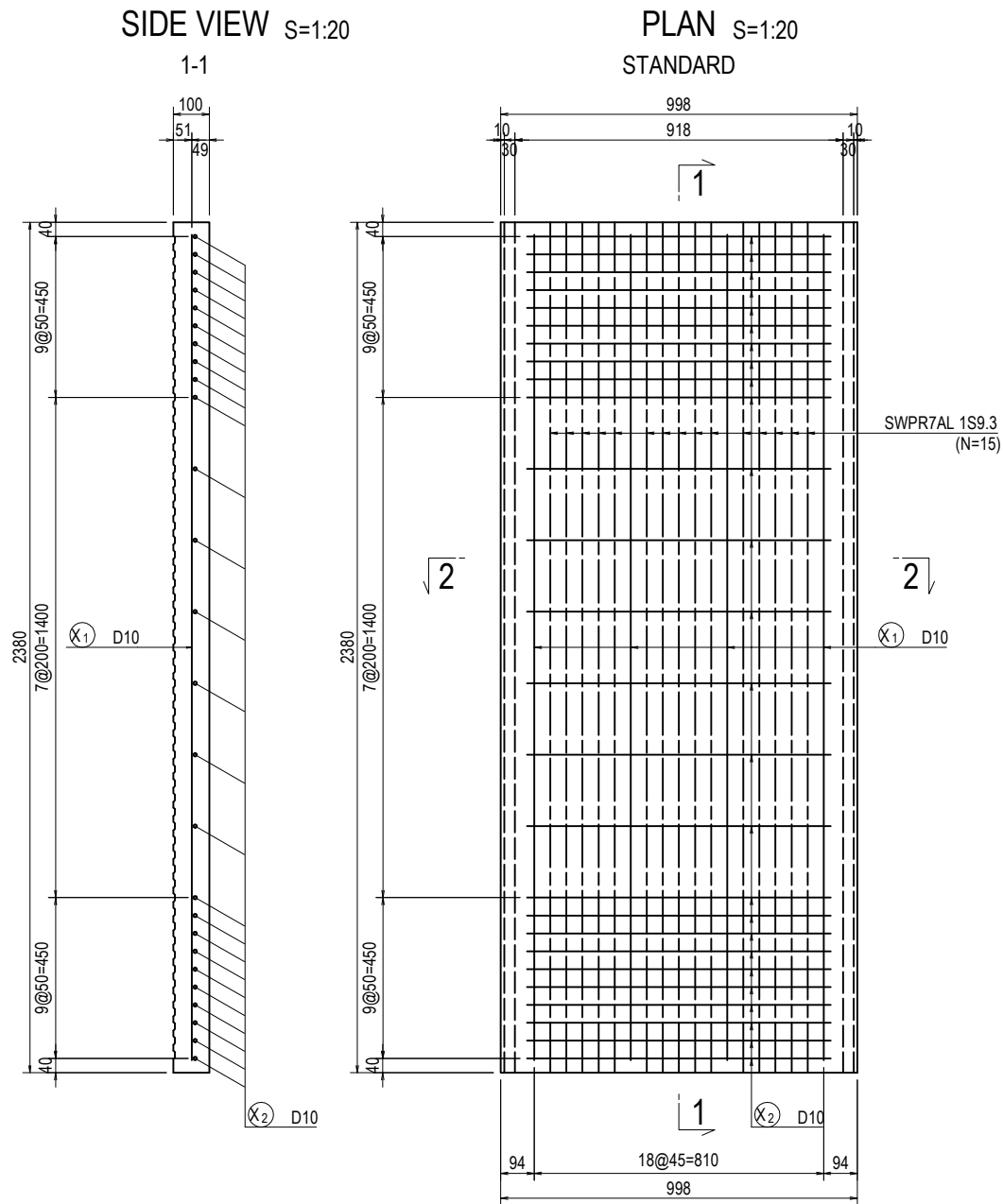

(X₁) 4-D10x2310
(X₂) 26-D10x850

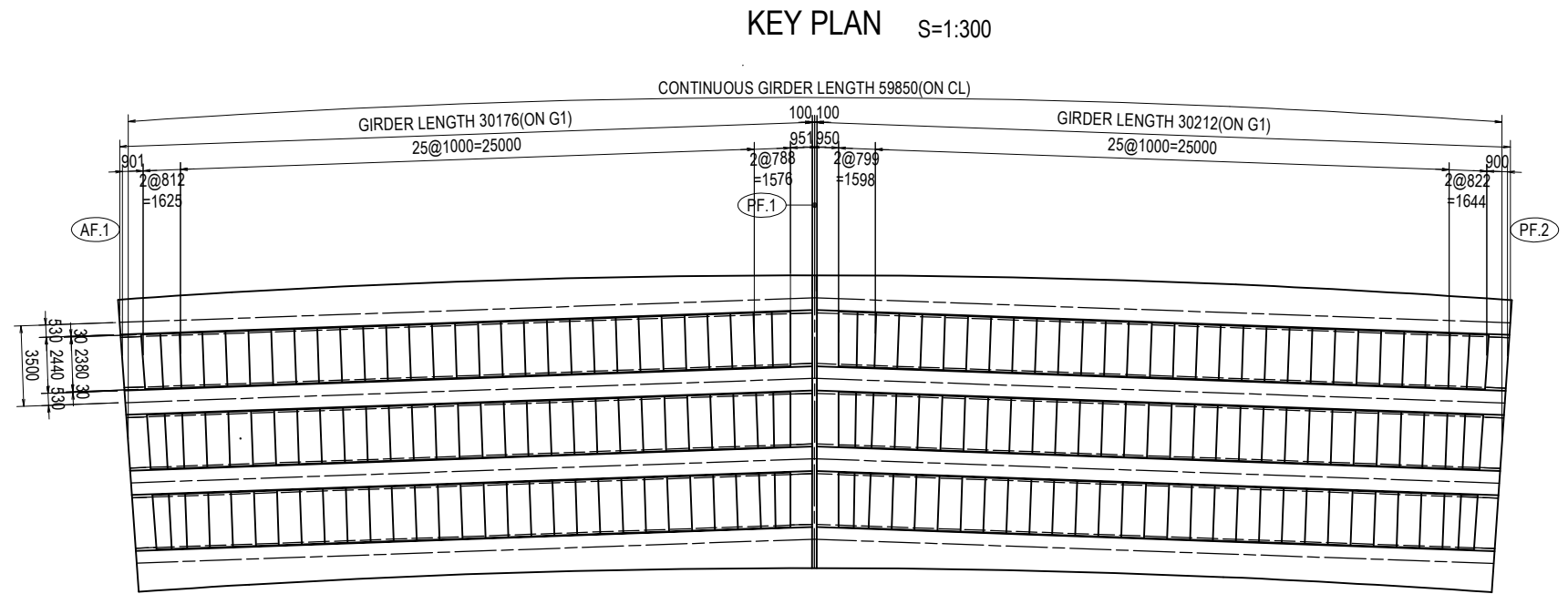

BAR LIST

REBAR NO.	DIA (mm)	LENGTH (mm)	NUMBER	UNIT WEIGHT (kg/m)	WEIGHT/ONE (kg)	WEIGHT (kg)	REMARKS
X ₁	D10	2310	4	0.56	1.29	5.2	
X ₂	D10	850	26	0.56	0.48	12.5	
						17.7 kg	
TOTAL					17.7 kg	×174 =	3079.8 kg

PC STRAND LIST

TYPE	LENGTH (mm)	NUMBER	UNIT WEIGHT (kg/m)	WEIGHT/ONE (kg)	WEIGHT (kg)	REMARKS	
SWPR7AL 1S9.3	2380	15	0.405	0.96	14.4		
TOTAL					14.4 kg	×174 =	2505.6 kg

BAR ARRANGEMENT OF DECK SLAB (AF1-PF2) (1)

PLAN S=1:100

CONTINUOUS GIRDER LENGTH 59850(O.N CL)

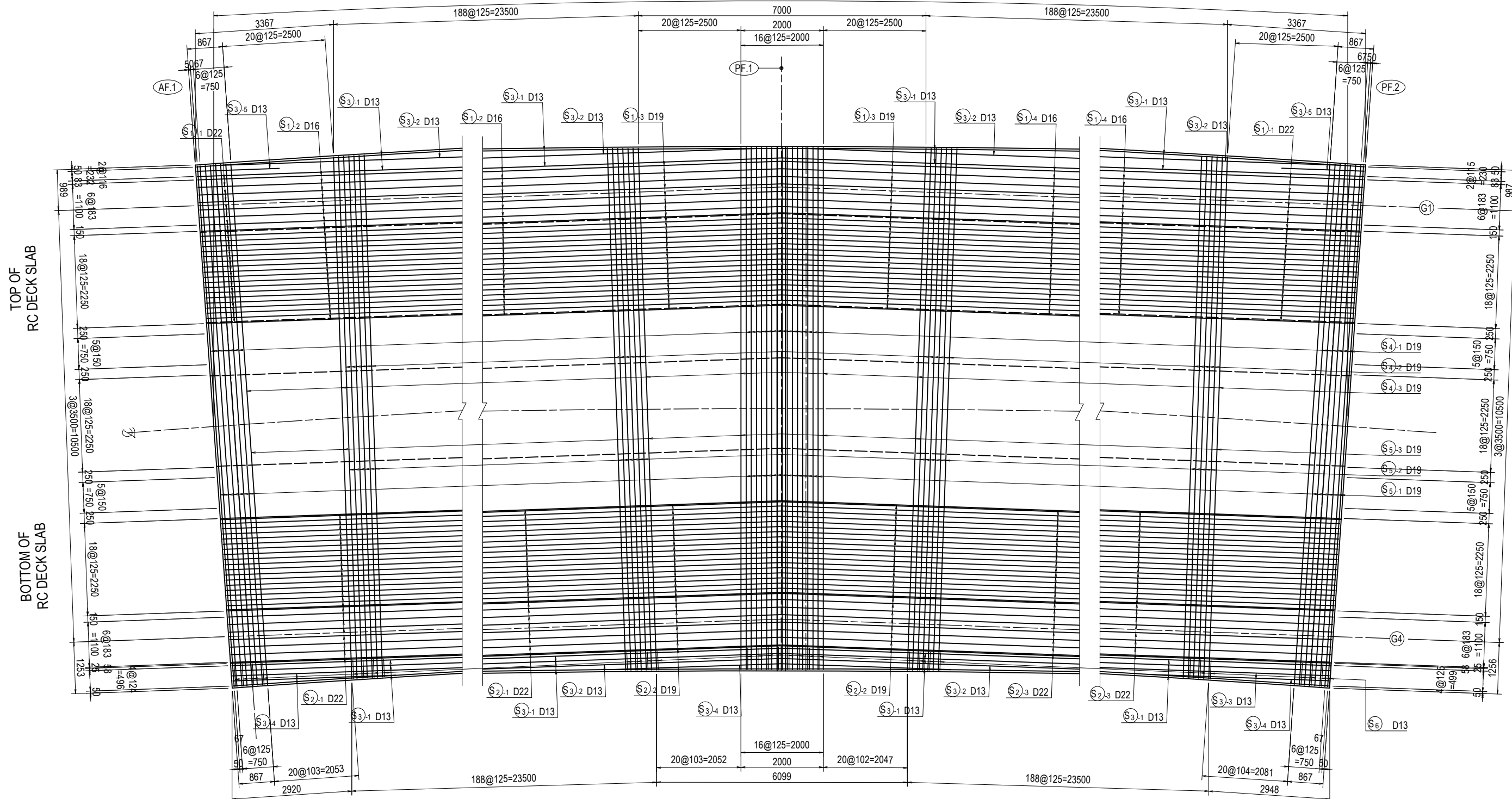

PROJECT NAME	FINANCED BY	COUNTERPART	JICA STUDY TEAM	NAME	SIGNATURE	DATE	DRAWING TITLE	PACKAGE
DETAILED DESIGN ON BAGO RIVER BRIDGE CONSTRUCTION PROJECT	JICA JAPAN INTERNATIONAL COOPERATION AGENCY	REPUBLIC OF THE UNION OF MYANMAR MINISTRY OF CONSTRUCTION DEPARTMENT OF BRIDGE	NIPPON KOEI CO., LTD. ORIENTAL CONSULTANTS GLOBAL CO., LTD. METROPOLITAN EXPRESSWAY COMPANY LIMITED CHODAI CO., LTD. NIPPON ENGINEERING CONSULTANTS CO., LTD.	Y. SUZUKI	<i>YS</i>	14 Jul. 2017	BAR ARRANGEMENT OF DECK SLAB (AF1-PF2) (1)	3
				T. HAYAKAWA	<i>TH</i>	20 Jul. 2017		DWG No.
				Y. SANO	<i>YS</i>	25 Jul. 2017		P3-FO-1017

BAR ARRANGEMENT OF DECK SLAB (AF1-PF2) (2)

CROSS SECTION S=1:100

END SECTION

CONNECTION SECTION

STANDARD SECTION

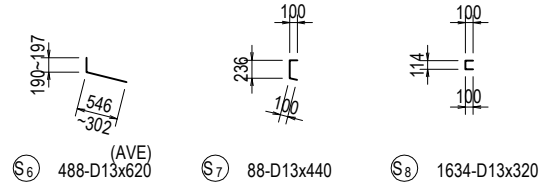
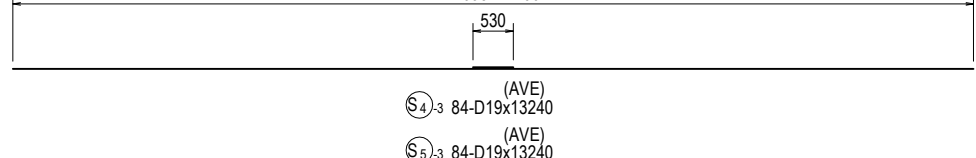
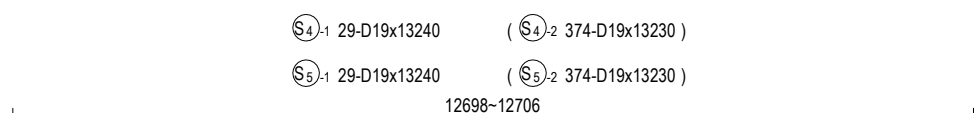
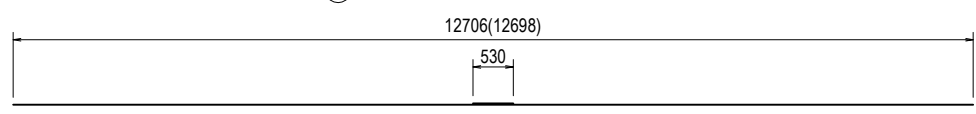
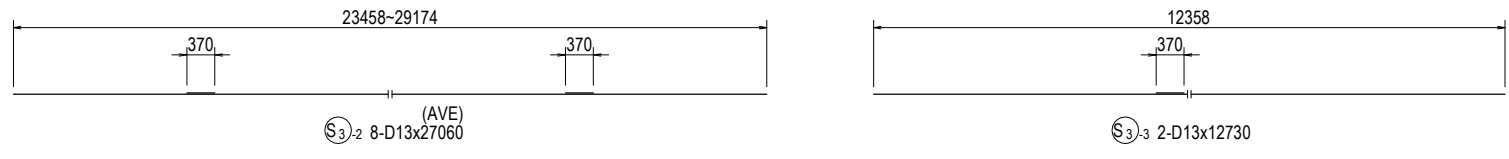
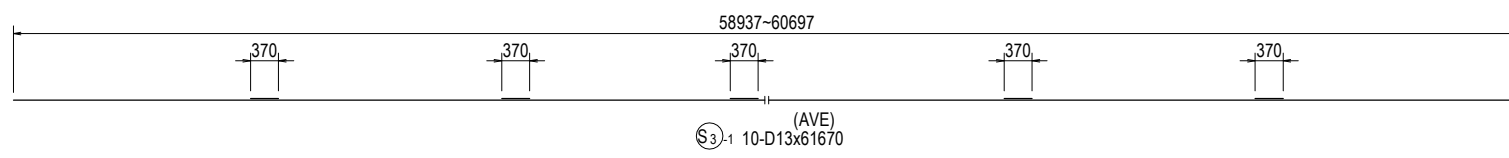
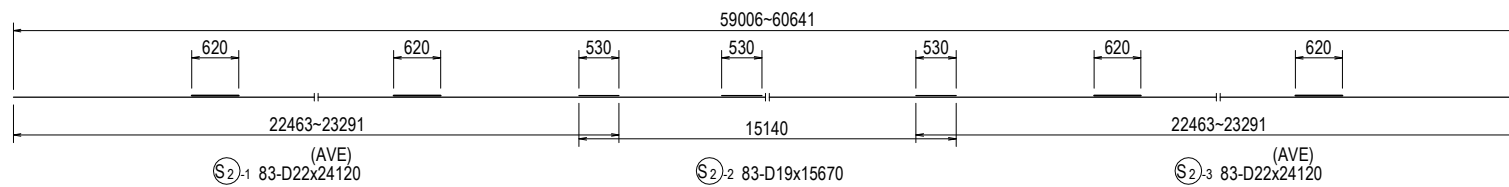
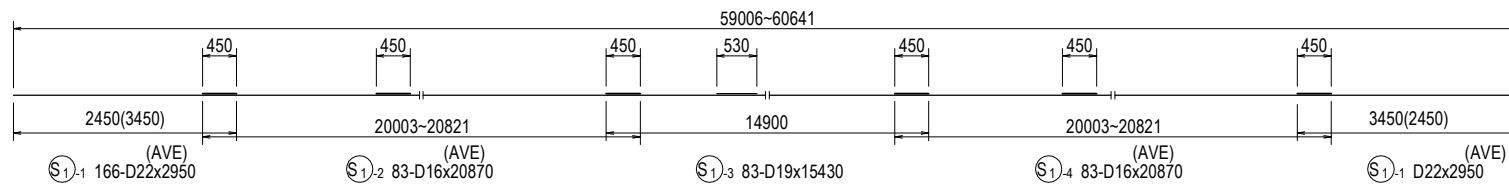
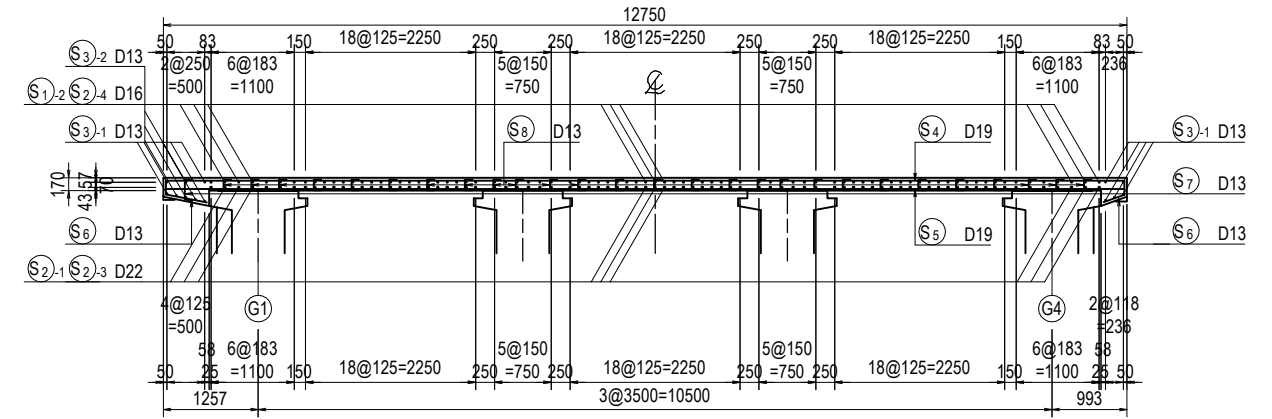
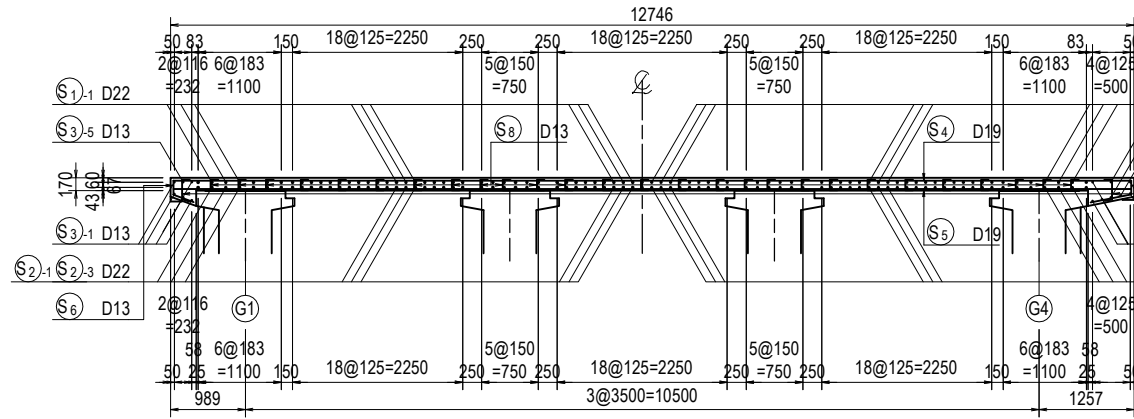

BAR LIST

REBAR NO.	DIA (mm)	LENGTH (mm)	NUMBER	UNIT WEIGHT (kg/m)	WEIGHT/ONE (kg)	WEIGHT (kg)	REMARKS
S 1 -1	D22	2950	166	3.04	8.97	1489	AVERAGE
S 1 -2	D16	20870	83	1.56	32.56	2702	AVERAGE
S 1 -3	D19	15430	83	2.25	34.72	2882	
S 1 -4	D16	20870	83	1.56	32.56	2702	AVERAGE
S 2 -1	D22	24120	83	3.04	73.32	6086	AVERAGE
S 2 -2	D19	15670	83	2.25	35.26	2927	
S 2 -3	D22	24120	83	3.04	73.32	6086	AVERAGE
S 3 -1	D13	61670	10	0.995	61.36	614	AVERAGE
S 3 -2	D13	27060	8	0.995	26.92	215	AVERAGE
S 3 -3	D13	12730	2	0.995	12.67	25	
S 3 -4	D13	7650	5	0.995	7.61	38	AVERAGE
S 3 -5	D13	2000	6	0.995	1.99	12	
S 4 -1	D19	13240	29	2.25	29.79	864	
S 4 -2	D19	13230	374	2.25	29.77	11134	
S 4 -3	D19	13240	84	2.25	29.79	2502	AVERAGE
S 5 -1	D19	13240	29	2.25	29.79	864	
S 5 -2	D19	13230	374	2.25	29.77	11134	
S 5 -3	D19	13240	84	2.25	29.79	2502	AVERAGE
S 6	D13	620	488	0.995	0.62	303	AVERAGE
S 7	D13	440	88	0.995	0.44	39	
S 8	D13	320	1634	0.995	0.32	523	
					D22	13661	kg
					D19	34809	kg
					D16	5404	kg
					D13	1769	kg
					TOTAL	55643	kg

PROJECT NAME
DETAILED DESIGN ON
BAGO RIVER BRIDGE
CONSTRUCTION PROJECT

FINANCED BY
JICA
JAPAN INTERNATIONAL
COOPERATION AGENCY

COUNTERPART
REPUBLIC OF THE UNION OF MYANMAR
MINISTRY OF CONSTRUCTION
DEPARTMENT OF BRIDGE

JICA STUDY TEAM
NIPPON KOEI CO., LTD.
ORIENTAL CONSULTANTS GLOBAL CO., LTD.
METROPOLITAN EXPRESSWAY COMPANY LIMITED
CHODAI CO., LTD.
NIPPON ENGINEERING CONSULTANTS CO., LTD.

	NAME	SIGNATURE	DATE
PREPARED BY	Y. SUZUKI	<i>YS</i>	14 Jul. 2017
CHECKED BY	T. HAYAKAWA	<i>TH</i>	20 Jul. 2017
APPROVED BY	Y. SANO	<i>YS</i>	25 Jul. 2017

DRAWING TITLE
BAR ARRANGEMENT OF DECK SLAB (AF1-PF2) (2)

PACKAGE
3
DWG No.
P3-FO-1018

DETAIL OF CONCRETE CURB, BARRIER AND MEDIUM (AF1-PF2) (1)

SIDE VIEW S=1:100

(L)

60737

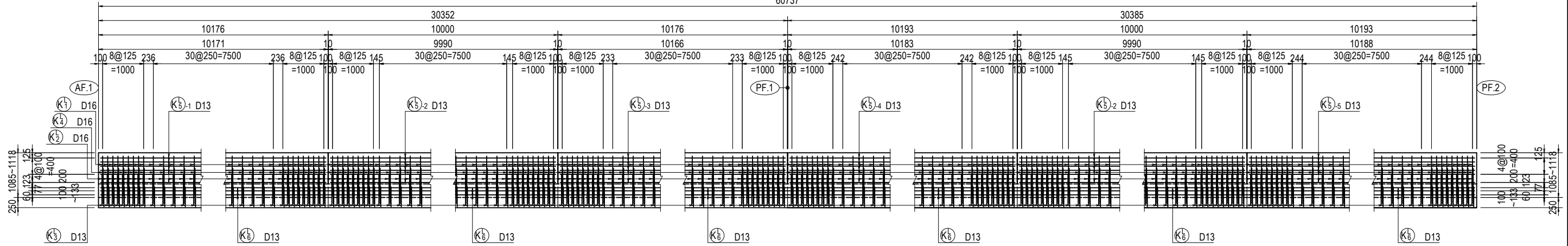

(R)

58963

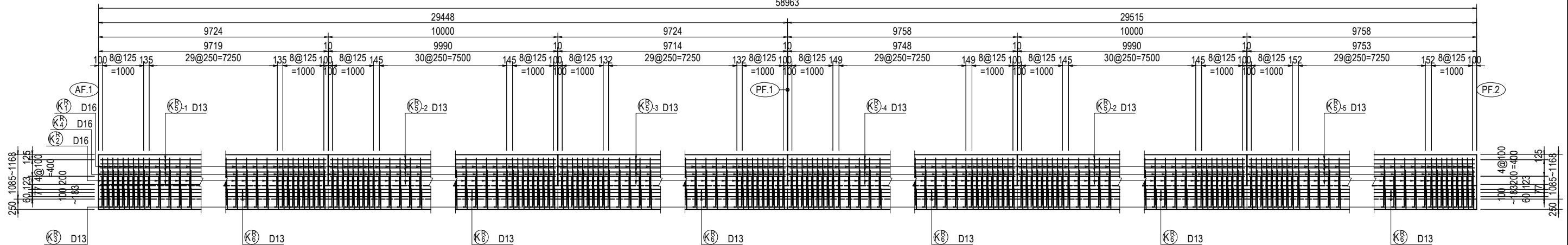

CROSS SECTION S=1:50

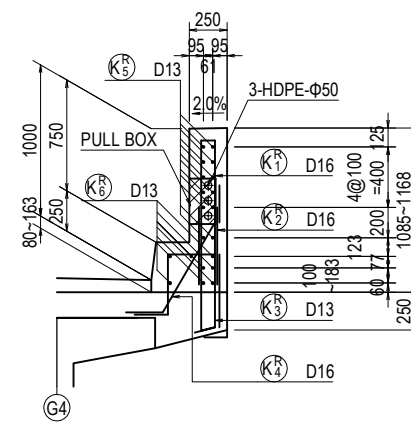
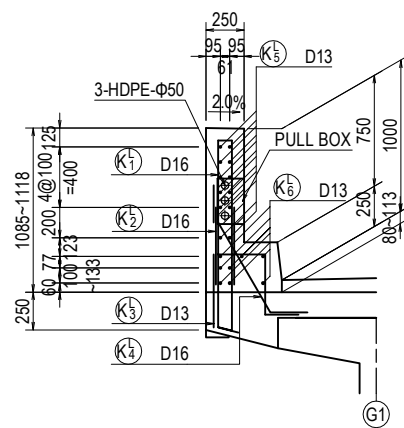

CROSS SECTION S=1:40

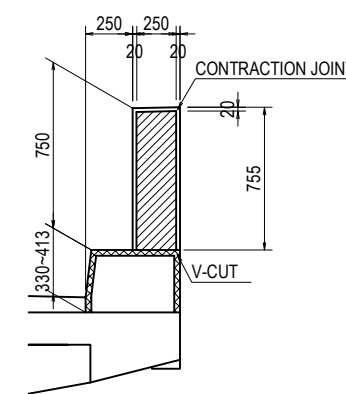
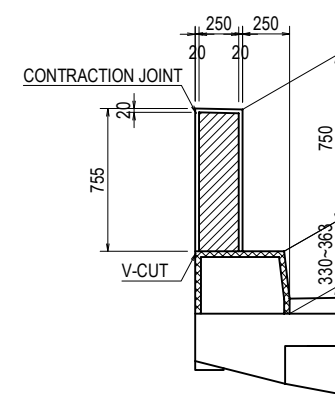

DETAIL OF CONSTRUCTION JOINT

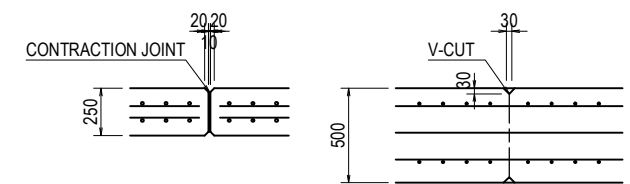

PROJECT NAME DETAILED DESIGN ON BAGO RIVER BRIDGE CONSTRUCTION PROJECT	FINANCED BY JAPAN INTERNATIONAL COOPERATION AGENCY	COUNTERPART REPUBLIC OF THE UNION OF MYANMAR MINISTRY OF CONSTRUCTION DEPARTMENT OF BRIDGE	JICA STUDY TEAM NIPPON KOEI CO., LTD. ORIENTAL CONSULTANTS GLOBAL CO., LTD. METROPOLITAN EXPRESSWAY COMPANY LIMITED CHODAI CO., LTD. NIPPON ENGINEERING CONSULTANTS CO., LTD.	NAME PREPARED BY Y. SUZUKI CHECKED BY T. HAYAKAWA APPROVED BY Y. SANO	SIGNATURE 	DATE 14 Jul. 2017 20 Jul. 2017 25 Jul. 2017	DRAWING TITLE DETAIL OF CONCRETE CURB, BARRIER AND MEDIUM (AF1-PF2) (1)	PACKAGE 3 DWG No. P3-FO-1019
---	--	---	--	--	-----------------------	--	---	---------------------------------------

DETAIL OF CONCRETE CURB, BARRIER AND MEDIUM (AF1-PF2) (2)

(L)

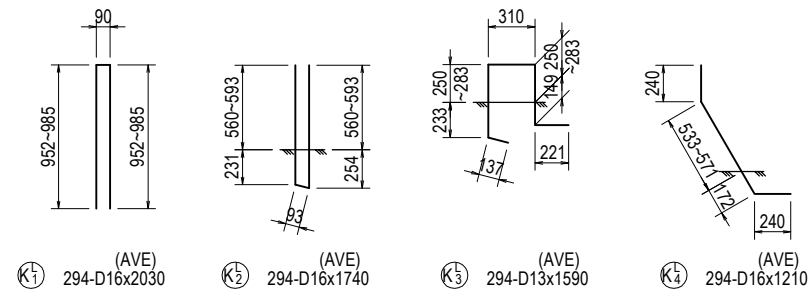

(R)

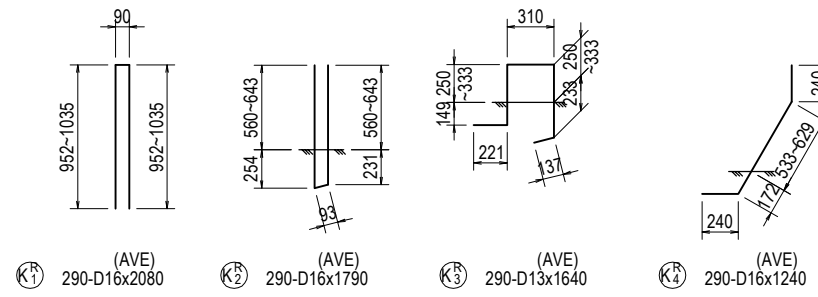

BAR LIST

REBAR NO.	DIA (mm)	LENGHT (mm)	NUMBER	UNIT WEIGHT (kg/m)	WEIGHT/ONE (kg)	WEIGHT (kg)	REMARKS
K1 ^L	D16	2030	294	1.56	3.17	932	AVERAGE
K2 ^L	D16	1740	294	1.56	2.71	797	AVERAGE
K3 ^L	D13	1590	294	0.995	1.58	465	AVERAGE
K4 ^L	D16	1210	294	1.56	1.89	556	AVERAGE
K5-1 ^L	D13	10070	12	0.995	10.02	120	AVERAGE
K5-2 ^L	D13	9890	24	0.995	9.84	236	AVERAGE
K5-3 ^L	D13	10060	12	0.995	10.01	120	AVERAGE
K5-4 ^L	D13	10080	12	0.995	10.03	120	AVERAGE
K5-5 ^L	D13	10090	12	0.995	10.04	120	AVERAGE
K6 ^L	D13	62660	8	0.995	62.35	499	AVERAGE
K1 ^R	D16	2080	290	1.56	3.24	940	AVERAGE
K2 ^R	D16	1790	290	1.56	2.79	809	AVERAGE
K3 ^R	D13	1640	290	0.995	1.63	473	AVERAGE
K4 ^R	D16	1240	290	1.56	1.93	560	AVERAGE
K5-1 ^R	D13	9610	12	0.995	9.56	115	AVERAGE
K5-2 ^R	D13	9890	24	0.995	9.84	236	AVERAGE
K5-3 ^R	D13	9640	12	0.995	9.59	115	AVERAGE
K5-4 ^R	D13	9660	12	0.995	9.61	115	AVERAGE
K5-5 ^R	D13	9650	12	0.995	9.60	115	AVERAGE
K6 ^R	D13	60950	8	0.995	60.65	485	AVERAGE
					D16	4594 kg	
					D13	3334 kg	
					TOTAL	7928 kg	

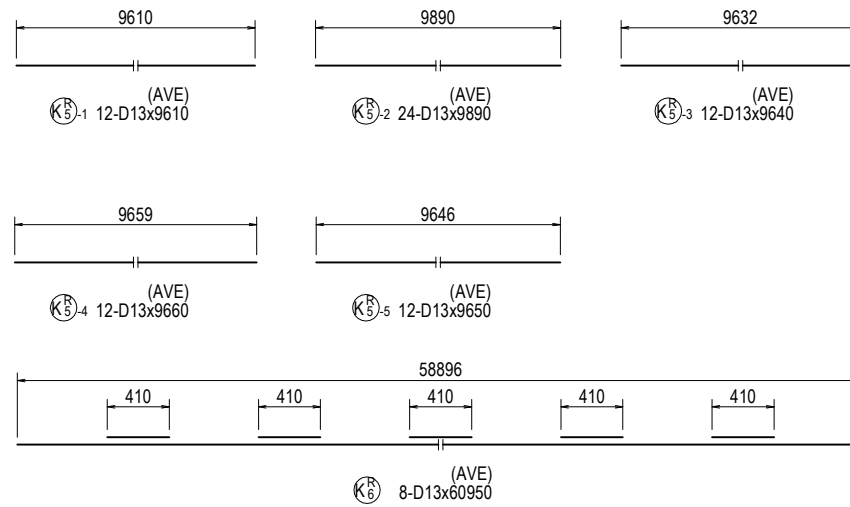
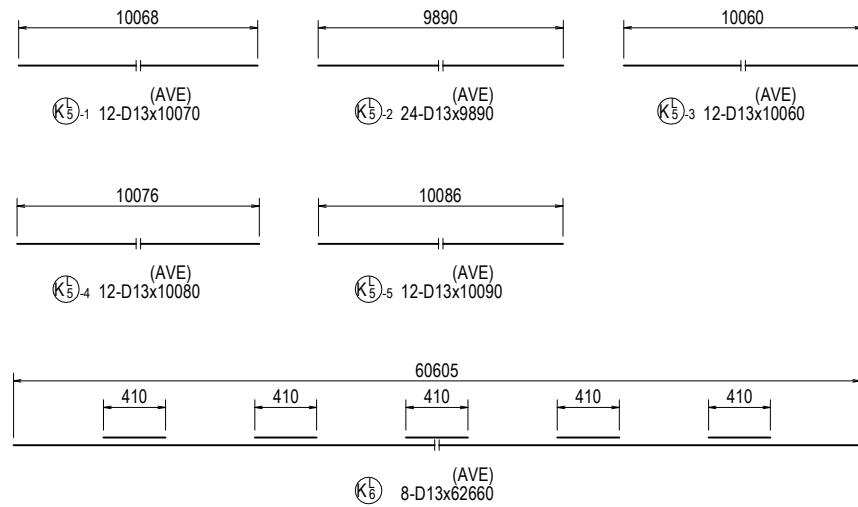

KEY PLAN S=1:500

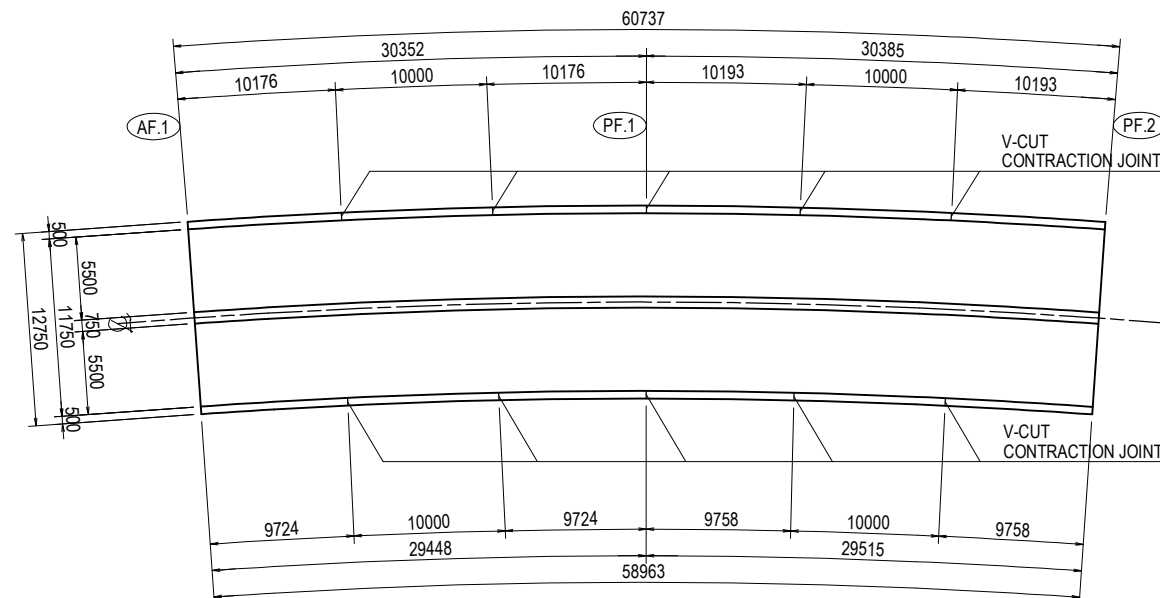

PROJECT NAME
DETAILED DESIGN ON
BAGO RIVER BRIDGE
CONSTRUCTION PROJECT

FINANCED BY
JICA
JAPAN INTERNATIONAL
COOPERATION AGENCY

COUNTERPART
REPUBLIC OF THE UNION OF MYANMAR
MINISTRY OF CONSTRUCTION
DEPARTMENT OF BRIDGE

JICA STUDY TEAM
NIPPON KOEI CO., LTD.
ORIENTAL CONSULTANTS GLOBAL CO., LTD.
METROPOLITAN EXPRESSWAY COMPANY LIMITED
CHODAI CO., LTD.
NIPPON ENGINEERING CONSULTANTS CO., LTD.

	NAME	SIGNATURE	DATE
PREPARED BY	Y. SUZUKI	<i>YS</i>	14 Jul. 2017
CHECKED BY	T. HAYAKAWA	<i>Hayakawa</i>	20 Jul. 2017
APPROVED BY	Y. SANO	<i>Y. Sano</i>	25 Jul. 2017

DRAWING TITLE
DETAIL OF CONCRETE CURB,
BARRIER AND MEDIUM (AF1-PF2) (2)

PACKAGE
3
DWG No.
P3-FO-1020

DETAIL OF CONCRETE CURB, BARRIER AND MEDIUM (AF1-PF2) (3)

PLAN S=1:100

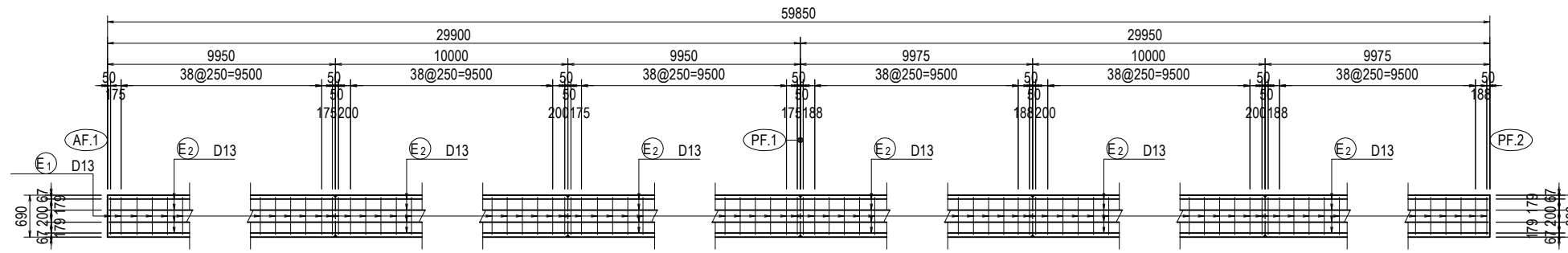

CROSS SECTION S=1:50

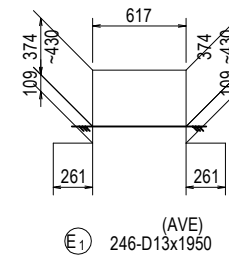
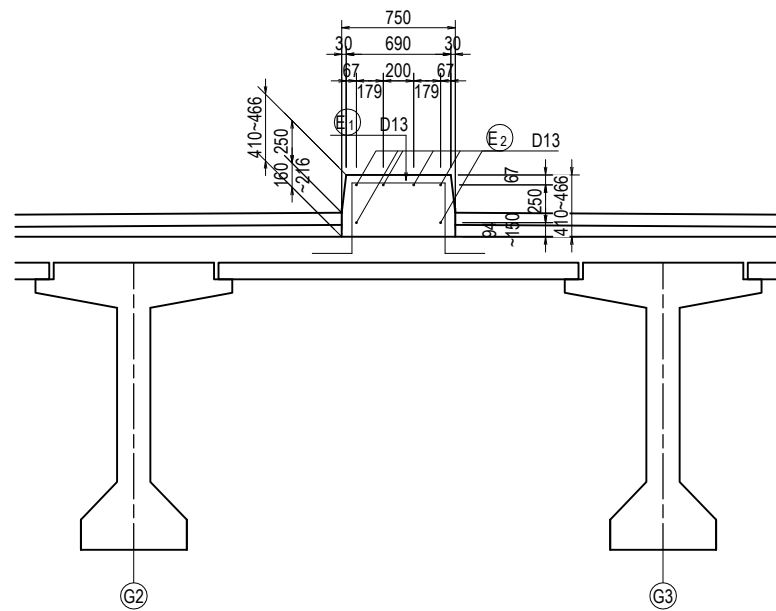

BAR LIST

REBAR NO.	DIA (mm)	LENGTH (mm)	NUMBER	UNIT WEIGHT (kg/m)	WEIGHT/ONE (kg)	WEIGHT (kg)	REMARKS
E 1	D13	1950	246	0.995	1.94	477	AVERAGE
E 2	D13	61840	6	0.995	61.53	369	AVERAGE
						939 kg	
TOTAL						939 kg	

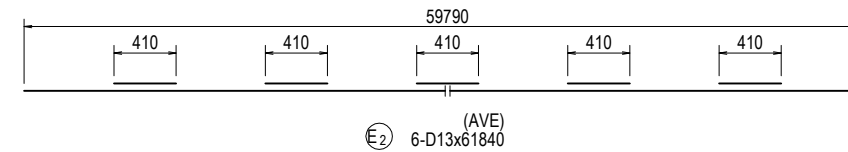

CROSS SECTION S=1:40

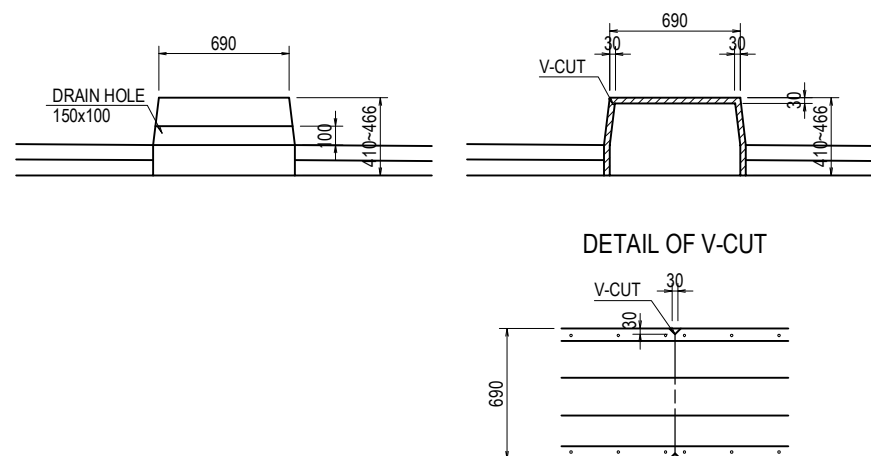

KEY PLAN S=1:500

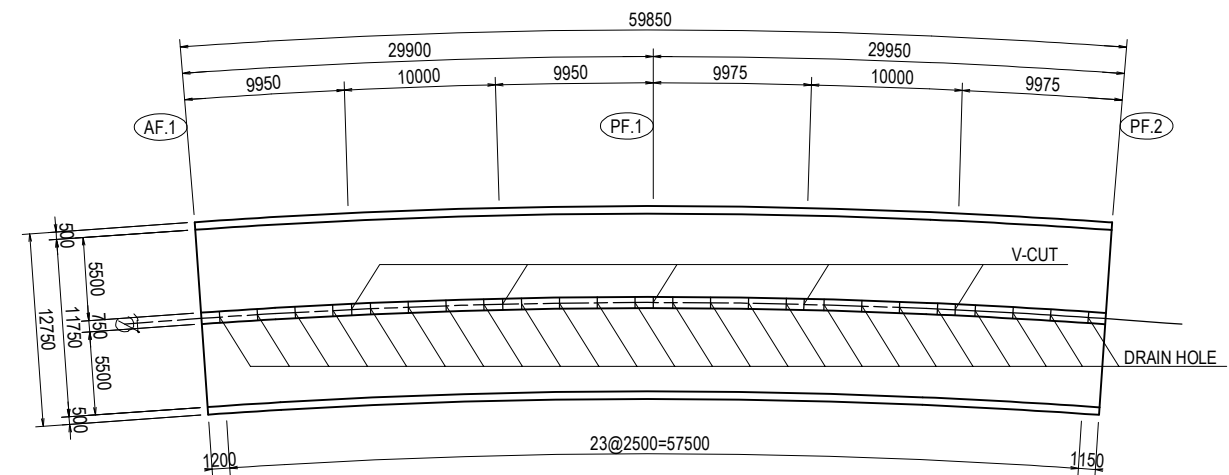

DETAIL OF LIGHTING FOUNDATION (AF1-PF2)

CROSS SECTION S=1:40

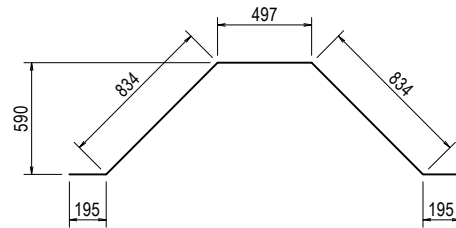
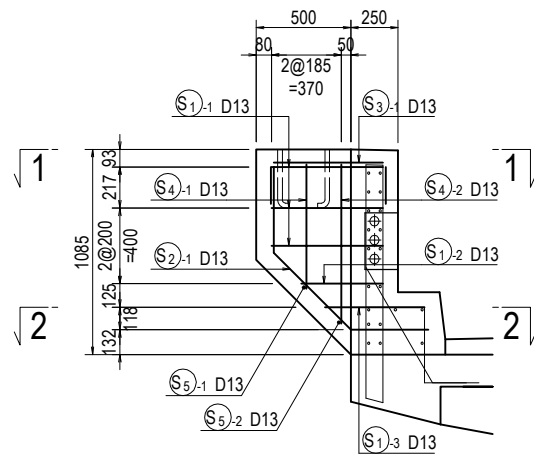

S1-1 3-D13x2560

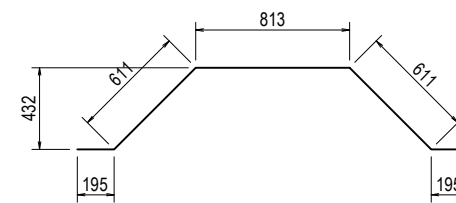

S1-2 1-D13x2430

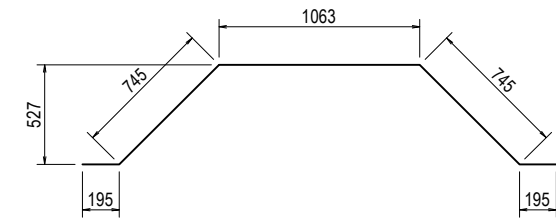

S1-3 1-D13x2950

PLAN S=1:40

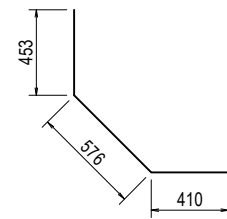
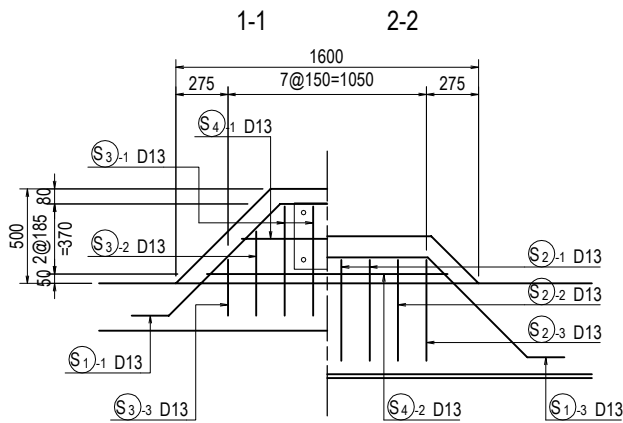

S2-1 4-D13x1440

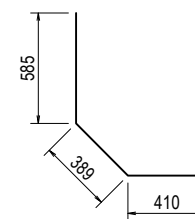

S2-2 2-D13x1390

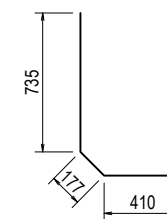

S2-3 2-D13x1330

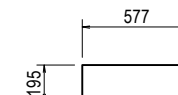

S3-1 4-D13x970

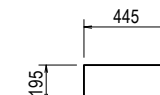

S3-2 2-D13x840

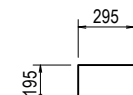

S3-3 2-D13x690

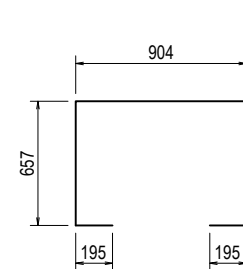

S4-1 1-D13x2610

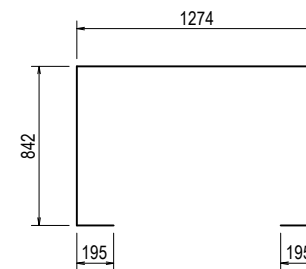

S4-2 1-D13x3350

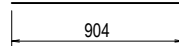

S5-1 1-D13x910

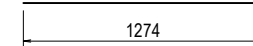

S5-2 1-D13x1280

PULLBOX DETAIL S=1:50

CROSS SECTION

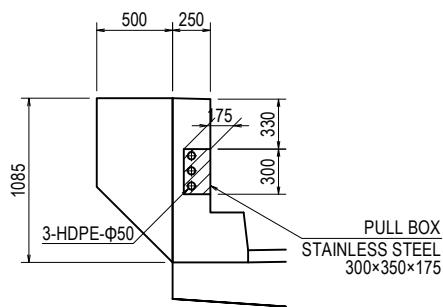

PLAN

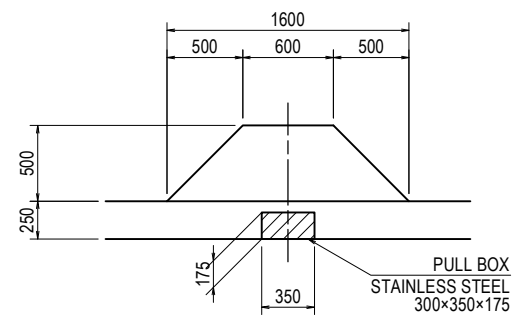

BAR LIST

REBAR NO.	DIA (mm)	LENGTH (mm)	NUMBER	UNIT WEIGHT (kg/m)	WEIGHT/ONE (kg)	WEIGHT (kg)	REMARKS
S1-1	D13	2560	3	0.995	2.55	8	
S1-2	D13	2430	1	0.995	2.42	2	
S1-3	D13	2950	1	0.995	2.94	3	
S2-1	D13	1440	4	0.995	1.43	6	
S2-2	D13	1390	2	0.995	1.38	3	
S2-3	D13	1330	2	0.995	1.32	3	
S3-1	D13	970	4	0.995	0.97	4	
S3-2	D13	840	2	0.995	0.84	2	
S3-3	D13	690	2	0.995	0.69	1	
S4-1	D13	2610	1	0.995	2.60	3	
S4-2	D13	3350	1	0.995	3.33	3	
S5-1	D13	910	1	0.995	0.91	1	
S5-2	D13	1280	1	0.995	1.27	1	
						40	kg
TOTAL						40	kg

DETAIL OF RUBBER BEARING (AF1-PF2) (1)

CROSS SECTION S= 1:60

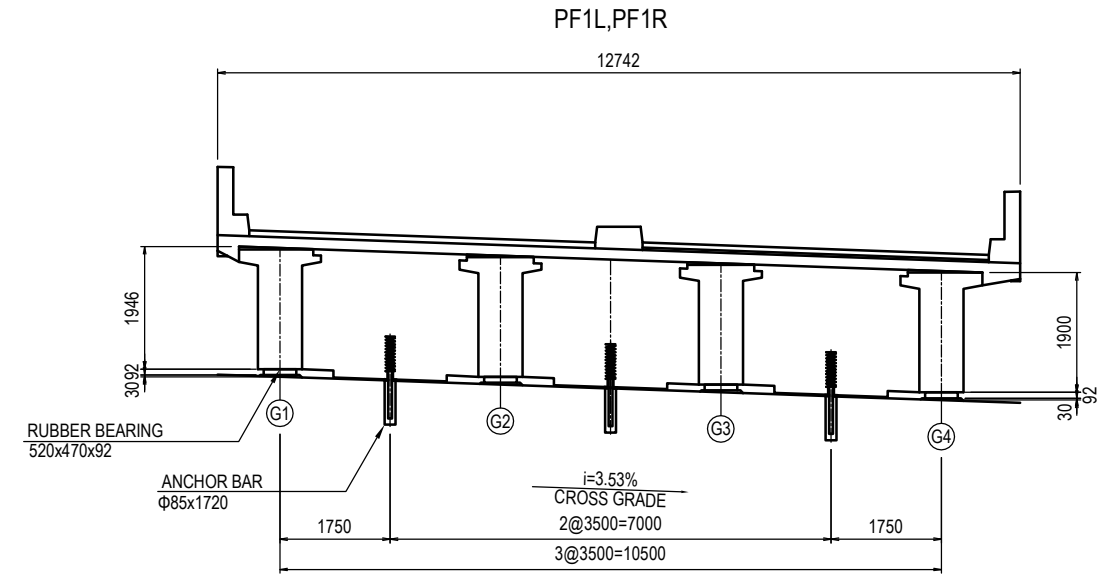
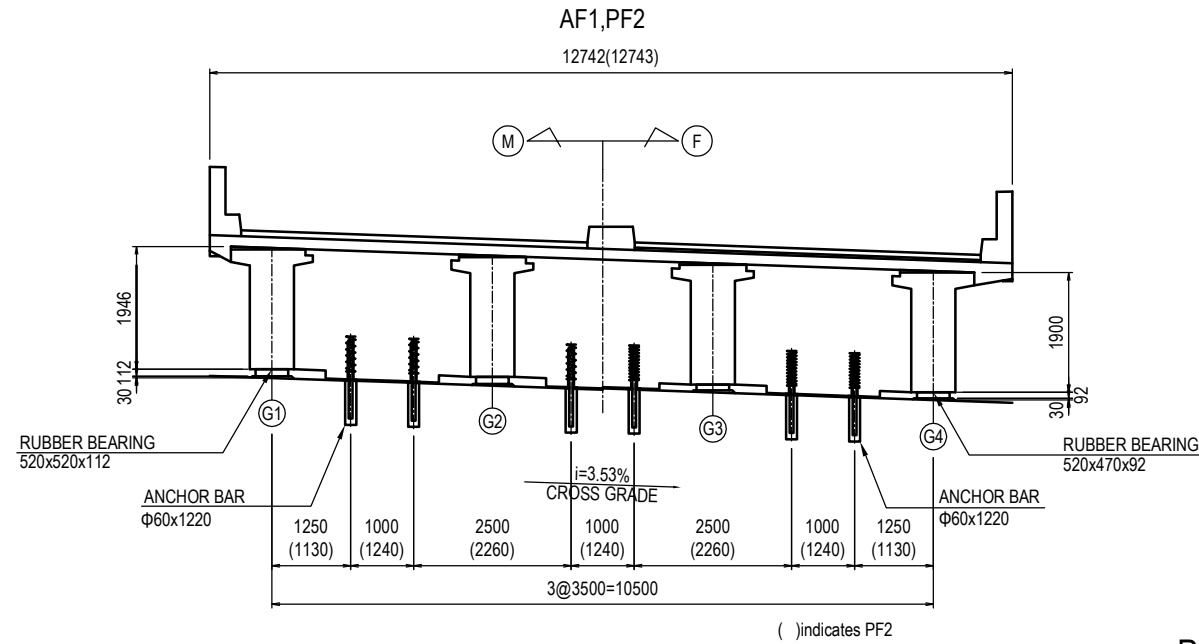

PLAN S= 1:60

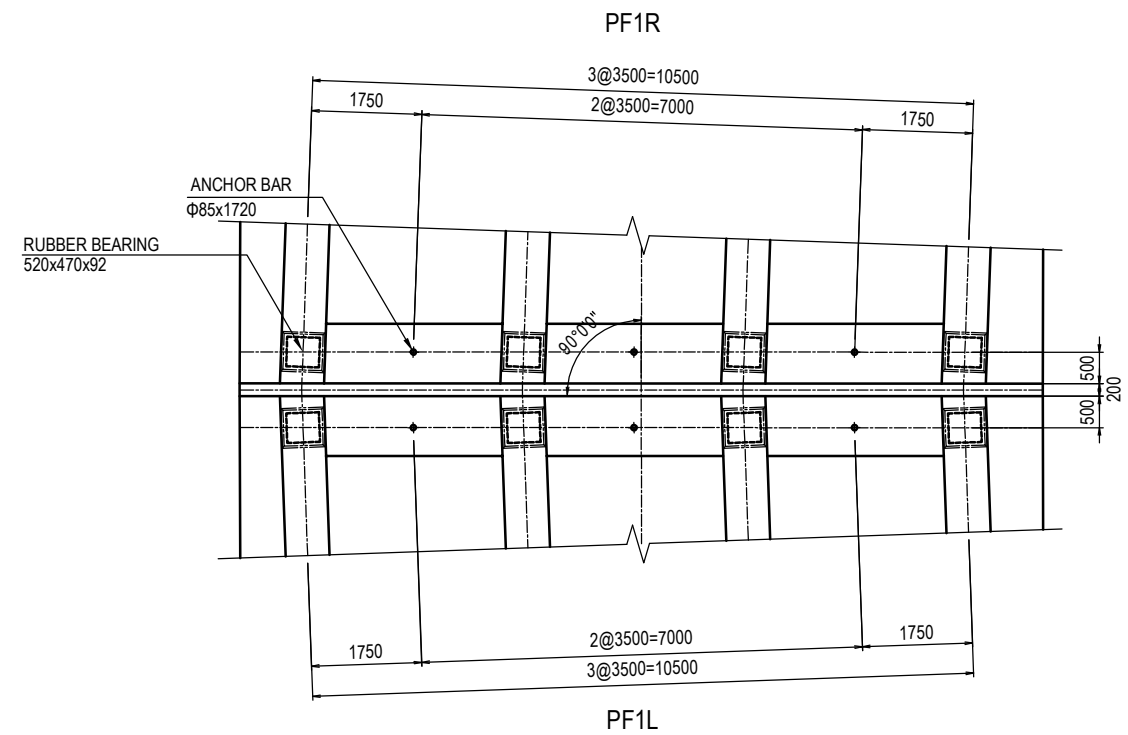
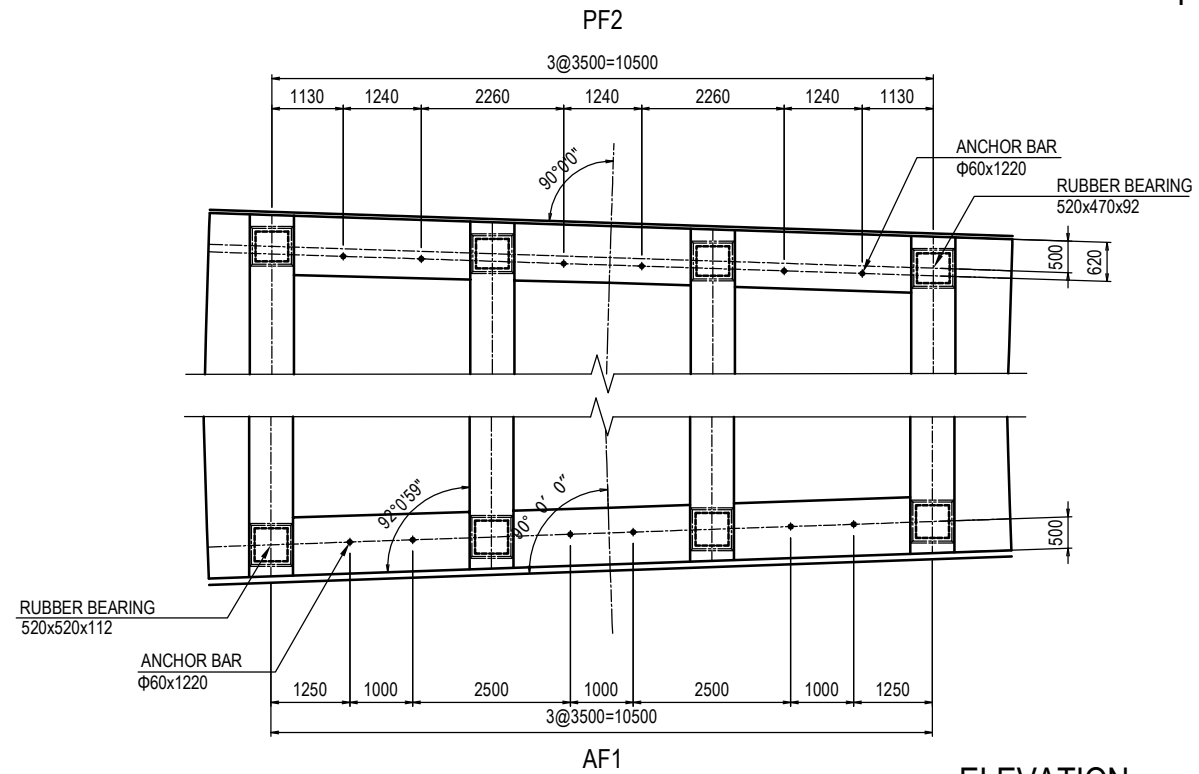

ELEVATION S= 1:250

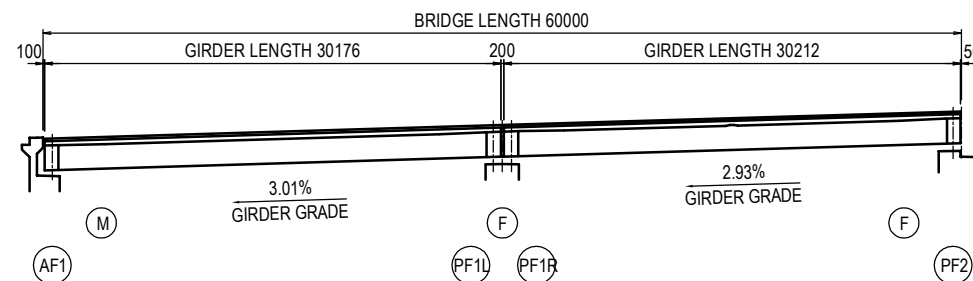

DESIGN CONDITION

REACTION			AF1 (M)	PF1L (F)	PF1R (F)	PF2 (F)
MAXIMUM REACTION	Rmax		1319 kN	1395 kN	1409 kN	1328 kN
	Rmax2		1213 kN	1290 kN	1334 kN	1219 kN
DEAD LOAD REACTION		Rd	991 kN	922 kN	944 kN	999 kN
MAXIMUM STRAIN FORCE	LONGITUDIAL	Rhe1	428 kN	464 kN	464 kN	500 kN
	TRANSVERSE	Rhe2	310 kN	242 kN	242 kN	310 kN
STRAIN VOLUME	ORDINARY	LONGITUDIAL	ΔL	25.7 mm	- mm	- mm
	LEVEL1	LONGITUDIAL	ΔLe1	76.1 mm	- mm	- mm
		TRANSVERSE	ΔLe2	- mm	- mm	- mm

NOTES:

- 1) Details of the slab and girder are designed based on the product (rubber bearing) shown in this Drawing.
- 2) The Contractor has option to propose an alternative equivalent to the specified product, which shall be subjected to the Engineer's approval.
- 3) All the structural steels shall be galvanized to the requirements specified by JIS H8641.

PROJECT NAME
DETAILED DESIGN ON
BAGO RIVER BRIDGE
CONSTRUCTION PROJECT

FINANCED BY
JICA
JAPAN INTERNATIONAL
COOPERATION AGENCY

COUNTERPART
REPUBLIC OF THE UNION OF MYANMAR
MINISTRY OF CONSTRUCTION
DEPARTMENT OF BRIDGE

JICA STUDY TEAM
NIPPON KOEI CO., LTD.
ORIENTAL CONSULTANTS GLOBAL CO., LTD.
METROPOLITAN EXPRESSWAY COMPANY LIMITED
CHODAI CO., LTD.
NIPPON ENGINEERING CONSULTANTS CO., LTD.

	NAME	SIGNATURE	DATE
PREPARED BY	Y. SUZUKI	<i>YS</i>	14 Jul. 2017
CHECKED BY	T. HAYAKAWA	<i>TH</i>	20 Jul. 2017
APPROVED BY	Y. SANO	<i>YS</i>	25 Jul. 2017

DRAWING TITLE
DETAIL OF RUBBER BEARING (AF1-PF2) (1)

PACKAGE
3
DWG No.
P3-FO-1023

DETAIL OF RUBBER BEARING (AF1-PF2) (2)

SIDE VIEW S= 1:20

RUBBER BEARING S= 1:10

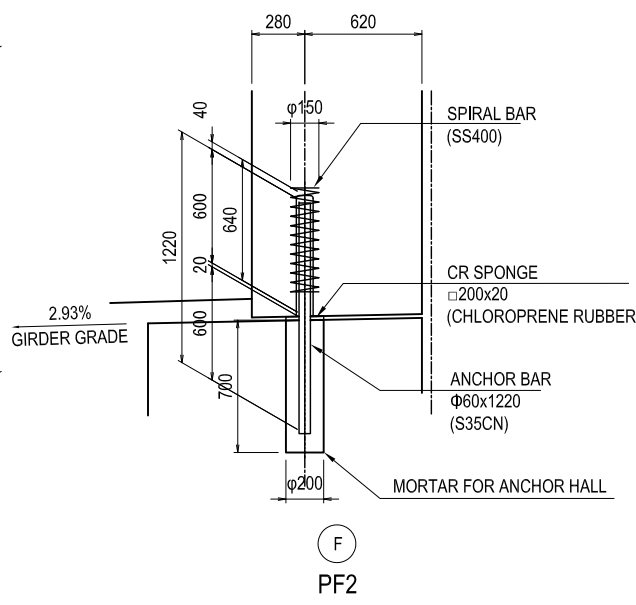
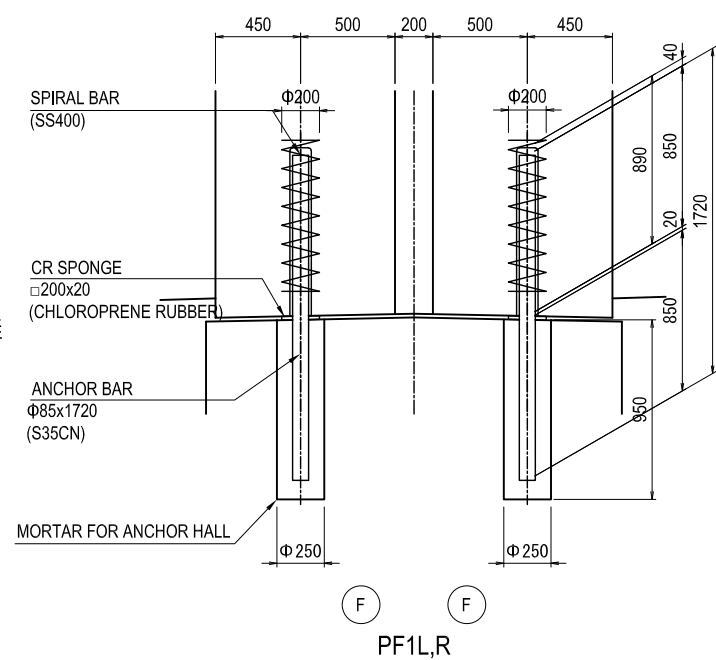
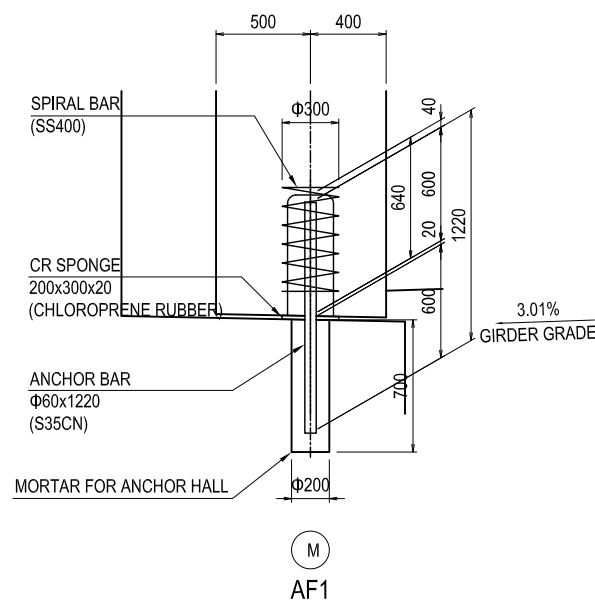
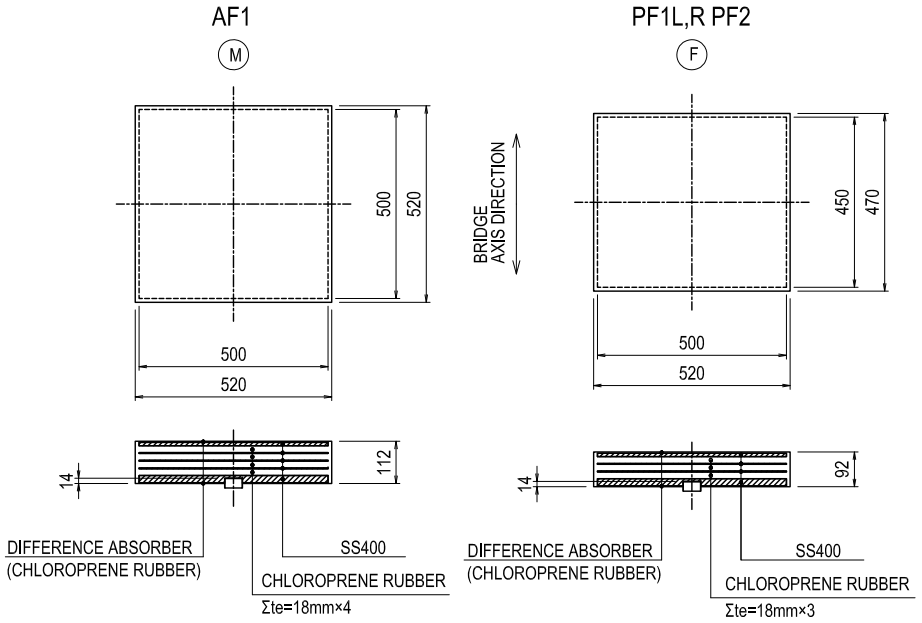
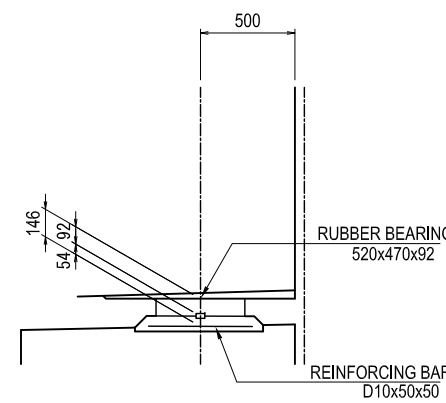
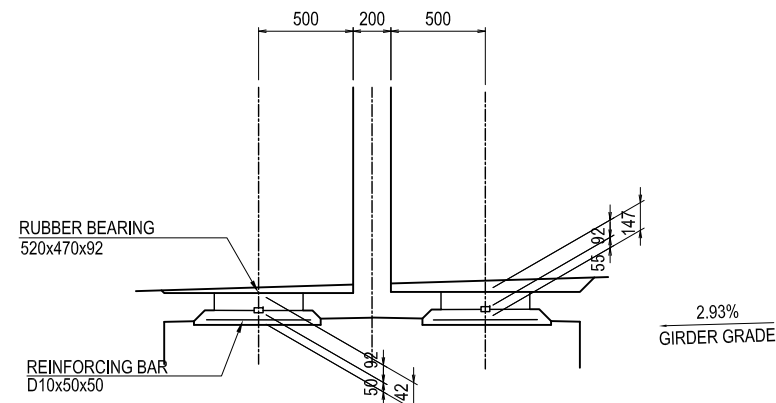
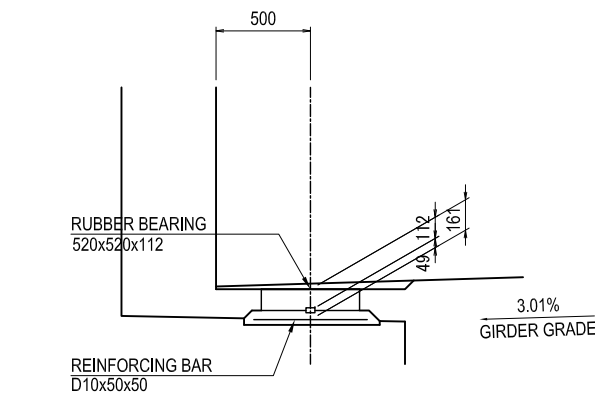

ANCHOR SYSTEM S= 1:5

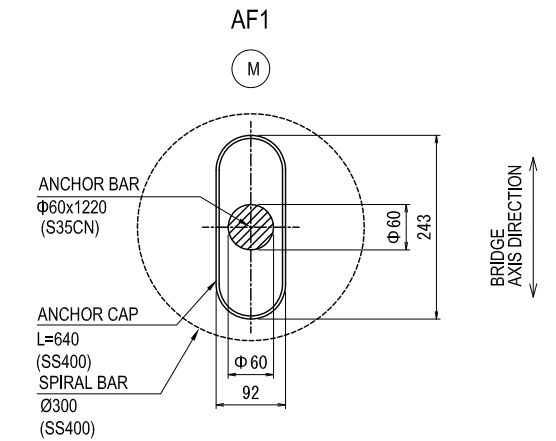

REINFORCING BAR S= 1:10

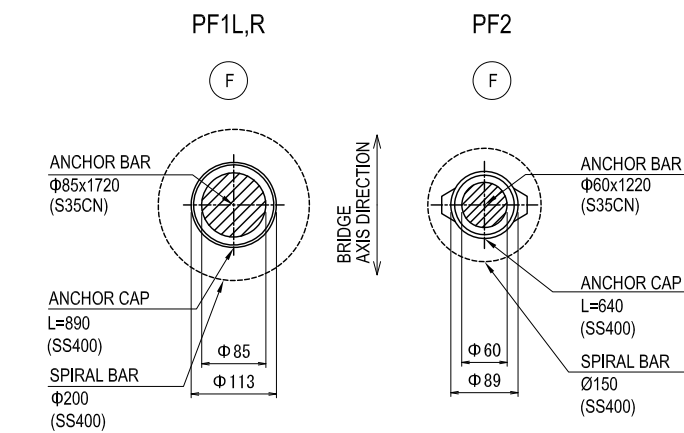
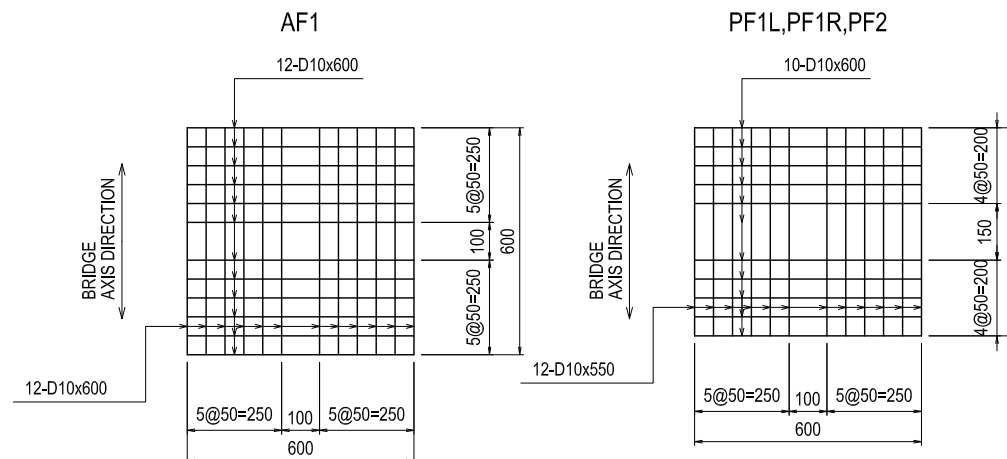

PARTS LIST

ITEM	DIMENSION	MATERIAL	UNIT	QUANTITY				WEIGHT (kg)	REMARKS
				AF1(M)	PF1L(F)	PF1R(F)	PF2(F)		
RUBBER BEARING	520x520x112	AS SHOWN	SHEET	4				4	
"	520x470x92	"	"		4	4	4	12	
ANCHOR SYSTEM	Φ60x1220	S35CN	SET	6				12	
"	Φ85x1720	"	"		3	3		6	
"	Φ60x1220	"	"				6	6	
CR SPONGE	200x300x20	CHLOROPRENE RUBBER	SHEET	6				6	
"	200x20	"	"		3	3	6	12	
REINFORCING BAR	D10x50x50	SD345	kg	32.26	28.22	28.22	28.22	116.92	
BED MORTAR FOR BEARING		NON SHRINKAGE MORTAR	m3	0.129	0.122	0.133	0.131	0.515	
MORTAR FOR ANCHOR HALLS		NON SHRINKAGE MORTAR	m3	0.122	0.125	0.125	0.122	0.494	

※An Anchor System includes anchor bar, anchor cap and spiral bar.

NOTES:

- Details of the slab and girder are designed based on the product (rubber bearing) shown in this Drawing.
- The Contractor has option to propose an alternative equivalent to the specified product, which shall be subjected to the Engineer's approval.
- All the structural steels shall be galvanized to the requirements specified by JIS H8641.

PROJECT NAME DETAILED DESIGN ON BAGO RIVER BRIDGE CONSTRUCTION PROJECT	FINANCED BY JICA JAPAN INTERNATIONAL COOPERATION AGENCY	COUNTERPART REPUBLIC OF THE UNION OF MYANMAR MINISTRY OF CONSTRUCTION DEPARTMENT OF BRIDGE	JICA STUDY TEAM NIPPON KOEI CO., LTD. ORIENTAL CONSULTANTS GLOBAL CO., LTD. METROPOLITAN EXPRESSWAY COMPANY LIMITED CHODAI CO., LTD. NIPPON ENGINEERING CONSULTANTS CO., LTD.	NAME Y. SUZUKI SIGNATURE T. HAYAKAWA DATE 14 Jul. 2017 20 Jul. 2017 25 Jul. 2017	DRAWING TITLE DETAIL OF RUBBER BEARING (AF1-PF2) (2)	PACKAGE 3 DWG No. P3-FO-1024
---	--	---	--	---	---	---------------------------------------

DETAIL OF EXPANSION JOINT (AF1-PF2) (1)

AF1

PLAN VIEW S=1:30

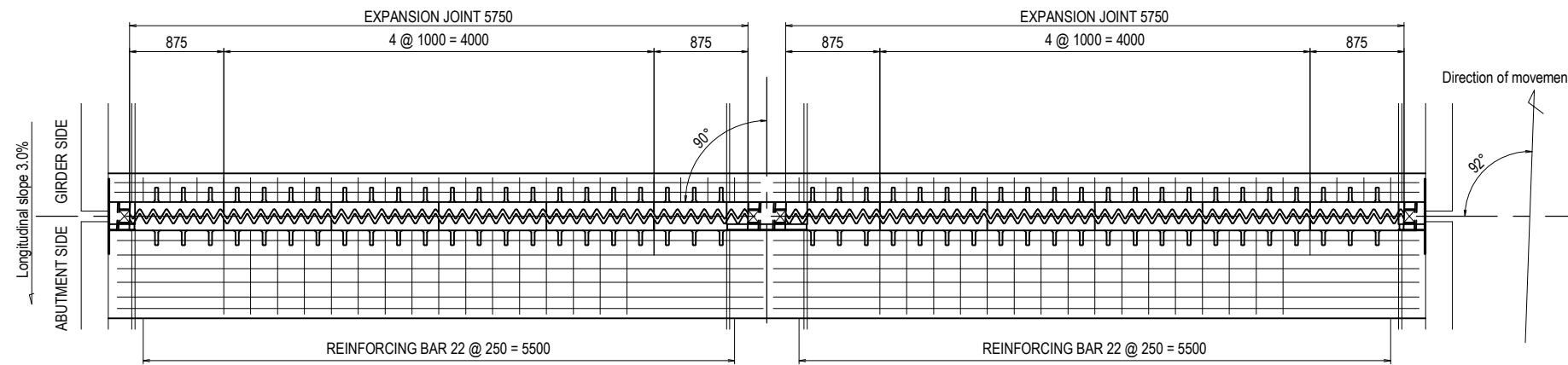

CROSS SECTION S=1:30

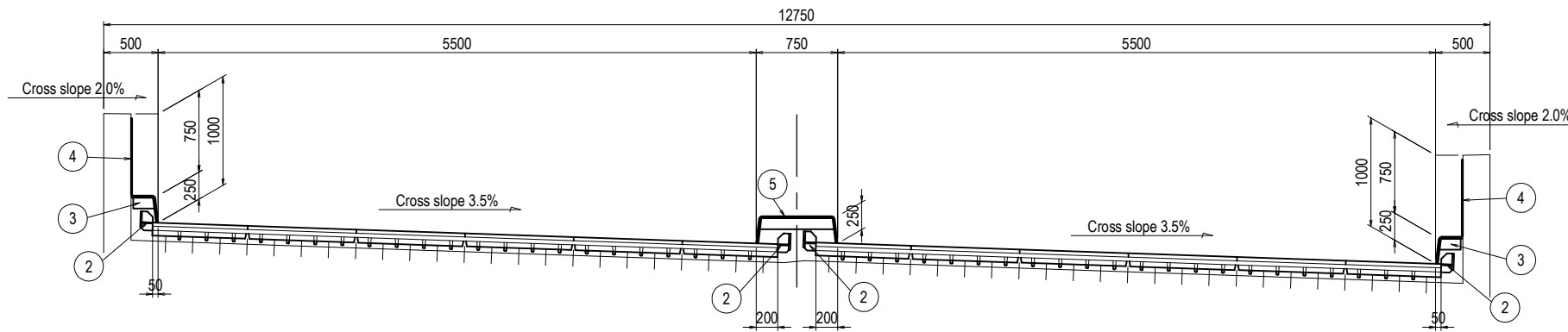

SECTION OF EXPANSION JOINT S=1:8

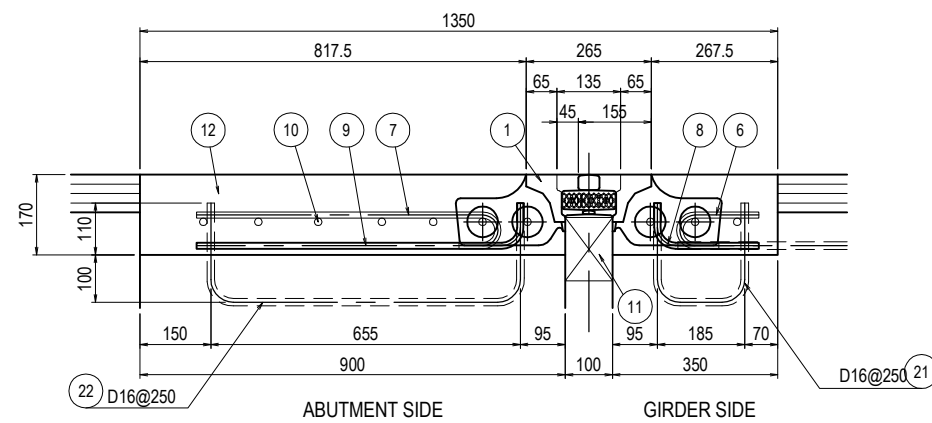

HARDWARE SECTION S=1:5

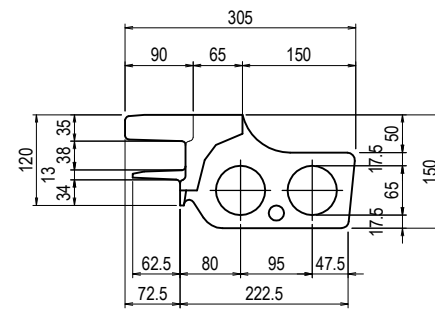

HARDWARE PLAN S=1:10

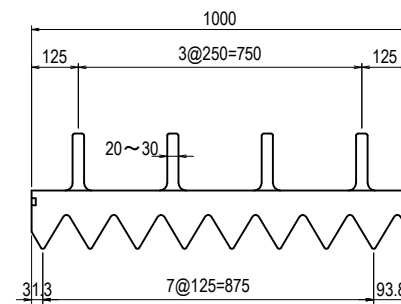

DETAIL OF REINFORCING BAR S=1:8

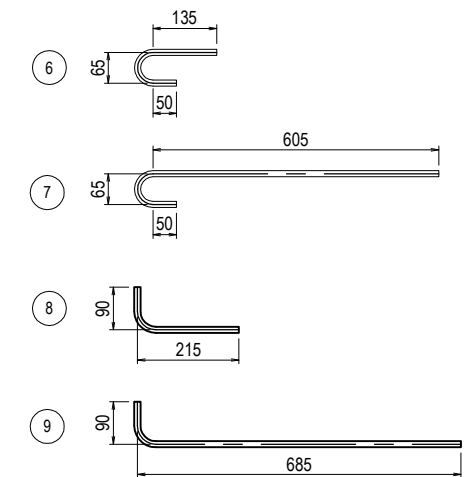

PLAN VIEW

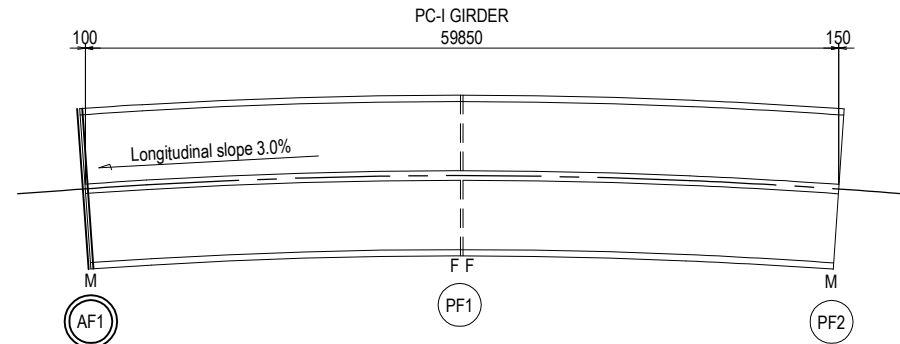

MATERIALS LIST					(1 per place)
No.	DESCRIPTION	MATERIALS	UNIT	QUANTITY	REMARK
1	EXPANSION JOINT	ALUMINUM ALLOY CASTING	m	11.500	80mm
2	UPSTAND		pieces	4	
3	COVER FOR CURB	SS400 or Equivalent	set	2	
4	COVER FOR BARRIER CURB	SUS304	set	2	t=2(include anchor)
5	COVER FOR MEDIAL DIVIDER	SS400 or Equivalent	set	1	
6	REINFORCING BAR	SD345	kg	13.27	D13 × 290 × 46 Nos.
7	REINFORCING BAR	SD345	kg	34.79	D13 × 760 × 46 Nos.
8	REINFORCING BAR	SD345	kg	13.96	D13 × 305 × 46 Nos.
9	REINFORCING BAR	SD345	kg	35.47	D13 × 775 × 46 Nos.
10	REINFORCING BAR	SD345	kg	187.20	D16 × 6.0m × 20 Nos.
11	BURIED FORMWORK	Foamed Styrene	m ³	0.19	100 × 150 × 12.7m
12	POST-CAST CONCRETE	High strength concrete	m ³	2.50	σ _{ck} = 30N/mm ²

EMBEDDED BAR

21	EMBEDDED BAR	SD345	kg	43.41	D16 × 605 × 46 Nos.
22	EMBEDDED BAR	SD345	kg	77.14	D16 × 1075 × 46 Nos.

DESIGN CONDITION

Temperature range	+5 ~ +45°C
Amount of temperature variation	12mm
Earthquake movement amount	±24mm

Note

- 1 Re-bar should be consider the developed length.
- 2 Allocation of the expansion joint is subject to change
- 3 Expansion joint should be placing to match the transverse gradient.
- 4 Expansion joint should be installed in consideration of the effect of Creep and Shrinkage.

NOTES:

- 1) Details of the slab and girder are designed based on the product (expansion joint) shown in this Drawing.
- 2) The Contractor has option to propose an alternative equivalent to the specified product, which shall be subjected to the Engineer's approval.
- 3) The expansion joint shall be set in consideration of thermal expansion, creep and shrinkage of concrete girder.

PROJECT NAME	FINANCED BY	COUNTERPART	JICA STUDY TEAM	NAME	SIGNATURE	DATE	DRAWING TITLE	PACKAGE
DETAILED DESIGN ON BAGO RIVER BRIDGE CONSTRUCTION PROJECT	JICA JAPAN INTERNATIONAL COOPERATION AGENCY	REPUBLIC OF THE UNION OF MYANMAR MINISTRY OF CONSTRUCTION DEPARTMENT OF BRIDGE	NIPPON KOEI CO., LTD. ORIENTAL CONSULTANTS GLOBAL CO., LTD. METROPOLITAN EXPRESSWAY COMPANY LIMITED CHODAI CO., LTD. NIPPON ENGINEERING CONSULTANTS CO., LTD.	Y. SUZUKI	<i>[Signature]</i>	14 Jul. 2017	DETAIL OF EXPANSION JOINT (AF1-PF2) (1)	3
				T. HAYAKAWA	<i>[Signature]</i>	20 Jul. 2017		DWG No.
				Y. SANO	<i>[Signature]</i>	25 Jul. 2017		P3-FO-1025

DETAIL OF EXPANSION JOINT (AF1-PF2) (2)

PF2

PLAN VIEW S=1:30

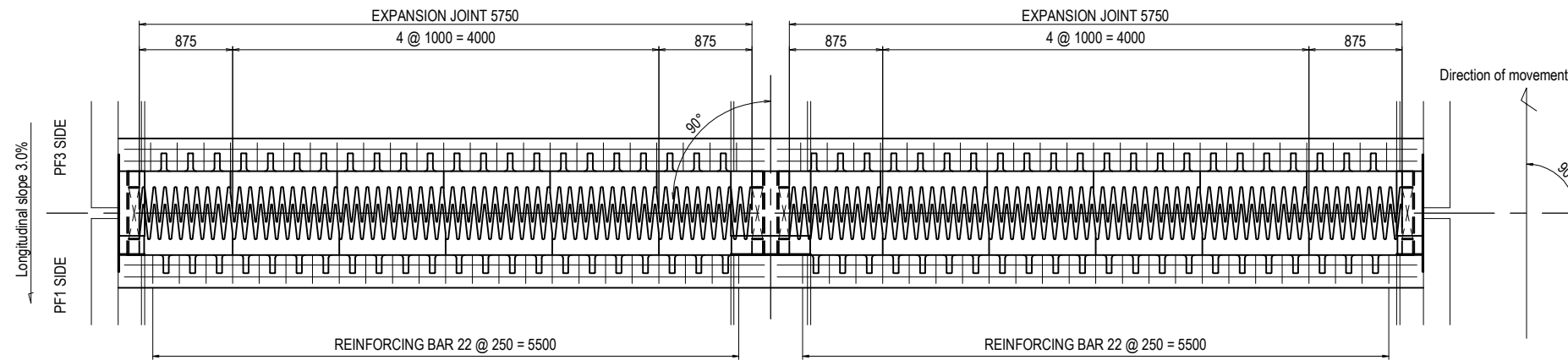

CROSS SECTION S=1:30

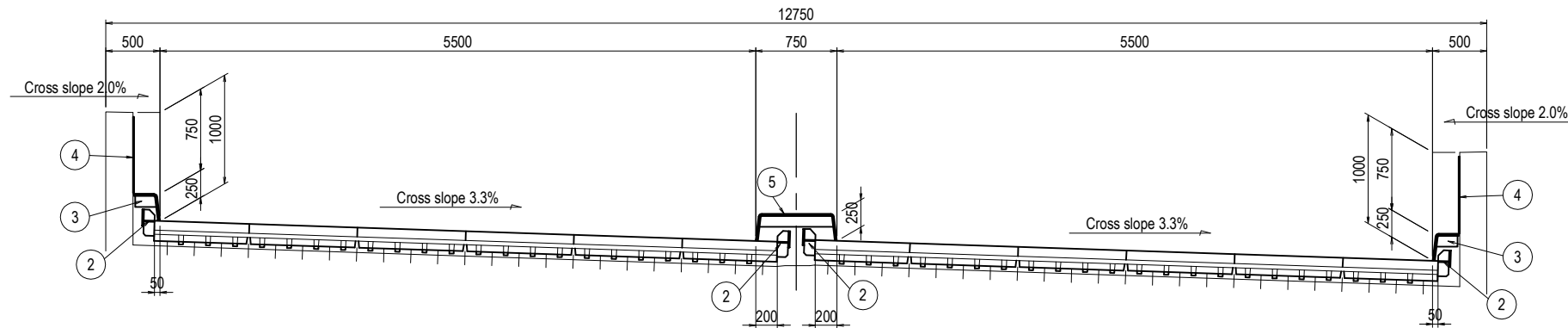

SECTION OF EXPANSION JOINT S=1:8

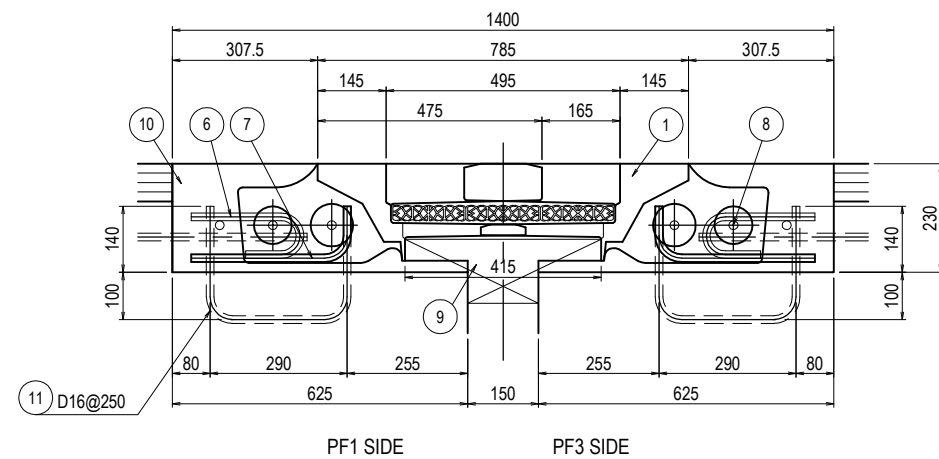

HARDWARE SECTION S=1:5

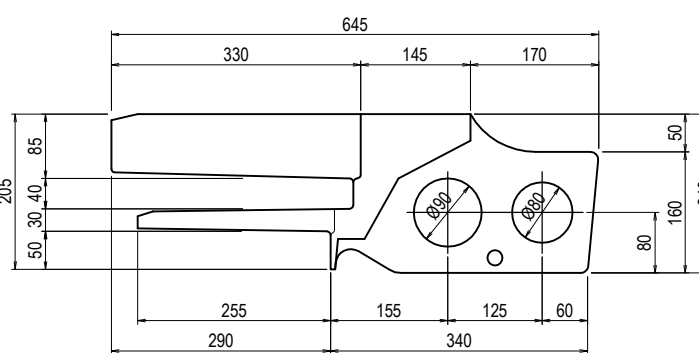

HARDWARE PLAN S=1:10

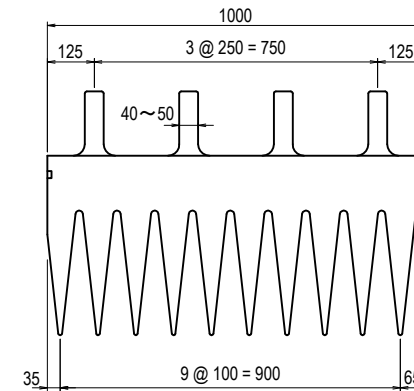

DETAIL OF REINFORCING BAR S=1:8

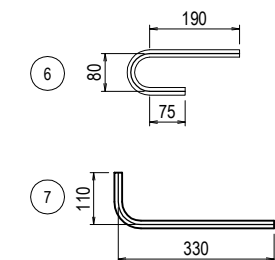

PLAN VIEW

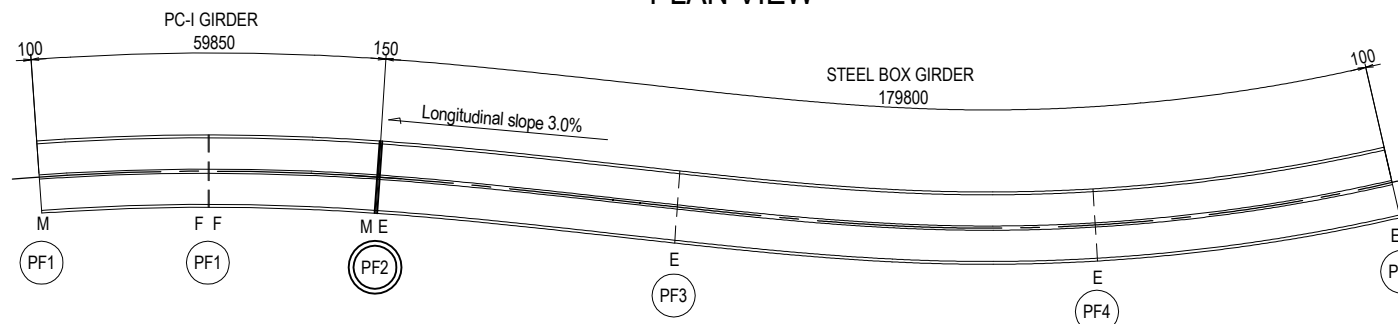

MATERIALS LIST					(1 par place)
No.	DESCRIPTION	MATERIALS	UNIT	QUANTITY	REMARK
1	EXPANSION JOINT	ALUMINUM ALLOY CASTING	m	11.500	320mm
2	UPSTAND		pieces	4	
3	COVER FOR CURB	SS400 or Equivalent	set	2	
4	COVER FOR BARRIER CURB	SUS304	set	2	t=2(include anchor)
5	COVER FOR MEDIAL DIVIDER	SS400 or Equivalent	set	1	
6	REINFORCING BAR	SD345	kg	55.97	D16 x 390 x 92 Nos.
7	REINFORCING BAR	SD345	kg	63.15	D16 x 440 x 92 Nos.
8	REINFORCING BAR	SD345	kg	162.00	D19 x 6.0m x 12 Nos.
9	BURIED FORMWORK	Foamed Styrene	m ³	0.76	400 x 150 x 12.7m
10	POST-CAST CONCRETE	High strength concrete	m ³	2.66	$\sigma_{ck} = 30\text{N/mm}^2$

EMBEDDED BAR

11	EMBEDDED BAR	SD345	kg	110.51	D16 x 770 x 92 Nos.
----	--------------	-------	----	--------	---------------------

DESIGN CONDITION

Temperature range	0 ~ +50°C
Amount of temperature variation	54mm
Earthquake movement amount	±130mm

Note

- 1 Re-bar should be consider the developed length.
- 2 Allocation of the expansion joint is subject to change
- 3 Expansion joint should be placing to match the transverse gradient.
- 4 Expansion joint should be installed in consideration of the effect of Creep and Shrinkage.

NOTES:

- 1) Details of the slab and girder are designed based on the product (expansion joint) shown in this Drawing.
- 2) The Contractor has option to propose an alternative equivalent to the specified product, which shall be subjected to the Engineer's approval.
- 3) The expansion joint shall be set in consideration of thermal expansion, creep and shrinkage of concrete girder.

SUPERSTRUCTURE COORDINATES (PF5-PF7) (1)

PLAN S=1:250

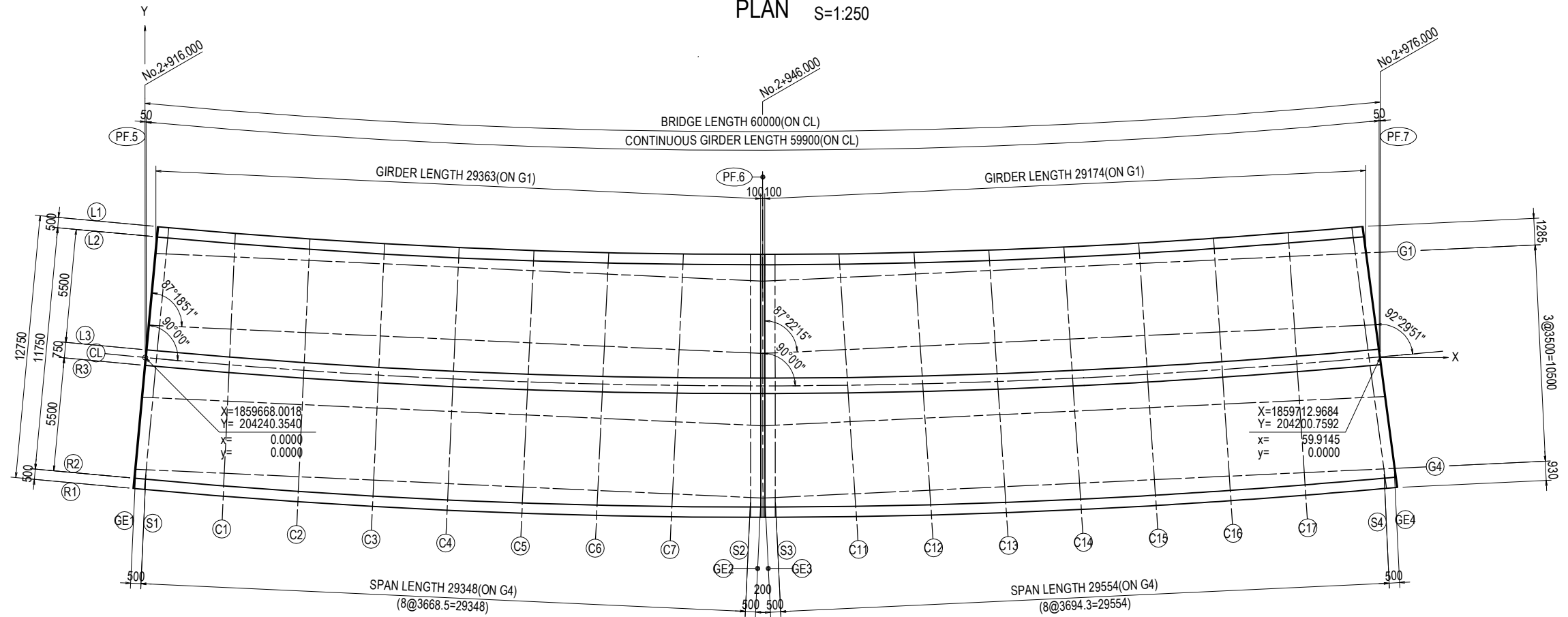

How to set the small coordinates
 X coordinate : Starting point is intersection of PF5 and CL
 Ending point is intersection of PF7 and CL
 Y coordinate : Perpendicular to X line

TYPICAL CROSS SECTION S=1:150

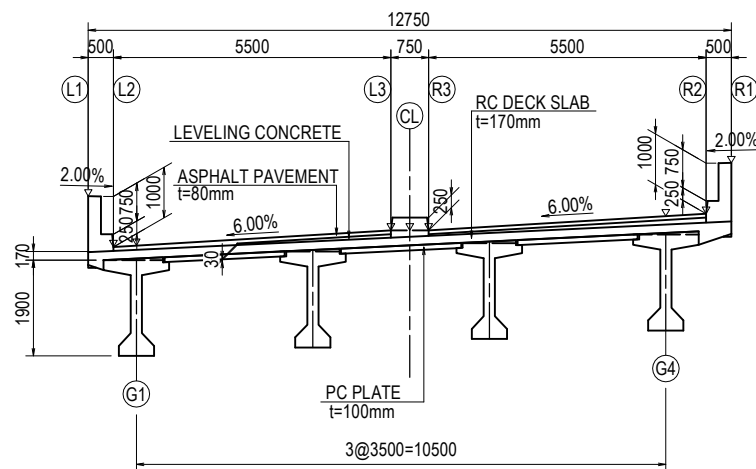

GRADE FOR LONGITUDINAL

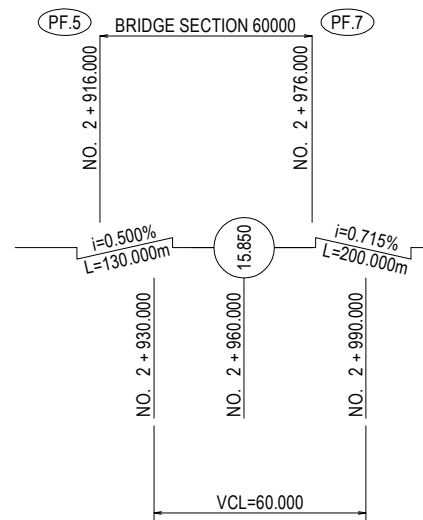

SUPER ELEVATION

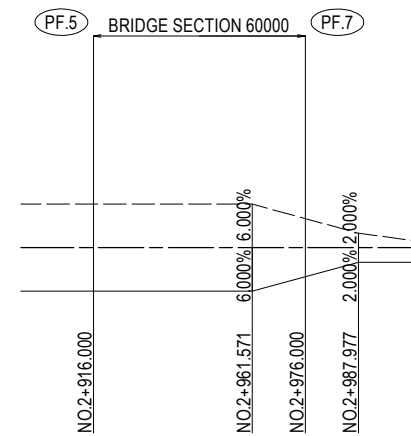

CURB ELEMENTS

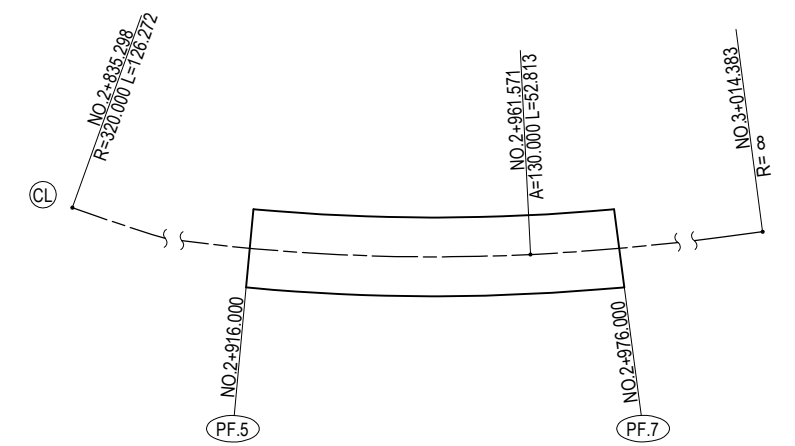

CHANGING POINT	STATION POINT	X COORDINATE	Y COORDINATE	ELEMENT
	2+835.298	1859597.4676	204279.1259	R=320.000
	2+961.571	1859702.8295	204211.0247	A=130.000
	3+014.383	1859738.6113	204172.2029	

SUPERSTRUCTURE COORDINATES (PF5-PF7) (2)

		PF5	GE1	S1	C1	C2	C3	C4	C5	C6	C7	S2	GE2	PF6	GE3	S3	C11	C12	C13	C14	C15	C16	C17	S4	GE4	PF7
L1	X	0.5937	0.6434	1.1407	4.4384	8.0346	11.6327	15.2327	18.8346	22.4385	26.0443	29.3543	29.8537	29.9536	30.0535	30.5530	33.7461	37.3539	40.9590	44.5613	48.1609	51.7579	55.3526	58.5303	59.0271	59.0768
	Y	6.3473	6.3427	6.2966	6.0116	5.7406	5.5111	5.3230	5.1762	5.0709	5.0070	4.9848	4.9845	4.9845	4.9846	4.9854	5.0093	5.0755	5.1831	5.3321	5.5222	5.7512	6.0163	6.2784	6.3216	6.3259
	Z	16.3000	16.3003	16.3028	16.3197	16.3381	16.3565	16.3748	16.3911	16.4046	16.4154	16.4230	16.4239	16.4241	16.4243	16.4251	16.4294	16.4316	16.4311	16.4278	16.4469	16.4688	16.4879	16.5025	16.5046	16.5048
L2	X	0.5471	0.5968	1.0941	4.4152	8.0114	11.6095	15.2095	18.8115	22.4153	26.0211	29.3545	29.8540	29.9539	30.0538	30.5532	33.7792	37.3870	40.9921	44.5944	48.1940	51.7910	55.3856	58.5960	59.0928	59.1425
	Y	5.8495	5.8448	5.7988	5.5118	5.2410	5.0116	4.8235	4.6767	4.5713	4.5072	4.4848	4.4845	4.4845	4.4846	4.4854	4.5097	4.5762	4.6840	4.8331	5.0233	5.2523	5.5173	5.7822	5.8254	5.8298
	Z	15.3000	15.3003	15.3028	15.3198	15.3381	15.3565	15.3748	15.3910	15.4046	15.4154	15.4230	15.4239	15.4241	15.4243	15.4251	15.4294	15.4316	15.4311	15.4278	15.4470	15.4688	15.4879	15.5026	15.5047	15.5049
G1	X	0.4727	0.5227	1.0221	4.3855	7.9865	11.5875	15.1885	18.7895	22.3905	25.9915	29.3549	29.8544	29.9543	30.0542	30.5536	33.8219	37.4230	41.0241	44.6253	48.2264	51.8275	55.4287	58.6969	59.1964	59.2463
	Y	5.0543	5.0520	5.0288	4.8727	4.7055	4.5384	4.3713	4.2041	4.0370	3.8698	3.7137	3.6905	3.6859	3.6905	3.7137	3.8654	4.0326	4.1997	4.3668	4.5340	4.7011	4.8683	5.0200	5.0431	5.0455
	Z	15.3479	15.3480	15.3492	15.3583	15.3704	15.3850	15.4019	15.4194	15.4366	15.4536	15.4692	15.4715	15.4720	15.4719	15.4714	15.4681	15.4643	15.4602	15.4558	15.4742	15.4963	15.5167	15.5330	15.5353	15.5355
G2	X	0.1464	0.1964	0.6958	4.2232	7.8242	11.4252	15.0262	18.6272	22.2282	25.8292	29.3566	29.8561	29.9560	30.0559	30.5553	34.0534	37.6545	41.2556	44.8567	48.4579	52.0590	55.6601	59.1581	59.6576	59.7076
	Y	1.5657	1.5634	1.5402	1.3764	1.2093	1.0422	0.8750	0.7079	0.5407	0.3736	0.2099	0.1867	0.1821	0.1867	0.2099	0.3722	0.5394	0.7065	0.8737	1.0408	1.2079	1.3751	1.5374	1.5606	1.5629
	Z	15.5581	15.5583	15.5594	15.5687	15.5807	15.5951	15.6119	15.6292	15.6463	15.6632	15.6795	15.6818	15.6822	15.6821	15.6816	15.6781	15.6742	15.6701	15.6658	15.6682	15.6710	15.6720	15.6706	15.6702	15.6702
L3	X	0.0349	0.0846	0.5820	4.1600	7.7563	11.3545	14.9545	18.5564	22.1602	25.7659	29.3572	29.8567	29.9566	30.0565	30.5559	34.1434	37.7510	41.3559	44.9581	48.5576	52.1547	55.7493	59.3188	59.8156	59.8653
	Y	0.3734	0.3687	0.3227	0.0145	-0.2545	-0.4829	-0.6706	-0.8177	-0.9242	-0.9900	-1.0152	-1.0155	-1.0155	-1.0155	-1.0154	-1.0146	-0.9860	-0.9166	-0.8065	-0.6558	-0.4648	-0.2357	0.0289	0.3242	0.3721
	Z	15.6300	15.6302	15.6327	15.6507	15.6688	15.6868	15.7048	15.7208	15.7342	15.7449	15.7530	15.7539	15.7541	15.7543	15.7551	15.7597	15.7616	15.7610	15.7571	15.7517	15.7431	15.7319	15.7182	15.7160	15.7158
CL	X	0.0000	0.0497	0.5471	4.1426	7.7389	11.3371	14.9371	18.5390	22.1429	25.7485	29.3574	29.8569	29.9568	30.0567	30.5561	34.1682	37.7758	41.3807	44.9829	48.5824	52.1794	55.7741	59.3681	59.8649	59.9145
	Y	0.0000	-0.0046	-0.0507	-0.3603	-0.6292	-0.8575	-1.0452	-1.1923	-1.2989	-1.3649	-1.3902	-1.3905	-1.3905	-1.3904	-1.3896	-1.3607	-1.2911	-1.1808	-1.0301	-0.8390	-0.6098	-0.3453	-0.0479	-0.0044	0.0000
	Z	15.6300	15.6302	15.6327	15.6508	15.6688	15.6868	15.7048	15.7208	15.7341	15.7449	15.7530	15.7539	15.7541	15.7543	15.7551	15.7597	15.7617	15.7610	15.7571	15.7517	15.7431	15.7319	15.7181	15.7160	15.7158
R3	X	-0.0349	0.0148	0.5121	4.1252	7.7215	11.3197	14.9197	18.5217	22.1255	25.7312	29.3576	29.8571	29.9569	30.0568	30.5563	34.1930	37.8006	41.4055	45.0077	48.6072	52.2042	55.7989	59.4174	59.9142	59.9638
	Y	-0.3734	-0.3780	-0.4241	-0.7351	-1.0039	-1.2321	-1.4198	-1.5669	-1.6736	-1.7397	-1.7652	-1.7655	-1.7655	-1.7654	-1.7654	-1.7654	-1.7551	-1.7597	-1.7617	-1.7610	-1.7576	-1.7517	-1.7431	-1.7320	-1.7159
	Z	15.6300	15.6302	15.6327	15.6509	15.6689	15.6869	15.7048	15.7208	15.7341	15.7448	15.7530	15.7539	15.7541	15.7543	15.7551	15.7597	15.7617	15.7610	15.7576	15.7517	15.7431	15.7320	15.7180	15.7159	15.7157
G3	X	-0.1799	-0.1299	0.3696	4.0610	7.6620	11.2630	14.8640	18.4650	22.0660	25.6670	29.3584	29.8578	29.9577	30.0576	30.5571	34.2848	37.8860	41.4871	45.0882	48.6893	52.2905	55.8916	59.6194	60.1188	60.1688
	Y	-1.9229	-1.9253	-1.9485	-2.1198	-2.2869	-2.4541	-2.6212	-2.7884	-2.9555	-3.1226	-3.2940	-3.3172	-3.3172	-3.3172	-3.2940	-3.1210	-2.9538	-2.7867	-2.6195	-2.4524	-2.2852	-2.1181	-1.9451	-1.9219	-1.9196
	Z	15.7234	15.7235	15.7246	15.7342	15.7461	15.7603	15.7769	15.7941	15.8110	15.8277	15.8447	15.8470	15.8475	15.8474	15.8469	15.8430	15.8391	15.8350	15.8307	15.8204	15.8082	15.7943	15.7774	15.7749	15.7747
G4	X	-0.5061	-0.4562	0.0433	3.8987	7.4997	11.1007	14.7017	18.3027	21.9037	25.5047	29.3601	29.8595	29.9594	30.0593	30.5588	34.5163	38.1174	41.7186	45.3197	48.9208	52.5219	56.1231	60.0806	60.5800	60.6300
	Y	-5.4116	-5.4139	-5.4371	-5.6160	-5.7832	-5.9503	-6.1174	-6.2846	-6.4517	-6.6189	-6.7978	-6.8210	-6.8256	-6.8210	-6.7978	-6.6141	-6.4470	-6.2799	-6.1127	-5.9456	-5.7784	-5.6113	-5.4276	-5.4044	-5.4021
	Z	15.9336	15.9337	15.9348	15.9447	15.9564	15.9705	15.9869	16.0039	16.0207	16.0373	16.0550	16.0572	16.0577	16.0576	16.0571	16.0529	16.0490	16.0449	16.0406	16.0139	15.9830	15.9505	15.9119	15.9068	15.9063
R2	X	-0.5471	-0.4974	0.0000	3.8701	7.4664	11.0647	14.6647	18.2666	21.8704	25.4760	29.3603	29.8598	29.9597	30.0596	30.5590	34.5572	38.1646	41.7693	45.3714	48.9709	52.5679	56.1626	60.1402	60.6369	60.6866
	Y	-5.8495	-5.8541	-5.9002	-6.2323	-6.4994	-6.7265	-6.9139	-7.0614	-7.1690	-7.2368	-7.2652	-7.2655	-7.2655	-7.2654	-7.2646	-7.2308	-7.1581	-7.0456	-6.8932	-6.7013	-6.4720	-6.2078	-5.8778	-5.8340	-5.8296
	Z	15.9600	15.9602	15.9627	15.9818	15.9995	16.0172	16.0348	16.0505	16.0634	16.0744	16.0830	16.0841	16.0843	16.0851	16.0900	16.0917	16.0909	16.0875	16.0557	16.0557	16.0177	15.9772	15.9292	15.9230	15.9223
R1	X	-0.5937	-0.5439	-0.0466	3.8469	7.4432	11.0415	14.6415	18.2434	21.8472	25.4528	29.3606	29.8600	29.9599	30.0598	30.5593	34.5903	38.1976	41.8024	45.4045	49.0040	52.6010	56.1957	60.2059	60.7026	60.7523
	Y	-6.3473	-6.3519	-6.3980	-6.7320	-6.9989	-7.2260	-7.4133	-7.5609	-7.6686	-7.7366	-7.7652	-7.7655	-7.7655	-7.7654	-7.7654	-7.7303	-7.6574	-7.5447	-7.3922	-7.2003	-6.9709	-6.7068	-6.3740	-6.3202	-6.3257
	Z	16.9600	16.9602	16.9627	16.9819	16.9995	17.0172	17.0348	17.0505	17.0637	17.0743	17.0830	17.0839	17.0839	17.0841	17.0843	17.0851	17.0900	17.0917	17.0909	17.0875	17.0557	17.0177	16.9772	16.9289	16.9227

STRUCTURE HEIGHT TABLE

		S1(PF5R)				S2(PF6L)				S3(PF6R)				S4(PF7L)			
		G1	G2	G3	G4	G1	G2	G3	G4	G1	G2	G3	G4	G1	G2	G3	G4
ROAD PLAN HEIGHT	Z1	15.349	15.559	15.725	15.935	15.469	15.679	15.845	16.055	15.471	15.682	15.847	16.057	15.533	15.671	15.777	15.912
PAVEMENT THICKNESS(mm)	H1	98	140	138	180	89	130	126	168	90	131	127	168	214	184	122	89
MAIN GIRDER HEIGHT(mm)	H2	2101	2101	2101	2101	2101	2101	2101	2101	2101	2101	2101	2101	2101	2101	2101	2101
LAYER HEIGHT(mm)	H3	30	30	30	30	30	30	30	30	30	30	30	30	30	30	30	30
BEARING HEIGHT(mm)	H4	92	92	92	92	92	92	92	92	92	92	92	92	112	112	112	112
BEARING MORTAR(mm)	H5	60	60	60	60	55	56	58	58	56	58	59	60	34	60	60	60
TOTAL STRUCTURE HEIGHT(mm)	ΣH	2381	2423	2421	2463	2367	2409	2407	2449	2369	2412	2409	2451	2491	2487	2425	2392
TOP OF PIER/ABUTMENT HEIGHT	Z2	12.968	13.136	13.304	13.472	13.102	13.270	13.438	13.606	13.102	13.270	13.438	13.606	13.042	13.184	13.352	13.520

GENERAL VIEW OF SUPERSTRUCTURE (PF5-PF7) (1)

SIDE VIEW S=1:250

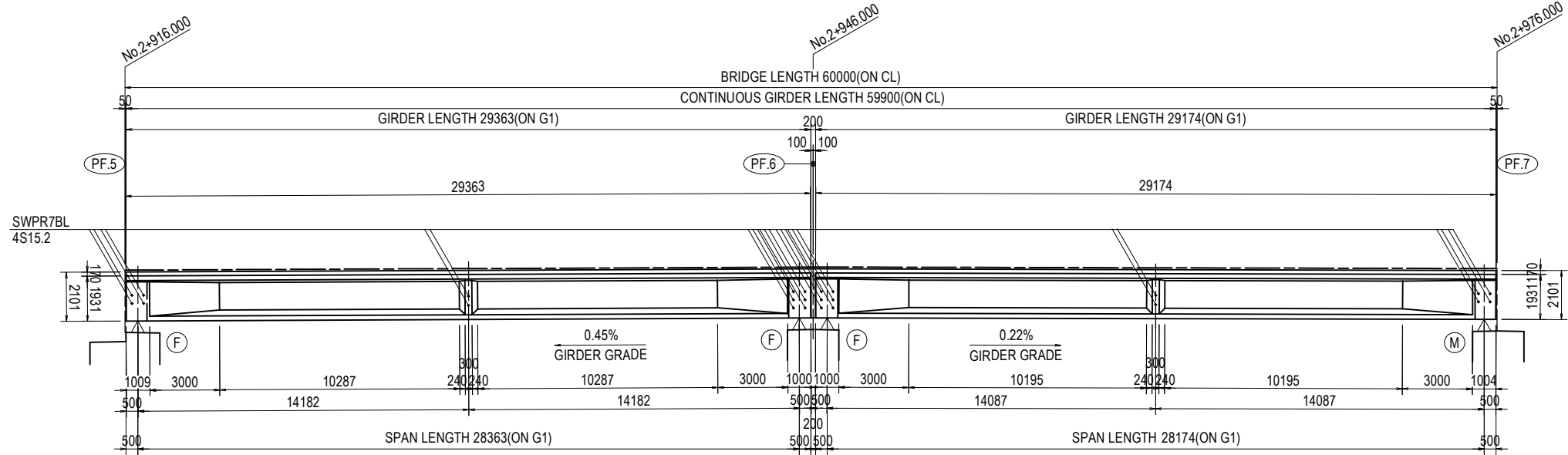

PLAN S=1:250

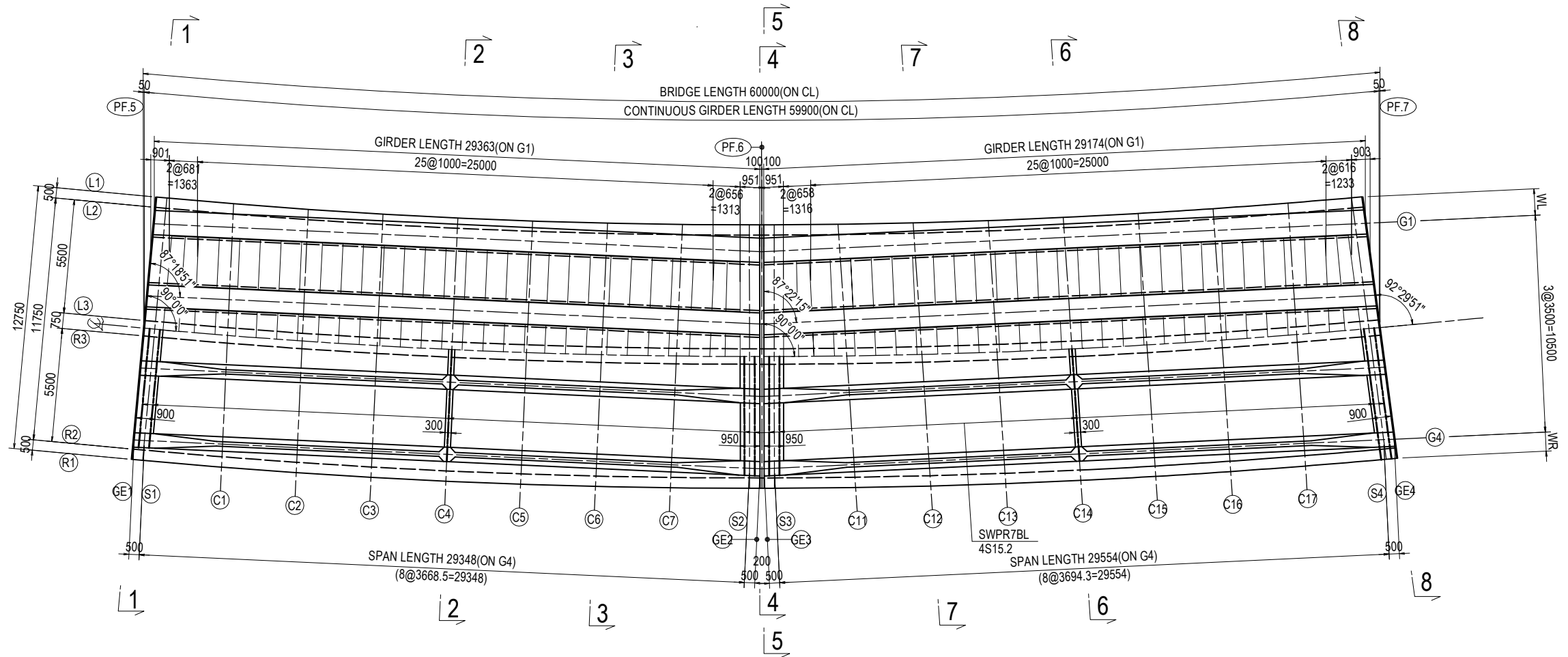

PROJECT NAME DETAILED DESIGN ON BAGO RIVER BRIDGE CONSTRUCTION PROJECT	FINANCED BY JAPAN INTERNATIONAL COOPERATION AGENCY	COUNTERPART REPUBLIC OF THE UNION OF MYANMAR MINISTRY OF CONSTRUCTION DEPARTMENT OF BRIDGE	JICA STUDY TEAM NIPPON KOEI CO., LTD. ORIENTAL CONSULTANTS GLOBAL CO., LTD. METROPOLITAN EXPRESSWAY COMPANY LIMITED CHODAI CO., LTD. NIPPON ENGINEERING CONSULTANTS CO., LTD.	NAME	SIGNATURE	DATE	DRAWING TITLE GENERAL VIEW OF SUPERSTRUCTURE (PF5-PF7) (1)	PACKAGE 3 DWG No. P3-FO-1103	
				PREPARED BY	Y. SUZUKI				14 Jul. 2017
				CHECKED BY	T. HAYAKAWA				20 Jul. 2017
				APPROVED BY	Y. SANO				25 Jul. 2017

GENERAL VIEW OF SUPERSTRUCTURE (PF5-PF7) (2)

CROSS SECTION S=1:150

PF5-PF6

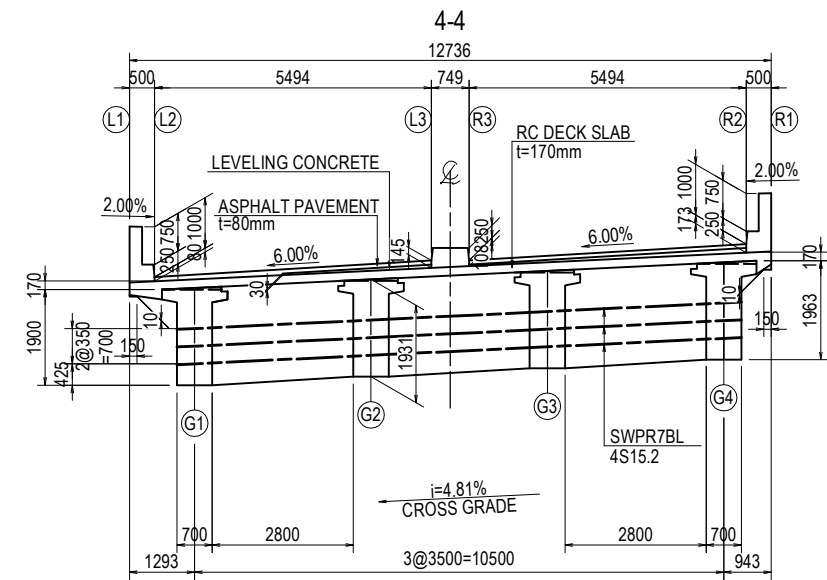
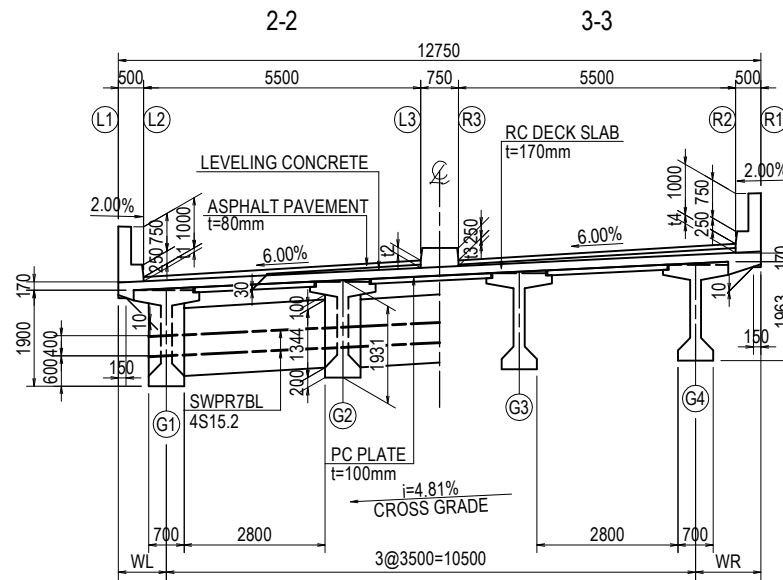
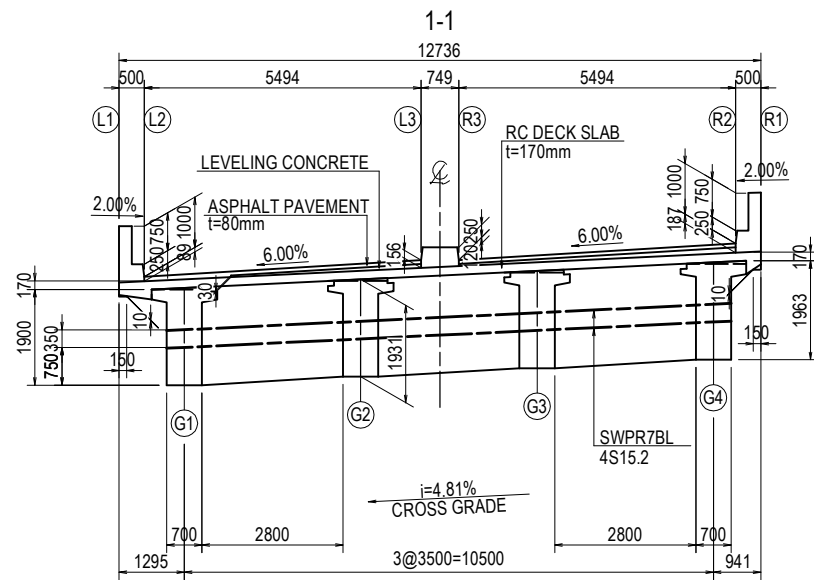

PF6-PF7

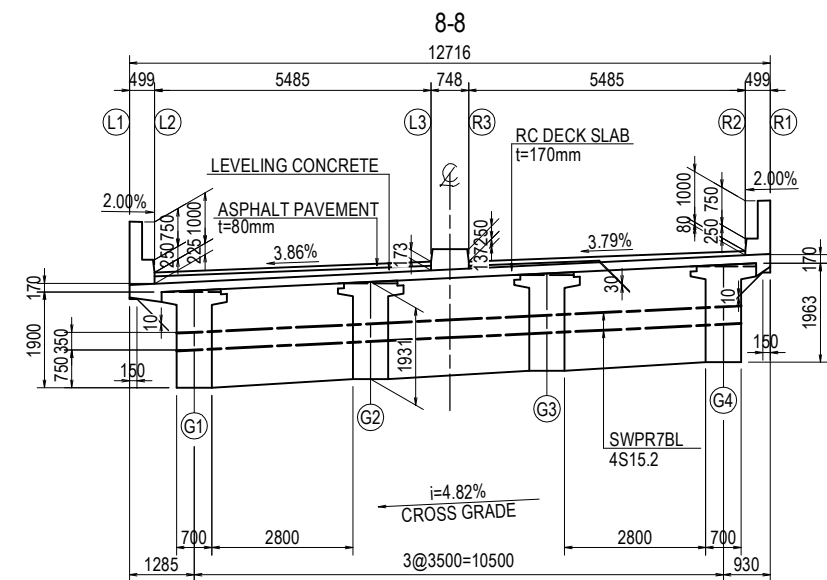
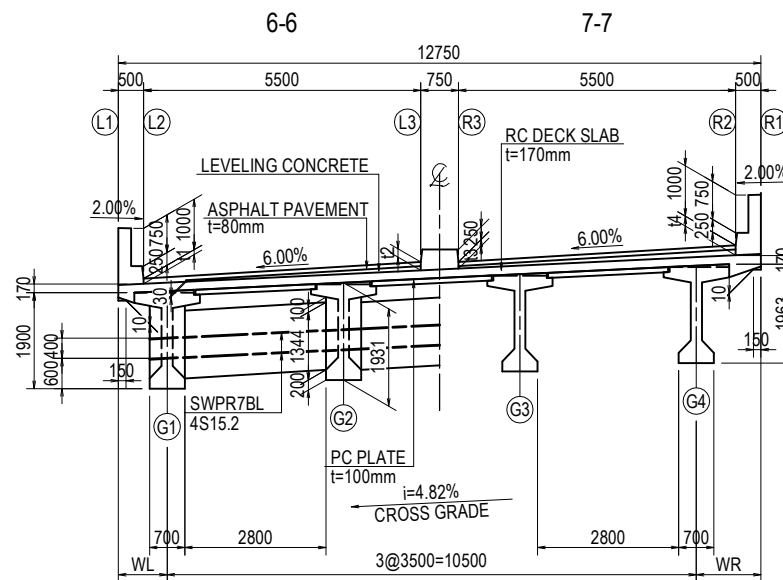
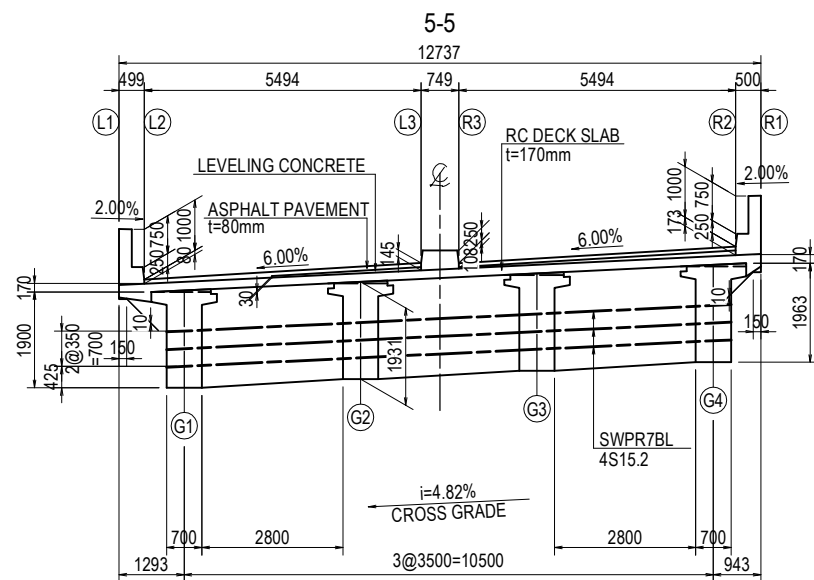

Note: Dimension of crosssection at end of girder is based on the actual angle of girder end.

LIST OF PAVEMENT THICKNESS (mm)

	GE1	S1	C1	C2	C3	C4	C5	C6	C7	S2	GE2	PF6
t1	89	88	84	81	80	81	82	82	82	80	80	80
t2	156	155	150	147	146	146	147	147	146	145	145	145
t3	120	119	114	111	110	110	111	111	110	109	108	108
t4	187	186	180	177	175	175	176	176	175	173	173	173

	PF6	GE3	S3	C11	C12	C13	C14	C15	C16	C17	S4	GE4
t1	80	80	81	86	92	96	100	129	162	194	221	225
t2	144	145	146	151	157	161	165	168	171	172	173	173
t3	108	108	109	115	120	125	129	132	135	136	137	137
t4	173	173	174	180	185	190	194	171	144	116	84	80

LIST OF WL/WR LENGTH (mm)

	GE1	S1	C1	C2	C3	C4	C5	C6	C7	S2	GE2	PF6
WL	1295	1272	1143	1037	974	953	973	1036	1141	1270	1293	1297
WR	941	964	1115	1216	1277	1297	1277	1217	1117	966	943	949

	PF6	GE3	S3	C11	C12	C13	C14	C15	C16	S17	S4	GE4
WL	1297	1293	1270	1149	1047	986	967	991	1054	1153	1265	1285
WR	949	943	966	1115	1212	1267	1282	1257	1193	1095	951	930

GENERAL VIEW OF SUPERSTRUCTURE (PF5-PF7) (3)

CROSS SECTION OF MAIN GIRDER S=1:50

PF5-PF6

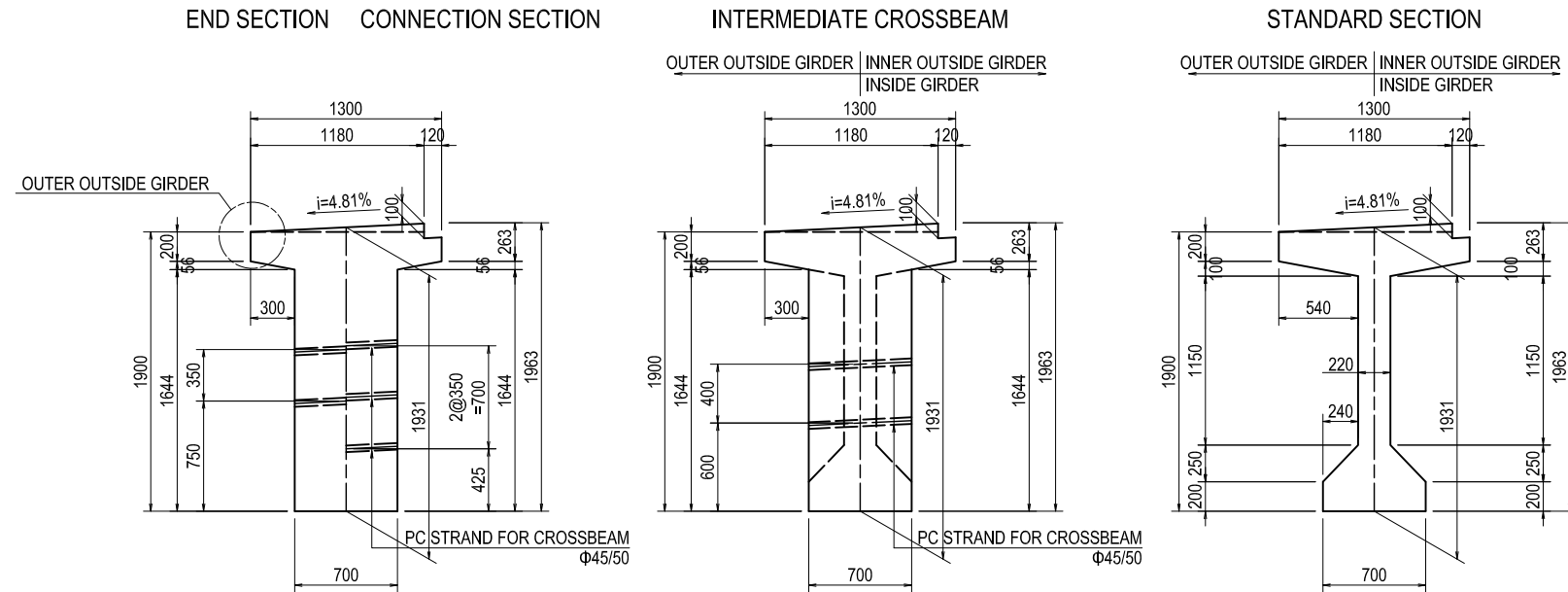

PF6-PF7

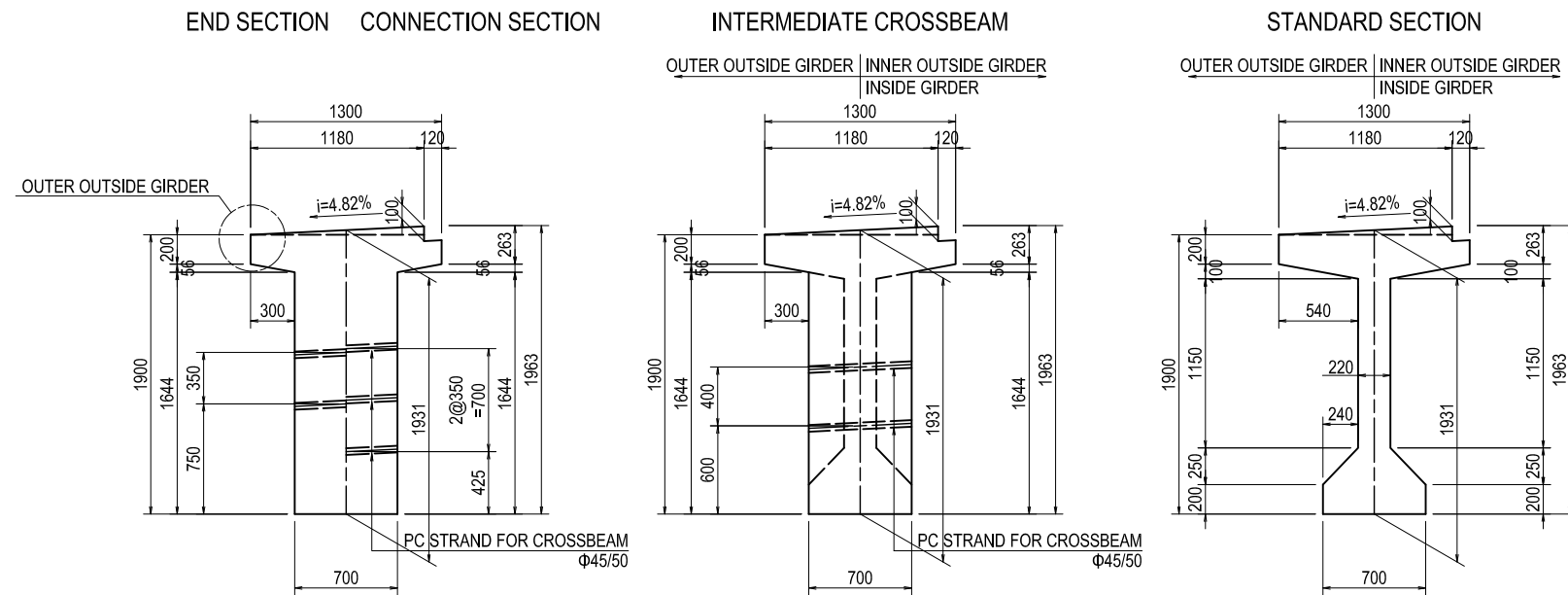

LAYER S=1:30

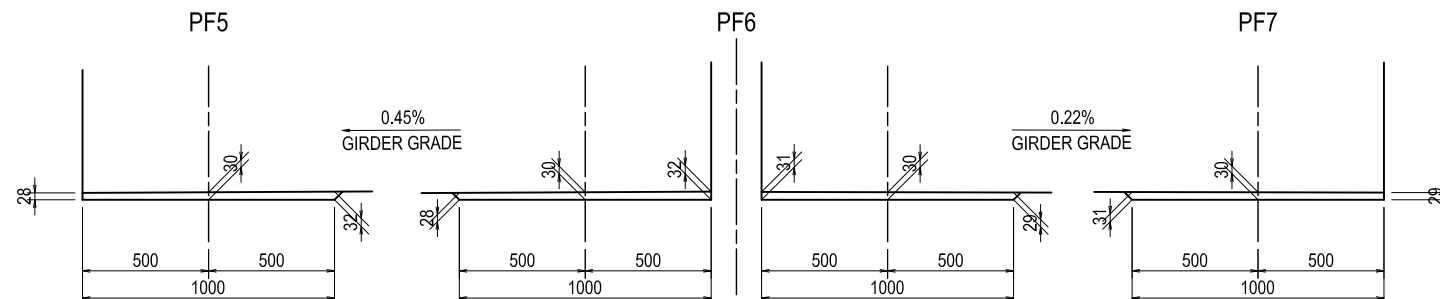

DESIGN CONDITION

ROAD GRADE	Equivalent to CLASS 4-1
BRIDGE TYPE	2 span continuous PC-I girder bridge with composite deck(PC plate and RC deck)
BRIDGE LENGTH	L = 60.000 m
SPAN LENGTH	L = 28.851 + 28.852 m
WIDTH OF THE ROAD	TOTAL : 12.750 m L = 0.500 + 5.500 + 0.750 + 5.500 + 0.500 m
HORIZONTAL ALIGNMENT	R=320-A=130
LONGITUDINAL SLOPE	0.50% ↖ 0.72% ↘
SECTION SLOPE	LEFT : -6.00%~-2.00% RIGHT : 6.00%~-2.00%
ANGLE OF SKEW	PF.5,PF.6 : 90°00'00" PF.7 : 92°29'51"
PAVEMENT	ASPHALT PAVEMENT t = 80 mm
SLAB	RC DECK SLAB t = 170 mm
PLATE	PRESTRESS CONCRETE PLATE t = 100 mm
LIVE ROAD	AASHTO HL-93
DESIGN STANDARD	AASHTO LRFD BRIDGE DESIGN 2014(LIVE ROAD) Specifications for highway bridges(Japan Road Association) 1 Common matters,3 Concrete bridges,5 seismic design (April 2012)

MATERIALS STRENGTH

CONCRETE	(N/mm ²)				
	MAIN GIRDER	CROSS BEAM	PC PLATE	RC SLAB	COUPLING CONCRETE
DESIGN STANDARD STRENGTH OF CONCRETE	40.0	30.0	40.0	30.0	30.0
BENDING COMPRESSIVE STRESS	IMMEDIATELY AFTER PRESTRESSING	19.0	14.0	19.0	—
	OTHERS	14.0	11.0	15.0	10.0
BENDING TENSILE STRESS	IMMEDIATELY AFTER PRESTRESSING	-1.5	-1.2	-1.5	—
	DEAD LOAD	0.0	0.0	—	—
	OTHERS	-1.5	-1.2	0.0	—
MEAN SHEAR STRESS CONCRETE CAN CARRY	0.55	0.45	—	—	—
MAXIMUM MEAN CONCRETE SHEAR STRESS	IN CASE WHERE ONLY SHEAR FORCES	5.3	4.0	—	—
ALLOWABLE DIAGONEL TENSILE STRESS (DEAD LOAD)	IN CASE WHERE ONLY SHEAR FORCES	-1.0	-0.8	—	—
ALLOWABLE DIAGONEL TENSILE STRESS (LIVE LOAD)	IN CASE WHERE ONLY SHEAR FORCES	-2.0	-1.7	—	—

PC STRAND	(N/mm ²)		
	SWPR7BL 7S15.2mm	SWPR7BL 4S15.2mm	SWPR7AL 1S9.3mm
TENSILE STRENGTH	1850	1850	1700
YIELD POINT	1600	1600	1450
ALLOWABLE TENSILE STRESS	DURING PRESTRESSING	1440	1305
	IMMEDIATELY AFTER PRESTRESSING	1295	1190
	UNDER DESIGN LOAD	1110	1020

REINFORCING STEEL	(N/mm ²)			
	MAIN GIRDER	CROSS BEAM	RC SLAB	COUPLING CONCRETE
STEEL TYPE	SD345	SD345	SD345	SD345
YIELD POINT	345	345	345	345
ALLOWABLE TENSILE STRESS	DEAD LOAD	—	100	100
	DESIGN LOAD	180	140	160
	EARTHQUAKE LOAD	—	200	—

PROJECT NAME
DETAILED DESIGN ON
BAGO RIVER BRIDGE
CONSTRUCTION PROJECT

FINANCED BY
JICA
JAPAN INTERNATIONAL
COOPERATION AGENCY

COUNTERPART
REPUBLIC OF THE UNION OF MYANMAR
MINISTRY OF CONSTRUCTION
DEPARTMENT OF BRIDGE

JICA STUDY TEAM
NIPPON KOEI CO., LTD.
ORIENTAL CONSULTANTS GLOBAL CO., LTD.
METROPOLITAN EXPRESSWAY COMPANY LIMITED
CHODAI CO., LTD.
NIPPON ENGINEERING CONSULTANTS CO., LTD.

	NAME	SIGNATURE	DATE
PREPARED BY	Y. SUZUKI	<i>[Signature]</i>	14 Jul. 2017
CHECKED BY	T. HAYAKAWA	<i>[Signature]</i>	20 Jul. 2017
APPROVED BY	Y. SANO	<i>[Signature]</i>	25 Jul. 2017

DRAWING TITLE
GENERAL VIEW OF SUPERSTRUCTURE (PF5-PF7) (3)

PACKAGE
3
DWG No.
P3-FO-105

PC STRAND ARRANGEMENT OF MAIN GIRDER (PF5-PF7) (1)

SIDE VIEW S=1:100

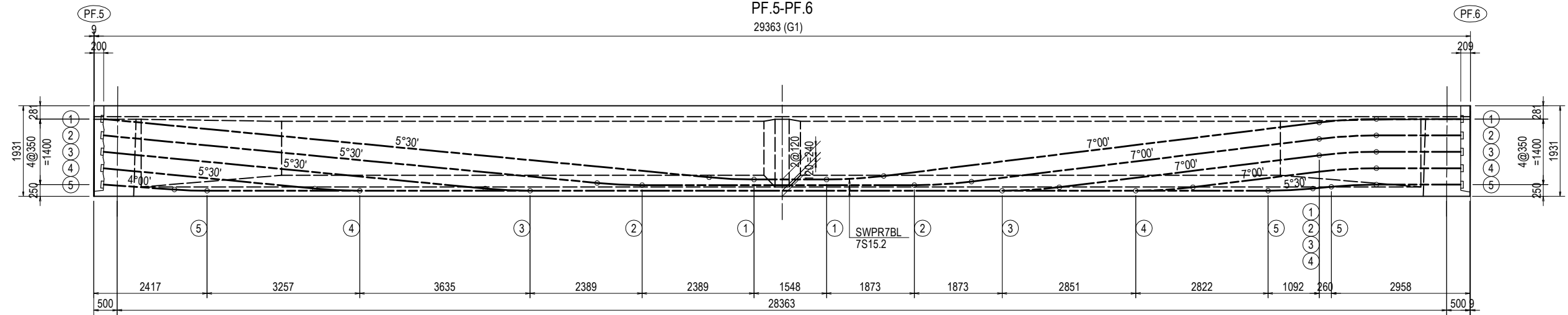

PC STRAND LENGTH & ELEVATION

7S15.2
w=7.707 kg/m
R=10.000m

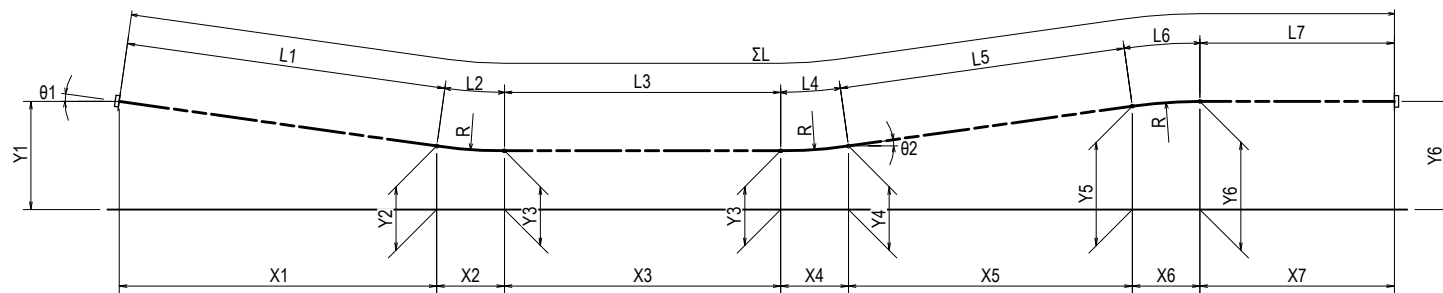

PF.5-PF.6

PC STRAND No	θ1	θ2	Y1	Y2	Y3	Y4	Y5	Y6	X1	X2	X3				X4	X5	X6	X7
											G1	G2	G3	G4				
1	5°30'	7°00'	1650	406	360	435	1576	1650	12919	959	1548	1877	2205	2533	1218	9292	1219	1800
2	5°30'	7°00'	1300	286	240	315	1226	1300	10530	959	5809	6138	6466	6794	1218	7419	1219	1800
3	5°30'	7°00'	950	166	120	195	876	950	8142	958	10071	10400	10728	11056	1219	5545	1219	1800
4	5°30'	7°00'	600	166	120	195	526	600	4507	958	16557	16886	17214	17542	1218	2695	1219	1800
5	4°00'	5°30'	250	144	120	166	204	250	1511	697	22636	22965	23293	23621	959	394	958	1800
											ΣL (UNIT:mm)				WEIGHT (UNIT:kg)			
PC STRAND No	L1	L2	L3				L4	L5	L6	L7								
1	12979	960	G1	G2	G3	G4	1222	9362	1222	1800	29093	29422	29750	30078	224.22	226.76	229.28	231.81
2	10579	960	5809	6138	6466	6794	1222	7475	1222	1800	29067	29396	29724	30052	224.02	226.55	229.08	231.61
3	8179	960	10071	10400	10728	11056	1222	5587	1222	1800	29041	29370	29698	30026	223.82	226.35	228.88	231.41
4	4528	960	16557	16886	17214	17542	1222	2715	1222	1800	29004	29333	29661	29989	223.53	226.70	228.60	231.13
5	1514	698	22636	22965	23293	23621	960	396	960	1800	28964	29293	29621	29949	223.23	225.76	228.29	230.82
TOTAL											145169	146814	148454	150094	1118.8	1132.1	1144.1	1156.8

CROSS SECTION OF MAIN GIRDER S=1:50

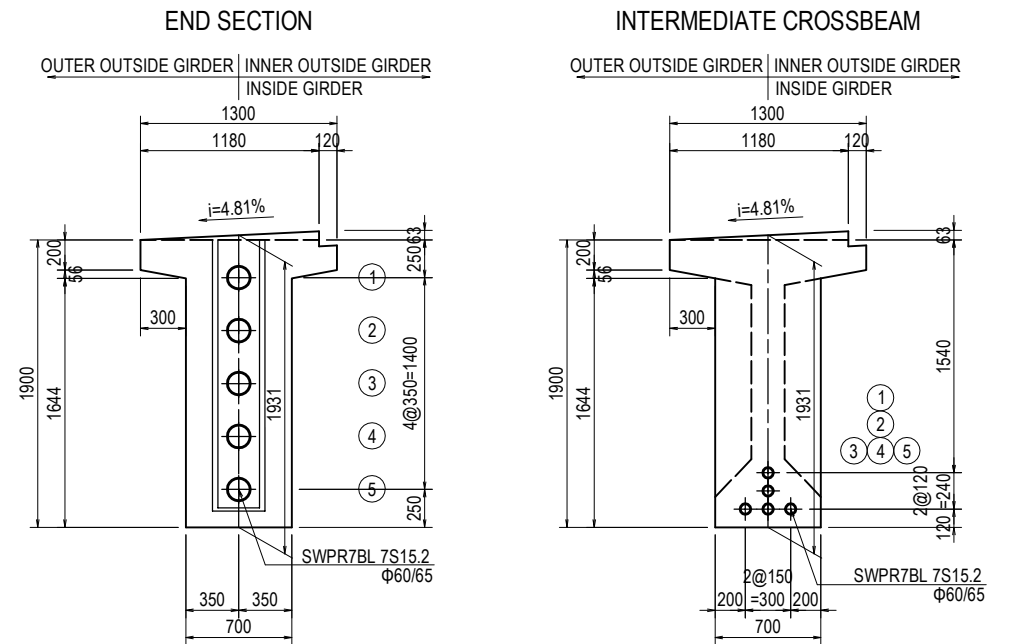

PC STRAND ARRANGEMENT OF MAIN GIRDER (PF5-PF7) (2)

SIDE VIEW S=1:100

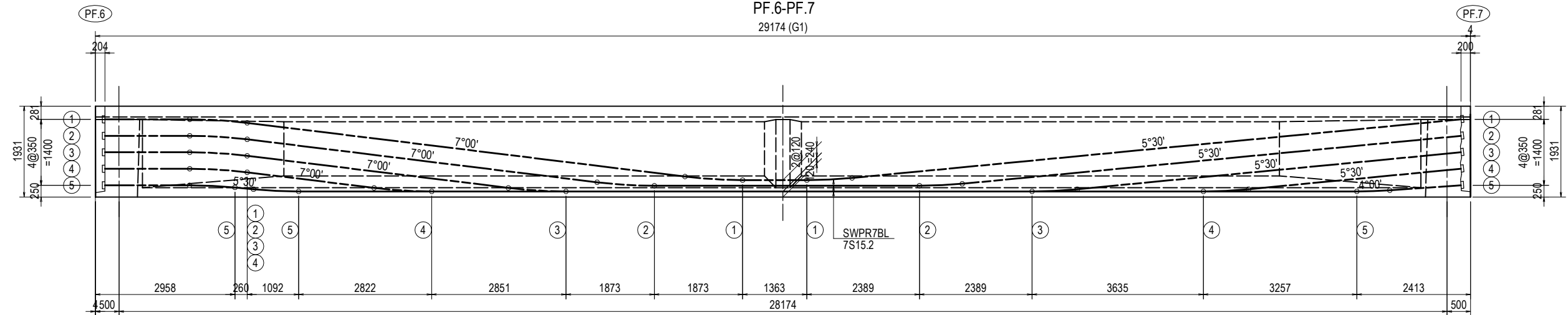

PC STRAND LENGTH & ELEVATION

7S15.2
w=7.707 kg/m
R=10.000m

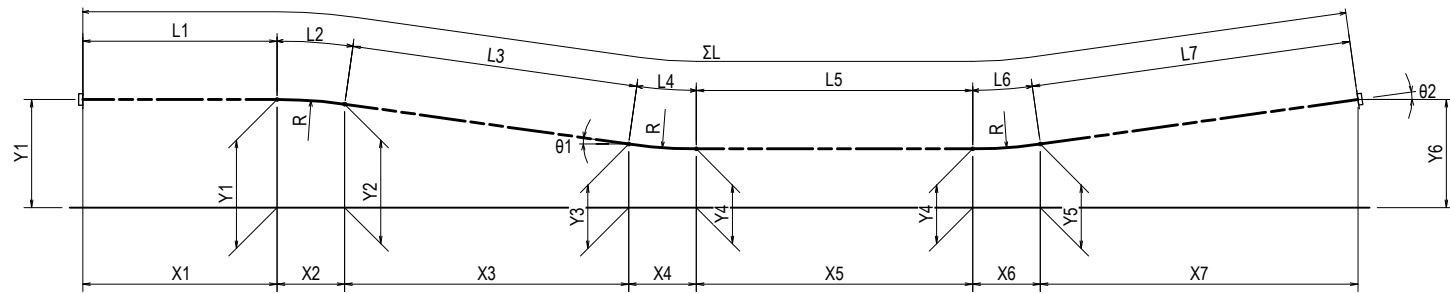

PF.6-PF.7

PC STRAND No	θ1	θ2	Y1	Y2	Y3	Y4	Y5	Y6	X1	X2	X3	X4	X5				X6	X7
													G1	G2	G3	G4		
1	7°00'	5°30'	1650	1576	435	360	406	1650	1800	1219	9292	1219	1363	1823	2283	2743	958	12919
2	7°00'	5°30'	1300	1226	315	240	286	1300	1800	1219	7419	1218	5625	6085	6545	7005	959	10530
3	7°00'	5°30'	950	876	195	120	166	950	1800	1219	5545	1219	9887	10347	10807	11267	958	8142
4	7°00'	5°30'	600	526	195	120	166	600	1800	1219	2695	1219	16372	16832	17292	17752	958	4507
5	5°30'	4°00'	250	204	166	120	144	250	1800	959	393	959	22451	22911	23371	23831	697	1511

PC STRAND No	L1	L2	L3	L4	L5				L6	L7	ΣL (UNIT:mm)				WEIGHT (UNIT:kg)							
					G1	G2	G3	G4			G1	G2	G3	G4	G1	G2	G3	G4				
1	1800	1222	9362	1222	1363	1823	2283	2743	960	12979	28908	29368	29828	30288	222.79	226.34	229.88	233.43				
2	1800	1222	7475	1222	5625	6085	6545	7005	960	10579	28883	29343	29803	30263	222.60	226.15	229.69	233.24				
3	1800	1222	5587	1222	9887	10347	10807	11267	960	8179	28857	29317	29777	30237	222.40	225.95	229.49	233.04				
4	1800	1222	2715	1222	16372	16832	17292	17752	960	4528	28819	29279	29739	30199	222.11	225.65	229.20	232.74				
5	1800	960	396	960	22451	22911	23371	23831	698	1514	28779	29239	29699	30159	221.80	225.34	228.89	232.44				
TOTAL											144246	146546	148846	151146	1111.7	1129.4	1147.2	1164.9				

CROSS SECTION OF MAIN GIRDER S=1:50

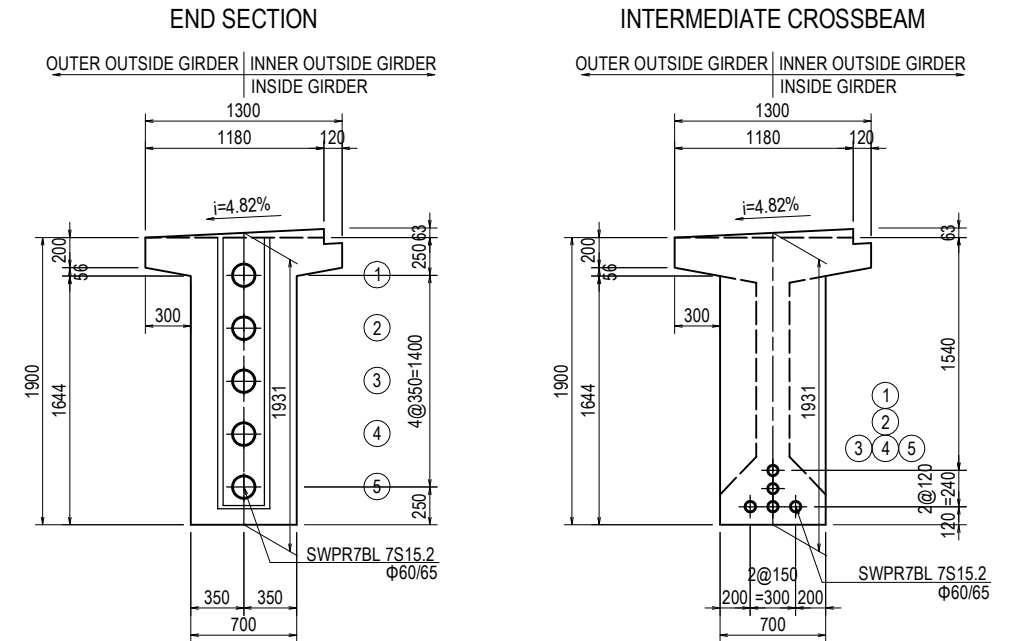

BAR ARRANGEMENT OF MAIN GIRDER (PF5-PF7) (1)

SIDE VIEW S=1:100

PF.5-PF.6

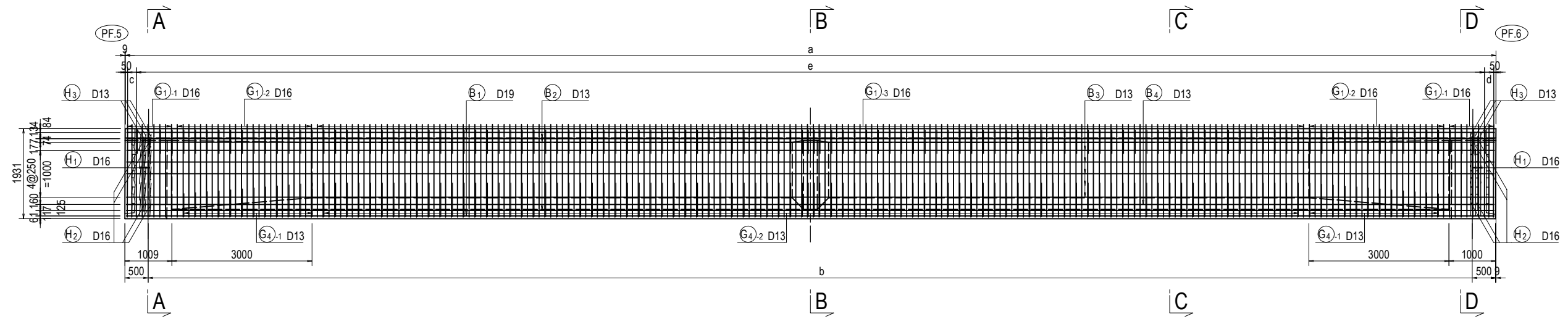

PLAN S=1:100

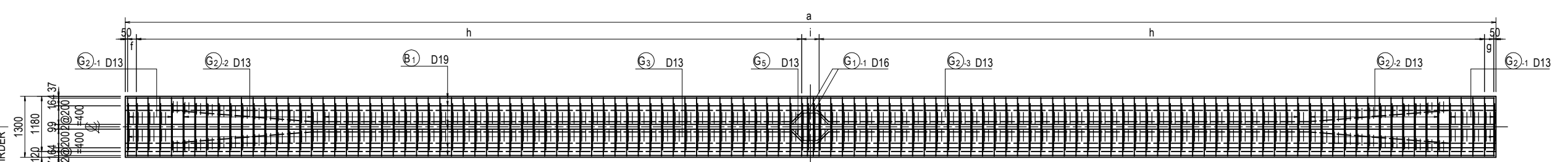

DIMENSION LIST

GIRDER No	a	b	c	d	e	f	g	h	i
G1	29363	28363	2@95=190	2@100=199	231@125=28875	190	199	57@250=14250	3@125=375
G2	29692	28692	2@115=229	2@119=238	233@125=29125	229	238	58@250=14500	125
G3	30020	29020	2@72=143	2@76=152	237@125=29625	143	152	59@250=14750	125
G4	30348	29348	2@91=182	2@96=191	239@125=29875	182	191	59@250=14750	3@125=375

CROSS SECTION OF MAIN GIRDER S=1:50

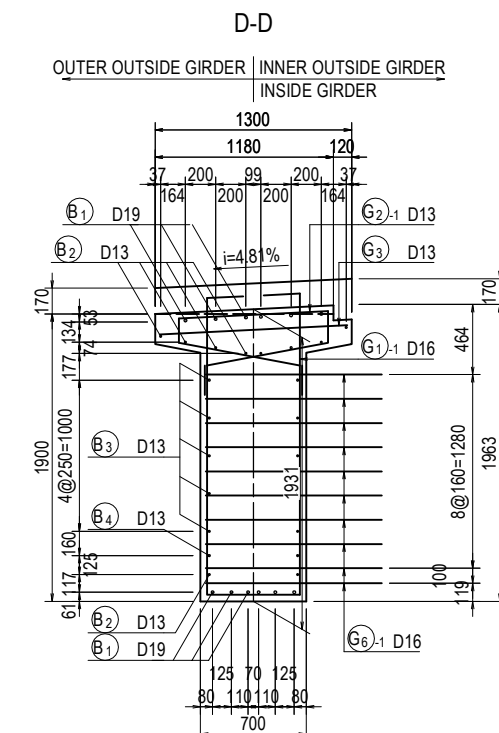
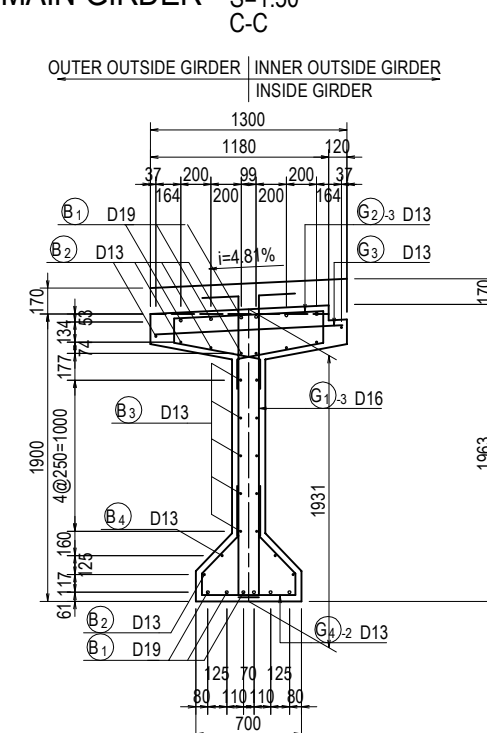
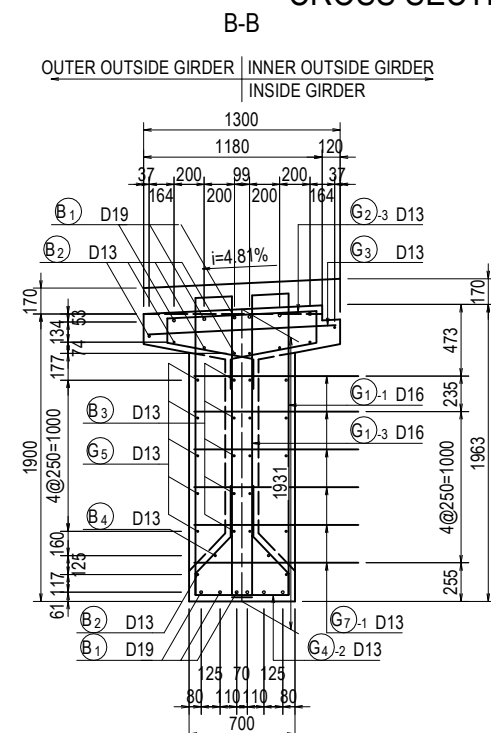
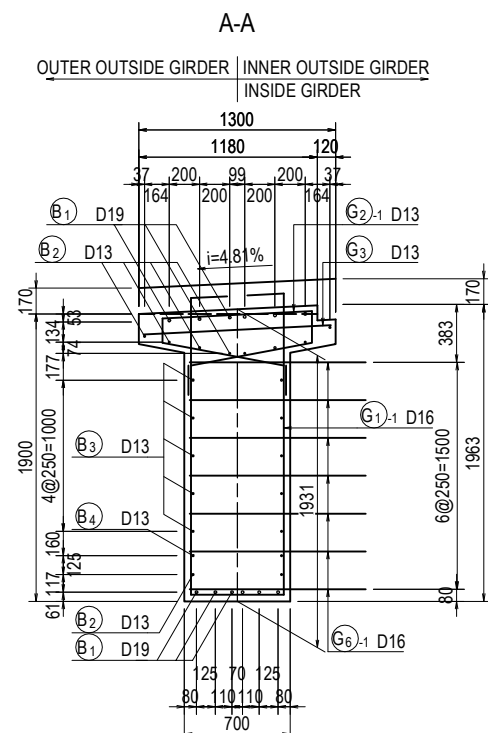

PROJECT NAME
DETAILED DESIGN ON
BAGO RIVER BRIDGE
CONSTRUCTION PROJECT

FINANCED BY
 JAPAN INTERNATIONAL
COOPERATION AGENCY

COUNTERPART
 REPUBLIC OF THE UNION OF MYANMAR
MINISTRY OF CONSTRUCTION
DEPARTMENT OF BRIDGE

JICA STUDY TEAM
 NIPPON KOEI CO., LTD.
ORIENTAL CONSULTANTS GLOBAL CO., LTD.
METROPOLITAN EXPRESSWAY COMPANY LIMITED
CHODAI CO., LTD.
NIPPON ENGINEERING CONSULTANTS CO., LTD.

	NAME	SIGNATURE	DATE
PREPARED BY	Y. SUZUKI		14 Jul. 2017
CHECKED BY	T. HAYAKAWA		20 Jul. 2017
APPROVED BY	Y. SANO		25 Jul. 2017

DRAWING TITLE
BAR ARRANGEMENT OF MAIN GIRDER (PF5-PF7) (1)

PACKAGE
3
DWG No.
P3-FO-108

BAR ARRANGEMENT OF MAIN GIRDER (PF5-PF7) (2)

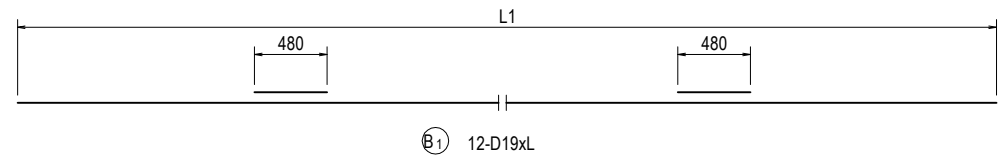

	L(mm)	
	B1	
	L1	L
G1	29293	30260
G2	29622	30590
G3	29950	30910
G4	30278	31240

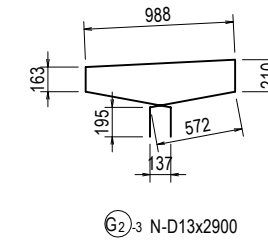
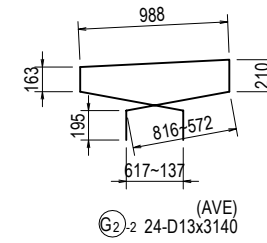
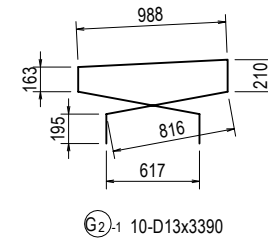

	N(number)	
	G2-3	N
G1	86	
G2	86	
G3	88	
G4	90	

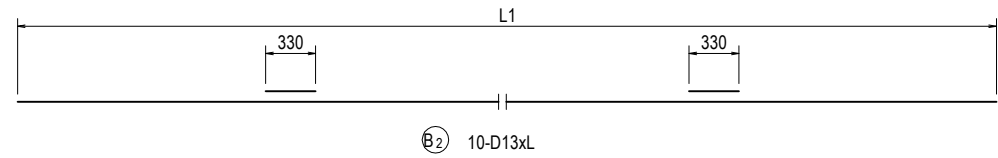

	L(mm)	
	B2	
	L1	L
G1	29293	29960
G2	29622	30290
G3	29950	30610
G4	30278	30940

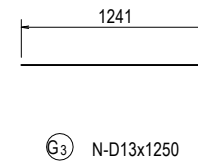

	N(number)	
	G3	N
G1	120	
G2	120	
G3	122	
G4	124	

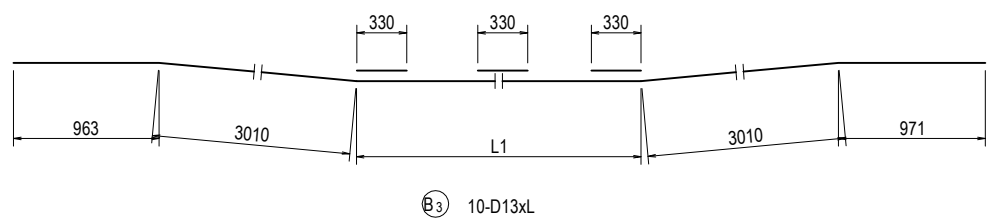

	L(mm)	
	B3	
	L1	L
G1	21359	30310
G2	21687	30640
G3	22016	30960
G4	22344	31290

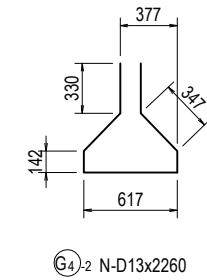
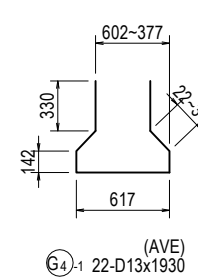

	N(number)	
	G4-2	N
G1	86	
G2	86	
G3	88	
G4	90	

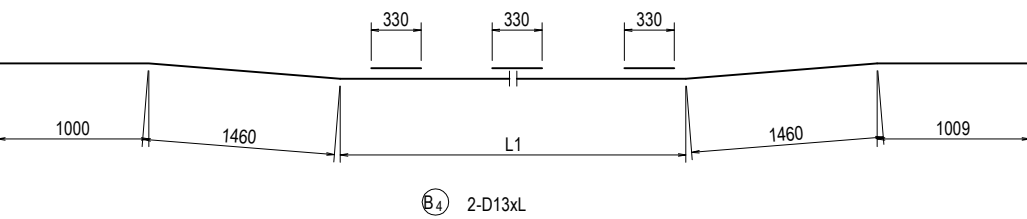

	L(mm)	
	B4	
	L1	L
G1	24373	30300
G2	24701	30620
G3	25030	30950
G4	25358	31280

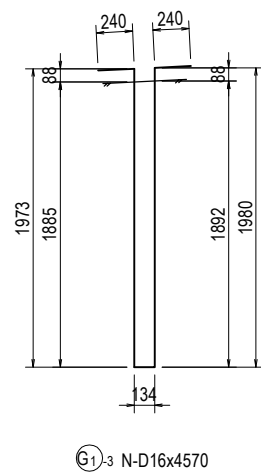
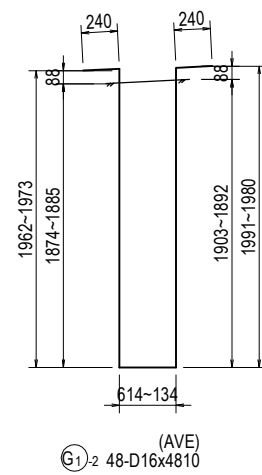
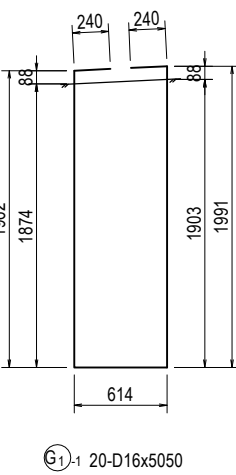

	N(number)	
	G1-3	N
G1	170	
G2	172	
G3	176	
G4	178	

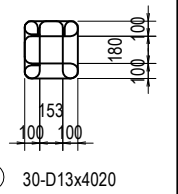
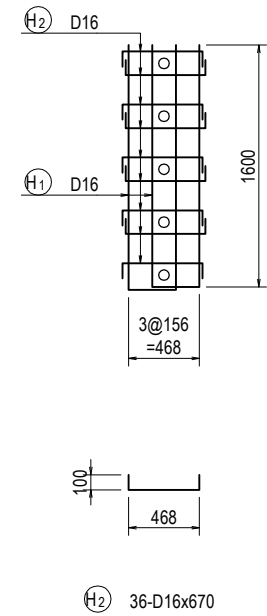
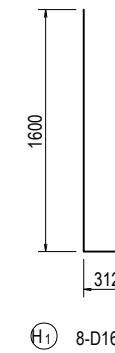
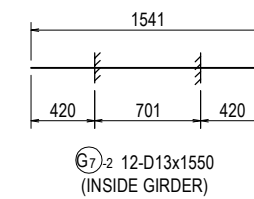
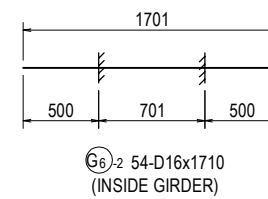
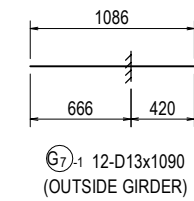
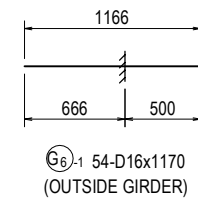

BAR ARRANGEMENT OF MAIN GIRDER (PF5-PF7) (3)

(G1)BAR LIST

REBAR NO.	DIA (mm)	LENGHT (mm)	NUMBER	UNIT WEIGHT (kg/m)	WEIGHT/ONE (kg)	WEIGHT (kg)	REMARKS
B 1	D19	30260	12	2.25	68.09	817	
B 2	D13	29960	10	0.995	29.81	298	
B 3	D13	30310	10	0.995	30.16	302	
B 4	D13	30300	2	0.995	30.15	60	
G 1 -1	D16	5050	20	1.56	7.88	158	
G 1 -2	D16	4810	48	1.56	7.50	360	AVERAGE
G 1 -3	D16	4570	170	1.56	7.13	1212	
G 2 -1	D13	3390	10	0.995	3.37	34	
G 2 -2	D13	3140	24	0.995	3.12	75	AVERAGE
G 2 -3	D13	2900	86	0.995	2.89	249	
G 3	D13	1250	120	0.995	1.24	149	
G 4 -1	D13	1930	22	0.995	1.92	42	AVERAGE
G 4 -2	D13	2260	86	0.995	2.25	194	
G 5	D13	1370	10	0.995	1.36	14	
G 6 -1	D16	1170	54	1.56	1.83	99	OUTSIDE GIRDER
G 7 -1	D13	1090	12	0.995	1.08	13	OUTSIDE GIRDER
H 1	D16	3520	8	1.56	5.49	44	
H 2	D16	670	36	1.56	1.05	38	
H 3	D13	4020	30	0.995	4.00	120	
						D19	817 kg
						D16	1911 kg
						D13	1550 kg
						TOTAL	4278 kg

(G3)BAR LIST

REBAR NO.	DIA (mm)	LENGHT (mm)	NUMBER	UNIT WEIGHT (kg/m)	WEIGHT/ONE (kg)	WEIGHT (kg)	REMARKS
B 1	D19	30910	12	2.25	69.55	835	
B 2	D13	30610	10	0.995	30.46	305	
B 3	D13	30960	10	0.995	30.81	308	
B 4	D13	30950	2	0.995	30.80	62	
G 1 -1	D16	5050	20	1.56	7.88	158	
G 1 -2	D16	4810	48	1.56	7.50	360	AVERAGE
G 1 -3	D16	4570	176	1.56	7.13	1255	
G 2 -1	D13	3390	10	0.995	3.37	34	
G 2 -2	D13	3140	24	0.995	3.12	75	AVERAGE
G 2 -3	D13	2900	88	0.995	2.89	254	
G 3	D13	1250	122	0.995	1.24	151	
G 4 -1	D13	1930	22	0.995	1.92	42	AVERAGE
G 4 -2	D13	2260	88	0.995	2.25	198	
G 5	D13	1370	10	0.995	1.36	14	
G 6 -2	D16	1710	54	1.56	2.67	144	INSIDE GIRDER
G 7 -2	D13	1550	12	0.995	1.54	18	INSIDE GIRDER
H 1	D16	3520	8	1.56	5.49	44	
H 2	D16	670	36	1.56	1.05	38	
H 3	D13	4020	30	0.995	4.00	120	
						D19	835 kg
						D16	1999 kg
						D13	1581 kg
						TOTAL	4415 kg

(G2)BAR LIST

REBAR NO.	DIA (mm)	LENGHT (mm)	NUMBER	UNIT WEIGHT (kg/m)	WEIGHT/ONE (kg)	WEIGHT (kg)	REMARKS
B 1	D19	30590	12	2.25	68.83	826	
B 2	D13	30290	10	0.995	30.14	301	
B 3	D13	30640	10	0.995	30.49	305	
B 4	D13	30620	2	0.995	30.47	61	
G 1 -1	D16	5050	20	1.56	7.88	158	
G 1 -2	D16	4810	48	1.56	7.50	360	AVERAGE
G 1 -3	D16	4570	172	1.56	7.13	1226	
G 2 -1	D13	3390	10	0.995	3.37	34	
G 2 -2	D13	3140	24	0.995	3.12	75	AVERAGE
G 2 -3	D13	2900	86	0.995	2.89	249	
G 3	D13	1250	120	0.995	1.24	149	
G 4 -1	D13	1930	22	0.995	1.92	42	AVERAGE
G 4 -2	D13	2260	86	0.995	2.25	194	
G 5	D13	1370	10	0.995	1.36	14	
G 6 -2	D16	1710	54	1.56	2.67	144	INSIDE GIRDER
G 7 -2	D13	1550	12	0.995	1.54	18	INSIDE GIRDER
H 1	D16	3520	8	1.56	5.49	44	
H 2	D16	670	36	1.56	1.05	38	
H 3	D13	4020	30	0.995	4.00	120	
						D19	826 kg
						D16	1970 kg
						D13	1562 kg
						TOTAL	4358 kg

(G4)BAR LIST

REBAR NO.	DIA (mm)	LENGHT (mm)	NUMBER	UNIT WEIGHT (kg/m)	WEIGHT/ONE (kg)	WEIGHT (kg)	REMARKS
B 1	D19	31240	12	2.25	70.29	843	
B 2	D13	30940	10	0.995	30.79	308	
B 3	D13	31290	10	0.995	31.13	311	
B 4	D13	31280	2	0.995	31.12	62	
G 1 -1	D16	5050	20	1.56	7.88	158	
G 1 -2	D16	4810	48	1.56	7.50	360	AVERAGE
G 1 -3	D16	4570	178	1.56	7.13	1269	
G 2 -1	D13	3390	10	0.995	3.37	34	
G 2 -2	D13	3140	24	0.995	3.12	75	AVERAGE
G 2 -3	D13	2900	90	0.995	2.89	260	
G 3	D13	1250	124	0.995	1.24	154	
G 4 -1	D13	1930	22	0.995	1.92	42	AVERAGE
G 4 -2	D13	2260	90	0.995	2.25	203	
G 5	D13	1370	10	0.995	1.36	14	
G 6 -1	D16	1170	54	1.56	1.83	99	OUTSIDE GIRDER
G 7 -1	D13	1090	12	0.995	1.08	13	OUTSIDE GIRDER
H 1	D16	3520	8	1.56	5.49	44	
H 2	D16	670	36	1.56	1.05	38	
H 3	D13	4020	30	0.995	4.00	120	
						D19	843 kg
						D16	1968 kg
						D13	1596 kg
						TOTAL	4407 kg

BAR ARRANGEMENT OF MAIN GIRDER (PF5-PF7) (5)

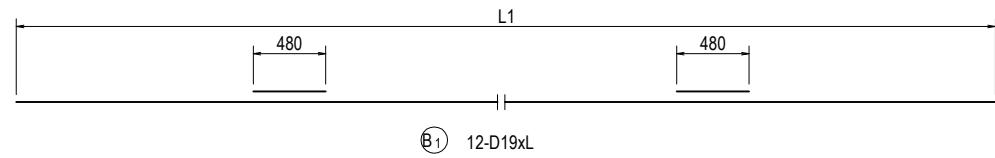

	L(mm)	
	L1	L
G1	29104	30070
G2	29564	30530
G3	30024	30990
G4	30484	31450

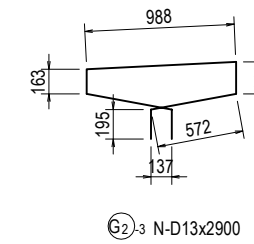
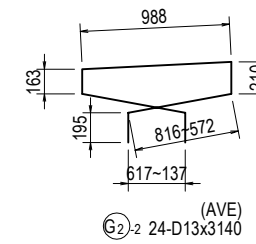
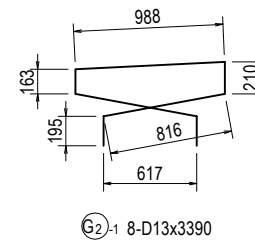

	N(number)	
	G2-3	N
G1	86	
G2	88	
G3	90	
G4	92	

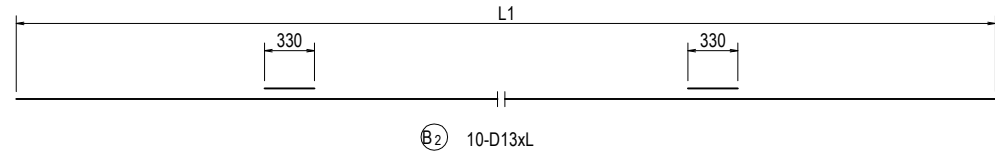

	L(mm)	
	L1	L
G1	29104	29770
G2	29564	30230
G3	30024	30690
G4	30484	31150

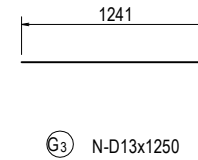

	N(number)	
	G3	N
G1	118	
G2	120	
G3	122	
G4	124	

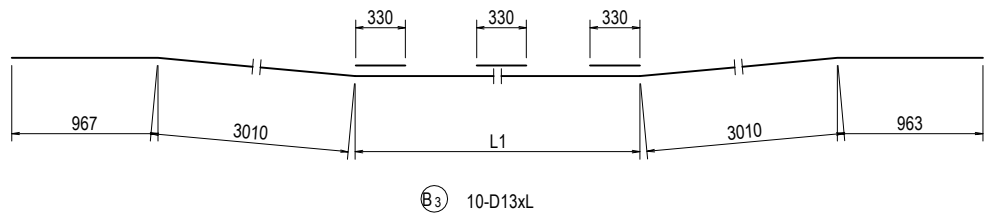

	L(mm)	
	L1	L
G1	21174	30120
G2	21634	30580
G3	22094	31040
G4	22554	31500

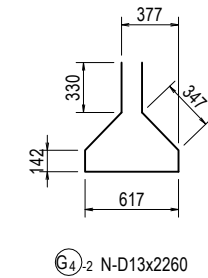
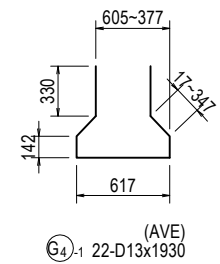

	N(number)	
	G4-2	N
G1	86	
G2	88	
G3	90	
G4	92	

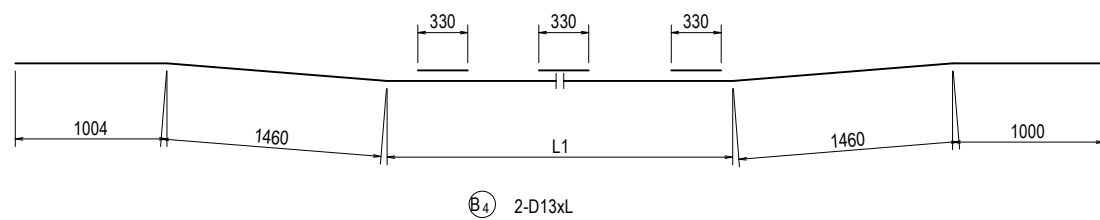
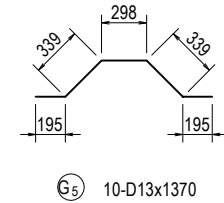

	L(mm)	
	L1	L
G1	24188	30110
G2	24648	30570
G3	25108	31030
G4	25568	31490

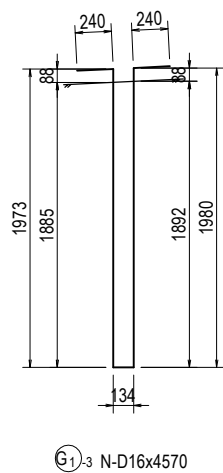
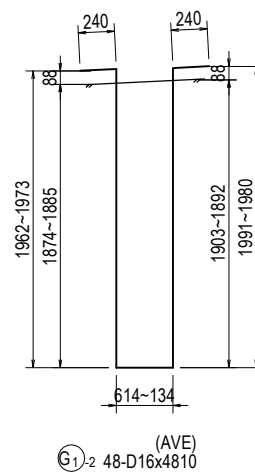
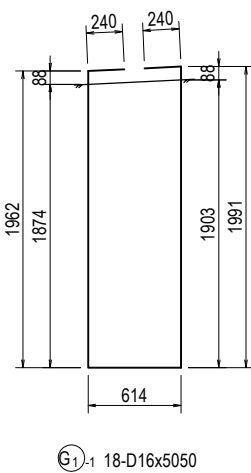

	N(number)	
	G1-3	N
G1	170	
G2	174	
G3	178	
G4	182	

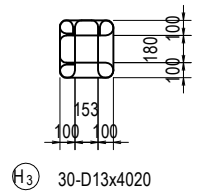
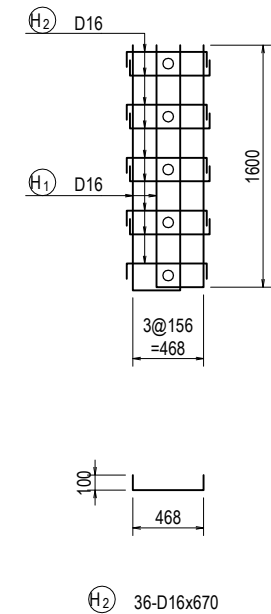
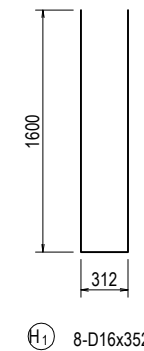
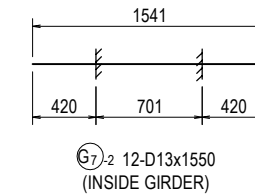
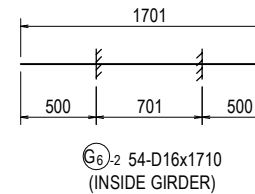
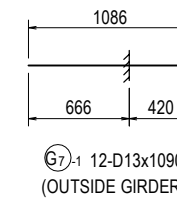
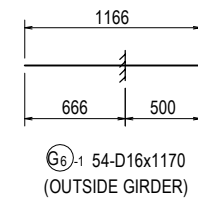

BAR ARRANGEMENT OF MAIN GIRDER (PF5-PF7) (6)

(G1)BAR LIST

REBAR NO.	DIA (mm)	LENGHT (mm)	NUMBER	UNIT WEIGHT (kg/m)	WEIGHT/ONE (kg)	WEIGHT (kg)	REMARKS
B 1	D19	30070	12	2.25	67.66	812	
B 2	D13	29770	10	0.995	29.62	296	
B 3	D13	30120	10	0.995	29.97	300	
B 4	D13	30110	2	0.995	29.96	60	
G 1 -1	D16	5050	18	1.56	7.88	142	
G 1 -2	D16	4810	48	1.56	7.50	360	AVERAGE
G 1 -3	D16	4570	170	1.56	7.13	1212	
G 2 -1	D13	3390	8	0.995	3.37	27	
G 2 -2	D13	3140	24	0.995	3.12	75	AVERAGE
G 2 -3	D13	2900	86	0.995	2.89	249	
G 3	D13	1250	118	0.995	1.24	146	
G 4 -1	D13	1930	22	0.995	1.92	42	AVERAGE
G 4 -2	D13	2260	86	0.995	2.25	194	
G 5	D13	1370	10	0.995	1.36	14	
G 6 -1	D16	1170	54	1.56	1.83	99	OUTSIDE GIRDER
G 7 -1	D13	1090	12	0.995	1.08	13	OUTSIDE GIRDER
H 1	D16	3520	8	1.56	5.49	44	
H 2	D16	670	36	1.56	1.05	38	
H 3	D13	4020	30	0.995	4.00	120	
						D19	812 kg
						D16	1895 kg
						D13	1536 kg
						TOTAL	4243 kg

(G3)BAR LIST

REBAR NO.	DIA (mm)	LENGHT (mm)	NUMBER	UNIT WEIGHT (kg/m)	WEIGHT/ONE (kg)	WEIGHT (kg)	REMARKS
B 1	D19	30990	12	2.25	69.73	837	
B 2	D13	30690	10	0.995	30.54	305	
B 3	D13	31040	10	0.995	30.88	309	
B 4	D13	31030	2	0.995	30.87	62	
G 1 -1	D16	5050	18	1.56	7.88	142	
G 1 -2	D16	4810	48	1.56	7.50	360	AVERAGE
G 1 -3	D16	4570	178	1.56	7.13	1269	
G 2 -1	D13	3390	8	0.995	3.37	27	
G 2 -2	D13	3140	24	0.995	3.12	75	AVERAGE
G 2 -3	D13	2900	90	0.995	2.89	260	
G 3	D13	1250	122	0.995	1.24	151	
G 4 -1	D13	1930	22	0.995	1.92	42	AVERAGE
G 4 -2	D13	2260	90	0.995	2.25	203	
G 5	D13	1370	10	0.995	1.36	14	
G 6 -2	D16	1710	54	1.56	2.67	144	INSIDE GIRDER
G 7 -2	D13	1550	12	0.995	1.54	18	INSIDE GIRDER
H 1	D16	3520	8	1.56	5.49	44	
H 2	D16	670	36	1.56	1.05	38	
H 3	D13	4020	30	0.995	4.00	120	
						D19	837 kg
						D16	1997 kg
						D13	1586 kg
						TOTAL	4420 kg

(G2)BAR LIST

REBAR NO.	DIA (mm)	LENGHT (mm)	NUMBER	UNIT WEIGHT (kg/m)	WEIGHT/ONE (kg)	WEIGHT (kg)	REMARKS
B 1	D19	30530	12	2.25	68.69	824	
B 2	D13	30230	10	0.995	30.08	301	
B 3	D13	30580	10	0.995	30.43	304	
B 4	D13	30570	2	0.995	30.42	61	
G 1 -1	D16	5050	18	1.56	7.88	142	
G 1 -2	D16	4810	48	1.56	7.50	360	AVERAGE
G 1 -3	D16	4570	174	1.56	7.13	1241	
G 2 -1	D13	3390	8	0.995	3.37	27	
G 2 -2	D13	3140	24	0.995	3.12	75	AVERAGE
G 2 -3	D13	2900	88	0.995	2.89	254	
G 3	D13	1250	120	0.995	1.24	149	
G 4 -1	D13	1930	22	0.995	1.92	42	AVERAGE
G 4 -2	D13	2260	88	0.995	2.25	198	
G 5	D13	1370	10	0.995	1.36	14	
G 6 -2	D16	1710	54	1.56	2.67	144	INSIDE GIRDER
G 7 -2	D13	1550	12	0.995	1.54	18	INSIDE GIRDER
H 1	D16	3520	8	1.56	5.49	44	
H 2	D16	670	36	1.56	1.05	38	
H 3	D13	4020	30	0.995	4.00	120	
						D19	824 kg
						D16	1969 kg
						D13	1563 kg
						TOTAL	4356 kg

(G4)BAR LIST

REBAR NO.	DIA (mm)	LENGHT (mm)	NUMBER	UNIT WEIGHT (kg/m)	WEIGHT/ONE (kg)	WEIGHT (kg)	REMARKS
B 1	D19	31450	12	2.25	70.76	849	
B 2	D13	31150	10	0.995	30.99	310	
B 3	D13	31500	10	0.995	31.34	313	
B 4	D13	31490	2	0.995	31.33	63	
G 1 -1	D16	5050	18	1.56	7.88	142	
G 1 -2	D16	4810	48	1.56	7.50	360	AVERAGE
G 1 -3	D16	4570	182	1.56	7.13	1298	
G 2 -1	D13	3390	8	0.995	3.37	27	
G 2 -2	D13	3140	24	0.995	3.12	75	AVERAGE
G 2 -3	D13	2900	92	0.995	2.89	266	
G 3	D13	1250	124	0.995	1.24	154	
G 4 -1	D13	1930	22	0.995	1.92	42	AVERAGE
G 4 -2	D13	2260	92	0.995	2.25	207	
G 5	D13	1370	10	0.995	1.36	14	
G 6 -1	D16	1170	54	1.56	1.83	99	OUTSIDE GIRDER
G 7 -1	D13	1090	12	0.995	1.08	13	OUTSIDE GIRDER
H 1	D16	3520	8	1.56	5.49	44	
H 2	D16	670	36	1.56	1.05	38	
H 3	D13	4020	30	0.995	4.00	120	
						D19	849 kg
						D16	1981 kg
						D13	1604 kg
						TOTAL	4434 kg

BAR ARRANGEMENT OF CROSSBEAM (PF5-PF7) (1)

CROSS SECTION S=1:60

SIDE VIEW S=1:60

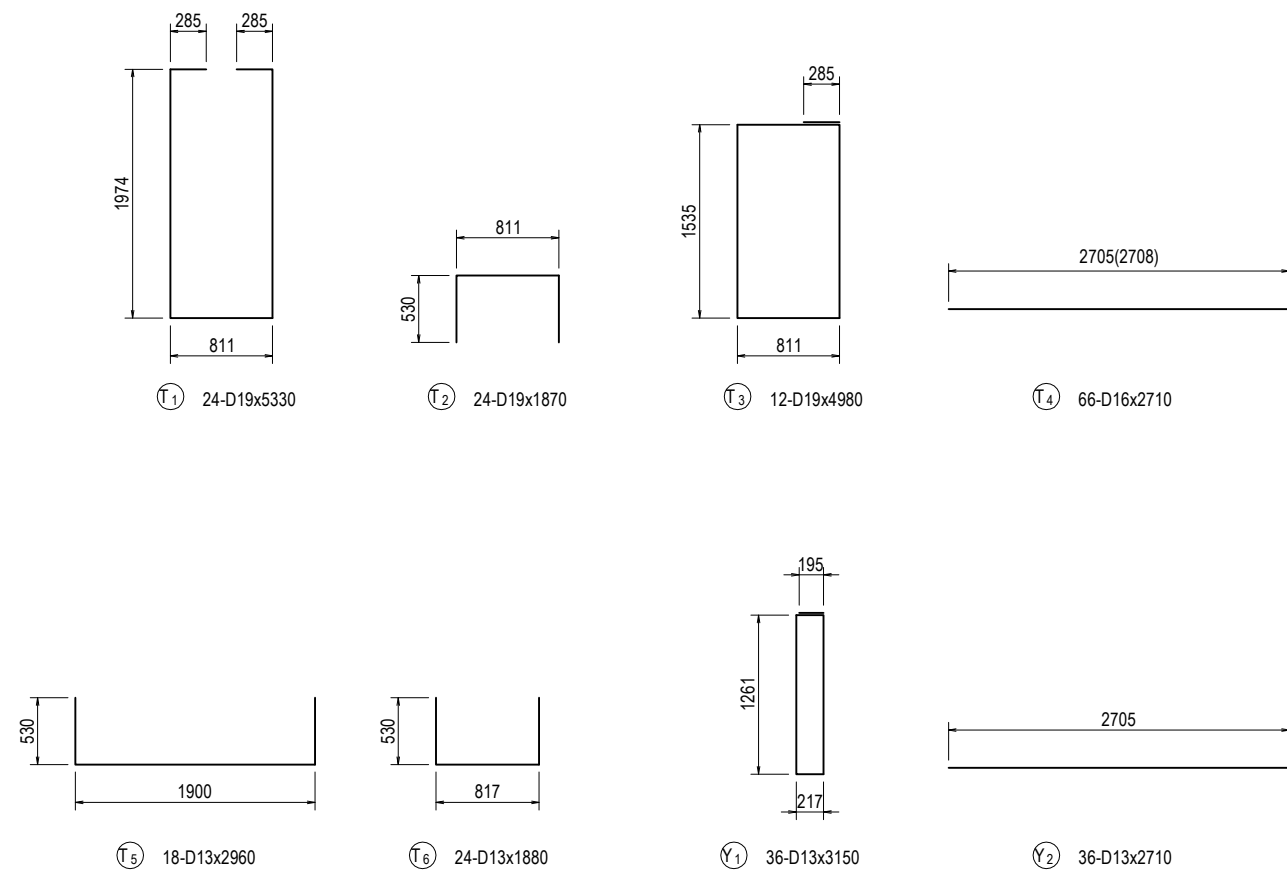
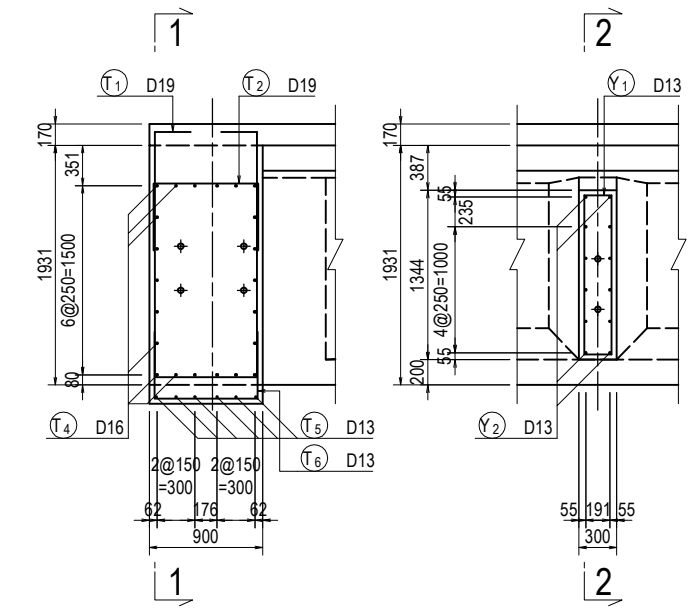
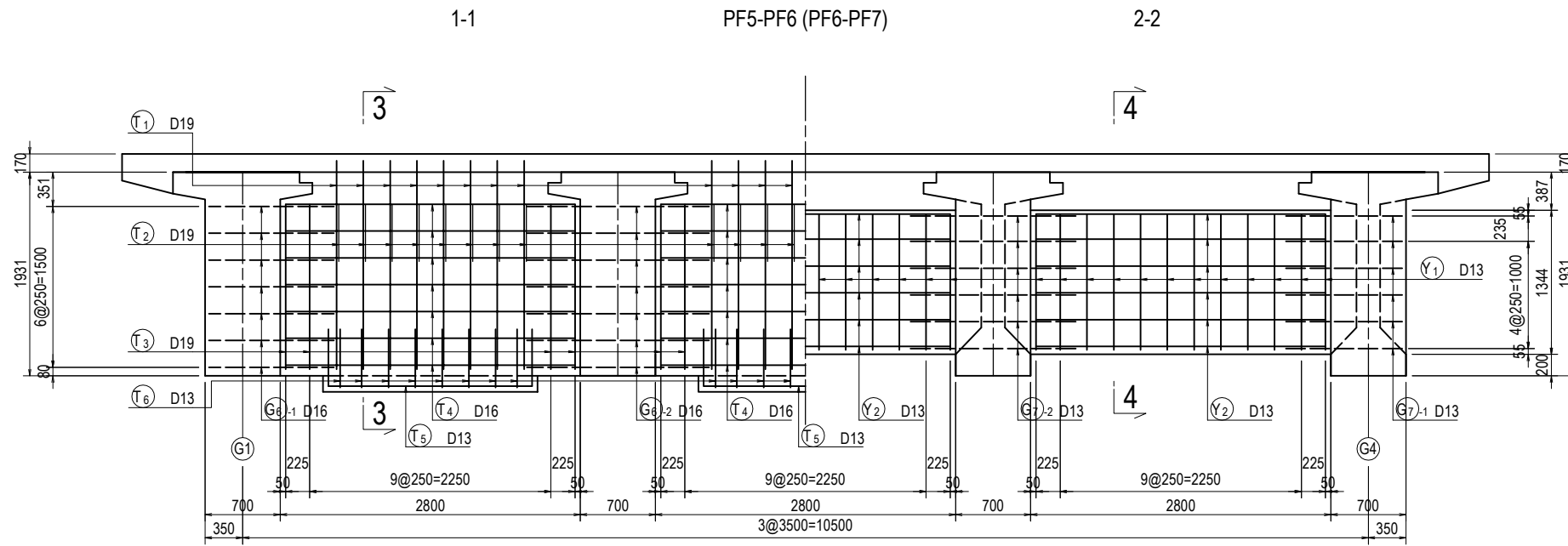

PC STRAND LIST

	TYPE	LENGTH (mm)	NUMBER	UNIT WEIGHT (kg/m)	WEIGHT/ONE (kg)	WEIGHT (kg)	REMARKS
	CROSSBEAM AT END OF MAIN GIRDER(PF5)	SWPR7BL 4S15.2	11212	4	4.404	49.378	197.5
	CROSSBEAM AT END OF MAIN GIRDER(PF7)	SWPR7BL 4S15.2	11241	4	4.404	49.505	198.0
	INTERMEDIATE CROSSBEAM(PF5-PF6)	SWPR7BL 4S15.2	11200	2	4.404	49.325	98.7
	INTERMEDIATE CROSSBEAM(PF6-PF7)	SWPR7BL 4S15.2	11202	2	4.404	49.334	98.7
				TOTAL LENGTH	ΣL=	134.616	m
				TOTAL WEIGHT	ΣW=	592.9	kg

BAR LIST

REBAR NO.	DIA (mm)	LENGTH (mm)	NUMBER	UNIT WEIGHT (kg/m)	WEIGHT/ONE (kg)	WEIGHT (kg)	REMARKS
T1	D19	5330	24	2.25	11.99	288	
T2	D19	1870	24	2.25	4.21	101	
T3	D19	4980	12	2.25	11.21	135	
T4	D16	2710	66	1.56	4.23	279	
T5	D13	2960	18	0.995	2.95	53	
T6	D13	1880	24	0.995	1.87	45	
Y1	D13	3150	36	0.995	3.13	113	
Y2	D13	2710	36	0.995	2.70	97	
				D19	524 kg	×2 =	1048 kg
				D16	279 kg	×2 =	558 kg
				D13	308 kg	×2 =	616 kg
				TOTAL	1111 kg	×2 =	2222 kg

BAR ARRANGEMENT OF CROSSBEAM (PF5-PF7) (2)

CROSS SECTION S=1:60

SIDE VIEW S=1:60

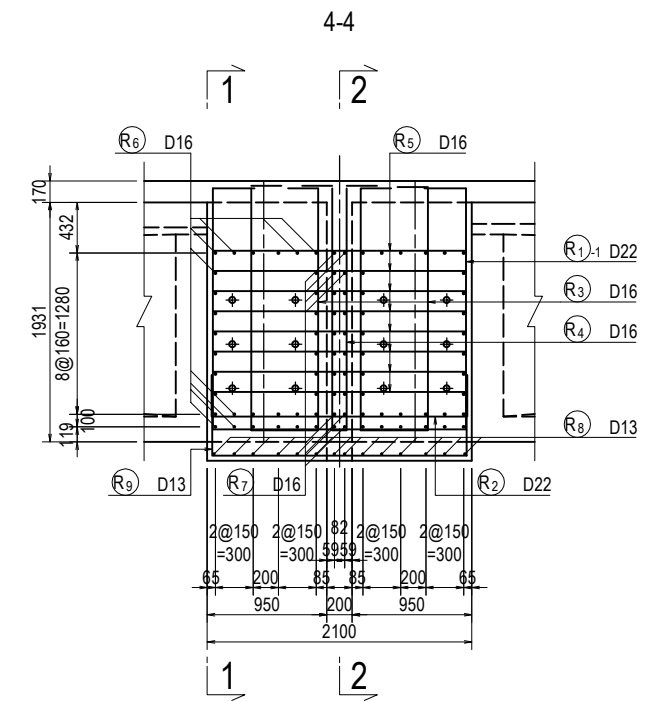
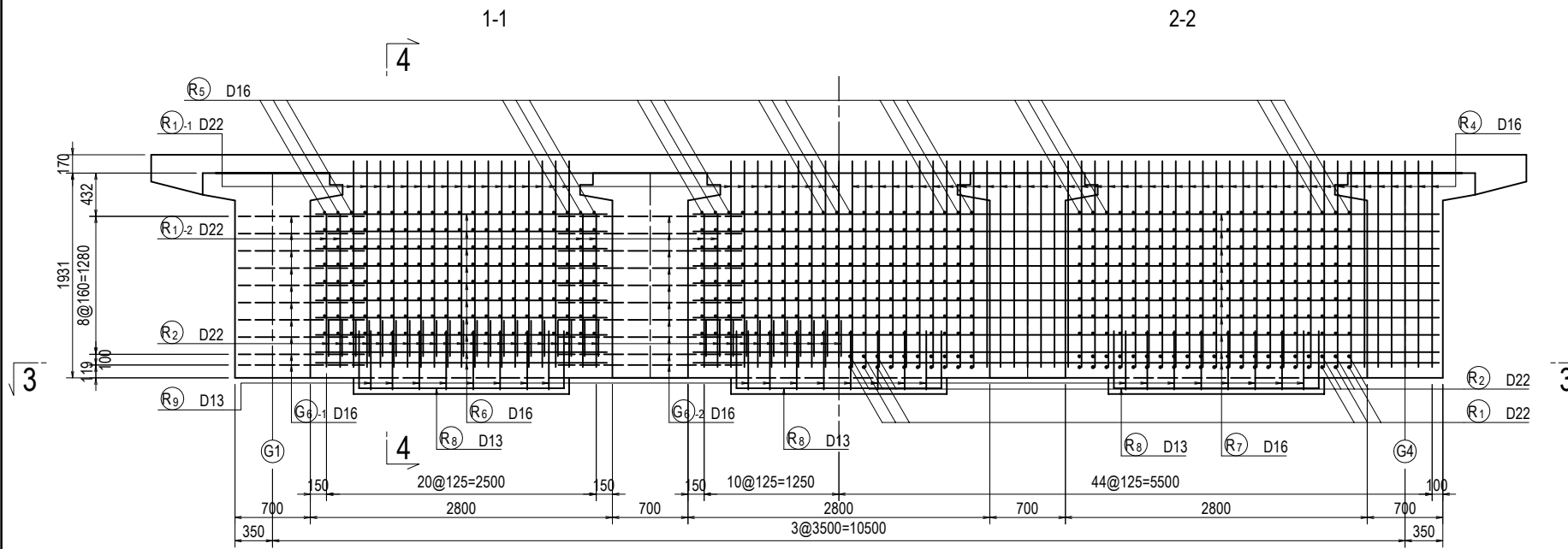

PLAN S=1:60

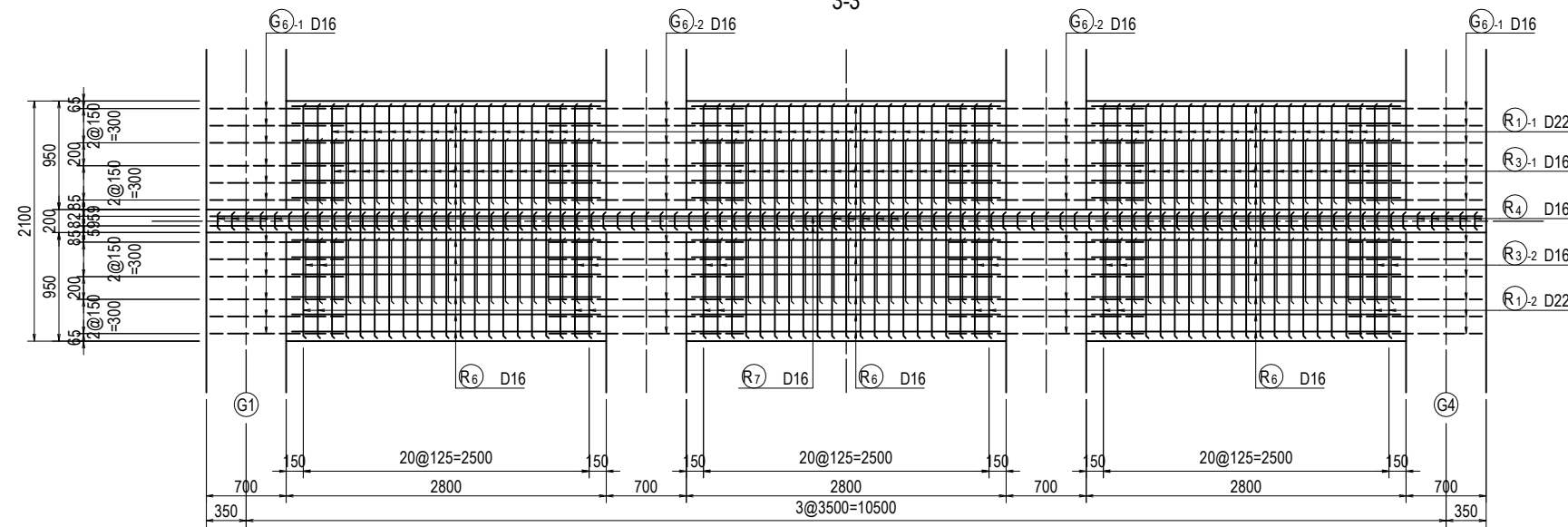

PC STRAND LIST

	TYPE	LENGTH (mm)	NUMBER	UNIT WEIGHT (kg/m)	WEIGHT/ONE (kg)	WEIGHT (kg)	REMARKS
CONNECTING CROSSBEAM	SWPR7BL 4S15.2	11212	12	4.404	49.378	592.5	
						TOTAL LENGTH	ΣL= 134.544 m
						TOTAL WEIGHT	ΣW= 592.5 kg

BAR LIST

REBAR NO.	DIA (mm)	LENGTH (mm)	NUMBER	UNIT WEIGHT (kg/m)	WEIGHT/ONE (kg)	WEIGHT (kg)	REMARKS
R1-1	D22	6550	51	3.04	19.91	1015	
R1-2	D22	5510	12	3.04	16.75	201	
R2	D22	2670	63	3.04	8.12	512	
R3-1	D16	4900	102	1.56	7.64	779	
R3-2	D16	3850	24	1.56	6.01	144	
R4	D16	4480	89	1.56	6.99	622	
R5	D16	2030	504	1.56	3.17	1598	
R6	D16	2710	192	1.56	4.23	812	
R7	D16	11150	20	1.56	17.39	348	
R8	D13	2960	42	0.995	2.95	124	
R9	D13	3080	24	0.995	3.06	73	
						D22	1728 kg
						D16	4303 kg
						D13	197 kg
						TOTAL	6228 kg

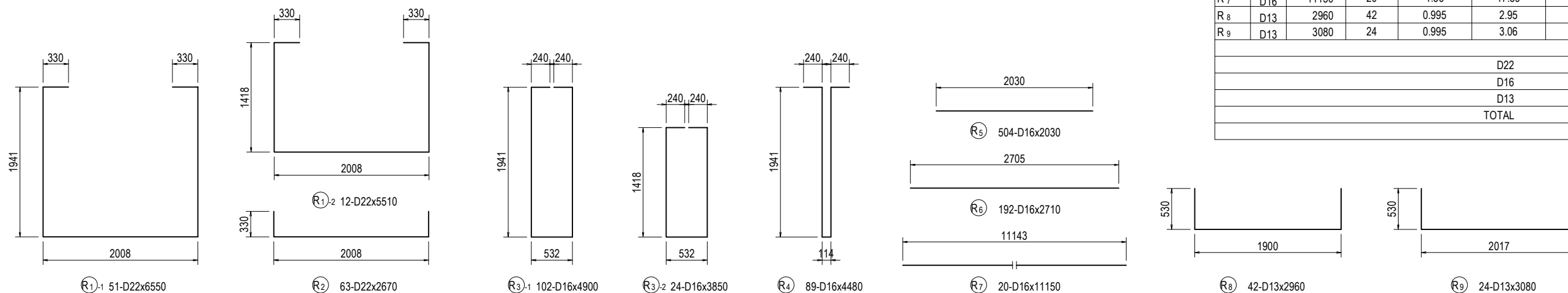

DETAIL OF PC PLATE FOR DECK SLAB (PF5-PF7)

SIDE VIEW S=1:20

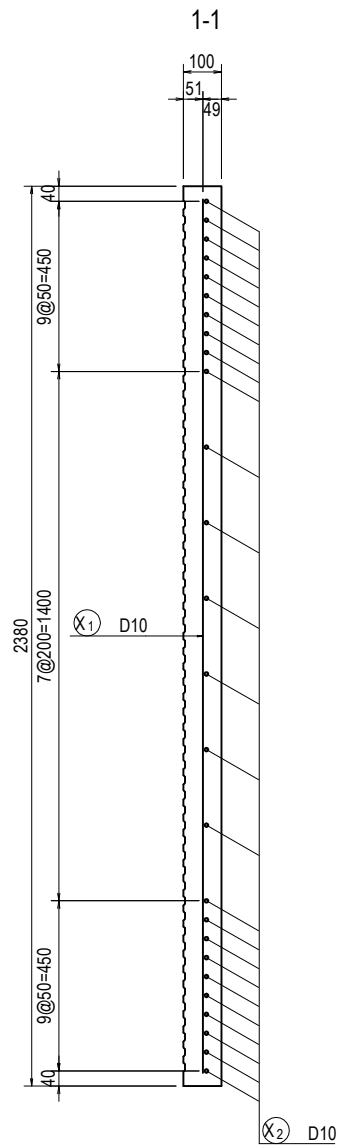

PLAN S=1:20
STANDARD

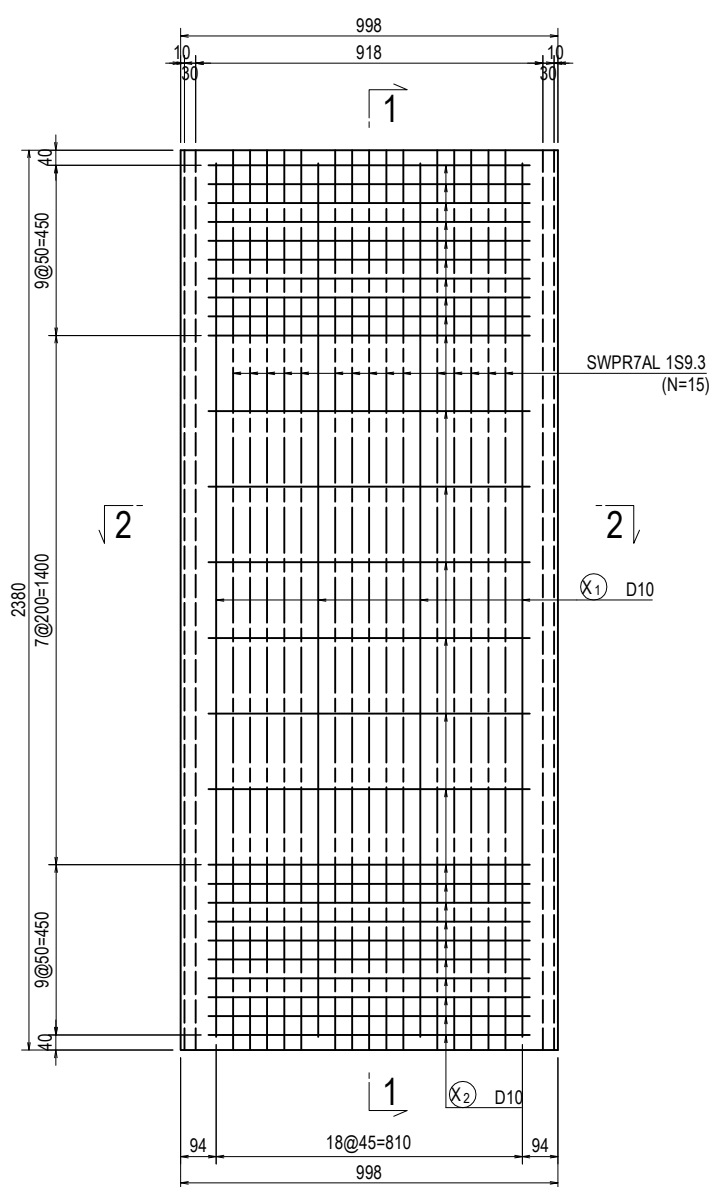

CROSS SECTION S=1:20

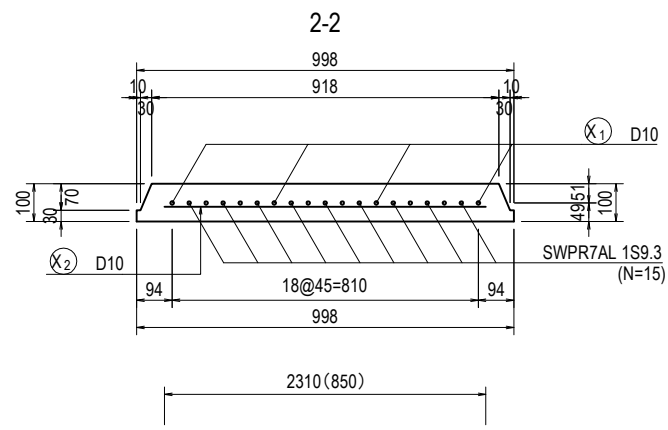

- (X1) 4-D10x2310
- (X2) 26-D10x850

KEY PLAN S=1:300

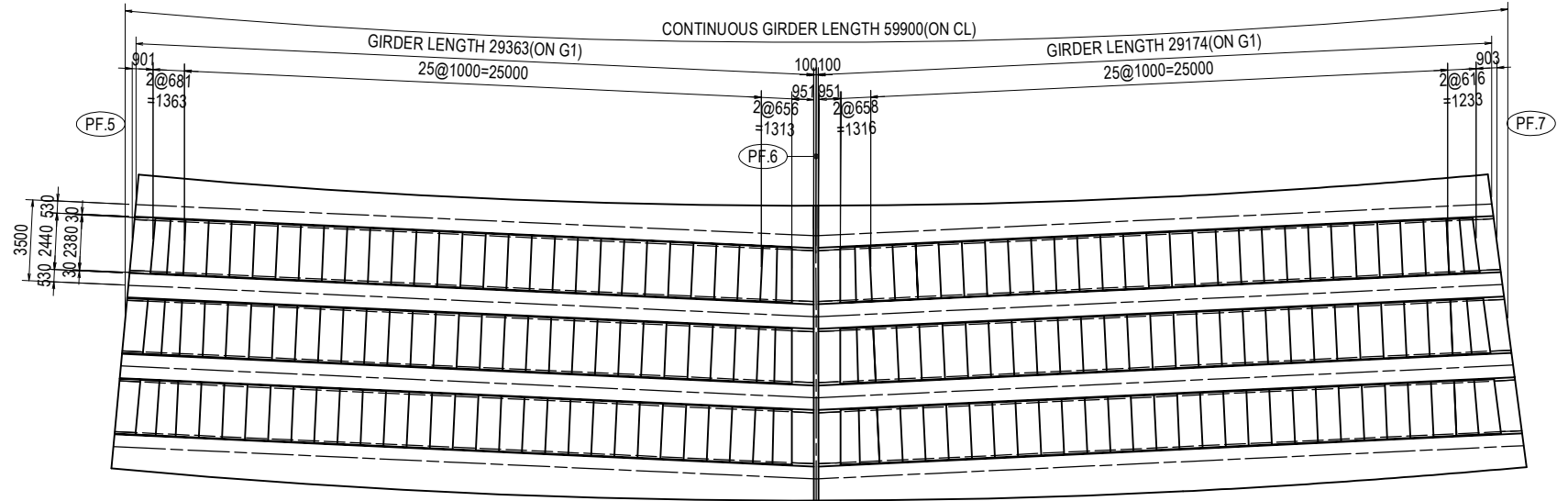

BAR LIST

REBAR NO.	DIA (mm)	LENGTH (mm)	NUMBER	UNIT WEIGHT (kg/m)	WEIGHT/ONE (kg)	WEIGHT (kg)	REMARKS
X1	D10	2310	4	0.56	1.29	5.2	
X2	D10	850	26	0.56	0.48	12.5	
						17.7 kg	
TOTAL					17.7 kg	×174 =	3079.8 kg

PC STRAND LIST

TYPE	LENGTH (mm)	NUMBER	UNIT WEIGHT (kg/m)	WEIGHT/ONE (kg)	WEIGHT (kg)	REMARKS	
SWPR7AL 1S9.3	2380	15	0.405	0.96	14.4		
TOTAL					14.4 kg	×174 =	2505.6 kg

BAR ARRANGEMENT OF DECK SLAB (PF5-PF7) (1)

PLAN S=1:100

CONTINUOUS GIRDER LENGTH 59900(O.N CL)

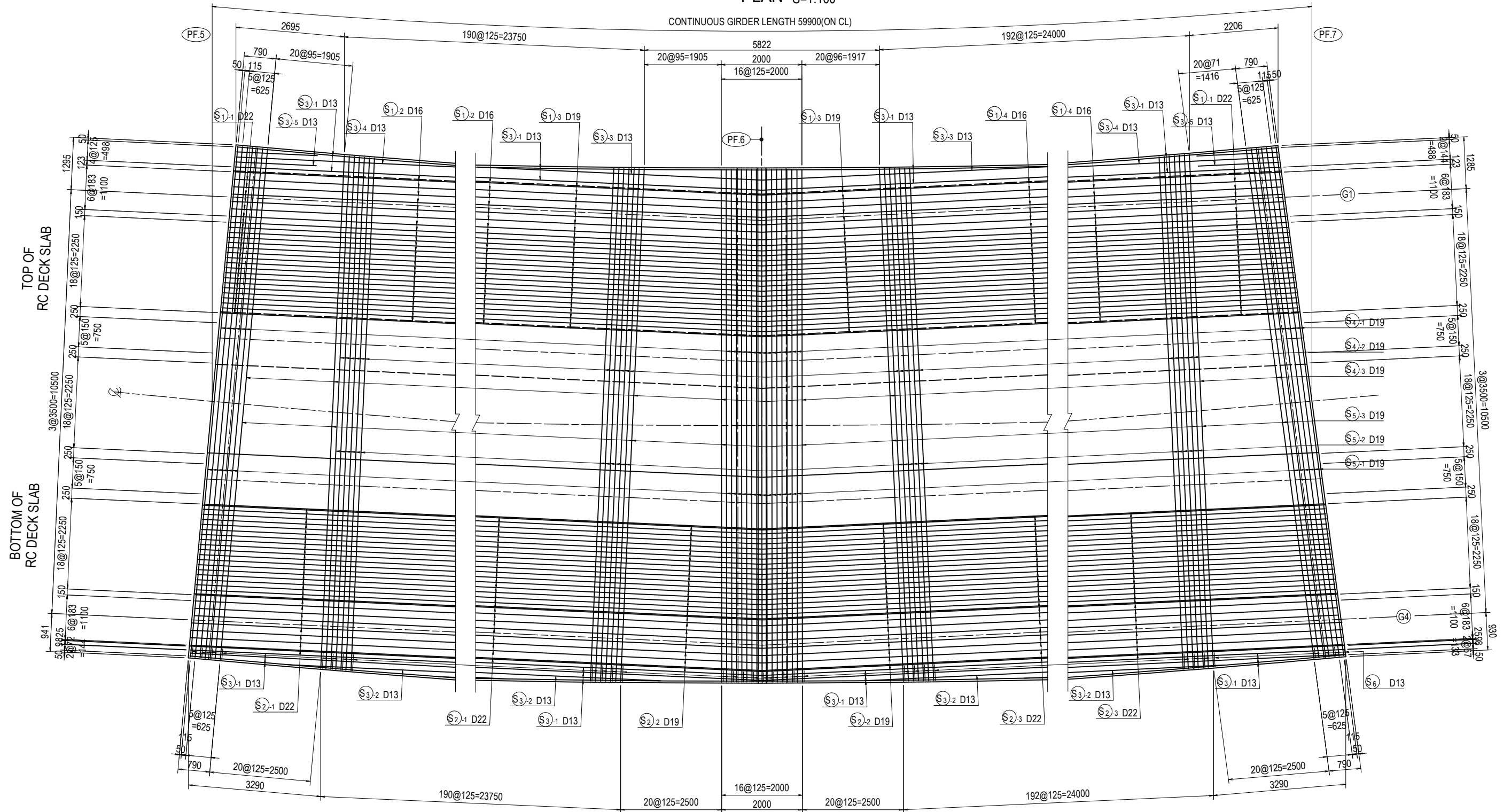

PROJECT NAME DETAILED DESIGN ON BAGO RIVER BRIDGE CONSTRUCTION PROJECT	FINANCED BY JAPAN INTERNATIONAL COOPERATION AGENCY	COUNTERPART REPUBLIC OF THE UNION OF MYANMAR MINISTRY OF CONSTRUCTION DEPARTMENT OF BRIDGE	JICA STUDY TEAM NIPPON KOEI CO., LTD. ORIENTAL CONSULTANTS GLOBAL CO., LTD. METROPOLITAN EXPRESSWAY COMPANY LIMITED CHODAI CO., LTD. NIPPON ENGINEERING CONSULTANTS CO., LTD.	NAME	SIGNATURE	DATE	DRAWING TITLE BAR ARRANGEMENT OF DECK SLAB (PF5-PF7) (1)	PACKAGE	
				PREPARED BY	Y. SUZUKI			14 Jul. 2017	3
				CHECKED BY	T. HAYAKAWA			20 Jul. 2017	DWG No.
				APPROVED BY	Y. SANO			25 Jul. 2017	P3-FO-1117

BAR ARRANGEMENT OF DECK SLAB (PF5-PF7) (2)

CROSS SECTION S=1:100

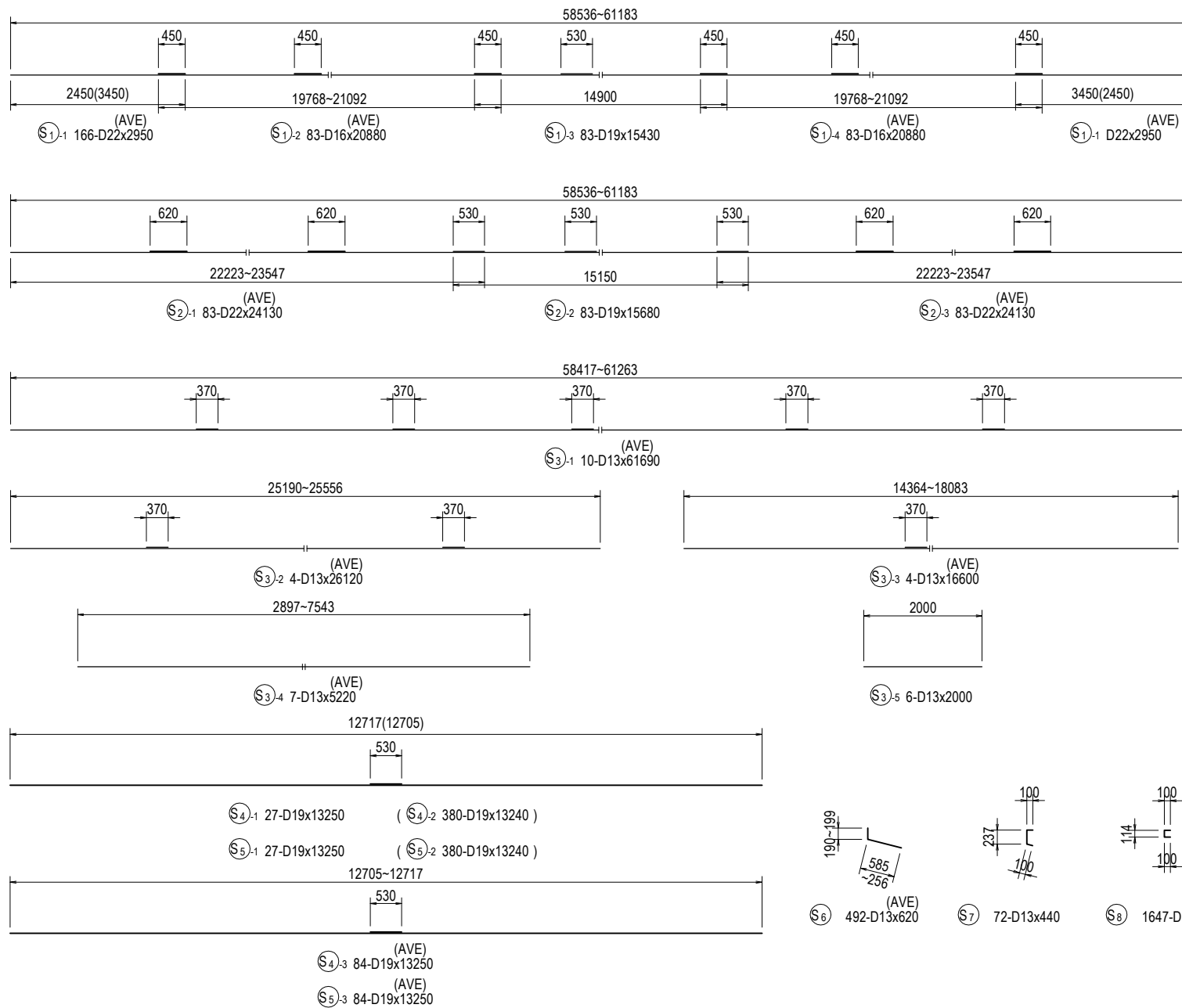
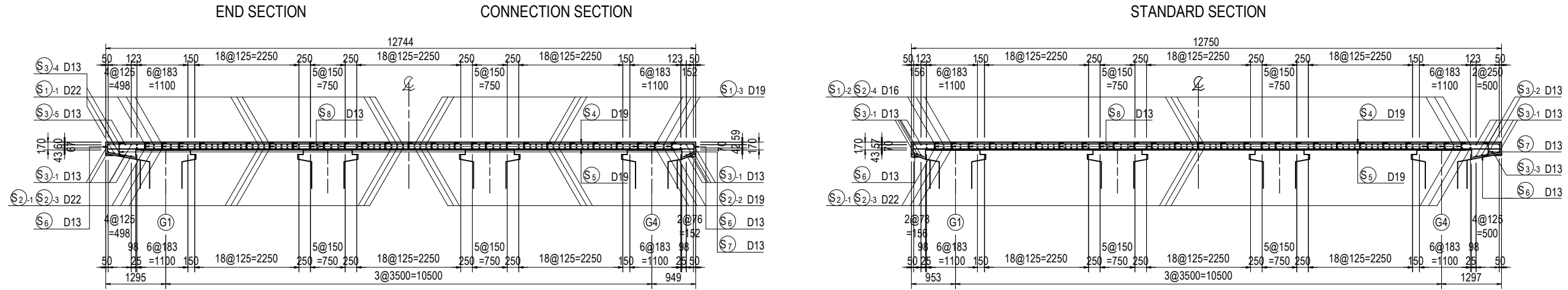

BAR LIST

REBAR NO.	DIA (mm)	LENGTH (mm)	NUMBER	UNIT WEIGHT (kg/m)	WEIGHT/ONE (kg)	WEIGHT (kg)	REMARKS	
S 1 - 1	D22	2950	166	3.04	8.97	1489	AVERAGE	
S 1 - 2	D16	20880	83	1.56	32.57	2703	AVERAGE	
S 1 - 3	D19	15430	83	2.25	34.72	2882		
S 1 - 4	D16	20880	83	1.56	32.57	2703	AVERAGE	
S 2 - 1	D22	24130	83	3.04	73.36	6089	AVERAGE	
S 2 - 2	D19	15680	83	2.25	35.28	2928		
S 2 - 3	D22	24130	83	3.04	73.36	6089	AVERAGE	
S 3 - 1	D13	61690	10	0.995	61.38	614	AVERAGE	
S 3 - 2	D13	26120	4	0.995	25.99	104	AVERAGE	
S 3 - 3	D13	16600	4	0.995	16.52	66	AVERAGE	
S 3 - 4	D13	5220	7	0.995	5.19	36	AVERAGE	
S 3 - 5	D13	2000	6	0.995	1.99	12		
S 4 - 1	D19	13250	27	2.25	29.81	805		
S 4 - 2	D19	13240	380	2.25	29.79	11320		
S 4 - 3	D19	13250	84	2.25	29.81	2504	AVERAGE	
S 5 - 1	D19	13250	27	2.25	29.81	805		
S 5 - 2	D19	13240	380	2.25	29.79	11320		
S 5 - 3	D19	13250	84	2.25	29.81	2504	AVERAGE	
S 6	D13	620	492	0.995	0.62	305	AVERAGE	
S 7	D13	440	72	0.995	0.44	32		
S 8	D13	320	1647	0.995	0.32	527		
					D22	13667	kg	
					D19	35068	kg	
					D16	5406	kg	
					D13	1696	kg	
					TOTAL	55837	kg	

DETAIL OF CONCRETE CURB, BARRIER AND MEDIUM (PF5-PF7) (1)

SIDE VIEW S=1:100

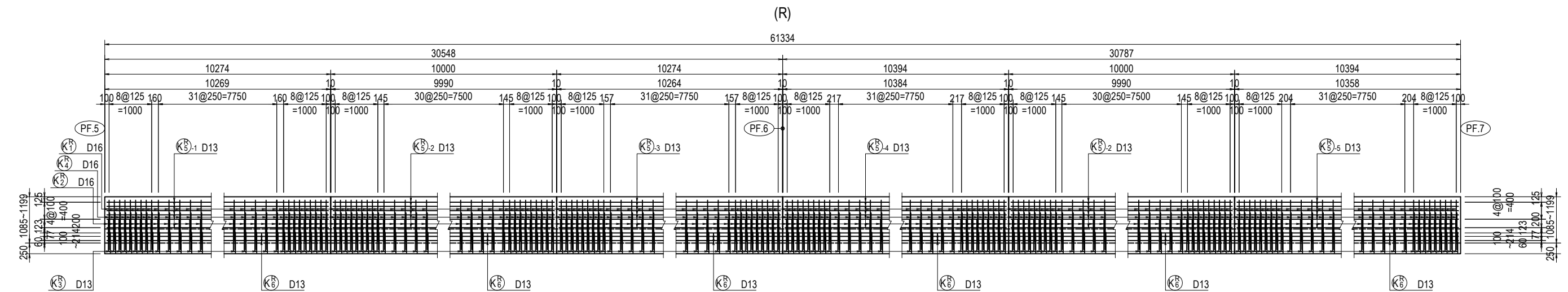
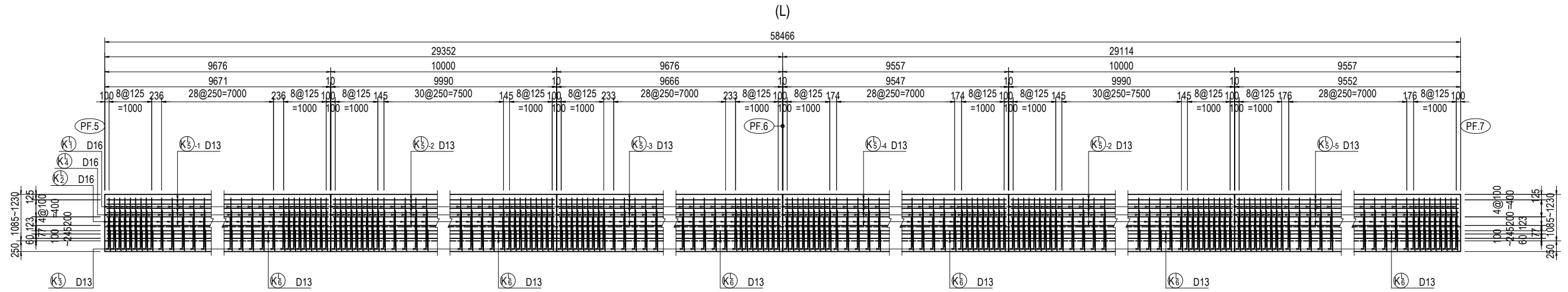

CROSS SECTION S=1:50

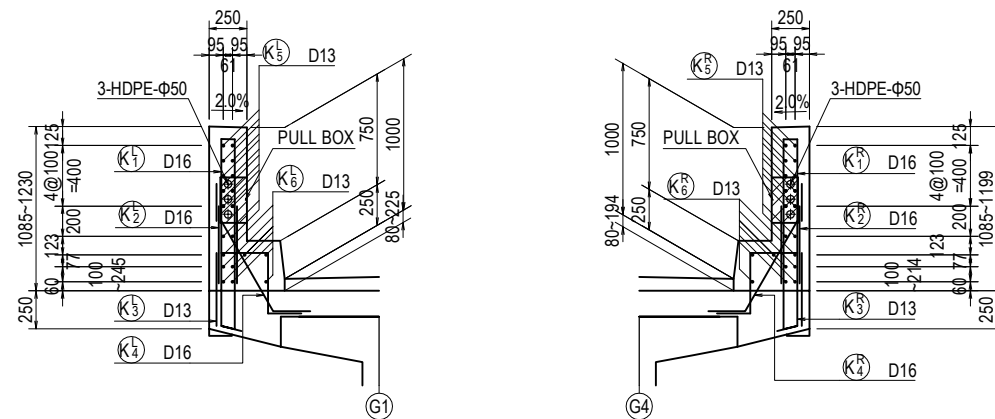

CROSS SECTION S=1:40

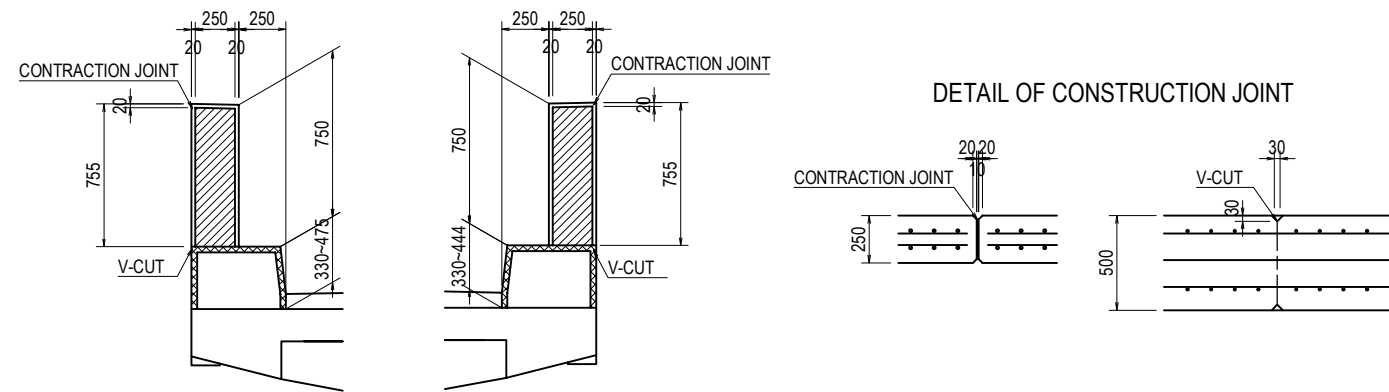

DETAIL OF CONSTRUCTION JOINT

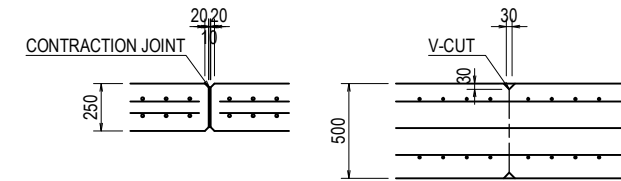

PROJECT NAME DETAILED DESIGN ON BAGO RIVER BRIDGE CONSTRUCTION PROJECT	FINANCED BY JAPAN INTERNATIONAL COOPERATION AGENCY	COUNTERPART REPUBLIC OF THE UNION OF MYANMAR MINISTRY OF CONSTRUCTION DEPARTMENT OF BRIDGE	JICA STUDY TEAM NIPPON KOEI CO., LTD. ORIENTAL CONSULTANTS GLOBAL CO., LTD. METROPOLITAN EXPRESSWAY COMPANY LIMITED CHODAI CO., LTD. NIPPON ENGINEERING CONSULTANTS CO., LTD.	NAME	SIGNATURE	DATE	DRAWING TITLE DETAIL OF CONCRETE CURB, BARRIER AND MEDIUM (PF5-PF7) (1)	PACKAGE 3 DWG No. P3-FO-119	
				PREPARED BY	Y. SUZUKI				14 Jul. 2017
				CHECKED BY	T. HAYAKAWA				20 Jul. 2017
				APPROVED BY	Y. SANO				25 Jul. 2017

DETAIL OF CONCRETE CURB, BARRIER AND MEDIUM (PF5-PF7) (2)

(L)

(R)

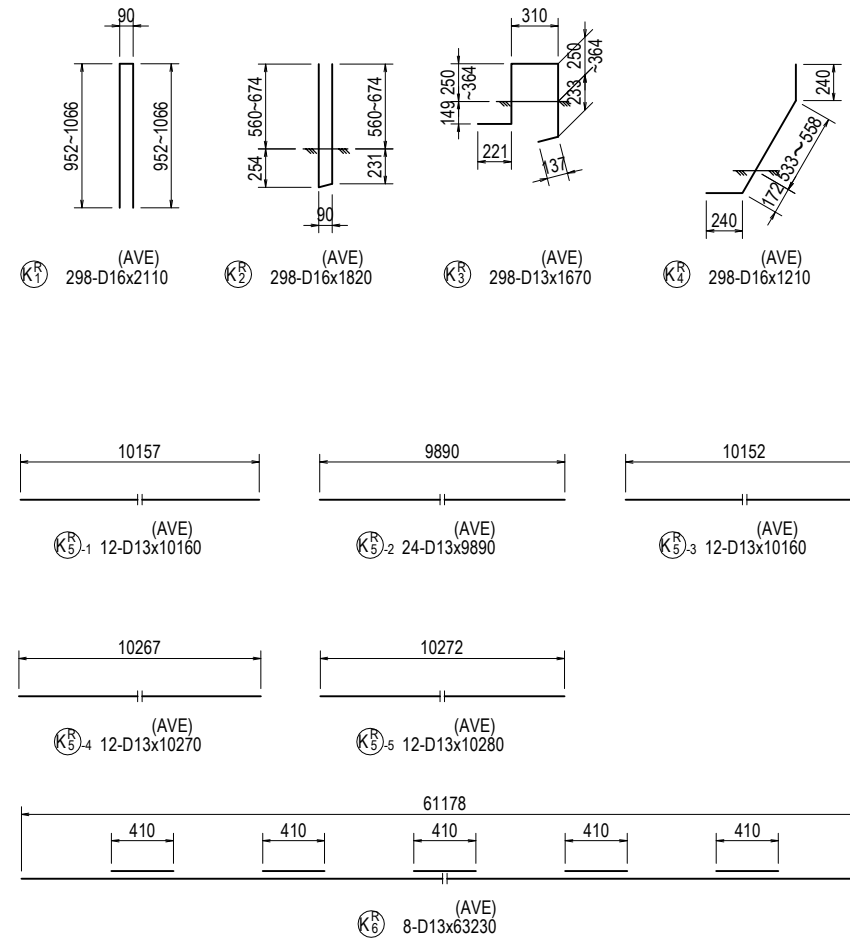
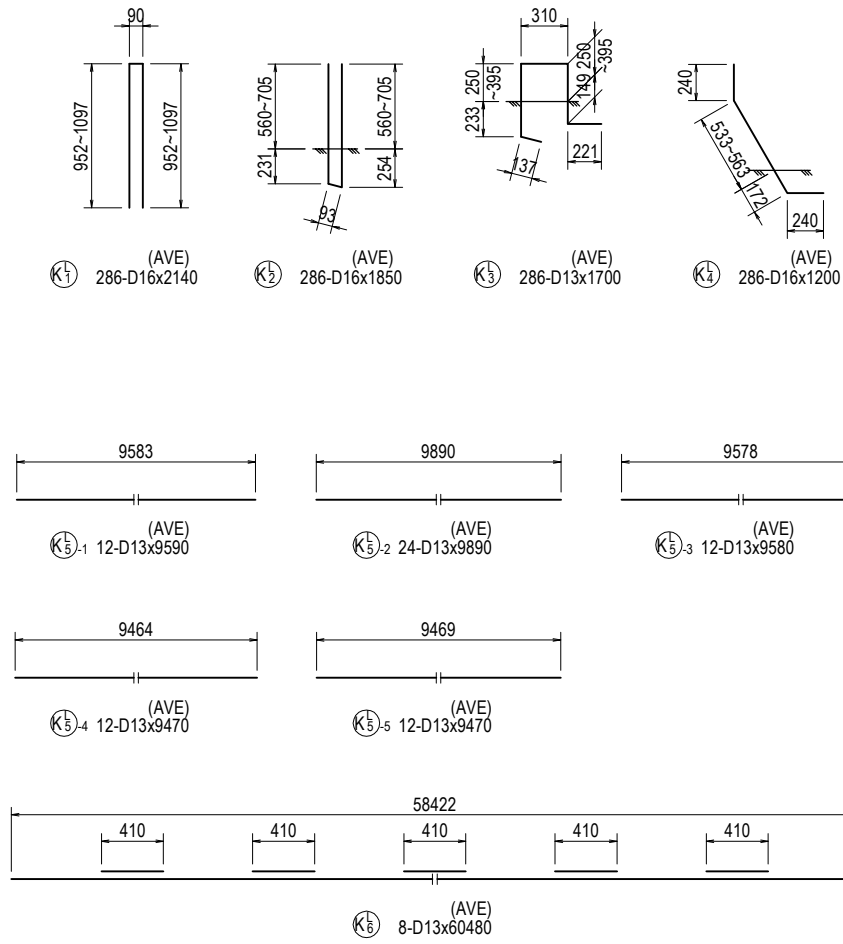

BAR LIST

REBAR NO.	DIA (mm)	LENGTH (mm)	NUMBER	UNIT WEIGHT (kg/m)	WEIGHT/ONE (kg)	WEIGHT (kg)	REMARKS
K ₁ ^L	D16	2140	286	1.56	3.34	955	AVERAGE
K ₂ ^L	D16	1850	286	1.56	2.89	827	AVERAGE
K ₃ ^L	D13	1700	286	0.995	1.69	483	AVERAGE
K ₄ ^L	D16	1200	286	1.56	1.87	535	AVERAGE
K ₅₋₁ ^L	D13	9590	12	0.995	9.54	114	AVERAGE
K ₅₋₂ ^L	D13	9890	24	0.995	9.84	236	AVERAGE
K ₅₋₃ ^L	D13	9580	12	0.995	9.53	114	AVERAGE
K ₅₋₄ ^L	D13	9470	12	0.995	9.42	113	AVERAGE
K ₅₋₅ ^L	D13	9470	12	0.995	9.42	113	AVERAGE
K ₆ ^L	D13	60480	8	0.995	60.18	481	AVERAGE
K ₁ ^R	D16	2110	298	1.56	3.29	980	AVERAGE
K ₂ ^R	D16	1820	298	1.56	2.84	846	AVERAGE
K ₃ ^R	D13	1670	298	0.995	1.66	495	AVERAGE
K ₄ ^R	D16	1210	298	1.56	1.89	563	AVERAGE
K ₅₋₁ ^R	D13	10160	12	0.995	10.11	121	AVERAGE
K ₅₋₂ ^R	D13	9890	24	0.995	9.84	236	AVERAGE
K ₅₋₃ ^R	D13	10160	12	0.995	10.11	121	AVERAGE
K ₅₋₄ ^R	D13	10270	12	0.995	10.22	123	AVERAGE
K ₅₋₅ ^R	D13	10280	12	0.995	10.23	123	AVERAGE
K ₆ ^R	D13	63230	8	0.995	62.91	503	AVERAGE
					D16	4706	kg
					D13	3376	kg
					TOTAL	8082	kg

KEY PLAN S=1:500

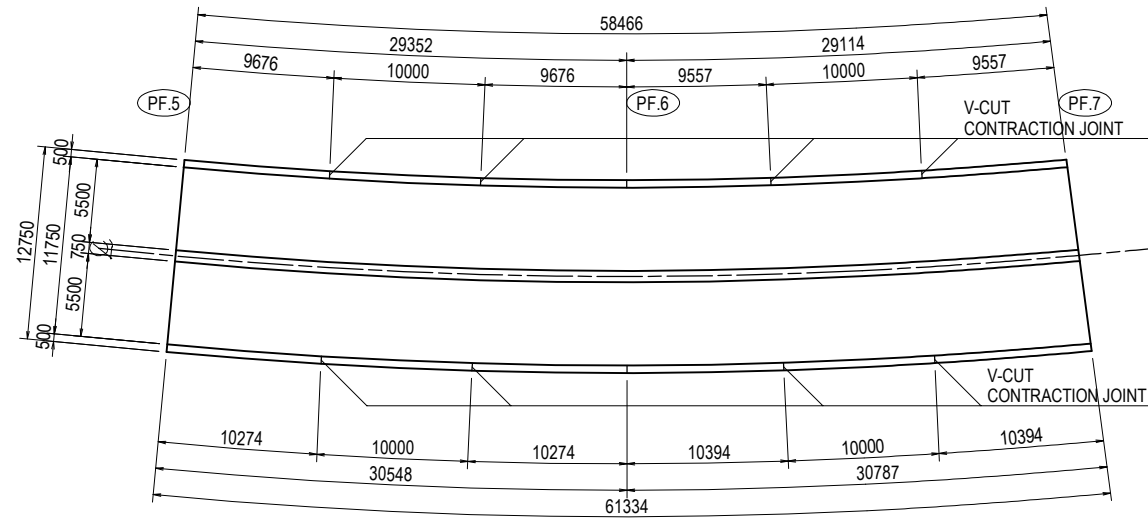

DETAIL OF CONCRETE CURB, BARRIER AND MEDIUM (PF5-PF7) (3)

PLAN S=1:100

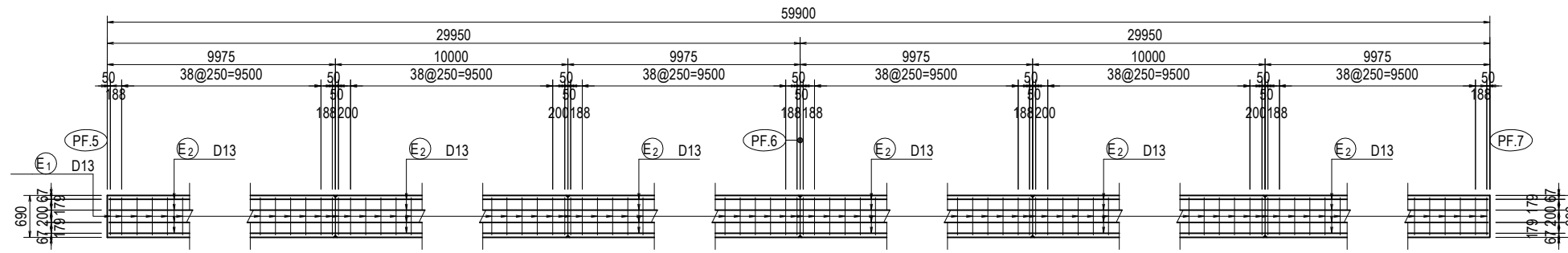

CROSS SECTION S=1:50

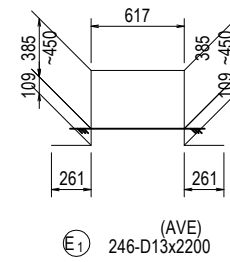
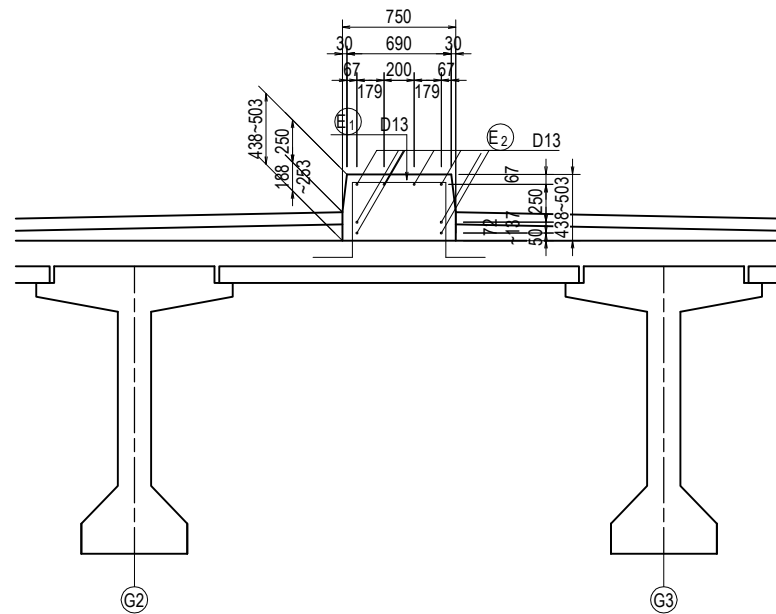

BAR LIST

REBAR NO.	DIA (mm)	LENGTH (mm)	NUMBER	UNIT WEIGHT (kg/m)	WEIGHT/ONE (kg)	WEIGHT (kg)	REMARKS
E 1	D13	2200	246	0.995	2.19	539	AVERAGE
E 2	D13	61890	8	0.995	61.58	493	AVERAGE
						1032 kg	
TOTAL						1032 kg	

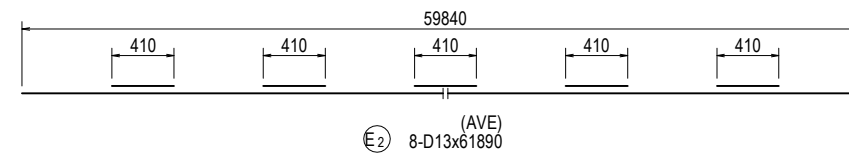

CROSS SECTION S=1:40

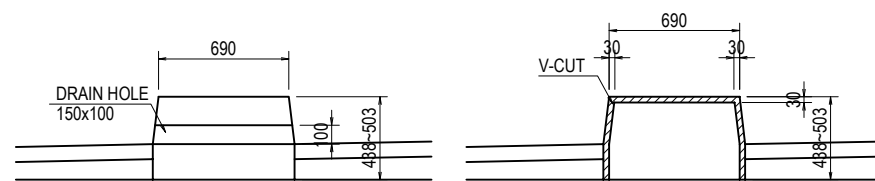

DETAIL OF V-CUT

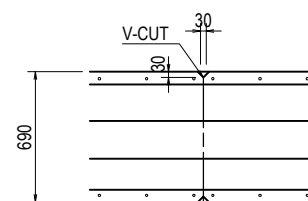

KEY PLAN S=1:500

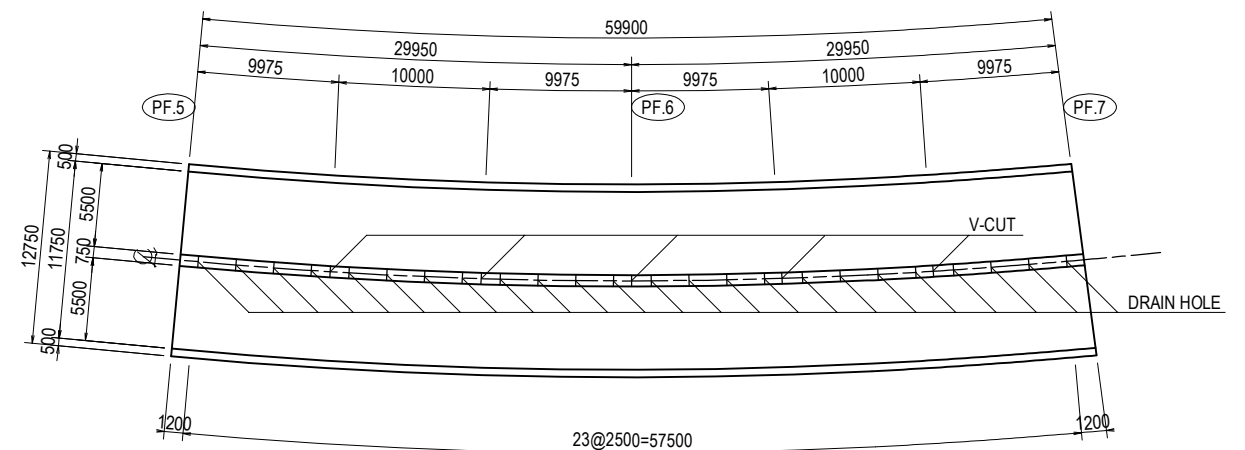

DETAIL OF LIGHTING FOUNDATION (PF5-PF7)

CROSS SECTION S=1:40

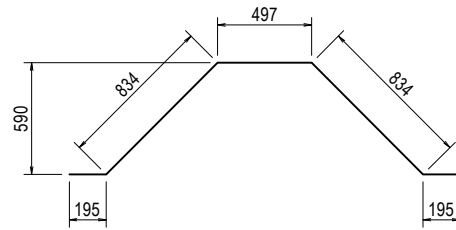
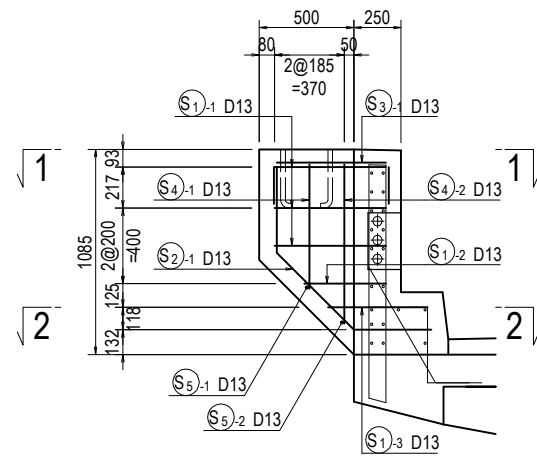

S1-1 3-D13x2560

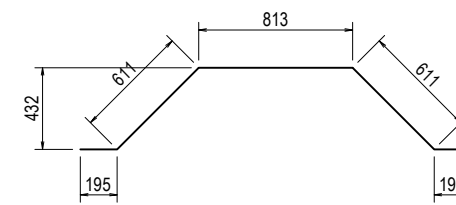

S1-2 1-D13x2430

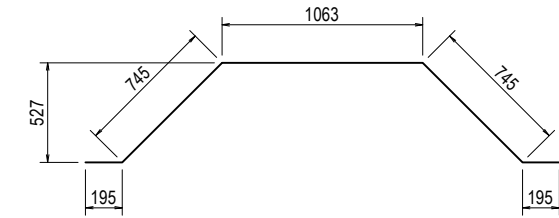

S1-3 1-D13x2950

PLAN S=1:40

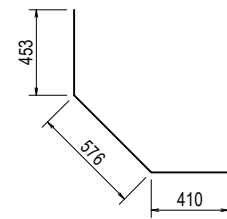
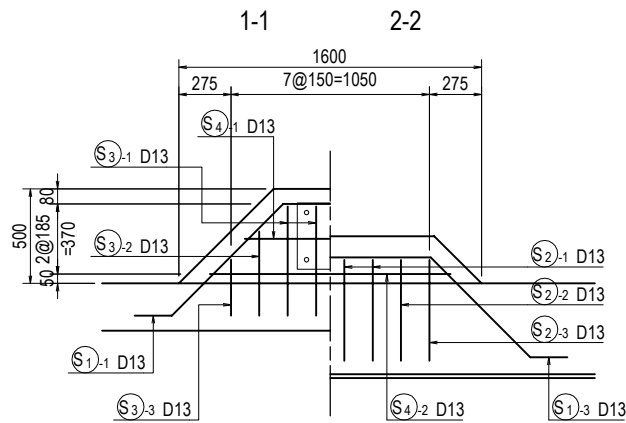

S2-1 4-D13x1440

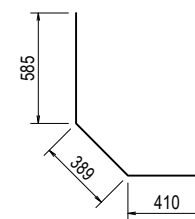

S2-2 2-D13x1390

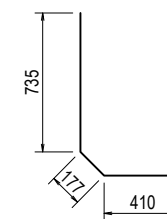

S2-3 2-D13x1330

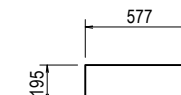

S3-1 4-D13x970

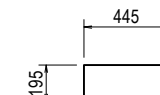

S3-2 2-D13x840

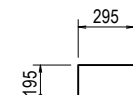

S3-3 2-D13x690

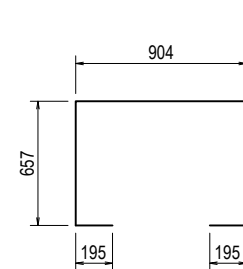

S4-1 1-D13x2610

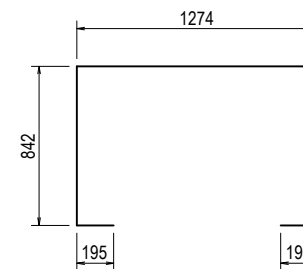

S4-2 1-D13x3350

PULLBOX DETAIL S=1:50

CROSS SECTION

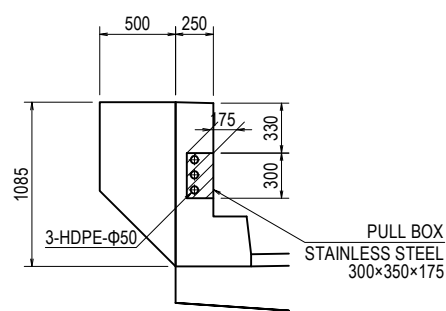

PLAN

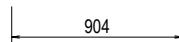
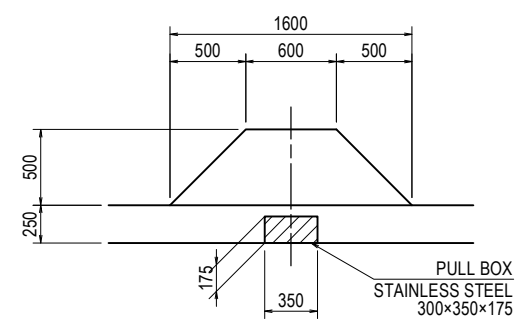

S5-1 1-D13x910

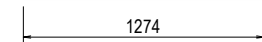

S5-2 1-D13x1280

BAR LIST

REBAR NO.	DIA (mm)	LENGTH (mm)	NUMBER	UNIT WEIGHT (kg/m)	WEIGHT/ONE (kg)	WEIGHT (kg)	REMARKS
S1-1	D13	2560	3	0.995	2.55	8	
S1-2	D13	2430	1	0.995	2.42	2	
S1-3	D13	2950	1	0.995	2.94	3	
S2-1	D13	1440	4	0.995	1.43	6	
S2-2	D13	1390	2	0.995	1.38	3	
S2-3	D13	1330	2	0.995	1.32	3	
S3-1	D13	970	4	0.995	0.97	4	
S3-2	D13	840	2	0.995	0.84	2	
S3-3	D13	690	2	0.995	0.69	1	
S4-1	D13	2610	1	0.995	2.60	3	
S4-2	D13	3350	1	0.995	3.33	3	
S5-1	D13	910	1	0.995	0.91	1	
S5-2	D13	1280	1	0.995	1.27	1	
						40	kg
TOTAL						40	kg

DETAIL OF RUBBER BEARING (PF5-PF7) (1)

CROSS SECTION S= 1:60

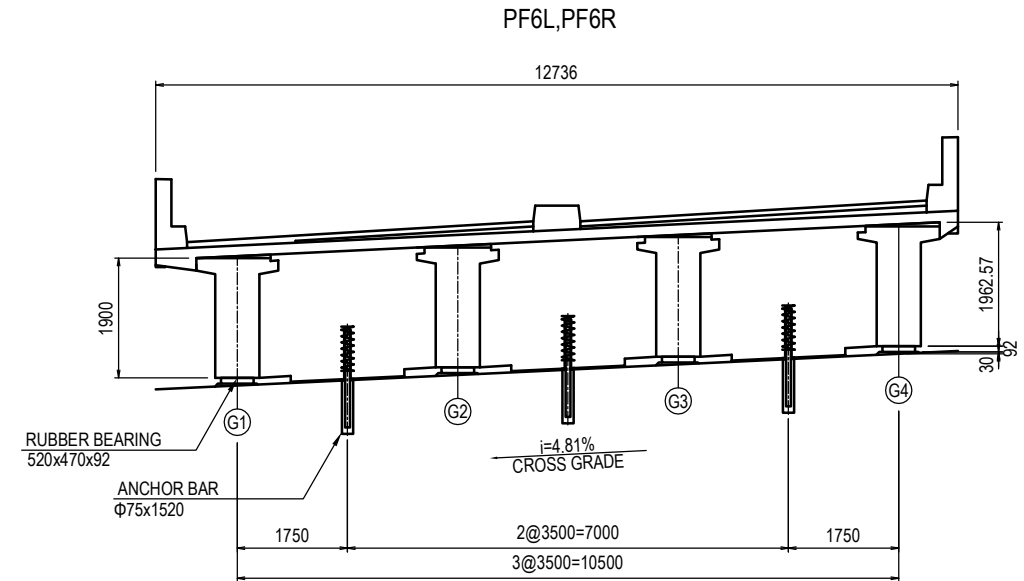
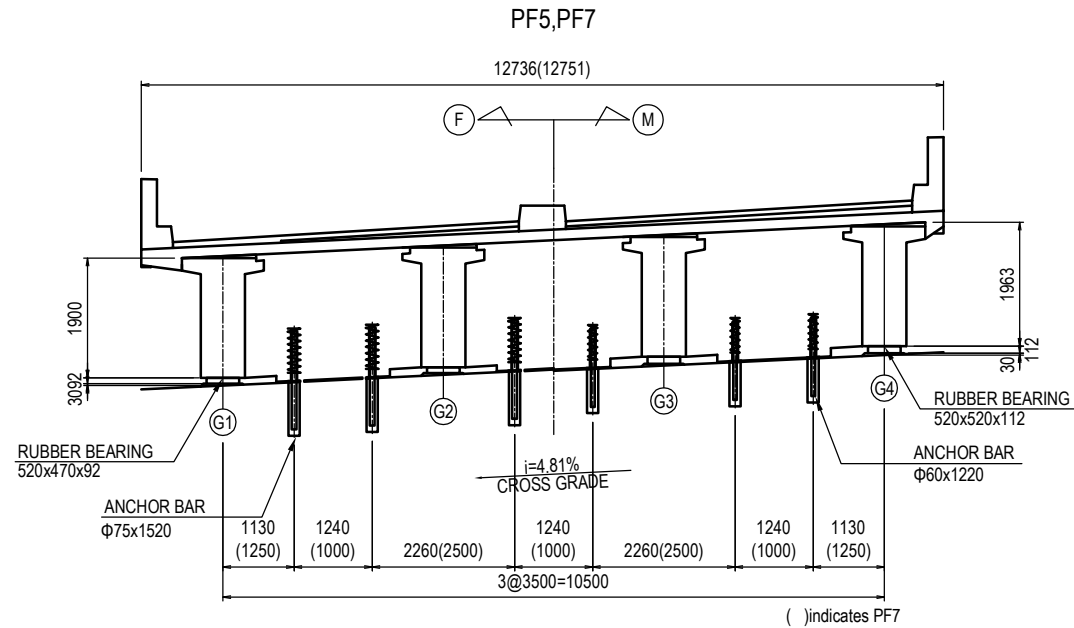

PLAN S= 1:60

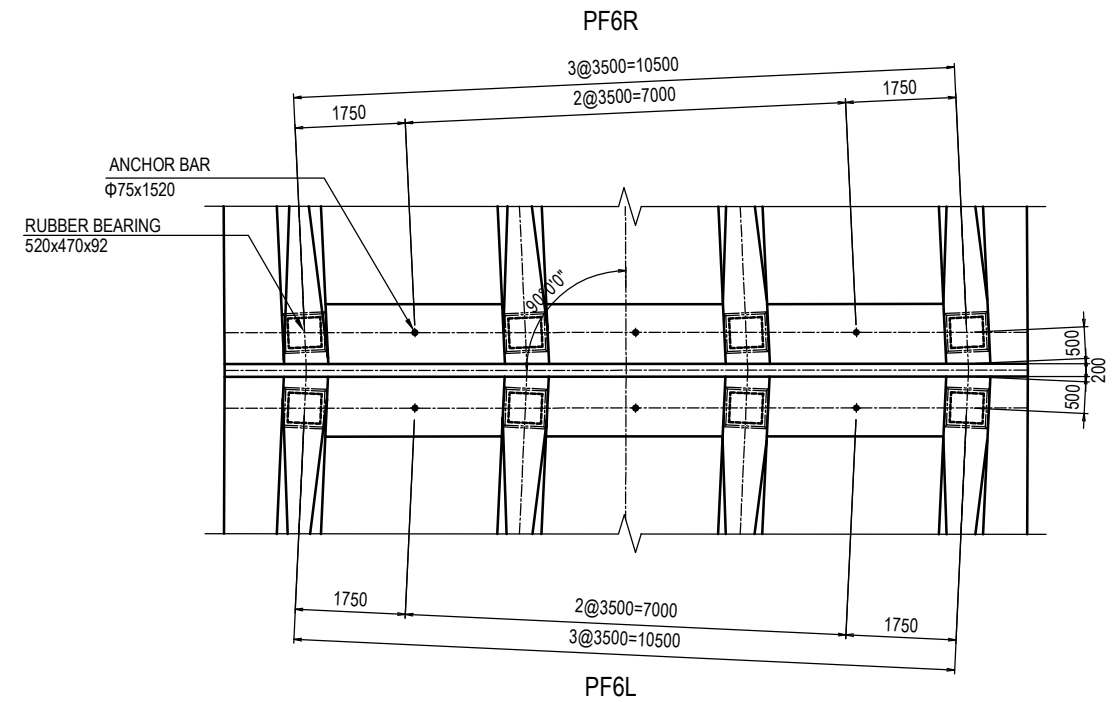
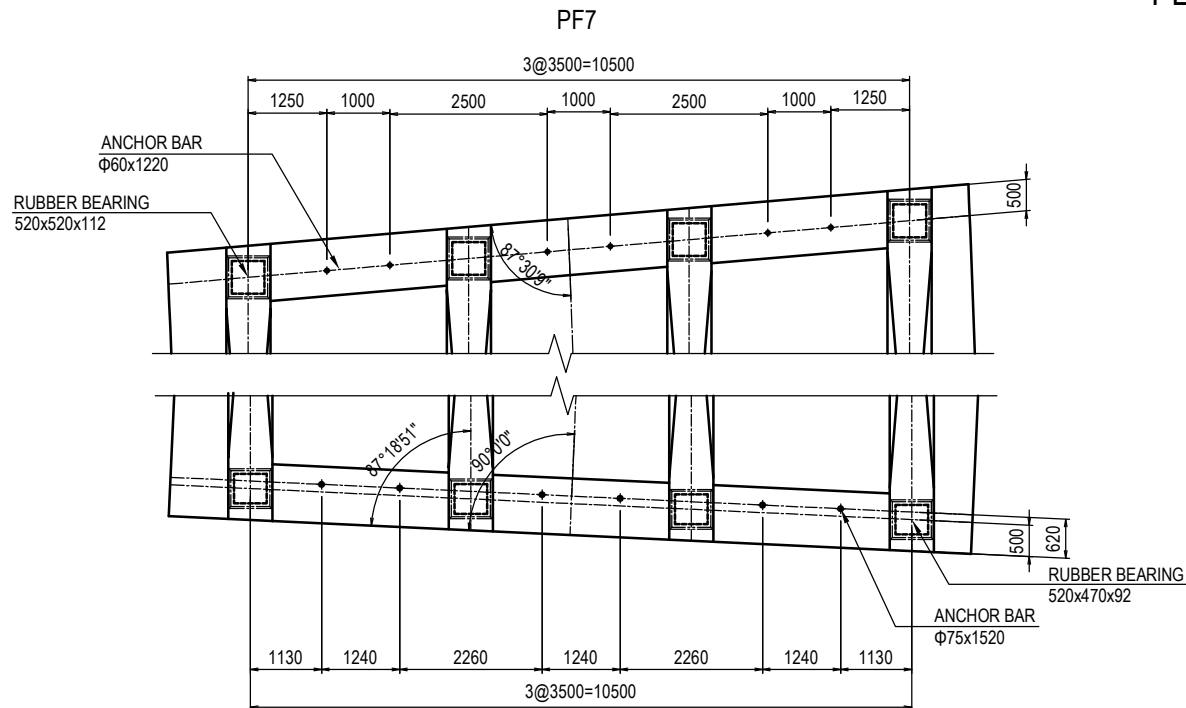

PF5

ELEVATION S= 1:250

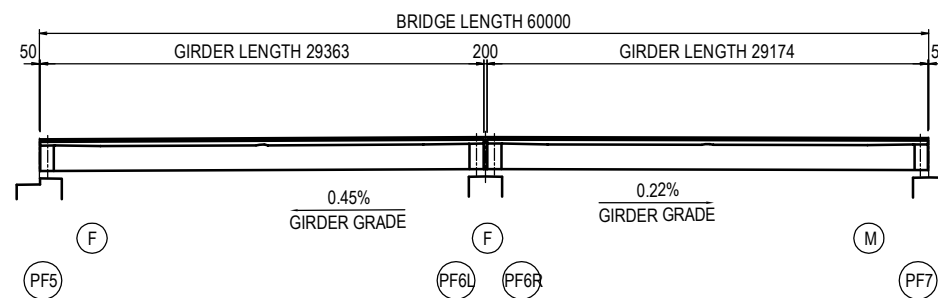

DESIGN CONDITION

REACTION		PF5 (F)	PF6L (F)	PF6R (F)	PF7 (M)		
MAXIMUM REACTION	R _{max}	1328 kN	1481 kN	1507 kN	1338 kN		
	R _{max2}	1195 kN	1328 kN	1389 kN	1226 kN		
DEAD LOAD REACTION		R _d	1001 kN	1004 kN	1029 kN	1012 kN	
MAXIMUM STRAIN FORCE	LONGITUDIAL	R _{he1}	745 kN	294 kN	294 kN	450 kN	
	TRANSVERSE	R _{he2}	223 kN	363 kN	363 kN	216 kN	
STRAIN VOLUME	ORDINARY	LONGITUDIAL	ΔL	- mm	- mm	38.9 mm	
		LONGITUDIAL	ΔL _{e1}	- mm	- mm	- mm	26.7 mm
	LEVEL1	LONGITUDIAL	ΔL _{e1}	- mm	- mm	- mm	- mm
		TRANSVERSE	ΔL _{e2}	- mm	- mm	- mm	- mm

NOTES:

- 1) Details of the slab and girder are designed based on the product (rubber bearing) shown in this Drawing.
- 2) The Contractor has option to propose an alternative equivalent to the specified product, which shall be subjected to the Engineer's approval.
- 3) All the structural steels shall be galvanized to the requirements specified by JIS H8641.

PROJECT NAME
DETAILED DESIGN ON
BAGO RIVER BRIDGE
CONSTRUCTION PROJECT

FINANCED BY
JICA
JAPAN INTERNATIONAL
COOPERATION AGENCY

COUNTERPART
REPUBLIC OF THE UNION OF MYANMAR
MINISTRY OF CONSTRUCTION
DEPARTMENT OF BRIDGE

JICA STUDY TEAM
NIPPON KOEI CO., LTD.
ORIENTAL CONSULTANTS GLOBAL CO., LTD.
METROPOLITAN EXPRESSWAY COMPANY LIMITED
CHODAI CO., LTD.
NIPPON ENGINEERING CONSULTANTS CO., LTD.

	NAME	SIGNATURE	DATE
PREPARED BY	Y. SUZUKI	<i>YS</i>	14 Jul. 2017
CHECKED BY	T. HAYAKAWA	<i>TH</i>	20 Jul. 2017
APPROVED BY	Y. SANO	<i>YS</i>	25 Jul. 2017

DRAWING TITLE
DETAIL OF RUBBER BEARING (PF5-PF7) (1)

PACKAGE
3
DWG No.
P3-FO-123

DETAIL OF RUBBER BEARING (PF5-PF7) (2)

SIDE VIEW S= 1:20

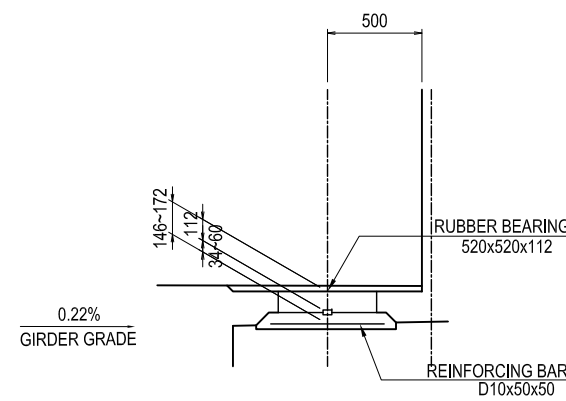
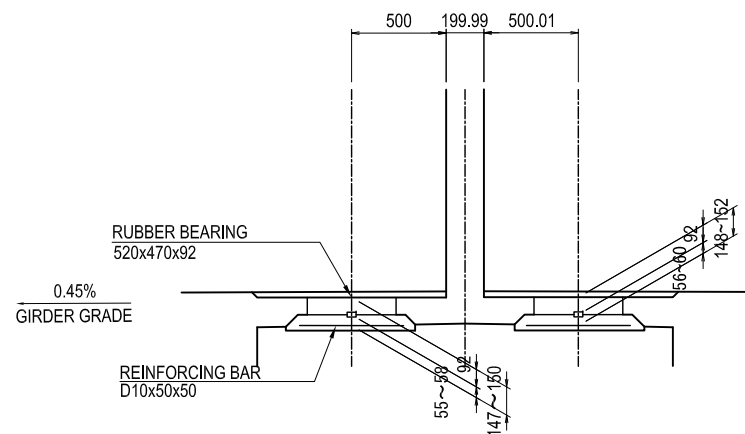
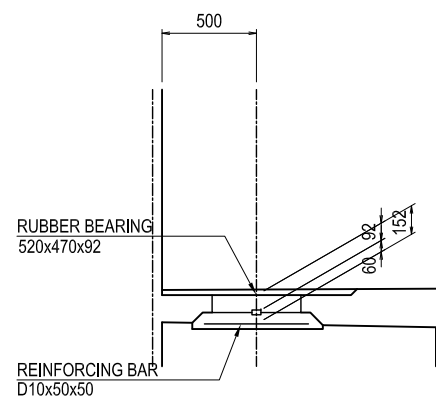

RUBBER BEARING S= 1:10

PF5,PF6L,PF6R

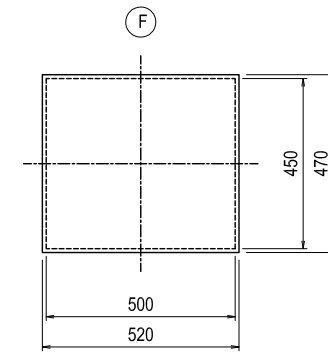

PF7

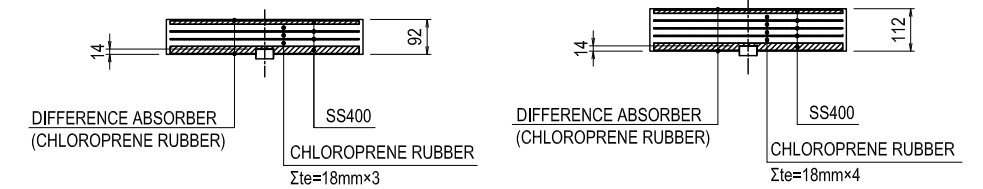
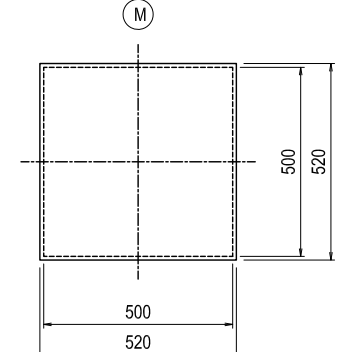

ANCHOR SYSTEM S= 1:5

PF5R,PF6L,PF6R

F

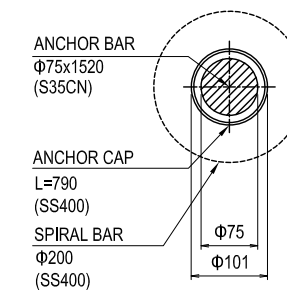

PF7

M

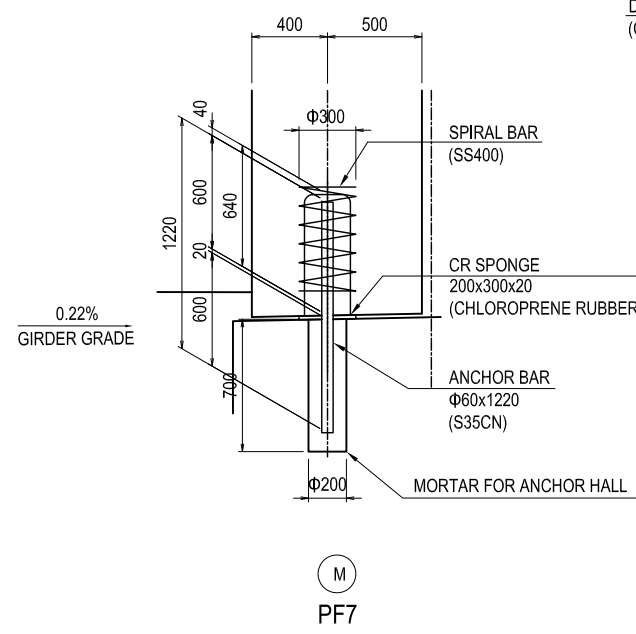
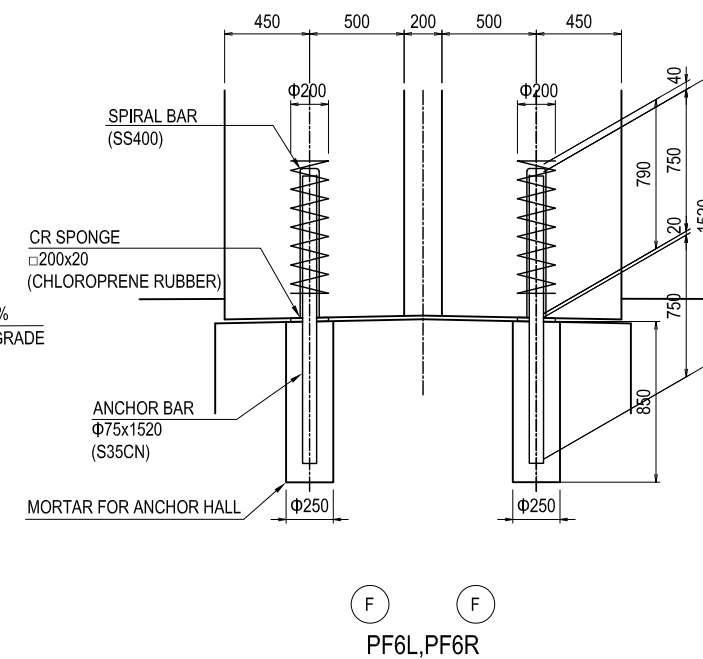
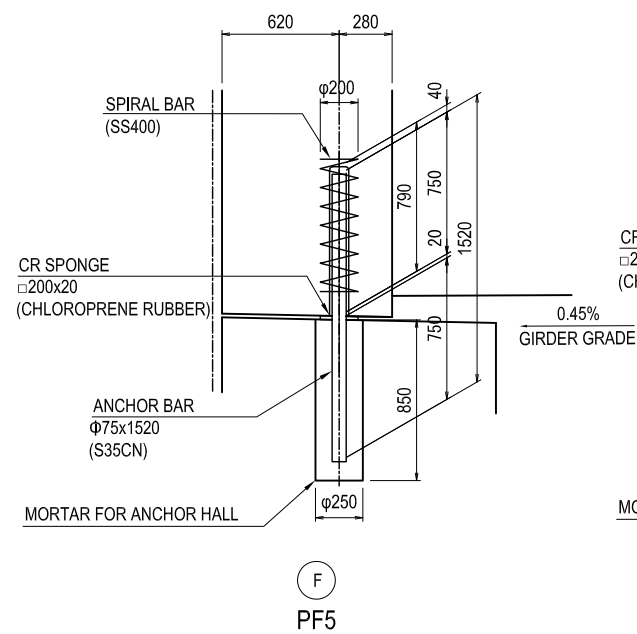
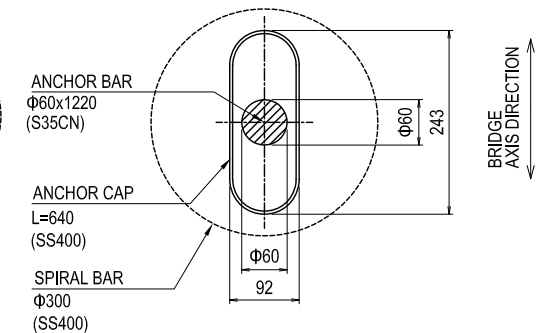

REINFORCING BAR S= 1:10

PF5,PF6L,PF6R

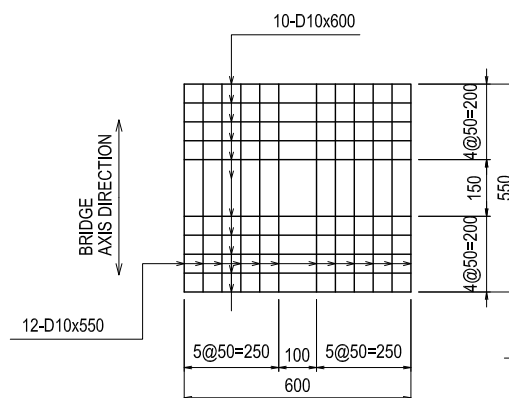

PF7

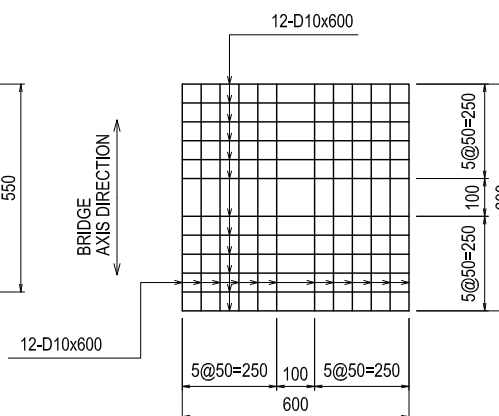

PARTS LIST

ITEM	DIMENSION	MATERIAL	UNIT	QUANTITY				WEIGHT (kg)	REMARKS
				PF5(F)	PF6L(F)	PF6R(F)	PF7(M)		
RUBBER BEARING	520x470x92	AS SHOWN	SHEET	4	4	4		12	
"	520x520x112	"	"				4	4	
ANCHOR SYSTEM	Φ75x1520	S35CN	SET	6	3	3		12	
"	Φ60x1220	"	"				6	6	
CR SPONGE	□200x20	CHLOROPRENE RUBBER	SHEET	6	3	3		12	
"	200x300x20	"	"				6	6	
REINFORCING BAR	D10x50x50	SD345	kg	28.22	28.22	28.22	32.26	116.92	
BED MORTAR FOR BEARING		NON SHRINKAGE MORTAR	m3	0.144	0.136	0.140	0.141	0.561	
MORTAR FOR ANCHOR HALLS		NON SHRINKAGE MORTAR	m3	0.230	0.115	0.115	0.122	0.582	

※An Anchor System includes anchor bar, anchor cap and spiral bar.

NOTES:

- 1) Details of the slab and girder are designed based on the product (rubber bearing) shown in this Drawing.
- 2) The Contractor has option to propose an alternative equivalent to the specified product, which shall be subjected to the Engineer's approval.
- 3) All the structural steels shall be galvanized to the requirements specified by JIS H8641.

PROJECT NAME DETAILED DESIGN ON BAGO RIVER BRIDGE CONSTRUCTION PROJECT	FINANCED BY JICA JAPAN INTERNATIONAL COOPERATION AGENCY	COUNTERPART REPUBLIC OF THE UNION OF MYANMAR MINISTRY OF CONSTRUCTION DEPARTMENT OF BRIDGE	JICA STUDY TEAM NIPPON KOEI CO., LTD. ORIENTAL CONSULTANTS GLOBAL CO., LTD. METROPOLITAN EXPRESSWAY COMPANY LIMITED CHODAI CO., LTD. NIPPON ENGINEERING CONSULTANTS CO., LTD.	NAME Y. SUZUKI	SIGNATURE <i>[Signature]</i>	DATE 14 Jul. 2017	DRAWING TITLE DETAIL OF RUBBER BEARING (PF5-PF7) (2)	PACKAGE 3
				CHECKED BY T. HAYAKAWA	<i>[Signature]</i>	20 Jul. 2017		DWG No.
				APPROVED BY Y. SANO	<i>[Signature]</i>	25 Jul. 2017		P3-FO-124

DETAIL OF EXPANSION JOINT (PF5-PF7) (1)

PF5

PLAN VIEW S=1:30

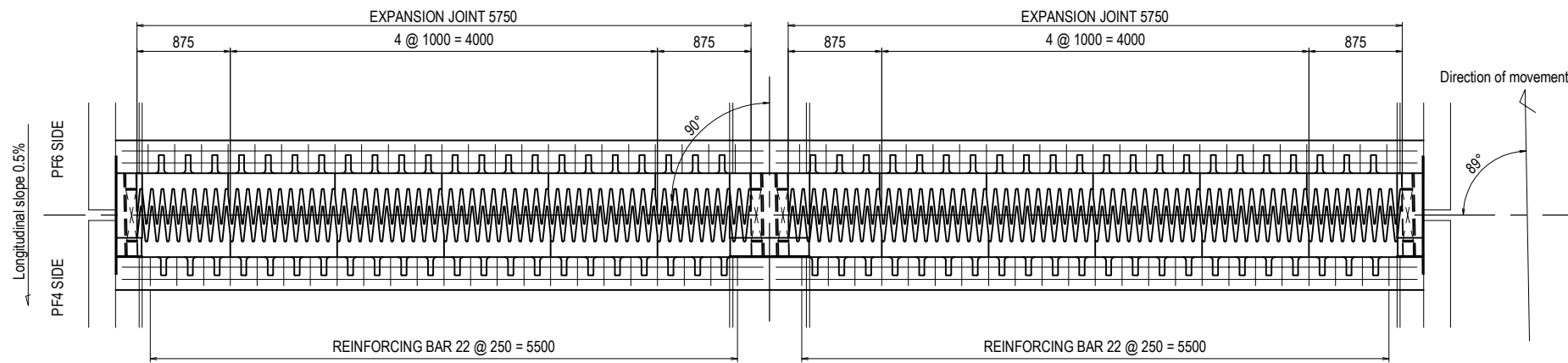

CROSS SECTION S=1:30

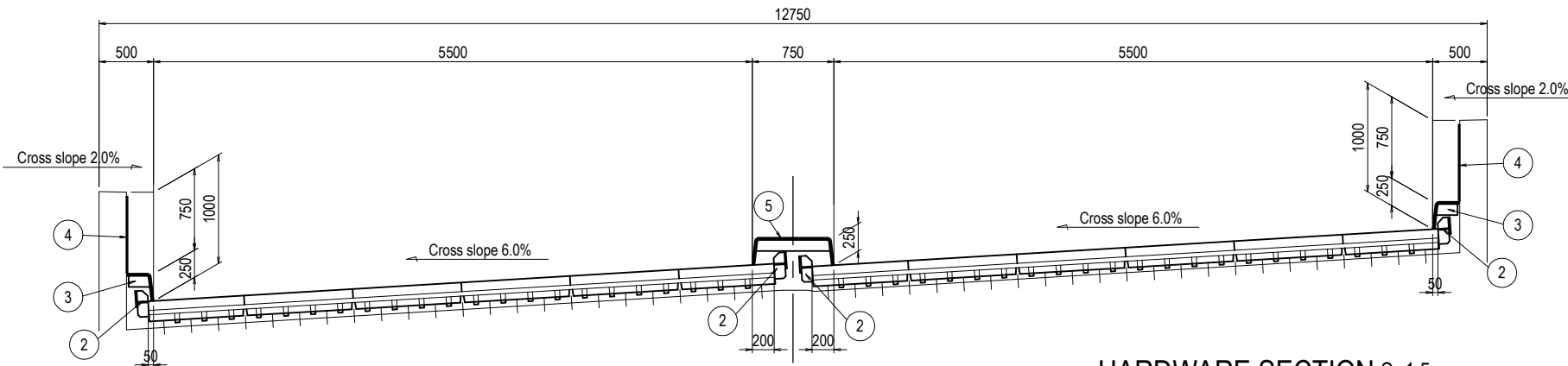

SECTION OF EXPANSION JOINT S=1:8

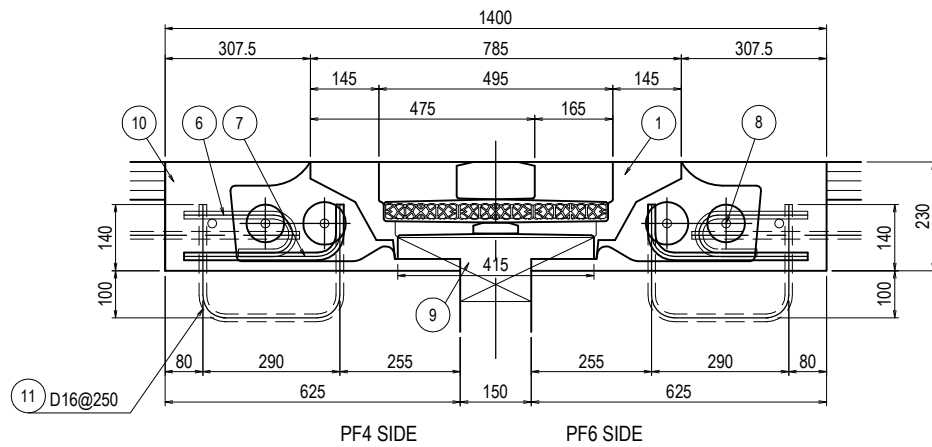

HARDWARE SECTION S=1:5

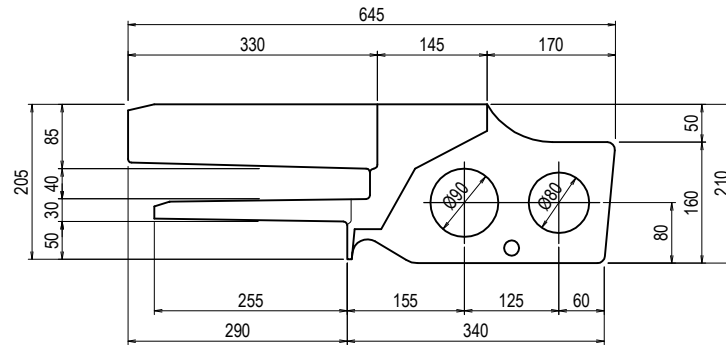

HARDWARE PLAN S=1:10

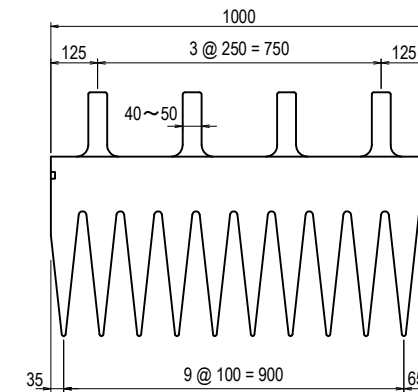

DETAIL OF REINFORCING BAR S=1:8

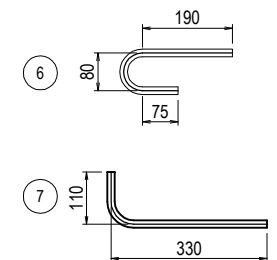

MATERIALS LIST					(1 par place)
No.	DESCRIPTION	MATERIALS	UNIT	QUANTITY	REMARK
1	EXPANSION JOINT	ALUMINUM ALLOY CASTING	m	11.500	320mm
2	UPSTAND		pieces	4	
3	COVER FOR CURB	SS400 or Equivalent	set	2	
4	COVER FOR BARRIER CURB	SUS304	set	2	t=2(include anchor)
5	COVER FOR MEDIAL DIVIDER	SS400 or Equivalent	set	1	
6	REINFORCING BAR	SD345	kg	55.97	D16 × 390 × 92 Nos.
7	REINFORCING BAR	SD345	kg	63.15	D16 × 440 × 92 Nos.
8	REINFORCING BAR	SD345	kg	162.00	D19 × 6.0m × 12 Nos.
9	BURIED FORMWORK	Foamed Styrene	m ³	0.76	400 × 150 × 12.7m
10	POST-CAST CONCRETE	High strength concrete	m ³	2.66	σ _{ck} = 30N/mm ²

EMBEDDED BAR

11	EMBEDDED BAR	SD345	kg	110.51	D16 × 770 × 92 Nos.
----	--------------	-------	----	--------	---------------------

DESIGN CONDITION

Temperature range	0°C~+50°C
Amount of temperature variation	54mm
Earthquake movement amount	±117mm

Note

- 1 Re-bar should be consider the developed length.
- 2 Allocation of the expansion joint is subject to change
- 3 Expansion joint should be placing to match the transverse gradient.
- 4 Expansion joint should be installed in consideration of the effect of Creep and Shrinkage.

PLAN VIEW

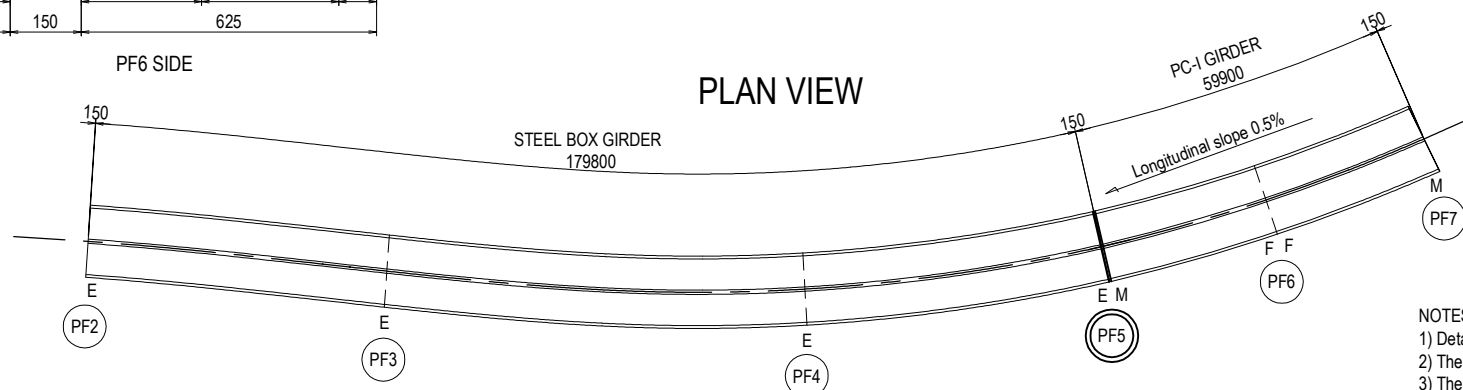

NOTES:

- 1) Details of the slab and girder are designed based on the product (expansion joint) shown in this Drawing.
- 2) The Contractor has option to propose an alternative equivalent to the specified product, which shall be subjected to the Engineer's approval.
- 3) The expansion joint shall be set in consideration of thermal expansion, creep and shrinkage of concrete girder.

PROJECT NAME	FINANCED BY	COUNTERPART	JICA STUDY TEAM	NAME	SIGNATURE	DATE	DRAWING TITLE	PACKAGE
DETAILED DESIGN ON BAGO RIVER BRIDGE CONSTRUCTION PROJECT	JICA JAPAN INTERNATIONAL COOPERATION AGENCY	REPUBLIC OF THE UNION OF MYANMAR MINISTRY OF CONSTRUCTION DEPARTMENT OF BRIDGE	NIPPON KOEI CO., LTD. ORIENTAL CONSULTANTS GLOBAL CO., LTD. METROPOLITAN EXPRESSWAY COMPANY LIMITED CHODAI CO., LTD. NIPPON ENGINEERING CONSULTANTS CO., LTD.	Y. SUZUKI	<i>[Signature]</i>	14 Jul. 2017	DETAIL OF EXPANSION JOINT (PF5-PF7) (1)	3
				T. HAYAKAWA	<i>[Signature]</i>	20 Jul. 2017		DWG No.
				Y. SANO	<i>[Signature]</i>	25 Jul. 2017		P3-FO-125

DETAIL OF EXPANSION JOINT (PF5-PF7) (2)

PF7

PLAN VIEW S=1:30

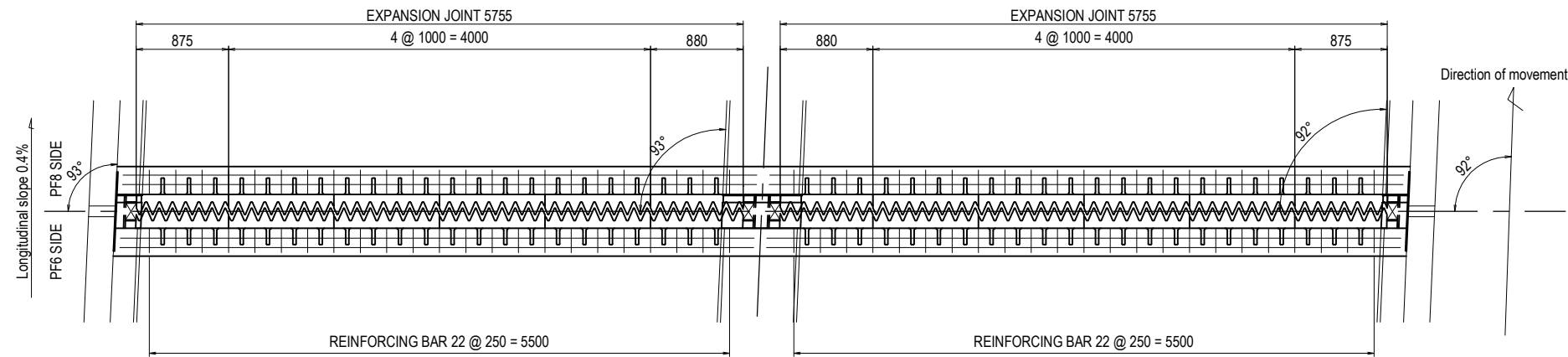

CROSS SECTION S=1:30

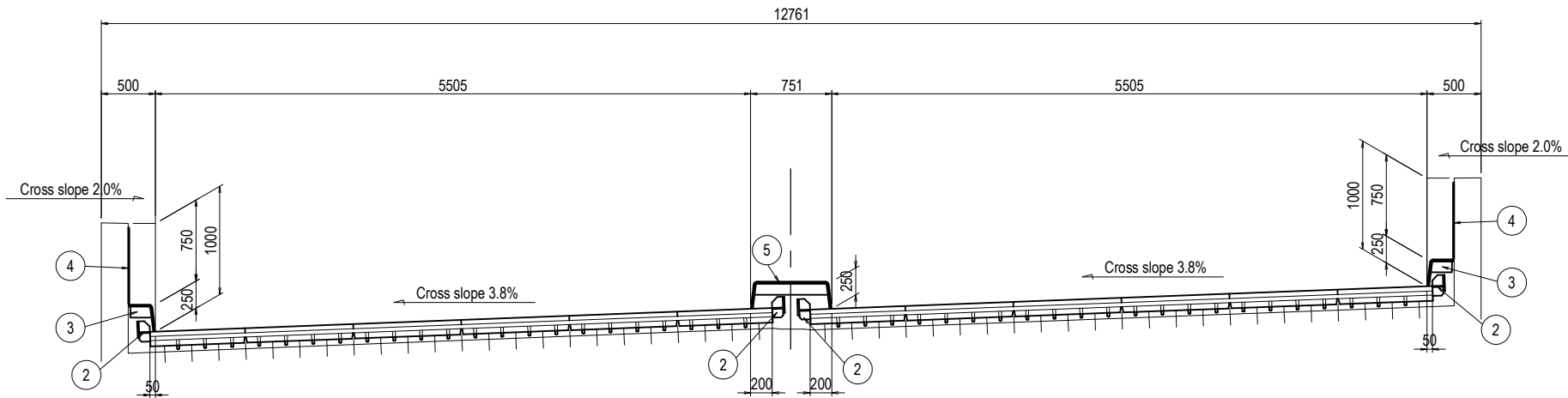

SECTION OF EXPANSION JOINT S=1:8

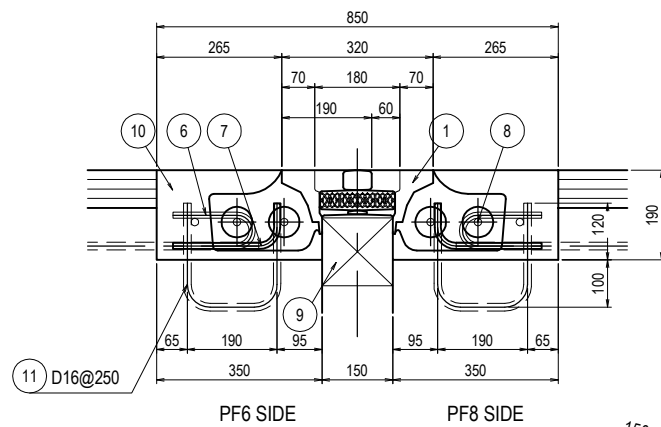

HARDWARE SECTION S=1:5

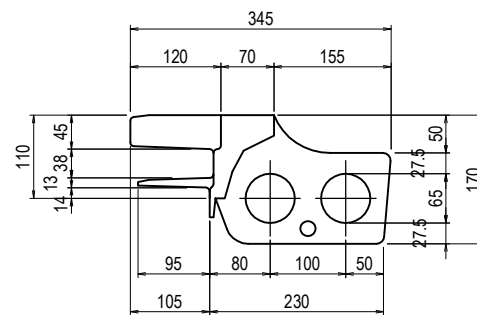

PLAN VIEW

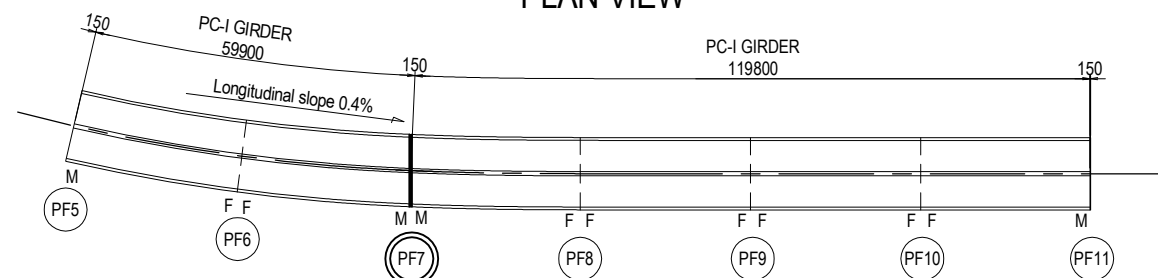

MATERIALS LIST (1 par place)					
No.	DESCRIPTION	MATERIALS	UNIT	QUANTITY	REMARK
1	EXPANSION JOINT	ALUMINUM ALLOY CASTING	m	11.510	110mm
2	UPSTAND		pieces	4	
3	COVER FOR CURB	SS400 or Equivalent	set	2	
4	COVER FOR BARRIER CURB	SUS304	set	2	t=2(include anchor)
5	COVER FOR MEDIAL DIVIDER	SS400 or Equivalent	set	1	
6	REINFORCING BAR	SD345	kg	26.55	D13 × 290 × 92 Nos.
7	REINFORCING BAR	SD345	kg	28.38	D13 × 310 × 92 Nos.
8	REINFORCING BAR	SD345	kg	112.32	D16 × 6.0m × 12 Nos.
9	BURIED FORMWORK	Foamed Styrene	m ³	0.29	150 × 150 × 12.7m
10	POST-CAST CONCRETE	High strength concrete	m ³	1.56	σ _{ck} = 30N/mm ²

EMBEDDED BAR

11	EMBEDDED BAR	SD345	kg	90.42	D16 × 630 × 92 Nos.
----	--------------	-------	----	-------	---------------------

DESIGN CONDITION

Temperature range	+5°C~+45°C
Amount of temperature variation	36mm
Earthquake movement amount	±55mm

Note

- 1 Re-bar should be consider the developed length.
- 2 Allocation of the expansion joint is subject to change
- 3 Expansion joint should be placing to match the transverse gradient.
- 4 Expansion joint should be installed in consideration of the effect of Creep and Shrinkage.

HARDWARE PLAN S=1:10

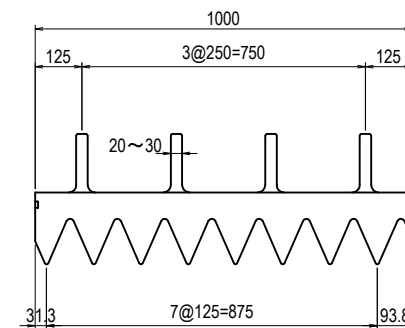

DETAIL OF REINFORCING BAR S=1:8

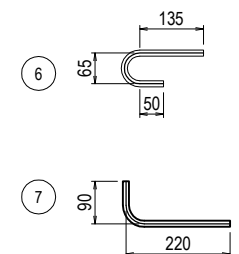

NOTES:

- 1) Details of the slab and girder are designed based on the product (expansion joint) shown in this Drawing.
- 2) The Contractor has option to propose an alternative equivalent to the specified product, which shall be subjected to the Engineer's approval.
- 3) The expansion joint shall be set in consideration of thermal expansion, creep and shrinkage of concrete girder.

PROJECT NAME DETAILED DESIGN ON BAGO RIVER BRIDGE CONSTRUCTION PROJECT	FINANCED BY jica JAPAN INTERNATIONAL COOPERATION AGENCY	COUNTERPART REPUBLIC OF THE UNION OF MYANMAR MINISTRY OF CONSTRUCTION DEPARTMENT OF BRIDGE	JICA STUDY TEAM NIPPON KOEI CO., LTD. ORIENTAL CONSULTANTS GLOBAL CO., LTD. METROPOLITAN EXPRESSWAY COMPANY LIMITED CHODAI CO., LTD. NIPPON ENGINEERING CONSULTANTS CO., LTD.	NAME	SIGNATURE	DATE	DRAWING TITLE DETAIL OF EXPANSION JOINT (PF5-PF7) (2)	PACKAGE 3 DWG No. P3-FO-126
				PREPARED BY	Y. SUZUKI	14 Jul. 2017		
				CHECKED BY	T. HAYAKAWA	20 Jul. 2017		
				APPROVED BY	Y. SANO	25 Jul. 2017		

SUPERSTRUCTURE COORDINATES (PF7-PF11) (1)

PLAN S=1:400

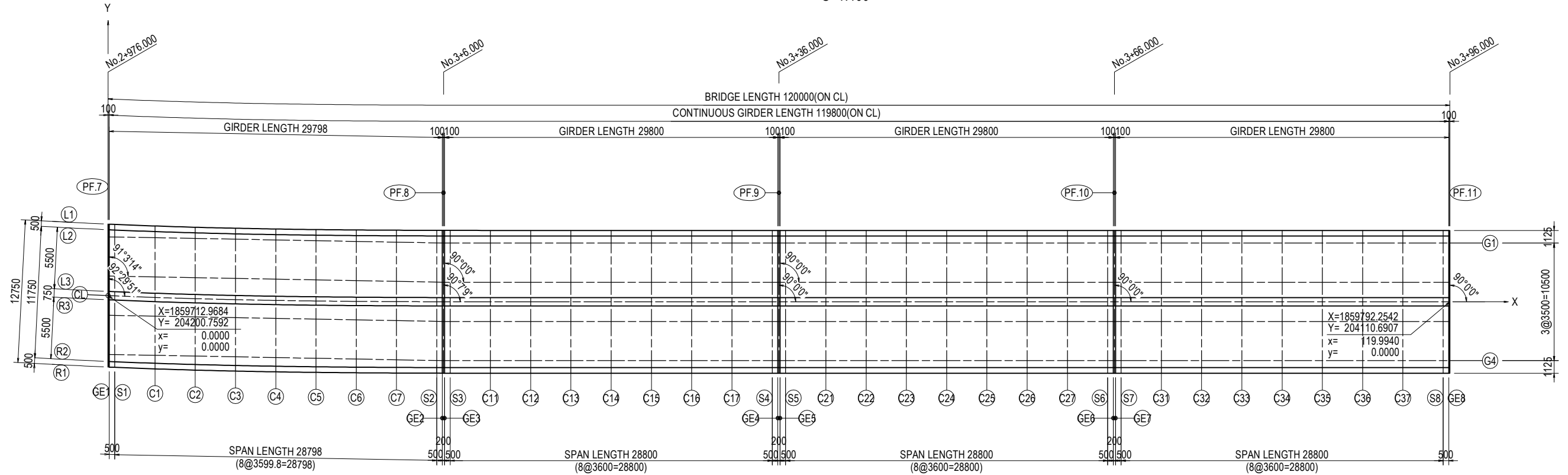

How to set the small coordinates
 X coordinate : Starting point is intersection of PF7 and CL
 Ending point is intersection of PF11 and CL
 Y coordinate : Perpendicular to X line

TYPICAL CROSS SECTION S=1:150

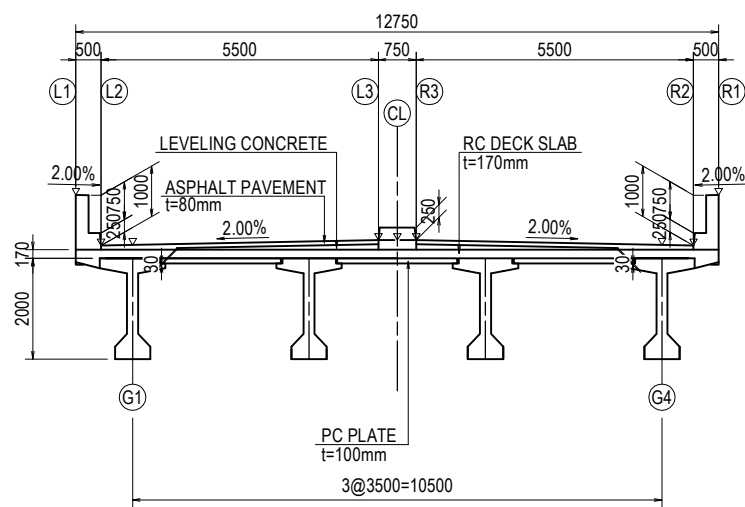

GRADE FOR LONGITUDINAL

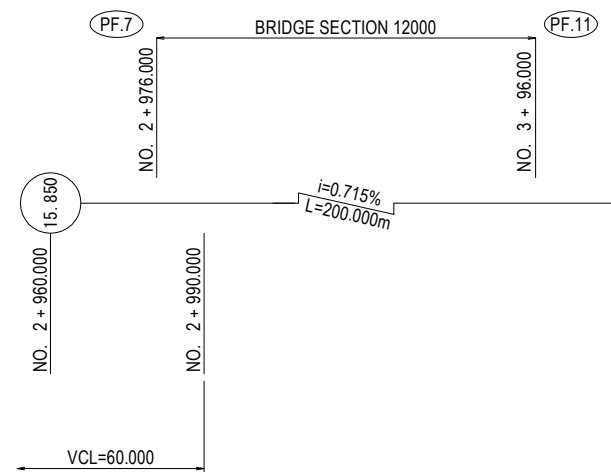

SUPER ELEVATION

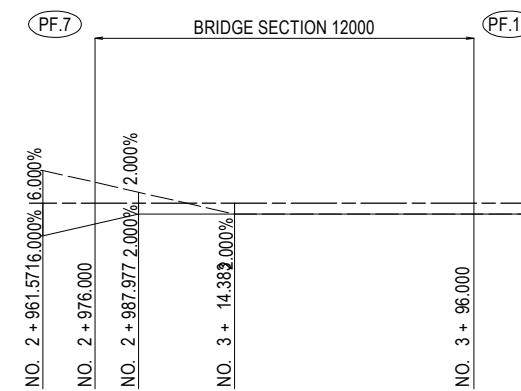

CURB ELEMENTS

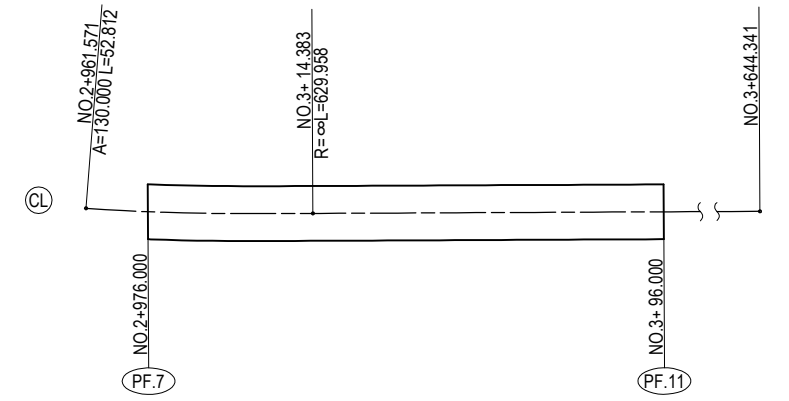

CHANGING POINT	STATION POINT	X COORDINATE	Y COORDINATE	ELEMENT
	2+961.571	1859702.8295	204211.0247	A= 130.000
	3+ 14.383	1859738.6113	204172.2029	R= ∞
	3+644.341	1860152.6530	203697.4219	

SUPERSTRUCTURE COORDINATES (PF7-PF11) (3)

STRUCTURE HEIGHT TABLE

		S1(PF7R)				S2(PF8L)				S3(PF8R)				S4(PF9L)			
		G1	G2	G3	G4	G1	G2	G3	G4	G1	G2	G3	G4	G1	G2	G3	G4
ROAD PLAN HEIGHT	Z1	15.531	15.662	15.763	15.892	15.428	15.498	15.517	15.494	15.419	15.489	15.505	15.477	15.213	15.283	15.283	15.213
PAVEMENT THICKNESS(mm)	H1	107	238	340	468	95	165	184	161	93	163	179	150	93	163	163	93
MAIN GIRDER HEIGHT(mm)	H2	2170	2170	2170	2170	2170	2170	2170	2170	2170	2170	2170	2170	2170	2170	2170	2170
LAYER HEIGHT(mm)	H3	30	30	30	30	30	30	30	30	30	30	30	30	30	30	30	30
BEARING HEIGHT(mm)	H4	142	142	142	142	92	92	92	92	92	92	92	92	92	92	92	92
BEARING MORTAR(mm)	H5	41	41	40	41	47	47	47	47	40	40	40	41	48	48	48	48
TOTAL STRUCTURE HEIGHT(mm)	ΣH	2490	2621	2722	2851	2434	2504	2523	2500	2425	2495	2511	2483	2433	2503	2503	2433
TOP OF PIER/ABUTMENT HEIGHT	Z2	13.041	13.041	13.041	13.041	12.994	12.994	12.994	12.994	12.994	12.994	12.994	12.994	12.780	12.780	12.780	12.780

		S5(PF9R)				S6(PF10L)				S7(PF10R)				S8(PF11L)			
		G1	G2	G3	G4	G1	G2	G3	G4	G1	G2	G3	G4	G1	G2	G3	G4
ROAD PLAN HEIGHT	Z1	15.205	15.275	15.275	15.205	14.999	15.069	15.069	14.999	14.990	15.060	15.060	14.990	14.784	14.854	14.854	14.784
PAVEMENT THICKNESS(mm)	H1	93	163	163	93	93	163	163	93	93	163	163	93	93	163	163	93
MAIN GIRDER HEIGHT(mm)	H2	2170	2170	2170	2170	2170	2170	2170	2170	2170	2170	2170	2170	2170	2170	2170	2170
LAYER HEIGHT(mm)	H3	30	30	30	30	30	30	30	30	30	30	30	30	30	30	30	30
BEARING HEIGHT(mm)	H4	92	92	92	92	92	92	92	92	92	92	92	92	142	142	142	142
BEARING MORTAR(mm)	H5	40	40	40	40	49	49	49	49	40	40	40	40	42	42	42	42
TOTAL STRUCTURE HEIGHT(mm)	ΣH	2425	2495	2495	2425	2434	2504	2504	2434	2425	2495	2495	2425	2477	2547	2547	2477
TOP OF PIER/ABUTMENT HEIGHT	Z2	12.780	12.780	12.780	12.780	12.565	12.565	12.565	12.565	12.565	12.565	12.565	12.565	12.307	12.307	12.307	12.307

GENERAL VIEW OF SUPERSTRUCTURE (PF7-PF11) (1)

SIDE VIEW S=1:400

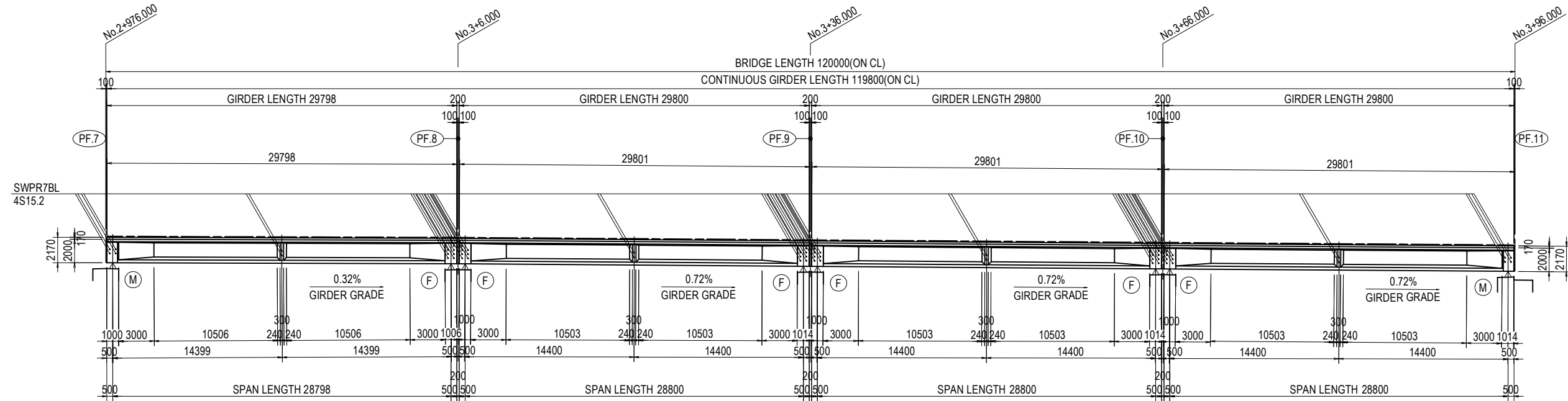

PLAN S=1:400

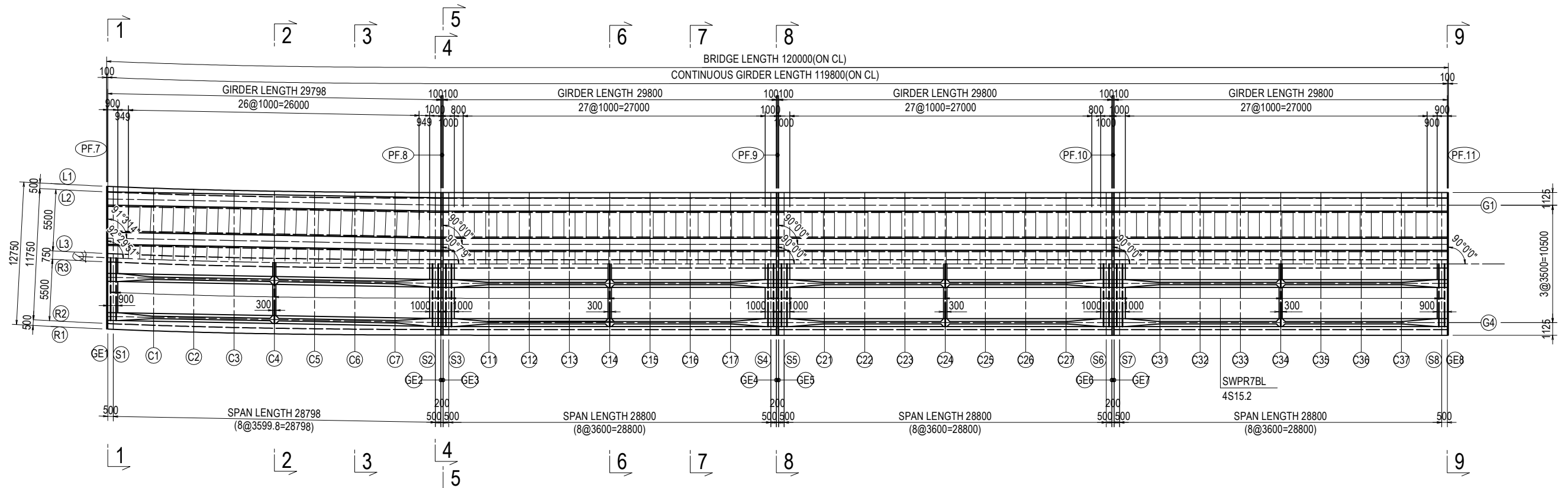

PROJECT NAME DETAILED DESIGN ON BAGO RIVER BRIDGE CONSTRUCTION PROJECT	FINANCED BY JAPAN INTERNATIONAL COOPERATION AGENCY	COUNTERPART REPUBLIC OF THE UNION OF MYANMAR MINISTRY OF CONSTRUCTION DEPARTMENT OF BRIDGE	JICA STUDY TEAM NIPPON KOEI CO., LTD. ORIENTAL CONSULTANTS GLOBAL CO., LTD. METROPOLITAN EXPRESSWAY COMPANY LIMITED CHODAI CO., LTD. NIPPON ENGINEERING CONSULTANTS CO., LTD.	NAME	SIGNATURE	DATE	DRAWING TITLE	PACKAGE	
				PREPARED BY	Y. SUZUKI				14 Jul. 2017
				CHECKED BY	T. HAYAKAWA				20 Jul. 2017
				APPROVED BY	Y. SANO				25 Jul. 2017
GENERAL VIEW OF SUPERSTRUCTURE (PF7-PF11) (1)							3	DWG No. P3-FO-1204	

GENERAL VIEW OF SUPERSTRUCTURE (PF7-PF11) (2)

CROSS SECTION S=1:150

PF7-PF8

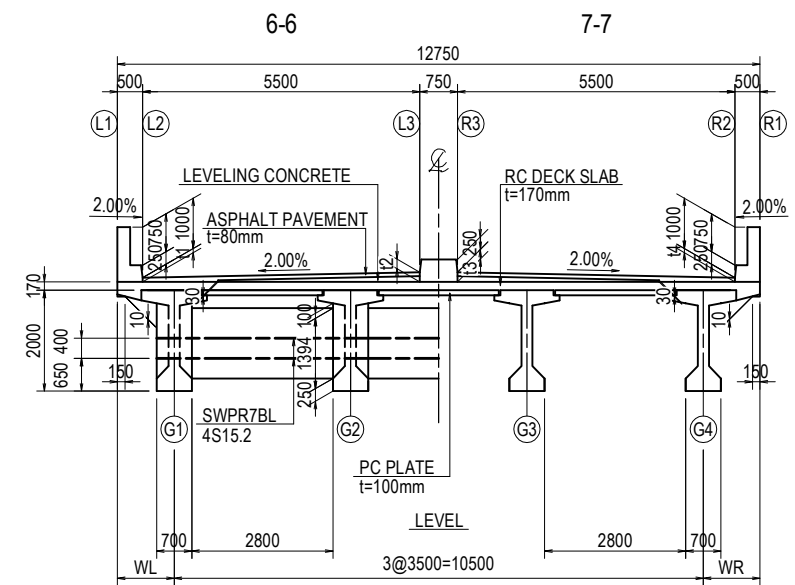
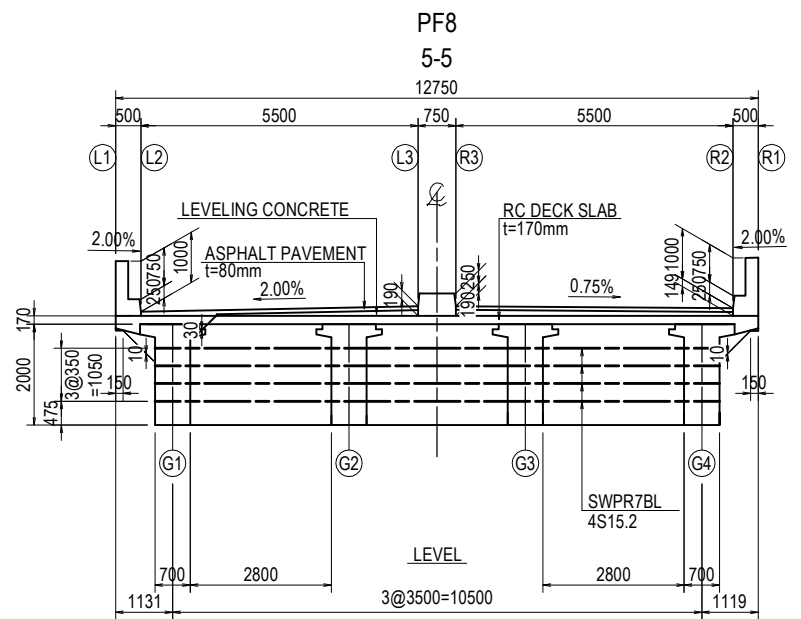
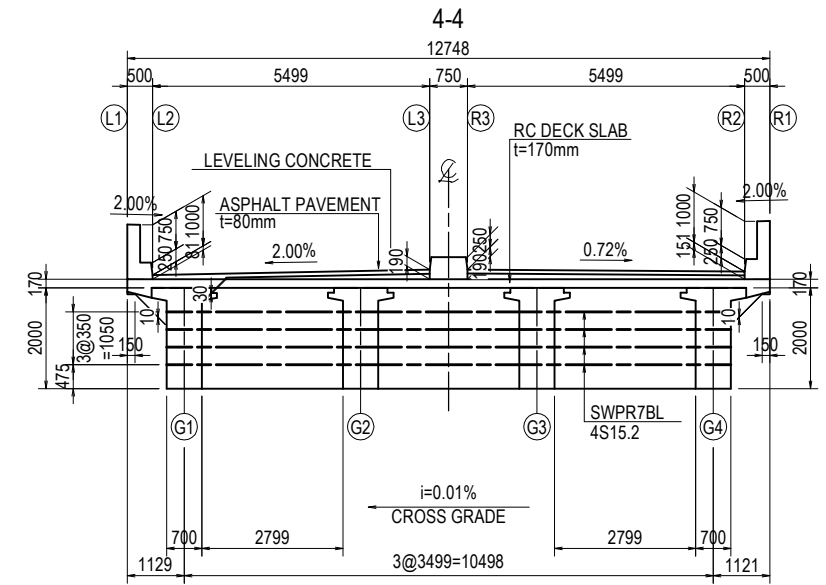
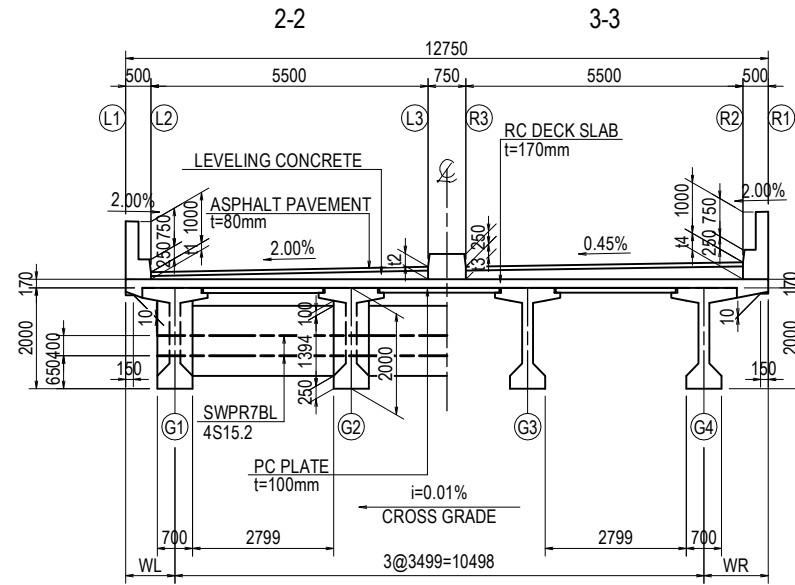
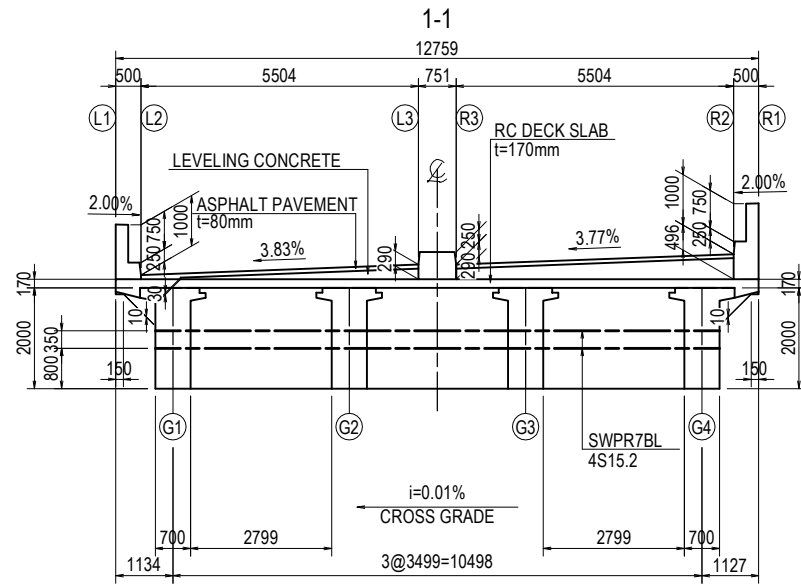

PF8-PF11

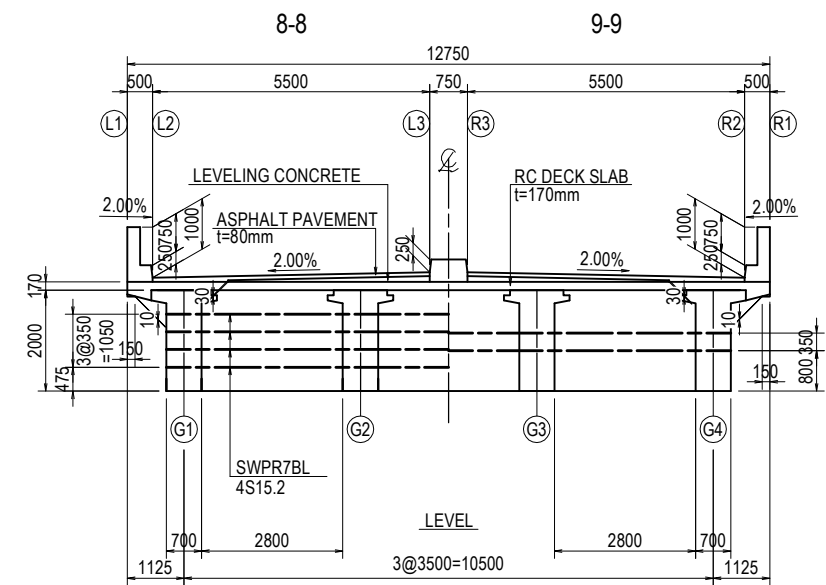

Note: Dimension of crosssection at end of girder is based on the actual angle of girder end.

LIST OF PAVEMENT THICKNESS (mm)

	GE1	S1	C1	C2	C3	C4	C5	C6	C7	S2	GE2	PF8
t1	80	84	108	130	149	141	126	112	97	83	81	80
t2	290	289	284	275	264	250	236	221	207	192	190	190
t3	290	289	283	275	264	250	236	221	207	192	190	190
t4	496	491	456	417	377	333	289	245	201	157	151	150

	PF8	GE3	S3	C11	C12	C13	C14	C15	C16	C17	S4	GE4
t1	80	80	80	80	80	80	80	80	80	80	80	80
t2	190	190	190	190	190	190	190	190	190	190	190	190
t3	190	190	190	190	190	190	190	190	190	190	190	190
t4	150	149	145	115	85	80	80	80	80	80	80	80

LIST OF WL/WR LENGTH (mm)

	GE1	S1	C1	C2	C3	C4	C5	C6	C7	S2	GE2	PF8
WL	1134	1122	1048	1001	978	976	992	1023	1067	1121	1129	1131
WR	1127	1139	1209	1254	1275	1276	1259	1227	1183	1129	1121	1119

	PF8	GE3	S3	C11	C12	C13	C14	C15	C16	S17	S4	GE4
WL	1131	1131	1130	1126	1125	1125	1125	1125	1125	1125	1125	1125
WR	1119	1119	1120	1124	1125	1125	1125	1125	1125	1125	1125	1125

PROJECT NAME
DETAILED DESIGN ON
BAGO RIVER BRIDGE
CONSTRUCTION PROJECT

FINANCED BY
JICA
JAPAN INTERNATIONAL
COOPERATION AGENCY

COUNTERPART
REPUBLIC OF THE UNION OF MYANMAR
MINISTRY OF CONSTRUCTION
DEPARTMENT OF BRIDGE

JICA STUDY TEAM
NIPPON KOEI CO., LTD.
ORIENTAL CONSULTANTS GLOBAL CO., LTD.
METROPOLITAN EXPRESSWAY COMPANY LIMITED
CHODAI CO., LTD.
NIPPON ENGINEERING CONSULTANTS CO., LTD.

	NAME	SIGNATURE	DATE
PREPARED BY	Y. SUZUKI	<i>YS</i>	14 Jul. 2017
CHECKED BY	T. HAYAKAWA	<i>TH</i>	20 Jul. 2017
APPROVED BY	Y. SANO	<i>YS</i>	25 Jul. 2017

DRAWING TITLE
GENERAL VIEW OF SUPERSTRUCTURE (PF7-PF11) (2)

PACKAGE
3
DWG No.
P3-FO-1205

GENERAL VIEW OF SUPERSTRUCTURE (PF7-PF11) (3)

CROSS SECTION OF MAIN GIRDER S=1:50

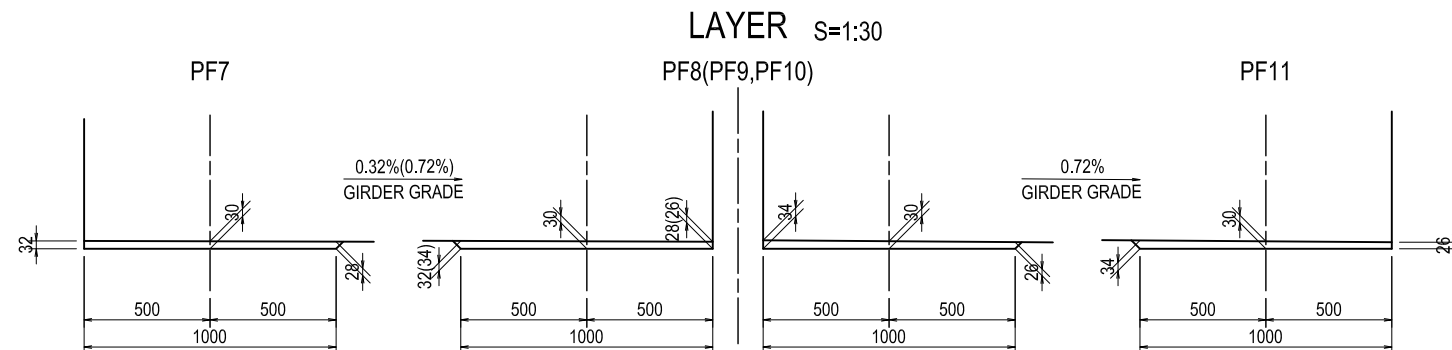
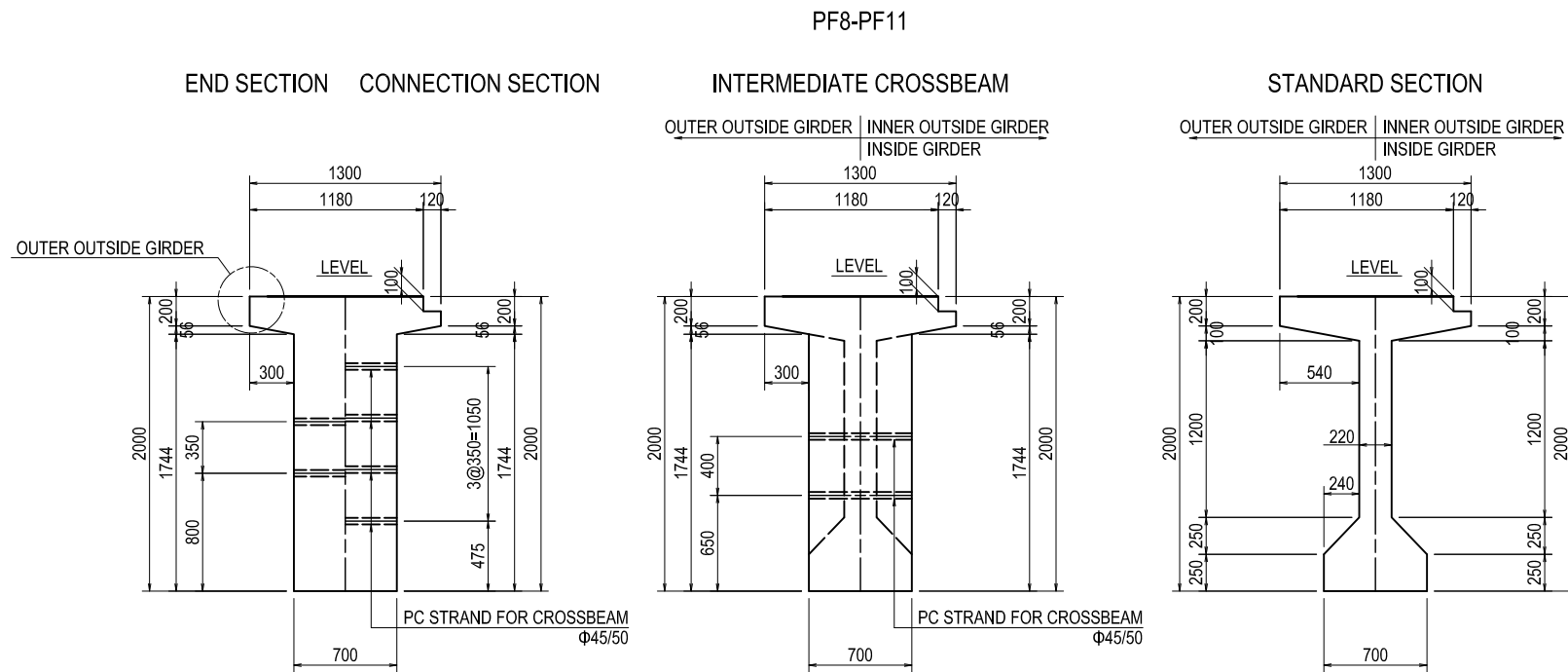
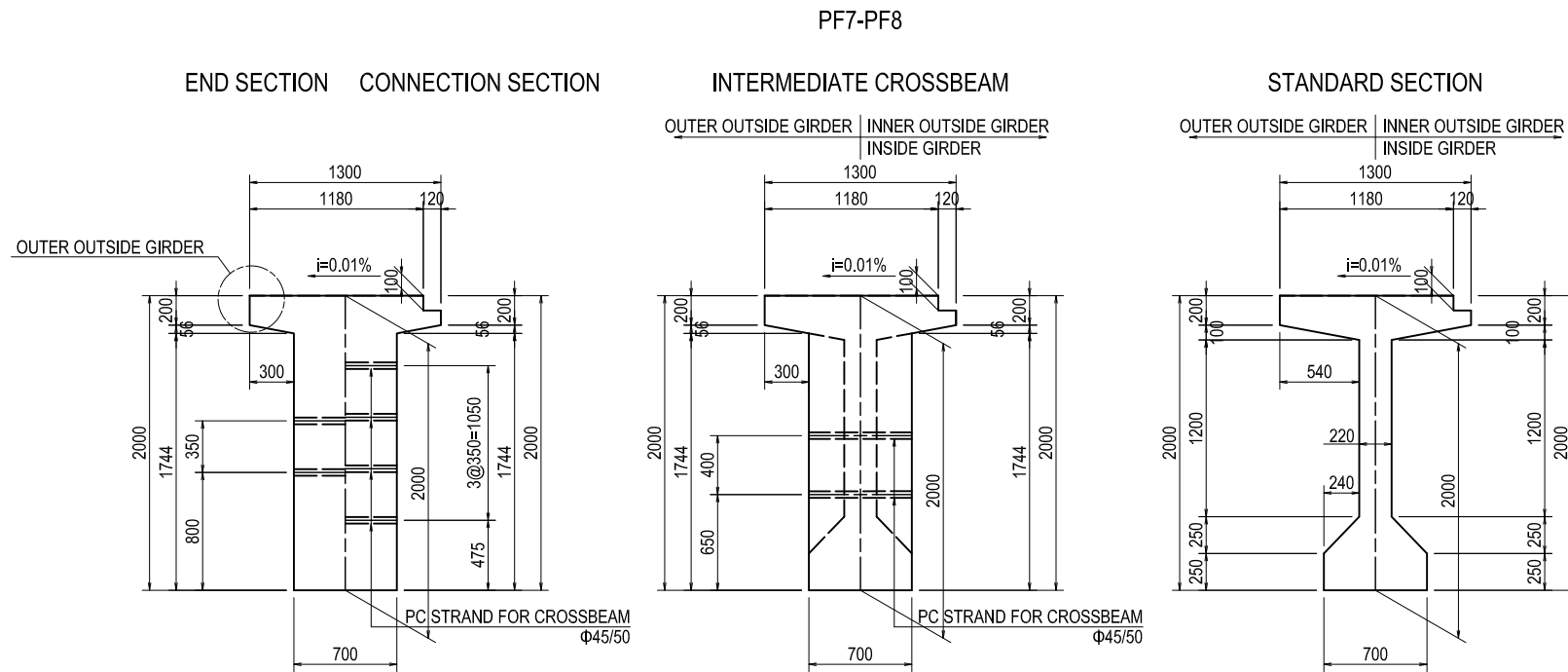

DESIGN CONDITION

ROAD GRADE	Equivalent to CLASS 4-1
BRIDGE TYPE	4 span continuous PC-I girder bridge with composite deck(PC plate and RC deck)
BRIDGE LENGTH	L = 120.000 m
SPAN LENGTH	L = 28.798 + 28.800 + 28.800 + 28.800 m
WIDTH OF THE ROAD	TOTAL : 12.750 m L = 0.500 + 5.500 + 0.750 + 5.500 + 0.500 m
HORIZONTAL ALIGNMENT	A=130-R=∞
LONGITUDINAL SLOPE	0.72%
SECTION SLOPE	LEFT : -6.00%~-2.00% RIGHT : 6.00%~-2.00%
ANGLE OF SKEW	PF.7 : 92°29'51" PF.8 : 90°07'09" PF.9,PF.10,PF.11 : 90°00'00"
PAVEMENT	ASPHALT PAVEMENT t = 80 mm
SLAB	RC DECK SLAB t = 170 mm
PLATE	PC PLATE t = 100 mm
LIVE ROAD	AASHTO HL-93
DESIGN STANDARD	AASHTO LRFD BRIDGE DESIGN 2014(LIVE ROAD) Specifications for highway bridges(Japan Road Association) 1 Common matters,3 Concrete bridges,5 seismic design (April 2012)

MATERIALS STRENGTH

CONCRETE	(N/mm ²)				
	MAIN GIRDER	CROSS BEAM	PC PLATE	RC SLAB	COUPLING CONCRETE
DESIGN STANDARD STRENGTH OF CONCRETE	40.0	30.0	40.0	30.0	30.0
BENDING COMPRESSIVE STRESS	IMMEDIATELY AFTER PRESTRESSING	19.0	14.0	19.0	—
	OTHERS	14.0	11.0	15.0	10.0
BENDING TENSILE STRESS	IMMEDIATELY AFTER PRESTRESSING	-1.5	-1.2	-1.5	—
	DEAD LOAD	0.0	0.0	—	—
	OTHERS	-1.5	-1.2	0.0	—
MEAN SHEAR STRESS CONCRETE CAN CARRY	0.55	0.45	—	—	—
MAXIMUM MEAN CONCRETE SHEAR STRESS	IN CASE WHERE ONLY SHEAR FORCES	5.3	4.0	—	—
ALLOWABLE DIAGONEL TENSILE STRESS (DEAD LOAD)	IN CASE WHERE ONLY SHEAR FORCES	-1.0	-0.8	—	—
ALLOWABLE DIAGONEL TENSILE STRESS (LIVE LOAD)	IN CASE WHERE ONLY SHEAR FORCES	-2.0	-1.7	—	—

PC STRAND	(N/mm ²)		
	SWPR7BL 7S15.2mm	SWPR7BL 4S15.2mm	SWPR7AL 1S9.3mm
TENSILE STRENGTH	1850	1850	1700
YIELD POINT	1600	1600	1450
ALLOWABLE TENSILE STRESS	DURING PRESTRESSING	1440	1305
	IMMEDIATELY AFTER PRESTRESSING	1295	1190
	UNDER DESIGN LOAD	1110	1020

REINFORCING STEEL	(N/mm ²)			
	MAIN GIRDER	CROSS BEAM	RC SLAB	COUPLING CONCRETE
STEEL TYPE	SD345	SD345	SD345	SD345
YIELD POINT	345	345	345	345
ALLOWABLE TENSILE STRESS	DEAD LOAD	—	100	100
	DESIGN LOAD	180	140	160
	EARTHQUAKE LOAD	—	200	—

PC STRAND ARRANGEMENT OF MAIN GIRDER (PF7-PF11) (1)

SIDE VIEW S=1:100

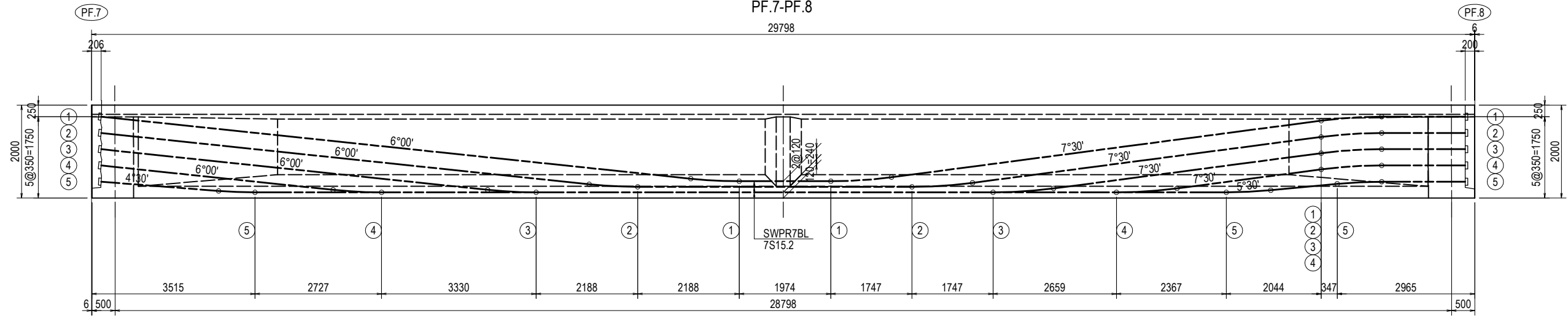

PC STRAND LENGTH & ELEVATION

7S15.2
w=7.707 kg/m
R=10.000m

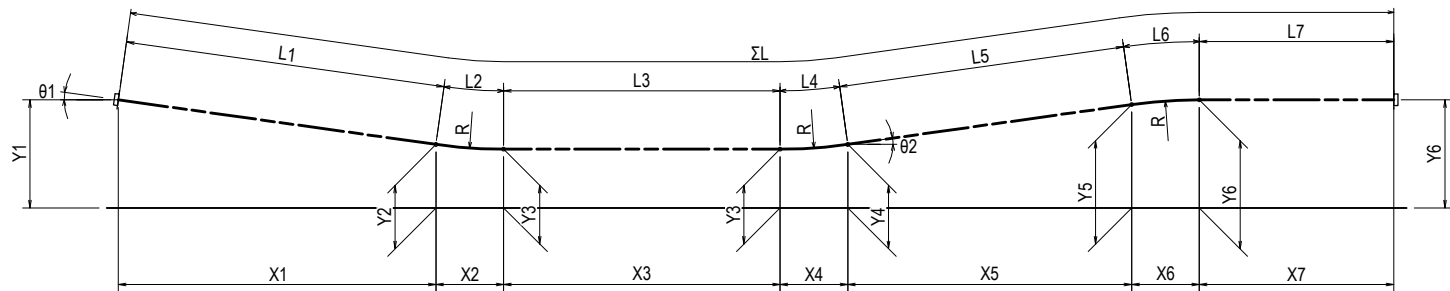

PF.7-PF.8

(UNIT:mm) (UNIT:kg)

PC STRAND No	θ1	θ2	Y1	Y2	Y3	Y4	Y5	Y6	X1	X2	X3	X4	X5	X6	X7	L1	L2	L3	L4	L5	L6	L7	ΣL	WEIGHT																				
1	6°00'	7°30'	1750	415	360	446	1664	1750	12704	1045	1974	1305	9259	1305	1800	12774	1047	1974	1309	9338	1309	1800	29551	227.75																				
2	6°00'	7°30'	1400	295	240	326	1314	1400	10516	1045	5909	1305	7512	1305	1800	10573	1047	5909	1309	7576	1309	1800	29523	227.53																				
3	6°00'	7°30'	1050	175	120	206	964	1050	8327	1045	9844	1305	5765	1305	1800	8373	1047	9844	1309	5814	1309	1800	29496	227.33																				
4	6°00'	7°30'	700	175	120	206	614	700	4997	1045	15833	1306	3106	1305	1800	5025	1047	15833	1309	3133	1309	1800	29456	227.02																				
5	4°30'	5°30'	350	151	120	166	304	350	2531	784	20927	958	1432	959	1800	2539	785	20927	960	1439	960	1800	29410	226.66																				
																						TOTAL	147436	1136.3																				

CROSS SECTION OF MAIN GIRDER S=1:50

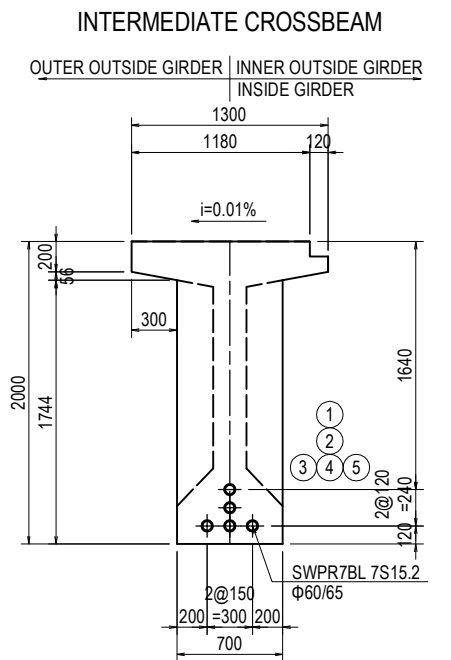
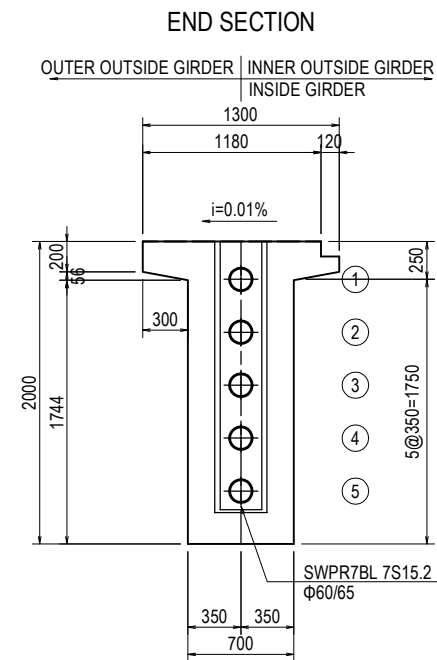

PC STRAND ARRANGEMENT OF MAIN GIRDER (PF7-PF11) (2)

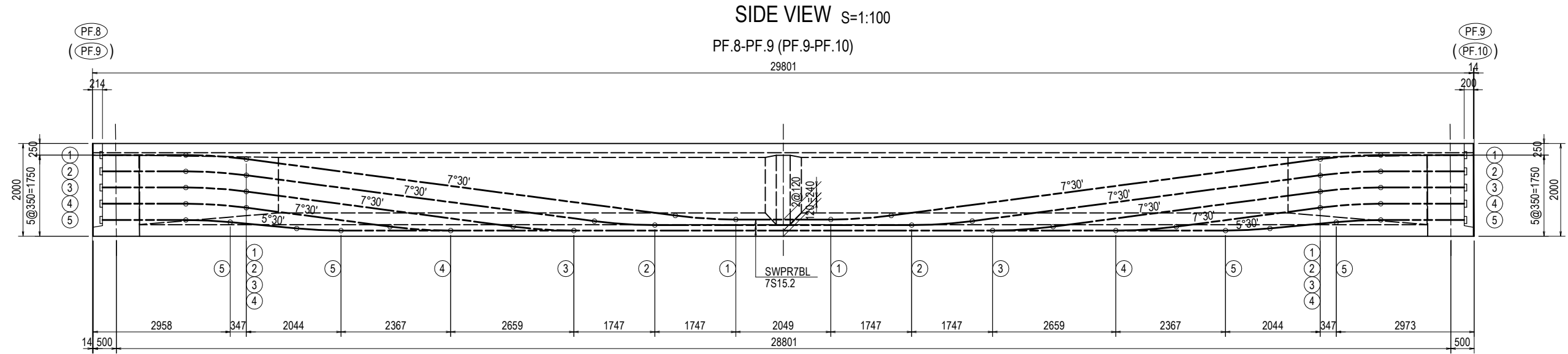

PC STRAND LENGTH & ELEVATION

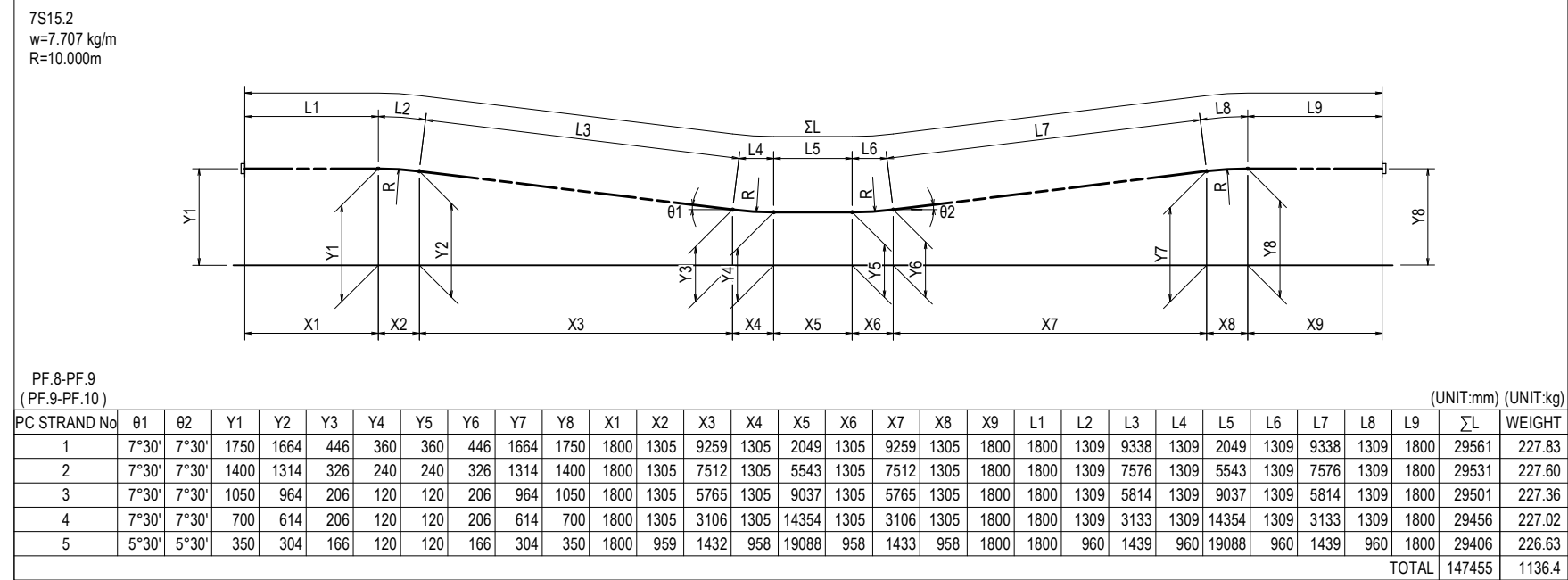

CROSS SECTION OF MAIN GIRDER S=1:50

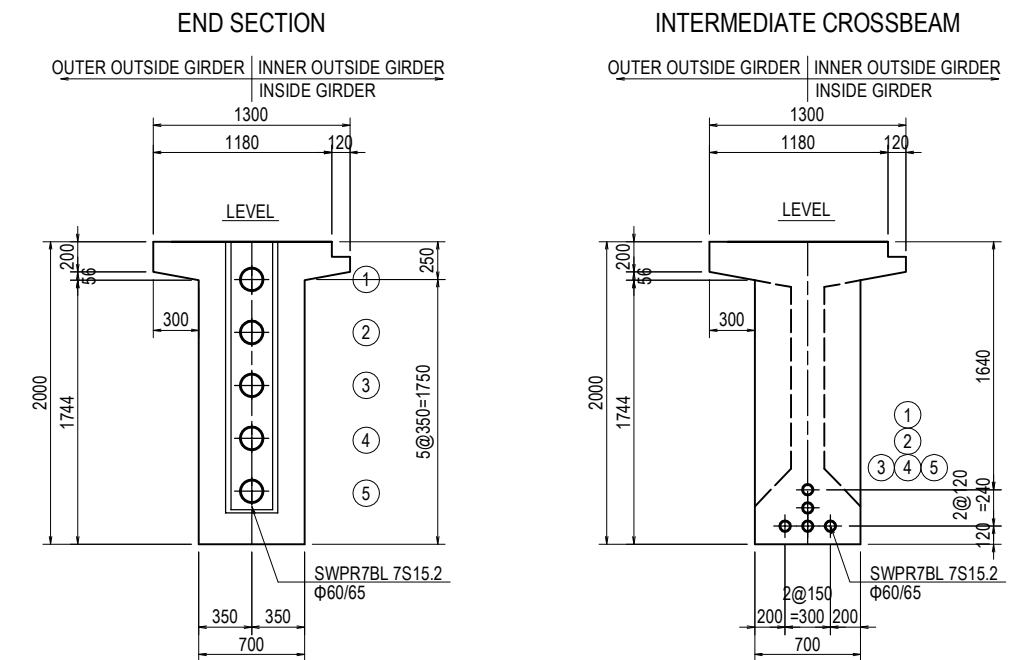

PC STRAND ARRANGEMENT OF MAIN GIRDER (PF7-PF11) (3)

SIDE VIEW S=1:100

PF.10-PF.11

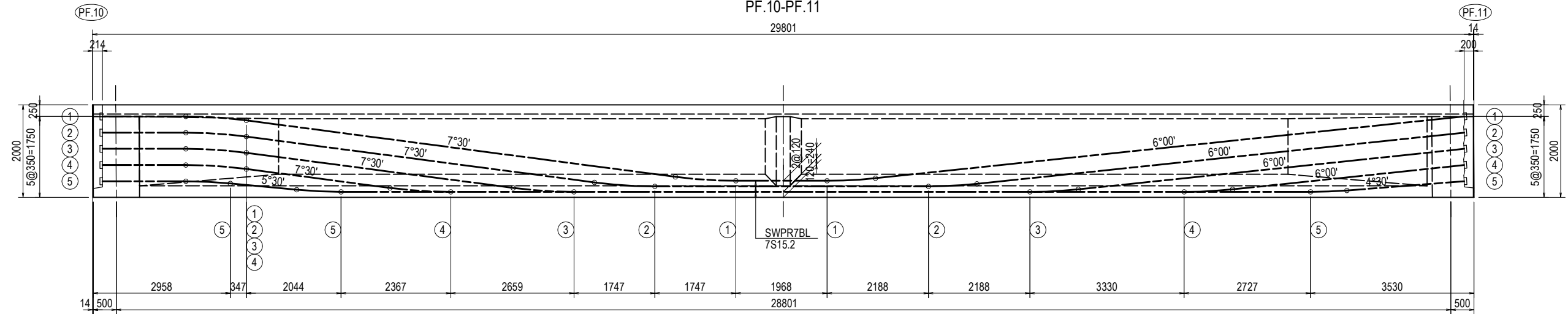

PC STRAND LENGTH & ELEVATION

7S15.2
w=7.707 kg/m
R=10.000m

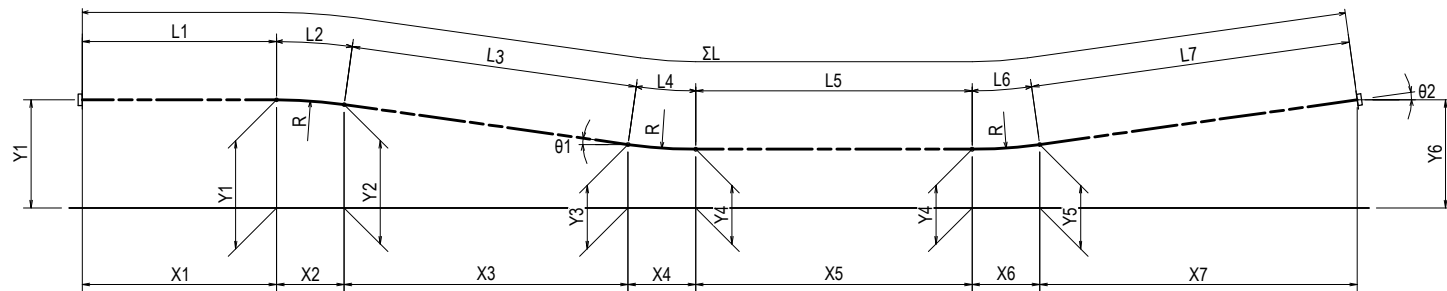

PF.10-PF.11

(UNIT:mm) (UNIT:kg)

PC STRAND No	θ1	θ2	Y1	Y2	Y3	Y4	Y5	Y6	X1	X2	X3	X4	X5	X6	X7	L1	L2	L3	L4	L5	L6	L7	ΣL	WEIGHT																				
1	7°30'	6°00'	1750	1664	446	360	415	1750	1800	1305	9259	1305	1968	1045	12704	1800	1309	9338	1309	1968	1047	12774	29545	227.70																				
2	7°30'	6°00'	1400	1314	326	240	295	1400	1800	1305	7512	1305	5904	1046	10515	1800	1309	7576	1309	5904	1047	10573	29518	227.50																				
3	7°30'	6°00'	1050	964	206	120	175	1050	1800	1305	5765	1305	9839	1045	8327	1800	1309	5814	1309	9839	1047	8373	29491	227.29																				
4	7°30'	6°00'	700	614	206	120	175	700	1800	1305	3106	1305	15828	1045	4997	1800	1309	3133	1309	15828	1047	5025	29451	226.98																				
5	5°30'	4°30'	350	304	166	120	151	350	1800	959	1432	958	20922	784	2531	1800	960	1439	960	20922	785	2539	29405	226.62																				
																						TOTAL	147410	1136.1																				

CROSS SECTION OF MAIN GIRDER S=1:50

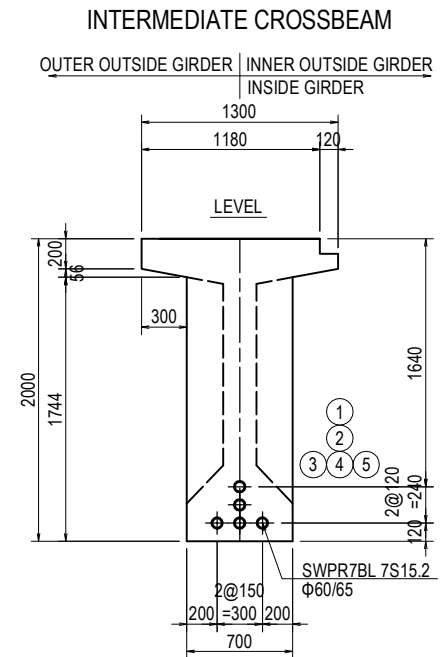
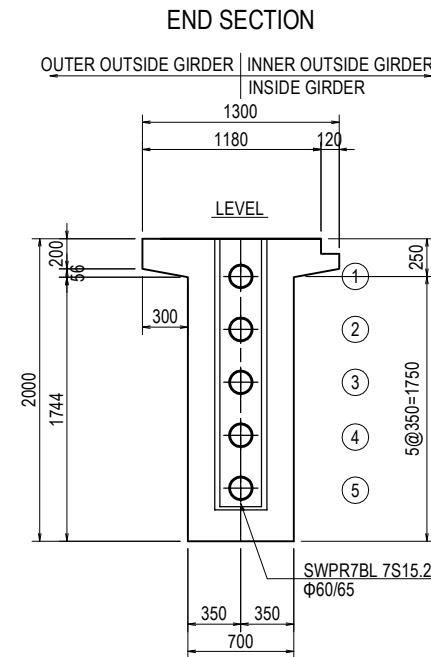

BAR ARRANGEMENT OF MAIN GIRDER (PF7-PF11) (1)

SIDE VIEW S=1:100

PF.7-PF.8

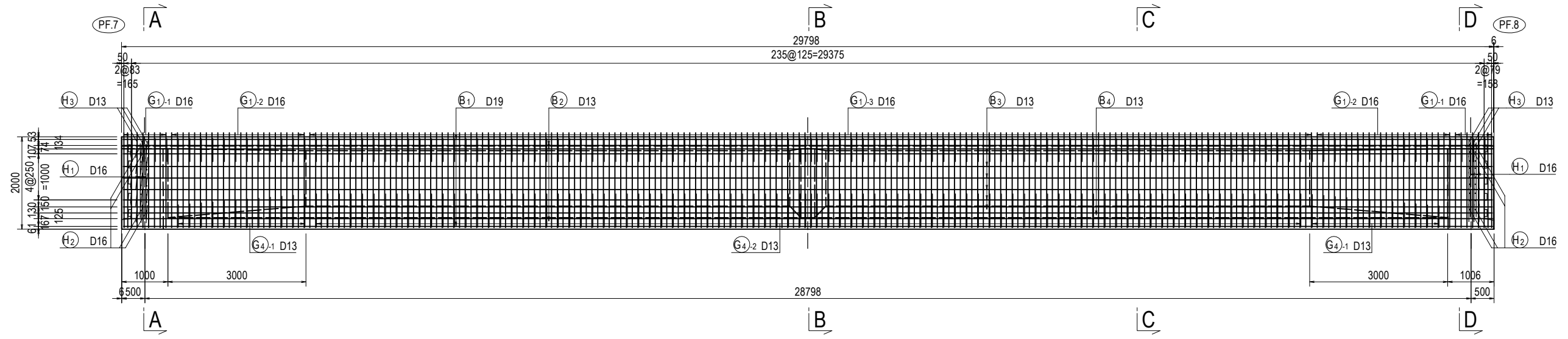

PLAN S=1:100

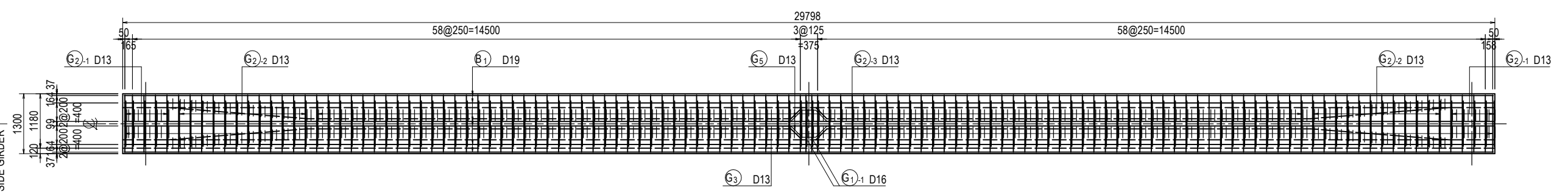

CROSS SECTION OF MAIN GIRDER S=1:50

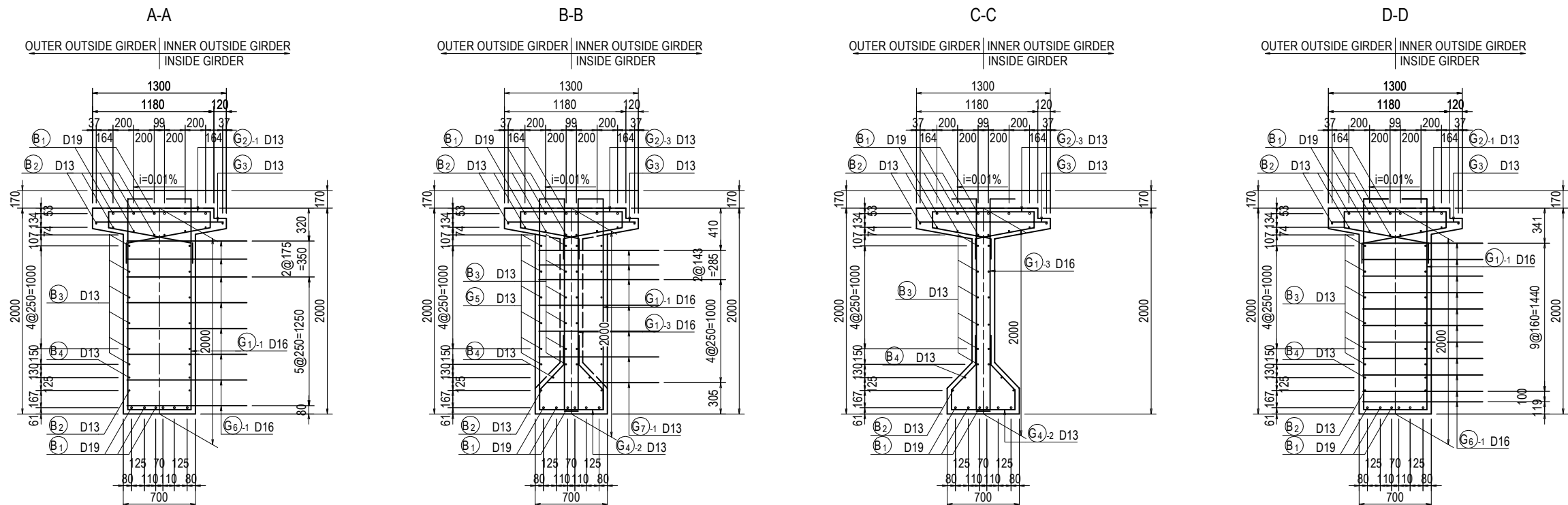

PROJECT NAME DETAILED DESIGN ON BAGO RIVER BRIDGE CONSTRUCTION PROJECT	FINANCED BY JAPAN INTERNATIONAL COOPERATION AGENCY	COUNTERPART REPUBLIC OF THE UNION OF MYANMAR MINISTRY OF CONSTRUCTION DEPARTMENT OF BRIDGE	JICA STUDY TEAM NIPPON KOEI CO., LTD. ORIENTAL CONSULTANTS GLOBAL CO., LTD. METROPOLITAN EXPRESSWAY COMPANY LIMITED CHODAI CO., LTD. NIPPON ENGINEERING CONSULTANTS CO., LTD.	NAME	SIGNATURE	DATE	DRAWING TITLE	PACKAGE				
				PREPARED BY	Y. SUZUKI				14 Jul. 2017	BAR ARRANGEMENT OF MAIN GIRDER (PF7-PF11) (1)	3	
				CHECKED BY	T. HAYAKAWA				20 Jul. 2017			DWG No.
				APPROVED BY	Y. SANO				25 Jul. 2017			

BAR ARRANGEMENT OF MAIN GIRDER (PF7-PF11) (2)

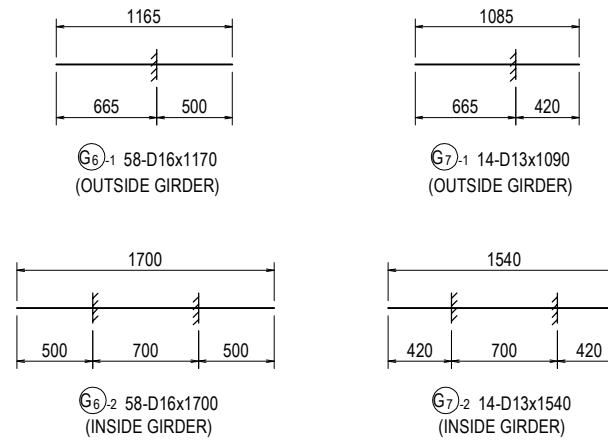
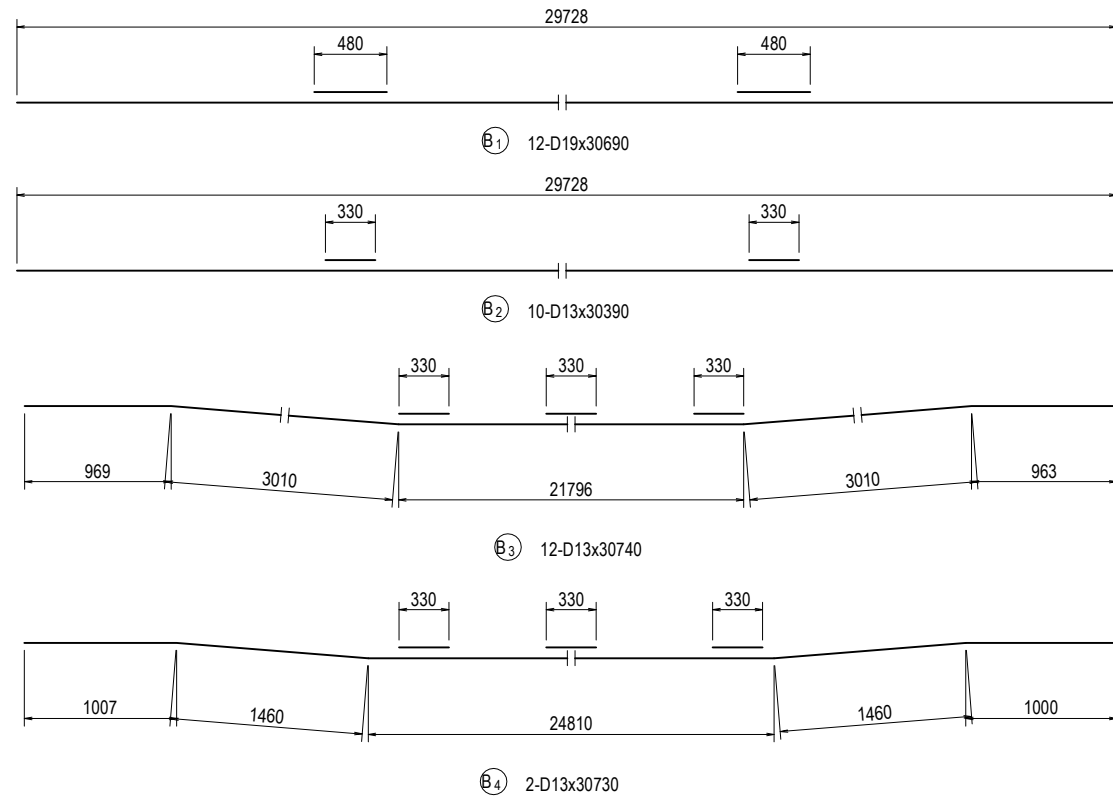

BAR LIST

REBAR NO.	DIA (mm)	LENGHT (mm)	NUMBER	UNIT WEIGHT (kg/m)	WEIGHT/ONE (kg)	WEIGHT (kg)	REMARKS
B 1	D19	30690	12	2.25	69.05	829	
B 2	D13	30390	10	0.995	30.24	302	
B 3	D13	30740	12	0.995	30.59	367	
B 4	D13	30730	2	0.995	30.58	61	
G 1 -1	D16	5190	20	1.56	8.10	162	
G 1 -2	D16	4950	48	1.56	7.72	371	AVERAGE
G 1 -3	D16	4710	174	1.56	7.35	1279	
G 2 -1	D13	3320	10	0.995	3.30	33	
G 2 -2	D13	3080	24	0.995	3.06	73	AVERAGE
G 2 -3	D13	2840	88	0.995	2.83	249	
G 3	D13	1240	122	0.995	1.23	150	
G 4 -1	D13	1940	24	0.995	1.93	46	AVERAGE
G 4 -2	D13	2260	88	0.995	2.25	198	
G 5	D13	1370	12	0.995	1.36	16	
G 6 -1	D16	1170	58	1.56	1.83	106	OUTSIDE GIRDER
G 6 -2	D16	1700	58	1.56	2.65	154	INSIDE GIRDER
G 7 -1	D13	1090	14	0.995	1.08	15	OUTSIDE GIRDER
G 7 -2	D13	1540	14	0.995	1.53	21	INSIDE GIRDER
H 1	D16	3520	8	1.56	5.49	44	
H 2	D16	670	36	1.56	1.05	38	
H 3	D13	4020	30	0.995	4.00	120	
				D19	829 kg	(829) kg	
				D16	2048 kg	(2000) kg	
				D13	1636 kg	(1630) kg	
				TOTAL	4513 kg	(4459) kg	

Note: The value of inside () are for OUTSIDE GIRDER.

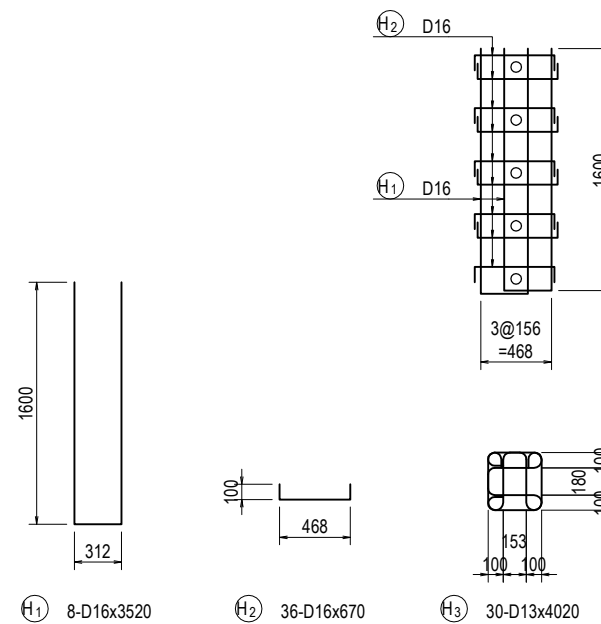
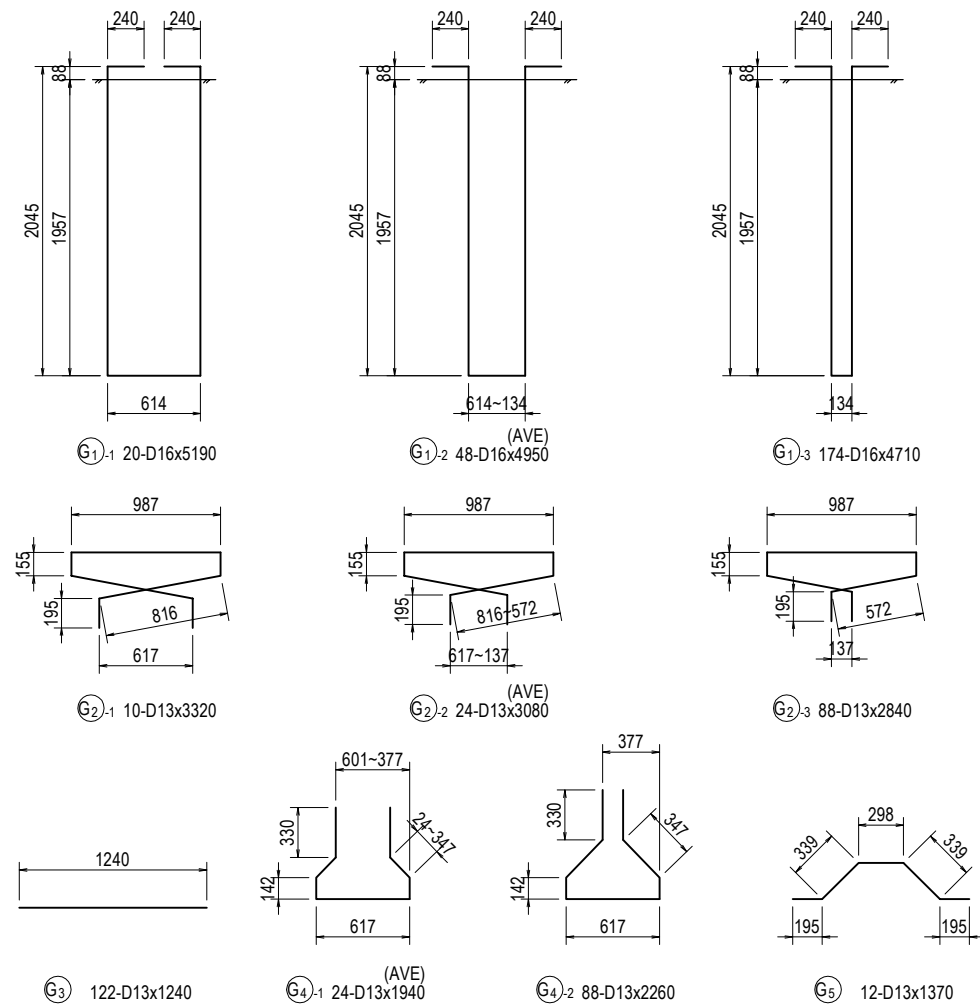

BAR ARRANGEMENT OF MAIN GIRDER (PF7-PF11) (3)

SIDE VIEW S=1:100

PF.8-PF.9
(PF.9-PF.10)
[PF.10-PF.11]

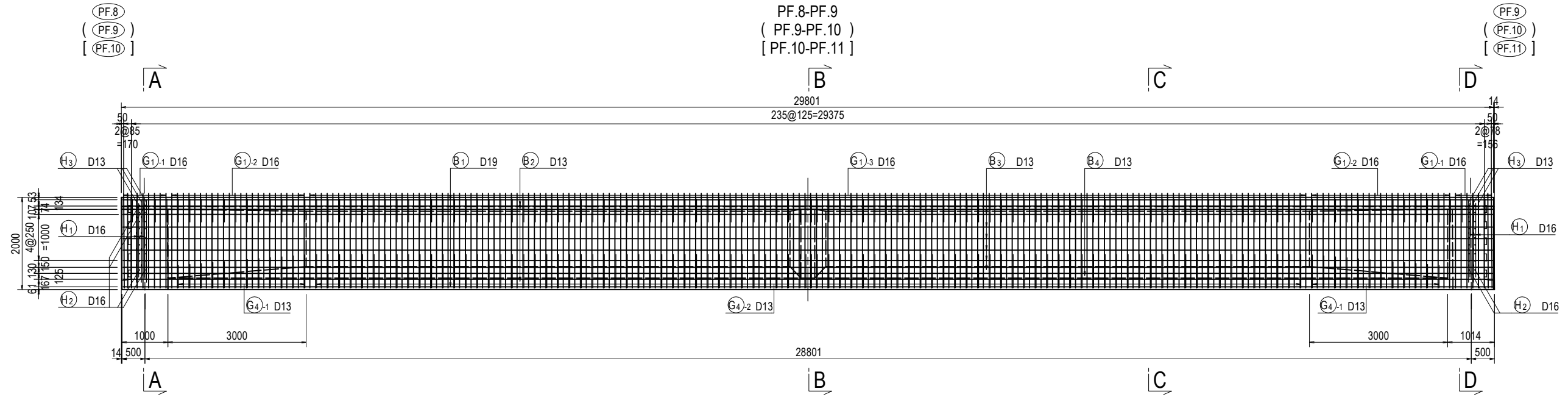

PLAN S=1:100

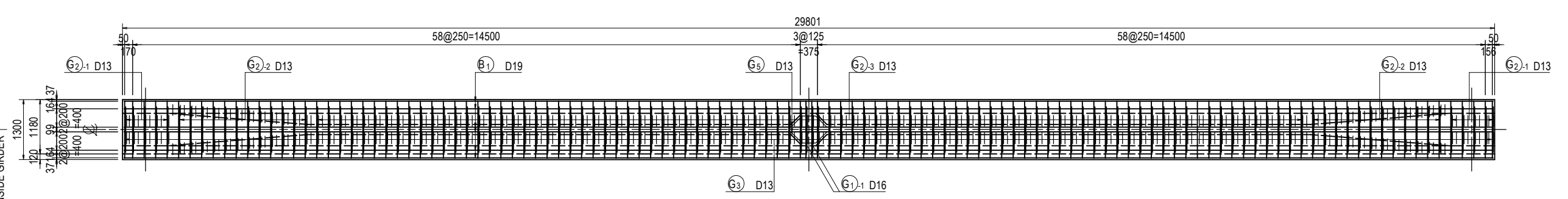

CROSS SECTION OF MAIN GIRDER S=1:50

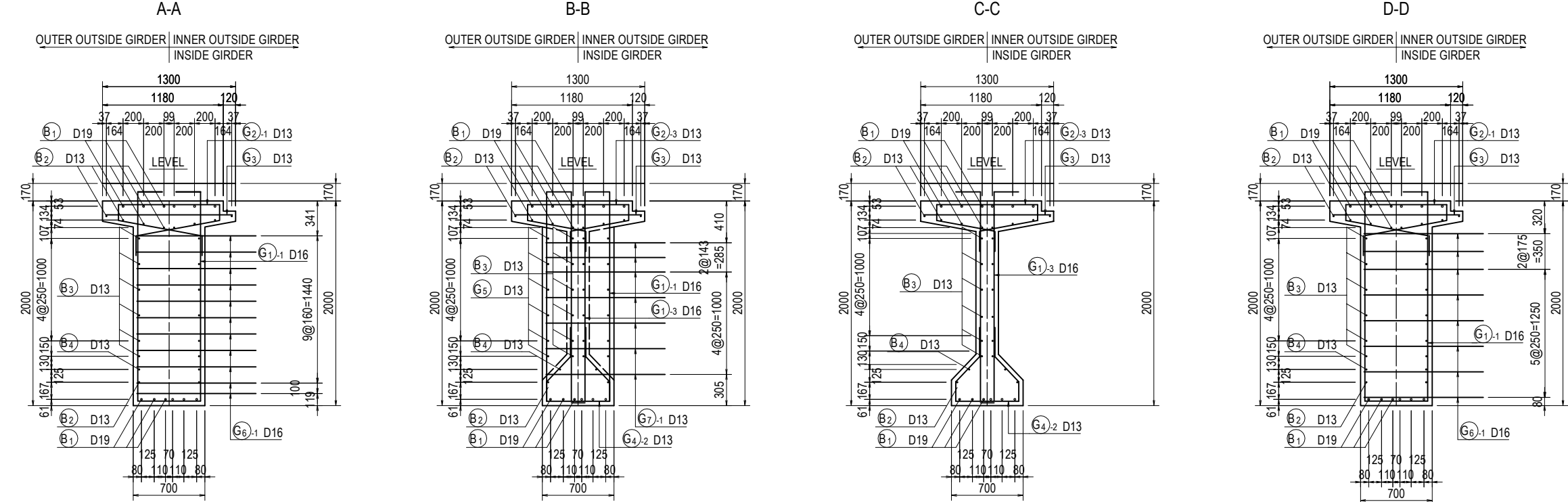

PROJECT NAME DETAILED DESIGN ON BAGO RIVER BRIDGE CONSTRUCTION PROJECT	FINANCED BY JAPAN INTERNATIONAL COOPERATION AGENCY	COUNTERPART REPUBLIC OF THE UNION OF MYANMAR MINISTRY OF CONSTRUCTION DEPARTMENT OF BRIDGE	JICA STUDY TEAM NIPPON KOEI CO., LTD. ORIENTAL CONSULTANTS GLOBAL CO., LTD. METROPOLITAN EXPRESSWAY COMPANY LIMITED CHODAI CO., LTD. NIPPON ENGINEERING CONSULTANTS CO., LTD.	NAME	SIGNATURE	DATE	DRAWING TITLE BAR ARRANGEMENT OF MAIN GIRDER (PF7-PF11) (3)	PACKAGE 3 DWG No. P3-FO-1212	
				PREPARED BY	Y. SUZUKI				14 Jul. 2017
				CHECKED BY	T. HAYAKAWA				20 Jul. 2017
				APPROVED BY	Y. SANO				25 Jul. 2017

BAR ARRANGEMENT OF MAIN GIRDER (PF7-PF11) (4)

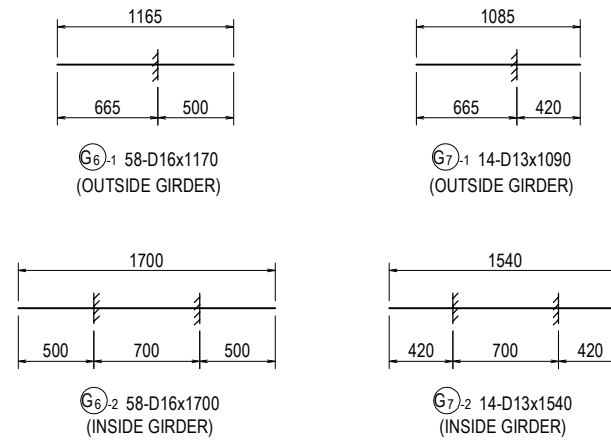
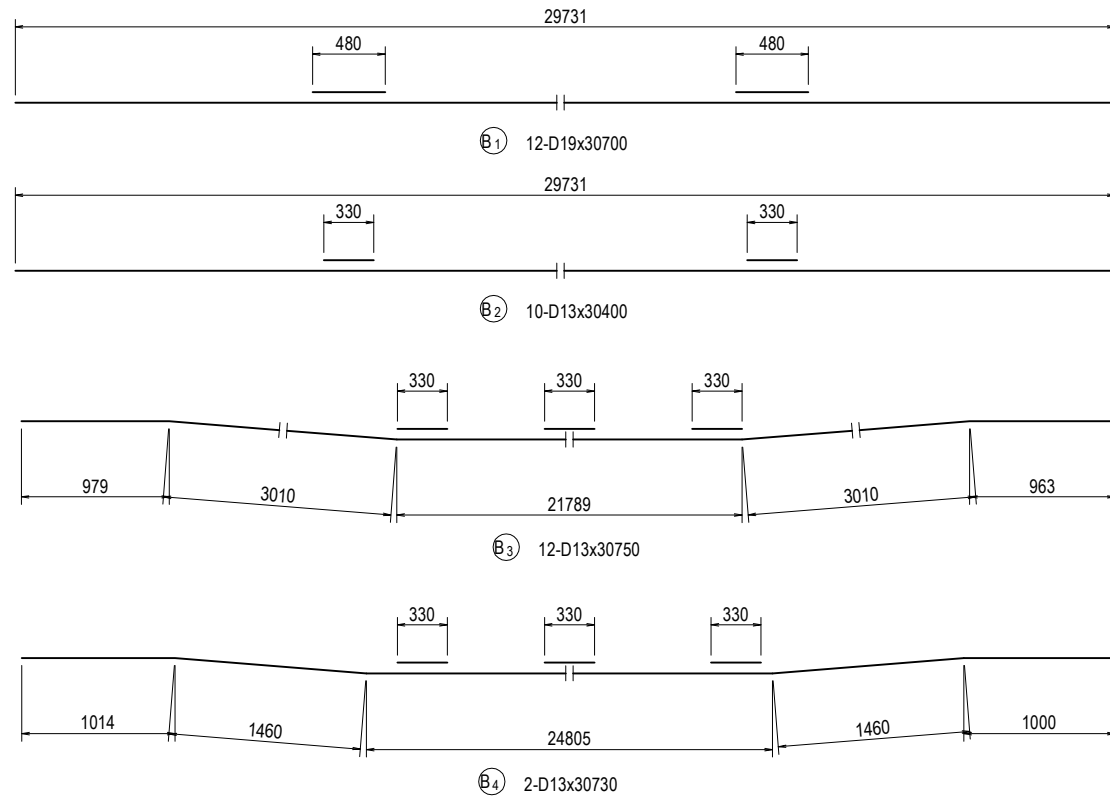

BAR LIST

REBAR NO.	DIA (mm)	LENGTH (mm)	NUMBER	UNIT WEIGHT (kg/m)	WEIGHT/ONE (kg)	WEIGHT (kg)	REMARKS
B 1	D19	30700	12	2.25	69.08	829	
B 2	D13	30400	10	0.995	30.25	303	
B 3	D13	30750	12	0.995	30.60	367	
B 4	D13	30730	2	0.995	30.58	61	
G 1 -1	D16	5190	20	1.56	8.10	162	
G 1 -2	D16	4950	48	1.56	7.72	371	AVERAGE
G 1 -3	D16	4710	174	1.56	7.35	1279	
G 2 -1	D13	3320	10	0.995	3.30	33	
G 2 -2	D13	3080	24	0.995	3.06	73	AVERAGE
G 2 -3	D13	2840	88	0.995	2.83	249	
G 3	D13	1240	122	0.995	1.23	150	
G 4 -1	D13	1940	24	0.995	1.93	46	AVERAGE
G 4 -2	D13	2260	88	0.995	2.25	198	
G 5	D13	1370	12	0.995	1.36	16	
G 6 -1	D16	1170	58	1.56	1.83	106	OUTSIDE GIRDER
G 6 -2	D16	1700	58	1.56	2.65	154	INSIDE GIRDER
G 7 -1	D13	1090	14	0.995	1.08	15	OUTSIDE GIRDER
G 7 -2	D13	1540	14	0.995	1.53	21	INSIDE GIRDER
H 1	D16	3520	8	1.56	5.49	44	
H 2	D16	670	36	1.56	1.05	38	
H 3	D13	4020	30	0.995	4.00	120	
					D19	829 kg	(829) kg
					D16	2048 kg	(2000) kg
					D13	1637 kg	(1631) kg
					TOTAL	4514 kg	(4460) kg

Note: The value of inside () are for OUTSIDE GIRDER.

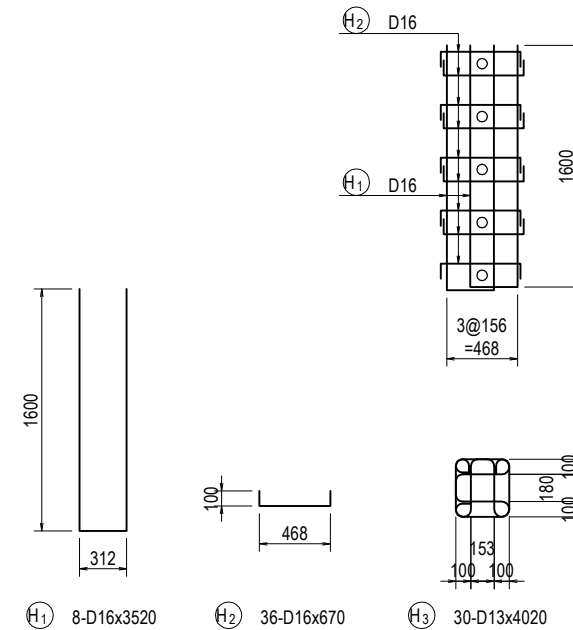
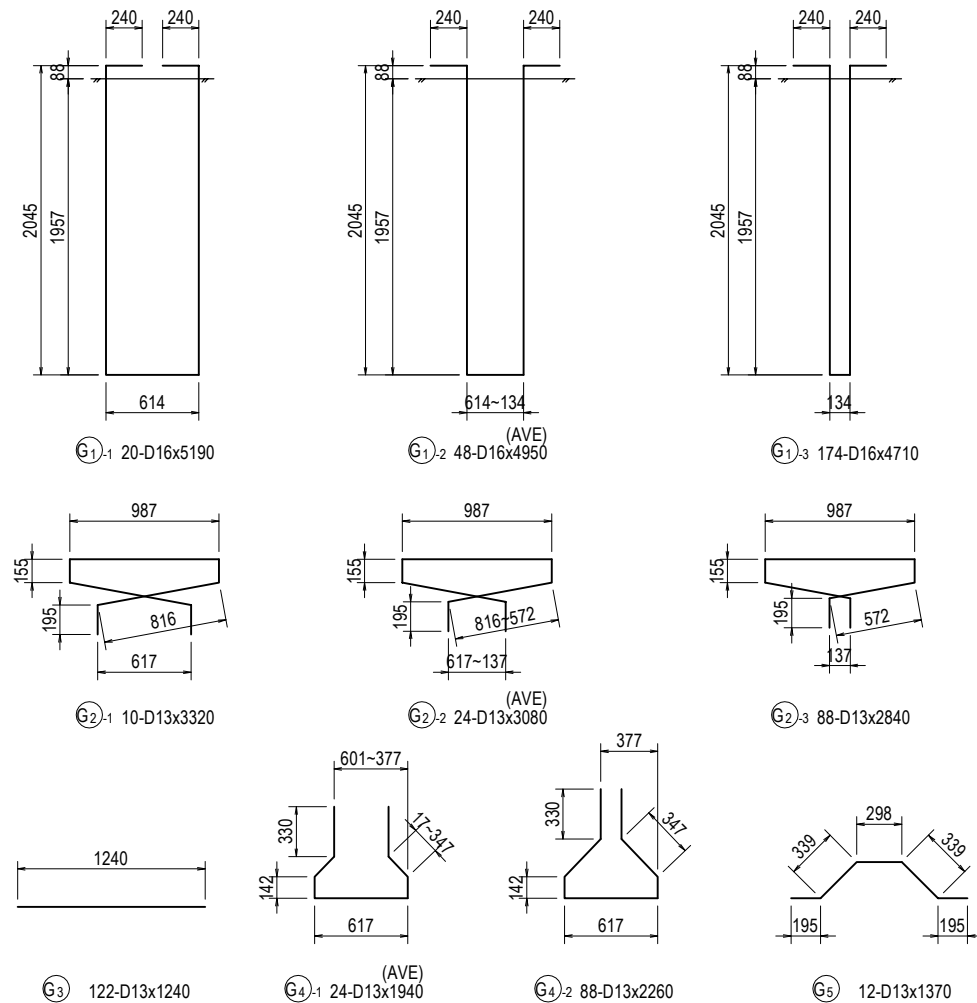

BAR ARRANGEMENT OF CROSSBEAM (PF7-PF11) (1)

CROSS SECTION S=1:60

SIDE VIEW S=1:60

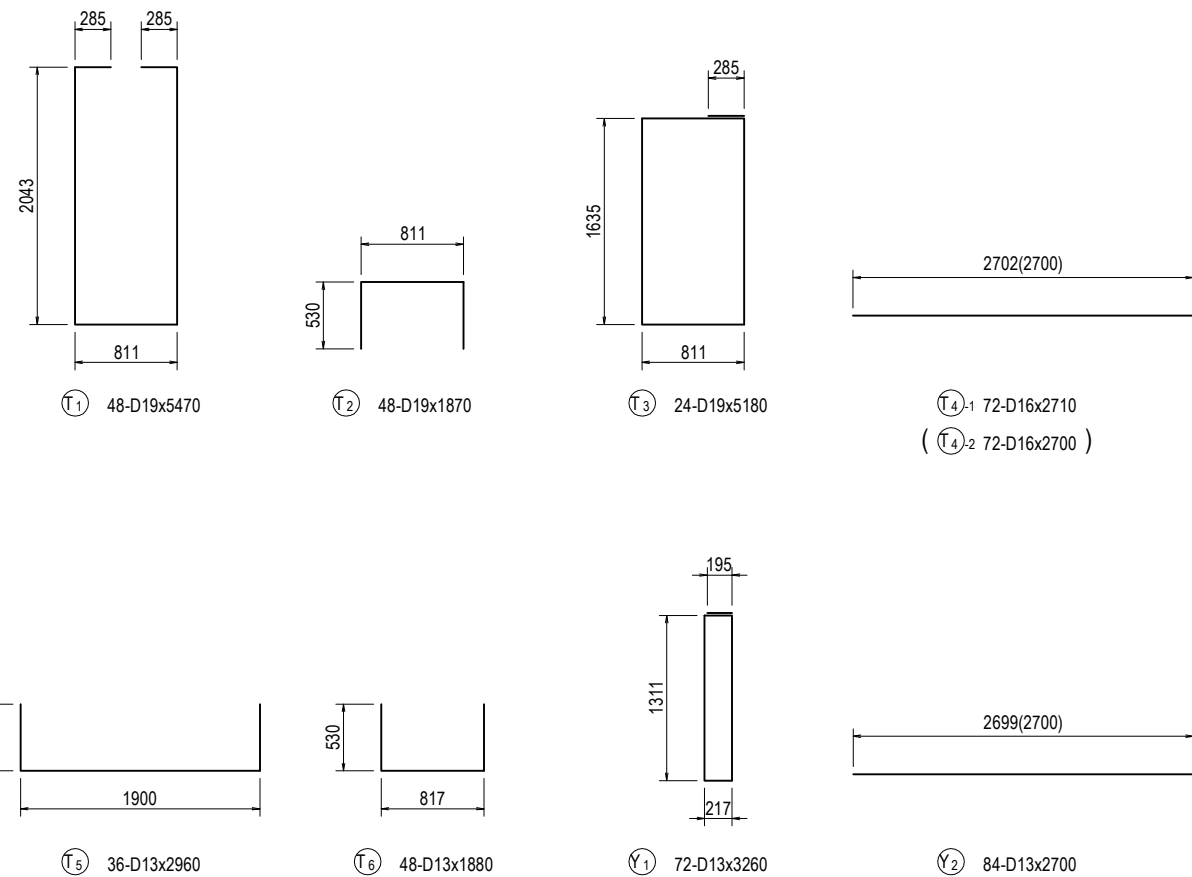
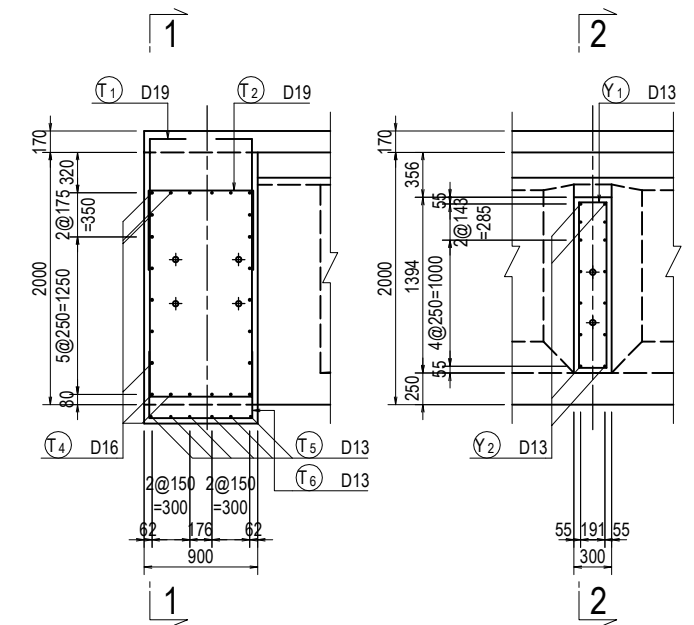
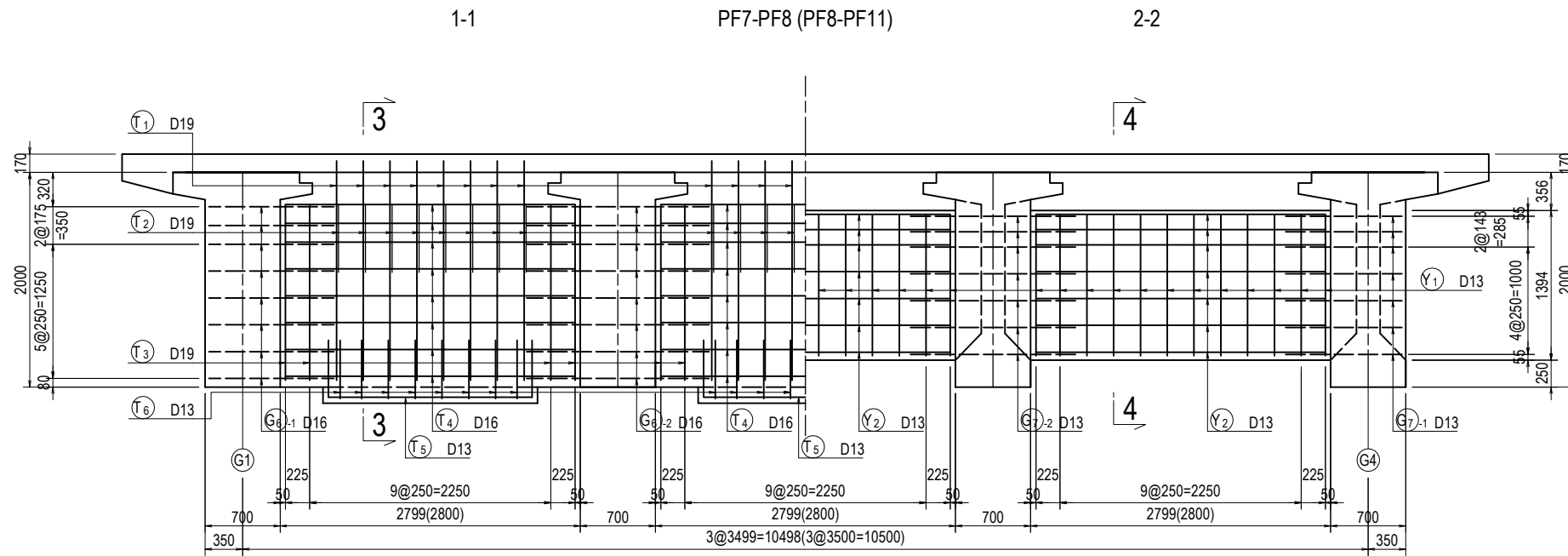

PC STRAND LIST

	TYPE	LENGTH (mm)	NUMBER	UNIT WEIGHT (kg/m)	WEIGHT/ONE (kg)	WEIGHT (kg)	REMARKS
CROSSBEAM AT END OF MAIN GIRDER	SWPR7BL 4S15.2	11200	8	4.404	49.325	394.6	
INTERMEDIATE CROSSBEAM	SWPR7BL 4S15.2	11200	8	4.404	49.325	394.6	
				TOTAL LENGTH	ΣL=	179.200 m	
				TOTAL WEIGHT	ΣW=	789.2 kg	

BAR LIST

REBAR NO.	DIA (mm)	LENGTH (mm)	NUMBER	UNIT WEIGHT (kg/m)	WEIGHT/ONE (kg)	WEIGHT (kg)	REMARKS
T1	D19	5470	48	2.25	12.31	591	
T2	D19	1870	48	2.25	4.21	202	
T3	D19	5180	24	2.25	11.66	280	
T4 -1	D16	2710	72	1.56	4.23	305	
T4 -2	D16	2700	72	1.56	4.21	303	
T5	D13	2960	36	0.995	2.95	106	
T6	D13	1880	48	0.995	1.87	90	
Y1	D13	3260	72	0.995	3.24	233	
Y2	D13	2700	84	0.995	2.69	226	
						D19	1073 kg
						D16	608 kg
						D13	655 kg
						TOTAL	2336 kg

PROJECT NAME
DETAILED DESIGN ON
BAGO RIVER BRIDGE
CONSTRUCTION PROJECT

FINANCED BY
JICA
JAPAN INTERNATIONAL
COOPERATION AGENCY

COUNTERPART
REPUBLIC OF THE UNION OF MYANMAR
MINISTRY OF CONSTRUCTION
DEPARTMENT OF BRIDGE

JICA STUDY TEAM
NIPPON KOEI CO., LTD.
ORIENTAL CONSULTANTS GLOBAL CO., LTD.
METROPOLITAN EXPRESSWAY COMPANY LIMITED
CHODAI CO., LTD.
NIPPON ENGINEERING CONSULTANTS CO., LTD.

	NAME	SIGNATURE	DATE
PREPARED BY	Y. SUZUKI	<i>YS</i>	14 Jul. 2017
CHECKED BY	T. HAYAKAWA	<i>Hayakawa</i>	20 Jul. 2017
APPROVED BY	Y. SANO	<i>Y. Sano</i>	25 Jul. 2017

DRAWING TITLE
BAR ARRANGEMENT OF CROSSBEAM (PF7-PF11) (1)

PACKAGE
3
DWG No.
P3-FO-1214

BAR ARRANGEMENT OF CROSSBEAM (PF7-PF11) (2)

CROSS SECTION S=1:60

SIDE VIEW S=1:60

1-1

PF7-PF8 (PF8-PF11)

2-2

4-4

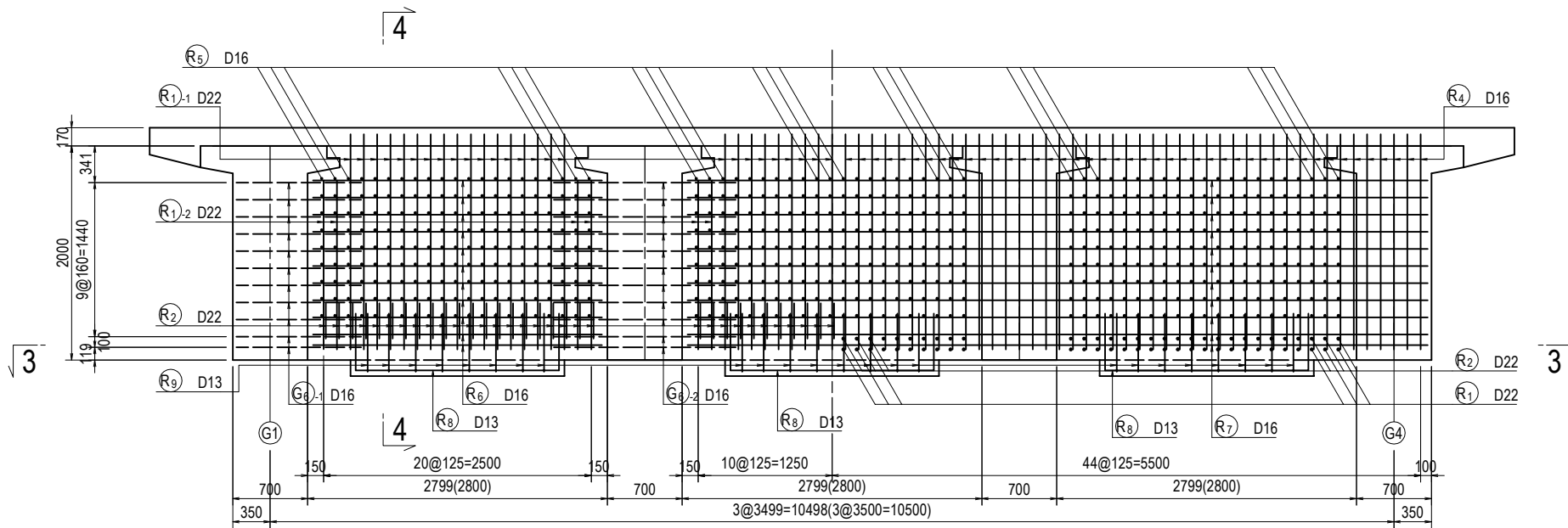

PLAN S=1:60

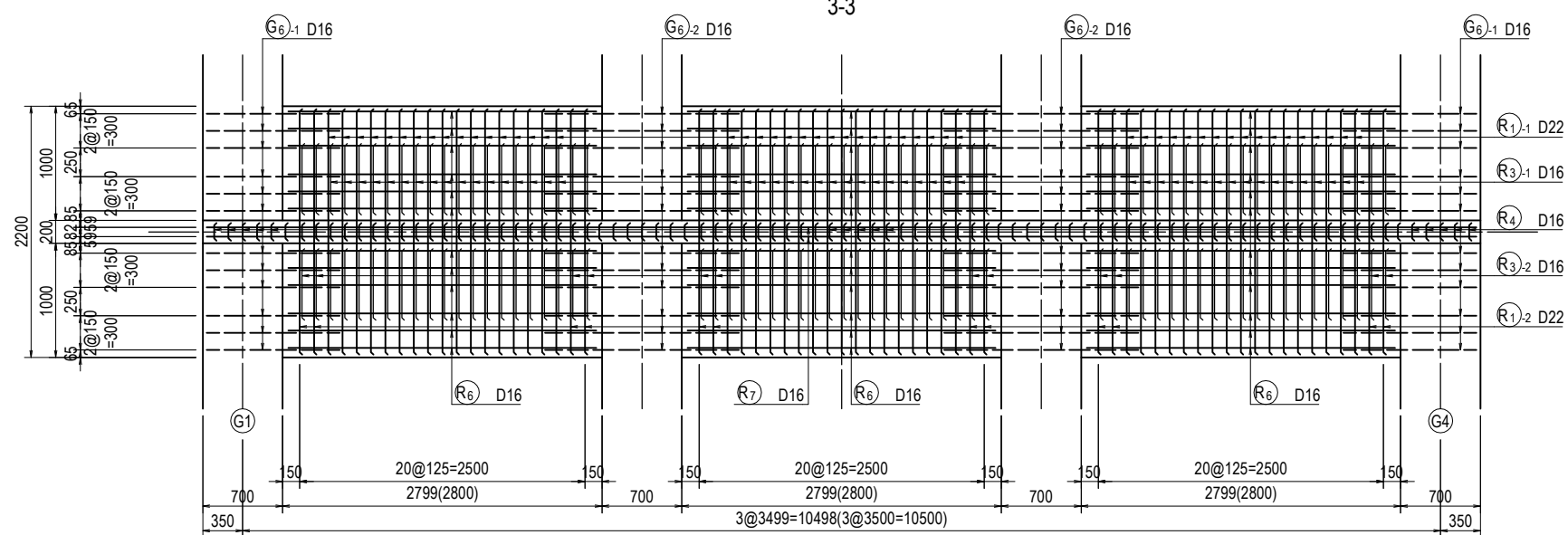
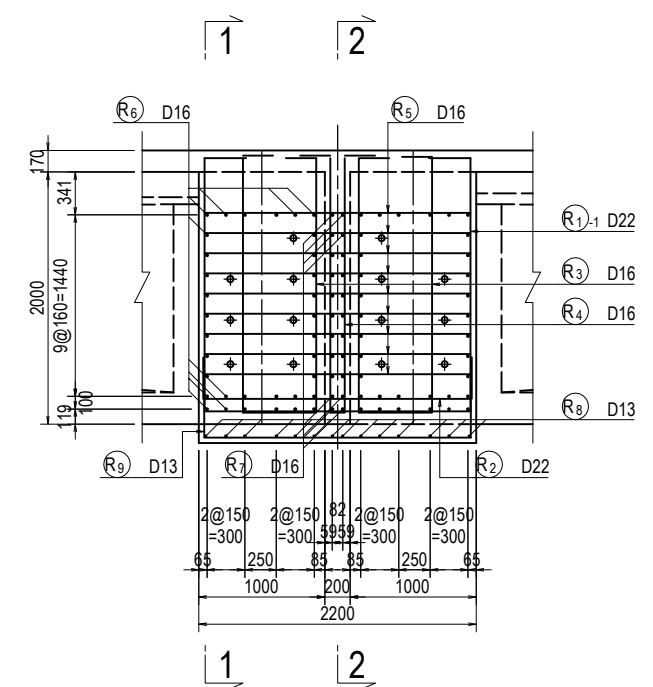

PC STRAND LIST

	TYPE	LENGTH (mm)	NUMBER	UNIT WEIGHT (kg/m)	WEIGHT/ONE (kg)	WEIGHT (kg)	REMARKS
	CONNECTING CROSSBEAM	SWPR7BL 4S15.2	11200	42	4.404	49.325	2071.7
						TOTAL LENGTH	ΣL= 470.400 m
						TOTAL WEIGHT	ΣW= 2071.6 kg

BAR LIST

REBAR NO.	DIA (mm)	LENGTH (mm)	NUMBER	UNIT WEIGHT (kg/m)	WEIGHT/ONE (kg)	WEIGHT (kg)	REMARKS
R1-1	D22	6790	51	3.04	20.64	1053	
R1-2	D22	5930	12	3.04	18.03	216	
R2	D22	2770	63	3.04	8.42	530	
R3-1	D16	5090	102	1.56	7.94	810	
R3-2	D16	4220	24	1.56	6.58	158	
R4	D16	4620	89	1.56	7.21	642	
R5	D16	2130	567	1.56	3.32	1882	
R6	D16	2700	204	1.56	4.21	859	
R7	D16	11130	22	1.56	17.36	382	
R8	D13	2960	42	0.995	2.95	124	
R9	D13	3180	24	0.995	3.16	76	
				D22	1799 kg	×3 =	5397 kg
				D16	4733 kg	×3 =	14199 kg
				D13	200 kg	×3 =	600 kg
				TOTAL	6732 kg	×3 =	20196 kg

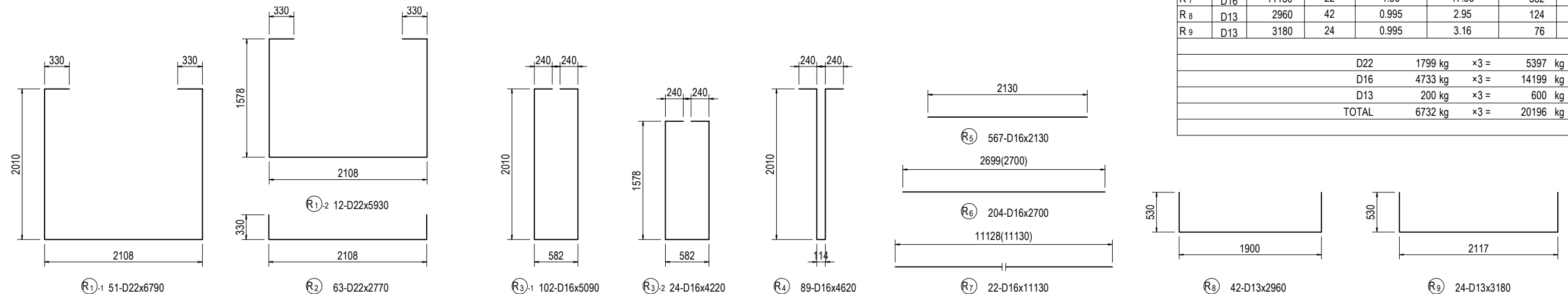

DETAIL OF PC PLATE FOR DECK SLAB (PF7-PF11)

SIDE VIEW S=1:20

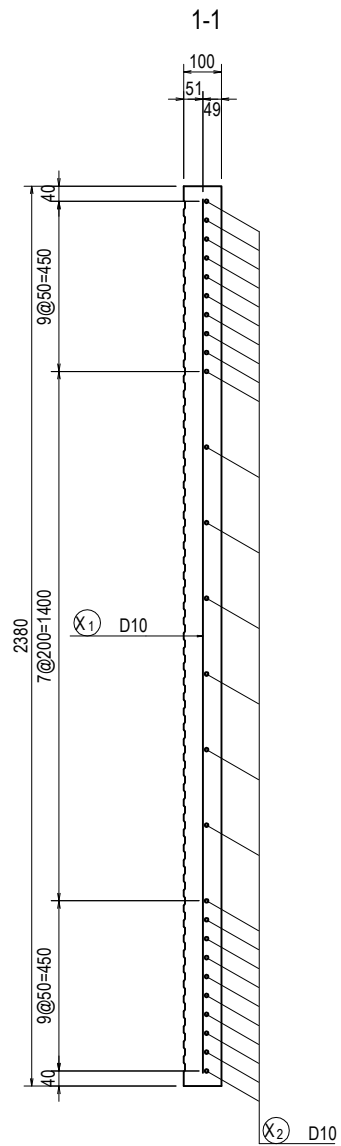

PLAN S=1:20 STANDARD

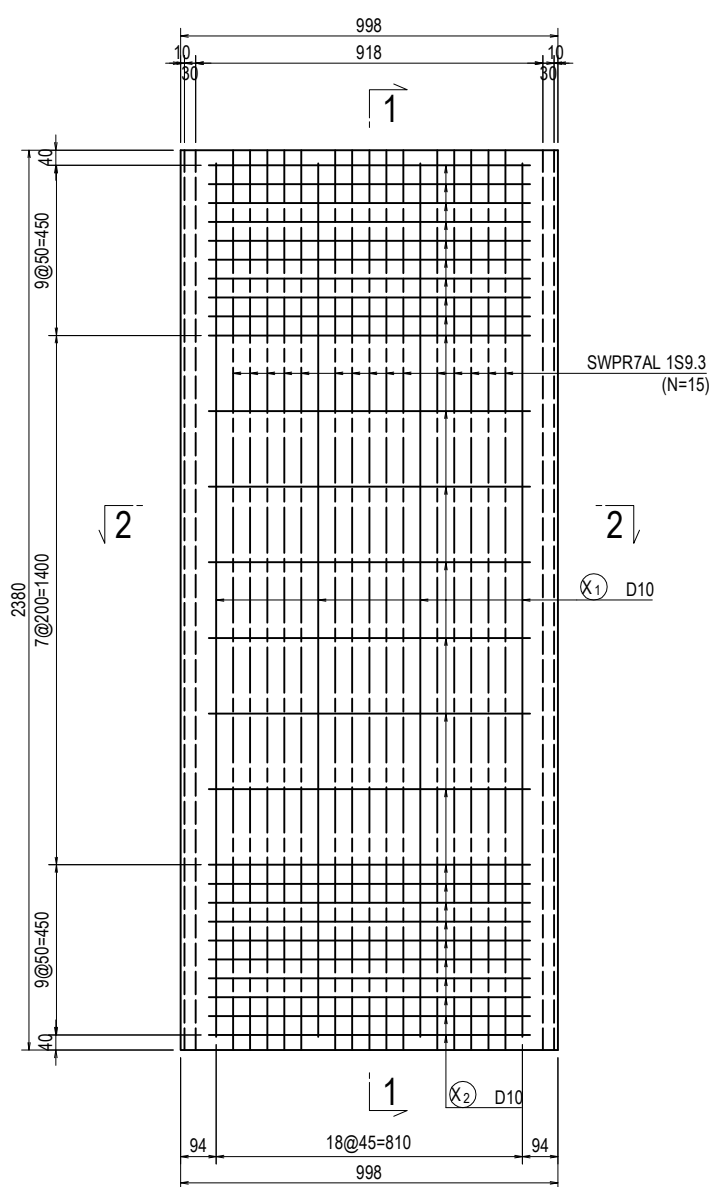

CROSS SECTION S=1:20

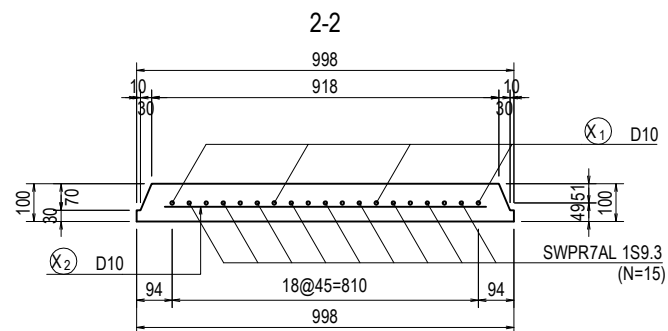

- (X1) 4-D10x2310
- (X2) 26-D10x850

KEY PLAN S=1:300

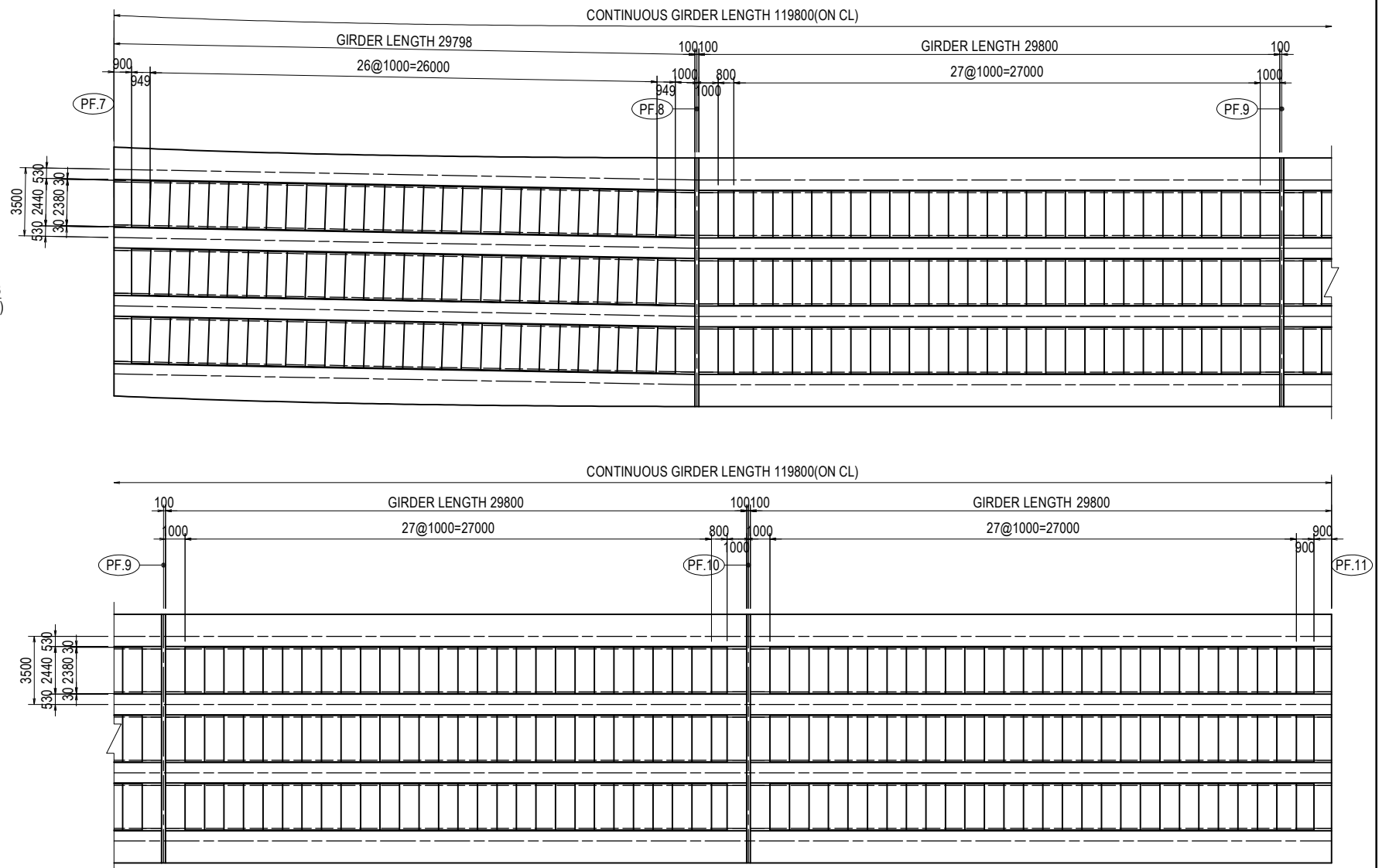

BAR LIST

REBAR NO.	DIA (mm)	LENGTH (mm)	NUMBER	UNIT WEIGHT (kg/m)	WEIGHT/ONE (kg)	WEIGHT (kg)	REMARKS
X1	D10	2310	4	0.56	1.29	5.2	
X2	D10	850	26	0.56	0.48	12.5	
						17.7 kg	
TOTAL						17.7 kg	×336 = 5947.2 kg

PC STRAND LIST

TYPE	LENGTH (mm)	NUMBER	UNIT WEIGHT (kg/m)	WEIGHT/ONE (kg)	WEIGHT (kg)	REMARKS	
SWPR7AL 1S9.3	2380	15	0.405	0.96	14.4		
TOTAL						14.4 kg	×336 = 4838.4 kg

BAR ARRANGEMENT OF DECK SLAB (PF7-PF11) (1)

PLAN S=1:200

CONTINUOUS GIRDER LENGTH 119800(ON CL)

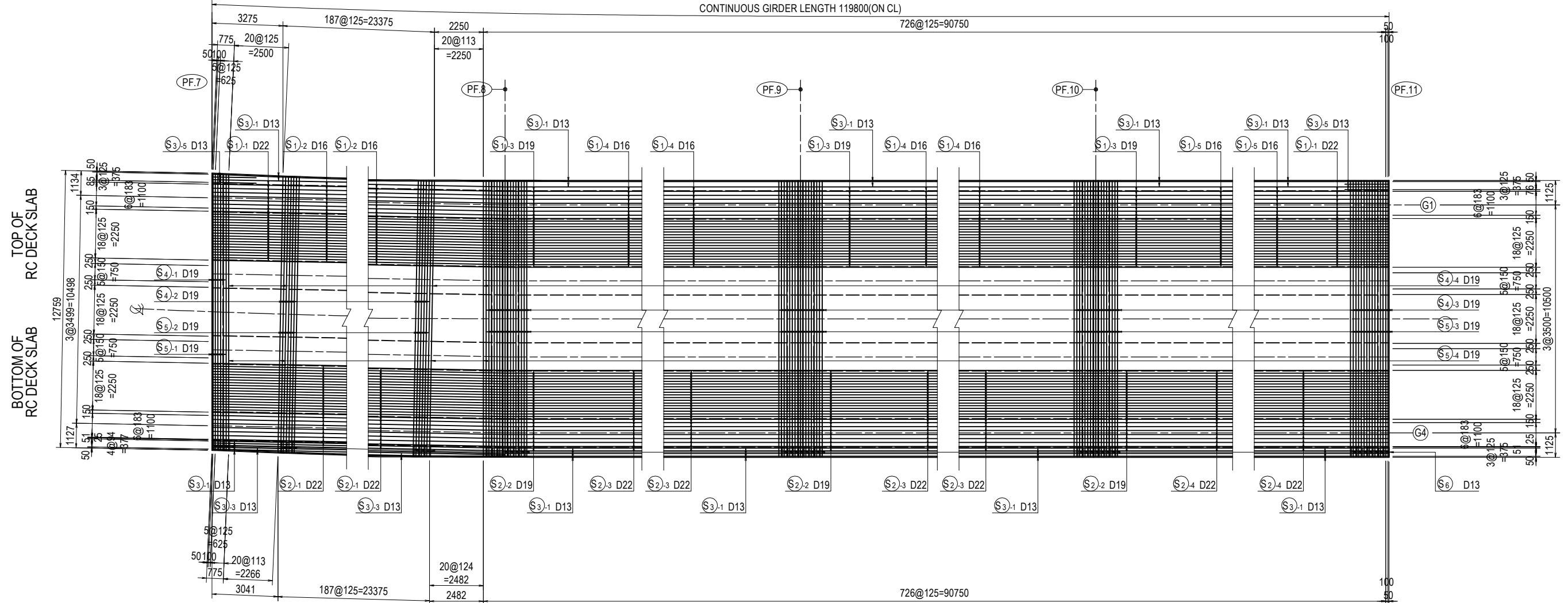

PROJECT NAME DETAILED DESIGN ON BAGO RIVER BRIDGE CONSTRUCTION PROJECT	FINANCED BY JAPAN INTERNATIONAL COOPERATION AGENCY	COUNTERPART REPUBLIC OF THE UNION OF MYANMAR MINISTRY OF CONSTRUCTION DEPARTMENT OF BRIDGE	JICA STUDY TEAM NIPPON KOEI CO., LTD. ORIENTAL CONSULTANTS GLOBAL CO., LTD. METROPOLITAN EXPRESSWAY COMPANY LIMITED CHODAI CO., LTD. NIPPON ENGINEERING CONSULTANTS CO., LTD.	NAME	SIGNATURE	DATE	DRAWING TITLE BAR ARRANGEMENT OF DECK SLAB (PF7-PF11) (1)	PACKAGE 3 DWG No. P3-FO-1217	
				PREPARED BY	Y. SUZUKI				14 Jul. 2017
				CHECKED BY	T. HAYAKAWA				20 Jul. 2017
				APPROVED BY	Y. SANO				25 Jul. 2017

BAR ARRANGEMENT OF DECK SLAB (PF7-PF11) (2)

CROSS SECTION S=1:100

END SECTION

CONNECTION SECTION

STANDARD SECTION

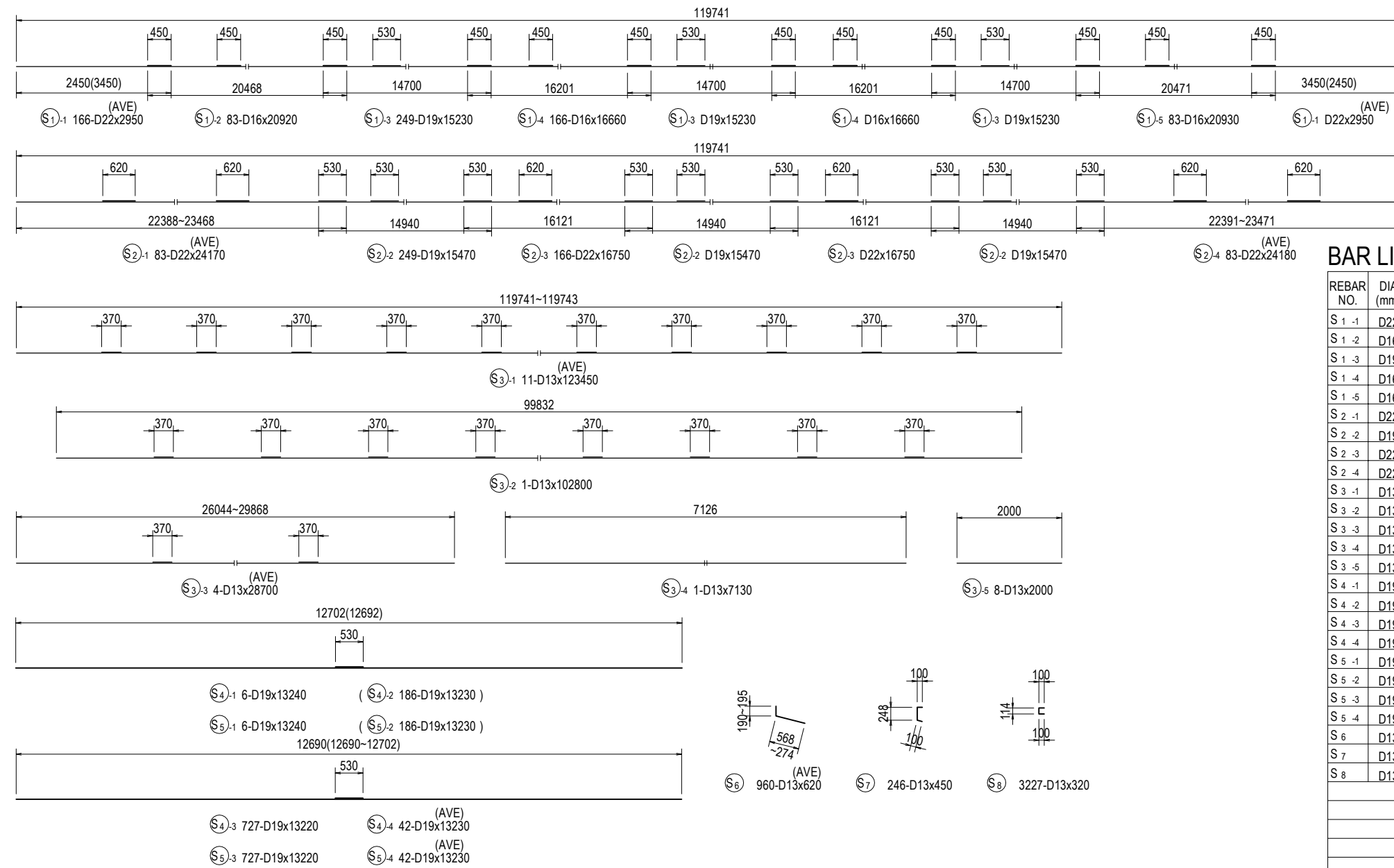
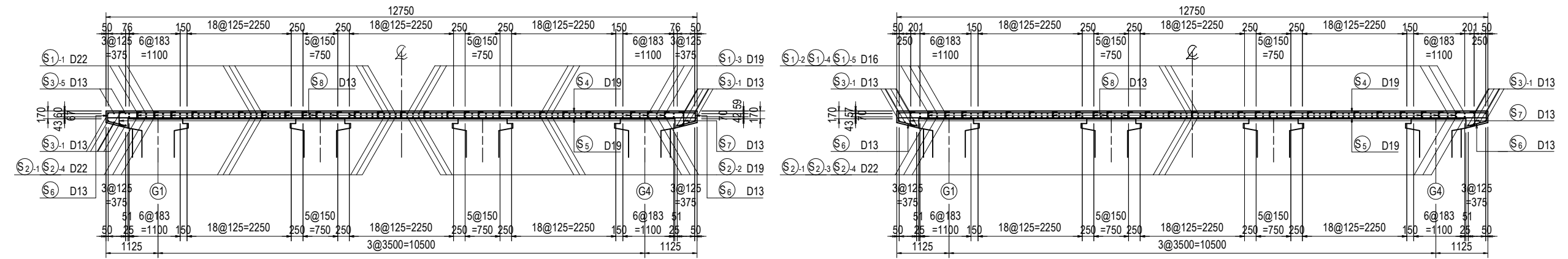

BAR LIST

REBAR NO.	DIA (mm)	LENGTH (mm)	NUMBER	UNIT WEIGHT (kg/m)	WEIGHT/ONE (kg)	WEIGHT (kg)	REMARKS
S 1 -1	D22	2950	166	3.04	8.97	1489	AVERAGE
S 1 -2	D16	20920	83	1.56	32.64	2709	
S 1 -3	D19	15230	249	2.25	34.27	8533	
S 1 -4	D16	16660	166	1.56	25.99	4314	
S 1 -5	D16	20930	83	1.56	32.65	2710	
S 2 -1	D22	24170	83	3.04	73.48	6099	AVERAGE
S 2 -2	D19	15470	249	2.25	34.81	8668	
S 2 -3	D22	16750	166	3.04	50.92	8453	
S 2 -4	D22	24180	83	3.04	73.51	6101	AVERAGE
S 3 -1	D13	123450	11	0.995	122.83	1351	AVERAGE
S 3 -2	D13	102800	1	0.995	102.29	102	
S 3 -3	D13	28700	4	0.995	28.56	114	AVERAGE
S 3 -4	D13	7130	1	0.995	7.09	7	
S 3 -5	D13	2000	8	0.995	1.99	16	
S 4 -1	D19	13240	6	2.25	29.79	179	
S 4 -2	D19	13230	186	2.25	29.77	5537	
S 4 -3	D19	13220	727	2.25	29.75	21628	
S 4 -4	D19	13230	42	2.25	29.77	1250	AVERAGE
S 5 -1	D19	13240	6	2.25	29.79	179	
S 5 -2	D19	13230	186	2.25	29.77	5537	
S 5 -3	D19	13220	727	2.25	29.75	21628	
S 5 -4	D19	13230	42	2.25	29.77	1250	AVERAGE
S 6	D13	620	960	0.995	0.62	595	AVERAGE
S 7	D13	450	246	0.995	0.45	111	
S 8	D13	320	3227	0.995	0.32	1033	
					D22	22142	kg
					D19	74389	kg
					D16	9733	kg
					D13	3329	kg
					TOTAL	109593	kg

DETAIL OF CONCRETE CURB, BARRIER AND MEDIUM (PF7-PF11) (1)

SIDE VIEW S=1:100
(L)

CROSS SECTION S=1:50

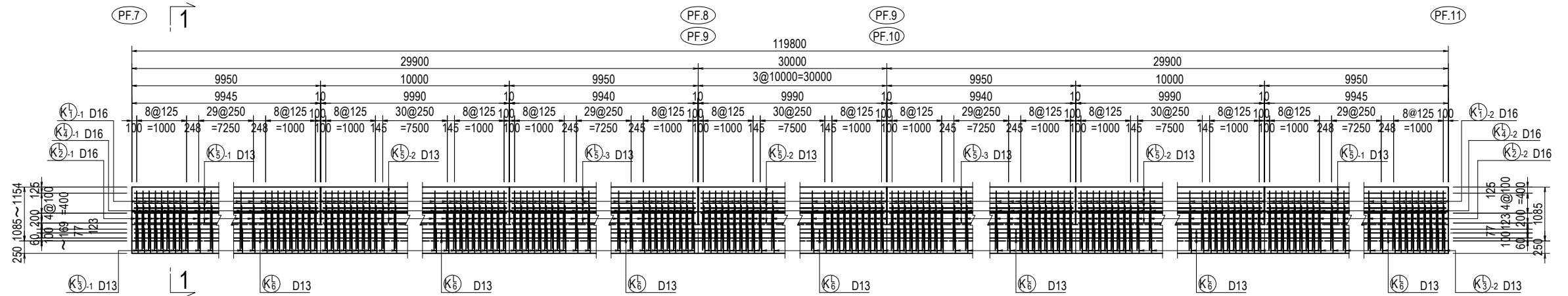
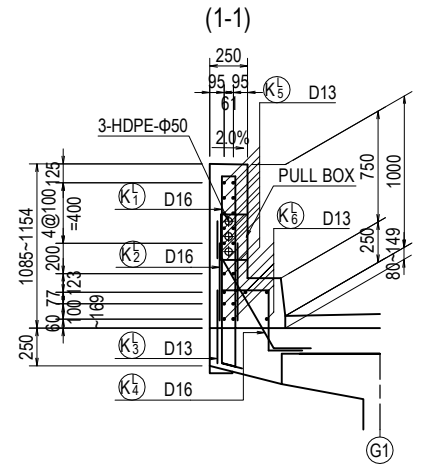

(R)

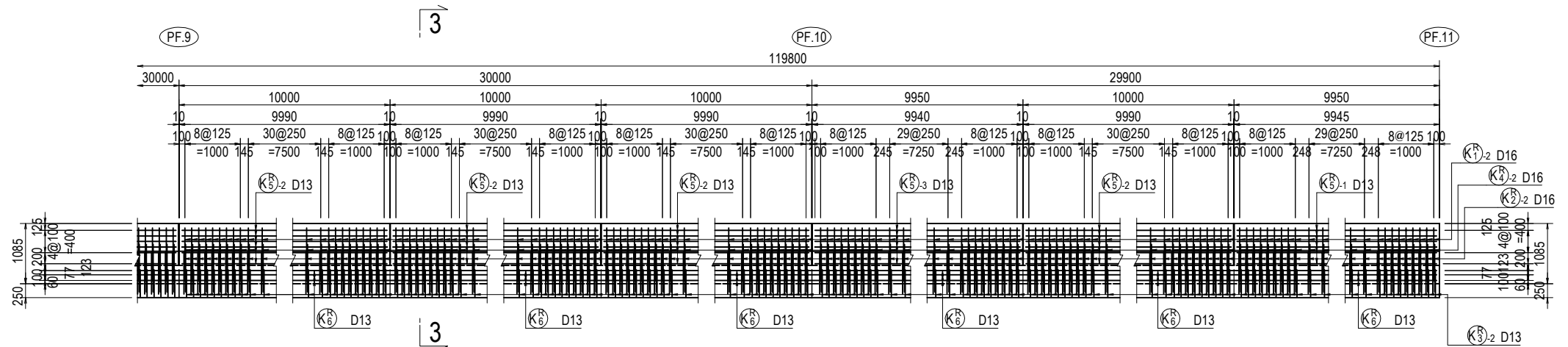
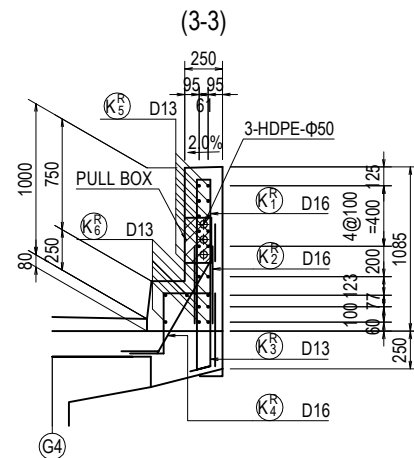
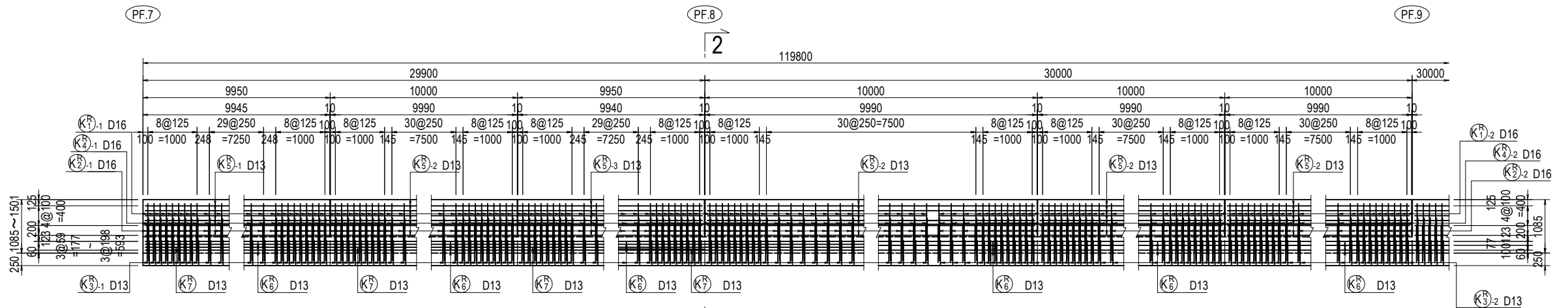
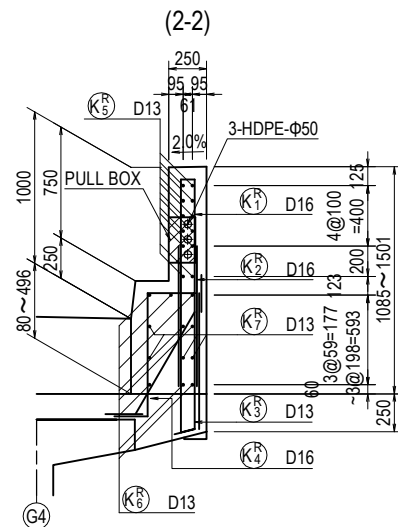

PROJECT NAME DETAILED DESIGN ON BAGO RIVER BRIDGE CONSTRUCTION PROJECT	FINANCED BY JAPAN INTERNATIONAL COOPERATION AGENCY	COUNTERPART REPUBLIC OF THE UNION OF MYANMAR MINISTRY OF CONSTRUCTION DEPARTMENT OF BRIDGE	JICA STUDY TEAM NIPPON KOEI CO., LTD. ORIENTAL CONSULTANTS GLOBAL CO., LTD. METROPOLITAN EXPRESSWAY COMPANY LIMITED CHODAI CO., LTD. NIPPON ENGINEERING CONSULTANTS CO., LTD.	<table border="1" style="width: 100%; border-collapse: collapse;"> <thead> <tr> <th style="width: 15%;">NAME</th> <th style="width: 15%;">SIGNATURE</th> <th style="width: 15%;">DATE</th> </tr> </thead> <tbody> <tr> <td>PREPARED BY Y. SUZUKI</td> <td><i>YS</i></td> <td>14 Jul. 2017</td> </tr> <tr> <td>CHECKED BY T. HAYAKAWA</td> <td><i>Hayakawa</i></td> <td>20 Jul. 2017</td> </tr> <tr> <td>APPROVED BY Y. SANO</td> <td><i>Y. Sano</i></td> <td>25 Jul. 2017</td> </tr> </tbody> </table>	NAME	SIGNATURE	DATE	PREPARED BY Y. SUZUKI	<i>YS</i>	14 Jul. 2017	CHECKED BY T. HAYAKAWA	<i>Hayakawa</i>	20 Jul. 2017	APPROVED BY Y. SANO	<i>Y. Sano</i>	25 Jul. 2017	DRAWING TITLE DETAIL OF CONCRETE CURB, BARRIER AND MEDIUM (PF7-PF11) (1)	PACKAGE 3 DWG No. P3-FO-1219
NAME	SIGNATURE	DATE																
PREPARED BY Y. SUZUKI	<i>YS</i>	14 Jul. 2017																
CHECKED BY T. HAYAKAWA	<i>Hayakawa</i>	20 Jul. 2017																
APPROVED BY Y. SANO	<i>Y. Sano</i>	25 Jul. 2017																

DETAIL OF CONCRETE CURB, BARRIER AND MEDIUM (PF7-PF11) (2)

(L)

(R)

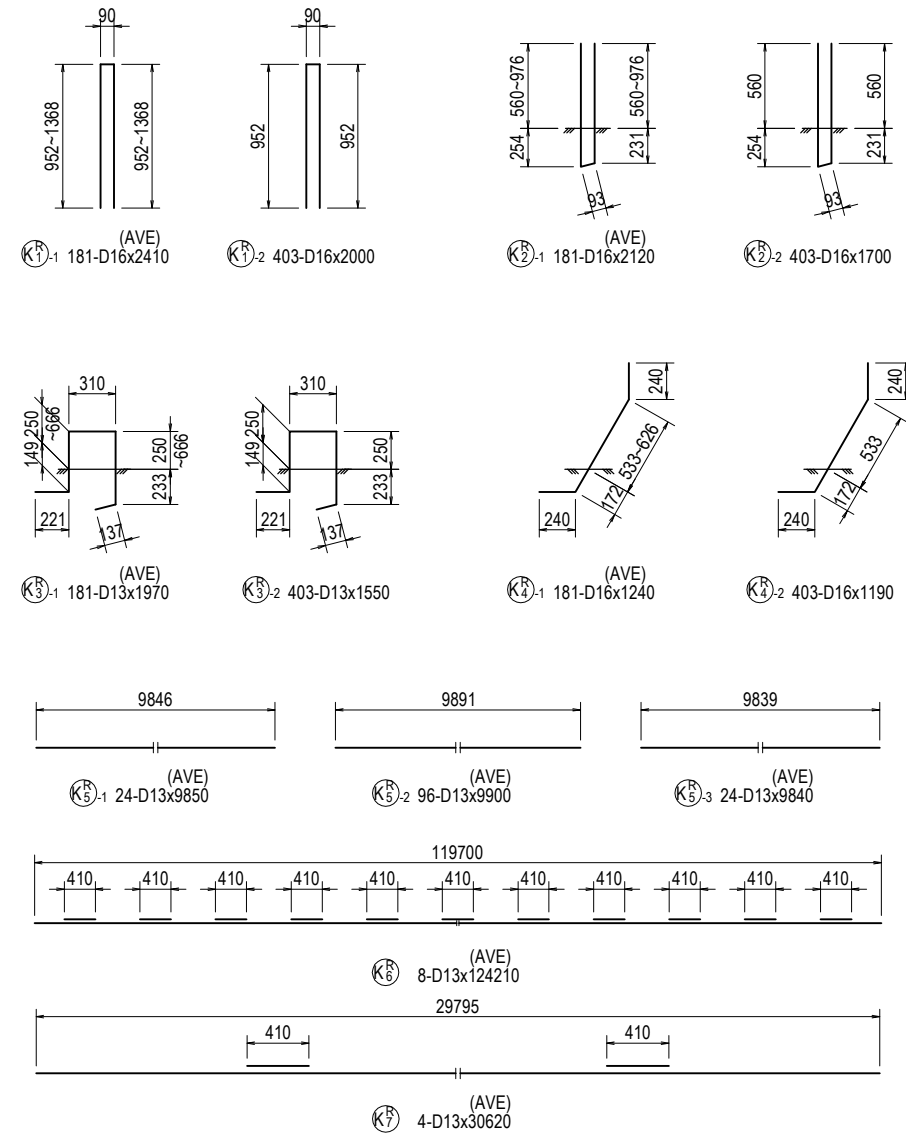
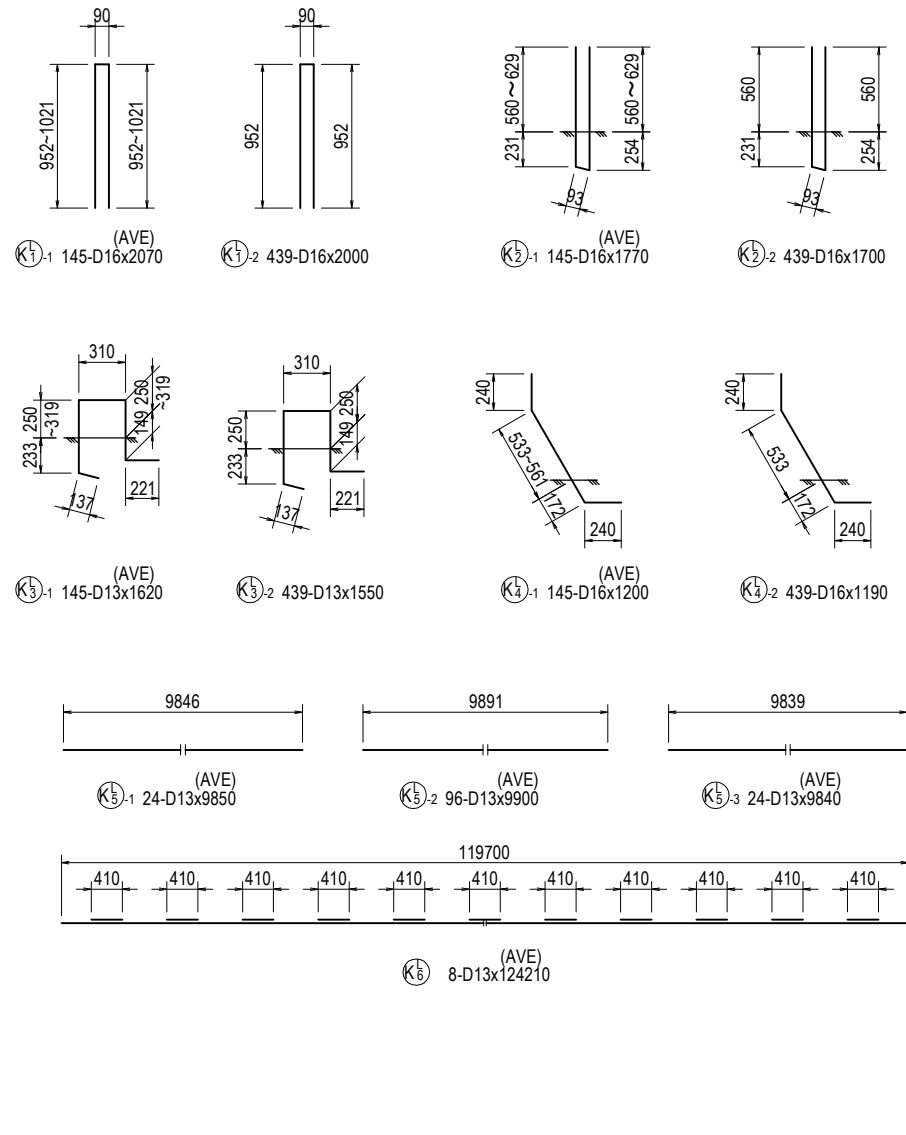

BAR LIST

REBAR NO.	DIA (mm)	LENGTH (mm)	NUMBER	UNIT WEIGHT (kg/m)	WEIGHT/ONE (kg)	WEIGHT (kg)	REMARKS
K1-1	D16	2070	145	1.56	3.23	468	AVERAGE
K1-2	D16	2000	439	1.56	3.12	1370	
K2-1	D16	1770	145	1.56	2.76	400	AVERAGE
K2-2	D16	1700	439	1.56	2.65	1163	
K3-1	D13	1620	145	0.995	1.61	233	AVERAGE
K3-2	D13	1550	439	0.995	1.54	676	
K4-1	D16	1200	145	1.56	1.87	271	AVERAGE
K4-2	D16	1190	439	1.56	1.86	817	
K5-1	D13	9850	24	0.995	9.80	235	AVERAGE
K5-2	D13	9900	96	0.995	9.85	946	AVERAGE
K5-3	D13	9840	24	0.995	9.79	235	AVERAGE
K6	D13	124210	8	0.995	123.59	989	AVERAGE
K1-1	D16	2410	181	1.56	3.76	681	AVERAGE
K1-2	D16	2000	403	1.56	3.12	1257	
K2-1	D16	2120	181	1.56	3.31	599	AVERAGE
K2-2	D16	1700	403	1.56	2.65	1068	
K3-1	D13	1970	181	0.995	1.96	355	AVERAGE
K3-2	D13	1550	403	0.995	1.54	621	
K4-1	D16	1240	181	1.56	1.93	349	AVERAGE
K4-2	D16	1190	403	1.56	1.86	750	
K5-1	D13	9850	24	0.995	9.80	235	AVERAGE
K5-2	D13	9900	96	0.995	9.85	946	AVERAGE
K5-3	D13	9840	24	0.995	9.79	235	AVERAGE
K6	D13	124210	8	0.995	123.59	989	AVERAGE
K7	D13	30620	4	0.995	30.47	122	AVERAGE
					D16	9193 kg	
					D13	6817 kg	
					TOTAL	16010 kg	

KEY PLAN S=1:800

CROSS SECTION S=1:40

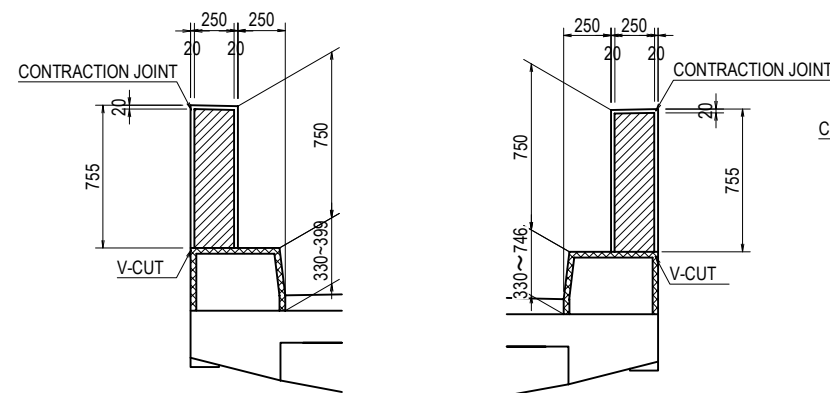

DETAIL OF CONSTRUCTION JOINT

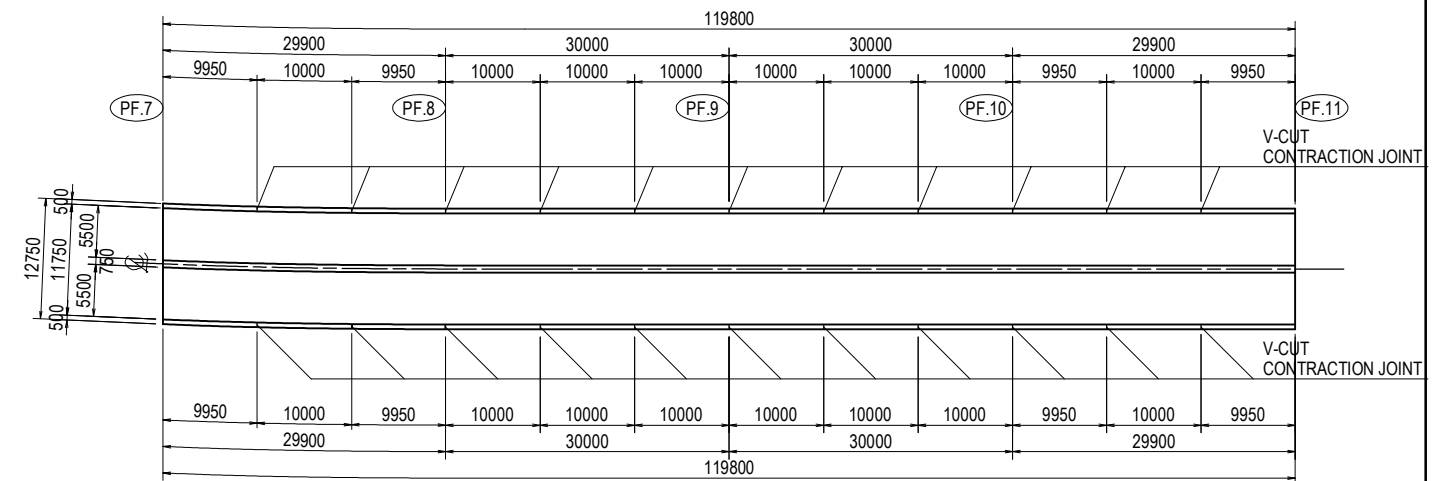
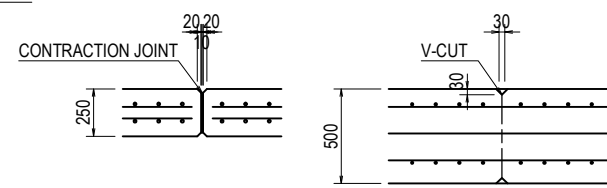

DETAIL OF CONCRETE CURB, BARRIER AND MEDIUM (PF7-PF11) (3)

PLAN S=1:100

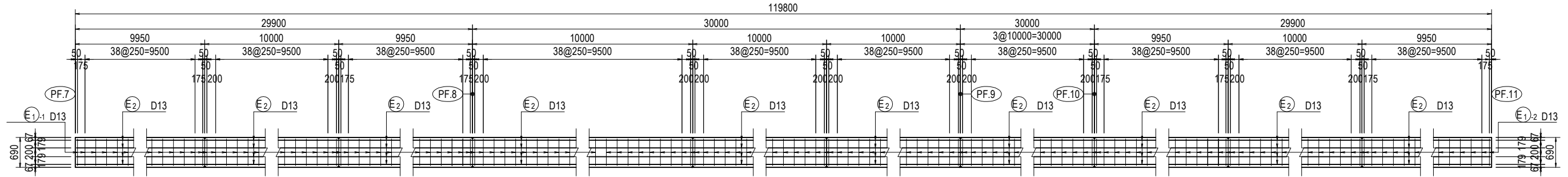

CROSS SECTION S=1:50

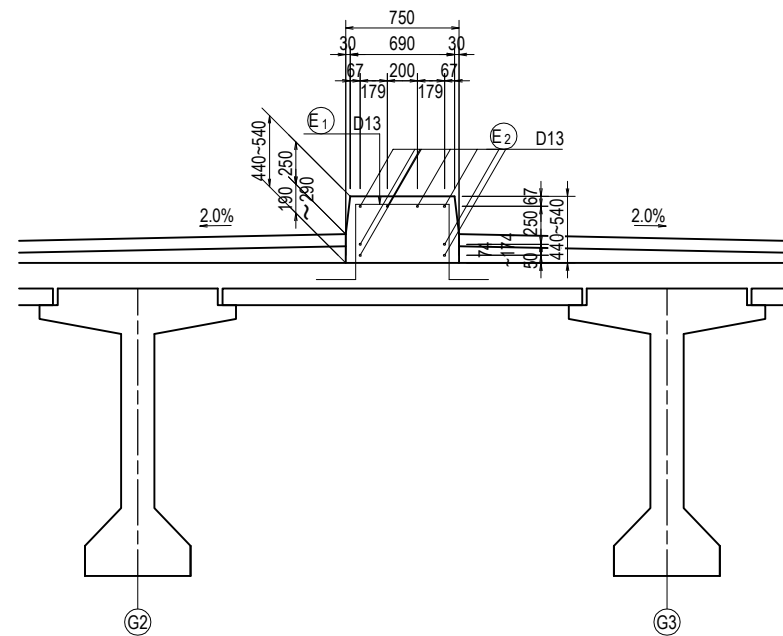

CROSS SECTION S=1:40

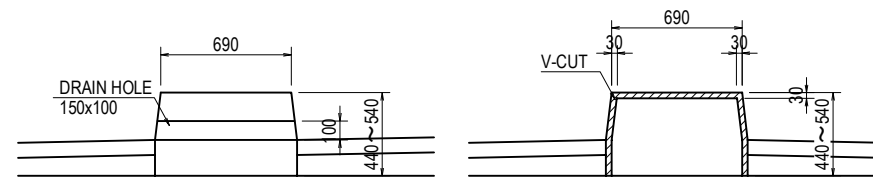

DETAIL OF V-CUT

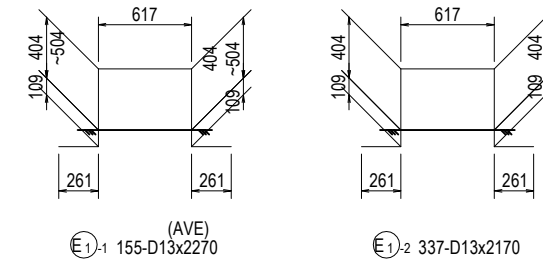
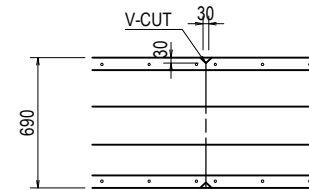

(AVE)
E1-1 155-D13x2270

(AVE)
E1-2 337-D13x2170

KEY PLAN S=1:800

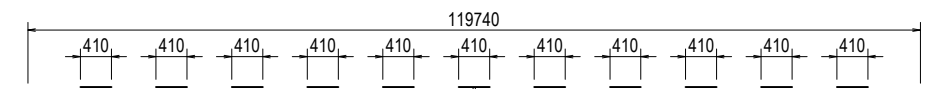
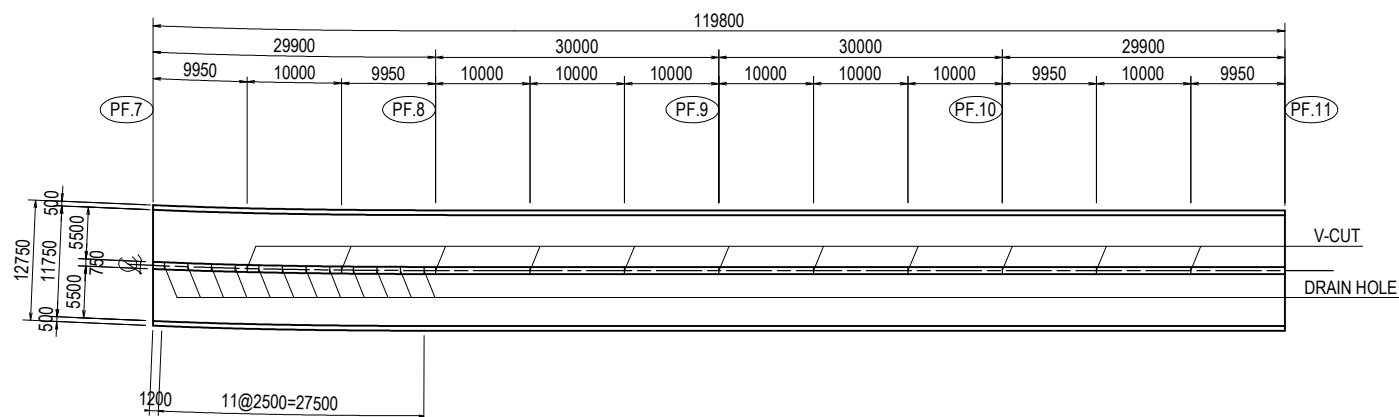

(AVE)
E2 8-D13x124250

BAR LIST

REBAR NO.	DIA (mm)	LENGTH (mm)	NUMBER	UNIT WEIGHT (kg/m)	WEIGHT/ONE (kg)	WEIGHT (kg)	REMARKS
E1-1	D13	2270	155	0.995	2.26	350	AVERAGE
E1-2	D13	2170	337	0.995	2.16	728	AVERAGE
E2	D13	124250	8	0.995	123.63	989	AVERAGE
						2067	
TOTAL						2067	kg

DETAIL OF LIGHTING FOUNDATION (PF7-PF11)

CROSS SECTION S=1:40

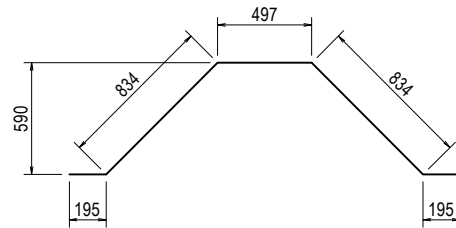
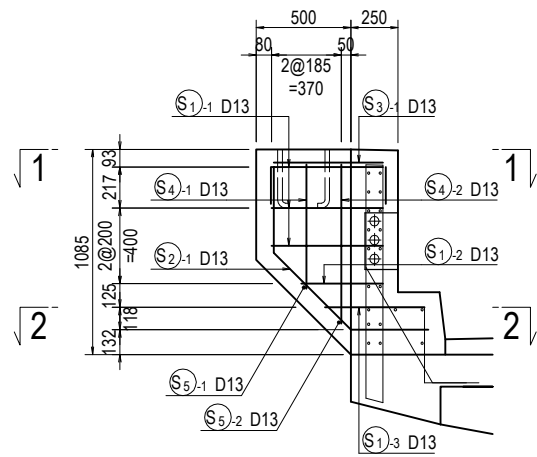

S1-1 3-D13x2560

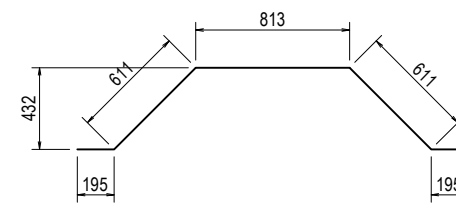

S1-2 1-D13x2430

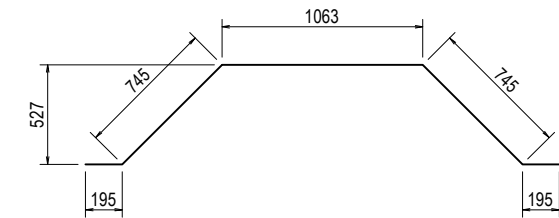

S1-3 1-D13x2950

PLAN S=1:40

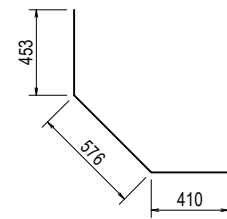
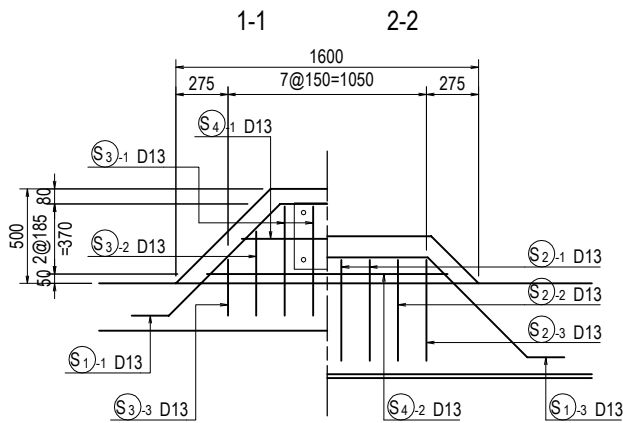

S2-1 4-D13x1440

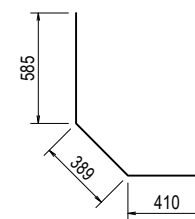

S2-2 2-D13x1390

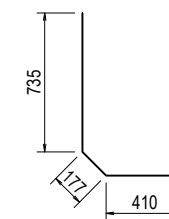

S2-3 2-D13x1330

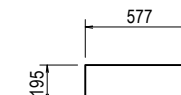

S3-1 4-D13x970

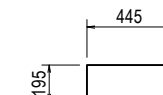

S3-2 2-D13x840

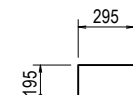

S3-3 2-D13x690

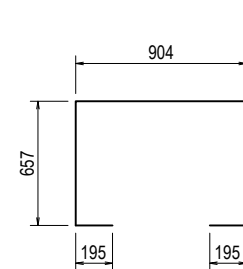

S4-1 1-D13x2610

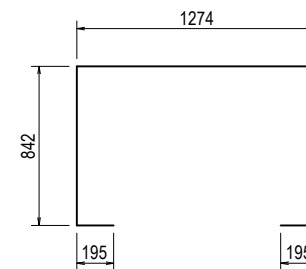

S4-2 1-D13x3350

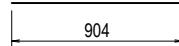

S5-1 1-D13x910

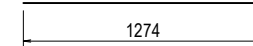

S5-2 1-D13x1280

PULLBOX DETAIL S=1:50

CROSS SECTION

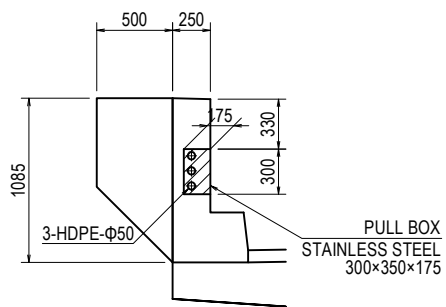

PLAN

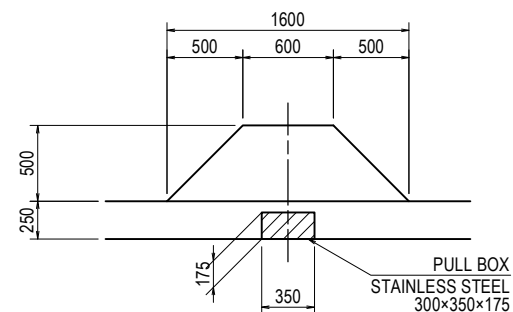

BAR LIST

REBAR NO.	DIA (mm)	LENGTH (mm)	NUMBER	UNIT WEIGHT (kg/m)	WEIGHT/ONE (kg)	WEIGHT (kg)	REMARKS
S1-1	D13	2560	3	0.995	2.55	8	
S1-2	D13	2430	1	0.995	2.42	2	
S1-3	D13	2950	1	0.995	2.94	3	
S2-1	D13	1440	4	0.995	1.43	6	
S2-2	D13	1390	2	0.995	1.38	3	
S2-3	D13	1330	2	0.995	1.32	3	
S3-1	D13	970	4	0.995	0.97	4	
S3-2	D13	840	2	0.995	0.84	2	
S3-3	D13	690	2	0.995	0.69	1	
S4-1	D13	2610	1	0.995	2.60	3	
S4-2	D13	3350	1	0.995	3.33	3	
S5-1	D13	910	1	0.995	0.91	1	
S5-2	D13	1280	1	0.995	1.27	1	
						40	kg
TOTAL						40	kg

DETAIL OF RUBBER BEARING (PF7-PF11) (1)

CROSS SECTION S= 1:100

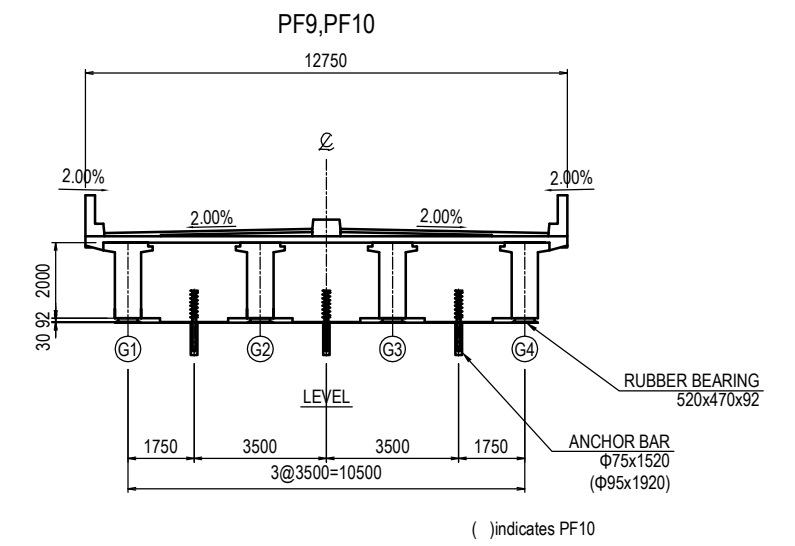
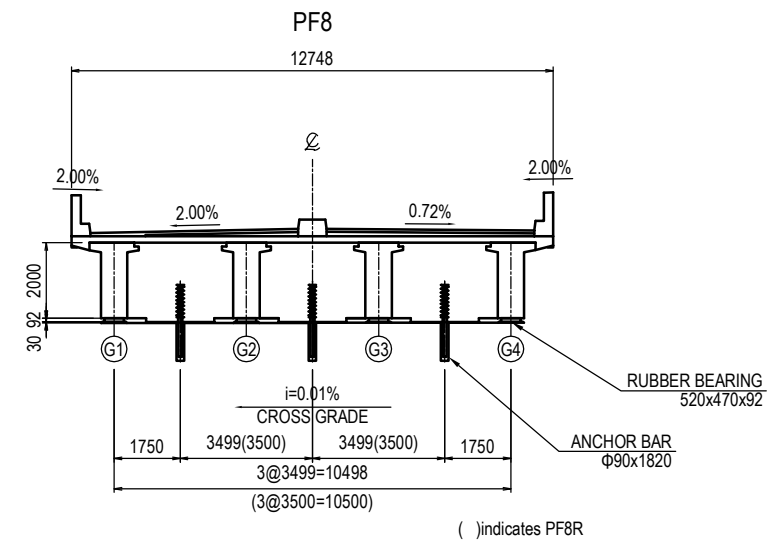
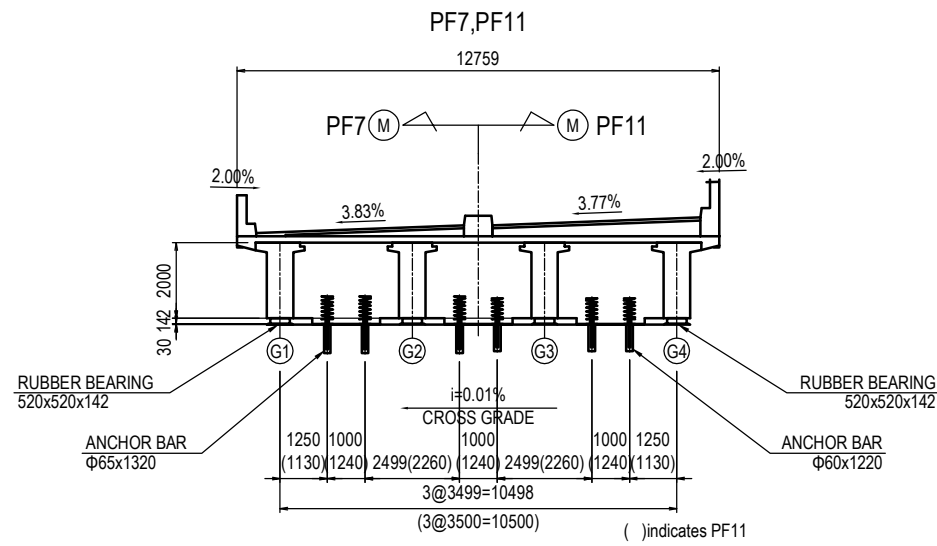

PLAN S= 1:100

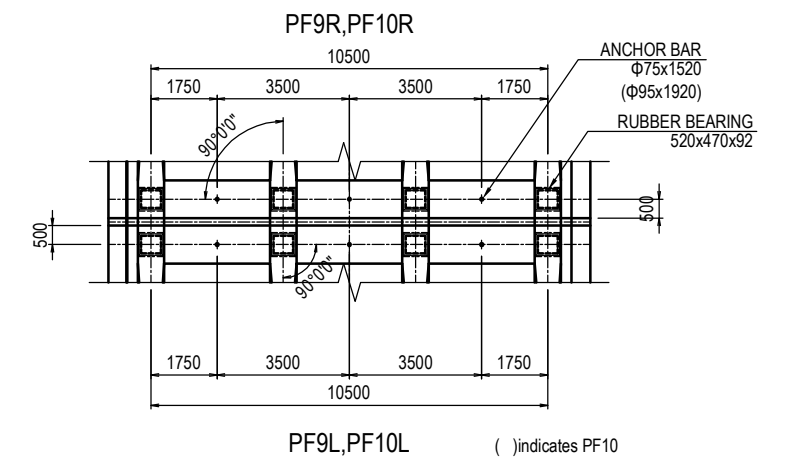
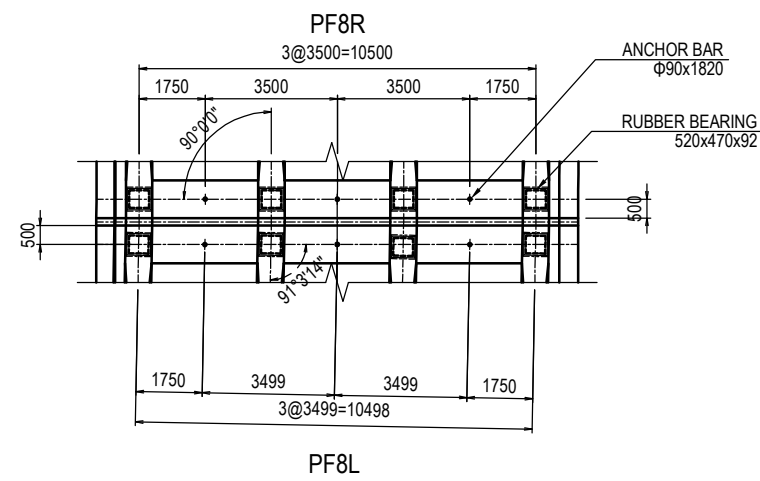
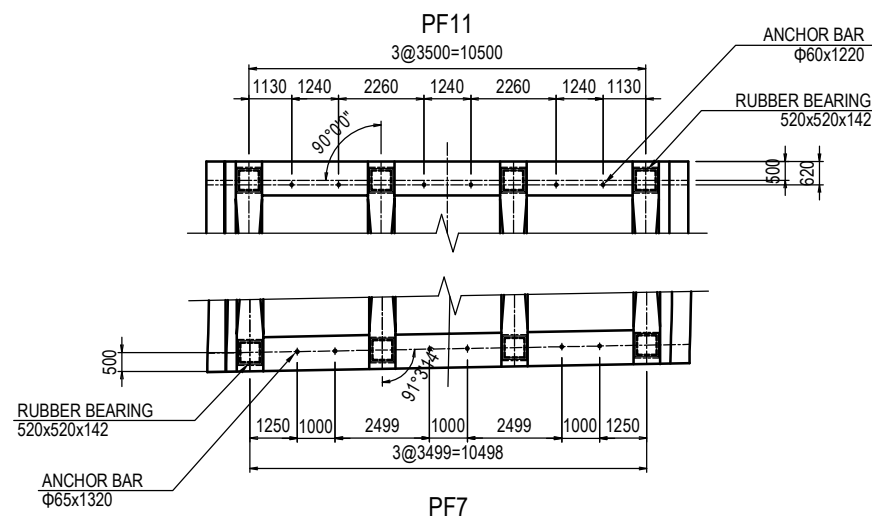

ELEVATION S= 1:400

REINFORCING BAR S= 1:10

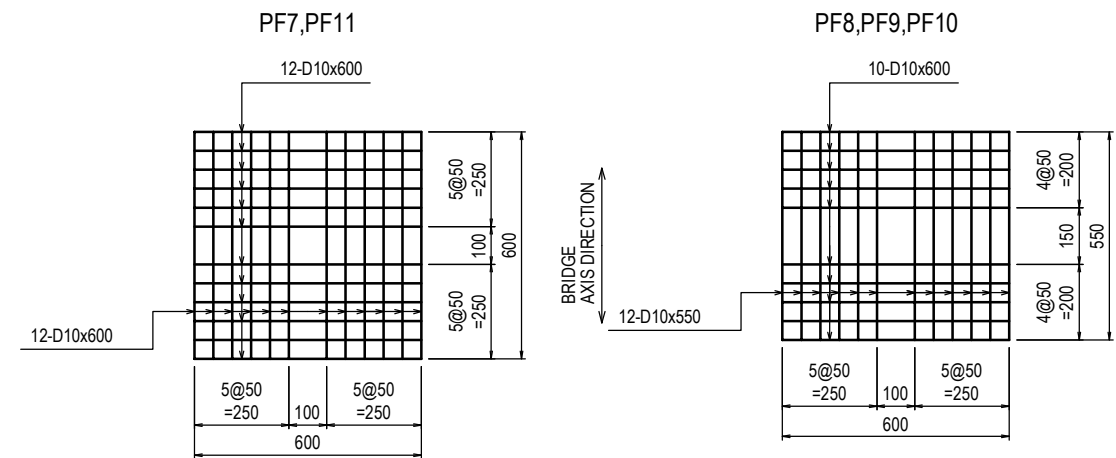
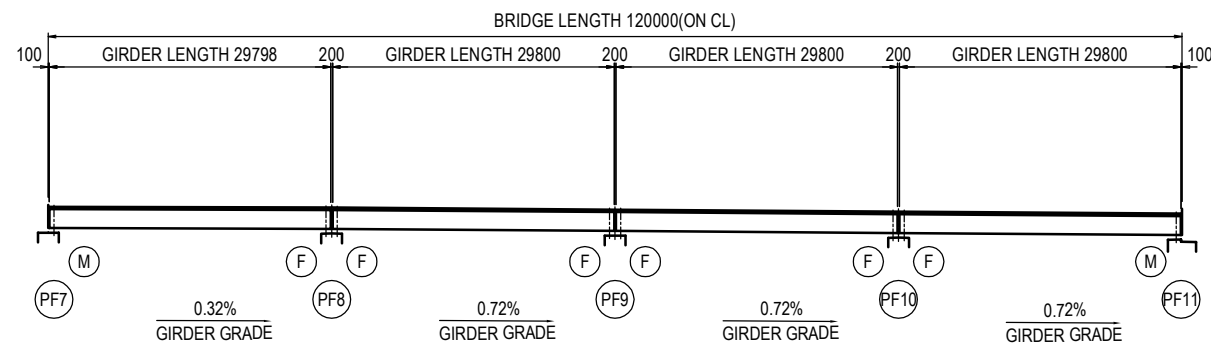

- NOTES:
- 1) Details of the slab and girder are designed based on the product (rubber bearing) shown in this Drawing.
 - 2) The Contractor has option to propose an alternative equivalent to the specified product, which shall be subjected to the Engineer's approval.
 - 3) All the structural steels shall be galvanized to the requirements specified by JIS H8641.

PROJECT NAME DETAILED DESIGN ON BAGO RIVER BRIDGE CONSTRUCTION PROJECT	FINANCED BY JICA JAPAN INTERNATIONAL COOPERATION AGENCY	COUNTERPART REPUBLIC OF THE UNION OF MYANMAR MINISTRY OF CONSTRUCTION DEPARTMENT OF BRIDGE	JICA STUDY TEAM NIPPON KOEI CO., LTD. ORIENTAL CONSULTANTS GLOBAL CO., LTD. METROPOLITAN EXPRESSWAY COMPANY LIMITED CHODAI CO., LTD. NIPPON ENGINEERING CONSULTANTS CO., LTD.	NAME	SIGNATURE	DATE	DRAWING TITLE DETAIL OF RUBBER BEARING (PF7-PF11) (1)	PACKAGE 3 DWG No. P3-FO-1223
				PREPARED BY	Y. SUZUKI	14 Jul. 2017		
				CHECKED BY	T. HAYAKAWA	20 Jul. 2017		
				APPROVED BY	Y. SANO	25 Jul. 2017		

DETAIL OF RUBBER BEARING (PF7-PF11) (2)

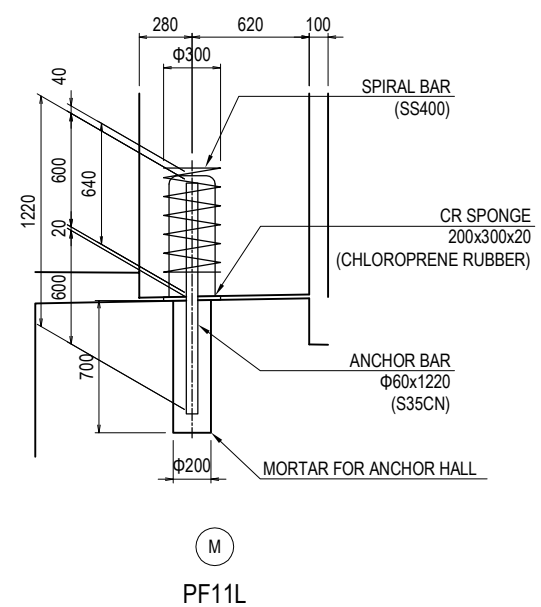
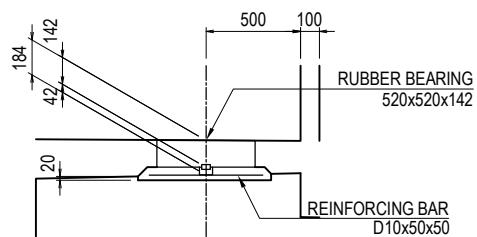
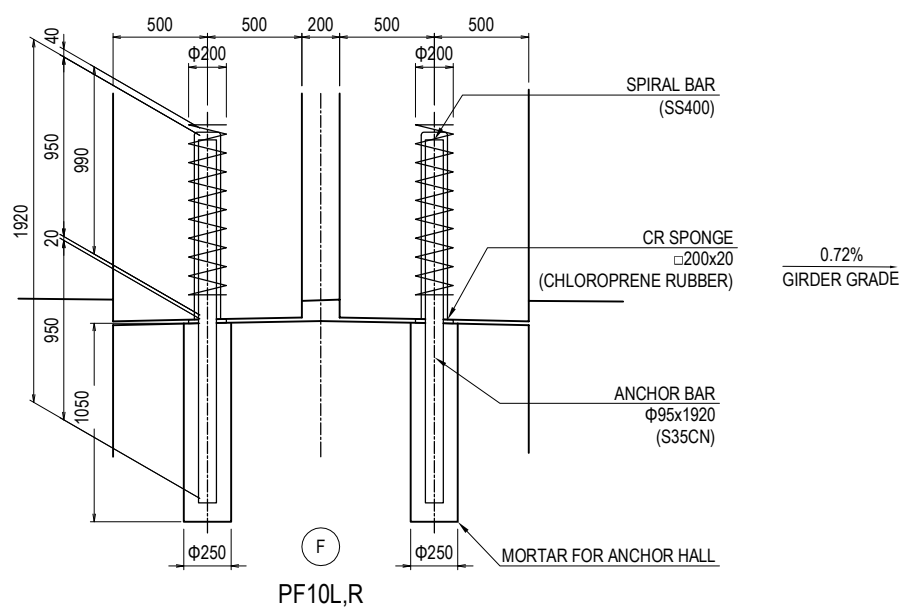
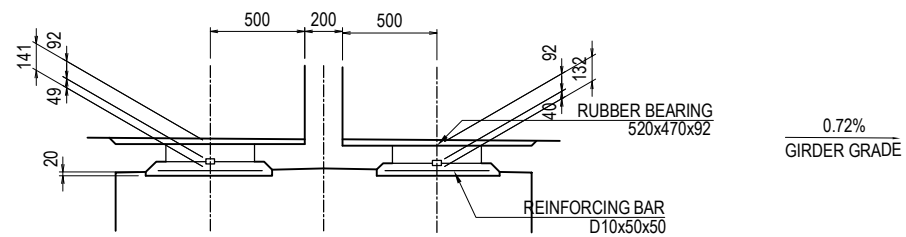
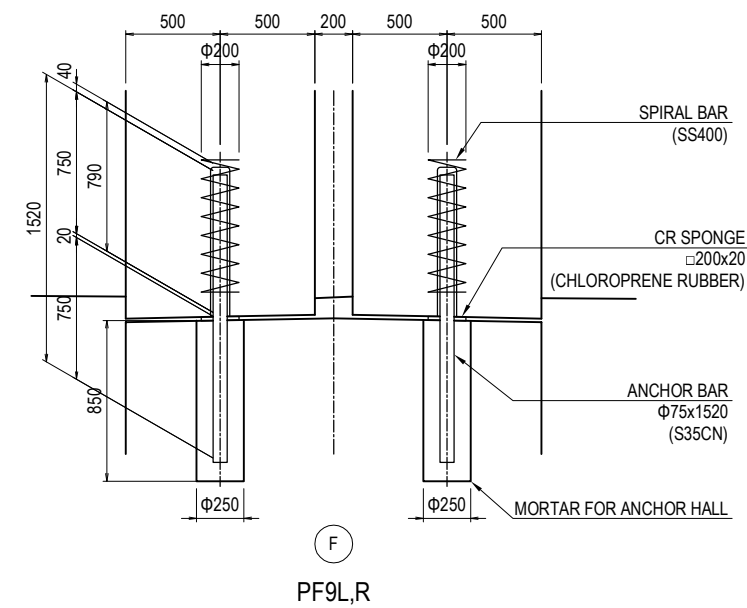
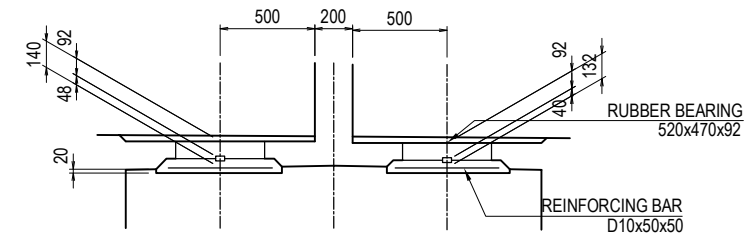
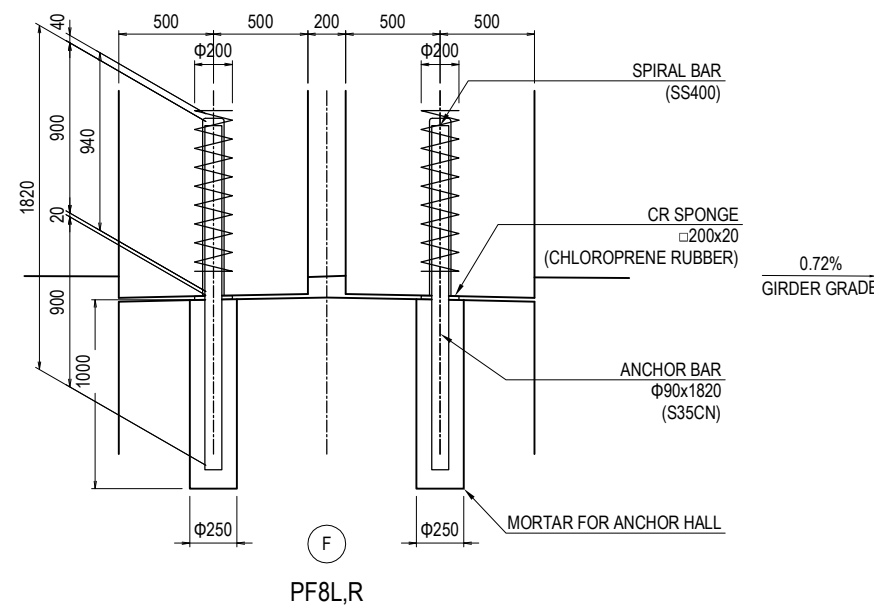
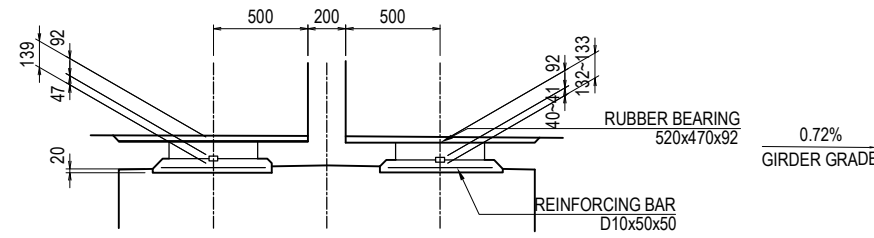
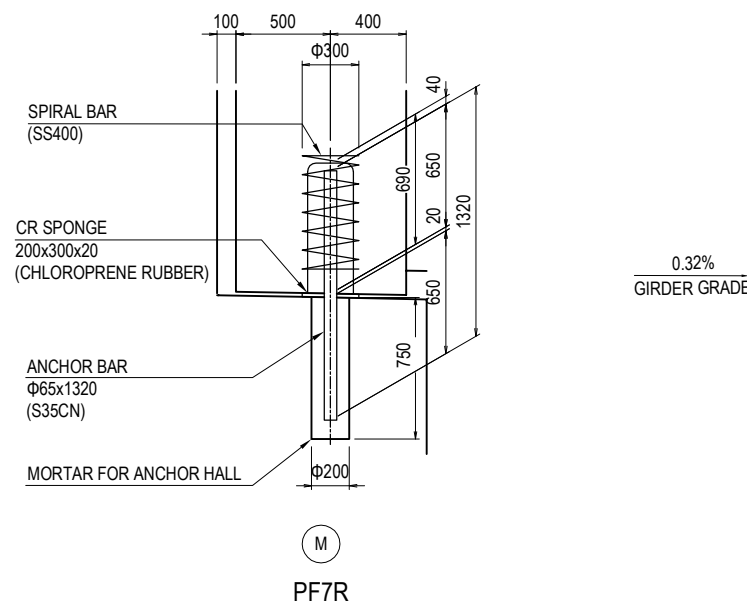
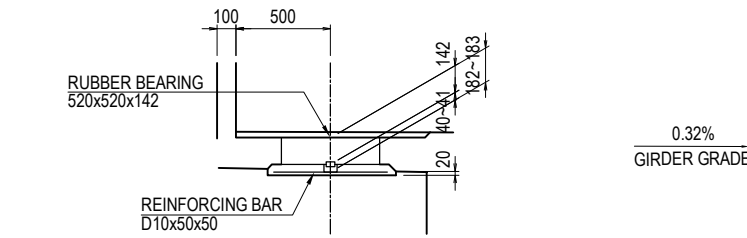

DESIGN CONDITION

REACTION		PF7 (M)	PF8L (F)	PF8R (F)	PF9L (F)	PF9R (F)	PF10L (F)	PF10R (F)	PF11 (M)	
MAXIMUM REACTION	Rmax	1465 kN	1697 kN	1428 kN	1404 kN	1443 kN	1450 kN	1450 kN	1340 kN	
	Rmax2	1250 kN	1344 kN	1320 kN	1306 kN	1364 kN	1377 kN	1335 kN	1253 kN	
DEAD LOAD REACTION		Rd	1132 kN	1226 kN	1033 kN	1015 kN	1054 kN	1011 kN	992 kN	
MAXIMUM STRAIN FORCE	LONGITUDIAL	Rhe1	495 kN	497 kN	497 kN	362 kN	362 kN	579 kN	450 kN	
	TRANSVERSE	Rhe2	169 kN	360 kN	360 kN	320 kN	320 kN	366 kN	162 kN	
STRAIN VOLUME	ORDINARY LEVEL 1	LONGITUDIAL	ΔL	- mm	- mm	- mm	54.0 mm	- mm	- mm	54.0 mm
		LONGITUDIAL	ΔLe1	- mm	- mm	- mm	32.3 mm	- mm	- mm	32.3 mm
		TRANSVERSE	ΔLe2	- mm	- mm	- mm	- mm	- mm	- mm	- mm

NOTES:

- Details of the slab and girder are designed based on the product (rubber bearing) shown in this Drawing.
- The Contractor has option to propose an alternative equivalent to the specified product, which shall be subjected to the Engineer's approval.
- All the structural steels shall be galvanized to the requirements specified by JIS H8641.

PROJECT NAME DETAILED DESIGN ON BAGO RIVER BRIDGE CONSTRUCTION PROJECT	FINANCED BY JICA JAPAN INTERNATIONAL COOPERATION AGENCY	COUNTERPART REPUBLIC OF THE UNION OF MYANMAR MINISTRY OF CONSTRUCTION DEPARTMENT OF BRIDGE	JICA STUDY TEAM NIPPON KOEI CO., LTD. ORIENTAL CONSULTANTS GLOBAL CO., LTD. METROPOLITAN EXPRESSWAY COMPANY LIMITED CHODAI CO., LTD. NIPPON ENGINEERING CONSULTANTS CO., LTD.	NAME	SIGNATURE	DATE	DRAWING TITLE DETAIL OF RUBBER BEARING (PF7-PF11) (2)	PACKAGE 3 DWG No. P3-FO-1224
				PREPARED BY	Y. SUZUKI	14 Jul. 2017		
				CHECKED BY	T. HAYAKAWA	20 Jul. 2017		
				APPROVED BY	Y. SANO	25 Jul. 2017		

DETAIL OF RUBBER BEARING (PF7-PF11) (3)

ANCHOR SYSTEM S= 1:5

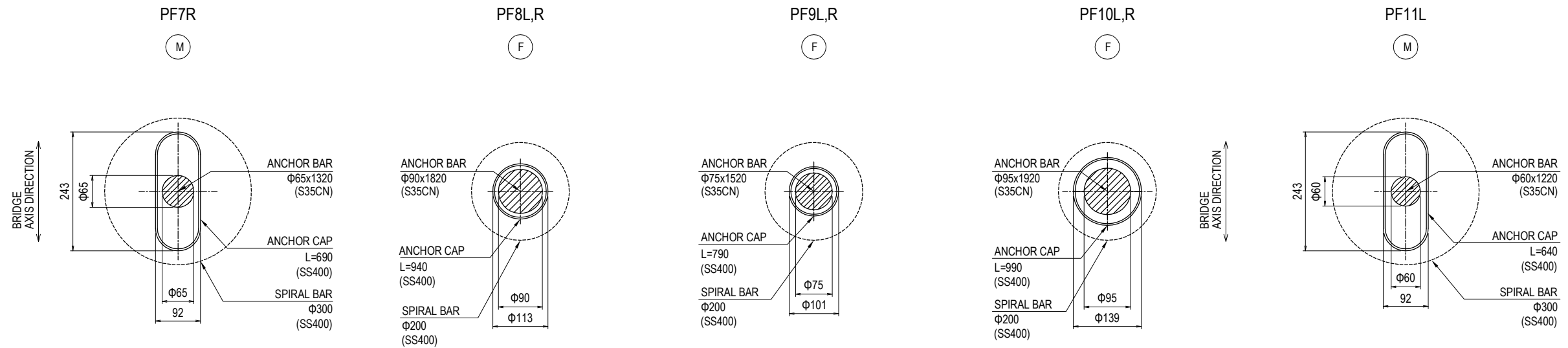

RUBBER BEARING S= 1:10

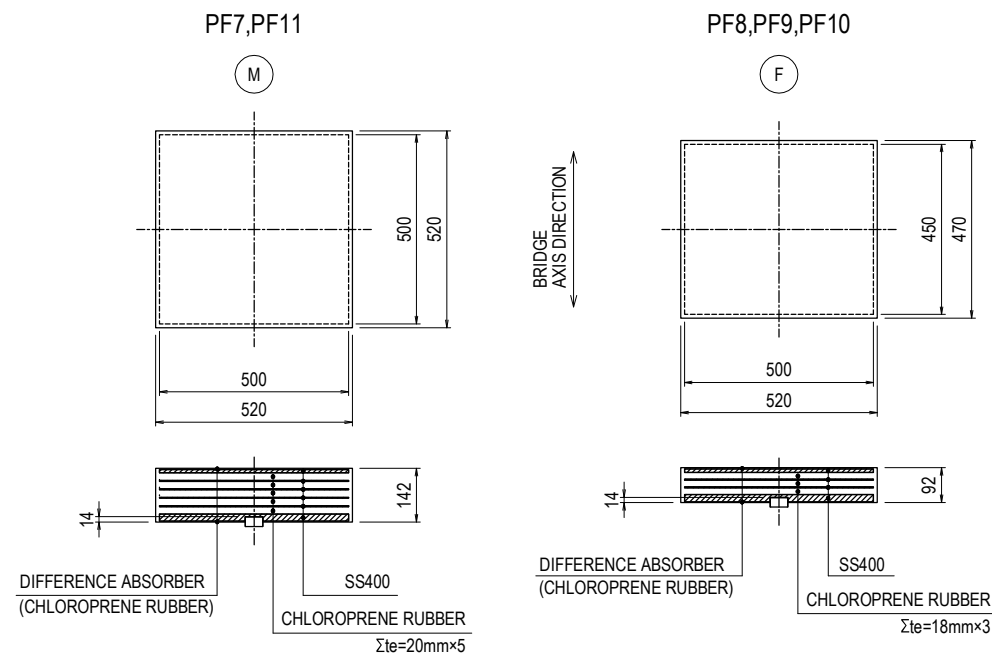

PARTS LIST

ITEM	DIMENSION	MATERIAL	UNIT	QUANTITY										WEIGHT (kg)	REMARKS
				PF7(M)	PF8(F)	PF8R(F)	PF9L(F)	PF9R(F)	PF10L(F)	PF10R(F)	PF11(M)	合計			
RUBBER BEARING	520x520x142	AS SHOWN	SHEET	4								4	8		
"	520x470x92	"	"		4	4	4	4	4	4		4	24		
ANCHOR SYSTEM	Φ65x1320	S35CN	SET	6									6		
"	Φ90x1820	"	"		3	3							6		
"	Φ75x1520	"	"				3	3					6		
"	Φ95x1920	"	"						3	3			6		
"	Φ60x1220	"	"									6	6		
CR SPONGE	200x300x20	CHLOROPRENE RUBBER	SHEET	6								6	12		
"	□200x20	"	"		3	3	3	3	3	3			18		
REINFORCING BAR	D10x50x50	SD345	kg	32.26	28.22	28.22	28.22	28.22	28.22	28.22	32.26		233.84		
BED MORTAR FOR BEARING		NON SHRINKAGE MORTAR	m3	0.111	0.114	0.101	0.118	0.101	0.120	0.101	0.112		0.878		
MORTAR FOR ANCHOR HALLS		NON SHRINKAGE MORTAR	m3	0.128	0.130	0.130	0.115	0.115	0.134	0.134	0.122		1.008		

An Anchor System includes anchor bar, anchor cap and spiral bar.

NOTES:

- 1) Details of the slab and girder are designed based on the product (rubber bearing) shown in this Drawing.
- 2) The Contractor has option to propose an alternative equivalent to the specified product, which shall be subjected to the Engineer's approval.
- 3) All the structural steels shall be galvanized to the requirements specified by JIS H8641.

PROJECT NAME DETAILED DESIGN ON BAGO RIVER BRIDGE CONSTRUCTION PROJECT	FINANCED BY JICA JAPAN INTERNATIONAL COOPERATION AGENCY	COUNTERPART REPUBLIC OF THE UNION OF MYANMAR MINISTRY OF CONSTRUCTION DEPARTMENT OF BRIDGE	JICA STUDY TEAM NIPPON KOEI CO., LTD. ORIENTAL CONSULTANTS GLOBAL CO., LTD. METROPOLITAN EXPRESSWAY COMPANY LIMITED CHODAI CO., LTD. NIPPON ENGINEERING CONSULTANTS CO., LTD.	NAME	SIGNATURE	DATE	DRAWING TITLE DETAIL OF RUBBER BEARING (PF7-PF11) (3)	PACKAGE
				PREPARED BY	Y. SUZUKI	14 Jul. 2017		3
				CHECKED BY	T. HAYAKAWA	20 Jul. 2017		DWG No.
				APPROVED BY	Y. SANO	25 Jul. 2017		P3-FO-1225

DETAIL OF EXPANSION JOINT (PF7-PF11) (1)

PF7

PLAN VIEW S=1:30

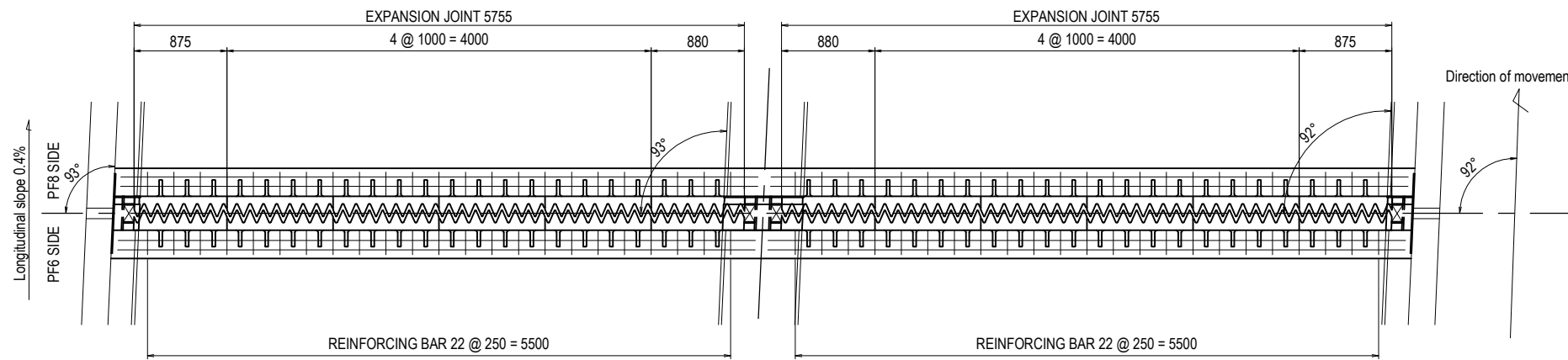

CROSS SECTION S=1:30

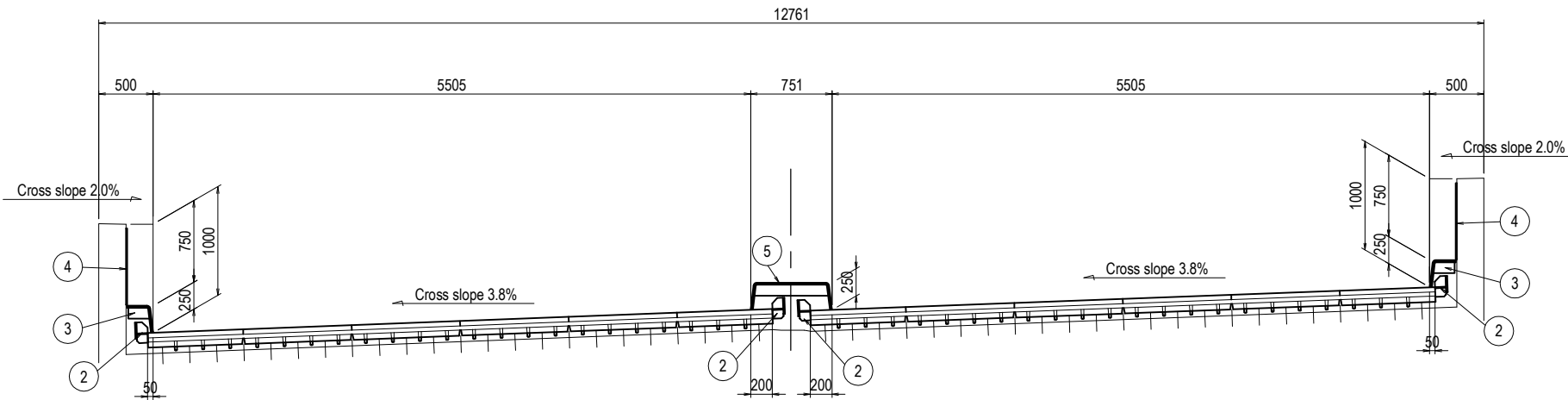

SECTION OF EXPANSION JOINT S=1:8

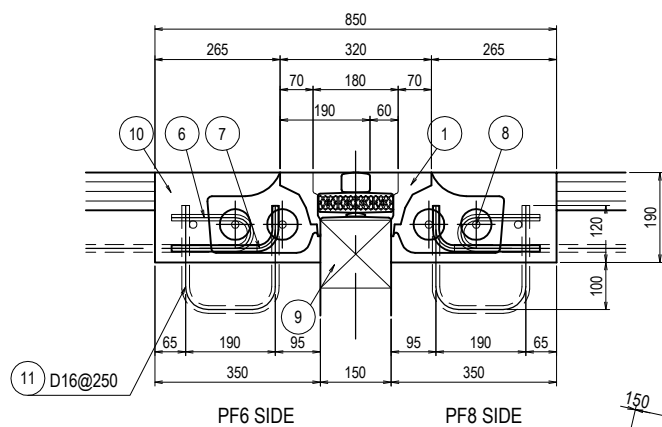

HARDWARE SECTION S=1:5

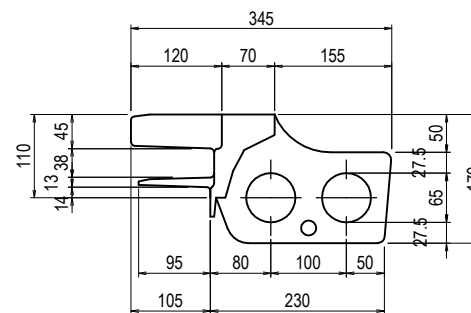

PLAN VIEW

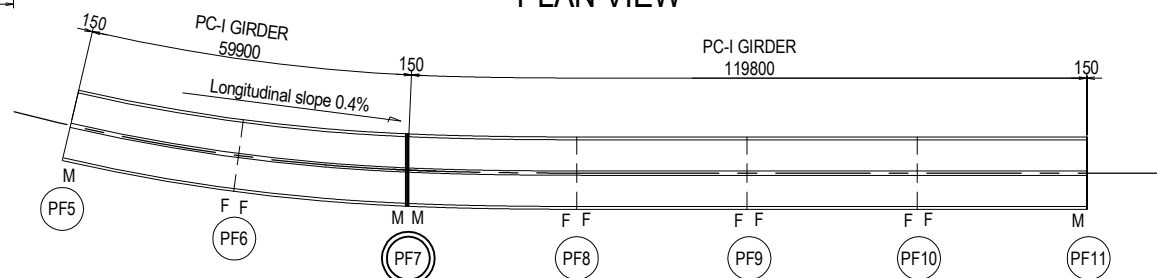

MATERIALS LIST					(1 per place)
No.	DESCRIPTION	MATERIALS	UNIT	QUANTITY	REMARK
1	EXPANSION JOINT	ALUMINUM ALLOY CASTING	m	11.510	110mm
2	UPSTAND		pieces	4	
3	COVER FOR CURB	SS400 or Equivalent	set	2	
4	COVER FOR BARRIER CURB	SUS304	set	2	t=2(include anchor)
5	COVER FOR MEDIAL DIVIDER	SS400 or Equivalent	set	1	
6	REINFORCING BAR	SD345	kg	26.55	D13 × 290 × 92 Nos.
7	REINFORCING BAR	SD345	kg	28.38	D13 × 310 × 92 Nos.
8	REINFORCING BAR	SD345	kg	112.32	D16 × 6.0m × 12 Nos.
9	BURIED FORMWORK	Foamed Styrene	m ³	0.29	150 × 150 × 12.7m
10	POST-CAST CONCRETE	High strength concrete	m ³	1.56	σ _{ck} = 30N/mm ²

EMBEDDED BAR

11	EMBEDDED BAR	SD345	kg	90.42	D16 × 630 × 92 Nos.
----	--------------	-------	----	-------	---------------------

DESIGN CONDITION	
Temperature range	+5°C~+45°C
Amount of temperature variation	36mm
Earthquake movement amount	±55mm

Note

- 1 Re-bar should be consider the developed length.
- 2 Allocation of the expansion joint is subject to change
- 3 Expansion joint should be placing to match the transverse gradient.
- 4 Expansion joint should be installed in consideration of the effect of Creep and Shrinkage.

HARDWARE PLAN S=1:10

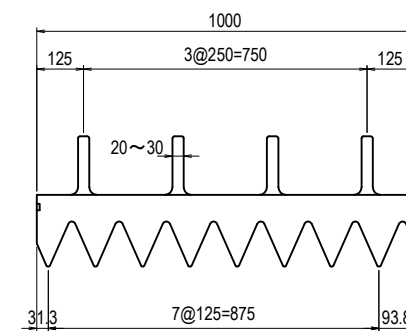

DETAIL OF REINFORCING BAR S=1:8

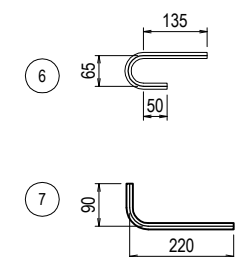

NOTES:

- 1) Details of the slab and girder are designed based on the product (expansion joint) shown in this Drawing.
- 2) The Contractor has option to propose an alternative equivalent to the specified product, which shall be subjected to the Engineer's approval.
- 3) The expansion joint shall be set in consideration of thermal expansion, creep and shrinkage of concrete girder.

PROJECT NAME DETAILED DESIGN ON BAGO RIVER BRIDGE CONSTRUCTION PROJECT	FINANCED BY jica JAPAN INTERNATIONAL COOPERATION AGENCY	COUNTERPART REPUBLIC OF THE UNION OF MYANMAR MINISTRY OF CONSTRUCTION DEPARTMENT OF BRIDGE	JICA STUDY TEAM NIPPON KOEI CO., LTD. ORIENTAL CONSULTANTS GLOBAL CO., LTD. METROPOLITAN EXPRESSWAY COMPANY LIMITED CHODAI CO., LTD. NIPPON ENGINEERING CONSULTANTS CO., LTD.	NAME	SIGNATURE	DATE	DRAWING TITLE DETAIL OF EXPANSION JOINT (PF7-PF11) (1)	PACKAGE 3 DWG No. P3-FO-1226
				PREPARED BY	Y. SUZUKI	14 Jul. 2017		
				CHECKED BY	T. HAYAKAWA	20 Jul. 2017		
				APPROVED BY	Y. SANO	25 Jul. 2017		

DETAIL OF EXPANSION JOINT (PF7-PF11) (2)

PF11

PLAN VIEW S=1:30

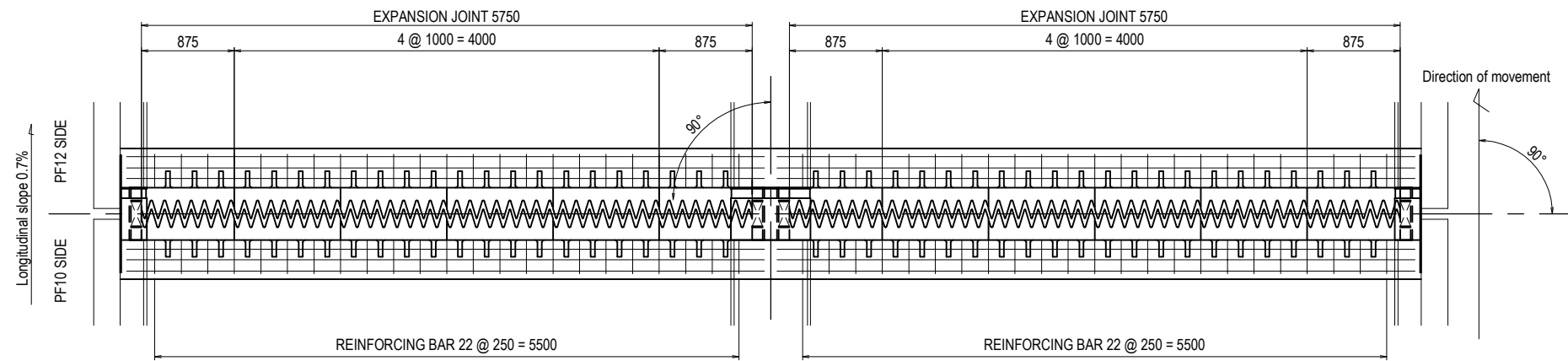

CROSS SECTION S=1:30

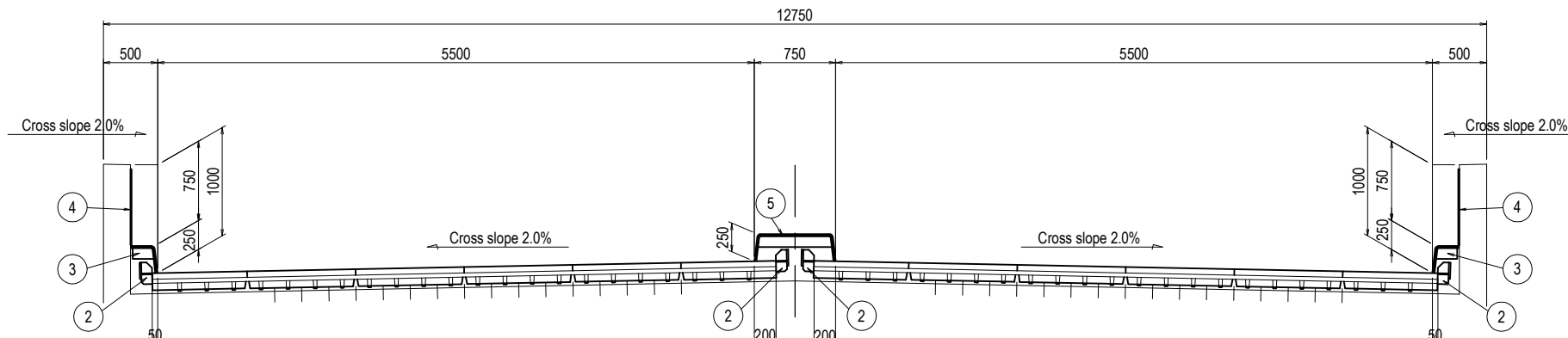

MATERIALS LIST					(1 per place)
No.	DESCRIPTION	MATERIALS	UNIT	QUANTITY	REMARK
1	EXPANSION JOINT	ALUMINUM ALLOY CASTING	m	11.500	160mm
2	UPSTAND		pieces	4	
3	COVER FOR CURB	SS400 or Equivalent	set	2	
4	COVER FOR BARRIER CURB	SUS304	set	2	t=2(include anchor)
5	COVER FOR MEDIAL DIVIDER	SS400 or Equivalent	set	1	
6	REINFORCING BAR	SD345	kg	61.71	D16 × 430 × 92 Nos.
7	REINFORCING BAR	SD345	kg	66.02	D16 × 460 × 92 Nos.
8	REINFORCING BAR	SD345	kg	162.00	D19 × 6.0m × 12 Nos.
9	BURIED FORMWORK	Foamed Styrene	m ³	0.44	230 × 150 × 12.7m
10	POST-CAST CONCRETE	High strength concrete	m ³	2.24	$\sigma_{ck} = 30\text{N/mm}^2$

EMBEDDED BAR					
11	EMBEDDED BAR	SD345	kg	109.08	D16 × 760 × 92 Nos.

DESIGN CONDITION	
Temperature range	+0°C~+50°C
Amount of temperature variation	62mm
Earthquake movement amount	±72mm

- Note
- 1 Re-bar should be consider the developed length.
 - 2 Allocation of the expansion joint is subject to change
 - 3 Expansion joint should be placing to match the transverse gradient.
 - 4 Expansion joint should be installed in consideration of the effect of Creep and Shrinkage.

SECTION OF EXPANSION JOINT S=1:8

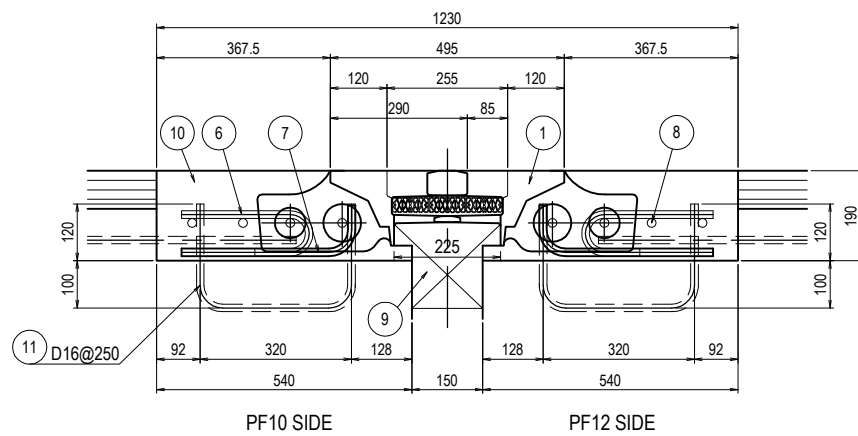

HARDWARE SECTION S=1:5

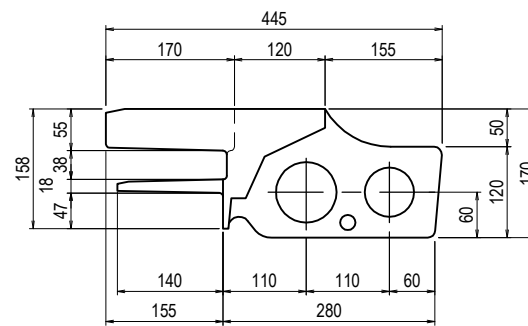

HARDWARE PLAN S=1:10

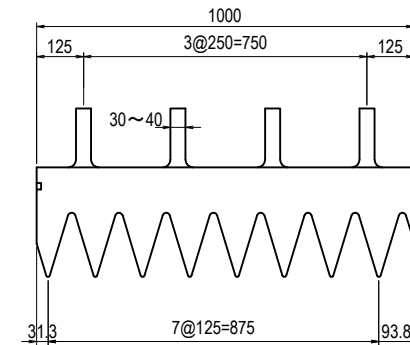

DETAIL OF REINFORCING BAR S=1:8

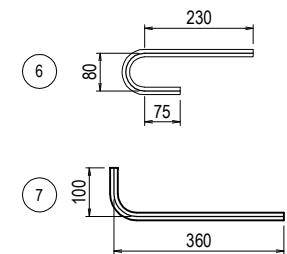

PLAN VIEW

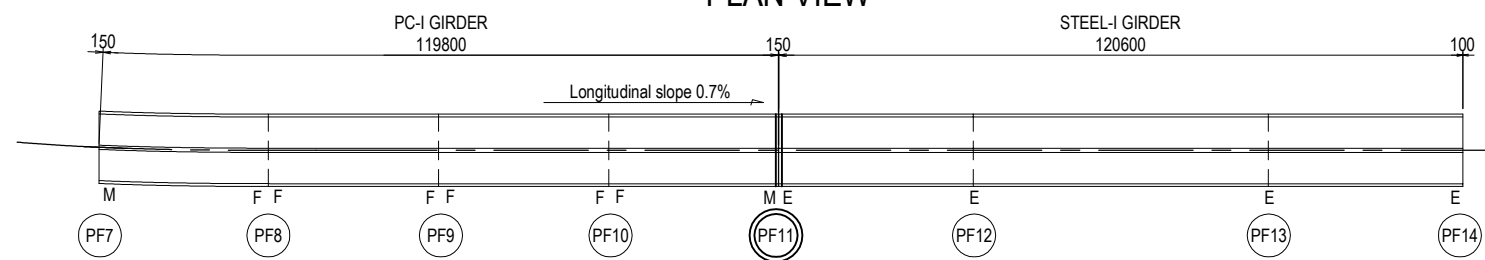

- NOTES:
- 1) Details of the slab and girder are designed based on the product (expansion joint) shown in this Drawing.
 - 2) The Contractor has option to propose an alternative equivalent to the specified product, which shall be subjected to the Engineer's approval.
 - 3) The expansion joint shall be set in consideration of thermal expansion, creep and shrinkage of concrete girder.