

Chapter 12 Preliminary Design of Water Supply and Sewerage Facilities for JICA Survey Project

12.1 CWSS Stage V Project

12.1.1 Water Treatment Plant (WTP)

(1) Design Fundamentals for WTP

1) Design Turbidity

The most useful parameter in selection of the optimum water treatment processes is turbidity. Past three (3) years' records of monthly average raw water turbidity are shown in Table 12.1.1 and daily fluctuations of turbidity from 2013 to 2015 are shown in Figure 12.1.1 to Figure 12.1.3.

These records revealed that normally, the turbidity is under 5 NTU, but it usually exceeds 10 NTU during monsoon seasons from July to October. Even the turbidity reaches 100 NTU, the peak turbidity does not continue for long time during monsoon seasons.

Under these conditions, annual average turbidity of 11 NTU (rounded from 10.8 NTU shown in Table 12.1.1) is applied for the design of water treatment facilities. While the highest monthly average turbidity of 33 NTU, which was found in August 2013 is adopted as the design turbidity for the sludge treatment facility.

Turbidity conditions

- Turbidity for Water Treatment design : 11 NTU, Annual Average
- Turbidity for Sludge Treatment design : 33 NTU, Maximum Monthly Mean

Table 12.1.1 Monthly Average Turbidity of Raw Water

Unit: NTU

	Month	2013	2014	2015	Average	Remarks
1	January	2.1	4.5	3.9	3.5	
2	February	2.1	7.2	4.5	4.6	
3	March	2.2	6.0	4.2	4.1	
4	April	2.3	7.1	3.7	4.4	
5	May	3.7	8.5	4.2	5.5	
6	June	5.6	8.5	7.0	7.0	
7	July	29.8	20.7	12.9	21.1	Monsoon Season
8	August	33.4	29.7	11.4	24.8	
9	September	31.3	28.6	10.1	23.3	
10	October	13.7	22.9	10.7	15.8	
11	November	11.6	8.0	10.7	10.1	
12	December	5.1	5.9	4.4	5.1	
	Average	11.9	13.1	7.3	10.8	
	Maximum	33.4	29.7	12.9	-	

Source: JICA Survey Team

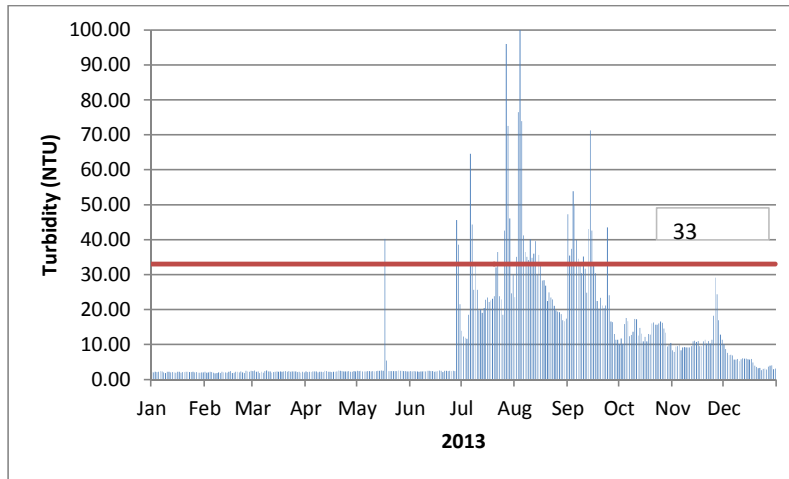

Source: JICA Survey Team

Figure 12.1.1 Daily Fluctuations of Raw Water Turbidity in 2013

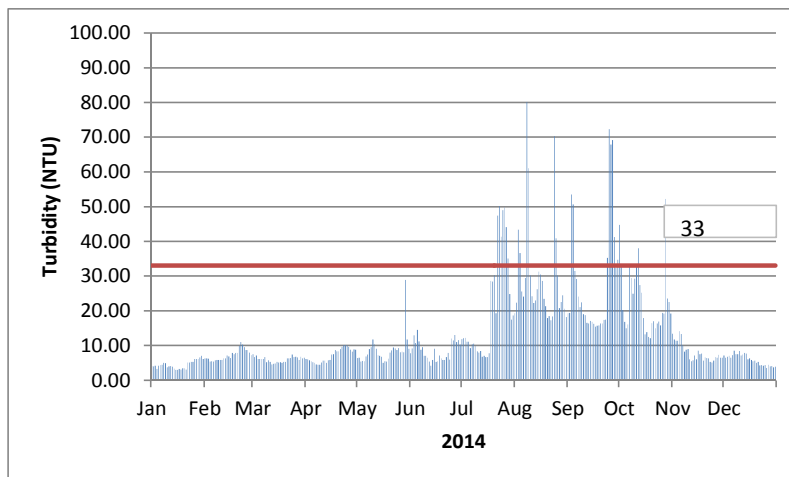

Source: JICA Survey Team

Figure 12.1.2 Daily Fluctuations of Raw Water Turbidity in 2014

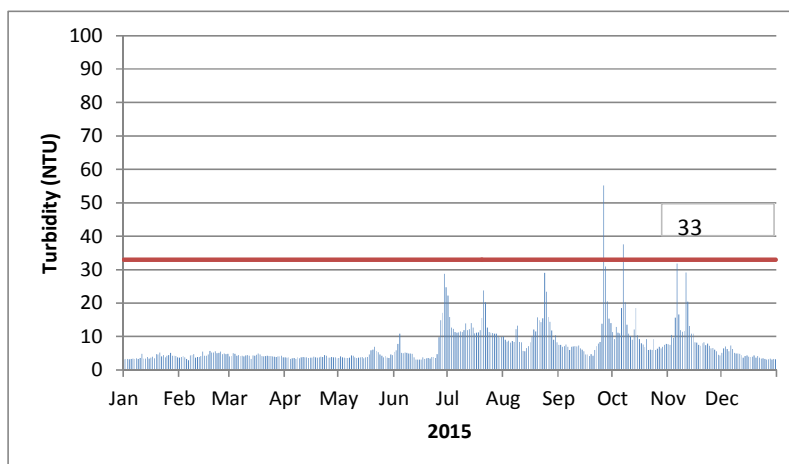

Source: JICA Survey Team

Figure 12.1.3 Daily Fluctuations of Raw Water Turbidity in 2015

2) Design Flow

As mentioned in Chapter 10, the water production of the WTP is 775 MLD. However, for sizing the facilities in the WTP, in addition to this amount, the returned water (e.g. backwash water from rapid sand filters, supernatant of thickeners) and production loss (e.g. sampling water, centrate, wash water) should be considered. Therefore, JICA Survey Team adopts the amount added 4% of water production (i.e. 806 MLD) as the design flow for flocculation, sedimentation, and filtration.

3) Process Flow

The proposed WTP is designed considering two (2) parallel series of the treatment system from cascade aerator to rapid sand filter for the convenience of operation and maintenance. An application of conventional treatment process is proposed as recommended in the DPR. Wastewater generated as the by-product from sludge treatment is planned to be returned to raw water inflow channel to use inflow water effectively. The process flow of WTP is shown in Figure 12.1.4.

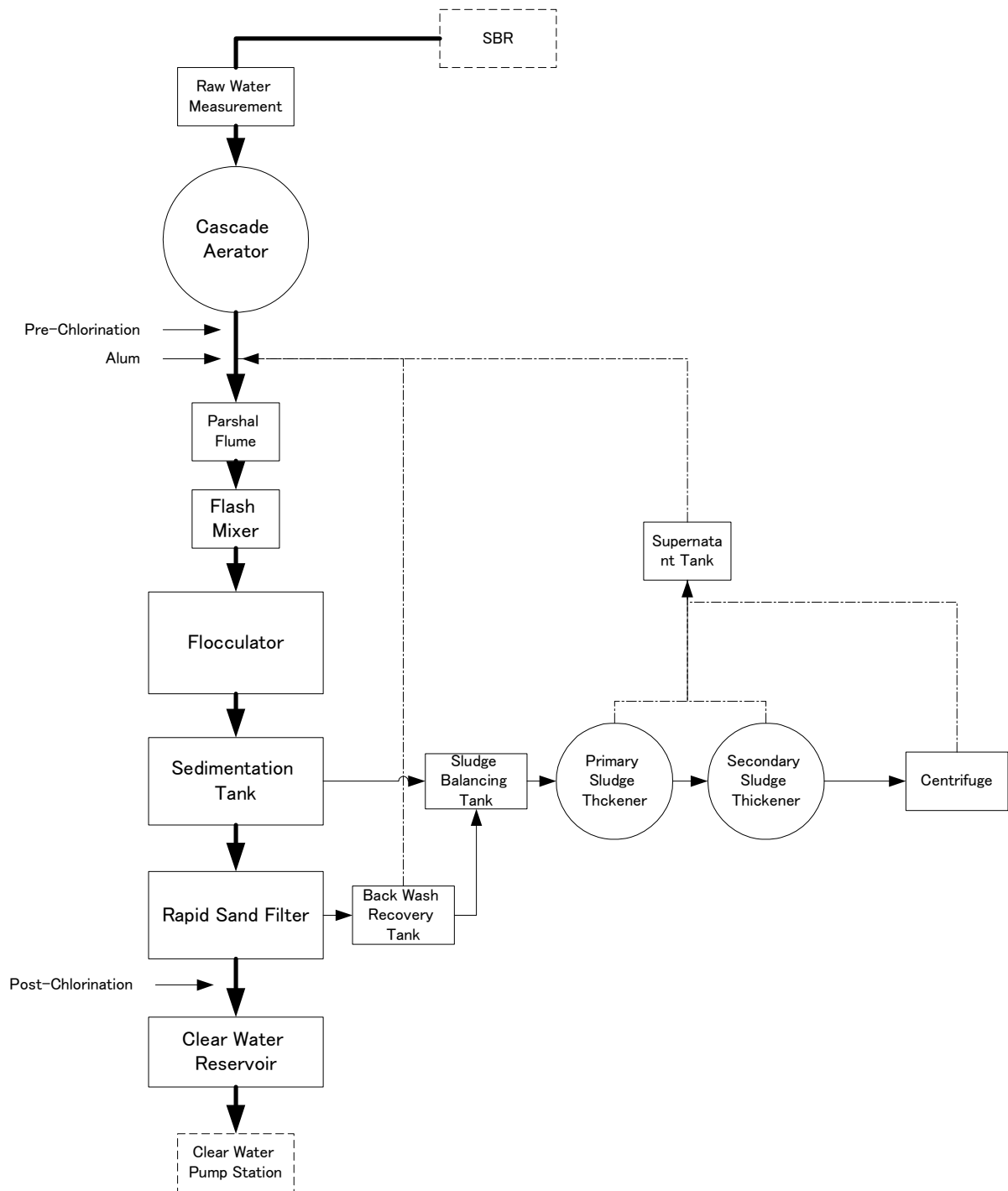

Source: JICA Survey Team

Figure 12.1.4 Process Flow of WTP

(2) Cascade Aerator and Raw Inflow Channel

1) Raw Water Flow Measurement

A flow meter is designed to install at the upstream of Cascade Aerator to measure inflow water volume from Cauvery River. Since flow measurement is planned at the large diameter pipe, an ultrasonic flow meter is used, which can be maintained and repaired without removing pipes and is cheaper than an electromagnetic type flowmeter.

Inflow measuring conditions

- Series: 1 Series
- Design Flow: $Q_0 = 775,000 \text{ m}^3/\text{day} = 32,292 \text{ m}^3/\text{hour} = 538.2 \text{ m}^3/\text{min} = 8.970 \text{ m}^3/\text{sec}$
- Type: Ultrasonic Flowmeter

2) Raw Water Flow Control Valve

Raw water flow control valve is planned to control water intake and production amount. Two parallel series of both inlet pipes into cascade aerator and Parshall Flume channels are proposed as shown in Figure 12.1.5.

The velocity in the conveyance pipe is 1.51 m/s as shown in Table 12.1.2 and Table 12.1.3 shows required diameter of parallel pipes with Dia. 1,950 mm. The diameter of the raw water flow control valve is designed with 1,700 mm diameter considering a faster velocity than conveyance pipe.

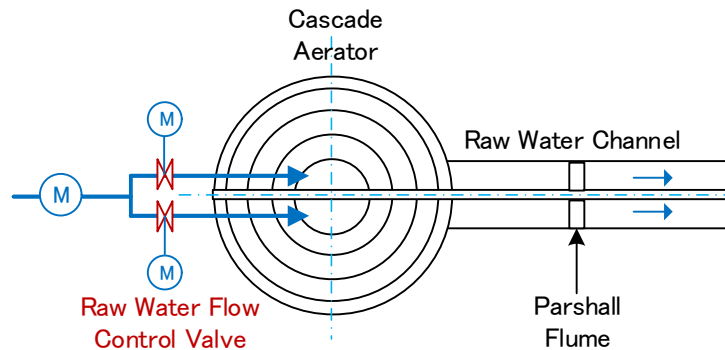

Source: JICA Survey Team

Figure 12.1.5 Water Conveyance Pipe, Cascade Aerator and Parshall Flume

Table 12.1.2 Velocity in the Conveyance Pipe

Raw Water Flow	$775,000 \text{ m}^3/\text{day} = 8.970 \text{ m}^3/\text{sec}$			
Diameter of Pipe (mm)	2,700	2,750	2,900	3,000
Velocity (m/s)	1.57	1.51	1.36	1.27

Source: JICA Survey Team

Table 12.1.3 Velocity of Parallel Series of Pipe

Raw Water Flow	387,500 m ³ /day = 4.485 m ³ /sec			
Diameter of Pipe (mm)	1,900	1,950	2,000	2,100
Velocity (m/s)	1.58	1.50	1.43	1.29

Source: JICA Survey Team

Inflow valve conditions

- Series: 2 Series
- Design Flow: $Q_0 = 775,000 \text{ m}^3/\text{day} / 2 \text{ Series} = 387,500 \text{ m}^3/\text{day}$
- Type: Butterfly Valve
- Diameter: Dia. 1,950 mm for parallel Conveyance Pipe
Dia. 1,700 mm for Raw Water Control Valve

3) Cascade Aerator

As shown in Figure 12.1.4, the supernatant from the sludge treatment facility is to be returned to raw water inflow channel followed by Parshall Flumes where raw water flow and supernatant from sludge treatment facility is measured. Aeration processes are designed to achieve an efficient mass transfer of gases, normally oxygen, into water for imparting freshness to maintain healthy levels of DO (Dissolve Oxygen) or for removal of gases, such as carbon dioxide and hydrogen sulphide or volatile compounds causing taste and odor from the water by air stripping. It is also used for the removal of iron by oxidizing the iron from the soluble ferric state to the insoluble ferric state.

Cascade Aerator conditions

- Series: 2 Series
- Design Flow: $Q_0 = 387,500 \text{ m}^3/\text{day} \times 2 \text{ Series} = 775,000 \text{ m}^3/\text{day}$
- Structure: RC, Circular, 5 Steps

4) Parshall Flume

As shown in the layout plan of WTP (Figure 12.1.8), the return water, which consists of backwash recovery water and supernatant from sludge treatment facility, is combined with the raw water at the outlet of the cascade aerator. Parshall Flume is intended to measure the combined water flow rate. The outflow from the aerator will be conveyed through a straight, reasonably smooth channel, of suitable length (10 times of the throat width of the flume) free from disturbances to maintain a steady flow upstream of the Parshall flume. Pre-chlorination will be done at the start of the raw water channel. As per CPHEEO guideline, a velocity of 1.0 m/s will be maintained in the channel for normal flow.

Parshall Flume conditions

- Series : 2 Series
- Design Flow: $Q_0 = 806,000 \text{ m}^3/\text{day} / 2 \text{ Series} = 403,000 \text{ m}^3/\text{day}$
- Structure: RC
- Type: Venturi (JIS B 7553-1993: PF - 100 Equivalent)

Dimension and measurable range are shown in Table 12.1.4 and Figure 12.1.6.

Table 12.1.4 Dimension and Measurable Range

Nominal	Throat W (m)	Flume L (m)	Depth E (m)	Upper D (m)	Lower C (m)	Width (upper) P (m)	Range	
							Min. m ³ /hr (m ³ /d)	Max. m ³ /hr (m ³ /d)
PF-100	3.048	7.010	1.219	4.756	3.658	9.754	612 (14,700)	20,388 (489,000)

Source: Japanese Industrial Standards

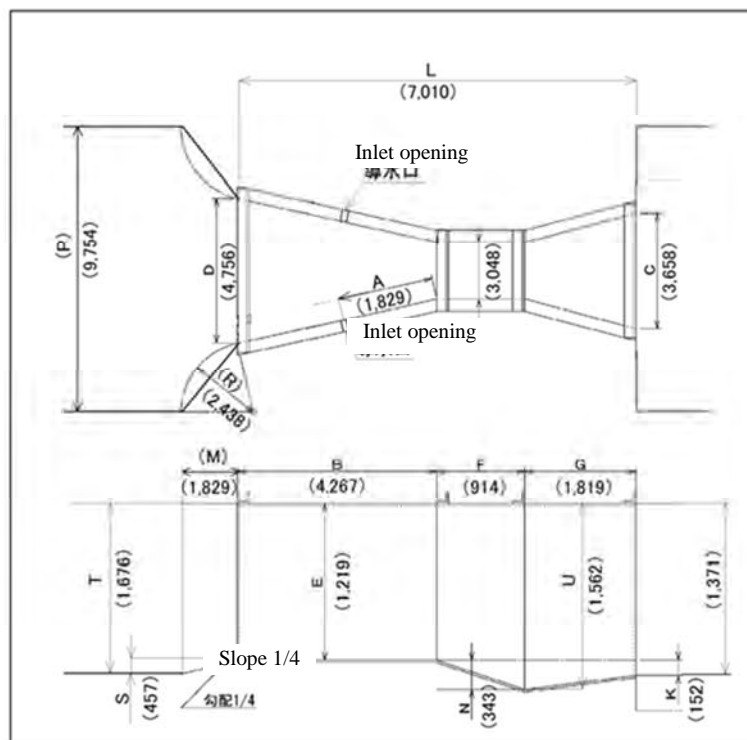

Figure 12.1.6 Dimension of Parshall Flume

(3) Flash Mixer

Coagulation process has two (2) separate and distinct steps. Coagulants are introduced into the water to combine small particles into larger aggregates by neutralization. This involves the addition of coagulant in the 1st step, to treat the particles chemically to make them sticky or unstable.

In the 2nd step, namely flocculation, destabilized particles are brought into contact with each other so that aggregation can occur.

The former process of destabilization is achieved with rapid and intimate mixing of coagulant and raw water by using a flash mixer. Alternatives using weir and baffle arrangements are possible but additional head is required in these cases. In order to limit the head, mechanical flash mixers will be specified. The flash mixer will be installed at a stirred tank rectangular in cross-section.

Flush Mixer conditions

- Series, Lines: 2 Series \times 2 Lines/series = 4 Lines
- Design Flow: $Q_0 = 806,000 \text{ m}^3/\text{day} / 4 \text{ Lines} = 201,500 \text{ m}^3/\text{day} = 8,395.8 \text{ m}^3/\text{hour} = 139.9 \text{ m}^3/\text{min}$
- Structure: RC (Rectangular)
- Type: Mechanical Mixer
- Number of Tanks: 2 Series \times 2 Lines = 4 Tanks
- Dimension: L 5.0 m \times W 5.0 m \times D 5.6 m
- HRT (Hydraulic Retention Time): 1.0 min
(Reference: 1-5min at Japan Water Works Association (JWWA))
- Required Volume: $V = 139.9 \text{ m}^3/\text{min} \times 1.0 \text{ min} = 139.9 \text{ m}^3 < \text{Actual Volume: } V = 140 \text{ m}^3$

(4) Flocculation

For efficient settling of the suspended matter, aggregation of the destabilized matter from the rapid mixing unit has to be done in the flocculation unit. In the flocculation unit, slow and gentle fluid motion by mechanical mixing brings the particles into contact so that aggregates can form. These aggregates are then settled out in the clarification unit.

Flocculation conditions

- Series, Lines: 2 Series \times 2 Lines/Series = 4 Lines
- Design Flow: $Q_0 = 806,000 \text{ m}^3/\text{day} / 4 \text{ Lines} = 201,500 \text{ m}^3/\text{day}/\text{Line} = 8,395.8 \text{ m}^3/\text{hr}/\text{Line} = 139.9 \text{ m}^3/\text{min}/\text{Line}$
- Type: Vertical Flocculator
- Number of Tanks: 4 Lines \times 16 Tanks/Lines = 64 Tanks
- Dimension: Length 7.0m \times Width 7.0 m \times Depth 3.78m
- HRT: 20 min (Reference: 10-40min at CPHEEO)
- Required Volume: $V_0 = 139.9 \text{ m}^3/\text{min}/\text{Line} \times 20 \text{ min} = 2,798 \text{ m}^3/\text{Line} < \text{Actual Volume } 2,963 \text{ m}^3/\text{Lines}$

(5) Sedimentation Tank

Sedimentation is the separation from water by gravitational settling of suspended particles that are heavier than water. It is one of the most commonly used operations in conventional water treatment. The major types of sedimentation methods are compared in Table 12.1.5.

Table 12.1.5 Sedimentation Method Selection

Method	Flow direction	HRT (min)	Shape	BWSSB Experience	Evaluation
A. Conventional	Horizontal	210 or larger	Rectangular	None	Bad It is effective in low turbidity waters but needs wider space
B. Plate Settler	Horizontal	40~60	Rectangular	Stage IV Phase 1	Good More effective than conventional sedimentation using plate settler
	Up-flow	40~60	Rectangular	DPR for Stage V	Better More effective than horizontal flow plate settler
C. Tube Settler	Up-flow	40~60	Rectangular	Selected	Best Mechanism is the same as above but more effective and low cost using pipe instead of stainless steel plate
D. Clariflocculator	Up-flow	90~120	Circular	Stage I, II, III	Poor It is not very effective in low turbid waters.
E. DAF	Water: Down flow Sludge: Up-flow	22	Rectangular	Stage IV Phase 1	Poor Need more power and chemical

Source: DPR for CWSS Stage V

The rectangular sedimentation with tube settlers has an edge over the other processes due to the smaller footprint and compactness of the plant, lower power consumption and flexibility for use due to its short start up time. The clarification unit can easily be bypassed, if the raw water is passed on for direct filtration.

Sedimentation conditions

- Series, Lines: 2 Series \times 2 Lines/Series = 4 Lines
- Design Flow: $Q_0 = 806,000 \text{ m}^3/\text{day} / 4 \text{ Lines} = 201,500 \text{ m}^3/\text{day}/\text{Line} = 8,395.8 \text{ m}^3/\text{hr}/\text{Line}$
 $= 139.9 \text{ m}^3/\text{min}/\text{Line}$
- Type: Rectangular Sedimentation with Tube Settler
- Number of Tanks: 4 Lines \times 8 Tanks/Lines = 32 Tanks
- Dimension: Length 14.0m \times Width 14.0 m \times Depth 3.6 m
- Water Surface Load: 10.5 mm/min (Reference: 7 - 14 mm/min at JWVA)
- Projected Area of tube settler: $9.0 \text{ m}^3/\text{m}^2$
- Required Area per Tank: $139.9 \text{ m}^3/\text{min} / 10.5 \text{ mm}/\text{min} \times 1,000 / 9\text{m}^3/\text{m}^2 / 8 \text{ Tanks} = 185 \text{ m}^2$
 $< \text{Actual area per tank: } 196 \text{ m}^2$
- HRT: 40 min
- Required Volume per Tank: $139.9 \text{ m}^3/\text{min} \times 40 \text{ min} = 5,596 \text{ m}^3 < \text{Actual Volume per tank: } 7,056 \text{ m}^3$

(6) Rapid Sand Filter

Filtration is a process for separating suspended and colloidal impurities from water by passage through a porous medium or porous media. Filtration has been employed for treatment of water to effectively remove turbidity (e.g. silt and clay), color, microorganisms, precipitated hardness from chemically softened waters and precipitated iron and manganese from aerated waters. Removal of turbidity is essential not only from the requirement of aesthetic acceptability but also for efficient disinfection which is difficult in the presence of suspended and colloidal impurities that serve as hideouts for the microorganisms.

Rapid Sand Filter conditions

- Series, Lines: 2 Series \times 2 Lines/Series = 4 Lines
- Design Flow: $Q_0 = 806,000 \text{ m}^3/\text{day} / 4 \text{ Lines} = 201,500 \text{ m}^3/\text{day}/\text{Line} = 8,395.8 \text{ m}^3/\text{hr}/\text{Line}$
 $= 139.9 \text{ m}^3/\text{min}/\text{Line}$
- Structure: RC Rectangular
- Type: Gravity Sand Filter
- Number of Tanks: 4 Lines \times 9 Tanks/Lines = 36 Tanks (include 2 stand-by)
- Dimension: Length 4.4m \times Width 16.0 m \times 2 unit (=70.4 m² \times 2 unit = 140.8 m²/tank)
- Design Filtration Rate: 168 m/day = 7.0 m/hr (Same as DPR)
- Actual Filtration Rate: $V_0 = 806,000 \text{ m}^3/\text{day} / 140.8 \text{ m}^2 / 34 \text{ tanks} = 168 \text{ m/day}$

Rapid sand filter is categorized into two (2) types: fine particle (0.7 mm) and thin layer (0.7 m), coarse particle (1.0 mm) and fat layer (1.0 m), Filtration performance of both types are almost same, but back wash/ cleaning system is different. Surface and back wash is applied for fine particle filters, and air and back wash is applied for coarse filters. Coarse particle filter was applied for Stage I to IV at TK Halli, but fine particle filter was applied in the DPR of Stage V for surface and back wash. Filtration rate of 7.0 m/hr is applied for Stage V in DPR, however, 4.8 to 6.0 m/hr is recommended and acceptable limit is 10 m/hr, in CPHEEO. After discussions with BWSSB, filtration rate of 7.0 m/hr and 0.7 mm particle/ 0.7 m depth type filter was applied. The comparison of criteria of gravity filtration is shown in Table 12.1.6.

Table 12.1.6 Comparison of Rapid Sand Filter Criteria

Item	Proposed	DPR
Filtration Rate	168 m/day (= 7.0 m ³ / m ² /hr)	168 m/day (= 7.0 m ³ / m ² /hr)
Sand Layer	0.7 m	0.7 m
Particle size	0.7 mm	0.45 to 0.7 mm
Wash Method	Surface and Back wash	Air and Back wash
Back wash Water	Surface wash 0.2 m ³ /(min \cdot m ²) 6 min	Air Wash < 0.83 m ³ /(min \cdot m ²) 3 min
	Back wash 0.8 m ³ /(min \cdot m ²) 10 min	Air + Backwash < 0.3 m ³ /(min \cdot m ²) 4 min
		Back wash < 0.833 m ³ /(min \cdot m ²) 8 min

Source: JICA Survey Team

(7) Clear Water Reservoir

As per CPHEEO guidelines, the clear water reservoir will be provided with a minimum of two (2) hr storage to provide for power outage and for effective disinfection of the treated water. A reservoir capacity of reinforced concrete construction is therefore provided with a baffle arrangement at the inlet and outlet. It will be sub-divided into two (or three) compartments, so that one compartment can be taken out of service for cleaning without disrupting the operation of the works. The tank will be baffled to prevent short circuiting at the inlet and outlet.

Clear Water Reservoir conditions

- Number of Tank : 2 tanks
- Design Flow: $Q_0 = 775,000 \text{ m}^3/\text{day} = 32,292 \text{ m}^3/\text{hr}$
- HRT: 2 hours
- Structure : RC Rectangular
- Dimension: Length 75.0 m \times Width 75.0 m \times Depth 6.0 m
- Required Volume: $V_0 = 32,292 \text{ m}^3/\text{hr} \times 2 \text{ hr} = 64,584 \text{ m}^3$
- Per Tank: $V_1 = 64,584 \text{ m}^3 / 2 \text{ tank} = 32,292 \text{ m}^3/\text{tank}$
- Actual Volume: $V = 64,800 \text{ m}^3$
- Level: Design GL: +590.0 m, HWL+591.03 m, LWL+585.03 m

(8) Chemical Dosing Facility**1) Alum Dosing Facility**

The processes of coagulation, sedimentation and filtration are combined to remove suspended particles from water. Coagulation/ flocculation helps increase the size of flocs and settling velocity.

The coagulation process involves, at first, the addition of a coagulant in a rapid mix tank to assist in the process of coagulation and flocculation. The choice of coagulant for use is made from among many options.

a) Comparison of Coagulant

Alum (Aluminum Sulfate) is applied in existing WTP. The major coagulants are compared in Table 12.1.7. Dosing system with PAC is an expensive alternative, but would be clean and easy to maintain, besides providing a minimal quantity of sludge. Considering the pH of raw water and the economics involved, Aluminum Sulfate (Alum) is suggested as the coagulant for use, due to its easy availability.

Table 12.1.7 Comparison of Chemicals

SN	Parameters	Aluminum Sulfate (Alum)	Ferrous Sulfate (Copperas)	PAC (Poly Aluminum Chloride)
1	Chemical formula	$\text{Al}_2(\text{SO}_4)_3 \cdot 18\text{H}_2\text{O}$ & Inorganic coagulant	$\text{FeSO}_4 \cdot 7\text{H}_2\text{O}$ Inorganic coagulant	$\text{Poly-Al}_2(\text{OH})_3\text{Cl}_3$ Organic coagulant

SN	Parameters	Aluminum Sulfate (Alum)	Ferrous Sulfate (Copperas)	PAC (Poly Aluminum Chloride)
2	Commercial Strength	7.5-8% Al ₂ O ₃ ; SG:1.3	10-10.5 % Fe(III); SG:1.5	10-11% Al ₂ O ₃ ; SG:1.18 Basicity: 55%
3	Available form	Blocks; powder; lumps	Granules; crystals; lumps	Granules; Liquid
4	Solution Concentration	5 - 10% (5% considered)	4 - 8 %	8%
5	Dosing rate	4 to 40 mg/l	-	0.2 mg/l as a coagulant aid More appropriate for use in direct filtration
6	Active pH range	5.8 to 6.5;	To be maintained above 9.5 to ensure complete precipitation of iron	< 6.5
7	Alkalinity Reduction per ppm of coagulant (ppm)	0.45	0.36	Used in lieu of Alum when raw water has low pH and alkalinity
8	Total solids increase (ppm)	High; 0.16	High; 0.13	Very low
9	Materials used for handling solution	Acid resistant tiles/fiber glass/ tanks bitumen coated concrete or rubber lined tanks	Iron stainless steel and concrete; Lead or stainless steel, plastics	Plastics
10	Lime requirement	Not required	Required to maintain pH	Not required
11	Advantages	-Preferred due to widespread availability -Substantially lower costs -Can be operated over a wide range of pH -Effective in removal of dissolved organic carbons (Humic acid and fulvic color constituents)	-Widespread availability -Low costs -Ferric floc is denser than alum floc	-Less than 50% of alum dosage -Sludge production is less -Cost reduces significantly if used in combination with alum -Reduced concentration of sulfate added to the treated water
12	Disadvantages	-Level of Al to be maintained below 0.03 mg/l. -Sludge production is higher -Supplemental addition of alkalinity to the raw water is required if pH lowered below the limits	-Requires addition of lime to maintain high pH to completely precipitate iron -Difficulties in dissolving and hence more agitation required	-Five times the cost of alum -It is less suitable for sludge blanket clarifiers -Removal of THM precursors may not be as complete as with alum
13	Evaluation	Adopted	Not recommended	Recommendable if cost effective

Source: JICA Survey Team

b) Design Alum Dosing Rate

Due to grasp of proper alum dosing rate, the correlation chart between turbidity and alum dosing rate is built, which have led from the operation record of the latest existing WTP, Stage IV phase II. (Refer to Figure 12.1.7 and Table 12.1.8.)

From the correlation chart, Design Alum Dosing Rates are determined, which are shown in Table 12.1.9.

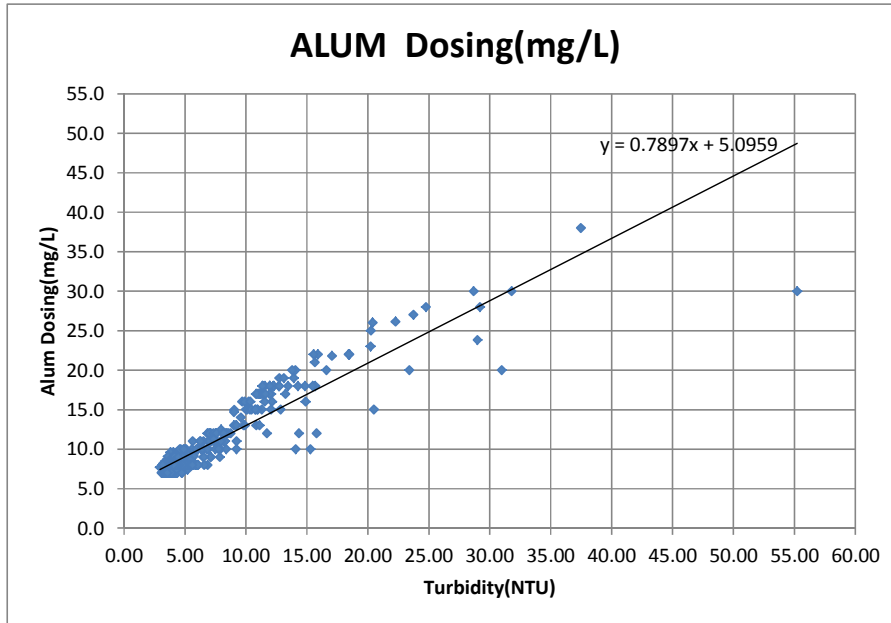

Source: JICA Survey Team

Figure 12.1.7 Relation with Dosing Rate and Raw Water Turbidity

Table 12.1.8 Present Alum Dosing Rate at TK Halli WTP (Stage IV Ph. 2) in 2015

Item	Raw Water Flow (MLD)	ALUM Dosing (kg/day)	ALUM Dosing (mg/L)
Average	416	4,479	11.2
Maximum	444	16,492	38.0
Minimum	368	2,702	7.0

Source: JICA Survey Team

Table 12.1.9 Design Alum Dosing Rate

Design Turbidity (NTU)		Design Dosing Rate (mg/L)	Design Flow (MLD)	ALUM Dosing (kg/day)
Annual Ave.	11	14	806	11,284
Max. Monthly Ave.	33	31	806	24,986

Source: JICA Survey Team

c) Alum Solution Tank

Alum Solution Tank

- Number of Tank : 12 tanks
- Alum dosing per day (Average): 11,284 kg/day
- Alum Solution Concentration: 5.0% , Specific Gravity 1.05%
- HRT: 3.0 days
- Structure : RC Rectangular

- Dimension: Length 4.5 m × Width 4.0 m × Depth 3.0 m
- Required Volume: $V_0 = 11,284 \text{ kg/day} \times 3 \text{ days} / 5.0 \% \times 100 / 1.05 \times 10^{-3} = 644.8 \text{ m}^3$
- Actual Volume: $V = 648.0 \text{ m}^3$

2) Chlorination Facility

Though the aforementioned physico-chemical processes assist in removal/killing of micro-organisms to varying degrees, disinfection of water has to be done for killing of disease producing organisms and viruses. Appropriate and judicious application of chlorine is therefore vital for the production of potable water.

Chlorination facility conditions

- Type: Liquid Chlorine (Adopted existing TK Halli WTP)
- Design Flow : $Q_0 = 775,000 \text{ m}^3/\text{day} = 32,292 \text{ m}^3/\text{hr}$

a) Present Dosing Rate

The present chlorine dosing rate at TK Halli WTP is shown in Table 12.1.10.

Table 12.1.10 Present Chlorine Dosing Rate at TK Halli WTP (Stage IV Ph.2) in 2015

Item	Raw Water Flow (MLD)	Treated Water low (MLD)	Chlorine (kg /day)	Pre Chlorine (mg/L)	Post Chlorine (mg/L)	Total Chlorine (mg/L)
Average	416	415	1,652	1.4	2.6	4.0
Maximum	444	443	2,424	1.8	4.4	6.1
Minimum	368	367	1,455	1.2	2.2	3.6

Source: JICA Survey Team

b) Design Chlorine Dosing Rate

Here, the designed chlorine dosing rate is based on the present dosing rate of CWSS Stage IV Ph.2. However, the re-chlorination is required at GLRs to assure the residual chlorine concentration to be maintained at least 1.5 mg/L at GLR. Table 12.1.11 shows design chlorine dosing rate.

Table 12.1.11 Design Chlorine Dosing Rate

Item	Treated Water Flow (MLD)	Pre Chlorine (mg/L)	Post Chlorine (mg/L)	Pre Chlorine (kg/day)	Post Chlorine (kg/day)	Total Chlorine (kg/day)
Average	775	1.4	2.6	1,085	2,015	3,100
Maximum	775	5.0	5.0	3,875	3,875	-

Item	Treated Water Flow (MLD)	Pre Chlorine (mg/L)	Post Chlorine (mg/L)	Pre Chlorine (kg/day)	Post Chlorine (kg/day)	Total Chlorine (kg/day)
Minimum	775	1.0	1.0	775	775	-

Source: JICA Survey Team

c) Chlorine Dosing Facility

Pre- Chlorination and post-chlorination are installed respectively.

Pre-chlorination conditions

- Chlorinator Type: Vacuum gas type
- Number of units: 4 units working, 1 unit standby
- Capacity: $3,875 \text{ kg /day} / 24\text{hr/day} / 4 \text{ units} = 40.36 \Rightarrow 41.0 \text{ kg-Cl}_2 / \text{hr} / \text{unit}$

Post-chlorination conditions

- Chlorinator Type: Vacuum gas type
- Number of units: 4 units working, 1 unit standby
- Capacity: $3,875 \text{ kg /day} / 24\text{hr/day} / 4 \text{ units} = 40.36 \Rightarrow 41.0 \text{ kg-Cl}_2 / \text{hr} / \text{unit}$

d) Chlorination Building

Chlorination Building conditions

- Structure: RC
- Dimension: Width 25.5 m × Length 55.0 m × Height 7.0 m × 1 building

(9) Sludge Treatment Facility

1) Design Fundamentals

The wastewater recovery from clarifier sludge (by providing a sludge balancing tank, thickener and centrifuge), and recycling of filter backwash will reduce the losses from the WTP less than 1%.

Recirculation can be considered only if the raw water parameters permit and after studying its impact on the quality of treated water. It should be noted that details of wastewater recovery specification may differ depending on the type of clarifiers adopted. The sludge treatment units are considered to accept raw water with turbidity 33 NTU, Maximum Monthly Average in monsoon season. The design flow for each sludge treatment facilities is shown in Table 12.1.12.

Table 12.1.12 Design Flow for each Sludge Treatment Facilities

Item	Unit	Value	
Design Flow	m ³ /day	775,000	
1. Raw Water		(Average) ^{*1}	(Maximum) ^{*2}
Turbidity	NTU	11	33
Turbidity Conversion Factor		1.2	1.2
Color		5	5
SS: (Turbidity) × (Turbidity conversion factor) + (Color)	mg/L	18.2	44.6
2. Flocculated Sludge		(Average) ^{*1}	(Maximum) ^{*2}
Influent Dry Solids	t/day	14.669	35.948
ALUM Solids as Al(OH) ₃	t/day	2.642	5.850
ALUM dosing rate as crystal (Al ₂ (SO ₄) ₃ .18H ₂ O)	mg/L	14	31
Total Solids	t/day	17.311	41.797
Sludge Concentration	%	1.0	1.0
Sludge Volume	m ³ /day	1,731	4,180
3. Backwash Water Sludge		(Average) ^{*1}	(Maximum) ^{*2}
Turbidity of Clarified water	NTU	1.0	1.0
Dry solids: (Turbidity) × 1.2	t/day	0.967	0.967
Sludge Concentration	%	0.07	0.07
Sludge Volume	m ³ /day	1,382	1,382
4. Combined Sludge (2. Flocculated Sludge + 3. Backwash Water Sludge)		(Average) ^{*1}	(Maximum) ^{*2}
Dry Solids	t/day	18.278	42.764
Sludge Volume	m ³ /d	3,113	5,561
5. Primary Sludge Thickener		(Average) ^{*1}	(Maximum) ^{*2}
Dry Solids	t/day	18.278	42.764
Sludge Concentration	%	2.5	2.5
Sludge Volume	m ³ /day	731.1	1,711
6. Secondary Sludge Thickener		(Average) ^{*1}	(Maximum) ^{*2}
Dry Solids	t/day	18.278	42.764
Sludge Concentration	%	4.0	4.0
Sludge Volume	m ³ /day	457.0	1,069
7. Centrifuge		(Average) ^{*1}	(Maximum) ^{*2}
Dry Solids	t/day	18.278	42.764
Sludge Concentration	%	25	25
Sludge Volume	m ³ /day	73.11	171.1
8. Supernatant		(Average) ^{*1}	(Maximum) ^{*2}
Supernatant: (4. Combined Sludge – 6. Secondary	m ³ /day	2,656	4,492

*1: The values are calculated as the case of annual average turbidity, 11 NTU.

*2: The values are calculated as the case of maximum monthly mean turbidity, 33 NTU.

Source: JICA Survey Team

2) Backwash Water Recovery Tank

The backwash water recovery tanks are to be constructed besides the sand filter units, which will receive a daily average of 28,244 m³/d filtered water from the sand filter units through an inflow pipe.

The required capacity and dimension of backwash water recovery tank are considered as below.

Backwash Water Recovery Tank

- Backwash Water: 28,244 m³/day = 1,661.4 m³/time
- Frequency of Backwash: 17 Times / day
- Unit Number: 2 tanks
- Dimension: W 13.0 m x L 32.0 m x H 4.0 m
(DPR: V=φ16.1 m × H 5.5 m × 1 unit = 1,119 m³)
- Required Volume: more than one time of the generated backwash water =1,661.4 m³
<Actual Volume: V = 1,664 m³/tank

3) Sludge Balancing Tank

The required capacity and dimension of sludge balancing tank are considered as below.

Sludge Balancing Tank conditions

- Sludge Generation: 5,561 m³/day
- Unit Number: 2 tanks
- Maximum Frequency: 2 times/ day
- Dimension: W 15.0 m x L 24.0 m x H 4.0 m
(DPR: V=φ34.5 m × H 4.0 m × 1 unit = 3,737 m³)
- Required volume V₁ = 5,561m³/day / 2 times/day / 2 tanks = 1,390 m³/ tank
< Actual Volume: V =1,440 m³/ tank

4) Primary Sludge Thickener

The sludge from sedimentation process and drainage from the backwash water will be conveyed and thickened at the primary sludge thickener.

The required capacity and dimension of primary sludge thickener are considered as below.

Primary Sludge Thickener conditions

- Type: Circular Type
- Design Solids: 42,764 kg/day
- Design Sludge: 5.561 m³/day
- Units : 4 tanks
- Design Solid Loading: 20 kg/ m²/ day (Reference: 10-20 kg/m²/day, JWWA)
- Required Area: $A_1 = 42,764 \text{ kg/day} / 20 \text{ kg/ m}^2/\text{day} / 4 \text{ tanks} = 534.55 \text{ m}^2$
- Diameter: 26.0 m (25.99 m is required, thus it's rounded to 26.0 m)
- Dimension: Dia. 26.0 m x Depth 4.0 m
(DPR: $V = \pi \times 29.0 \text{ m} \times 4.0 \text{ m} \times 3 \text{ tank} = 7,981 \text{ m}^3$)
- Actual Volume: 2,124 m³/tank (8,495 m³ in total)

5) Secondary Sludge Thickener

The required capacity and dimension of secondary sludge thickener are considered as below.

Secondary Sludge Thickener conditions

- Type: Circular Type
- Design Solids: 42,764 kg/day
- Design Sludge: 1,711 m³/day
- Units : 1 tanks
- Design Solid Loading: 90 kg/ m²/ day
- Required Area: $A_1 = 42,764 \text{ kg/day} / 90 \text{ kg/ m}^2/\text{day} / 1 \text{ tank} = 475.16 \text{ m}^2$
- Diameter: 26.0 m (24.5 m is required, and here 26.0m is adopted to fit primary one)
- Dimension: Dia. 26.0 m x Depth 4.0 m
- Actual Volume: 2,124 m³/tank

6) Supernatant Tank

The required capacity and dimension of supernatant tank are considered as below.

Supernatant Tank conditions

- | | |
|-----------------------------|---|
| • Type: | Circular Type |
| • Sludge Volume: | 4,492 m ³ /day |
| • Number of Units: | 1 unit |
| • Diameter: | 23.0 m |
| • Side Water Depth: | 5.0 m |
| • Effective capacity: | 2,077 m ³ /unit |
| • Dimension: | Dia. 23.0 m × D 5.0 m × 1 unit
(DPR: V = ϕ 22.0 m × H 5.0 m × 1 tank = 1,900 m ³) |
| • Hydraulic Retention Time: | 11.1 hr |

7) Centrifuge

The required capacity and dimension of centrifuge are considered as below.

8) Centrifuge conditions

	(Maximum)* ¹	(Average)* ²
• Design Sludge Volume:	Sv = 1,069 m ³ /day	457.0m ³ /day
• Operating units number:	Un = 4 units	3 units
• Sludge solid contents:	4.0 %	4.0 %
• Operating days:	Od = 6 days/week	5 days/week
• Operation Time:	Ot = 12.0 hr/day	8.0 hr/day
• Required capacity:	Cr = 25.98 m ³ /hr/unit	26.65 m ³ /hr/unit
	Cr=Sv/Un × 7/Od /Ot	
• Specification:	30 m ³ /hr × 5 units (4 units, working + 1 unit, stand-by)	

*1: The values are calculated as the case of annual average turbidity, 11 NTU.

*2: The values are calculated as the case of maximum monthly mean turbidity, 33 NTU.

(10) Layout Plan

The proposed land is inclined from north to south, thus facilities are set from north to south considering natural water flow and sludge treatment facilities are shifted to southern side. The power receiving facility is decided considering the location of power supply cable. The conveyance from rapid sand filter to clear water tank was changed from DPR in order to make shorten the length. The layout plan is shown in Figure 12.1.8.

(11) Hydraulic Profile

Hydraulic profile is shown in Figure 12.1.9.



Figure 12.1.8 Layout Plan of WTP

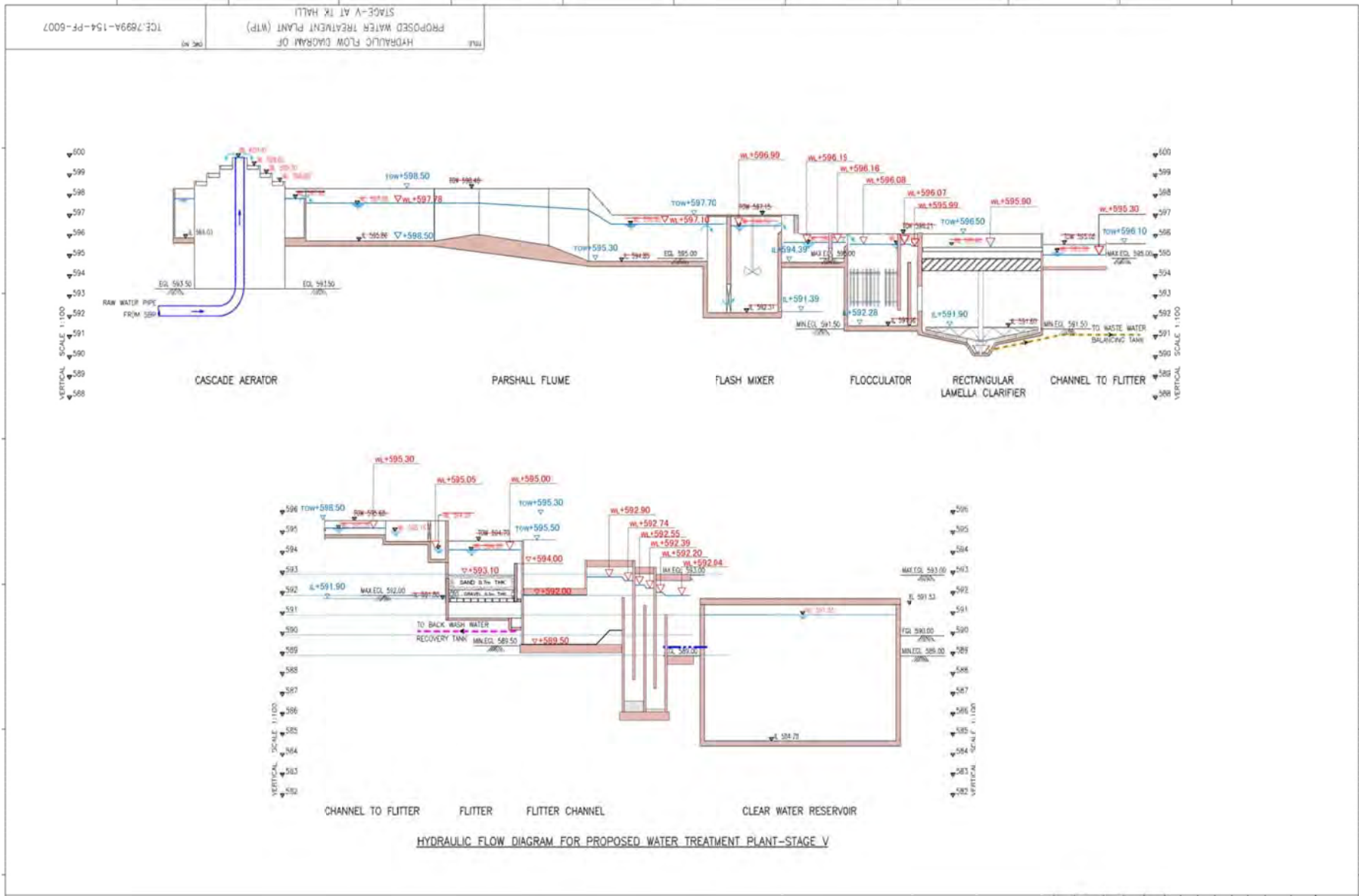

Figure 12.1.9 Hydraulic Profile

(12) Specifications for Major Facilities and Equipment

The dimensions and specifications for major facilities and equipment are shown in Table 12.1.13. Table 12.1.14 shows specifications of major facilities.

Table 12.1.13 Dimension of Major Facilities

No.	Facility	Q'ty	Dimension In Meters		
			L	W	D/H
1	Cascade Aerator	1	φ42.9		—
1-2	Parshall Flume	2	41.9	9.8	1.7
1-3	Raw Water Channel 1	1	213.0	6.0	1.8
1-4	Raw Water Channel 2	1	106.0	6.0	1.8
2	Flash Mixer	4	5.0	5.0	5.6
3	Flocculator	64	7.0	7.0	3.78
4	Sedimentation Tank with Tube Settler	32	14.0	14.0	3.6
5	Rapid Sand Filters	36 (2)	16.0	4.4	1.9
6	Clear Water Reservoir (CWR)	2	75.0	75.0	6.0
7-1	Backwash Water Recovery Tank	2	32.0	13.0	4.0
7-2	Sludge Balancing Tank	2	24.0	15.0	4.0
7-3	Primary Sludge Thickener	4	φ 26.0		4.0
7-4	Secondary Sludge Thickener	1	φ 26.0		4.0
7-5	Supernatant Tank	1	φ 23.0		5.0
8	Centrifuge Building	1	49.0	15.5	16.0
9	Chemical Building	1	46.0	18.6	12.0
10	Chlorine Building	1	55.0	25.5	7.0
11	Filter Annex Building	1	45.5	12.0	7.0
12	Electrical Switch Yard	1	55.0	40.0	-
13	Electrical Sub Station	1	25.0	15.0	4.5

Source: JICA Survey Team

Table 12.1.14 Specifications of Major Facilities

W: working, S: standby

Items	Specification	kW per unit	Unit Number
1. Cascade Aerator			
1) Inlet Valve	Electric Operated Cast Iron	Dia. 1700(mm)×PN 10	- 2W
2. Flash Mixer			
1) Inlet Gates	Electric operated Cast Iron	Width 2.2(m)×Height :2.2(m)	5.50 4W
2) Flash Mixers	Vertical Type SS316	Tank Width :5.0 (m)×Length :5.0(m) ×Side Water Depth(SWD) :5.6(m)	11.0 4W
3) Electric Hoist	I-girder Overhead Type	Rated Load :2.0(Ton)×Lift :6(m)	4.80 1W
3. Flocculator			
1) Inlet Gates	Electric operated Cast Iron	Width 1.10(m)×Height :1.10(m)	2.20 16W
2) Flocculators	Square Horizontal SS316	Width :7.00 (m)×Length :7.00(m)×SWD :3.78 (m)	0.75 64W
3) Electric Hoist	I-girder Overhead Type	Rated Load :2.0(Ton)×Lift :6(m)	4.80 1W
4. Sedimentation Tank			
1) Final Clarifiers	Central Driven MS+ Galvanized	Width :14.00 (m)×Length :14.00(m)×SWD :3.60 (m)	1.50 32W
2) Tube Settler	Tube Settler PVC	Width :14.00 (m)×Length :14.00(m)×Height :1.00 (m)	- 32W
3) Sludge Valve	Electric Operated Cast Iron	Sluice valve, Dia. 200(mm)×PN 10	1.50 32W
4) Sampling Pumps for clarified water	Monobloc Cast Iron	Dia. :25 (mm)×Discharge:2(m ³ /h)×Total Head:10.0 (m)	0.40 32W
5) Sampling Pumps for sludge	Monobloc Cast Iron	Dia. :25 (mm)×Discharge:2(m ³ /h)×Total Head:10.0 (m)	0.40 4W
5. Rapid Sand Filter			
1) Under Drainage System	Filter Nozzle PVC	Width :4.40 (m)×Length :16.00(m)×2 filter beds	- 36
2) Wash Water Trough	SS316L	Width :0.60 (m)×Height :0.60(m)×Length: Approx.4.00(m) × 20 (no./basin)	- 36
3) Inflow Gates	Electric operated Cast Iron	Width 0.60(m)×Height :0.60(m)	0.75 36W
4) Wash Waste Gates	Electric operated Cast Iron	Width 1.00(m)×Height :1.40(m)	1.50 36W
5) Backwash Valve	Electric Operated Cast Iron	Butterfly valve, Dia. 1,000(mm)×PN 10	1.50 36W
6) Backwash Slow-down Valve	Electric Operated Cast Iron	Butterfly valve, Dia. 1,000(mm)×PN 10	1.50 2W
7) Outflow Valve	Electric Operated Cast Iron	Butterfly valve, Dia. 600(mm)×PN 10	0.40 36W

Items	Specification	kW per unit	Unit Number
8) Rinse Valve	Electric Operated Cast Iron Butterfly valve, Dia. 600(mm)×PN 10	0.40	36W
9) Surface Wash Valve	Electric Operated Cast Iron Butterfly valve, Dia. 0.60(m)×PN 10	0.40	36W
10) Drain Valve	Electric Operated Cast Iron Sluce valve, Dia. 200 (mm)×PN 10	0.40	36W
11) Sampling Pumps for filtered water	Monobloc Cast Iron Dia. :25 (mm)×Discharge:2(m ³ /h)×Total Head:10.0 (m)	0.40	72W
12) Sampling Pumps for bypass channel	Monobloc Cast Iron Dia. :25 (mm)×Discharge:2(m ³ /h)×Total Head:20.0 (m)	0.40	2W
13) Sampling Pumps for filter outlet	Monobloc Cast Iron Dia. :25 (mm)×Discharge:2(m ³ /h)×Total Head:20.0 (m)	0.40	2W
14) Sampling Pumps for CWR	Monobloc Cast Iron Dia. :25 (mm)×Discharge:4(m ³ /h)×Total Head:35.0 (m)	1.50	2W
15) Electric Hoist	I-girder Overhead Type Rated Load :1.0(Ton)×Lift :6(m)	3.90	1W
16) Drainage Pumps	Submersible Cast Iron Dia. :50 (mm)×Discharge:8(m ³ /h)×Total Head:15.0 (m)	1.50	6W
6. Clear Water Reservoir			
7-1. Backwash Water Recovery Tank			
1) Backwash Water Pumps	Submersible Cast Iron Dia. :350 (mm)×Discharge:850(m ³ /h)×Total Head:15.0 (m)	75.00	4W+2S
2) Backwash Sludge Pumps	Submersible Cast Iron Dia. :100 (mm)×Discharge:85 (m ³ /h)×Total Head:10.0 (m)	7.50	2W+2S
3) Electric Hoist	I-girder Overhead Type Rated Load :3.0(Ton)×Lift :6(m)	7.80	1W
7-2. Sludge balancing Tank			
1) Thickener Feed Pumps	Submersible Cast Iron Dia. :250 (mm)×Discharge:500(m ³ /h)×Total Head:15.0 (m)	45.00	4W+2S
2) Mixers for Sludge Balancing Tank	Submersible SS316 Tank Width : 15.00(m)×Length:24.00(m)×SWD:4.0 0(m)	13.00	2W
3) Electric Hoist	I-girder Overhead Type Rated Load :3.0(Ton)×Lift :6(m)	7.80	1W
7-3. Primary Sludge Thickener			
1) Sludge Thickener	Bridge-supported MS+ Galvanized Dia. :26.0 (m)×SWD:4.0(m)	2.20	4W
2) Thickened Sludge Pumps	Progress cavity Cast Iron Dia. :150 (mm)×Discharge:60(m ³ /h)×Total Head:15.0 (m)	15.00	4W+2S
7-4. Secondary Sludge Thickener			
1) Sludge Thickener	Bridge-supported MS+ Galvanized Dia. :26.0 (m)×SWD:4.0(m)	2.20	1W
2) Thickened Sludge Pumps	Progress cavity Cast Iron Dia. :150 (mm)×Discharge:60(m ³ /h)×Total Head:15.0 (m)	15.00	2W+1S

Items	Specification	kW per unit	Unit Number
7-5. Supernatant Tank			
1) Supernatant Transfer Pumps	Submersible Cast Iron Dia. :250 (mm)×Discharge:400(m ³ /h)×Total Head:15.0 (m)	37.00	4W+2S
8. Centrifuge Building			
1) Mixers for Thickened Sludge Storage Tank	Submersible SS316 Tank Width : 6.00(m)×Length:12.00(m)×SWD:4.00(m)	7.50	2W
2) Centrifuge Feed Pumps	Progress Cavity Cast Iron Dia. :150 (mm)×Discharge:15-45(m ³ /h)×Total Head:20.0 (m)	15.00	4W+1S
3) Centrifuge Inlet Valve	Electric Operated Cast Iron Sluice valve, Dia. 100(mm)×PN 10	1.50	4W+1S
4) Centrifuges	Centrifuge SS316 Capacity:30(m ³ /h)	66.00	4W+1S
5) Belt Conveyor	Nylon fabric 3ply Belt Width :0.60(m)×Length :30.00 (m)	2.20	2W
6) Electric Hoist Crane	Single-girder Overhead Type Rated Load :5.0(Ton)×Lift :6(m)	17.10	1W
7) Mixers for Polyelectrolyte Solution	Agitator SS316 Tank Dia.: 2.70(m)×SWD:3.50(m)	7.50	4W
8) Polyelectrolyte Dosing Pumps	Progressive Cavity Pump Dia.: 50(mm)×Discharge :3.9(m ³ /h)×Total Head:20.0 (m)	1.5	4W+1S
9. Chemical Building			
1) Alum Mixing Blowers	Rotary blower Tri-lobe Type Dia. :100 (mm)× Air Flow :650(m ³ /h) ×Pressure: 40 (K Pa)	15.00	2W+1S
2) Alum Transfer Pumps	Horizontal SS Dia. :50 (mm)×Discharge:16(m ³ /h)×Total Head:20.0 (m)	2.20	2W+1S
3) Alum Dosing Pumps	Diaphragm Pump PVC Dia.:65 (mm)×Discharge :8000(L/h)× Pressure:0.3(MPa)	4.50 VFD	4W+4S
4) Drainage Pumps	Submersible Cast Iron Dia. :50 (mm)×Discharge:5(m ³ /h)×Total Head:10.0 (m)	0.75	1W+1S
10. Chlorine Building			
1) Pre-Chlorinator	Vacuum gas Type Capacity:41(m ³ /h)	1.00	4W+1S
2) Pre-Chlorine Booster Pumps	Horizontal Cast Iron Dia. :80 (mm)×Discharge:45(m ³ /h)×Total Head:35.0 (m)	11.00	4W+1S
3) Post-Chlorinator	Vacuum gas Type Capacity:41(m ³ /h)	1.00	4W+1S
4) Post-Chlorine Booster Pumps	Horizontal Cast Iron Dia. :80 (mm)×Discharge:45(m ³ /h)×Total Head:35.0 (m)	11.00	4W+1S
5) Chlorine Ton-ners	Volume:900(kg/Unit)	-	108
6) Drainage Pumps	Submersible Cast Iron Dia. :50 (mm)×Discharge:8(m ³ /h)×Total Head:15.0 (m)	1.50	1W+1S
7) Crane	Single-girder Overhead Type Rated Load :3.0(Ton)×Lift :6(m)	8.60	1W

Items	Specification	kW per unit	Unit Number
8) Neutralization Scrubber System	Wet Scrubber Capacity: 3,500m ³ (1,000kg-Cl ₂ /h) GRP	14.00	1W
9) Neutralization Pit Pumps	Horizontal PP Dia. :40 (mm)×Discharge:11(m ³ /h)×Total Head:15.0 (m)	1.50	1W+1S
11. Filter Annex Building			
1) Discharge Valve	Electric Operated Cast Iron Sluice valve, Dia. 300(mm)×PN 10	0.40	36W
2) Backwash Water Transfer Pumps	Horizontal Cast Iron Dia. :350 (mm)×Discharge:850(m ³ /h)×Total Head:20.0 (m)	75.0	4W+2S
3) Surface Wash Pumps	Horizontal Cast Iron Dia. :250 (mm)×Discharge:430(m ³ /h)×Total Head:30.0 (m)	60.0	8W+4S
4) Discharge Valve	Electric Operated Cast Iron Sluice valve, Dia. 400(mm)×PN 10	0.40	36W
5) Crane	Single-girder Overhead Type Rated Load :5.0 (Ton)×Lift :6(m)	17.10	1W
12. Electrical Switch Yard			
13. Electrical Sub Station			
(Electrical)			
1. Power receiving facilities at electrical substation	HV incoming panel: IP52, 11kV, VCB HV outgoing feeder panels, IP52, 11kV, VCB Power transformers: outdoor use, 11/0.415-0.24 kV,2000 kVA Diesel engine generator set: 415 V, 50 Hz, 500 kVA		1pc 1pc 2pcs 1pc
2. LV incoming panel, LV switchgears, and MCCs	LV incoming panels: IP52, 600V, ACB LV feeder panels: IP52, 600V MCC for Flash Mixer MCC for Flocculation MCC for Rapid Sand Filter MCC for Chemical MCC for Chlorination MCC for Sludge Thickener MCC for Centrifuge		1pc 1pc 1pc 1pc 1pc 1pc 1pc 1pc 1pc

Items	Specification	kW per unit	Unit Number
3. Instrumentation devices	Inlet flow meter		2pcs
	Electromagnetic flow meter for Surface Wash		2pcs
	Electromagnetic flow meter for Backwash water filling		2pcs
	Electromagnetic flow meter for Backwash water service		2pcs
	Electromagnetic flow meter for Pre/Post Chlorination		2pcs
	Electromagnetic flow meter for Service water		1pc
	Electromagnetic flow meter for treated water		1pc
	Electromagnetic flow meter for backwash return water		2pcs
	Electromagnetic flow meter for Thickener feed sludge		2pcs
	Electromagnetic flow meter for thickened sludge		3pcs
	Electromagnetic flow meter for Centrifuge feed sludge		5pcs
	Electromagnetic flow meter for Centrifuge feed polymer		5pcs
	Electromagnetic flow meter for Supernatant return water		4pcs
	Electromagnetic flow meter for Alum dosing		4pcs
	Level meter in Rapid Sand Filter		36pcs
	Level meter in Backwash Water Filling Sump		2pcs
	Level meter in Overhead Backwash Tank		2pcs
	Level meter in Alum Solution Preparation Tank		12pcs
	Level meter in Alum Solution Tank		2pcs
	Level meter in Polymer Solution Tank		4pcs
	Level meter in Thickened Sludge Tank		2pcs
	Level meter in Supernatant Tank		1pc
	Level meter in Backwash Water Recovery Tank		2pcs
	Level meter in Sludge Balancing Tank		2pcs
	Alum Mixing Blower flow meters		2pcs
	Pressure Switch for Pre/Post Chlorination		24pcs
	Turbidity analyzers		4pcs
	Residual chlorine analyzer		4pcs
	pH analyzer		4pcs
	Chlorine gas indicator		4pcs
Chlorine tonner weight indicator		14pcs	

Source: JICA Survey Team

12.1.2 Transmission and Pumping Facilities

(1) Design Fundamentals and Common Items

1) Typical Pump House Structure

The pump house shall be made of RC (reinforced concrete). 12 pumps (8 Working + 4 Stand-by) are planned in the DPR for each transmission Pumping Station. However, in view of economical and convenient O&M of the facilities, the number of pumps is recommended to be nine (9) units in a total (6 W + 3 S). The dimension of the pump house is almost same as that in the DPR as design water flow is same. The typical drawings for plan and section of pump house is shown in Figure 12.1.10 and Figure 12.1.11.

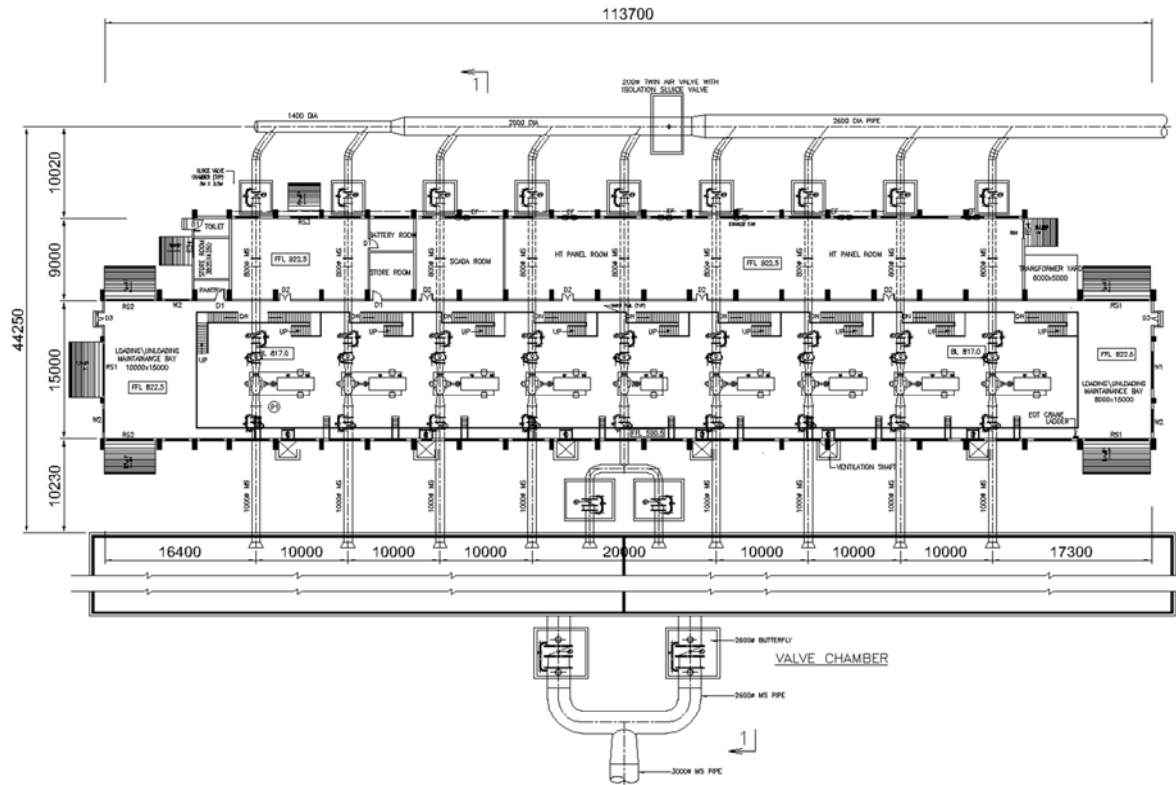

Source: JICA Survey Team

Figure 12.1.10 Typical Plan of Pump House

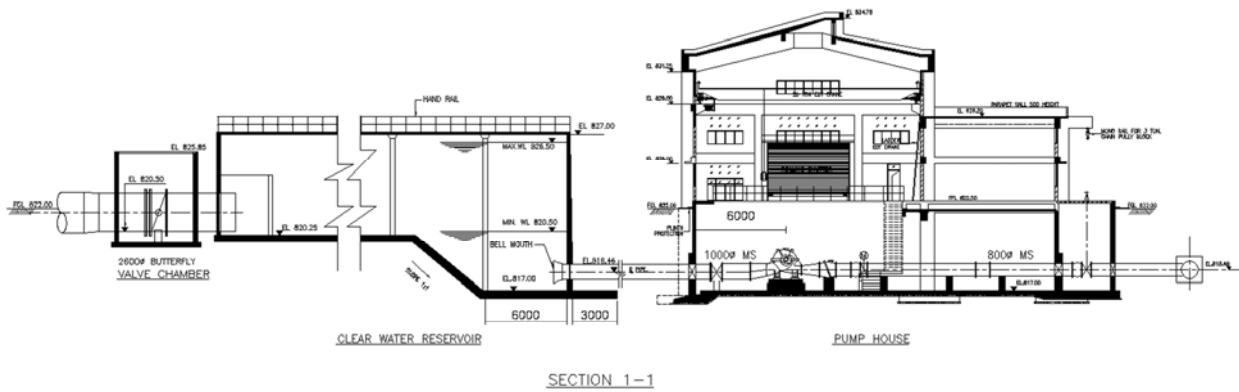

Source: JICA Survey Team

Figure 12.1.11 Typical Section of Pump House

2) Clear Water Reservoir Structure

The typical drawings for plan and section of clear water reservoir is shown in Figure 12.1.12 and Figure 12.1.13.

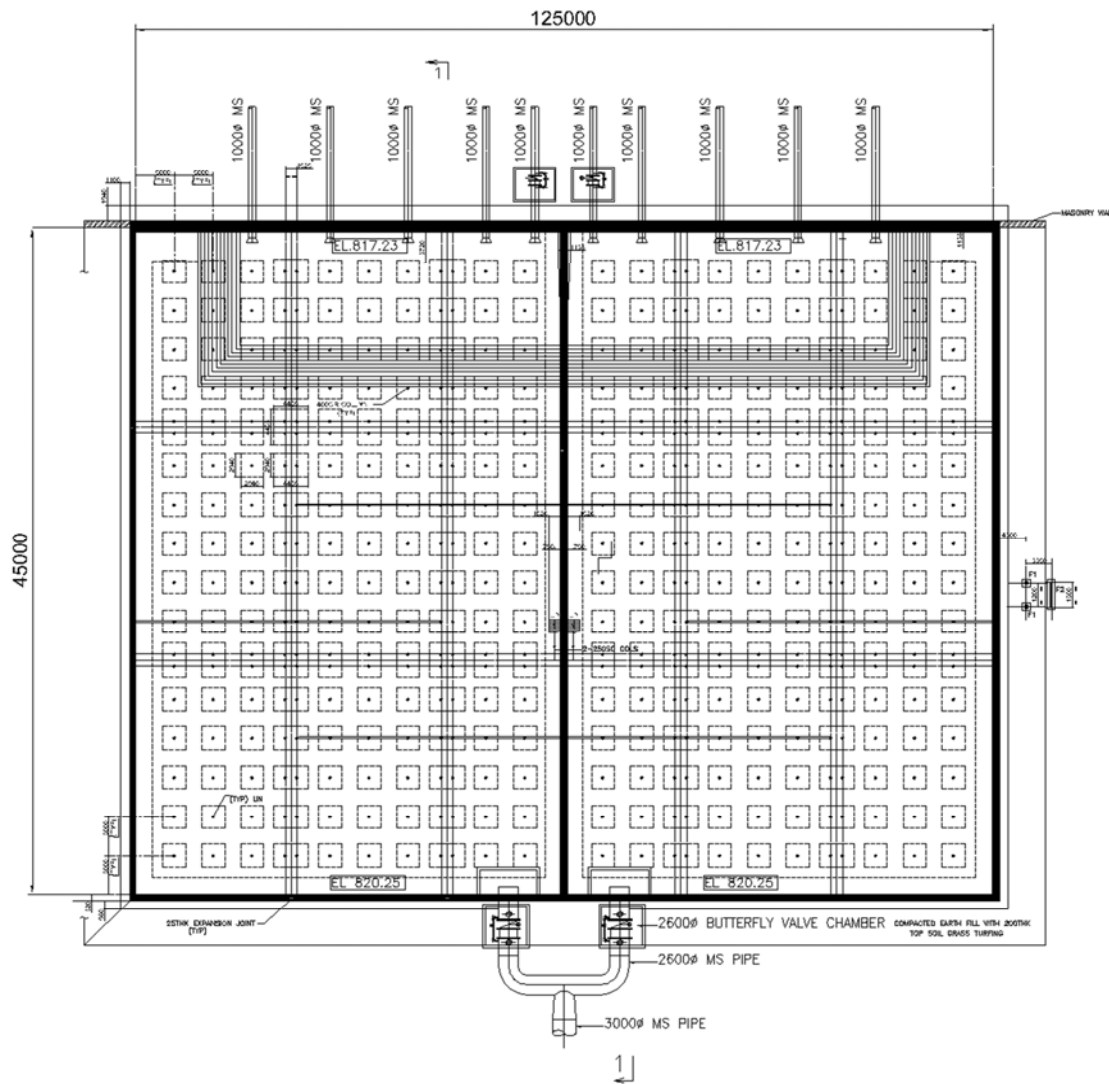

Source: JICA Survey Team

Figure 12.1.12 Typical Plan of Clear Water Reservoir

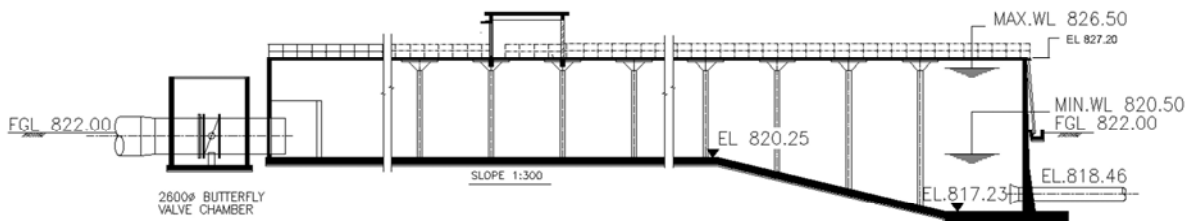

Source: JICA Survey Team

Figure 12.1.13 Typical Section of Clear Water Reservoir

3) Water Hammer Countermeasures

Air vessels are mechanical devices installed on the pipelines to remove accumulated air and admit air

into the system. It comes in the form of compressor vessels accumulators and vessels with a vent pipe. In the preliminary design, air vessels are chosen as the countermeasure against water hammer and the typical air vessels are shown in Figure 12.1.14.

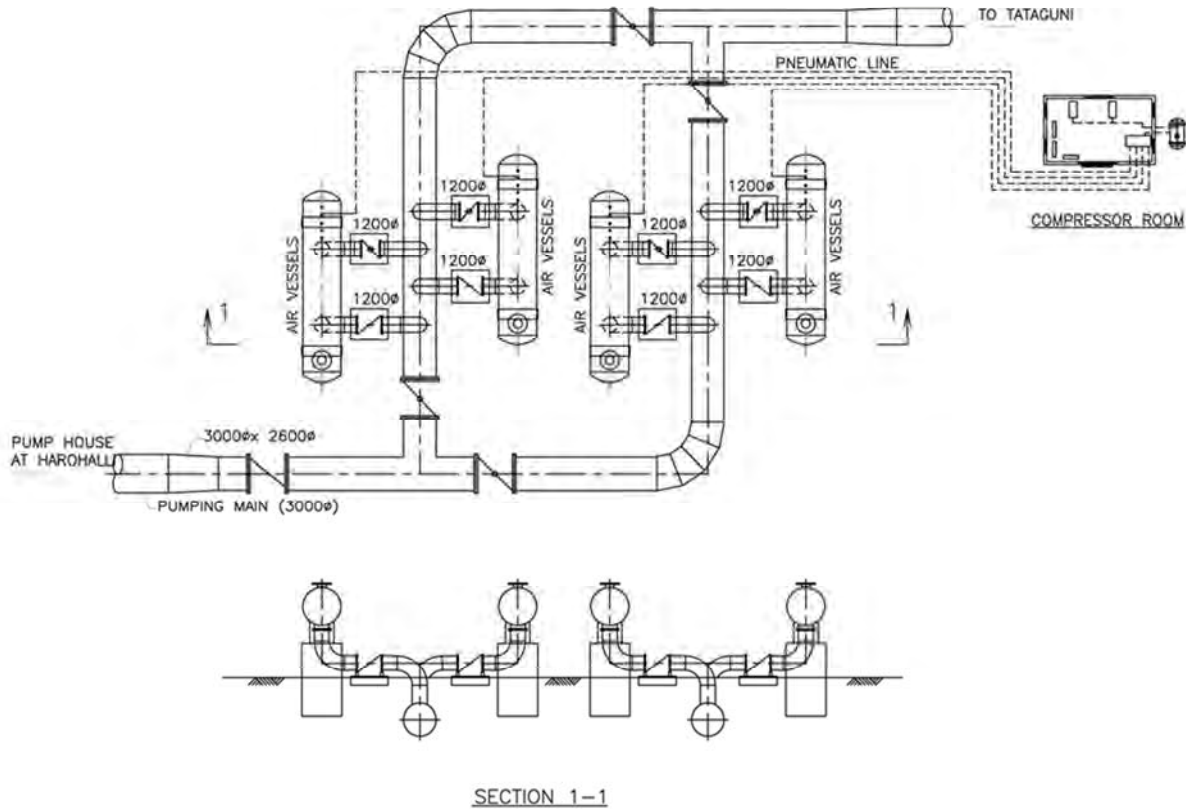

Source: JICA Survey Team

Figure 12.1.14 Typical Air Vessels

4) Flow Meters

Multi-path/multi-beam type Ultrasonic flow meters insertion type, flight on type or clamp on type shall be provided with meter rooms. Flow meters will be provided on raw water pipeline inlet as well as outlet of three (3) pumping stations at TK Halli, Harohalli and Tataguni.

(2) TK Halli Pumping Station

Specifications for major facilities of TK Halli Pumping Station are shown in Table 12.1.15 and the layout is referred to Figure 12.1.8.

Table 12.1.15 Specifications for Major Equipment at TK Halli

Items	Specification		kW per unit	Unit number
1. Clear Water Reservoir				
Inlet Valve	Electric Operated Cast Iron	Butterfly Valve, Dia. 2,600 (mm)×PN 10	1.50	2W
2. Pumping Station				
CW Pumps	Horizontal Cast Iron	Dia. :800(mm)×500(mm) ×Discharge:5,390 (m ³ /h)×Total Head:130.0 (m)	2700 (11kV)	6W+3S
Common Suction Valve	Electric Operated Cast Iron	Butterfly Valve, Dia. 1,700(mm)×PN 10	0.75	2
Suction Valve	Manually Operated Cast Iron	Sluice Valve, Dia. 1,000(mm)×PN 10	-	9W
Non-return Valve	Multi door type Cast Iron	Swing Check Valve, Dia. 800(mm)×PN 24	-	9W
Discharge Valve	Electric Operated Cast Iron	Butterfly Valve, Dia. 800(mm)×PN 24	0.75	9W
Discharge Valve	Manually Operated Cast Iron	Sluice Valve, Dia. 800(mm)×PN 24	-	9W
Discharge Valve	Electric Operated Cast Iron	Butterfly Valve, Dia. 2,600(mm)×PN 24	1.50	1W
Discharge Valve	Electric Operated Cast Iron	Butterfly Valve, Dia. 3,000(mm)×PN 24	3.70	1W
Crane	Double-girder Overhead Type	Rated Load :20.0(Ton)×Lift :10(m)	22.00	1W
Electric Hoist	I-girder Overhead Type	Rated Load :3.0(Ton)×Lift :10(m)	7.80	1W
Drainage Pumps	Submersible Cast Iron	Dia. :65(mm)×Discharge:20(m ³ /h) ×Total Head:10.0 (m)	2.20	1W+1S
Service Water Pumps	Monobloc Cast Iron	Dia. :25(mm)×Discharge:5(m ³ /h) ×Total Head:20.0 (m)	0.75	2W+2S
3. Surge Protection System				
Air Vessel	Horizontal Boiler Quality Steel	Capacity: 100(m ³)	-	9
Air Receiver	Horizontal Boiler Quality Steel	Capacity: 50(m ³)	-	1
Reciprocating Air Compressors	Water cooled type	Discharge :6.0 (m ³ /min)×Pressure :2.0 (MPa)	150.00	2W

Note: W: working, S: standby Source: JICA Survey Team

(3) Harohalli Pumping Station

Specifications for major facilities of Harohalli Pumping Station are shown in Table 12.1.16 and the layout plan is shown in Figure 12.1.15.

Table 12.1.16 Specifications for Major Equipment at Harohalli

W: working, S: standby

Items	Specification		kW per unit	Unit number
1. Clear Water Reservoir				
Inlet Valve	Electric Operated Cast Iron	Butterfly Valve, Dia. 2,600(mm)×PN 10	1.50	2W
2. Pumping Station				
CW Pumps	Horizontal Cast Iron	Dia. :800(mm)×500(mm) ×Discharge:5,390(m ³ /h)×Total Head:152.0 (m)	3,300 (11kV)	6W+3S
Common Suction Valve	Electric Operated Cast Iron	Butterfly Valve, Dia. 1700(mm)×PN 10	0.75	2
Suction Valve	Manually Operated Cast Iron	Sluice Valve, Dia. 1,000(mm)×PN 10	-	9W
Non-return Valve	Multi door type Cast Iron	Swing Check Valve, Dia. 800(mm)×PN 24	-	9W
Discharge Valve	Electric Operated Cast Iron	Butterfly Valve, Dia. 800(mm)×PN 24	0.75	9W
Discharge Valve	Manually Operated Cast Iron	Sluice Valve, Dia. 800(mm)×PN 24	-	9W
Discharge Valve	Electric Operated Cast Iron	Butterfly Valve, Dia. 2,600(mm)×PN 24	1.50	1W
Discharge Valve	Electric Operated Cast Iron	Butterfly Valve, Dia. 3,000(mm)×PN 24	3.70	1W
Crane	Double-girder Overhead Type	Rated Load :20.0(Ton)×Lift :10(m)	22.00	1W
Electric Hoist	I-girder Overhead Type	Rated Load :3.0(Ton)×Lift :10(m)	7.80	1W
Drainage Pumps	Submersible Cast Iron	Dia. :65(mm)×Discharge:20(m ³ /h) ×Total Head:10.0 (m)	2.20	1W+1S
Service Water Pumps	Monobloc Cast Iron	Dia. :25(mm)×Discharge:5(m ³ /h) ×Total Head:20.0 (m)	0.75	2W+2S
3. Surge Protection System				
Air Vessel	Horizontal Boiler Quality Steel	Capacity: 100(m ³)	-	4
Air Receiver	Horizontal Boiler Quality Steel	Capacity: 50(m ³)	-	1
Reciprocating Air Compressors	Water cooled type	Discharge :6.0 (m ³ /min)×Pressure :2.0 (MPa)	150.00	2W

Source: JICA Survey Team

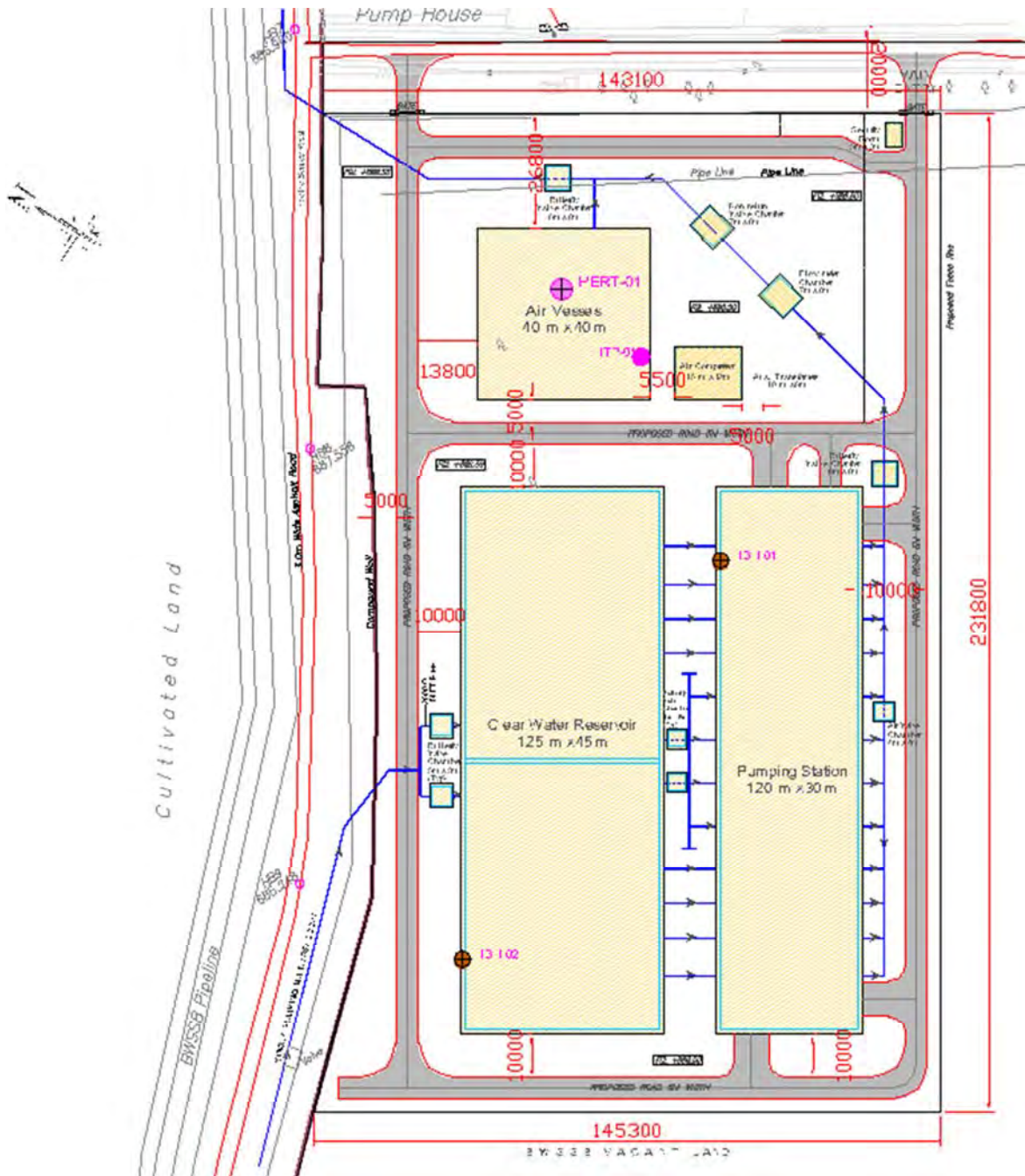

Source: JICA Survey Team

Figure 12.1.15 Layout Plan of Harohalli Pumping Station and Clear Water Reservoir

(4) Tataguni Pumping Station

Specifications for major facilities of Tataguni Pumping Station are shown in Table 12.1.17 and the layout plan is shown in Figure 12.1.16.

Table 12.1.17 Specifications for Major Equipment at Tataguni

Items	Specification		kW per unit	Unit number
1. Clear Water Reservoir				
Inlet Valve	Electric Operated Cast Iron	Butterfly Valve, Dia. 2,600(mm)×PN 10	1.50	2W
2. Pumping Station				
CW Pumps	Horizontal Cast Iron	Dia. :800(mm)×500(mm) ×Discharge:5,390(m ³ /h)×Total Head:150.0 (m)	3,400 (11kV)	6W+3S
Common Suction Valve	Electric Operated Cast Iron	Butterfly Valve, Dia. 1,700(mm)×PN 10	0.75	2
Suction Valve	Manually Operated Cast Iron	Sluice Valve, Dia. 1,000(mm)×PN 10	-	9W
Non-return Valve	Multi door type Cast Iron	Swing Check Valve, Dia. 800(mm)×PN 24	-	9W
Discharge Valve	Electric Operated Cast Iron	Butterfly Valve, Dia. 800(mm)×PN 24	0.75	9W
Discharge Valve	Manually Operated Cast Iron	Sluice Valve, Dia. 800(mm)×PN 24	-	9W
Discharge Valve	Electric Operated Cast Iron	Butterfly Valve, Dia. 2,600(mm)×PN 24	1.50	1W
Discharge Valve	Electric Operated Cast Iron	Butterfly Valve, Dia. 3,000(mm)×PN 24	3.70	1W
Crane	Double-girder Overhead Type	Rated Load :20.0(Ton)×Lift :10(m)	22.00	1W
Electric Hoist	I-girder Overhead Type	Rated Load :3.0(Ton)×Lift :10(m)	7.80	1W
Drainage Pumps	Submersible Cast Iron	Dia. :65(mm)×Discharge:20(m ³ /h) ×Total Head:10.0 (m)	2.20	1W+1S
Service Water Pumps	Monobloc Cast Iron	Dia. :25(mm)×Discharge:5(m ³ /h) ×Total Head:20.0 (m)	0.75	2W+2S
3. Surge Protection System				
Air Vessel	Horizontal Boiler Quality Steel	Capacity: 100(m ³)	-	11
Air Receiver	Horizontal Boiler Quality Steel	Capacity: 50(m ³)	-	1
Reciprocating Air Compressors	Water cooled type	Discharge :6.0 (m ³ /min)×Pressure :2.0 (MPa)	150.00	2W

Note: W: working, S: standby

Source: JICA Survey Team

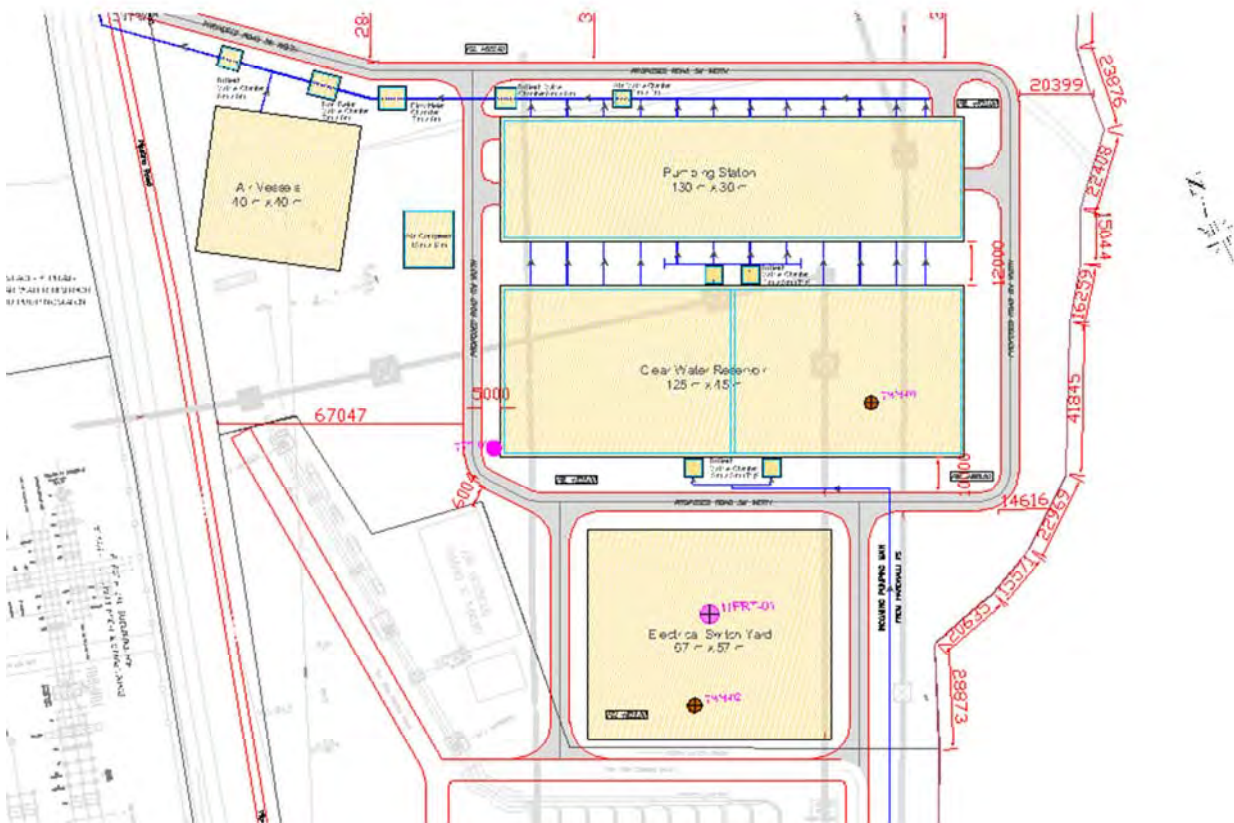

Source: JICA Survey Team

Figure 12.1.16 Plan of Tataguni Pumping Station and Clear Water Reservoir

(5) Connection Pipe and Branch Pipe in Tataguni Complex

In this preliminary design, two (2) Branch Feeding Pipelines (see 11.4.2) are considered for sharing water of CWSS Stage V to Core and ULB areas. As Pumping Stations in Tataguni complex are the final pumping facilities on the transmission pipelines, a connecting pipe and branch pipelines are considered from the view point of risk management to connect CWRs of all stages in Tataguni complex for emergency accidents somehow like malfunction of TK Halli or Harohalli PS in different stages. Here, the connection pipe is the main pipe to the area of other CWRs in Tataguni complex and branch pipes are to connect the connection pipe and CWRs. The connectivity of connection pipe and branch pipes is shown in Figure 12.1.17 and Table 12.1.18.

Table 12.1.18 Length of Diversion Pipe (Connection Pipe and Branch Pipe)

Connection Pipe		Branch Pipe	
Diameter (mm)	Length (m)	Diameter (mm)	Length (m)
1900	400	1500	90

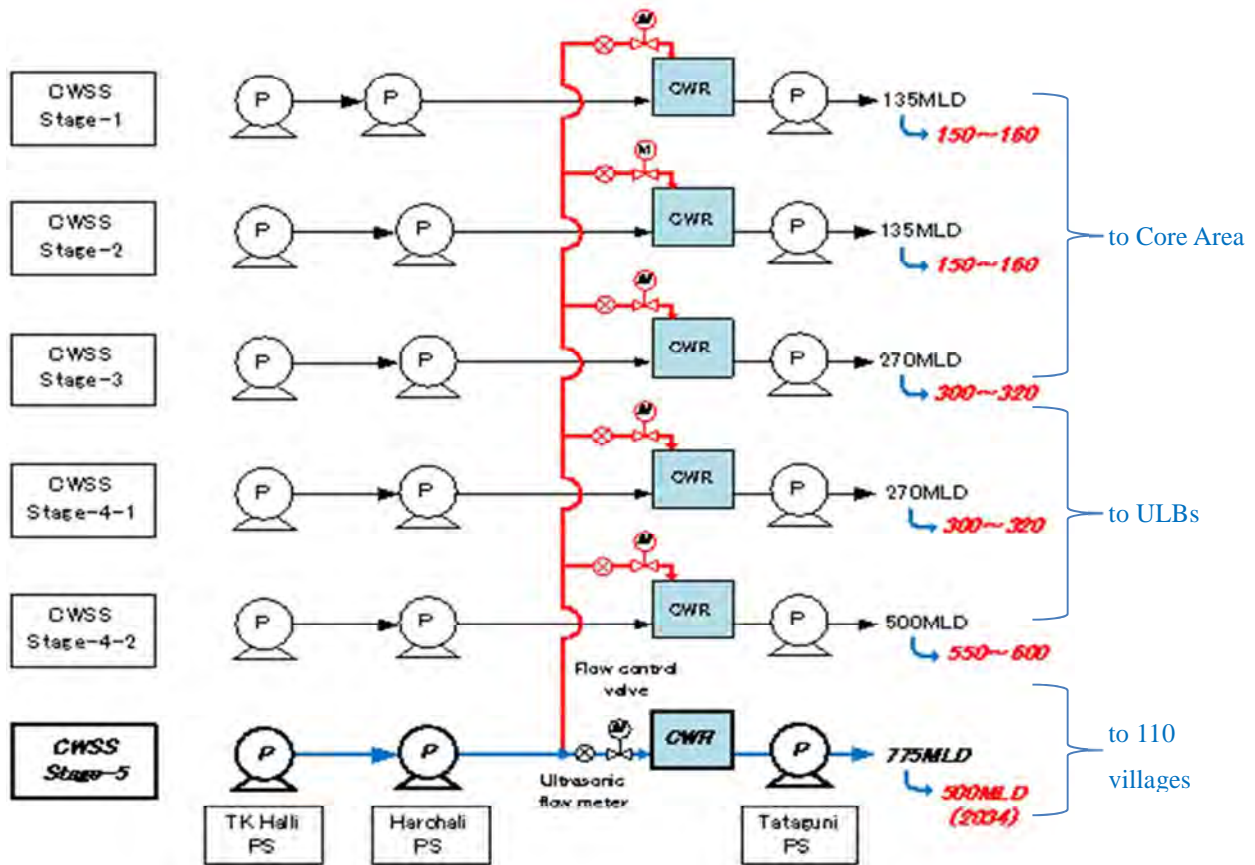
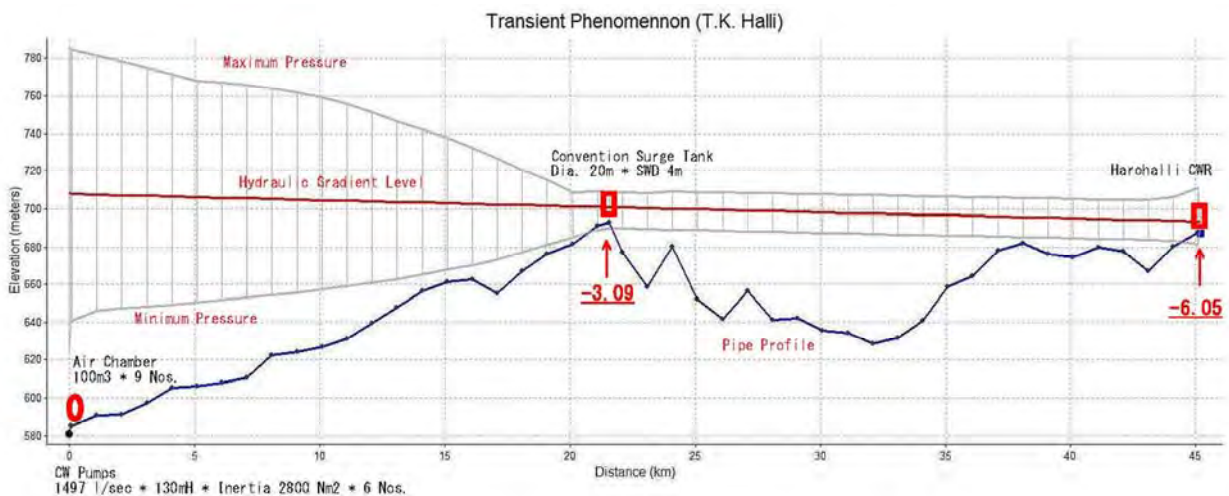

Figure 12.1.17 Arrangement of Diverting Water among Existing Stages and Proposed Stage V

(6) JK Doddi Surge Tank

Preliminary surge analysis result is shown in Figure 12.1.18, which indicates that conventional surge tank of 20 m diameter and 7 m depth at JK Doddi is necessary in addition to air chamber at TK Halli. Specifications of surge tank are shown in Table 12.1.19 and the layout plan is shown in Figure 12.1.19.



Source: JICA Survey Team

Figure 12.1.18 Surge Analysis from TK Halli to Harohalli

Table 12.1.19 Specifications of Surge Tank at JK Doddi

Item	Contents
Dimension	Dia. 20 m x D 7.0 m (V=2200m ³) Bottom GL-1.600
Water Level	HWL EL+705.700 Bottom EL+698.700

Source: JICA Survey Team

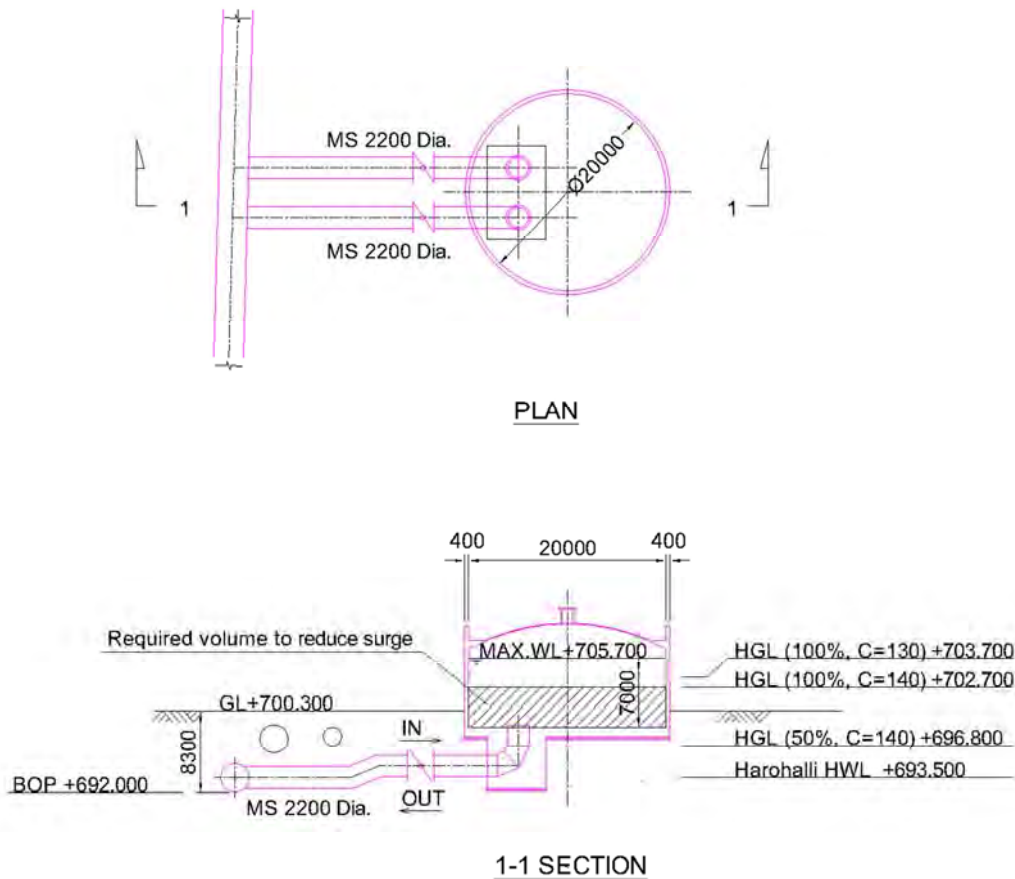

Source: JICA Survey Team

Figure 12.1.19 Plan and Section of Surge Tank at JK Doddi

12.1.3 Transmission Pipeline

(1) Design Fundamentals

It is proposed that the conveyance pipeline for Stage V system shall be laid between service road and the existing Stage IV, Phase-2 pipeline.

The transmission pipeline from TK Halli to Vajarahalli junction (City entry) shall be laid between service road and the existing Stage IV, Phase 2 pipeline. The pipeline may require to lay under the service road only in Kanakapura town stretch. For the stretch of pipeline within Kanakapura town, an alternative route can be studied during detail engineering stage. In general, it is proposed that the pipeline will be

buried with a minimum cover of 1.20 m from the existing ground level. However, there may be places where it will be inappropriate to provide a buried pipeline in case of inaccessibility and in those locations where a pipeline above ground will be adopted.

In view of the above, the design of transmission pipeline shall consider two categories

- i. Pipe under the ground and
- ii. Pipe on the ground:
 - ⇒ Over saddle or
 - ⇒ Over Bridges

The design considerations and criteria in the DPR is summarized in Table 12.1.20.

Table 12.1.20 Design Considerations and Criteria in the DPR

Item	Contents
Pipe below Ground	The following loads shall be considered. <ol style="list-style-type: none"> a) The externally applied, vertically acting gravitational loads caused by the fill and surface surcharges b) Fluid pressure applied either externally or internally or both. Internal pressure shall include water hammer effects/surge pressures.
Pipe above Ground	The transmission pipeline above ground or on river crossings shall be supported either on concrete saddle or with ring girders again supported on concrete bases (bridge). In general forces due to gravitational component of pipelines laid on slopes, thermal stresses, provision of expansion joints etc. shall be considered.
Design Criteria	Following parameters and codes form a part of the design criteria <ol style="list-style-type: none"> a) Pipe material to IS 2062 Gr.B Fe410 / IS 10748, Grade III or equivalent b) Manufacturing tolerance – Positive tolerance as per IS 1852 - Negative tolerance - Nil c) Modulus of soil reaction (E') is considered as for initial design. d) Pipe laying as per IS 5822 and in line with AWWA M11 norms/recommendation e) Internal epoxy lining of 0.5 mm thickness and 30 mm external guniting. f) Corrosion allowance – Nil No allowance in pipe wall thickness for corrosion is anticipated since transmission pipeline will be designed for standard coating and lining material, the required level of corrosion protection can be obtained (As per AWWA M11).
Internal Pressure	IS 5822: 1986 states that the internal design pressure shall not be less than the maximum pressure to which the pipe line is likely to be subjected including allowance for surge pressure. AWWA manual M11 mentions that internal design pressure should be that to which a pipe line is subjected to a long period, including surge or water hammer effects. In the present study the internal design pressure shall be considered 1.5 times the working pressure. It is proposed that under critical surge conditions, the maximum pressure in the system will be restricted to below 1.5 times the working pressure at the location of maximum head.
Field Test Pressure	Considering the provisions of IS 5822, IS 1916: 1989, IS 3589: 1991 it is recommended that the field test pressure be limited to 1.5 times the working pressure at the point of max head.
Hydraulic test pres-	Each fabricated pipe shell shall be tested to the test pressures indicated in IS 1916: 1989 i.e.,

Item	Contents
sure at Shop/ Manufacturing Mill	1.5 times of maximum working pressure in the pipeline.
Deflection Criteria	As internal epoxy lining and external guniting are proposed the deflection shall be limited to 2% of pipe diameter.
Buried Pipeline	<p>BWSSB have indicated to have preferably buried pipeline. It is therefore recommended that most of the pipeline will be embedded in ground with minimum depth of overburden as 1.20 meters.</p> <p>The wall thickness of buried steel pipe will be governed by, in addition to internal pressures, external pressures such as</p> <ol style="list-style-type: none"> Earth pressure due to backfill Uniform collapse pressure Super imposed concentrated or distributed line loads of vehicles at road crossings Buoyancy forces on empty pipelines Handling stresses Sub-soil water pressure
Above Ground Pipe Lines	<p>Above ground sections of the pipeline will be limited to areas where special considerations apply e.g., presence of outcrop, river crossings, water logged areas and at cross drainage works. The wall thickness of pipe will be governed by not only internal pressures but also on following special physical loadings.</p> <ol style="list-style-type: none"> Pipe on saddle supports Pipe on ring girder supports Handling stresses Wind and earthquake forces Stresses due to thermal movement Frictional forces at supports Gravitational component of pipe laid on slopes
Permissible Stresses	<p>The permissible stresses in the pipe shall be related to yield stress (f_y) of pipe material (MS) making due allowance for weld efficiency of joints.</p> <p>For above ground pipelines following allowable stresses shall be adopted.</p> <ol style="list-style-type: none"> Working stress for combined bending and direct tensile stress shall not exceed 60% of yield stress of the material making due allowance for efficiency of welded joint. Welding stress for combined bending and direct compressive stress shall not exceed 50% of yield stress of the material making due allowance for weld efficiency. Buckling stress shall be based on Timoshenko's equation with a safety factor of 2.0. <p>The design of buried pipelines shall be based on guidelines given in American Water Works Association (AWWA) manual M11.</p>
Pipeline Structural Design	<p>Based on the guidelines given in AWWA manual M11 for buried pipelines designs carried out.</p> <p>From the initial design it is observed that direct tension and buckling stresses are within limits for all diameters and pipe wall thicknesses considered for various depth of overburden. The deflections are within allowable limits for normal depth of overburden of about 2 to 3 m. However the deflection can be limited by selecting higher shell thickness of pipe or encasement pipe in a particular reach. This shall be decided at the detail engineering stage.</p>
Line Valves	<p>Line valves are provided to isolate and regulate the flow during normal and emergency conditions. The spacing of the line valves along a pipeline depends upon topography and operational flexibility required.</p> <p>Manual on Water Supply and Treatment, CPHEEO mentions isolating valves are to be in-</p>

Item	Contents
	<p>stalled at intervals of 1 to 5 km. Indian Standard IS 5822 provides the following guidelines for installing isolating valves</p> <ul style="list-style-type: none"> a) At the beginning and at the end of the pipeline; b) For long pipelines, isolating valves should be provided at intervals not exceeding 6 km; and c) On the either side of major crossing <p>Butterfly Valves (BFV)</p> <p>For large diameter pipes rubber seated Butterfly valves are used to regulate and isolate the flow. They are cheaper than sluice valves for larger sizes and occupy less space and hence there is reduction in valve cistern size also. Since Butterfly valves are not having any sliding parts they are relatively easy to operate. The head loss coefficient under valve fully open condition is about 0.3 for Butterfly valve.</p> <p>Total nineteen (19) numbers of butterfly valves of size 2500 mm (PN 16) are proposed for clear water transmission pipeline from TK Halli to Vajarahalli.</p>
Air valves	<p>The principal reasons for incorporating air valves (admission/release) at peak points and at significant changes in slope in a pipeline system are ventilation and the partial control of hydraulic transients.</p> <p>The ventilation requirements are a) expulsion of air when filling the system; b) admission of air when draining the system and c) slow release of air during normal operation. The partial control of hydraulic transients with air valves are usually affected due to a) the admission of air at critical points and b) the very slow release of the entrapped air. However for the design of surge protection system it is assumed that all air valves are nonfunctional.</p> <p>The total number of air valves estimated for clear water transmission pipeline is about one hundred fifty (150). However, the actual number and location and size of air valves will be decided during detailed engineering. Pressure rating is PN 16 for clear water pumping main. Air valve size is proposed as 200 mm. Every alternative location twin air valves (each 200 mm) is proposed.</p>
Scour valves	<p>Scour valves are provided in a pipeline system at low points, facilitating draining of pipeline. The discharge generally will be disposed into a nearby natural stream/valley. The exact locations of scour valves are often influenced by opportunities to dispose the water. The size depends upon the time in which given section of the line is designed to be emptied and the resulting velocity considerations. Proposed scour valve size for pumping main is 600 mm (PN 16 rating). The actual number, location and size of scour valves for will be decided at the time of detailed engineering.</p>

Based on design criteria, the pipe wall thickness and pump head for three different reaches are calculated. The details of water transmission pipelines are presented in Table 12.1.21.

Table 12.1.21 Details of Clear Water Transmission Pipelines

Section	Diameter (mm)	Thickness (mm)
TK Halli to Harohalli	3000	18
Harohalli to Tataguni	3000	20/18

Source: JICA Survey Team

(2) TK Halli to Harohalli

The water transmission pipeline (MS pipe) from TK Halli to Harohalli will be about 43.9 km long with a diameter of 3,000 mm. The significant high point in this stretch is the JK Doddi peak at about 21 km chainage with the ground elevation at around 700 m. In order to avoid the water column separation at this high point due to pumps tripping at TK Halli and to avoid unnecessary accumulation of air, a gravity feeder tank (GFT) and one-way surge tank (OST) were constructed for Stage I, and Stages II, III and IV, respectively.

The transmission pipelines for Stages I, II, III & IV Phase 1 & 2 are running in parallel in the section of the upstream of the JK Doddi peak. The Stage III and IV Phase 1 & 2 transmission pipelines, however, take a deviation crossing the State Highway at approximately 19.1 km chainage and then leads to OSTs. Similar OST for Stage V transmission pipeline is planned in the same site. The Stages I & II transmission pipelines after the peak at JK Doddi, traverses a distance of 4.6 km before crossing the Kanakapura Road (NH 209) at 24.6 km chainage and subsequently all of them run in parallel. The transmission pipeline from TK Halli to Harohalli involves two river crossings - Bhima and Arkavathi rivers at chainage 9.25 km and 30 km.

As shown in Figure 12.1.20, the transmission pipeline for Stage V is proposed to install under BWSSB's lands beside service road in the same arrangement as Stage I to Stage IV Phase 2. Typical cross section of transmission pipeline is shown in Figure 12.1.21.

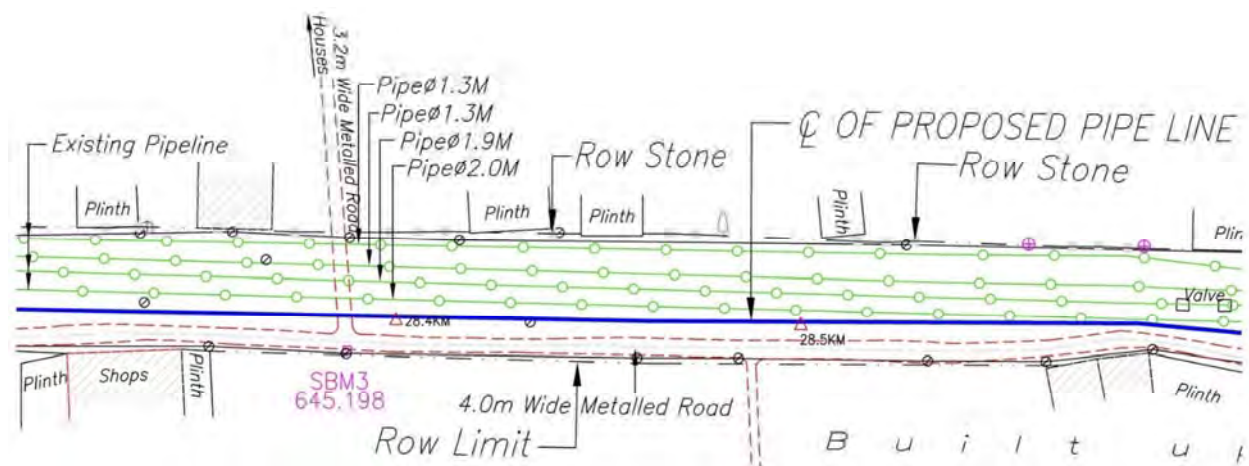

Source: JICA Survey Team

Figure 12.1.20 Topographic Survey Drawing of Transmission Pipeline (Sample Section)

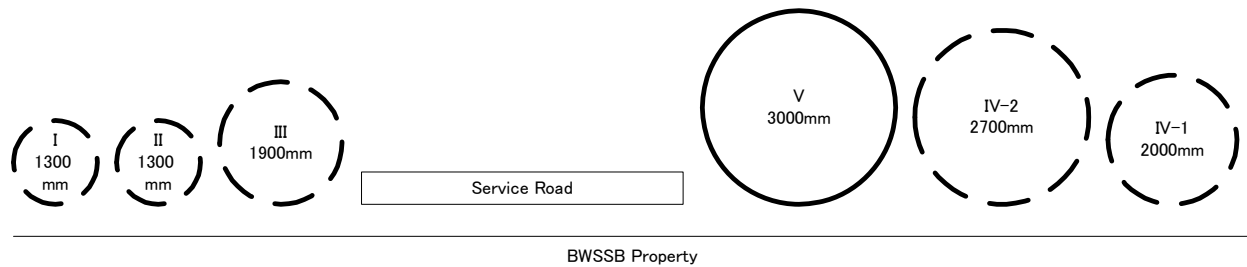

Source: JICA Survey Team

Figure 12.1.21 Typical Cross Section of Transmission pipeline

The existing Bhima River crossings for Stages I and II are made of RC-T-beam, while the Stage III is of Pratt truss construction and Stage IV, Phase 1 & 2 are made of RCC Bridge. The total crossing length is 53 m and the maximum height is 4.3 m. This bridge has to cater for moderate flow from the adjacent catchment area. The existing Arkavathi river bridge spans 188 m and is of RC beam construction. This is a major river crossing close to Kanakapura township. The transmission pipelines for Stages I, II and III are laid on saddle supports on a RC beam. For Stage IV, Phase 1 & 2, RCC Bridge was constructed. For Stage V transmission pipeline, RCC Bridges are to be provided at these locations.

(3) Harohalli to Tataguni

The transmission pipeline length from Harohalli to Tataguni is approximately 21.5 km, starting from Harohalli pumping station to Tataguni pumping station. This stretch has Suvarnamukhi River crossing at about 53 km chainage. The existing bridge crossing for Stages I, II and III is of RC T-beam construction and Stage IV, Phase 1 & 2 with RCC Bridges. The total crossing length is 80 m. The maximum height is 9 m. For Stage V pipeline, new RCC Bridge is to be constructed. The transmission pipeline from Harohalli to Tataguni crosses the National Highway 209 at about 53 km and 58 km chainages. RC box culverts with trenchless technology are to be proposed for these NH crossings. The length of each culvert shall be 25 m. The profile is shown in Figure 12.1.22 and Figure 12.1.23.

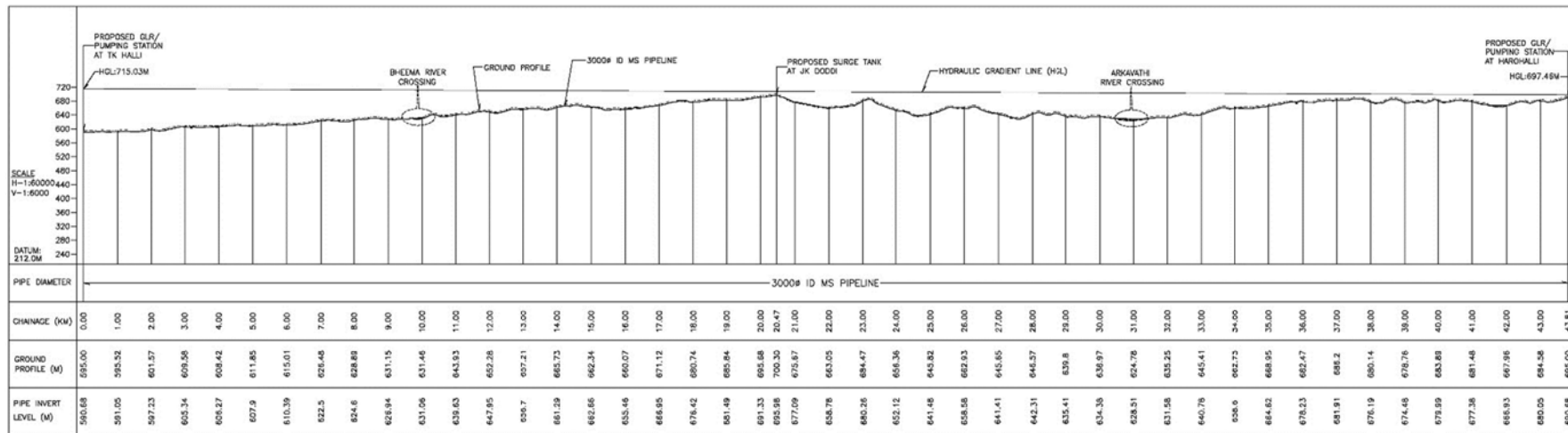

Figure 12.1.22 Profile of TK Halli to Harohalli

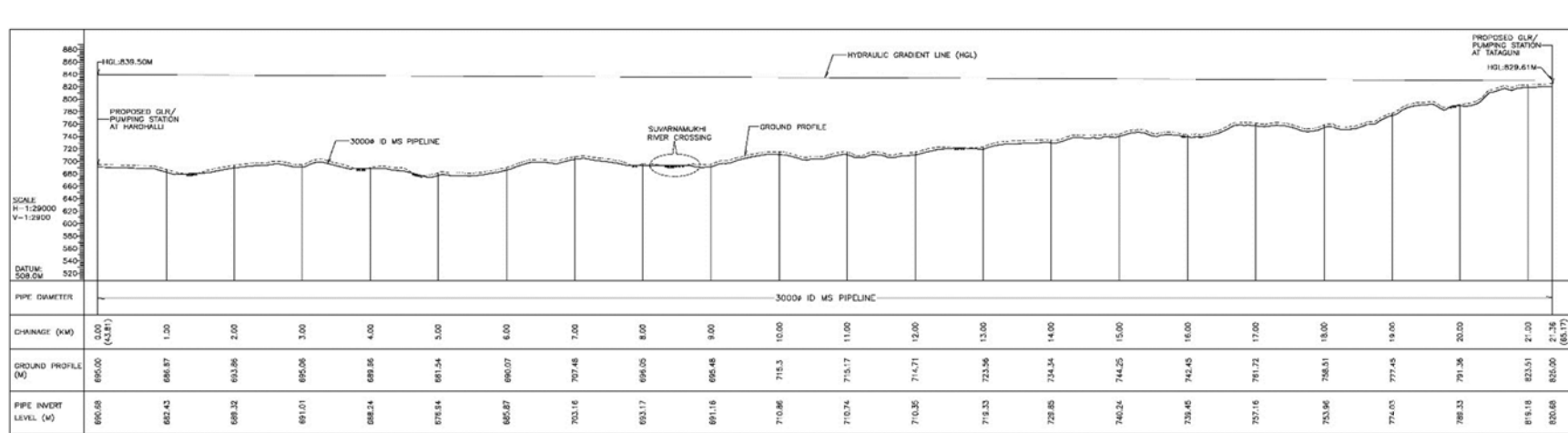

Figure 12.1.23 Profile of Harohalli to Tataguni

(4) Tataguni to City Entry (Vajarahalli Junction)

The stretch from Tataguni to Vajarahalli crossing involves about 4.05 km length of pipeline along the existing pipeline route. This stretch involves several peaks and depressions. The ground level varies from 822 m at Tataguni to around 885.73 m at Vajarahalli crossing. There is a peak point (EL 885.73 m) near Vajarahalli. The proposed transmission pipeline therefore has to be aligned amidst these valleys with several cross drainage works along the route. One (1) major road crossing near Vajarahalli and some small village road crossings are envisaged in this stretch.

(5) Road and River Crossing**1) Road Crossings**

The water transmission pipeline undergoes National Highway No.209 (NH-209) crossing at 7 (Seven) locations and RCC culverts will be constructed for this type of crossings. In addition to that, there is a lot of small village road crossings. At these village road crossings, the buried pipelines shall be designed for superimposed concentrated or distributed line loads, I.R.C highway Class A loads. However, it is recommended to encase the pipe in concrete if the depth of soil overburden is more than 1.80 m and at major road crossings or stream crossings. For small stream crossings, the pipeline will cross below the stream with concrete encasement which will be below the bed level of stream or drain.

2) Cross Drainage Works

At the cross - drainage and in water logged areas, pipes shall be placed on saddle supports.

3) River & Water Course Crossings

This section discusses the basic design of river crossings for the water transmission pipeline. Five major river crossings three on water transmission pipeline are scheduled in this project at Bhima, Arkavathi and Suvarnamukhi. All the pipelines of Stages I, II, III & IV are running on existing bridges. For Stage V pipeline separate RCC bridges are proposed.

The existing three (3) pipelines for Stages I, II & III cross the rivers individually on truss bridges and Stage IV of Phase 1 & 2 pipelines on RC girder Bridge. The features of existing river crossings are shown in Table 12.1.22.

Table 12.1.22 Major River Crossings in Stages I, II, III, IV (Pha 1 & Pha 2) and Stage V Pipeline

Rivers and Chainage	Crossing Length	Type of Crossing
Bheema River @ 9.85km	200 m	Stages I & II: RC T-beam Stage III: Pratt truss, Stage IV, Phase 1 & 2 RCC bridge, Proposed Stage V Pipeline: RCC Bridge
Arkavathi River @ 30.9km	120 m	Stage I, II & III RC T-beam: Stage IV, Phase 1 & 2 RCC bridge. Proposed Stage V Pipeline: RCC Bridge
Suvarnamukhi River @ 52.3km	100 m	Stage I, II & III RC T-beam: Stage IV, Phase 1 & 2 RCC bridge. Proposed Stage V Pipeline: RCC Bridge

12.1.4 City Trunk Mains and GLRs

(1) City Trunk Mains

Planned routes of City Trunk Mains are almost same as those planned in the DPR. The differences are caused by the following reasons.

- Change of GLR sites (Lingaderanahalli and Vasudevapura GLR)
- Move of a part of service area covered by Lingaderanahalli GLR to Existing Hegganahalli GLR

The revised routes of city trunk main are shown in Figure 12.1.24. Figure 12.1.25 presents schematic diagram. The summary of City Trunk Main is shown in Table 12.1.23.

Table 12.1.23 Summary of City Trunk Main

Label	Start Node		Stop Node		Diameter (mm)	Material	Length (m)	Flow (MLD)	Velocity (m/sec)
ER-1	C-1	Tataguni PS	C-2	Vajarahalli	3,000	Mild Steel	3,800	775	1.27
ER-2	C-2	Vajarahalli	C-20	Gottigere GLR	2,200	Mild Steel	8,638	419	1.28
ER-3	C-2	Vajarahalli	C-3	BSK 6th Block Tapping	2,000	Mild Steel	1,853	356	1.31
ER-4	C-3	BSK 6th Block Tapping	C-4	BSK 6th Block GLR	600	DI	199	29	1.19
ER-5	C-3	BSK 6th Block Tapping	C-5	SMV 6th Block Tapping	1,900	Mild Steel	13,147	327	1.33
ER-6	C-5	SMV 6th Block Tapping	C-6	SMV 6th Block GLR	350	DI	1,538	11	1.32
ER-7	C-5	SMV 6th Block Tapping	C-7	SMV 8th Block Tapping	1,900	Mild Steel	1,245	316	1.29
ER-8	C-7	SMV 8th Block Tapping	C-8	SMV 8th Block GLR	400	DI	164	16	1.47
ER-9	C-7	SMV 8th Block Tapping	C-9	Pipeline Rd. JCT near Herohalli Lake	1,800	Mild Steel	3,274	300	1.36
ER-10	C-9	Pipeline Rd. JCT near Herohalli Lake	C-10	Hegganahalli-2 GLR	1,500	Mild Steel	2,940	223	1.46
ER-11	C-9	Pipeline Rd. JCT near Herohalli Lake	C-11	Lingaderanahalli Tapping	1,600	Mild Steel	244	256	1.47
ER-12	C-11	Lingaderanahalli Tapping	C-12	Lingaderanahalli GLR	700	DI	421	48	1.44
ER-13	C-11	Lingaderanahalli Tapping	C-13	M S Palya Circle	1,600	Mild Steel	14,250	208	1.20
ER-14	C-13	M S Palya Circle	C-14	Singapura GLR	700	Mild Steel	1,043	41	1.23
ER-15	C-13	M S Palya Circle	C-15	GKVK Tapping	1,300	Mild Steel	1,596	167	1.46
ER-16	C-15	GKVK Tapping	C-16	GKVK GLR	500	DI	34	20	1.18
ER-17	C-15	GKVK Tapping	C-17	Yelahanka JCT	1,300	Mild Steel	3,309	147	1.28
ER-18	C-17	Yelahanka JCT	C-18	Vasudevapura GLR	500	DI	3,043	17	1.00
ER-19	C-17	Yelahanka JCT	C-19	Chokkanahalli GLR	1,200	Mild steel	8,775	130	1.33
Total							69,513		

Label	Start Node		Stop Node		Diameter (mm)	Material	Length (m)	Flow (MLD)	Velocity (m/sec)
WR-1	C-20	Gottigere GLR	C-21	Doddakanahalli Tapping	1,600	Mild Steel	15,656	221	1.27
WR-2	C-21	Doddakanahalli Tapping	C-22	Doddakanahalli GLR	1,100	Mild Steel	5,256	110	1.34
WR-3	C-21	Doddakanahalli Tapping	C-23	Kadugodi Tapping	1,100	Mild Steel	11,936	111	1.35
WR-4	C-23	Kadugodi Tapping	C-24	Kadugodi GLR	1,000	Mild Steel	7,238	86	1.27
WR-5	C-23	Kadugodi Tapping	C-25	OMBR GLR	500	DI	4,863	25	1.47
Total							44,949		

*The pipeline diameter is considered by the water demand of the year 2049 and only ER-10 pipeline is considered by the demand in the year of 2024 (13 MLD) and the sharing water to Core and ULB areas (210 MLD).

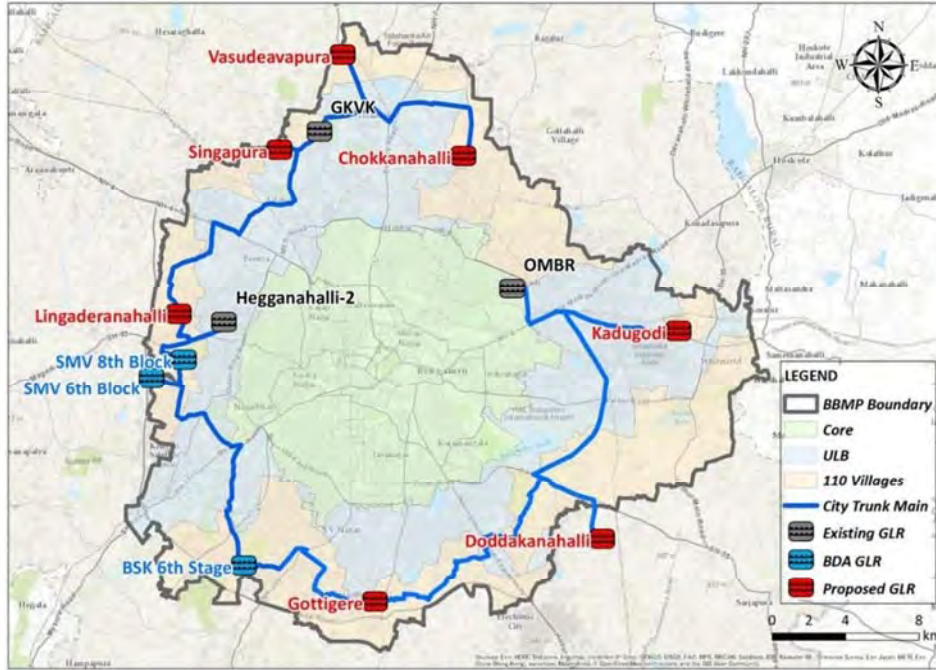

Source: JICA Survey Team

Figure 12.1.24 Layout of City Trunk Main and GLRs

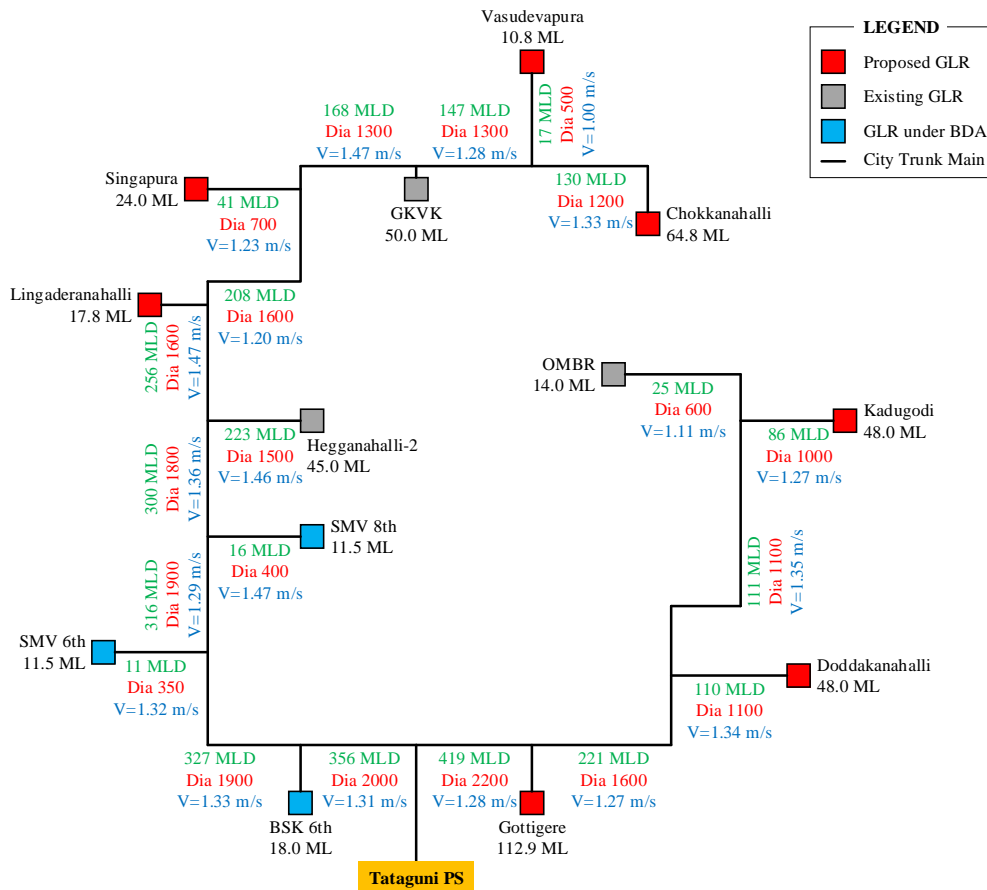

Source: JICA Survey Team

Figure 12.1.25 Schematic Diagram of City Trunk Main and GLRs

1) Western Route

All sections (from the Vajarahalli junction to Chokkanahalli GLR) of City Trunk Mains in the western route are pressured pipelines. The profile of the western route of city trunk mains is shown in Figure 12.1.26.

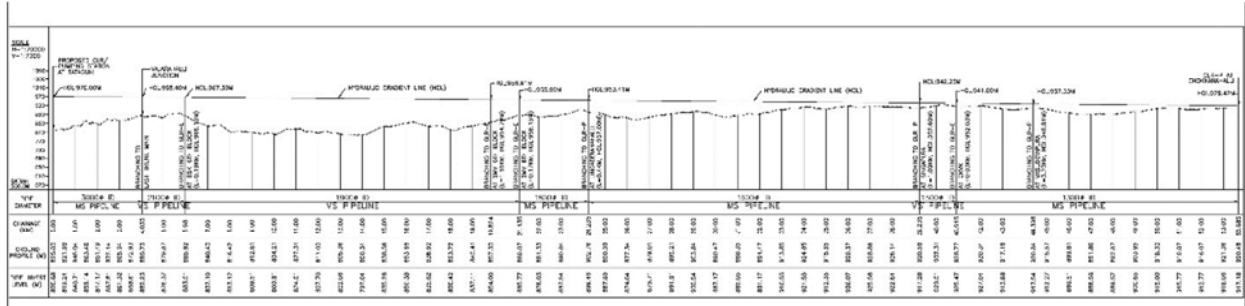

Figure 12.1.26 Profile of Trunk Mains in West Route (Pressured System)

2) Eastern Route

The Eastern route of city trunk mains includes pipelines with pressured and gravity sections. The City Trunk Mains from the Vajarahalli junction to Gottigere GLR is pressured and the profile is shown in Figure 12.1.27. As the elevation of Gottigere GLR is the highest among those of concerned GLRs in Eastern route, the city trunk mains after Gottigere GLR are gravity system. The profile of city trunk main after Gottigere GLR is shown in Figure 12.1.28.

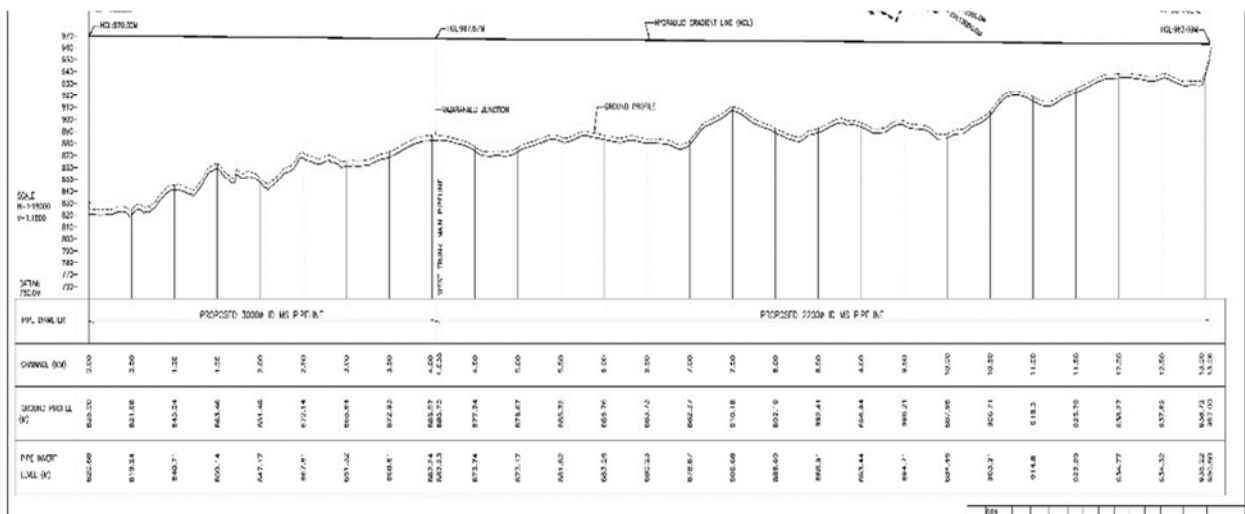

Figure 12.1.27 Profile of Eastern Route (Pressured System)

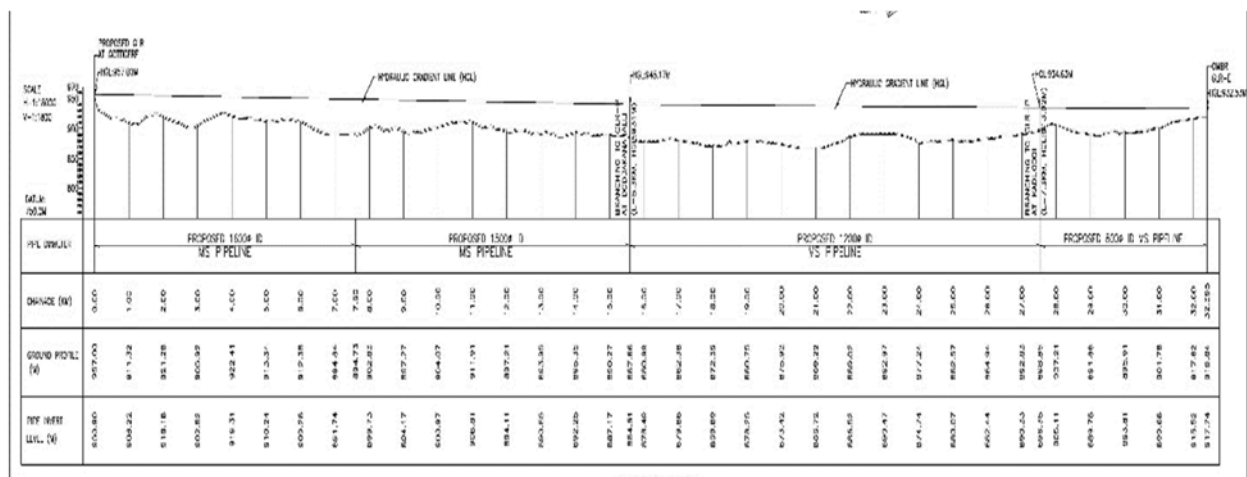

Figure 12.1.28 Profile of Eastern Route (Gravity System)

3) Numbers of Location of Trenchless Crossing, Drains and Pipe Bridges

The length of city trunk main is more than 114 km in total and it crosses roads, highways, railways and drains. The trenchless method is adopted at the locations where there are roads, highways and railways. In the case of small drain crossings, the steel pipeline shall be installed without piers or support. On the other hand, in case of large rivers, the construction of pipe bridge may be adopted.

The number of trenchless crossings, drains and pipe bridges are summarized in Table 12.1.24 and Table 12.1.25 and their locations are given in Figure 12.1.29.

Table 12.1.24 Trenchless Crossing Locations at City Trunk Main Eastern Route

S/N	City Trunk Main Route / Location	Dia (mm)	Trenchless Crossing			Drain (No.)	Pipe Bridge (No.)	Remark
			Road (No.)	Highway (No.)	Railway (No.)			
Eastern Route								
1	Kanakpura Road	2,200	1					
2	Bannerghatta Road	1,600	1					
3	Begur Road Junction	1,600	1					
4	Hosur Road	1,600	1					
5	Sarjapur Road	1,500	1					
6	Sarjapur Road	1,000	1					
7	Kadabesanhalli STP ORR	1,200					1	
8	Marathahalli Junction	1,200	1					
9	Naryanpura ORR	1,200	1					
10	Hudi Junction	1,000	1					
11	Naryanpura ORR Junction	800	1					
12	KR Puram Railway Bridge	800	1					
13	KR Puram Lake	800			1			
TOTAL								
		800	2		1			
		1,000	2					
		1,200	2				1	
		1,500	1					
		1,600	3					
		2,200	1					
	Σ		11	0	1	0	1	

Source: JICA Survey Team

Table 12.1.25 Trenchless Crossing Locations at City Trunk Main Western Route

S/N	City Trunk Main Route / Location	Dia (mm)	Trenchless Crossing			Drain (No.)	Pipe Bridge (No.)	Remark
			Road (No.)	Highway (No.)	Railway (No.)			
Western Route								
1	Nice Road	2,000	1					
2	Channasandra Main Road	2,000				1		
3	RR Nagar Arch	2,000				1		
4	Bangalore University Entrance	2,000				1		
5	Mysore Road	2,000	1					
6	Bangalore University	2,000			1			
7	BDA Ring Road at Ullal Junction	2,000	1					
8	Magadi Main Road	2,000	1					
9	Lingaderanahalli	1,600				1		
10	National Highway No.4	1,600		1				
11	Jalahalli Air force Station	1,600					1	
12	Yelahanka Police Station	1,300	1					
13	Ylahanka Old Town	1,300			1			
14	Kogilu Junction	1,300	1					
TOTAL								
	1,300	2		1				
	1,600		1		1	1		
	2,000	4		1	3			
	Σ		6	1	2	4	1	

Source: JICA Survey Team

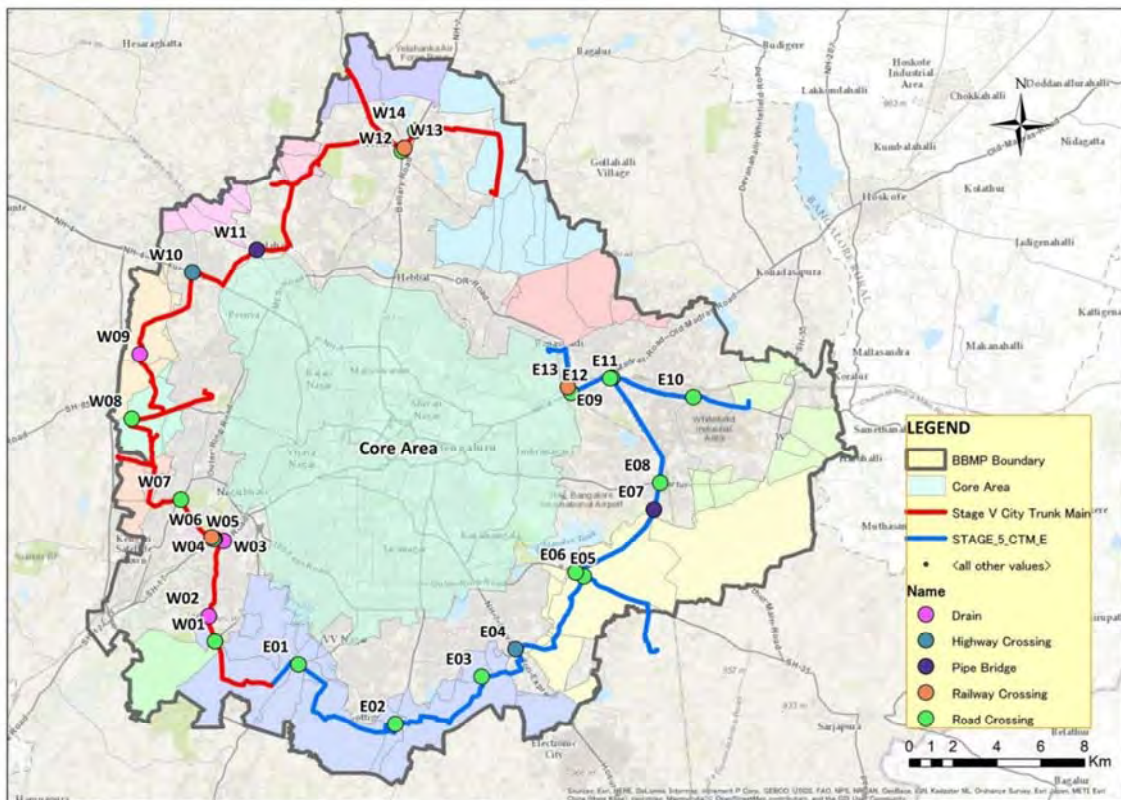

Source: JICA Survey Team

Figure 12.1.29 Trenchless Crossing Locations at City Trunk Main

(2) GLRs

1) Design Fundamentals and Common Items for New GLRs

a) Capacity, Structure and other Conditions

According to the water demand projection, the demand in distribution areas of each GLR and other conditions are given in Table 12.1.26. Finally, all proposed sites were decided in government properties. Inflow and outflow shall be measured and transmitted to SCADA server. Electric driven valves are equipped at inlet and outlet of GLRs, they are controlled both on site and remote.

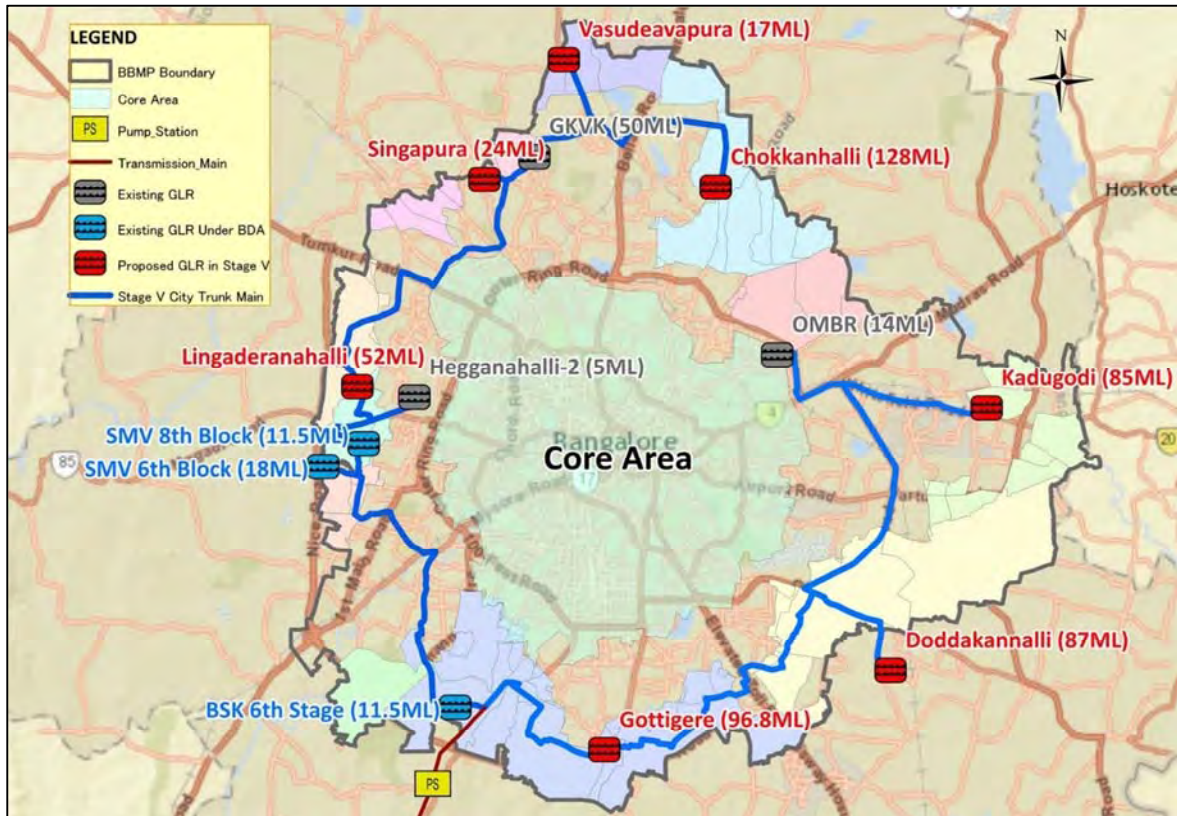

Source: JICA Survey Team

Figure 12.1.30 Location of GLRs of CWSS Stage V

All proposed GLRs are planned to apply RCC type. For the proper O&M of facilities, proposed GLRs shall consider two (2) series of tanks, except for Lingaderanahalli GLR as its land available is limited. Two tanks could be operated individually, but the low and high water level shall be the same even present ground level is different at the construction site. The flow arrangement walls are proposed for all GLRs to avoid stagnant water (dead water). Based on BWSSB experience, the maximum effective water depth shall be 7.0 m and the standard effective water depth for GLRs is planned to be 6.0 m with a 0.5 m free board. However, to secure GLRs' detention time, the effective water depth for Gottigere GLR is modified to be 7.0 m and it is planned to be 9.0 m for Lingaderanahalli GLR.

Table 12.1.26 Summary of GLR Structure and Detention Time

Name of Proposed GLR	Demand (MLD)	Proposed Dimension (m)			No of Tanks	Proposed Capacity (m ³)	Detention Time (Hour)
		L	x	W x H			
1 Gottigere	198	48	x	48 x 7.5	6	112,896	13.7
2 Doddakanahalli	110	80	x	50 x 6.5	2	48,000	10.5
3 Kadugodi	86	80	x	50 x 6.5	2	48,000	13.4
4 Chokkanahalli	130	90	x	60 x 6.5	2	64,800	12.0
5 Vasudevapura	17	30	x	30 x 6.5	2	10,800	15.2
6 Singapura	41	50	x	40 x 6.5	2	24,000	14.0
7 Lingaderanahalli	47	52	x	38 x 9.5	1	17,784	9.1
Total	629					326,280	

Note: Gottigere GLR is in trapezoidal shape

Note: Proposed height in the table above includes effective height and 0.5m free board

Note: The effective water depth was decided in the C/P meeting (4/FEB/2017)

b) Disinfection

The disinfection is planned by chlorine and due to a long transmission after post chlorination at TK Halli WTP, residual chlorine concentration may be reduced. Disinfection facilities are planned and operated for each GLRs to keep the required chlorine concentration based on daily monitoring. The detail of disinfection facility in GLRs are shown in Table 12.1.27.

Table 12.1.27 Summary of Disinfection Facility of GLR

Proposed GLR	Water Demand		Proposed Capacity (m ³)	Chlorine Dosage (mg/L)	Chlorine Capacity		No. of Working Injector	Chlorine Required (Kg/day)	Storage Required (Unit)
	(MLD)	(m ³ /hr)			Required (Kg/hr)	Provided (Kg/hr)			
Gottigere	198	8,250	96,768	2	16.50	17	1	408.0	10
Doddakanahalli	110	4,583	48,000	2	9.17	10	1	240.0	10
Kadugodi	86	3,583	48,000	2	7.17	8	1	192.0	10
Chokkanahalli	130	5,417	64,800	2	10.83	11	1	264.0	10
Vasudevapura	17	708	10,800	2	1.42	2	1	48.0	10
Singapura	41	1,708	24,000	2	3.42	4	1	96.0	10
Lingaderanahalli	47	1,958	17,784	2	3.92	4	1	96.0	10
Total	629	26,207	310,152	-	52.43	56	-	1,344.0	70

2) Plan of New GLR

a) Gottigere GLR

BWSSB has already prepared the land for proposed Gottigere GLR as shown in Photo 12.1.1. The shape of the land is isosceles triangle and it grounds difficulty on design layout of storage tanks. The most effective shape of tanks for the limited land has been sought as shown in Figure 12.1.31.



Photo 12.1.1 Current Status of Proposed Land for the construction of Gottigere GLR



Figure 12.1.31 Outline of Gottigere GLR on the Topography Map

b) Doddakanahalli GLR

The proposed land for Doddakanahalli GLR is nearby Bangalore Technological Institute and as it is GoK's property as shown in Photo 12.1.2 and Figure 12.1.32 . The land transfer is required.



Photo 12.1.2 Current Status of Proposed Land for Doddakanahalli GLR

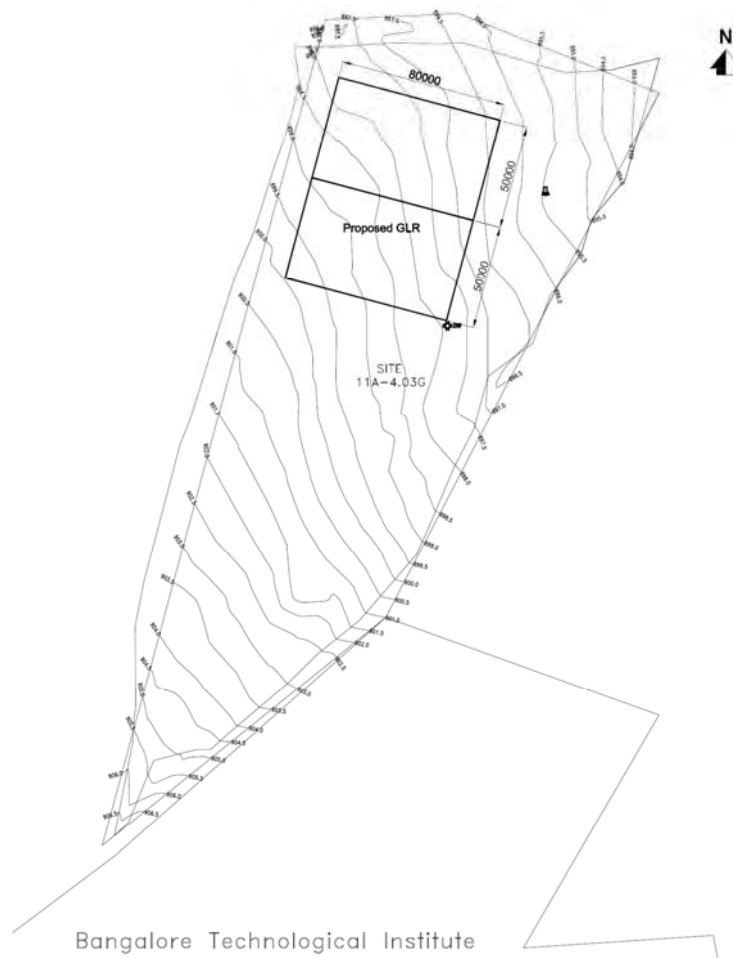

Figure 12.1.32 Outline of Doddakanahalli GLR on Topographic Map

c) Kadugodi GLR

The proposed land for Kadugodi GLR is GoK's property and it is sufficient for the planned GLR.



Photo 12.1.3 Current Status of Proposed Land for Kadugodi GLR

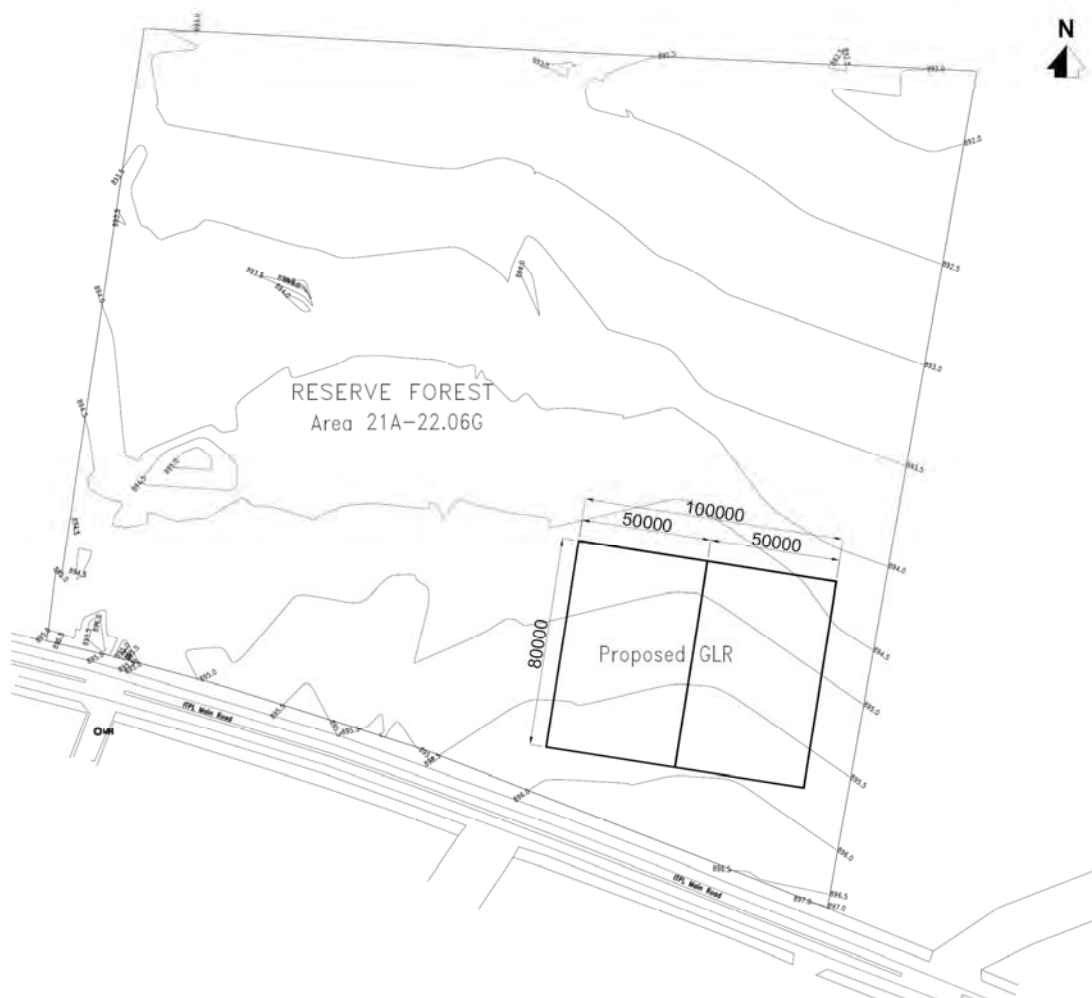

Figure 12.1.33 Outline of Kadugodi GLR on Topographic Map

d) Chokkanahalli GLR

The proposed land for Chokkanahalli GLR, as shown in Photo 12.1.4 and Figure 12.1.34, is GoK's property and the land transfer is necessary. The land is a wooded area and faces main road with enough width for large size vehicles.



Photo 12.1.4 Current Status of Proposed Land for Chokkanahalli GLR

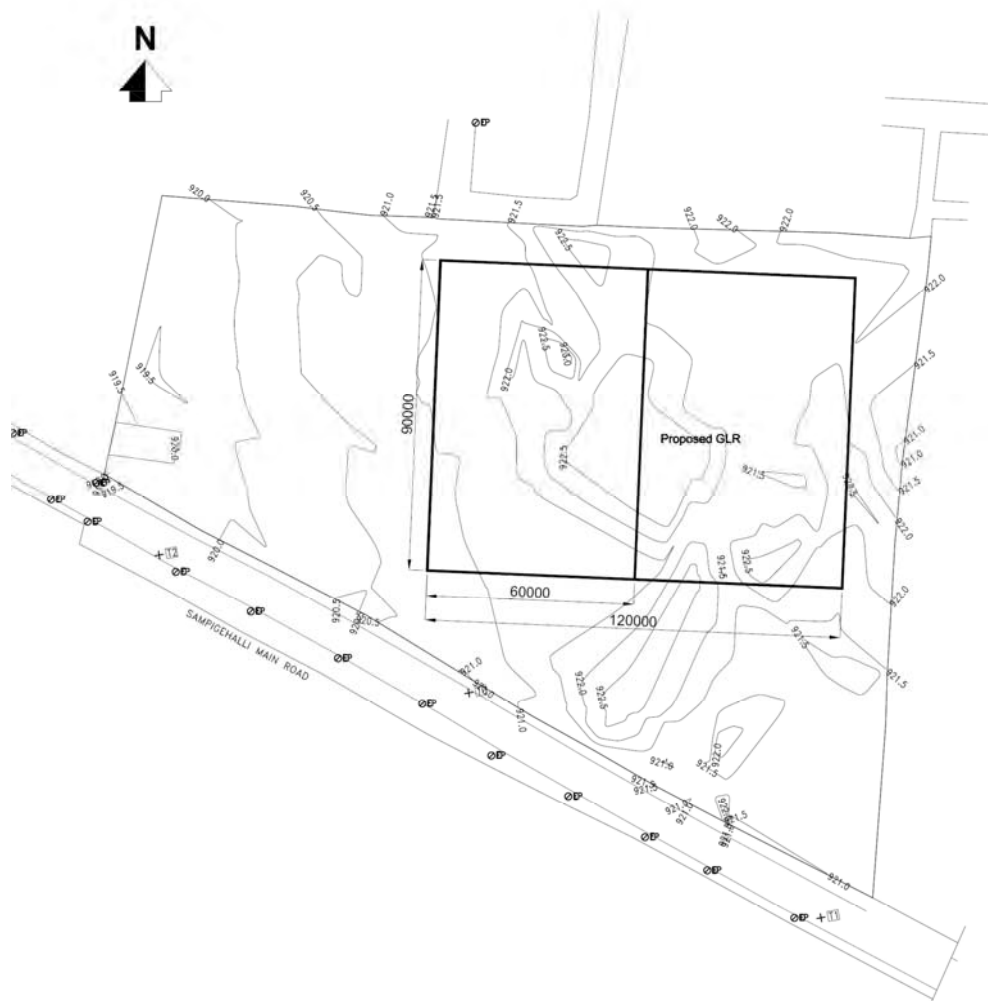

Figure 12.1.34 Outline of Chokkanahalli GLR on Topographic Map

e) Vasudevapura GLR

The proposed land for Vasudevapura GLR, as shown in Photo 12.15, is near the planned route of outer ring road and a presidency school. As it is GoK's property. The land transfer from GoK to BWSSB is required. The land is a wooden area with high elevation and faces main road with enough width for construction vehicles as shown in Figure 12.1.35.



Photo 12.1.5 Current Status of Proposed Land for Vasudevapura GLR

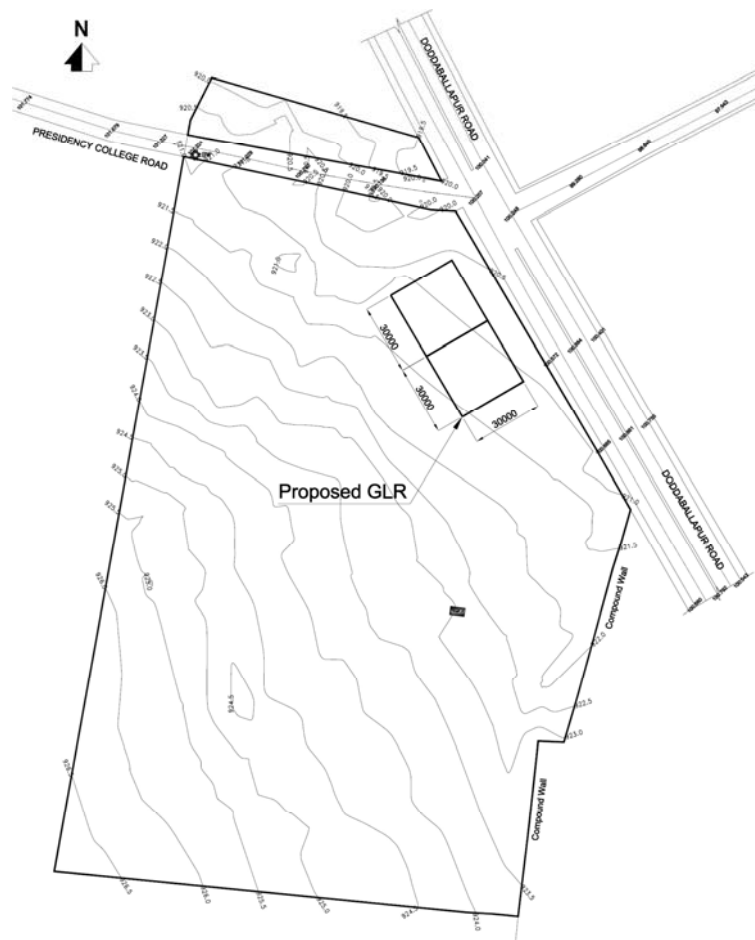

Figure 12.1.35 Outline of Vasudevapura GLR on Topographic Map

f) Singapura GLR

The proposed location for a new GLR is in the site of the existing Singapura GLR, which is owned by BWSSB and the site has plenty of clear space and the elevation is high as shown in Photo 12.1.6 and Figure 12.1.36. There are three (3) religious facilities to be relocated as shown in Photo 12.1.6 (right photo).



Photo 12.1.6 Current Status of Proposed Land for Singapura GLR

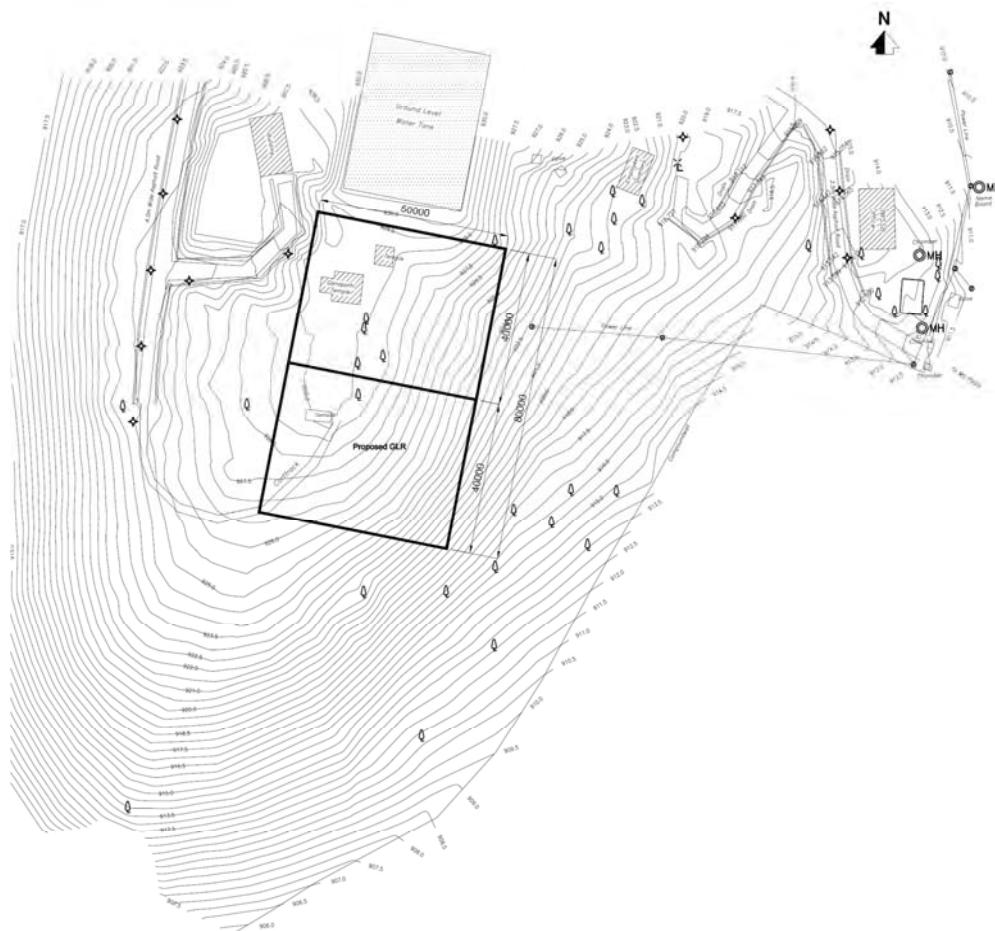

Figure 12.1.36 Outline of Singapura GLR on Topographic Map

g) Lingaderanahalli GLR

The proposed area for Lingaderanahalli GLR is a non-functioning existing GLR. As shown in Photo 12.1.7 and Figure 12.1.37, there is a religious facility there, but since the land belonged to the local society at the first and transferred to BWSSB later, the religious facility would not be relocated.



Photo 12.1.7 Current Status of Proposed Land for Lingaderanahalli GLR

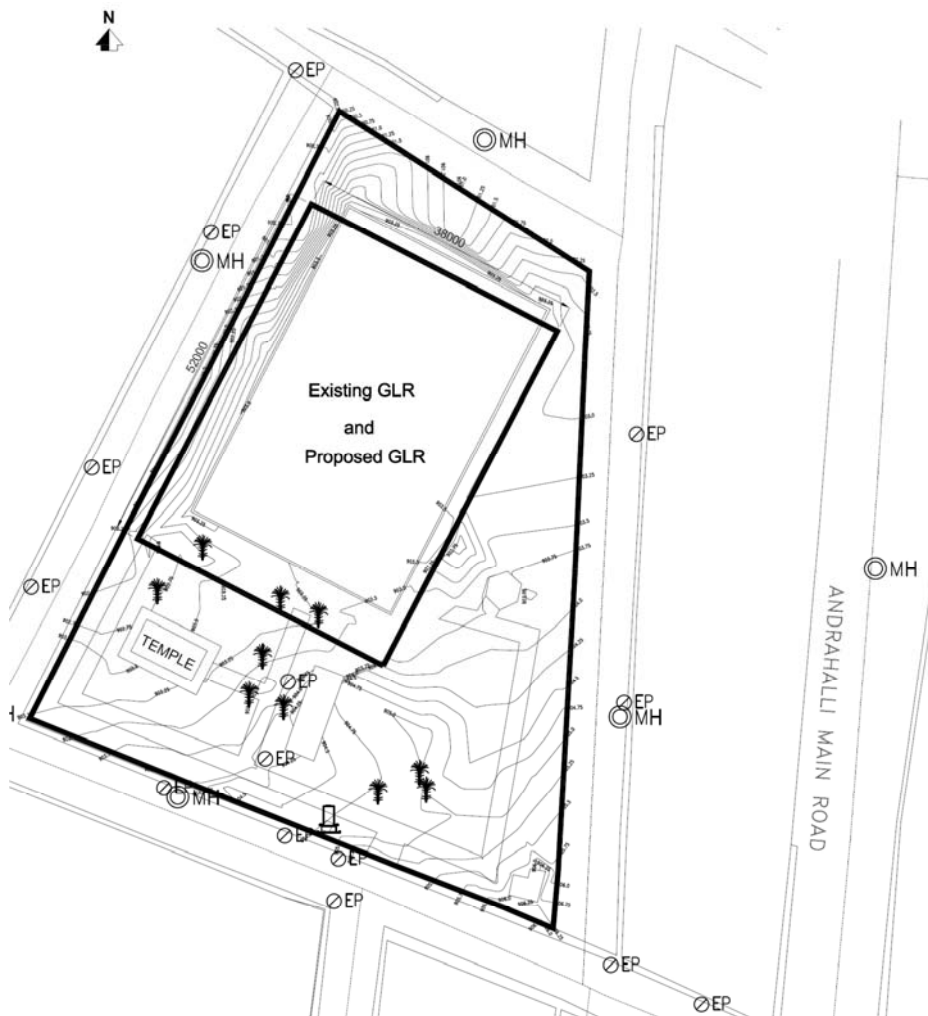

Figure 12.1.37 Outline of Lingaderanahalli GLR on Topographic Map

3) Connection to Existing GLR

Following 6 GLRs are expected to be connected in CWSS Stage V project, their information is shown in Table 12.1.28.

Table 12.1.28 Information of Existing GLRs to be Connected

S/ N	Name of GLR	Demand (MLD)	Capacity (ML)	Ground Elevation (+ m)	Dimension W x L x D (m)	Water Level High/Low (+ m)	Construction Year
1	GKVK	-	24.0 50.0	-	-	+ 934 + 928	2012
2	OMBR	-	13.5 14.0	-	-	+ 925 + 919	2013
3	Hegganahalli-2	-	48.0 5.0	-	-	+ 929 + 924	2002
4	BDA BSK 6 th Stage	66.00	18.0	877.0	50 x 60 x 6.5	883.15	Work to be awarded
5	BDA SMV 6 th Block	34.18	11.5	874.4	40 x 50 x 6.4	879.0	Work to be awarded
6	BDA SMV 8 th Block	31.50	11.5	902.0	40 x 50 x 6.4	904.6	Land to be al- lotted

a) GKVK GLR

There are two (2) tanks in GKVK GLR, as shown in Photo 12.1.8 and they were constructed in CWSS Stage IV Phase 1 and 2. In Stage V, the city trunk main is designed to connect to the tank constructed in Phase 2 directly.



Photo 12.1.8 Current Status of Existing GKVK GLR

b) OMBR GLR

OMBR GLR as shown in Photo 12.1.9 is located in the residence area and it has two (2) tanks. One (1)

was constructed previously and another one was completed in CWSS Stage IV Phase 2 with 14 ML capacity. It is designed as the end point of the eastern city trunk main and planned to connect to the tank of Stage IV Phase 2 directly.



Photo 12.1.9 Current Status of Existing OMBR GLR

c) Hegganahalli-2 GLR

Hegganahalli-2 as shown in Photo 12.1.10 is a balancing reservoir and receiving water from Tataguni Pumping Station. It has two (2) tanks and their capacities are 48 ML and five (5) ML. In Stage V, a branch of the city trunk main (Dia 1500 mm, length 2.94 km) is planned to connect to the later one for Stage V distribution and branch feeding pipe for Core area (CJF and HGR GLR, See Figure 11.4.5).



Photo 12.1.10 Current Status of Existing Hegganahalli-2 GLR

d) GLRs under BDA Contribution Basis Projects

Three (3) GLRs under BDA deposit contribution projects are under tendering as of February 2017 and they are expected to be completed before the completion of Stage V project. Valve chambers will also be prepared by BDA and branches of the city trunk main are planned to be installed till those chambers in Stage V project for connection.

12.2 110 Villages Sewerage Project

12.2.1 Main Sewers and Intermediate Sewage Pumping Stations (ISPSs)

(1) Design Fundamentals

Preliminary design of the facilities was prepared in use of the CPHEEO manual. Design fundamentals adopted for sewer systems and ISPSs are shown in Table 12.2.1.

Table 12.2.1 Design Fundamentals for Sewer Systems and ISPSs

Item	Applied conditions	Remarks																										
(1) Design Criteria	CPHEEO Manual CPCB Guideline																											
(2) Design Period	Main Sewer : 30 years ISPS (Civil): 30 years ISPS (Equipment): 15 years Rising Main Pipe : 30 years	<u>Target Year</u> Sewer Network, ISPS (Civil) and Rising Main Pipe : 2049 ISPS (Equipment) : 2034																										
(3) Hydraulic Criteria																												
a) Hydraulic Formula	Manning Formula $Q=AV$ $v = \frac{1}{n} \times R^{\frac{2}{3}} \times I^{\frac{1}{2}}$ Haezen Williams Formula $V = 0.84935 \times C \times R^{0.63} \times I^{0.54}$	Where, V: flow velocity (m/s) n: Roughness Coefficient (-) R: Hydraulic Radius (m) I: Gradient(-) Where, Q: Flow (m ³ /sec), V: Velocity of Flow (m/sec), C: Flow Velocity Coefficient, R: Hydraulic Radius (m), I: Hydraulic Gradient, A: Cross Section Area (m ²)																										
b) Peak Factor	By Contributory Population Up to 20,000 : 3.00 20,000~50,000 : 2.50 50,000~750,000 : 2.25 Above 750,000 : 2.00																											
c) Sewer Capacity Allowance	1.0 times (Not Considered)	As considered in Peak Factor																										
d) Hydraulic Depth	0.8 times of the nominal diameter																											
e) Velocity	Minimum: 0.6 m/s (Present Peak flow) 0.8 m/s (Ultimate Peak flow) Maximum: 3.0 m/s																											
f) Minimum Slope	<table border="1"> <thead> <tr> <th rowspan="2">Sewer Size (mm)</th> <th colspan="2">Minimum Slope</th> </tr> <tr> <th>As percent</th> <th>As 1 in</th> </tr> </thead> <tbody> <tr> <td>150</td> <td>0.60</td> <td>170</td> </tr> <tr> <td>200</td> <td>0.40</td> <td>250</td> </tr> <tr> <td>250</td> <td>0.28</td> <td>360</td> </tr> <tr> <td>300</td> <td>0.22</td> <td>450</td> </tr> <tr> <td>375</td> <td>0.15</td> <td>670</td> </tr> <tr> <td>400</td> <td>0.12</td> <td>830</td> </tr> <tr> <td>≥ 525</td> <td>0.10</td> <td>1000</td> </tr> </tbody> </table>	Sewer Size (mm)	Minimum Slope		As percent	As 1 in	150	0.60	170	200	0.40	250	250	0.28	360	300	0.22	450	375	0.15	670	400	0.12	830	≥ 525	0.10	1000	
Sewer Size (mm)	Minimum Slope																											
	As percent	As 1 in																										
150	0.60	170																										
200	0.40	250																										
250	0.28	360																										
300	0.22	450																										
375	0.15	670																										
400	0.12	830																										
≥ 525	0.10	1000																										
(4) Interval of Manhole	90m (Dia. Up to 900mm) 120m (Dia. Above 900~1,500mm) 150m (Dia. Above 1,500mm)																											

Item	Applied conditions		Remarks
(5) Minimum Diameter	150mm		
(6) Roughness Coefficient	Type of Material	Manning's n	Haezen's C
	Salt glazed stone ware pipe	0.012	-
	Cement concrete pipes	0.013	-
	Cast Iron / Ductile Iron	0.013	140 (Strait Pipe)
	HDPE / uPVC	0.010	140
(7) Minimum Earth Cover	1.0 m		Special conditions such as river bed, crossing existing facility etc. are exceptional.

Source: CPHEEO Manual

(2) Construction Method of Main Sewer

The project area poses some of the unique and challenging physical and geotechnical conditions. Generally, sewer shall be constructed using an open cut method unless otherwise mandated by physical / other constraints. Use of a trenchless method is envisaged for railway crossings as well as major road crossings (roads which cannot be closed either fully or partially when construction is ongoing) or the depth of excavation exceeds 6 to 7 m especially in hard rock. The geotechnical conditions in Bengaluru are varied and need detailed technical investigations before finalizing the method of excavation.

The execution of work can be planned considering the following methods.

Open Cut Method

- Conventional trenching with trench boxes
- Conventional trenching with sheet piling

Trenchless technology

- Pipe Ramming
- Pipe Jacking
- Horizontal Directional Drilling (HDD)
- Auger Boring
- Micro-tunneling
- Tunneling

1) Open-cut Method

Open cut method is classified into three (3) construction methods by excavation depth and soil condition. The details are as follows;

a) Conventional Trenching

Conventional trench pipe laying has been considered where the road width and depth of excavation safely permit the same. This typically covers pipes of all diameter and depths not exceeding 4 to 5 m (see Photo 12.2.1). This type of pipe laying method is recommended for sewers in good ground conditions. Normal

to compact shoring is necessary in this case.

For this project, it is recommended to use compact shoring and to ensure safety of surrounding structures and workmen, it is recommended to leave shoring in trenches where the ground conditions are unstable like those in black cotton soils or where water table is high or where loose boulder may be dislodged causing cavity behind the shoring.



Photo 12.2.1 Conventional Trenching Method

b) Trenching with Trench Boxes

Pre-fabricated trench boxes capable of withstanding certain anticipated lateral pressure due to soil and water are a safe way to lay pipe lines in trenches than conventional timber shoring. These shoring systems are available in the form of prefabricated plates and strut systems which can be configured to provide safe shoring systems for depth ranging up to 7.5 to 9.0 m (see Photo 12.2.2).

Pre-fabricated steel shoring boxes which can be installed in telescopic manner are quite convenient and safe ways of installing underground pipelines up to depths extending to 7.5 m or so. Trench boxes have been used in the past in Bengaluru.

Trench boxes shall conform to EN 13331 and shall be designed to resist the anticipated lateral earth and hydrostatic pressure safely.

Different types of trench boxes are as follows;

- Rugged Box type Pre-fabricated metallic shoring
- With rolling strut double slide rail system shoring

These come in branded shoring systems like SHB Shoring Systems; Germany, Premier Trench Box by Premier Shorco, Condor Systems; Italy etc. These systems are available to resist lateral pressures ranging between 45 kN/m² to 145 kN/m².

Crossing supply lines, building next to building, narrow access and close traffic – these are typical problems for trench shoring projects inside the city. On top, there is the necessity for noise control and for vibration-free installation of profiles. Another aspect of inner-city trench construction is the challenge to perform a work free of settling and the aspect of compacting.

The trench box system from SBH could be solution under such circumstances. A trench shoring system which perfectly combines the fulfilment of technical requirements and cost-effectiveness. Even bad soil

conditions, as for example gritty or non-cohesive grounds, one can realize a completely shored pit up to the trench bottom.

Lowering and pulling of box sections is done by hydraulic propulsion while the box sections support the trench walls.

When the ground is sensitive and damageable for vibrations, for example close to buildings, it is not possible to drive the piles as the resulting shock waves would damage the buildings. At the same time, pile driving would involve high costs and would create an immense noise pollution. In such cases, the SBH trench box is the ideal solution.



Photo 12.2.2 Trenching with Trench Boxes

c) Trenching with Sheet Piling

This can work in variety of ground and extend up to quite high depths say up to 10 to 12 m (see Photo 12.2.3). Steel sheeting provides resistance during installation stresses. The sheets must be driven into the ground and they have high resistance to the force of being driven down. It is extremely light weight and makes it easier to lift and handle. Steel sheeting is reusable and recyclable. There is a long life for it both above and under water. It only requires light protection to keep it maintained. The pile length is easily adaptable and can be welded or bolted to make it work. They have stronger joints that can withstand the force of being driven into place.

However, there are limitations in this approach as it requires sheet pile driving equipment and access roads adequate for the same. Besides this method can lead to severe vibrations which may damage adjoining structures or utilities. It is extremely difficult to install steel sheeting in soil that is rocky or has large boulders. Many times the sheeting cannot be installed to the required depth. Sheet piling is generally more expensive as compared to conventional wooden shuttering.



Photo 12.2.3 Trenching with Sheet Piling

2) Trenchless Method

Trenchless method is classified into six (6) construction methods by pipe diameter, soil condition and length. The details are as follows;

a) Pipe Ramming

It is a trenchless method of installation for new pipes over, typically, short, shallow distances. This common method has been widely used for installation under railway lines and roadways because it causes little ground movement in comparison to other methods (see Figure 12.2.1). Most often, the pipe is hammered into the side of an embankment to pass under the obstacle. The pipe is open-ended to allow the soil to move into the pipe rather than compacting it outside the pipe, thus, reducing surface heave and allowing this method to be used at shallow surfaces.

The major advantages are effective for installing medium size pipes, method being economic, pipe can be installed in one piece or segments, in all types of soils and the method does not require thrust reaction structure. The major disadvantages are no control on line and grade. In case of obstructions like boulders the pipe may be deflected and for large diameter it is uneconomical.

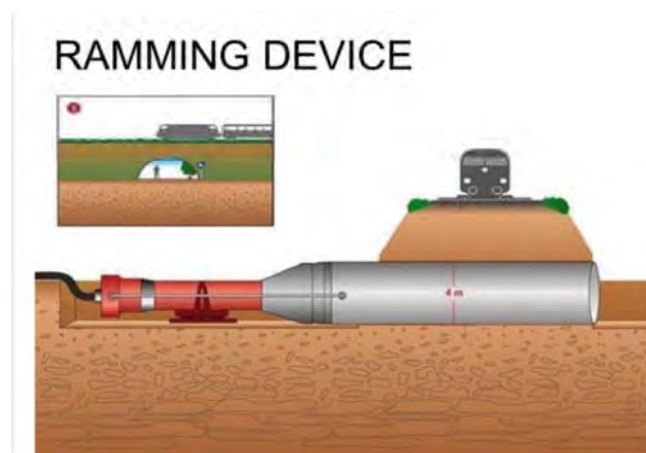

Figure 12.2.1 Pipe Ramming Method

b) Pipe Jacking

Pipe jacking is a trenchless technology method for installing a prefabricated pipe through the ground from a drive shaft to a reception shaft (see Figure 12.2.2). The pipe is propelled by jacks located in the drive shaft. The jacking force is transmitted through the pipe to the face of the Pipe Jacking excavation. The spoil is transported out of the jacking pipe and shaft manually or mechanically. Both the excavation and spoil removal processes require workers to be inside the pipe during the jacking operation. Therefore, the minimum recommended diameter for pipes installed by PJ is 1,075 mm (42 in). However, it is feasible to install Reinforced Concrete Pipes (RCPs) with 900 mm (36 in) (I.D.) and 1,100 mm (44 in) (O.D.).

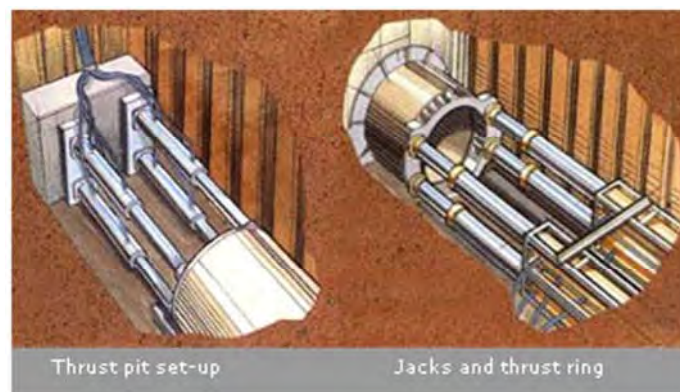

Figure 12.2.2 Pipe Jacking Method

c) Horizontal Directional Drilling (HDD) / Directional Boring

This is one of the most widely used continuous trenchless technologies. It is used for the installation of everything from service connections to residential and commercial/institutional buildings, to pipes and cables under roadways and rivers (see Figure 12.2.3). HDD is used for installing pressure pipes and conduits, where precise grades are not required and are applicable for diameters up to 1,200 mm. The main components of HDD are: a directional drill rig of a size suitable for the job; drill rods linked together to form a drill string to advance the drill bit and for pulling back reamers and products (pipe); a transmitter/receiver for positioning of the location of the drill and product; a tank for mixing and holding drilling fluid; and a pump for circulating the drilling fluid. This is in addition to drilling bits, reamers, swivels and pulling heads. The main advantage is the speed of installation combined with the minimum environmental and social impact. Sufficient depth can be achieved by avoiding utilities. Limitation of access and reception pits is another advantage. Disadvantage is the specialized equipment and operational skill is required. As the cost of equipment and operation are high, bore length should be sufficient in order for it to be economical.

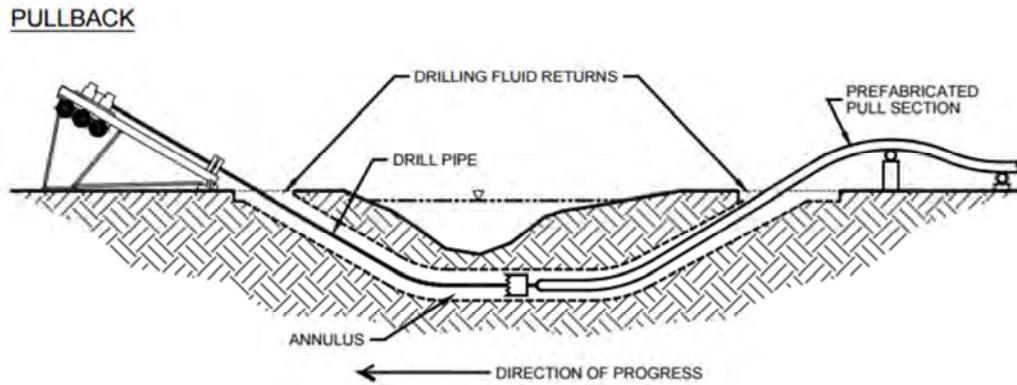

Figure 12.2.3 Horizontal Drilling Method

d) Auger Boring (Case Boring/Jack & Bore)

The auger boring process employs an auger boring machine to rotate a series of connected continuous flight augers (auger chain) positioned within a casing pipe and fitted to a cutter head at the front of the casing (see Figure 12.2.4). The rotating cutter head, which is slightly larger in diameter than the casing pipe, excavates the soil in front of the casing. The soil is transported back to the machine via the helical auger chain. At the original entry point the soil is removed by hand or machine. The auger boring machine advances along a track, which is aligned to drive the casing pipe on the designed installation line. Once the machine reaches the end of the track arrangement, the auger chain is disconnected from the machine and the machine is moved back to the original starting point on the track where a new casing segment is welded to the existing casing pipe, and a new auger length (chain) is connected to the machine and to the existing chain/cutter head. The excavation and thrust process is repeated until the planned bore is completed. The main advantage is that the pipe casing is installed at the same time as the borehole excavation takes place. This method can be used in wide variety of soil applications. The main disadvantage is that it requires different sized cutting heads for each diameter of pipe, which increase investment. The investment in bore, pit construction and the initial set up is also required. In case of soils containing large boulders, this method cannot be used.

Considering the above, and lack of steering control, auger boring has not been considered for the project.



Figure 12.2.4 Auger Boring Method

e) Micro Tunneling

This process uses a remotely controlled Micro-Tunneling Boring Machine (MTBM, see Figure 12.2.5) combined with the pipe jacking technique to directly install product pipelines underground in a single pass. The term micro-tunneling applies to remotely controlled, steerable, controlled excavation tunneling methods for pipelines of 3,400 mm diameter or less and usually for lengths up to 460 m. The spoil is removed from the cutting head within the new pipeline which is advanced by pipe jacking. This process avoids the need to have long stretches of open trench for pipe laying. Thus, this method reduces extreme disruption to the community during construction. Spoil may be removed by auger, slurry conversion or vacuum extraction.

As Micro-tunneling can be used in all types of terrain using different types of cutter heads, it has been suggested as the preferred method of trenchless technology.

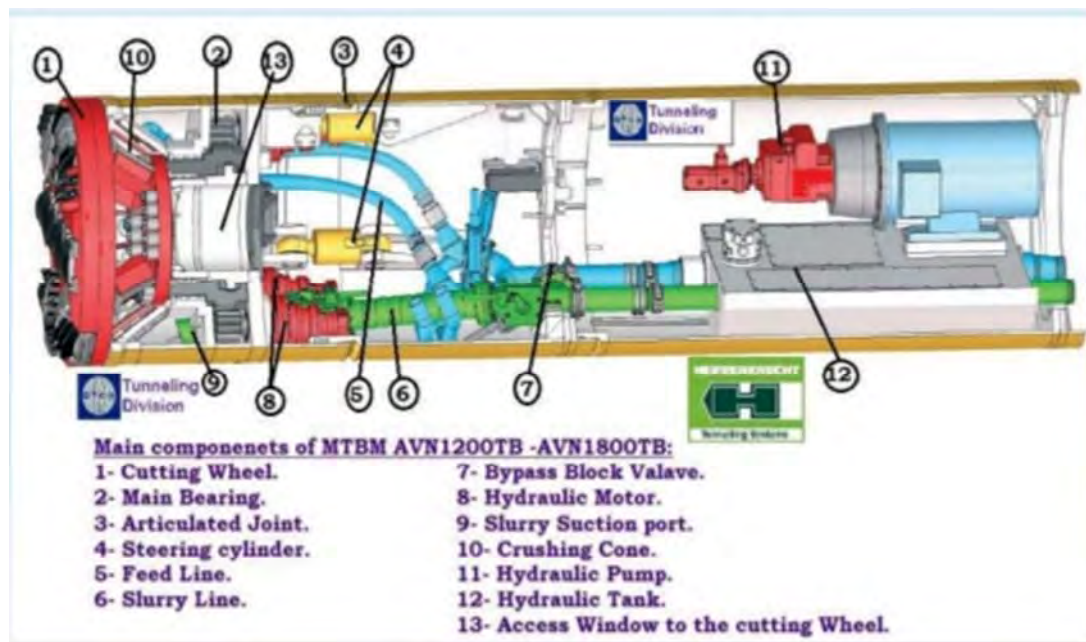

Figure 12.2.5 Micro Tunneling Method

f) Tunneling

Tunneling process needs an entry and exit pit. It involves four main steps,

- i. soil excavation,
- ii. spoil removal,
- iii. segmental pipe installation, and
- iv. alignment control.

Soil excavation can be carried out by any excavation method, including hand mining, open-face mechanical excavation, or any tunnel boring machines (see Figure 12.2.6). The available space dictates the appropriate spoil removal (such as slurry systems, vacuum extraction systems, belt and chain conveyors, etc.

In this project tunneling method is not considered since the size are small.

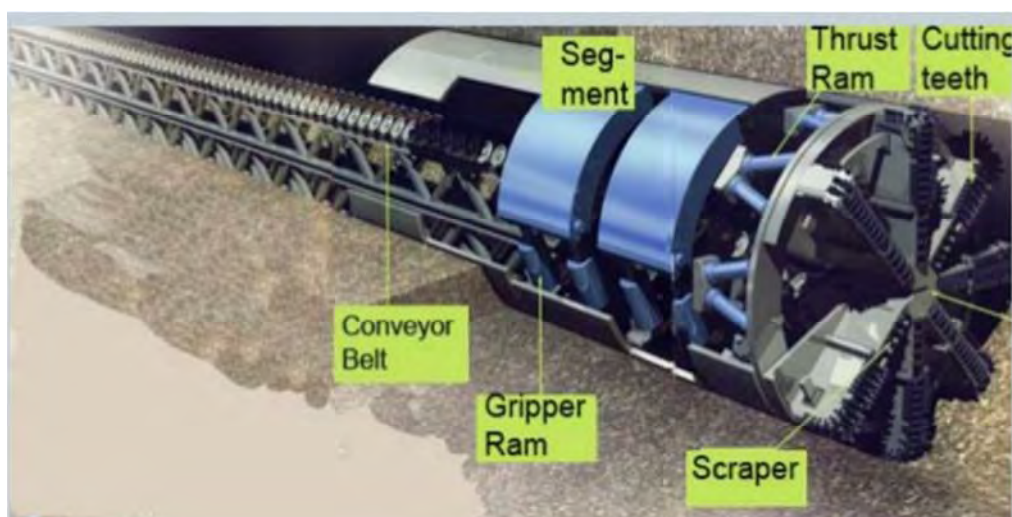

Figure 12.2.6 Tunneling Method

(3) Preliminary Design for Sewers

Summary of main sewers for all zones are shown in Table 12.2.2. Plans and profiles are shown in “Preliminary Design Drawings”.

Table 12.2.2 Summary of Main Sewer

Zone	JICA Survey		DPR	
	Range of Pipe Size (mm)	Length (km)	Range of Pipe Size (mm)	Length (km)
Bytrayanapura	φ300 ~ φ1,000	50.3	φ300 ~ φ900	44.4
Mahadevpura	φ300 ~ φ800	44.7	φ300 ~ φ900	43.6
Bommanahalli	φ300 ~ φ1,200	65.0	φ300 ~ φ1,000	58.8
R.R. Nagar	φ300 ~ φ500	14.8	φ300 ~ φ900	19.0
Dasarahalli	φ300 ~ φ700	27.5	φ300 ~ φ600	23.9
Total	-	202.3		189.7

Source: JICA Survey Team

1) Bytrayanapura Zone

Summary of main sewers for Bytrayanapura zone is shown in Table 12.2.3. Flow calculation sheets are compiled in the Supporting Report 12.2.1.

Table 12.2.3 Summary of Main Sewer in Bytrayanapura Zone

Treatment Area	Pipe Size (mm)	Length (m)		
		Open-cut	Trench-less	Total
Jakkur, Allal-sandra, Yelahanka, Doddabettahalli, Billishivale, Raja	300	18,501	120	18,621
	400	19,337	30	19,367
	450	174	-	174

Treatment Area	Pipe Size (mm)	Length (m)		
		Open-cut	Trench-less	Total
Canal, Horamavu, Chikkabanavara	500	5,915	-	5,915
	600	1,865	140	2,005
	700	1,645	-	1,645
	800	1,441	-	1,441
	900	957	-	957
	1,000	129	-	129
Total	-	49,964	290	50,254

Source: JICA Survey Team

2) Mahadevpura Zone

Summary of main sewers for Mahadevpura zone is shown in Table 12.2.4. Flow calculation sheets are compiled in the Supporting Report 12.2.1.

Table 12.2.4 Summary of Main Sewer in Mahadevpura Zone

Treatment Area	Pipe Size (mm)	Length (m)		
		Open-cut	Trench-less	Total
Varthur, Billishivale, Belandur Amanikere, Kadugodi	300	18,120	120	18,240
	400	3,154	-	3,154
	450	11,349	-	11,349
	500	2,696	-	2,696
	600	2,521	50	2,571
	700	4,730	-	4,730
	800	1,931	-	1,931
Total	-	44,501	170	44,671

Source: JICA Survey Team

3) Bommanahalli Zone

Summary of main sewers for Bommanahalli zone is shown in Table 12.2.5. Flow calculation sheets are compiled in the Supporting Report 12.2.1.

Table 12.2.5 Summary of Main Sewer in Bommanahalli Zone

Treatment Area	Pipe Size (mm)	Length (m)		
		Open-cut	Trench-less	Total
Naganathapura, Belandur Amanikere, Pillaganahalli, Thalaghattapura,	300	22,265	70	22,335
	400	21,235	200	21,435
	450	2,186	50	2,236

Treatment Area	Pipe Size (mm)	Length (m)		
		Open-cut	Trench-less	Total
Anjanapura	500	4,397	100	4,497
	600	4,839	100	4,939
	700	2,825	-	2,825
	800	211	-	211
	900	4,036	-	4,036
	1,000	1,050	120	1,170
	1,200	1,327	-	1,327
Total	-	64,371	640	65,011

Source: JICA Survey Team

4) R.R. Nagar Zone

Summary of main sewers for R.R. Nagar zone is shown in Table 12.2.6. Flow calculation sheets are compiled in the Supporting Report 12.2.1.

Table 12.2.6 Summary of Main Sewer in R.R. Nagar Zone

Treatment Area	Pipe Size (mm)	Length (m)		
		Open-cut	Trench-less	Total
Somapura, Hemi-gepura, Mail-sandra/Doddabele	300	10,114	30	10,144
	400	3,936	-	3,936
	450	128	-	128
	500	610	-	610
Sub Total	-	14,788	30	14,818

Source: JICA Survey Team

5) Dasarahalli Zone

Summary of main sewers for Dasarahalli zone is shown in Table 12.2.7. Flow calculation sheets are compiled in the Supporting Report 12.2.1.

Table 12.2.7 Summary of Main Sewer in Dasarahalli Zone

Treatment Area	Pipe Size (mm)	Length (m)		
		Open-cut	Trench-less	Total
Doddabidarakallu, Karivobanahalli, Herohalli, Hosahalli, Chikkabanavara	300	14,949	210	15,159
	400	7,198	-	7,198
	450	457	-	457
	500	1,370	-	1,370
	600	2,285	-	2,285

Treatment Area	Pipe Size (mm)	Length (m)		
		Open-cut	Trench-less	Total
	700	1,025	-	1,025
Total	-	27,284	210	27,494

Source: JICA Survey Team

(4) Preliminary Design for ISPSs and Pressure Main

ISPS facilities is to lift up/pressure feed the sewage collected by sewer systems at the lowest point to main sewer, another ISPS or STPs. Main facilities at ISPS are; Inlet Chamber, Screen Channel, and Wet Well (Pump Sump) as well as Substation and Generator room. Substation is the power receiving facility and generator is backup for power supply in case of power cut. Inlet Chamber is sewage receiving facility which includes emergency shutoff gate for inflow. Screen Channel is to screen larger particles in the sewage to prevent damage of pumps. Sewage pumps are installed in Wet Well (Pump sump). Table 12.2.8 shows daily average and hourly maximum flow for target year 2034 and 2049 for proposed ISPSs.

Table 12.2.8 Design Flow for ISPSs

Zone	ISPS		Design Flow (MLD)			
	No	Name	2034		2049	
			Daily Average	Hourly Maximum	Daily Average	Hourly Maximum
Bytrayanapura	A-1	Bellahalli	0.9	2.7	1.5	4.5
Mahadevpura	B-1	Hagadur	15.0	33.8	24.0	54.0
Bommanahalli	C-1	Naganathapura	9.0	20.3	13.0	29.3
R.R. Nagar	D-1	Arehalli 1	1.1	3.3	1.7	5.1
	D-2	Hemigepura	1.6	4.8	2.4	7.2
Dasarahalli	E-1	Herohalli	0.5	1.5	0.7	2.1
	E-2	Doddabidarakallu	8.1	18.2	12.8	28.8

Source: JICA Survey Team

Table 12.2.9 shows the diameter and velocity of proposed pressure main. Basically, velocity in the pipe are set as 1.0~1.5m/s, which is economical in capital and operation cost. Calculation basis is included in 12.2.2, Supporting Report and drawings are compiled in “Preliminary Design Drawings”.

Table 12.2.9 Diameter and Velocity of Proposed Pressure Main

Zone	ISPS		Diameter mm	Length m	Total Head m	*V ₂₀₃₄ m/s	*V ₂₀₄₉ m/s
	No	Name					
Bytrayanapura	A-1	Bellahalli	250	1,380	37	0.71	1.06
Mahadevpura	B-1	Hagadur	800	5,300	29	0.78	1.25
Bommanahalli	C-1	Naganathapura	600	3,000	36	0.83	1.20

Zone	ISPS		Diameter	Length	Total Head	*V ₂₀₃₄	*V ₂₀₄₉
	No	Name	mm	m	m	m/s	m/s
R.R. Nagar	D-1	Arehalli 1	250	730	24	0.78	1.13
	D-2	Hemigepura	400	1,500	25	0.61	0.90
Dasarahalli	E-1	Herohalli	200	1,100 (60m: Trenchless)	15	0.56	0.89
	E-2	Doddabidarakallu	600	2,300	33	0.75	1.20

Note: *V₂₀₃₄ is velocity in the year 2034. *V₂₀₄₉ is velocity at the year in 2049.
Source: JICA Survey Team

1) Belahalli ISPS

Plan and section for Belahalli ISPS is shown in Figure 12.2.7. Table 12.2.10 shows major equipment list including mechanical and electrical facilities for Belahalli ISPS. Figure 12.2.8 shows layout of Belahalli ISPS.

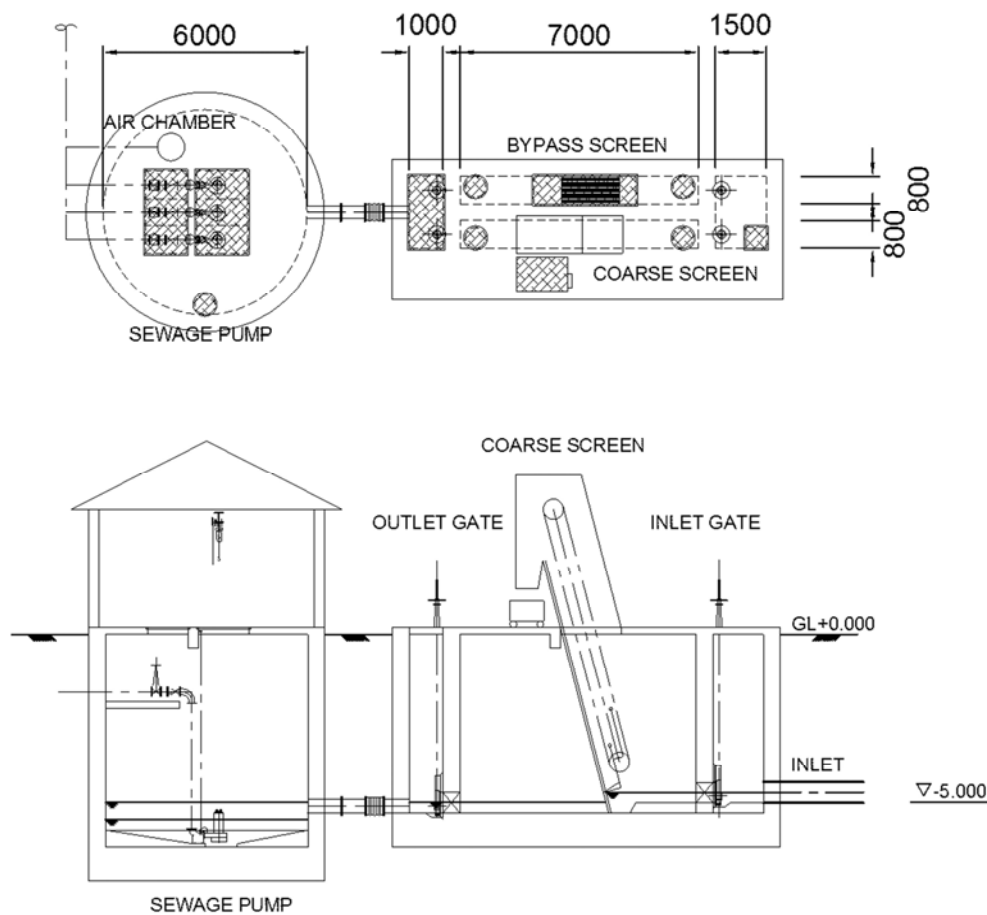

Source: JICA Survey Team

Figure 12.2.7 Plan and Section of Belahalli ISPS

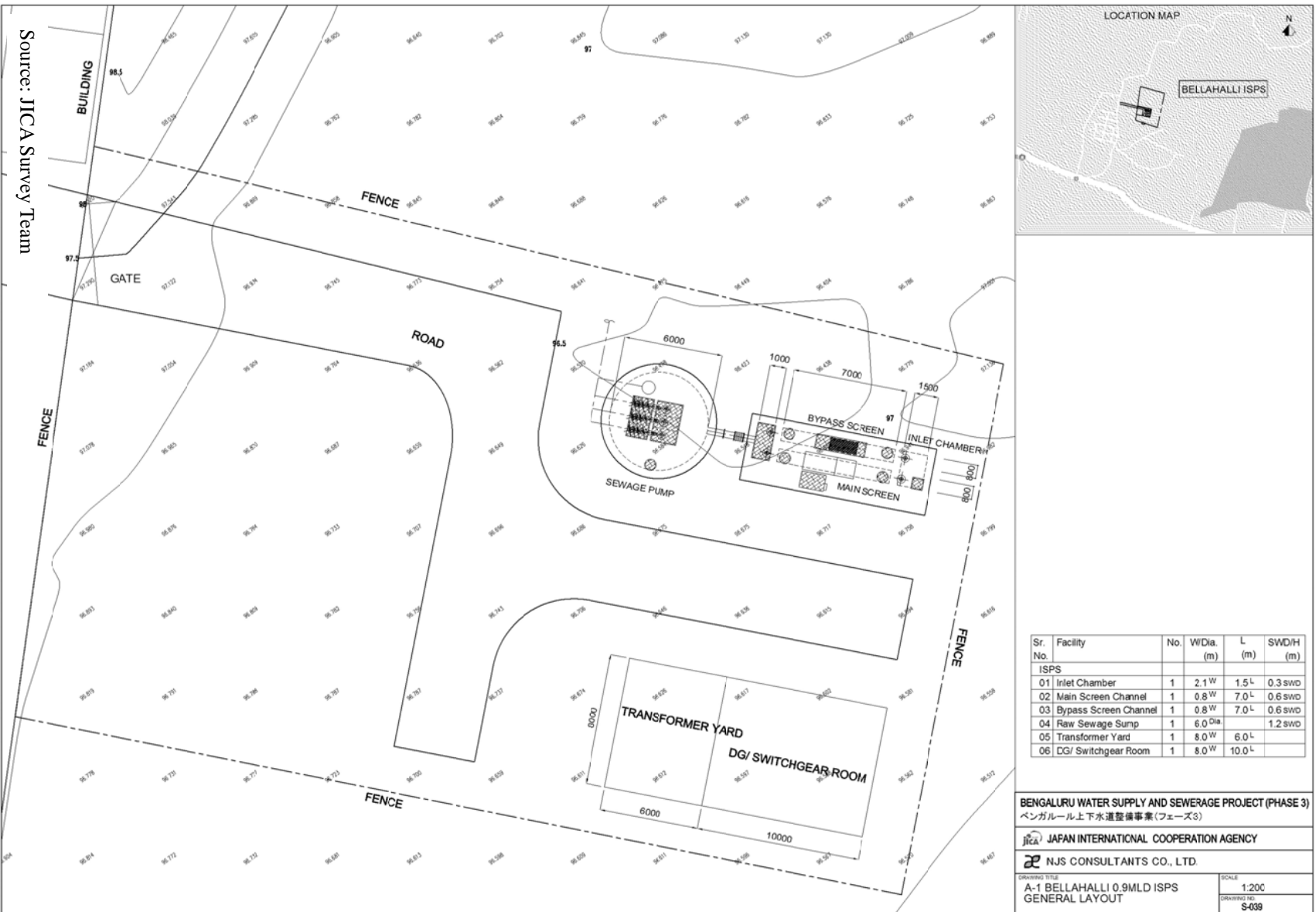

Figure 12.2.8 Layout of Bellahalli ISPS

Table 12.2.10 Major Equipment List for Belahalli ISPS

Items	Specification	kW per unit	Unit number
(Mechanical)			
1. Inlet Gates	Manually Operated Cast Iron	Width 0.4(m)×Height :0.6(m)	- 2
2. Coarse Screens (Mechanical)	Climber Type SS316L	Channel Width :0.80 (m)×SWD :0.70 (m) ×Open Space:20(mm)	1.50 1W
3. Coarse Screens (Manual)	Climber Type SS316L	Channel Width :0.80 (m)×SWD :0.70 (m) ×Open Space:50(mm)	- 1
4. Outlet Gates	Manually Operated Cast Iron	Width 0.4(m)×Height :0.6(m)	- 2
5. Sewage Pump	Submersible Cast Iron	Dia:150 (mm)×Discharge :125 (m ³ /h) ×Total Head:35.0 (m)	30.0 1W+1S
6. Discharge Valve	Electric Operated Cast Iron	Sluice Valve, Dia:150 (mm)×PN10	0.75 2W
7. Electric Hoist	I-girder Type	Rated Load :1.0(Ton)×Lift :6(m)	3.90 1W
8. Air Chamber	Hydro pneumatic Surge Vessel	Capacity :1.0(m ³)	0.40 1W
Items	Specification	Unit number	
(Electrical)	Total electric capacity 37.30 kW		
1. Power receiving facilities at electrical substation	HV incoming panel, IP42, 11kV, VCB HV outgoing feeder panels, IP42, 11kV, VCB Power transformers: outdoor use, 11/0.415-0.24 kV,150 kVA Diesel engine generator set: 415 V, 50 Hz, 100 kVA	1 pc 2 pcs 2 sets 1 pc	
2. LV switchgears, and MCCs	LV panel: IP42, 600V, ACB 200A x 4, MCCB 100A x 5 MCC for ISPS	1 pc 1 pc	
3. Instrumentation devices	Inlet flow meter Level meter in inlet chamber Level meter in sewage pump sump Level meters of pre and post screens	1 pc 1 pc 1 pc 2 pcs	
4. PLC panel	PLC with HMI, GPRS Modem, UPS	1 ls	

Source: JICA Survey Team

2) Hagadur ISPS

Plan and section for Hagadur ISPS is shown in Figure 12.2.9. Table 12.2.11 shows major equipment list including mechanical and electrical facility for Hagadur ISPS. Figure 12.2.10 presents layout of Hagadur ISPS.

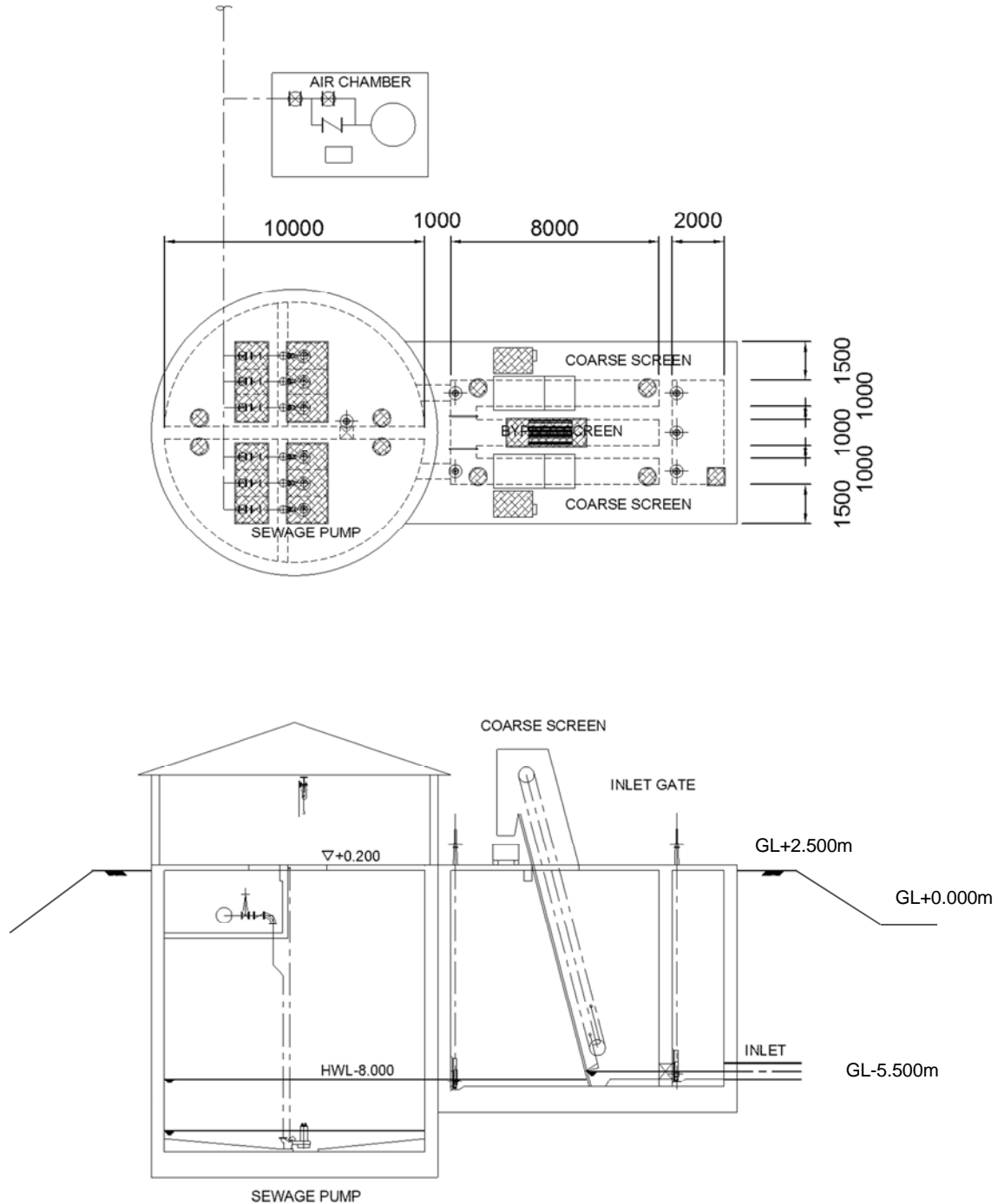

Source: JICA Survey Team

Figure 12.2.9 Plan and Section of Hagadur ISPS

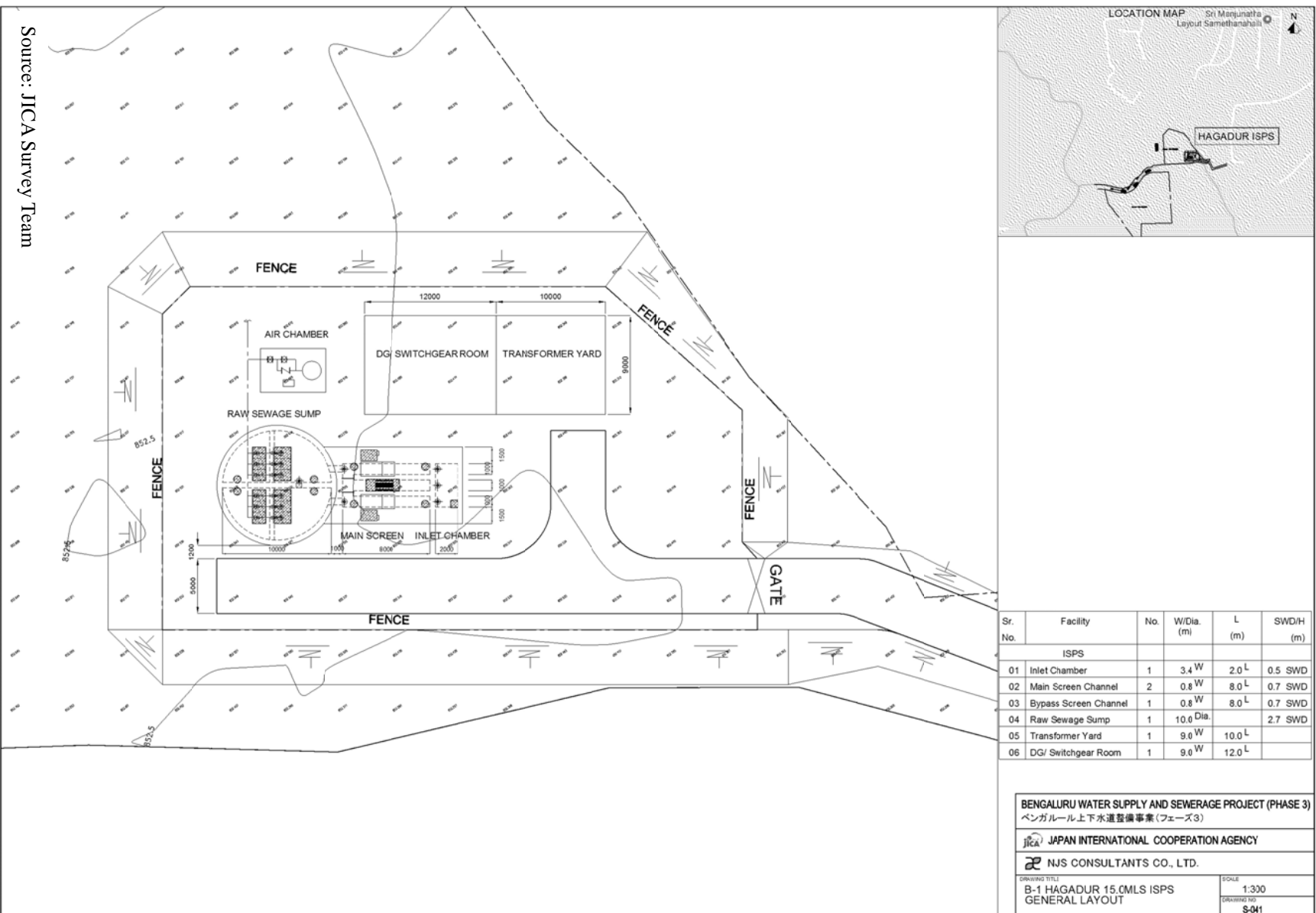

Source: JICA Survey Team

Figure 12.2.10 Layout of Hagadur ISPS

Table 12.2.11 Major Equipment List for Hagadur ISPS

Items	Specification	kW per unit	Unit number
(Mechanical)			
1. Inlet Gates	Manually Operated Cast Iron	Width 0.6(m)×Height :0.9(m)	- 3
2. Coarse Screens (Mechanical)	Climber Type SS316L	Channel Width :1.00 (m)×SWD :0.60 (m) ×Open Space:20(mm)	1.50 2W
3. Coarse Screens (Manual)	Climber Type SS316L	Channel Width :1.00 (m)×SWD :0.60 (m) ×Open Space:50(mm)	- 1
4. Belt conveyer	NBR MS +Epoxy	Belt Width :0.60 (m)×Length :5.00 (m)	1.50 1W
5. Outlet Gates	Manually Operated Cast Iron	Width 0.6(m)×Height :0.9(m)	- 2
6. Interface Gates	Manually Operated Cast Iron	Width 0.7(m)×Height :0.7(m)	- 1
7. Sewage Pump 1	Submersible Cast Iron	Dia:300 (mm)×Discharge :564 (m ³ /h) ×Total Head:25.0 (m)	75.0 2W+1S
8. Sewage Pump 2	Submersible Cast Iron	Dia:200 (mm)×Discharge :282 (m ³ /h) ×Total Head:25.0 (m)	45.0 1W+1S
9. Discharge Valve 1	Electric Operated Cast Iron	Sluice Valve, Dia:300 (mm)×PN10	1.50 3W
10. Discharge Valve 2	Electric Operated Cast Iron	Sluice Valve, Dia:200 (mm)×PN10	0.75 2W
11. Electric Hoist	Single-girder Overhead Type	Rated Load :3.0(Ton)×Lift :6(m)	8.60 1W
Items	Specification		Unit number
(Electrical)	Total electric capacity 214.85 kW		
1. Power receiving facilities at electrical substation	HV incoming panel, IP42, 11kV, VCB HV outgoing feeder panels, IP42, 11kV, VCB Power transformers: outdoor use, 11/0.415-0.24 kV, 500 kVA Diesel engine generator set: 415 V, 50 Hz, 350 kVA		1 pc 2 pcs 2 sets 1 pc
2. LV switchgears, and MCCs	LV panel: IP42, 600V, ACB 800A x 3, ACB 630A x 1, MCCB 100A x 5 MCC for ISPS Sewage pumps starter panel with 75 kW star-delta		1 pc 1 pc 3 pcs
3. Instrumentation devices	Inlet flow meter Level meter in inlet chamber Level meter in sewage pump sump Level meters of pre and post screens		1 pc 1 pc 1 pc 2 pcs
4. PLC panel	PLC with HMI, GPRS Modem, UPS		1 ls

Source: JICA Survey Team

3) Naganathapura ISPS

Plan and section for Naganathapura ISPS is shown in Figure 12.2.11. Table 12.2.12 shows major equipment list including mechanical and electrical facility for Naganathapura ISPS. Figure 12.2.12 presents layout of Naganathapura ISPS.

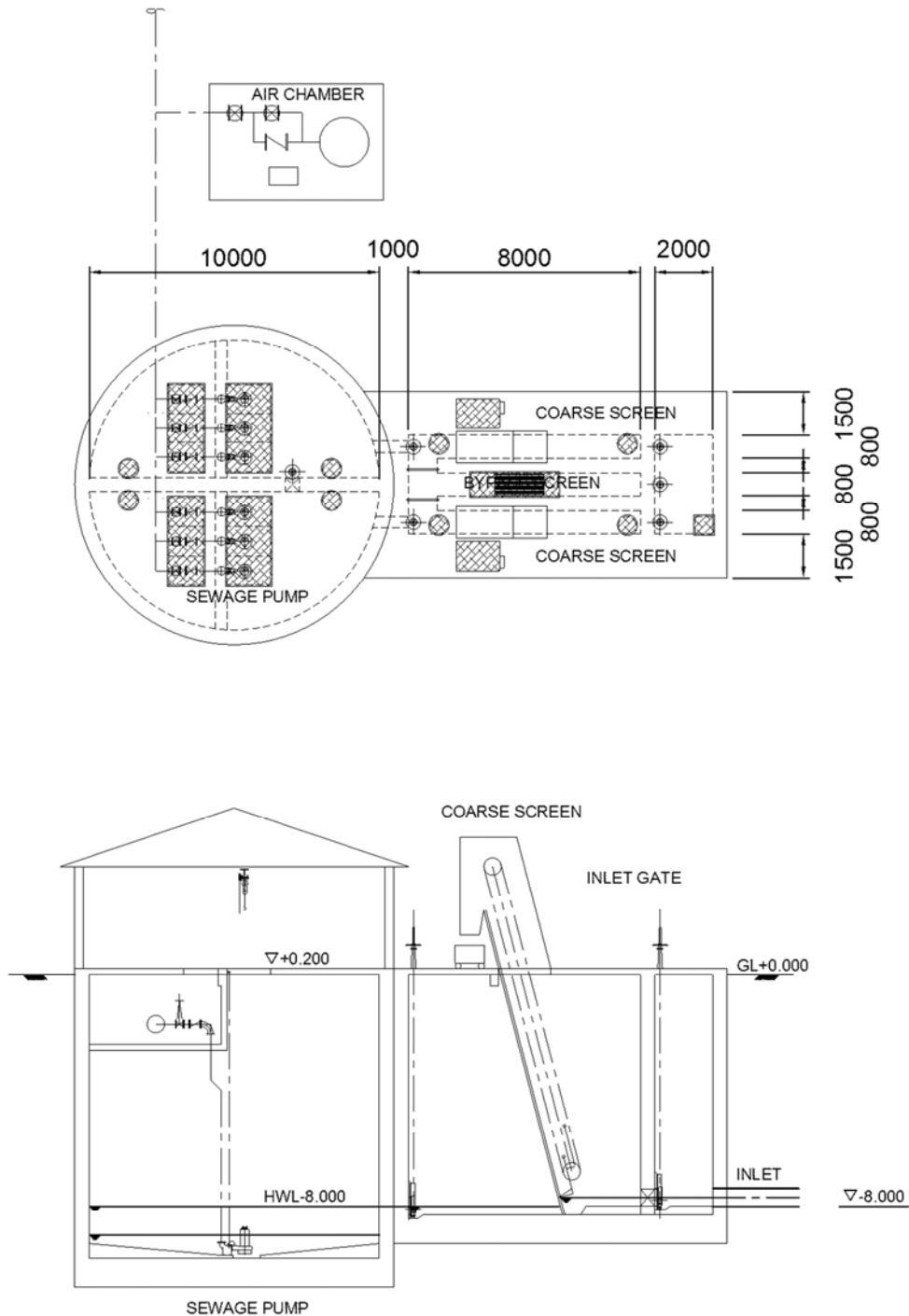

Source: JICA Survey Team

Figure 12.2.11 Plan and Section of Naganathapura ISPS

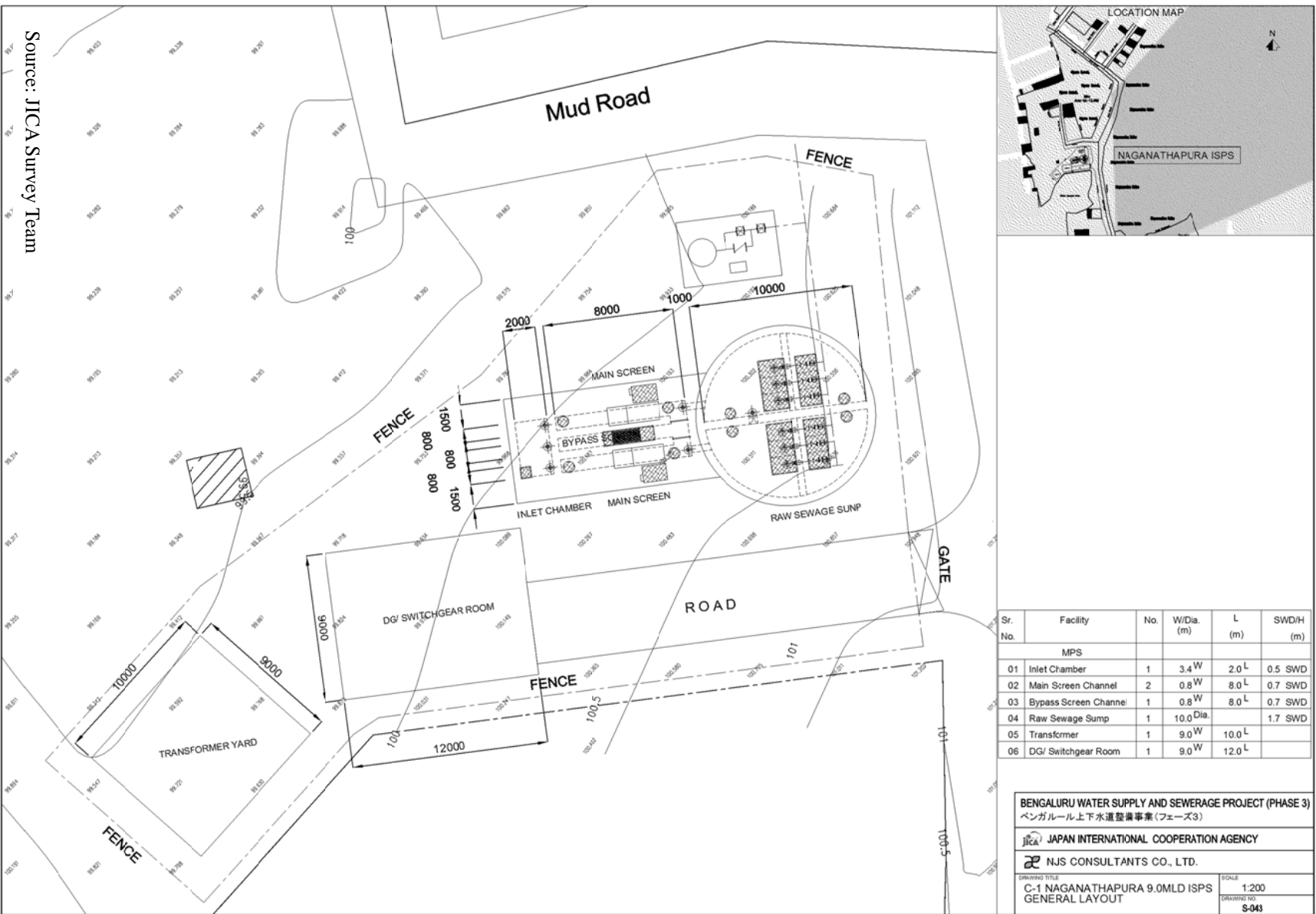

Table 12.2.12 Major Equipment List for Naganathapura ISPS

Items	Specification	kW per unit	Unit number
(Mechanical)			
1. Inlet Gates	Manually Operated Cast Iron	Width 0.50(m)×Height :0.75(m)	- 3
2. Coarse Screens (Mechanical)	Climber Type SS316L	Channel Width :0.80 (m)×SWD :0.70 (m) ×Open Space:20(mm)	1.50 1W
3. Coarse Screens (Manual)	Climber Type SS316L	Channel Width :0.80 (m)×SWD :0.70 (m) ×Open Space:50(mm)	- 1
4. Outlet Gates	Manually Operated Cast Iron	Width 0.50(m)×Height :0.75(m)	- 2
5. Interface Gates	Manually Operated Cast Iron	Width 0.60(m)×Height :0.60(m)	- 1
6. Sewage Pump 1	Submersible Cast Iron	Dia:300 (mm)×Discharge :338 (m ³ /h) ×Total Head:36.0 (m)	75.0 2W+1S
7. Sewage Pump 2	Submersible Cast Iron	Dia:200 (mm)×Discharge :169 (m ³ /h) ×Total Head:36.0 (m)	37.0 1W+1S
8. Discharge Valve 1	Electric Operated Cast Iron	Sluice Valve, Dia:300 (mm)×PN10	1.50 3W
9. Discharge Valve 2	Electric Operated Cast Iron	Sluice Valve, Dia:200 (mm)×PN10	0.75 2W
10. Electric Hoist	Single-girder Overhead Type	Rated Load :3.0(Ton)×Lift :6(m)	8.60 1W
11. Air Chamber	Hydro pneumatic Surge Vessel	Capacity :1.0(m ³)	0.40 1W
Items	Specification		Unit number
(Electrical)	Total electric capacity 201.25 kW		
1. Power receiving facilities at electrical substation	HV incoming panel, IP42, 11kV, VCB HV outgoing feeder panels, IP42, 11kV, VCB Power transformers: outdoor use, 11/0.415-0.24 kV,500 kVA Diesel engine generator set: 415 V, 50 Hz, 300 kVA		1 pc 2 pcs 2 sets 1 pc
2. LV switchgears, and MCCs	LV panel: IP42, 600V, ACB 800A x 3, ACB 630A x 1, MCCB 200A x 4, MCCB 100A x 5 MCC for ISPS Sewage pumps starter panel with 75 kW star-delta		1 pc 3 pcs
3. Instrumentation devices	Inlet flow meter Level meter in inlet chamber Level meter in sewage pump sump Level meters of pre and post screens		1 pc 1 pc 1 pc 2 pcs
4. PLC panel	PLC with HMI, GPRS Modem, UPS		1 ls

Source: JICA Survey Team

4) Arehalli 1 ISPS

Plan and section for Arehalli 1 ISPS is shown in Figure 12.2.13. Table 12.2.13 shows major equipment list including mechanical and electrical facility for Arehalli 1 ISPS. Figure 12.2.14 presents layout of Arehalli 1 ISPS.

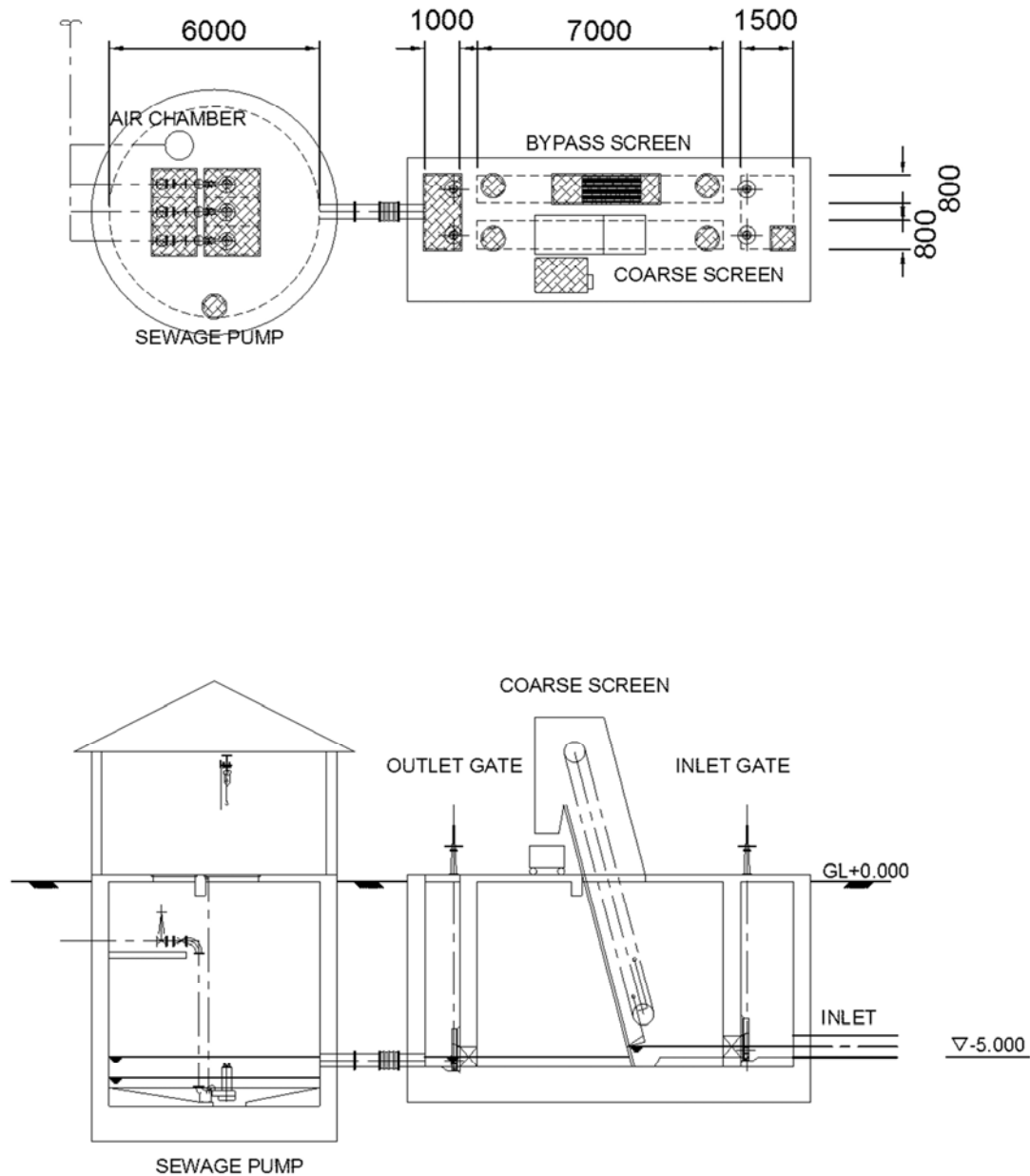

Source: JICA Survey Team

Figure 12.2.13 Plan and Section of Arehalli 1 ISPS

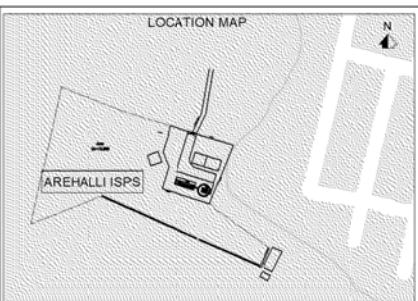

Sr. No.	Facility	No.	W/Dia. (m)	L (m)	SWD/H (m)
ISPS					
01	Inlet Chamber	1	2.1 W	1.5 L	0.3 SWD
02	Main Screen Channel	1	0.8 W	7.0 L	0.6 SWD
03	Bypass Screen Channel	1	0.8 W	7.0 L	0.6 SWD
04	Raw Sewage Sump	1	6.0 Dia.		1.3 SWD
05	Transformer	1	6.0 W	8.0 L	
06	DG/ Switchgear Room	1	6.0 W	7.0 L	

BENGALURU WATER SUPPLY AND SEWERAGE PROJECT (PHASE 3)
 ベンガルール上下水道整備事業(フェーズ3)

JICA JAPAN INTERNATIONAL COOPERATION AGENCY

NJS CONSULTANTS CO., LTD.

DRAWING TITLE
 D-1 AREHALLI 1 1.1MLD ISPS
 GENERAL LAYOUT

SCALE
 1:200
 DRAWING NO.
 S-045

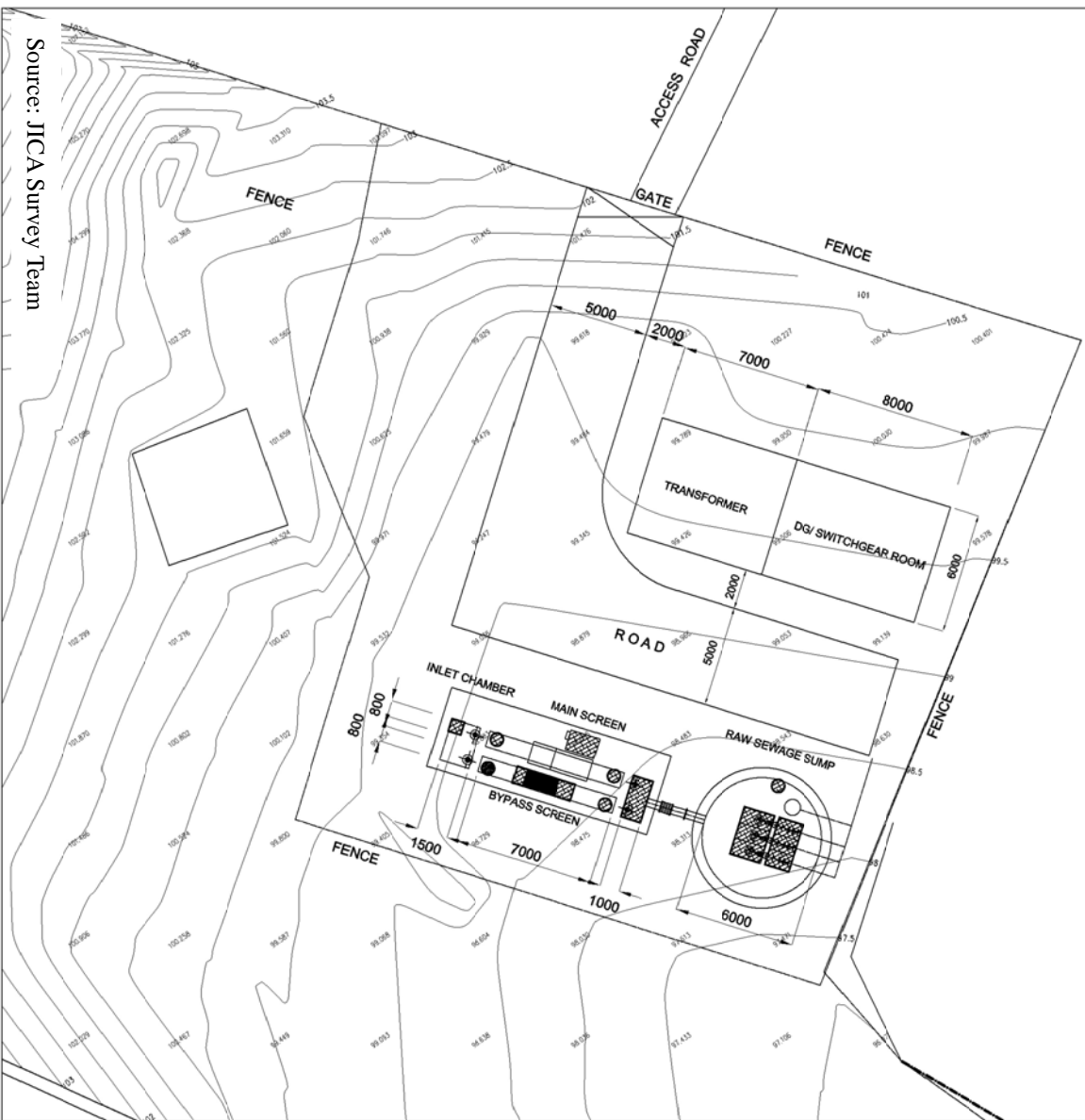

Source: JICA Survey Team

Figure 12.2.14 Layout of Arehalli 1 ISPS

Table 12.2.13 Major Equipment List for Arehalli ISPS

Items	Specification	kW per unit	Unit number
(Mechanical)			
1. Inlet Gates	Manually Operated Cast Iron	Width 0.4(m)×Height :0.6(m)	- 2
2. Coarse Screens (Mechanical)	Climber Type SS316L	Channel Width :0.80 (m)×SWD :0.70 (m) ×Open Space:20(mm)	1.50 1W
3. Coarse Screens (Manual)	Climber Type SS316L	Channel Width :0.80 (m)×SWD :0.70 (m) ×Open Space:50(mm)	- 1
4. Outlet Gates	Manually Operated Cast Iron	Width 0.4(m)×Height :0.6(m)	- 2
5. Sewage Pump	Submersible Cast Iron	Dia:150 (mm)×Discharge :138 (m ³ /h) ×Total Head:25.0 (m)	18.50 1W+1S
6. Discharge Valve	Electric Operated Cast Iron	Sluice Valve, Dia:150 (mm)×PN10	0.75 2W
7. Electric Hoist	I-girder Type	Rated Load :1.0(Ton)×Lift :6(m)	3.90 1W
8. Air Chamber	Hydro pneumatic Surge Vessel	Capacity :2.0(m ³)	0.40 1W
Items	Specification		Unit number
(Electrical)			
1. Power receiving facilities at electrical substation	HV incoming panel, IP42, 11kV, VCB HV outgoing feeder panels, IP42, 11kV, VCB Power transformers: outdoor use, 11/0.415-0.24 kV,100 kVA Diesel engine generator set: 415 V, 50 Hz, 50 kVA		1 pc 2 pcs 2 sets 1 pc
2. LV switchgears, and MCCs	LV panel: IP42, 600V, ACB 200A x 4, MCCB 100A x 5 MCC for ISPS		1 pc 1 pc
3. Instrumentation devices	Inlet flow meter Level meter in inlet chamber Level meter in sewage pump sump Level meters of pre and post screens		1 pc 1 pc 1 pc 2 pcs
4. PLC panel	PLC with HMI, GPRS Modem, UPS		1 ls

Source: JICA Survey Team

5) Hemigepura ISPS

Plan and section for Hemigepura ISPS is shown in Figure 12.2.15. Table 12.2.14 shows major equipment list including mechanical and electrical item for Hemigepura ISPS. Figure 12.2.16 presents layout of Hemigepura ISPS.

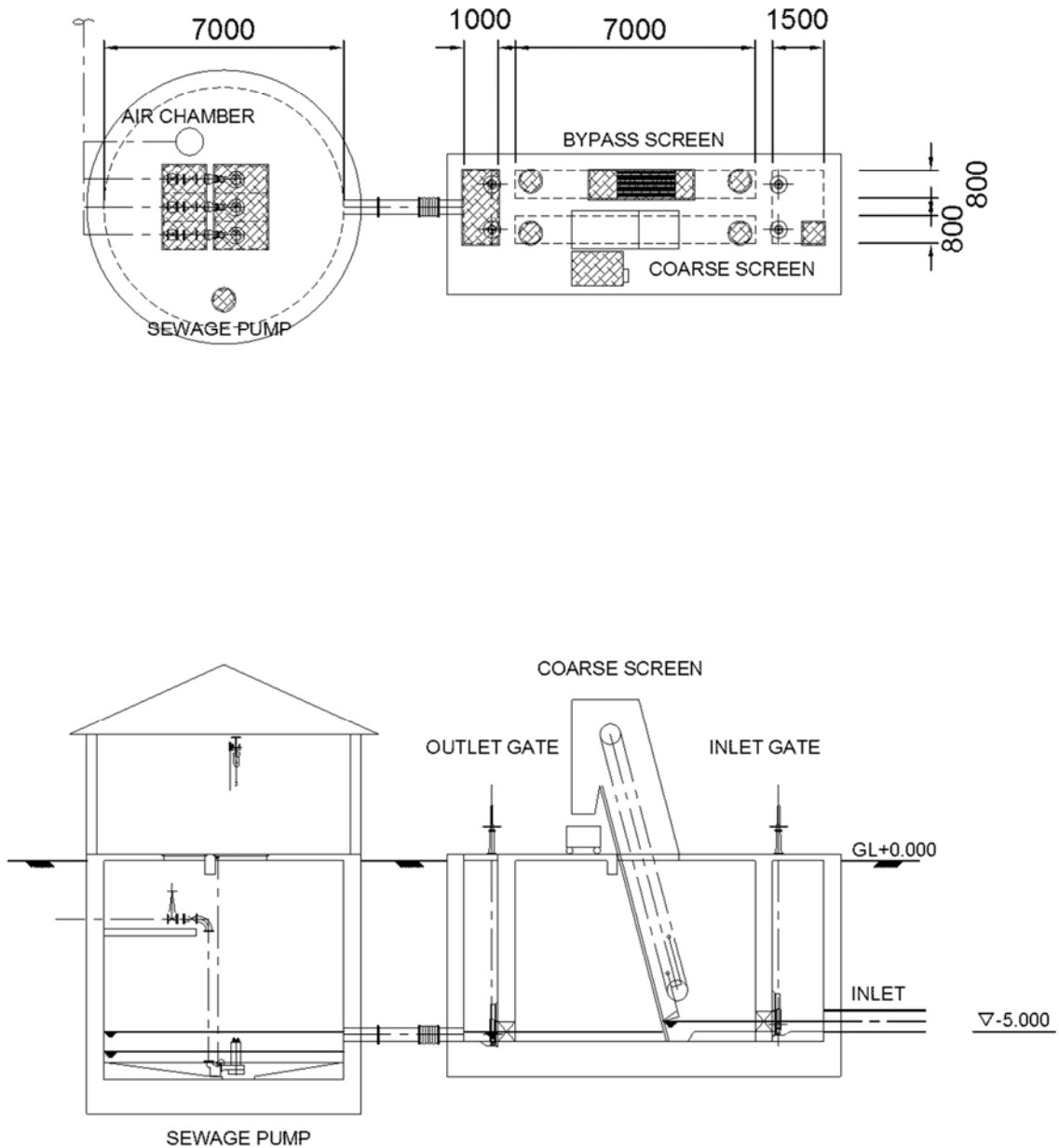

Source: JICA Survey Team

Figure 12.2.15 Plan and Section of Hemigepura ISPS

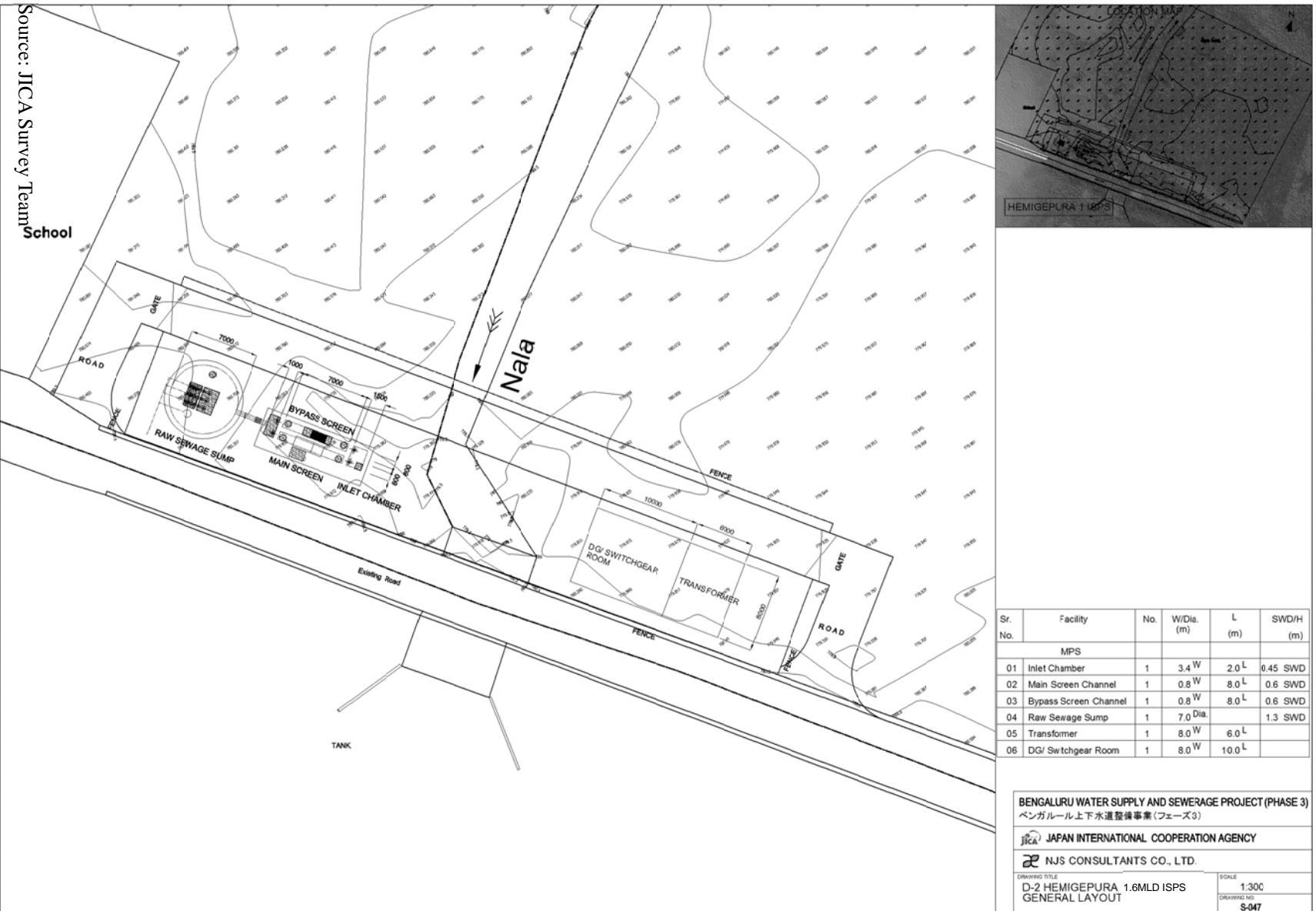

Figure 12.2.16 Layout of Hemigepura ISPS

Table 12.2.14 Major Equipment List for Hemigepura ISPS

Items	Specification	kW per unit	Unit number
(Mechanical)			
1. Inlet Gates	Manually Operated Cast Iron	Width 0.4(m)×Height :0.6(m)	- 2
2. Coarse Screens (Mechanical)	Climber Type SS316L	Channel Width :0.80 (m)×SWD :0.70 (m) ×Open Space:20(mm)	1.50 1W
3. Coarse Screens (Manual)	Climber Type SS316L	Channel Width :0.80 (m)×SWD :0.70 (m) ×Open Space:50(mm)	- 1
4. Outlet Gates	Manually Operated Cast Iron	Width 0.4(m)×Height :0.6(m)	- 2
5. Sewage Pump	Submersible Cast Iron	Dia:200 (mm)×Discharge :213 (m ³ /h) ×Total Head:23.0 (m)	30.00 1W+1S
6. Discharge Valve	Electric Operated Cast Iron	Sluice Valve, Dia:200 (mm)×PN10	0.75 2W
7. Electric Hoist	I-girder Type	Rated Load :1.0(Ton)×Lift :6(m)	3.90 1W
8. Air Chamber	Hydro pneumatic Surge Vessel	Capacity :1.0(m ³)	0.40 1W

Items	Specification	Unit number
(Electrical)	Total electric capacity 37.30 kW	
1. Power receiving facilities at electrical substation	HV incoming panel, IP42, 11kV, VCB HV outgoing feeder panels, IP42, 11kV, VCB Power transformers: outdoor use, 11/0.415-0.24 kV,150 kVA Diesel engine generator set: 415 V, 50 Hz, 75 kVA	1 pc 2 pcs 2 sets 1 pc
2. LV switchgears, and MCCs	LV panel: IP42, 600V, ACB 400A x 4, MCCB 100A x 5 MCC for ISPS	1 pc 1 pc
3. Instrumentation devices	Inlet flow meter Level meter in inlet chamber Level meter in sewage pump sump Level meters of pre and post screens	1 pc 1 pc 1 pc 2 pcs
4. PLC panel	PLC with HMI, GPRS Modem, UPS	1 ls

Source: JICA Survey Team

6) Herohalli ISPS

Plan and section for Herohalli ISPS is shown in Figure 12.2.17. Table 12.2.15 shows major equipment list including mechanical and electrical facility for Herohalli ISPS. Figure 12.2.18 presents layout of Herohalli ISPS.

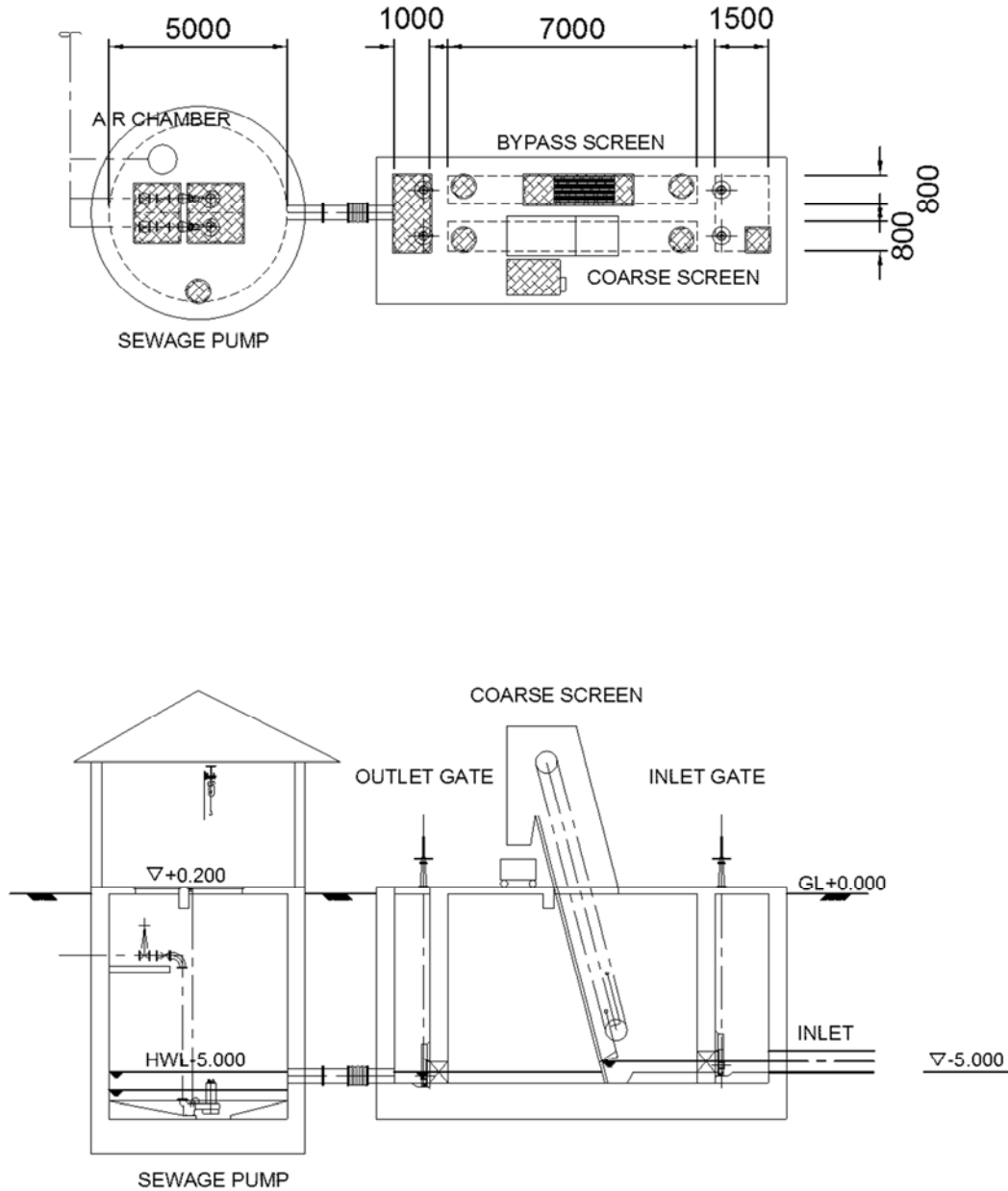

Source: JICA Survey Team

Figure 12.2.17 Plan and Section of Herohalli ISPS

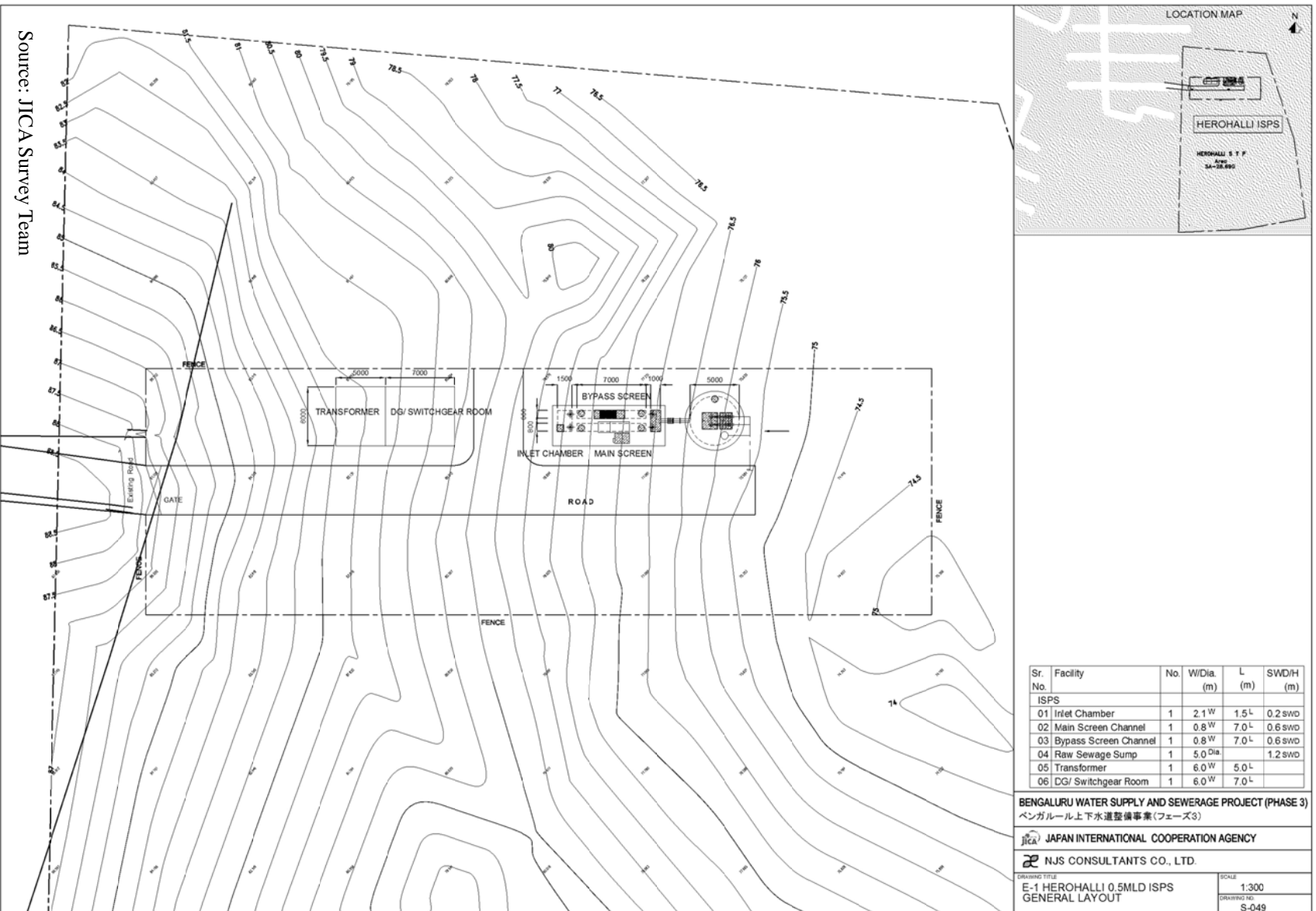

Figure 12.2.18 Layout of Herohalli ISPS

Table 12.2.15 Major Equipment List for Herohalli ISPS

Items	Specification	kW per unit	Unit number
(Mechanical)			
1. Inlet Gates	Manually Operated Cast Iron	Width 0.3(m)×Height :0.3(m)	- 2
2. Coarse Screens (Mechanical)	Climber Type SS316L	Channel Width :0.80 (m)×SWD :0.60 (m) ×Open Space:20(mm)	1.50 1W
3. Coarse Screens (Manual)	Climber Type SS316L	Channel Width :0.80 (m)×SWD :0.60 (m) ×Open Space:50(mm)	- 1
4. Outlet Gates	Manually Operated Cast Iron	Width 0.3(m)×Height :0.3(m)	- 2
5. Sewage Pump	Submersible Cast Iron	Dia:100 (mm)×Discharge :63 (m ³ /h) ×Total Head:15.0 (m)	5.50 1W+1S
6. Discharge Valve1	Electric Operated Cast Iron	Sluice Valve, Dia:100 (mm)×PN10	0.75 3W
7. Electric Hoist	I-girder Type	Rated Load :1.0(Ton)×Lift :6(m)	3.90 1W
8. Air Chamber	Hydro pneumatic Surge Vessel	Capacity :1.0(m ³)	0.40 1W
Items	Specification		Unit number
(Electrical)	Total electric capacity 12.80 kW		
1. Power receiving facilities at electrical substation	HV incoming panel, IP42, 11kV, VCB HV outgoing feeder panels, IP42, 11kV, VCB Power transformers: outdoor use, 11/0.415-0.24 kV,50 kVA Diesel engine generator set: 415 V, 50 Hz, 37.5 kVA		1 pc 2 pcs 2 sets 1 pc
2. LV switchgears, and MCCs	LV panel: IP42, 600V, ACB 100A x 4, MCCB 100A x 5 MCC for ISPS		1 pc 1 pc
3. Instrumentation devices	Inlet flow meter Level meter in inlet chamber Level meter in sewage pump sump Level meters of pre and post screens		1 pc 1 pc 1 pc 2 pcs
4. PLC panel	PLC with HMI, GPRS Modem, UPS		1 ls

Source: JICA Survey Team

7) Doddabidarakallu ISPS

Plan and section for Doddabidarakallu ISPS is shown in Figure 12.2.19. Table 12.2.16 shows major equipment list including mechanical and electrical facility for Doddabidarakallu ISPS. Figure 12.2.20 presents layout of Doddabidarakallu ISPS.

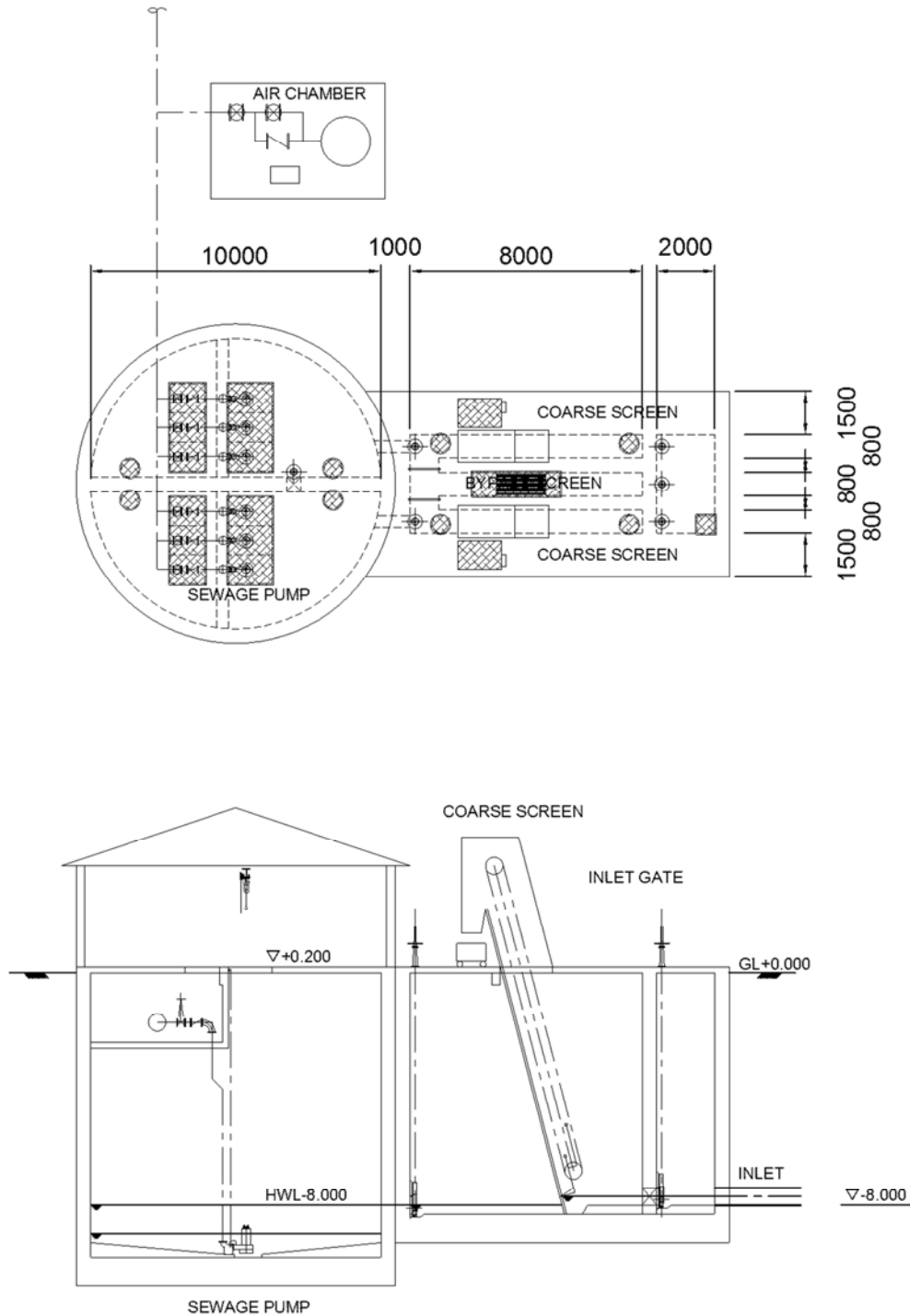

Source: JICA Survey Team

Figure 12.2.19 Plan and Section of Doddabidarakallu ISPS

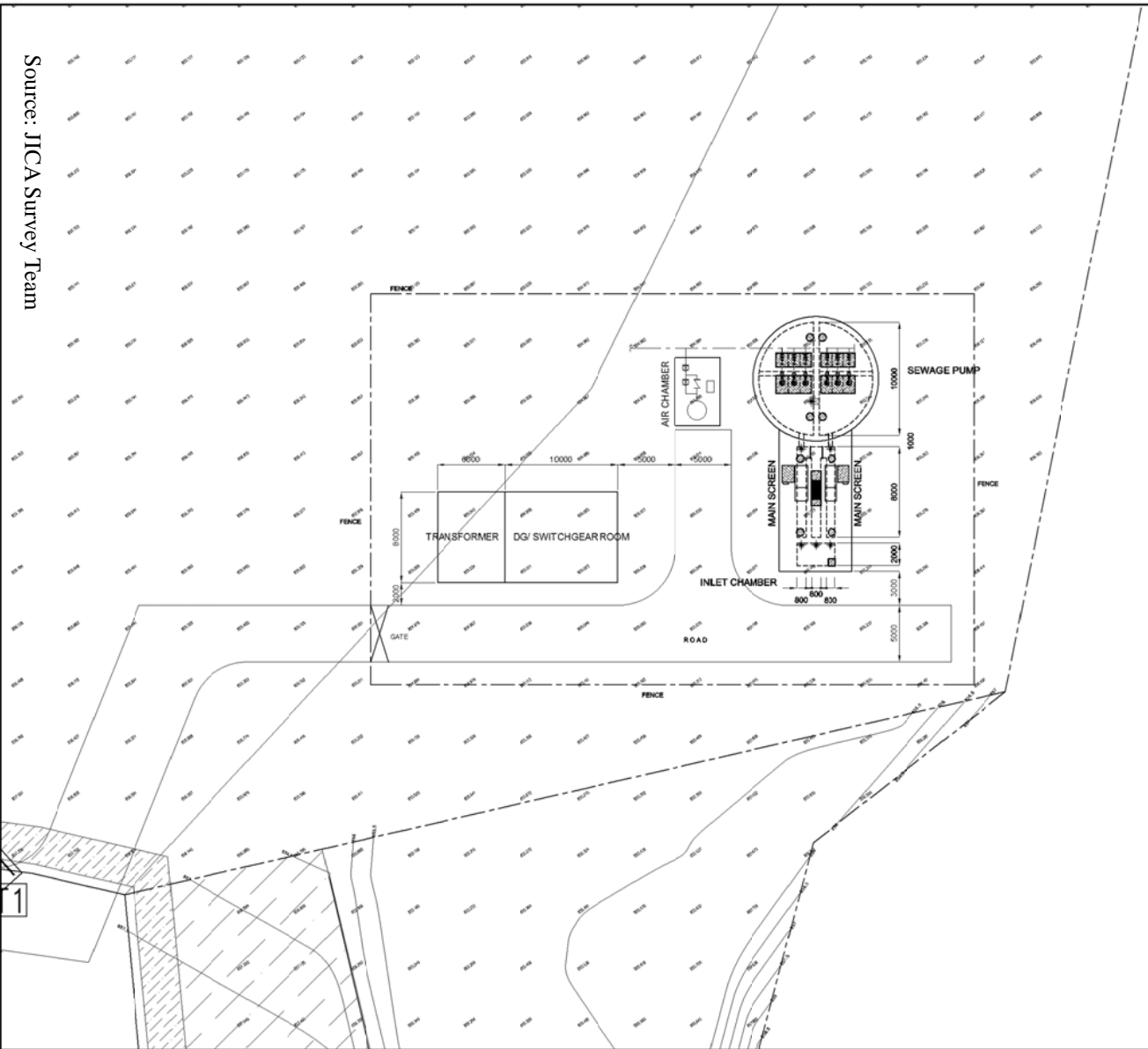
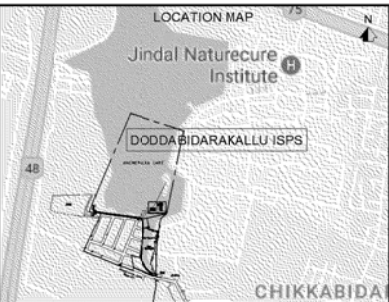

Source: JICA Survey Team

Sr. No.	Facility	No.	W/Dia. (m)	L (m)	SWD/H (m)
ISPS					
01	Inlet Chamber	1	3.4 ^W	2.0 ^L	0.5 swd
02	Main Screen Channel	2	0.8 ^W	8.0 ^L	0.7 swd
03	Bypass Screen Channel	1	0.8 ^W	8.0 ^L	0.7 swd
04	Raw Sewage Sump	1	10.0 ^{Dia.}		1.7 swd
05	Transformer	1	8.0 ^W	6.0 ^L	
06	DG/ Switchgear Room	1	8.0 ^W	10.0 ^L	

BENGALURU WATER SUPPLY AND SEWERAGE PROJECT (PHASE 3)
 ベンガルール上下水道整備事業(フェーズ3)

JICA JAPAN INTERNATIONAL COOPERATION AGENCY

NJS CONSULTANTS CO., LTD.

DRAWING TITLE: E-2 DODDABIDARAKALLU 8.1MLD ISPS GENERAL LAYOUT
 SCALE: 1:300
 DRAWING NO: S-051

Figure 12.2.20 Layout of Doddabidarakallu ISPS

Table 12.2.16 Major Equipment List for Doddabidarakallu ISPS

Items	Specification	kW per unit	Unit number
(Mechanical)			
1. Inlet Gates	Manually Operated Cast Iron	Width 0.50(m)×Height :0.75(m)	- 3
2. Coarse Screens (Mechanical)	Climber Type SS316L	Channel Width :0.80 (m)×SWD :0.70 (m) ×Open Space:20(mm)	1.50 1W
3. Coarse Screens (Manual)	Climber Type SS316L	Channel Width :0.80 (m)×SWD :0.70 (m) ×Open Space:50(mm)	- 1
4. Outlet Gates	Manually Operated Cast Iron	Width 0.50(m)×Height :0.75(m)	- 2
5. Interface Gates	Manually Operated Cast Iron	Width 0.50(m)×Height :0.50(m)	- 1
6. Sewage Pump 1	Submersible Cast Iron	Dia:250 (mm)×Discharge :304 (m ³ /h) ×Total Head:34.0 (m)	75.00 2W+1S
7. Sewage Pump 2	Submersible Cast Iron	Dia:150 (mm)×Discharge :152 (m ³ /h) ×Total Head:34.0 (m)	30.00 1W+1S
8. Discharge Valve 1	Electric Operated Cast Iron	Sluice Valve, Dia:250 (mm)×PN10	0.75 3W
9. Discharge Valve 2	Electric Operated Cast Iron	Sluice Valve, Dia:150 (mm)×PN10	0.75 2W
10. Electric Hoist	Single-girder Overhead Type	Rated Load :3.0(Ton)×Lift :6(m)	8.60 1W
11. Air Chamber	Hydro pneumatic Surge Vessel	Capacity :6.0(m ³)	0.40 1W
Items	Specification		Unit number
(Electrical)	Total electric capacity 164.60 kW		
1. Power receiving facilities at electrical substation	HV incoming panel, IP42, 11kV, VCB HV outgoing feeder panels, IP42, 11kV, VCB Power transformers: outdoor use, 11/0.415-0.24 kV,300 kVA Diesel engine generator set: 415 V, 50 Hz, 250 kVA		1 pc 2 pcs 2 sets 1 pc
2. LV switchgears, and MCCs	LV panel: IP42, 600V, ACB 630A x 3, ACB 400A x 1, MCCB 200A x 4, MCCB 100A x 5 MCC for ISPS Sewage pumps starter panel with 60 kW star-delta		1 pc 3 pcs
3. Instrumentation devices	Inlet flow meter Level meter in inlet chamber Level meter in sewage pump sump Level meters of pre and post screens		1 pc 1 pc 1 pc 2 pcs
4. PLC panel	PLC with HMI, GPRS Modem, UPS		1 ls

Source: JICA Survey Team

12.2.2 Sewage Treatment Plants (STPs)

(1) Design Fundamentals

1) Design Flow of STPs

Table 12.2.17 shows design flow of proposed STPs.

Table 12.2.17 Design Flow of Proposed STPs

Zone	STP		Design Flow (MLD)		Effluent Discharge Water Body
	No	Name	2034	2049	
Bytrayanapura	A-1	Jakkur	7.0	11.0	Jakkur Lake
	A-2	Yelahankakere	6.0	15.0	Yelahankakere Lake
	A-3	Doddabettahalli	7.0	10.0	Attur Lake
	A-4	Bilishivalli	17.0	27.0	Rampura kere Lake
Mahadevpura	B-1	Varthur (Stage V)	15.0	24.0	Pinakini River
Bommanahalli	C-1	Pillaganahalli	4.0	6.0	Bilvardalli Lake
	C-2	Talaghattapura	5.0	8.0	Talaghattapura kere Lake
R.R. Nagar	D-1	Somapura	8.0	12.0	Somapura Lake
	D-2	Hemigepura	13.0	20.0	Vrishabhavati River
Dasarahalli	E-1	Nagasandra (Stage V)	9.0	13.0	Arkavathi River
	E-2	Karivobanahalli	10.0	16.0	Gangodanahalli kere Lake
	E-3	Herohalli	3.0	5.0	Herohalli Kere Lake
	E-4	Hosahalli	6.0	10.0	Lingadeeranahalli Lake
	E-5	Chikkabanavara-2	4.0	10.0	Chikkabanavara kere Lake

Source: JICA Survey Team

2) Soil Conditions and Soil Improvement Measure

Based on the findings through site visit and information available on soil conditions summarized in Chapter 10, soil improvement measures are studied. As a result of the study, the need of soil improvement was identified including the replacement of the soil at six (6) sites, land filling at one (1) site, and cut & embankment at two (2) sites (see Table 12.2.18).

Table 12.2.18 Soil Conditions and Required Measures for the Construction of STPs

Zone	STP		Site Condition	Soil Improvement Measure	
	No	Name		Method	Area × Depth
Bytrayanapura	A-1	Jakkur	Vacant land	—	—
	A-2	Yelahankakere	Wet land	Replacement by fine soil	26,000m ² × H4m
	A-3	Doddabettahalli	Vacant land	—	—
	A-4	Bilishivalli	Wet land	Replacement by fine soil	27,000m ² × H6m
Mahadevpura	B-1	Varthur (Stage V)	Depression	Land Filling	35,000m ² × H10m
Bommanahalli	C-1	Pillaganahalli	Sloping land	Cut & Filling	24,000m ² × H5m
	C-2	Talaghattapura	Reclaimed land	Replacement by fine soil	8,000m ² × H5m

Zone	STP		Site Condition	Soil Improvement Measure	
	No	Name		Method	Area × Depth
R.R. Nagar	D-1	Somapura	Vacant land	—	—
	D-2	Hemigepura	Sloping and Reclaimed land	Cut & Filling	40,000m ² × H5m
Dasarahalli	E-1	Nagasandra (Stage V)	Vacant land	—	—
	E-2	Karivobanahalli	Wet land	Replacement by fine soil	16,000m ² × H5m
	E-3	Herohalli	Wet land	Replacement by fine soil	5,000m ² × H5m
	E-4	Hosahalli	Vacant land	—	—
	E-5	Chikkabanavara-2	Reclaimed land	Replacement by fine soil	10000m ² × H4m

Source: JICA Survey Team

3) Design Conditions for Sewage Treatment Plants

Design Conditions for the design of facilities are tabulated in Table 12.2.19. Design criteria is based on CPHEEO Manual and METCALF&EDDY Wastewater Engineering Fourth Edition (hereinafter MET. & EDY). The criteria used for existing or under construction facility are also applied.

Table 12.2.19 Design Conditions for STPs

Facility	Unit	Design Value	CPHEEO Manual	Remarks
1 Coarse Screen & Pump Sump				
(1) Opening	mm	20	25	
(2) Passage velocity	m/sec	Less than 0.8	0.6 to 1.2 (P5-30)	at peak flow
2 Raw Sewage Sump			(P4-10)	Minimum pump cycle shall be more than 15 minutes.
(1) HRT	min	3.75	T/4 15/4=3.75	
3 Fine Screen				
(1) Opening	min	6	N.A.	Refer to Existing STP
(2) Passage velocity	m/sec	Less than 0.8	0.6 to 1.2 (P5-30)	at peak flow
4 Grit Chamber				
(1) Surface Load	m ³ /m ² /day	960	1,555 at dia.0.15mm	at peak flow 864 to 1,296 (P.371 of MET.&EDY)
5.1 Anaerobic Tank				
(1) HRT	hour	1.5	N.A.	0.5 to 1.5 (P.873 of MET.&EDY)
5.2 Anoxic Tank				
(1) HRT	hour	5.0	N.A.	Based on the Capacity Calculation
5.3 Aerobic Tank				
(1) Temperature (min)	°C	20	N.A.	19-26 (P5-3 of DPR)

Facility	Unit	Design Value	CPHEEO Manual	Remarks
(2) MLSS	mg/L	3,000	N.A.	3,000 to 4,000
(3) SRT	day	5.0	N.A.	Based on the Capacity Calculation
(4) HRT	hour	18.0	N.A.	Ditto
(5) Return sludge ratio	%	60	N.A.	Ditto
(6) Circulation ratio	%	366	N.A.	Ditto
6. Final Clarifier			(P5-53)	Refer to Raja Canal Existing STP (= 12)
(1) Surface Load	m ³ /m ² /day	12	8 to 15	
7. Chlorination Tank			(P5-116)	
(1) Contact time	min	more than 30	30	
(2) Injection rate	mg/L	10.0	10	
8. Sludge Thickener				In case of the STPs with the capacity of more than 10 MLD. 40 to 80 (P.1490 of MET.&EDY)
(1) Sludge loading	kg/m ² ·day	40	25 to 30	
(2) Thickened sludge	%	2.5	2.5 to 3.0	
9. Dewatering		Centrifuge		
(1) Operating time	hr/day	12	N.A.	6 days a week
(2) Water contents	%	82	60 (N.A.)	Referred to Phase 2 Project
(3) Polyelectrolyte dosage rate	%	0.5	N.A.	Ditto

N.A.: Not Applicable

Source: JICA Survey Team

(2) Outline of Treatment Facilities

1) Process Flow for Small Size STPs

Process flow for small size STP with less than 10 MLD is shown in Figure 12.2.21. Direct sludge dewatering method so called “volute” shall be applied to reduce the number of mechanical equipment and simplify required maintenance work. This method is commonly used in Japan especially for small size STPs having an advantage to reduce the foot print omitting sludge thickening facilities.

a) Inlet/Terminal Sewage Pumping Station (TSPS) and Pre-treatment Facilities

Pre-treatment facilities for screening and grit removal are set after an inlet pumping station as employed at the existing STPs. According to the features of raw sewage, coarse screens are set before lifting up sewage and fine screens and grit chamber are set after pumping up. It is cost effective and easy in operation to construct fine screens and grit chamber after inlet pumping facilities which are located on the ground surface.

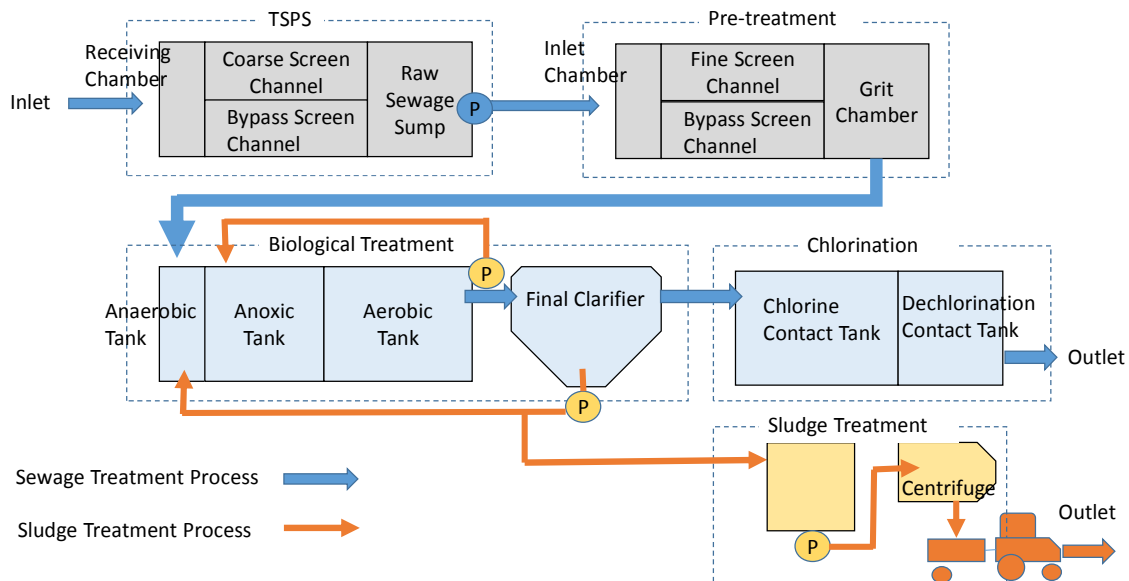

Source: JICA Survey Team

Figure 12.2.21 Process Flow for STP Capacity Less than 10 MLD

The sewage pump unit shall be submersible type, as commonly used in Bengaluru. Usually, inlet sewage pump facilities are planned within STP premises. Inflow receiving Chamber is equipped with manually operating gates, where raw sewage is distributed to coarse screen channels. Each coarse screen channel is equipped with a Mechanical Coarse Screen with opening size of 20 mm, which removes large substances and garbage to refrain from clogging at sewage pump units. The retention time for each raw sewage sump shall have more than 3.75 min., resulted in the total retention time of more than 15 min., as mentioned in CPHEEO. (3.75min. x 4Nos. =15 min.).

Step-type mechanical fine screen with opening size of 6mm and Horizontal Squire-type Grit Chamber shall be adopted, because of their reliability and experience in India. After Grit Chamber, a Parshall Flume is set for measuring inlet sewage flow rate.

b) Biological Treatment (Anaerobic/Anoxic/Aerobic Tank and Final Clarifier)

As a result of comparative study on some alternatives, Extended Aeration (EA) process with enhanced nutrient removal is selected (refer to Chapter-10 for the details). EA process comprises reactor tank and final clarifier. This process is adopted for smaller capacity STPs for easy operation ensuring better effluent quality.

The selected process has Anaerobic Tank with alum dosing facility to remove phosphorus and Anoxic Tank for nitrogen removal. Both Anaerobic and Anoxic tanks have submersible mixers for stirring, and the retention time is more than 1.5 hours and 5 hours as HRT (Hydraulic Retention Time), respectively. HRT of Aeration Tank for EA is longer than conventional activated sludge (CAS) process, and more than 18 hours is adopted for this project. Fine bubble diffusers shall be installed for the aeration, which allows for

more than 28 % of high efficiency for oxygen transfer rate comparing with the normal diffusers.

Usually water depth is designed as 5.5 m. However, deep aeration is not considered in this project, because of difficulty of the maintenance with less experience in India. Nitrified mixed-liquor is transferred from the effluent pit of Aerobic Tank to inlet point of Anoxic Tank by circulation pump which is submersible type with a screw impeller. For the design of Final Clarifier, circular radial flow type is applied with the design surface load of 12 m/day.

c) Disinfection

Chlorine gas is adopted for disinfection, which is commonly used in Bengaluru. The minimum contact time is set 30 min. according to CPHEEO manual. The capacity of Chlorine Contact Tank is designed considering 30 min. contact time. The dosing rate of 10 mg/l is considered as the most economical rate. De-chlorination Contact Tank followed by Chlorine Contact Tank is proposed with the HRT of 10 min.

d) Sludge Treatment

A gravity type thickener is adopted for the STP with the capacity of more than or equal to 10 MLD considering its economic advantage for the maintenance. As dewatering facility, centrifuge is recommended, because of its reasonable cost, cleanness, and widely used experience. However, Sludge thickening facilities are omitted for the STP with the capacity of less than 10 MLD. After secondary sludge is withdrawn from Final Clarifier, the sludge is dewatered directly using centrifuge type of machine.

The dewatered sludge is carried to the outside by a tractor with trailer container, and the sludge is utilized mainly for agriculture or horticulture.

2) Process Flow for Large Size STPs

Process flow for the STP with more than 10 MLD is shown in Figure 12.2.22. To reduce the cost for operation and maintenance of sludge treatment, sludge thickener is considered before dewatering the sludge. As a sludge thickening facility, conventional Gravity Thickener with circular shape is recommended. Although installation of sludge thickener increases the capital cost and maintenance cost for the facilities, it can reduce the size of centrifuge and can save capital cost and power consumption. In addition, the maintenance of Gravity Thickener is comparatively easy. Other facilities are same as those to be applied for small size STPs.

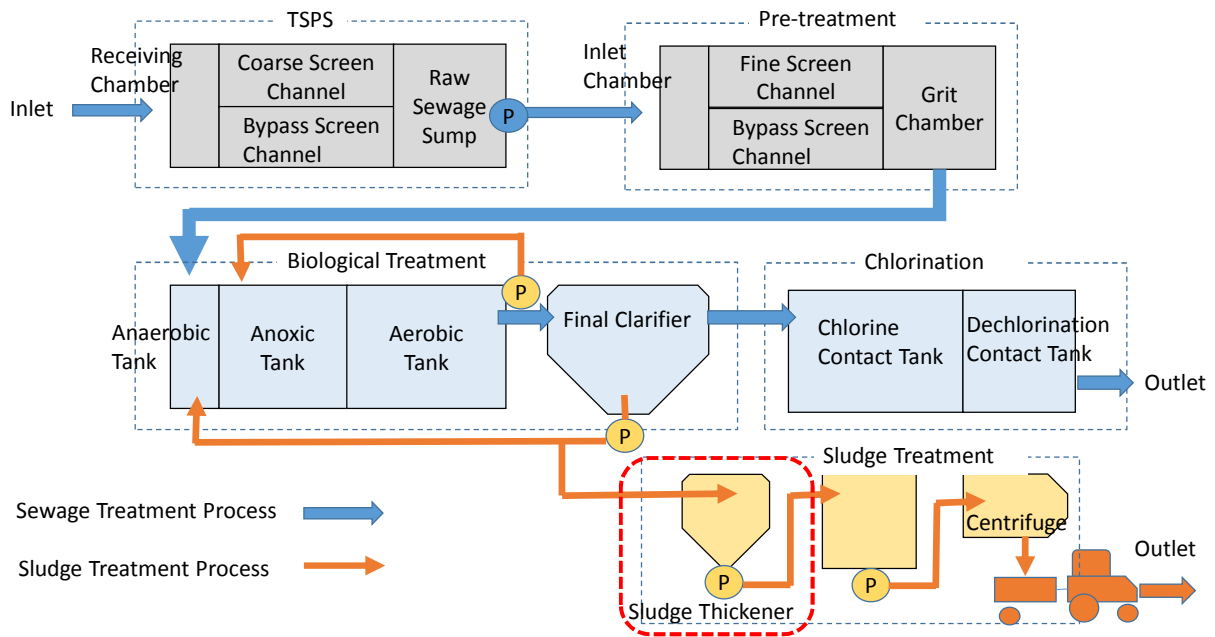

Source: JICA Survey Team

Figure 12.2.22 Process Flow for STP with a Capacity of More than 10MLD

(3) Preliminary Design of STPs

Process calculations are compiled in 12.2.3, Supporting Report. A set of design and documents for planned 14 STPs is presented including layout plan of STP, process flow diagram with hydraulic profile and specifications for major equipment (refer to Figure 12.2.23 to Figure 12.2.50 and Table 12.2.20 to Table 12.2.33).

1) Jakkur STP

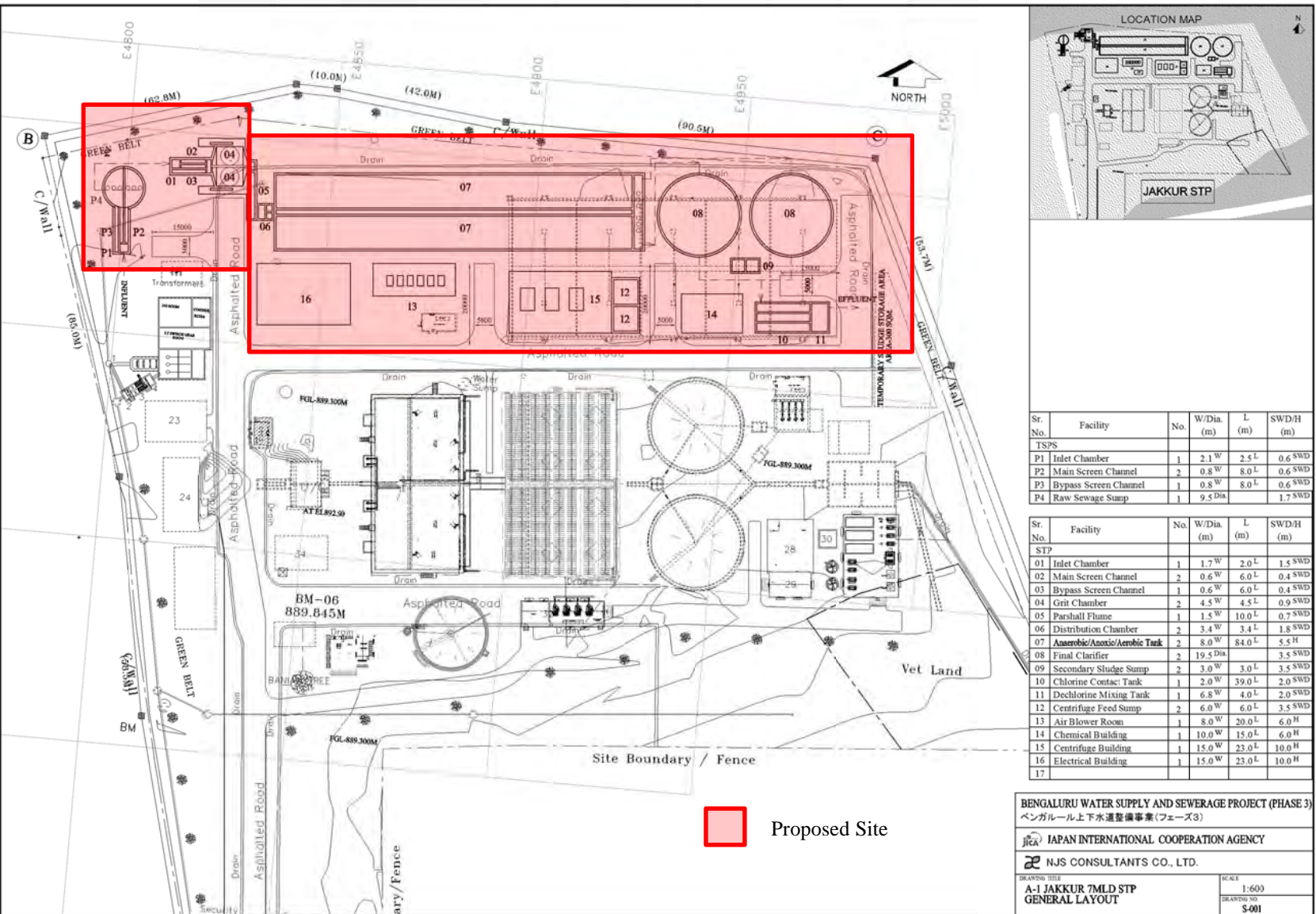

Figure 12.2.23 Layout plan of Jakkur STP

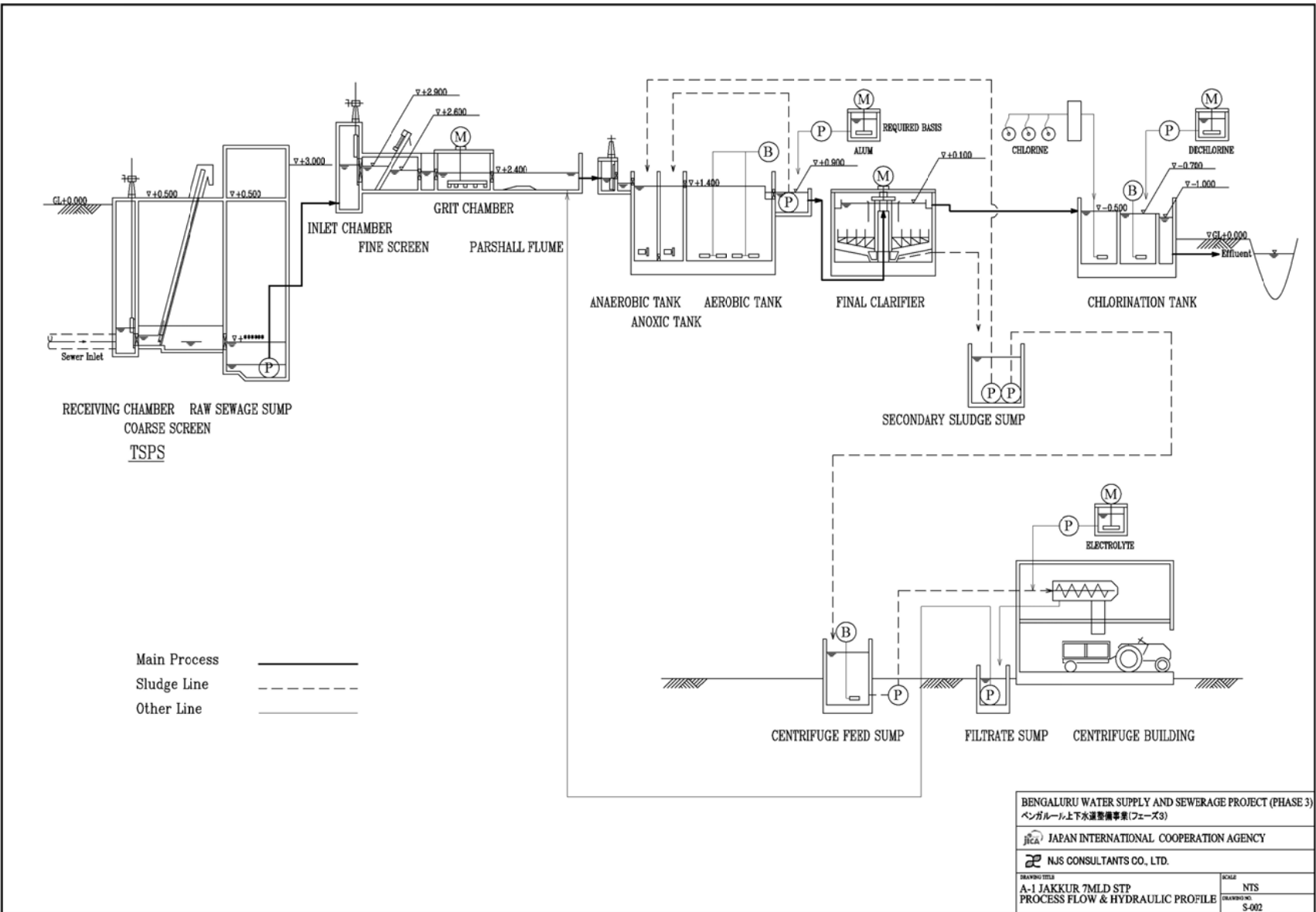

Figure 12.2.24 Process Flow Diagram with Hydraulic Profile

Table 12.2.20 Specifications for Major Equipment (Jakkur STP)

Items	Specification	kW per unit	Unit number
(Mechanical)			
1. Inlet Gates	Manually Operated Cast Iron	Width 0.4(m)×Height :0.6(m)	- 3
2. Coarse Screens (Mechanical)	Climber Type SS316L	Channel Width :0.80 (m)×SWD :0.60 (m) ×Open Space:20(mm)	1.50 1W
3. Coarse Screens (Manual)	Climber Type SS316L	Channel Width :0.80 (m)×SWD :0.60 (m) ×Open Space:50(mm)	- 1
4. Belt Conveyor	Nylon fabric 3ply	Belt Width :0.60(m)×Length :5.0 (m)	1.50 1W
5. Sewage Pump 1	Submersible Cast Iron	Dia:200 (mm)×Discharge :270 (m ³ /h) ×Total Head:15.0 (m)	22.0 2W+1S
6. Sewage Pump 2	Submersible Cast Iron	Dia:150 (mm)×Discharge :135 (m ³ /h) ×Total Head:15.0 (m)	11.0 1W+1S
7. Electric Hoist	Single-girder Overhead Type	Rated Load :3.0(Ton)×Lift :6(m)	8.50 1W
8. Inlet Gates	Manually Operated Cast Iron	Width 0.3(m)×Height :0.45(m)	- 3
9. Fine Screens (Mechanical)	Step Type SS316L	Channel Width :0.60 (m)×SWD :0.40 (m) ×Open Space:6(mm)	1.50 2W
10. Fine Screen (Manual)	Bar Screen SS316L	Channel Width :0.60 (m)×SWD:0.40 (m) ×Open Space:20(mm)	- 1
11. Belt Conveyor	Nylon fabric 3ply	Belt Width :0.60(m)×Length :7.0 (m)	1.50 1W
12. Grit Chamber	Square Horizontal MS+ Epoxy	Width :4.50 (m)×Length :4.5(m)×SWD :0.90 (m)	2.25 1W+1S
13. Inlet Weir Gates	Manually operated Cast Iron	Width 0.6(m)×Height :0.4(m)	- 2
14. Mixers for Anaerobic Tank	Submersible Type SS316L	Tank Width :8.0 (m)×Length :6.0(m)×SWD :5.5(m)	4.0 2W
15. Mixers for Anoxic Tank	Submersible Type SS316L	Tank Width :8.0 (m)×Length :8.5(m)×SWD :5.5(m)	4.0 4W
16. Diffusers	Fine Bubble Mem- brane	SOR:161 (kg/h·basin)×setting Depth :5.0(m) ×Efficiency:28 %	- 2
17. Air Blowers	Rotary blower Tri-lobe Type	Dia. :150 (mm)× Air Flow :1200(m ³ /h) ×Pressure: 65 (K Pa)	37.0 4W+2S
18. Circulation Pumps	Submersible Cast Iron	Dia. :200 (mm)×Discharge:270(m ³ /h) ×Total Head:5.0 (m)	7.5 4W+2S
19. RAS Pumps	Submersible Cast Iron	Dia. :100 (mm)×Discharge:90(m ³ /h) ×Total Head:5.0 (m)	3.7 2W+2S
20. SAS Pumps	Submersible Cast Iron	Dia.:100 (mm)×Discharge :35(m ³ /h) ×Total Head:15.0 (m)	5.50 2W+2S
21. Hand Operation Chain Block	With Geared Trolley	Rated Load :1.0(Ton)×Lift :6(m)	- 3
22. Final Clarifiers	Column-supported MS+ Epoxy	Dia. :19.5 (m)×SWD:3.5(m)	2.2 2W
23. Alum Dosing Pumps	Diaphragm Pump SS/ PTFE	Dia.:25(mm)×Discharge:120(L/h) ×Pressure: 0.7(MPa)	0.4 2W+1S
24. Mixer for Alum Solution	Turbine impeller SS316	Tank Width: 1.2(m)×Length:1.2(m)×SWD:1.8(m)	0.75 2W

Items	Specification	kW per unit	Unit number
25. Chlorinators	Gas Chlorination System Dosing Rate :6.6(kg/h)	0.10	1W+1S
26. Chlorine Tonners	Volume:928(kg/Unit)	-	4
27. Chlorine Booster Pumps	Submersible Cast Iron Dia.:25 (mm)×Discharge :3.6(m ³ /h) ×Total Head:50.0 (m)	1.50	1W+1S
28. Electric Hoist for Tonners	Single-girder Overhead Type Rated Load :3.0(Ton)×Lift :6(m)	8.60	1W
29. Dechlorine Dosing Pumps	Diaphragm Pump SS/ PTFE Dia.:15 (mm)×Discharge:16(L/h) ×Pressure:1.0(MPa)	0.2	1W+1S
30. Mixer for Dechlorine Solution	Turbine impeller SS316 Tank Width: 0.5(m)×Length:0.5(m)×SWD:0.8(m)	0.1	1W
31. Air Blowers For Dechlorine Mixing Tank	Rotary blower Tri-lobe Type Dia. :40 (mm)× Air Flow:27(m ³ /h) ×Pressure: 20 (K Pa)	1.50	1W+1S
32. Electric Hoist for Chemicals	Single-girder Overhead Type Rated Load :1.0(Ton)×Lift :6(m)	4.70	1W
33. Air Blowers For Centrifuge Feed Sump	Rotary blower Tri-lobe Type Dia. :100 (mm)× Air Flow:310(m ³ /h) ×Pressure: 40 (K Pa)	7.50	1W+1S
34. Centrifuge Feed Pumps	Progressive Cavity Pump, Cast Iron Dia.:125 (mm)×Discharge :19(m ³ /h) ×Total Head:20.0 (m)	7.50	2W+1S
35. Centrifuges	Centrifuge SS316 Capacity:19(m ³ /h)	22.2	2W+1S
36. Electric Hoist Crane	Single-girder Overhead Type Rated Load :5.0(Ton)×Lift :15(m)	17.10	1W
37. Mixers for Polyelectrolyte Solution	Agitator SS304 Tank Width: 1.0(m)×Length:1.5(m)×SWD:1.5(m)	0.75	2W
38. Dry Polyelectrolyte Feeder	Volumetric metering SS304 Capacity: 9.0(kg/h)	0.40	2W
39. Polyelectrolyte Dosing Pumps	Progressive Cavity Pump Dia.:32 (mm)×Discharge :0.6(m ³ /h) ×Total Head:20.0 (m)	0.75	2W+1S
40. Centrate Transfer Pumps	Submersible Cast Iron Dia:100 (mm)×Discharge :40(m ³ /h) ×Total Head:15.0 (m)	5.50	2W+1S

Note: W: Working, S: Stand-by

Items	Specification	Unit number
(Electrical)		
1. Power receiving facilities at electrical substation	HV incoming panel, IP42, 11kV, VCB HV outgoing feeder panels, IP42, 11kV, VCB Power transformers: outdoor use, 11/0.415-0.24 kV,750 kVA Diesel engine generator set: 415 V, 50 Hz, 500 kVA	1 pc 2 pcs 2 sets 1 pc

2) Yelahankakere STP

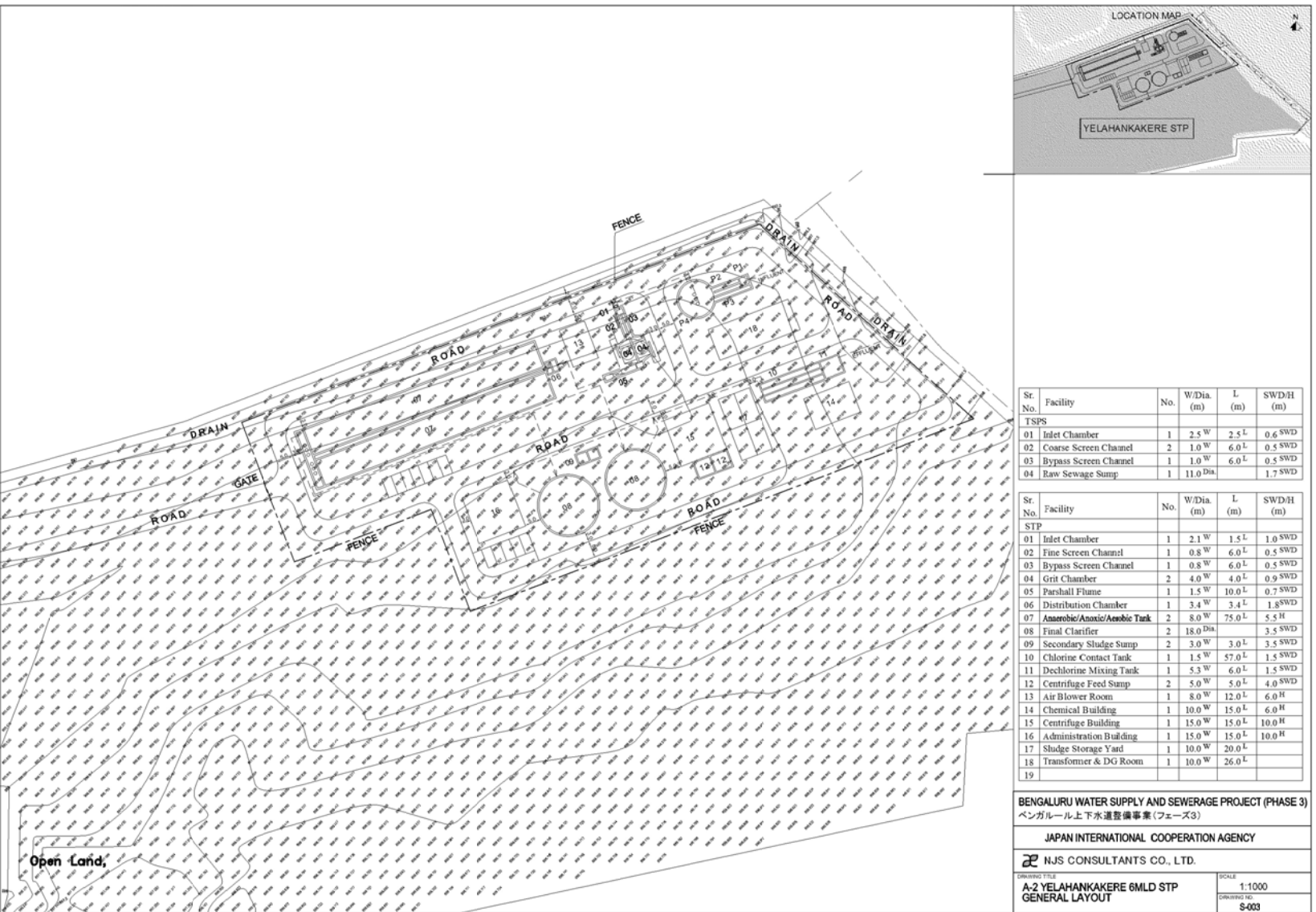

Figure 12.2.25 Layout plan of Yelahankakere STP

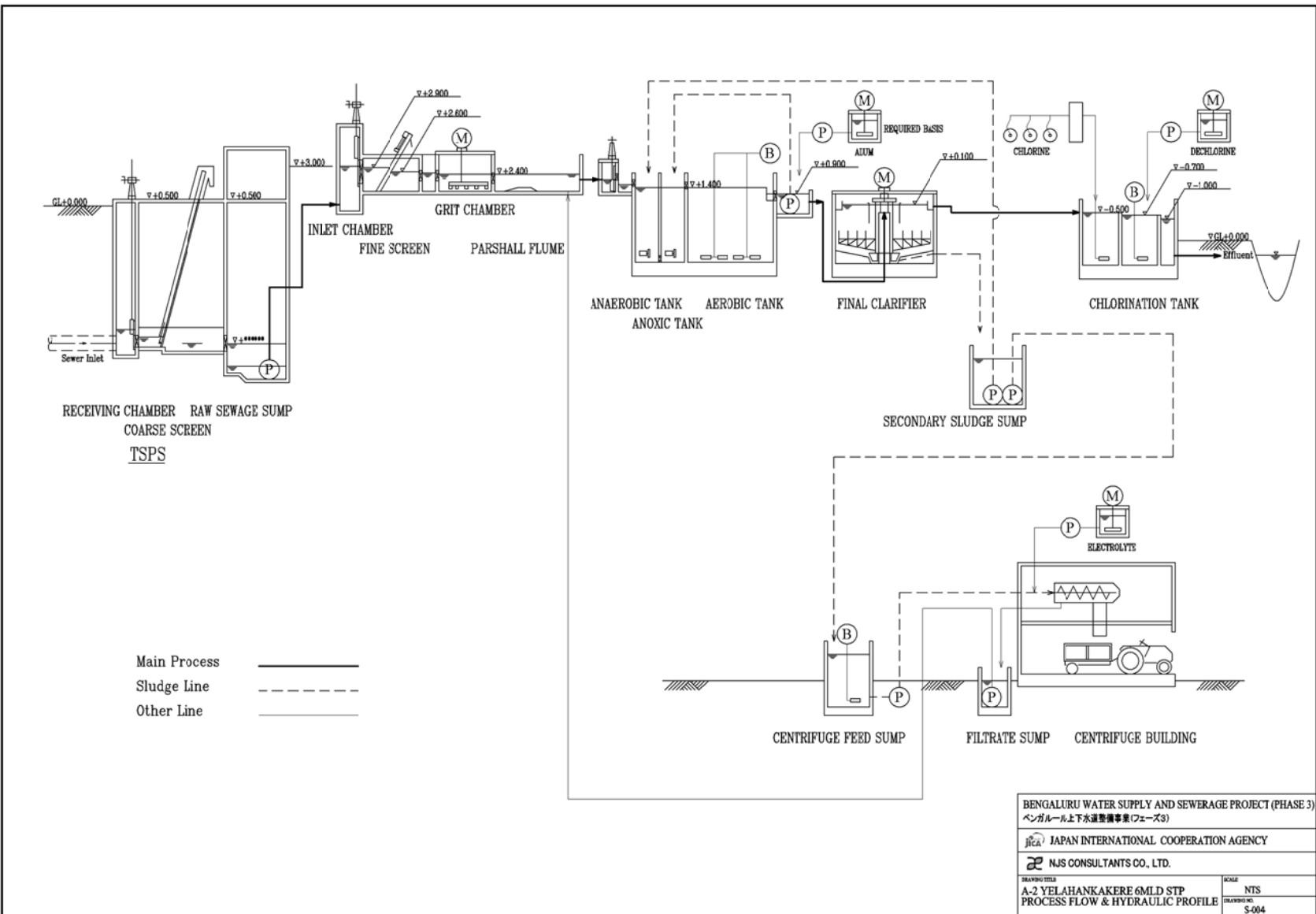

Figure 12.2.26 Process Flow Diagram with Hydraulic Profile

Table 12.2.21 Specifications for Major Equipment (Yelahankakere STP)

Items	Specification	kW per unit	Unit number
(Mechanical)			
1. Inlet Gates	Manually Operated Cast Iron Width 0.5(m)×Height :0.75(m)	-	3
2. Coarse Screens (Mechanical)	Climber Type SS316L Channel Width :1.00 (m)×SWD :0.50 (m) ×Open Space:20(mm)	1.50	1W
3. Coarse Screens (Manual)	Climber Type SS316L Channel Width :1.00 (m)×SWD :0.50 (m) ×Open Space:50(mm)	-	1
4. Sewage Pump	Submersible Cast Iron Dia:200 (mm)×Discharge :315 (m ³ /h) ×Total Head:15.0 (m)	30.0	2W+1S
5. Electric Hoist	Single-girder Overhead Type Rated Load :3.0(Ton)×Lift :6(m)	8.50	1W
6. Inlet Gates	Manually Operated Cast Iron Width 0.4(m)×Height :0.6(m)	-	2
7. Fine Screens (Mechanical)	Step Type SS316L Channel Width :0.80 (m)×SWD :0.50 (m) ×Open Space:6(mm)	1.50	1W
8. Fine Screen (Manual)	Bar Screen SS316L Channel Width :0.80 (m)×SWD:0.50 (m) ×Open Space:20(mm)	-	1
9. Belt Conveyor	Nylon fabric 3ply Belt Width :0.60(m)×Length :7.0 (m)	1.50	1W
10. Grit Chamber	Square Horizontal MS+Epoxy Width :4.00 (m)×Length :4.0(m)×SWD :0.90 (m)	2.25	1W+1S
11. Inlet Weir Gates	Manually operated Cast Iron Width 0.4(m)×Height :0.4(m)	-	2
12. Mixers for Anaerobic Tank	Submersible Type SS316L Tank Width :8.0 (m)×Length :6.0(m)×SWD :5.5(m)	4.0	2W
13. Mixers for Anoxic Tank	Submersible Type SS316L Tank Width :8.0 (m)×Length :15(m)×SWD :5.5(m)	4.0	2W
14. Diffusers	Fine Bubble Mem- brane SOR:138 (kg/h·basin)×setting Depth :5.0(m) ×Efficiency:28 %	-	2
15. Air Blowers	Rotary blower Tri-lobe Type Dia. :150 (mm)× Air Flow :2100(m ³ /h) ×Pressure: 65 (K Pa)	75.0	2W+1S
16. Circulation Pumps	Submersible Cast Iron Dia. :200 (mm)×Discharge:230(m ³ /h) ×Total Head:5.0 (m)	7.5	4W+2S
17. RAS Pumps	Submersible Cast Iron Dia. :100 (mm)×Discharge:75(m ³ /h) ×Total Head:5.0 (m)	2.2	2W+2S
18. SAS Pumps	Submersible Cast Iron Dia.:100 (mm)×Discharge:28 (m ³ /h) ×Total Head:15.0 (m)	3.70	2W+2S
19. Hand Operation Chain Block	With Geared Trolley Rated Load :1.0(Ton)×Lift :6(m)	-	3
20. Final Clarifiers	Column-supported MS+ Epoxy Dia. :18.0 (m)×SWD:3.5(m)	1.5	2W
21. Alum Dosing Pumps	Diaphragm Pump SS/ PTFE Dia.:25(mm)×Discharge:110(L/h) ×Pressure:0.7(MPa)	0.4	2W+1S
22. Mixer for Alum Solution	Turbine impeller SS316 Tank Width: 1.0(m)×Length:1.0(m)×SWD:1.5(m)	0.4	2W
23. Chlorinators	Gas Chlorination Sys- tem Dosing Rate :6.3(kg/h)	0.10	1W+1S
24. Chlorine Tonners	Volume:928(kg/Unit)	-	4
25. Chlorine Booster Pumps	Submersible Cast Iron Dia.:25 (mm)×Discharge :2.7(m ³ /h) ×Total Head:50.0 (m)	1.50	1W+1S

Items	Specification	kW per unit	Unit number
26. Electric Hoist for Tonners	Single-girder Overhead Type Rated Load :3.0(Ton)×Lift :6(m)	8.60	1W
27. Dechlorine Dosing Pumps	Diaphragm Pump SS/ PTFE Dia.:15 (mm)×Discharge:15(L/h)×Pressure:1.0(MPa)	0.2	1W+1S
28. Mixer for Dechlorine Solution	Turbine impeller SS316 Tank Width: 0.5(m)×Length:0.5(m)×SWD:0.8(m)	0.1	1W
29. Air Blowers For Dechlorine Mixing Tank	Rotary blower Tri-lobe Type Dia. :40 (mm)× Air Flow:24(m ³ /h) ×Pressure: 20 (K Pa)	1.50	1W+1S
30. Electric Hoist for Chemicals	Single-girder Overhead Type Rated Load :1.0(Ton)×Lift :6(m)	4.70	1W
31. Air Blowers For Centrifuge Feed Sump	Rotary blower Tri-lobe Type Dia. :100 (mm)× Air Flow:240(m ³ /h) ×Pressure: 40 (K Pa)	7.50	1W+1S
32. Centrifuge Feed Pumps	Progressive Cavity Pump, Cast Iron Dia.:125 (mm)×Discharge :32(m ³ /h) ×Total Head:20.0 (m)	11.0	1W+1S
33. Centrifuges	Centrifuge SS316 Capacity:32(m ³ /h)	62.6	1W+1S
34. Electric Hoist Crane	Single-girder Overhead Type Rated Load :5.0(Ton)×Lift :15(m)	17.10	1W
35. Mixers for Polyelectrolyte Solution	Agitator SS304 Tank Width: 1.5(m)×Length:1.5(m)×SWD:1.8(m)	1.5	2W
36. Polyelectrolyte Dosing Pumps	Progressive Cavity Pump Dia.:32 (mm)×Discharge :1.0(m ³ /h) ×Total Head:20.0 (m)	0.75	1W+1S
37. Centrate Transfer Pumps	Submersible Cast Iron Dia:100 (mm)×Discharge :60(m ³ /h) ×Total Head:15.0 (m)	5.50	1W+1S

Items	Specification	Unit number
(Electrical)		
1. Power receiving facilities at electrical substation	HV incoming panel, IP42, 11kV, VCB HV outgoing feeder panels, IP42, 11kV, VCB Power transformers: outdoor use, 11/0.415-0.24 kV,750 kVA Diesel engine generator set: 415 V, 50 Hz, 500 kVA	1 pc 2 pcs 2 sets 1 pc
2. LV incoming panel, LV switchgears, and MCCs	LV incoming panels: IP42, 600V, ACB 1600A x 3, ACB 800A x 1 LV feeder panels: IP52, 600V, MCCB 200 A x 6, MCCB 100 A x 7, Static capacitors MCC for TSPS MCC for Headworks MCCs for Liquid process (Anaerobic/anoxic/aeration tanks, secondary clarifiers) Air blower starter panels with 75 kW VFD MCCs for Solid process	1 pc 1 pc 1 pc 1 pc 1 pc 3 pcs 1 pc
3. Instrumentation devices	Inlet flow meter Level meter in inlet chamber Level meter in sewage pump sump Level meters of pre and post screens Air blow flow meters Air blow pressure meters MLR (Mixed Liquor Recycle) flow meters	1 pc 1 pc 1 pc 4 pcs 2 pcs 2 pcs 2 pcs

Items	Specification	Unit number
	RAS (Return Activated Sludge) flow meters DO analyzers MLSS analyzers Level meters in alum solution tank Alum dosing flow meters Residual chlorine analyzer Effluent flow meter Level meters in de-chlorine tank De-chlorine flow meter Level meter in secondary sludge sump WAS (Waste Activated Sludge) flow meters Level meters in centrifuge sump Centrifuge feed flow meters Level meter in polyelectrolyte solution tank Centrifuge polymer dosing flow meters Level meter in filtrate sump Filtrate flow meter	2 pcs 2 pcs 2 pcs 2 pcs 1 pc 1 pc 1 pc 1 pc 1 pc 1 pc 1 pc 1 pc 1 pc 2 pcs 2 pcs 2 pcs 1 pc 1 pc
4. Local SCADA system	Operator stations, SCADA servers, PLCs, router, etc.	1 ls

Source: JICA Survey Team

3) Doddabettahalli STP



Figure 12.2.27 Layout Plan of Doddabettahalli STP

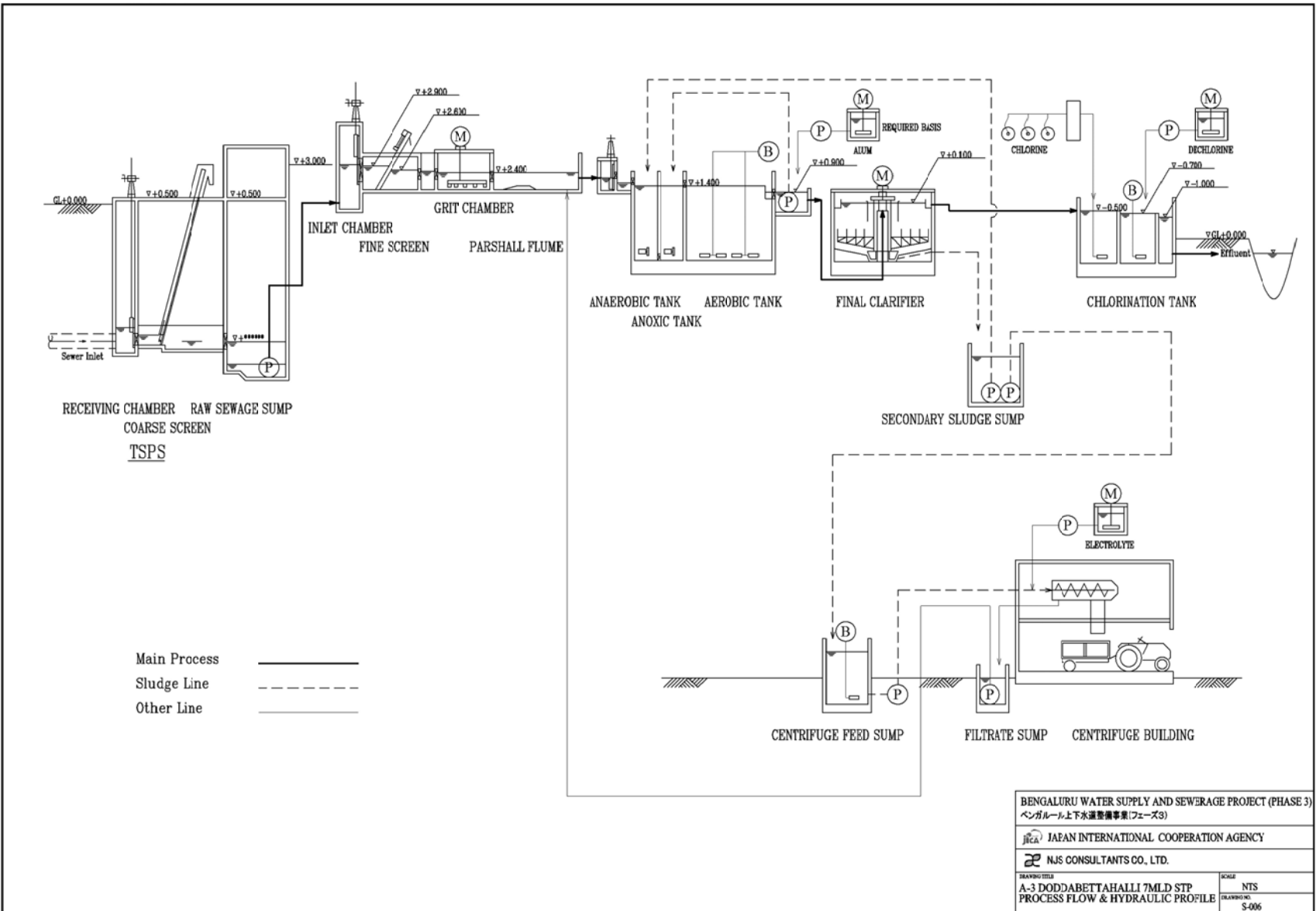

Figure 12.2.28 Process Flow Diagram with Hydraulic Profile

Table 12.2.22 Specifications for Major Equipment (Doddabettahalli STP)

Items	Specification	kW per unit	Unit number
(Mechanical)			
1. Inlet Gates	Manually Operated Cast Iron Width 0.4(m)×Height :0.6(m)	-	3
2. Coarse Screens (Mechanical)	Climber Type SS316L Channel Width :0.80 (m)×SWD :0.60 (m) ×Open Space:20(mm)	1.50	1W
3. Coarse Screens (Manual)	Climber Type SS316L Channel Width :0.80 (m)×SWD :0.60 (m) ×Open Space:50(mm)	-	1
4. Belt Conveyor	Nylon fabric 3ply Belt Width :0.60(m)×Length :5.0 (m)	1.50	1W
5. Sewage Pump 1	Submersible Cast Iron Dia:200 (mm)×Discharge :270 (m ³ /h) ×Total Head:15.0 (m)	22.0	2W+1S
6. Sewage Pump 2	Submersible Cast Iron Dia:150 (mm)×Discharge :135 (m ³ /h) ×Total Head:15.0 (m)	11.0	1W+1S
7. Electric Hoist	Single-girder Overhead Type Rated Load :3.0(Ton)×Lift :6(m)	8.50	1W
8. Inlet Gates	Manually Operated Cast Iron Width 0.3(m)×Height :0.45(m)	-	3
9. Fine Screens (Mechanical)	Step Type SS316L Channel Width :0.60 (m)×SWD :0.40 (m) ×Open Space:6(mm)	1.50	2W
10. Fine Screen (Manual)	Bar Screen SS316L Channel Width :0.60 (m)×SWD:0.40 (m) ×Open Space:20(mm)	-	1
11. Belt Conveyor	Nylon fabric 3ply Belt Width :0.60(m)×Length :7.0 (m)	1.50	1W
12. Grit Chamber	Square Horizontal MS+Epoxy Width :4.50 (m)×Length :4.5(m)×SWD :0.90 (m)	2.25	1W+1S
13. Inlet Weir Gates	Manually operated Cast Iron Width 0.6(m)×Height :0.4(m)	-	2
14. Mixers for An-aerobic Tank	Submersible Type SS316L Tank Width :8.0 (m)×Length :6.0(m)×SWD :5.5(m)	4.0	2W
15. Mixers for An-oxic Tank	Submersible Type SS316L Tank Width :8.0 (m)×Length :8.5(m)×SWD :5.5(m)	4.0	4W
16. Diffusers	Fine Bubble Mem-brane SOR:161 (kg/h• basin)×setting Depth :5.0(m) ×Efficiency:28 %	-	2
17. Air Blowers	Rotary blower Tri-lobe Type Dia. :150 (mm)× Air Flow :1200(m ³ /h) ×Pressure: 65 (K Pa)	37.0	4W+2S
18. Circulation Pumps	Submersible Cast Iron Dia. :200 (mm)×Discharge:270(m ³ /h) ×Total Head:5.0 (m)	7.5	4W+2S
19. RAS Pumps	Submersible Cast Iron Dia. :100 (mm)×Discharge:90(m ³ /h) ×Total Head:5.0 (m)	3.7	2W+2S
20. SAS Pumps	Submersible Cast Iron Dia.:100 (mm)×Discharge :35(m ³ /h) ×Total Head:15.0 (m)	5.50	2W+2S
21. Hand Operation Chain Block	With Geared Trolley Rated Load :1.0(Ton)×Lift :6(m)	-	3
22. Final Clarifiers	Column-supported MS+ Epoxy Dia. :19.5 (m)×SWD:3.5(m)	2.2	2W
23. Alum Dosing Pumps	Diaphragm Pump SS/ PTFE Dia.:25(mm)×Discharge:120(L/h) ×Pressure:0.7(MPa)	0.4	2W+1S
24. Mixer for Alum Solution	Turbine impeller SS316 Tank Width: 1.2(m)×Length:1.2(m)×SWD:1.8(m)	0.75	2W
25. Chlorinators	Gas Chlorination Sys-tem Dosing Rate :6.6(kg/h)	0.10	1W+1S

Items	Specification	kW per unit	Unit number
26. Chlorine Tonners	Volume:928(kg/Unit)	-	4
27. Chlorine Booster Pumps	Submersible Cast Iron Dia.:25 (mm)×Discharge :3.6(m ³ /h) ×Total Head:50.0 (m)	1.50	1W+1S
28. Electric Hoist for Tonners	Single-girder Overhead Type Rated Load :3.0(Ton)×Lift :6(m)	8.60	1W
29. Dechlorine Dosing Pumps	Diaphragm Pump SS/ PTFE Dia.:15(mm)×Discharge:16(L/h) ×Pressure:1.0(MPa)	0.2	1W+1S
30. Mixer for Dechlorine Solution	Turbine impeller SS316 Tank Width: 0.5(m)×Length:0.5(m)×SWD:0.8(m)	0.1	1W
31. Air Blowers For Dechlorine Mixing Tank	Rotary blower Tri-lobe Type Dia. :40 (mm)× Air Flow:27(m ³ /h) ×Pressure: 20 (KPa)	1.50	1W+1S
32. Electric Hoist for Chemicals	Single-girder Overhead Type Rated Load :1.0(Ton)×Lift :6(m)	4.70	1W
33. Air Blowers For Centrifuge Feed Sump	Rotary blower Tri-lobe Type Dia. :100 (mm)× Air Flow:310(m ³ /h) ×Pressure: 40 (K Pa)	7.50	1W+1S
34. Centrifuge Feed Pumps	Progressive Cavity Pump, Cast Iron Dia.:125 (mm)×Discharge :19(m ³ /h) ×Total Head:20.0 (m)	7.50	2W+1S
35. Centrifuges	Centrifuge SS316 Capacity:19(m ³ /h)	22.2	2W+1S
36. Electric Hoist Crane	Single-girder Overhead Type Rated Load :5.0(Ton)×Lift :15(m)	17.10	1W
37. Mixers for Polyelectrolyte Solution	Agitator SS304 Tank Width: 1.0(m)×Length:1.5(m)×SWD:1.5(m)	0.75	2W
38. Dry Polyelectrolyte Feeder	Volumetric metering SS304 Capacity: 9.0(kg/h)	0.40	2W
39. Polyelectrolyte Dosing Pumps	Progressive Cavity Pump Dia.:32 (mm)×Discharge :0.6(m ³ /h) ×Total Head:20.0 (m)	0.75	2W+1S
40. Centrate Transfer Pumps	Submersible Cast Iron Dia:100 (mm)×Discharge :40(m ³ /h) ×Total Head:15.0 (m)	5.50	2W+1S

Items	Specification	Unit number
(Electrical)		
1. Power receiving facilities at electrical substation	HV incoming panel, IP42, 11kV, VCB HV outgoing feeder panels, IP42, 11kV, VCB Power transformers: outdoor use, 11/0.415-0.24 kV,750 kVA Diesel engine generator set: 415 V, 50 Hz, 500 kVA	1 pc 2 pcs 2 sets 1 pc
2. LV incoming panel, LV switchgears, and MCCs	LV incoming panels: IP42, 600V, ACB 1600A x 3, ACB 800A x 1 LV feeder panels: IP52, 600V, MCCB 200 A x 10, MCCB 100 A x 7, Static capacitors MCC for TSPS MCC for Headworks MCCs for Liquid process (Anaerobic/anoxic/aeration tanks, secondary clarifiers) Air blower starter panels with 37 kW VFD	1 pc 1 pc 1 pc 1 pc 1 pc 6 pcs

Items	Specification	Unit number
	MCCs for Solid process	1 pc
3. Instrumentation devices	Inlet flow meter Level meter in inlet chamber Level meter in sewage pump sump Level meters of pre and post screens Air blow flow meters Air blow pressure meters MLR (Mixed Liquor Recycle) flow meters RAS (Return Activated Sludge) flow meters DO analyzers MLSS analyzers Level meters in alum solution tank Alum dosing flow meters Residual chlorine analyzer Effluent flow meter Level meters in de-chlorine tank De-chlorine flow meter Level meter in secondary sludge sump WAS (Waste Activated Sludge) flow meters Level meters in centrifuge sump Centrifuge feed flow meters Level meter in polyelectrolyte solution tank Centrifuge polymer dosing flow meters Level meter in filtrate sump Filtrate flow meter	1 pc 1 pc 1 pc 4 pcs 2 pcs 2 pcs 2 pcs 2 pcs 2 pcs 2 pcs 2 pcs 2 pcs 1 pc 1 pc 1 pc 1 pc 1 pc 1 pc 1 pc 1 pc 1 pc 1 pc 3 pcs 2 pcs 3 pcs 1 pc 1 pc
4. Local SCADA system	Operator stations, SCADA servers, PLCs, router, etc.	1 ls

Source: JICA Survey Team

4) Bilishivalli STP

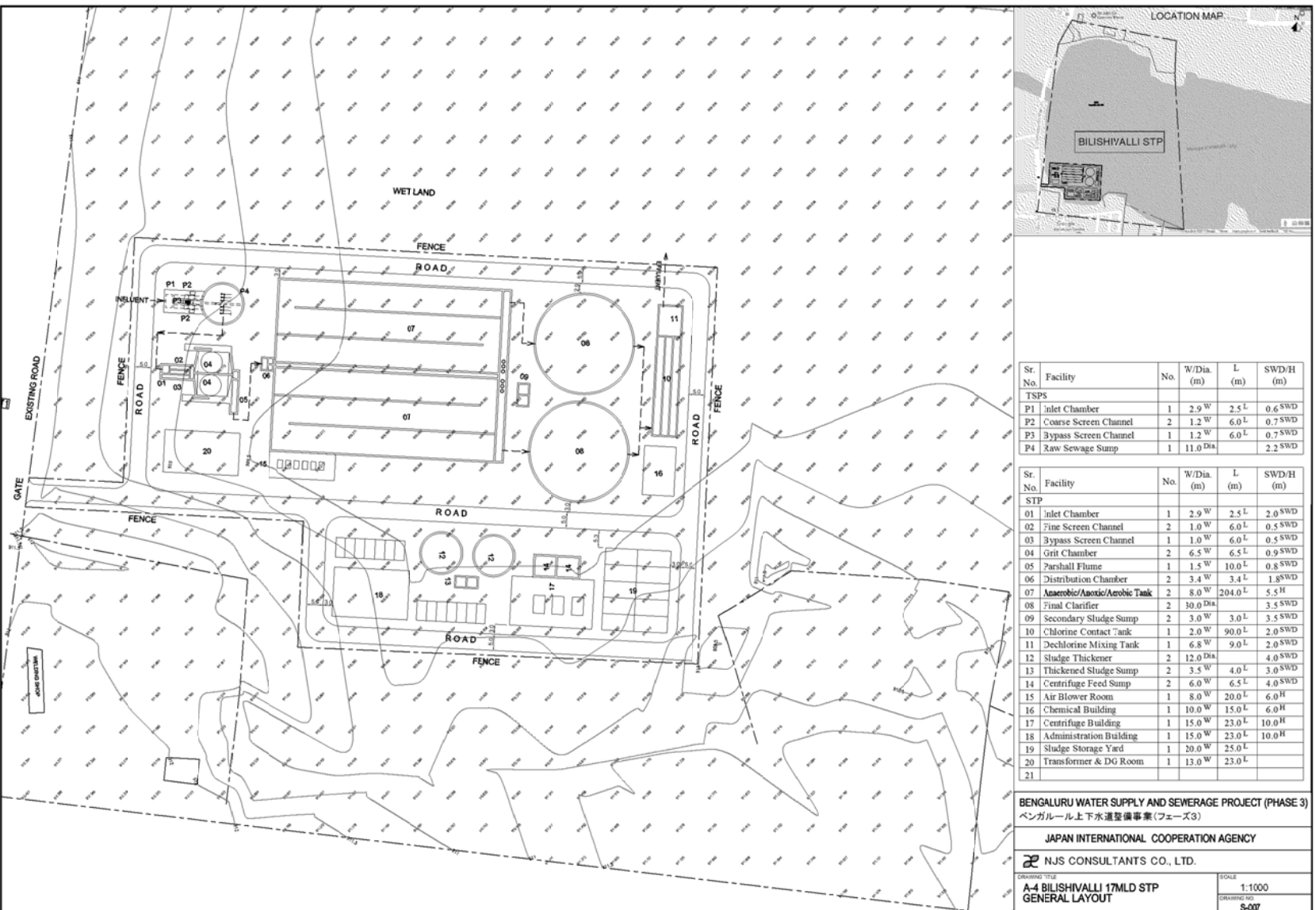

Figure 12.2.29 Layout plan of Bilishivalli STP

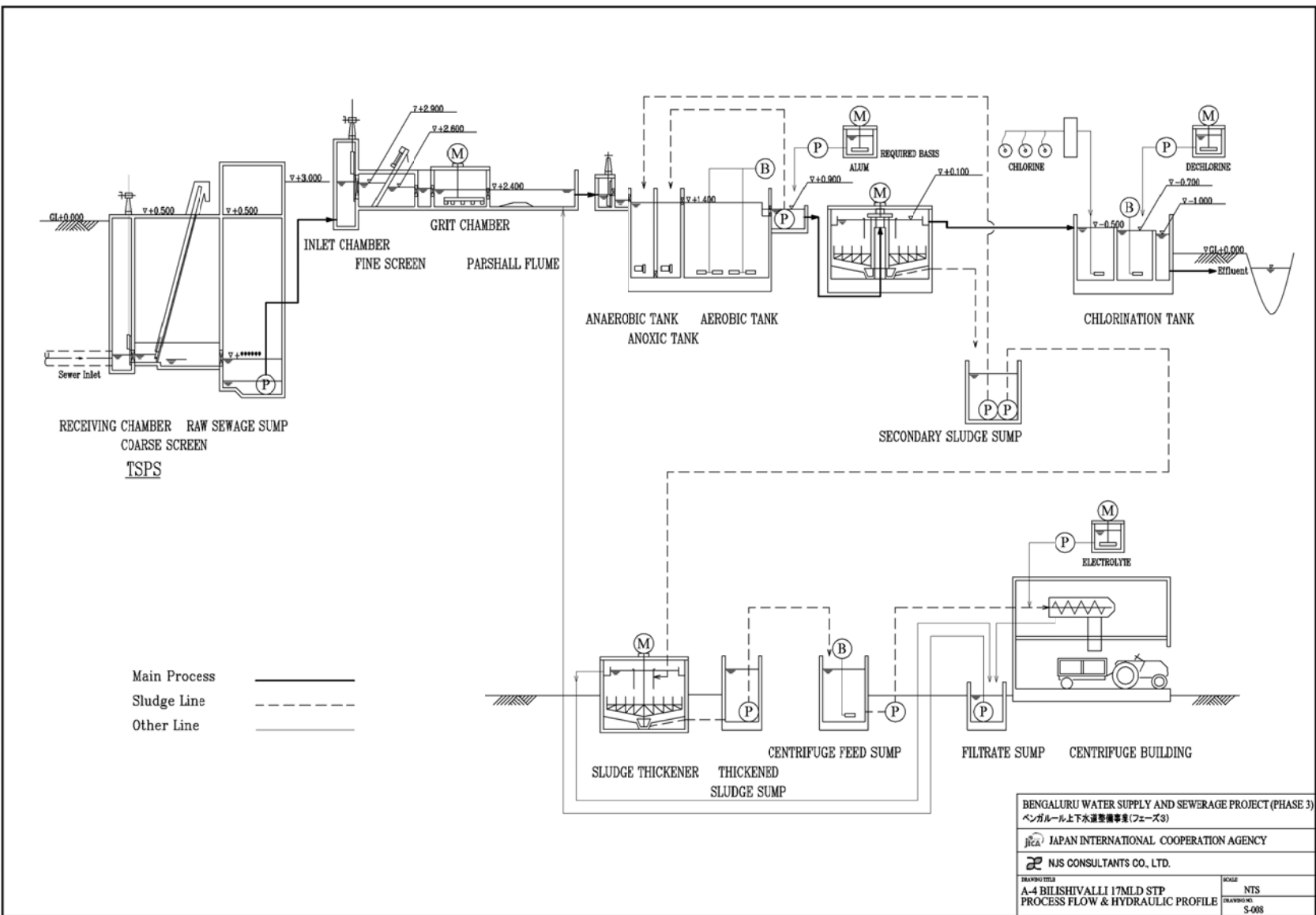

Figure 12.2.30 Process Flow Diagram with Hydraulic Profile

Table 12.2.23 Specifications for Major Equipment (Bilishivalli STP)

Items	Specification	kW per unit	Unit number
(Mechanical)			
1. Inlet Gates	Manually Operated Cast Iron Width 0.6(m)×Height :0.9(m)	-	3
2. Coarse Screens (Mechanical)	Climber Type SS316L Channel Width :1.20 (m)×SWD :0.70 (m) ×Open Space:20(mm)	1.50	1W
3. Coarse Screens (Manual)	Climber Type SS316L Channel Width :1.20 (m)×SWD :0.70 (m) ×Open Space:50(mm)	-	1
4. Belt Conveyor	Nylon fabric 3ply Belt Width :0.60(m)×Length :5.0 (m)	1.50	1W
5. Sewage Pump 1	Submersible Cast Iron Dia:300 (mm)×Discharge :640 (m ³ /h) ×Total Head:15.0 (m)	55.0	2W+1S
6. Sewage Pump 2	Submersible Cast Iron Dia:200 (mm)×Discharge :320 (m ³ /h) ×Total Head:15.0 (m)	30.0	1W+1S
7. Electric Hoist	Single-girder Overhead Type Rated Load :3.0(Ton)×Lift :6(m)	8.50	1W
8. Inlet Gates	Manually Operated Cast Iron Width 0.5(m)×Height :0.75(m)	-	3
9. Fine Screens (Mechanical)	Step Type SS316L Channel Width :1.00 (m)×SWD :0.50 (m) ×Open Space:6(mm)	1.50	2W
10. Fine Screen (Manual)	Bar Screen SS316L Channel Width :1.00 (m)×SWD:0.50 (m) ×Open Space:20(mm)	-	1
11. Belt Conveyor	Nylon fabric 3ply Belt Width :0.60(m)×Length :7.0 (m)	1.50	1W
12. Grit Chamber	Square Horizontal MS+ Epoxy Width :6.50 (m)×Length :6.5(m)×SWD :0.90 (m)	2.25	1W+1S
13. Inlet Weir Gates	Manually operated Cast Iron Width 0.8(m)×Height :0.5(m)	-	2
14. Mixers for An-aerobic Tank	Submersible Type SS316L Tank Width :8.0 (m)×Length :13.0(m)×SWD :5.5(m)	4.0	2W
15. Mixers for An-oxic Tank	Submersible Type SS316L Tank Width :8.0 (m)×Length :14.0(m)×SWD :5.5(m)	4.0	6W
16. Diffusers	Fine Bubble Mem-brane SOR:391 (kg/h·basin)×setting Depth :5.0(m) ×Efficiency:28 %	-	2
17. Air Blowers	Rotary blower Tri-lobe Type Dia. :200 (mm)× Air Flow :2,900(m ³ /h) ×Pressure: 65 (K Pa)	90.0	4W+2S
18. Circulation Pumps	Submersible Cast Iron Dia. :300 (mm)×Discharge:650(m ³ /h) ×Total Head:5.0 (m)	18.5	4W+2S
19. RAS Pumps	Submersible Cast Iron Dia. :150 (mm)×Discharge:220(m ³ /h) ×Total Head:5.0 (m)	7.5	2W+2S
20. SAS Pumps	Submersible Cast Iron Dia.:100 (mm)×Discharge :90(m ³ /h) ×Total Head:15.0 (m)	11.0	2W+2S
21. Hand Operation Chain Block	With Geared Trolley Rated Load :1.0(Ton)×Lift :6(m)	-	3
22. Final Clarifiers	Column-supported MS+ Epoxy Dia. :30.0 (m)×SWD:3.5(m)	2.2	2W
23. Alum Dosing Pumps	Diaphragm Pump SS/ PTFE Dia.:40(mm)×Discharge:290(L/h) ×Pressure:0.3(MPa)	0.75	2W+1S
24. Mixer for Alum Solution	Turbine impeller SS316 Tank Width: 1.5(m)×Length:1.5(m)×SWD:1.8(m)	1.5	2W
25. Chlorinators	Gas Chlorination Sys-tem Dosing Rate :16.0(kg/h)	0.10	1W+1S

Items	Specification	kW per unit	Unit number
26. Chlorine Tonners	Volume:928(kg/Unit)	-	4
27. Chlorine Booster Pumps	Submersible Cast Iron Dia.:25 (mm)×Discharge :6.0(m ³ /h) ×Total Head:50.0 (m)	2.20	1W+1S
28. Electric Hoist for Tonners	Single-girder Overhead Type Rated Load :3.0(Ton)×Lift :6(m)	8.60	1W
29. Dechlorine Dosing Pumps	Diaphragm Pump SS/ PTFE Dia.:15(mm)×Discharge :20(L/h) ×Pressure:1.0(MPa)	0.2	2W+1S
30. Mixer for Dechlorine Solution	Turbine impeller SS316 Tank Width: 0.6(m)×Length:0.6(m)×SWD:0.9(m)	0.1	2W
31. Air Blowers For Dechlorine Mixing Tank	Rotary blower Tri-lobe Type Dia. :40 (mm)× Air Flow:55(m ³ /h) ×Pressure: 20 (K Pa)	1.50	1W+1S
32. Electric Hoist for Chemicals	Single-girder Overhead Type Rated Load :1.0(Ton)×Lift :6(m)	4.70	1W
33. Sludge Thickener	Bridge-supported MS+ Epoxy Dia. :12.0 (m)×SWD:4.0(m)	0.4	2W
34. Thickened Sludge Pumps	Submersible Cast Iron Dia.:100 (mm)×Discharge :90(m ³ /h) ×Total Head:15.0 (m)	11.0	2W+2S
35. Air Blowers For Centrifuge Feed Sump	Rotary blower Tri-lobe Type Dia. :100 (mm)× Air Flow:380(m ³ /h) ×Pressure: 40 (K Pa)	11.0	1W+1S
36. Centrifuge Feed Pumps	Progressive Cavity Pump, Cast Iron Dia.:100 (mm)×Discharge :15(m ³ /h) ×Total Head:20.0 (m)	5.50	2W+1S
37. Centrifuges	Centrifuge SS316 Capacity:15(m ³ /h)	22.2	2W+1S
38. Electric Hoist Crane	Single-girder Overhead Type Rated Load :3.0(Ton)×Lift :15(m)	8.60	1W
39. Mixers for Polyelectrolyte Solution	Agitator SS304 Tank Width: 1.5(m)×Length:2.0(m)×SWD:2.0(m)	1.5	2W
40. Dry Polyelectrolyte Feeder	Volumetric metering SS304 Capacity: 22.0(kg/h)	0.40	2W
41. Polyelectrolyte Dosing Pumps	Progressive Cavity Pump Dia.:32 (mm)×Discharge :1.4(m ³ /h) ×Total Head:20.0 (m)	0.75	2W+1S
42. Centrate Transfer Pumps	Submersible Cast Iron Dia:100 (mm)×Discharge :40(m ³ /h)×Total Head:15.0 (m)	5.50	2W+1S

Items	Specification	Unit number
(Electrical)		
1. Power receiving facilities at electrical substation	HV incoming panel, IP42, 11kV, VCB HV outgoing feeder panels, IP42, 11kV, VCB Power transformers: outdoor use, 11/0.415-0.24 kV,100 kVA Diesel engine generator set: 415 V, 50 Hz, 750 kVA	1 pc 2 pcs 2 sets 1 pc
2. LV incoming panel, LV	LV incoming panels: IP42, 600V, ACB 1600A x 4 LV feeder panels: IP52, 600V, MCCB 400 A x 2, MCCB 200 A x 8, MCCB 100 A x8,	1 pc 1 pc

Items	Specification	Unit number
switchgears, and MCCs	Static capacitors	1 pc
	MCC for TSPS	1 pc
	MCC for Headworks	1 pc
	MCCs for Liquid process (Anaerobic/anoxic/aeration tanks, secondary clarifiers)	6 pcs
	Air blower starter panels with 90 kW VFD	1 pc
3. Instrumentation devices	MCCs for Solid process	1 pc
	Inlet flow meter	1 pc
	Level meter in inlet chamber	1 pc
	Level meter in sewage pump sump	1 pc
	Level meters of pre and post screens	4 pcs
	Air blow flow meters	2 pcs
	Air blow pressure meters	2 pcs
	MLR (Mixed Liquor Recycle) flow meters	2 pcs
	RAS (Return Activated Sludge) flow meters	2 pcs
	DO analyzers	2 pcs
	MLSS analyzers	2 pcs
	Level meters in alum solution tank	2 pcs
	Alum dosing flow meters	1 pc
	Residual chlorine analyzer	1 pc
	Effluent flow meter	1 pc
	Level meters in de-chlorine tank	1 pc
	De-chlorine flow meter	1 pc
	Level meters in secondary sludge sump	1 pc
	WAS (Waste Activated Sludge) flow meters	1 pc
	Level meters in thickened sludge sump	1 pc
	Level meters in centrifuge sump	1 pc
	Centrifuge feed flow meters	3 pcs
	Level meter in polyelectrolyte solution tank	2 pcs
	Centrifuge polymer dosing flow meters	3 pcs
	Level meter in filtrate sump	1 pc
	Filtrate flow meter	1 pc
4. Local SCADA system	Operator stations, SCADA servers, PLCs, router, etc.	1 ls

Source: JICA Survey Team

5) Varthur (Stage V) STP

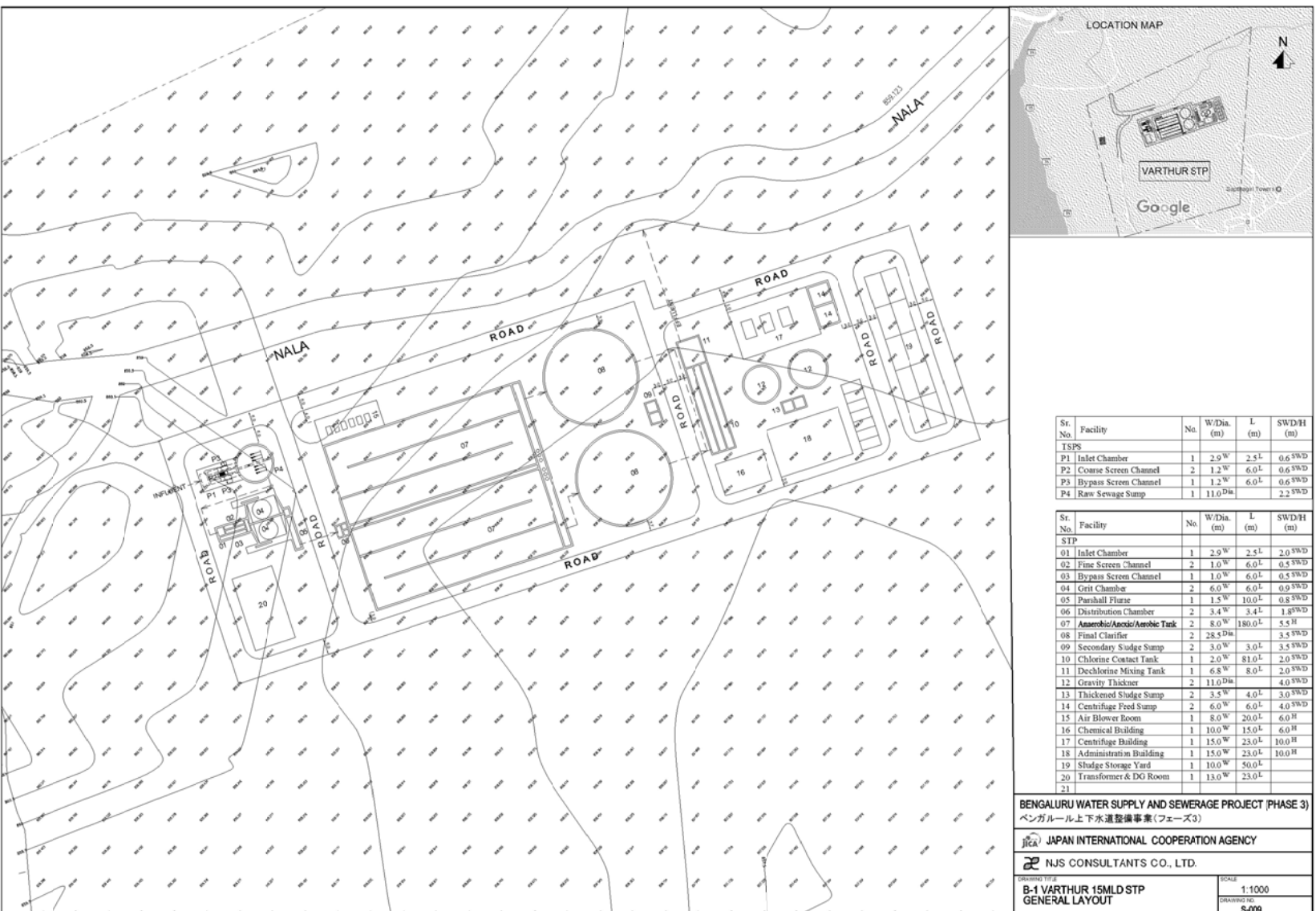

Figure 12.2.31 Layout plan of Varthur (Stage V) STP

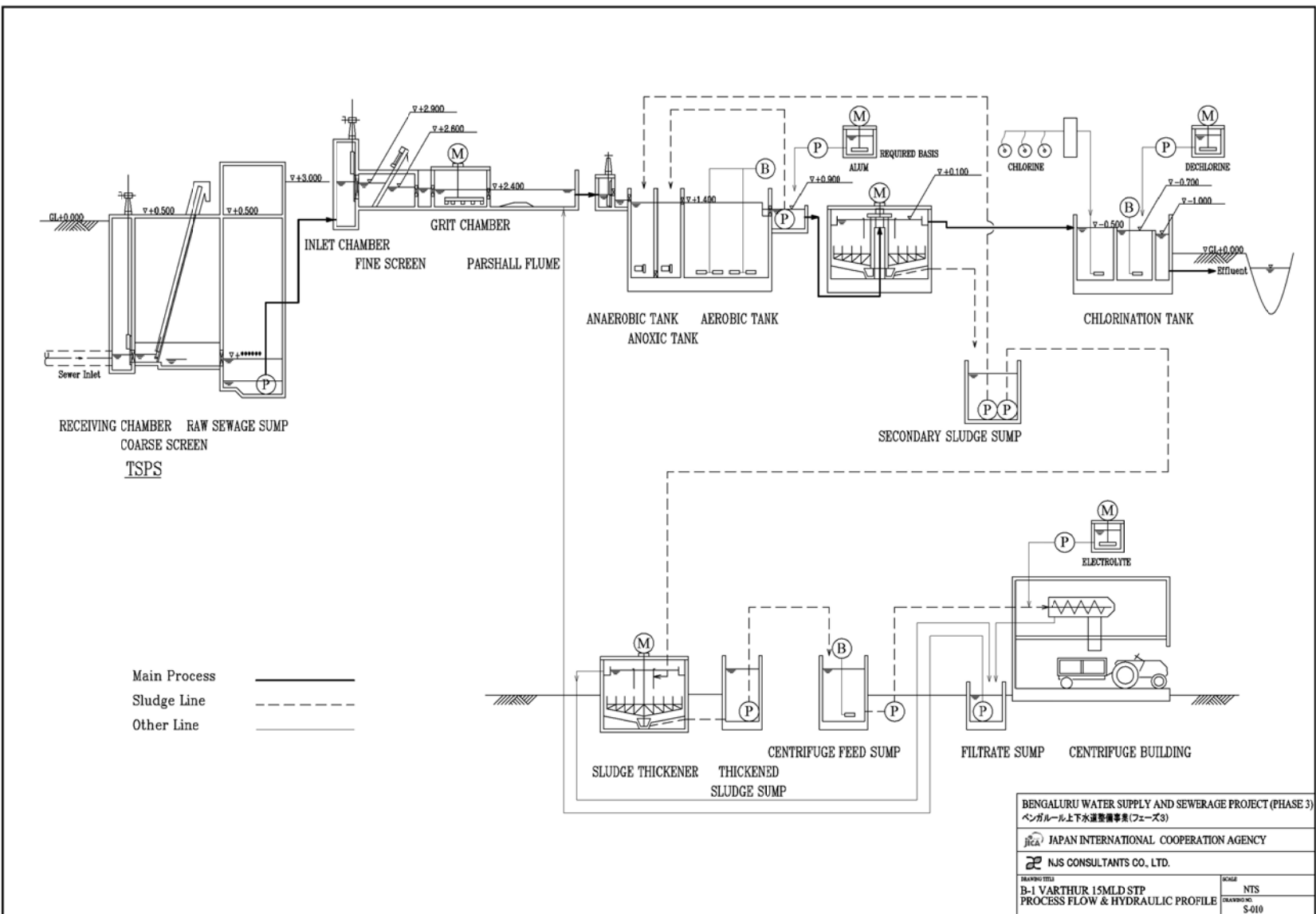

Figure 12.2.32 Process Flow Diagram with Hydraulic Profile

Table 12.2.24 Specifications for Major Equipment (Varthur STP)

Items	Specification	kW per unit	Unit number
(Mechanical)			
1. Inlet Gates	Manually Operated Cast Iron	Width 0.6(m)×Height :0.9(m)	- 3
2. Coarse Screens (Mechanical)	Climber Type SS316L	Channel Width :1.00 (m)×SWD :0.60 (m) ×Open Space:20(mm)	1.50 1W
3. Coarse Screens (Manual)	Climber Type SS316L	Channel Width :1.00 (m)×SWD :0.60 (m) ×Open Space:50(mm)	- 1
4. Belt Conveyor	Nylon fabric 3ply	Belt Width :0.60(m)×Length :5.0 (m)	1.50 1W
5. Sewage Pump 1	Submersible Cast Iron	Dia:300 (mm)×Discharge :570 (m ³ /h)×Total Head:15.0 (m)	45.0 2W+1S
6. Sewage Pump 2	Submersible Cast Iron	Dia:200 (mm)×Discharge :285 (m ³ /h)×Total Head:15.0 (m)	30.0 1W+1S
7. Electric Hoist	Single-girder Overhead Type	Rated Load :3.0(Ton)×Lift :6(m)	8.50 1W
8. Inlet Gates	Manually Operated Cast Iron	Width 0.5(m)×Height :0.75(m)	- 3
9. Fine Screens (Mechanical)	Step Type SS316L	Channel Width :1.00 (m)×SWD :0.50 (m) ×Open Space:6(mm)	1.50 2W
10. Fine Screen (Manual)	Bar Screen SS316L	Channel Width :1.00 (m)×SWD:0.50 (m) ×Open Space:20(mm)	- 1
11. Belt Conveyor	Nylon fabric 3ply	Belt Width :0.60(m)×Length :7.0 (m)	1.50 1W
12. Grit Chamber	Square Horizontal MS+Epoxy	Width :6.00 (m)×Length :6.00(m)×SWD :0.90 (m)	2.25 1W+1S
13. Inlet Weir Gates	Manually operated Cast Iron	Width 0.8(m)×Height :0.5(m)	- 2
14. Mixers for An-aerobic Tank	Submersible Type SS316L	Tank Width:8.0(m)×Length :12.0(m) ×SWD :5.5(m)	4.0 2W
15. Mixers for An-oxic Tank	Submersible Type SS316L	Tank Width :8.0(m)×Length :12.4(m) ×SWD :5.5(m)	4.0 6W
16. Diffusers	Fine Bubble Mem-brane	SOR:345 (kg/h·basin)×setting Depth :5.0(m) ×Efficiency:28 %	- 2
17. Air Blowers	Rotary blower Tri-lobe Type	Dia. :200 (mm)× Air Flow :2,600(m ³ /h) ×Pressure: 65 (K Pa)	90.0 4W+2S
18. Circulation Pumps	Submersible Cast Iron	Dia.:300(mm)×Discharge:580(m ³ /h) ×Total Head:5.0 (m)	18.5 4W+2S
19. RAS Pumps	Submersible Cast Iron	Dia. :150 (mm)×Discharge:190(m ³ /h) ×Total Head:5.0 (m)	5.5 2W+2S
20. SAS Pumps	Submersible Cast Iron	Dia.:100 (mm)×Discharge :80(m ³ /h) ×Total Head:15.0 (m)	7.5 2W+2S
21. Hand Operation Chain Block	With Geared Trolley	Rated Load :1.0(Ton)×Lift :6(m)	- 3
22. Final Clarifiers	Column-supported MS+ Epoxy	Dia. :28.5 (m)×SWD:3.5(m)	2.2 2W
23. Alum Dosing Pumps	Diaphragm Pump SS/ PTFE	Dia.:40(mm)×Discharge:260(L/h) ×Pressure:0.3(MPa)	0.75 2W+1S
24. Mixer for Alum Solution	Turbine impeller SS316	Tank Width: 1.4(m)×Length:1.4(m)×SWD:1.8(m)	0.75 2W
25. Chlorinators	Gas Chlorination Sys-tem	Dosing Rate :14.1(kg/h)	0.10 1W+1S

Items	Specification	kW per unit	Unit number
26. Chlorine Tonners	Volume:928(kg/Unit)	-	4
27. Chlorine Booster Pumps	Submersible Cast Iron Dia.:25 (mm)×Discharge :5.4(m ³ /h)×Total Head:50.0 (m)	2.20	1W+1S
28. Electric Hoist for Tonners	Single-girder Overhead Type Rated Load :3.0(Ton)×Lift :6(m)	8.60	1W
29. Dechlorine Dosing Pumps	Diaphragm Pump SS/ PTFE Dia.:15 (mm)×Discharge :17(L/h)×Pressure:1.0(MPa)	0.2	2W+1S
30. Mixer for Dechlorine Solution	Turbine impeller SS316 Tank Width: 0.5(m)×Length:0.5(m)×SWD:0.8(m)	0.10	2W
31. Air Blowers For Dechlorine Mixing Tank	Rotary blower Tri-lobe Type Dia. :40 (mm)× Air Flow:55(m ³ /h) ×Pressure: 20 (K Pa)	1.50	1W+1S
32. Electric Hoist for Chemicals	Single-girder Overhead Type Rated Load :1.0(Ton)×Lift :6(m)	4.70	1W
33. Sludge Thickener	Bridge-supported MS+ Epoxy Dia. :11.0 (m)×SWD:4.0(m)	0.4	2W
34. Thickened Sludge Pumps	Submersible Cast Iron Dia.:100(mm)×Discharge:80(m ³ /h) ×Total Head:15.0 (m)	11.0	2W+2S
35. Air Blowers For Centrifuge Feed Sump	Rotary blower Tri-lobe Type Dia. :100 (mm)× Air Flow:350(m ³ /h) ×Pressure: 40 (K Pa)	11.0	1W+1S
36. Centrifuge Feed Pumps	Progressive Cavity Pump, Cast Iron Dia.:100(mm)×Discharge:14(m ³ /h) ×Total Head:20.0 (m)	5.50	2W+1S
37. Centrifuges	Centrifuge SS316 Capacity:14(m ³ /h)	22.2	2W+1S
38. Electric Hoist Crane	Single-girder Overhead Type Rated Load :3.0(Ton)×Lift :15(m)	8.60	1W
39. Mixers for Polyelectrolyte Solution	Agitator SS304 Tank Width: 1.5(m)×Length:2.0(m)×SWD:2.0(m)	1.5	2W
40. Dry Polyelectrolyte Feeder	Volumetric metering SS304 Capacity: 20.0(kg/h)	0.40	2W
41. Polyelectrolyte Dosing Pumps	Progressive Cavity Pump Dia.:32(mm)×Discharge:1.3(m ³ /h) ×Total Head:20.0 (m)	0.75	2W+1S
42. Centrate Transfer Pumps	Submersible Cast Iron Dia:100 (mm)×Discharge :40(m ³ /h)×Total Head:15.0 (m)	5.50	2W+1S

Items	Specification	Unit number
(Electrical)		
1. Power receiving facilities at electrical substation	HV incoming panel, IP42, 11kV, VCB HV outgoing feeder panels, IP42, 11kV, VCB Power transformers: outdoor use, 11/0.415-0.24 kV, 100 kVA Diesel engine generator set: 415 V, 50 Hz, 750 kVA	1 pc 2 pcs 2 sets 1 pc
2. LV incoming panel, LV	LV incoming panels: IP42, 600V, ACB 1600A x 4 LV feeder panels: IP52, 600V, MCCB 400 A x 2, MCCB 200 A x 8, MCCB 100 A x 8,	1 pc 1 pc

Items	Specification	Unit number
switchgears, and MCCs	Static capacitors MCC for TSPS MCC for Headworks MCCs for Liquid process (Anaerobic/anoxic/aeration tanks, secondary clarifiers) Air blower starter panels with 90 kW VFD MCCs for Solid process	1 pc 1 pc 1 pc 6 pcs 1 pc
3. Instrumentation devices	Inlet flow meter Level meter in inlet chamber Level meter in sewage pump sump Level meters of pre and post screens Air blow flow meters Air blow pressure meters MLR (Mixed Liquor Recycle) flow meters RAS (Return Activated Sludge) flow meters DO analyzers MLSS analyzers Level meters in alum solution tank Alum dosing flow meters Residual chlorine analyzer Effluent flow meter Level meters in de-chlorine tank De-chlorine flow meter Level meters in secondary sludge sump WAS (Waste Activated Sludge) flow meters Level meters in thickened sludge sump Level meters in centrifuge sump Centrifuge feed flow meters Level meter in polyelectrolyte solution tank Centrifuge polymer dosing flow meters Level meter in filtrate sump Filtrate flow meter	1 pc 1 pc 1 pc 4 pcs 2 pcs 2 pcs 2 pcs 2 pcs 2 pcs 2 pcs 2 pcs 1 pc 1 pc 1 pc 1 pc 1 pc 1 pc 1 pc 1 pc 1 pc 3 pcs 2 pcs 3 pcs 1 pc 1 pc
4. Local SCADA system	Operator stations, SCADA servers, PLCs, router, etc.,	1 ls

Source: JICA Survey Team

6) Pillaganahalli STP

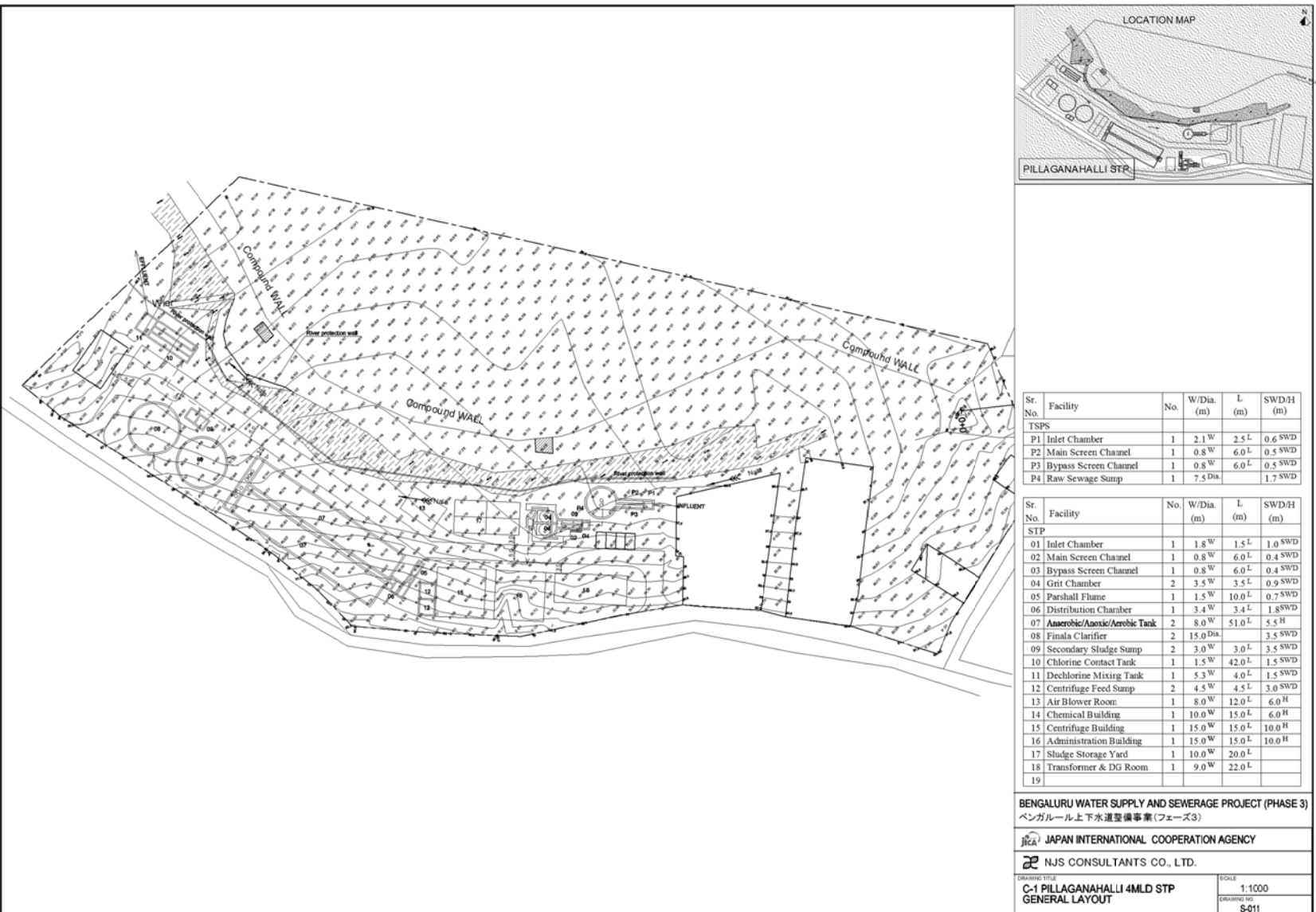

Figure 12.2.33 Layout plan of Pillaganahalli STP

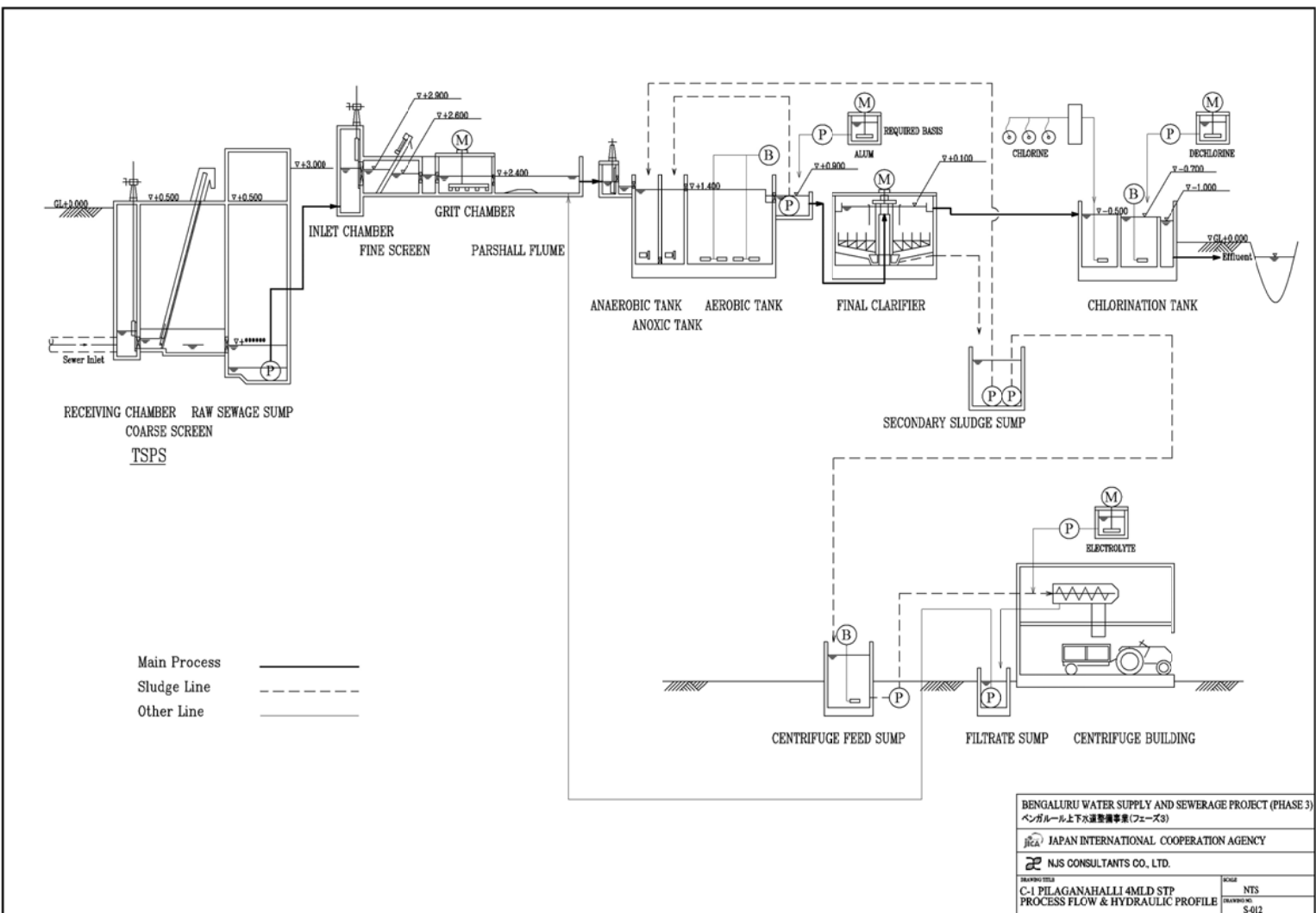

Figure 12.2.34 Process Flow Diagram with Hydraulic Profile

Table 12.2.25 Specifications for Major Equipment (Pillaganahalli STP)

Items	Specification	kW per unit	Unit number
(Mechanical)			
1. Inlet Gates	Manually Operated Cast Iron Width 0.40(m)×Height :0.60(m)	-	2
2. Coarse Screens (Mechanical)	Climber Type SS316L Channel Width :1.00 (m)×SWD :0.50 (m) ×Open Space:20(mm)	1.50	1W
3. Coarse Screens (Manual)	Climber Type SS316L Channel Width :1.00 (m)×SWD :0.50 (m) ×Open Space:50(mm)	-	1
4. Sewage Pump	Submersible Cast Iron Dia:250 (mm)×Discharge :418 (m ³ /h)×Total Head:15.0 (m)	37.0	1W+1S
5. Electric Hoist	Single-girder Overhead Type Rated Load :3.0(Ton)×Lift :6(m)	8.50	1W
6. Inlet Gates	Manually Operated Cast Iron Width 0.4(m)×Height :0.6(m)	-	2
7. Fine Screens (Mechanical)	Step Type SS316L Channel Width :0.80 (m)×SWD :0.40 (m) ×Open Space:6(mm)	1.50	1W
8. Fine Screen (Manual)	Bar Screen SS316L Channel Width :0.80 (m)×SWD:0.40 (m) ×Open Space:20(mm)	-	1
9. Belt Conveyor	Nylon fabric 3ply Belt Width :0.60(m)×Length :5.0 (m)	1.50	1W
10. Grit Chamber	Square Horizontal MS+ Epoxy Width :3.50 (m)×Length :3.50(m)×SWD :0.90 (m)	2.25	1W+1S
11. Inlet Weir Gates	Manually operated Cast Iron Width 0.4(m)×Height :0.4(m)	-	2
12. Mixers for Anaerobic Tank	Submersible Type SS316L Tank Width :8.0 (m)×Length :4.0(m)×SWD :5.5(m)	4.0	2W
13. Mixers for Anoxic Tank	Submersible Type SS316L Tank Width :8.0 (m)×Length :10(m)×SWD :5.5(m)	4.0	2W
14. Diffusers	Fine Bubble Mem- brane SOR:92 (kg/h·basin)×setting Depth :5.0(m) ×Efficiency:28 %	-	2
15. Air Blowers	Rotary blower Tri-lobe Type Dia. :150 (mm)× Air Flow :1400(m ³ /h) ×Pressure: 65 (KPa)	45.0	2W+1S
16. Circulation Pumps	Submersible Cast Iron Dia. :150 (mm)×Discharge:155(m ³ /h) ×Total Head:5.0 (m)	5.5	4W+2S
17. RAS Pumps	Submersible Cast Iron Dia. :100 (mm)×Discharge:50(m ³ /h) ×Total Head:5.0 (m)	1.5	2W+2S
18. SAS Pumps	Submersible Cast Iron Dia.:80 (mm)×Discharge :18 (m ³ /h) ×Total Head:15.0 (m)	2.20	2W+2S
19. Hand Operation Chain Block	With Geared Trolley Rated Load :1.0(Ton)×Lift :6(m)	-	3
20. Final Clarifiers	Bridge-supported MS+ Epoxy Dia. :15.0 (m)×SWD:3.5(m)	0.4	2W
21. Alum Dosing Pumps	Diaphragm Pump SS/ PTFE Dia.:25 (mm)×Discharge :70(L/h) ×Pressure:0.7(MPa)	0.4	2W+1S
22. Mixer for Alum Solution	Turbine impeller SS316 Tank Width: 1.0(m)×Length:1.0(m)×SWD:1.0(m)	0.4	2W
23. Chlorinators	Gas Chlorination Sys- tem Dosing Rate :4.2(kg/h)	0.10	1W+1S
24. Chlorine Tonners	Volume:928(kg/Unit)	-	4
25. Chlorine Booster Pumps	Submersible Cast Iron Dia.:25 (mm)×Discharge :2.4(m ³ /h) ×Total Head:50.0 (m)	0.75	1W+1S

Items	Specification	kW per unit	Unit number
26. Electric Hoist for Tonners	Single-girder Overhead Type Rated Load :3.0(Ton)×Lift :6(m)	8.60	1W
27. Dechlorine Dosing Pumps	Diaphragm Pump SS/ PTFE Dia.:15 (mm)×Discharge :10(L/h) ×Pressure:1.0(MPa)	0.2	1W+1S
28. Mixer for Dechlorine Solution	Turbine impeller SS316 Tank Width: 0.5(m)×Length:0.5(m)×SWD:0.8(m)	0.1	1W
29. Air Blowers For Dechlorine Mixing Tank	Rotary blower Tri-lobe Type Dia. :40 (mm)× Air Flow:16(m ³ /h) ×Pressure: 20 (K Pa)	0.75	1W+1S
30. Electric Hoist for Chemicals	Single-girder Overhead Type Rated Load :1.0(Ton)×Lift :6(m)	4.70	1W
31. Air Blowers For Centrifuge Feed Sump	Rotary blower Tri-lobe Type Dia. :80 (mm)× Air Flow:150(m ³ /h) ×Pressure: 40 (KPa)	5.50	1W+1S
32. Centrifuge Feed Pumps	Progressive Cavity Pump, Cast Iron Dia.:125 (mm)×Discharge :22(m ³ /h) ×Total Head:20.0 (m)	7.5	1W+1S
33. Centrifuges	Centrifuge SS316 Capacity:22(m ³ /h)	44.5	1W+1S
34. Electric Hoist Crane	Single-girder Overhead Type Rated Load :5.0(Ton)×Lift :15(m)	17.10	1W
35. Mixers for Polyelectrolyte Solution	Agitator SS304 Tank Width: 1.0(m)×Length:1.5(m)×SWD:1.8(m)	0.75	2W
36. Polyelectrolyte Dosing Pumps	Progressive Cavity Pump Dia.:20 (mm)×Discharge:0.65(m ³ /h) ×Total Head:20.0 (m)	0.40	1W+1S
37. Centrate Transfer Pumps	Submersible Cast Iron Dia:100 (mm)×Discharge :60(m ³ /h) ×Total Head:15.0 (m)	5.50	1W+1S

Items	Specification	Unit number
(Electrical)		
1. Power receiving facilities at electrical substation	HV incoming panel, IP42, 11kV, VCB HV outgoing feeder panels, IP42, 11kV, VCB Power transformers: outdoor use, 11/0.415-0.24 kV,500 kVA Diesel engine generator set: 415 V, 50 Hz, 375 kVA	1 pc 2 pcs 2 sets 1 pc
2. LV incoming panel, LV switchgears, and MCCs	LV incoming panels: IP42, 600V, ACB 800A x 3, ACB 630A x 1 LV feeder panels: IP52, 600V, MCCB 100 A x 13, Static capacitors MCC for TSPS MCC for Headworks MCCs for Liquid process (Anaerobic/anoxic/aeration tanks, secondary clarifiers) Air blower starter panels with 45 kW VFD MCCs for Solid process	1 pc 1 pc 1 pc 1 pc 1 pc 3 pcs 1 pc
3. Instrumentation devices	Inlet flow meter Level meter in inlet chamber Level meter in sewage pump sump Level meters of pre and post screens Air blow flow meters Air blow pressure meters MLR (Mixed Liquor Recycle) flow meters	1 pc 1 pc 1 pc 4 pcs 2 pcs 2 pcs 2 pcs

Items	Specification	Unit number
	RAS (Return Activated Sludge) flow meters DO analyzers MLSS analyzers Level meters in alum solution tank Alum dosing flow meters Residual chlorine analyzer Effluent flow meter Level meters in de-chlorine tank De-chlorine flow meter Level meter in secondary sludge sump WAS (Waste Activated Sludge) flow meters Level meters in centrifuge sump Centrifuge feed flow meters Level meter in polyelectrolyte solution tank Centrifuge polymer dosing flow meters Level meter in filtrate sump Filtrate flow meter	2 pcs 2 pcs 2 pcs 2 pcs 1 pc 1 pc 1 pc 1 pc 1 pc 1 pc 1 pc 1 pc 2 pcs 2 pcs 2 pcs 1 pc 1 pc
4. Local SCADA system	Operator stations, SCADA servers, PLCs, router, etc.	1 ls

Source: JICA Survey Team

7) Talaghattapura STP

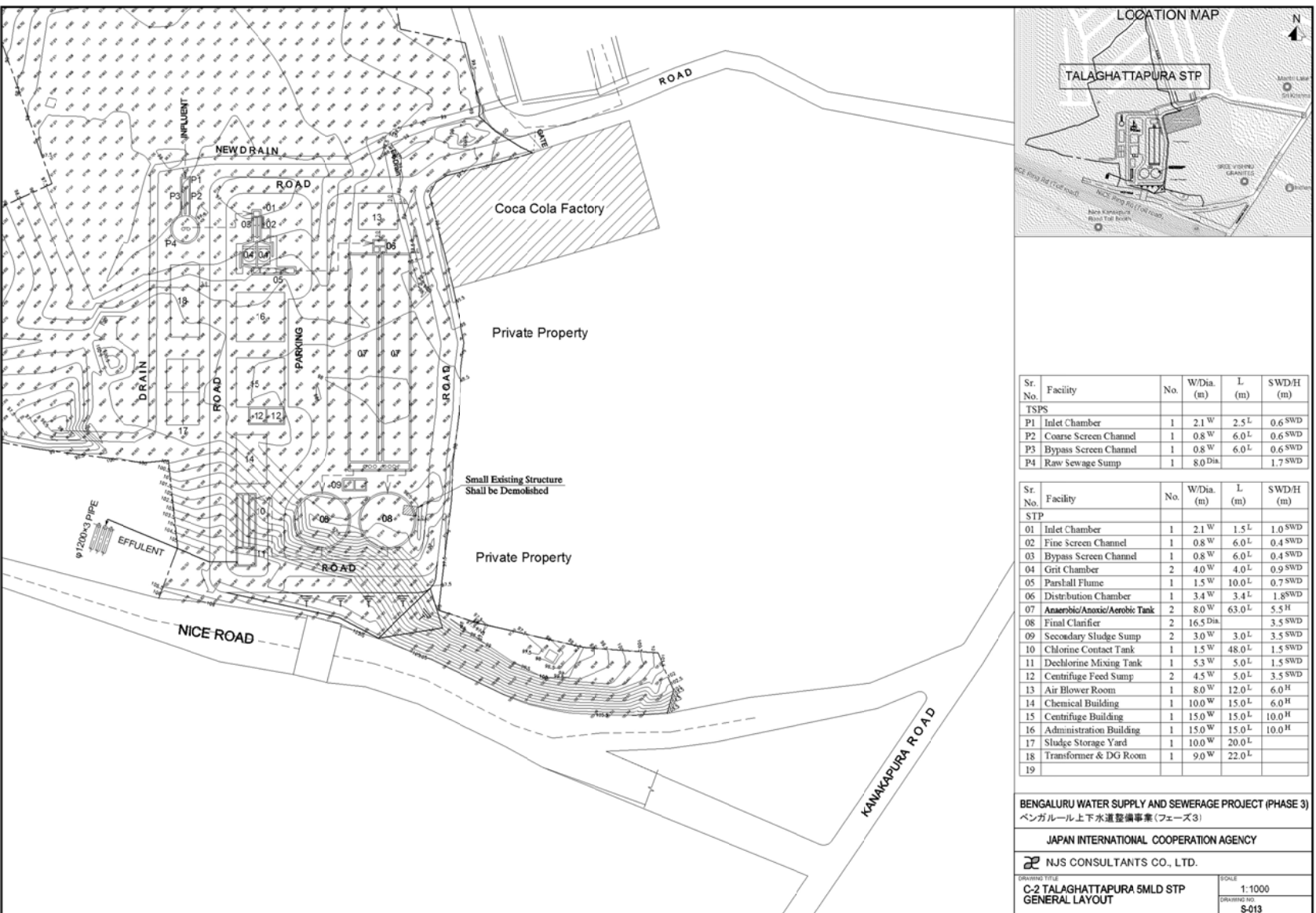

Figure 12.2.35 Layout plan of Talaghattapura STP

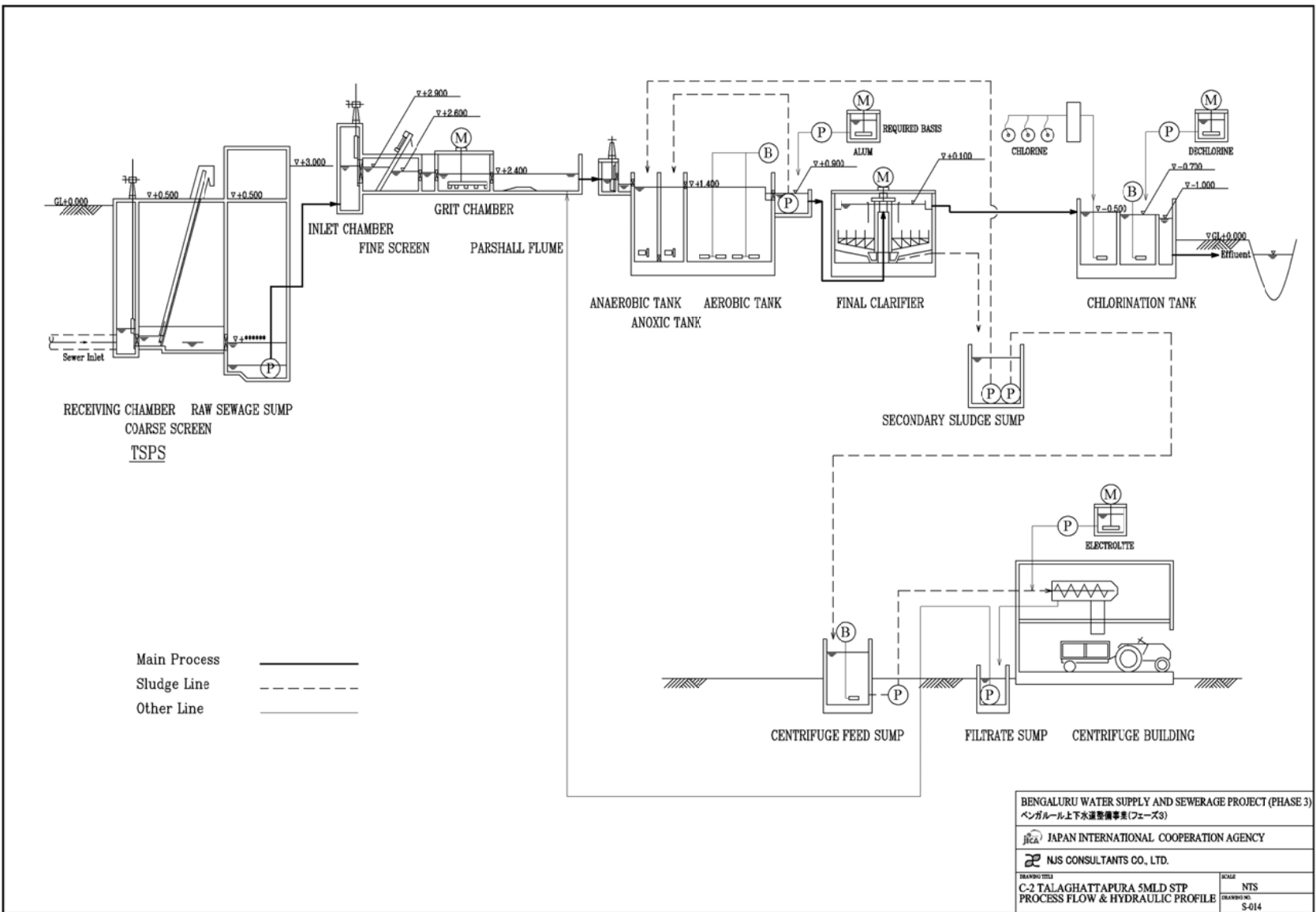

Figure 12.2.36 Process Flow Diagram with Hydraulic Profile

Table 12.2.26 Specifications for Major Equipment (Talaghattapura STP)

Items	Specification	kW per unit	Unit number
(Mechanical)			
1. Inlet Gates	Manually Operated Cast Iron	Width 0.40(m)×Height :0.60(m)	- 2
2. Coarse Screens (Mechanical)	Climber Type SS316L	Channel Width :0.80 (m)×SWD :0.60 (m) ×Open Space:20(mm)	1.50 1W
3. Coarse Screens (Manual)	Climber Type SS316L	Channel Width :0.80 (m)×SWD :0.60 (m) ×Open Space:50(mm)	- 1
4. Sewage Pump	Submersible Cast Iron	Dia:300 (mm)×Discharge :522 (m ³ /h) ×Total Head:15.0 (m)	45.0 1W+1S
5. Electric Hoist	Single-girder Overhead Type	Rated Load :3.0(Ton)×Lift :6(m)	8.50 1W
6. Inlet Gates	Manually Operated Cast Iron	Width 0.4(m)×Height :0.6(m)	- 2
7. Fine Screens (Mechanical)	Step Type SS316L	Channel Width :0.80 (m)×SWD :0.40 (m) ×Open Space:6(mm)	1.50 1W
8. Fine Screen (Manual)	Bar Screen SS316L	Channel Width :0.80 (m)×SWD:0.40 (m) ×Open Space:20(mm)	- 1
9. Belt Conveyor	Nylon fabric 3ply	Belt Width :0.60(m)×Length :5.0 (m)	1.50 1W
10. Grit Chamber	Square Horizontal MS+Epoxy	Width :4.00 (m)×Length :4.00(m)×SWD :0.90 (m)	2.25 1W+1S
11. Inlet Weir Gates	Manually operated Cast Iron	Width 0.4(m)×Height :0.4(m)	- 2
12. Mixers for An-aerobic Tank	Submersible Type SS316L	Tank Width :8.0 (m)×Length :5.0(m)×SWD :5.5(m)	4.0 2W
13. Mixers for An-oxic Tank	Submersible Type SS316L	Tank Width :8.0 (m)×Length :13.0(m)×SWD :5.5(m)	4.0 2W
14. Diffusers	Fine Bubble Mem-brane	SOR:115 (kg/h·basin)×setting Depth :5.0(m) ×Efficiency:28 %	- 2
15. Air Blowers	Rotary blower Tri-lobe Type	Dia. :150 (mm)× Air Flow :1700(m ³ /h) ×Pressure: 65 (K Pa)	55.0 2W+1S
16. Circulation Pumps	Submersible Cast Iron	Dia. :150 (mm)×Discharge:190(m ³ /h) ×Total Head:5.0 (m)	5.50 4W+2S
17. RAS Pumps	Submersible Cast Iron	Dia. :100 (mm)×Discharge:65(m ³ /h) ×Total Head:5.0 (m)	2.20 2W+2S
18. SAS Pumps	Submersible Cast Iron	Dia.:80 (mm)×Discharge :23 (m ³ /h) ×Total Head:15.0 (m)	3.70 2W+2S
19. Hand Operation Chain Block	With Geared Trolley	Rated Load :1.0(Ton)×Lift :6(m)	- 3
20. Final Clarifiers	Column-supported MS+ Epoxy	Dia. :16.5 (m)×SWD:3.5(m)	1.5 2W
21. Alum Dosing Pumps	Diaphragm Pump SS/ PTFE	Dia.:25 (mm)×Discharge :90(L/h)×Pressure:0.7(MPa)	0.4 2W+1S
22. Mixer for Alum Solution	Turbine impeller SS316	Tank Width: 1.0(m)×Length:1.0(m)×SWD:1.5(m)	0.4 2W
23. Chlorinators	Gas Chlorination Sys-tem	Dosing Rate :5.2(kg/h)	0.10 1W+1S
24. Chlorine Ton-ners		Volume:928(kg/Unit)	- 4

Items	Specification	kW per unit	Unit number
25. Chlorine Booster Pumps	Submersible Cast Iron Dia.:25 (mm)×Discharge :2.7(m ³ /h) ×Total Head:50.0 (m)	1.50	1W+1S
26. Electric Hoist for Tonners	Single-girder Overhead Type Rated Load :3.0(Ton)×Lift :6(m)	8.60	1W
27. Dechlorine Dosing Pumps	Diaphragm Pump SS/ PTFE Dia.:15 (mm)×Discharge :13(L/h)×Pressure:1.0(MPa)	0.2	1W+1S
28. Mixer for Dechlorine Solution	Turbine impeller SS316 Tank Width: 0.5(m)×Length:0.5(m)×SWD:0.8(m)	0.1	1W
29. Air Blowers For Dechlorine Mixing Tank	Rotary blower Tri-lobe Type Dia. :40 (mm)× Air Flow:20(m ³ /h) ×Pressure: 20 (K Pa)	0.75	1W+1S
30. Electric Hoist for Chemicals	Single-girder Overhead Type Rated Load :1.0(Ton)×Lift :6(m)	4.70	1W
31. Air Blowers For Centrifuge Feed Sump	Rotary blower Tri-lobe Type Dia. :80 (mm)× Air Flow:190(m ³ /h) ×Pressure: 40 (K Pa)	5.50	1W+1S
32. Centrifuge Feed Pumps	Progressive Cavity Pump, Cast Iron Dia.:125 (mm)×Discharge :27(m ³ /h) ×Total Head:20.0 (m)	7.5	1W+1S
33. Centrifuges	Centrifuge SS316 Capacity:27(m ³ /h)	44.5	1W+1S
34. Electric Hoist Crane	Single-girder Overhead Type Rated Load :5.0(Ton)×Lift :15(m)	17.10	1W
35. Mixers for Polyelectrolyte Solution	Agitator SS304 Tank Width: 1.5(m)×Length:1.5(m)×SWD:1.8(m)	1.50	2W
36. Polyelectrolyte Dosing Pumps	Progressive Cavity Pump Dia.:32 (mm)×Discharge :0.80(m ³ /h) ×Total Head:20.0 (m)	0.75	1W+1S
37. Centrate Transfer Pumps	Submersible Cast Iron Dia:100 (mm)×Discharge :40(m ³ /h) ×Total Head:15.0 (m)	5.50	1W+1S

Items	Specification	Unit number
(Electrical)		
1. Power receiving facilities at electrical substation	HV incoming panel, IP42, 11kV, VCB HV outgoing feeder panels, IP42, 11kV, VCB Power transformers: outdoor use, 11/0.415-0.24 kV,500 kVA Diesel engine generator set: 415 V, 50 Hz, 375 kVA	1 pc 2 pcs 2 sets 1 pc
2. LV incoming panel, LV switchgears, and MCCs	LV incoming panels: IP42, 600V, ACB 800A x 3, ACB 630A x 1 LV feeder panels: IP52, 600V, MCCB 200 A x 4 MCCB 100 A x 10, Static capacitors MCC for TSPS MCC for Headworks MCCs for Liquid process (Anaerobic/anoxic/aeration tanks, secondary clarifiers) Air blower starter panels with 55 kW VFD MCCs for Solid process	1 pc 1 pc 1 pc 1 pc 1 pc 3 pcs 1 pc
3. Instrumentation devices	Inlet flow meter Level meter in inlet chamber Level meter in sewage pump sump	1 pc 1 pc 1 pc

Items	Specification	Unit number
	Level meters of pre and post screens Air blow flow meters Air blow pressure meters MLR (Mixed Liquor Recycle) flow meters RAS (Return Activated Sludge) flow meters DO analyzers MLSS analyzers Level meters in alum solution tank Alum dosing flow meters Residual chlorine analyzer Effluent flow meter Level meters in de-chlorine tank De-chlorine flow meter Level meter in secondary sludge sump WAS (Waste Activated Sludge) flow meters Level meters in centrifuge sump Centrifuge feed flow meters Level meter in polyelectrolyte solution tank Centrifuge polymer dosing flow meters Level meter in filtrate sump Filtrate flow meter	4 pcs 2 pcs 2 pcs 2 pcs 2 pcs 2 pcs 2 pcs 2 pcs 1 pc 1 pc 1 pc 1 pc 1 pc 1 pc 1 pc 1 pc 2 pcs 2 pcs 2 pcs 1 pc 1 pc
4. Local SCADA system	Operator stations, SCADA servers, PLCs, router, etc.	1 ls

Source: JICA Survey Team

8) Somapura STP

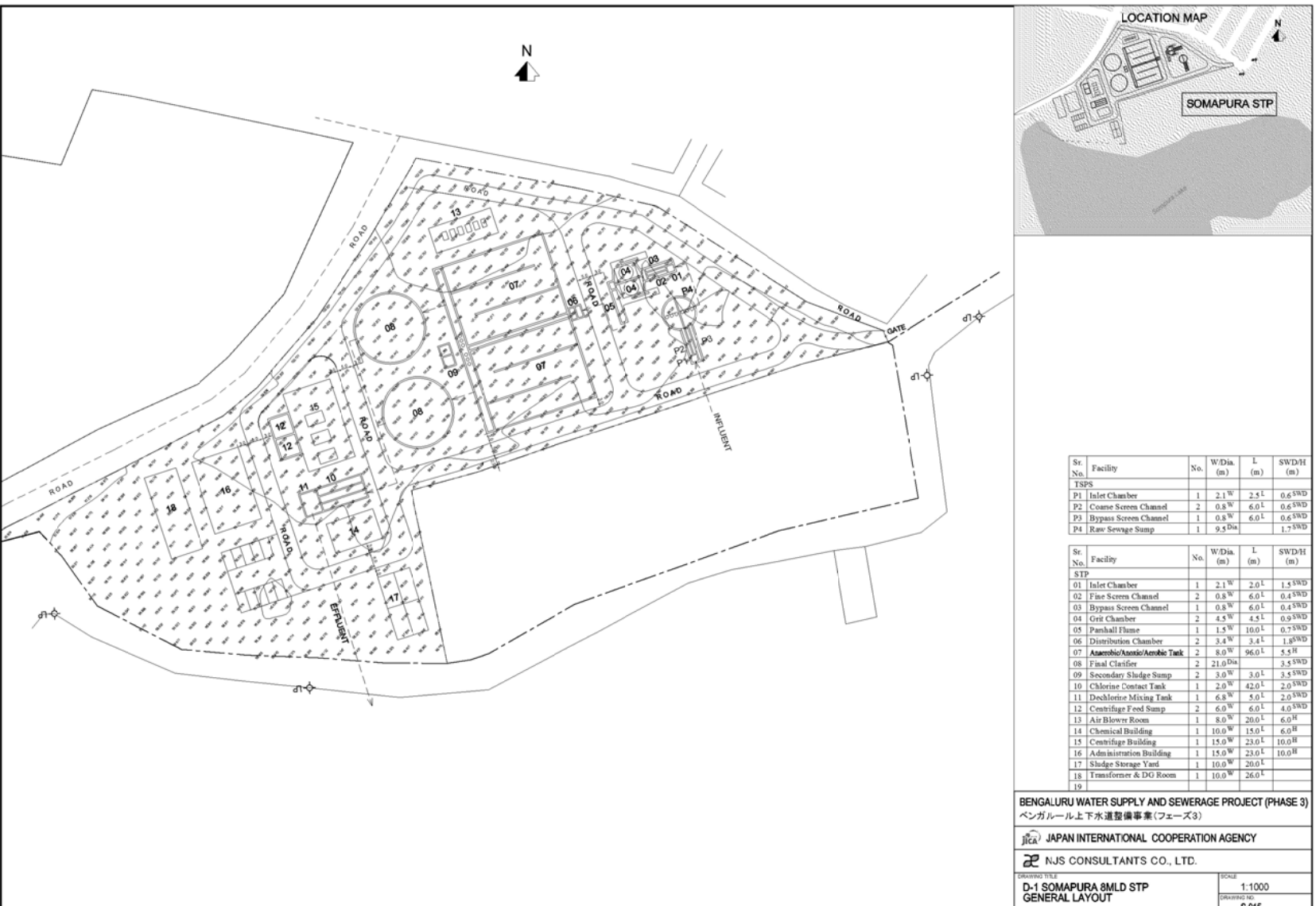

Figure 12.2.37 Layout plan of Somapura STP

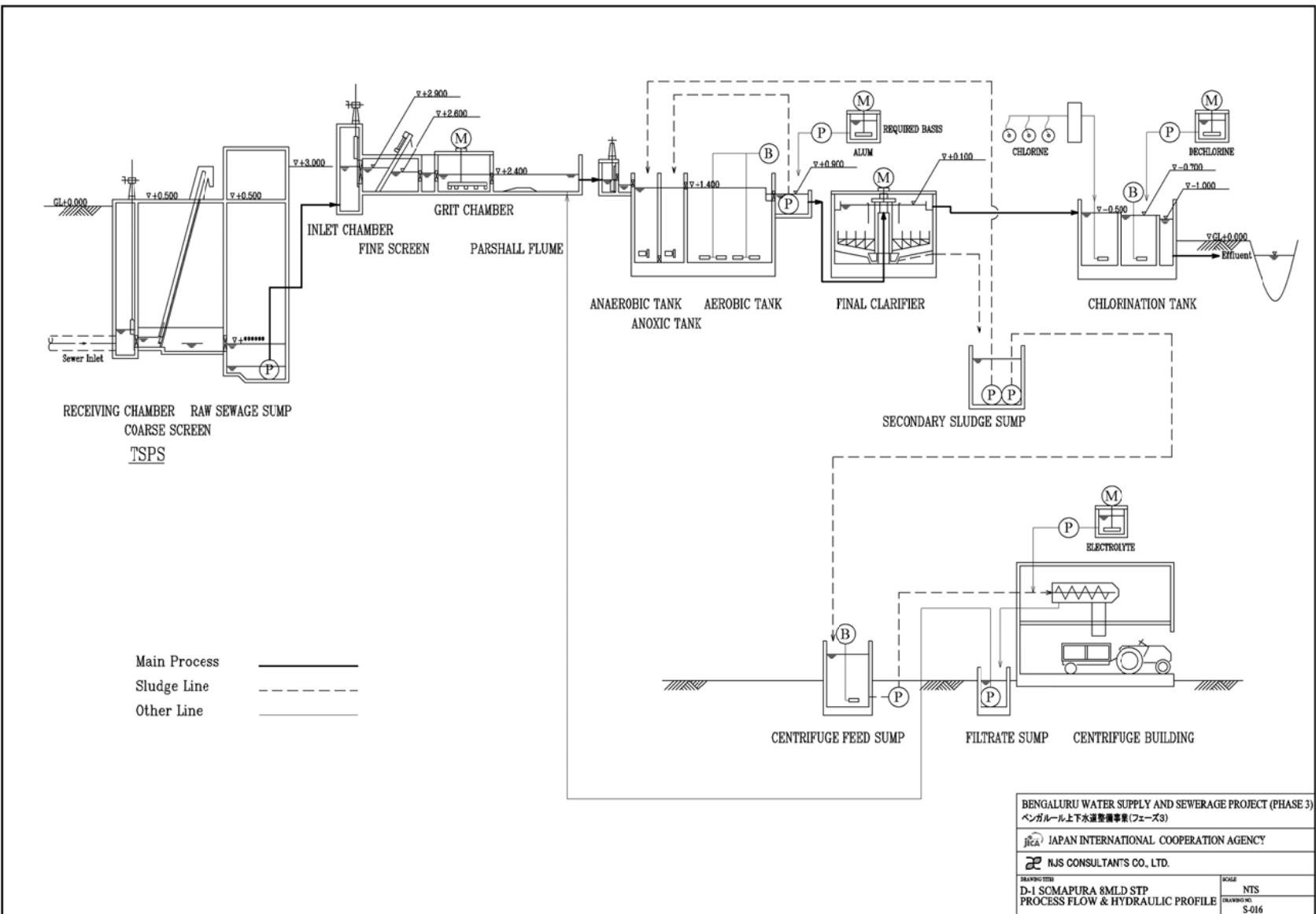

Figure 12.2.38 Process Flow Diagram with Hydraulic Profile

Table 12.2.27 Specifications for Major Equipment (Somapura STP)

Items	Specification	kW per unit	Unit number
(Mechanical)			
1. Inlet Gates	Manually Operated Cast Iron Width 0.50(m)×Height :0.75(m)	-	3
2. Coarse Screens (Mechanical)	Climber Type SS316L Channel Width :0.80 (m)×SWD :0.60 (m) ×Open Space:20(mm)	1.50	1W
3. Coarse Screens (Manual)	Climber Type SS316L Channel Width :0.80 (m)×SWD :0.60 (m) ×Open Space:50(mm)	-	1
4. Belt Conveyor	Nylon fabric 3ply Belt Width :0.60(m)×Length :5.0 (m)	1.50	1W
5. Sewage Pump 1	Submersible Cast Iron Dia:200 (mm)×Discharge :300 (m ³ /h) ×Total Head:15.0 (m)	30.0	2W+1S
6. Sewage Pump 2	Submersible Cast Iron Dia:150 (mm)×Discharge :150 (m ³ /h) ×Total Head:15.0 (m)	15.0	1W+1S
7. Electric Hoist	Single-girder Overhead Type Rated Load :3.0(Ton)×Lift :6(m)	8.50	1W
8. Inlet Gates	Manually Operated Cast Iron Width 0.40(m)×Height :0.60(m)	-	3
9. Fine Screens (Mechanical)	Step Type SS316L Channel Width :0.80 (m)×SWD :0.40 (m) ×Open Space:6(mm)	1.50	2W
10. Fine Screen (Manual)	Bar Screen SS316L Channel Width :0.80 (m)×SWD:0.40 (m) ×Open Space:20(mm)	-	1
11. Belt Conveyor	Nylon fabric 3ply Belt Width :0.60(m)×Length :7.0 (m)	1.50	1W
12. Grit Chamber	Square Horizontal MS+Epoxy Width :4.50 (m)×Length :4.5(m)×SWD :0.90 (m)	2.25	1W+1S
13. Inlet Weir Gates	Manually operated Cast Iron Width 0.6(m)×Height :0.4(m)	-	2
14. Mixers for An-aerobic Tank	Submersible Type SS316L Tank Width :8.0 (m)×Length :6.0(m)×SWD :5.5(m)	4.0	2W
15. Mixers for An-oxic Tank	Submersible Type SS316L Tank Width :8.0 (m)×Length :10.0(m)×SWD :5.5(m)	4.0	4W
16. Diffusers	Fine Bubble Mem-brane SOR:184 (kg/h·basin)×setting Depth :5.0(m) ×Efficiency:28 %	-	2
17. Air Blowers	Rotary blower Tri-lobe Type Dia. :150 (mm)× Air Flow :1,400(m ³ /h) ×Pressure: 65 (KPa)	45.0	4W+2S
18. Circulation Pumps	Submersible Cast Iron Dia. :200 (mm)×Discharge:305(m ³ /h) ×Total Head:5.0 (m)	11.0	4W+2S
19. RAS Pumps	Submersible Cast Iron Dia. :100 (mm)×Discharge:100(m ³ /h) ×Total Head:5.0 (m)	3.7	2W+2S
20. SAS Pumps	Submersible Cast Iron Dia.:100 (mm)×Discharge :40(m ³ /h) ×Total Head:15.0 (m)	5.50	2W+2S
21. Hand Operation Chain Block	With Geared Trolley Rated Load :1.0(Ton)×Lift :6(m)	-	3
22. Final Clarifiers	Column-supported MS+ Epoxy Dia. :21.0 (m)×SWD:3.5(m)	2.2	2W
23. Alum Dosing Pumps	Diaphragm Pump SS/ PTFE Dia.:25 (mm)×Discharge :140(L/h) ×Pressure:0.7(MPa)	0.4	2W+1S
24. Mixer for Alum Solution	Turbine impeller SS316 Tank Width: 1.2(m)×Length:1.2(m)×SWD:1.8(m)	0.75	2W
25. Chlorinators	Gas Chlorination Sys-tem Dosing Rate :7.5(kg/h)	0.10	1W+1S

Items	Specification	kW per unit	Unit number
26. Chlorine Tonners	Volume:928(kg/Unit)	-	4
27. Chlorine Booster Pumps	Submersible Cast Iron Dia.:25 (mm)×Discharge :3.6(m ³ /h) ×Total Head:50.0 (m)	1.50	1W+1S
28. Electric Hoist for Tonners	Single-girder Overhead Type Rated Load :3.0(Ton)×Lift :6(m)	8.60	1W
29. Dechlorine Dosing Pumps	Diaphragm Pump SS/ PTFE Dia.:15 (mm)×Discharge :18(L/h) ×Pressure:1.0(MPa)	0.2	1W+1S
30. Mixer for Dechlorine Solution	Turbine impeller SS316 Tank Width: 0.5(m)×Length:0.5(m)×SWD:0.8(m)	0.1	1W
31. Air Blowers For Dechlorine Mixing Tank	Rotary blower Tri-lobe Type Dia. :40 (mm)× Air Flow:34(m ³ /h) ×Pressure: 20 (K Pa)	1.50	1W+1S
32. Electric Hoist for Chemicals	Single-girder Overhead Type Rated Load :1.0(Ton)×Lift :6(m)	4.70	1W
33. Air Blowers For Centrifuge Feed Sump	Rotary blower Tri-lobe Type Dia. :100 (mm)× Air Flow:350(m ³ /h) ×Pressure: 40 (K Pa)	11.00	1W+1S
34. Centrifuge Feed Pumps	Progressive Cavity Pump, Cast Iron Dia.:125 (mm)×Discharge :22(m ³ /h) ×Total Head:20.0 (m)	7.50	2W+1S
35. Centrifuges	Centrifuge SS316 Capacity:22(m ³ /h)	44.5	2W+1S
36. Electric Hoist Crane	Single-girder Overhead Type Rated Load :5.0(Ton)×Lift :15(m)	17.10	1W
37. Mixers for Polyelectrolyte Solution	Agitator SS304 Tank Width: 1.5(m)×Length:1.5(m)×SWD:1.5(m)	1.50	2W
38. Dry Polyelectrolyte Feeder	Volumetric metering SS304 Capacity: 10.0(kg/h)	0.40	2W
39. Polyelectrolyte Dosing Pumps	Progressive Cavity Pump Dia.:32 (mm)×Discharge :0.70(m ³ /h) ×Total Head:20.0 (m)	0.75	2W+1S
40. Centrate Transfer Pumps	Submersible Cast Iron Dia:100 (mm)×Discharge :40(m ³ /h) ×Total Head:15.0 (m)	5.50	2W+1S

Items	Specification	Unit number
(Electrical)		
1. Power receiving facilities at electrical substation	HV incoming panel, IP42, 11kV, VCB HV outgoing feeder panels, IP42, 11kV, VCB Power transformers: outdoor use, 11/0.415-0.24 kV,750 kVA Diesel engine generator set: 415 V, 50 Hz, 500 kVA	1 pc 2 pcs 2 sets 1 pc
2. LV incoming panel, LV switchgears, and MCCs	LV incoming panels: IP42, 600V, ACB 1600A x 3, ACB 800A x 1 LV feeder panels: IP52, 600V, MCCB 200 A x 4 MCCB 100 A x 10, Static capacitors MCC for TSPS MCC for Headworks MCCs for Liquid process (Anaerobic/anoxic/aeration tanks, secondary clarifiers) Air blower starter panels with 45 kW VFD MCCs for Solid process	1 pc 1 pc 1 pc 1 pc 1 pc 6 pcs 1 pc

Items	Specification	Unit number
3. Instrumentation devices	Inlet flow meter Level meter in inlet chamber Level meter in sewage pump sump Level meters of pre and post screens Air blow flow meters Air blow pressure meters MLR (Mixed Liquor Recycle) flow meters RAS (Return Activated Sludge) flow meters DO analyzers MLSS analyzers Level meters in alum solution tank Alum dosing flow meters Residual chlorine analyzer Effluent flow meter Level meters in de-chlorine tank De-chlorine flow meter Level meter in secondary sludge sump WAS (Waste Activated Sludge) flow meters Level meters in centrifuge sump Centrifuge feed flow meters Level meter in polyelectrolyte solution tank Centrifuge polymer dosing flow meters Level meter in filtrate sump Filtrate flow meter	1 pc 1 pc 1 pc 4 pcs 2 pcs 2 pcs 2 pcs 2 pcs 2 pcs 2 pcs 2 pcs 2 pcs 1 pc 1 pc 1 pc 1 pc 1 pc 1 pc 1 pc 1 pc 3 pcs 2 pcs 3 pcs 1 pc 1 pc
4. Local SCADA system	Operator stations, SCADA servers, PLCs, router, etc.,	1 ls

Source: JICA Survey Team

9) Hemigepura STP



Figure 12.2.39 Layout plan of Hemigepura STP

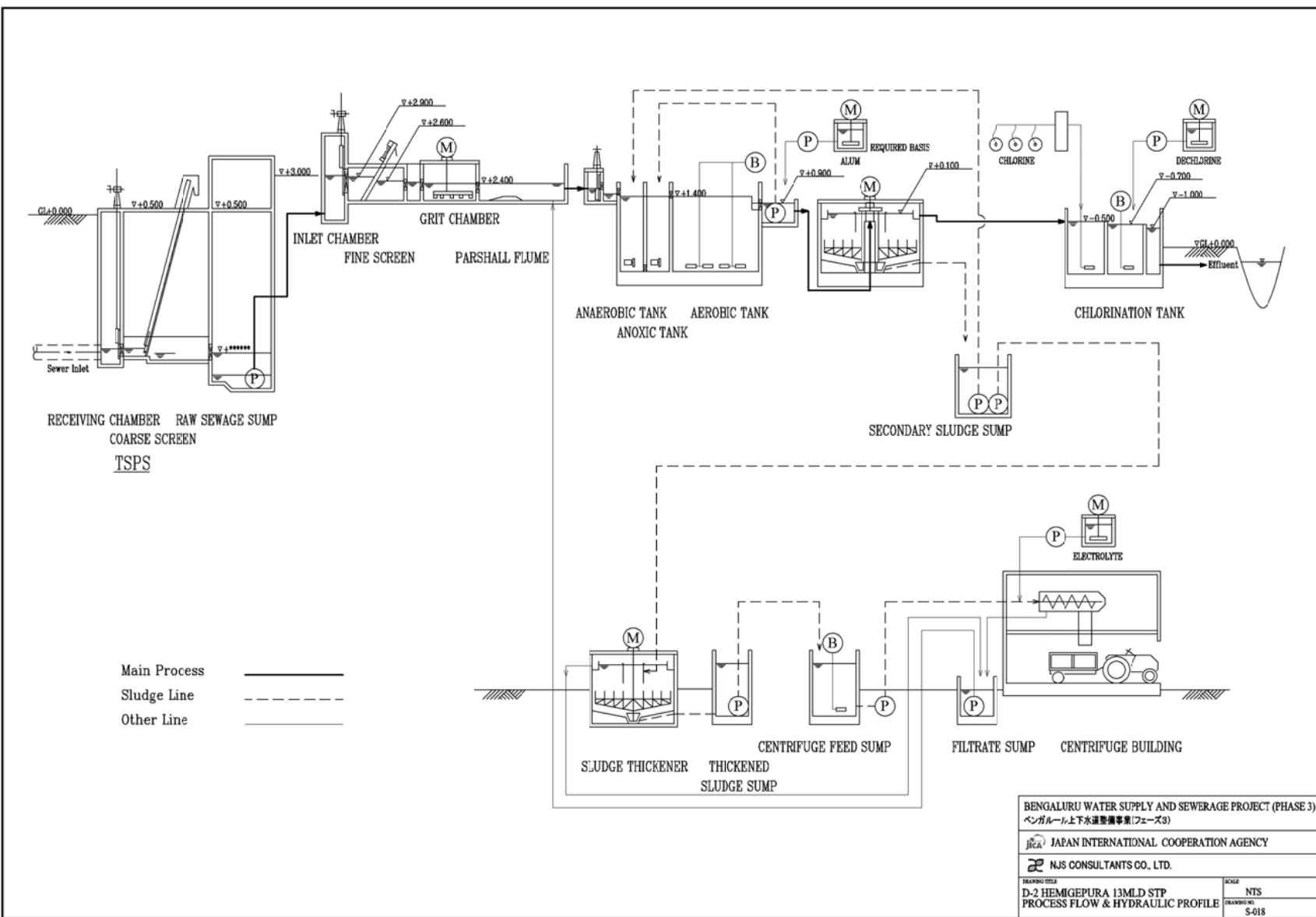

Figure 12.2.40 Process Flow Diagram with Hydraulic Profile

Table 12.2.28 Specifications for Major Equipment (Hemigepura STP)

Items	Specification	kW per unit	Unit number
(Mechanical)			
1. Inlet Gates	Manually Operated Cast Iron Width 0.6(m)×Height :0.9(m)	-	3
2. Coarse Screens (Mechanical)	Climber Type SS316L Channel Width :1.00 (m)×SWD :0.60 (m) ×Open Space:20(mm)	1.50	1W
3. Coarse Screens (Manual)	Climber Type SS316L Channel Width :1.00 (m)×SWD :0.60 (m) ×Open Space:50(mm)	-	1
4. Belt Conveyor	Nylon fabric 3ply Belt Width :0.60(m)×Length :5.0 (m)	1.50	1W
5. Sewage Pump 1	Submersible Cast Iron Dia:250 (mm)×Discharge :490 (m ³ /h) ×Total Head:15.0 (m)	45.0	2W+1S
6. Sewage Pump 2	Submersible Cast Iron Dia:200 (mm)×Discharge :245 (m ³ /h) ×Total Head:15.0 (m)	22.0	1W+1S
7. Electric Hoist	Single-girder Overhead Type Rated Load :3.0(Ton)×Lift :6(m)	8.50	1W
8. Inlet Gates	Manually Operated Cast Iron Width 0.5(m)×Height :0.75(m)	-	3
9. Fine Screens (Mechanical)	Step Type SS316L Channel Width :0.80 (m)×SWD :0.50 (m) ×Open Space:6(mm)	1.50	2W
10. Fine Screen (Manual)	Bar Screen SS316L Channel Width :0.80 (m)×SWD:0.50 (m) ×Open Space:20(mm)	-	1
11. Belt Conveyor	Nylon fabric 3ply Belt Width :0.60(m)×Length :7.0 (m)	1.50	1W
12. Grit Chamber	Square Horizontal MS+Epoxy Width :6.00 (m)×Length :6.00(m)×SWD :0.90 (m)	2.25	1W+1S
13. Inlet Weir Gates	Manually operated Cast Iron Width 0.8(m)×Height :0.5(m)	-	2
14. Mixers for An-aerobic Tank	Submersible Type SS316L Tank Width :8.0 (m)×Length :10.0(m)×SWD :5.5(m)	4.0	2W
15. Mixers for An-oxic Tank	Submersible Type SS316L Tank Width :8.0 (m)×Length :11.0(m)×SWD :5.5(m)	4.0	6W
16. Diffusers	Fine Bubble Mem-brane SOR:299 (kg/h·basin)×setting Depth :5.0(m) ×Efficiency:28 %	-	2
17. Air Blowers	Rotary blower Tri-lobe Type Dia. :200 (mm)× Air Flow :2200(m ³ /h) ×Pressure: 65 (KPa)	75.0	4W+2S
18. Circulation Pumps	Submersible Cast Iron Dia. :250 (mm)×Discharge:500(m ³ /h) ×Total Head:5.0 (m)	15.0	4W+2S
19. RAS Pumps	Submersible Cast Iron Dia. :150 (mm)×Discharge:170(m ³ /h) ×Total Head:5.0 (m)	5.5	2W+2S
20. SAS Pumps	Submersible Cast Iron Dia.:100 (mm)×Discharge :70(m ³ /h) ×Total Head:15.0 (m)	7.5	2W+2S
21. Hand Operation Chain Block	With Geared Trolley Rated Load :1.0(Ton)×Lift :6(m)	-	3
22. Final Clarifiers	Column-supported MS+ Epoxy Dia. :26.5 (m)×SWD:3.5(m)	2.2	2W
23. Alum Dosing Pumps	Diaphragm Pump SS/ PTFE Dia.:40 (mm)×Discharge :230(L/h) ×Pressure:0.3(MPa)	0.75	2W+1S
24. Mixer for Alum Solution	Turbine impeller SS316 Tank Width: 1.4(m)×Length:1.4(m)×SWD:1.8(m)	0.75	2W

Items	Specification	kW per unit	Unit number
25. Chlorinators	Gas Chlorination System Dosing Rate :12.2(kg/h)	0.10	1W+1S
26. Chlorine Tonners	Volume:928(kg/Unit)	-	4
27. Chlorine Booster Pumps	Submersible Cast Iron Dia.:25 (mm)×Discharge :5.4(m ³ /h) ×Total Head:50.0 (m)	2.20	1W+1S
28. Electric Hoist for Tonners	Single-girder Overhead Type Rated Load :3.0(Ton)×Lift :6(m)	8.60	1W
29. Dechlorine Dosing Pumps	Diaphragm Pump SS/ PTFE Dia.:15 (mm)×Discharge :15(L/h) ×Pressure:1.0(MPa)	0.2	2W+1S
30. Mixer for Dechlorine Solution	Turbine impeller SS316 Tank Width: 0.5(m)×Length:0.5(m)×SWD:0.8(m)	0.10	2W
31. Air Blowers For Dechlorine Mixing Tank	Rotary blower Tri-lobe Type Dia. :40 (mm)× Air Flow:48(m ³ /h) ×Pressure: 20 (KPa)	1.50	1W+1S
32. Electric Hoist for Chemicals	Single-girder Overhead Type Rated Load :1.0(Ton)×Lift :6(m)	4.70	1W
33. Sludge Thickener	Bridge-supported MS+ Epoxy Dia. :10.50 (m)×SWD:4.0(m)	0.40	2W
34. Thickened Sludge Pumps	Submersible Cast Iron Dia.:100 (mm)×Discharge :70(m ³ /h) ×Total Head:15.0 (m)	7.50	2W+2S
35. Air Blowers For Centrifuge Feed Sump	Rotary blower Tri-lobe Type Dia. :100 (mm)× Air Flow:290(m ³ /h) ×Pressure: 40 (KPa)	7.50	1W+1S
36. Centrifuge Feed Pumps	Progressive Cavity Pump, Cast Iron Dia.:100 (mm)×Discharge :12(m ³ /h) ×Total Head:20.0 (m)	5.50	2W+1S
37. Centrifuges	Centrifuge SS316 Capacity:12(m ³ /h)	19.7	2W+1S
38. Electric Hoist Crane	Single-girder Overhead Type Rated Load :3.0(Ton)×Lift :15(m)	8.60	1W
39. Mixers for Polyelectrolyte Solution	Agitator SS304 Tank Width: 1.5(m)×Length:1.5(m)×SWD:2.0(m)	1.5	2W
40. Dry Polyelectrolyte Feeder	Volumetric metering SS304 Capacity: 17.0(kg/h)	0.40	2W
41. Polyelectrolyte Dosing Pumps	Progressive Cavity Pump Dia.:32 (mm)×Discharge :1.1(m ³ /h) ×Total Head:20.0 (m)	0.75	2W+1S
42. Centrate Transfer Pumps	Submersible Cast Iron Dia:100 (mm)×Discharge :40(m ³ /h) ×Total Head:15.0 (m)	5.50	2W+1S

Items	Specification	Unit number
(Electrical)		
1. Power receiving facilities at electrical substation	HV incoming panel, IP42, 11kV, VCB HV outgoing feeder panels, IP42, 11kV, VCB Power transformers: outdoor use, 11/0.415-0.24 kV,100 kVA Diesel engine generator set: 415 V, 50 Hz, 625 kVA	1 pc 2 pcs 2 sets 1 pc

10) Nagasandra STP

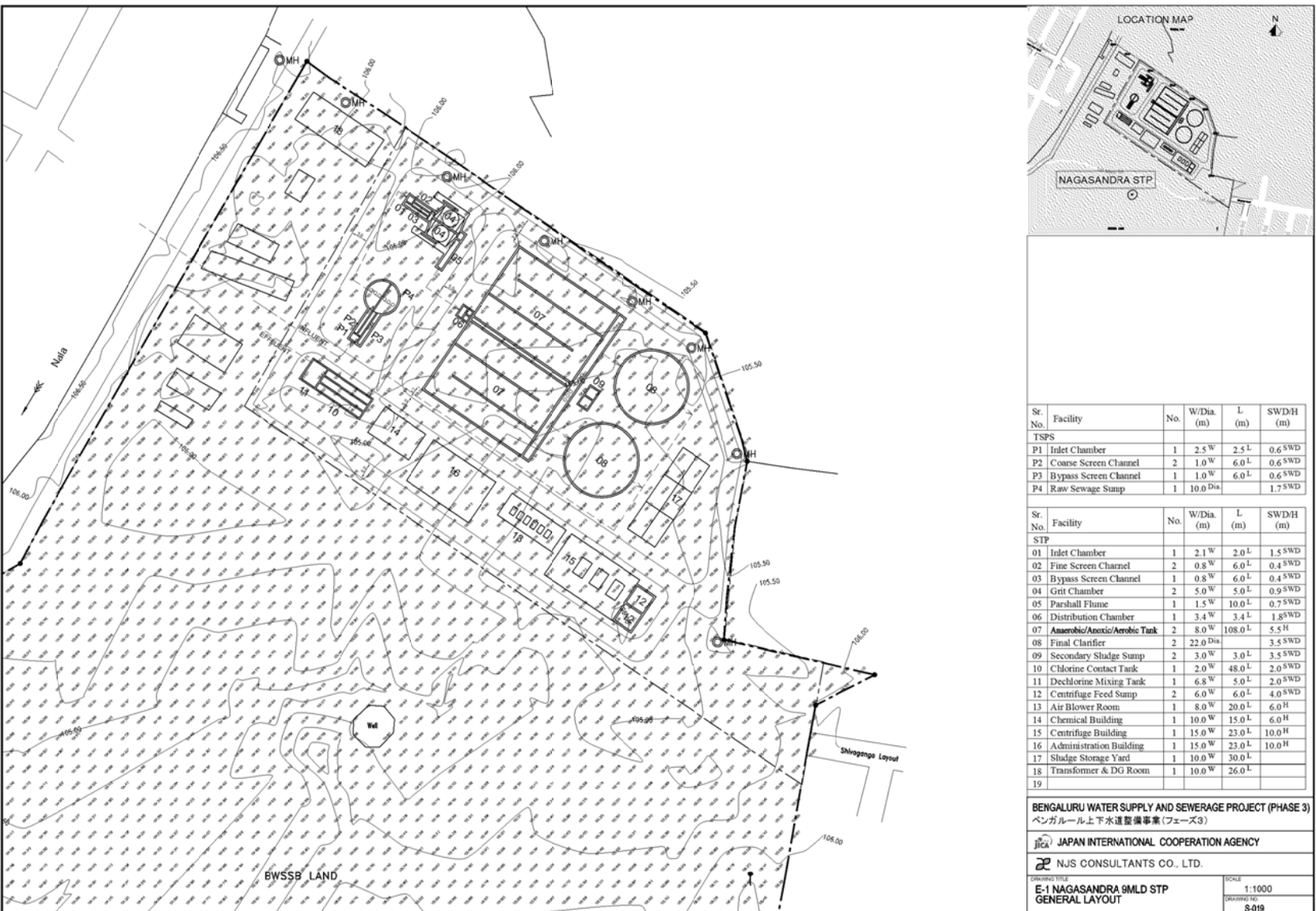

Figure 12.2.41 Layout Plan of Nagasandra (Stage V) STP

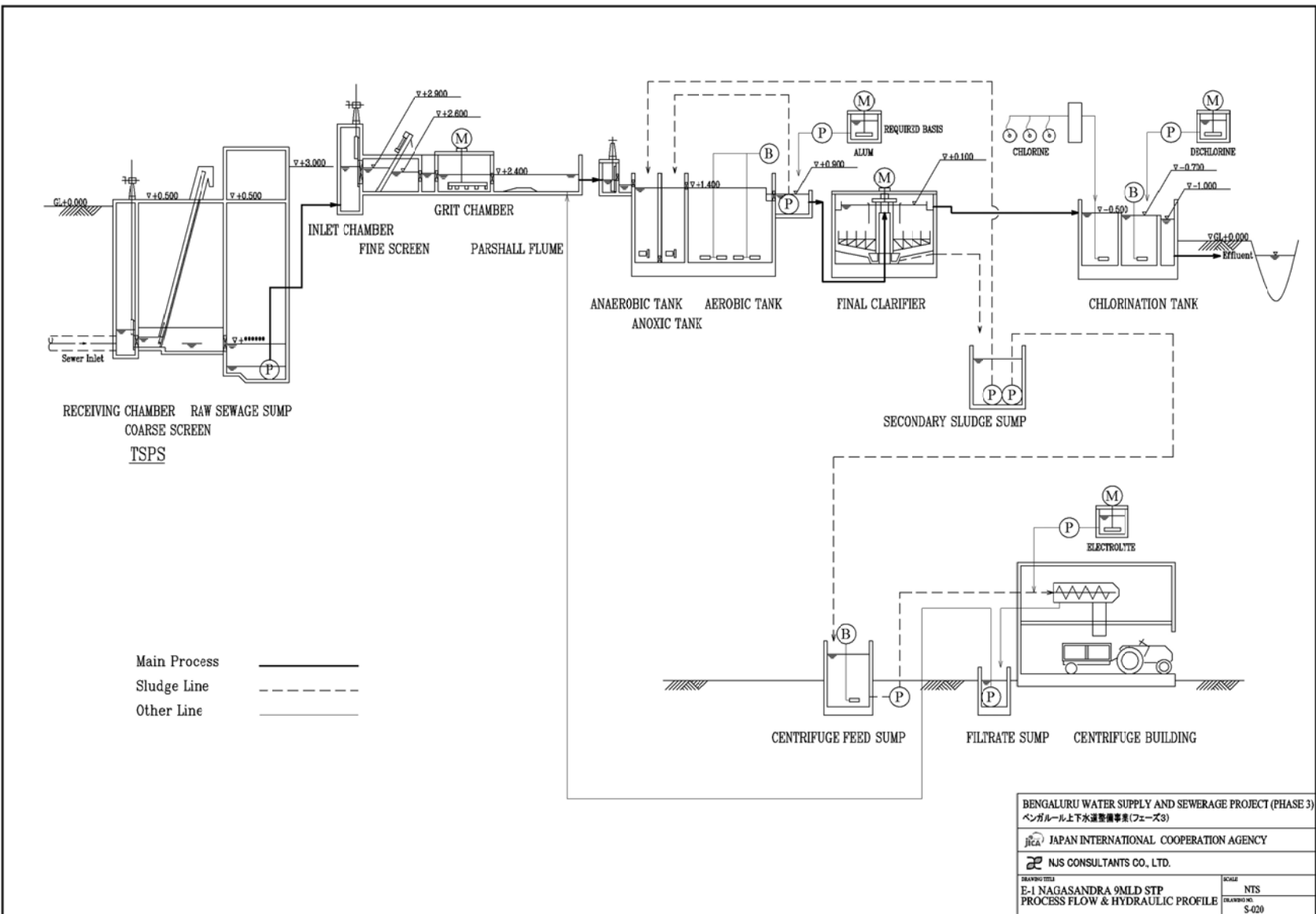

Table 12.2.29 Specifications for Major Equipment (Nagasandra STP)

Items	Specification	kW per unit	Unit number
(Mechanical)			
1. Inlet Gates	Manually Operated Cast Iron	Width 0.60(m)×Height :0.90(m)	- 3
2. Coarse Screens (Mechanical)	Climber Type SS316L	Channel Width :1.00 (m)×SWD :0.60 (m) ×Open Space:20(mm)	1.50 1W
3. Coarse Screens (Manual)	Climber Type SS316L	Channel Width :1.00 (m)×SWD :0.60 (m) ×Open Space:50(mm)	- 1
4. Belt Conveyor	Nylon fabric 3ply	Belt Width :0.60(m)×Length :5.0 (m)	1.50 1W
5. Sewage Pump 1	Submersible Cast Iron	Dia:200 (mm)×Discharge :340 (m ³ /h) ×Total Head:15.0 (m)	30.0 2W+1S
6. Sewage Pump 2	Submersible Cast Iron	Dia:150 (mm)×Discharge :170 (m ³ /h) ×Total Head:15.0 (m)	15.0 1W+1S
7. Electric Hoist	Single-girder Overhead Type	Rated Load :3.0(Ton)×Lift :6(m)	8.50 1W
8. Inlet Gates	Manually Operated Cast Iron	Width 0.40(m)×Height :0.60(m)	- 3
9. Fine Screens (Mechanical)	Step Type SS316L	Channel Width :0.80 (m)×SWD :0.40 (m) ×Open Space:6(mm)	1.50 2W
10. Fine Screen (Manual)	Bar Screen SS316L	Channel Width :0.80 (m)×SWD:0.40 (m) ×Open Space:20(mm)	- 1
11. Belt Conveyor	Nylon fabric 3ply	Belt Width :0.60(m)×Length :7.0 (m)	1.50 1W
12. Grit Chamber	Square Horizontal MS+Epoxy	Width :5.00 (m)×Length :5.00(m)×SWD :0.90 (m)	2.25 1W+1S
13. Inlet Weir Gates	Manually operated Cast Iron	Width 0.60(m)×Height :0.40(m)	- 2
14. Mixers for An-aerobic Tank	Submersible Type SS316L	Tank Width :8.0 (m)×Length :7.0(m)×SWD :5.5(m)	4.0 2W
15. Mixers for An-oxic Tank	Submersible Type SS316L	Tank Width :8.0 (m)×Length :11.0(m)×SWD :5.5(m)	4.0 4W
16. Diffusers	Fine Bubble Mem-brane	SOR:207 (kg/h·basin)×setting Depth :5.0(m) ×Efficiency:28 %	- 2
17. Air Blowers	Rotary blower Tri-lobe Type	Dia. :150 (mm)× Air Flow :1600(m ³ /h) ×Pressure: 65 (K Pa)	55.0 4W+2S
18. Circulation Pumps	Submersible Cast Iron	Dia. :200 (mm)×Discharge:345(m ³ /h) ×Total Head:5.0 (m)	11.0 4W+2S
19. RAS Pumps	Submersible Cast Iron	Dia. :100 (mm)×Discharge:115(m ³ /h) ×Total Head:5.0 (m)	3.70 2W+2S
20. SAS Pumps	Submersible Cast Iron	Dia.:100 (mm)×Discharge :45(m ³ /h) ×Total Head:15.0 (m)	5.50 2W+2S
21. Hand Operation Chain Block	With Geared Trolley	Rated Load :1.0(Ton)×Lift :6(m)	- 3
22. Final Clarifiers	Column-supported MS+ Epoxy	Dia. :22.0 (m)×SWD:3.5(m)	2.2 2W
23. Alum Dosing Pumps	Diaphragm Pump SS/ PTFE	Dia.:25 (mm)×Discharge :160(L/h) ×Pressure:0.7(MPa)	0.4 2W+1S
24. Mixer for Alum Solution	Turbine impeller SS316	Tank Width: 1.20(m)×Length:1.20(m)×SWD:1.80(m)	0.75 2W

Items	Specification	kW per unit	Unit number
25. Chlorinators	Gas Chlorination System Dosing Rate :8.5(kg/h)	0.10	1W+1S
26. Chlorine Tonners	Volume:928(kg/Unit)	-	4
27. Chlorine Booster Pumps	Submersible Cast Iron Dia.:25 (mm)×Discharge :3.6(m ³ /h) ×Total Head:50.0 (m)	1.50	1W+1S
28. Electric Hoist for Tonners	Single-girder Overhead Type Rated Load :3.0(Ton)×Lift :6(m)	8.60	1W
29. Dechlorine Dosing Pumps	Diaphragm Pump SS/ PTFE Dia.:15 (mm)×Discharge :21(L/h) ×Pressure:1.0(MPa)	0.2	1W+1S
30. Mixer for Dechlorine Solution	Turbine impeller SS316 Tank Width: 0.65(m)×Length:0.65(m)×SWD:0.9(m)	0.1	1W
31. Air Blowers For Dechlorine Mixing Tank	Rotary blower Tri-lobe Type Dia. :40 (mm)× Air Flow:34(m ³ /h) ×Pressure: 20 (K Pa)	1.50	1W+1S
32. Electric Hoist for Chemicals	Single-girder Overhead Type Rated Load :1.0(Ton)×Lift :6(m)	4.70	1W
33. Air Blowers For Centrifuge Feed Sump	Rotary blower Tri-lobe Type Dia. :100 (mm)× Air Flow:350(m ³ /h) ×Pressure: 40 (K Pa)	11.00	1W+1S
34. Centrifuge Feed Pumps	Progressive Cavity Pump, Cast Iron Dia.:125 (mm)×Discharge :24(m ³ /h) ×Total Head:20.0 (m)	7.50	2W+1S
35. Centrifuges	Centrifuge SS316 Capacity:24(m ³ /h)	44.5	2W+1S
36. Electric Hoist Crane	Single-girder Overhead Type Rated Load :5.0(Ton)×Lift :15(m)	17.10	1W
37. Mixers for Polyelectrolyte Solution	Agitator SS304 Tank Width: 1.5(m)×Length:1.5(m)×SWD:1.5(m)	1.50	2W
38. Dry Polyelectrolyte Feeder	Volumetric metering SS304 Capacity: 11.0(kg/h)	0.40	2W
39. Polyelectrolyte Dosing Pumps	Progressive Cavity Pump Dia.:32 (mm)×Discharge :0.80(m ³ /h) ×Total Head:20.0 (m)	0.75	2W+1S
40. Centrate Transfer Pumps	Submersible Cast Iron Dia:100 (mm)×Discharge :40(m ³ /h) ×Total Head:15.0 (m)	5.50	2W+1S

Items	Specification	Unit number
(Electrical)		
1. Power receiving facilities at electrical substation	HV incoming panel, IP42, 11kV, VCB HV outgoing feeder panels, IP42, 11kV, VCB Power transformers: outdoor use, 11/0.415-0.24 kV,750 kVA Diesel engine generator set: 415 V, 50 Hz, 500 kVA	1 pc 2 pcs 2 sets 1 pc
2. LV incoming panel, LV switchgears,	LV incoming panels: IP42, 600V, ACB 1600A x 3, ACB 800A x 1 LV feeder panels: IP52, 600V, MCCB 200 A x 9, MCCB 100 A x 8, Static capacitors MCC for TSPS	1 pc 1 pc 1 pc

Items	Specification	Unit number
and MCCs	MCC for Headworks MCCs for Liquid process (Anaerobic/anoxic/aeration tanks, secondary clarifiers) Air blower starter panels with 55 kW VFD MCCs for Solid process	1 pc 1 pc 6 pcs 1 pc
3. Instrumentation devices	Inlet flow meter Level meter in inlet chamber Level meter in sewage pump sump Level meters of pre and post screens Air blow flow meters Air blow pressure meters MLR (Mixed Liquor Recycle) flow meters RAS (Return Activated Sludge) flow meters DO analyzers MLSS analyzers Level meters in alum solution tank Alum dosing flow meters Residual chlorine analyzer Effluent flow meter Level meters in de-chlorine tank De-chlorine flow meter Level meter in secondary sludge sump WAS (Waste Activated Sludge) flow meters Level meters in centrifuge sump Centrifuge feed flow meters Level meter in polyelectrolyte solution tank Centrifuge polymer dosing flow meters Level meter in filtrate sump Filtrate flow meter	1 pc 1 pc 1 pc 4 pcs 2 pcs 2 pcs 2 pcs 2 pcs 2 pcs 2 pcs 2 pcs 1 pc 1 pc 1 pc 1 pc 1 pc 1 pc 1 pc 1 pc 1 pc 1 pc 3 pcs 2 pcs 3 pcs 1 pc 1 pc
4. Local SCADA system	Operator stations, SCADA servers, PLCs, router, etc.	1 ls

Source: JICA Survey Team

11) Kairivobanahalli STP

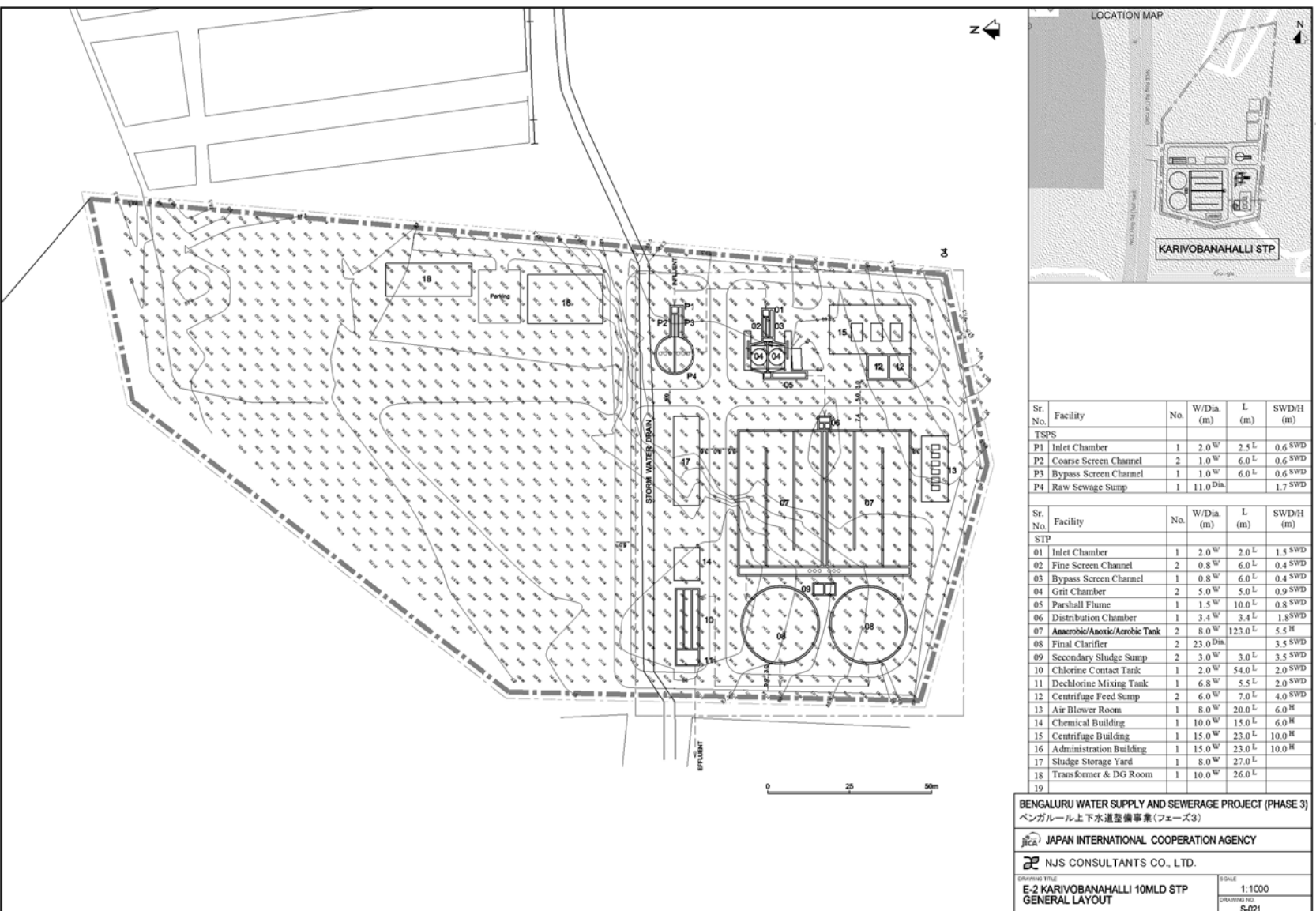

Figure 12.2.43 Layout plan of Kairivobanahalli STP

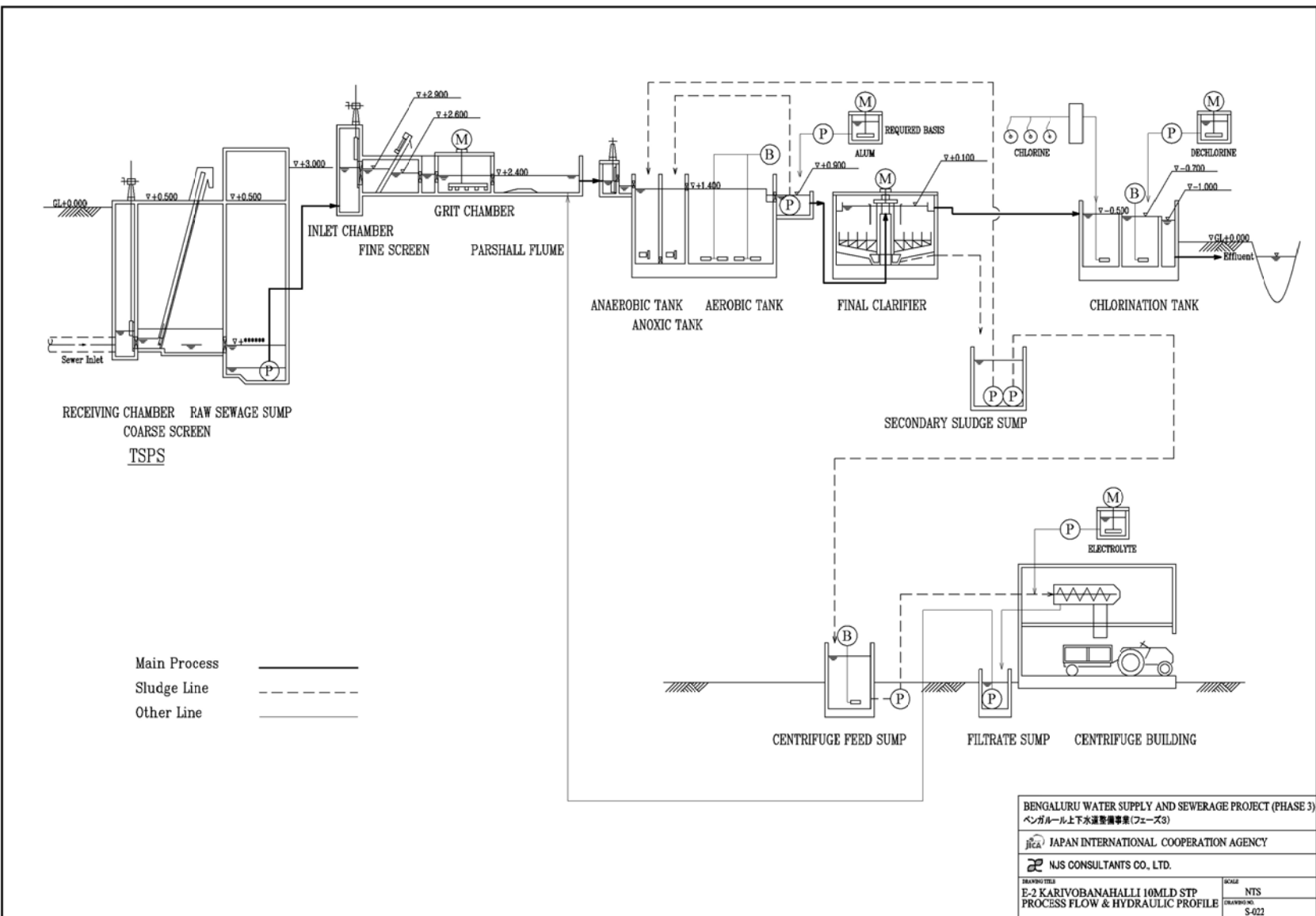

Figure 12.2.44 Process Flow Diagram with Hydraulic Profile

Table 12.2.30 Specifications for Major Equipment (Kariobanahalli STP)

Items	Specification	kW per unit	Unit number
(Mechanical)			
1. Inlet Gates	Manually Operated Cast Iron	Width 0.60(m)×Height :0.90(m)	- 3
2. Coarse Screens (Mechanical)	Climber Type SS316L	Channel Width :1.00 (m)×SWD :0.60 (m) ×Open Space:20(mm)	1.50 1W
3. Coarse Screens (Manual)	Climber Type SS316L	Channel Width :1.00 (m)×SWD :0.60 (m) ×Open Space:50(mm)	- 1
4. Belt Conveyor	Nylon fabric 3ply	Belt Width :0.60(m)×Length :5.0 (m)	1.50 1W
5. Sewage Pump 1	Submersible Cast Iron	Dia:200 (mm)×Discharge :380 (m ³ /h) ×Total Head:15.0 (m)	30.0 2W+1S
6. Sewage Pump 2	Submersible Cast Iron	Dia:150 (mm)×Discharge :190 (m ³ /h) ×Total Head:15.0 (m)	15.0 1W+1S
7. Electric Hoist	Single-girder Overhead Type	Rated Load :3.0(Ton)×Lift :6(m)	8.50 1W
8. Inlet Gates	Manually Operated Cast Iron	Width 0.40(m)×Height :0.60(m)	- 3
9. Fine Screens (Mechanical)	Step Type SS316L	Channel Width :0.80 (m)×SWD :0.40 (m) ×Open Space:6(mm)	1.50 2W
10. Fine Screen (Manual)	Bar Screen SS316L	Channel Width :0.80 (m)×SWD:0.40 (m) ×Open Space:20(mm)	- 1
11. Belt Conveyor	Nylon fabric 3ply	Belt Width :0.60(m)×Length :7.0 (m)	1.50 1W
12. Grit Chamber	Square Horizontal MS+Epoxy	Width :5.00 (m)×Length :5.00(m)×SWD :0.90 (m)	2.25 1W+1S
13. Inlet Weir Gates	Manually operated Cast Iron	Width 0.80(m)×Height :0.40(m)	- 2
14. Mixers for An-aerobic Tank	Submersible Type SS316L	Tank Width :8.0 (m)×Length :8.0(m)×SWD :5.5(m)	4.0 2W
15. Mixers for An-oxic Tank	Submersible Type SS316L	Tank Width :8.0 (m) ×Length :12.50(m)×SWD :5.5(m)	4.0 4W
16. Diffusers	Fine Bubble Mem-brane	SOR:218 (kg/h·basin)×setting Depth :5.0(m) ×Efficiency:28 %	- 2
17. Air Blowers	Rotary blower Tri-lobe Type	Dia. :150 (mm)× Air Flow :1700(m ³ /h) ×Pressure: 65 (KPa)	55.0 4W+2S
18. Circulation Pumps	Submersible Cast Iron	Dia. :200 (mm)×Discharge:385(m ³ /h) ×Total Head:5.0 (m)	11.0 4W+2S
19. RAS Pumps	Submersible Cast Iron	Dia. :100 (mm)×Discharge:125(m ³ /h) ×Total Head:5.0 (m)	3.70 2W+2S
20. SAS Pumps	Submersible Cast Iron	Dia.:100 (mm)×Discharge :50(m ³ /h) ×Total Head:15.0 (m)	5.50 2W+2S
21. Hand Operation Chain Block	With Geared Trolley	Rated Load :1.0(Ton)×Lift :6(m)	- 3
22. Final Clarifiers	Column-supported MS+ Epoxy	Dia. :23.0 (m)×SWD:3.5(m)	2.2 2W
23. Alum Dosing Pumps	Diaphragm Pump SS/ PTFE	Dia.:25 (mm)×Discharge :180(L/h) ×Pressure:0.7(MPa)	0.4 2W+1S
24. Mixer for Alum Solution	Turbine impeller SS316	Tank Width: 1.20(m)×Length:1.20(m)×SWD:1.80(m)	0.75 2W
25. Chlorinators	Gas Chlorination Sys-tem	Dosing Rate :9.4(kg/h)	0.10 1W+1S

Items	Specification	kW per unit	Unit number
26. Chlorine Tonners	Volume:928(kg/Unit)	-	4
27. Chlorine Booster Pumps	Submersible Cast Iron Dia.:25 (mm)×Discharge :3.6(m ³ /h) ×Total Head:50.0 (m)	1.50	1W+1S
28. Electric Hoist for Tonners	Single-girder Overhead Type Rated Load :3.0(Ton)×Lift :6(m)	8.60	1W
29. Dechlorine Dosing Pumps	Diaphragm Pump SS/ PTFE Dia.:15 (mm)×Discharge :23(L/h) ×Pressure:1.0(MPa)	0.2	1W+1S
30. Mixer for Dechlorine Solution	Turbine impeller SS316 Tank Width: 0.65(m)×Length:0.65(m)×SWD:0.9(m)	0.1	1W
31. Air Blowers For Dechlorine Mixing Tank	Rotary blower Tri-lobe Type Dia. :40 (mm)× Air Flow:40(m ³ /h) ×Pressure: 20 (KPa)	1.50	1W+1S
32. Electric Hoist for Chemicals	Single-girder Overhead Type Rated Load :1.0(Ton)×Lift :6(m)	4.70	1W
33. Air Blowers For Centrifuge Feed Sump	Rotary blower Tri-lobe Type Dia. :100 (mm)× Air Flow:400(m ³ /h) ×Pressure: 40 (KPa)	11.00	1W+1S
34. Centrifuge Feed Pumps	Progressive Cavity Pump, Cast Iron Dia.:125 (mm)×Discharge :27(m ³ /h) ×Total Head:20.0 (m)	7.50	2W+1S
35. Centrifuges	Centrifuge SS316 Capacity:27(m ³ /h)	44.5	2W+1S
36. Electric Hoist Crane	Single-girder Overhead Type Rated Load :5.0(Ton)×Lift :15(m)	17.10	1W
37. Mixers for Polyelectrolyte Solution	Agitator SS304 Tank Width: 1.5(m)×Length:1.5(m)×SWD:2.0(m)	1.50	2W
38. Dry Polyelectrolyte Feeder	Volumetric metering SS304 Capacity: 15.0(kg/h)	0.40	2W
39. Polyelectrolyte Dosing Pumps	Progressive Cavity Pump Dia.:32 (mm)×Discharge :0.80(m ³ /h) ×Total Head:20.0 (m)	0.75	2W+1S
40. Centrate Transfer Pumps	Submersible Cast Iron Dia:100 (mm)×Discharge :40(m ³ /h) ×Total Head:15.0 (m)	5.50	2W+1S

Items	Specification	Unit number
(Electrical)		
1. Power receiving facilities at electrical substation	HV incoming panel, IP42, 11kV, VCB HV outgoing feeder panels, IP42, 11kV, VCB Power transformers: outdoor use, 11/0.415-0.24 kV,750 kVA Diesel engine generator set: 415 V, 50 Hz, 500 kVA	1 pc 2 pcs 2 sets 1 pc
2. LV incoming panel, LV switchgears, and MCCs	LV incoming panels: IP42, 600V, ACB 1600A x 3, ACB 800A x 1 LV feeder panels: IP52, 600V, MCCB 200 A x 9, MCCB 100 A x 8, Static capacitors MCC for TSPS MCC for Headworks MCCs for Liquid process (Anaerobic/anoxic/aeration tanks, secondary clarifiers) Air blower starter panels with 55 kW VFD	1 pc 1 pc 1 pc 1 pc 1 pc 6 pcs

Items	Specification	Unit number
	MCCs for Solid process	1 pc
3. Instrumentation devices	Inlet flow meter Level meter in inlet chamber Level meter in sewage pump sump Level meters of pre and post screens Air blow flow meters Air blow pressure meters MLR (Mixed Liquor Recycle) flow meters RAS (Return Activated Sludge) flow meters DO analyzers MLSS analyzers Level meters in alum solution tank Alum dosing flow meters Residual chlorine analyzer Effluent flow meter Level meters in de-chlorine tank De-chlorine flow meter Level meter in secondary sludge sump WAS (Waste Activated Sludge) flow meters Level meters in centrifuge sump Centrifuge feed flow meters Level meter in polyelectrolyte solution tank Centrifuge polymer dosing flow meters Level meter in filtrate sump Filtrate flow meter	1 pc 1 pc 1 pc 4 pcs 2 pcs 2 pcs 2 pcs 2 pcs 2 pcs 2 pcs 2 pcs 2 pcs 1 pc 1 pc 1 pc 1 pc 1 pc 1 pc 1 pc 1 pc 1 pc 1 pc 3 pcs 2 pcs 3 pcs 1 pc 1 pc
4. Local SCADA system	Operator stations, SCADA servers, PLCs, router, etc.	1 ls

Source: JICA Survey Team

12) Herohalli STP

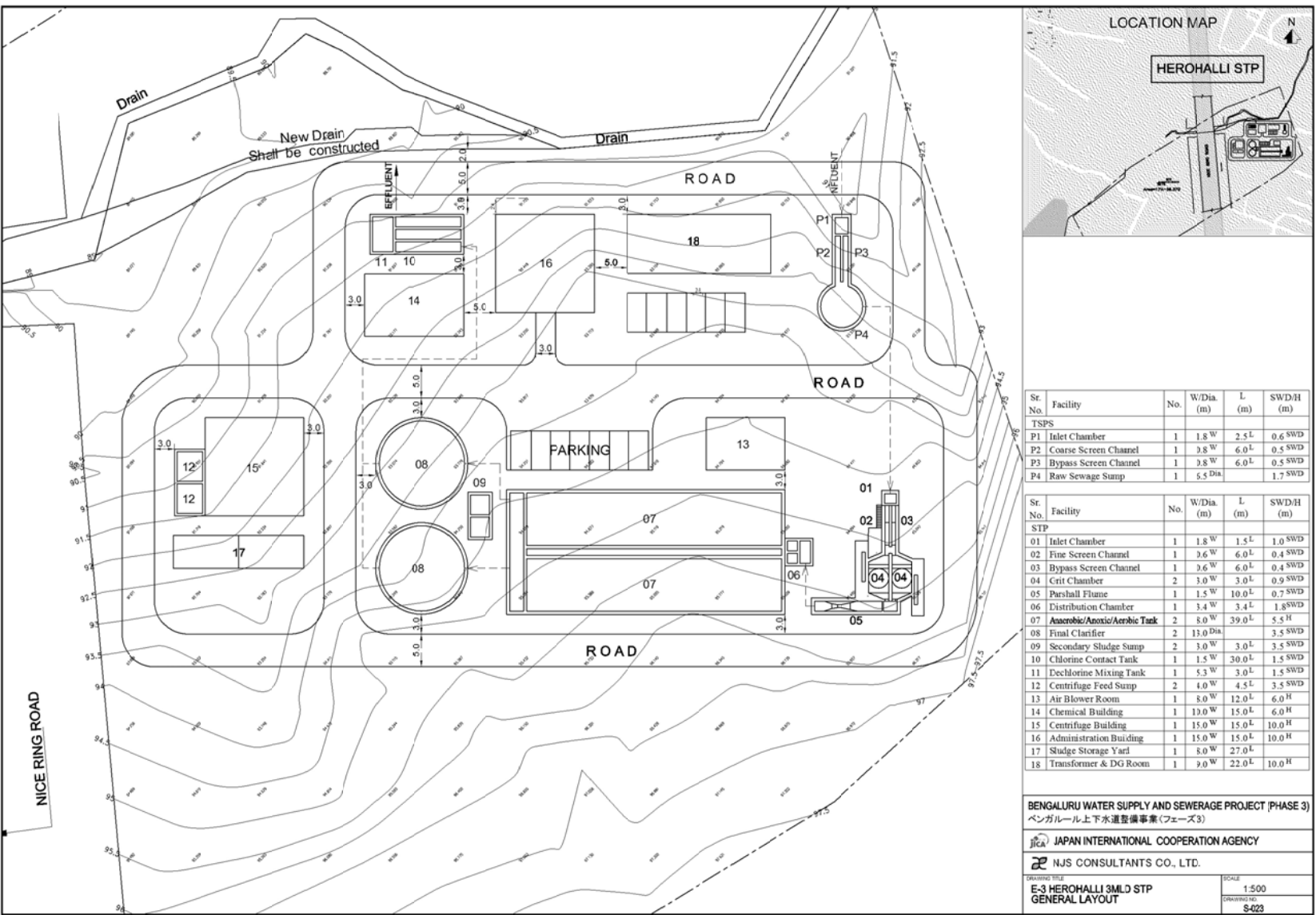

Figure 12.2.45 Layout plan of Herohalli STP

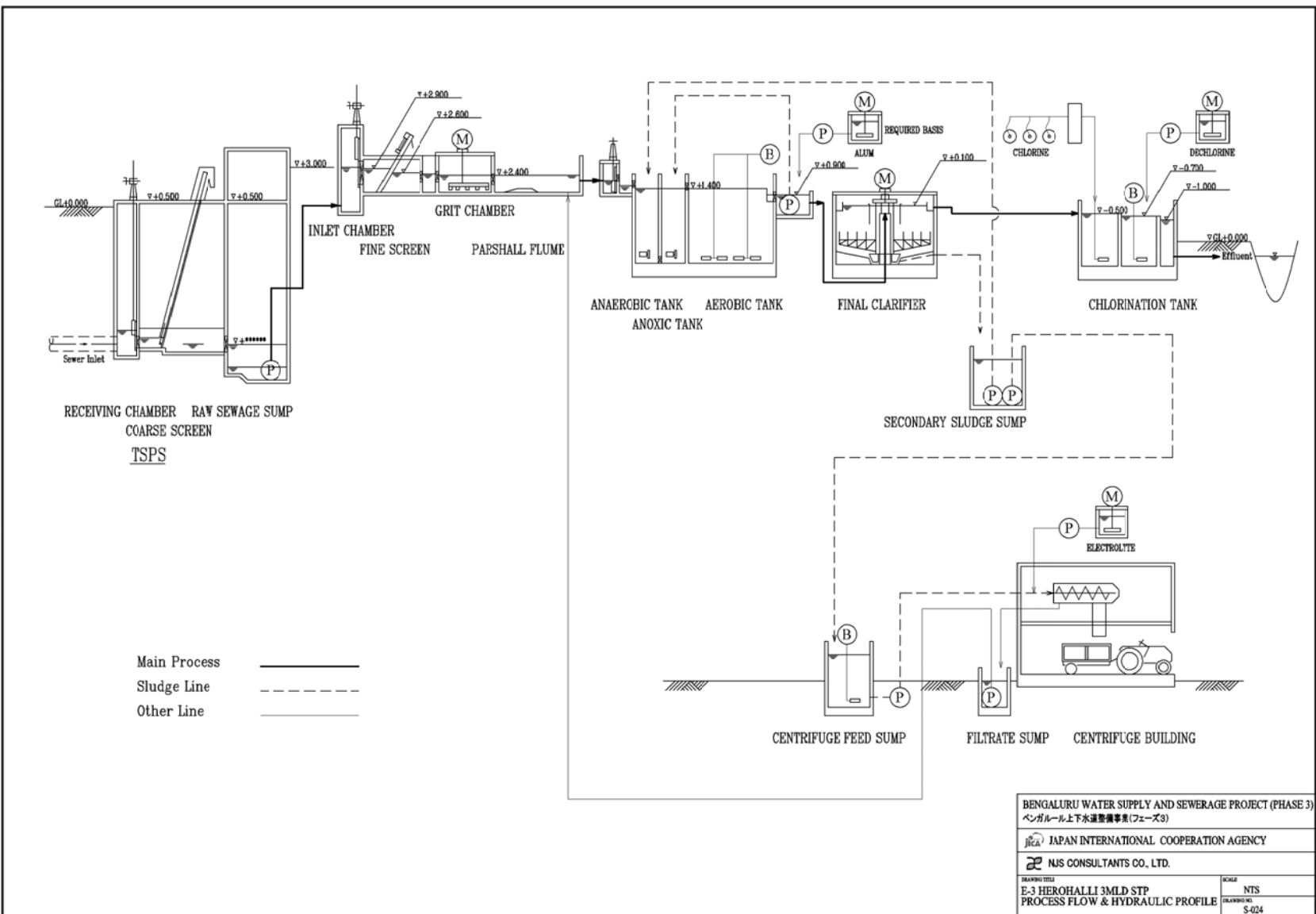

Figure 12.2.46 Process Flow Diagram with Hydraulic Profile

Table 12.2.31 Specifications for Major Equipment (Herohalli STP)

Items	Specification	kW per unit	Unit number
(Mechanical)			
1. Inlet Gates	Manually Operated Cast Iron Width 0.40(m)×Height :0.60(m)	-	2
2. Coarse Screens (Mechanical)	Climber Type SS316L Channel Width :0.80 (m)×SWD :0.50 (m) ×Open Space:20(mm)	1.50	1W
3. Coarse Screens (Manual)	Climber Type SS316L Channel Width :0.80 (m)×SWD :0.50 (m) ×Open Space:50(mm)	-	1
4. Sewage Pump	Submersible Cast Iron Dia:250 (mm)×Discharge :315 (m ³ /h) ×Total Head:15.0 (m)	30.0	1W+1S
5. Electric Hoist	Single-girder Overhead Type Rated Load :3.0(Ton)×Lift :6(m)	8.50	1W
6. Inlet Gates	Manually Operated Cast Iron Width 0.4(m)×Height :0.6(m)	-	2
7. Fine Screens (Mechanical)	Step Type SS316L Channel Width :0.60 (m)×SWD :0.40 (m) ×Open Space:6(mm)	1.50	1W
8. Fine Screen (Manual)	Bar Screen SS316L Channel Width :0.60 (m)×SWD:0.40 (m) ×Open Space:20(mm)	-	1
9. Belt Conveyor	Nylon fabric 3ply Belt Width :0.60(m)×Length :5.0 (m)	1.50	1W
10. Grit Chamber	Square Horizontal MS+Epoxy Width :3.00 (m)×Length :3.00(m)×SWD :0.90 (m)	2.25	1W+1S
11. Inlet Weir Gates	Manually operated Cast Iron Width 0.3(m)×Height :0.3(m)	-	2
12. Mixers for An-aerobic Tank	Submersible Type SS316L Tank Width :8.0 (m)×Length :3.0(m)×SWD :5.5(m)	4.0	2W
13. Mixers for An-oxic Tank	Submersible Type SS316L Tank Width :8.0 (m)×Length :8(m)×SWD :5.5(m)	4.0	2W
14. Diffusers	Fine Bubble Mem-brane SOR:65 (kg/h·basin)×setting Depth :5.0(m) ×Efficiency:28 %	-	2
15. Air Blowers	Rotary blower Tri-lobe Type Dia. :150 (mm)× Air Flow :1000(m ³ /h) ×Pressure: 65 (K Pa)	30.0	2W+1S
16. Circulation Pumps	Submersible Cast Iron Dia. :150 (mm)×Discharge:120(m ³ /h) ×Total Head:5.0 (m)	3.70	4W+2S
17. RAS Pumps	Submersible Cast Iron Dia. :100 (mm)×Discharge:40(m ³ /h) ×Total Head:5.0 (m)	1.50	2W+2S
18. SAS Pumps	Submersible Cast Iron Dia.:80 (mm)×Discharge :14 (m ³ /h) ×Total Head:15.0 (m)	2.20	2W+2S
19. Hand Operation Chain Block	With Geared Trolley Rated Load :1.0(Ton)×Lift :6(m)	-	3
20. Final Clarifiers	Bridge-supported MS+ Epoxy Dia. :13.0 (m)×SWD:3.5(m)	0.4	2W
21. Alum Dosing Pumps	Diaphragm Pump SS/ PTFE Dia.:25 (mm)×Discharge :60(L/h) ×Pressure:0.7(MPa)	0.4	2W+1S
22. Mixer for Alum Solution	Turbine impeller SS316 Tank Width: 1.0(m)×Length:1.0(m)×SWD:1.0(m)	0.4	2W
23. Chlorinators	Gas Chlorination Sys-tem Dosing Rate :3.1(kg/h)	0.10	1W+1S
24. Chlorine Ton-ners	Volume:928(kg/Unit)	-	4
25. Chlorine Booster	Submersible Dia.:25 (mm)×Discharge :2.1(m ³ /h)	0.75	1W+1S

Items	Specification	kW per unit	Unit number
Pumps	Cast Iron ×Total Head:50.0 (m)		
26. Electric Hoist for Tonners	Single-girder Overhead Type Rated Load :3.0(Ton)×Lift :6(m)	8.60	1W
27. Dechlorine Dosing Pumps	Diaphragm Pump SS/ PTFE Dia.:15 (mm)×Discharge :7.5(L/h) ×Pressure:1.0(MPa)	0.2	1W+1S
28. Mixer for Dechlorine Solution	Turbine impeller SS316 Tank Width: 0.5(m)×Length:0.5(m)×SWD:0.8(m)	0.1	1W
29. Air Blowers For Dechlorine Mixing Tank	Rotary blower Tri-lobe Type Dia. :40 (mm)× Air Flow:12(m ³ /h) ×Pressure: 20 (K Pa)	0.75	1W+1S
30. Electric Hoist for Chemicals	Single-girder Overhead Type Rated Load :1.0(Ton)×Lift :6(m)	4.70	1W
31. Air Blowers For Centrifuge Feed Sump	Rotary blower Tri-lobe Type Dia. :65 (mm)× Air Flow:130(m ³ /h) ×Pressure: 40 (K Pa)	3.70	1W+1S
32. Centrifuge Feed Pumps	Progressive Cavity Pump, Cast Iron Dia.:100 (mm)×Discharge :16(m ³ /h) ×Total Head:20.0 (m)	5.5	1W+1S
33. Centrifuges	Centrifuge SS316 Capacity:16(m ³ /h)	22.20	1W+1S
34. Electric Hoist Crane	Single-girder Overhead Type Rated Load :5.0(Ton)×Lift :15(m)	17.10	1W
35. Mixers for Polyelectrolyte Solution	Agitator SS304 Tank Width: 1.0(m)×Length:1.5(m)×SWD:1.8(m)	0.75	2W
36. Polyelectrolyte Dosing Pumps	Progressive Cavity Pump Dia.:20 (mm)×Discharge :0.50(m ³ /h) ×Total Head:20.0 (m)	0.40	1W+1S
37. Centrate Transfer Pumps	Submersible Cast Iron Dia:100 (mm)×Discharge :60(m ³ /h) ×Total Head:15.0 (m)	5.50	1W+1S

Items	Specification	Unit number
(Electrical)		
1. Power receiving facilities at electrical substation	HV incoming panel, IP42, 11kV, VCB HV outgoing feeder panels, IP42, 11kV, VCB Power transformers: outdoor use, 11/0.415-0.24 kV,500 kVA Diesel engine generator set: 415 V, 50 Hz, 300 kVA	1 pc 2 pcs 2 sets 1 pc
2. LV incoming panel, LV switchgears, and MCCs	LV incoming panels: IP42, 600V, ACB 800A x 3, ACB 630A x 1 LV feeder panels: IP52, 600V, MCCB 100 A x 13, Static capacitors MCC for TSPS MCC for Headworks MCCs for Liquid process (Anaerobic/anoxic/aeration tanks, secondary clarifiers) Air blower starter panels with 30 kW VFD MCCs for Solid process	1 pc 1 pc 1 pc 1 pc 1 pc 3 pcs 1 pc
3. Instrumentation devices	Inlet flow meter Level meter in inlet chamber Level meter in sewage pump sump	1 pc 1 pc 1 pc

Items	Specification	Unit number
	Level meters of pre and post screens Air blow flow meters Air blow pressure meters MLR (Mixed Liquor Recycle) flow meters RAS (Return Activated Sludge) flow meters DO analyzers MLSS analyzers Level meters in alum solution tank Alum dosing flow meters Residual chlorine analyzer Effluent flow meter Level meters in de-chlorine tank De-chlorine flow meter Level meter in secondary sludge sump WAS (Waste Activated Sludge) flow meters Level meters in centrifuge sump Centrifuge feed flow meters Level meter in polyelectrolyte solution tank Centrifuge polymer dosing flow meters Level meter in filtrate sump Filtrate flow meter	4 pcs 2 pcs 2 pcs 2 pcs 2 pcs 2 pcs 2 pcs 2 pcs 1 pc 1 pc 1 pc 1 pc 1 pc 1 pc 1 pc 1 pc 2 pcs 2 pcs 2 pcs 1 pc 1 pc
4. Local SCADA system	Operator stations, SCADA servers, PLCs, router, etc.	1 ls

Source: JICA Survey Team

13) Hosahalli STP

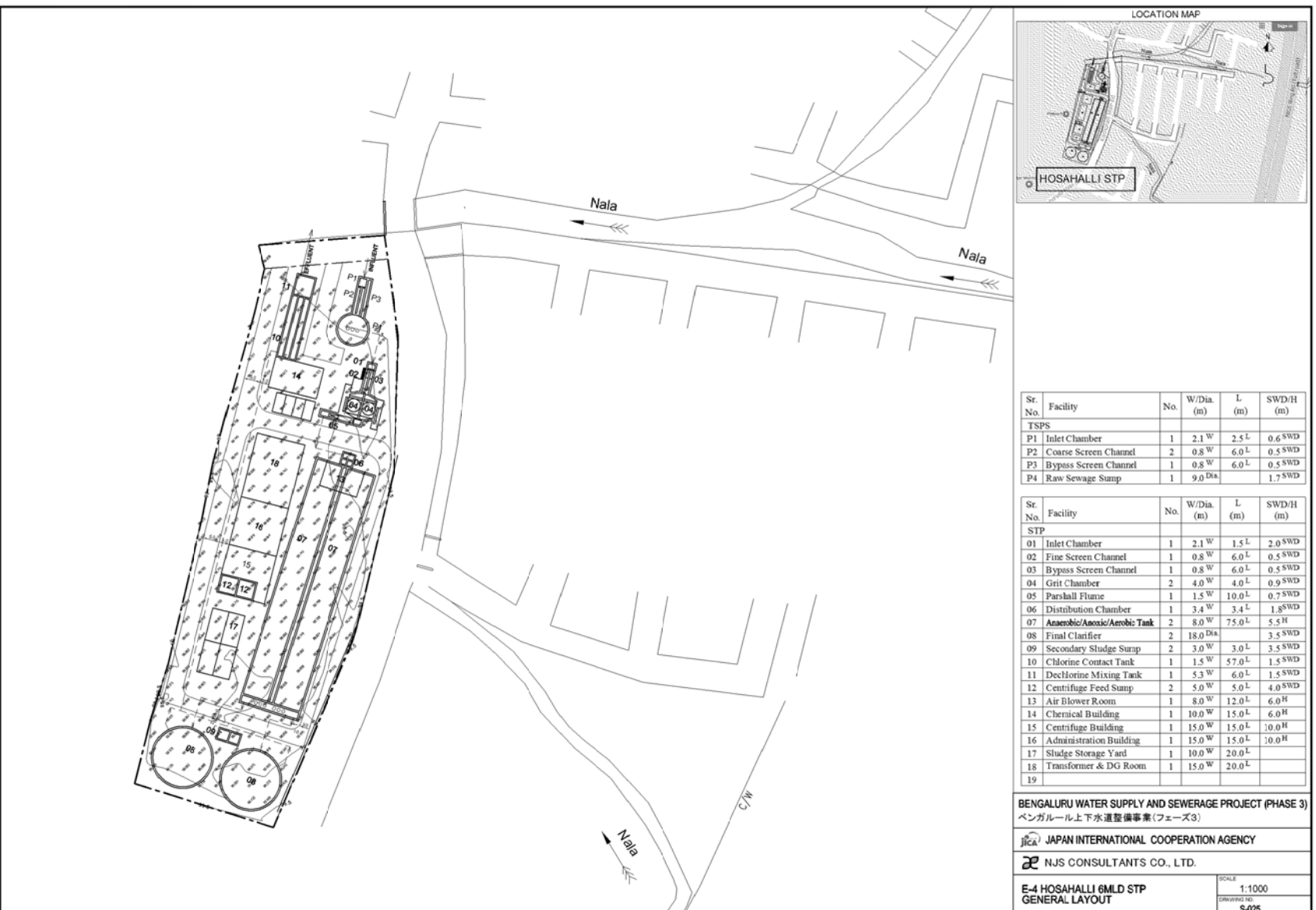

Figure 12.2.47 Layout plan of Hosahalli STP

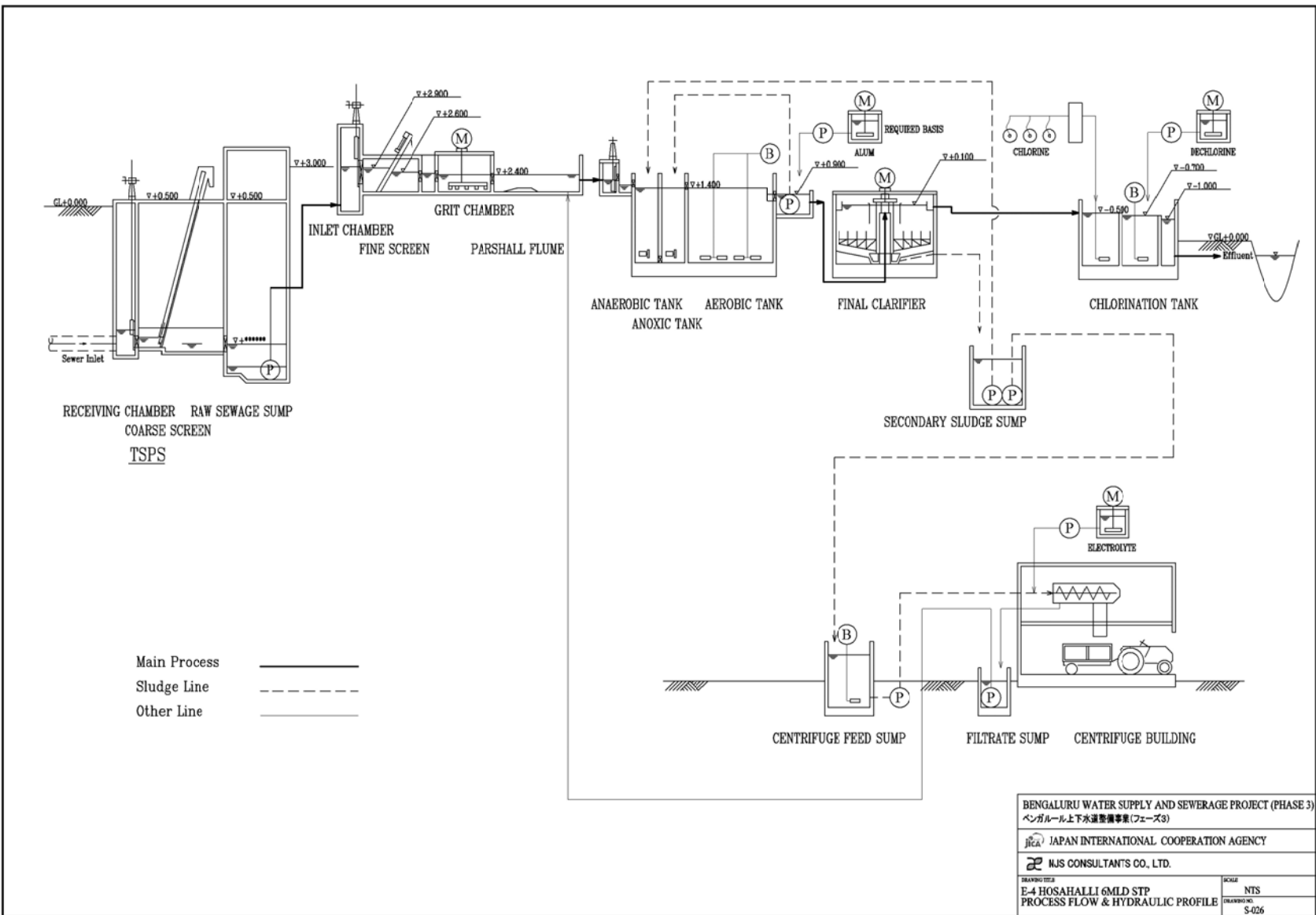

Figure 12.2.48 Process Flow Diagram with Hydraulic Profile

Table 12.2.32 Specifications for Major Equipment (Hosahalli STP)

Items	Specification	kW per unit	Unit number
(Mechanical)			
1. Inlet Gates	Manually Operated Cast Iron Width 0.40(m)×Height :0.60(m)	-	3
2. Coarse Screens (Mechanical)	Climber Type SS316L Channel Width :0.80 (m)×SWD :0.50 (m) ×Open Space:20(mm)	1.50	1W
3. Coarse Screens (Manual)	Climber Type SS316L Channel Width :0.80 (m)×SWD :0.50 (m) ×Open Space:50(mm)	-	1
4. Sewage Pump	Submersible Cast Iron Dia:200 (mm)×Discharge :315 (m ³ /h) ×Total Head:15.0 (m)	30.0	2W+1S
5. Electric Hoist	Single-girder Overhead Type Rated Load :3.0(Ton)×Lift :6(m)	8.50	1W
6. Inlet Gates	Manually Operated Cast Iron Width 0.4(m)×Height :0.6(m)	-	2
7. Fine Screens (Mechanical)	Step Type SS316L Channel Width :0.80 (m)×SWD :0.50 (m) ×Open Space:6(mm)	1.50	1W
8. Fine Screen (Manual)	Bar Screen SS316L Channel Width :0.80 (m)×SWD:0.50 (m) ×Open Space:20(mm)	-	1
9. Belt Conveyor	Nylon fabric 3ply Belt Width :0.60(m)×Length :7.0 (m)	1.50	1W
10. Grit Chamber	Square Horizontal MS+ Epoxy Width :4.00 (m)×Length :4.0(m)×SWD :0.90 (m)	2.25	1W+1S
11. Inlet Weir Gates	Manually operated Cast Iron Width 0.4(m)×Height :0.4(m)	-	2
12. Mixers for Anaerobic Tank	Submersible Type SS316L Tank Width :8.0 (m)×Length :6.0(m)×SWD :5.5(m)	4.0	2W
13. Mixers for Anoxic Tank	Submersible Type SS316L Tank Width :8.0 (m)×Length :15(m)×SWD :5.5(m)	4.0	2W
14. Diffusers	Fine Bubble Membrane SOR:138 (kg/h·basin)×setting Depth :5.0(m) ×Efficiency:28 %	-	2
15. Air Blowers	Rotary blower Tri-lobe Type Dia. :150 (mm)× Air Flow :2100(m ³ /h) ×Pressure: 65 (K Pa)	75.0	2W+1S
16. Circulation Pumps	Submersible Cast Iron Dia. :200 (mm)×Discharge:230(m ³ /h) ×Total Head:5.0 (m)	7.5	4W+2S
17. RAS Pumps	Submersible Cast Iron Dia. :100 (mm)×Discharge:75(m ³ /h) ×Total Head:5.0 (m)	2.2	2W+2S
18. SAS Pumps	Submersible Cast Iron Dia.:100 (mm)×Discharge :28 (m ³ /h) ×Total Head:15.0 (m)	3.70	2W+2S
19. Hand Operation Chain Block	With Geared Trolley Rated Load :1.0(Ton)×Lift :6(m)	-	3
20. Final Clarifiers	Column-supported MS+ Epoxy Dia. :18.0 (m)×SWD:3.5(m)	1.5	2W
21. Alum Dosing Pumps	Diaphragm Pump SS/ PTFE Dia.:25 (mm)×Discharge :110(L/h) ×Pressure:0.7(MPa)	0.4	2W+1S
22. Mixer for Alum Solution	Turbine impeller SS316 Tank Width: 1.0(m)×Length:1.0(m)×SWD:1.5(m)	0.4	2W
23. Chlorinators	Gas Chlorination System Dosing Rate :6.3(kg/h)	0.10	1W+1S
24. Chlorine Tonners	Volume:928(kg/Unit)	-	4
25. Chlorine Booster Pumps	Submersible Cast Iron Dia.:25 (mm)×Discharge :2.7(m ³ /h) ×Total Head:50.0 (m)	1.50	1W+1S

Items	Specification	kW per unit	Unit number
26. Electric Hoist for Tonners	Single-girder Overhead Type Rated Load :3.0(Ton)×Lift :6(m)	8.60	1W
27. Dechlorine Dosing Pumps	Diaphragm Pump SS/ PTFE Dia.:15 (mm)×Discharge :15(L/h) ×Pressure:1.0(MPa)	0.2	1W+1S
28. Mixer for Dechlorine Solution	Turbine impeller SS316 Tank Width: 0.5(m)×Length:0.5(m)×SWD:0.8(m)	0.1	1W
29. Air Blowers For Dechlorine Mixing Tank	Rotary blower Tri-lobe Type Dia. :40 (mm)× Air Flow:24(m ³ /h) ×Pressure: 20 (K Pa)	1.50	1W+1S
30. Electric Hoist for Chemicals	Single-girder Overhead Type Rated Load :1.0(Ton)×Lift :6(m)	4.70	1W
31. Air Blowers For Centrifuge Feed Sump	Rotary blower Tri-lobe Type Dia. :100 (mm)× Air Flow:240(m ³ /h) ×Pressure: 40 (K Pa)	7.50	1W+1S
32. Centrifuge Feed Pumps	Progressive Cavity Pump, Cast Iron Dia.:125 (mm)×Discharge :32(m ³ /h) ×Total Head:20.0 (m)	11.0	1W+1S
33. Centrifuges	Centrifuge SS316 Capacity:32(m ³ /h)	62.6	1W+1S
34. Electric Hoist Crane	Single-girder Overhead Type Rated Load :5.0(Ton)×Lift :15(m)	17.10	1W
35. Mixers for Polyelectrolyte Solution	Agitator SS304 Tank Width: 1.5(m)×Length:1.5(m)×SWD:1.8(m)	1.5	2W
36. Polyelectrolyte Dosing Pumps	Progressive Cavity Pump Dia.:32 (mm)×Discharge :1.0(m ³ /h) ×Total Head:20.0 (m)	0.75	1W+1S
37. Centrate Transfer Pumps	Submersible Cast Iron Dia:100 (mm)×Discharge :60(m ³ /h) ×Total Head:15.0 (m)	5.50	1W+1S

Items	Specification	Unit number
(Electrical)		
5. Power receiving facilities at electrical substation	HV incoming panel, IP42, 11kV, VCB HV outgoing feeder panels, IP42, 11kV, VCB Power transformers: outdoor use, 11/0.415-0.24 kV,750 kVA Diesel engine generator set: 415 V, 50 Hz, 500 kVA	1 pc 2 pcs 2 sets 1 pc
6. LV incoming panel, LV switchgears, and MCCs	LV incoming panels: IP42, 600V, ACB 1600A x 3, ACB 800A x 1 LV feeder panels: IP52, 600V, MCCB 200 A x 6, MCCB 100 A x 7, Static capacitors MCC for TSPS MCC for Headworks MCCs for Liquid process (Anaerobic/anoxic/aeration tanks, secondary clarifiers) Air blower starter panels with 75 kW VFD MCCs for Solid process	1 pc 1 pc 1 pc 1 pc 1 pc 3 pcs 1 pc
7. Instrumentation devices	Inlet flow meter Level meter in inlet chamber Level meter in sewage pump sump Level meters of pre and post screens Air blow flow meters	1 pc 1 pc 1 pc 4 pcs 2 pcs

Items	Specification	Unit number
	Air blow pressure meters MLR (Mixed Liquor Recycle) flow meters RAS (Return Activated Sludge) flow meters DO analyzers MLSS analyzers Level meters in alum solution tank Alum dosing flow meters Residual chlorine analyzer Effluent flow meter Level meters in de-chlorine tank De-chlorine flow meter Level meter in secondary sludge sump WAS (Waste Activated Sludge) flow meters Level meters in centrifuge sump Centrifuge feed flow meters Level meter in polyelectrolyte solution tank Centrifuge polymer dosing flow meters Level meter in filtrate sump Filtrate flow meter	2 pcs 2 pcs 2 pcs 2 pcs 2 pcs 2 pcs 1 pc 1 pc 1 pc 1 pc 1 pc 1 pc 1 pc 1 pc 1 pc 2 pcs 2 pcs 2 pcs 1 pc 1 pc
8. Local SCADA system	Operator stations, SCADA servers, PLCs, router, etc.	1 ls

Source: JICA Survey Team

14) Chikkabanavara-2 STP

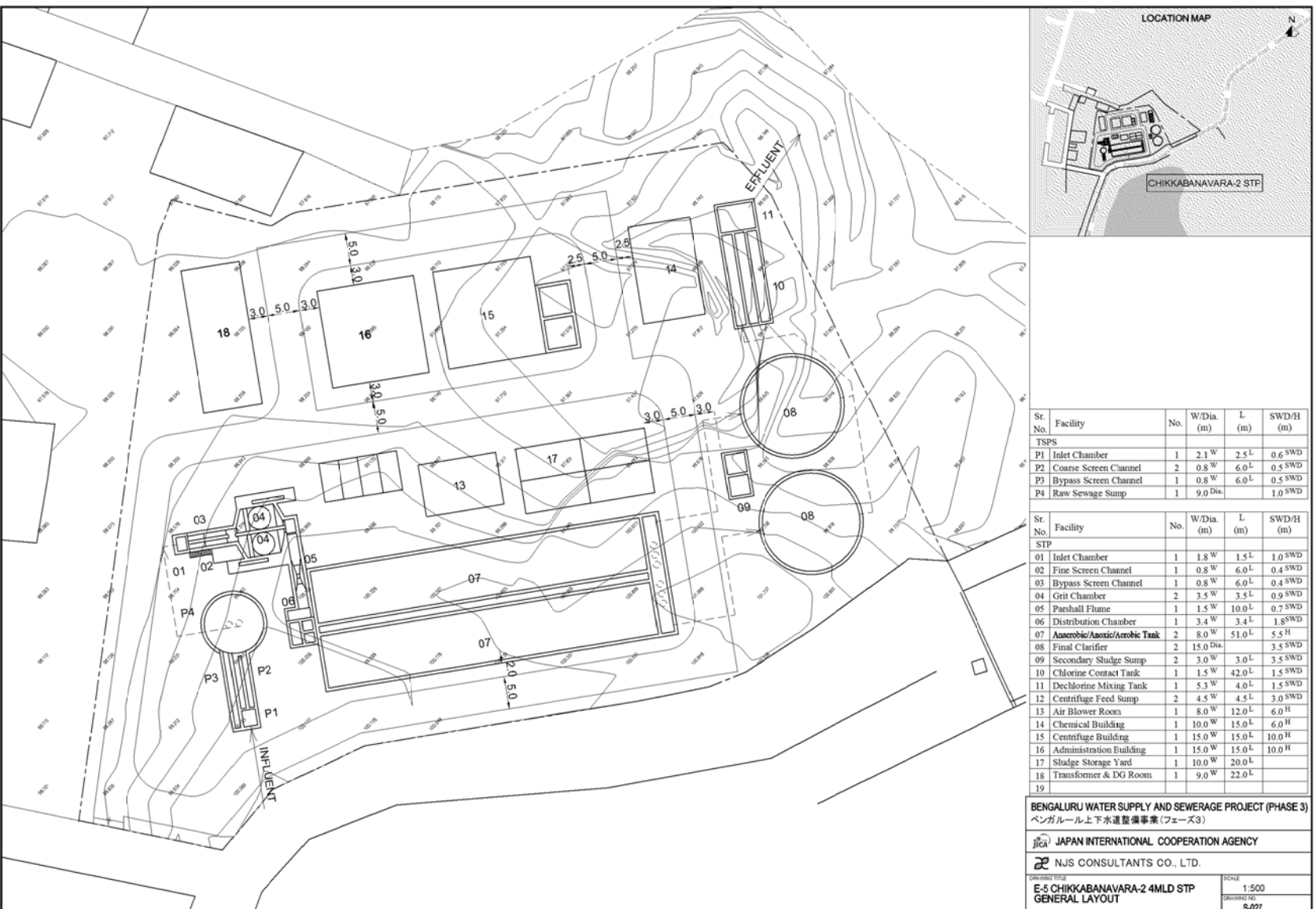

Figure 12.2.49 Layout plan of Chikkabanavara-2 STP

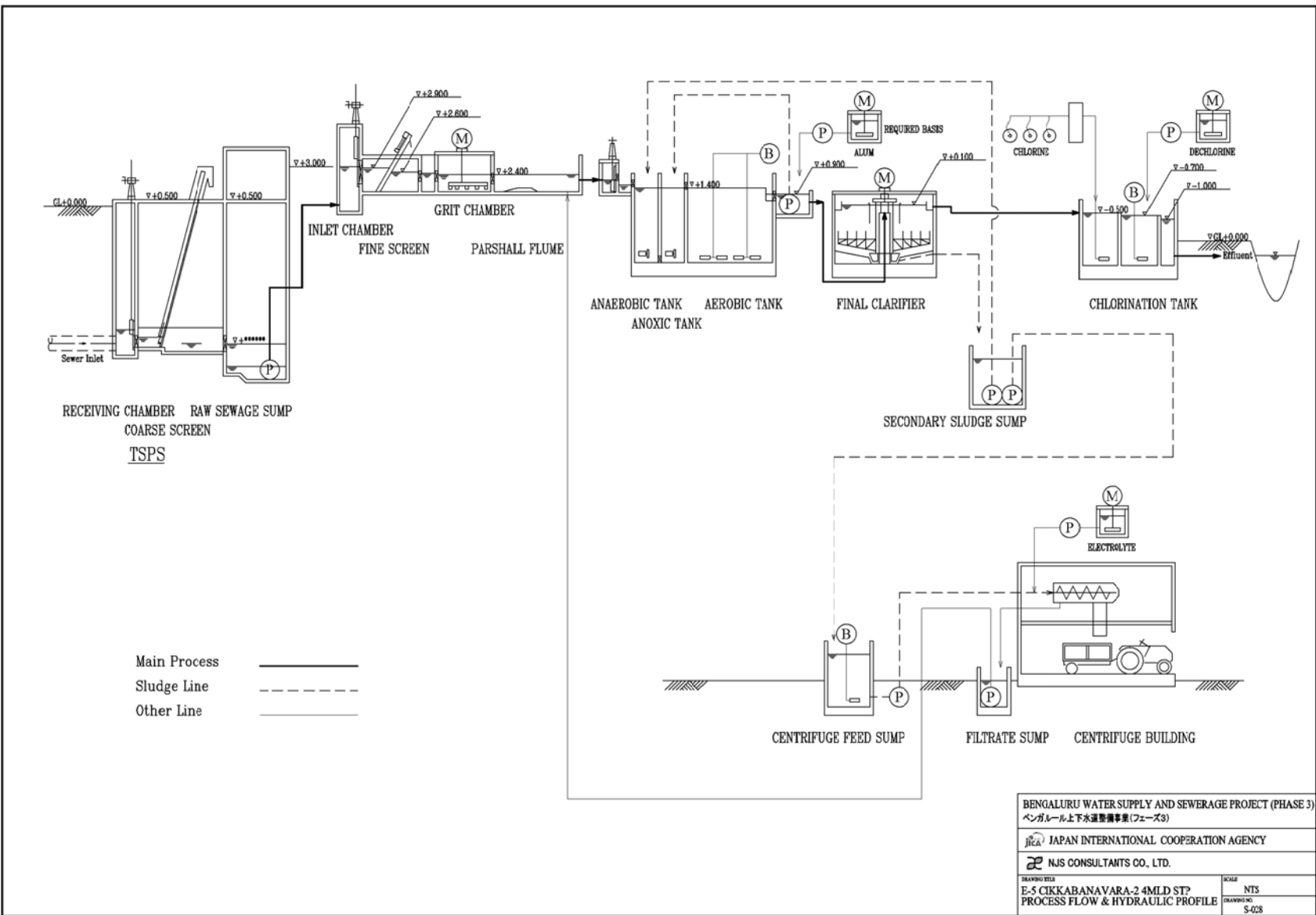

Figure 12.2.50 Process Flow Diagram with Hydraulic Profile

Table 12.2.33 Specifications for Major Equipment (Chikkabanavara-2 STP)

Items	Specification	kW per unit	Unit number
(Mechanical)			
1. Inlet Gates	Manually Operated Cast Iron Width 0.40(m)×Height :0.60(m)	-	2
2. Coarse Screens (Mechanical)	Climber Type SS316L Channel Width :0.80 (m)×SWD :0.50 (m) ×Open Space:20(mm)	1.50	1W
3. Coarse Screens (Manual)	Climber Type SS316L Channel Width :0.80 (m)×SWD :0.50 (m) ×Open Space:50(mm)	-	1
4. Sewage Pump	Submersible Cast Iron Dia:250 (mm)×Discharge :418 (m ³ /h) ×Total Head:15.0 (m)	37.0	1W+1S
5. Electric Hoist	Single-girder Overhead Type Rated Load :3.0(Ton)×Lift :6(m)	8.50	1W
6. Inlet Gates	Manually Operated Cast Iron Width 0.4(m)×Height :0.6(m)	-	2
7. Fine Screens (Mechanical)	Step Type SS316L Channel Width :0.80 (m)×SWD :0.40 (m) ×Open Space:6(mm)	1.50	1W
8. Fine Screen (Manual)	Bar Screen SS316L Channel Width :0.80 (m)×SWD:0.40 (m) ×Open Space:20(mm)	-	1
9. Belt Conveyor	Nylon fabric 3ply Belt Width :0.60(m)×Length :5.0 (m)	1.50	1W
10. Grit Chamber	Square Horizontal MS+ Epoxy Width :3.50 (m)×Length :3.50(m)×SWD :0.90 (m)	2.25	1W+1S
11. Inlet Weir Gates	Manually operated Cast Iron Width 0.4(m)×Height :0.4(m)	-	2
12. Mixers for Anaerobic Tank	Submersible Type SS316L Tank Width :8.0 (m)×Length :4.0(m)×SWD :5.5(m)	4.0	2W
13. Mixers for Anoxic Tank	Submersible Type SS316L Tank Width :8.0 (m)×Length :10(m)×SWD :5.5(m)	4.0	2W
14. Diffusers	Fine Bubble Mem- brane SOR:92 (kg/h·basin)×setting Depth :5.0(m) ×Efficiency:28 %	-	2
15. Air Blowers	Rotary blower Tri-lobe Type Dia. :150 (mm)× Air Flow :1400(m ³ /h) ×Pressure: 65 (KPa)	45.0	2W+1S
16. Circulation Pumps	Submersible Cast Iron Dia. :150 (mm)×Discharge:155(m ³ /h) ×Total Head:5.0 (m)	5.5	4W+2S
17. RAS Pumps	Submersible Cast Iron Dia. :100 (mm)×Discharge:50(m ³ /h) ×Total Head:5.0 (m)	1.5	2W+2S
18. SAS Pumps	Submersible Cast Iron Dia.:80 (mm)×Discharge :18 (m ³ /h) ×Total Head:15.0 (m)	2.20	2W+2S
19. Hand Operation Chain Block	With Geared Trolley Rated Load :1.0(Ton)×Lift :6(m)	-	3
20. Final Clarifiers	Bridge-supported MS+ Epoxy Dia. :15.0 (m)×SWD:3.5(m)	0.4	2W
21. Alum Dosing Pumps	Diaphragm Pump SS/ PTFE Dia.:25 (mm)×Discharge :70(L/h) ×Pressure:0.7(MPa)	0.4	2W+1S
22. Mixer for Alum Solution	Turbine impeller SS316 Tank Width: 1.0(m)×Length:1.0(m)×SWD:1.0(m)	0.4	2W
23. Chlorinators	Gas Chlorination Sys- tem Dosing Rate :4.2(kg/h)	0.10	1W+1S
24. Chlorine Tonners	Volume:928(kg/Unit)	-	4
25. Chlorine Booster Pumps	Submersible Cast Iron Dia.:25 (mm)×Discharge :2.4(m ³ /h) ×Total Head:50.0 (m)	0.75	1W+1S

Items	Specification	kW per unit	Unit number
26. Electric Hoist for Tonners	Single-girder Overhead Type Rated Load :3.0(Ton)×Lift :6(m)	8.60	1W
27. Dechlorine Dosing Pumps	Diaphragm Pump SS/ PTFE Dia.:15 (mm)×Discharge :10(L/h) ×Pressure:1.0(MPa)	0.2	1W+1S
28. Mixer for Dechlorine Solution	Turbine impeller SS316 Tank Width: 0.5(m)×Length:0.5(m)×SWD:0.8(m)	0.1	1W
29. Air Blowers For Dechlorine Mixing Tank	Rotary blower Tri-lobe Type Dia. :40 (mm)× Air Flow:16(m ³ /h) ×Pressure: 20 (KPa)	0.75	1W+1S
30. Electric Hoist for Chemicals	Single-girder Overhead Type Rated Load :1.0(Ton)×Lift :6(m)	4.70	1W
31. Air Blowers For Centrifuge Feed Sump	Rotary blower Tri-lobe Type Dia. :80 (mm)× Air Flow:150(m ³ /h) ×Pressure: 40 (KPa)	5.50	1W+1S
32. Centrifuge Feed Pumps	Progressive Cavity Pump, Cast Iron Dia.:125 (mm)×Discharge :22(m ³ /h) ×Total Head:20.0 (m)	7.5	1W+1S
33. Centrifuges	Centrifuge SS316 Capacity:22(m ³ /h)	44.5	1W+1S
34. Electric Hoist Crane	Single-girder Overhead Type Rated Load :5.0(Ton)×Lift :15(m)	17.10	1W
35. Mixers for Polyelectrolyte Solution	Agitator SS304 Tank Width: 1.0(m)×Length:1.5(m)×SWD:1.8(m)	0.75	2W
36. Polyelectrolyte Dosing Pumps	Progressive Cavity Pump Dia.:20 (mm)×Discharge :0.65(m ³ /h) ×Total Head:20.0 (m)	0.40	1W+1S
37. Centrate Transfer Pumps	Submersible Cast Iron Dia:100 (mm)×Discharge :60(m ³ /h) ×Total Head:15.0 (m)	5.50	1W+1S

Items	Specification	Unit number
(Electrical)		
5. Power receiving facilities at electrical substation	HV incoming panel, IP42, 11kV, VCB HV outgoing feeder panels, IP42, 11kV, VCB Power transformers: outdoor use, 11/0.415-0.24 kV,500 kVA Diesel engine generator set: 415 V, 50 Hz, 375 kVA	1 pc 2 pcs 2 sets 1 pc
6. LV incoming panel, LV switchgears, and MCCs	LV incoming panels: IP42, 600V, ACB 800A x 3, ACB 630A x 1 LV feeder panels: IP52, 600V, MCCB 100 A x 13, Static capacitors MCC for TSPS MCC for Headworks MCCs for Liquid process (Anaerobic/anoxic/aeration tanks, secondary clarifiers) Air blower starter panels with 45 kW VFD MCCs for Solid process	1 pc 1 pc 1 pc 1 pc 1 pc 3 pcs 1 pc
7. Instrumentation devices	Inlet flow meter Level meter in inlet chamber Level meter in sewage pump sump Level meters of pre and post screens	1 pc 1 pc 1 pc 4 pcs

Items	Specification	Unit number
	Air blow flow meters	2 pcs
	Air blow pressure meters	2 pcs
	MLR (Mixed Liquor Recycle) flow meters	2 pcs
	RAS (Return Activated Sludge) flow meters	2 pcs
	DO analyzers	2 pcs
	MLSS analyzers	2 pcs
	Level meters in alum solution tank	2 pcs
	Alum dosing flow meters	1 pc
	Residual chlorine analyzer	1 pc
	Effluent flow meter	1 pc
	Level meters in de-chlorine tank	1 pc
	De-chlorine flow meter	1 pc
	Level meter in secondary sludge sump	1 pc
	WAS (Waste Activated Sludge) flow meters	1 pc
	Level meters in centrifuge sump	1 pc
	Centrifuge feed flow meters	2 pcs
	Level meter in polyelectrolyte solution tank	2 pcs
	Centrifuge polymer dosing flow meters	2 pcs
	Level meter in filtrate sump	1 pc
	Filtrate flow meter	1 pc
8. Local SCADA system	Operator stations, SCADA servers, PLCs, router, etc.,	1 ls

Source: JICA Survey Team