

**REPUBLIC OF THE UNION OF MYANMAR
MINISTRY OF CONSTRUCTION
DEPARTMENT OF BRIDGE**

**THE SUPPLEMENTAL SURVEY
FOR
THE PROJECT FOR CONSTRUCTION
OF
BAGO RIVER BRIDGE**

FINAL REPORT

DECEMBER 2016

JAPAN INTERNATIONAL COOPERATION AGENCY

NIPPON KOEI CO., LTD.

1R
JR(先)
16-068

**REPUBLIC OF THE UNION OF MYANMAR
MINISTRY OF CONSTRUCTION
DEPARTMENT OF BRIDGE**

**THE SUPPLEMENTAL SURVEY
FOR
THE PROJECT FOR CONSTRUCTION
OF
BAGO RIVER BRIDGE**

FINAL REPORT

DECEMBER 2016

JAPAN INTERNATIONAL COOPERATION AGENCY

NIPPON KOEI CO., LTD.

Table of Contents

CHAPTER 1. Introduction	1-1
1.1 Background	1-1
1.2 Summary of Feasibility Study	1-4
1.3 Objectives of Supplemental Survey	1-5
1.4 Work Schedule	1-6
CHAPTER 2. Study on Adjacent Intersection and Connecting Roads	2-1
2.1 Introduction	2-1
2.2 Yangon Side	2-2
2.2.1 Introduction	2-2
2.2.2 Traffic Demand Forecast	2-3
2.2.3 Intersection Improvement	2-15
2.2.4 Thaketa Roundabout	2-41
2.3 Thanlyin Side	2-45
2.3.1 Introduction	2-45
2.3.2 Traffic Demand Forecast	2-46
2.3.3 Improvement for On-ramp Traffic	2-49
CHAPTER 3. Summary of Geological Condition	3-1
3.1 Summary of Geological Condition	3-1
3.2 Geological Survey	3-2
3.3 Geotechnical Design Parameters	3-15
3.4 Design Consideration	3-16
CHAPTER 4. Update of Environmental and Social Considerations	4-1
4.1 Introduction	4-1
4.1.1 Background	4-1
4.1.2 Project Owner and Proponent	4-1
4.1.3 Type of Environmental Impact Assessment Study	4-1
4.1.4 Type of Resettlement Action Plan (RAP)	4-3
4.1.5 Policy, Legislation, and Institutional Framework	4-3
4.2 Existing Social and Environmental Conditions around the Project Area	4-24
4.3 Initial Environmental Examination (IEE) of the Project	4-24
4.3.1 Table of Contents of IEE report	4-24
4.3.2 Identification and Evaluation of Possible Impacts	4-25
4.3.3 Mitigation Measures against Negative Impacts and Environmental Management Plan (EMP) and Environmental Monitoring Plan (EMoP)	4-34

4.4	A-RAP.....	4-35
4.4.1	Table of Contents of A-RAP.....	4-35
4.4.2	A summary of land acquisition and PAPs and PAHs	4-36
4.4.3	Entitlement Policy Matrix	4-40
4.4.4	Removal of trees and replanting of nursery trees cost and relocation cost for Utilities	4-47
4.5	Stakeholder Meeting	4-49
4.5.1	First Stakeholder Meeting	4-49
4.5.2	Second Stakeholder Meeting	4-49
4.6	JICA Environmental Checklist, Screening Format, Environmental and Social Monitoring Form and Abbreviated Resettlement Action Plan Monitoring Form.....	4-51
CHAPTER 5. Update of Implementation Program		5-1
5.1	Implementation Structure.....	5-1
5.1.1	Implementation Agency.....	5-1
5.1.2	Project Management Unit	5-2
5.1.3	Demarcation among DoB, DoH and YCDC	5-3
CHAPTER 6. Project Evaluation		6-1
6.1	General.....	6-1
6.2	Socio-Economic Framework and Updated Traffic Demand Forecast	6-1
6.2.1	Socio-Economic Framework.....	6-1
6.2.2	Transport Demand Forecast (Do Nothing + Bago Bridge Case)	6-2
6.2.3	Demand Forecast.....	6-8
CHAPTER 7. Operation and Maintenance.....		7-1
7.1	Introduction.....	7-1
7.2	Toll Collection Plan	7-1
7.3	Proposed O&M Structure.....	7-4
7.4	Preliminary Estimate of O&M cost	7-4
7.4.1	Maintenance Cost.....	7-4
7.4.2	Operation Cost	7-5
7.4.3	Total operation and maintenance cost.....	7-6
CHAPTER 8. Conclusions and Recommendations.....		8-1
8.1	Conclusions.....	8-1
8.2	Recommendations.....	8-3

Appendices

Appendix A: Drawing List	A-1
Appendix B: Environmental and Social Considerations.....	B-1
Appendix C: Results of Intersection Analysis	C-1
Appendix D: Comparison for Width of Bridge between Bago River Bridge and Dala Bridge	D-1
Appendix E: Structural comparison of Bago River Bridge and Dala Bridge	E-1
Appendix F: Construction Plan of Flyover on Yangon Side	F-1
Appendix G: Area for Construction Yards	G-1
Appendix H: Study of Toll Gate for Bago Bridge	H-1
Appendix I: Report on Geological Survey on the Supplement Survey for Bago River Bridge Construction Project Thanlyin Chin Kat Road, Thaketa Township	I-1

Abbreviations

AASHTO	American Association of State Highway and Transportation Officials
ADB	Asia Development Bank
ADT	Average Daily Traffic
AIDS	Acquired Immune Deficiency Syndrome
ARP (A-RAP)	Abbreviated Resettlement Plan
ASEAN	Association of Southeast Asian Nations
B/C	Cost Benefit Ratio
BOD	Biological Oxygen Demand
BRT	Bus rapid transit
CBD	Central business district
CO	Carbon Monoxide
COD	Chemical Oxygen Demand
CPLAD	City Planning and Land Administration Department
CS	Construction Supervision
CT	Contractor
D/D	Detailed Design
DHSHD	Department of Human Settlement and Housing Development
DO	Dissolved Oxygen
DOB	Department of Road
DOH	Department of Highway
DUHD	Department of Urban Housing Development
ECC	Environmental Compliance Certificate
ECD	Environmental Conservation Department
EIA	Environmental impact assessment
EIRR	Economic internal rate of return
EMoP	Environmental Monitoring Plan
EMP	Environmental Management Plan
E/N	Exchange of Notes
EQG	National Environmental Quality (Emission) Guidelines
EQS	Environmental Quality Standards
E/S	Engineering Service
FD	Forest Department
F/S	Feasibility Study
GOM	Government of Myanmar
HIV	Human Immunodeficiency Virus
ICB	International Competitive Bidding
IEE	Initial environmental examination
IFC	International Finance Corporation
IMG	International Management Group
I/P	Implementation Program
IUCN	International Union for Conservation of Nature
JICA	Japan International Cooperation Agency
JPY	Japanese Yen
L/A	Loan Agreement
LCB	Local Competitive Bidding
MCDC	Mandalay City Development Committee

MCIT	Ministry of Communication and Information Technology
MITT	Myanmar International Thilawa Terminal
MMK	Myanmar Kyats
MOAI	Ministry of Agriculture and Irrigation
MOALI	Ministry of Agriculture, Livestock and Irrigation
MOC	Ministry of Construction
MOE	Ministry of Energy
MOECAF	Ministry of Environment Conservation and Forestry
MOEE	Ministry of Electricity Power and Energy
MOEP	Ministry of Electric Power
MOF	Ministry of Fishery
MOGE	Myanmar Oil and Gas Enterprise
MOH	Ministry of Health
MOHS	Ministry of Health and Sports
MOI	Ministry of Industry
MOL	Ministry of Labour
MOLIP	Ministry of Labour, Immigration and Population
MONREC	Ministry of Natural Resources and Environmental Conservation
MORT	Ministry of Rail Transportation
MOT	Ministry of Transport
MPT	Myanmar Port and Telecommunication
MR	Myanmar Railways
MRT	Ministry of Rail Transportation
MTC	Ministry of Transport and Communication
NCDC	Naypyitaw City Development Committee
NEXCO	Nippon Expressway Company
NGO	Non-Governmental Organization
NK	Nippon Koei
NO ₂	Nitrogen Dioxide
NPV	Net Present Value
NWRC	National Water Resources Committee
ODA	Official Development Assistance
O&M	Operation and Maintenance
PAFs	Project Affected Facilities
PAHs	Project Affected Households
PAPs	Project Affected Persons
PCD	Pollution and Cleansing Department
PC-T	Prestressed Concrete T-shaped
PCU	Passenger Car Unit
PM _{2.5}	Fine particulate matter 2.5
PM ₁₀	Suspended particulate matter 10
PMU	Project Management Unit
PPGD	Playgrounds, Parks and Gardening Department
ROW	Right of Way
Rd	Road
SCF	Standard Conversion Factor
SEZ	Special Economic Zone
SO ₂	Sulphur Dioxide
SPT	Standard Penetration Test

SS	Suspended Solids
SUDP	The Strategic Urban Development Plan of the Greater Yangon, JICA (2013)
SV	Supervision
TKT	Thaketa
TN	Total Nitrogen
TOC	Total Organic Carbon
TP	Total Phosphorus
TTC	Travel Time Costs
USD	US Dollar
V/C	Volume to Capacity
VOC	Vehicle Operation Cost
VOT	Value of Time
WB	World Bank
WHO	World Health Organization
WSSD	Water Supply and Sanitation Department
YCDC	Yangon City Development Committee
YRDC	Yangon Region Development Committee
YRG	Yangon Regional Government
YUTRA	Project for Comprehensive Urban Transport Plan of the Greater Yangon
YZN	Yuzana

Note: From 1st April, 2016, the name of some ministries are changed as below.

- * The Ministry of Rail Transportation (MRT) is changed to the Ministry of Transport and Communication
- * The Ministry of Communication and Information Technology (MCIT) is changed to the Ministry of Transport and Communication
- * The Ministry of Environmental Conservation and Forestry (MOECAAF) is changed to the Ministry of Natural Resources and Environmental Conservation
- * The Ministry of Energy is changed to the Ministry of Electric Power and Energy
- * The Ministry of Ministry of Agriculture and Irrigation is changed to the Ministry of Agriculture, Livestock and Irrigation
- * The Ministry of Labor is changed to the Ministry of Labour, Immigration and Population

CHAPTER 1. INTRODUCTION

1.1 BACKGROUND

The region of Yangon has been expanding along with the growth of the city. As shown in Figure 1-1 below, economic areas have been moving outwards and include development of New Towns, Satellite Towns, Industrial Zones, and Green & Reclamation.

There is development in Land Use as shown in Figure 1-2 that is creating Sub Centers surrounding CBD including Hlaing Tharya, Mindama, Dagon Myothit, Dala, Thanlyin, and Thilawa.

These developments and expansions in Future Land Use will be supported by Transportation Enhancements including Arterial Roads, Outer Ring Roads, Railways, MRT, and BRT, as defined in SUDP.

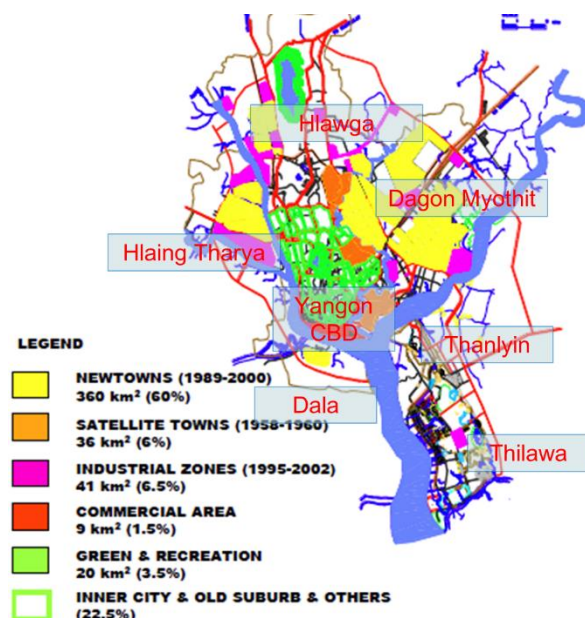

Source: DHSHD

Figure 1-1 New Towns, Satellite Towns and Industrial Zones in Yangon Region up to 2002

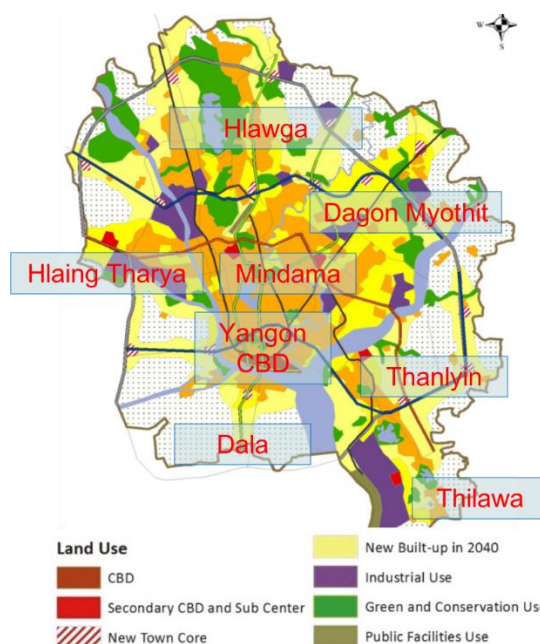

Source: SUDP

Figure 1-2 Future Land Use MAP (2040)

Figure 1-3 shows the high-order transit services needed in 2013 and 2035 together with the estimated daily person trips. In the next 20 years, the person trip will increase dramatically, in particular, between Thilawa and Yangon CBD mainly as a result of development of Thilawa SEZ. As a result, high-order transit services will be expanded as shown highlighted in red.

Similarly, traffic between Yangon CBD and Thilawa will increase. The truck traffic demand between Thilawa and CBD, crossing Bago River will triple. The truck traffic between Thilawa and Bago Riverside Subcenter (Bago Riverside SC.) crossing Bago River is also similarly expected to increase.

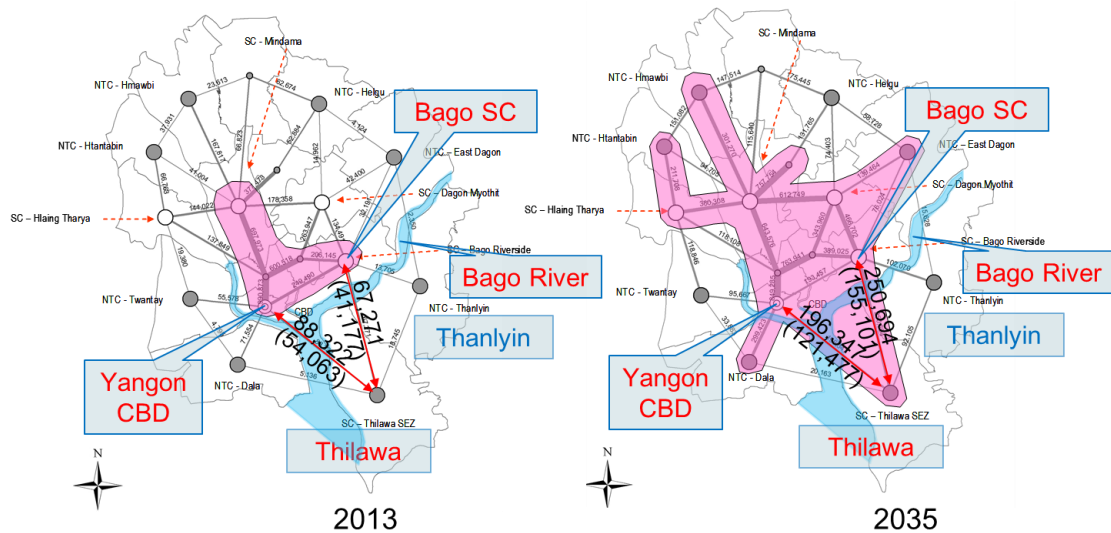

Route	2013	2035	increment
Yangon CBD - Thilawa	88,322	196,347	2.2
Thilawa – Bago Riverside SC.	67,271	250,694	3.7

Source: YUTRA

Figure 1-3 Daily Person Trips between Centers (Commuting Trips in parenthesis)

As a result, new bridges crossing Bago River are needed in the near future for accommodating the increased traffic demand. Figure 1-4 shows road capacity increase between the sub-centers suggested by Comprehensive Urban Transport Plan of the Greater Yangon.

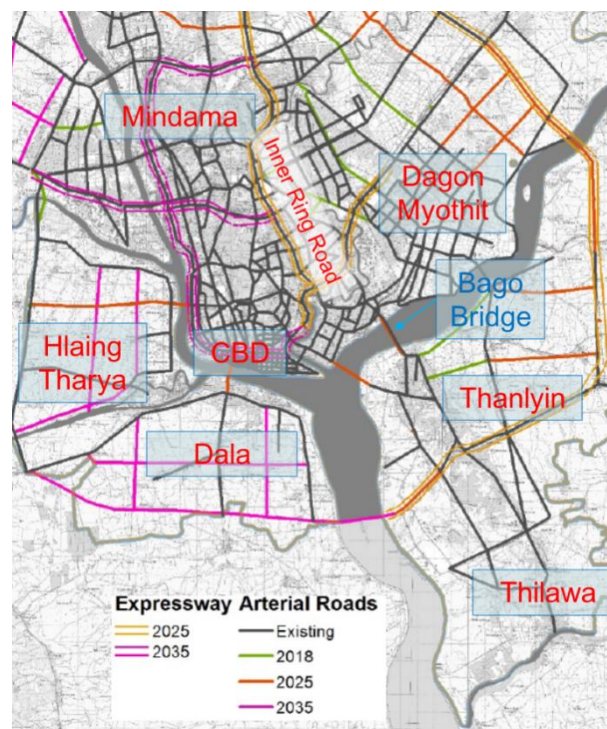

Source: YUTRA

Figure 1-4 Recommended Road Network for Short-, Middle- and Long-term

Currently, there are 2 existing bridges connecting Yangon CBD and Thilawa crossing Bago River; these are Thanlyin Bridge and Dagon Bridge.

Comparing the 2 bridges in terms of current traffic volume, the traffic volume on Thanlyin Bridge route is much larger because Dagon Bridge route has longer distance and narrower access roads. As a result the travel time is much longer as shown in Table 1-1 below.

Similarly, the majority of traffic between Bago Subcenter and Thialawa passes Thanlyin Bridge. The Thanlyin Bridge is the access route between Thilawa and CBD or Bago Subcenter.

Table 1-1 Comparison of Travel between Yangon CBD and Thilawa (2013)

	Travel Distance	Travel Time (2013)	Traffic Volume at Bridge (2013)
Thanlyin Bridge Route	19.5 km	44.4 min	18,991 PCU
Dagon Bridge Route	38.1 km	68.6 min	1,529 PCU

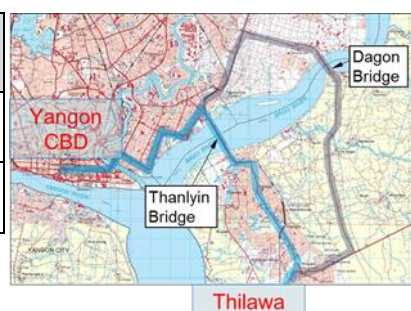

Source: extracted from YUTRA by JICA Study Team

Thanlyin Bridge has two major problems for accommodating such large traffic demand in the near future, namely the number of lanes and weight limitation. The bridge has only 1 lane in each direction which leads to terrible congestion when a small incident like a vehicle trouble occurs. The bridge has weight limitation of 32 tons, which will not accommodate heavier trucks like large trailers.



Source: JICA Study Team

Figure 1-5 Photos of Thanlyin Bridge

Table 1-2 shows the estimated traffic volume in 2025 based on the ratio of Traffic Volume and Capacity of the roads. In ten years, the traffic volume along Thanlyin Bridge will nearly double its capacity and it is estimated that the travel time on the bridge will be 88 minutes and jam length will be more than 6 km. With a new bridge with 4 lanes, the travel time is going to be reduced to 6 minutes and Jam Length to 150 m. Consequently, construction of a new bridge is expected to be very effective for accommodating the larger traffic demand on Thanlyin Bridge.

Table 1-2 Estimated Travel Time and Jam Length of based on V/C at Thanlyin Bridge (2025)

	Volume / Capacity (V/C)	Travel Time (min.)	Jam Length* (km)
Without New Bridge	1.8	88	6.37
With New Bridge	1.0	6	0.15

Note(*): (peak volume - capacity)*(vehicle distance) / (number of lanes)

Source: extracted from YUTRA by JICA Study Team

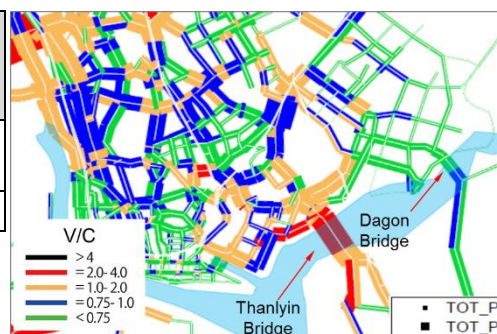

1.2 SUMMARY OF FEASIBILITY STUDY

The Feasibility Study for the new bridge conducted in 2014 included route selection, preliminary design, cost estimate, and project evaluation.

The route, as shown in Figure 1-6 below, is located just downstream side of Thanlyin Bridge connecting directly to Thilawa Access Road, “Infrastructure Development Project in Thilawa Area Phase 2”, which is under detailed design for road improvement by JICA ODA Loan.

The outline of the preliminary design is shown in Table 1-3. The spans of the bridge are arranged for the Thanlyin Bridge to avoid harmful impacts from river flow (e.g. scouring) and to maintain navigation clearance.



Source: JICA Study Team

Figure 1-6 Location of Bago River Bridge

Table 1-3 Outline of Preliminary Design for Bago Bridge

Item	Description
Superstructure	Prestressed concrete precast box girder with 6 spans Steel box girder (steel deck) with 7 spans Steel cable stayed bridge with 3 spans Prestressed concrete precast box girder with (4+4) spans
Substructure	Concrete wall pier on steel pipe sheet pile foundation (SPSP), bored pile foundation
Bridge length	1,928 m
Spans	6@50+(104+6@112)+(112+224+112)+(2@52+2@50)+4@50
Traffic lanes	Vehicle : 4 lanes (2 lanes each) Pedestrian: both sides (W=2m)
Access road	Right bank side 539m, left bank side 647m

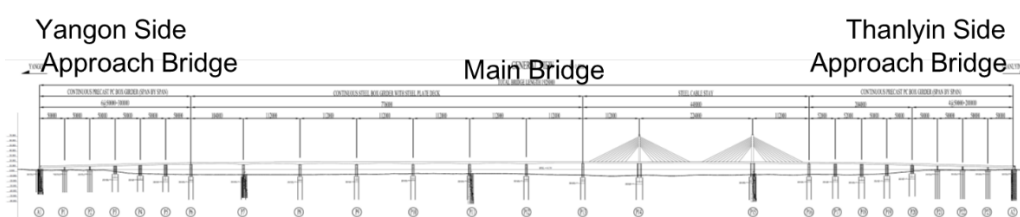

Source: Feasibility Study for Construction Project of Bago River Bridge

1.3 OBJECTIVES OF SUPPLEMENTAL SURVEY

One and a half years have passed from the Preparatory Survey, and surrounding circumstances have changed dramatically. As more public and private investment have been attracted to Greater Yangon, the importance of improvement of the existing infrastructure has increased. New road transportation projects such as inner and outer ring road, extension of Yangon-Nay Phi Taw-Mandalay expressway etc., proposed in SUDP and YUTRA, must be prepared steadily for the coming economic development of Greater Yangon and Myanmar.

Accordingly, JICA decided to conduct this supplemental survey for the project for the construction of Bago River Bridge.

The objectives of the supplemental survey are:

- To review “the Preparatory Survey for the project for construction of the Bago River Bridge” from the viewpoint of implementation time differences.
- To perform an intensive study on the intersections and the connecting roads adjacent to the Bridge based on the latest traffic conditions.
- To update the documents of environmental and social considerations.
- To prepare the documents of updated implementation plan of the project to meet the Japanese loan scheme.

1.4 WORK SCHEDULE

The supplemental survey was implemented between the middle of February to November 2016 and the major work items were completed by the end of June 2016 and followed by additional geotechnical survey and stakeholder meeting as shown in Table 1-4 below.

Table 1-4 Work Items and Time Schedule of Supplemental Survey

Work Item	Period	FY 2015					FY2016						
		Feb.	Mar.	Apr.	May	June	July	August	September	October	November		
[A] Preparation of Inception Report													
[A-1] Review of Feasibility Study Report, Cost Estimation and Relevant Documents		□											
[A-2] Preparation of Inception Report		□											
[A-3] Description and Discussion of Inception Report		□											
[B] Confirmation of Existing Condition and Issue Related to Road Plan and Design													
[B-1] Collection and Review of Existing Documents		■											
[B-2] Site Survey and Traffic Analysis on Adjacent Intersection		■											
[B-3] Traffic Demand Forecast		□											
[B-4] Study on Intersection Improvement		■	■										
[C] Bridge Plan and Design													
[C-1] Collection and Review of Existing Documents		■											
[C-2] Plan and Preliminary Design of Overpass		■	■										
[D] Construction Plan / Project Cost Estimate													
[D-1] Collection and Review of Existing Documents		■											
[D-2] Update of Project Cost		■	■										
[D-3] Review of Validity of Estimated Cost		■	■										
[D-4] Economic Evaluation		□											
[D-5] Preliminary Project Cost Estimate of Intersection Improvement		■	■										
[D-6] Planning of Project Schedule		□											
[E] Environmental and Social Considerations													
[E-1] Collection and Review of Existing Documents		■											
[E-2] Update of IEE and ARAP		■	■										
[E-3] Assist for Stake Holder Meeting												■	■
[F] Additional Study for Implementation													
[F-1] Further Update of Project Cost				□	□	■							
[F-2] Technology Transfer				□	□								
[F-3] Toll Fee Collection				□	□								
[F-4] Study on Flyover on Yangon Side				□	□	■							
[F-5] Additional Geological Survey on Yangon Side								■		■			
[G] Preparation of Final Report													
[G-1] Preparation of Brief Summary of Site Survey Results			□										
[G-2] Preparation of Interim Report			□										
[G-3] Preparation of Final Report										□			□

Legend : □ Work in Japan ■ Work in Myanmar

Source: JICA Study Team

CHAPTER 2. STUDY ON ADJACENT INTERSECTION AND CONNECTING ROADS

2.1 INTRODUCTION

In reference to YUTRA, major future traffic flow through Bago Bridge is expected as shown in Figure 2-1 considering development of Thilawa Port, Thilawa SEZ, several housing projects in Thanlyin Township, Sub-centers and Expressways.

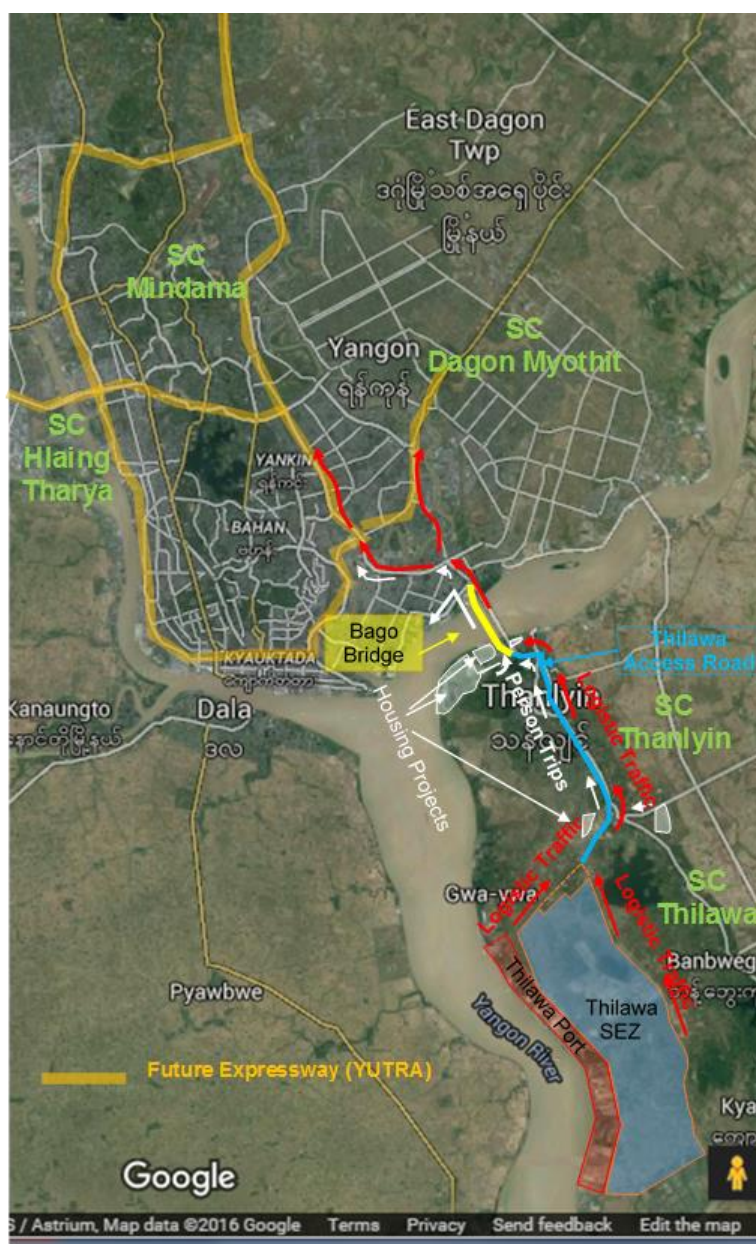

Source: JICA Study Team

Figure 2-1 Expected Major Traffic Flow (North Bound) through Bago Bridge in the Future

In this supplemental survey, traffic demand forecast at the adjacent intersections and connecting roads for both ends of the bridge was updated and necessary improvement plan was also studied.

Located at the bridge end on Yangon side, Shukhinthar Intersection connecting to Thanlyin Chin Kat Rd, Shukhinthar Myopat Rd and Nawarat Pat Rd were focused on in this study as shown in Figure 2-2.

Located at the other bridge end on Thanlyin side, the intersection connecting with Kyaik Khauk Pagoda Road (Thilawa Access Road) and a new residential area on West side of the bridge were also focused on in this study.

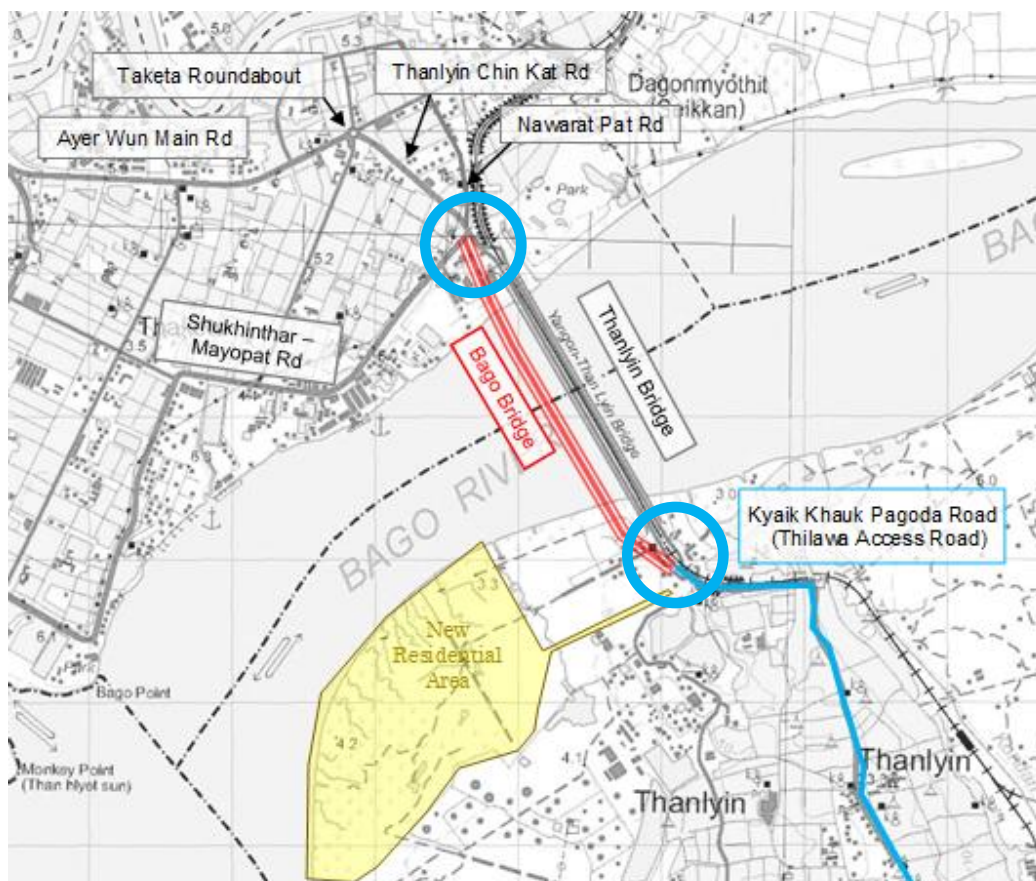

Source: JICA Study Team

Figure 2-2 Location of Adjacent Intersections and Connecting Roads of Bago Bridge

2.2 YANGON SIDE

2.2.1 Introduction

In relation to construction of Bago Bridge, there is a concern about traffic capacity at Shukhinthar Intersection, since two major traffic flows are meeting each other, which may induce traffic jam in the near future. In the following sub-sections, the situations of traffic at this intersection after completion of Bago Bridge is shown by updating demand forecast, followed by study for intersection improvement.

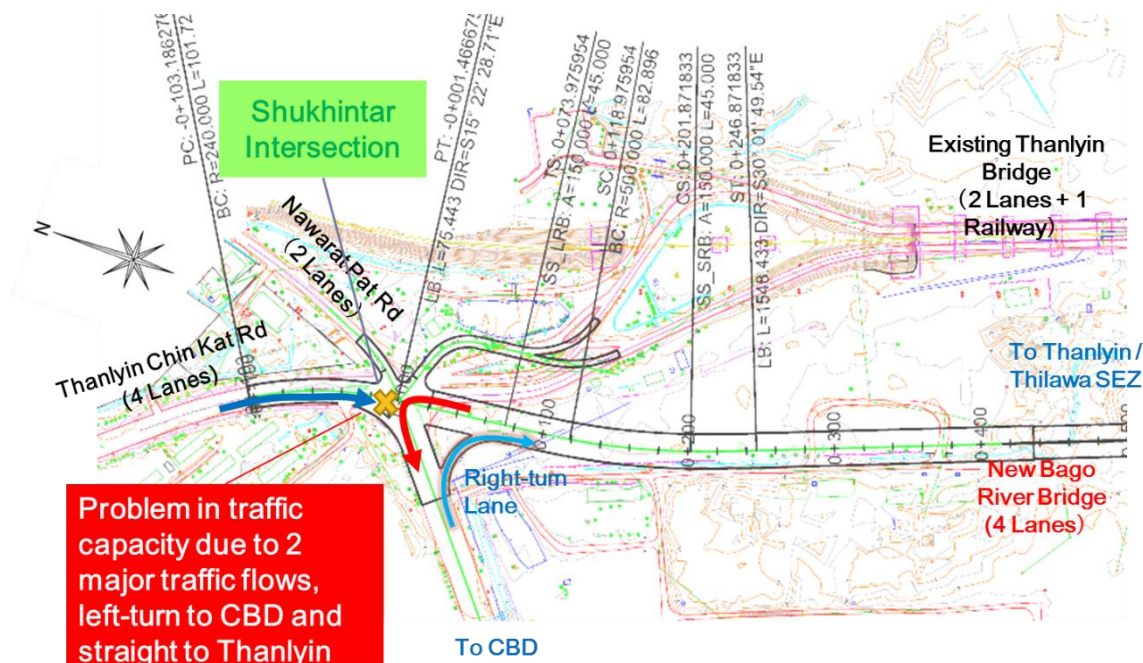

Source: JICA Study Team

Figure 2-3 Concern about Future Traffic at Shukhinthar Intersection

2.2.2 Traffic Demand Forecast



(1) Traffic Count Survey

The intersection traffic survey was conducted to obtain the traffic volumes on the target roads. Survey results were analyzed and utilized for the intersection design.

The traffic count survey was conducted to count the traffic volume by vehicle groups, directions, and peak hours in a weekday. The traffic volumes were recorded for each hour of traffic peak time. Traffic peak time for these survey location was defined as morning time from 07:00 to 10:00 and evening time from 16:00 to 19:00.

The vehicle group classification is described in Table 2-1 below.

Table 2-1 Vehicle Group Classification for Traffic Count Survey

Type	Code Number of Vehicle Group	Description
Private	1	Bicycle (Non-motorized) 
	2	Motorcycle (including motorcycle taxi) 
	3	Passenger Car & Taxi 
	4	Van (box car) Pick-up, SUV & 4WD

Type	Code Number of Vehicle Group	Description
		
Public	5	Passenger Truck / Small Bus 
	6	Large Bus 
Cargo	7	Small Truck 
	8	Truck (2 axles, over 4.5t) 
	9	Truck (3 axles) 
	10	Truck (more than 4 axles) & Trailer (separated type) 
Others	11	

Source: JICA Study Team

The traffic volume survey was conducted at two major intersections near Thanlyin Bridge. These survey points are located at ward 11, Thaketa Township, Yangon Region. The detail locations of survey points are shown in Table 2-2. All two survey points are located on Thanlyin Chin Kat Road. The first survey point is intersection of Thanlyin Chin Kat Road and Shukhinthar Road which is also known as Shukhinthar Mayopat Road (referred to as “Point 1: Shukhinthar Road Intersection”). The second survey point is intersection of Thanlyin Chin Kat Road and Yadanar Road (referred to as “Point 2: Yadanar Road Intersection”).

Table 2-2 Survey Locations of Traffic Count Survey Points

No.	Survey Point	Coordinate	Remarks
1	Point 1: Shukhinthar Road Intersection	16°48'3.02"N, 96°13'32.48"E	Detailed locations are shown in Figures 2-4, 2-5 and 2-6.
2	Point 2: Yadanar Road Intersection	16°48'10.74"N, 96°13'24.91"E	

Source: JICA Study Team



Source: JICA Study Team

Figure 2-4 Overall Traffic Volume Survey Locations

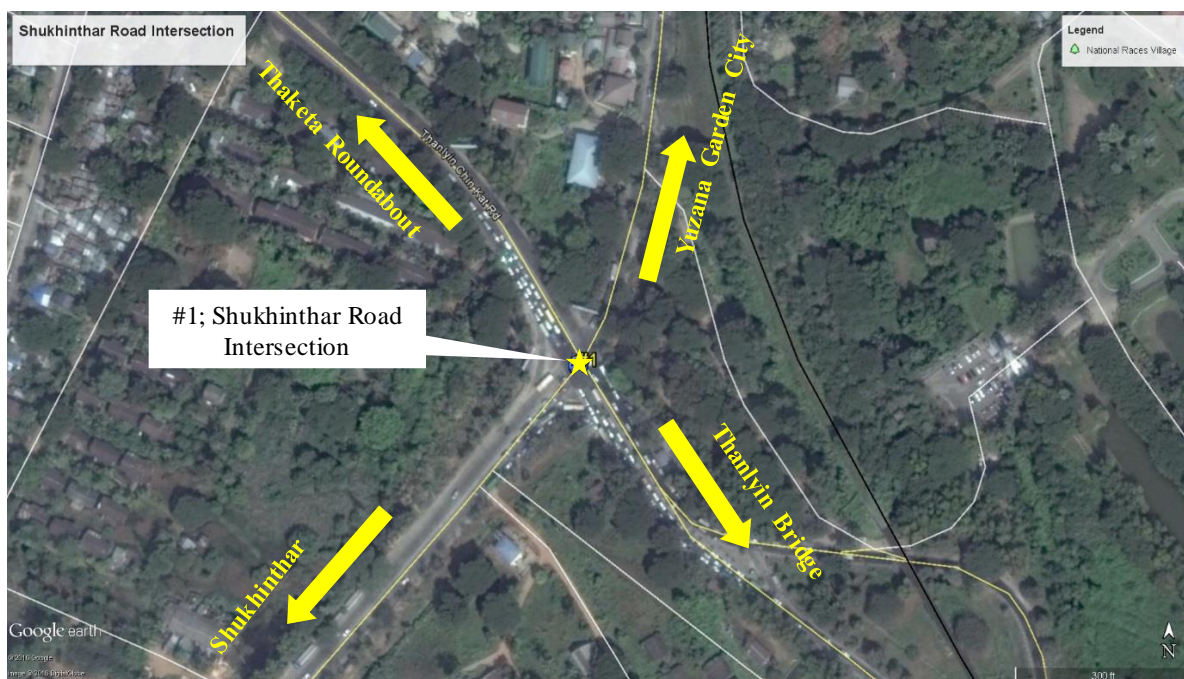

Source: JICA Study Team

Figure 2-5 Detail view of Point 1: Shukhinthar Road Intersection

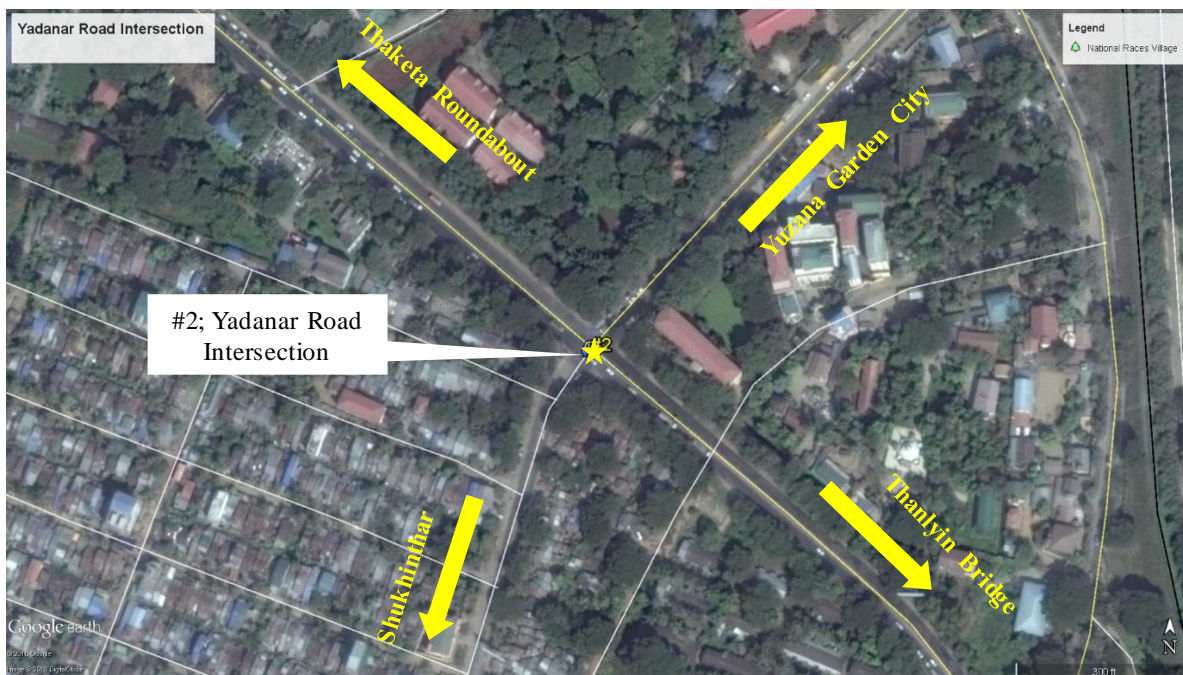

Source: JICA Study Team

Figure 2-6 Detail view of Point 2: Yadanar Road Intersection

The overall traffic count survey schedule is shown in Table 2-3.

Table 2-3 Overall Schedule of Traffic Count Survey

Schedule	2016 Feb																												2016 Mar				
	1	2	3	4	5	6	7	8	9	10	11	12	13	14	15	16	17	18	19	20	21	22	23	24	25	26	27	28	29	1	2	3	4
	M	T	W	T	F	S	S	M	T	W	T	F	S	S	M	T	W	T	F	S	S	M	T	W	T	F	S	S	M	T	W	T	F
Traffic Volume Survey for Bago Bridge Project																																	
I. Traffic Volume Survey																																	
1 Preparation and Arrangements																																	
2 Field Survey																																	
3 Data compilation / analysis																																	
4 Report																																	

Source: JICA Study Team

The survey was conducted at traffic peak hours of morning three hours from 07:00 to 10:00 and evening three hours from 16:00 to 19:00 on 16th February 2016.

The survey was conducted under the supervision of NK experts by surveyors of Myanmar Koei International Ltd. The survey is conducted with the following team composition.

Table 2-4 Team Composition of the Traffic Survey Team

Sr.	Position	Number of persons
1.	Survey Leader	4 person*day
2.	Survey Coordinator	5 person*day
3.	Field Team Leader	3 person*day
4.	Field Supervisor	2 person*day
5.	Surveyors / Survey Backup	34 person*day

Source: JICA Study Team

i) Survey Results of Shukhinthar Road Intersection

The width of the cross-section of Thanlyin Road at Point 1: Shukhinthar Road Intersection was approximately 19.2 m with 3 one-way lanes and total of 6 lanes. The width of cross-section of Shukhinthar road at the direction to Shukhinthar was approximately 20.4 m with 3 one-way lanes and total of 6 lanes. The width of Shukhinthar Road at the direction to Yuzana Garden City was approximately 7.6 m with one-way 1 lane and total of 2 lanes. The sketch and dimension of Point 1 Intersection is shown in Figure 2-7.

The summarized survey results of traffic volume at Point 1: Shukhinthar Road Intersection are shown in Table 2-5 The total traffic volume of morning and evening six peak hours at Point 1: Shukhinthar Road Intersection was 16,608 vehicles. This is the amount of all types of vehicles which passed through the intersection from each direction. The dominant type of vehicle group is classification 3, light vehicle car and taxi group and it is nearly half of total number of all types of vehicles.

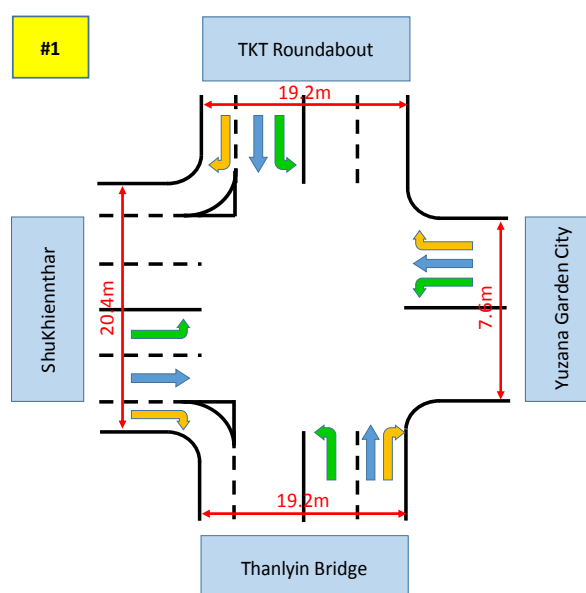

Source: JICA Study Team

Figure 2-7 Width of Roads at Point 1: Shukhinthar Road Intersection

Table 2-5 Summary of Survey Results of Traffic Volume at Point 1: Shukhinthar Road Intersection

		Unit: Vehicle										
Road Cross Section of Point 1: Shukhinthar Road Intersection		1	2	3	4	5	6	7	8	9	10	11
		Bicycle	Motorcycle	Car & Taxi	Van, Pick-up & 4WD	Passenger Truck / Small Bus	Large Bus	Small Truck	Truck (2 axles)	Truck (3 axles)	Truck (more than 4 axles)	Other
Traffic Direction from Thanlyin Bridge												
Average of peak hours for 6 hours		2	49	550	119	185	54	51	12	12	3	0
Max of peak hours for 6 hours		4	83	624	152	200	86	66	16	28	4	0
Total of peak hours for 6 hours		11	294	3,300	711	1,112	321	308	73	74	16	0
Total vehicle of peak hours for 6 hours		6,220										
Traffic Direction from Yuzana Garden City												
Average of peak hours for 6 hours		11	16	133	20	44	2	28	9	9	12	0

Road Cross Section of Point 1: Shukhinthar Road Intersection	1	2	3	4	5	6	7	8	9	10	11
	Bicycle	Motorcycle	Car & Taxi	Van, Pick-up & 4WD	Passenger Truck / Small Bus	Large Bus	Small Truck	Truck (2 axles)	Truck (3 axles)	Truck (more than 4 axles)	Other
Max of peak hours for 6 hours	26	29	189	30	57	3	34	12	15	20	1
Total of peak hours for 6 hours	66	96	797	122	264	10	165	55	56	73	2
Total vehicle of peak hours for 6 hours	1,706										
Traffic Direction from Thaketa Roundabout											
Average of peak hours for 6 hours	11	30	264	62	130	17	15	20	10	2	4
Max of peak hours for 6 hours	15	46	344	75	149	27	59	32	18	4	9
Total of peak hours for 6 hours	64	179	1,583	373	782	104	92	119	57	9	23
Total vehicle of peak hours for 6 hours	3,385										
Traffic Direction from Shukhinthar											
Average of peak hours for 6 hours	13	41	450	114	115	45	37	33	20	15	0
Max of peak hours for 6 hours	29	72	608	141	136	61	50	43	31	18	1
Total of peak hours for 6 hours	76	245	2,699	685	691	269	224	199	118	90	1
Total vehicle of peak hours for 6 hours	5,297										
Overall total vehicle of all direction for 6 hours	16,608										

Source: JICA Study Team

ii) Survey Results of Yadanar Road Intersection

The width of the cross-section of Thanlyin Road at Point 2: Yadanar Road Intersection was approximately 15.2 m with 2 one-way lanes and total of 4 lanes. The width of cross-section of Yadanar Road at the direction to Shukhinthar was also approximately 15.2m with 2 one-way lanes and total of 4 lanes. The width of Yadanar Road at the direction to Yuzana Garden City was approximately 14.0 m with 2 one-way lanes and total of 4 lanes. The sketch and dimension of Point 2 intersection is shown in Figure 2-8.

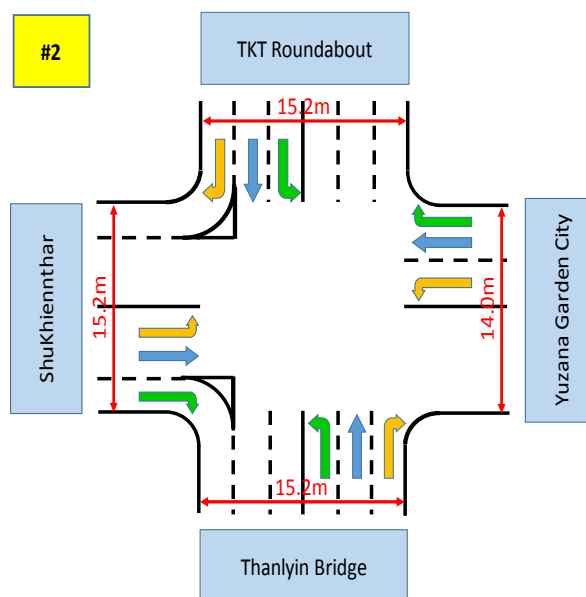

Source: JICA Study Team

Figure 2-8 Width of Point 2: Roads at Yadanar Road Intersection

The summarized survey results of traffic volume at Point 2: Yadanar Road Intersection are shown in Table 2-6. The total traffic volume of morning and evening six traffic peak hours at Point 2: Yadanar Road Intersection was 17,551 vehicles. The dominant type of vehicle group is classification 3, light vehicle car and taxi group and it is also nearly half of total number of all types of vehicles.

Table 2-6 Summary of Survey Results of Traffic Volume at Point 2: Yadanar Road Intersection

Road Cross Section of Point 2: Yadanar Road Intersection	Unit: Vehicle										
	1	2	3	4	5	6	7	8	9	10	11
	Bicycle	Motorcycle	Car & Taxi	Van, Pick-up & 4WD	Passenger Truck / Small Bus	Large Bus	Small Truck	Truck (2 axes)	Truck (3 axes)	Truck (more than 4 axes)	Other
Traffic Direction from Thanlyin Bridge											
Average of peak hours for 6 hours	14	32	335	67	140	14	24	24	9	2	1
Max of peak hours for 6 hours	25	55	391	88	176	20	42	43	16	6	4
Total of peak hours for 6 hours	85	191	2,012	400	839	85	143	143	56	11	4
Total vehicle of peak hours for 6 hours	3,969										
Traffic Direction from Yuzana Garden City											
Average of peak hours for 6 hours	51	52	353	52	56	22	72	28	12	15	1
Max of peak hours for 6 hours	109	62	464	64	80	34	100	38	17	29	4
Total of peak hours for 6 hours	307	310	2,116	311	337	129	434	166	70	90	8
Total vehicle of peak hours for 6 hours	4,278										
Traffic Direction from Thaketa Roundabout											
Average of peak hours for 6 hours	35	49	494	78	185	40	20	21	16	9	0
Max of peak hours for 6 hours	40	70	594	93	210	50	34	31	26	23	1
Total of peak hours for 6 hours	212	294	2,963	465	1,112	242	117	123	94	56	2
Total vehicle of peak hours for 6 hours	5,680										
Traffic Direction from Shukhinthar											
Average of peak hours for 6 hours	74	54	255	62	41	3	57	14	10	23	11
Max of peak hours for 6 hours	106	82	311	110	50	5	81	23	22	43	24
Total of peak hours for 6 hours	445	326	1,530	371	248	19	342	81	59	137	66
Total vehicle of peak hours for 6 hours	3,624										
Overall total vehicle of all direction for 6 hours	17,551										

Source: JICA Study Team

(2) Traffic Demand Forecast

i) Traffic Demand of Route

In the period 2012–2014, the JICA-funded YUTRA (Project for Comprehensive Urban Transport Plan of the Greater Yangon), conducted a person trip survey in Yangon metropolitan area. Based on the result of this survey, YUTRA developed a demand forecast model explaining the travel behavior of persons in the study area. The demand forecast model was the conventional four-step demand forecast process. For this

study, the demand forecast model and input data were calibrated and updated using the latest traffic count data collected by the traffic count data above.

Two network cases, “Do Nothing + Bago Bridge Case” and “YUTRA Master Plan Case”, were prepared. The road and rail network in the future years of Do Nothing + Bago Bridge Case will not change from current network. On the other hand, YUTRA Master Plan Case that included the new road and rail projects which were proposed in YUTRA master plan. Bago Bridge is included in both cases.

The estimated traffic demand at Shulhinthar Road intersection and Yadanar Road intersection by direction were shown in the following tables (Table 2-7 to Table 2-10). In Do Nothing + Bago Bridge Case, the traffic demand in 2035 will be 2 to 3 times compared to current volume. However, the traffic demand of Master Plan Case is smaller than that of Do Nothing + Bago Bridge Case because alternative routes will be provided in the future.

Table 2-7 Daily Traffic Demand at Shulhinthar Road intersection (Do Nothing + Bago Bridge Case)

Unit: PCU/day

Direction Code	2016	2017	2018	2019	2020	2021	2022	2023	2024	2025
3	740	870	1,000	1,130	1,260	1,480	1,700	1,920	2,140	2,350
4	9,380	10,620	11,860	13,100	14,340	14,840	15,340	15,840	16,340	16,840
5	8,480	9,860	11,250	12,640	14,020	15,030	16,040	17,050	18,060	19,070
6	1,050	1,210	1,360	1,510	1,660	1,900	2,140	2,370	2,610	2,850
7	4,370	4,590	4,800	5,020	5,230	5,700	6,160	6,620	7,090	7,550
8	100	310	520	730	940	800	660	520	380	240
9	110	570	1,040	1,500	1,960	1,740	1,520	1,300	1,080	860
10	8,820	8,750	8,690	8,630	8,560	9,600	10,640	11,680	12,720	13,770
11	1,270	1,290	1,320	1,340	1,370	1,440	1,520	1,590	1,670	1,740
12	1,570	2,250	2,920	3,600	4,280	4,050	3,830	3,610	3,390	3,170
13	6,350	7,070	7,780	8,500	9,220	9,990	10,760	11,530	12,310	13,080
14	8,350	8,840	9,330	9,820	10,320	11,090	11,860	12,640	13,410	14,190
Direction Code	2026	2027	2028	2029	2030	2031	2032	2033	2034	2035
3	2,310	2,260	2,220	2,170	2,130	2,180	2,240	2,290	2,340	2,400
4	17,870	18,890	19,920	20,950	21,980	23,450	24,920	26,400	27,870	29,350
5	19,870	20,660	21,460	22,260	23,060	23,380	23,710	24,040	24,360	24,690
6	2,820	2,790	2,760	2,730	2,700	2,700	2,700	2,690	2,690	2,690
7	7,760	7,980	8,190	8,410	8,620	8,540	8,460	8,380	8,300	8,220
8	240	240	240	240	240	330	420	520	610	700
9	910	960	1,000	1,050	1,100	1,220	1,340	1,460	1,580	1,700
10	14,560	15,350	16,140	16,920	17,710	19,070	20,420	21,770	23,120	24,480
11	1,790	1,840	1,890	1,940	2,000	2,120	2,250	2,370	2,500	2,630
12	3,270	3,370	3,470	3,570	3,680	3,800	3,930	4,050	4,180	4,300
13	13,050	13,020	12,990	12,950	12,920	13,020	13,110	13,200	13,290	13,380
14	14,900	15,620	16,340	17,060	17,780	18,110	18,450	18,780	19,120	19,450

Source: JICA Study Team

Table 2-8 Daily Traffic Demand at Yadonar Road intersection (Do Nothing + Bago Bridge Case)

Unit: PCU/day

Direction Code	2016	2017	2018	2019	2020	2021	2022	2023	2024	2025
15	180	280	370	460	560	780	1,000	1,230	1,450	1,680
16	11,060	11,970	12,880	13,790	14,690	15,190	15,680	16,170	16,660	17,150
17	570	540	500	460	420	480	530	580	630	690
18	110	180	240	310	370	430	490	550	610	670
19	8,740	9,170	9,600	10,030	10,460	11,190	11,930	12,660	13,390	14,120
20	3,550	3,930	4,320	4,710	5,100	5,750	6,410	7,060	7,720	8,370
21	3,210	3,730	4,260	4,780	5,310	5,740	6,170	6,600	7,020	7,450
22	9,560	10,050	10,530	11,010	11,490	12,290	13,090	13,890	14,680	15,480
23	3,990	4,040	4,090	4,140	4,200	3,840	3,490	3,140	2,790	2,440
24	3,190	3,180	3,180	3,180	3,170	2,940	2,700	2,470	2,230	1,990
25	6,140	6,550	6,970	7,380	7,800	8,200	8,600	9,000	9,400	9,800
26	770	710	640	580	520	540	570	600	630	660
Direction Code	2026	2027	2028	2029	2030	2031	2032	2033	2034	2035
15	1,860	2,050	2,230	2,420	2,610	3,280	3,960	4,630	5,310	5,980
16	17,740	18,320	18,910	19,490	20,080	21,060	22,040	23,020	24,000	24,980
17	690	700	710	720	730	770	800	840	880	920
18	940	1,220	1,490	1,770	2,040	2,600	3,150	3,700	4,250	4,800
19	15,100	16,080	17,050	18,030	19,010	19,550	20,090	20,630	21,170	21,710
20	8,500	8,640	8,770	8,900	9,040	9,990	10,950	11,900	12,860	13,810
21	7,390	7,330	7,270	7,210	7,150	7,400	7,640	7,890	8,130	8,380
22	16,030	16,580	17,140	17,690	18,240	19,150	20,050	20,960	21,860	22,770
23	2,450	2,470	2,480	2,500	2,510	2,410	2,310	2,210	2,110	2,010
24	2,070	2,150	2,220	2,300	2,380	2,290	2,210	2,130	2,050	1,970
25	10,340	10,880	11,430	11,970	12,510	12,860	13,200	13,540	13,890	14,230
26	700	730	770	810	850	930	1,010	1,090	1,180	1,260

Source: JICA Study Team

Table 2-9 Daily Traffic Demand at Shulhinthar Road intersection (YUTRA Master Plan Case)

Unit: PCU/day

Direction Code	2016	2017	2018	2019	2020	2021	2022	2023	2024	2025
3	740	930	1,120	1,320	1,510	2,210	2,920	3,630	4,340	5,050
4	9,380	9,320	9,260	9,200	9,140	9,960	10,770	11,590	12,410	13,220
5	8,480	9,910	11,350	12,790	14,220	12,680	11,140	9,600	8,060	6,510
6	1,050	1,160	1,270	1,370	1,480	2,010	2,540	3,070	3,610	4,140
7	4,370	4,780	5,180	5,590	5,990	5,750	5,500	5,250	5,010	4,760
8	100	100	100	100	90	310	520	740	950	1,160
9	110	110	120	120	120	350	570	800	1,020	1,250
10	8,820	8,540	8,260	7,990	7,710	8,530	9,350	10,170	10,990	11,810
11	1,270	1,200	1,130	1,060	990	920	840	770	700	620
12	1,570	1,460	1,350	1,240	1,140	1,130	1,130	1,120	1,110	1,110
13	6,350	7,310	8,270	9,220	10,180	9,660	9,150	8,630	8,110	7,590
14	8,350	9,060	9,780	10,490	11,200	9,550	7,900	6,240	4,590	2,940
Direction Code	2026	2027	2028	2029	2030	2031	2032	2033	2034	2035
3	4,830	4,610	4,400	4,180	3,960	3,930	3,900	3,870	3,840	3,810
4	12,860	12,490	12,120	11,760	11,390	11,620	11,860	12,090	12,320	12,560
5	6,600	6,680	6,760	6,840	6,930	7,550	8,170	8,780	9,400	10,020
6	4,090	4,030	3,970	3,920	3,860	3,840	3,820	3,800	3,790	3,770
7	5,070	5,370	5,680	5,990	6,290	6,530	6,770	7,010	7,250	7,480
8	1,220	1,280	1,340	1,400	1,460	1,510	1,560	1,610	1,660	1,710
9	1,150	1,060	960	870	770	770	770	770	760	760
10	11,460	11,110	10,750	10,400	10,050	10,170	10,300	10,420	10,550	10,670
11	670	710	750	800	840	870	900	920	950	980
12	1,120	1,140	1,160	1,170	1,190	1,220	1,260	1,300	1,340	1,370
13	8,090	8,580	9,080	9,570	10,070	10,470	10,870	11,280	11,680	12,080
14	3,230	3,530	3,820	4,120	4,410	4,780	5,150	5,510	5,880	6,250

Source: JICA Study Team

Table 2-10 Daily Traffic Demand at Yadanar Road intersection (YUTRA Master Plan Case)

Unit: PCU/day

Direction Code	2016	2017	2018	2019	2020	2021	2022	2023	2024	2025
15	180	280	380	470	570	620	670	720	770	820
16	11,060	10,390	9,730	9,060	8,390	9,190	9,980	10,780	11,570	12,370
17	570	510	450	380	320	500	680	860	1,050	1,230
18	110	150	200	240	280	400	510	630	750	860
19	8,740	9,710	10,690	11,660	12,630	13,090	13,540	13,990	14,440	14,900
20	3,550	4,300	5,050	5,800	6,550	6,030	5,510	4,990	4,470	3,950
21	3,210	3,650	4,090	4,530	4,970	4,700	4,430	4,160	3,900	3,630
22	9,560	9,320	9,070	8,820	8,570	9,220	9,870	10,520	11,170	11,820
23	3,990	4,160	4,320	4,490	4,650	4,360	4,070	3,780	3,490	3,200
24	3,190	3,190	3,200	3,200	3,210	3,180	3,160	3,140	3,110	3,090
25	6,140	6,880	7,620	8,360	9,100	9,580	10,060	10,540	11,020	11,500
26	770	740	720	700	670	790	910	1,030	1,160	1,280
Direction Code	2026	2027	2028	2029	2030	2031	2032	2033	2034	2035
15	730	640	560	470	380	390	400	400	410	420
16	12,400	12,430	12,460	12,490	12,520	12,730	12,930	13,140	13,350	13,560
17	1,110	980	860	740	620	630	650	670	680	700
18	730	600	470	340	200	210	220	230	230	240
19	15,310	15,730	16,140	16,560	16,980	17,430	17,880	18,330	18,790	19,240
20	4,220	4,490	4,760	5,040	5,310	5,380	5,460	5,530	5,600	5,680
21	3,810	3,990	4,170	4,350	4,530	4,530	4,520	4,510	4,510	4,500
22	11,560	11,310	11,050	10,800	10,540	10,660	10,780	10,890	11,010	11,130
23	3,540	3,870	4,210	4,550	4,890	4,830	4,760	4,700	4,640	4,570
24	3,320	3,550	3,770	4,000	4,230	4,240	4,250	4,260	4,270	4,280
25	11,640	11,780	11,920	12,060	12,200	12,520	12,840	13,160	13,480	13,800
26	1,200	1,110	1,030	950	870	900	920	950	970	1,000

Source: JICA Study Team

The direction codes in the tables above are shown in Figure 2-9 below.

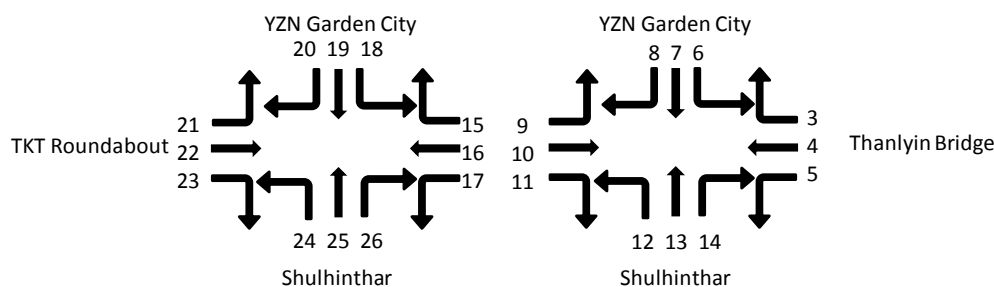

Source: JICA Study Team

Figure 2-9 Direction Code

ii) Intersection Analysis

An intersection analysis for Shukhinthar Intersection was conducted based on the results of the traffic demand forecast mentioned above.

The purpose of the intersection analysis is for obtaining of the capacity of the intersection after opening of the Bago River Bridge.

The conditions of the intersection analysis are shown in Table 2-11 below.

Table 2-11 Conditions of Intersection Analysis

Item	Condition
Target Intersection	Shukhinthar Intersection
Target Year	2025
Case of Traffic Volume	Do Nothing + Bago Bridge Case
Traffic Volume each Direction	Shown in Figure 2-11
Unit of Traffic Volume	pcu/hr (at peak hour)
Assumptive Cycle Time of Signal	100 sec
Signal Phase	4 phases
Software of Analysis	APS-λ win (MTC Co., Ltd.)

Source: JICA Study Team

According to the traffic demand of YUTRA Master Plan Case, the peak of the traffic capacity of this intersection is 2025. Therefore, the target year of the intersection analysis was set 2025.

Considering the traffic congestion, Do Nothing + Bago Bridge Case was adopted as case of traffic volume because the traffic congestion becomes serious in this case.

Therefore, JICA Study Team used the traffic demand of Do Nothing + Bago Bridge Case in 2025.

In the intersection analysis, the unit of traffic volume is pcu/hr at peak hour.

The peak ratio is 6.8% of the traffic volume per day.

After opening of Bago River Bridge, Thanlyin Bridge is used as BRT lane according to YUTRA (shown in Figure 2-10 below). Therefore, the traffic flow of Thanlyin Bridge is not considered in the traffic analysis of improved intersection.



Source: Project for Comprehensive Urban Transport Plan of the Greater Yangon (YUTRA)

Figure 2-10 Proposed BRT routes (Master Plan)

The traffic volume of peak hour at Shukhinthar intersection in 2025 is shown in Figure 2-11 below.

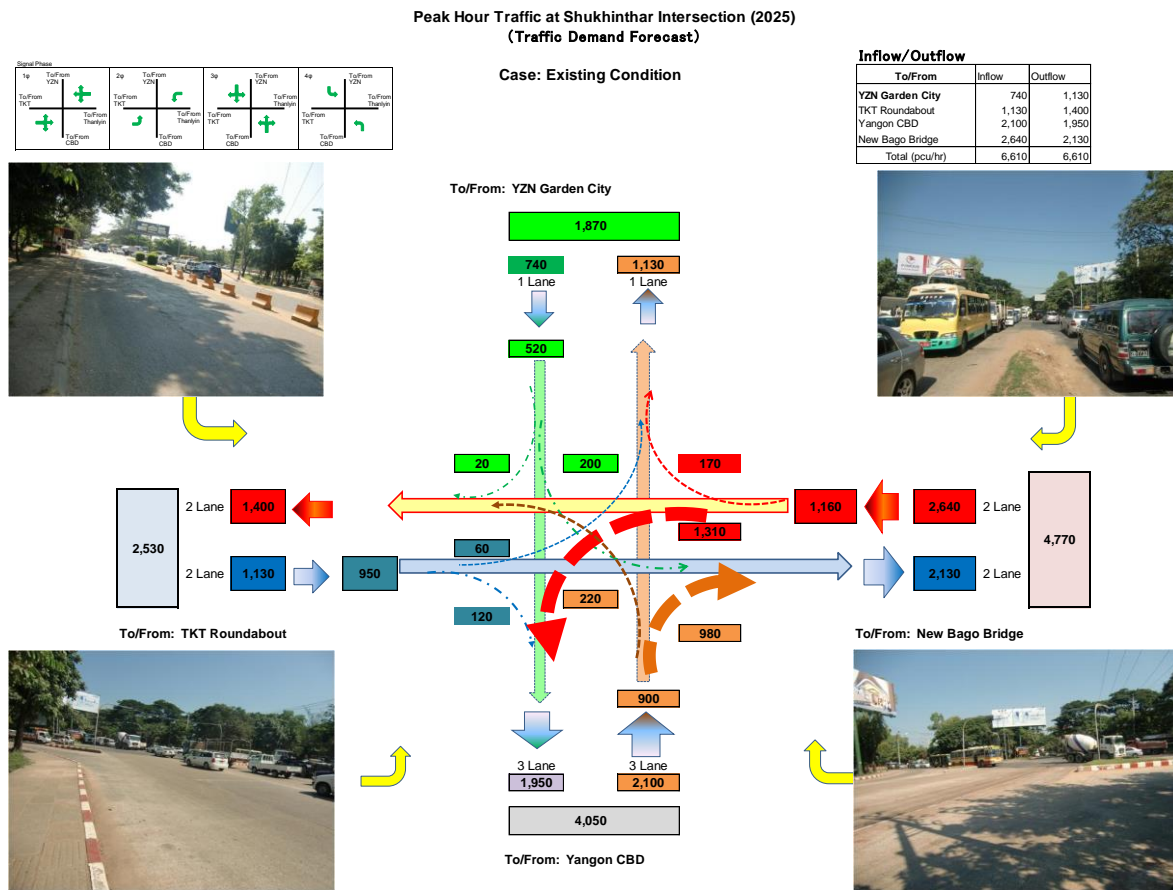

Source: JICA Study Team

Figure 2-11 Traffic volume of Shukhinthar intersection in 2025

The cycle time of signal of 100 sec was assumed in accordance with the existing signal condition.

The signal phases are 4 phases in accordance with existing signal condition as shown in Figure 2-12 below.

The software “APS-λ win, MTC Co., Ltd.” was used for the analysis.

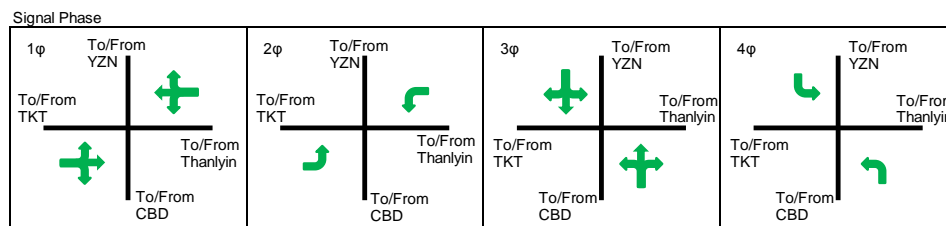

Source: JICA Study Team

Figure 2-12 Signal Phases at Shukhinthar Intersection

The results of intersection analysis in 2025 are shown in Table 2-12 below.

Table 2-12 Results of Intersection Analysis in 2025

Entry	Thanlyin to TKT		YZN to CBD		TKT to Thanlyin		CBD to YZN		
	LT	TH+RT	LT	TH+RT	LT	TH+RT	LT	TH	RT
Direction									
Number of Lane: a	1	1	1	1	1	1	1	1	1
Basic value of saturation flow rate (PCU/hr): b	1,800	2,000	1,800	2,000	1,800	2,000	1,800	2,000	1,800
Reduction coefficient: c (Lane width: m)	1.000 (3.25)	1.000 (3.25)	1.000 (3.25)	1.000 (3.25)	1.000 (3.25)	1.000 (3.25)	1.000 (3.25)	1.000 (3.25)	1.000 (3.25)
Reduction coefficient: d (Gradient: %)	1.000 (0.30)	1.000 (0.30)	1.000 (0.30)	1.000 (0.30)	1.000 (0.30)	1.000 (0.30)	1.000 (0.30)	1.000 (0.30)	1.000 (0.30)
Reduction coefficient: e (Share of large vehicle: %)	1.000 (0.00)	1.000 (0.00)	1.000 (0.00)	1.000 (0.00)	1.000 (0.00)	1.000 (0.00)	1.000 (0.00)	1.000 (0.00)	1.000 (0.00)
Reduction coefficient: f (Share of right turn : %)		0.986 (12.8)		0.996 (3.7)		0.988 (11.2)			
Reduction coefficient: g (Share of left turn: %) (No. of left turn for transition time (nos./cycle): h)									
Saturation flow ratio: $i=a*b*c*d*e*f*g$	1,800	1,972	1,800	1,992	1,800	1,976	1,800	2,000	1,800
Traffic volume (pcu/hr): V	1,310	1,330 (170+1160)	200	540 (20+520)	60	1,070 (120+950)	220	900	980
Traffic volume with compensation of left turn (pcu/hr): $V'=V-h$	1,238		128		0		148		
Flow ratio: $j=V/i$ or $j=V'/i$	0.688	0.674	0.071	0.271	0.000	0.541	0.082	0.450	0.544
Current cycle length (sec): k	100								
Phase ratio	1φ	0.674				0.541			
	2φ	0.688			0.000				
	3φ			0.271				0.450	0.544
	4φ		0.071				0.082		
Demand ratio of intersection *	1.988								
Current green time (sec): l	1φ	30				30			
	2φ	29			29				
	3φ			24				24	24
	4φ		5				5		
Capacity (pcu/hr): $C=i*l/k$ or $C=i*l/k+h*3600/k$	594	592	162	478	594	593	162	480	432
Degree of Saturation: V/C **	2.205	2.247	1.235	1.130	0.101	1.804	1.358	1.875	2.269
Check	NG	NG	NG	NG	OK	NG	NG	NG	NG

TH: Through LT: Left turn RT: Right turn

Note(*): Evaluation of Demand Ratio of Intersection: Over 0.9 means that improvement of intersection is necessary.

Note(**): Evaluation of Degree of Saturation: Over 1.0 means that improvement of intersection is necessary.

Source: JICA Study Team

According to the results of the intersection analysis, the demand ratio of intersection (congestion rate) is 2.0.

If the congestion rate is more than 0.9, the intersection is congested.

Therefore, intersection improvement is necessary for mitigation of congestion.

2.2.3 Intersection Improvement

(1) Alternative Study

Since intersection improvement is required for mitigation of congestion in accordance with the results of the intersection analysis, an alternative study for intersection improvement was conducted.

The cases of comparison were set as follows.

- Alt-0: Improvement of at-grade intersection
- Alt-1: Flyover for left-turn from Bridge
- Alt-2: Flyover for straight direction
- Alt-3: Flyover for left-turn and straight direction

1) Alt-0: Improvement of at-grade intersection

The brief overview of Alt-0 is shown in Figure 2-13 below.

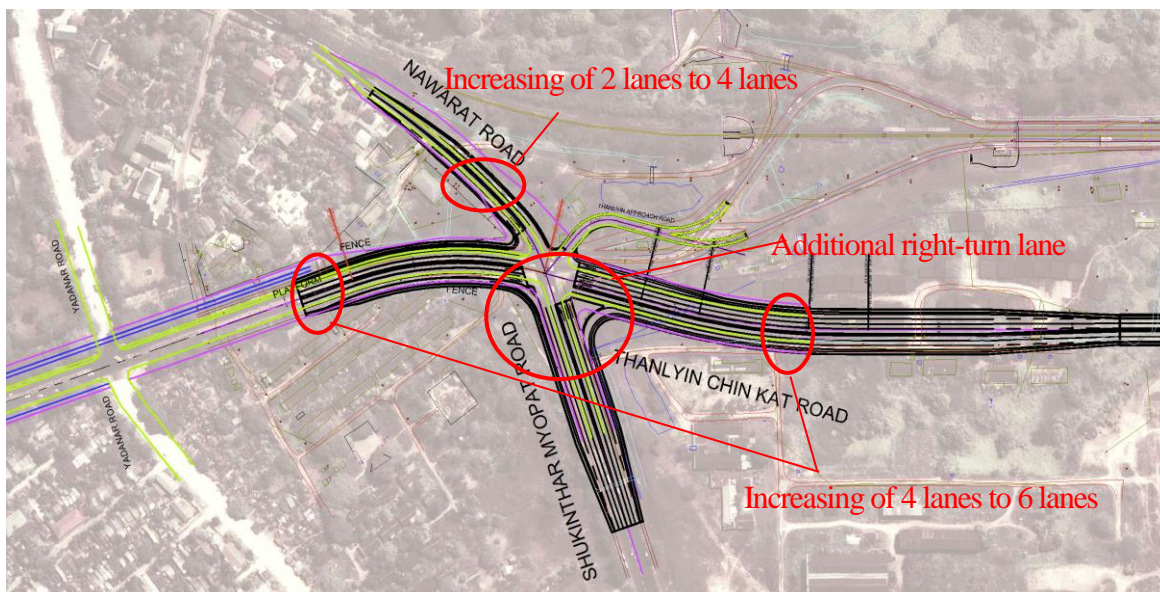

Source: JICA Study Team

Figure 2-13 Brief Overview of Alternate-0

Features of Alt-0:

- Increasing the number of lanes from 4 lanes to 6 lanes and additional right-turn lane at Shukhinthar Road and Thanlyin Chin Kat Road.
- Increasing the number of lanes from 2 lanes to 4 lanes at Nawarat Road.

As a result of intersection analysis, the traffic capacity of the Shukhinthar Intersection will increase and then the congestion rate will improve from 2.0 to 1.0. This indicates that this improvement is not enough for the future traffic demand.

Table 2-13 Summary of Traffic Capacity of Shukhinthar Intersection in 2025 (Alt-0)

Entry	Thanlyin to TKT			YZN to CBD		TKT to Thanlyin		CBD to YZN	
	LT	TH	RT	LT	TH+RT	LT	TH	LT	TH
Direction									
Number of Lane: a	2	2	1	1	1	1	2	1	2
Traffic volume (pcu/hr): V	1,310	1,160	170	200	540 (20+520)	60	950	220	900
Current cycle length (sec): k	100								
Demand ratio of intersection *	0.987								

TH: Through LT: Left turn RT: Right turn

Note(*): Evaluation of Demand Ratio of Intersection: Over 0.9 means that improvement of intersection is necessary.

Source: JICA Study Team

Because the congestion rate of Yadanar Intersection is 1.4, more mitigation will be needed.

Table 2-14 Summary of Traffic Capacity of Yadanar Intersection in 2025 (Alt-0)

Entry	Thanlyin to TKT			YZN to CBD		TKT to Thanlyin			CBD to YZN	
	LT	TH	TH+RT	LT	TH+RT	LT	TH	TH+RT	LT	TH+RT
Direction										
Number of Lane: a	1	1	1	1	1	1	1	1	1	1
Traffic volume (pcu/hr): V	50	1,300 (120+1180)		50	1,550 (580+970)	520	1,240 (170+1070)		140	730 (50+680)
Current cycle length (sec): k	100									
Demand ratio of intersection *	1.422									

TH: Through LT: Left turn RT: Right turn

Note(*): Evaluation of Demand Ratio of Intersection: Over 0.9 means that improvement of intersection is necessary.

Source: JICA Study Team

The result of the intersection analysis is shown in Appendix C.

2) Alt-1: Flyover for left-turn from Bridge

The brief overview of Alt-1 is shown in Figure 2-14 below.

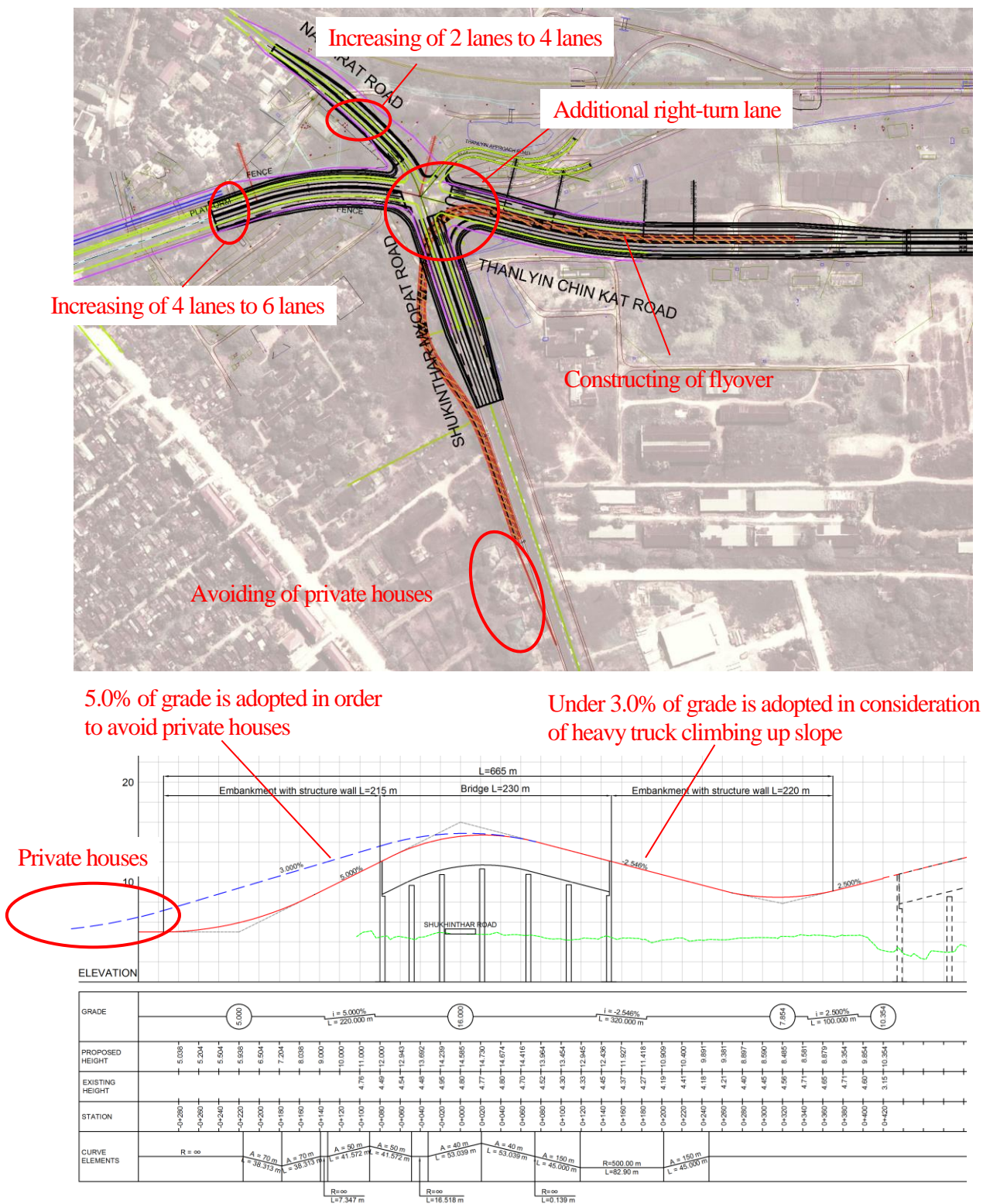

Source: JICA Study Team

Figure 2-14 Brief Overview of Alternate-1

Features of Alt-1:

- At-grade improvement of the intersection and construction of flyover for left-turn from bridge.
- Increasing the number of lanes from 4 lanes to 6 lanes and additional right-turn lane at Shukhinthar Road and Thanlyin Chin Kat Road.
- Increasing the number of lanes from 2 lanes to 4 lanes at Nawarat Road.
- At upgrading lane, under 3.0% of grade is adopted in consideration of heavy truck climbing up.
- At down grade lane, 5.0% of grade is adopted in order to avoid private houses.

As a result of intersection analysis, the traffic capacity of the Shukhinthar Intersection is increased and the congestion rate is improved from 2.0 to 0.6.

Table 2-15 Summary of Traffic Capacity of Shukhinthar Intersection in 2025 (Alt-1)

Entry Direction	Thanlyin to TKT		YZN to CBD		TKT to Thanlyin		CBD to YZN	
	TH	RT	LT	TH+RT	LT	TH	LT	TH
Number of Lane: a	2	1	1	1	1	2	1	2
Traffic volume (pcu/hr): V	1,160	170	200	540 (20+520)	60	950	220	900
Current cycle length (sec): k	100							
Demand ratio of intersection *	0.643							

TH: Through LT: Left turn RT: Right turn

Note(*): Evaluation of Demand Ratio of Intersection: Over 0.9 means that improvement of intersection is necessary.

Source: JICA Study Team

However, since the congestion rate of Yadanar Intersection is 1.4, the mitigation of congestion is necessary. (Summary of Traffic Capacity of Yadanar Intersection is same as Alt-0.)

The result of the intersection analysis is shown in Appendix C.

3) Alt-2: Flyover for straight direction

The brief overview of Alt-2 is shown in Figure 2-15 below.

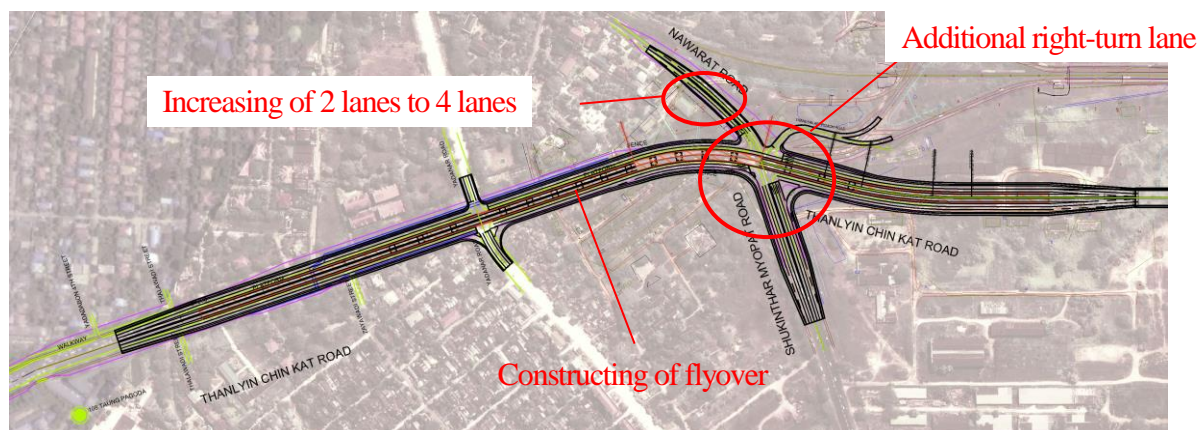

Straight flyover was planned over Shukhinthar Intersection and Yadanar Intersection for mitigation of traffic jam of both intersections.

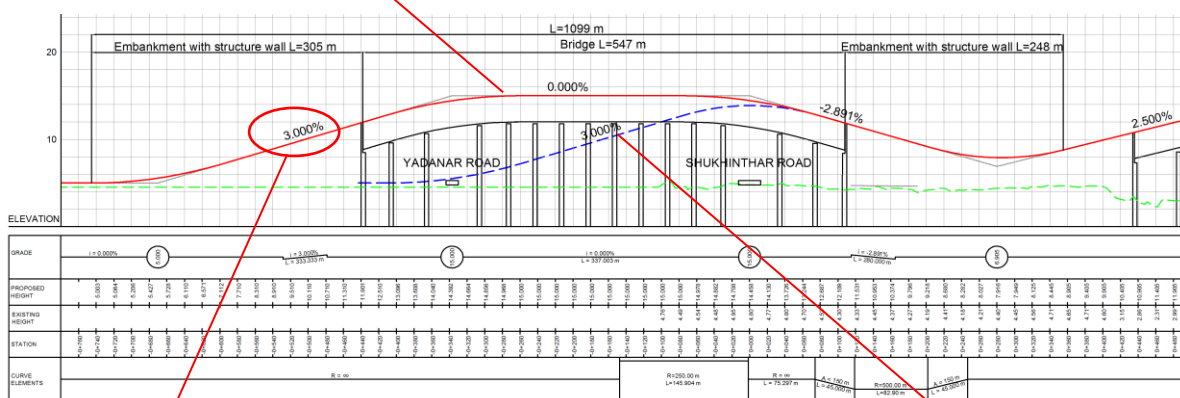

Under 3.0% of grade is adopted in consideration of heavy truck climbing up slope.

If straight flyover is planned over only Shukhinthar Intersection, end of approach section overlaps with Yadanar intersection.

Source: JICA Study Team

Figure 2-15 Brief Overview of Alternate-2

Features of Alt-2:

- At-grade improvement of the intersection and construction of flyover for straight direction from bridge.
- Increasing the number of lanes from 4 lanes to 6 lanes and additional right-turn lane at Shukhinthar Road and Thanlyin Chin Kat Road.
- Increasing the number of lanes from 2 lanes to 4 lanes at Nawarat Road.
- Straight flyover was planned over Shukhinthar Intersection and Yadanar Intersection, because of:
 - If straight flyover is planned over only Shukhinthar Intersection, end of approach section overlaps with Yadanar intersection.
 - Traffic jam of both intersections are mitigated.
- Under 3.0% of grade is adopted in consideration of heavy truck climbing up slope.

As a result of intersection analysis, the traffic capacity of the Shukhinthar Intersection is increased and the congestion rate is improved from 2.0 to 0.7.

Table 2-16 Summary of Traffic Capacity of Shukhinthar Intersection in 2025 (Alt-2)

Entry	Thanlyin to TKT		YZN to CBD		TKT to Thanlyin	CBD to YZN	
	LT	RT	LT	TH+RT		LT	TH
Direction							
Number of Lane: a	2	1	1	1	2	1	2
Traffic volume (pcu/hr): V	1,310	170	200	540 (20+520)	60	220	900
Current cycle length (sec): k	100						
Demand ratio of intersection *	0.717						

TH: Through LT: Left turn RT: Right turn

Note(*): Evaluation of Demand Ratio of Intersection: Over 0.9 means that improvement of intersection is necessary.

Source: JICA Study Team

Additionally, the congestion rate of Yadanar Intersection is improved from 1.4 to 0.8.

Table 2-17 Summary of Traffic Capacity of Yadanar Intersection in 2025 (Alt-2)

Entry	Thanlyin to TKT		YZN to CBD		TKT to Thanlyin		CBD to YZN	
	LT	TH+RT	TH+LT	TH+RT	LT	TH+RT	TH+LT	TH+RT
Direction								
Number of Lane: a	1	1	1	1	1	1	1	1
Traffic volume (pcu/hr): V	50	250 (120+130)	1,600 (50+580+970)		520	230 (170+60)	870 (140+50+680)	
Current cycle length (sec): k	100							
Demand ratio of intersection *	0.815							

TH: Through LT: Left turn RT: Right turn

Note(*): Evaluation of Demand Ratio of Intersection: Over 0.9 means that improvement of intersection is necessary.

Source: JICA Study Team

The result of the intersection analysis is shown in Appendix C.

4) Alt-3: Flyover for left-turn and straight direction

The brief overview of Alt-3 (combination of Alt-1 and Alt-2) is shown in Figure 2-16 below.



Source: JICA Study Team

Figure 2-16 Brief Overview of Alternate-3

Features of Alt-3:

- At-grade improvement of the intersection and construction of flyover for left-turn and straight direction from bridge.

- Increasing the number of lanes from 4 lanes to 6 lanes and additional right-turn lane at Shukhinthar Road and Thanlyin Chin Kat Road.
- Increasing the number of lanes from 2 lanes to 4 lanes at Nawarat Road.

As a result of intersection analysis, the traffic capacity of the Shukhinthar Intersection is increased and the congestion rate is improved from 2.0 to 0.4.

Table 2-18 Summary of Traffic Capacity of Shukhinthar Intersection in 2025 (Alt-3)

Entry	Thanlyin to TKT		YZN to CBD		TKT to Thanlyin		CBD to YZN	
	TH	RT	LT	TH+RT	LT	TH	LT	TH
Number of Lane: a	1	1	1	1	1	1	1	2
Traffic volume (pcu/hr): V	0	170	200	540 (20+520)	60	0	220	900
Current cycle length (sec): k	100							
Demand ratio of intersection *	0.447							

TH: Through LT: Left turn RT: Right turn

Note(*): Evaluation of Demand Ratio of Intersection: Over 0.9 means that improvement of intersection is necessary.

Source: JICA Study Team

Additionally, the congestion rate of Yadanar Intersection is improved from 1.6 to 0.8. (Summary of Traffic Capacity of Yadanar Intersection is same as Alt-2.)

The result of the intersection analysis is shown in Appendix C.

5) Summary of Alternative Study on Yangon Side Intersection

Table 2-19 shows the summary of alternative study on intersection improvement on Yangon Side.

The items of consideration are shown below.

- Mitigation of traffic jam at the intersection: Degree of saturation at Shukhinthar Intersection and Yadanar Intersection
- Social consideration: Additional land acquisition and number of PAPs
- Construction cost of flyover: Preliminary cost estimate
- Consistency with master plan: Plan for mitigation congestion in CBD and leading traffic flow to sub-centers





Above items are evaluated by using following marks:

- ◎ : Very Good
- : Good
- △ : Average
- × : No Good

The alternative with straight flyover (Alt-2) is most recommend in accordance with the results of the alternative study for the intersection improvement, because the effect for congestion mitigation is very good and leading major traffic to North-South direction is consistent with the Master Plan.

The summary of alternative study on Yangon Side Intersection is shown in Table 2-19 below.

Table 2-19 Summary of Alternative Study on Yangon Side Intersection

Name of Alternate	Alternate-0	Alternate-1	Alternate-2	Alternate-3
	Improvement of at-grade intersection	Flyover for left-turn from Bridge	Flyover for straight direction	Flyover for left-turn and straight direction
Image				
Contents of Improvement				
Constructing of Flyover	- None	- Flyover for left-turn from bridge	- Flyover for straight direction from/to bridge	- Flyover for left-turn from bridge and straight direction from/to bridge
Increasing of lane	- Increasing of 4 lanes to 6 lanes at approach section of Bago River Bridge and Thanlyin Chin Kat Rd - Increasing of 2 lanes to 4 lanes at Nawarat Rd - Addition of right-turn lane at approach section of Bago River Bridge, Shukhinthar Rd and Thanlyin Chin Kat Rd	- Increasing of 4 lanes to 6 lanes at Thanlyin Chin Kat Rd - Increasing of 2 lanes to 4 lanes at Nawarat Rd - Addition of right-turn lane at approach section of Bago River Bridge, Shukhinthar Rd and Thanlyin Chin Kat Rd	- Increasing of 2 lanes to 4 lanes at Nawarat Rd - Addition of right-turn lane at approach section of Bago River Bridge, Shukhinthar Rd and Thanlyin Chin Kat Rd	- Increasing of 2 lanes to 4 lanes at Nawarat Rd - Addition of right-turn lane at approach section of Bago River Bridge, Shukhinthar Rd and Thanlyin Chin Kat Rd
Mitigation of Traffic Jam				
Demand Ratio of Intersection at Shukhinthar Intersection	1.0 (≥ 0.9 ∙ ∙ NG)	0.6 (< 0.9 ∙ ∙ OK)	0.7 (< 0.9 ∙ ∙ OK)	0.4 (< 0.9 ∙ ∙ OK)
Demand Ratio of Intersection at Yadanar Intersection	1.4 (≥ 0.9 ∙ ∙ NG)	1.4 (≥ 0.9 ∙ ∙ NG)	0.8 (< 0.9 ∙ ∙ OK)	0.8 (< 0.9 ∙ ∙ OK)
Social Consideration				
Additional Land Acquisition	0.1 ha	0.5 ha	0.2 ha	0.7 ha
Number of PAPs	30	30	167	167
Construction Cost of Flyover				
Structural Features	- None	- Length of bridge: 230m - Length of embankment with structure wall: 435m - Road width: 6.5m (1 lane)	- Length of bridge: 547m - Length of embankment with structure wall: 552m - Road width: 12.5m (2 lane)	- Length of bridge: 547m (straight), 500m (left-turn) - Length of embankment with structure wall: 552m (straight), 435m (left-turn) - Road width: 12.5m (2 lane) (straight), 6.5m (1 lane) (left-turn)
Preliminary Cost Estimate	None	10 million USD	30 million USD	45 million USD
Consistency with Master Plan**	Intermediate	Leading traffic to CBD	Leading traffic to Inner Ring Road	Intermediate
Evaluation	- Mitigation of Traffic Jam: Δ - Social Consideration: Δ - Construction Cost of flyover: None - Consistency with Master Plan: Δ Un-Recommended - Effect for congestion mitigation is not good - It is desirable to implement with constructing of flyover	- Mitigation of Traffic Jam: Δ - Social Consideration: Δ - Construction Cost of flyover: ○ - Consistency with Master Plan: Δ Less Recommended - Traffic flow from Bridge is crowded at Yadanar intersection - It is not consistent with Master Plan	- Mitigation of Traffic Jam: ◎ - Social Consideration: Δ - Construction Cost of flyover: Δ - Consistency with Master Plan: ◎ Most Recommended - Effect for congestion mitigation is very good - Leading major traffic to North-South direction which is consistent to Master Plan	- Mitigation of Traffic Jam: ○ - Social Consideration: Δ - Construction Cost of flyover: × - Consistency with Master Plan: Δ Less Recommended - Construction cost is most expensive

Qualitative Evaluation: ◎ Very Good, ○ Good, Δ Average, × No Good

Note(*): Traffic capacity of flyover is based on report of YUTRA

Note(**): Plan for mitigation congestion in CBD and for leading traffic flow to sub-centers

Source: JICA Study Team

6) Confirmation of Lane Number for Flyover

The lane number of flyover was confirmed based on the traffic volume per traffic capacity.

According to YUTRA, the traffic capacity of flyover is 1,380 PCU/hr per lane.

Table 2-20 shows the results of confirmation of the traffic capacity for flyover.

Table 2-20 Traffic Capacity of Flyover in 2025

	Left-turn Flyover	Straight Flyover
Traffic Volume (PCU/hr)	1,310	1,160
Traffic Capacity per Lane (PCU/hr)	1,380 *	1,380 *
Volume / Capacity	0.95	0.84

-Note*):Traffic capacity of flyover is based on report of YUTRA

Source: JICA Study Team

With reference to Table 2-20, the traffic capacity per lane is enough for the traffic volume each flyover.

Therefore, lane number of flyover are confirmed 2 lanes.

7) Possibility of Application of Roundabout at Shukhinthar Intersection

The possibility to apply the roundabout intersection at Shukhinthar Intersection as one of the options for improvement of intersection was considered. After improvement of intersection with construction of straight flyover, the traffic volume at Shukhinthar intersection in 2025 becomes 54,700 veh/day (65,100 pcu/day).

According to the German study on designing roundabout intersection, the capacity of large 2-lane roundabout like Thaketa Roundabout (diameter is 80 m) is approximately 40,000 veh/day. This indicates that the capacity of roundabout intersection is not enough for the future traffic demand.

It can be concluded that the improvement method for Shukhinthar Intersection with roundabout is not appropriate.

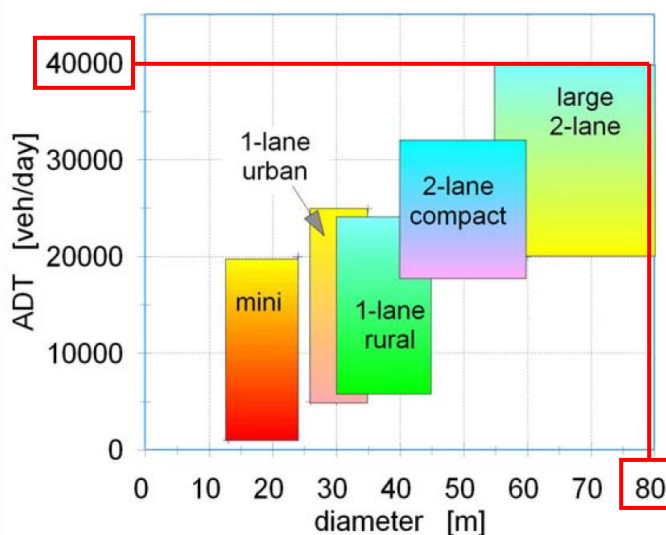

Source: Werner Brilon: Studies on Roundabouts in Germany: Lessons Learned 3rd International TRB, May 2011

Figure 2-17 Capacity of Roundabout Intersection

(2) Preliminary Design

i) Preliminary Design of Road and Intersection

The preliminary design for intersection improvement with recommended plan was conducted.

a) Preliminary Road Design

The conditions for preliminary road design for the flyover section are shown in Table 2-21 below.

Table 2-21 Conditions for Preliminary Road Design for Flyover Section

Item	AASHTO	Recommendation for this study	Remarks
Road Classification	Urban Arterials	Urban Arterials	
Design Speed (km/hr)	60	60	
Width of Lane (m)	2.7 ~ 3.6	3.5	To be made consistent with condition of F/S Bago Bridge
Width of Right Shoulder (m)	0.3 ~ 3.6	1.5	To be made consistent with condition of F/S Bago Bridge
Width of Median (m)	1.2 ~ 24.0	1.6	To be made consistent with condition of F/S Bago Bridge
Vertical Clearance	4.5	5.0	
Minimum Horizontal Curve Radius (m)	123	250	
Minimum Radius not introducing a Spiral Curve (m)	213	250	
Cross slope	2.0%	2.0%	
Maximum Vertical Grades	7.0%	3.0%	
Change Ratio of Longitudinal Curve (K Value of Crest/Sag)	11 / 18	50 / 28	

Source: JICA Study Team

The major controls of alignment and profile are shown below:

- Horizontal alignment of Straight Flyover was allocated consistent with the existing horizontal alignment of Thanlyin Chin Kat Rd.
- Maximum grade 3.0% was adopted in consideration of heavy trucks.
- Straight flyover was planned to pass both Shukhinthar Intersection and Yadanar Intersection continuously, because the distance between two intersections are too short to arrange the longitudinal gradient.

The plan and profile are shown in Figure 2-18 below.

The cross section design referred to the AASHTO as shown in Table 2-21.

- The width of lane was adopted 3.5 m. It is made consistent with condition of F/S of Bago Bridge.
- The width of median was adopted 1.6 m. It is made consistent with condition of F/S of Bago Bridge.
- The width of right shoulder was adopted 1.5 m so that large vehicles can pass a troubled vehicle as shown in Figure 2-19.

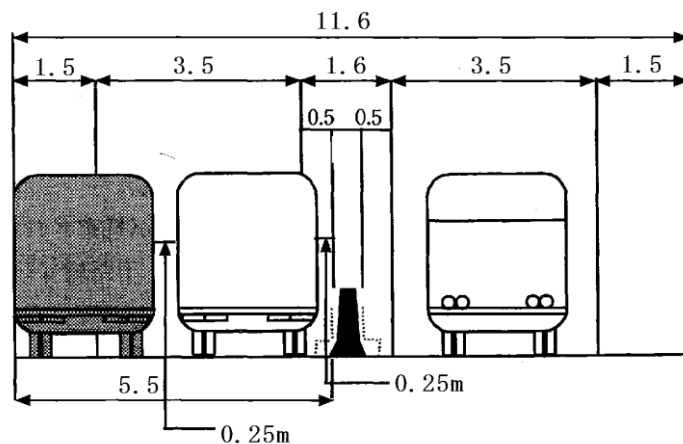

Source: JICA Study Team (Refer to Japanese Road Design Standards)
 Note: Since this figure follows traffic regulation of Japan, vehicle keeps to the left.
 In Myanmar, vehicle keeps to the right.

Figure 2-19 Carriageways and shoulders

The typical cross section is shown in Figure 2-20 below.

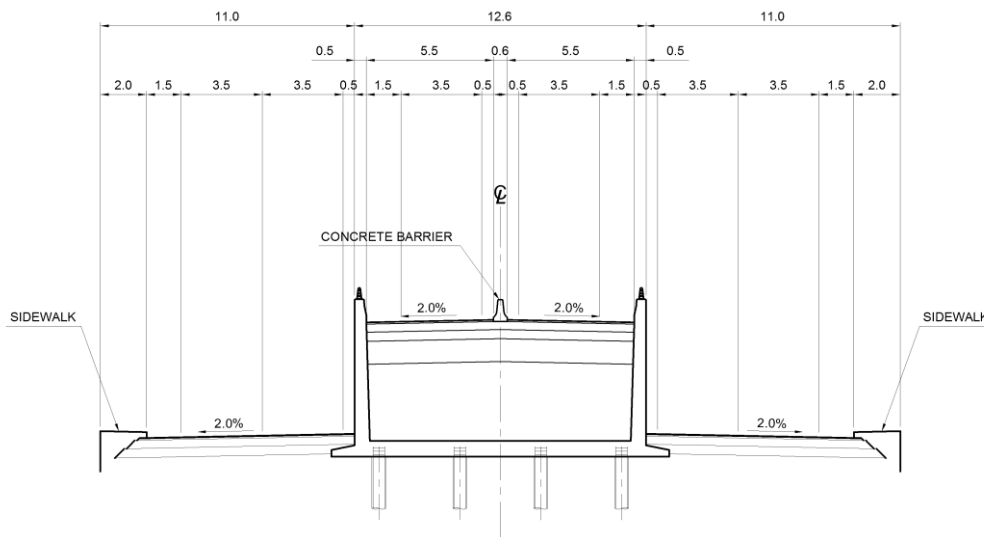

Source: JICA Study Team

Figure 2-20 Typical Cross Section of Approach Section

b) Preliminary Design of Intersection

The design of the intersection was conducted considering these points below;

- Safety of left-turn traffic: Due to sharp curve for left-turn from the bridge, lane markings with appropriate curve at the intersection will be provided.
- Combination with improvement of at-grade intersection: 2 lanes for left-turn from the bridge with effective signal controls will be provided.
- Improvement for safety flow of traffic: Additional right-turn lane for Shukhinthar Road and Thanlyin Thin Kat Road will be provided. Also median strip (W=1.6 m) at Shukhinthar Road and Nawarat Pat Road will be installed for safety flow of traffic.

The Plan of Shukhinthar Intersection is shown in Figure 2-21 below.

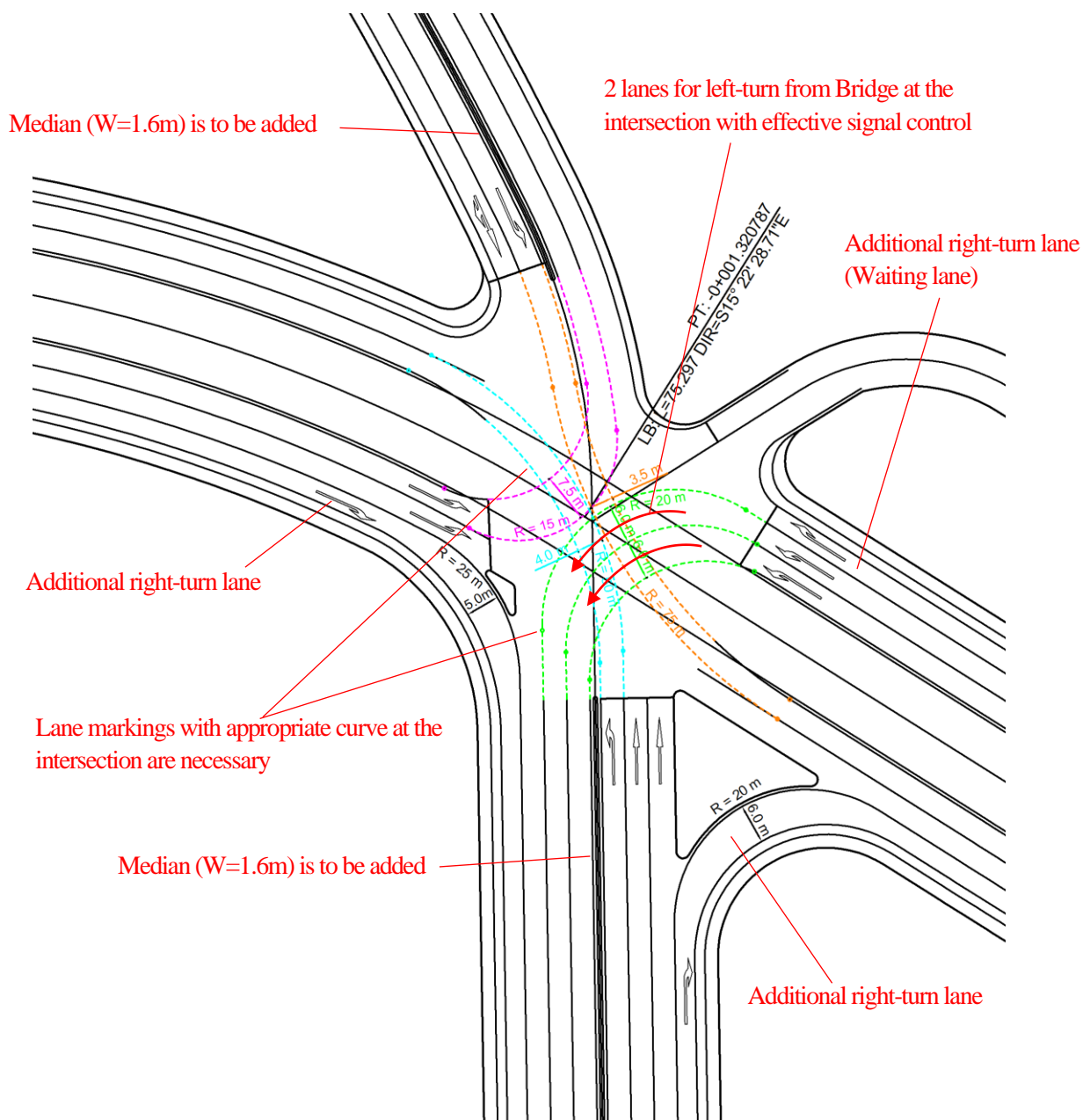

Source: JICA Study Team

Figure 2-21 Plan of Shukhinthar Intersection

c) Considerations for Road Design on Yangon Side

The following points should be considered in the detailed design stage.

- YCDC has a plan for widening of Thanlyin Chin Kat Rd to 6 lanes. Since Straight Flyover is along to the road, the construction plan needs to be in accordance with the plans of road widening.
- Since alignment and profile were arranged based on the information of preliminary survey and satellite map in this study, revision of the alignment and profile are necessary based on detailed survey in the next stage.
- Since Thanlyin Chin Kat Road is planned as a BRT route in YUTRA, the improvement plan of the road need to be in accordance with BRT plan.

ii) Preliminary Design of Flyover

a) Structural Guidelines

For preliminary design of the flyover bridge, AASHTO is applied as a standard design code as applied in preliminary design of Main Bridge.

b) Selection of Structure Types

b-1) General

1) Concept for Selection of Structure Types

For selecting the appropriate structure types, a comparative study is conducted by itemizing the evaluation aspects including:

- Construction cost;
- Workability and simplicity in quality control
- Structural stability
- Construction period
- Maintenance
- Environmental impact.

The concept for selecting structure types is determined according to the following procedures:

- To review the existing viaducts and examine their advantages and disadvantages.
- To propose the criteria for screening the structure types for each evaluation item.
- To nominate a couple of alternatives appropriate to the conditions.
- To compare these alternatives with regard to each evaluation item.
- To integrate the results of evaluation for each item and obtain comprehensive evaluation.

2) Criteria of Selection

For selecting the most appropriate alternative in structure types, the evaluation criteria with scoring as shown in Table 2-22 is applied.

Table 2-22 Scoring for Evaluation of Alternatives

Evaluation Item	Maximum Points	Very Good 100%	Good 80%	Fair 60%	Bad 40%	Very Bad 0%
Construction Cost	30	30	24	18	12	0
Workability and Quality Control	20	10	16	12	8	0
Structural Stability	10	10	8	6	4	0
Construction Period	20	20	16	12	8	0
Maintenance /Environmental Consideration	20	20	16	12	8	0

Source: JICA Study Team

b-2) Selection of Structure Types

1) General

The route of the elevated Access Spur Road can be divided into following three sections:

- Standard Sections of Viaducts
- Flyover Section of Viaducts (Intersection Portions)
- Approach Section of Flyover.

Comparative studies for selecting structure type were conducted for the above-mentioned sections of the route.

In addition, a comparative study for selecting foundation was also performed.

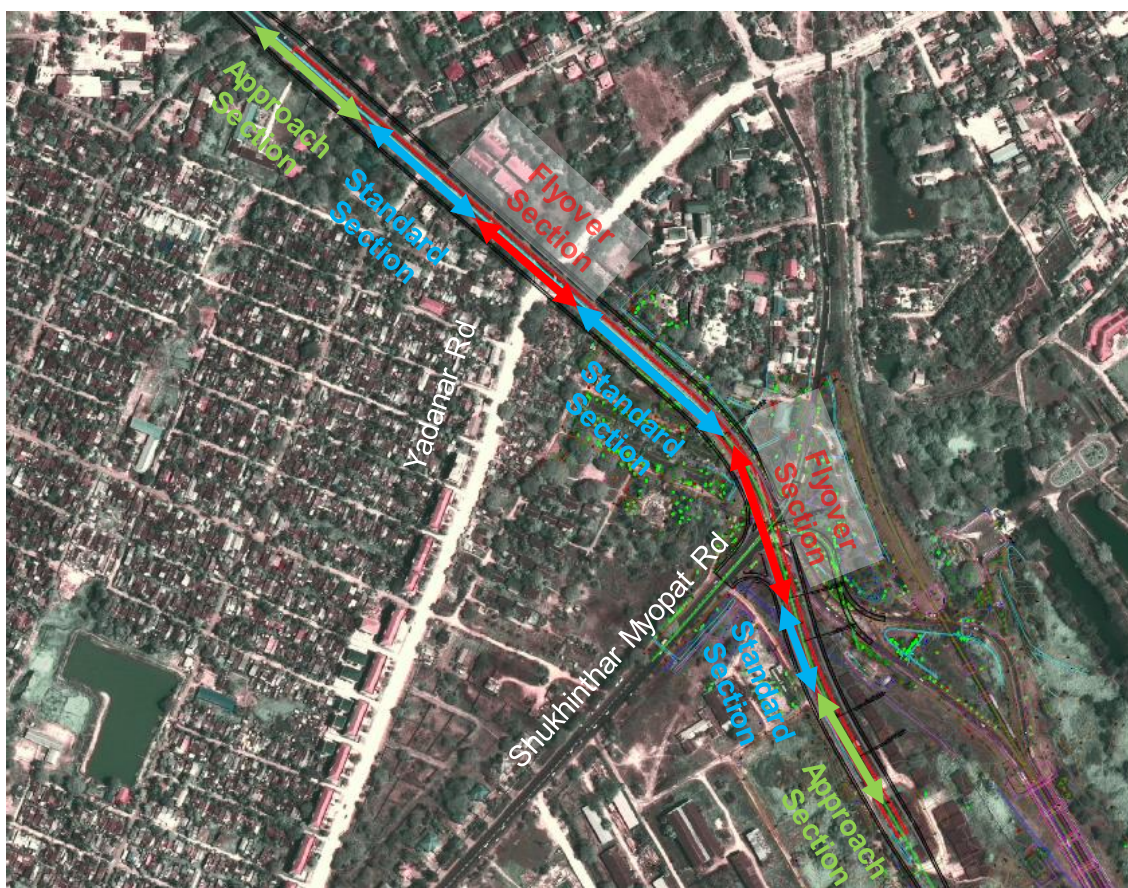

Source: JICA Study Team

Figure 2-22 Route Alignment of Straight Flyover

2) Comparative Study of Straight Viaducts

A comparative study of viaducts in the straight sections was conducted among the structure types of steel I girder, PC-T girder and PC Hollow slab.

The result of the comparative study is shown in Table 2-23. As shown in this table, PC-T girder is the most recommended among the alternatives because it is superior in construction cost, construction period and aesthetics.

3) Comparative Study of Curved Viaducts

A comparative study of viaducts in the curve section was conducted among structure types of PC Box girder, Steel-I girder and Steel box girder, which are appropriate to be applied to a longer section with a span of around 60 m.

The result of the comparative study is shown in Table 2-24. As shown in this table, Steel I girder is the most recommended among the alternatives because it is superior in applicability to the corresponding span length ($L=60$ m), construction cost and aesthetic aspect.

4) Comparative Study of Foundation

Considering the subsoil conditions of the site that is a 5m-thick top layer is clay with SPT N-value of 0-5 lying on a 10m-thick clay layer with SPT N-value of 5 a 30m-thick firm clay layer with SPT N-value of

20-30 and a bearing layer with SPT N-value of 50, foundation types of Pre-fabricated PC Pile, Cast-in-place RC Pile and Steel Pipe Pile are nominated as alternatives in this comparative study.

The result of the comparative study is shown in Table 2-25. As shown in this table, Cast-in-place RC Pile is the most recommended among the alternatives because it is superior in workability and environmental consideration.

5) Approach Section of Flyover

The structure type of the approach section of flyover is selected as the same as the structure of the approach section of Main Bridge as shown in Figure 2-23 below.

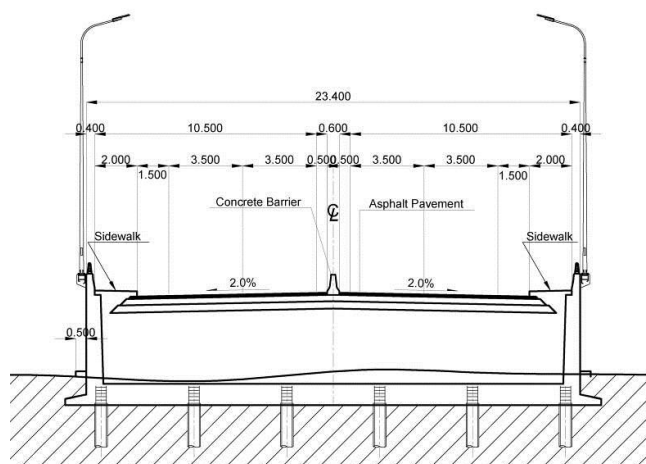

Source: JICA Study Team

Figure 2-23 Typical Cross Section of Approach Section (Preparatory Survey)

Table 2-23 Comparative Study on Viaducts in Standard Section

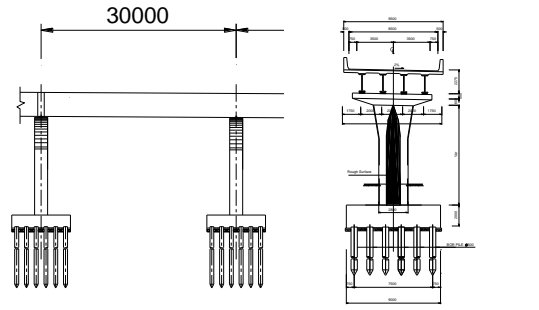
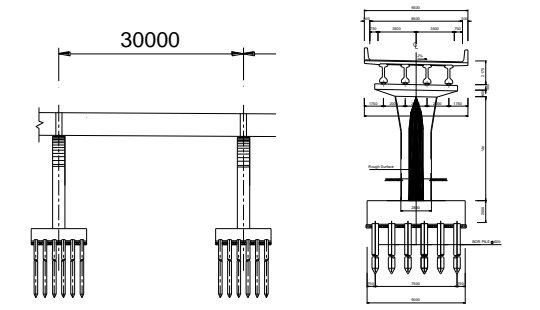
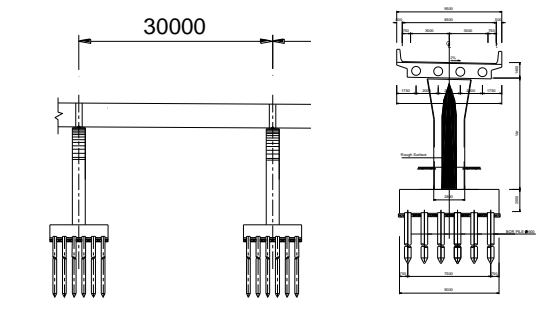
Evaluation Item	Max. Rate	Alternative 1 Steel-I Girder + RC T Type Pier	Alternative 2 PC-T Girder + RC T-Type Pier	Alternative 3 PC Hollow Slab + RC T Type Pier
Schematic View				
Erection Method		Crane Erection Method	Crane Erection Method	All-staging Method (Cast-in-place)
Construction Cost	30	Ratio=1.5 (USD 3,000./m ²) 12	Ratio=1.0 (USD 2,000 /m ²) 30	Ratio=1.2 (USD 2,500 /m ²) 18
Workability and Quality Control	20	- The procedures of field works can be simplified and the quantities of field works can be reduced by applying pre-fabrication. - The quality of girders can be assured by using pre-fabrication in a factory. 16	- The procedures of field works can be simplified and the quantities of field works can be reduced by applying pre-fabricated pre-assembled girders. - The quality of girders can be assured by using pre-fabrication in a factory. 16	- Hence the shape of formwork is simple, formwork setting is easy. - Quality control for in-situ concrete casting tends to be difficult for the place where PC sheaths are concentrated. 12
Structural Aspect and Stability	10	- Applicable span length is 30-65m. - Steel girders are lightweight, which leads small seismic loading on piers. - The girders are more stable during erection than Alternative 2. 8	- Applicable span length is 20-40m. - Superstructure is heavier than that of Alternative 1 but lighter than Alternative 3. - Section can be trimmed down by applying high strength concrete. 8	- Applicable span length is 20-35m. - The weight of superstructure is heaviest among the alternatives, which leads large seismic loading on piers. 8
Construction Period (L=300m)	20	- Construction period can be shortened by applying pre-fabricated/pre-assembled girders. - Construction Period: approx. 5 months 20	- Construction period can be shortened by applying pre-fabricated/pre-assembled girders. - Construction Period: approx. 7 months (L=300m) 20	- Cast-in-place takes time for scaffolding and formwork setting, rebar works and concrete curing. - Construction Period: approx. 10 months 12
Maintenance	20	- Periodical painting on the girders is necessary in addition to inspection on the surface. - The number of incidental facilities to be replaced such as bearings and expansion joints are large.. 8	- Only minimum maintenance for the girders such as inspection on concrete surface is required. - The pieces to be exchanged are more than Alternative 3. 16	- Only minimum maintenance for the girders such as inspection on concrete surface is required. - This alternative has the least consumable parts such as bearings and expansion to be exchanged. 20
Evaluation	100	This alternative is inferior in construction cost. 63	Most Recommended 90	This alternative is inferior in construction cost and period. 70

Source: JICA Study Team

Table 2-24 Comparative Study on Viaducts in Flyover Section

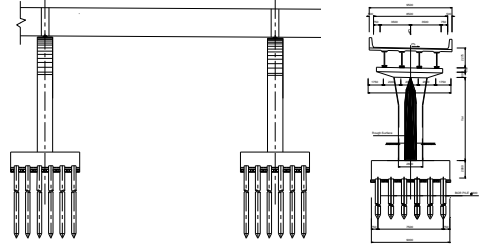
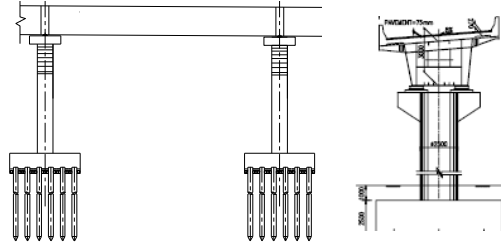
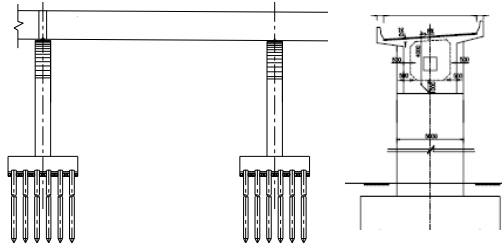
Evaluation Item	Max. Rate	Alternative 1 Steel-I Girder + RC-T Type Pier	Alternative 2 Steel Box Girder + RC-T Type Pier	Alternative 3 Concrete Box Girder + RC-T Type Pier
Schematic View				
Erection Method		All Staging	Crane Erection Method	All Staging Method (Cast-In-Place)
Construction Cost	30	Ratio=1.0 (USD 3,000./m ²)	Ratio=1.2 (USD 3,500 /m ²)	Ratio=1.1 (USD 3,500 /m ²)
Workability and Quality Control	20	<ul style="list-style-type: none"> - The procedures of field works can be simplified and the quantities of field works can be reduced by applying pre-fabrication. - The quality of girders can be assured by using pre-fabrication in a factory. 	<ul style="list-style-type: none"> - The procedures of field works can be simplified and the quantities of field works can be reduced by applying pre-fabricated pre-assembled girders. - The quality of girders can be assured by using pre-fabrication in a factory. 	<ul style="list-style-type: none"> - All staging method needs traffic diversion at the intersection, but - The period for diversion is more than 2 months, which is not feasible for the intersection with heavy traffic demand and difficulty for detour.
Structural Aspect and Stability	10	<ul style="list-style-type: none"> - Applicable span length is 30-80m. - Superstructure is heavier than that of Alternative 2 but lighter than Alternative 3. - The girders are more stable during erection than Alternative 2. 	<ul style="list-style-type: none"> - Applicable span length is 50-120m. - Steel girders are lightweight, which leads small seismic loading on piers. - Section can be trimmed down by applying high strength concrete. 	<ul style="list-style-type: none"> - Applicable span length is 30-90m. - The weight of superstructure is heaviest among the alternatives, which leads large seismic loading on piers.
Construction Period (L=120m)	20	<ul style="list-style-type: none"> - Construction period can be shortened by applying pre-fabricated/pre-assembled girders. - Construction Period: approx. 1 months (girder) 	<ul style="list-style-type: none"> - Construction period can be shortened by applying pre-fabricated/pre-assembled girders. - Construction Period: approx. 1 months (girder) 	<ul style="list-style-type: none"> - Cast-in-place takes time for scaffolding and formwork setting, rebar works and concrete curing. - Construction Period: approx. 2 months (girder)
Maintenance	20	<ul style="list-style-type: none"> - Periodical painting on the girders is necessary in addition to inspection on the surface. - This alternative has the least consumable parts such as bearings and expansion to be exchanged. 	<ul style="list-style-type: none"> - Periodical painting on the girders is necessary in addition to inspection on the surface. - This alternative has the least consumable parts such as bearings and expansion to be exchanged. 	<ul style="list-style-type: none"> - Only minimum maintenance for the girders such as Inspection on concrete surface is required. - This alternative has the least consumable parts such as bearings and expansion to be exchanged.
Evaluation	100	Most Recommended	This alternative is inferior in construction cost.	This alternative is inferior in workability, construction cost and period.

Source: JICA Study Team

Table 2-25 Comparative Study on Foundation

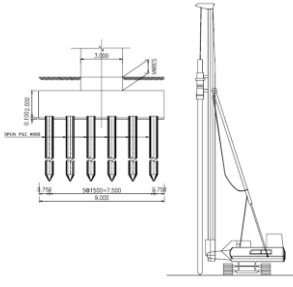
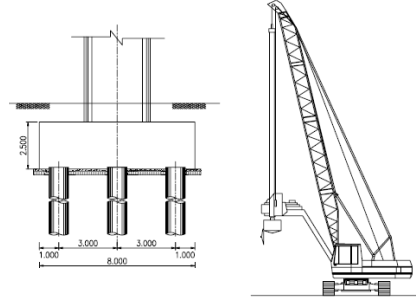
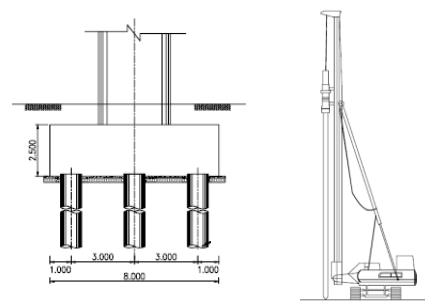
Evaluation Item	Max. Rate	Alternative-1 Pre-cast PC Pile by Pile Driving Machine	Alternative-2 Cast-in-place RC Pile by Earth Auger	Alternative-3 Steel Pipe Pile by Pile Driving Machine			
Schematic View							
Construction Cost	30	- Ratio of construction cost: 1.00	30	- Ratio of construction cost: 1.00	30	- Ratio of construction cost: 1.22	12
Workability and Quality Control	20	- Pre-cast PC concrete piles are driven into the ground by pile driving machine to the bearing layer. -Pile length is adjustable by jointing additional piles. -The bearing layer is confirmed by measuring driving efficiency. -Quality of pre-cast piles is well controlled.	20	- An earth auger excavates to make a bore hole, followed by steel cage installation and concrete casting. - Measures against collapse of bore hole should be taken. -The bearing layer is confirmed directly by excavation. - Qualities of cast-in-place pile are relatively varied.	16	- Steel piles are driven into the ground by pile driving machine to the bearing layer. -Pile length is adjustable by welding additional piles. -The bearing layer is confirmed by measuring driving efficiency. -Quality of steel piles is well controlled.	16
Structural Aspect and Stability	10	-Concrete strength of pre-cast piles is as high as 60MPa. -The diameter of the piles is maximum 0.6m. Therefore, the number of the piles is lot more than other alternatives, which results in large footing - Long pile more than 50m is not general.	4	- Soil properties can be directly confirmed by testing the soil excavated by the earth auger. -Large diameter up to 2m is applicable, so that the number of the piles can be reduced.	10	- Large diameter up to 1.2m is applicable, so that the number of the piles can be reduced.	10
Construction Period	20	-Construction period: 8days/footing	16	- Construction period: 10days/footing + concrete curing	12	- Construction Period : 8 days/footing	20
Environmental Considerations	20	- Noise and vibration by pile driving cause nuisance - It is possible to induce ground deformation in the vicinity due to pile driving.	4	- Noise and vibration are the lowest. - Disposal of excavated soil is necessary.	16	- Noise and vibration by pile driving cause nuisance. - No disposal of soil is necessary.	4
Evaluation	30	-It is superior in workability, quality, construction cost and period. It is recommended if the influence of pile driving noise and vibration is accepted.	76	-It is acceptable for workability and cost efficiency. If Alternative 1 is not applicable for environmental reason, it is recommended.	80	-It is acceptable for constructability and environmental aspect but economically inferior.	62
		Less Recommended		Most Recommended		Not Recommended	

Source: JICA Study Team

6) Conclusion and Recommendation

The recommended structure types from this comparative study are summarized as follows:

- Standard Sections of Viaducts: PC-T Girder and RC Pier with Cast-in-place RC Piles
- Flyover Section of Viaducts: Steel I Girder and RC Pier with PC Piles
- Approach Section of Flyover: Embankment with retaining walls.

Figure 2-24 shows the recommended structure types on the route alignment.

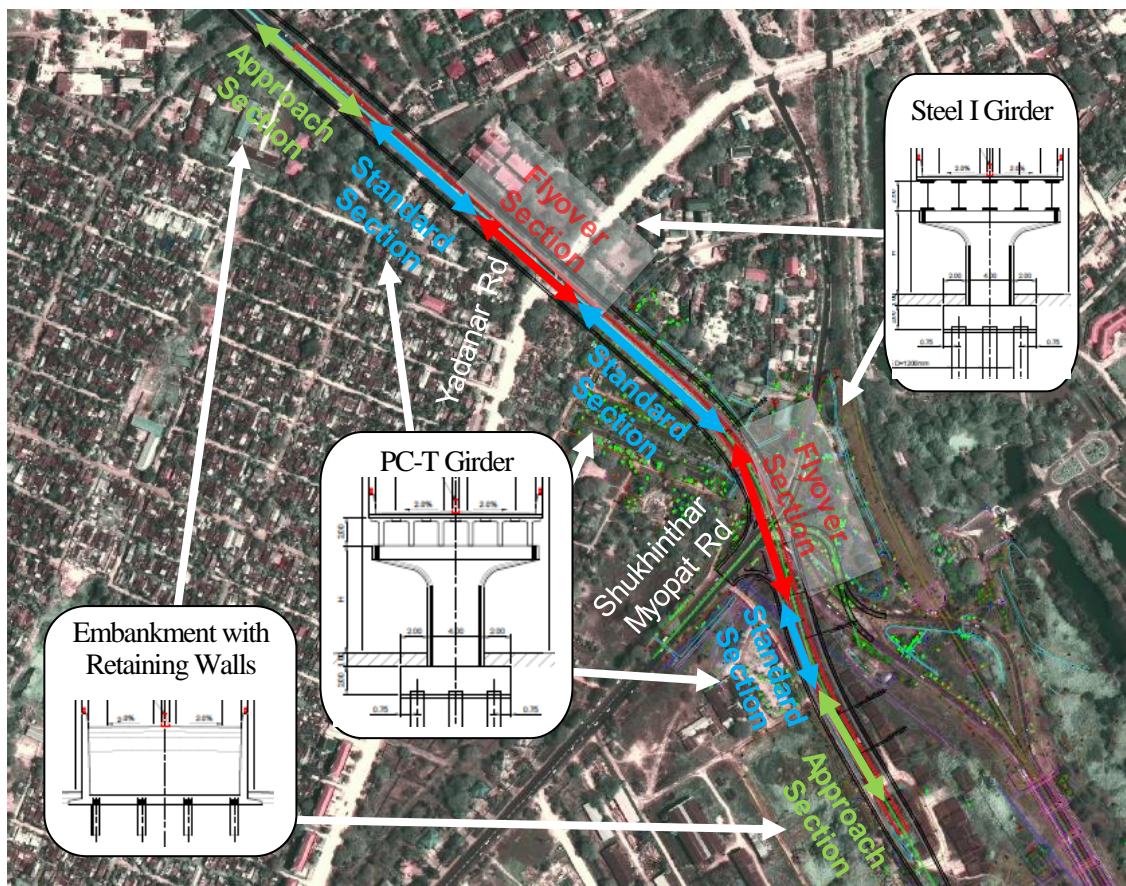

Source: JICA Study Team

Figure 2-24 Summary of Recommended Structure Types

c) Span Arrangement and Dimensions of Structural Members

c-1) General

In this clause, the span arrangement and the dimensions of structure members of the Elevated Access Spur Road is discussed based on the conditions and the recommended structure type in the previous sections.

c-2) Appropriate Span Length of Viaduct

1) General

In consequence of the comparative study for selecting structure type discussed in the previous sections, the recommended structure types are summarized as follows:

- Standard Sections of Viaducts: PC-T Girder and RC Pier with PC Piles
- Flyover Section of Viaducts: Steel I Girder and RC Pier with PC Piles

- Approach Section of Flyover: Embankment with retaining walls.

(Note: The structure in the embankment section will be optimized based on the result of geological survey in D/D stage)

In this section, appropriate span lengths of selected bridge types are discussed in order to propose an appropriate span arrangement.

2) Appropriate Span Length

In general, the economically optimal spans for PC-T girder and Steel I girder are 30m-35m and 45-65m, respectively.

As for Steel I Girder, 60-65m is recommended by considering the conditions of the intersection and the width of the crossing streets, Shukhinthar Myotit Rd and Yadanar Rd. Since, structurally, a continuous girder can be slenderer than a single-span so that the clearance at the intersection can be secured, continuous girder such as 40m + 60m + 40m is recommended to be applied.

As for PC-T girder, one optimum span of 30m is recommended to be selected in order to utilize the pre-fabricated girders with the same length except for the section at the beginning and the end next to the approach sections.

3) Boundary between Viaduct and Embankment

The height of the viaducts from the ground level at the boundary to the approach sections is defined as 8m from the existing ground level in consideration of the maximum height of the embankment and the structural resistance of the retaining wall.

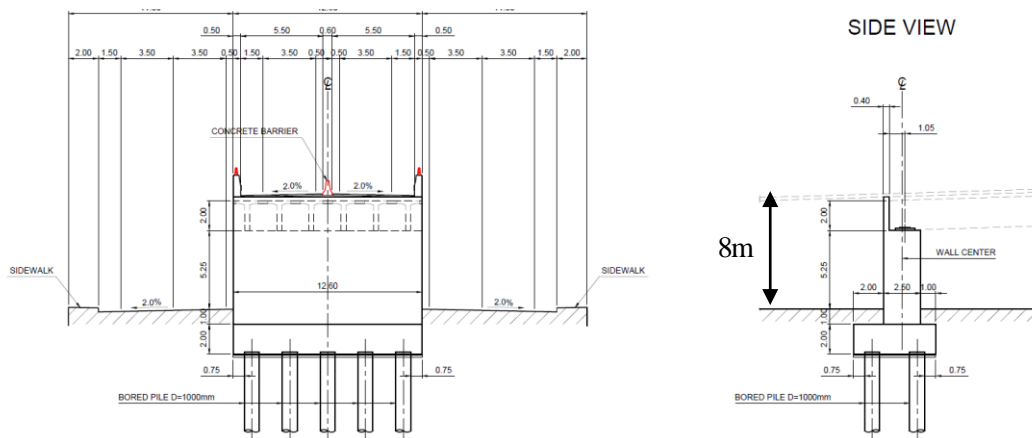

Source: JICA Study Team

Figure 2-25 Dimensions of Abutment and Height of Embankment

4) Proposed Span Arrangement

Figure 2-26 to Figure 2-28 show the general views of the flyover with the proposed span arrangement superimposed on the horizontal and vertical profiles based on the above-mentioned considerations.

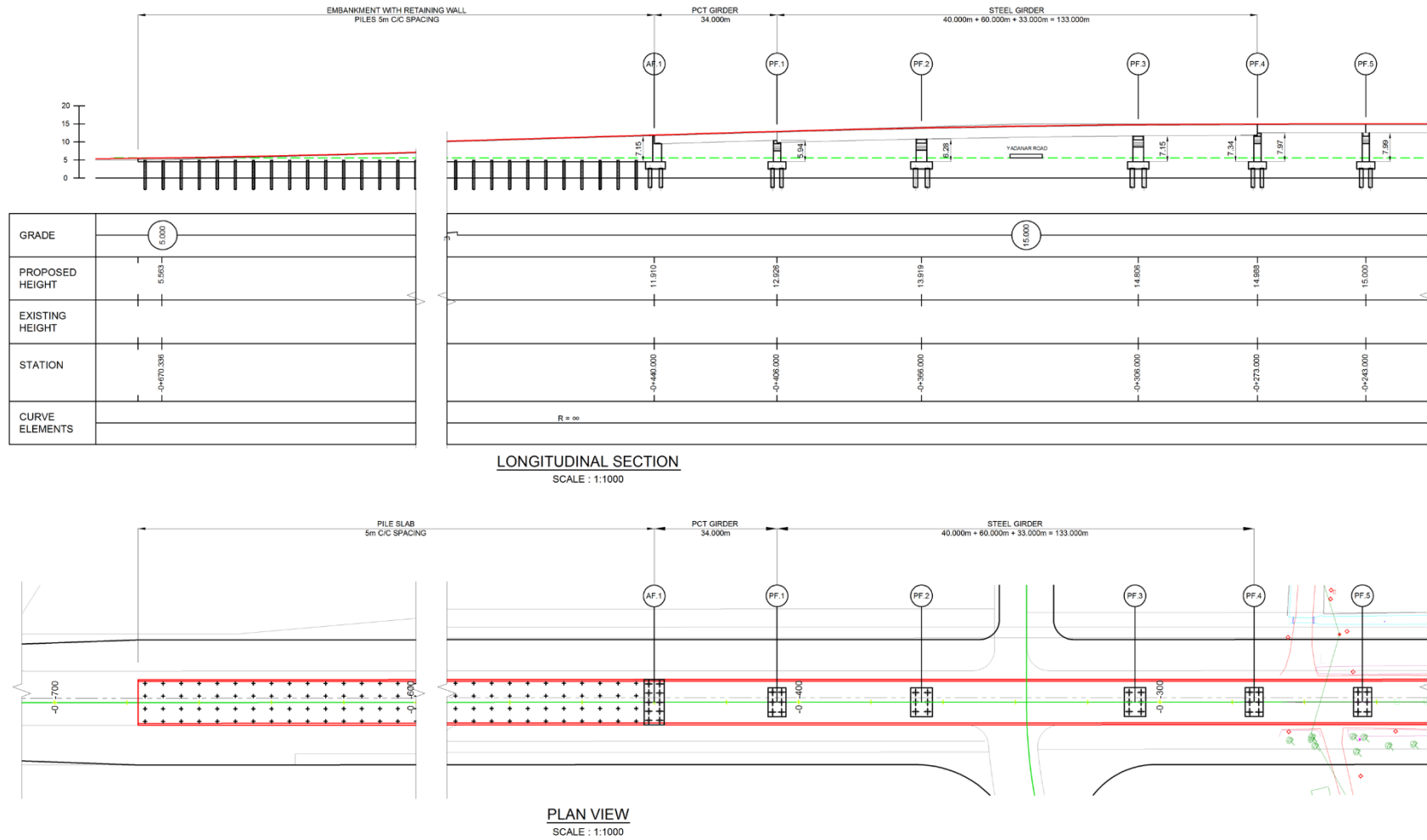

Source: JICA Study Team

Figure 2-26 General View of Flyover (1)

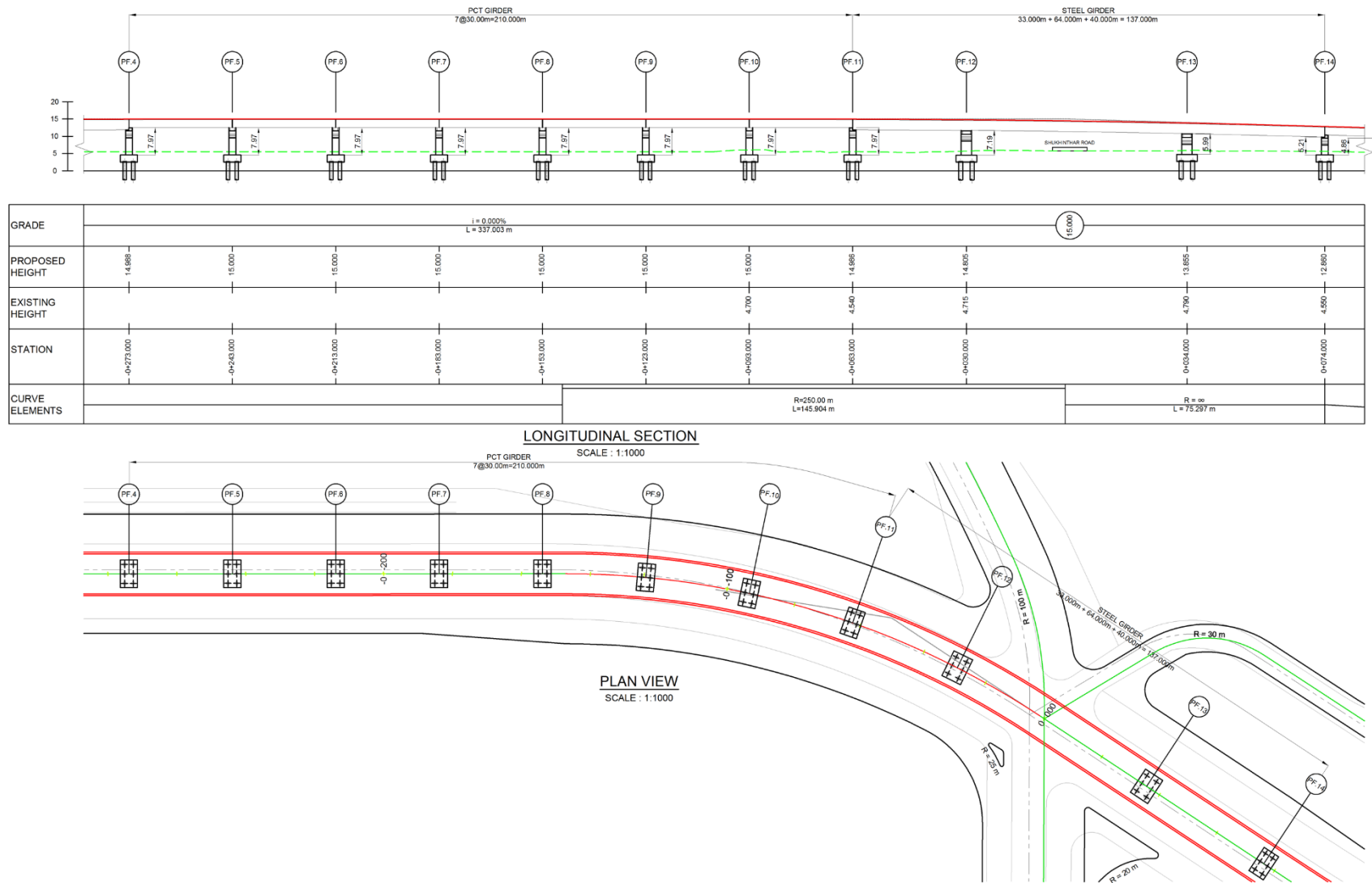

Source: JICA Study Team

Figure 2-27 General View of Flyover (2)

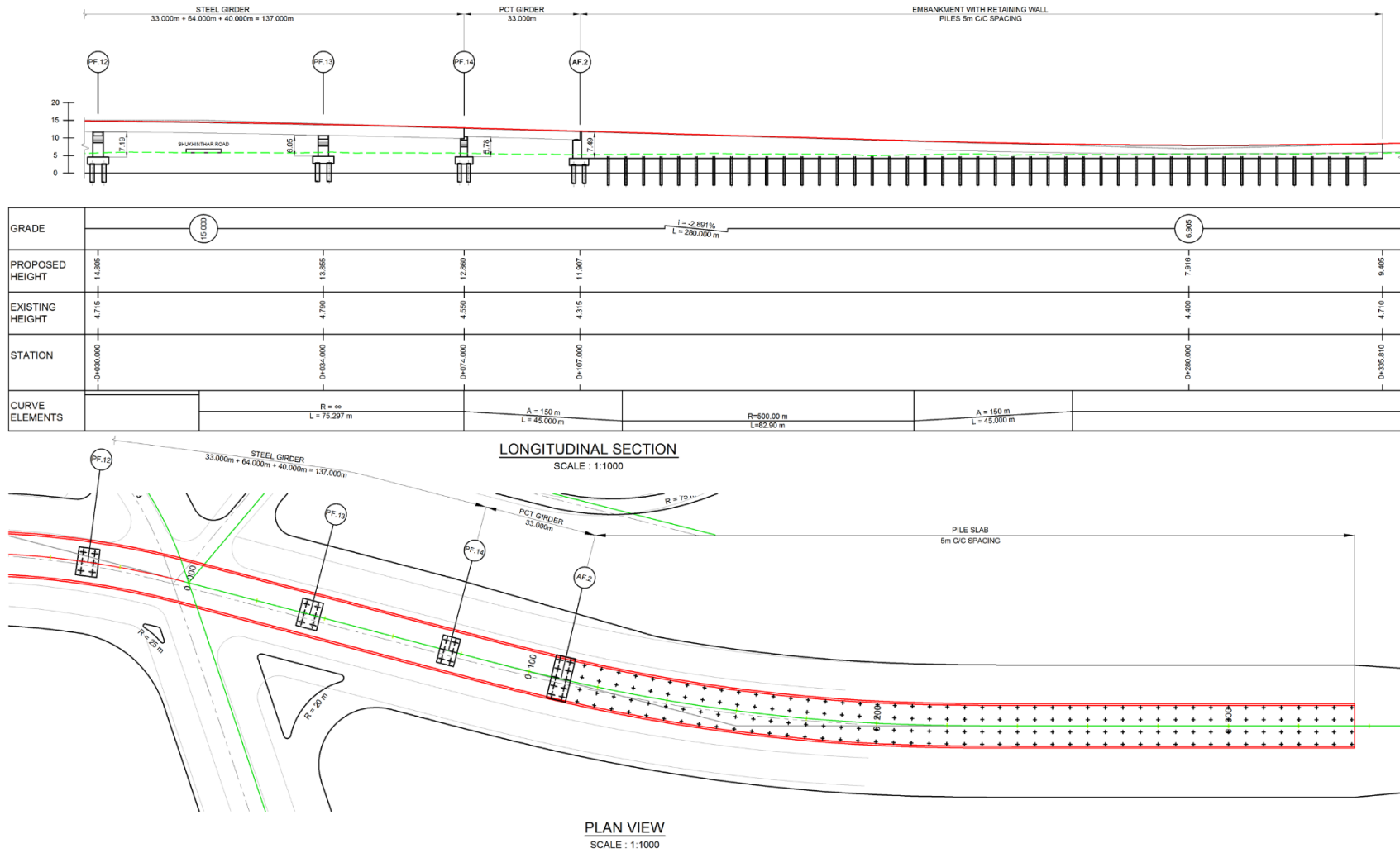

Source: JICA Study Team

Figure 2-28 General View of Flyover (1)

2.2.4 Thaketa Roundabout

(1) Concern on Roundabout

The traffic volume at the roundabout will exceed its capacity and so it is recommended to improve the capacity of the roundabout.

According to demand forecast for 2016, 55,000 PCU/Day (48,000 ADT veh/day) transit in the Roundabout. This is more than capacity of a large 2-lane roundabout by referring to Studies on Roundabouts in Germany as shown in Figure 2-29. The estimated congestion rate is about 1.2.

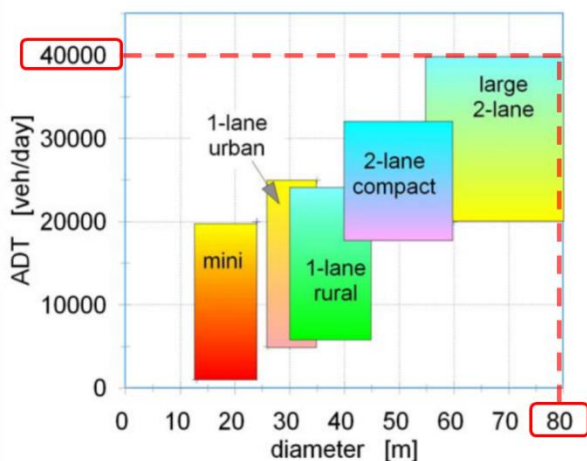

Source: Werner Brilon

Figure 2-29 Inscribed Circle Diameter and Maximum Capacity of Roundabout



Source: JICA Study Team

Figure 2-30 Estimated Traffic Volume (PCU/Day) in 2025 at Thaketa Roundabout

According to the estimated traffic volume in 2025, congestion rate is going to be increased as 1.7 and the estimated jam length is about 1.4 km, which imply that improvement of this roundabout is necessary.

Table 2-26 Preliminarily Estimated Peak Traffic Volume at Thaketa Roundabout in 2025

	Thanlyin Chin Kat Rd	Ayer Wun Setsat Rd	From New Thuwunna Br	Ayer Wun Main Rd
Traffic Volume (PCU/hr)	1,500	1,200	1,260	1,240
Traffic Capacity (PCU/hr)	870	690	730	720
Volume/Capacity	1.7	1.7	1.7	1.7
Jam Length* (km)	1.2	1.4	1.4	1.4



-Note(*): Jam Length : preliminary estimated by following formula

$$(\text{Traffic Volume} - \text{Traffic Capacity}) \times (\text{distance between vehicles: } 5.5\text{m}) / (\text{number of Lanes})$$

Source: JICA Study Team

(2) Preliminary Study on Improvement of Thaketa Roundabout

In this preliminary study, the following 4 alternatives are introduced for consideration of MOC:

- Alt-1 At-grade Improvement of Intersection
- Alt-2 Flyover/Underpass to Ayer Wun Main Rd from Bago Bridge
- Alt-3 Flyover/Underpass to New Thuwunna Bridge from Bago Bridge
- Alt-4 At-grade Improvement + Flyover

i) Alt-1: At-grade Improvement of Intersection

The first alternative is to change the intersection from a roundabout to signal intersection with 4 streets, by dead-ending Inner Shukhinthar Rd, which has very small traffic volume compared to the other roads.

By this improvement, right-turn lanes can be installed for free movement from Ayer Wun Main Rd to Thanlyin Chin Kat Rd.

By this improvement, traffic congestion will be mitigated effectively, but smooth traffic flow will not be fully achieved. Capacity shortage is expected after 2021.

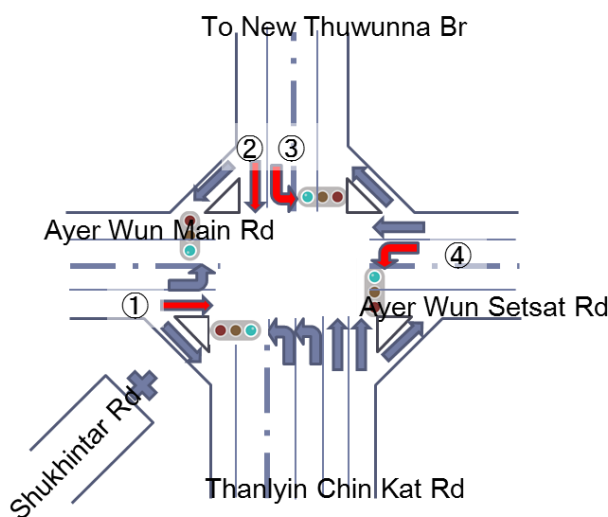

Source: JICA Study Team

Figure 2-31 Example of At-grade Improvement

Table 2-27 Preliminarily Estimated Peak Traffic Volume at Thaketa Roundabout in 2025

	①Straight from Ayer Wun Main Rd	②Straight from New Thuwunna Br	③Left-turn from New Thuwunna Br	④Lef-tum from Ayer Wun Setsat Rd
Traffic Volume (PCU/hr)	620	760	380	480
Traffic Capacity (PCU/hr)	520	620	310	400
Volume/Capacity	1.2	1.2	1.2	1.2
Jam Length* (km)	0.6	0.7	0.4	0.5

-Note(*): Jam Length : preliminary estimated by following formula

$$(\text{Traffic Volume} - \text{Traffic Capacity}) \times (\text{distance between vehicles:5.5m}) / (\text{number of Lanes})$$

Source: JICA Study Team

ii) Alt-2: Flyover/Underpass to Ayer Wun Main Rd. from Thanlyin Chin Kat Rd.

The second alternative is to have a flyover with 2-lanes of carriageway between Thanlyin Chin Kat Rd and Ayer Wun Main Rd. Since the traffic volume coming from other directions to this roundabout is still large, traffic jam is not fully mitigated.

For keeping scenery of the roundabout as a landmark, an underpass is also one solution instead of a flyover. Disturbance of traffic during construction and vulnerability to flood is the disadvantages compared to flyover. The effect on mitigation of traffic congestion is the same as the flyover option.

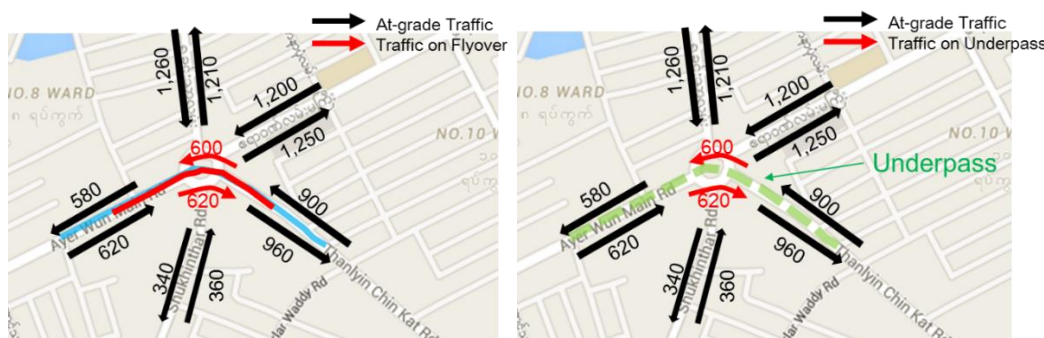

Source: JICA Study Team

Figure 2-32 Example of Flyover/Underpass to Ayer Wun Main Rd

Table 2-28 Preliminary Estimated Peak Traffic Volume at Thaketa Roundabout in 2025

Alt-2: Flyover/Underpass to Ayer Wun Main Rd. from Thanlyin Chin Kat Rd.

	Thanlyin Chin Kat Rd	Ayer Wun Setsat Rd	From New Thuwunna Br	Ayer Wun Main Rd
Traffic Volume (PCU/hr)	900	1,200	1,260	620
Traffic Capacity (PCU/hr)	670	900	940	480
Volume/Capacity	1.3	1.3	1.3	1.3
Jam Length* (km)	0.4	0.8	0.9	0.4

-Note(*): Jam Length : preliminary estimated by following formula (Traffic Volume – Traffic Capacity) x (distance between vehicles:5.5m) / (number of Lanes)

Source: JICA Study Team

iii) Alt-3: Flyover/Underpass to New Thuwunna Bridge from Thanlyin Chin Kat Rd.

The third alternative is to have a flyover with 2-lanes of carriageway between Thanlyin Chin Kat Rd and the road to New Thuwunna Bridge. Similar to Alternative-1, since the traffic volume coming from other directions to this roundabout is still large, traffic jam is not fully mitigated.

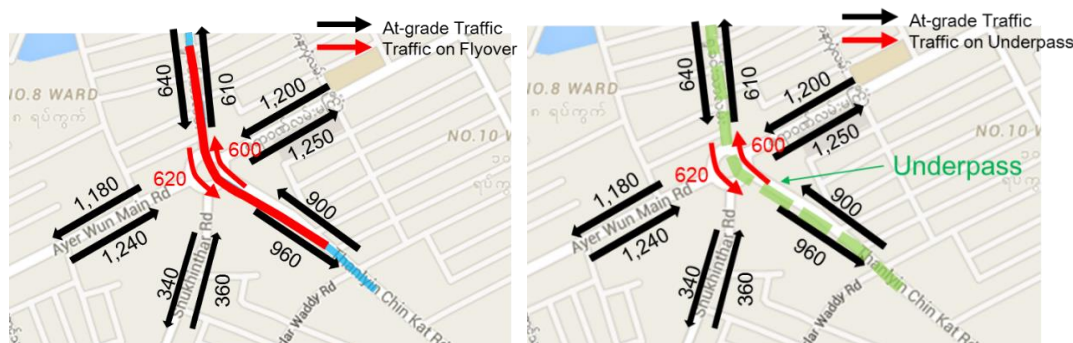

Source: JICA Study Team

Figure 2-33 Example of Flyover/Underpass to New Thuwunna Rd.

Table 2-29 Preliminarily Estimated Peak Traffic Volume at Thaketa Roundabout in 2025

Alt-3: Flyover/Underapss to New Thuwunna Bridge from Thanlyin Chin Kat Rd.

	Thanlyin Chin Kat Rd	Ayer Wun Setsat Rd	From New Thuwunna Br	Ayer Wun Main Rd
Traffic Volume (PCU/hr)	900	1,200	640	1,240
Traffic Capacity (PCU/hr)	680	900	580	880
Volume/Capacity	1.3	1.3	1.3	1.3
Jam Length* (km)	0.4	0.8	0.4	0.8

-Note(*): Jam Length : preliminary estimated by following formula

$$(Traffic\ Volume - Traffic\ Capacity) \times (distance\ between\ vehicles:5.5m) / (number\ of\ Lanes)$$

Source: JICA Study Team

iv) Alt-4: At-grade Improvement + Flyover

For achieving full mitigation of congestion, one of the solutions is a combination of signal intersection and flyover between Thanlyin Chin Kat Rd and the road to New Thuwunna Br, by which the congestion rate will be improved to 0.7.

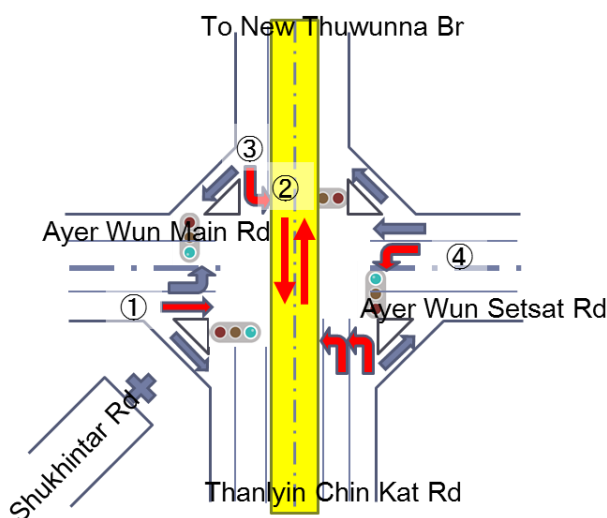

Source: JICA Study Team

Figure 2-34 Example of Flyover/Underpass to New Thuwunna Rd.

Table 2-30 Preliminarily Estimated Peak Traffic Volume at Thaketa Roundabout in 2025

Alt-4: At-grade Improvement + Flyover to New Thuwunna Br from Thanlyin Chin Kat Rd.

	① Straight from Ayer Wun Main Rd	② Straight from New Thuwunna Br	③ Left-turn from New Thuwunna Br	④ Left-turn from Ayer Wun Setsat Rd
Traffic Volume (PCU/hr)	620	760	380	480
Traffic Capacity (PCU/hr)	840	1380	580	650
Volume/Capacity	0.7	0.6	0.7	0.7
Jam Length* (km)	-	-	-	-

-Note(*): Jam Length : preliminary estimated by following formula

$$(Traffic\ Volume - Traffic\ Capacity) \times (distance\ between\ vehicles:5.5m) / (number\ of\ Lanes)$$

Source: JICA Study Team

v) Summary of Preliminary Alternative Study

Table 2-31 summarizes the results of preliminary alternative study on intersection improvement of Thaketa Roundabout for MOC's reference.

Table 2-31 Summary of Preliminary Alternative Study on Intersection Improvement at Thaketa Roundabout

	Alt-1: At-grade Improvement (Signal Intersection)	Alt-2: Flyover /Underpass to Thuwunna Bridge	Alt-3: Flyover / Underpass to New Thuwunna Bridge	Alt-4: Signal + Flyover (Alt1+Alt3)
Mitigation of Traffic Jam at Intersection	Congestion Rate in 2025: 1.2	Congestion Rate in 2025: 1.3	Congestion Rate in 2025: 1.3	Congestion Rate in 2025: 0.7
Social Consideration	Shukhintar Rd will be dead end	- Additional land acquisition is necessary - Many number of PAPs	- Additional land acquisition is necessary - Many number of PAPs	Considerations for Alt-1 and Alt-3
Construction Cost	Cheapest	Costly	Costly	Costly

Source: JICA Study Team

vi) Considerations for Improvement of Thaketa Roundabout

Two points to be considered for improvement of Thaketa Roundabout are introduced in this section.

- Firstly, since YCDC does not have any plan to improve Thaketa Roundabout, common understanding with Thanlyin Township is important. It is also important for MOC to decide about the improvement after discussion with YCDC.
- Secondly, since one of the recommended improvement methods is to change Inner Shukhintar Rd to dead end at Thaketa Roundabout, negotiation with the residents is necessary if MOC and YCDC decide to take the option of the signal intersection.

2.3 THANLYIN SIDE

2.3.1 Introduction

Adjacent to Thanlyin Side of Bago Bridge, there are 3 major housing development projects: Thiri Han Thar Housing Project with 70 houses, Thanlyin Yadanar Housing Project with 350 houses and Star City Project with 9000 houses (4000 houses will be completed by 2022). See Figure 2-35.

In addition to cargo traffic from Thilawa Port and Thilawa SEZ, the corresponding person trips are expected to be added to the traffic volume along Bago Bridge.

In the following sub-sections, the situations of traffic at this intersection after completion of Bago Bridge is shown by updating demand forecast, followed by study for intersection improvement.

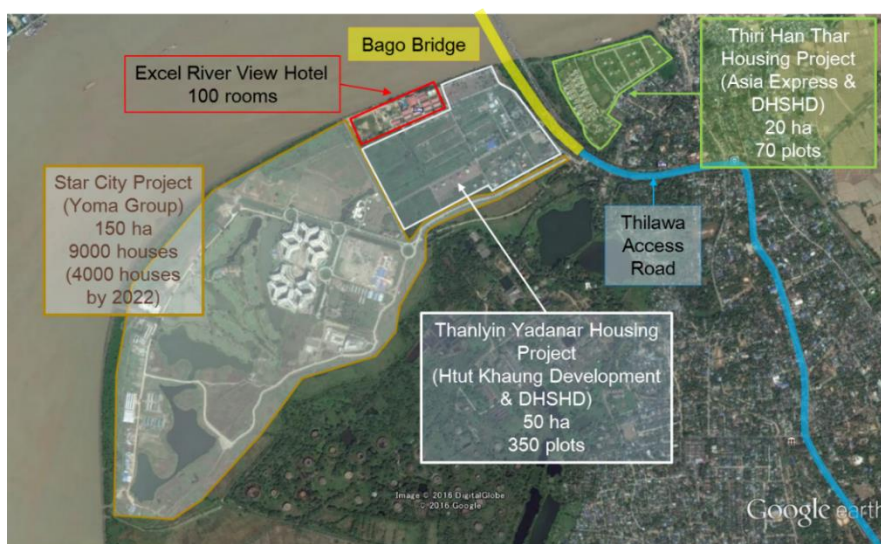

Source: JICA Study Team

Figure 2-35 Housing Development Projects adjacent to Thanlyin Side of Bago Bridge

Figure 2-36 shows the close-up view with the intersection of concern.



Source: JICA Study Team

Figure 2-36 Intersection adjacent to the end of Bago Bridge

2.3.2 Traffic Demand Forecast

JICA Study Team conducted the intersection analysis of Star City Intersection based on the result of the traffic demand forecast for the year 2025.

The traffic demand forecast of Star City Intersection consists of general traffic and traffic from residential area.

The traffic demand forecast of general traffic for 2025 was estimated in accordance with the information from Thilawa Access Road Project Team based on the Traffic Count Survey Report (Consulting Services for Infrastructure Development Project In Thilawa Area Phase II, February 2016). Additionally, the traffic demand forecast of traffic from residential area was estimated in accordance with the information from Thilawa Access Road Project Team based on the plan of Star City Residential Project.

The result of the traffic demand forecast of general traffic for 2025 is shown in Table 2-32 below.

Table 2-32 Result of Traffic Demand Forecast of general traffic for 2025

Traffic Demand Estimate		Peak 1 Hour Averag											YEAR 2025				
01 Star City Intersection																Unit: PCU/hr	
From	To	Direction	1	2	3	4	5	6	7	8	9	10	11	1+2	3-11	Total	Dir.Total
Thanlyin Bridge	SEZ		1	58	729	127	253	198	62	79	57	38	1	59	1,543	1,602	
Thanlyin Bridge	Star City		5	29	88	27	32	0	7	4	0	4	1	33	164	198	1,800
Star City	Thanlyin Bridge		0	5	73	33	24	0	7	4	1	1	0	5	143	148	
Star City	SEZ		34	113	23	12	12	0	3	4	0	3	1	147	57	204	352
SEZ	Star City		0	86	6	3	2	0	1	1	0	1	1	86	16	102	
SEZ	Thanlyin Bridge		0	37	780	162	205	183	136	119	41	42	0	37	1,668	1,706	1,807
Total			39	328	1,698	362	529	381	217	212	99	90	4	368	3,591	3,959	3,959
(Share)			1.0%	8.3%	42.9%	9.2%	13.4%	9.6%	5.5%	5.3%	2.5%	2.3%	0.1%	9.3%	90.7%	100%	

Note: 1. Bicycle & Tricycle (Non-motorized), 2. Motor cycle, 3. Passenger Car (incl. Taxi), 4. Van, Pick-up, SUV, 4WD, 5. Passenger Truck, Small Bus, 6. Large Bus, 7. Small Truck, 8. Truck (2 axles, over 4.5t), 9. Truck (3 axles), 10. Trucks (4axles) / Trailer (separated type), 11. Others

Source: JICA Study Team (refer to information from Thilawa Access Road Project Team based on Traffic Count Survey Report (Consulting Services for Infrastructure Development Project In Thilawa Area Phase II, February 2016))

The result of the traffic demand forecast of traffic from residential area for 2025 is shown in Table 2-33 below.

Table 2-33 Result of Traffic Demand Forecast of Traffic from residential area for 2025

Conditions for Estimation							
(1) Directional distribution between Star City and Yangon is 70%							
(2) Directional distribution between Star City and SEZ is 30%							
(3) Outbound traffic from Star City has morning peak distributed for 2 hours (school, working etc)							
(4) Inbound traffic to Star City from Yangon has evening peak distributed to 3 hours (1hr school, 2 hrs working)							
(5) Inbound traffic to Star City from SEZ has evening peak distributed to 2 hours (working)							
Year	Direction	Housing Units	Ratio of Sale	Ratio of Car-use	Directional Distribution	Peak Hour	Estimated Volume (pcu/hr)
2025	Star City - Yangon	4000	100%	80%	70%	2	1120
	Star City - SEZ	4000	100%	80%	30%	2	480
	Yangon - Star City	4000	100%	80%	70%	3	747
	SEZ - Star City	4000	100%	80%	30%	2	480

Source: JICA Study Team (refer to information from Thilawa Access Road Project Team based on plan of Star City Residential Project)

With reference to the result of the traffic demand forecast, Table 2-34 shows the traffic volumes corresponding to all the flow directions at the intersection estimated for 2025. In the same table, traffic capacity and jam length are also shown estimated by JICA Study Team.

The traffic volumes for straight from Bago Bridge, straight from Thilawa and left-turn from the residential area are beyond the capacity of the corresponding lanes in 2025 as the congestion rate of 2.1, for which improvement is recommended. The major concern is the left-turn traffic from the residential area is confronting to the traffic flows from Bago Bridge and Thilawa.

Table 2-34 Estimated Peak Traffic Volume at Thanlyin Side Intersection in 2025

	from Bago Bridge		from Thilawa		From Residential Area	
	①Straight	②Right-tum	③Straight	④Left-tum	⑤Left-tum	⑥Right-tum
Traffic Volume (PCU/hr)	1,602	945 (198+747)	1,706	582 (102+480)	1,268 (148+1120)	684 (204+480)
Traffic Capacity (PCU/hr)	760	1,584	1,080	288	612	900
Volume/Capacity	2.108	0.597	1.580	2.021	2.072	0.760
Jam Length* (km)	2.3	-	1.7	0.8	1.8	-

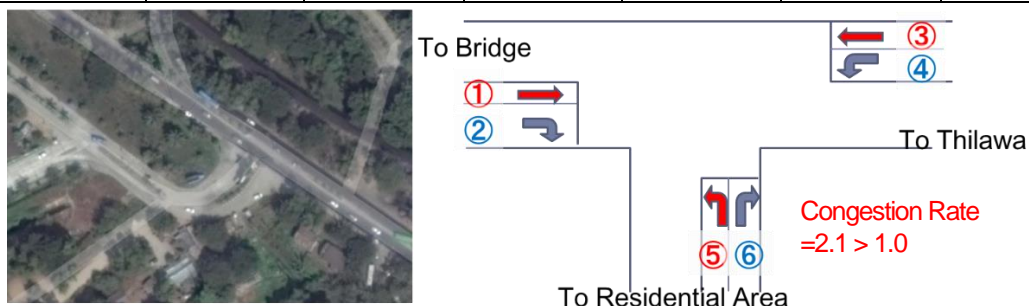

-Note(*): Jam Length : preliminary estimated by following formula
 (Traffic Volume – Traffic Capacity) x (distance between vehicles:5.5m) / (number of Lanes)

Source: Thilawa Access Road Project and JICA Study Team

The plan to provide a new access road from the roundabout near Star City project was conducted for another alternative to mitigate the traffic congestion.

Even in this plan, the left-turn traffic from Star City side to Thilawa Access Road will cause similar congestion by the traffic from existing road. The existence of many houses around the alternative intersection will make construction of the alternative route more difficult.

So this plan to construct an alternative route at existing intersection is considered not to be feasible.



Source: JICA Study Team

Figure 2-37 Another Route for avoiding congestion at Existing Intersection

Table 2-35 Preliminarily Estimated Peak Traffic Volume at Alternative Intersection in 2025

	①Left-tum to Bridge	②Straight from Bridge	③Straight from Thilawa
Traffic Volume (PCU/hr)	1,100	1,602	1,706
Traffic Capacity (PCU/hr)	500	750	1,100
Volume/Capacity	2.2	2.1	1.6
Jam Length* (km)	1.7	2.3	1.7

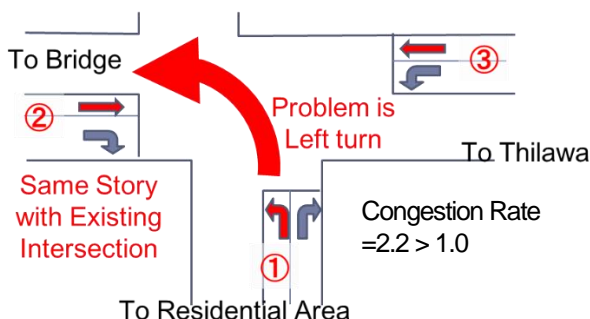

-Note(*): Jam Length : preliminary estimated by following fomula
 (Traffic Volume – Traffic Capacity) x (distance between vehicles:5.5m) / (number of Lanes)

Source: Thilawa Access Road Project and JICA Study Team

2.3.3 Improvement for On-ramp Traffic

(1) Alternative Study

For improvement of this intersection, following 3 alternatives are compared:

- Alt-1 Improvement of at-grade Intersection
- Alt-2 At-grade On-ramp
- Alt-3 Straight Flyover.

1) Alt-1: Improvement of at-grade intersection

Table 2-36 shows the traffic capacity after at-grade improvement of the intersection, by increasing the number of lanes, additional 1 lane for left-turn from the residential area, additional 1 lane for straight from bridge, and additional 1 lane straight from Thilawa are assumed.

As a result, the traffic capacity of the intersection is increased and the congestion rate is improved from 2.1 to 1.25 in 2025, but still overcapacity after 2022.

Therefore, other options shall be considered.

Table 2-36 Preliminary Estimated Peak Traffic Volume at Improved Intersection in 2025

	①Left-turn to Bridge (2 lanes)	②Straight from Bridge (2 lanes)	③Straight from Thilawa (2 lanes)
Traffic Volume (PCU/hr)	1,268	1,602	1,706
Traffic Capacity (PCU/hr)	1,044	1,280	2,360
Volume/Capacity	1.21	1.25	0.723
Jam Length* (km)	0.6	0.9	-

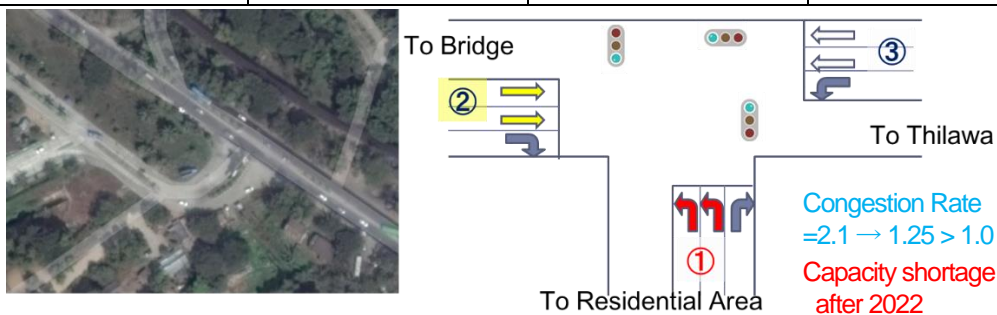

-Note(*): Jam Length : preliminary estimated by following formula
 (Traffic Volume – Traffic Capacity) x (distance between vehicles:5.5m) / (number of Lanes)
 Source: Thilawa Access Road Project and JICA Study Team

2) Alt-2: at grade On-ramp

Figure 2-38 shows a plan view of an at-grade on-ramp from West Side of the Bridge.

This alternative is starting from Township road, passing under Bago Bridge, passing under Thanlyin Bridge, going backward for connecting at grade, so that the traffic can make free right-turn to the Bridge.

As shown in the picture, the clearance of Thanlyin Bridge was measured for checking the clearance for under-passing.

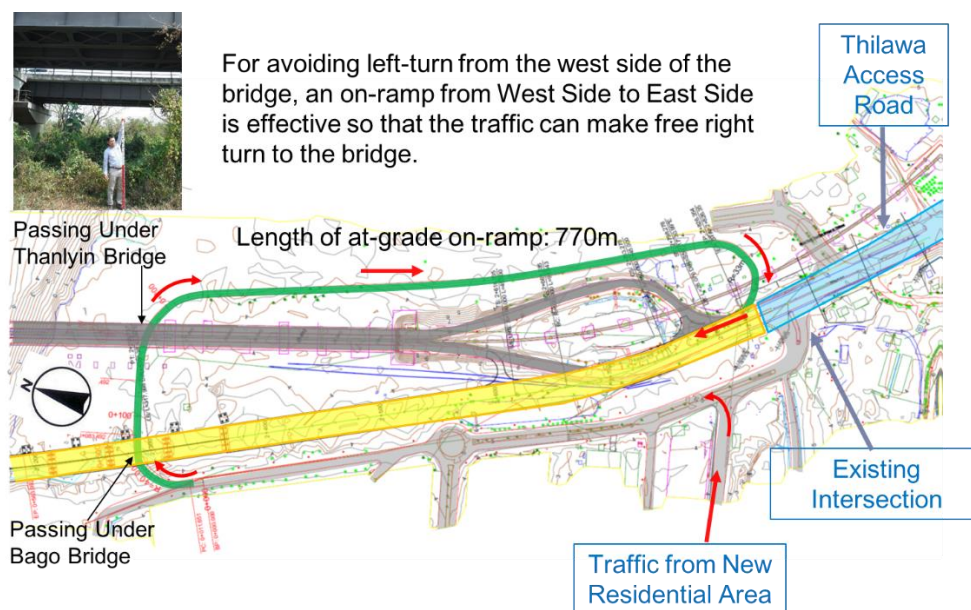

Source: JICA Study Team

Figure 2-38 Alt-2: At-grade On-ramp from West Side of Bago Bridge

Table 2-37 shows the effect of the on-ramp option on mitigation of traffic jam by comparing to the Alt-1. Since the traffic flow ① can be neglected at the intersection, the capacity for straight traffic from/to Bridge and Thilawa is improved for smooth traffic flow.

Table 2-37 Effect of On-ramp on Mitigation of Traffic Jam at Existing Intersection in 2025

	①Left-turn to Bridge (2 lanes)	②Straight from Bridge (2 lanes)	③Straight from Thilawa (2 lanes)
Traffic Volume (PCU/hr)	1,268	1,602	1,706
Traffic Capacity (PCU/hr)	1,380	1,880	3,680
Volume/Capacity	0.92	0.85	0.46
Jam Length* (km)	-	-	-

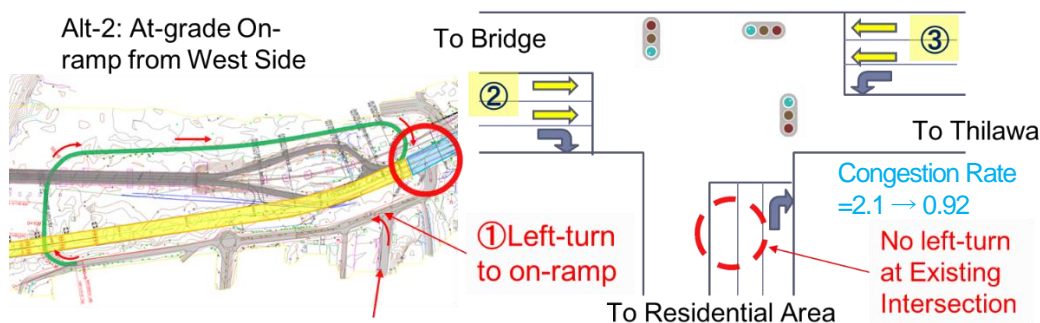

-Note(*): Jam Length : preliminary estimated by following formula
 $(\text{Traffic Volume} - \text{Traffic Capacity}) \times (\text{distance between vehicles:5.5m}) / (\text{number of Lanes})$
 Source: Thilawa Access Road Project and JICA Study Team

3) Alt-3: Straight Flyover

For mitigation of traffic congestion at the intersection, the construction of the flyover on the Thilawa Access Road can be considered. Figure 2-39 shows a conceptual drawing of the flyover for straight traffic from/to the bridge and Thilawa. Since there are small four intersections nearby the concerned intersection, the length of the flyover will be approximately 600 m long.

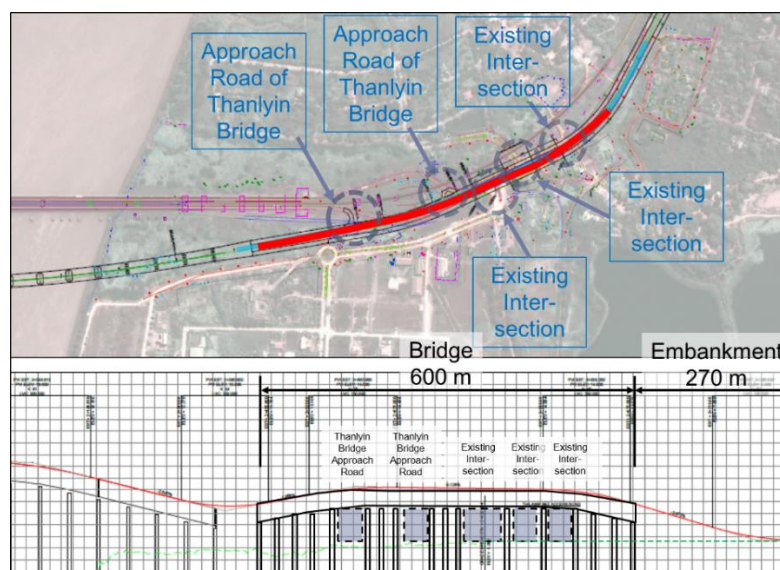

Source: JICA Study Team

Figure 2-39 Alt-3: Straight Flyover

The flyover option have a positive effect on mitigation of traffic congestion at the intersection by reducing the both traffic volumes straight from the Bridge and Thilawa. Since the estimated peak traffic volume in the straight direction is more than the capacity of the 2-lane flyover, it is considered that smooth traffic flow will not be fully achieved.

Table 2-38 Preliminary Estimate on Mitigation of Traffic Jam by Straight Flyover at Existing Intersection in 2025

	①Left-tum to Bridge (2 lanes)	②Straight from Bridge (1 lanes)	③Straight from Thilawa (1 lanes)
Traffic Volume (PCU/hr)	1,300	1,400	1,500
Traffic Capacity (PCU/hr)	1,150	1,380	1,380
Volume/Capacity	1.1	1.0	1.1
Jam Length* (km)	0.5	0.1	0.5

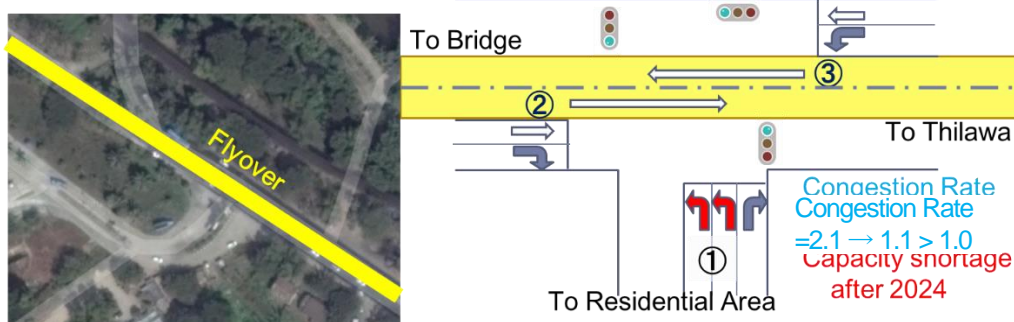

-Note(*): Jam Length : preliminary estimated by following formula
 (Traffic Volume – Traffic Capacity) x (distance between vehicles:5.5m) / (number of Lanes)

Source: Thilawa Access Road Project and JICA Study Team

The structural features of the straight flyover option are as follows:

- Length of Bridge: 600 m
- Length of Embankment with structure wall: 270 m
- Road width: 12.5 m (2 lanes)

The preliminarily estimated cost of construction is approximately USD 30 mil.

4) Summary of Alternative Study on Thanlyin Side Intersection

Table 2-39 shows the summary of alternative study on intersection improvement on Thanlyin Side. For mitigation of traffic jam, at-grade on-ramp option is the most effective comparing to at-grade intersection improvement and flyover options.

Regarding public benefit, since the intersection is only for the west side of the bridge, its improvement and the on-ramp options are beneficial only to the west side of the intersection, while the flyover option is beneficial for all the area connected by the other intersections over which it is passing.

Regarding social consideration, no PAP is expected for all the alternatives, while additional land acquisition is expected for all the alternatives.

Regarding the cost, the alternative with at-grade intersection improvement is the cheapest, at-grade on-ramp is the second cheapest, and Straight flyover option is the most expensive.

By comprehensively comparing these alternatives, Alt-2: at-grade on-ramp from West Side is the most recommended since this option effectively mitigates traffic jam.

Table 2-39 Summary of Alternative Study on Thanlyin Side Intersection

	At-grade Intersection Improvement (Alt-1)		On-ramp from West Side (Alt-2)		Straight Flyover (Alt-3)	
Mitigation of Traffic Jam at Intersection (Congestion in 2025)	Straight from Bridge: 1.25 Resident Area to Bridge: 1.21	△	Straight from Bridge: 0.85 Resident Area to Bridge: 0.92	⊙	Straight from Bridge: 1.1 Resident Area to Bridge: 1.1	△
Public Benefit	Limited to West Side of the intersection	△	Limited to West Side of the intersection	△	Beneficial to all the area surrounding the flyover	⊙
Social Consideration	Additional land acquisition: 0.1 ha	○	Additional land acquisition: 0.7 ha	△	- Additional land acquisition: 0.4 ha - A few PAPs are expected	△
Preliminary Estimated Construction Cost	Less than USD1 mil.	⊙	Approx. USD 2 mil.	⊙	Approx. USD 30 mil.	×
Evaluation	Less Recommended Capacity Shortage in 2022		Most Recommended Cost effective		Less Recommended Not cost effective	

Qualitative Evaluation: ⊙ Very Good, ○ Good, △ Average, × No Good

Source: JICA Study Team

5) Concerns of At-grade On-ramp

There are concerns of the at-grade on-ramp on interference with the existing intersections as shown in Figure 2-40. There are already three intersections very close (60 m) to each other nearby this alternative. In particular, the traffic flow to Thanlyin Bridge (blue arrow) is conflicting to the on-ramp traffic (red arrow). In addition, a 165m-long lane needed for merging to main traffic stream with 60 km/h cannot be installed with this alternative.

Even if combining with the road from Thiri Han Tar Housing Project, the traffic will be stopped by the signal at the existing intersection.

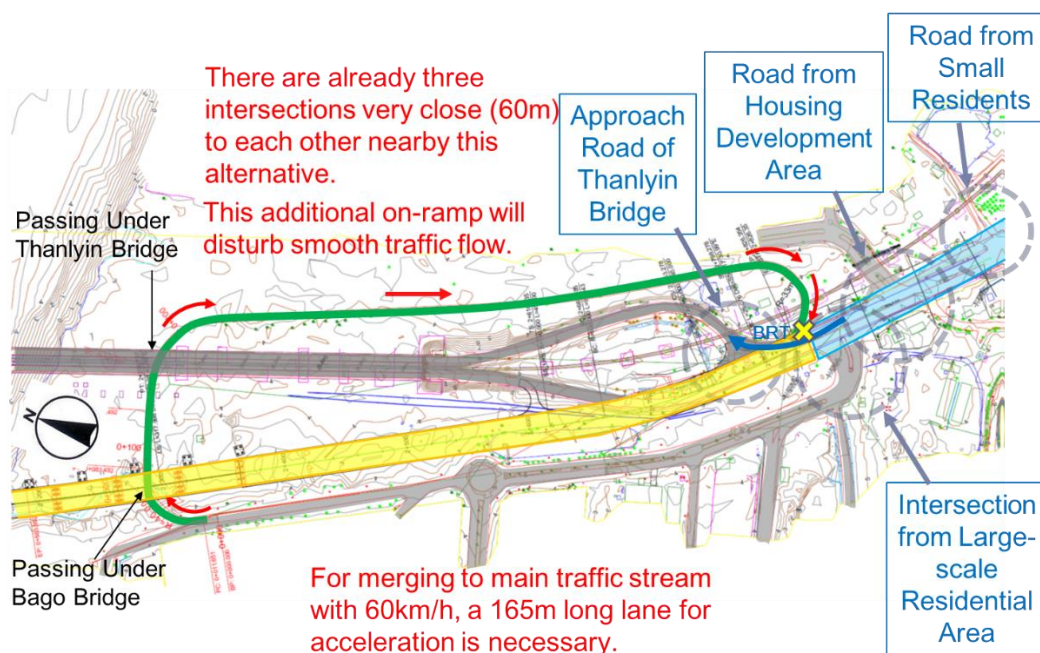

(a) Conflicts with Adjacent Intersections

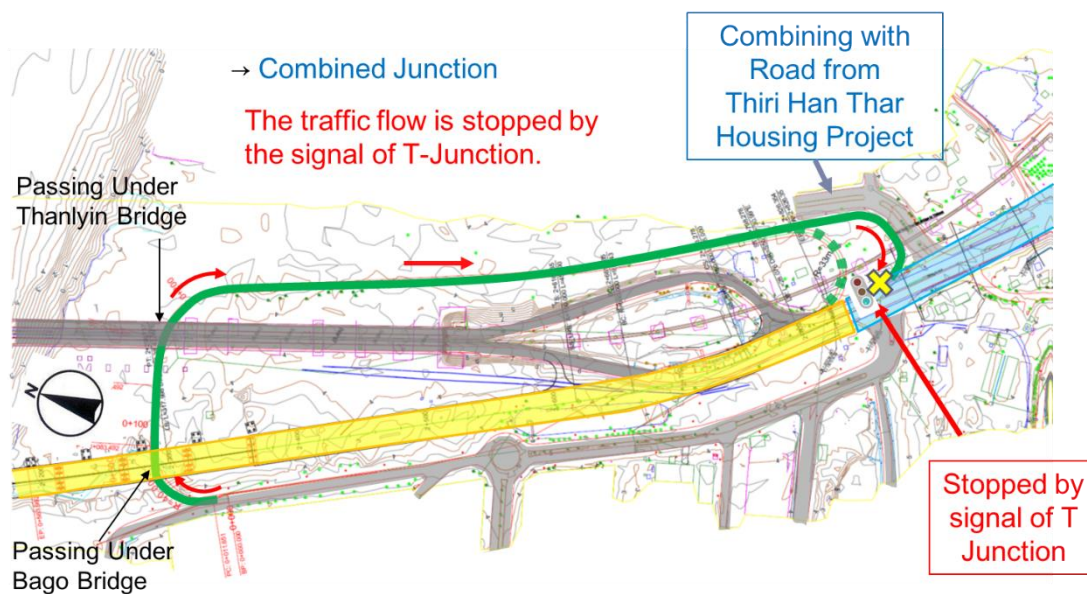

(b) Interference with Existing Intersection

Source: JICA Study Team

Figure 2-40 Concerns of At-grade On-ramp

Since this additional at-grade on-ramp will disturb smooth traffic flow, it is recommended to make an on-ramp merging at further north from the existing intersection.

6) Other Options of On-ramp

A couple of options of on-ramp with similar effect on traffic-jam mitigation are introduced in this section.

Figure 2-41 shows another option of on-ramp from West Side.

Instead of going backward for at-grade connection, this option makes a loop-turn by under-passing Thanlyin Bridge twice, climbing up to the Bridge.

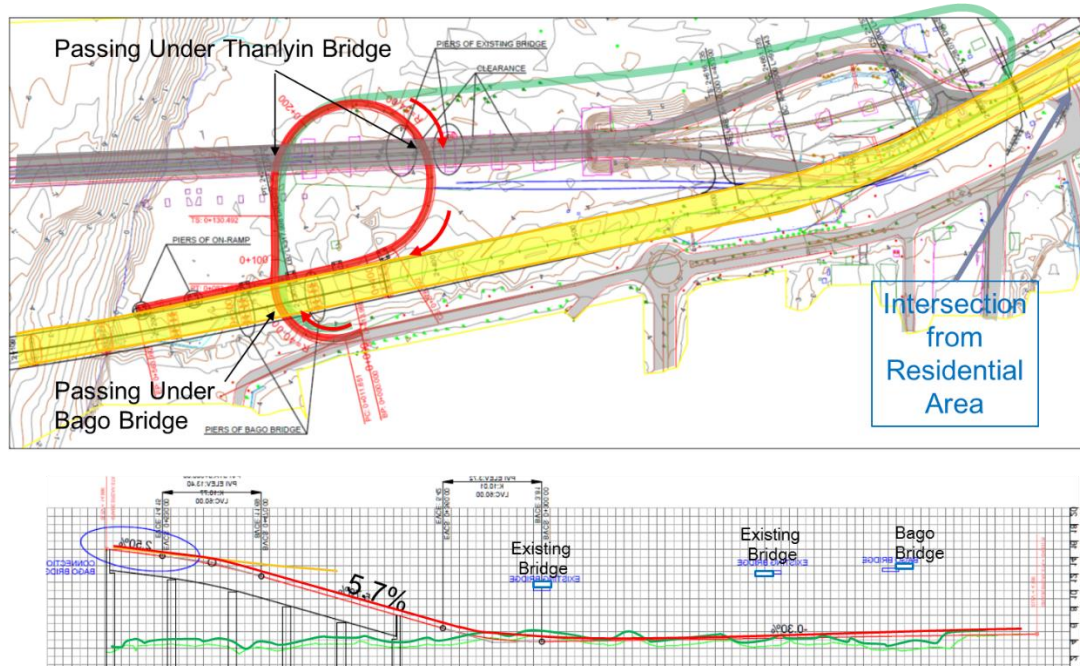

Source: JICA Study Team

Figure 2-41 Other option: On-ramp directly to Bago Bridge

The structural features of the option is as follows:

- Length of Bridge: 188 m
- Length of Embankment with structure wall: 391 m
- Road width: 5.75 m (1-lane)

The preliminarily estimated construction cost is approximately USD 6 million, which is still cost effective.

The following Figure 2-42 shows the other option of on-ramp which is starting at the access road of the new residential area, passing over the township road, the new approach road of Bago Bridge and the existing approach road of Thanlyin Bridge.

The structural features of this option are as follows:

- Length of Bridge: 688 m
- Length of Embankment with structure wall: 163 m
- Road width: 5.75 m (1-lane)

The preliminarily estimated construction cost is approximately USD 18 million, which is not cost effective comparing to the at-grade option.

In this option, there is a concern in public benefit since the on-ramp will be almost exclusively used by the traffic from the new residential area.

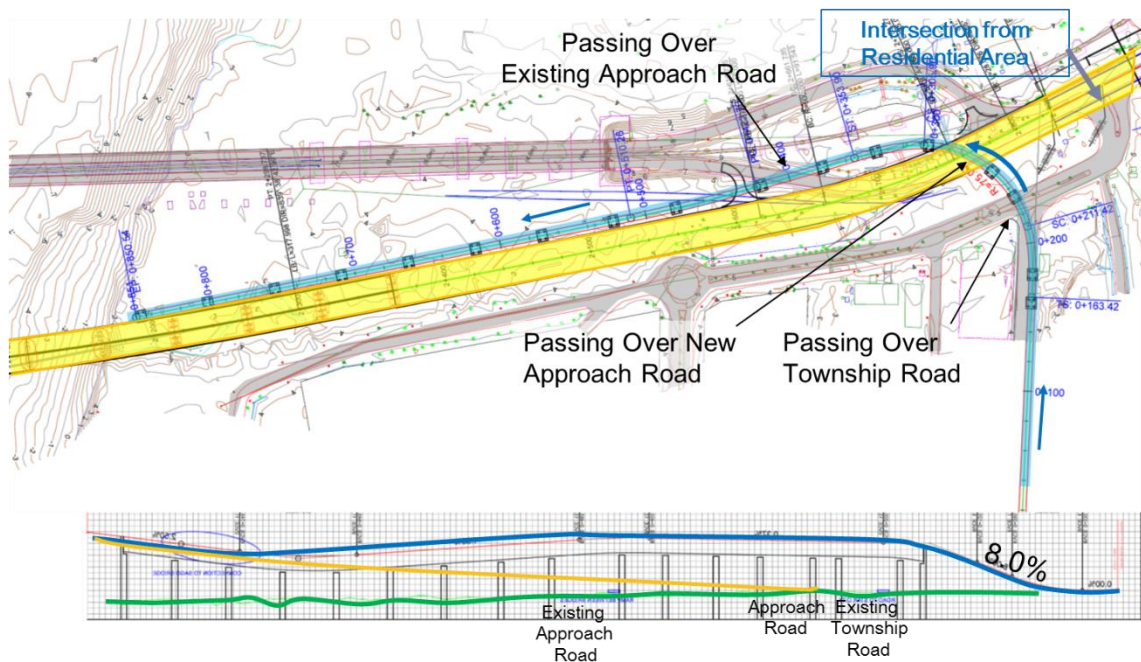

Source: JICA Study Team

Figure 2-42 Other option: On-ramp directly from Residential Area

7) Other Points to be considered with on-ramp flyover option

In addition to the construction of on-ramp flyover, three major consideration points for the intersection from residential area are issued.

- a) For the smooth traffic flow from Bridge to Thilawa, installation of right-turn-only lane to allow the commuting trips back to the new residential area will be effective.

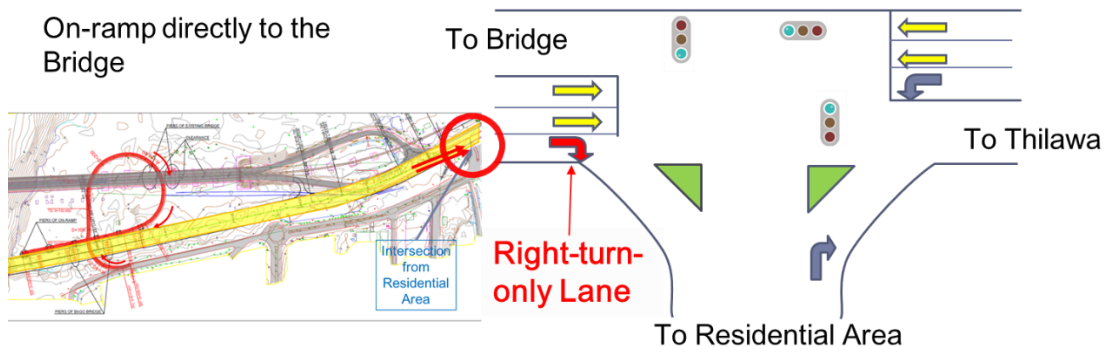

Source: JICA Study Team

Figure 2-43 Right-turn only Lane to be added to Existing Intersection

- b) Because the connection between the approach of on-ramp flyover and Township Road is important, the coordination with Thanlyin Township is necessary.

c) Since the on-ramp is located in Myanmar Railway Compound, negotiation with Myanmar Railways is necessary.

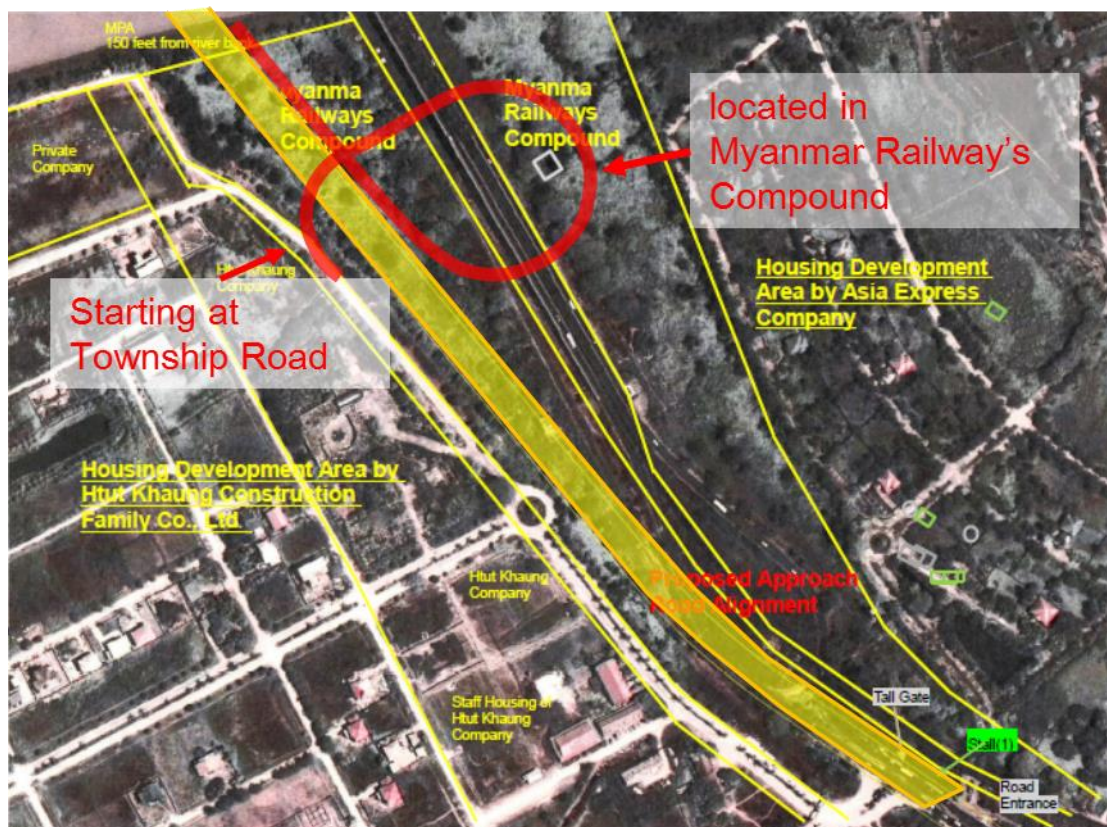

Source: JICA Study Team

Figure 2-44 Land Owners in Area surrounding to Thanlyin Side of Bago Bridge

(2) Preliminary Design of On-ramp

i) Preliminary Design for Approach Section of On-ramp

The preliminary design for approach section of on-ramp was conducted according to the results of alternative study for on-ramp.

Since the design vehicle of the on-ramp is passenger vehicles from residence area, it is desirable to adopt the conditions for a minor on-ramp.

The conditions for a minor on-ramp is particularly mentioned in Japanese Road Design Standards; therefore, the conditions for the on-ramp are adopted by comparing AASHTO with Japanese Road Design Standards.

The conditions for the on-ramp are shown in Table 2-40 below.

Table 2-40 Conditions for Preliminary Design of On-ramp

Item	AASHTO	Japanese Road Design Standards	Recommendation for this study	Remarks
Road Classification	Urban Arterials	Class D	Class D	
Design Speed (km/hr)	40	40	40	
Width of Lane (m)	2.7 ~ 3.6	3.25	3.25	
Width of Right Shoulder (m)	0.3 ~ 3.6	1.0	1.0	
Vertical Clearance	4.5	4.5	4.5	
Minimum Horizontal Curve Radius (m)	38	40	40	
Cross slope	2.0%	2.0%	2.0%	
Maximum Vertical Grades	8.0%	8.0%	5.7%	

Source: JICA Study Team

The major controls of alignment and profile are shown below.

- Piers of Thanlyin Bridge and new Bago River Bridge.
- Clearance of Thanlyin Bridge and new Bago River Bridge.
- Maximum radius 40m which can bypass the piers of Bago Bridge was adopted at the entrance of on-ramp.
- Maximum radius 54m which can bypass the piers of Thanlyin Bridge was adopted at loop portion.
- Installing 165m-long straight portion enough for merging to main traffic.
- A longitudinal gradient of Bago Bridge, 2.5%, was adopted at the connecting area to Bago Bridge.

The plan and profile are shown in Figure 2-45.

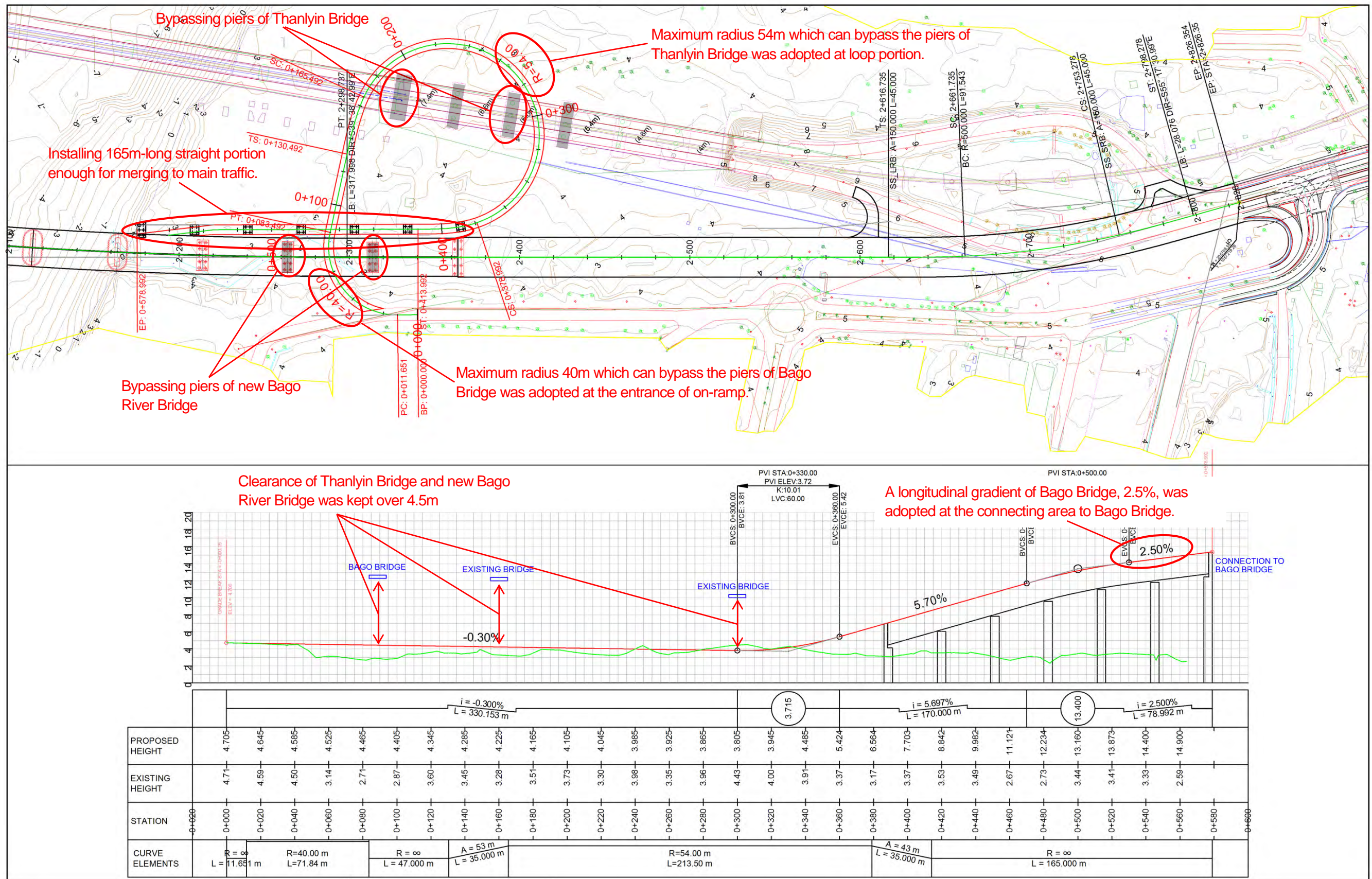

Source: JICA Study Team

Figure 2-45 Plan and Profile of On-ramp

The major contents of cross section design are shown below.

- The width of lane was adopted 3.25m in accordance with the Japanese Road Design Standards.
- The width of right shoulder, 1.0m, was adopted for emergency passing as shown in Figure 2-46 below.

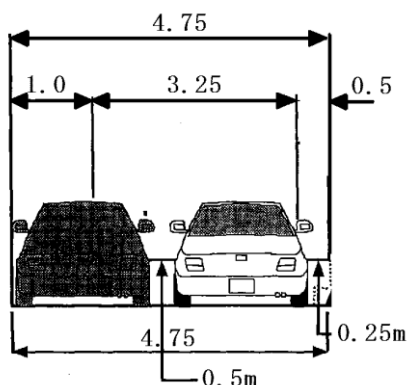

Source: JICA Study Team (Refer to Japanese Road Design Standards)
 Note: Since this figure follows traffic regulation of Japan, vehicle keeps to the left.
 In Myanmar, vehicle keeps to the right.

Figure 2-46 Carriageway and Shoulder

The typical cross section is shown in Figure 2-47 below.

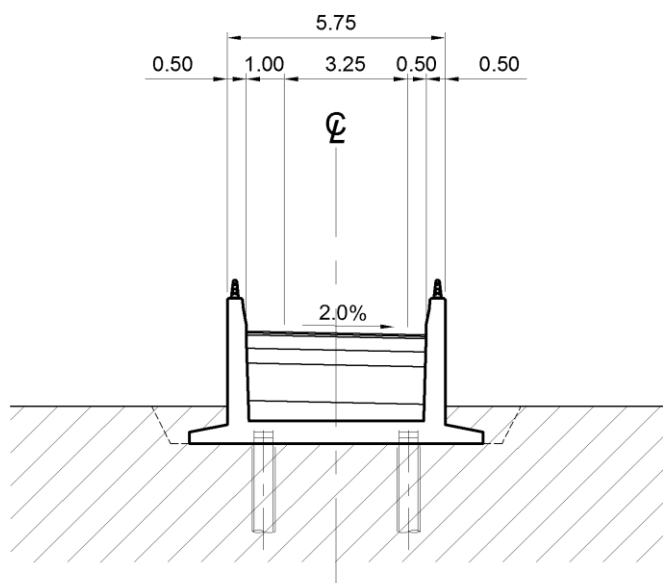

Source: JICA Study Team

Figure 2-47 Typical Cross Section for Approach Section of On-ramp

Since this study is the feasibility study stage only, the following matters should be considered in detailed design stage.

- Since alignment and profile were arranged based on the information of preliminary survey and satellite map in this study, revision of the alignment and profile are necessary based on detailed survey in the next stage.

ii) Preliminary Design of Bridge

a) Structural Guidelines

For preliminary design of the flyover bridge, AASHTO is applied as a standard design code as applied in preliminary design of Main Bridge.

b) Selection of Structure Types

1) General

The route of the elevated Access Spur Road can be divided into following three sections as shown in the following:

- Approach Section of On-ramp
- Structural Section of On-ramp

Comparative studies for selecting structure type were conducted for the above-mentioned sections of the route. In addition, a comparative study for selecting foundation was also performed.

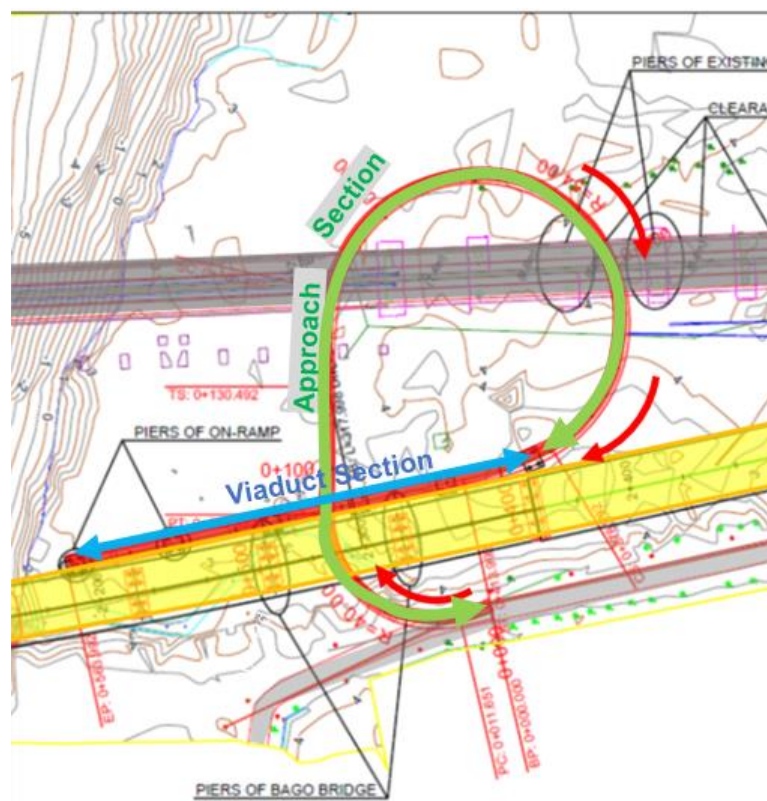

Source: JICA Study Team

Figure 2-48 Route Alignment of On-ramp

2) Comparative Study of Viaduct Section

As discussed in Section 2.2.3(2) of Straight Flyover in Yangon Side, a comparative study of the viaducts section is in the straight sections was conducted among the structure types of steel I girder, PC-T girder and PC Hollow slab. PC-T girder is the most recommended among the alternatives because it is superior in construction cost and construction period.

3) Comparative Study of Foundation

As discussed in Section 2.2.3(2) of Straight Flyover in Yangon Side, Cast-in-place PC Pile is the most recommended among the alternatives because it is superior in workability and usage of common temporary facilities and machines with the construction of the main bridge.

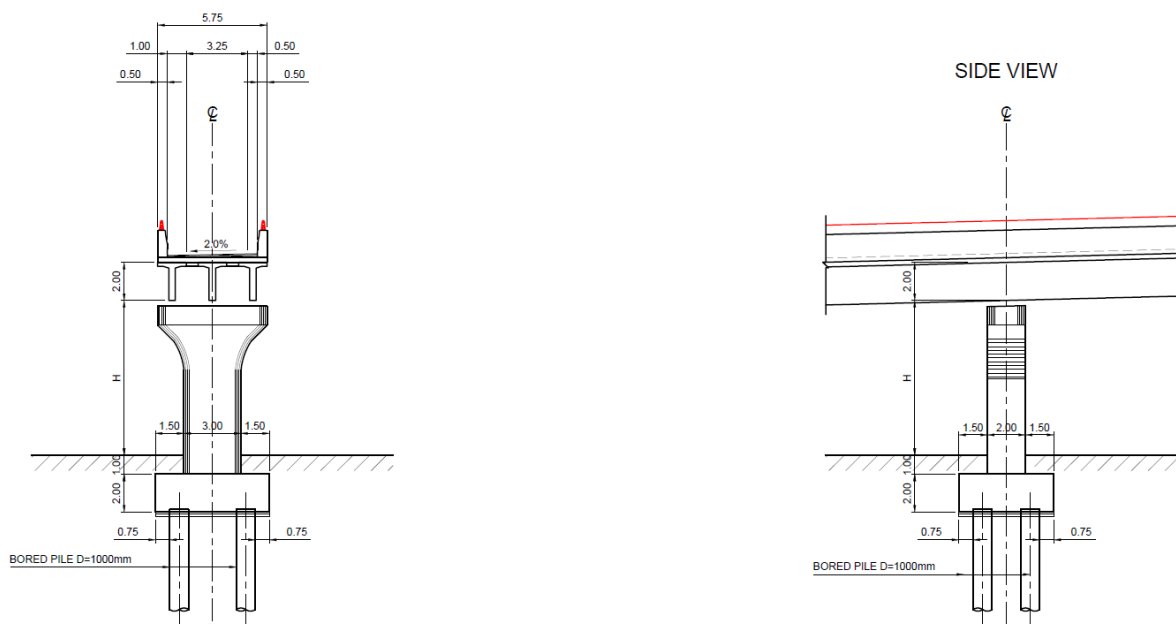

Source: JICA Study Team

Figure 2-49 Typical Cross Section of Viaduct Section

4) Approach Section of On-ramp

The structure type of the Approach section of on-ramp is selected as the same as the structure of the approach section of Main Bridge.

5) Conclusion and Recommendation

In consequence of this comparative study, the recommended structure types are summarized as follows:

- Standard Sections of Viaducts: PC-T Girder and RC Pier with PC Piles.
- Embankment Section of Road: Embankment with retaining walls.

Figure 2-50 shows the recommended structure types on the route alignment.

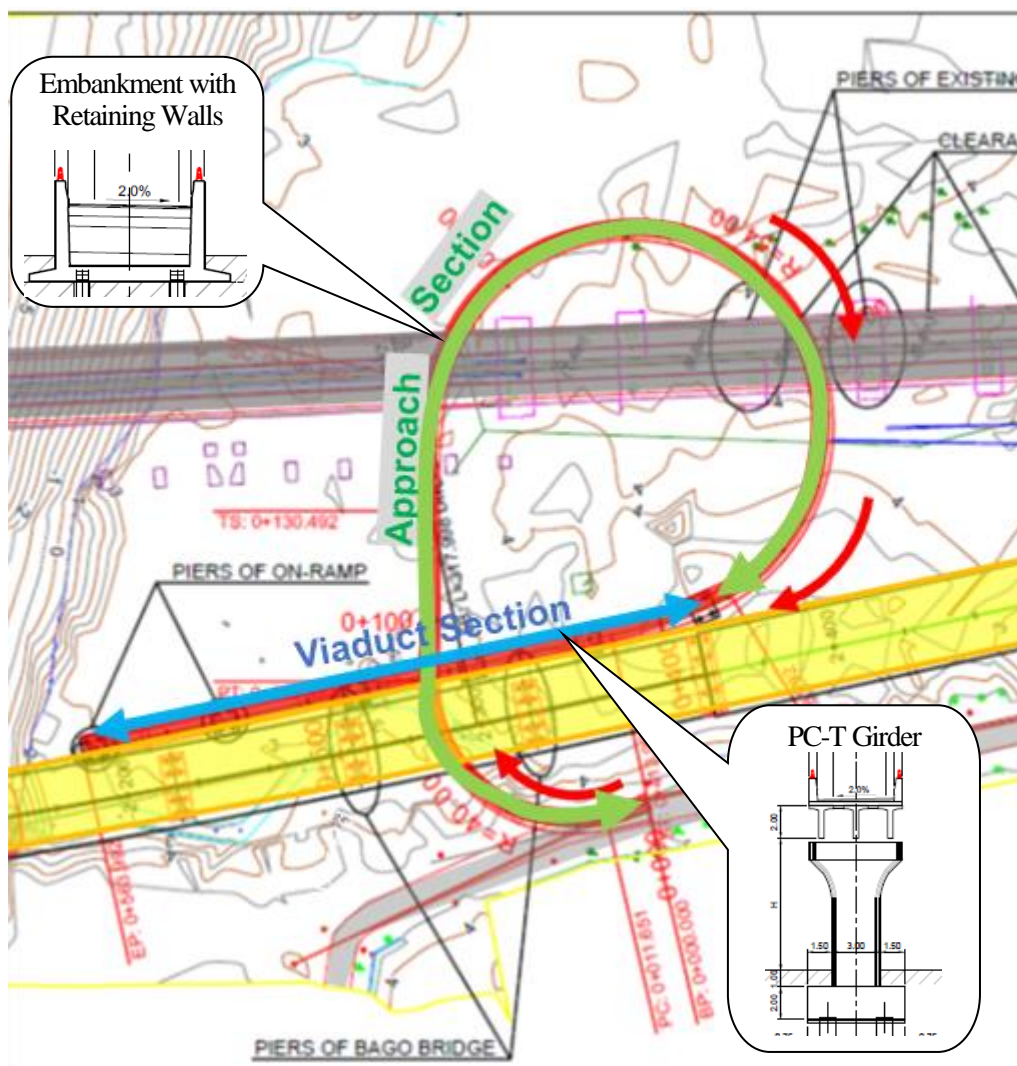

Source: JICA Study Team

Figure 2-50 Summary of Recommended Structure Types

c) Span Arrangement and Dimensions of Structural Members

c-1) General

In this clause, the span arrangement and the dimensions of structure members of the Elevated Access Spur Road is discussed based on the conditions and the recommended structure type in the previous sections.

c-2) Appropriate Span Length of Viaduct

1) General

In consequence of the comparative study for selecting structure type discussed in the previous sections, the recommended structure types are summarized as follows:

- Viaduct Sections of Viaducts: PC-T Girder and RC Pier with Cast-in-place RC Piles.
- Embankment Section of Road: Embankment with retaining walls.

(Note: as stated in the previous section, the structure in the embankment section will be optimized based on the result of geological survey in D/D stage)

In this section, appropriate span lengths of selected bridge types are discussed in order to propose an appropriate span arrangement.

2) Appropriate Span Length

In general, the economically optimal spans for PC-T girder and Steel I girder are 30m-35m and 45-65m, respectively.

As for PC-T girder, one optimum span of 30 m is recommended to be selected in order to utilize the pre-fabricated girders with the same length except for the section at the beginning and the end next to the embankment sections.

3) Boundary between Viaduct and Embankment

The height of the viaducts from the ground level at the boundary to the embankment sections is defined as 4m from the existing ground level in consideration of economical height of the embankment and the structural resistance of the retaining wall comparing to the structural viaduct.



Source: JICA Study Team

Figure 2-51 Dimensions of Abutment and Height of Embankment

4) Proposed Span Arrangement

Figure 2-52 shows the general views of the flyover with the proposed span arrangement superimposed on the horizontal and vertical profiles based on the above-mentioned considerations.

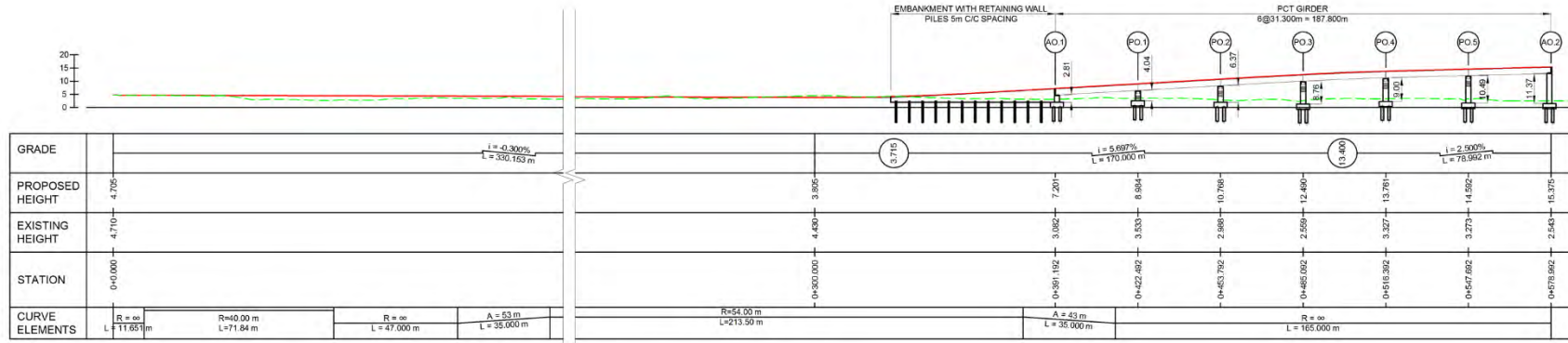

LONGITUDINAL SECTION
SCALE : 1:1500

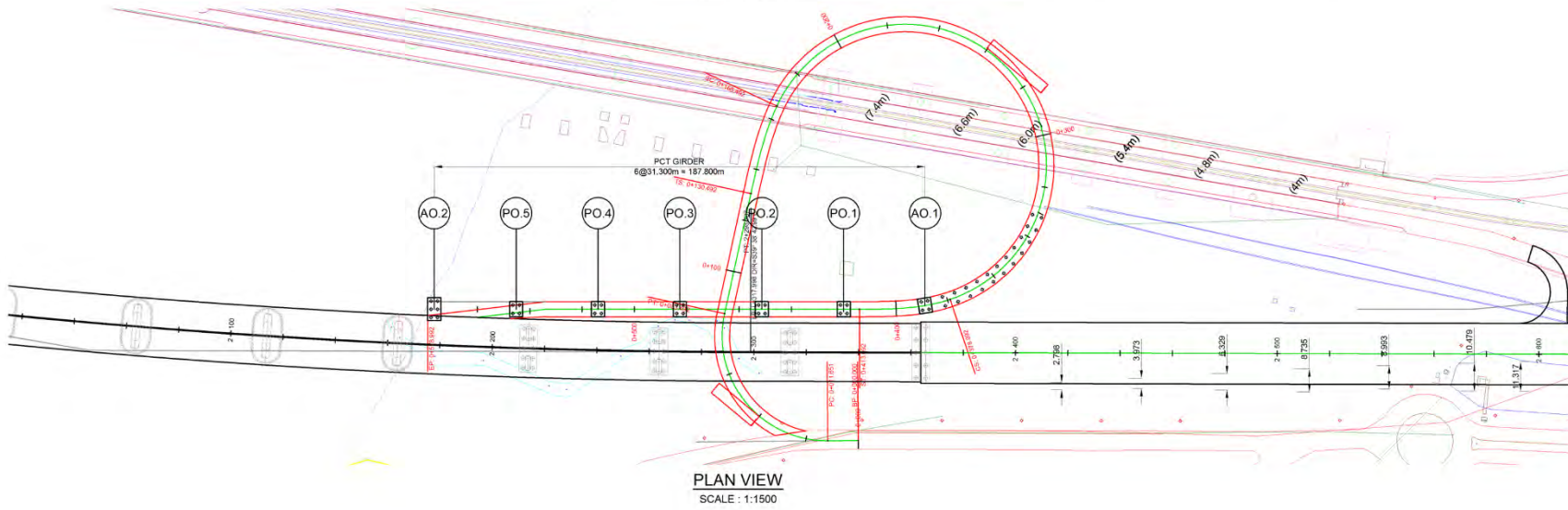

Source: JICA Study Team

Figure 2-52 General View of Flyover (1)

(3) Adjustment Plan for Intersection of Thilawa Access Road

According to the plan for intersection improvement of Thilawa Access Road, the plan for approach section of Bago Bridge was adjusted.

- The length of adjustment (storage lane and taper) was 108m based on the drawing of Thilawa Access Road Project (Infrastructure Development Project in Thilawa Area Phase II).
- The adjustment section is between Sta.2+718 and Sta.2+826.

The drawing of adjustment plan is shown in Figure 2-53 below.

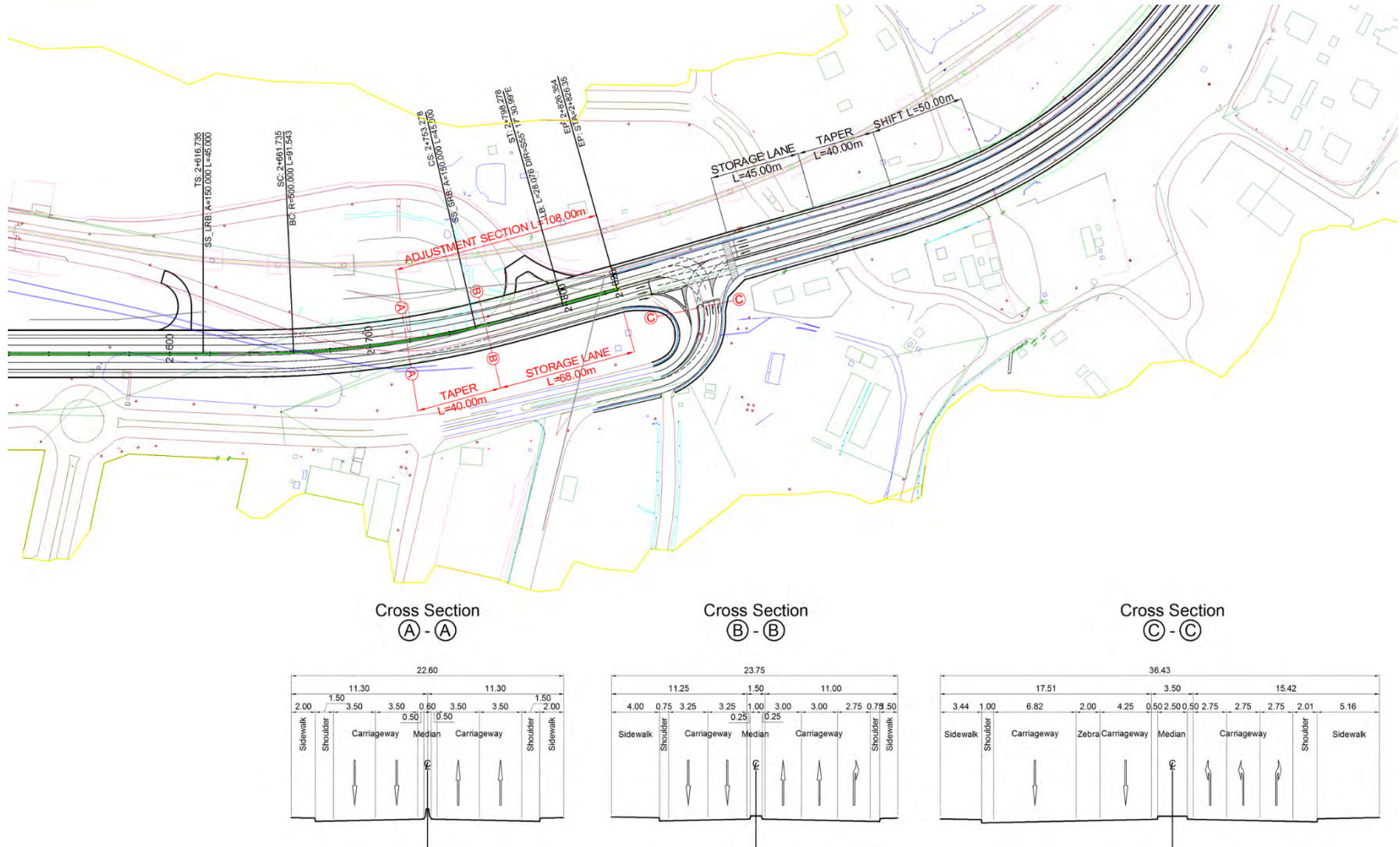

Source: Thilawa Access Road Project (Infrastructure Development Project in Thilawa Area Phase II)

Figure 2-53 Adjustment Plan for Intersection of Thilawa Access Road