

資料一6 サイト調査結果一覧(無線端末設置候補地)

6. サイト調査結果一覧(無線端末設置候補地)

Summary of the Site Survey for the Base Radio Stations (Group-B)

Shows the site deleted.

Site Code	ODPEM Name	Official name	GPS Receiver Data (DD°MM'SS.S")		Height Above the See Level Google Earth Data (m)	LOS of Radio Repeater Station				Voice Call Merit Test (Sensitivity of Transceiver)		Electric Field Strength Measurement		Result of Electric Field Strength	Antenna Installation Plan&Method ·Type-A: Roof top mount ·Type-B: Roof edge mount ·Type-C: Ground Mast mount ·Type-D: Indoor Whip Antenna				Public Property	Site Design Result	Decision of Site Survey Result	
			Longitude	Latitude		Name of Target Repeater	Status (Visible/ Not Visible)	Path Length Between Repeater and Site (km)	Direction to Target Repeater (Degree)	Antenna Gain	Result	Antenna Gain	Field Strength (Measurement Level) (dBm)		Installation Type	Antenna Height (GL+m)	Feeder Length Out door (m)	Feeder Length Indoor (m)				
Min001	Portmore Municipal	Deleted(duplication Par004)																				
Min002	St. Catherine PDC	Deleted(same as St. Catherine Parish Council)																				
Min003	Earthquake Unit	The University of the west indies Earthquake Unit	18°00'16.2"N	76°44'57.5"W	182	Rep015	Not Visible	14.59	304	0	5	1.15	-100	OK	Type-A	10	30	4	OK	OK		
Min004	KSAC	KSAC	17°58'19.59"N	76°47'19.11"W	11	Rep012	Visible	10.32	260	0	5			OK	Type-B	13	15	5	OK	OK		
Min005	MET Office	Meteorological Office (MET Office)	17°56'15.2"N	76°46'42.9"W	5	Rep012	Not Visible	11.66	277	0	5	1.15	-95	OK	Type-D	12	2	2	OK	OK		
Min006	NSWMA	National Solid Waste Management Authority	18°00'17.74"N	76°47'37.29"W	74	Rep014	Visible	12.62	52	0	5			OK	Type-B	22	50	5	OK	OK		
Min007	Ministry of Local Government	Ministry of Local Government	18°00'24.13"N	76°48'47.71"W	43	Rep014	Not Visible	14.01	60	0	5			OK	Type-B	8	15	5	OK	OK		
Min008	St. Thomas PDC	St. Thomas Parish Disaster Committee	17°52'51.65"N	76°24'32.96"W	10	Rep010	Not Visible	10	274	0	5			OK	Type-C	8	30	10	OK	OK		
Min009	NWA	National Works Agency	18°00'28.62"N	76°47'57.89"W	70	Rep014	Not Visible	12.63	52	0	5			OK	Type-B	13.5	10	10	OK	OK		
Min010	WRA	Water Resource Authority (WRA)	18°01'11.8"N	76°44'55.6"W	207	Rep015	Not Visible	13.66	300	0	5	1.15	-97	OK	Type-B	4	10	5	OK	OK		

Summary of the Site Survey for the Base Radio Stations (Group-B)
Shows the site deleted.

Items			GPS Receiver Data (DD°MM'SS.S")		Height Above the See Level	LOS of Radio Repeater Station				Voice Call Merit Test (Sensitivity of Transceiver)		Electric Field Strength Measurement		Result of Electric Field Strength	Antenna Installation Plan&Method -Type-A: Roof top mount -Type-B: Roof edge mount -Type-C: Ground Mast mount -Type-D: Indoor Whip Antenna				Public Property	Site Design Result	Decision of Site Survey Result
Site Code	ODPEM Name	Official name	Longitude	Latitude	Google Earth Data (m)	Name of Target Repeater	Status (Visible/ Not Visible)	Path Length Between Repeater and Site (km)	Direction to Target Repeater (Degree)	Antenna Gain	Result	Antenna Gain	Field Strength (Measurement Level) (dBm)		Installation Type	Antenna Height (GL+m)	Feeder Length Out door (m)	Feeder Length Indoor (m)			
Fir001	York Park	York Park Fire Station - Divisional Headquarters	17°58'54.6"N	76°47'31.0"W	39	Rep015	Not Visible	12.93	320	1.15	5			OK	Type-B	10	20	5	OK	OK	
Fir002	Half Way Tree	Half Way Tree Fire Station	18°00'36.08"N	76°47'52.29"W	73	Rep014	Not Visible	12.66	52	0	5			OK	Type-B	15	10	15	OK	OK	
Fir003	Trench Town	Trench Town Fire Station	17°58'53.42"N	76°48'23.47"W	21	Rep012	Not Visible	9.27	248	0	5	1.15	-75	OK	Type-B	10	20	5	OK	OK	
Fir004	Rollington Town	Rollington Town Fire Station	17°58'41.6"N	76°45'59.5"W	33	Rep015	Not Visible	14.52	320	0	5	1.15	-100	OK	Type-B	9	20	3	OK	OK	
Fir005	Stony Hill	Stony Hill Fire Station	18°04'56.67"N	76°47'46.63"W	439	Rep015	Not Visible	7.84	361	1.15	5	1.15	-90	OK	Type-B	15	20	2	OK	OK	
Fir006	Port Royal	Port Royal Fire Station	17°56'20.6"N	76°50'31.1"W	5	Rep012	Not Visible	5.16	285	0	5	1.15	-88	OK	Type-B	4	10	10	OK	OK	
Fir007	Fire Boat	Fire Boa (Kingston)	17°57'57.33"N	76°48'07.22"W	3	Rep012		9.23	260												
Fir008	Morant Bay	Morant Bay Fire Station	17°52'53.11"N	76°24'27.99"W	17	Rep010	Not Visible	11.37	274	0	5	1.15	-90	OK	Type-C	8	25	10	OK	OK	
Fir009	Yallahs	Yallahs Fire Station	17°52'50.6"N	76°35'01.8"W	28	Rep011	Not Visible	9.84	351	11.9	5	1.15 11.9	-100 -85	OK	Type-B	8	30	3	OK	OK	
Fir010	St. Anns Bay	St. Anns Bay Fire Station	18°26'12.9"N	77°11'58.4"W	10	Rep001	Not Visible	8.89	237	0	5	1.15	-108	OK	Type-B	4	10	4	OK	OK	

Summary of the Site Survey for the Base Radio Stations (Group-B)

Shows the site deleted.

Items			GPS Receiver Data (DD°MM'SS.S")		Height Above the See Level	LOS of Radio Repeater Station				Voice Call Merit Test (Sensitivity of Transceiver)		Electric Field Strength Measurement		Result of Electric Field Strength	Antenna Installation Plan&Method •Type-A: Roof top mount •Type-B: Roof edge mount •Type-C: Ground Mast mount •Type-D: Indoor Whip Antenna			Public Property	Site Design Result	Decision of Site Survey Result
Site Code	ODPEM Name	Official name	Longitude	Latitude	Google Earth Data (m)	Name of Target Repeater	Status (Visible/ Not Visible)	Path Length Between Repeater and Site (km)	Direction to Target Repeater (Degree)	Antenna Gain	Result	Antenna Gain	Field Strength (Measurement Level) (dBm)		Installation Type	Antenna Height (GL+m)	Feeder Length Out door (m)	Feeder Length Indoor (m)		
Fir011	Ocho Rios	Ocho Rios Fire Station	18°24'02.66"N	77°06'01.32"W	40	Rep002	Not Visible	4.16	207	0	5	1.15	-87	OK	Type-C	6	20	7	OK	OK
Fir012	Browns Town	Brown's Town Fire Station	18°23'48.87"N	77°22'02.38"W	430	Rep001	Not Visible	10.2	92	1.15	5	11.9	-102	OK	Type-B	15	30	10	OK	OK
Fir013	Fire Boat (Ocho Rios)	Fire Boat (Ocho Rios Police Station)	18°24'32.27"N	77°06'35.79"W	0	Rep002	Not Visible	7.27	226	0	5			OK	Type-B	3	10	5	OK	OK
Fir014	Port Maria	Portmaria Fire Station	18°21'33.33"N	76°53'51.88"	13	Rep003	Not Visible	19.64	200°	0	5	1.15	-80	OK	Type-B	4	10	5	OK	OK
Fir015	Annotto Bay	Annotto Bay Fire Station	18°16'13.5"N	76°46'45.9"W	15	Rep003	Not Visible	18.92	287	0	5	1.15	-83	OK	Type-B	5	10	5	OK	OK
Fir016	Port Antonio	Port Antonio Fire Station- Divisional headquarter	18°10'38.65"N	76°27'18.20"W	16	Rep006	Not Visible	2.94	260	1.15	5	11.9	-105	OK	Type-A	12	20	8	OK	OK
Fir017	Buff Bay	Buff Bay Fire Station	18°13'58.13"N	76°39'34.39"W	12	Rep014	Not Visible	7.82	112	11.9	5	11.9	-95	OK	Type-A	13	20	5	OK	OK
Fir018	Falmouth	Falmouth Fire Station- Headquarter	18°29'27.04"N	77°39'06.01"W	2	Rep029	Visible	13.48	101	0	5	1.15	-85	OK	Type-C	12	20	5	OK	OK
Fir019	Spanish Town	Spanish Town Fire Station	17°59'31.01"N	76°57'08.68"W	32	Rep020	Not Visible	11.45	1.5	0	5			OK	Type-B	9.5	15	2	OK	OK
Fir020	Old Harbour	Old Harbour Fire Station	17°56'00.01"N	77°06'35.25"W	28	Rep016	Not Visible	8.65	320	0	5			OK	Type-B	10	10	10	OK	OK

Summary of the Site Survey for the Base Radio Stations (Group-B)

Shows the site deleted.

Items			GPS Receiver Data (DD°MM'SS.S")		Height Above the See Level	LOS of Radio Repeater Station				Voice Call Merit Test (Sensitivity of Transceiver)		Electric Field Strength Measurement		Result of Electric Field Strength	Antenna Installation Plan&Method •Type-A: Roof top mount •Type-B: Roof edge mount •Type-C: Ground Mast mount •Type-D: Indoor Whip Antenna			Public Property	Site Design Result	Decision of Site Survey Result
Site Code	ODPEM Name	Official name	Longitude	Latitude	Google Earth Data (m)	Name of Target Repeater	Status (Visible/ Not Visible)	Path Length Between Repeater and Site (km)	Direction to Target Repeater (Degree)	Antenna Gain	Result	Antenna Gain	Field Strength (Measurement Level) (dBm)		Installation Type	Antenna Height (GL+m)	Feeder Length Out door (m)	Feeder Length Indoor (m)		
Fir021	Linstead	Linstead Fire Station	18°08'49.70"N	77°02'05.57"W	119	Rep020	Visible	9.86	121	0	5			OK	Type-B	6	10	5	OK	OK
Fir022	Waterford	Waterford Fire Station	17°57'48.99"N	76°52'05.19"W	5	Rep012	Visible	4.19	209	0	5			OK	Type-B	12	20	5	OK	OK
Fir023	May Pen	May Pen Fire Station	17°57'53.3"N	77°14'25.24"W	76	Rep016	Not Visible	9.6	65	0	5	1.15	-105	OK	Type-C	5	20	10	OK	OK
Fir024	Frankfield	Frankfield Fire Station	18°08'40.36"N	77°21'51.31"W	300	Rep018	Not Visible	17.44	300	1.15	5	11.9	-107	OK	Type-B	13	20	10	OK	OK
Fir025	Mandeville	Mandeville Fire Station- Divisional Headquarters	18°02'26.46"N	77°30'28.79"W	618	Rep019	Not Visible	10.23	300	0	5	1.15	-85	OK	Type-B	8	40	8	OK	OK
Fir026	Christiana	Christiana Fire Station	18°10'19.26"N	77°29'28.64"W	823	Rep018	Not Visible	6.43	345	0	5	1.15	-78	OK	Type-B	13	20	5	OK	OK
Fir027	Montego Bay	Free Port Fire Department Head Quarter	18°28'14.94"N	77°55'27.42"W	5	Rep027	Visible	8.86	140	1.15	5	1.15	-85	OK						
Fir028	Ironshore	Ironshore Fire Station	18°30'33.2"N	77°53'39.9"W	10	Rep028	Not Visible	18.24	10	0	5			OK	Type-B	5	10	8	OK	OK
Fir029	Black River	Black River Fire Station Divisional Head Quarters	18°01'28.41"N	77°50'51.06"W	2	Rep019	Not Visible	28	76	0	5	1.15	-98	OK	Type-B	10	20	10	OK	OK
Fir030	Junction	Junction Fire Station	17°54'19.3"N	77°36'22.7"W	366	Rep022	Visible	8.73	284	0	5	1.15	-93	OK	Type-B	10	20	4	OK	OK

Summary of the Site Survey for the Base Radio Stations (Group-B)
Shows the site deleted.

Items			GPS Receiver Data (DD°MM'SS.S")		Height Above the See Level	LOS of Radio Repeater Station				Voice Call Merit Test (Sensitivity of Transceiver)		Electric Field Strength Measurement		Result of Electric Field Strength	Antenna Installation Plan&Method ·Type-A: Roof top mount ·Type-B: Roof edge mount ·Type-C: Ground Mast mount ·Type-D: Indoor Whip Antenna			Public Property	Site Design Result	Decision of Site Survey Result
Site Code	ODPEM Name	Official name	Longitude	Latitude	Google Earth Data (m)	Name of Target Repeater	Status (Visible/ Not Visible)	Path Length Between Repeater and Site (km)	Direction to Target Repeater (Degree)	Antenna Gain	Result	Antenna Gain	Field Strength (Measurement Level) (dBm)		Installation Type	Antenna Height (GL+m)	Feeder Length Out door (m)	Feeder Length Indoor (m)		
Fir031	Santa Cruz	Santa Cruz Fire Station	18°03'23.51"N	77°41'56.47"W	8	Rep019	Not Visible	12	71	0	5	1.15	-75	OK	Type-B	6.5	10	5	OK	OK
Fir032	Savanna-La-Mar	Savanna-La-Mar Fire Station	18°12'55.33"N	78°08'06.39"W	4	Rep023	Not Visible	17.33	105	1.15	5	1.15	-100	OK	Type-B	6	10	6	OK	OK
Fir033	Negril	Negril Fire Station	18°16'41.92"N	78°20'38.44"W	21	Rep024	Not Visible	9.27	248	0	5	1.15	-98	OK	Type-B	10	20	5	OK	OK
Fir034	Lucea	Lucea Fire Station- Headquarters	18°26'48.81"N	78°10'20.95"W	9	Rep026	Visible	10.5	130	0	5	1.15	-84	OK	Type-B	10	20	5	OK	OK
Pol001	Spanish Town	Spanish Town Police Station	17°59'30.22"N	76°57'01.65"W	29	Rep020	Not Visible	11.45	1.5	0	5	1.15	-92	OK	Type-B	5	10	7	OK	OK
Pol003	May Pen	May Pen Police Station	17°57'54.4"N	77°14'21.5"W	63	Rep016	Not Visible	9.6	65	0	5	1.15	-105	OK	Type-B	14	10	2	OK	OK
Pol004	Port Maria	Portmaria Command Center	18°22'21.26"N	76°53'28.36"W	4	Rep003	Not Visible	11.59	200	0	5	1.15	-100	OK	Type-B	10	20	5	OK	OK
Pol008	Castleton	Castleton Police Station	18°10'20.27"N	76°49'26.19"W	145	Rep015	Not Visible	11.78	195	11.9	4	1.15	-95	OK	Type-B	10	20	8	OK	OK
Pol019	Buff Bay	Buff Bay Police Station	18°13'55.02"N	76°39'37.17"W	10	Rep014	Not Visible	7.82	112	11.9	5	11.9	-98	OK	Type-B	8	20	4	OK	OK
Pol020	Old Harbour	Old Harbour Police Station	17°56'18.18"N	77°06'41.54"W	31	Rep016	Not Visible	8.56	320	1.15	5			OK	Type-B	10	10	15	OK	OK

Summary of the Site Survey for the Base Radio Stations (Group-B)

Shows the site deleted.

Items			GPS Receiver Data (DD°MM'SS.S")		Height Above the See Level	LOS of Radio Repeater Station				Voice Call Merit Test (Sensitivity of Transceiver)		Electric Field Strength Measurement		Result of Electric Field Strength	Antenna Installation Plan&Method •Type-A: Roof top mount •Type-B: Roof edge mount •Type-C: Ground Mast mount •Type-D: Indoor Whip Antenna			Public Property	Site Design Result	Decision of Site Survey Result
Site Code	ODPEM Name	Official name	Longitude	Latitude	Google Earth Data (m)	Name of Target Repeater	Status (Visible/ Not Visible)	Path Length Between Repeater and Site (km)	Direction to Target Repeater (Degree)	Antenna Gain	Result	Antenna Gain	Field Strength (Measurement Level) (dBm)		Installation Type	Antenna Height (GL+m)	Feeder Length Out door (m)	Feeder Length Indoor (m)		
Pol021	Old Harbour Bay	Old Harbour Bay Police Station	17°54'24.67"N	77°05'47.75"W	3	Rep016	Not Visible	12.1	326	0	5			OK	Type-B	6	10	10	OK	OK
Pol025	Mavis Bank	Mavis Bank Police Station	18°01'47.47"N	76°39'26.92"W	700	Rep014	Not Visible	7.11	317	0	5			OK	Type-B	10	10	5	OK	OK
Pol032	Cedar Valley	Cedar Valley Police Station	17°59'41.9"N	76°35'16.7"	613	Rep011	Not Visible	3.59	170	0	5	1.15	-90	OK	Type-B	8.2	20	8.2	OK	OK
Pol037	Ellestson Road	Ellestson Road Police Station	17°56'08.00"N	76°46'44.86"W	14	Rep012	Not Visible	11.71	261	0	5			OK	Type-B	6	10	5	OK	OK
Pol040	Port Royal	Port Royal Police Station	17°56'20.0"N	76°50'35.0"W	3	Rep012	Not Visible	5.1	285	0	5	1.15	-90	OK	Type-C	8	20	5	OK	OK
Pol041	Norman Manley	Norman Manley International Airport Fire Station	17°56'15.3"N	76°46'38.1"W	4	Rep012	Not Visible	11.54	277	0	5	1.15	-95	OK	Type-B	4	10	6	OK	OK
Pol042	Bull Bay	Bull Bay Police Station	17°56'27.70"N	76°40'12.40"	13	Rep011	Not Visible	9.6	74°	0	5	1.15 11.9	-100 -80	OK	Type-C	10	40	40	OK	OK
Pol046	Trinity Ville	Trinity Ville Police Station	17°57'36.8"N	76°31'19.5"W	202	Rep011	Not Visible	6.48	272°	0	5	1.15	-90	OK	Type-B	4.5	20	10	OK	OK
Pol049	Port Morant	Port Morant Police Station	17°53'17.09"N	76°19'45.07"W	19	Rep030	Not Visible	9.59	20	0	5	1.15	-100	OK	Type-B	7	20	5	OK	OK
Pol055	Port Antonio	Portland Police Station - Divisional Headquarter	18°10'43.0"N	76°27'05.2"W	7	Rep006	Not Visible	3.36	260	0	5	1.15	-78	OK	Type-B	10	10	5	OK	OK

Summary of the Site Survey for the Base Radio Stations (Group-B)

Shows the site deleted.

Items			GPS Receiver Data (DD°MM'SS.S")		Height Above the See Level	LOS of Radio Repeater Station				Voice Call Merit Test (Sensitivity of Transceiver)		Electric Field Strength Measurement		Result of Electric Field Strength	Antenna Installation Plan&Method ·Type-A: Roof top mount ·Type-B: Roof edge mount ·Type-C: Ground Mast mount ·Type-D: Indoor Whip Antenna			Public Property	Site Design Result	Decision of Site Survey Result
Site Code	ODPEM Name	Official name	Longitude	Latitude	Google Earth Data (m)	Name of Target Repeater	Status (Visible/ Not Visible)	Path Length Between Repeater and Site (km)	Direction to Target Repeater (Degree)	Antenna Gain	Result	Antenna Gain	Field Strength (Measurement Level) (dBm)		Installation Type	Antenna Height (GL+m)	Feeder Length Out door (m)	Feeder Length Indoor (m)		
Poi061	Linstead	Linstead Police Station	18°08'03.89"N	77°01'54.39"W	128	Rep015	Not Visible	19.57	109	0	5			OK	Type-B	7	20	5	OK	OK
Poi067	Moneague	Moneague Police Station	18°16'20.04"N	77°06'57.07"W	336	Rep003	Not Visible			0	5			OK	Type-B	8	20	15	OK	OK
Poi076	Manchioneal	Manchioneal Police Station	18°02'00.36"N	76°16'46.32"W	24	Rep030	Not Visible	7.31	93	0	5	1.15	-110	OK	Type-C	25	40	8	OK	OK
Poi093	Marine	Marine Police Station	17°57'56.77"N	76°48'10.75"W	5	Rep012	Not Visible	9.08	260	0	5	1.15	-75	OK	Type-B	10	10	10	OK	OK
Poi095	Green Island	Green Island Police Station	18°23'17.78"N	78°16'29.34"W	11	Rep026	Not Visible	18.76	90	11.9	5	11.9	-100	OK	Type-B	6	10	3	OK	OK
Poi099	Lucea	Lucea Police Station- Headquarter	18°26'59.25"N	78°10'13.58"W	14	Rep026	Not Visible	10.5	130	0	5	1.15	-87	OK	Type-B	6	10	5	OK	OK
Poi105	Montego Bay	Area1 Police Emergency Communication Center	18°28'23.9"N	77°55'15.6"W	8	Rep027	Visible	9.15	140	0	5	1.15	-102	OK	Type-B	10	40	18	OK	OK
Poi111	Falmouth	Trelawny Police Station (Falmouth Police Station and headquarter)	18°29'45.65"N	77°39'24.21"W	6	Rep029	Not Visible	13.5	101	0	5	1.15	-95	OK	Type-B	10	30	5	OK	OK
Poi120	Negril	Negril Police Station	18°16'44.40"N	78°20'34.51"W	6	Rep024	Not Visible	3.95	140	0	5	1.15	-100	OK	Type-B	8	20	6	OK	OK
Poi122	Savanna-La-Mar	Savanna-La-Mar Police Station- Headquarter	18°13'06.3"N	78°08'00.00"W	9	Rep023	Not Visible	17.33	106	1.15	5	1.15	-105	OK	Type-B	6.5	10	5	OK	OK

Summary of the Site Survey for the Base Radio Stations (Group-B)

Shows the site deleted.

Items			GPS Receiver Data (DD°MM'SS.S")		Height Above the See Level	LOS of Radio Repeater Station				Voice Call Merit Test (Sensitivity of Transceiver)		Electric Field Strength Measurement		Result of Electric Field Strength	Antenna Installation Plan&Method ·Type-A: Roof top mount ·Type-B: Roof edge mount ·Type-C: Ground Mast mount ·Type-D: Indoor Whip Antenna			Public Property	Site Design Result	Decision of Site Survey Result
Site Code	ODPEM Name	Official name	Longitude	Latitude	Google Earth Data (m)	Name of Target Repeater	Status (Visible/ Not Visible)	Path Length Between Repeater and Site (km)	Direction to Target Repeater (Degree)	Antenna Gain	Result	Antenna Gain	Field Strength (Measurement Level) (dBm)		Installation Type	Antenna Height (GL+m)	Feeder Length Out door (m)	Feeder Length Indoor (m)		
Pol129	St. Anns Bay	St. Ann's Bay Police Station-Headquarter	18°26'07.33"N	77°11'57.80"W	15		Not Visible			0	5	1.15	-75	OK	Type-B	10.5	10	6	OK	OK
Pol130	Ocho Rios	Ocho Rios Police Station	18°24'30.45"N	77°06'07.65"W	6	Rep002	Not Visible	4.78	207	0	5	1.15	-82	OK	Type-B	6	10	15	OK	OK
Pol139	Newmarket	Newmarket Police Station	18°09'43.1"N	77°54'55.0"W	357	Rep023	Not Visible	8.33	N/A	0	5	1.15	-88	OK	Type-C	7	10	5	OK	OK
Pol141	Black River	Black River Police Station	18°01'29.05"N	77°50'56.24"W	7	Rep019	Not Visible	28	76	0	5	1.15	-85	OK	Type-B	11	10	30	OK	OK
Pol143	Santa Cruz	Santa Cruz Police Station	18°03'02.24"N	77°41'55.27"W	24	Rep019	Not Visible	12.22	71	0	5	1.15	78	OK	Type-B	5	10	5	OK	OK
Pol154	Alligator Pond	Alligator Pond Police Station	17°52'12.75"N	77°33'56.91"W	8	Rep019	Not Visible	24.05	300	11.9	5	11.9	-108	OK	Type-C	10	20	4	OK	OK
Pol156	Porus	Porus Police Station	18°02'04.1"N	77°24'40.2"W	134	Rep019	Not Visible	19.73	286	0	5	1.15	-105	OK	Type-C	10	20	5	OK	OK
Pol157	Mandeville	Mandeville Police Station	18°02'23.21"N	77°30'25.69"W	628	Rep019	Not Visible	10.23	300	0	5	1.15	-85	OK	Type-B	10	10	5	OK	OK
Pol165	Whitehouse	Whitehouse Police Station	18°05'26.03"	77°57'57.39"	21	Rep023	Not Visible	9.66	340	1.15	5	1.15	-100	OK	Type-B	6	10	3	OK	OK
Pol182	Lionel Town	Lionel Town police Station	17°46'27.44"N	77°14'34.13"W	12	Rep017	Not Visible	11.64	128	0	5			OK	Type-B	15	10	15	OK	OK

Summary of the Site Survey for the Base Radio Stations (Group-B)
Shows the site deleted.

Items			GPS Receiver Data (DD°MM'SS.S")		Height Above the See Level	LOS of Radio Repeater Station				Voice Call Merit Test (Sensitivity of Transceiver)		Electric Field Strength Measurement		Result of Electric Field Strength	Antenna Installation Plan&Method •Type-A: Roof top mount •Type-B: Roof edge mount •Type-C: Ground Mast mount •Type-D: Indoor Whip Antenna			Public Property	Site Design Result	Decision of Site Survey Result
Site Code	ODPEM Name	Official name	Longitude	Latitude	Google Earth Data (m)	Name of Target Repeater	Status (Visible/ Not Visible)	Path Length Between Repeater and Site (km)	Direction to Target Repeater (Degree)	Antenna Gain	Result	Antenna Gain	Field Strength (Measurement Level) (dBm)		Installation Type	Antenna Height (GL+m)	Feeder Length Out door (m)	Feeder Length Indoor (m)		
Pol184	Annotto Bay	Annotto Bay Police Station	18°16'13.7"N	76°46'22.1"W	6	Rep003	Not Visible	19.59	287	0	5	1.15	-85	OK	Type-B	6	10	6	OK	OK
Hos001	Victoria Jubilee	Victoria Jubilee Hospital	17°58'37.98"N	76°47'43.08"W	25	Rep015	Visible	13.13	320	0	5			OK	Type-B	25	10	40	OK	OK
Hos002	National Chest Hospital (Kingston Public)	National Chest Hospital	18°01'20.50"N	76°45'39.77"W	173	Rep014	Not Visible	8.8	45.08				Refer to Hos009	OK	Type-B	6	20	5	OK	OK
Hos003	Bustamante Children's	Bustamante Hospital for Children	17°59'58.38"N	76°46'40.82"W	90	Rep014	Not Visible	11.54	43	0	5			OK	Type-B	4.7	10	10	OK	OK
Hos004	Kingston Public	Kingston Public Hospital	17°58'34.92"N	76°47'44.08"W	25	Rep015	Visible	13.23	320	0	4			OK	Type-B	8	10	10	OK	OK
Hos005	University	University Hospitals Kingston Foundation	18°00'41.80"N	76°44'39.20"W	179	Rep015	Not Visible	15.48	303	0	4			OK	Type-B	6	10	10	OK	OK
Hos006	Sir. John Golding	Sir. John Golding Rehabilitation Center	18°00'15.0"N	76°44'23.8"W	183	Rep015	Not Visible	15.43	303	0	5	1.15	-90	OK	Type-B	8	20	25	OK	OK
Hos007	Hope Institute	Hope Institute Hospital			143	Rep015	Not Visible	15.86	303	0	5	1.15	-93	OK	Type-C	5	10	8	OK	OK
Hos008	Bellevue	Bellevue Hospital	17°58'15.1"N	76°46'20.8"W	14	Rep012	Not Visible	12.52	261	0	5	1.15	-82	OK	Type-B	3.5	10	8	OK	OK
Hos009	Andrews Memorial	Andrews Memorial Hospital	18°00'52.96"N	76°47'18.54"W	97	Rep014	Not Visible	11.46	52	0	5			OK	Type-B	7	10	15	OK	OK

Summary of the Site Survey for the Base Radio Stations (Group-B)

Shows the site deleted.

Items			GPS Receiver Data (DD°MM'SS.S")		Height Above the See Level	LOS of Radio Repeater Station				Voice Call Merit Test (Sensitivity of Transceiver)		Electric Field Strength Measurement		Result of Electric Field Strength	Antenna Installation Plan&Method ·Type-A: Roof top mount ·Type-B: Roof edge mount ·Type-C: Ground Mast mount ·Type-D: Indoor Whip Antenna			Public Property	Site Design Result	Decision of Site Survey Result
Site Code	ODPEM Name	Official name	Longitude	Latitude	Google Earth Data (m)	Name of Target Repeater	Status (Visible/ Not Visible)	Path Length Between Repeater and Site (km)	Direction to Target Repeater (Degree)	Antenna Gain	Result	Antenna Gain	Field Strength (Measurement Level) (dBm)		Installation Type	Antenna Height (GL+m)	Feeder Length Out door (m)	Feeder Length Indoor (m)		
Hos010	Medical Associates	Medical Associates Hospital	18°00'23.60"N	76°47'32.00"W	30	Rep014	Not Visible	14.9	48	0	5			OK	Type-B	5	10	15	OK	OK
Hos011	Maxfiled Medical	Deleted(Small Clinic)																		
Hos012	St. Joseph's	St. Joseph's Hospital & Medical Centre	17°58'49.10"N	76°46'17.41"W	74	Rep014	Not Visible	12.71	43	0	5			OK	Type-B	4.5	10	10	OK	OK
Hos013	Nuttal Memorial	Nuttal Memorial Hospital	17°59'40.7"N	76°47'08.7"W	39	Rep015	Not Visible	14.52	320	0	5			OK	Type-B	7	20	5	OK	OK
Hos014	Princess Margaret	Princess Margaret Hospital	17°52'49.09"N	76°23'27.13"W	23	Rep010	Not Visible	9.51	274	0	5	1.15	-90	OK	Type-C	10	30	10	OK	OK
Hos015	Port Antonio	Port Antonio Hospital	18°10'34.68"N	76°27'21.80"W	50	Rep006	Not Visible	2.72	260	1.15	5	1.15	-98	OK	Type-B	7	10	7	OK	OK
Hos016	Annotto Bay	Annotto Bay Hospital	18°16'23.4"N	76°45'42.9"W	9	Rep003	Not Visible	20.61	284	0	5	1.15	-95	OK	Type-B	4	20	9	OK	OK
Hos017	Port Maria	Portmaria Hospital	18°21'29.20"N	76°53'42.67"W	34	Rep003	Not Visible		200°	0	5	1.15	-95	OK	Type-B	6	10	5	OK	OK
Hos018	St.Anns's Bay	St. Ann's Bay Hospital	18°26' 10.8"N	77° 12'36.9"W	32	Rep001	Not Visible	7.84	232	0	5	1.15	-107	OK	Type-B	5	20	12	OK	OK
Hos019	Falmouth	Falmouth Hospital	18°29'48.17"N	77°39'36.83"W	3	Rep029	Visible	13.15	101	0	5	1.15	-95	OK	Type-B	10	10	5	OK	OK

Summary of the Site Survey for the Base Radio Stations (Group-B)

Shows the site deleted.

Items			GPS Receiver Data (DD°MM'SS.S")		Height Above the See Level	LOS of Radic Repeater Station				Voice Call Merit Test (Sensitivity of Transceiver)		Electric Field Strength Measurement		Result of Electric Field Strength	Antenna Installation Plan&Method ·Type-A: Roof top mount ·Type-B: Roof edge mount ·Type-C: Ground Mast mount ·Type-D: Indoor Whip Antenna				Public Property	Site Design Result	Decision of Site Survey Result
Site Code	ODPEM Name	Official name	Longitude	Latitude	Google Earth Data (m)	Name of Target Repeater	Status (Visible/ Not Visible)	Path Length Between Repeater and Site (km)	Direction to Target Repeater (Degree)	Antenna Gain	Result	Antenna Gain	Field Strength (Measurement Level) (dBm)		Installation Type	Antenna Height (GL+m)	Feeder Length Out door (m)	Feeder Length Indoor (m)			
Hos020	Cornwall Regional	Cornwall Regional Hospital	18°28'08.57"N	77°54'34.97"W	68	Rep027	Not Visible	7.9	140	0	5	1.15	-81	OK	Type-B	9.6	10	5	OK	OK	
Hos021	Doctors Hospital	Doctors' Surgi Clinic	18°27'29.73"N	77°56'19.34"W	39	Rep027	Not Visible	6.13	140	0	5	1.15	-98	OK	Type-B	10	40	10	OK	OK	
Hos022	Mobay Hope	Deleted (Private hospital)																			
Hos023	Faith Maternity	Deleted (old-age home)																			
Hos024	Noel Holmes	Noel Holmes Hospital	18°27'07.92"N	78°10'03.51"W	11	Rep026	Visible	10.46	130	0	5	1.15	-84	OK	Type-B	10	40	10	OK	OK	
Hos025	Sav-La-Mar	Savanna-La-Mar Hospital	18°13'34.9"N	78°07'44.6"W	14	Rep023	Not Visible	17.33	106	0	5	1.15	-98	OK	Type-B	14	30	20	OK	OK	
Hos026	Royal Medical	Royale Medical Hospital	18°13'21.2"N	78°07'54.1"W	9	Rep025	Not Visible			0	5	1.15	-98	OK	Type-B	8.2	40	14	OK	OK	
Hos027	Black River	Black River Hospital	18°01'36.67"N	77°51'31.83"W	3	Rep019	Not Visible	28	76	0	5	1.15	-85	OK	Type-B	8	20	25	OK	OK	
Hos028	Mandeville Regional	Mandeville Regional Hospital	18°02'32.7"N	77°30'32.7"W	628	Rep019	Not Visible	9.65	300	0	5	1.15	-90	OK	Type-B	8	40	8	OK	OK	
Hos029	Hargreaves Memorial	Deleted (Private hospital)																			

Summary of the Site Survey for the Base Radio Stations (Group-B)

Shows the site deleted.

Items			GPS Receiver Data (DD°MM'SS.S")		Height Above the See Level	LOS of Radio Repeater Station				Voice Call Merit Test (Sensitivity of Transceiver)		Electric Field Strength Measurement		Result of Electric Field Strength	Antenna Installation Plan&Method •Type-A: Roof top mount •Type-B: Roof edge mount •Type-C: Ground Mast mount •Type-D: Indoor Whip Antenna			Public Property	Site Design Result	Decision of Site Survey Result
Site Code	ODPEM Name	Official name	Longitude	Latitude	Google Earth Data (m)	Name of Target Repeater	Status (Visible/ Not Visible)	Path Length Between Repeater and Site (km)	Direction to Target Repeater (Degree)	Antenna Gain	Result	Antenna Gain	Field Strength (Measurement Level) (dBm)		Installation Type	Antenna Height (GL+m)	Feeder Length Out door (m)	Feeder Length Indoor (m)		
Hos030	Percy Junior	Percy Junior Hospital	18°09'18.0"N	77°27'55.9"W	826	Rep017	Not Visible			0	5	1.15	-93	OK	Type-B	7	10	5	OK	OK
Hos031	May Pen	May Pen Hospital	17°58'25.2"N	77°15'37.9"W	64	Rep016	Not Visible	109	76	0	5	1.15	-105	OK	Type-B	5	10	15	OK	OK
Hos032	Lionel Town	Lionel Town Hospital	17°48'29.01"N	77°14'29.10"W	10	Rep017	Not Visible	11.39	128	0	5			OK	Type-C	9	10	10	OK	OK
Hos033	Spanish Town	Spanish Town Hospital	17°59'30.28"N	76°56'49.94"W	25	Rep020	Not Visible	11.53	1.5	0	5			OK	Type-B	6.5	20	5	OK	OK
Hos034	Linstead	Linstead Hospital	18° 7'58.73"N	77° 1'53.27"W	128	Rep020	Not Visible	9.86	116	1.15	5	1.15	-112	OK	Type-B	8.5	20	10	OK	OK
Hos035	Mona Rehabilitation Centre	Deleted (duplication, a part of Sir. John Golding(Hos006))																		
Par001	Clarendon Parish Council	Clarendon Parish Council	17°58'04.0"N	77°14'23.5"W	81	Rep016	Visible	9.17	65	0	5			OK	Type-A	10	20	5	OK	OK
Par002	Hanover Parish Council	Hanover Parish Council	18°26'48.7"N	78°10'20.08"W	7	Rep026	Visible	10.4	130	0	5	1.15	-84	OK	Type-B	12	20	5	OK	OK
Par003	Manchester Parish Council	Manchester Parish Council	18° 2'33.9"N	77°30'26.1"W	611	Rep019	Not Visible	9.95	300	0	5	1.15	-87	OK	Type-B	UHF:6 VHF:6 HF: 8	30	5	OK	OK
Par004	Municipal Office of Portmore	Municipal Office of Portmore	17°55'48.99"N	76°53'35.34"W	8	Rep012	Visible	1.47	158	0	5	1.15	-80	OK	Type-B	UHF: 10 VHF: 10 HF: 14	UHF/VHF 10 HF 10	8	OK	OK

Summary of the Site Survey for the Base Radio Stations (Group-B)

Shows the site deleted.

Items			GPS Receiver Data (DD°MM'SS.S")		Height Above the See Level	LOS of Radio Repeater Station				Voice Call Merit Test (Sensitivity of Transceiver)		Electric Field Strength Measurement		Result of Electric Field Strength	Antenna Installation Plan&Method ·Type-A: Roof top mount ·Type-B: Roof edge mount ·Type-C: Ground Mast mount ·Type-D: Indoor Whip Antenna				Public Property	Site Design Result	Decision of Site Survey Result
Site Code	ODPEM Name	Official name	Longitude	Latitude	Google Earth Data (m)	Name of Target Repeater	Status (Visible/ Not Visible)	Path Length Between Repeater and Site (km)	Direction to Target Repeater (Degree)	Antenna Gain	Result	Antenna Gain	Field Strength (Measurement Level) (dBm)		Installation Type	Antenna Height (GL+m)	Feeder Length Out door (m)	Feeder Length Indoor (m)			
Par005	Portland Parish Council	Portland Parish Council	18°10'47.4"N	76°27'04.2"W	8	Rep006	Not Visible	3.43	260	0	5	1.15	-100	OK	Type-B	UHF: 10 VHF: 10 HF: 12	UHF/VHF 8 HF 30	UHF/VH F 12 HF 10	OK	OK	
Par006	Trelawny Parish Council	Trelawny Parish Council	18°29'25.28"N	77°39'05.59"W	1	Rep029	Visible	12.42	101	0	5	1.15	-85	OK	Type-B	10	10	5	OK	OK	
Par007	St. Catherine Parish Council	St. Catherine Parish Council	17°59'46.41"N	76°57'16.97"W	34	Rep020	Not Visible	11.02	1.5	0	5			OK	Type-B	14	20	10	OK	OK	
Par008	St. Elizabeth Parish Council	St. Elizabeth Parish Council	18°01'33.60"N	77°51'12.89"W	3	Rep019	Not Visible	28	76	0	5	1.15	-92	OK	Type-B	UHF: 7.2 VHF: 7.2 HF: 10.2	20	11	OK	OK	
Par009	St. James Parish Council	St. James Parish Council	18°28'28.4"N	77°55'18.2"W	7	Rep027	Visible	8.99	140	0	5	1.15	-88	OK	Type-B	23	30	46	OK	OK	
Par010	St. Mary Parish Council	St. Mary Parish Council	18°22'23.25"N	76°53'37.59"	12	Rep003	Not Visible	4.59	200°	0	4	1.15 11.9	-105 -92	OK	Type-B	UHF: 9 VHF: 9 HF: 12	20	5	OK	OK	
Par011	Kingston & St. Andrew Corporation	KSAC Corporation Office	17°58'01.1"N	76°47'30.9"W	20	Rep015	Not Visible	13.96	320	0	5	1.15	-100	OK	Type-B	10	20	20	OK	OK	
Par012	St. Thomas Parish Council	St. Thomas Parish Council	17°52'50.39"N	76°24'47.49"W	11	Rep010	Not Visible	10.01	274	0	5	1.15	-90	OK	Type-B	14	40x3	15x3	OK	OK	
Par013	Westmoreland Parish Council	Westmoreland Parish Council	18°13'06.3"N	78°08'01.5"W	7	Rep023	Not Visible	15.66	106	0	5			OK	Type-B	8	40	20			
Par014	St. Ann Parish Council	St. Ann Parish Council	18°26'09.8"N	77°12'09.3"W	18	Rep001	Not Visible	8.51	237	0	5	1.15	-110	OK	Type-B	UHF: 4 VHF: 4 HF: 6	20	30	OK	OK	

資料一7 サイト調査結果一覧(サイレンシステム設置候補地)

7. サイト調査結果一覧(サイレンシステム設置候補地)

Site			Parish	Location (GPS Receiver Data)		Height (ASL)	Electric Field Strength Measurement & Voice Call Merit Test		Siren		Decision of Site Survey Result	Remarks
Site Area	Site Code	Site Name	Parish Name	Longitude (DD°MMSS.S'')	Latitude (DD°MMSS.S'')	Google Earth Data (m)	Repeater Site	Result	Land Owner	Availability for Installation*1		
Old Harbour Bay	Sir001	Narine Lane	St. Catherine	17°54'48.16"N	77°05'33.90"W	1	Planters Hall	OK	Parish Council	OK(A)	OK	
	Sir002	Old Harbour Bay Fishing Village	St. Catherine	17°54'19.88"N	77°05'39.29"W	3		OK	Parish Council	OK(A)	OK	fish market
	Sir003	Blackwood Gardens	St. Catherine	17°54'36.34"N	77°06'03.04"W	5		OK	Parish Council	OK(A)	OK	
	Sir004	New Harbour Village	St. Catherine	17°55'32.28"N	77°06'19.66"W	18		OK	Parish Council	OK(A)	OK	
Bog Walk	Sir005	Bog walk	St. Catherine	18°06'08.08"N	77°00'17.91"W	88	Sligoville	OK	National Land Agency	OK(A)	OK	
	Sir006	kent Village	St. Catherine	18°05'18.26"N	76°59'39.92"W	79		OK	National Land Agency	TBC:	OK	Require confirmation of land owner
	Sir007	Steep Slope	St. Catherine	18°03'44.66"N	76°59'39.92"W	77		OK	Private	TBC:	OK	Require confirmation of land owner
	Sir008	Dam Head Tower	St. Catherine	18°02'43.09"N	76°58'54.58"W	71		OK	Private	TBC:	OK	Require confirmation of land owner
	Sir009	angele Roond A Bout	St. Catherine	18°02'03.55"N	76°58'47.35"W	58		OK	National Land Agency	OK(A)	OK	
Port Maria	Sir010	Castel Garden	St. Mary	18°23'22.41"N	76°53'45.72"W	25	Bonny Gate	OK	Parish Council	OK(A)	OK	
	Sir011	Parish Council	St. Mary	18°22'23.07"N	76°53'38.06"W	13		OK	Parish Council	OK(A)	OK	
	Sir012	Town Center	St. Mary	18°22'13.02"N	76°53'33.72"W	5		OK	Parish Council	OK(A)	OK	
	Sir013	RADA Office	St. Mary	18°22'01.68"N	76°53'22.19"W	20		OK	RADA	OK(A)	OK	ST MARY Rural Agriculture Development Authority Office
	Sir014	Clembhards Park	St. Mary	18°22'03.75"N	76°53'10.81"W	7		OK	Parish Council	OK(A)	OK	
	Sir015	Trinity	St. Mary	18°21'33.42"N	76°53'50.39"W	14		OK	Parish Council	OK(A)	OK	

*1 Legend: OK (A): Available as it is.
TBC: To Be Confirmed

資料一8 概略設計図

目次

図表番号	名称
G-01	プロジェクトサイト位置図 Locations of the Project sites
DS-01	災害緊急通信システム 概要図 Overall of DECOM System
DS-02	災害緊急通信システム ネットワーク図 Network Diagram of DECOM
DS-03	固定 UHF 中継装置 (4 チャンネル) 系統図 Block Diagram of Fixed UHF Repeater Station (4ch)
DS-04	固定 UHF 中継装置 (7 チャンネル) 系統図 Block Diagram of Fixed UHF Repeater Station (7ch)
DS-05	移動 UHF 中継装置 系統図 Block Diagram of Transportable UHF Repeater Station
DS-06	移動 UHF 中継装置用機器ラック 外観図 Appearance of Transportable UHF Repeater Station
DS-07	固定 UHF 中継装置 (4 チャンネル) 用電源システム 系統図 Block Diagram of Power Supply System for Fixed UHF Repeater Station (4ch)
DS-08	固定 UHF 中継装置 (4 チャンネル) 用電源システム (太陽光発電付) 系統図 Block Diagram of Power Supply System for Fixed UHF Repeater Station (4ch) with Solar Backup (Portland Cottage Lighthouse)
DS-09	太陽光パネル用フレーム 外観図 Outside View of Frame for Solar Panels
DS-10	固定 UHF 中継装置 (7 チャンネル) 用電源システム 系統図 Block Diagram of Power Supply System for Fixed UHF Repeater Station (7ch)
DS-11	移動 UHF 中継装置用電源システム 系統図 Block Diagram of Power Supply System for Transportable UHF Repeater Station
DS-12	マイクロ波中継装置用電源システム 系統図 Block Diagram of Power Supply System for Microwave Link Repeater Station
DS-13	NWA ネットワーク接続システム / NWA 中継局用電源システム 系統図 Block Diagram of NWA Network Connection System/NWA Power Supply System
DS-14	固定 UHF 中継装置 (4 チャンネル) 用 19 インチラック 外観図 Rack Arrangement for Fixed UHF Repeater Station (4ch)
DS-15	固定 UHF 中継装置 (7 チャンネル) 用 19 インチラック 外観図 Rack Arrangement for Fixed UHF Repeater Station (7ch)
DS-16	バッテリーラック 外観図 Outside View of Battery Rack
DS-17	全国指令無線基地局 電源システム 系統図 Block Diagram of Power Supply System for National Command Station [1.3(1)]
DS-18	Parish 無線基地局用 固定無線機 電源システム 系統図 Block Diagram of UHF Base Radio for Parish Control Station
DS-19	コミュニティ用可搬型無線局 電源システム 系統図 Block Diagram of Power Supply System for Portable Radio Station for Community [1.3(3)]
DS-20	コミュニティ用可搬型無線局 収納ケース 外観図 Appearance of Case for Portable Radio Station for Community
DS-21	VHF-AM 地对空無線中継装置 / VHF-FM 海上無線中継装置 系統図 Network Diagram of VHF-AM Ground to Air Radio / Marine Radio Interface
ES-01	早期警報システム 系統図 Block Diagram of Early Warning System
ES-02	サイレンシステム電源 系統図 Block Diagram of Power Supply for Siren System
A-01	無線中継局建屋 (標準型) 平面図・断面図・立面図 New Repeater Station Hut Plan (Standard type)
A-02	無線中継局建屋 (省スペース型) 平面図・断面図・立面図 New Repeater Station Hut Plan (Compact type)

Montego Bay

-  : Repeater Station (24 locations)
-  : Microwave Repeater Equipment (1 location)
-  : ODPEM
-  : New Repeater Station Huts (6 locations)
-  : Outdoor Rack and Solar System (1 location)
-  : ODPEM Warehouse (Kingston)
-  : ODPEM Warehouse (Montpelier)
-  : EWANS (3 areas/15 locations)

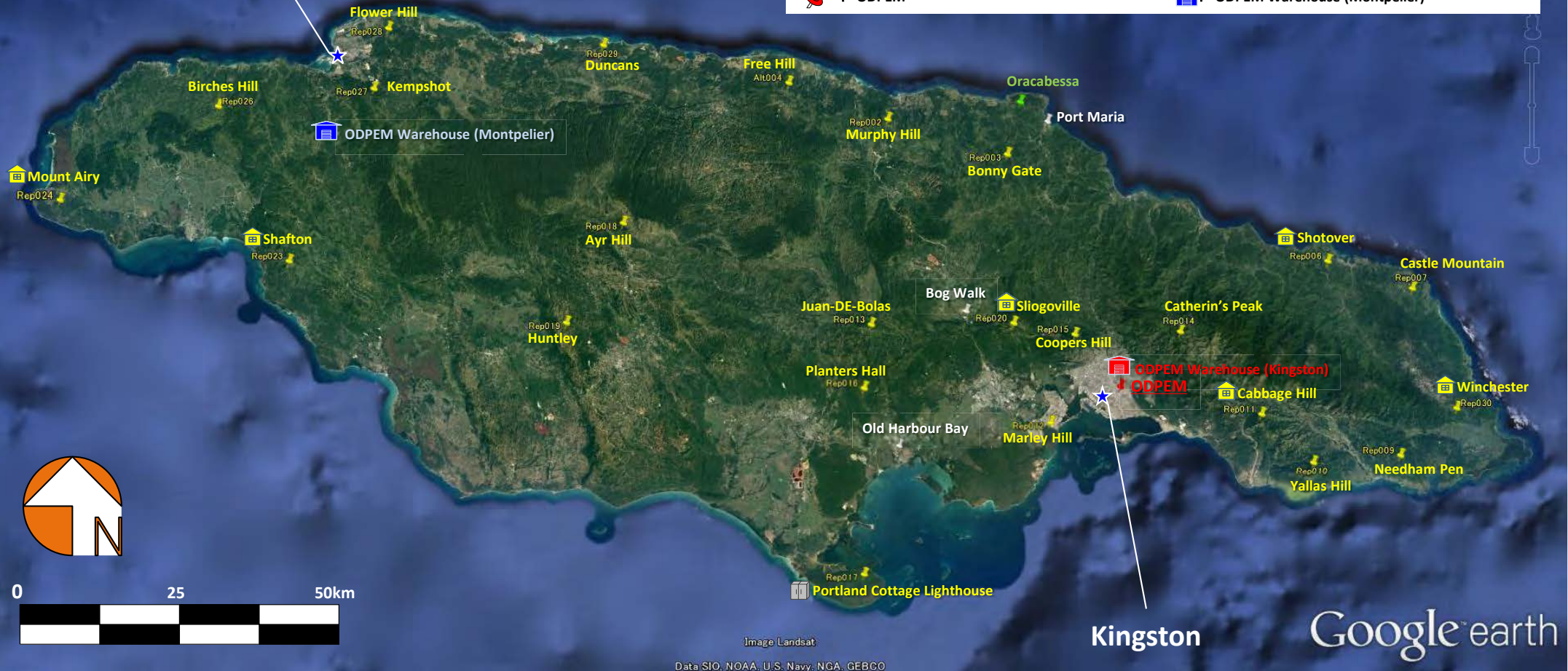

A-8-1

PROJECT NAME	EXECUTING AGENCY	TITLE	SCALE	DATE	DESIGNED	CHECKED	APPROVED	DWG No.
The Project for Improvement of Emergency Communication System in Jamaica	ODPEM	Location of the Project sites	---	Apr. 2016	K. Harikae	K. Tanaka	T. Kobayashi	G-01
				 YACHIYO ENGINEERING CO., LTD. TOKYO, JAPAN				

A-8-2

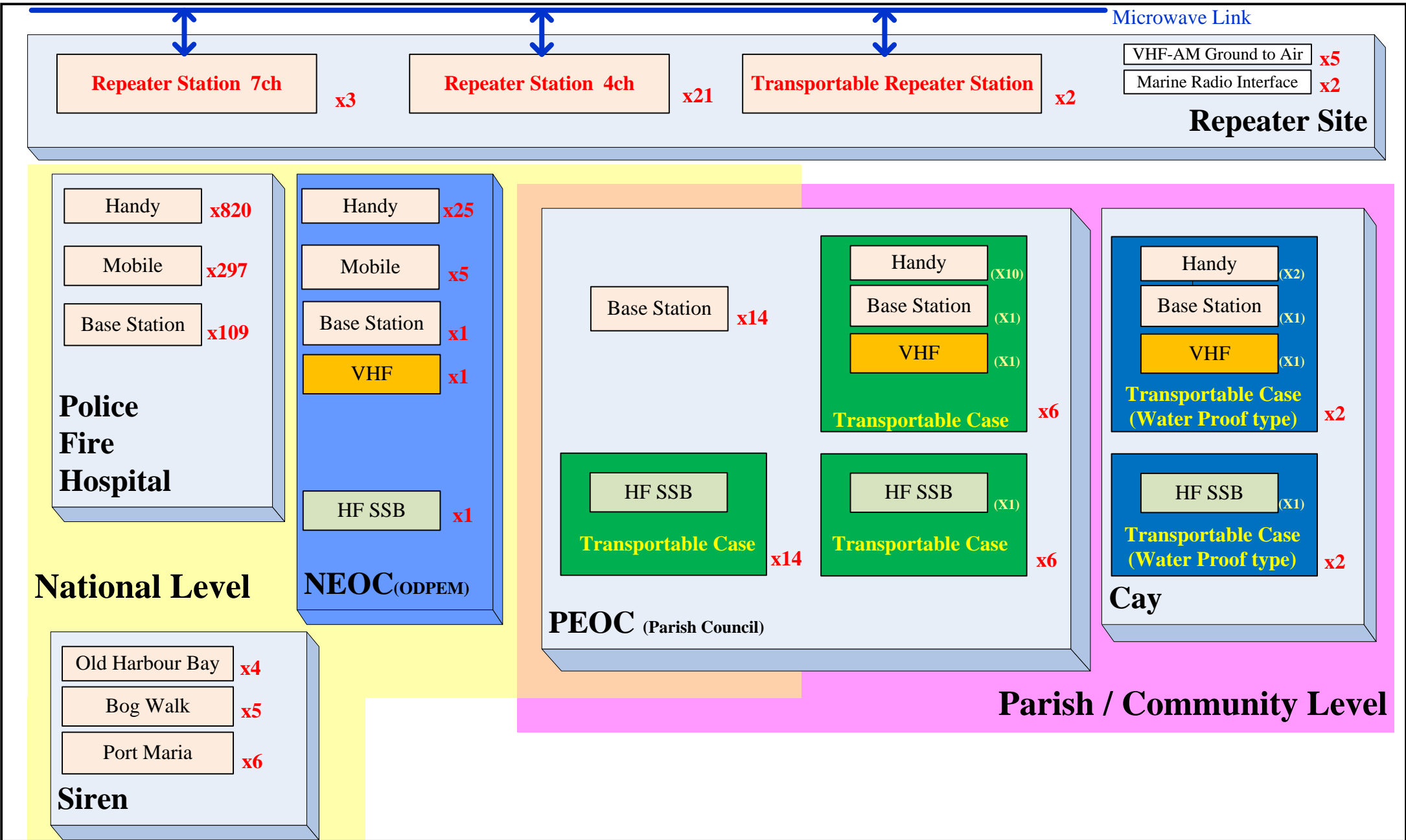

PROJECT NAME	EXECUTING AGENCY	TITLE	SCALE	DATE	DESIGNED	CHECKED	APPROVED	DWG No.
The Project for Improvement of Emergency Communication System in Jamaica	ODPEM	Overall of DECOM System	---	Apr. 2016	K. Harikae	K. Tanaka	T. Kobayashi	DS-01
				YACHIYO ENGINEERING CO., LTD. TOKYO, JAPAN				

A-8-V

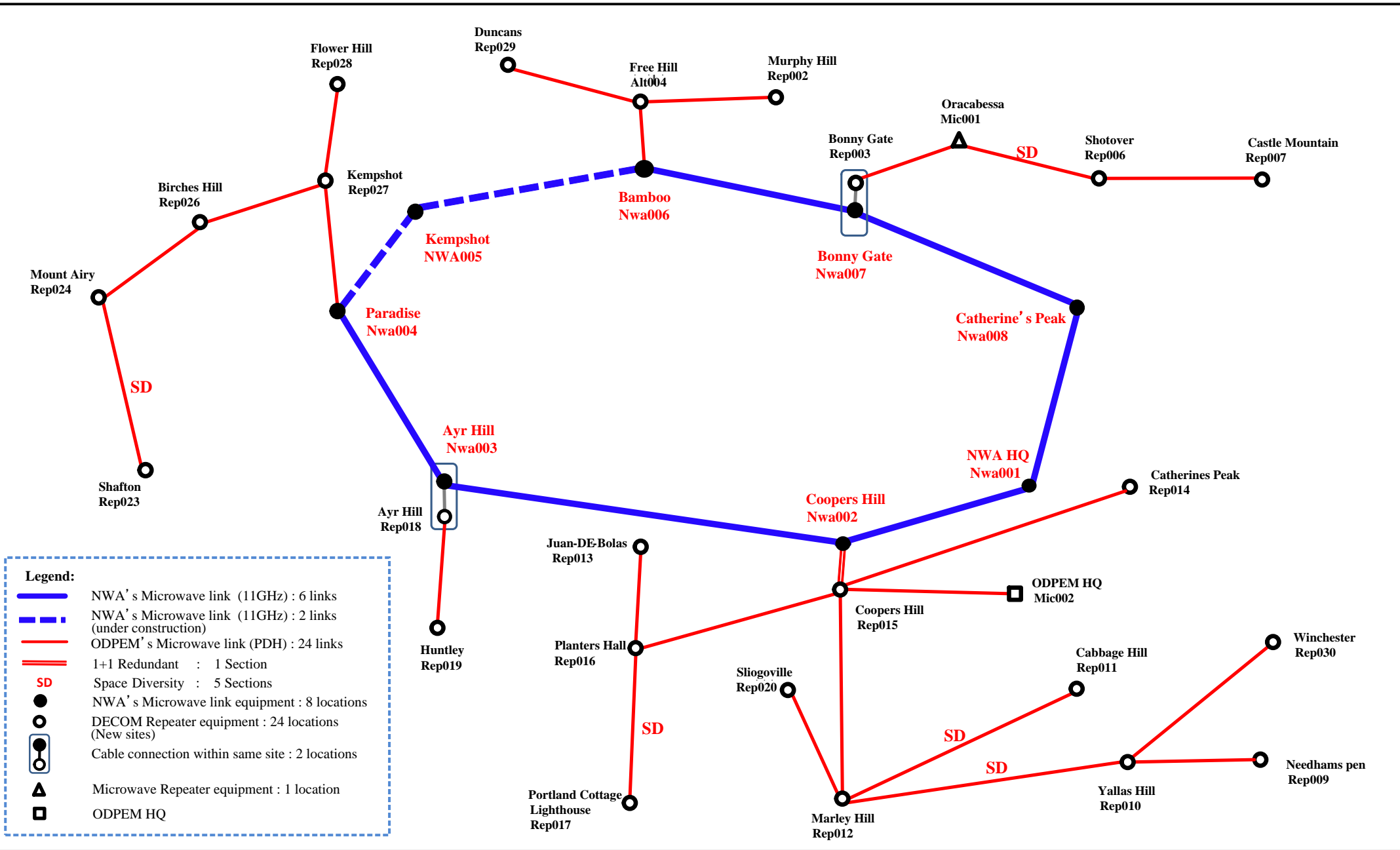

PROJECT NAME	EXECUTING AGENCY	TITLE	SCALE	DATE	DESIGNED	CHECKED	APPROVED	DWG No.
The Project for Improvement of Emergency Communication System in Jamaica	ODPEM	Network Diagram of DECOM	---	Sep. 2016	K. Harikae	K. Tanaka	T. Kobayashi	DS-02
				YEC YACHIYO ENGINEERING CO., LTD. TOKYO, JAPAN				

Legend
 BPF : Band Pass Filter
 L2 : Layer 2 Network Switch
 TX : Transmitter
 RX : Receiver
 ANT : Antenna

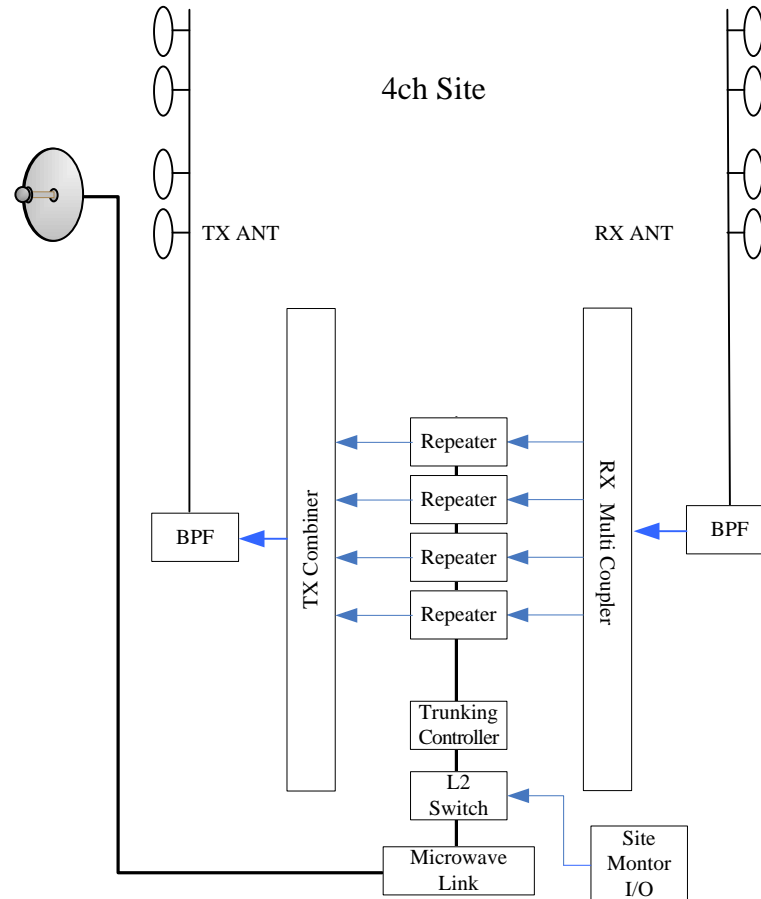

A-8-4

PROJECT NAME	EXECUTING AGENCY	TITLE	SCALE	DATE	DESIGNED	CHECKED	APPROVED	DWG No.
The Project for Improvement of Emergency Communication System in Jamaica	ODPEM	Block Diagram of Fixed UHF Repeater Station (4ch)	---	Apr. 2016	K. Harikae	K. Tanaka	T. Kobayashi	DS-03
				 YACHIYO ENGINEERING CO., LTD. TOKYO, JAPAN				

Legend
 BPF : Band Pass Filter
 L2 : Layer 2 Network Switch
 TX : Transmitter
 RX : Receiver
 ANT : Antenna

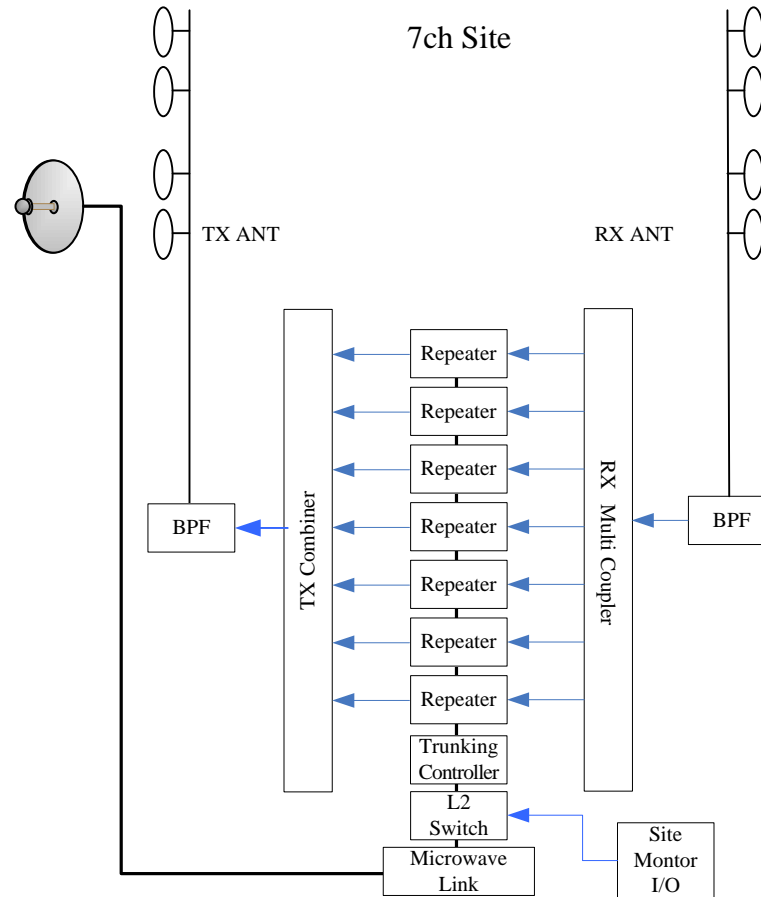

C-8-V

PROJECT NAME	EXECUTING AGENCY	TITLE	SCALE	DATE	DESIGNED	CHECKED	APPROVED	DWG No.
The Project for Improvement of Emergency Communication System in Jamaica	ODPEM	Block Diagram of Fixed UHF Repeater Station (7ch)	---	Apr. 2016	K. Harikae	K. Tanaka	T. Kobayashi	DS-04
				 YACHIYO ENGINEERING CO., LTD. TOKYO, JAPAN				

0-8-V

Transportable UHF Repeater Station

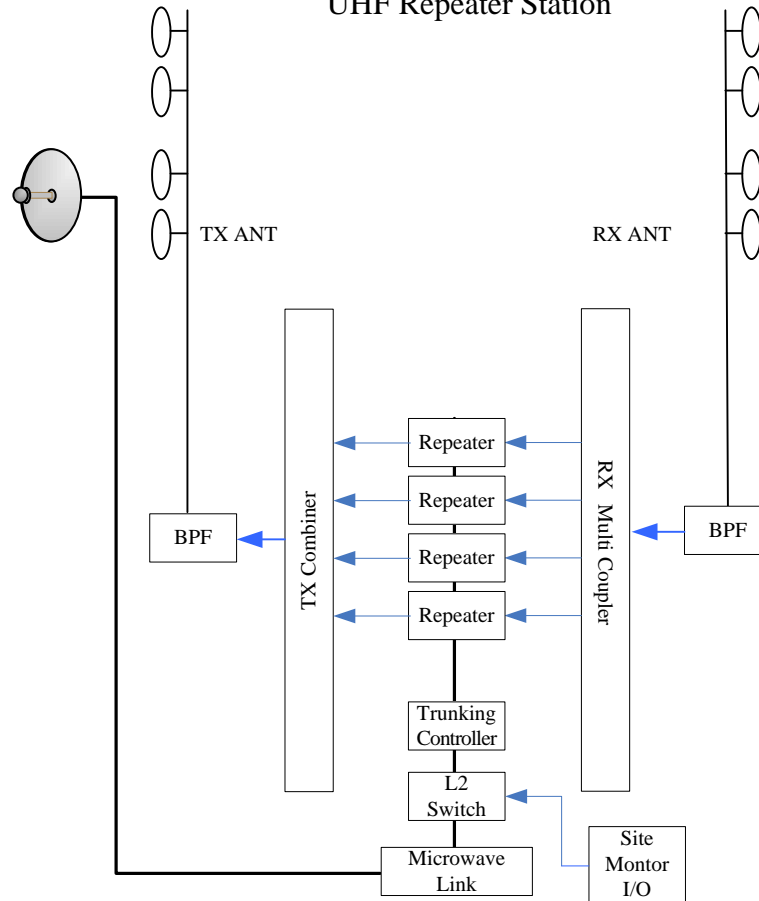

- Legend
 BPF : Band Pass Filter
 L2 : Layer 2 Network Switch
 TX : Transmitter
 RX : Receiver
 ANT : Antenna

PROJECT NAME	EXECUTING AGENCY	TITLE	SCALE	DATE	DESIGNED	CHECKED	APPROVED	DWG No.
The Project for Improvement of Emergency Communication System in Jamaica	ODPEM	Block Diagram of Transportable UHF Repeater Station	---	Apr. 2016	K. Harikae	K. Tanaka	T. Kobayashi	DS-05
				 YACHIYO ENGINEERING CO., LTD. TOKYO, JAPAN				

Portable Site

RX ANT

TX ANT

Carton No.3 (Antenna & Poles)



Carton No.4

(Battery, Cable & Accessory Case)



Carton No.1 (Equipment)

Carton No.2 (Filter)

- Site Monitor I/O
- RX Distributer
- PDH IDU
- Trunking Controller
- Repeater 1
- Repeater 2
- Repeater 3
- Repeater 4

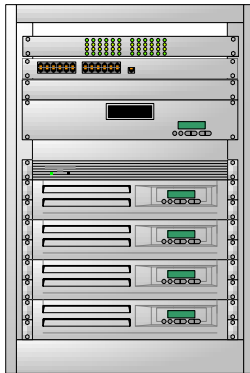

4ch
TX Combiner

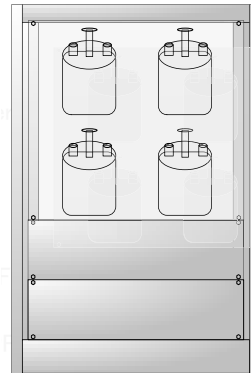

TX BPF
RX BPF

Carton No.5,6

(Portable Antenna & Accessory Case)

Microwave link



x2

- 1.1 (4) Microwave Link
- 4) Short Range (Transportable Type)
- PDH Microwave Radio (ODU) x1
- Parabolic Antenna X 1

Carton No.7(PDH Microwave Radio (IDU))



- 1.1 (4) Microwave Link
- 4) Short Range (Transportable Type)
- PDH Microwave Radio (IDU) x1

Carton No.8 (12DC-48VDC Converter for Microwave Link)



- 1.1 (5) Power Supply System
- 6) 12DC-48VDC Converter for Microwave Link x1

Case for Carton No.1 and No.2



A-8-7

PROJECT NAME	EXECUTING AGENCY	TITLE	SCALE	DATE	DESIGNED	CHECKED	APPROVED	DWG No.
The Project for Improvement of Emergency Communication System in Jamaica	ODPEM	Appearance of Transportable UHF Repeater Station	---	Apr. 2016	K. Harikae	K. Tanaka	T. Kobayashi	DS-06
				 YACHIYO ENGINEERING CO., LTD. TOKYO, JAPAN				

8-8-V

1.1 (1) Fixed UHF Repeater Station (4ch Type)

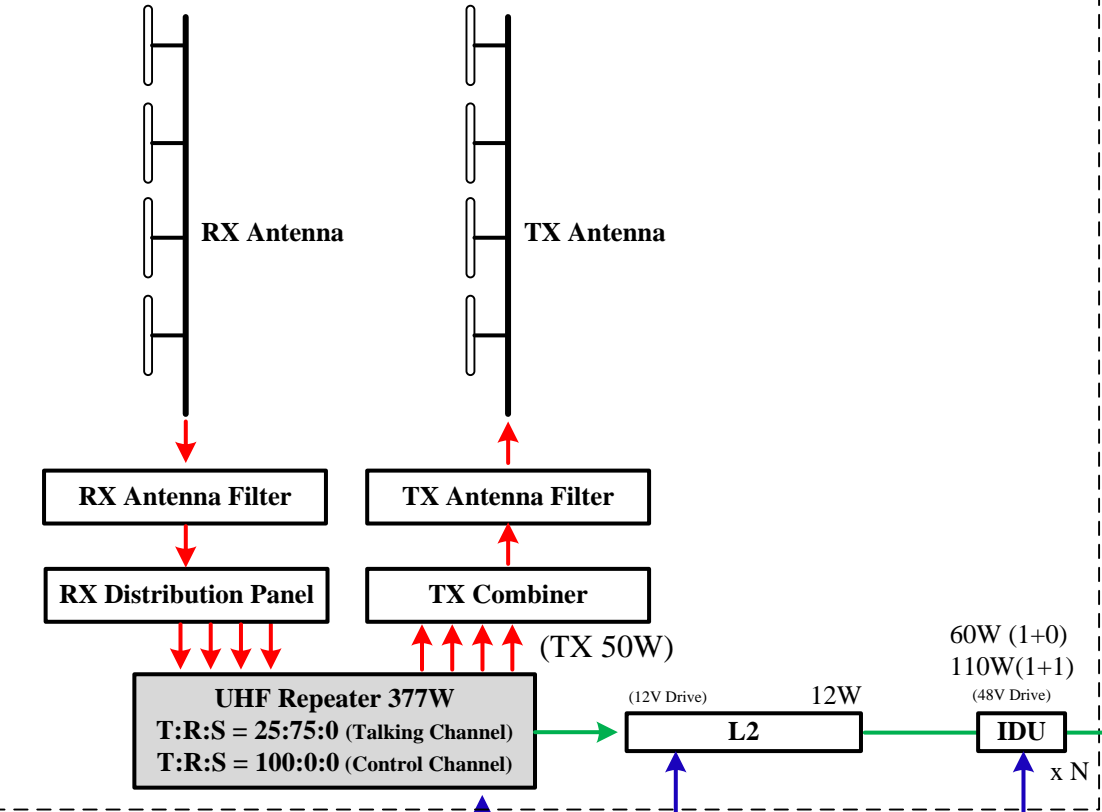

Legend
 LVD : Low Voltage Disconnect
 NFB : Non Fuse Breaker
 TX : Transmitter
 RX : Receiver

1.1 (4) Microwave Link

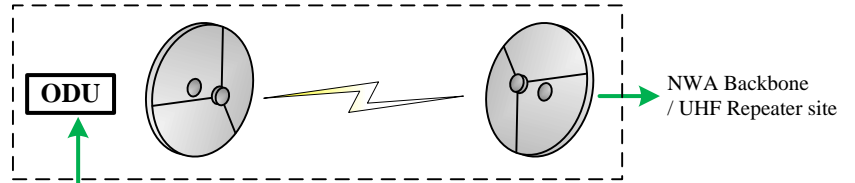

1.1 (5) Power Supply System

1) For Fixed UHF Repeater Station (4ch)

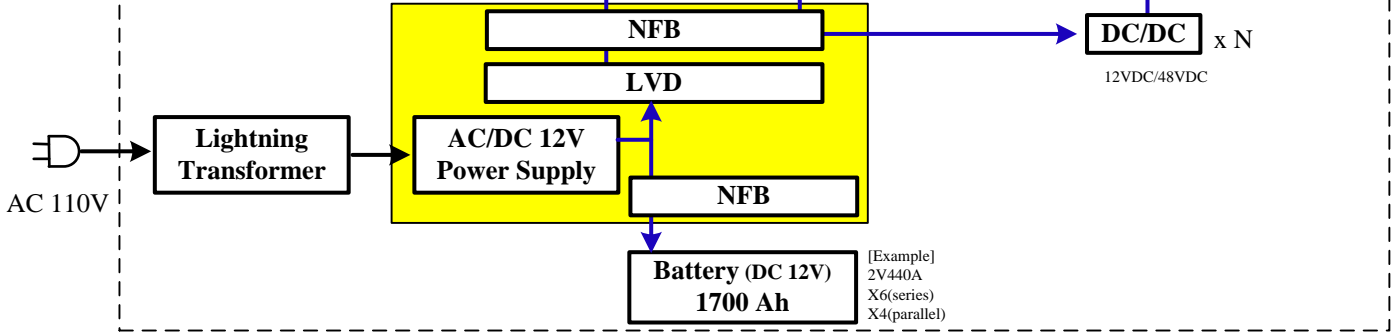

PROJECT NAME	EXECUTING AGENCY	TITLE	SCALE	DATE	DESIGNED	CHECKED	APPROVED	DWG No.
The Project for Improvement of Emergency Communication System in Jamaica	ODPEM	Block Diagram of Power Supply System for UHF Repeater Station (4ch)	---	Apr. 2016	K. Harikae	K. Tanaka	T. Kobayashi	DS-07
				YACHIYO ENGINEERING CO., LTD. TOKYO, JAPAN				

6-8-V

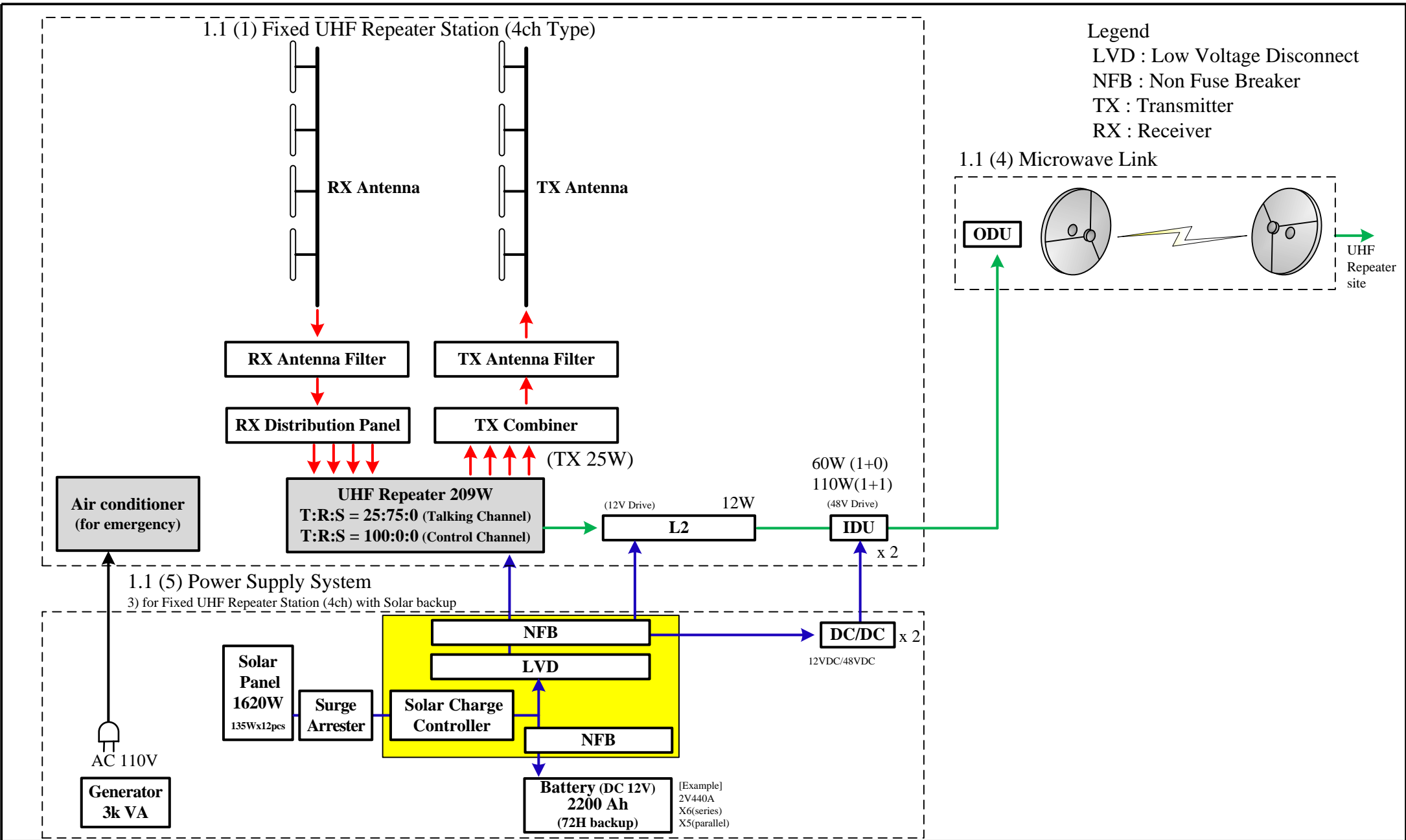

PROJECT NAME	EXECUTING AGENCY	TITLE	SCALE	DATE	DESIGNED	CHECKED	APPROVED	DWG No.
The Project for Improvement of Emergency Communication System in Jamaica	ODPEM	Block Diagram of Power Supply System for UHF Repeater Station (4ch) with Solar Backup (Portland Cottage Lighthouse)	---	Apr. 2016	K. Harikae	K. Tanaka	T. Kobayashi	DS-08
 YEC YACHIYO ENGINEERING CO., LTD. TOKYO, JAPAN								

A-8-10

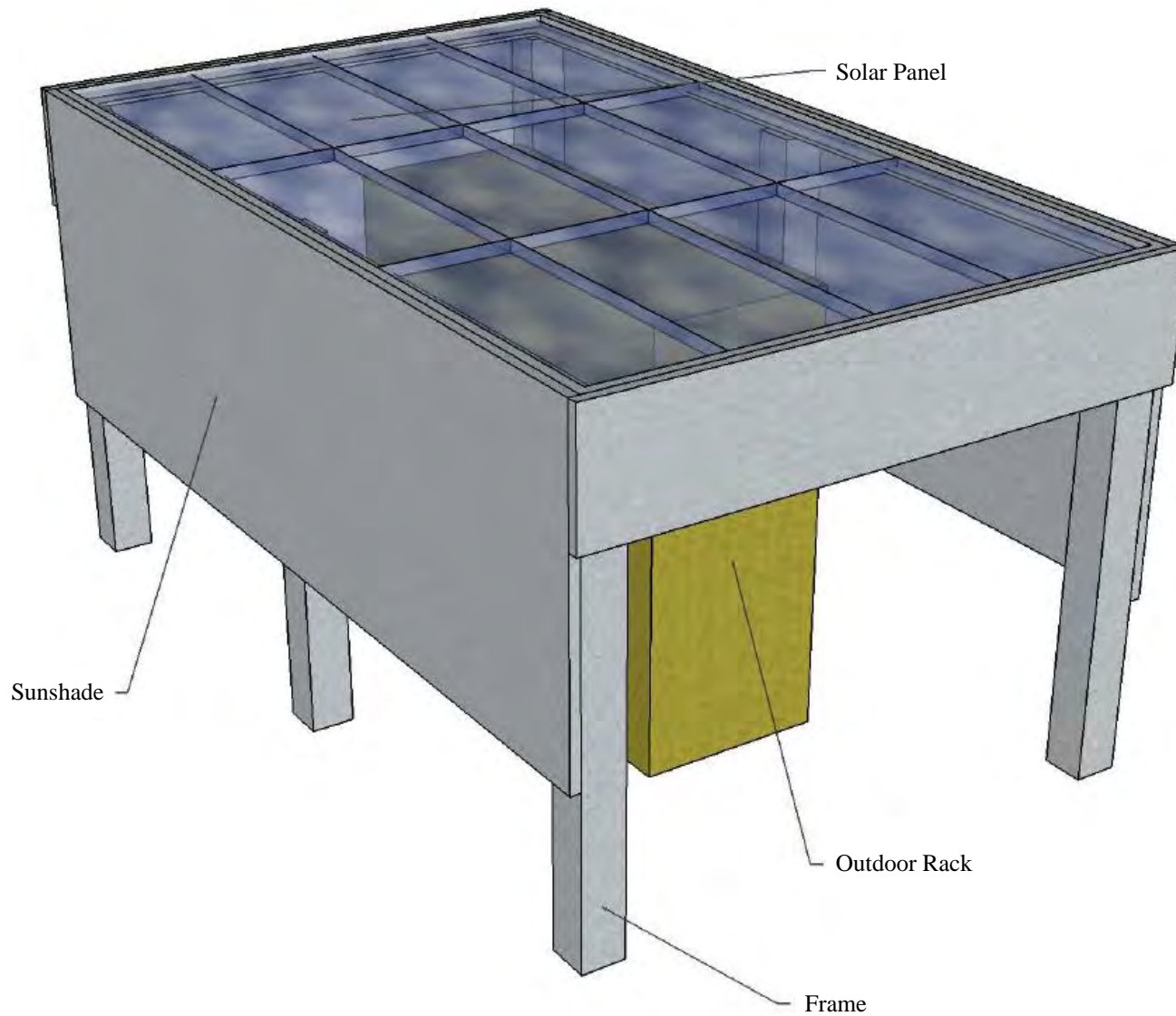

Frame for Solar Panels
(Sample for reference)

PROJECT NAME	EXECUTING AGENCY	TITLE	SCALE	DATE	DESIGNED	CHECKED	APPROVED	DWG No.
The Project for Improvement of Emergency Communication System in Jamaica	ODPEM	Outside View of Frame for Solar Panels	---	Apr. 2016	K. Harikae	K. Tanaka	T. Kobayashi	DS-09
				 YACHIYO ENGINEERING CO., LTD. TOKYO, JAPAN				

II-8-V

1.1 (2) Fixed UHF Repeater Station (7ch Type)

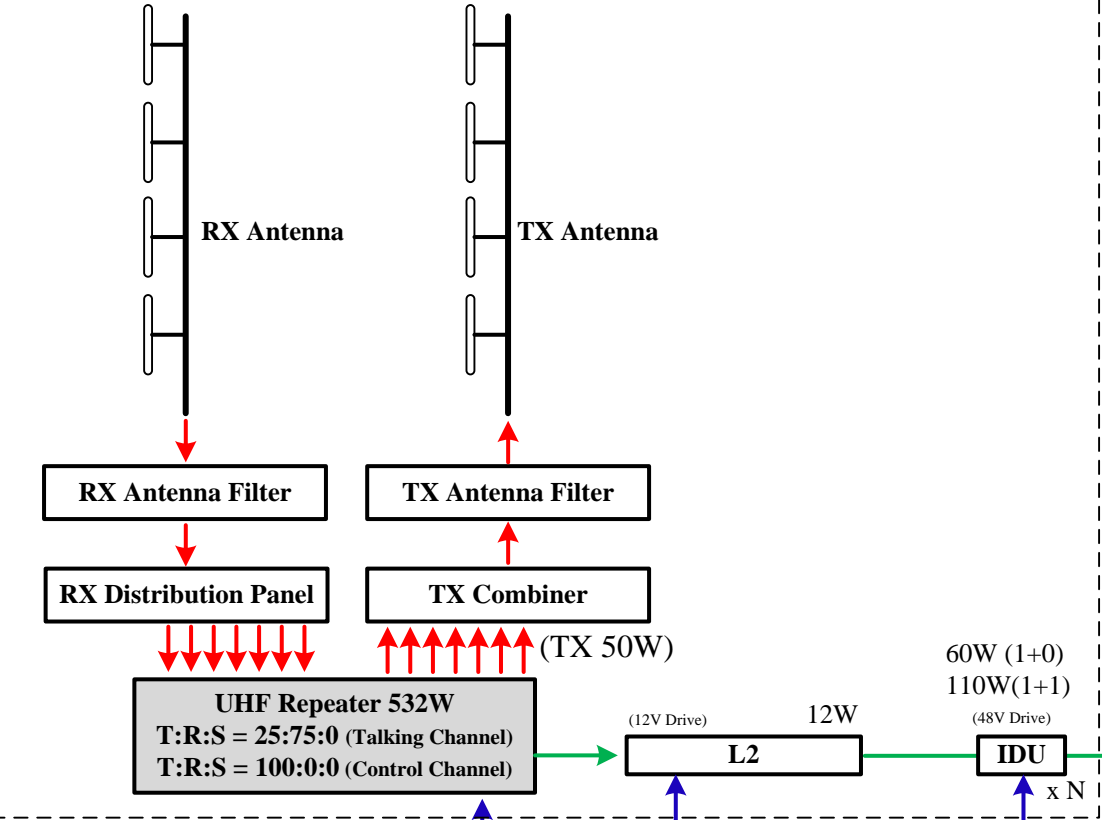

Legend
 LVD : Low Voltage Disconnect
 NFB : Non Fuse Breaker
 TX : Transmitter
 RX : Receiver

1.1 (4) Microwave Link

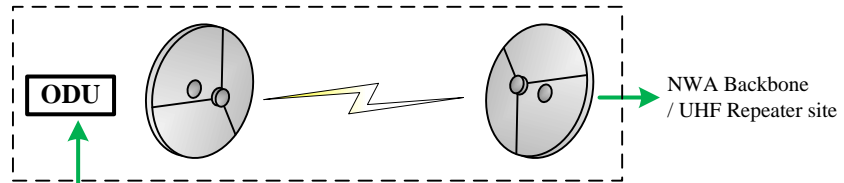

1.1 (5) Power Supply System

4) For Fixed UHF Repeater Station (7ch)

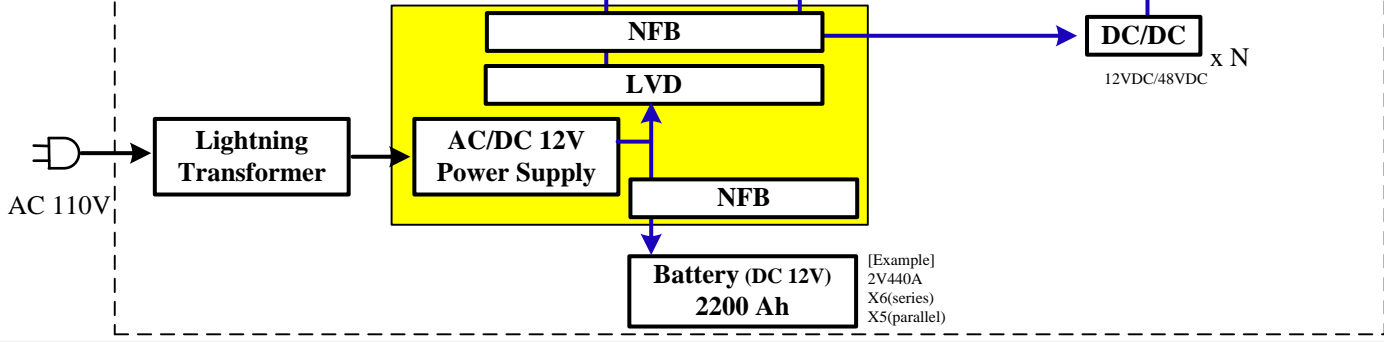

[Example]
 2V440A
 X6(series)
 X5(parallel)

PROJECT NAME	EXECUTING AGENCY	TITLE	SCALE	DATE	DESIGNED	CHECKED	APPROVED	DWG No.
The Project for Improvement of Emergency Communication System in Jamaica	ODPEM	Block Diagram of Power Supply System for UHF Repeater Station (7ch)	---	Apr. 2016	K. Harikae	K. Tanaka	T. Kobayashi	DS-10
YACHIYO ENGINEERING CO., LTD. TOKYO, JAPAN								

A-8-12

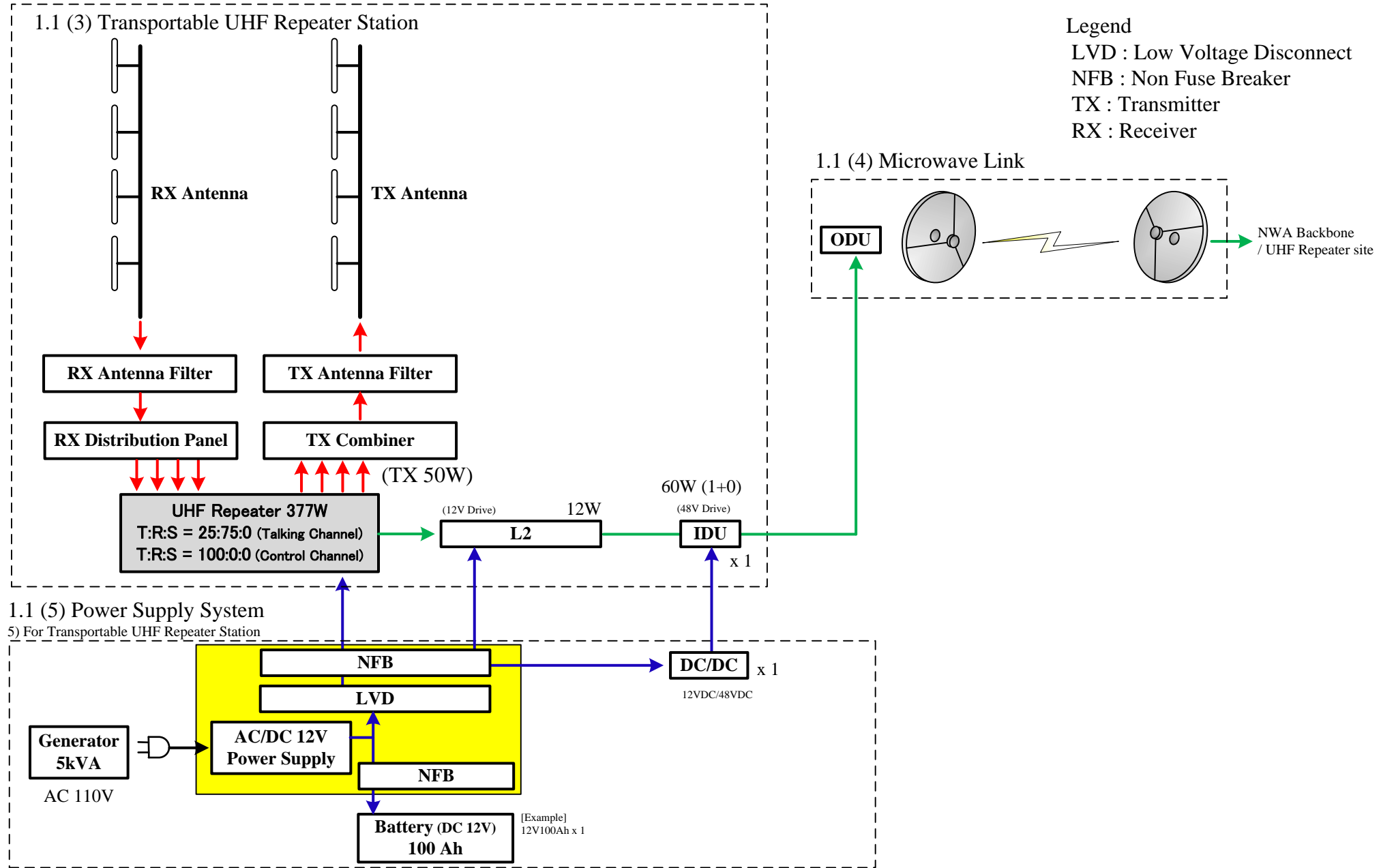

Legend
 LVD : Low Voltage Disconnect
 NFB : Non Fuse Breaker
 TX : Transmitter
 RX : Receiver

PROJECT NAME	EXECUTING AGENCY	TITLE	SCALE	DATE	DESIGNED	CHECKED	APPROVED	DWG No.
The Project for Improvement of Emergency Communication System in Jamaica	ODPEM	Block Diagram of Power Supply System for Transportable UHF Repeater Station	---	Apr. 2016	K. Harikae	K. Tanaka	T. Kobayashi	DS-11
YEC YACHIYO ENGINEERING CO., LTD. TOKYO, JAPAN								

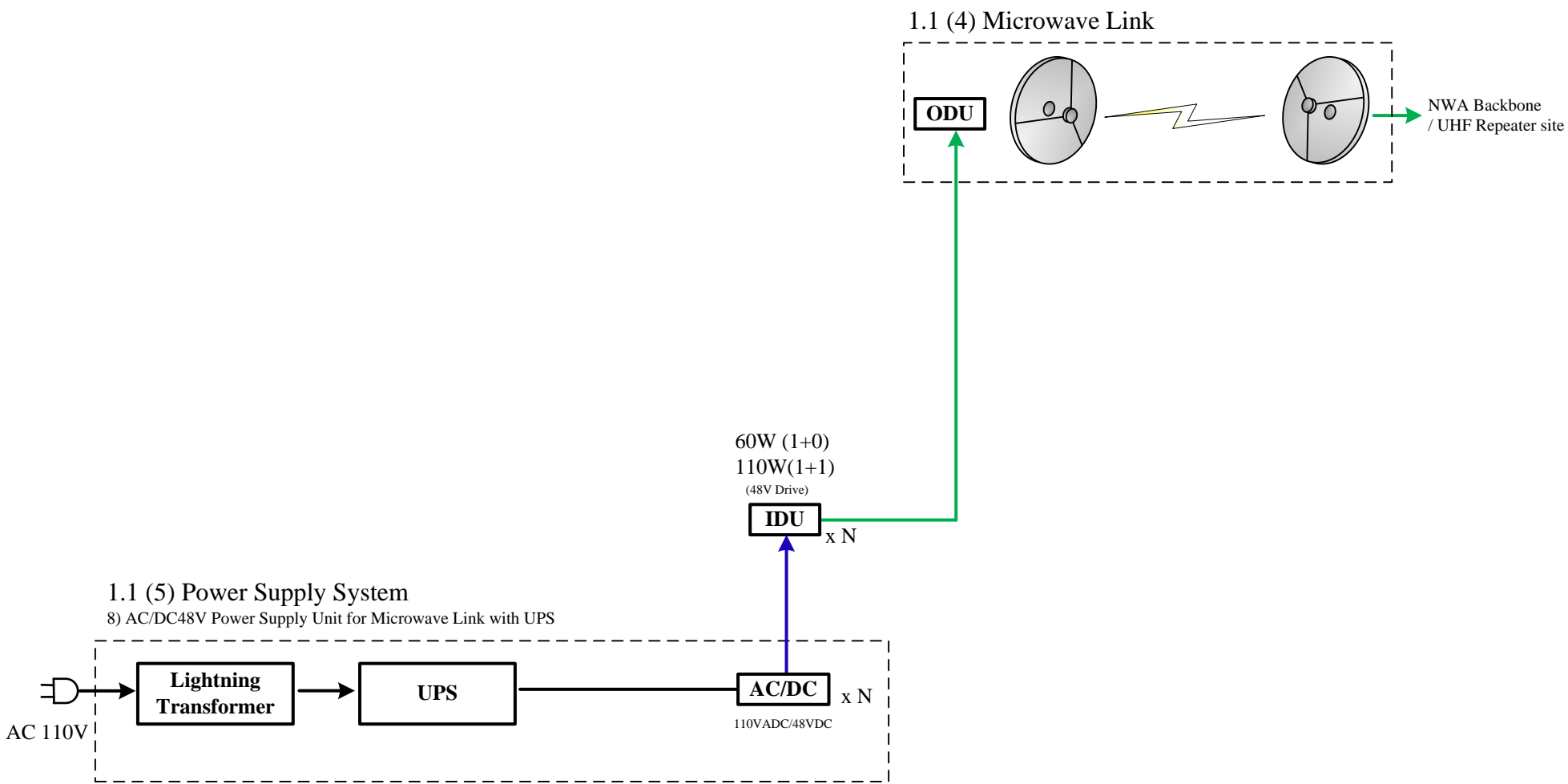

PROJECT NAME	EXECUTING AGENCY	TITLE	SCALE	DATE	DESIGNED	CHECKED	APPROVED	DWG No.
The Project for Improvement of Emergency Communication System in Jamaica	ODPEM	Block Diagram of Power Supply System for Microwave Link Repeater Station	---	Apr. 2016	K. Harikae	K. Tanaka	T. Kobayashi	DS-12
				 YACHIYO ENGINEERING CO., LTD. TOKYO, JAPAN				

A-8-14

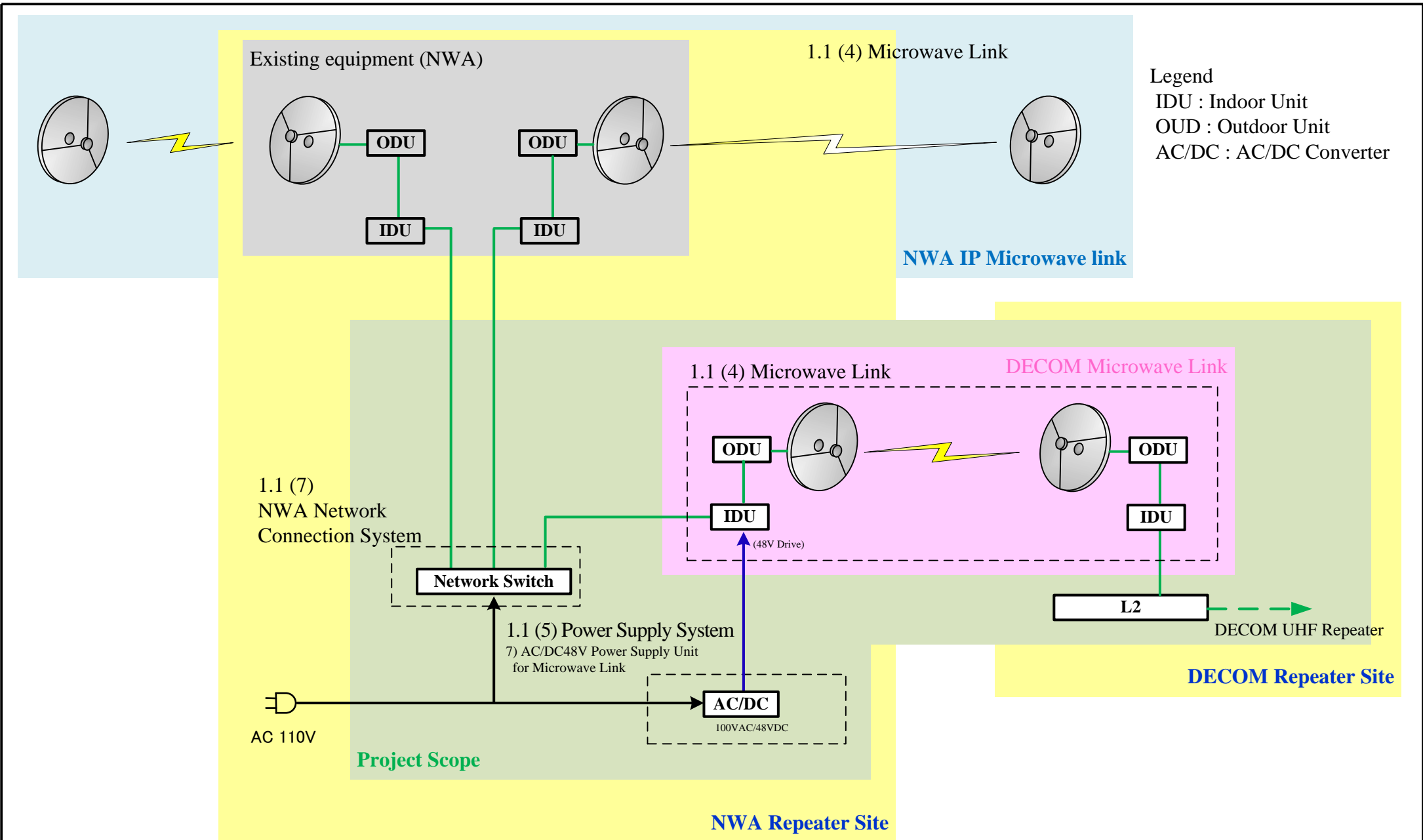

PROJECT NAME	EXECUTING AGENCY	TITLE	SCALE	DATE	DESIGNED	CHECKED	APPROVED	DWG No.
The Project for Improvement of Emergency Communication System in Jamaica	ODPEM	Block Diagram of NWA Network Connection System / NWA Power Supply System	---	Apr. 2016	K. Harikae	K. Tanaka	T. Kobayashi	DS-13
				YACHIYO ENGINEERING CO., LTD. TOKYO, JAPAN				

A-8-15

RX Distributer

Repeater 1

Repeater 2

Repeater 3

Repeater 4

Trunking Controller

L2 Switch

PDH IDU

Site Monitor I/O

DC Distribuer

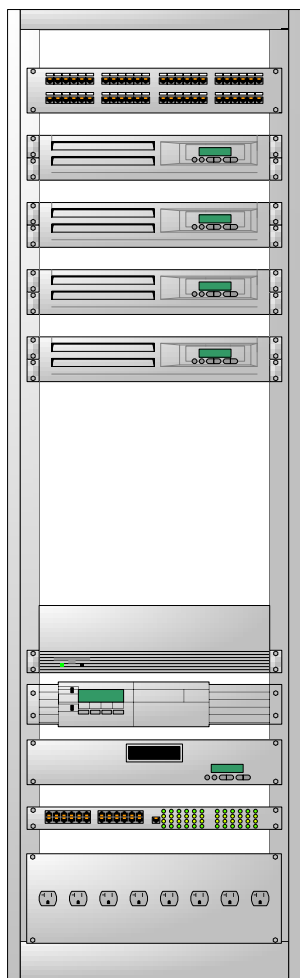

Repeater Rack

4ch
TX Combiner

TX BPF

RX BPF

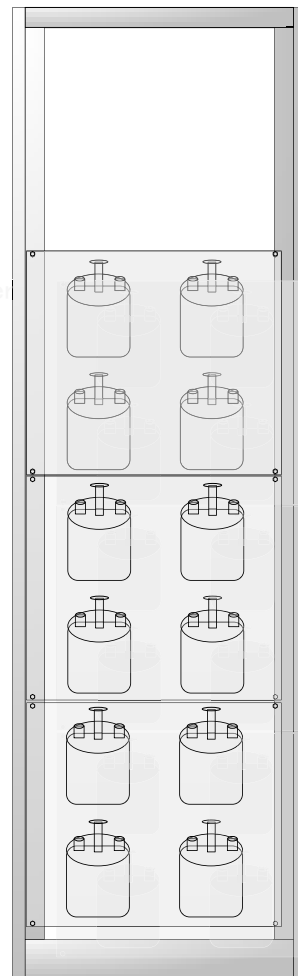

Filters/ Duplexer

ANT x 2

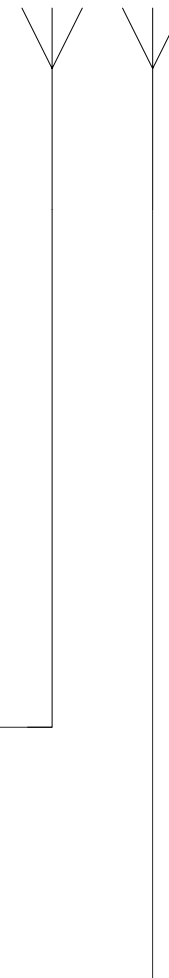

Legend

- TX : Transmitter
- RX : Receiver
- PDH : Plesiochronous Digital Hierarchy
- IDU : Indoor Unit
- BPF : Band Pass Filter
- ANT : Antenna

PROJECT NAME	EXECUTING AGENCY	TITLE	SCALE	DATE	DESIGNED	CHECKED	APPROVED	DWG No.
The Project for Improvement of Emergency Communication System in Jamaica	ODPEM	Rack Arrangement for Fixed UHF Repeater Station (4ch)	---	Apr. 2016	K. Harikae	K. Tanaka	T. Kobayashi	DS-14
				YACHIYO ENGINEERING CO., LTD. TOKYO, JAPAN				

RX Distributer
 Repeater 1
 Repeater 2
 Repeater 3
 Repeater 4
 Repeater 5
 Repeater 6
 Repeater 7
 Trunking Controller
 L2 Switch
 PDH IDU
 Site Monitor I/O
 DC Distribuer

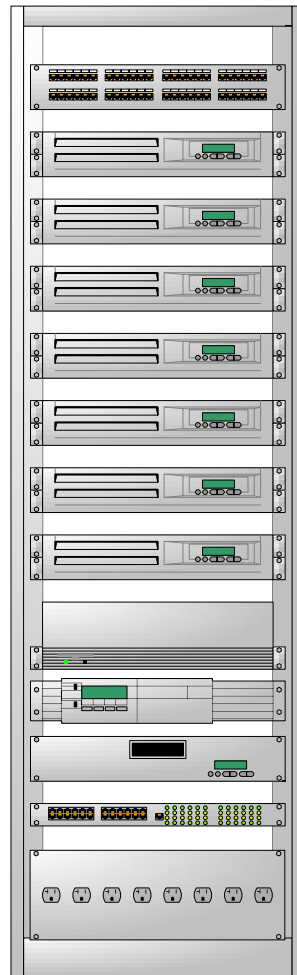

Repeater Rack

7ch
 TX Combiner

TX BPF

RX BPF

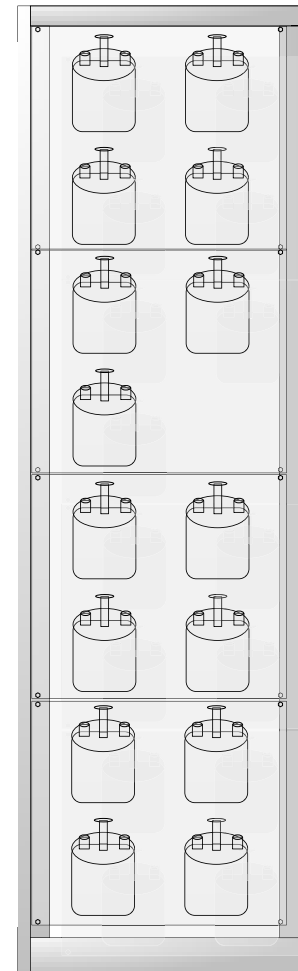

Filters/ Duplexer

ANT x 2

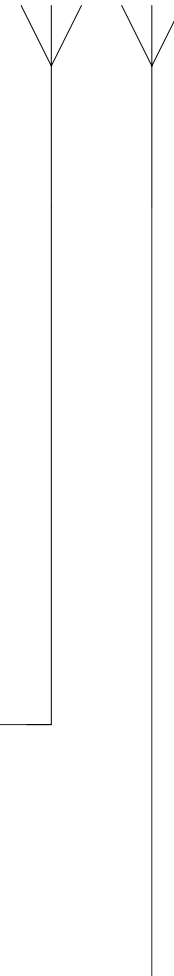

Legend

- TX : Transmitter
- RX : Receiver
- PDH : Plesiochronous Digital Hierarchy
- IDU : Indoor Unit
- BPF : Band Pass Filter
- ANT : Antenna

PROJECT NAME	EXECUTING AGENCY	TITLE	SCALE	DATE	DESIGNED	CHECKED	APPROVED	DWG No.
The Project for Improvement of Emergency Communication System in Jamaica	ODPEM	Rack Arrangement for Fixed UHF Repeater Station (7ch)	---	Apr. 2016	K. Harikae	K. Tanaka	T. Kobayashi	DS-15
				 YEC YACHIYO ENGINEERING CO., LTD. TOKYO, JAPAN				

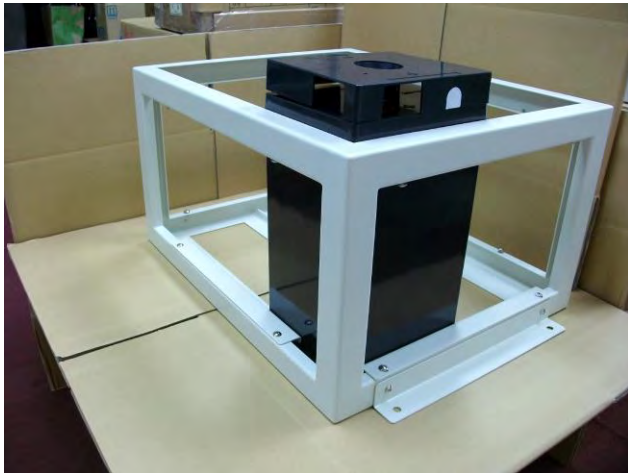

Battery tray
(Sample for reference)

PROJECT NAME	EXECUTING AGENCY	TITLE	SCALE	DATE	DESIGNED	CHECKED	APPROVED	DWG No.
The Project for Improvement of Emergency Communication System in Jamaica	ODPEM	Outside View of Battery Rack	---	Apr. 2016	K. Harikae	K. Tanaka	T. Kobayashi	DS-16
				 YACHIYO ENGINEERING CO., LTD. TOKYO, JAPAN				

Legend
 LVD : Low voltage Disconnect
 NFB : Non Fuse Breaker
 TX : Transmitter
 RX : Receiver

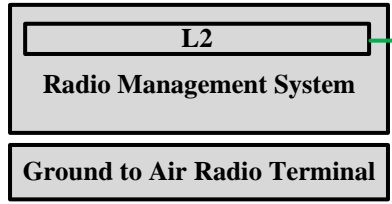

High power Amplifier (1kW)

HF-SSB
3.9A (T:R:S=10:10:80)
 Current drain(assumption)
 Tx (125W): 28A
 Rx(Max.audio):3A
 Standby: 1A

VHF Base Station
0.86A (T:R:S=10:10:80)
 Current drain(assumption)
 Tx(25W): 5A
 Rx(Max.audio):1.2A
 Standby: 300mA

UHF Base Station
0.86A (T:R:S=10:10:80)
 Current drain(assumption)
 Tx(25W): 5A
 Rx(Max.audio):1.2A
 Standby: 300mA

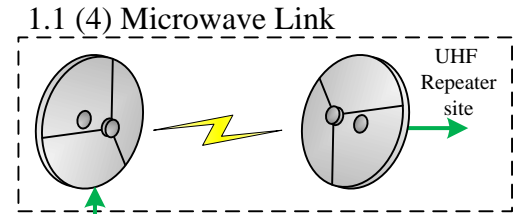

ODU

IDU
 60W (1+0)
 1.3 A
 (48V Drive)

DC/DC
 12VDC/48VDC

NFB Total 5.62A

LVD

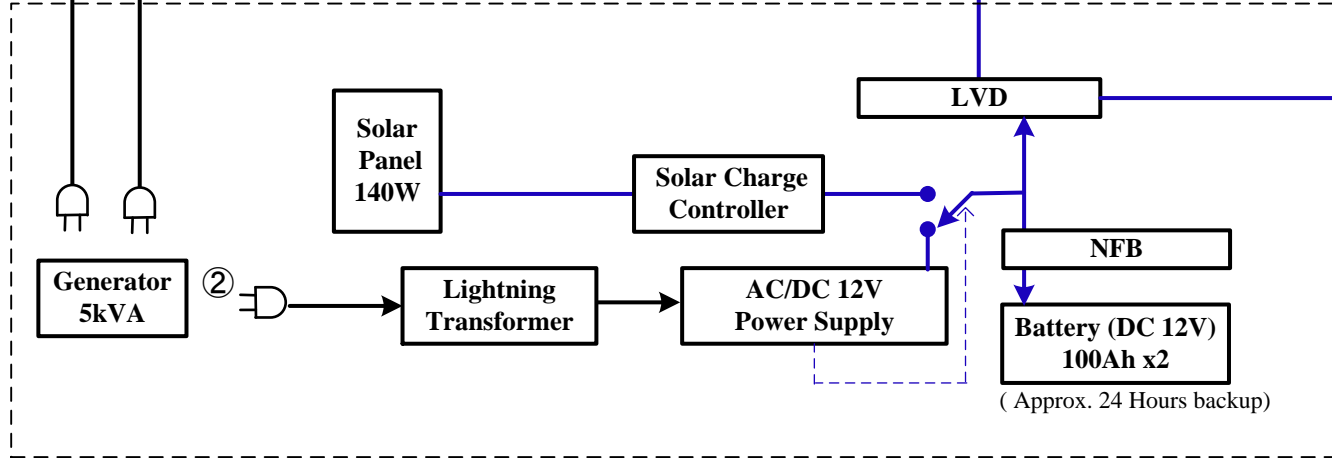

1.3 Integrated Command and Control Station

- (1) National Command Station
- 4) Power Supply System

Calculation of max Power consumption
 $471.6VA : 12V DC, 39.3A = 28A(HF-SSB, Tx) + 5(VHF Base Station, Tx) + 5(UHF Base Station, Tx) + 1.3(PDH)$

A-8-V
81-8-18

PROJECT NAME	EXECUTING AGENCY	TITLE	SCALE	DATE	DESIGNED	CHECKED	APPROVED	DWG No.
The Project for Improvement of Emergency Communication System in Jamaica	ODPEM	Block Diagram of Power Supply System for National Command Station [1.3 (1)]	---	Apr. 2016	K. Harikae	K. Tanaka	T. Kobayashi	DS-17
				YACHIYO ENGINEERING CO., LTD. TOKYO, JAPAN				

1.3 Integrated Command and Control Station

(2) Parish Control Station

Legend

LVD : Low Voltage Disconnect

NFB : Non Fuse Breaker

TX : Transmitter

RX : Receiver

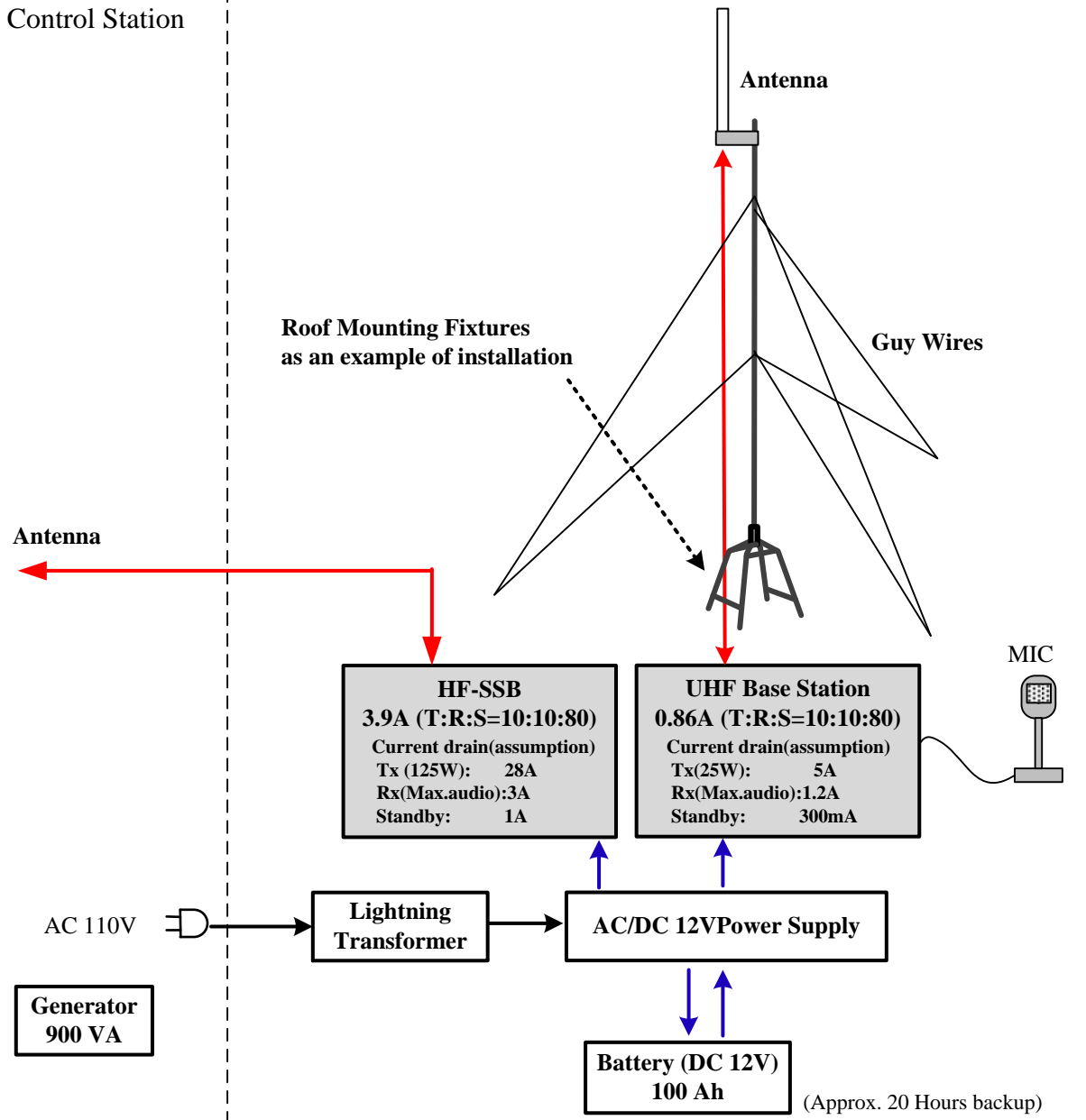

A-8-19

PROJECT NAME	EXECUTING AGENCY	TITLE	SCALE	DATE	DESIGNED	CHECKED	APPROVED	DWG No.
The Project for Improvement of Emergency Communication System in Jamaica	ODPEM	Block Diagram of UHF Base Radio for Parish Control Station	---	Apr. 2016	K. Harikae	K. Tanaka	T. Kobayashi	DS-18
				 YACHIYO ENGINEERING CO., LTD. TOKYO, JAPAN				

Legend

LVD : Low Voltage Disconnect

NFB : Non Fuse Breaker

TX : Transmitter

RX : Receiver

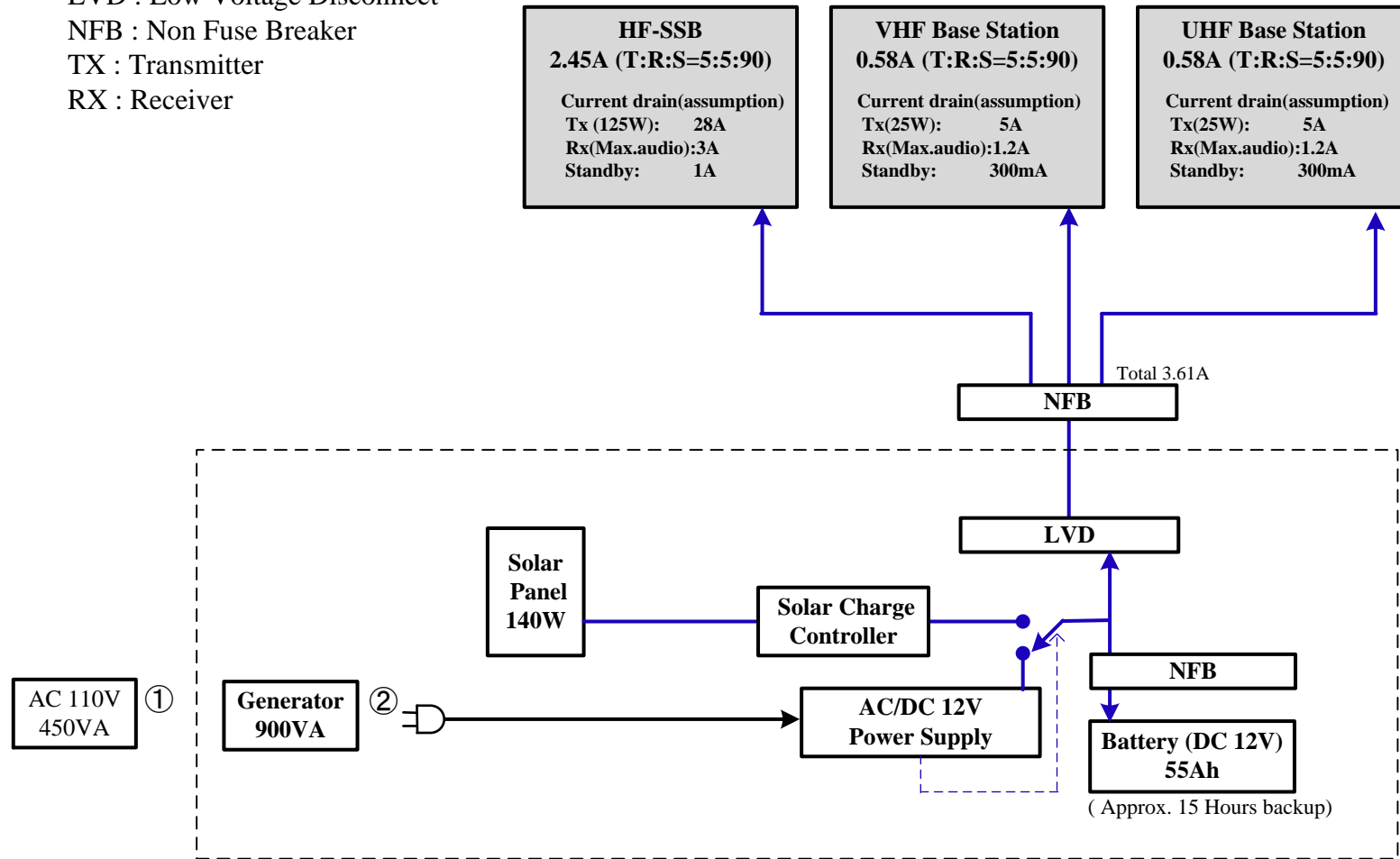

1.3 Integrated Command and Control Station

(3) Community Operation Station

4) Power Supply System

Calculation of max Power consumption

456VA : 12V DC, 38A = 28A(HF-SSB,Tx)+5(VHF Base Station,Tx)+5(UHF Base Station,Tx)

PROJECT NAME	EXECUTING AGENCY	TITLE	SCALE	DATE	DESIGNED	CHECKED	APPROVED	DWG No.
The Project for Improvement of Emergency Communication System in Jamaica	ODPEM	Block Diagram of Power Supply System for Portable Radio Station for Community [1.3 (3)]	---	Apr. 2016	K. Harikae	K. Tanaka	T. Kobayashi	DS-19
				YEC YACHIYO ENGINEERING CO., LTD. TOKYO, JAPAN				

Carton No.1 (HF-SSB)



1.3 (3) Portable Radio Station for Community
1) HF-SSB (Transportable Type)

2 U

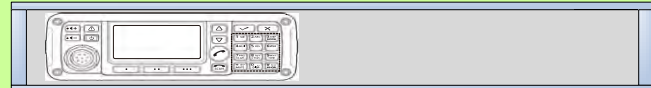

Carton No.3 (Handheld Radio)



1.3 (3) Portable Radio Station for Community
5) Hand held Radio x10

Carton No.4 (Cable & Accessory)



1.3 (3) Portable Radio Station for Community
Cables and Others

Carton No.2 (VHF, UHF)



1.3 (3) Portable Radio Station for Community
2) VHF Base Radio
3) UHF Base Radio

2 U



Carton No.5 (Antenna & Poles)



1.3 (3) Portable Radio Station for Community
Antenna & Poles

Carton No.6 (Battery Case)



1.3 (3) Portable Radio Station for Community
4) Power Supply System

A-8-21

PROJECT NAME	EXECUTING AGENCY	TITLE	SCALE	DATE	DESIGNED	CHECKED	APPROVED	DWG No.
The Project for Improvement of Emergency Communication System in Jamaica	ODPEM	Appearance of Case for Portable Radio Station for Community	---	Apr. 2016	K. Harikae	K. Tanaka	T. Kobayashi	DS-20
				 YEC YACHIYO ENGINEERING CO., LTD. TOKYO, JAPAN				

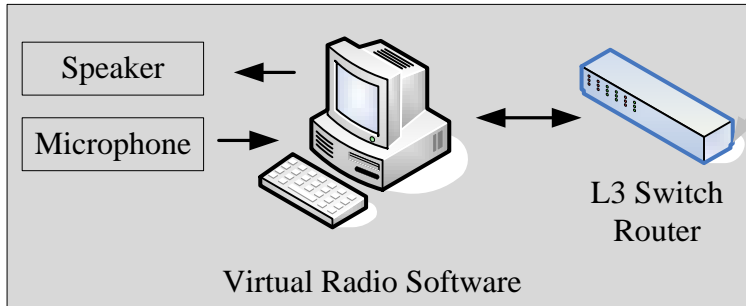
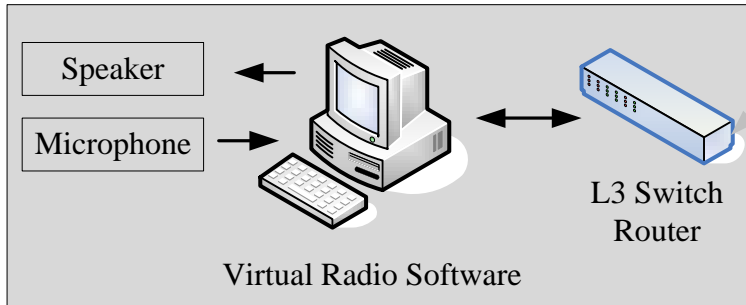
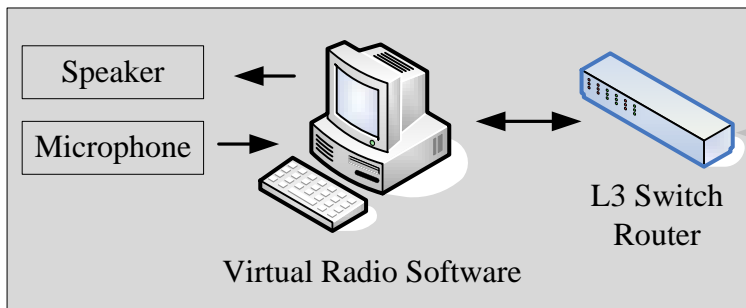
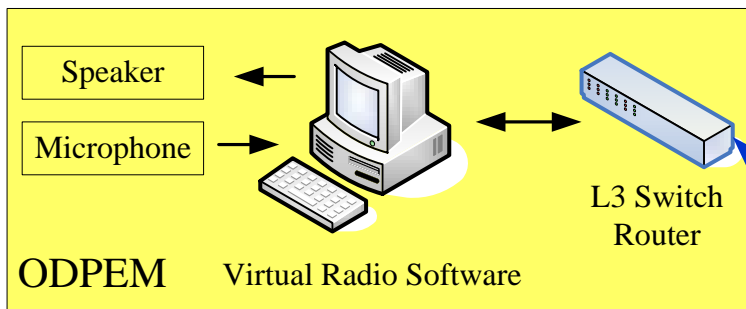

Microwave Link

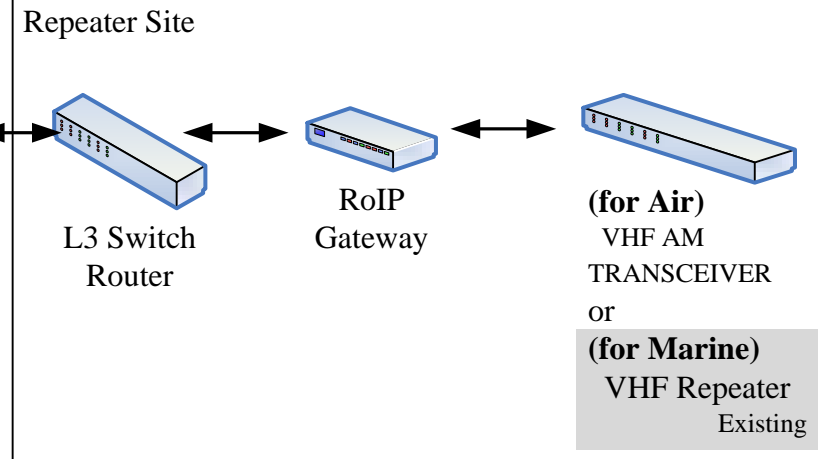
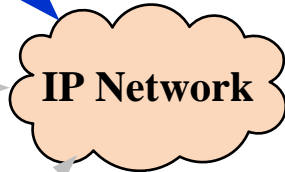

Legend
RoIP : Radio Over IP
L3 : Layer 3 Network Switch

A-8-22

PROJECT NAME	EXECUTING AGENCY	TITLE	SCALE	DATE	DESIGNED	CHECKED	APPROVED	DWG No.
The Project for Improvement of Emergency Communication System in Jamaica	ODPEM	Network Diagram of VHF-AM Ground to Air Radio / Marine Radio Interface	---	Apr. 2016	K. Harikae	K. Tanaka	T. Kobayashi	DS-21
				YEC YACHIYO ENGINEERING CO., LTD. TOKYO, JAPAN				

A-8-23

Legend
 PWR Control : Power Control
 AF OUT : Audio Frequency Output
 SP Det : Speaker Detector
 PA AMP: Public Address Amplifier
 PTT : Push to Talk

Siren Control

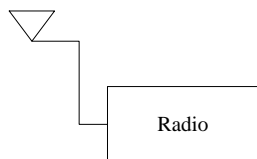

Siren Site

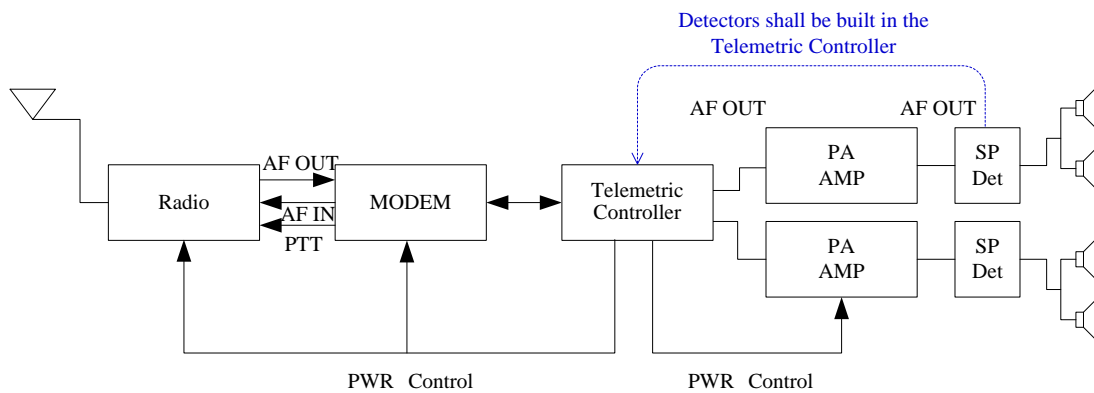

Siren Tower with Solar Panel and Outdoor Equipment Rack (Sample for reference)

PROJECT NAME	EXECUTING AGENCY	TITLE	SCALE	DATE	DESIGNED	CHECKED	APPROVED	DWG No.
The Project for Improvement of Emergency Communication System in Jamaica	ODPEM	Block Diagram of Siren System	---	Apr. 2016	K. Harikae	K. Tanaka	T. Kobayashi	ES-01
				 YACHIYO ENGINEERING CO., LTD. TOKYO, JAPAN				

A-8-24

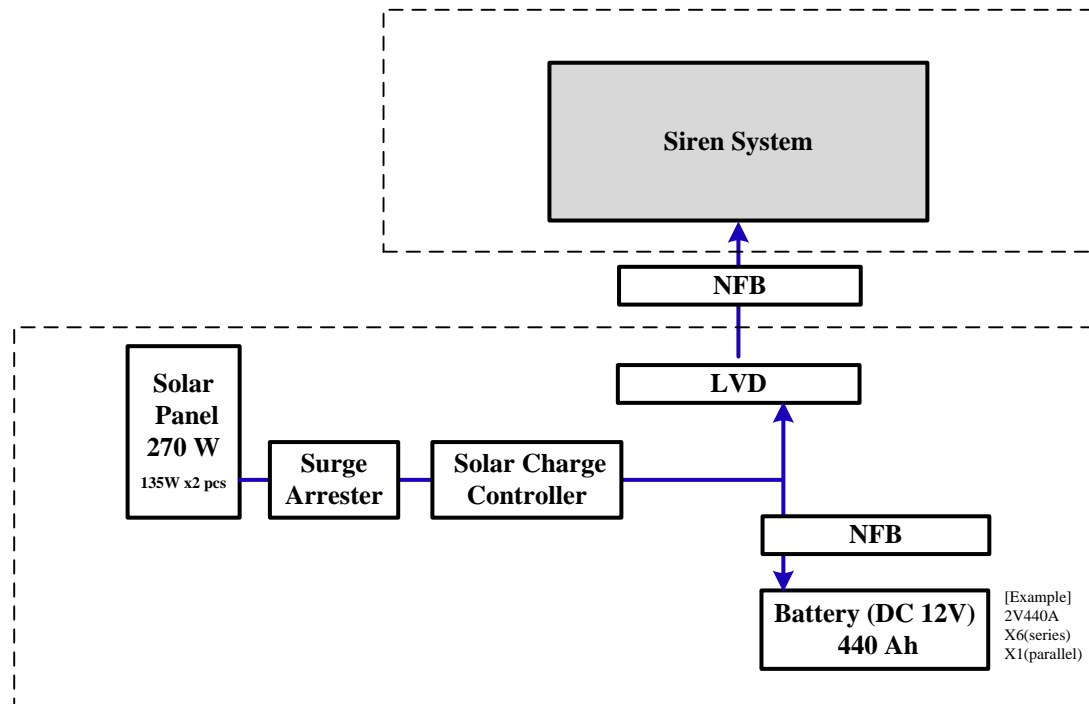

PROJECT NAME	EXECUTING AGENCY	TITLE	SCALE	DATE	DESIGNED	CHECKED	APPROVED	DWG No.
The Project for Improvement of Emergency Communication System in Jamaica	ODPEM	Block Diagram of Power Supply for Siren System	---	Apr. 2016	K. Harikae	K. Tanaka	T. Kobayashi	ES-02
 YACHIYO ENGINEERING CO., LTD. TOKYO, JAPAN								

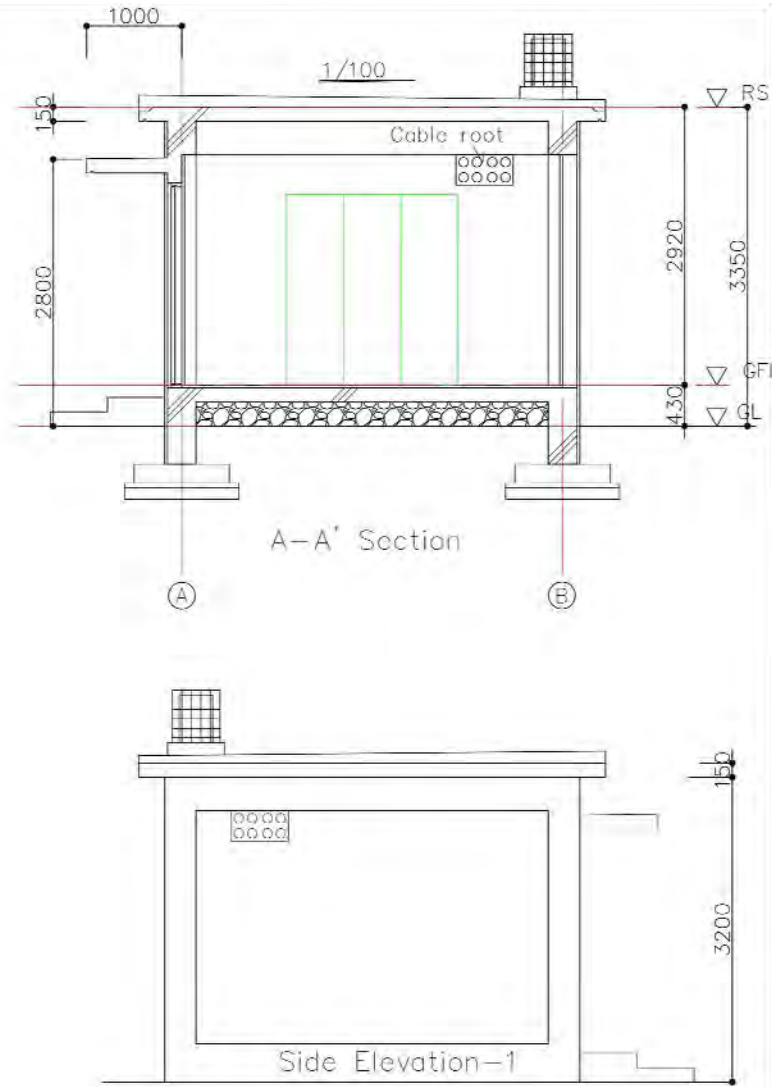
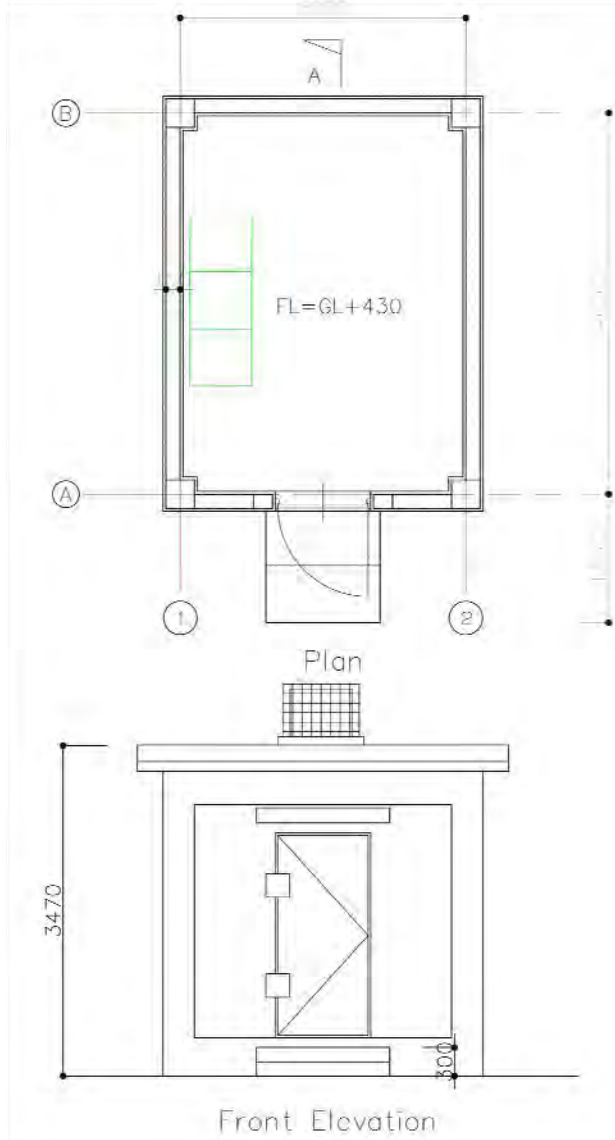

A-8-25

PROJECT NAME	EXECUTING AGENCY	TITLE	SCALE	DATE	DESIGNED	CHECKED	APPROVED	DWG No.
The Project for Improvement of Emergency Communication System in Jamaica	ODPEM	New Repeater Station Hut Plan (Standard type)	S=1/50 for A3 paper	Apr. 2016	A. Maruyama	D. Kanazashi	T. Kobayashi	A-01
				 YACHIYO ENGINEERING CO., LTD. TOKYO, JAPAN				

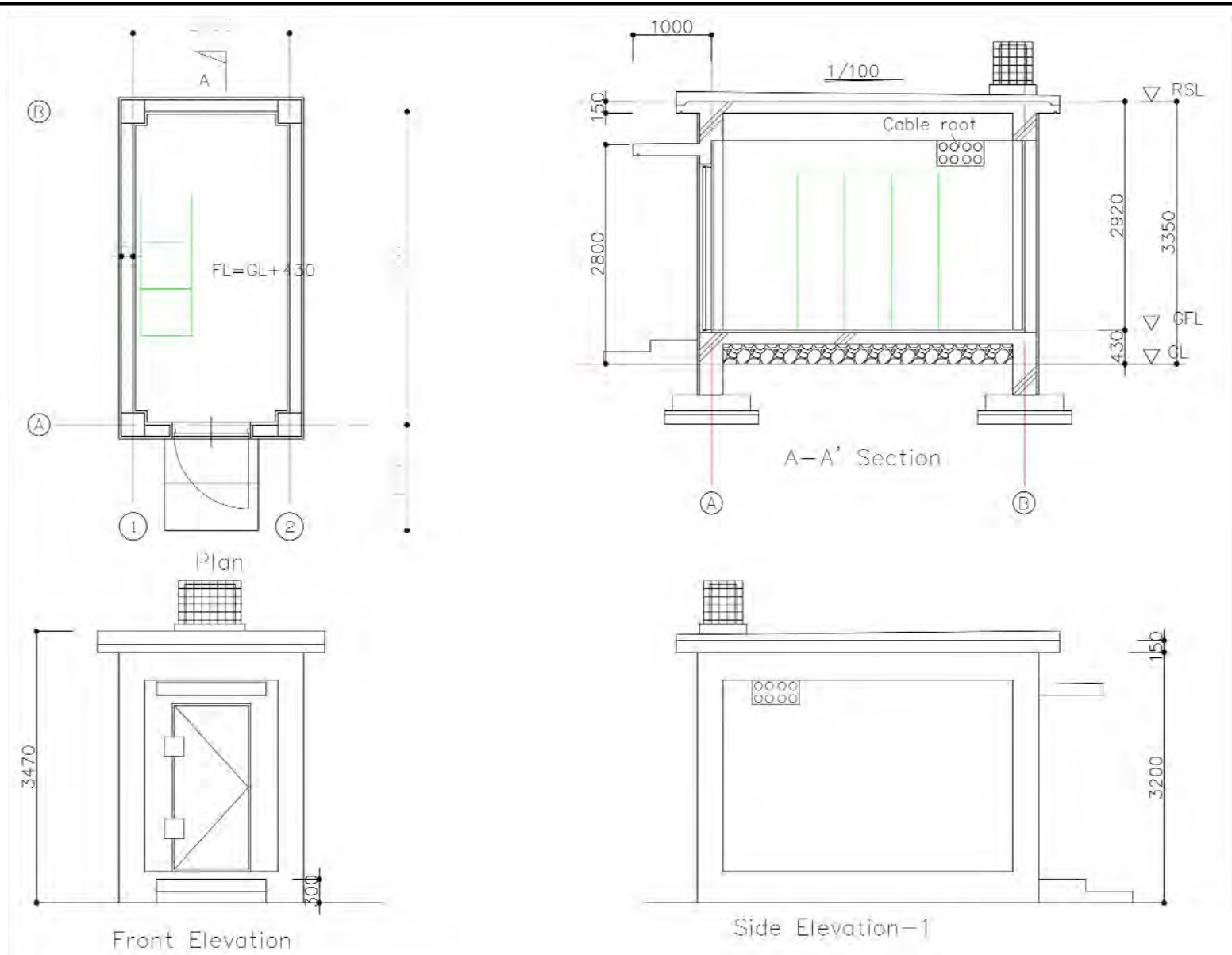

PROJECT NAME	EXECUTING AGENCY	TITLE	SCALE	DATE	DESIGNED	CHECKED	APPROVED	DWG No.
The Project for Improvement of Emergency Communication System in Jamaica	ODPEM	New Repeater Station Hut Plan (Compact type)	S=1/50 for A3 paper	Apr. 2016	A. Maruyama	D. Kanazashi	T. Kobayashi	A-02
				YACHIYO ENGINEERING CO., LTD. TOKYO, JAPAN				

資料－9 免税措置フロー図

9. 免税措置フロー図

① 輸入税

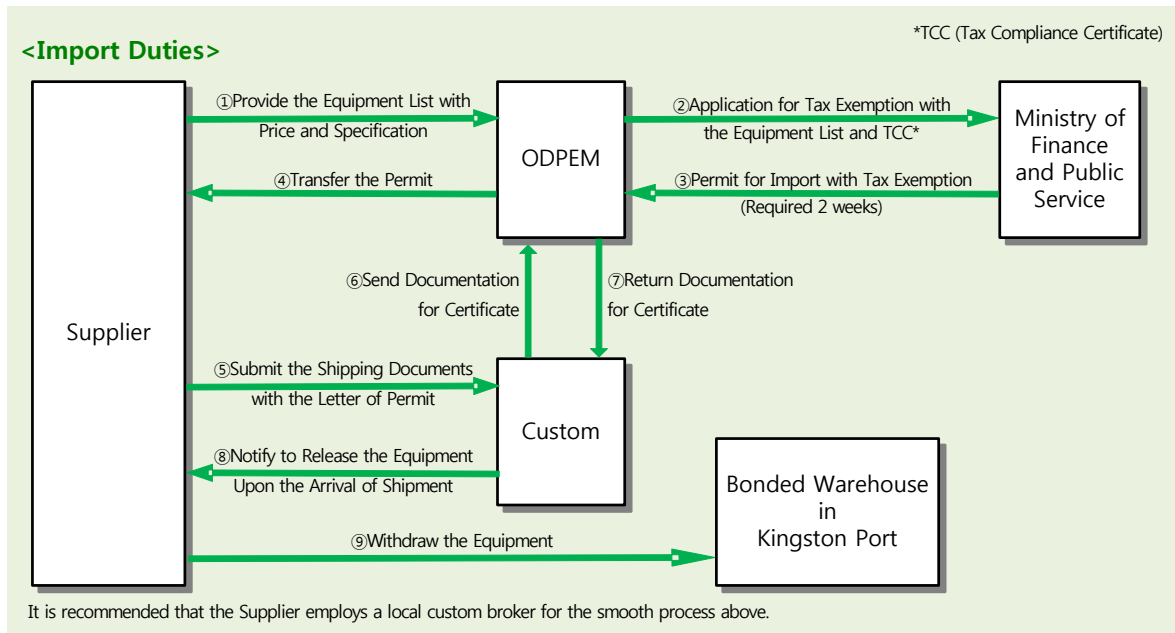

② 税関検査費用

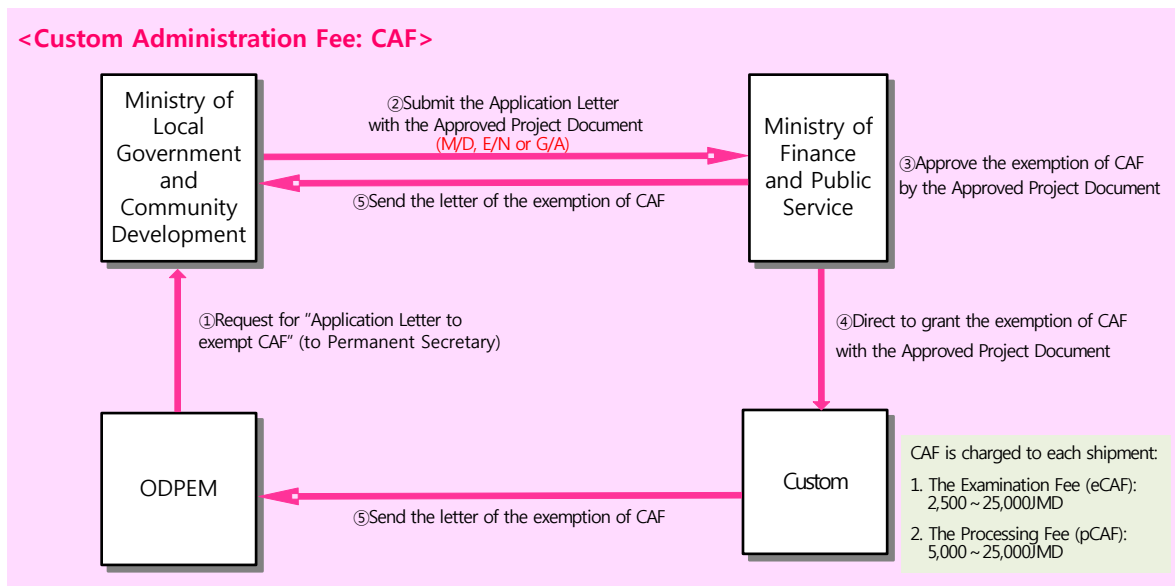

③ 消費税

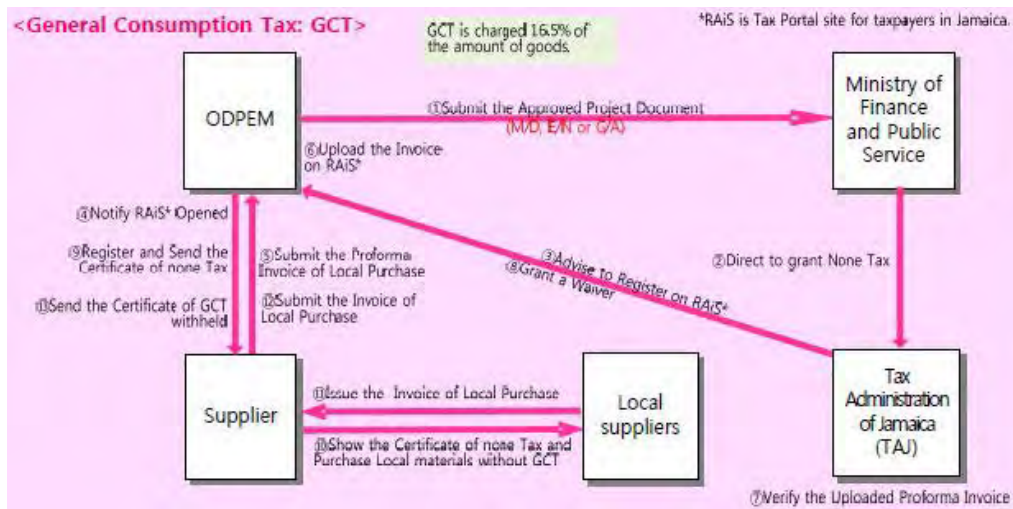

④ 源泉徴収税

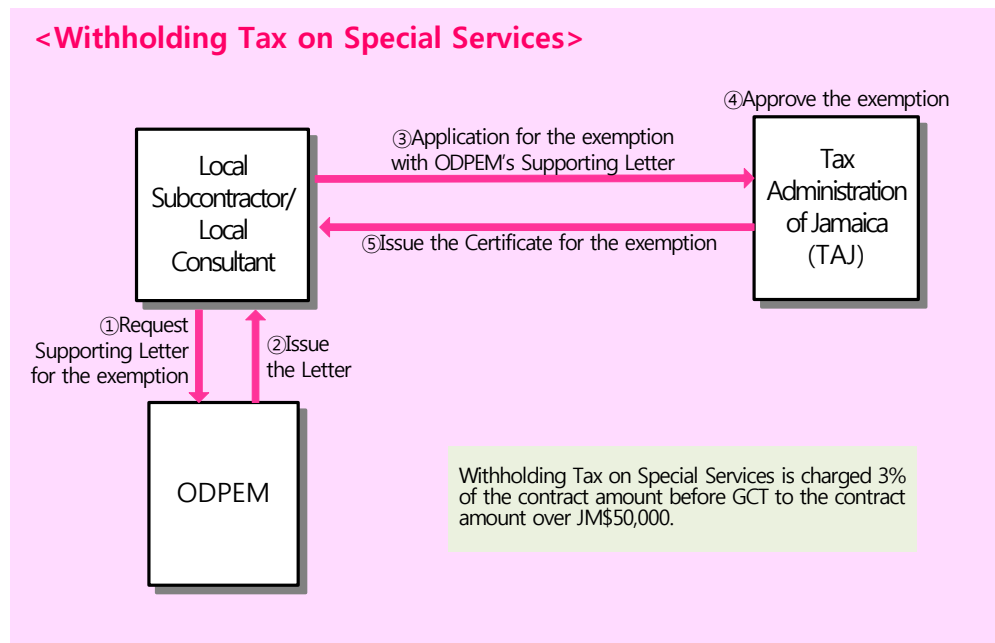

⑤ 事業税

事業税は、ジャマイカ国側の契約者がプロジェクト関連書類（E/N 又は G/A）をジャマイカ国税庁に提出することで免税となる。

⑥ 環境税

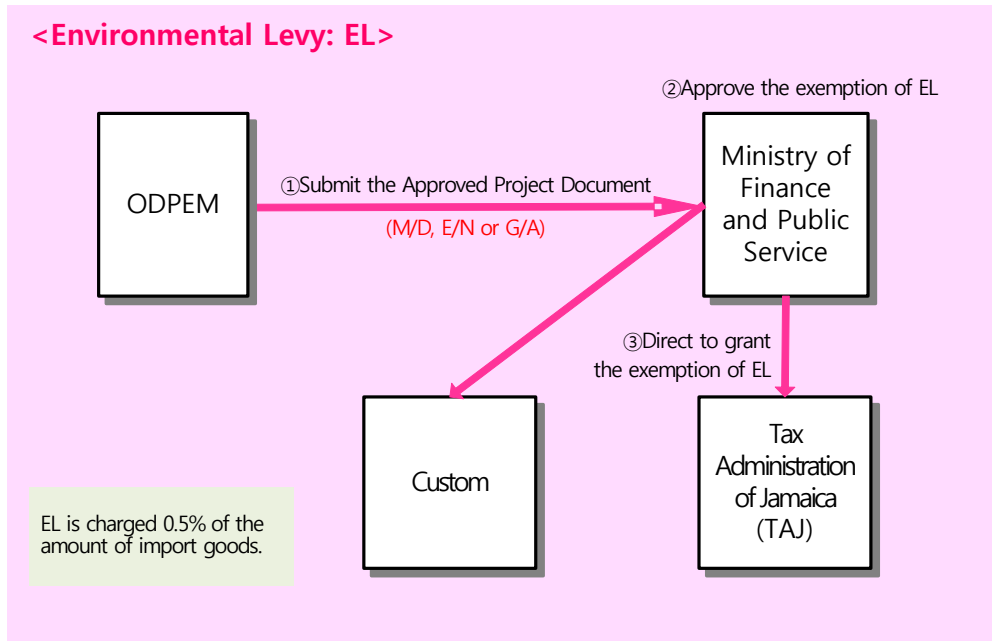

⑦ 規格準拠費

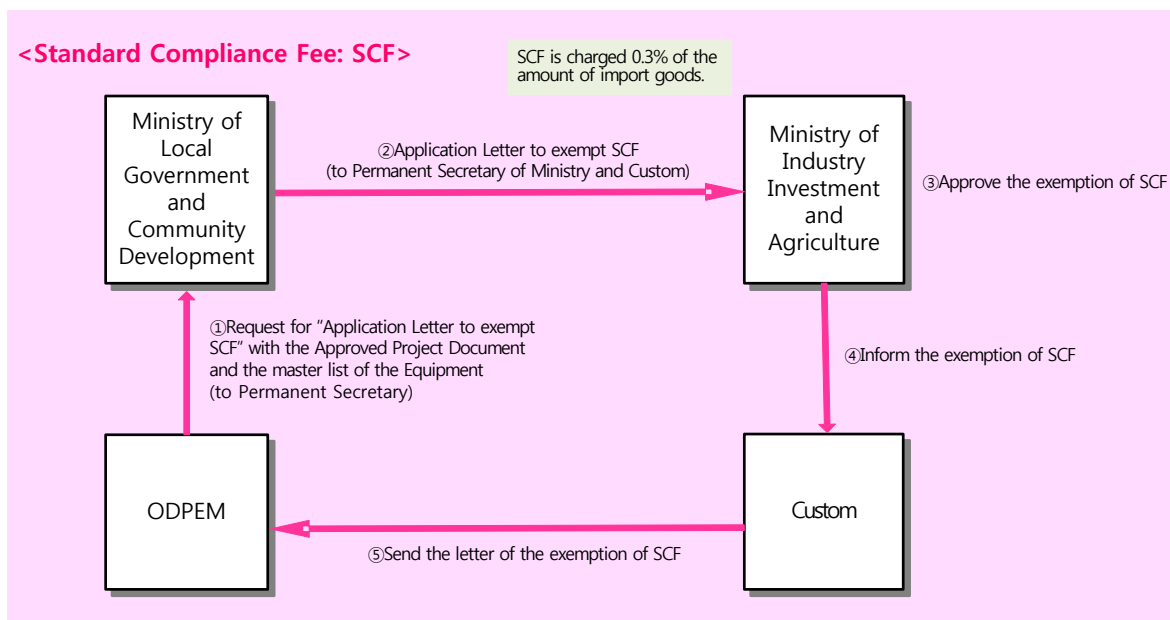

資料－10 地盤・地質調査結果

地盤・地質調査結果目次

A-10-1 無線中継局新設建屋候補地調査報告書	
(Rep011, Rep017, Rep020, Rep023, Rep024, Rep030).....	A-10-1-1
(Rep006).....	A-10-1-101
A-10-2 サイレンシステム候補地調査報告書.....	A-10-2-1
A-10-3 無線中継局既設建屋 (Rep006) コンクリート基礎コア抜き試験報告書 .	A-10-3-1

**A REPORT ON SOIL INVESTIGATIONS AT SELECTED REPEATER STATIONS (PROJECT FOR
IMPROVEMENT OF EMERGENCY COMMUNICATION SYSTEM IN JAMAICA**

Table of Contents

EXECUTIVE SUMMARY	3
1.0 INTRODUCTION	9
1.1 OBJECTIVES	9
1.2 BACKGROUND	9
1.3 PROJECT SCOPE	9
1.4 PROJECT DESCRIPTION	10
1.5 PROJECT LOCATION	10
1.5.1 MOUNT AIRY, WESTMORELAND	11
1.5.2 SHAFSTON, WESTMORELAND	12
1.5.3 PORTLAND COTTAGE, CLARENDON	12
1.5.4 SLIGOVILLE, ST. CATHERINE.....	13
1.5.5 CABBAGE HILL, ST THOMAS	14
1.5.6 WINCHESTER, ST. THOMAS.....	14
2.0 GEOLOGY	15
2.1 INTRODUCTION	15
2.2 METHODOLOGY	15
2.3 MOUNT AIRY, WESTMORELAND	16
2.3.1 REGIONAL GEOLOGY SETTING.....	16
2.3.2 LOCAL GEOLOGY	17
2.3.3 PETROGRAPHIC ANALYSIS.....	19
2.3.4 GEOLOGICAL/GEOTECHNICAL HAZARDS	20
2.4 SHAFSTON, WESTMORELAND	21
2.4.1 REGIONAL GEOLOGY SETTING.....	21
2.4.2 LOCAL GEOLOGY	21
2.4.3 PETROGRAPHIC ANALYSIS.....	22
2.4.4 GEOLOGICAL/GEOTECHNICAL HAZARDS	23
2.5 PORTLAND COTTAGE, CLARENDON	24
2.5.1 REGIONAL GEOLOGY SETTING.....	24

2.5.2	LOCAL GEOLOGY	24
2.5.3	PETROGRAPHIC ANALYSIS	25
2.5.4	GEOLOGICAL/GEOTECHNICAL HAZARDS	26
2.6	SLIGOVILLE, ST. CATHERINE	26
2.6.1	REGIONAL GEOLOGY SETTING	26
2.6.2	LOCAL GEOLOGY	27
2.6.3	PETROGRAPHIC ANALYSIS	28
2.6.4	GEOLOGICAL/GEOTECHNICAL HAZARDS	30
2.7	CABBAGE HILL, ST. THOMAS	31
2.7.1	REGIONAL GEOLOGY SETTING	31
2.7.2	LOCAL GEOLOGY	32
2.7.3	PETROGRAPHIC ANALYSIS	32
2.7.4	GEOLOGICAL/GEOTECHNICAL HAZARDS	33
2.8	WINCHESTER, ST. THOMAS	34
2.8.1	REGIONAL GEOLOGY SETTING	34
2.8.2	LOCAL GEOLOGY	34
2.8.3	PETROGRAPHIC ANALYSIS	35
2.8.4	GEOLOGICAL/GEOTECHNICAL HAZARDS	37
3.0	GEOTECHNICAL ASSESSMENT	37
3.1	INTRODUCTION	37
3.2	METHODOLOGY	37
3.3	SOIL INVESTIGATIONS RESULTS / FINDINGS	38
3.3.1	MOUNT AIRY, WESTMORELAND	38
3.3.2	SHAFSTON, WESTMORELAND	40
3.3.3	PORTLAND COTTAGE, CLARENDON	42
3.3.4	SLIGOVILLE, ST. CATHERINE	43
3.3.5	CABBAGE HILL, ST. THOMAS	46
3.3.6	WINCHESTER, ST. THOMAS	48
4.0	RECOMMENDATIONS FOR DESIGN AND CONSTRUCTION	51
4.1	MOUNT AIRY, WESTMORELAND	52
4.1.1	EARTHWORKS	52
4.1.2	FOUNDATIONS	52

4.2 SHAFSTON, WESTMORELAND.....	53
4.2.1 EARTHWORKS	53
4.2.2 FOUNDATIONS	54
4.3 PORTLAND COTTAGE, CLARENDON	54
4.3.1 EARTHWORKS	54
4.3.2 FOUNDATIONS	55
4.4 SLIGOVILLE, ST. CATHERINE	55
4.4.1 EARTHWORKS	55
4.4.2 FOUNDATIONS	56
4.5 CABBAGE HILL, ST. THOMAS.....	57
4.5.1 EARTHWORKS	57
4.5.2 FOUNDATIONS	57
4.6 WINCHESTER, ST. THOMAS.....	58
4.6.1 EARTHWORKS	58
4.6.2 FOUNDATIONS	59
5.0 REFERENCES.....	60
APPENDICES.....	61
APPENDIX A1 - EXPLORATION LOGS – MOUNT AIRY, WESTMORELAND	61
APPENDIX A2 - LAB REPORT – MOUNT AIRY, WESTMORELAND	61
APPENDIX A3 - PETROGRAPHIC ANALYSIS – MOUNT AIRY, WESTMORELAND	61
APPENDIX A4 – PRINCIPAL AND SHEAR STRENGTH GRAPHS – MOUNT AIRY, WESTMORELAND.....	61
APPENDIX B1 – EXPLORATION LOGS – SHAFSTON, WESTMORELAND.....	61
APPENDIX B2 – LAB REPORT – SHAFSTON, WESTMORELAND	61
APPENDIX B3 – PETROGRAPHIC ANALYSIS – SHAFSTON, WESTMORELAND.....	61
APPENDIX B4 – PRINCIPAL AND SHEAR STRENGTH GRAPHS – SHAFSTON, WESTMORELAND	61
APPENDIX C1 – EXPLORATION LOGS – PORTLAND COTTAGE, CLARENDON	61
APPENDIX C2 – LAB REPORT – PORTLAND COTTAGE, CLARENDON.....	61
APPENDIX C3 – PETROGRAPHIC ANALYSIS – PORTLAND COTTAGE, CLARENDON	61
APPENDIX C4 – PRINCIPAL AND SHEAR STRENGTH GRAPHS – PORTLAND COTTAGE, CLARENDON	61
APPENDIX D1 - EXPLORATION LOGS – SLIGOVILLE, ST. CATHERINE.....	61
APPENDIX D2 - LAB REPORT – SLIGOVILLE, ST. CATHERINE	61
APPENDIX D3 - PETROGRAPHIC ANALYSIS – SLIGOVILLE, ST. CATHERINE	61

APPENDIX D4 – PRINCIPAL AND SHEAR STRENGTH GRAPHS – SLIGOVILLE, ST. CATHERINE 61

APPENDIX E1 - EXPLORATION LOGS – CABBAGE HILL, ST. THOMAS 61

APPENDIX E2 - LAB REPORT – CABBAGE HILL, ST. THOMAS..... 61

APPENDIX E3 - PETROGRAPHIC ANALYSIS – CABBAGE HILL, ST. THOMAS 61

APPENDIX E4 – PRINCIPAL AND SHEAR STRENGTH GRAPHS – CABBAGE HILL, ST. THOMAS 61

APPENDIX F1 - EXPLORATION LOGS – WINCHESTER, ST. THOMAS 61

APPENDIX F2 - LAB REPORT – WINCHESTER, ST. THOMAS 61

APPENDIX F3 - PETROGRAPHIC ANALYSIS – WINCHESTER, ST. THOMAS..... 61

APPENDIX F4 – PRINCIPAL AND SHEAR STRENGTH GRAPHS – WINCHESTER, ST. THOMAS 61

LIST OF FIGURES

Figure 1 Table showing geographic coordinate locations of each selected tower site..... 10

Figure 2. Map showing location of selected Repeater stations where soil investigations were conducted 11

Figure 3 Map showing location of tower site in Mount Airy, Westmoreland 12

Figure 4 Map showing location of tower site, Shafston, Westmoreland 12

Figure 5 Map showing location of tower site, Portland Cottage, Clarendon 13

Figure 6 Map showing location of tower site, Sligoville, St. Catherine 13

Figure 7 Map showing location of tower site, Cabbage Hill, St. Thomas 14

Figure 8 Map showing location of tower site, Winchester, St. Thomas..... 15

Figure 9 Map showing generalized geology of Jamaica and locations of sample sites..... 16

Figure 10 Map showing Regional Geology of Western Westmoreland 17

Figure 11. Picture showing outcropping of bedrock at the Mt. Airy Tower site 18

Figure 12. Photo micrographs showing sample in (A) Plane Polarized light and (B) cross Polarized light. F-Foraminifera, Ps- Pore space 20

Figure 13. Map showing Regional Geology of Southeast Westmoreland 21

Figure 14. Map showing Regional Geology of Southern Clarendon..... 24

Figure 15 Map showing Regional Geology of Central St. Catherine 27

Figure 16 Photo micrographs showing sample in plane (1) and crossed (2) polarized light with large cavity 29

Figure 17 Photo micrographs showing samples in cross (3) polarized light (F-foraminifera, Ps – Pore space) and plane polarized light showing large cavity..... 29

Figure 18 Photo micrograph of sample showing (5) micrite with pore spaces and sample showing (6) Foraminifera (F) within micrite matrix with pore spaces indicated by blue dye..... 30

Figure 19. Map showing Regional Geology of Western St. Thomas..... 31

Figure 20. Map showing regional geology of Eastern St. Thomas..... 34

Figure 21 Picture showing core samples collected from borehole, Mt. Airy, Westmoreland 38

Figure 22. Lithological profile generated from borelog, Mt. Airy, Westmoreland..... 39

Figure 23 Picture showing core samples collected from Shafton, Westmoreland 40

Figure 24. Lithological profile generated from borelog, Shafston, Westmoreland..... 40

Figure 25. Plasticity chart for sample, Shafston, Westmoreland 41

Figure 26. Table showing unconfined compression Strength in rock samples-Shafton, Westmoreland..... 41

Figure 27 Pictures showing core samples collected from Portland Cottage, Clarendon 42

Figure 28. Lithological profile generated from borelog, Portland Cottage, Clarendon..... 42

Figure 29 Table showing Unconfined Compression Strength test results for Portland Cottage, Clarendon 43

Figure 30 Picture showing core samples from borehole at Sligoville, St. Catherine 43

Figure 31. Lithological profile generated from borelog, Sligoville, St. Catherine 44

Figure 32. Table showing grain size distribution of three (3) samples taken from 2ft 6", 5ft and 7ft 6" respectively, Sligoville, St. Catherine 44

Figure 33. Grain size distribution graphs for sieve analyses done @ 2ft 6", 5ft & 7ft 6" 45

Figure 34. Table showing Unconfined Compression Strength test result, Sligoville, St. Catherine 45

Figure 35. Picture showing use of coring machine at Cabbage Hill, St. Thomas 46

Figure 36 Picture showing core samples collected from borehole, Cabbage Hill, St. Thomas..... 46

Figure 37. Lithological profile generated from borelog, Cabbage Hill, St. Thomas 47

Figure 38. Table showing Unconfined Compression Strength test result, Cabbage Hill, St. Thomas 47

Figure 39 Picture showing use of coring machine at Winchester Site 48

Figure 40. Picture showing test pit dug at Winchester, St. Thomas..... 49

Figure 41 Picture showing core sample collected from borehole, Winchester, St. Thomas..... 49

Figure 42. Lithological profile generated from borelog, Winchester, St. Thomas 50

Figure 43. Table showing Unconfined Compression Strength test result, Winchester, St. Thomas..... 50

Figure 44. Diagram showing average principal and normal vs shear stress envelopes, Mt. Airy 52

Figure 45. Diagram showing average principal and normal vs shear stress envelopes, Shafston 53

Figure 46. Diagram showing average principal and normal vs shear stress envelopes, Portland Cottage..... 55

Figure 47. Diagram showing average principal and normal vs shear stress envelopes, Sligoville 56

Figure 48. Diagram showing average principal and normal vs shear stress envelopes, Cabbage Hill, St. Thomas 57

Figure 49. Diagram showing average principal and normal vs shear stress envelopes, Winchester, St. Thomas..... 58

1.0 INTRODUCTION

1.1 OBJECTIVES

The aim of this geotechnical report is to:

- Review and conduct geological assessment of selected repeater stations by employing physical subsurface exploration methods
- Present findings on geological and geotechnical study
- Present recommendations on anticipated earthworks and its potential impact on construction foundation design

1.2 BACKGROUND

In recent years the Japan International Cooperation Agency; JICA, and the Jamaican Government have strengthened bilateral arrangements with the aim of promoting the islands social and economic development.

A crucial component of JICA's operation is aimed at strengthening the goals and strategic objectives of the islands Comprehensive Disaster Management Framework, which partly involves the improvement of Jamaica's emergency communication infrastructure.

Hence, the objective of the project is to improve the existing emergency communication infrastructure in Jamaica. This will be accomplished by upgrading the existing communication infrastructure which will inevitably result in more efficient and effective communication island wide, and by extension a stronger emergency response mechanism in the event of natural disasters

1.3 PROJECT SCOPE

The scope of works provided and commissioned by Yachiyo Engineering Company Limited (YEC) and guided by contract dated April 14th 2016 included all activities necessary to produce findings of geotechnical investigations at target sites and recommendations for construction and design. Sites for geotechnical investigations were chosen by YEC and shared with Geo-Edge Ltd via maps and geographical coordinates. This was further confirmed by reconnaissance visits to each site by representatives of both companies. A work implementation schedule was prepared and shared with YEC to outline sequence of field activities at selected, existing telecommunication tower facilities located in Mount Airy, and Shafston in Westmoreland, Portland Cottage in Clarendon, Sligoville, St. Catherine and Cabbage Hill and Winchester in the parish of St. Thomas. Field activities of the subsurface exploration included acquisition of soil samples and rock cores from underlying strata at each site employing use of HQ coring. A field geological assessment was also requested by scope. The scope also included production of field reports and logs and transportation of won samples to laboratory for testing. Record of Groundwater levels if encountered was also included. Geotechnical Laboratory testing of soil and rock samples should not exceed three (3) samples per site. Results from these test

should then form the basis of geotechnical report to be supplied along with supporting field reports which constitute final deliverables

This report was prepared for the exclusive use of our client and their consultants for design of this project. In the event that any changes are made in the character, design or layout of the improvements, we must be contacted to review the conclusions and recommendations contained in this report to determine whether modifications are necessary. This document may not be reproduced in whole or in part by any means whatsoever, nor may it be quoted or excerpted without our express written consent.

1.4 PROJECT DESCRIPTION

The purpose of this project is to improve the existing emergency telecommunication infrastructure in Jamaica. This involves installing the requisite wireless communication systems and relevant infrastructure.

The preparation of a geological/geotechnical report serves as a major component of study, as it assesses the engineering characteristics of the site and its suitability for the various communication related infrastructure. The availability of such data allows engineers and architects to either proceed by implementing structural designs in accordance with the findings or to find engineering solutions where onsite conditions are challenging.

The report hereby presents the findings of the site investigation carried out at selected tower sites located in Mount Airy, Shafston, Westmoreland, Portland Cottage, Clarendon, Sligoville, Clarendon and Cabbage Hill and Winchester, St Thomas.

No.	Name	Parish	Longitude	Latitude
RP011	Cabbage Hill	St. Thomas	17°57'46.5"N	76°34'57.4"W
RP023	Shafston	Westmoreland	18°10'21.8"N	77°59'31.7"W
RP024	Mount Airy	Westmoreland	18°15'20.3"N	78°19'44.7"W
RP030	Winchester	St. Thomas	17°58'10.0"N	76°17'47.6"W
Rp020	Sligoville	St. Catherine	18°05'44.00"N	76°56'51.00"W
Rp017	Portland Cottage	Clarendon	17°44'31.50"N	77°09'26.92"W

Figure 1 Table showing geographic coordinate locations of each selected tower site

1.5 PROJECT LOCATION

This project involves geotechnical and geological assessment at six (6) telecommunication towers located in the parishes of Westmoreland, Clarendon, St. Catherine and St. Thomas. Nomenclature for these selected sites were guided by and taken from technical specifications for project supplied by Yachiyo Engineering Co. Ltd.(YEC). Two (2) tower sites are located in the parish of Westmoreland. Tower Rep024

is located in eastern Westmoreland in the rural community of Mount Airy while the second tower Rep024 was located in the southeastern section of the parish. Tower Rep017 is located in the southernmost tip of the parish of Clarendon. Tower Rep020 is located in east central St. Catherine. The remaining two (2) repeater stations are found in St. Thomas. Tower Rep011 and Tower Rep030 found in the western and eastern sections of the parish respectively. (See fig.2). All tower sites are located at high points relative to their surrounding landscape.

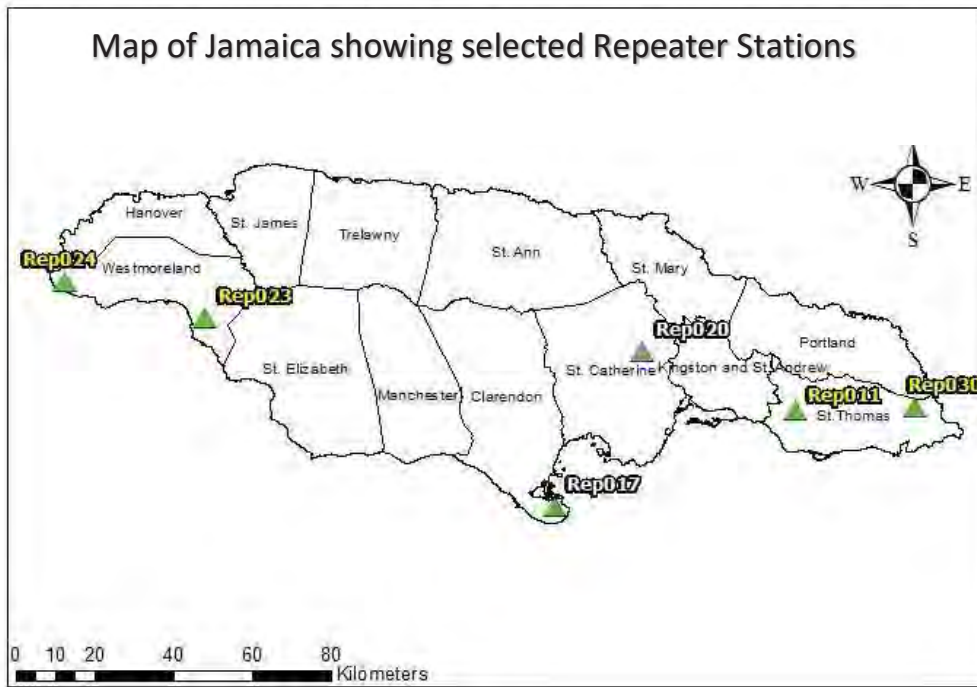

Figure 2. Map showing location of selected Repeater stations where soil investigations were conducted

1.5.1 MOUNT AIRY, WESTMORELAND

Tower Rep024 is located in the western section of Westmoreland within the rural community of Mount Airy, some four kilometers from the tourist centre of Negril. The tower is sited within the Negril Hills which run parallel to the southern coastline of Westmoreland in this area.

The site is accessed via a parochial road traversing through Mount Airy and serving the adjacent rural communities of southwestern Westmorland.



Figure 3 Map showing location of tower site in Mount Airy, Westmoreland

1.5.2 SHAFSTON, WESTMORELAND

The Tower Rep023 is found in the hills of southeastern Westmoreland overlooking the southwestern coastline of St. Elizabeth. It is accessed via a Class C road leading from the linear settlement of New Works, four kilometers (4km) to the east.

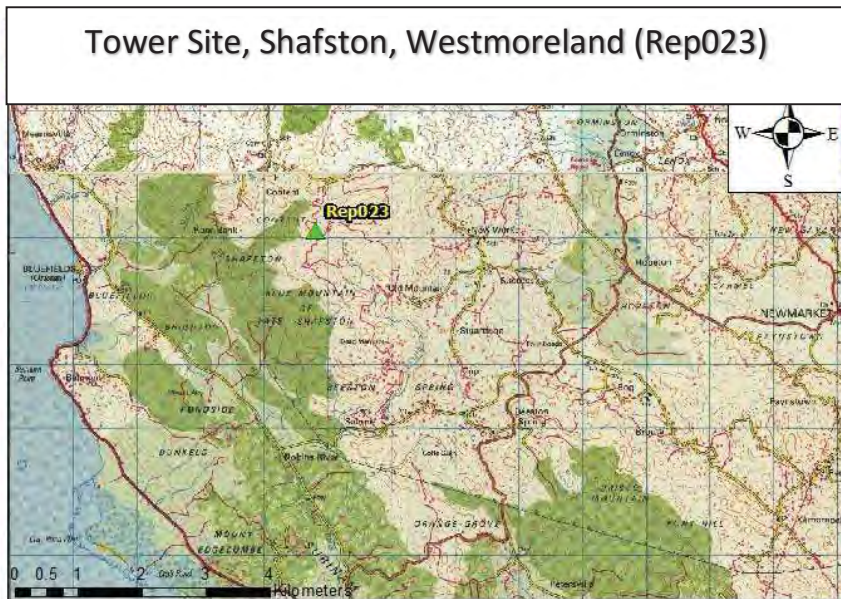

Figure 4 Map showing location of tower site, Shafston, Westmoreland

1.5.3 PORTLAND COTTAGE, CLARENDON

The Tower Rep017 is found on the southernmost tip of the parish of Clarendon on a small, scarcely inhabited peninsula. The high points on this peninsula exhibit an average height of 120' with the tower site being located in close proximity to local Portland Lighthouse. This site is

accessed by a parochial road leading from the rural fishing community of Portland Cottage some fourteen kilometers (14km) to the west northwest.



Figure 5 Map showing location of tower site, Portland Cottage, Clarendon

1.5.4 SLIGOVILLE, ST. CATHERINE

The Tower site Rep020 is located near the rural community of Sligoville, twenty kilometers (20km) due north of the parish capital, Spanish Town. The site is accessed via a Class C road leading to the Dove Hall area, northwest of Sligoville. (see fig 6)



Figure 6 Map showing location of tower site, Sligoville, St. Catherine

1.5.5 CABBAGE HILL, ST THOMAS

The Tower site Rep011 is found at Cabbage Hill, in the Mount Vernon and Orange Grove area in the district of Upper St. David. The site is accessed via the Mango Row road leading from Wilson Gap found some four kilometers (4km) northwest of the site. (See fig. 7). The highlands on which this site is located forms a natural divide between the upper reaches of the Morant and Yallahs Rivers watersheds to the east and west respectively.

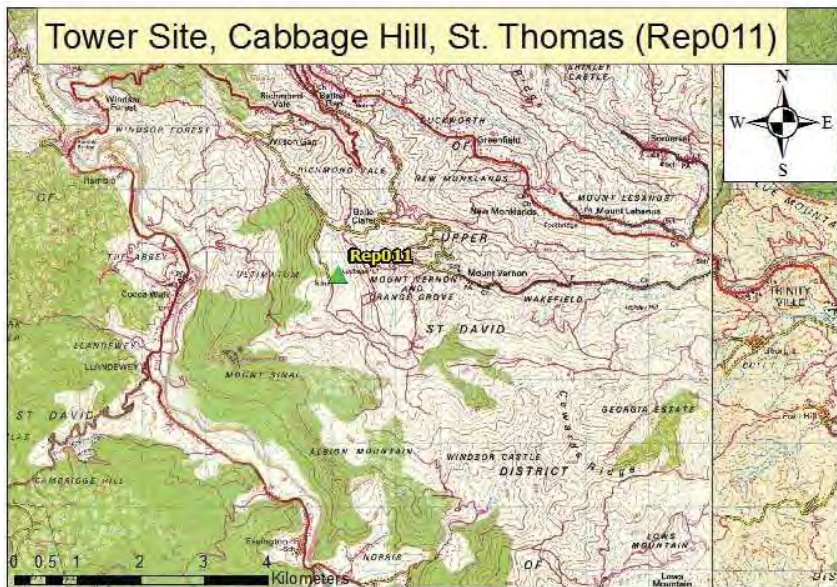

Figure 7 Map showing location of tower site, Cabbage Hill, St. Thomas

1.5.6 WINCHESTER, ST. THOMAS

The tower Rep030 is found in the Johnson Mountain area of eastern St. Thomas on hills which overlook Amity Hall and the southeastern coastline of Jamaica. The tower sits on a crest of a hill that represents the southeastern tip of the John Crow Mountains, which descends into the rural community of Wheelerfield, less than two kilometers (2km) south southeast of the site. (See fig. 8)

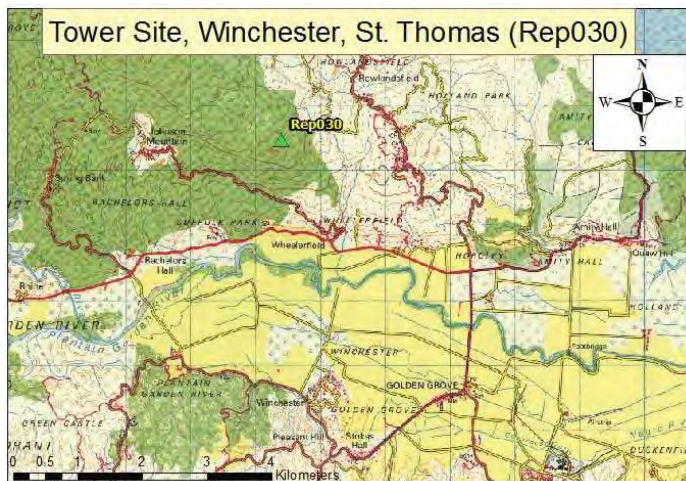

Figure 8 Map showing location of tower site, Winchester, St. Thomas

2.0 GEOLOGY

2.1 INTRODUCTION

This section of the report documents the findings of the geological assessment conducted for and at each of the selected sites

2.2 METHODOLOGY

The geology at each target location is presented from a regional to a local, site specific perspective. A regional geological report was done from desktop study which highlighted the surrounding geological formations and regional structure (See fig.9). Site specific geological assessment included outcrop sampling, identification and measurement of the orientation and thickness of bedding, identification of minor faults or evidence of major faulting, identification of any major formation contacts and assessment of potential geohazards that may impact the site. Petrographic analyses were then done on core and outcrop samples to further classify the lithology, paleontology, formation grouping and identification of cementation and interstitial porosity.

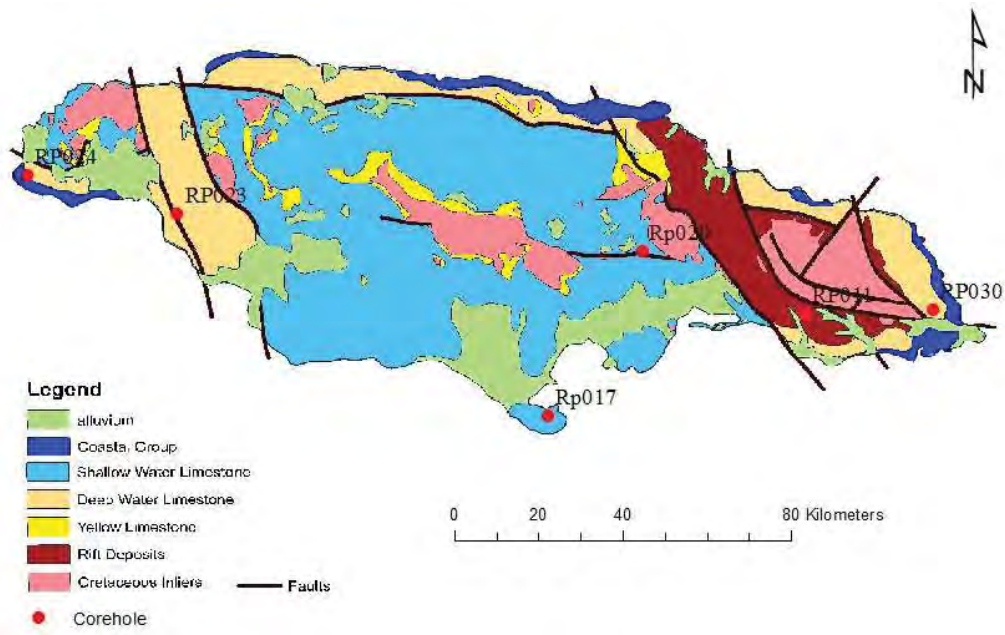

Figure 9 Map showing generalized geology of Jamaica and locations of sample sites

2.3 MOUNT AIRY, WESTMORELAND

2.3.1 REGIONAL GEOLOGY SETTING

The targeted site is found within the southwestern corner of the geological sheet within the Negril Hills. This area is dominated by the outcropping of the Gibraltar-Bonny Gate Limestone Formation (Egb), a subdivision of the White Limestone Group. At this locality this formation is characterized by a fine grained, soft to moderately hard planktonic micrite, deposited in deep water. (See fig.10)

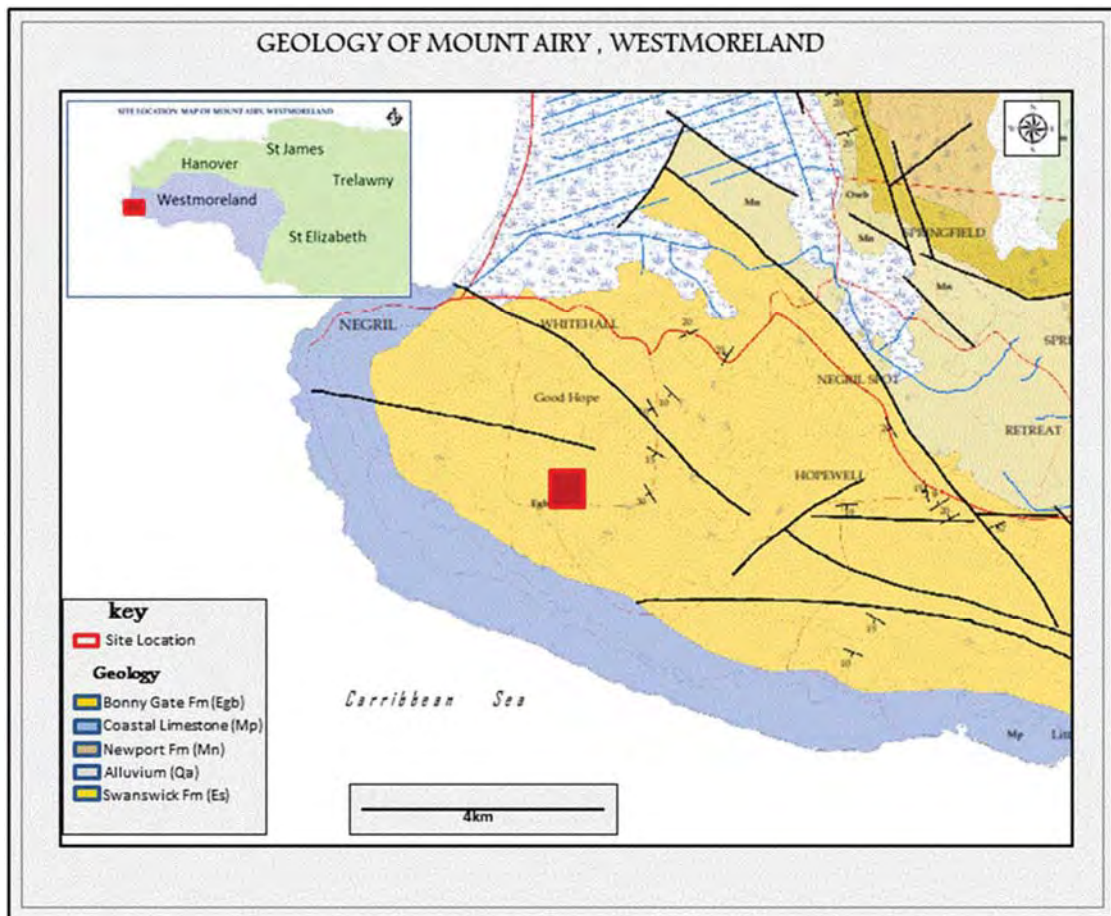

Figure 10 Map showing Regional Geology of Western Westmoreland

2.3.2 LOCAL GEOLOGY

2.3.2.1 LITHOLOGY

At the target site the bedrock is seen outcropping extensively. Field investigation indicated a massive micritic limestone with thin to absent topsoil. (See fig. 11)

An outcrop sample taken from this site indicates it is a coralline limestone with benthic forams. It is a grain stone representing possibly the Coastal Group or the impure limestones of the Yellow Limestone Group (Fisher and Mitchell 2012). This area has not been adequately studied and as such no references are found in literature.



Figure 11. Picture showing outcropping of bedrock at the Mt. Airy Tower site

2.3.2.2 GEOLOGICAL STRUCTURE

The dominant structural feature of this area is faulting. Faults occur mainly in three directions E-W, NM-SE or N-S. The NW-SE faults appear to be the most recent. It's believed faulting was initiated in the mid-Tertiary with subsequent movement until relatively recent geologic time. The general distribution and attitude of the stratigraphic units conforms to a westward plunging anticline complicated by faulting and minor folding.

2.3.2.3 SURFICIAL DEPOSITS

Soil development at the target site in the Mount Airy area is poor to non-existent with limestone bedrock outcropping extensively. At the tower site the surface is covered by a thin, loose layer of alluvial aggregate (gravel with sand), spread over the working area within a perimeter fence.

2.3.2.4 SURFACE WATER AND GROUNDWATER

Groundwater was not encountered during the field drilling activity. Reports indicate that nearby wells (Duck Pond, Mt Airy) water was struck in excess of one hundred and seventy feet (170')

2.3.3 PETROGRAPHIC ANALYSIS

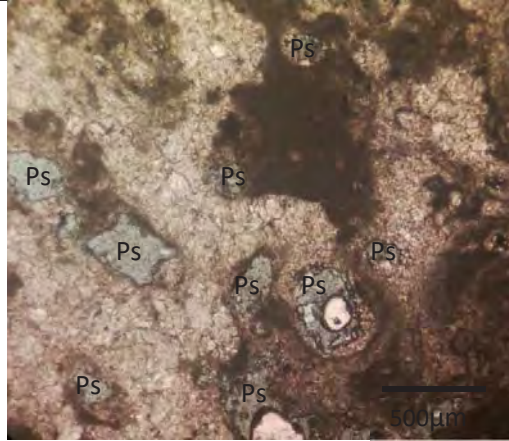
Description		Photo-documentation
Macroscopic		
Colour	Creamish white	 <p>1cm</p>
External Features	Cavities (small vugs)	
Mineralogy	Calcite	
Allochems	fossils (corals)	
Spar cement or Mud	Spar	
Microscopic		
Folk Classification	biosparite	
Dunham Classification	grainstone	
Porosity	high	
Fossils	Benthic Foram, corals	
Other		
		<p>Photo micrographs showing sample with coral with inter fossil pore space in Plane Polarized light. Ps - pore space</p>

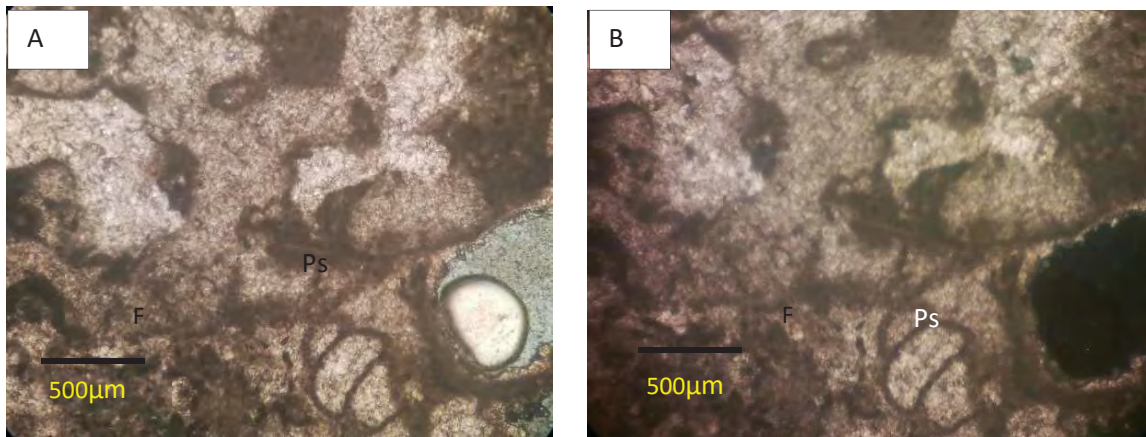

Figure 12. Photo micrographs showing sample in (A) Plane Polarized light and (B) cross Polarized light. F- Foraminifera, Ps- Pore space

Comments: The sample is an algae foraminiferal biosparite. The presence of algae and benthic foraminifera makes the limestone a shallow water limestone. The sample is consolidated as the allochems are cemented to each other by calcite cement. There are pore spaces between allochems (fossils) and within the corals.

2.3.4 GEOLOGICAL/GEOTECHNICAL HAZARDS

The formation on which the tower site rests is a massive deposit with no apparent bedding. There was little to no fracturing or jointing seen in rock at the immediate site.

2.4 SHAFSTON, WESTMORELAND

2.4.1 REGIONAL GEOLOGY SETTING

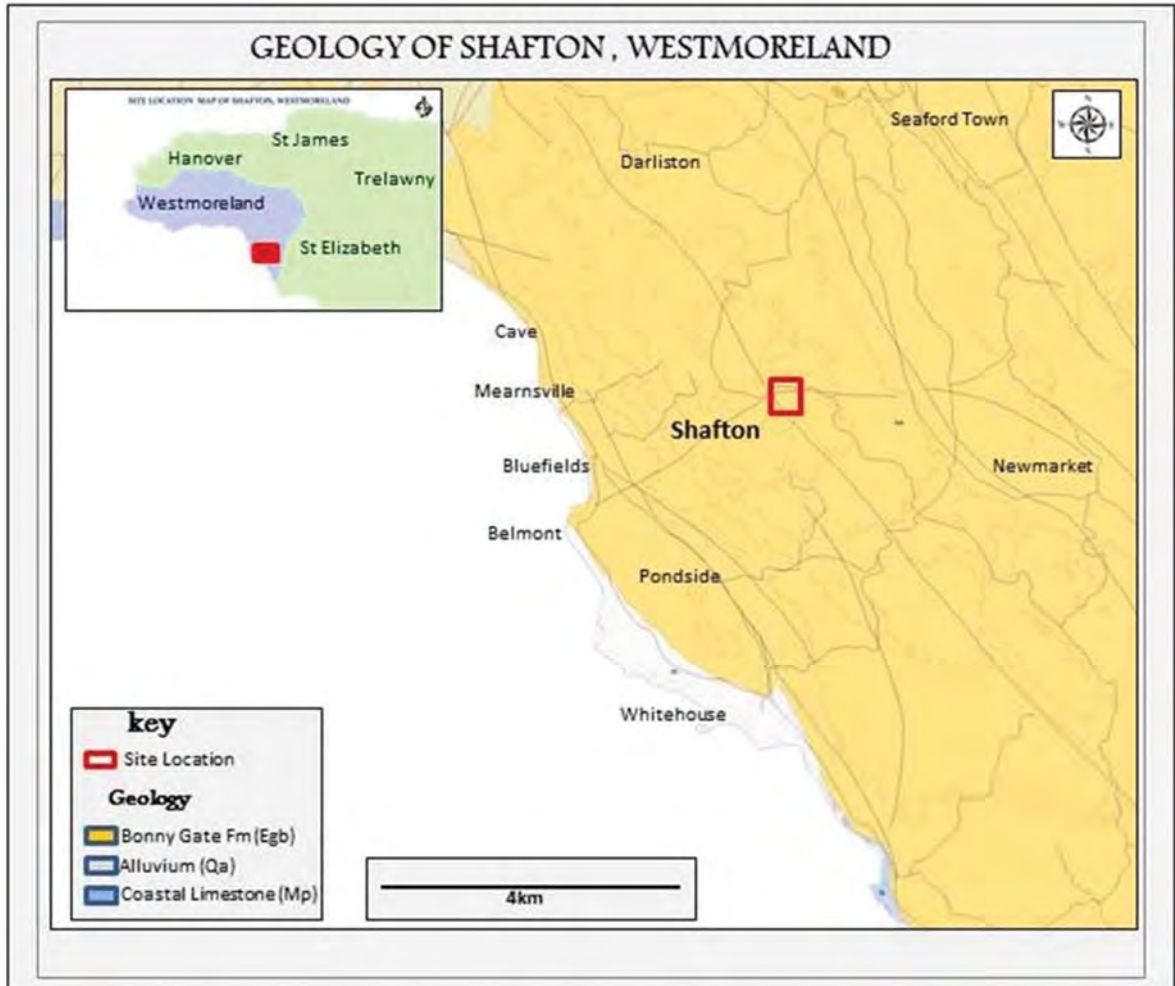

Figure 13. Map showing Regional Geology of Southeast Westmoreland

2.4.2 LOCAL GEOLOGY

2.4.2.1 LITHOLOGY

The sample is a dense micrite with abundant planktic forams and rare benthic forams possibly of the chalks of the Montpelier Limestone (Figure 1) (Robinson and Mitchell 1999; Mitchell 2013).

2.4.2.2 GEOLOGICAL STRUCTURE

Faulting has been indicated to be present from the regional geology of southeastern Westmoreland. The main fault direction is NW-SE.

2.4.2.3 SURFICIAL DEPOSITS

Soil development at the Shafston target site is poor with limestone boulders and bedrock seen outcropping. At the tower site the surface is covered by a thin, loose

layer of alluvial aggregate (gravel with sand), spread over the working area within a perimeter fence. Soil beyond the immediate site was a creamish brown loam.

2.4.2.4 SURFACE WATER AND GROUNDWATER

Groundwater was not encountered during the field drilling activity. There are no nearby well to provide background well data. The closet well is located more than six kilometres (6km) to the northeast. Water was struck at one hundred feet 100’.

2.4.3 PETROGRAPHIC ANALYSIS

Sample ID : No ID _(9ft)

Description		Photo-documentation
Macroscopic		
Colour	Cream	
External Features		
Mineralogy	Calcite	
Allochems	No visible fossils or other allochems	
Spar cement or Mud	Mud	
Microscopic		
Folk Classification	Biomicrite	
Dunham Classification	Wackestone	
Porosity	Low	
Fossils	Planktonic Foram (high percentage) Benthic Foram (low percentage)	

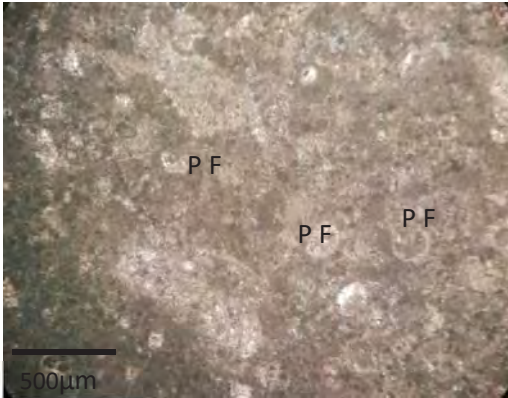
Other		 <p>Photo micrograph of sample showing Planktonic Forams (PF) within micrite matrix</p>
-------	--	---

Comments: The sample is a deep water limestone which is term chalk. Deep water limestone due to high percentage of planktonic Foraminifera while low benthic Forams content. The sample is poorly consolidated, which makes water absorption high

Additional Micrograph

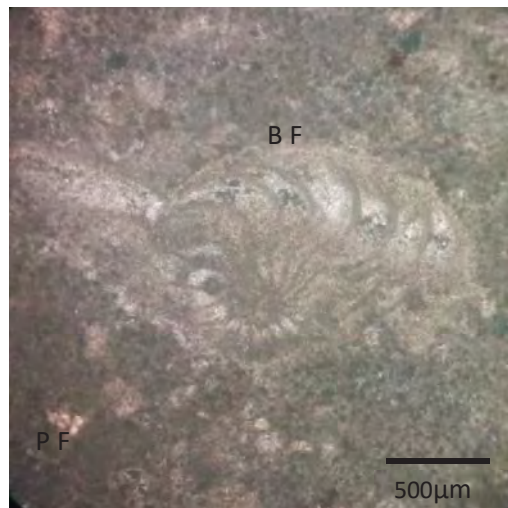

Photo micrograph of sample showing Planktonic Forams (PF) and Benthic Forams (BF) within micrite matrix

2.4.4 GEOLOGICAL/GEOTECHNICAL HAZARDS

The formation on which the tower site rests is a massive deposit with no apparent bedding. There was little to no fracturing or jointing seen in rock at the immediate site. There are no geological hazards anticipated at this site.

2.5 PORTLAND COTTAGE, CLARENDON

2.5.1 REGIONAL GEOLOGY SETTING

The regional geology indicates that the landscape of Portland Ridge is dominated by the Newport Formation of the White Limestone Group. The formation is of Miocene age and occurs as a poorly bedded to massive, white-pink micrite with faunal assemblages.

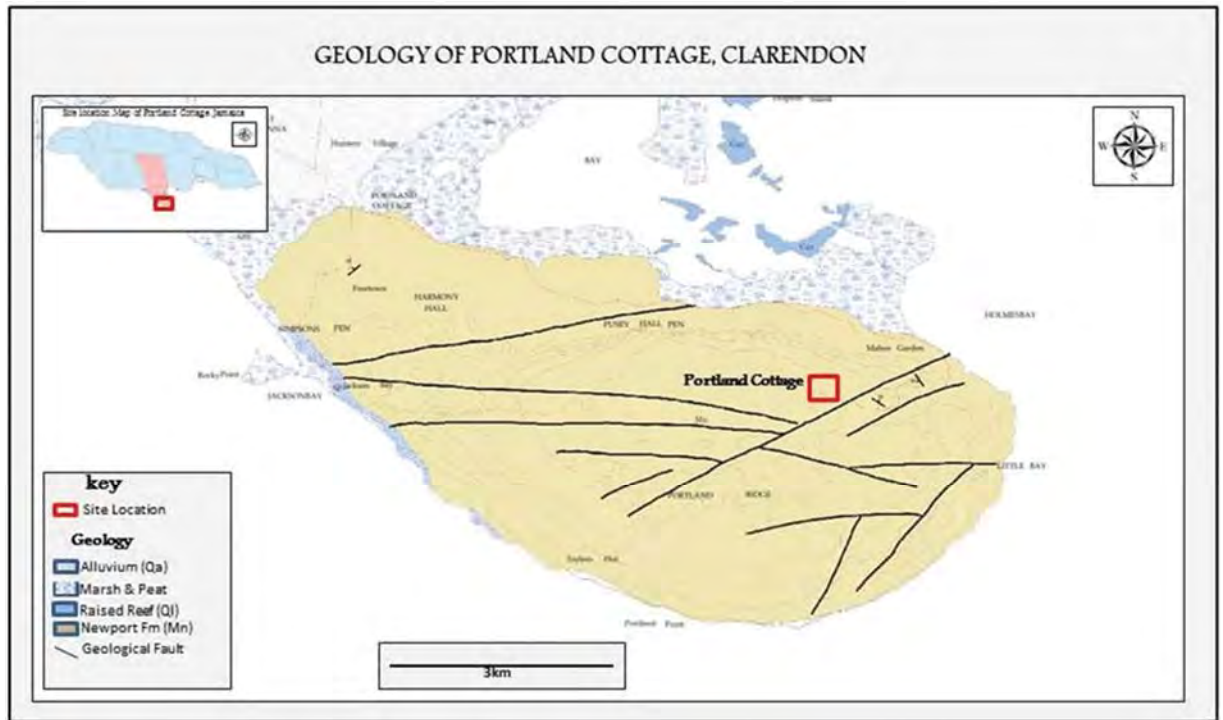

Figure 14. Map showing Regional Geology of Southern Clarendon

2.5.2 LOCAL GEOLOGY

2.5.2.1 LITHOLOGY

The sample from Portland Cottage belong to the Walderston/Browns Town Formation. The material is dominated by shallow-water species and shows Numulites sp. along with halimeda fragments and coral fragments.

The Walderston Formation has been separated from the Browns Town Formation by Mitchel (2013). He describes the Walderston as a foraminiferal grainstone. The Browns Town Formation has been described as the Eulepidina-rich limestones representing the platform margins (Mitchell 2013)

Browns Town to Newport and Walderston are characterized to be Oligocene shelf edge carbonates Robinson and Mitchel 1999; Mitchell 2013).

2.5.2.2 GEOLOGICAL STRUCTURE

The main geological structure indicated for this area is faulting. Structural info is however sparse due to the massive to poor bedding of the deposit. This ridge was formerly characterized as an anticline with later studies indicating it being a horst which was uplifted during Pliocene times

2.5.2.3 SURFICIAL DEPOSITS

Soil development on the ridge is poor to non-existent in sections where bedrock outcrops.

2.5.2.4 SURFACE WATER AND GROUNDWATER

No ground water was struck during the drilling of this site. There are no nearby streams or main drainage routes in the area. The closest well is found I Portland cottage some nine kilometers (9km) away to the northwest. Water was struck at fourteen feet (14') this occurs some one hundred and twenty feet (120') below the drilled site at the Portland Cottage Lighthouse.

2.5.3 PETROGRAPHIC ANALYSIS

Sample ID : Portland Cottage – 5ft

Description		Photo-documentation
Macroscopic		
Colour	Creamish white	 <p style="text-align: center;">1cm</p>
External Features	Cavities (small vugs)	
Mineralogy	Calcite	
Allochems	fossils (foraminifera)	
Spar cement or Mud	Spar	
Microscopic		
Folk Classification	biosparite	
Dunham Classification	grainstone	
Porosity	high	

Fossils	Benthic Foram, algae	
Other		

Comments: The sample is an algae foraminiferal biosparite. The presence of algae and benthic foraminifera makes the limestone a shallow water limestone. The sample is consolidated as the allochems are cemented to each other by calcite cement. There is pore space between allochems (fossils).

2.5.4 GEOLOGICAL/GEOTECHNICAL HAZARDS

The formation on which the tower site rests is a massive deposit with no apparent bedding. There was little to no fracturing or jointing seen in rock at the immediate site. There are no geological hazards anticipated.

2.6 SLIGOVILLE, ST. CATHERINE

2.6.1 REGIONAL GEOLOGY SETTING

The Newport formation consists of alternating unfossiliferous compact calcite mudstones or siltstones and foraminiferal limestones with abundant miliolids, and can be broadly subdivided into three horizons. The lower horizon is essentially micrite and is characterized by an abundance of corals. The middle horizon consists of a rubbly, reef deposit with thin beds and pockets of clays and quartzose sands, containing a coral fauna. The upper horizon is a massive white to pink micrite whose faunal composition is characterized by forams.

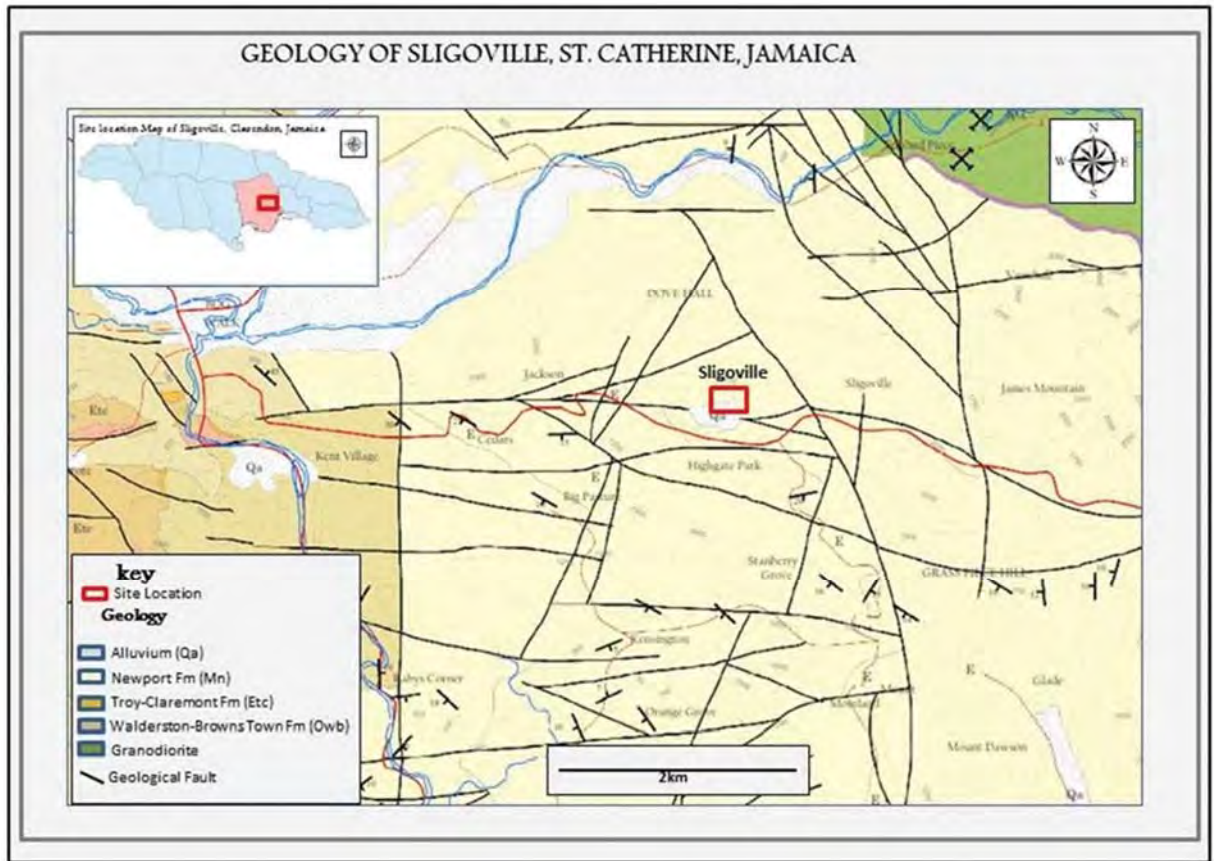

Figure 15 Map showing Regional Geology of Central St. Catherine

Rock mass comprises of recrystallized limestone with patches of chalk. Textures identified in the Newport Formation include pale coloured wackestones and carbonate mudstones. Rock material is compact and typically thickly bedded or massive. Bearing capacity is presumed to be good (1000 – 4000 KN/m²) and should offer sound foundation.

Soil development is minor or thin in mountainous areas and considerably thicker in depressions and low-lying regions. Karstic drainage features such as solution features (sinkholes) are present and checks need to be done for such structures wherever major structures will be placed. Slope stability is generally good but landslip risk increases along faults and rock falls should be anticipated.

2.6.2 LOCAL GEOLOGY

2.6.2.1 LITHOLOGY

The local lithology is dominated by white to cream coloured limestone which is seen outcropping in vicinity of the target site.

2.6.2.2 GEOLOGICAL STRUCTURE

The main geological structure indicated for this area is faulting. The major Sligoville Fault occurs just two kilometers (2KM) east of the site trending in a NNW-SSE

orientation. This orientation mimics the Wagwater fault complex which occurs west of the Above Rocks Massif.

2.6.2.3 SURFICIAL DEPOSITS

Soil development at the target site is dominated by a silty clay to stony loam soil. The development is generally poor to thin on slopes with some accumulation seen in depressions.

2.6.2.4 SURFACE WATER AND GROUNDWATER

No ground water was struck during the drilling of this site. There are no nearby streams or main drainage routes in the area.

2.6.3 PETROGRAPHIC ANALYSIS

Sample ID: Sligoville 8-13' A

Description		Photo-documentation
Macroscopic		
Colour	Cream	
External Features	Cavities (small vugs) about a ≤ 5mm	
Mineralogy	Calcite	
Allochems	No visible fossils or other allochems	
Spar cement or Mud	Mud	

Microscopic	
Folk Classification	Micrite
Dunham Classification	Mudstone
Porosity	High (large cavities/vugs), approx... 12%

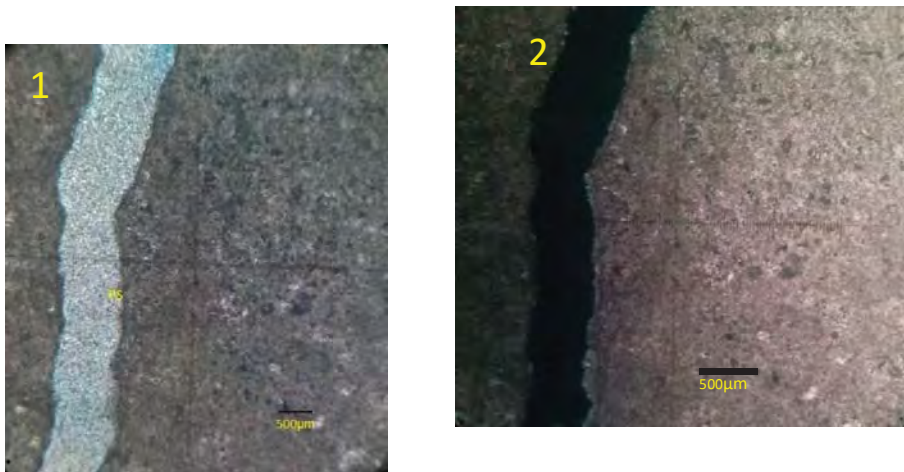

Figure 16 Photo micrographs showing sample in plane (1) and crossed (2) polarized light with large cavity

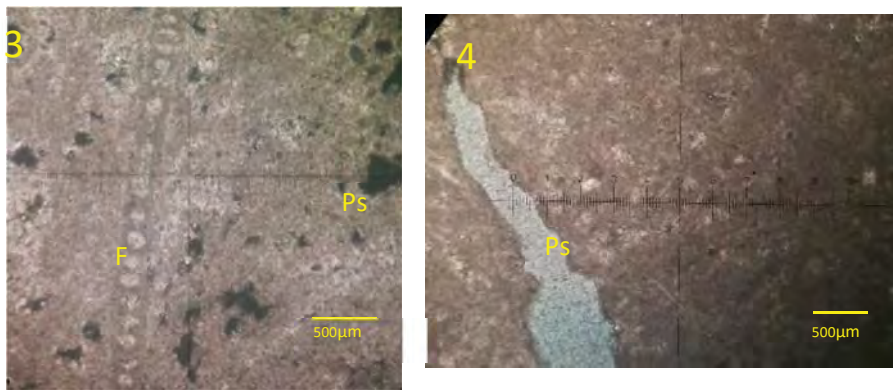

Figure 17 Photo micrographs showing samples in cross (3) polarized light (F-foraminifera, Ps – Pore space) and plane polarized light showing large cavity

Sample ID: Sligoville 8-13' B

Description		Photo-documentation
Macroscopic		
Colour	Cream	
External Features	Cavities (small vugs) about a \leq 1mm	
Mineralogy	Calcite	

Allochems	No visible fossils or other allochems	
Spar cement or Mud	Mud	

Microscopic	
Folk Classification	Dismicrite
Dunham Classification	Mudstone
Porosity	moderate

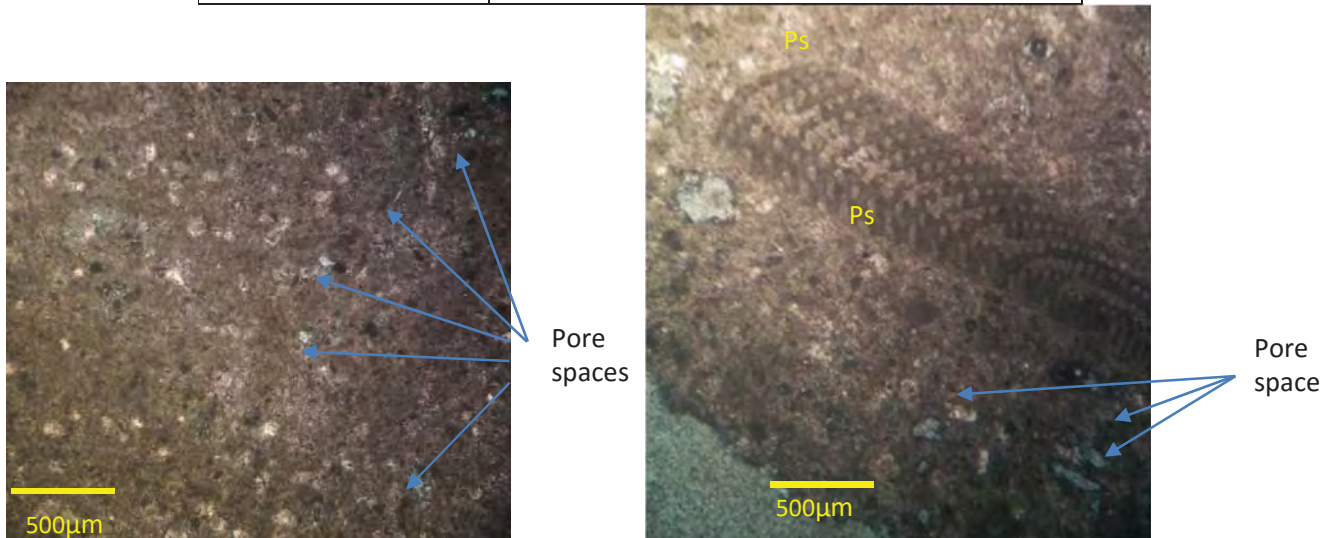

Figure 18 Photo micrograph of sample showing (5) micrite with pore spaces and sample showing (6) Foraminifera (F) within micrite matrix with pore spaces indicated by blue dye

Relationship to regional Geology:

This sample belongs to the Newport Formation. The Newport Formation has been photographed and described from the Sligoville area by Mitchell (2013, p. 117) as “Newport Formation (Sample WL1632), carbonate mudstones, sparsely fossiliferous, Sligoville, parish of St. Catherine.”

2.6.4 GEOLOGICAL/GEOTECHNICAL HAZARDS

There are no geological hazards anticipated for this site.

2.7 CABBAGE HILL, ST. THOMAS

2.7.1 REGIONAL GEOLOGY SETTING

The 1:50,000 Morant Bay, Metric Geological Sheet 19 indicates the site is underlain by the Gibraltar-Bonny Gate Formation (Egb). This formation is composed of evenly bedded white micrites typically chalky and porous. The chalky layers are separated by layers of dark brown platy chert and bioclastic layers of crystalline foraminiferal limestones. The Bonny Gate Formation is approximately 1500ft. thick, Robinson (1967) and ranges from Middle Eocene to Oligocene in age.

Based on the Soil Map of Jamaica, produced by the National Land Agency, the Bonnygate Stony Loam is the dominant soil type within the proposed site. The Bonnygate soil type is characterised by its sandy loam texture with high erodibility, very low moisture content and very rapid internal drainage.

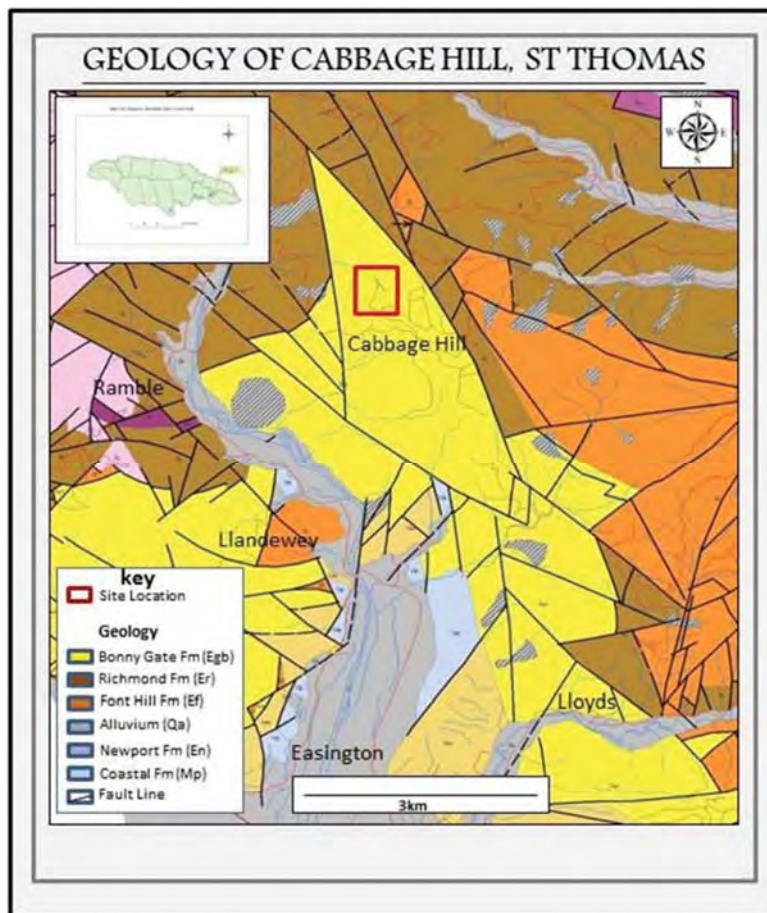

Figure 19. Map showing Regional Geology of Western St. Thomas

Bearing capacity of the Gibraltar Bonny Gate Limestone is presumed to be good; ~4000 KN/m² (O’Hara and Bryce,1983). Primary permeability is generally low, however secondary permeability may be very high, due to the faulted nature of the bedrock.

This facilitates moderate to relatively high infiltration rates for storm water runoff and therefore reduces the potential for ponding. The excavatability of the material will vary spatially. Rock material can be easily ripped where soft calcareous marls and rubbly, fractured limestone are located. On the contrary sound, massive bedrock may require blasting. Slope stability of this material is generally good and the potential for landslips are negligible

2.7.2 LOCAL GEOLOGY

2.7.2.1 LITHOLOGY

Based on observation, outcrops of hard to moderately hard, micritic limestone with occasional chert nodules were observed onsite, while highly fractured micrites were observed along road cut exposures within close proximity to the existing communication tower. Soil development onsite is minor, and consists of a very thin upper layer of reddish brown silty clay.

The outcrop sample investigated indicates the deposit is a dense micrite with abundant planktic forams and chert nodules and calcite veins. The presence of chert in the sample suggests Montpelier Formation which is characterized by the presence of chert (Robinson and Mitchell 1999; Mitchell 2013).

2.7.2.2 GEOLOGICAL STRUCTURE

This locality is dominated by faulting. Moderate density of jointing and disorganized beds were observed in the area.

2.7.2.3 SURFICIAL DEPOSITS

Soil development at this location is thin to absent where bedrock outcrops

2.7.2.4 SURFACE WATER AND GROUNDWATER

There are no nearby surface drainage routes and ground water was not encountered during the drilling activity.

2.7.3 PETROGRAPHIC ANALYSIS

Sample ID -6 No ID _(0-5ft)

Description		Photo-documentation
Macroscopic		
Colour	Creamish white	

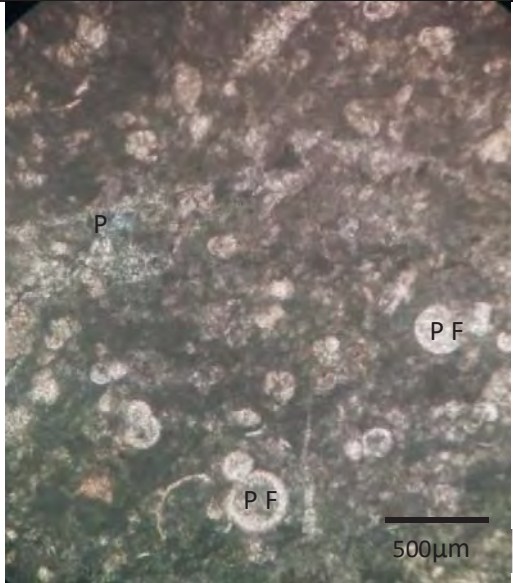
External Features	Chert nodules, calcite veins	 <p>2cm</p>
Mineralogy	Calcite, Chert	
Allochems	No visible fossils or other allochems	
Spar cement or Mud	Mud	
Microscopic		
Folk Classification	Biomicrite	 <p>500µm</p> <p>Photo micrograph of sample showing recrystallized Planktonic Forams (PF) within micrite matrix</p>
Dunham Classification	Wackestone	
Porosity	moderate	
Fossils	Planthic Foram	
Other	Veins with recrystallized calcite, chert	

Comments: The sample is a deep water limestone which is term chalk. Deep water limestone due to high percentage of planktic Foraminifera as well as chert. The sample is consolidated, which may be due to presence of microcrystalline silica (chert) making the sampling harder. Pore space is observed between the cert and the chalk interface.

2.7.4 GEOLOGICAL/GEOTECHNICAL HAZARDS

There are no geological hazards anticipated at this site.

2.8 WINCHESTER, ST. THOMAS

2.8.1 REGIONAL GEOLOGY SETTING

Review of the 1:50,000 Morant Bay, Metric Geological Sheet 19 indicates the site is underlain by the Gibraltar-Bonny Gate Formation (Egb). This formation consists of evenly bedded white planktonic foraminiferal micrites, separated by thinner layers of platy dark-brown and grey-green to buff clay (Robinson, 1969).

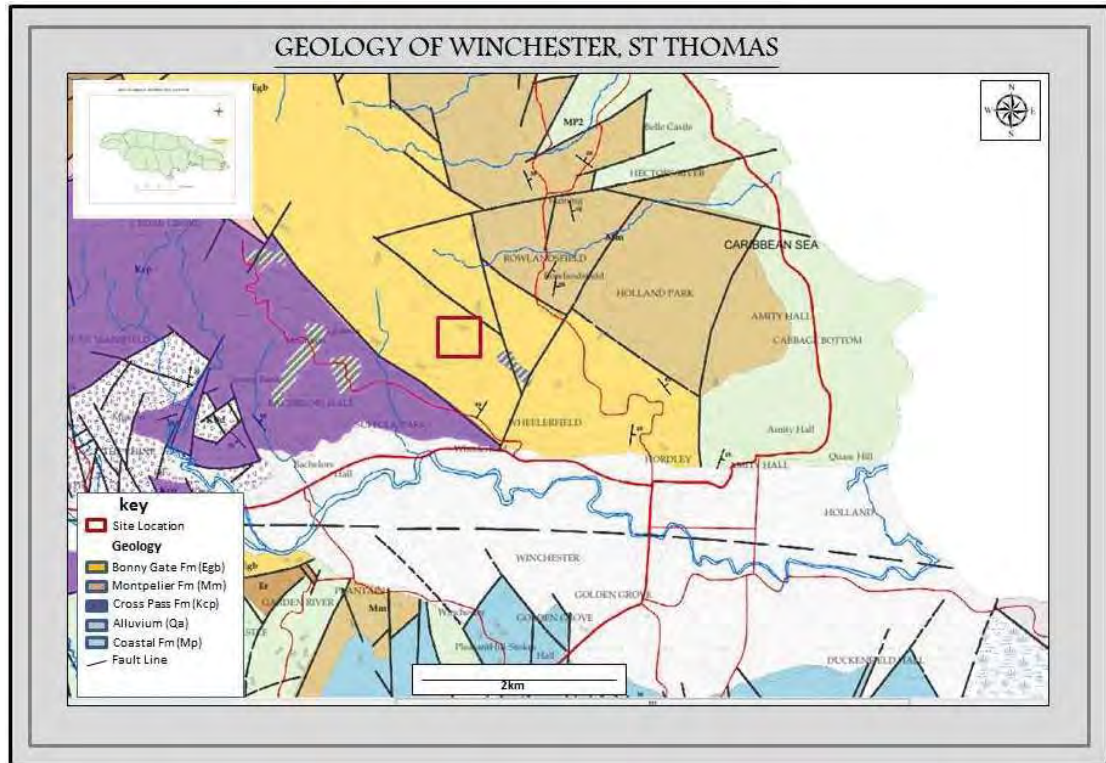

Figure 20. Map showing regional geology of Eastern St. Thomas

Bearing capacity of the Gibraltar Bonny Gate Limestone is presumed to be good; $\sim 4000 \text{ KN/m}^2$ (O'Hara and Bryce, 1983). Primary permeability is generally low, however secondary permeability may be very high, due to the faulted nature of the bedrock. This facilitates moderate to relatively high infiltration rates for storm water runoff and therefore reduces the potential for ponding. The excavatability of the material will vary spatially. Rock material can be easily ripped where soft calcareous marls and rubbly, fractured limestone are located. On the contrary sound, massive bedrock may require blasting. Slope stability of this material is generally good and the potential for landslips are negligible

2.8.2 LOCAL GEOLOGY

2.8.2.1 LITHOLOGY

In-situ outcrops of Gibraltar-Bonny Gate limestone were generally observed along the road cut exposures leading to the communication tower. Notwithstanding, in-situ

outcrops of white limestone from the Gibraltar-Bonny Gate Formation were not generally observed onsite. The site however, appears to have been modified during the construction of the existing communication tower. As such a thin veneer of volcanic gravel, pebbles and cobbles (river shingles) is spread across the site. Shallow pitting of the area was also carried out with the pick of a geological hammer and could only reveal a thin surficial layer of gravelly silty soil.

Outcrop sample analyzed indicate that the deposit is a micrite devoid of chert but is packed with planktic forams and calcite veins. The chalky nature of the sample suggests Montpelier Formation or possibly Pelleu Island Formation. Larger specimens or outcrop study to determine if chert is really absent would indicate Pelleu Island. Similarly, the presence of chert would confirm Montpelier. Both the Montpelier and Pelleu Island are deep-water limestones with abundant planktics.

2.8.2.2 GEOLOGICAL STRUCTURE

The main geological feature in this area of the geological sheet is dominated by faulting. The faults sets indicate an intersecting NW-SE and NE-SW trending fault sets.

2.8.2.3 SURFICIAL DEPOSITS

The soil at the surface consist of a thin layer of alluvial gravel lying above a compacted marl layer of calcareous gravel with some sand size grains. The soil horizon encountered at site does not represent typical soil development of surrounding area as it was modified by previous construction

2.8.2.4 SURFACE WATER AND GROUNDWATER

No groundwater was encountered during the drilling of this site.

2.8.3 PETROGRAPHIC ANALYSIS

Sample ID: No ID_ (7ft)

Description		Photo-documentation	
Macroscopic			
Colour	Creamish white		
External Features			
Mineralogy	Calcite		
Allochems	No visible fossils or		

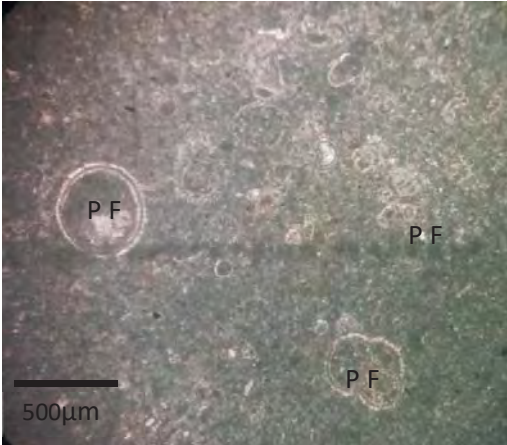
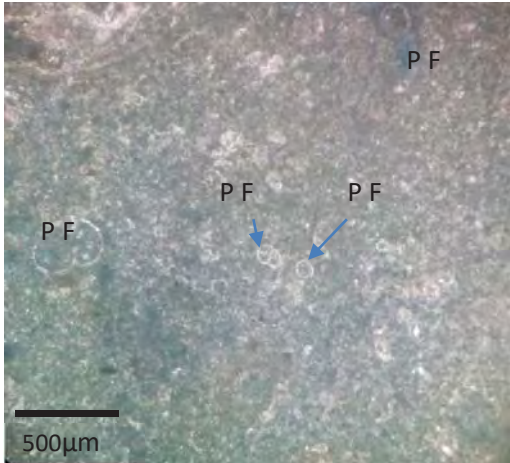
	other allochems	
Spar cement or Mud	Mud	
Microscopic		
Folk Classification	Biomicrite	 <p>Photo micrograph of sample showing abundant Planktonic Forams (PF) within micrite matrix</p>  <p>Photo micrograph of sample showing Planktonic Forams (PF) within micrite matrix</p>
Dunham Classification	Wakestone	
Porosity	Low	
Fossils	Planktic Foram	
Other		

Comments: The sample is a deep water limestone which is term chalk. Deep water limestone due to high percentage of planktic Foraminifera content. The sample is poorly consolidated, which makes water absorption high

2.8.4 GEOLOGICAL/GEOTECHNICAL HAZARDS

There are no geological hazards anticipated at this site

3.0 GEOTECHNICAL ASSESSMENT

3.1 INTRODUCTION

The scope of work involves the following:

- Subsurface drilling of a single borehole to a depth of 5m at each selected tower site.
- Borehole shall be drilled below the footprint or as close as possible to the proposed structure.
- Samples shall be logged and RQD results calculated from core recovery.
- Moisture content, grainsize distribution analysis and plasticity index will be assessed and determined where applicable.
- Uniaxial Compressive Strength Testing of cores shall be carried out in order to determine bearing capacity of rock material.
- Thin sections will be produced for microscopic analysis.
- Preliminary geological and geotechnical assessment of the site shall be outlined
- Test pits shall be excavated as deemed fit by the project geologist

3.2 METHODOLOGY

We observed drilling of 6 borings in total for all the targeted sites and logged the subsurface conditions at each location. Boring locations were selected in the field by representatives of Yachiyo Engineering Ltd. Boreholes were advanced through rock using a truck mounted (CME75) rotary rig with diamond coring using a NQ series, double tubed core barrel in approximately 1.5 metre runs. We used the field logs to develop the report logs in the Appendices. The logs depict subsurface conditions at the exploration locations for the date of exploration. Borings were advanced to depths ranging from 8 to 15 feet below existing grade. Borings were backfilled with drill cuttings.

Conditions encountered at each boring location are indicated on the individual boring logs. Stratification boundaries on the boring logs represent the approximate location of changes in soil and rock types; in-situ, the transition between materials may be gradual. Details for each of the borings can be found on the bore logs in Appendices of this report.

Atterberg Limits (ASTM 04318) were determined for soil encountered at the sites. Where rock cores were retrieved the determination of Unconfined Compressive Strengths (ASTM 07012-C) was employed. ASTM D2216 Standard Test Methods for Laboratory Determination of Water (Moisture) Content of Soil and Rock by Mass guided the determination of soil moisture where applicable. Results of the tests performed are presented in Appendices to this report; soil description and classification are in accordance with the Unified Soil Classification System (USCS).

3.3 SOIL INVESTIGATIONS RESULTS / FINDINGS

Presentation of the findings will indicate results of the field exercise and laboratory analysis. A physical description of downhole conditions will be provided accompanied by the results geotechnical tests on won samples.

3.3.1 MOUNT AIRY, WESTMORELAND

3.3.1.1 BORINGS

A single borehole was cored to a depth of 3.1 metres and core recovery averaged 58.3 percent while the RQD¹ ranged from 25-40 percent. (See fig.21). Initially the coring encountered a creamish calcareous coarse fine sand and gravel which transitioned to a medium cream porous limestone at three feet (3ft). The rock formation remains relatively unchanged downhole, (see fig.22). The rock sample exhibited a number of small voids filled with calcite and trace amounts of clay within sections of the core.



Figure 21 Picture showing core samples collected from borehole, Mt. Airy, Westmoreland

¹ ROD -The Rock Quality Designation is a rough measure of the amount of fracturing within a rock mass. It is determined by summing all core pieces of 100mm or greater length and determining their proportion of the core run (expressed as percentage).

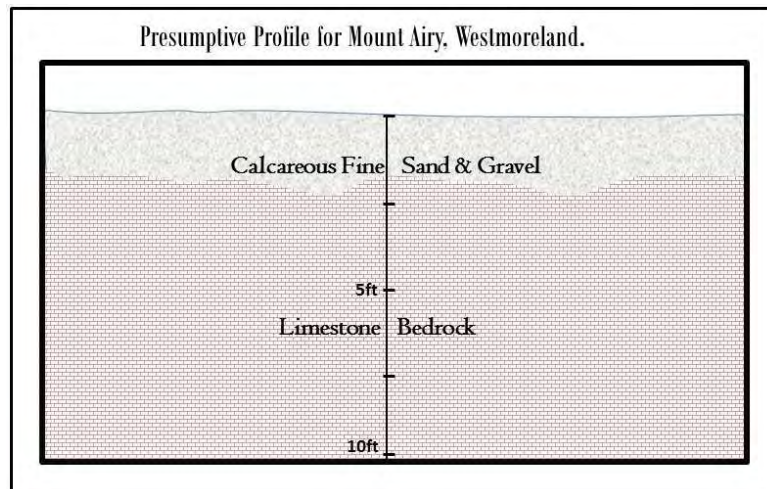

Figure 22. Lithological profile generated from borelog, Mt. Airy, Westmoreland

3.3.1.2 LAB REPORT

Three (3) rock samples were selected for the determination of Unconfined Compressive Strengths (ASTM 07012-C). Soil description and classification are in accordance with the Unified Soil Classification System (USCS)

Unconfined Compression Strength (Rock)

Three (3) specimens from the core samples returned were submitted for unconfined compressive strength testing and summary of results obtained are shown in the table below. A more detailed report can be obtained from lab report attached in the Appendices. The analysis indicates an average density of 161.5 pounds per cubic foot (p.c.f) and compressive strength in excess of five thousand pounds per square inch (psi)

UNCONFINED COMPRESSION TEST RESULTS			
Location	<u>Mount Airy, Westmoreland</u>		
Specimen Number (Comp. Strength Specimen No.)	1	2	3
Specimen Depth	5'-10'	5'-10'	0'-5'
Density p.c.f	161.2	159.5	163.7
Compressive Strength - Mpa (cylinder)	40.40	41.16	34.96
Compressive Strength - PSI (cylinder)	5860	5970	5070

3.3.2 SHAFSTON, WESTMORELAND

3.3.2.1 BORINGS

A single borehole was cored to a depth of 4.9 metres and core recovery averaged 93.7 percent while the RQD² ranged from 11.7-47.0 percent. (See fig. 23). Initially 0.7 metres of brown clay mixed with some gravel material was encountered atop the limestone rock. The Limestone was cream to light grey in colour and tended to be moderately hard and moderately fractured with some slightly weathered areas. (See fig.24). There were also small cavities infilled with either clayey or sandy material encountered within the top and bottom 1.5 metre runs. The rock sample encountered between depths of 1.8-3.3 metres was the most fractured with a large fraction of cobble sized fragments returned.



Figure 23 Picture showing core samples collected from Shafton, Westmoreland

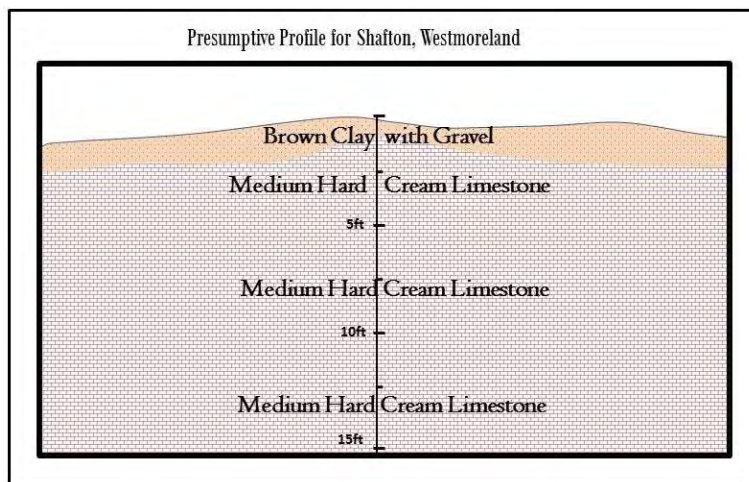

Figure 24. Lithological profile generated from borelog, Shafton, Westmoreland

² ROD -The Rock Quality Designation is a rough measure of the amount of fracturing within a rock mass. It is determined by summing all core pieces of 100mm or greater length and determining their proportion of the core run (expressed as percentage).

3.3.2.2 LAB REPORT

Atterberg Limits (ASTM 04318) were determined for the clay encountered at the top of the borehole while three (3) rock samples were selected for the determination of Unconfined Compressive Strengths (ASTM 07012-C). Soil description and classification are in accordance with the Unified Soil Classification System (USCS)

Atterberg Limits

The results of the Atterberg limits testing was plotted on the Plasticity Chart and the sample plotted above the Casagrande A-Line in the CH region of the Chart and thus classifies as a high plastic clay with liquid limit of 91.7 percent, plastic limit of 35.2 percent and plasticity index of 56.5 percent and average moisture content of 31 percent.

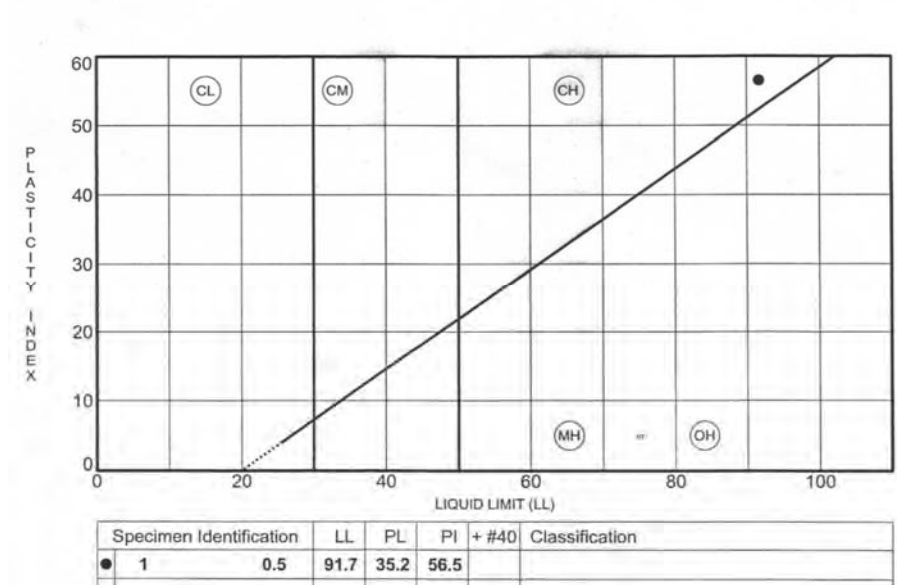

Figure 25. Plasticity chart for sample, Shafston, Westmoreland

Unconfined Compression Strength (Rock)

Four (4) specimens from the core samples returned were submitted for unconfined compressive strength testing and summary of results obtained are shown in the table below.

UNCONFINED COMPRESSION TEST RESULTS				
Location	Shafston, Westmoreland			
Specimen Number (Comp. Strength Specimen No.)	1	2	3	4
Specimen Depth	1'-6'	6'-11'	6'-11'	11'-15.5'
Density p.c.f	142.5	155.3	156.9	157.2
Compressive Strength - Mpa (cylinder)	32.68	45.09	57.77	41.43
Specific Gravity	2.284	2.489	2.516	2.519

Figure 26. Table showing unconfined compression Strength in rock samples-Shafton, Westmoreland

3.3.3 PORTLAND COTTAGE, CLARENDON

3.3.3.1 BORINGS

A single borehole was cored to a depth of 4.6 metres and core recovery averaged 50 percent while the RQD³ ranged from 10-25 percent. (See fig.26). The rock core sample won from this site indicates that the bedrock at this site remains relatively unchanged from the medium hard cream limestone that was encountered at surface. (See fig. 27). Some fracturing of core was evident.



Figure 27 Pictures showing core samples collected from Portland Cottage, Clarendon

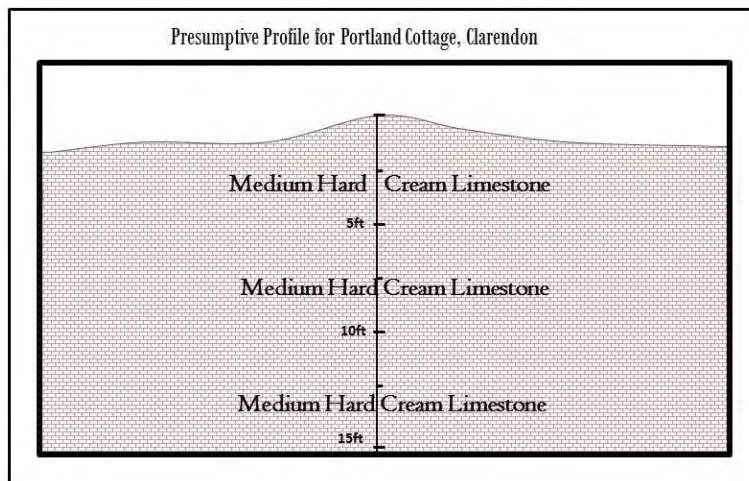

Figure 28. Lithological profile generated from borelog, Portland Cottage, Clarendon

3.3.3.2 LAB REPORT

Three (3) rock samples were selected for the determination of Unconfined Compressive Strengths (ASTM 07012-C). Soil description and classification are in accordance with the Unified Soil Classification System (USCS)

Unconfined Compression Strength (Rock)

Three (3) specimens from the core samples returned were submitted for unconfined compressive strength testing and summary of the results obtained are shown in the table below. A more detailed report can be obtained from lab report attached in the

³ ROD -The Rock Quality Designation is a rough measure of the amount of fracturing within a rock mass. It is determined by summing all core pieces of 100mm or greater length and determining their proportion of the core run (expressed as percentage).

Appendices. The analysis indicates an average density of 159 pounds per cubic foot (p.c.f) and compressive strength in excess of five thousand five hundred pounds per square inch (psi)

UNCONFINED COMPRESSION TEST RESULTS			
Location	Portland Cottage (Lighthouse)		
Specimen Number (Comp. Strength Specimen No.)	1	2	3
Specimen Depth	10'-15'	10'-1 5'	5'-10'
Density p.c.f	158.5	156.8	160.2
Compressive Strength - Mpa (cylinder)	30.54	28.20	62.74
Compressive Strength - PSI (cylinder)	4430	4090	9100

Figure 29 Table showing Unconfined Compression Strength test results for Portland Cottage, Clarendon

3.3.4 SLIGOVILLE, ST. CATHERINE

3.3.4.1 BORINGS

A single borehole was cored to a depth of 4.3 metres and core recovery averaged 81 percent while the RQD⁴ was 50.0 percent. (See fig. 29). Boring initially encountered 0.3 metres of a gravel fill. The boring then transitioned to a hard brown silty clay with some sand and gravel which increased in density and compaction until refusal at eight feet / 2.4 meters. Grain size distribution analysis indicates that this horizon is a well-graded gravel with sand. This granular material overlaid a hard cream coloured limestone. (See fig. 30). A low to moderate void density was observed in limestone with very little fracturing.



Figure 30 Picture showing core samples from borehole at Sligoville, St. Catherine

⁴ ROD -The Rock Quality Designation is a rough measure of the amount of fracturing within a rock mass. It is determined by summing all core pieces of 100mm or greater length and determining their proportion of the core run (expressed as percentage).

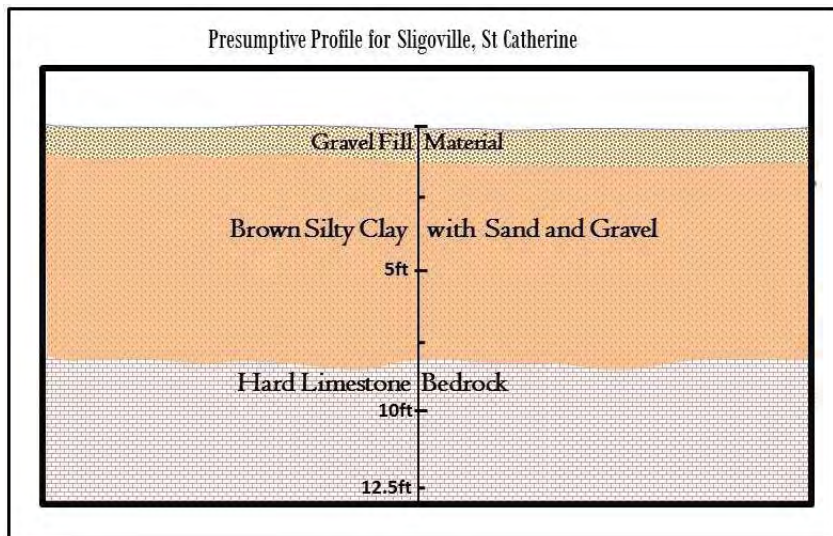

Figure 31. Lithological profile generated from borelog, Sligoville, St. Catherine

3.3.4.2 LAB REPORT

Grain size distribution analysis

Three (3) soil specimens from the boring at Sligoville were submitted for grain/particle size distribution analysis. A summary of the results is shown in the table below. The material down to 8ft is on average a well graded gravel with sand.

GRAIN SIZE ANALYSIS		WET SIEVE		
U.S. SIEVE SIZES		PERCENTAGE PASSING		
SAMPLE IDENTIFICATION		0089 @ 2ft 6"	0089 @ 5ft	0089 @ 7ft 6"
IMPERIAL (in)	METRIC			
1	25.000	100.00	100.00	
3/4"	19.000	94.50	94.50	100.00
1/2"	12.500	89.60	84.80	81.00
3/8"	9.500	85.50	78.30	69.30
#4	4.750	74.20	64.70	50.30
#10	2.000	57.60	50.20	28.10
#20	0.850	43.30	37.10	15.40
#40	0.425	32.00	25.80	8.20
#100	0.150	20.20	13.40	3.00
#200	0.075	15.50	8.80	1.70

Figure 32. Table showing grain size distribution of three (3) samples taken from 2ft 6", 5ft and 7ft 6" respectively, Sligoville, St. Catherine

Individual gran size distribution graphs are presented below. A summary report showing all graphs and the moisture content determination can be seen in the Appendices attached. Grain size distribution graphs below indicate a fining upward sequence of the sands within the first 8ft.

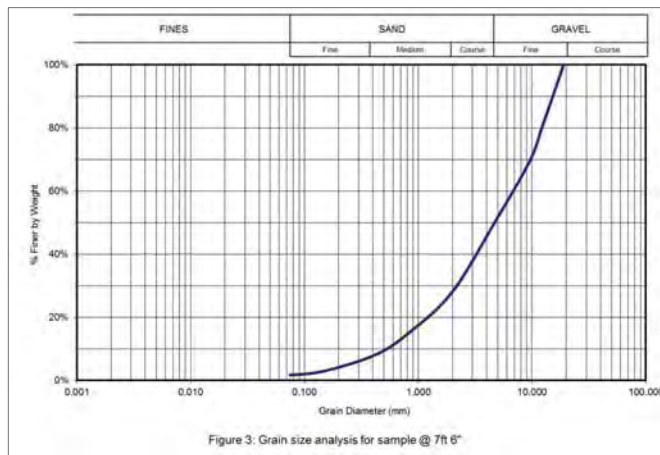
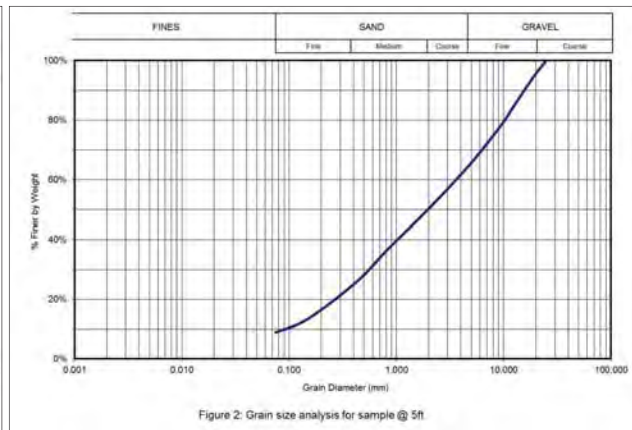
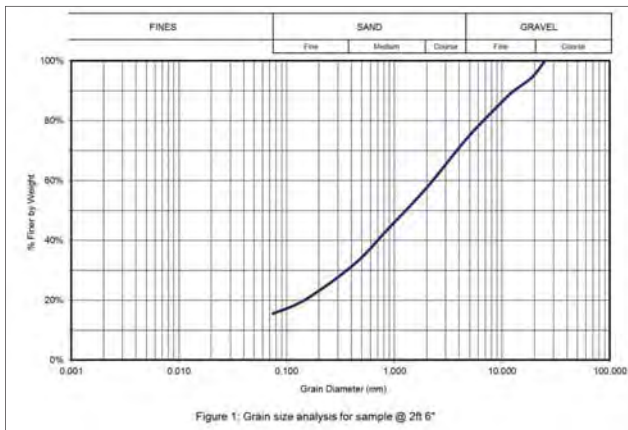

Figure 33. Grain size distribution graphs for sieve analyses done @ 2ft 6", 5ft & 7ft 6"

Two (2) rock samples were selected for the determination of Unconfined Compressive Strengths (ASTM 07012-C). Soil description and classification are in accordance with the Unified Soil Classification System (USCS)

Unconfined Compression Strength (Rock)

Two (2) specimens from the core samples returned were submitted for unconfined compressive strength testing and summary of the results obtained are shown in the table below. A more detailed report can be obtained from lab report attached in the Appendices. The analysis indicates an average density of 160.3 pounds per cubic foot (p.c.f) and compressive strength in excess of three thousand pounds per square inch (psi)

UNCONFINED COMPRESSION TEST RESULTS		
Location	Sligoville, St. Catherine	
Specimen Number (Comp. Strength Specimen No.)	1	2
Specimen Depth	8'-13'	8'-1 3'
Density p.c.f	160.8	159.9
Compressive Strength - Mpa (cylinder)	22.55	23.51
Compressive Strength - PSI (cylinder)	3270	3410

Figure 34. Table showing Unconfined Compression Strength test result, Sligoville, St. Catherine

3.3.5 CABBAGE HILL, ST. THOMAS

As planned for similar tower sites, boring should have been achieved with use of drill rig employing HQ coring rods. The equipment that was earmarked for use was a truck mounted Mobile B40 drill rig. On the days that the boring was attempted occurred shortly after a number of days of consistent, heavy rainfall. Due to the extremely steep and unstable slopes, narrow unpaved road network, and prolonged torrential rainfall, access to the site using a mobile B40 truck-mounted drill rig proved futile. In addition, access to the site by a water truck was also a major challenge. Due to the inaccessibility, a portable coring machine was employed to carry out subsurface drilling.



Figure 35. Picture showing use of coring machine at Cabbage Hill, St. Thomas

3.3.5.1 BORINGS

A single borehole was cored to a depth of 2 metres using concrete coring machine which did not produce reliable results to calculate core recovery. (See fig. 35). RQD⁵ was however recorded at 60.0 percent.



Figure 36 Picture showing core samples collected from borehole, Cabbage Hill, St. Thomas

⁵ ROD -The Rock Quality Designation is a rough measure of the amount of fracturing within a rock mass. It is determined by summing all core pieces of 100mm or greater length and determining their proportion of the core run (expressed as percentage).

Boring encountered a very hard creamish white limestone with some chert nodules which extended down to 0.5 metres. This overlies a moderately weathered limestone which is about 0.2 meters thick. The weathered limestone unit sits on a reddish brown gravelly, silty clay. This clay is underlain by a fractured weathered micritic limestone. (See fig. 36).

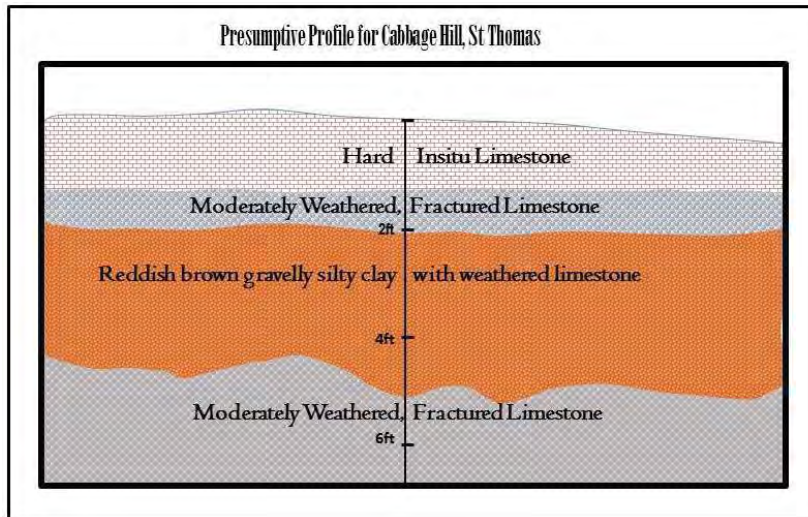

Figure 37. Lithological profile generated from borelog, Cabbage Hill, St. Thomas

3.3.5.2 LAB REPORT

Unconfined Compression Strength (Rock)

One (1) specimen from the core samples returned were submitted for unconfined compressive strength testing and summary of the results obtained are shown in the table below. A more detailed report can be obtained from lab report attached in the Appendices. The analysis indicates an average density of 148.7 pounds per cubic foot (p.c.f) and compressive strength in excess of eight thousand pounds per square inch (psi)

UNCONFINED COMPRESSION TEST RESULTS	
Location	<u>Cabbage Hill, St. Thomas</u>
Specimen Number (Comp. Strength Specimen No.)	1
Specimen Depth	0'-5'
Density p.c.f	148.7
Compressive Strength - Mpa (cylinder)	58.12
Compressive Strength - PSI (cylinder)	8430

Figure 38. Table showing Unconfined Compression Strength test result, Cabbage Hill, St. Thomas

3.3.6 WINCHESTER, ST. THOMAS

As planned for similar tower sites, boring should have been achieved with use of drill rig employing HQ coring rods. The equipment that was earmarked for use was a truck mounted Mobile B40 drill rig. On the days that the boring was attempted occurred shortly after a number of days of consistent, heavy rainfall. Due to the extremely steep and unstable slopes, narrow unpaved road network, and prolonged torrential rainfall, access to the site using a mobile B40 truck-mounted drill rig proved futile. In addition, access to the site by a water truck was also a major challenge. Due to the inaccessibility, a portable coring machine was employed to carry out subsurface drilling.

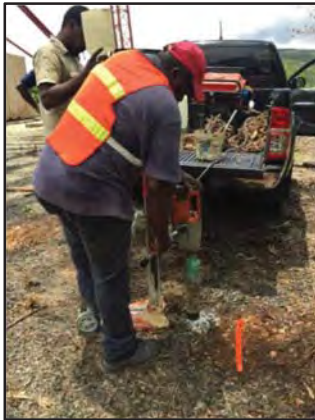

Figure 39 Picture showing use of coring machine at Winchester Site

The coring machine was fitted with a 15'' core barrel which produces cores 3'' in diameter. Two 24'' extensions were also used to achieve the required depth.

In order to further verify and evaluate the subsurface strata, a shallow exploratory pit or test pit was excavated at the Winchester site (See fig.40).

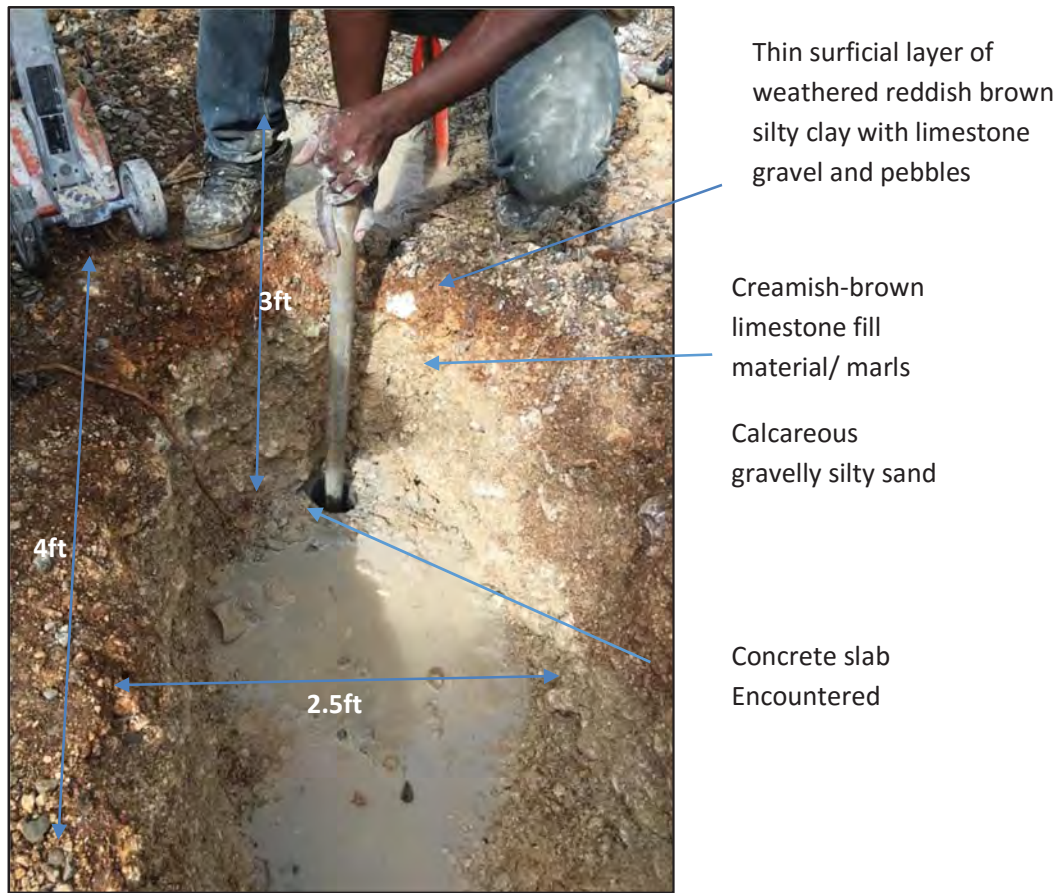

Figure 40. Picture showing test pit dug at Winchester, St. Thomas

3.3.6.1 BORINGS

A single borehole was cored to a depth of 2.1 metres using concrete coring machine which did not produce reliable results to calculate core recovery. (See fig. 39). RQD⁶ ranged between 26-40%.



Figure 41 Picture showing core sample collected from borehole, Winchester, St. Thomas

⁶ ROD -The Rock Quality Designation is a rough measure of the amount of fracturing within a rock mass. It is determined by summing all core pieces of 100mm or greater length and determining their proportion of the core run (expressed as percentage).

Boring initially encountered a compact marl with limestone boulders. This material extended down to a 10 inch thick concrete slab at 0.8 meters. Below this concrete slab coring entered a medium hard micritic limestone. (See fig. 40).

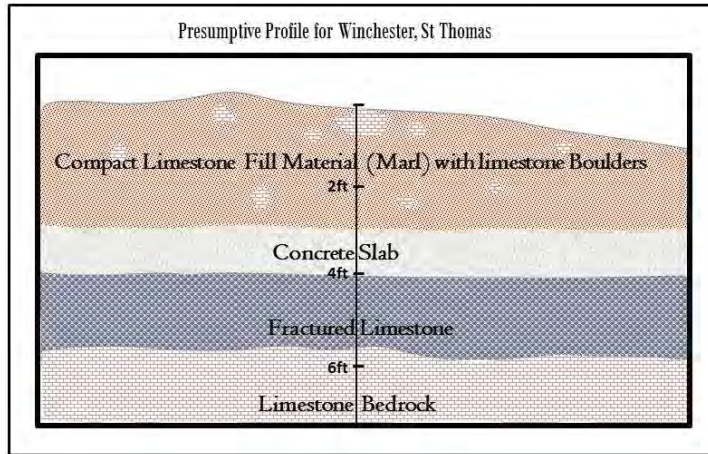

Figure 42. Lithological profile generated from borelog, Winchester, St. Thomas

3.3.6.2 LAB REPORT

Unconfined Compression Strength (Rock)

One (1) specimen from the core samples returned were submitted for unconfined compressive strength testing and summary of the results obtained are shown in the table below. A more detailed report can be obtained from lab report attached in the Appendices. The analysis indicates an average density of 144.1 pounds per cubic foot (p.c.f) and compressive strength in excess of six thousand pounds per square inch (psi)

UNCONFINED COMPRESSION TEST RESULTS	
Location	<u>Winchester, St. Thomas</u>
Specimen Number (Comp. Strength Specimen No.)	1
Specimen Depth	0'-5'
Density p.c.f	144.1
Compressive Strength - Mpa (cylinder)	45.40
Compressive Strength - PSI (cylinder)	6585

Figure 43. Table showing Unconfined Compression Strength test result, Winchester, St. Thomas

4.0 RECOMMENDATIONS FOR DESIGN AND CONSTRUCTION

The evaluation of subsoil parameters for a site is generally made by assuming that the sampling of the site is representative of the site. It is explicitly a stochastic process and our confidence in these assumptions and the probability that an evaluation will yield a design suitable for problem free construction and long-term performance, is a function of the available database as well as the intrinsic variability of the subsoils on the site. In cases, where a single borehole only was requested, larger factors of safety will be applied to recommended values in an attempt to counteract even greater assumptions along with the caveat that our recommendations hold as long as the subsoil encountered during construction is similar to what was encountered in the borehole.

The base material underlying the six (6) selected sites are from the white limestone series of Jamaica and as such tends to contain solution cavities due to its permeable and porous nature. It is practically impossible to determine the extent of possible cavities from borehole exploration only, and generally, geophysical methods are needed for suitable determination. During the drilling of the single boreholes on selected sites, there were no indication of open or unfilled cavities though the returned material had some unconsolidated material (clay, sand, gravel) which suggest the presence of small infilled cavities. There were no surface manifestations of possible cavities observed on any of the sites.

The table below show the generalized bearing capacities associated with the formations on which these six (6) repeater sites rest. The information provided acts as a guide but design should be guided by local conditions and analysis

Geological Formation	Bearing Capacity	Permeability	Method of Excavation	Slope Stability	Construction Problem
Newport Formation Ranges from nodular chalks to compact or hard recrystallized limestones.	Bearing capacity usually good where sound rock is at or near surface. The presumed bearing capacity ranges from 1000-4000KN/m ²	Generally low primary porosity While very high secondary porosity is achieved from extensively fractured rocks.	Generally Blasting is recommended, especially where hard, recrystallized limestone is encountered. Material can be easily ripped where soft calcareous marls and rubbly limestone is encountered.	Generally good except in fault zones where rock is highly fractured or in weak marls.	Depth of bedrock is extremely variable and can lead to differential settlement. Landslide risk along fault scarps.
Gibraltar-Bonny Gate, Formation Consists of evenly bedded white micrites typically chalky and porous	In sound rock ~ 4000KN/M ² In depression where soil is stiff and clay content is high ~ 40 – 500KN/m ²	Primary Permeability is generally low. Secondary permeability may be very high.	Variable Blast/ Rip	Reasonable in sound rocks, while on soil near vertical cuts should be stable, given that soil cohesion is high.	Landslip along fault scarps Underground cavities Flood risk in depressions Depth of bedrock may be variable

4.1 MOUNT AIRY, WESTMORELAND

4.1.1 EARTHWORKS

The estimation of rock parameters to determine its strength in-situ was done using the Hoek-Brown Method and the results obtained are presented. (See fig.42). The rock is estimated to have a cohesion (c) of 1.98 MPa and a friction angle (ϕ) of 29.75 degrees. Using the Hoek-Brown Method, a Geological Strength Index (GSI) of 66 was obtained and a global strength of 5.99 MPa. It is theorized that rocks with a GSI of up to 40 can be dug while those with global strength of above 1 MPa can be ripped. If rock is to be excavated on site for foundations or other reasons, we would recommend the use of ripping equipment like a D8 or equivalent along with bucket and hammer attachments for operation or use of hydraulic jackhammer given the limited operating space at the repeater station.

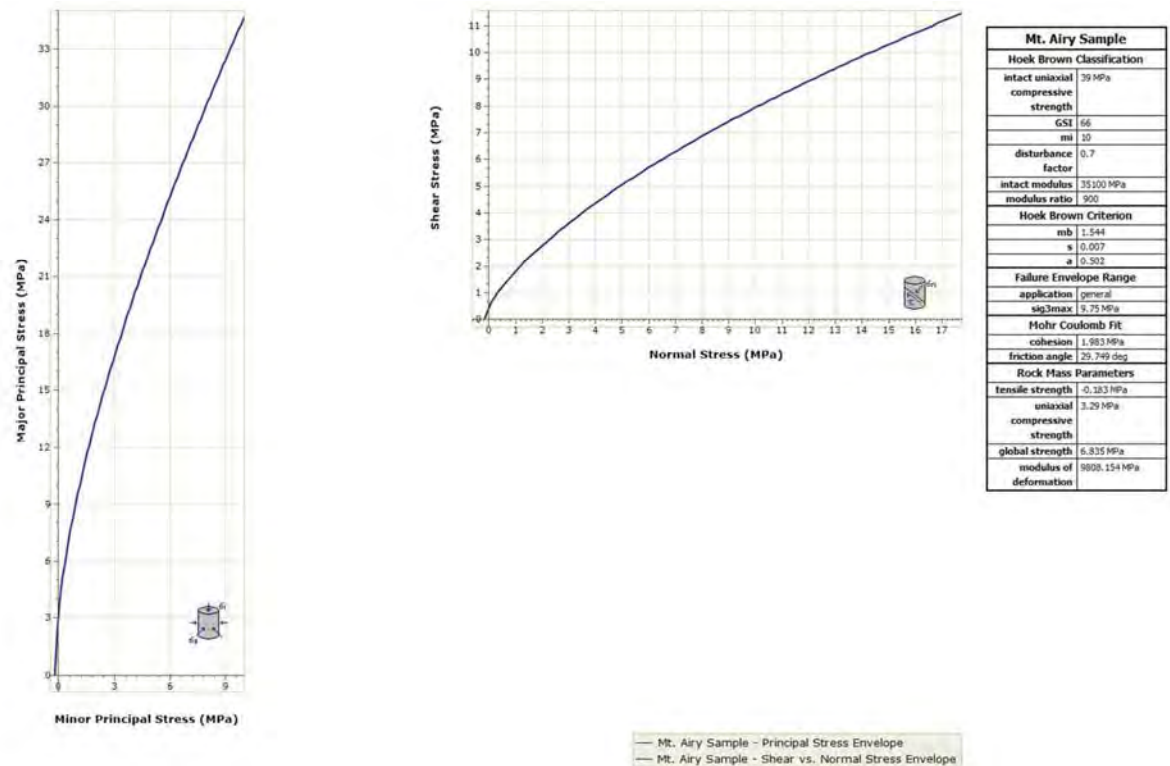

Figure 44. Diagram showing average principal and normal vs shear stress envelopes, Mt. Airy

4.1.2 FOUNDATIONS

Foundations on site can be founded to a depth of 3ft within limestone encountered at the surface. Foundations on rock should have no bearing capacity or settlement issues, and in-fact our recommendations for ultimate and allowable bearing capacities for foundations in rock at this site range are indicated in the table below.

MT. AIRY		
NO	ITEM DESCRIPTION	mPa
1	AVERAGE UCS	38.84
2	ALLOWABLE BEARING CAPACITY	23.304
3	ULTIMATE BEARING CAPACITY	139.824

SAFETY FACTOR = 6 - Some vugs seen in limestone with moderate density of fracturing (RQD - 40%)

4.2 SHAFSTON, WESTMORELAND

4.2.1 EARTHWORKS

The estimation of rock parameters to determine its strength in-situ was done using the Hoek-Brown Method and the results obtained are presented in Figure 43. The rock is estimated to have a cohesion (c) of 1.225 MPa and a friction angle (ϕ) of 19.7 degrees. Using the Hoek-Brown Method, a Geological Strength Index (GSI) of 44 was obtained and a global strength of 3.48 MPa. It is theorized that rocks with a GSI of up to 40 can be dug while those with global strength of above 1 MPa can be ripped. If rock is to be excavated on site for foundations or other reasons, we would recommend the use of ripping equipment like a D8 or equivalent along with bucket and hammer attachments for operation or use of hydraulic jackhammer given the limited operating space at the repeater station.

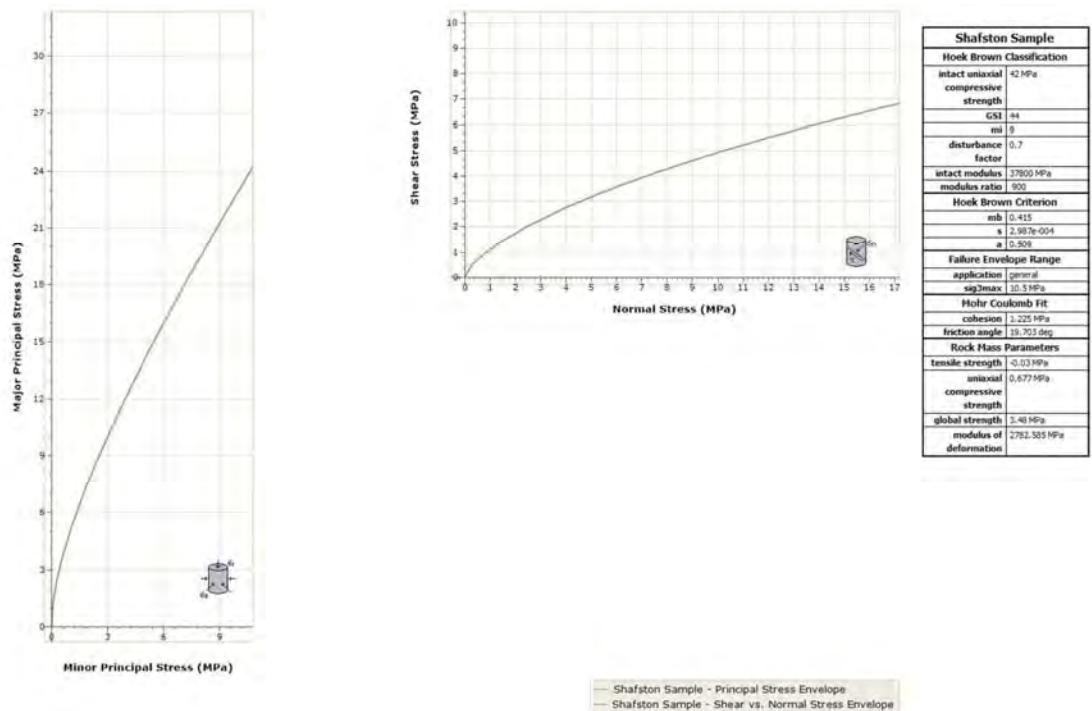

Figure 45. Diagram showing average principal and normal vs shear stress envelopes, Shafston

4.2.2 FOUNDATIONS

Foundations on site should be founded below the unconsolidated material encountered atop the rock, which was found to be a high plastic clay in the borehole advanced. Foundations on rock should have no bearing capacity or settlement issues, and in-fact our recommendations for ultimate and allowable bearing capacities for foundations in rock at this site range are indicated in the table below.

SHAFSTON		
NO	ITEM DESCRIPTION	mPa
1	AVERAGE UCS	41.99
2	ALLOWABLE BEARING CAPACITY	25.194
3	ULTIMATE BEARING CAPACITY	176.358

SAFETY FACTOR = 7 - Medium hard limestone with some fracturing. (RQD-47%)

4.3 PORTLAND COTTAGE, CLARENDON

4.3.1 EARTHWORKS

The estimation of rock parameters to determine its strength in-situ was done using the Hoek-Brown Method and the results obtained are presented. (See fig.44). The rock is estimated to have a cohesion (c) of 1.52 MPa and a friction angle (ϕ) of 24.12 degrees. Using the Hoek-Brown Method, a Geological Strength Index (GSI) of 53 was obtained and a global strength of 4.69 MPa. It is theorized that rocks with a GSI of up to 40 can be dug while those with global strength of above 1 MPa can be ripped. If rock is to be excavated on site for foundations or other reasons, we would recommend the use of ripping equipment like a D8 or equivalent along with bucket and hammer attachments for operation or use of hydraulic jackhammer given the limited operating space at the repeater station.

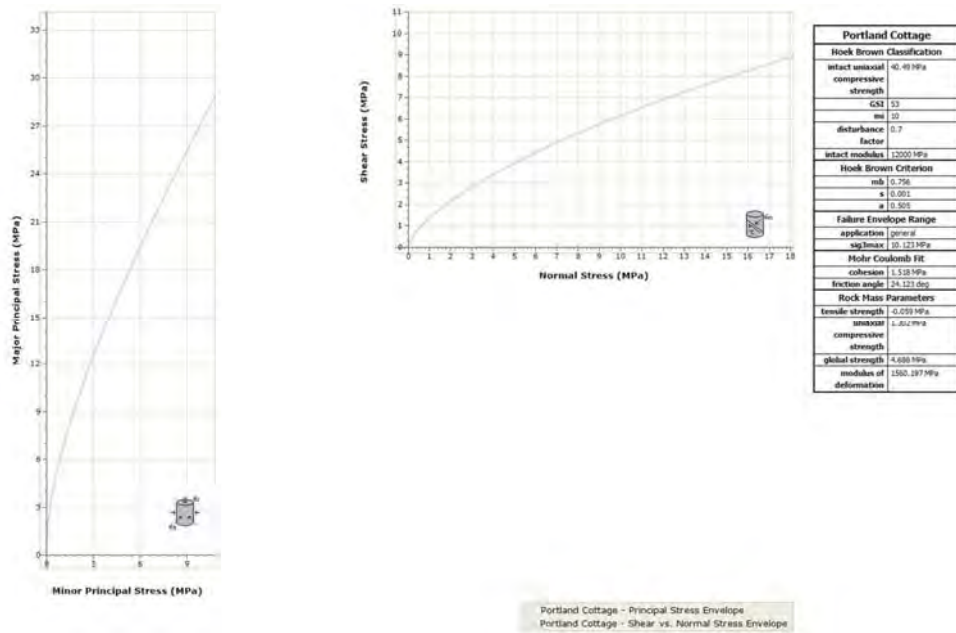

Figure 46. Diagram showing average principal and normal vs shear stress envelopes, Portland Cottage

4.3.2 FOUNDATIONS

Foundations on site can be founded to a depth of 3ft within limestone encountered at the surface. Foundations on rock should have no bearing capacity or settlement issues, and in-fact our recommendations for ultimate and allowable bearing capacities for foundations in rock at this site range are indicated in the table below.

PORTLAND COTTAGE		
NO	ITEM DESCRIPTION	mPa
1	AVERAGE UCS	40.49
2	ALLOWABLE BEARING CAPACITY	24.294
3	ULTIMATE BEARING CAPACITY	145.764

SAFETY FACTOR = 6 - moderate density of fracturing seen (RQD - 25%)

4.4 SLIGOVILLE, ST. CATHERINE

4.4.1 EARTHWORKS

The estimation of rock parameters to determine its strength in-situ was done using the Hoek-Brown Method and the results obtained are presented. (See fig.45). The rock is estimated to have a cohesion (c) of 0.78 MPa and a friction angle (ϕ) of 22.09 degrees. Using the Hoek-Brown Method, a Geological Strength Index (GSI) of 50 was obtained and a global strength of 2.31 MPa. It is theorized that rocks with a GSI of up to 40 can be dug while those with global strength of above 1 MPa can be ripped. If rock is to be excavated on site for foundations or other reasons, we would recommend the use of ripping equipment like a D8 or equivalent along with bucket

and hammer attachments for operation or use of hydraulic jackhammer given the limited operating space at the repeater station.

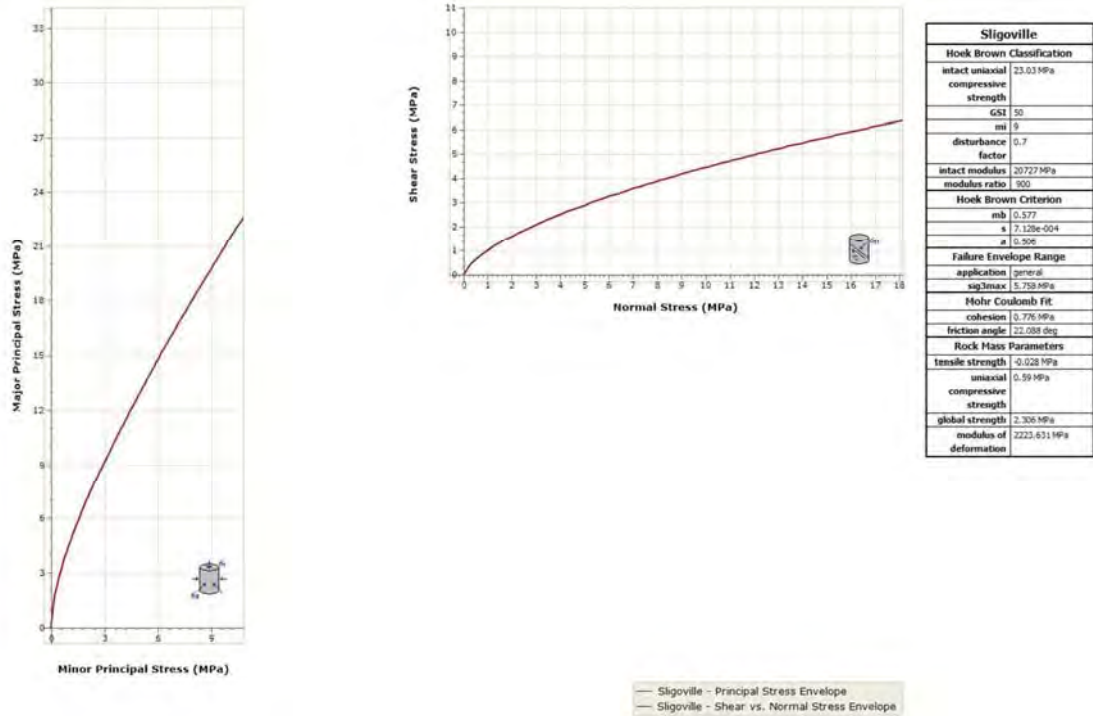

Figure 47. Diagram showing average principal and normal vs shear stress envelopes, Sligoville

4.4.2 FOUNDATIONS

Foundations on site should be founded below the unconsolidated material encountered atop the rock, which was found to be a well-graded gravel with sand in the borehole advanced. Foundations on rock should have no bearing capacity or settlement issues, and in-fact our recommendations for ultimate and allowable bearing capacities for foundations in rock at this site range are indicated in the table below.

SLIGOVILLE		
NO	ITEM DESCRIPTION	mPa
1	AVERAGE UCS	23.03
2	ALLOWABLE BEARING CAPACITY	16.121
3	ULTIMATE BEARING CAPACITY	112.847

SAFETY FACTOR = 7 - vuggy limestone with low density of fracturing present (RQD - 50%)

4.5 CABBAGE HILL, ST. THOMAS

4.5.1 EARTHWORKS

The estimation of rock parameters to determine its strength in-situ was done using the Hoek-Brown Method and the results obtained are presented. (See fig.46). The rock is estimated to have a cohesion (c) of 2.36 MPa and a friction angle (ϕ) of 25.42 degrees. Using the Hoek-Brown Method, a Geological Strength Index (GSI) of 58 was obtained and a global strength of 7.47 MPa. It is theorized that rocks with a GSI of up to 40 can be dug while those with global strength of above 1 MPa can be ripped. If rock is to be excavated on site for foundations or other reasons, we would recommend the use of ripping equipment like a D8 or equivalent along with bucket and hammer attachments for operation or use of hydraulic jackhammer given the limited operating space at the repeater station.

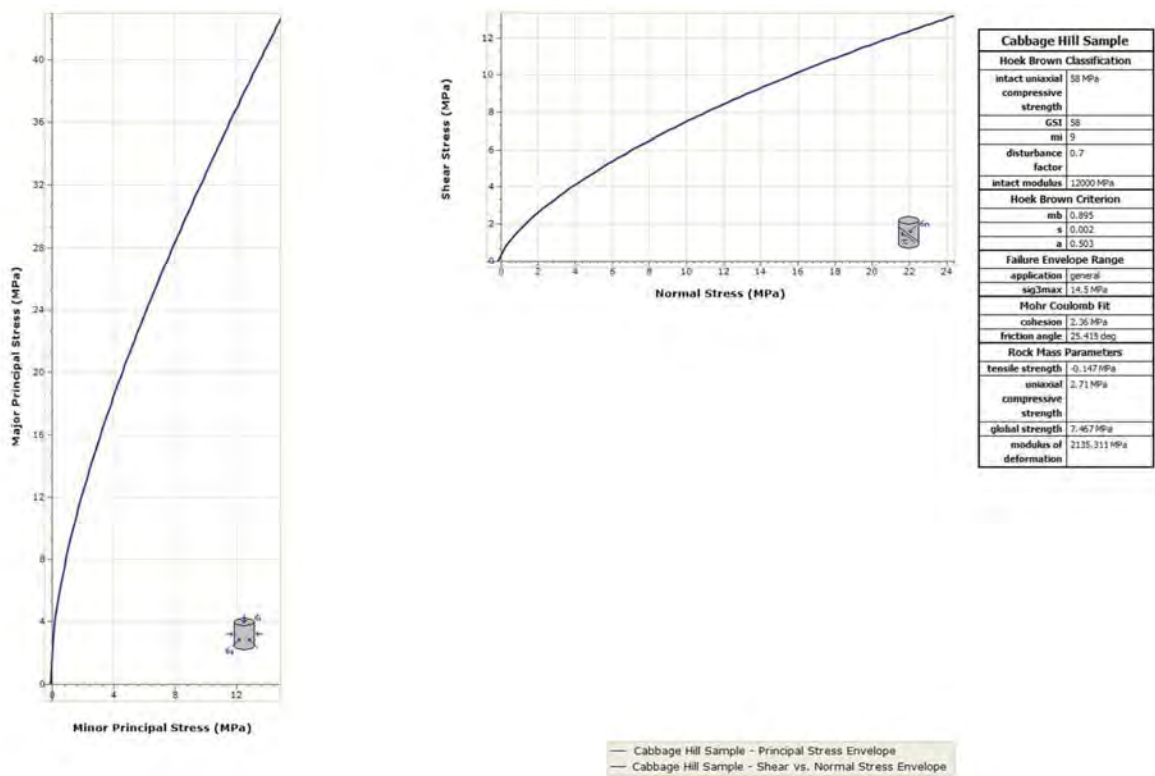

Figure 48. Diagram showing average principal and normal vs shear stress envelopes, Cabbage Hill, St. Thomas

4.5.2 FOUNDATIONS

Foundations on site can be founded to a depth of 3ft within limestone encountered at the surface. Foundations on rock should have no bearing capacity or settlement issues, and in-fact our recommendations for ultimate and allowable bearing capacities for foundations in rock at this site range are indicated in the table below.

CABBAGE HILL		
NO	ITEM DESCRIPTION	mPa
1	AVERAGE UCS	58.12
2	ALLOWABLE BEARING CAPACITY	29.06
3	ULTIMATE BEARING CAPACITY	145.3

SAFETY FACTOR = 5 - hard limestone with siting on weathered material and silty clay (RQD - 60%)

4.6 WINCHESTER, ST. THOMAS

4.6.1 EARTHWORKS

The estimation of rock parameters to determine its strength in-situ was done using the Hoek-Brown Method and the results obtained are presented. (See fig.47). The rock is estimated to have a cohesion (c) of 1.56 MPa and a friction angle (ϕ) of 22.50 degrees. Using the Hoek-Brown Method, a Geological Strength Index (GSI) of 51 was obtained and a global strength of 4.65 MPa. It is theorized that rocks with a GSI of up to 40 can be dug while those with global strength of above 1 MPa can be ripped. A test pit was dug at site which revealed that the core retrieve was actually taken from a limestone bolder within a layer of compacted marl. These results therefore do not typically represent the entire horizon. This test pit was dug with use of pick axe and shovel down to the 10" concrete slab discovered. We will therefore recommend use of manual digging equipment at this site.

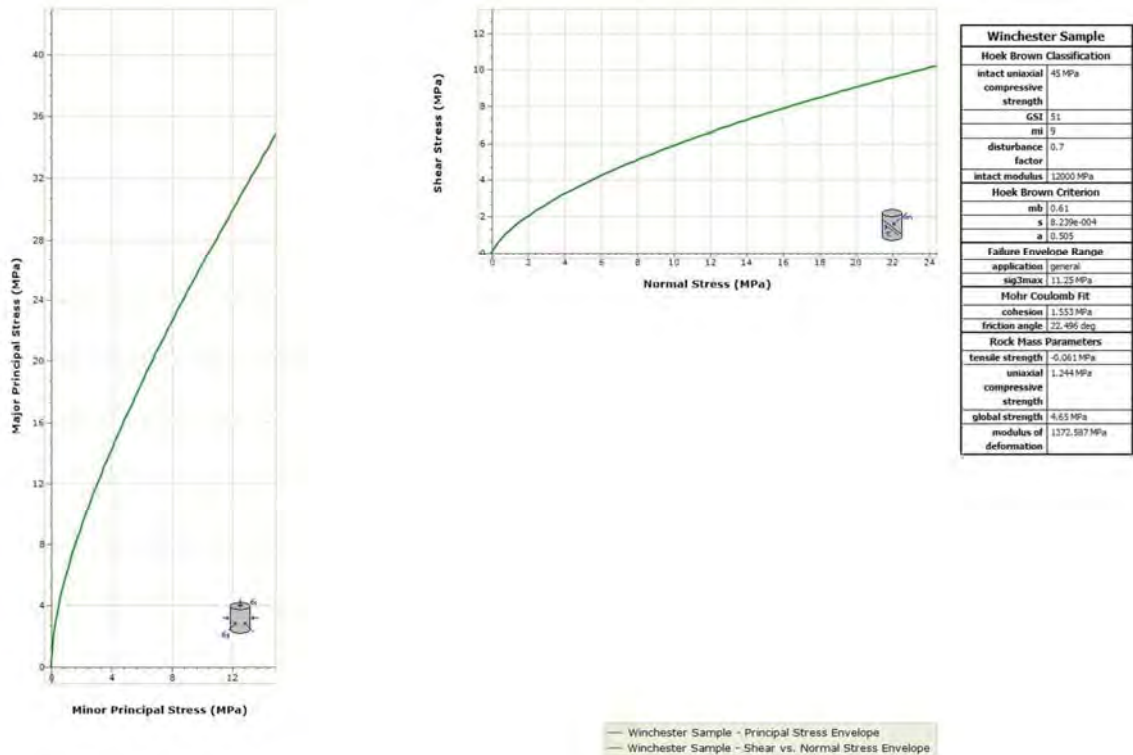

Figure 49. Diagram showing average principal and normal vs shear stress envelopes, Winchester, St. Thomas

4.6.2 FOUNDATIONS

Foundations on site can be founded to an approximate depth of 3ft within limestone encountered at the surface and above the concrete slab encountered. Our recommendations for ultimate and allowable bearing capacities for foundations in rock at this site range are indicated in the table below.

WINCHESTER		
NO	ITEM DESCRIPTION	mPa
1	AVERAGE UCS	45.4
2	ALLOWABLE BEARING CAPACITY	22.7
3	ULTIMATE BEARING CAPACITY	68.1

SAFETY FACTOR = 3 - medium hard limestone with low density of fracturing present above and below concrete slab. Marl fill found near surface(RQD - 26%)

5.0 REFERENCES

Mitchell, S. F. 2013. Stratigraphy of the White Limestone of Jamaica. *Bulletin de la Societe Geologique de France*, 184 (1-2), 111-118

Zans, V.A., Chubb, L.J., Versey, H.R., Williams, J.B., Robinson, E. and Cooke, D.L. 1963. Synopsis of Jamaican Geology. Geological Survey of Jamaica Bulletin 4. 1-72.

Robinson, E & Mitchell, S.F. 1999. Middle Eocene to Oligocene Stratigraphy and Palaeogeography in Jamaica: a window on the Nicaragua Rise, Prepared for the Fourth Annual Meeting of IGCP 393, 12-18 July, 1999. Contributions to Geology #4, 1-47.

Fisher, J.D. and Mitchell, S.F. 2012. Lithostratigraphy of the Grange Inlier, Westmoreland, Jamaica. Caribbean Journal of Earth Science, Volume 44 (in memory of the late Dr. Raymond Wright), 19-24. Available online: 11th December 2012.

James-Williamson, S.A. and Mitchell, S.F. 2012. Revised lithostratigraphy of the Coastal Group of south-eastern St. Thomas, Jamaica. Caribbean Journal of Earth Science, Volume 44 (in memory of the late Dr. Raymond Wright), 9-17. Available online: 26th November 2012.