

付録-4

Utility Survey Report

TABLE OF CONTENTS	Page No.
EXECUTIVE SUMMARY.....	3
1. INTRODUCTION.....	4
2. SURVEY LOCATION.....	5
3. SCOPE OF WORK.....	9
4. SURVEY DESIGN.....	10
5. PERSONNEL.....	11
6. SURVEY CONTROL.....	12
7. FIELD PHOTOGRAPHS	13
8. Conclusions	18

List of tables

Table No.	Description	Page No.
Table 1	Sections of Survey area	9
Table 2	Survey Personal	10
Table 3	Utility and Obstacle coming under MTHL alignment	12

List of Figure

Figure number.	Description	Page No.
Figure 1	Key plan of Survey Location	5
Figure 2	Survey location on Eastern freeway Interchange side	5
Figure 3	Survey area Shivaji Nagar side	6
Figure 4	Survey area at Chirle side	7
Figure 5	HP Oil pipe line at Sewri side	13
Figure 6	BP LUBE Oil pipe line at Sewri side	14
Figure 7	Indian Oil petrol pipe line Sewri Side	14
Figure 8	Hindustan Petroleum petrol pipe line Sewri Side	15
Figure 9	Indian oil pipe line Sewri Side	15
Figure 10	Railway line at Jasai crossing the MTHL alignment and electric transformer	16
Figure 11	Transmission tower and electric line at Gavan gaon	16
Figure 12	Water pipe line of CIDCO at Jasai Village	17

EXECUTIVE SUMMARY

SOWiL Ltd. was contracted by Oriental Consultant Global Co. Ltd. Japan wide service agreement between them on 19th May 2015 to carry out the utility and obstacle surveys (the Works) to be conducted for The Preparatory Survey on the Project for Construction of Mumbai Trans Harbour Link (MTHL) across the Mumbai Bay between Mumbai and Navi-Mumbai City which conducted by the JICA Study Team

The Works is carried out to obtain utility information at bridge sites on proposed MTHL alignment.

The objectives of the survey to clarifying the utility and obstacle (under-ground utilities, aerial line, power pole, hazardous objects, marine structures, etc.) and their condition (authority, location, kind, size, construction year, future plan, etc.) to make a plan of MTHL.

Utility Survey on landside was commence on 25th May and completed on 30th June.

This report consist the information about the utility and obstacle crossing and along the proposed alignment of MTHL project.

Utility of different owners namely HPC, IOCL, BPCL, MBPT, Tata Power , MJP , Reliance, Cidco, etc. where contacted contractors and information collected from the utility owner and marked on the drawings and drawings are included in this report

1. INTRODUCTION

Mumbai Trans Harbor Link (MTHL), also known as Sewri-Nhava Sheva Trans Harbor Link, is a proposed 22 km, freeway grade road bridge connecting the Indian city of Mumbai with Navi Mumbai. It would be the longest sea bridge in India after completion. The bridge will begin in Sewri, Mumbai and cross Thane Creek north of Elephanta Island and will terminate at Chirle village, near Nhava Sheva. The road will be linked to the Mumbai Pune Expressway in the east, and to the proposed Western Freeway along the west coast of Mumbai.

SOWiL Ltd. was contracted by Oriental Consultant Global Co. Ltd. Japan vide service agreement between them on 19th May 2015 to carry out the utility and obstacle surveys (the Works) to be conducted for The Preparatory Survey on the Project for Construction of Mumbai Trans Harbour Link (MTHL) across the Mumbai Bay between Mumbai and Navi-Mumbai City which conducted by the JICA Study Team

Survey was based on the survey area details provided by the client .

2. SURVEY LOCATION

The survey area specified by the client is shown in the Google image below. The coordinates of the survey routes were extracted from the drawing provided by the client.

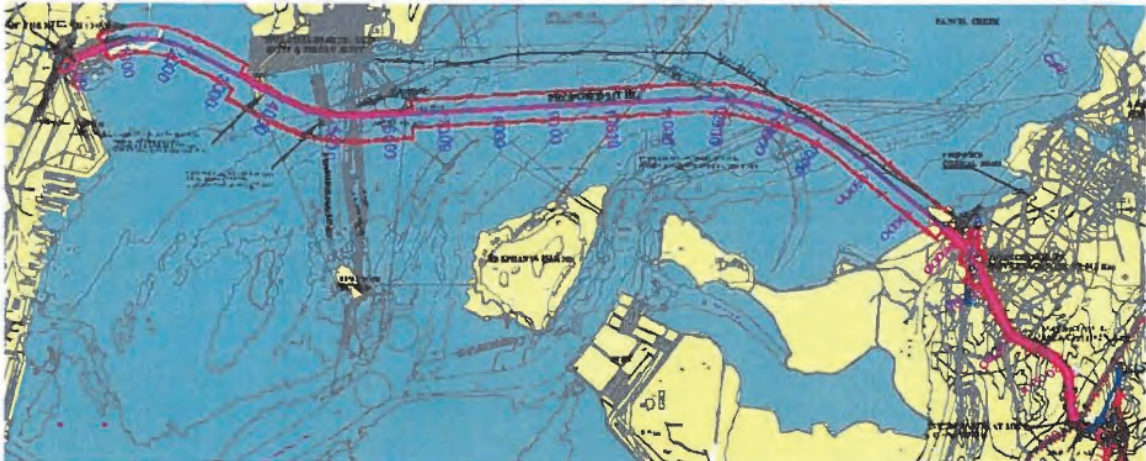

Figure 1:- Key plan of Survey location

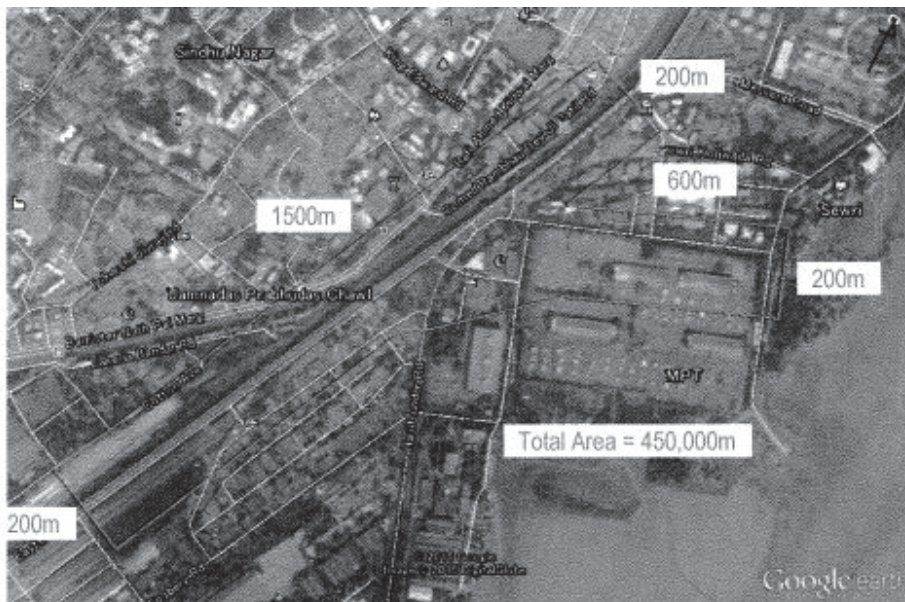

Figure 2:- Survey location on Eastern freeway Interchange side



Figure 3:- Survey area Shivaji Nagar side



Figure 4:- Survey area at Chirle side

3. SCOPE OF WORK

- 1) Utilities Survey which includes the preparation of survey sheets / drawings and the site reconnaissance, along the proposed route of MTHL.
- 2) Collecting information on obstacles from related organizations. In the information, the facility name, location, type of utility , utility size and the opinion to the alignment of proposed bridge , When possible, collection of as as-built drawing and future plan .
- 3) Carry out the site reconnaissance except for the Marine section.
- 4) Preparation of survey drawings, survey sheets, reports, site photograph and other references, based on the Engineer-supplied survey-sheet

Preparation of report

After completion of field report the report preparation is done which includes the following points

- 1) Evaluation of the survey results
- 2) Drawing of Surveys (Plan drawings of Obstacles location with having coordinates of UTM-WGS84, Typical cross-section drawing only for main and complicated structures, etc.)
- 3) Reports including Survey sheet, Site photograph, etc.
- 4) Reference data (As-built drawings, future plan, other references, etc.)

4. Survey Design

Survey area is constuted by marine section and land section on both the side. The survey area on the main line is 50m on the up stream side and 50 down stream side of the MTHL alignment as given in the table below.

Section		Length	Assumed Main Utility and Obstacle	Remark
1	Mumbai Side	0.49 km	Power Cable/Pole Under-ground Utilities Existing Road Existing Railway Others	
2	Marine (Mumbai Bay Section)	18.33 km	Tata Intake/Discharge Channel Tata Coal Berth Channel Oil Product, Freshwater Pipelines Power, Telephone Cables Pir Pau Jetty Thane Creek ONGC*&BPLC Pipelines Panvel Creek Others	
3	Navi Mumbai side (Chirle) Land section	3 39 km	Power Cable/Pole Under ground Utilities Existmg Road Proposed Road Existing Railway others	
Table 1. Sections of Survey area				

5. PERSONNEL

The following survey personnel were involved in the survey.

Topographic Survey		
Name	Designation	Duration
Binno Kuruvilla	Chief Surveyor consultant	Project Duration
Arun	Traffic Engineer	Project Duration
Prakash Gode	Surveyor	Project Duration
Prashant	Draftsman	Project Duration
Hari	Surveyor Assistant	Project Duration
Table 2:-Survey Personal		

5.1 HSE Management System

The project manager took responsibility for all HSE related issues during the survey. Prior to survey, the party chief carried out a safety briefing for the survey personnel. The survey operations were performed in day-light hours and regular safety “tool-box” meetings were conducted to ensure smooth deck operations for the deployment and recovery of survey sensors. All HSE related measures were fully implemented to the survey team during the course of the survey.

6. SURVEY CONTROL

The survey operations were conducted visiting the survey locations

- 1) Visible inspections and observations for utilities
- 2) At site alignment marker, post for underground utility
- 3) Information regarding the utility owner collected and contacted their respective office/ project locations
- 4) Utility owner informed the about the proposed MTHL alignment plan and given drawings to marked there utilities on the drawings
- 5) The drawings marking the utilities from the owner collected .

List of the utility owners, there contact details location of the utility type and size of utility is given in the table below.

Table number 3 UTILITY AND OBSTACLES COMING UNDER MTHL ALIGNMENT

SR. NO.	UTILITY OWNER NAME	CONTACT DETAILS	LOCATION	SEA / GROUND	TYPE OF UTILITY
1	RELIANCE	JNPT, MR. SANJAY CHOPRA - 9920546112	SHIVAJI NAGAR, KOPAR	G/S	PETROLIUM PIPE LINE
2	MJP	MJP,PANVEL MR.	JASAI, SH	G	WATER PIPE LINE 445 mm DIA.
3	DEEPAK FERTILIZER	TALOGA MIDC, MR ANTHONY ROADRISK, 9765568126	JASAI	G	GAS PIPE LINE 300 mm Dia.
4	IOCL	SEWRI TERMINAL Mr. Sanjay Talukdar, 022 24147129, MR. A.T. Khobarekar (Deputy Manager) Mob. 88791 96222 email - atkhobrekar@indianoil.co.in	SEWRI	G	PETROLIUM PIPE LINE, dia 300 mm
5	BPCL	MR. Sunil Mali , Mob. 9930765237	SEWRI	G	Lube Oil pipe line dia. 300 mm
6	BPCL REFINERY	MR. Mangesh jadhav Mob. 9920666544, email - mangeshcjadhav@bharatpetroleum.in, Mr. Deepak Chinta (Dy manager) 9820219683 email- chintadeepak@bharatpetroleum.in	SEA (Co-ordinates given in the drawings)	S	LPG GAS PIPE LINE
7	BMC	PAREL - WARD -F	BPT AREA	G	WATER PIPE LINE
8	CIDCO	CBD BELAPUR - RAIIGAD BHAWAN Mr. Sai Madvi Mob. 9619263535	JASAI	G	825 mm Dia water pipe line
9	MBPT	MR. D.Vishwanathan (9820020572) ADD. Chief Mechanical Engineer)	SEA (Co-ordinates given in the drawings)	S	OIL PIPE LINE
10	HPCL	Lube gate, Mahul gaon, opp. Tata power, Mr. V.K. Singh (022 2554 5810) Mob. 97020 44207 . Email vsingh@hpcl.in	SEWRI	G	PETROLIUM PIPE LINE, dia 300 mm
11	TATA POWER (CABLE DETAILS)	1) Mr. N.R. Sirdesai (Head EHV Cable) Lower parel - Mob. 92233 11454, e-mail nrsirdesai@tatapower.com. 2) Mr. K B Pawar, mob. 90290 16881	SEWRI	S	CABLE
12	TATA POWER (JETTY)	Mr. J. Dsouza, Phone no. 022 6717 5110, email - jvdsouza@tatapower.com, MOB- 92233 83841	SEWRI	S	JETTY, CABLE
13	GAIL INDIA LIMITED	GAIL INDIA LIMITED, CBD BELAPUR CONTACT PERSON MR. GONDANE, MOB. 9819734375	NH4-B	G	GAS PIPE LINE 300 mm Dia. DEPTH BELOW GROUND IS 1.5 M.

7. Field Photograph



Figure 5 HP Oil pipe line at Sewri side



Figure 6 BP LUBE Oil pipe line at Sewri side



Figure 7 Indian Oil petrol pipe line Sewri Side



Figure 8 Hindustan Petroleum petrol pipe line Sewri Side



Figure 9 Indian oil pipe line Sewri Side



Figure 10 Railway line at Jasai crossing the MTHL alignment and electric transformer



Figure 11 Transmission tower and electric line at Gavan gaon



Figure 12 Water pipe line of CIDCO at Jasai Village

8.0 Conclusion

On completion of the survey information collected from different utility agencies marked on autocad drawings in WGS84 system and they are included in the drawings and included into the report

DRAWING LIST OF MTHL TOPOGRAPHY SURVEY

Sl. No.	Drawing No.	Drawing Title	Rev.	Submission DATE
1	SOWiL/MTHL/TOPO/LAND-01	LAYOUT TOPOGRAPHY DETAILS OF MTHL	R0	04.07.2015
2	SOWiL/MTHL/TOPO/LAND-02	LAYOUT TOPOGRAPHY DETAILS OF MTHL	R0	04.07.2015
3	SOWiL/MTHL/TOPO/LAND-03	LAYOUT TOPOGRAPHY DETAILS OF MTHL	R0	04.07.2015
4	SOWiL/MTHL/TOPO/LAND-04	LAYOUT TOPOGRAPHY DETAILS OF MTHL	R0	04.07.2015
5	SOWiL/MTHL/TOPO/LAND-05	LAYOUT TOPOGRAPHY DETAILS OF MTHL	R0	04.07.2015
6	SOWiL/MTHL/CM/01 SH. 1 OF 7	CONTOUR MAP	R0	11.07.15
7	SOWiL/MTHL/CM/01 SH. 2 OF 7	CONTOUR MAP	R0	11.07.15
8	SOWiL/MTHL/CM/01 SH. 3 OF 7	CONTOUR MAP	R0	11.07.15
9	SOWiL/MTHL/CM/01 SH. 4 OF 7	CONTOUR MAP	R0	11.07.15
10	SOWiL/MTHL/CM/01 SH. 5 OF 7	CONTOUR MAP	R0	11.07.15
11	SOWiL/MTHL/CM/01 SH. 6 OF 7	CONTOUR MAP	R0	11.07.15
12	SOWiL/MTHL/CM/01 SH. 7 OF 7	CONTOUR MAP	R0	11.07.15
7	SOWiL/MTHL/SC/01 SH. 1 OF 9	SECTIONAL DETAILS OF GROUND LEVEL AT SEWRI SIDE	R0	10.06.15
8	SOWiL/MTHL/SC/01 SH. 2 OF 9	SECTIONAL DETAILS OF GROUND LEVEL AT SEWRI SIDE	R0	10.06.15
9	SOWiL/MTHL/SC/01 SH. 3 OF 9	SECTIONAL DETAILS OF GROUND LEVEL AT SEWRI SIDE	R0	10.06.15
10	SOWiL/MTHL/SC/01 SH. 4 OF 9	SECTIONAL DETAILS OF GROUND LEVEL AT SHIVAJINAGAR AND CHIRLE	R0	10.06.15
11	SOWiL/MTHL/SC/01 SH. 5 OF 9	SECTIONAL DETAILS OF GROUND LEVEL AT SHIVAJINAGAR AND CHIRLE	R0	10.06.15
12	SOWiL/MTHL/SC/01 SH. 6 OF 9	SECTIONAL DETAILS OF GROUND LEVEL AT SHIVAJINAGAR AND	R0	10.06.15

		CHIRLE		
13	SOWiL/MTHL/SC/01 SH. 7 OF 9	SECTIONAL DETAILS OF GROUND LEVEL AT SHIVAJINAGAR AND CHIRLE	R0	10.06.15
14	SOWiL/MTHL/SC/01 SH. 8 OF 9	SECTIONAL DETAILS OF GROUND LEVEL AT SHIVAJINAGAR AND CHIRLE	R0	10.06.15
15	SOWiL/MTHL/SC/01 SH. 9 OF 9	SECTIONAL DETAILS OF GROUND LEVEL AT SHIVAJINAGAR AND CHIRLE	R0	10.06.15
8	SOWiL/MTHL/SURVEY/GL/01	VERTICAL PROFILE OF SEA AND LAND PORTION..	R0	11.07.2015
9	SOWiL/MTHL/SURVEY/COMBINED(SEA&LAND)-01	ROUTE 1 BATHYMETRY (Sheet 1 of 3)	R0	11.06.2015
10	SOWiL/MTHL/SURVEY/COMBINED(SEA&LAND)-01	ROUTE 1 BATHYMETRY (Sheet 2 of 3)	R0	11.06.2015
11	SOWiL/MTHL/SURVEY/COMBINED(SEA&LAND)-01	ROUTE 1 BATHYMETRY (Sheet 3 of 3)	R0	11.06.2015
12	SOWiL/MTHL/SURVEY/COMBINED(SEA&LAND)-02	ROUTE 2 & 3 BATHYMETRY	R0	11.06.2015
13	OSaS/P19415/SOWiL/Mum/Bathy/01	Route 1 bathemetry	R0	04.06.2015
14	OSaS/P19415/SOWiL/Mum/Bathy/02	Route 2 and 3 bathemetry	R0	04.06.2015
15	Utility report MTHL TOPO & UTILITY FINAL as on 030.08.15 R2.dwg			
DRAWING LIST OF MTHL UTILITY SURVEY				
1	SOWiL/MTHL/UTILITY/BPCL-01	LOCATION OF EXISTING UTILITY OF BPCL	R0	04.07.2015
2	SOWiL/MTHL/UTILITY/IOCL-01	LOCATION OF EXISTING UTILITY OF IOCL	R0	04.07.2015
3	SOWiL/MTHL/UTILITY/BMC-01	LOCATION OF EXISTING UTILITY OF BMC	R0	04.07.2015
4	SOWiL/MTHL/UTILITY/RIL-01	LOCATION OF EXISTING UTILITY OF RELIANCE	R0	04.07.2015
5	SOWiL/MTHL/UTILITY/RIL-02	LOCATION OF EXISTING UTILITY OF RELIANCE	R0	04.07.2015
6	SOWiL/MTHL/UTILITY/CIDCO-01	LOCATION OF EXISTING UTILITY OF CIDCO	R0	04.07.2015
7	SOWiL/MTHL/UTILITY/CIDCO-01	LOCATION OF EXISTING UTILITY OF CIDCO	R0	04.07.2015
8	SOWiL/MTHL/UTILITY/DF-01	LOCATION OF EXISTING UTILITY OF D. FERTILIZER	R0	04.07.2015
9	SOWiL/MTHL/UTILITY/GAIL-01	LOCATION OF EXISTING UTILITY OF GAIL INDIA	R0	04.07.2015
10	SOWiL/MTHL/UTILITY/CIDCO-01	LOCATION OF EXISTING UTILITY OF MJP	R0	04.07.2015
11	SOWiL/MTHL/UTILITY/MBPT-01	LOCATION OF EXISTING UTILITY OF MBPT	R0	04.07.2015

DRAWINGS RECEIVED FROM MBPT				
1	J034/MBPT/AS-BUILT-BT-PL_SF/2000/02/634	BATHYMETRY & PIPELINE AND SEABED FEATURES KP 2.100 TO KP 4.070 (JAWAHAR DEEP TO PIRPAU)	R1	04.07.2015
2	J034/MBPT/AS-BUILT/SP-PP/2000/01/636	LONGITUDINAL SEABED & PIPELINE PROFILE KP 0.014 TO KP 0.680 (JAWAHAR DEEP TO PIRPAU)	R0	04.07.2015
3	J034/MBPT/AS-BUILT/SP-PP/2000/02/636	LONGITUDINAL SEABED & PIPELINE PROFILE KP 0.680 TO KP 1.580(JAWAHAR DEEP TO PIRPAU)	R0	04.07.2015
4	J034/MBPT/AS-BUILT/SP-PP/2000/03/636	LONGITUDINAL SEABED & PIPELINE PROFILE KP 2.360 TO KP 2.520(JAWAHAR DEEP TO PIRPAU)	R0	04.07.2015
5	J034/MBPT/AS-BUILT/SP-PP/2000/04/636	LONGITUDINAL SEABED & PIPELINE PROFILE KP 2.520 TO KP 3.420(JAWAHAR DEEP TO PIRPAU)	R0	04.07.2015
6	J034/MBPT/AS-BUILT/SP-PP/2000/05/636	LONGITUDINAL SEABED & PIPELINE PROFILE KP 3.420 TO KP 4.070(JAWAHAR DEEP TO PIRPAU)	R0	04.07.2015
7	J034/MBPT/AS-BUILT/PL-SF-SP/2000/01/639	PIPELINE AND SEABED FETURES CENTRAL LINE SEABED PROFILE (KP. 0.000 TO 4.128)	R1	04.07.2015
DRAWINGS RECEIVED FROM BPCL				
1	BPCL/PDIL/JPL/LOBS/AG/01 OF 07	12" DIA. LUBE OIL PIPE LINE AT CH. 00.00 TO 00.687 KM.	R0	04.07.2015
2	BPCL/PDIL/JPL/LOBS/AG/02 OF 07	12" DIA. LUBE OIL PIPE LINE AT CH. 00.00 TO 00.960 KM.	R0	04.07.2015
3	BPCL/PDIL/JPL/LOBS/AG/03 OF 07	12" DIA. LUBE OIL PIPE LINE AT CH. 00.960TO 01.920 KM.	R0	04.07.2015
4	BPCL/PDIL/JPL/LOBS/AG/04 OF 07	12" DIA. LUBE OIL PIPE LINE AT CH. 00.920 TO 02.880 KM.	R0	04.07.2015
5	BPCL/PDIL/JPL/LOBS/AG/05 OF 07	12" DIA. LUBE OIL PIPE LINE AT CH. 02.880 TO 03.840 KM.	R0	04.07.2015
6	BPCL/PDIL/JPL/LOBS/AG/07 OF 07	12" DIA. LUBE OIL PIPE LINE AT CH. 04.800 TO 005.165 KM.	R0	04.07.2015
7	BPCL/PDIL/JPL/LOBS/UG/01 OF 06	12" DIA. LUBE OIL PIPE LINE AT CH. 05.175 TO 06.300 KM.	R0	04.07.2015
8	BPCL/PDIL/JPL/LOBS/UG/02 OF 06	12" DIA. LUBE OIL PIPE LINE AT CH. 06.300 TO 07.300 KM.	R0	04.07.2015
9	BPCL/PDIL/JPL/LOBS/UG/03 OF 06	12" DIA. LUBE OIL PIPE LINE AT CH. 07.300 TO 08.300 KM.	R0	04.07.2015
10	BPCL/PDIL/JPL/LOBS/UG/04 OF 06	12" DIA. LUBE OIL PIPE LINE AT CH. 08.300 TO 09.300 KM.	R0	04.07.2015
11	BPCL/PDIL/JPL/LOBS/UG/05 OF 06	12" DIA. LUBE OIL PIPE LINE AT CH. 09.300 TO 10.300 KM.	R0	04.07.2015
12	BPCL/PDIL/JPL/LOBS/UG/06 OF 06	12" DIA. LUBE OIL PIPE LINE AT CH. 10.300 TO 10.700 KM.	R0	04.07.2015

DRAWINGS RECEIVED FROM DEEPAK FERTILIZER				
1	DFPCL-99/GL/001	ROUTE MAP - GAS PIPELINE 41.5 KMS.		04.09.1999
BPCL Drawing				
1	Seabed Coordinates from BPCL	Coordinates of BPCL seabed pipeline of 12 kms		17.08.15
Tata power Cable				
1	Acknowledgement copy from SOWIL.pdf	Ltr from TATA to Sowil regarding Utility details		24.07.2015
2	Authority letter from MMRDA.pdf	Document and Drawing in PDF		24.07.2016
3	Letter Reply from EHV Team.PDF	Ltr from TATA to Sowil regarding EVH		24.07.2017
4	MMRDA BRIDGE ON TPCL PROPERTY.(11-07-15)-Model (1).pdf	TATA property and Utility		24.07.2018
5	Past communication to MMRDA from Engineering team.pdf	Communication with MMRDA in 2012 regarding Laying og HDVC cables		24.07.2019
6	PROPOSED MTHL ALIGNMENT (1).pdf	Document and Drawing in PDF		24.07.2020
7	Request letter from sowil.PDF	Document in PDF		24.07.2021
8	TATA cable on land_1 (1).PDF	TATA cables on Sewri (Land)-1		24.07.2022
9	TATA cable on land_2 (1).PDF	TATA cables on Sewri (Land)-2		24.07.2023
10	TPCL PROPERTY ON MMRDA BRIDGE DWG.(14-07-15)-Model (1).pdf	Document and Drawing in PDF		24.07.2024

付録-5

Letter of Shipping Channels



GOVERNMENT OF MAHARASHTRA, HOME DEPARTMENT (PORTS & TRANSPORT)
MAHARASHTRA MARITIME BOARD

Indian Mercantile Chambers, 3rd Floor, Ramjibhai Kamani Marg, Ballard Estate,
 Mumbai - 400 001. Tel.: 22612143 Fax : 22614331,
 Website : www.mahammb.com Email: ceommb@gmail.com



No. MMB/ENG/MTHL/1942

Date: 31 AUG 2012

To
 ✓ The Metropolitan Commissioner,
 Mumbai Metropolitan Region Development Authority,
 Bandra-Kurla Complex, Bandra (E),
 Mumbai- 400 051.
 Tel: 2659 4000
 Fax: 2659 1264

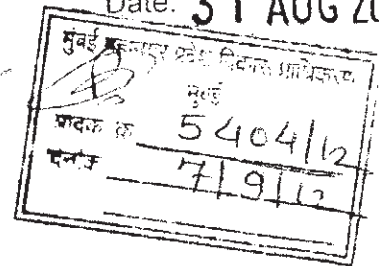

Sub: Mumbai Trans Harbour Link Project- Clearance for the project

- Ref: (1) This office letter no. MMB/ENG/MTHL/36, dtd. 4.1.2012
 (2) Meetings held on 10.1.2012 and 23.2.2012 at MMB office
 (3) Your letter no. ED/MTHL/MMB/Spans/12, dtd. 24.2.2012
 written to M/s ARUP-CES-KPMG and copy endorsed to MMB
 (4) Your letter no. ED/MMRDA/MMB/NC/12, dtd. 2.3.2012
 (5) Your letter no. ED/MTHL/Clearances from various Depts./land/
 Meeting/12, dtd. 14.6.2012 forwarding minutes of meeting held
 on 24.5.2012 by Metropolitan Commissioner

SECURITY
 SECURITY

Adtl. M.C. (2)'s Office
 No. 1377
 Date 10/9/2012

Sir,

Kindly refer to the discussions in the above mentioned meetings and the correspondence regarding above subject matter.

2. The Maharashtra Maritime Board hereby confirms and grants clearance for the navigational spans in Thane and Panvel creeks for the proposed Mumbai Trans Harbour Link (MTHL) Project as follows and also, clearance to work in the harbour area.

Sr.No.	Name of creek	Horizontal Clearance	Vertical Clearance
1.	Panvel creek	Two spans each with horizontal clearance of 100 mtrs. between fender systems measured perpendicular to the channel.	31 mtrs. above the chart datum

MC
 BMC/11
 CECS

16/9/2012
 5:30 PM

MTHL (EE/CS)/EE(SSW)
 2

Sr.No.	Name of creek	Horizontal Clearance	Vertical Clearance
2.	Thane creek	Two spans each with horizontal clearance of 94.6 mtrs. between fender systems measured perpendicular to the channel.	31 mtrs. above the chart datum

3. It is requested that the General Arrangement Drawings (GAD) with the above requirements and copy of bid document, as and when ready, may please be forwarded to this office.

Yours faithfully,

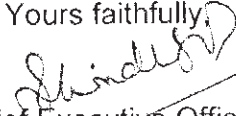

Chief Executive Officer,
Maharashtra Maritime Board, Mumbai.

C.C.:

- 1) The Principal Secretary (Ports), Home Department, Mantralaya, Mumbai- 32 for information please.
- 2) Regional Ports Officer, Mora Group of Ports for information.
- 3) M/s Ambuja Cements Ltd. (Unit: Panvel) Moha village, Near Ulwa Reti Bunder, Post: Ulwa, Tal. Panvel, Dist. Raigad- 410 306 for information.

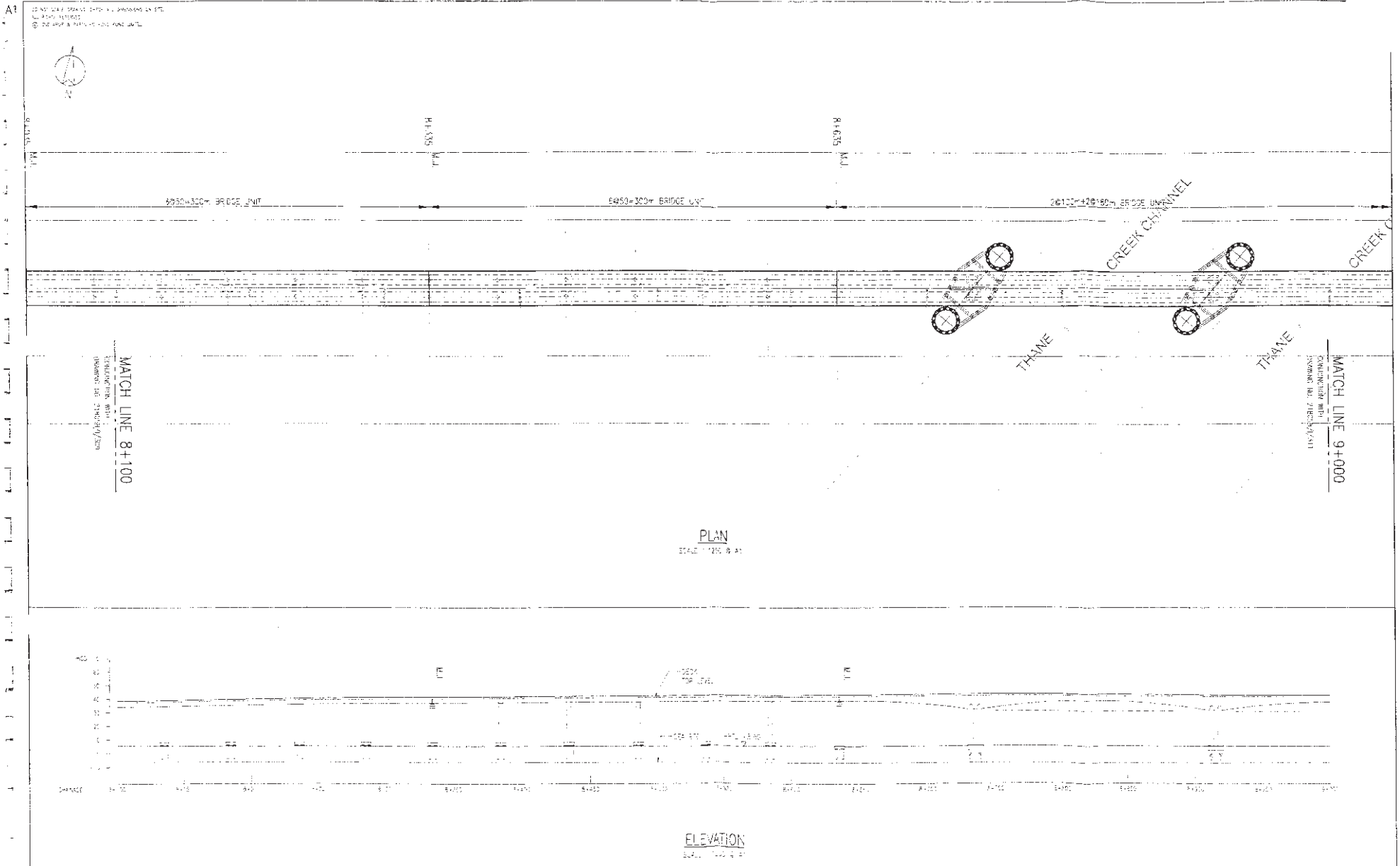

MMRDA
 MUMBAI METROPOLITAN REGION
 DEVELOPMENT AUTHORITY

MUMBAI TRANS HARBOUR LINK
 Illustrative Design Drawing



MAINLINE GENERAL ARRANGEMENT
 CHAINAGE 8+100 TO 9+000
 TENDER
 210204/310

A1

DO NOT SCALE DRAWING EXCEPT AS INDICATED BY NOTE
ALL RIGHTS RESERVED
© 2014 MMRDA & KPMG LLP AND PUNE LIMITED

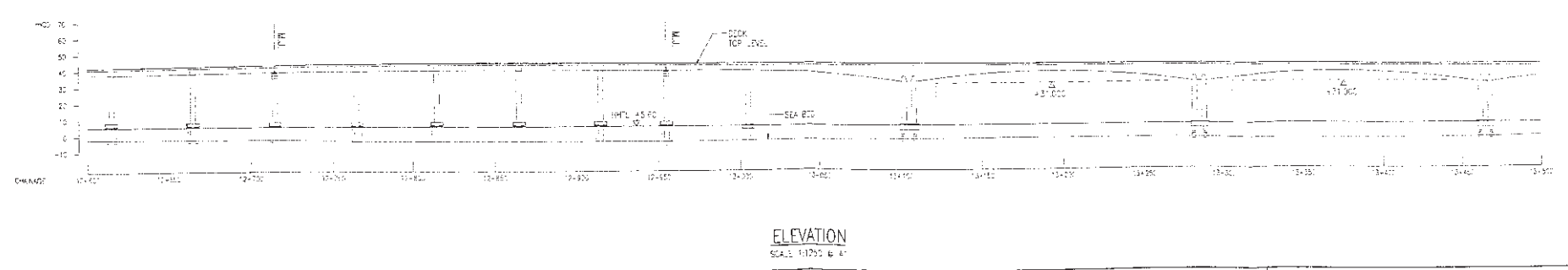
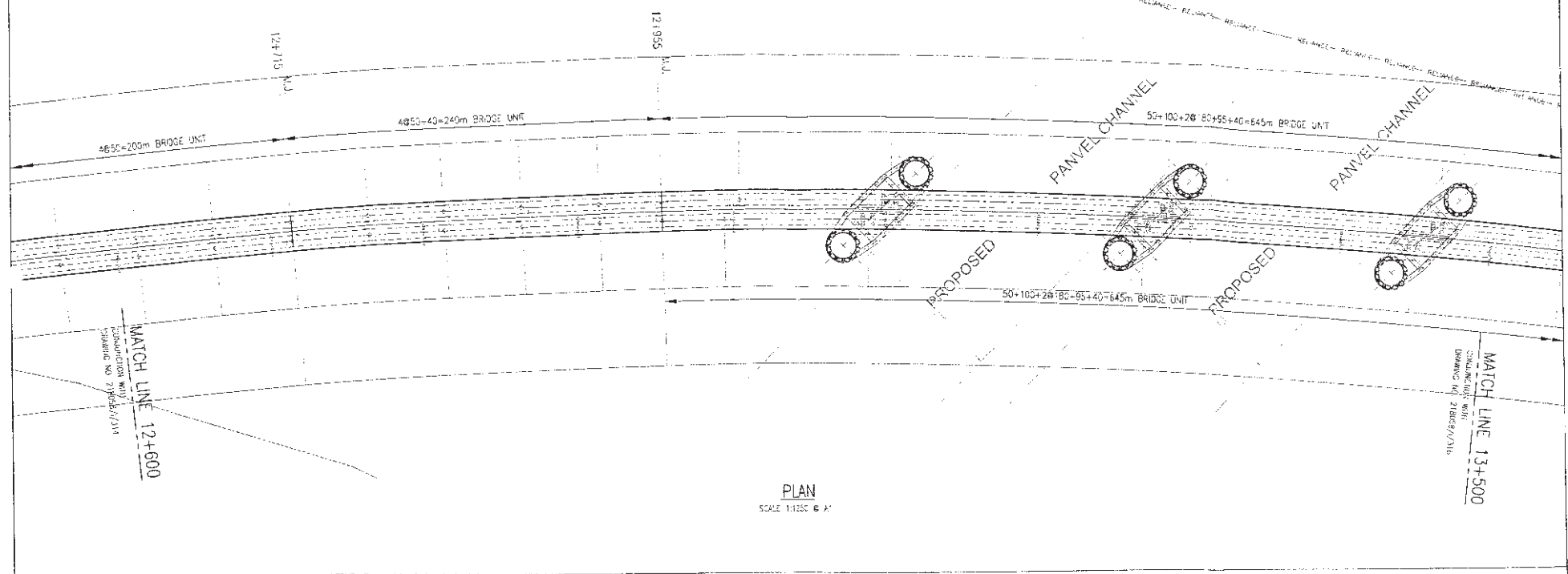

付録5-4



MMRDA
MUMBAI METROPOLITAN REGION
DEVELOPMENT AUTHORITY

MUMBAI TRANS HARBOUR LINK
Illustrative Design Drawing



MAINLINE GENERAL ARRANGEMENT
CHAINAGE 12+600 TO 13+500

TENDER	216058/1/315
--------	--------------

付録-6

MTHL Drawings over Railways

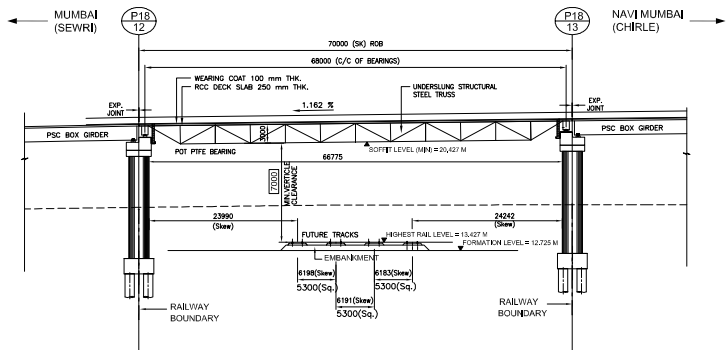

FINISHED ROAD LVL.	26.951	27.794
EXISTING GROUND LEVEL (m)	19.958	19.958
CHAINAGE	18+325	18+459

ELEVATION

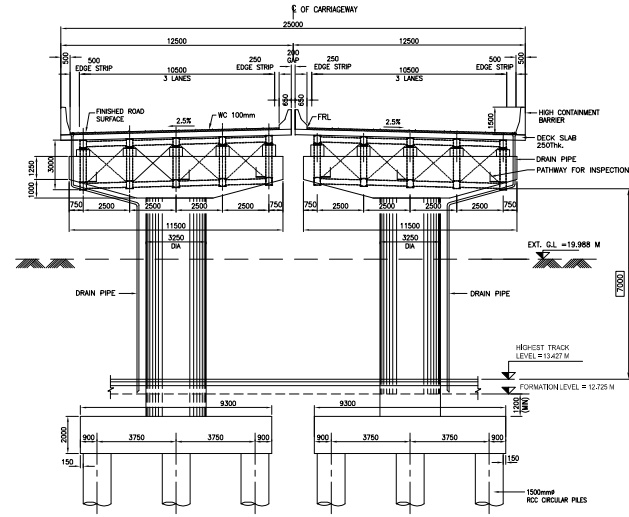

CROSS SECTION AT A - A

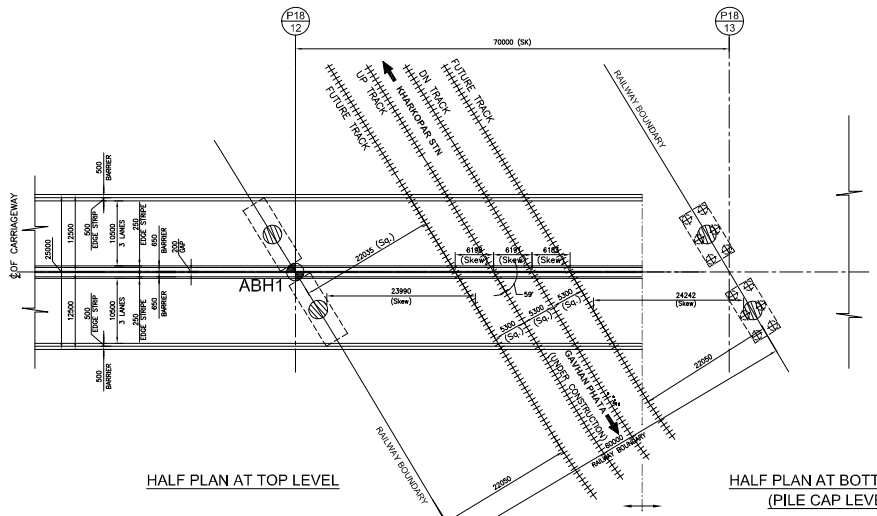

HALF PLAN AT TOP LEVEL

HALF PLAN AT BOTTOM LEVEL (PILE CAP LEVEL)

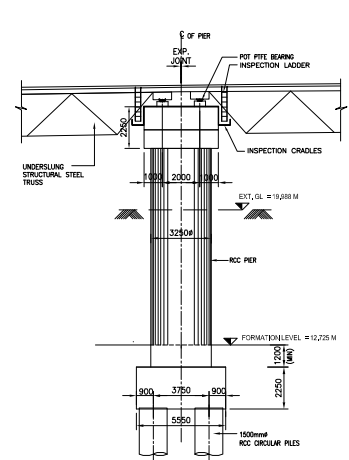

SIDE VIEW

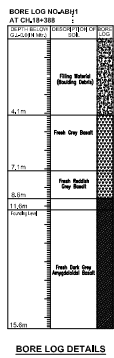

BORE LOG DETAILS

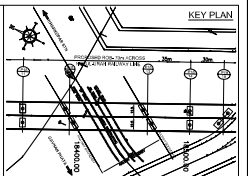

KEY PLAN

- NOTES
- ALL DIMENSIONS ARE IN MILLIMETERS AND LEVELS ARE IN METERS UNLESS STATED OTHERWISE.
 - DIMENSIONS IN RECTANGULAR AND OBLIQUE.
 - NO DIMENSIONS SHALL BE SCALE FROM THE DRAWING. ONLY WRITTEN DIMENSION SHALL BE FOLLOWED.
 - SHAPES AND SIZES OF STEEL JOISTS, PILES, PER CAPS, PER SHAFTS AND FOOTINGS SHOWN IN THE DRAWING ARE TENTATIVE AND ARE SUBJECT TO CHANGES DURING DETAILED DESIGN.
 - VERTICAL CLEARANCE FROM HIGHEST RAIL TOP LEVEL TO BOTTOM OF ROOF SHALL NOT BE LESS THAN 800MM PER I.C. TRACK.
 - CLEAR HORIZONTAL DISTANCE AT RAIL LEVEL OF PIERS FROM NEAREST CENTER LINE OF TRACK SHALL NOT BE LESS THAN 3.10 METERS.
 - THE DESIGN OF ROOF SHALL CONFORM TO THE LATEST RCO CODES AND SPECIFICATIONS.
 - WEARING COAT OF 100mm THICKNESS SHALL BE PROVIDED ON RIGID DECK.
 - DESIGN LOADING - EACH CARRIAGEWAY SHALL BE DESIGNED FOR 1-3 LANES OF CLASS A OR 1 LANE OF CLASS FOR 2 LANES OF CLASS A.
 - CONTROLLED CEMENT CONCRETE MIX IS TO BE PROVIDED.
 - MINIMUM SPREAD OF CONCRETE:
 - PSC GIRDER, DECK SLAB - M-45
 - PSC, MED, PER CAP, PILE, PILE CAP, PEDESTALS - M-20
 - RCC - M-20
 - ACTUAL LOCATION OF ROOF SHALL BE DECIDED JOINTLY IN CONSULTATION WITH RAILWAY AND ROAD AUTHORITY AT THE TIME OF CONSTRUCTION.
 - ANTICORROSION BARRIER SHALL BE PROVIDED AS PER M.O.S.T. STANDARD.
 - BEARINGS SHALL BE POT-PIPE TYPE ONLY.
 - STRIP SEAL TYPE EXPANSION JOINTS SHALL BE USED.
 - O.H.E. STANDARD WING PROTECTION FRAMES SHALL BE PROVIDED OVER THE CROSS BARRIER AND OVER LOCATION OF EACH RAILWAY TRACK.
 - ANTI CORROSION TREATMENT SHALL BE GIVEN TO REINFORCEMENT & OTHER STRUCTURAL MEMBERS AS PER SPECIFICATIONS.
 - THE SUPERSTRUCTURE PIR/A3-P18/14 SHALL BE OF COMPOSITE TYPES WITH STEEL PLATE GIRDERS AND RCC DECK AS PER IRC-24 FOR STEEL BUILT UP PLATE GIRDER W.S. PLATES SHALL BE OF IS 2062 GRADE-8 TYPE.
 - DEPTH OF FOUNDATION MAY BE ALTERED BY ENGINEER IN-CHARGE TO SUIT THE SITE CONDITION.
 - THE PROPOSED ROOF IS NOT IN LIEU OF CLOSURE OF ANY LEVEL CROSSING.
 - DRAWING AND DESIGN OF APPROACH SPANS SHALL BE DECIDED BY SPONSORING AUTHORITY AS PER CLAUSE 217-3 OF IRC CODE.
 - STEEL GIRDERS OF ROOF SHALL BE FABRICATED OUT SIDE AND THEN LAID ON.
 - DRAWING AND DESIGN OF EACH MEMBER OF ROOF SHALL BE SUBJECT TO APPROVAL BY DESIGN CELL OF CENTRAL RAILWAY.
 - ALL WORKS WITHIN RAILWAY PREMISES SHALL BE CARRIED OUT UNDER SUPERVISION OF RAILWAY ENGINEERS.
 - FOR ANY EXCAVATION NEAR RAILWAY MADE PROPER SHORING HAS TO BE DONE AS DIRECTED BY RAILWAY ENGINEER.
 - NO BLASTING SHALL BE PERMITTED. IN CASE BLASTING IS TO BE CARRIED OUT IN THE VICINITY OF RAILWAY LINE NECESSARY PRECAUTIONS AND BLOCK SHALL BE OBSERVED AS PER PARA 1000S OF R & M MANUAL.
 - A SEPARATE LAUNCHING SCHEDULE DRAWING SHALL BE SUBMITTED FOR APPROVAL RAILWAY.
 - PAINTING OF NEW STEEL WORK OF ROOF AND SAND BLASTING OF STEEL GIRDERS/MEMBERS/METALIZING & PAINTING OF STEEL COMPONENTS COMPLETE WITH APPROVED ALUMINUM ZINC METAL FOLLOWED BY PROTECTIVE COATING AS PER IRIS 1908 OF PARA-216.
 - FOR FABRICATION OF STEEL GIRDERS FOLLOW THE RCO CODES, BS-11012 & SPECIFICATION OF B-1.
 - FABRICATION OF STEEL GIRDERS SHALL BE FABRICATED BY ROOF APPROVED WORK SHOP.
 - FOR BOLTING ARRANGEMENT FOLLOW RCO CODE LINE FOR USE.
 - HSR BUILT ON BRIDGE BS-41 REVISED.
 - FOR INSPECTION OF RAILWAY SPAN PROVISION OF INSPECTION CRADLES FOR BOTH SIDE OF PIER/ABUTMENT WITH RAILING AND LADDER.
 - DESIGN AND DRAWING BEFORE SUBMIT IN TO RAILWAY SHOULD BE PROOF CHECKED BY APPROVED CHECKERS.
 - RESEARCH DESIGN AND STANDARD ORGANIZATION (RD&O)
 - RAIL INDA TECHNICAL AND ECONOMIC SERVICE (ITES)
 - INDIAN INSTITUTE OF TECHNOLOGY, KANPUR (IIT KANPUR)
 - VEER JAWAHAR TECHNICAL INSTITUTE MUMBAI (VJTI)
 - GOVERNMENT COLLEGE OF ENGINEERING, PUNE
 - V. N. T. NAGPUR
 - FOR CIVIL SANCTION TO BE OBTAINED BEFORE EXECUTION OF WORK.
 - STEEL STRUCTURE IN ROOF SHOULD BE GALVANIZED.
 - USE ANTI CORROSION ADHESIVE IN RCC WORK.
 - ROOF STRUCTURE IN RAILWAY PORTION SHOULD BE PAINTED AFTER CONSTRUCTION.
 - NO PROVISION OF FOOTPATH ON ROOF AS LOCAL ACCESS FROM LAND IS PROHIBITED.

MMRDA		CONSULTANT		APPROVAL OF DIVISIONAL RAILWAY OFFICE MUMBAI C. S. T.				
DESIGNATION	SIGNATURE	DESIGNATION		DEN (STM)	SR DEN (E)	SR DEN (CO)	OSDS	DRM, MB, CST
		SIGNATURE						

APPROVAL OF HEADQUARTER

DESIGNATION	SIGNATURE
CHIEF BRIDGE ENGINEER	
BY CE (RA)	
BY CE (RA)	
VEN (ROB)	
CHECKED	
APPROVED	
DESIGN	SE DESIGN
DRAWN	JE L408

MUMBAI METROPOLITAN REGION DEVELOPMENT AUTHORITY

CONSTRUCTION OF ROOF ON BRIDGE - URBAN LINE AT BETWEEN (QA) 44-45 AT RAILWAY CONSTRUCTION DEPARTMENT CH 84-400.

MUMBAI TRANS HANDBOOK - 124 PROJECT

CENTRAL RAILWAY MAINTENANCE DIVISION

GAD OF ROOF ON BRIDGE BETWEEN STATION KUMHAROPUR & GAUWAPURVA

SCALE # A2 : 1/100, 1/500

DATE: 18.06.2014

Q1 (0) BR 080 102 - 12

SENT: MFP

RECEIVED: MFP

APPROVED: SDC

DRAWING NO. 21000811R02-01

ARUP

REV: R4

DO NOT SCALE DRAWING. CHECK ALL DIMENSIONS ON SITE.
 ALL RIGHTS RESERVED.
 © DVE ARUP & PARTNERS HONG KONG LIMITED.

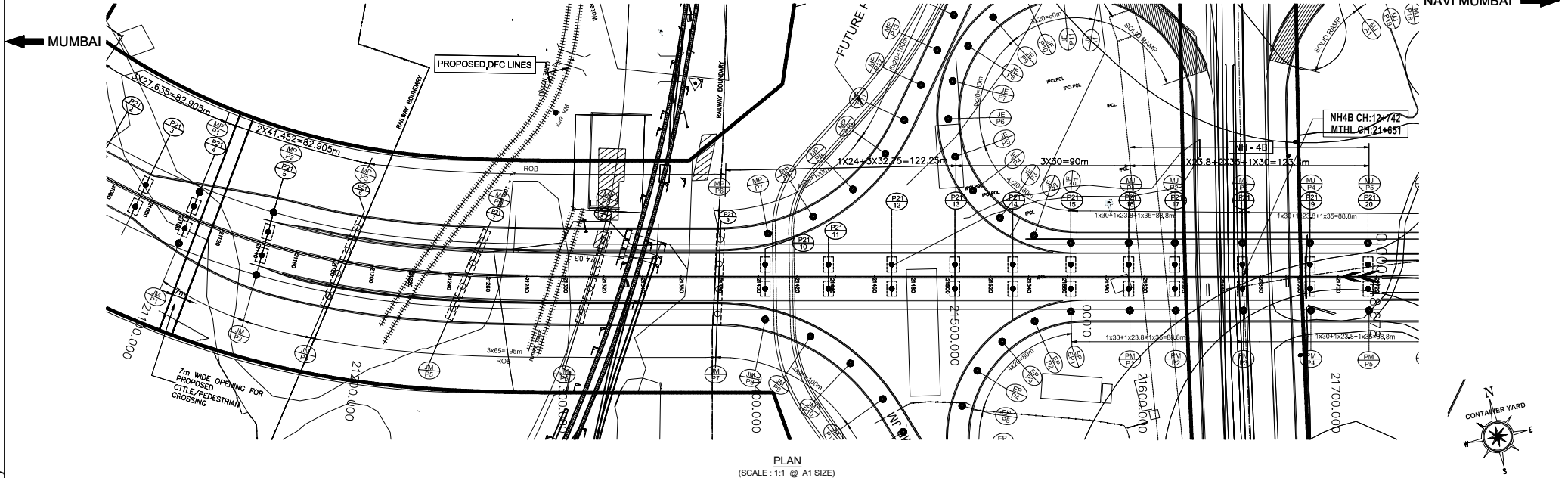

PLAN
 (SCALE: 1:1 @ A1 SIZE)

付録6-2

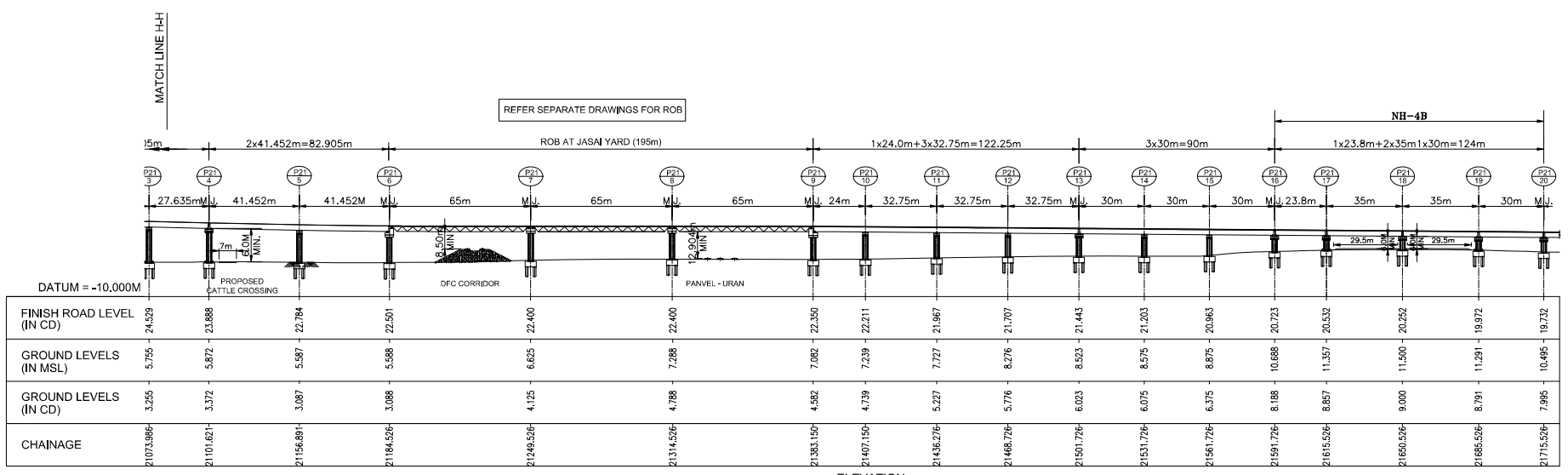

ELEVATION
 (SCALE: 1:1 @ A1 SIZE)

Mark	Date	By	Revisions
R4	MAR.16	MFP	REVISED AS PER MODIFIED AS PER MMRDA COMMENTS VIDE LETTER NO. NHAI/PM/ARUP/PM/2016/2533 DATED 12.02.2016
R3	JAN.16	MFP	REVISED AS PER MODIFIED HIGHWAY PLAN & PROFILE
R2	JULY.15	YDF	REVISED AS PER MODIFIED HIGHWAY PLAN & PROFILE
R1	OCT.13	MFP	PROFILE REVISED DUE TO PROPOSED DFC CORRIDOR



MUMBAI TRANS HARBOUR LINK
 Illustrative Design Drawing



Drawing Title	MAIN LINE GENERAL ARRANGMENT CHAINAGE - 21+082 TO 21+716		
Drawing Status	TENDER	Drawing No.	2011090_RH_NHAI_NH-4B_GAD_001
Rev.			R4

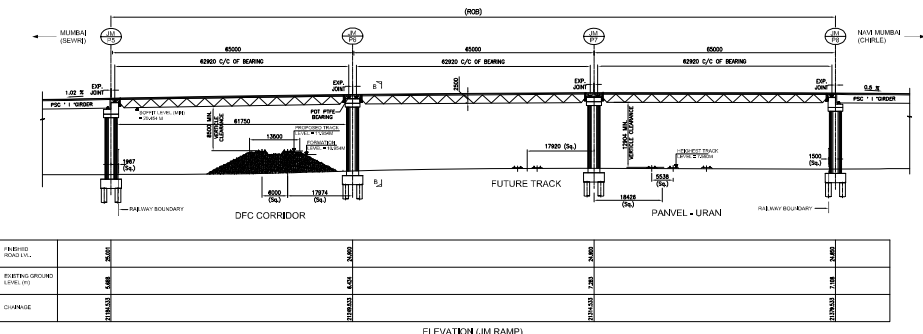
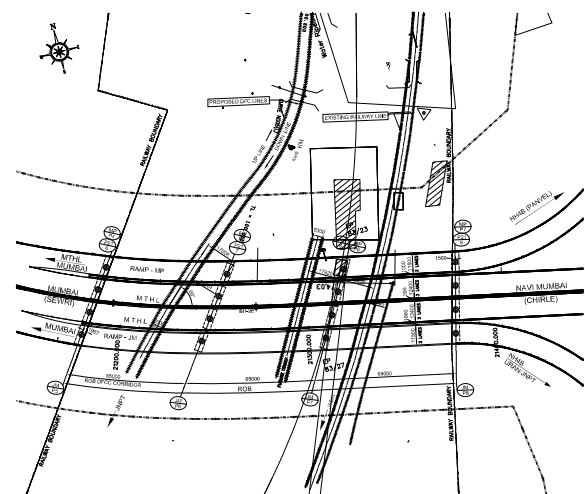

FINISHED ROAD LEVEL	3200	3200	3200	3200	3200
EXISTING GROUND LEVEL (m)	2800	2800	2800	2800	2800
CHANGELINE	3200	3200	3200	3200	3200

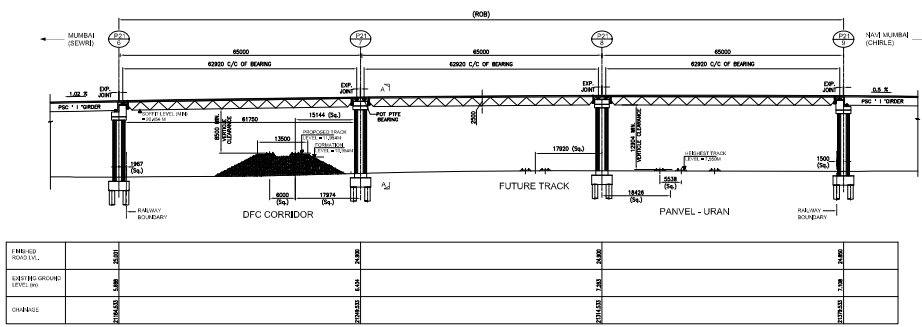
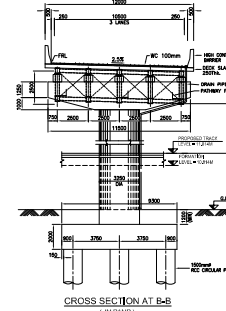

FINISHED ROAD LEVEL	3200	3200	3200	3200	3200
EXISTING GROUND LEVEL (m)	2800	2800	2800	2800	2800
CHANGELINE	3200	3200	3200	3200	3200

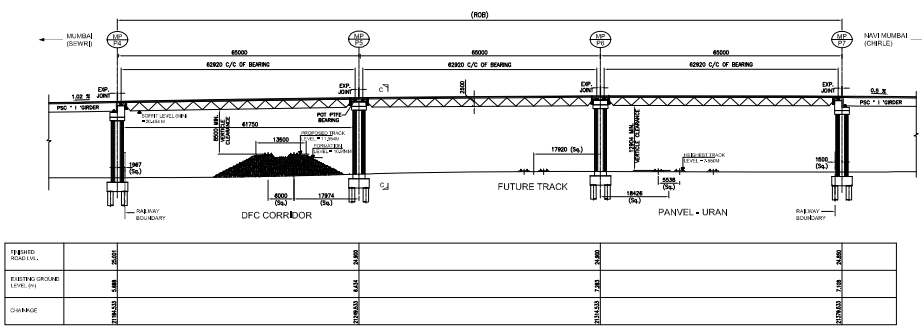
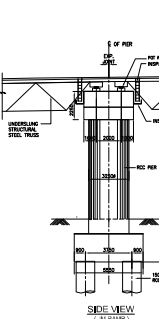
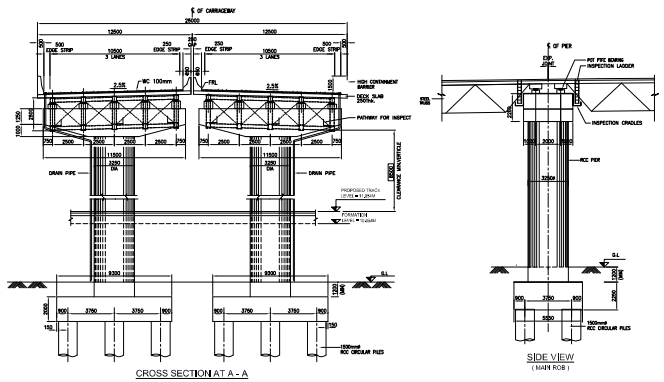

FINISHED ROAD LEVEL	3200	3200	3200	3200	3200
EXISTING GROUND LEVEL (m)	2800	2800	2800	2800	2800
CHANGELINE	3200	3200	3200	3200	3200

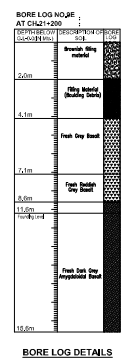
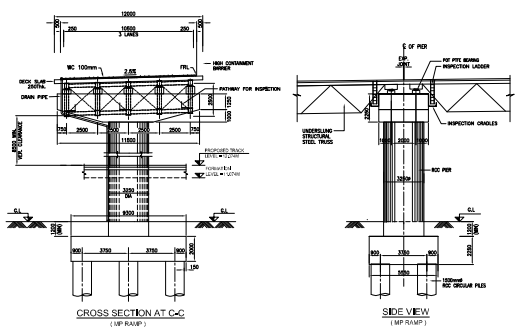

- NOTES**
- ALL DIMENSIONS ARE IN MILLIMETERS AND LEVELS ARE IN METERS UNLESS STATED OTHERWISE.
 - DIMENSIONS IN RECTANGLE ARE ORIGINARY.
 - NO DIMENSIONS SHALL BE TAKEN FROM THE DRAWING UNLESS WRITTEN DIMENSION SHALL BE FOLLOWED.
 - SHAPES AND SIZES OF STEEL AND P.C. ORDERS, PIERS, PER CAPS, PER SHAFT AND FOOTINGS SHOWN IN THE DRAWING ARE TENTATIVE AND ARE SUBJECT TO CHANGES DURING DETAIL DESIGN.
 - VERTICAL CLEARANCE FROM HIGHEST RAIL TOP LEVEL TO BOTTOM OF ORDER SHALL NOT BE LESS THAN ROOM CLEARANCE OF SPEC CORRIDOR.
 - CLEAR HORIZONTAL DISTANCE AT RAIL LEVEL OF PIERS FROM NEAREST CENTER LINE OF TRACK SHALL NOT BE LESS THAN 3.0 METERS.
 - THE DESIGN OF ROB SHALL CONFORM TO THE LATEST IRC CODES AND SPECIFICATIONS.
 - MEASURING CHAIN OF 100mm THICKNESS SHALL BE PROVIDED ON BRIDGE DECK.
 - DESIGN LOADINGS - EACH CARRIAGEWAY SHALL BE DESIGNED FOR - 3 Lanes of CLASS A OR 2 Lane of CLASS B.
 - CONTROLLED CEMENT CONCRETE MIX IS TO BE PROVIDED.
 - MINIMUM GRADE OF CONCRETE :
a) PSC ORDER, DECK SLAB : M-40
b) RC ORDER, PER CAP, PILE CAP, PIERS, PILES : M-35
c) PCC : M-20
 - ACTUAL LOCATION OF ROB SHALL BE DECIDED DURING CONSULTATION WITH RAILWAY AND ROAD AUTHORITY AT THE TIME OF CONSTRUCTION.
 - ANTICRAWL BARRIERS SHALL BE PROVIDED AS PER M.S.T. STANDARD.
 - BEARINGS SHALL BE PSC TYPE.
 - STEP SEAL TYPE EXPANSION JOINTS SHALL BE USED.
 - ANTI CORROSION TREATMENT SHALL BE GIVEN TO REINFORCEMENT & OTHER STRUCTURAL MEMBERS AS PER SPECIFICATIONS.
 - THE SUPERSTRUCTURE OVER RAILWAY TRACK SHALL BE OF COMPOSITE TYPE WITH STEEL PLATE GIRDERS AND RCC DECK AS PER IRC-84 FOR STEEL BUILT UP PLATE GIRDER WS PLATES SHALL BE OF S205 GRADE-B TYPE.
 - DEPTH OF FOUNDATION MAY BE ALTERED BY ENGINEER-IN-CHARGE TO SUIT THE SITE CONDITION.
 - THE PROPOSED ROB IS NOT IN LIEU OF CLOSURE OF ANY LEVEL CROSSING.
 - DRAWING AND DESIGN OF APPROACH SPANS SHALL BE DECIDED BY SPONSORING AUTHORITY AS PER CLAUSE 217-3 of IRC CODE.
 - STEEL ORDERS OF ROB SHALL BE FABRICATED OUTSIDE AND THEN LAUNCHED.
 - DRAWING AND DESIGN OF EACH MEMBER OF ROB SHALL BE SUBMITTED TO APPROVAL BY DESIGN CELL OF CENTRAL RAILWAY.
 - ALL WORKS WITH RAILWAY PRESENCE SHALL BE CARRIED OUT UNDER SUPERVISION OF RAILWAY ENGINEER.
 - FOR ANY EXCAVATION NEAR RAILWAY TRACK PROPER SHORING HAS TO BE DONE AS DIRECTED BY RAILWAY ENGINEER.
 - NO BLASTING SHALL BE PERMITTED. IN CASE BLASTING IS TO BE CARRIED OUT IN THE VICINITY OF RAILWAY LINE NECESSARY PRECAUTIONS AND BLOCK SHALL BE OBSERVED AS PER PARA 1008 OF I & M MANUAL.
 - A SEPARATE LAUNCHING SCHEME DRAWING SHALL BE SUBMITTED FOR APPROVAL OF CRE.
 - GALV. MESH NO. 83/25 & 83/24 TO BE HANGED UNDER ROB ORDERS OF STEEL GIRDS.
 - PAINTING OF NEW STEEL WORK OF ROB AND SAND BLASTING OF STEEL ORDER/MEMBER/METALTING & PAINTING OF STEEL COMPONENTS COMPLETE WITH APPROVED ALUMINUM METAL FOLIOLED BY PROTECTIVE COATING AS PER IS:9000 OR IS:9002.
 - FOR FABRICATION OF STEEL ORDER FOLLOW THE ROB GUIDE: BS-10112 & SPECIFICATION OF B-1.
 - FABRICATION OF STEEL ORDER SHALL BE FABRICATED BY RSC APPROVED WORK SHOP.
 - FOR BOLTING ARRANGEMENT FOLLOW RSC GUIDE LINE FOR USE OF HRSV BOLT ON BRIDGE BS-8 IS REVISED.
 - FOR INSPECTION OF RAILWAY SPAN PROVISION OF INSPECTION CHAIR FOR BOTH SIDE OF PIERS/ABUTMENT WITH RAILING AND LAODER SHALL BE PROVIDED BY APPROVED CHECKERS.
 - RESEARCH DESIGN AND STANDARD ORGANIZATION (RD&S) :
a) RAIL INDIA TECHNICAL AND ECONOMIC SERVICE (RIES)
b) INDIAN INSTITUTE OF TECHNOLOGY, KANPUR (IIT KANPUR)
c) IIT KANPUR TECHNICAL INSTITUTE MEMBAR (IITM)
d) GOVERNMENT COLLEGE OF ENGINEERING, PUNE
e) IITM, NAGPUR
f) CRE SANCTION TO BE OBTAINED BEFORE EXECUTION OF WORK.
34. STEEL STRUCTURE IN ROB SHOULD BE GALVANIZED.
35. USE ANTICORROSION AGENT IN RCC WORK.
36. ROB STRUCTURE IN RAILWAY PORTION SHOULD BE PAINTED AFTER CONSTRUCTION.
37. NO PROVISION OF FOOTPATH ON ROB AS LOCAL ACCESS FROM LAND IS PROHIBITED.
- REVISIONS**
- | NO. | REVISION | |
|-----|--|-------------|
| R5 | REVISED AS PER CENTRAL RAILWAY LETTER NO. BR/3252/2004/PTA/RAIL/21.333/MHO/DOR | |
| R4 | REVISED AS PER CENTRAL RAILWAY LETTER NO. MRA/PHAN DATA/2004/21.333/MHO/DOR | |
| R3 | REVISED AS PER CENTRAL RAILWAY LETTER NO. R2/03/PTR/ DATE 30/03/2014 | |
| R2 | GENERALLY REVISED AS PER FORMER REVISED UNDER LETTER NO. MRA/PHAN DATA/19-10 DATED 09-08-2010 FROM CRE, LTD. | |
| R1 | ALIGNED OF RAMP 'MP' & 'MP' REVISED DUE TO RESTRICTION IN ROB. | |
| NO. | ISSUED | DESCRIPTION |
| MHO | 11.08.12 | 11.08.12 |
| | 11.08.12 | 11.08.12 |
- PURPOSE : PRELIMINARY
STATUS : FOR APPROVAL
ISSUED DATE : 11.08.2012

MMRDA		CONSULTANT		APPROVAL OF DIVISIONAL RAILWAY OFFICE MUMBAI C. S. T.				
DESIGNATION	SIGNATURE	DESIGNATION	DFCIL	DEN CSTM	SR DEN (E)	SR DEN (CO)	OSDS	DRM. MB. CST

APPROVAL OF HEADQUARTER	
DESIGNATION	SIGNATURE
CHIEF BRIDGE ENGINEER	
BY CE (BR)	
BY CE (BR)	
VEN (ROB)	
CHECKED	
APPROVED OFFICE	SIGNATURE
DESIGN	SE DESIGN
DRAWN	JE-L40B

MUMBAI METROPOLITAN REGION DEVELOPMENT AUTHORITY	CONSTRUCTION OF ROB OVERMETH (CH21-333) ACROSS PANVEL-URAN QUART RLY LINE BETWEEN KM 89/23-89/27
MUMBAI TRANS HARBOR DM PROJECT	CENTRAL RAILWAY MAINTENANCE DIVISION
SCALE # A2 : 1/1000	DRAWING NO. : 2100011R020-01
DWG. SHEET : 020-01	REV. NO. :
DATE : 02.08.2012	REV. :
Q1 (0) BE DRG NO. 12-	REV. :
REV. NO.	REV. :
REV. NO.	REV. :
REV. NO.	REV. :
REV. NO.	REV. :
REV. NO.	REV. :

付録-7

Gap Analysis Between Applicable Land Acts with CIDCO Schemes and JICA Environmental Social Guidelines 2010

Gap Analysis Between Applicable Land Acts with CIDCO Schemes and JICA Environmental Social Guidelines 2010

Sr. No.	JICA Guidelines 2010	LA1894 + MMRDA Act	CIDCO 12.5 Scheme	GAP	LARR 2013	CIDCO 22.5 Scheme	GAP	MUTP2000 with minor updat LA2013
1	Involuntary resettlement and loss of means of livelihood are to be avoided when feasible by exploring all viable alternatives.	No such provision of minimization of resettlement effect.	No such provision but CIDCO while acquiring avoids settlement part of the village.	No Gap	Only the minimum area of land required for the project is acquired. The appropriate government shall examine to ensure minimum displacement of people, minimum disturbance to the infrastructure, ecology and minimum adverse impact on the individuals affected. No irrigated	No such provision but CIDCO while acquiring avoids settlement part of the village.	No Gap	Involuntary resettlement should be avoided or minimized where feasible, exploring all viable alternative project designs.

					multi-cropped land shall be acquired under this Act.			
2	When population displacement is unavoidable, effective measures to minimize impact and to compensate for losses should be taken.	Only compensation is paid for the lost assets. No provision for minimization of impacts.	Compensation paid as per LA Act 1894. CIDCO tries to reduce impacts by minimizing land acquisition in settlement areas.	No Gap	Whenever the appropriate Government intends to acquire land for a public purpose, it will carry out a Social Impact Assessment study in consultation with affected people. A Rehabilitation and Resettlement Scheme shall be prepared including the particulars of the rehabilitation and resettlement entitlements of	Compensation paid as per LA Act 1894. CIDCO tries to reduce impacts by minimizing land acquisition in settlement areas.	No Gap	Where displacement is unavoidable, resettlement plans should be developed. All involuntary resettlement should be conceived and executed as development programs

					each landowner and landless whose livelihoods are primarily dependent on the lands being acquired and where resettlement of affected families is involved.			
3	People who must be resettled involuntarily and people whose means of livelihood will be hindered or lost must be sufficiently compensated and supported, so that they can improve or at least restore their standard of living, income	Only compensation is paid at market value. No provision for livelihood restoration, income opportunities and restoration of standard of living.	PAPs will be provided with compensatory developed land which is 12.5% of the land acquired. 8.75% of the developed land is directly provided to PAP and 3.75% is used to provide civic amenities.	No Gap	Adequate provisions for affected persons for their rehabilitation and resettlement and for ensuring that the cumulative outcome of compulsory acquisition should be that affected persons become	PAPs will be provided with compensatory developed land which is 22.5% of the land acquired. 15.75% of the developed land is directly provided to PAP and 6.75% is used to provide civic amenities.	No Gap	PAPs should be assisted in their efforts to improve their former living standards, income earning capacity, and production levels, or at least to restore them.

	opportunities and production levels to pre-project levels.				partners in development leading to an improvement in their post-acquisition social and economic status.			
4	Compensation must be based on the full replacement cost as much as possible.	Only compensation is paid at market value.	Additional to the compensation provided in LA Act 1894 the 8.75% developed land is provided with 1.5 FSI of which 15% can be used as commercial. This provides more value than replacement cost to the PAPs.	No Gap	Payment of compensation at market value multiplied by factor determined by the government. Additional payment of solatium of one hundred percent of compensation amount. Additional compensation in case of multiple displacement.	The scheme provides for 7.0% developed land is provided with 2.5 FSI and 8.75 land with 1.5 FSI of which 15% can be used as commercial. This provides more value than replacement cost to the PAPs.	No Gap	The policy ensures benefits of R & R to PAPs for lost assets at replacement value. PAPs should be compensated for their losses at full replacement cost.

5	Compensation and other kinds of assistance must be provided prior to displacement.	Compensation is paid prior to displacement but there is no provision for assistance.	Compensation is paid prior to displacement. Assistance is provided in the form of scholarships to students, vocational training, reserved jobs which continues lifelong.	No Gap	Possession of land after ensuring that full payment of compensation as well as rehabilitation and resettlement entitlements are paid or tendered to the entitled persons within a period of three months for the compensation and a period of six months for the monetary part of rehabilitation and resettlement entitlements.	Compensation is paid prior to displacement. Assistance is provided in the form of scholarships to students, vocational training, reserved jobs which continues lifelong	No Gap	PAPs should be compensated for their losses at full replacement cost prior to the actual move; and should be assisted with the move and supported during the transition period in the resettlement site.
---	--	--	--	--------	---	---	--------	--

6	For projects that entail large-scale involuntary resettlement, resettlement action plans must be prepared and made available to the public	No provision of preparation of Resettlement Action Plan.	<p>Master plan for entire development and total land acquisition was prepared by CIDCO in 1973. The scheme is part of the resettlement and rehabilitation efforts by CIDCO.</p> <p>The scheme widely published and is open for public comments and has been updated from time to time as per inputs provided by PAPs. The scheme was first published in 1987 and was modified</p>	No Gap	<p>The Act ensures participation of affected stakeholders in each stages of SIA and development of R&R package.</p> <p>The act also ensure that public hearing is held at the affected area, after giving adequate publicity about the date, time and venue for the public hearing, to ascertain the views of the affected families to be recorded and included in the Social Impact Assessment</p>	<p>Master plan for entire development and total land acquisition was prepared by CIDCO in 1973. The scheme is part of the resettlement and rehabilitation efforts by CIDCO.</p> <p>The scheme widely published and is open for public comments and has been updated from time to time as per inputs provided by PAPs. The scheme was first published in 1987 and was modified</p>	No Gap	The policy ensures meaningful consultations with stakeholders in planning and implementation of the resettlement program in order to suitably accommodate their inputs and make rehabilitation and resettlement plan more participatory and broad based.
---	--	--	---	--------	---	---	--------	--

			<p>as per public demand in 1990 and again in 1994.</p> <p>The scheme documents are available in local language (Marathi) and are made easily accessible through publication of small booklets and availability on internet.</p>		<p>Report.</p> <p>Social Impact Assessment study report and the Social Impact Management Plan are made available in the local language to the Panchayat, Municipality or Municipal Corporation, as the case may be, and the offices of the District Collector the Sub Divisional Magistrate and the Tehsil, and shall be published in the affected areas' in such manner and uploaded on the website of</p>	<p>as per public demand in 1990 and again in 1994.</p> <p>The scheme documents are available in local language (Marathi) and are made easily accessible through publication of small booklets and availability on internet.</p>		
--	--	--	---	--	---	---	--	--

					the appropriate Government.			
7	In preparing a resettlement action plan, consultations must be held with the affected people and their communities based on sufficient information made available to them in advance.							
8	When consultations							

	are held, explanations must be given in a form, manner, and language that are understandable to the affected people.							
9	Appropriate participation of affected people must be promoted in planning, implementation, and monitoring of resettlement action plans.							
10	Appropriate and accessible grievance mechanisms must be established for the affected people and their communities.	No provision for Grievance Redressal Mechanism.	CIDCO Grievance Redressal System is an online system through which citizens will be able to register complaints and seek redressal.	No Gap	The act has provision of Rehabilitation and resettlement committee at project level with representative from all section of stakeholders,	CIDCO Grievance Redressal System is an online system through which citizens will be able to register complaints and seek redressal.	No Gap	The Grievance Redressal Committee appointed by R&R Agency comprising its officials shall have the power to consider and dispose of all complaints

					subject to acquisition of more than 100 acres of land.			relating to resettlement and rehabilitation issues
11	Affected people are to be identified and recorded as early as possible in order to establish their eligibility through an initial baseline survey (including population census that serves as an eligibility cut-off date, asset inventory, and socioeconomic survey), preferably at the project identification stage, to	No provision of baseline survey.	The scheme puts a cut of date of 1971 census and give rights to the officials to take decision based on availability of documents to prove eligibility.	No provision of baseline survey may be considered as a gap but it is compensated by using Census survey of India records as on 1971.	Provision of social impact assessment at early stage to ascertain project impact and census and socioeconomic survey to identify affected families and person with interest for preparation of rehabilitation and resettlement package.	The scheme puts a cut of date of 1971 census and give rights to the officials to take decision based on availability of documents to prove eligibility.	No Gap	Baseline Socio Economic Survey of affected people should be carried out at the initial stage of the project. The policy ensures benefits of R&R to PAPs including non-title holders if they are enumerated during baseline survey

	prevent a subsequent influx of encroachers of others who wish to take advance of such benefits. (WB OP4.12 Para.6)							
12	Eligibility of benefits includes, the PAPs who have formal legal rights to land (including customary and traditional land rights recognized under law), the PAPs who don't have formal legal rights to land at the time of census but have a claim to such land or assets and the PAPs who have no recognizable	Non-title holders are not eligible.	The scheme provides 40 sq. m. developed plots to all farm workers and village craftsman who do not have formal legal rights.	Gap exists in identification of PAP but CIDCO provides plots as well as vocational training for non title holders.	(1) a family whose land or other immovable property has been acquired; (ii) a family which does not own any land but a member or members of such family may be agricultural labourers, tenants including any form of tenancy or holding of usufruct right,	The scheme provides 40 sq. m. developed plots to all farm workers and village craftsman who do not have formal legal rights.	Gap in RFCTLARR Act 2013, with condition of three year for recognition of non-titleholders. CIDCO provides plots as well as vocational training for non title holders.	The policy will confirm identification of PAPs who are present on the site at the time of baseline survey which will act as a cut of date for identification of PAPs whether title holder or not.

	<p>legal right to the land they are occupying. (WB OP4.12 Para.15)</p>				<p>share-croppers or artisans or who may be working in the affected area for three years prior to the acquisition of the land, whose primary source of livelihood stand affected by the acquisition of land; (iii) the Scheduled Tribes and other traditional forest dwellers who have lost any of their forest rights recognised under the Scheduled Tribes and Other Traditional Forest</p>			
--	--	--	--	--	---	--	--	--

					Dwellers (Recognition of Forest Righ6) Act, 2006 due to acquisition of land (iv) family whose primary source of livelihood for three years prior to the acquisition of the land is dependent on forests or water bodies and includes gatherers of forest produce, hunters, fisher folk and boatmen and such livelihood is affected due to acquisition of land; (v) a member of the family who has been assigned			
--	--	--	--	--	---	--	--	--

					land by the State Government or the Central Government under any of its schemes and such land is under acquisition; (vi) a family residing on any land in the urban areas for preceding three years or more prior to the acquisition of the land or whose primary source of livelihood for three years prior to the acquisition of the land is affected by the acquisition of such land.			
13	Preference should be given to land-based	No provision of land for land option.	The scheme provides developed	No Gap	Land for Land - In the case of irrigation	The scheme provides for 7.0%	No Gap	The policy offers two resettlement

	<p>resettlement strategies for displaced persons whose livelihoods are land-based. (WB OP4.12 Para.11)</p>		<p>land for agricultural land. The developed land is provided with 1.5 FSI which includes 15% commercially development permission. These aspects provide potential for land based income.</p>		<p>project, as far as possible and in lieu of compensation to be paid for land acquired, each affected family owning agricultural land in the affected area and whose land has been acquired or lost.</p>	<p>developed land is provided with 2.5 FSI and 8.75 land with 1.5 FSI of which 15% can be used as commercial. These aspects provide potential for land based income PAPs.</p>		<p>options to the affected community. First is township option wherein a fully developed plot of 25 sq.m in a green field site is allotted and second option is a tenement of 20.91 sq.m in multi-storeyed buildings.</p>
14	<p>Provide support for the transition period (between displacement and livelihood restoration). (WB OP4.12 Para.6)</p>	<p>No provision for transition period.</p>	<p>CIDCO provides assistance in many forms viz. Scholarships are provided to all PAP students till 12th standard. Vocational training institutes are provided to improve skill</p>	<p>No Gap</p>	<p>Offer for Developed Land - In case the land is acquired for urbanisation purposes, twenty per cent. of the developed land will be reserved and offered to land owning project affected</p>	<p>The scheme has provision for monetary support as lump sum payment for displacement and transition allowance.</p>	<p>No Gap</p>	<p>The policy provides for providing cost of shifting to PAPs or free transport arrangements. For those who permanently lose their jobs, the rehabilitation package shall include access to employment</p>

			set of PAPs. CIDCO also provides reservations in CIDCO jobs for all the PAPs as way of livelihood restoration.		families, in proportion to the area of their land acquired and at a price equal to the cost of acquisition and the cost of development:			information through employment exchange and training facilities.
15	Particular attention must be paid to the needs of the vulnerable groups among those displaced, especially those below the poverty line, landless, elderly, women and children, ethnic minorities etc. (WB OP4.12 Para.8)	There is no provision for vulnerable group.	There is no provision for vulnerable group.	Special treatment to vulnerable is gap.	Vulnerable group such as SC and ST are provided with additional provisions under the Act.	There is no provision for vulnerable group.	Gap because of limited definition of vulnerable group in the RFTCLARR Act 2013.	Vulnerable households such as women headed households, handicapped and the aged will extended an additional package of rehabilitation services to help them overcome the difficulties on account of resettlement. This will include preference in

								allotment of dwelling units on the ground floor for handicapped. Any further assistance required for vulnerable PAPs will be determined during SIA preparation.
--	--	--	--	--	--	--	--	---

付録-8

Fishing Survey Track and Photos

Fishing Survey Track and Photos

Mumbai Trans Harbour Link – Sea Link Section

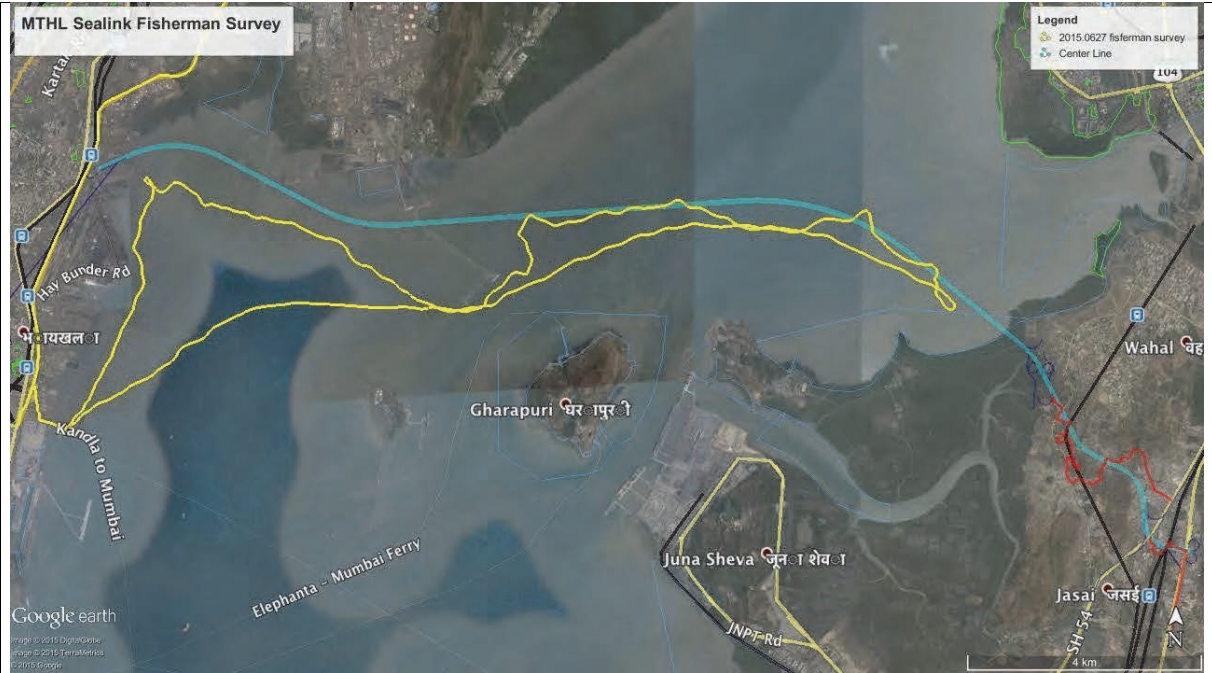

Centre Line (light blue), Survey Boat Track (Yellow) on Google Earth



Survey Boat Track (Yellow) on Nautical Chart



Fishing Boats Close to JNPT



Fishing Boat Around the Project Area



Fishing Net Marks (Black Buoys)



Placing Fishing Nets



Bamboo Fencing



Bamboo Fencing and Fishing Boat

2nd Fishing Survey Guided by the Representative of Trombay Fishing Society with A Fisherman Boat



2nd Fishing Survey Track (Pink) / 1st Survey Track (Yellow)



Fishing Jetty (restricted access for security reasons)



Mud Crab Catching/Fishing



Fishing Net Recovery



Rich Catch (normal catch/1-tide, commonly two tide-fishing/d)
Source: JICA Study Team



Another Type of Fishing Nets under Buoys

付録-9

Navi Mumbai Land Use Survey Track and Photos

Navi Mumbai Land Use Survey Track and Photos

Confirmation of Land Use Type along Navi Mumbai Section on 24th June, 2015



Light Blue (Center Line of MTHL), Red (Survey Track)



1: Small/Poor Mangroves <toward SE>



2: Small but Healthy Mangroves <toward NW>



3: Small/Poor Mangroves (far), wetland (front) <toward W>



4: wetland (front), unused land & buildings(far) <toward N>



5: ROW (unused land(front) & hills(far)) <toward E>



6: Hills adjacent to ROW <toward E>



7: Land Fill(front) & Unused land in ROW(far) <toward NW>



8: ROW (Rock & Sand Mining)



9: ROW (Rock & Sand Mining)



10: Adjacent to ROW (hills)



11: Adjacent to ROW (access roads of mining sites)



12: ROW (rock & sand crashing plant)



13: road crossing point with existing trunk road<toward N>



14: ROW (temporay truck garage) <toward E>



15: ROW (temporal container yard) <toward E>



16: ROW (abandoned buidling and railway track) <toward W>



17: ROW (temporay storage) <toward E>



18: ROW (temporal container yard) <toward W>



19: road crossing point with JNPT highway <toward N>



20: Terminal Point/ROW (temporay container yard) <tw.E>

付録-10

Sample Grievance Registration Form

Sample Grievance Registration Form

Reference No.		Date	
Aggrieved party	Individual	Group	Community
Full Name/ description in case of group or community			
Address			
Phone no.			
Date, time & venue of FLGRC meeting			
Description of Grievance (add page if space is not sufficient)			
Description of FLGRC* decision (add page if space is insufficient): -			
Description of HLGRC* decision (add page if space is insufficient): -			
Signature/thumb complainant	impression	of	Signature of NGO representative

*FLGRC: Field Level Grievance Redress Committee, HLGRC: High Level Grievance Redress Committee

付録-11

Monthly Progress Report on R&R Implementation

Monthly Progress Report on R&R Implementation

Report for the month of
Part-I: Quantitative monitoring format

Activity	Indicator	Total Target	Progress for the reporting month	Cumulative progress of reporting month plus month prior to that	% to total target	Remarks
Verification of impact	No. of project affected households					
	No. of project affected people					
	No. of people loss residence					
	No. of people loss business					
	No. of people loss livelihood					
	No. of people displace					
	No. of venerable PAPs					
	No. of community assets affected					
Resettlement	No. of families provided with ID Card					
	No. of families provided with alternate residential accommodation					
	No. of business families provided with alternate shops					
	No. of people received compensation before starting construction activities					
	Area of Govt. land transferred					
	No. of religious properties relocated					
	No. of community properties relocated					
	No. of societies registered					
	No. of Govt. properties relocated					
Rehabilitation	No. of people undergone skill development training					

Activity	Indicator	Total Target	Progress for the reporting month	Cumulative progress of reporting month plus month prior to that	% to total target	Remarks
	No. of people restarted their income restoration activities					
	No. of PAPs received travel passes					
	No. of PAPs received transitional allowance					
	No. of PAPs received vulnerability allowance					
	No. of new enterprises started					
Grievance Redress	No. grievances received					
	No. of FLGRC meetings conducted					
	No. of SLGRC meetings conducted					
	No. of grievances resolved					
Stakeholders Meeting and disclosure	No. of meetings organised					
	No. of participants					
Awareness programme	No. of awareness Programs conducted for PAPs about life in flat living.					
Fund	No. of household community revolving fund has been transferred					

付録-12

Terms of Reference for Qualitative Independent Evaluation Specialist/ Agency

Terms of Reference for Qualitative Independent Evaluation Specialist/Agency

1. Project Description

This project is being implemented by MMRDA with financial support of Japan International Corporation Agency (JICA). The project gives utmost importance to the Rehabilitation and Resettlement (R&R) of project affected families. Accordingly, a SIA has been developed for implementation. The project includes a provision for monitoring and evaluation of the implementation of the R&R by an external monitor. Therefore, the Executing Agency (EA) requires services of a reputed Social Sector specialist individual /firm for monitoring and evaluation of R&R implementation referred to as the “Qualitative Independent Evaluation Agency” (IEA).

2. Scope of Work - Generic

To review and verify the progress in resettlement implementation as outlined in the RAP

To monitor the effectiveness and efficiency of Social Development Cell (SDC) of MMRDA and the concerned agency in RAP implementation.

To assess whether resettlement objectives, particularly livelihoods and living standards of the affected persons have been restored or enhanced

To assess the efforts of SDC/MMRDA and concerned agency in implementation of the ‘Community Participation strategy’ with particular attention on participation of vulnerable groups namely (i) those who are below poverty line (BPL), (ii) those who belong to Scheduled Castes (SC) and Scheduled Tribes (ST), (iii) Women headed families, (iv) elderly and (v) disabled persons.

To assess resettlement efficiency, effectiveness, impact and sustainability, drawing both on policies and practices and to suggest any corrective measures, if necessary.

3. Scope of work- Specific

The qualitative independent evaluation specialist/agency will evaluate the resettlement efforts by the EA. The major tasks expected from the external evaluator are:

Review pre-displaced baseline data on income and expenditure, occupational and livelihood patterns, arrangements for use of common property, social organization, community organizations and cultural parameters.

To review and verify the progress in land acquisition/resettlement implementation of subproject on a sample basis and prepare reports for the EA.

To evaluate and assess the livelihood opportunities and income as well as quality of life of affected persons of project induced changes.

To evaluate and assess the adequacy and effectiveness of consultative process with affected persons, particularly those vulnerable, including the adequacy and effectiveness of grievance procedures and legal redress available to the affected parties and dissemination of information about these. Identify an appropriate set of indicators for gathering and analyzing information on resettlement impacts; the indicators shall include but not

limited to issues like restoration of income and living standards and level of satisfaction by the APs in post-resettlement period.

Review results of internal monitoring and verify claims through random checking at the field level to assess whether resettlement objectives have been generally met. Involve the APs, host population, and community groups in assessing the impact of resettlement for monitoring and evaluation purposes.

Conduct both individual and community level impact analysis through the use of formal and informal surveys, key informant interviews, focus group discussions, community public meetings, and in-depth case studies of APs and host population from various social classes to assess the impact of resettlement.

Identify the strengths and weaknesses of basic resettlement objectives and approaches, implementation strategies, including institutional issues, and provides suggestions for improvements in future resettlement policy making and planning

4. Time frame and Reporting

The specialist/ agency will be responsible for independent evaluation of the R&R implementation. The work is scheduled to start halfway through the R&R implementation period and end six month after the implementation of R&R. During the engagement period, the qualitative evaluation specialist/agency shall submit two reports, viz. (1) first evaluation report after six months into the SIA implementation; (2) six months after the implementation the R&R. The duration of SIA implementation is as per the given time schedule in SIA report. The monitoring and evaluation report should be submitted to EA.

5. Qualifications

The qualitative independent evaluation specialist/agency will have significant experience in resettlement policy analysis and RAP implementation. Further, work experience and familiarity with all aspects of resettlement operations would be desirable. Interested specialist/agencies should submit proposal for the work with a brief statement of the approach, methodology, staff strength, and relevant information concerning previous experience on monitoring and evaluation of resettlement and rehabilitation implementation and preparation of reports.

6. Budget and Logistics

Copies of the proposal- both Technical and Financial- should be submitted and the budget should include all cost, taxes and any other logistics details necessary for resettlement monitoring. Additional expense claims whatsoever outside the budget will not be entertained.

付録-13

Minutes of Meeting – SIA 2nd Stakeholder Consultation for Sewri Section

Preparatory Survey on the Project for Construction of Mumbai Trans Harbour Link

Minutes of Meeting – SIA 2nd Stakeholder Consultation for Sewri Section

MINUTES OF MEETING – SIA Second Stakeholders Consultation at Sewri section

Name of Organization/ Place of Visit: Sewri section of MTHL Project

Purpose of Meeting: To discuss with PAPs at the Sewri section of MTHL Project

Date: 25/08/2015

Time: 5.30 pm – 7.00 pm

Venue : Sewri Koli Samaj Hall, Near KoliSamaj Building, Sewri (E), Mumbai - 400 015.

Members Represent Project Proponent and the Key Representative of PAPs

- 1) Mr. Vishram Patil – Chief Social Development Cell, MMRDA, Mumbai.
 - 2) Mr. Konishi – Dy. Team Leader, JICA Study team, Oriental Consultants Global, Japan.
 - 3) Mr. Hrushikesh Kolatkar – Project Coordinator & MD of BEIPL, Mumbai
 - 4) Mr. Vivek Kulkarni – CEO of BEIPL
 - 5) Dr. Nilambari Bhingarde – Social Expert, BEIPL
 - 6) Mr. T. B. Patil – Managing Director of Komal Engineering (BSES surveyor)
 - 7) Mr. Indradeo (Baba) Mishra – Representative of PAPs of Sewri site.
-

Initially, the JICA Study Team made a presentation about project description with necessity of land acquisition, findings of socio economic survey, and expected MMRDA's compensation packages. Then, as the responses to project affected person's (PAPs) questions, either MMRDA representative or JICA Study Team gave the salient features of the MUTP R&R¹ Policy including the eligibility and entitlement framework for various types of PAPs, grievance redress mechanism, need for verification of survey details by concerned PAPs and common amenities and funds that will be provided to the registered Co-operative Housing Societies of the resettled PAPs.

¹ Mumbai Urban Transport Project Resettlement and Rehabilitation (2000), Government of Maharashtra

Preparatory Survey on the Project for Construction of Mumbai Trans Harbour Link

Minutes of Meeting – SIA 2nd Stakeholder Consultation for Sewri Section

Records of the Points/ Questions asked by the PAPs

ID. No.	Name of the Stakeholder/ PAP who asked the question	Position/ Role played by Stakeholder	Questions asked by Stakeholders	Response Given by OCG/BEIPL or MMRDA	Response in detail
479	[REDACTED]	Commercial PAP	<ul style="list-style-type: none"> • Is there any area for resettlement other than Bhakti Park ? • Can they be resettled in nearby areas since all facilities are available there ? 	MMRDA response	<ul style="list-style-type: none"> • The Bhakti Park resettlement site was suggested because it was the nearest site as compared to other sites and where all the PAPs could be accommodated due to availability of required no. of tenements. • Other resettlement sites are located at farther locations such as Mankhurd, Mahul, Govandi, Oshiware etc. and it will be possible to resettle PAPs at such sites if so desired by the PAPs in writing. • The MMRDA does not own any land or there are no resettlement sites in the nearby areas including in the MPT area. • The resettlement sites are developed as per the applicable Development Control Regulations for Greater Mumbai and are accordingly provided various amenities and facilities as per such rules.
486	[REDACTED]	Chairman, Om Sai Dutta Housing Society	<ul style="list-style-type: none"> • Some PAPs are lessees of Mumbai Port Trust (MPT). The cases are in court. Will they be considered as legal title holders in deciding their resettlement entitlement ? 	MMRDA response	<ul style="list-style-type: none"> • It is understood from the experience of the Eastern Freeway project that occupants of most structures on MPT land do not have legally valid claims. However, the concerned PAPs should submit to MMRDA the relevant documents, which will be scrutinized and verified for legal validity of

Preparatory Survey on the Project for Construction of Mumbai Trans Harbour Link

Minutes of Meeting – SIA 2nd Stakeholder Consultation for Sewri Section

ID. No.	Name of the Stakeholder/ PAP who asked the question	Position/ Role played by Stakeholder	Questions asked by Stakeholders	Response Given by OCG/BEIPL or MMRDA	Response in detail
					such claims. Entitlements in such cases will be considered depending on the outcome of such scrutiny.
08	[REDACTED]	PAP	<ul style="list-style-type: none"> •What are the details about other resettlement sites? •When is the project implementation likely to start? •Is Lallubhai Compound site for footpath dwellers ? What is the area of tenements at other resettlement sites? 	MMRDA response	<ul style="list-style-type: none"> •The other resettlement sites are at Mankhurd, Mahul, Govandi, Oshiware etc. •At present details of the project and its funding are being worked out and various arrangements are yet to be finalized. It is hence not possible to indicate accurate project commencement schedule. •All resettlement sites are planned and developed under the same Regulations and most of the stock of tenements is of 225 sq.ft. carpet area.

Preparatory Survey on the Project for Construction of Mumbai Trans Harbour Link

Minutes of Meeting – SIA 2nd Stakeholder Consultation for Sewri Section

ID. No.	Name of the Stakeholder/ PAP who asked the question	Position/ Role played by Stakeholder	Questions asked by Stakeholders	Response Given by OCG/BEIPL or MMRDA	Response in detail
48	[REDACTED]	Physician	<ul style="list-style-type: none"> • Is JICA using Resettlement & Rehabilitation policy of the World Bank ? • Is MUTP Policy also as per World Bank policy? • What is the agreement between MPT and MMRDA? We are not encroachers we have lease agreement with MPT and our case with MPT is in court. 	<p>JICA Study team, OCG, Mr. Konishi's response -</p> <p>MMRDA response</p>	<ul style="list-style-type: none"> • Yes, JICA uses its own guidelines but referring to World Bank OP 4.12. • Yes, the MUTP R&R Policy was formulated as per the requirement of World Bank, which had funded the MUTP. The final Policy was approved by Govt. of Maharashtra in 2000 after consulting the World Bank. The MUTP policy is proposed to be applied to this project. • The execution of the project will be carried out as per the approval of MPT. The concerned PAPs should submit to MMRDA the relevant documents, which will be scrutinized and verified for legal validity of such claims. Entitlements in such cases will be considered depending on the outcome of such scrutiny.
104	[REDACTED]	Residential PAP	<ul style="list-style-type: none"> • How will the occupants of partially affected structures resettled ? Can people staying in the same settlement but not affected by the project be resettled ? 	MMRDA response	<ul style="list-style-type: none"> • In case of partially affected structures, the PAPs would have a choice of either shifting to resettlement site or surrendering the affected part of the structure without any entitlement and staying in the remaining unaffected part of the structure. • The MMRDA is not required to shift the unaffected

Preparatory Survey on the Project for Construction of Mumbai Trans Harbour Link

Minutes of Meeting – SIA 2nd Stakeholder Consultation for Sewri Section

ID. No.	Name of the Stakeholder/ PAP who asked the question	Position/ Role played by Stakeholder	Questions asked by Stakeholders	Response Given by OCG/BEIPL or MMRDA	Response in detail
					people. However, if unaffected people want to get resettled, they should together make a written request to MMRDA, the feasibility of which will be considered and a decision will be taken in consultation with all stakeholders.



2nd Consultation Notices in the PAP's Community

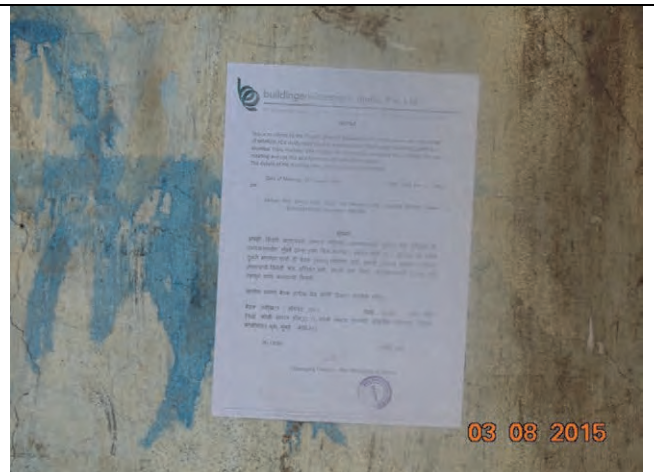

2nd Consultation Notices in the PAP's Community



Consultation Room



Registration

Preparatory Survey on the Project for Construction of Mumbai Trans Harbour Link

Minutes of Meeting – SIA 2nd Stakeholder Consultation for Sewri Section



PAPs



PAPs (Behind) and BSES Surveyor (Front)



Presentation Given By JICA Study Team (BEIPL)



MMRDA/Local Representative/JICA Study Team/JICA Study Team (Local)



Questioned by Local Representative



Questioned by a Local Resident

Preparatory Survey on the Project for Construction of Mumbai Trans Harbour Link

Minutes of Meeting – SIA 2nd Stakeholder Consultation for Sewri Section



Discussion After The Consultation



Discussion After the Consultation

付録-14

専門家ヒアリング結果 2015 年

専門家ヒアリング結果 2015年

影響項目	有識者ヒアリング	発言者	影響予測	事例収集結果	保全措置	CRZ 条件	既存 Rapid EIA 対策	JICA 新対策 (補足 EIA)	ハースライ ン調査 対応	
工 事 中	湿地・干潟等の改 変/埋立て	沖縄県の漫湖における事例では、施工終了後に橋脚周りの微地形の変化に伴う潮流の変化により、干潟の乾燥化が進行し、マングローブ林が拡大したことで、渡り鳥の渡来場が失われたことがあった。	村田	・周辺の開発による汚濁水の流入による水生生物への影響が懸念される。 ・湿地・干潟等の改変/埋立てにより、微地形の変化はあるが、大きな潮流の変化は発生しない ・多様な藻類の生育を促す可能性がある。	【沖縄県漫湖の対策事例】 ・要因分析に向けた自然環境調査の実施 ・泥干潟の採餌環境が残っているマングローブ域におけるマングローブの伐採 ・マングローブ後背の土砂が堆積しやすい環境を縮小するためのマングローブ域の整形伐採（水の流れを形成するため） ・マングローブ伐採後の稚樹の除去 【四国横断自動車道の対策事例】 ・工事中は水質汚濁、騒音・振動対策を実施 ・環境影響の少ない浚渫土砂の処理方法の検討 ・環境モニタリング調査計画の立案・実施 【北九州都市計画道路の対策事例】 ・河口干潟の保全対策として、重要種の移植・移殖、モニタリング調査計画を実施・立案。	・工事中の濁水防止※1 (bored-pilling 手法)	必須	-	実施	水質調査
		沖縄県の漫湖における事例では、橋梁工事に伴い干潟の乾燥化が進み、マングローブ林の拡大が発生している。	風呂田	・マングローブ林の拡大により底生動物相が変化し、渡り鳥の餌資源が変化する可能性がある。		・工事実施時の干潟形状の追跡調査	-	-	モニタリング	干潟確認調査
	森林伐採（マングローブ含む）	橋梁工事が行われると、当該地域のマングローブ林はむしろ拡大すると考えている。	村田	開発事業の実施により、マングローブ林の規模縮小が懸念される。ただし、干潟の乾燥化によりマングローブ林の範囲が拡大することも考えられる。		・マングローブの追跡調査	-	○	モニタリング	調査
工 事 関 係 車 両 ・ 重 機 等 の 稼 働	レッサーフラミンゴは、身の危険を感じた時に繁殖・採餌場所を放棄する可能性がある。当該地域では、採餌場（干潟）周辺での建設活動によって一時的にフラミンゴの群れが他地域へ避難するケースがあると考えられる。	突発音の発生や低周波音が続くと考えられる「工事中」に対するフラミンゴの配慮が必要だと考える。	村田	工事実施時のフラミンゴの一時的な採餌環境への影響が懸念される。	【四国横断自動車道/伊勢湾岸道路の対策事例】 ・渡来時期を考慮した工事計画の立案（工期短縮、工事範囲） （可能であれば雨期における工事中用機橋の建設） ・低騒音・低振動工法の採用などの工種選定（事例：クローラクレーンやパイプロハンマー、アースドリル、発動発電機などの使用に際して低騒音型建設機械を採用する）	・渡来時期を考慮した工事計画の立案（工期短縮、工事範囲） （可能であれば雨期における工事中用機橋の建設）	-	○	可能であれば実施	-
		渡来ピーク時を考慮した工期短縮、工事範囲の選定を行うこと	村田			・低騒音低振の工夫	必須	○	実施	-
		工事関係者の流入及びベースキャンプの設置	村田			・工事実施時のフラミンゴの追跡調査	-	○	モニタリング	調査
工 事 関 係 者 の 流 入 及 び ベ ー ス キ ャ ン プ の 設 置	レッサーフラミンゴは、身の危険を感じた時に繁殖・採餌場所を放棄する可能性がある。当該地域では、採餌場（干潟）周辺での建設活動によって一時的にフラミンゴの群れが他地域へ避難するケースがあると考えられる。	レッサーフラミンゴは、身の危険を感じた時に繁殖・採餌場所を放棄する可能性がある。当該地域では、採餌場（干潟）周辺での建設活動によって一時的にフラミンゴの群れが他地域へ避難するケースがあると考えられる。	村田	【福岡アイランドシティ線の対策事例】 ・生態系の注目種・群集（指標種）の保全の観点より自然環境の改変量を最小化する ・事後評価（モニタリング）の計画立案・実施	・変更範囲の最小化（盛土構造ではなく高架構造採用）	-	-	実施	-	
		ベースキャンプ設置前後のフラミンゴ追跡調査	-		-	実施	調査			
		労働者への自然環境教育	-		-	実施	調査			
供 用 時	交通量の増大	フラミンゴのロードキルに関する情報は聞いたことがない。	村田	【京葉線内のレールキル事例】 ・走行中の野鳥との衝突、線路内の斃死・負傷や地下鉄内への迷入等の報告例が多数ある ・衝突事故回避のための取り組み（警笛の使用・前照灯の消灯・危険区間で減速等ソフト対策を実施）	・CRZ 区間及び干潟区間を対象とした遮へい施設の設置（遮音壁を兼ねる）	必須	-	実施	-	
		沿岸を通過する京葉線では渡り鳥のレールキルが確認されていることから、乗用車（2m程度）の遮蔽板の設置することが望ましい。	風呂田							
	道路及び関連施設 の存在	フラミンゴは橋梁が当該地域に建設された後には橋梁上部を超えて飛翔すると考えられる。フラミンゴの飛翔高さに関する知見はないため、現地写真から試算してみたい。	村田							高架道路の存在により、フラミンゴの飛翔経路を阻害するおそれがあるが、回避行動をとると推定される。
大型鳥類であるフラミンゴにとっては、橋脚の存在により回避行動をとるのではないかと。	風呂田	大型鳥類であるフラミンゴにとっては、橋脚の存在により回避行動をとるのではないかと。	【四国横断自動車道の対策事例】 ・渡り鳥の飛行経路に配慮した橋梁形式（斜張橋のように上部面に施設がない）の採用	・フラミンゴの飛翔経路の追跡調査	-	-	モニタリング	調査		
フラミンゴの飛翔経路を日周期（ねぐらと採餌場所との移動）及び月周期（渡り期）の双方の視点で影響を検討する方法もある。	風呂田									

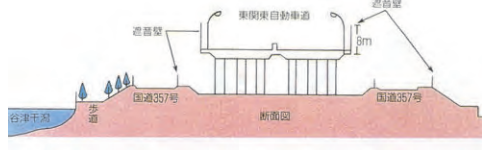

図 飛翔経路と橋脚のイメージ図
(四国横断自動車道-吉野川渡河部の環境保全の取組みより引用)

影響項目	有識者ヒアリング	発言者	影響予測	事例収集結果	保全措置	CRZ 条件	既存 Rapid EIA 対策	JICA 新対策 (補足 EIA)	ハースライ ン調査 対応	
供用時 道路及び関連施設 の存在	ねぐら（休息地域）を車両照明等で照らさないように配慮した設計とすることが望ましい。	村田	道路照明の照射によりフラミンゴの生息（ねぐら）への影響が懸念される。	【伊勢湾岸道路の対策事例】 ・照明等の遺漏光を抑制するために、遮光フェンスの設置や植樹の推進に努める 	・道路照明で渡り鳥やフラミンゴの塹への影響を緩和する（高欄照明）	必須	-	実施	-	
	事業実施に伴い潮流や干満の変化があれば、フラミンゴの餌環境や植生等も大きく変化すると考えられる。	村田	道路の存在による潮流や干満への影響は少なく干潟の生態系への影響は軽微と考えられる。	【沖縄県漫湖の対策事例】 ・渡り鳥の餌資源となる魚類、底生動物の個体数変化に関する調査・分析の実施 ・上記の個体数変化の要因となる植生調査（マングローブ林分布面積等の変化等） ・マングローブ後背の土砂が堆積しやすい環境を縮小するためのマングローブ域の整形伐採（シミュレーションも含む）	・高架構造の採用や橋脚を少なくすることによる改変の最小化 ・干潟の生態系、潮流、干潟形状の追跡調査	-	-	実施	-	
	橋梁部の環境変化に伴い、フラミンゴの主食となるベントス相も必ず変化することが予測される。	風呂田	なお、ミクروسケールでの潮流や微地形の変化は生じるため、生態系の多様化が生じることも想定される。							
	事前調査結果を踏まえるとマクロ視点での干潟の変化はほとんどないと考えられるが、橋梁周辺部は乱流が発生するため必ず微地形（底質、塩分濃度等）の変化が予測される。	風呂田								
当該事業により微地形が変化することでむしろ生物相は多様化する傾向になるのではないか。	風呂田									

(注意)「クロトキ(*Threskiornis melanocephalus*) : ICUN レッドリスト (NT) に指定されるが、本調査地では 2008 年調査において 2 月に 18 羽と 4 羽の幼鳥が確認されたのみであり、営巣地は確認されて折らず、本事業への影響はほとんどないものと推定される。

付録-15

MTHL Drawings over SH54

DO NOT SCALE DRAWING. CHECK ALL DIMENSIONS ON SITE.
ALL RIGHTS RESERVED.
© OVE ARUP & PARTNERS HONG KONG LIMITED.

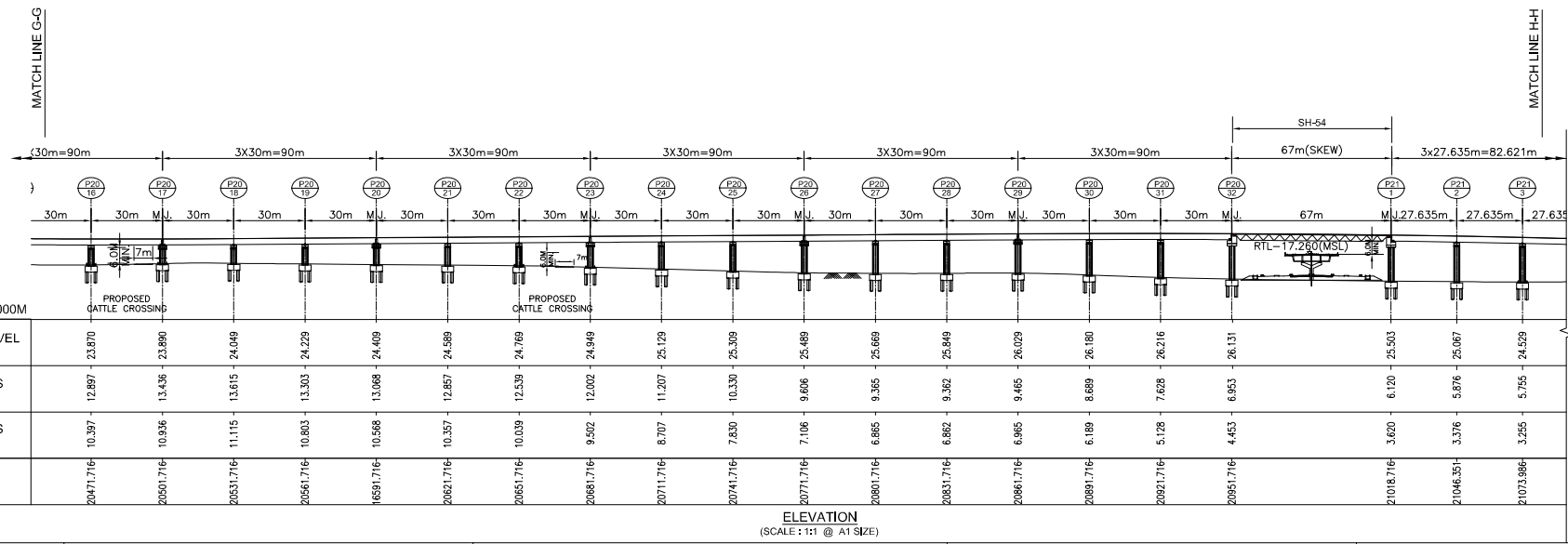
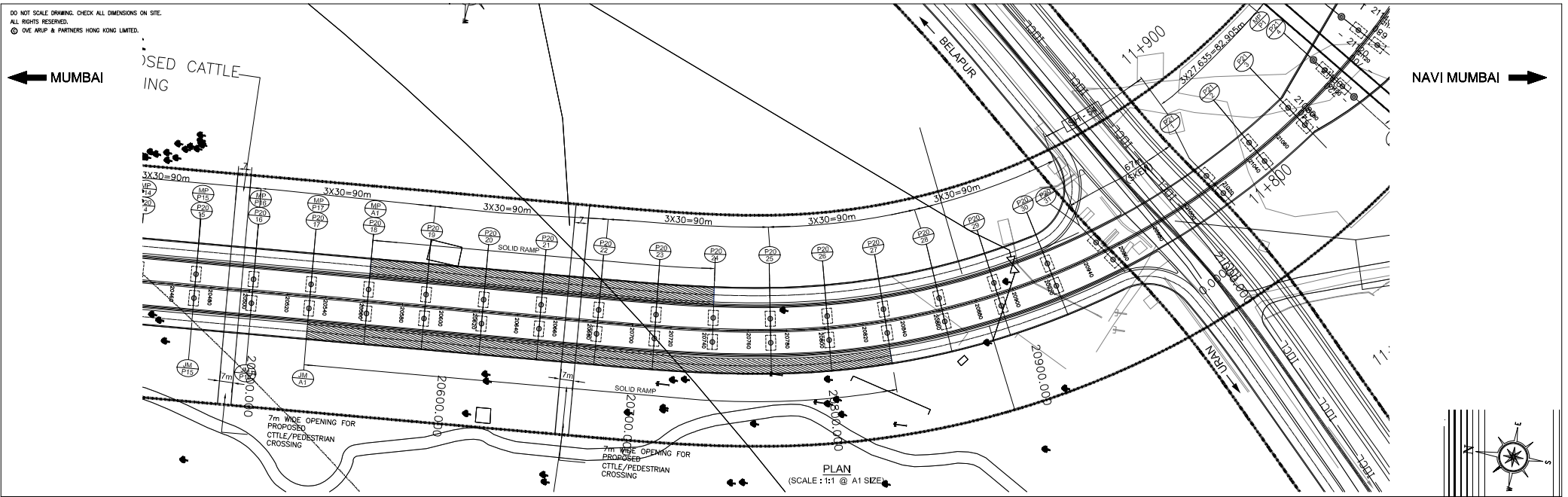

Mark	Date	By	Revisions
R2	JULY.15	YSP	REVISED AS PER MODIFIED HIGHWAY PLAN & PROFILE
R1	OCT.13	MWP	PROFILE REVISED DUE TO PROPOSED DFC CORRIDOR



MMRDA
MUMBAI METROPOLITAN REGION
DEVELOPMENT AUTHORITY

MUMBAI TRANS HARBOUR LINK
Illustrative Design Drawing



Drawing Title		MAINLINE GENERAL ARRANGEMENT CHAINAGE - 20+452 TO 21+082	
Drawing Status	TENDER	Drawing No.	2011090_RH_NHAL_SH-54_GAD_001
		Rev.	R2

DO NOT SCALE DRAWING. CHECK ALL DIMENSIONS ON SITE.
 ALL RIGHTS RESERVED.
 © OVE ARUP & PARTNERS HONG KONG LIMITED.

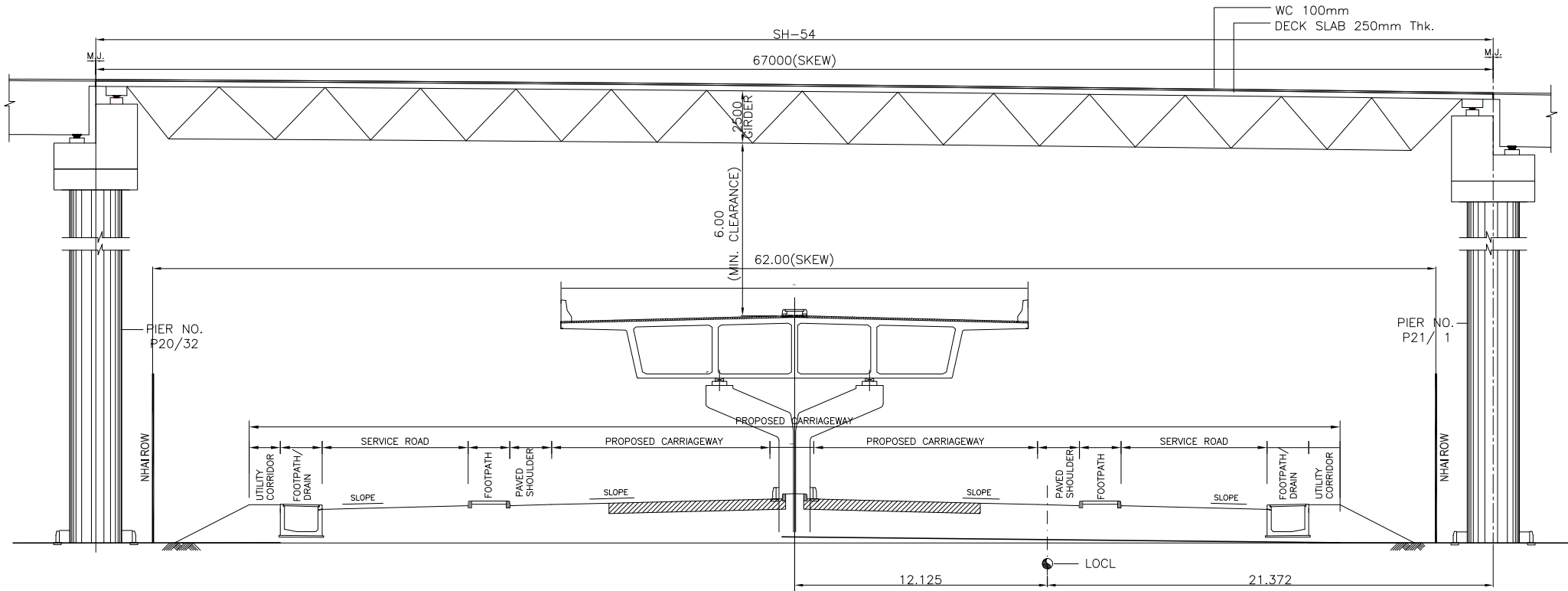

CROSS SECTION ON SH54

(SCALE 1:125)

付録15-2

Mark	Date	By	Rev.
R2	JAN 16	MP	REVISED AS PER MODIFIED HIGHWAY PLAN & PROFILE
R1	JULY 15	YDP	REVISED AS PER MODIFIED HIGHWAY PLAN & PROFILE



MMRDA
 MUMBAI METROPOLITAN REGION
 DEVELOPMENT AUTHORITY

MUMBAI TRANS HARBOUR LINK
 Illustrative Design Drawing



Drawing Title		DATE: 27-11-2012	
CROSS OF ENTRY/EXIT RAMPS AT AT SH-54			
Drawing Status	Drawing No.	Rev.	
PRELIMINARY	2011090/RH/NHAI/SH54/TCS-001	R2	

付録-16

O/M コストブレイクダウン

O/M コストブレイクダウン

Operation and Maintenance Cost

Unit: million INR

Year	MMRDA	Project Management Consultant	Inspection & Maintenance	Toll Management	Traffic Management	Others (Electricity)	Routine O/M Total	Pavement	Road marking	Touch-up painting	Repainting	Expansion device	Bearing	Bridge inspection passage	Noise barrier	Traffic Management system	Toll Management system	Periodic Maintenance	O/M Total
1	16	15	95	101	40	10	276	0	0	0	0	0	0	0	0	0	0	0	276
2	16	15	95	101	40	10	276	0	0	0	0	0	0	0	0	0	0	0	276
3	16	15	95	101	40	10	276	0	0	0	0	0	0	0	0	0	0	0	276
4	16	15	95	101	40	10	276	0	0	0	0	0	0	0	0	0	0	0	276
5	16	15	95	101	40	10	276	0	0	0	0	0	0	0	0	0	0	0	276
6	16	15	95	101	40	10	276	0	8	0	0	0	0	0	0	0	0	8	285
7	16	15	95	101	40	10	276	0	8	0	0	0	0	0	0	0	0	8	285
8	16	15	95	101	40	10	276	0	8	0	0	0	0	0	0	0	0	8	285
9	16	15	95	101	40	10	276	0	8	0	0	0	0	0	0	0	0	8	285
10	16	15	95	101	40	10	276	0	8	0	0	0	0	0	448	200	657	933	
11	16	15	95	101	40	10	276	0	0	0	0	0	0	0	0	0	0	0	276
12	16	15	95	101	40	10	276	0	0	0	0	0	0	0	0	0	0	0	276
13	16	15	95	101	40	10	276	0	0	0	0	0	0	0	0	0	0	0	276
14	16	15	95	101	40	10	276	0	0	0	0	0	0	0	0	0	0	0	276
15	16	15	95	101	40	10	276	0	0	0	0	0	0	0	0	0	0	0	276
16	16	15	95	101	40	10	276	85	8	12	0	0	0	0	0	0	0	106	382
17	16	15	95	101	40	10	276	85	8	12	0	0	0	0	0	0	0	106	382
18	16	15	95	101	40	10	276	85	8	12	0	0	0	0	0	0	0	106	382
19	16	15	95	101	40	10	276	85	8	12	0	0	0	0	0	0	0	106	382
20	16	15	95	101	40	10	276	85	8	12	0	0	0	0	128	448	200	883	1,159
21	16	15	95	101	40	10	276	0	0	12	0	33	0	24	0	0	0	69	345
22	16	15	95	101	40	10	276	0	0	12	0	33	0	24	0	0	0	69	345
23	16	15	95	101	40	10	276	0	0	12	0	33	0	24	0	0	0	69	345
24	16	15	95	101	40	10	276	0	0	12	0	33	0	24	0	0	0	69	345
25	16	15	95	101	40	10	276	0	0	12	0	33	0	24	0	0	0	69	345

《 Routine Maintenance 》

■ MMRDA:

Inhouse 人件費

Chief Engineer: 1 名、Superintending Engineer: 1 名、Executive Engineer: 2 名、
Deputy Engineer: 2 名

■ Project Management Consultant

Outsource 人件費

Resident Engineer: 1 名、Site Engineer: 2 名、Assistant Site Engineer: 3 名、
Support staff (Office Manager, Typist, Office boy): 各 1 名

■ Inspection and Maintenance

Outsource 人件費

業務管理 : Chief Engineer: 1 名、Engineer(Road): 1 名、Engineer(Facility):1 名
 専門会社 : Inspector(Road): 3 名、Engineer(Road): 3 名、Skilled Labor(Road): 3 名、
 Unskilled Labor(Road): 20 名、Engineer(Facility): 2 名、
 Electrical Engineer(Facility):1 名*(3 シフト+1 交替シフト)、
 IT Engineer(Facility): 1 名、Technicians(Facility): 2 名、
 Operator(Bridge inspection vehicle, etc): 1 名、Operator(Road sweeper): 1 名、
 Driver: 1 名

■Toll Management

－Outsource 人件費

業務管理：Toll Manager: 1名

専門会社：Cashier: 2名、Clerk: 2名*(3シフト+1交替シフト)、Shift-in-charge: 1名*(3シフト+1交替シフト)、
Supervisor: 2名*(3シフト+1交替シフト)、Toll Collector: 24名*(3シフト+1交替シフト)、
Lane Assistant: 24名*(3シフト+1交替シフト)、Security shift in charge: 1名*(3シフト+1交替シフト)、
Security Guards 24名*(3シフト+1交替シフト)

－電気・通信費

料金システム 通信料金、電気料金

■Traffic Management

－Outsource 人件費

業務管理：Traffic Manager: 1名

専門会社：Shift-in-charge(Traffic control): 1名*(3シフト+1交替シフト)、
Operator(Traffic control): 2名*(3シフト+1交替シフト)、
Shift-in-charge(Patrol): 1名*(3シフト+1交替シフト)、
Road Patrol(Patrol): 2名*(3シフト+1交替シフト)、
Driver(Emergency Vehicle): 2名*(3シフト+1交替シフト)、

－電気・通信費

交通管制システム 通信料金、電気料金

■Others

－電気料金

道路付属設備（照明等）

《Periodic Maintenance》

■Pavement

－ベース単価：表層のイニシャルコスト

－インターバル：15年（5年間で按分）

■Road Marking

－ベース単価：路面標示のイニシャルコスト

－インターバル：5年（5年間で按分）

■Touchup Painting

－ベース単価：鋼橋塗装のイニシャルコスト×0.7%

－インターバル：15年（10年間）

■Repainting

－ベース単価：塗装費（上塗り）のイニシャルコスト

－インターバル：25年（15年間）期間中の補修計画無し

■Expansion device

－ベース単価：伸縮装置のイニシャルコスト×1/4

－インターバル：20年（5年間で按分）

■ Bearing

－期間中の補修計画無し

■ Bridge Inspection Passage

－ベース単価：橋梁検査路のイニシャルコスト

－インターバル：20年（5年間で按分）

■ Noise Barrier

－ベース単価：イニシャルコスト

－インターバル：20年

■ Traffic Management System

－ベース単価：イニシャルコスト

－インターバル：10年

■ Toll Management System

－ベース単価：イニシャルコスト

－インターバル：10年