

Republic of the Union of Myanmar

Myanma Railways, Ministry of Rail Transportation

**PROJECT ON IMPROVEMENT OF
SERVICE AND SAFETY OF RAILWAY
IN MYANMAR**

**PROJECT PROGRESS REPORT
(7th Joint Coordination Committee)**

July 2015

JAPAN INTERNATIONAL COOPERATION AGENCY

JICA Expert Team

**JAPAN INTERNATIONAL CONSULTANTS FOR TRANSPORTATION CO., LTD.
ORIENTAL CONSULTANTS GLOBAL CO., LTD.
SUMITOMO CORPORATION.**

**Project on Improvement of Service and Safety
of Railway in Myanmar
Progress Report, July 2015
Table of Contents**

	PAGE
1 Preface	1
2. Extension of the project	
2.1 Major progress of the Project	2-1
2.2 Contents of Extension of the Project	2-2
3 Detailed Methods for the Project Implementation	
3.1 Track Maintenance	3-1
3.2 Procedure of outsourcing the track maintenance work (New Item)	3-9
3.3 Outline of maintenance of bridge (New Item)	3-11
4 Project implementation Organization	
4.1 Structure of project implementation Organization	4-1
4.2 Implementation body on Myanmar side	4-1
4.3 Implementation body on Japan side	4-2
5. Schedule	5
Appendix-1 Minutes of meetings for the amendment to the record of discussions on the project on improvement of service and safety of railway in Myanmar in the Republic of the union of Myanmar between Myanma Railways Ministry of Rail Transport and Japan International Cooperation Agency.	
Appendix-2 Member List of JICA Expert Team	

Project on Improvement of Service and Safety of Railway in Myanmar Progress Report, July 2015

1. Preface

Since we started the Project in June 2013, about 2 years have passed and the Project has been implemented effectively under the close cooperation between MR officials concerned and JICA Expert Team.

We, JICA Expert Team, would like to express our sincere appreciation to MR officials concerned for their kindness extended to us during the execution of the Project.

This Progress Report deals with the major activities of the Project implemented around between March and July of this year.

We should be grateful, if the members of the JCC would review the Report and provide us with the various advices.

Table 2.1.2 The schedule of technology transfer of track maintenance

Subject	F Year	2013												2014												2015					Note
	Month	5	6	7	8	9	10	11	12	1	2	3	4	5	6	7	8	9	10	11	12	1	2	3	4	5					
	Past Month	0	1	2	3	4	5	6	7	8	9	10	11	12	13	14	15	16	17	18	19	20	21	22	23	24					
4.2.1 Drawing up a technical transfer plan (1) Collection of basic information (2) Plan of technical transfer					■	■																									
4.2.2 Selection/procurement of equipments/tools (1) Selection of equipments/tools (2) Acquisition of import license, tax exemption procedure (3) Import procedure (4) Freight control					■	■	■	■	■	■	■	■	■	■	■	■	■	■	■	■	■	■	■	■	■	■	■				
4.2.3 Selection of Pilot Section (1) Site witnessing (2) Selection of a section (3) Base line survey					■	■	■	■	■	■	■	■	■	■	■	■	■	■	■	■	■	■	■	■	■	■	■	Change pilot section several times.			
4.2.4 Implementation of track maintenance work (inspection, planning, work, control) (1) Compilation of text books (2) Classroom education and practical training (seminar) (3) Prior measurement and survey at the Pilot Section Implementation of work					■	■	■	■	■	■	■	■	■	■	■	■	■	■	■	■	■	■	■	■	■	■	■	Parallel with Implementation of work			
4.2.5 Education/training (1) Seminars on the improvement of track maintenance technologies (2) Education/training in Japan																												Including workshop safety and service improvement.			
4.2.6 Summarization of the points of improvement and reflecting them in the track maintenance manuals/standards																															
4.2.7 Final summarization and seminars																												Under preparing			
Discussion on the report/JCC																												▲ IC/R JCC			
Submission of the report (JICA)																												▲ DPPR JCC ▲ PPR ▲ PR JCC ▲ PR JCC ▲ PR JCC ▲ PR JCC ▲ DFR JCC			

2.2 Contents of Extension of the Project

At first this project was planning to finish on May in 2015. But amendment of the Record of Discussion (hereinafter referred to as the “R/D”) were signed by JICA and Myanma Railways on 6th April in 2015. (refer to Appendix-1)

Contents of Extension of the Project are as bellow.

- To continue training for track maintenance of the Yangon-Mandalay line including Thilawa line.
- To conduct lecture(s) in Myanmar on the Japanese experience on the procedure of outsourcing the track maintenance work.
- To conduct lecture(s) in Myanmar on outline of maintenance of bridges.

For the implementation of the three items mentioned above, both sides agreed to extend the Project duration from 2 years (up to May 2015) to 2 years and 10 months (up to March 2016).

3 Detailed Methods for the Project Implementation

3.1 Track Maintenance

(1) Track Record

At the beginning, technology transfer of track maintenance started for 30 trainees in the Pilot Section. At present, accumulated number of trainees amounts to 400, and the various situations relating to technology transfer had been changed. Further, in order to implement the training efficiently, trainings were sometimes repeated in the same place, and also on Dagon line. In this regard, we consulted with MR about various matters including the suitable change of the length of the Pilot Section.

Trainees of MR change every month. We show divisions of trainee and members till now (Table 3.1). We have educated about 400 trainees who are belonging to all divisions in Myanmar Railways.

Table 3.1 Divisions of trainee and members till now

	Date	Date	Division	Number	Remark
	From	To			
1	25.10.2013	12.5.2014	(7)Yangon (6)Bago	24 6	
2	12.5.2014	12.6.2014	(7) Yangon (5)Taunggu (7)Yangon (8)Mawlamying (9)Hinthada	10 6 5 4 5	To perform the chainging of trainees
3	12.6.2014	12.7.2014	(7) Yangon (2)Ywataung (3)Mandalay (10)Pakauku	10 8 8 7	To perform the chainging of trainees
4	12.7.2014	12.8.2014	(7) Yangon (1)Myitgyinar (4)Kalaw (11)Bagan	10 6 7 7	To perform the chainging of trainees
5	12.8.2014	12.9.2014	(7) Yangon (5) Taunggu (8) Mawlamying (9) Hinthada	10 6 6 8	To perform the chainging Of trainees
6	12.9.2014	13.10.2014	(7) Yangon (2) Ywataung (3) Mandalay (6) Bago	10 6 6 8	To perform the chainging Of trainees
7	13.10.2014	12.11.2014	(7) Yangon (9)Hinthada (8)Mawlamying (5)Taunggu	10 7 7 6	To perform the chainging Of trainees
8	12.11.2014	Until now	(5)Taunggu (2)Ywataung (3)Mandalay (10)Pakauku	10 8 9 7	To perform the chainging Of trainees

9	9.1.2015	6.2.2015	(7) Yangon (4)Kalaw (9) Hinthada (11)Bagan	10 7 7 7	To perform the chainging Of trainees
10	9.2.2015	4.3.2015	(7) Yangon (1)Myitgyinar (6)Insein (10)Pakauku	10 6 7 7	To perform the chainging Of trainees
11	9.3.2015	8.4.2015	(7) Yangon (4)Kalaw (5)Taungu (11)Bagan	10 6 7 7	To perform the chainging Of trainees
12	27.4.2015	22.5.2015	(7) Yangon (1)Myitgyinar (5)Taungu (8)Mawlamying	10 5 7 7	To perform the chainging Of trainees
13	25.5.2015	19.6.2015	(7) Yangon (2)Ywahtaung (3)Mandalay (10)Pakauku	10 6 7 7	To perform the chainging Of trainees
14	22.6.2015	17.7.2015	(7) Yangon (4)Kalaw (5)Taungu (11)Bagan	10 6 7 7	To perform the chainging Of trainees
Total				427	

We educated 1st group for half year and many kinds of program. From 2nd group, trainees change every month. So we are programing training schedule to master many things about track maintenance for short term.

We will continue this program till December.

We indicate track maintenance which we conducted from April to June by photo.



Carry out equipments from warehouse



Chord-to-rail measurement



Calculating survey data by inspectors



Changing sleepers



Installing fastening (First Clip)



Amending alignment



Tamping by hand tie tamper



After replacing sleepers



Cutting rail on the trunk line (Pre-Work)



Drilling rail on the trunk line (Pre-Work)



Removal of fastening (Pre-Work)



Lift up 50N Rail



Changing track pad



Installing fastening (First Clip)



Reverse direction operation under track 3.2



After changing from 75lb rail to 50N Rail

(2) Speed increasing test

We are going to conduct high speed at the place where we changed from 75lb rail to 50N rail. Outline of high speed test is as below.

1. Date : Around October
2. Place : Up line from 14 k250m to 15k700m
3. Speed : 3 kinds of speed (60km/h, 70km/h, 80km/h)
4. Measurement :

- ① Vibration test (up-and-down, right and left, back and forth)

We check riding comfort by measuring train vibration against 3 kinds of speed as we measured before.

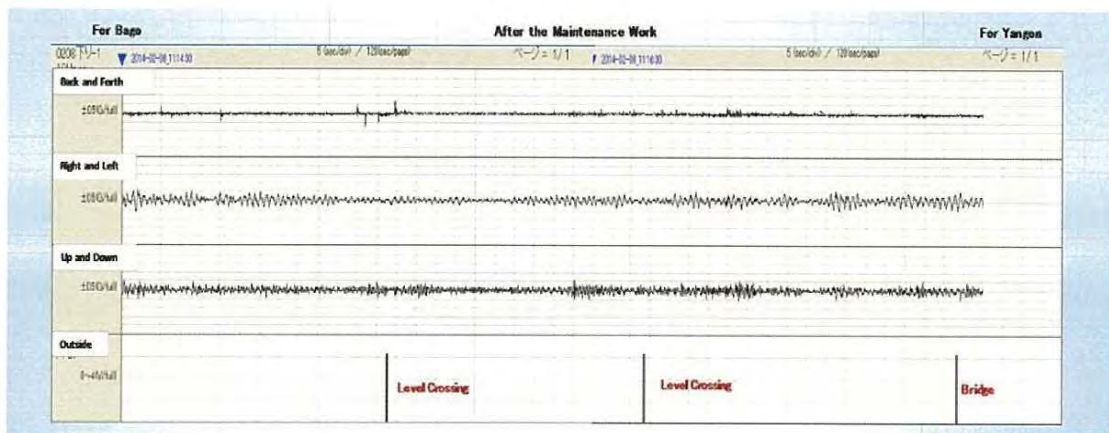

- ② Rail Stress

We attach strain gauge at the back of rail and check the value of rail stress by running train.

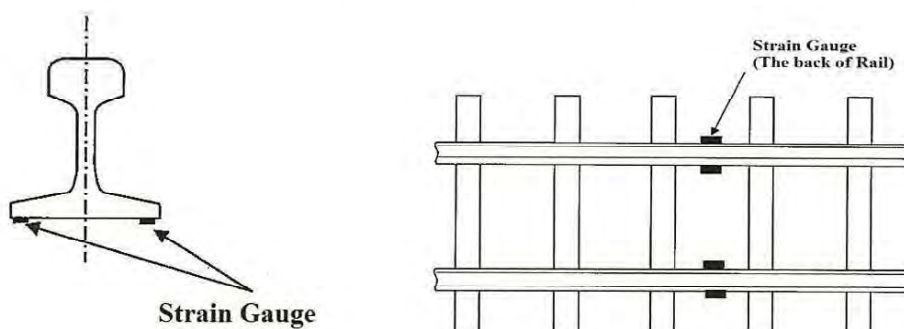

③ Stress of fishplate

We prepare 3 kinds of fishplate for 75lb, N37 and 50N. We measure 3 stress (Around hole of bolt, fishplate and bolt) against each fishplate and each train speed .

Stress around hole of bolt

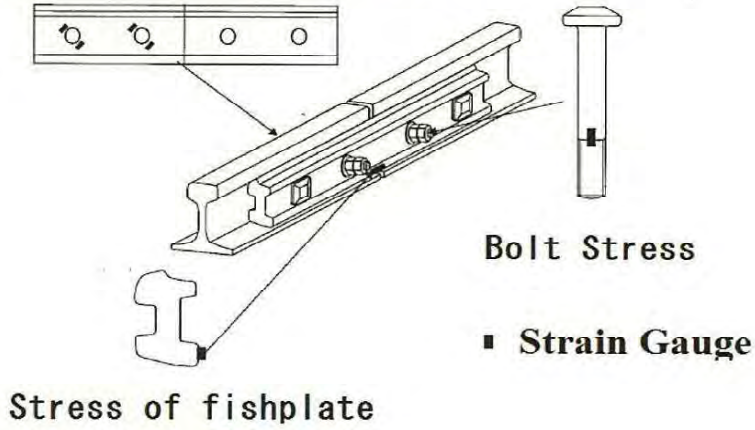

We will prove the advantage of 50N rail compared to 75lb rail by measuring many kinds of stress and strain.

④ Stress of Turnout

We attach strain gauge at the rail of turnout. We are going to measure stress of turnout when train is running.

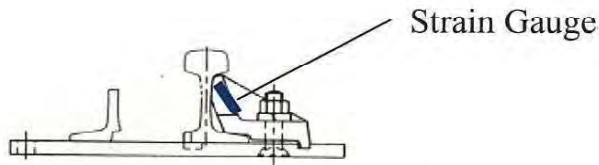
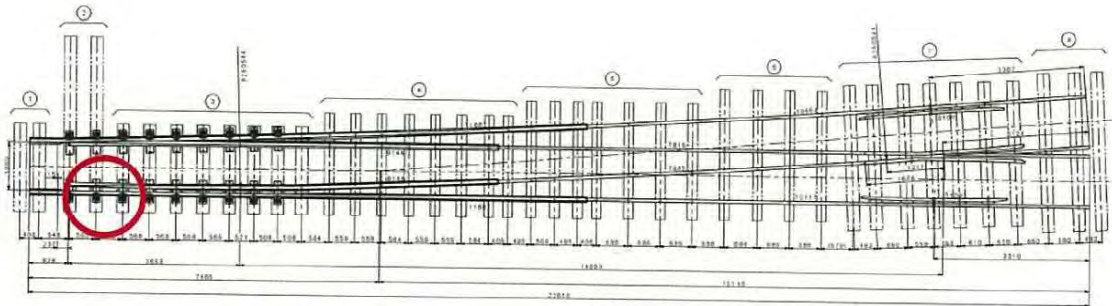

(3)Thilawa line

In R/D signed on 6th April, Thilawa line was added in track maintenance. So we surveyed Thilawa line from Togyauungale to Thilawa from cabin as first step. Thilawa line is improved little by little. Especially, ballasts are input at many places. We feel track condition is better than 3 years ago. But some places are not improved yet and should be improved more. For example, cutting section needs drain route. We would like to discuss which are MR want to advice and how to countermeasure.



Embankment near Aungthuhka Sta.(2012)



Embankment near Aungthuhka Sta.(2015)



Cutting section (2012)



Cutting section (2015)

3.2 Outsourcing of track maintenance work

This was added at R/D signed on 6th April. We are thinking that we hold meeting or discussion about outsourcing once a month

Contents are as below.

(1)Current Situation in Myanma Railways

Survey of outsourcing of track maintenance work in Myanma Railways

(2)Introduce of Japanese experience

In Japan, the outsourcing of track maintenance has changed. At the same time, organization changes, too. (Ref. next page)

(3)Discussing about outsourcing of track maintenance

Based on (1) and (2), MR and we share basic stance of outsourcing of track maintenance. .

(4)Mixing opinion of Myanmar and Japan

MR and we take good opinion for the future.

(5)Proposal of procedure of outsourcing track maintenance work by Myanmar style

Make proposal of procedure of outsourcing track maintenance work for MR.

(6)Seminar or presentation by Experts

We hold final seminar. or presentation.

Above flow is example and we are thinking that we can change procedure if there are more good ways.

Outsourcing is usually conducted with improvement of organization and mechanization.

So we may sometimes discuss improvement of organization and mechanization through outsourcing of track maintenance work.

3.3 Outline of maintenance of bridge

This was added at R/D signed on 6th April, too.

3.3.1 Expected output

Technical capability is improved through bridge maintenance to improve the level of service and safety.

3.3.2 Implementation plan for output

To draw up technology transfer plan of bridge maintenance through OJT at the Pilot Bridge
To conduct seminars, training for technical improvement of the bridge maintenance

3.3.3 Detailed methods for Project implementation

(1) Survey

Selecting (1) pilot bridge, present situation on bridge maintenance work in Myanmar Railways, Material available situation for painting and repairing, Mahlwagon Dept.

(2) Provision of bridge maintenance tool and safety equipment for each trainee

Necessary tools be selected after survey

(3) Seminars and Trainings by Japanese Experts

Bridge maintenance training on super structure of pilot bridge with Japanese Experts (inspection, judgement, countermeasure, repairing and painting)

Drawing training for bridge maintenance work

Bridge maintenance recording training, to be recorded check point for inspection on several bridges (such as their super structure are "Deck Girder, Through Girder, I beam, Through Truss, Reinforced Concrete, Pre-stress Concrete")

Manufacturing repairing material in Mahlwagon, and repairing bridge using them

Relevant seminars for those trainings

Other supplementary seminars and trainings

(4) Trainings by MR themselves

Bridge maintenance recording training

(5) Compiling text book

3.3.5. Outline of Schedule

	Event	Period
	Survey	3days:22 nd July – 24th July
1	Seminars and Trainings by Japanese Experts in Yangon and hard deteriorated bridge survey in around trip	2 and half weeks:27th July – 12 th August
2	Trainings by MR themselves	About 2 month:August – September or October
3	Closing seminar in Nay Pyi Taw	1 week: September or October

4. Project implementation Organization

4.1 Structure of project implementation Organization

Based on R/D, we will organize a project implementation Organization in Fig. 4-1.

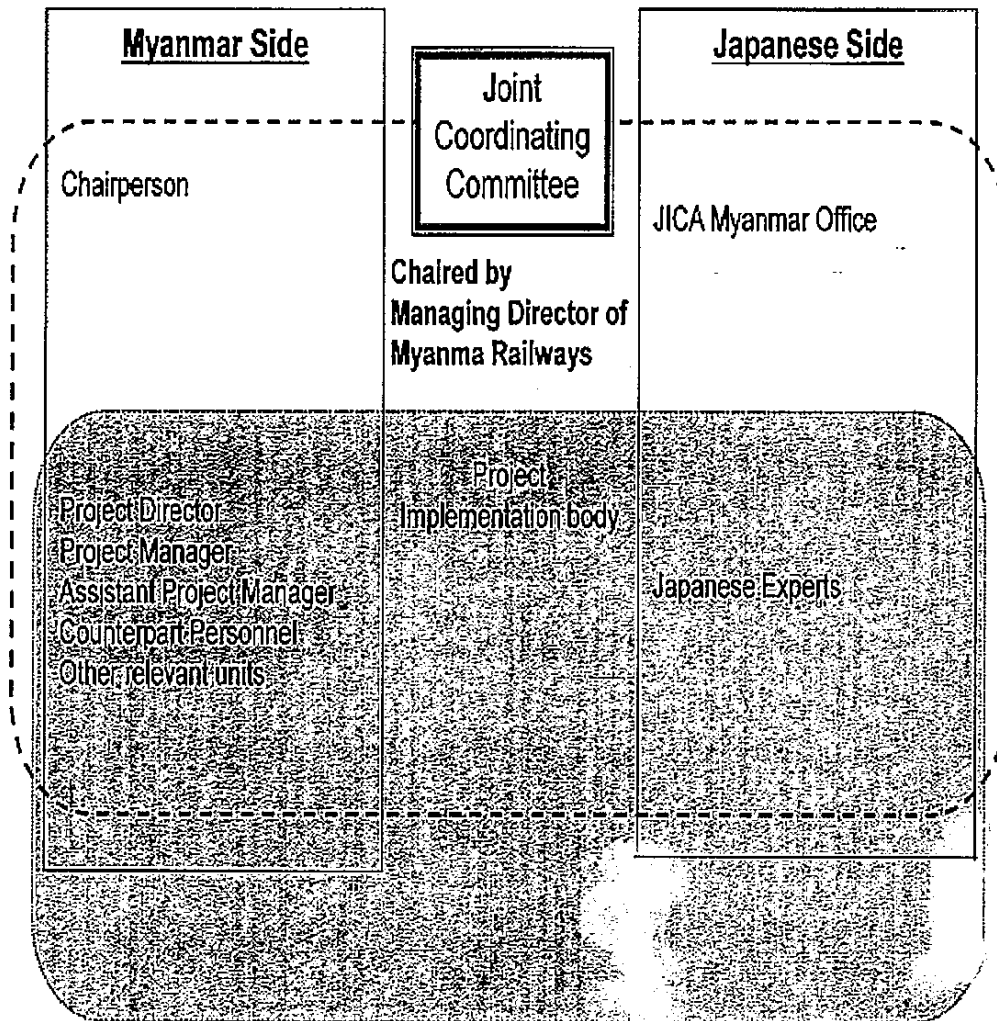

Fig. 4-1: Structure of project implementation Organization

4.2 Implementation body on the Myanmar side

MR will play a central role on the Myanmar side. To correspond to Japanese experts, a Counterpart Team is organized for this project. See Table 4-1. Project Director commands the general affairs and implementation of the project, while Project Manager manages the projects and directs technical affairs.

In On the Job Training (OJT) of track maintenance and bridge maintenance, project is the mainstream of the field work, which will be led by (1) the leaders for civil engineering structures of Division 7 (Yangon) and (2) those supporting the field of Lower Mayamar section and (3) the staff at the Head Office. Regarding procedure of outsourcing the track maintenance work Head Office located at Naypyidaw has the initiative to the implementation of the project.

4.3 Implementation body on the Japan side

The JICA experts selected from Japan International Consultants for Transportation Co., Ltd.(JIC), Oriental Consultants Global Co., Ltd.(OCG) and Sumitomo Corporation will guide/advise the personnel on the Myanmar side and offer recommendations where necessary for the project. See Appendix-2 for the list of JICA Expert Team members.

Japan International Consultants for Transportation, a leader of the consortium, which was instituted in November 2011 by JR Companies, private railways and other enterprises as a comprehensive consultant for overseas railways, is privileged to enjoy whole hearted cooperation for this project from JR Companies and Japan Railway Track Consultants, an expert consultant on track technologies.

5. Schedule (PLAN)

Year/Month	2015/7	2015/8	2015/9	2015/10	2015/11	2015/12	2016/1	2016/2	2016/3
Common	▽7th JCC				▽8th JCC	▽New equipments will arrive	▽Final JCC	▽Activity Report (at Yangon, NPT and Japan)	
Track Maintenance	▽Replace to 50N Rail	▽Speed increasing test	▽Finish OUT of track Maintenance						
Bridge Maintenance	▽Bridge Maintenance Training	▽Bridge Maintenance Seminar							
Outsourcing of track maintenance work	▽Meeting	▽Meeting	▽Meeting	▽Meeting	▽Meeting	▽Meeting	▽Meeting	▽Presentation	
Others		▽Sanitary System for rolling stock							

The Project on Improvement of Service and Safety of Railway in Myanmar



Progress Report
July 17th, 2015 at Nay Pyi Taw

JICA EXPERT TEAM



Japan International Cooperation Agency

1

Table of Content

- 1 Preface
- 2 Extension of the project
 - 2.1 Major progress of the Project
 - 2.2 Contents of Extension of the Project
- 3 Detailed Methods for the Project Implementation
 - 3.1 Track Maintenance
 - 3.2 Procedure of outsourcing the track maintenance work (New Item)
 - 3.3 Outline of maintenance of bridge (New Item)
- 4 Project implementation Organization
 - 4.1 Structure of project implementation Organization
 - 4.2 Implementation body on Myanmar side
 - 4.3 Implementation body on Japan side
- 5 Schedule

2

Appendix-1 Minutes of meetings for the amendment to the record of discussions on the project on improvement of service and safety of railway in Myanmar in the Republic of the union of Myanmar between Myanmar Railways Ministry of Rail Transport and Japan International Cooperation Agency.

Appendix-2 Member List of JICA Expert Team

3

1. Preface

This Progress Report deals with the major activities of the Project implemented around between March and July of this year.

We should be grateful, if MR senior officials concerned review the Report and provide us with the various advices so that the Project will be implemented more fruitfully in the coming period.

2.Extension of the Project

2.1 Major progress of the project

We have implemented 2 main project as below..

- Recommendation of technical standard relating to administrative and maintenance aspect and drawing up railway facilities improvement plan to improve service and safety level.
- Technology Transfer of Track Maintenance Technology to improve the level of Service and Safety through Implementation of The Pilot Project.

4

2.2 Contents of Extension of the Project

At first this project was planning to finish on May in 2015. But amendment of the Record of Discussion (hereinafter referred to as the “R/D”) were signed by JICA and Myanma Railways on 6th April in 2015. (Refer to Appendix-1)

Contents of Extension of the Project are as bellow.

- To continue training for track maintenance of the Yangon-Mandalay line including Thilawa line.
- To conduct lecture(s) in Myanmar on the Japanese experience on the procedure of outsourcing the track maintenance work.
- To conduct lecture(s) in Myanmar on outline of maintenance of bridges.

For the implementation of the three items mentioned above, both sides agreed to extend the Project duration from 2 years (up to May 2015) to 2 years and 10 months (up to March 2016).

7

3 Detailed Methods for the Project Implementation

3.1 Track Maintenance

(1)Track Record

At the beginning, technology transfer of track maintenance started for 30 trainees in the Pilot Section. At present, accumulated number of trainees amounts to 400, and the various situations relating to technology transfer had been changed. Further, in order to implement the training efficiently, trainings were sometimes repeated in the same place, and also on Dagon University line.

In this regard, we consulted with MR about various matters including the suitable change of the length of the Pilot Section.

We are planning in this way till coming December.

We show activity of track maintenance work for 3 months from next page.

8



Carry out equipments from warehouse



Chord-to-rail measurement



Calculating survey data by inspectors



Changing sleepers

9



Installing fastening (First Clip)



Amending alignment



Tamping by hand tie tamper



After replacing sleepers

10



Cutting rail on the trunk line (Pre-Work)



Drilling rail on the trunk line (Pre-Work)



Removal of fastening (Pre-Work)



Lift up 50N Rail

11



Changing track pad



Installing fastening (First Clip)



Reverse direction operation under track closing



After changing from 75lb rail to 50N Rail

12

(2) Speed increasing test

We are going to conduct speed increasing test at the place where we changed from 75lb rail to 50N rail. Outline of test is as below.

1. Date : Around October
2. Place : Up line from 14 k250m to 15k700m
3. Speed : 3 kinds of speed (60km/h, 70km/h, 80km/h)
4. Measurement :

① Vibration test (up-and -down, right and left, back and forth)

We check riding comfort by measuring train vibration against 3 kinds of speed as we measured before.

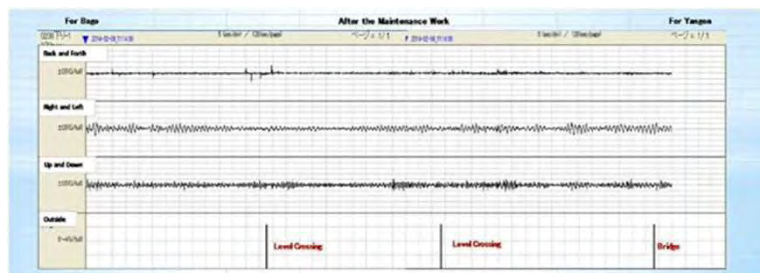

13

② Rail Stress

We attach strain gauge at the back of rail and check the value of rail stress by running train.

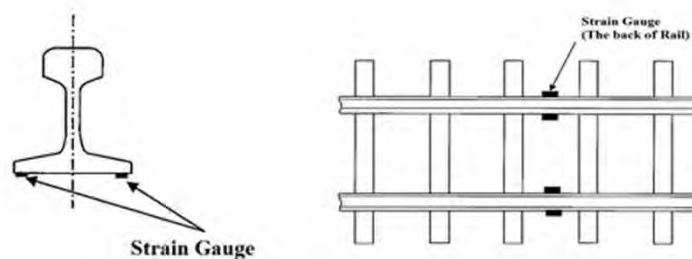

14

③ Stress of fishplate

We prepare 3 kinds of fishplate for 75lb, N37 and 50N. We measure 3 stress (Around hole of bolt, fishplate and bolt) against each fishplate and each train speed.

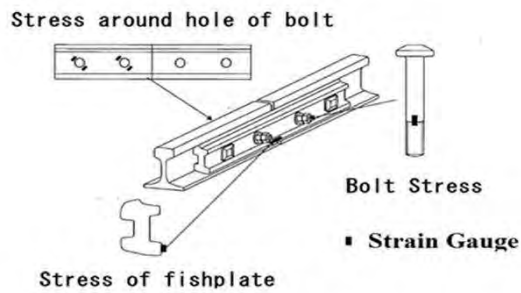

We will prove the advantage of 50N rail compared to 75lb rail by measuring many kinds of stress and strain.

15

④ Stress of Turnout

We attach strain gauge at the rail of turnout. We are going to measure stress of turnout when train is running.

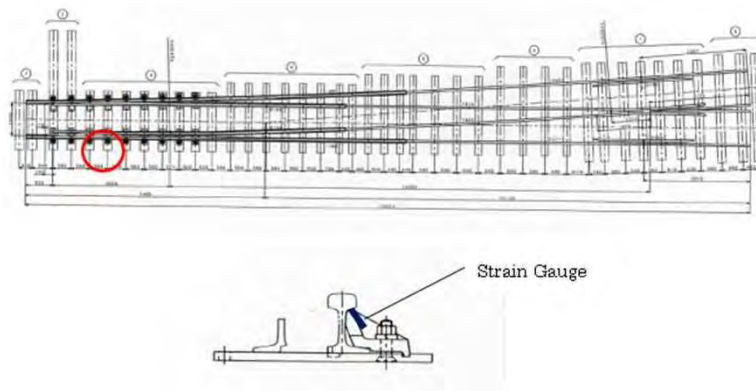

16

(3) Thilawa line

In R/D signed on 6th April, Thilawa line was added in track maintenance. So we surveyed Thilawa line from Togyauungale to Thilawa from cabin as first step. Thilawa line is improved little by little. Especially, ballasts are input at many places. We feel track condition is better than 3 years ago. But some places are not improved yet and should be improved more. We would like to discuss which are MR want to advice and how to countermeasure.



Embankment near Aungthuhka Sta.(2012)



Embankment near Aungthuhka Sta.(2015)

17

3.2 Outsourcing of track maintenance work

We are thinking that we hold meeting or discussion about outsourcing once a month .

(1)Current Situation in Myanma Railways

Survey of outsourcing of track maintenance work in Myanma Railways

(2)Introduce of Japanese experience

In Japan, the outsourcing of track maintenance has changed. At the same time, organization changes, too. (Ref. next page)

(3)Discussing about outsourcing of track maintenance

Based on (1) and (2), MR and we share basic stance of outsourcing of track maintenance. .

(4)Mixing opinion of Myanmar and Japan

MR and we take good opinion for the future.

(5)Proposal of procedure of outsourcing track maintenance work by Myanmar style

Make proposal of procedure of outsourcing track maintenance work for MR.

(6)Seminar or presentation by Experts

We hold final seminar. or presentation.

Above flow is example and we are thinking that we can change procedure if there are more good ways. Outsourcing is usually conducted with improvement of organization and mechanization. So we may sometimes discuss improvement of organization and mechanization through outsourcing of track maintenance work.

18

History of Track Maintenance Organization in Japan

Classification Type	Organization		Feature
Track Maintenance Before Modernization	Track Maintenance Section	Subdistrict	1. Dispersed work of small unit 2. Repairing at any time 3. Unification of inspection and working (survey and maintenance by ourselves) 4. Human-wave tactics of hand working mainly
		Gang (Track) Gang (Track) Gang (Track) (Length of Line) 5~10km	
Modernization of Track Maintenance	Track Maintenance Section	Subdistrict	1. Concentrated work in large unit 2. Planning and repairing 3. Separate inspection and work 4. Introduction of machine (Length 10~50 km)
		(40~60km) Gang (Track) Gang (Inspection) Gang (Inspection) Gang (Inspection) (10~15km)	
New Track Maintenance Organization	Track Maintenance Section	Subdistrict	1. Specialization of Operator 2. Mechanization deeply ・1 Multiple Tie Tamper per 1 Subdistrict ・Productive Basement of operation ・Save working time 3. Outsourcing of simple task (Ex. Replacement of sleepers)
		(40~60km) Gang (Working) Machine Working G Gang (Inspection) Working G Gang (Inspection) (10~15km)	
Improvement of Track Maintenance	Track Maintenance Section	Subdistrict	1. Change to technical group 2. Abolish working G (Outsourcing of simple work and fluctuated work) 3. Leave track its maintenance G 4. Efficiency by diversity of job content ・Track Supervision G Supervision of inspection, planning and outsourcing ・Track Machine G Survey, planning and operation work of MTT
		(40~60km) Track Machine G Track Supervision G (10~15km) (Track Residence Track Supervision G) [Installation in case of charging of large yard]	
Improvement of work (Track Maintenance and Civil Engineering)	Track Maintenance Section	Subdistrict	1. Simplification and efficiency by review of working content ・Review of MTT and Track inspection 2. Diversity of job content and efficiency by fusion ・Integrate of position of Technique G (Track Maintenance, Civil Engineering, Forestry) ・Relegation some parts of civil work to Track Supervision G 3. Efficiency by simplification of organization
		(50~80km) Track Machine G Track Supervision G (10~15km) (Track Residence Track Supervision G) [Installation as necessary]	
Improvement of Track Facility	Track Maintenance Section	Subdistrict	1. Detailed supervision according to characteristics of line 2. Trv efficiencv and diversity of work 3. Secure safety and stable transportation 4. Concrete contents ・Review of workers per 1 party of Track Machine G ・Abolish subdistricts and Track Residence in lower line and reconstruct supervision section and track maintenance section ・Integrate Track Supervision G and Track Machine G in lower line ・Review of inspection by getting on train
		(50~80km) Track Machine G Track Supervision G (15~30km) (Track Residence Track Supervision G) [Installation as necessary] Supervision Section Installation in lower line Track Machine G Track Supervision G	

19

3.3 Outline of maintenance of bridge

3.3.1 Expected output

Technical capability is improved through bridge maintenance to improve the level of service and safety.

3.3.2 Implementation plan for output

To draw up technology transfer plan of bridge maintenance through OJT at the Pilot Bridge

To conduct seminars, training for technical improvement of the bridge maintenance

3.3.3 Detailed methods for Project implementation

(1) Survey

Selecting (1) pilot bridges, present situation on bridge maintenance work in Myanmar Railways, Material available situation for painting and repairing, Mahlwagon Dept.

20

(2) Provision of bridge maintenance tool and safety equipment for each trainee

Necessary tools be selected after survey

(3) Seminars and Trainings by Japanese Experts

Bridge maintenance training on super structure of pilot bridge with Japanese Experts (inspection, judgement, countermeasure , repairing and painting)

Drawing training for bridge maintenance work

Bridge maintenance recording training, to be recorded check point for inspection on several bridges (such as their super structure are “Deck Girder, Through Girder, I beam, Through Truss, Reinforced Concrete, Pre-stress Concrete”

Manufacturing repairing material in Mahlwagon, and repairing bridge using them

Relevant seminars for those trainings

Other supplementary seminars and trainings

(4) Trainings by MR themselves

Bridge maintenance recording training

(5) Compiling text book

21

4 Project implementation Organization

4.1 Structure of project implementation Organization

Based on R/D, we will organize a project implementation Organization

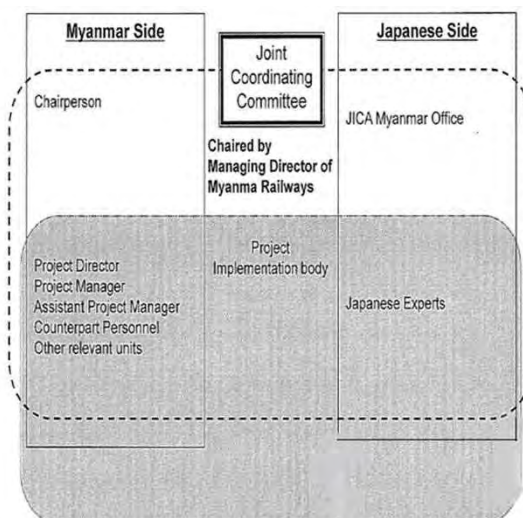

22

4.2 Implementation body on the Myanmar side

4.3 Implementation body on the Japan side

Administrative and Counterpart Personnel for the Project (PLAN)

Fields	Myanma Railways	Japanese Side
Project Director	U Aung Win, General Manager (Technical & Admin Support)	Nobuyuki MATSUO (Leader)
Project Manager	U Tin Soe, General Manager (Civil) U Saw Valentine, Advisor	Mitsuru TAKAMI (Deputy Leader)
Track Maintenance	Tin Myint, Assistant General Manager(Civil)	Hiroshi KOMATSU Osamu HAGA
Outsourcing of track maintenance work	Maung Maung Than, Deputy General Manager(Civil)	Nobuyuki MATSUO
Bridge maintenance		Mitsuru TAKAMI
Procurement of Equipment and Materials	U Khin Maung Than, Deputy General Manager (Supply)	Tomohiro AIZUKI
Rolling Stock	U Win Oo, General Manager (Rolling Stock)	Makoto ISHIKAWA
Train Operation	U Hlay Myint Aung, Deputy General Manager (Train Operation)	Sunji MORIHARA
Signal & Telecommunication	U Khin Maung Thein, Deputy General Manager (Signal & Telecommunication)	Ryuhei MITANI
Policy Advisor	Mitsuo HIGASHI	

23

5 Schedule (PLAN)

Year/Month	2015/7	2015/8	2015/9	2015/10	2015/11	2015/12	2016/1	2016/2	2016/3
Common	▽7th JCC				▽8th JCC		▽New equipments will arrive	▽Final JCC	▽Activity Report (at Yangon, NPT and Japan)
Track Maintenance	▽Replace to 50N Rail				▽Speed increasing test		▽Finish OJT of track Maintenance	Summary	
Bridge Maintenance	▽Bridge Maintenance Training			▽Bridge Maintenance Seminar			Summary		
Outsourcing of track maintenance work	▽Meeting	▽Meeting	▽Meeting	▽Meeting	▽Meeting	▽Meeting	▽Meeting	▽Presentation	Summary
Others				▽Sanitary System for rolling stock					

24

Thank you for your attention.

Republic of the Union of Myanmar

Myanma Railways, Ministry of Rail Transportation

**PROJECT ON IMPROVEMENT OF
SERVICE AND SAFETY OF RAILWAY
IN MYANMAR**

**PROJECT PROGRESS REPORT
(8th Joint Coordination Committee)**

October 2015

JAPAN INTERNATIONAL COOPERATION AGENCY

JICA Expert Team

**JAPAN INTERNATIONAL CONSULTANTS FOR TRANSPORTATION CO., LTD.
ORIENTAL CONSULTANTS GLOBAL CO., LTD.
SUMITOMO CORPORATION.**

**Project on Improvement of Service and Safety
of Railway in Myanmar
Progress Report, October 2015
Table of Contents**

	PAGE
1. Preface	1
2. Major progress of the Project	2-1
3. Detailed Methods for the Project Implementation	
3.1 Sanitary system on Rolling Stock	3-1
3.2 Track Maintenance	
3.2.1 Track record	3-2
3.2.2 Measurement of rail stress and Train Running Test	3-2
3.3 Outsourcing of track Maintenance	3-3
3.4 Bridge Maintenance	3-4
4. Supply of additional equipments	4
5. About how to proceed until end of this project	5
6. Schedule	6
Appendix-1 Text of sanitary system of rolling stock	
Appendix-2 Text of bridge maintenance	

Project on Improvement of Service and Safety of Railway in Myanmar Progress Report, October 2015

1. Preface

Since we started the Project in June 2013, about 2 and a half years have passed and the Project has been implemented effectively under the close cooperation between MR officials concerned and JICA Expert Team.

We, JICA Expert Team, would like to express our sincere appreciation to MR officials concerned for their kindness extended to us during the execution of the Project.

This Progress Report deals with the major activities of the Project implemented around between July and October of this year.

We should be grateful, if the members of the JCC would review the Report and provide us with the various advices.

2 Major progress of the Project

We have implemented 2 main project as below..

- Recommendation of technical standard relating to administrative and maintenance aspect and drawing up railway facilities improvement plan to improve service and safety level
- Technology Transfer of Track Maintenance Technology to improve the level of Service and Safety through Implementation of The Pilot Project

Recommendation of technical standard finished last March. Technology Transfer of Track Maintenance Technology is currently in process

Amendment of the Record of Discussion (hereinafter referred to as the “R/D”) were signed by JICA and Myanma Railways on 6th April in 2015.

Contents of Extension of the Project are as bellow.

- To continue training for track maintenance of the Yangon-Mandalay line including Thilawa line.
- To conduct lecture(s) in Myanmar on the Japanese experience on the procedure of outsourcing the track maintenance work.
- To conduct lecture(s) in Myanmar on outline of maintenance of bridges.

In addition to these, to conduct lecture about sanitary system on rolling stock was added in contents of extension of the project.

For the implementation of the three items mentioned above, both sides agreed to extend the Project duration from 2 years (up to May 2015) to 2 years and 10 months (up to March 2016).

3. Detailed Methods for the Project

3.1 Sanitary system on Rolling Stock

Date : 30/9/2015 (Wed)

Place : MR Training Center in Nay Pyi Taw

The number of participants : 40

Training instructor : Makoto ISHIKAWA (Oriental Consultants Global)

Contents :

There were many requests from MR about sanitary system on rolling stock. In this workshop, Mr. Ishikawa introduced Japanese sanitary system and transition on rolling stock in the morning. He explained each type of sanitary system in detail and had a question and answer session in the afternoon. Many contents were discussed about equipment or cost in the Q and A session. There were many opinions that which type was suitable for MR.



3-1

3.2 Track Maintenance

3.2.1 Track Record

At the beginning, technology transfer of track maintenance started for 30 trainees in the Pilot Section. At present, accumulated number of trainees amounts to over 500, and the various situations relating to technology transfer had been changed. Further, in order to implement the training efficiently, trainings were sometimes repeated in the same place, and also on Dagon line. In this regard, we consulted with MR about various matters including the suitable change of the length of the Pilot Section.

Trainees of MR change every month. We show divisions of trainee and members till now (Table 3.2.1). We have educated about 500 trainees who are belonging to all divisions in Myanmar Railways.

Table 3.2.1 Divisions of trainee and members till now

	Date	Date	Division	Number	Remark
	From	To			
1	25.10.2013	12.5.2014	(7)Yangon (6)Bago	24 6	
2	12.5.2014	12.6.2014	(7) Yangon (5)Taunggu (7)Yangon (8)Mawlamying (9)Hinthada	10 6 5 4 5	To perform the changing of trainees
3	12.6.2014	12.7.2014	(7) Yangon (2)Ywataung (3)Mandalay (10)Pakauku	10 8 8 7	To perform the changing of trainees
4	12.7.2014	12.8.2014	(7) Yangon (1)Myitgyinar (4)Kalaw (11)Bagan	10 6 7 7	To perform the changing of trainees
5	12.8.2014	12.9.2014	(7) Yangon (5) Taunggu (8) Mawlamying (9) Hinthada	10 6 6 8	To perform the changing of trainees
6	12.9.2014	.10.2014	(7) Yangon (2) Ywataung (3) Mandalay (6) Bago	10 6 6 8	To perform the changing of trainees
7	13.10.2014	12.11.2014	(7) Yangon (9)Hinthada (8)Mawlamying (5)Taunggu	10 7 7 6	To perform the changing of trainees

8	12.11.2014	11.12.2014	(7) Yangon (2)Ywataung (3)Mandalay (10)Pakauku	10 8 9 7	To perform the changing of trainees
9	9.1.2015	6.2.2015	(7) Yangon (4)Kalaw (9) Hinthada (11)Bagan	10 7 7 7	To perform the changing of trainees
10	9.2.2015	4.3.2015	(7) Yangon (1)Myitgyinar (6)Insein (10)Pakauku	10 6 7 7	To perform the changing of trainees
11	9.3.2015	8.4.2015	(7) Yangon (4)Kalaw (5)Taungu (11)Bagan	10 6 7 7	To perform the changing of trainees
12	27.4.2015	22.5.2015	(7) Yangon (1)Myitgyinar (5)Taungu (8)Mawlamying	10 5 7 7	To perform the changing of trainees
13	25.5.2015	19.6.2015	(7) Yangon (2)Ywahtaung (3)Mandalay (10)Pakauku	10 6 7 7	To perform the changing of trainees
14	22.6.2015	17.7.2015	(7) Yangon (4)Kalaw (6)Pyon tan sar (11)Bagan	10 6 7 7	To perform the changing of trainees
15	23.7.2015	--.8.2015	(7) Yangon (8)Mawlamying (9)Hinthada (10)Pakauku	10 6 7 7	To perform the changing of trainees
16	24.8.2015	18.9.2015	(7) Yangon (1)Myitgyinar (3)Mandalay (6)Bago	10 6 7 6	To perform the changing of trainees
17	21.9.2015	16.10.2015	(7) Yangon (2)Ywahtaung (4)Kalaw (11)Bagan	10 6 7 7	To perform the changing of trainees
18	19.10.2015		(7) Yangon (1)Myitgyinar (5)Taunggu (9)Hintada	10 6 7 7	To perform the changing of trainees
Total				546	

We will continue this program till December.

We indicate track maintenance which we conducted from July to October by photo.



Drilling a hole of the rail



Cutting a rail



Tightening fishplates by bolts



Chamfering (Removing sharp edges)



Removing 75lb Rail



Installing 50N Rail



Passing first train



After replacing from 75lb rail to 50N rail

3-2-3



Entire work



Draining water



Exchanging PC Sleeper



Adjustment of joint gaps



Spot surfacing



Amending alignment



Tamping by hand tie tamper (Around bridge)



Tamping with rammer

3-2-4

3.2.2 Measuring of Rail Stress and Train Running Test

(1) Purpose

Intend to train running with high speed at the Yangon – Mandalay Railway Line in Myanmar, due to recheck for the speed of Straight Line and Turnout, to be performed measuring and testing of rail stress and train running speed at the present railway Line.

(2) Measuring Outline

① Measuring Place

Various Factors and Measuring Place of Running Test is as follows (Fig.3.2.1)

Rail	:	50 N,	BS 75 R
Fastening Device	:	Pandrol First Clip(FD),	Local(MR) made e-clip
Sleeper	:	PC Sleeper,	PC Sleeper
Line Type	:	Parts of Straight Line	R = 2276 m
Place of Measuring	:	Togyauungale (7 1/4) ~ Ywathagyi (12 3/4)	

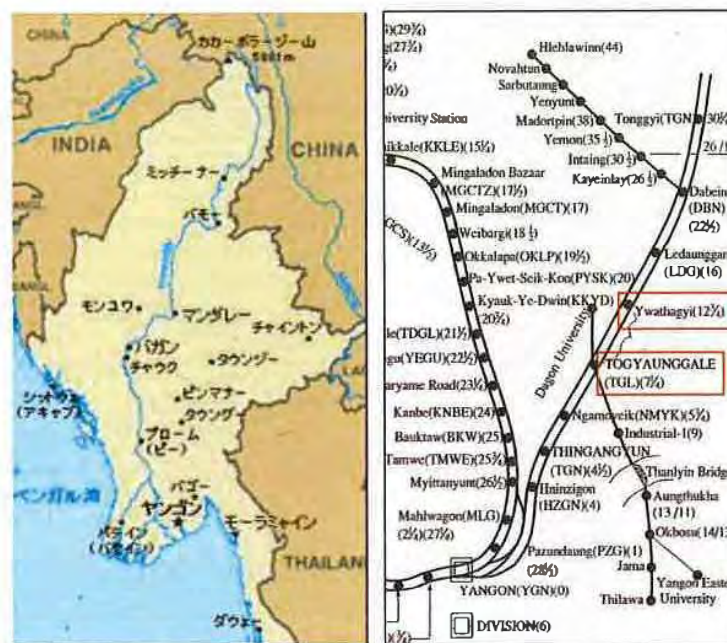

Fig. 3.2.1 Measuring place

② **Work Process**

Work Content is as follow.

Table 3.2.2 Work Process

DATE	Work Content	Note
14.10.15(WED)	Preparing of measuring work	1 st day
15.10.15(THUR)	Measuring work	2 nd day
16.10.15(FRI)	Measuring work and Removal Work	3 rd day

1. Train (going) Togyauungale(Departure) 11:50 →Ywathagyi(arrival) 12:06
(Return) Ywathagyi (Departure) 12:10 →Togyauungale (arrival) 12:26
2. Train (going) Togyauungale (Departure) 12:30 → Ywathagyi (arrival) 12:46
(Return) Ywathagyi (Departure) 12:50 →Togyauungale (arrival) 13:06
3. Train (going) Togyauungale (Departure) 13:10 → Ywathagyi (arrival) 13:26
(Return) Ywathagyi (Departure) 12:30 → Togyauungale (arrival) 13:46

③ **Measuring Items**

Measuring 4 items are Wheel Load - Lateral Force, Joint Plate Stress, Tongue rail stress and Train vibration.

Table 3.2.3 Measuring Items

Content	Measuring Items	Place	Measuring members	Remark
Strength of track material Destruction amount of track	Wheel load. lateral force	2	4	Straight line
Strength of track material, Destruction amount of track	Joint plate stress	4	8	BS75、 N37
Turnout Strength. function	Tongue rail	1	1	37(BS75)
Train vibration (Between Togyauungale and Ywathagyi)	Last and First Carriage of Train Vibration	1	1	
Total		8	14	

④ Arrangement of measuring point

Concerning of wheel load and rail strain, arrangement of measuring point is as follow.

(See Fig. 3.2.2 ~ 3.2.5)

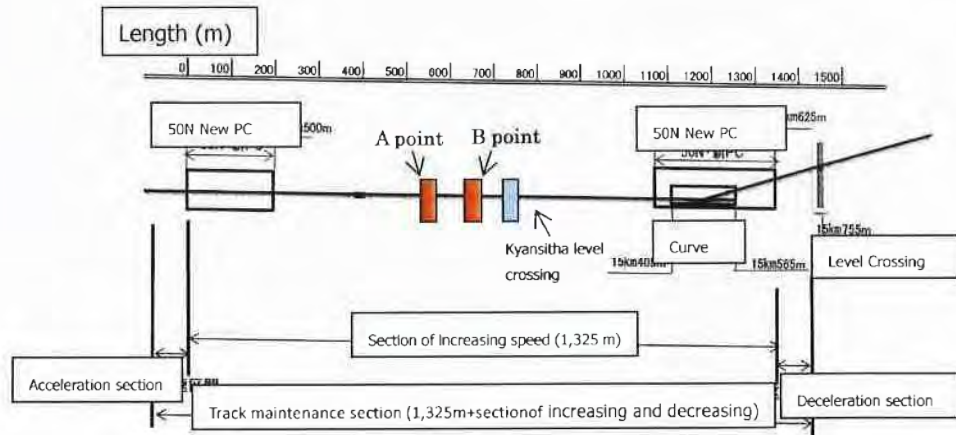

Fig. 3.2.2 Arrangement of measuring point

1) Point- A (near 14k 535m): Straight line

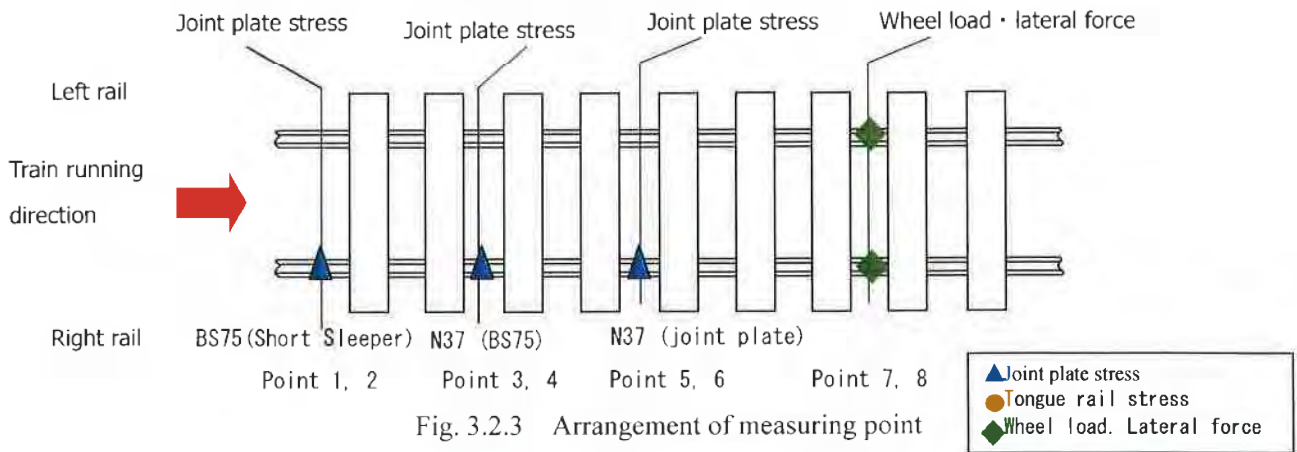

Fig. 3.2.3 Arrangement of measuring point

2) Point- B (near 14k600m): Turnout

Measuring place is the changing part of cross section of Stock rail and Tongue rail.

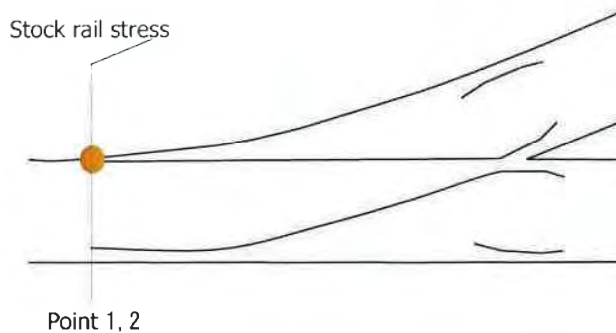

Fig. 3.2.4 Arrangement of measuring point

(3) Measuring Item

① Wheel load

Wheel load is as the showing of Fig. 3.2.5. To measure the shearing strain, after apply the gauge set of using wheel load and adhesive on the grinded web of rail. And then due to change from strain to wheel load, using the measuring device of Fig. 3.2.6 in advance, measure within 1kN of sensitivity of strain.

② Lateral force

Lateral force also similarly as the showing of Fig. 3.2.5. To measure the shearing strain, after apply the gauge set of using lateral force and adhesive on the base of rail. And then due to change from strain to lateral force, using the measuring device of Fig. 3.2.6 in advance, measure within 1kN of sensitivity of strain.

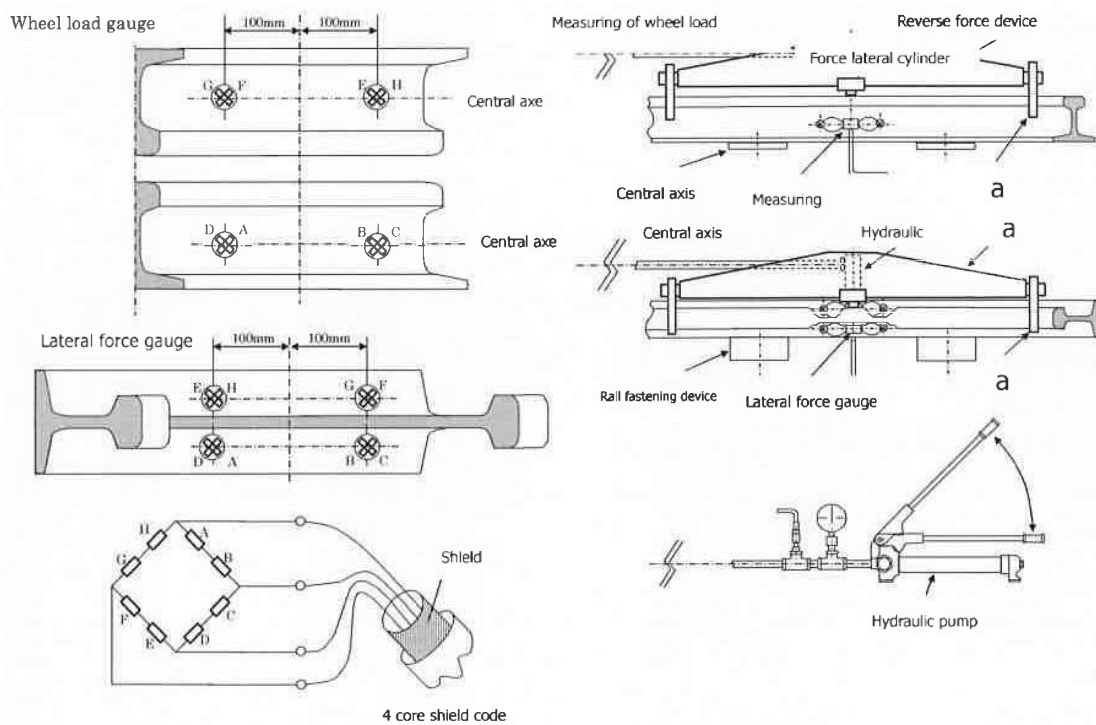

Fig. 3.2.5 Gauge place of wheel load, Lateral force. Fig. 3.2.6 Measuring way of wheel load, Lateral force.

③ Joint plate stress

As the showing of Fig. 3.2.7, stick the strain gauge on the base of joint plate face (10mm) of train running direction side, through the bridge box and set up the moving strain measurement device, and then measure the joint plate stress. (One side only)

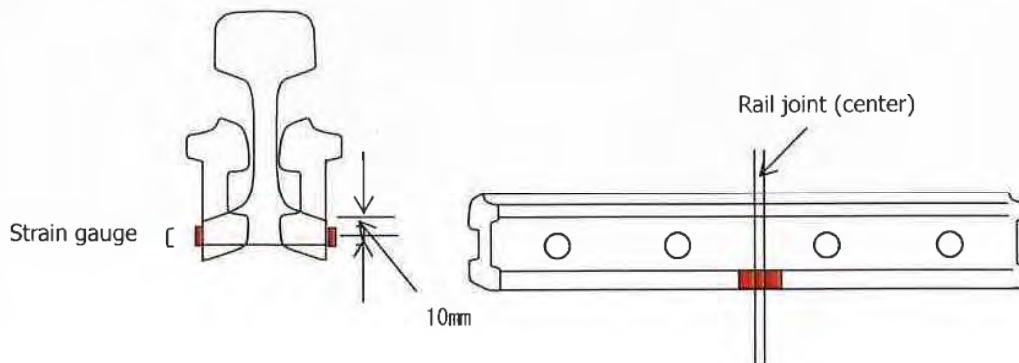

Fig. 3.2.7 Joint plate stress (conventional pattern)

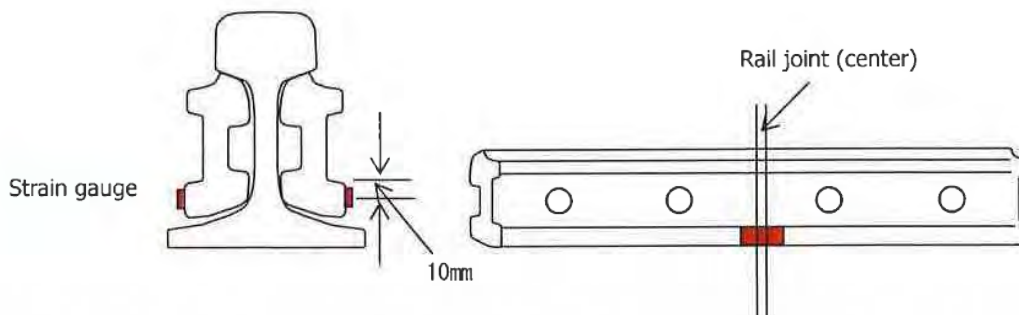

Fig. 3.2.8 Joint plate stress (Improvement)

④ Tongue rail stress

As the showing of Fig. 3.2.9, stick the strain gauge on the changing part of cross section of stock rail and tongue rail, through the bridge box and set up the measuring device. And then measure the tongue rail stress.

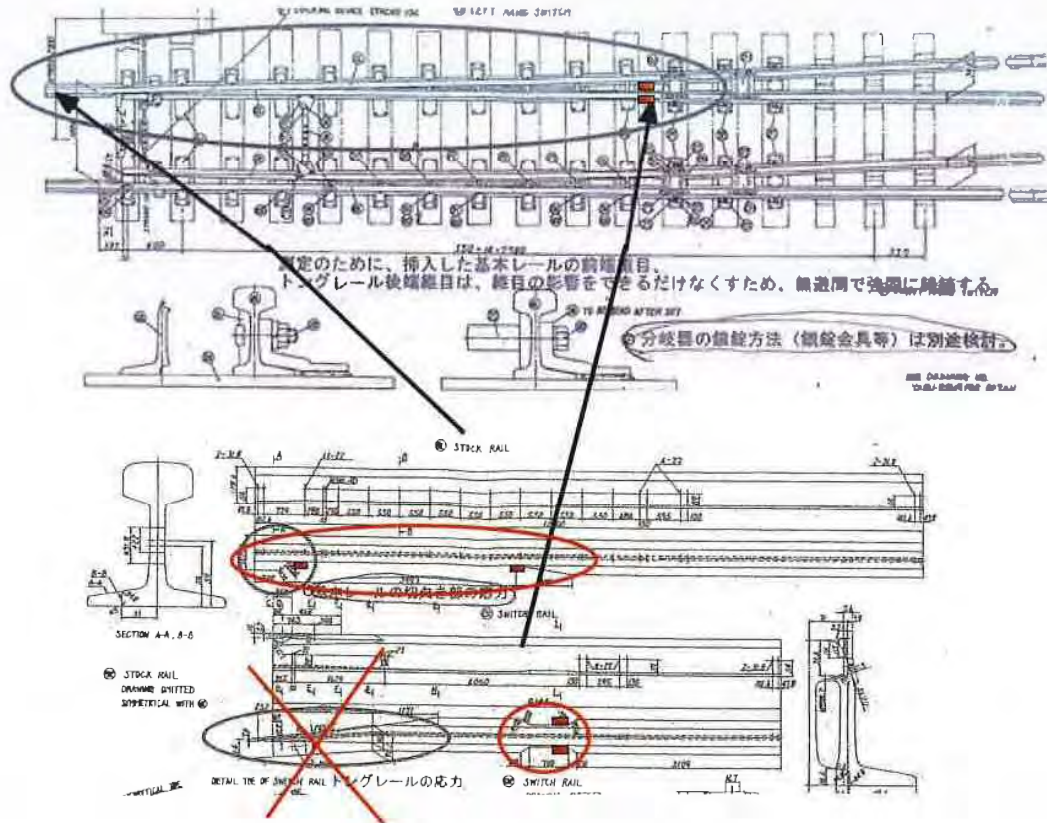

Fig. 3.2.9 Tongue rail stress

⑤ Train vibration

For Train Vibration, measure at last carriage for going and first carriage for return.

(4) Test Condition

Test train running with 50km/h, 60 km/h speed each 3 times over.

(5) Judgement of Train Running Standard

Accompanied by increasing of train running standard is as follow.

Table 3.2.4 Judgement of Train running standard

Measuring content		Standard value	Reference value
Wheel load	Max value	225kN	200kN
	Mini value	25kN	35kN
Lateral force		68kN	40kN
Joint plate		137N/mm ²	137N/mm ²
Tongue rail stress		137N/mm ²	137N/mm ²

Besides, due to the consideration of safety rate, perform the under 70% of reference value.

Table 3.2.5 Judgement of Train running standard

Measuring content		Reference value
Wheel load	Max value	140kN
	Mini value	25kN
Lateral force		28kN
Joint plate		96N/mm ²
Tongue rail		96N/mm ²

(3) Measuring device and attachment of Wheel load

① Reverse device force (Hydraulic cylinder)

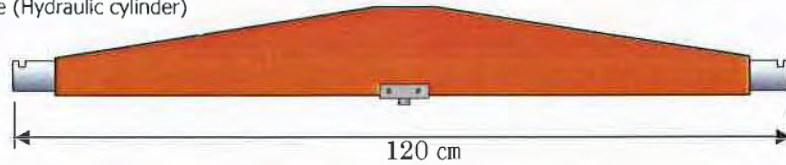

② Reverse force device (metal fitting device wheel)

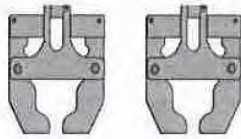

④ hydraulic pump (including converter, hydraulic host)

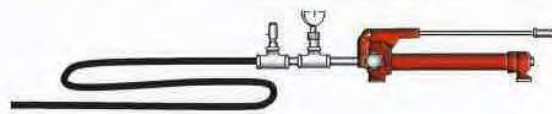

③ Reverse force device metal fitting force



⑤ Spacer



⑥ Relay cable



⑦ Storage box

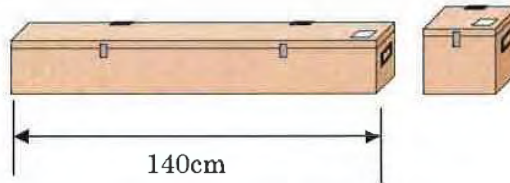

A-8-8-19



To Dagon University

To Mandalay

U Tun Myat Level Crossing
15km750m

Dagon University Line

End point of 50N Rail 15km575m

Beginning point of 50N Rail 15km375m

End point of 50N Rail
14km500m

No.16 Bridge

Kyan Sittha Level Crossing
14km700m

Beginning point of 50N Rail
14km250m

To Yangon

Image © 2015 DigitalGlobe

Google earth

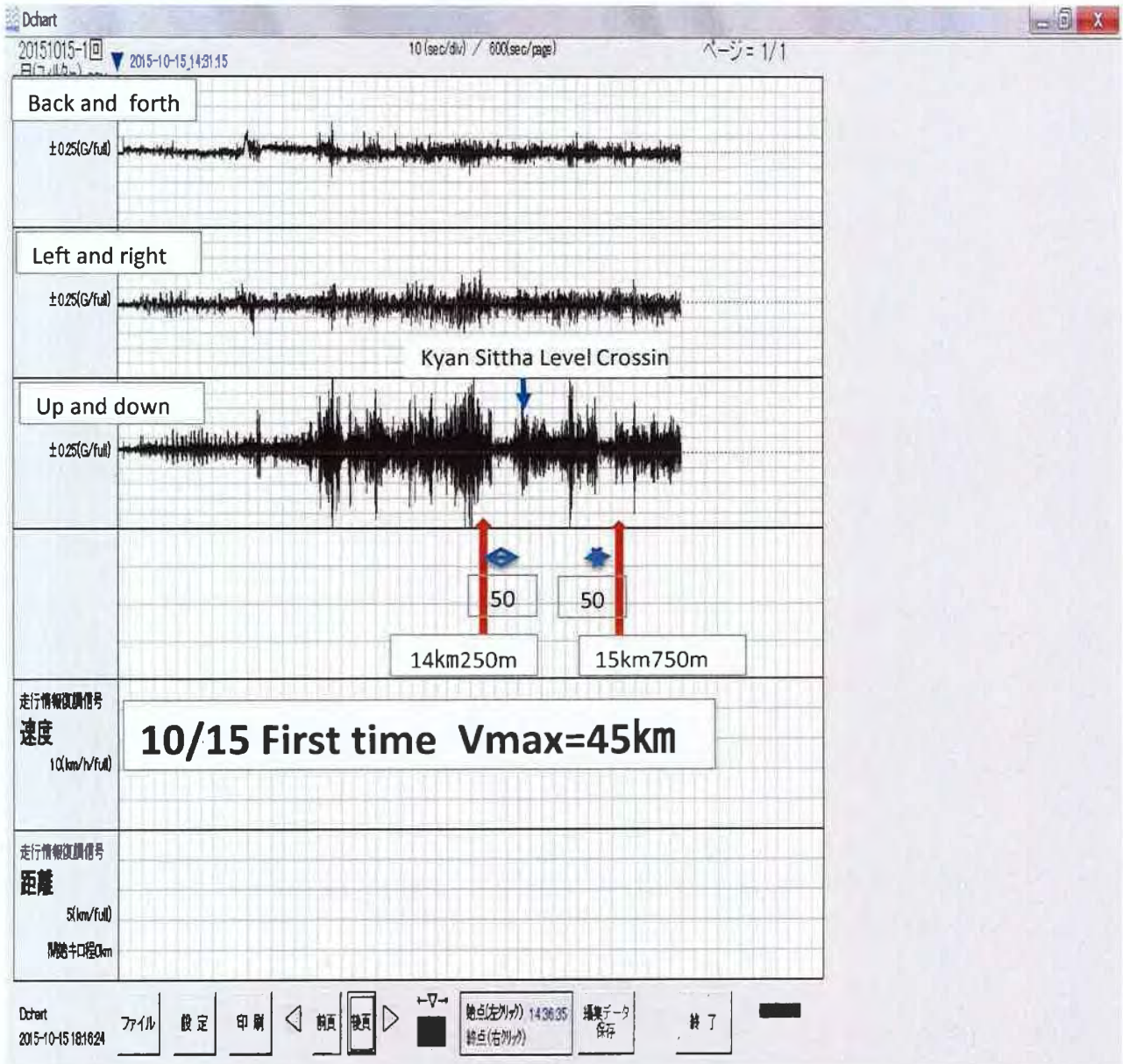

The result of vibration test

A-8-8-21

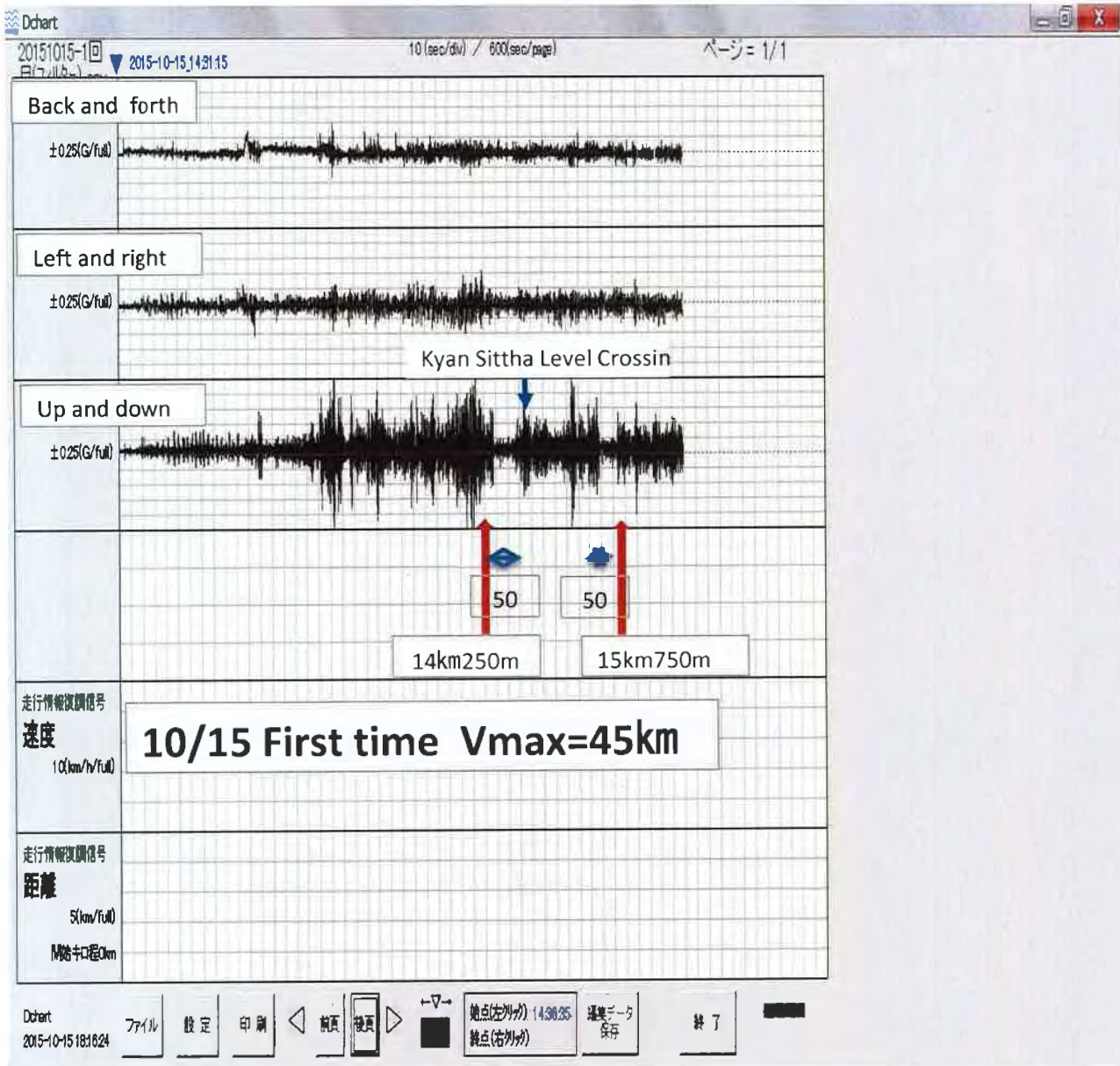

A-8-8-22

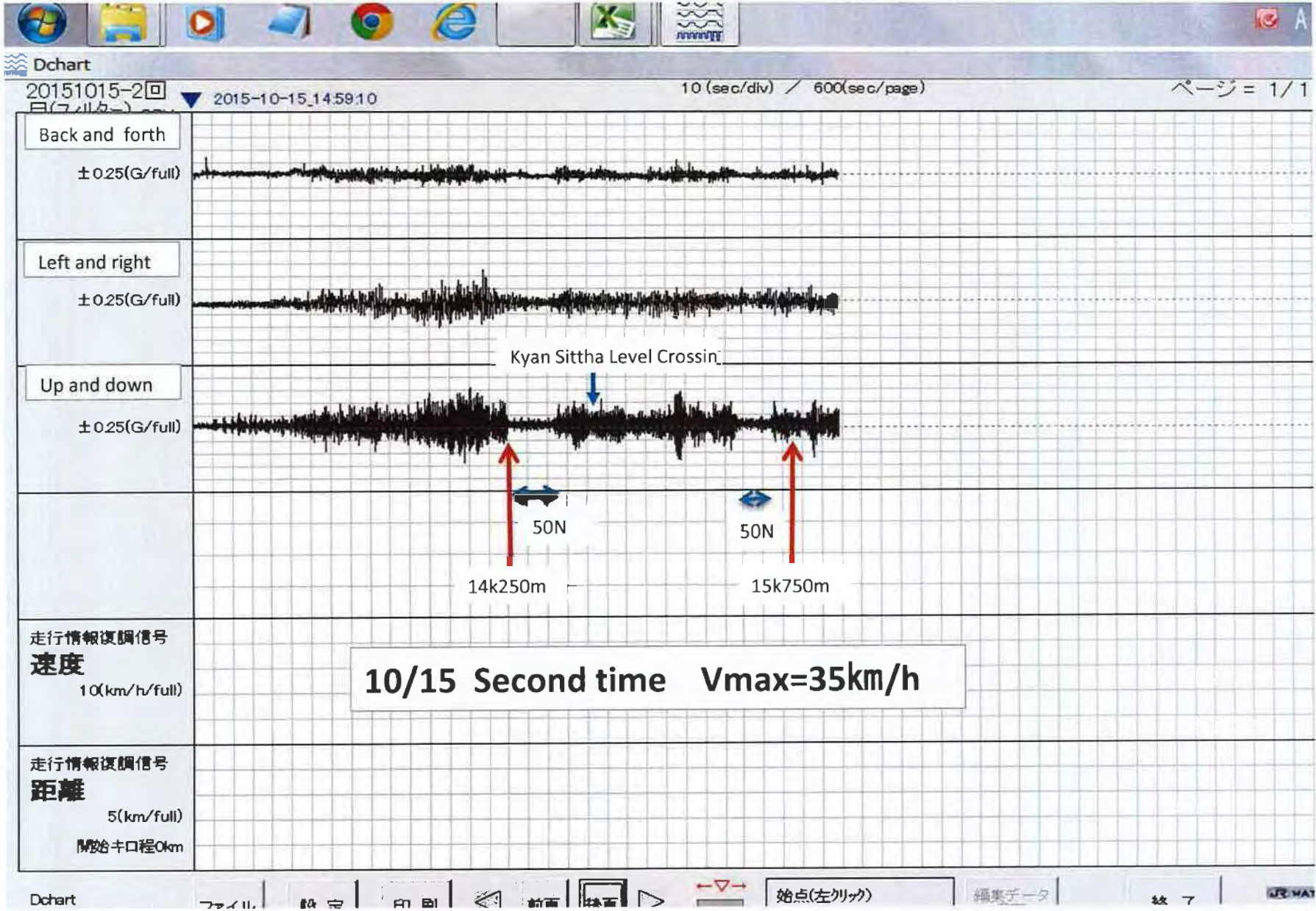

A-8-8-23

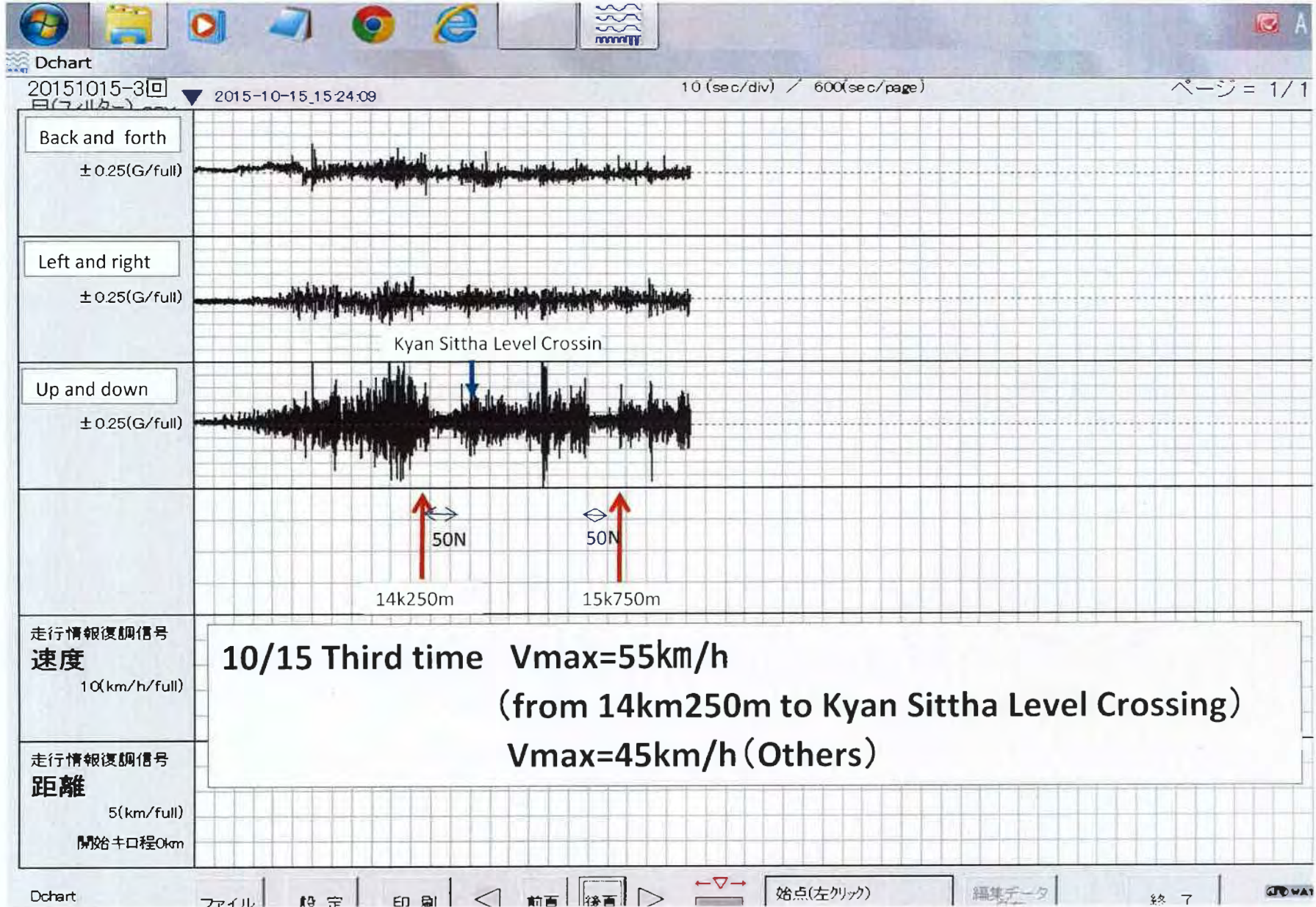

A-8-8-24

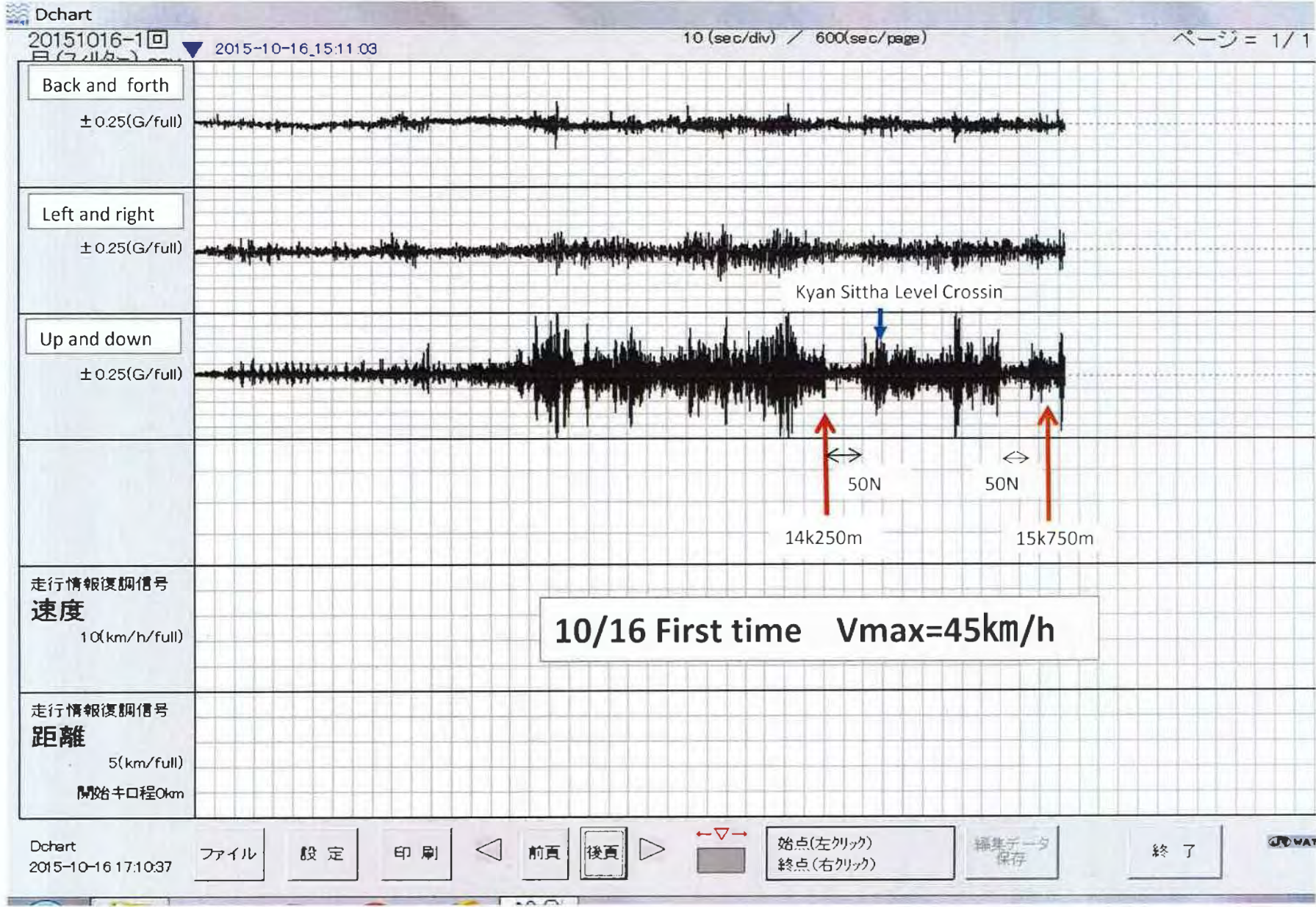

A-8-8-25

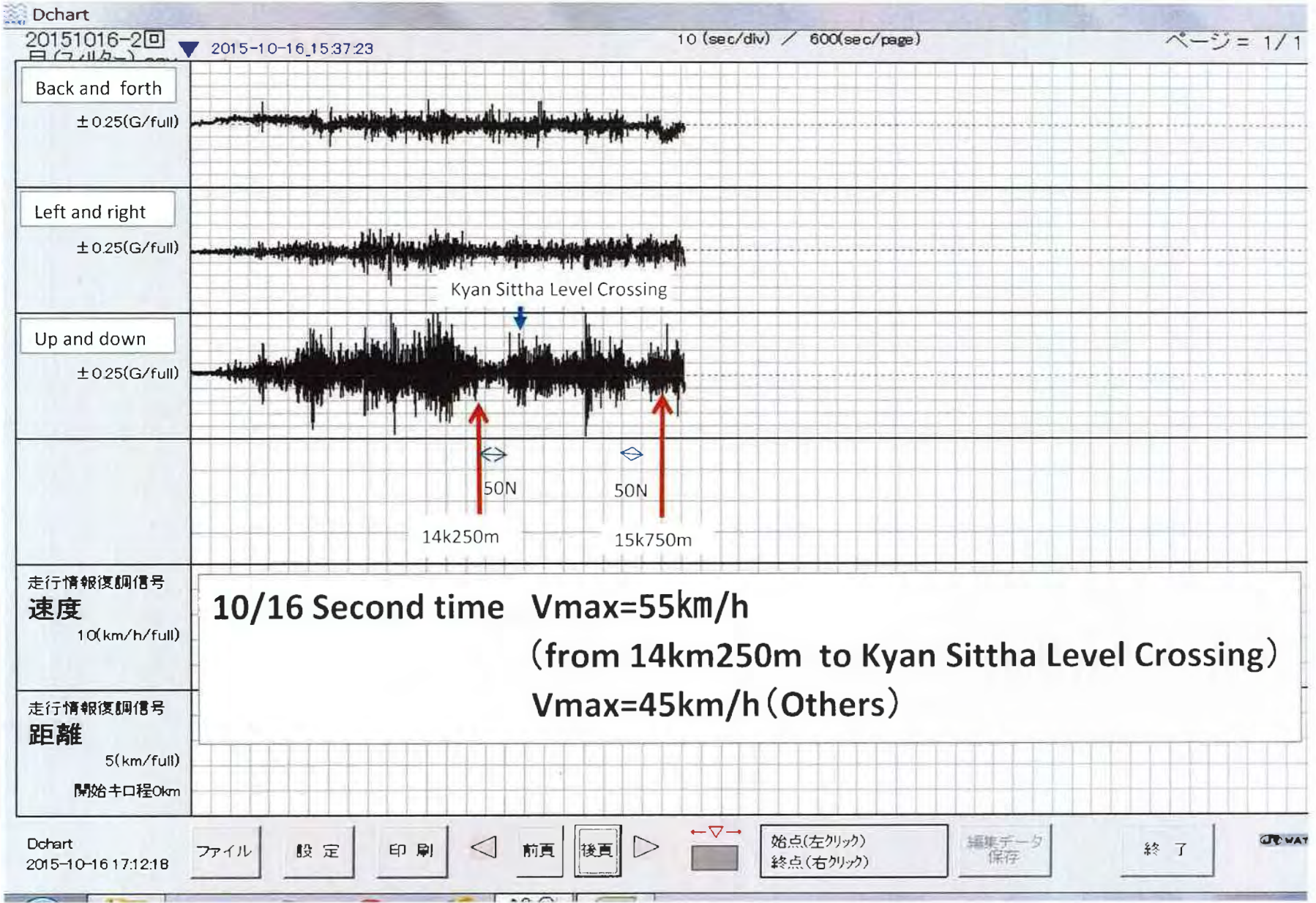

Dchart

20151016-2回
目(フォルダ)

2015-10-16_15:37:23

10 (sec/div) / 600(sec/page)

ページ = 1 / 1

Back and forth

± 0.25 (G/full)

Left and right

± 0.25 (G/full)

Up and down

± 0.25 (G/full)

Kyan Sittha Level Crossing

50N

50N

14k250m

15k750m

走行情報復調信号
速度
10(km/h/full)

10/16 Second time Vmax=55km/h
(from 14km250m to Kyan Sittha Level Crossing)

走行情報復調信号
距離
5(km/full)
開始キロ程0km

Vmax=45km/h (Others)

Dchart
2015-10-16 17:12:18

ファイル

設定

印刷

◀ 前頁

後頁 ▶



始点(左クリック)
終点(右クリック)

編集データ
保存

終了

GD-MAT

A-8-8-26

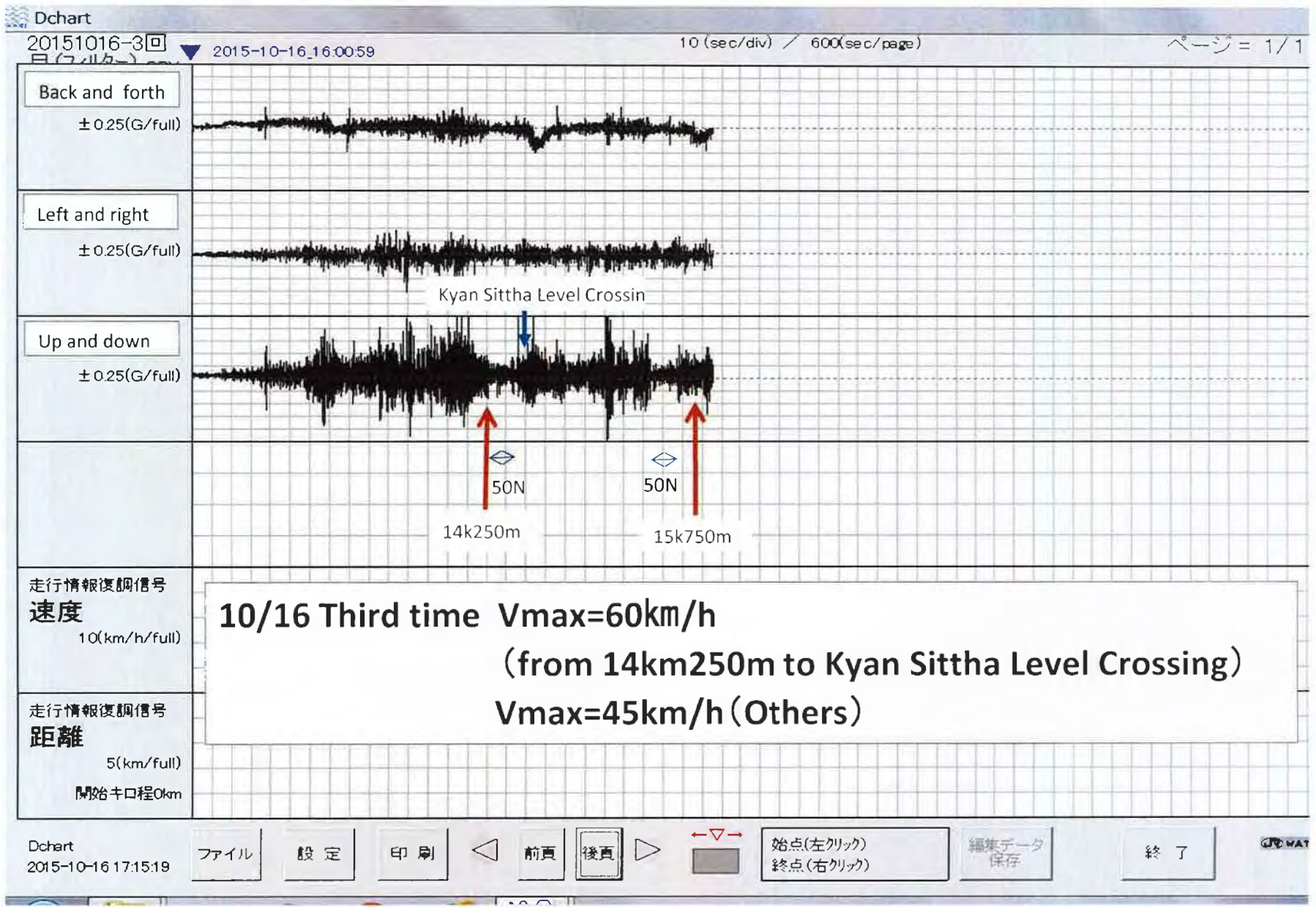

3.3 Outsourcing of track maintenance

This was added at R/D signed on 6th April. We hold meeting or discussion about outsourcing once a month. Contents are as below.

(1)Current Situation in Myanmar Railways

Outline

- Necessary of outsourcing and mechanization because of less engineer
- Workers have some jobs and can't devote themselves to one job.
- Outsourcing has begun between Bago and Waw by 2 groups
- Cooperate with China between Mandalay and Myitkyina
- MR wants to outsource all track maintenance in the future.
- It is difficult to outsource and change organization at the same time.
- Elders should teach to young generation not only technic but also safety.
- Track maintenance will change to mechanization near future.

(2)Introduce of Japanese experience

Outline

- Direct control and contract control (Outsourcing)
- Memorandum between JR and contractor
- Transition process of track maintenance by outsourcing in Japan
- History of track maintenance Organization in Japan (Table 3.3.1)
- Current organization of track maintenance in Japan
- Railway track closing work
- Maintenance car work
- Utilization of outsourcing in track maintenance work

We are thinking work plan as below.

(1)Mixing opinion of Myanmar and Japan

MR and we take good opinion for the future.

(2)Proposal of procedure of outsourcing track maintenance work by Myanmar style

Make proposal of procedure of outsourcing track maintenance work for MR.

(3)Seminar or presentation by Experts

We hold final seminar. or presentation.

Table 3.3.1 History of Track Maintenance Organization in Japan

Classification Type	Organization	Feature
Track Maintenance Before Modernization		<ol style="list-style-type: none"> 1. Dispersed work of small unit 2. Repairing at any time 3. Unification of inspection and working (survey and maintenance by ourselves) 4. Human-wave tactics of hand working mainly
Modernization of Track Maintenance	<p>1964.4</p>	<ol style="list-style-type: none"> 1. Concentrated work in large unit 2. Planning and repairing 3. Separate inspection and work 4. Introduction of machine (Length 10~50 km)
New Track Maintenance Organization	<p>1978.7</p>	<ol style="list-style-type: none"> 1. Specialization of Operator 2. Mechanization deeply <ul style="list-style-type: none"> • 1 Multiple Tie Tamper per 1 Subdistrict • Productive Basement of operation • Save working time 3. Outsourcing of simple task (Ex. Repracement of sleepers)
Improvement of Track Maintenance	<p>1982.3</p>	<ol style="list-style-type: none"> 1. Change to technical group 2. Abolish working G (Outsourcing of simple work and fluctuated work) 3. Leave track its maintenance G 4. Efficiency by diversity of job content <ul style="list-style-type: none"> • Track Supervision G Supervision of inspection, planning and outsourcing • Track Machine G Survey, planning and operationwork of MTT
Improvement of work (Track Maintenance and Civil Engineering)	<p>1985.4</p>	<ol style="list-style-type: none"> 1. Simplification and efficiency by review of working content <ul style="list-style-type: none"> • Review of MTT and Track inspection 2. Diversity of job content and efficiency by fusion <ul style="list-style-type: none"> • Integrate of position of Technique G (Track Maintenance, Civil Engineering, Forestry) • Relegation some parts of civil work to Track Supervision G 3. Efficiency by simplification of organization
Improvement of Track Facility	<p>1986.11</p>	<ol style="list-style-type: none"> 1. Detailed supervision according to characteristics of line 2. Try efficiency and diversity of work 3. Secure safety and stable transportation 4. Concrete contents <ul style="list-style-type: none"> • Review of workers per 1 party of Track Machine G • Abolish subdistricts and Track Residence in lower line and reconstruct supervision section and track maintenance section • Integrate Track Supervision G and Track Machine G in lower line • Review of inspection by getting on train

3.4 Bridge Maintenance (Workshop)

Date : 1,2/10/2015 (Thu. and Fri.)

Place : MR Training Center in Nay Pyi Taw

The number of participants : 20

Training instructor : Mitsuru TAKAMI (Japan International Consultants for Transportation)

Contents :

Mr. Takami reviewed phase 1 (Training of bridge inspection and record, lecture about repairing) and phase 2 (MR's Inspection and repair by themselves). This time was phase 3. He lectured waterway control and mechanism about scour of pier, ratio of stress at steel girder and its calculation, survey result of bridge which MR worried about and how to repair



3.4 Bridge Maintenance

The training for bridge maintenance improvement are consist of 4 phase. From Phase 1 to Phase 3 are already implemented.

3.4.1 Report of Phase 1

The schedule of phase 1 and its participants are shown in table 3.4.1, and table 3.4.2. It was implemented from 27th July to 11th August. Japanese experts assigned for lecturer are Mr. Kazuki KOMON (BMC), Mr. Kazuaki NANAMURA (Rail Tech) and Mr. Mitsuru TAKAMI (Deputy Leader of JICA Expert Team). Its textbook was compiled based on “Modern Inspection and Maintenance Procedure for Railway Structure (ESCAP, 1990)” as attached on Appendix-2 of this report.

Table 3.4.1 Schedule of Phase 1

DD/MM	Training	Place
27 th July	Orientation, Lecture (History of bridge maintenance in JPN, Present bridge maintenance)	Mahalwagon
28 th July	Lecture (Bridge chart and BMC system) Site visit (DG:No.21, DG:No.9)	Mahalwagon Yangon – Bago
29 th July	Site visit (TT:No.32U, TG:No.32D)	Yangon – Bago
30 th July	Site visit (TT:No.13U&D, DG:No.13D)	Yangon – Bago
31 st July	Day off	
1 st August	Day off	
2 nd August	Site visit (Steel trestle: Gokteik viaduct)	Shan State
3 rd August	Site visit (TT: Inwa Bridge)	Sagaing
4 th August	Lecture (site visit result 1)	Mahalwagon
5 th August	Site visit (TT: Sittaung Bridge)	Sittaung
6 th August	Lecture (Site visit result 2 and repairing plan)	Mahalwagon
7 th August	Orientation (BMC measurement system rental)	Mahalwagon
8 th August	Day off	
9 th August	Site visit (PC and Composite Structure: Insein Rail over Bridge), Extra (Nyaung Don Bridge)	Insein
10 th August	Lecture (Site visit review, Stress Ratio theory, Water way control, Painting, Record, etc)	Mahalwagon
11 th August	Orientation	Mahalwagon

Here, DG means Deck Plate Girder, TT means Through Truss, TG means Through Plate Girder, PC means Pre-stressed Concrete Girder, U means Up Line, and D means Down Line.

Table 3.4.2 Participants of Phase 1

No	Name	Department	Position
1	U Zaw Min Oo	Yangon – Mandalay Railway Improvement Project (JICA) Phase 1	Executive Engineer (Civil)
2	U Tin Moe	Yangon – Pathain Railway Project	Assistant Engineer
3	U Than Lwin	Minbu-Ann-Sittwe Railway Project	Work Inspector(1)
4	U Than Swe	Division(7) Yangon	Work Inspector(2)
5	U Maung Chit	Girder Depot (Yangon)	Bridge Inspector(2)
6	U Kyaw Swar Htay	Division(6) Bago	Work Inspector(2)
7	U Tun Tun Win	Girder Depot (Yangon)	Bridge Inspector(2)

During the Phase 1, Japanese experts and Myanmar Railway experts visited 10 bridges including Gokteik Viaduct, Inwa Bridge and Sittaung Bridge. At the each bridge, Japanese expert train MR Expert to improve bridge maintenance technology through the implementation of detail procedures of inspection, record, measurement, judgement, and study for countermeasure. Summary of these 10 bridges inspection results are shown in table 3.4.3.

Table 3.4.3 Summary of 10 bridges

Bridge name	Remarkable deterioration	Counter measure	Suggestion for better maintenance
Gokteik DT	corrosion on floor plate	Cleaning, usual maintenance, repainting	Replace rotted wooden sleeper with fuck bolt, install drainage
Inwa TT	Corrosion on cross beam web, losing rivet on bracing	Cleaning, Usual maintenance, repainting, fasten rivet and bolt	Monitor the under surface of traffic road floor, Replace rotted wooden sleeper with fuck bolt
Sittaung TT	Loosing rivet on additional stringer edge	Cleaning, Usual maintenance, repainting, fasten rivet and bolt	Remove waste wooden sleeper Monitor the under surface of traffic road floor
No.9	Main girder corrosion Sleeper support	Cleaning , Repainting, Remove wooden sleeper	Replace the corroded lower flange of main girder
No.13 DG	Crack on welded attached plate	Monitoring	Remove existing plate and attach new plate with hi-tension bolt
No.13 TT	Crack on web of stringer	Plate attaching with hi tension bolt	At first installing stop hole
No.21 DG	Crack on pier	Temporary repairing, Zonal plate wrapping, monitoring	Reconstruction pier
No.32 TT	Damage of train derailment	Monitoring, especially stringer end	Replace damaged member
No.32 TG	Corrosion on cross beam	Monitoring, especially stringer end	Attaching plate, lateral replace
Insein PC	Additional mortar on surface	Monitoring	Remove mortar which has closed crack

Among these, Japanese experts worried about No.13TT and No.21 DG. They were necessary to implement emergency counter measure by consideration of Japanese Standard. Thus, finally, Japanese expert suggest MR how to measure them after exchanging opinion with MR engineer.

The 3 bridges, Gokteik Viaduct, Inwa Bridge and Sittaung Bridge, are not so bad condition. Due to MR earnest maintenance, there is no heavy deterioration should be repaired in urgently. Moreover, regarding to quantitative measurement by Japanese expert, we didn't confirm irregularity. It should be better that heavy rotted wooden sleeper upon these bridges are replaced and fasten on girder with hook bolts. Keeping exist maintenance work, 3 bridges can be in good condition for long time with existing train operation. But, for improving train speed, another detail study will be necessary.

Reviewing phase 1, MR trainee's, 7 person's, attitude toward this training are quite positive,

active, and earnest. Japanese lecturers are fully satisfied through the training with MR trainee and honor of them. And it is confirmed that MR has a high level of bridge maintenance technology beyond our expectation, inspection and repairing and other counter measure and record.

U Myat Lin, former secondary headmaster of CITC, compiled “ Inspection and Maintenance for Rail Structure” in 2014. In 1990, he participated ESCAP program, and learned modern inspection and maintenance technology for railway structure from Japanese Expert (JARTS and JICA). The compiled text book should be reference of MR bridge maintenance.



Displacement measurement on Gokteik Viaduct



Inspection training on Inwa Bridge



Lecture in Girder Depot



Inspection training on No.32



Skelton drawing training on No.9



Stress measurement training on No.13

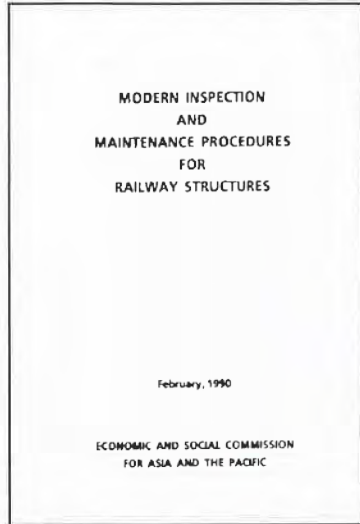

1990 ESCAP



2014 C.I.T.C(U Myat Lin)

3.4.2 Report of Phase 2

After completing of Phase 1, Phase 2 program had been started. This phase is training of MR expert by themselves using some equipment that Japanese expert rented to MR. MR experts would inspect bridge, and repair some bridges which inspected on Phase 1. From 5th October to 8th October, Japanese Expert, Mr. Mitsuru TAKAMI, inspected their progress and suggested their improvement and followed up MR referring their report. Follow up schedule is shown in table 3.4.4 and relevant participants are shown in table 3.4.5.

Table 3.4.4 Follow up schedule on Phase 2

DD/MM	Training	Place
5 th October	Preparation, Bridge depot survey, site visit (DG:No.9)	Mahalwagon
6 th October	Site visit (DG:No.21, DG/TT:No13,DG:No.9)	Yangon – Bago
7 th October	Site visit and measurement training (TT:No.32U),	Yangon – Bago
8 th October	Supplementary teaching for stress analyzation and fatigue	Yangon – Bago

Table 3.4.5 Participants of Phase 2 follow up

No	Name	Department	Position
1	U Zaw Min Oo	Yangon – Mandalay Railway Improvement Project(JICA) Phase 1	Executive Engineer (Civil)
2	U Sein Myint	Girder Depot (Yangon)	Bridge Inspector(2)
3	U Than Swe	Division(7) Yangon	Work Inspector(2)
4	U Maung Chit	Girder Depot (Yangon)	Bridge Inspector(2)
5	U Han Sein	Division(6) Bago	Work Inspector(2)
6	U Tun Tun Win	Girder Depot (Yangon)	Bridge Inspector(2)
7	U Aung Win Myint	Division(2) Ywahtaung	Work Inspector(3)



Report from MR



Inspection measurement training follow up

4 Supply of additional equipments

JICA Expert team has conducted technical transfer of track maintenance and we have donated more than 70 kinds of equipments. We decided to donate additional equipments which need to maintain track for MR.(Table 3.4.1) Especially, we think that analog standard gauge, tie tamper, generator and jack for rail are very important. 1 set is necessary for each division.

These equipments will arrive in Yangon Port end of November or beginning of December. As soon as import procedure finish, we'd like to hand over.

Table 3.4.1 Additional equipments

	Equipment	Nos	Manufacturer
1	Analog standard gauge G=1000	8	KANEKO CO.,LTD.
2	Instrument detection for track	8	KIDOUGIKEN
3	Tie tamper (1set=4pieces)	8	SHIBAURA ELRTEC CORPORATION
4	Generator	8	SHIBAURA ELRTEC CORPORATION
5	Equipment for ballast tamping	8	HITACHI KENKI KAMINO CO., LTD.
6	Basket made by bamboo or plastic	40	SEKISUI KAGAKU KOGYO CO., LTD.
7	Light track trolley 1ton G=1000	8	YOSHIKE KAKEN KIKI CO., LTD.
8	Rail lifting machine	10	TOKO SANGYO CO.,LTD
9	Jack for rail	48	NICH CO., LTD.

5 How to proceed until end of this project

This project (including Recommendation of technical standards relating to administrative and maintenance aspect and drawing up railway facilities improvement plan to improve service and safety level) began in May 2013. Technical transfer of track maintenance began from October 2013.

At first, pilot section of technical transfer was about 20km between Yangon and Bago. But we and MR changed the way to make trainees replace in 1 month. So we and MR changed to the place around Toeggyaunggale Sta. to teach many technical things (For instance turnout, bridge and curve, etc.) in 1 month.

Now signal and telecommunication project is proceeding. Therefore turnout will be very important for civil and track maintenance. We are going to teach technical transfer (especially, turnout) near Yangon Sta. In detail, we would like to discuss with counterpart.

6. Schedule (PLAN)

Year/Month	2015/10	2015/11	2015/12	2016/1	2016/2	2016/3	Remark
Common	▽8th JCC	▽New equipments will arrive	▽Hand over additional equipments (at Yangon, NPT and Japan)	▽Final JCC	▽Activity Report		
Track Maintenance	▽Test Run	▽Finish OJT of track Maintenance					Yangon Sta.
Bridge Maintenance							
Outsourcing of track maintenance work							
Others							

Toilet System of Rolling Stock



Part 1

History of Toilet System in Japanese Railway

Opening of Japanese Railway

Japanese railway opened in 1872 between Tokyo and Yokohama



Installation of Toilet

At first there was no toilet on the coach.

Toilet was installed on the coach from 1889.

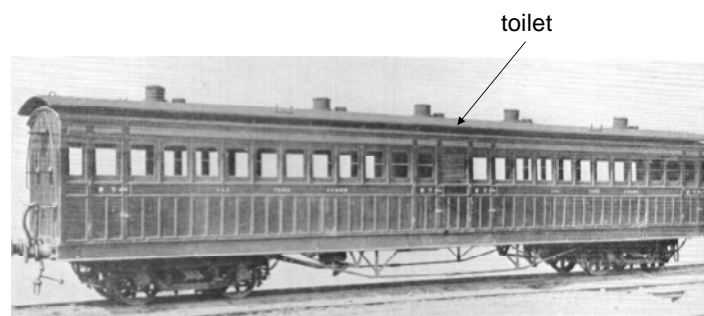

Hopper Toilet

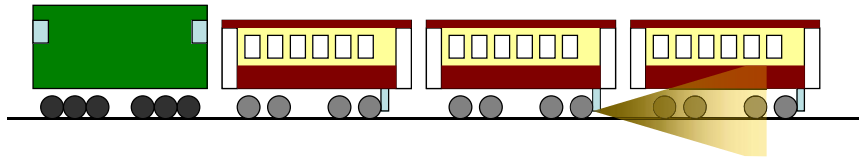

Crush Type Sanitation System

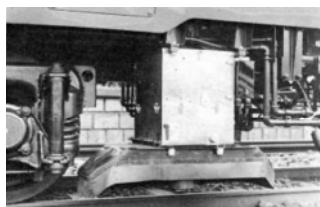
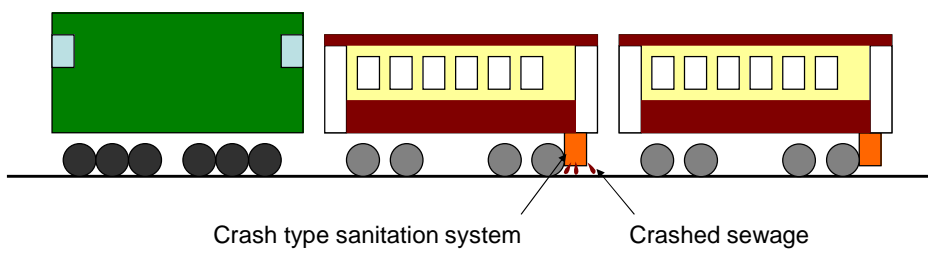

Excretion Tank System

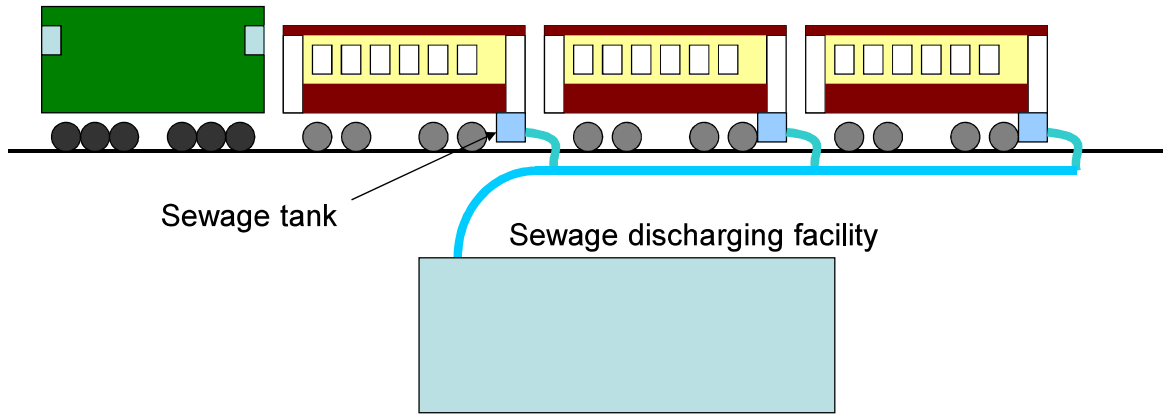

Excretion Tank System



Opening ceremony of Tokaido Shinansen (Oct.1 1964)

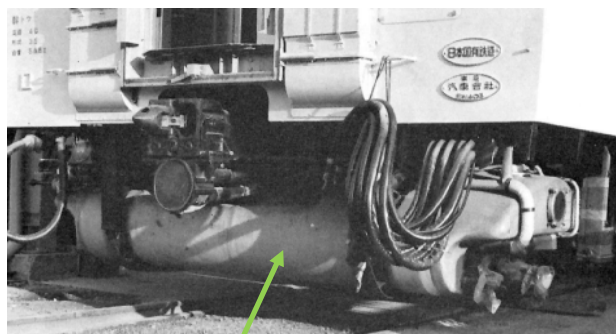

Excretion Tank

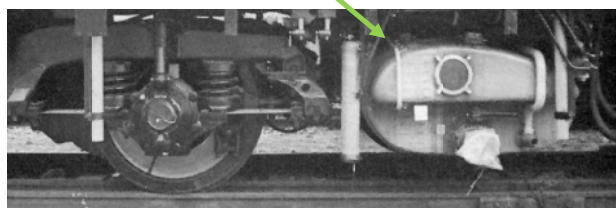

Excretion Tank System

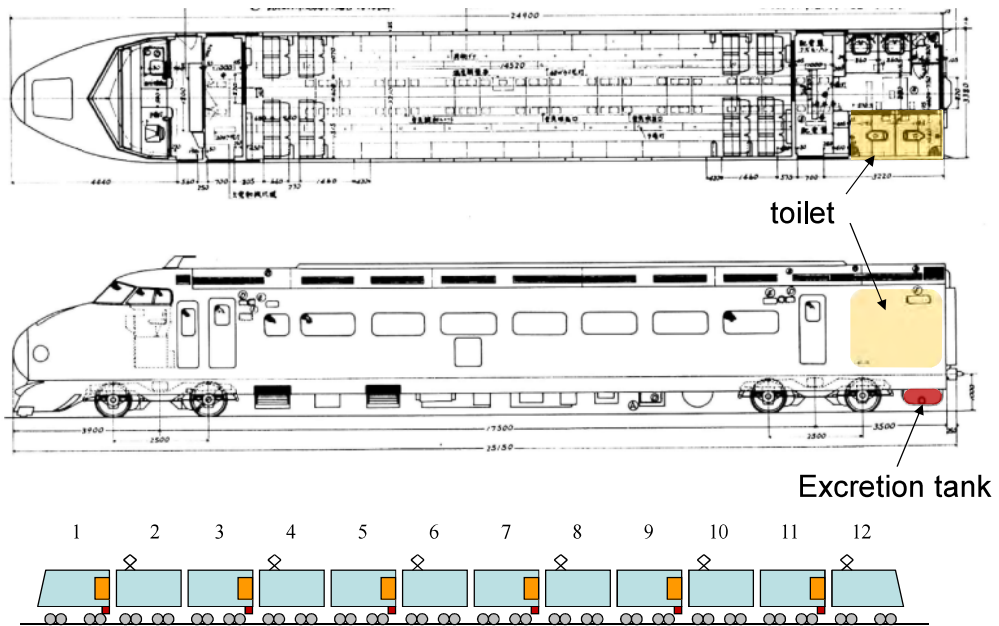

Circulate Type Sanitation System



Cassette Type Sanitation System



Cassette Type Sanitation System

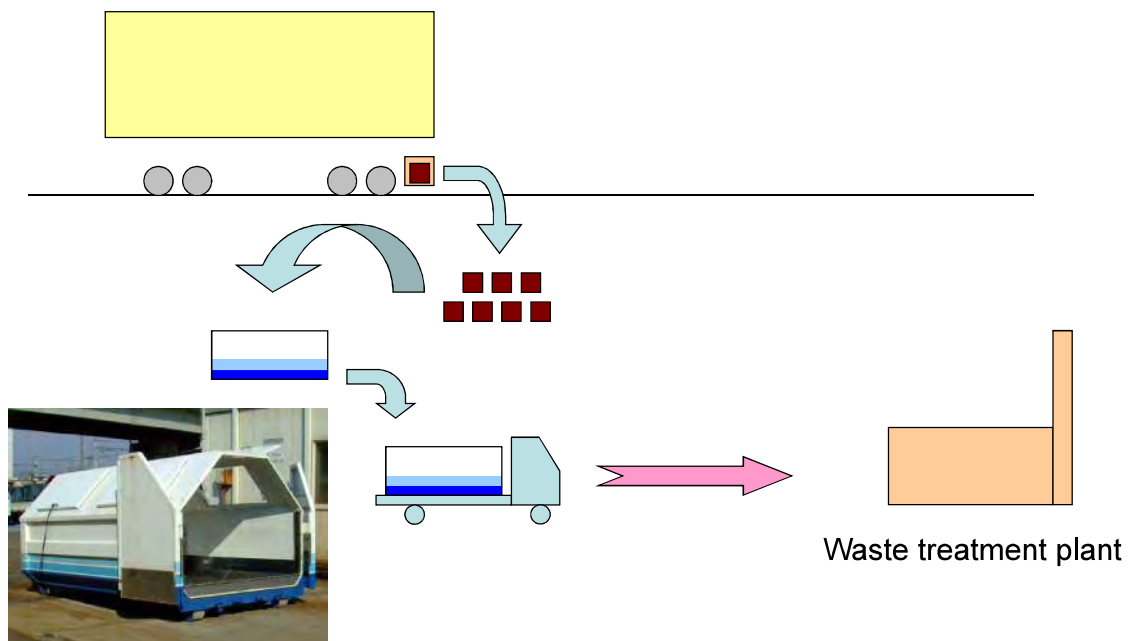

Vacuum Type Sanitation System



Discharging Facility of Depot

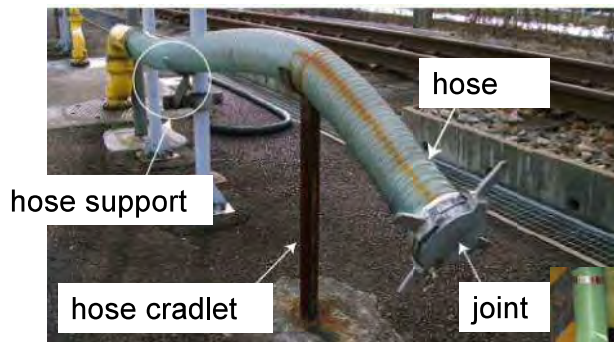

Flow of Excretion of Tank System (1)

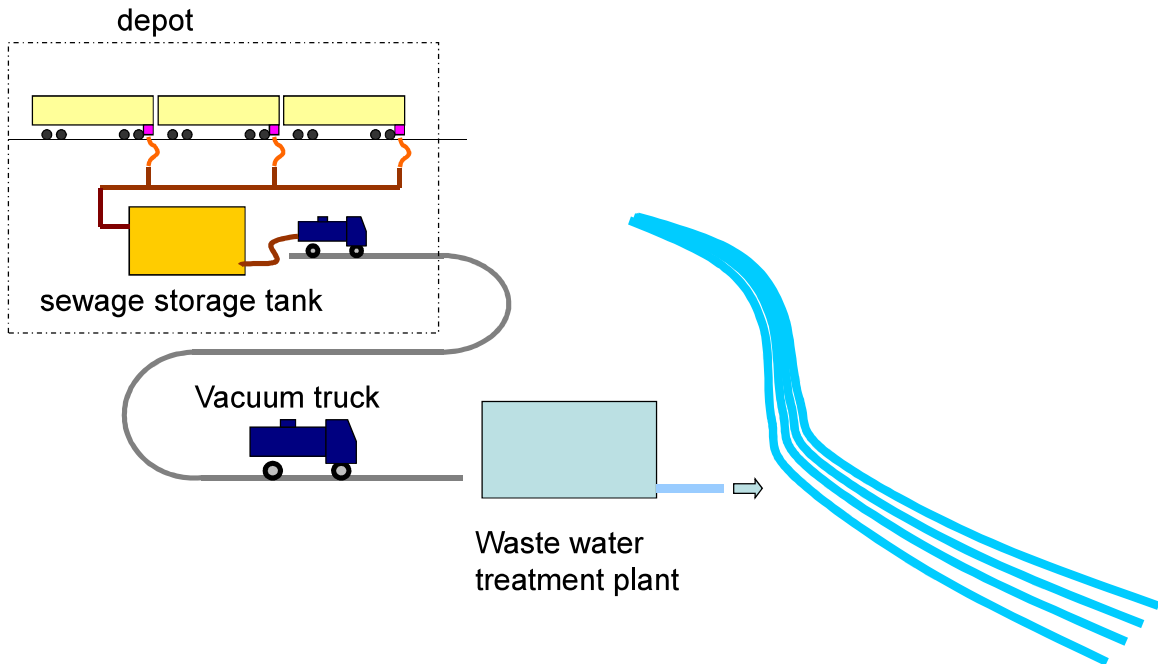

Flow of Excretion of Tank System (2)

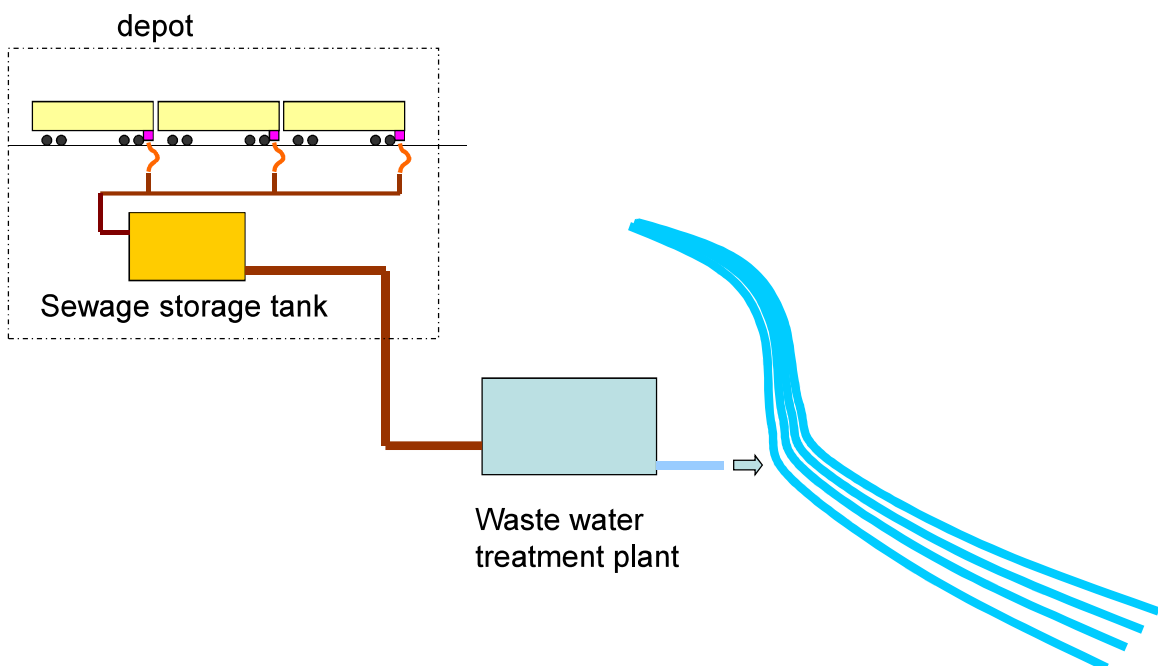

Flow of Excretion of Tank System (2)

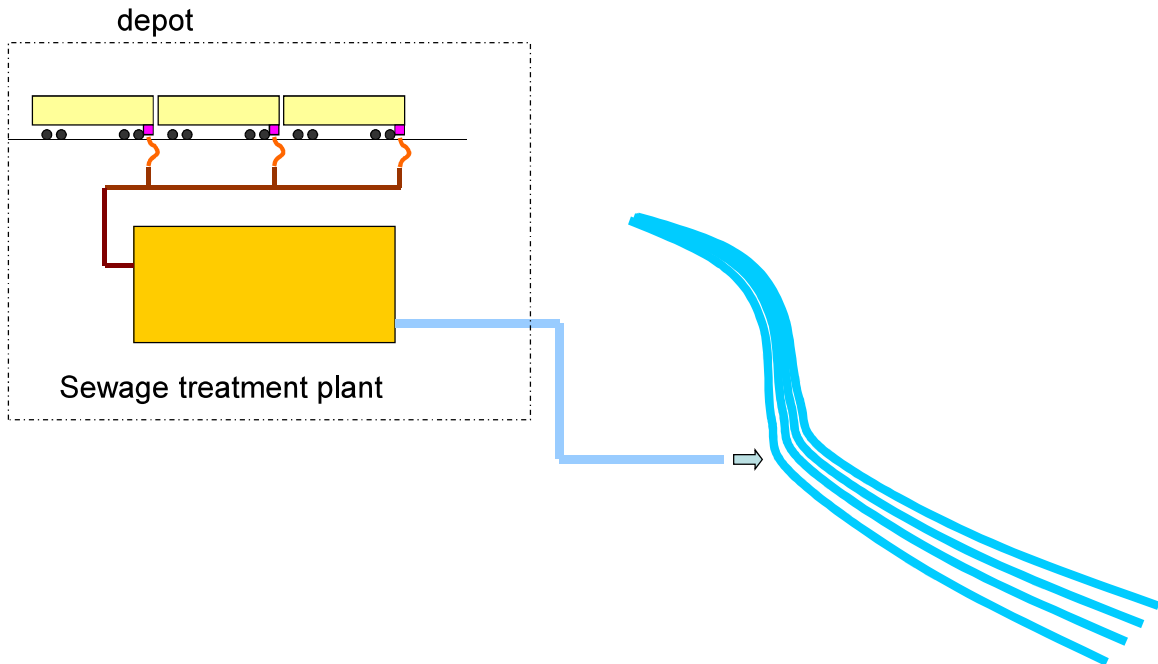

Sewage Treatment System of Depot

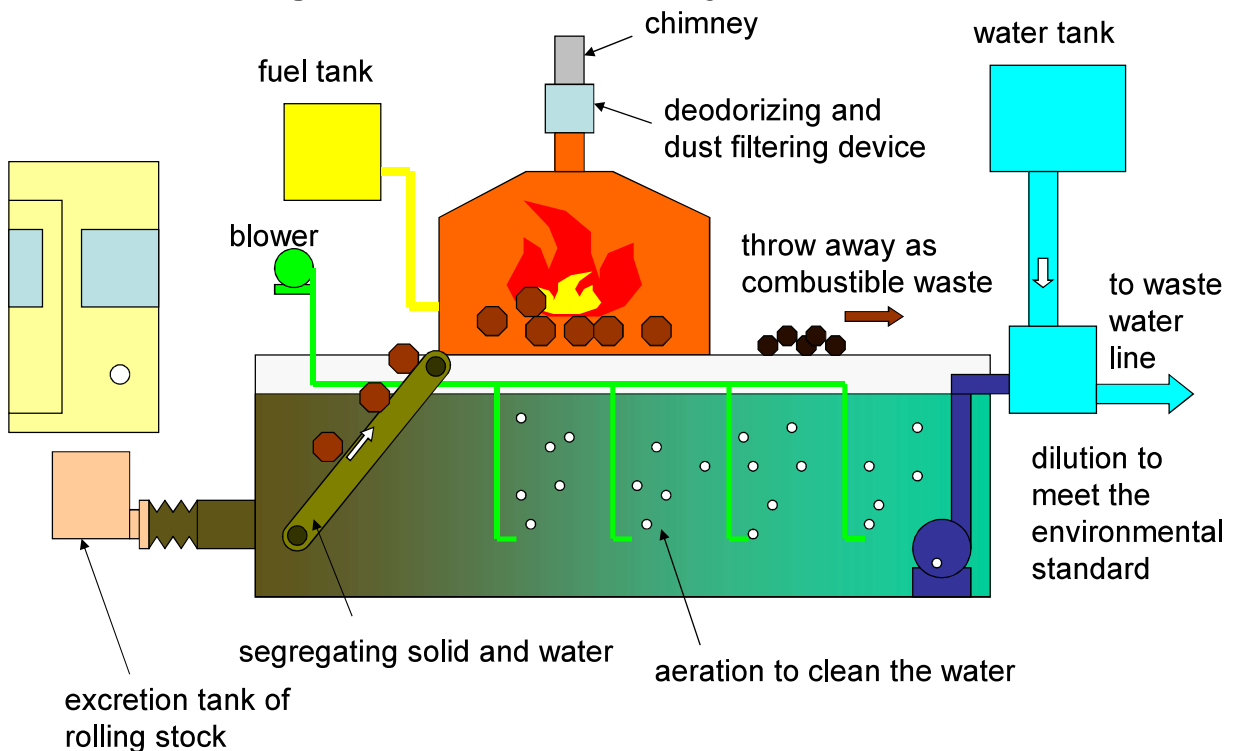

Burning Type Sanitation System



Electric Train that burning type sanitation is installed

Biotechnological Type Sanitation System



Change of Toilet System of Railway in Japan

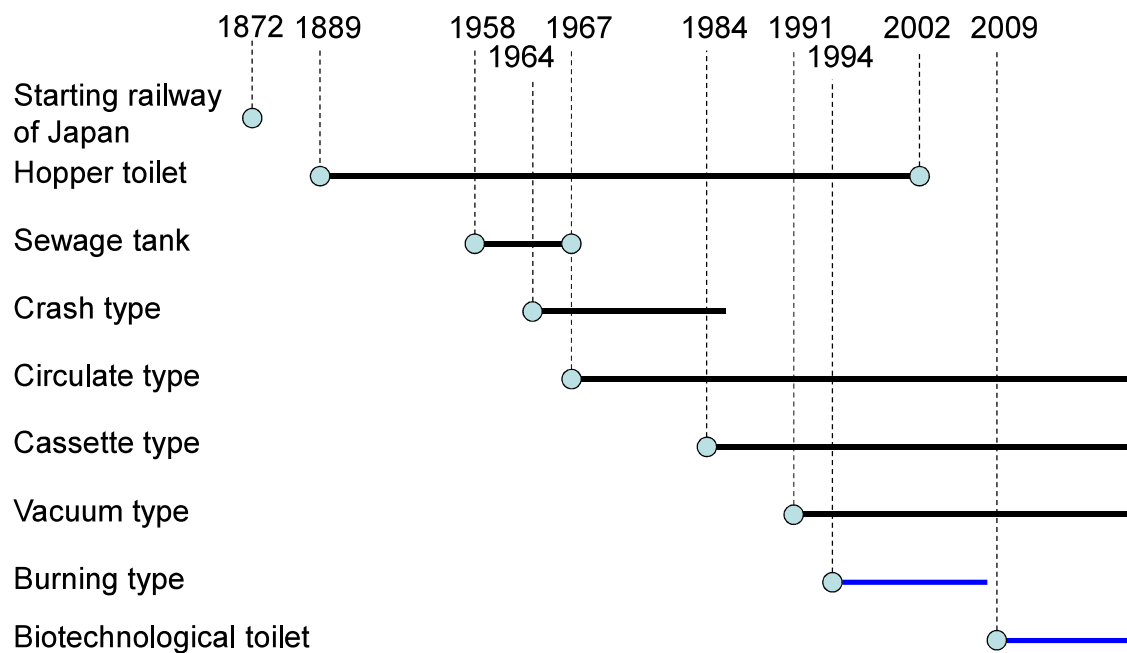

Regal regulations about toilet of railway

Toilet of Rail Car

1964: Waste Disposal Act: Railway operator is forced to solve the problem of hopper toilet.

1987: Standards of Railway Structure: Hopper toilet is prohibited.
(It is applied for the cars newly constructed or toilet newly installed.)

Wastewater Standards of Japan (Health Item)

Kinds of harmful substances	Tolerable limit	Kinds of harmful substances	Tolerable limit
Cadmium and its compounds	0.1 mg/L	1,2-dichloroethane	0.04 mg/L
Cyanide compounds	1 mg/L	1,1-dichloroethylene	0.2 mg/L
Organic compound (limited to parathion, methyl parathion, methyl demeton and EPN (ethyl p-nitrophenyl phenylphosphorothioate))	1 mg/L	cis-1,2-dichloroethylene	0.4 mg/L
Lead and its compounds	0.1 mg/L	1,1,1-trichloroethane	3 mg/L
Hexavalent chromium compounds	0.5 mg/L	1,1,2-trichloroethane	0.06 mg/L
Arsenics and its compounds	0.1 mg/L	1,3-dichloropropene	0.02 mg/L
Mercury and alkyl mercury, and other mercury compounds	0.005 mg/L	Thiram	0.06 mg/L
Alkyl mercury compounds	Not detected	Simazine	0.03 mg/L
Polychlorinated biphenyl	0.003 mg/L	Thiobencarb	0.3 mg/L
Trichloroethylene	0.3 mg/L	Benzene	0.1 mg/L
Tetrachloroethylene	0.1 mg/L	Selenium and its compounds	0.1 mg/L
Dichloromethane	0.2 mg/L	Boron and its compounds	Other than sea area: 10 mg/L Sea area: 230 mg/L
Carbon tetrachloride	0.02 mg/L	Fluorine and its compounds	Other than sea area: 8 mg/L Sea area: 1 mg/L
		Ammonia, ammonium compounds, nitrite compounds and nitrate compounds	(*) 100 mg/L
		1,4-dioxane	0.5mg/L

(*) 0.4 times the ammonia nitrogen compound, and the total of nitrite nitrogen and nitrate nitrogen

Wastewater Standards of Japan (Living Environment Item)

Kinds of harmful substances	Tolerable limit
Hydrogen ion concentration (pH)	Other than sea area: 5.8 – 8.6 Sea area: 5.0 – 9.0.
Biochemical oxygen demand (BOD)	160 mg/L (Daily mean value: 120 mg/L)
Chemical oxygen demand (COD)	160 mg/L (Daily mean value: 120 mg/L)
Suspended solids (SS)	200 mg/L (Daily mean value: 150 mg/L)
Normal-hexane extracts content (mineral oils content)	5 mg/L
Normal-hexane extracts content (animal and plant fats content)	30 mg/L
Phenols content	5 mg/L
Copper content	3 mg/L
Zinc content	2 mg/L
Soluble iron content	10 mg/L
Soluble manganese content	10 mg/L
Chromium content	2 mg/L
Coliform group number	Daily mean value: 3,000/cm ³
Nitrogen content	120 mg/L (Daily mean value: 60 mg/L)
Phosphorus content	16 mg/L (Daily mean value: 8 mg/L)

Note: The effluent standard shown in this table is applicable to the effluent water discharged by a plant, factory, or business establishment which discharges 50m³/day or more of effluent water on daily average.

Part 2

Outline of Toilet System

Classification of Toilet System of Rolling Stock

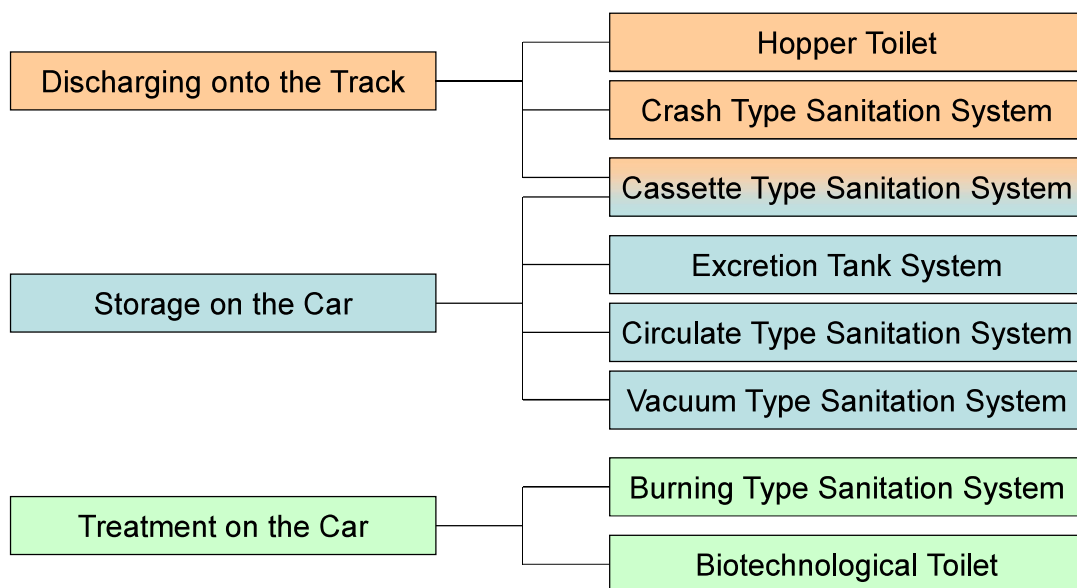

Hopper Toilet (Open Type)

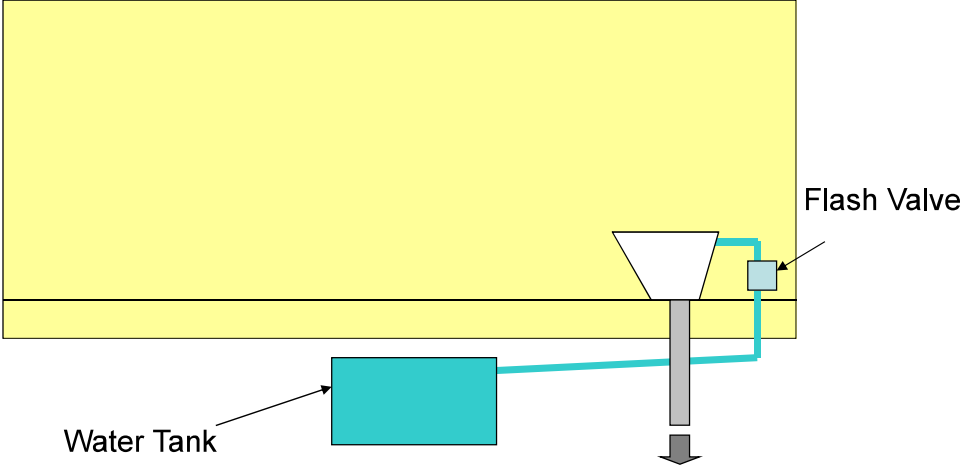

Ventilator of Hopper Toilet

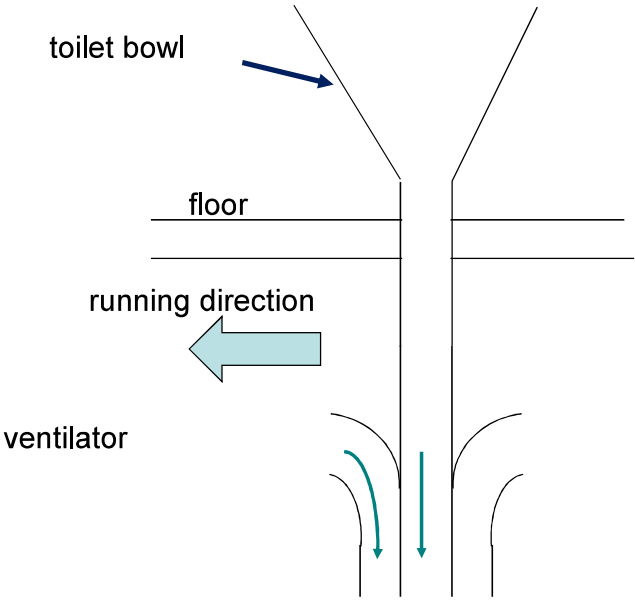

Crush Type Sanitation System

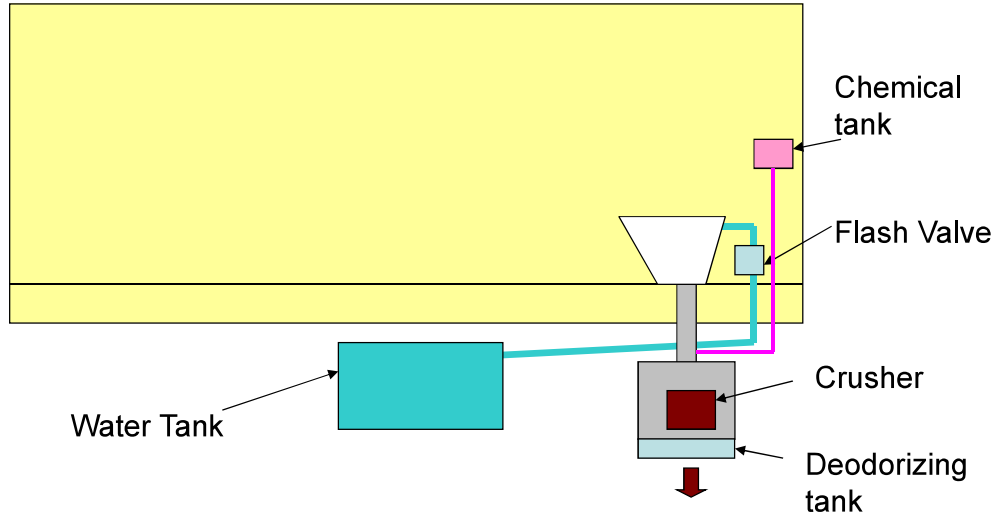

Crush Type Sanitation System

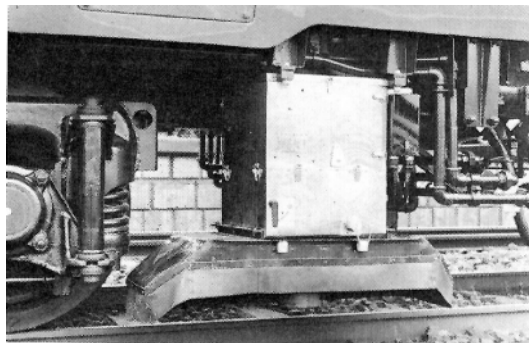
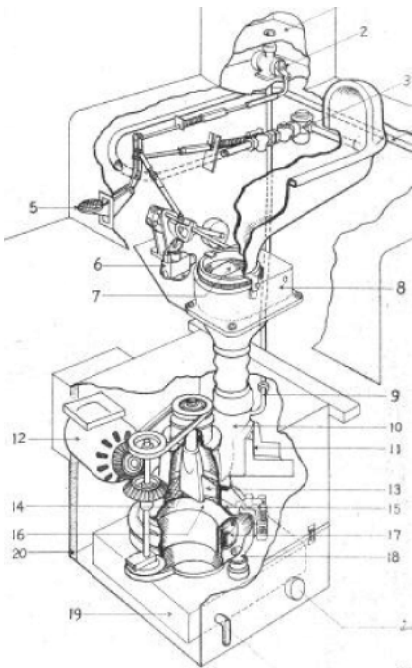

Cassette Type Sanitation System

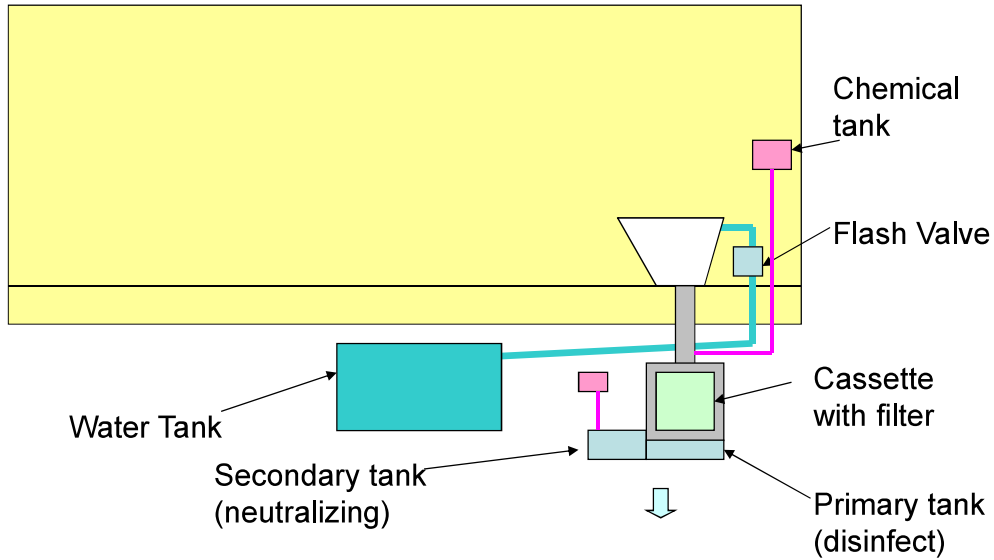

Cassette Type Sanitation System

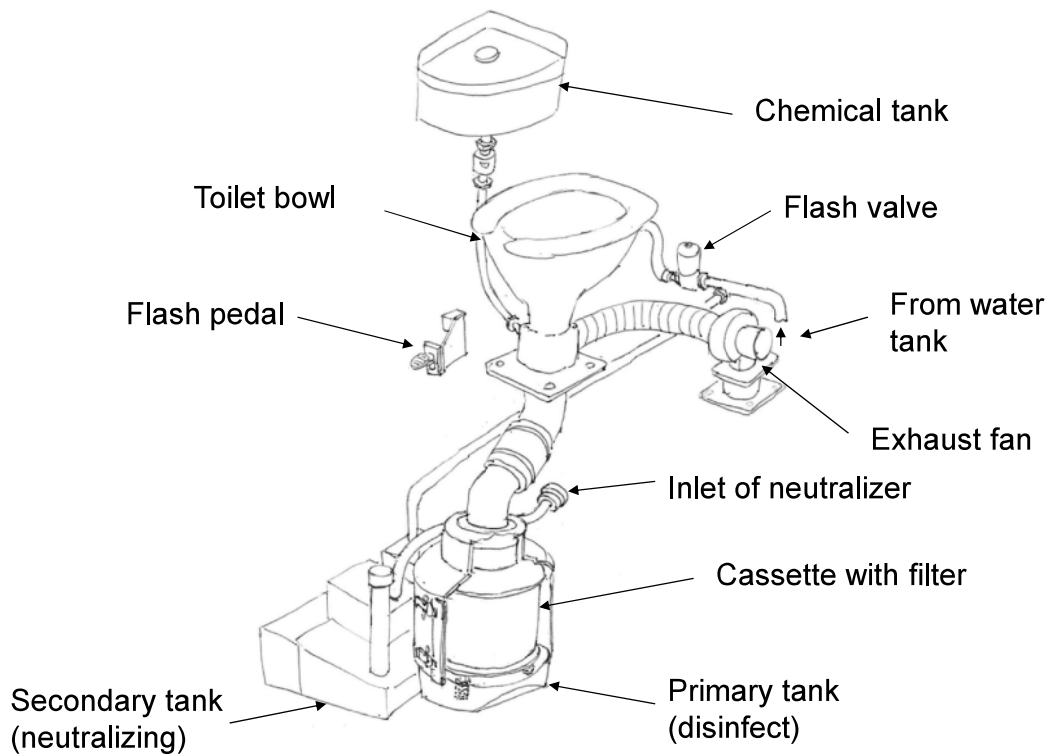

Cassette Type Sanitation System



Cassette Type Sanitation System



Excretion Tank System (Simple Tank)

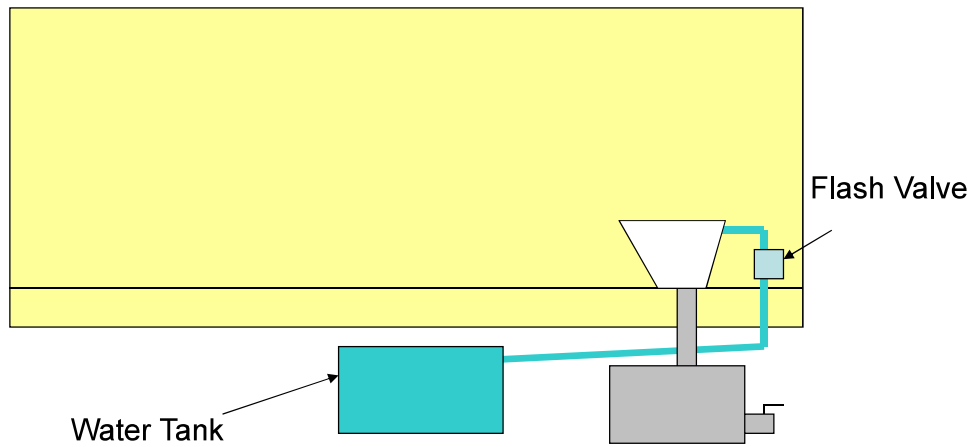

Circulate Type Sanitation System

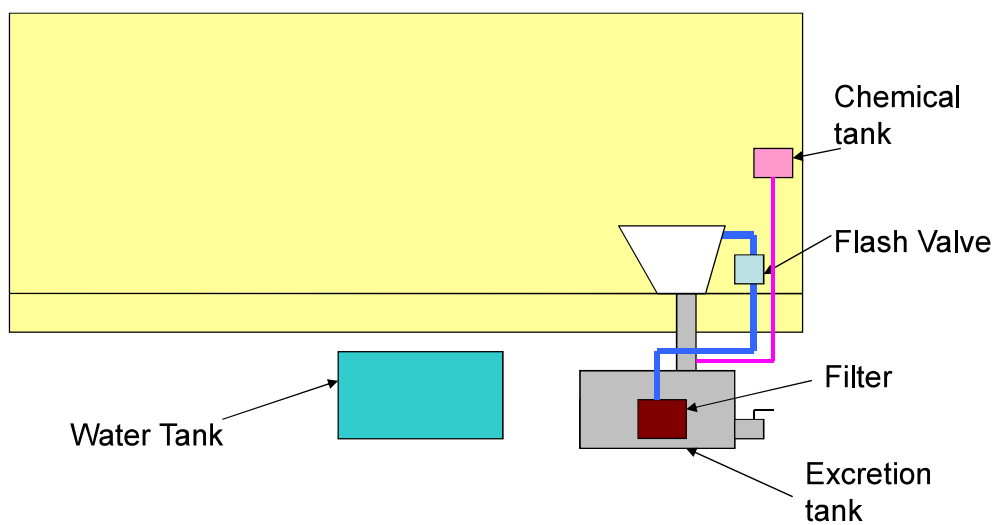

Circulate Type Sanitation System

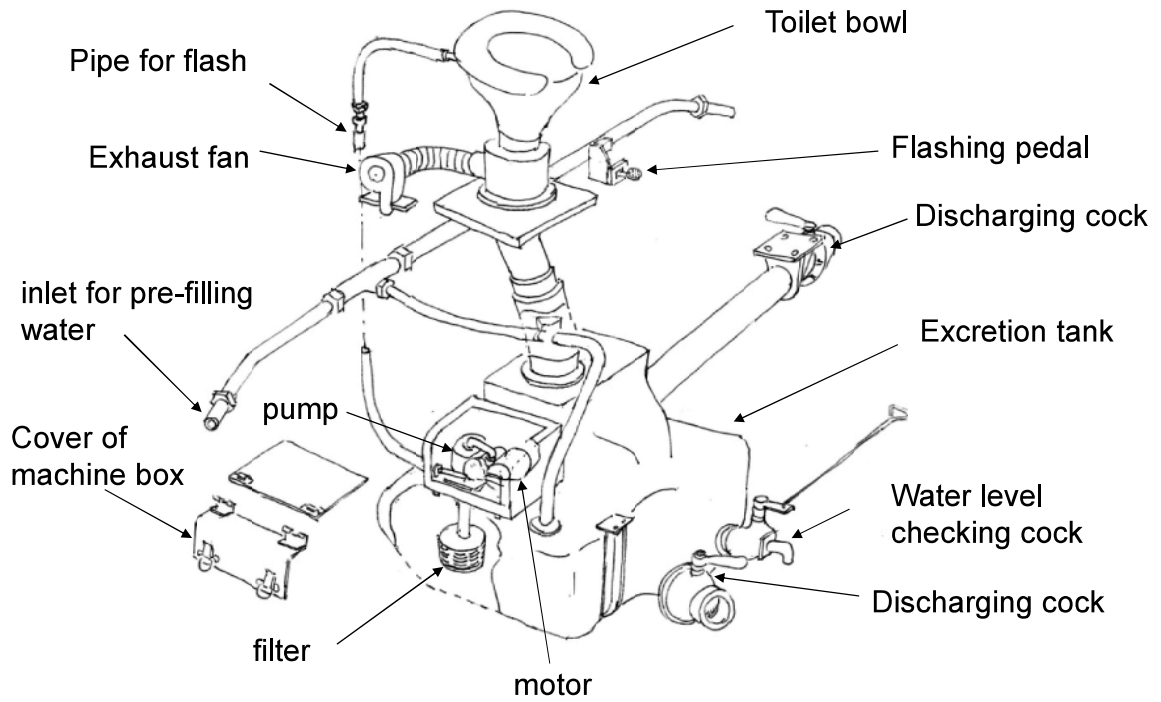

Circulate Type Sanitation System



Circulate Type Sanitation System



Vacuum Type Sanitation System

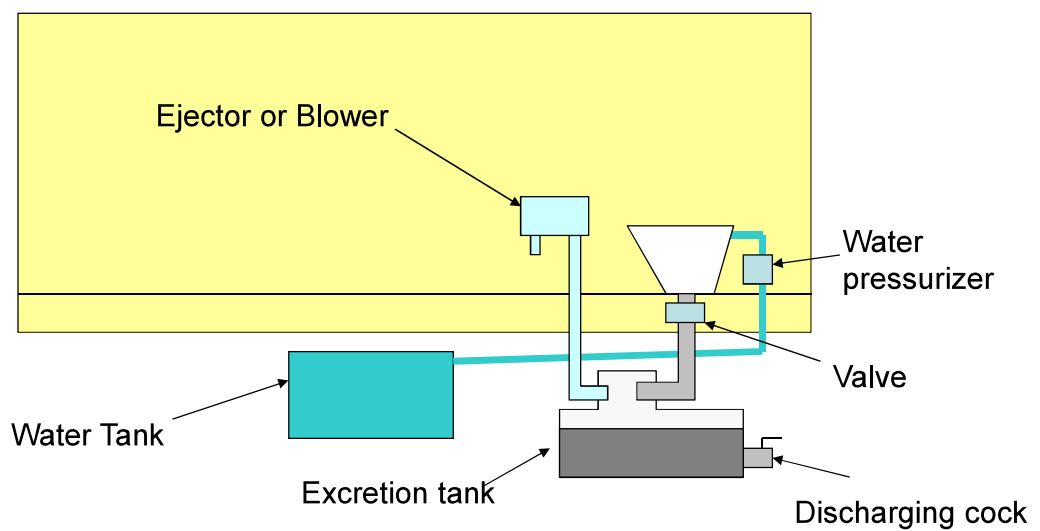

Vacuum Type Sanitation System (compact type)

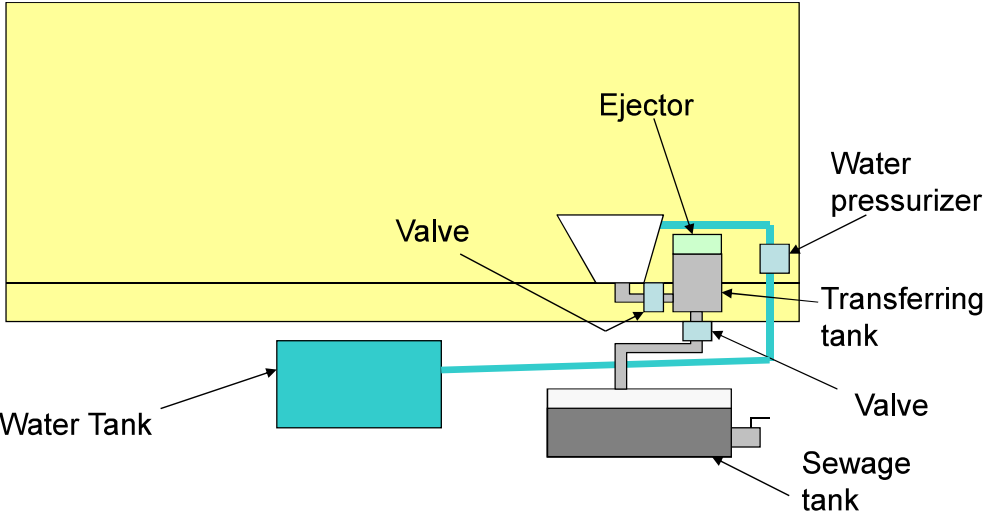

Vacuum Type Sanitation System



Burning Type Sanitation System

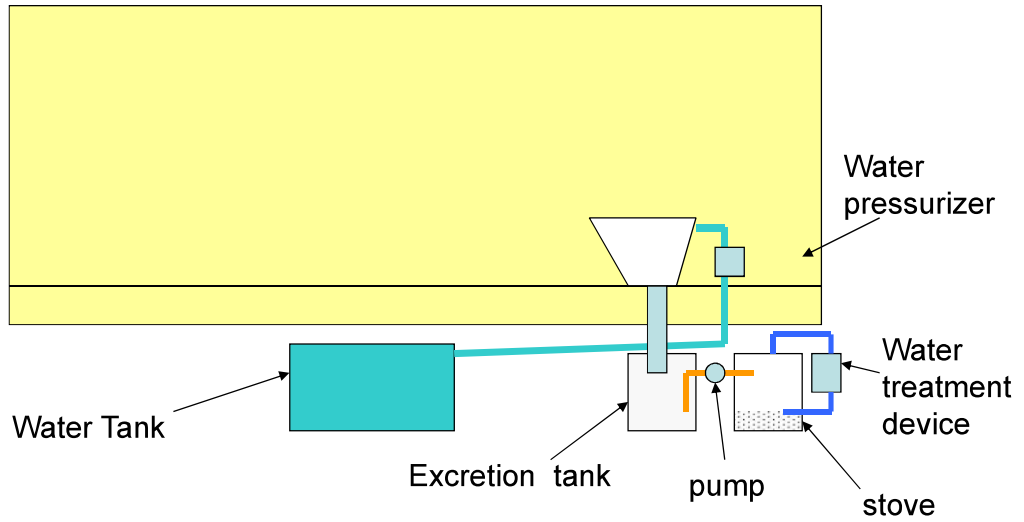

Biotechnological Sanitation System

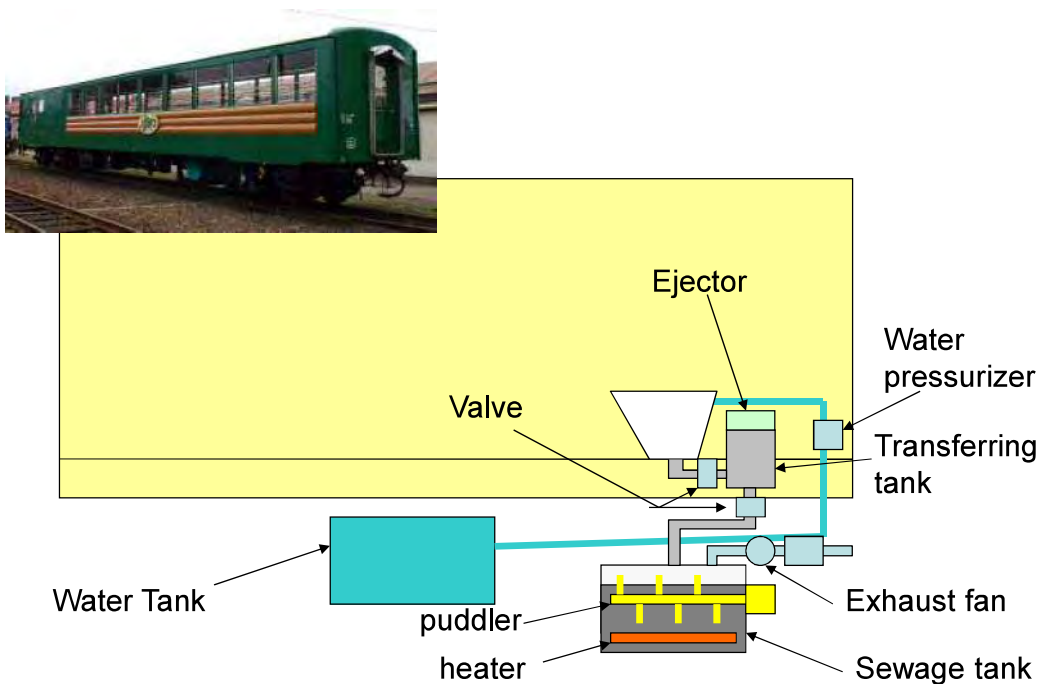

Facilities for Toilet System of Rolling Stock

Type of System	Water supply	Electricity	Ground facility
Hopper toilet	for flashing	not required	not required
Crush type	for flashing	for crusher	not required
Cassette type	for flashing	for valve and exhaust fan	storage for cassette
Simple tank	for flashing	for exhaust fan	Waste water treatment plant
Circulate type	*not required	for exhaust fan, filter and pump	Waste water treatment plant
Vacuum type	for flashing	for blower and valve	Waste water treatment plant
Burning type	for flashing	for burning	not required
Biotechnological	for flashing	for valve	not required

* Water is filled in the tank before using. Water supply is used for washing hands.

Comparison of Toilet System of Rolling Stock (1)

Type of System	Advantage	Disadvantage
Hopper toilet	<ul style="list-style-type: none"> • Simple • No facility in the depot is required 	<ul style="list-style-type: none"> • Not hygienic at wayside • Damaging wayside equipment • Damaging under floor equipment of rolling stock • Passengers are prohibited to use the toilet while train stops at station
Crush type	<ul style="list-style-type: none"> • No facility in the depot is required 	<ul style="list-style-type: none"> • Swage is discharged on the track • There are mechanical moving parts that require maintenance. • Crusher will be broken when things are thrown into the bowl
Cassette type	<ul style="list-style-type: none"> • No mechanical moving parts to maintain • Equipment is smaller compare to other system 	<ul style="list-style-type: none"> • Water is discharged on the track • Treatment of cassette at the depot is required

Comparison of Toilet System of Rolling Stock (2)

Type of System	Advantage	Disadvantage
Simple tank	<ul style="list-style-type: none"> No mechanical moving parts to maintain 	<ul style="list-style-type: none"> Waste water treatment facility is required at the depot Large tank capacity is required Frequent discharging at the depot is required
Circulate type	<ul style="list-style-type: none"> Tank is smaller compare to simple tank Water consumption is minimized 	<ul style="list-style-type: none"> Waste water treatment facility is required at the depot There are mechanical moving parts that require maintenance. Water in the tank become high density of chemical
Vacuum type	<ul style="list-style-type: none"> Odor is suctioned by vacuum Tank can be located not just beneath the toilet 	<ul style="list-style-type: none"> Waste water treatment facility is required in the depot
Burning type	<ul style="list-style-type: none"> No facility in the depot is required 	<ul style="list-style-type: none"> High consumption of electrical power supply on the car
Biotechnological	<ul style="list-style-type: none"> No facility in the depot is required 	<ul style="list-style-type: none"> There are mechanical moving parts that require maintenance

Thank You Very Much

Appendix-2

Project on Improvement of Service and Safety of Railways in Myanmar

**TEXT BOOK
FOR
MAINTENANCE OF RAILWAY BRIDGES**

July 2015

JICA Expert Team

Page	
1. Brief history of railway structure maintenance development in Japan	1
1.1 Organizational changes	1
1.2 Establishment of technical standards	3
1.3 Administrative measures to make effective use of the inspection system	5
1.4 Operational Safety during abnormal weather of disaster	6
2. Bridge maintenance	8
2.1 Inspection	8
2.2 Standards for judgment of structure soundness	11
2.3 Countermeasures based on inspection results	13
2.4 Check points of deformation and inspection of railway structures	15
2.5 Countermeasure for rehabilitation	44
2.6 Recording inspection results	46
2.7 Structure inspection chart	49
3. Patrol inspection	52
3.1 Purpose of patrol inspection of rail tracks	52
3.2 Monitoring of rail tracks	53
3.3 Principle of guarding against disasters	53
Appendix	
1 The way to consider the train speed restriction due to state of damaged deck girder	58
2 The processes of repairing brick piers	64

1. Brief history of railway structure maintenance development in Japan

“To inspect them regularly and to repair in proper timing is the only way to maintain rail way structures in safe and good conditions,” as stated in the beginning of the Modern Inspection and Maintenance Procedures for Railway Structures, and is a commonly recognized standard in many countries and organizations other than railways, such as highway, electric power, water works, and sewerage authorities. However, it was not until the 1960’s that systematic inspection and repair had been effected in Japan. In the following below, we will take a brief look at the history of inspection systems for railway structures in that country.

1.1 Organizational Changes

Generally, when there are few railway facilities, there are many cases where one organization is in charge of track, buildings, electricity, etc., with individual supervisors managing various fields themselves as well. Similarly, when the number of lines is small and their operating length short, the area of operation is not divided up and is administered by one organization.

Divisions in the hierarchy of management procedures: inspection, planning of repair works, discussion with outside organizations, formulating the budget, and executing the works have also formed into the present state from rougher ones in accordance with the numerical growth of railway property and development of technologies.

By the way, in the period from 1860’ till 1910, when the development of railway network was roughly completed, the technologies in relation with railways were accumulated exclusively inside the railway authorities, and the complementary systems in private sectors were not enough to substitute for the work force under direct government control. As personnel expenses were generally cheap at that time, it was better in regard of security for safety by reliable craft and quick solution to let the work force under direct government control compare with to try to reduce the personnel expenses by investing the systems and facilities of the outside sectors and utilizing their results. If we go back further to the past, we will find the tendency that more and more matters are taken charge of by the same persons and organizations and under direct government control.

The story in which Japanese railways have formed the present organizations after many changes in themselves would be suggestive to the future organizations of the railways in those countries which keep more features of early times.

In the organization norm established right after the integration and nationalization of Japanese railways in 1909, civil engineering structures were classified into the same sections buildings, though distinguished from tracks.

This organization lasted until the division between civil structures and building emerged in the organization norm established in 1936.

The department of works of reform and repair, which lasted until 1965 with minor modifications, took charge of repair works of railway civil engineering structures and had a large numbers of work force for masonry repointing the bridge painting. No department exclusive for inspection

existed at that time. But this does not mean that there was not any idea to repair the structure on the basis of inspection results. Especially after World War 2, significance of inspection became to be recognized through " investigation into the actual conditions of railway structures" carried out by civil engineering department of rail way headquarters, for many structures were seriously damaged by the war and neglected to be repaired because of the delay of recovery in the national economy, and therefore typhoons and heavy rains easily affected the railways to long term suspension of many structures in poor conditions caused restriction of the train speed. The findings in this investigation gave one of the motivations for the modernization of the organizations in 1965.

The period around 1965 was the era when Japanese National Railways carried out the modernization of organizations in almost every division on the principle of substituting outside sectors for the work force under direct control, and slimming of the organizations and the work force. As the results of the modernization in the department of works, that followed this principle, all kinds of occupation in charge of direct execution of repair works were abolished, and at same time, the former department of works became to be divided into "works" and "inspection"; the split of this is to supply ample man power for grasping the actual conditions of the structure, which was neglected when execution of repair works and inspection of structures are assigned to the same persons. This is how the work system in which the repair works are executed on the basis of the inspection results was established.

The second modernization in 1971, which was aimed to strengthen the advantage of the separate system of works and inspection, gave birth to the "structure inspection center" in each regional office. After the second modernization, it was decided that while the routine inspection to find the defects on a structure is carried out by the inspection group of track maintenance sections, high level surveys and decision of countermeasures for the known defects are left to the structure inspection centers.

At that time, it was possible to reduce the total work force and to increase commission to outside sectors, because the outside sectors had growth to have substantial abilities to execute such business as geological surveys and stress measurements, and it had become possible to formulate the budget enough to entrust outside sectors with necessary inspections on the judgement of the responsible engineers inside the railway authorities.

Another sprit of this modernization is to improve the quality of inspection by founding the structure inspection centers: uniting the rating judgements, which had varied among the each inspection group of track maintenance sections; and raising the members' morale by setting persons of high ranks as the head of the structure inspection centers.

The third modernization was effected in 1981, where the functions of structure inspection centers were strengthened and the group of works and the inspection in the level of track maintenance sections were re-united for the sake of more effective and slimmer organizations.

This was resulted from the circumstances of that time in which an independent inspection group in track maintenance sections was unnecessary and unattractive since the inspection of structures

had been built up as a sound technological field by the members of the structure inspection centers.

The newly established railway companies, which were founded by division and privatization of Japanese National Railways inherited these scheme of the structure inspection.

1.2 Establishment of technical standards

As mentioned in the preceding chapter, the numbers of professional engineers and their technical ability in the field of the structure inspection have increased in Japan through the long term course of separation and stabilization as an independent field of technology in the organizations.

But mere establishment of organizations is not enough to execute inspections without serious deviation or errors in data and judgements. As a matter of course, technical standards and some text books for practical inspection procedures are requested to be edited. And responsibilities of the persons in charge of inspection throughout all priorities must be provided in the regulations.

It was not before the time of the modernization effected in 1965 that the technical standards and operational regulations for the structure inspection as a whole was built up in Japan, though each technical guide had been given in each period. This may be considered to be rather late compared with the main technical standards and operational regulations for construction of railway structures, which were built up in around 1930's.

There was no comment about bridges in "the Patrol Knowledge", which was edited as the rules on the whole line and dates back to 1870's. In 1906, new circumstances came out where 17 private railway companies were absorbed into the national railways, so that it became to be necessary to grasp the physical conditions of the bridges which were inherited from the former private companies and sometimes doubtful for their load capacity because they had been constructed various designs different from those of the national railways.

Accordingly, an overall survey into the actual conditions of the bridges, which are the most important structures, was executed in accordance with "The knowledge for inspection of the existing bridges" published in 1914. It was followed by "The bridge inspection regulation" in 1923, in which the inspection period of once every 2years for every bridge was settled. It can be understood that this regulation also settled to check the scouring of the bridges, for one of the items of this regulation says "Check tilt, settlement, or track of erosion on the pier and the abutment."

Inventional plans and documents of civil engineering structures, buildings and track facilities were standardized by "Knowledge of maintaining inventories for fixed assets" in 1935, probably in order to compile the information about the bridges obtained by the inspections since 1920's.

The above tells us a rudimentary system in the way to maintain structure had been built up by around 1925, as well as other major technical standards such as "construction regulation" and "design standard", and this system lasted without any noticeable change for the time beginning.

It was by the investigation in to the actual conditions of the bridges, which was carried out in 1949 for need of the re-assessment of the total fixed assets involved by the alternation of the

management form to a public corporation, that the total number and price of the fixed assets by region, by line, by kind of structure, by type of structure, by group of age and in need of repair and replacement was clarified.

The actual conditions of the structures should have been grasped on the regulation in 1920's, but not enough in reality. Besides, civil engineering structures were regarded to be permanent aside from the cases of partial repairs and disasters. But the results of the nationwide investigation showed that aging and deterioration of the structures had advanced more badly than expected, and the problem came to be regarded to be serious also from the viewpoint of management.

Under these circumstances, the methods of maintenance and checking of structures at that time were complied to "Knowledge of structure maintenance" (draft) in 1956, and it gave a foundation for further steps of the modernization.

"Structure inspection standard" was edited in 1965, in accordance with the start of the inspection department, in which inspection items and period for all types of structures were fixed. Some problems emerged after introducing "Structure inspection standard": how it is clear when, what and how to inspect, but how to rate the results? And, when and what to do against the defects?

Comprehensive technologies in a whole cycle of inspection, rating and repairing were compiled into "Standard for replacement of civil engineering structures" edited in 1973. In this standard, the classification of rating, that is, AA, A1, A2, B, C, and S was fixed in accordance with the definition of the physical conditions of structures. The linkage of the rules in structure maintenance was completed systematically at this time.

Since the Japanese National Railways (JNR) was privatized the regulations differ from those in the corporation era.

Previously JNR's regulations were in three parts. The first part was the supervision regulations approved by the President which concerned JNR policy. The second part was the standards approved by the relevant Director concerning the executive policy of each section, and the third part was the standards concerning management control of technical aspects within the approved standards.

The "Regulations on Supervision for Structures" covered the maintenance work for structures. These included several standard regulations for guidance by the relevant Director. Following those regulations, the "Regulations on Standard for Structure Inspection" were formulated. They covered such fundamental issues as the type and detail of inspections, officers in charge of inspection works and analysis of the inspection findings.

The items of the regulation were as follows:

(a) Inspection Works

- i. Inspection of structures and environmental investigation
- ii. Measures concerning the results of the inspection and investigation
- iii. Layout of diagrammes and notes on the inspection

(b) Types of Inspection

- i. General inspection – Regular / periodical inspection decided by the responsible director

- ii. Extra ordinary inspection – this inspection was carried out in the case of unexpected circumstances
- iii. Individual inspection – this was made if there was a need for accurate and particular inspection or system – wide inspection

(c) Responsible inspector

The person responsible for the regular and extraordinary inspection was either a chief or an equivalent official with similar qualification.

(d) Measures against defects

Following inspection, if the divisional chief discovered defects in structures the defects were to be rehabilitated according to their seriousness by:

- i. Emergency measures – to maintain safe train operation for passengers, these measures should be taken immediately/
- ii. General measures – following inspections, necessary negotiation with the maintenance personnel, requirements of construction and simple repairs are needed. Another regulation, “ Standard Regulation for Installing Track Protection Equipment” concerns the disaster-resistant strength for track structures. A part of this regulation reads as follows

*Formulation of disaster-resistant strength

The General Manager must devise by sections disaster-resistant strength complying with the degree of importance of the railway line. In this case, the disaster –resistant strength should not be lower than the following excess probability years: 1st priority grade line is 70 years, 2nd is 30 years, 3rd is 10 years, 4th is 2years.

Regarding the inspection work for structures, “The structure Inspection Standard” was devised in 1965. This gives details items of inspection periods and points in accordance with the above-mentioned regulations. Field inspections are mainly carried out by complying with these regulations.

1.3 Administrative measures to make effective use of the inspection system

As mentioned above, the inspection organization for railway structures in Japan had formulated and prepared the technical standard and regulations. However, these inspections form accurate records of the structures, which are updated periodically. However, if there is no change, the regular inspections are continued. However, if there has been change, more rigorous inspections are introduced. Therefore the inspection procedures monitor the conditions of the structures. And it can be said that there were many cases where no change was shown or of the change not being noticed. These cases tended to become stereotyped. Therefore, the engineer in charge of the inspection, had to stimulate and activate the organization for inspection.

In order to ensure that all structures were safe, the railway companies in Japan have introduced several measures:

(a) Dissemination of the results of inspection and Planning

The responsible organization in head office, receives the results of inspections and checks the

results and recommends the forthcoming schedule, bearing in mind the budget implications of the regional organization's request.

(b) Relating the results of inspection to the necessary rehabilitating works. It is necessary to allocate the budget for rehabilitating works that the responsible engineer has judged to be necessary and ensure the inspection results will provide the rehabilitation.

(c) Holding of technical workshops, where public recognition can be given to excellence of the inspectors.

(d) Ensuring the human resources. Highly educated and experienced engineers should be allocated to the inspection department. And the post of the engineers in the said department should be elevated to the highest rank.

(e) Development of inspection technology and its improvement. In order to make the best use of the establishment of the above-mentioned organization for the inspection, it is necessary to prepare the regulation techniques.

It is important to measure more precisely such things as the stresses and deflections that the structure is bearing and to be able to predict the deterioration of the materials so that rehabilitating work can be planned to maintain the permanent way in a safe operation condition.

Regarding the current condition of the structures, it is necessary to interpret the data from both an engineering and a quantitative stand point.

Regarding these technical developments in Japan, the examination commences in the laboratory. Progresses are always being made on inspection procedures.

Regarding the current condition of the structures, it is necessary to interpret the data from both an engineering and a quantitative standard point. Additionally, it is necessary to analyze the results and the condition of the structures.

Regarding these technical developments in Japan, the examination commences in the laboratory. Progress is always being made on inspection procedures.

1.4 Operational Safety during abnormal weather of disaster

In an ideal situation the aboved mentioned organization and regulations are used to inspect the actual condition of the structures on a day to day basis and maintain them to carry normal traffic. However, when such natural calamities such as earthquakes, flooding, etc. which exceed the bearing capacity of the structures, it is not possible to avoid structural damage. In order to minimize the damage, it is essential to protect the structures against the abnormal weather and ascertain their safety by restricting movements if necessary. Nowadays, in Japan the above-mentioned routines are covered by regulations. Such a maintenance system is essential for the progress of inspection technology. But this is not limited to civil structures. Therefore the safety system is little different from that which aims at inspection only.

Hereby, the history and the present status of the safety system used in Japan are described as followings.

Formerly there was no method for ensuring safe operation in abnormal conditions. Only routing

monitoring was stipulated in the "Regulations and Train operation" (Aug. 1900):

In order to avoid the danger of train operation, the track should be inspected by linemen at least daily.

In extreme cases watchmen were stationed at key points.

The method used in the event of abnormal weather was described in "Natural Disaster Guard Information"(1923). This covered the following:

- (a) A roster was produced for the emergency call of every track gang.
- (b) Depending on the seriousness of the situation there were two types of patrol. One by all members of the track maintenance team, the other by half of them
- (c) Even if no patrol was called for, the track maintenance group remained on standby for inspection of the line
- (d) Methods of dealing with accidents

According to the list, it would appear that there were no standard of weather conditions for inspection, and no standard for judging the degree of danger to the tracks and the structures. This judgment was made based on the experience of the responsible engineers. Track safety was maintained by calling out a number of railway clerks who lived along the railway.

With regard to flooding the "Regulation on Installation of Water Gauges" was formulated in 1921 and was revised in 1929 as follows

- (a) Location for installation of water gauges
- (b) How to deal with rising water and how to allocate a watchman
- (c) Description of diagrams on flood water levels

The responsible engineer determined when it was necessary to provide a watchman for rising water levels. The " Natural Calamity Watch Instructions" was revised in 1943 as follows:

- (a) fixed watchman (a watchman is stationed at all necessary locations)
- (b) Patrolling watchman patrolled each section.

There were three kinds of patrols, i.e. a full gang, a half gang or a third gang. This division was adopted for allocating the maintenance workers because of shortage due to mobilization in the army. Naturally the watch is dependent on the prediction of bad weather. However, there was no quantitative regulation before the World War 2 because the patrols were implemented by the responsible engineers.

By the mid 1950s this judgement method was supervised by routine measurements with restricted train operating speed or operation cancellation. Rain gauges were installed at intervals of 20-30km along the railways and alarm was sounded to order for the watchman and to slow the train operations. Technical judgement for deciding when the volume of precipitation became critical after the gauges were installed. It was also necessary to decide the critical water level for bridges. These decisions remained the responsible of the engineers judgement.

Therefore, it was possible that if the boundaries of the administrative officers for track maintenance depots were changed then the critical levels of precipitation of water level could also change.

2. Bridge maintenance

To inspect railway structures regularly and to repair in proper time is the only way to maintain railway structures in safe and good conditions. This is commonly recognized standard in many countries and organizations.

After the project construction has been constructed, not only newly rehabilitated bridges but also the existing bridges should be maintained by effective inspection and maintenance with new machines/equipment necessary for maintenance activities.

In the chapter, useful contents will be described mainly based on Japanese Railways system.

2.1 Inspection

(1) Frequency & kind of inspection

Frequency and kind of inspection should be established, and in JR group, they are established as shown in Table 2.1-1

Table 2.1-1 Frequency and Kind of Inspection

Kinds				Frequency
Civil structure	General inspection	Periodic inspection	Visual inspection	Once every 2 years
			Special Inspection by use of stage or lifting car on and off rail	Once every 10 years
				Once every 20 years for tunnel
	Extra inspection		As necessary	
	Detailed inspection		As necessary, taking deteriorated condition of each structure into consideration.	
	Comprehensive inspection		As necessary	

(a) General inspection

General inspection is performed to examine whether deformation of a structure will be existing or not, and to clarify whether the level of deformation of structure is increasing or not. General inspection is also executed to detect a deteriorated structure or the one of which function will lowered in the near future.

(b) Detailed inspection

Detailed inspection is performed with respect to a railway structure that is decreasing its function or will lose its function in the near future, and to clarify the cause of deformation, to evaluate the deteriorated degree of structural function accurately, and to decide the timing and method for countermeasures to be taken.

(c) Comprehensive inspection

Comprehensive inspection is performed to grasp change of environmental (i.e., surrounding) conditions which may have affected railway track condition by aerial patrol (i.e., aerial photograph).

(d) Responsible person for execution of inspection

Responsible person for execution of inspection should be decided, and in case of JR group, a chief of civil technical center is nominated.

(2) How to inspect structures

(a) General inspection

General inspection is performed by on-foot patrol by an inspector carrying test hammer or simple inspection instruments to detect deformation and defects of structures mainly by visual inspection.

Contents of general inspection are as shown below.

- To detect deformation of structures
- To grasp degree of deformation
 - whether the deformation is progressing or not
 - whether its function of structure is affected or not
- To detect environmental changes around railway track
- Whether the deformation affects on the safety operation of trains or not
- To confirm the necessity for measures to be taken

① Periodic inspection

General inspection can be classified into periodic inspection performed periodically and extra inspection performed whenever needed. Periodical inspection is further classified into usual inspection executed every two years and special inspection performed once every 10 years while it is performed once every 20 years for tunnel.

Visual inspection

Visual inspection is performed mainly on foot, as necessary, some simple portable instruments are used.

Special inspection

Special inspection is performed by use of stage, lifting car on and off rail or binocular. It is also executed by portable inspection devices or test hammer as necessary.

Periodic inspection is generally performed for the section unit between the stations or between big structures. From past inspection experiences, it is recommended that rational inspection plan should be made based on the kinds or quantity of structures in each section (or station interval) and on meteorological conditions.

② Extra inspection(Non periodic inspection)

After abnormal weather or accidents (as shown below) have occurred, extra inspection is performed to confirm the presence or absence of deformation of structures. It is also executed as required.

- After typhoon, heavy rain or Tsunami
- At the time of the rise of water
- After accidents

In addition, if inspection for cracks in steel girders is necessary, it may be done after surface preparation for recoating. For portions that can not be seen because of the finish of interior decorations, inspection may be executed when the renewal of interior decoration is done.

(b) Detailed inspection

Detailed inspection is performed for structures classified as A (refer to Table 7.2-2, 3) and is executed for the purpose as described below.

- Detailed grasp of deformations of structures
- To clarify the cause of deformations
- Evaluation of soundness of bearing capacity & durability of structures
- To ensure the safety operation of trains
- To decide the timing and method for countermeasures to be taken

From the facts mentioned above, it is difficult to decide detailed inspection timing and intervals simply; therefore, rational inspection plan should be made depending on the situations of structures described below.

- Structures of almost no progress in deformation
- Structures necessary to inspect the progress of the deformations periodically in order to predict the progress in future and to clarify the cause of deformations.
- Structures necessary to confirm functional degree after affected by abnormal external forces such as flood, earthquake, etc .

(c) Comprehensive inspection

Comprehensive inspection is performed to protect the railway tracks from landslides, etc. Therefore, they should be carried out through confirming environmental changes around the railway tracks.

Disaster occurrence due to environmental changes is caused by cutting down forest, construction of roads, houses, factories and so forth. Therefore, comprehensive inspection should be covering wide area, from railway lines up to water shed of mountains.

In addition to aerial photo, aerial patrol, etc, it is important to try to collect information relating to environment change as much as possible. As there will be limit to collecting information by oneself; therefore, it is better to consult with the government ministries or local organizations concerned.

(3) Recording inspection results

In case of execution of inspections, the results of inspection should be recorded as shown below.

- General inspection, comprehensive inspection recording inspection results
- Detailed inspection preparing structure deformation report

As for recording inspection results, it is important not only to record degree of soundness but also to record conditions of deformation precisely, attaching sketches or photos of structure deformations.

2.2 Standards for Judgment of Structure Soundness

Even though structures are the same kinds and the same aging, function for each of them is very different on contents of design and construction method.

Therefore, it is difficult to determine the standards for judgment of structure soundness covering all structures. On the other hand, we must establish common standards to maintain various kinds of structure effectively with due consideration on the followings

- Degree of deformations
- Degree of effect for safety operation of trains and passengers
- Timing for necessary countermeasures

The function of structure is defined as having sufficient strength and durability for train running and also allowing train operation with required speed, good riding comfort and sufficient safety. As the railway structure is constructed by cutting or transforming a part of the balanced surrounding environment (ground, slope, etc.), the soundness of structure should be evaluated not only by inspection of defects of the structure, but also by considering the whole balance between structures and processed surrounding environment.

Further, structure is composed of various members of parts, each of which has different function respectively. Accordingly, the soundness of structure should be judged not only by inspection of the defected parts, but also by evaluating the structure as a whole. Standard for judging soundness of railway structure is shown in Table 2.2-1 and image of classification for judging soundness of railway structure is shown in Fig 2.2-1.

As for general inspection, the condition of structures can be classified into one of the four basic classes, such as A, B, C, S and those structures classified as A are further classified into three types, such as AA, A1, A2, by using precise equipment, etc in detailed inspection.

Table2.2-1 Standards for judging the soundness of railway structures

Classification	Influence on train operational safety	Degree of Deformation	Measures
AA	Imminent danger	Serious	Repair immediately
A1	Threatening to have an affect in the near future Dangerous when there are abnormal external forces	Deformation and reduction of performance are in progress	Repair at an early time
A2	Threatening to have an affect in the future	Deformation is in progress and a reduction in performance may result	Repair when necessary
B	Possibility to become class A if progressed	Possibility to become class A	Surveillance(repair dependent upon the need)
C	No influence at present	Slight	Inspections with emphasis on points of concern
S	No influence	No deformation or defect	

Fig2.2-1 Image of classification for judging soundness of railway structures

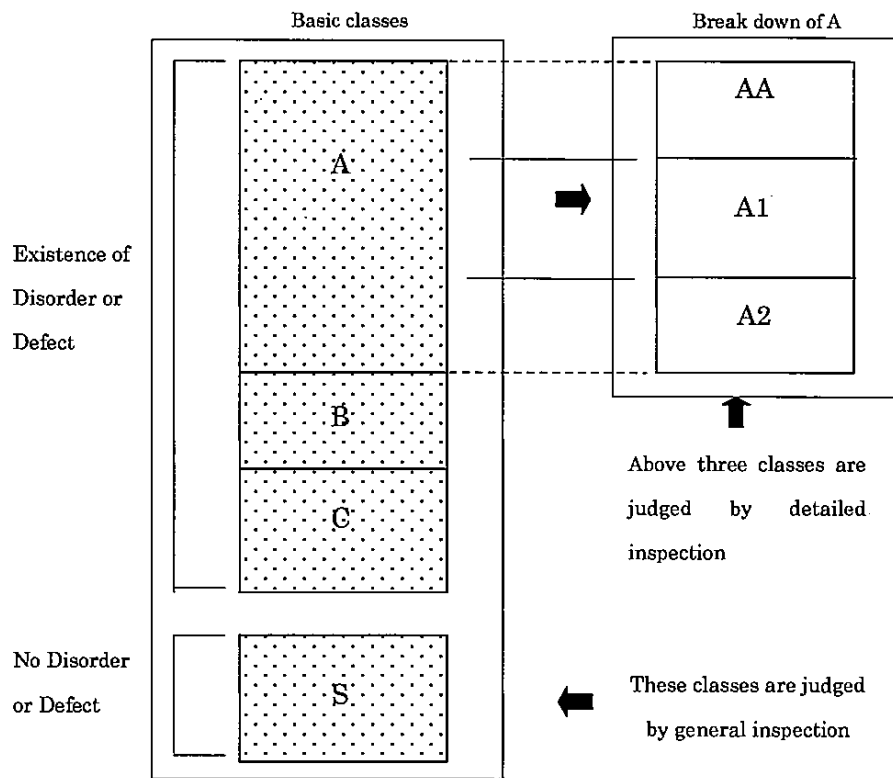

2.3 Countermeasures based on inspection results

Countermeasure based on inspection result shown below should be performed. When selecting one of the below countermeasures, not only technical soundness, but also the degree of importance of a structure's area, purpose of use and economy should be considered.

- Measures to prevent the degrading of functions (repair).
- Measures to rehabilitate degraded functions (reinforcement, replacement)
- Strengthening of surveillance and inspection
- Measures for providing conditions for operation suited to present structural strength (limiting use of structures)

Kinds and purpose of limiting use of railway structures is shown in Table2.3-1.

Table2.3-1 Kinds and purpose of limiting use of railway structures

Kinds	Purposes
Suspension of train operation	This is done to secure train safety or prevent accidents when train safety cannot be secured even speed reduction measures.
Prohibition on entering of certain type of rolling stock	This is done when the strength of structures such as bridges is insufficient and neither train safety nor structural soundness is assured even by reducing speed.
Limitation loads	Where the yield strength of structures such as bridges is insufficient, the loads of trains are restricted.
Speed restrictions	Speed restrictions are enforced for the following purpose: <ol style="list-style-type: none"> 1) To reduce impact during running and decrease the loads acting on a bridge. 2) To secure running safety and ride comfort by reducing speed against track displacement. 3) To reduce the oscillation and tilting of rolling stock 4) To assure timely stopping after detecting any obstacles. 5) To quickly sense any problems and immediately take measures for preventing an accident.

Flow for methods of countermeasures and structures inspection is indicated as shown in Fig2.3-2

Fig2.3-2 Flow for methods of countermeasures and structures inspection

KINDS OF COUNTERMEASURES

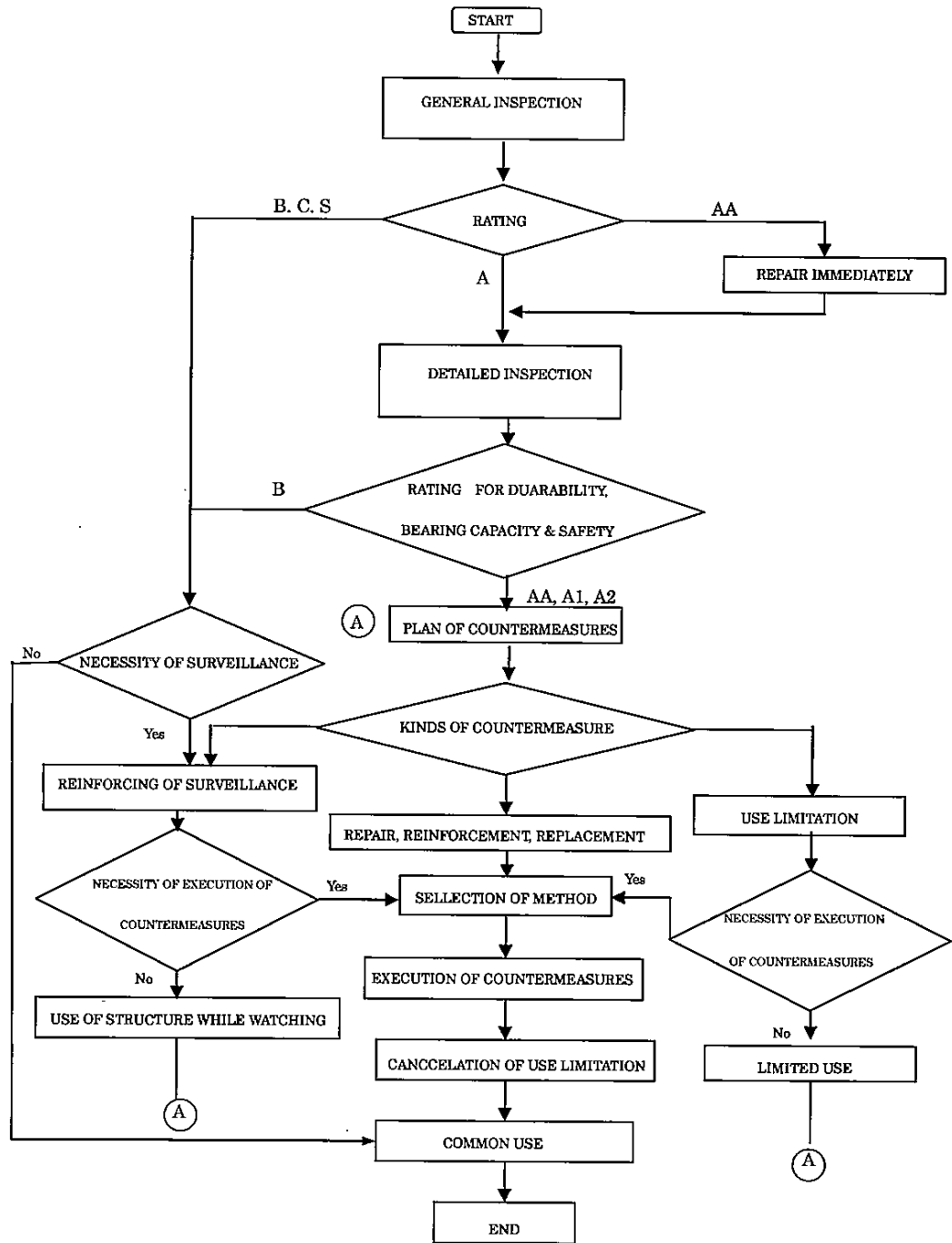

2.4 Checkpoints of deformation and inspection of railway structures

(1) Steel structure

(a) Steel girder

Main inspection works of steel structures are as shown below. The presence and absence or degree of deformation of structures should be grasped.

- Deterioration of coating & condition of corrosion
- The presence and absence of obstacles of construction gauge
- Condition of vibration of girder when trains pass through
- Disorder or defect of bearing
- Deformation of rivets and bolts
- Deformation of welded portion
- Condition of drainage facilities
- Deformation of accessories such as foot path,
- Re-deformation of repaired & reinforced portions
- Deformation such as fire, collision, earthquake, etc

(b) Deformation and inspection of steel girder

① Corrosion

When steel girder corrodes, its strength will decrease and make its life-span short. Therefore, it is important to protect steel girders from corrosion and extend their durable years. Main causes of corrosion are dust, filth, damp, tidal-wind, and no drain well, etc. Places where deformation is apt to occur by corrosion are bottom of sleeper, bearing, sway bracing, gusset plate, etc (refer to Table 2.4-1).

Table 2.4-1 Places where corrosion is apt to occur

	1st	2nd	3rd	4th
I-beams	Upper flange	Lower flange	Bearing	Sway bracing
Deck plate girder				
Trough girder	Lower flange	Bearing	Upper flange	Beneath rail
Through plate girder	Lower flange of main girder	Upper flange of main girder	Web of main girder	Lower flange of floor beam

These places mentioned above should be inspected carefully and it is important to execute such countermeasure as partly re-coating and so forth as necessary.

To extend the span of life of steel bridge is necessary for replacement of sub-members when the corrosion of sub-member become more than one seconds of design section.

② Functional deficit

Deformations of functional deficit are looseness of rivets & bolts, fissure of member, deflection, abnormal vibration, etc.

- Looseness of rivets & bolts, corrosion

Places where rivets and bolts are apt to loosen are: not enough places for stress, bearing's

adjacent, difficult places of execution for works. Degree of looseness of rivets and bolts can be detected by vibration with striking the head of them by hammer. When more than 30% of rivets and bolts arose loose connection, breakage or falling, they affect safety of structures. In case of functional rivets, limit of corrosion of head of rivets is one seconds of original size and further corroded structures are going to lose their function.

○ Fissure of member

Places where fissures are apt to occur are: bearing, concentrated stress place, corroded place. To inspect fissures, there are external appearance inspection by method of visual and test hammer. In case of necessary of furthermore detailed inspection, there are dye penetrating test (surface inspection), ultrasonic inspection (external inspection). Factors which have effect against limit fissures of occurrence of each member are as indicated below;

- minimum temperature in establishment limitation of structure concerned
- “absorbing energy value” on used steel materials
- detailed structure on portion of occurrence of fissures

It is very difficult to decide simply limit length of fissure for each member, but serious accident will occur at a certain time, therefore in case of judging of soundness, careful decision should be necessary taking materials into consideration.

○ Abnormal of deflection

Abnormal for deflection and vibration of girder has effect on train safety operation. These concerned are critical value respectively. These critical values are as shown in the Table 2.4-2, 2.4-3.

Table2.4-2 Critical value of deflection of main girder

Span(m)		$0 < L < 50$	$L \geq 50$
Deflection	plate girder	$L/800$	$L/700$
	truss	$L/1000$	

Table2.4-3 Critical value of deflection at stinger connecting points to floor beam

End floor beam	Intermediate floor beam
4mm	5mm

Critical values of deflection difference at the position of right and left rails at the main girder end portion of oblique girder is 3mm.(refer to Fig2.4-1)

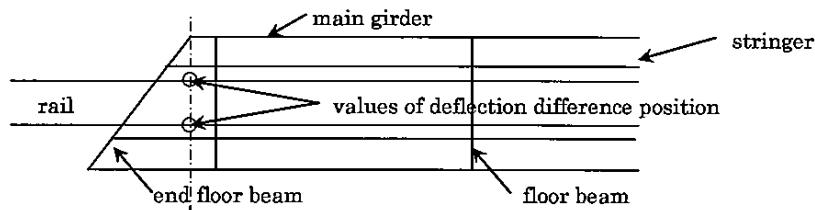

Fig2.4-1 Critical values of deflection difference at the portion of right and left rail

○ Vibration of girder

Looseness of connecting portion by rivets and bolts, pins are caused not only abnormal vibration of girder but also breakage of lateral, bracing, etc, abnormal of bearing. As for deformation of structure, immediate detailed inspection should be necessary to be supposed serious functional deficits. As for method of vibration of girder, there is not only appearing inspection that confirms sensory vibration of girder when trains in business pass by but also the use of instruments of deflects meter, accelerometer, micrograph, etc.

○ Limit value of the lateral vibration of girder

Limit value of the lateral vibration of girder can be obtained from the following formula:

Lateral vibration of girder (a: half amplitude: cm)

$$a \leq 9.93 / ((V/L)^2 + 4nH^2)$$

V : Train speed (m/s)

L : Span

nH : Frequency of lateral vibration (Hz)

= Vertical natural frequency / 2 \cong 70L-0.8/2

③ Deformation of bearing

Many common deficits for steel girder of each structure are deformations of bearing. These deformations cause unsteady situation of girder and irregular settlement of bearing and even more damage of girder in itself, therefore immediate repair should be needed.

Fig2.4-2 Deformation of bearing

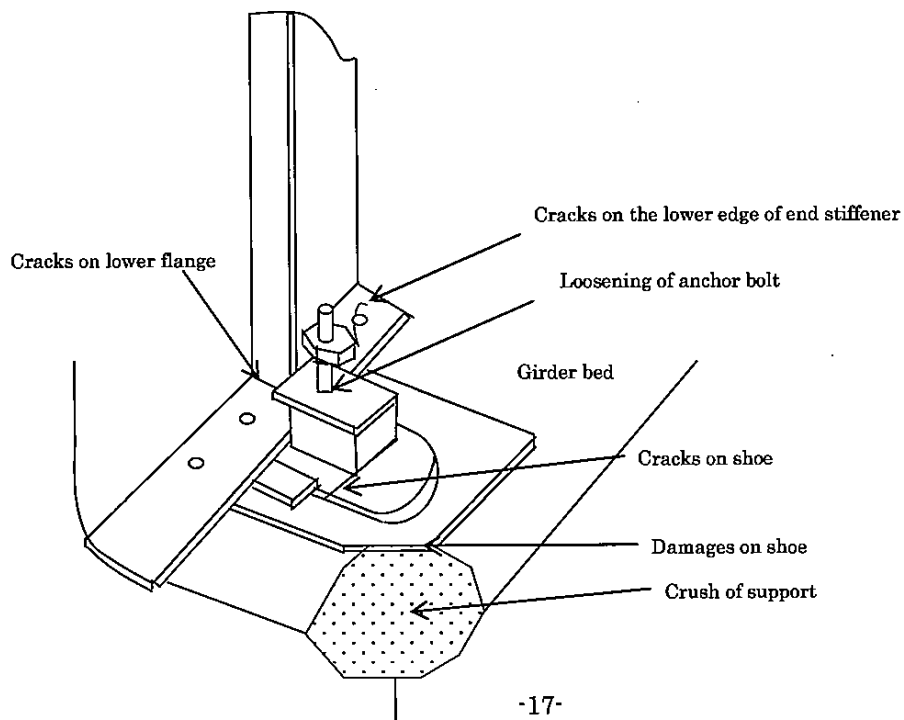

(c) Inspection items and methods by instruments of steel structures

The following detailed inspection should be performed by using instruments:

① Dimensional measurement of present section

Crack length and deformation are measured with scales. If data in time series are needed, marking and data should be made with oil paint or the like.

Some cracks occurred in bridges can be clearly recognized by eyes while others such as cracks in weld bead cannot. For the cracks in weld, fatigue cracks and cracks caused by the collision with ships or cars, the following non-destructive inspection may be adopted.

- 1) Dye penetrant test
- 2) Ultrasonic test
- 3) Magnetic particle inspection

② Measurement of present section

The following tools are used for measuring the present sections:

1) Descaling tools

For removing rust and paint, descaling should be fully performed by using hammers and scrapers. In this case, the hammer should have a thin tip for removing rust and paint from a crack in cover plate or narrow place.

2) Measuring tools

Steel tape, small measuring tape, folding scale, etc. are used for measuring the dimensions.

③ Measurement of live load

Situation of loaded train should be measured with rail and so forth in order to find the axle load, wheel base, frequency of passages, etc. of actual vehicles.

④ Stress measurement

Generally, wire strain gauge are bonded to the surface of members, strain is determined from change in electric resistance, and stress occurred in the member is measured. This method is convenient for finding the situation of stress in members or the stress concentration. But errors and misunderstanding may be resulted if the position of bonded gauges is not adequate. If the measurement is made by bonding the gauges to one side only of a board, even the bending stress changing in the thickness direction may be added to the average stress in board where the board has a tendency of warping. Therefore, it is necessary to measure on both the surface in this case.

⑤ Deflection and displacement measurement

Expansion and contraction of each part of a girder due to stress will generally affect the deflection; thus a local decrease in sectional area due to rust will not give significant influence upon the deflection of girders. If the member is broken and connection gets loose, then there is a high possibility of increase in deflection.

Therefore, abnormal increase in deflection suggests the presence of considerable deformations, and thus efforts must be made for immediately finding the deformations.

Also, lateral swing and shoe movement should be measured as required. When calculating the deflection of plate girder, the following simplified equation may be used; but actual train is accompanied with unclear impacts; a through girder having a floor system acts in cooperation with its main girder so that the measured values will not always agree with the calculated values.

$$\sigma = \frac{5.5 ML^2}{48EI} \quad (\text{in the case of non-uniform section using cover plates, etc.})$$

$$\sigma = \frac{5 ML^2}{48EI} \quad (\text{section of girder is constant, that is, central section is used up to the end of girder without cover plates})$$

Some plate girders which are not corroded and have no proper sway bracing or have a small girder width, swing considerably during the passage of trains.

Standard value of allowable horizontal vibration is about 1/3000. Also, it should be noted that if girder with sway bracing and lateral bracing vibrates considerably, then some of bracing members may be broken.

In the case of pin connected truss, the tensioning situation of eye-bars may be found by knowing the frequency of the vibration. Also, the swing increases if the pins connecting eye-bars are loose. Some girders have a large swing from the beginning because of structural defects. But broken members, loose coupling portions, deteriorated shoe pedestal also cause abnormal vibration, so that they can be clues for finding the anomaly of members.

⑥ Material test

Materials of bridge members are clearly specified on the drawings. If there are no drawings and the history of girders is not known, then the allowable stress required for calculating the yield strength cannot be determined, and thus the material must be surveyed.

But quality of materials used for bridges are roughly possible to be classified by age.

⑦ Other analysis

(d) Rating

① Method of rating

The following each items should be reviewed, and the degree of soundness of structure as a whole should be diagnosed comprehensively:

- 1) Diagnosis of degree of soundness against deformation
- 2) Yield strength, durability and running safety of trains
- 3) Safety for general public

The diagnosis of the degree of soundness for members should be performed by comprehensively diagnosing and evaluating again the judgment made based on the deformation of members previously performed in general inspection, through the clarification of mutual actions and synergetic effects of deformation, or local stress occurred in the in the structure as a whole with professional eyes. Items diagnosed and classified into deformations AA or A in regular inspection will be verified here to check if the diagnosis was correct or not; at the same time, it becomes necessary to subdivide them into A1 and A2 in detailed inspection.

“Stress ratio (SR)” is as defined as the scale of yield strength evaluation of girder as the method of evaluating the yield strength and durability of steel structures and running safety of trains.

Concerning SR is described in the next paragraph (d).

(e) Investigation relating to yield strength, durability

① Soundness evaluation of steel girder

Soundness of steel girder should be judged all-around as the evaluation for deformation mentioned, as the method of evaluating the yield strength and durability of steel girder.

② Evaluation of yield strength and durability of steel girder

Yield strength of steel girder is estimated as the following "stress ratio".

$$\text{Stress ratio (SR)} = \frac{\sigma_m}{\sigma} \times 100\%$$

Where σ_m : Maintenance limit stress

σ : Maximum unit stress ($= \sigma_d + \sigma_l + \sigma_i$) created in members when a vehicle enter into the line at the allowable maximum speed in the relevant district.

σ_d : Unit stress created by dead load

σ_l : Unit stress created by live load

σ_i : Unit stress created by impact load

σ_m , the maintenance limit stress is allowable stress which is determined by the yield strength of actual structure at the present time against the allowable stress in construction age. The maintenance limit stress is determined by considering both the aspects of static yield strength and fatigue, whichever is the smallest.

The maintenance limit stress of tensile members should be basically considered the same as that of compressive members.

③ Classifications for judging of soundness to stress ratio

Classifications for judging of soundness according to stress ratio are as indicated in Table2.4-4.

Table2.4-4 Classification for judging of soundness

Classification for judging of soundness	Stress ratio : SR (%)
AA	$SR \leq 100$
A1 or A2	$100 < SR \leq 120$
B	$120 < SR \leq 150$
C or S	$150 < SR$

(2) Concrete structure

Matters common to concrete are that crack can be always detected along with deformation and that characteristics of deformation can be generally made clear by examining the crack. When crack has been found in the concrete structure, it is important to make clear whether the crack is of progressive type or not, and also to find out the time when crack was generation. These are significant information for studying the causes of deformation, for making clear the characteristics of crack, and for deciding the repair method. Generally speaking, crack generated due to some causes relating to execution is not of progressive type. On the other hand, crack generated due to some causes relating to design or material is generally of progressive type.

(a) Crack of concrete

Methods of test whether the crack is of progressive or not are given as follows.

- Mark the end of crack and observe whether the crack develop passing by the mark or not
(Fig 2.4-3 (a))
- Insert the tapered pin between the crack and examine whether the pin will be loosened or not.
(Fig 2.4-3 (b))
- Paste the mortar on the crack and observe whether the new crack will be developed or not.
(Fig 2.4-3 (c))
- Mark the points on each side of crack and measure the distance of the points periodically.
(Fig 2.4-3 (d))

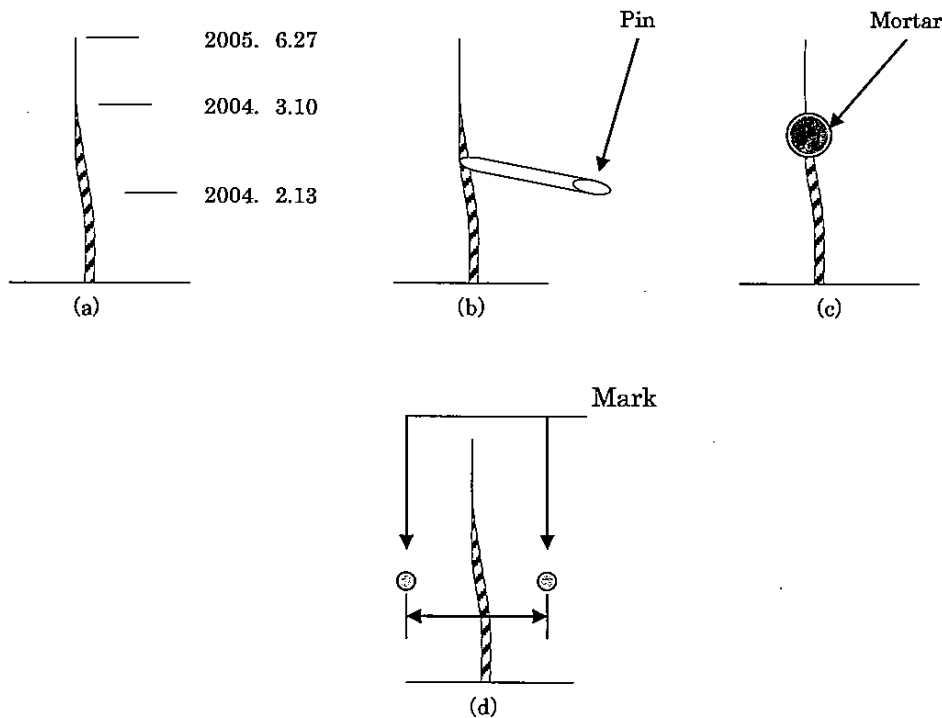

Fig 2.4-3 Various methods to test whether cracks are of progressive type or not

Causes of crack can be classified into 2 categories, namely crack generated during the execution of work and that generated after the execution of work.

① Cracks generated during the execution of work are given below. These cracks can be prevented by careful execution of work.

○ Initial crack due to drying

When the surface of concrete is exposed to sudden drying while it is not solidified, concrete will be constructed due to evaporation of water and crack will be developed. This kind of crack is called “initial crack due to drying”.

○ Crack due to sinking

After placing fresh concrete, bleeding will happen due to sinking of materials having large specific gravity. In case sinking of these materials is interrupted by reinforcing bar or form, sinking of material will become uneven, and crack will be generated on the surface of concrete just above these interrupting objects. This kind of crack is called “crack due to sinking”.

(Refer to Fig 2.4-4)

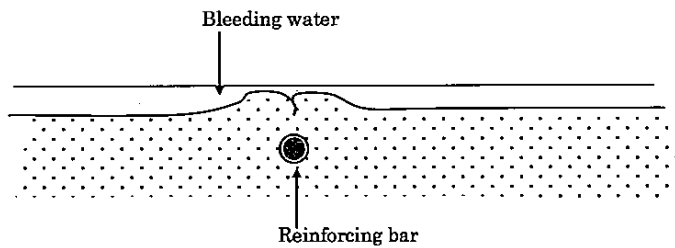

Fig 2.4-4 Crack due to sinking

○ Crack due to sinking of support or form

When support is loosened, or the foundation is weak, support or form will sink. In case such sink occurs while concrete is not yet hardened, crack will be generated. This kind of crack is generally large and will affect the durability of structure after its completion.

(Refer to Fig 2.4-5)

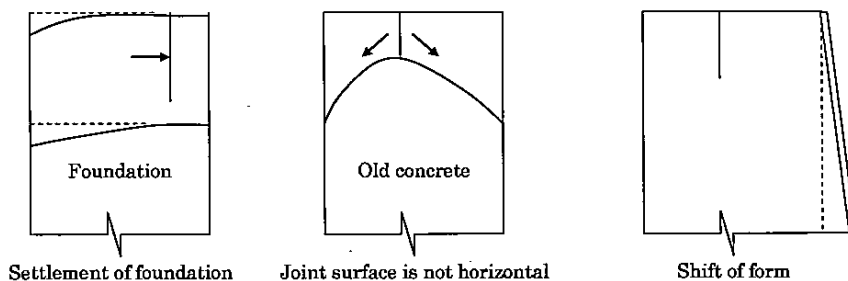

Fig 2.4-5 Crack due to sink of support or form

○ Crack due to hardening heat

When hydration is caused and cement is hardened, heat will be generated, accordingly concrete will be expanded due to rise of temperature inside of concrete. While concrete is hardening, temperature will be lowered, causing contraction of concrete, resulting in generation of crack. This kind of crack is called "crack due to hardening heat".

② Cracks generated after the execution of work

○ Crack due to temperature change or drying shrinkage

In case concrete having large unit water content or deformation of concrete member is restricted, there might occur crack due to drying shrinkage or temperature change, even after strength of concrete reaches the prescribed level.

○ Crack due to design reason

In case the load exceeding the design load will act on the structure, or in case the load not considered in the design such as external force due to differential settlement of foundation or force generated due to execution of another structure just close to the structure concerned, will act on the structure, crack will occur. Generally speaking, concrete is so designed as crack will inevitably occur in the tension side of concrete. However, width of such crack in the standard design of concrete will be less than 0.2mm. In case crack wider than 0.2mm occurs, there might be some problem in the design aspect.

(b) Other kinds of harmful deformation

① Carbonation (Neutralization) of concrete

The phenomenon where calcium hydroxide generated by hydration reaction of cement transforms itself to calcium carbonation due to reaction with carbon dioxide of the air, is called carbonation of concrete. Carbonation of concrete does not affect the strength of concrete, however it will promote the corrosion of iron reinforcing bar which usually does not occur due to alkaline property of normal concrete. (Refer to (c) ①)

② Salt damage

Interior part of sound concrete has a strong alkaline property, therefore tight passivity film will be developed on the surface of iron reinforcing bar. However, salt penetrates into concrete body; passivity film will be destroyed, making iron reinforcing bar being apt to corrode. This phenomenon is called "salt damage".

There may be two reasons for penetration of salt into concrete body, as given below.

○ the case the salt has been included in the concrete material used for producing the concrete.

If the sea sand is used as fine aggregate and is not washed sufficiently, the salt may be remained in the concrete body. It is stipulated at present that chloride ion content included in fine aggregate should be less than 0.02% in terms of weight.

○ the case the salt may penetrate into concrete body after execution of work. In the area near

the sea coast, salt flying from sea water may penetrate into concrete body.

(c) Detailed inspection items of concrete structures

Detailed inspection items should be considered in accordance with its objects. Main detailed inspection items for deformation of structure are shown in Table 2.5-6.

Table2.4-6 Main detailed inspection items for deformation of structure

Sort of Deformation and Objects		Detailed inspection article
Cracks due to stress	Bending cracks	Material test (strength of concrete structure) Stress measurement of concrete Vibration test
	Shear cracks	Stress measurement of concrete(stirrup bent up bar)
Exfoliation of concrete		Measurement of effective section for member
Cracks of deteriorated concrete (Aging)	Reaction of aggregate	Material test (concrete stress and neutrality)
	Cracks due to neutrality and salt	Measurement of stress Measurement of deflection Measurement of effective section for member
Fire damage		Material test (concrete stress and neutrality analysis) Measurement of effective section for member Measurement of deflection Measurement of stress
PC steel material corrosion, inferior grout		Inner investigation (X ray, endoscope)
Stress of girder		Measurement of stress Measurement of deflection
Abutment, pier displacement and soundness		Vibration test, elastic wave test, sharp breaking test

Concerning material, vibration test and measurement of deflection in Table2.5-6-A are as given below.

① Material test of structure

The material inspection of structure contain the following type of inspection, and most popular among them.

○ Strength test of concrete

Concrete strength test for structures contain direct strength test and non-destructive strength test, the measurement are performed by Schmidt concrete test hammer, ultrasonic pulse and so on. Investigation of the Schmidt concrete test hammer is simple and can be applied to the concrete executed. However, when crack surface becomes weak, aggregate grain is buried on face, outcome does not show clear relation between repulsion coefficient and strength, or between inner and surface strength.

Ultrasonic pulse technique is not available for rough concrete. There are considerable mutual relation between pulse velocity and concrete strength. But they depend on many factors such as curing condition, aggregate size and ratio of water to cement. So the precision measurement tends to be bad in applying to actual structure. Accordingly, these results are only beneficial as a reference data. Strength test of concrete should be based on direct strength test on core sample taken from the structure.

○ Carbonation (Neutralization) test of concrete

Investigation of inferiority of concrete is needed for evaluation of strength and durability. Inferiority of concrete is commonly indicated by progressed degree of neutrality in the concrete.

The concrete shall be chipped off to the depth of the reinforcing steel bar, and then is sprayed 1 % of phenol phthalein solution. When the concrete show alkalinity, it will present vivid red color. If the neutrality of concrete is progressing to the depth of reinforcing bar, the color of concrete does not change. You may consider that the rust of bar is progressing to a certain extent.

The relationship between the neutrality depth of concrete and elapse year is said to be related as following.

$$t = KX^2$$

t : elapsed year

K : constant number

X : neutrality depth (cm)

W: water cement ratio

$$K = \frac{0.3(1.15 + 3W)}{(W - 0.25)^2}$$

In case of W = 60% become K = 7.2, $t = 7.2X^2$

We may estimate the residual life of concrete by applying the measured value into this formula.

Phenol phthalein solution is composed of 1g phenol in ethyl alcohol 100cc. Phenol phthalein solution is changed to red color in pH8.4 or more. As concrete is neutralized in pH10 or less, attention should be paid to the degree of red color.

② Vibration test of structure

As natural frequencies of structures change with cracking, deterioration, etc., the result obtained by comparing the natural frequency measured while the structure was still in sound state and that measured later can be used as a basis for judging the soundness of the structure.

③ Sharp breaking test

For the purpose of inspecting the horizontal displacement, vibration properties and operation of shoe of pier, displacement and stress due to the horizontal force are measured by sharp breaking of running train on bridge.

④ Deflection measurement of structure

Data for finding magnitude of applied load, Young's modulus and allowance of car entrance, etc., and by comparing with value of deflection obtained from calculations.

Deflection is measured using mechanical or electrical gauge. Vertical deflection measurement in girder is executed in central part of span as a rule. In case support is subsided, measurement of subsidence value is also necessary. The difference between value obtained by measurement and that of calculation is considerable and in many case it is 70% or so of calculated one. In calculating deflection we should take into account the influence of ballast stopper, footway concrete, water-proof concrete etc, which acts together with main girder.

When deflection obtained by measurement is too small, it should be checked whether function of supports deteriorate or not, or whether parapet and girder are thrusting each other or not.

⑤ Non-destructive test

There are many kinds of non-destructive tests utilized in detailed inspection. Therefore, appropriate test should be selected depending on the object. At present, the non-destructive tests available are shown in Table 2.5-7. As the outcome obtained in non-destructive test is not accurate, the final judgment should be based on core sampling or destructive test.

Table 2.4-7 List of non-destructive test for detailed inspection

Object of measurement	Sort of non-destructive test method	
Compressive strength of concrete	* Repulsive strength method * Sound speed method	Schmidt hammer method, etc. (Lateral wave supersonic wave method)
Bending strength in the joint parts of brick and stone laid structure	* Sound speed method	Impact elastic wave method, etc.
Diameter and position of reinforcement	* Magnetic method	Percolator method Eddy defect method
Thickness and inner defect of concrete	* Sound speed method * Radio active method	Side wave, supersonic method Impact elastic wave method X and γ ray method, etc.
The penetration ratio of structure	* Sound speed method	Impact elastic method
Neutralized concrete		Phenol-phthalein
Dynamic characteristic of concrete (natural frequency, dynamic elastic modulus)	* Sympathetic method	Length sympathetic method Deflection sympathetic method
Static characteristic of concrete (static elastic modulus)	* Repulsive strength method * Sound speed method	Schmidt hammer method Impact elastic wave method

(3) Substructure of bridge

(a) Introduction

Bridge substructures in Southeast Asian nations were made mainly of brick or stone masonry, in the early period of railway construction. As concrete technology developed, piers and abutments with plain concrete, and later with reinforced concrete with a small number of reinforcing bars were introduced. Improvement in the quality of reinforcing bars made it possible to build slender substructures, more and more of which have been used for aesthetic reasons and to lessen hindrances to the roads and rivers being crossed.

Piling machines and the materials of piles had not been developed before the present railway networks were completed, so that most substructures of the period have spread foundations and rest on wooden well cribs or chopped cobble stones. Piles, if used, were from 7 to 8m long wooden piles. But thereafter, reinforced concrete precast piles and steel pipe piles were introduced, and they were followed by cast in place piles such as benoto piles and reverse circulation piles. For larger scale foundations, brick walls were used in early periods, and reinforced walls or caissons were used thereafter. The introduction of continuous auger wall such as ICOS method helped to diversify types of foundations, and nowadays there are many kinds.

Substructures of piers and abutments are generally durable regardless of whether the material is concrete or brick, and as long as the design and construction work are well done, there are very few examples of known deformations caused by strength deficiency.

With respect to concrete girders, deformations such as fissures caused by poor treatment of construction joints and honeycombing by poor construction work quality of the structure, but deformations of this kind seldom affect the total durability of the structures, and can be easily repaired. Unlike concrete structures, the use of brick and stone masonry often lead to bond-failures as a result of aging. Their repair is sometimes neglected although this is known not to be a desirable situation.

Deformations caused by environmental changes such as scouring of river bridges, settlement or inclination of the substructures on soft ground. In the case of settlement and inclination, adjacent embankment or nearby structures can be affected as well as the structure itself. Settlement may be caused by poor design and aging of the structure as well as the softness of the ground.

Also in the case of scouring, its influence does not stay in the substructure itself, but reaches as far as the bearing and the girders. Generally speaking, bridge bearings are the connecting portion of upper and lower structures, and their construction requires greater skill than other portions. By the way, it is important to inspect not only the condition of the piers and abutments themselves, but also the bearings, girders and the surrounding area closely.

In case of the scoring of the bridge substructures, it is not an exaggeration to say that it is the most prevalent deformation in bridge substructures. Old bridges furnished with shallow

foundations and wooden piles of small length are easily eroded by scouring.

The outlines of the inspection of foundations are explained in the following. Bridge foundations, especially piles, which support the rest of the bridge, lie under the ground surface, so that they can not be viewed directly. Consequently deformations in them must be detected through indirect inspection or by technical judgment. The detection of deformations in bridge foundations is possible and is done by accumulating information about the foundation and ground. As mentioned in the beginning, old bridges have shallow foundations and short piles, and major theories in soil mechanics such as consolidation settlement were developed after the introduction of steel and concrete structures. Therefore the design and construction of the foundations of older structures were carried out without any technical regard for soil mechanics. Accordingly, consolidation settlement was taken into consideration. Therefore the inspection with ample consideration for the results of geological survey, or soil tests is both necessary and effective.

Vibration and settlements of the piers during the passage of trains has been utilized to evaluate the soundness of the structures in Japan. Accelerographs are put on the top of pier, and configuration, amplitude, and cycles of the vibration wave are measured. In Japan, it has been possible to measure the natural frequency of the structure by impacting a weight, and measuring the seriousness of the deterioration of the structures.

Inspection of honeycombing in the concrete surface, inspection of concrete quality with Schmidt hammers and core drilling, and mechanical measurements of stress and dynamic behaviors of the structure, which are used in the inspection of concrete girders, can be also applied to the inspection of a pier.

(b) General inspection

When substructures of bridges such as abutment and pier are deformed, superstructure of bridge will also cause deformation such as settlement, inclination, lateral shift, etc, and initial symptoms will appear at bearing or girder bed. Necessary inspection plan and items of substructure of bridges are as given below.

① Inspection plan

General inspection of substructures should be performed carefully in accordance with the characteristics of the foundation and ground. Also, it should be performed with the recognition in advance about the possible signs of foundation deformation to be appeared on the superstructures.

Foundation structures, which are normally underground parts of a bridge, cannot be directly observed within eyeshot. Thus, even if deformation occurs, it may not be always verifiable. However, when the foundation of structure has deformation, it will usually give some signs of influence upon the superstructure.

Most deformation of foundation can be detected by careful survey of the superstructure.

Especially, any changes in the environment of the bridge due to construction works being performed in the nearby area or due to gravel taking should be also carefully watched.

Scheduling of inspection is obviously important. The seasons of the year in which it is easy to find particular deformation should be selected. The periodic inspection should be performed in a season or time when deformation is apt to occur; when the influence of environmental change can be easily found out.

Extra inspection should be made after a disastrous phenomenon such as a flood which has a high possibility of causing another deformation. In addition, if a construction work is scheduled in the adjacent place, inspection should be performed before the work is started.

② Inspection items

1) Environment

Inspectors should watch any changes in the surroundings environment carefully in addition to the structures themselves.

a) Change in river environment

Information about the items mentioned below is important:

- The location of the stream line in the river
- Dams or weirs recently built or removed in the upstream area
- Levee construction work under way in the up or downstream area
- Dredging

b) Soil-foundation interaction

It is important to pay attention to the bridge built on soft soil and to the construction works being performed nearby. In soft soils, the ground is easily settled due to consolidation; structures will be also settled or tilted; and also a large displacement may be created at abutment and pier due to lateral flow.

Subsidence of structure often occurs during construction work being executed near the railway structures. If ground is excavated at one side of a structure, the structure tends to be tilted or displaced toward the excavated side. If earth is filled at one side of the structure on soft ground, then the structure will cause a deformation toward the opposite side of the filled earth. Thus, if a construction work is scheduled near the railway structure, the behavior of the structure should be measured periodically to value the seriousness of the influence of the work to the structure.

2) Principal inspection items for abutments and piers

- Bearing condition
- Scouring
- Subsidence, movement, tilting

If any deformation occurs at the foundation of bridge abutment or pier, the symptom of subsidence, tilting, or horizontal movement which occur in the superstructure will first

appear at the shoes and pedestals. For instance, expansion bearings lose their correct configuration or the expansion clearance, and in the other case, the gap between the breast-wall of abutment and the girder decreases to result a jostle. This deformation can be easily detected, and if existing location is marked with painting, the progress of the movement can be estimated.

As to scouring, inspector should carefully observe the change in the center line of stream in river, change in the overall river, and changes in footing protection and groundsel near the railway structures. Inspector should measure the depth of scouring as necessary.

(c) Detailed inspection

① Inspection plan

Inspection planning should be made by fully recognizing the characteristics of bridge foundation. Execution of the inspection should be so planned that season, period and method of inspection will be suited for finding out deformation and defects.

1) Materials required for inspection

When performing detailed inspection, following materials should be arranged depending on the purpose and then an inspection plan should be prepared:

a) Historical survey data

- Year of construction
- Records of damages due to floods in the past
- Changes in environment
- Records of repairs, reinforcement, rehabilitation

b) Design documents and records of construction works

- Design drawings and calculation sheets for structures
- Records of foundation, substructure and superstructure

c) Ground survey materials

- Geological column
- Soil test results
- others

d) General inspection records

Survey records of the present location and state of deformation compared with structural drawings, and the follow-up records of deformation. And most of the basic data related to the rating of foundations such as the situation of the foundation, situation of ground and soil data cannot be obtained from the ground surface. Time and expenses are necessary for surveying, verifying and collecting data in the inspection. Moreover, surveying is not possible after deformations are found in some cases.

The inspector should collect various data related to deformation of foundation at ordinary times and utilize them in the inspection of foundations. He should also pay attention to the arrangement of various data related to the detection of deformation, which is the important key of inspection.

2) Inspection procedure

Inspection procedure in detailed inspection is as shown in Fig.3-1-1. Detailed inspection is performed mainly for displacement such as movement, tilting, settlement of structures and environmental disruption near the structures. If it is difficult to presume the causes or make a diagnosis, then detailed inspection including soil survey should be performed.

3) Inspection schedule

Inspection schedule and intervals should be considered depending on the purposes of the

following inspection:

a) Inspection of external situation which may cause the displacement of foundation:

This case corresponds to the external situation described in Par.2-2 (1), and it is normally impossible to establish the inspection interval in advance.

In case of displacement that is likely to be caused by external situation, proper inspection should be performed immediately or at the right time, and then inspection intervals should be determined. In this case, the period generally should be shorter for rapid change and longer for slow change.

② Inspection items

1) Environment

External force often causes deformation in bridge foundation. Influence of the following items should be carefully checked:

- Ground settlement
- Slope creeping
- Construction works in adjacent site
- Earthquake
- Degradation of river bed and scouring

Details of each inspection items are as indicated in Table 2.4-8.

Table 2.4-8 Inspection items for the case of external conditions

Inspection items	Details
1. Influence due to settlement	(1) Data collection on ground settlement (2) Settlement situation of surrounding ground (3) Situation of ground and soil (4) Environmental changes (5) Structure displacement measure
2. Influence of slope	(1) Data collection on slope movement and failure (2) Environment situation and its change (3) Structure displacement measure
3. Influence due to adjacent construction	(1) Construction status (2) Topographical and geological survey (3) Investigation of actual condition of structures (4) Measurement of ground displacement (5) Structure displacement measure
4. Influence due to lowering of river bed and scouring	(1) Ratio of embed depth to width of pier (Z_s/D) (2) Obstruction ratio of water flow (3) Lowering of river bed (4) Scouring records (5) Ground condition (6) Environmental change (7) Measuring of scouring depth As for bridges remarkably influenced by lowering of river bed and scouring , detail inspection should be performed as soon as possible after flood.
5. Influence due to earthquake	(1) Earthquake records (2) Selection of weak structure by earthquake (3) Structure displacement measure (4) Measurement of crack (5) Study of changes of external conditions

Note: Inspection items should be selected in accordance with the situation of deformation.

Concerning item 4 in Table 2.4-8

Degradation of river and scouring are one of the most frequently recognized deformations at river bridges. And they greatly affect the stability of bridges and thus should be carefully inspected. However, this inspection generally should have a wide measuring range and is technically complicated in many cases. Thus, its procedures should be formulated first and then smoothly carried out.

Table2.4-9 Inspection items for structure

Inspection items	Details
1. Static displacement	(1) Structure displacement measure (2) Structure inclination measure (3) Displacement measure of girder position (4) Settlement measure of embankment behind abutment
2. Crack	(1) Observation of cracks of abutment, pier, bearing
3. Vibration property	(1) Vibration property of pier

Items of this inspection are as indicated in Table2.4-9, and the points of this inspection are explained hereinafter.

1) Survey on watershed environment

Main items to be surveyed in the detailed inspection on the watershed environment are as explained below.

a) Topographical map of river watershed

These maps are necessary to know the topographic situation of river watershed, and normally the watershed is drawn on a map with the scale of 1/50,000 to 1/500,000 depending on the scale of watershed. However, for the upstream of a bridge, the whole watershed is required but, for the downstream, the areas not related to the degradation of river and scouring may be omitted.

b) Topographical map near bridges

Topographical maps near bridges should be detailed as much as possible. Normally, 1/500, 1/2,500, 1/10,000 and 1/50,000 scales are applied.

c) Geological map at bridge positions

Geological map at bridge positions can be valid data for diagnosing scouring, etc, but also provide valuable data concerning bearing capacity and others. These maps should be collected and arranged as much as possible.

If there are no geological maps at old bridges positions, efforts shall be made for collecting data related to nearby construction works, etc. Method of recording the bridge location

should be as indicated below (refer to Fig2.4-6-A and B)

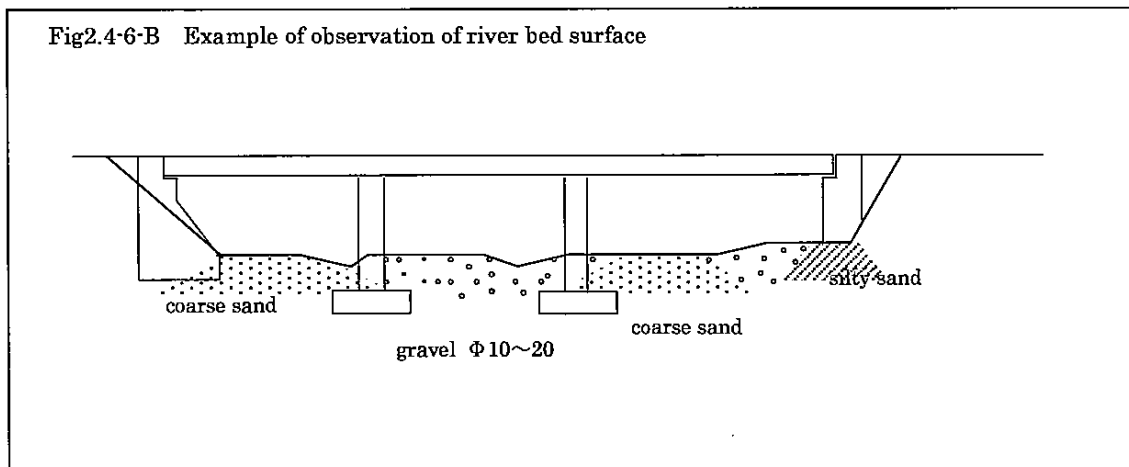
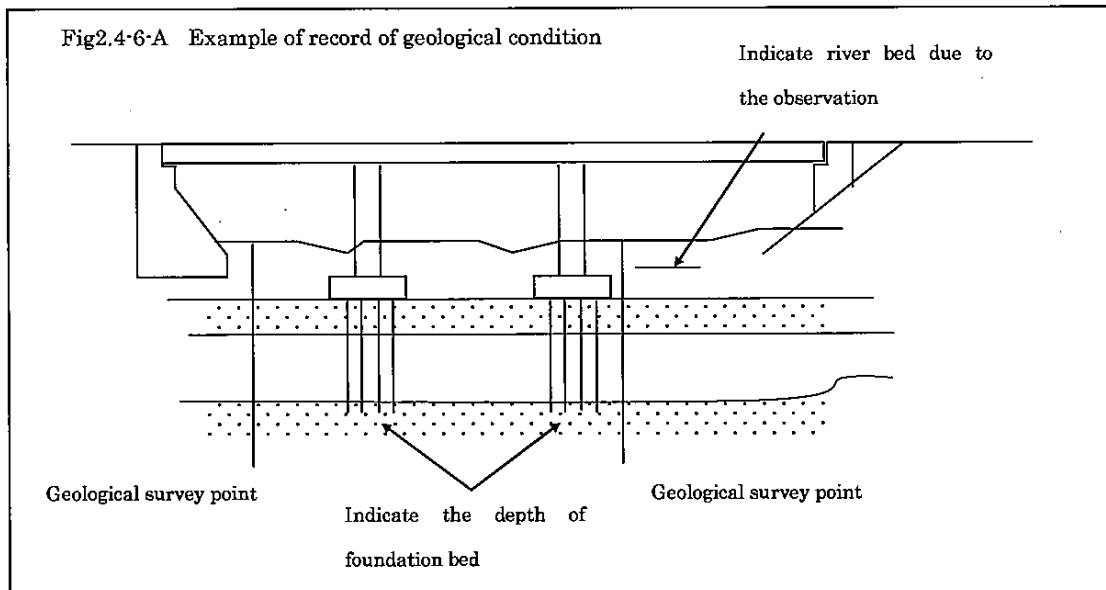

d) History of river gradient

History of river gradient should be checked and collected by river administrator. An example of the indication is shown in Fig2.4-7-A. The measured position (such as center line of stream or central portion) should be indicated. An example of record of variation of river bed of depending on elapse of time is shown in Fig2.4-7-B

Fig2.4-7-A Example of history of river gradient

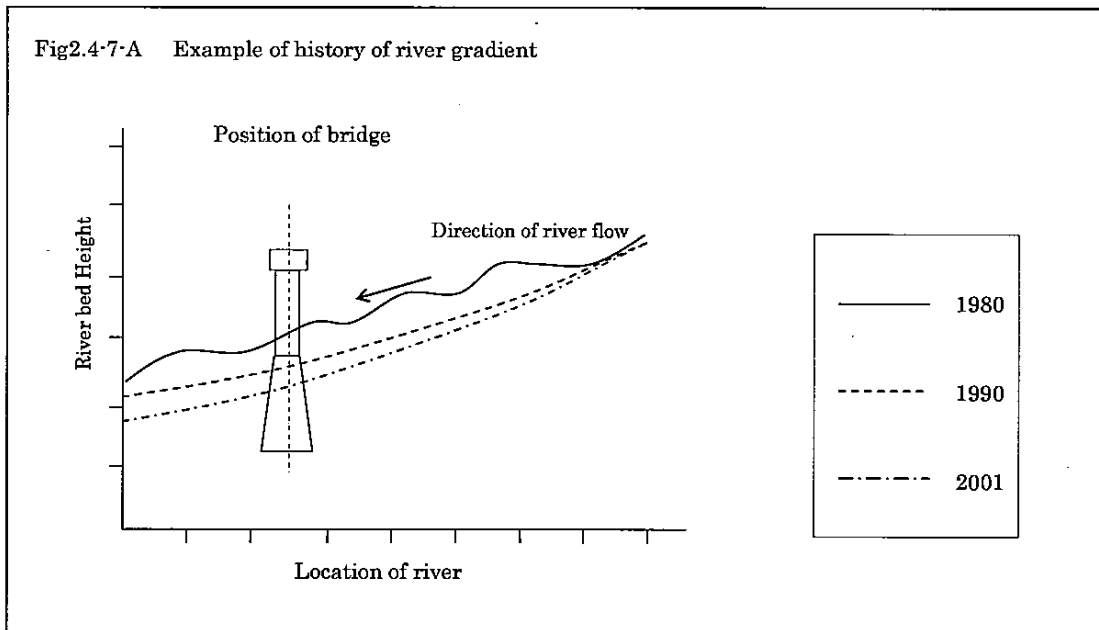
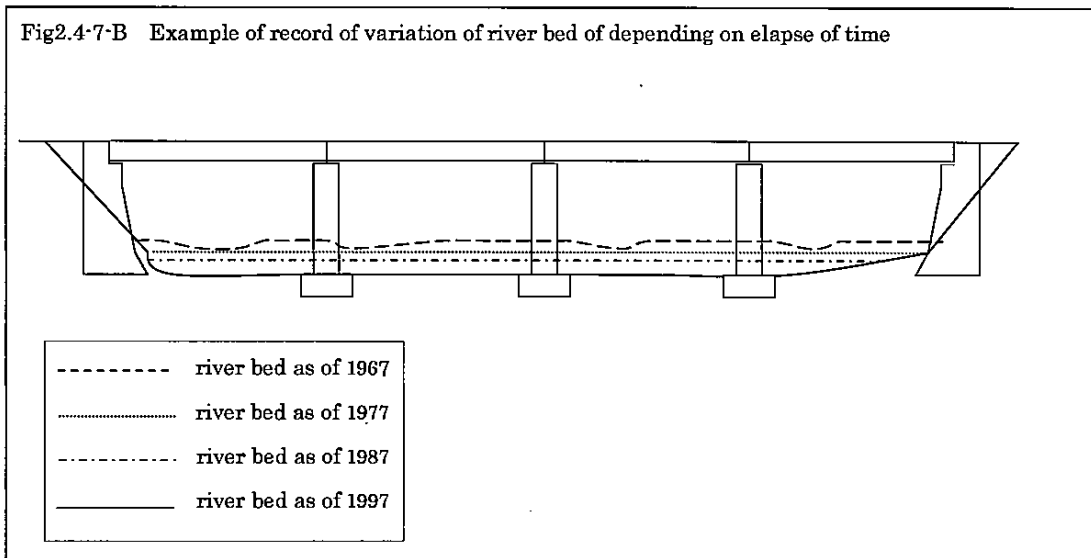

Fig2.4-7-B Example of record of variation of river bed of depending on elapse of time



e) Records of environmental changes in river watershed

Methods of recording the environmental changes in river watershed, such as those related to scouring and degradation of river bed near the bridges is explained below.

- Survey area
 - All watersheds upstream of bridge.
 - Within river reservation for main stream downstream of bridge.

- Survey objects
 - Cutting or reforestation
 - Development of roads, housing lots, factory sites, etc.
 - Various river works such as dam, erosion control dam, weir and levee improvement
 - Gravel taking
 - Other various items considered to be related to the degradation of river bed or scouring.
- Recording format
 - Items of survey objects should be indicated on topographical maps of 1/50,000 or 1/25,000 for river watershed by showing their location, length, area, etc.
 - Various items that cannot be indicated on the maps may be accompanied with numerals or letters.
- For rapidly changing items, the records of changes with timer should be prepared.(refer to Fig1.5-8)

Fig2.4-8 Example of history of environment

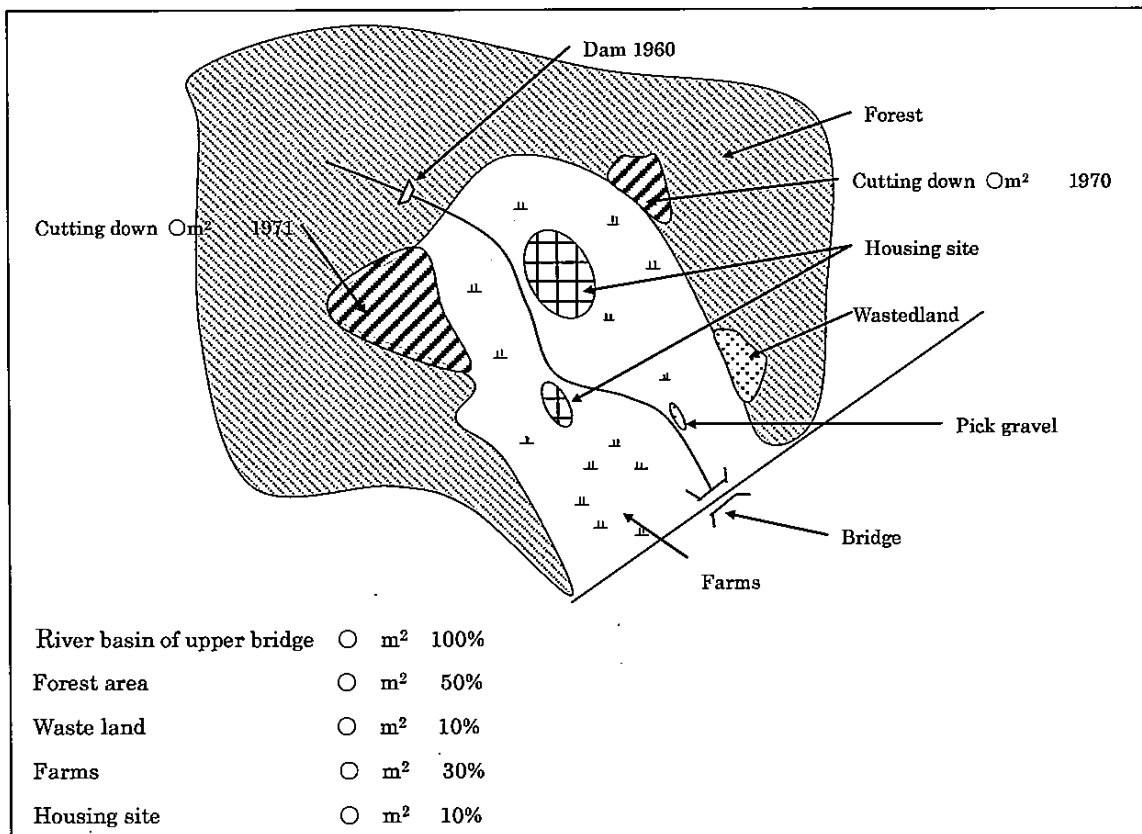

2) River regime survey

a) records of freshets in the past

Data of freshets near the railway bridge should be collected and recorded as much as

possible. Hydrological data such as water level, damages, amount of rain fall, should be actually surveyed. And the background of data (such as old records or words told old men) should be also accompanied.

b) Records of river history

History of the river at the section covering the whole length of bridge should be recorded as follows:

- Survey time
Before rainy season and immediately after rainy season
- Survey intervals
Every year as a rule, additional survey should be performed as required, such as after abnormal freshet.
- Method of records

River situation in the whole area near and directly below the bridge should be indicated. In this case, also show the maximum water level, maximum daily rainfall and annual rainfall amount in that year. Fig2.4-9 shows an example of history of change in river bed.

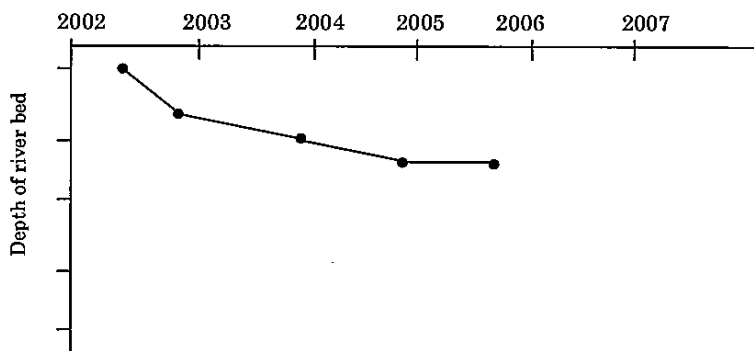
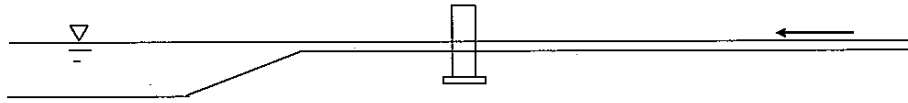

Fig2.4-9 Example of history of change in river bed

- Condition of river bed of traversal direction of river

Judging from the level of river bed, even if condition of the depth of foundation is enough, Embedded depth of substructure foundation may decrease rapidly for illbalanced height of traversal direction of river bed. In case of gravel as materials of river bed, bearing capacity of foundation ground may also decrease for undercurrent water.

In case of lower river bed level at side of downstream of bridge



In case of lower river bed level at both sides of upstream and downstream of bridge

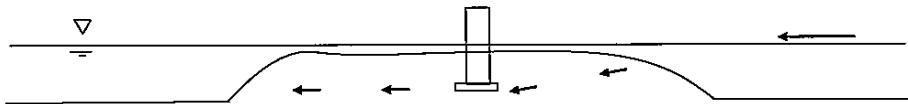
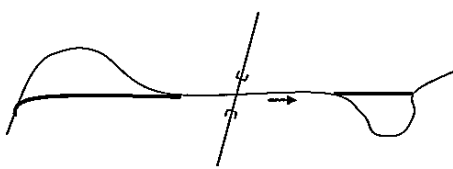

Fig2.4-10 Example of imbalanced river bed condition of traversal direction of river

Condition of river bed should be inspected along the center line of stream ranging about 300m at side of upstream, about 200m at side of downstream.

- Check points of changes in river environment

When the stream or environment of river basin changes, it may cause river bed to influence as indicated follows.



a short cut at up & down stream of bridge

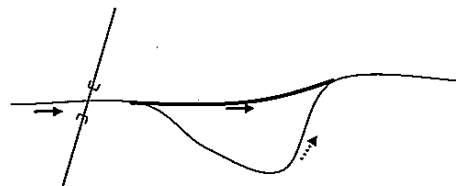

b short cut at down stream of bridge, lowering of river bed

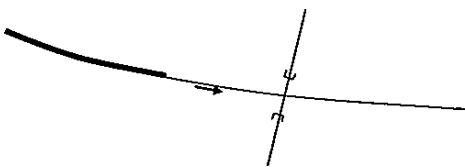

c construction of embankment, to widen river

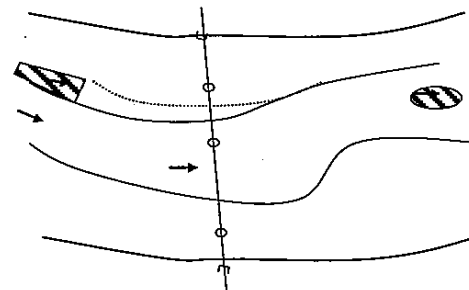

d removal of river bed materials near bridge

Fig2.4-11 Example of environmental changes near bridge

- Rainfall records, water level records, velocity records

In order to know the relations between rainfall, water level and velocity, these records corresponding to the freshets should be arranged. Fig2.4-12 is an example of records of the relation between rainfall and water level.

○ ○ Bridge: Rainfall-water level curve (Year____, Month____, Day____)

Flood velocity is important information but not easily obtained. It may be roughly estimated based on flowing objects or photographic records of running water at bridge pier.

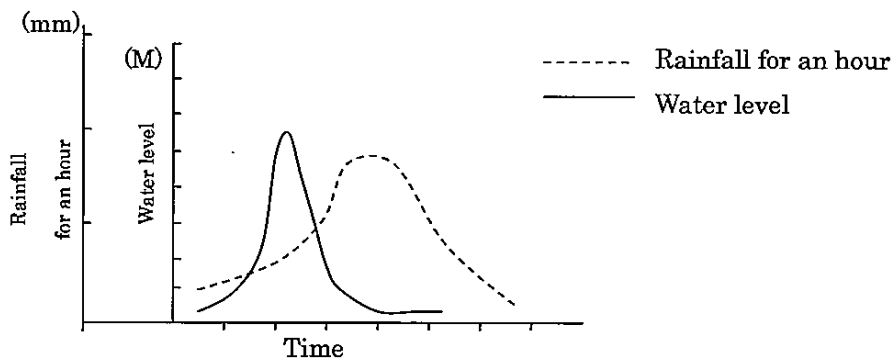

Fig2.4-12 Rainfall-water level curve

3) Evaluation of stability of pier of bridge

- Examination of depth of scouring

Localized scouring will be happen near the pier, due to downward water flow, concentration of river flow, occurrence of eddy etc. in estimating the depth of scouring near the pier, localized scouring and variation of river bed should be duly taken into consideration,

$$Z = Z_0 + Z_s$$

Where Z : depth of scouring

Z_0 : amount of overall variation of river bed

Z_s : depth of localized scouring

In estimating depth of scouring in the case where no protection work is provided, the following equation can be used,

$$Z_s/D = 1.45 h_o/D \quad \dots \dots \dots \quad \text{for } h_o/D < 1$$

$$Z_s/D = 1.45 \quad \dots \dots \dots \quad \text{for } h_o/D \geq 1$$

Where h_o : average depth of river water

D : width of pier

Z_s : depth of localized scouring

These relationships are shown in Fig2.4-13.

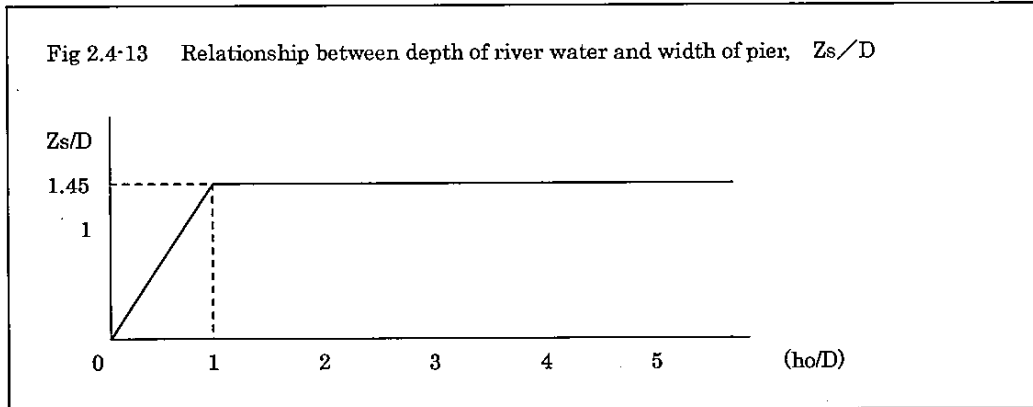

Presumptive picture of scope and form of scouring is shown in Fig2.5-14.

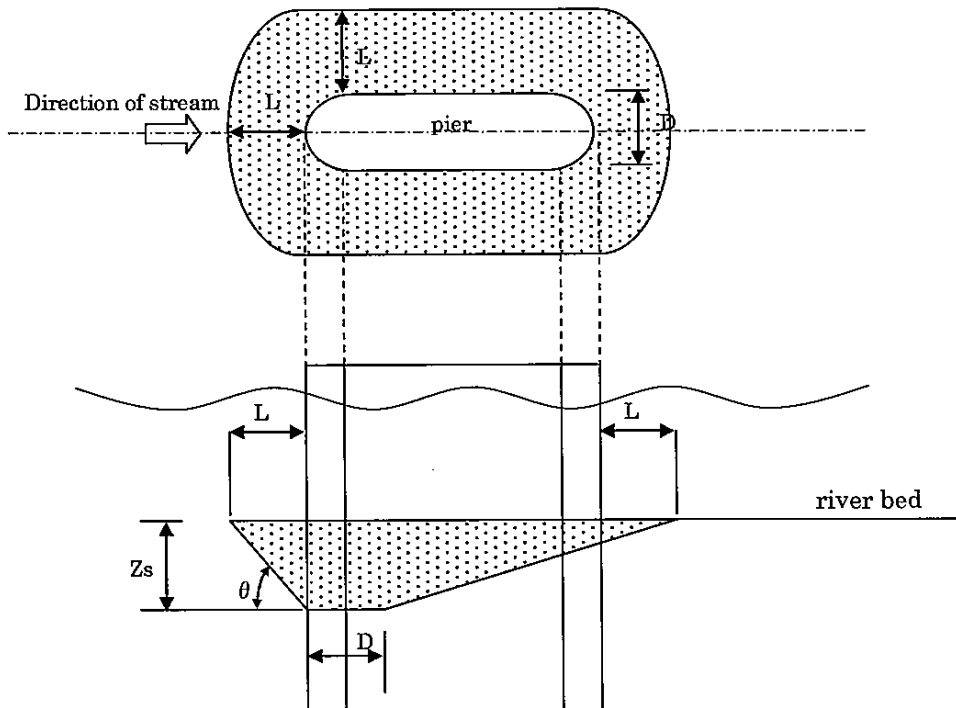

Fig2.4-14 Presumptive picture of scope and form of scouring

Where

L : scope of localized scouring

θ : angle of repose in water

Z_s : depth of localized scouring

D : width of pier

$$L = \frac{Z_s}{\tan \theta}$$

2.5 Countermeasures for rehabilitation

The plan of countermeasures should be formulated by fully recognizing the purposes and effects of countermeasures and determining proper time and method for the execution.

(1) Kinds of countermeasures for rehabilitation

In the rehabilitation planning, it is necessary to review effective methods corresponding to the countermeasure.

Foot protection methods for the rehabilitation of foundation are shown in Table2.5-1. Principal methods of degradation prevention works are shown in Table2.5-2.

Table2.5-1 Foot protection methods

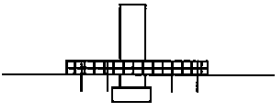
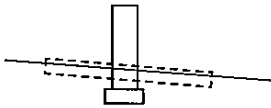
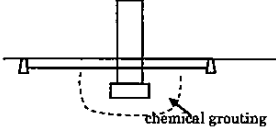
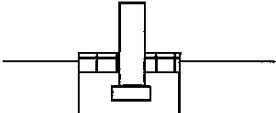
Methods	Requirement for application	Restriction
① wire cylinder works (Gabionade) 	<ul style="list-style-type: none"> - Unstable river bed 	<ul style="list-style-type: none"> - It is necessary to strengthen the fastening between wire cylinders and stabilize the whole wire cylinders.
② Block works 	<ul style="list-style-type: none"> - Unstable river bed and a shallow embedment 	<ul style="list-style-type: none"> - Not to carry out a partial construction in the running water. - To stretch a footing both to upstream and downstream directions.
③ Pitched concrete works ④ Pitched concrete works + chemical grouting 	<ul style="list-style-type: none"> - Unstable river bed and a shallow embedment - Relatively narrow width of a river - If river bed water is likely to occur, it is necessary to carry out a chemical grouting as well. 	<ul style="list-style-type: none"> - It is necessary that the foot protection works do not exceed the river bed in height.
⑤ Framed stone pitching works Framed wire cylinder works 	<ul style="list-style-type: none"> - Relatively stable river bed and a shallow embedment. 	<ul style="list-style-type: none"> - It is necessary that the level crown of the foot protection works do not exceed the average river bed in height.
⑥ Rubblestone or block masonry ⑦ Rubblestone + pressing block	<ul style="list-style-type: none"> - A torrential river which supplies plenty of sand and gravel - Relatively broad local scouring 	

	<ul style="list-style-type: none"> - If the rubblestone works are insufficient to make stable situations, the block masonry should be added to press the foundation. 	
---	---	--

Table2.5-2 Prevention methods against degradation of river bed

Methods	Requirement for application	Restriction
<p>① Super-weight concrete block method</p> 	<ul style="list-style-type: none"> - Torrent - Plenty of discharge 	<ul style="list-style-type: none"> - Each block is needed to be stable.
<p>② Block combination method</p> 	<ul style="list-style-type: none"> - A river which supplies sand and gravel 	<ul style="list-style-type: none"> - Combination of blocks are needed to be stable.
<p>③ Frame method</p> 	<ul style="list-style-type: none"> - A river which hardly supplies sand and gravel. 	
<p>④ Weir method</p> 	<ul style="list-style-type: none"> - A river which hardly supplies sand and gravel. 	

2.6 Recording inspection results

Items to be recorded in the Inspection reports should include the data of inspection, name of inspecting person, place of inspection performed, etc.

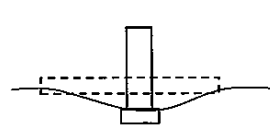
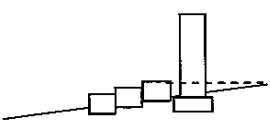
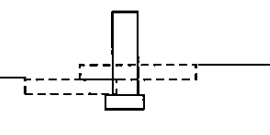
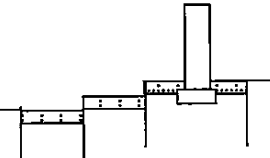
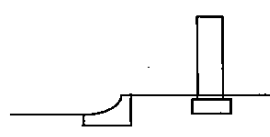
For the structures with deformations, the following items should be recorded, and the records should be orderly arranged, filed and stored.

Detailed inspection is performed with respect to a railway structure that is decreasing its function or will lose its function in the near future, and to clarify the cause of deformation, to evaluate the deteriorated degree of structural function accurately, and to decide the timing and method for countermeasures to be taken.

(1) Items to be indicated

(a) Records of deformations

(b) Items to be recorded together with the records of deformations are:

- ① Location of structures
- ② Surrounding environment
- ③ Completion date of construction work
- ④ Design drawing, design calculation sheets
- ⑤ Name of contractor
- ⑥ Relevant construction logs
- ⑦ Loading history
- ⑧ Geologic columnar section and other data for ground
- ⑨ Repairing history

(2) Arrangement and storage

(a) The results of inspection are desired to be classified and arranged by the quantity of inspection performed, by station, and by structure.

(b) Inspection records should be stored for a long period of time. This is also useful for foreseeing the progress of future from present status or from the records performed in the past. Table 2.6-1 shows standard forms and examples of recording for inspection records.

Table 2.6-1
Maintenance Company

Recording Format of Inspection Data (General)

No. _____

Inspection date, weather, etc.	Date	Weather	Signature	Inspector	
Line, Section, Position	Structures	Inspection Items and Findings		Rating of classification	
Line from 00km+00m To 00km+00m 00km+00m(right)					
Others		No abnormality		S	
		<div style="border: 1px solid black; padding: 5px; display: inline-block;"> The statement necessary to affirm the completion of the inspection </div>			

A-8-8-111

Recording Format of Inspection Data (Individual bridge)

Bridge type	Gd																			
Bridge name	XX bridge																			
Upper/down	上-4V	Sub title	8																	
Line name	Hokuriku main line			Inspection	Assistant	Supervisor	Weather	Judgment		Deterioration sheet										
Closest both station		Now	YY/MM/DD	AAAA	DDDD	Fine	A1													
Closest both station	1103k247m	Next	YY/MM/DD	BBBB	EEEE		A2													
Assets code	110219110	Last one before next	YY/MM/DD	CCCC	FFFF		B													

[Major inspection items]									
Location	Item	Methods	Judgment			Remark			
			Now	Last	Low				
Around bearing	Damage, settle down, gap, moving failure	Visual	A1	A2	B	Settle down,			
Around bearing	Crack on lower flange	Visual	A2	B	C	Occurred? Progressed?			
End cross bracing, lateral	Rivet loosening or breaking	Visual	C	C	C	Especially bearing settle down			
Welded part around bearing	crack	Visual	B	B	C	Progressed?			
Main girder	rust	Visual	B	C	C	U-FLG. Around bearing			

[Common inspection items]										
Inspection position and deterioration position		Inspection result				Judgment			Evaluation of coat	
						Now	Last	Low	Now	Last
Main Function	Paint	Coat degradation	Degree		P-		I		UV	IV
		(P Judgement)	Last Painted date	2008/7					UV	IV
	Bearing	Bearing gap	Amount	50	Position	起点方左右 許容値54.6mm	C	C		
		Anchor Bolt deterioration	Type		Position		S	S		
		Splitting	Amount		Position		S	S		
	Bridge seat	Crack	Position				S	S		
			Scale		Degree					
		Flaking / spalling	position				S	S		(Left)
		Penetration	Amount		Position		S	S		Last Now
		Up/Down moving	Amount		Position		S	S		Protection work height
	Girder	Touching contact	Scale		Position		S	S		Girder height
		Crack					S	S		
		Erosion	Tiny erosion on web and rivet of lower flange				C	C		Shown height
		Loosening	Loosening rivet on upper lateral for 2 numbers, and bracing for 1 number				A1	A1		
		Others								(Right)
Other Function	Corrosion/Damage	Repair		Repair					Last Now	
	Foot	Coat degradation	Repair	Repair					Protection work height	
	Way	Bolt drop out	Position							
	Cover Plate	Broken/Damage	Repair	Repair					Girder height	
	Scarfing	Coat degradation	Repair	Repair						
	Drain pipe	Erosion/Damage	Repair						Shown height	
	Others									

[Verification for last prediction of deterioration]					
From	Future	Year	Prediction contents	Verification on year	Verification for last prediction
2008	2Y later	2010	Erosion around bearing are progressed		
	4Y later	2012	Settlement down around bearing are progressed		
	10Y later	2018	Crack is occurred from welded part around bearing. Stut or lateral will drop out from girder.		
	2Y later				
	4Y later				
	10Y later				

2.7 Structure inspection chart

Example of structure inspection chart which contains general inspection, detailed inspection and countermeasure is shown in Table 2.7-1.

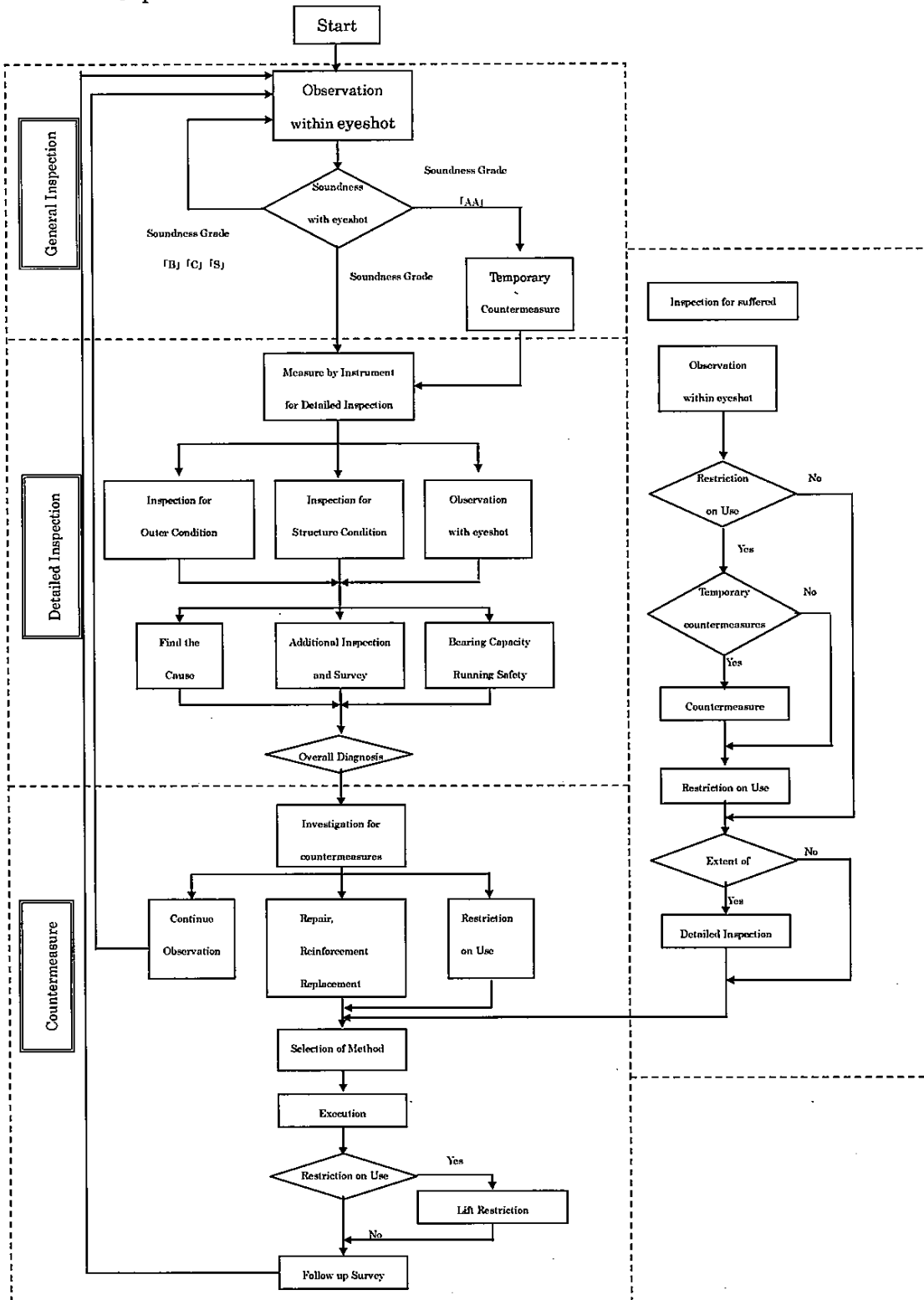
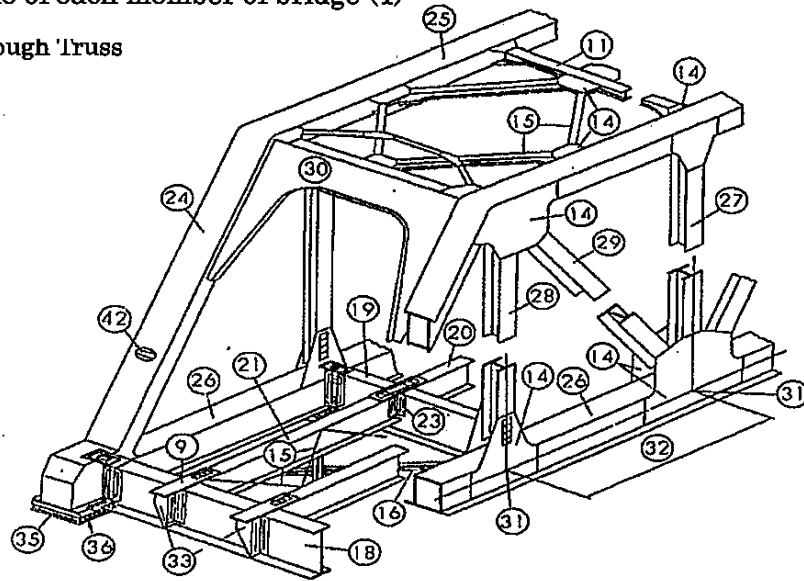

Fig2.7-1 Structure inspection chart

Name of each member of bridge (1)

Through Truss



Through Plate Girder

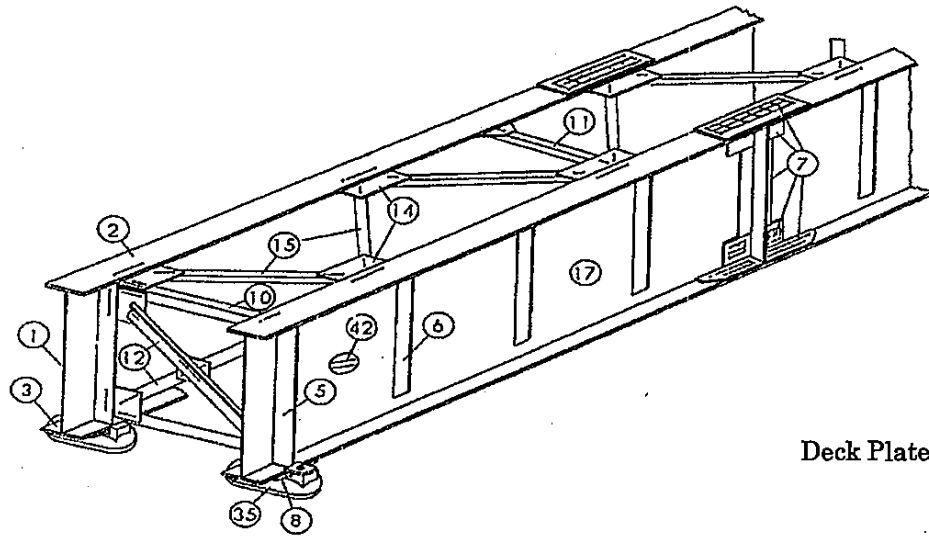
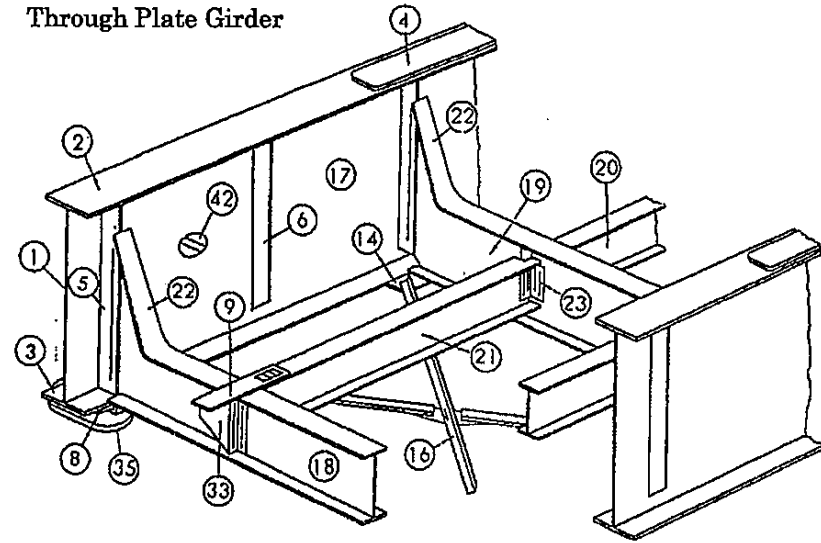

Deck Plate Girder

- | | |
|--------------------------|---------------------------|
| ① Web plate | ⑩ Lower lateral bracing |
| ② Upper flange | ⑪ Main girder |
| ③ Lower flange | ⑫ End floor beam |
| ④ Cover plate | ⑬ Intermediate floor beam |
| ⑤ End stiffener | ⑭ Knee brace |
| ⑥ Intermediate stiffener | ⑮ End stringer |
| ⑦ Splice plate | ⑯ Knee brace |
| ⑧ Sole plate | ⑰ Connection angle |
| ⑨ Moment plate | ⑱ End post |
| ⑩ End strut | ⑲ Upper chord member |
| ⑪ Intermediate strut | ⑳ Lower chord member |
| ⑫ way bracing | ㉑ Vertical member |
| ⑬ Intermediate bracing | ㉒ Hip vertical or hanger |
| ⑭ Gusset plate | ㉓ Diagonal member |
| ⑮ Upper latera | ㉔ Portal |

Name of each member of bridge (2)
Deck Plate Girder
(Direct Fastening Type)

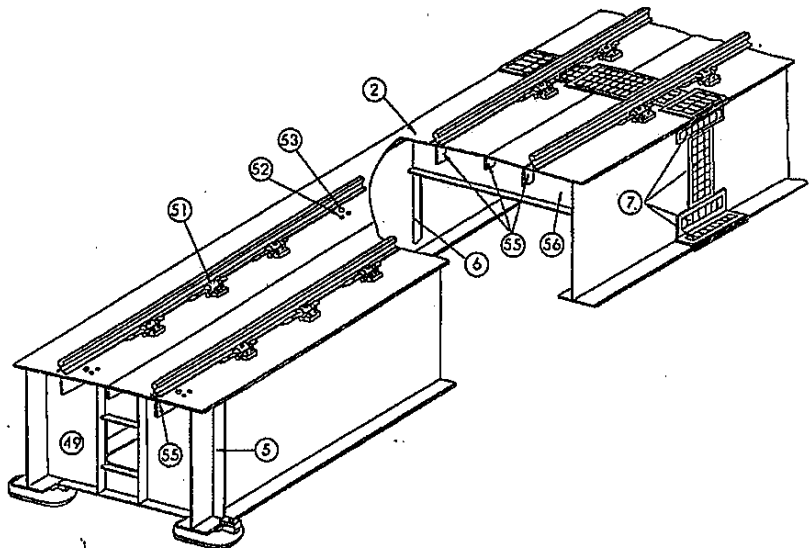

Composite Beam

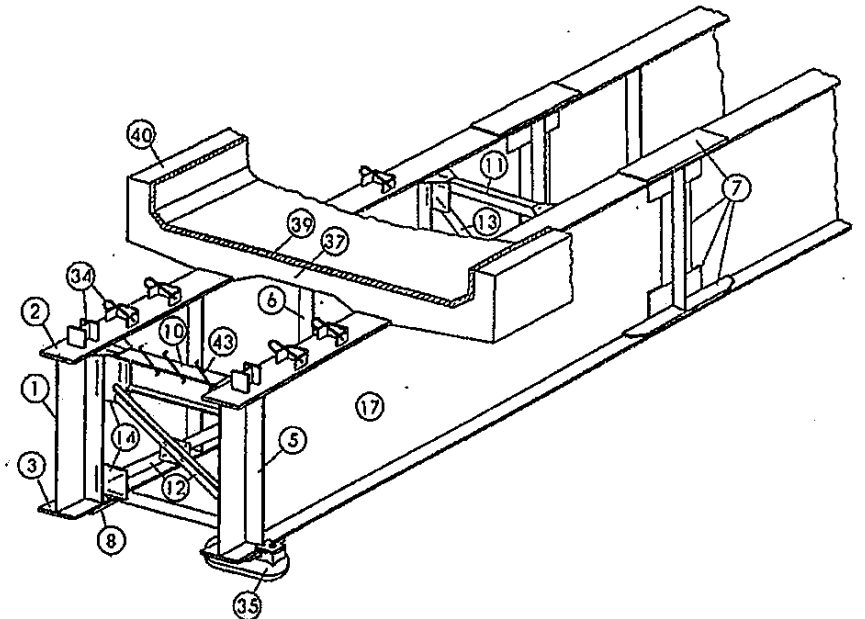

Through Plate Girder
(Steel Plate Floor)

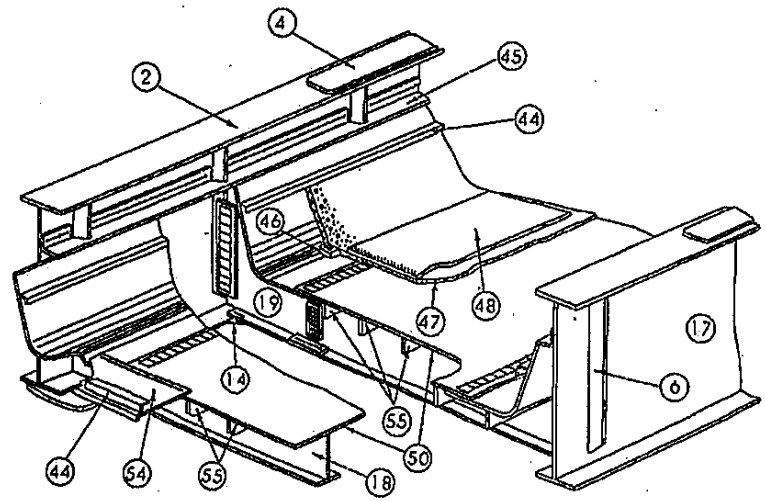

- ① Panel point
- ② Panel length
- ③ Bracket
- ④ Shear connector
- ⑤ Shoe
- ⑥ Roller
- ⑦ Slab
- ⑧ Pavement
- ⑨ Water proof membrane
- ⑩ Ballast stopper
- ⑪ Coping
- ⑫ Name plate
- ⑬ Slab anchor
- ⑭ Tight plate
- ⑮ Coping plate
- ⑯ Water filter
- ⑰ Water resistant layer
- ⑱ Ballast mat
- ⑲ End diaphragm
- ⑳ Steel plate floor
- ㉑ Rail fastening
- ㉒ Hole of lateral load stopper
- ㉓ Hole of rail fastening
- ㉔ Tongue plate
- ㉕ Longitudinal rib
- ㉖ Transverse rib

A-8-8-115

3. Patrol inspection

This chapter stipulates matters pertaining to the patrol inspection and monitoring of rail tracks, and the inspection of trains in order to maintain the rail tracks, overhead contact lines and trains in conditions that ensure safe train operation at all times.

3.1 Patrol inspection of rail tracks

(1) Purpose of patrol inspection of rail tracks

The function of rail tracks is to support the trains and secure their running space, and thus they must be maintained in conditions that ensure safe train operation at all times.

The conditions of a rail track constantly change depending on various factors including the influence of train traffic and aging, and the environment along the track such as drainage, water retention capability, etc. which are affected by land development, deforestation, etc. in the surrounding area. Therefore, it is necessary to periodically inspect the functions of individual facilities and to know the state of these functions as well as the overall maintenance conditions of the rail track, whether or not construction limits are exceeded, changes in the surrounding environment, etc. through periodic patrol inspection of the rail track.

(2) Frequency of patrol inspection of rail tracks

Patrol inspection of a rail track is required to ensure the safety and stability of daily train operation over the entire rail track, and the frequency of inspection must be set by comprehensively considering various factors including the conditions of track structures (rail weight, sleeper type, trackbed thickness, roadbed, etc.) and civil engineering structures (bridges, tunnels, banking, cutting, etc.) of the line section, the expected loading force on the rail track based on the bearing capacity, train speed, vehicle performance, traffic volume, etc., the method of periodic inspection, and the natural environment and site conditions such as the terrain, geology, land use, weather conditions, etc. in the surrounding area.

The methods for track patrol inspection include inspection over the entire line on foot or by a service car to check the maintenance conditions of the entire rail track, on-vehicle inspection performed from the driver's platform of a train to check the maintenance conditions as well as the train ride comfort. Effective inspection should be conducted by combining these methods according to the frequency of inspection and the items to be checked. Introducing an important inspection item in different seasons, etc. is also an effective means for enhancing the awareness of inspection personnel.

If any abnormal condition is found during the track patrol, it is necessary to promptly contact the relevant departments and take necessary actions including inspection, monitoring, operation control, etc.

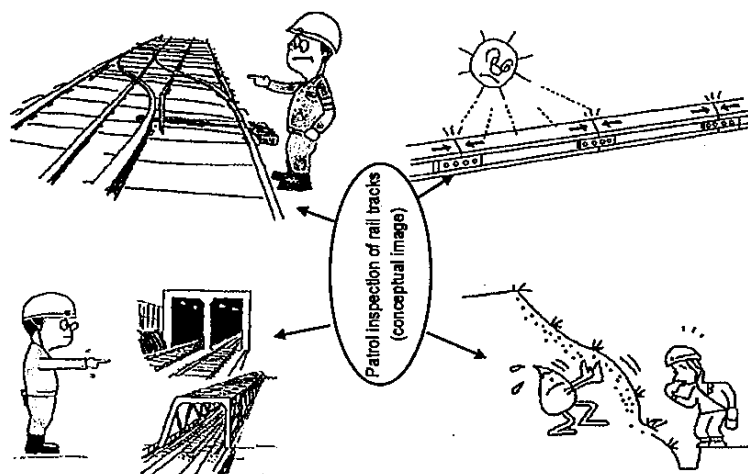

3.2 Monitoring of rail tracks

(1) Monitoring of tracks

In the case of the discovery of a damaged rail, joint bar, etc., poor bonding/adhesion of a turnout, a sunken roadbed or other conditions that may affect safe train operation, appropriate actions must be taken based on the nature and severity of the problem in order to avoid a serious accident. Such actions include making arrangements for stopping trains, arrangements for slowing down trains while preparing for the replacement of materials, placing a monitoring mark to indicate a place that requires special attention and periodic monitoring.

(2) Monitoring of civil engineering structures

In the case of discovery of a deformation of a slope, risk of falling rocks, crack in a bridge girder or other conditions that may affect safe train operation, appropriate actions must be taken based on the nature and severity of the problem in order to avoid a serious accident, while making arrangements for protecting the trains and conducting periodical monitoring.

Once an accident occurs involving a civil engineering structure, train operation is often restricted for a long period of time. Therefore, it is necessary to recognize the warning signs as early as possible and systematically install prevention facilities.

(3) Monitoring of rail tracks when there is a risk of disaster

In cases where damage to a rail track is expected due to a natural disaster such as typhoon, heavy rainfall, flood, tsunami, snowfall, dense fog, earthquake, etc. or other factors such as a fire in the vicinity of the track, construction work close to the track, rise in rail temperature, etc., the subject rail track must be effectively monitored in accordance with the respective situation. In addition, appropriate actions must be taken to ensure safe train operation, such as restricting the operation speed by setting a slow speed as required or canceling train operation in the relevant line or line section depending on the circumstances.

Attempting to devise appropriate measures after a disaster has occurred may result in serious damage. Therefore, assuming the possibility of a disaster, it is desirable that susceptible line sections be specified, and the monitoring method and system, speed reduction, etc. be determined in advance.

3.3 Principle of guarding against disasters

Railway structures are exposed to external natural forces such as rain and earthquake; it is difficult to completely avoid the deformation or damage of structures caused by these forces. Therefore, safe train operation should be ensured by keeping guard when there is a risk of disaster, or by carrying out operation control, while steadily promoting disaster prevention measures for improving the yield strength of structures.

(1) Guarding plan

The purpose of guarding against disasters is to ensure safe train operation by checking for abnormalities in rail tracks in the event of weather conditions that pose a high risk of a natural disaster. To appropriately and securely implement protection measures against disasters, a plan must be created in advance so that the necessary protection system is appropriately established.

(2) Example of guarding and standard values for operation control, etc.

(a) Rainfall

Typical disasters caused by rainfall include landslide disasters on earthworks such as cutting and banking or on natural slopes. These disasters are often caused by factors such as amount or intensity of rainfall, etc. Therefore, rainfall is generally monitored in order to ensure safe train operation by detecting signs of a disaster, and an alert is issued or operation control is executed when the observed

amount of precipitation (rainfall), intensity of rainfall, etc. has exceeded the predetermined standard value.

○ Examples of JR (conventional line)

Examples of categories, methods and release criteria for operation control, etc. depending on the rainfall situation are shown in Table 89.1 and onward. In cases where, due to structural and geographical conditions, etc. there is no risk of disaster caused by rainfall or only minor damage is expected in the event of a disaster, it is possible that some or all of the categories of operation control are not applied.

Table 3.2-1 Example of categories, methods and release criteria for operation control, etc.

Category	Alert	Speed control	Operation cancellation
	There is almost no risk of disaster, but some of the signs are observed.	There may be a risk of minor disaster.	There is a risk of disaster.
Operation control method	—	Train speed is restricted if the standard value is reached.	Suspend train operation.
Guarding method	The predetermined guarding places are patrolled on foot, etc. at intervals of 3 to 4 hours.	In addition to the method shown on the left, the entire section is guarded by train at 2-hour intervals.	The entire section is patrolled on foot, etc. whenever and wherever possible.
Release criteria	Rainfall ending trend is confirmed and the hourly rainfall has dropped to below the alert standard value. Alternatively, a significant length of time has passed since the rain stopped.	It is confirmed that there are no abnormal conditions in the predetermined guarding places, the rainfall has dropped to below the alert standard value, and it is confirmed by passing trains, etc. that there are no abnormal conditions over the entire section.	The rain has stopped or the rainfall has dropped to below the standard value, and it is confirmed on foot, etc. that there are no abnormal conditions over the entire section.

The rainfall indexes used for operation control include the amount of hourly rainfall and amount of continuous rainfall, which are applied alone or in combination with each other. One example of application is shown below.

○ Hourly rainfall, continuous rainfall and their combination

Operation control, etc. is issued if the amount of hourly rainfall or continuous rainfall has exceeded the respective standard value. The standard value for hourly rainfall may be reduced in some cases if continuous rainfall has exceeded a certain value (Fig. 3.2-1).

- Hourly rainfall is the total amount of rainfall until any given time starting from one hour before that time.
- Continuous rainfall is the total amount of rainfall that has continued without interruption of more than a certain period of time (12 hours or more) until any given time starting from the start of the rain.

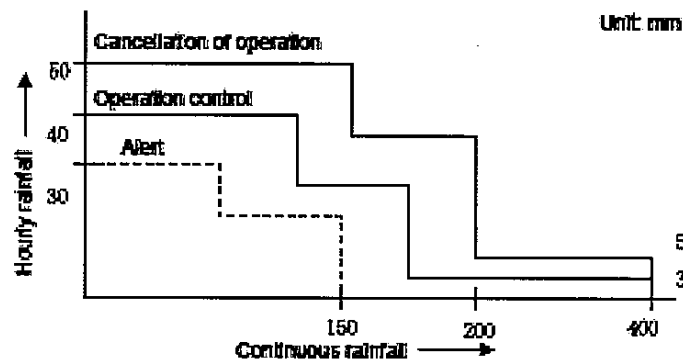

Fig.3.2-1 Example of operation control based on combination of hourly rainfall and continuous rainfall (conceptual image)

○ Example of private railway

There are two types of operation control due to rainfall: speed control and cancellation of operation. The sections subject to operation control are classified as follows:

Section A: Relatively strong main line section where only slight damage, if any, is expected.

Section B: Main line section where significant damage such as a landslide is expected due to heavy rain.

Section C: Branch line or a section where cancellation of operation has little effect.

The standard values for issuing operation control, etc. are shown in Table 3.3-2

Table 3.3-2 Standard values for operation control, etc.

Operati on control section class	Type of operation control	Standard value		
		Accumulative rainfall of less than 200 mm	Accumulative rainfall of 200 mm up to 300 mm	Accumulative rainfall of 300 mm or more
A	Speed control	Hourly rainfall of 40 mm or more	Hourly rainfall of 35 mm or more	Hourly rainfall of 30 mm or more
		Hourly rainfall of 40 mm or more	Hourly rainfall of 35 mm or more	Hourly rainfall of 30 mm or more
B	Speed control	Hourly rainfall of 40 mm or more	Hourly rainfall of 35 mm or more	Hourly rainfall of 30 mm or more
	Operation cancellation	Hourly rainfall of 60 mm or more	Hourly rainfall of 35 mm or more	Hourly rainfall of 40 mm or more
C	Speed control	Hourly rainfall of 30 mm or more		
	Operation cancellation	Hourly rainfall of 50 mm or more	Hourly rainfall of 40 mm or more	

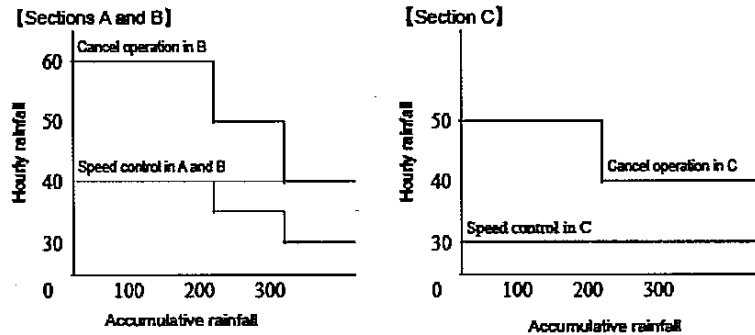

- Hourly rainfall is the amount of rainfall in the last one hour, which is measured every 15 minutes (4 times: 0, 15, 30 and 45 minutes of each hour).
- Accumulative rainfall is the cumulative amount of rainfall starting from a point of time when there has been no rain for the last 48 hours. (Rainfall is measured every 15 minutes as in hourly rainfall.)

(b) Strong Wind

Strong wind is generally monitored in order to ensure safe train operation by detecting signs of a disaster, and an alert is issued or operation control is executed when the observed wind velocity has exceeded the predetermined standard value, shown in Table 3.2-3.

Table 3.2-3 Standard values for train operation (strong wind)

Wind velocity	Type of operation control	
	Normal Section	Specific Section
15m/s and over, under 20m/s	-	Alert
20m/s and over, under 25m/s	Alert	Speed control
25m/s and over, under 30m/s	Speed control	Operation cancellation
30m/s and over	Operation cancellation	

“Specific Section” is where threaten by strong wind without countermeasure works such as wind-shield. “Normal Section” is where threaten by strong wind without countermeasure works

(c) Water way control

Train control, “operation cancellation”, “speed control”, ”alert” are regulated by water level or amount of rain fall considering the effects to structure by scouring pier, riverbed settlement, flowing object impact and height of dike and shore protection. Regulation value is shown as Table 3.2-4

Table3.2-4 Regulation value against water level raising.

Study items	Speed control	operation cancellation	object of bridge
Stability	The water level which margin of safety ratio is 1.5 in stability analysis	The water level which margin of safety ratio is 1.2 in stability analysis	Bridges threaten by the disaster concern with these study items
Following object	-	The water level which the height is “h(m)” below from the bottom edge of girder.	
Height of dike	-	The water level which the height is “h(m)” below form the top of dike .	

* “h” means the margin height between water surface and bottom edge of girder, and the margin height is determined individually by river condition and surrounding environment and so on. And “h” is regulated by Japanese law,” Cabinet Order concerning Structural Standards for River Management Facilities, etc”

Appendix-1

The way to consider the train speed restriction due to state of damaged deck girder

The way to consider the speed restriction due to rusted Deck Girder (DG), one example in Japanese railway, is named “Stress Ratio method (SR)”. Using the method, comparing the present proof stress and limit stress for maintaining the required performance of girder basically, it can evaluate proof stress, durability and running stability reasonably. The calculation example of SR for rusted Deck Girder is shown as follows.

[Calculation Example]

(1) General Information of girder and result of individual inspection (refer to Fig A-1)

- A) Deterioration of bearing : None
- B) Shaped hole by corrosion on end of girder : None
- C) Shaped hole by corrosion on web member : None
- D) Shaped hole by corrosion on upper flange and main member : 5mm average thickness
- E) Shaped hole by corrosion on lower flange : 10mm average thickness

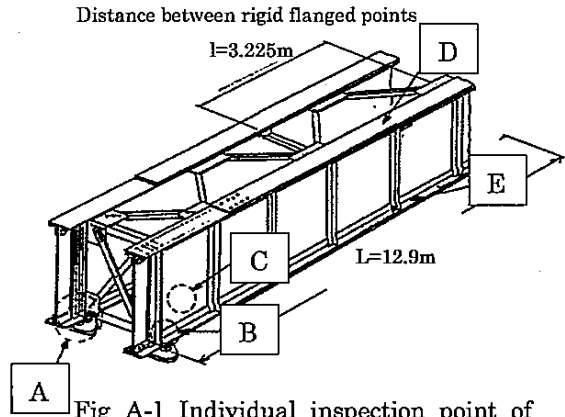

Fig A-1 Individual inspection point of

(2) Live load conditions

- Type of heaviest rolling stock loaded on the bridge : EF64
- Train speed : 110km/h
- Capacity (track grade) : over 20 million tonnage

(3) Study member and items

- Members to be judged soundness : main girder, floor or cross beam, stringer
- Detail survey point : end of cover plate, remarkable shaped hole by corrosion, the place with shaped hole by corrosion on floor or cross beam and stringer, and joint of them
- Assuming condition for this case: none shaped hole by corrosion on end of cover plate, remarkable shaped hole by corrosion around the center of effective span that their thickness are 5mm on upper flange and .10mm on lower flange, no shaped hole by corrosion on the end of girder.

Due to the above results, it should be studied for SR only on the center of span of girder.

(4) Calculation procedure of SR

Refer to Fig A-2, SR is calculated based on it.

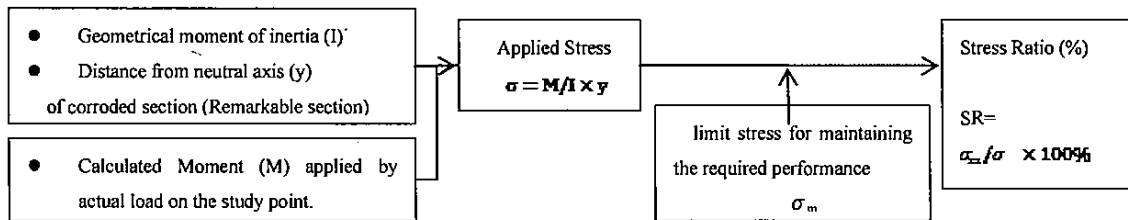

Fig A-2 Calculation procedure of SR

(5) Calculation of Geometrical moment of inertia and distance from neutral axis of remarkable corroded section.

Geometrical moment of inertia and distance from neutral axis of remarkable corroded section should be calculated based on Fig A-3

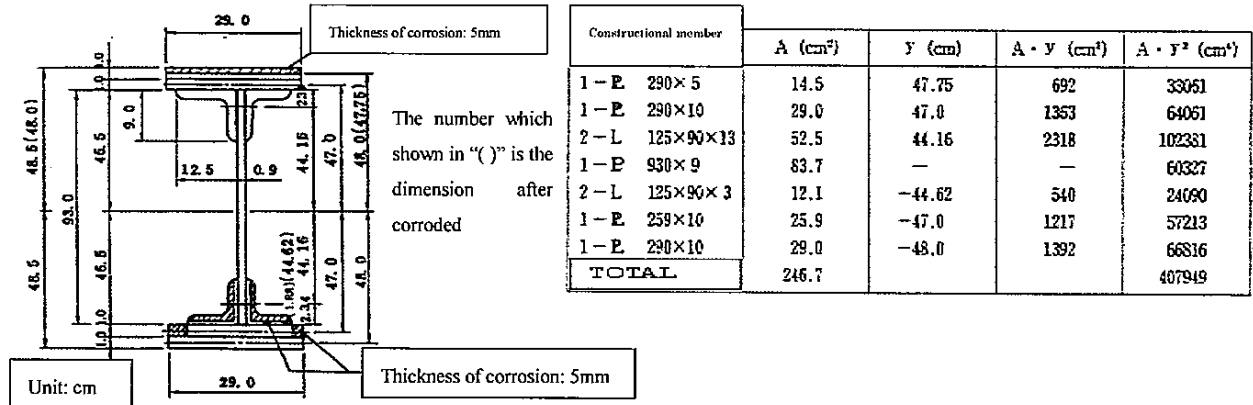

Fig A-3 Corroded Section

Gap of neutral axis: $\delta = 1224/246.7 = 4.96$ $-A \delta^2 = -6069$

Therefore, Geometrical moment of inertia is: $I_{xx} = 401880 \approx 401900 \text{ cm}^4$

Distance from neutral axis is: $y_{upper} = 93/2 + 1.5 - 4.96 = 43.04 \text{ cm}$

: $y_{lower} = 93/2 + 2.0 - 4.96 = 53.46 \text{ cm}$

*corroded thickness is converted per original section

(6) Calculation of bending moment

① Bending moment applied by dead load, per 1 rail: M_d

Self-weight $8.4 \text{ t} / 12.9 \text{ m} / 2 \text{ rail} \approx 0.326 \text{ t/m}$

Track-weight 0.225 t/m

Foot-path 0.15 t/m

Since, dead load is $W = 0.701 \text{ t/m}$

Therefore,

$$M_d = \frac{1}{8} W \times l^2 = \frac{1}{8} \times 0.701 \times 12.9^2 \approx 14.6 \text{ (t} \cdot \text{m)}$$

② Bending moment applied by live load, Ks-18: M_l

Bending moment applied by KS-18, refer to table-3.1.

$$M_{18} = 95.21 + (101.8 - 95.21) \times 4/5 = 100.48 \text{ t} \cdot \text{m}$$

The equivalent value to live load KS series for the train set which EF68 pulls on the span length 12.9m: 11.7 t

*

Therefore,

$$M_l = M_{18} \times 11.7/18 = 100.48 \times 11.7/18 \approx 65.3 \text{ (t} \cdot \text{m)}$$

③ Bending moment applied by impact load, allowable passage train speed : 110km/h : M_i

$$\text{Impact coefficient: } i = \frac{K_a \cdot V}{500 \cdot L^{0.2}} + \frac{10}{65 + L}$$

Here, $K_a=1.0$ (for shinkansen), 2.0 (for conventional train)

$$i = \frac{2 \cdot 110}{500 \cdot (12.9)^{0.2}} + \frac{10}{65 + 12.9} = 0.392$$

Therefore,

$$M_i = M_1 \cdot i = 65.3 \cdot 0.392 = 25.6$$

Conclusionary, the total of bending moment is:

$$M = M_d + M_1 + M_i = 14.6 + 65.3 + 25.6 = 105.5 (\text{t} \cdot \text{m})$$

(7) Calculation of applied stress

$$\text{Compressive stress: } \sigma_c = \frac{M}{I} y_u = \frac{105.5 \times 10^5}{401900} \times 43.03 = 1130 \text{ kg/cm}^2$$

$$\text{Tensile stress: } \sigma_t = \frac{M}{I} y_l = \frac{105.5 \times 10^5}{401900} \times 53.46 = 1403 \text{ kg/cm}^2$$

Considering the two rivet sections to be subtracted from σ_t

$$\sigma_t = \sigma_t \times \frac{A_{fe}}{A_{fe} - A_r} = 1403 \times \frac{67.0}{(67.0 - 2 \times 2.5 \times 2.3)} = 1693 \text{ kg/cm}^2$$

Here, A_{fe} : Girder section which were considered corroded flange

A_r : Rivet section to be subtracted from girder section

(8) Calculation of limit stress for maintaining the required performance

Tonnage: over 20 million tonnage

Effective span: $10 \leq L < 20$

Material type: SS41 *Bridges, constructed before 1950 in Japan, is made of SS41 mainly. And this bridge was constructed before 1950

① Tensile part

Refer to table 3.2, $\sigma_{mt} = 1500 \text{ kg/cm}^2$

② Compressive part

Refer to table 3.3,

$$l/b = \text{Distance between rigid flanged points} / \text{Upper flange width} = 3225/290 = 11.1$$

Therefore, $\sigma_{mc} = 1380 - 0.7(11.1)^2 = 1294 \text{ kg/cm}^2$

(9) Calculation of SR

Tensile $SR = \sigma_{mt} / \sigma_t \times 100 = (1500/1693) \times 100\% = 89\%$

Compressive $SR = \sigma_{mc} / \sigma_c \times 100 = (1294/1130) \times 100\% = 115\%$

Therefore, this bridge's stress ratio is 89%

(10) Deflection

➤ Calculation for deflection

In the case of section with "cover plate":

$$\delta = \frac{5.5ML^2}{48EI} = \frac{5.5 \times 90.9 \times 10.5 \times 1290^2}{48 \times 2.1 \times 10^6 \times 401900} = 2.1 (\text{cm})$$

➤ Converted deflection by actual measurement

Bending moment applied by design live load, KS-18: $M_{18} = 100.5 (1+0.392) \cong 140.0 t \cdot m$

Bending moment applied by EF64: $M_s = M_{18} \times \frac{11.7}{18} = 140.0 \times \frac{11.7}{18} \cong 90.9 (t \cdot m)$

Deflection by actual measurement: $\delta_s = 15 \text{ mm}$

Therefore

$$\text{Converted deflection} = M_{18}/M_s \times \delta_s = 140.0/90.9 \times 15 = 2.3 (cm)$$

From the above, assuming in the case of KS-H type rolling stock passage, it can be thought that 2.1cm deflection would occur according to calculations, but regarding to the actual measurement of it, in the case of KS-H type rolling stock passage, 2.3 cm deflection would occur. Therefore, it can be thought that the stiffness of this bridge had already degraded.

(11) Judgment of SR

SR ≤ 100% : AA,

100 ≤ SR ≤ 120% : A1

For Myanma Railways, the study of train speed improvement should be done as above. If the SR ≤ 120, review input data V, the train speed, and should try to calculate again until the SR would be over 120%. The train speed which SR would be over 120% is the suitable restriction speed for the bridge. And if SR never be over 120%, it should be considered the strength work for the bridge.

TableA-1 List of Sharing force, Support Reaction, Bending moment applied by live load KS-18 on 1 rail

Sharing force

Support Reaction

Bending moment

l = effective span

"E" show the point applied maximum force.

l (m)	せん断力 (t)					軸脚反力 (t)	曲げモーメント (t·m)					e (m)	l (m)
	S _a	S _b	S _c	S _d	S _e		M _a	M _b	M _c	M _d	M _e		
1.0	11.00	9.625	8.250	6.875	5.500	11.00	1.203	2.063	2.578	2.750	2.750	0	1.0
1.5	11.00	9.625	8.250	6.875	5.500	11.00	1.805	3.094	3.867	4.125	4.125	0	1.5
2.0	11.25	9.625	8.250	6.875	5.500	13.50	2.406	4.125	5.156	5.500	5.500	0	2.0
2.5	13.20	10.45	8.250	6.875	5.500	16.20	3.266	5.156	6.445	6.875	6.875	0	2.5
3.0	14.67	11.92	9.167	6.875	5.500	18.00	4.469	6.875	7.734	8.250	8.250	0	3.0
3.5	15.71	12.96	10.21	7.464	5.500	20.57	5.672	8.938	9.797	10.13	10.13	0	3.5
4.0	16.88	13.75	11.00	8.250	5.625	22.61	6.875	11.00	12.38	13.50	13.50	0	4.0
4.5	18.00	14.63	11.61	8.861	6.111	24.60	8.227	13.06	14.98	16.88	16.88	0	4.5
5.0	19.80	15.53	12.15	9.350	6.600	26.19	9.703	15.19	18.56	20.25	20.25	0	5.0
5.5	21.27	16.77	12.89	9.750	7.000	27.68	11.53	17.72	22.78	23.63	23.63	0	5.5
6.0	22.50	18.00	13.50	10.13	7.333	29.55	13.50	20.25	27.00	27.00	27.00	0.375	6.0
6.5	23.54	19.04	14.54	10.64	7.615	31.32	15.47	23.63	31.22	31.50	32.28	0.375	6.5
7.0	24.49	19.93	15.43	11.09	7.857	32.83	17.44	27.00	35.44	36.00	36.72	0.375	7.0
7.5	25.56	20.70	16.20	11.61	8.067	34.14	19.41	30.63	39.66	40.50	41.18	0.375	7.5
8.0	26.49	21.43	16.88	12.15	8.250	35.81	21.43	34.43	43.88	45.23	45.63	0.375	8.0
8.5	27.39	22.26	17.47	12.63	8.412	37.50	23.65	38.22	48.09	50.29	50.35	0.117	8.5
9.0	28.40	22.99	18.00	13.05	8.556	39.00	25.86	42.08	52.69	55.35	55.41	0.117	9.0
9.5	29.43	23.68	18.58	13.43	8.684	40.78	28.12	46.01	57.44	60.41	60.47	0.117	9.5
10.0	30.36	24.36	19.17	13.79	8.800	42.57	30.45	50.40	62.18	65.48	65.53	0.117	10.0
10.5	31.20	25.20	19.70	14.13	9.064	44.19	33.08	54.90	67.01	70.65	70.66	0.281	10.5
11.0	32.24	25.96	20.16	14.43	9.368	45.69	35.70	59.40	72.46	76.13	76.46	0.281	11.0
11.5	33.18	26.66	20.54	14.71	9.646	47.33	38.33	63.90	77.91	82.09	82.26	0.281	11.5
12.0	34.05	27.30	21.08	15.11	9.900	48.96	40.95	68.40	84.04	88.65	88.68	0.077	12.0
12.5	35.09	28.10	21.63	15.49	10.13	50.55	43.90	73.46	90.19	95.21	95.24	0.077	12.5
13.0	36.05	28.83	22.14	15.84	10.35	52.18	46.86	78.53	96.94	101.8	101.8	0.077	13.0
13.5	36.93	29.52	22.61	16.16	10.55	53.83	49.81	83.59	102.5	108.3	108.4	0.077	13.5
14.0	37.78	30.26	23.05	16.48	10.74	55.42	52.95	88.65	108.6	114.9	114.9	0.077	14.0
14.5	38.63	31.02	23.61	16.89	10.93	56.95	56.23	94.28	114.9	121.5	121.5	0.454	14.5
15.0	39.47	31.74	24.14	17.27	11.19	58.47	59.51	99.90	121.8	128.0	128.8	0.454	15.0
15.5	40.30	32.41	24.63	17.63	11.43	60.16	62.79	105.5	129.4	135.3	136.1	0.454	15.5
16.0	41.12	33.06	25.09	17.96	11.66	61.96	66.12	111.5	136.9	143.3	143.4	0.454	16.0
16.5	41.95	33.71	25.66	18.28	11.88	63.74	69.52	117.6	144.5	151.3	151.3	0.049	16.5
17.0	42.76	34.35	26.19	18.62	12.08	65.65	72.99	123.8	152.0	159.4	159.4	0.049	17.0
17.5	43.58	34.99	26.70	19.00	12.29	67.65	76.53	130.1	159.7	167.4	167.4	0.049	17.5
18.0	44.39	35.62	27.18	19.36	12.55	69.59	80.15	136.5	167.5	175.5	176.2	0.428	18.0
18.5	45.19	36.25	27.64	19.71	12.80	71.46	83.84	143.0	175.3	184.3	185.0	0.428	18.5
19.0	46.07	36.88	28.10	20.03	13.03	73.27	87.59	149.7	183.3	193.7	193.8	0.428	19.0
19.5	47.01	37.50	28.56	20.40	13.26	75.09	91.60	156.4	191.4	203.3	203.3	0.029	19.5
20.0	47.99	38.11	29.01	20.78	13.47	76.91	95.93	163.2	199.6	212.9	212.9	0.029	20.0
20.5	49.05	38.71	29.47	21.15	13.67	78.67	100.4	170.2	208.0	222.4	222.4	0.029	20.5
21.0	50.06	39.32	29.92	21.50	13.86	80.39	105.0	177.2	216.9	232.0	232.0	0.037	21.0
21.5	51.10	39.94	30.37	21.83	14.12	82.06	110.0	184.4	226.3	241.6	241.6	0.102	21.5
22.0	52.23	40.66	30.83	22.15	14.36	83.74	115.0	191.6	235.8	251.3	251.4	0.167	22.0
22.5	53.30	41.35	31.27	22.47	14.59	85.43	120.0	199.0	245.4	261.5	261.8	0.280	22.5
23.0	54.33	42.13	31.72	22.79	14.81	87.08	125.4	206.5	255.2	272.2	272.3	0.215	23.0
23.5	55.31	42.93	32.17	23.11	15.02	88.69	130.9	215.3	265.0	282.9	283.0	0.149	23.5
24.0	56.25	43.69	32.62	23.43	15.23	90.26	136.4	224.3	275.0	293.7	293.8	0.083	24.0
24.5	57.28	44.47	33.06	23.74	15.48	91.80	141.9	233.5	285.1	304.7	304.7	0.029	24.5
25.0	58.26	45.33	33.50	24.06	15.73	93.31	147.4	243.3	296.1	315.9	316.0	0.460	25.0
25.5	59.21	46.15	34.03	24.37	15.96	94.79	152.9	253.2	307.5	327.2	327.7	0.394	25.5
26.0	60.23	46.94	34.55	24.69	16.19	96.24	158.6	263.0	319.0	339.2	339.5	0.327	26.0
26.5	61.22	47.71	35.07	25.00	16.41	97.71	164.4	272.9	330.4	351.2	351.4	0.260	26.5
27.0	62.17	48.44	35.67	25.31	16.62	99.19	170.2	282.7	342.1	363.4	363.5	0.193	27.0
27.5	63.16	49.16	36.25	25.62	16.82	100.6	176.1	292.6	354.6	375.6	375.7	0.126	27.5
28.0	64.11	49.94	36.80	25.93	17.03	102.1	182.3	302.4	367.0	387.9	387.9	0.058	28.0
28.5	65.07	50.69	37.37	26.24	17.23	103.5	188.4	312.8	379.8	400.4	400.4	0.010	28.5
29.0	66.03	51.41	38.00	26.55	17.44	104.9	194.6	323.2	393.4	412.9	412.9	0.078	29.0
29.5	67.02	52.17	38.62	26.86	17.64	106.2	200.7	333.6	407.4	425.5	425.5	0.146	29.5
30.0	67.98	52.94	39.21	27.17	17.84	107.6	207.2	344.0	422.0	438.5	439.1	0.797	30.0

Table A-2 Limit tensile stress for maintaining the required performance SS41 (in Japan)

Tonnage	Effective span length(m)	Constructed from 1929 to1950	
		Ordinary passage	Temporary passage
20 million ton or above	<10	1500	1760
	$10 \leq L < 20$	1500	1760
	≥ 20	1700	1760
From 10 million ton or above to less than 20 million ton	<10	1760	1760
	$10 \leq L < 20$	1760	1760
	≥ 20	1760	1760
Less than 10 million ton	<10	1760	1760
	$10 \leq L < 20$	1760	1760
	≥ 20	1760	1760

Table A-3 Limit compressive stress for maintaining the required performance SS41 (in Japan)

Rivet type		SV34	
Compressive stress applied on all section	Axial stress	<ul style="list-style-type: none"> When: $0 < l/r \leq 110$ $1380 - 0.065(l/r)^2$ When: $l/r > 110$ $7200000(r/l)^2$ 	①
	Bending	<ul style="list-style-type: none"> When: $l/b \leq 30$ $1380 - 0.7(l/b)^2$ When buckle plate existing on the edge of compressive side or the section shape of web is double, using following formula. $1380 - 0.4(l/b)^2$ 	②

*Regarding to ①, l (cm): frame length of member, r (cm) : radius of gyration of all section. But, in the consideration of buckling occurred on the plane of structure of web member which jointed with rivet, l should be 0.9 time as long as actual frame length of member

*Regarding to ②, l (cm): Distance between rigid flanged points, b (cm): Width of frange

*Regarding to girder made of wrought iron or Bessemer steel, it can be applied this table as a rivet girder, but the maximum value must be 1050 kg/cm^2

Appendix-2

The processes of repairing brick piers

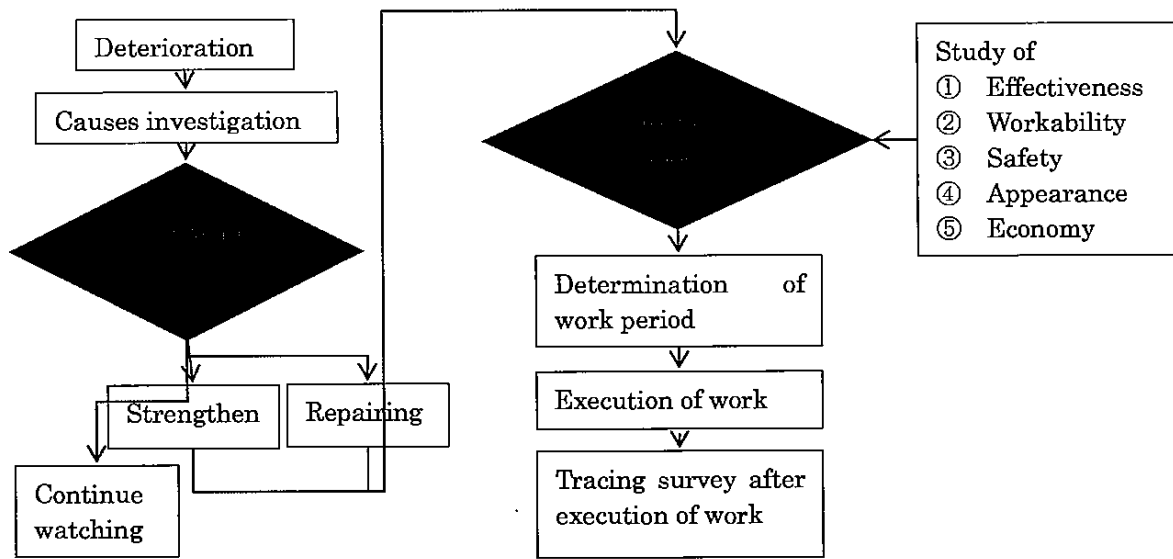

Fig A-4. Major processes of repairing brick piers in Japan

(1) Deteriorations of brick piers

- ① Horizontal masonry joints breakage
- ② Vertical masonry joints breakage and vertical crack
- ③ Swelling, Loosing
- ④ Chipping, Peering out

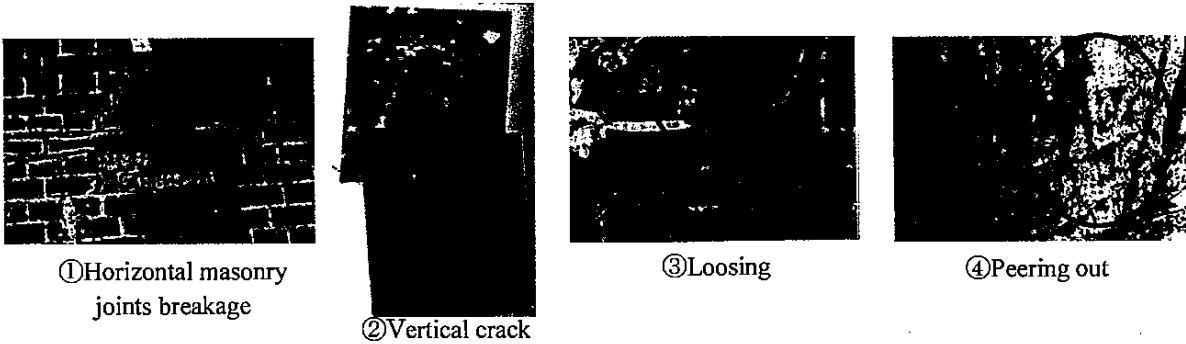

Fig A-5 Major deteriorations of brick pier

(2) Causes of deterioration

- ① Aging material degradation
- ② Wooden foundation rotting
- ③ Degradation by repetition of live load (fatigue)
- ④ Train load (live load) increasing, load characteristics changing
- ⑤ Plants growth

(3) Selecting of work method

- ① Effectiveness

It should be studied whether repairing work or strength work is effective, proof stress and durability of pier by the deterioration degree.

② Workability

It should be studied working condition and environment, consultation with road or river administrative office, effect for train operation and other structure and so on, by required performance, surrounding environment, condition for execution of work.

③ Safety

Before execution of work, it should be studied possibility of existence of underground facilities, falling objects to an urban area.

④ Appearance

It should be studied the coordination with surrounding environment, relevance with existing structure.

⑤ Economy

It should be studied the method that carry out the most effectiveness with minimum cost.

(4) Work period

Work period should be selected, except the emergency case, after the sufficient study for kind of deterioration, importance of structure, working method, material for work, environmental conditions, and then executing in the suitable period.

(5) Tracing survey after execution of work

Tracing survey should be done to check the working effectiveness for a time.

(6) Repairing work

① Zonal steel plate wrapping method

This method is to protect missing bricks, stones and bed stones by wrapping zonal steel plate, their width is 10-20cm and their thickness is 5-10mm, horizontally (shown in Fig A-6). It is major that installing steel plate to pier with gap 10-20mm by bolting, and then injecting non compacting mortar.

And, in the time of fixing bolt into pier, mortar anchor should be used standardly. Steel plate and installing bolt head should be painted for anti-rust.

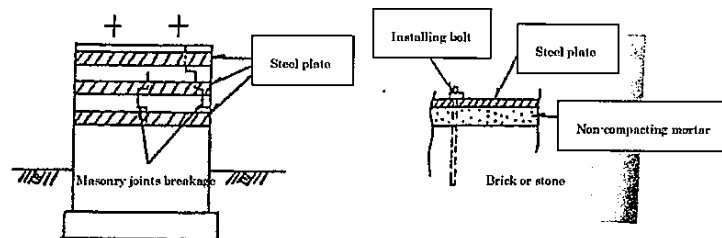

Fig A-6 Zonal steel plate wrapping method

② Replacing by concreting

This method is breaking down the part of pier which had been deteriorated remarkably, such as cracks on brick and stone, then concreting thereon (shown in Fig A-7). In this method, it is general to measure against the sliding occurred between exist pier and new concrete, such as inserting steel bar for resist horizontal force.

Design standard strength of concreting (σ_{ck}) should be approximately 240kg/cm^2 , and supplying water into original face before concreting for prevent missing water from concrete.

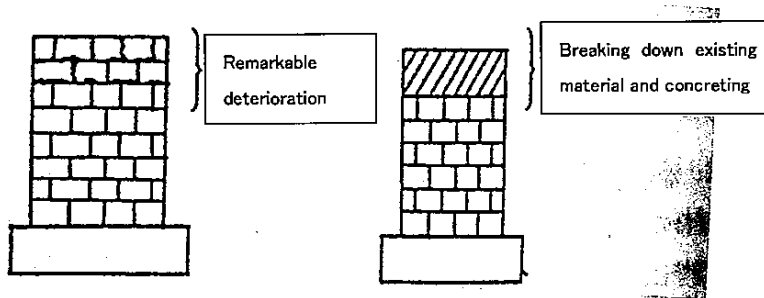

Fig A-7 Replacing by concreting

③ Partial repairing

In the case that horizontal masonry joint breakage occurred only in a limited area of pier and others are in good soundness, it should be better partial repairing (shown in Fig A-8). When the progress of joint breakage and slipping stone had stopped, spraying concrete would be one of repairing method.

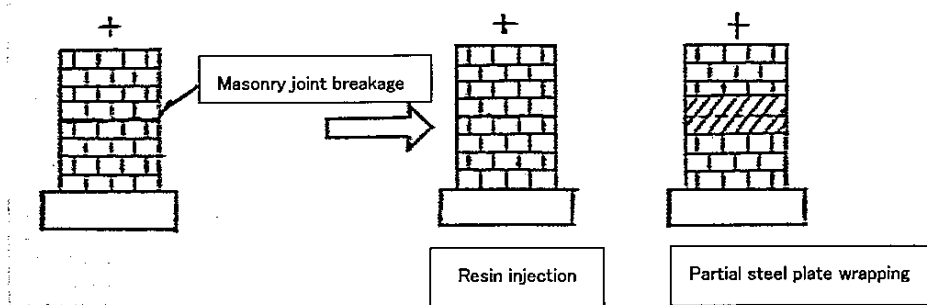

Fig A-8 Partial repairing

(7) Strengthen work

① Concrete wrapping

This work is to wrap the pier by concreting after casting steel bar along the pier fixing sufficiently bottom part of steel bar into the footing of pier.(shown in Fig A-9) In this work, fixing strength main steel bar sufficiently and uniting pier and new concrete completely, it can be calculated proof force like other reinforce concrete parts with regarding pier as concrete. Therefore, although dead load increases and section becomes bigger by strengthen concrete, this work would be best method for strengthen work in the case that there are no regulation for blocking rate on river and supporting force.

Design standard strength of strengthen concrete(σ_{ck}) should be approximately 240kg/cm^2 , and, in the time of fixing steel bar into pier, mortar anchor should be used standardly. Before concreting, it should be mixed superplasticizer into concrete for keeping good workability of concreting and compacting, and expanding agent for preventing crack occurred by drying shrinkage.

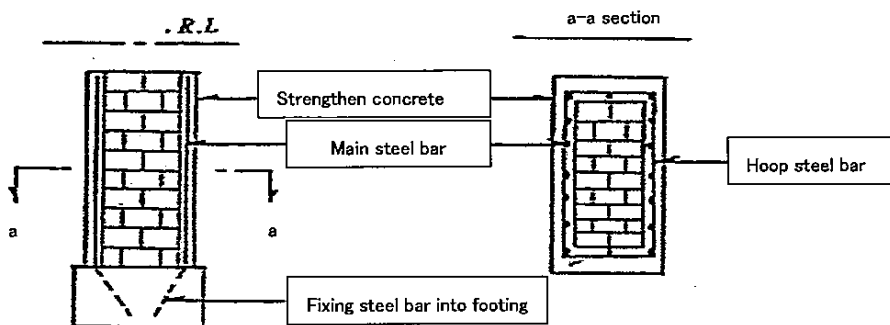

Fig A-9 Concrete wrapping

② Steel plate wrapping

This work is to wrap pier by steel plate installing with dowel bar, and to strengthen the pier by fixing steel plate sufficiently on footing with anchor steel bar (shown in figA-10). This work is generally used in the case that there is a problem about blocking rate on river and supporting force.

It should be kept gap, approximately 10-20mm, between steel plate and pier, and no compacting mortar should be injected into the gap. And, it is necessary to anti-rust measurement on part of mounting steel plate and anchor steel bar.

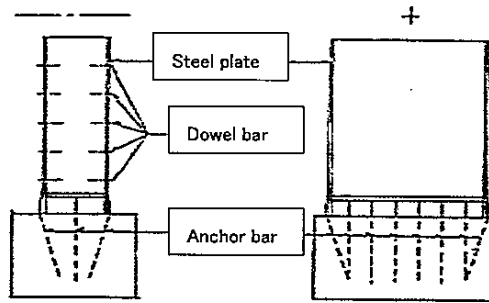

Fig A-10 Steel plate wrapping

Bridge maintenance work shop, remarkable Questions and answer

1st October, 2015: Water Way Control

Q : How range should be countered against local scouring around pier by installation of massive stones etc.

A : As I explained, at least counter measures should be implemented to the area indicated "L". But suitable counter measure is determined by Weight of block and tractive force, stream velocity and some condition.

Q : Does it cause any problems by implementing much countermeasures.

A : It would affect for bridges which located upper or lower of stream, and piers with no countermeasure. It is necessary to make confirmation with administer of water way. I heard that Works on Myanma river are regulated by law, it is hoped all rivers are administrated by law.

2nd October, 2015: Stress Ratio Method of Steel Bridge, Steel Bridge Repairing

Q : How to calculate bending moment when many corrosion is occurred in one girder?

A : firstly, each dimension which has corrosion should be measure. Secondary, study the SR value comparing maximum force and most deteriorated dimension. And, if the SR would not exceed 100%, study the bending moment applied on actual dimension, and calculate SR.

Q : Is it temporary to repair the deteriorated pier by partial steel wrapping method?

A : It is just temporary counter measure until complementation of improvement work. It should be measure the gap in periodic inspection.

Q : How to study the bending moment around bearing?

A : Around the bearing, it should be studied the sharing force.

Q : How to study the Stress Ratio against shearing force?

A : Calculating sharing stress considering geometrical moment of inertia by shearing force and cross dimension area, and comparing it with maintenance limit stress. And besides, around bearing, it is easy to occurred fatigue crack to be checked.

Q : How to repair the deteriorated stiffener ?

A : End Stiffener should reach upper member and lower member. Other stiffener is not necessary to reach, because they are worked against twist force.

JICA Expert Team

PROJECT ON IMPROVEMENT OF SERVICE AND SAFETY OF RAILWAY IN MYANM

Attendance List of Workshop of Bridge Maintenance

Date :1st and 2nd Oct 2015

	Name	Department	Position	Signature
1	Mr. Aung win Myint	Division(2)Ywahtaung	JE Inspector of Work (3)	
2	Mr. Maung Maung Chit	Girder depot (Mahlwagone)	S.A.E Inspector of Work (2)	
3	Mr. Kyaw Swar Htay	Division(6)Letpadan	JE Inspector of Work(3)	
4	Mr. Tun Tun Win	Girder depot (Mahlwagone)	S.A.E Inspector of Work (2)	
5	Mr. Thein Sue Oo	Head office	General worker	
6	Mr. Thet Htwe Oo	Kabaung Bridge Project	S.A.E Inspector of Work (1)	
7	Ms. Thida Kheing	Division(4)Kalaw	supervisor	
8	Ms. Htwe Nge	Division(4)Kalaw	supervisor	
9	Mr. Han Sein	Division(6)Bago	S.A.E Inspector of Work(2)	
10	Ms. San Win Maw	Divion(5)Taungoo	supervisor	
11	Mr. Win Myint	Division(2)Ywahtaung	S.A.E Inspector of Work(3)	
12	Mr. Than Lwin	Division(1)Moenyin	S.A.E Inspector of Work(1)	
13	Mr. Zaw Min Oo	Yangon-Mandalay (JICA)Project	Executive Engineer	
14	Mr. Zaw Ye Myint	Head office	Assistant Engineer	
15	Mr. Zaw Ko Lutt	Division(3)Mandalay	supervisor	

JICA Expert Team

PROJECT ON IMPROVEMENT OF SERVICE AND SAFETY OF RAILWAY IN MYANM

Attendance List of Workshop of Bridge Maintenance

Date :1st and 2nd Oct 2015

	Name	Department	Position	Signature
16	Mr. Aung Phyo Wai	NayPyiTaw Project	S.A.E Inspector of Work(1)	
17	Mr. Aung Kyaw Nyunt	Division(5)Pyinmana	S.A.E Inspector of Work(1)	
18	Mr. Than Lwin	Sittwe Project	S.A.E Inspector of Bridge(1)	
19	Mr. Kyaw Lwin Oo	Division(8)Thanbyuzaye	S.A.E Permanent Way of Inspector(1)	
20	Mr. Zaw Naing Lin	Division(6)Phaungtawthi	JE Permanent Way of Inspector(3)	

Measuring of Rail Stress and Train Running Test



1



Part of Turnout



Tongue rail



Wheel load



Lateral force



BS75 fishplate



New BS75 fishplate



Measuring fishplate's stress



Measuring fishplate's stress



Measuring fishplate's stress at short sleeper



Short sleeper at joint



50N rail joint



50N fishplate

The Project on Improvement of Service and Safety of Railway in Myanmar



Progress Report
October 29th, 2015 at Nay Pyi Taw

JICA Expert Team



Japan International Cooperation Agency

1

Table of Content

- 1 Preface
- 2 Major progress of the Project
- 3 Detailed Methods for the Project Implementation
 - 3.1 Sanitary system on Rolling Stock
 - 3.2 Track Maintenance
 - 3.2.1 Track record
 - 3.2.2 Measurement of rail stress and Train Running Test
 - 3.3 Outsourcing of track Maintenance
 - 3.4 Bridge Maintenance
- 4 Supply of additional equipments
- 5 About how to proceed until end of this project
- 6 Schedule

Appendix-1 Text of sanitary system of Rolling Stock

Appendix-2 Text of bridge maintenance

Appendix-3 Measuring of Rail Stress and Train Running Test (Photo)

2

1. Preface

This Progress Report deals with the major activities of the Project implemented around between July and October of this year.

We should be grateful, if MR senior officials concerned review the Report and provide us with the various advices so that the Project will be implemented more fruitfully in the coming period.

2. Major progress of the project

We have implemented 2 main project as below..

- Recommendation of technical standard relating to administrative and maintenance aspect and drawing up railway facilities improvement plan to improve service and safety level.
- Technology Transfer of Track Maintenance Technology to improve the level of Service and Safety through Implementation of The Pilot Project.

→ Recommendation of technical standard finished last March. Technology Transfer of Track Maintenance Technology is currently in process.

3

Contents of Extension of the Project are as bellow.

- To continue training for track maintenance of the Yangon-Mandalay line including Thilawa line.
- To conduct lecture(s) in Myanmar on the Japanese experience on the procedure of outsourcing the track maintenance work.
- To conduct lecture(s) in Myanmar on outline of maintenance of bridges.

In addition to these, to conduct lecture about sanitary system on rolling stock was added in contents of extension of the project.

For the implementation of the three items mentioned above, both sides agreed to extend the Project duration from 2 years (up to May 2015) to 2 years and 10 months (up to March 2016).

4

3 Detailed Methods for the Project Implementation

3.1 Sanitary system on Rolling Stock

Date : 30/9/2015 (Wed)

Place : MR Training Center in Nay Pyi Taw

The number of participants : 40

Training instructor : Makoto ISHIKAWA (Oriental Consultants Global)



5

Change of Toilet System of Railway in Japan

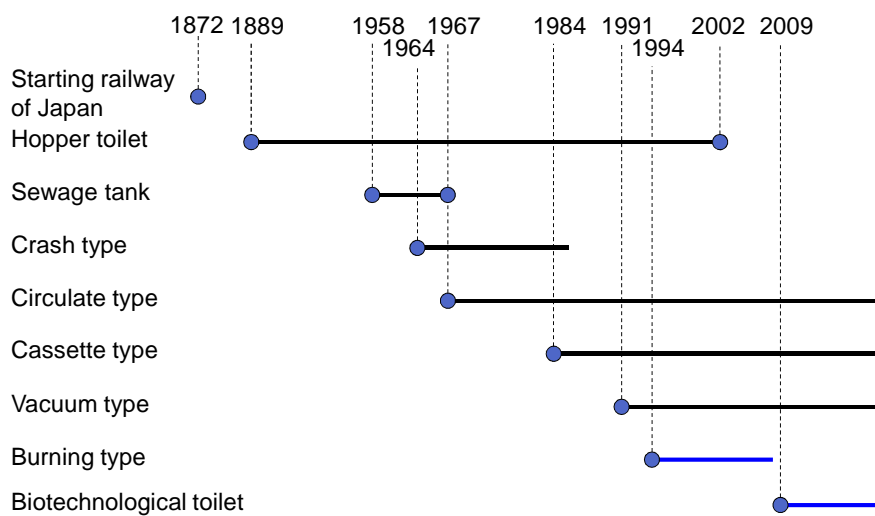

Comparison of Toilet System of Rolling Stock (1)

Type of System	Advantage	Disadvantage
Hopper toilet	<ul style="list-style-type: none"> • Simple • No facility in the depot is required 	<ul style="list-style-type: none"> • Not hygienic at wayside • Damaging wayside equipment • Damaging under floor equipment of rolling stock • Passengers are prohibited to use the toilet while train stops at station
Crush type	<ul style="list-style-type: none"> • No facility in the depot is required 	<ul style="list-style-type: none"> • Swage is discharged on the track • There are mechanical moving parts that require maintenance. • Crusher will be broken when things are thrown into the bowl
Cassette type	<ul style="list-style-type: none"> • No mechanical moving parts to maintain • Equipment is smaller compare to other system 	<ul style="list-style-type: none"> • Water is discharged on the track • Treatment of cassette at the depot is required

Comparison of Toilet System of Rolling Stock (2)

Type of System	Advantage	Disadvantage
Simple tank	<ul style="list-style-type: none"> • No mechanical moving parts to maintain 	<ul style="list-style-type: none"> • Waste water treatment facility is required at the depot • Large tank capacity is required • Frequent discharging at the depot is required
Circulate type	<ul style="list-style-type: none"> • Tank is smaller compare to simple tank • Water consumption is minimized 	<ul style="list-style-type: none"> • Waste water treatment facility is required at the depot • There are mechanical moving parts that require maintenance. • Water in the tank become high density of chemical
Vacuum type	<ul style="list-style-type: none"> • Odor is suctioned by vacuum • Tank can be located not just beneath the toilet 	<ul style="list-style-type: none"> • Waste water treatment facility is required in the depot
Burning type	<ul style="list-style-type: none"> • No facility in the depot is required 	<ul style="list-style-type: none"> • High consumption of electrical power supply on the car
Biotechnological	<ul style="list-style-type: none"> • No facility in the depot is required 	<ul style="list-style-type: none"> • There are mechanical moving parts that require maintenance

Q&A(Main)

1. How much does it cost for each toilet system ?

- It costs about 4 million YEN (33,333USD) in case of vacuum type. (120YEN ≈ 1 USD)
 - 2.5million YEN (20,833USD) for only each parts (toilet bowl, water tank etc.)
 - 1.5million YEN (12,500USD) for toilet room with automatic door
 - Furthermore, regularly replacement parts are required which costs about 600 thousand YEN per 8years.
- Probably circulate type is more expensive than vacuum type, because vacuum type is the latest trend in Japan. And cassette type and biotechnological type are cheaper than vacuum type.

2. What is chemical product ?

- For circulate type sewage disposal facilities : DelisanT-P (Ibukisho Co.,Ltd.) Powder in pouch (250g) blue
They make treatment powder depend on train operation (especially discharging interval)
For cassette type sewage disposal facilities
 - Ibuki on floor purifying agent-R (Ibukisho Co.,Ltd),
 - Ibuki under floor reducing agent-B (Ibukisho Co.,Ltd)
- Liquid 20ℓ In addition, they use chlorine agent (it is not special, generally using solid agent for sterilize)

3. Which part of the circulate type toilet is important for maintenance ?

- Pump malfunction often happens because of paper jams.

4. How much is the power capacity of the burning type toilet ?

- Probably about 1kw is required same as heating appliance.

9

3 Detailed Methods for the Project Implementation

3.1 Track Maintenance

3.1.1 Track Record

At the beginning, technology transfer of track maintenance started for 30 trainees in the Pilot Section. At present, accumulated number of trainees amounts to 546.

Various situations relating to technology transfer had been changed. Further, in order to implement the training efficiently, trainings were sometimes repeated in the same place, and also on Dagon University line.

In this regard, we consulted with MR about various matters including the suitable change of the length of the Pilot Section. We are planning in this way till coming December.

We show activity of track maintenance work for 3 months from next page.

10



Drilling a hole of the rail



Cutting a rail



Tightening fishplates by bolts



Chamfering (Removing sharp edges)



Removing 75lb Rail



Installing 50N Rail



Passing first train



After replacing from 75lb rail to 50N rail

3.2.2 Measuring of Rail Stress and Train Running Test

(1) Purpose

Intend to train running with high speed at the Yangon – Mandalay Railway Line in Myanmar, due to recheck for the speed of Straight Line and Turnout, to be performed measuring and testing of rail stress and train vibration at the present railway Line.

(2) Measuring Outline

① Measuring Place

Various Factors and Measuring Place of Running Test is as follows

Rail	: 50 N,	BS 75 R
Fastening Device	: Pandrol First Clip,	Local(MR) made e-clip (Local(MR) made e-clip), (Pandrol First Clip)
Sleeper	: PC Sleeper,	PC Sleeper
Line Type	: Parts of Straight Line	R = 2276 m
Place of Measuring	: Togyaunggale (7 1/4) ~ Ywathagyi (12 3/4)	

13

② Work Process

Work Content is as follow.

DATE	Work Content	Note
14.10.15(WED)	Preparing of measuring work	1 st day
15.10.15(THUR)	Measuring work	2 nd day
16.10.15(FRI)	Measuring work and Removal Work	3 rd day

Diagram (3 round trip between Togyaunggale and Ywathagyi)

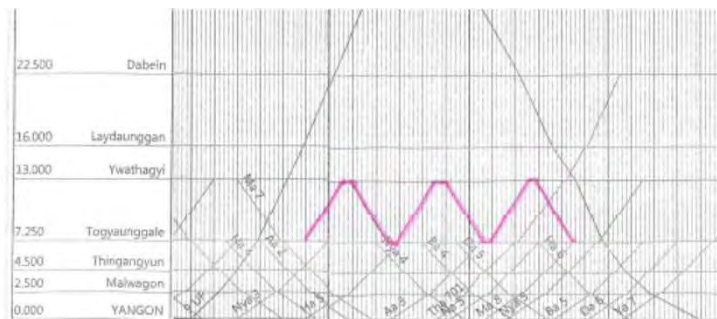

Train : RBE KIHA38 5coaches

③ Measuring Items

Measuring 4 items are Wheel Load - Lateral Force, Fishplate Stress, Tongue rail stress and Train vibration.

Content	Measuring Items	Place	Measuring members	Remark
Strength of track material Destruction amount of track	Wheel load, lateral force	2	4	Straight line
Strength of track material, Destruction amount of track	Fishplate stress	4	8	BS75、N37
Turnout Strength, function	Tongue rail	1	1	37(BS75)
Train vibration (Between Togyuangale and Ywathagyi)	Last and First Carriage of Train Vibration	1	1	
Total		8	14	

④ Arrangement of measuring point

Concerning of wheel load and rail strain, arrangement of measuring point is as follow.

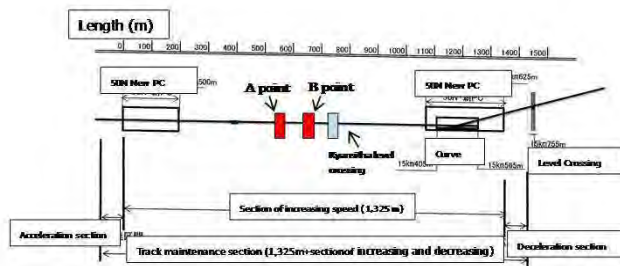

1) Point- A (near 14k 535m): Straight line

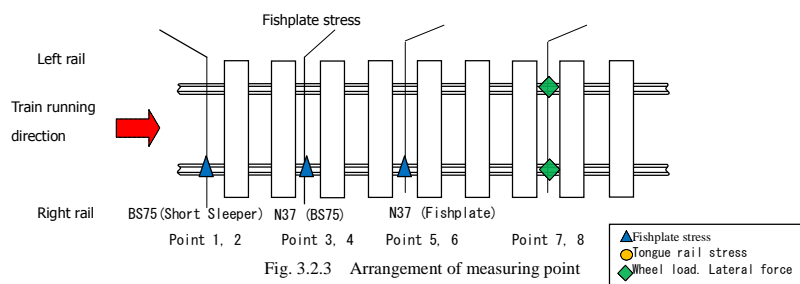

Fig. 3.2.3 Arrangement of measuring point

2) Point- B (near 14k600m): Turnout

Measuring place is the changing part of cross section of Stock rail and Tongue rail.

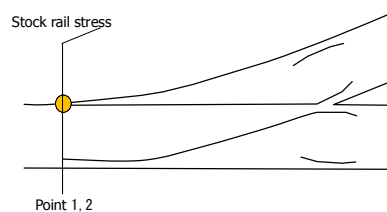

Fig. 3.2.4 Arrangement of measuring point

(3) Measuring Item

① Wheel load

Wheel load is as the showing of Fig. 3.2.5. To measure the shearing strain, after apply the gauge set of using wheel load and adhesive on the grinded web of rail. And then due to change from strain to wheel load, using the measuring device of Fig. 3.2.6 in advance, measure within 1kN of sensitivity of strain.

② Lateral force

Lateral force also similarly as the showing of Fig. 3.2.5. To measure the shearing strain, after apply the gauge set of using lateral force and adhesive on the base of rail. And then due to change from strain to lateral force, using the measuring device of Fig. 3.2.6 in advance, measure within 1kN of sensitivity of strain.

17

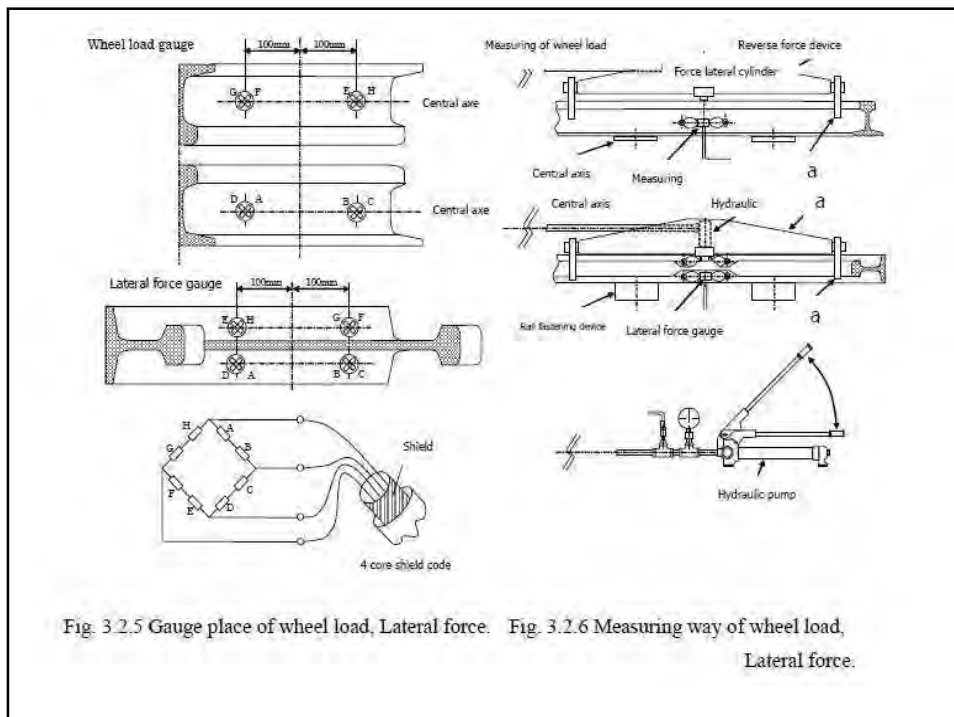

Fig. 3.2.5 Gauge place of wheel load, Lateral force. Fig. 3.2.6 Measuring way of wheel load, Lateral force.

③ Fishplate stress

As the showing of Fig. 3.2.7, stick the strain gauge on the base of fishplate face (10mm) of train running direction side, through the bridge box and set up the moving strain measurement device, and then measure the fishplate stress. (One side only)

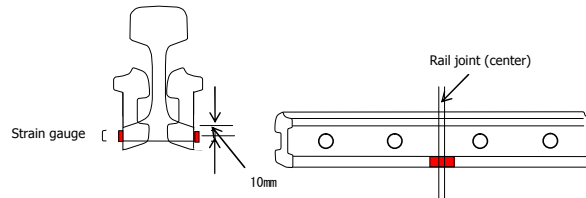

Fig. 3.2.7 Fishplate stress (conventional pattern)

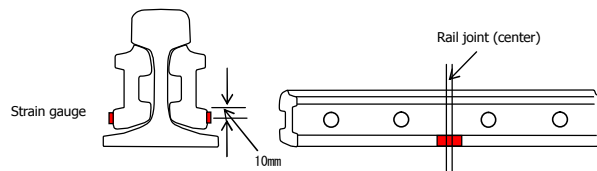

Fig. 3.2.8 Fishplate stress (Improvement)



BS75 fishplate



New BS75 fishplate

④ Tongue rail stress

As the showing of Fig. 3.2.9, stick the strain gauge on the changing part of cross section of stock rail and tongue rail, through the bridge box and set up the measuring device. And then measure the tongue rail stress.

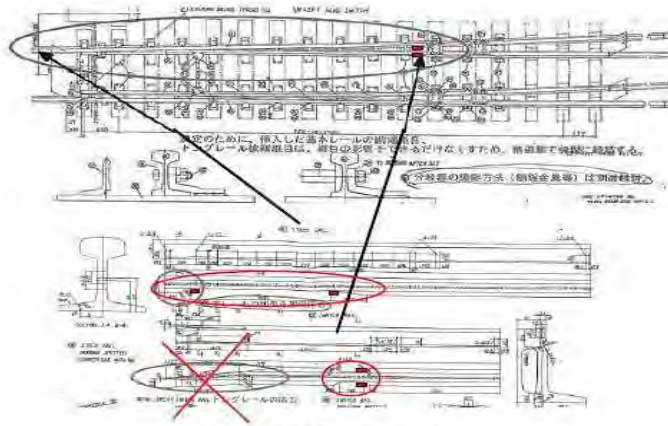

Fig. 3.2.9 Tongue rail stress

⑤ Train vibration

For Train Vibration, measure at last carriage for going and first carriage for return.

(4) Test Condition

Test train running with 50km/h, 60 km/h speed each 3 times over.

(5) Judgement of Train Running Standard

Accompanied by increasing of train running standard is as follow.

Measuring content		Standard value	Reference value
Wheel load	Max value	225kN	200kN
	Mini value	25kN	35kN
Lateral force		68kN	40kN
Fishplate		137N/mm ²	137N/mm ²
Tongue rail stress		137N/mm ²	137N/mm ²

Besides, due to the consideration of safety rate, perform the under 70% of reference value.

Measuring content		Reference value
Wheel load	Max value	140kN
	Mini value	25kN
Lateral force		28kN
Fishplate		96N/mm ²
Tongue rail		96N/mm ²

Photo Map



23

List

Test Date : 2015, October

Name of : Myanmar tracks _DC104

Name of Site Place : Myanmar Railway, Rail Stress Test (On the ground)

Input Channel		ch1	ch2	ch3	ch4	ch5	ch6	ch7	ch8	ch9	ch10	ch11	ch12	ch13			
Track (external, internal)		Left Rail internal	Right Rail internal	Left Rail external	Right Rail	Left Rail internal	Left Rail external	Left Rail internal	Left Rail external	Left Rail internal	Left Rail external	Left Rail internal	Left Rail external	Stock Rail stress			
Measuring Item		Wheel Load	Wheel load	Lateral force	Lateral force	Joint plate Rail stress(BS75) ordinary type	Joint plate Rail stress(BS75) ordinary type	Joint plate Rail stress(N27) New type	Joint plate Rail stress(N27) New type	Joint plate (50N)	Joint plate (50N)	Vertical Cleaver Joint plate (BS75)	Vertical Sweeper Joint plate (BS75)	Stock Rail stress (Pwnt)			
Mastering point		P1	P2	Q1	Q2	31	32	33	34	35	36	37	38	No1			
Mastering range (m)		4N	4N	4N	4N	Min	Min	Min	Min	Min	Min	Min	Min	Min			
Signal range (V)		5000	5000	5000	5000	5000	5000	5000	5000	5000	5000	5000	5000	5000			
Filter—3dB		30	30	30	30	30	30	30	30	30	30	30	30	30			
Data	Testing time (second)	Speed (km/h)	Measuring train	ID													
06/10/2015	11:18		Station name	I0001	88	80	7	-5	85	30	27	24	31	35	34	41	81
	11:41		Express	I0002	83	72	6	-4	78	38	36	-35	43	43	38	38	80
	12:10	45	Testing train	I0003	44	43	7	-6	61	-33	39	-32	21	34	-48	30	88
	12:23	35	Testing train rear	I0004	43	48	7	-7	51	-31	25	40	29	30	48	88	71
	12:35	35	Testing train	I0005	47	53	7	-7	64	-29	24	-34	31	39	42	-42	71
	12:47	35	Testing train rear	I0006	45	52	7	-9	66	22	35	34	33	39	32	88	84
	12:58	55	Testing train	I0007	45	48	8	7	50	-41	32	-24	30	30	32	-21	68
	8:25		Express	I0001	89	75	6.5	-11.5	101	-35	49	43	48	51	31	63	92
	8:52		Station name	I0002	72	58	8.1	-13.6	93	-28	57	47	50	54	88	37	85
	9:48		Locomotive & Cargo	I0003	89	78	5	-8	82	-48	51	-42	43	49	111	67	89
	10:17		Station	I0004	82	70	12	-12	85	-32	42	47	39	47	78	33	88
	10:48		Locomotive (only)	I0005	83	81	-2	-6	82	28	61	42	42	43	73	27	82
	11:32		General	I0006	78	72	8	-12	88	-31	34	47	51	56	86	33	106
	11:55		Express	I0007	81	67	6	8	80	-37	62	47	39	38	72	30	79
	12:30	45	Testing train	I0008	40	50	8	-7	55	-48	50	33	28	35	47	30	71
	13:04	45	Testing train(rear?)	I0009	42	49	8	-7	46	30	45	36	34	27	41	75	74
	13:13	35	Testing train	I0010	37	42	8	6	72	-22	48	43	51	39	56	-36	84
	13:21	38	Testing train(rear?)	I0011	24	40	8	7	66	24	47	57	35	42	51	73	70
	13:37	63	Testing train	I0012	28	47	8	-7	78	23	51	42	33	37	84	42	83
	13:50	68	Testing train(rear?)	I0013	24	44	7	-7	83	27	22	80	29	23	48	85	87

24

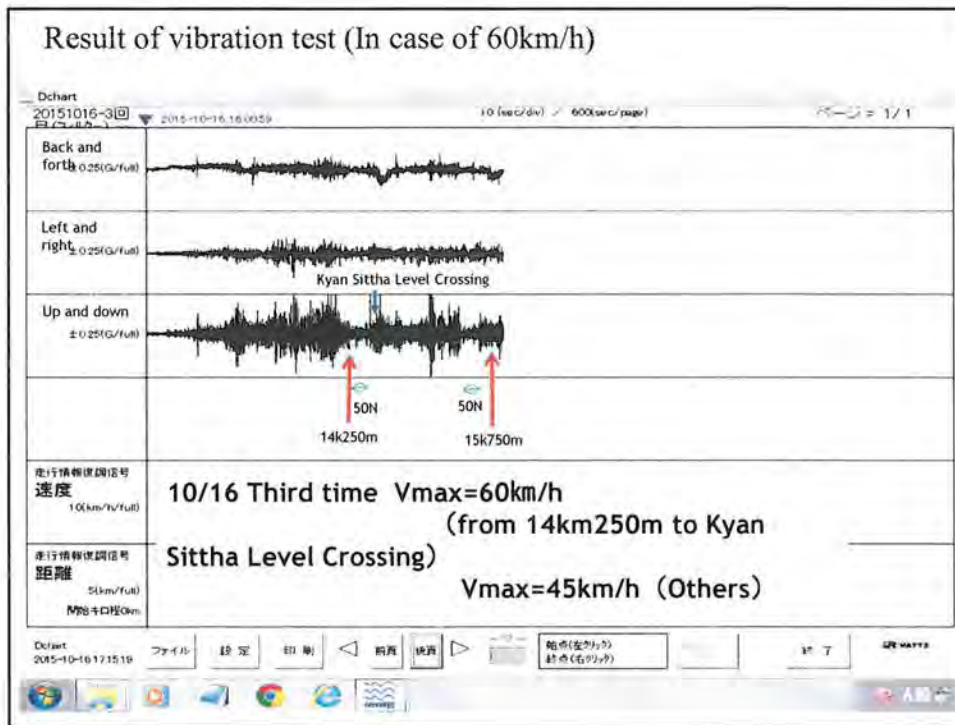

3.3 Outsourcing of track maintenance

This was added at R/D signed on 6th April. We hold meeting or discussion about outsourcing once a month. Contents are as below.

(1) Current Situation in Myanmar Railways

Outline

- Necessary of outsourcing and mechanization because of less engineer
- Workers have some jobs and can't devote themselves to one job.
- Outsourcing has begun between Bago and Waw by 2 groups
- Cooperate with China between Mandalay and Myitkyina
- MR wants to outsource all track maintenance in the future.
- It is difficult to outsource and change organization at the same time.
- Elders should teach to young generation not only technic but also safety.
- Track maintenance will change to mechanization near future.

(2) Introduce of Japanese experience

Outline

- Direct control and contract control (Outsourcing)
- Memorandum between JR and contractor
- Transition process of track maintenance by outsourcing in Japan
- History of track maintenance Organization in Japan
- Current organization of track maintenance in Japan
- Railway track closing work
- Maintenance car work
- Utilization of outsourcing in track maintenance work

We are thinking work plan as below.

(1) Mixing opinion of Myanmar and Japan

MR and we take good opinion for the future.

(2) Proposal of procedure of outsourcing track maintenance work by Myanmar style

Make proposal of procedure of outsourcing track maintenance work for MR.

(3) Seminar or presentation by Experts

We hold final seminar. or presentation.

History of Track Maintenance Organization in Japan

Classification Type	Organization	Feature
Track Maintenance Before Modernization		<ol style="list-style-type: none"> 1 Dispersed work of small unit 2 Repairing at any time 3 Unification of inspection and working (survey and maintenance by ourselves) 4 Human-wave tactics of hand working mainly
Modernization of Track Maintenance	<p>1964.4</p>	<ol style="list-style-type: none"> 1 Concentrated work in large unit 2 Planning and repairing 3 Separate inspection and work 4 Introduction of machine (Length 10~50 km)
New Track Maintenance Organization	<p>1976.7</p>	<ol style="list-style-type: none"> 1 Specialization of Operator 2 Mechanization deeply · 1 Multiple Tie Tamper per 1 Subdistrict · Productive Basement of operation · Save working time 3 <i>Outstanding of about 100 (100 Employees) of Workers</i>
Improvement of Track Maintenance	<p>1982.3</p>	<ol style="list-style-type: none"> 1 Change to technical group 2 <i>Abolish (changing) 200 (employees) of government job Employees</i> 3 Leave track its maintenance G 4 Efficiency by diversity of job content · Track Supervision G Supervision of inspection, planning and outsourcing · Track Machine G Survey, planning and operation work of MTT
Improvement of work (Track Maintenance and Civil Engineering)	<p>1985.4</p>	<ol style="list-style-type: none"> 1 Simplification and efficiency by review of working content · Review of MTT and Track inspection 2 Diversity of job content and efficiency by fusion · Integrate of position of Technique G (Track Maintenance, Civil Engineering, Forestry) · Relegation some parts of civil work to Track Supervision G 3 Efficiency by simplification of organization
Improvement of Track Facility	<p>1986.11</p>	<ol style="list-style-type: none"> 1 Detailed supervision according to characteristics of line 2 Try efficiency and diversity of work 3 Secure safety and stable transportation 4 Concrete contents · Review of workers per 1 party of Track Machine G · Abolish subdistricts and Track Residence in lower line and reconstruct supervision section and track maintenance section · Integrate Track Supervision G and Track Machine G in lower line · Review of inspection by getting on train

3.4 Bridge maintenance

Expected output

- Technical capability of MR is improved through bridge maintenance to improve the level of service and safety.

Implementation plan for output

- To draw up technology transfer plan of bridge maintenance through OJT at the Pilot Bridge
- To conduct seminars, training for technical improvement of the bridge maintenance

Preventive maintenance

- In the modernization of maintenance period, "Japan National Railway" changed its maintenance method, corrective to preventive. Moreover investment for preventing disaster work, the number of disaster finally could be reduced. (1965: Approx. 8500, 1986: Approx.1000)

Schedule of training

Schedule		Remarks
Phase 1: 27 July – 11 August	Basic training with Japanese Expert • Survey for Gokteik Viaduct, Inwa Br, Sittaung Br. • Actual maintenance training on Typical 7 bridges • Lecture and advice for maintenance improvement	Completed
Phase 2: 12 August – 10 November	Training by MR themselves using • Inspection, record and countermeasure • Repairing for 7 bridges of Phase 1	On progress 5-8 October follow up
Phase 3: 1 October, and 2 October	Supplementary Seminar • Water Way Control, Stress Ratio Method of Steel Girder, Repairing of Steel girder,	Completed
Phase 4: 11 November – 17 November	Closing • Report the result of Phase 2 from MR • Site visit and patrol • Lecture and general review of this training • Closing ceremony and advice	Tentative plan

Report of Phase 1



Measurement of displacement on Gokteik Viaduct



Inspection training on Inwa Bridge



Inspection training on No9 Br



Inspection training on No32 Br

Report of Phase 1

Bridge name	Remarkable deterioration	Counter measure	Suggestion for better maintenance
Gokteik DT	corrosion on floor plate	Cleaning, usual maintenance, repainting	Replace rotted wooden sleeper with fuck bolt, install drainage
Inwa TT	Corrosion on cross beam web, losing rivet on bracing	Cleaning, Usual maintenance, repainting, fasten rivet and bolt	Monitor the under surface of traffic road floor, Replace rotted wooden sleeper with fuck bolt
Sittaung TT	Loosing rivet on additional stringer edge	Cleaning, Usual maintenance, repainting, fasten rivet and bolt	Remove waste wooden sleeper Monitor the under surface of traffic road floor
No.9	Main girder corrosion Sleeper support	Cleaning , Repainting, Remove wooden sleeper	Replace the corroded lower flange of main girder
No.13 DG	Crack on welded attached plate	Monitoring	Remove existing plate and attach new plate with hi-tension bolt
No.13 TT	Crack on web of stringer	Plate attaching with hi tension bolt	At first installing stop hole
No.21 DG	Crack on pier	Temporary repairing, Zonal plate wrapping, monitoring	Reconstruction pier
No.32 TT	Damage of train derailment	Monitoring, especially stringer end	Replace damaged member
No.32 TG	Corrosion on cross beam	Monitoring, especially stringer end	Attaching plate, lateral replace
Insein PC	Additional mortar on surface	Monitoring	Remove mortar which has closed crack

Report of Phase 2



Progress Report from MR and some of repaired bridges (1st October)



Follow up for inspection and stress measurement

Report of Phase 3



Supplementary seminar on seminar house in NPT

Plan of Phase 4 (Tentative)

- From 11th Nov, 2015 to 17th Nov, 2015
- Presentation from MR the result of phase2
- Site Visit, Visual inspection training to grasp deterioration summary
- Lecture "Fatigue Crack on Steel Girder", "PC girder maintenance", "General Review and technical advice for bridge maintenance improvement", "Advice for MR", Closing Ceremony

Remarks

- We would like to express appreciation for MR to select key person of bridge maintenance. Their attitude to participate training are earnest, positive, and active.

U Zaw Min Oo	U Kyaw Swar Htay
U Tin Moe	U Tun Tun Win
U Than Lwin	U Sein Myint
U Than Swe	U Han Sein
U Maung Chit	U Aung Win Myint

- U Myat Lin, former secondary headmaster of CITC, compiled “Inspection and Maintenance for Rail Structure” based on his learning on 1990. It should be reference of MR bridge maintenance.



1974 Japan

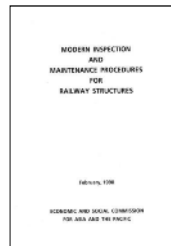

1990 ESCAP



2014 C.I.T.C

Remarks

- MR bridge inspectors have higher technology beyond our expectation. For more improvement, it should be prepare following equipment and tools.
 - Hi-tension bolt, Stress
 - Displacement measurement tools
 - Wrenching machine, Grinder, Sander, Drilling machine for steel girder on site
- It is first step to grasp situation of all bridge deterioration through the inspection with judgement such as judgement (AA, A1, A2, B, C, S) in MR for modernization of bridge maintenance work.

4 Supply of additional equipments

JICA Expert team has conducted technical transfer of track maintenance and we have donated more than 70 kinds of equipments. We decided to donate additional equipments which need to maintain track for MR.(Table 3.4.1) Especially, we think that analog standard gauge, tie tamper, generator and jack for rail are very important. 1 set is necessary for each division.

These equipments will arrive in Yangon Port end of November or beginning of December. As soon as import procedure finish, we'd like to hand over.

Table 3.4.1 Additional equipments

	Equipment	Nos	Manufacturer
1	Analog standard gauge G=1000	8	KANEKO CO.,LTD.
2	Instrument detection for track	8	KIDOUGIKEN
3	Tie tamper (1set=4pieces)	8	SHIBAURA ELRTEC CORPORATION
4	Generator	8	SHIBAURA ELRTEC CORPORATION
5	Equipment for ballast tamping	8	HITACHI KENKI KAMINO CO., LTD.
6	Basket made by bamboo or plastic	40	SEKISUI KAGAKU KOGYO CO., LTD.
7	Light track trolley 1ton G=1000	8	YOSHIKE KAKEN KIKI CO., LTD.
8	Rail lifting machine	10	TOKO SANGYO CO.,LTD
9	Jack for rail	48	NICH CO., LTD.

37

5 How to proceed until end of this project

This project (including Recommendation of technical standards relating to administrative and maintenance aspect and drawing up railway facilities improvement plan to improve service and safety level) began in May 2013. Technical transfer of track maintenance began from October 2013.

At first, pilot section of technical transfer was about 20km between Yangon and Bago. But we and MR changed the way to make trainees replace in 1 month. So we and MR changed to the place around Toeggyaunggale Sta. to teach many technical things (For instance turnout, bridge and curve, etc.) in 1 month.

Now signal and telecommunication project is proceeding. Therefore turnout will be very important for civil and track maintenance. We are going to teach technical transfer (especially, turnout) near Yangon Sta. In detail, we would like to discuss with counterpart.

38

6 Schedule(Plan)

Year/Month	2015/10	2015/11	2015/12	2016/1	2016/2	2016/3	Remark
Common		▽8th JCC		▽New equipments will arrive	▽Final JCC		
				▽Hand over additional equipments	▽Activity Report		
					(at Yangon, NPT and Japan)		
Track Maintenance	▽Test Run			▽Finish OJT of track Maintenance			Yangon Sta.
				Summary			
Bridge Maintenance							
Outsourcing of track maintenance work		▽Meeting	▽Meeting	▽Meeting	▽Presentation		
				Summary			
Others							

39

Thank you for your attention.

40

