

## **APPENDIX F**

### **INVENTORY SHEET OF CULVERT**

### INVENTORY SHEET OF CULVERT

S/N	STATION KM	SHEET NUMBER
1	283.6	PCL -283.6
2	283.9	BCL-283.9
3	284.47	BCL -284.47
4	285.45	BCL -285.45
5	285.65	BCL -285.65
6	286.15	PCL-286.15
7	286.4	PCL -286.4
8	286.65	PCL -286.65
9	286.88	PCL -286.88
10	287.15	PCL- 287.15
11	287.25	BCL -287.25
12	287.3	PCL-287.3
13	287.7	BCL- 287.7
14	288.35	PCL-288.35
15	289.0	BCL -289.0
16	289.1	BCL-289.1
17	289.3	PCL-289.3
18	289.6	PCL-289.6
19	289.9	PCL-289.9
20	290.4	BCL -290.4
21	290.6	PCL-290.6
22	290.9	BR -290.9
23	291.2	PCL-291.2
24	291.5	PCL-291.5
25	291.5B	PCL-291.5B
26	291.7	PCL-291.7
27	291.9	PCL-291.9
28	292.2	BCL -292.2
29	292.6	BCL -292.6
30	292.7	PCL-292.7
31	292.8	BCL -292.8
32	293.0	BCL -293.0
33	293.1	BCL -293.1
34	293.8	PCL-293.8
35	294.2	PCL-294.2
36	294.5	BCL -294.5
37	295.1	BCL-295.1
38	295.3	BCL-295.3
39	295.7	BCL-295.7
40	295.9	BCL-295.9
41	296.4	BCL-296.4
42	296.7	BCL-296.7
43	297.1	BCL-297.1

44	297.6	BCL-297.6
45	299.3	PCL-299.3
46	299.7	PCL-299.7
47	300.1	PCL-300.1
48	300.2	PCL-300.2
49	300.5	PCL-300.5
50	300.6	BCL -300.6
51	302.0	PCL-302.0
52	302.2	BCL -302.2
53	303.3	BCL- 303.3
54	303.4	BCL -303.4
55	308.1	BCL -308.1
56	308.3	BCL -308.3
57	308.4	PCL-308.4
58	308.9	PCL-308.9
59	309.4	BCL -309.4
60	309.9	BCL -309.9
61	310.5	BCL -310.5
62	310.8	PCL-310.8
63	311.0	PCL-311.0
64	311.2	BR -311.2
65	312.2	BCL -312.2
66	312.3	BCL -312.3
67	312.4	BCL -312.4
68	312.8	BCL -312.8
69	312.9	BCL- 312.9
70	313.3	PCL-313.3
71	313.4	BCL -313.4
72	314.1	BCL -314.1
73	314.4	PCL-314.4
74	314.5	PCL- 314.5
75	314.9	BCL-314.9
76	325.7	PCL-325.7
77	325.75	PCL-325.75
78	326.9	PCL-326.9
79	327.4	BCL-327.4
80	327.9	PCL-327.9
81	328.8	PCL-328.8
82	333.1	BCL- 333.1
83	333.6	BCL -333.6
84	334.1	BCL -334.1
85	334.3	PCL-334.3
86	334.7	BCL -334.7
87	334.8	BCL- 334.8
88	335.0	BCL -335.0
89	335.1	BCL- 335.1

90	335.3	BCL- 335.3
91	335.5	BCL -335.5
92	335.8	BCL -335.8
93	336.1	BCL -336.1
94	336.3	BCL- 336.3
95	336.7	BCL- 336.7
96	337.0	BCL -337.0
97	337.0	PCL- 337.0
98	344.8	PCL-344.8
99	344.8	BCL-344.8
100	345.0	BCL-345.0
101	345.5	PCL-345.5
102	345.6	PCL345.6
103	345.6	PCL345.6
104	346.0	PCL-346.0
105	346.2	PCL-346.2
106	346.6	BCL-346.6
107	346.6	PCL346.6
108	347.5	BCL347.5
109	348.0	BCL348.0
110	348.3	PCL-348.3
111	348.8	BCL-348.8
112	349.4A	BCL -349.4A
113	349.0B	PCL-349.0B
114	349.4B	BCL- 349.4B
115	349.5B	BCL -349.5B
116	349.6B	BCL- 349.6B
117	349.8B	BCL -349.8B
118	349.9B	BCL- 349.9B
119	352.9	BCL -352.9
120	352.9	BCL-352.9
121	354.3	BCL -354.3
122	355.6	BCL -355.6
123	356.1	BCL -356.1
124	360.0	BCL-360.0
125	360.6	BCL-360.6
126	360.9	BCL-360.9
127	361.1	BCL-361.1
128	361.9	BCL-361.9
129	362.1	BCL-362.1
130	362.5	PCL-362.5
131	362.9	BCL-362.9
132	363.3	BCL-363.3
133	363.7	BCL-363.7
134	364.2	BCL-364.2
135	364.4	BCL-364.4



## Inventory Sheet for Culvert

**Station: at KM 283.6**      **Sheet No.: PCL 283.6**

1. General		
1-1	Name of Inspector	T. Kawaguchi , Hussein , Abiud
1-2	Organization of Inspector	JICA Study Team
1-3	Date/Time of Inspection	2014/5/12
1-4	Location	Lat 06° 49' 48" 17"
1-5		Long 036° 58' 38" 27"
1-6	Elevation	

2. Characteristics of Physical Condition of Culvert		
2-1	Length of Culvert	5.0 m
2-2	Shape of Cross Section	Square: Rectangular: Circle: (1)
2-3	Height	Hc1 = 0.9 m , Hc2 = 0.9 m
2-4	Flow Area	Width Dc1 = 0.9 m , Dc2 = 0.9 m
2-5	Other	Hs1 = 1.2 m , Hs2 = 1.2 m
2-6	Connecting Channel	Height
2-7		Width
2-8		Side Slope
2-9	Type of Culvert	Concrete
2-10	Riverbed	Material Silty sand
2-11	Sediment	u/s No ( 0% rate)
2-12	deposition	d/s No ( 0% rate)
2-13	Topography	u/s: , d/s:
2-14	Land Use	
2-15	Structures/Houses, road	

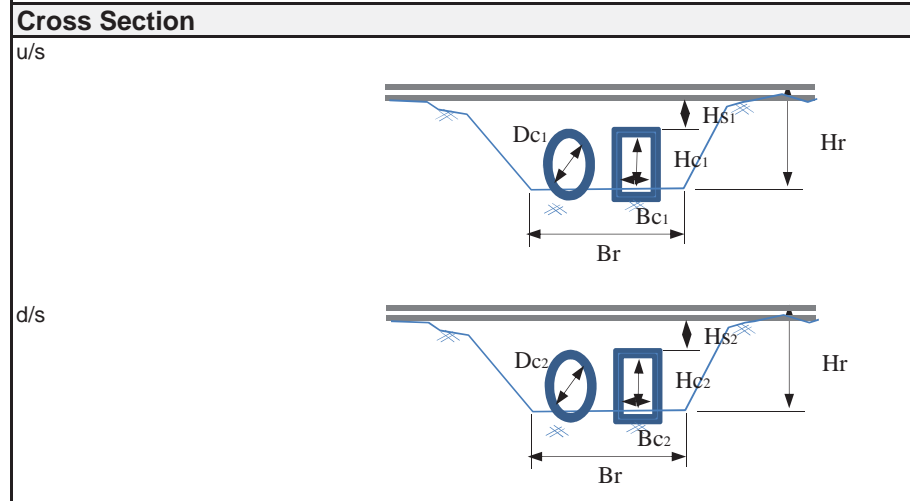
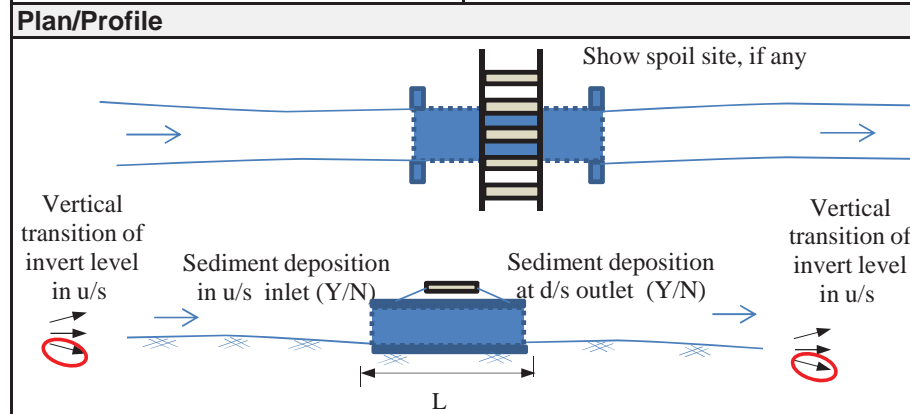
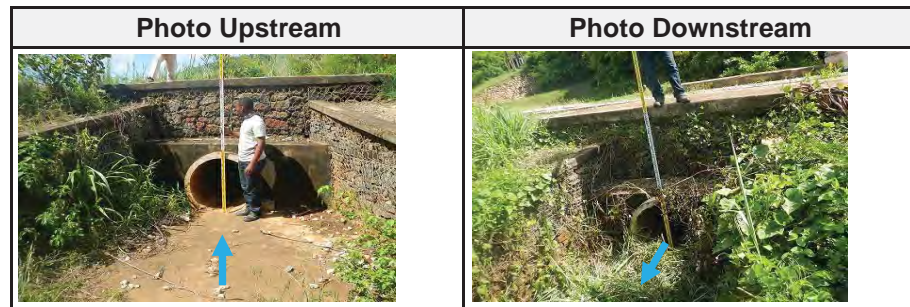

3. Damaged Flood Records			
3-1	(Year/Month)	(Type)	(Reason, etc.)



F-4

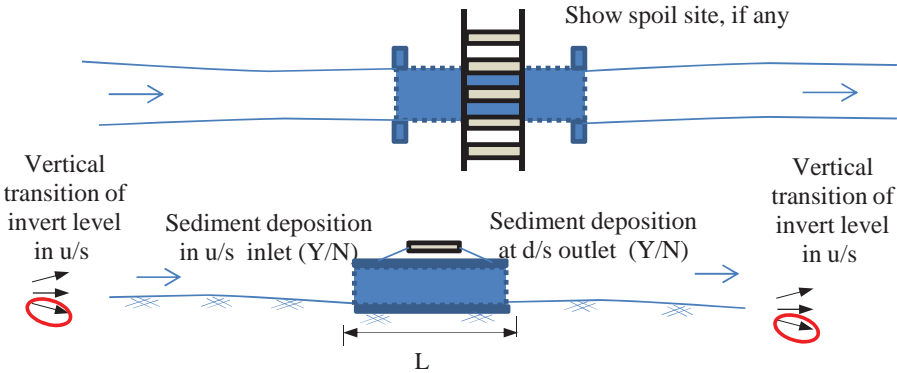
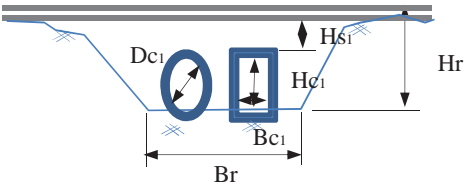
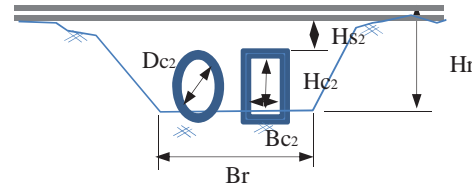

## Inventory Sheet for Culvert

<b>Station: at KM 283.9</b>		<b>Sheet No.: BCL 283.9</b>	
<b>1. General</b>			
1-1	Name of Inspector	T. Kawaguchi , Hussein , Abiud	
1-2	Organization of Inspector	JICA Study Team	
1-3	Date/Time of Inspection	2014/5/12	
1-4	Location	Lat	06° 49' 38" 36"
1-5		Long	036° 58' 31" 13"
1-6	Elevation		
<b>2. Characteristics of Physical Condition of Culvert</b>			
2-1	Length of Culvert	6.0 m	
2-2	Shape of Cross Section	Square: Rectangular: (1) Circle:	
2-3	Flow Area	Height	Hc1 = 1.7 m , Hc2 = 1.7 m
2-4		Width	Bc1 = 1.0 m , Bc2 = 1.0 m
2-5		Other	Hs1 = 1.2 m , Hs2 = 1.2 m
2-6	Connecting Channel	Height	
2-7		Width	
2-8		Side Slope	
2-9	Type of Culvert	Concrete	
2-10	Riverbed	Material	Silty sand
2-11	Sediment deposition	u/s	No ( 0% rate)
2-12		d/s	No ( 0% rate)
2-13	Topography	u/s:  , d/s:	
2-14	Land Use		
2-15	Structures/Houses, road		
<b>3. Damaged Flood Records</b>			
3-1	(Year/Month)	(Type)	(Reason, etc.)

<b>Photo Upstream</b>	<b>Photo Downstream</b>
	
<b>Plan/Profile</b>	
	
<b>Cross Section</b>	
u/s	
d/s	

## Inventory Sheet for Culvert

<b>Station: at KM 284.47</b>		<b>Sheet No.: BCL 284.47</b>	
<b>1. General</b>			
1-1	Name of Inspector	T. Kawaguchi , Hussein , Abiud	
1-2	Organization of Inspector	JICA Study Team	
1-3	Date/Time of Inspection	2014/5/12	
1-4	Location	Lat	06° 49' 28" 56'''
1-5		Long	036° 58' 18" 31'''
1-6	Elevation		
<b>2. Characteristics of Physical Condition of Culvert</b>			
2-1	Length of Culvert	5.0 m	
2-2	Shape of Cross Section	Square: <u>Rectangular:(1)</u> Circle:	
2-3	Flow Area	Height	Hc1 = 0.65 m , Hc2 = 0.9 m
2-4		Width	Bc1 = 1.0 m , Bc2 = 1.9 m
2-5	Other	Hs1 = 0.4 m , Hs2 = 0.8 m	
2-6	Connecting Channel	Height	
2-7		Width	
2-8		Side Slope	
2-9	Type of Culvert	Concrete	
2-10	Riverbed	Material	Silty sand
2-11	Sediment deposition	u/s	Light ( 30% rate)
2-12		d/s	Light ( 20% rate)
2-13	Topography	u/s:  , d/s:	
2-14	Land Use		
2-15	Structures/Houses, road		
<b>3. Damaged Flood Records</b>			
3-1	(Year/Month)	(Type)	(Reason,etc.)

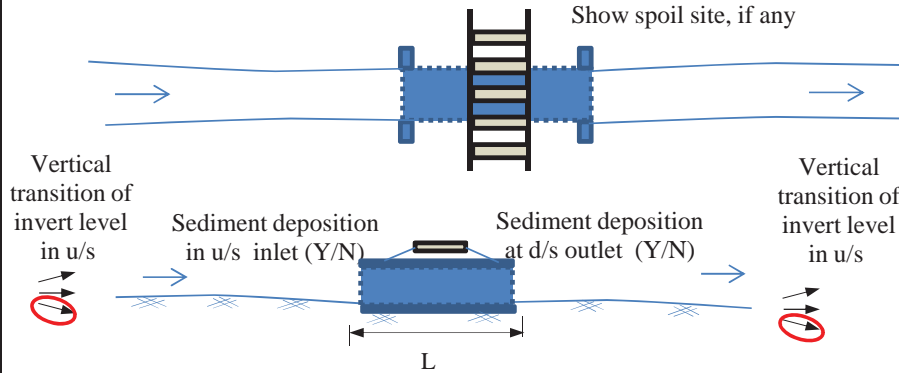
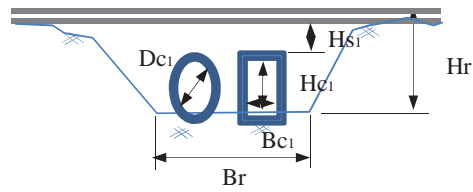
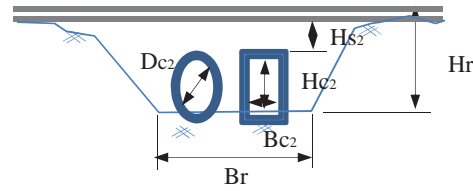
<b>Photo Upstream</b>	<b>Photo Downstream</b>
	
<b>Plan/Profile</b>	
	
<b>Cross Section</b>	
u/s	
d/s	

## Inventory Sheet for Culvert

**Station: at KM 285.45**      **Sheet No.: BCL 285.45**

<b>1. General</b>			
1-1	Name of Inspector	T. Kawaguchi , Hussein , Abiud	
1-2	Organization of Inspector	JICA Study Team	
1-3	Date/Time of Inspection	2014/4/12	
1-4	Location	Lat	06° 49' 00" 32'''
1-5		Long	036° 58' 04" 84'''
1-6	Elevation		

**2. Characteristics of Physical Condition of Culvert**

2-1	Length of Culvert	4.0 m	
2-2	Shape of Cross Section	Square: Rectangular:(1) Circle:	
2-3	Flow Area	Height	Hc1 = 1.4 m , Hc2 = 1.5 m
2-4		Width	Bc1 = 1.0 m , Bc2 = 1.0 m
2-5		Other	Hs1 = 0.4 m , Hs2 = 0.4 m
2-6	Connecting Channel	Height	
2-7		Width	
2-8		Side Slope	
2-9	Type of Culvert	Concrete	
2-10	Riverbed	Material	Silty sand
2-11	Sediment deposition	u/s	Light ( 10% rate)
2-12		d/s	Light ( 10% rate)
2-13	Topography	u/s: ↻ , d/s: ↻	
2-14	Land Use		
2-15	Structures/Houses, road		

**3. Damaged Flood Records**

3-1	(Year/Month)	(Type)	(Reason,etc.)

**Photo Upstream**      **Photo Downstream**



**Plan/Profile**

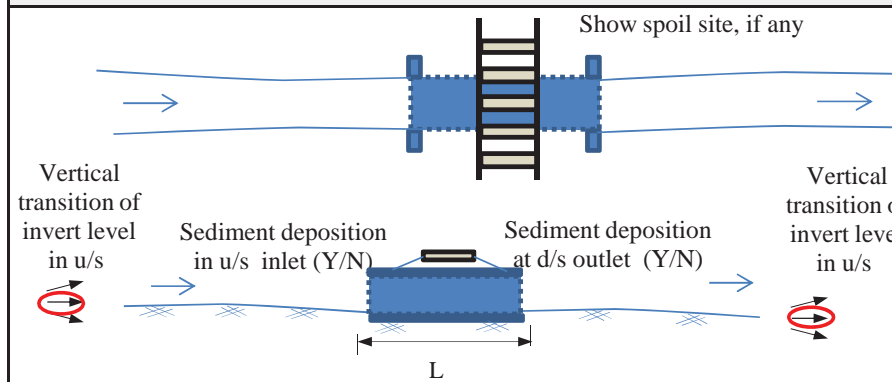

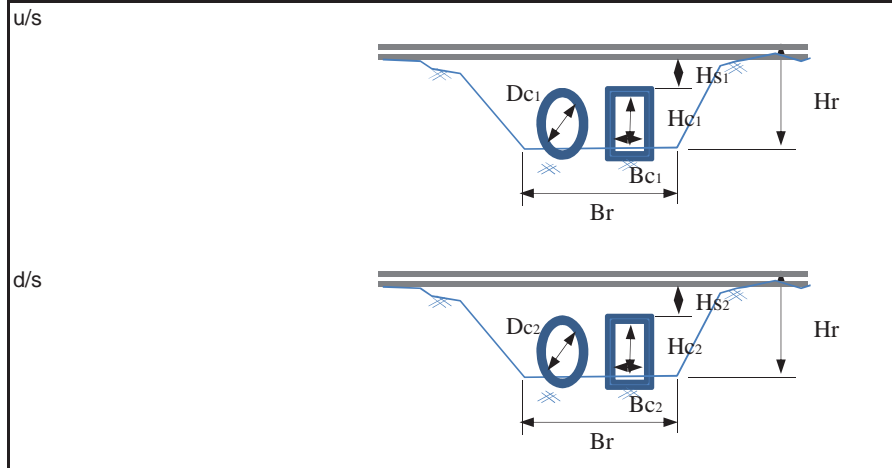

**Cross Section**



## Inventory Sheet for Culvert

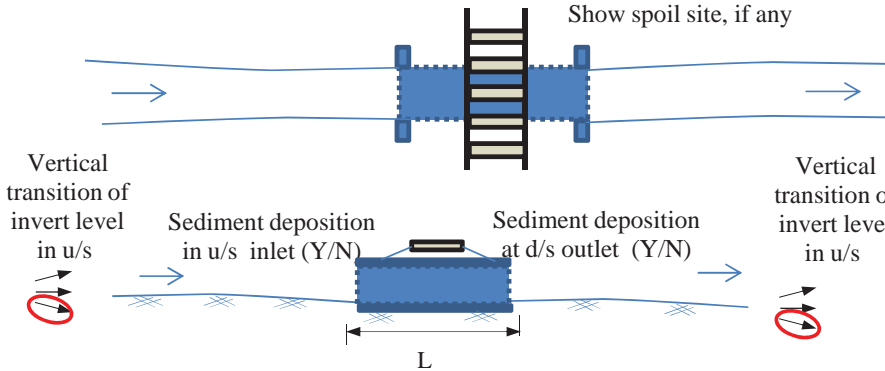
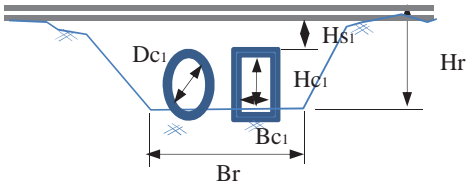
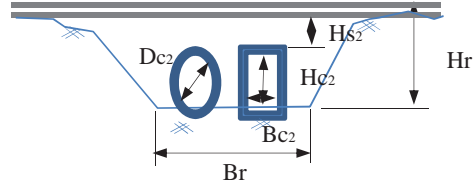

<b>Station: at KM 285.65</b>		<b>Sheet No.: BCL 285.65</b>	
<b>1. General</b>			
1-1	Name of Inspector	T. Kawaguchi , Hussein , Abiud	
1-2	Organization of Inspector	JICA Study Team	
1-3	Date/Time of Inspection	2014/5/12	
1-4	Location	Lat	06° 48' 54" 41'''
1-5		Long	036° 58' 02" 51'''
1-6	Elevation		
<b>2. Characteristics of Physical Condition of Culvert</b>			
2-1	Length of Culvert	5.0 m	
2-2	Shape of Cross Section	Square: <u>Rectangular:(1)</u> Circle:	
2-3	Flow Area	Height	Hc1 = 1.2 m , Hc2 = 1.2 m
2-4		Width	Bc1 = 1.0 m , Bc2 = 1.0 m
2-5		Other	Hs1 = 0.4 m , Hs2 = 0.4 m
2-6	Connecting Channel	Height	
2-7		Width	
2-8		Side Slope	
2-9	Type of Culvert	Concrete	
2-10	Riverbed	Material	Silty sand
2-11	Sediment deposition	u/s	No ( 0% rate)
2-12		d/s	No ( 0% rate)
2-13	Topography	u/s:  , d/s:	
2-14	Land Use		
2-15	Structures/Houses, road		
<b>3. Damaged Flood Records</b>			
3-1	(Year/Month)	(Type)	(Reason,etc.)

<b>Photo Upstream</b>	<b>Photo Downstream</b>
	
<b>Plan/Profile</b>	
 <p style="text-align: center;">Show spoil site, if any</p> <p style="text-align: center;">Vertical transition of invert level in u/s      Sediment deposition in u/s inlet (Y/N)      Sediment deposition at d/s outlet (Y/N)      Vertical transition of invert level in u/s</p> <p style="text-align: center;">L</p>	
<b>Cross Section</b>	
u/s	
d/s	



## Inventory Sheet for Culvert

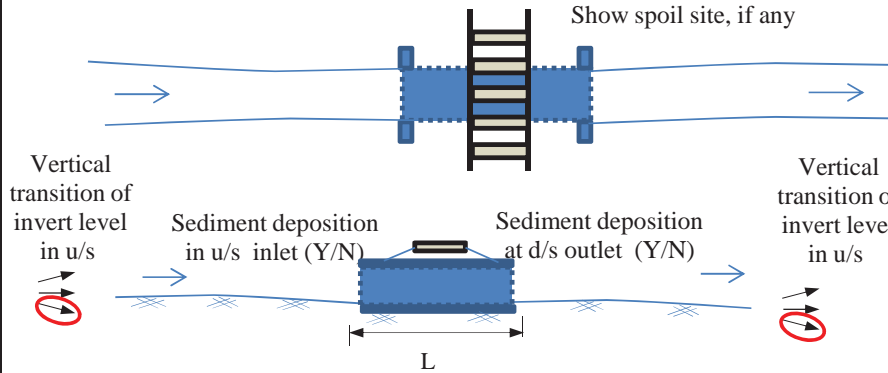
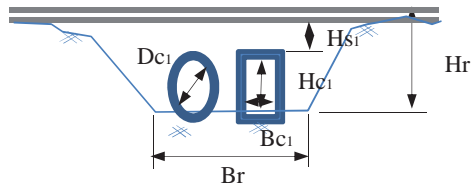
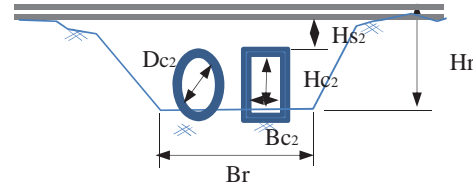

<b>Station: at KM 286.15</b>		<b>Sheet No.: PCL 286.15</b>	
<b>1. General</b>			
1-1	Name of Inspector	T. Kawaguchi , Hussein , Abiud	
1-2	Organization of Inspector	JICA Study Team	
1-3	Date/Time of Inspection	2014/5/12	
1-4	Location	Lat 06° 48' 38" 58"	
1-5		Long 036° 58' 02" 40"	
1-6	Elevation		
<b>2. Characteristics of Physical Condition of Culvert</b>			
2-1	Length of Culvert	5.0 m	
2-2	Shape of Cross Section	Square: Rectangular: Circle:(1)-with steel lining	
2-3	Flow Area	Height Hc1 = 2.0 m , Hc2 = 2.0 m	
2-4		Width Dc1 = 2.0 m , Dc2 = 2.0 m	
2-5		Other Hs1 = 0.4 m , Hs2 = 0.4 m	
2-6	Connecting Channel	Height	
2-7		Width	
2-8		Side Slope	
2-9	Type of Culvert	Concrete	
2-10	Riverbed	Material Silty sand	
2-11	Sediment	u/s No ( 0% rate)	
2-12	deposition	d/s No ( 0% rate)	
2-13	Topography	u/s:  , d/s	
2-14	Land Use		
2-15	Structures/Houses, road		
<b>3. Damaged Flood Records</b>			
3-1	(Year/Month)	(Type)	(Reason, etc.)

<b>Photo Upstream</b>	<b>Photo Downstream</b>
	
<b>Plan/Profile</b>	
	
<b>Cross Section</b>	
u/s	
d/s	

## Inventory Sheet for Culvert

<b>Station: at KM 286.4</b>		<b>Sheet No.: PCL 286.4</b>	
<b>1. General</b>			
1-1	Name of Inspector	T. Kawaguchi , Hussein , Abiud	
1-2	Organization of Inspector	JICA Study Team	
1-3	Date/Time of Inspection	2014/5/12	
1-4	Location	Lat	06° 48' 30" 04'''
1-5		Long	036° 58' 02" 83'''
1-6	Elevation		
<b>2. Characteristics of Physical Condition of Culvert</b>			
2-1	Length of Culvert	5.0 m	
2-2	Shape of Cross Section	Square: Rectangular: Circle:(3)	
2-3	Flow Area	Height	Hc1 = 0.45 m , Hc2 = 0.63 m
2-4		Width	Dc1 = 0.9 m , Dc2 = 0.9 m
2-5		Other	Hs1 = 1.0 m , Hs2 = 1.0 m
2-6	Connecting Channel	Height	
2-7		Width	
2-8		Side Slope	
2-9	Type of Culvert	Concrete	
2-10	Riverbed	Material	Silty sand
2-11	Sediment deposition	u/s	Middle ( 40% rate)
2-12		d/s	Middle ( 30% rate)
2-13	Topography	u/s:	,d/s:
2-14	Land Use		
2-15	Structures/Houses, road		
<b>3. Damaged Flood Records</b>			
3-1	(Year/Month)	(Type)	(Reason,etc.)

F-10

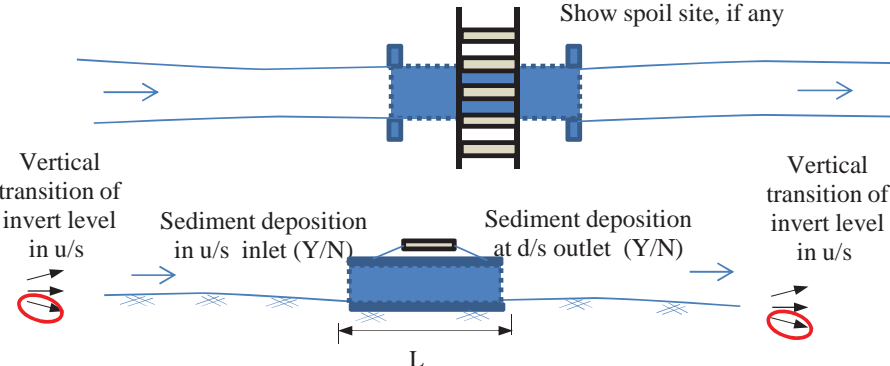
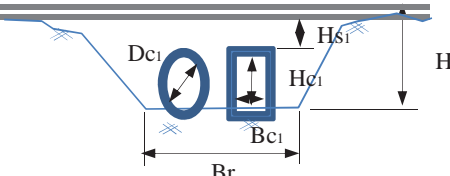
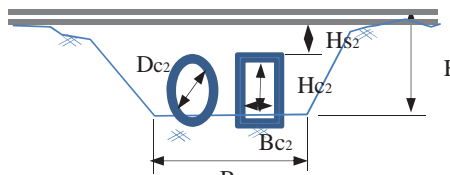
<b>Photo Upstream</b>	<b>Photo Downstream</b>
	
<b>Plan/Profile</b>	
 <p style="text-align: center;">Show spoil site, if any</p> <p style="text-align: center;">Vertical transition of invert level in u/s      Sediment deposition in u/s inlet (Y/N)      Sediment deposition at d/s outlet (Y/N)      Vertical transition of invert level in u/s</p> <p style="text-align: center;">      L      </p>	
<b>Cross Section</b>	
u/s	
d/s	

## Inventory Sheet for Culvert

**Station: at KM 286.65**      **Sheet No.: PCL 286.65**

<b>1. General</b>			
1-1	Name of Inspector		T. Kawaguchi , Hussein , Abiud
1-2	Organization of Inspector		JICA Study Team
1-3	Date/Time of Inspection		2014/5/12
1-4	Location	Lat	06° 48' 23" 25'''
1-5		Long	036° 57' 59" 44'''
1-6	Elevation		

### 2. Characteristics of Physical Condition of Culvert

2-1	Length of Culvert		5.0 m
2-2	Shape of Cross Section		Square: Rectangular: Circle: (1)
2-3	Flow Area	Height	Hc1 = 0.95 m , Hc2 = 0.8 m
2-4		Width	Dc1 = 1.0 m , Dc2 = 1.0 m
2-5		Other	Hs1 = 0.6 m , Hs2 = 0.6 m
2-6	Connecting Channel	Height	
2-7		Width	
2-8		Side Slope	
2-9	Type of Culvert		Concrete
2-10	Riverbed	Material	Silty sand
2-11	Sediment	u/s	Light ( 5% rate )
2-12	deposition	d/s	Light ( 20% rate)
2-13	Topography		u/s:  , d/s:
2-14	Land Use		
2-15	Structures/Houses, road		

### 3. Damaged Flood Records

3-1	(Year/Month)	(Type)	(Reason,etc.)

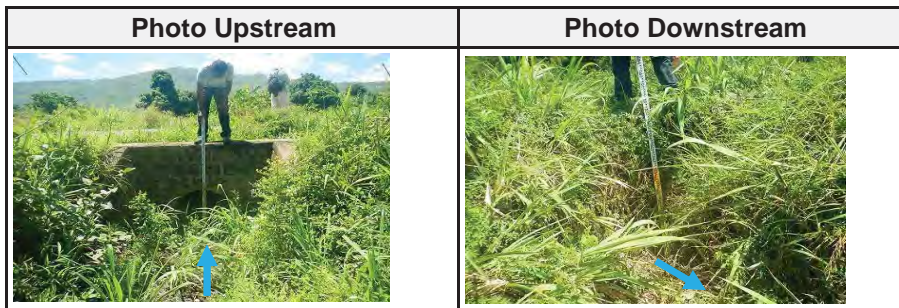

### Plan/Profile

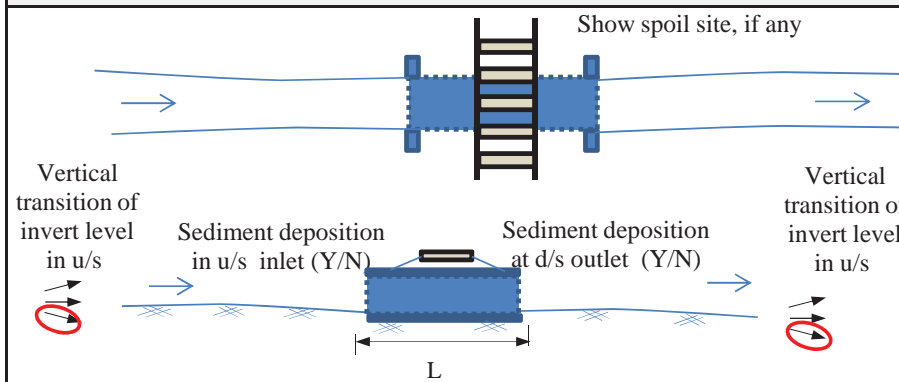

### Cross Section

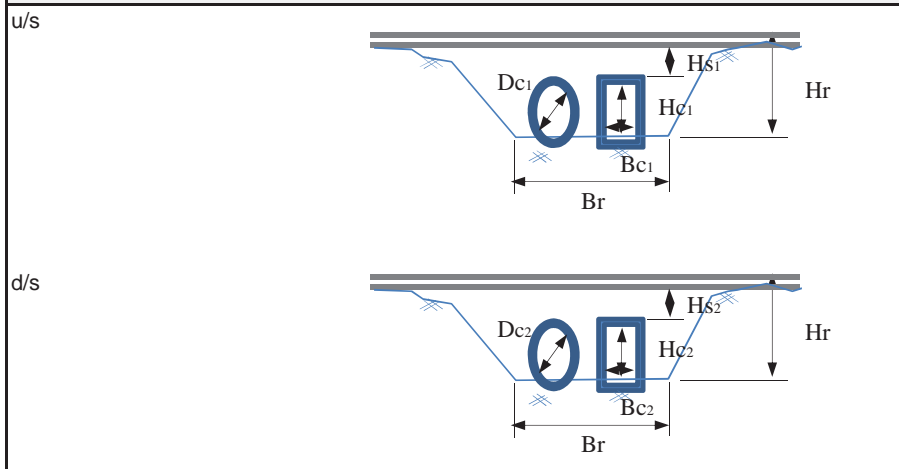



F-11



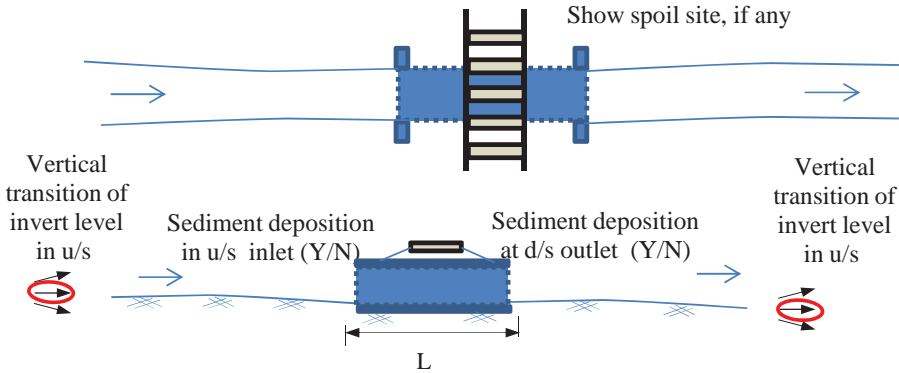
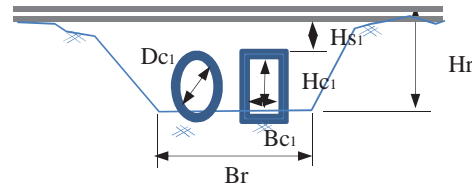
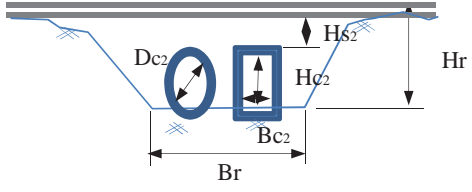

## Inventory Sheet for Culvert

<b>Station: at KM 286.88</b>		<b>Sheet No.: PCL 286.88</b>	
<b>1. General</b>			
1-1	Name of Inspector	T. Kawaguchi , Hussein , Abiud	
1-2	Organization of Inspector	JICA Study Team	
1-3	Date/Time of Inspection	2014/5/12	
1-4	Location	Lat	06° 48' 16" 25'''
1-5		Long	036° 57' 55" 65'''
1-6	Elevation		
<b>2. Characteristics of Physical Condition of Culvert</b>			
2-1	Length of Culvert	5.0 m	
2-2	Shape of Cross Section	Square: Rectangular: Circle:(2)	
2-3	Flow Area	Height	Hc1 = 0.9 m , Hc2 = 0.9 m
2-4		Width	Dc1 = 0.9 m , Dc2 = 0.9 m
2-5		Other	Hs1 = 1.0 m , Hs2 = 1.0 m
2-6	Connecting Channel	Height	
2-7		Width	
2-8		Side Slope	
2-9	Type of Culvert	Concrete	
2-10	Riverbed	Material	Silty sand
2-11	Sediment deposition	u/s	No ( 0% rate)
2-12		d/s	No ( 0% rate)
2-13	Topography	u/s: , d/s:	
2-14	Land Use		
2-15	Structures/Houses, road		
<b>3. Damaged Flood Records</b>			
3-1	(Year/Month)	(Type)	(Reason, etc.)

<b>Photo Upstream</b>	<b>Photo Downstream</b>
	
<b>Plan/Profile</b>	
 <p style="text-align: center;">Show spoil site, if any</p> <p style="text-align: center;">Vertical transition of invert level in u/s      Sediment deposition in u/s inlet (Y/N)      Sediment deposition at d/s outlet (Y/N)      Vertical transition of invert level in u/s</p> <p style="text-align: center;">L</p>	
<b>Cross Section</b>	
u/s	
d/s	

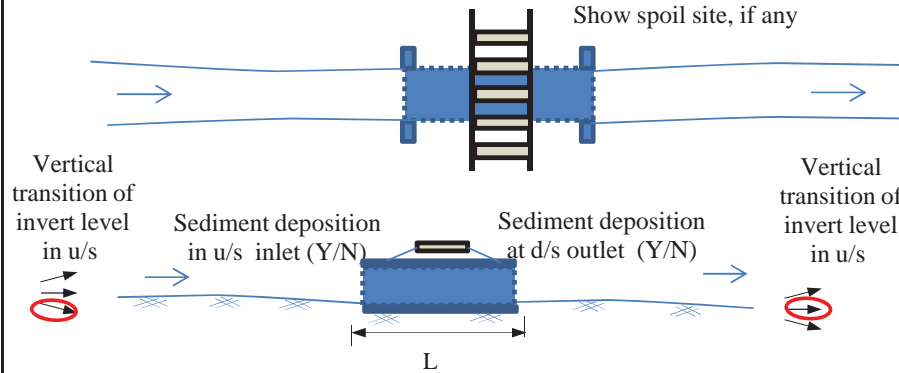
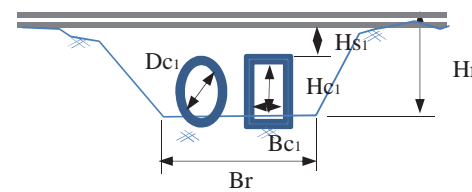
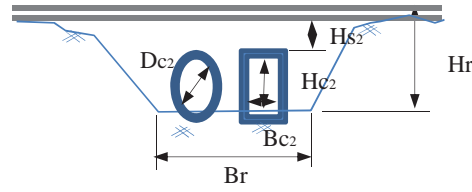

## Inventory Sheet for Culvert

<b>Station: at KM 287.15</b>		<b>Sheet No.: PCL 287.15</b>	
<b>1. General</b>			
1-1	Name of Inspector	T. Kawaguchi , Hussein , Abiud	
1-2	Organization of Inspector	JICA Study Team	
1-3	Date/Time of Inspection	2014/5/12	
1-4	Location	Lat	06° 48' 06" 44"
1-5		Long	036° 57' 52" 13"
1-6	Elevation		
<b>2. Characteristics of Physical Condition of Culvert</b>			
2-1	Length of Culvert	6.0 m	
2-2	Shape of Cross Section	Square: Rectangular: Circle:(2)	
2-3	Flow Area	Height	Hc1 = 0.18 m , Hc2 = 0.0 m
2-4		Width	Dc1 = 0.9 m , Dc2 = 0.9 m
2-5		Other	Hs1 = 0.5 m , Hs2 = 0.5 m
2-6	Connecting Channel	Height	
2-7		Width	
2-8		Side Slope	
2-9	Type of Culvert	Concrete	
2-10	Riverbed	Material	Silty sand
2-11	Sediment deposition	u/s	Heavy ( 80% rate)
2-12		d/s	(Heavy (100% rate)
2-13	Topography	u/s: , d/s:	
2-14	Land Use		
2-15	Structures/Houses, road		
<b>3. Damaged Flood Records</b>			
3-1	(Year/Month)	(Type)	(Reason, etc.)

<b>Photo Upstream</b>	<b>Photo Downstream</b>
	
<b>Plan/Profile</b>	
	
<b>Cross Section</b>	
u/s	
d/s	

## Inventory Sheet for Culvert

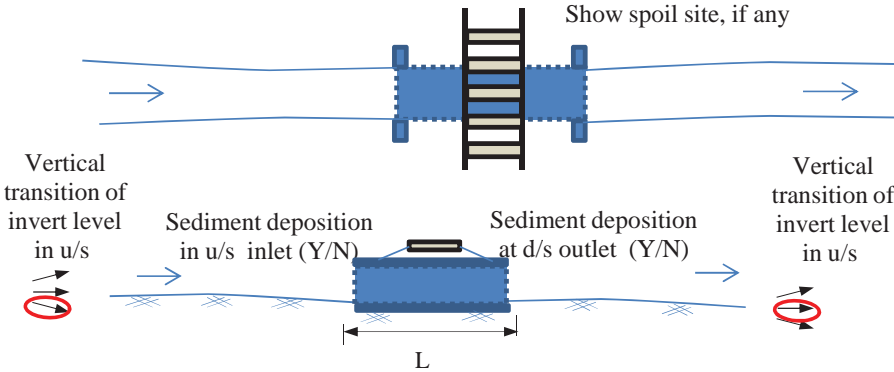
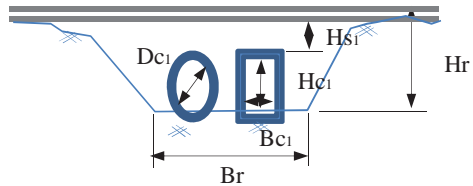
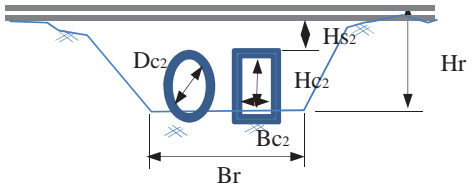

<b>Station: at KM 287.25</b>		<b>Sheet No.: BCL 287.25</b>	
<b>1. General</b>			
1-1	Name of Inspector	T. Kawaguchi , Hussein , Abiud	
1-2	Organization of Inspector	JICA Study Team	
1-3	Date/Time of Inspection	2014/5/12	
1-4	Location	Lat	06° 48' 04" 11"
1-5		Long	036° 57' 50" 84"
1-6	Elevation		
<b>2. Characteristics of Physical Condition of Culvert</b>			
2-1	Length of Culvert	5.0 m	
2-2	Shape of Cross Section	Square: <u>Rectangular:(1)</u> Circle:	
2-3	Flow Area	Height	Hc1 = 1.0 m , Hc2 = 0.9 m
2-4		Width	Bc1 = 7.0 m , Bc2 = 7.0 m
2-5	Other	Hs1 = 0.5 m , Hs2 = 0.5 m	
2-6	Connecting Channel	Height	
2-7		Width	
2-8		Side Slope	
2-9	Type of Culvert	Concrete	
2-10	Riverbed	Material	Silty sand
2-11	Sediment deposition	u/s	Middle ( 40% rate)
2-12		d/s	Heavy ( 60% rate)
2-13	Topography	u/s: , d/s:	
2-14	Land Use		
2-15	Structures/Houses, road		
<b>3. Damaged Flood Records</b>			
3-1	(Year/Month)	(Type)	(Reason,etc.)

<b>Photo Upstream</b>	<b>Photo Downstream</b>
	
<b>Plan/Profile</b>	
	
<b>Cross Section</b>	
u/s	
d/s	

## Inventory Sheet for Culvert

<b>Station: at KM 287.3</b>		<b>Sheet No.: PCL 287.3</b>	
<b>1. General</b>			
1-1	Name of Inspector	T. Kawaguchi , Hussein , Abiud	
1-2	Organization of Inspector	JICA Study Team	
1-3	Date/Time of Inspection	2014/5/12	
1-4	Location	Lat	06° 48' 01" 45'''
1-5		Long	036° 57' 48" 35'''
1-6	Elevation		
<b>2. Characteristics of Physical Condition of Culvert</b>			
2-1	Length of Culvert	5.0 m	
2-2	Shape of Cross Section	Square: Rectangular: Circle: (1)	
2-3	Flow Area	Height	Hc1 = 0.18 m , Hc2 = 0.09 m
2-4		Width	Dc1 = 0.9 m , Dc2 = 0.9 m
2-5		Other	Hs1 = 0.4 m , Hs2 = 0.4 m
2-6	Connecting Channel	Height	
2-7		Width	
2-8		Side Slope	
2-9	Type of Culvert	Concrete	
2-10	Riverbed	Material	Silty sand
2-11	Sediment deposition	u/s	Heavy ( 80% rate)
2-12		d/s	Heavy ( 90% rate)
2-13	Topography	u/s:  , d/s:	
2-14	Land Use		
2-15	Structures/Houses, road		
<b>3. Damaged Flood Records</b>			
3-1	(Year/Month)	(Type)	(Reason, etc.)

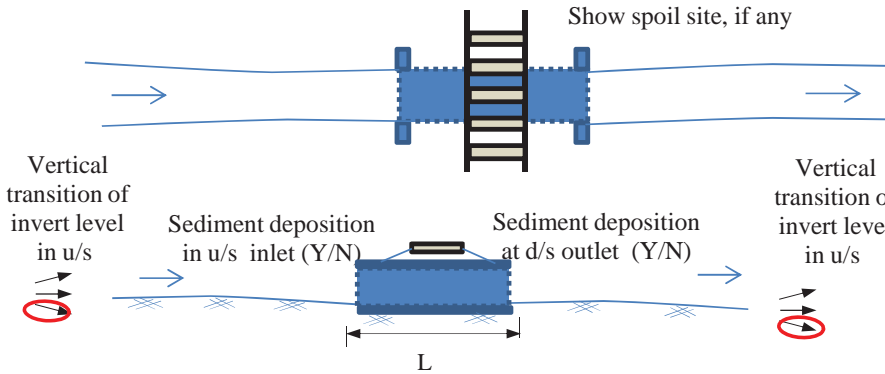
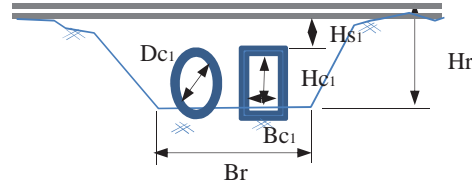
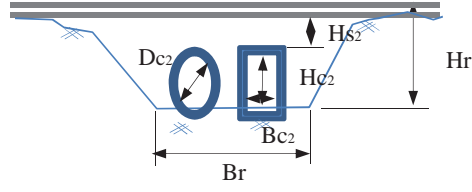

F-15

<b>Photo Upstream</b>	<b>Photo Downstream</b>
	
<b>Plan/Profile</b>	
 <p style="text-align: center;">Show spoil site, if any</p> <p style="text-align: center;">Vertical transition of invert level in u/s      Sediment deposition in u/s inlet (Y/N)      Sediment deposition at d/s outlet (Y/N)      Vertical transition of invert level in u/s</p> <p style="text-align: center;">L</p>	
<b>Cross Section</b>	
u/s	
d/s	

## Inventory Sheet for Culvert

<b>Station: at KM 287.7</b>		<b>Sheet No.: BCL 287.7</b>	
<b>1. General</b>			
1-1	Name of Inspector	T. Kawaguchi , Hussein , Abiud	
1-2	Organization of Inspector	JICA Study Team	
1-3	Date/Time of Inspection	2014/5/12	
1-4	Location	Lat	06° 47' 51" 65'''
1-5		Long	036° 57' 42" 79'''
1-6	Elevation		
<b>2. Characteristics of Physical Condition of Culvert</b>			
2-1	Length of Culvert	6.0 m	
2-2	Shape of Cross Section	Square:(2) Rectangular: Circle:	
2-3	Flow Area	Height	Hc1 = 1.8 m , Hc2 = 1.8 m
2-4		Width	Bc1 = 2.0 m , Bc2 = 2.0 m
2-5		Other	Hs1 = 0.5 m , Hs2 = 0.5 m
2-6	Connecting Channel	Height	
2-7		Width	
2-8		Side Slope	
2-9	Type of Culvert	Concrete	
2-10	Riverbed	Material	Silty sand
2-11	Sediment deposition	u/s	Light ( 10% rate)
2-12		d/s	Light ( 10% rate)
2-13	Topography	u/s: , d/s:	
2-14	Land Use		
2-15	Structures/Houses, road		
<b>3. Damaged Flood Records</b>			
3-1	(Year/Month)	(Type)	(Reason,etc.)

F-16

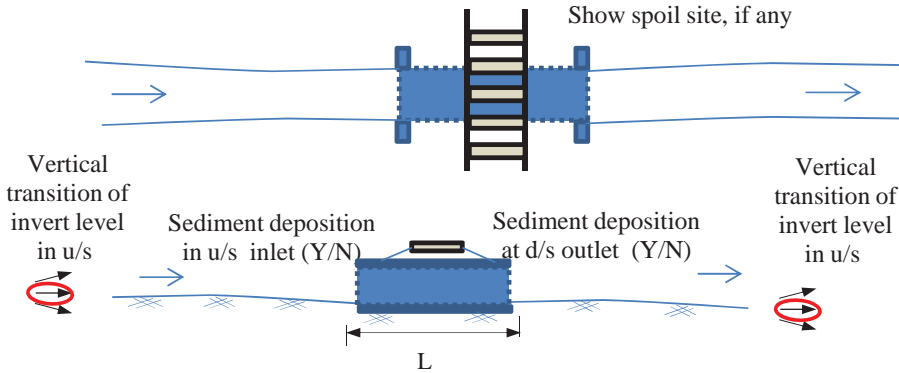
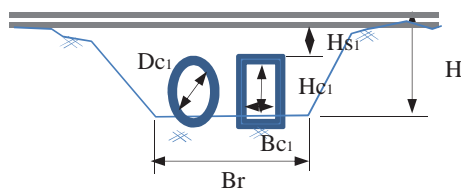
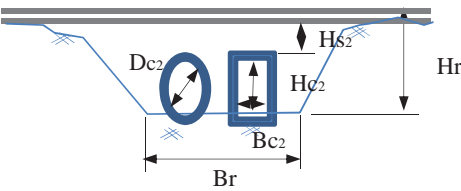
<b>Photo Upstream</b>	<b>Photo Downstream</b>
	
<b>Plan/Profile</b>	
	
<b>Cross Section</b>	
u/s	
d/s	



## Inventory Sheet for Culvert

**Station: at KM 288.35**      **Sheet No.: PCL 288.35**

1. General			
1-1	Name of Inspector		T. Kawaguchi , Hussein , Abiud
1-2	Organization of Inspector		JICA Study Team
1-3	Date/Time of Inspection		2014/5/12
1-4	Location	Lat	06° 47' 45" 52"
1-5		Long	036° 57' 23" 65"
1-6	Elevation		

### 2. Characteristics of Physical Condition of Culvert

2-1	Length of Culvert		7.0 m
2-2	Shape of Cross Section		Square: Rectangular: Circle:(3)
2-3	Flow Area	Height	Hc1 = 1.2 m, Hc2 = 1.2 m
2-4		Width	Dc1 = 1.2 m, Dc2 = 1.2 m
2-5		Other	Hs1 = 1.5 m, Hs2 = 1.5 m
2-6	Connecting Channel	Height	
2-7		Width	
2-8		Side Slope	
2-9	Type of Culvert		Concrete
2-10	Riverbed	Material	Silty sand
2-11	Sediment	u/s	No ( 0% rate)
2-12	deposition	d/s	No ( 0% rate)
2-13	Topography		u/s: , d/s:
2-14	Land Use		
2-15	Structures/Houses, road		

### 3. Damaged Flood Records

3-1	(Year/Month)	(Type)	(Reason,etc.)

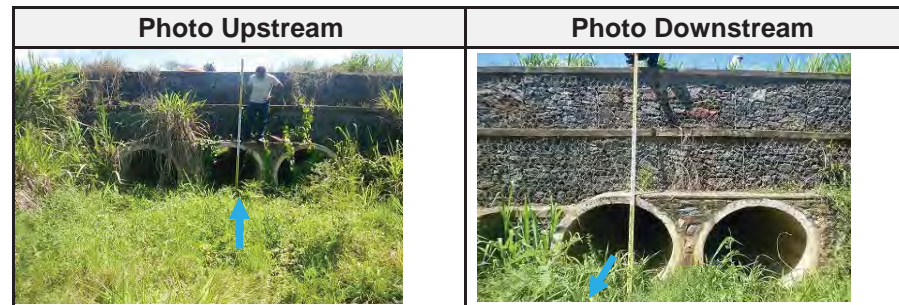

### Plan/Profile

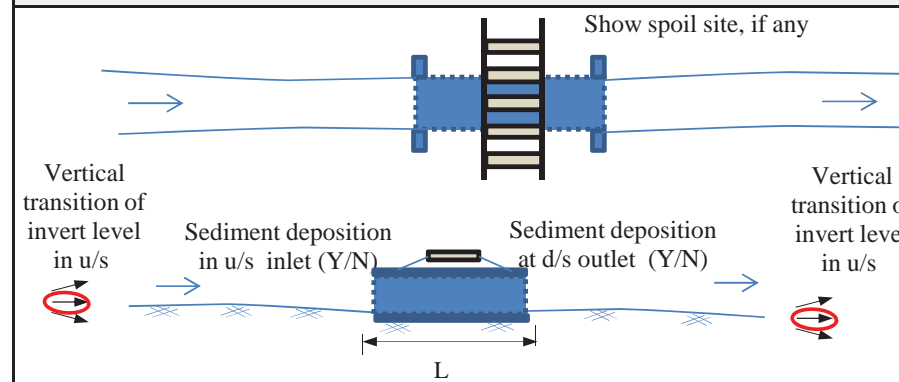

### Cross Section

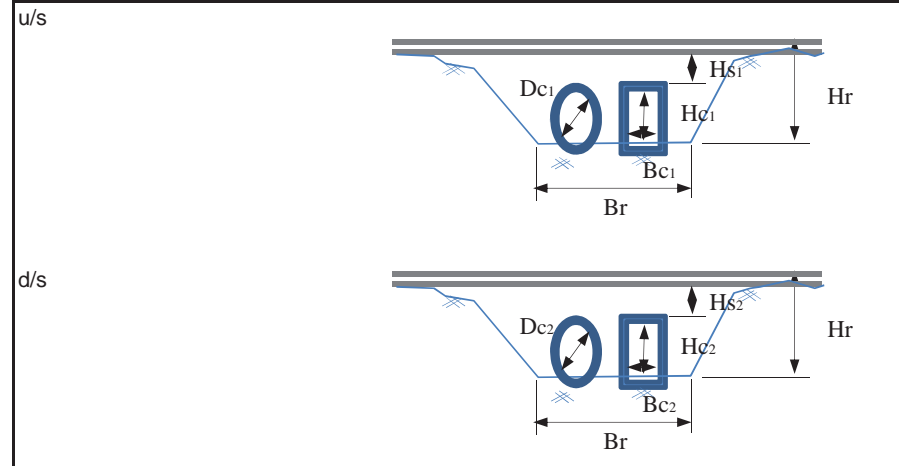

## Inventory Sheet for Culvert

**Station: at KM 289/0**      **Sheet No.: BCL289.0**

1. General			
1-1	Name of Inspector		T.Fukuda, Mr.Kido, Mr.Philipo
1-2	Organization of Inspector		B
1-3	Date/Time of Inspection		DEC 5 2014      1435
1-4	Location	Lat	06°45'34.7"
1-5		Long	036°57'00.9"
1-6	Elevation		n/a

### 2. Characteristics of Physical Condition of Culvert

2-1	Length of Culvert		n/a
2-2	Shape of Cross Section		Rectangular × 1
2-3	Flow Area	Height	Hc=1.0m
2-4		Width	Bc= 0.95m
2-5		Other	WL=2.0m, Hs= 0.4m
2-6	Connecting Channel	Height	n/a
2-7		Width	n/a
2-8		Side Slope	n/a
2-9	Type of Culvert		Concrete
2-10	Riverbed	Material	n/a
2-11	Sediment deposition	u/s	Y, 0%
2-12		d/s	Y, 0%
2-13	Topography		u/s: ↘      ,d/s: ↗
2-14	Land Use		n/a
2-15	Structures/Houses, road		n/a

### 3. Damaged Flood Records

3-1	(Year/Month)	(Type)	(Reason,etc.)
	n/a	n/a	n/a

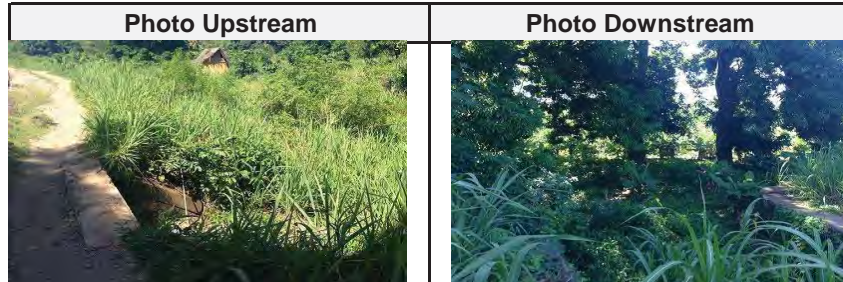

### Plan/Profile

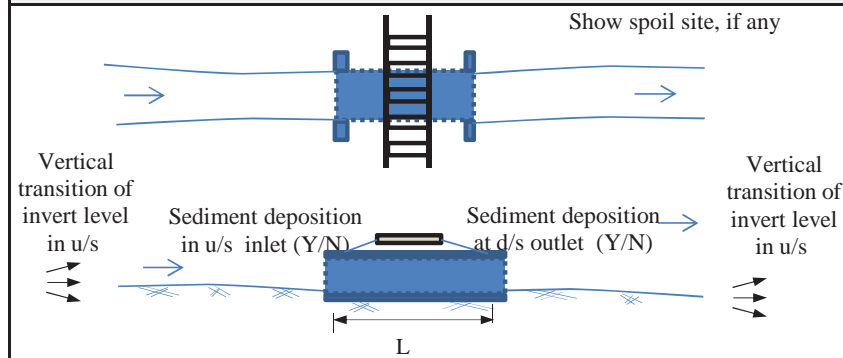

### Cross Section

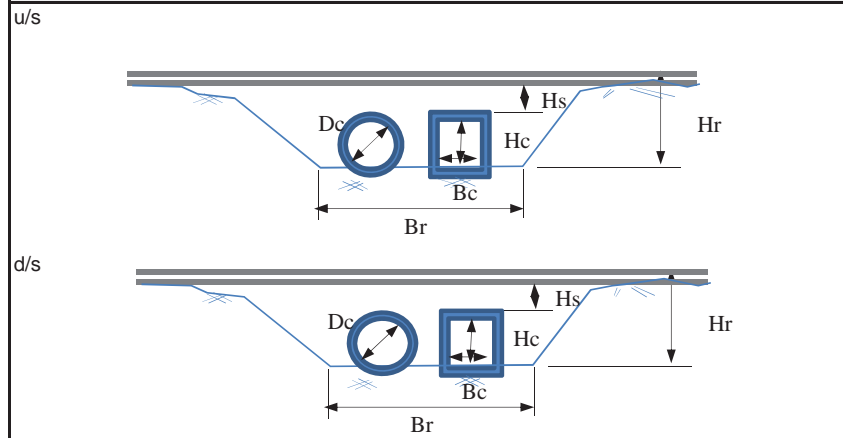

## Inventory Sheet for Culvert

**Station: at KM 289.1**      **Sheet No.: BCL 289.1**

### 1. General

1-1	Name of Inspector	Mr Motoki/ Semaya/ France	
1-2	Organization of Inspector	River Group B	
1-3	Date/Time of Inspection	05/12/2014 12:45 - 12:55	
1-4	Location	Lat	06° 44' 43.7"
1-5		Long	036° 53' 59.1"
1-6	Elevation	547m	

### 2. Characteristics of Physical Condition of Culvert

2-1	Length of Culvert	9.1m	
2-2	Shape of Cross Section	Square: <u>Rectangular: (3)</u> Circle:	
2-3	Flow Area	Height	1.92m
2-4		Widdth	open 3m, 3m, 3m full W (10.5m)
2-5	Connecting Channel	Other	
2-6		Height	
2-7		Widdth	
2-8	Side Slope		
2-9		Type of Culvert	Concrete
2-10	Riverbed	Material	silt sand
2-11	Sediment deposition	u/s	Little
2-12		d/s	Little
2-13	Topography	u/s:  , d/s:	
2-14	Land Use		
2-15	Structures/Houses, road		

### 3. Damaged Flood Records

3-1	(Year/Month)	(Type)	(Reason, etc.)

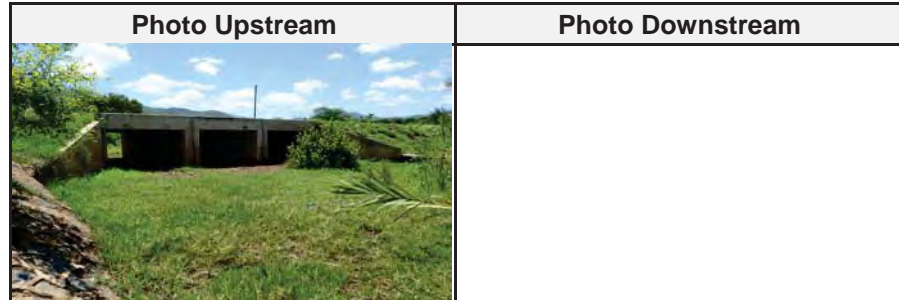

### Plan/Profile

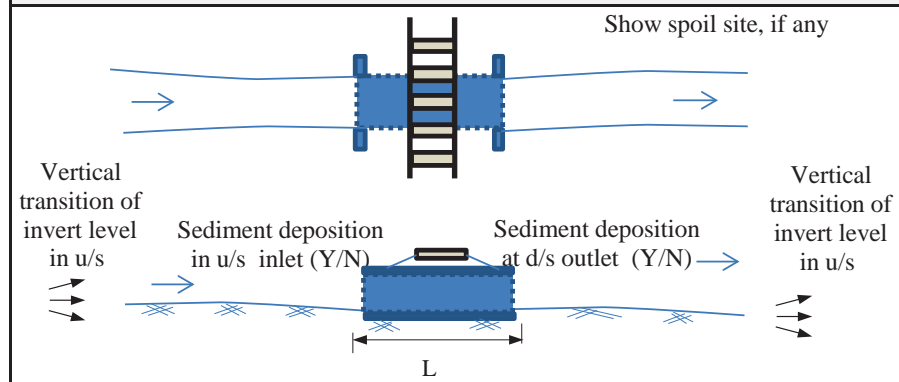

### Cross Section

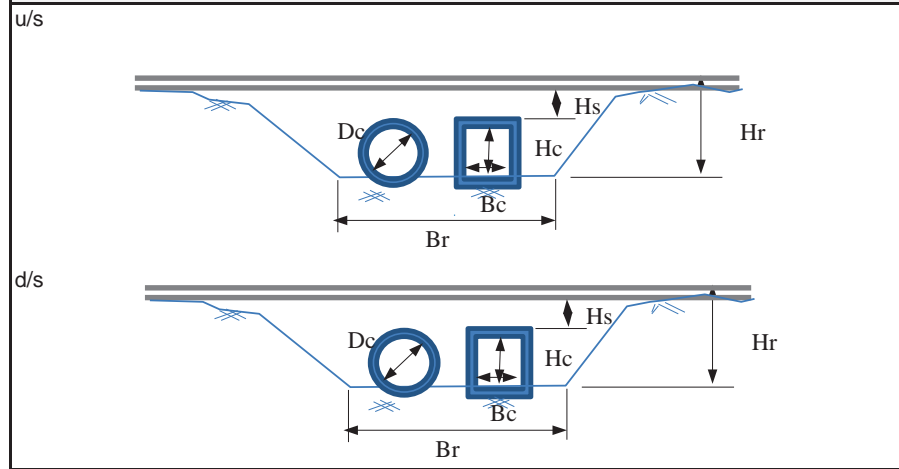

F-19



### Inventory Sheet for Culvert

**Station: at KM 289/3**      **Sheet No.: PCL289.3**

1. General			
1-1	Name of Inspector	T.Fukuda, Mr.Kido, Mr.Philipo	
1-2	Organization of Inspector	B	
1-3	Date/Time of Inspection	DEC 5 2014	1425
1-4	Location	Lat	06°47'25.4"
1-5		Long	036°56'58.3"
1-6	Elevation	n/a	

#### 2. Characteristics of Physical Condition of Culvert

2-1	Length of Culvert	n/a	
2-2	Shape of Cross Section	Circle x 1	
2-3	Flow Area	Height	n/a
2-4		Width	n/a
2-5		Other	d= 0.5m, WL=1.0m, Hs= 0.3m
2-6	Connecting Channel	Height	n/a
2-7		Width	n/a
2-8		Side Slope	n/a
2-9	Type of Culvert	Concrete	
2-10	Riverbed	Material	n/a
2-11	Sediment deposition	u/s	Y, ?
2-12		d/s	Y, ?
2-13	Topography	u/s: ↘ ,d/s ↗	
2-14	Land Use	n/a	
2-15	Structures/Houses, road	n/a	

#### 3. Damaged Flood Records

3-1	(Year/Month)	(Type)	(Reason,etc.)
	n/a	n/a	n/a

Photo UpstreamPhoto Downstream



#### Plan/Profile

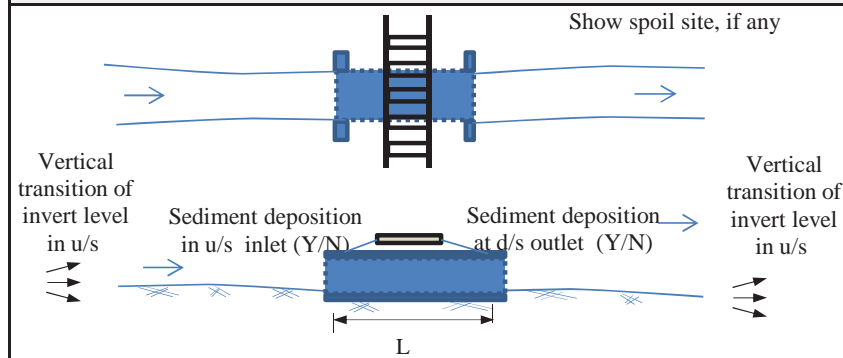

#### Cross Section

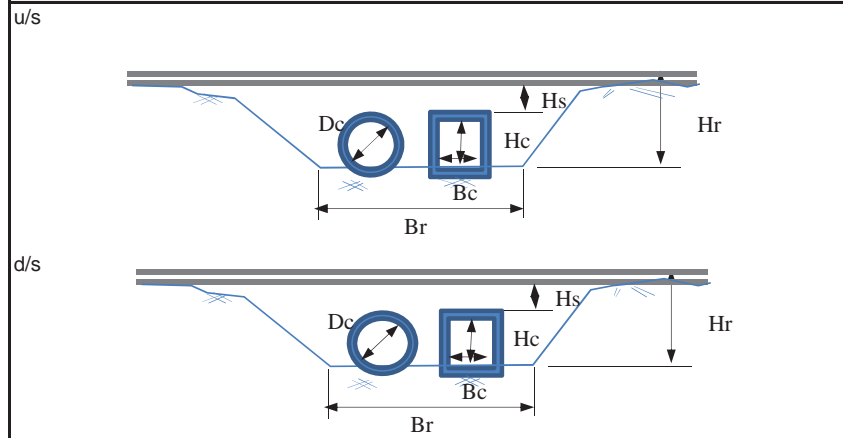

## Inventory Sheet for Culvert

<b>Station: at KM 289/6</b>		<b>Sheet No.: PCL289.6</b>	
<b>1. General</b>			
1-1	Name of Inspector	T.Fukuda, Mr.Kido, Mr.Philipo	
1-2	Organization of Inspector	B	
1-3	Date/Time of Inspection	DEC 5 2014 1416	
1-4	Location	Lat	06°47'15.8"
1-5		Long	036°56'58.5"
1-6	Elevation	n/a	
<b>2. Characteristics of Physical Condition of Culvert</b>			
2-1	Length of Culvert	n/a	
2-2	Shape of Cross Section	Circle x 1	
2-3	Flow Area	Height	n/a
2-4		Width	n/a
2-5		Other	d= 0.9m, WL=5.0m, Hs= 0.2m
2-6	Connecting Channel	Height	n/a
2-7		Width	n/a
2-8		Side Slope	n/a
2-9	Type of Culvert	Concrete	
2-10	Riverbed	Material	n/a
2-11	Sediment deposition	u/s	Y, ?
2-12		d/s	Y, ?
2-13	Topography	u/s: → ,d/s →	
2-14	Land Use	n/a	
2-15	Structures/Houses, road	n/a	
<b>3. Damaged Flood Records</b>			
3-1	(Year/Month)	(Type)	(Reason,etc.)
	n/a	n/a	n/a

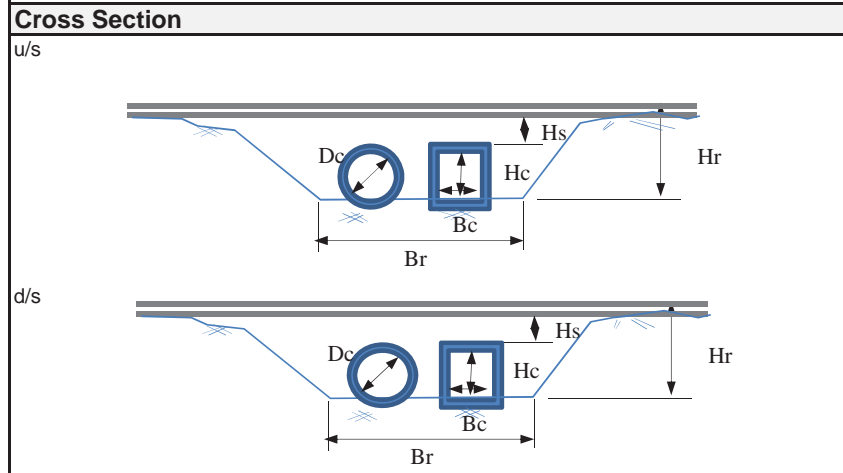
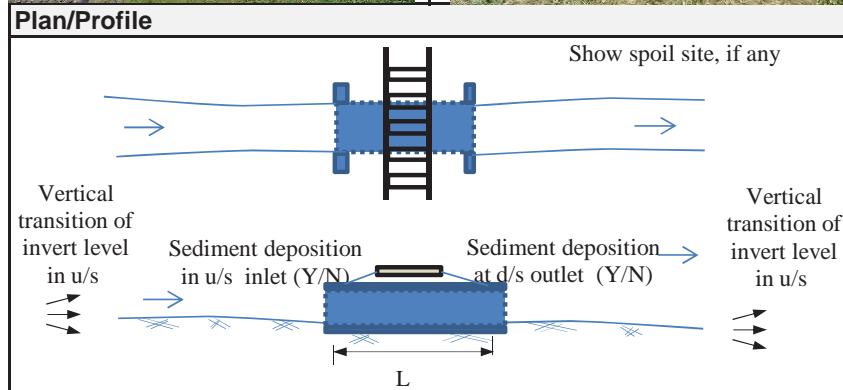
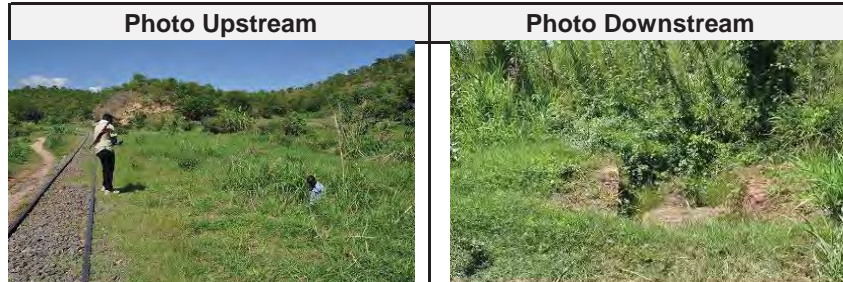

## Inventory Sheet for Culvert

**Station: at KM 289/9**      **Sheet No.: PCL289.9**

1. General		
1-1	Name of Inspector	T.Fukuda, Mr.Kido, Mr.Philipo
1-2	Organization of Inspector	B
1-3	Date/Time of Inspection	DEC 5 2014      1410
1-4	Location	Lat      06°47'06.8"
1-5		Long      036°56'58.8"
1-6	Elevation	n/a

2. Characteristics of Physical Condition of Culvert		
2-1	Length of Culvert	n/a
2-2	Shape of Cross Section	Circle × 2
2-3	Flow Area	Height      n/a
2-4		Width      n/a
2-5		Other      d= 1.2m, WL=4.0m, Hs= 0.6m
2-6	Connecting Channel	Height      n/a
2-7		Width      n/a
2-8		Side Slope      n/a
2-9	Type of Culvert	Concrete
2-10	Riverbed	Material      n/a
2-11	Sediment deposition	u/s      Y, 30%
2-12		d/s      Y, 30%
2-13	Topography	u/s: ↘      ,d/s      ↗
2-14	Land Use	n/a
2-15	Structures/Houses, road	n/a

3. Damaged Flood Records			
3-1	(Year/Month)	(Type)	(Reason,etc.)
	n/a	n/a	n/a

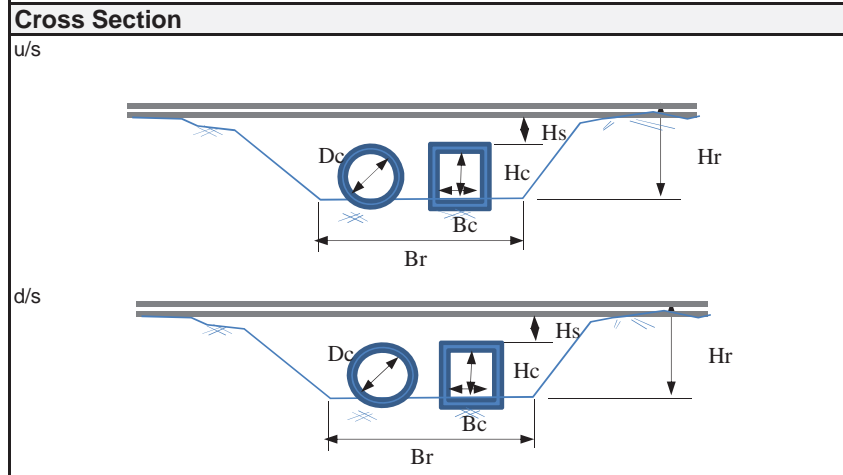
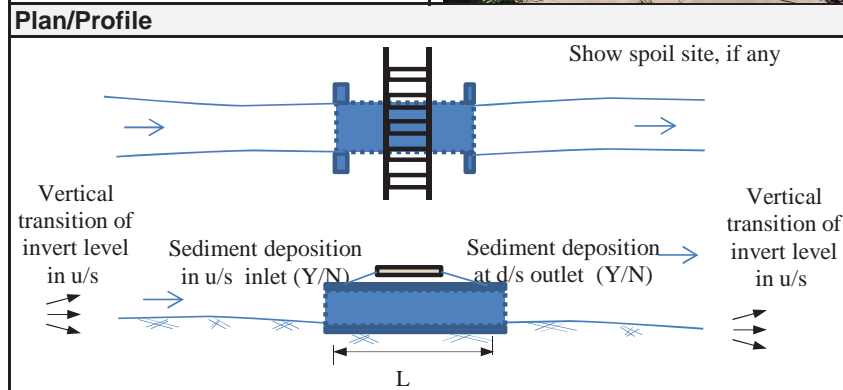
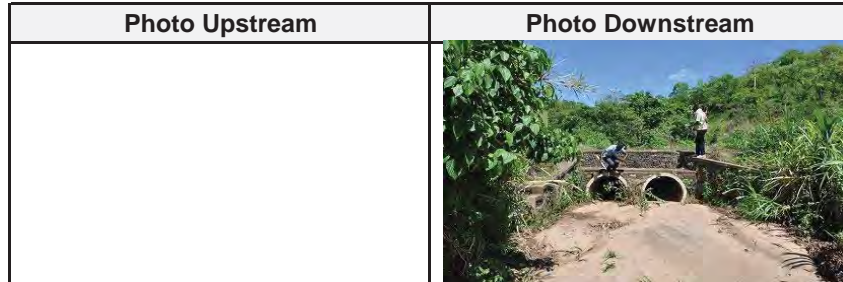

## Inventory Sheet for Culvert

**Station: at KM 290/4**      **Sheet No.: BCL290.4**

### 1. General

1-1	Name of Inspector	T.Fukuda, Mr.Kido, Mr.Philipo	
1-2	Organization of Inspector	B	
1-3	Date/Time of Inspection	DEC 5 2014	1357
1-4	Location	Lat	0646'52.0"
1-5		Long	036°56'54.0"
1-6	Elevation	n/a	

### 2. Characteristics of Physical Condition of Culvert

2-1	Length of Culvert	n/a	
2-2	Shape of Cross Section	Rectangular: × 1	
2-3	Flow Area	Height	Hc= 1.3m
2-4		Width	Bc= 3.0m
2-5		Other	WL= 3.0m, Hs= 0.5m
2-6	Connecting Channel	Height	n/a
2-7		Width	n/a
2-8		Side Slope	n/a
2-9	Type of Culvert	Concrete	
2-10	Riverbed	Material	n/a
2-11	Sediment deposition	u/s	Y, 60%
2-12		d/s	Y, 60%
2-13	Topography	u/s: → ,d/s →	
2-14	Land Use	n/a	
2-15	Structures/Houses, road	n/a	

### 3. Damaged Flood Records

3-1	(Year/Month)	(Type)	(Reason,etc.)
	n/a	n/a	n/a

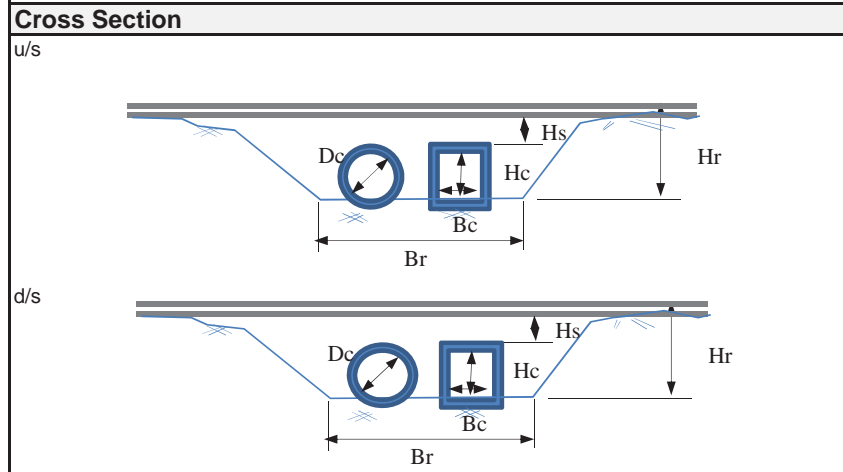
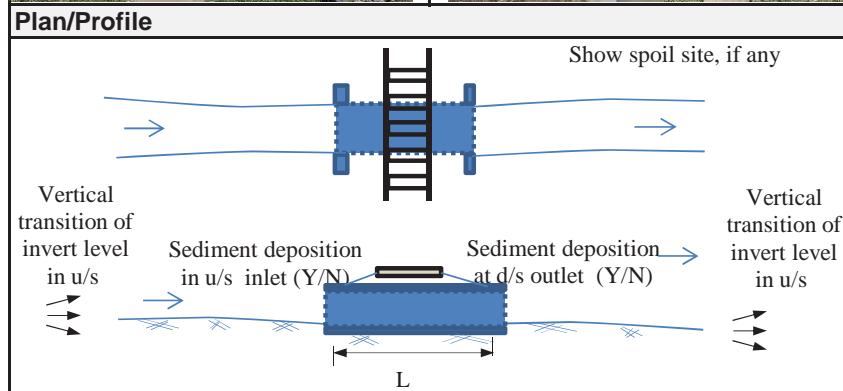
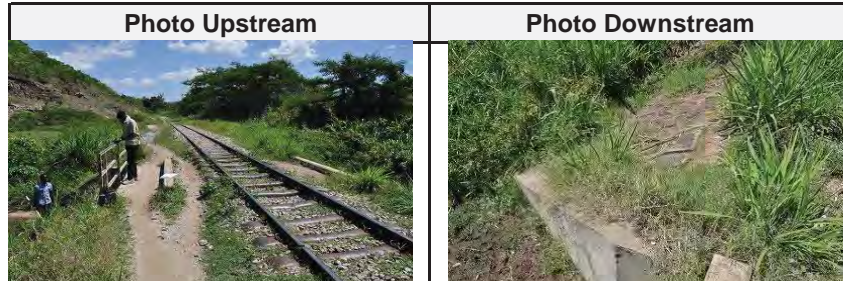

## Inventory Sheet for Culvert

**Station: at KM 290/6**      **Sheet No.: PCL290.6**

<b>1. General</b>		
1-1	Name of Inspector	T.Fukuda, Mr.Kido, Mr.Philipo
1-2	Organization of Inspector	B
1-3	Date/Time of Inspection	DEC 5 2014      1353
1-4	Location	Lat      0646'46.4"
1-5		Long      036°56'51.5"
1-6	Elevation	n/a

**2. Characteristics of Physical Condition of Culvert**

2-1	Length of Culvert	n/a
2-2	Shape of Cross Section	Circle x 1
2-3	Flow Area	Height      n/a
2-4		Width      n/a
2-5		Other      d= 0.9m, WL= 3.7m, Hs= 1.0m
2-6	Connecting Channel	Height      n/a
2-7		Width      n/a
2-8		Side Slope      n/a
2-9	Type of Culvert	Concrete
2-10	Riverbed	Material      n/a
2-11	Sediment deposition	u/s      Y, 10%
2-12		d/s      Y, 10%
2-13	Topography	u/s:      ,d/s      →
2-14	Land Use	n/a
2-15	Structures/Houses, road	n/a

**3. Damaged Flood Records**

3-1	(Year/Month)	(Type)	(Reason,etc.)
	2010	Flood	Railway track was diverted.

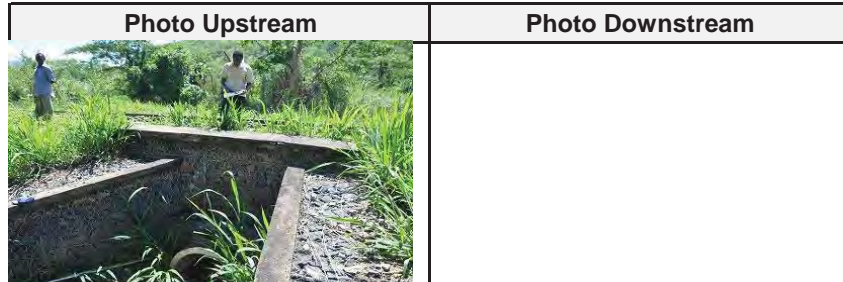

**Plan/Profile**

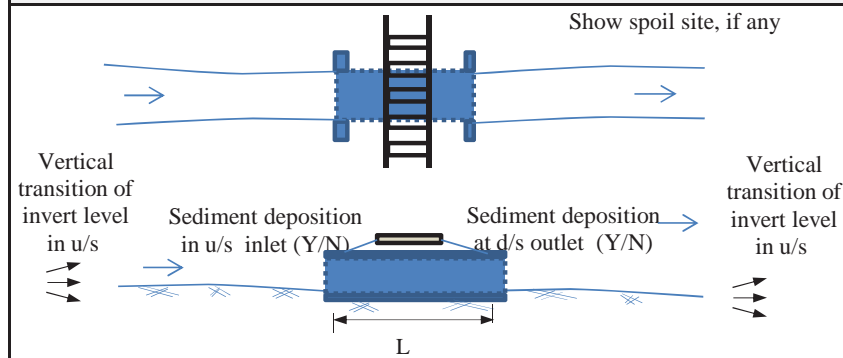

**Cross Section**

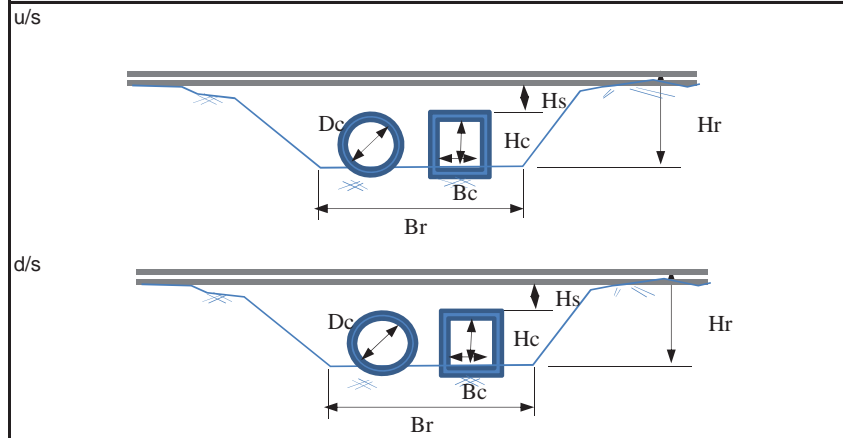



## Inventory Sheet for Culvert

**Station: at KM 290/9**      **Sheet No.: BR290.9**

<b>1. General</b>			
1-1	Name of Inspector	T.Fukuda, Mr.Kido, Mr.Philipo	
1-2	Organization of Inspector	B	
1-3	Date/Time of Inspection	DEC 5 2014	1348
1-4	Location	Lat	06°46'34.8"
1-5		Long	036°56'45.7"
1-6	Elevation	n/a	

**2. Characteristics of Physical Condition of Culvert**

2-1	Length of Culvert	L= 10.0m	
2-2	Shape of Cross Section	Rectangular × 1	
2-3	Flow Area	Height	Hc=1.5m
2-4		Width	Bc= 10.0m
2-5		Other	WL= 3.0m
2-6	Connecting Channel	Height	n/a
2-7		Width	n/a
2-8		Side Slope	n/a
2-9	Type of Culvert	Concrete	
2-10	Riverbed	Material	n/a
2-11	Sediment deposition	u/s	n/a, 20%
2-12		d/s	n/a, 20%
2-13	Topography	u/s: ↘ ,d/s ↗	
2-14	Land Use	n/a	
2-15	Structures/Houses, road	n/a	

**3. Damaged Flood Records**

3-1	(Year/Month)	(Type)	(Reason,etc.)
	n/a	n/a	n/a

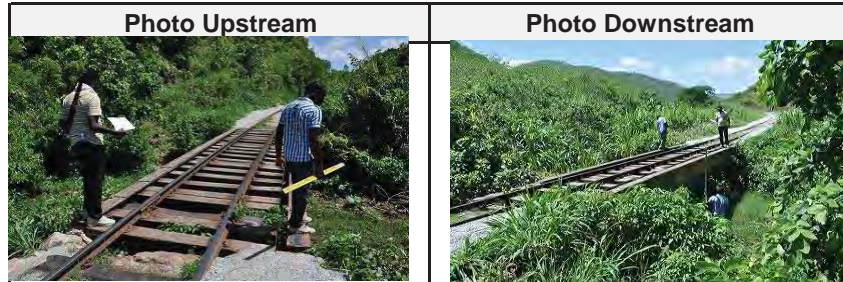

**Plan/Profile**

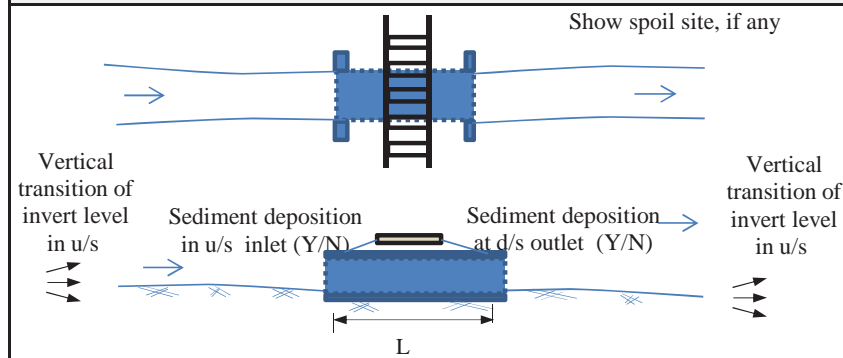

**Cross Section**

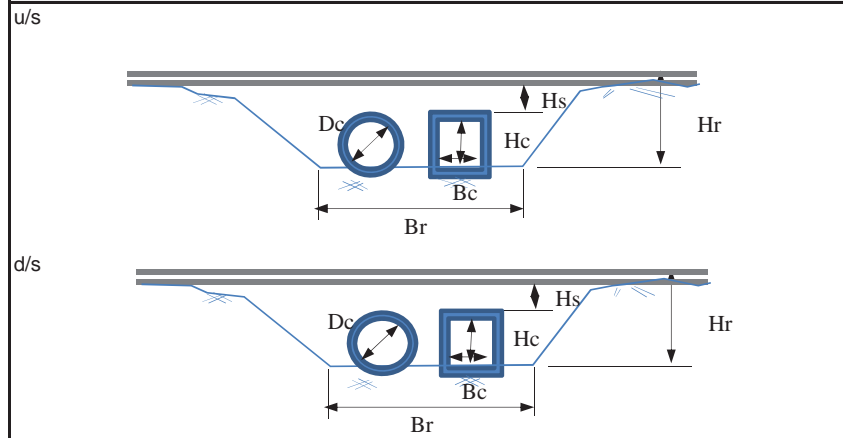

## Inventory Sheet for Culvert

**Station: at KM 291/2**      **Sheet No.: PCL291.2**

### 1. General

1-1	Name of Inspector	T.Fukuda, Mr.Kido, Mr.Philipo	
1-2	Organization of Inspector	B	
1-3	Date/Time of Inspection	DEC 5 2014	1348
1-4	Location	Lat	0646'28.7"
1-5		Long	036°56'38.6"
1-6	Elevation	n/a	

### 2. Characteristics of Physical Condition of Culvert

2-1	Length of Culvert	n/a	
2-2	Shape of Cross Section	Circle x 5	
2-3	Flow Area	Height	n/a
2-4		Width	n/a
2-5		Other	d=0.75m, WL= 1.5m, Hs= 0.6m
2-6	Connecting Channel	Height	n/a
2-7		Width	n/a
2-8		Side Slope	n/a
2-9	Type of Culvert	Concrete	
2-10	Riverbed	Material	n/a
2-11	Sediment deposition	u/s	Y, 20%
2-12		d/s	Y, 20%
2-13	Topography	u/s: ↘ ,d/s ↗	
2-14	Land Use	n/a	
2-15	Structures/Houses, road	n/a	

### 3. Damaged Flood Records

3-1	(Year/Month)	(Type)	(Reason,etc.)
	n/a	n/a	n/a

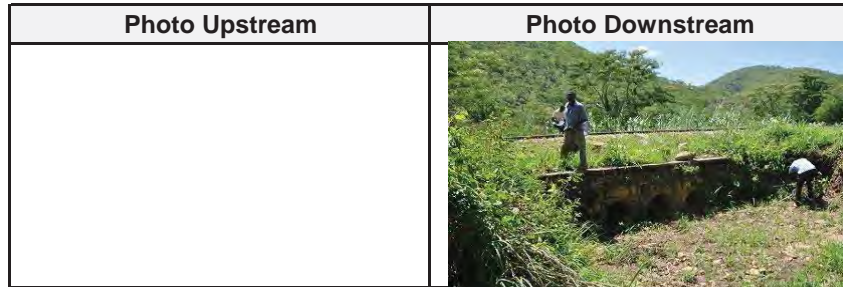

### Plan/Profile

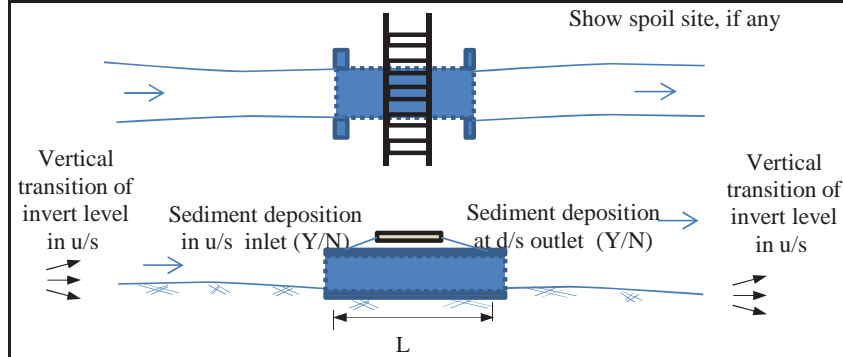

### Cross Section

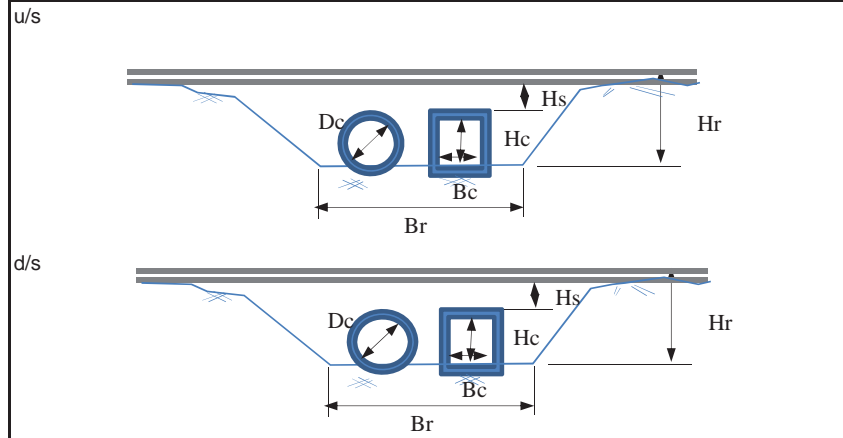

## Inventory Sheet for Culvert

**Station: at KM 291/5**      **Sheet No.: PCL291.5**

### 1. General

1-1	Name of Inspector		T.Fukuda, Mr.Kido, Mr.Philipo
1-2	Organization of Inspector		B
1-3	Date/Time of Inspection		DEC 5 2014      1325
1-4	Location	Lat	06°46'21.8"
1-5		Long	036°56'31.9"
1-6	Elevation		n/a

### 2. Characteristics of Physical Condition of Culvert

2-1	Length of Culvert		n/a
2-2	Shape of Cross Section		Circlex 1
2-3	Flow Area	Height	n/a
2-4		Width	n/a
2-5		Other	d=0.75m, W L= 2.0m, Hs= 0.5m
2-6	Connecting Channel	Height	n/a
2-7		Width	n/a
2-8		Side Slope	n/a
2-9	Type of Culvert		Concrete
2-10	Riverbed	Material	n/a
2-11	Sediment deposition	u/s	Y, ?
2-12		d/s	Y, ?
2-13	Topography		u/s: ↘      ,d/s      ↗
2-14	Land Use		n/a
2-15	Structures/Houses, road		n/a

### 3. Damaged Flood Records

3-1	(Year/Month)	(Type)	(Reason,etc.)
	n/a	n/a	n/a

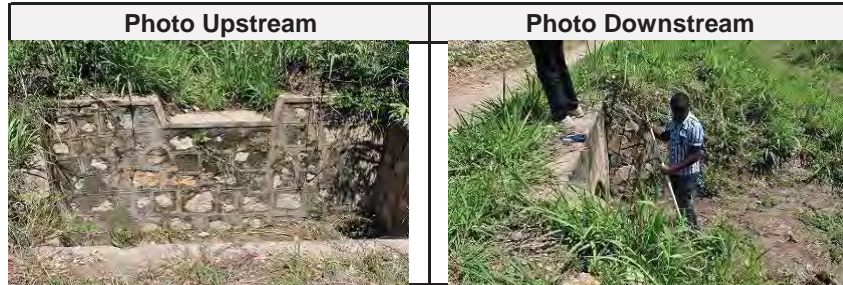

### Plan/Profile

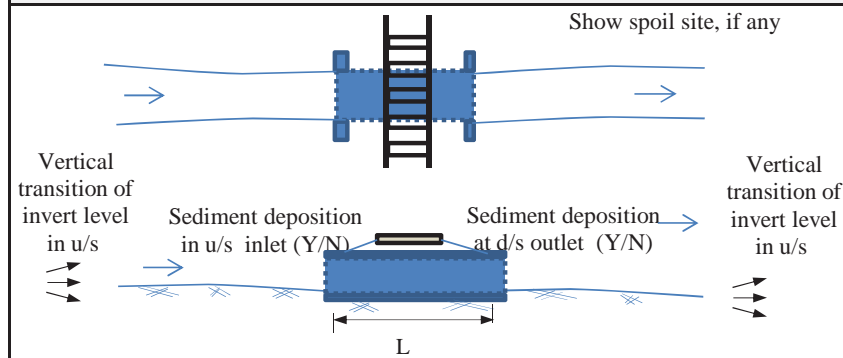

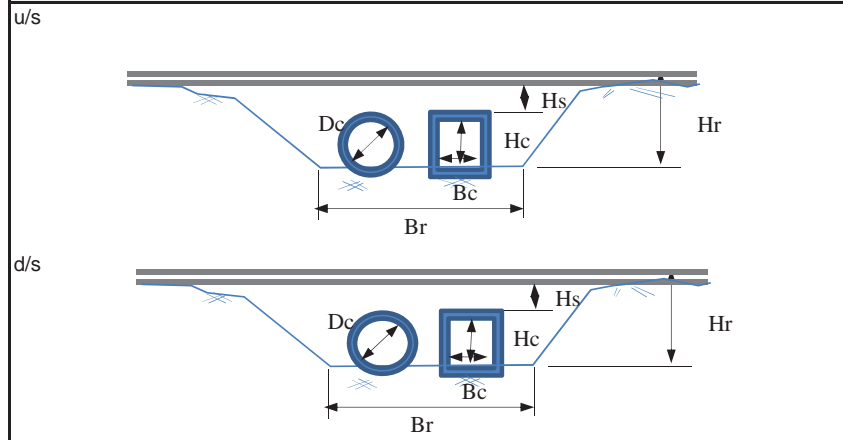

### Cross Section





## Inventory Sheet for Culvert

<b>Station: at KM 291/5</b>		<b>Sheet No.: PCL291.5b</b>	
<b>1. General</b>			
1-1	Name of Inspector	T.Fukuda, Mr.Kido, Mr.Philipo	
1-2	Organization of Inspector	B	
1-3	Date/Time of Inspection	DEC 5 2014	1321
1-4	Location	Lat	06°46'20.6"
1-5		Long	036°56'30.9"
1-6	Elevation	n/a	
<b>2. Characteristics of Physical Condition of Culvert</b>			
2-1	Length of Culvert	n/a	
2-2	Shape of Cross Section	Circle x 2	
2-3	Flow Area	Height	n/a
2-4		Width	n/a
2-5		Other	d=0.75m, WL= 1.5m, Hs= 0.7m
2-6	Connecting Channel	Height	n/a
2-7		Width	n/a
2-8		Side Slope	n/a
2-9	Type of Culvert	Concrete	
2-10	Riverbed	Material	n/a
2-11	Sediment deposition	u/s	Y, 80%
2-12		d/s	Y, 80%
2-13	Topography	u/s: ↘ ,d/s ↗	
2-14	Land Use	n/a	
2-15	Structures/Houses, road	n/a	
<b>3. Damaged Flood Records</b>			
3-1	(Year/Month)	(Type)	(Reason,etc.)
	n/a	n/a	n/a

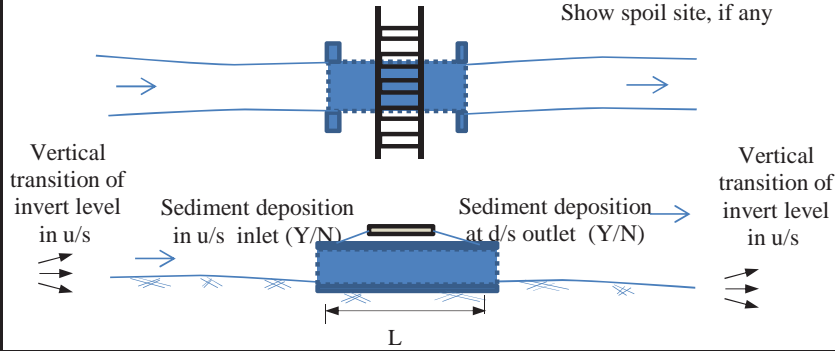
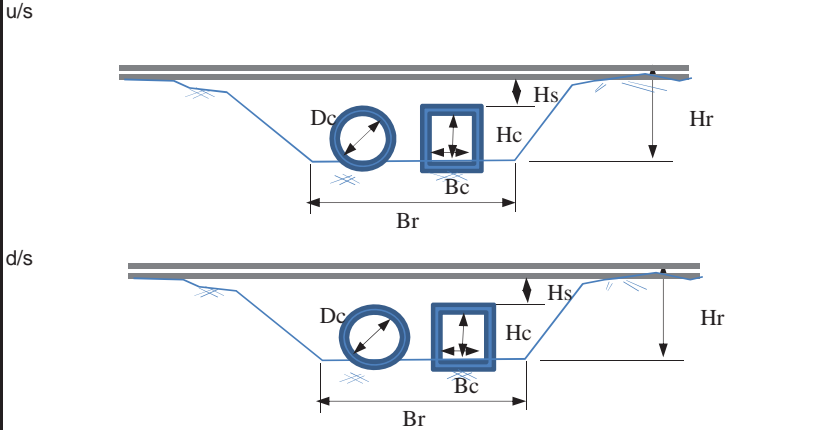
<b>Photo Upstream</b>	<b>Photo Downstream</b>
	
<b>Plan/Profile</b>	
 <p style="text-align: center;">Show spoil site, if any</p>	
<b>Cross Section</b>	
	

## Inventory Sheet for Culvert

**Station: at KM 291/7**      **Sheet No.: PCL291.7**

### 1. General

1-1	Name of Inspector	T.Fukuda, Mr.Kido, Mr.Philipo	
1-2	Organization of Inspector	B	
1-3	Date/Time of Inspection	DEC 5 2014	1321
1-4	Location	Lat	0646'17.5"
1-5		Long	036°56'27.8"
1-6	Elevation	n/a	

### 2. Characteristics of Physical Condition of Culvert

2-1	Length of Culvert	n/a	
2-2	Shape of Cross Section	Circle × 2	
2-3	Flow Area	Height	Hc=0m,
2-4		Width	n/a
2-5		Other	WL= 1.8m, Hs= 0.9m,
2-6	Connecting Channel	Height	n/a
2-7		Width	n/a
2-8		Side Slope	n/a
2-9	Type of Culvert	Concrete	
2-10	Riverbed	Material	n/a
2-11	Sediment deposition	u/s	Y, 100%
2-12		d/s	Y, 100%
2-13	Topography	u/s: ↘ ,d/s ↗	
2-14	Land Use	n/a	
2-15	Structures/Houses, road	n/a	

### 3. Damaged Flood Records

3-1	(Year/Month)	(Type)	(Reason,etc.)
	n/a	n/a	n/a

Photo Upstream Photo Downstream



### Plan/Profile

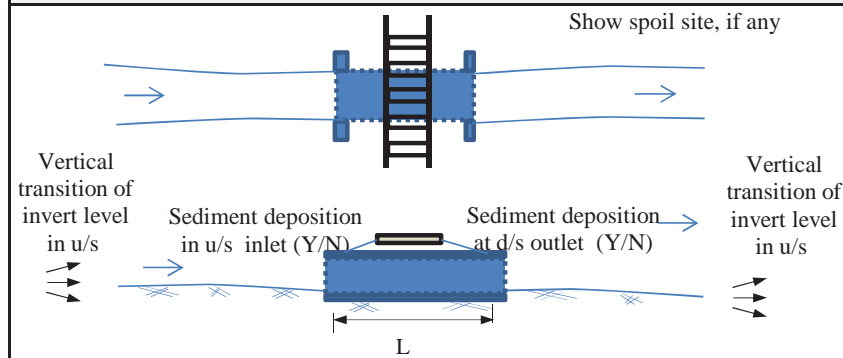

### Cross Section

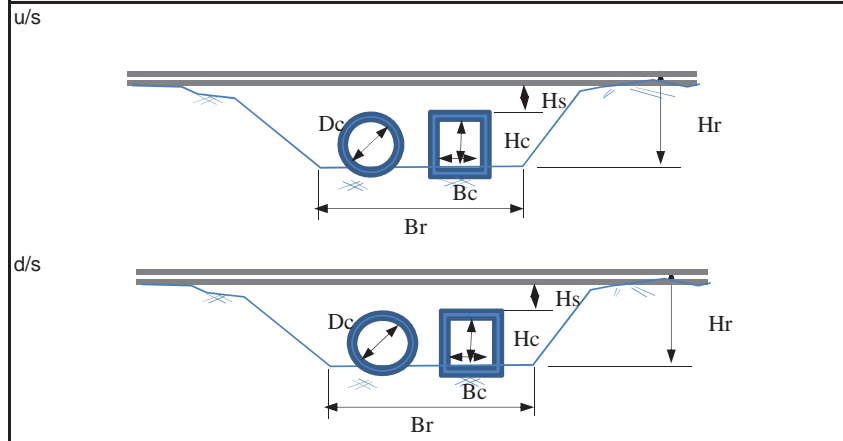

## Inventory Sheet for Culvert

**Station: at KM 291/9**      **Sheet No.: PCL291.9**

1. General			
1-1	Name of Inspector		T.Fukuda, Mr.Kido, Mr.Philipo
1-2	Organization of Inspector		B
1-3	Date/Time of Inspection		DEC 5 2014    1250
1-4	Location	Lat	06°46'11.9"
1-5		Long	036°56'23.2"
1-6	Elevation		n/a

2. Characteristics of Physical Condition of Culvert			
2-1	Length of Culvert		n/a
2-2	Shape of Cross Section		Circle x 4
2-3	Flow Area	Height	n/a
2-4		Width	n/a
2-5		Other	d=0.75m, WL= 1.5m, Hs= 0.7m
2-6	Connecting Channel	Height	n/a
2-7		Width	n/a
2-8		Side Slope	n/a
2-9	Type of Culvert		Concrete
2-10	Riverbed	Material	n/a
2-11	Sediment deposition	u/s	Y, 40%
2-12		d/s	Y, 40%
2-13	Topography		u/s:    ,d/s    →
2-14	Land Use		n/a
2-15	Structures/Houses, road		n/a

3. Damaged Flood Records			
3-1	(Year/Month)	(Type)	(Reason,etc.)
	n/a	n/a	n/a

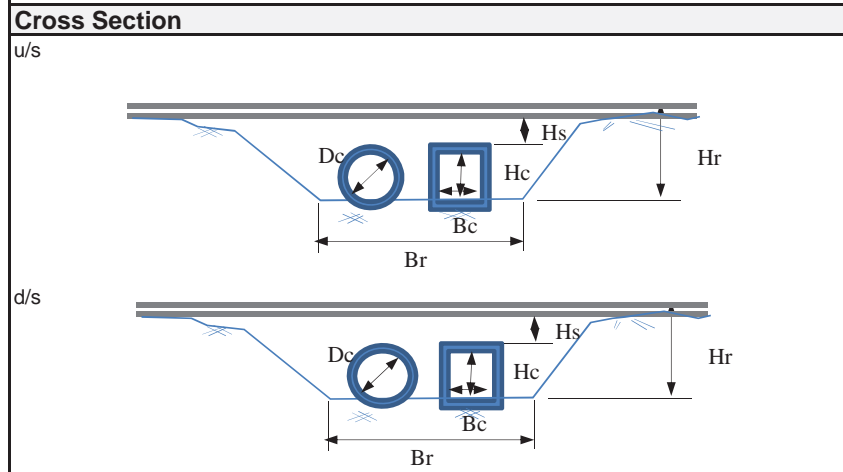
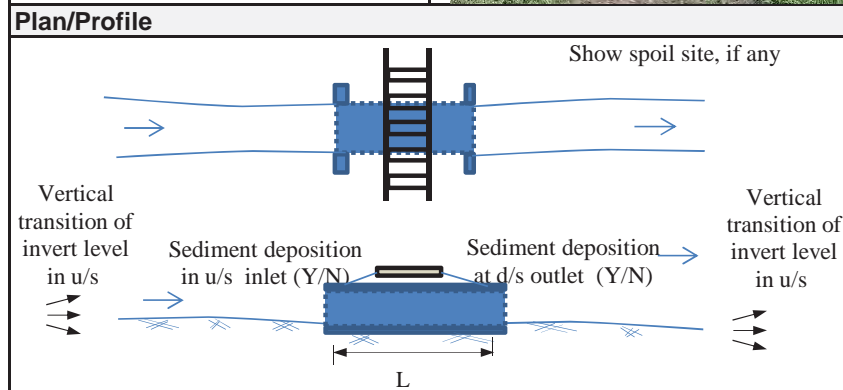
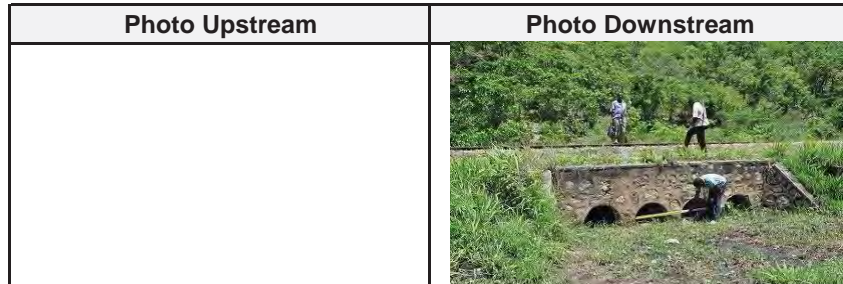

## Inventory Sheet for Culvert

**Station: at KM 292/2**      **Sheet No.: BCL292.2**

### 1. General

1-1	Name of Inspector	T.Fukuda, Mr.Kido, Mr.Philipo	
1-2	Organization of Inspector	B	
1-3	Date/Time of Inspection	DEC 5 2014	1241
1-4	Location	Lat	0646'03.9"
1-5		Long	03656'18.4"
1-6	Elevation	n/a	

### 2. Characteristics of Physical Condition of Culvert

2-1	Length of Culvert	n/a	
2-2	Shape of Cross Section	Rectangular × 1	
2-3	Flow Area	Height	Hc = 1.6m
2-4		Width	Bc = 2.5m
2-5		Other	WL= 3.5m, Hs= 0.6m
2-6	Connecting Channel	Height	n/a
2-7		Width	n/a
2-8		Side Slope	n/a
2-9	Type of Culvert	Concrete	
2-10	Riverbed	Material	n/a
2-11	Sediment deposition	u/s	N, 0%
2-12		d/s	Y, 40%
2-13	Topography	u/s: ↘ ,d/s ↗	
2-14	Land Use	n/a	
2-15	Structures/Houses, road	n/a	

### 3. Damaged Flood Records

3-1	(Year/Month)	(Type)	(Reason,etc.)
	n/a	n/a	n/a

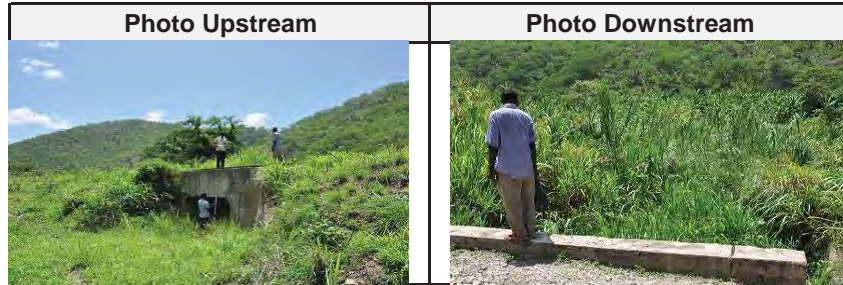

### Plan/Profile

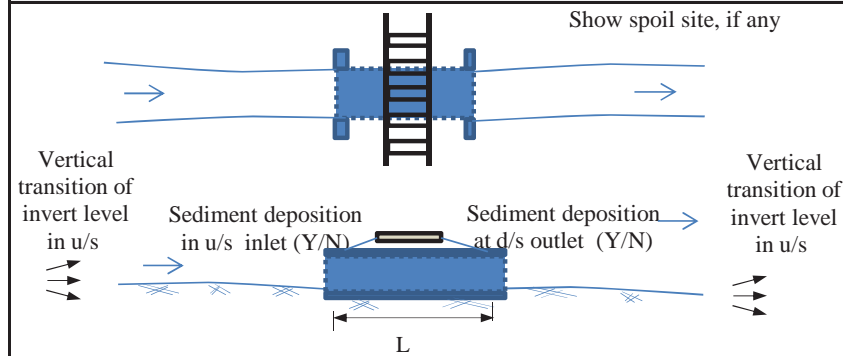

### Cross Section

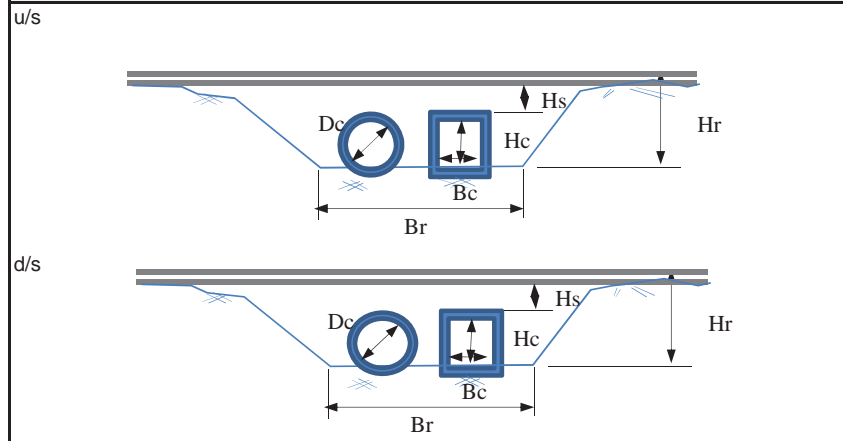

## Inventory Sheet for Culvert

**Station: at KM 292/6**      **Sheet No.: BCL292.6**

### 1. General

1-1	Name of Inspector	T.Fukuda, Mr.Kido, Mr.Philipo	
1-2	Organization of Inspector	B	
1-3	Date/Time of Inspection	DEC 5 2014	1225
1-4	Location	Lat	06°45'52.3"
1-5		Long	036°56'15.4"
1-6	Elevation	n/a	

### 2. Characteristics of Physical Condition of Culvert

2-1	Length of Culvert	L=31.8m	
2-2	Shape of Cross Section	Rectangular × 1	
2-3	Flow Area	Height	Hc = 3.0m
2-4		Width	Bc = 31.8m
2-5		Other	WL= 14.2m, Hs= 1.4m
2-6	Connecting Channel	Height	n/a
2-7		Width	n/a
2-8		Side Slope	n/a
2-9	Type of Culvert	Concrete	
2-10	Riverbed	Material	n/a
2-11	Sediment deposition	u/s	Y, 10%
2-12		d/s	Y, 10%
2-13	Topography	u/s: ↘ ,d/s: →	
2-14	Land Use	n/a	
2-15	Structures/Houses, road	n/a	

### 3. Damaged Flood Records

3-1	(Year/Month)	(Type)	(Reason,etc.)
	n/a	n/a	n/a

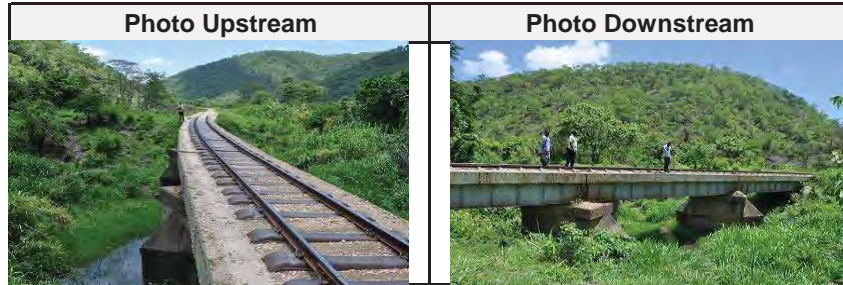

### Plan/Profile

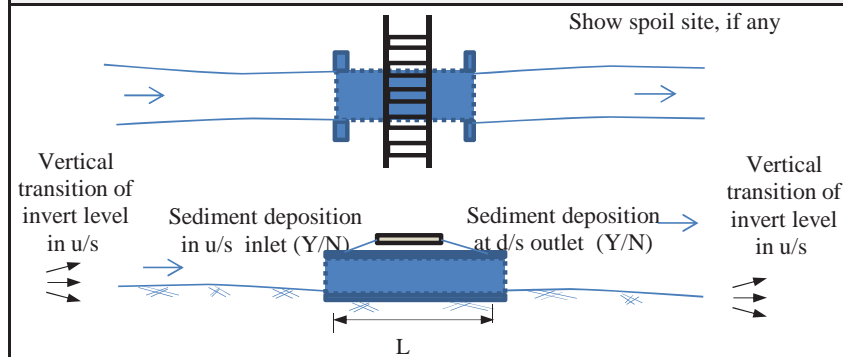

### Cross Section

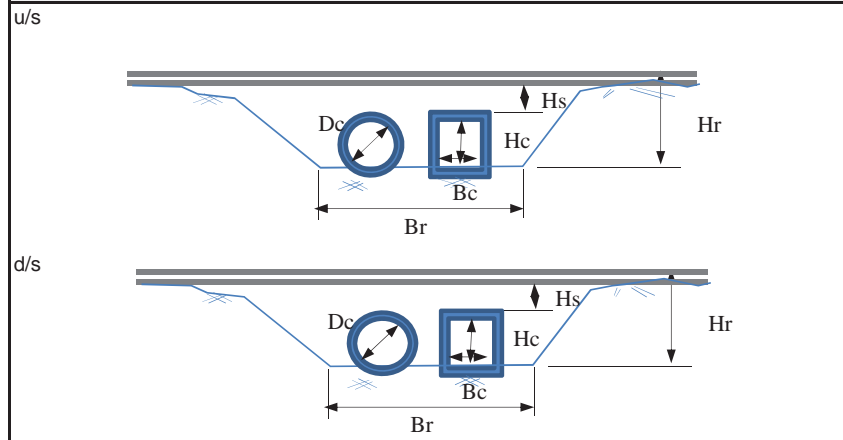



## Inventory Sheet for Culvert

**Station: at KM 292/7**      **Sheet No.: PCL292.7**

### 1. General

1-1	Name of Inspector		T.Fukuda, Mr.Kido, Mr.Philipo
1-2	Organization of Inspector		B
1-3	Date/Time of Inspection		DEC 5 2014    1220
1-4	Location	Lat	06°45'48.2"
1-5		Long	036°56'13.0"
1-6	Elevation		n/a

### 2. Characteristics of Physical Condition of Culvert

2-1	Length of Culvert		n/a
2-2	Shape of Cross Section		Circle x 1
2-3	Flow Area	Height	n/a
2-4		Width	n/a
2-5		Other	d =0.45m
2-6	Connecting Channel	Height	n/a
2-7		Width	n/a
2-8		Side Slope	n/a
2-9	Type of Culvert		Concrete
2-10	Riverbed	Material	n/a
2-11	Sediment deposition	u/s	Y, ?
2-12		d/s	Y, ?
2-13	Topography		u/s:    ,d/s    →
2-14	Land Use		n/a
2-15	Structures/Houses, road		n/a

### 3. Damaged Flood Records

3-1	(Year/Month)	(Type)	(Reason,etc.)
	n/a	n/a	n/a

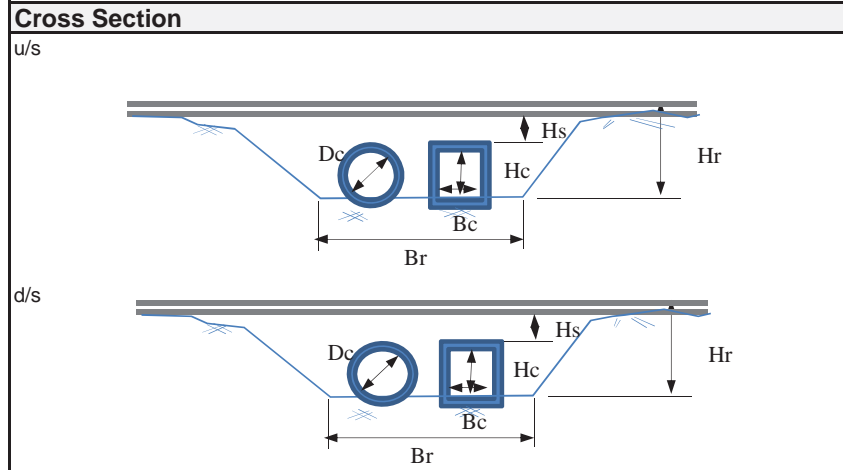
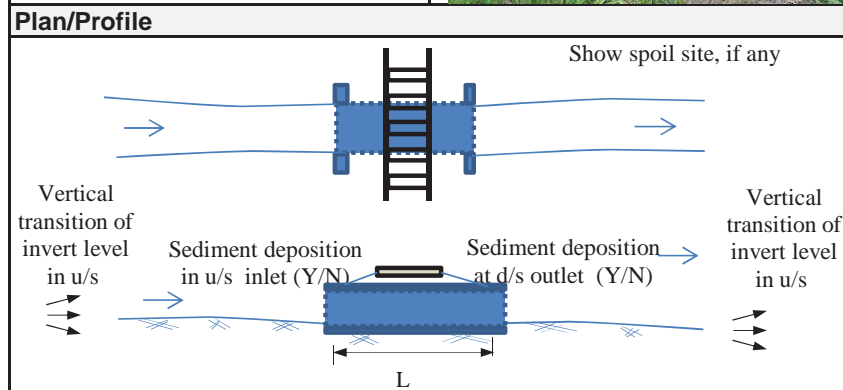
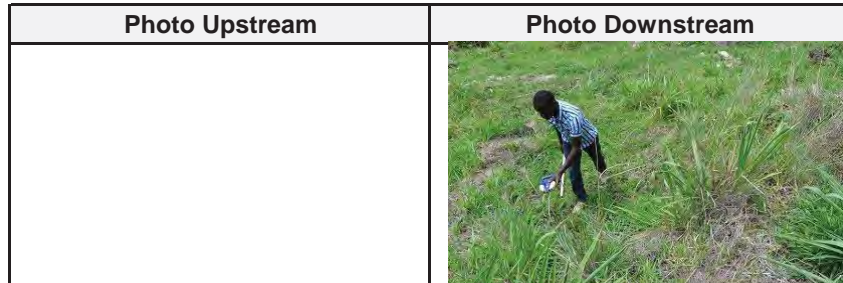

## Inventory Sheet for Culvert

**Station: at KM 292/8**      **Sheet No.: BCL292.8**

<b>1. General</b>			
1-1	Name of Inspector	T.Fukuda, Mr.Kido, Mr.Philipo	
1-2	Organization of Inspector	B	
1-3	Date/Time of Inspection	DEC 5 2014	1214
1-4	Location	Lat	06°45'46.8"
1-5		Long	036°56'11.5"
1-6	Elevation	n/a	

**2. Characteristics of Physical Condition of Culvert**

2-1	Length of Culvert	n/a	
2-2	Shape of Cross Section	Rectangular × 1	
2-3	Flow Area	Height	Hc = 0.8m
2-4		Width	Bc = 2.0m
2-5		Other	n/a
2-6	Connecting Channel	Height	n/a
2-7		Width	n/a
2-8		Side Slope	n/a
2-9	Type of Culvert	Concrete	
2-10	Riverbed	Material	n/a
2-11	Sediment deposition	u/s	Y, 60%
2-12		d/s	Y, 60%
2-13	Topography	u/s: ↘ ,d/s: ↗	
2-14	Land Use	n/a	
2-15	Structures/Houses, road	n/a	

**3. Damaged Flood Records**

3-1	(Year/Month)	(Type)	(Reason,etc.)
	n/a	n/a	n/a

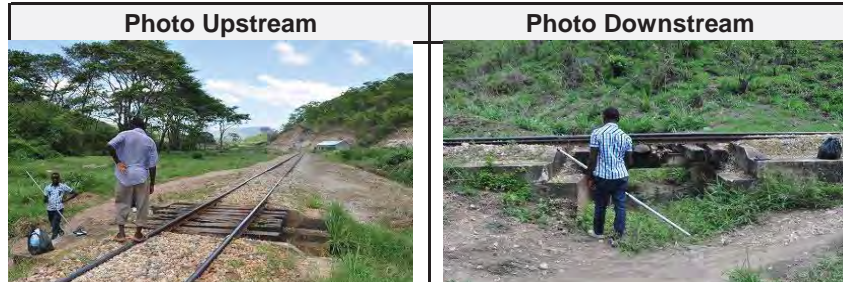

**Plan/Profile**

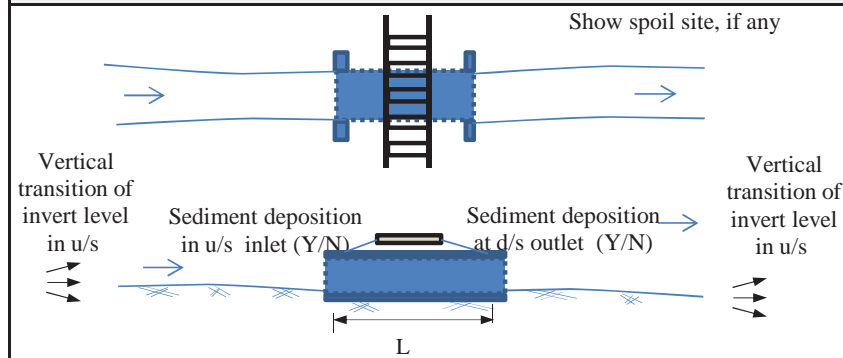

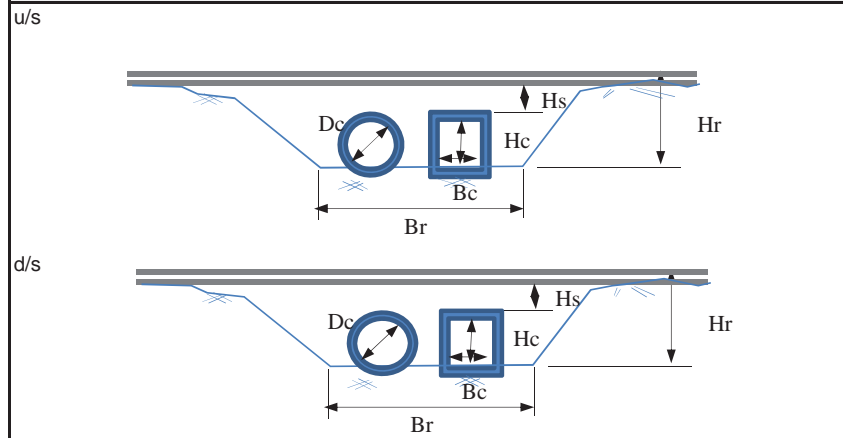

**Cross Section**



## Inventory Sheet for Culvert

<b>Station: at KM 293/0</b>		<b>Sheet No.: BCL293.0</b>	
<b>1. General</b>			
1-1	Name of Inspector	T.Fukuda, Mr.Kido, Mr.Philipo	
1-2	Organization of Inspector	B	
1-3	Date/Time of Inspection	DEC 5 2014 1207	
1-4	Location	Lat	0645'43.9"
1-5		Long	036°56'06.6"
1-6	Elevation	n/a	
<b>2. Characteristics of Physical Condition of Culvert</b>			
2-1	Length of Culvert	n/a	
2-2	Shape of Cross Section	Rectangular × 1	
2-3	Flow Area	Height	Hc = 1.8m
2-4		Width	Bc = 2.0m
2-5		Other	WL = 3.6m, Hs = 0.3m
2-6	Connecting Channel	Height	n/a
2-7		Width	n/a
2-8		Side Slope	n/a
2-9	Type of Culvert	Concrete	
2-10	Riverbed	Material	n/a
2-11	Sediment deposition	u/s	Y, 10%
2-12		d/s	Y, 10%
2-13	Topography	u/s: ↘ ,d/s: →	
2-14	Land Use	n/a	
2-15	Structures/Houses, road	n/a	
<b>3. Damaged Flood Records</b>			
3-1	(Year/Month)	(Type)	(Reason,etc.)
	2010	Flood	Overtop

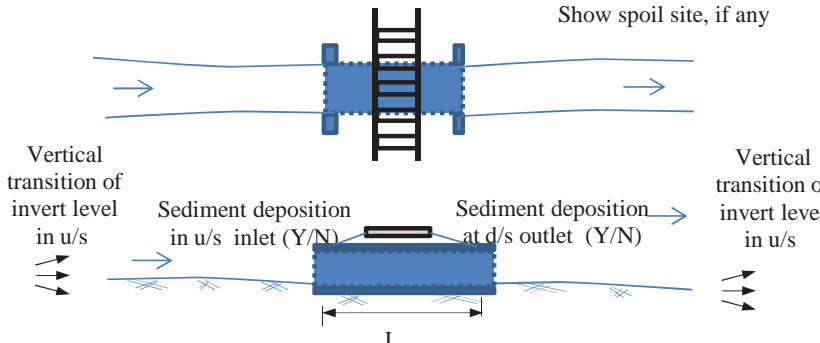
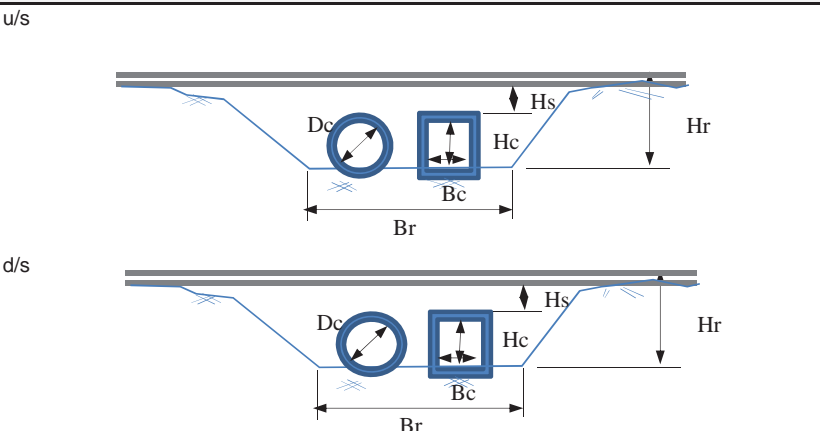
<b>Photo Upstream</b>	<b>Photo Downstream</b>
	
<b>Plan/Profile</b>	
 <p style="text-align: right;">Show spoil site, if any</p>	
<b>Cross Section</b>	
	



## Inventory Sheet for Culvert

**Station: at KM 293/1**      **Sheet No.: BCL293.1**

### 1. General

1-1	Name of Inspector	T.Fukuda, Mr.Kido, Mr.Philipo	
1-2	Organization of Inspector	B	
1-3	Date/Time of Inspection	DEC 5 2014	1200
1-4	Location	Lat	06°45'42.8"
1-5		Long	036°56'01.9"
1-6	Elevation	n/a	

### 2. Characteristics of Physical Condition of Culvert

2-1	Length of Culvert (Bridge)	L = 90.0m, B = 9.5m	
2-2	Shape of Cross Section	Rectangular × 1	
2-3	Flow Area	Height	Hc = 3.6m
2-4		Width	Bc = 90m (including 2 piers)
2-5		Other	WL = 66.0m (left), approx 1,100m(right)
2-6	Connecting Channel	Height	-
2-7		Width	-
2-8		Side Slope	-
2-9	Type of Culvert	Steel Bridge	
2-10	Riverbed	Material	n/a
2-11	Sediment deposition	u/s	Y, ?
2-12		d/s	Y, ?
2-13	Topography	u/s: → , d/s: →	
2-14	Land Use	n/a	
2-15	Structures/Houses, road	n/a	

### 3. Damaged Flood Records

3-1	(Year/Month)	(Type)	(Reason,etc.)
	2010(2008?)	Flood	Overtop, wash out of bridge
	1998	Flood	Overtop, wash out of bridge

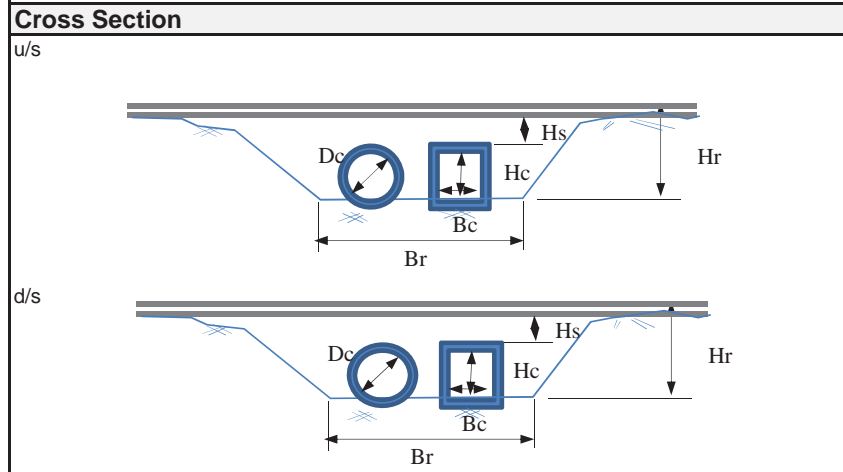
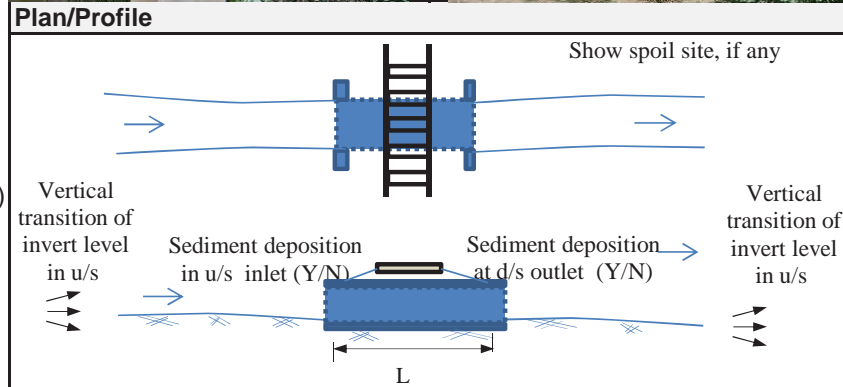
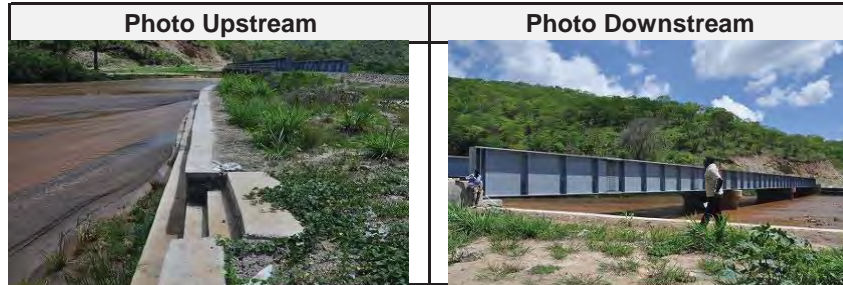

## Inventory Sheet for Culvert

**Station: at KM 293/8**      **Sheet No.: PCL293.8**

1. General			
1-1	Name of Inspector		T.Fukuda, Mr.Kido, Mr.Philipo
1-2	Organization of Inspector		B
1-3	Date/Time of Inspection		DEC 5 2014      1105
1-4	Location	Lat	06°45'38.4"
1-5		Long	036°55'38.7"
1-6	Elevation		n/a

2. Characteristics of Physical Condition of Culvert			
2-1	Length of Culvert		n/a
2-2	Shape of Cross Section		Circle x 1
2-3	Flow Area	Height	n/a
2-4		Width	n/a
2-5		Other	d = 0.6m, WL = 4.4m, Hs = 0.5m
2-6	Connecting Channel	Height	n/a
2-7		Width	n/a
2-8		Side Slope	n/a
2-9	Type of Culvert		Concrete
2-10	Riverbed	Material	n/a
2-11	Sediment deposition	u/s	Y, ?
2-12		d/s	Y, ?
2-13	Topography		u/s: → , d/s →
2-14	Land Use		n/a
2-15	Structures/Houses, road		n/a

3. Damaged Flood Records			
3-1	(Year/Month)	(Type)	(Reason,etc.)
	n/a	n/a	n/a

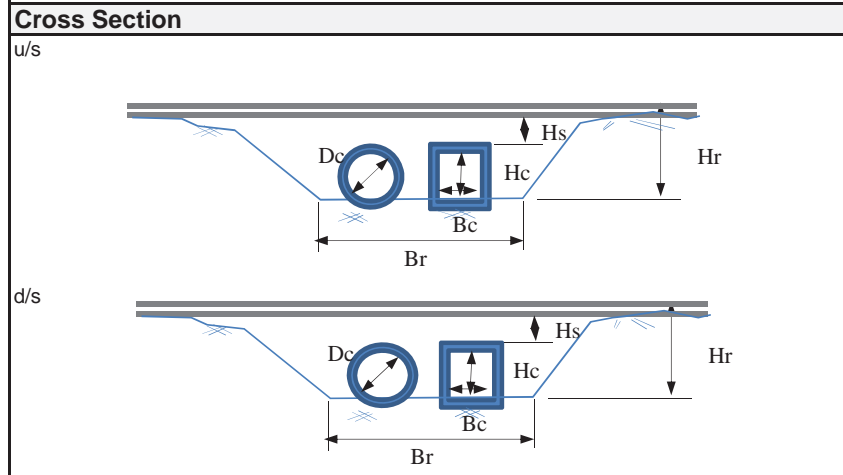
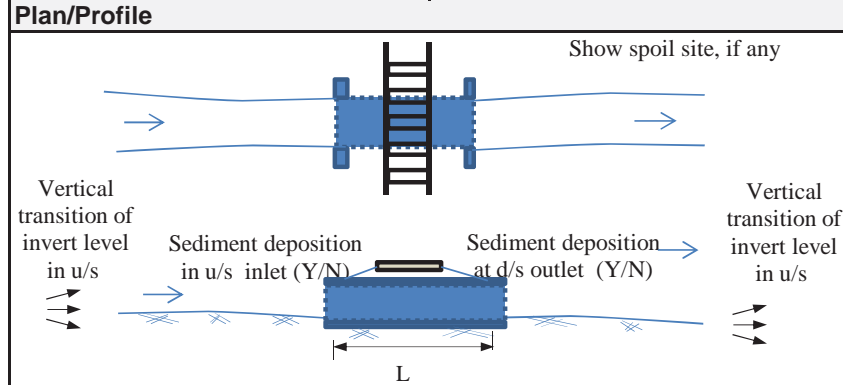
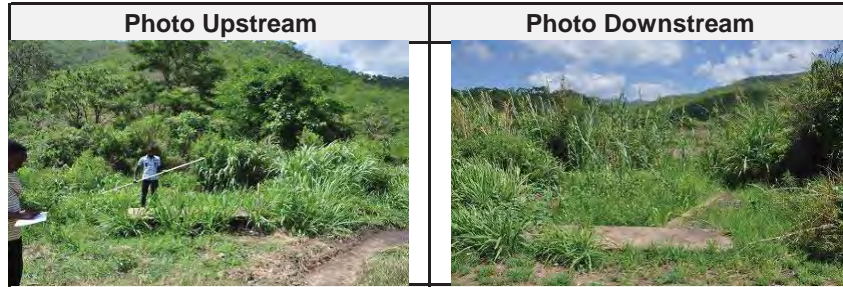

## Inventory Sheet for Culvert

<b>Station: at KM 294/2</b>		<b>Sheet No.: PCL294.2</b>	
<b>1. General</b>			
1-1	Name of Inspector	T.Fukuda, Mr.Kido, Mr.Philipo	
1-2	Organization of Inspector	B	
1-3	Date/Time of Inspection	DEC 5 2014 1045	
1-4	Location	Lat	0645'34.4"
1-5		Long	036°55'25.9"
1-6	Elevation	n/a	
<b>2. Characteristics of Physical Condition of Culvert</b>			
2-1	Length of Culvert	n/a	
2-2	Shape of Cross Section	Circle x 2	
2-3	Flow Area	Height	n/a
2-4		Width	n/a
2-5		Other	d = 0.95m, Hs = 0.9m
2-6	Connecting Channel	Height	n/a
2-7		Width	n/a
2-8		Side Slope	n/a
2-9	Type of Culvert	Concrete	
2-10	Riverbed	Material	n/a
2-11	Sediment deposition	u/s	Y, 80%
2-12		d/s	Y, 80?
2-13	Topography	u/s: → ,d/s →	
2-14	Land Use	n/a	
2-15	Structures/Houses, road	n/a	
<b>3. Damaged Flood Records</b>			
3-1	(Year/Month)	(Type)	(Reason,etc.)
	2010?	washed out	overtop

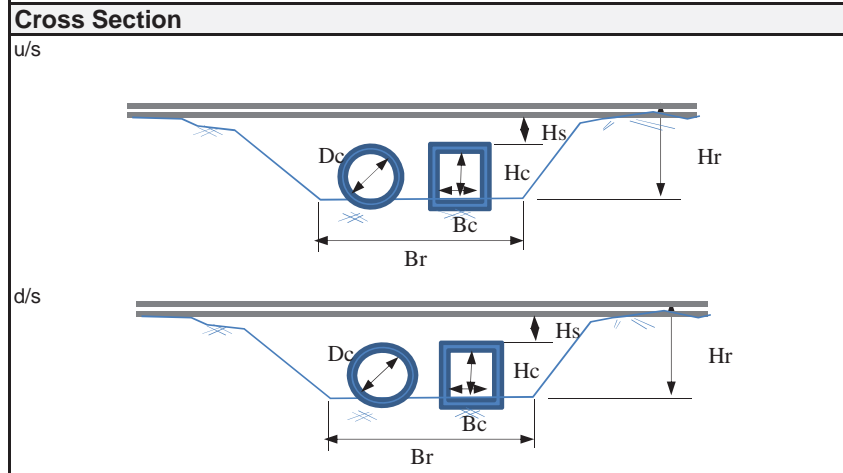
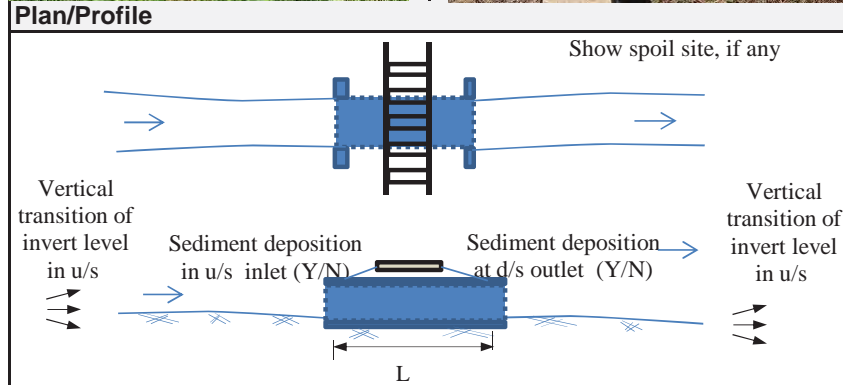
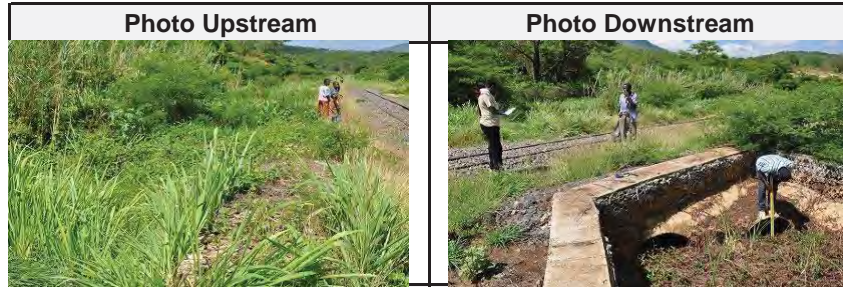

## Inventory Sheet for Culvert

**Station: at KM 294/5**      **Sheet No.: BCL294.5**

### 1. General

1-1	Name of Inspector	T.Fukuda, Mr.Kido, Mr.Philipo	
1-2	Organization of Inspector	B	
1-3	Date/Time of Inspection	DEC 5 2014	1025
1-4	Location	Lat	06°45'31.1"
1-5		Long	036°55'14.7"
1-6	Elevation	n/a	

### 2. Characteristics of Physical Condition of Culvert

2-1	Length of Culvert	n/a	
2-2	Shape of Cross Section	Rectangular ×1	
2-3	Flow Area	Height	Hc = 1.1m
2-4		Width	Bc = 2.0m
2-5		Other	WL = 1.6m, Hs= 0.45m
2-6	Connecting Channel	Height	n/a
2-7		Width	n/a
2-8		Side Slope	n/a
2-9	Type of Culvert	Concrete	
2-10	Riverbed	Material	n/a
2-11	Sediment deposition	u/s	Y, 45%
2-12		d/s	Y, 45%
2-13	Topography	u/s: → ,d/s →	
2-14	Land Use	n/a	
2-15	Structures/Houses, road	n/a	

### 3. Damaged Flood Records

3-1	(Year/Month)	(Type)	(Reason,etc.)
	n/a	n/a	n/a

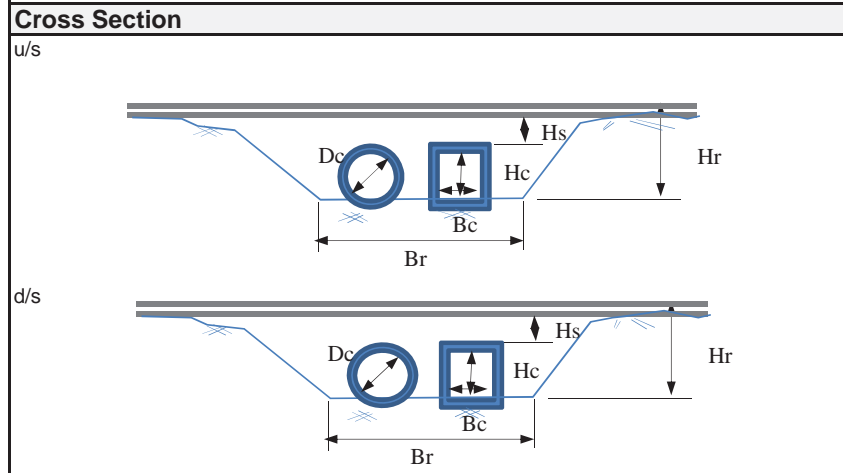
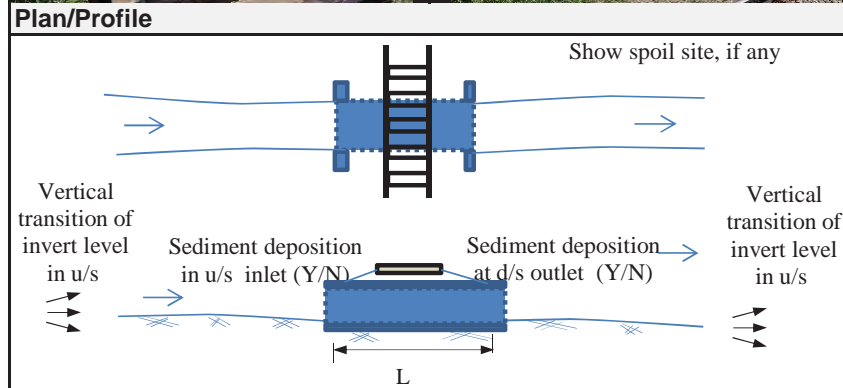
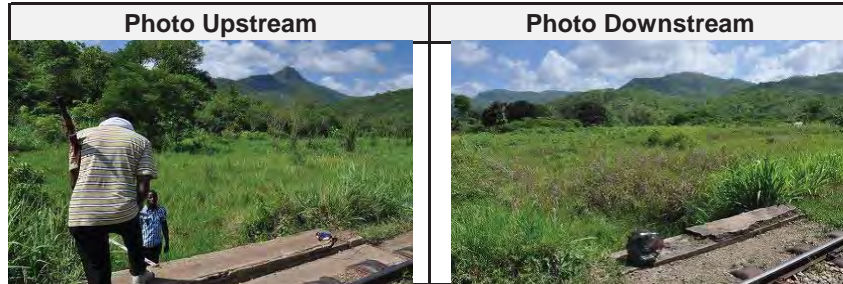

## Inventory Sheet for Culvert

**Station: at KM 295.1**      **Sheet No.: BCL 295.1**

### 1. General

1-1	Name of Inspector	Mr Motoki/ Semaya/ France	
1-2	Organization of Inspector	River Group B	
1-3	Date/Time of Inspection	05/12/2014 10:20 - 10:25	
1-4	Location	Lat	06° 45' 19.9"
1-5		Long	036° 55' 05.7"
1-6	Elevation	528m	

### 2. Characteristics of Physical Condition of Culvert

2-1	Length of Culvert	3.6m	
2-2	Shape of Cross Section	Square: Rectangular: (2) Circle:	
2-3	Flow Area	Height	0.9m, 0.9m
2-4		Widdth	2m 2m
2-5	Connecting Channel	Other	
2-6		Height	
2-7		Widdth	9.0m
2-8	Side Slope		
2-9	Type of Culvert	Concrete	
2-10	Riverbed	Material	silt sand
2-11	Sediment deposition	u/s	litle
2-12		d/s	litle
2-13	Topography	u/s:  , d/s:	
2-14	Land Use		
2-15	Structures/Houses, road		

### 3. Damaged Flood Records

3-1	(Year/Month)	(Type)	(Reason,etc.)

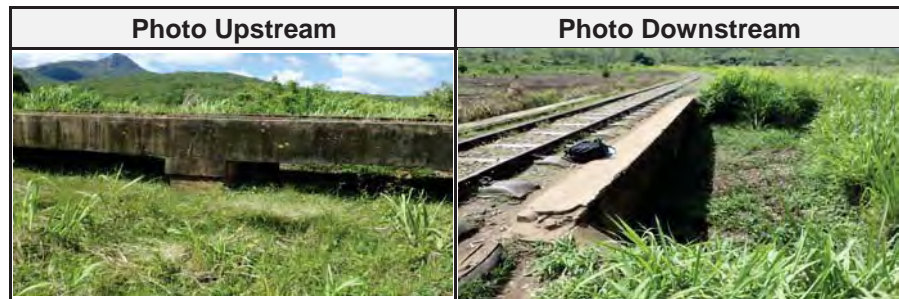

### Plan/Profile

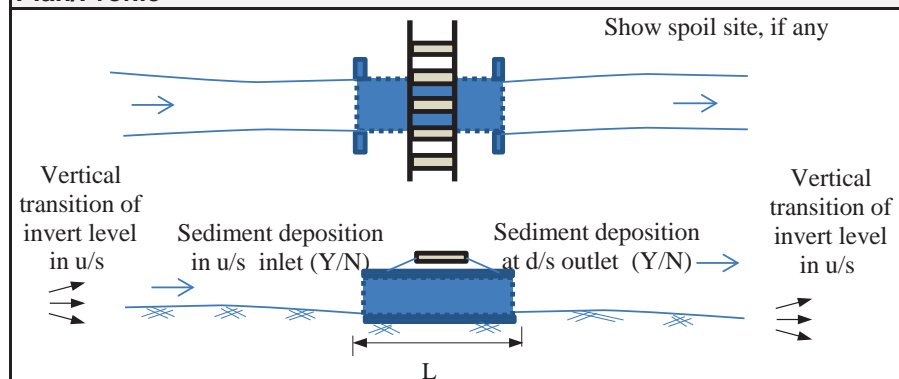

### Cross Section

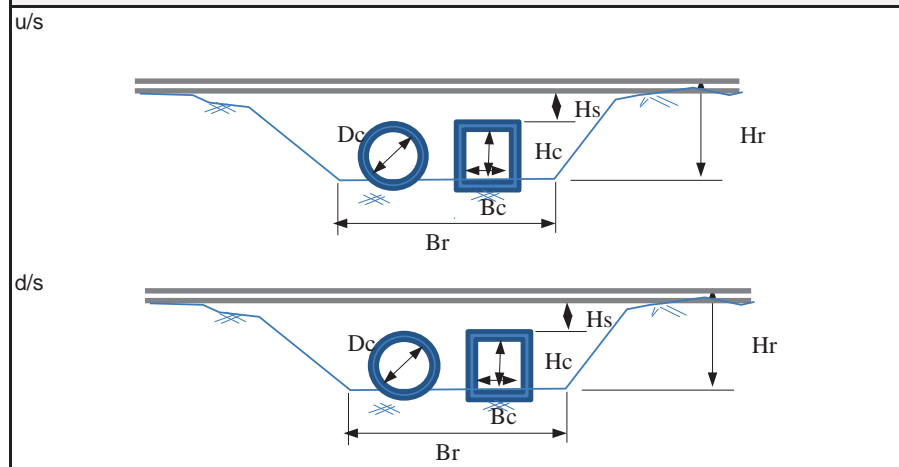



## Inventory Sheet for Culvert

**Station: at KM 295.3**      **Sheet No.: BCL 295.3**

### 1. General

1-1	Name of Inspector	Mr Motoki/ Semaya/ France	
1-2	Organization of Inspector	River Group B	
1-3	Date/Time of Inspection	05/12/2014 10:28 - 10:35	
1-4	Location	Lat	06° 45' 11.8"
1-5		Long	036° 55' 05.3"
1-6	Elevation	530m	

### 2. Characteristics of Physical Condition of Culvert

2-1	Length of Culvert	3.6m	
2-2	Shape of Cross Section	Square: <u>Rectangular: (1)</u> Circle:	
2-3	Flow Area	Height	1.3m
2-4		Widdth	2.0m
2-5	Connecting Channel	Other	
2-6		Height	
2-7		Widdth	
2-8	Side Slope		
2-9	Type of Culvert	Concrete	
2-10	Riverbed	Material	silt sand
2-11	Sediment deposition	u/s	little
2-12		d/s	little
2-13	Topography	u/s:  , d/s:	
2-14	Land Use		
2-15	Structures/Houses, road		

### 3. Damaged Flood Records

3-1	(Year/Month)	(Type)	(Reason, etc.)

Photo Upstream	Photo Downstream
----------------	------------------



### Plan/Profile

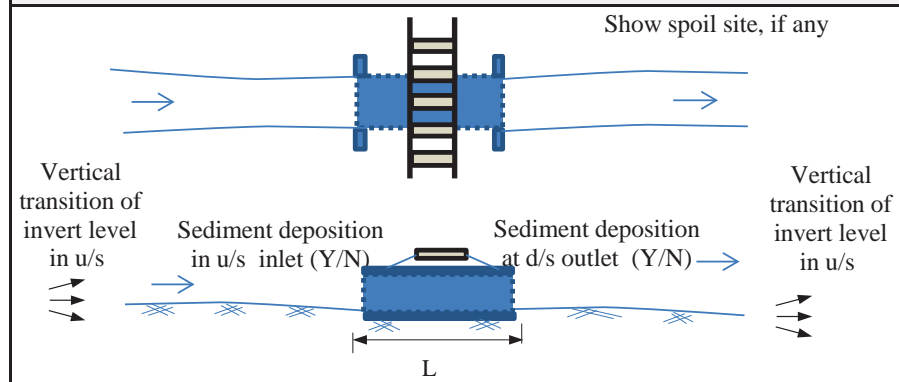

### Cross Section

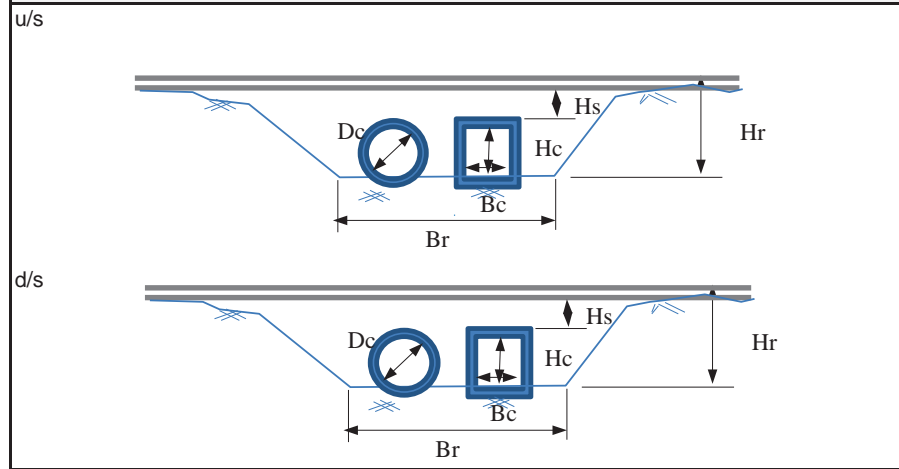

## Inventory Sheet for Culvert

**Station: at KM 295.7**      **Sheet No.: BCL 295.7**

### 1. General

1-1	Name of Inspector		Mr Motoki/ Semaya/ France
1-2	Organization of Inspector		River Group B
1-3	Date/Time of Inspection		05/12/2014 10:38 - 10:45
1-4	Location	Lat	06° 45' 59.5"
1-5		Long	036° 55' 04.6"
1-6	Elevation		531m

### 2. Characteristics of Physical Condition of Culvert

2-1	Length of Culvert		8.0m
2-2	Shape of Cross Section		Square: Rectangular: Circle: (1)
2-3	Flow Area	Height	0.9m
2-4		Widdth	1.7m
2-5	Other		diameter 1.15m
2-6	Connecting Channel	Height	
2-7		Widdth	
2-8		Side Slope	
2-9	Type of Culvert		Concrete
2-10	Riverbed	Material	silt sand
2-11	Sediment deposition	u/s	little
2-12		d/s	little
2-13	Topography		u/s:  ,d/s:
2-14	Land Use		Bush      Agri field
2-15	Structures/Houses, road		

### 3. Damaged Flood Records

3-1	(Year/Month)	(Type)	(Reason,etc.)



### Plan/Profile

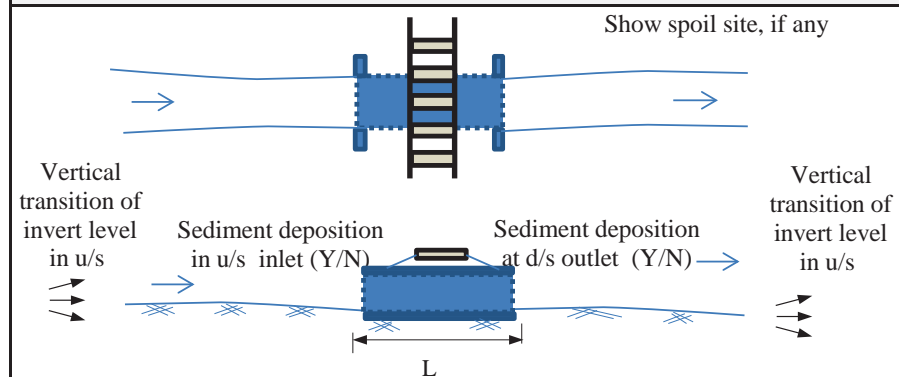

### Cross Section

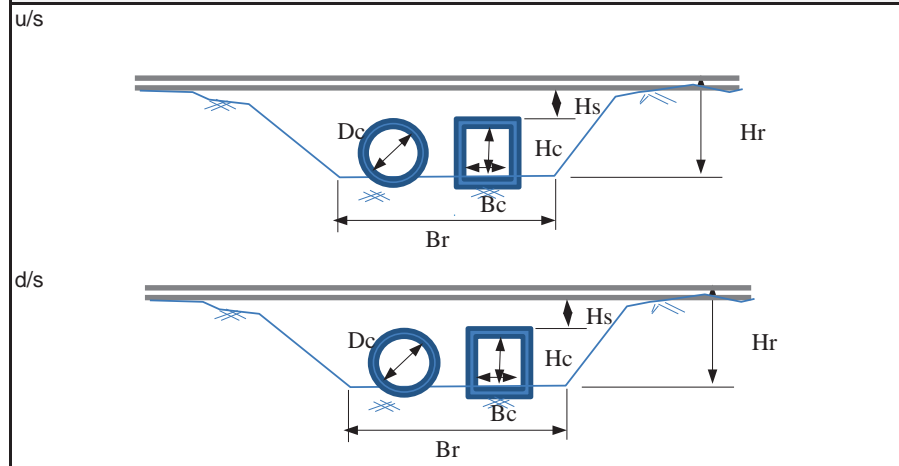

## Inventory Sheet for Culvert

**Station: at KM 295.9**      **Sheet No.: BCL 295.9**

### 1. General

1-1	Name of Inspector	Mr Motoki/ Semaya/ France	
1-2	Organization of Inspector	River Group B	
1-3	Date/Time of Inspection	05/12/2014 10:49 - 10:55	
1-4	Location	Lat	06° 44' 51.2"
1-5		Long	036° 55' 01.2"
1-6	Elevation	534m	

### 2. Characteristics of Physical Condition of Culvert

2-1	Length of Culvert	3.6m	
2-2	Shape of Cross Section	Square: Rectangular: (1) Circle:	
2-3	Flow Area	Height	0.44m
2-4		Widdth	0.9m
2-5	Connecting Channel	Other	
2-6		Height	
2-7		Widdth	
2-8	Side Slope		
2-9	Type of Culvert	Concrete	
2-10	Riverbed	Material	silt sand
2-11	Sediment deposition	u/s	Midium
2-12		d/s	Midium
2-13	Topography	u/s:  , d/s:	
2-14	Land Use		
2-15	Structures/Houses, road		

### 3. Damaged Flood Records

3-1	(Year/Month)	(Type)	(Reason, etc.)

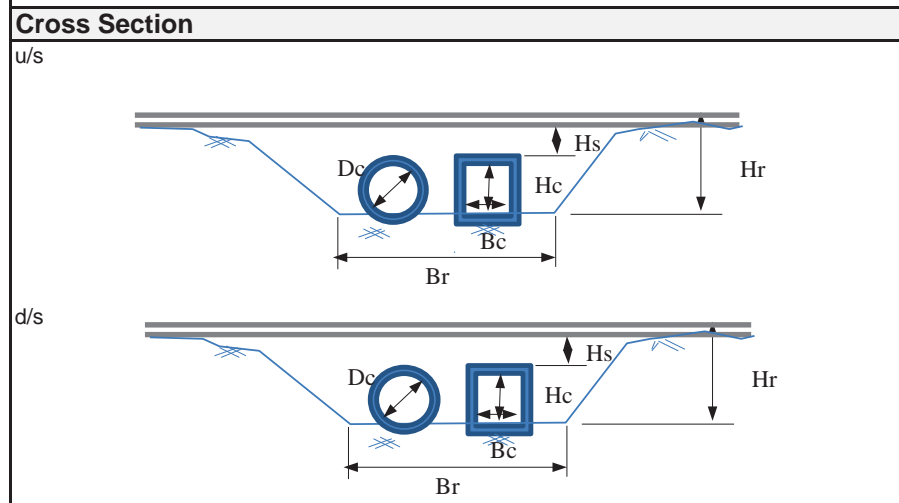
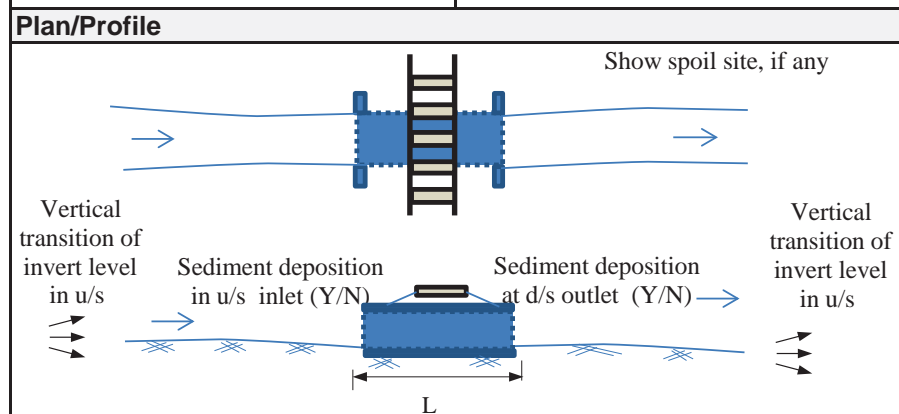
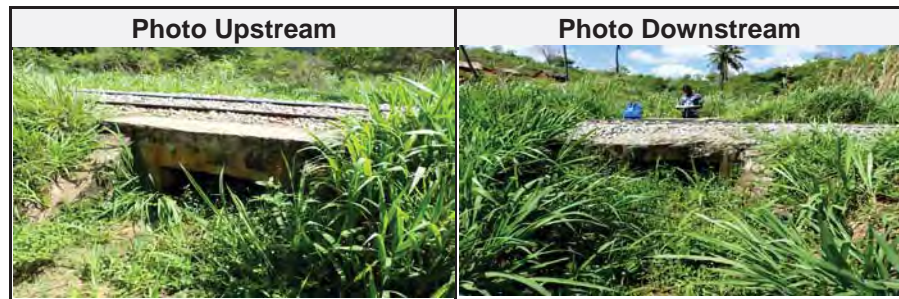

## Inventory Sheet for Culvert

**Station: at KM**    296.4                      **Sheet No.:** BCL 296.4

### 1. General

1-1	Name of Inspector	Mr Motoki/ Semaya/ France	
1-2	Organization of Inspector	River Group B	
1-3	Date/Time of Inspection	05/12/2014 11:15 - 11:20	
1-4	Location	Lat	06° 44' 40.5"
1-5		Long	036° 54' 51.5"
1-6	Elevation	538m	

### 2. Characteristics of Physical Condition of Culvert

2-1	Length of Culvert	3.55m	
2-2	Shape of Cross Section	Square: <u>Rectangular: (1)</u> Circle:	
2-3	Flow Area	Height	0.8mm
2-4		Widdth	0.92m
2-5	Connecting Channel	Other	
2-6		Height	
2-7		Widdth	
2-8	Side Slope		
2-9	Type of Culvert	Concrete	
2-10	Riverbed	Material	silt sand
2-11	Sediment deposition	u/s	Little
2-12		d/s	Little
2-13	Topography	u/s:  , d/s:	
2-14	Land Use		
2-15	Structures/Houses, road		

### 3. Damaged Flood Records

3-1	(Year/Month)	(Type)	(Reason, etc.)

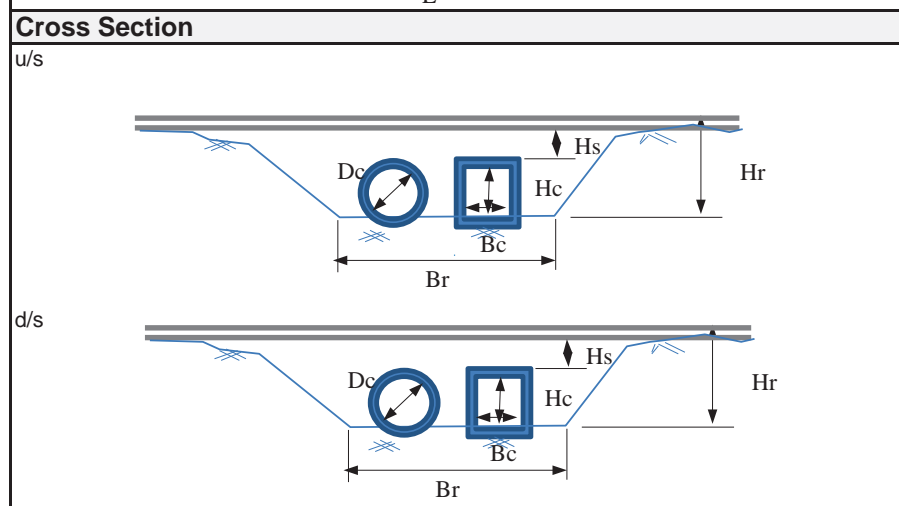
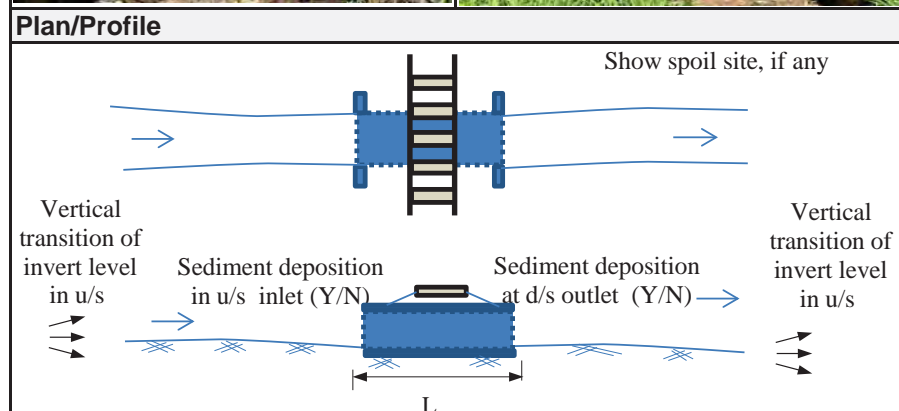
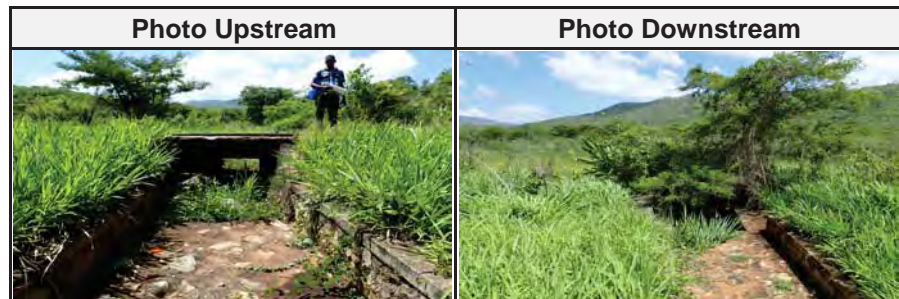



## Inventory Sheet for Culvert

**Station: at KM**    **296.7**                      **Sheet No.: BCL 296.7**

### 1. General

1-1	Name of Inspector	Mr Motoki/ Semaya/ France	
1-2	Organization of Inspector	River Group B	
1-3	Date/Time of Inspection	05/12/2014 11:23 - 11:28	
1-4	Location	Lat	06° 44' 37.2"
1-5		Long	036° 54' 42.2"
1-6	Elevation	540m	

### 2. Characteristics of Physical Condition of Culvert

2-1	Length of Culvert	3.6m	
2-2	Shape of Cross Section	Square: <u>Rectangular: (1)</u> Circle:	
2-3	Flow Area	Height	1.0m
2-4		Widdth	0.93m
2-5	Connecting Channel	Other	
2-6		Height	
2-7		Widdth	
2-8	Side Slope		
2-9	Type of Culvert	Concrete	
2-10	Riverbed	Material	silt sand
2-11	Sediment deposition	u/s	Little
2-12		d/s	Little
2-13	Topography	u/s:  , d/s:	
2-14	Land Use		
2-15	Structures/Houses, road		

### 3. Damaged Flood Records

3-1	(Year/Month)	(Type)	(Reason, etc.)

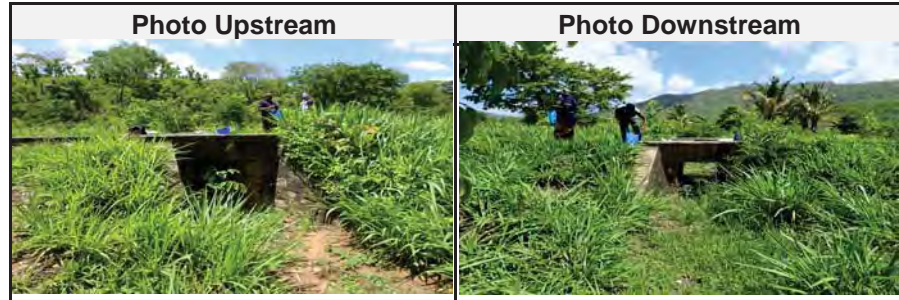

### Plan/Profile

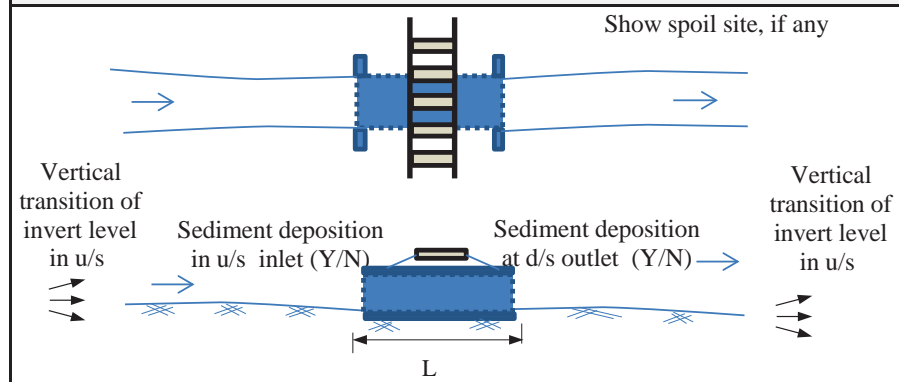

### Cross Section

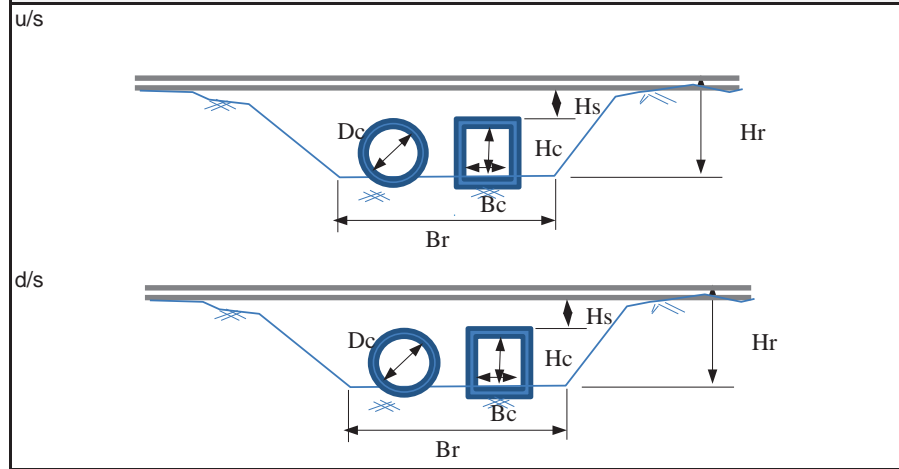

F-45



## Inventory Sheet for Culvert

**Station: at KM**    297.1                      **Sheet No.:** BCL 297.1

### 1. General

1-1	Name of Inspector	Mr Motoki/ Semaya/ France	
1-2	Organization of Inspector	River Group B	
1-3	Date/Time of Inspection	05/12/2014 11:40 - 11:45	
1-4	Location	Lat	06° 44' 35.3"
1-5		Long	036° 54' 29.6"
1-6	Elevation	535m	

### 2. Characteristics of Physical Condition of Culvert

2-1	Length of Culvert	3.65m	
2-2	Shape of Cross Section	Square: <u>Rectangular: (1)</u> Circle:	
2-3	Flow Area	Height	0.8m
2-4		Widdth	1.93m
2-5	Connecting Channel	Other	
2-6		Height	
2-7		Widdth	
2-8	Side Slope		
2-9	Type of Culvert	Concrete	
2-10	Riverbed	Material	silt sand
2-11	Sediment deposition	u/s	Midium
2-12		d/s	midium
2-13	Topography	u/s:	, d/s:
2-14	Land Use		
2-15	Structures/Houses, road		

### 3. Damaged Flood Records

3-1	(Year/Month)	(Type)	(Reason, etc.)

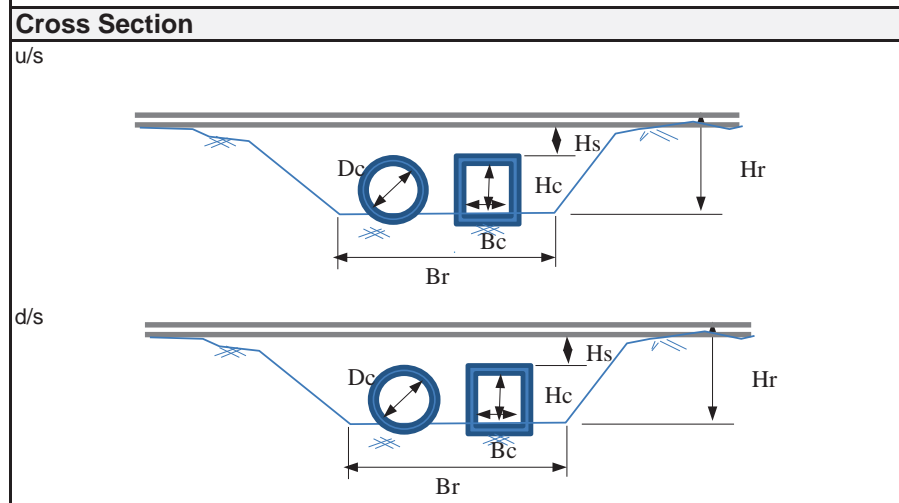
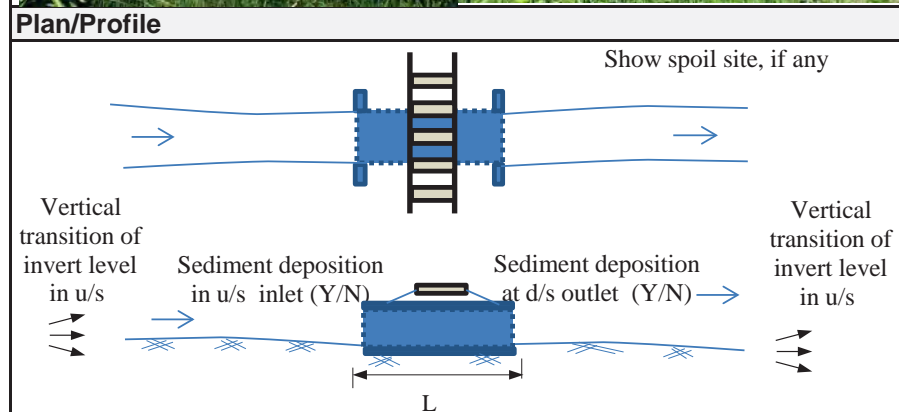
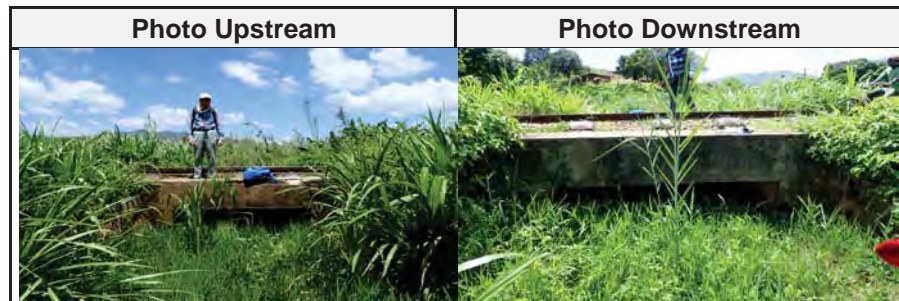

## Inventory Sheet for Culvert

**Station: at KM**    297.6            **Sheet No.:** BCL 297.6

### 1. General

1-1	Name of Inspector	Mr Motoki/ Semaya/ France	
1-2	Organization of Inspector	River Group B	
1-3	Date/Time of Inspection	05/12/2014 12:20 - 12:25	
1-4	Location	Lat	06° 44' 40.7"
1-5		Long	036° 54' 15.9"
1-6	Elevation	546m	

### 2. Characteristics of Physical Condition of Culvert

2-1	Length of Culvert	3.6m	
2-2	Shape of Cross Section	Square: <u>Rectangular: (1)</u> Circle:	
2-3	Flow Area	Height	1.2m
2-4		Widdth	0.9m
2-5	Connecting Channel	Other	
2-6		Height	
2-7		Widdth	
2-8	Side Slope		
2-9	Type of Culvert	Concrete	
2-10	Riverbed	Material	silt sand
2-11	Sediment deposition	u/s	Little
2-12		d/s	Little
2-13	Topography	u/s: $\Rightarrow$ , d/s: $\Rightarrow$	
2-14	Land Use		
2-15	Structures/Houses, road		

### 3. Damaged Flood Records

3-1	(Year/Month)	(Type)	(Reason, etc.)

Photo Upstream	Photo Downstream

### Plan/Profile

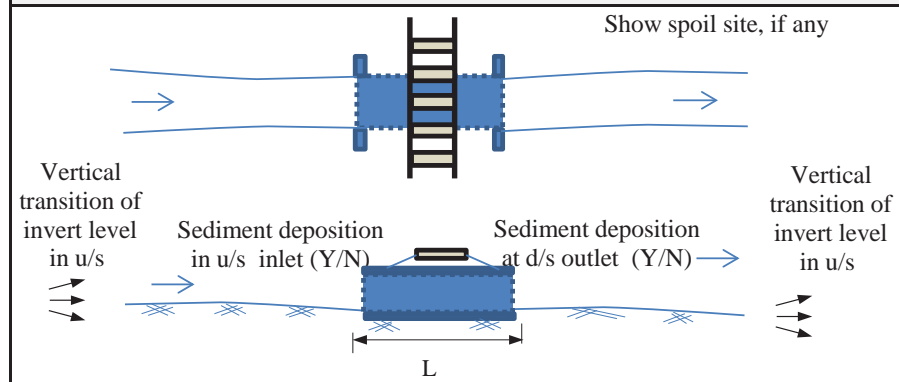

### Cross Section

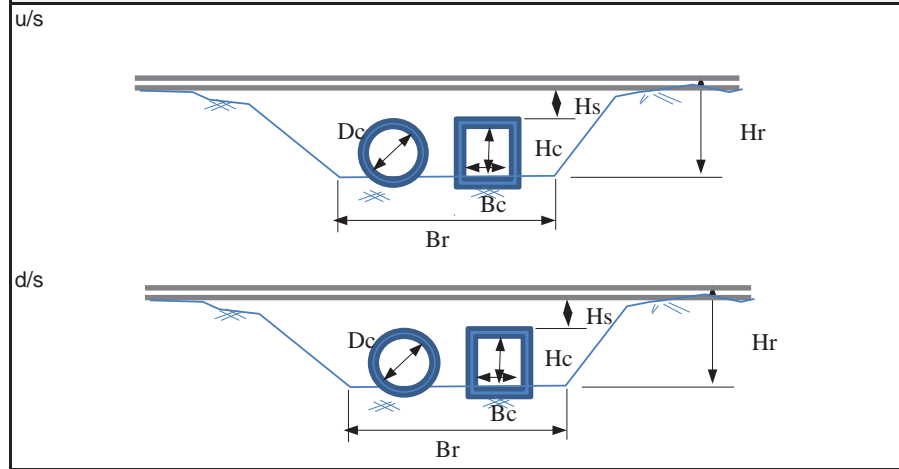

F-47

## Inventory Sheet for Culvert

**Station: at KM**    **299.3**                      **Sheet No.: PCL 299.3**

### 1. General

1-1	Name of Inspector	Mr Motoki/ Semaya/ France	
1-2	Organization of Inspector	River Group B	
1-3	Date/Time of Inspection	05/12/2014 13:56 - 14:05	
1-4	Location	Lat	06° 44' 34.6"
1-5		Long	036° 53' 22.7"
1-6	Elevation	549m	

### 2. Characteristics of Physical Condition of Culvert

2-1	Length of Culvert	3.85m	
2-2	Shape of Cross Section	Square: Rectangular: Circle: (4)	
2-3	Flow Area	Height	0.38
2-4		Widdth	6.4m
2-5	Connecting Channel	Other	Diameter 1.1m
2-6		Height	
2-7	Channel	Widdth	
2-8		Side Slope	
2-9	Type of Culvert	Concrete	
2-10	Riverbed	Material	silt sand
2-11	Sediment deposition	u/s	Heavy
2-12		d/s	Heavy
2-13	Topography	u/s: $\Rightarrow$ , d/s: $\Rightarrow$	
2-14	Land Use		
2-15	Structures/Houses, road		

### 3. Damaged Flood Records

3-1	(Year/Month)	(Type)	(Reason, etc.)

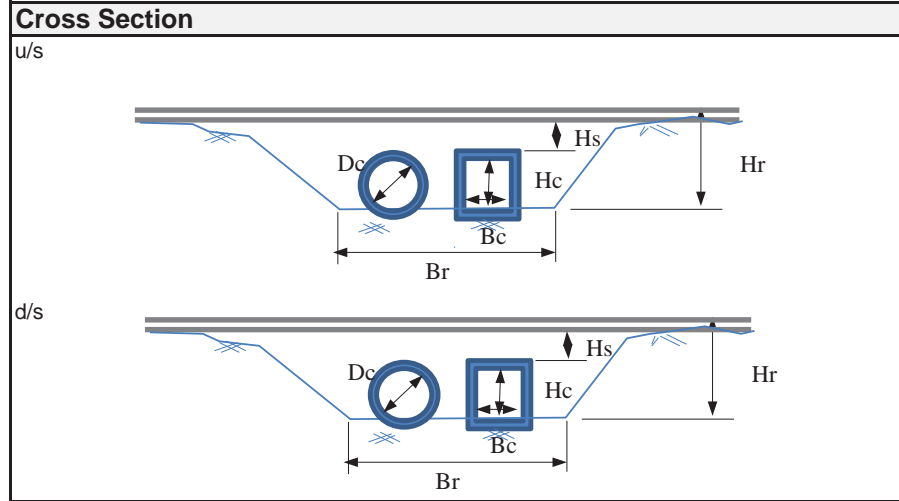
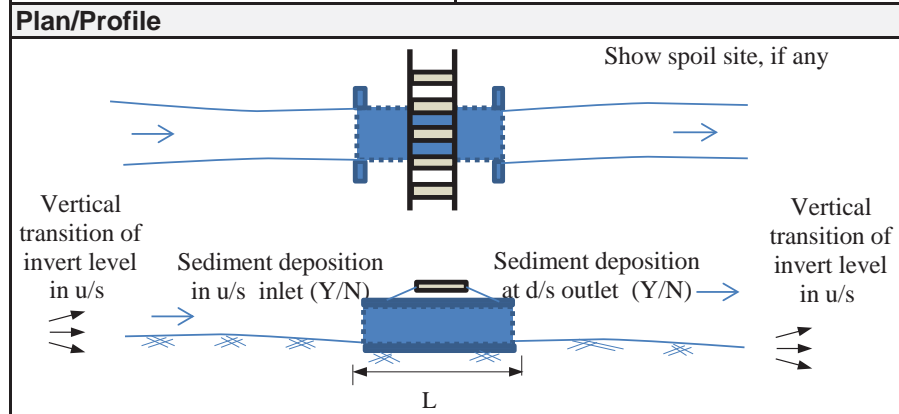
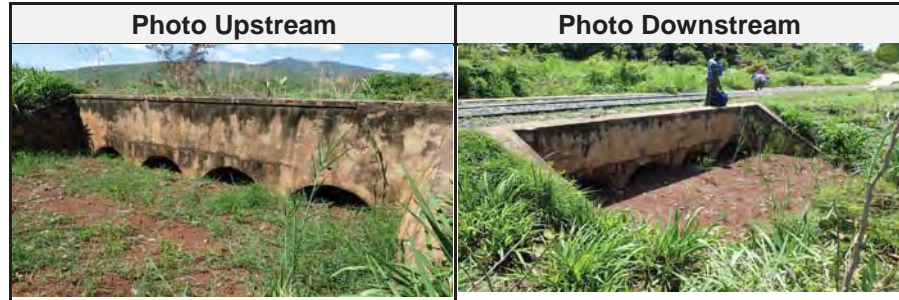

## Inventory Sheet for Culvert

**Station: at KM 299.7**      **Sheet No.: PCL 299.7**

### 1. General

1-1	Name of Inspector		Mr Motoki/ Semaya/ France
1-2	Organization of Inspector		River Group B
1-3	Date/Time of Inspection		05/12/2014 14:33 - 14:40
1-4	Location	Lat	06° 44' 34.3"
1-5		Long	036° 53' 09.8"
1-6	Elevation		549m

### 2. Characteristics of Physical Condition of Culvert

2-1	Length of Culvert		10.60m
2-2	Shape of Cross Section		Square: Rectangular: Circle: (3)
2-3	Flow Area	Height	0.5m
2-4		Widdth	5.5m
2-5	Connecting Channel	Other	Diameter 1.17m
2-6		Height	
2-7		Widdth	
2-8	Side Slope		
2-9		Type of Culvert	Concrete
2-10	Riverbed	Material	silt sand
2-11	Sediment deposition	u/s	Heavy
2-12		d/s	Heavy
2-13	Topography		u/s:  , d/s:
2-14	Land Use		
2-15	Structures/Houses, road		

### 3. Damaged Flood Records

3-1	(Year/Month)	(Type)	(Reason, etc.)

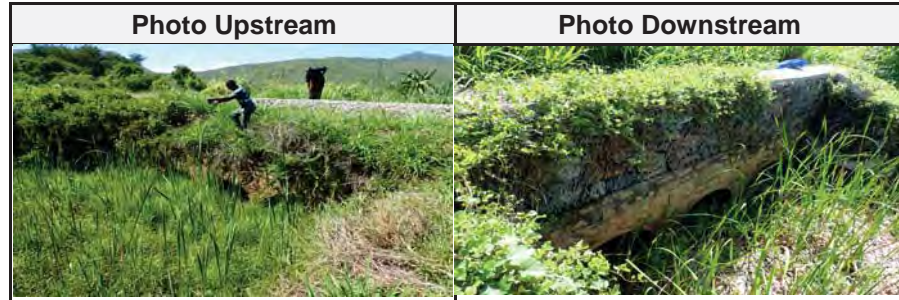

### Plan/Profile

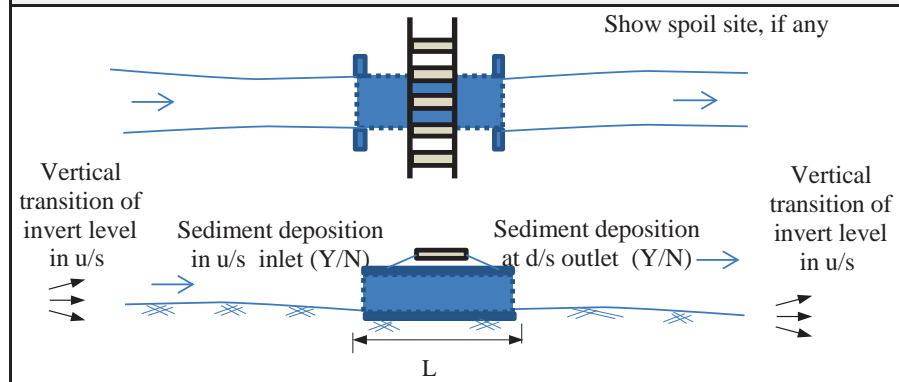

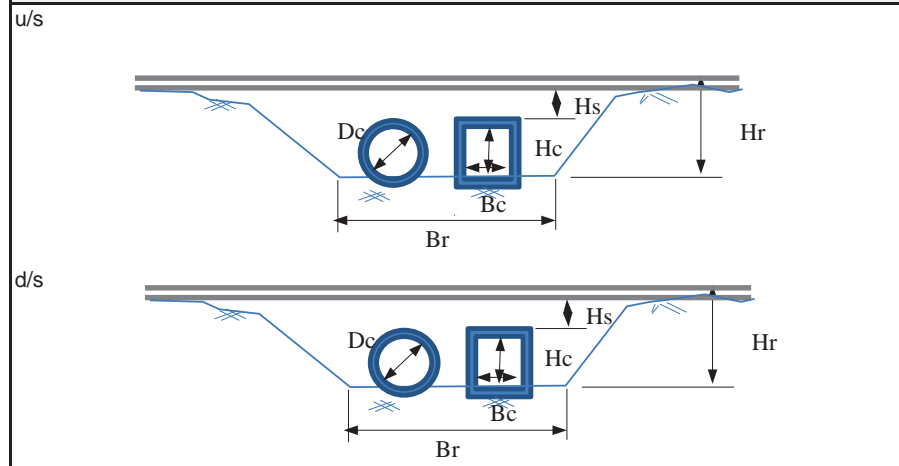

### Cross Section



## Inventory Sheet for Culvert

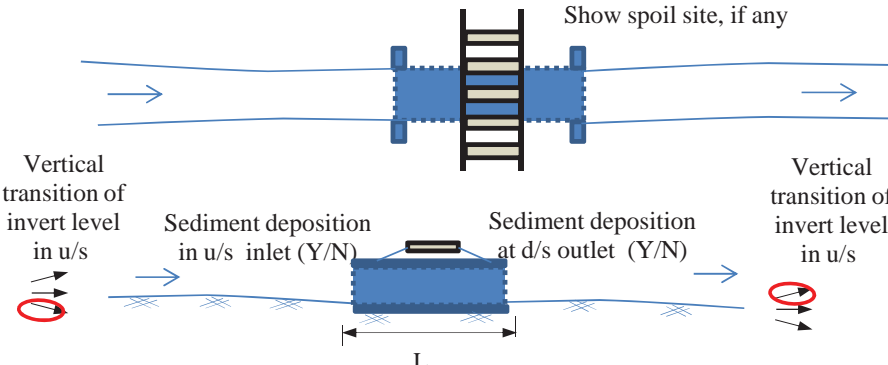
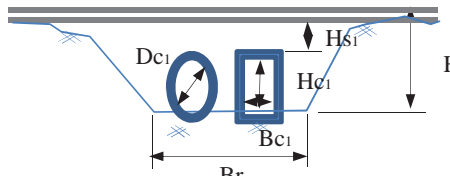
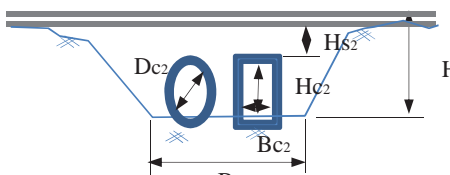

<b>Station: at KM 300.1</b>		<b>Sheet No.: PCL 300.1</b>	
<b>1. General</b>			
1-1	Name of Inspector	T. Kawaguchi , Hussein , Abiud	
1-2	Organization of Inspector	JICA Study Team	
1-3	Date/Time of Inspection	2014/4/12	
1-4	Location	Lat	06° 44' 30" 94'''
1-5		Long	036° 52' 54" 76'''
1-6	Elevation		
<b>2. Characteristics of Physical Condition of Culvert</b>			
2-1	Length of Culvert	5.0 m	
2-2	Shape of Cross Section	Square: Rectangular: Circle: (1)	
2-3	Flow Area	Height	Hc1 = 0.18 m , Hc2 = 0.5 m
2-4		Width	Dc1 = 0.9 m , Dc2 = 0.9 m
2-5		Other	Hs1 = 2.2 m , Hs2 = 2.4 m
2-6	Connecting Channel	Height	
2-7		Width	
2-8		Side Slope	
2-9	Type of Culvert	Concrete	
2-10	Riverbed	Material	Silty sand
2-11	Sediment deposition	u/s	Heavy ( 90% rate)
2-12		d/s	Heavy ( 80% rate)
2-13	Topography	u/s: , d/s:	
2-14	Land Use		
2-15	Structures/Houses, road		
<b>3. Damaged Flood Records</b>			
3-1	(Year/Month)	(Type)	(Reason, etc.)

<b>Photo Upstream</b>	<b>Photo Downstream</b>
	
<b>Plan/Profile</b>	
 <p style="text-align: center;">Show spoil site, if any</p> <p style="text-align: center;">Vertical transition of invert level in u/s      Sediment deposition in u/s inlet (Y/N)      Sediment deposition at d/s outlet (Y/N)      Vertical transition of invert level in u/s</p> <p style="text-align: center;">L</p>	
<b>Cross Section</b>	
u/s	
d/s	



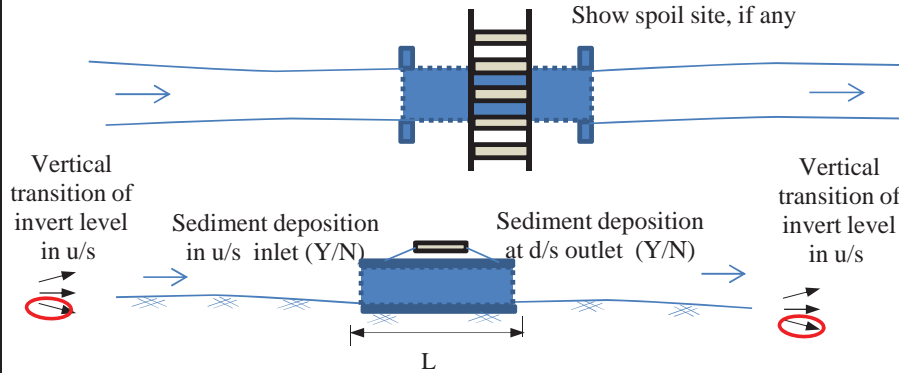
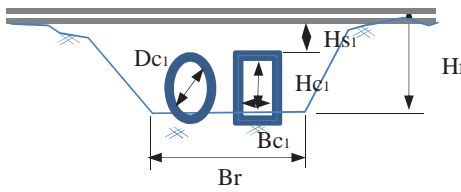
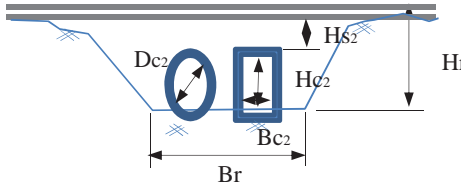

## Inventory Sheet for Culvert

<b>Station: at KM 300.2</b>		<b>Sheet No.: PCL 300.2</b>	
<b>1. General</b>			
1-1	Name of Inspector	T. Kawaguchi , Hussein , Abiud	
1-2	Organization of Inspector	JICA Study Team	
1-3	Date/Time of Inspection	2014/4/12	
1-4	Location	Lat	06° 44' 31" 17"
1-5		Long	036° 52' 51" 08"
1-6	Elevation		
<b>2. Characteristics of Physical Condition of Culvert</b>			
2-1	Length of Culvert	6.0 m	
2-2	Shape of Cross Section	Square: Rectangular: Circle:(1)	
2-3	Flow Area	Height	Hc1 = 1.1 m , Hc2 = 0.9 m
2-4		Width	Dc1 = 1.2 m , Dc2 = 1.2 m
2-5		Other	Hs1 = 1.9 m , Hs2 = 1.9 m
2-6	Connecting Channel	Height	
2-7		Width	
2-8		Side Slope	
2-9	Type of Culvert	Concrete	
2-10	Riverbed	Material	Silty sand
2-11	Sediment deposition	u/s	Light ( 10% rate)
2-12		d/s	Light ( 10% rate)
2-13	Topography	u/s:  , d/s:	
2-14	Land Use		
2-15	Structures/Houses, road		
<b>3. Damaged Flood Records</b>			
3-1	(Year/Month)	(Type)	(Reason,etc.)

<b>Photo Upstream</b>	<b>Photo Downstream</b>
	
<b>Plan/Profile</b>	
	
<b>Cross Section</b>	
u/s	
d/s	

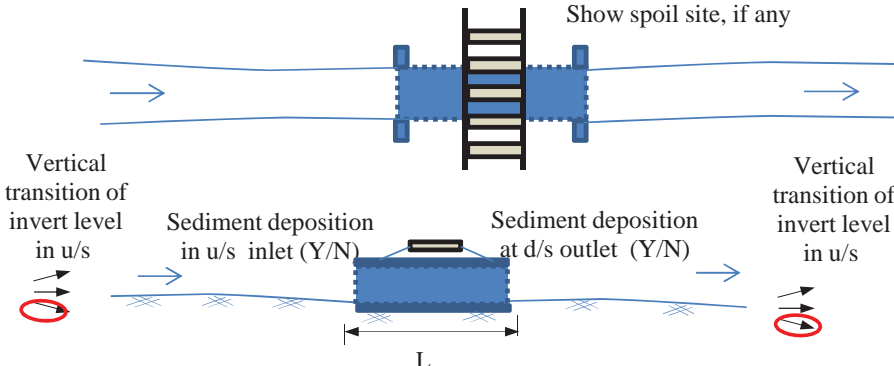
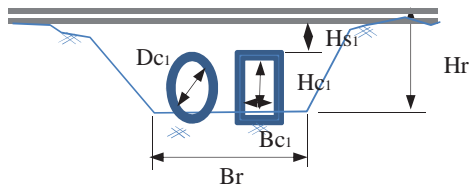
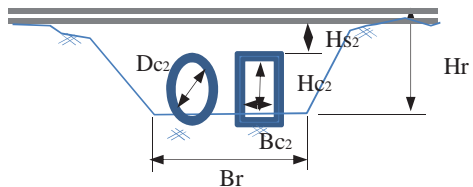

## Inventory Sheet for Culvert

<b>Station: at KM 300.5</b>		<b>Sheet No.: PCL 300.5</b>	
<b>1. General</b>			
1-1	Name of Inspector	T. Kawaguchi , Hussein , Abiud	
1-2	Organization of Inspector	JICA Study Team	
1-3	Date/Time of Inspection	2014/4/12	
1-4	Location	Lat	06° 44' 31" 95'''
1-5		Long	036° 52' 44" 74'''
1-6	Elevation		
<b>2. Characteristics of Physical Condition of Culvert</b>			
2-1	Length of Culvert	6.0 m	
2-2	Shape of Cross Section	Square: Rectangular: Circle:(1)	
2-3	Flow Area	Height	Hc1 = 1.2 m , Hc2 = 1.1 m
2-4		Width	Dc1 = 1.2 m , Dc2 = 1.2 m
2-5		Other	Hs1 = 1.8 m , Hs2 = 2.0 m
2-6	Connecting Channel	Height	
2-7		Width	
2-8		Side Slope	
2-9	Type of Culvert	Concrete	
2-10	Riverbed	Material	Silty sand
2-11	Sediment deposition	u/s	No ( 0% rate)
2-12		d/s	Light ( 5% rate)
2-13	Topography	u/s:  , d/s:	
2-14	Land Use		
2-15	Structures/Houses, road		
<b>3. Damaged Flood Records</b>			
3-1	(Year/Month)	(Type)	(Reason, etc.)

<b>Photo Upstream</b>	<b>Photo Downstream</b>
	
<b>Plan/Profile</b>	
	
<b>Cross Section</b>	
u/s	
d/s	

## Inventory Sheet for Culvert

<b>Station: at KM 300.6</b>		<b>Sheet No.: BCL 300.6</b>	
<b>1. General</b>			
1-1	Name of Inspector	T. Kawaguchi , Hussein , Abiud	
1-2	Organization of Inspector	JICA Study Team	
1-3	Date/Time of Inspection	2014/4/12	
1-4	Location	Lat	06° 44' 33" 44"
1-5		Long	036° 52' 39" 05"
1-6	Elevation		
<b>2. Characteristics of Physical Condition of Culvert</b>			
2-1	Length of Culvert	5.0 m	
2-2	Shape of Cross Section	Square: <u>Rectangular:(1)</u> Circle:	
2-3	Flow Area	Height	Hc1 = 0.95 m , Hc2 = 0.95 m
2-4		Width	Bc1 = 2.0 m , Bc2 = 2.0 m
2-5	Connecting Channel	Other	Hs1 = 0.5 m , Hs2 = 0.5 m
2-6		Height	
2-7	Width		
2-8	Side Slope		
2-9	Type of Culvert	Concrete	
2-10	Riverbed	Material	Silty sand
2-11	Sediment deposition	u/s	Light ( 10% rate)
2-12		d/s	Light ( 10% rate)
2-13	Topography	u/s:  , d/s:	
2-14	Land Use		
2-15	Structures/Houses, road		
<b>3. Damaged Flood Records</b>			
3-1	(Year/Month)	(Type)	(Reason,etc.)

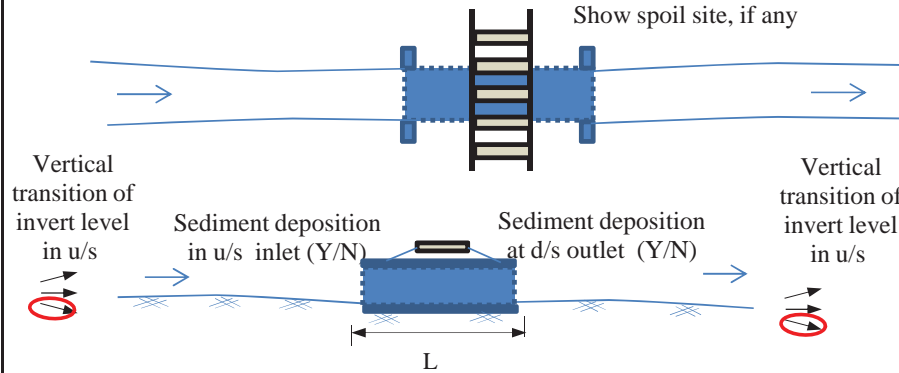
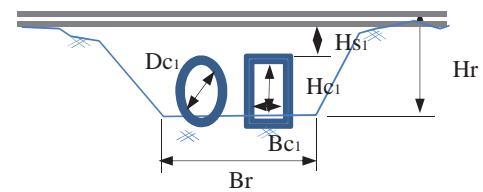
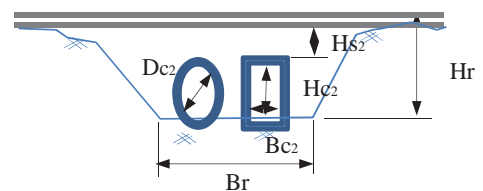
<b>Photo Upstream</b>	<b>Photo Downstream</b>
	
<b>Plan/Profile</b>	
	
<b>Cross Section</b>	
u/s	
d/s	

## Inventory Sheet for Culvert

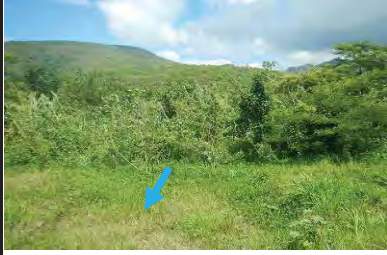
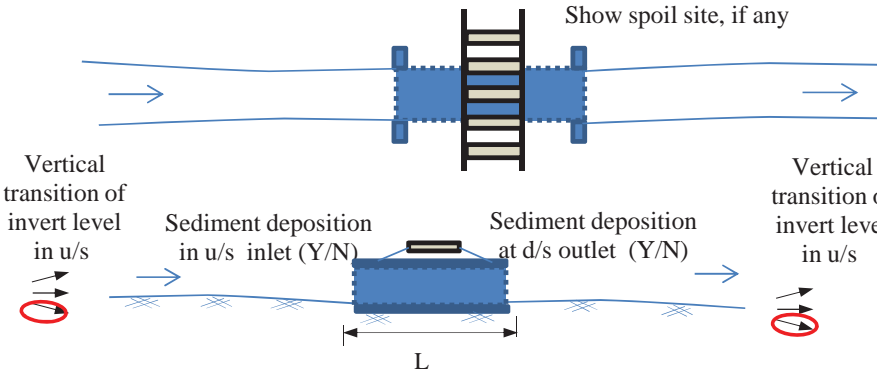
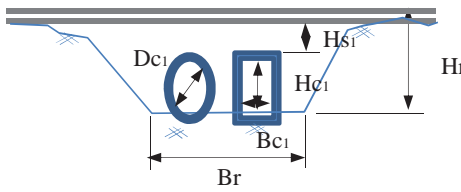
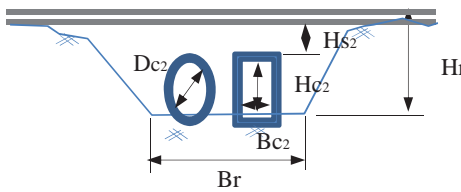

<b>Station: at KM 302.0</b>		<b>Sheet No.: PCL 302.0</b>	
<b>1. General</b>			
1-1	Name of Inspector	T. Kawaguchi , Hussein , Abiud	
1-2	Organization of Inspector	JICA Study Team	
1-3	Date/Time of Inspection	2014/4/12	
1-4	Location	Lat	06° 44' 46" 74 '''
1-5		Long	036° 51' 55" 75'''
1-6	Elevation		
<b>2. Characteristics of Physical Condition of Culvert</b>			
2-1	Length of Culvert	6.0 m	
2-2	Shape of Cross Section	Square: Rectangular: Circle:(2)	
2-3	Flow Area	Height	Hc1 = 0.6 m , Hc2 = 0.6 m
2-4		Width	Dc1 = 0.6 m , Dc2 = 0.6 m
2-5		Other	Hs1 = 1.0 m , Hs2 = 1.0 m
2-6	Connecting Channel	Height	
2-7		Width	
2-8		Side Slope	
2-9	Type of Culvert	Concrete	
2-10	Riverbed	Material	Silty sand
2-11	Sediment deposition	u/s	No ( 0% rate)
2-12		d/s	No ( 0% rate)
2-13	Topography	u/s:  , d/s:	
2-14	Land Use		
2-15	Structures/Houses, road		
<b>3. Damaged Flood Records</b>			
3-1	(Year/Month)	(Type)	(Reason,etc.)

F-54

<b>Photo Upstream</b>	<b>Photo Downstream</b>
	
<b>Plan/Profile</b>	
	
<b>Cross Section</b>	
u/s	
d/s	

## Inventory Sheet for Culvert

<b>Station: at KM 302.2</b>		<b>Sheet No.: BCL 302.2</b>	
<b>1. General</b>			
1-1	Name of Inspector	T. Kawaguchi , Hussein , Abiud	
1-2	Organization of Inspector	JICA Study Team	
1-3	Date/Time of Inspection	2014/4/12	
1-4	Location	Lat	06° 44' 47" 17"
1-5		Long	036° 51' 49" 34"
1-6	Elevation		
<b>2. Characteristics of Physical Condition of Culvert</b>			
2-1	Length of Culvert	5.0 m	
2-2	Shape of Cross Section	Square: Rectangular:(1) Circle:	
2-3	Flow Area	Height	Hc1 = 1.7 m , Hc2 = 1.7 m
2-4		Width	Bc1 = 1.0 m , Bc2 = 1.0 m
2-5		Other	Hs1 = 0.5 m , Hs2 = 0.5 m
2-6	Connecting Channel	Height	
2-7		Width	
2-8		Side Slope	
2-9	Type of Culvert	Concrete	
2-10	Riverbed	Material	Silty sand
2-11	Sediment deposition	u/s	Light ( 10% rate)
2-12		d/s	Light ( 10% rate)
2-13	Topography	u/s:  , d/s:	
2-14	Land Use		
2-15	Structures/Houses, road		
<b>3. Damaged Flood Records</b>			
3-1	(Year/Month)	(Type)	(Reason,etc.)

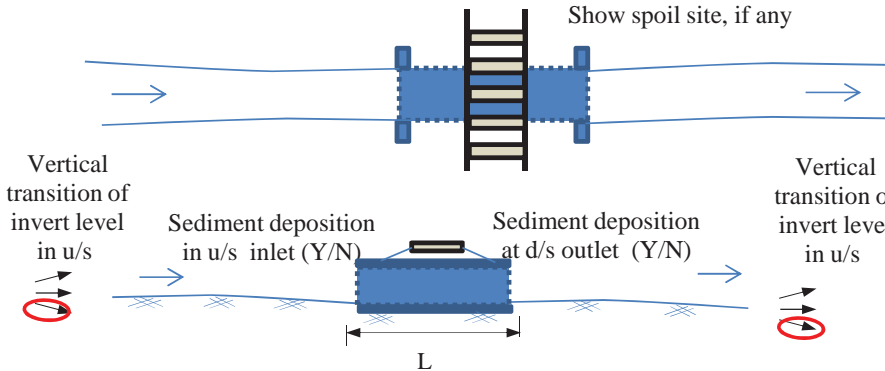
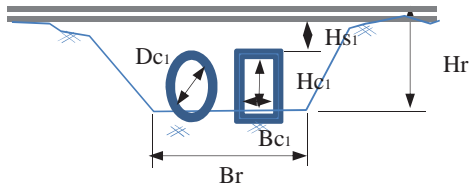
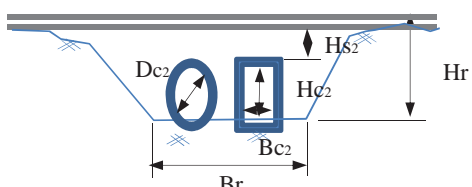

<b>Photo Upstream</b>	<b>Photo Downstream</b>
	
<b>Plan/Profile</b>	
	
<b>Cross Section</b>	
u/s	
d/s	



## Inventory Sheet for Culvert

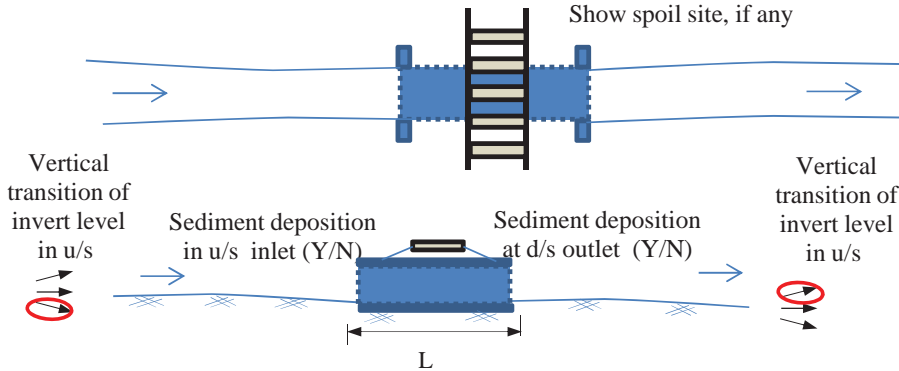
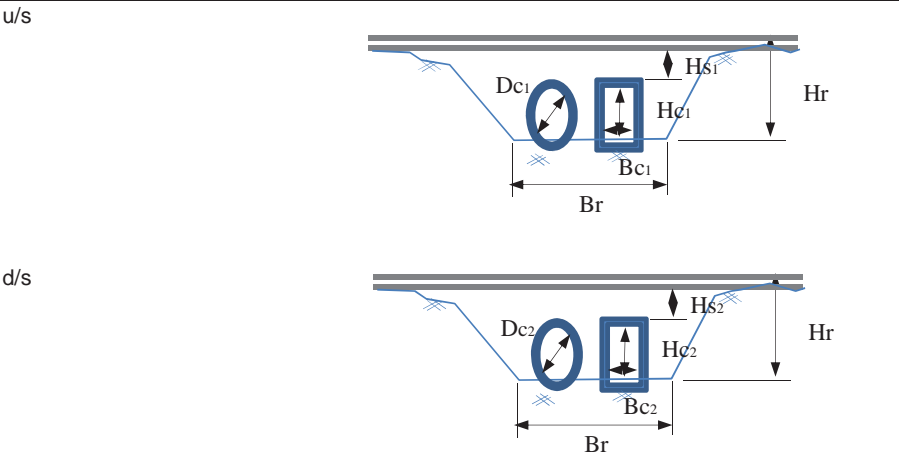

Station: at KM 303.3		Sheet No.: BCL 303.3	
<b>1. General</b>			
1-1	Name of Inspector	T. Kawaguchi , Hussein , Abiud	
1-2	Organization of Inspector	JICA Study Team	
1-3	Date/Time of Inspection	2014/4/12	
1-4	Location	Lat 06° 44' 33" 29"	
1-5		Long 036° 51' 15" 08"	
1-6	Elevation		
<b>2. Characteristics of Physical Condition of Culvert</b>			
2-1	Length of Culvert	6.0 m	
2-2	Shape of Cross Section	Square:(1) Rectangular: Circle:	
2-3	Height	Hc1 = 1.7 m , Hc2 = 1.8 m	
2-4	Flow Area	Width Bc1 = 2.5 m , Bc2 = 2.5 m	
2-5	Other	Hs1 = 0.8 m , Hs2 = 0.8 m	
2-6	Connecting Channel	Height	
2-7		Width	
2-8		Side Slope	
2-9	Type of Culvert	Concrete	
2-10	Riverbed	Material Silty sand	
2-11	Sediment	u/s Light ( 15% rate)	
2-12	deposition	d/s Light ( 15% rate)	
2-13	Topography	u/s: , d/s:	
2-14	Land Use		
2-15	Structures/Houses, road		
<b>3. Damaged Flood Records</b>			
3-1	(Year/Month)	(Type)	(Reason,etc.)

F-56

Photo Upstream	Photo Downstream
	
<b>Plan/Profile</b>	
	
<b>Cross Section</b>	
	

## Inventory Sheet for Culvert

<b>Station: at KM 303.4</b>		<b>Sheet No.: BCL 303.4</b>	
<b>1. General</b>			
1-1	Name of Inspector	T. Kawaguchi , Hussein , Abiud	
1-2	Organization of Inspector	JICA Study Team	
1-3	Date/Time of Inspection	2014/4/12	
1-4	Location	Lat	06° 44' 29" 55'''
1-5		Long	036° 51' 13" 27'''
1-6	Elevation		
<b>2. Characteristics of Physical Condition of Culvert</b>			
2-1	Length of Culvert	6.0 m	
2-2	Shape of Cross Section	Square: (1) Rectangular: Circle:	
2-3	Flow Area	Height	Hc1 = 1.7 m , Hc2 = 1.9 m
2-4		Width	Bc1 = 2.0 m , Bc2 = 2.0 m
2-5		Other	Hs1 = 0.8 m , Hs2 = 0.8 m
2-6	Connecting Channel	Height	
2-7		Width	
2-8		Side Slope	
2-9	Type of Culvert	Concrete	
2-10	Riverbed	Material	Silty sand
2-11	Sediment deposition	u/s	Light ( 10% rate)
2-12		d/s	Light ( 5% rate)
2-13	Topography	u/s:  , d/s:	
2-14	Land Use		
2-15	Structures/Houses, road		
<b>3. Damaged Flood Records</b>			
3-1	(Year/Month)	(Type)	(Reason,etc.)

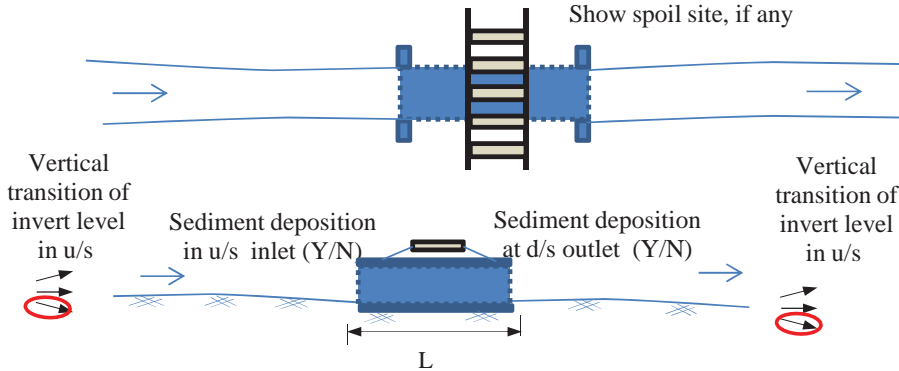
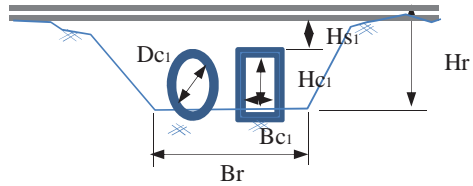
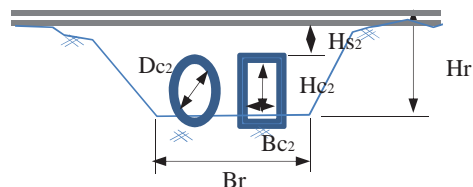
<b>Photo Upstream</b>	<b>Photo Downstream</b>
	
<b>Plan/Profile</b>	
 <p style="text-align: center;">Show spoil site, if any</p> <p style="text-align: center;">Vertical transition of invert level in u/s      Sediment deposition in u/s inlet (Y/N)      Sediment deposition at d/s outlet (Y/N)      Vertical transition of invert level in u/s</p> <p style="text-align: center;">L</p>	
<b>Cross Section</b>	
u/s	
d/s	

## Inventory Sheet for Culvert

**Station: at KM 308/1**      **Sheet No.: BCL308.1**

<b>1. General</b>			
1-1	Name of Inspector	T.Fukuda, Mr.Kido, Mr.Philipo	
1-2	Organization of Inspector	B	
1-3	Date/Time of Inspection	DEC 4 2014	1010
1-4	Location	Lat	06°42'38.1"
1-5		Long	036°49'54.4"
1-6	Elevation	n/a	

**2. Characteristics of Physical Condition of Culvert**

2-1	Length of Culvert	n/a	
2-2	Shape of Cross Section	Rectangular ×1	
2-3	Flow Area	Height	Hc = 1.1m
2-4		Width	Bc = 2.0m
2-5		Other	WL = 1.8m, Hs= 0.5m
2-6	Connecting Channel	Height	n/a
2-7		Width	n/a
2-8		Side Slope	n/a
2-9	Type of Culvert	Concrete	
2-10	Riverbed	Material	n/a
2-11	Sediment deposition	u/s	Y, 45%
2-12		d/s	Y, 45%
2-13	Topography	u/s: → ,d/s →	
2-14	Land Use	n/a	
2-15	Structures/Houses, road	n/a	

**3. Damaged Flood Records**

3-1	(Year/Month)	(Type)	(Reason,etc.)
	n/a	n/a	n/a



**Plan/Profile**

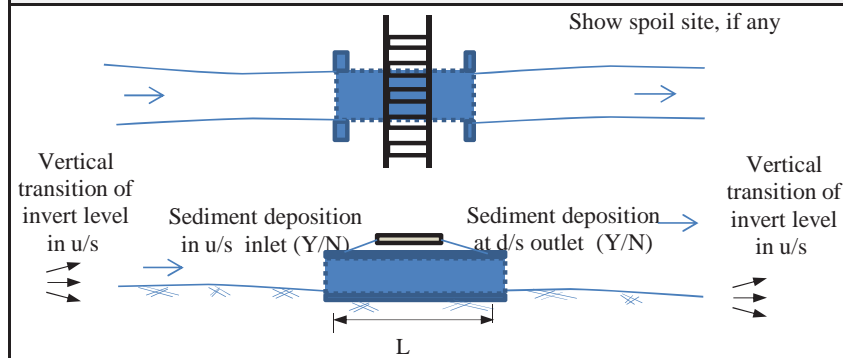

**Cross Section**

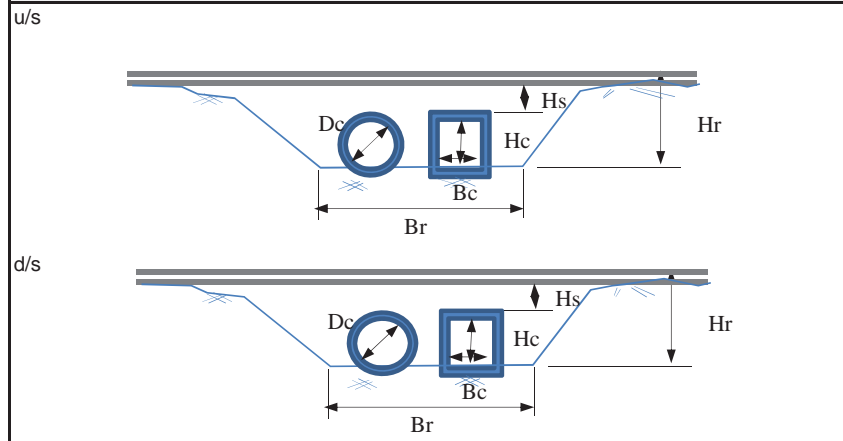

## Inventory Sheet for Culvert

**Station: at KM 308/3**      **Sheet No.: BCL308.3**

<b>1. General</b>			
1-1	Name of Inspector	T.Fukuda, Mr.Kido, Mr.Philipo	
1-2	Organization of Inspector	B	
1-3	Date/Time of Inspection	DEC 4 2014	1015
1-4	Location	Lat	06°42'33.1"
1-5		Long	036°49'49.6"
1-6	Elevation	n/a	

**2. Characteristics of Physical Condition of Culvert**

2-1	Length of Culvert	n/a	
2-2	Shape of Cross Section	Rectangular ×1	
2-3	Flow Area	Height	Hc = 0.0m
2-4		Width	Bc = 3.6m
2-5		Other	n/a
2-6	Connecting Channel	Height	n/a
2-7		Width	n/a
2-8		Side Slope	n/a
2-9	Type of Culvert	Concrete	
2-10	Riverbed	Material	n/a
2-11	Sediment deposition	u/s	Y, 100%
2-12		d/s	Y, 100%
2-13	Topography	u/s: → , d/s →	
2-14	Land Use	n/a	
2-15	Structures/Houses, road	n/a	

**3. Damaged Flood Records**

3-1	(Year/Month)	(Type)	(Reason,etc.)
	n/a	n/a	n/a

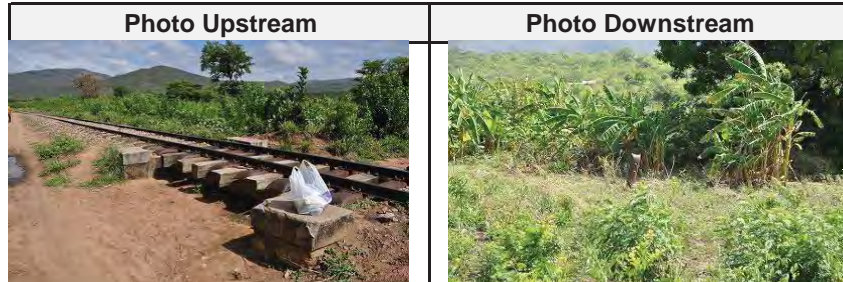

**Plan/Profile**

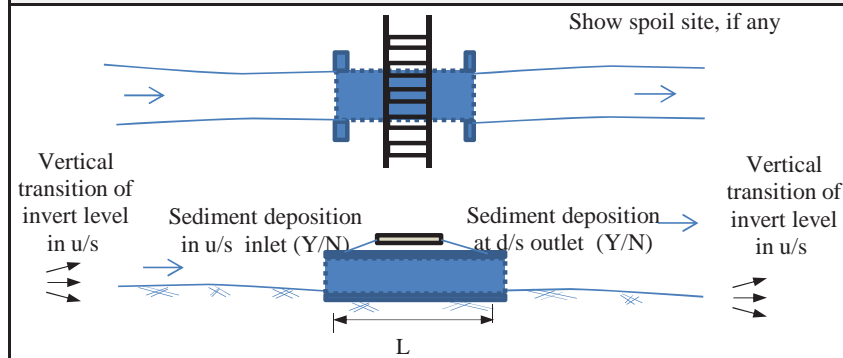

**Cross Section**

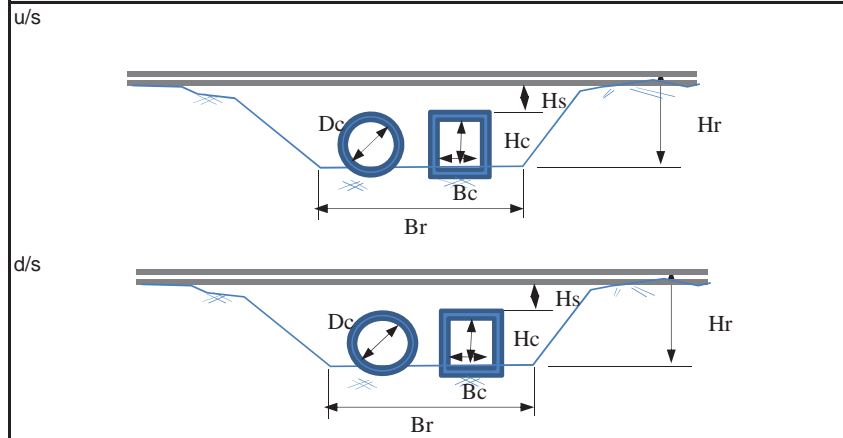

## Inventory Sheet for Culvert

<b>Station: at KM 308/4</b>		<b>Sheet No.: PCL308.4</b>	
<b>1. General</b>			
1-1	Name of Inspector	T.Fukuda, Mr.Kido, Mr.Philipo	
1-2	Organization of Inspector	B	
1-3	Date/Time of Inspection	DEC 4 2014 1022	
1-4	Location	Lat	0642'31.1"
1-5		Long	03649'47.3"
1-6	Elevation	n/a	
<b>2. Characteristics of Physical Condition of Culvert</b>			
2-1	Length of Culvert	n/a	
2-2	Shape of Cross Section	Circle x1	
2-3	Flow Area	Height	n/a
2-4		Width	n/a
2-5		Other	d1=1.0m, d2=0.65m, WL=1.3m, Hs=0.2m
2-6	Connecting Channel	Height	n/a
2-7		Width	n/a
2-8		Side Slope	n/a
2-9	Type of Culvert	Concrete	
2-10	Riverbed	Material	n/a
2-11	Sediment deposition	u/s	Y, 20%
2-12		d/s	Y, 20%
2-13	Topography	u/s: → ,d/s →	
2-14	Land Use	n/a	
2-15	Structures/Houses, road	n/a	
<b>3. Damaged Flood Records</b>			
3-1	(Year/Month)	(Type)	(Reason,etc.)
	n/a	n/a	n/a

<b>Photo Upstream</b>	<b>Photo Downstream</b>
<b>Plan/Profile</b>	
<p style="text-align: right;">Show spoil site, if any</p>	
<b>Cross Section</b>	



## Inventory Sheet for Culvert

**Station: at KM 308/9**      **Sheet No.: PCL308.9**

<b>1. General</b>		
1-1	Name of Inspector	T.Fukuda, Mr.Kido, Mr.Philipo
1-2	Organization of Inspector	B
1-3	Date/Time of Inspection	DEC 4 2014      10355
1-4	Location	Lat      0642'23.8"
1-5		Long      036° 49'35.1"
1-6	Elevation	n/a

**2. Characteristics of Physical Condition of Culvert**

2-1	Length of Culvert	L = 10.7m	
2-2	Shape of Cross Section	Circle x1	
2-3	Flow Area	Height	n/a
2-4		Width	n/a
2-5		Other	d=1.0m, WL=2.7m, Hs=0.8m
2-6	Connecting Channel	Height	n/a
2-7		Width	n/a
2-8		Side Slope	n/a
2-9	Type of Culvert	Concrete	
2-10	Riverbed	Material	n/a
2-11	Sediment deposition	u/s	Y, 10%
2-12		d/s	Y, 10%
2-13	Topography	u/s:      ,d/s:      →	
2-14	Land Use	n/a	
2-15	Structures/Houses, road	n/a	

**3. Damaged Flood Records**

3-1	(Year/Month)	(Type)	(Reason,etc.)
	?	washout	?

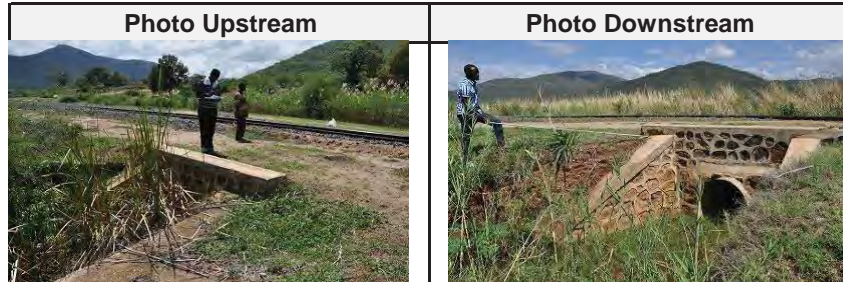

**Plan/Profile**

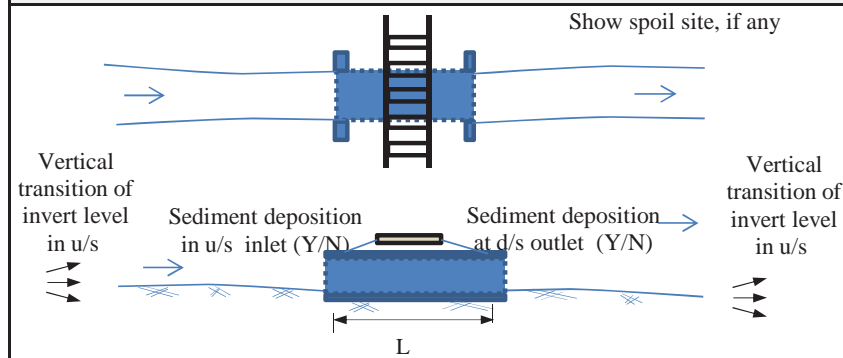

**Cross Section**

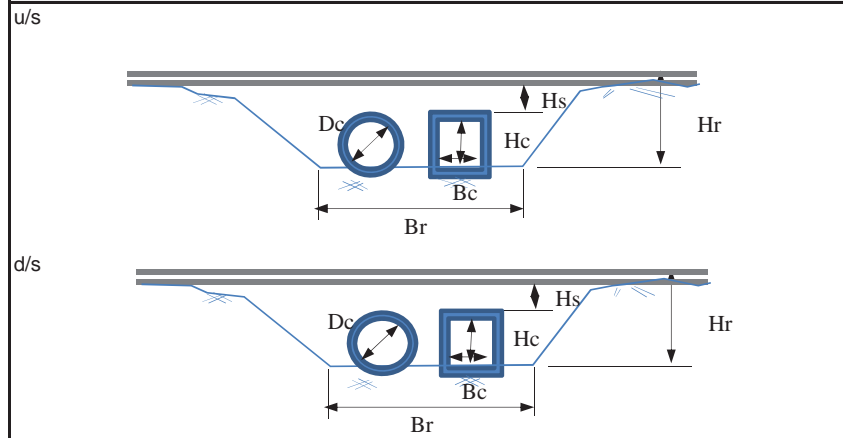

## Inventory Sheet for Culvert

**Station: at KM 309/4**      **Sheet No.: BCL309.4**

### 1. General

1-1	Name of Inspector	T.Fukuda, Mr.Kido, Mr.Philipo	
1-2	Organization of Inspector	B	
1-3	Date/Time of Inspection	DEC 4 2014	1105
1-4	Location	Lat	06°42'20.6"
1-5		Long	036°49'19.6"
1-6	Elevation	n/a	

### 2. Characteristics of Physical Condition of Culvert

2-1	Length of Culvert	n/a	
2-2	Shape of Cross Section	Rectangular ×1	
2-3	Flow Area	Height	Hc= 0.9m
2-4		Width	Bc= 1.0m
2-5		Other	WL=1.2m, Hs=0.4m
2-6	Connecting Channel	Height	n/a
2-7		Width	n/a
2-8		Side Slope	n/a
2-9	Type of Culvert	Concrete	
2-10	Riverbed	Material	n/a
2-11	Sediment deposition	u/s	Y, 10%
2-12		d/s	Y, 10%
2-13	Topography	u/s: → ,d/s →	
2-14	Land Use	n/a	
2-15	Structures/Houses, road	n/a	

### 3. Damaged Flood Records

3-1	(Year/Month)	(Type)	(Reason,etc.)
	n/a	n/a	n/a

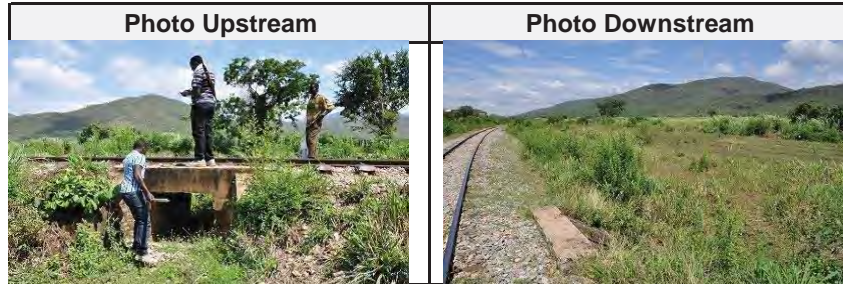

### Plan/Profile

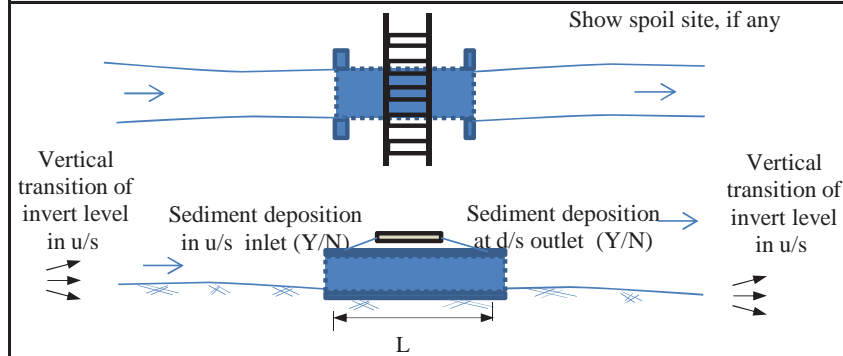

### Cross Section

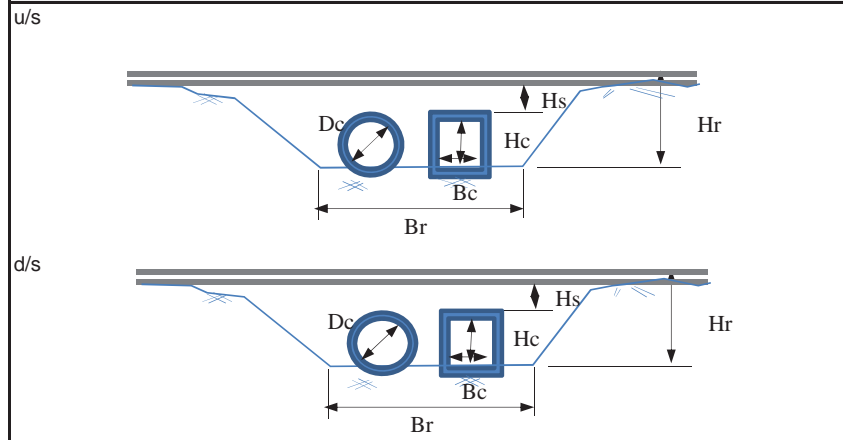

## Inventory Sheet for Culvert

**Station: at KM 309/9**      **Sheet No.: BCL309.9**

### 1. General

1-1	Name of Inspector		T.Fukuda, Mr.Kido, Mr.Philipo
1-2	Organization of Inspector		B
1-3	Date/Time of Inspection		DEC 4 2014    1115
1-4	Location	Lat	06°42'15.6"
1-5		Long	036°49'03.0"
1-6	Elevation		n/a

### 2. Characteristics of Physical Condition of Culvert

2-1	Length of Culvert		n/a
2-2	Shape of Cross Section		Rectangular x1
2-3	Flow Area	Height	Hc= 0.4m
2-4		Width	Bc= 2.0m
2-5		Other	WL=0.8m, Hs=0.38m
2-6	Connecting Channel	Height	n/a
2-7		Width	n/a
2-8		Side Slope	n/a
2-9	Type of Culvert		Concrete
2-10	Riverbed	Material	n/a
2-11	Sediment deposition	u/s	Y, 80%
2-12		d/s	Y, 80%
2-13	Topography		u/s: → , d/s →
2-14	Land Use		n/a
2-15	Structures/Houses, road		n/a

### 3. Damaged Flood Records

3-1	(Year/Month)	(Type)	(Reason,etc.)
	n/a	n/a	n/a

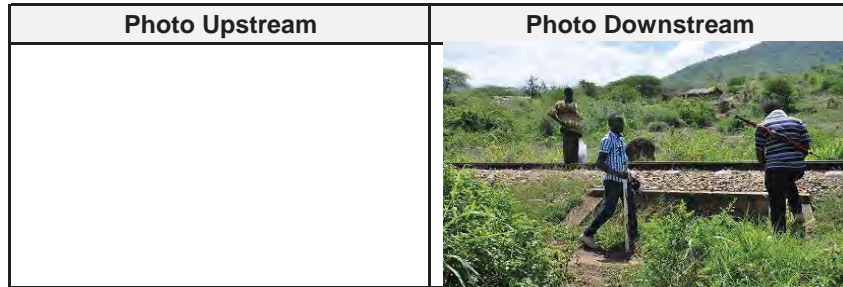

### Plan/Profile

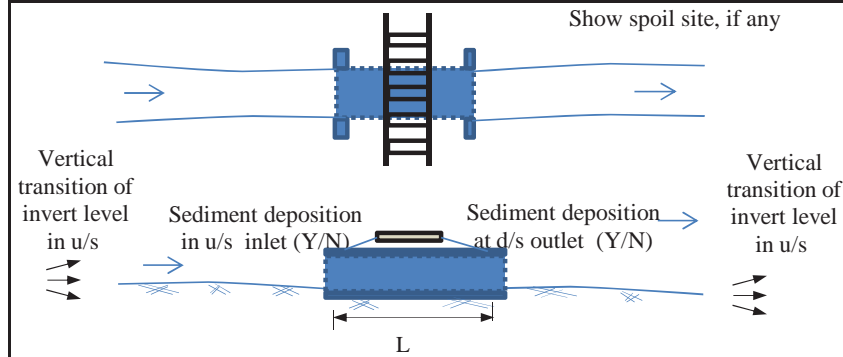

### Cross Section

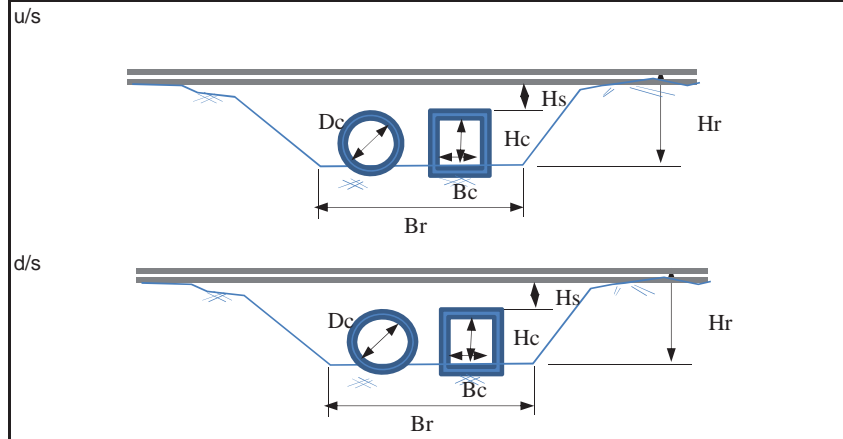

## Inventory Sheet for Culvert

<b>Station: at KM 310/5</b>		<b>Sheet No.: BCL310.5</b>	
<b>1. General</b>			
1-1	Name of Inspector	T.Fukuda, Mr.Kido, Mr.Philipo	
1-2	Organization of Inspector	B	
1-3	Date/Time of Inspection	DEC 4 2014 1125	
1-4	Location	Lat	0642'19.4"
1-5		Long	03648'43.6"
1-6	Elevation	n/a	
<b>2. Characteristics of Physical Condition of Culvert</b>			
2-1	Length of Culvert	n/a	
2-2	Shape of Cross Section	Rectangular x1	
2-3	Flow Area	Height	Hc= 1.5m
2-4		Width	Bc= 2.0m
2-5		Other	WL=2.0m, Hs=0.45m
2-6	Connecting Channel	Height	n/a
2-7		Width	n/a
2-8		Side Slope	n/a
2-9	Type of Culvert	Concrete	
2-10	Riverbed	Material	n/a
2-11	Sediment deposition	u/s	Y, 25%
2-12		d/s	Y, 25%
2-13	Topography	u/s: $\rightarrow$ ,d/s $\rightarrow$	
2-14	Land Use	n/a	
2-15	Structures/Houses, road	n/a	
<b>3. Damaged Flood Records</b>			
3-1	(Year/Month)	(Type)	(Reason,etc.)
	n/a	n/a	n/a

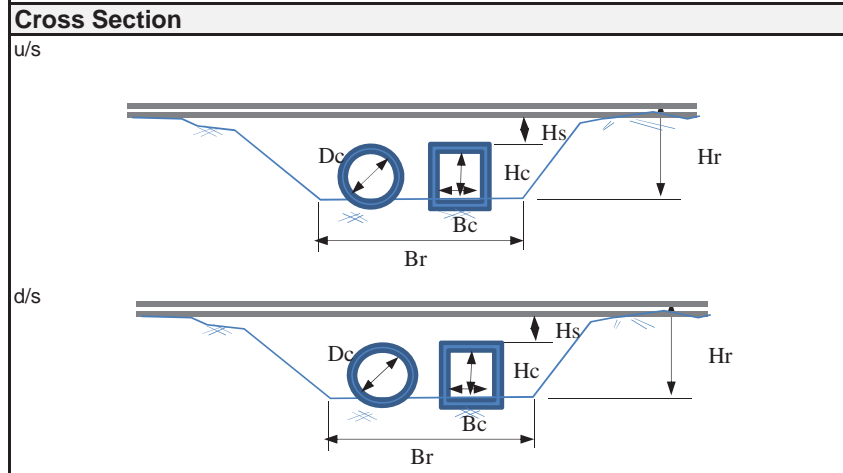
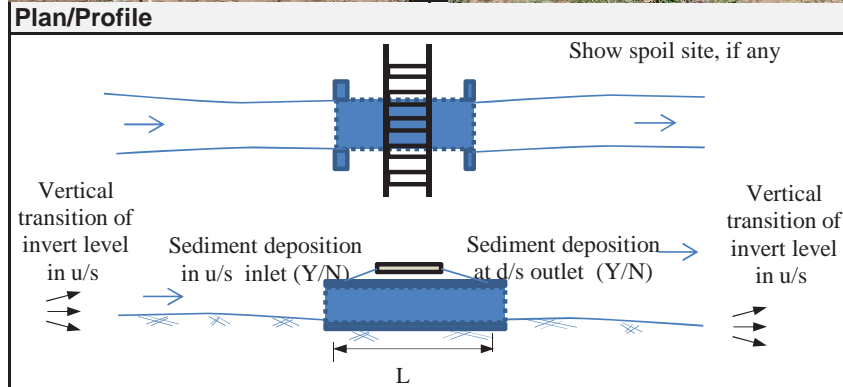
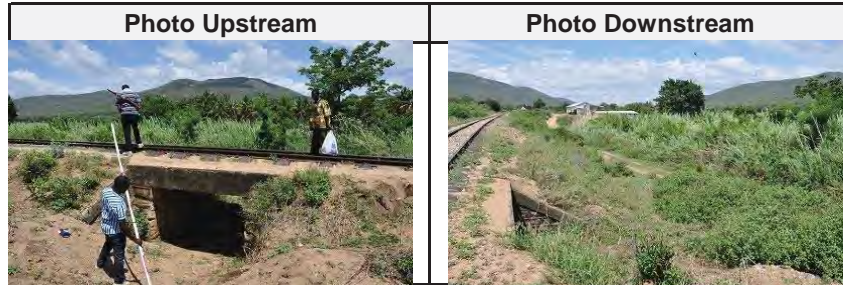

## Inventory Sheet for Culvert

**Station: at KM 310/8**      **Sheet No.: PCL310.8**

### 1. General

1-1	Name of Inspector		T.Fukuda, Mr.Kido, Mr.Philipo
1-2	Organization of Inspector		B
1-3	Date/Time of Inspection		DEC 4 2014      1133
1-4	Location	Lat	06°42'18.1"
1-5		Long	036°48'34.2"
1-6	Elevation		n/a

### 2. Characteristics of Physical Condition of Culvert

2-1	Length of Culvert		L= 41.7m
2-2	Shape of Cross Section		Circle × 2
2-3	Flow Area	Height	n/a
2-4		Width	n/a
2-5		Other	d=0.9m, WL=2.15m, Hs=0.3m
2-6	Connecting Channel	Height	n/a
2-7		Width	n/a
2-8		Side Slope	n/a
2-9	Type of Culvert		Concrete
2-10	Riverbed	Material	n/a
2-11	Sediment deposition	u/s	Y, 20%
2-12		d/s	Y, 20%
2-13	Topography		u/s: → ,d/s →
2-14	Land Use		n/a
2-15	Structures/Houses, road		n/a

### 3. Damaged Flood Records

3-1	(Year/Month)	(Type)	(Reason,etc.)
	n/a	n/a	n/a

**Photo Upstream**      **Photo Downstream**

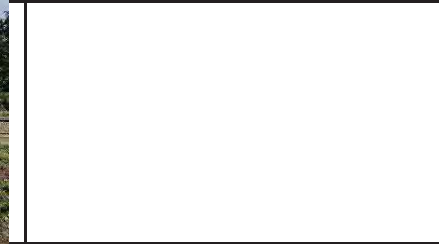

### Plan/Profile

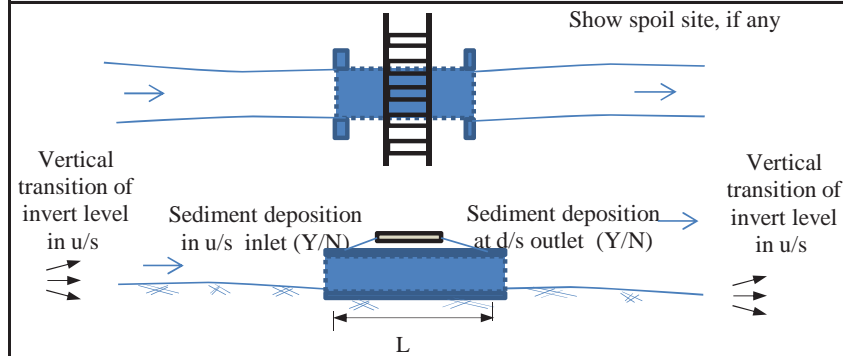

### Cross Section

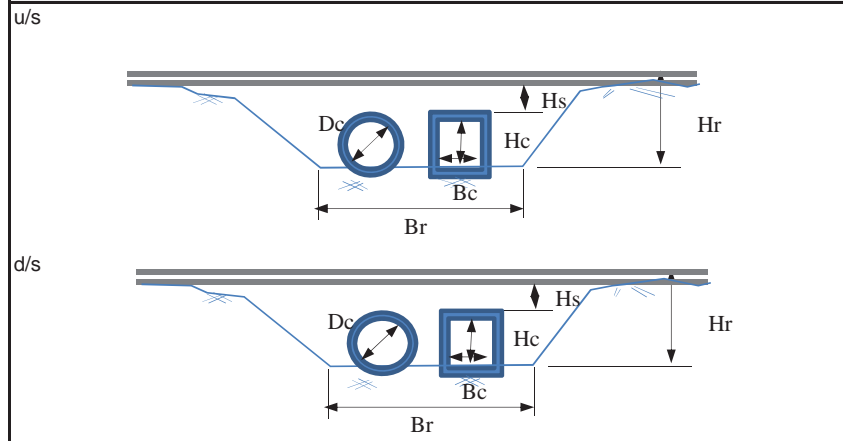



### Inventory Sheet for Culvert

**Station: at KM 311/0**      **Sheet No.: PCL311.0**

<b>1. General</b>			
1-1	Name of Inspector	T.Fukuda, Mr.Kido, Mr.Philipo	
1-2	Organization of Inspector	B	
1-3	Date/Time of Inspection	DEC 4 2014	1200
1-4	Location	Lat	0642'16.9"
1-5		Long	03648'28.1"
1-6	Elevation	n/a	

**2. Characteristics of Physical Condition of Culvert**

2-1	Length of Culvert	n/a	
2-2	Shape of Cross Section	Circle x 2	
2-3	Flow Area	Height	n/a
2-4		Width	n/a
2-5		Other	d=0.75m, WL=3.0m, Hs=1.0m
2-6	Connecting Channel	Height	n/a
2-7		Width	n/a
2-8		Side Slope	n/a
2-9	Type of Culvert	Concrete	
2-10	Riverbed	Material	n/a
2-11	Sediment deposition	u/s	Y, 40%
2-12		d/s	Y, 40%
2-13	Topography	u/s: → ,d/s →	
2-14	Land Use	n/a	
2-15	Structures/Houses, road	n/a	

**3. Damaged Flood Records**

3-1	(Year/Month)	(Type)	(Reason,etc.)
	n/a	n/a	n/a

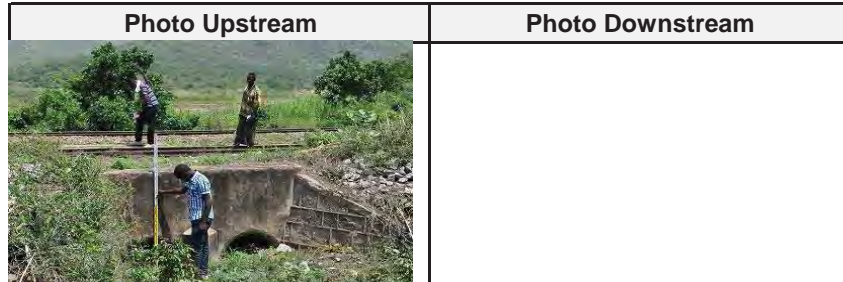

**Plan/Profile**

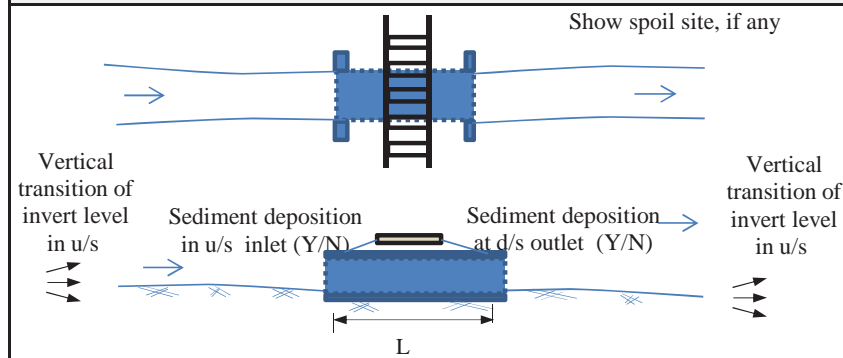

**Cross Section**

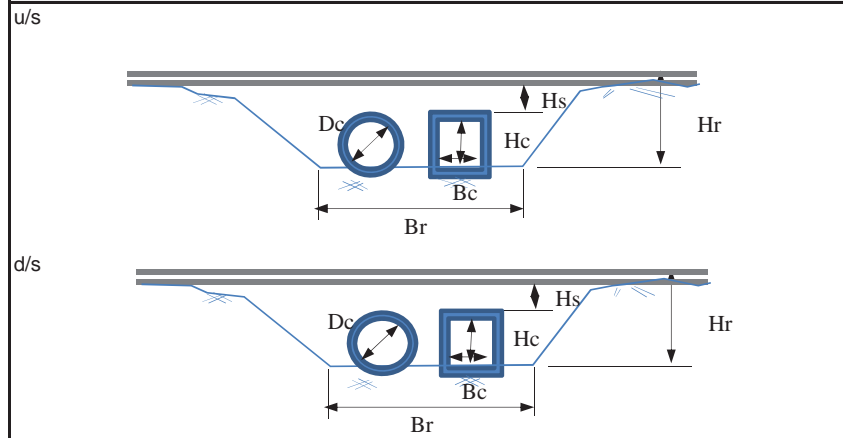

## Inventory Sheet for Culvert

**Station: at KM 311/2**      **Sheet No.: BR311.2**

### 1. General

1-1	Name of Inspector	T.Fukuda, Mr.Kido, Mr.Philipo	
1-2	Organization of Inspector	B	
1-3	Date/Time of Inspection	DEC 4 2014	1210
1-4	Location	Lat	0642'13.8"
1-5		Long	036°48'20.6"
1-6	Elevation	n/a	

### 2. Characteristics of Physical Condition of Culvert

2-1	Length of Culvert	n/a	
2-2	Shape of Cross Section	Rectangular × 1	
2-3	Flow Area	Height	Hc= 1.0m
2-4		Width	Bc= 4.7m
2-5		Other	WL=1.4m, Hs=0.0m
2-6	Connecting Channel	Height	n/a
2-7		Width	n/a
2-8		Side Slope	n/a
2-9	Type of Culvert	Concrete	
2-10	Riverbed	Material	n/a
2-11	Sediment deposition	u/s	Y, 20%
2-12		d/s	Y, 20%
2-13	Topography	u/s: → ,d/s →	
2-14	Land Use	n/a	
2-15	Structures/Houses, road	n/a	

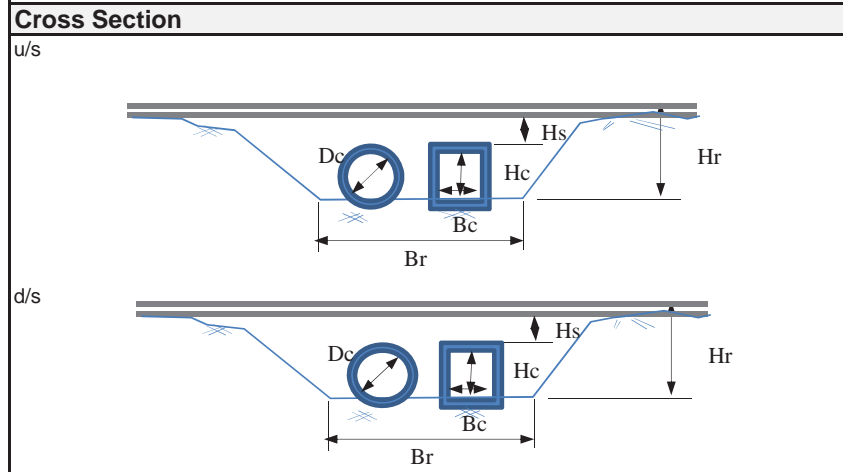
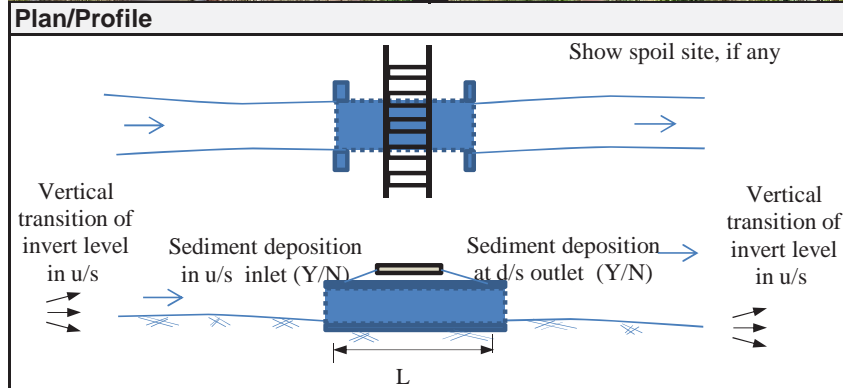
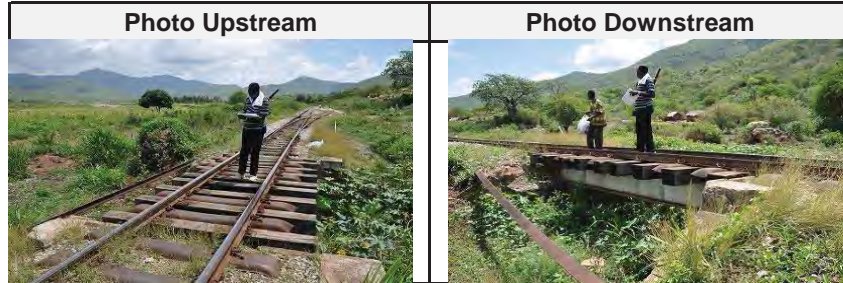

### 3. Damaged Flood Records

3-1	(Year/Month)	(Type)	(Reason,etc.)
	n/a	n/a	n/a



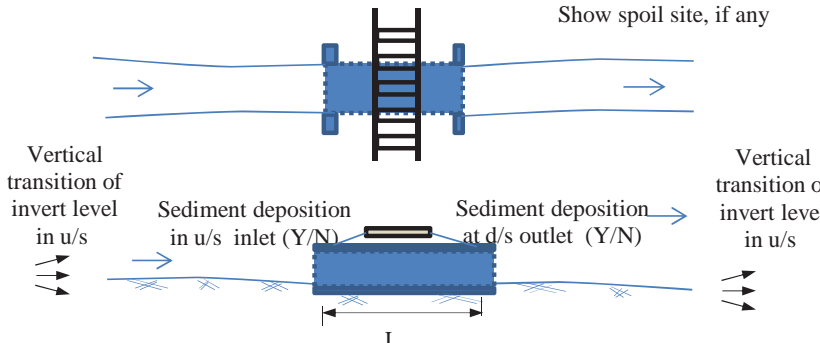
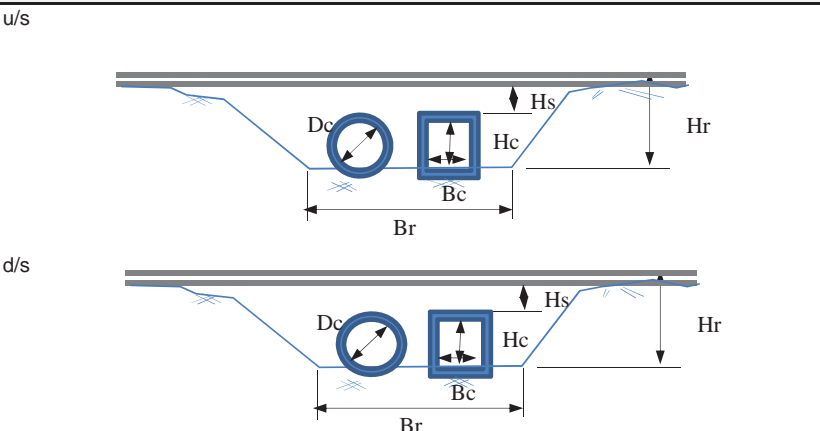

## Inventory Sheet for Culvert

<b>Station: at KM 312/2</b>		<b>Sheet No.: BCL312.2</b>	
<b>1. General</b>			
1-1	Name of Inspector	T.Fukuda, Mr.Kido, Mr.Philipo	
1-2	Organization of Inspector	B	
1-3	Date/Time of Inspection	DEC 4 2014 1225	
1-4	Location	Lat	0642'02.8"
1-5		Long	03647'53.0"
1-6	Elevation	n/a	
<b>2. Characteristics of Physical Condition of Culvert</b>			
2-1	Length of Culvert	n/a	
2-2	Shape of Cross Section	Rectangular × 1	
2-3	Flow Area	Height	Hc= 1.35m
2-4		Width	Bc= 1.0m
2-5		Other	WL=2.0m, Hs=0.5m
2-6	Connecting Channel	Height	n/a
2-7		Width	n/a
2-8		Side Slope	n/a
2-9	Type of Culvert	Concrete	
2-10	Riverbed	Material	n/a
2-11	Sediment deposition	u/s	Y, 0%
2-12		d/s	Y, 0%
2-13	Topography	u/s: → ,d/s →	
2-14	Land Use	n/a	
2-15	Structures/Houses, road	n/a	
<b>3. Damaged Flood Records</b>			
3-1	(Year/Month)	(Type)	(Reason,etc.)
	?	damaged on	gaion is insatalled along the bank

<b>Photo Upstream</b>	<b>Photo Downstream</b>
	
<b>Plan/Profile</b>	
 <p style="text-align: center;">Show spoil site, if any</p> <p style="text-align: center;">Vertical transition of invert level in u/s      Sediment deposition in u/s inlet (Y/N)      Sediment deposition at d/s outlet (Y/N)      Vertical transition of invert level in u/s</p> <p style="text-align: center;">L</p>	
<b>Cross Section</b>	
 <p style="text-align: center;">u/s</p> <p style="text-align: center;">d/s</p>	

## Inventory Sheet for Culvert

<b>Station: at KM 312/3</b>		<b>Sheet No.: BCL312.3</b>	
<b>1. General</b>			
1-1	Name of Inspector	T.Fukuda, Mr.Kido, Mr.Philipo	
1-2	Organization of Inspector	B	
1-3	Date/Time of Inspection	DEC 4 2014 1232	
1-4	Location	Lat	06°42'01.8"
1-5		Long	03647'49.9"
1-6	Elevation	n/a	
<b>2. Characteristics of Physical Condition of Culvert</b>			
2-1	Length of Culvert	n/a	
2-2	Shape of Cross Section	Rectangular × 1	
2-3	Flow Area	Height	Hc= 0.8m
2-4		Width	Bc= 1.0m
2-5		Other	WL=1.4m, Hs=0.4m
2-6	Connecting Channel	Height	n/a
2-7		Width	n/a
2-8		Side Slope	n/a
2-9	Type of Culvert	Concrete	
2-10	Riverbed	Material	n/a
2-11	Sediment deposition	u/s	Y, 20%
2-12		d/s	Y, 20%
2-13	Topography	u/s: → ,d/s →	
2-14	Land Use	n/a	
2-15	Structures/Houses, road	n/a	
<b>3. Damaged Flood Records</b>			
3-1	(Year/Month)	(Type)	(Reason,etc.)
	n/a	n/a	n/a

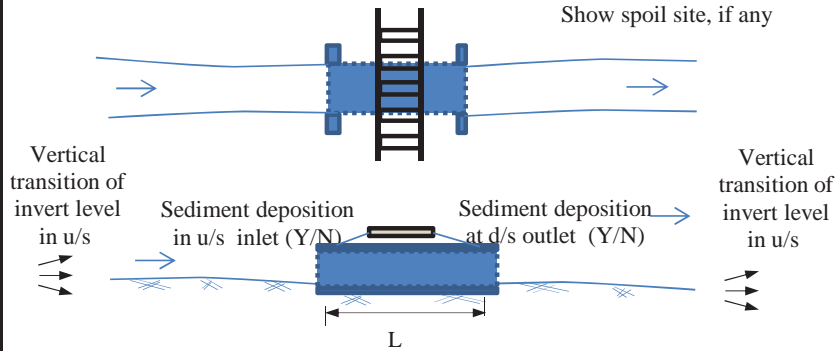
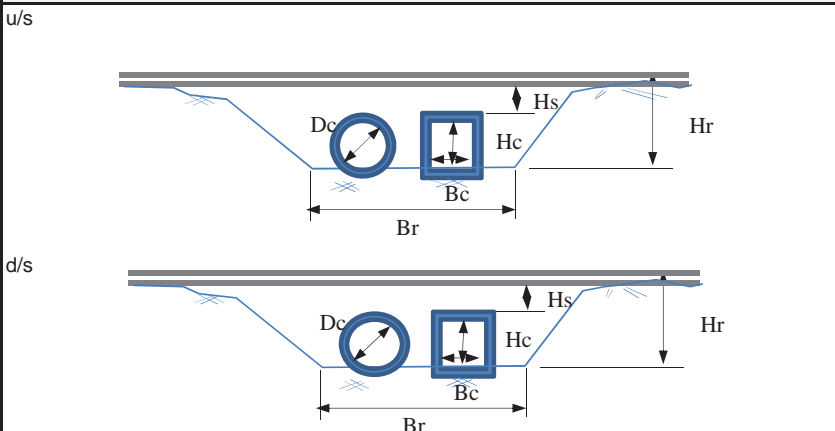
<b>Photo Upstream</b>	<b>Photo Downstream</b>
	
<b>Plan/Profile</b>	
 <p style="text-align: center;">Show spoil site, if any</p>	
<b>Cross Section</b>	
	

## Inventory Sheet for Culvert

<b>Station: at KM 312/4</b>		<b>Sheet No.: BCL312.4</b>	
<b>1. General</b>			
1-1	Name of Inspector	T.Fukuda, Mr.Kido, Mr.Philipo	
1-2	Organization of Inspector	B	
1-3	Date/Time of Inspection	DEC 4 2014 1242	
1-4	Location	Lat	0642'01.7"
1-5		Long	036°47'44.6"
1-6	Elevation	n/a	
<b>2. Characteristics of Physical Condition of Culvert</b>			
2-1	Length of Culvert	n/a	
2-2	Shape of Cross Section	Rectangular × 1	
2-3	Flow Area	Height	Hc= 1.8m
2-4		Width	Bc= 4.4m
2-5		Other	WL=2.5m, Hs=0.0m
2-6	Connecting Channel	Height	n/a
2-7		Width	n/a
2-8		Side Slope	n/a
2-9	Type of Culvert	Concrete	
2-10	Riverbed	Material	n/a
2-11	Sediment deposition	u/s	Y, ?
2-12		d/s	Y, ?
2-13	Topography	u/s: → ,d/s →	
2-14	Land Use	n/a	
2-15	Structures/Houses, road	n/a	
<b>3. Damaged Flood Records</b>			
3-1	(Year/Month)	(Type)	(Reason,etc.)
	n/a	n/a	n/a

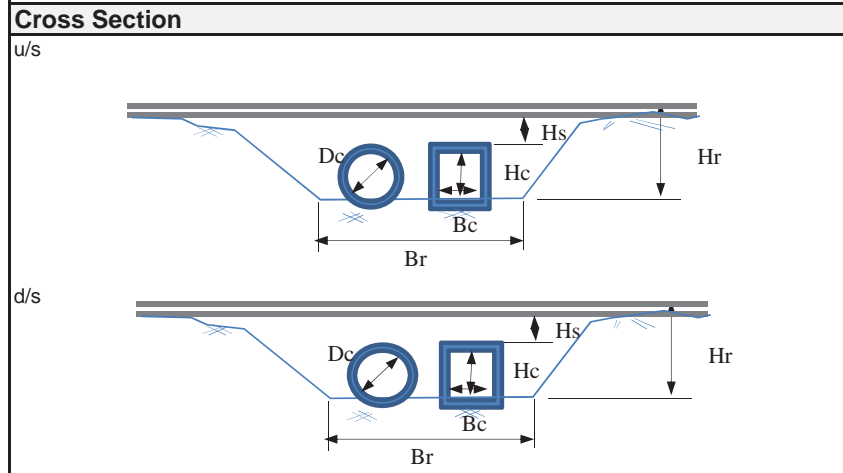
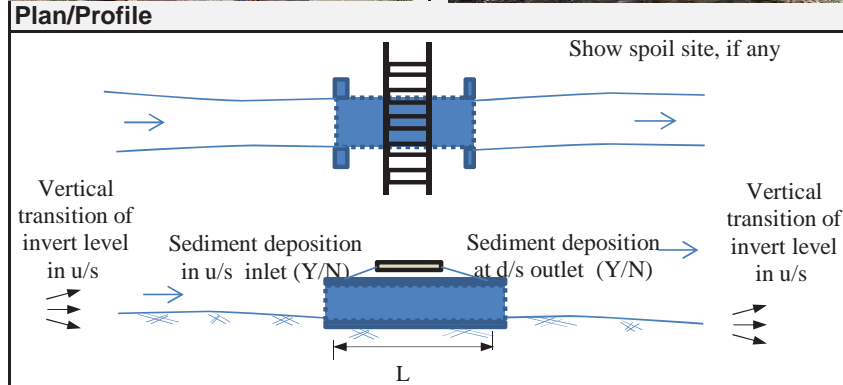
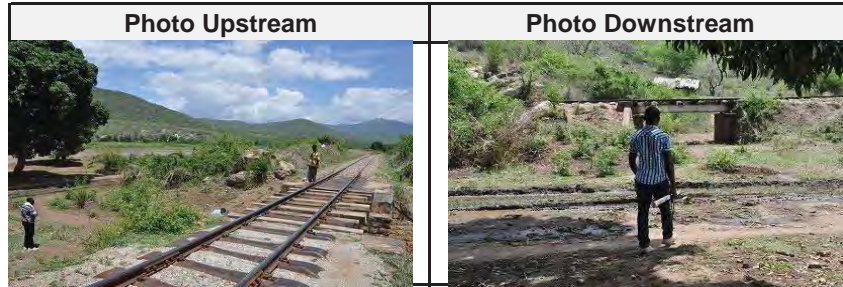



### Inventory Sheet for Culvert

**Station: at KM 312/8**      **Sheet No.: BCL312.8**

1. General		
1-1	Name of Inspector	T.Fukuda, Mr.Kido, Mr.Philipo
1-2	Organization of Inspector	B
1-3	Date/Time of Inspection	DEC 4 2014    1305
1-4	Location	Lat    0642'00.5"
1-5		Long    036°47'33.3"
1-6	Elevation	n/a

2. Characteristics of Physical Condition of Culvert		
2-1	Length of Culvert	n/a
2-2	Shape of Cross Section	Rectangular × 1
2-3	Flow Area	Height $H_c = 1.6\text{m}$
2-4		Width $B_c = 1.0\text{m}$
2-5		Other $WL = 2.6\text{m}, H_s = 0.35\text{m}$
2-6	Connecting Channel	Height    n/a
2-7		Width    n/a
2-8		Side Slope    n/a
2-9	Type of Culvert	Concrete
2-10	Riverbed	Material    n/a
2-11	Sediment deposition	u/s    Y, 0%
2-12		d/s    Y, 0%
2-13	Topography	u/s:    →    ,d/s    →
2-14	Land Use	n/a
2-15	Structures/Houses, road	n/a

3. Damaged Flood Records			
3-1	(Year/Month)	(Type)	(Reason,etc.)
	n/a	n/a	n/a

Photo Upstream	Photo Downstream

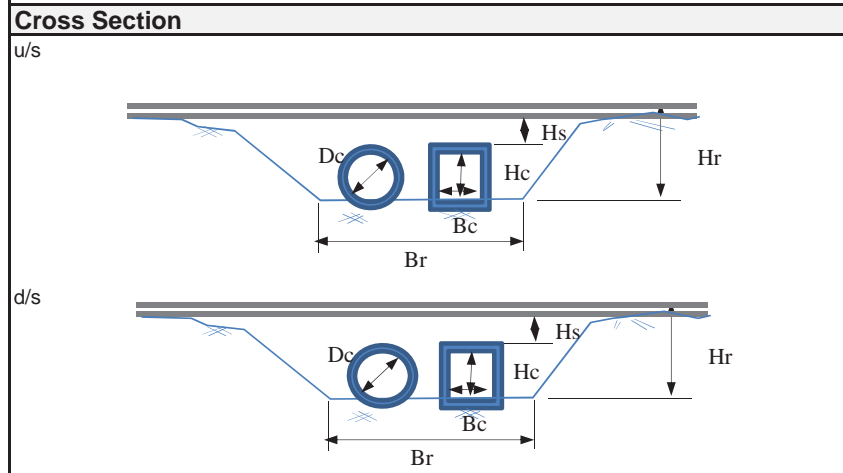
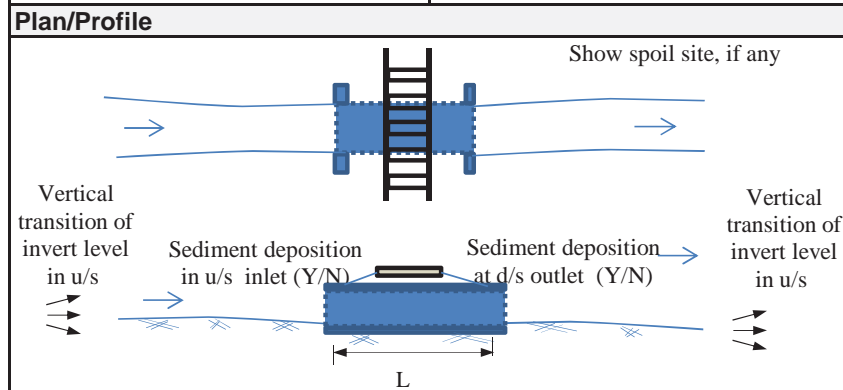

## Inventory Sheet for Culvert

**Station: at KM 312/9**      **Sheet No.: BCL312.9**

### 1. General

1-1	Name of Inspector	T.Fukuda, Mr.Kido, Mr.Philipo	
1-2	Organization of Inspector	B	
1-3	Date/Time of Inspection	DEC 4 2014	1315
1-4	Location	Lat	0641'59.6"
1-5		Long	03647'28.7"
1-6	Elevation	n/a	

### 2. Characteristics of Physical Condition of Culvert

2-1	Length of Culvert	n/a	
2-2	Shape of Cross Section	Rectangular × 1	
2-3	Flow Area	Height	Hc= 1.7m
2-4		Width	Bc= 2.0m
2-5		Other	WL=3.0m, Hs=0.5m
2-6	Connecting Channel	Height	n/a
2-7		Width	n/a
2-8		Side Slope	n/a
2-9	Type of Culvert	Concrete	
2-10	Riverbed	Material	n/a
2-11	Sediment deposition	u/s	Y, 15%
2-12		d/s	Y, 15%
2-13	Topography	u/s: → ,d/s →	
2-14	Land Use	n/a	
2-15	Structures/Houses, road	n/a	

### 3. Damaged Flood Records

3-1	(Year/Month)	(Type)	(Reason,etc.)
	n/a	n/a	n/a

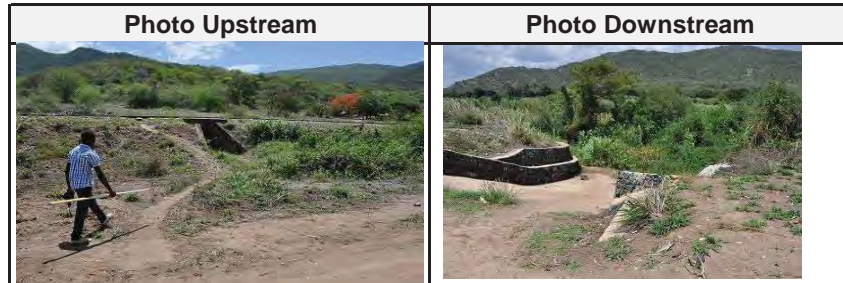

### Plan/Profile

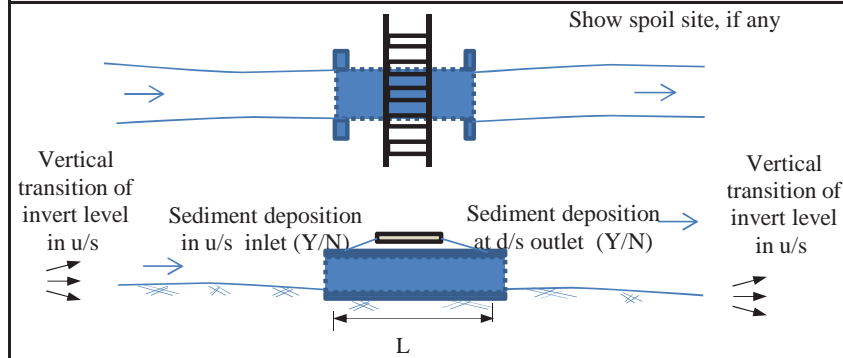

### Cross Section

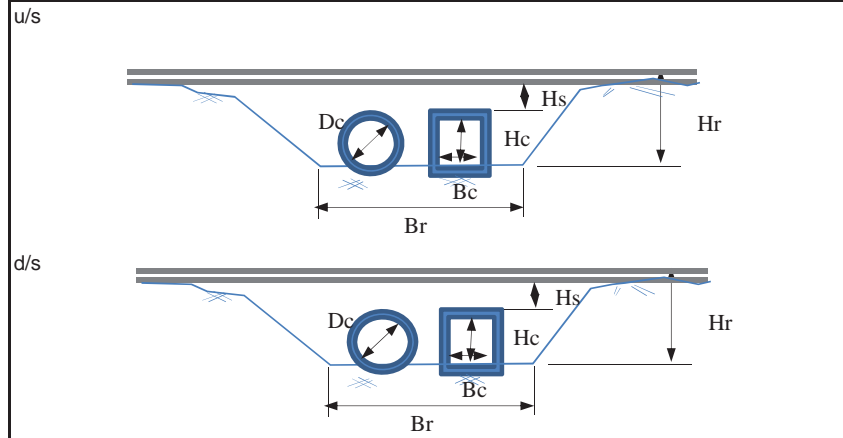

## Inventory Sheet for Culvert

**Station: at KM 313/3**      **Sheet No.: PCL313.3**

### 1. General

1-1	Name of Inspector	T.Fukuda, Mr.Kido, Mr.Philipo	
1-2	Organization of Inspector	B	
1-3	Date/Time of Inspection	DEC 4 2014	1330
1-4	Location	Lat	06°41'56.2"
1-5		Long	036°47'16.8"
1-6	Elevation	n/a	

### 2. Characteristics of Physical Condition of Culvert

2-1	Length of Culvert	n/a	
2-2	Shape of Cross Section	Circle x 2	
2-3	Flow Area	Height	n/a
2-4		Width	n/a
2-5		Other	d= 0.9m, WL=2.0m, Hs=1.1m
2-6	Connecting Channel	Height	n/a
2-7		Width	n/a
2-8		Side Slope	n/a
2-9	Type of Culvert	Concrete	
2-10	Riverbed	Material	n/a
2-11	Sediment deposition	u/s	Y, ?
2-12		d/s	Y, ?
2-13	Topography	u/s:    →    , d/s    →	
2-14	Land Use	n/a	
2-15	Structures/Houses, road	n/a	

### 3. Damaged Flood Records

3-1	(Year/Month)	(Type)	(Reason,etc.)
	?	washout	?

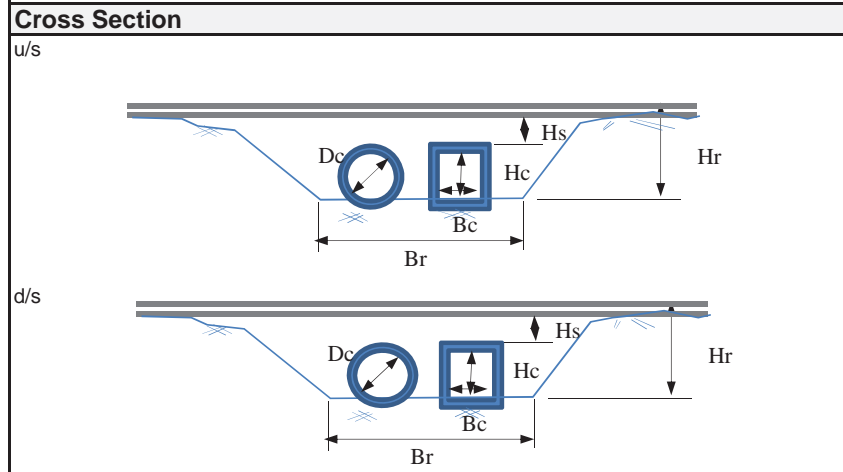
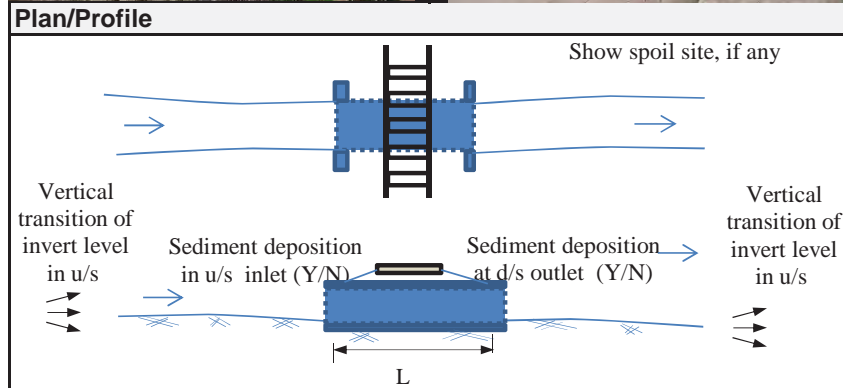
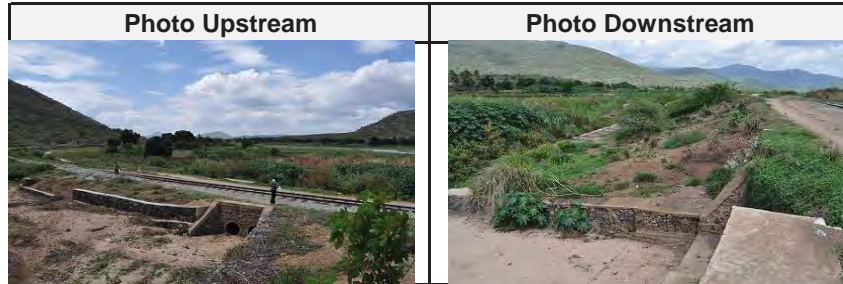

## Inventory Sheet for Culvert

**Station: at KM 313/4**      **Sheet No.: BCL313.3**

### 1. General

1-1	Name of Inspector		T.Fukuda, Mr.Kido, Mr.Philipo
1-2	Organization of Inspector		B
1-3	Date/Time of Inspection		DEC 4 2014    1333
1-4	Location	Lat	0641'56.2"
1-5		Long	036°47'15.7"
1-6	Elevation		n/a

### 2. Characteristics of Physical Condition of Culvert

2-1	Length of Culvert		n/a
2-2	Shape of Cross Section		Rectangular × 1
2-3	Flow Area	Height	Hc= 2.0m
2-4		Width	Bc= 2.0m
2-5		Other	WL=3.7m, Hs=0.45m
2-6	Connecting Channel	Height	n/a
2-7		Width	n/a
2-8		Side Slope	n/a
2-9	Type of Culvert		Concrete
2-10	Riverbed	Material	n/a
2-11	Sediment deposition	u/s	N, 0%
2-12		d/s	N, 0%
2-13	Topography		u/s: →      ,d/s →
2-14	Land Use		n/a
2-15	Structures/Houses, road		n/a

### 3. Damaged Flood Records

3-1	(Year/Month)	(Type)	(Reason,etc.)
	?	washout	?

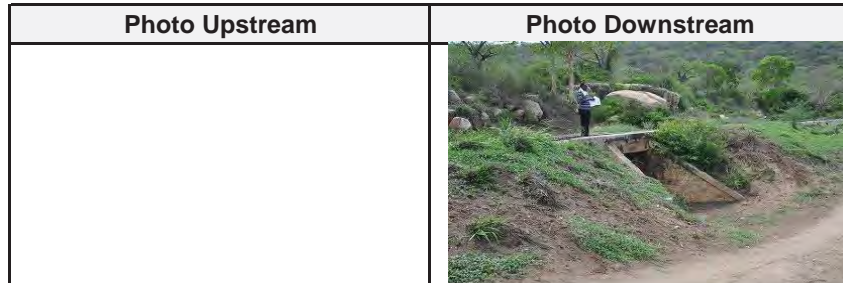

### Plan/Profile

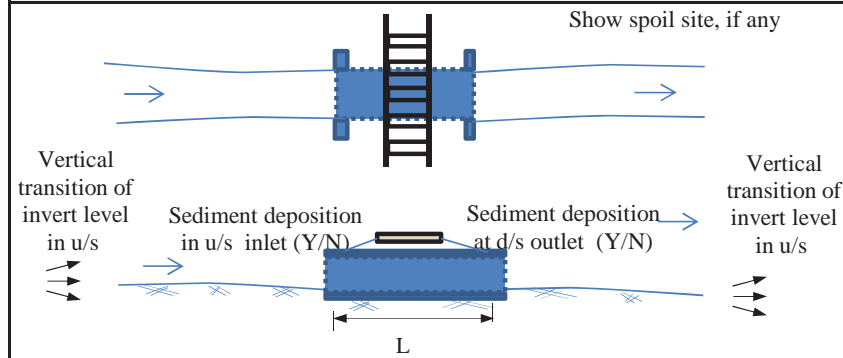

### Cross Section

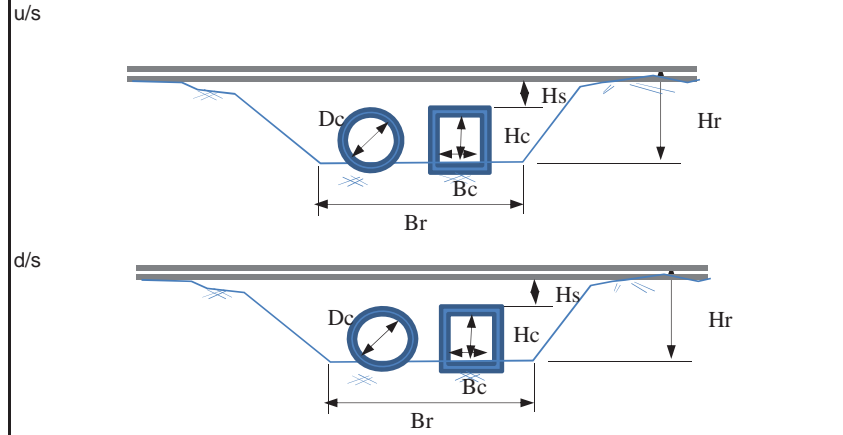

## Inventory Sheet for Culvert

**Station: at KM 314/1**      **Sheet No.: BCL314.1**

### 1. General

1-1	Name of Inspector	T.Fukuda, Mr.Kido, Mr.Philipo	
1-2	Organization of Inspector	B	
1-3	Date/Time of Inspection	DEC 4 2014	1355
1-4	Location	Lat	0641'46.6"
1-5		Long	036°46'55.4"
1-6	Elevation	n/a	

### 2. Characteristics of Physical Condition of Culvert

2-1	Length of Culvert	n/a	
2-2	Shape of Cross Section	Rectangular × 1	
2-3	Flow Area	Height	Hc= 0.6m
2-4		Width	Bc= 1.0m
2-5		Other	WL=2.0m, Hs=0.45m
2-6	Connecting Channel	Height	n/a
2-7		Width	n/a
2-8		Side Slope	n/a
2-9	Type of Culvert	Concrete	
2-10	Riverbed	Material	n/a
2-11	Sediment deposition	u/s	Y, 40%
2-12		d/s	Y, 40%
2-13	Topography	u/s: → ,d/s →	
2-14	Land Use	n/a	
2-15	Structures/Houses, road	n/a	

### 3. Damaged Flood Records

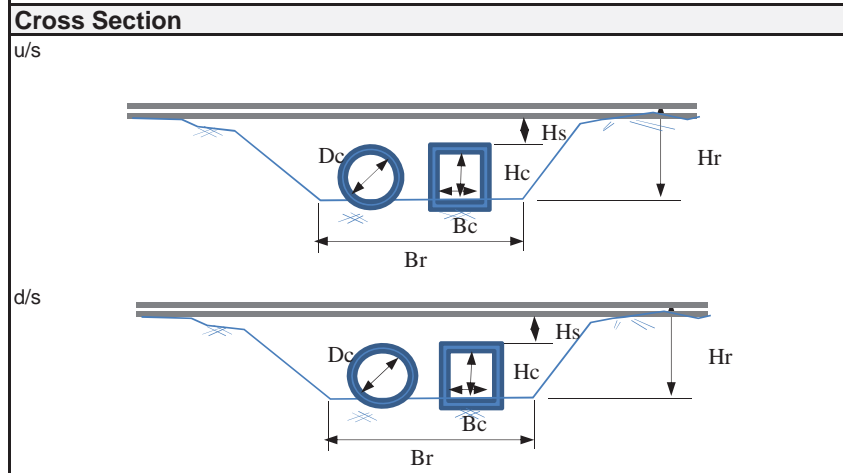
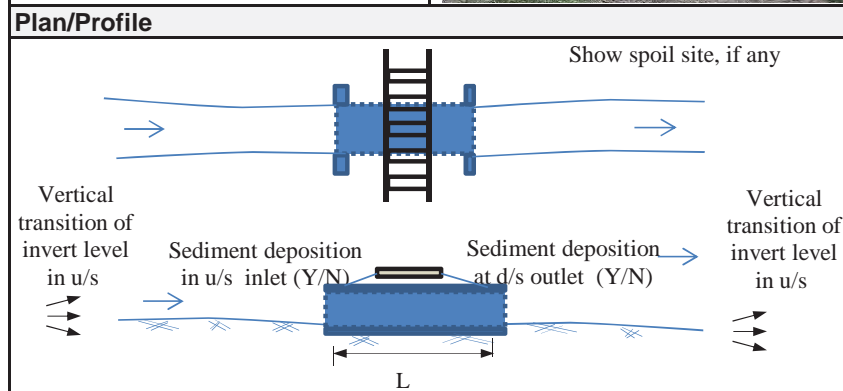

3-1	(Year/Month)	(Type)	(Reason,etc.)
	n/a	n/a	n/a





## Inventory Sheet for Culvert

<b>Station: at KM 314/4</b>		<b>Sheet No.: PCL314.4</b>	
<b>1. General</b>			
1-1	Name of Inspector	T.Fukuda, Mr.Kido, Mr.Philipo	
1-2	Organization of Inspector	B	
1-3	Date/Time of Inspection	DEC 4 2014 1401	
1-4	Location	Lat	0641'44.1"
1-5		Long	036°46'47.3"
1-6	Elevation	n/a	
<b>2. Characteristics of Physical Condition of Culvert</b>			
2-1	Length of Culvert	n/a	
2-2	Shape of Cross Section	Circle x 1	
2-3	Flow Area	Height	n/a
2-4		Width	n/a
2-5		Other	d= 0.95m, WL=3.6m, Hs= 1.1m
2-6	Connecting Channel	Height	n/a
2-7		Width	n/a
2-8		Side Slope	n/a
2-9	Type of Culvert	Concrete	
2-10	Riverbed	Material	n/a
2-11	Sediment deposition	u/s	Y, ?
2-12		d/s	Y, ?
2-13	Topography	u/s: → ,d/s →	
2-14	Land Use	n/a	
2-15	Structures/Houses, road	n/a	
<b>3. Damaged Flood Records</b>			
3-1	(Year/Month)	(Type)	(Reason,etc.)
	n/a	n/a	n/a

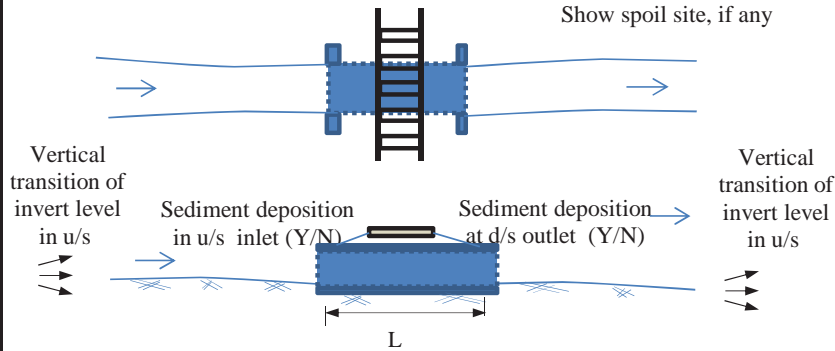
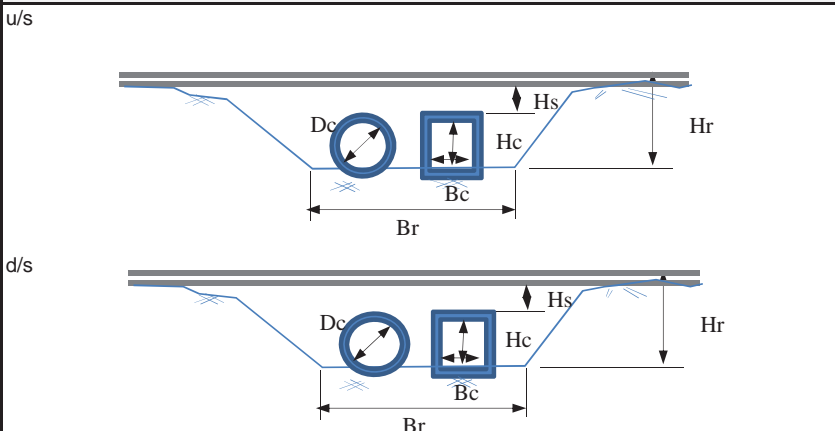
<b>Photo Upstream</b>	<b>Photo Downstream</b>
	
<b>Plan/Profile</b>	
	
<b>Cross Section</b>	
	

## Inventory Sheet for Culvert

**Station: at KM 314/5**      **Sheet No.: PCL314.5**

<b>1. General</b>			
1-1	Name of Inspector	T.Fukuda, Mr.Kido, Mr.Philipo	
1-2	Organization of Inspector	B	
1-3	Date/Time of Inspection	DEC 4 2014	1413
1-4	Location	Lat	0641'40.9"
1-5		Long	03646'42.5"
1-6	Elevation	n/a	

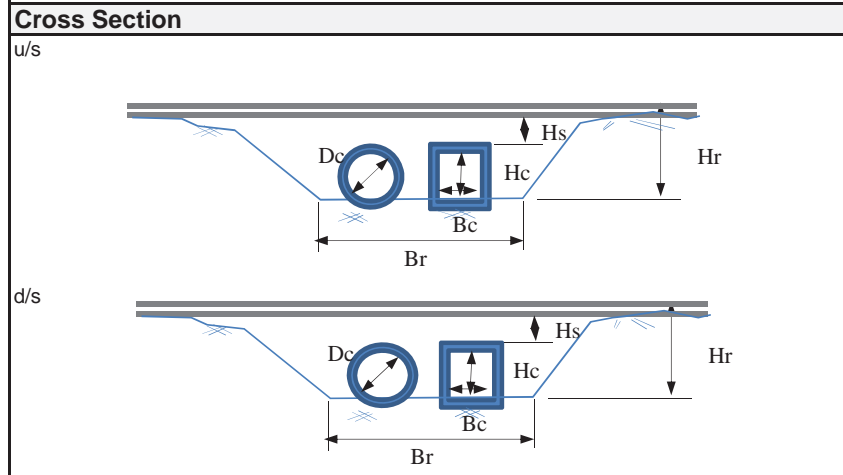
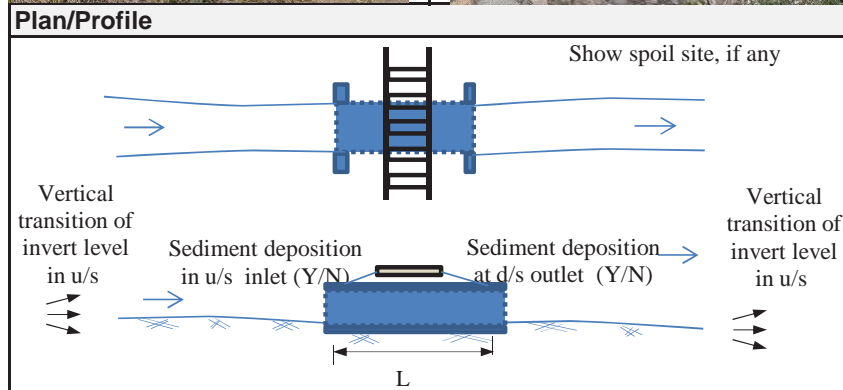
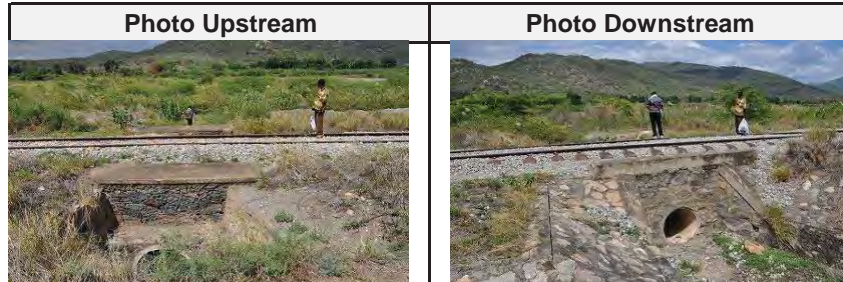

<b>2. Characteristics of Physical Condition of Culvert</b>			
2-1	Length of Culvert	n/a	
2-2	Shape of Cross Section	Circle x 1	
2-3	Flow Area	Height	n/a
2-4		Width	n/a
2-5		Other	d= 0.9m, WL=2.0m, Hs= 0.75m
2-6	Connecting Channel	Height	n/a
2-7		Width	n/a
2-8		Side Slope	n/a
2-9	Type of Culvert	Concrete	
2-10	Riverbed	Material	n/a
2-11	Sediment deposition	u/s	N, 0%
2-12		d/s	N, 0%
2-13	Topography	u/s:    →    ,d/s    →	
2-14	Land Use	n/a	
2-15	Structures/Houses, road	n/a	

<b>3. Damaged Flood Records</b>			
3-1	(Year/Month)	(Type)	(Reason,etc.)
	n/a	n/a	n/a



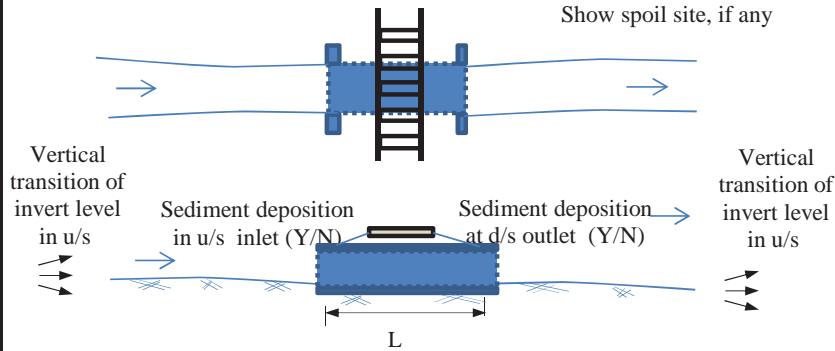
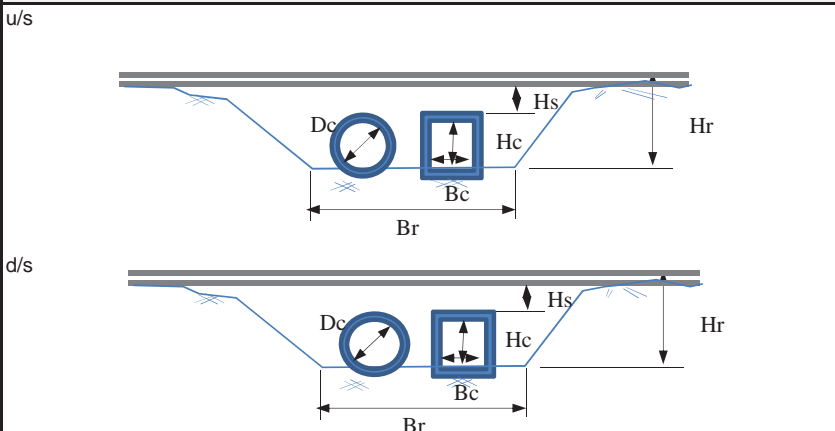

## Inventory Sheet for Culvert

<b>Station: at KM 314/9</b>		<b>Sheet No.: BCL314.9</b>	
<b>1. General</b>			
1-1	Name of Inspector	T.Fukuda, Mr.Kido, Mr.Philipo	
1-2	Organization of Inspector	B	
1-3	Date/Time of Inspection	DEC 4 2014 1420	
1-4	Location	Lat	0641'34.3"
1-5		Long	036°46'30.5"
1-6	Elevation	n/a	
<b>2. Characteristics of Physical Condition of Culvert</b>			
2-1	Length of Culvert	n/a	
2-2	Shape of Cross Section	Rectangular × 1	
2-3	Flow Area	Height	Hc= 1.8m
2-4		Width	Bc= 2.0m
2-5		Other	WL=3.0m, Hs= 0.35m
2-6	Connecting Channel	Height	n/a
2-7		Width	n/a
2-8		Side Slope	n/a
2-9	Type of Culvert	Concrete	
2-10	Riverbed	Material	n/a
2-11	Sediment deposition	u/s	Y, 10%
2-12		d/s	Y, 10%
2-13	Topography	u/s: → ,d/s →	
2-14	Land Use	n/a	
2-15	Structures/Houses, road	n/a	
<b>3. Damaged Flood Records</b>			
3-1	(Year/Month)	(Type)	(Reason,etc.)
	n/a	overtop	n/a

<b>Photo Upstream</b>	<b>Photo Downstream</b>
	
<b>Plan/Profile</b>	
 <p style="text-align: center;">Show spoil site, if any</p> <p style="text-align: center;">Vertical transition of invert level in u/s      Sediment deposition in u/s inlet (Y/N)      Sediment deposition at d/s outlet (Y/N)      Vertical transition of invert level in u/s</p> <p style="text-align: center;">L</p>	
<b>Cross Section</b>	
 <p style="text-align: center;">u/s</p> <p style="text-align: center;">d/s</p>	

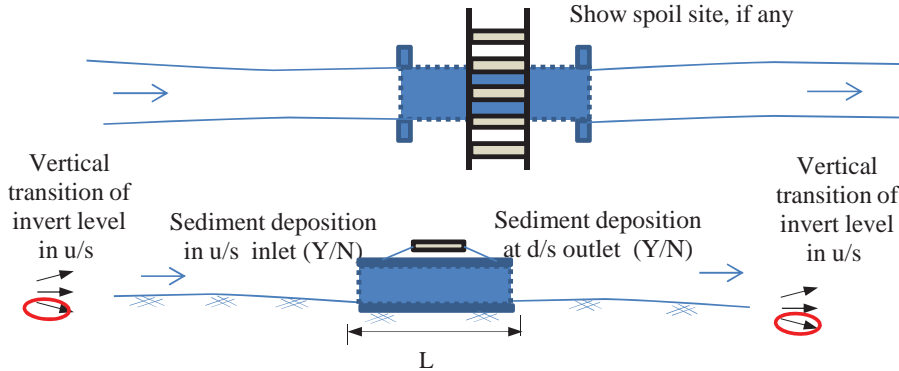
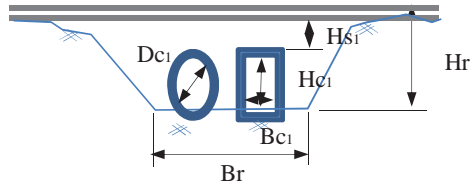
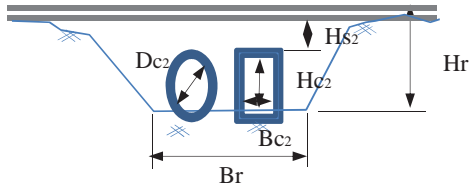

## Inventory Sheet for Culvert

<b>Station: at KM 325.7</b>		<b>Sheet No.: PCL 325.7</b>	
<b>1. General</b>			
1-1	Name of Inspector	T. Kawaguchi , Hussein , Abiud	
1-2	Organization of Inspector	JICA Study Team	
1-3	Date/Time of Inspection	2014/3/12	
1-4	Location	Lat	06° 38' 45" 94"
1-5		Long	036° 42' 20" 55"
1-6	Elevation		
<b>2. Characteristics of Physical Condition of Culvert</b>			
2-1	Length of Culvert	6.0 m	
2-2	Shape of Cross Section	Square: Rectangular:(1) Circle: (2)	
2-3	Flow Area	Height	Hc1 = 0.36 m , Hc2 = 2.2 m
2-4		Width	Dc1 = 0.9 m , Bc2 = 2.0 m
2-5		Other	Hs1 = 2.6 m , Hs2 = 1.3 m
2-6	Connecting Channel	Height	
2-7		Width	
2-8		Side Slope	
2-9	Type of Culvert	Concrete	
2-10	Riverbed	Material	Silty sand
2-11	Sediment deposition	u/s	Heavy ( 60% rate)
2-12		d/s	No ( 0% rate)
2-13	Topography	u/s:  , d/s:	
2-14	Land Use		
2-15	Structures/Houses, road		
<b>3. Damaged Flood Records</b>			
3-1	(Year/Month)	(Type)	(Reason,etc.)

<b>Photo Upstream</b>	<b>Photo Downstream</b>
	
<b>Plan/Profile</b>	
	
<b>Cross Section</b>	
u/s	
d/s	

## Inventory Sheet for Culvert

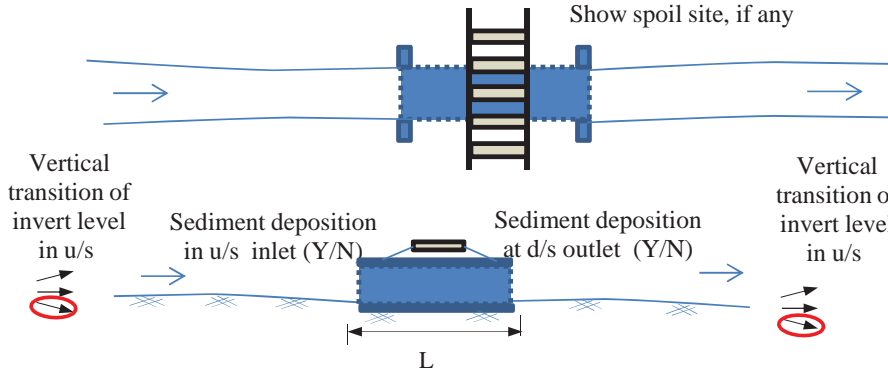
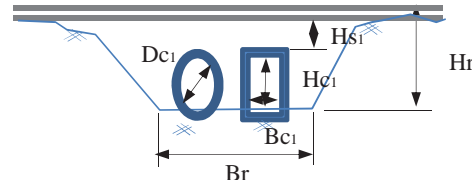
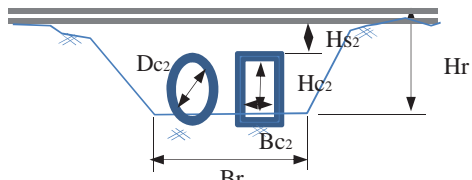

<b>Station: at KM 325.7</b>		<b>Sheet No.: PCL 325.75</b>	
<b>1. General</b>			
1-1	Name of Inspector	T. Kawaguchi , Hussein , Abiud	
1-2	Organization of Inspector	JICA Study Team	
1-3	Date/Time of Inspection	2014/3/12	
1-4	Location	Lat	06° 38' 43" 15"
1-5		Long	036° 42' 20" 54"
1-6	Elevation		
<b>2. Characteristics of Physical Condition of Culvert</b>			
2-1	Length of Culvert	7.0 m	
2-2	Shape of Cross Section	Square: Rectangular: Circle:(2)	
2-3	Flow Area	Height	Hc1 = 0.45 m , Hc2 = 0.72 m
2-4		Width	Dc1 = 0.90 m , Dc2 = 0.90 m
2-5		Other	Hs1 = 1.2 m , Hs2 = 1.3 m
2-6	Connecting Channel	Height	
2-7		Width	
2-8		Side Slope	
2-9	Type of Culvert	Concrete	
2-10	Riverbed	Material	Silty sand
2-11	Sediment deposition	u/s	Heavy ( 50% rate)
2-12		d/s	Light ( 20% rate)
2-13	Topography	u/s:	, d/s:
2-14	Land Use		
2-15	Structures/Houses, road		
<b>3. Damaged Flood Records</b>			
3-1	(Year/Month)	(Type)	(Reason,etc.)

<b>Photo Upstream</b>	<b>Photo Downstream</b>
	
<b>Plan/Profile</b>	
	
<b>Cross Section</b>	
u/s	
d/s	



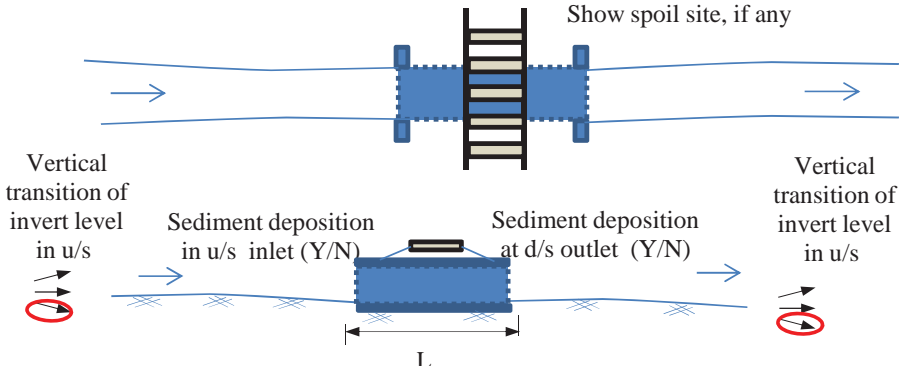
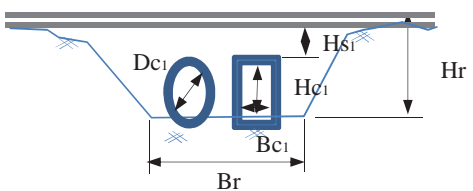
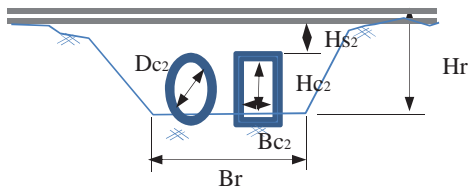

## Inventory Sheet for Culvert

<b>Station: at KM 326.9</b>		<b>Sheet No.: PCL 326.9</b>	
<b>1. General</b>			
1-1	Name of Inspector	T. Kawaguchi , Hussein , Abiud	
1-2	Organization of Inspector	JICA Study Team	
1-3	Date/Time of Inspection	2014/3/12	
1-4	Location	Lat	06° 38' 20" 57"
1-5		Long	036° 41' 48" 67"
1-6	Elevation		
<b>2. Characteristics of Physical Condition of Culvert</b>			
2-1	Length of Culvert	8.0 m	
2-2	Shape of Cross Section	Square: Rectangular: Circle: (Arch- half circle)	
2-3	Flow Area	Height	Hc1 = 2.3 m , Hc2 = 2.3 m
2-4		Width	Bc1 = 2.5 m , Bc2 = 2.5 m
2-5		Other	Hs1 = 5.0 m , Hs2 = 5.0 m
2-6	Connecting Channel	Height	
2-7		Width	
2-8		Side Slope	
2-9	Type of Culvert	Concrete	
2-10	Riverbed	Material	Silty sand
2-11	Sediment deposition	u/s	No ( 0% rate)
2-12		d/s	No ( 0% rate)
2-13	Topography	u/s:  , d/s:	
2-14	Land Use		
2-15	Structures/Houses, road		
<b>3. Damaged Flood Records</b>			
3-1	(Year/Month)	(Type)	(Reason, etc.)

<b>Photo Upstream</b>	<b>Photo Downstream</b>
	
<b>Plan/Profile</b>	
 <p style="text-align: center;">Vertical transition of invert level in u/s      Sediment deposition in u/s inlet (Y/N)      Sediment deposition at d/s outlet (Y/N)      Vertical transition of invert level in u/s</p>	
<b>Cross Section</b>	
u/s	
d/s	

## Inventory Sheet for Culvert

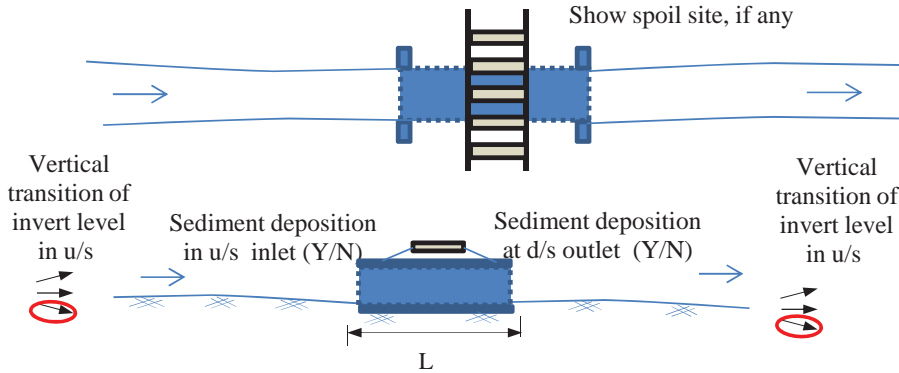
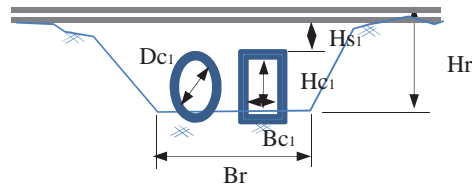
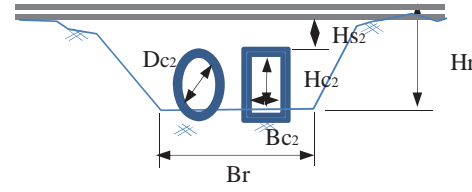

<b>Station: at KM 327.4</b>		<b>Sheet No.: BCL 327.4</b>	
<b>1. General</b>			
1-1	Name of Inspector	T. Kawaguchi , Hussein , Abiud	
1-2	Organization of Inspector	JICA Study Team	
1-3	Date/Time of Inspection	2014/3/12	
1-4	Location	Lat	06° 38' 11" 02"
1-5		Long	036° 41' 39" 53"
1-6	Elevation		
<b>2. Characteristics of Physical Condition of Culvert</b>			
2-1	Length of Culvert	5.0 m	
2-2	Shape of Cross Section	Square: <u>Rectangular:(1)</u> Circle:	
2-3	Flow Area	Height	Hc1 = 2.6 m , Hc2 = 3.6 m
2-4		Width	Bc1 = 3.0 m , Bc2 = 3.0 m
2-5	Connecting Channel	Other	Hs1 = 0.9 m , Hs2 = 0.9 m
2-6		Height	
2-7	Width		
2-8	Side Slope		
2-9	Type of Culvert	Concrete	
2-10	Riverbed	Material	Silty sand
2-11	Sediment deposition	u/s	No ( 0% rate)
2-12		d/s	No ( 0% rate)
2-13	Topography	u/s:  , d/s:	
2-14	Land Use		
2-15	Structures/Houses, road		
<b>3. Damaged Flood Records</b>			
3-1	(Year/Month)	(Type)	(Reason,etc.)

<b>Photo Upstream</b>	<b>Photo Downstream</b>
	
<b>Plan/Profile</b>	
	
<b>Cross Section</b>	
u/s	
d/s	

## Inventory Sheet for Culvert

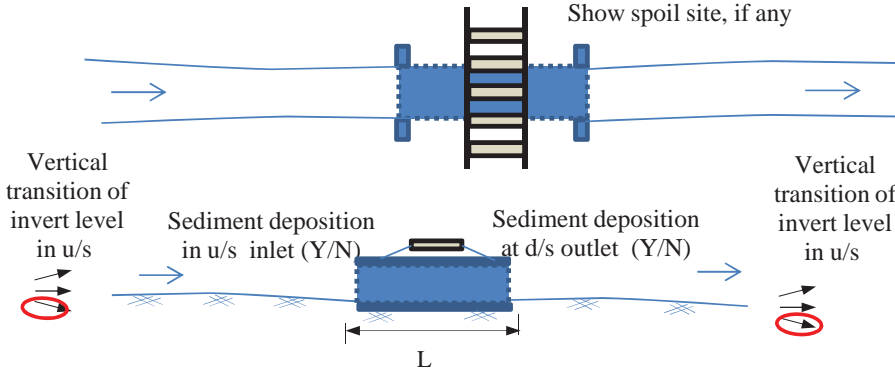
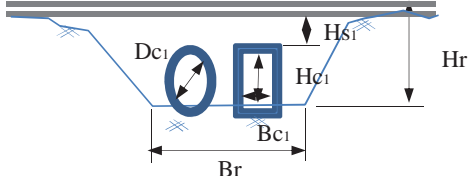
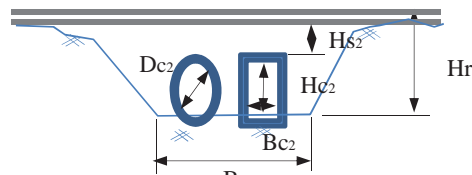

<b>Station: at KM 327.9</b>		<b>Sheet No.: PCL 327.9</b>	
<b>1. General</b>			
1-1	Name of Inspector	T. Kawaguchi , Hussein , Abiud	
1-2	Organization of Inspector	JICA Study Team	
1-3	Date/Time of Inspection	2014/3/12	
1-4	Location	Lat	06° 37' 54" 97"
1-5		Long	036° 41' 38" 77"
1-6	Elevation		
<b>2. Characteristics of Physical Condition of Culvert</b>			
2-1	Length of Culvert	8.0 m	
2-2	Shape of Cross Section	Square: Rectangular: Circle:(Arch -Half circle)	
2-3	Flow Area	Height	Hc1 = 3.8 m , Hc2 = 3.8 m
2-4		Width	Bc1 = 5.0 m , Bc2 = 5.0 m
2-5		Other	Hs1 = 2.0 m , Hs2 = 2.0 m
2-6	Connecting Channel	Height	
2-7		Width	
2-8		Side Slope	
2-9	Type of Culvert	Concrete	
2-10	Riverbed	Material	Silty sand
2-11	Sediment	u/s	No ( 0% rate)
2-12	deposition	d/s	No ( 0% rate)
2-13	Topography	u/s:	, d/s:
2-14	Land Use		
2-15	Structures/Houses, road		
<b>3. Damaged Flood Records</b>			
3-1	(Year/Month)	(Type)	(Reason,etc.)

F-83

<b>Photo Upstream</b>	<b>Photo Downstream</b>
	
<b>Plan/Profile</b>	
 <p style="text-align: right; margin-right: 50px;">Show spoil site, if any</p>	
<b>Cross Section</b>	
u/s	
d/s	

## Inventory Sheet for Culvert

<b>Station: at KM 328.8</b>		<b>Sheet No.: PCL 328.8</b>	
<b>1. General</b>			
1-1	Name of Inspector	T. Kawaguchi , Hussein , Abiud	
1-2	Organization of Inspector	JICA Study Team	
1-3	Date/Time of Inspection	2014/3/12	
1-4	Location	Lat	06° 37' 35" 62"
1-5		Long	036° 41' 28" 64"
1-6	Elevation		
<b>2. Characteristics of Physical Condition of Culvert</b>			
2-1	Length of Culvert	8.0 m	
2-2	Shape of Cross Section	Square: Rectangular: Circle:(Arch -half circle)	
2-3	Flow Area	Height	Hc1 = 2.7 m , Hc2 = 2.9 m
2-4		Width	Bc1 = 4.0 m , Bc2 = 4.0 m
2-5	Other	Hs1 = 2.0 m , Hs2 = 2.5 m	
2-6	Connecting Channel	Height	
2-7		Width	
2-8		Side Slope	
2-9	Type of Culvert	Concrete	
2-10	Riverbed	Material	Silty sand
2-11	Sediment deposition	u/s	Light ( 5% rate)
2-12		d/s	No ( 0% rate)
2-13	Topography	u/s:  , d/s:	
2-14	Land Use		
2-15	Structures/Houses, road		
<b>3. Damaged Flood Records</b>			
3-1	(Year/Month)	(Type)	(Reason,etc.)

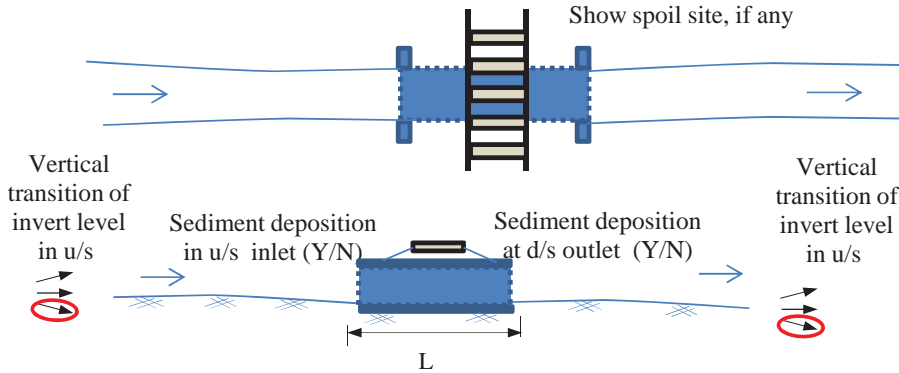
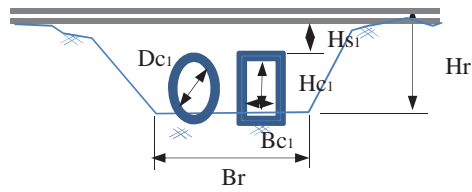
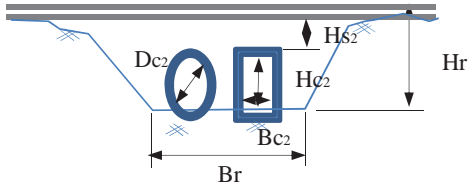
<b>Photo Upstream</b>	<b>Photo Downstream</b>
	
<b>Plan/Profile</b>	
 <p style="text-align: center;">Vertical transition of invert level in u/s      Sediment deposition in u/s inlet (Y/N)      Sediment deposition at d/s outlet (Y/N)      Vertical transition of invert level in u/s</p>	
<b>Cross Section</b>	
u/s	
d/s	

### Inventory Sheet for Culvert

**Station: at KM 333/1**      **Sheet No.: BCL333.1**

1. General			
1-1	Name of Inspector		T.Fukuda, Mr.Kido, Mr.Philipo
1-2	Organization of Inspector		B
1-3	Date/Time of Inspection		DEC 3 2014      1200
1-4	Location	Lat	06°36'15.5"
1-5		Long	036°39'46.6"
1-6	Elevation		n/a

#### 2. Characteristics of Physical Condition of Culvert

2-1	Length of Culvert		n/a
2-2	Shape of Cross Section		Rectangular × 1
2-3	Flow Area	Height	Hc= 0.4m
2-4		Width	Bc= 2.0m
2-5		Other	WL=2.0m, Hs= 0.45m
2-6	Connecting Channel	Height	n/a
2-7		Width	n/a
2-8		Side Slope	n/a
2-9	Type of Culvert		Concrete
2-10	Riverbed	Material	n/a
2-11	Sediment deposition	u/s	Y, 80%
2-12		d/s	Y, 80%
2-13	Topography		u/s:      ,d/s
2-14	Land Use		n/a
2-15	Structures/Houses, road		n/a

#### 3. Damaged Flood Records

3-1	(Year/Month)	(Type)	(Reason,etc.)
	n/a	n/a	n/a

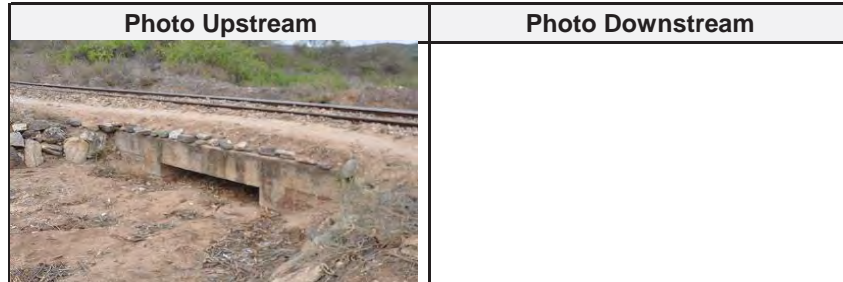

#### Plan/Profile

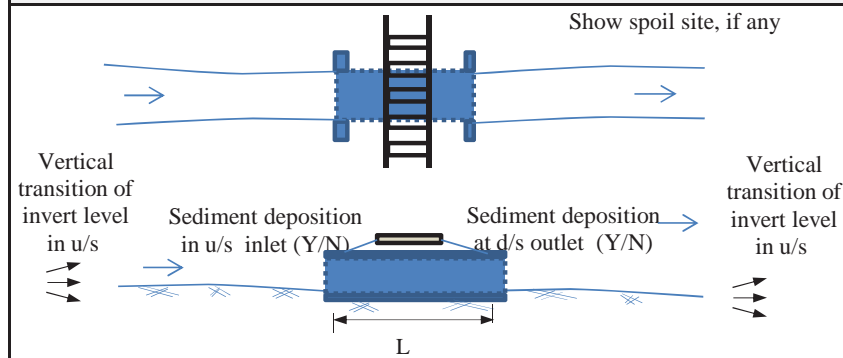

#### Cross Section

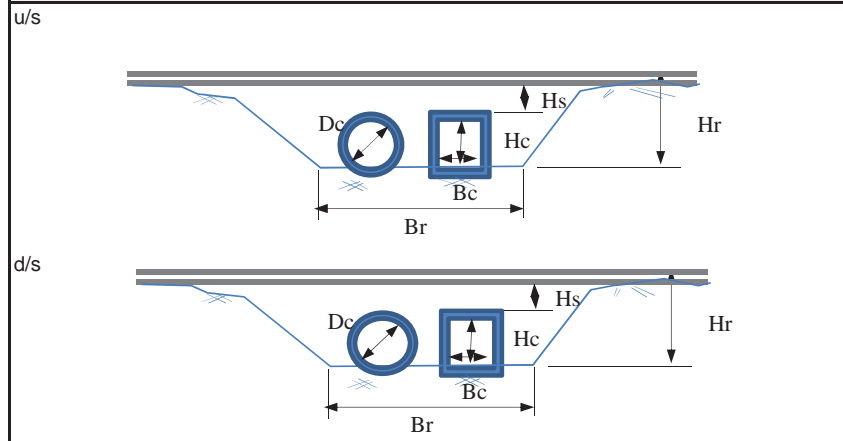



## Inventory Sheet for Culvert

**Station: at KM 333/6**      **Sheet No.: BCL333.6**

### 1. General

1-1	Name of Inspector	T.Fukuda, Mr.Kido, Mr.Philipo	
1-2	Organization of Inspector	B	
1-3	Date/Time of Inspection	DEC 3 2014	1210
1-4	Location	Lat	06°36'06.1"
1-5		Long	036°39'40.1"
1-6	Elevation	n/a	

### 2. Characteristics of Physical Condition of Culvert

2-1	Length of Culvert	n/a	
2-2	Shape of Cross Section	Rectangular × 1	
2-3	Flow Area	Height	Hc= 3.1m
2-4		Width	Bc= 5.0m
2-5		Other	WL=5.0m, Hs= 0.85m
2-6	Connecting Channel	Height	n/a
2-7		Width	n/a
2-8		Side Slope	n/a
2-9	Type of Culvert	Concrete	
2-10	Riverbed	Material	n/a
2-11	Sediment deposition	u/s	Y, 40%
2-12		d/s	Y, 40%
2-13	Topography	u/s: → ,d/s →	
2-14	Land Use	n/a	
2-15	Structures/Houses, road	n/a	

### 3. Damaged Flood Records

3-1	(Year/Month)	(Type)	(Reason,etc.)
	n/a	n/a	n/a

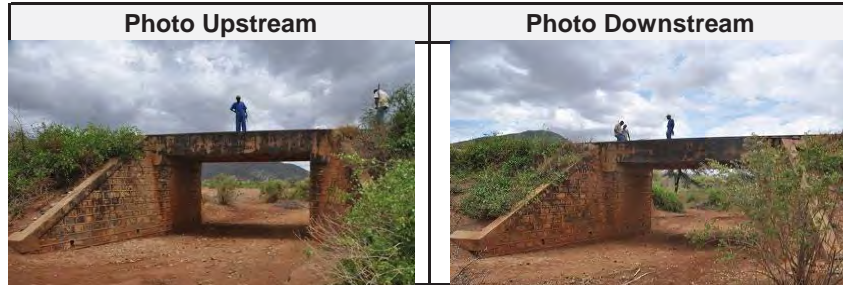

### Plan/Profile

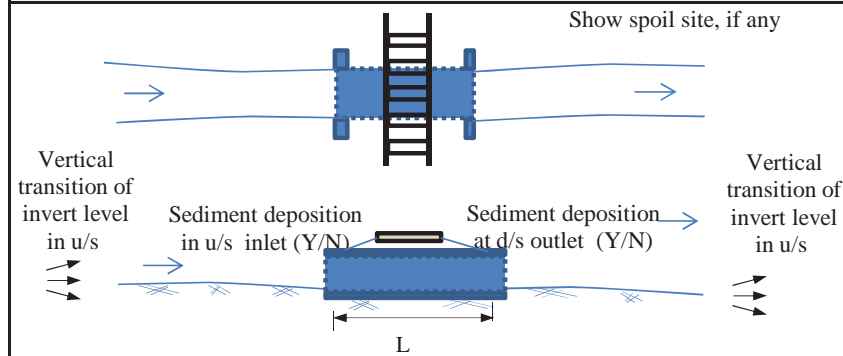

### Cross Section

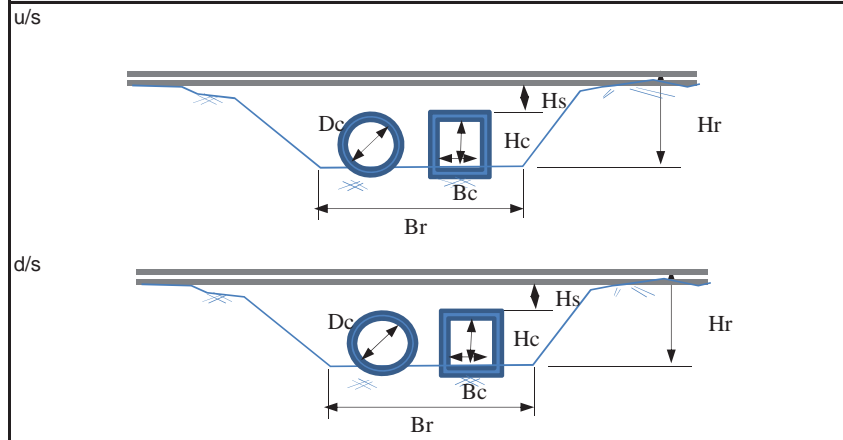

## Inventory Sheet for Culvert

**Station: at KM 334/1**      **Sheet No.: BCL334.1**

### 1. General

1-1	Name of Inspector	T.Fukuda, Mr.Kido, Mr.Philipo	
1-2	Organization of Inspector	B	
1-3	Date/Time of Inspection	DEC 3 2014	1225
1-4	Location	Lat	06°35'53.1"
1-5		Long	036°39'30.2"
1-6	Elevation	n/a	

### 2. Characteristics of Physical Condition of Culvert

2-1	Length of Culvert	n/a	
2-2	Shape of Cross Section	Rectangular × 1	
2-3	Flow Area	Height	Hc= 2.1m
2-4		Width	Bc= 2.0m
2-5		Other	WL=3.2m, Hs= 0.6m
2-6	Connecting Channel	Height	n/a
2-7		Width	n/a
2-8		Side Slope	n/a
2-9	Type of Culvert	Concrete	
2-10	Riverbed	Material	n/a
2-11	Sediment deposition	u/s	N, 0%
2-12		d/s	N, 0%
2-13	Topography	u/s: → ,d/s →	
2-14	Land Use	n/a	
2-15	Structures/Houses, road	n/a	

### 3. Damaged Flood Records

3-1	(Year/Month)	(Type)	(Reason,etc.)
	n/a	n/a	n/a

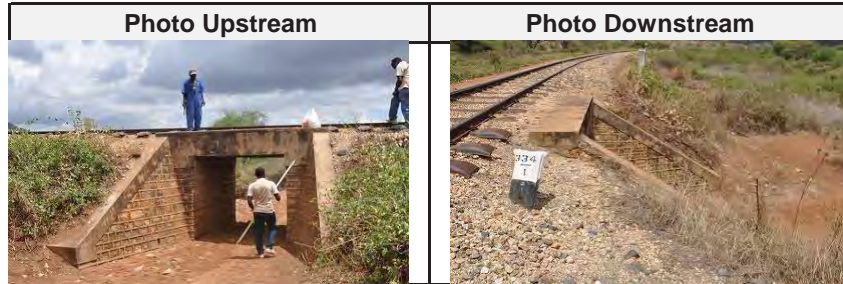

### Plan/Profile

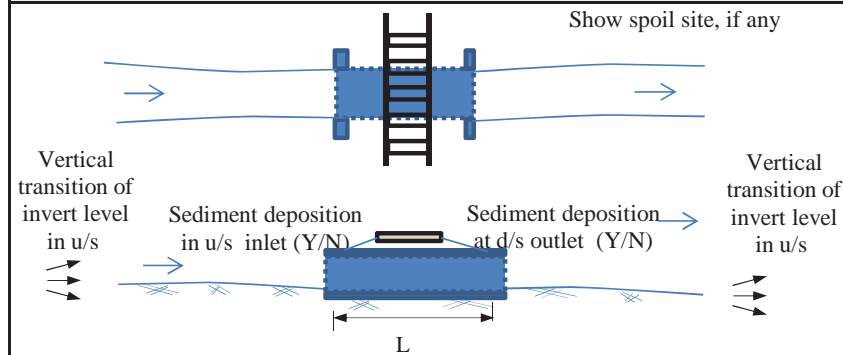

### Cross Section

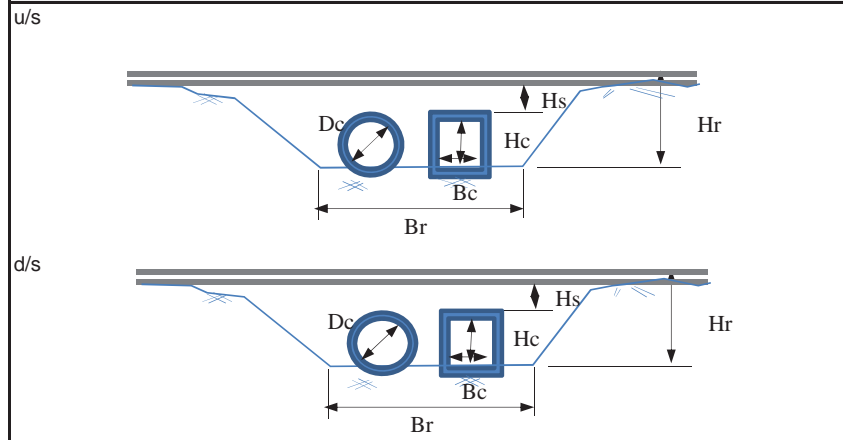

## Inventory Sheet for Culvert

**Station: at KM 334/3**      **Sheet No.: PCL334.3**

### 1. General

1-1	Name of Inspector	T.Fukuda, Mr.Kido, Mr.Philipo	
1-2	Organization of Inspector	B	
1-3	Date/Time of Inspection	DEC 3 2014	1240
1-4	Location	Lat	06°35'45.5"
1-5		Long	036°39'31.8"
1-6	Elevation	n/a	

### 2. Characteristics of Physical Condition of Culvert

2-1	Length of Culvert	n/a	
2-2	Shape of Cross Section	Half Circle x 1	
2-3	Flow Area	Height	n/a
2-4		Width	n/a
2-5		Other	d=4.0m, WL=4.0m, Hs= 0.5m
2-6	Connecting Channel	Height	n/a
2-7		Width	n/a
2-8		Side Slope	n/a
2-9	Type of Culvert	Concrete	
2-10	Riverbed	Material	n/a
2-11	Sediment deposition	u/s	Y, 10%
2-12		d/s	Y, 10%
2-13	Topography	u/s: → ,d/s →	
2-14	Land Use	n/a	
2-15	Structures/Houses, road	n/a	

### 3. Damaged Flood Records

3-1	(Year/Month)	(Type)	(Reason,etc.)
	n/a	n/a	n/a

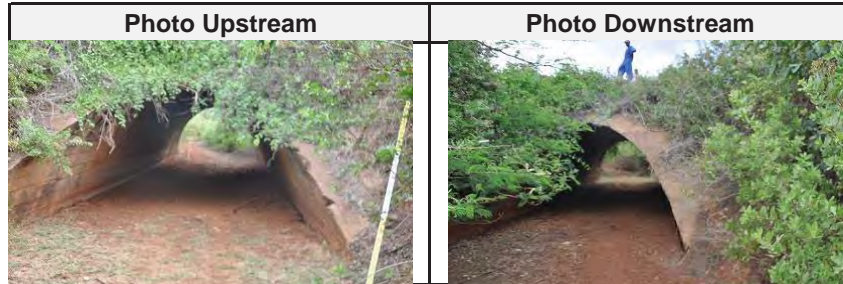

### Plan/Profile

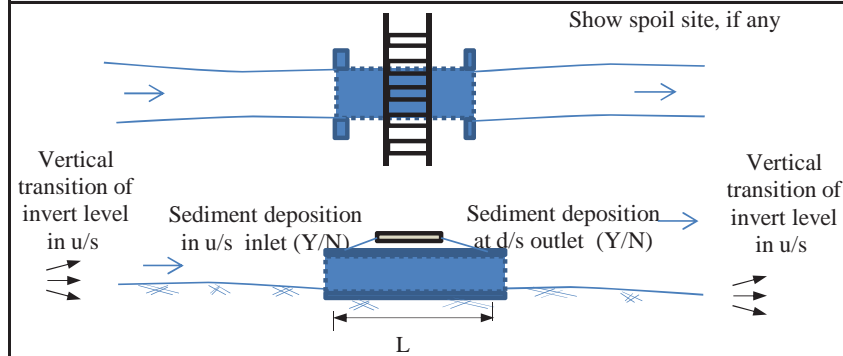

### Cross Section

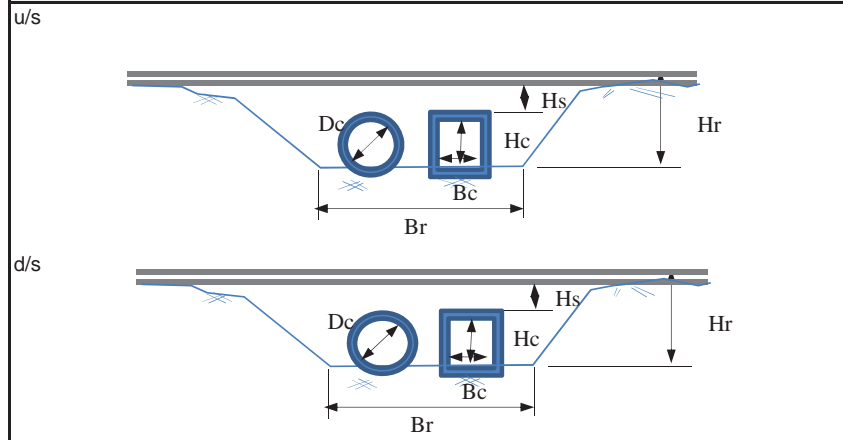

## Inventory Sheet for Culvert

**Station: at KM 334/7**      **Sheet No.: BCL334.7**

<b>1. General</b>			
1-1	Name of Inspector		T.Fukuda, Mr.Kido, Mr.Philipo
1-2	Organization of Inspector		B
1-3	Date/Time of Inspection		DEC 3 2014      1240
1-4	Location	Lat	06°35'45.5"
1-5		Long	036°39'31.8"
1-6	Elevation		n/a

<b>2. Characteristics of Physical Condition of Culvert</b>			
2-1	Length of Culvert		n/a
2-2	Shape of Cross Section		Rectangular × 1
2-3	Flow Area	Height	Hc= 0.9m
2-4		Width	Bc= 1.8m
2-5		Other	WL=3.0m, Hs= 0.55m
2-6	Connecting Channel	Height	n/a
2-7		Width	n/a
2-8		Side Slope	n/a
2-9	Type of Culvert		Concrete
2-10	Riverbed	Material	n/a
2-11	Sediment deposition	u/s	Y, 50%
2-12		d/s	Y, 50%
2-13	Topography		u/s: → ,d/s →
2-14	Land Use		n/a
2-15	Structures/Houses, road		n/a

<b>3. Damaged Flood Records</b>			
3-1	(Year/Month)	(Type)	(Reason,etc.)
	n/a	n/a	n/a

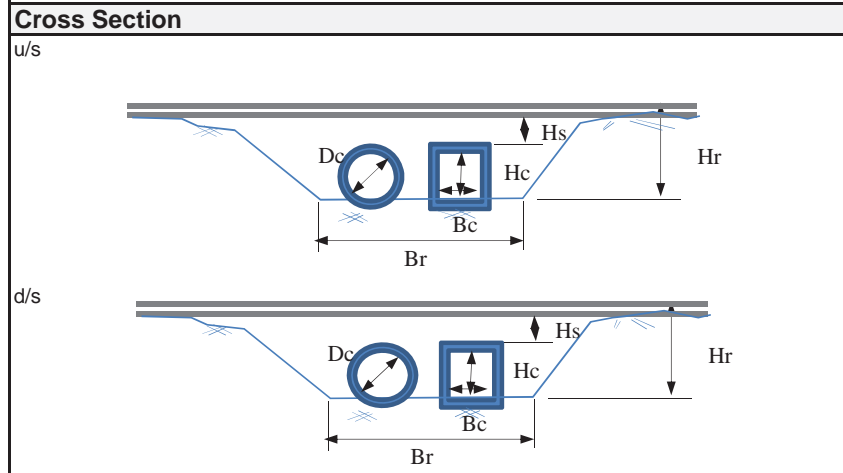
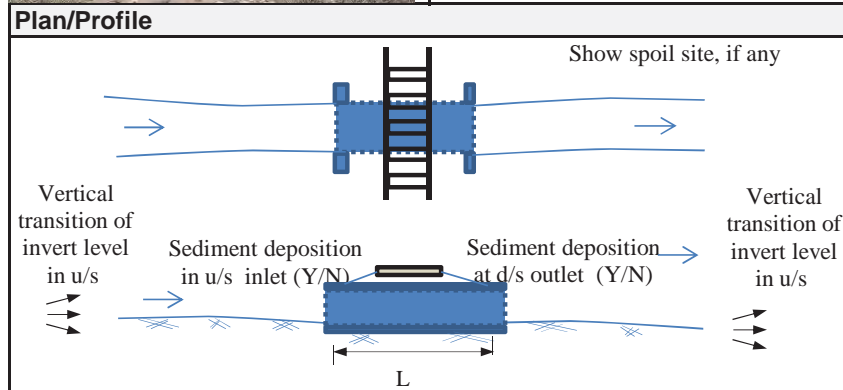
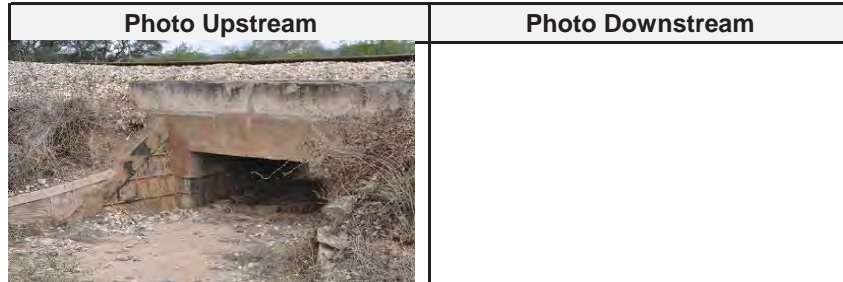

## Inventory Sheet for Culvert

**Station: at KM 334/8**      **Sheet No.: BCL334.8**

### 1. General

1-1	Name of Inspector		T.Fukuda, Mr.Kido, Mr.Philipo
1-2	Organization of Inspector		B
1-3	Date/Time of Inspection		DEC 3 2014    1249
1-4	Location	Lat	06°35'33.0"
1-5		Long	036°39'39.1"
1-6	Elevation		n/a

### 2. Characteristics of Physical Condition of Culvert

2-1	Length of Culvert		n/a
2-2	Shape of Cross Section		Rectangular × 1
2-3	Flow Area	Height	Hc= 0.5m
2-4		Width	Bc= 2.0m
2-5		Other	WL=0.0m, Hs= 0.5m
2-6	Connecting Channel	Height	n/a
2-7		Width	n/a
2-8		Side Slope	n/a
2-9	Type of Culvert		Concrete
2-10	Riverbed	Material	n/a
2-11	Sediment deposition	u/s	Y, 75%
2-12		d/s	Y, 75%
2-13	Topography		u/s: → ,d/s →
2-14	Land Use		n/a
2-15	Structures/Houses, road		n/a

### 3. Damaged Flood Records

3-1	(Year/Month)	(Type)	(Reason,etc.)
	n/a	n/a	n/a

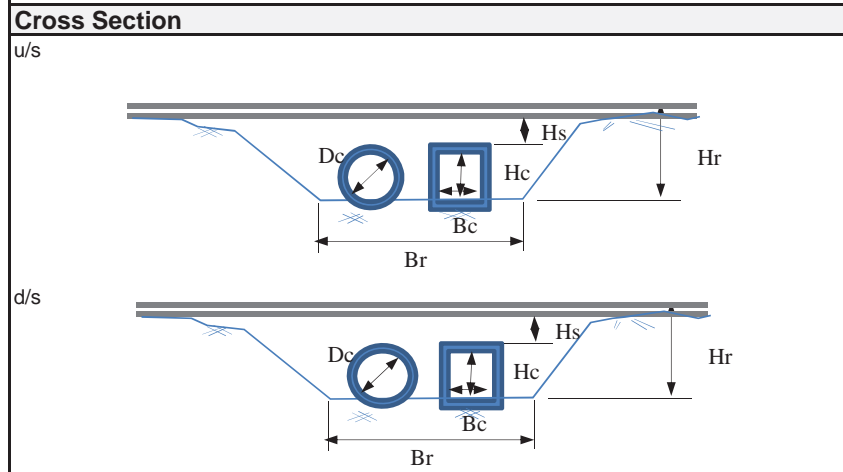
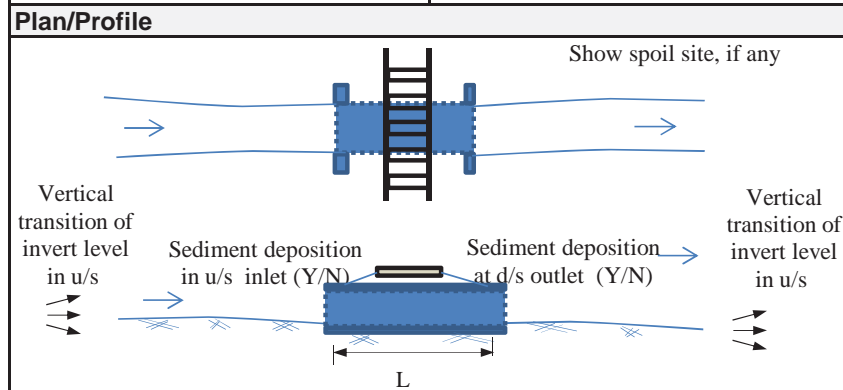
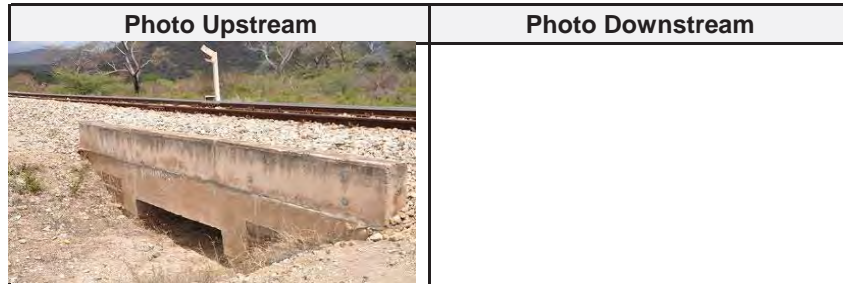



## Inventory Sheet for Culvert

**Station: at KM 335/0**      **Sheet No.: BCL335.0**

### 1. General

1-1	Name of Inspector	T.Fukuda, Mr.Kido, Mr.Philipo	
1-2	Organization of Inspector	B	
1-3	Date/Time of Inspection	DEC 3 2014	1325
1-4	Location	Lat	06°35'26.0"
1-5		Long	036°39'36.9"
1-6	Elevation	n/a	

### 2. Characteristics of Physical Condition of Culvert

2-1	Length of Culvert	n/a	
2-2	Shape of Cross Section	Rectangular × 1	
2-3	Flow Area	Height	Hc= 0.5m
2-4		Width	Bc= 2.0m
2-5		Other	WL=0.0m, Hs= 0.5m
2-6	Connecting Channel	Height	n/a
2-7		Width	n/a
2-8		Side Slope	n/a
2-9	Type of Culvert	Concrete	
2-10	Riverbed	Material	n/a
2-11	Sediment deposition	u/s	Y, 75%
2-12		d/s	Y, 75%
2-13	Topography	u/s: → ,d/s →	
2-14	Land Use	n/a	
2-15	Structures/Houses, road	n/a	

### 3. Damaged Flood Records

3-1	(Year/Month)	(Type)	(Reason,etc.)
	n/a	n/a	n/a

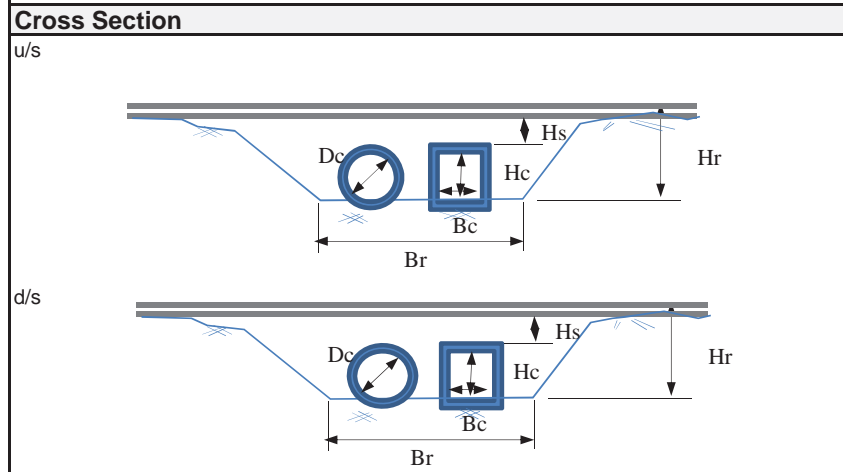
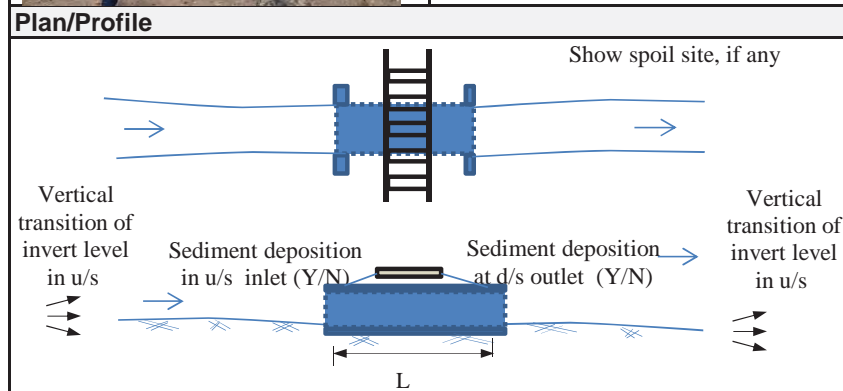
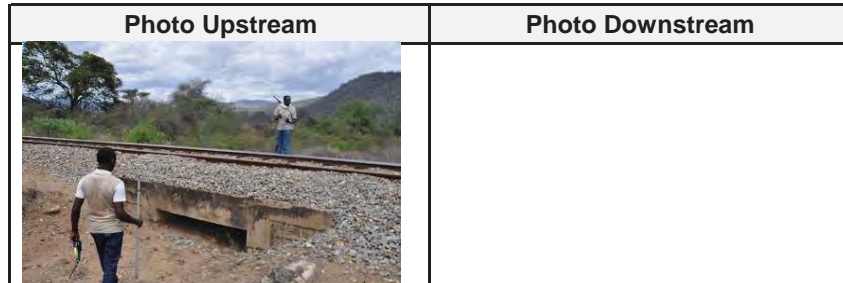

## Inventory Sheet for Culvert

<b>Station: at KM 335/1</b>		<b>Sheet No.: BCL335.1</b>	
<b>1. General</b>			
1-1	Name of Inspector	T.Fukuda, Mr.Kido, Mr.Philipo	
1-2	Organization of Inspector	B	
1-3	Date/Time of Inspection	DEC 3 2014 1330	
1-4	Location	Lat	06°35'23.6"
1-5		Long	036°39'34.3"
1-6	Elevation	n/a	
<b>2. Characteristics of Physical Condition of Culvert</b>			
2-1	Length of Culvert	n/a	
2-2	Shape of Cross Section	Rectangular × 1	
2-3	Flow Area	Height	Hc=1.75m
2-4		Width	Bc= 2.0m
2-5		Other	WL=2.9m, Hs= 0.5m
2-6	Connecting Channel	Height	n/a
2-7		Width	n/a
2-8		Side Slope	n/a
2-9	Type of Culvert	Concrete	
2-10	Riverbed	Material	n/a
2-11	Sediment deposition	u/s	Y, 15%
2-12		d/s	Y, 15%
2-13	Topography	u/s:  ,d/s:	
2-14	Land Use	n/a	
2-15	Structures/Houses, road	n/a	
<b>3. Damaged Flood Records</b>			
3-1	(Year/Month)	(Type)	(Reason,etc.)
	n/a	n/a	n/a

<b>Photo Upstream</b>	<b>Photo Downstream</b>
<b>Plan/Profile</b>	
<p style="text-align: right;">Show spoil site, if any</p>	
<b>Cross Section</b>	
u/s	d/s

## Inventory Sheet for Culvert

**Station: at KM 335/3**      **Sheet No.: BCL335.3**

1. General		
1-1	Name of Inspector	T.Fukuda, Mr.Kido, Mr.Philipo
1-2	Organization of Inspector	B
1-3	Date/Time of Inspection	DEC 3 2014      1335
1-4	Location	Lat      06°35'20.0"
1-5		Long      036°39'29.0"
1-6	Elevation	n/a

2. Characteristics of Physical Condition of Culvert		
2-1	Length of Culvert	n/a
2-2	Shape of Cross Section	Rectangular × 1
2-3	Flow Area	Height $H_c = 1.1\text{m}$
2-4		Width $B_c = 2.0\text{m}$
2-5		Other $WL = 2.4\text{m}$ , $H_s = 0.55\text{m}$
2-6	Connecting Channel	Height      n/a
2-7		Width      n/a
2-8		Side Slope      n/a
2-9	Type of Culvert	Concrete
2-10	Riverbed	Material      n/a
2-11	Sediment deposition	u/s      Y, 45%
2-12		d/s      Y, 45%
2-13	Topography	u/s:      ,d/s      →
2-14	Land Use	n/a
2-15	Structures/Houses, road	n/a

3. Damaged Flood Records			
3-1	(Year/Month)	(Type)	(Reason,etc.)
	n/a	n/a	n/a

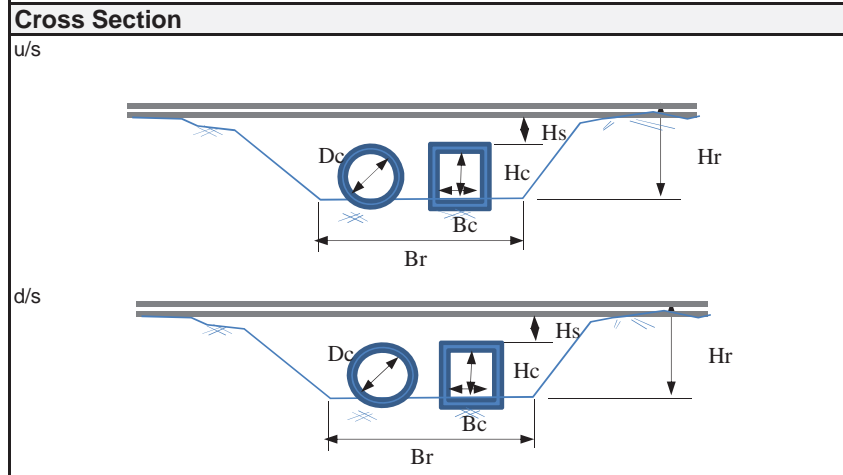
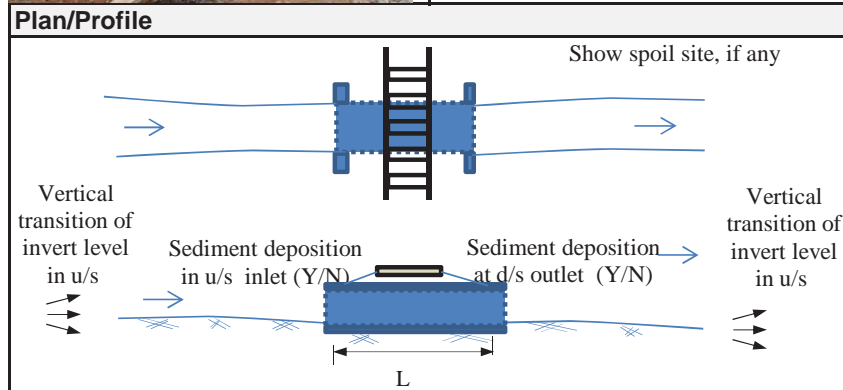

### Inventory Sheet for Culvert

**Station: at KM 335/5**      **Sheet No.: BCL335.5**

<b>1. General</b>			
1-1	Name of Inspector	T.Fukuda, Mr.Kido, Mr.Philipo	
1-2	Organization of Inspector	B	
1-3	Date/Time of Inspection	DEC 3 2014	1342
1-4	Location	Lat	06°35'15.9"
1-5		Long	036°39'22.8"
1-6	Elevation	n/a	

**2. Characteristics of Physical Condition of Culvert**

2-1	Length of Culvert	n/a	
2-2	Shape of Cross Section	Rectangular × 2	
2-3	Flow Area	Height	Hc=1.75m
2-4		Width	Bc= 2.0m
2-5		Other	WL=3.2m, Hs= 0.3m
2-6	Connecting Channel	Height	n/a
2-7		Width	n/a
2-8		Side Slope	n/a
2-9	Type of Culvert	Concrete	
2-10	Riverbed	Material	n/a
2-11	Sediment deposition	u/s	Y, 15%
2-12		d/s	Y, 15%
2-13	Topography	u/s: → ,d/s →	
2-14	Land Use	n/a	
2-15	Structures/Houses, road	n/a	

**3. Damaged Flood Records**

3-1	(Year/Month)	(Type)	(Reason,etc.)
	n/a	n/a	n/a

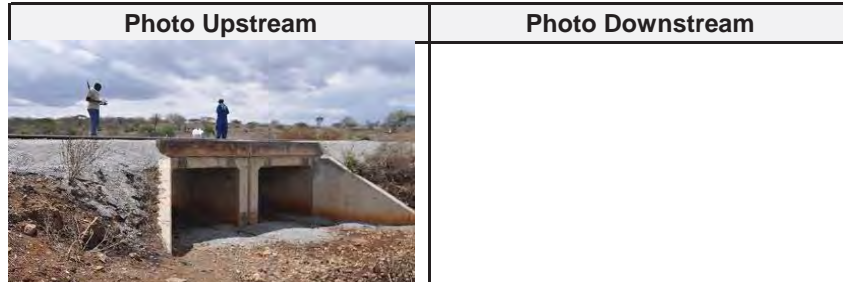

**Plan/Profile**

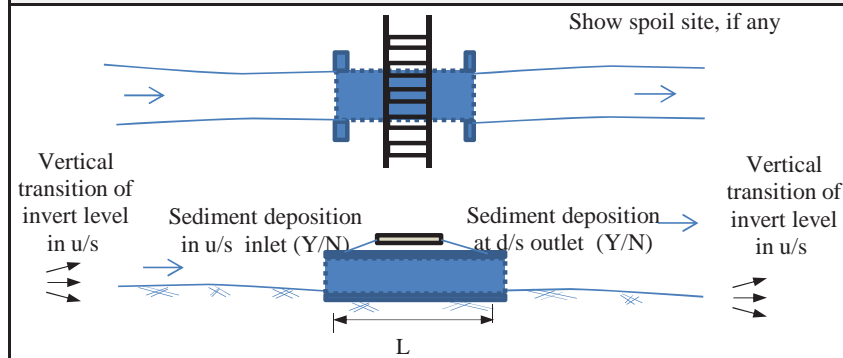

**Cross Section**

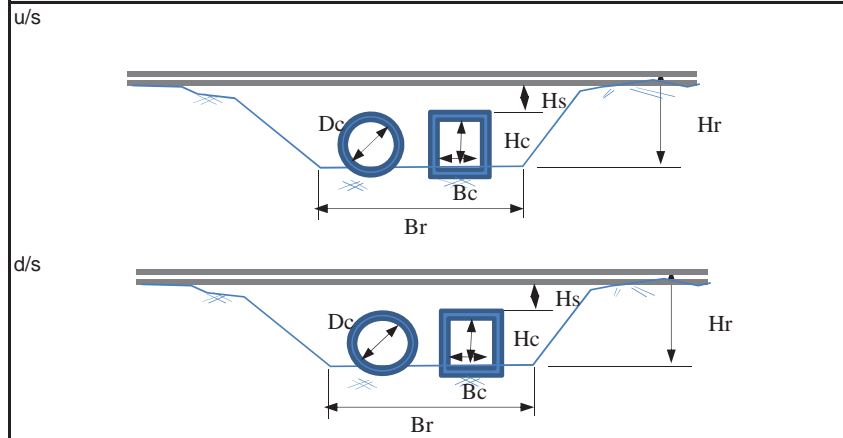

## Inventory Sheet for Culvert

**Station: at KM 335/8**      **Sheet No.: BCL335.8**

1. General		
1-1	Name of Inspector	T.Fukuda, Mr.Kido, Mr.Philipo
1-2	Organization of Inspector	B
1-3	Date/Time of Inspection	DEC 3 2014      1350
1-4	Location	Lat      06°47'02.5"
1-5		Long      036°56'58.2"
1-6	Elevation	n/a

### 2. Characteristics of Physical Condition of Culvert

2-1	Length of Culvert	n/a	
2-2	Shape of Cross Section	Rectangular × 1	
2-3	Flow Area	Height	Hc=1.55m
2-4		Width	Bc= 2.0m
2-5		Other	WL=3.0m, Hs= 0.3m
2-6	Connecting Channel	Height	n/a
2-7		Width	n/a
2-8		Side Slope	n/a
2-9	Type of Culvert	Concrete	
2-10	Riverbed	Material	n/a
2-11	Sediment deposition	u/s	Y, 25%
2-12		d/s	Y, 25%
2-13	Topography	u/s:      ,d/s      →	
2-14	Land Use	n/a	
2-15	Structures/Houses, road	n/a	

### 3. Damaged Flood Records

3-1	(Year/Month)	(Type)	(Reason,etc.)
	n/a	n/a	n/a

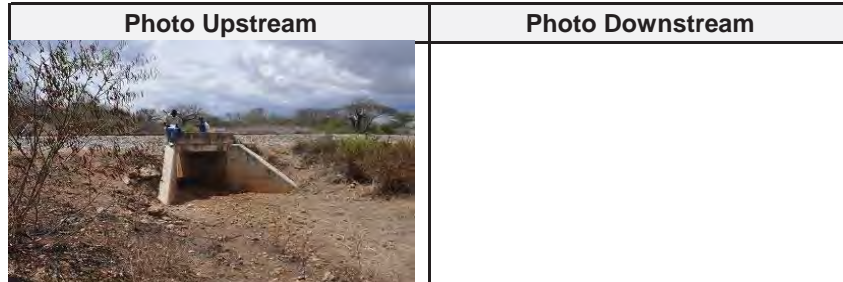

### Plan/Profile

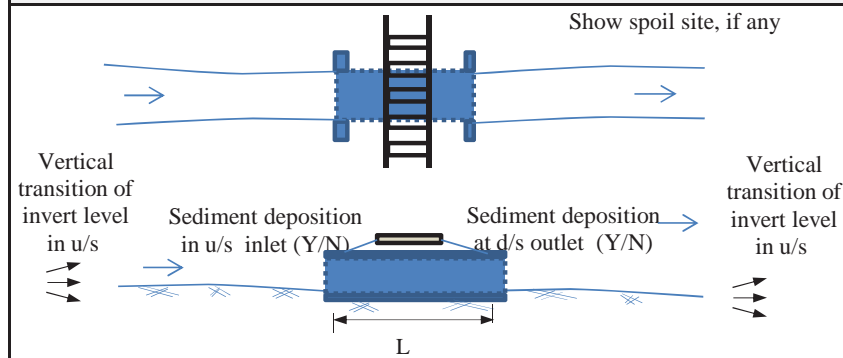

### Cross Section

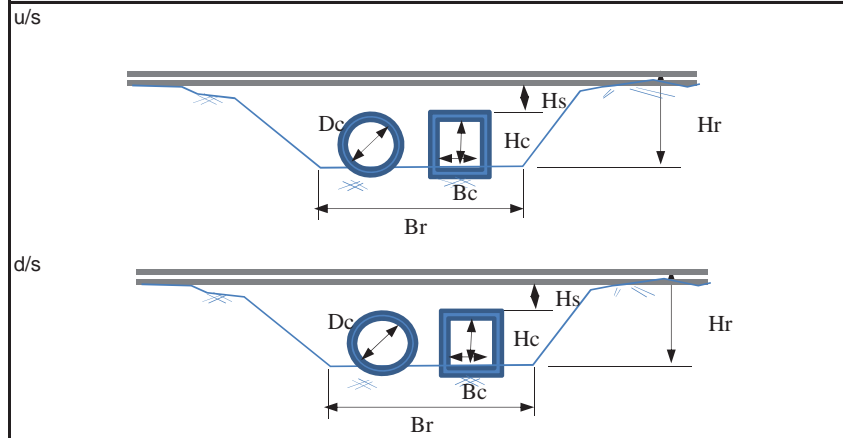



## Inventory Sheet for Culvert

**Station: at KM 336/1**      **Sheet No.: BCL336.1**

### 1. General

1-1	Name of Inspector	T.Fukuda, Mr.Kido, Mr.Philipo	
1-2	Organization of Inspector	B	
1-3	Date/Time of Inspection	DEC 3 2014	1355
1-4	Location	Lat	06°35'00.6"
1-5		Long	036°39'12.9"
1-6	Elevation	n/a	

### 2. Characteristics of Physical Condition of Culvert

2-1	Length of Culvert	n/a	
2-2	Shape of Cross Section	Rectangular × 1	
2-3	Flow Area	Height	Hc= 0.85m
2-4		Width	Bc= 2.0m
2-5		Other	WL=2.0m, Hs= 0.3m
2-6	Connecting Channel	Height	n/a
2-7		Width	n/a
2-8		Side Slope	n/a
2-9	Type of Culvert	Concrete	
2-10	Riverbed	Material	n/a
2-11	Sediment deposition	u/s	Y, 60%
2-12		d/s	Y, 60%
2-13	Topography	u/s: ↘ ,d/s ↗	
2-14	Land Use	n/a	
2-15	Structures/Houses, road	n/a	

### 3. Damaged Flood Records

3-1	(Year/Month)	(Type)	(Reason,etc.)
	n/a	n/a	n/a

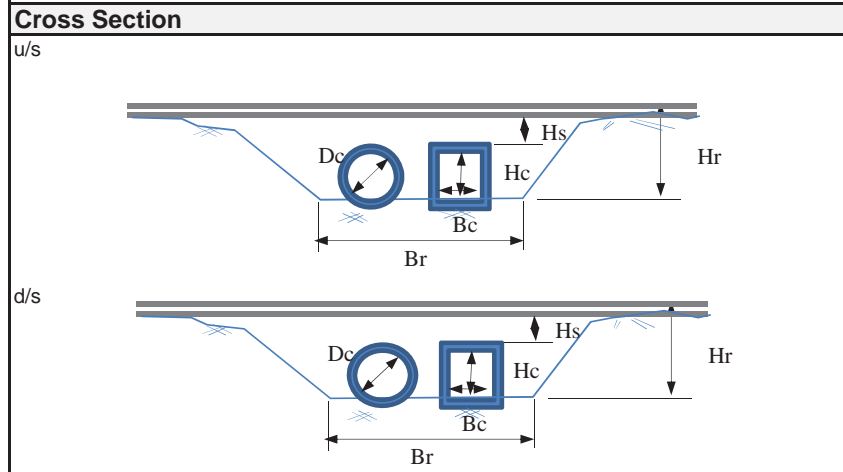
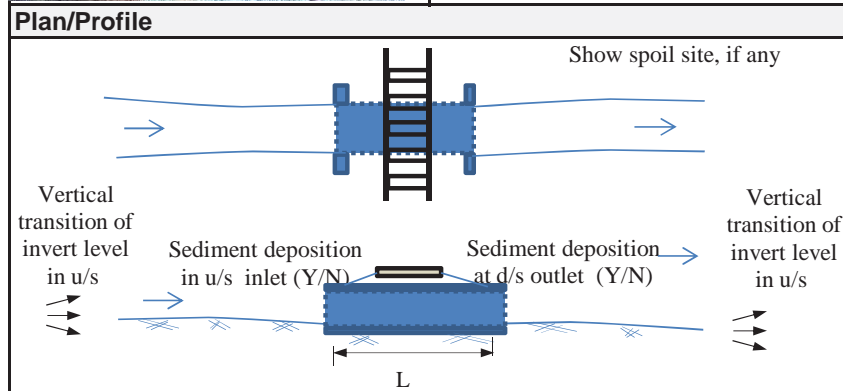
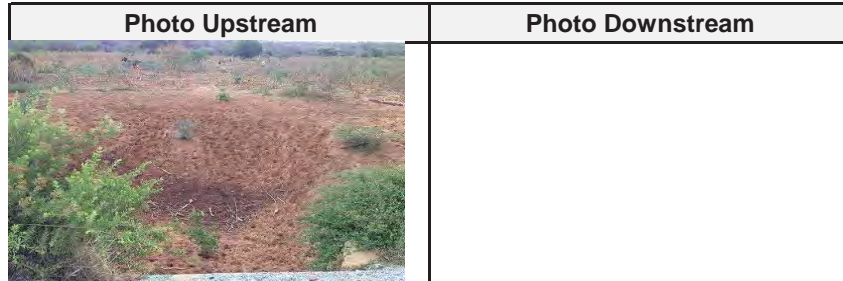

## Inventory Sheet for Culvert

**Station: at KM 336/3**      **Sheet No.: BCL336.3**

### 1. General

1-1	Name of Inspector	T.Fukuda, Mr.Kido, Mr.Philipo	
1-2	Organization of Inspector	B	
1-3	Date/Time of Inspection	DEC 3 2014	1404
1-4	Location	Lat	06°34'58.8"
1-5		Long	036°39'66.1"
1-6	Elevation	n/a	

### 2. Characteristics of Physical Condition of Culvert

2-1	Length of Culvert	n/a	
2-2	Shape of Cross Section	Rectangular × 1	
2-3	Flow Area	Height	Hc= 1.05m
2-4		Width	Bc= 2.0m
2-5		Other	WL=2.2m, Hs= 0.3m
2-6	Connecting Channel	Height	n/a
2-7		Width	n/a
2-8		Side Slope	n/a
2-9	Type of Culvert	Concrete	
2-10	Riverbed	Material	n/a
2-11	Sediment deposition	u/s	Y, 45%
2-12		d/s	Y, 45%
2-13	Topography	u/s: ↘ ,d/s ↘	
2-14	Land Use	n/a	
2-15	Structures/Houses, road	n/a	

### 3. Damaged Flood Records

3-1	(Year/Month)	(Type)	(Reason,etc.)
	n/a	n/a	n/a

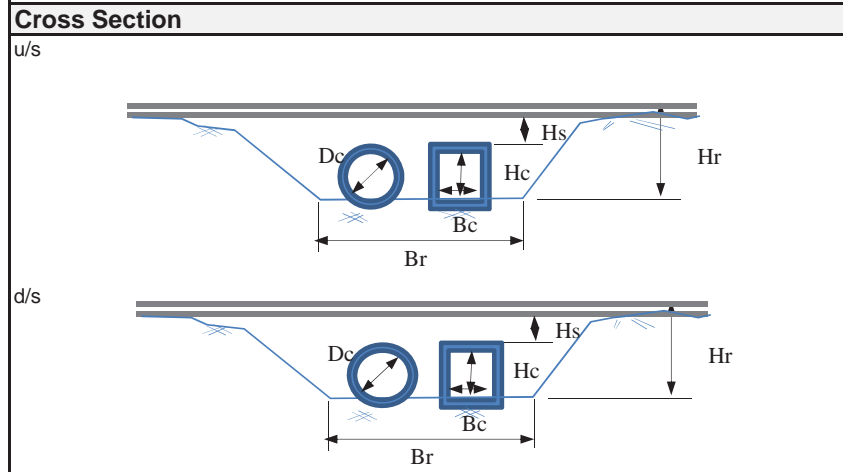
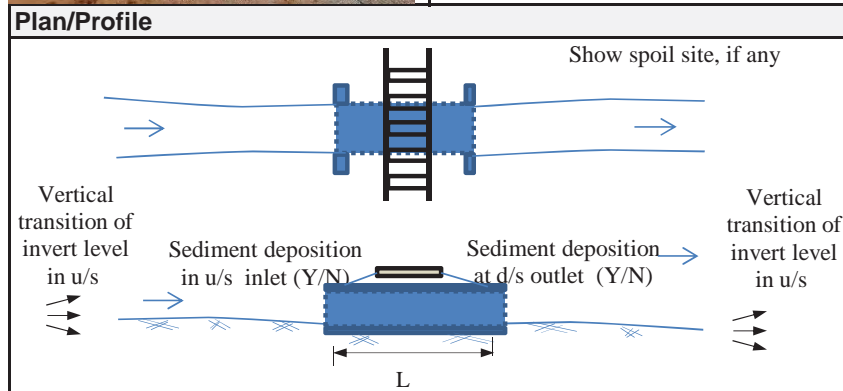
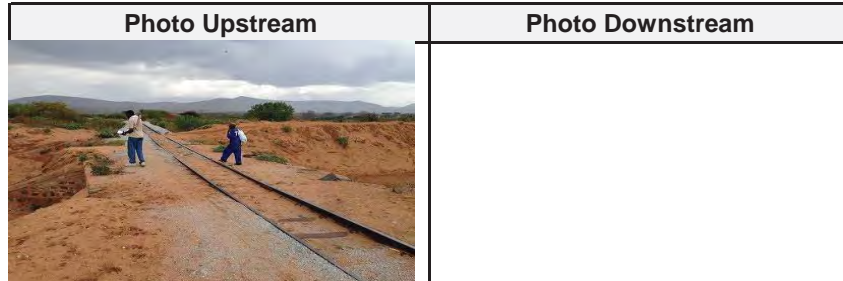

## Inventory Sheet for Culvert

**Station: at KM 336/7**      **Sheet No.: BCL336.7**

1. General			
1-1	Name of Inspector		T.Fukuda, Mr.Kido, Mr.Philipo
1-2	Organization of Inspector		B
1-3	Date/Time of Inspection		DEC 3 2014      1420
1-4	Location	Lat	06°34'53.0"
1-5		Long	036°38'54.1"
1-6	Elevation		n/a

2. Characteristics of Physical Condition of Culvert			
2-1	Length of Culvert		n/a
2-2	Shape of Cross Section		Rectangular × 1
2-3	Flow Area	Height	Hc= 2.3m
2-4		Width	Bc= 2.0m
2-5		Other	WL=4.0m, Hs= 0.3m
2-6	Connecting Channel	Height	n/a
2-7		Width	n/a
2-8		Side Slope	n/a
2-9	Type of Culvert		Concrete
2-10	Riverbed	Material	n/a
2-11	Sediment deposition	u/s	Y, 0%
2-12		d/s	Y, 0%
2-13	Topography		u/s: → ,d/s →
2-14	Land Use		n/a
2-15	Structures/Houses, road		n/a

3. Damaged Flood Records			
3-1	(Year/Month)	(Type)	(Reason,etc.)
	n/a	n/a	n/a

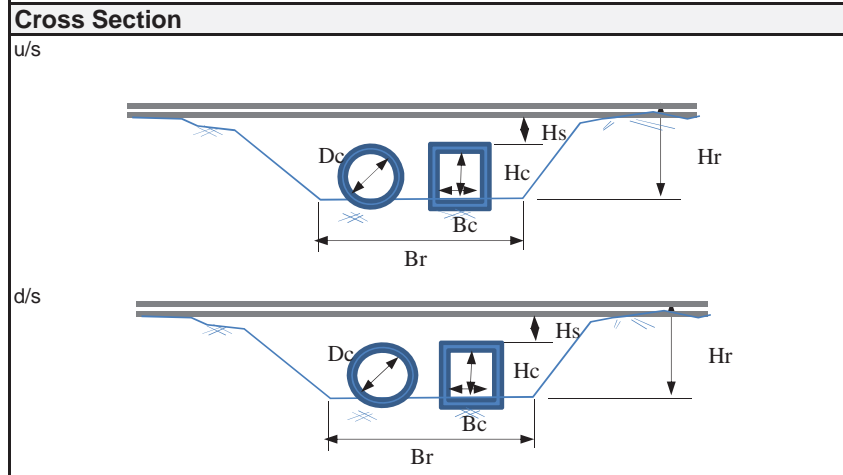
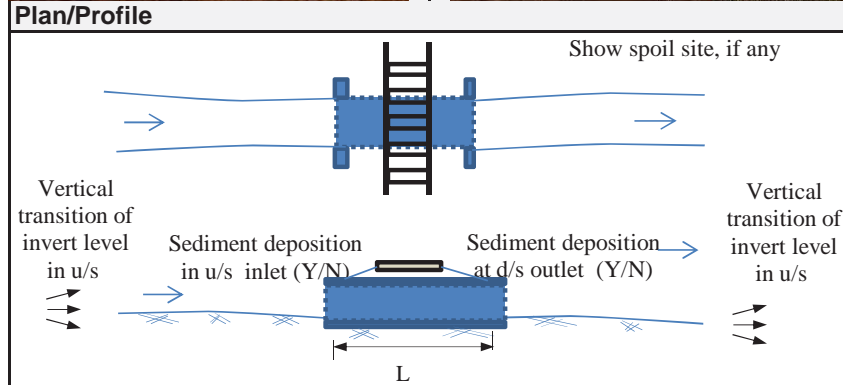
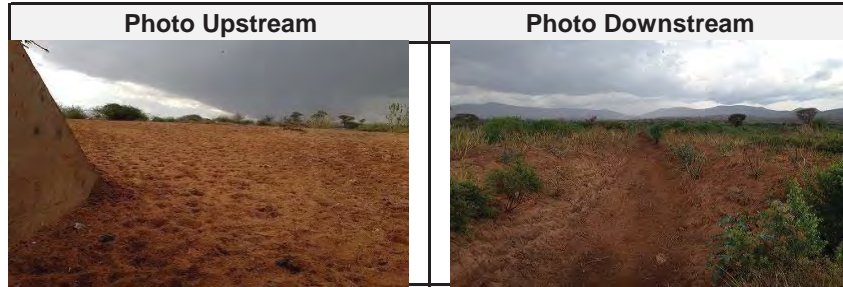

## Inventory Sheet for Culvert

**Station: at KM 337/0**      **Sheet No.: PCL337.0**

<b>1. General</b>		
1-1	Name of Inspector	T.Fukuda, Mr.Kido, Mr.Philipo
1-2	Organization of Inspector	B
1-3	Date/Time of Inspection	DEC 3 2014      1430
1-4	Location	Lat      06°34'46.2"
1-5		Long      036°38'47.1"
1-6	Elevation	n/a

**2. Characteristics of Physical Condition of Culvert**

2-1	Length of Culvert	n/a	
2-2	Shape of Cross Section	Circle x 2	
2-3	Flow Area	Height	n/a
2-4		Width	n/a
2-5		Other	d= 1.2m, WL=3.9m, Hs= 1.0m
2-6	Connecting Channel	Height	n/a
2-7		Width	n/a
2-8		Side Slope	n/a
2-9	Type of Culvert	Concrete	
2-10	Riverbed	Material	n/a
2-11	Sediment deposition	u/s	Y, ?
2-12		d/s	Y, ?
2-13	Topography	u/s:      ,d/s      →	
2-14	Land Use	n/a	
2-15	Structures/Houses, road	n/a	

**3. Damaged Flood Records**

3-1	(Year/Month)	(Type)	(Reason,etc.)
	n/a	washout	ballasts

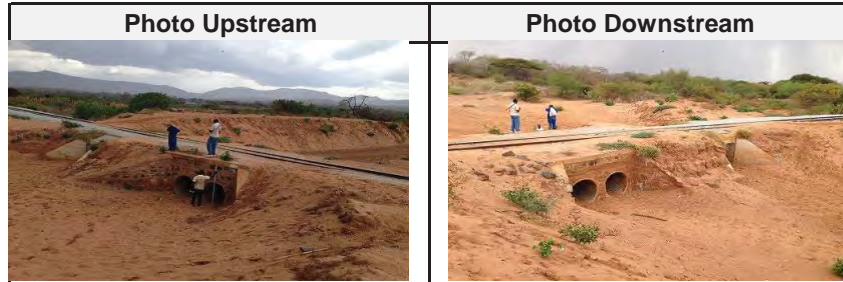

**Plan/Profile**

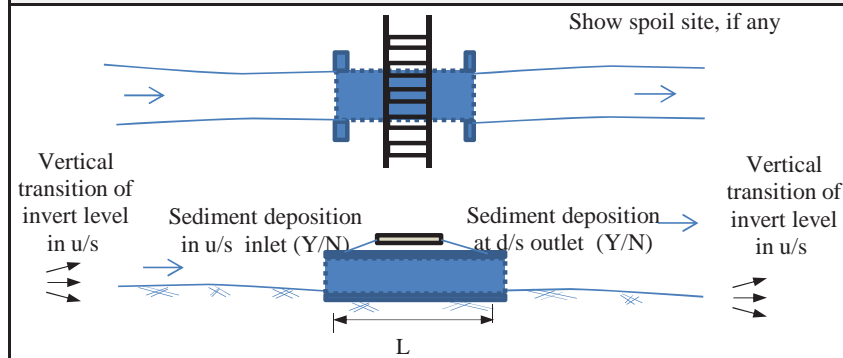

**Cross Section**

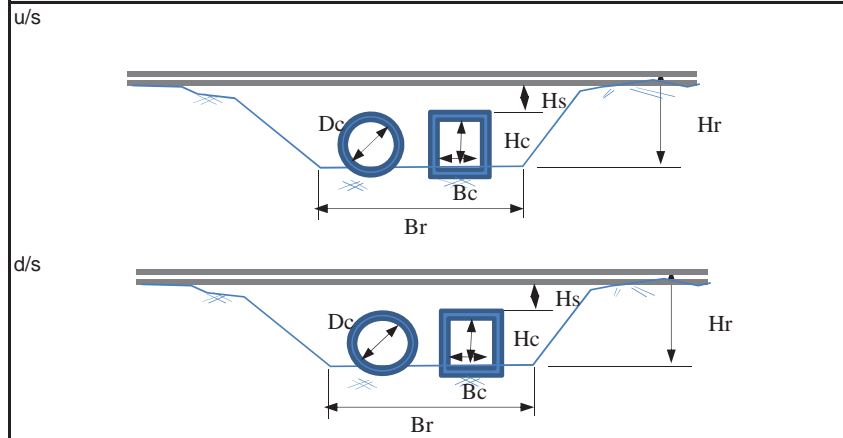

## Inventory Sheet for Culvert

**Station: at KM 337/0**      **Sheet No.: BCL337.0**

### 1. General

1-1	Name of Inspector	T.Fukuda, Mr.Kido, Mr.Philipo	
1-2	Organization of Inspector	B	
1-3	Date/Time of Inspection	DEC 3 2014	1432
1-4	Location	Lat	06°34'46.3"
1-5		Long	036°38'47.0"
1-6	Elevation	n/a	

### 2. Characteristics of Physical Condition of Culvert

2-1	Length of Culvert	n/a	
2-2	Shape of Cross Section	Rectangular × 1	
2-3	Flow Area	Height	Hc=1.4m
2-4		Width	Bc= 2.0m
2-5		Other	WL=2.5m, Hs= 0.3m
2-6	Connecting Channel	Height	n/a
2-7		Width	n/a
2-8		Side Slope	n/a
2-9	Type of Culvert	Concrete	
2-10	Riverbed	Material	n/a
2-11	Sediment deposition	u/s	Y, 30%
2-12		d/s	Y, 30%
2-13	Topography	u/s: ↘ ,d/s ↗	
2-14	Land Use	n/a	
2-15	Structures/Houses, road	n/a	

### 3. Damaged Flood Records

3-1	(Year/Month)	(Type)	(Reason,etc.)
	n/a	n/a	n/a

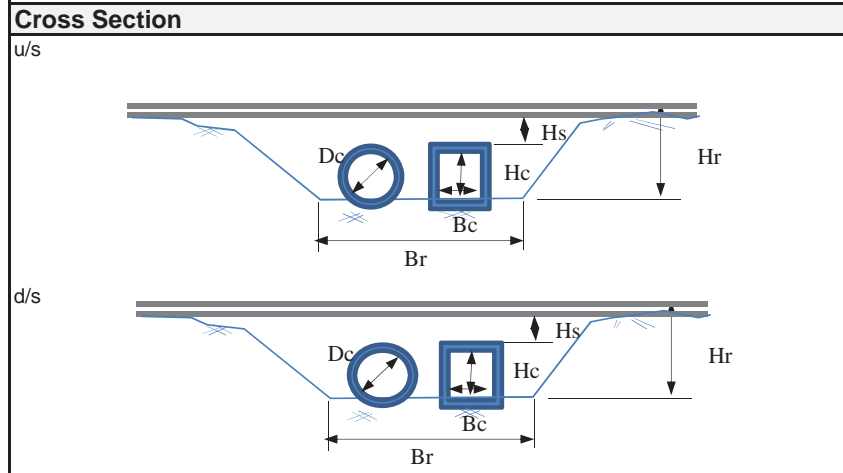
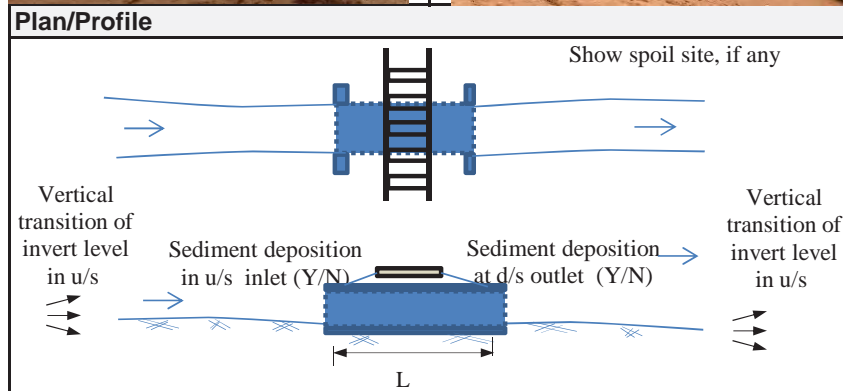
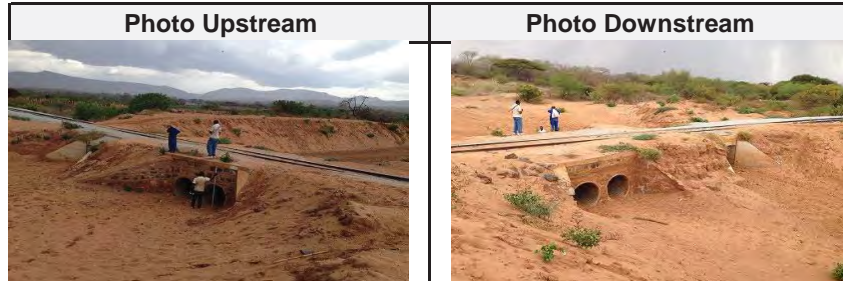



## Inventory Sheet for Culvert

**Station: at KM 344.8**      **Sheet No.: PCL 344.8**

### 1. General

1-1	Name of Inspector	Mr Motoki/ Semaya/ France	
1-2	Organization of Inspector	River Group B	
1-3	Date/Time of Inspection	04/12/2014 12:05 - 12:10	
1-4	Location	Lat	06° 32' 29.0"
1-5		Long	036° 35' 52.9"
1-6	Elevation	723m	

### 2. Characteristics of Physical Condition of Culvert

2-1	Length of Culvert	15.9m	
2-2	Shape of Cross Section	Square: Rectangular: Circle: (2)	
2-3	Flow Area	Height	0.92m
2-4		Width	2mm
2-5		Other	diameter 0.92m
2-6	Connecting Channel	Height	
2-7		Width	
2-8		Side Slope	
2-9	Type of Culvert	Concrete	
2-10	Riverbed	Material	silt sand
2-11	Sediment deposition	u/s	No
2-12		d/s	No
2-13	Topography	u/s:  , d/s:	
2-14	Land Use		
2-15	Structures/Houses, road		

### 3. Damaged Flood Records

3-1	(Year/Month)	(Type)	(Reason, etc.)

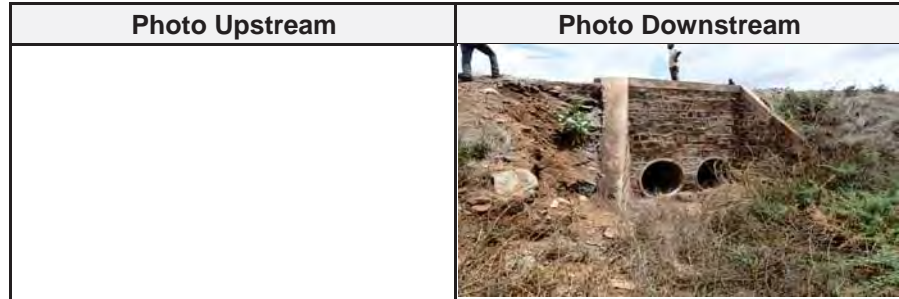

### Plan/Profile

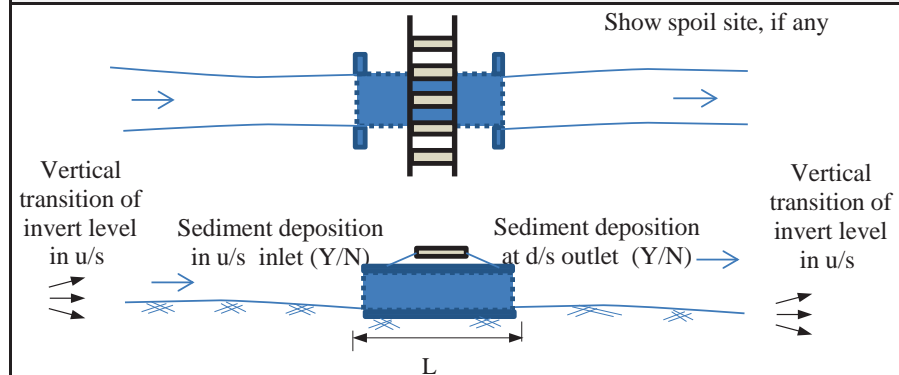

### Cross Section

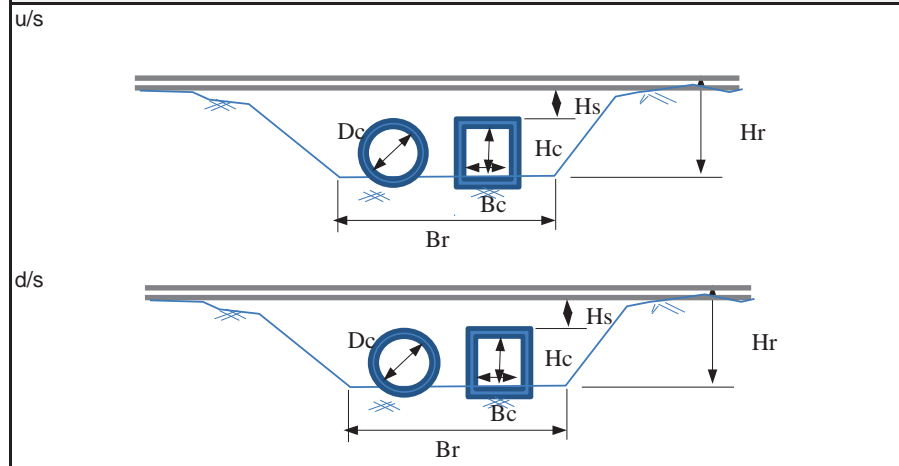

### Inventory Sheet for Culvert

**Station: at KM 344.8**      **Sheet No.: BCL 344.8**

1. General		
1-1	Name of Inspector	Mr Motoki/ Semaya/ France
1-2	Organization of Inspector	River Group B
1-3	Date/Time of Inspection	04/12/2014 11:40 - 11:45
1-4	Location	Lat 06° 32' 34.3"
1-5		Long 036° 35' 45.1"
1-6	Elevation	733m

2. Characteristics of Physical Condition of Culvert		
2-1	Length of Culvert	4.0m
2-2	Shape of Cross Section	Square: <u>Rectangular: (1)</u> Circle:
2-3	Flow Area	Height 1.25m
2-4		Width 2.0m
2-5	Connecting Channel	Other
2-6		Height
2-7		Width
2-8	Side Slope	
2-9	Type of Culvert	Concrete
2-10	Riverbed	Material silt sand
2-11	Sediment deposition	u/s No
2-12		d/s No
2-13	Topography	u/s:  , d/s:
2-14	Land Use	
2-15	Structures/Houses, road	

3. Damaged Flood Records			
3-1	(Year/Month)	(Type)	(Reason, etc.)

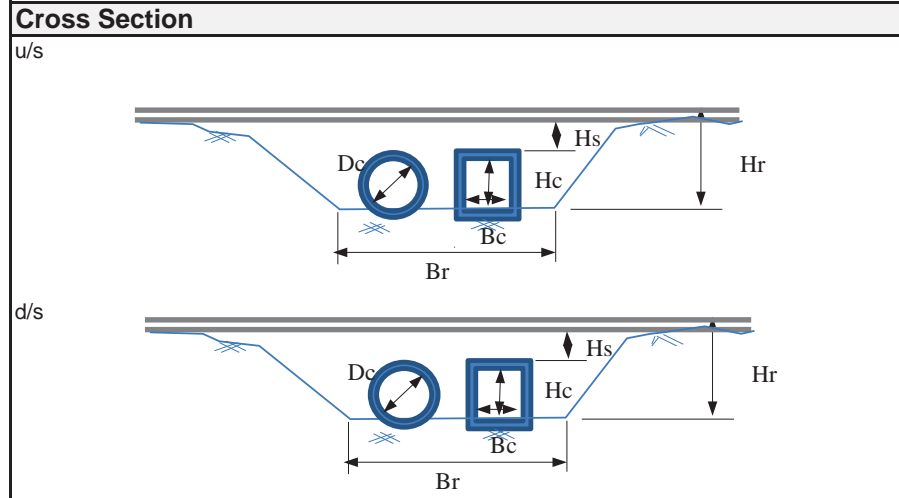
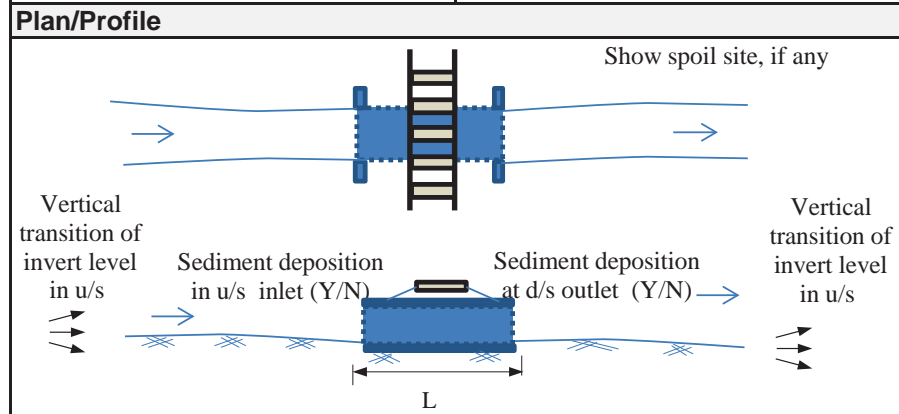
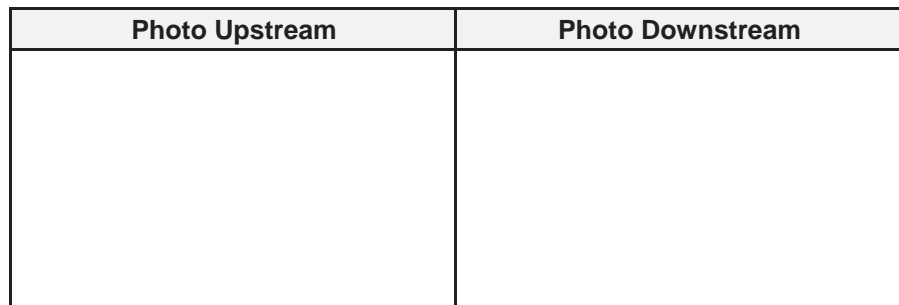

F-102

## Inventory Sheet for Culvert

**Station: at KM 345.0**      **Sheet No.: BCL 345.0**

### 1. General

1-1	Name of Inspector		Mr Motoki/ Semaya/ France
1-2	Organization of Inspector		River Group B
1-3	Date/Time of Inspection		04/12/2014 11:35 - 11:40
1-4	Location	Lat	06° 32' 36.1"
1-5		Long	036° 35' 30.3"
1-6	Elevation		735m

### 2. Characteristics of Physical Condition of Culvert

2-1	Length of Culvert		8.0m
2-2	Shape of Cross Section		Square: Rectangular: (1) Circle: half circle
2-3	Flow Area	Height	2.2m
2-4		Widdth	2.0m
2-5	Connecting Channel	Other	
2-6		Height	
2-7	Channel	Widdth	
2-8		Side Slope	
2-9	Type of Culvert		Concrete
2-10	Riverbed	Material	silt sand
2-11	Sediment deposition	u/s	No
2-12		d/s	No
2-13	Topography		u/s: $\Rightarrow$ , d/s: $\Rightarrow$
2-14	Land Use		
2-15	Structures/Houses, road		

### 3. Damaged Flood Records

3-1	(Year/Month)	(Type)	(Reason, etc.)

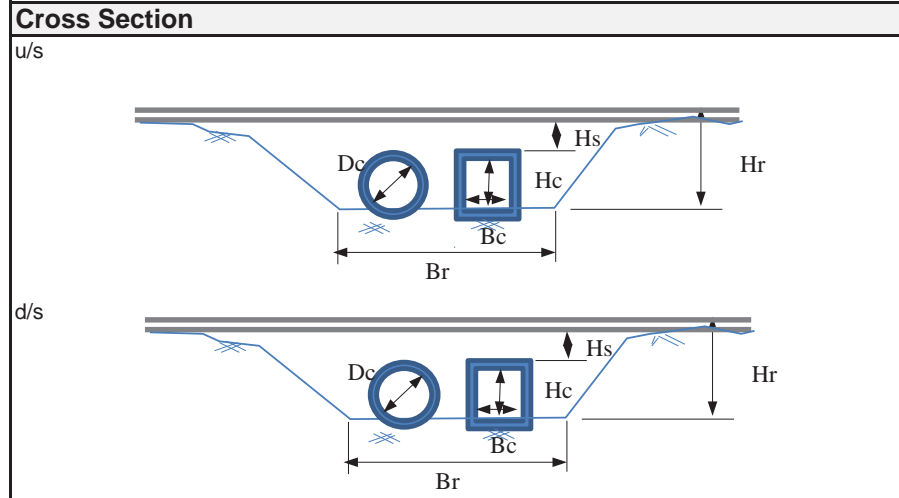
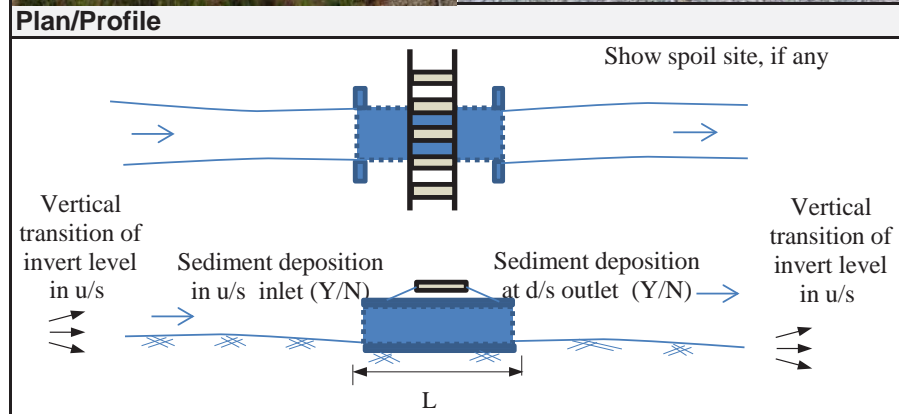
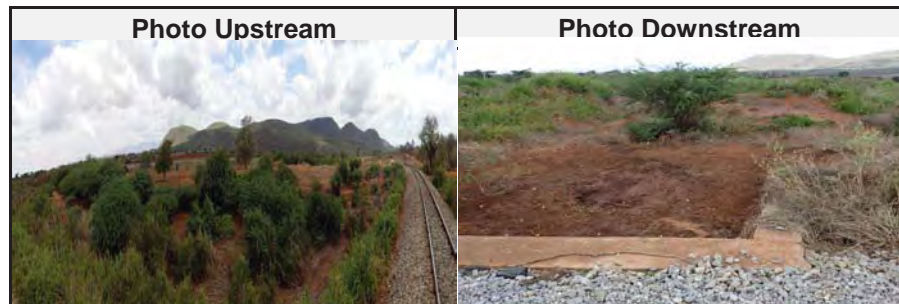

## Inventory Sheet for Culvert

**Station: at KM 345.5**      **Sheet No.: PCL 345.5**

### 1. General

1-1	Name of Inspector	Mr Motoki/ Semaya/ France
1-2	Organization of Inspector	River Group B
1-3	Date/Time of Inspection	04/12/2014 11:20 - 11:40
1-4	Location	Lat 06° 32' 33.7"
1-5		Long 036° 35' 14.9"
1-6	Elevation	736m

### 2. Characteristics of Physical Condition of Culvert

2-1	Length of Culvert	5.5m
2-2	Shape of Cross Section	Square: Rectangular: Circle: half circle (3)
2-3	Flow Area	Height 0.55m 0.55m 0.55m
2-4		Width 5.5m
2-5	Connecting Channel	Other Diameter 0.9
2-6		Height
2-7	Channel	Width
2-8		Side Slope
2-9	Type of Culvert	Concrete
2-10	Riverbed	Material silt sand
2-11	Sediment deposition	u/s little
2-12		d/s little
2-13	Topography	u/s:  , d/s:
2-14	Land Use	
2-15	Structures/Houses, road	

### 3. Damaged Flood Records

3-1	(Year/Month)	(Type)	(Reason, etc.)

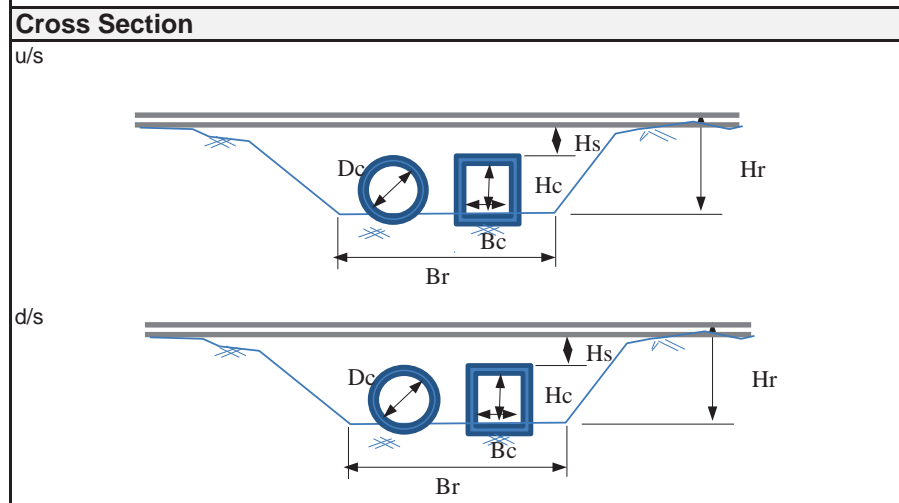
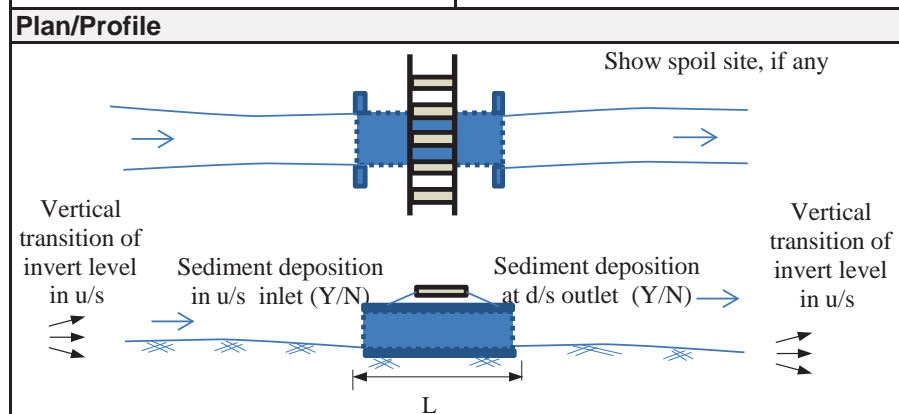

## Inventory Sheet for Culvert

**Station: at KM 345.6**      **Sheet No.: PCL 345.6**

### 1. General

1-1	Name of Inspector	Mr Motoki/ Semaya/ France	
1-2	Organization of Inspector	River Group B	
1-3	Date/Time of Inspection	04/12/2014 11:10 - 11:15	
1-4	Location	Lat	?
1-5		Long	?
1-6	Elevation	?	

### 2. Characteristics of Physical Condition of Culvert

2-1	Length of Culvert	5.5m	
2-2	Shape of Cross Section	Square: Rectangular: Circle: (2)	
2-3	Flow Area	Height	?
2-4		Widdth	3.2m
2-5	Connecting Channel	Other	diameter 0.9
2-6		Height	
2-7	Channel	Widdth	
2-8		Side Slope	
2-9	Type of Culvert	Concrete	
2-10	Riverbed	Material	silt sand
2-11	Sediment deposition	u/s	little
2-12		d/s	little
2-13	Topography	u/s: $\Rightarrow$ , d/s: $\Rightarrow$	
2-14	Land Use		
2-15	Structures/Houses, road		

### 3. Damaged Flood Records

3-1	(Year/Month)	(Type)	(Reason, etc.)

**Photo Upstream**                      **Photo Downstream**



### Plan/Profile

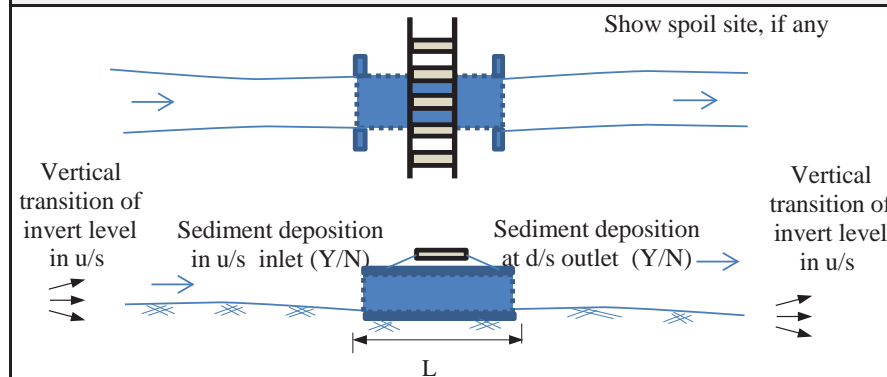

### Cross Section

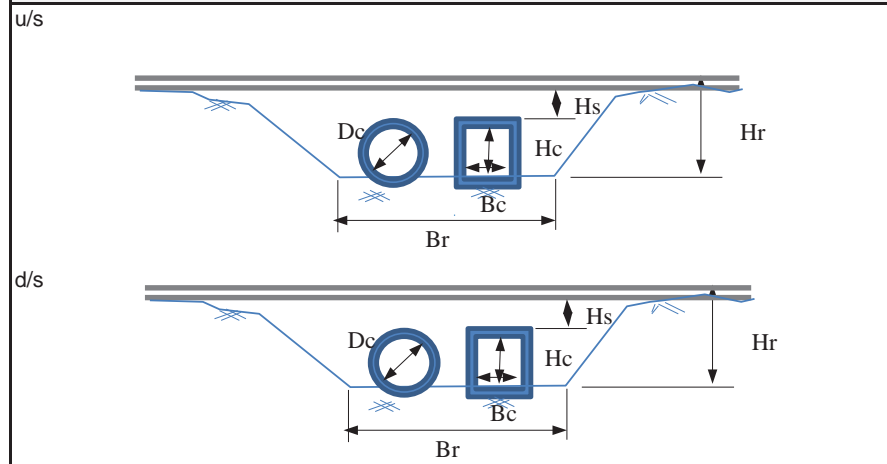



## Inventory Sheet for Culvert

**Station: at KM 345.6**      **Sheet No.: PCL 345.6**

### 1. General

1-1	Name of Inspector		Mr Motoki/ Semaya/ France
1-2	Organization of Inspector		River Group B
1-3	Date/Time of Inspection		03/12/2014 14:20 - 14:30
1-4	Location	Lat	06° 32' 34.3"
1-5		Long	036° 35' 10.0"
1-6	Elevation		733m

### 2. Characteristics of Physical Condition of Culvert

2-1	Length of Culvert		0.92m
2-2	Shape of Cross Section		Square: Rectangular: Circle: (3)
2-3	Flow Area	Height	0.92
2-4		Width	4.4m
2-5	Connecting Channel	Other	diameter 0.92m
2-6		Height	
2-7		Width	
2-8	Side Slope		
2-9		Type of Culvert	Concrete
2-10	Riverbed	Material	silt sand
2-11	Sediment deposition	u/s	No
2-12		d/s	No
2-13	Topography		u/s: $\Rightarrow$ , d/s: $\Rightarrow$
2-14	Land Use		
2-15	Structures/Houses, road		

### 3. Damaged Flood Records

3-1	(Year/Month)	(Type)	(Reason, etc.)

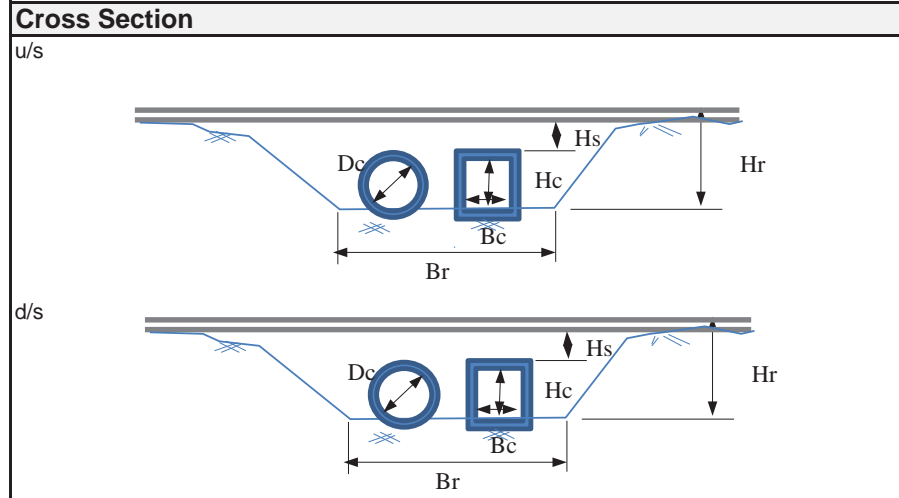
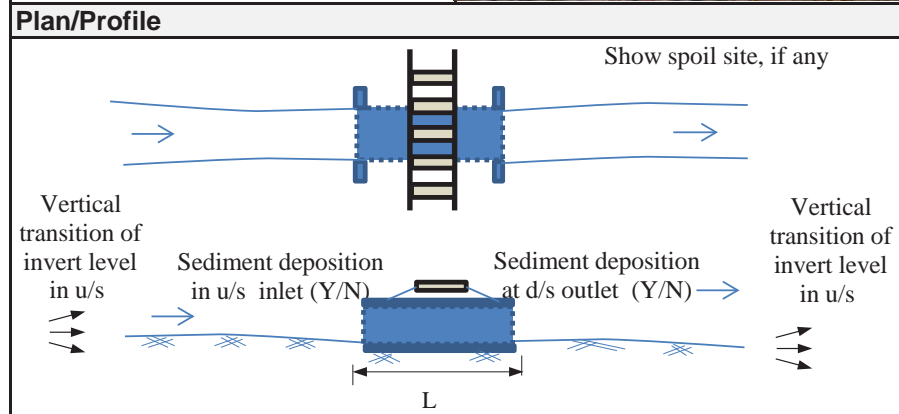
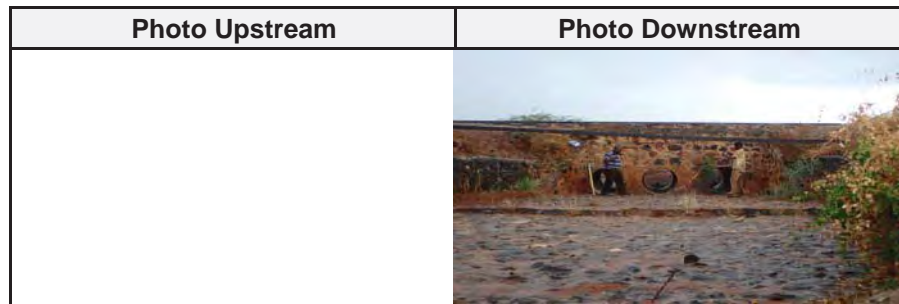



## Inventory Sheet for Culvert

**Station: at KM**    **346.2**                      **Sheet No.: PCL 346.2**

### 1. General

1-1	Name of Inspector	Mr Motoki/ Semaya/ France
1-2	Organization of Inspector	River Group B
1-3	Date/Time of Inspection	03/12/2014 14:05 - 14:10
1-4	Location	Lat 06° 32' 35.1"
1-5		Long 036° 34' 54.6"
1-6	Elevation	740m

### 2. Characteristics of Physical Condition of Culvert

2-1	Length of Culvert	3.5m
2-2	Shape of Cross Section	Square: Rectangular: Circle: (2)
2-3	Flow Area	Height 0.9 0.5
2-4		Widdth 3.2m
2-5	Connecting Channel	Other diameter 0.93
2-6		Height
2-7		Widdth
2-8	Side Slope	
2-9	Type of Culvert	Concrete
2-10	Riverbed	Material silt sand
2-11	Sediment deposition	u/s little
2-12		d/s little
2-13	Topography	u/s:  , d/s:
2-14	Land Use	
2-15	Structures/Houses, road	

### 3. Damaged Flood Records

3-1	(Year/Month)	(Type)	(Reason, etc.)

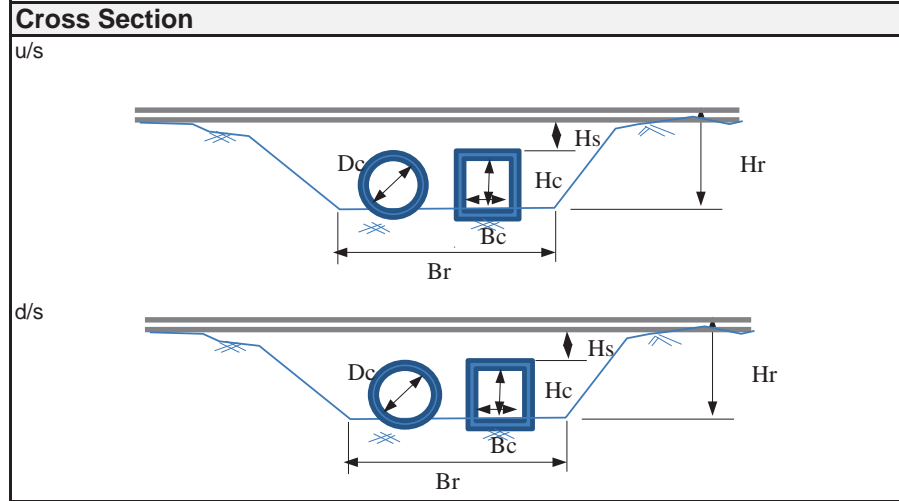
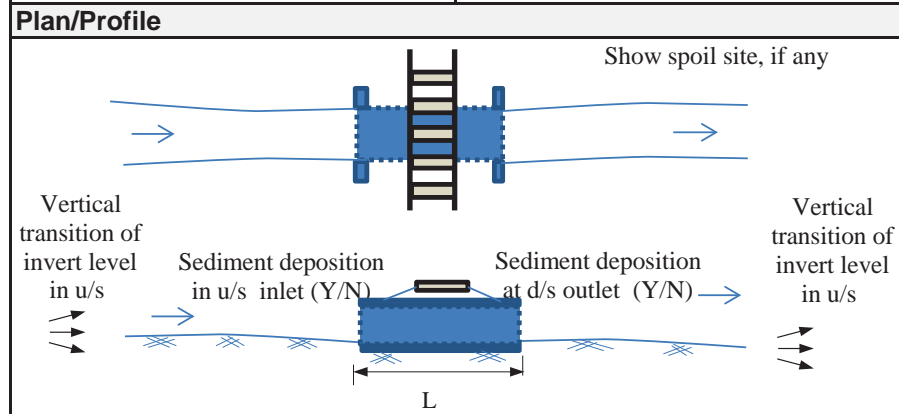
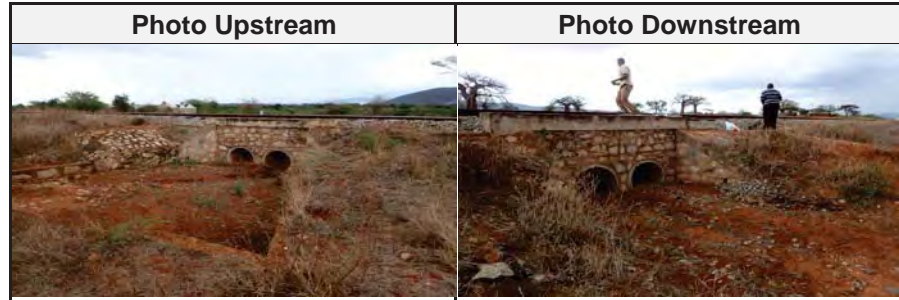

## Inventory Sheet for Culvert

**Station: at KM**    **346.6**                      **Sheet No.: PCL 346.6**

### 1. General

1-1	Name of Inspector	Mr Motoki/ Semaya/ France	
1-2	Organization of Inspector	River Group B	
1-3	Date/Time of Inspection	04/12/2014 11:15 - 11:20	
1-4	Location	Lat	06° 32' 33.9"
1-5		Long	036° 35' 13.0"
1-6	Elevation	736m	

### 2. Characteristics of Physical Condition of Culvert

2-1	Length of Culvert	5.6m	
2-2	Shape of Cross Section	Square: Rectangular: Circle: (1)	
2-3	Flow Area	Height	0.15m
2-4		Widdth	2.7m
2-5	Connecting Channel	Other	
2-6		Height	
2-7		Widdth	
2-8	Side Slope		
2-9	Type of Culvert	Concrete	
2-10	Riverbed	Material	silt sand
2-11	Sediment deposition	u/s	medium
2-12		d/s	medium
2-13	Topography	u/s:  , d/s:	
2-14	Land Use		
2-15	Structures/Houses, road		

### 3. Damaged Flood Records

3-1	(Year/Month)	(Type)	(Reason, etc.)

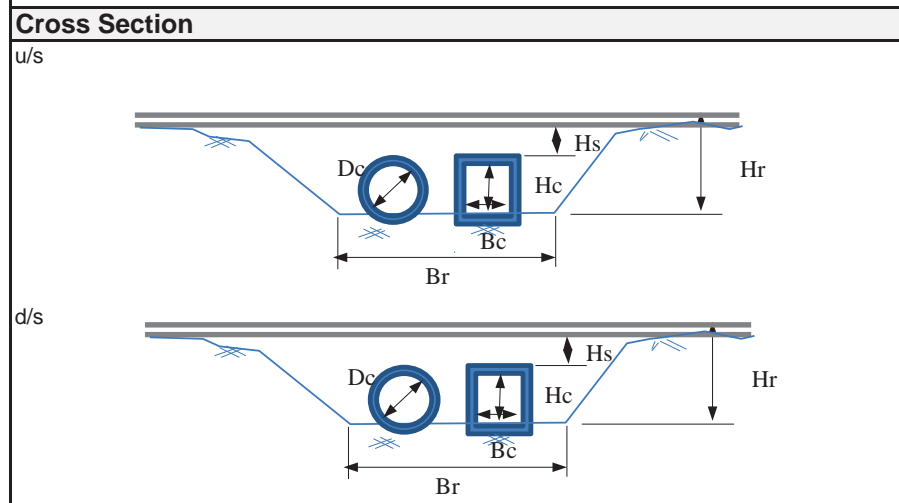
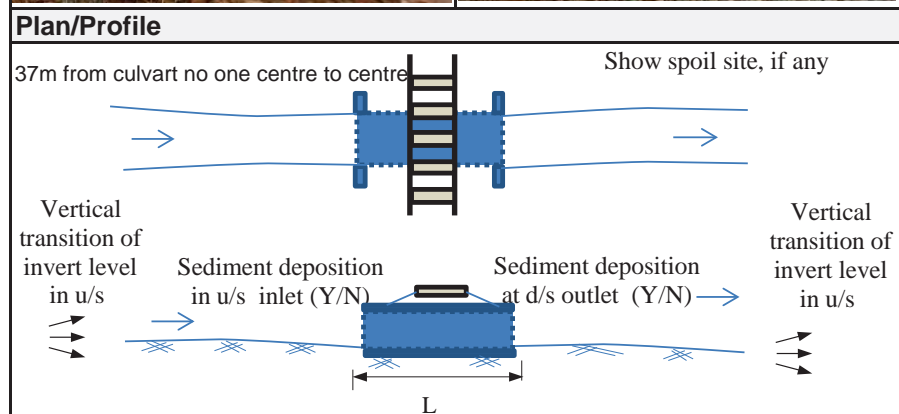
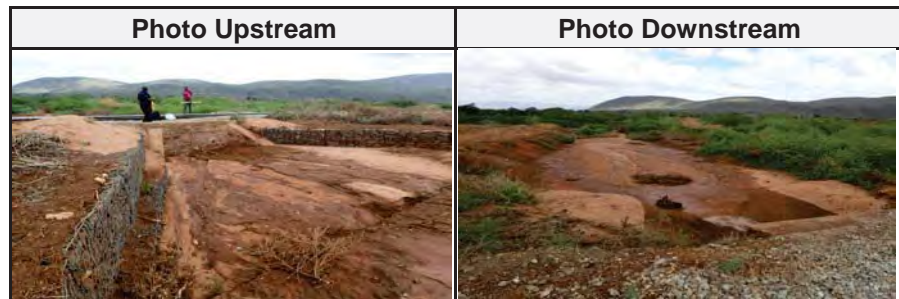

## Inventory Sheet for Culvert

**Station: at KM**    **346.6**                      **Sheet No.:** BCL 346.6

### 1. General

1-1	Name of Inspector	Mr Motoki/ Semaya/ France	
1-2	Organization of Inspector	River Group B	
1-3	Date/Time of Inspection	03/12/2014 13:55 - 14:00	
1-4	Location	Lat	06° 32' 35.8"
1-5		Long	036° 34' 38.7"
1-6	Elevation	739m	

### 2. Characteristics of Physical Condition of Culvert

2-1	Length of Culvert	4.0m	
2-2	Shape of Cross Section	Square: Rectangular: (1) Circle:	
2-3	Flow Area	Height	1.85m
2-4		Widdth	4.0m
2-5	Connecting Channel	Other	
2-6		Height	
2-7		Widdth	
2-8	Side Slope		
2-9	Type of Culvert	Concrete	
2-10	Riverbed	Material	silt sand
2-11	Sediment deposition	u/s	little
2-12		d/s	little
2-13	Topography	u/s: $\Rightarrow$ , d/s: $\Rightarrow$	
2-14	Land Use		
2-15	Structures/Houses, road		

### 3. Damaged Flood Records

3-1	(Year/Month)	(Type)	(Reason, etc.)

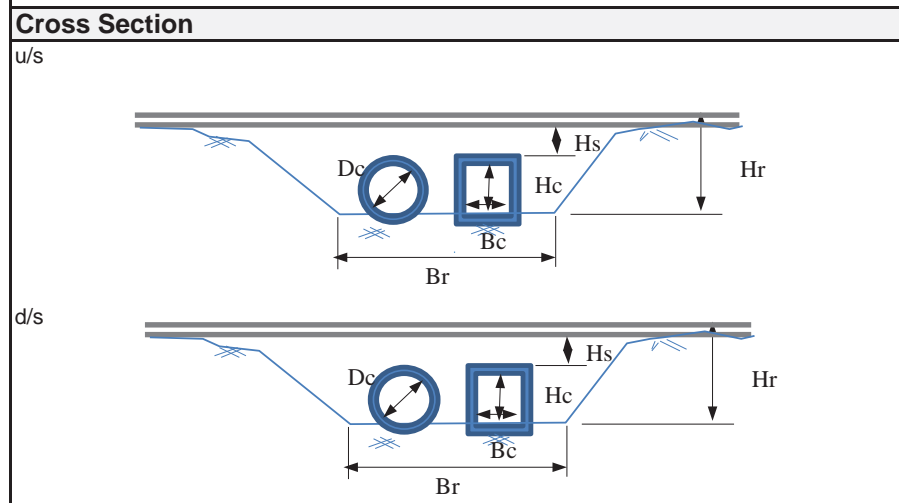
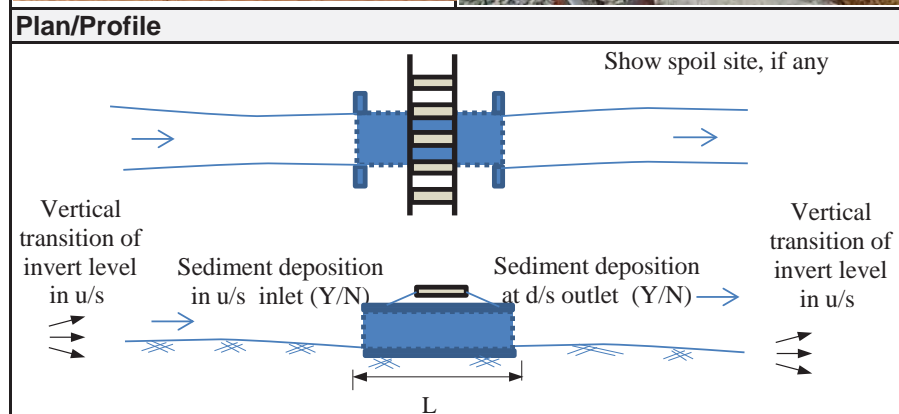
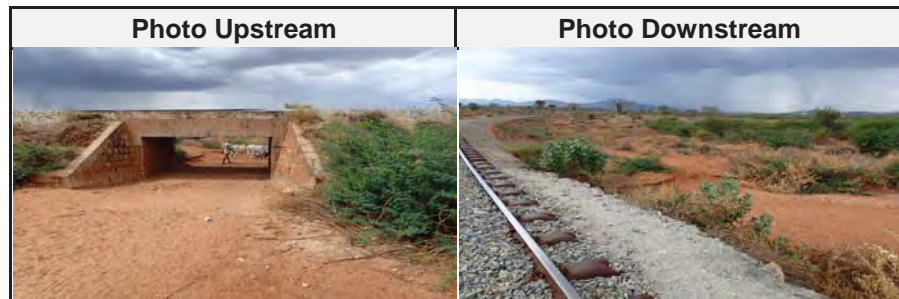



## Inventory Sheet for Culvert

**Station: at KM**    **347.5**                      **Sheet No.: BCL 347.5**

### 1. General

1-1	Name of Inspector	Mr Motoki/ Semaya/ France	
1-2	Organization of Inspector	River Group B	
1-3	Date/Time of Inspection	03/12/2014 13:35 - 13:40	
1-4	Location	Lat	06° 32' 31.0"
1-5		Long	036° 34' 13.7"
1-6	Elevation	743m	

### 2. Characteristics of Physical Condition of Culvert

2-1	Length of Culvert	4.0m	
2-2	Shape of Cross Section	Square: Rectangular: (2) Circle:	
2-3	Flow Area	Height	0.5m, 0.52
2-4		Widdth	2.0m, 2.9m
2-5	Other	Distance between 21.7m	
2-6	Connecting Channel	Height	
2-7		Widdth	
2-8		Side Slope	
2-9	Type of Culvert	Concrete	
2-10	Riverbed	Material	silt sand
2-11	Sediment deposition	u/s	midium
2-12		d/s	
2-13	Topography	u/s: $\Rightarrow$	,d/s: $\Rightarrow$
2-14	Land Use		
2-15	Structures/Houses, road		

### 3. Damaged Flood Records

3-1	(Year/Month)	(Type)	(Reason,etc.)

**Photo Upstream**                                      **Photo Downstream**



### Plan/Profile

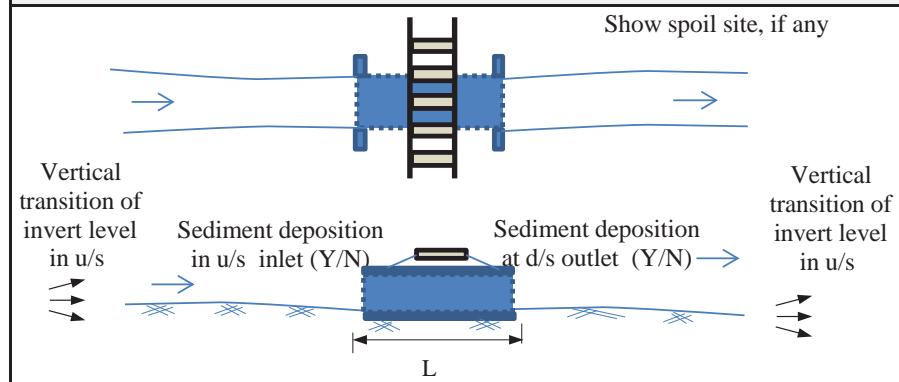

### Cross Section

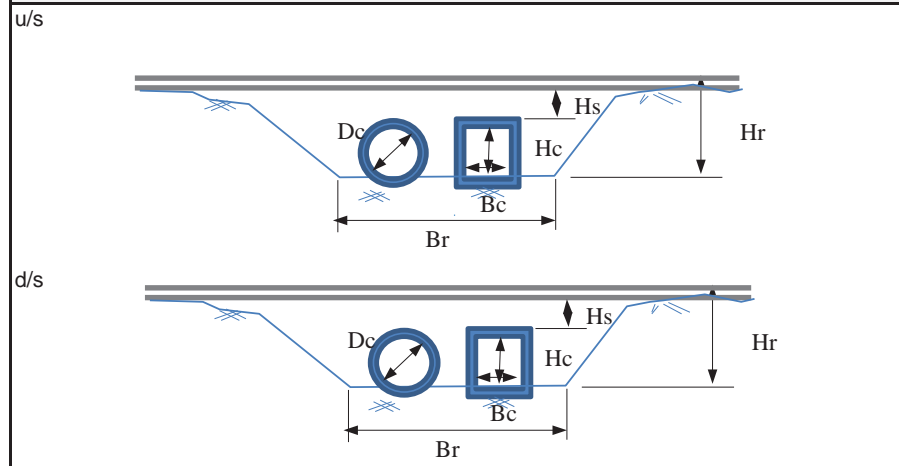

F-111

## Inventory Sheet for Culvert

**Station: at KM 348.0**      **Sheet No.: BCL 348.0**

### 1. General

1-1	Name of Inspector	Mr Motoki/ Semaya/ France	
1-2	Organization of Inspector	River Group B	
1-3	Date/Time of Inspection	03/12/2014 13:20 - 13:25	
1-4	Location	Lat	06° 32' 22.3"
1-5		Long	036° 33' 51.3"
1-6	Elevation	748m	

### 2. Characteristics of Physical Condition of Culvert

2-1	Length of Culvert	4.0m	
2-2	Shape of Cross Section	Square: Rectangular: (2) Circle:	
2-3	Flow Area	Height	0.81m, 0.85m
2-4		Widdth	2m, 2m
2-5	Connecting Channel	Other	
2-6		Height	
2-7		Widdth	
2-8	Side Slope		
2-9	Type of Culvert	Concrete	
2-10	Riverbed	Material	silt sand
2-11	Sediment deposition	u/s	midium
2-12		d/s	
2-13	Topography	u/s:	,d/s:
2-14	Land Use		
2-15	Structures/Houses, road		

### 3. Damaged Flood Records

3-1	(Year/Month)	(Type)	(Reason,etc.)

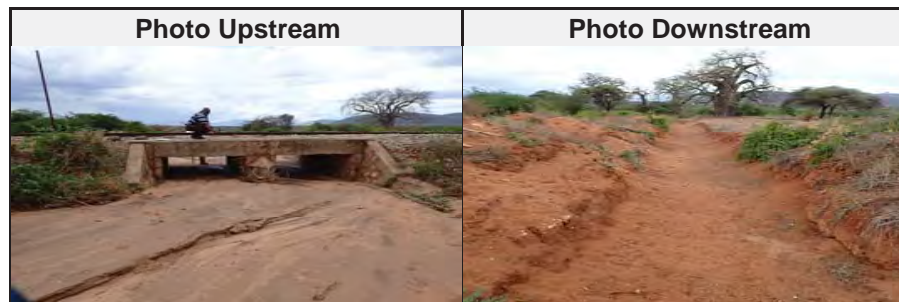

### Plan/Profile

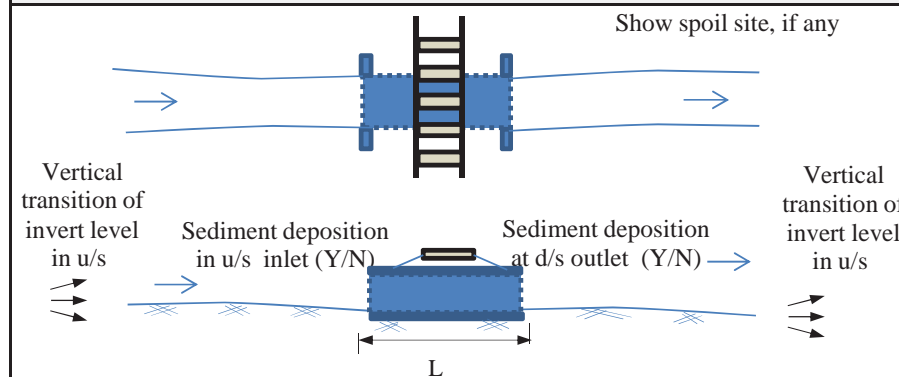

### Cross Section

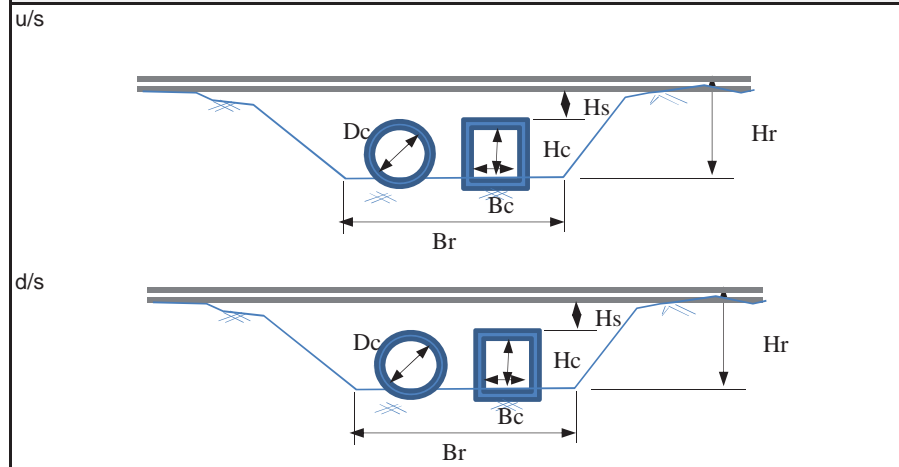

## Inventory Sheet for Culvert

**Station: at KM 348.3**      **Sheet No.: PCL 348.3**

### 1. General

1-1	Name of Inspector	Mr Motoki/ Semaya/ France	
1-2	Organization of Inspector	River Group B	
1-3	Date/Time of Inspection	03/12/2014 13:15 - 13:20	
1-4	Location	Lat	06° 32' 22.3"
1-5		Long	036° 33' 51.3"
1-6	Elevation	746m	

### 2. Characteristics of Physical Condition of Culvert

2-1	Length of Culvert	4.0m	
2-2	Shape of Cross Section	Square: Rectangular: Circle: half circle (1)	
2-3	Flow Area	Height	0.74
2-4		Widdth	3.5m (diameter 0.72)
2-5	Connecting Channel	Other	
2-6		Height	No channel
2-7		Widdth	
2-8	Side Slope		
2-9	Type of Culvert	Concrete	
2-10	Riverbed	Material	silt sand
2-11	Sediment deposition	u/s	Midium
2-12		d/s	Midium
2-13	Topography	u/s: $\Rightarrow$	,d/s: $\Rightarrow$
2-14	Land Use		
2-15	Structures/Houses, road		

### 3. Damaged Flood Records

3-1	(Year/Month)	(Type)	(Reason,etc.)



### Plan/Profile

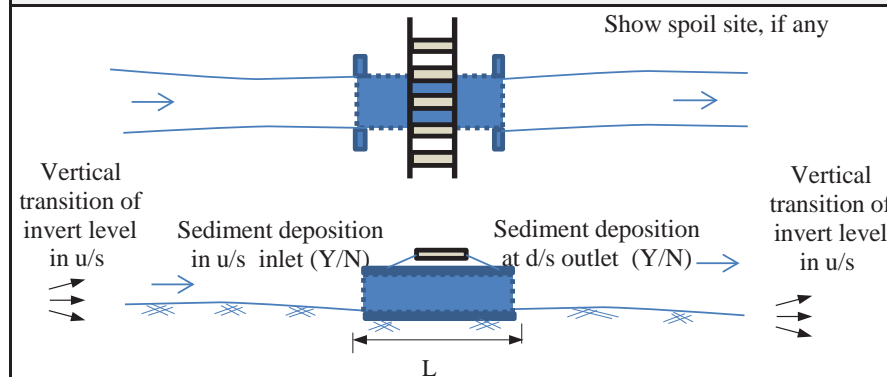

### Cross Section

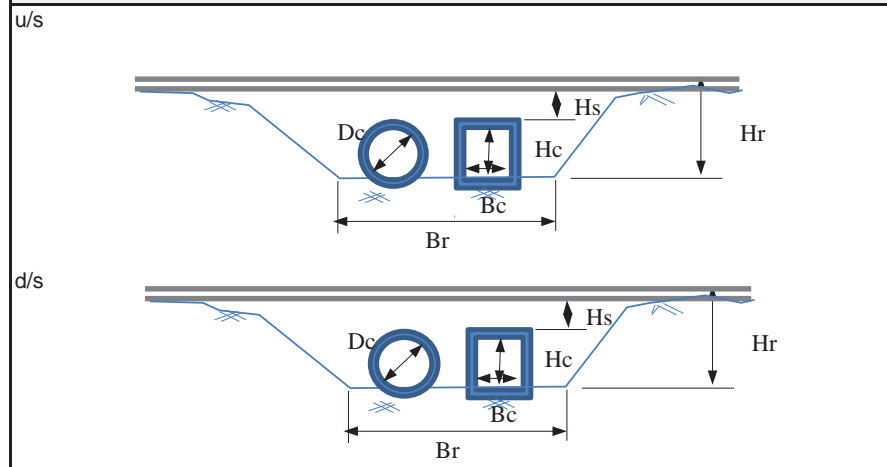

## Inventory Sheet for Culvert

**Station: at KM**    **348.8**                      **Sheet No.:** BCL 348.8

### 1. General

1-1	Name of Inspector	Mr Motoki/ Semaya/ France	
1-2	Organization of Inspector	River Group B	
1-3	Date/Time of Inspection	03/12/2014 13:05 - 13:10	
1-4	Location	Lat	06° 32' 11.4"
1-5		Long	036° 33' 36.1"
1-6	Elevation	748m	

### 2. Characteristics of Physical Condition of Culvert

2-1	Length of Culvert	4.0m	
2-2	Shape of Cross Section	Square: Rectangular: (1) Circle:	
2-3	Flow Area	Height	1.13m
2-4		Widdth	2.0m
2-5	Connecting Channel	Other	
2-6		Height	
2-7		Widdth	
2-8	Side Slope		
2-9	Type of Culvert	Concrete	
2-10	Riverbed	Material	silt sand
2-11	Sediment deposition	u/s	little
2-12		d/s	little
2-13	Topography	u/s:  , d/s:	
2-14	Land Use		
2-15	Structures/Houses, road		

### 3. Damaged Flood Records

3-1	(Year/Month)	(Type)	(Reason, etc.)

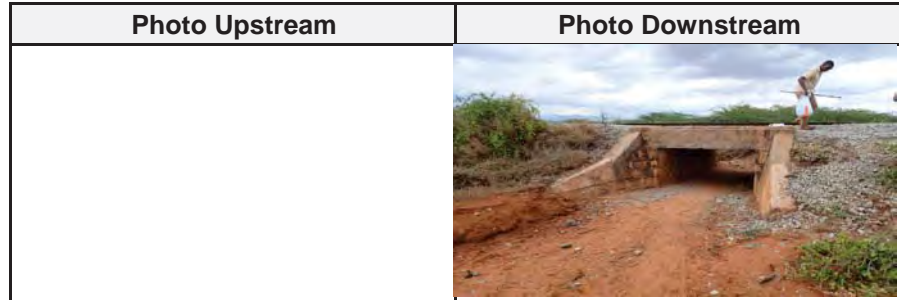

### Plan/Profile

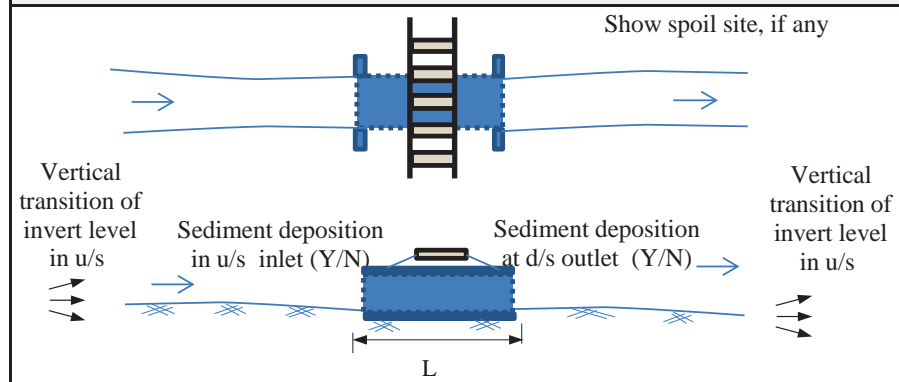

### Cross Section

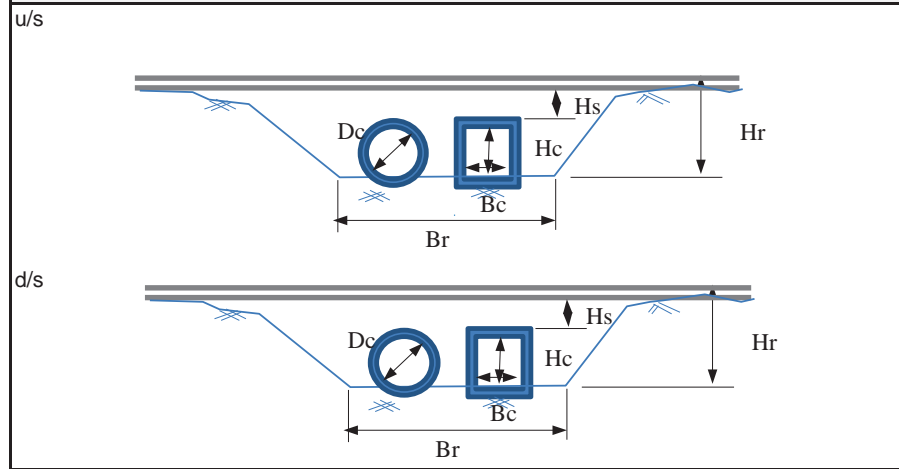



F-114

## Inventory Sheet for Culvert

Station: at KM 349.4 A		Sheet No.: BCL 349.4A	
<b>1. General</b>			
1-1	Name of Inspector	T. Kawaguchi , Hussein , Abiud	
1-2	Organization of Inspector	JICA Study Team	
1-3	Date/Time of Inspection	2014/2/12	
1-4	Location	Lat 06° 32' 00" 94'''	
1-5		Long 036° 33' 21" 55'''	
1-6	Elevation		
<b>2. Characteristics of Physical Condition of Culvert</b>			
2-1	Length of Culvert	5.0 m	
2-2	Shape of Cross Section	Square:(2) Rectangular: Circle:	
2-3	Flow Area	Height Hc1 = 0.8 m , Hc2 = 0.8 m	
2-4		Width Bc1 = 1.5 m , Bc2 = 1.5 m	
2-5		Other Hs1 = 0.5 m , Hs2 = 0.5 m	
2-6	Connecting Channel	Height	
2-7		Width	
2-8		Side Slope	
2-9	Type of Culvert	Concrete	
2-10	Riverbed	Material Silty sand	
2-11	Sediment deposition	u/s Heavy ( 50% rate)	
2-12		d/s Heavy ( 50% rate)	
2-13	Topography	u/s: , d/s:	
2-14	Land Use		
2-15	Structures/Houses, road		
<b>3. Damaged Flood Records</b>			
3-1	(Year/Month)	(Type)	(Reason,etc.)

F-115

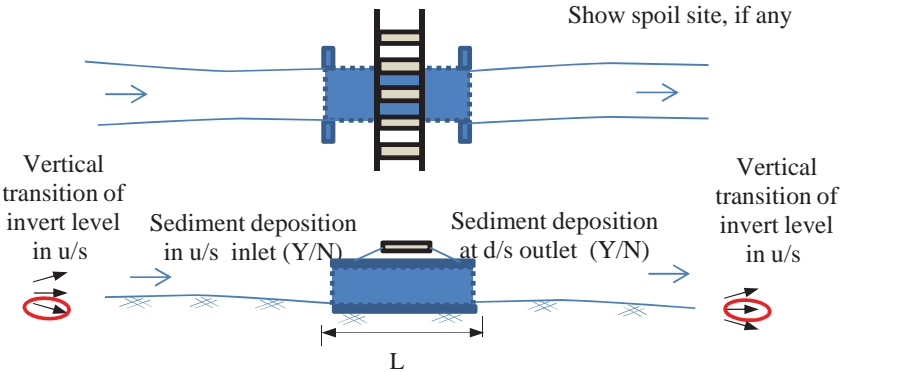
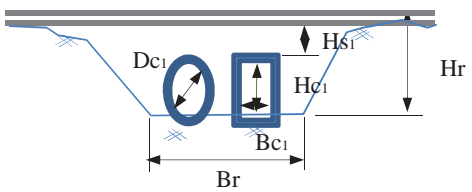
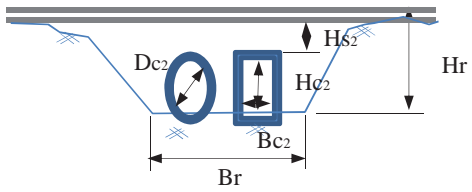
Photo Upstream	Photo Downstream
	
<b>Plan/Profile</b>	
 <p style="text-align: right;">Show spoil site, if any</p>	
<b>Cross Section</b>	
u/s	
d/s	



## Inventory Sheet for Culvert

**Station: at KM 349.0B**      **Sheet No.: PCL 349.0B**

1. General			
1-1	Name of Inspector		T. Kawaguchi , Hussein , Abiud
1-2	Organization of Inspector		JICA Study Team
1-3	Date/Time of Inspection		2014/2/12
1-4	Location	Lat	06° 31' 48" 65"
1-5		Long	036° 33' 05" 15"
1-6	Elevation		

### 2. Characteristics of Physical Condition of Culvert

2-1	Length of Culvert		6.0 m
2-2	Shape of Cross Section		Square: Rectangular: Circle:(2)
2-3	Flow Area	Height	Hc1 = 0.6 m , Hc2 = 0.6 m
2-4		Width	Dc1 = 0.6 m , Dc2 = 0.6 m
2-5		Other	Hs1 = 1.0 m , Hs2 = 1.0 m
2-6	Connecting Channel	Height	
2-7		Width	
2-8		Side Slope	
2-9	Type of Culvert		Concrete
2-10	Riverbed	Material	Silty sand
2-11	Sediment	u/s	No ( 0% rate)
2-12	deposition	d/s	No ( 0% rate)
2-13	Topography		u/s: , d/s:
2-14	Land Use		
2-15	Structures/Houses, road		

### 3. Damaged Flood Records

3-1	(Year/Month)	(Type)	(Reason,etc.)

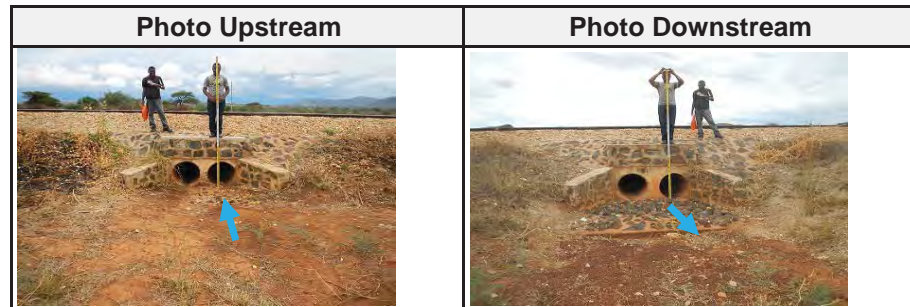

### Plan/Profile

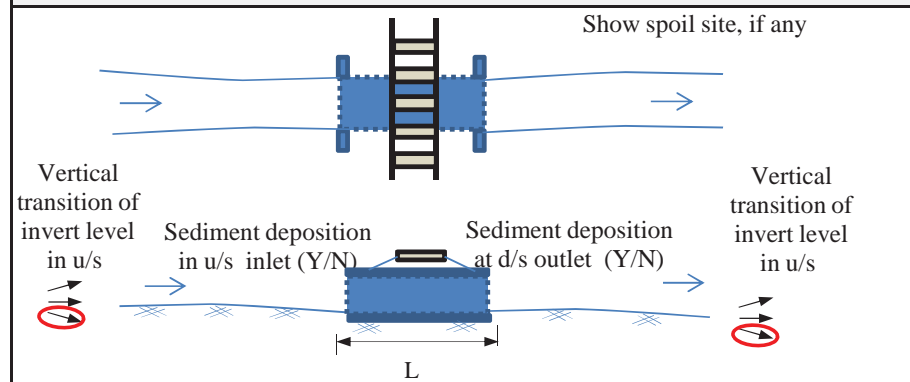

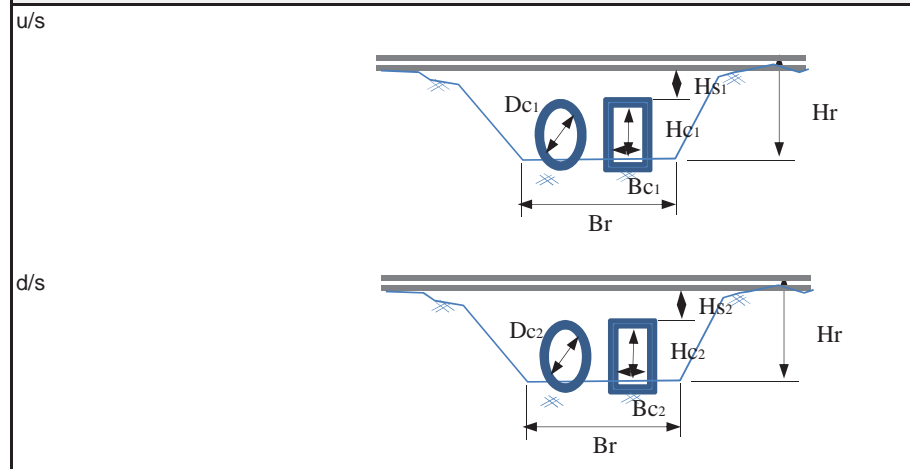

### Cross Section



F-116

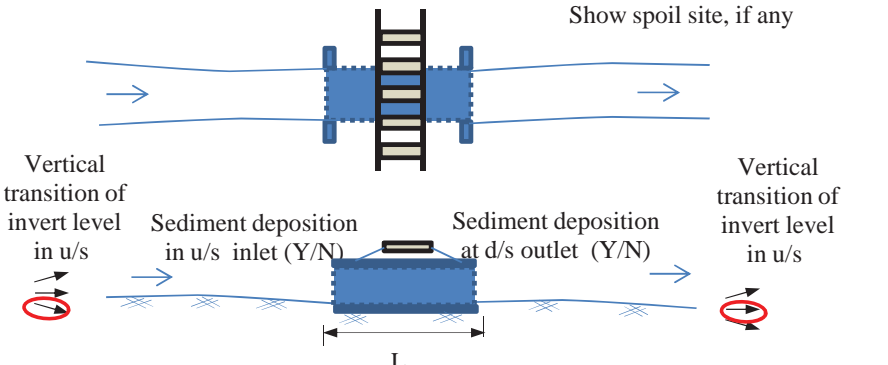
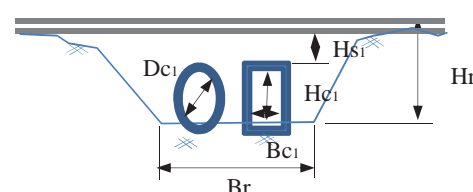
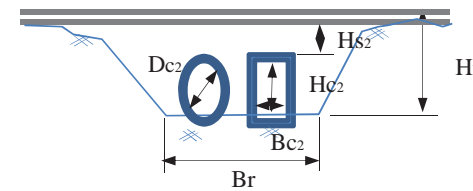

## Inventory Sheet for Culvert

<b>Station: at KM 349.4B</b>		<b>Sheet No.: BCL 349.4B</b>	
<b>1. General</b>			
1-1	Name of Inspector	T. Kawaguchi , Hussein , Abiud	
1-2	Organization of Inspector	JICA Study Team	
1-3	Date/Time of Inspection	2014/2/12	
1-4	Location	Lat	06° 31' 41" 17"
1-5		Long	036° 32' 54" 70"
1-6	Elevation		
<b>2. Characteristics of Physical Condition of Culvert</b>			
2-1	Length of Culvert	5.0 m	
2-2	Shape of Cross Section	Square:(3) Rectangular: Circle:	
2-3	Flow Area	Height	Hc1 = 1.7 m , Hc2 = 1.7 m
2-4		Width	Bc1 = 2.0 m , Bc2 = 2.0 m
2-5		Other	Hs1 = 1.0 m , Hs2 = 1.0 m
2-6	Connecting Channel	Height	
2-7		Width	
2-8		Side Slope	
2-9	Type of Culvert	Concrete	
2-10	Riverbed	Material	Silty sand
2-11	Sediment deposition	u/s	Light ( 30% rate)
2-12		d/s	Light ( 30% rate)
2-13	Topography	u/s:  , d/s:	
2-14	Land Use		
2-15	Structures/Houses, road		
<b>3. Damaged Flood Records</b>			
3-1	(Year/Month)	(Type)	(Reason,etc.)

<b>Photo Upstream</b>	<b>Photo Downstream</b>
	
<b>Plan/Profile</b>	
 <p style="text-align: right;">Show spoil site, if any</p>	
<b>Cross Section</b>	
u/s	
d/s	

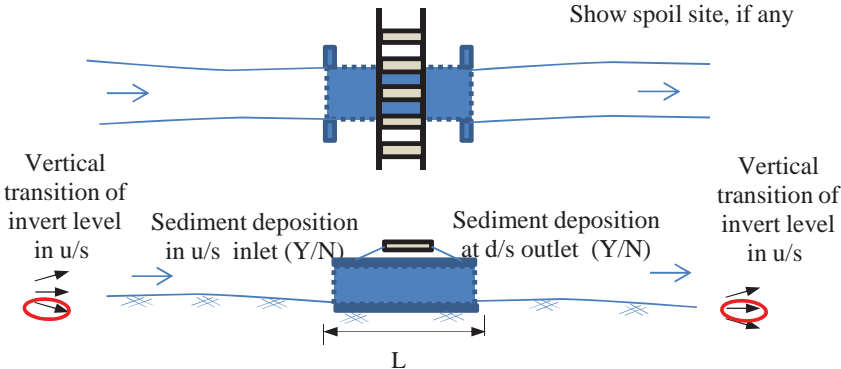
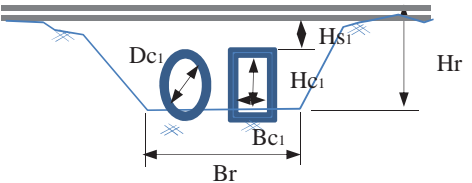
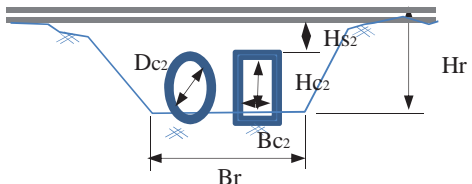

## Inventory Sheet for Culvert

<b>Station: at KM 349.5B</b>		<b>Sheet No.: BCL 349.5B</b>	
<b>1. General</b>			
1-1	Name of Inspector	T. Kawaguchi , Hussein , Abiud	
1-2	Organization of Inspector	JICA Study Team	
1-3	Date/Time of Inspection	212/2014	
1-4	Location	Lat	06° 31' 39" 50'''
1-5		Long	036° 32' 52" 25'''
1-6	Elevation		
<b>2. Characteristics of Physical Condition of Culvert</b>			
2-1	Length of Culvert	6.0 m	
2-2	Shape of Cross Section	Square:(3) Rectangular: Circle:	
2-3	Flow Area	Height	Hc1 = 0.7 m , Hc2 = 0.7 m
2-4		Width	Bc1 = 2.0 m , Bc2 = 2.0 m
2-5		Other	Hs1 = 0.3 m , Hs2 = 0.3 m
2-6	Connecting Channel	Height	
2-7		Width	
2-8		Side Slope	
2-9	Type of Culvert	Concrete	
2-10	Riverbed	Material	Silty sand
2-11	Sediment	u/s	Heavy ( 60% rate)
2-12	deposition	d/s	Heavy ( 60% rate)
2-13	Topography	u/s:  , d/s:	
2-14	Land Use		
2-15	Structures/Houses, road		
<b>3. Damaged Flood Records</b>			
3-1	(Year/Month)	(Type)	(Reason,etc.)

<b>Photo Upstream</b>	<b>Photo Downstream</b>
	
<b>Plan/Profile</b>	
 <p style="text-align: center;">Show spoil site, if any</p> <p style="text-align: center;">Vertical transition of invert level in u/s    Sediment deposition in u/s inlet (Y/N)    Sediment deposition at d/s outlet (Y/N)    Vertical transition of invert level in u/s</p> <p style="text-align: center;">L</p>	
<b>Cross Section</b>	
u/s	
d/s	

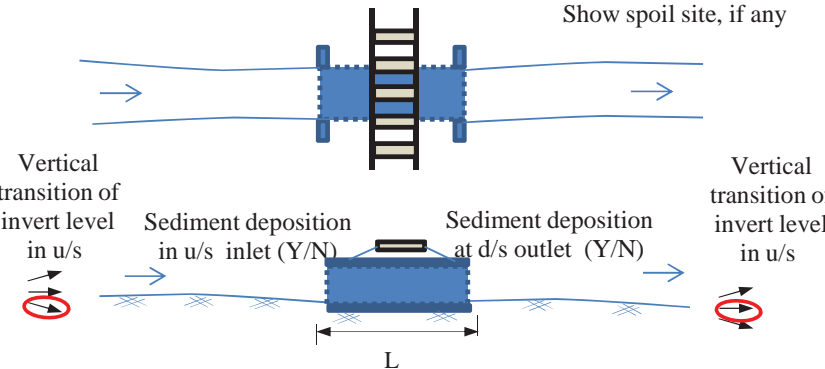
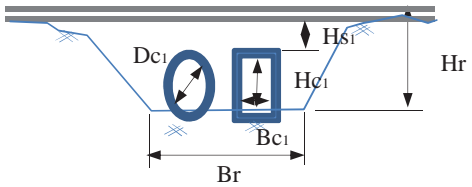
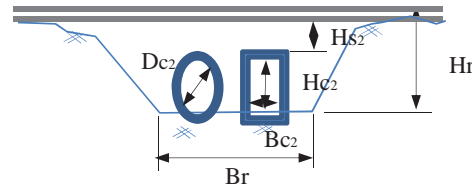

## Inventory Sheet for Culvert

<b>Station: at KM 349.6B</b>		<b>Sheet No.: BCL 349.6B</b>	
<b>1. General</b>			
1-1	Name of Inspector	T. Kawaguchi , Hussein , Abiud	
1-2	Organization of Inspector	JICA Study Team	
1-3	Date/Time of Inspection	2014/2/12	
1-4	Location	Lat	06° 31' 37" 36 ""
1-5		Long	036° 32' 49" 49""
1-6	Elevation		
<b>2. Characteristics of Physical Condition of Culvert</b>			
2-1	Length of Culvert	6.0 m	
2-2	Shape of Cross Section	Square:(1) Rectangular: Circle:	
2-3	Flow Area	Height	Hc1 = 1.1 m , Hc2 = 1.2 m
2-4		Width	Bc1 = 2.0 m , Bc2 = 2.0 m
2-5		Other	Hs1 = 0.3 m , Hs2 = 0.3 m
2-6	Connecting Channel	Height	
2-7		Width	
2-8		Side Slope	
2-9	Type of Culvert	Concrete	
2-10	Riverbed	Material	Silty sand
2-11	Sediment	u/s	Light ( 30% rate)
2-12	deposition	d/s	Light ( 30% rate)
2-13	Topography	u/s:  , d/s:	
2-14	Land Use		
2-15	Structures/Houses, road		
<b>3. Damaged Flood Records</b>			
3-1	(Year/Month)	(Type)	(Reason,etc.)

<b>Photo Upstream</b>	<b>Photo Downstream</b>
	
<b>Plan/Profile</b>	
<p style="text-align: right;">Show spoil site, if any</p> 	
<b>Cross Section</b>	
u/s	
d/s	

## Inventory Sheet for Culvert

<b>Station: at KM 349.8 B</b>		<b>Sheet No.: BCL 349.8B</b>	
<b>1. General</b>			
1-1	Name of Inspector	T. Kawaguchi , Hussein , Abiud	
1-2	Organization of Inspector	JICA Study Team	
1-3	Date/Time of Inspection	2014/2/12	
1-4	Location	Lat	06° 31' 30" 80'''
1-5		Long	036° 32' 40" 39'''
1-6	Elevation		
<b>2. Characteristics of Physical Condition of Culvert</b>			
2-1	Length of Culvert	6.0 m	
2-2	Shape of Cross Section	Square:(1) Rectangular: Circle:	
2-3	Flow Area	Height	Hc1 = 1.7 m , Hc2 = 1.7 m
2-4		Width	Bc1 = 2.0 m , Bc2 = 2.0 m
2-5		Other	Hs1 = 0.3 m , Hs2 = 0.3 m
2-6	Connecting Channel	Height	
2-7		Width	
2-8		Side Slope	
2-9	Type of Culvert	Concrete	
2-10	Riverbed	Material	Silty sand
2-11	Sediment deposition	u/s	Light ( 20% rate)
2-12		d/s	Light ( 20% rate)
2-13	Topography	u/s:  , d/s:	
2-14	Land Use		
2-15	Structures/Houses, road		
<b>3. Damaged Flood Records</b>			
3-1	(Year/Month)	(Type)	(Reason,etc.)

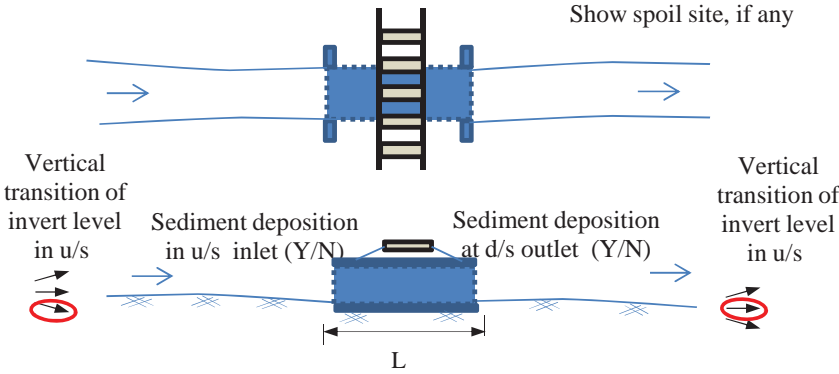
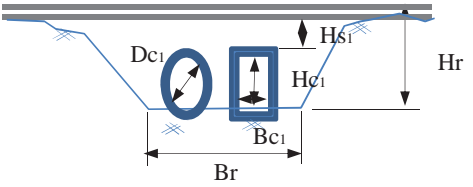
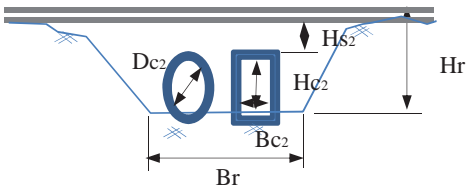
<b>Photo Upstream</b>	<b>Photo Downstream</b>
	
<b>Plan/Profile</b>	
 <p style="text-align: center;">Show spoil site, if any</p> <p style="text-align: center;">Vertical transition of invert level in u/s    Sediment deposition in u/s inlet (Y/N)    Sediment deposition at d/s outlet (Y/N)    Vertical transition of invert level in u/s</p> <p style="text-align: center;">L</p>	
<b>Cross Section</b>	
u/s	
d/s	



## Inventory Sheet for Culvert

**Station: at KM 349.9 B**      **Sheet No.: BCL 349.9B**

1. General			
1-1	Name of Inspector		T. Kawaguchi , Hussein , Abiud
1-2	Organization of Inspector		JICA Study Team
1-3	Date/Time of Inspection		2014/2/12
1-4	Location	Lat	06° 31' 30" 83'''
1-5		Long	036° 32' 40" 49'''
1-6	Elevation		

### 2. Characteristics of Physical Condition of Culvert

2-1	Length of Culvert		6.0 m
2-2	Shape of Cross Section		Square:(1) Rectangular: Circle:
2-3	Flow Area	Height	Hc1 = 0.9 m , Hc2 = 0.9 m
2-4		Width	Bc1 = 2.0 m , Bc2 = 2.0 m
2-5		Other	Hs1 = 0.3 m , Hs2 = 0.3 m
2-6	Connecting Channel	Height	
2-7		Width	
2-8		Side Slope	
2-9	Type of Culvert		Concrete
2-10	Riverbed	Material	Silty sand
2-11	Sediment	u/s	Heavy ( 60% rate)
2-12	deposition	d/s	Heavy ( 60% rate)
2-13	Topography		u/s: , d/s:
2-14	Land Use		
2-15	Structures/Houses, road		

### 3. Damaged Flood Records

3-1	(Year/Month)	(Type)	(Reason,etc.)

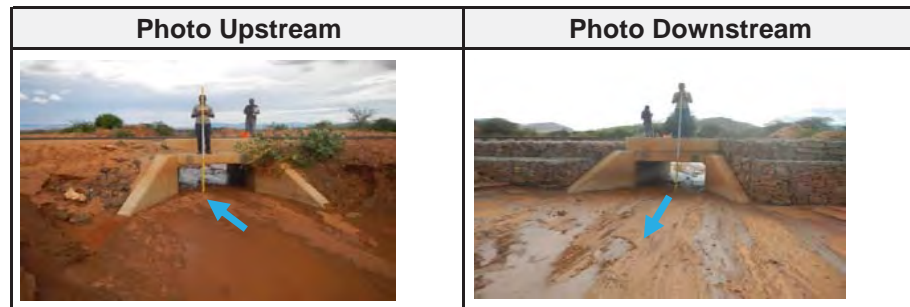

### Plan/Profile

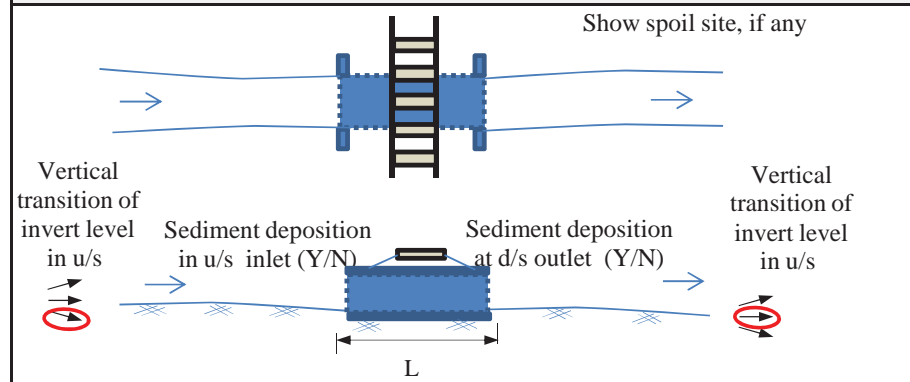

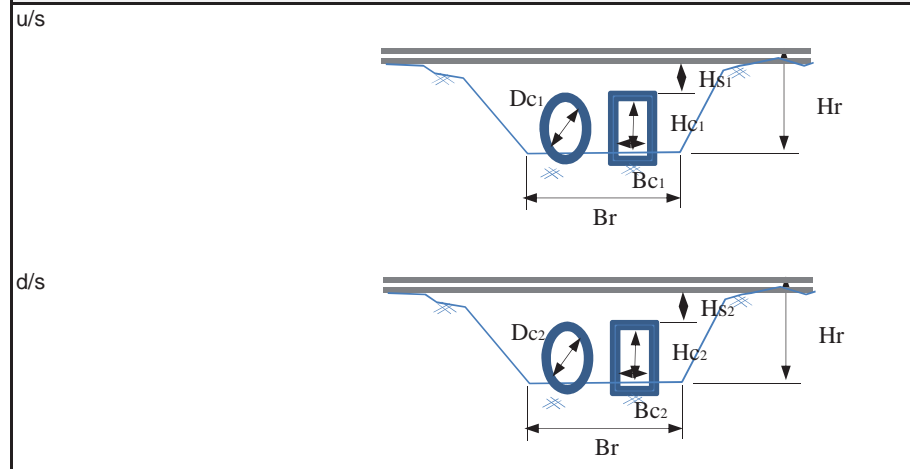

### Cross Section



F-121

## Inventory Sheet for Culvert

<b>Station: at KM 352/9</b>		<b>Sheet No.: CBL352.9</b>	
<b>1. General</b>			
1-1	Name of Inspector	T.Fukuda, Mr.Kido, Mr.Philipo	
1-2	Organization of Inspector	B	
1-3	Date/Time of Inspection	DEC 2 2014	
1-4	Location	Lat	
1-5		Long	
1-6	Elevation	n/a	
<b>2. Characteristics of Physical Condition of Culvert</b>			
2-1	Length of Culvert	n/a	
2-2	Shape of Cross Section	Circle x 1	
2-3	Flow Area	Height	D=0.9m(2)
2-4		Width	
2-5		Other	
2-6	Connecting Channel	Height	n/a
2-7		Width	n/a
2-8		Side Slope	n/a
2-9	Type of Culvert	Concrete	
2-10	Riverbed	Material	n/a
2-11	Sediment deposition	u/s	Y, 20%
2-12		d/s	Y, 20%
2-13	Topography	u/s: ,d/s	
2-14	Land Use	n/a	
2-15	Structures/Houses, road	n/a	
<b>3. Damaged Flood Records</b>			
3-1	(Year/Month)	(Type)	(Reason,etc.)
	n/a	n/a	n/a

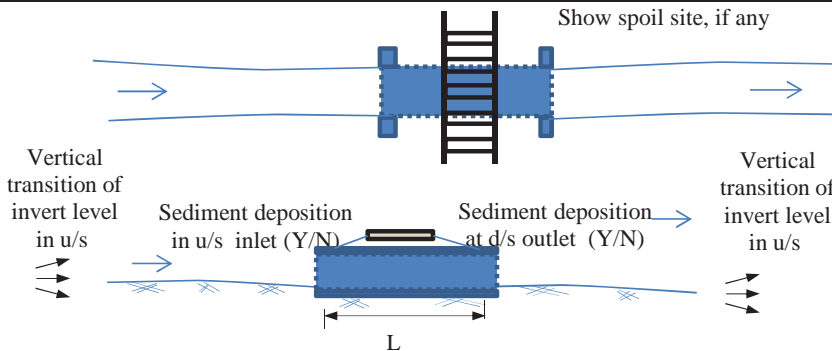
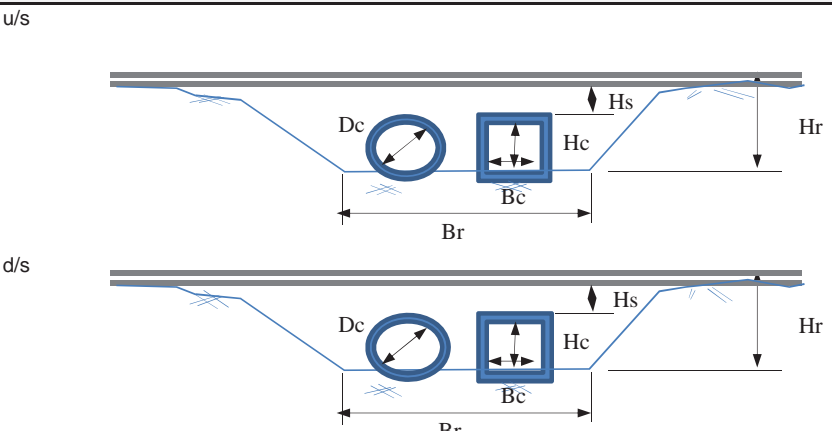
<b>Photo Upstream</b>	<b>Photo Downstream</b>
	
<b>Plan/Profile</b>	
 <p style="text-align: center;">Show spoil site, if any</p> <p style="text-align: center;">Vertical transition of invert level in u/s      Sediment deposition in u/s inlet (Y/N)      Sediment deposition at d/s outlet (Y/N)      Vertical transition of invert level in u/s</p> <p style="text-align: center;">L</p>	
<b>Cross Section</b>	
 <p style="text-align: center;">u/s</p> <p style="text-align: center;">d/s</p>	

## Inventory Sheet for Culvert

**Station: at KM 352/9**      **Sheet No.: CBL352.9**

### 1. General

1-1	Name of Inspector	T.Fukuda, Mr.Kido, Mr.Philipo	
1-2	Organization of Inspector	B	
1-3	Date/Time of Inspection	DEC 2 2014	
1-4	Location	Lat	06°29'55.5"
1-5		Long	036°30'40.8"
1-6	Elevation	n/a	

### 2. Characteristics of Physical Condition of Culvert

2-1	Length of Culvert	n/a	
2-2	Shape of Cross Section	Rectangular × 1	
2-3	Flow Area	Height	Hc=1.6m
2-4		Width	Bc= 4.0m
2-5		Other	WL=2.2m, Hs= 0.5m
2-6	Connecting Channel	Height	n/a
2-7		Width	n/a
2-8		Side Slope	n/a
2-9	Type of Culvert	Concrete	
2-10	Riverbed	Material	n/a
2-11	Sediment deposition	u/s	N, 0%
2-12		d/s	N, 0%
2-13	Topography	u/s: → ,d/s →	
2-14	Land Use	n/a	
2-15	Structures/Houses, road	n/a	

### 3. Damaged Flood Records

3-1	(Year/Month)	(Type)	(Reason,etc.)
	n/a	n/a	n/a

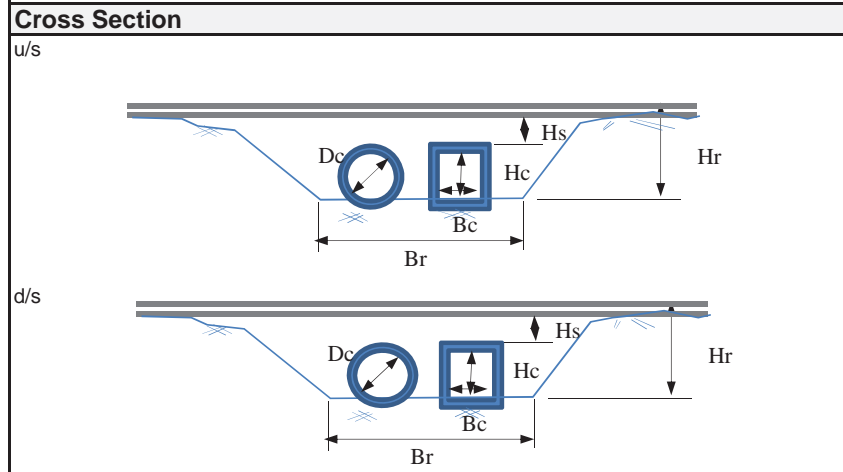
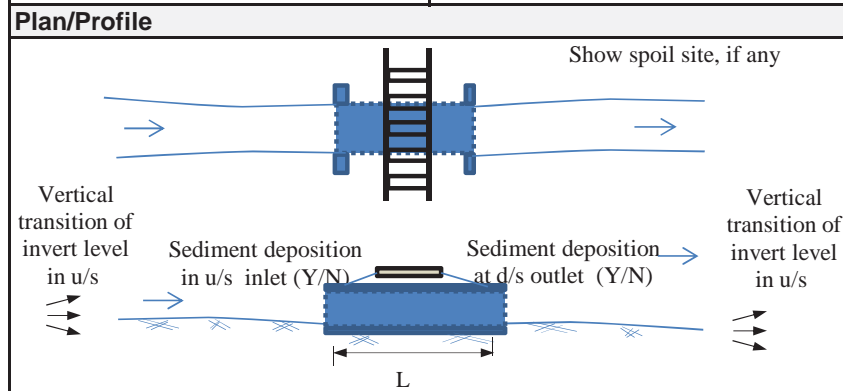
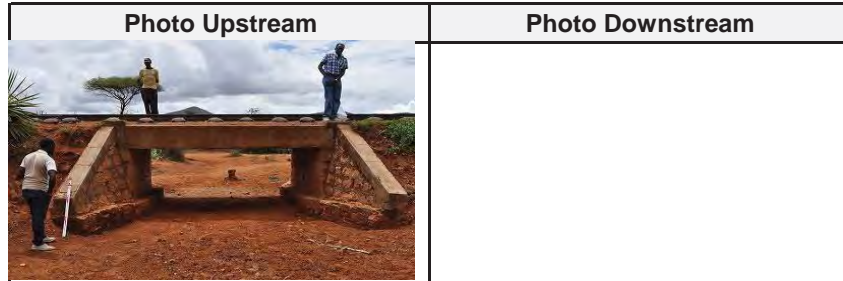

## Inventory Sheet for Culvert

**Station: at KM 354/3**      **Sheet No.: BCL354.3**

<b>1. General</b>			
1-1	Name of Inspector		T.Fukuda, Mr.Kido, Mr.Philipo
1-2	Organization of Inspector		B
1-3	Date/Time of Inspection		DEC 2 2014
1-4	Location	Lat	06°29'46.6"
1-5		Long	036°30'25.1"
1-6	Elevation		n/a

**2. Characteristics of Physical Condition of Culvert**

2-1	Length of Culvert		n/a
2-2	Shape of Cross Section		Rectangular × 1
2-3	Flow Area	Height	Hc=0.55m
2-4		Width	Bc= 2.0m
2-5		Other	WL=1..0m, Hs= 0.45m
2-6	Connecting Channel	Height	n/a
2-7		Width	n/a
2-8		Side Slope	n/a
2-9	Type of Culvert		Concrete
2-10	Riverbed	Material	n/a
2-11	Sediment deposition	u/s	Y, 75%
2-12		d/s	Y, 75%
2-13	Topography		u/s: → ,d/s →
2-14	Land Use		n/a
2-15	Structures/Houses, road		n/a

**3. Damaged Flood Records**

3-1	(Year/Month)	(Type)	(Reason,etc.)
	n/a	n/a	n/a

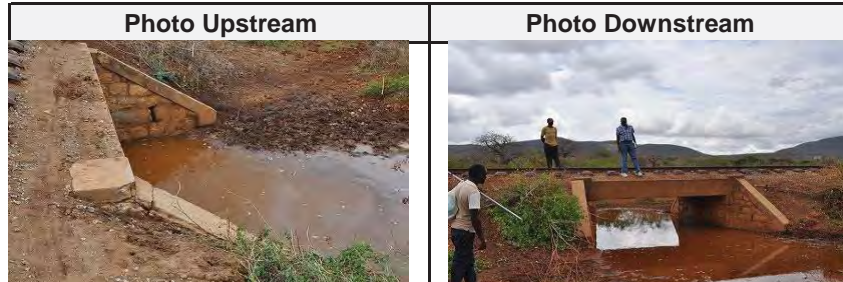

**Plan/Profile**

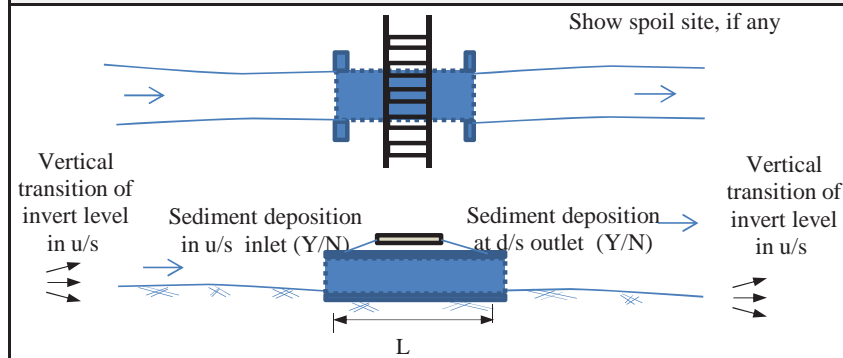

**Cross Section**

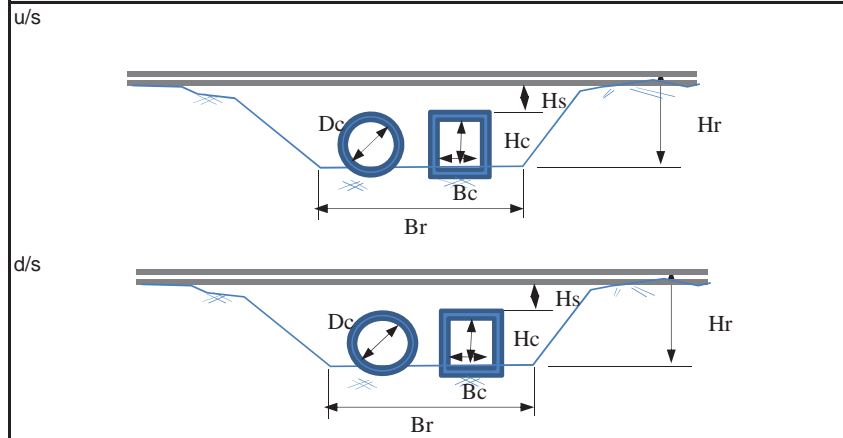

### Inventory Sheet for Culvert

**Station: at KM 355/6**      **Sheet No.: BCL355.6**

<b>1. General</b>		
1-1	Name of Inspector	T.Fukuda, Mr.Kido, Mr.Philipo
1-2	Organization of Inspector	B
1-3	Date/Time of Inspection	DEC 2 2014
1-4	Location	Lat 06°29'37.7"
1-5		Long 036°30'13.4"
1-6	Elevation	n/a

<b>2. Characteristics of Physical Condition of Culvert</b>		
2-1	Length of Culvert	n/a
2-2	Shape of Cross Section	Rectangular × 1
2-3	Flow Area	Height Hc=0.95m
2-4		Width Bc= 3.0m
2-5		Other WL=5.4m, Hs= 0.65m
2-6	Connecting Channel	Height n/a
2-7		Width n/a
2-8		Side Slope n/a
2-9	Type of Culvert	Concrete
2-10	Riverbed	Material n/a
2-11	Sediment deposition	u/s Y, 75%
2-12		d/s Y, 75%
2-13	Topography	u/s: ↘ ,d/s ↘
2-14	Land Use	n/a
2-15	Structures/Houses, road	n/a

<b>3. Damaged Flood Records</b>			
3-1	(Year/Month)	(Type)	(Reason,etc.)
	n/a	n/a	n/a

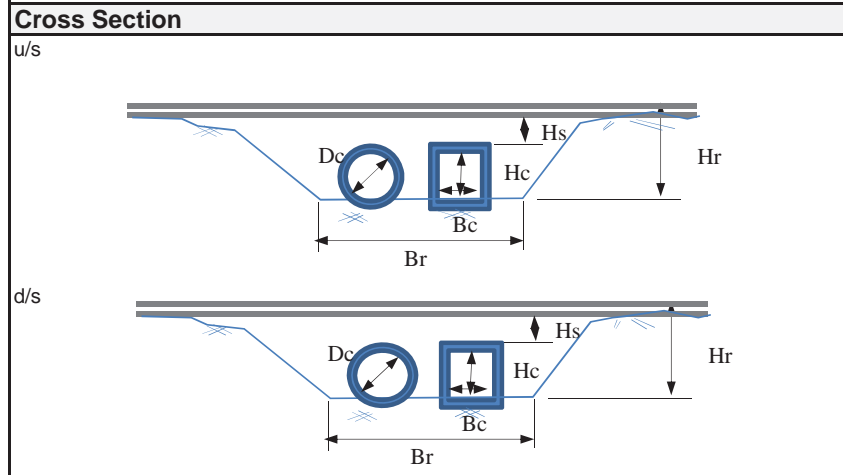
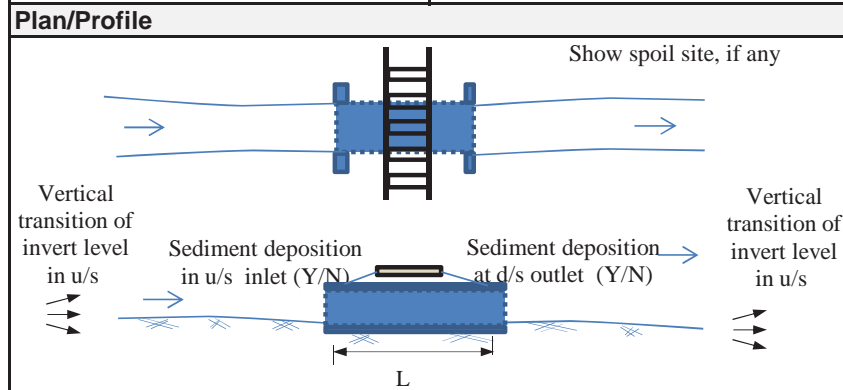
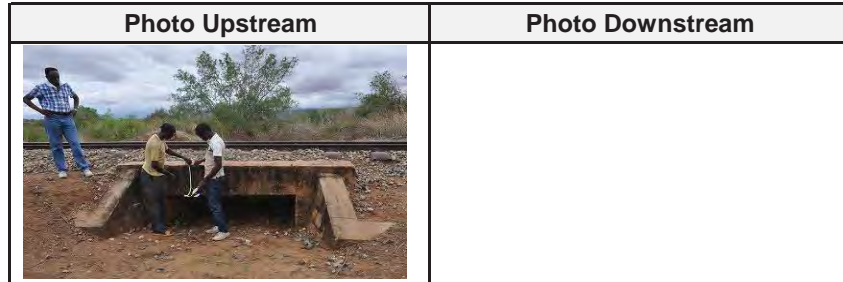



## Inventory Sheet for Culvert

**Station: at KM 356/1**      **Sheet No.: BCL356.1**

<b>1. General</b>			
1-1	Name of Inspector		T.Fukuda, Mr.Kido, Mr.Philipo
1-2	Organization of Inspector		B
1-3	Date/Time of Inspection		DEC 2 2014      1432
1-4	Location	Lat	06°29'36.4"
1-5		Long	036°29'59.5"
1-6	Elevation		n/a

<b>2. Characteristics of Physical Condition of Culvert</b>			
2-1	Length of Culvert		n/a
2-2	Shape of Cross Section		Rectangular × 1
2-3	Flow Area	Height	Hc=0.8m
2-4		Width	Bc= 3.0m
2-5		Other	WL=1.45m, Hs= 0.65m
2-6	Connecting Channel	Height	n/a
2-7		Width	n/a
2-8		Side Slope	n/a
2-9	Type of Culvert		Concrete
2-10	Riverbed	Material	n/a
2-11	Sediment deposition	u/s	Y, 75%
2-12		d/s	Y, 75%
2-13	Topography		u/s: ↘      ,d/s      ↗
2-14	Land Use		n/a
2-15	Structures/Houses, road		n/a

<b>3. Damaged Flood Records</b>			
3-1	(Year/Month)	(Type)	(Reason,etc.)
	n/a	n/a	n/a

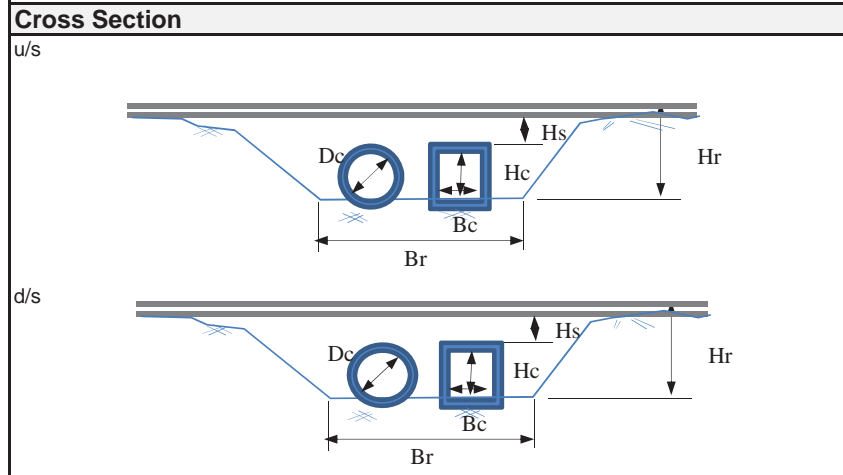
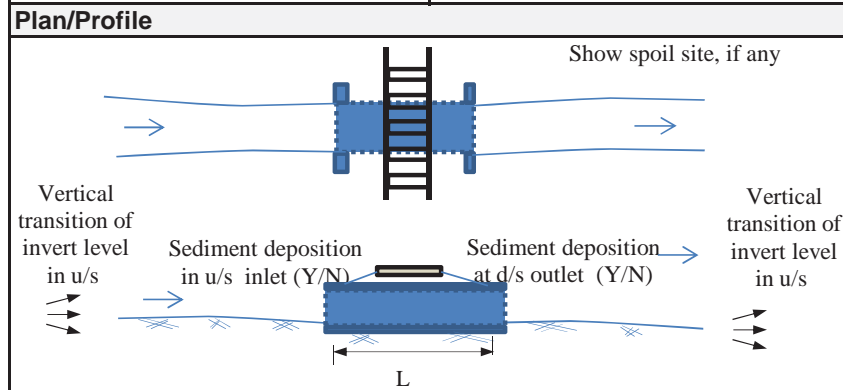
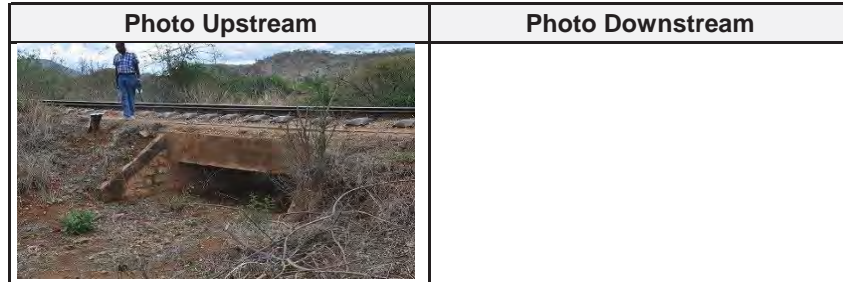

## Inventory Sheet for Culvert

**Station: at KM 360.0**      **Sheet No.: BCL 360.0**

### 1. General

1-1	Name of Inspector	Mr Motoki/ Semaya/ France	
1-2	Organization of Inspector	River Group B	
1-3	Date/Time of Inspection	Dec 2 2014 14:27 - 14:35	
1-4	Location	Lat	06° 28' 44.6"
1-5		Long	036° 27' 13.8"
1-6	Elevation	778m	

### 2. Characteristics of Physical Condition of Culvert

2-1	Length of Culvert	5.0m	
2-2	Shape of Cross Section	Square: <u>Rectangular: (1)</u> Circle:	
2-3	Flow Area	Height	1.0m
2-4		Widdth	2.0m
2-5	Connecting Channel	Other	
2-6		Height	
2-7		Widdth	
2-8	Side Slope		
2-9	Type of Culvert	Concrete	
2-10	Riverbed	Material	silt sand
2-11	Sediment deposition	u/s	heavy
2-12		d/s	heavy
2-13	Topography	u/s: $\Rightarrow$ , d/s: $\Rightarrow$	
2-14	Land Use		
2-15	Structures/Houses, road		

### 3. Damaged Flood Records

3-1	(Year/Month)	(Type)	(Reason, etc.)



### Plan/Profile

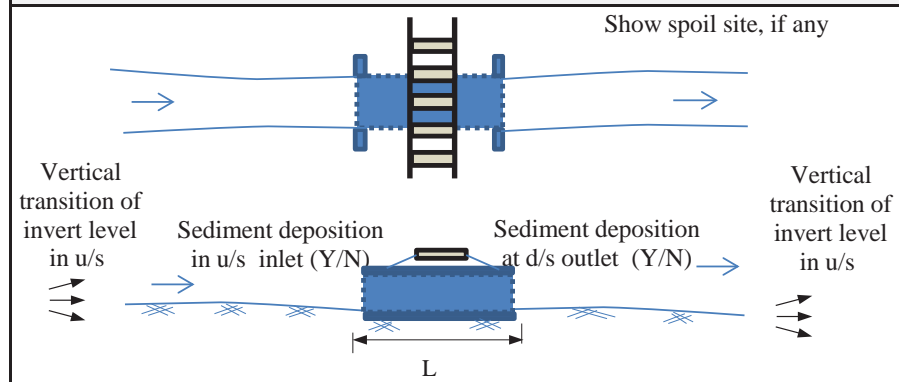

### Cross Section

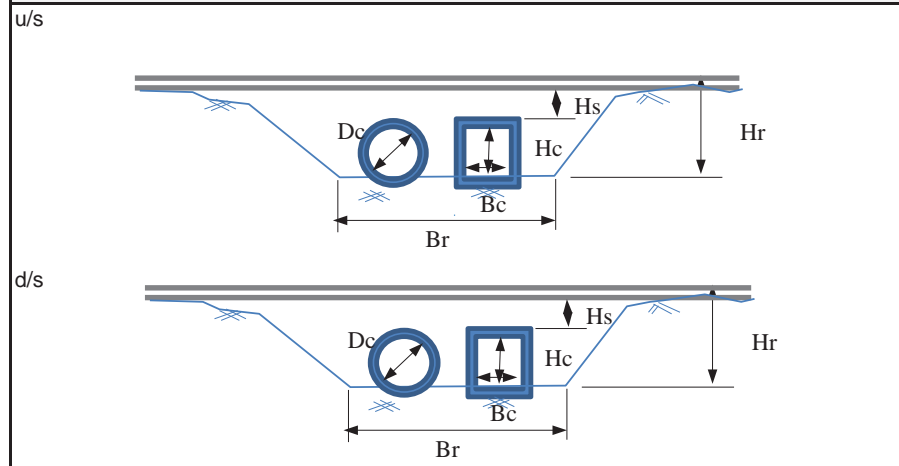

F-127

## Inventory Sheet for Culvert

**Station: at KM**    **360.6**                      **Sheet No.: BCL 360.6**

### 1. General

1-1	Name of Inspector	Mr Motoki/ Semaya/ France
1-2	Organization of Inspector	River Group B
1-3	Date/Time of Inspection	Dec 2 2014 14:10 - 14:20
1-4	Location	Lat 06° 28' 33.7"
1-5		Long 036° 26' 58.3"
1-6	Elevation	781m

### 2. Characteristics of Physical Condition of Culvert

2-1	Length of Culvert	3.6m
2-2	Shape of Cross Section	Square: <u>Rectangular: (1)</u> Circle:
2-3	Flow Area	Height 0.62m
2-4		Widdth 4.95m
2-5	Other	
2-6	Connecting Channel	Height
2-7		Widdth
2-8		Side Slope
2-9	Type of Culvert	Concrete
2-10	Riverbed	Material silt sand
2-11	Sediment deposition	u/s heavy
2-12		d/s heavy                      bush
2-13	Topography	u/s:  , d/s:
2-14	Land Use	
2-15	Structures/Houses, road	

### 3. Damaged Flood Records

3-1	(Year/Month)	(Type)	(Reason, etc.)

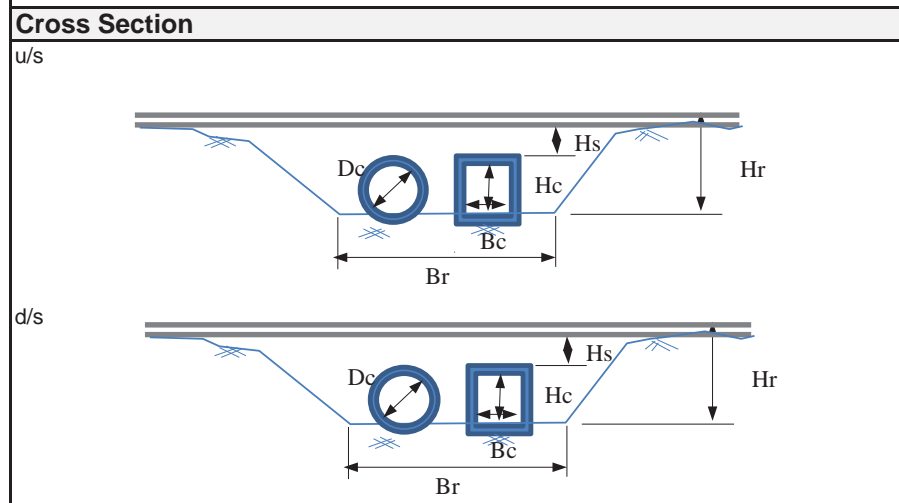
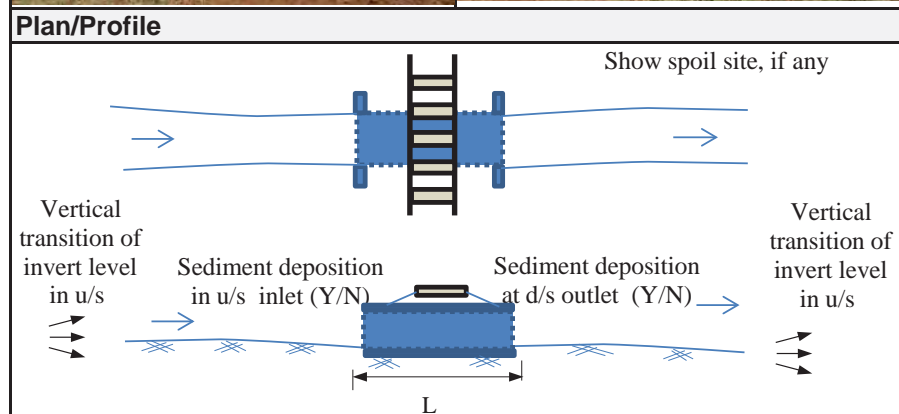

## Inventory Sheet for Culvert

**Station: at KM 360.9**      **Sheet No.: BCL 360.9**

### 1. General

1-1	Name of Inspector	Mr Motoki/ Semaya/ France	
1-2	Organization of Inspector	River Group B	
1-3	Date/Time of Inspection	Dec 2 2014 14:00 - 14:10	
1-4	Location	Lat	06° 28' 22.4"
1-5		Long	036° 26' 55.9"
1-6	Elevation	782m	

### 2. Characteristics of Physical Condition of Culvert

2-1	Length of Culvert	5.0m	
2-2	Shape of Cross Section	Square: <u>Rectangular: (1)</u> Circle:	
2-3	Flow Area	Height	1.3m
2-4		Widdth	2.0m
2-5	Connecting Channel	Other	
2-6		Height	
2-7		Widdth	
2-8	Side Slope		
2-9	Type of Culvert	Concrete	
2-10	Riverbed	Material	silt sand
2-11	Sediment deposition	u/s	heavy
2-12		d/s	heavy      bush
2-13	Topography	u/s:  , d/s:	
2-14	Land Use		
2-15	Structures/Houses, road		

### 3. Damaged Flood Records

3-1	(Year/Month)	(Type)	(Reason, etc.)



### Plan/Profile

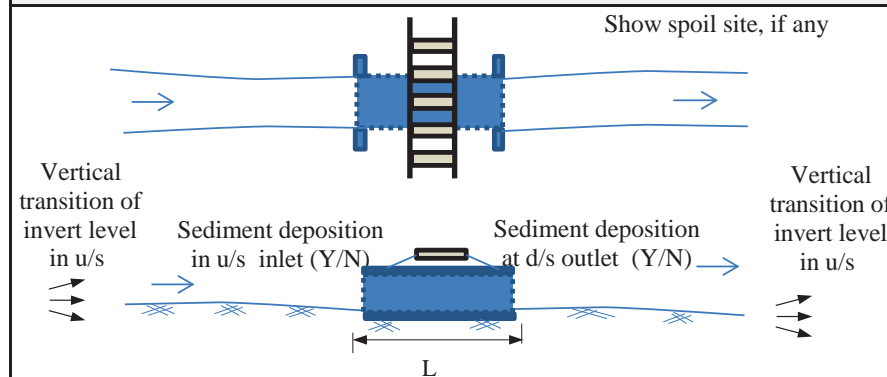

### Cross Section

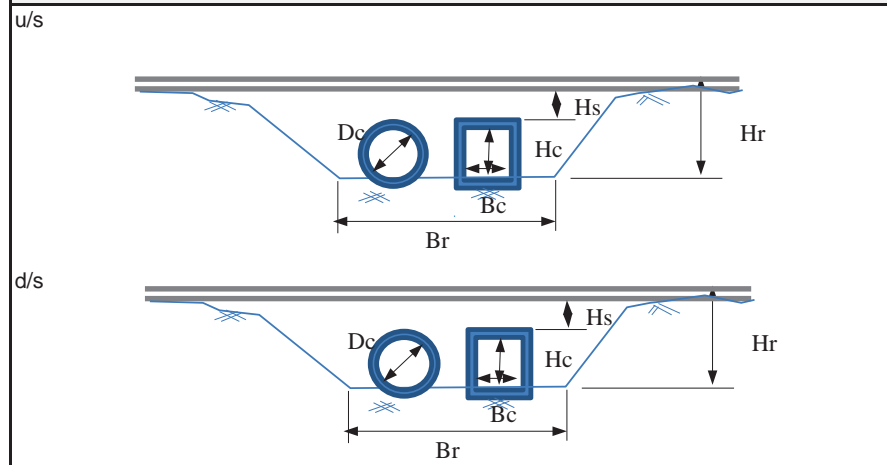

## Inventory Sheet for Culvert

**Station: at KM 361.1**      **Sheet No.: BCL 361.1**

### 1. General

1-1	Name of Inspector	Mr Motoki/ Semaya/ France	
1-2	Organization of Inspector	River Group B	
1-3	Date/Time of Inspection	Dec 2 2014 13:45 - 13:50	
1-4	Location	Lat	06° 28' 16.8"
1-5		Long	036° 26' 52.6"
1-6	Elevation	780m	

### 2. Characteristics of Physical Condition of Culvert

2-1	Length of Culvert	3.7m	
2-2	Shape of Cross Section	Square: <u>Rectangular: (1)</u> Circle:	
2-3	Flow Area	Height	0.55m
2-4		Widdth	2.0m
2-5	Connecting Channel	Other	
2-6		Height	
2-7		Widdth	
2-8	Side Slope		
2-9	Type of Culvert	Concrete	
2-10	Riverbed	Material	silt sand
2-11	Sediment deposition	u/s	heavy
2-12		d/s	heavy
2-13	Topography	u/s:  , d/s:	
2-14	Land Use		
2-15	Structures/Houses, road		

### 3. Damaged Flood Records

3-1	(Year/Month)	(Type)	(Reason, etc.)

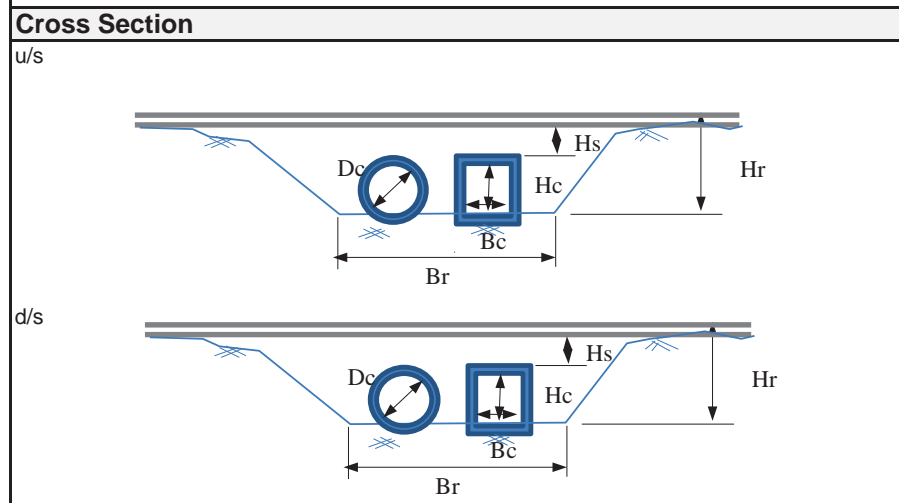
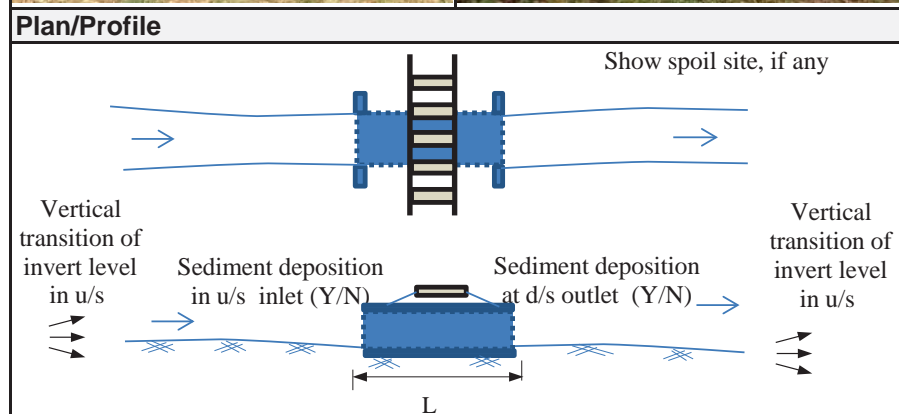
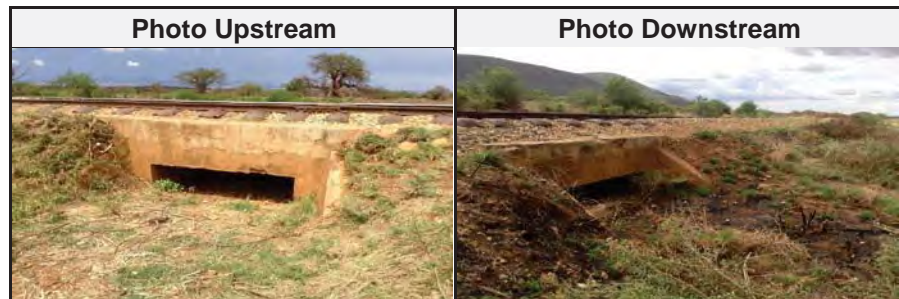



## Inventory Sheet for Culvert

**Station: at KM 361.9**      **Sheet No.: BCL 361.9**

### 1. General

1-1	Name of Inspector	Mr Motoki/ Semaya/ France	
1-2	Organization of Inspector	River Group B	
1-3	Date/Time of Inspection	Dec 2 2014 10:40 - 11:00	
1-4	Location	Lat	06° 28' 08.9"
1-5		Long	036° 26' 36.7"
1-6	Elevation	783m	

### 2. Characteristics of Physical Condition of Culvert

2-1	Length of Culvert	3.6m	
2-2	Shape of Cross Section	Square: <u>Rectangular: (1)</u> Circle:	
2-3	Flow Area	Height	0.33m
2-4		Widdth	5.0m
2-5	Connecting Channel	Other	
2-6		Height	
2-7		Widdth	
2-8	Side Slope		
2-9	Type of Culvert	Concrete	
2-10	Riverbed	Material	silt sand
2-11	Sediment deposition	u/s	heavy
2-12		d/s	heavy
2-13	Topography	u/s:  , d/s:	
2-14	Land Use		
2-15	Structures/Houses, road		

### 3. Damaged Flood Records

3-1	(Year/Month)	(Type)	(Reason, etc.)

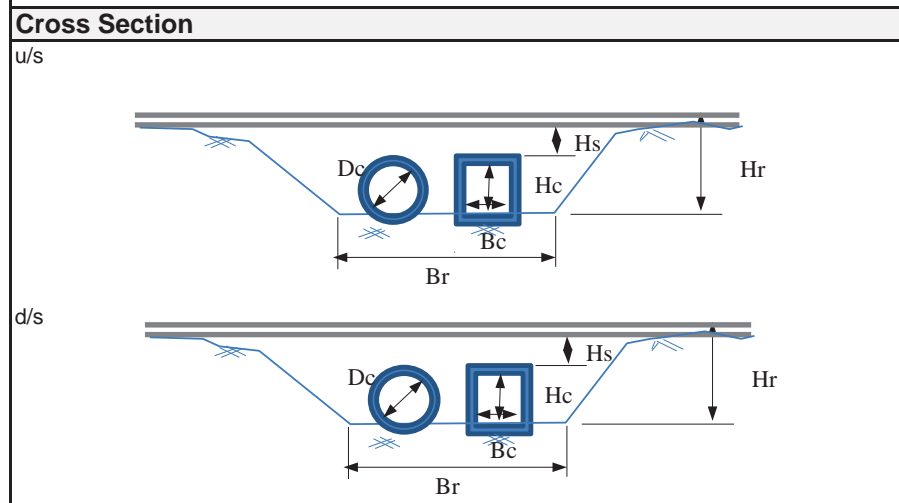
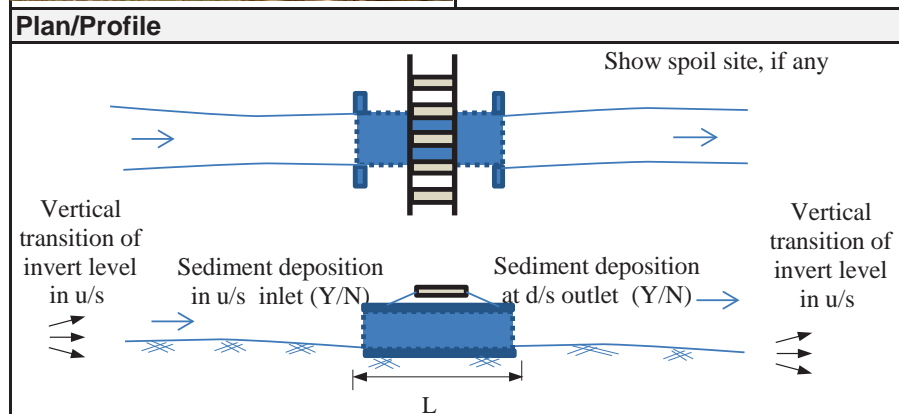
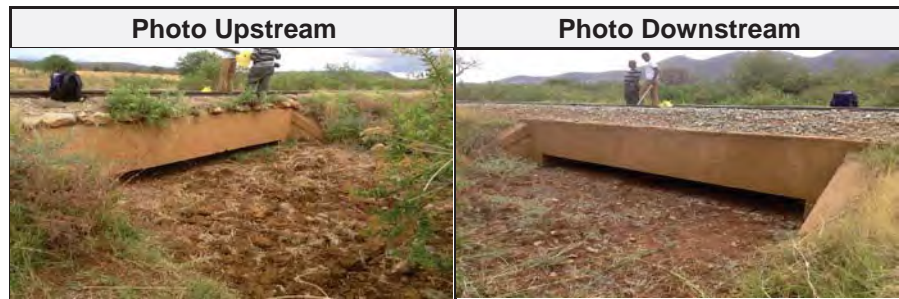

## Inventory Sheet for Culvert

**Station: at KM 362.1**      **Sheet No.: BCL 362.1**

### 1. General

1-1	Name of Inspector		Mr Motoki/ Semaya/ France
1-2	Organization of Inspector		River Group B
1-3	Date/Time of Inspection		Dec 2 2014 13:03 - 13:10
1-4	Location	Lat	06° 27' 58.7"
1-5		Long	036° 26' 26.1"
1-6	Elevation		785m

### 2. Characteristics of Physical Condition of Culvert

2-1	Length of Culvert		4.9m
2-2	Shape of Cross Section		Square: Rectangular: (3) Circle:
2-3	Height		0.7, 0.62, 0.6m
2-4	Flow Area	Widdth	open width 1.95 full width 7.23m
2-5		Other	
2-6	Connecting Channel	Height	
2-7		Widdth	
2-8		Side Slope	
2-9	Type of Culvert		Concrete
2-10	Riverbed	Material	silt sand
2-11	Sediment deposition	u/s	yes
2-12		d/s	
2-13	Topography		u/s:  , d/s:
2-14	Land Use		
2-15	Structures/Houses, road		

### 3. Damaged Flood Records

3-1	(Year/Month)	(Type)	(Reason, etc.)



### Plan/Profile

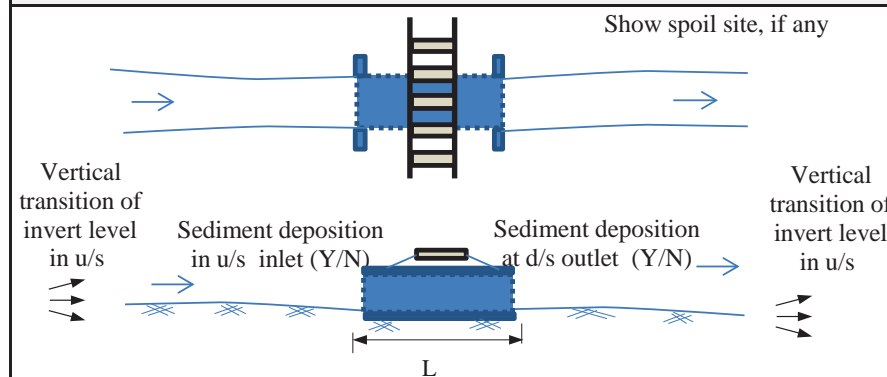

### Cross Section

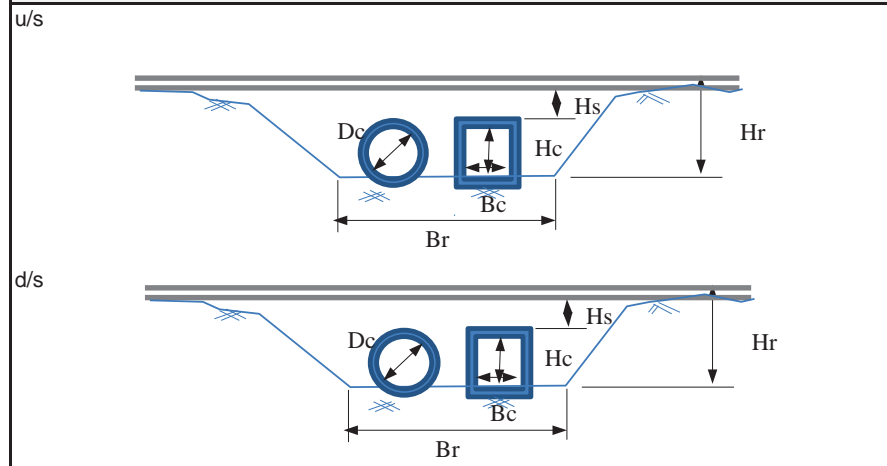

## Inventory Sheet for Culvert

**Station: at KM 362.5**      **Sheet No.: PCL 362.5**

### 1. General

1-1	Name of Inspector		Mr Motoki/ Semaya/ France
1-2	Organization of Inspector		River Group B
1-3	Date/Time of Inspection		
1-4	Location	Lat	06° 27' 46.0"
1-5		Long	036° 26' 18.1"
1-6	Elevation		780m

### 2. Characteristics of Physical Condition of Culvert

2-1	Length of Culvert		8.6m
2-2	Shape of Cross Section		Square: Rectangular: Circle: (2)
2-3	Flow Area	Height	0.8m (diameter)
2-4		Widdth	2.1m
2-5	Connecting Channel	Other	
2-6		Height	
2-7		Widdth	
2-8	Side Slope		
2-9		Type of Culvert	Concrete
2-10	Riverbed	Material	silt sand
2-11	Sediment deposition	u/s	yes
2-12		d/s	yes
2-13	Topography		u/s:  , d/s:
2-14	Land Use		
2-15	Structures/Houses, road		

### 3. Damaged Flood Records

3-1	(Year/Month)	(Type)	(Reason, etc.)

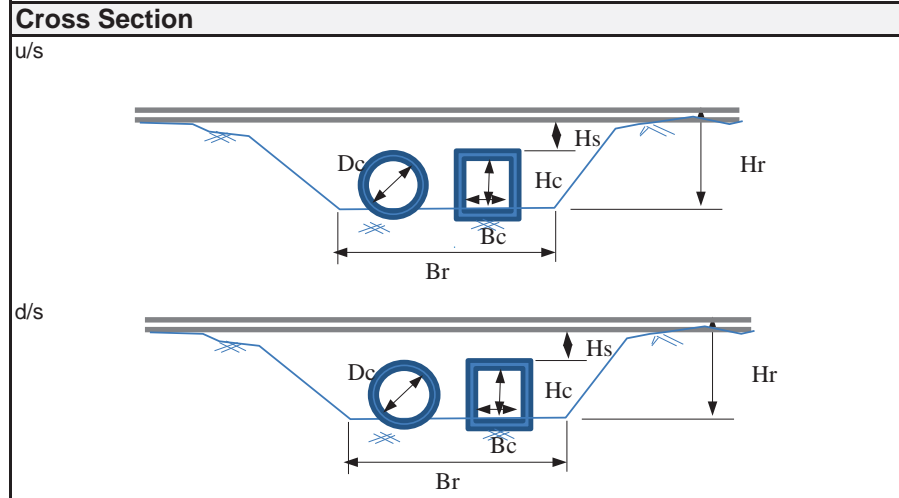
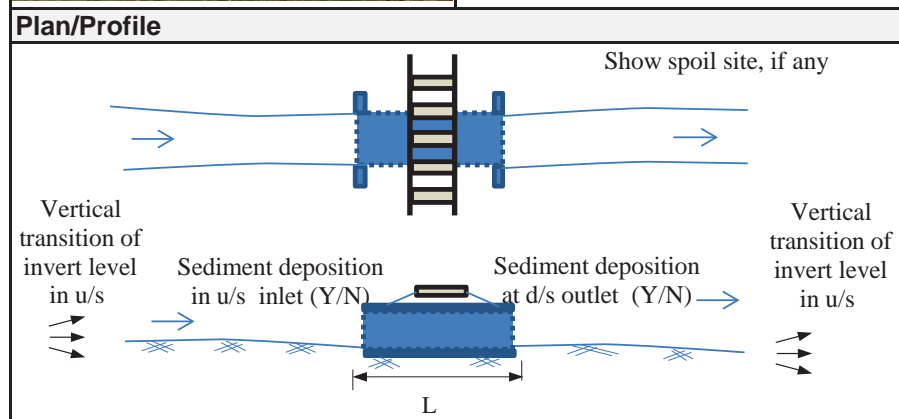
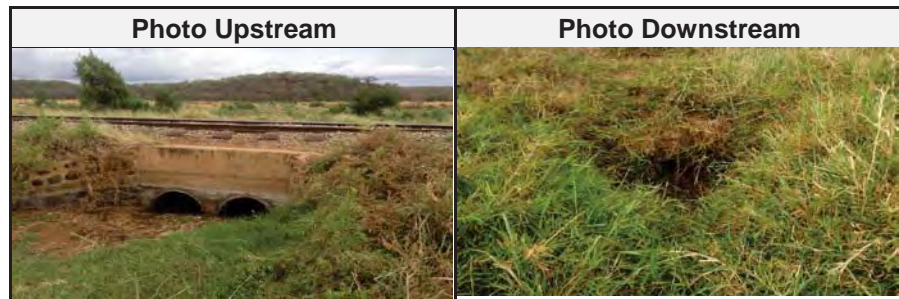

## Inventory Sheet for Culvert

**Station: at KM 362.9**      **Sheet No.: BCL 362.9**

1. General		
1-1	Name of Inspector	Mr Motoki/ Semaya/ France
1-2	Organization of Inspector	River Group B
1-3	Date/Time of Inspection	Dec 2 2014 12:05 - 12:10
1-4	Location	Lat 06° 27' 45.9"
1-5		Long 036° 26' 18.0"
1-6	Elevation	778m

2. Characteristics of Physical Condition of Culvert		
2-1	Length of Culvert	5.0m
2-2	Shape of Cross Section	Square: <u>Rectangular: (1)</u> Circle:
2-3	Flow Area	Height 0.66m
2-4		Width 2.0m
2-5	Other	
2-6	Connecting Channel	Height 1.1m
2-7		Width 3.15m
2-8		Side Slope
2-9	Type of Culvert	Concrete
2-10	Riverbed	Material silt sand
2-11	Sediment deposition	u/s
2-12		d/s yes
2-13	Topography	u/s: $\Rightarrow$ , d/s: $\Rightarrow$
2-14	Land Use	
2-15	Structures/Houses, road	

3. Damaged Flood Records			
3-1	(Year/Month)	(Type)	(Reason, etc.)

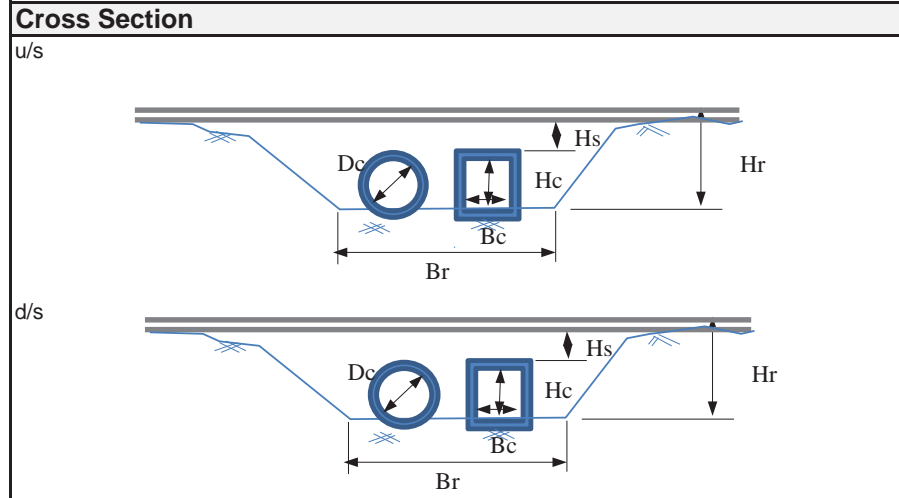
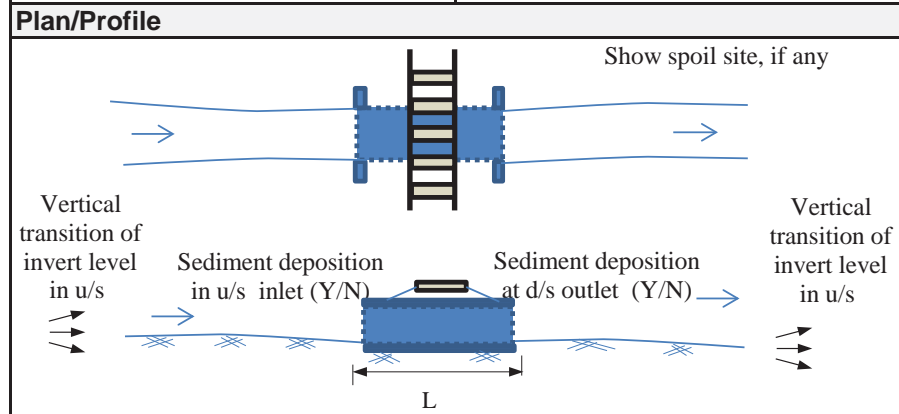





## Inventory Sheet for Culvert

**Station: at KM 363.7**      **Sheet No.:B CL 363.7**

### 1. General

1-1	Name of Inspector	Mr Motoki/ Semaya/ France	
1-2	Organization of Inspector	River Group B	
1-3	Date/Time of Inspection	Dec 2 2014 11:33 - 11:40	
1-4	Location	Lat	06° 27' 33.2"
1-5		Long	036° 25' 47.8"
1-6	Elevation	780m	

### 2. Characteristics of Physical Condition of Culvert

2-1	Length of Culvert	5.0m	
2-2	Shape of Cross Section	Square: <u>Rectangular: (1)</u> Circle:	
2-3	Flow Area	Height	1.6m
2-4		Widdth	2m
2-5	Connecting Channel	Other	no channel
2-6		Height	
2-7		Widdth	
2-8	Side Slope		
2-9	Type of Culvert	Concrete	
2-10	Riverbed	Material	silt sand
2-11	Sediment deposition	u/s	yes
2-12		d/s	
2-13	Topography	u/s:	, d/s:
2-14	Land Use		
2-15	Structures/Houses, road		

### 3. Damaged Flood Records

3-1	(Year/Month)	(Type)	(Reason,etc.)

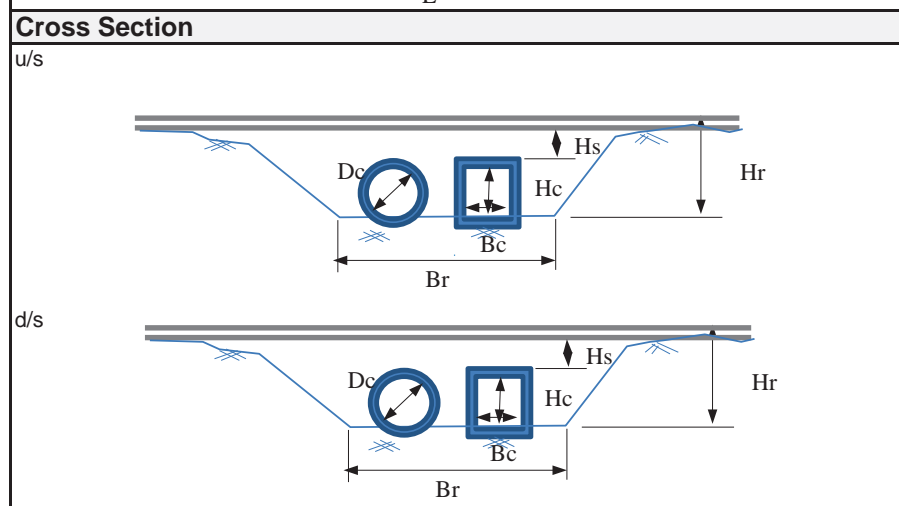
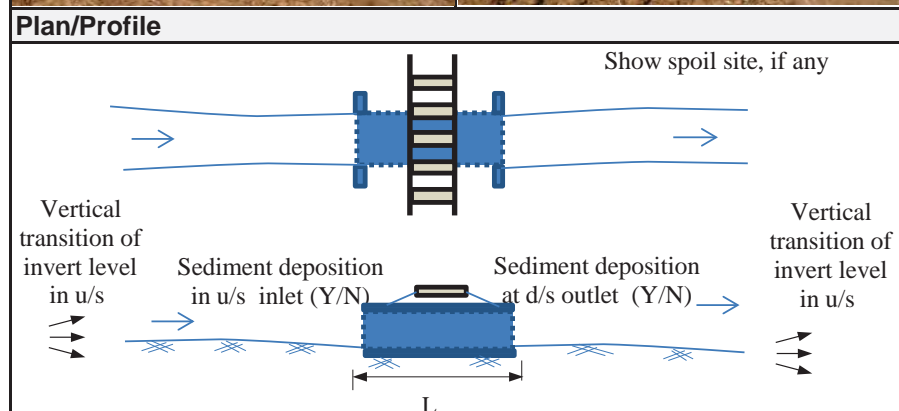

## Inventory Sheet for Culvert

**Station: at KM 364.2**      **Sheet No.: BCL 364.2**

### 1. General

1-1	Name of Inspector	Mr Motoki/ Semaya/ France	
1-2	Organization of Inspector	River Group B	
1-3	Date/Time of Inspection	Dec 2 2014 10:40 - 11:05	
1-4	Location	Lat	06° 27' 23.2"
1-5		Long	036° 25' 31.5"
1-6	Elevation	781m	

### 2. Characteristics of Physical Condition of Culvert

2-1	Length of Culvert	5m	
2-2	Shape of Cross Section	Square: Rectangular: (2) Circle:	
2-3	Flow Area	Height	0.5m, 0.2m
2-4		Width	4.65m
2-5	Connecting Channel	Other	
2-6		Height	
2-7		Width	
2-8		Side Slope	
2-9	Type of Culvert	Concrete	
2-10	Riverbed	Material	silt sand
2-11	Sediment deposition	u/s	yes
2-12		d/s	yes
2-13	Topography	u/s:  , d/s:	
2-14	Land Use	forest	
2-15	Structures/Houses, road	No house	

### 3. Damaged Flood Records

3-1	(Year/Month)	(Type)	(Reason, etc.)



### Plan/Profile

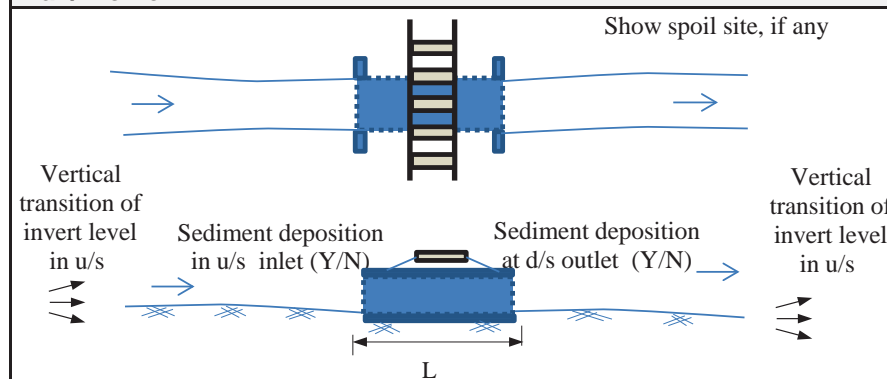

### Cross Section

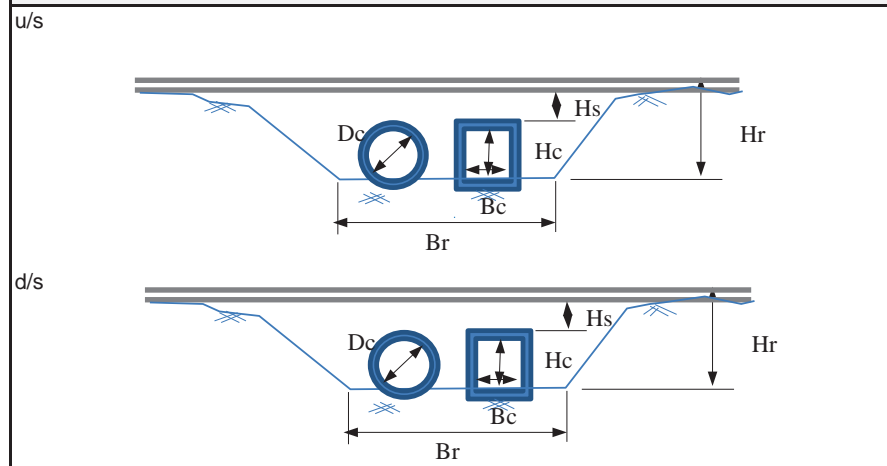

## Inventory Sheet for Culvert

**Station: at KM**      **364.4**      **Sheet No.: BCL 364.4**

<b>1. General</b>		
1-1	Name of Inspector	Mr Motoki/ Semaya/ France
1-2	Organization of Inspector	River Group B
1-3	Date/Time of Inspection	Dec 2 2014 10:40 - 11:00
1-4	Location	Lat 06° 27' 19.9"
1-5		Long 036° 25' 25.9"
1-6	Elevation	784m

**2. Characteristics of Physical Condition of Culvert**

2-1	Length of Culvert	4.9m
2-2	Shape of Cross Section	Square: Rectangular: (1) Circle:
2-3	Flow Area	Height 1.24m
2-4		Widdth 2.0m
2-5	Connecting Channel	Other
2-6		Height 0.9m
2-7		Widdth 3m
2-8	Side Slope	
2-9	Type of Culvert	Concrete
2-10	Riverbed	Material silt sand
2-11	Sediment deposition	u/s yes
2-12		d/s yes
2-13	Topography	u/s:  ,d/s
2-14	Land Use	spotted cultivation
2-15	Structures/Houses, road	No house

**3. Damaged Flood Records**

3-1	(Year/Month)	(Type)	(Reason,etc.)

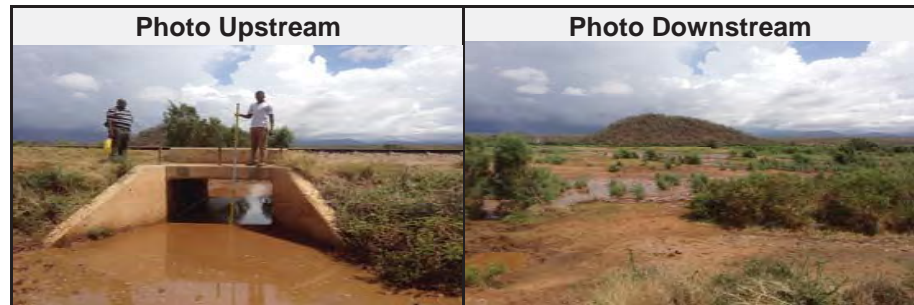

**Plan/Profile**

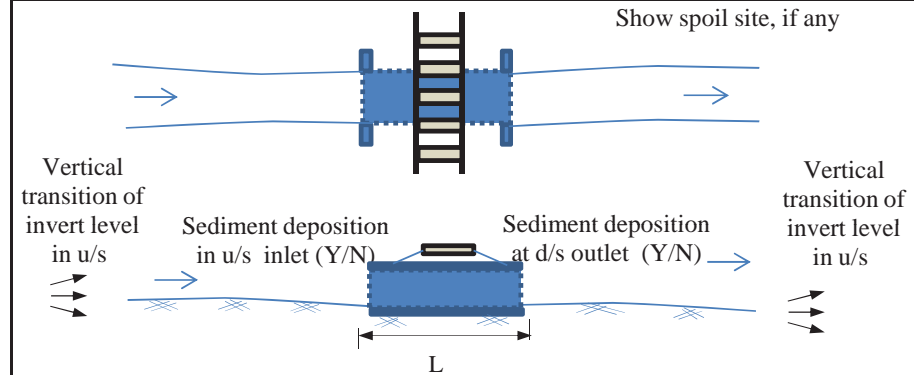

**Cross Section**

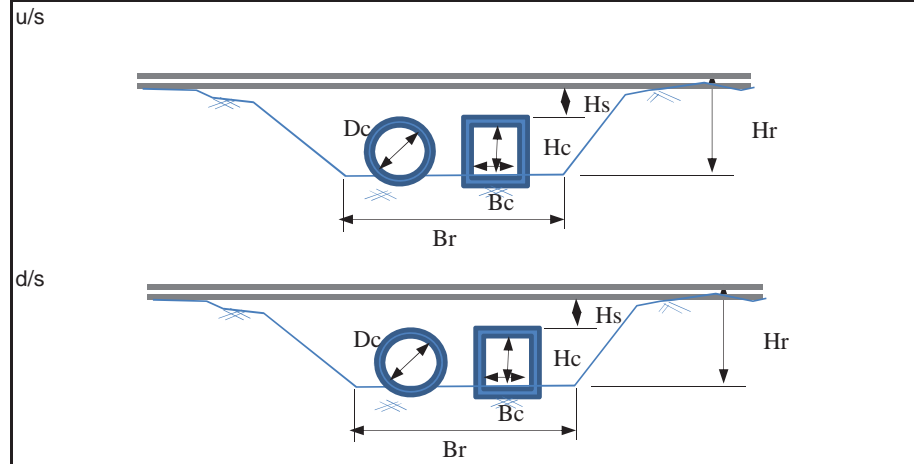

## **APPENDIX G**

### **STRAIGHT LINE DIAGRAM**

Straight Line Diagram

From Kilosa Station to Munisagara Station (km283 - km298)

Station	River Bank	Facility		Affected by Past Floods			Present Condition of River Bank			Present Condition of Culvert			Damage Pattern				Plan for Restoration Works	Note	Risk Level	Proposed Plan for Urgent Protection Measures		
		Type of Structure	Dimension (m)	1998-Flood	2010-Flood	2014-Flood	Height (m)	Dist. from Railway (m)	Water hit area	Rate of Clogging (%)	Inundation due to Clogging	Protection Structures	Bank Erosion	Overflow	Clogging of Culvert	Conf. Tributary						
283.0		Kilosa Sta.	L																			
	283.5	River Bank	L	Earth Embankment	L=500m, H=5m		○		5	32	50m	–	–	–	○	○	–	–	None	Steel Sheet Pile (L=300m) at Left Side of Low Water Channel had been installed	Medium Risk	–
	283.6	PCL283.6	L	Pipe Culvert	Hc0.9, Bc0.9, L5.0 (1)		○		–	–	–	0	○	×			–	–	None		–	–
	283.9	BCL283.9	L	Box Culvert	Hc1.7, Bc1.0, L6.0 (1)		○		–	–	–	0	○	×			–	–	None		–	–
284.0																						
	284.1	River Bank	L	Earth Embankment	H=3m				3	240		–	–	–	○		–	–	None		Low Risk	–
	284.47	BCL284.47	L	Box Culvert	Hc0.65, Bc1.0, L5.0 (1)				–	–	–	30	○	×			–	–	None		–	–
285.0																						
	285.45	BCL285.45	L	Box Culvert	Hc1.4, Bc1.0, L4.0 (1)				–	–	–	10	○	×			–	–	None		–	–
	285.65	BCL285.65	L	Box Culvert	Hc1.2, Bc1.0, L5.0 (1)				–	–	–	0	○	×			–	–	None		–	–
	285.7	River Bank	L	Earth Embankment	H=3m				3	220		–	–	–	○		–	–	None		Low Risk	–
286.0																						
	286.0	River Bank	L	Earth Embankment	H=3m				3	170		–	–	–	○		–	–	None		Low Risk	–
	286.15	PCL286.15	L	Pipe Culvert	Hc2.0, Bc2.0, L5.0 (1)				–	–	–	0	○	×			–	–	None		–	–
	286.40	PCL286.40	L	Pipe Culvert	Hc0.45, Bc0.9, L5.0 (3)				–	–	–	40	○	×			–	–	None		–	–
	286.65	PCL286.65	L	Pipe Culvert	Hc0.8, Bc1.0, L5.0 (1)				–	–	–	20	○	×			–	–	None		–	–
	286.88	PCL286.88	L	Pipe Culvert	Hc0.9, Bc0.9, L5.0 (2)				–	–	–	0	○	×			–	–	None		–	–
287.0																						
	287.15	PCL287.15	L	Pipe Culvert	Hc0.0, Bc0.0, L6.0 (2)				–	–	–	100	○	×			○	–	None	Clogging of culvert	High Risk	Removal of sediment
	287.25	BCL287.25	L	Box Culvert	Hc0.9, Bc7.0, L5.0 (1)				–	–	–	60	○	×			○	–	None	Clogging of culvert	High Risk	Removal of sediment
	287.30	PCL287.30	L	Pipe Culvert	Hc0.1, Bc0.9, L5.0 (1)				–	–	–	90	○	×			○	–	None	Clogging of culvert	High Risk	Removal of sediment
	287.5	River Bank	L	Earth Embankment	H=3m				3	400		–	–	–	○		–	–	None		Low Risk	–
	287.70	BCL287.70	L	Box Culvert	Hc1.8, Bc2.0, L6.0 (2)				–	–	–	10	○	×			–	–	None		–	–
288.0																						
	288.35	PCL288.35	L	Pipe Culvert	Hc1.2, Bc1.2, L7.0 (3)				–	–	–	0	○	×			○	–	None		–	–
289.0		PCL334.3	L	Pipe Culvert																By 1998 Flood, track of 5km section between Km293 and Km289 was washed away. After that, the track was diverted to mountain side. At present, the section is relatively safe because of diversion of the track and shifting of river course to opposite bank.	Low Risk	Monitoring and Maintenance
	289.3	PCL289.3	L	Box Culvert	D0.5, L-, Hs0.3, WL1.0 (1)				–	–	–	?	×	×			–	–	None		Low Risk	Monitoring and Maintenance
	289.6	Mdukwi River	L	Tributary					–	–	–	–	–	–			○	–	None			
	289.6	PCL289.6	L	Box Culvert	D0.9, Hs0.2, L-, WL5.0 (1)		○		–	–	–	?	×	×			–	–	None			
	289.9	PCL289.9	L	Pipe Culvert	D1.2, Hs0.6, WL4.0, L-(2)				–	–	–	30	×	×			–	–	None			

G-1



Straight Line Diagram

From Kilosa Station to Munisagara Station (km283 - km298)

Station	River Bank	Facility		Affected by Past Floods			Present Condition of River Bank			Present Condition of Culvert			Damage Pattern				Plan for Restoration Works	Note	Risk Level	Proposed Plan for Urgent Protection Measures									
		Type of Structure	Dimension (m)	1998-Flood	2010-Flood	2014-Flood	Height (m)	Dist. from Railway (m)	Water hit area	Rate of Clogging (%)	Inundation due to Clogging	Protection Structures	Bank Erosion	Overflow	Clogging of Culvert	Conf. Tributary													
290.0				L																									
290.0	BCL290.0			L	Box Culvert	Hc1.0, Bc0.95, WL2.0, Hs0.4					-	-	-	0	x	x					None								
290.4	BCL290.4			L	Box Culvert	H1.3, Bc3.0, L-, Hs0.5, WL3.0 (1)					-	-	-	60	x	x					○	-	None	Clogging of culvert	High Risk	Removal of sediment			
290.6	PCL290.6			L	Box Culvert	D0.9, Hs1.0, WL3.7, L-(1)					-	-	-	10	x	x									None				
290.9	BCL290.9			L	Bridge	Hc11.5, WL3.0, L10.0 (1)					-	-	-	20	x	x							○	None	A bridge across small tributary	Low Risk	Monitoring and Maintenance		
291.0																													
291.2	PCL291.2			L	Pipe Culvert	D0.75, Hs0.6, WL1.5, L-(5)					-	-	-	20	x	x										None			
291.5	PCL291.5-1			L	Box Culvert	Hs0.5, WL2.0, L- (1)					-	-	-	?	x	x										None			
291.5	PCL291.5-2			L	Pipe Culvert	D0.75, Hs0.7, WL1.5 (2)					-	-	-	80	x	x							○	-	None	Clogging of culvert	High Risk	Removal of sediment	
291.7	BCL291.7			L	Box Culvert	Hs0.9, WL1.8, L- (1)					-	-	-	100	x	x							○	-	None	Clogging of culvert	High Risk	Removal of sediment	
291.9	PCL291.9			L	Pipe Culvert	D0.75, Hs0.7, WL1.5, L-(4)					-	-	-	40	x	x										None			
292.0																													
292.0	Gang Camp			L	Camp																								
292.2	BCL292.2			L	Box Culvert	Hc1.6, Bc2.5, Hs0.6, WL3.5, L- (1)					-	-	-	40	x	x										None			
292.6	BR292.6			L	Bridge	L=31.8m, 3 spans, Hs1.4, WL14.2 (1)					-	-	-	10	x	○								○	None	A Bridge (L=31.8m with 3 spans) at KM292.6	Low Risk	Monitoring and Maintenance	
292.7	PCL292.7			L	Box Culvert	D0.45, L- (1)					-	-	-	?	x	x										None			
292.8	BCL292.9			L	Box Culvert	Hc0.8, Bc2.0, L- (1)					-	-	-	60	x	x							○	○	-	None	By 2010 Flood, the box culvert at Km292.9 was damaged due to overtopping of flood from the left upstream of the bridge. At present, it was restored together with the bridge.	High Risk	Removal of sediment deposit
293.0																													
293.0	BCL293.0			L	Box Culvert	Hc1.8, Bc2.0, Hs0.3, WL3.6, L- (1)					-	-	-	10	x	○								○	-	None			
293.1	km293-Bridge			L	Bridge	L=90.0m, Bc=9.5m, 3 spans, WL26.0					○	○														None	A Bridge (L=90 m, W=9.5m with 3 spans) at KM292.6 was damaged by 1998 and 2010 floods. In 2014, it was restored by Chinese Contractor at immediately upstream of the old bridge which was composed of two bridges previously. Less clearance due to sediment deposition in river channel. As for the urgent measures, it is recommended to repair the damaged gabion at right downstream of the bridge and to reinforce and heighten the gabions at left upstream bank of the bridge.	High Risk	1) Repair damaged gabion at right downstream of the bridge 2) Reinforcement and heightening the gabions at left upstream bank of the bridge.
293.8	PCL293.8			R	Box Culvert	2 steps					-	-	-	?	x	x								○	○	-	None		

G-2

Straight Line Diagram

From Kilosa Station to Munisagara Station (km283 - km298)

Station	River Bank	Facility		Affected by Past Floods			Present Condition of River Bank			Present Condition of Culvert			Damage Pattern				Plan for Restoration Works	Note	Risk Level	Proposed Plan for Urgent Protection Measures		
		Type of Structure	Dimension (m)	1998-Flood	2010-Flood	2014-Flood	Height (m)	Dist. from Railway (m)	Water hit area	Rate of Clogging (%)	Inundation due to Clogging	Protection Structures	Bank Erosion	Overflow	Clogging of Culvert	Conf. Tributary						
293.8		Revetment	R	Gabion	2 steps				4.5	33.7									None	Gabions are installed over banks of lowwater channel in upstream and downstream of the bridge. The bank is deemed stable against erosion at present. The closest distance from river bank to railway trak is 14. 7m at Km293.9. After 1998 Flood, there was a plan to divert the track in this area but not realized.	Middlium Risk for Bank Erosion	Maintenance an rehabilitation of existing gabion for low water bank protection
293.9		Revetment 293.8-294.1	R	Gabion	2 steps				2.3	14.7									None			
294.0			R																			
294.0		Revetment 293.8-294.1		Gabion	2 steps				2.3	20.0									None			
294.2		CL294.2		Pipe Culvert	DO.95, Hs0.9, L-							80	x	x	x				None	Clogging of culvert	High Risk	Removal of sediment
294.5		CL294.5		Box Culvert	Hc1.1, Bc2.0, WL1.6, Hso.45							45	x	x		x			None			
295.0			R																			
295.1		BCL295.1		Box culvert	Hc0.9, Bc3.9, L3.6 (2)							60	x	x					None	Clogging of culvert	High Risk	Removal of sediment
295.3		BCL295.3		Box culvert	Hc1.3, Bc2.0, L3.6 (1)							40	x	x					None		Low Risk	
295.7		PCL295.7		Pipe culvert	D1.5, L8.0 (1)							20	x	x					None		Low Risk	
295.9		BCL295.9		Box culvert	Hc0.4, Bc0.9, L3.6 (1)							50	x	x					None	Clogging of culvert	High Risk	Removal of sediment
296.0																						
296.0		River bank	R						1.0	100									None			
296.3		River bank							2.1	30									None		Middlium Risk for	
296.4		CL296.4		Box culvert	Hc0.8, Bc0.9, L3.6 (1)							10	x	x					None		Low Risk	
296.7		CL296.7		Box culvert	Hc1.0, Bc0.9, L3.6 (1)							10	x	x					None		Low Risk	
297.0			R																			
297.1		CL297.1		Box culvert	Hc0.8, Bc1.9, L3.6 (1)							60	x	x					None	Clogging of culvert	High Risk	Removal of sediment
297.2		River bank							2.1	15									None		Middlium Risk	
297.6		CL297.6		Box culvert	Hc1.2, Bc0.9, L3.6 (1)							60	x	x					None	Clogging of culvert	High Risk	Removal of sediment
298.0																						

G-3

**Straight Line Diagram From Munisagara Station to Mzaganza Station (km298 - km311)**

Station	River Bank	Facility		Affected by Past Floods			Present Condition of River Bank			Present Condition of Culvert			Damage Pattern				Plan for Restoration Works	Note	Risk Level	Proposed Plan for Urgent Protection Measures
		Type of Structure	Dimension (m)	1998-Flood	2010-Flood	2014-Flood	Height (m)	Dist. from Railway (m)	Water hit area	Rate of Clogging (%)	Inundation due to Clogging	Protection Structures	Bank Erosion	Overflow	Clogging of Culvert	Conf. Tributary				
298.0		Munisagara Sta.																		
298.0		Revetment 297.9-298.1	R	Gabion	1 step				1.7	43	-	-	-	-	-	-	-	None		
298.0		Munisagara Sta.							-	-	-	-	-	-	-	-	-			
298.1		BCL298.1		Box culvert	Hc1.9, Bc3.0, L9.1 (3)				-	-	-	30	○	○	-	-	○	-	None	
299.0			R																	
299.3		BCL345.6		Box Culvert	D1.1, L3.9 (4)				-	-	-	80	×	×	-	-	○	-	None	Clogging of culvert
299.4																		None	Riverbed material sampling conducted on Dec.5, 2014.	
299.7		PCL299.7		Pipe culvert	D1.2, L10.6 (3)				-	-	-	70	×	×	-	-	○	-	None	Clogging of culvert
300.0																				
300.10		PCL300.10	R	Pipe culvert	Hc0.2, Bc0.9, L5.0 (1)				-	-	-	90	○	×	-	-	○	-	None	Clogging of culvert
300.20		PCL300.20	R	Pipe Culvert	Hc0.9, Bc1.2, L6.0 (1)				-	-	-	10	○	×	-	-	-	-	None	
300.50		PCL300.50	R	Pipe Culvert	Hc1.1, Bc1.2, L6.0 (1)				-	-	-	5	○	×	-	-	-	-	None	
300.50		River Bank	R	Earth Embankment	H=3m				2	25	100m	-	-	-	○	-	-	-	None	Water Colliding Front Section
300.60		BCL300.60	R	Box Culvert	Hc0.95, Bc2.0, L5.0 (1)				-	-	-	10	○	×	-	-	-	-	None	
301.0																				
301.3		River Bank	R	Earth Embankment	H=3m				3	180	-	-	-	-	○	-	-	-	None	
302.0																				
302.0		PCL302.0	R	Pipe Culvert	Hc0.6, Bc0.6, L6.0 (2)				-	-	-	0	○	×	-	-	-	-	None	- The right side bank had been eroded about 30m width and one Culvert and Gabion had been washed out by a flood in Mar 2014.
302.05		River Bank	R	Earth Embankment	H=5m				○	3	5	-	-	-	-	-	-	-	On-going Works	- Restoration works of the Culvert and Gabion are on going. The eroded bank (30m width) had been already filled by the restoration works.
302.10		BCL302.15	R	Box Culvert					○	-	-	-	-	×	×	-	-	-	On-going Works	- The river is curving to left side and it is assumed that a right side low water channel will turn into a mainstream way from now on.
302.2		BCL302.2	R	Box Culvert	Hc1.7, Bc1.0, L5.0 (1)				-	-	-	10	○	×	-	-	-	-	None	- A flood risk is judged as High since the distance from bank to track is 33m and the bank height is 3m.
303.0																				
303.3		BCL303.3	R	Box Culvert	Hc1.7, Bc2.5, L6.0 (1)				-	-	-	15	○	×	-	-	-	-	None	
303.4		BCL303.4	R	Box Culvert	Hc1.7, Bc2.0, L6.0 (1)				-	-	-	10	○	×	-	-	-	-	None	

G-4

**Straight Line Diagram From Munisagara Station to Mzaganza Station (km298 - km311)**

Station	River Bank	Facility		Affected by Past Floods			Present Condition of River Bank			Present Condition of Culvert			Damage Pattern				Plan for Restoration Works	Note	Risk Level	Proposed Plan for Urgent Protection Measures	
		Type of Structure	Dimension (m)	1998-Flood	2010-Flood	2014-Flood	Height (m)	Dist. from Railway (m)	Water hit area	Rate of Clogging (%)	Inundation due to Clogging	Protection Structures	Bank Erosion	Overflow	Clogging of Culvert	Conf. Tributary					
300.80	River Bank	R	Earth Embankment	H=3m				3	80	100m	—	—	—	○	—	—	—	None	Water Colliding Front Section	Medium Risk	—
304.0																					
304.8	River Bank	R	Earth Embankment	H=3m				3	170		—	—	—	○	—	—	—	None		Low Risk	—
305.0																					
305.00	River Bank	R	Earth Embankment	H=3m				3	40		—	—	—	○	—	—	—	None	Confluence Point of Magao River	Medium Risk	—
306.0																					
306.70	River Bank	R	Earth Embankment	H=3m				3	75		—	—	—	○	—	—	—	None	Water Colliding Front Section	Medium Risk	—
307.0																					
307.2	River Bank	R	Earth Embankment	H=3m				3	130		—	○	—	○	—	—	—	None		Low Risk	—
308.0		R																			
308.1	BCL308.1	R	Box Culvert	Hc1.1, Bc2.0, Hs0.5, WL1.8, L- (1)				—	—	—	45	×	×	—	—	—	—	None		—	—
308.3	BCL308.3	R	Box Culvert	Bc3.6, L-, Hc0.0 (1)				—	—	—	100	×	×	—	—	○	—	None	Clogging of culvert	High Risk	Removal of sediment
308.4	BCL308.4	R	Box Culvert	D1.0&0.65, Hs0.2, WL1.3 (1)				—	—	—	20	×	×	—	—	—	—	None		—	—
308.6	Revetment 308.6-309.0	R	Gabion	2 steps,				1.5	12.5 +10.8	○	—	—	—	○	○	—	—	None	No damage by overtopping in 2010 Flood. River bank height is low as about 1.5m. The bank erosion is progress, and the shortest distance from river bank to railway track is 16.2m at Km308.6	Low Risk	Monitoring and Maintenance
308.7	Revetment 308.6-309.0	R	Box Culvert	2 steps,				2.5	16.2	○	—	—	—	○	○	—	—	None	After 2010 Flood, in the section of 400m between Km308.6 and Km 309.0, gabions (2 steps) are installed for slope protection of bank of low water channel. These gabions are deemed to work well.	Low Risk	Monitoring and Maintenance
308.9	PCL308.9	R	Pipe Culvert	D1.0, Hs0.8, WL2.7, L- (1)				—	—	—	10	×	×	—	—	—	—	None		—	—
309.0	Gang Camp	R																			
309.4	BCL309.4	R	Box Culvert	Hc0.9, Bc1.0, Hs0.4, WL1.2, L- (1)				—	—	—	10	×	×	—	—	—	—	None		—	—
309.9	BCL309.9	R	Box Culvert	Hc0.4, Bc2.0, Hs0.38, WL0.8, L- (1)				—	—	—	80	×	×	—	—	○	—	None	Clogging of culvert	High Risk	Removal of sediment
310.0		R																			
310.5	BCL310.5	R	Box Culvert	Hc1.5, Bc2.0, Hs0.45, WL2.0, L- (1)				—	—	—	25	×	×	○	—	—	—	None		—	—

G-5

**Straight Line Diagram From Munisagara Station to Mzaganza Station (km298 - km311)**

Station			River Bank	Facility		Affected by Past Floods			Present Condition of River Bank			Present Condition of Culvert			Damage Pattern				Plan for Restoration Works	Note	Risk Level	Proposed Plan for Urgent Protection Measures
				Type of Structure	Dimension (m)	1998-Flood	2010-Flood	2014-Flood	Height (m)	Dist. from Railway (m)	Water hit area	Rate of Clogging (%)	Inundation due to Clogging	Protection Structures	Bank Erosion	Overflow	Clogging of Culvert	Conf. Tributary				
310.8	PCL310.9		R	Pipe Culvert /River Bank	D0.9, L41.7, Hs0.3, WL2.15 (2)				1.3	93	○	20	x	x	-	-	-	-	None	At the back of Km310.9 of Mzagaza Station is low land and innudated furing flood. No damage are reported due to overtopping.	Low Risk	Monitoring and Maintenance
311.0	Mzaganza Sta.		R																			

**Straight Line Diagram From Mzagaza Station to Kidete Station (km311 - km326)**

Station	River Bank	Facility		Affected by Past Floods			Present Condition of River Bank			Present Condition of Culvert			Damage Pattern				Plan for Restoration Works	Note	Risk Level	Proposed Plan for Urgent Protection Measures	
		Type of Structure	Dimension (m)	1998-Flood	2010-Flood	2014-Flood	Height (m)	Dist. from Railway (m)	Water hit area	Rate of Clogging (%)	Inundation due to Clogging	Protection Structures	Bank Erosion	Overflow	Clogging of Culvert	Conf. Tributary					
311.0		Mzagaza Sta.	R																		
	311.0	PCL311.0	R	Pipe Culvert	D0.75, WL3.0, Hs1.0													None			
	311.1		R	River Bank					4.3	45	○	-	-	-	○	-	-	None	At the back of Mzagaza Station is low land and inundated during flood. No damage are reported due to overtopping. The shortest distance from river bank to railway track is 45 m at Km 311.1.	Low Risk	Monitoring and Maintenance
	311.2	BCL311.2	R	Box Culvert	Hc1.0, Bc4.7, WL1.4, L-(1)													None			
312.0			R																		
	312.2	BCL312.2	R	Box Culvert	Hc1.35, Bc1.0, Hs0.5, WL2.0, L-(1)													None			
	312.2	Revetment 312.2-312.4	R	Gabion	1 step					○								None	Damaged in past floods. Bank height is ranging from 2.0 to 3.4m. Bank erosion is in progress and the shortest distance from river bank to railway is 21m at Km312.3. After 2010 Flood, gabion (1step) was installed for protection of bank of low water channel in 200m section from Km312.2 to Km312.4	Low Risk	Monitoring and Maintenance
	312.3	BCL312.2	R	Box Culvert	Hc0.8, Bc1.0, Hs0.4, WL1.4, L-(1)													None	Some of local residents afraid for further progress of bank erosion, and insisting to extend the gabion toward upstream bank.	Low Risk	Monitoring and Maintenance
	312.4	Revetment 312.2-312.4	R	Gabion	1 step				3.4	21	○	-	-	-	○	-	-	None		Medium Risk	
	312.8	BCL312.8	R	Box Culvert	Hc1.6, Bc1.0, Hs0.35, WL2.6 (1)													None			
	312.8	Revetment 312.8-313.3	R	Gabion	2 steps				3.0	28	○	-	-	-	○	-	-	None	Gabions (2 steps) are installed for bank protection of low water channel in the 500m section and at outlet of culvert.	Medium Risk	
	312.9	BCL312.9	R	Box Culvert	Hc1.7, Hs0.5, Bc2.0, WL=3.0, L-(1)													None			
313.0			R																		
	313.3	BCL313.3	R	Box Culvert	D0.9, Hs1.1, WL2.0, L-(2) and Hc2.0, Bc2.0,													None	At Km313.3 where small tributary joins to mainstream has damaged of wash out of embankment and culvert. The outlet of culvert was restored and reinforced by installation of gabion and apron.		
	313.4	BCL313.4	R	Box Culvert	Hc2.0, Bc2.0, WL3.6, Hs0.45, L-													None			
	313.4	Revetment 313.3-313.4	R	Gabion	2 steps					>100m								None		Low Risk	Monitoring and Maintenance
314.0			R																		

G-7



**Straight Line Diagram From Mzaganza Station to Kidete Station (km311 - km326)**

Station	River Bank	Facility		Affected by Past Floods			Present Condition of River Bank			Present Condition of Culvert			Damage Pattern				Plan for Restoration Works	Note	Risk Level	Proposed Plan for Urgent Protection Measures	
		Type of Structure	Dimension (m)	1998-Flood	2010-Flood	2014-Flood	Height (m)	Dist. from Railway (m)	Water hit area	Rate of Clogging (%)	Inundation due to Clogging	Protection Structures	Bank Erosion	Overflow	Clogging of Culvert	Conf. Tributary					
314.1	BCL314.1	R	Box Culvert	Hc0.6, Bc1.0, Hs0.45, WL2.0, L- (1)				-	-	-	40	x	x	-	-	-	-	None			
314.4	PCL314.4	R	Pipe Culvert	D0.95, Hs1.1, WL3.6, L- (1)				4.4	19+100	○	10	x	○	-	-	-	-	None	At the upstream of the culvert (BCL311.1) step of stone pitching are installed. for drainage of a local tributary. The shortest distance from river bank to railway track is 19m. The river bank with 4.4m in height s protected by wide flood plain of 100m in width with dense vegetations.	Low Risk	Monitoring and Maintenance
314.5	PCL314.5	R	Pipe Culvert	D0.9, Hs0.75, WL2.0, L- (1)				-	-	-	0	x	○	-	-	-	-	None			
314.9	BCL314.9	R	Box Culvert	Hc1.8, Bc2.0, Hs0.35, WL3.0, L- (1)				5	32	○	10	x	○	○	-	-	-		The shortest distance from river bank (H5m) to railway track is 32m. A new culvert will be installed at upstream of this section as a part of on-going restoration work in this area	High Risk	(Resoration works are being undertaken by RAHCO/TRL)
315.0		R																			
315.0	On-going works	R	River Bank				○	6	32	○	-	-	-	○	-	-	-		In march 2014, the bank was seriously eroded by flood. At present, urgent restoration works are being undertaken by TRL/RACHO.	High Risk	(Resoration works are being undertaken by RAHCO/TRL)
315.1	On-going works	R	River Bank				○	6	9.9	○	-	-	-	○	-	-	-		- Diversion of railway track (300m) to land side by 18m		
315.2	On-going works	R	River Bank				○	6	6.3	○	-	-	-	○	-	-	-		- trimming of eroded slope and backfilling at most eroded section		
315.3	On-going works	R	River Bank				○	6	9	○	-	-	-	○	-	-	-		- installation of gabions (3 steps) at toe of ban - installation of two culvert at Km315.0 and Km315.7		
315.7	BCL315.7	R	Box Culvert							○	?	x	x	○	-	-	-		At Km315.7, a new pipe culver (4 pipes) is being constructed at immediately upstream of the existing culvert.		
316.0		R																			
317.0		R																			
318.0		R																			
319.0		R																			
320.0		R																			
321.0		R																			

C-8

**Straight Line Diagram From Mzaganza Station to Kidete Station (km311 - km326)**

Station	River Bank	Facility		Affected by Past Floods			Present Condition of River Bank			Present Condition of Culvert			Damage Pattern				Plan for Restoration Works	Note	Risk Level	Proposed Plan for Urgent Protection Measures	
		Type of Structure	Dimension (m)	1998-Flood	2010-Flood	2014-Flood	Height (m)	Dist. from Railway (m)	Water hit area	Rate of Clogging (%)	Inundation due to Clogging	Protection Structures	Bank Erosion	Overflow	Clogging of Culvert	Conf. Tributary					
322.0																					
323.0																					
324.0																					
325.0																					
		Lumuna River	R	Confluence				-	-	-											
325.0		Kidete Dam						-	-	-				-	-	-	-				There is a site of Kidete Dam at km325. The dam was damaged by 1998 Flood. Then restoration works had been started but suspended until now. There is an information to resume the works soon.
325.5		Kidete Sta.	R											-	-	-	-				Located relatively high elevation.

G-9

**Straight Line Diagram From Kidete Station to Godegode Station (km326 - km344)**

Station	River Bank	Facility		Affected by Past Floods			Present Condition of River Bank			Present Condition of Culvert			Damage Pattern				Plan for Restoration Works	Note	Risk Level	Proposed Plan for Urgent Protection Measures
		Type of Structure	Dimension (m)	1998-Flood	2010-Flood	2014-Flood	Height (m)	Dist. from Railway (m)	Water hit area	Rate of Clogging (%)	Inundation due to Clogging	Protection Structures	Bank Erosion	Overflow	Clogging of Culvert	Conf. Tributary				
325.5	Kidete Sta.	R																		
325.70	PCL325.70	R	Pipe Culvert	Hc0.36, Bc0.9, L6.0 (2)				–	–	–	60	○	Not Exist	–	○	–	None	Different Culvert Type: Upstream Pipe, Downstream Box Type	High Risk	Rebuild to Box Culvert
325.75	PCL325.75	R	Pipe Culvert	Hc0.45, Bc0.9, L7.0 (2)				–	–	–	50	○	Not Exist	–	○	–	None	Clogging of culvert	High Risk	Canal Dredging
325.8	River Bank	R	Earth Embankment	H=3m				3	600		–	–	–	○	–	–	None		Low Risk	–
326.0																				
326.7	River Bank	R	Earth Embankment	H=3m				3	310		–	–	–	○	–	–	None		Low Risk	–
326.90	BCL326.90	R	Arch Culvert	Hc2.3, Bc2.5, L8.0 (1)				–	–	–	0	○	Not Exist	–	○	–	None		–	–
327.0																				
327.40	BCL327.40	R	Box Culvert	Hc2.6, Bc3.0, L5.0 (1)				–	–	–	0	○	Not Exist	–	○	–	None		–	–
327.90	BCL327.90	R	Arch Culvert	Hc3.8, Bc5.0, L8.0 (1)				–	–	–	0	○	Not Exist	–	○	–	None		–	–
327.95	River bank	R	Earth Embankment	H=8m			○	8	60	50m	–	–	–	○	–	–	None	Remarkable riverbank corrosion has occurred at 327.95 km point of the water colliding front. About 50m corrosion is advancing during two years and a half between present (December, 2014) and the aerial photograph as of June, 2012. The width of the high water channel remains just only 60m, therefore, countermeasures such as a backfill and installation of low water channel protection are required.	Medium Risk	–
328.0																				
328.7	River Bank	R	Earth Embankment	H=3m				3	110		–	–	–	○	–	–	None		Low Risk	–
328.80	BCL328.80	R	Arch Culvert	Hc2.7, Bc4.0, L8.0 (1)				–	–	–	5	○	Not Exist	–	○	–	None		–	–
329.0																				
329.80	River bank	R	Earth Embankment	H=2.5m			○	2.5	22	100m	–	–	–	○	–	–	None	Water Colliding Front Section	Medium Risk	–
330.0																				
330.80	River bank	R	Earth Embankment	H=3m			○	3	80	100m	–	–	–	○	–	–	None	Water Colliding Front Section	Medium Risk	–
331.0																				
331.60	River bank	R	Earth Embankment	H=3m			○	3	50	50m	–	–	–	○	–	–	None	Water Colliding Front Section	Medium Risk	–
332.0																				
332.90	River bank	R	Earth Embankment	H=3m			○	3	80	100m	–	–	–	○	–	–	None	Water Colliding Front Section	Medium Risk	–
333.0	Gang Camp	R																		

G-10

**Straight Line Diagram From Kidete Station to Godegode Station (km326 - km344)**

Station	River Bank	Facility		Affected by Past Floods			Present Condition of River Bank			Present Condition of Culvert			Damage Pattern				Plan for Restoration Works	Note	Risk Level	Proposed Plan for Urgent Protection Measures					
		Type of Structure	Dimension (m)	1998-Flood	2010-Flood	2014-Flood	Height (m)	Dist. from Railway (m)	Water hit area	Rate of Clogging (%)	Inundation due to Clogging	Protection Structures	Bank Erosion	Overflow	Clogging of Culvert	Conf. Tributary									
333.1	BCL333.1	R	Box Culvert	Hc0.4, Bc2.0, Hs0.45, WL2.0, L- (1)				-	-	-	80						O	-	None	Clogging of Culver	High Risk	Removal of sediment			
333.6	BCL333.6	R	Box Culvert	Hc3.1, Bc5.0, Hs0.85, WL5.0, L- (1)				-	-	-	40							-	-	None					
334.0		R																							
334.1	BCL334.1	R	Box Culvert	Hc2.1, Bc2.0, Hs0.6, WL3.2, L- (1)				-	-	-	0							-	-	None					
334.3	PCL334.3	R	Pipe Culvert	D0.75, Hs0.5, WL4.0, L- (1)				-	-	-	10							-	-	None					
334.7	BCL334.7	R	Box Culvert	Hc0.9, Bc1.8, Hs0.55, WL3.0, L- (1)				-	-	-	50							O	-	None	Clogging of culvert	High Risk	Removal of sediment		
334.8	BCL334.8	R	Box Culvert	Hc0.5, Bc2.0, Hs0.5, L- (1)				-	-	-	75							O	-	None	Clogging of culvert	High Risk	Removal of sediment		
334.8		R	River Bank					3	116	O	-	-	-	O				-	-	None	After 2010 Flood, gabion were installed at split of the channel in order to shift the river course to opposite bank. The shortest distance from river bank to railway track is 116m. Due to site conditions located at water hit area there is a possibility of progress of river bank. It is reported a trend of riverbed siltation in this section.	Low Risk	Monitoring and Maintenance		
335.0		R																							
335.0	BCL335.0	R	Box Culvert	Hc0.5, Bc2.0, Hs0.5, L- (1)				-	-	-	75							O	-	None	Clogging of culvert	High Risk	Removal of sediment		
335.1	BCL335.1	R	Box Culvert	Hc1.75, Bc2.0, Hs0.5, WL2.9, L- (1)				-	-	-	15								-	-	None				
335.3	BCL335.3	R	Box Culvert	Hc1.1, Bc2.0, Hs0.55, WL2.4, L- (1)				-	-	-	45								-	-	None				
335.5	BCL335.5	R	Box Culvert	Hc1.75, Bc2.0, Hs0.3, WL3.2, L- (1)				-	-	-	15								-	-	None				
335.8	BCL335.8	R	Box Culvert	Hc1.55, Bc2.0, Hs0.3, WL3.0, L- (1)				-	-	-	25								-	-	None	The culverts in this area are installed aiming at drainage of rainwater from the mountain area.			
336.0		R																			* The track in km336-338 were diverted 7 times previously.				
336.1	BCL336.1	R	Box Culvert	Hc0.85, Bc2.0, Hs0.3, WL2.0, L- (1)				-	-	-	60								O	-	None				
336.3	BCL336.3	R	Box Culvert	Hc1.05, Bc2.0, Hs0.3, WL2.2, L- (1)				-	-	-	45								O	-	None				
336.7	BCL336.7	R	Box Culvert	Hc2.3, Bc2.0, Hs0.3, WL4.0, L- (1)				-	-	-	0									-	-	None			
337.0		R																							
337.0	PCL/BCL337.1	R	Box Culvert	Hc1.4, Bc2.0, Hs0.3, WL2.5, L- (1)				-	-	-	30									O	-	None	Outlet channel is excavated without slope protection and disposal spoils are left on the bank shoulder. Proper treatment of spoils is necessary.	Medium Risk	Removal of disposal soils on bank sholder of outlet channel

G-11

**Straight Line Diagram From Kidete Station to Godegode Station (km326 - km344)**

Station	River Bank	Facility		Affected by Past Floods			Present Condition of River Bank			Present Condition of Culvert			Damage Pattern				Plan for Restoration Works	Note	Risk Level	Proposed Plan for Urgent Protection Measures
		Type of Structure	Dimension (m)	1998-Flood	2010-Flood	2014-Flood	Height (m)	Dist. from Railway (m)	Water hit area	Rate of Clogging (%)	Inundation due to Clogging	Protection Structures	Bank Erosion	Overflow	Clogging of Culvert	Conf. Tributary				
337.2-337.7	R	River Bank(no revetment)		?	?	○	4.5	18	○	-	-	-	○	-	-	○	None	At present, serious bank erosion is observed in this section. Height of river bank is 4.5m and the shortest distance from river bank to railway track is 18 m. There is a possibility to be damaged during next rainy season. It is recommended to conduct an urgent measure in the section between Km337.2 an Km337.7. For a long term measure, it is possible to divert the railway track to land side as there is a wider and flat space along this section.	High Risk	1) Installation of gabions for bank protection of low water channel (approx. L=550m)  2) Installation of spur dikes (L=25m@50m, 11 units)
338.0	R																			
339.0	R																			
340.0	R																			
341.0	R																			
341.7	R	Guide Dike	Earth Dike with slope protection works of stone pitching , L=xxxm, Crest width=7m										○				None	By 2010 Flood ,the bank was eroded. In Sep.2011, a guide dike (crest width of 7m with earth embankment and stone pitching) was constructed at Km 341.7 to shift river course to the opposite bank. At present, the edge of the guide dike is eroded and scoured. It is recommended to rehabilitate and reinforce the guide dike.	Medium Risk	Rehabilitation and reinforcement of the guide dike
342.0	R																			
343.0	R																			
344.0	R																			

G-12

**Straight Line Diagram From Godegode Station to Gulwe (km344 - km366)**

Station	River Bank	Facility		Affected by Past Floods			Present Condition of River Bank			Present Condition of Culvert			Damage Pattern				Plan for Restoration Works	Note	Risk Level	Proposed Plan for Urgent Protection Measures			
		Type of Structure	Dimension (m)	1998-Flood	2010-Flood	2014-Flood	Height (m)	Dist. from Railway (m)	Water hit area	Rate of Clogging (%)	Inundation due to Clogging	Protection Structures	Bank Erosion	Overflow	Clogging of Culvert	Conf. Tributary							
344.0																							
345.0																							
	345.6	CL345.6		Box Culvert	D0.9, L? (3)				-	-	-	Net yet confirmed			-	-	-	-		Small-scale flash flood occurred from 14:00 to 15:00			
346.0		PCL346.0	R	Pipe culvert	D0.9, L5.2 (1)																		
	346.2	PCL346.2		Box Culvert	D0.9, L3.5 (2)				-	-	-	Net yet confirmed			-	-	-	-					
	346.6	BCL346.6		Box Culvert	Hc1.9, Bc4.0, L4.0 (1)				-	-	-	Net yet confirmed			-	-	-	-					
347.0			R	Box Culvert																			
	347.5	BCL347.5		Box Culvert	Hc0.5, Bc2.9, L4.0 (1)				-	-	-	Net yet confirmed			-	-	-	-		Distance between 2 culverts is 21.7m			
	347.5	BCL347.5		Box Culvert	Hc0.5, Bc2.0, L4.0 (1)				-	-	-	Net yet confirmed			-	-	-	-					
348.0		CL348.0	R	Box Culvert	Hc0.8, Bc2.0, L4.0 (2)																		
	348.3	PCL348.2		Pipe culvert	D1.0, L4.0 (1)				-	-	-	Net yet confirmed			-	-	-	-					
	348.8	BCL348.8		Box Culvert	Hc1.1, Bc2.0, L4.0 (1)				-	-	-	Net yet confirmed			-	-	-	-					
349.1A		Godegode Sta.																					
	349.4A	River Bank	R	Earth Embankment	H=3m				3	700		-	-	-	○	-	-	-	None		Low Risk	-	
	349.4A	CL349.4A	R	Box Culvert	Hc0.8, Bc1.5, L5.0 (2)				○	-	-	50	○	Not Exist	-	○	○	-	None	Clogging of culvert		High Risk	Removal of sediment deposit
	349.0B	CL349.0B	R	Pipe Culvert	Hc0.6, Bc0.6, L6.0 (2)				○	-	-	0	○	Not Exist	-	○	-	-	None			-	-

G-13



**Straight Line Diagram From Godegode Station to Gulwe (km344 - km366)**

Station	River Bank	Facility		Affected by Past Floods			Present Condition of River Bank			Present Condition of Culvert			Damage Pattern				Plan for Restoration Works	Note	Risk Level	Proposed Plan for Urgent Protection Measures	
		Type of Structure	Dimension (m)	1998-Flood	2010-Flood	2014-Flood	Height (m)	Dist. from Railway (m)	Water hit area	Rate of Clogging (%)	Inundation due to Clogging	Protection Structures	Bank Erosion	Overflow	Clogging of Culvert	Conf. Tributary					
349.4B																					
	349.4B	River Bank	R	Earth Embankment	H=3m				3	800								None		Low Risk	—
	349.4B	Tributary CL349.4B	R	Box Culvert	Hc1.7, Bc2.0, L5.0 (3)													None	- Culverts of the railroad have been deposited by the sediment in the tributary MASUWALA RIVER, and river flow prevention has been occurred. - Erosion at the left-bank side right upstream of culvert has been occurred due to flow prevention of culvert, and concerned that the waterway will be formed along the railroad. Countermeasures such as bank protection at the left-bank side are necessities.	High Risk	Removal of sediment deposit
	349.5B	Tributary CL349.5B	R	Box Culvert	Hc0.7, Bc2.0, L6.0 (3)													None	- A culvert of the new road caught the floating logs and flow prevention has been occurred. The railroad bank has been scored by the overflow every year. The countermeasures on sediment outflow control or railroad heighten, etc. are required.		Removal of sediment deposit and Revetment
	349.6B	Tributary CL349.6B	R	Box Culvert	Hc1.1, Bc2.0, L6.0 (1)													None	- The culverts of the old road along the railway are almost filled out by sediment due to shortage of the section and the height. However, the old road will be removed after the new road completion of now under construction.		Removal of sediment deposit
	349.8B	Tributary CL349.8B	R	Box Culvert	Hc1.7, Bc2.0, L6.0 (1)													None			Removal of sediment deposit
	349.9B	Tributary CL349.9B	R	Box Culvert	Hc0.9, Bc2.0, L6.0 (1)													None			Removal of sediment deposit
349.9B																					
	349.00	River Bank	R	Earth Embankment	H=3m				3	40	100m							Rebuild Bridge	Water Colliding Front Section	Medium Risk	
349.9C																					
	349.5D	River Bank	R	Earth Embankment	H=3m				3	150								None		Low Risk	—
350.0																					
	350.0	River Bank	R	Earth Embankment	H=3m				3	280								None		Low Risk	—
351.0																					
	351.3	River Bank	R	Earth Embankment	H=3m				3	390								None		Low Risk	—
352.0		Gang Camp	R																		
	352.9	BCL352.9	R	Box Culvert	Hc1.6, Bc4.0, Hs0.5, WL2.2, L- (1)													None			
353.0			R																		
	353.2	BCL353.2	R	Box Culvert														None			
	353.6	River Bank	R	None					5	90								None		Medium Risk	

G-14

**Straight Line Diagram From Godegode Station to Gulwe (km344 - km366)**

Station	River Bank	Facility		Affected by Past Floods			Present Condition of River Bank			Present Condition of Culvert			Damage Pattern				Plan for Restoration Works	Note	Risk Level	Proposed Plan for Urgent Protection Measures		
		Type of Structure	Dimension (m)	1998-Flood	2010-Flood	2014-Flood	Height (m)	Dist. from Railway (m)	Water hit area	Rate of Clogging (%)	Inundation due to Clogging	Protection Structures	Bank Erosion	Overflow	Clogging of Culvert	Conf. Tributary						
354.0																						
	354.3	BCL354.3	R	Box Culvert	Hc0.55, Bc2.0, Hs0.45, WL1.0, L- (1)				-	-	-	75	x	x	-	-	O	-	None	Clogging of culvert	High Risk	Removal of sediment deposit
355.0			R																			
	355.1	BCL355.1	R	Pipe Culvert	D0.9, L- (2)				-	-	-	20	x	x	-	-	-	-	None			
	355.2	Kidivo River	R	Confluence								-	-	x	O	-	-	O	At the confluence of Kidivo River, construction of guide dike (around L=200m) is on-going. Bank protection of SSP at left bank downstream of the bridge is tilted due to pressure of back soil. It should be urgently repaired. Existing gabion (3 steps) installed at transition between SSP and original river bank at the confluence can be heightened to protect from over topping. Guide dike constructed in the middle of river channel should be protected by toe and slope protection works so that it will sustain against erosion and scouring during flood.		High Risk	1)Repair of existing SSP bank protection 2) Removal of spoils in the middle of the river channel 3) Insatllation of toe and slope protection works for the guide dike
	355.6	CL355.6	R	Box Culvert	Hc0.85, Bc3.0, Hs0.65, WL5.4, L- (1)				-	-	-	75	-	x	-	-	O	-	None	Clogging of culvert	High Risk	
356.0			R																			
	356.1	BCL356.1	R	Box Culvert	Hc0.81, Bc3.0, Hs0.62, WL1.45, L- (1)				-	-	-	75	-	x	-	-	O	-	None	Clogging of culvert	High Risk	
357.0			R																			
358.0			R																			
359.0			R																			
	359.7																			Overtopping on the track at km359.7		
360.0																						
	360.0	BCL360.0	R	Box Culvert	Hc1.0, Bc2.0, L5.0 (1)				-	-	-	40	O	x	-	-	-	-	None		Medium Risk	
	360.6	BCL360.6		Box Culvert	Hc0.6, Bc5.0, L3.6 (1)				-	-	-	70	O	x	-	-	O	-	None	Clogging of culvert	High Risk	Removal of sediment deposit
	360.9	BCL360.9		Box Culvert	Hc1.3, Bc2.0, L5.0 (1)				-	-	-	30	O	x	-	-	-	-	None		Medium Risk	
361.0			R																			
	361.1	BCL361.1		Box culvert	Hc0.6, Bc2.0, L3.7 (1)				-	-	-	60	x	x	-	-	O	-	None	Clogging of culvert	High Risk	Removal of sediment deposit
	361.9	BCL361.9		Box Culvert	Hc0.3, Bc5.0, L3.6 (1)				-	-	-	80	O	x	-	-	O	-	None	Clogging of culvert	High Risk	Removal of sediment deposit
362.0			R	Box Culvert	2 steps																	
	362.1	BCL362.1		Box culvert	2 steps				-	-	-	70	O	x	-	-	O	-	None	Clogging of culvert	High Risk	Removal of sediment deposit
	362.5	PCL362.5		Pipe culvert	D0.8, L8.6 (2)				-	-	-	70	O	x	-	-	O	-	None	Heavily silted	High Risk	Removal of sediment deposit

G-15

**Straight Line Diagram From Godegode Station to Gulwe (km344 - km366)**

Station	River Bank	Facility		Affected by Past Floods			Present Condition of River Bank			Present Condition of Culvert			Damage Pattern				Plan for Restoration Works	Note	Risk Level	Proposed Plan for Urgent Protection Measures	
		Type of Structure	Dimension (m)	1998-Flood	2010-Flood	2014-Flood	Height (m)	Dist. from Railway (m)	Water hit area	Rate of Clogging (%)	Inundation due to Clogging	Protection Structures	Bank Erosion	Overflow	Clogging of Culvert	Conf. Tributary					
362.9	BCL362.9		Box culvert	2 steps				-	-	-	60	○	x	-	-	○	-	None	Clogging of culvert	High Risk	Removal of sediment deposit
363.0		R																			
363.3	BCL363.3		Box culvert	Hc0.2, Bc2.0, L5.0 (2)				-	-	-	80	○	x	-	-	○	-	None	Clogging of culvert	High Risk	Removal of sediment deposit
363.7	BCL363.7		Box culvert	Hc1.6, Bc?, L5.0 (1)				-	-	-	90	○	x	-	-	○	-	None	Clogging of culvert	High Risk	Removal of sediment deposit
364.0		R																			
364.1	River bank							0.8		x	-	-	-	○	-	-	-		Bank height is very low and river bank erosion is in progress to railway track.		
364.2	BCL364.2		Box culvert	Hc0.3, Bc2.5, L5.0 (2)				-	-	-	80	○	x	-	-	○	-	None	Clogging of culvert	High Risk	Removal of sediment deposit
364.4	BCL364.4		Box culvert	Hc1.2, Bc2.0, L4.9 (1)				-	-	-	10	x	x	-	-	-	-	None		Low Risk	
365.0	Gulwe Sta.	R	Station																Flood in March 2014		
	Mzase River	R	Confluence													○	○		Removal of sediment deposits in culvert and river channel.		
366.0		R																			
366.4	Kinyasingwe		Culvert	Not measured															For road construction		
367.0		R																			

G-16

## **APPENDIX H**

### **PICTORIAL MAPS FOR SELECTED AREAS FOR URGENT PROTECTION MEASURES**

**PICTORIAL MAPS FOR SELECTED AREAS FOR URGENT PROTECTION MEASURES.**

<b>S/N</b>	<b>STATION KM</b>	<b>S/N</b>	<b>STATION KM</b>
1	283-284	26	314-315
2	284-285	27	315-316
3	285-286	28	325.5-326
4	286-287	29	326-327
5	287-288	30	327-328
6	289-290	31	328-329
7	290-291	32	329-330
8	291-292	33	331-332
9	292-293	34	332-333
10	293-294	35	333-334
11	294-295	36	334-335
12	300-301	37	335-336
13	301-302	38	336-337
14	302-303	39	337-338
15	303-304	40	349.1A-349.4B
16	304-305	41	349.4B-349.9B
17	305-306	42	349.9B-349.9C
18	306-307	43	349.9C-350
19	307-308	44	350-351
20	308-309	45	351-352
21	309-310	46	352-353
22	310-311	47	353-354
23	311-312	48	354-355
24	312-313	49	355-356
25	313-314		

# KM283(Station Kilosa) – Km284

 :Risk Level: Low

 :Risk Level: Medium

 :Risk Level: High

H-2





# KM284 – Km285

 :Risk Level: Low

 :Risk Level: Medium

 :Risk Level: High

H-3

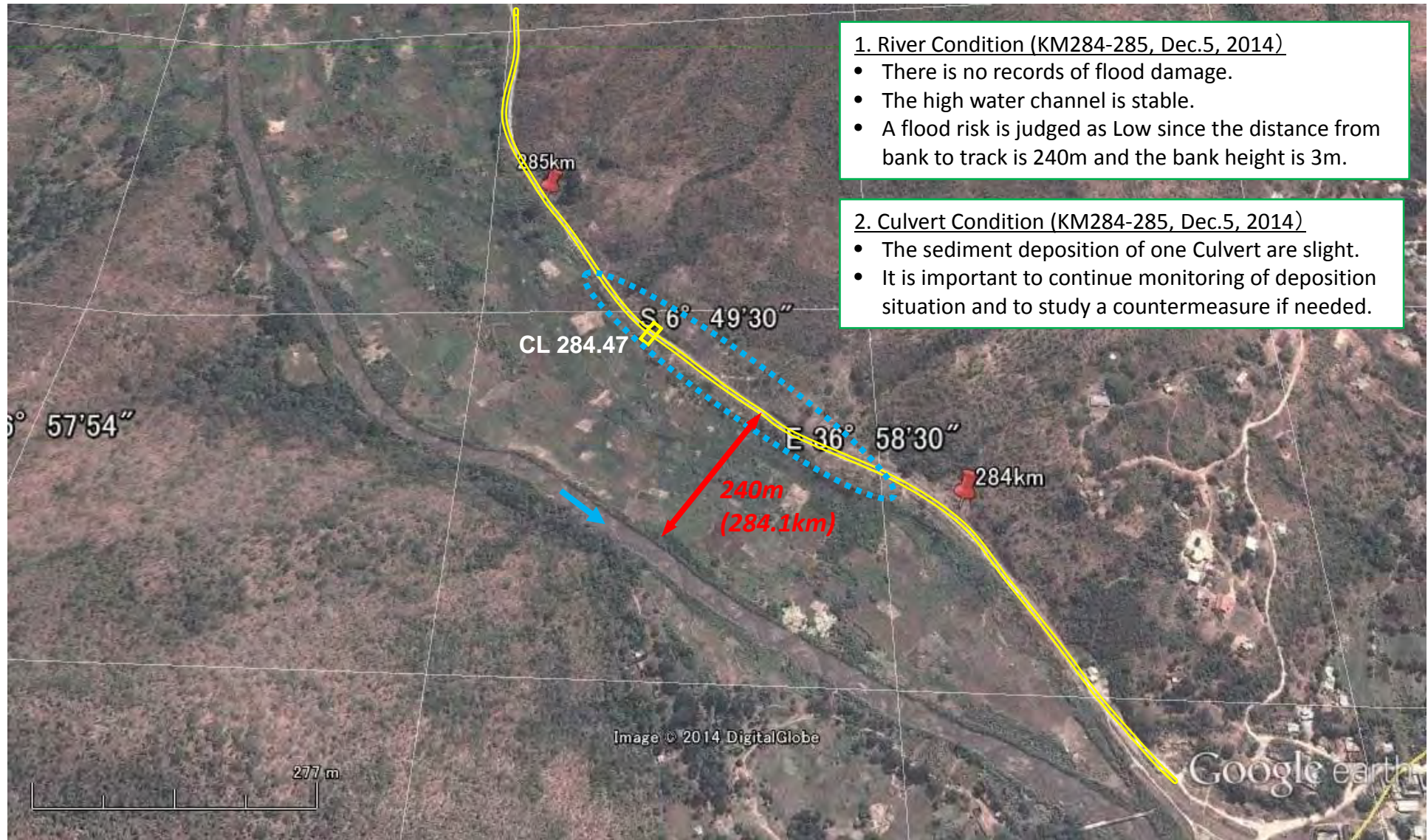



# KM285 – Km286

-  :Risk Level: Low
-  :Risk Level: Medium
-  :Risk Level: High

- 1. River Condition (KM285-286, Dec.5, 2014)**
  - There is no records of flood damage.
  - The high water channel is stable.
  - A flood risk is judged as Low since the distance from bank to track is 220m and the bank height is 3m.
- 2. Culvert Condition (KM285-286, Dec.5, 2014)**
  - The sediment depositions of two Culverts are slight.
  - It is important to continue monitoring of deposition situation and to study a countermeasure if needed.

H-4

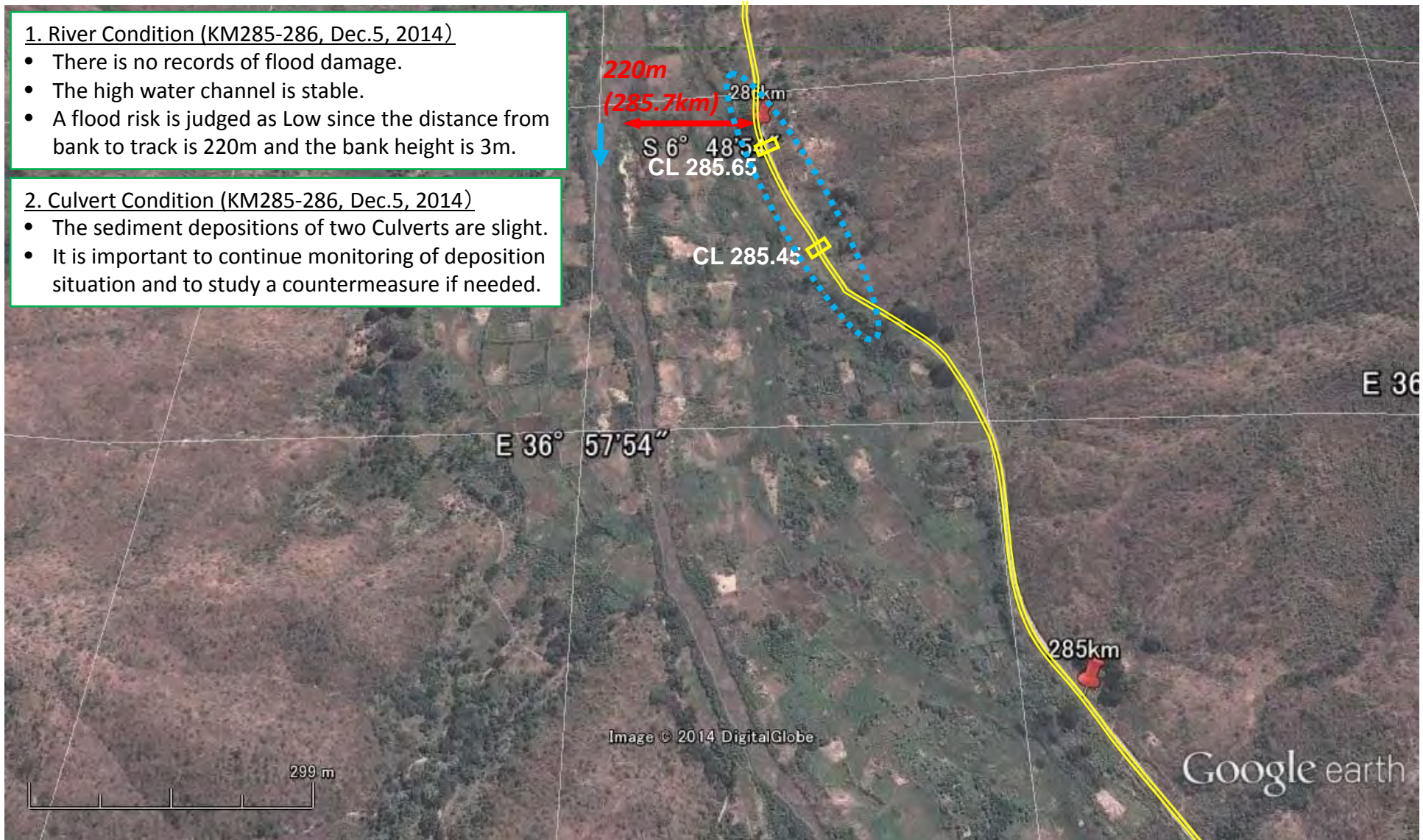



# KM286 – Km287

-  :Risk Level: Low
-  :Risk Level: Medium
-  :Risk Level: High

S-H

## 1. River Condition (KM286-287, Dec.5, 2014)

- There is no records of flood damage.
- The high water channel is stable.
- A flood risk is judged as Low since the distance from bank to track is 170m and the bank height is 3m.

## 2. Culvert Condition (KM286-287, Dec.5, 2014)

- The sediment depositions of four Culverts are slight.
- It is important to continue monitoring of deposition situation and to study a countermeasure if needed.

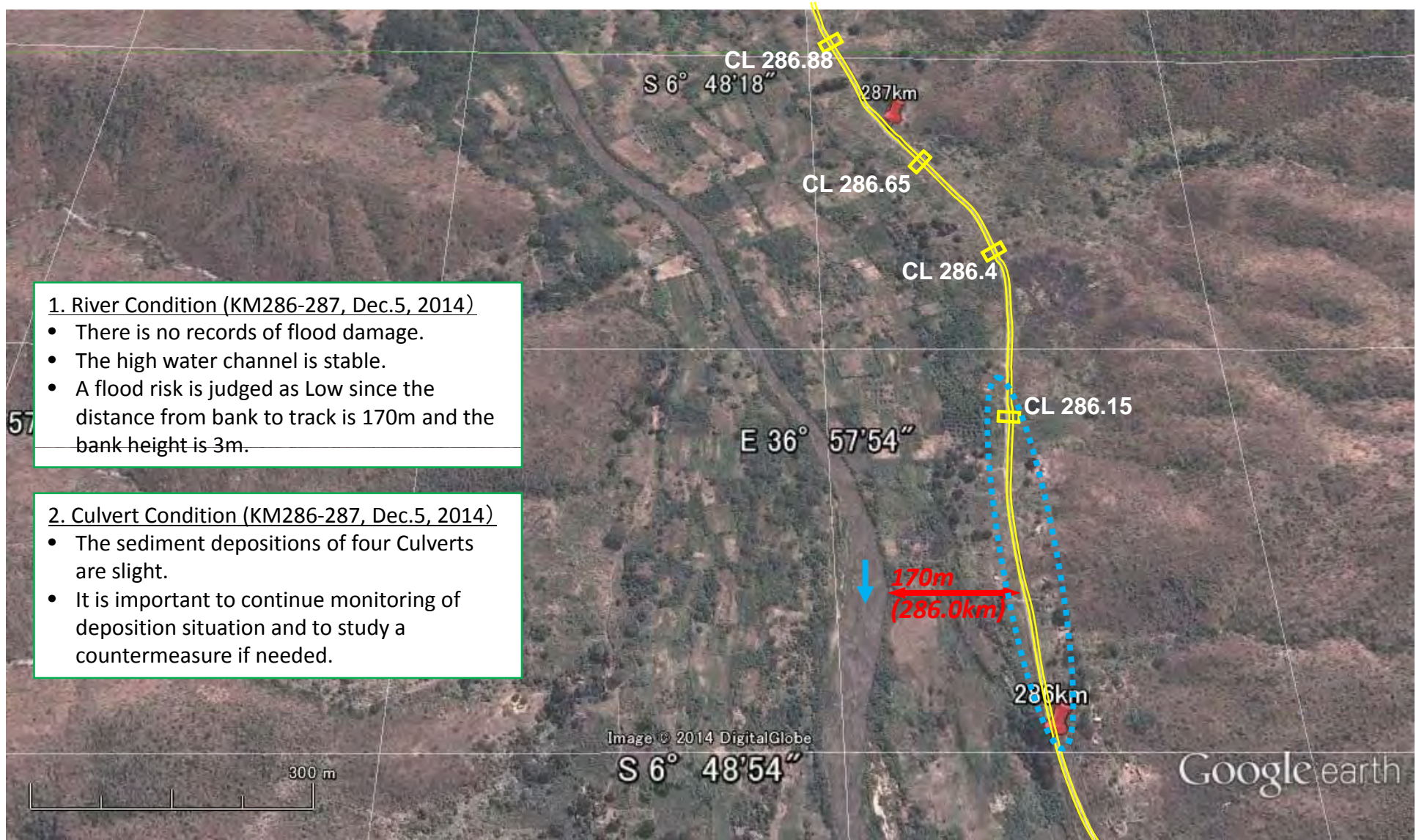



# KM287 – Km288

-  :Risk Level: Low
-  :Risk Level: Medium
-  :Risk Level: High

9-H

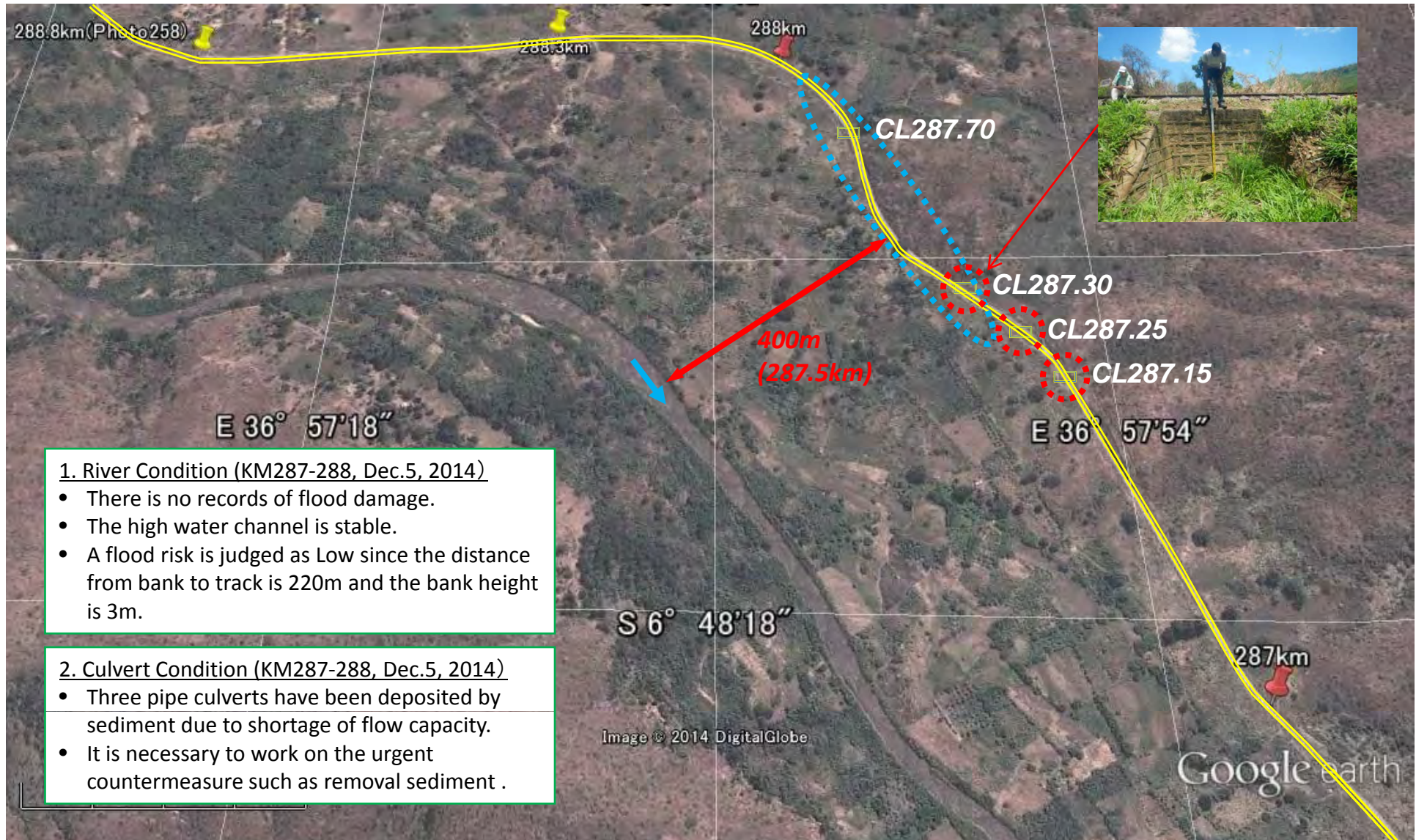



# KM289 – Km290

○ :Risk Level: Low

○ :Risk Level: Medium

○ :Risk Level: High

KM293-KM289, Dec.05,2014

“ By 1998 Flood, track of 5km section between Km293 and Km289 was washed away. After that, the track was diverted to mountain side. At present, the section is relatively safe because of diversion and shifting of river course to opposite bank.

H-7

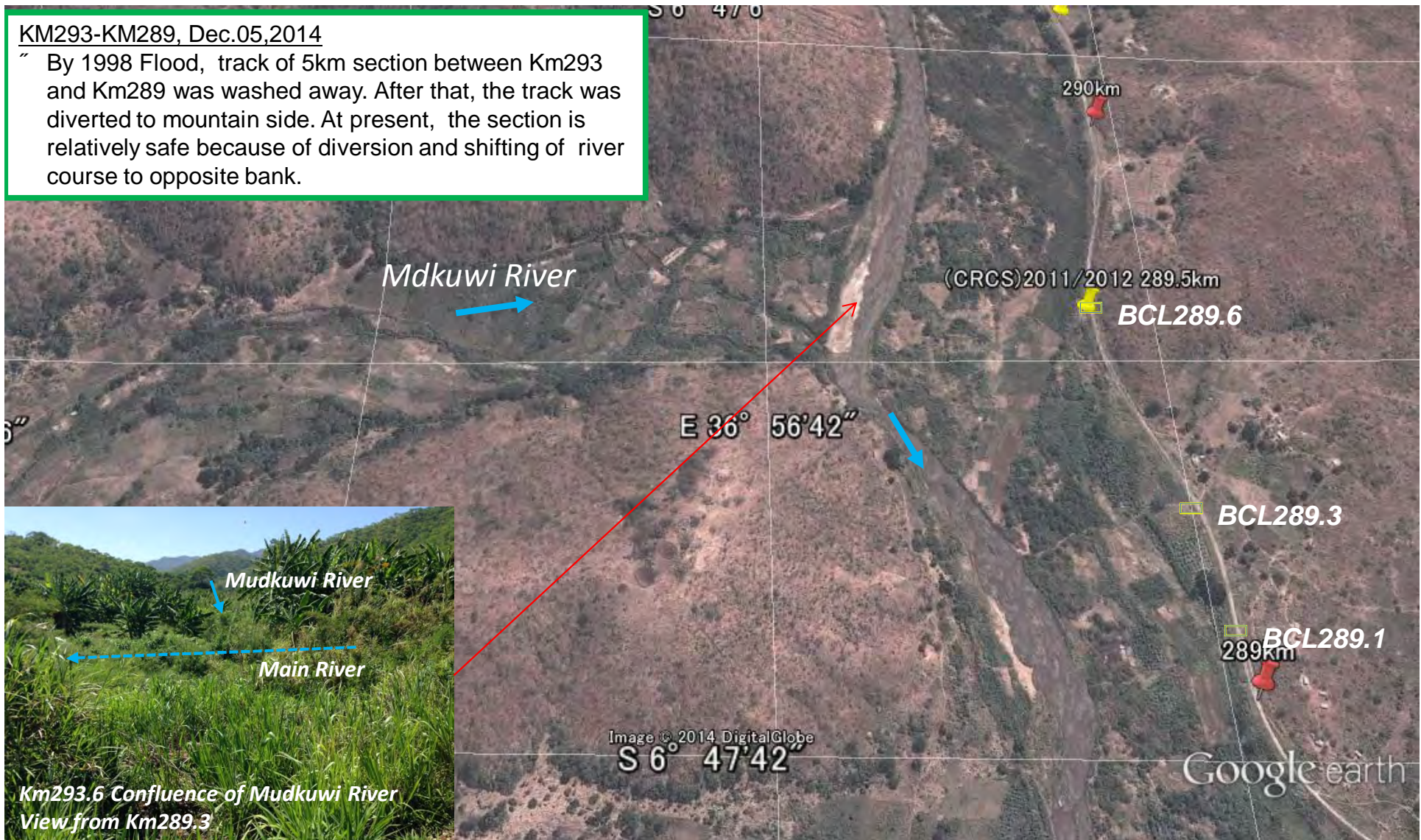



# KM290 – Km291

-  :Risk Level: Low
-  :Risk Level: Medium
-  :Risk Level: High

KM290-KM291, December 5, 2014  
" At present, the section is relatively safe because of diversion of the track and shifting of river course to opposite bank.

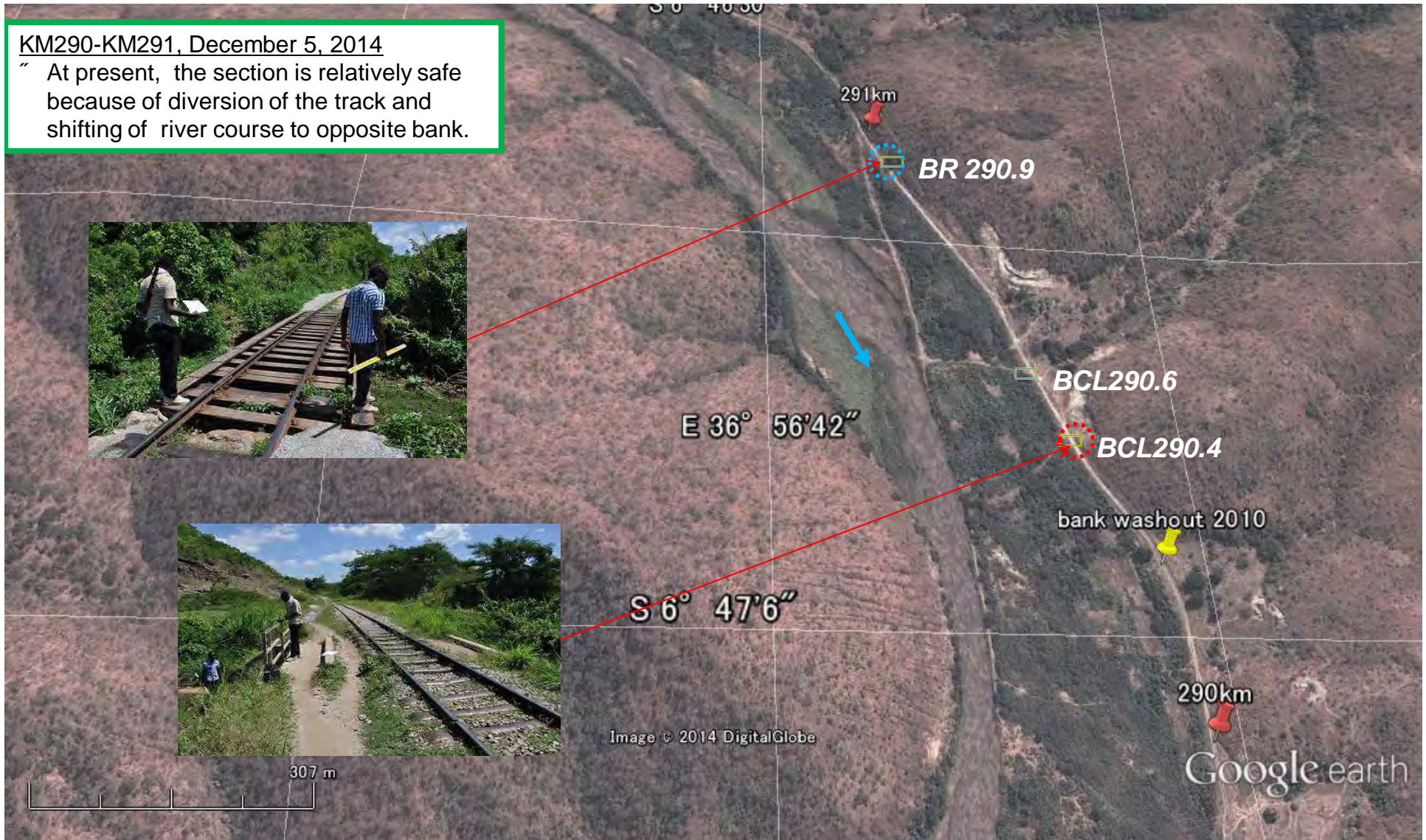



# KM291 – Km292

 :Risk Level: Low

 :Risk Level: Medium

 :Risk Level: High

Km291-Km292, December 5, 2014

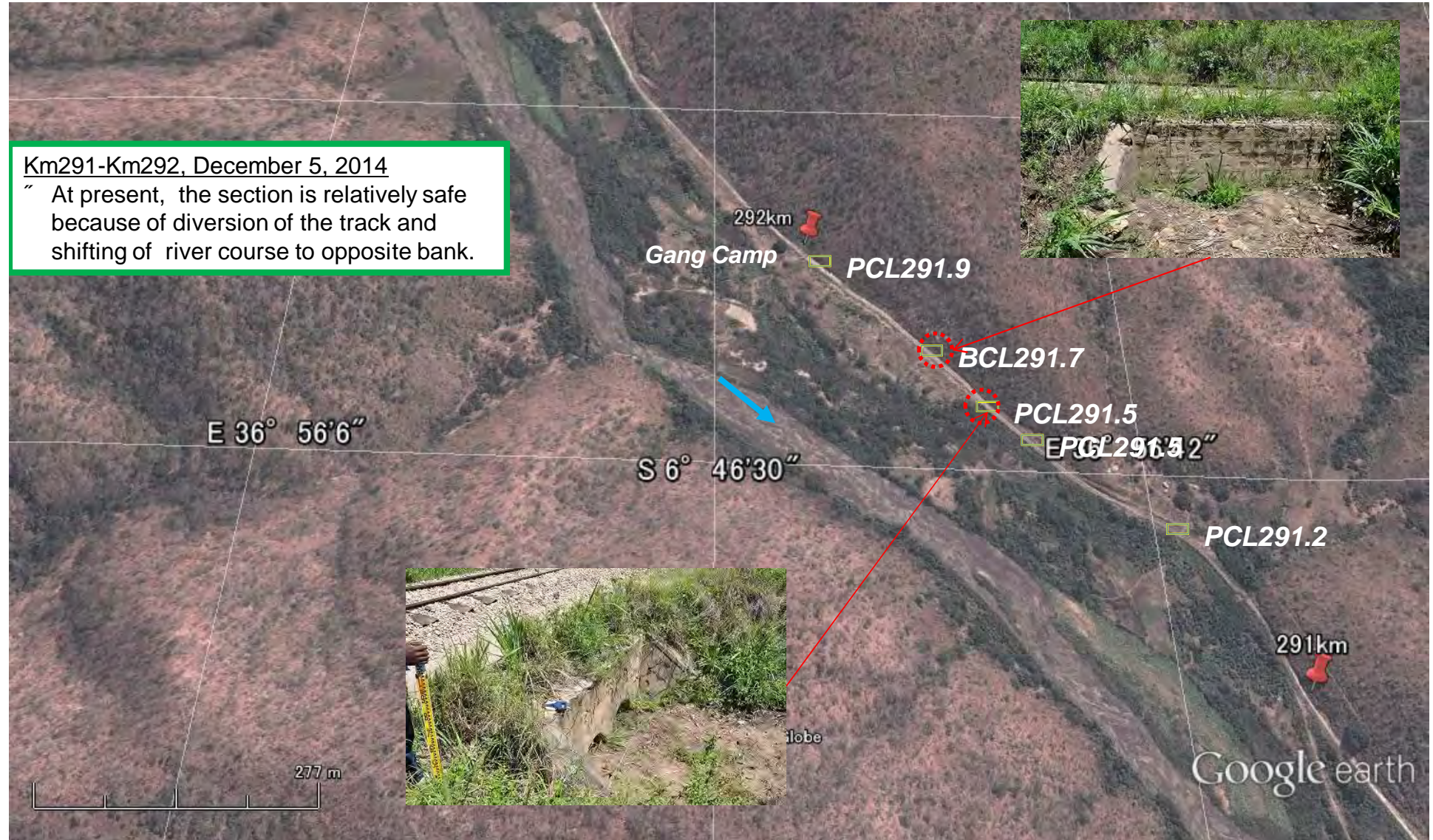

“ At present, the section is relatively safe because of diversion of the track and shifting of river course to opposite bank.

6-H





# KM292 – Km293

-  :Risk Level: Low
-  :Risk Level: Medium
-  :Risk Level: High

H-10

## KM292.9, December 5, 2014

- By 2010 Flood, the box culvert at KM292.9 was damaged due to overtopping of flood from the left upstream of the bridge. At present, it was restored together with the bridge.



## KM292-KM293, December 5, 2014

“ At present, the section is relatively safe because of diversion of the track and shifting of river course to opposite bank.

## Km292.6, December 5, 2014

- “ A Bridge (L=31.8m with 3 spans) at KM292.6
- “ Steel sheet piles (L=14m) were driven for the river bank protection of the right downstream of the bridge.
- “ It is recommended to conduct maintenance and rehabilitation of the bridge and slope protection in long term plan.



SSP at right d/s of Bridge

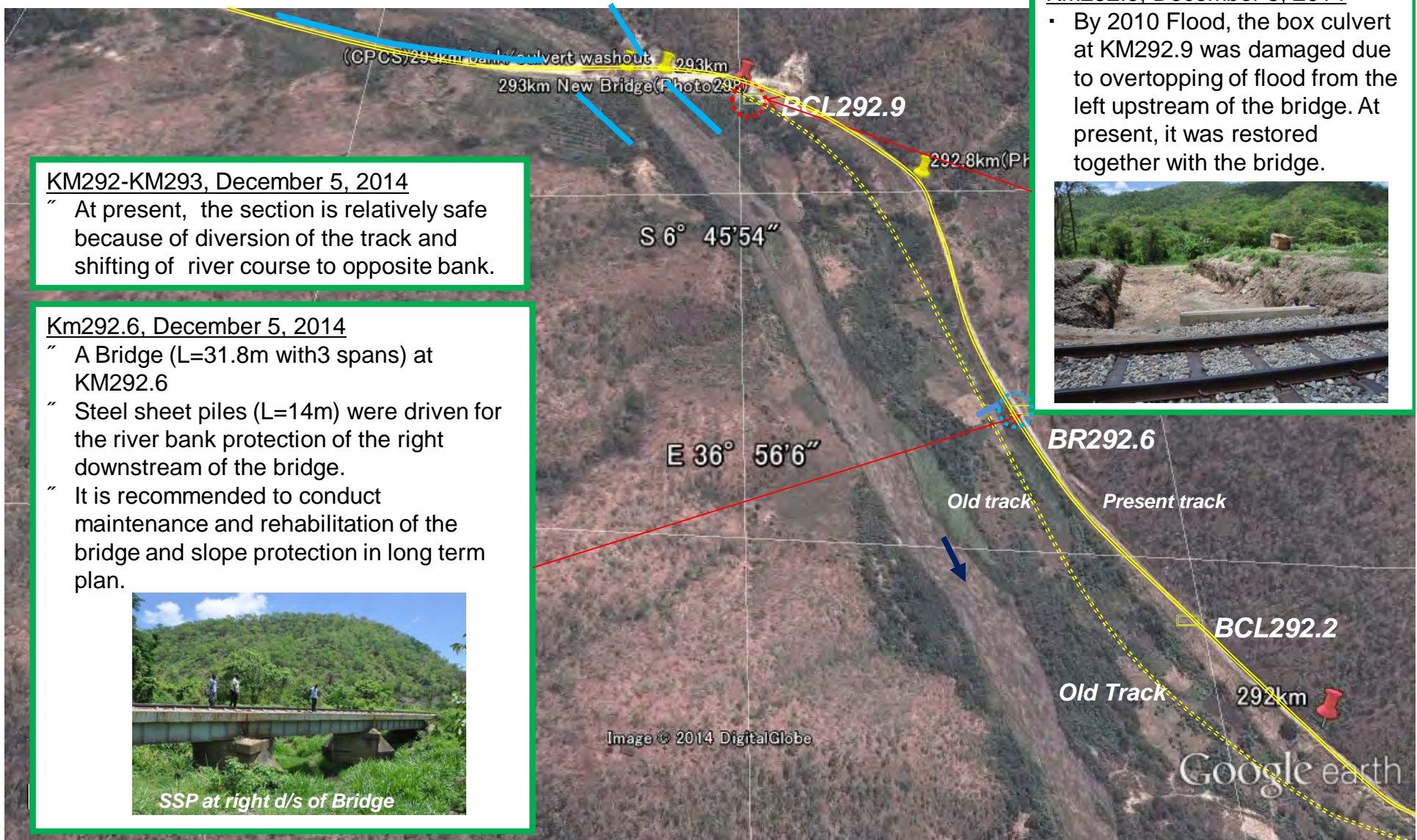

Image © 2014 DigitalGlobe

Google earth



# KM293 – Km294

- ⦿ :Risk Level: Low
- ⦿ :Risk Level: Medium
- ⦿ :Risk Level: High

**KM293, December 5, 2014**

- “ A Bridge (L=90 m, W=10m with 3 spans) at KM293 was damaged by 1998 and 2010 floods
- “ In 2014, it was restored by Chinese Contractor at immediately upstream of the old bridge which was composed of two bridges previously)
- “ Less clearance due to sediment deposition in river channel
- “ As for the urgent measures, it is recommended to repair the damaged gabion at right downstream of the bridge and to reinforce and heighten the gabions at left upstream bank of the bridge.

H-11





KM294 – Km295

- ⦿ :Risk Level: Low
- ⦿ :Risk Level: Medium
- ⦿ :Risk Level: High

H-12

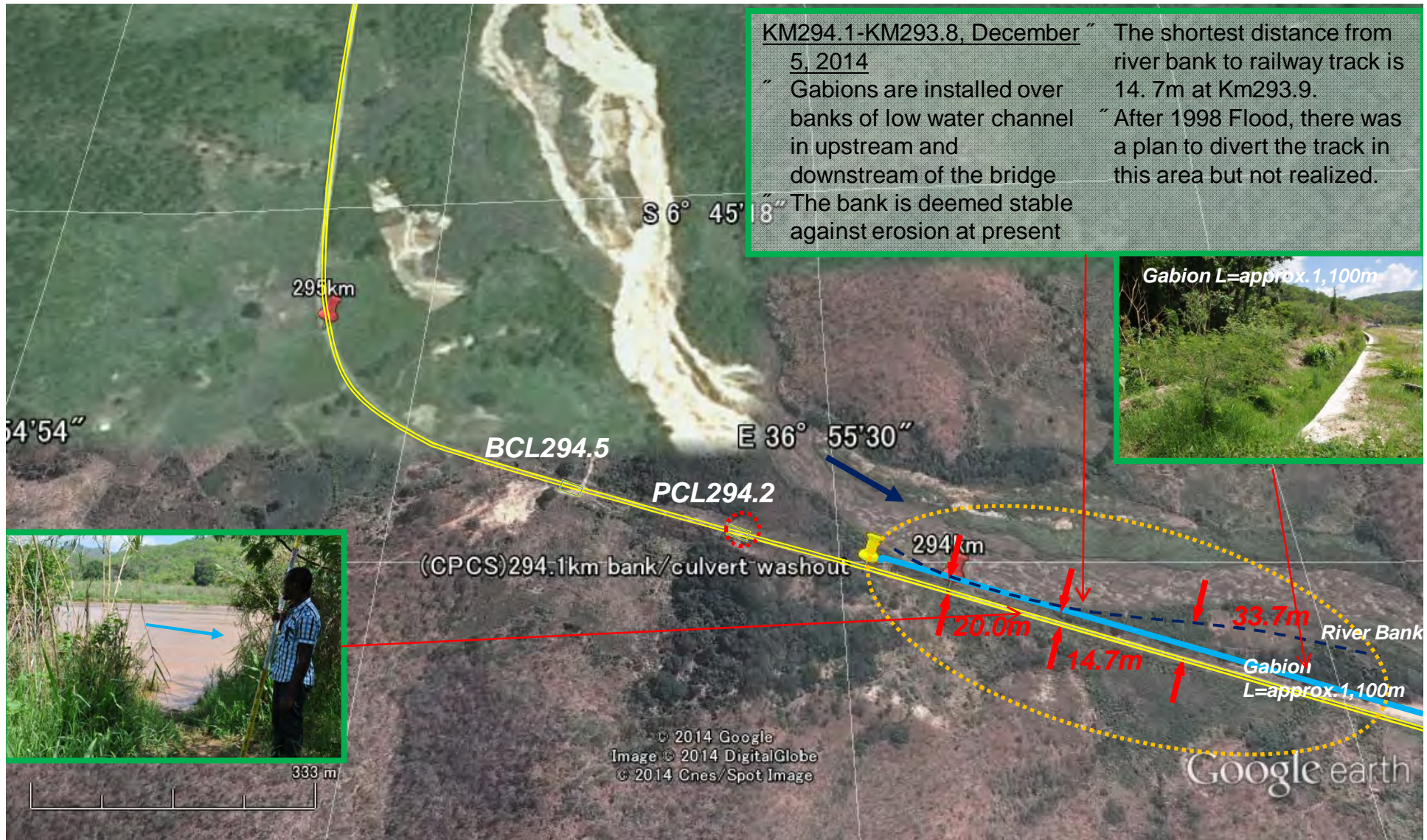



# KM300 – Km301

-  :Risk Level: Low
-  :Risk Level: Medium
-  :Risk Level: High

## 1. River Condition (KM300 – KM301, Dec.4, 2014)

- The flow of low water channel turns to the right bank side at 300.5km point and it is assumed that the low water channel has been moved to right side.
- The flood risk is judged as Medium since the distance from bank to track is 25m and the bank height is 2m.
- The countermeasures for keeping the distance from bank to track are required.

## 2. Culvert Condition (KM300 – KM301, Dec.4, 2014)

- One pipe culvert of four has been deposited by sediment due to shortage of flow capacity.
- It is necessary to work on the urgent countermeasure such as removal sediment .

## 3. Monitoring Recommendation (KM300– KM301)

- The left bank at 300.5km point is colliding front section.
- Monitoring the distance from bank to track and Culverts sediment deposition situation is recommended.

H-13



Google earth



# KM301 – Km302

-  :Risk Level: Low
-  :Risk Level: Medium
-  :Risk Level: High

H-14

1. River Condition (KM301-302, Dec.4, 2014)

- There is no records of flood damage.
- The high water channel is stable.
- A flood risk is judged as Low since the distance from bank to track is 180m and the bank height is 3m.

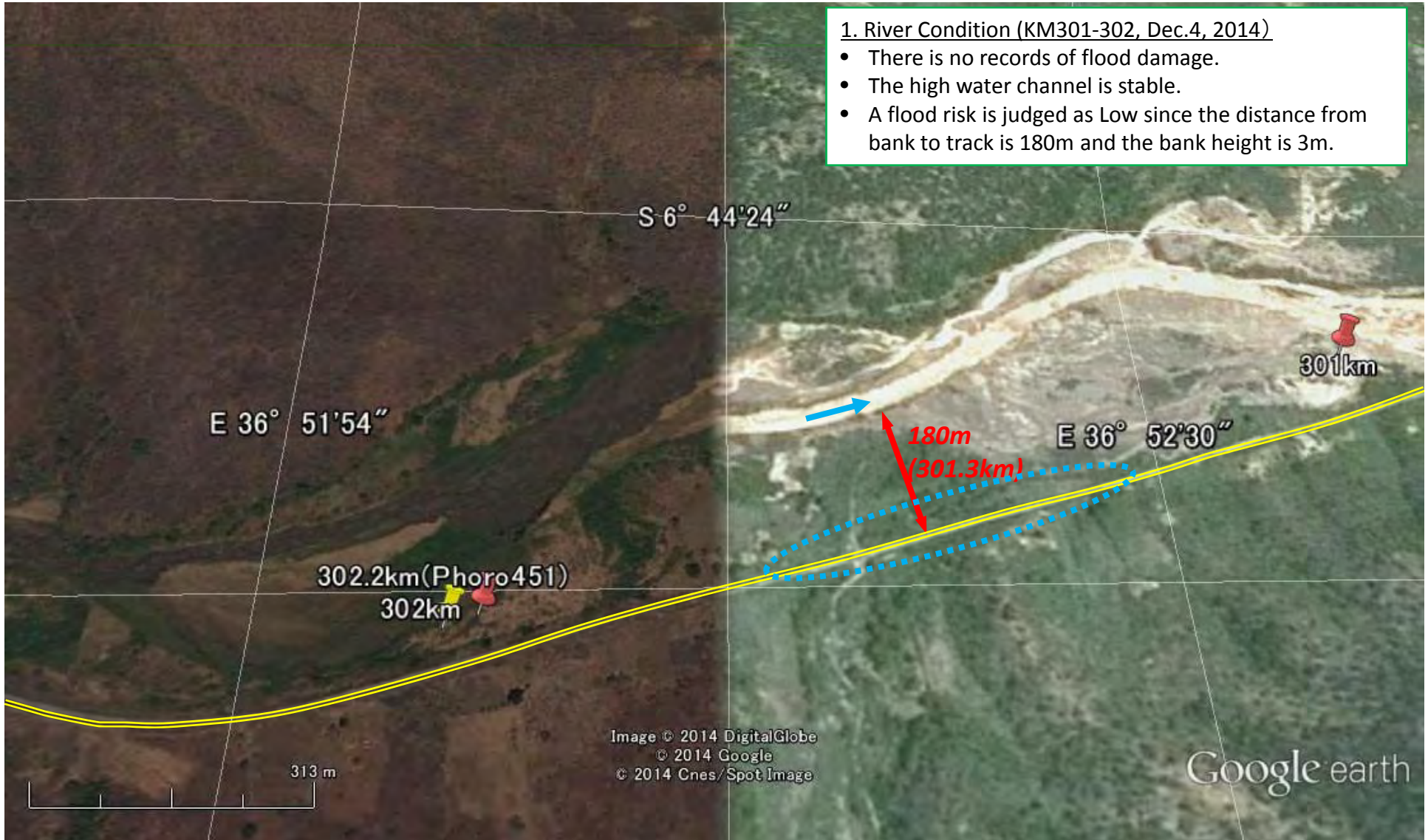

# KM302 – Km303

-  :Risk Level: Low
-  :Risk Level: Medium
-  :Risk Level: High

## 1. River Condition (KM302 – KM303, Dec.4, 2014)

- The right side bank had been eroded about 30m width and one Culvert and Gabion had been washed out by a flood in Mar 2014.
- Restoration works of the Culvert and Gabion are on going. The eroded bank (30m width) had been already filled by the restoration works.
- The river is curving to left side and it is assumed that a right side low water channel will turn into a mainstream way from now on.
- A flood risk is judged as High since the distance from bank to track is 33m and the bank height is 3m.
- The countermeasures for keeping the distance from bank to track are required.

## 2. Culvert Condition (KM302 – KM303, Dec.4, 2014)

- The sediment depositions of three Culverts are slight (one Culvert under restoration contains).
- It is important to continue monitoring of deposition situation and to study a countermeasure if needed.

## 3. Monitoring Recommendation (KM302 – KM303)

- The river is curving to left side and it is assumed that a right side low water channel will turn into a mainstream way from now on.
- Monitoring the distance from bank to track and Culverts sediment deposition situation is recommended.

H-15

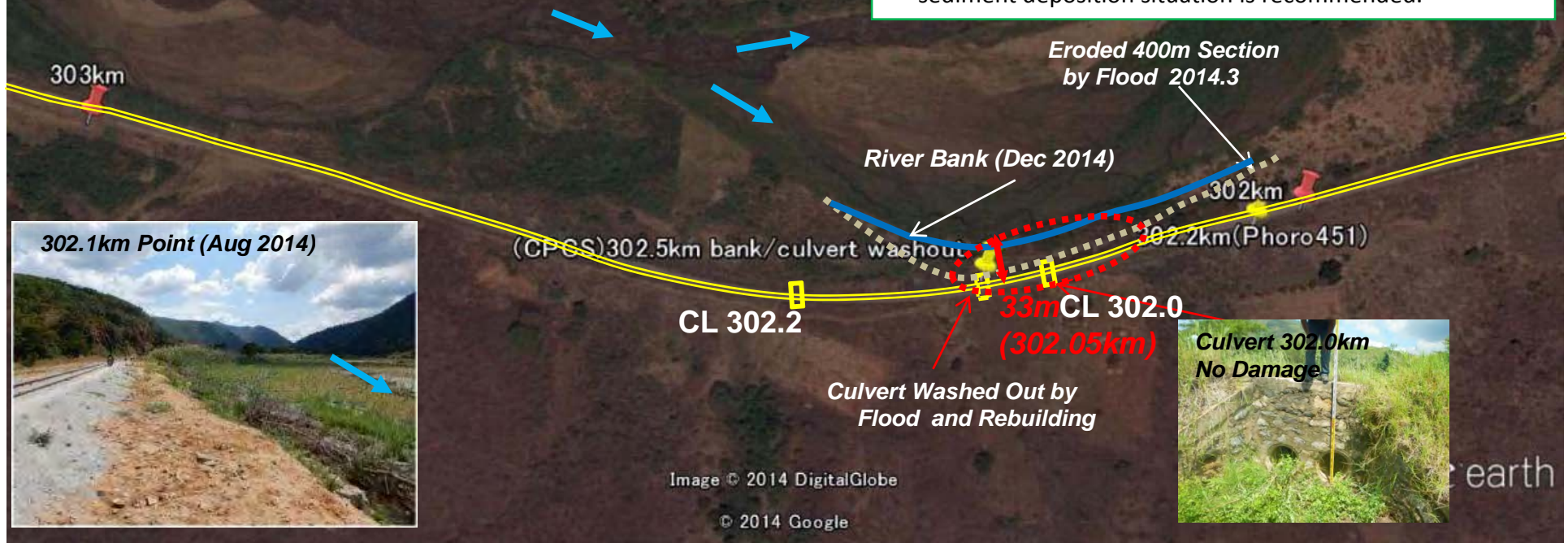



-  :Risk Level: Low
-  :Risk Level: Medium
-  :Risk Level: High

H-16

**1. River Condition (KM303-KM304, Dec.4, 2014)**

- The bridge of the right tributary had washed out by a flood in 2010.
- A new bridge had been completed in 2014 and the railroad line had been moved to the mountain side.
- Since the river bank alignment at right upstream of the new bridge is meandering, Gabion was installed for protection of bank erosion.
- Since the high water channel width is kept 80m by railway relocation, flood risk is judged as Medium.

**2. Culvert Condition (KM303 – KM304, Dec.4, 2014)**

- The sediment depositions of two Culverts are slight.
- It is important to continue monitoring of deposition situation and to study a countermeasure if needed.

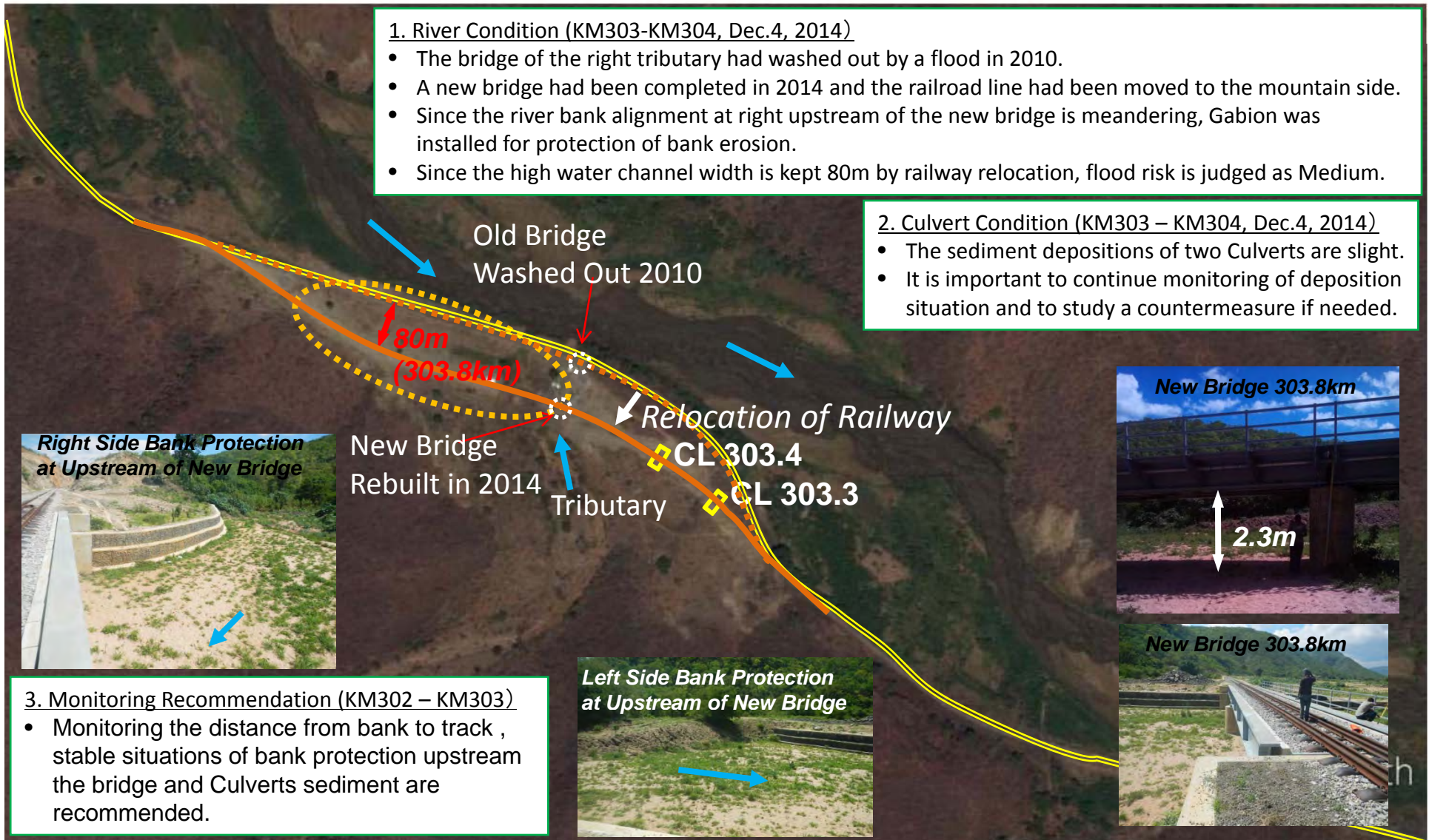

- 3. Monitoring Recommendation (KM302 – KM303)**
- Monitoring the distance from bank to track , stable situations of bank protection upstream the bridge and Culverts sediment are recommended.



# KM304 – Km305

-  :Risk Level: Low
-  :Risk Level: Medium
-  :Risk Level: High

H-17

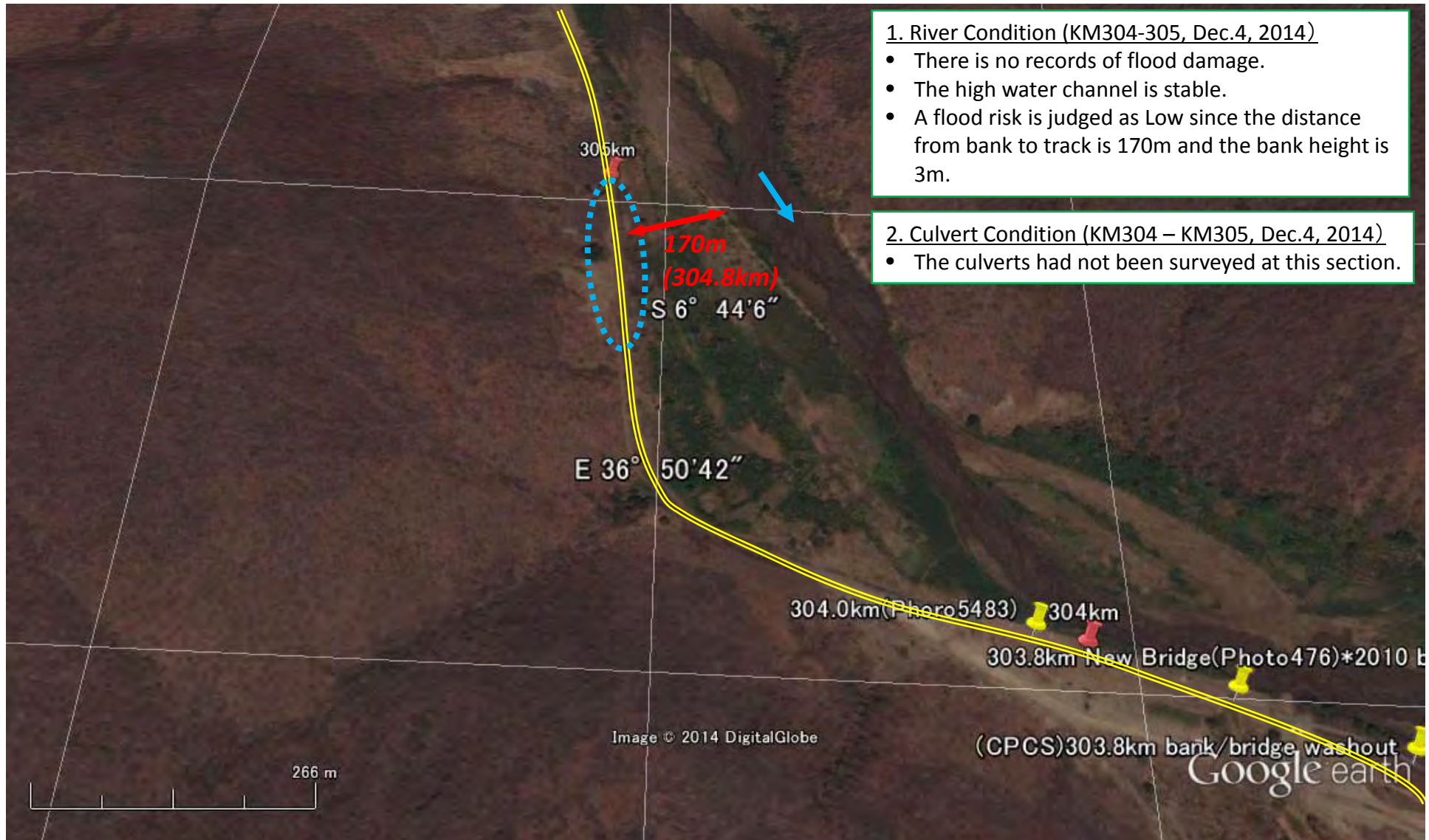

1. River Condition (KM304-305, Dec.4, 2014)

- There is no records of flood damage.
- The high water channel is stable.
- A flood risk is judged as Low since the distance from bank to track is 170m and the bank height is 3m.

2. Culvert Condition (KM304 – KM305, Dec.4, 2014)

- The culverts had not been surveyed at this section.



# KM305 – Km306

-  :Risk Level: Low
-  :Risk Level: Medium
-  :Risk Level: High

H-18

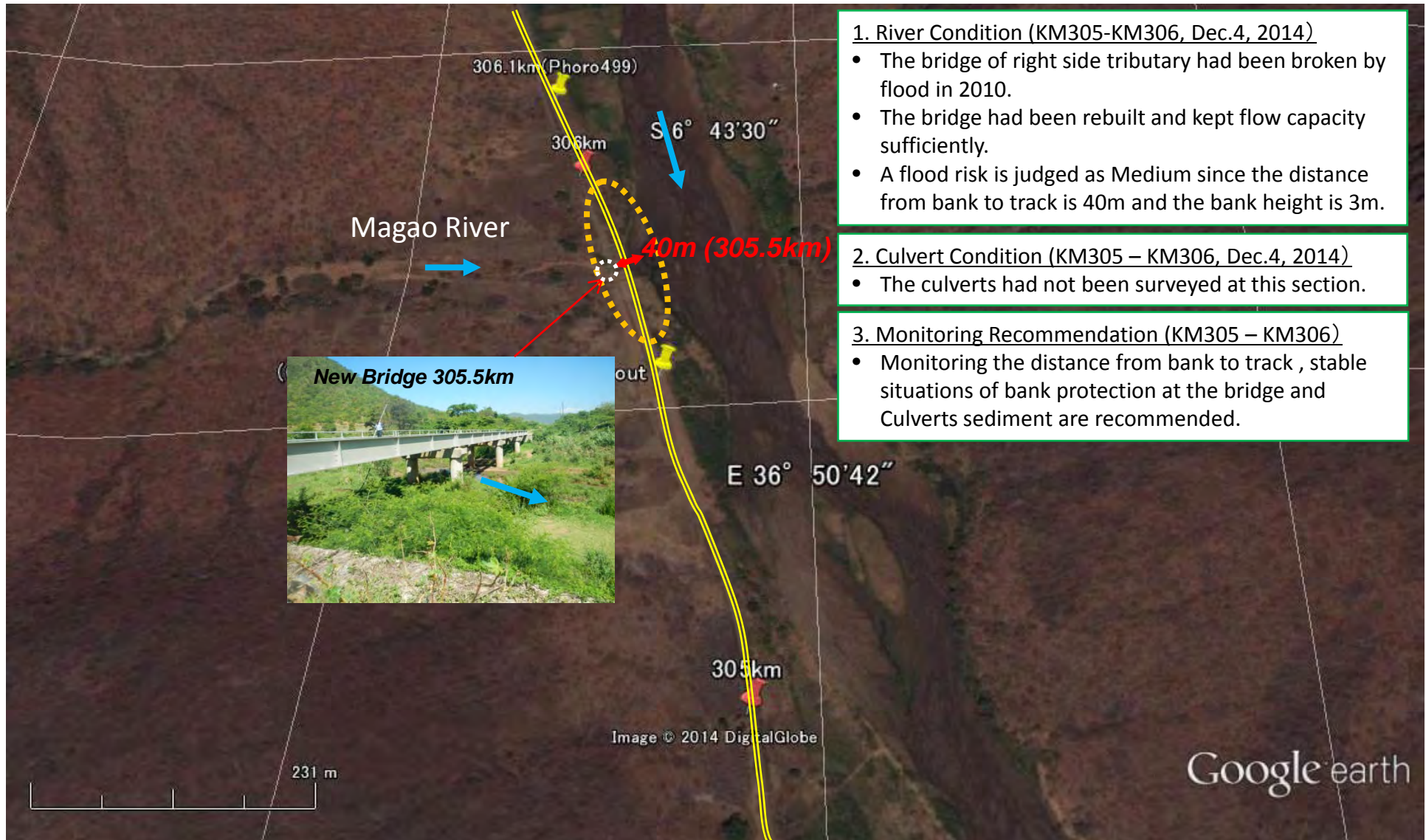

1. River Condition (KM305-KM306, Dec.4, 2014)
  - The bridge of right side tributary had been broken by flood in 2010.
  - The bridge had been rebuilt and kept flow capacity sufficiently.
  - A flood risk is judged as Medium since the distance from bank to track is 40m and the bank height is 3m.
2. Culvert Condition (KM305 – KM306, Dec.4, 2014)
  - The culverts had not been surveyed at this section.
3. Monitoring Recommendation (KM305 – KM306)
  - Monitoring the distance from bank to track , stable situations of bank protection at the bridge and Culverts sediment are recommended.



# KM306 – Km307

-  :Risk Level: Low
-  :Risk Level: Medium
-  :Risk Level: High

H-19

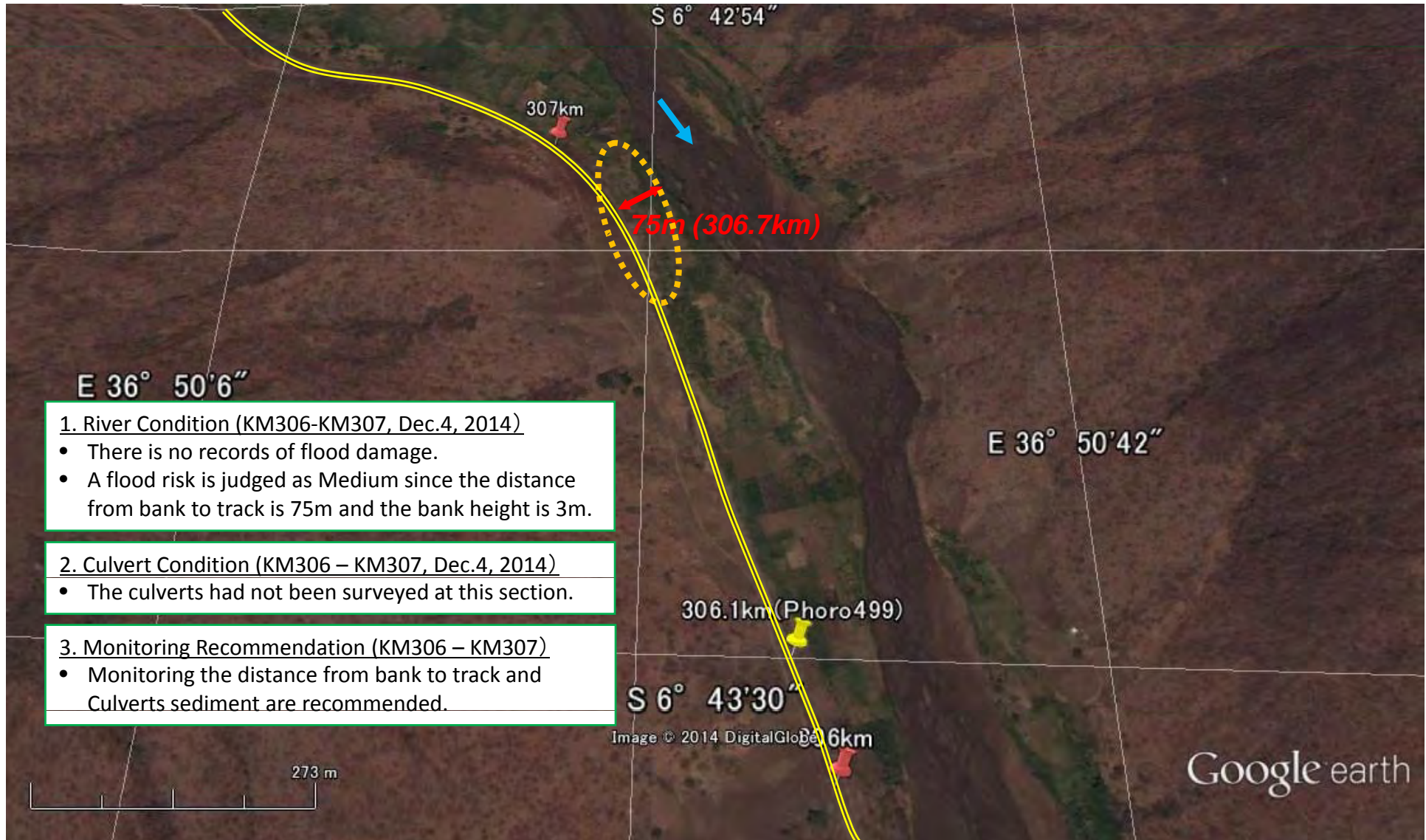

# KM307 – Km308

-  :Risk Level: Low
-  :Risk Level: Medium
-  :Risk Level: High

H-20

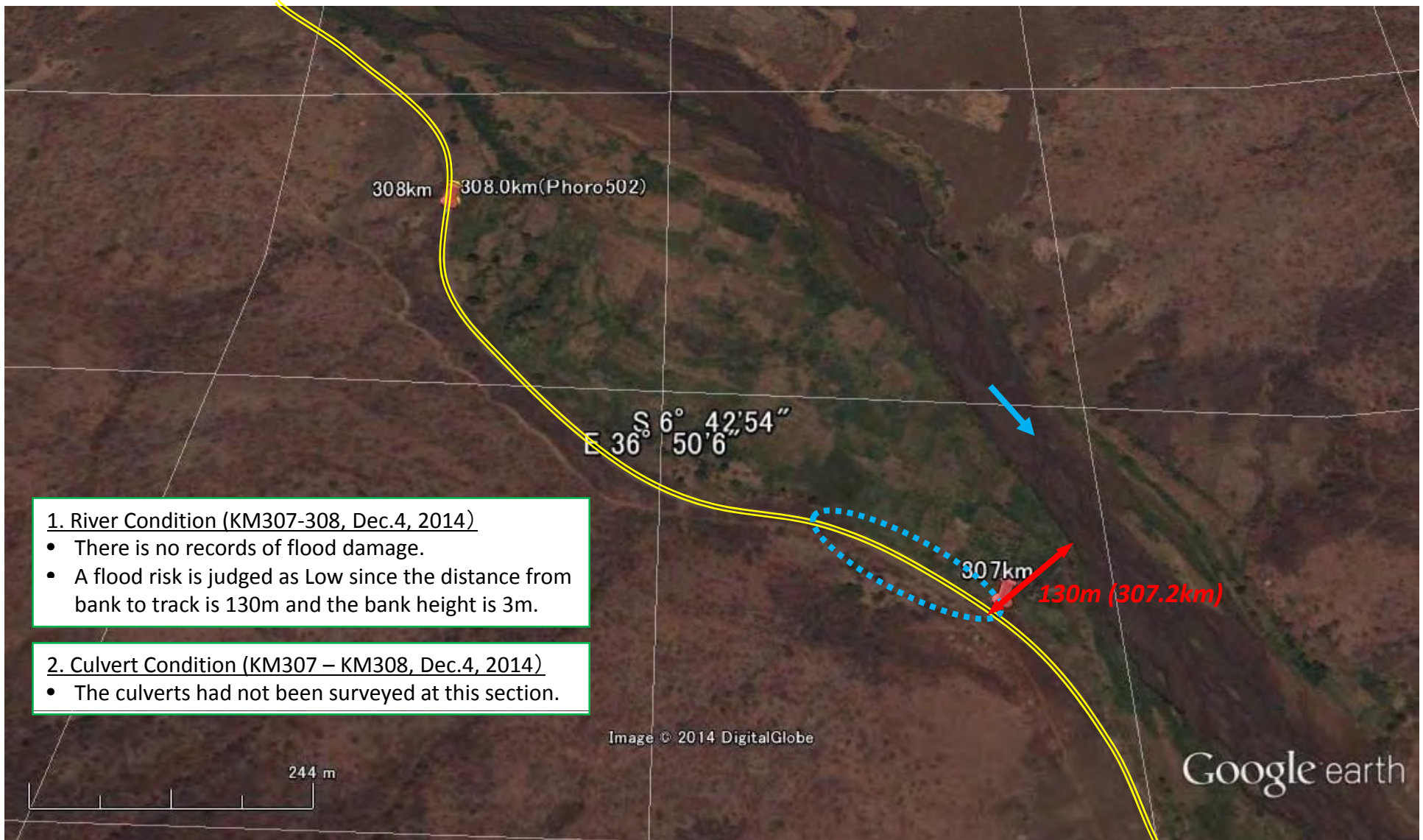

## 1. River Condition (KM307-308, Dec.4, 2014)

- There is no records of flood damage.
- A flood risk is judged as Low since the distance from bank to track is 130m and the bank height is 3m.

## 2. Culvert Condition (KM307 – KM308, Dec.4, 2014)

- The culverts had not been surveyed at this section.



KM308 – Km309

○ :Risk Level: Low

○ :Risk Level: Medium

○ :Risk Level: High

H-21

**KM308.6, Dec.04,2014**

- No damage by overtopping in 2010 Flood.
- River bank height is low as about 1.5m. The bank erosion is progress, and the shortest distance from river bank to railway track is 16.2m.

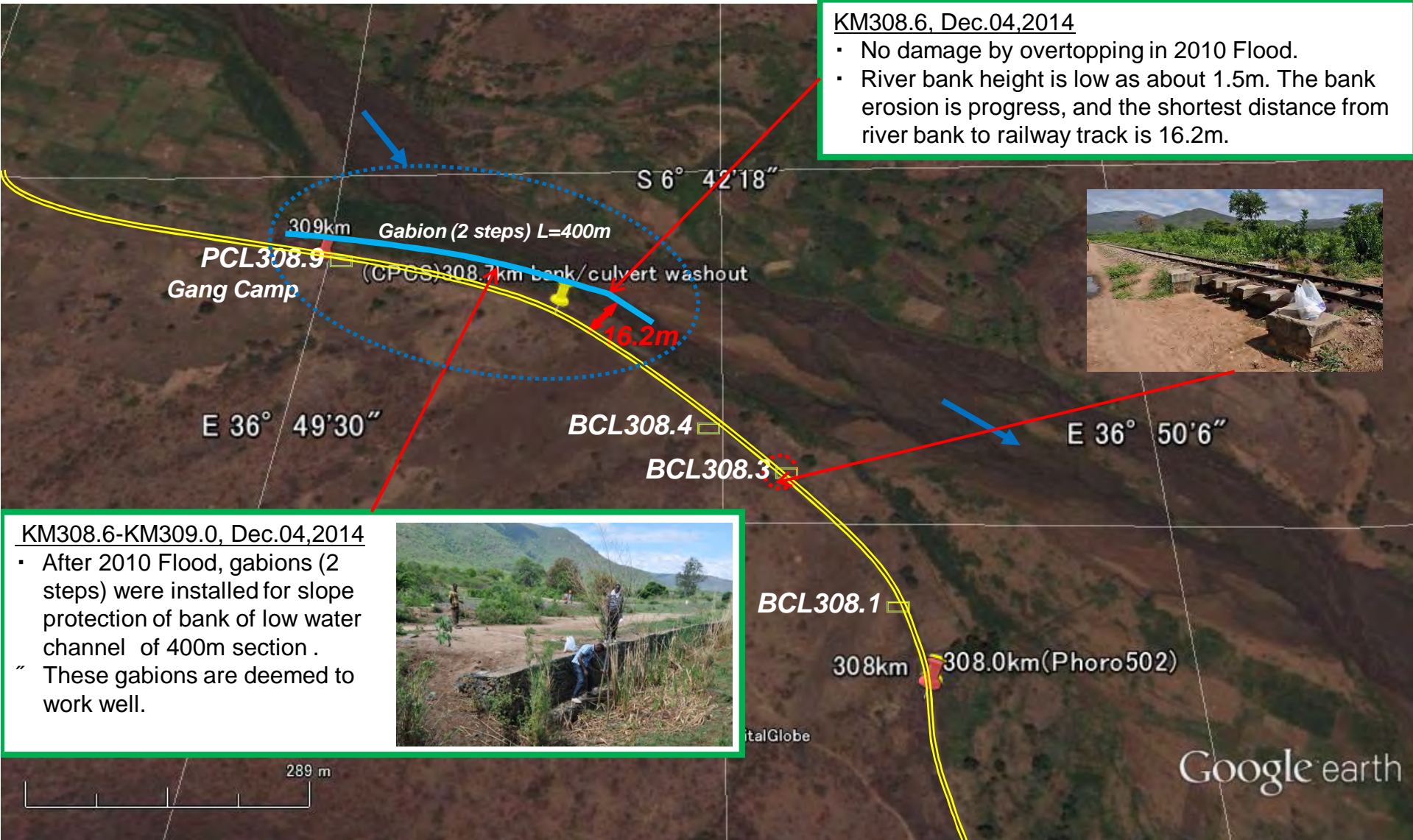

**KM308.6-KM309.0, Dec.04,2014**

- After 2010 Flood, gabions (2 steps) were installed for slope protection of bank of low water channel of 400m section .
- “ These gabions are deemed to work well.





KM309 – Km310

 :Risk Level: Low

 :Risk Level: Medium

 :Risk Level: High

H-22

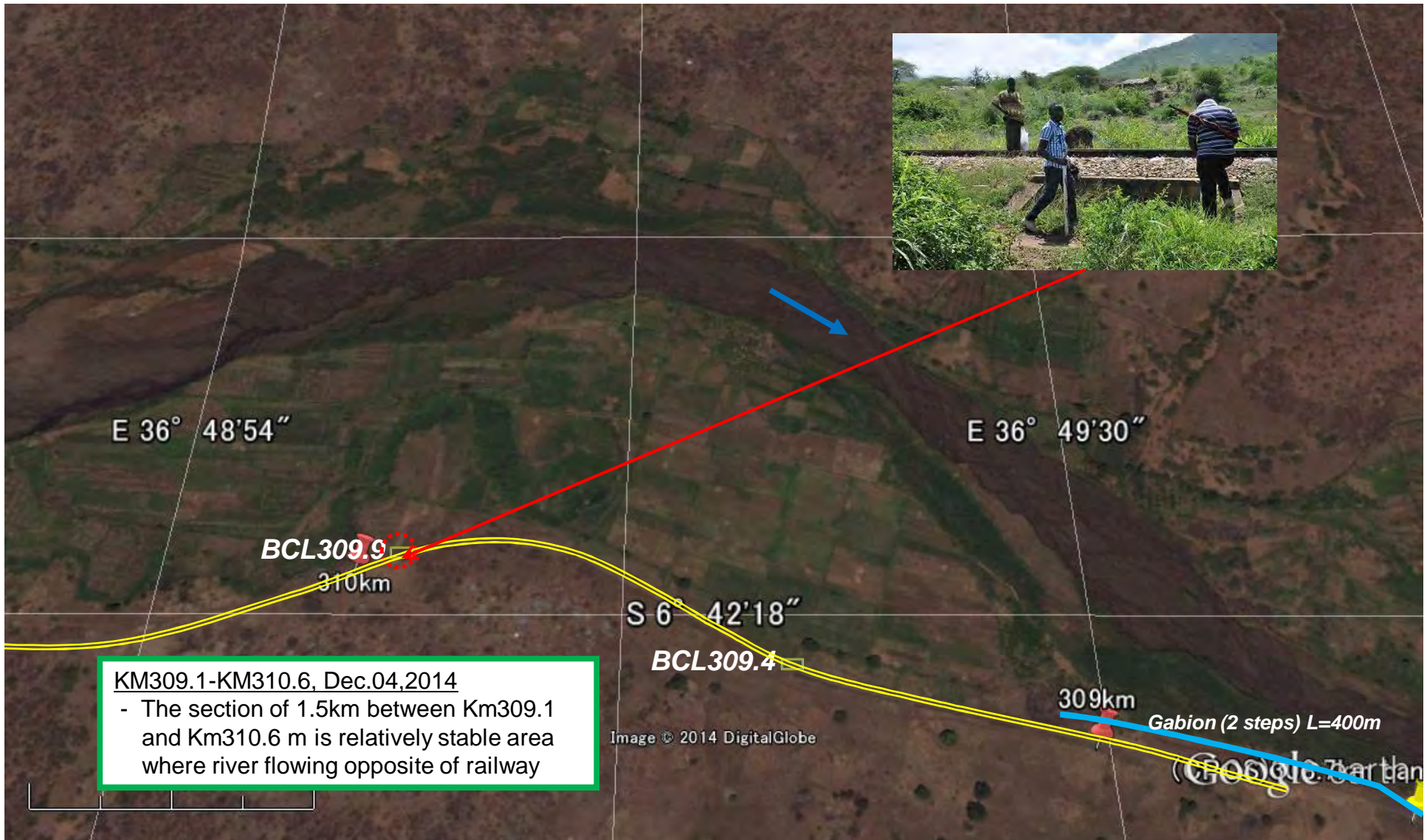

**KM309.1-KM310.6, Dec.04,2014**  
- The section of 1.5km between Km309.1 and Km310.6 m is relatively stable area where river flowing opposite of railway

Image © 2014 DigitalGlobe

Google Earth



# KM310 – Km311 (Station Mzaganza)

 :Risk Level: Low

 :Risk Level: Medium

 :Risk Level: High

H-23

KM310.5, Dec.04,2014  
 " - The area at back of Mzakanza station building is located in low laying area, but no damage is reported on the building.  
 " As the back of the station is located at water hit portion, it is recommended to install river bank protection considering the existence of station.

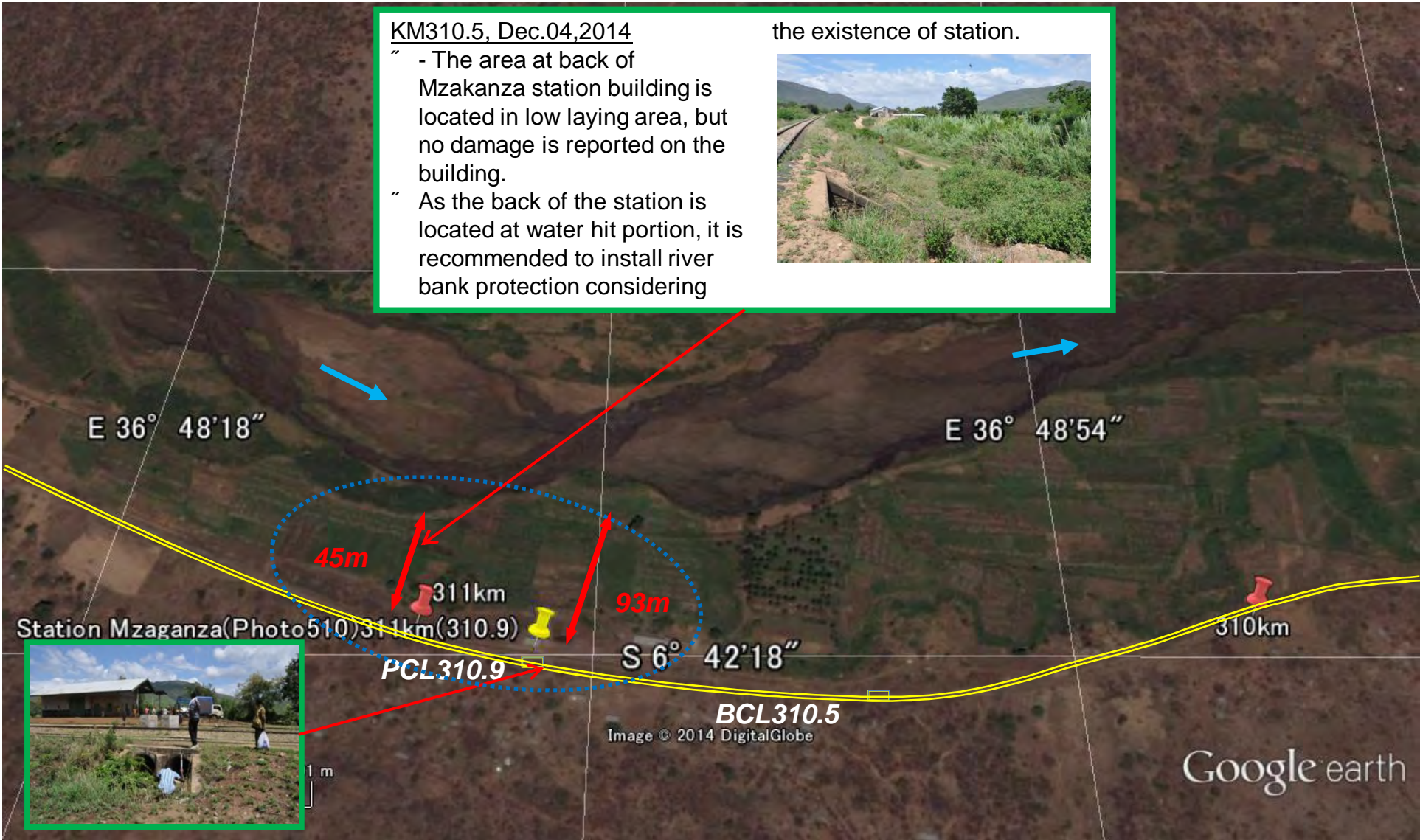

Image © 2014 DigitalGlobe

Google earth



# KM311 (Station Mzaganza) – Km312

 :Risk Level: Low

 :Risk Level: Medium

 :Risk Level: High

H-24

(KM311.1:Dec.4, 2014)

- “ The shortest distance from river bank to railway track is 45 m at Km311.1.
- “ Bank height is 4.5m



*River bank and flood plain at back of Mzaganza Station (Km311.1)*



*River bank and flood plain at back of Mzaganza Station (Km311.1)*

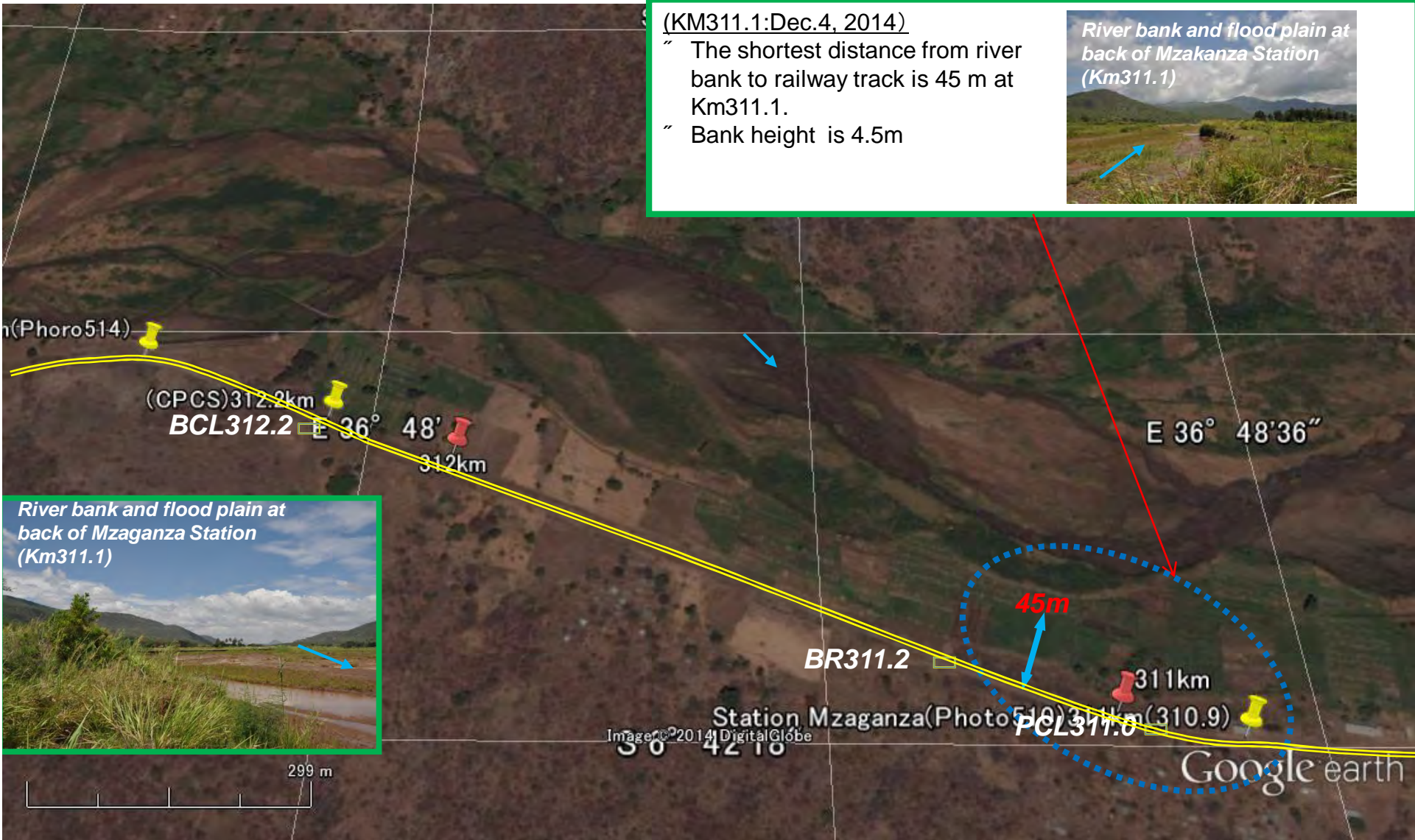



KM312– Km313

-  :Risk Level: Low
-  :Risk Level: Medium
-  :Risk Level: High

H-25

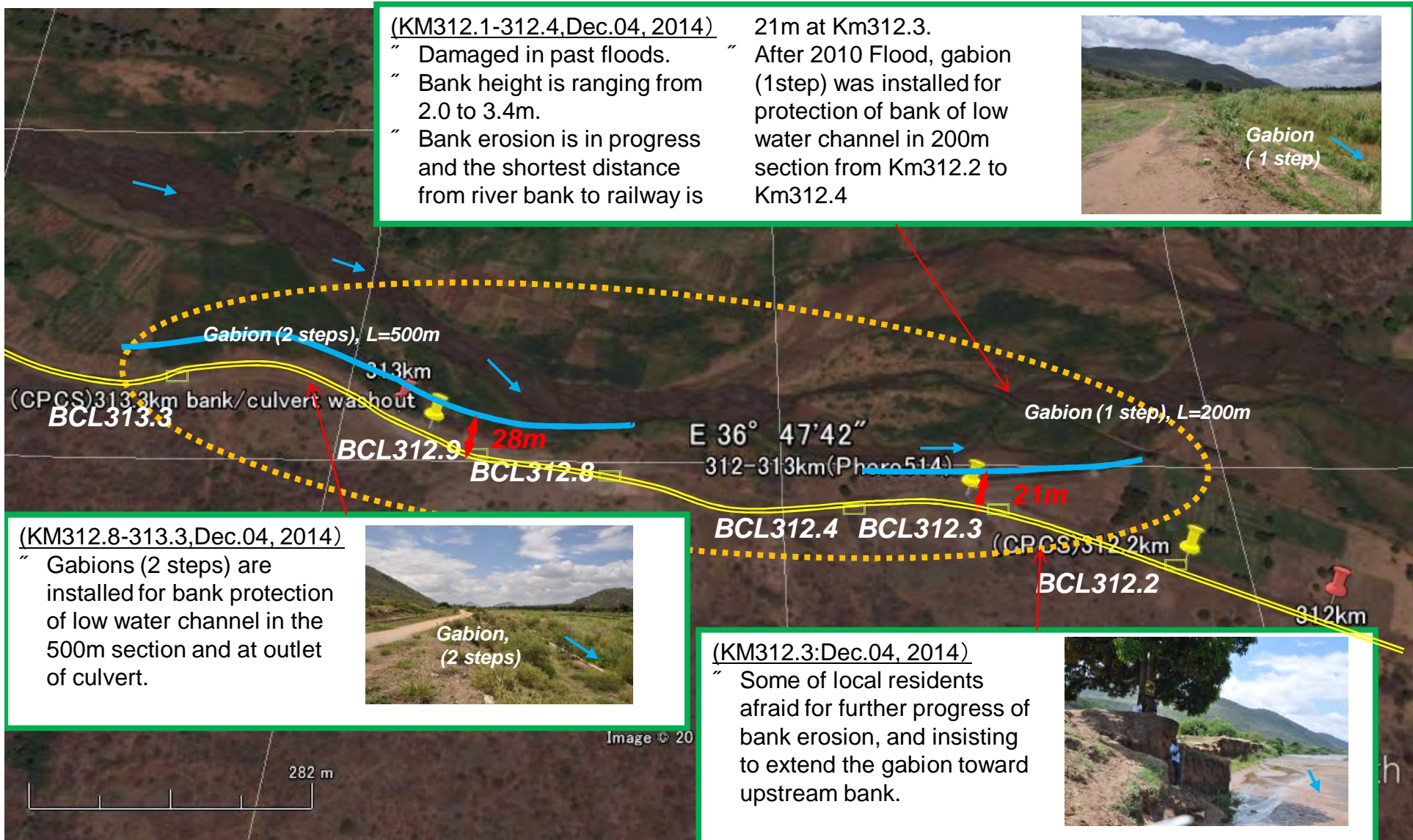

(KM312.1-312.4, Dec.04, 2014)  
 " Damaged in past floods.  
 " Bank height is ranging from 2.0 to 3.4m.  
 " Bank erosion is in progress and the shortest distance from river bank to railway is

21m at Km312.3.  
 " After 2010 Flood, gabion (1step) was installed for protection of bank of low water channel in 200m section from Km312.2 to Km312.4



(KM312.8-313.3, Dec.04, 2014)  
 " Gabions (2 steps) are installed for bank protection of low water channel in the 500m section and at outlet of culvert.



(KM312.3: Dec.04, 2014)  
 " Some of local residents afraid for further progress of bank erosion, and insisting to extend the gabion toward upstream bank.



Image © 20



KM313– Km314

-  :Risk Level: Low
-  :Risk Level: Medium
-  :Risk Level: High

H-26

(KM313.3, Dec. 04, 2014)

- ~ A small tributary joins to mainstream
- ~ A culvert had been damaged and washed out. After that, the outlet of culvert was restored and reinforced by installation of gabion and apron.

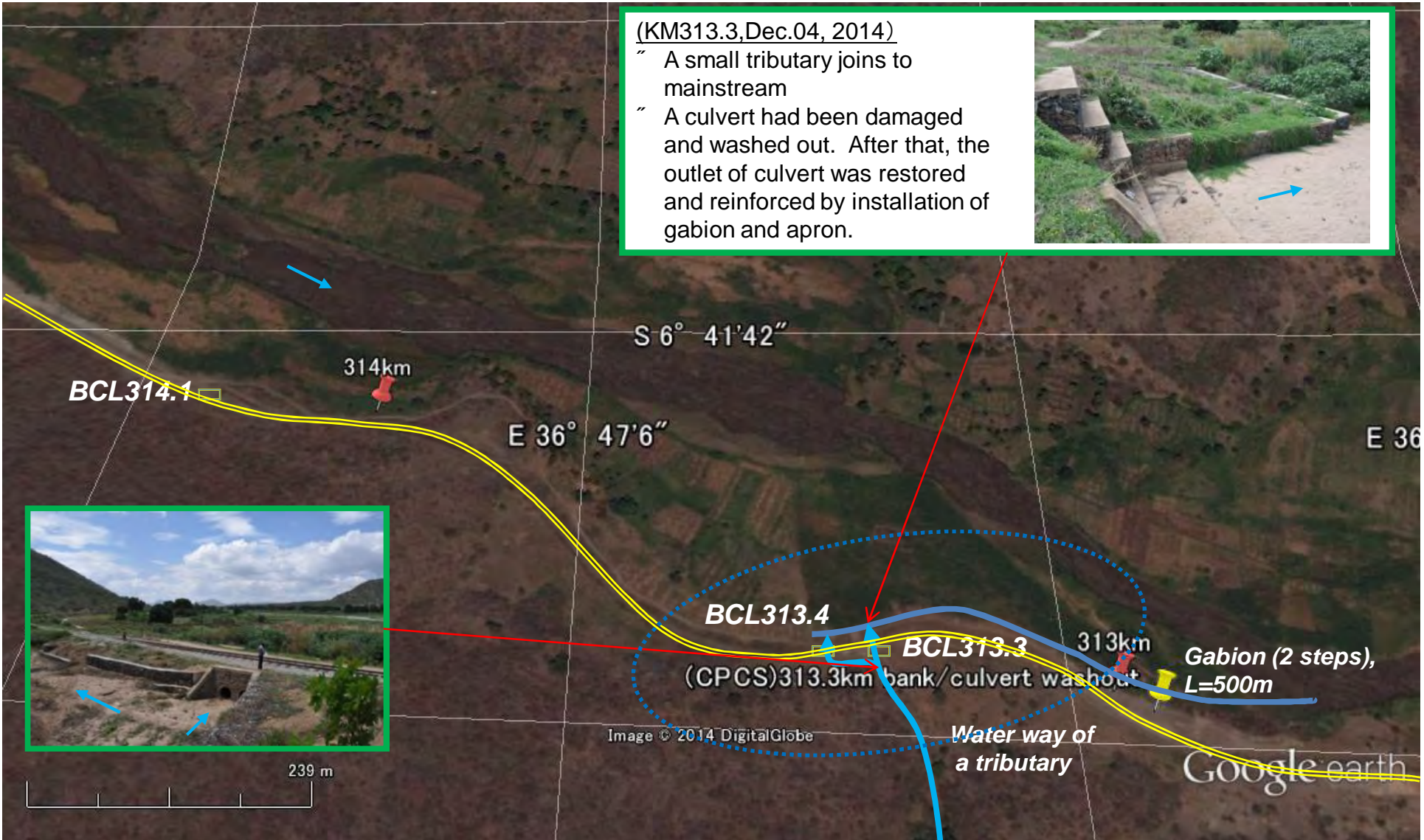



KM314– Km315

○ :Risk Level: Low

○ :Risk Level: Medium

○ :Risk Level: High

H-27

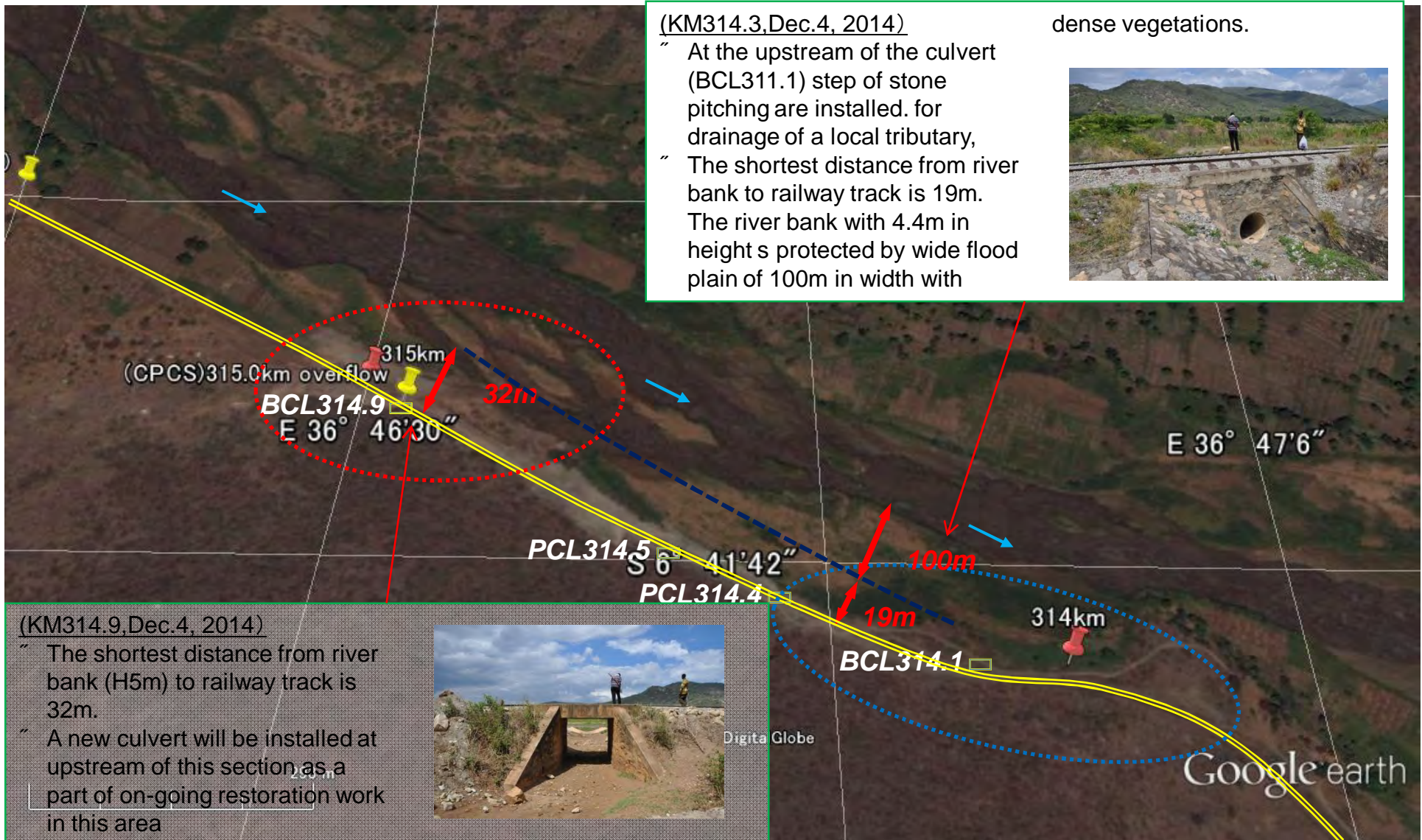

(KM314.3, Dec.4, 2014)

- At the upstream of the culvert (BCL311.1) step of stone pitching are installed. for drainage of a local tributary,
- The shortest distance from river bank to railway track is 19m. The river bank with 4.4m in height s protected by wide flood plain of 100m in width with dense vegetations.



(KM314.9, Dec.4, 2014)

- The shortest distance from river bank (H5m) to railway track is 32m.
- A new culvert will be installed at upstream of this section as a part of on-going restoration work in this area



Digit Globe

Google earth



# KM315– Km316

- ⦿ :Risk Level: Low
- ⦿ :Risk Level: Medium
- ⦿ :Risk Level: High

(KM315.0-315.8, Dec.4, 2014)  
 " In march 2014, river bank was seriously eroded by flood. At present, urgent restoration works are being undertaken by TRL/RACHO as follow:

- 1) Diversion of railway track (800m) to land side by 18m
- 2) trimming of eroded slope and backfilling at most eroded section
- 3) installation of gabions (3 steps) at toe of bank



**From 2012.10 to 2014.03**  
**Progress of river bank erosion by approx.50-70m / 2years**

H-28

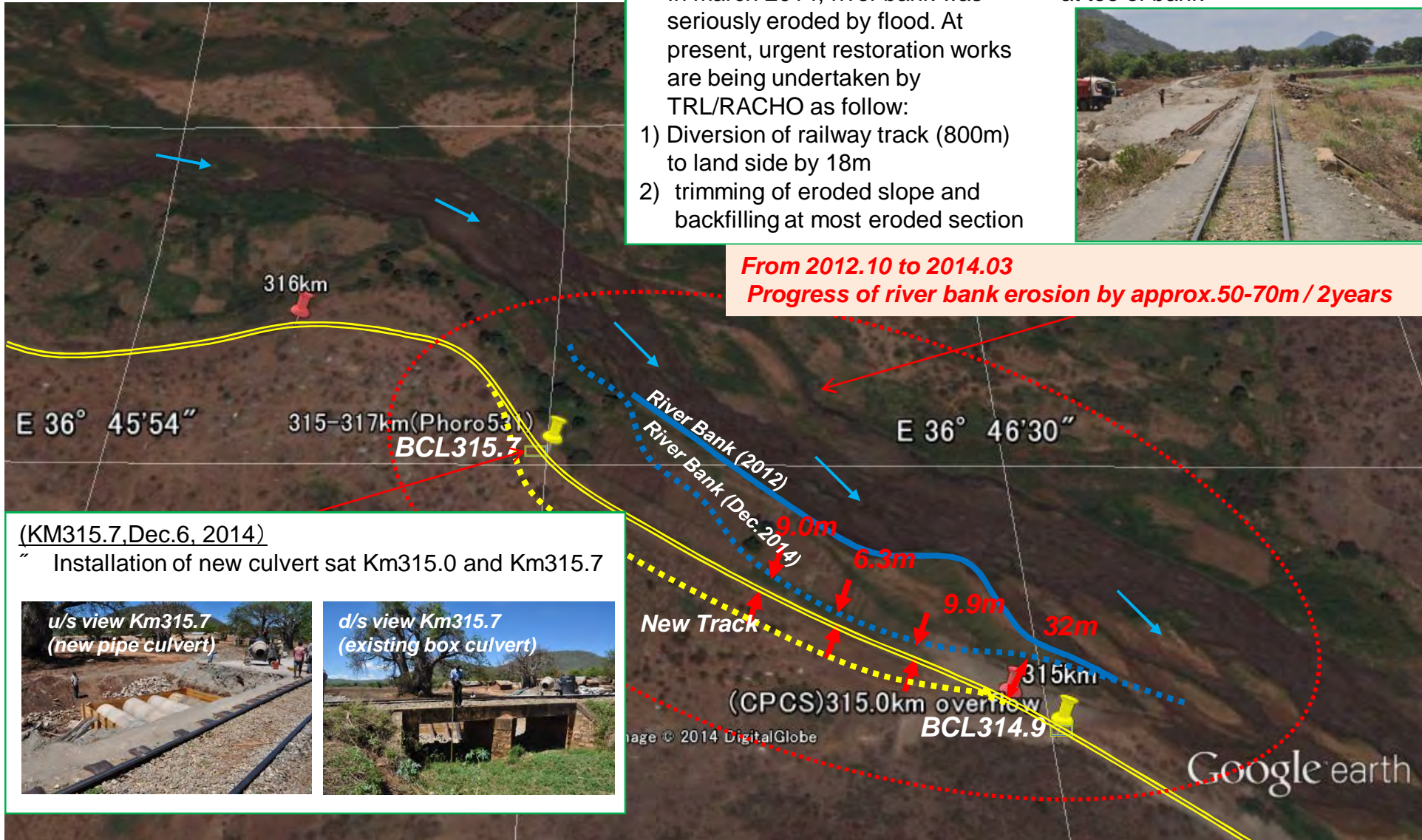

(KM315.7, Dec.6, 2014)  
 " Installation of new culvert sat Km315.0 and Km315.7





# KM325.5 (Station Kidete) – Km326

 :Risk Level: Low

 :Risk Level: Medium

 :Risk Level: High

H-29

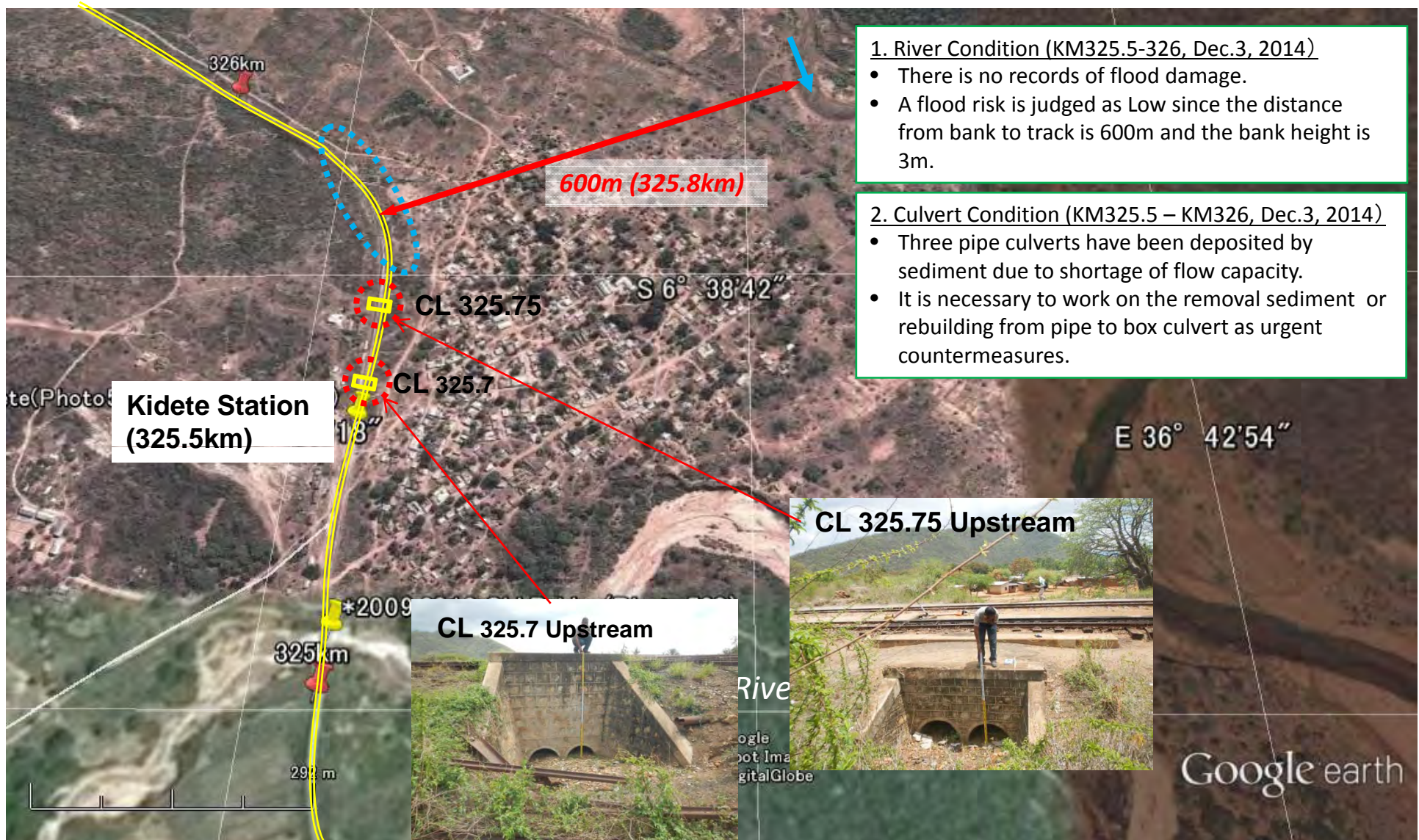

**1. River Condition (KM325.5-326, Dec.3, 2014)**

- There is no records of flood damage.
- A flood risk is judged as Low since the distance from bank to track is 600m and the bank height is 3m.

**2. Culvert Condition (KM325.5 – KM326, Dec.3, 2014)**

- Three pipe culverts have been deposited by sediment due to shortage of flow capacity.
- It is necessary to work on the removal sediment or rebuilding from pipe to box culvert as urgent countermeasures.



Google earth



# KM326– Km327

 :Risk Level: Low

 :Risk Level: Medium

 :Risk Level: High

H-30

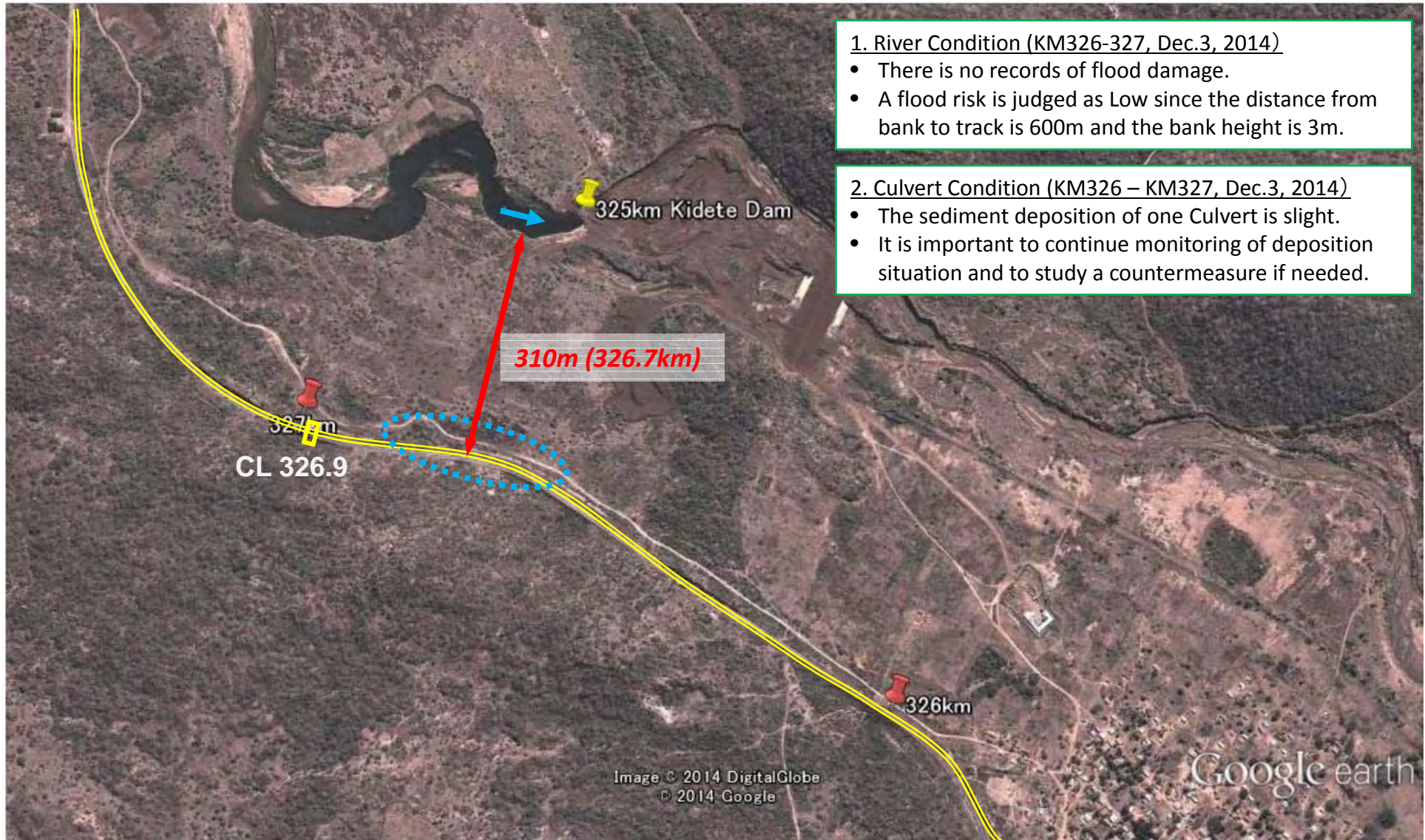



 :Risk Level: Low

 :Risk Level: Medium

 :Risk Level: High

**From Jun 2012 to Dec 2014  
Progress of river bank  
erosion by approx.50m**



CL 327.9

60m (327.95km)

E 36° 41'42"

S 6° 38'6"

CL 327.4

327km

**1. River Condition (KM327-KM328, Dec.3, 2014)**

- Notable riverbank corrosion has been occurred at 327.95 km point of the water colliding front.
- About 50m corrosion has been advancing during two years and a half between present (December, 2014) and the aerial photograph as of June, 2012.
- A flood risk is judged as Medium since the distance from bank to track is 60m and the bank height is 8m.
- Countermeasures of backfill and installation of low water channel protection are required.

**2. Culvert Condition (KM327 – KM328, Dec.3, 2014)**

- The sediment depositions of two Culverts are slight.
- It is important to continue monitoring of deposition situation and to study a countermeasure if needed.

**3. Monitoring Recommendation (KM327 – KM328)**

- Monitoring the distance from bank to track at 327.95km point are recommended.



# KM328 – Km329

-  :Risk Level: Low
-  :Risk Level: Medium
-  :Risk Level: High

H-32

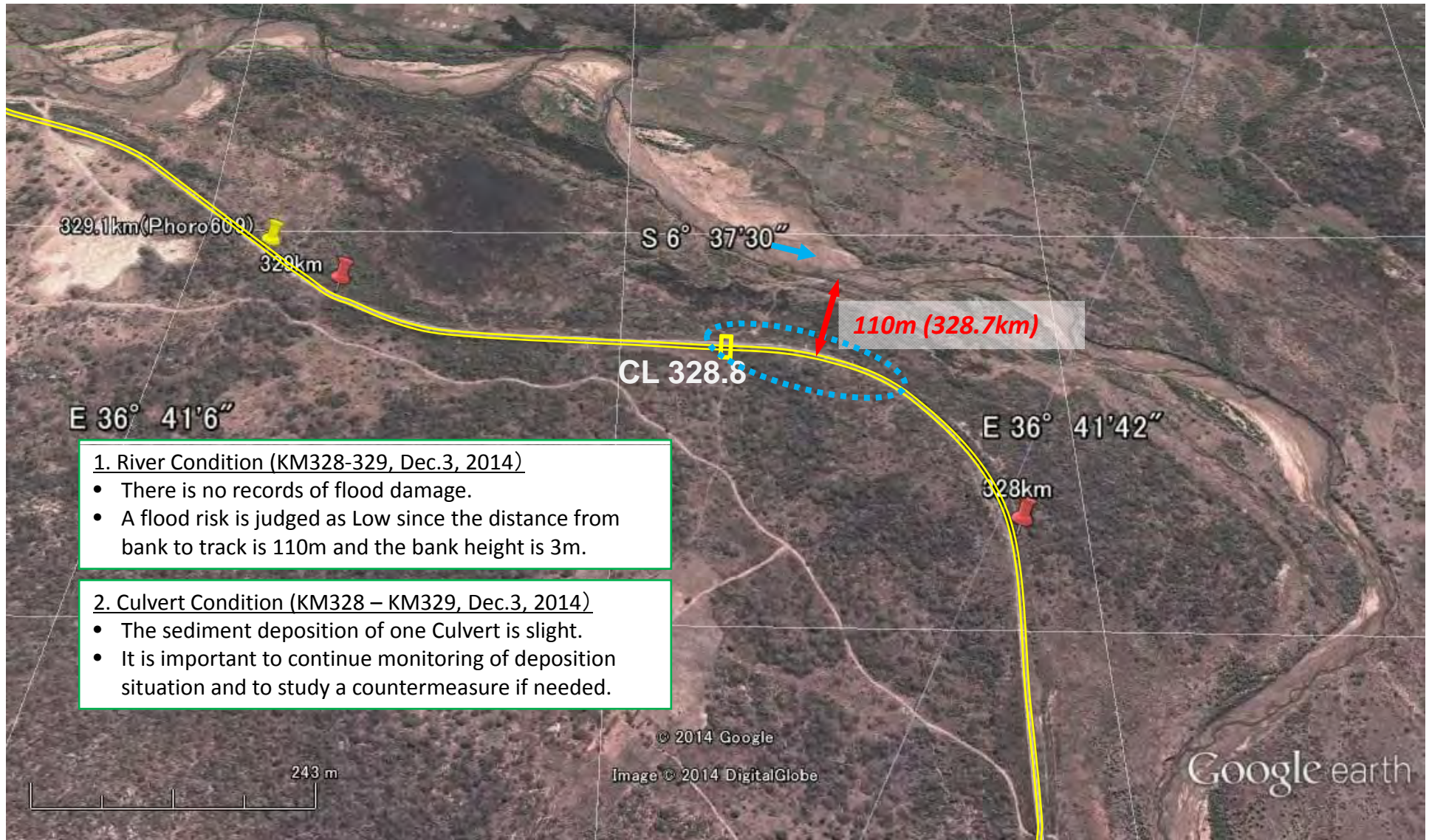



# KM329 – Km330

○ :Risk Level: Low

○ :Risk Level: Medium

○ :Risk Level: High

1. River Condition (KM329-KM330, Dec.3, 2014)

- Low water channel is separated two ways. The distance from right side low water channel to railroad is 22m at 329.8km point.
- A flood risk is judged as Medium since the distance from low water channel bank to track is 22m and the bank height is 3m.
- The countermeasure for keeping the distance between low water channel bank to track, because the 329.8km point is colliding section.

H-33

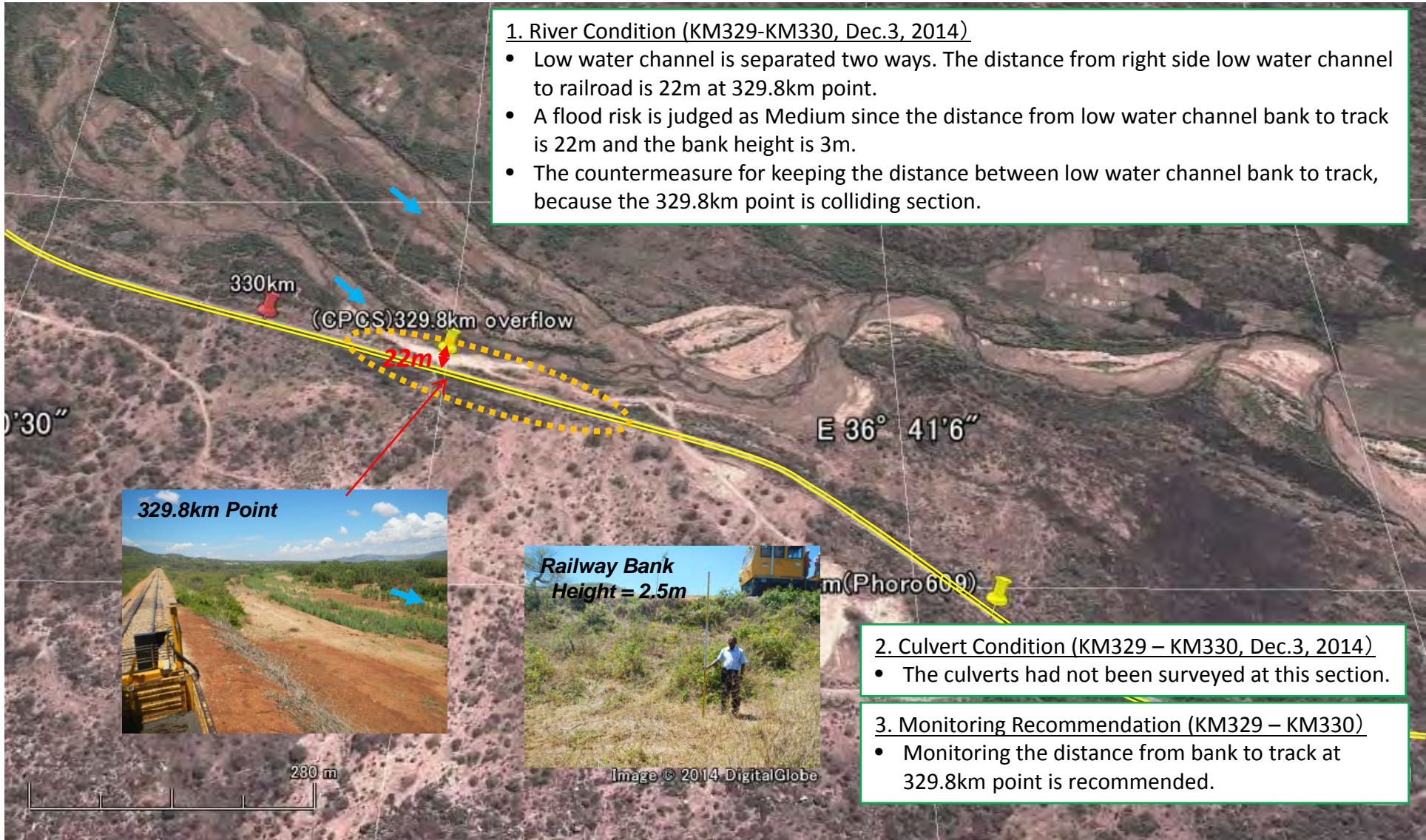

2. Culvert Condition (KM329 – KM330, Dec.3, 2014)

- The culverts had not been surveyed at this section.

3. Monitoring Recommendation (KM329 – KM330)

- Monitoring the distance from bank to track at 329.8km point is recommended.



# KM330 – Km331

-  :Risk Level: Low
-  :Risk Level: Medium
-  :Risk Level: High

H-34

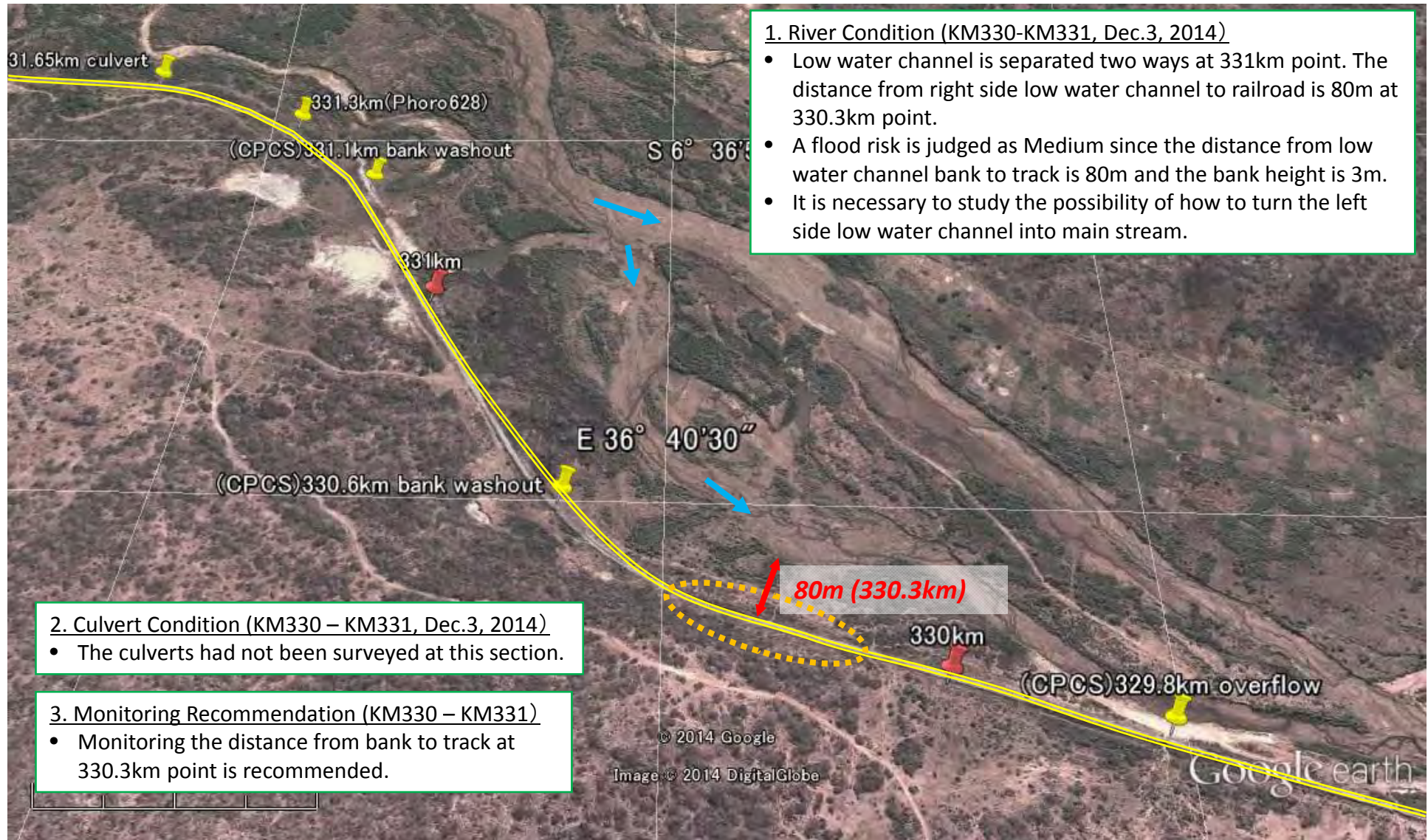



# KM331 – Km332

 :Risk Level: Low

 :Risk Level: Medium

 :Risk Level: High

H-35

1. River Condition (KM331-KM332, Dec.3, 2014)

- Low water channel is separated two ways and the left side one is main stream.
- It is found from aerial photograph that recently water had been flown on the right side low water channel.
- The distance from right side low water channel to railroad is 50m at 331.6km point.
- A flood risk is judged as Medium since the distance from low water channel bank to track is 50m and the bank height is 3m.
- The countermeasures for keeping the distance from low water channel bank to track is required.

2. Culvert Condition (KM331 – KM332, Dec.3, 2014)

- The culverts had not been surveyed at this section.

3. Monitoring Recommendation (KM331 – KM332)

- Monitoring the distance from bank to track at 331.6km point is recommended.

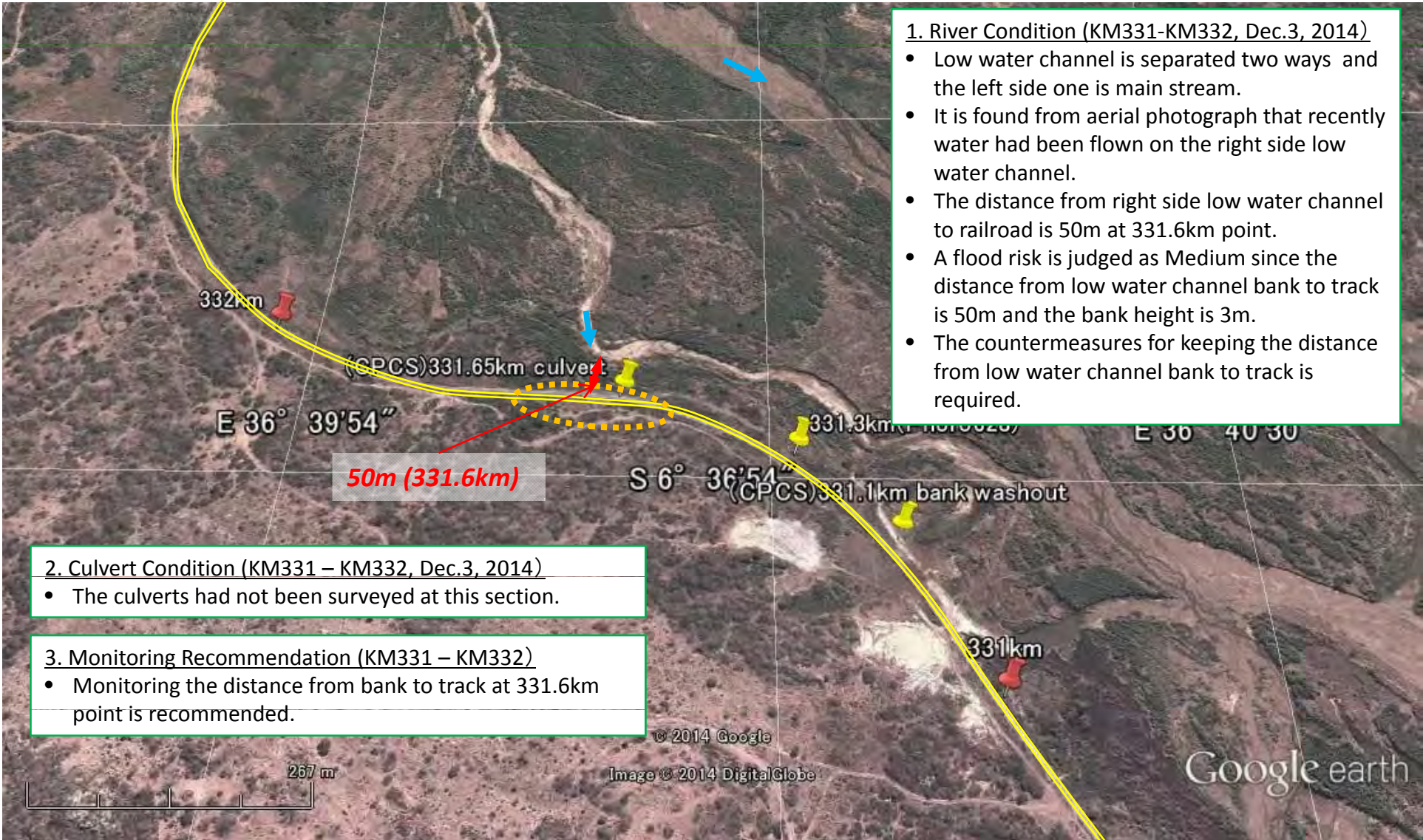



# KM332 – Km333

 :Risk Level: Low

 :Risk Level: Medium

 :Risk Level: High

H-36

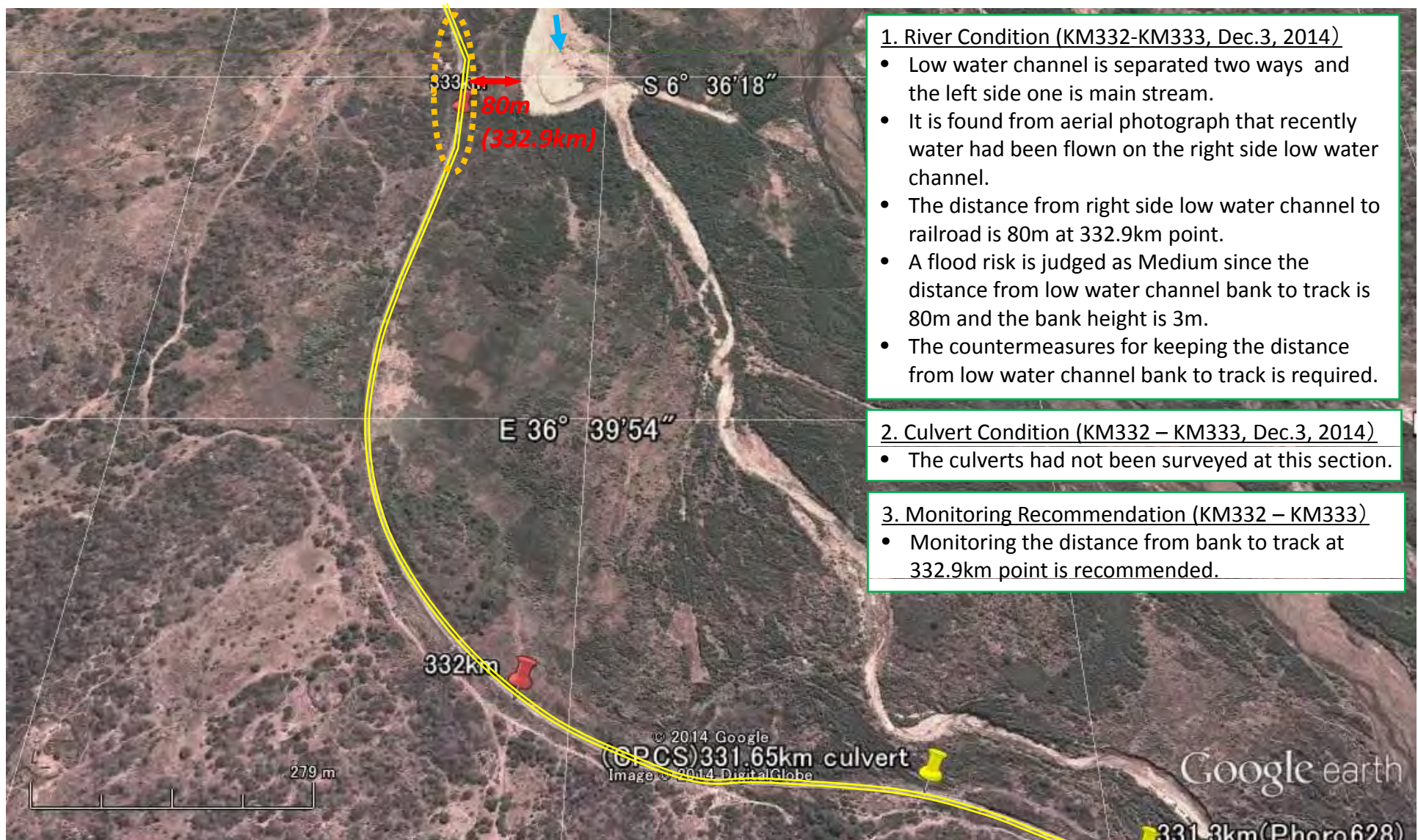

1. River Condition (KM332-KM333, Dec.3, 2014)
- Low water channel is separated two ways and the left side one is main stream.
  - It is found from aerial photograph that recently water had been flown on the right side low water channel.
  - The distance from right side low water channel to railroad is 80m at 332.9km point.
  - A flood risk is judged as Medium since the distance from low water channel bank to track is 80m and the bank height is 3m.
  - The countermeasures for keeping the distance from low water channel bank to track is required.

2. Culvert Condition (KM332 – KM333, Dec.3, 2014)
- The culverts had not been surveyed at this section.

3. Monitoring Recommendation (KM332 – KM333)
- Monitoring the distance from bank to track at 332.9km point is recommended.



KM333 – Km334

○ :Risk Level: Low

○ :Risk Level: Medium

○ :Risk Level: High

H-37

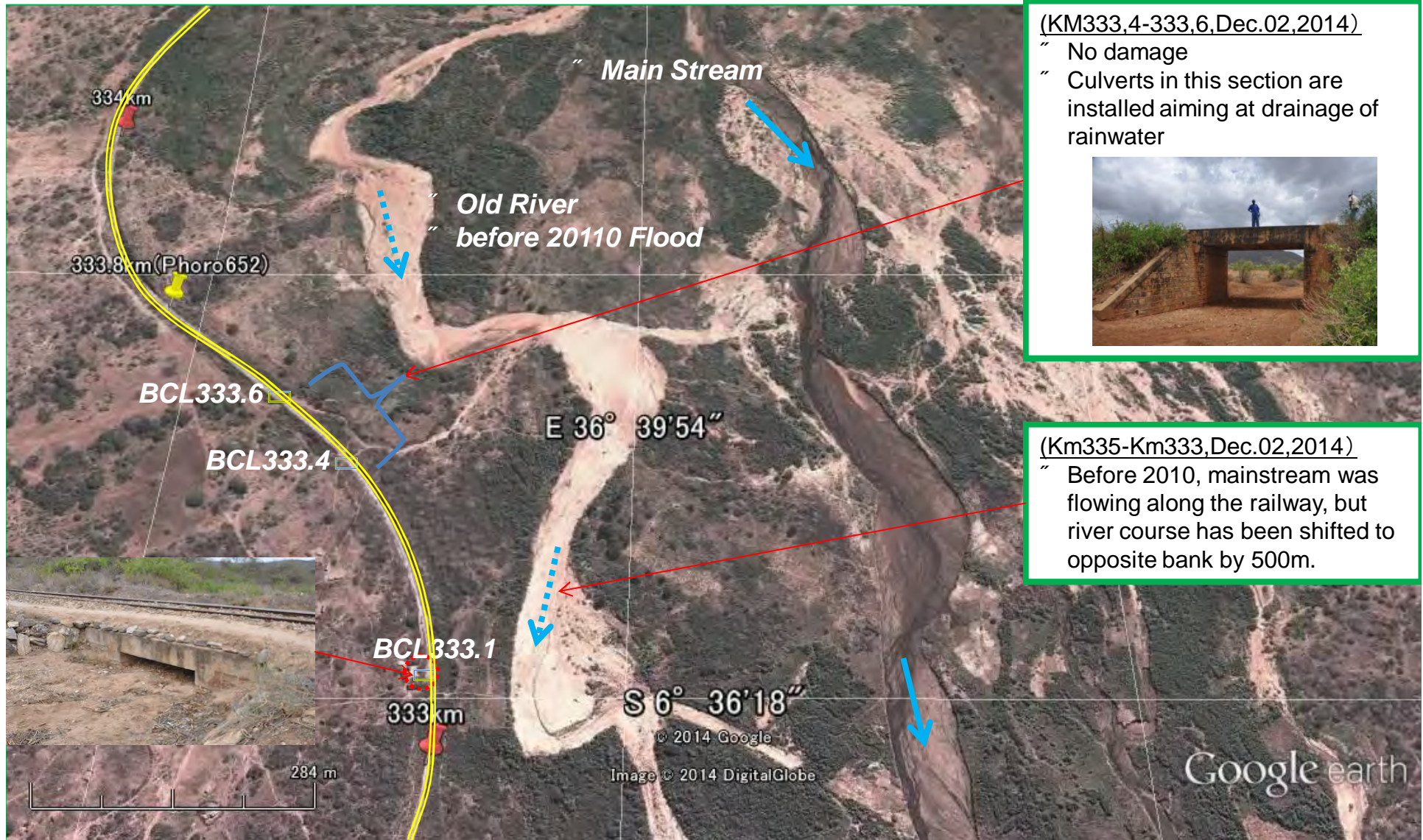

(KM333,4-333,6,Dec.02,2014)

- “ No damage
- “ Culverts in this section are installed aiming at drainage of rainwater



(Km335-Km333,Dec.02,2014)

- “ Before 2010, mainstream was flowing along the railway, but river course has been shifted to opposite bank by 500m.



KM334 – Km335

- ⊙ :Risk Level: Low
- ⊙ :Risk Level: Medium
- ⊙ :Risk Level: High

H-38

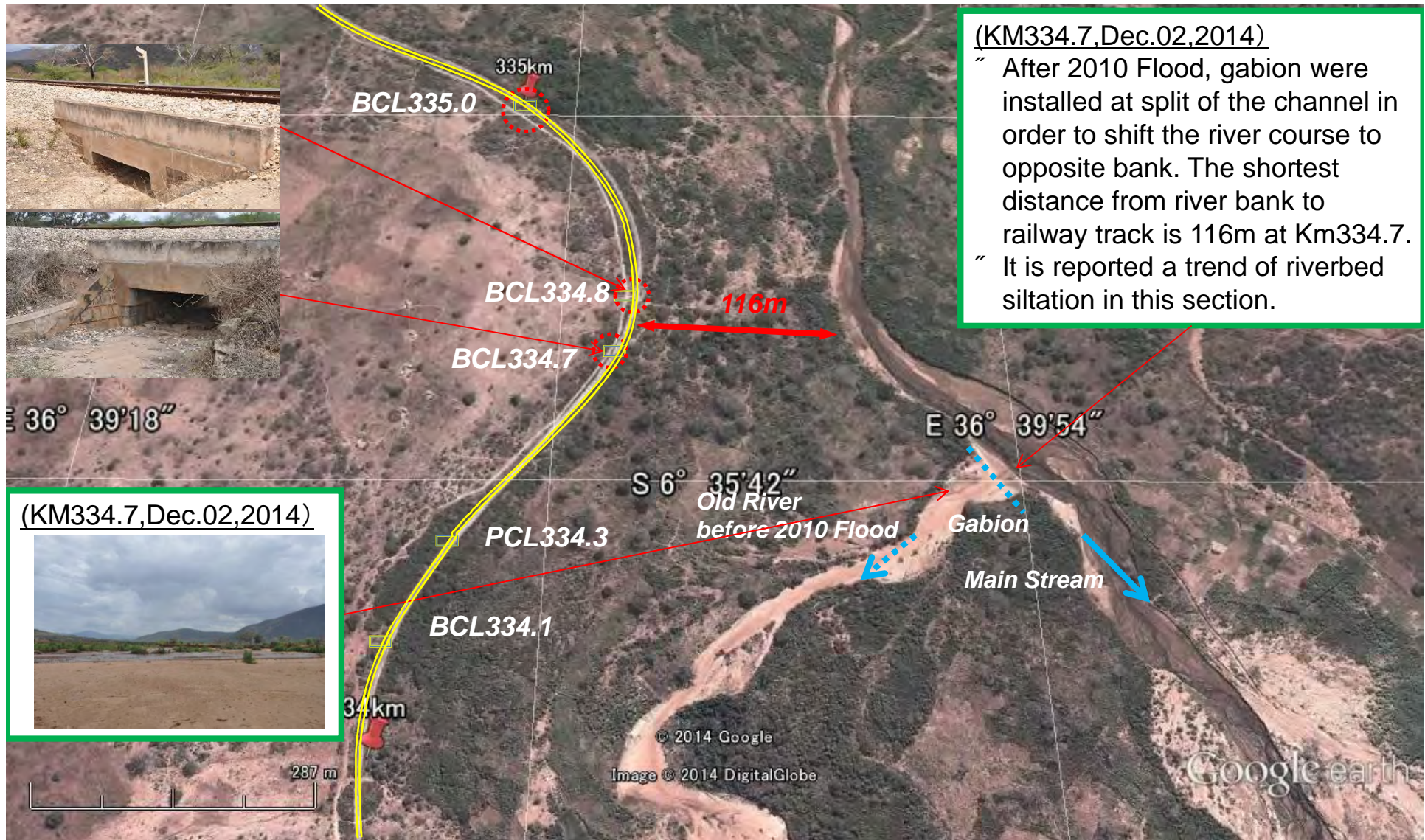

(KM334.7, Dec.02, 2014)  
 " After 2010 Flood, gabion were installed at split of the channel in order to shift the river course to opposite bank. The shortest distance from river bank to railway track is 116m at Km334.7.  
 " It is reported a trend of riverbed siltation in this section.

(KM334.7, Dec.02, 2014)

© 2014 Google  
 Image © 2014 DigitalGlobe

Google earth



KM335 – Km336

- :Risk Level: Low
- :Risk Level: Medium
- :Risk Level: High

H-39





KM336 – Km337

○ :Risk Level: Low

○ :Risk Level: Medium

○ :Risk Level: High

H-40

(KM336.1 – 336.5 Dec.02,2014)  
 " Overflow in past flood at BCL336.3, but no damage  
 " Culverts in this section are installed aiming at drainage of rainwater  
 " As no culvert exists at KM336.5, a Gang requests to install a culvert

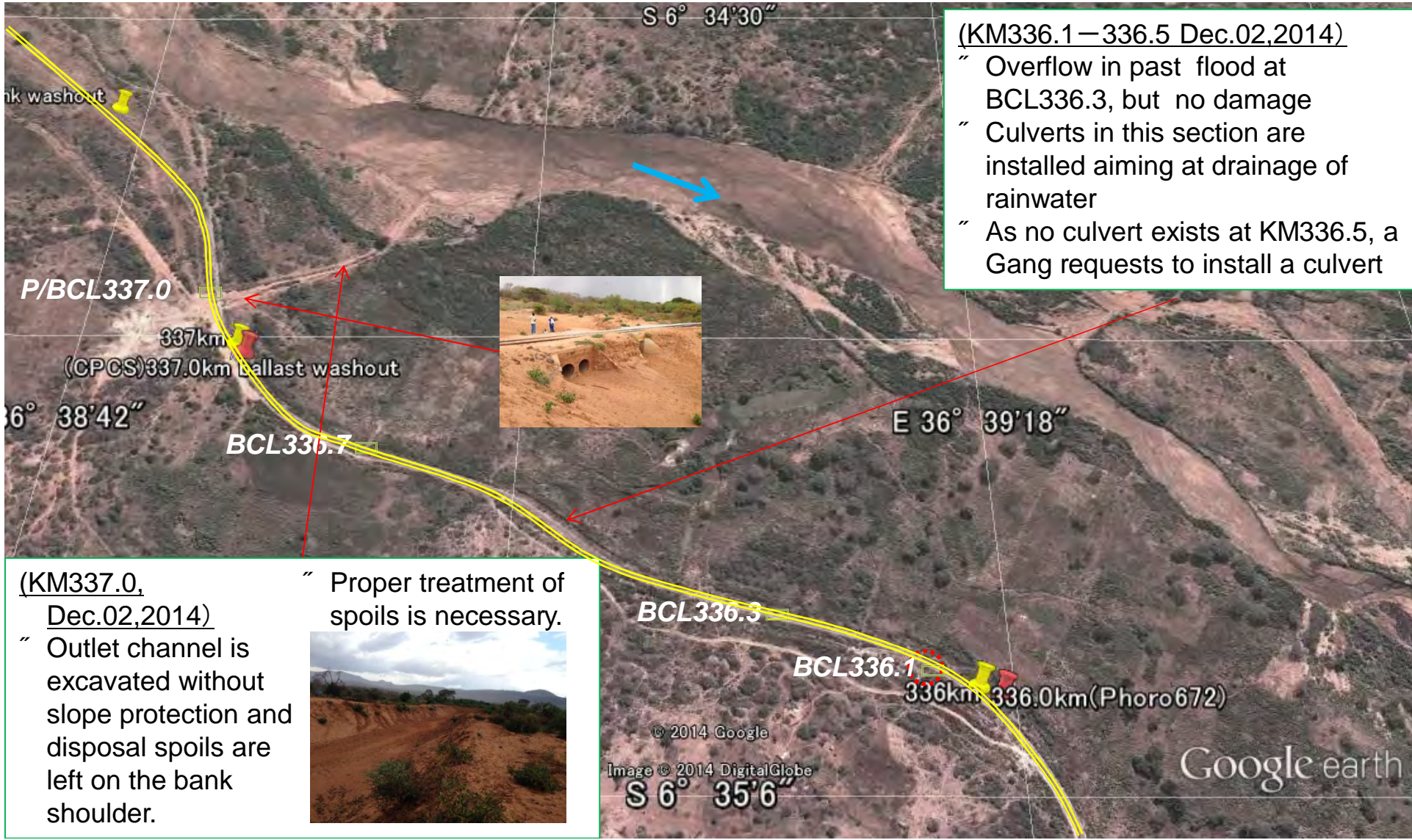

(KM337.0, Dec.02,2014)  
 " Outlet channel is excavated without slope protection and disposal spoils are left on the bank shoulder.  
 " Proper treatment of spoils is necessary.





KM337 – Km338

○ :Risk Level: Low

○ :Risk Level: Medium

○ :Risk Level: High

H-41

(KM337.2-337.7, Dec.2, 2014)

- " At present, serious bank erosion is observed in this section.
- " Height of river bank is 4.5m and the shortest distance from river bank to railway track is 18 m.
- " There is a possibility to be damaged during next rainy season.
- " -It is recommended to conduct an urgent measure in the section between Km337.2 an Km337.7.

(KM337.2-337.7, Dec.2,2014)

- For a long term measure, it is possible to divert the railway track to land side as there is a wider and flat space in mountain side of the track.



Google earth



# KM349 1A (Godegode Station) – KM349 4B

○ :Risk Level: Low

○ :Risk Level: Medium

○ :Risk Level: High

H-42

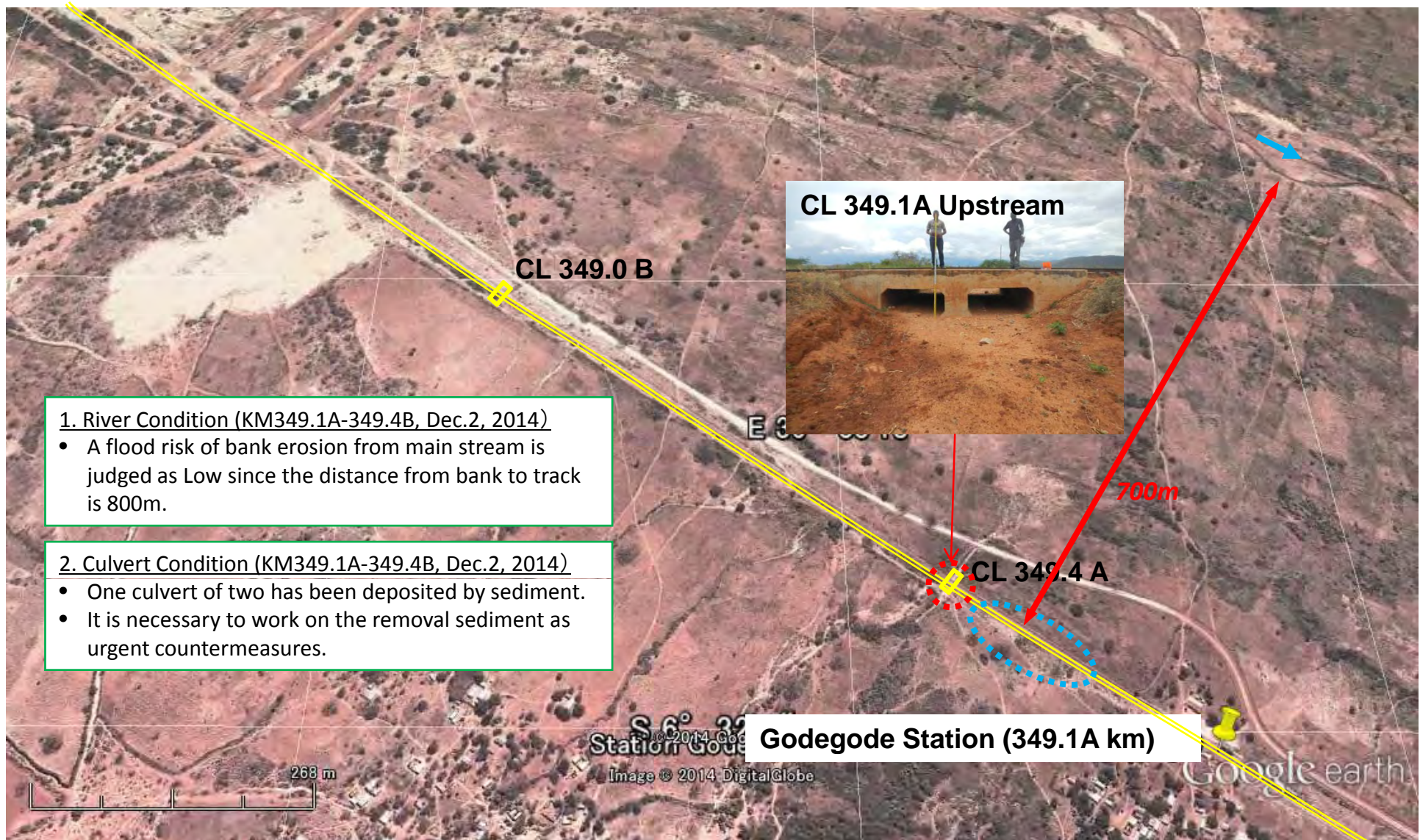



 :Risk Level: Low

 :Risk Level: Medium

 :Risk Level: High

H-43



1. River Condition (KM349.4B-349.9B: Dec.2, 2014)

- A flood risk of bank erosion from main stream is judged as Low since the distance from bank to track is 800m and the bank height is 3m.

2. Tributary Condition (KM349.4B-349.9B: Dec.2, 2014)

- Culverts of the railroad have been deposited by the sediment in the tributary MASUWALA RIVER, and river flow prevention has been occurred (Photo (1)).
- Erosion at the left-bank side right upstream of culvert has been occurred due to flow prevention of culvert, and concerned that the waterway will be formed along the railroad. Countermeasures such as bank protection at the left-bank side are necessities (Photo (2)).
- A culvert of the new road caught the floating logs and flow prevention has been occurred. (Photo (3)). The railroad bank has been scored by the overflow every year. The countermeasures on sediment outflow control or railroad heighten, etc. are required.
- The culverts of the old road along the railway are almost filled out by sediment due to shortage of the section and the height. However, the old road will be removed after the new road completion of now under construction (Photo (4)).

3. Maintenance Issue

- The dredged sediment had been banked both side of channel.
- It is concerned that the dredged sediment release to channel.





# KM349.9B – KM349.9C

-  :Risk Level: Low
-  :Risk Level: Medium
-  :Risk Level: High

H-44

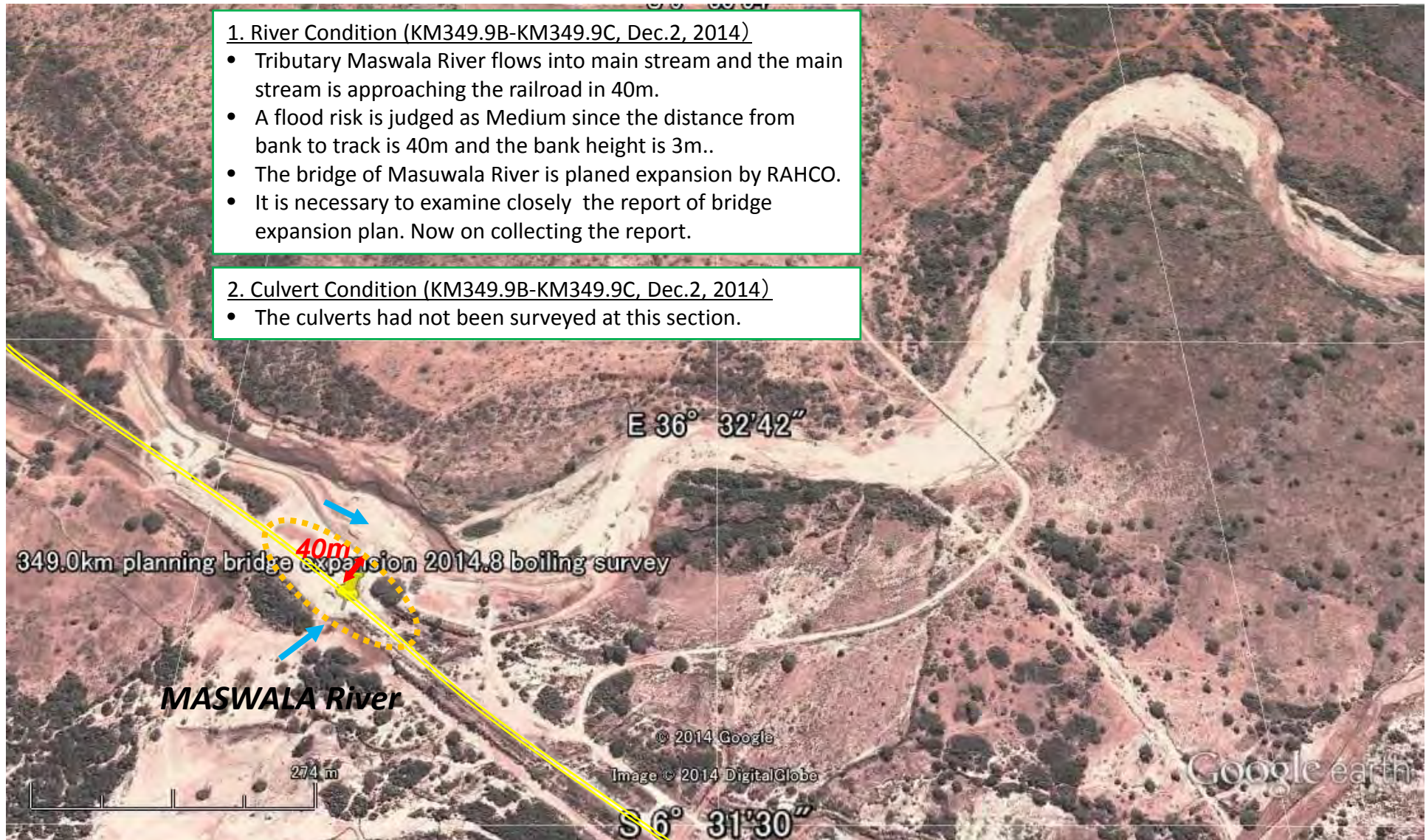



# KM349.9C – KM350

 :Risk Level: Low

 :Risk Level: Medium

 :Risk Level: High

H-45

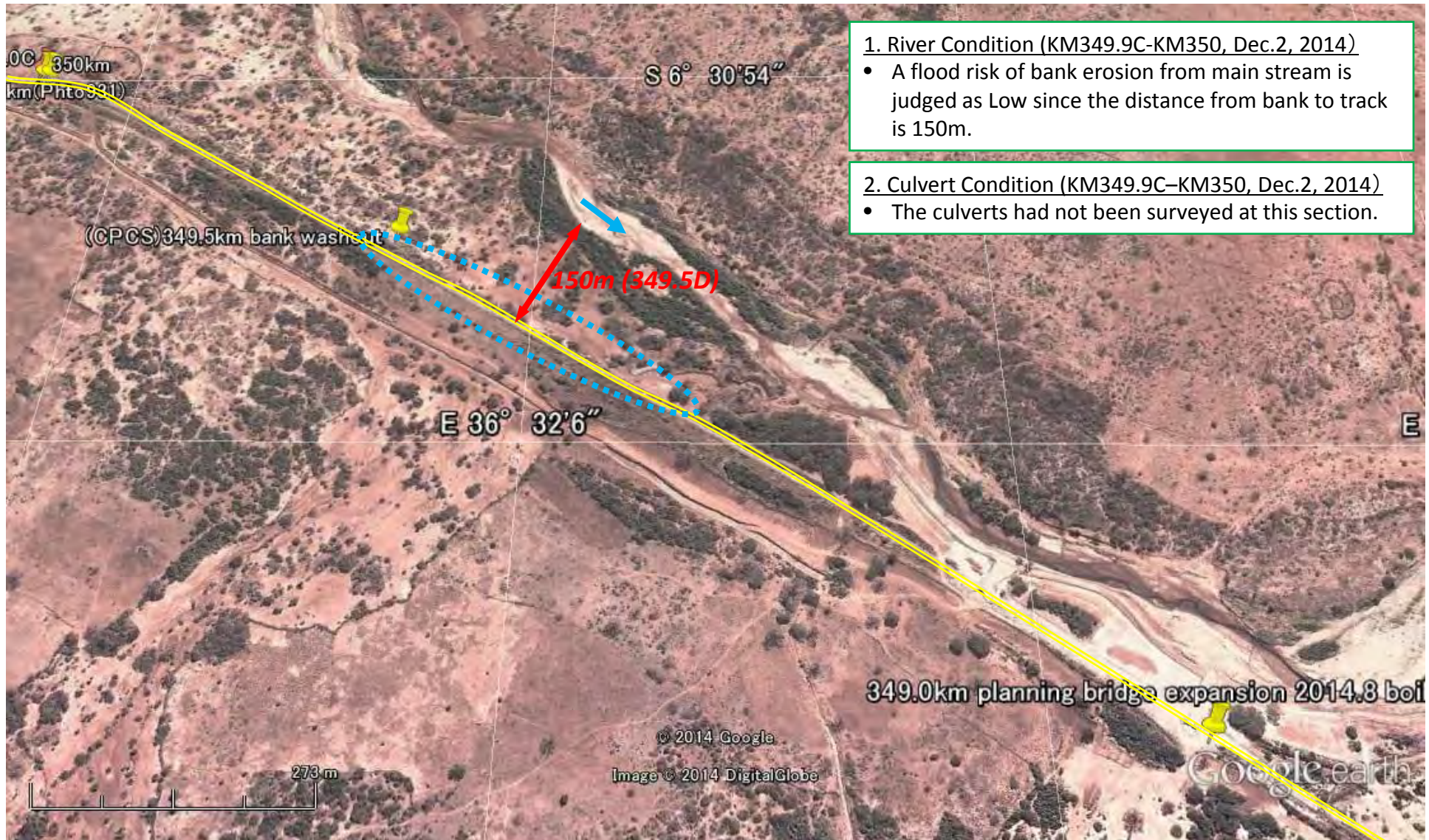

1. River Condition (KM349.9C-KM350, Dec.2, 2014)

- A flood risk of bank erosion from main stream is judged as Low since the distance from bank to track is 150m.

2. Culvert Condition (KM349.9C-KM350, Dec.2, 2014)

- The culverts had not been surveyed at this section.



# KM350 – KM351

-  :Risk Level: Low
-  :Risk Level: Medium
-  :Risk Level: High

H-46

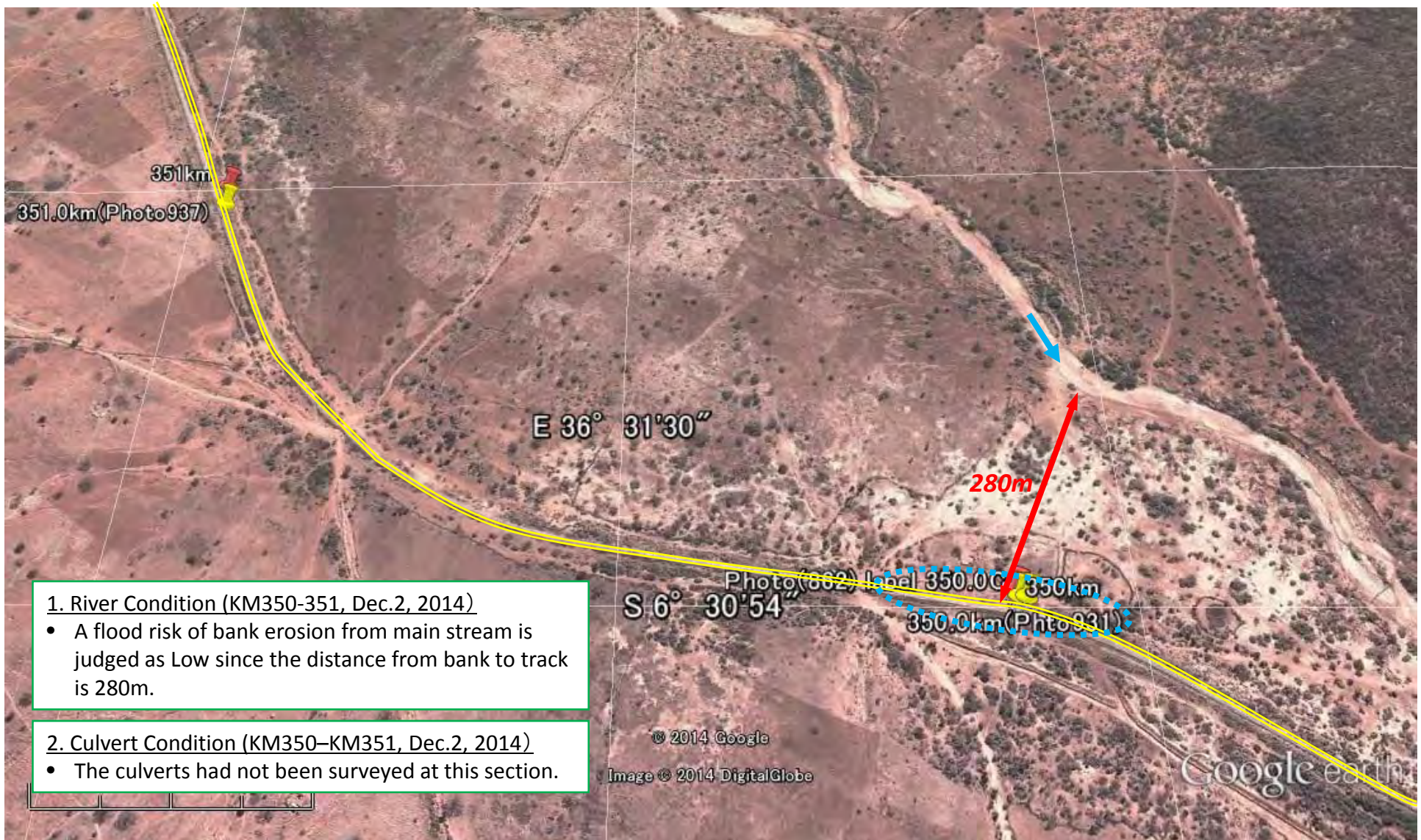



# KM351 – KM352

 :Risk Level: Low

 :Risk Level: Medium

 :Risk Level: High

H-47

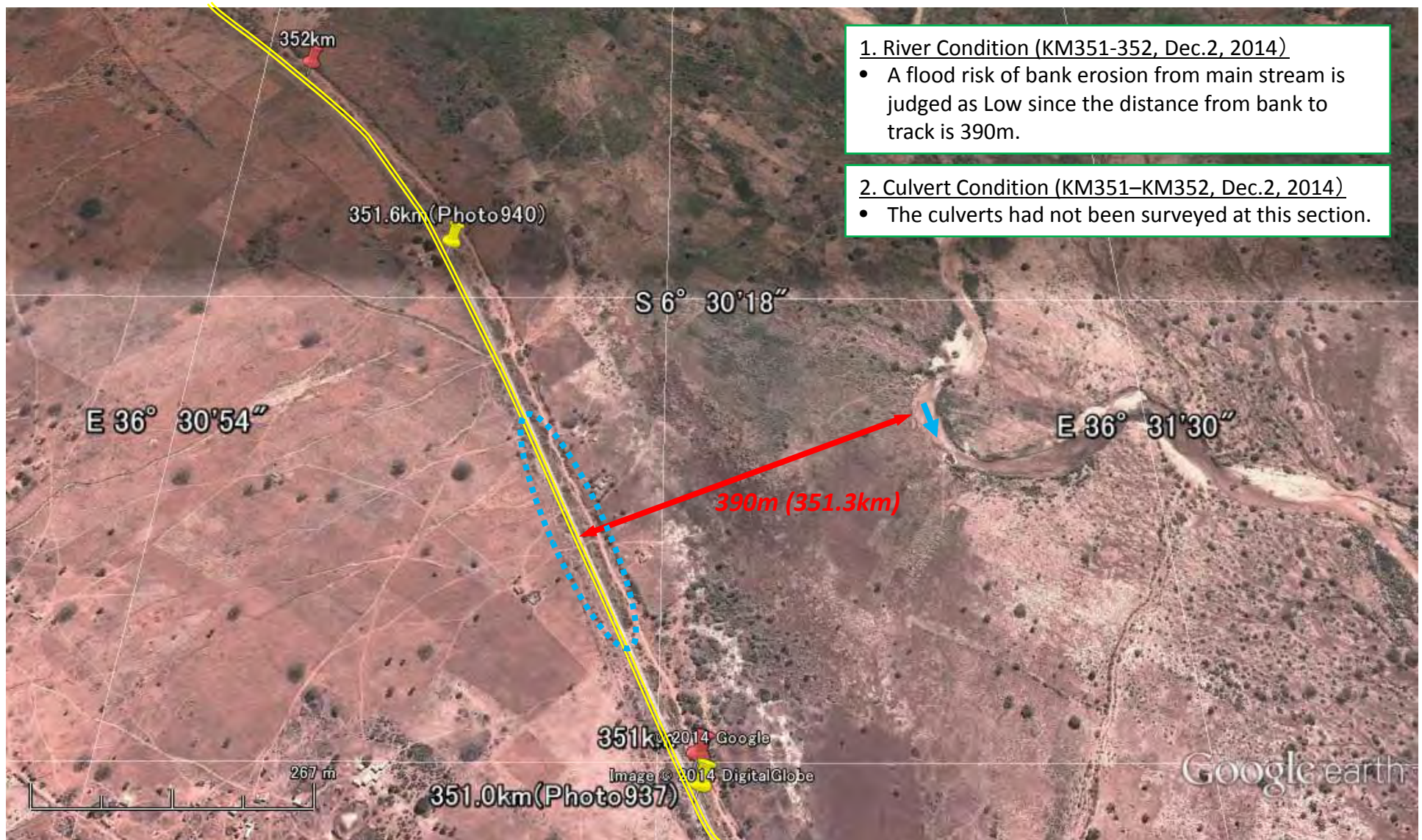



KM352 – KM353

○ :Risk Level: Low

○ :Risk Level: Medium

○ :Risk Level: High

H-48

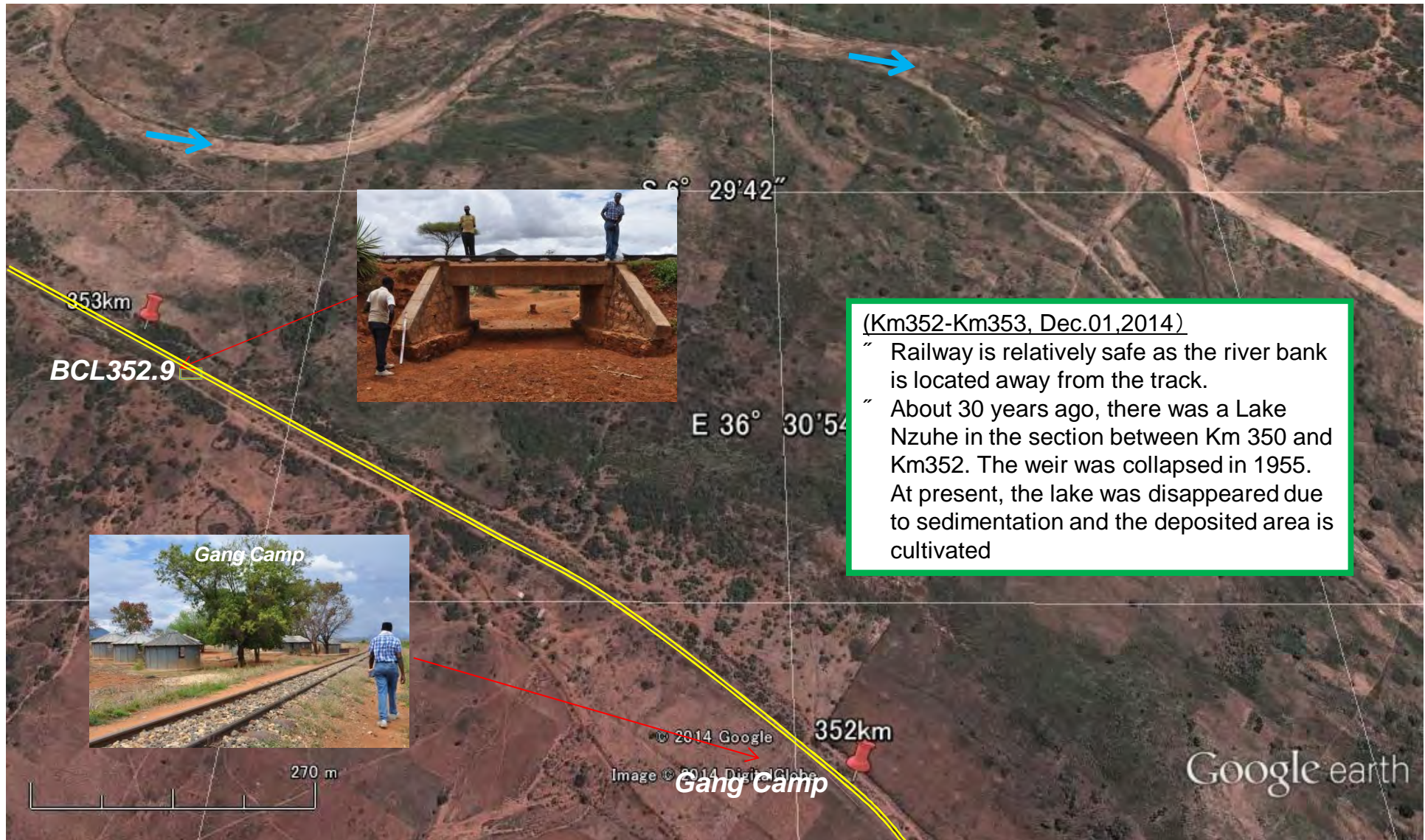



KM353 – KM354

○ :Risk Level: Low

○ :Risk Level: Medium

○ :Risk Level: High

H-49





KM354 – KM355

-  :Risk Level: Low
-  :Risk Level: Medium
-  :Risk Level: High





# KM355 – KM356

(Km353.6, Dec.01,2014)

- At the confluence of Kidivo River, construction of guide dike (around L=200m) is on-going.
- Guide dike constructed in the middle of river channel should be protected by toe and slope protection works so that it will sustain against erosion and scouring during flood.

 :Risk Level: Low

 :Risk Level: Medium

 :Risk Level: High



(Km353.6, Dec.01,2014)

- Bank protection of SSP at left bank downstream of the bridge is tilted due to pressure of back soil. It should be urgently repaired. Existing gabion (3 steps) installed at transition between SSP and original river bank at the confluence can be heightened to protect from over topping.

H-51