

Republic of India

Bihar State Power Generation Company Limited

Republic of India

**Preparatory Survey on
Barauni Supercritical Thermal Power
Project**

Final Report (3/4)

JICA LIBRARY



1226228 [3]

June 2016

**Japan International Cooperation Agency
(JICA)**

Kyushu Electric Power Co., Inc.

4R

CR(3)

16-016

LIST OF ANNEXURES

LIST OF ANNEXURES

Annexure - I	Soil Investigation and Topographical Survey	410
Annexure - II	Geo-Technical Investigation / Geo-Hydrological Study	442
Annexure - III	ESIA report (Draft)	808
Annexure - IV	Land Acquisition Due Diligence Report	1258
Annexure - V	Resettlement Action Plan Framework	1295
Annexure - VI	Stakeholders Engagement Plan (Draft)	1365
Annexure - VII	Initial Environmental Evaluation of Transmission line Project (Draft)	1371
Annexure - VIII	Drainage Study	1413
Annexure - IX	Railway Siding Feasibility Study	1415
Annexure - X	Tariff Calculation	1490

ANNEXURE - I

SOIL INVESTIGATION AND TOPOGRAPHICAL SURVEY

**TOPOGRAPHIC SURVEY REPORT
FOR
(ASH DYKE AREA, PIPE CORRIDOR, INTAKE,
WATER RESERVOIR)**

**RELATED TO
THE PREPARATORY SURVEY FOR
CONSTRUCTION OF
BARAUNI SUPER CRITICAL COAL FIRED
THERMAL POWER STATION
(UNIT#10)
OF
BIHAR STATE POWER GENERATION COMPANY LTD.
CONSULTANT**

steag



STEAG Energy Services India Pvt. Ltd.

(Formerly Evonik Energy Services India Ltd.)

(A wholly owned subsidiary of Steag Energy Services GmbH, Germany)

A-29, Sector-16, NOIDA-201301, India

DECEMBER 2015

Information about the Project

SL. No.		
1	Name of the Project	TOPOGRAPHIC SURVEY AND GEOTECHNICAL INVESTIGATION FOR BARAUNI COAL FIRE SUPER CRITICAL THERMAL POWER PLANT
2	Main client	Bihar State Power Generation Company Limited
3	Main Contractor	KYUSHU ELECTRIC POWER CO. INC.
4	Sub Contractor	STEAG Energy Services (India) Pvt. Ltd.
5	Date of start	12 th May, 2015.
6	Date of Completion	17 th June, 2015.
7	Total area	431.25Hectares

TABLE CONTENTS

SECTIONS	PAGE
1.0 INTRODUCTION.....	4
2.0 ABOUT THE AREAS.....	4
3.0 SCOPE OF WORK	5
3.1 TECHNICAL SPECIFICATION OF TOPOGRAPHICAL & CONTOUR SURVEY WORKS	5
3.2 BOUNDARY LINES.....	6
3.3 HORIZONTAL AND VERTICAL CONTROL.....	6
3.4 SPOT LEVELS AND OTHER LEVELS	8
3.5 REQUIREMENT OF GRID, CONTOURS, SECTIONS ETC.....	8
4.0 SURVEY METHODOLOGY	9
5.0 SURVEY DATA	10
6.0 DATA PROCESSING	10
7.0 OUTPUT MAPS.....	10
8.0 CONCLUSION	11
ANNEXURE-I	12
ANNEXURE -II.....	133
BOUNDARY PILLAR TABLE.....	14

1.0 INTRODUCTION

Topographic survey work is carried out for water intake area, fresh water reservoir area, ash dyke area and ash transport pipe corridor. This topographic survey work was carried out from 12th May, 2015 to 17th June, 2015. Topographic survey works of these areas are required to start construction works of Coal fire Barauni Super Critical Thermal Power Plant unit no: 10. Survey work was started from water intake area and reservoir near river Ganga. Next, topographic survey work was conducted at Ash pond area and pipe corridor. Ash pond is the largest area of all the areas covering an area of 371.82 hectares, taking a buffer of 10m from the kutcha roads surrounding the area. This area also covers four villages namely Kasaha Diara, Dumra Diara, Vijaygarh and Sitarampur. Most of the areas are agriculture land and some areas are settlement. From this survey, detail maps of these areas are prepared. Not only detail map Contours were also generated from the ground levels surveyed.

2.0 ABOUT THE AREAS

The areas which are survey can be grouped into two groups. 1. Intake and Water reservoir area at Village Simariya. These two areas are attached to each other and are located in the flood plains of river Ganga, therefore the area is totally plain and monotonous. An artificial levee is passing through in the project site near river Ganga. Height of this artificial levee is about 5.3m in average from the ground. The area is flooded by monsoon rain at every 3-4 years. A railway track is passing through at about 680m away from the project site from North east to south west direction. This railway line is connecting between Barauni Junction and Begusarai. The area is very near to Simariya Ghat a worshipping place for Hindu at river Ganga. The area is extended between longitude degree 85°59'38.97" and 86°00'13.23", Latitude degree 25°23'03.83" to 25°23'34.21".

In this area group, two areas of Ash Dyke and ash transport pipe corridor include.

Ash dyke area is surrounded by kutcha roads from all directions. Total area of Ash Dyke area is 371.82 hectares including 10m buffer from the kutcha roads. In this area, four villages namely Kasaha diara, Dumra Diara, Vijaygarh and Sitarampur are located. Dumra diara is the largest village amongst them. Size of the total survey area is increased by 167.82 hectares because of possibility of shifting the ash pond area towards north east direction, towards village Dumra. This is because of strong objection by the villagers of Kasaha diara and Sitarampur. This area is mainly agricultural land, plain in nature, ground level hardly change above 3m in entire area. Isolated and very small forested area is available in the area. Majority of the houses are Kutcha. No important worshipping place or any historically important monuments is located in the area. The pipe corridor connects with this ash dyke area at Village Vijaygarh at the North West. Pipe corridor is a 60m wide corridor which comes out of the power plant at eastern side at village Malhipur. The Aerial distance or pipe corridor distance is 2.5km from the power plant passing through two villages namely Vijaygarh and Malhipur.

All the villages mention here are sparsely populated hamlets. Ash dyke area is located between Latitude degree 25°21'10.17432" to 25°22'26.91032" and longitude degree 86°02'20.83726" to 86°03'51.18601".

3.0 SCOPE OF WORK

3.1 TECHNICAL SPECIFICATION OF TOPOGRAPHICAL & CONTOUR SURVEY WORKS

3.1.1 Scope

The scope covers all the work for conducting site survey using “Total Station” instruments for the total land area which is 201 Ha of Ash pond area, 18 Ha of Water Intake area (at river Ganges), 33 Ha of raw water reservoir area and 60m width of route survey along ash pipe corridor (2.5km). The scope also covers preparation of detailed drawings on the basis of the survey carried out by the Consultant and collated information gathered by the Consultant all as detailed in the Tender document and as directed by Engineer in charge. The scope also includes preparation of a detailed survey report, and recommendation.

The scope of work also includes mobilization of necessary instruments and equipment providing necessary skilled, semi-skilled and unskilled personnel, conducting all the field and design office work and preparation of detailed drawings and reports all as required for the successful completion of the work.

The brief scope of work for different areas as mentioned shall generally cover but not limited to the following

- a) Marking of boundary between Baruani Thermal Power Station and other owners
- b) Locating the existing and/ or under construction structures of Unit 6-9 of the station within the area to be surveyed
- c) Contouring of the whole scope area.
- d) Locating all structures, nallah, ponds, transmission towers and poles, pipelines, roads, culverts, graveyard or any other structures etc. existing within scope area and dimensioning the same.
- e) Locating all approaches to the area, structures, buildings, nallah, ponds, transmission lines and poles existing nearby, those may have a bearing on construction of the plant; dimensioning these.
- f) Developing cross sections of the existing nallah and discharge channels
- g) Clearing of small plants, bushes & debris and (to the minimum extent as required for the work and as per instruction of the Client) etc. shall also form a part of the scope of work.
- h) Determination of latitude and longitude for the project area.

3.1.2 Technical Specification for Survey Works

The technical details for the survey works to be carried out for the scope of works as mentioned hereinabove shall be as follows. This is basically a detailed technical description for survey works and form a part of scope of work.

- a) To demarcate the plant and existing Ash Pond areas and check Boundary Pillars at site in co-ordination with Engineer in charge and as well as representatives of other agencies as applicable. Lengths and bearings with respect to the Magnetic North of each Boundary line shall be determined.
- b) To establish a Baseline, with reference to grid lines provided by the Client, within the area being surveyed at suitable location in consultation with the Engineer in Charge and determination of its bearings with respect to the True (geographic) North as well as the Magnetic North.
- c) To establish and construct permanent Benchmarks on site at locations to be indicated by the Engineer in Charge. These shall be tied to the nearest authenticated

- GTS/Survey of India Benchmark or reference benchmarks provided by the Client.
- d) For Ash Pond area, reference baseline and benchmarks has to be transferred from plant Area (approx. 2km distance) and similarly for Ash Pipe corridor also which connects the main Plant area to the Ash Pond.
 - e) For raw water intake and reservoir area, reference baseline and benchmarks has to be transferred from plant Area (approx. 4.5km distance) and similarly for raw water pipe corridor also which connects the main Plant area to the intake area.
 - f) To establish Horizontal Ground Control Points including those defining the baseline and demarcate them by permanent pillars within the area by Triangular or Closed Traverse or both based on the nearest GTS/ Survey of India station. These control points shall form the basis of the Site Triangulation Network.
 - g) To determine the latitude and longitude of one of the Horizontal Ground Control Points, decided in co-ordination with the Engineer in Charge.
 - h) To establish a Site Co-ordinate Grid at specified intervals as per clause 6.7, incorporating the established baseline. Each intersection grids shall be demarcated by a grid pillar with the co-ordinate engraved on the plate.
 - i) To survey and determine the ground levels and map (incorporating contour and topographic details) of the entire site including land 50 m beyond the boundaries or to the opposite edge of adjoining roads/major rail track whichever is farther, as directed by the Engineer in charge.
 - j) To measure size and depths of wells, nullahs if any, tanks, ponds, etc. within the scope area, temperature of water in these and simultaneously recording the ambient temperature and the time of the day and the date. Levels of the ground at the well locations shall be specifically taken and recorded. The survey shall also record bed levels including lowest invert of the nullahs if any.
 - k) To obtain Highest High Flood Levels and Lowest Low Water Levels of nullahs; overflow levels and lowest levels of ponds levels, etc. and high and low tide levels as applicable.
 - l) To record clearance below bridges, telephone lines, transmission lines, etc. at the lowest point of the catenary.
 - m) To identify and mark on the Survey Drawings places of worship, tombs, relics of archaeological importance, trees with girth more than 300 mm at 1 m above ground level, transmission lines and towers, telephone/telegraph lines and poles, power and lighting poles, trenches, identified underground services, all permanent and temporary structures, etc. Temporary structures shall be indicated separately.
 - n) To locate any other existing structures with their dimensions including its height coming in the scope area.

3.2 BOUNDARY LINES

Boundary lines of the land plot, shall be physically established at site by Closed Traverse with a precision theodolite at all bends, turning points and at intermediate points of the boundaries located not more than 100 m as shown on the drawing or as directed by the Engineer in charge. The sub-contractor shall establish co-ordinates of each of these Boundary Pillars with respect to the Site Co-ordinate Grid. Bearings of all boundary lines shall be established with respect to the Magnetic North. The general directions of the next Boundary Pillar on either side shall also be etched on the plate. For straight stretches of lengths exceeding 100 m, Boundary Pillars shall be established at every 100 m interval. The establishment of such pillars shall apply in case of roads, railway alignment and pipe-cable routes also.

3.3 HORIZONTAL AND VERTICAL CONTROL

Horizontal control and vertical control of the topographic survey being carried out shall be with reference to the nearest GTS control pillars and benchmarks of the Survey of India / reference gridlines and benchmark pillars provided by the Client. These GTS

control pillars / reference gridlines and benchmark pillars provided by the Client shall be the basis for the Baseline on the site being surveyed. The levels from such benchmarks shall be transferred to the site being surveyed either on a permanent and firm feature or on a pillar as specified and specially erected for the purpose.

In case there are existing Control Points at the site being surveyed or near the site, the same shall be identified and a preliminary survey shall be carried out to check their correctness. All such control points shall be identified and demarcated in the area plan.

Horizontal Control shall be fixed by either any or a combination of Triangulation Method or Closed Traverse Method or as directed by the Engineer in charge. All angles shall be measured by theodolite only. In case of the Traverse Method distance between any two consecutive traverse stations shall not exceed 100 m.

The Baseline shall first be conveniently defined at site by a series of Control Pillars. The length of the Baseline shall be at least 100 m. The baseline shall be the basis of an orthogonal co-ordinate system for the site. Hence, the Baseline shall be oriented as directed by the Engineer in charge.

The Baseline shall then be established with respect to the GTS Control Point Pillars / reference gridlines and benchmark pillars provided by the Client.

The Bearing of the Baseline shall be determined with respect to the Magnetic North. While determining the Magnetic North, the Consultant shall ensure minimum interference from external factors such as transmission lines, telephone line, significant metal objects, etc. Any error due to such interference shall be rectified. Vertical control points shall be established by theodolite and level on all Triangulation or Closed Traverse Stations. The vertical control shall be closed by returning the traverse to the starting point.

Features that shall be incorporated in the Land Survey shall include, but shall not be limited to the following:

- a. Buildings, houses, huts, other structures
- b. Compound walls, fencing, gates, etc.
- c. Places of worship
- d. Burial grounds, isolated graves, cremation grounds
- e. Transmission lines, towers, poles and power transformers
- f. Microwave towers
- g. Underground utilities
- h. Cable (buried or above ground)
- i. Pipelines (buried or above ground)
- j. Telephone lines and poles
- k. Road side lighting poles and cables
- l. Highways, pucca topped roads, macadam roads, dirt roads
- m. Cart tracks, pathways, causeways
- n. Railway tracks if any
- o. Culverts, bridges, cross drainage, open wells, bore wells, pumps
- p. Underground water tanks, overhead water tanks
- q. Cultivated areas;
- r. Rock outcrops;
- s. Channels, drains, nallah if any
- t. Ponds, lakes, reservoirs and any natural or man-made water body
- u. Marshy areas
- v. Bunds, dykes, levees, embankments, weirs, dams

- w. Trees of girth more than 300 mm measured at 1000 mm above ground level, orchards, grooves, etc.
- x. All temporary structures

The details shall incorporate inter alia all the above features which adjoin the plot or have any approach path or right of way adjacent to or through the plot or are located up to about 50 m from the plot boundary or to the opposite edge of adjoining roads, rail tracks, boundary walls or major structures whichever is farther as directed by the Engineer in charge.

The list given above shall not be construed as being exhaustive and complete and the Consultant shall include all features in the Survey Drawings and Maps with their proper sizes (dimensions), elevations or depths, co-ordinates and bearings, names of places, road numbers or names, etc.

3.4 SPOT LEVELS AND OTHER LEVELS

Spot level if any shall be taken at nodes on grids as mentioned in clause 6.7. The grid shall essentially be perpendicular and parallel to the established Baseline. A finer grid shall be plotted in the field drawing. Contours shall also be drawn in the field and their trend checked in situ with the general ground profile and terrain.

3.5 REQUIREMENT OF GRID, CONTOURS, SECTIONS ETC.

The Consultant shall establish one Base Line in consultation with the Engineer in charge. The bearing of the base line shall be in the direction of the plant North-South or plant East-West. The base line shall be identified and marked permanently by Benchmark Pillars.

Gridlines shall be established in two orthogonal directions with grid distance as mentioned in below table in either direction. Grid pillars shall be established with co-ordinates and RL written on the top to serve as permanent reference.

The reference pillars shall be of PCC structure founding minimum 1.5 meter depth from ground level with minimum 0.5meter projection from ground level. The size of pillars shall be as shown in the drawing.

The grid pillars/ boundary pillars shall be of PCC structure founding minimum 0.5 meter depth from ground level with minimum 0.3 meter projection from ground level. The size of pillars shall be as shown in the drawing.

Location of the pillars shall be such that these should cover a minimum of four pillars, two in each orthogonal direction.

Concrete for reference pillars shall be of mix 1:2:4 (one cement: two coarse sand: four 20 mm down stone aggregates) and those for boundary demarcation shall be in P.C.C. 1:2:4. All the component materials shall be of best and acceptable quality and conforming to the provisions of the latest version of the Indian Standards.

Steel plates for engraving B.M. value and reference grids shall be of mild steel, conforming to IS: 2062.

The entire area shall be surveyed and contours developed. However, unevenness of ground shall be appropriately covered by taking spot levels at closer intervals wherever required. Contour drawings shall be drawn to a scale as with this specification and shall

identify and depict all prominent features and details with their sizes, bearings and coordinates.

Cross-Sections of the alignment of roads, railway lines and power lines shall be developed as mentioned later in this clause or at every 25 m for cross distances of 10 m on either side of the centerline. For ash/ pipe and coal conveyer and transmission line corridor, the route survey shall be done at 25 m longitudinal interval with cross section developed on each side of the centerline as per the available corridor (half width or 15 m whichever is less i.e. total maximum width 30 m) .

4.0 SURVEY METHODOLOGY

This was conducted applying all the technical specification mentioned in the work order. Ground level was transfer from nearest Permanent Bench Marks established by government approved departments. A pair of Temporary Bench Marks is established using Differential Global Positioning System (DGPS) for each site **See Photo no: 1**. the following table shows list of Temporary Bench Marks established on the different sites.

Projection: UTM Datum: WGS 84 Everest Zone: 45 North

SL. No.	TBM No.	LOCATION	EASTING	NORTHING	ELEVATION (METER)
1	B.M-1	Water Intake area	398976.7139	2808320.5782	38.838 RL
2	B.M-2	Water Intake area	399058.8627	2808369.6602	38.231 RL
3	B.M-3	Water Reservoir	399343.2300	2808503.1666	38.246 RL
4	B.M-4	Water Reservoir	399365.5894	2808575.8493	38.357 RL
5	B.M-5	Ash pond area	403420.4223	2805382.1716	42.78627MSL
6	B.M-6	Ash Pond area	403471.3439	2805452.4024	42.74264MSL
			LATITUDE	LONGITUDE	
1	B.M-1	Water Intake area	25°23'17.7540"	85°59'44.6214"	38.838 RL
2	B.M-2	Water Intake area	25°23'19.3704"	85°59'47.5478"	38.231 RL
3	B.M-3	Water Intake area	25°23'23.7768"	85°59'57.6876"	38.246 RL
4	B.M-4	Water Intake area	25°23'26.1456"	85°59'58.4682"	38.357 RL
5	B.M-5	Ash pond area	25°21'43.3008"	86°02'24.3878"	42.78627MSL
6	B.M-6	Ash pond area	25°21'45.5940"	86°02'26.1916"	42.74264MSL

Table no: 1 **List of Temporary Bench Marks Established at Different site**

These TBMs are connected with Permanent Bench Marks by Closed traversing Method. Level is transferred by using auto levels with proper closing. The following table shows instruments and equipments use in establishing TBMs, traversing and transferring of levels from Permanent Bench Marks at Unit 9 and 10.

SL. No.	Instruments	Model no.	No of Instruments	Equipments	Purpose
1.	DGPS	Trimble R3	2	Tripods	Establishing TBMs
2.	ETS	Topcon 235N	1	2Prisms	Traversing
3	ETS	Topcon 235N	1	2 Prisms	Ground levels
4	Auto level	Sokkia	1	Tripod, Staff	Transferring level

Table No.2 List of Instruments used in this survey work.

TBMs are established using concrete pillars as specified on technical specification.

Photo no.1 shows DGPS establishing a TBM.

After establishing these TBMs ground levels were picked up at the interval of 10m by close traversing method. **Photo no.2 shows ground level survey.**

5.0 SURVEY DATA

The data which is captured by DGPS is in the form of DAT or To2 file format which after downloading and processing is can be saved as *ESIR shape files* or *Auto Cad DWG files*.

The data captured by Electronic total Station is in the form of csv. file format separated the value by coma. This data format can easily be plotted on auto cad software.

6.0 DATA PROCESSING

The DGPS data of Trimble R3 is processed through Trimble Business Centre. Electronic Total Station data does not need to process so it is downloaded using Topcon link software 7.5. After Processing and downloading of survey data, mapping is done using software Auto cad and ESRI software *Arc- GIS 10.2*.

7.0 OUTPUT MAPS

As final output from this survey, we get four different maps for each area. Details of maps for each area is as follows: **Map Plats is attached as Annexure-II**

I. Intake and water Reservoir area

Map Plate no: 1 Detail map of intake and Fresh Water Reservoir Area

Map Plate no: 2 Contour map of Intake and Fresh Water Reservoir Area

Map Plate no: 3 Superimposition of contour over Detail map of Intake and Reservoir Area

Map Plate no: 4 Superimposition of Khasra map over Contour and Detail map of Intake and Reservoir

II. Ash Dyke area

Map Plate no: 5 Detail map of Ash Dyke Area

Map Plate no: 6 Contour map of Ash Dyke Area

Map Plate no: 7 Superimposition of contour over Detail map of Ash Dyke Area

Map Plate no: 8 Superimposition of Khasra map over Contour and Detail map of Ash Dyke area

III. Ash Transport Pipe Corridor

Map Plate no: 9 Detail map of Ash Pipe Corridor Area

Map Plate no: 10 Contour map of Ash Pipe Corridor Area

Map Plate no: 11 Superimposition of contour over Detail map of Ash Pipe Corridor Area

IV. L-Section and Cross Section of Ash Pipe Corridor

Map Plate no.12 L- Section Pipe Corridor

Map Plate no.13 Cross Section of ash pipe corridor

From this survey boundary pillars co-ordinates data in table format is fixed.

Table no. 3 List of Boundary Pillars for Intake and Water reservoir area

Table no: 4 list of boundary Pillars for Ash Pond area

Table no: 5 List of Boundary Pillars for Transport Pipe Corridor.

7.1 ROAD NETWORK IN THE PROJECT SITE:

The approaching road in Intake area i.e. road on embankment is 2.28m wide in half southern portion and half northern portion is 2 m width. The Concrete road of Ash pond area has an average width of 2.5 m and that of Temporary unpaved road is 2m wide. Those roads passing through Pipe Corridor have average width of 2.5 m

8.0 CONCLUSION

From this topographic survey, we are able to generate required information and data about the area on which construction will start in near future. Digital Elevation Model (DEM) is generated from the data collected for all the areas which are surveyed. From this DEM contours of required interval can generate. Detail map about the surface features both artificial and natural is captured also. From these maps, we can plan future course of action and estimation of materials and cost

List of Photographs.



1. Photo no.1 shows DGPS Establishing a TBM.



Photo no.2 Shows Ground Level survey

ANNEXURE -II

- Map Plate no: 1 - Detail map of intake and Fresh Water Reservoir Area**
- Map Plate no: 2 - Contour map of Intake and Fresh Water Reservoir Area**
- Map Plate no: 3 - Superimposition of contour over Detail map of Intake and Reservoir Area**
- Map Plate no: 4 - Superimposition of Khasra map over Contour and Detail map of Intake and Reservoir**
- Map Plate no: 5 - Detail map of Ash Dyke Area**
- Map Plate no: 6 - Contour map of Ash Dyke Area**
- Map Plate no: 7 - Superimposition of contour over Detail map of Ash Dyke Area**
- Map Plate no: 8 - Superimposition of Khasra map over Contour and Detail map of Ash Dyke area**
- Map Plate no: 9 - Detail map of Ash Pipe Corridor Area**
- Map Plate no: 10 - Contour map of Ash Pipe Corridor Area**
- Map Plate no: 11 - Superimposition of contour over Detail map of Ash Pipe Corridor Area**
- Map Plate no: 12- L- Section Pipe Corridor**
- Map Plate no: 13- Cross Section of Ash Pipe Corridor**

Table no: 3

Boundary Pillars with Co-ordinates Pipe Corridor.

Pillar No	Longitude	Latitude
1	86° 1' 49.245" E	25° 23' 23.424" N
2	86° 1' 51.494" E	25° 23' 20.839" N
3	86° 1' 53.742" E	25° 23' 18.253" N
4	86° 1' 55.990" E	25° 23' 15.667" N
5	86° 1' 58.239" E	25° 23' 13.082" N
6	86° 2' 0.487" E	25° 23' 10.496" N
7	86° 2' 2.735" E	25° 23' 7.910" N
8	86° 2' 4.984" E	25° 23' 5.324" N
9	86° 2' 7.230" E	25° 23' 2.738" N
10	86° 2' 9.477" E	25° 23' 0.151" N
11	86° 2' 11.724" E	25° 22' 57.564" N
12	86° 2' 13.971" E	25° 22' 54.977" N
13	86° 2' 16.218" E	25° 22' 52.391" N
14	86° 2' 18.464" E	25° 22' 49.804" N
15	86° 2' 20.711" E	25° 22' 47.217" N
16	86° 2' 22.958" E	25° 22' 44.630" N
17	86° 2' 25.204" E	25° 22' 42.044" N
18	86° 2' 27.451" E	25° 22' 39.457" N
19	86° 2' 29.698" E	25° 22' 36.870" N
20	86° 2' 31.944" E	25° 22' 34.283" N
21	86° 2' 34.191" E	25° 22' 31.696" N
22	86° 2' 36.437" E	25° 22' 29.109" N
24	86° 2' 35.598" E	25° 22' 26.873" N
25	86° 2' 33.504" E	25° 22' 29.287" N
26	86° 2' 31.259" E	25° 22' 31.875" N
27	86° 2' 29.014" E	25° 22' 34.463" N
28	86° 2' 26.769" E	25° 22' 37.051" N
29	86° 2' 24.524" E	25° 22' 39.639" N
30	86° 2' 22.279" E	25° 22' 42.227" N
31	86° 2' 20.034" E	25° 22' 44.815" N
32	86° 2' 17.789" E	25° 22' 47.402" N
33	86° 2' 15.544" E	25° 22' 49.990" N
34	86° 2' 13.299" E	25° 22' 52.578" N
35	86° 2' 11.053" E	25° 22' 55.166" N

36	86° 2' 8.808" E	25° 22' 57.754" N
37	86° 2' 6.563" E	25° 23' 0.342" N
38	86° 2' 4.318" E	25° 23' 2.930" N
39	86° 2' 2.072" E	25° 23' 5.518" N
40	86° 1' 59.827" E	25° 23' 8.105" N
41	86° 1' 57.582" E	25° 23' 10.693" N
42	86° 1' 55.336" E	25° 23' 13.281" N
43	86° 1' 53.091" E	25° 23' 15.869" N
44	86° 1' 50.845" E	25° 23' 18.457" N
45	86° 1' 48.600" E	25° 23' 21.044" N
46	86° 1' 46.355" E	25° 23' 23.632" N
48	86° 1' 46.997" E	25° 23' 26.010" N
47	86° 1' 45.499" E	25° 23' 25.698" N
49	86° 2' 38.565" E	25° 22' 26.707" N

Table no: 4 Boundary Pillars for Ash Pond area

PillarNo	Longitude	Latitude
1	86° 3' 7.408" E	25° 22' 26.976" N
2	86° 3' 8.771" E	25° 22' 23.756" N
3	86° 3' 10.275" E	25° 22' 20.600" N
4	86° 3' 11.694" E	25° 22' 17.405" N
5	86° 3' 13.120" E	25° 22' 14.212" N
6	86° 3' 14.547" E	25° 22' 11.019" N
7	86° 3' 15.922" E	25° 22' 7.804" N
8	86° 3' 17.451" E	25° 22' 4.665" N
9	86° 3' 18.992" E	25° 22' 1.526" N
10	86° 3' 20.502" E	25° 21' 58.373" N
11	86° 3' 22.003" E	25° 21' 55.214" N
12	86° 3' 23.438" E	25° 21' 52.026" N
13	86° 3' 25.122" E	25° 21' 49.054" N
14	86° 3' 26.470" E	25° 21' 45.829" N
15	86° 3' 27.923" E	25° 21' 42.648" N
16	86° 3' 29.281" E	25° 21' 39.429" N
17	86° 3' 30.853" E	25° 21' 36.314" N
18	86° 3' 32.386" E	25° 21' 33.178" N
19	86° 3' 34.054" E	25° 21' 30.107" N
20	86° 3' 35.705" E	25° 21' 27.035" N
21	86° 3' 38.469" E	25° 21' 25.171" N
22	86° 3' 41.019" E	25° 21' 22.960" N
23	86° 3' 43.374" E	25° 21' 20.390" N
24	86° 3' 45.408" E	25° 21' 17.577" N
25	86° 3' 47.662" E	25° 21' 14.904" N
26	86° 3' 49.766" E	25° 21' 12.114" N
27	86° 3' 51.008" E	25° 21' 9.599" N
28	86° 3' 47.597" E	25° 21' 8.851" N
29	86° 3' 44.129" E	25° 21' 8.837" N
30	86° 3' 40.653" E	25° 21' 9.220" N
31	86° 3' 37.167" E	25° 21' 9.480" N
32	86° 3' 33.696" E	25° 21' 9.325" N
33	86° 3' 30.390" E	25° 21' 8.271" N
34	86° 3' 26.902" E	25° 21' 8.154" N
35	86° 3' 23.440" E	25° 21' 7.680" N
36	86° 3' 20.000" E	25° 21' 7.074" N
37	86° 3' 16.512" E	25° 21' 7.282" N
38	86° 3' 13.029" E	25° 21' 7.158" N

39	86° 3' 9.563" E	25° 21' 6.760" N
40	86° 3' 6.176" E	25° 21' 6.799" N
41	86° 3' 3.398" E	25° 21' 8.922" N
42	86° 3' 0.576" E	25° 21' 10.987" N
43	86° 2' 57.759" E	25° 21' 13.059" N
44	86° 2' 54.885" E	25° 21' 15.039" N
45	86° 2' 51.785" E	25° 21' 16.657" N
46	86° 2' 48.696" E	25° 21' 18.279" N
47	86° 2' 46.031" E	25° 21' 20.542" N
48	86° 2' 43.321" E	25° 21' 22.751" N
49	86° 2' 40.629" E	25° 21' 24.983" N
50	86° 2' 37.952" E	25° 21' 27.232" N
51	86° 2' 35.275" E	25° 21' 29.482" N
52	86° 2' 32.586" E	25° 21' 31.718" N
53	86° 2' 29.886" E	25° 21' 33.940" N
54	86° 2' 27.193" E	25° 21' 36.170" N
55	86° 2' 24.374" E	25° 21' 38.221" N
56	86° 2' 21.393" E	25° 21' 40.048" N
57	86° 2' 19.653" E	25° 21' 42.407" N
58	86° 2' 20.819" E	25° 21' 45.702" N
59	86° 2' 21.910" E	25° 21' 49.024" N
60	86° 2' 23.001" E	25° 21' 52.347" N
61	86° 2' 24.225" E	25° 21' 55.618" N
62	86° 2' 25.288" E	25° 21' 58.946" N
63	86° 2' 26.389" E	25° 22' 2.265" N
64	86° 2' 27.579" E	25° 22' 5.552" N
65	86° 2' 28.646" E	25° 22' 8.882" N
66	86° 2' 29.762" E	25° 22' 12.196" N
67	86° 2' 30.880" E	25° 22' 15.509" N
68	86° 2' 31.994" E	25° 22' 18.824" N
69	86° 2' 33.085" E	25° 22' 22.146" N
70	86° 2' 34.189" E	25° 22' 25.464" N
71	86° 2' 35.626" E	25° 22' 28.556" N
72	86° 2' 39.003" E	25° 22' 27.750" N
73	86° 2' 42.423" E	25° 22' 27.029" N
74	86° 2' 45.863" E	25° 22' 26.417" N
75	86° 2' 49.353" E	25° 22' 26.271" N
76	86° 2' 52.779" E	25° 22' 26.800" N
77	86° 2' 55.919" E	25° 22' 28.286" N
78	86° 2' 59.130" E	25° 22' 29.661" N
79	86° 3' 2.566" E	25° 22' 30.003" N
80	86° 3' 6.014" E	25° 22' 30.172" N

Table no: 5 Intake and Reservoir Boundary Pillars co-ordinates table.

PillarsNo	Longitude	Latitude
1	86° 0' 10.153" E	25° 23' 16.461" N
2	85° 59' 44.272" E	25° 23' 24.164" N
3	86° 0' 7.160" E	25° 23' 14.645" N
4	86° 0' 4.168" E	25° 23' 12.828" N
5	86° 0' 1.176" E	25° 23' 11.012" N
6	85° 59' 58.183" E	25° 23' 9.196" N
7	85° 59' 55.191" E	25° 23' 7.379" N
8	85° 59' 52.208" E	25° 23' 5.550" N
9	85° 59' 49.239" E	25° 23' 3.702" N
10	85° 59' 46.669" E	25° 23' 3.914" N
11	85° 59' 44.571" E	25° 23' 6.571" N
12	85° 59' 42.473" E	25° 23' 9.227" N
13	85° 59' 40.376" E	25° 23' 11.883" N
14	85° 59' 38.278" E	25° 23' 14.540" N
15	85° 59' 36.180" E	25° 23' 17.196" N
16	85° 59' 36.587" E	25° 23' 19.447" N
17	85° 59' 39.566" E	25° 23' 21.280" N
18	85° 59' 42.546" E	25° 23' 23.114" N
19	85° 59' 45.538" E	25° 23' 24.931" N
20	85° 59' 48.532" E	25° 23' 26.744" N
21	85° 59' 51.527" E	25° 23' 28.558" N
22	85° 59' 54.521" E	25° 23' 30.371" N
23	85° 59' 57.516" E	25° 23' 32.185" N
24	86° 0' 0.511" E	25° 23' 33.998" N
25	86° 0' 2.652" E	25° 23' 31.557" N
26	86° 0' 4.751" E	25° 23' 28.901" N
27	86° 0' 6.849" E	25° 23' 26.245" N
28	86° 0' 8.948" E	25° 23' 23.589" N
29	86° 0' 11.047" E	25° 23' 20.933" N
30	86° 0' 13.145" E	25° 23' 18.277" N

CONTOUR & GROUND DETAIL DATA OF INTAKE & RESERVOIR AREA

ANNEXURE -II

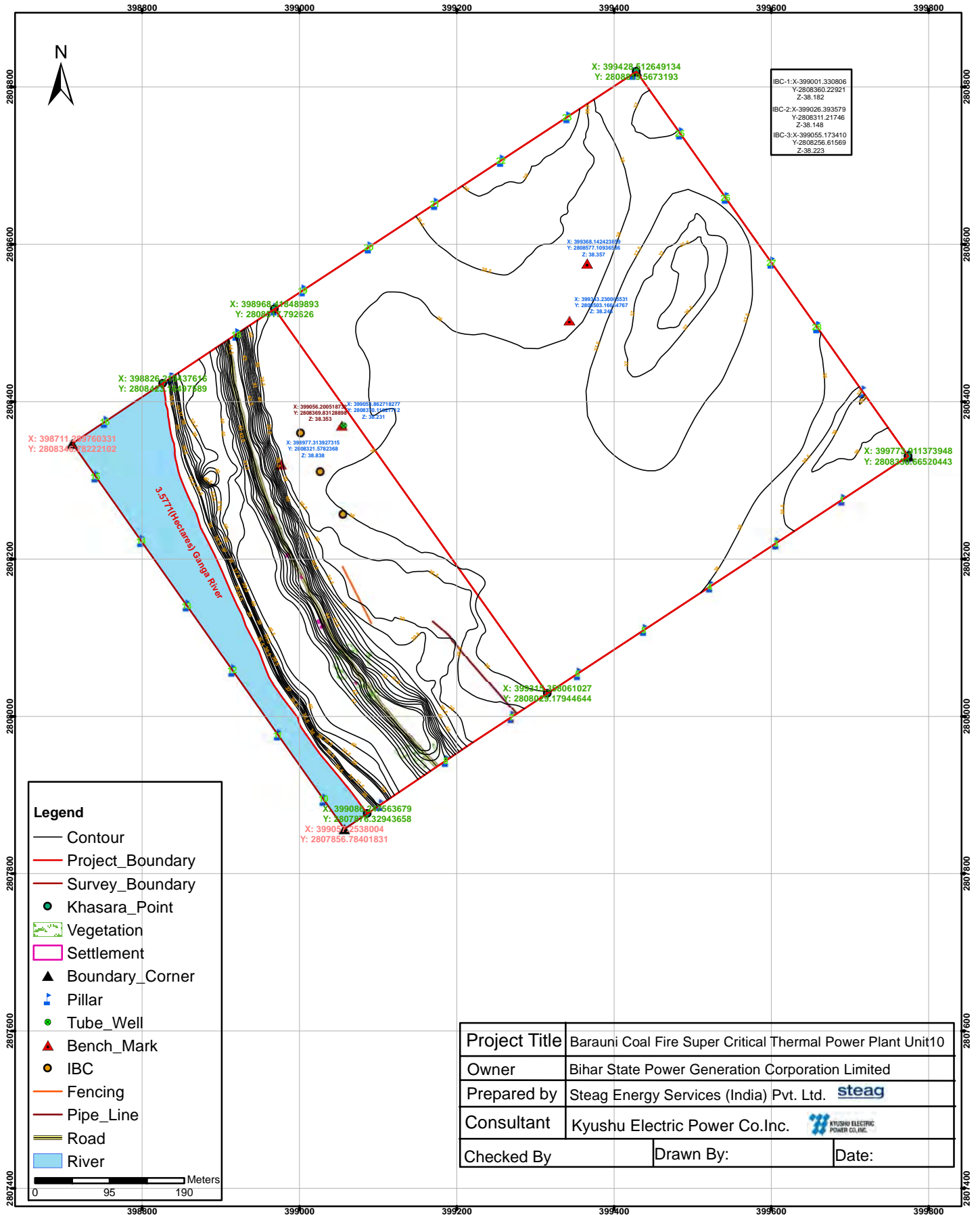

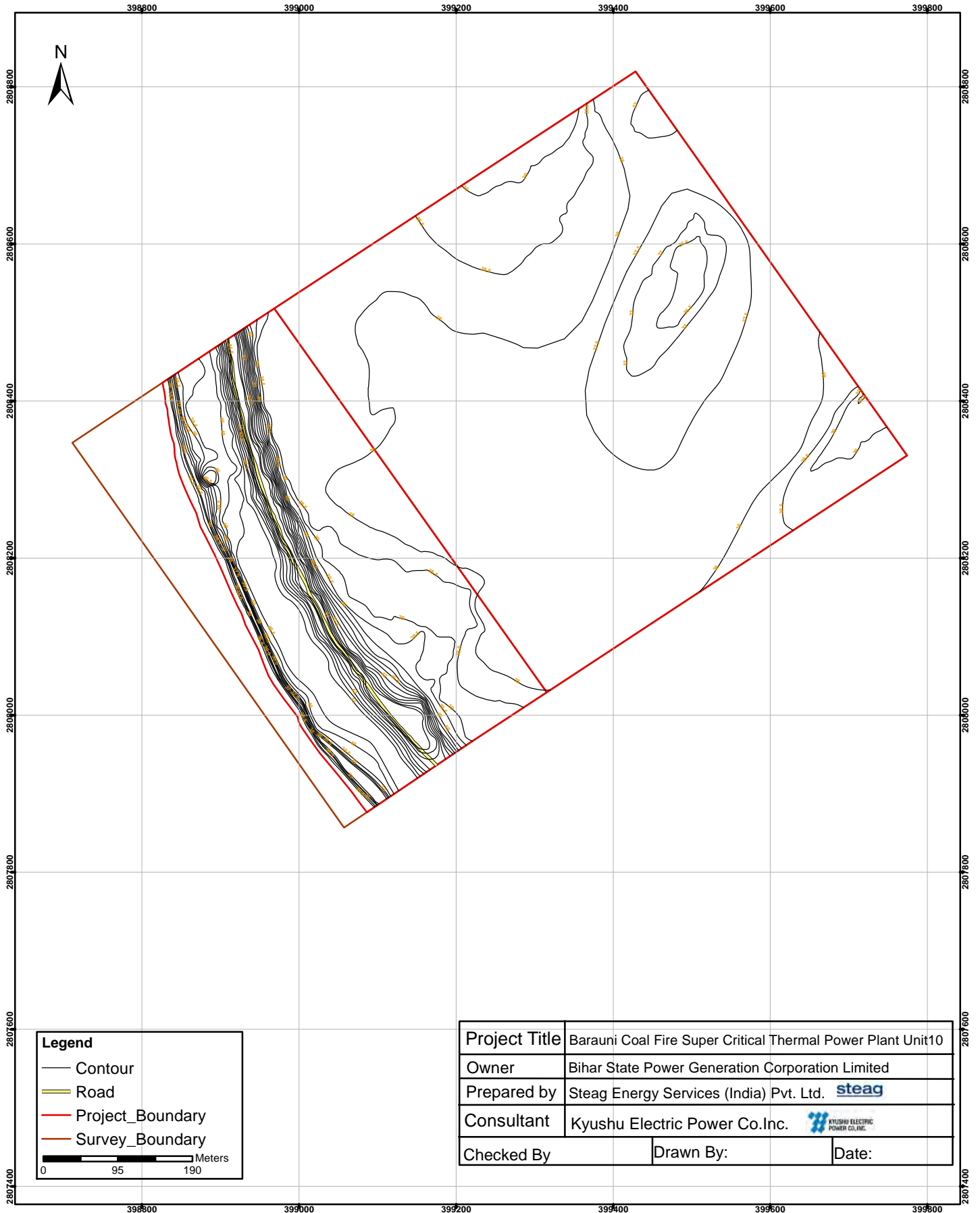

CONTOUR PLAN & ROAD MAPS OF INTAKE & RESERVOIR AREA



Legend

- Contour
- Road
- Project_Boundary
- Survey_Boundary

0 95 190 Meters

Project Title	Barauni Coal Fire Super Critical Thermal Power Plant Unit10		
Owner	Bihar State Power Generation Corporation Limited		
Prepared by	Steag Energy Services (India) Pvt. Ltd. 		
Consultant	Kyushu Electric Power Co.Inc. 		
Checked By	Drawn By:	Date:	

CONTOUR & GROUND DETAIL DATA OF INTAKE & RESERVOIR AREA

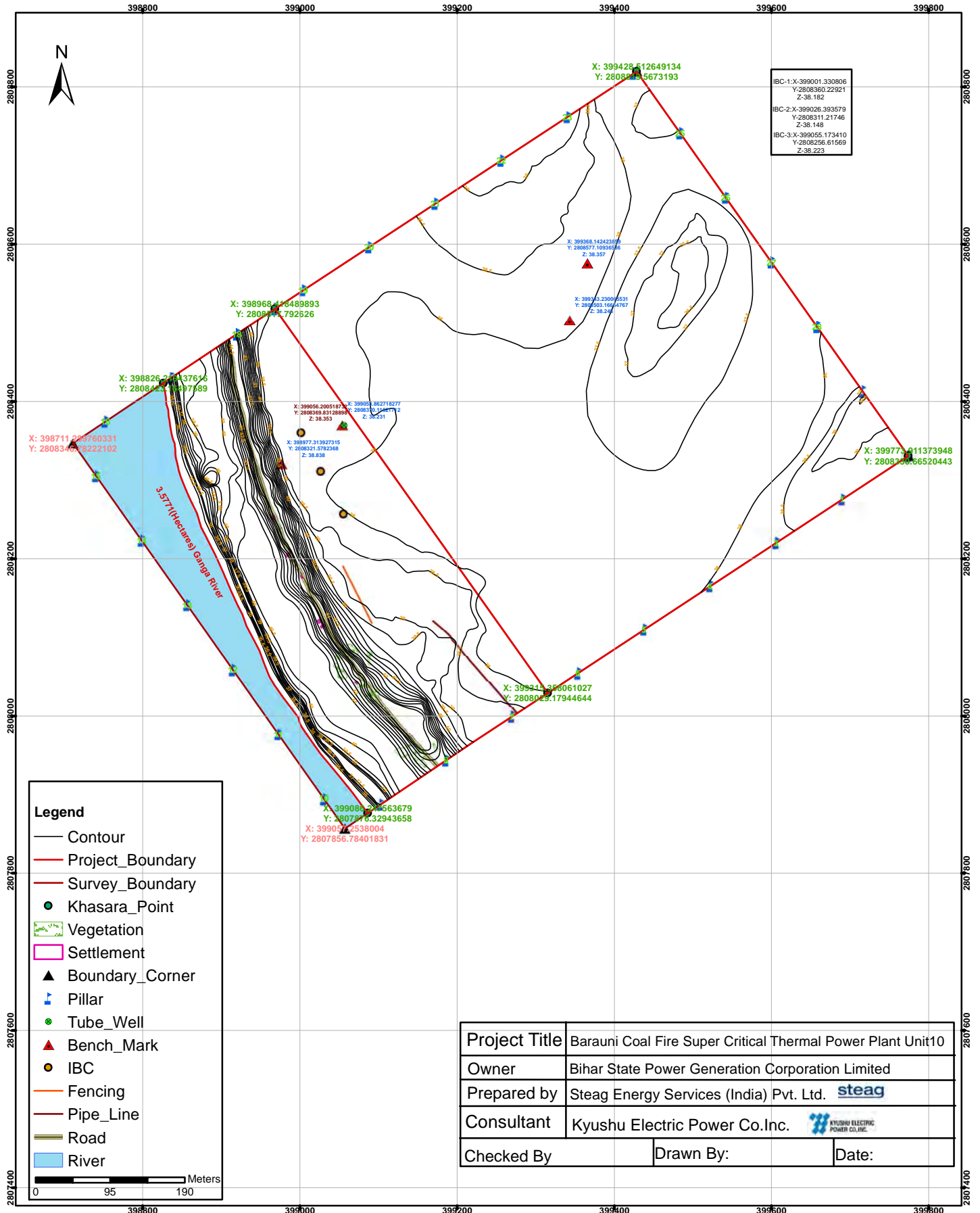

IBC-1: X:399001.330806
Y:2808360.22921
Z:38.182
IBC-2: X:399026.393579
Y:2808311.21746
Z:38.148
IBC-3: X:399055.173410
Y:2808256.61569
Z:38.223

Legend

- Contour
- Project_Boundary
- Survey_Boundary
- Khasara_Point
- Vegetation
- Settlement
- ▲ Boundary_Corner
- ▬ Pillar
- Tube_Well
- ▲ Bench_Mark
- IBC
- Fencing
- Pipe_Line
- Road
- River

Meters
0 95 190

Project Title	Barauni Coal Fire Super Critical Thermal Power Plant Unit10	
Owner	Bihar State Power Generation Corporation Limited	
Prepared by	Steg Energy Services (India) Pvt. Ltd.	
Consultant	Kyushu Electric Power Co.Inc.	
Checked By	Drawn By:	Date:

SUPERIMPOSITION OF CONTOUR & GROUND DETAIL DATA OVER KHASARA OF INTAKE & RESERVOIR AREA

ANNEXURE -II

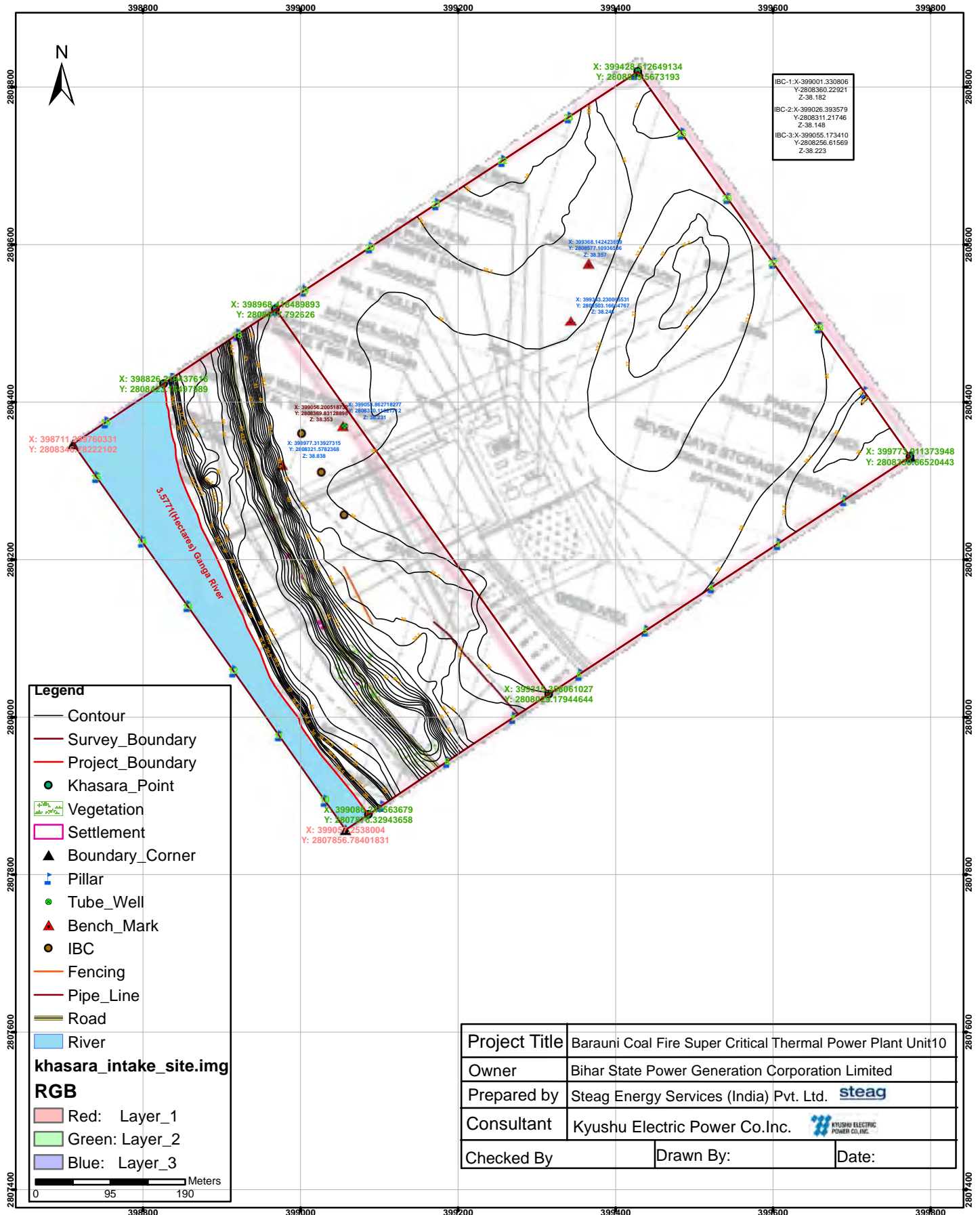

IBC-1: X:399001.330806
Y:2808360.22921
Z:38.182
IBC-2: X:399026.393579
Y:2808311.21746
Z:38.148
IBC-3: X:399055.173410
Y:2808256.61569
Z:38.223

Legend

- Contour
- Survey_Boundary
- Project_Boundary
- Khasara_Point
- Vegetation
- Settlement
- ▲ Boundary_Corner
- ⊥ Pillar
- Tube_Well
- ▲ Bench_Mark
- IBC
- Fencing
- Pipe_Line
- Road
- River

khasara_intake_site.img

RGB

- Red: Layer_1
- Green: Layer_2
- Blue: Layer_3

0 95 190 Meters

Project Title	Barauni Coal Fire Super Critical Thermal Power Plant Unit10	
Owner	Bihar State Power Generation Corporation Limited	
Prepared by	Steg Energy Services (India) Pvt. Ltd.	
Consultant	Kyushu Electric Power Co.Inc.	
Checked By	Drawn By:	Date:

CONTOUR & GROUND DETAIL DATA OF ASH POND AREA

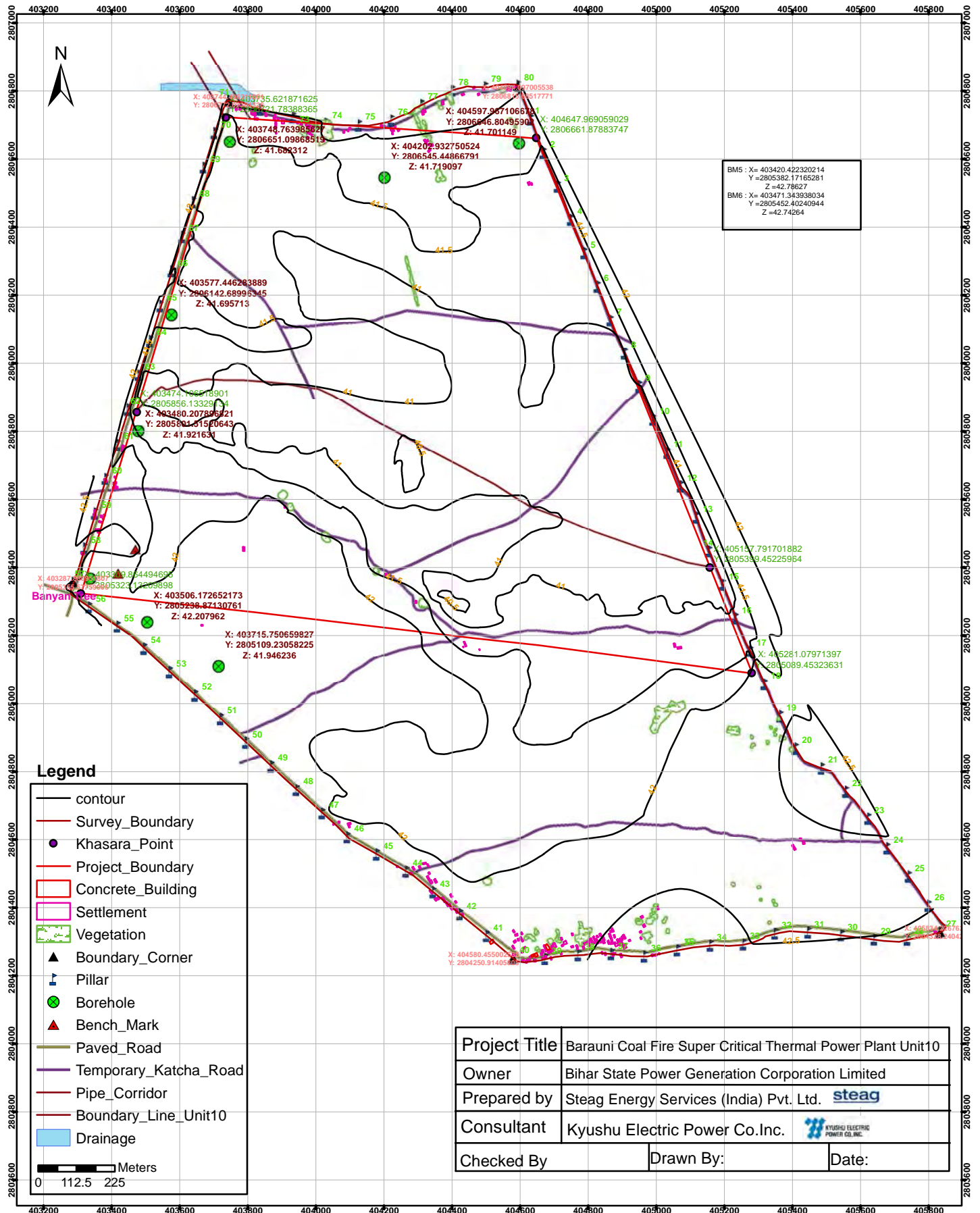

BM5 : X= 403420.422320214
 Y=2805382.17165281
 Z =42.78627
 BM6 : X= 403471.343938034
 Y =2805452.40240944
 Z =42.74264

Legend

- contour
- Survey_Boundary
- Khasara_Point
- Project_Boundary
- ▭ Concrete_Building
- ▭ Settlement
- Vegetation
- ▲ Boundary_Corner
- ▬ Pillar
- Borehole
- ▲ Bench_Mark
- Paved_Road
- Temporary_Katcha_Road
- Pipe_Corridor
- Boundary_Line_Unit10
- Drainage

0 112.5 225 Meters

Project Title	Barauni Coal Fire Super Critical Thermal Power Plant Unit10	
Owner	Bihar State Power Generation Corporation Limited	
Prepared by	Steag Energy Services (India) Pvt. Ltd.	
Consultant	Kyushu Electric Power Co. Inc.	
Checked By	Drawn By:	Date:

CONTOUR PLAN MAP OF ASH POND AREA

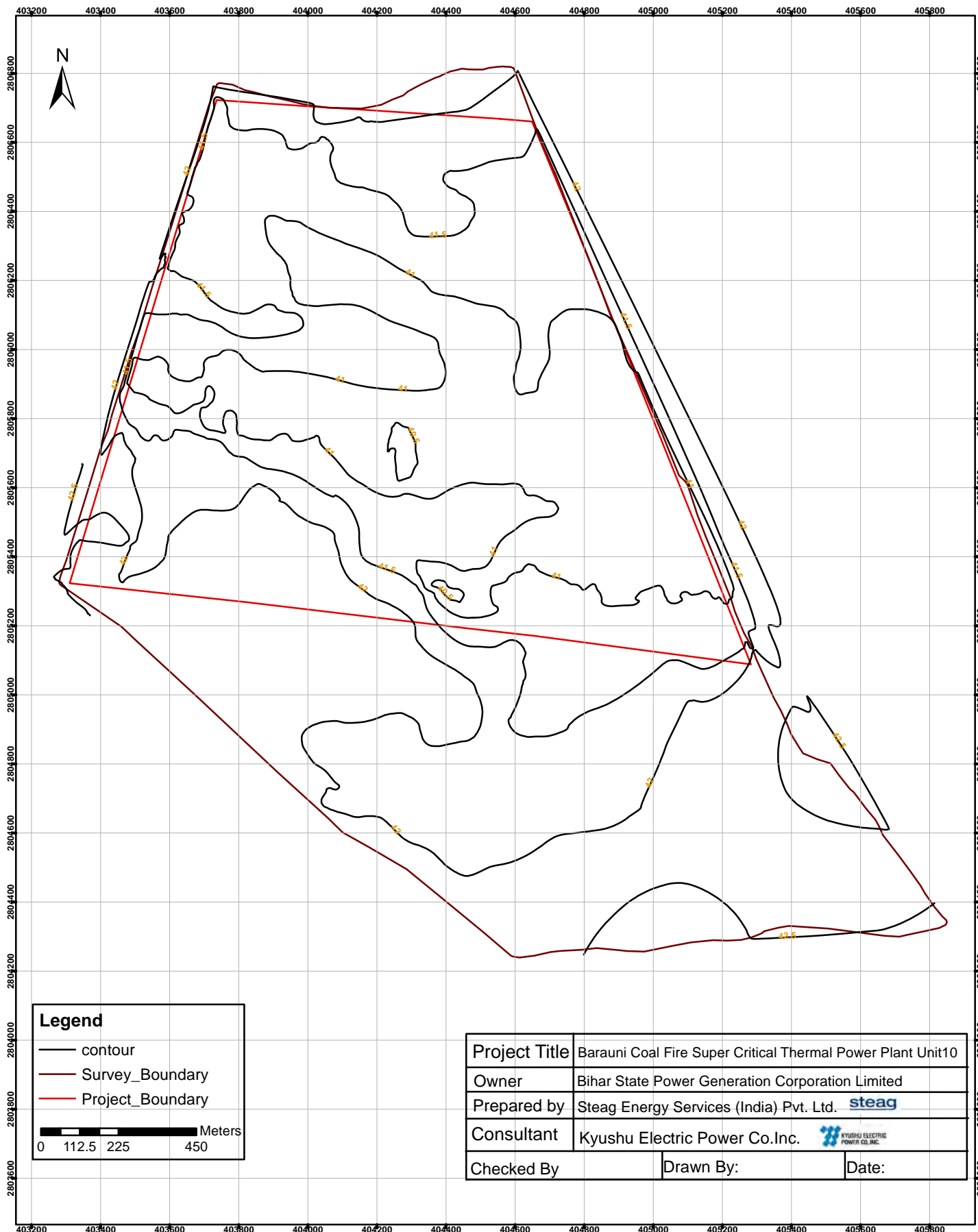

Legend

- contour
- Survey_Boundary
- Project_Boundary

0 112.5 225 450 Meters

Project Title	Barauni Coal Fire Super Critical Thermal Power Plant Unit10		
Owner	Bihar State Power Generation Corporation Limited		
Prepared by	Steag Energy Services (India) Pvt. Ltd.		
Consultant	Kyushu Electric Power Co.Inc.		
Checked By	Drawn By:	Date:	

SUPERIMPOSITION OF CONTOUR & GROUND DETAIL DATA OVER KHASARA OF ASH POND AREA

ANNEXURE - II

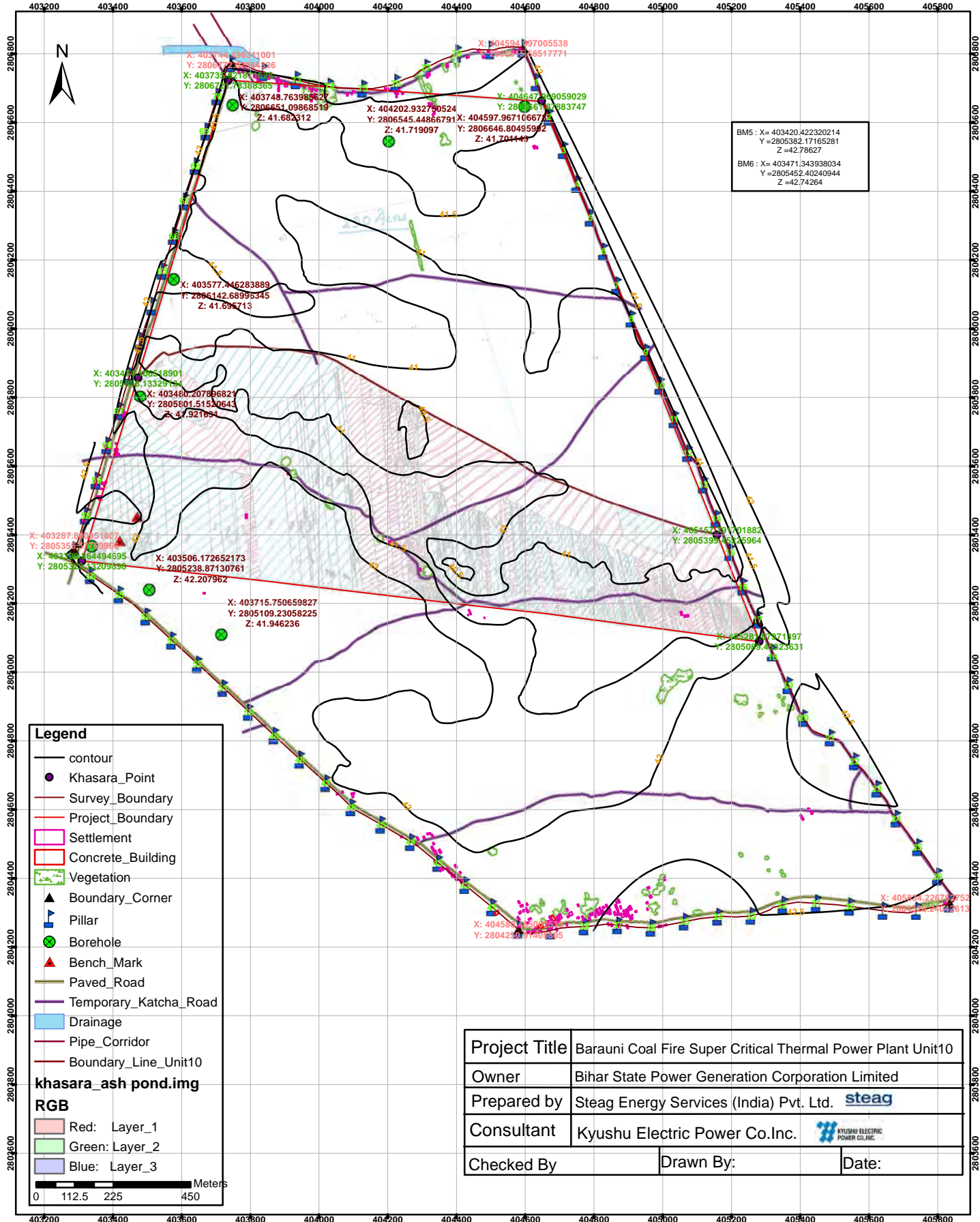

SUPERIMPOSITION OF CONTOUR & GROUND DETAIL DATA OVER KHASARA OF ASH POND AREA

ANNEXURE -II

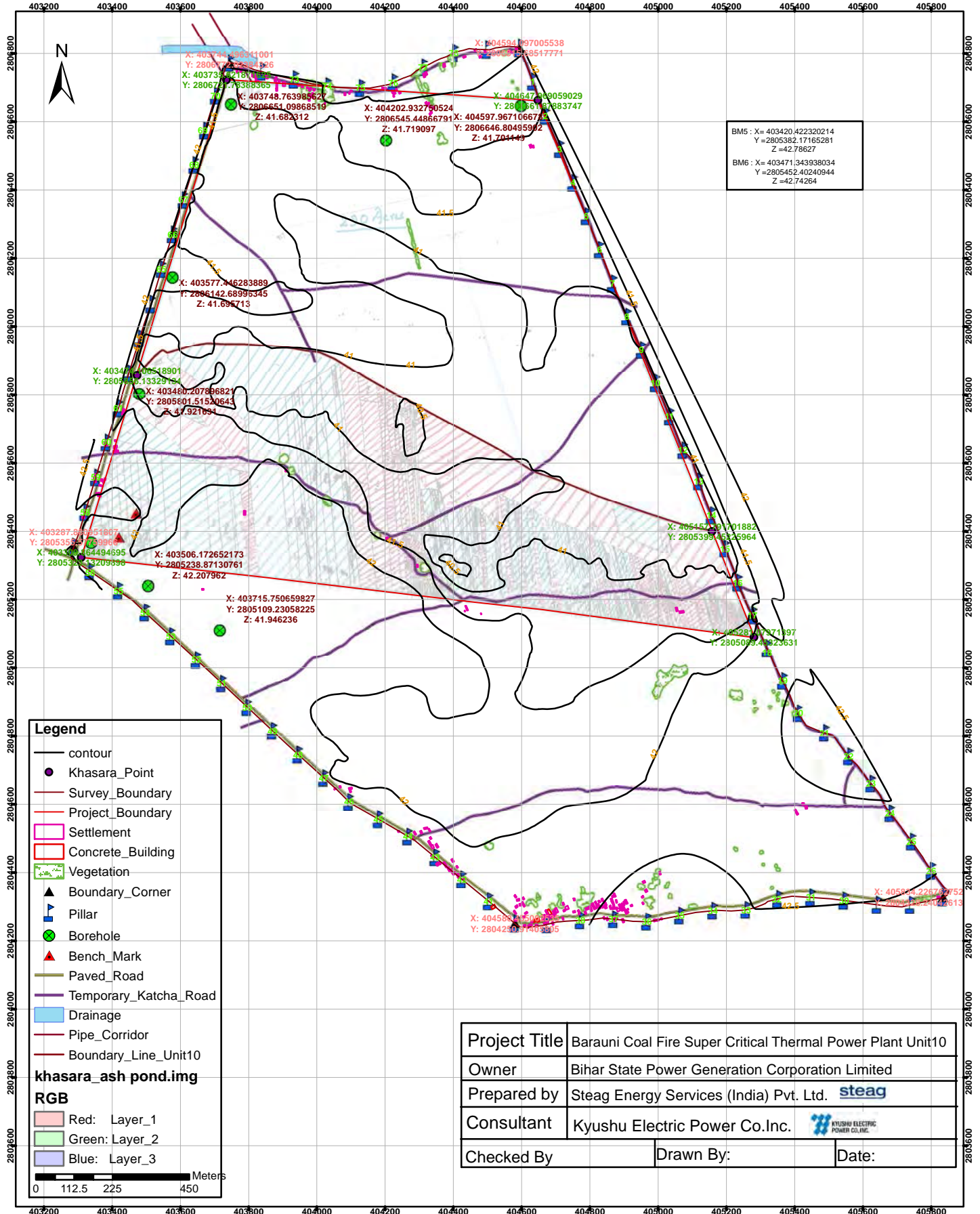

CONTOUR & GROUND DETAIL DATA OF PIPE CORRIDOR

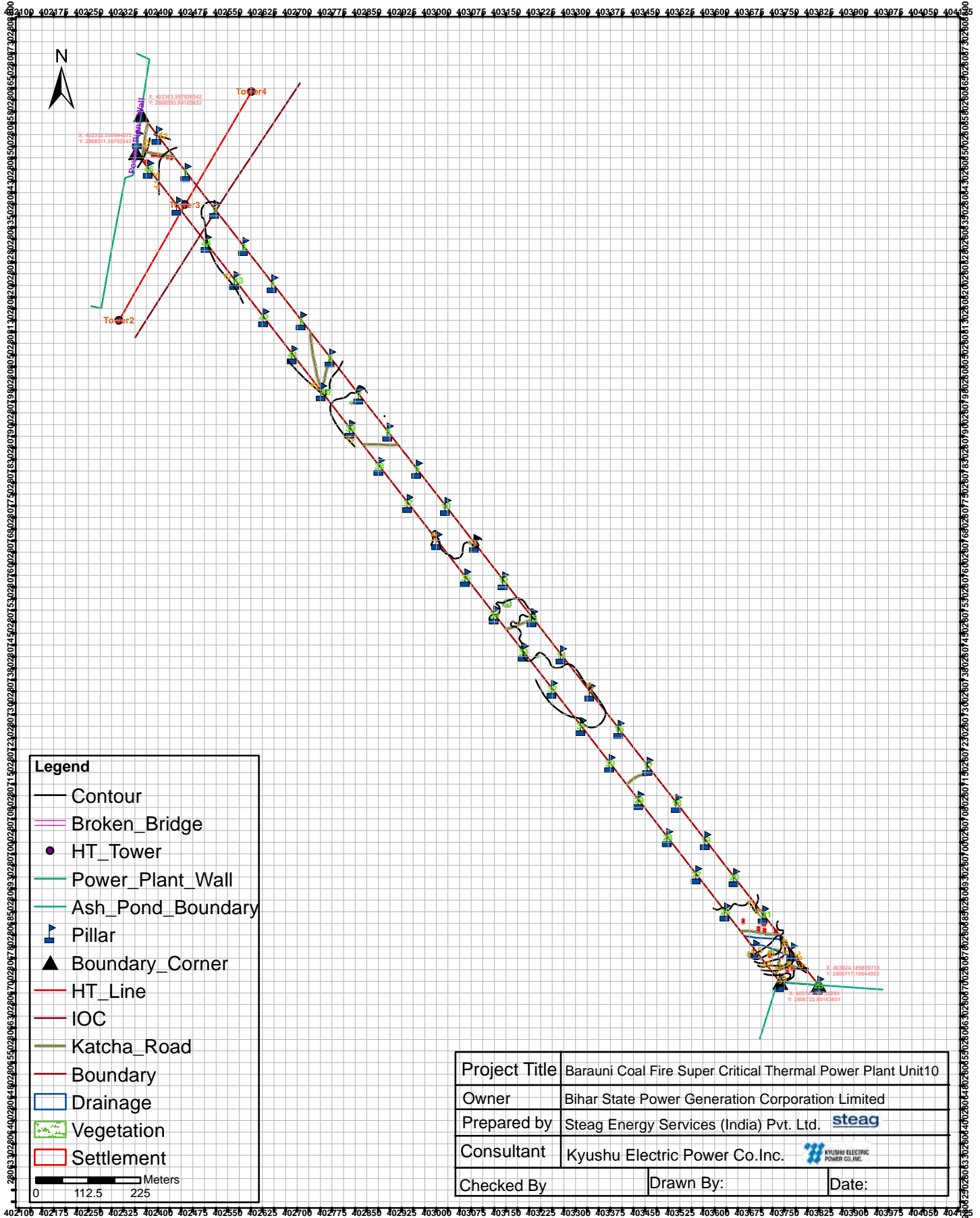

CONTOUR PLAN & ROAD MAPS OF PIPE CORRIDOR

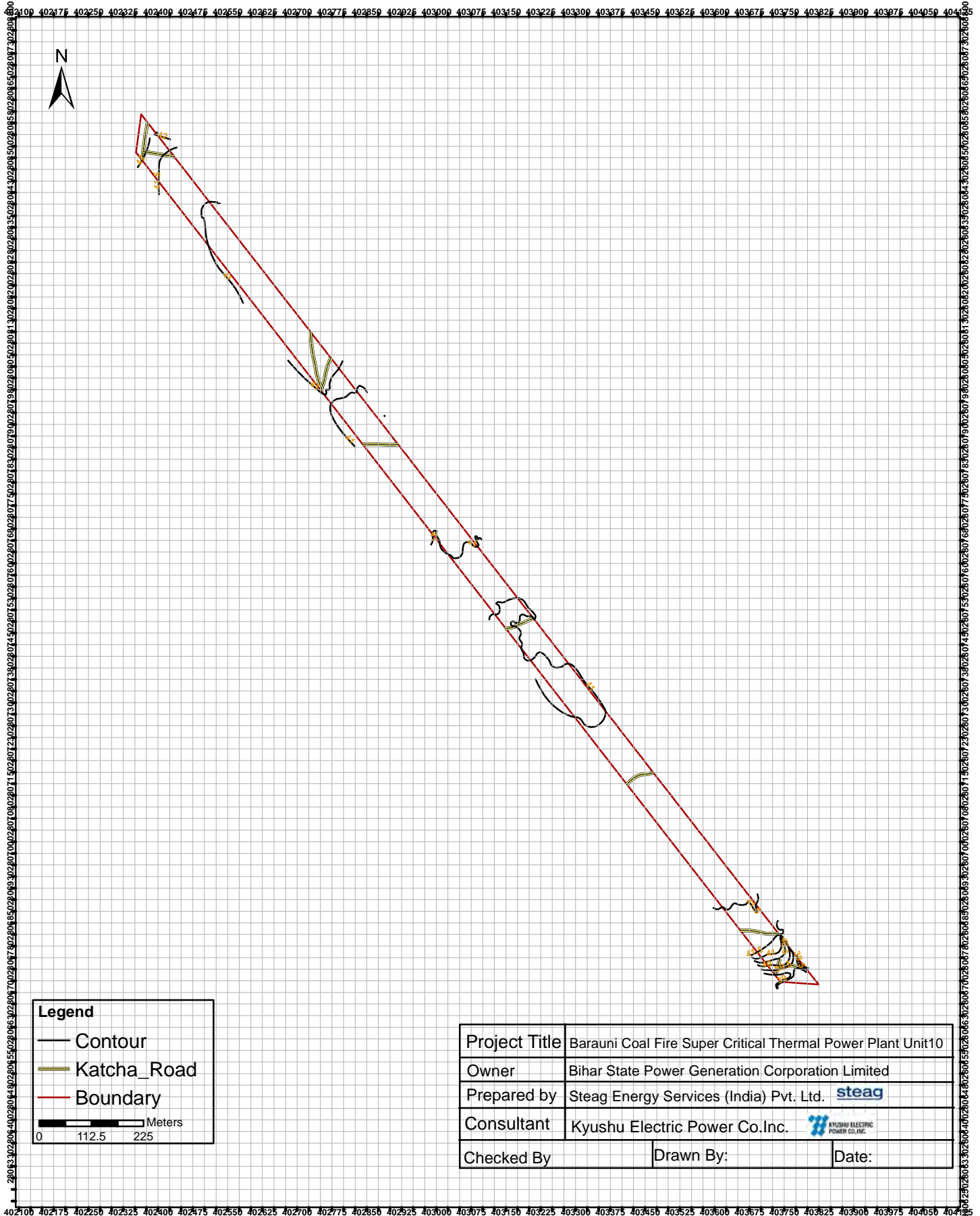

Legend



- Contour
- Katcha_Road
- Boundary

Meters
0 112.5 225

Project Title	Barauni Coal Fire Super Critical Thermal Power Plant Unit10	
Owner	Bihar State Power Generation Corporation Limited	
Prepared by	Steag Energy Services (India) Pvt. Ltd.	
Consultant	Kyushu Electric Power Co.Inc.	
Checked By	Drawn By:	Date:

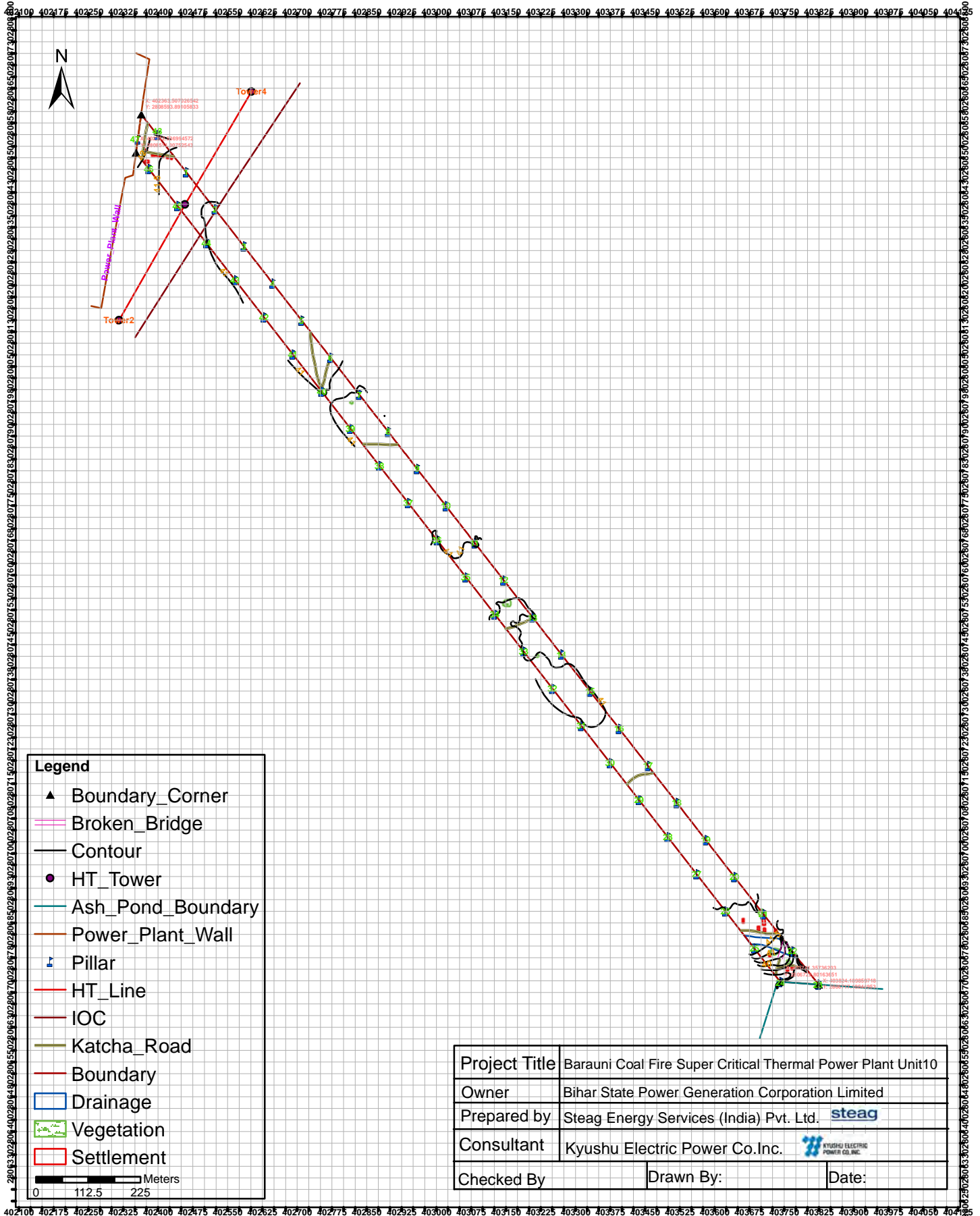
SUPERIMPOSITION OF CONTOUR & GROUND DETAIL DATA OF PIPE CORRIDOR



Project Title	Barauni Coal Fire Super Critical Thermal Power Plant Unit10	
Owner	Bihar State Power Generation Corporation Limited	
Prepared by	Steag Energy Services (India) Pvt. Ltd.	
Consultant	Kyushu Electric Power Co.Inc.	
Checked By	Drawn By:	Date:

L-SECTION MAP OF PIPE CORRIDOR

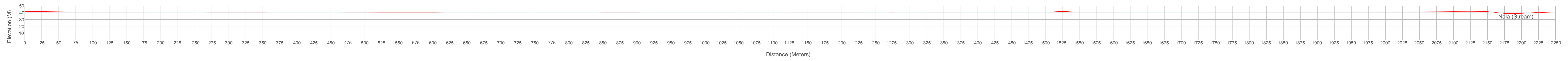

CROSS SECTION MAP OF PIPE CORRIDOR

Distance From Ash Pond Area (2264m)

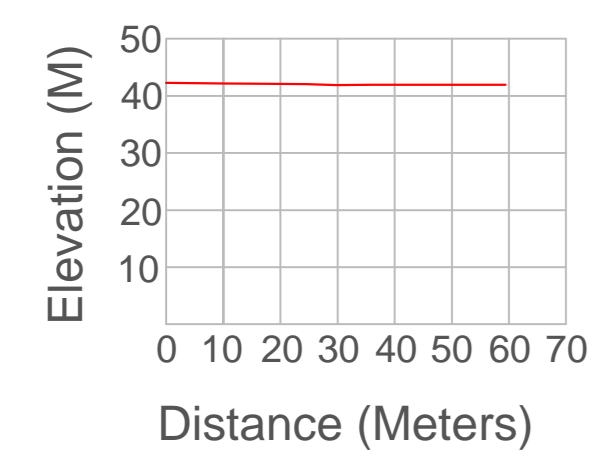

Distance From Ash Pond Area (2209m)

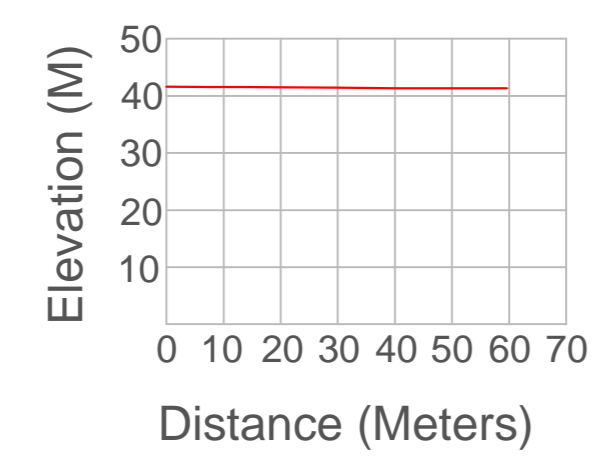

Distance From Ash Pond Area (2190m)

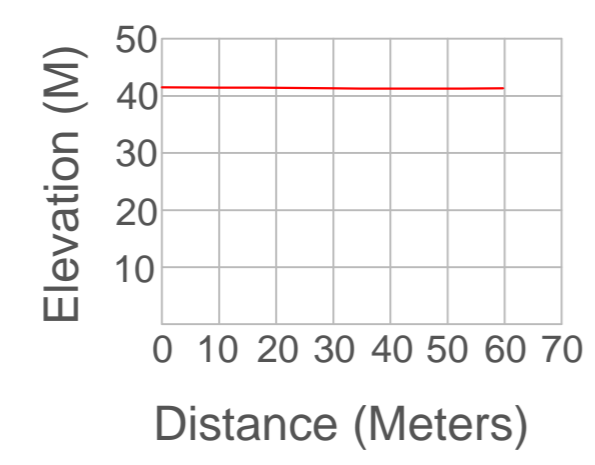

Distance From Ash Pond Area (2076m)

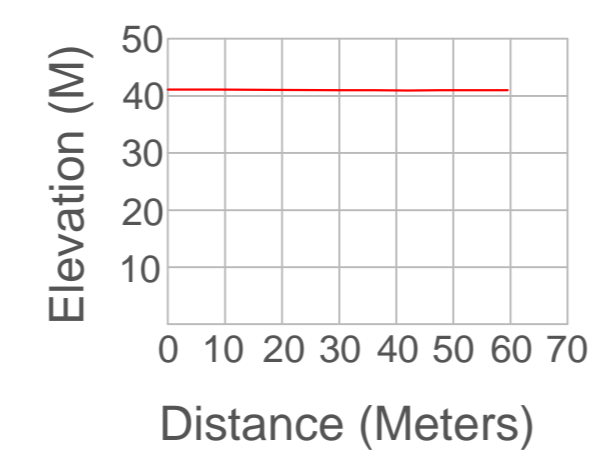

Distance From Ash Pond Area (2030m)

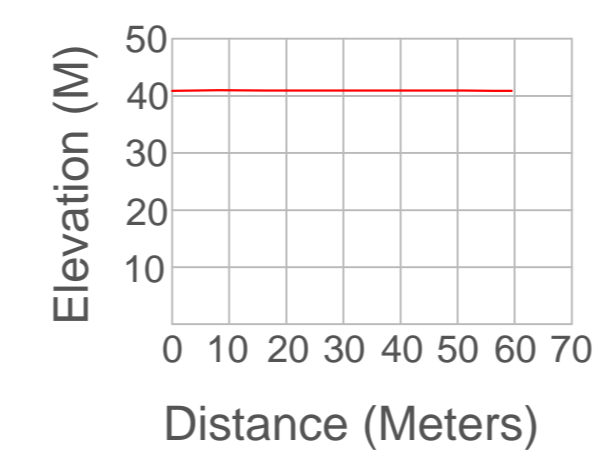

Distance From Ash Pond Area (1429m)

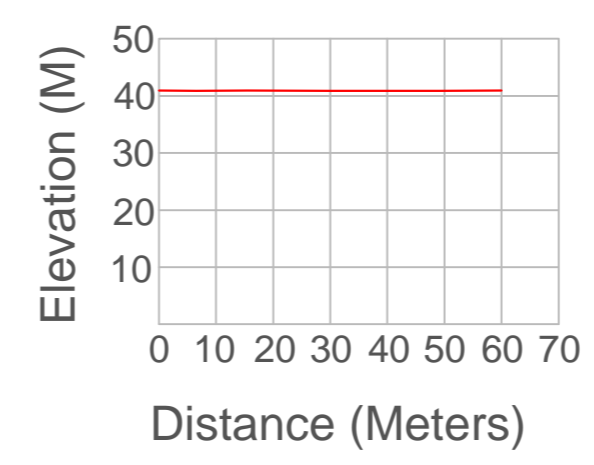

Distance From Ash Pond Area (649m)

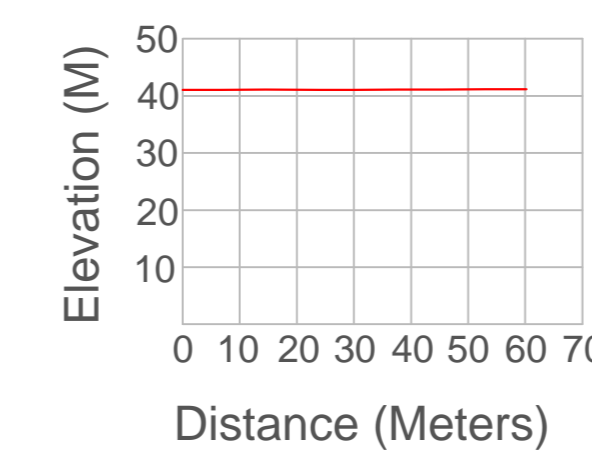

Distance From Ash Pond Area (154m)

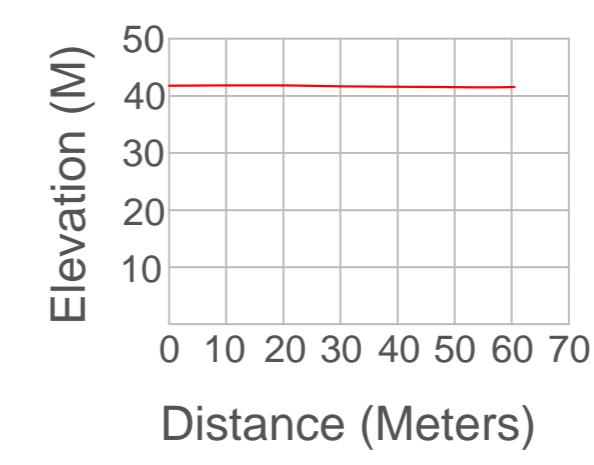

Distance From Ash Pond Area (65m)

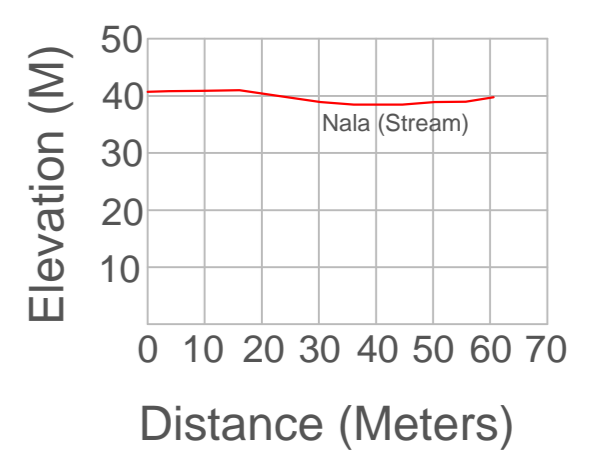

ANNEXURE - II

**GEO-TECHNICAL INVESTIGATION /
GEO-HYDROLOGICAL STUDY**

**GEOTECHNICAL INVESTIGATION REPORT
(VOLUME-1)**

**FOR
ASH POND AREA**

**RELATED TO
THE PREPARATORY SURVEY FOR
CONSTRUCTION OF
BARAUNI SUPER CRITICAL COAL FIRED
THERMAL POWER STATION
(UNIT#10)**

OF

BIHAR STATE POWER GENERATION COMPANY LTD.

CONSULTANT

steag



STEAG Energy Services India Pvt. Ltd.

(Formerly Evonik Energy Services India Ltd.)

(A wholly owned subsidiary of Steag Energy Services GmbH, Germany)

A-29, Sector-16, NOIDA-201301, India

TABLE OF CONTENTS

		<u>Sheet No.</u>
1.0	INTRODUCTION	4
1.1	Project Description	4
1.2	Purposes of Study	4
1.3	Report Format	4
1.4	Scope of Geotechnical Investigations covered in this Report (<i>Ash Pond Area</i>)	5
2.0	FIELD INVESTIGATIONS	5
2.1	Soil Boring	5
2.2	Groundwater	6
2.3	Field Permeability Tests	6
2.3.1	Constant Head Method	6
2.3.2	Falling Head Method	7
3.0	LABORATORY TESTS	7
4.0	GENERAL SITE CONDITIONS	8
4.1	Site Details	8
4.2	Regional Geology	8
4.3	Site Stratigraphy	8
4.4	Groundwater	9
5.0	FIELD PERMEABILITY TEST RESULTS	9
6.0	FOUNDATION ANALYSIS AND RECOMMENDATIONS	11
6.1	General	11
6.2	Liquefaction Susceptibility Assessment	11
6.3	Construction of Ash Dyke	11
6.4	Foundation Type and Depth	11
6.5	Concept for Foundation Analysis	12
6.6	Design Soil Parameters	13
6.7	Recommended Net Allowable Bearing Pressures	13
6.8	Definition of Gross and Net Bearing Pressure	14
7.0	FOUNDATION CONSTRUCTION CONSIDERATION	14
7.1	Excavation	14
7.2	Foundation Level Preparation	14
7.3	Chemical Attack	15
8.0	VARIABILITY IN SUB-SURFACE CONDITIONS	15

LIST OF ILLUSTRATIONS

<u>Caption</u>	<u>Plate</u>
Satellite Image of Site and Test Locations	1
Engineering Description of Soils	2
Uncertainty in Laboratory Measurements	3
Soil Profiles	4 to 19
Summary of Borehole Profiles	20
Standard Penetration Test Results	21 to 24
Field Permeability Test	25 to 121
Grain Size Analysis	122 to 137
Shear Test Results	138 to 153
Chemical Test Results	154

Appendix A: Typical Calculations

DEFINITION OF ACRONYMS

USL	United Spirit Limited
CENGRS	Cengrs Geotechnica Pvt. Ltd.
UTM	Universal Transverse Mercator coordinates system
NABL	National Accreditation Board for Testing and Calibration Laboratories
ISO	International Standards Organization
BIS	Bureau of Indian Standards
EGL	Existing Ground Level
NGL	Natural Ground Level
RL	Reduced Level
SPT	Standard Penetration Test
NCEER	National Center for Earthquake Engineering Research
UUT	Unconsolidated undrained triaxial shear test
DS	Consolidated drained direct shear test

BIS REFERENCES

- Compendium of Indian Standard on Soil Engineering (Part-2, Field Testing of Soils for Civil Engineering Purposes), SP36 (Part-2:1988)-RA 2006
- Compendium of Indian Standard on Soil Engineering (Part-1, Laboratory Testing of Soils for Civil Engineering Purposes), SP36 (Part-1:1987)-RA 2006

1.0 INTRODUCTION

1.1 Project Description

Japan International Cooperation Agency (JICA) has appointed Kyushu Electric Power Co. INC. as a consultant, to conduct the preparatory survey on construction of the Barauni Super Critical Coal Fired Thermal Power Station. Kyushu Electric Power Co. INC has appointed M/s. STEAG Energy Services (India) Pvt. Ltd to conduct the civil construction work at site.

M/s. Cengrs Geotechnica Pvt. Ltd. (Cengrs) has been contracted by M/s. STEAG Energy Services (India) Pvt. Ltd to carry out the geotechnical investigation for the project. The site has been divided into three different areas as detailed below:

- Ash Pond Site
- Powerhouse Site
- Raw Water Intake Site

This report volume (Volume-I) presents field and laboratory test results along with our geotechnical recommendations for the proposed pump house in ash pond area. An accompanying volume (Volume-II) presents results of the geotechnical investigation for the Powerhouse facilities & Volume-III for the Raw Water Intake area.

1.2 Purposes of Study

The overall purposes of this study are to investigate the stratigraphy at the site, and to develop geotechnical recommendations for design and construction of foundations for the Ash Pond, Powerhouse and Raw Water Intake Areas.

To accomplish these purposes, the study was conducted in the following phases:

- (i) **drilling 8 boreholes to 20m depth in the Ash Pond area, in order to evaluate the stratigraphy, and to collect soil and groundwater samples for laboratory testing;**
- (ii) **performing seventy three (73) field permeability tests in the Ash Pond area at eight (8) borehole locations to assess the in-situ coefficient of permeability of the strata;**
- (iii) drilling 6 boreholes to 40m depth in the Powerhouse area in order to evaluate the stratigraphy, and to collect soil and groundwater samples for laboratory testing;
- (iv) drilling 3 boreholes to 20m depth at the Raw Water Intake location in order to evaluate the stratigraphy, and to collect soil and groundwater samples for laboratory testing;
- (v) testing selected soil and groundwater samples in the laboratory to determine pertinent index and engineering properties; and
- (vi) analyzing all field and laboratory data to develop geotechnical recommendations for foundations.

The scope of work presented in this report volume (*Volume-I*) consists of 8 boreholes to 20m depth & 73 permeability tests for the proposed Ash Pond area.

1.3 Report Format

This report is presented in three volumes. The scope of work included in each volume is as described below:

Report Volume	Proposed Structures	Scope of Work
Volume-I	Ash Pond	<ul style="list-style-type: none"> ▪ Eight (8) Boreholes ▪ Seventy three (73) field permeability tests
Volume-II	Powerhouse	<ul style="list-style-type: none"> ▪ Six (6) Boreholes
Volume-III	Raw Water Intake	<ul style="list-style-type: none"> ▪ Three (3) Boreholes

This volume, designated as Volume-I, includes field and laboratory data together with our engineering recommendations for the proposed **Pump House in Ash Pond area**.

The initial sections of this volume of the report present brief descriptions of the field procedures together with a list of various laboratory tests conducted. General site conditions, including geology and stratigraphy along the cross bridge alignment, are then presented. This is followed by our foundation analysis and recommendations.

Plates of soil profiles and various laboratory tests follow the report text. The illustrations section includes a site plan, graphical plots of various field and laboratory test results, summary of borehole profiles, sectional profiles and other related sketches.

1.4 Scope of Geotechnical Investigations covered in this Report (**Ash Pond Area**)

Details of in-situ tests completed on site are as follows:

Sr. No.	Borehole Designation	UTM Coordinates ⁽¹⁾ , m		Existing Ground Level ⁽¹⁾ (RL), m	Depth (m) of Field Permeability Tests	Borehole Termination Depth, m
		Easting	Northing			
1	BH-1	403339	2805366	42.8	2, 4, 6	20.36
2	BH-2	403577	2806143	41.7	2,4,6,8,10,12,14,16,18,20	20.95
3	BH-3	403748	2806652	41.7	2,4,6,8,10,12,14,16,18,20	20.36
4	BH-4	404203	2806545	41.7	2,4,6,8,10,12,14,16,18,20	20.85
5	BH-5	404597	2806647	41.7	2,4,6,8,10,12,14,16,18,20	20.36
6	BH-6	403480	2805802	41.9	2,4,6,8,10,12,14,16,18,20	20.36
7	BH-7	403506	2805239	42.8	2,4,6,8,10,12,14,16,18,20	20.85
8	BH-8	404586	2805103	41.9	2,4,6,8,10,12,14,16,18,20	20.35

⁽¹⁾ UTM coordinates and existing ground level provided us by Steag

The test locations were given to us on the ground by the client representatives at site. The locations were marked in the field using a hand-held Global Positioning System (GPS). A satellite image illustrating the approximate test locations (*as recorded by GPS*) is presented on Plate 1.

2.0 FIELD INVESTIGATIONS

2.1 Soil Boring

The borings were progressed using a shell and auger to the specified depth. The diameter of the borehole was 150 mm. Casing was used for advancing boring below water table at all borehole locations. The work was in general accordance with IS: 1892-1979.

Standard Penetration Tests (SPT) were conducted in the boreholes at 1.0 m depth interval. The test was conducted by connecting a split spoon sampler to 'A' rods and driving it by 45 cm using a 63.5 kg hammer falling freely from a height of 75 cm. The tests were conducted in accordance with IS: 2131-1981.

The number of blows for each 15 cm of penetration of the split spoon sampler was recorded. The blows required to penetrate the initial 15 cm of the split spoon for seating the sampler is ignored due to the possible presence of loose materials or cuttings from the drilling operation. Where refusal (N>100) to further penetration of the split spoon sampler is encountered in the first 15 cm seating penetration itself, SPT test could not be completed and "Ref" is indicated in the bore logs, along with the penetration achieved. The 'N' values are presented on the soil profile for each borehole.

Disturbed samples were collected from the split spoon after conducting SPT. The samples were preserved in transparent polythene bags. Undisturbed samples were collected by attaching 75 mm diameter thin walled 'Shelby' tubes and driving the sampler using a 63.5 kg hammer in accordance with IS: 2132-1986. The tubes were sealed with wax at both ends. All samples were transported to our NABL accredited laboratory at Noida for further examination and testing.

2.2 Groundwater

Groundwater level was measured in the boreholes after drilling and sampling was completed. The measured water levels are recorded on the individual soil profiles.

2.3 Field Permeability Tests

In soils, field permeability tests were done by constant head & falling head methods. In soils with high permeability, constant head permeability test was performed. In soils where fines content exceeded 25-30%, falling head permeability test was performed.

2.3.1 Constant Head Method

The constant head tests were carried out in sands with high permeability accordance with IS: 5529 (Part-I) -1985 (RA 2013). The borehole was drilled to the desired depth and was casing was placed in the hole, ensuring a tight fit.

To conduct the test, a large water storage tank was kept at the ground surface. A GI pipe was placed in the hole to the bottom of the test. The flow of the water into the hole was controlled using a valve at the connection of the tank and the pipe. The volume of water flowing into the hole was measured using a water meter.

The flow of water into the hole was regulated using the control valve so that the water does not overflow the casing and remains at the same level. The tests were conducted at the depths specified by client.

In general, the casing extended to the bottom of the hole and the water seepage occurred through the bottom of the hole only, the following equation (In accordance with IS: 5529 (Part-I) -1985 RA 2013) was used to compute the coefficient of permeability:

$$k = C \left[\frac{Q}{H} \right] \quad \text{where} \quad C = \left[\frac{1}{5.5r} \right]$$

where:

- k = mean coefficient of permeability, cm/sec
- Q = Discharge, litre /min
- r = radius of casing, mm
- H = Differential Head, m

2.3.2 Falling Head Method

The falling head tests were carried out in accordance with IS: 5529 (Part-I) -1985 RA 2013. The tests were conducted in selected boreholes at the specified depths. The field coefficient of permeability was computed using the following equation;

$$k = \frac{d^2}{8L} \ln \left(\frac{L}{r} \right) \frac{\ln (h_1 / h_2)}{(t_2 - t_1)}$$

where:

<i>k</i>	=	mean coefficient of permeability
<i>d</i>	=	diameter of intake pipe (stand pipe)
<i>r</i>	=	radius of hole
<i>L</i>	=	length of test section
<i>h₁</i>	=	head at time <i>t₁</i>
<i>h₂</i>	=	head at time <i>t₂</i>

3.0 LABORATORY TESTS

The laboratory testing has been carried out in our NABL accredited laboratory. The quality procedures in our laboratory conform to ISO/IEC-17025-2005.

Laboratory tests were conducted on selected soil and groundwater samples, to determine their physical and engineering properties. The testing procedures were in accordance with current applicable IS specifications.

The following tests were conducted on selected soil and groundwater samples recovered from the boreholes:

Name of Test		IS Code No.
Bulk Density		IS : 2386 (Part-3)-1963
Natural moisture content		IS : 2720 (Part-2)-1973, RA-2010
Grain size analysis		IS : 2720 (Part-4)-1985, RA-2010
Specific gravity		IS : 2720 (Part-3)-1980, RA-2007
Liquid and plastic limits		IS : 2720 (Part-5)-1985, RA-2010
Consolidated drained direct shear test		IS : 2720 (Part-13)-1986, RA-2010
Chemical analysis of soil*	pH value	IS : 2720 (Part 26)-1987, RA-2007
	Total soluble sulphates	IS : 2720 (Part-27)-1977, RA-2010
	Total soluble chlorides	IS : 3025 (Part-32)-1988, RA-2009
Chemical analysis of water*	pH value	IS : 3025 (Part-11)-1983, RA-2006
	Total soluble sulphates	IS : 3025 (Part-24)-1986, RA-2009
	Total soluble chlorides	IS : 3025 (Part-32)-1988, RA-2009

* Outside NABL Scope

Engineering terms used to describe soils are explained on Plate 2. A note on our NABL accreditation together with the uncertainty in laboratory measurements is presented on Plate 3.

4.0 GENERAL SITE CONDITIONS

4.1 Site Details

The site located in Barauni district, Bihar. Rajendra pul railway Station is located about 2.5 k m west of the site. The site is open land and fairly level.

4.2 Regional Geology

The deposits in the project area belong to the Indo-Gangetic alluvium⁽¹⁾. The alluvial tract is of the nature of a synclinal basin formed concomitantly with the elevation of the Himalaya to its North.

The Indo-Gangetic depression was formed in the later stages of Himalayan Orogeny when the Indian shield under-thrust the Asian continent. The well-consolidated crust of the shield became engulfed under the light, soft, moist sediments. As the northward drift of India continued, the more consolidated and metamorphosed older strata and the granitic magmas intrusive into them slid southwards, impelled partly by gravity and partly by compressive force.

The Pleistocene and recent deposits covering the Indo-Gangetic Basin are upto 1,000 m thick. They are composed of gravels, sands and clays with remains of animals and plants.

The older alluvium (called Bhangar) is rather dark colored and generally rich in concretions and nodules of impure calcium carbonate (kankar). It is of Middle to Upper Pleistocene age.

The Newer alluvium (called Khadar) is light colored and poor in calcareous matter. It contains lenticular beds of sand and gravel and peat beds. It merges by insensible gradations into the recent or deltaic alluvia and should be assigned an Upper Pleistocene to Recent age.

4.3 Site Stratigraphy

The stratigraphy at site may be divided into two (2) generalized strata as described below:

Stratum – I (Sandy silt silt): A medium dense surficial sandy silt layer is present all over the site to about 0.5-2.0 m depth (RL 39.9-42.2 m).

Stratum – II (Medium dense to very dense silty fine sand / fine sand): Stratum-II consists of loose to very dense silty fine sand / fine sand to the maximum explored depth of 20 m (RL 37.7 m). The field SPT values generally range from 10 to 19 to about 4 m depth (RL 37.7 m) and 20 to 30 to 8 m depth (RL 33.7 m). Below this, SPT values range from 26 to 42 to about 12 m depth (RL 29.7 m). SPT values then range from 36 to 58 to 16 m depth (RL 25.7 m). In the underlying soils, the SPT values range from 51 to refusal (N>100) to the final explored depth of 20 m (RL 37.7 m).

In this stratum, bulk density values range from 1.80 g/cm³ to 1.87 g/cm³ and moisture content values range from 13.3 % to 18.5 %.

Detailed description of the soil encountered at the borehole locations are presented on the individual soil profiles in Plate 4 to 19. A pictorial summary of the borehole profiles is illustrated on Plate 20. Plots of field and corrected SPT values versus depth are presented on Plate 21 to 24.

⁽¹⁾ Krishnan, M.S. (1982), "**Geology of India and Burma**", CBS Publishers & Distributors, Delhi, Sixth Edition.

4.4 Groundwater

Based on the field data of eight (8) completed boreholes, groundwater was met at 7.0-7.1 m depth during the period of our field investigation (June-July, 2015). Fluctuations may occur in the measured water levels due to seasonal variations in rainfall and surface evaporation rates.

5.0 FIELD PERMEABILITY TEST RESULTS

Seventy three (73) field permeability tests have been conducted in the boreholes at depths as specified by client. The tests were conducted by constant head method in soils with high permeability. In soils with more than 25-35% fines and where some clay is present, falling head permeability test was performed. The decision regarding conducting falling head or constant head test was taken on site after visual assessment of soil gradation by our site engineer.

Field permeability results are presented on Plate 25 to 121. The test results are summarized below together with the soil classification and fines content:

S. No.	Test Designation	Borehole Location	Test Depth below EGL, m	Soil Classification	Fines Content, %	Coefficient of Permeability (k), cm/s	Test Method
1	FPT-1	BH-1	2.00	Silty fine sand	38	7.8×10^{-5}	Falling Head
2	FPT-2		4.00	Silty fine sand	22	1.0×10^{-4}	Falling Head
3	FPT-3		6.00	Silty fine sand	14	2.6×10^{-4}	Falling Head
4	FPT-4	BH-2	2.00	Silty fine sand	20	4.6×10^{-4}	Falling Head
5	FPT-5		4.00	Silty fine sand	20	1.2×10^{-4}	Falling Head
6	FPT-6		6.00	Fine sand	14	1.2×10^{-5}	Falling Head
7	FPT-7		8.00	Fine sand	5	8.6×10^{-3}	Constant Head
8	FPT-8		10.00	Fine sand	5	1.5×10^{-2}	Constant Head
9	FPT-9		12.00	Fine sand	4	1.8×10^{-2}	Constant Head
10	FPT-10		14.00	Fine sand	7	2.3×10^{-2}	Constant Head
11	FPT-11		16.00	Fine sand	2	1.8×10^{-2}	Constant Head
12	FPT-12		18.00	Fine sand	2	1.2×10^{-2}	Constant Head
13	FPT-13		20.00	Fine sand	2	9.6×10^{-3}	Constant Head
14	FPT-14	BH-3	2.00	Silty fine sand	39	3.2×10^{-4}	Falling Head
15	FPT-15		4.00	Silty fine sand	16	4.7×10^{-4}	Falling Head
16	FPT-16		6.00	Silty fine sand	40	6.0×10^{-4}	Falling Head
17	FPT-17		8.00	Silty fine sand	19	1.1×10^{-1}	Constant Head
18	FPT-18		10.00	Fine sand	5	1.3×10^{-2}	Constant Head
19	FPT-19		12.00	Fine sand	5	6.6×10^{-2}	Constant Head
20	FPT-20		14.00	Fine sand	18	6.7×10^{-2}	Constant Head
21	FPT-21		16.00	Fine sand	1	5.5×10^{-2}	Constant Head
22	FPT-22		18.00	Fine sand	1	5.3×10^{-2}	Constant Head
23	FPT-23		20.00	Fine sand	1	5.3×10^{-2}	Constant Head
24	FPT-24	BH-4	2.00	Silty fine sand	44	1.1×10^{-3}	Falling Head
25	FPT-25		4.00	Silty fine sand	44	4.7×10^{-4}	Falling Head
26	FPT-26		6.00	Silty fine sand	42	1.7×10^{-4}	Falling Head
27	FPT-27		8.00	Fine sand	8	1.1×10^{-1}	Constant Head
28	FPT-28		10.00	Fine sand	8	8.7×10^{-2}	Constant Head
29	FPT-29		12.00	Fine sand	1	6.1×10^{-2}	Constant Head
30	FPT-30		14.00	Fine sand	1	1.0×10^{-1}	Constant Head
31	FPT-31		16.00	Fine sand	5	6.7×10^{-2}	Constant Head
32	FPT-32		18.00	Fine sand	2	7.1×10^{-2}	Constant Head
33	FPT-33		20.00	Fine sand	2	4.8×10^{-2}	Constant Head

S. No.	Test Designation	Borehole Location	Test Depth below EGL, m	Soil Classification	Fines Content, %	Coefficient of Permeability (k), cm/s	Test Method
34	FPT-34	BH-5	2.00	Silty fine sand	38	2.5×10^{-4}	Falling Head
35	FPT-35		4.00	Silty fine sand	38	8.3×10^{-4}	Falling Head
36	FPT-36		6.00	Silty fine sand	38	2.8×10^{-4}	Falling Head
37	FPT-37		8.00	Fine sand	3	1.2×10^{-1}	Constant Head
38	FPT-38		10.00	Fine sand	3	8.9×10^{-2}	Constant Head
39	FPT-39		12.00	Fine sand	4	5.3×10^{-2}	Constant Head
40	FPT-40		14.00	Fine sand	4	1.3×10^{-1}	Constant Head
41	FPT-41		16.00	Fine sand	4	8.4×10^{-2}	Constant Head
42	FPT-42		18.00	Fine sand	4	6.8×10^{-2}	Constant Head
43	FPT-43		20.00	Fine sand	4	4.8×10^{-2}	Constant Head
44	FPT-44		BH-6	2.00	Clayey Silt	80	2.7×10^{-4}
45	FPT-45	4.00		Silty fine sand	36	3.6×10^{-4}	Falling Head
46	FPT-46	6.00		Silty fine sand	20	1.1×10^{-3}	Falling Head
47	FPT-47	8.00		Fine sand	3	6.3×10^{-2}	Constant Head
48	FPT-48	10.00		Fine sand	3	2.2×10^{-2}	Constant Head
49	FPT-49	12.00		Fine sand	3	6.7×10^{-2}	Constant Head
50	FPT-50	14.00		Fine sand	3	3.6×10^{-2}	Constant Head
51	FPT-51	16.00		Fine sand	3	3.1×10^{-2}	Constant Head
52	FPT-52	18.00		Fine sand	2	2.6×10^{-2}	Constant Head
53	FPT-53	20.00		Fine sand	2	3.3×10^{-2}	Constant Head
54	FPT-54	BH-7		2.00	Silty fine sand	49	4.2×10^{-4}
55	FPT-55		4.00	Silty fine sand	49	2.7×10^{-4}	Falling Head
56	FPT-56		6.00	Silty fine sand	36	7.5×10^{-4}	Falling Head
57	FPT-57		8.00	Silty fine sand	15	6.5×10^{-2}	Constant Head
58	FPT-58		10.00	Fine sand	11	2.6×10^{-2}	Constant Head
59	FPT-59		12.00	Silty fine sand	35	7.9×10^{-2}	Constant Head
60	FPT-60		14.00	Fine sand	9	4.3×10^{-2}	Constant Head
61	FPT-61		16.00	Fine sand	9	4.6×10^{-2}	Constant Head
62	FPT-62		18.00	Fine sand	9	4.5×10^{-2}	Constant Head
63	FPT-63		20.00	Fine sand	9	4.2×10^{-2}	Constant Head
64	FPT-64	BH-8	2.00	Sandy silt	19	6.6×10^{-4}	Falling Head
65	FPT-65		4.00	Silty fine sand	36	4.0×10^{-4}	Falling Head
66	FPT-66		6.00	Silty fine sand	19	1.0×10^{-3}	Falling Head
67	FPT-67		8.00	Silty fine sand	19	9.4×10^{-2}	Constant Head
68	FPT-68		10.00	Silty fine sand	19	8.2×10^{-2}	Constant Head
69	FPT-69		12.00	Silty fine sand	21	1.1×10^{-1}	Constant Head
70	FPT-70		14.00	Silty fine sand	21	8.4×10^{-2}	Constant Head
71	FPT-71		16.00	Silty fine sand	21	7.3×10^{-2}	Constant Head
72	FPT-72		18.00	Silty fine sand	21	5.9×10^{-2}	Constant Head
73	FPT-73		20.00	Silty fine sand	21	4.3×10^{-2}	Constant Head

The lower permeabilities are in soils with higher fines content and in samples containing some quantity of clay.

6.0 FOUNDATION ANALYSIS AND RECOMMENDATIONS

6.1 General

A suitable foundation for any structure should have an adequate factor of safety against exceeding the bearing capacity of the supporting soils. Also the vertical movements due to compression of the soils should be within tolerable limits for the structure. We consider that foundations designed in accordance with the recommendations herein will satisfy these criteria.

6.2 Liquefaction Susceptibility Assessment

Liquefaction is defined as the transformation of a granular material from a solid to a liquefied state as a consequence of increased pore-water pressure and reduced effective stress (Marcuson, 1978²). Increased pore pressure may be induced by the tendency of granular materials to compact when subjected to cyclic shear deformation, such as in the event of an earthquake.

As per IS: 1893 (Part 1) - 2002, liquefaction is likely in loose fine sand (SP) below the water table. The following issues are highlighted below with regard to liquefaction potential in the Ash Pond area:

1. The natural soils at the site consist of sandy silt from ground level to 0.5-2.0 m depth. This is underlain by silty fine sand/ fine sand to the maximum explored depth of 20 m.
2. Groundwater was met at depth of about 7.0- 7.1 m depth below EGL.
3. SPT values indicate soils are in medium dense to dense conditions below water table.

Reviewing the site conditions, we are of the opinion that the soils at this site are not likely to liquefy in the event of an earthquake. According Fig. 2 of IS: 1893 (Part-1)-2002 showing seismic zones, the project site falls under Zone-IV. The design for seismic forces should be done considering the project site in Zone- IV.

6.3 Construction of Ash Dyke

The ash dyke is planned to have a height of 18 m. We suggest that a clay core with an outer shell of sand be used to construct the dyke. In general, we suggest slopes of 1-vertical on 2.5-3.5-horizontal for the dyke with 3-4 m wide horizontal berms at every 4-5 m height. A slope stability analysis should be done to ensure a safety factor of not less than 1.5.

To limit seepage of the water into the ground, HDPE / LDPE lining is suitable. Other materials such as geotextile clay liners are also suitable. The overlap / joint between adjacent sheets should be checked carefully for any leakage.

6.4 Foundation Type and Depth

Open foundation may be used to support the structural loads of foundations of the proposed ash dyke. Our recommended values of net allowable bearing pressures for open foundations bearing at 1.5 – 3.0 m embedment depth are presented in **Section 6.6**.

⁽²⁾ Marcuson, W.F. (III) (1978), "**Definition of terms related to liquefaction**", J. Geotech Engg. Div., ASCE, 104(9), 1197-1200.

Ash pond is generally built using a ring embankment to enclose the disposal site. For the design process primarily focus is on handling seepage and ensuring slope stability.

6.5 Concept for Foundation Analysis

Bearing capacity analysis for open foundations has been done in general accordance with IS: 6403-1981.

The bearing capacity equation used is as follows:

$$q_{net\ safe} = \frac{1}{F} [cN_c\zeta_c d_c + q(N_q - 1)\zeta_q d_q + 0.5 B \gamma N_\gamma \zeta_\gamma d_\gamma R_w]$$

Where:

- $q_{net\ safe}$ = safe net bearing capacity of soil based on the shear failure criterion.
 q = overburden pressure
 R_w = water table correction factor,
 F = Factor of safety, taken as equal to 2.5 in accordance with IS:1904-1986.
 $\zeta_c, \zeta_q, \zeta_\gamma$ = Shape factors. For Strip footings, $\zeta_c = \zeta_q = \zeta_\gamma = 1$
 For Square footing, $\zeta_c = 1.3, \zeta_q = 1.2, \zeta_\gamma = 0.6$
 d_c, d_q, d_γ = Depth factors
 For $\phi \leq 10$, $d_c = 1 + 0.2 \tan(45 + \phi / 2) D / B$, $d_q = d_\gamma = 1$
 For $\phi > 10$, $d_c = d_q = d_\gamma = 1 + 0.1 \tan(45 + \phi / 2) D / B$

Appropriate values have been substituted into the bearing capacity equation given above to compute the safe net bearing capacity. The values have been checked to determine the settlement of the foundation under the safe bearing pressure. The allowable bearing pressure has been taken as the lower of the two values computed from the bearing capacity shear failure criterion as well as that computed from the tolerable settlement criterion.

Settlement analysis has been performed based on SPT values in accordance with Clause 9.1.4 of IS 8009 (Part 1) - 1976 Fig.9. The values have been cross checked with the classical theory as the sum of immediate settlement and consolidation settlement. Since sand is primarily encountered, consolidation is not likely to occur. Thus the total settlement is equal to the immediate settlement, which is computed using the following equation [Clause 9.2.3 of IS 8009 Part 1-1976]⁽³⁾:

$$S_i = \frac{qB'(1 - \mu^2)}{E} I_d f d_r$$

where:

- S_i = immediate (elastic) settlement
 B = foundation width, $B' = B/2$
 μ = Poisson's ratio
 q = applied bearing pressure
 E = modulus of elasticity
 d_f = depth factor
 d_r = rigidity factor
 I = influence factor at corner of rectangular loaded area (B'x L')

⁽³⁾ Bowles, J.E. (1996), "**Foundation Analysis and Design**", International Edition, pp. 303-317.

6.6 Design Soil Parameters

Soil parameters used for foundation analysis based on shear criterion are as follows:

Foundation Depth below EGL	c, T/m ²	φ°	Bearing Capacity Factors						Failure Criterion Used for Analysis
			N _c	N _q	N _γ	N _c '	N _q '	N _γ '	
1.5-3.0	0	30	30.14	18.40	22.40	15.87	7.11	6.24	Average of Local and General Shear Failure

where:

c	=	cohesion intercept
φ	=	angle of internal friction
N _c , N _q , N _γ	=	bearing capacity factors (General Shear Failure Criterion)
N _c ', N _q ', N _γ '	=	bearing capacity factors (Local Shear Failure Criterion)

Reviewing the soil characteristics, the following soil parameters have been selected for foundation settlement analysis:

Depth, m		Stratigraphy	c, T/m ²	φ	γ, T/m ³	E, T/m ²
From	To					
0.0	1.5	Sandy silt			1.70	650
1.5	4.0	Silty fine sand	0	30	1.80	1000
4.0	8.0	Silty fine sand	0	31	1.85	1200
8.0	12.0	Silty fine sand	0	31	1.90	1600
12.0	20.0	Silty fine sand	0	32	2.00	2800

where:

c	=	cohesion intercept
φ	=	angle of internal friction
γ	=	bulk density
E	=	modulus of elasticity ⁴

6.7 Recommended Net Allowable Bearing Pressures

The following table presents our recommended net allowable bearing pressures for open foundations in the ash dyke area:

Foundation Embedment Depth below EGL, m	Recommended Net Allowable Bearing Pressure, T/m ²		Suggested Modulus of Subgrade Reaction, kN/m ³
	Total Settlement = 25 mm	Total Settlement = 40 mm	
1.5	9.0	14.4	3600
3.0	13.0	20.8	5200

The above recommended values include a bearing capacity safety factor of 2.5. The appropriate value of net bearing pressure may be selected as per the permissible settlement criterion. Net bearing pressure for foundations at intermediate depths may be interpolated linearly between the values given above. Fill placed above EGL should be treated as surcharge load.

⁴ estimated based on empirical correlations with SPT N-values

In order to restrict the influence of adjacent footings on each other, the lateral edge-to-edge spacing between the foundations should at least be equal to "0.8B" where "B" is the width of the larger footing.

The suggested modulus of sub grade reaction (k) has been computed based on empirical relationships as given in published literature⁽⁵⁾, and is applicable for minimum 2-6 m size square footing at the center of the loaded area.

6.8 Definition of Gross and Net Bearing Pressure

For the purposes of this report, the net allowable bearing pressure should be calculated as the difference between total load on the foundation and the weight of the soil overlying the foundation divided by the effective area of the foundation. The gross bearing pressure is the total pressure at the foundation level including overburden pressure and surcharge load.

The following equations may be used –

$$\begin{aligned} q_{net} &= [(P_s + W_f + W_s) / A_f] - S_v \\ q_{gross} &= q_{net} + S_v = (P_s + W_f + W_s) / A_f \end{aligned}$$

where:

q_{net}	=	net allowable bearing pressure
q_{gross}	=	gross bearing pressure
P_s	=	superimposed static load on foundation
W_f	=	weight of foundation
W_s	=	weight of soil overlying foundation
A_f	=	effective area of foundation
S_v	=	overburden pressure at foundation level prior to excavation for foundation.

It may please be noted that safe bearing pressures recommended in this report refer to "**net values**". Where filling is done, it should be treated as a surcharge over the foundation. The advantage of this gross bearing pressure may be taken while designing the basement and other underground structures.

7.0 FOUNDATION CONSTRUCTION CONSIDERATION

7.1 Excavation

Temporary open cut excavations to about 3.0-3.5 m depth for foundation construction may be cut using side slopes of 1-vertical on 0.8 to 1.0 horizontal. If excessive sloughing or caving is observed, the slopes may be flattened further to ensure stability. A horizontal berm, at least 1.5 m wide, should be provided at every 2 m depth interval for stability purpose.

The engineer should monitor the excavation of slopes. In case excessive sloughing or caving occurs, the slope may be flattened further to ensure stability.

7.2 Foundation Level Preparation

All loose soils should be removed and the exposed foundation bearing surface should be watered and compacted properly using rammers / rollers. The surface should then be protected from

⁽⁵⁾ Bowles, J.E. (1996), "**Foundation Analysis and Design Fifth Edition**", The McGraw-Hill Companies Inc., pp. 503

disturbances due to construction activities so that the foundations may bear on the natural undisturbed ground. We recommend the placement of a 75 to 100 mm thick “blinding layer” of lean concrete to facilitate placement of reinforcing steel and to protect the soils from disturbance.

In case mechanical means like excavators are deployed for excavations, the excavations should be carried out up to 0.5 m above the proposed level. The last 0.5 m depth of excavation should be carried out manually, so that the founding soils are not disturbed / loosened.

7.3 Chemical Attack

Results of chemical test on selected soil samples are presented on Plate 154. The results indicate that the soils contain 0.10-0.11 percent sulphates and 0.03 percent chlorides. The groundwater contains 330-364 mg / litre of sulphates and 287-407 mg / litre of chlorides. The pH value of soil is 7.3-7.4 and that of groundwater is 7.3-7.7 indicating nearly neutral condition.

IS: 456-2000 recommends that precautions should be taken against chemical degradation of concrete if

- sulphates content of the soils exceeds 0.2 percent, or
- groundwater contains more than 300 mg /litre of sulphates (SO_3).

Comparing the test results with these specified limits, the sulphate content of the groundwater is higher than the specified limit. Groundwater is encountered at about 7.0-7.1 m and is likely to influence foundation concrete. Therefore, strata at the site may be treated in **Class-2** category as described on IS: 456-2000.

In our opinion, the groundwater is marginally aggressive to foundation concrete. We recommend the following to limit the potential for chemical attack:

- (1) The cement content in foundations concrete should be at least 330 kg/m^3 .
- (2) Water cement ratio in foundation concrete should generally not exceed 0.50.
- (3) A clear concrete cover over the reinforcement steel of at least 50 mm should be provided for all foundations.
- (4) Foundation concrete should be densified adequately using a vibrator so as to form a dense impervious mass.
- (5) The water to be used for construction should be tested in accordance with the requirements in Clause – of IS: 456 – 2000 to ensure suitability.

8.0 VARIABILITY IN SUB-SURFACE CONDITIONS

Subsurface conditions encountered during construction may vary somewhat from the conditions encountered during the site investigation. In case significant variations are encountered during construction, we request to be notified so that our engineers may review the recommendations in this report in light of these variations.



- Satellite image taken from Google Earth®
- Test Locations marked as per GPS coordinates taken on site using hand-held Garmin® device
- Accuracy of hand-held GPS device generally ranges from 4-6m, and varies depending on the availability of satellite connection at the site

Location: Ash Pond Area
Satellite Image of Site and Test Locations



Plasticity of Clay

Plasticity	Liquid Limit
Low Plastic	< 35
Medium Plastic	35 to 50
High Plastic	> 50

Plasticity Chart

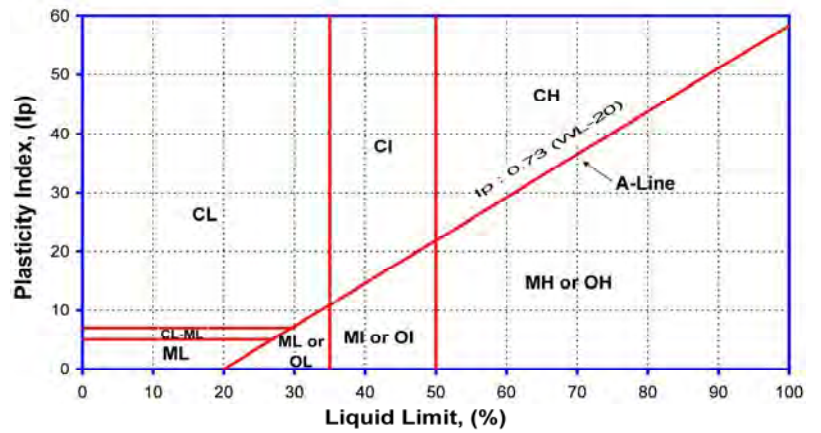

Consistency of Cohesive Soils

Consistency	Cohesion Intercept, kg/sq.cm	SPT (N) Value
Very Soft	< 0.1	0 to 2
Soft	0.1 to 0.25	2 to 4
Firm/Medium	0.25 to 0.5	4 to 8
Stiff	0.5 to 1.0	8 to 15
Very Stiff	1.0 to 2.0	15 to 30
Hard	> 2.0	> 30

Density Condition of Granular Soils

Density Descriptor	SPT (N) Value	Static Cone Tip Resistance kg/sq.cm
Very Loose	0 to 4	< 20
Loose	4 to 10	20 to 40
Medium Dense	10 to 30	40 to 120
Dense	30 to 50	120 to 200
Very dense	> 50	> 200

Degree of Expansion of Fine Grained Soils

Liquid Limit	Plasticity Index	Shrinkage Index	Free Swell Percent	Degree of Expansion	Degree of Severity
20 - 35	< 12	< 15	< 50	Low	Non-critical
35 - 50	12 - 23	15 - 30	50 - 100	Medium	Marginal
50 - 70	23 - 32	30 - 60	100 - 200	High	Critical
70 - 90	> 32	> 60	> 200	Very High	Severe

Engineering Description of Soils



NABL Accredited Laboratory

Our laboratory is accredited to **National Accreditation Board for Testing and Calibration Laboratories (NABL)**, New Delhi. The quality procedures in our laboratory conform to the International Standard **ISO/IEC: 17025-2005**.

The accreditation assures our clients of work quality in conformance with international norms and practices. It authorizes us to use the NABL logo on test results.

To maintain the necessary level of quality and reliability in all measurements on a continual basis, we indulge in the following:

- Use of calibrated equipment, regular maintenance and good housekeeping are a part of our work culture.
- Inter-laboratory comparison, proficiency testing and replicate testing, continuing education - ensure uniform quality of results.
- Internal Audit of quality procedures is done by our qualified ISO 17025 auditors to maintain the requisite standards. NABL conducts external audit.

Uncertainty

Every measurement entails an uncertainty. It is well known that no measuring instrument can determine the true value of any measurement. The cumulative effect of factors such as sensitivity of equipment, accuracy in calibration, human factors and environmental conditions will determine the overall uncertainty in the parameter determined from these measurements.

As a part of our commitment to our clients, we have worked out the uncertainty in the parameters reported by our laboratory. Although this does not form a part of our contract agreement, we present below our statistical estimate of uncertainty of various parameters based on our most recent evaluation (Feb., 2015).

Test / Parameter		Uncertainty*	Test / Parameter		Uncertainty*
Moisture Content		± 0.13 %	Free Swell Index, %		± 2.0 %
Bulk & Dry Density		± 0.0015 g/cc	Swell Pressure		± 0.43 %
Specific Gravity		± 0.014	Consolidation	c _{c1}	± 0.0003
Liquid Limit		± 0.27 %		c _{c2}	± 0.003
Plastic Limit		± 0.19 %		m _v	± 0.0003 cm ² /kg
Shrinkage Limit		± 0.30 %		p _c	± 0.15 kg/cm ²
Unconfined Compression	c	± 0.079 kg/cm ²	CD Direct Shear Test	φ	± 0.29°
UU Triaxial Test	c	± 0.42 %	Soil Gradation	Coarse grained soils	± 0.6% of particle size
	φ	± 0.2 %		Fine grained soils	± 0.5% of particle size
Std/Mod Proctor Compaction	MDD	± 0.03 g/cc	Coefficient of Permeability		± 1.3 % of value
	OMC	± 0.13 %	Rock	Crushing Strength	± 0.80 % of value
Laboratory CBR	± 0.57%	Point Load Strength Index		± 0.04 % of value	

* at 95 percent confidence level for coverage factor of 2

Uncertainty in Laboratory Measurements

Soil Profile (BH-1)

Location : Ash Pond Area

Termination Depth : 20.36 m (RL 22.4 m)

Boring Method : Shell & Auger

UTM Coordinates : 403339.31 m E, 2805366.99 m N

Ground Water Depth : 7.00 m

Casing Depth : 19.9 m

Surface Elevation : RL 42.79 m

Boring Start : 10-Jun-15

Ground Water Level : RL 35.79 m

Boring Finish : 11-Jun-15

ISO/IEC 17025:2005
Certified Laboratory
(NABL)



Certificate No. T-1741

Depth, m		Sample No.	SPT ⁽¹⁾		Symbol	SOIL DESCRIPTION	Depth of Strata, (m)	Grain Size Analysis				Atterberg Limits			Density and Moisture			Specific Gravity	Shear Tests			
From	To		Field Value, N _f	Corrected Value, N _c				Gravel (%)	Sand (%)	Silt (%)	Clay (%)	Liquid (%)	Plastic (%)	Plasticity Index (%)	Bulk Density (gms/cm ³)	Dry Density (gms/cm ³)	Moisture Content (%)		Type of Test	Confining Pressures, (kg/cm ²)	Cohesion Intercept, 'c' (kg/cm ²)	Angle of Internal Friction, φ (degrees)
0.00	0.50	DS1			□	Medium dense brown sandy silt, low plastic (CL)	0.50	0	17	62	20	27.5	16.4	11.1								
0.50	1.00	DS2			■	Medium dense to dense grey silty fine sand (SM)																
1.00	1.45	SPT1	14	20		- medium dense, 0.5 to 8.0 m		0	62	35	3	Non Plastic										
2.00	2.45	SPT2	16	20				0	83	17	0											
3.00	3.30	UDS1										1.83	1.57	16.5	DS	0.5 , 1, 1.5	0.0			32.1		
4.00	4.45	SPT3	22	24				0	78	17	5											
5.00	5.45	SPT4	24	24				0	79	16	5											
6.00	6.30	UDS2										1.85	1.59	16.6								
7.00	7.45	SPT5	28	26											2.65							
8.00	8.45	SPT6	32	29		- dense, 8.0 to 11.0 m		0	86	14	0											
9.00	9.45	SPT7	32	28																		
10.00	10.45	S[PT8	34	29			11.00															

⁽¹⁾ SPT is outside NABL scope.

Soil Profile (BH-1)

Location : Ash Pond Area

Termination Depth : 20.36 m (RL 22.4 m)

Boring Method : Shell & Auger

UTM Coordinates : 403339.31 m E, 2805366.99 m N

Ground Water Depth : 7.00 m

Casing Depth : 19.9 m

Surface Elevation : RL 42.79 m

Boring Start : 10-Jun-15

Ground Water Level : RL 35.79 m

Boring Finish : 11-Jun-15

ISO/IEC 17025:2005
Certified Laboratory
(NABL)



Certificate No. T-1741

Depth, m		SPT ⁽¹⁾	Symbol	SOIL DESCRIPTION	Depth of Strata, (m)	Grain Size Analysis				Atterberg Limits			Density and Moisture			Specific Gravity	Shear Tests				
From	To					Sample No.	Field Value, N _f	Corrected Value, N _c	Gravel (%)	Sand (%)	Silt (%)	Clay (%)	Liquid (%)	Plastic (%)	Plasticity Index (%)		Bulk Density (gms/cm ³)	Dry Density (gms/cm ³)	Moisture Content (%)	Type of Test	Confining Pressures, (kg/cm ²)
11.00	11.45	SPT9	36	31	Dense to very dense grey fine sand (SP-SM) - SP, 14.0 to 20.36 m																
12.00	12.45	SPT10	36	30		0	95	5	0												
13.00	13.45	SPT11	39	32																	
14.00	14.45	SPT12	39	31		0	96	4	0												
15.00	15.00	SPT13	44	35																	
16.00	16.45	SPT14	46	36		1	99	0	0												
17.00	17.45	SPT15	51	39																	
18.00	18.45	SPT16	65	49		0	97	3	0												
19.00	19.41	SPT17	100/ 26cm	100/ 26cm																	
20.00	20.36	SPT18	100/ 21cm	100/ 21cm		20.36	0	98	2	0											

⁽¹⁾ SPT is outside NABL scope.

Soil Profile (BH-2)

Location : Ash Pond Area

Termination Depth : 20.95 m (RL 20.8 m)

Boring Method : Shell & Auger

UTM Coordinates : 403577.35 m E, 2806143.01 m N

Ground Water Depth : 7.10 m

Casing Depth : 19.5 m

Surface Elevation : RL 41.70 m

Boring Start : 13-Jun-15

Ground Water Level : RL 34.60 m

Boring Finish : 15-Jun-15

ISO/IEC 17025:2005
Certified Laboratory
(NABL)



Certificate No. T-1741

Depth, m		Sample No.	SPT ⁽¹⁾		Symbol	SOIL DESCRIPTION	Depth of Strata, (m)	Grain Size Analysis				Atterberg Limits			Density and Moisture			Specific Gravity	Shear Tests			
From	To		Field Value, N _f	Corrected Value, N _c				Gravel (%)	Sand (%)	Silt (%)	Clay (%)	Liquid (%)	Plastic (%)	Plasticity Index (%)	Bulk Density (gms/cm ³)	Dry Density (gms/cm ³)	Moisture Content (%)		Type of Test	Confining Pressures, (kg/cm ²)	Cohesion Intercept, 'c' (kg/cm ²)	Angle of Internal Friction, φ (degrees)
0.00	0.50	DS1			Green Grid	Medium dense brown sandy silt, low plastic (CL)	0.50	0	36	51	12	26.8	14.6	12.2								
0.50	1.00	DS2			Yellow Dotted	Medium dense grey silty fine sand (SM)																
1.50	1.80	UDS1			Yellow Dotted		2.50					1.85	1.59	16.1	DS	0.5 , 1, 1.5	0.0				32.3	
2.50	2.95	SPT1	15	18	Green Grid	Medium dense brown sandy silt, low plastic (CL)	3.50	0	19	61	20	31.8	16.8	15.0								
3.50	3.95	SPT2	33	37	Yellow Dotted	Medium dense to dense brown silty fine sand (SM)																
4.50	4.80	UDS2			Yellow Dotted	- dense, 3.5 to 5.5 m		0	80	16	4	1.83	1.57	16.5	DS	0.5 , 1, 1.5	0.0				30.2	
5.50	5.95	SPT3	21	21	Yellow Dotted	- medium dense, 5.5 to 11.0 m - grey, 5.5 to 11.0 m																
6.50	6.95	SPT4	24	22	Yellow Dotted																	
7.50	7.80	UDS3			Yellow Dotted			0	86	12	2	1.86	1.60	16.0	DS	0.5 , 1, 1.5	0.0				36.2	
8.50	8.95	SPT5	26	23	Yellow Dotted	- dense, 8.0 to 11.0 m									2.62							
9.50	9.95	SPT6	28	24	Yellow Dotted																	
10.50	10.80	DS3			Yellow Dotted		10.80															

⁽¹⁾ SPT is outside NABL scope.

Soil Profile (BH-2)

Location : Ash Pond Area

Termination Depth : 20.95 m (RL 20.8 m)

Boring Method : Shell & Auger

UTM Coordinates : 403577.35 m E, 2806143.01 m N

Ground Water Depth : 7.10 m

Casing Depth : 19.5 m

Surface Elevation : RL 41.70 m

Boring Start : 13-Jun-15

Ground Water Level : RL 34.60 m

Boring Finish : 15-Jun-15

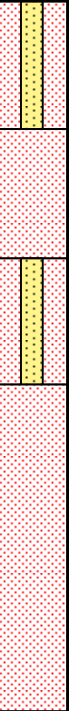

Depth, m		Sample No.	SPT ⁽¹⁾		Symbol	SOIL DESCRIPTION	Depth of Strata, (m)	Grain Size Analysis				Atterberg Limits			Density and Moisture			Specific Gravity	Shear Tests			
From	To		Field Value, N _f	Corrected Value, N _c				Gravel (%)	Sand (%)	Silt (%)	Clay (%)	Liquid (%)	Plastic (%)	Plasticity Index (%)	Bulk Density (gms/cm ³)	Dry Density (gms/cm ³)	Moisture Content (%)		Type of Test	Confining Pressures, (kg/cm ²)	Cohesion Intercept, 'c' (kg/cm ²)	Angle of Internal Friction, φ (degrees)
10.80	11.25	SPT7	34	29		Dense to very dense grey fine sand (SP-SM)		0	95	5	0											
11.50	11.95	SPT8	36	30		- dense, 11.0 to 16.5 m																
12.00	12.95	SPT9	41	34		- SP, 12.0 to 14.5 m		0	96	4	0											
13.50	13.95	SPT10	41	33																		
14.50	14.95	SPT11	42	33		- SP-SM, 14.5 to 16.5 m		0	93	7	0											
15.50	15.95	SPT12	45	35																		
16.50	16.95	SPT13	51	39		- SP, 16.5 to 20.95 m - very dense, 16.5 to 20.95 m		0	98	2	0											
17.50	17.95	SPT14	58	44																		
18.50	18.95	SPT15	68	50				0	98	2	0											
19.50	19.95	SPT16	70	51																		
20.50	20.95	SPT17	91	65			20.95															

⁽¹⁾ SPT is outside NABL scope.

Soil Profile (BH-3)

Location : Ash Pond Area

Termination Depth : 20.36 m (RL 21.3 m)

Boring Method : Shell & Auger

UTM Coordinates : 403748.78 m E, 2806652.14 m N

Ground Water Depth : 7.00 m

Casing Depth : 19.5 m

Surface Elevation : RL 41.70 m

Boring Start : 18-Jun-15

Ground Water Level : RL 34.70 m

Boring Finish : 20-Jun-15

ISO/IEC 17025:2005
Certified Laboratory
(NABL)



Certificate No. T-1741

Depth, m		Sample No.	SPT ⁽¹⁾		Symbol	SOIL DESCRIPTION	Depth of Strata, (m)	Grain Size Analysis				Atterberg Limits			Density and Moisture			Specific Gravity	Shear Tests			
From	To		Field Value, N _f	Corrected Value, N _c				Gravel (%)	Sand (%)	Silt (%)	Clay (%)	Liquid (%)	Plastic (%)	Plasticity Index (%)	Bulk Density (gms/cm ³)	Dry Density (gms/cm ³)	Moisture Content (%)		Type of Test	Confining Pressures, (kg/cm ²)	Cohesion Intercept, 'c' (kg/cm ²)	Angle of Internal Friction, φ (degrees)
0.00	0.50	DS1				Medium dense brown sandy silt, low plastic (CL)	0.50	0	25	58	17	30.9	15.3	15.6								
0.50	1.00	DS2				Medium dense to dense grey silty fine sand (SM)																
1.00	1.45	SPT1	10	14		- medium dense, 0.5 to 8.0 m		0	61	36	3	Non Plastic										
2.00	2.45	SPT2	13	17				0	84	16	0											
3.00	3.30	DS3										1.83	1.59	15.4								
4.00	4.45	SPT3	21	23																		
5.00	5.45	SPT4	25	25				0	81	19	0											
6.00	6.30	UDS1						0	60	35	5	Non Plastic			1.84	1.58	16.4	DS	0.5 ,1, 1.5	0.0	32.3	
7.00	7.45	SPT5	14	13			8.00											2.67				
8.00	8.45	SPT6	14	13		- dense, 8.0 to 11.0 m	9.00	0	40	50	10	25.3	15.2	10.1								
9.00	9.30	UDS2				Medium dense grey fine sand (SP-SM)						1.85	1.58	17.0				DS	0.5 ,1, 1.5	0.0	32.4	
10.00	10.45	SPT7	28	24																		

⁽¹⁾ SPT is outside NABL scope.

Soil Profile (BH-3)

Location : Ash Pond Area

Termination Depth : 20.36 m (RL 21.3 m)

Boring Method : Shell & Auger

UTM Coordinates : 403748.78 m E, 2806652.14 m N

Ground Water Depth : 7.00 m

Casing Depth : 19.5 m

Surface Elevation : RL 41.70 m

Boring Start : 18-Jun-15

Ground Water Level : RL 34.70 m

Boring Finish : 20-Jun-15

ISO/IEC 17025:2005
Certified Laboratory
(NABL)



Certificate No. T-1741

Depth, m		SPT ⁽¹⁾	SOIL DESCRIPTION	Depth of Strata, (m)	Grain Size Analysis				Atterberg Limits			Density and Moisture			Specific Gravity	Shear Tests					
From	To				Field Value, N _f	Corrected Value, N _c	Symbol	Gravel (%)	Sand (%)	Silt (%)	Clay (%)	Liquid (%)	Plastic (%)	Plasticity Index (%)		Bulk Density (gms/cm ³)	Dry Density (gms/cm ³)	Moisture Content (%)	Type of Test	Confining Pressures, (kg/cm ²)	Cohesion Intercept, 'c' (kg/cm ²)
11.00	11.45	SPT8	29	25	14.00																
12.00	12.45	SPT9	35	29		0	95	5	0												
13.00	13.45	SPT10	42	34																	
14.00	14.45	SPT11	42	34	16.00	0	82	18	0												
15.00	15.45	SPT12	46	36																	
16.00	16.45	SPT13	51	39	20.36	0	99	1	0												
17.00	17.45	SPT14	54	41																	
18.00	18.45	SPT15	66	49																	
19.00	19.40	SPT16	100/ 25cm	100/ 25cm																	
20.00	20.36	SPT17	100/ 21cm	100/ 21cm		0	99	1	0												

⁽¹⁾ SPT is outside NABL scope.

Soil Profile (BH-4)

Location : Ash Pond Area

Termination Depth : 20.85 m (RL 20.9 m)

Boring Method : Shell & Auger

UTM Coordinates : 404203.43 m E, 2806545.85 m N

Ground Water Depth : 7.02 m

Casing Depth : 19.9 m

Surface Elevation : RL 41.72 m

Boring Start : 21-Jun-15

Ground Water Level : RL 34.70 m

Boring Finish : 22-Jun-15

ISO/IEC 17025:2005
Certified Laboratory
(NABL)



Certificate No. T-1741

Depth, m		Sample No.	SPT ⁽¹⁾		Symbol	SOIL DESCRIPTION	Depth of Strata, (m)	Grain Size Analysis				Atterberg Limits			Density and Moisture			Specific Gravity	Shear Tests			
From	To		Field Value, N _f	Corrected Value, N _c				Gravel (%)	Sand (%)	Silt (%)	Clay (%)	Liquid (%)	Plastic (%)	Plasticity Index (%)	Bulk Density (gms/cm ³)	Dry Density (gms/cm ³)	Moisture Content (%)		Type of Test	Confining Pressures, (kg/cm ²)	Cohesion Intercept, 'c' (kg/cm ²)	Angle of Internal Friction, φ (degrees)
0.00	0.50	DS1				Medium dense brown sandy silt, low plastic (CL)																
0.50	1.00	DS2				Medium dense to dense grey silty fine sand (SM)	1.50															
1.50	1.80	UDS1				- medium dense, 0.5 to 8.0 m						1.83	1.59	15.4	DS	0.5 ,1, 1.5	0.0				30.8	
2.50	2.95	SPT1	19	23				0	56	40	4	Non Plastic										
3.50	3.95	SPT2	25	28			4.50															
4.50	4.80	UDS2				Medium dense grey sandy silt, low plastic (CL)	5.50	0	4	68	27	34.0	17.9	16.1	1.86	1.60	15.8					
5.50	5.95	SPT3	27	26		Medium dense brown silty fine sand (SM)									2.63							
6.50	6.95	SPT4	19	18		- with traces of gravel, 6.5 to 7.5 m	7.50	3	55	37	5											
7.50	7.80	UDS3				Dense grey fine sand (SP-SM)		0	92	8	0	1.87	1.62	15.7	DS	0.5 ,1, 1.5	0.0				35.1	
8.50	8.95	SPT5	36	32				0	89	11	0											
9.50	9.95	SPT6	36	32																		
10.50	10.95	SPT7	39	33			11.00															

⁽¹⁾ SPT is outside NABL scope.

Soil Profile (BH-4)

Location : Ash Pond Area

Termination Depth : 20.85 m (RL 20.9 m)

Boring Method : Shell & Auger

UTM Coordinates : 404203.43 m E, 2806545.85 m N

Ground Water Depth : 7.02 m

Casing Depth : 19.9 m

Surface Elevation : RL 41.72 m

Boring Start : 21-Jun-15

Ground Water Level : RL 34.70 m

Boring Finish : 22-Jun-15



Depth, m	Sample No.	SPT ⁽¹⁾		Symbol	SOIL DESCRIPTION	Depth of Strata, (m)	Grain Size Analysis				Atterberg Limits			Density and Moisture			Specific Gravity	Shear Tests				
		Field Value, N _f	Corrected Value, N _c				Gravel (%)	Sand (%)	Silt (%)	Clay (%)	Liquid (%)	Plastic (%)	Plasticity Index (%)	Bulk Density (gms/cm ³)	Dry Density (gms/cm ³)	Moisture Content (%)		Type of Test	Confining Pressures, (kg/cm ²)	Cohesion Intercept, 'c' (kg/cm ²)	Angle of Internal Friction, φ (degrees)	
11.50	11.95	SPT8	40	34	Dense to very dense grey fine sand (SP) - dense, 11.0 to 14.5 m - very dense, 14.5 to 20.85 m - SP-SM, 15.5 to 17.5 m - SP, 17.5 to 20.85 m	20.85	0	99	1	0												
12.00	12.95	SPT9	42	35																		
13.50	13.95	SPT10	48	39																		
14.50	14.95	SPT11	56	44																		
15.50	15.95	SPT12	58	45																		
16.50	16.95	SPT13	68	52																		
17.50	17.95	SPT14	71	53																		
18.50	18.95	SPT15	80	59																		
19.50	19.89	SPT16	100/ 24cm	100/ 24cm			0	98	2	0												
20.50	20.85	SPT17	100/ 20cm	100/ 20cm																		

⁽¹⁾ SPT is outside NABL scope.

Soil Profile (BH-5)

Location : Ash Pond Area Termination Depth : 20.36 m (RL 21.3 m) Boring Method : Shell & Auger
 UTM Coordinates : 404597.72 m E, 2806647.28 m N Ground Water Depth : 7.00 m Casing Depth : 20.0 m
 Surface Elevation : RL 41.70 m Boring Start : 23-Jun-15
 Ground Water Level : RL 34.70 m Boring Finish : 24-Jun-15



Depth, m		Sample No.	SPT ⁽¹⁾		Symbol	SOIL DESCRIPTION	Depth of Strata, (m)	Grain Size Analysis				Atterberg Limits			Density and Moisture			Specific Gravity	Shear Tests			
From	To		Field Value, N _f	Corrected Value, N _c				Gravel (%)	Sand (%)	Silt (%)	Clay (%)	Liquid (%)	Plastic (%)	Plasticity Index (%)	Bulk Density (gms/cm ³)	Dry Density (gms/cm ³)	Moisture Content (%)		Type of Test	Confining Pressures, (kg/cm ²)	Cohesion Intercept, 'c' (kg/cm ²)	Angle of Internal Friction, φ (degrees)
0.00	0.50	DS1				Medium dense brown sandy silt, low plastic (CL)																
0.50	1.00	DS2				Medium dense to dense grey silty fine sand (SM)	1.00															
1.00	1.45	SPT1	17	24		- medium dense, 0.5 to 8.0 m		0	62	35	3	31.8	17.9	13.9								
2.00	2.45	SPT2	19	24																		
3.00	3.30	UDS1										1.80	1.55	16.3	DS	0.5 ,1, 1.5	0.0	29.8				
4.00	4.45	SPT3	20	22											2.64							
5.00	5.45	SPT4	24	24																		
6.00	6.30	UDS2					7.00					1.86	1.62	14.9								
7.00	7.45	SPT5	20	18		Medium dense to dense grey fine sand (SP)																
8.00	8.45	SPT6	36	32		- dense, 8.0 to 11.0 m		0	97	3	0											
9.00	9.30	UDS3				- dense, 8.0 to 11.0 m						1.86	1.62	14.8	DS	0.5 ,1, 1.5	0.0	31.1				
10.00	10.45	SPT7	38	33																		

⁽¹⁾ SPT is outside NABL scope.

Soil Profile (BH-5)

Location : Ash Pond Area

Termination Depth : 20.36 m (RL 21.3 m)

Boring Method : Shell & Auger

UTM Coordinates : 404597.72 m E, 2806647.28 m N

Ground Water Depth : 7.00 m

Casing Depth : 20.0 m

Surface Elevation : RL 41.70 m

Boring Start : 23-Jun-15

Ground Water Level : RL 34.70 m

Boring Finish : 24-Jun-15



Depth, m		Sample No.	SPT ⁽¹⁾		Symbol	SOIL DESCRIPTION	Depth of Strata, (m)	Grain Size Analysis				Atterberg Limits			Density and Moisture			Specific Gravity	Shear Tests			
From	To		Field Value, N _f	Corrected Value, N _c				Gravel (%)	Sand (%)	Silt (%)	Clay (%)	Liquid (%)	Plastic (%)	Plasticity Index (%)	Bulk Density (gms/cm ³)	Dry Density (gms/cm ³)	Moisture Content (%)		Type of Test	Confining Pressures, (kg/cm ²)	Cohesion Intercept, 'c' (kg/cm ²)	Angle of Internal Friction, φ (degrees)
11.00	11.45	SPT8	42	36	[Red Dotted Pattern]	Dense to very dense grey fine sand (SP)																
12.00	12.45	SPT9	48	40		- dense, 11.0 to 13.0 m																
13.00	13.45	SPT10	58	47		- very dense, 13.0 to 20.36 m	0	96	4	0												
14.00	14.45	SPT11	62	50																		
15.00	15.45	SPT12	68	54																		
16.00	16.45	SPT13	70	54																		
17.00	17.45	SPT14	76	58																		
18.00	18.45	SPT15	89	66																		
19.00	19.40	SPT16	100/ 25cm	100/ 25cm																		
20.00	20.36	SPT17	100/ 21cm	100/ 21cm			20.36															

⁽¹⁾ SPT is outside NABL scope.

Soil Profile (BH-6)

Location : Ash Pond Area Termination Depth : 20.36 m (RL 21.6 m) Boring Method : Shell & Auger
 UTM Coordinates : 403480.69 m E E, 2805802.09 m N N Ground Water Depth : 7.10 m Casing Depth : 20.0 m
 Surface Elevation : RL 41.92 m Boring Start : 01-Jul-15
 Ground Water Level : RL 34.82 m Boring Finish : 02-Jul-15

ISO/IEC 17025:2005
Certified Laboratory
(NABL)



Certificate No. T-1741

Depth, m		Sample No.	SPT ⁽¹⁾		Symbol	SOIL DESCRIPTION	Depth of Strata, (m)	Grain Size Analysis				Atterberg Limits			Density and Moisture			Specific Gravity	Shear Tests			
From	To		Field Value, N _f	Corrected Value, N _c				Gravel (%)	Sand (%)	Silt (%)	Clay (%)	Liquid (%)	Plastic (%)	Plasticity Index (%)	Bulk Density (gms/cm ³)	Dry Density (gms/cm ³)	Moisture Content (%)		Type of Test	Confining Pressures, (kg/cm ²)	Cohesion Intercept, 'c' (kg/cm ²)	Angle of Internal Friction, φ (degrees)
0.00	0.50	DS1				Loose grey silty fine sand (SM)																
0.50	1.00	DS2				Medium dense to dense grey silty fine sand (SM)	1.00															
1.00	1.45	SPT1	9	9		- medium dense, 0.5 to 8.0 m	2.00	0	20	59	21	41.0	21.3	19.7								
2.00	2.45	SPT2	11	14		Medium dense grey silty fine sand (SM)									1.81	1.58	14.8		DS	0.5 ,1, 1.5	0.0	30.8
3.00	3.30	UDS1																				
4.00	4.45	SPT3	15	16				0	64	31	5	Non Plastic										
5.00	5.45	SPT4	20	20				0	80	20	0											
6.00	6.30	UDS2					7.00								1.86	1.59	17.2		DS	0.5 ,1, 1.5	0.0	32.6
7.00	7.45	SPT5	24	22		Medium dense to dense grey fine sand (SP)																
8.00	8.45	SPT6	30	27		- dense, 8.0 to 11.0 m																
9.00	9.45	SPT7	33	29		- dense, 9.0 to 11.0 m																
10.00	10.45	SPT8	34	29														2.64				

⁽¹⁾ SPT is outside NABL scope.

Soil Profile (BH-6)

Location : Ash Pond Area Termination Depth : 20.36 m (RL 21.6 m) Boring Method : Shell & Auger
 UTM Coordinates : 403480.69 m E E, 2805802.09 m N N Ground Water Depth : 7.10 m Casing Depth : 20.0 m
 Surface Elevation : RL 41.92 m Boring Start : 01-Jul-15
 Ground Water Level : RL 34.82 m Boring Finish : 02-Jul-15

ISO/IEC 17025:2005
Certified Laboratory
(NABL)



Certificate No. T-1741

Depth, m		SPT ⁽¹⁾	Symbol	SOIL DESCRIPTION	Depth of Strata, (m)	Grain Size Analysis				Atterberg Limits			Density and Moisture			Specific Gravity	Shear Tests			
From	To					Sample No.	Field Value, N _f	Corrected Value, N _c	Gravel (%)	Sand (%)	Silt (%)	Clay (%)	Liquid (%)	Plastic (%)	Plasticity Index (%)		Bulk Density (gms/cm ³)	Dry Density (gms/cm ³)	Moisture Content (%)	Type of Test
11.00	11.45	SPT9	37	31	21.36	0	97	3	0											
12.00	12.45	SPT10	46	38		- dense, 11.0 to 14.0 m														
13.00	13.45	SPT11	46	37																
14.00	14.45	SPT12	51	41		- very dense, 14.0 to 21.36 m														
15.00	15.45	SPT13	58	46																
16.00	16.45	SPT14	59	46		0	98	2	0											
17.00	17.45	SPT15	66	50																
18.00	18.45	SPT16	75	56																
19.00	19.41	SPT17	100/ 26cm	100/ 26cm		0	98	2	0											
20.00	20.36	SPT18	100/ 21cm	100/ 21cm																

⁽¹⁾ SPT is outside NABL scope.

Soil Profile (BH-7)

Location : Ash Pond Area

Termination Depth : 20.85 m (RL 21.9 m)

Boring Method : Shell & Auger

UTM Coordinates : 403506.46 m E E, 2805239.68 m N N

Ground Water Depth : 7.10 m

Casing Depth : 20.0 m

Surface Elevation : RL 42.79 m

Boring Start : 28-Jun-15

Ground Water Level : RL 35.69 m

Boring Finish : 30-Jun-15

ISO/IEC 17025:2005
Certified Laboratory
(NABL)



Certificate No. T-1741

Depth, m		Sample No.	SPT ⁽¹⁾		Symbol	SOIL DESCRIPTION	Depth of Strata, (m)	Grain Size Analysis				Atterberg Limits			Density and Moisture			Specific Gravity	Shear Tests			
From	To		Field Value, N _f	Corrected Value, N _c				Gravel (%)	Sand (%)	Silt (%)	Clay (%)	Liquid (%)	Plastic (%)	Plasticity Index (%)	Bulk Density (gms/cm ³)	Dry Density (gms/cm ³)	Moisture Content (%)		Type of Test	Confining Pressures, (kg/cm ²)	Cohesion Intercept, 'c' (kg/cm ²)	Angle of Internal Friction, φ (degrees)
0.00	0.50	DS1				Medium dense brown sandy silt, low plastic (CL)																
0.50	1.00	DS2				Medium dense to dense grey silty fine sand (SM)	1.00															
1.50	1.80	UDS1				- medium dense, 0.5 to 8.0 m						1.83	1.55	18.1		DS	0.5 ,1, 1.5	0.0	28.3			
2.50	2.95	SPT1	20	24		- medium dense, 1.5 to 5.5 m		0	51	45	4	Non Plastic										
3.50	3.95	SPT2	27	30																		
4.50	4.80	UDS2										1.82	1.58	15.2								
5.50	5.95	SPT3	30	29		- dense, 5.5 to 11.0 m		0	62	35	3	Non Plastic										
6.50	6.95	SPT4	31	29				0	64	34	2											
7.50	7.80	UDS3						0	85	15	0	1.84	1.60	14.9		DS	0.5 ,1, 1.5	0.0	31.5			
8.50	8.95	SPT5	37	33		- dense, 8.0 to 9.5 m	9.50															
9.50	9.95	SPT6	41	36		Dense grey fine sand (SP-SM)									2.65							
10.50	10.95	SPT7	42	36			11.00	0	89	11	0											

⁽¹⁾ SPT is outside NABL scope.

Soil Profile (BH-7)

Location : Ash Pond Area

Termination Depth : 20.85 m (RL 21.9 m)

Boring Method : Shell & Auger

UTM Coordinates : 403506.46 m E E, 2805239.68 m N N

Ground Water Depth : 7.10 m

Casing Depth : 20.0 m

Surface Elevation : RL 42.79 m

Boring Start : 28-Jun-15

Ground Water Level : RL 35.69 m

Boring Finish : 30-Jun-15

ISO/IEC 17025:2005
Certified Laboratory
(NABL)



Certificate No. T-1741

Depth, m		SPT ⁽¹⁾	Symbol	SOIL DESCRIPTION	Depth of Strata, (m)	Grain Size Analysis				Atterberg Limits			Density and Moisture			Specific Gravity	Shear Tests			
From	To					Sample No.	Field Value, N _f	Corrected Value, N _c	Gravel (%)	Sand (%)	Silt (%)	Clay (%)	Liquid (%)	Plastic (%)	Plasticity Index (%)		Bulk Density (gms/cm ³)	Dry Density (gms/cm ³)	Moisture Content (%)	Type of Test
11.50	11.95	SPT8	47	39	13.50	0	65	33	2	Non Plastic										
12.00	12.95	SPT9	48	39						Dense grey silty fine sand (SM)										
13.50	13.95	SPT10	51	41	20.85	0	91	9	0											
14.50	14.95	SPT11	56	44						Very dense grey fine sand (SP-SM)										
15.50	15.95	SPT12	66	51																
16.50	16.95	SPT13	68	52																
17.50	17.95	SPT14	75	56																
18.50	18.95	SPT15	100/25cm	100/25cm																
19.50	19.89	SPT16	100/23cm	100/23cm																
20.50	20.85	SPT17	100/20cm	100/20cm																

⁽¹⁾ SPT is outside NABL scope.

Soil Profile (BH-8)

Location : Ash Pond Area

Termination Depth : 20.35 m (RL 21.6 m)

Boring Method : Shell & Auger

UTM Coordinates : 404586.77 m E, 2805103.37 m N

Ground Water Depth : 7.12 m

Casing Depth : 20.0 m

Surface Elevation : RL 41.95 m

Boring Start : 26-Jun-15

Ground Water Level : RL 34.83 m

Boring Finish : 28-Jun-15

ISO/IEC 17025:2005
Certified Laboratory
(NABL)



Certificate No. T-1741

Depth, m		Sample No.	SPT ⁽¹⁾		Symbol	SOIL DESCRIPTION	Depth of Strata, (m)	Grain Size Analysis				Atterberg Limits			Density and Moisture			Specific Gravity	Shear Tests			
From	To		Field Value, N _f	Corrected Value, N _c				Gravel (%)	Sand (%)	Silt (%)	Clay (%)	Liquid (%)	Plastic (%)	Plasticity Index (%)	Bulk Density (gms/cm ³)	Dry Density (gms/cm ³)	Moisture Content (%)		Type of Test	Confining Pressures, (kg/cm ²)	Cohesion Intercept, 'c' (kg/cm ²)	Angle of Internal Friction, φ (degrees)
0.00	0.50	DS1				Medium dense brown sandy silt, low plastic (CL)																
0.50	1.00	DS2				Medium dense to dense grey silty fine sand (SM)																
1.00	1.45	SPT1	15	22		- medium dense, 0.5 to 8.0 m	1.50	0	40	55	5	27.6	15.8	11.8								
2.00	2.45	SPT2	19	24		Medium dense to dense brown silty fine sand (SM)																
3.00	3.30	UDS1				- medium dense, 2.0 to 5.0 m									1.85	1.56	18.5	DS	0.5 ,1, 1.5	0.0	28.3	
4.00	4.45	SPT3	27	29				0	64	33	3	Non Plastic										
5.00	5.45	SPT4	34	34		- dense, 5.0 to 8.0 m		0	81	19	0											
6.00	6.30	UDS2													1.82	1.61	13.3	DS	0.5 ,1, 1.5	0.0	33.7	
7.00	7.45	SPT5	37	34													2.64					
8.00	8.45	SPT6	28	25		- dense, 8.0 to 11.0 m																
9.00	9.45	SPT7	40	35		- dense, 9.0 to 11.0 m																
10.00	10.45	SPT8	42	36			11.00															

⁽¹⁾ SPT is outside NABL scope.

Soil Profile (BH-8)

Location : Ash Pond Area

Termination Depth : 20.35 m (RL 21.6 m)

Boring Method : Shell & Auger

UTM Coordinates : 404586.77 m E, 2805103.37 m N

Ground Water Depth : 7.12 m

Casing Depth : 20.0 m

Surface Elevation : RL 41.95 m

Boring Start : 26-Jun-15

Ground Water Level : RL 34.83 m

Boring Finish : 28-Jun-15

ISO/IEC 17025:2005
Certified Laboratory
(NABL)



Certificate No. T-1741

Depth, m		SPT ⁽¹⁾	SOIL DESCRIPTION	Depth of Strata, (m)	Grain Size Analysis				Atterberg Limits			Density and Moisture			Specific Gravity	Shear Tests						
From	To				Sample No.	Field Value, N _f	Corrected Value, N _c	Symbol	Gravel (%)	Sand (%)	Silt (%)	Clay (%)	Liquid (%)	Plastic (%)		Plasticity Index (%)	Bulk Density (gms/cm ³)	Dry Density (gms/cm ³)	Moisture Content (%)	Type of Test	Confining Pressures, (kg/cm ²)	Cohesion Intercept, 'c' (kg/cm ²)
11.00	11.45	SPT9	45	38	Dense brown fine sand (SP-SM) Very dense brown silty fine sand (SM)	12.00	0	90	10	0												
12.00	12.45	SPT10	56	46																		
13.00	13.45	SPT11	58	47																		
14.00	14.45	SPT12	59	47																		
15.00	15.45	SPT13	66	52																		
16.00	16.45	SPT14	70	54																		
17.00	17.45	SPT15	78	59																		
18.00	18.41	SPT16	100/ 26cm	100/ 26cm				0	79	21	0											
19.00	19.38	SPT17	100/ 23cm	100/ 23cm																		
20.00	20.35	SPT18	100/ 20cm	100/ 20cm			20.35															

⁽¹⁾ SPT is outside NABL scope.

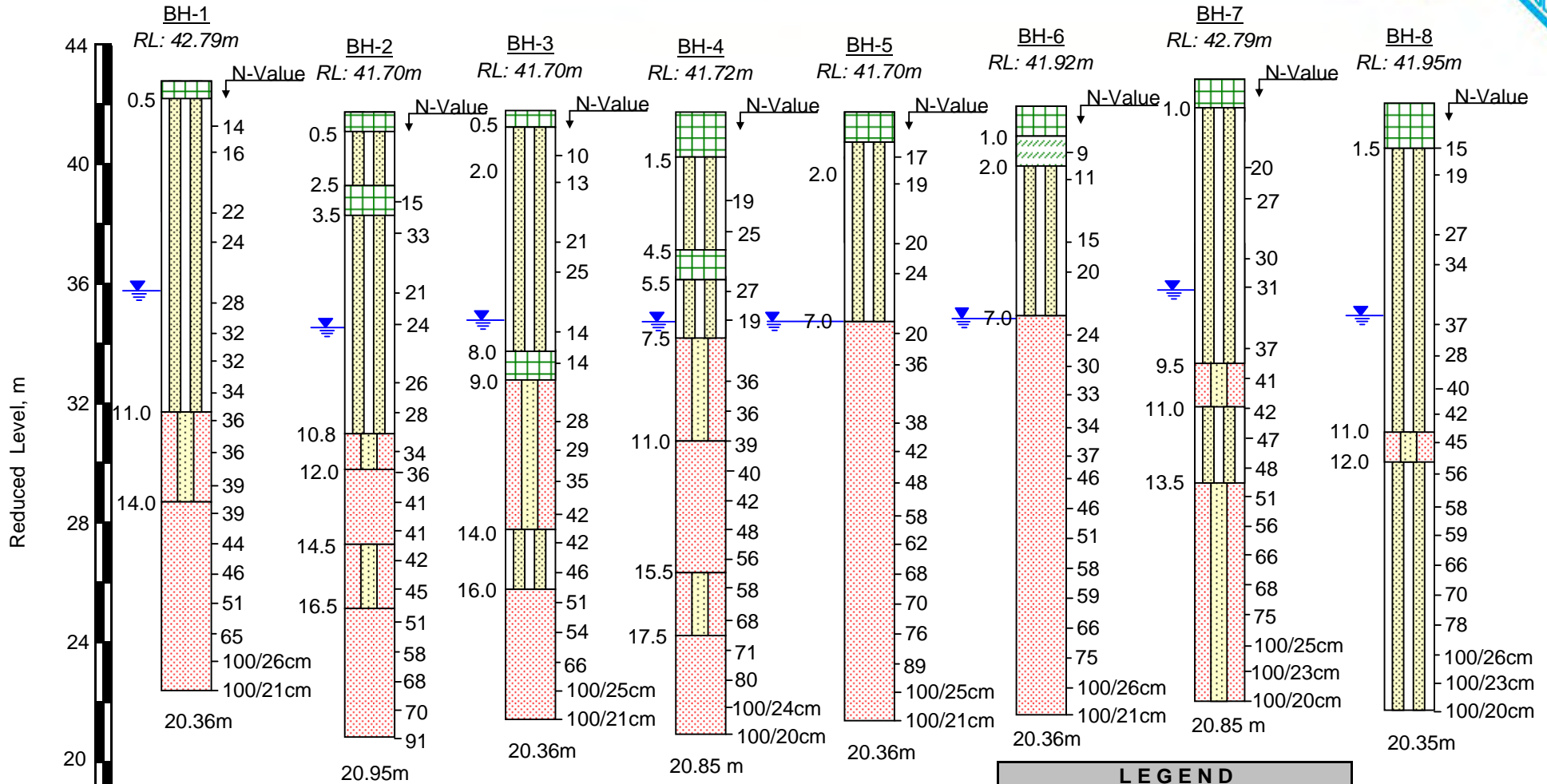

LEGEND	
SYMBOL	DESCRIPTION
	Silty fine sand (SM)
	Fine sand (SP-SM)
	Sandy silt (CL)
	Fine sand (SP)
	Clayey silt (CI)
	Water table

Location : Ash Pond Area
Summary of Borehole Profiles



Standard Penetration Test

IS : 2131-1981, RA-2007

Borehole Details			
Symbol	Borehole Number	Reduced Level, m	Location
○	BH-1	42.79	Ash Pond Area
●	BH-2	41.70	
△	BH-3	41.70	
▲	BH-4	41.72	
□	BH-5	41.70	
■	BH-6	41.92	

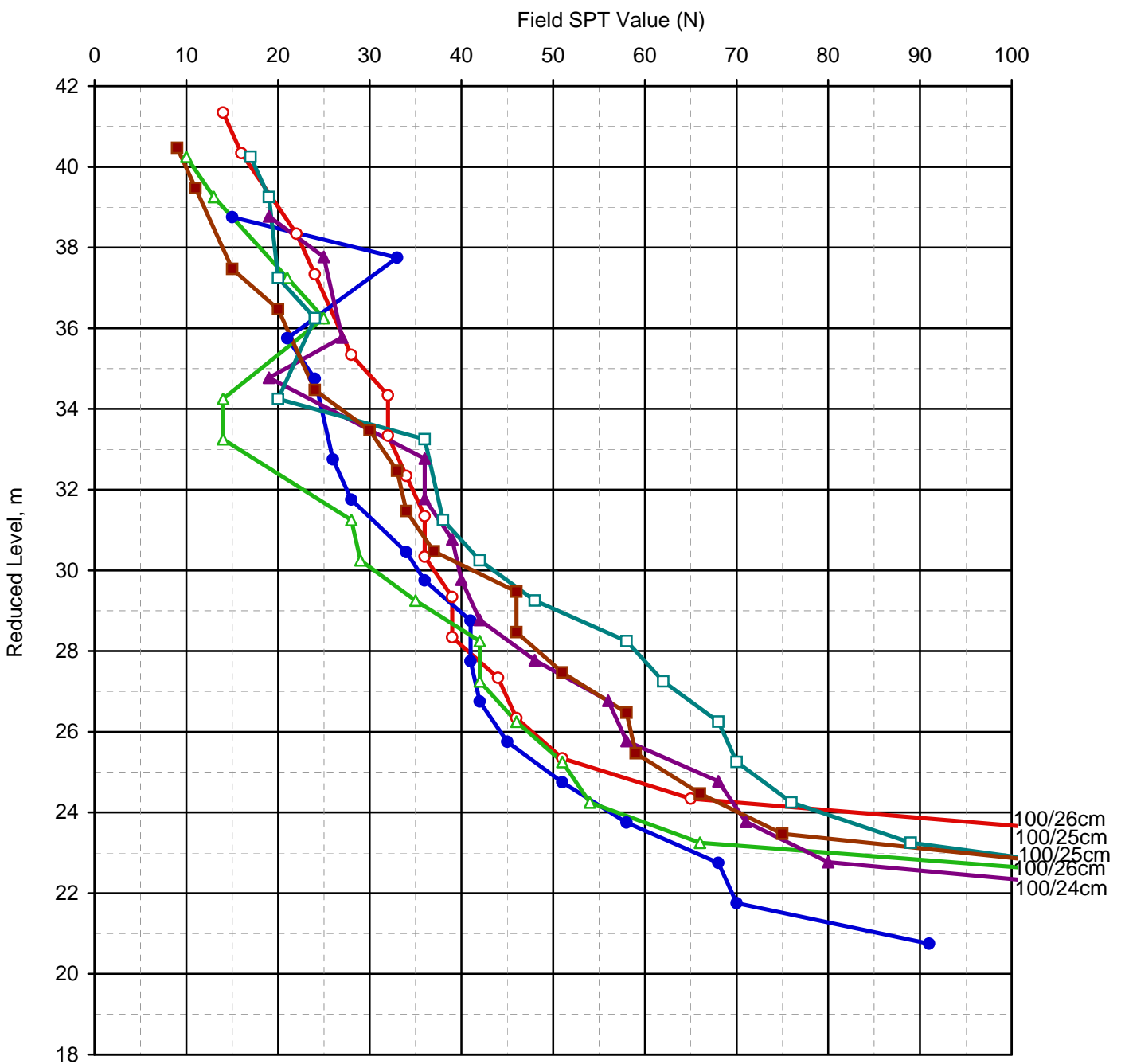

Field SPT Values vs. Reduced Level



Standard Penetration Test

IS : 2131-1981, RA-2007

Borehole Details			
Symbol	Borehole Number	Reduced Level, m	Location
○	BH-1	42.79	Ash Pond Area
●	BH-2	41.70	
△	BH-3	41.70	
▲	BH-4	41.72	
□	BH-5	41.70	
■	BH-6	41.92	

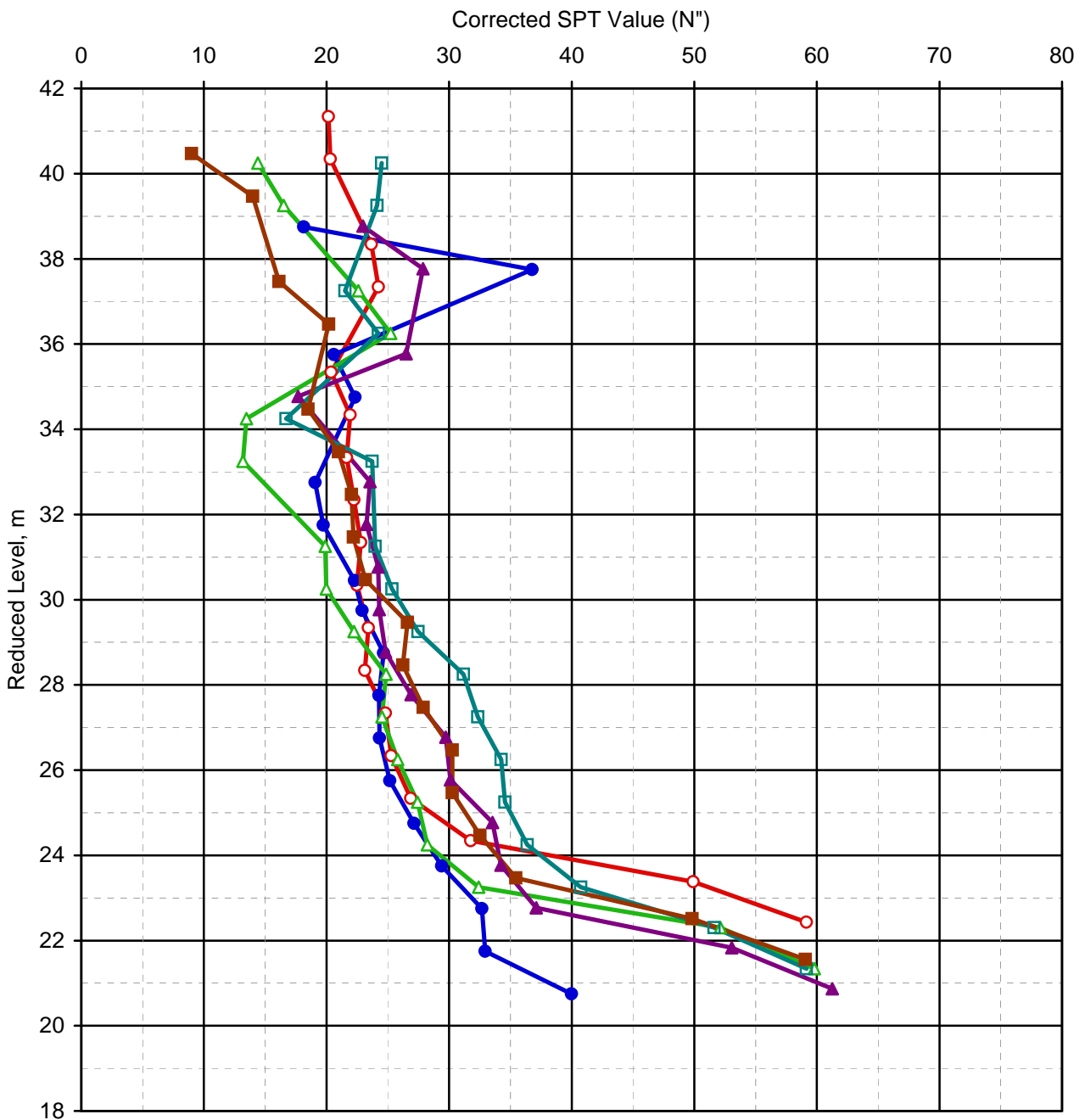

Corrected SPT Values vs. Reduced Level



Standard Penetration Test

IS : 2131-1981, RA-2007

Borehole Details			
Symbol	Borehole Number	Reduced Level, m	Location
○	BH-7	42.79	Ash Pond Area
●	BH-8	41.95	

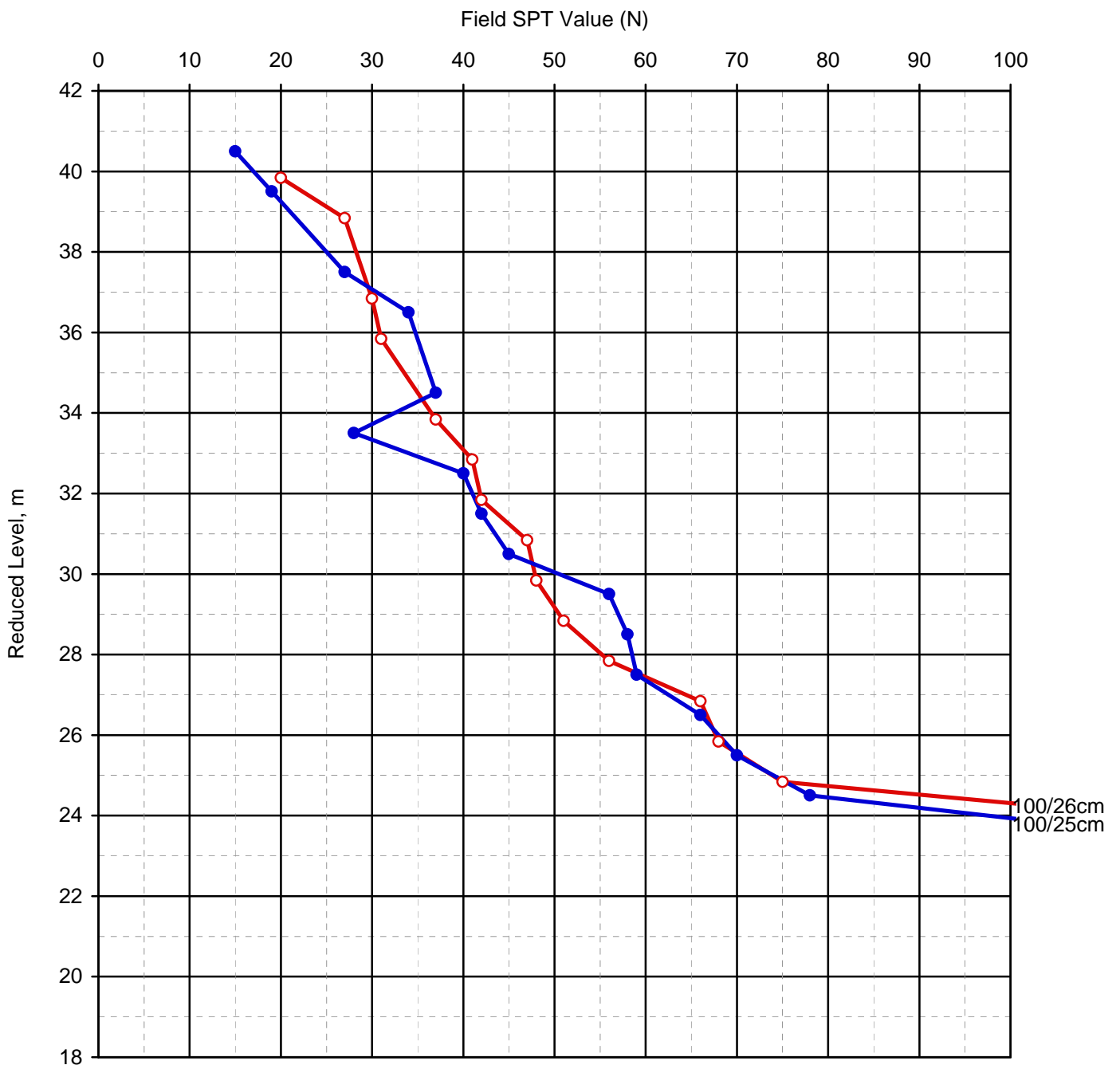

Field SPT Values vs. Reduced Level



Standard Penetration Test

IS : 2131-1981, RA-2007

Borehole Details			
Symbol	Borehole Number	Reduced Level, m	Location
○	BH-7	42.79	Ash Pond Area
●	BH-8	41.95	

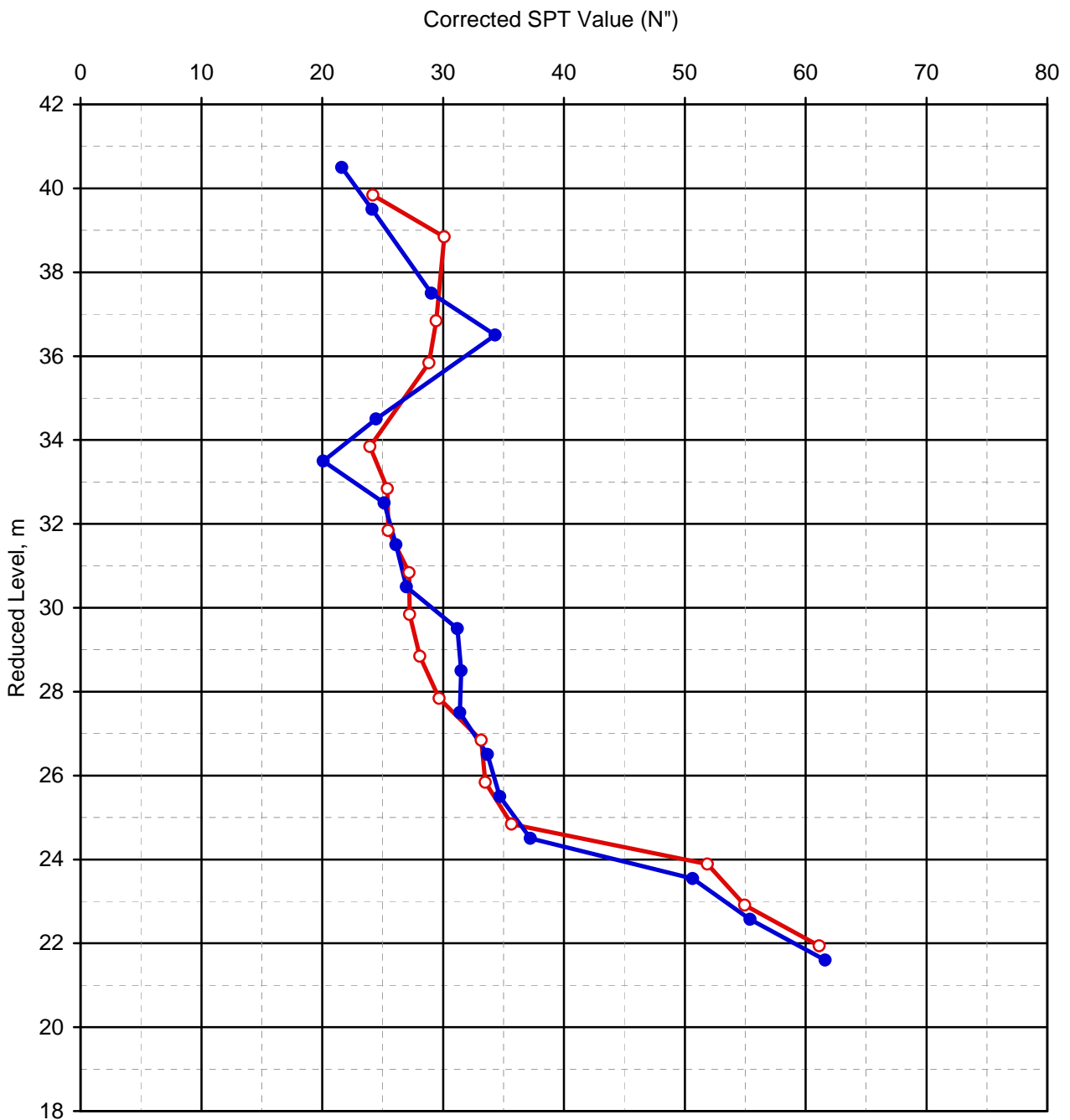

Corrected SPT Values vs. Reduced Level



Field Permeability Test No.: FPT-1

By Falling Head Method

IS: 5529-Part-1-1985, RA-2009

Test Details	
Borehole No. :	BH : 1
Location :	Ash Pond Area
Reduced Level (RL) :	N/A
UTM Coordinates :	403339.31 m E, 2805366.99 m N
Depth of Borehole :	2.0 m
Depth of bottom of casing below EGL :	1.50 m
Diameter of Intake Pipe :	15.0 cm
Length of Test Section :	50.0 cm
Depth of Water Table :	7.0 m
Height of Casing above GL :	0.60 m
Hydraulic Head at Start of test :	235 cm
Soil Classification :	Silty fine sand

Sl. No.	Time in Minutes	Water Level in Intake Pipe, cm	Head, cm	Sl. No.	Time in Minutes	Water Level in Intake Pipe, cm	Head, cm
1	0.0	0.0	235				
2	1.0	1.0	234				
3	2.0	2.0	233				
4	3.0	3.0	232				
5	4.0	4.0	231				
6	5.0	5.0	230				
7	7.0	7.0	228				
8	9.0	9.0	226				
9	11.0	11.0	224				
10	13.0	13.0	222				
11	15.0	15.0	220				
12	20.0	20.0	215				
13	25.0	25.0	210				
14	30.0	30.0	205				
15	35.0	35.0	200				

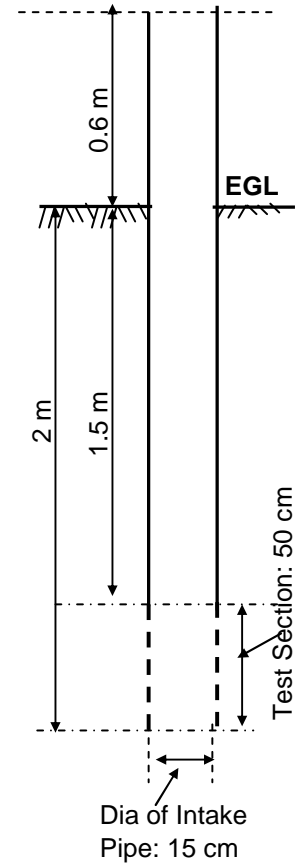

$$k = \text{Coefficient of Permeability} = \frac{d^2}{8L(t_2 - t_1)} \ln\left(\frac{2L}{d}\right) \ln\left(\frac{h_1}{h_2}\right)$$

Where:

L =	50.0	cm	d =	15.0	cm
2L/d =	6.67		R =	7.5	cm
$h_1/h_0 =$	0.86		$t_1 =$	30	minutes
$h_2/h_0 =$	0.84		$t_2 =$	35.6	minutes
$h_1/h_2 =$	1.025				

Calculations based on semilog plot of Head Ratio vs. Time, as per IS:5529 (Part-I)

$$k = 7.8E-05 \text{ cm/sec}$$

Determination of Coefficient of Permeability (FPT-1)



Field Permeability Test No.: FPT-1

By Falling Head Method

(IS: 5529-Part-1-1985, RA-2009)

Test Details
Borehole No. : BH : 1
Location : Ash Pond Area
Reduced Level (RL) : N/A
UTM Coordinates : 403339.31 m E, 2805366.99 m N
Depth of Borehole : 2.0
Calculated value of k : 7.8E-05

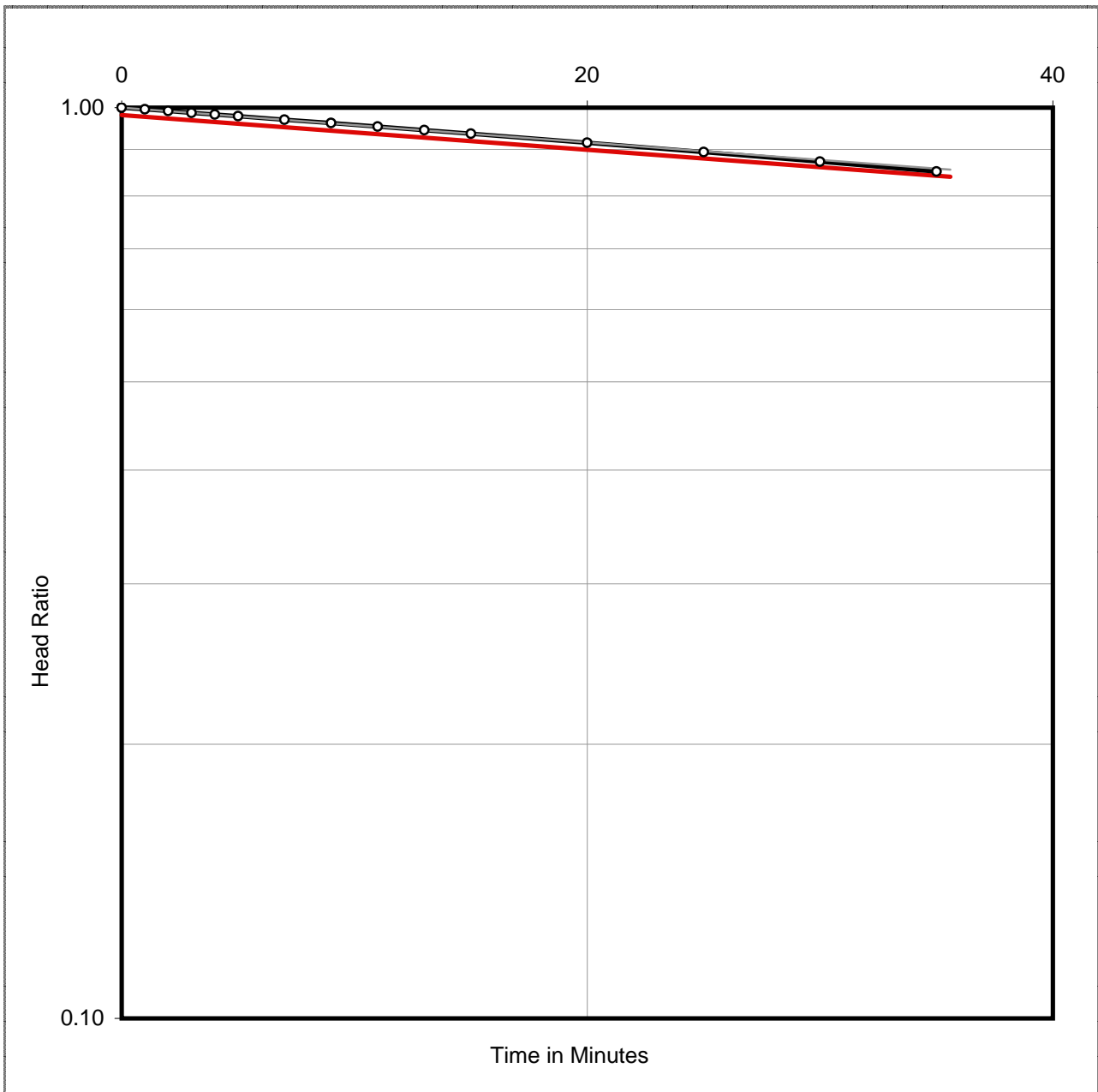

Semi-Log Plot of Head Ratio Vs Time (FPT-1)



Field Permeability Test No.: FPT-2

By Falling Head Method

IS: 5529-Part-1-1985, RA-2009

Test Details	
Borehole No. :	BH : 1
Location :	Ash Pond Area
Reduced Level (RL) :	N/A
UTM Coordinates :	403339.31 m E, 2805366.99 m N
Depth of Borehole :	4.0 m
Depth of bottom of casing below EGL :	3.50 m
Diameter of Intake Pipe :	15.0 cm
Length of Test Section :	50.0 cm
Depth of Water Table :	7.0 m
Height of Casing above GL :	0.31 m
Hydraulic Head at Start of test :	406 cm
Soil Classification :	Silty fine sand

Sl. No.	Time in Minutes	Water Level in Intake Pipe, cm	Head, cm	Sl. No.	Time in Minutes	Water Level in Intake Pipe, cm	Head, cm
1	0.0	0.0	406	19	55.0	232.0	174
2	1.0	20.0	386	20	60.0	240.0	166
3	2.0	33.0	373	21	65.0	247.0	159
4	3.0	44.0	362	22	70.0	254.0	152
5	4.0	53.0	353	23	75.0	259.0	147
6	5.0	64.0	342	24	80.0	265.0	141
7	7.0	73.0	333	25	85.0	270.0	136
8	9.0	90.0	316	26	90.0	274.0	132
9	11.0	91.0	315	27	95.0	278.0	128
10	13.0	110.0	296	28	100.0	282.0	124
11	15.0	119.0	287	29	105.0	286.0	120
12	20.0	145.0	261				
13	25.0	163.0	243				
14	30.0	175.0	231				
15	35.0	190.0	216				
16	40.0	203.0	203				
17	45.0	216.0	190				
18	50.0	225.0	181				

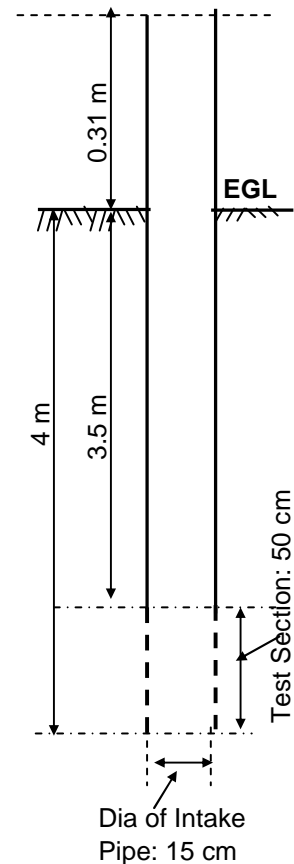

$$k = \text{Coefficient of Permeability} = \frac{d^2}{8L(t_2 - t_1)} \ln\left(\frac{2L}{d}\right) \ln\left(\frac{h_1}{h_2}\right)$$

Where:

L =	50.0	cm	d =	15.0	cm
2L/d =	6.67		R =	7.5	cm
h ₁ /h ₀ =	0.46		t ₁ =	30	minutes
h ₂ /h ₀ =	0.30		t ₂ =	106	minutes
h ₁ /h ₂ =	1.539				

Calculations based on semilog plot of Head Ratio vs. Time, as per IS:5529 (Part-I)

$$k = 1.0E-04 \text{ cm/sec}$$

Determination of Coefficient of Permeability (FPT-2)



Field Permeability Test No.: FPT-2

By Falling Head Method

(IS: 5529-Part-1-1985, RA-2009)

Test Details
Borehole No. : BH : 1
Location : Ash Pond Area
Reduced Level (RL) : N/A
UTM Coordinates : 403339.31 m E, 2805366.99 m N
Depth of Borehole : 4.0
Calculated value of k : 1.0E-04

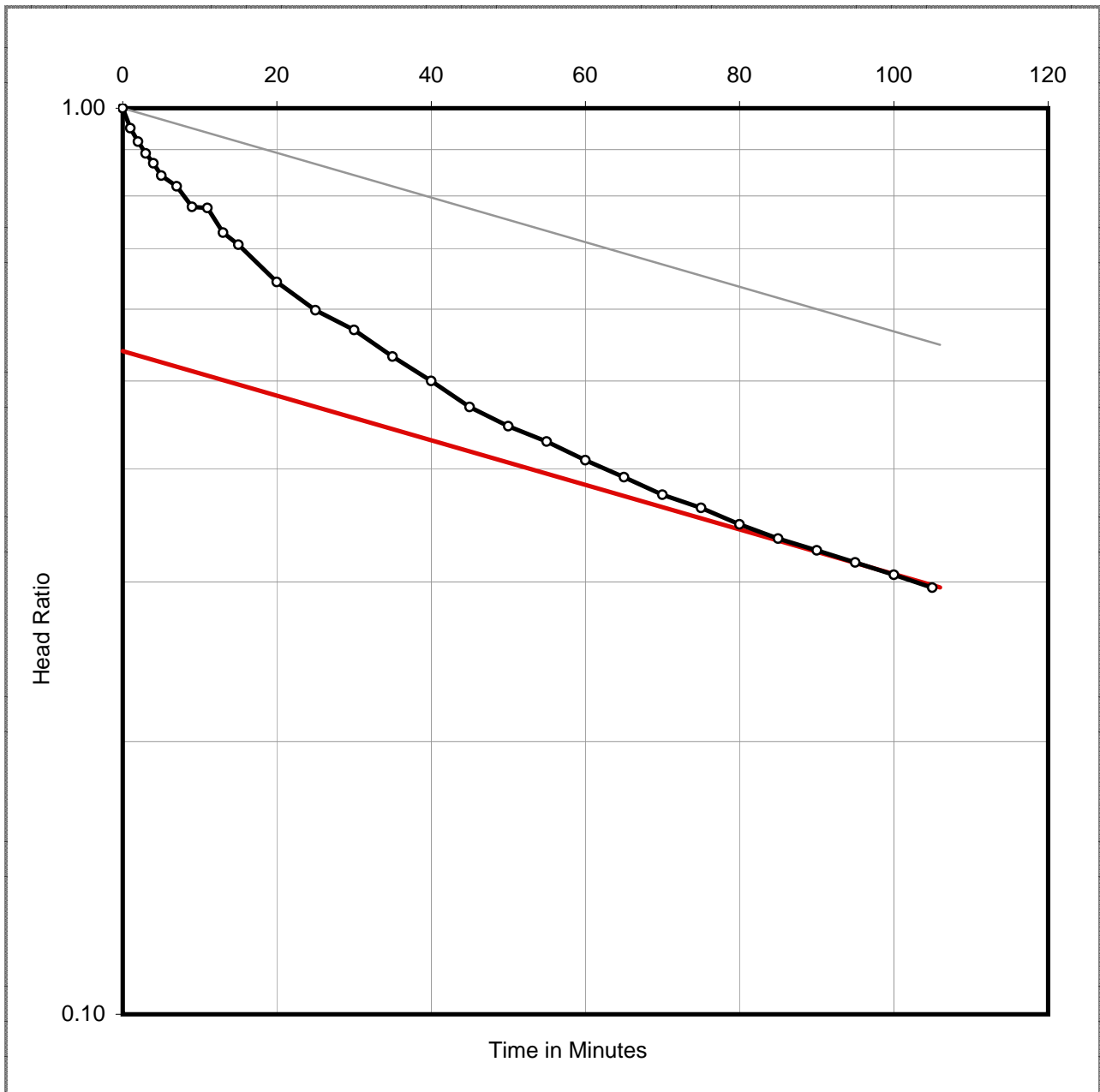

Semi-Log Plot of Head Ratio Vs Time (FPT-2)



Field Permeability Test No.: FPT-3

By Falling Head Method

IS: 5529-Part-1-1985, RA-2009

Test Details	
Borehole No. :	BH : 1
Location :	Ash Pond Area
Reduced Level (RL) :	N/A
UTM Coordinates :	403339.31 m E, 2805366.99 m N
Depth of Borehole :	6.0 m
Depth of bottom of casing below EGL :	5.50 m
Diameter of Intake Pipe :	15.0 cm
Length of Test Section :	50.0 cm
Depth of Water Table :	7.0 m
Height of Casing above GL :	0.25 m
Hydraulic Head at Start of test :	600 cm
Soil Classification :	Silty fine sand

Sl. No.	Time in Minutes	Water Level in Intake Pipe, cm	Head, cm	Sl. No.	Time in Minutes	Water Level in Intake Pipe, cm	Head, cm
1	0.0	0.0	600	19	31.0	433.0	167
2	1.0	65.0	535	20	36.0	447.0	153
3	2.0	118.0	482	21	41.0	458.0	142
4	3.0	155.0	445	22	46.0	466.0	134
5	4.0	185.0	415				
6	5.0	220.0	380				
7	6.0	245.0	355				
8	7.0	270.0	330				
9	8.0	285.0	315				
10	9.0	300.0	300				
11	10.0	308.0	292				
12	11.0	318.0	282				
13	13.0	336.0	264				
14	15.0	353.0	247				
15	17.0	364.0	236				
16	19.0	380.0	220				
17	21.0	393.0	207				
18	26.0	415.0	185				

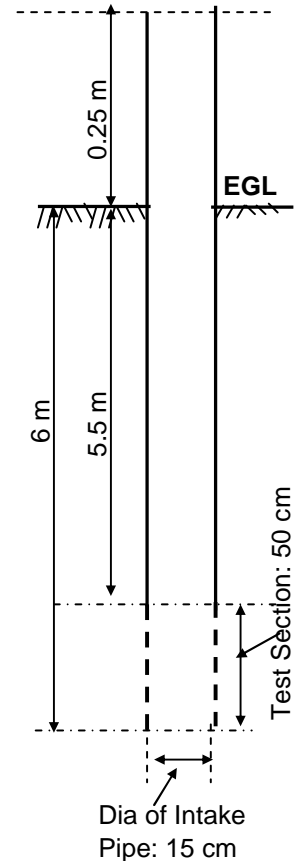

$$k = \text{Coefficient of Permeability} = \frac{d^2}{8L(t_2 - t_1)} \ln\left(\frac{2L}{d}\right) \ln\left(\frac{h_1}{h_2}\right)$$

Where:

L =	50.0	cm	d =	15.0	cm
2L/d =	6.67		R =	7.5	cm
$h_1/h_0 =$	0.28		$t_1 =$	30	minutes
$h_2/h_0 =$	0.17		$t_2 =$	61.4	minutes
$h_1/h_2 =$	1.592				

Calculations based on semilog plot of Head Ratio vs. Time, as per IS:5529 (Part-I)

$$k = 2.6E-04 \text{ cm/sec}$$

Determination of Coefficient of Permeability (FPT-3)



Field Permeability Test No.: FPT-3

By Falling Head Method

(IS: 5529-Part-1-1985, RA-2009)

Test Details
Borehole No. : BH : 1
Location : Ash Pond Area
Reduced Level (RL) : N/A
UTM Coordinates : 403339.31 m E, 2805366.99 m N
Depth of Borehole : 6.0
Calculated value of k : 2.6E-04

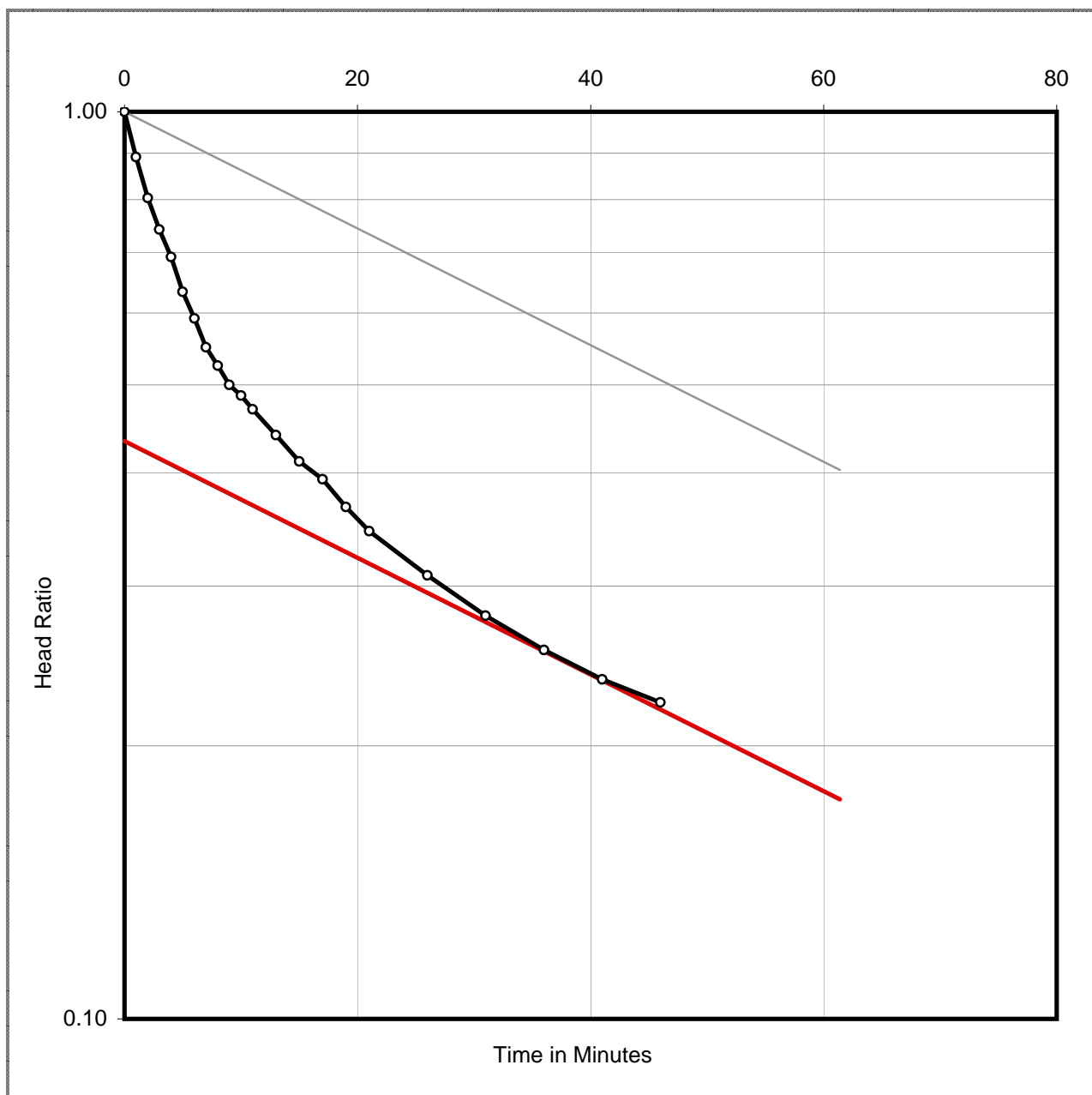

Semi-Log Plot of Head Ratio Vs Time (FPT-3)



Field Permeability Test No.: FPT-4

By Falling Head Method

IS: 5529-Part-1-1985, RA-2009

Test Details	
Borehole No. :	BH : 2
Location :	Ash Pond Area
Reduced Level (RL) :	N/A
UTM Coordinates :	403577.35 m E, 2806143.01 m N
Depth of Borehole :	2.0 m
Depth of bottom of casing below EGL :	1.50 m
Diameter of Intake Pipe :	15.0 cm
Length of Test Section :	50.0 cm
Depth of Water Table :	7.1 m
Height of Casing above GL :	0.12 m
Hydraulic Head at Start of test :	187 cm
Soil Classification :	Silty fine sand

Sl. No.	Time in Minutes	Water Level in Intake Pipe, cm	Head, cm	Sl. No.	Time in Minutes	Water Level in Intake Pipe, cm	Head, cm
1	0.0	0.0	187	19	40.0	160.0	27
2	1.0	30.0	157	20	45.0	164.0	23
3	2.0	52.0	135	21	50.0	167.0	20
4	3.0	65.0	122	22	55.0	169.0	18
5	4.0	75.0	112	23	60.0	171.0	16
6	6.0	87.0	100				
7	8.0	99.0	88				
8	10.0	107.0	80				
9	12.0	115.0	72				
10	14.0	122.0	65				
11	16.0	128.0	59				
12	18.0	133.0	54				
13	20.0	138.0	49				
14	22.0	142.0	45				
15	24.0	145.0	42				
16	26.0	148.0	39				
17	30.0	152.0	35				
18	35.0	157.0	30				

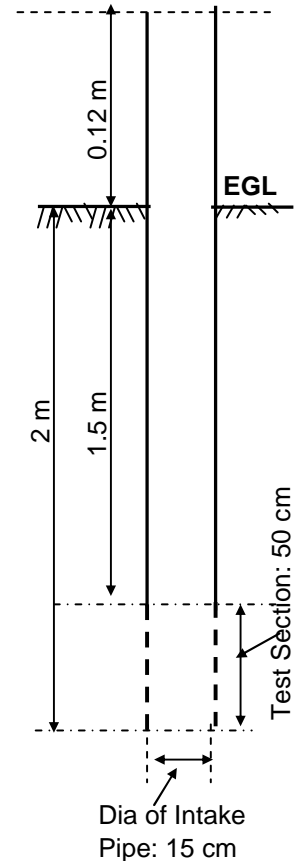

$$k = \text{Coefficient of Permeability} = \frac{d^2}{8L(t_2 - t_1)} \ln\left(\frac{2L}{d}\right) \ln\left(\frac{h_1}{h_2}\right)$$

Where:

L =	50.0	cm	d =	15.0	cm
2L/d =	6.67		R =	7.5	cm
h ₁ /h ₀ =	0.18		t ₁ =	30	minutes
h ₂ /h ₀ =	0.07		t ₂ =	68.1	minutes
h ₁ /h ₂ =	2.683				

Calculations based on semilog plot of Head Ratio vs. Time, as per IS:5529 (Part-I)

$$k = 4.6E-04 \text{ cm/sec}$$

Determination of Coefficient of Permeability (FPT-4)



Field Permeability Test No.: FPT-4

By Falling Head Method

(IS: 5529-Part-1-1985, RA-2009)

Test Details
Borehole No. : BH : 2
Location : Ash Pond Area
Reduced Level (RL) : N/A
UTM Coordinates : 403577.35 m E, 2806143.01 m N
Depth of Borehole : 2.0
Calculated value of k : 4.6E-04

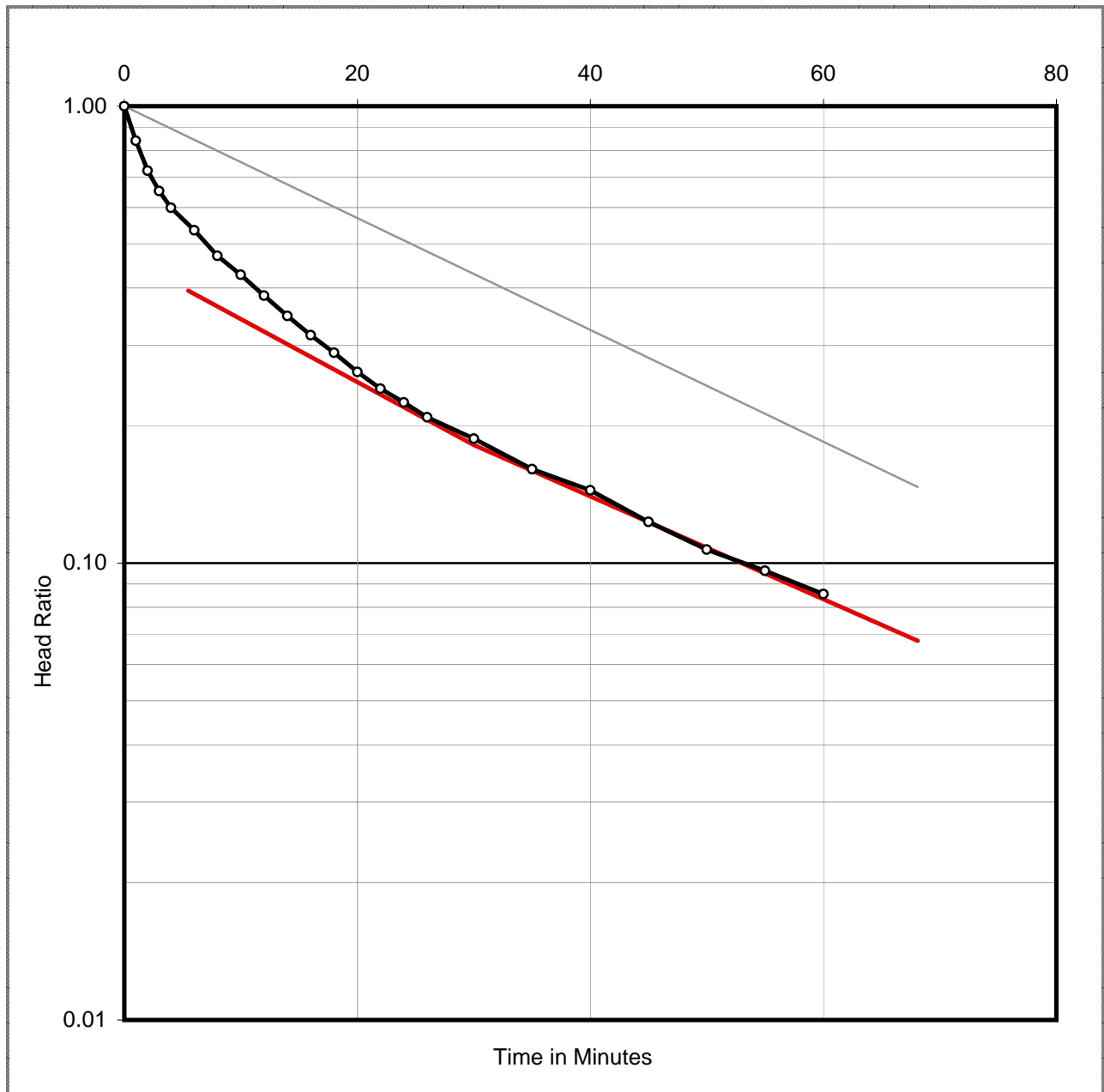

Semi-Log Plot of Head Ratio Vs Time (FPT-4)



Field Permeability Test No.: FPT-5

By Falling Head Method

IS: 5529-Part-1-1985, RA-2009

Test Details	
Borehole No. :	BH : 2
Location :	Ash Pond Area
Reduced Level (RL) :	N/A
UTM Coordinates :	403577.35 m E, 2806143.01 m N
Depth of Borehole :	4.0 m
Depth of bottom of casing below EGL :	3.50 m
Diameter of Intake Pipe :	15.0 cm
Length of Test Section :	50.0 cm
Depth of Water Table :	7.1 m
Height of Casing above GL :	0.16 m
Hydraulic Head at Start of test :	391 cm
Soil Classification :	Silty fine sand

Sl. No.	Time in Minutes	Water Level in Intake Pipe, cm	Head, cm	Sl. No.	Time in Minutes	Water Level in Intake Pipe, cm	Head, cm
1	0.0	0.0	391	19	29.0	140.0	251
2	1.0	29.0	362	20	31.0	145.0	246
3	2.0	35.0	356	21	33.0	149.0	242
4	3.0	44.0	347	22	35.0	154.0	237
5	4.0	51.0	340	23	40.0	166.0	225
6	5.0	57.0	334	24	45.0	175.0	216
7	6.0	62.0	329	25	50.0	185.0	206
8	7.0	70.0	321	26	55.0	195.0	196
9	9.0	78.0	313	27	60.0	206.0	185
10	11.0	86.0	305	28	65.0	215.0	176
11	13.0	93.0	298	29	70.0	222.0	169
12	15.0	100.0	291	30	75.0	228.0	163
13	17.0	106.0	285	31	80.0	232.0	159
14	19.0	112.0	279				
15	21.0	117.0	274				
16	23.0	124.0	267				
17	25.0	130.0	261				
18	27.0	136.0	255				

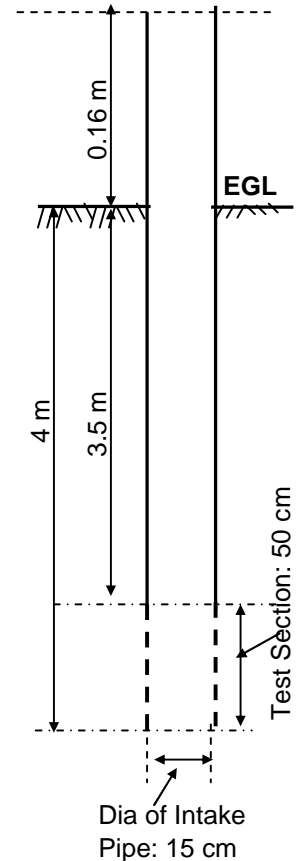

$$k = \text{Coefficient of Permeability} = \frac{d^2}{8L(t_2 - t_1)} \ln\left(\frac{2L}{d}\right) \ln\left(\frac{h_1}{h_2}\right)$$

Where:

L = 50.0 cm	d = 15.0 cm
2L/d = 6.67	R = 7.5 cm
$h_1/h_0 = 0.46$	$t_1 = 61.2$ minutes
$h_2/h_0 = 0.33$	$t_2 = 110.4$ minutes
$h_1/h_2 = 1.399$	

Calculations based on semilog plot of Head Ratio vs. Time, as per IS:5529 (Part-I)

$$k = 1.2E-04 \text{ cm/sec}$$

Determination of Coefficient of Permeability (FPT-5)



Field Permeability Test No.: FPT-5

By Falling Head Method

(IS: 5529-Part-1-1985, RA-2009)

Test Details
Borehole No. : BH : 2
Location : Ash Pond Area
Reduced Level (RL) : N/A
UTM Coordinates : 403577.35 m E, 2806143.01 m N
Depth of Borehole : 4.0
Calculated value of k : 1.2E-04

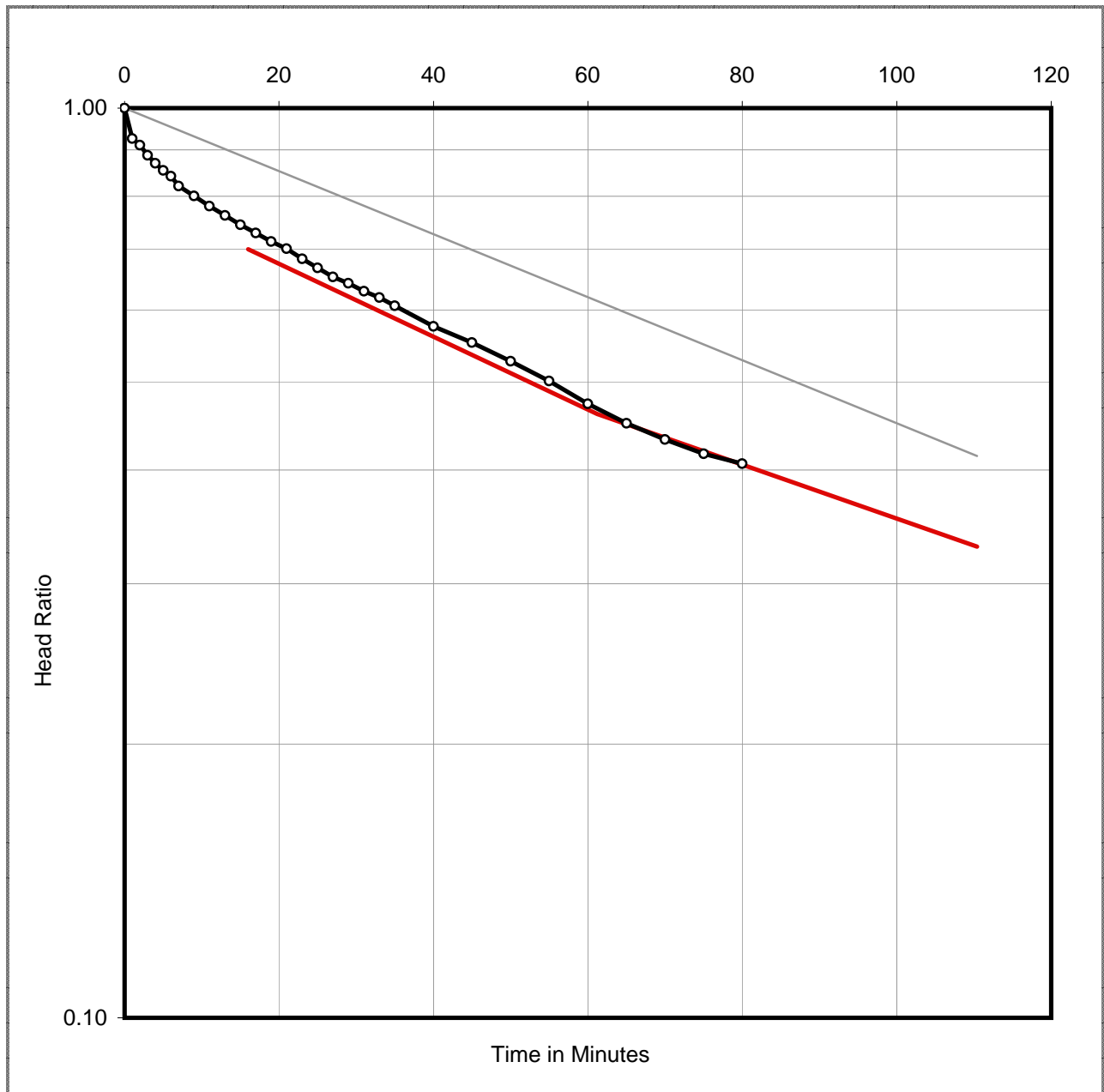

Semi-Log Plot of Head Ratio Vs Time (FPT-5)



Field Permeability Test No.: FPT-6

By Falling Head Method

IS: 5529-Part-1-1985, RA-2009

Test Details	
Borehole No. :	BH : 2
Location :	Ash Pond Area
Reduced Level (RL) :	N/A
UTM Coordinates :	403577.35 m E, 2806143.01 m N
Depth of Borehole :	6.0 m
Depth of bottom of casing below EGL :	5.50 m
Diameter of Intake Pipe :	15.0 cm
Length of Test Section :	50.0 cm
Depth of Water Table :	7.1 m
Height of Casing above GL :	0.83 m
Hydraulic Head at Start of test :	658 cm
Soil Classification :	Silty fine sand

Sl. No.	Time in Minutes	Water Level in Intake Pipe, cm	Head, cm	Sl. No.	Time in Minutes	Water Level in Intake Pipe, cm	Head, cm
1	0.0	0.0	658	19	53.0	454.0	204
2	1.0	100.0	558	20	63.0	454.0	204
3	2.0	151.0	507	21	73.0	454.0	204
4	3.0	180.0	478				
5	4.0	205.0	453				
6	5.0	230.0	428				
7	7.0	274.0	384				
8	9.0	309.0	349				
9	11.0	324.0	334				
10	13.0	337.0	321				
11	15.0	355.0	303				
12	17.0	368.0	290				
13	19.0	379.0	279				
14	21.0	388.0	270				
15	23.0	395.0	263				
16	29.0	418.0	240				
17	33.0	430.0	228				
18	43.0	449.0	209				

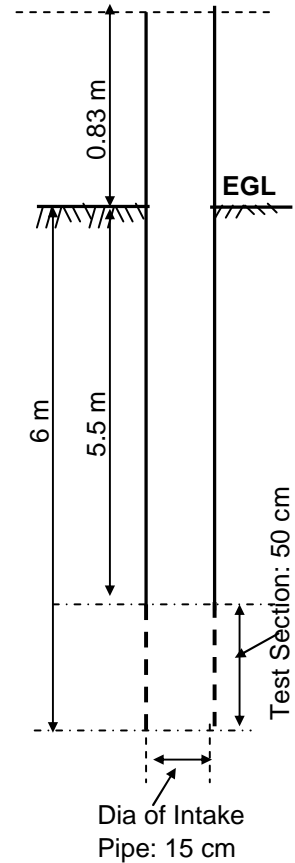

$$k = \text{Coefficient of Permeability} = \frac{d^2}{8L(t_2 - t_1)} \ln\left(\frac{2L}{d}\right) \ln\left(\frac{h_1}{h_2}\right)$$

Where:

L = 50.0 cm	d = 15.0 cm
2L/d = 6.67	R = 7.5 cm
$h_1/h_0 = 0.32$	$t_1 = 30$ minutes
$h_2/h_0 = 0.31$	$t_2 = 73.6$ minutes
$h_1/h_2 = 1.030$	

Calculations based on semilog plot of Head Ratio vs. Time, as per IS:5529 (Part-I)

$$k = 1.2E-05 \text{ cm/sec}$$

Determination of Coefficient of Permeability (FPT-6)



Field Permeability Test No.: FPT-6

By Falling Head Method

(IS: 5529-Part-1-1985, RA-2009)

Test Details
Borehole No. : BH : 2
Location : Ash Pond Area
Reduced Level (RL) : N/A
UTM Coordinates : 403577.35 m E, 2806143.01 m N
Depth of Borehole : 6.0
Calculated value of k : 1.2E-05

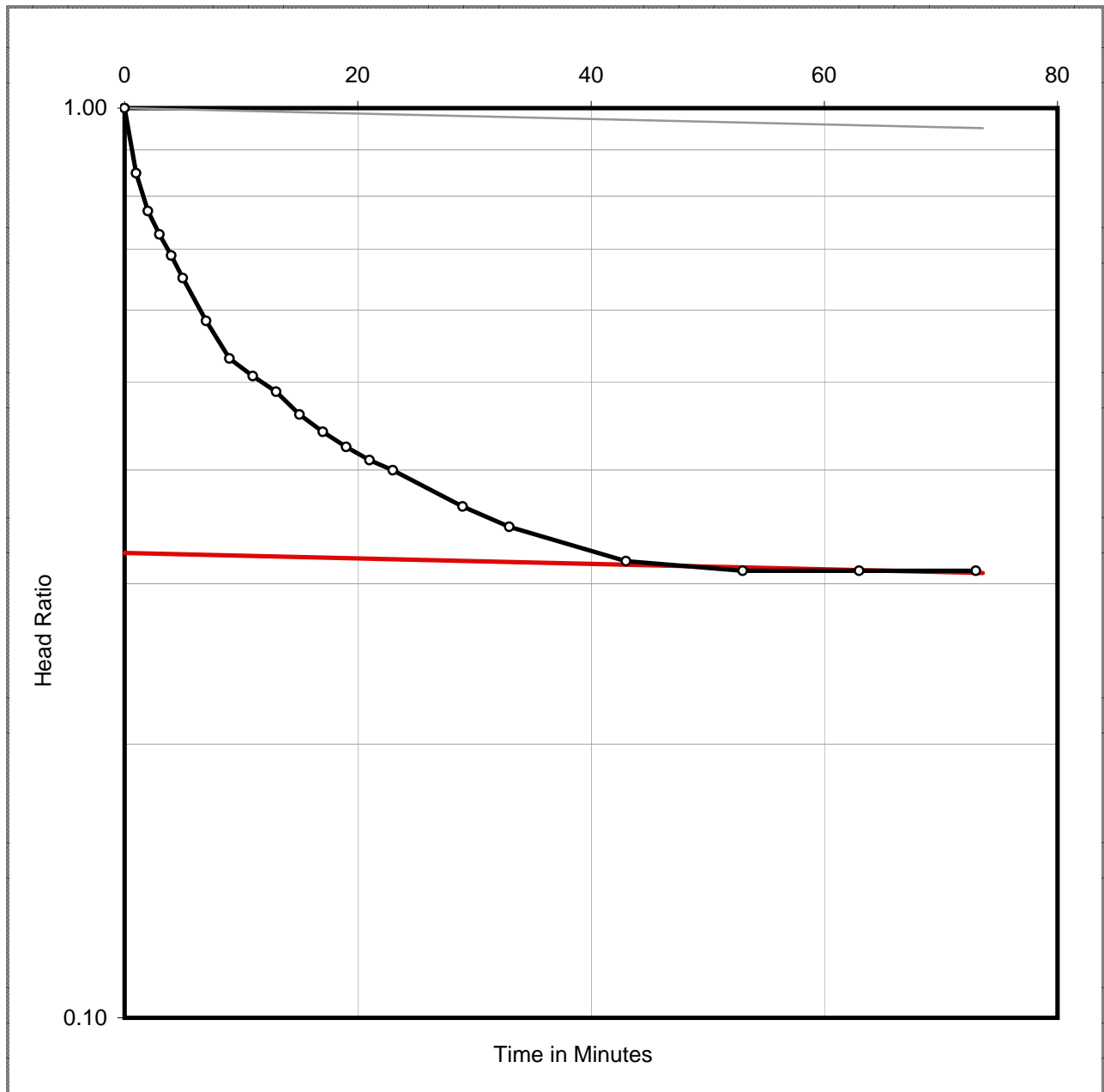

Semi-Log Plot of Head Ratio Vs Time (FPT-6)



Field Permeability Test No. : FPT-7

By Constant Head Method

IS: 5529-Part-1-1985, RA-2009

Test Details	
Borehole No. :	BH-2
Location :	Ash Pond Area
UTM Coordinates :	403577.35 m E, 2806143.01 m N
Depth of Borehole :	8.0 m = 800 cm
Depth of bottom of casing below EGL :	800 cm
Diameter of Intake Pipe :	15 cm
Depth of Water Table :	710.0 cm
Effective Height of water in Tank :	92 cm
Differential Head :	802.0 cm
Soil Classification :	Silty fine sand

Time, min	Q(litre)	Discharge, Q (litre/min)	Q _{average} litre/min	Borehole Radius (r), mm	Differential Head (H), m	C	k, cm/s
0	92.0	0.000					
1	92.4	40.0					
2	92.7	30.0					
4	93.3	30.0					
6	93.8	25.0					
8	94.1	15.0	17.0	75	8.0	4E-03	8.6E-03
10	94.4	15.0					
15	95.3	18.0					
20	96.3	20.0					

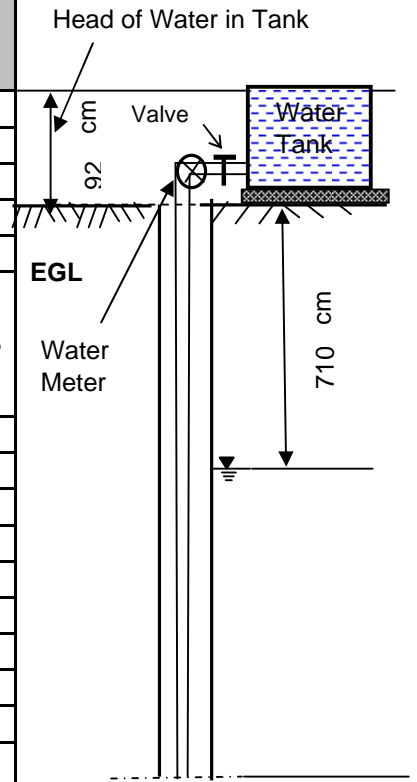

Equation used for calculation

Where:

$$k = C * \left[\frac{Q}{H} \right] \quad C = \left[\frac{1}{5.5 r} \right]$$

Q=Discharge,(litre/min)

H=Differential Head,(m)

r=radius of casing,(mm)

Determination of Coefficient of Permeability (FPT-7)



Field Permeability Test No. : FPT-8

By Constant Head Method

IS: 5529-Part-1-1985, RA-2009

Test Details	
Borehole No. :	BH-2
Location :	Ash Pond Area
UTM Coordinates :	403577.35 m E, 2806143.01 m N
Depth of Borehole :	10 m = 1000 cm
Depth of bottom of casing below EGL :	1000.0 cm
Diameter of Intake Pipe :	15 cm
Depth of Water Table :	710.0 cm
Effective Height of water in Tank :	92 cm
Differential Head :	802.0 cm
Soil Classification :	Silty fine sand

Time, min	Q(litre)	Discharge, Q (litre/min)	Q _{average} litre/min	Borehole Radius (r), mm	Differential Head (H), m	C	k, cm/s
0	110.0	0.000					
1	110.4	40.0					
2	110.7	30.0					
4	111.2	25.0					
6	111.7	25.0					
8	112.3	30.0	29.5	75	8.0	4E-03	1.5E-02
10	112.9	30.0					
15	114.4	30.0					
20	115.8	28.0					

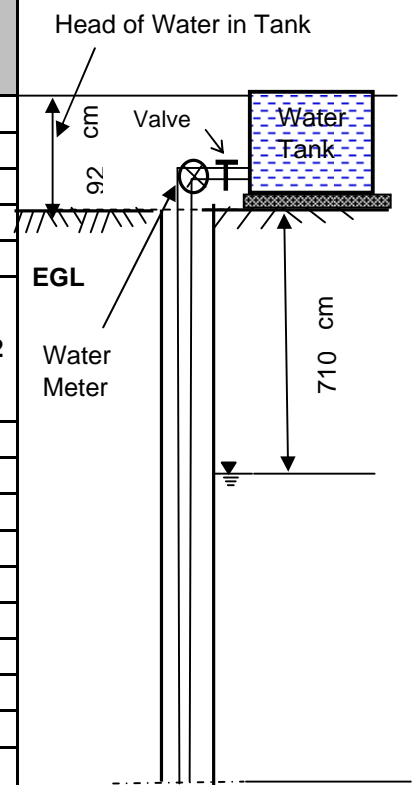

Equation used for calculation

$$k = C * \left[\frac{Q}{H} \right] \quad C = \left[\frac{1}{5.5 r} \right]$$

Where:

Q=Discharge,(litre/min)

H=Differential Head,(m)

r=radius of casing,(mm)

Determination of Coefficient of Permeability (FPT-8)



Field Permeability Test No. : FPT-9

By Constant Head Method

IS: 5529-Part-1-1985, RA-2009

Test Details	
Borehole No. :	BH-2
Location :	Ash Pond Area
UTM Coordinates :	403577.35 m E, 2806143.01 m N
Depth of Borehole :	12 m = 1200 cm
Depth of bottom of casing below EGL :	1200.0 cm
Diameter of Intake Pipe :	15 cm
Depth of Water Table :	710.0 cm
Effective Height of water in Tank :	92 cm
Differential Head :	802.0 cm
Soil Classification :	Fine sand

Time, min	Q(litre)	Discharge, Q (litre/min)	Q _{average} (litre/min)	Borehole Radius (r), mm	Differential Head (H), m	C	k, cm/s
0	118.0	0.000					
1	118.4	35.0					
2	118.7	35.0					
4	119.5	40.0					
6	120.2	35.0					
8	121.0	40.0					
10	121.7	35.0	36.1	75	8.0	4E-03	1.8E-02
15	123.5	36.0					
20	125.3	36.0					
25	127.0	34.0					
30	128.7	34.0					

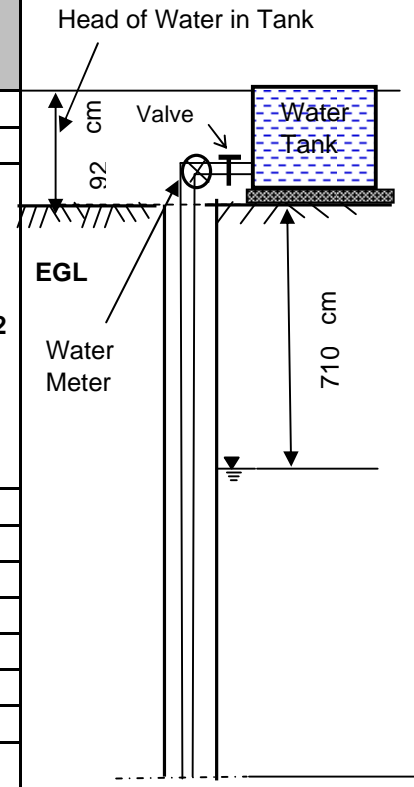

Equation used for calculation

$$k = C * \left[\frac{Q}{H} \right] \quad C = \left[\frac{1}{5.5 r} \right]$$

Where:

Q=Discharge,(litre/min)

H=Differential Head,(m)

r=radius of casing,(mm)

Determination of Coefficient of Permeability (FPT-9)

Field Permeability Test No. : FPT-10

By Constant Head Method

IS: 5529-Part-1-1985, RA-2009

Test Details	
Borehole No. :	BH-2
Location :	Ash Pond Area
UTM Coordinates :	403577.35 m E, 2806143.01 m N
Depth of Borehole :	14 m = 1400 cm
Depth of bottom of casing below EGL :	1400.0 cm
Diameter of Intake Pipe :	15 cm
Depth of Water Table :	710.0 cm
Effective Height of water in Tank :	92 cm
Differential Head :	802.0 cm
Soil Classification :	Fine sand

Time, min	Q(litre)	Discharge, Q (litre/min)	Q _{average} (litre/min)	Borehole Radius (r), mm	Differential Head (H), m	C	k, cm/s
0	129.4	0.000					
1	129.8	40.0					
2	130.3	50.0	45.0	75	8.0	4E-03	2.3E-02
4	131.1	40.0					
6	132.2	55.0					
8	133.0	40.0					
10	133.8	40.0					

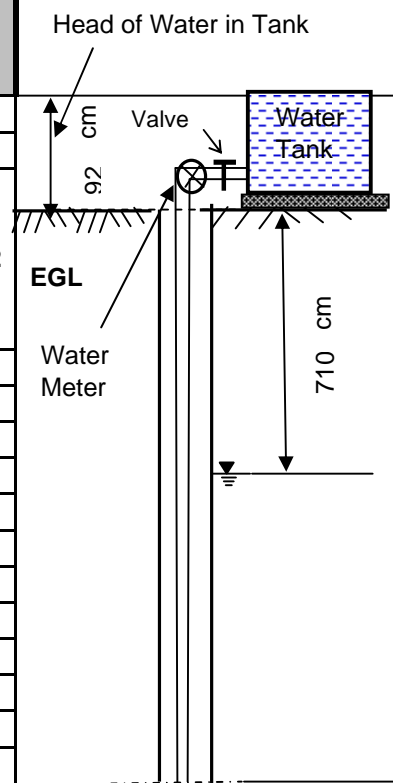

Equation used for calculation

Where:

$$k = C * \left[\frac{Q}{H} \right] \quad C = \left[\frac{1}{5.5 r} \right]$$

Q=Discharge,(litre/min)

H=Differential Head,(m)

r=radius of casing,(mm)

Determination of Coefficient of Permeability (FPT-10)



Field Permeability Test No. : FPT-11

By Constant Head Method

IS: 5529-Part-1-1985, RA-2009

Test Details	
Borehole No. :	BH-2
Location :	Ash Pond Area
UTM Coordinates :	403577.35 m E, 2806143.01 m N
Depth of Borehole :	16 m = 1600 cm
Depth of bottom of casing below EGL :	1600 cm
Diameter of Intake Pipe :	15 cm
Depth of Water Table :	710.0 cm
Effective Height of water in Tank :	92 cm
Differential Head :	802.0 cm
Soil Classification :	Fine sand

Time, min	Q(litre)	Discharge, Q (litre/min)	Q _{average} (litre/min)	Borehole Radius (r), mm	Differential Head (H), m	C	k, cm/s
0	134.0	0.000					
1	134.4	40.0					
2	134.8	40.0					
4	135.4	30.0					
6	136.1	35.0	35.3	75	8.0	4E-03	1.8E-02
8	136.8	35.0					
10	137.5	35.0					
15	139.3	36.0					

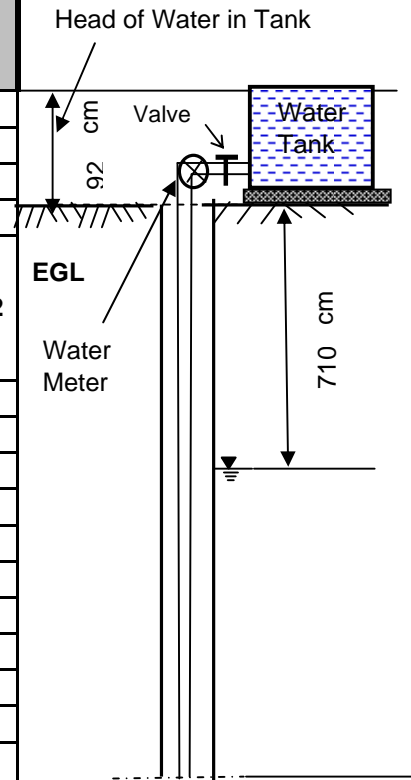

Equation used for calculation

$$k = C * \left[\frac{Q}{H} \right] \quad C = \left[\frac{1}{5.5 r} \right]$$

Where:

Q=Discharge,(litre/min)

H=Differential Head,(m)

r=radius of casing,(mm)

Determination of Coefficient of Permeability (FPT-11)



Field Permeability Test No. : FPT-12

By Constant Head Method

IS: 5529-Part-1-1985, RA-2009

Test Details	
Borehole No. :	BH-2
Location :	Ash Pond Area
UTM Coordinates :	403577.35 m E, 2806143.01 m N
Depth of Borehole :	18 m = 1800 cm
Depth of bottom of casing below EGL :	1800 cm
Diameter of Intake Pipe :	15 cm
Depth of Water Table :	710.0 cm
Effective Height of water in Tank :	92 cm
Differential Head :	802.0 cm
Soil Classification :	Fine sand

Time, min	Q(litre)	Discharge, Q (litre/min)	Q _{average} (litre/min)	Borehole Radius (r), mm	Differential Head (H), m	C	k, cm/s
0	139.4	0.000					
1	139.7	30.0					
2	139.9	20.0					
4	140.5	30.0					
6	141.0	25.0	23.2	75	8.0	4E-03	1.2E-02
8	141.4	20.0					
10	141.9	25.0					
15	143.0	22.0					
20	144.2	24.0					

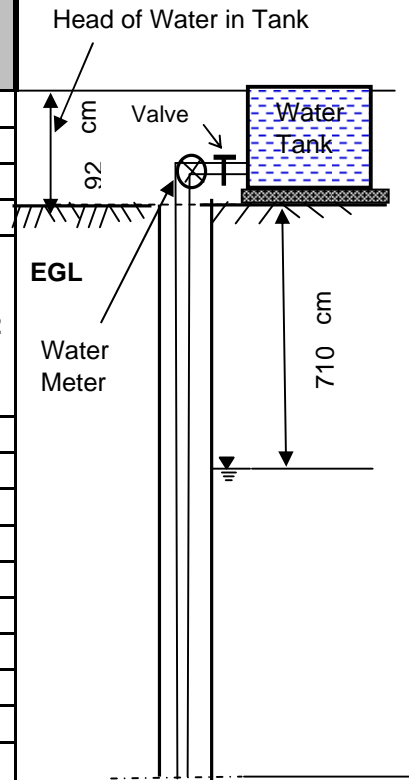

Equation used for calculation

Where:

$$k = C * \left[\frac{Q}{H} \right] \quad C = \left[\frac{1}{5.5 r} \right]$$

Q=Discharge,(litre/min)

H=Differential Head,(m)

r=radius of casing,(mm)

Determination of Coefficient of Permeability (FPT-12)



Field Permeability Test No. : FPT-13

By Constant Head Method

IS: 5529-Part-1-1985, RA-2009

Test Details	
Borehole No. :	BH-2
Location :	Ash Pond Area
UTM Coordinates :	403577.35 m E, 2806143.01 m N
Depth of Borehole :	20 m = 2000 cm
Depth of bottom of casing below EGL :	2000 cm
Diameter of Intake Pipe :	15 cm
Depth of Water Table :	710.0 cm
Effective Height of water in Tank :	92 cm
Differential Head :	802.0 cm
Soil Classification :	Fine sand

Time, min	Q(litre)	Discharge, Q litre/min)	Q _{average} litre/min	Borehole Radius (r), mm	Differential Head (H), m	C	k, cm/s
0	144.6	0.000					
1	144.8	20.0					
2	145.0	20.0					
4	145.4	20.0					
6	145.8	20.0	19.0	75	8.0	4E-03	9.6E-03
8	146.1	15.0					
10	146.5	20.0					
15	147.6	22.0					
20	148.5	18.0					

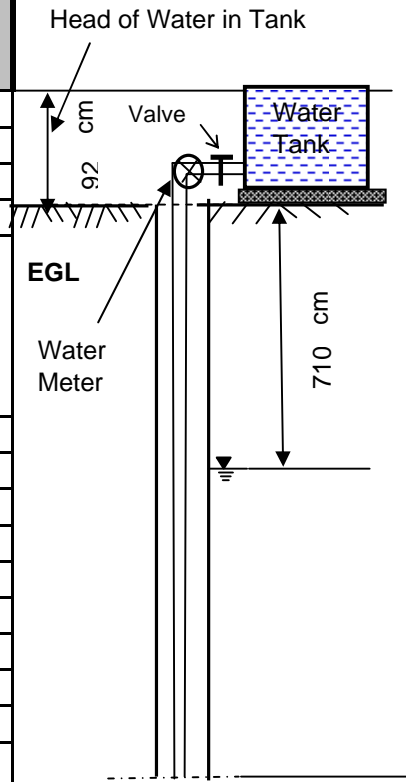

Equation used for calculation

$$k = C * \left[\frac{Q}{H} \right] \quad C = \left[\frac{1}{5.5 r} \right]$$

Where:

Q=Discharge,(litre/min)

H=Differential Head,(m)

r=radius of casing,(mm)

Determination of Coefficient of Permeability (FPT-13)



Field Permeability Test No.: FPT-14

By Falling Head Method

IS: 5529-Part-1-1985, RA-2009

Test Details	
Borehole No. :	BH : 3
Location :	Ash Pond Area
Reduced Level (RL) :	N/A
UTM Coordinates :	403748.78 m E, 2806652.14 m N
Depth of Borehole :	2.0 m
Depth of bottom of casing below EGL :	1.50 m
Diameter of Intake Pipe :	15.0 cm
Length of Test Section :	50.0 cm
Depth of Water Table :	7.0 m
Height of Casing above GL :	0.10 m
Hydraulic Head at Start of test :	185 cm
Soil Classification :	Silty fine sand

Sl. No.	Time in Minutes	Water Level in Intake Pipe, cm	Head, cm	Sl. No.	Time in Minutes	Water Level in Intake Pipe, cm	Head, cm
1	0.0	0.0	185				
2	0.3	16.0	169				
3	1.0	20.0	165				
4	2.0	44.0	141				
5	4.0	68.0	117				
6	6.0	86.0	99				
7	8.0	94.0	91				
8	10.0	103.0	82				
9	15.0	117.0	68				
10	20.0	129.0	56				
11	25.0	136.0	49				
12	30.0	141.0	44				
13	40.0	149.0	36				

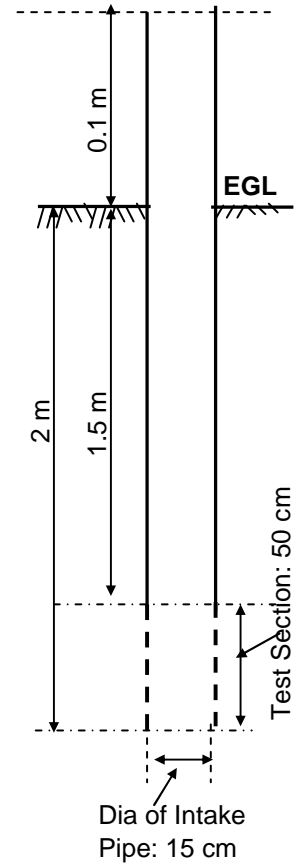

$$k = \text{Coefficient of Permeability} = \frac{d^2}{8L(t_2 - t_1)} \ln\left(\frac{2L}{d}\right) \ln\left(\frac{h_1}{h_2}\right)$$

Where:

L = 50.0 cm	d = 15.0 cm
2L/d = 6.67	R = 7.5 cm
$h_1/h_0 = 0.21$	$t_1 = 35.2$ minutes
$h_2/h_0 = 0.15$	$t_2 = 55.9$ minutes
$h_1/h_2 = 1.443$	

Calculations based on semilog plot of Head Ratio vs. Time, as per IS:5529 (Part-I)

$$k = 3.2E-04 \text{ cm/sec}$$

Determination of Coefficient of Permeability (FPT-14)



Field Permeability Test No.: FPT-14

By Falling Head Method

(IS: 5529-Part-1-1985, RA-2009)

Test Details
Borehole No. : BH : 3
Location : Ash Pond Area
Reduced Level (RL) : N/A
UTM Coordinates : 403748.78 m E, 2806652.14 m N
Depth of Borehole : 2.0
Calculated value of k : 3.2E-04

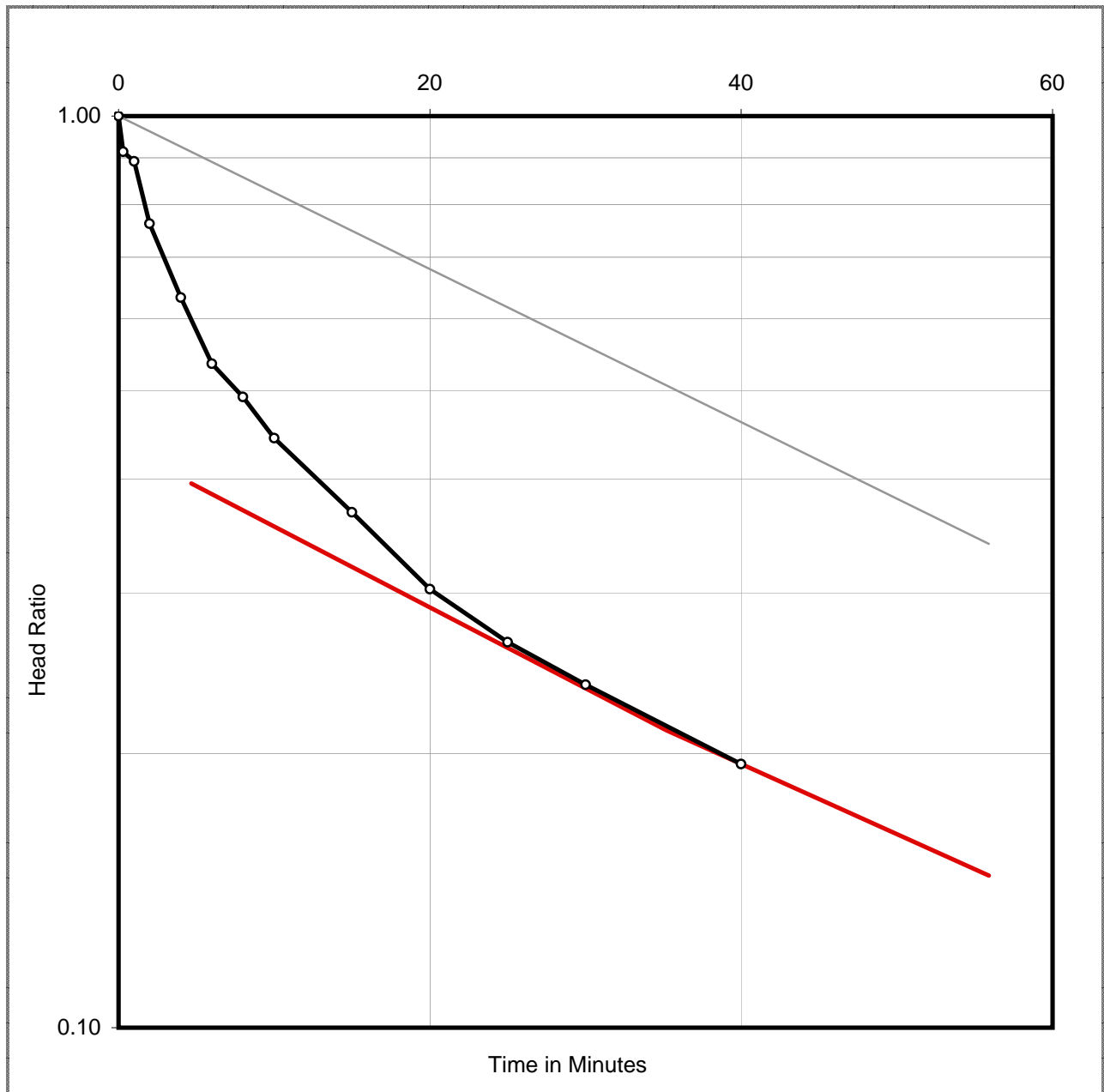

Semi-Log Plot of Head Ratio Vs Time (FPT-14)



Field Permeability Test No.: FPT-15

By Falling Head Method

IS: 5529-Part-1-1985, RA-2009

Test Details	
Borehole No. :	BH : 3
Location :	Ash Pond Area
Reduced Level (RL) :	N/A
UTM Coordinates :	403748.78 m E, 2806652.14 m N
Depth of Borehole :	4.0 m
Depth of bottom of casing below EGL :	3.50 m
Diameter of Intake Pipe :	15.0 cm
Length of Test Section :	50.0 cm
Depth of Water Table :	7.0 m
Height of Casing above GL :	0.60 m
Hydraulic Head at Start of test :	435 cm
Soil Classification :	Silty fine sand

Sl. No.	Time in Minutes	Water Level in Intake Pipe, cm	Head, cm	Sl. No.	Time in Minutes	Water Level in Intake Pipe, cm	Head, cm
1	0.0	0.0	435				
2	1.0	79.0	356				
3	2.0	130.0	305				
4	4.0	158.0	277				
5	6.0	185.0	250				
6	8.0	212.0	223				
7	10.0	230.0	205				
8	15.0	260.0	175				
9	20.0	281.0	154				
10	25.0	300.0	135				
11	30.0	320.0	115				
12	40.0	345.0	90				
13	50.0	360.0	75				

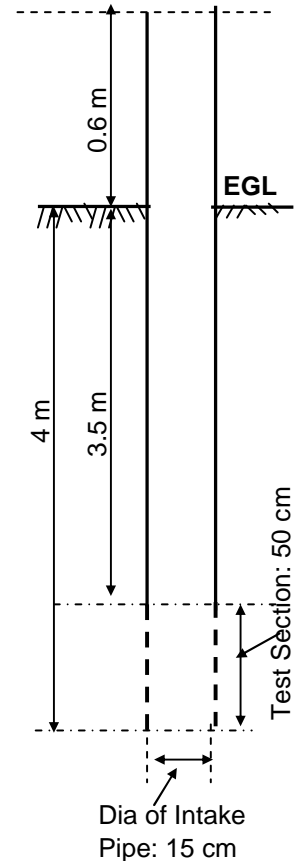

$$k = \text{Coefficient of Permeability} = \frac{d^2}{8L(t_2 - t_1)} \ln\left(\frac{2L}{d}\right) \ln\left(\frac{h_1}{h_2}\right)$$

Where:

L =	50.0	cm	d =	15.0	cm
2L/d =	6.67		R =	7.5	cm
h ₁ /h ₀ =	0.44		t ₁ =	11	minutes
h ₂ /h ₀ =	0.12		t ₂ =	59.4	minutes
h ₁ /h ₂ =	3.548				

Calculations based on semilog plot of Head Ratio vs. Time, as per IS:5529 (Part-I)

$$k = 4.7\text{E-}04 \text{ cm/sec}$$

Determination of Coefficient of Permeability (FPT-15)



Field Permeability Test No.: FPT-15

By Falling Head Method

(IS: 5529-Part-1-1985, RA-2009)

Test Details
Borehole No. : BH : 3
Location : Ash Pond Area
Reduced Level (RL) : N/A
UTM Coordinates : 403748.78 m E, 2806652.14 m N
Depth of Borehole : 4.0
Calculated value of k : 4.7E-04

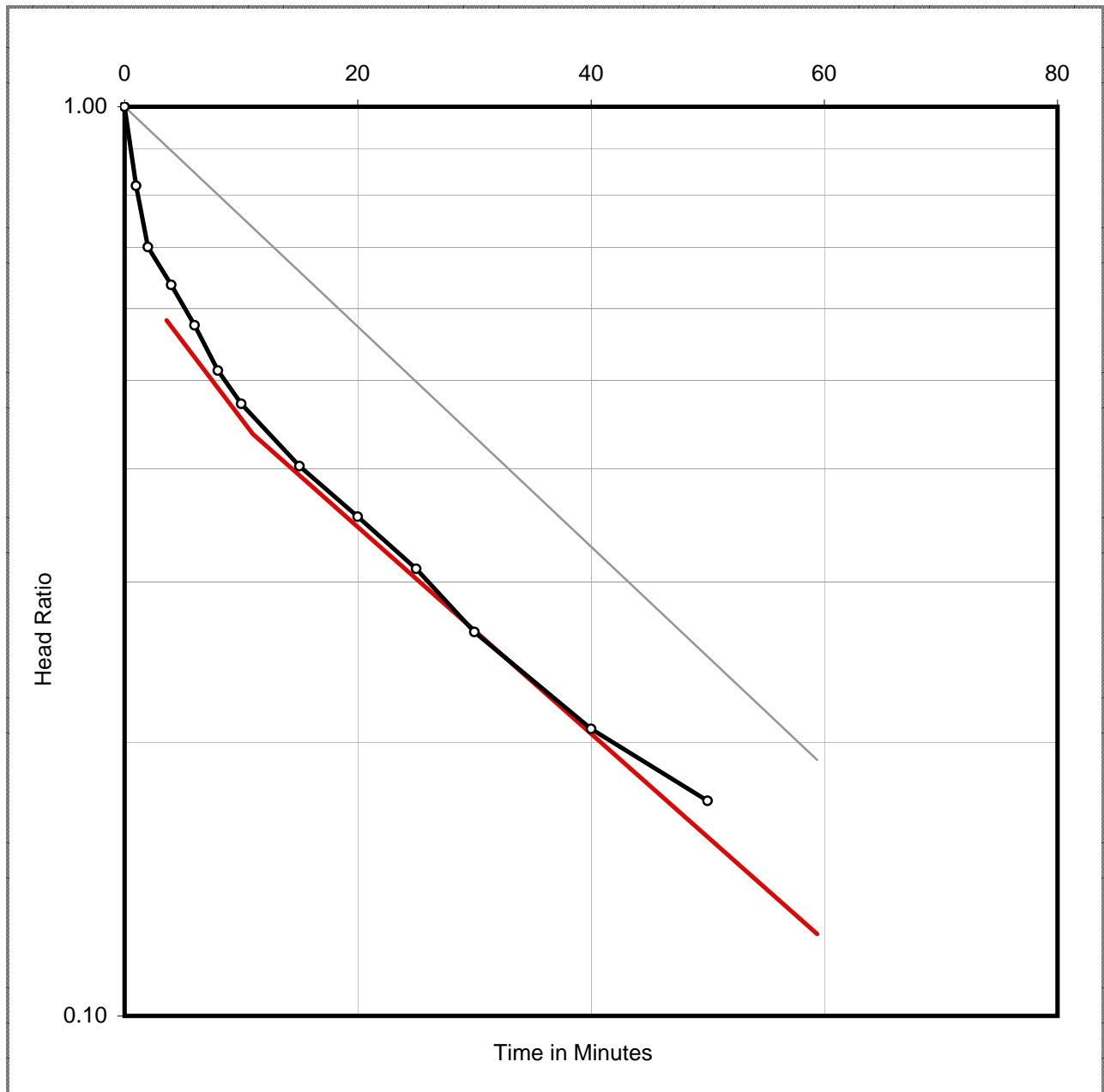

Semi-Log Plot of Head Ratio Vs Time (FPT-15)



Field Permeability Test No.: FPT-16

By Falling Head Method

IS: 5529-Part-1-1985, RA-2009

Test Details	
Borehole No. :	BH : 3
Location :	Ash Pond Area
Reduced Level (RL) :	N/A
UTM Coordinates :	403748.78 m E, 2806652.14 m N
Depth of Borehole :	6.0 m
Depth of bottom of casing below EGL :	5.50 m
Diameter of Intake Pipe :	15.0 cm
Length of Test Section :	50.0 cm
Depth of Water Table :	7.0 m
Height of Casing above GL :	0.20 m
Hydraulic Head at Start of test :	595 cm
Soil Classification :	Silty fine sand

Sl. No.	Time in Minutes	Water Level in Intake Pipe, cm	Head, cm	Sl. No.	Time in Minutes	Water Level in Intake Pipe, cm	Head, cm
1	0.0	0.0	595				
2	1.0	103.0	492				
3	2.0	160.0	435				
4	4.0	258.0	337				
5	6.0	320.0	275				
6	8.0	370.0	225				
7	10.0	392.0	203				
8	15.0	460.0	135				
9	20.0	505.0	90				
10	25.0	525.0	70				
11	30.0	540.0	55				
12	40.0	556.0	39				
13	50.0	567.0	28				
14	60.0	575.0	20				

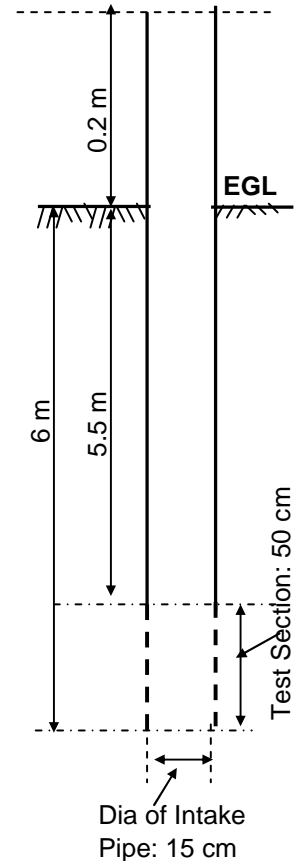

$$k = \text{Coefficient of Permeability} = \frac{d^2}{8L(t_2 - t_1)} \ln\left(\frac{2L}{d}\right) \ln\left(\frac{h_1}{h_2}\right)$$

Where:

L = 50.0 cm	d = 15.0 cm
2L/d = 6.67	R = 7.5 cm
$h_1/h_0 = 0.09$	$t_1 = 30$ minutes
$h_2/h_0 = 0.03$	$t_2 = 60.7$ minutes
$h_1/h_2 = 2.816$	

Calculations based on semilog plot of Head Ratio vs. Time, as per IS:5529 (Part-I)

$$k = 6.0E-04 \text{ cm/sec}$$

Determination of Coefficient of Permeability (FPT-16)



Field Permeability Test No.: FPT-16

By Falling Head Method

(IS: 5529-Part-1-1985, RA-2009)

Test Details
Borehole No. : BH : 3
Location : Ash Pond Area
Reduced Level (RL) : N/A
UTM Coordinates : 403748.78 m E, 2806652.14 m N
Depth of Borehole : 6.0
Calculated value of k : 6.0E-04

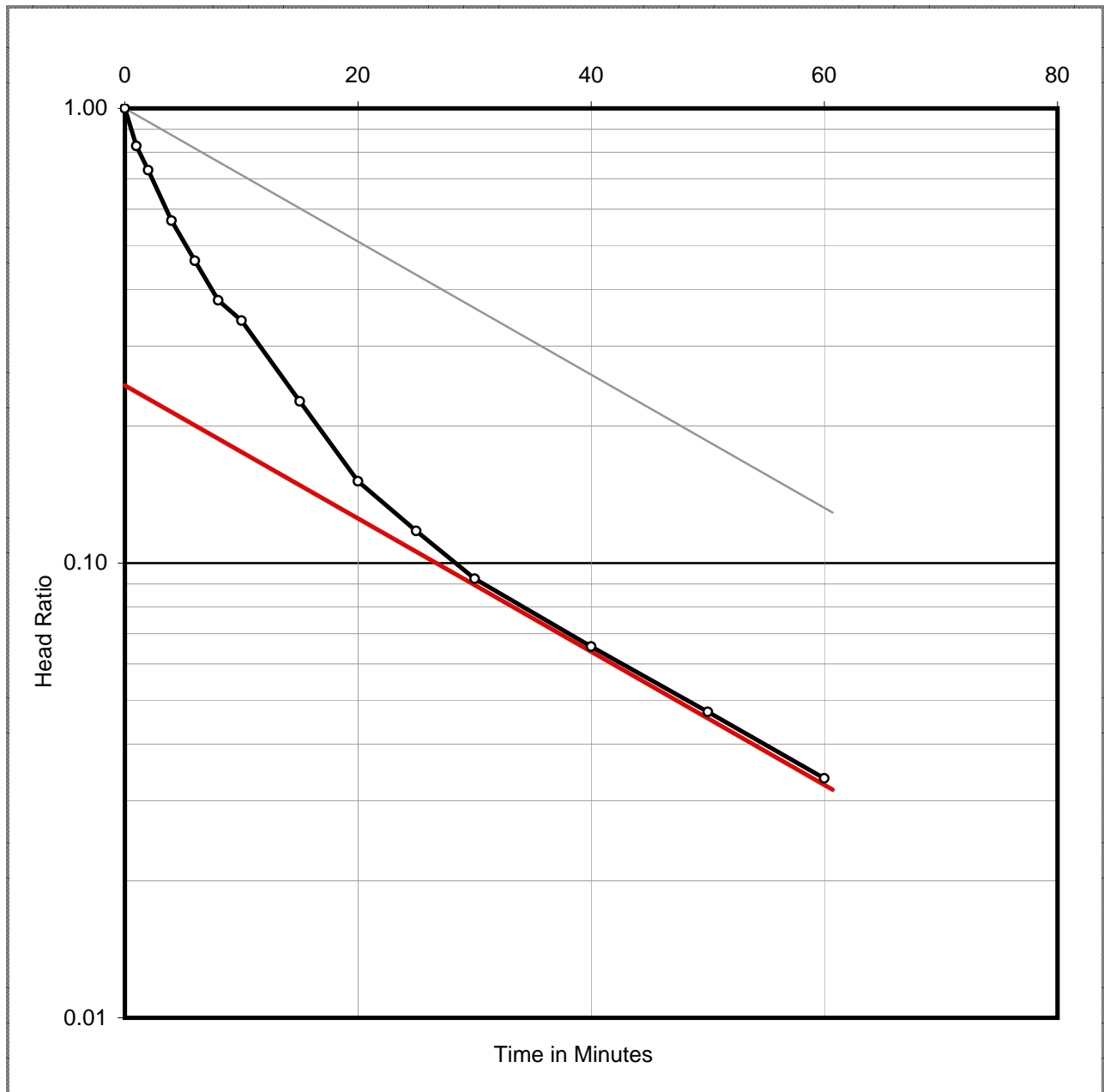

Semi-Log Plot of Head Ratio Vs Time (FPT-16)

Field Permeability Test No. : FPT-17

By Constant Head Method

IS: 5529-Part-1-1985, RA-2009

Test Details	
Borehole No. :	BH-3
Location :	Ash Pond Area
UTM Coordinates :	403748.78 m E, 2806652.14 m N
Depth of Borehole :	8.0 m = 800 cm
Depth of bottom of casing below EGL :	800 cm
Diameter of Intake Pipe :	15 cm
Depth of Water Table :	7.0 cm
Effective Height of water in Tank :	92 cm
Differential Head :	99.0 cm
Soil Classification :	Silty fine sand

Time, min	Q(litre)	Discharge, Q (litre/min)	Q _{average} (litre/min)	Borehole Radius (r), mm	Differential Head (H), m	C	k, cm/s
0	149.0	0.000					
1	149.4	40.0					
2	149.7	30.0					
4	150.5	40.0					
6	151.5	50.0					
8	152.6	55.0					
10	153.2	30.0	27.3	75	1.0	4E-03	1.1E-01
15	154.4	24.0					
20	155.8	28.0					

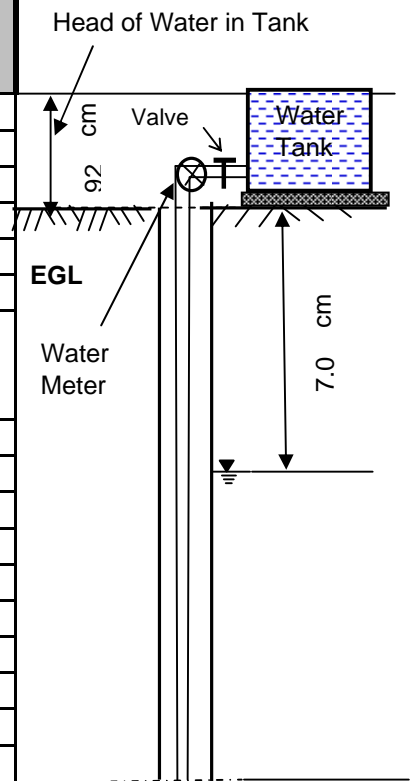

Equation used for calculation

$$k = C * \left[\frac{Q}{H} \right] \quad C = \left[\frac{1}{5.5 r} \right]$$

Where:

Q=Discharge,(litre/min)

H=Differential Head,(m)

r=radius of casing,(mm)

Determination of Coefficient of Permeability (FPT-17)



Field Permeability Test No. : FPT-18

By Constant Head Method

IS: 5529-Part-1-1985, RA-2009

Test Details	
Borehole No. :	BH-3
Location :	Ash Pond Area
UTM Coordinates :	403748.78 m E, 2806652.14 m N
Depth of Borehole :	10.0 m = 1000 cm
Depth of bottom of casing below EGL :	1000 cm
Diameter of Intake Pipe :	15 cm
Depth of Water Table :	7.0 cm
Effective Height of water in Tank :	92 cm
Differential Head :	99.0 cm
Soil Classification :	Fine sand

Time, min	Q(litre)	Discharge, Q (litre/min)	Q _{average} (litre/min)	Borehole Radius (r), mm	Differential Head (H), m	C	k, cm/s
0	155.2	0.000					
1	155.3	10.0					
2	155.4	10.0					
4	155.5	5.0					
6	155.6	5.0					
8	155.6	1.0					
10	155.7	4.0	3.2	75	1.0	4E-03	1.3E-02
15	155.9	3.0					
20	156.0	3.0					

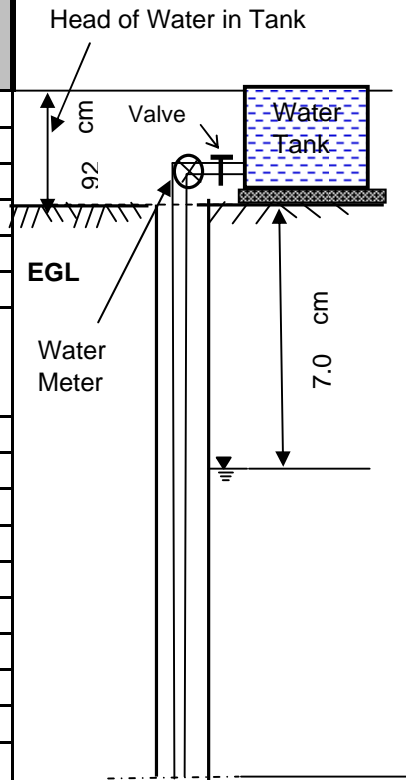

Equation used for calculation

Where:

$$k = C * \left[\frac{Q}{H} \right] \quad C = \left[\frac{1}{5.5 r} \right]$$

Q=Discharge,(litre/min)

H=Differential Head,(m)

r=radius of casing,(mm)

Determination of Coefficient of Permeability (FPT-18)



Field Permeability Test No. : FPT-19

By Constant Head Method

IS: 5529-Part-1-1985, RA-2009

Test Details	
Borehole No. :	BH-3
Location :	Ash Pond Area
UTM Coordinates :	403748.78 m E, 2806652.14 m N
Depth of Borehole :	12.0 m = 1200 cm
Depth of bottom of casing below EGL :	1200 cm
Diameter of Intake Pipe :	15 cm
Depth of Water Table :	7.0 cm
Effective Height of water in Tank :	92 cm
Differential Head :	99.0 cm
Soil Classification :	Fine sand

Time, min	Q(litre)	Discharge, Q litre/min)	Q _{average} litre/min	Borehole Radius (r), mm	Differential Head (H), m	C	k, cm/s
0	157.0	0.000					
1	157.2	20.0					
2	157.4	20.0					
4	157.6	10.0					
6	158.1	25.0					
8	158.4	15.0	16.3	75	1.0	4E-03	6.6E-02
10	158.8	20.0					
15	159.5	14.0					
20	160.3	16.0					

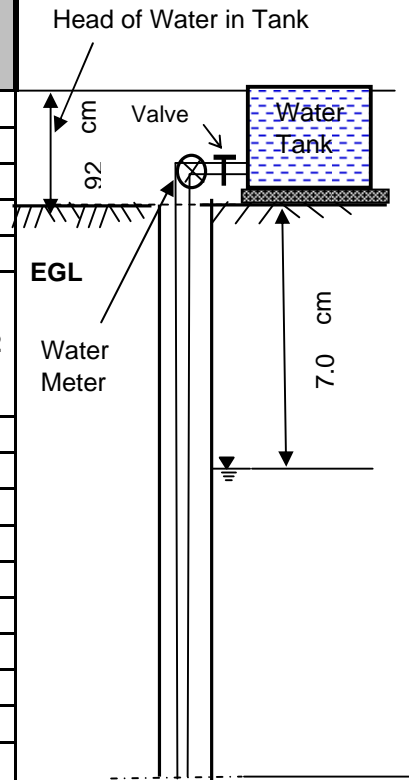

Equation used for calculation

Where:

$$k = C * \left[\frac{Q}{H} \right] \quad C = \left[\frac{1}{5.5 r} \right]$$

Q=Discharge,(litre/min)

H=Differential Head,(m)

r=radius of casing,(mm)

Determination of Coefficient of Permeability (FPT-19)

Field Permeability Test No. : FPT-20

By Constant Head Method

IS: 5529-Part-1-1985, RA-2009

Test Details	
Borehole No. :	BH-3
Location :	Ash Pond Area
UTM Coordinates :	403748.78 m E, 2806652.14 m N
Depth of Borehole :	14.0 m = 1400 cm
Depth of bottom of casing below EGL :	1400 cm
Diameter of Intake Pipe :	15 cm
Depth of Water Table :	7.0 cm
Effective Height of water in Tank :	92 cm
Differential Head :	99.0 cm
Soil Classification :	Silty fine sand

Time, min	Q(litre)	Discharge, Q litre/min)	Q _{average} litre/min	Borehole Radius (r), mm	Differential Head (H), m	C	k, cm/s
0	160.5	0.000					
1	160.8	30.0					
2	161.0	20.0					
4	161.3	15.0					
6	161.6	15.0					
8	162.0	20.0					
10	162.3	15.0					
15	163.2	18.0	16.3	75	1.0	4E-03	6.7E-02
20	164.0	16.0					

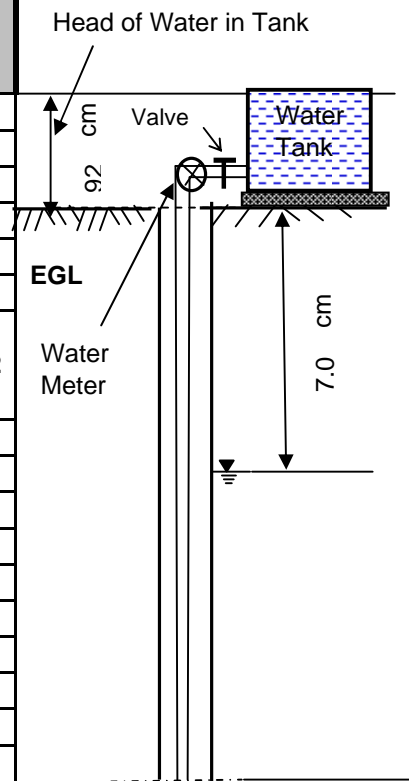

Equation used for calculation

$$k = C * \left[\frac{Q}{H} \right] \quad C = \left[\frac{1}{5.5 r} \right]$$

Where:

Q=Discharge,(litre/min)

H=Differential Head,(m)

r=radius of casing,(mm)

Determination of Coefficient of Permeability (FPT-20)



Field Permeability Test No. : FPT-21

By Constant Head Method

IS: 5529-Part-1-1985, RA-2009

Test Details	
Borehole No. :	BH-3
Location :	Ash Pond Area
UTM Coordinates :	403748.78 m E, 2806652.14 m N
Depth of Borehole :	16.00 m = 1600 cm
Depth of bottom of casing below EGL :	1600 cm
Diameter of Intake Pipe :	15 cm
Depth of Water Table :	7.0 cm
Effective Height of water in Tank :	92 cm
Differential Head :	99.0 cm
Soil Classification :	Fine sand

Time, min	Q(litre)	Discharge, Q litre/min)	Q _{average} litre/min	Borehole Radius (r), mm	Differential Head (H), m	C	k, cm/s
0	165.0	0.000					
1	165.2	20.0					
2	165.4	20.0					
4	165.7	15.0	13.5	75	1.0	4E-03	5.5E-02
6	166.0	15.0					
8	166.3	15.0					
10	166.5	10.0					
15	167.1	12.0					
20	167.8	14.0					

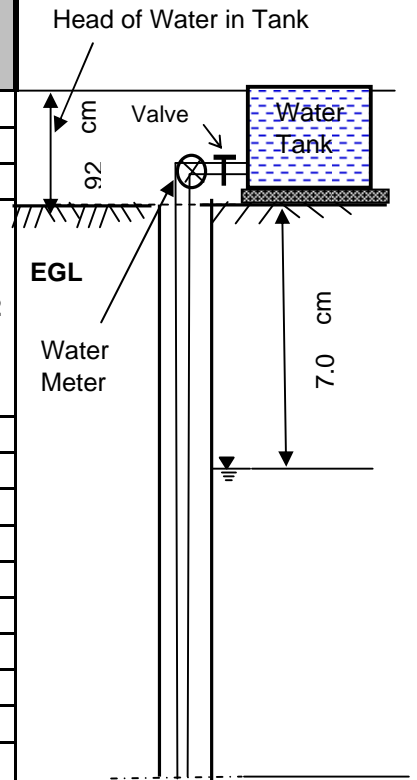

Equation used for calculation

Where:

$$k = C * \left[\frac{Q}{H} \right] \quad C = \left[\frac{1}{5.5 r} \right]$$

Q=Discharge,(litre/min)

H=Differential Head,(m)

r=radius of casing,(mm)

Determination of Coefficient of Permeability (FPT-21)



Field Permeability Test No. : FPT-22

By Constant Head Method

IS: 5529-Part-1-1985, RA-2009

Test Details	
Borehole No. :	BH-3
Location :	Ash Pond Area
UTM Coordinates :	403748.78 m E, 2806652.14 m N
Depth of Borehole :	18.00 m = 1800 cm
Depth of bottom of casing below EGL :	1800 cm
Diameter of Intake Pipe :	15 cm
Depth of Water Table :	7.0 cm
Effective Height of water in Tank :	92 cm
Differential Head :	99.0 cm
Soil Classification :	Fine sand

Time, min	Q(litre)	Discharge, Q litre/min)	Q _{average} litre/min	Borehole Radius (r), mm	Differential Head (H), m	C	k, cm/s
0	168.0	0.000					
1	168.2	20.0					
2	168.3	10.0	13.0	75	1.0	4E-03	5.3E-02
4	168.6	15.0					
6	168.9	15.0					
8	169.1	10.0					
10	169.4	15.0					
15	170.0	12.0					
20	170.7	14.0					

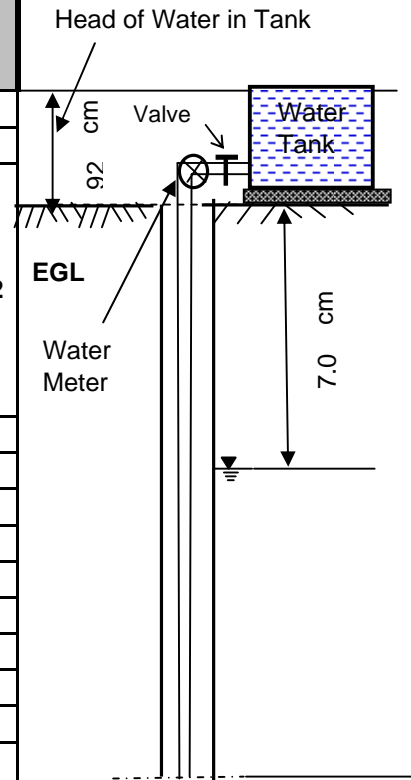

Equation used for calculation

$$k = C * \left[\frac{Q}{H} \right] \quad C = \left[\frac{1}{5.5 r} \right]$$

Where:

Q=Discharge,(litre/min)

H=Differential Head,(m)

r=radius of casing,(mm)

Determination of Coefficient of Permeability (FPT-22)



Field Permeability Test No. : FPT-23

By Constant Head Method

IS: 5529-Part-1-1985, RA-2009

Test Details	
Borehole No. :	BH-3
Location :	Ash Pond Area
UTM Coordinates :	403748.78 m E, 2806652.14 m N
Depth of Borehole :	20.00 m = 2000 cm
Depth of bottom of casing below EGL :	2000 cm
Diameter of Intake Pipe :	15 cm
Depth of Water Table :	7.0 cm
Effective Height of water in Tank :	92 cm
Differential Head :	99.0 cm
Soil Classification :	Fine sand

Time, min	Q(litre)	Discharge, Q litre/min)	Q _{average} litre/min	Borehole Radius (r), mm	Differential Head (H), m	C	k, cm/s
0	171.0	0.000					
1	171.2	20.0					
2	171.3	10.0	13.0	75	1.0	4E-03	5.3E-02
4	171.5	10.0					
6	171.8	15.0					
8	172.1	15.0					
10	172.4	15.0					
15	173.1	14.0					
20	173.7	12.0					

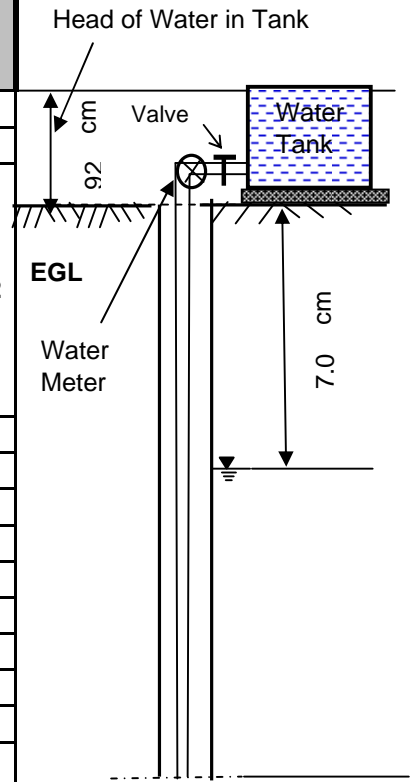

Equation used for calculation

$$k = C * \left[\frac{Q}{H} \right] \quad C = \left[\frac{1}{5.5 r} \right]$$

Where:

Q=Discharge,(litre/min)

H=Differential Head,(m)

r=radius of casing,(mm)

Determination of Coefficient of Permeability (FPT-23)



Field Permeability Test No.: FPT-24

By Falling Head Method

IS: 5529-Part-1-1985, RA-2009

Test Details	
Borehole No. :	BH : 4
Location :	Ash Pond Area
Reduced Level (RL) :	N/A
UTM Coordinates :	404203.43 m E, 2806545.85 m N
Depth of Borehole :	2.0 m
Depth of bottom of casing below EGL :	1.50 m
Diameter of Intake Pipe :	15.0 cm
Length of Test Section :	50.0 cm
Depth of Water Table :	7.0 m
Height of Casing above GL :	0.15 m
Hydraulic Head at Start of test :	190 cm
Soil Classification :	Silty fine sand

Sl. No.	Time in Minutes	Water Level in Intake Pipe, cm	Head, cm	Sl. No.	Time in Minutes	Water Level in Intake Pipe, cm	Head, cm
1	0.0	0.0	190				
2	1.0	22.0	168				
3	2.0	39.0	151				
4	4.0	54.0	136				
5	6.0	68.0	122				
6	8.0	85.0	105				
7	10.0	101.0	89				
8	15.0	130.0	60				
9	20.0	147.0	43				
10	25.0	160.0	30				
11	30.0	170.0	20				
12	40.0	180.0	10				
13	50.0	184.0	6				

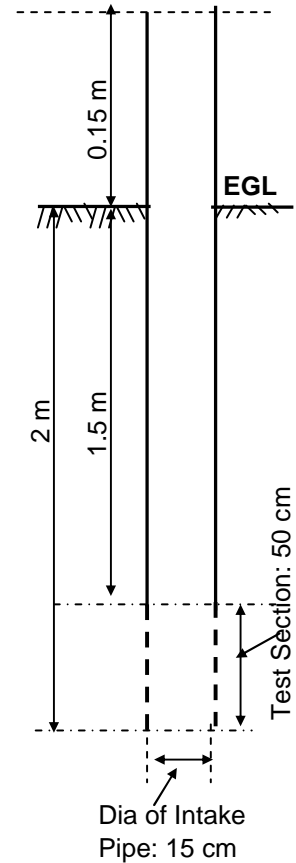

$$k = \text{Coefficient of Permeability} = \frac{d^2}{8L(t_2 - t_1)} \ln\left(\frac{2L}{d}\right) \ln\left(\frac{h_1}{h_2}\right)$$

Where:

L =	50.0 cm	d =	15.0 cm
2L/d =	6.67	R =	7.5 cm
h ₁ /h ₀ =	0.10	t ₁ =	30 minutes
h ₂ /h ₀ =	0.01	t ₂ =	64.5 minutes
h ₁ /h ₂ =	9.236		

Calculations based on semilog plot of Head Ratio vs. Time, as per IS:5529 (Part-I)

$$k = 1.1E-03 \text{ cm/sec}$$

Determination of Coefficient of Permeability (FPT-24)



Field Permeability Test No.: FPT-24

By Falling Head Method

(IS: 5529-Part-1-1985, RA-2009)

Test Details
Borehole No. : BH : 4
Location : Ash Pond Area
Reduced Level (RL) : N/A
UTM Coordinates : 404203.43 m E, 2806545.85 m N
Depth of Borehole : 2.0
Calculated value of k : 1.1E-03

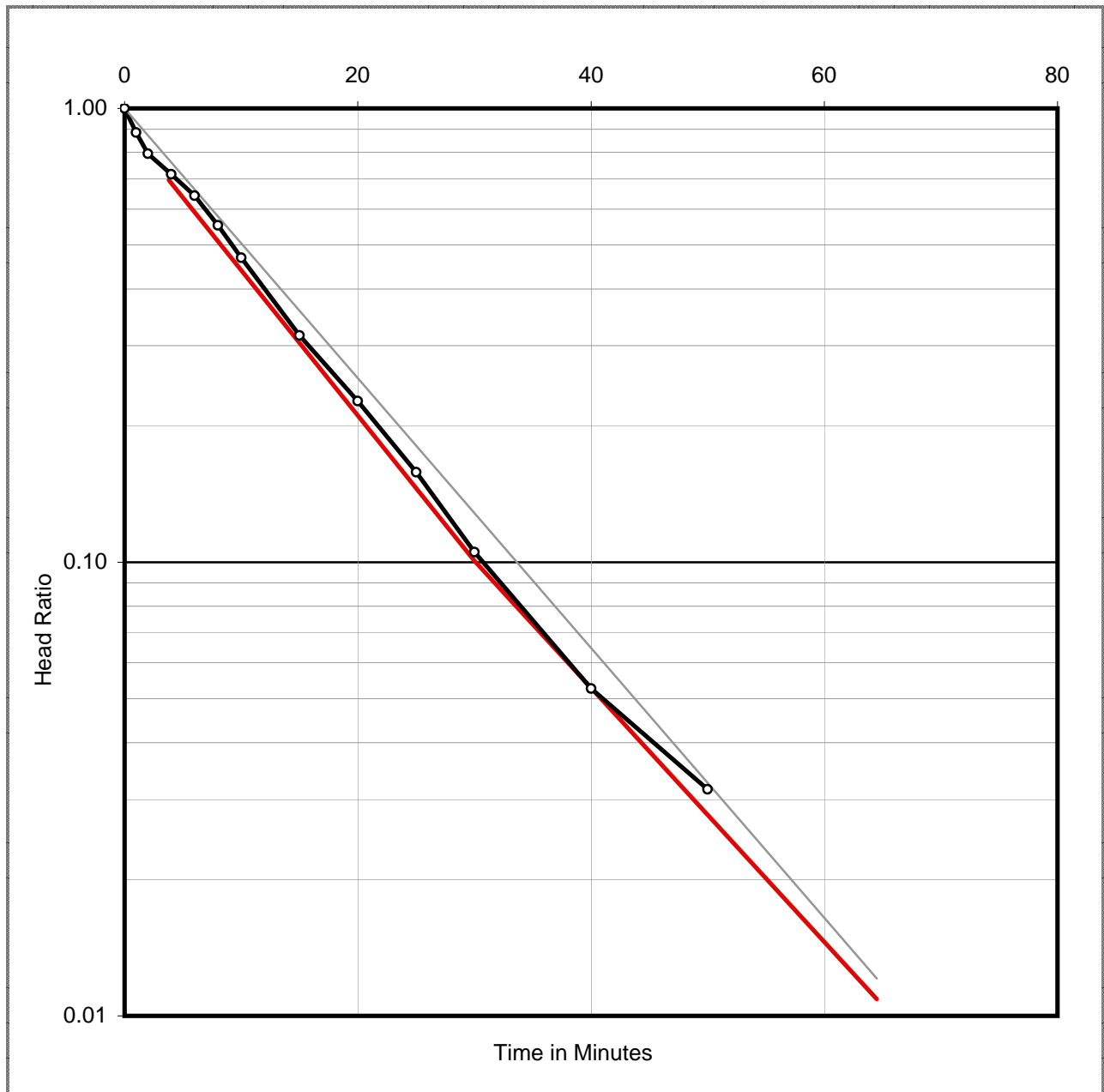

Semi-Log Plot of Head Ratio Vs Time (FPT-24)



Field Permeability Test No.: FPT-25

By Falling Head Method

IS: 5529-Part-1-1985, RA-2009

Test Details	
Borehole No. :	BH : 4
Location :	Ash Pond Area
Reduced Level (RL) :	N/A
UTM Coordinates :	404203.43 m E, 2806545.85 m N
Depth of Borehole :	4.0 m
Depth of bottom of casing below EGL :	3.50 m
Diameter of Intake Pipe :	15.0 cm
Length of Test Section :	50.0 cm
Depth of Water Table :	7.0 m
Height of Casing above GL :	0.12 m
Hydraulic Head at Start of test :	387 cm
Soil Classification :	Silty fine sand

Sl. No.	Time in Minutes	Water Level in Intake Pipe, cm	Head, cm	Sl. No.	Time in Minutes	Water Level in Intake Pipe, cm	Head, cm
1	0.0	0.0	387				
2	1.0	82.0	305				
3	2.0	140.0	247				
4	4.0	170.0	217				
5	6.0	192.0	195				
6	8.0	215.0	172				
7	10.0	237.0	150				
8	15.0	270.0	117				
9	20.0	294.0	93				
10	25.0	308.0	79				
11	30.0	318.0	69				
12	40.0	335.0	52				
13	50.0	396.0	-9				

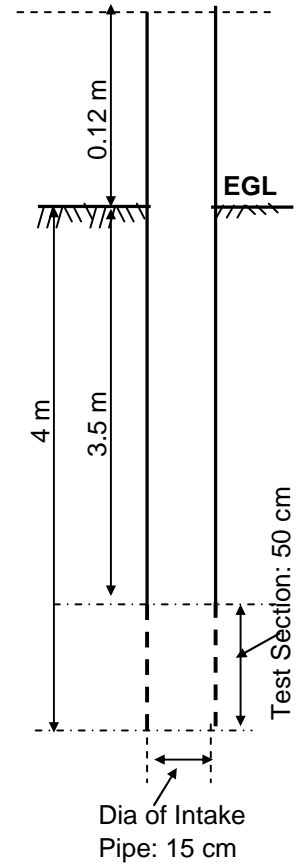

$$k = \text{Coefficient of Permeability} = \frac{d^2}{8L(t_2 - t_1)} \ln\left(\frac{2L}{d}\right) \ln\left(\frac{h_1}{h_2}\right)$$

Where:

L =	50.0 cm	d =	15.0 cm
2L/d =	6.67	R =	7.5 cm
$h_1/h_0 =$	0.17	$t_1 =$	30.8 minutes
$h_2/h_0 =$	0.10	$t_2 =$	50.2 minutes
$h_1/h_2 =$	1.662		

Calculations based on semilog plot of Head Ratio vs. Time, as per IS:5529 (Part-I)

$$k = 4.7E-04 \text{ cm/sec}$$

Determination of Coefficient of Permeability (FPT-25)



Field Permeability Test No.: FPT-25

By Falling Head Method

(IS: 5529-Part-1-1985, RA-2009)

Test Details
Borehole No. : BH : 4
Location : Ash Pond Area
Reduced Level (RL) : N/A
UTM Coordinates : 404203.43 m E, 2806545.85 m N
Depth of Borehole : 4.0
Calculated value of k : 4.7E-04

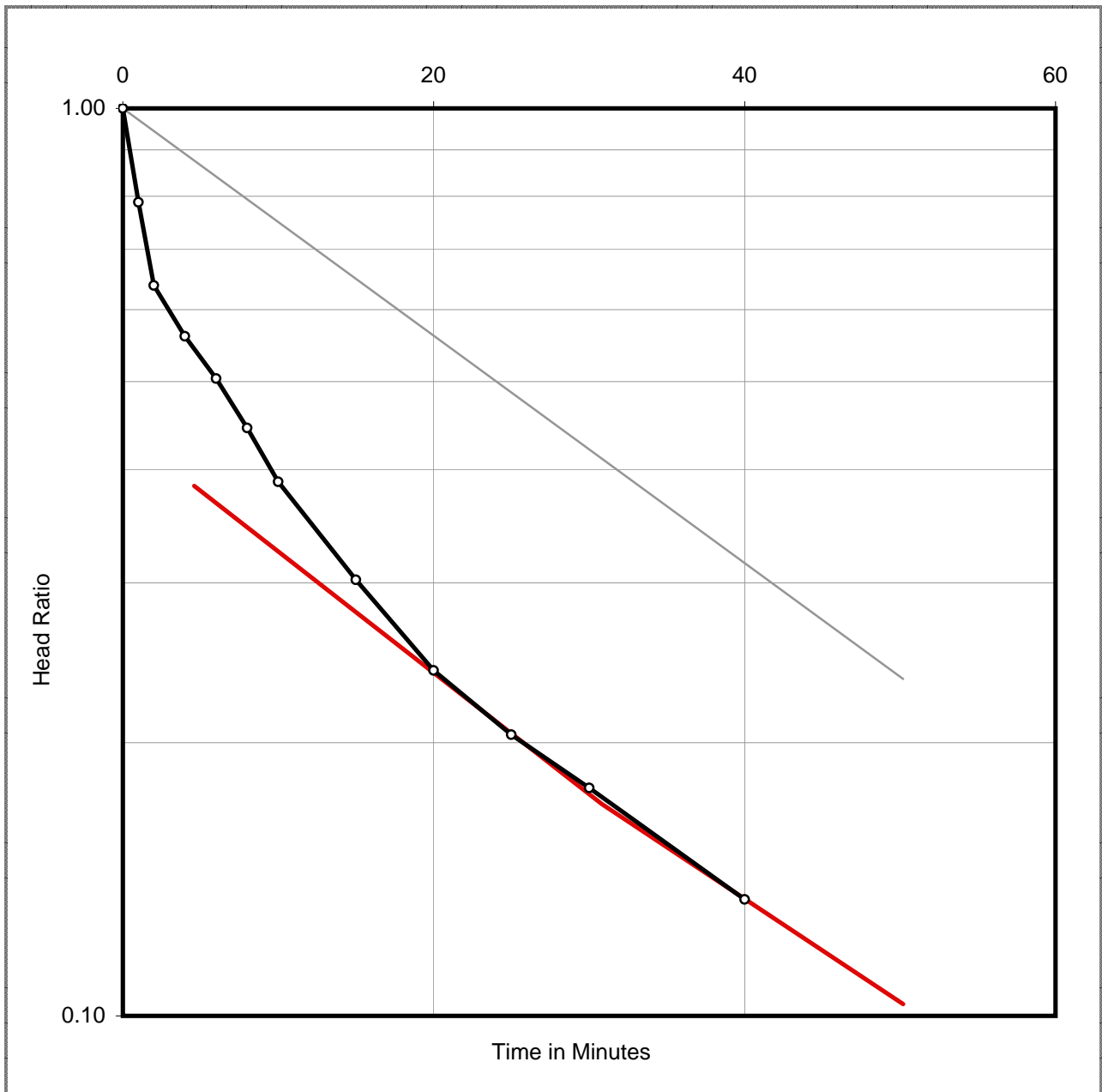

Semi-Log Plot of Head Ratio Vs Time (FPT-25)



Field Permeability Test No.: FPT-26

By Falling Head Method

IS: 5529-Part-1-1985, RA-2009

Test Details	
Borehole No. :	BH : 4
Location :	Ash Pond Area
Reduced Level (RL) :	N/A
UTM Coordinates :	404203.43 m E, 2806545.85 m N
Depth of Borehole :	6.0 m
Depth of bottom of casing below EGL :	5.50 m
Diameter of Intake Pipe :	15.0 cm
Length of Test Section :	50.0 cm
Depth of Water Table :	7.0 m
Height of Casing above GL :	0.80 m
Hydraulic Head at Start of test :	655 cm
Soil Classification :	Silty fine sand

Sl. No.	Time in Minutes	Water Level in Intake Pipe, cm	Head, cm	Sl. No.	Time in Minutes	Water Level in Intake Pipe, cm	Head, cm
1	0.0	0.0	655				
2	1.0	115.0	540				
3	2.0	170.0	485				
4	4.0	257.0	398				
5	6.0	327.0	328				
6	8.0	388.0	267				
7	10.0	418.0	237				
8	15.0	470.0	185				
9	20.0	515.0	140				
10	25.0	536.0	119				
11	30.0	552.0	103				
12	40.0	568.0	87				
13	50.0	579.0	76				
14	60.0	588.0	67				

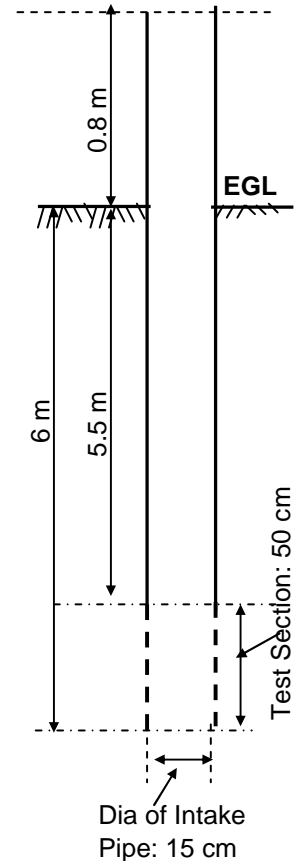

$$k = \text{Coefficient of Permeability} = \frac{d^2}{8L(t_2 - t_1)} \ln\left(\frac{2L}{d}\right) \ln\left(\frac{h_1}{h_2}\right)$$

Where:

L = 50.0 cm	d = 15.0 cm
2L/d = 6.67	R = 7.5 cm
$h_1/h_0 = 0.10$	$t_1 = 59.9$ minutes
$h_2/h_0 = 0.08$	$t_2 = 85.3$ minutes
$h_1/h_2 = 1.283$	

Calculations based on semilog plot of Head Ratio vs. Time, as per IS:5529 (Part-I)

$$k = 1.7E-04 \text{ cm/sec}$$

Determination of Coefficient of Permeability (FPT-26)



Field Permeability Test No.: FPT-26

By Falling Head Method

(IS: 5529-Part-1-1985, RA-2009)

Test Details
Borehole No. : BH : 4
Location : Ash Pond Area
Reduced Level (RL) : N/A
UTM Coordinates : 404203.43 m E, 2806545.85 m N
Depth of Borehole : 6.0
Calculated value of k : 1.7E-04

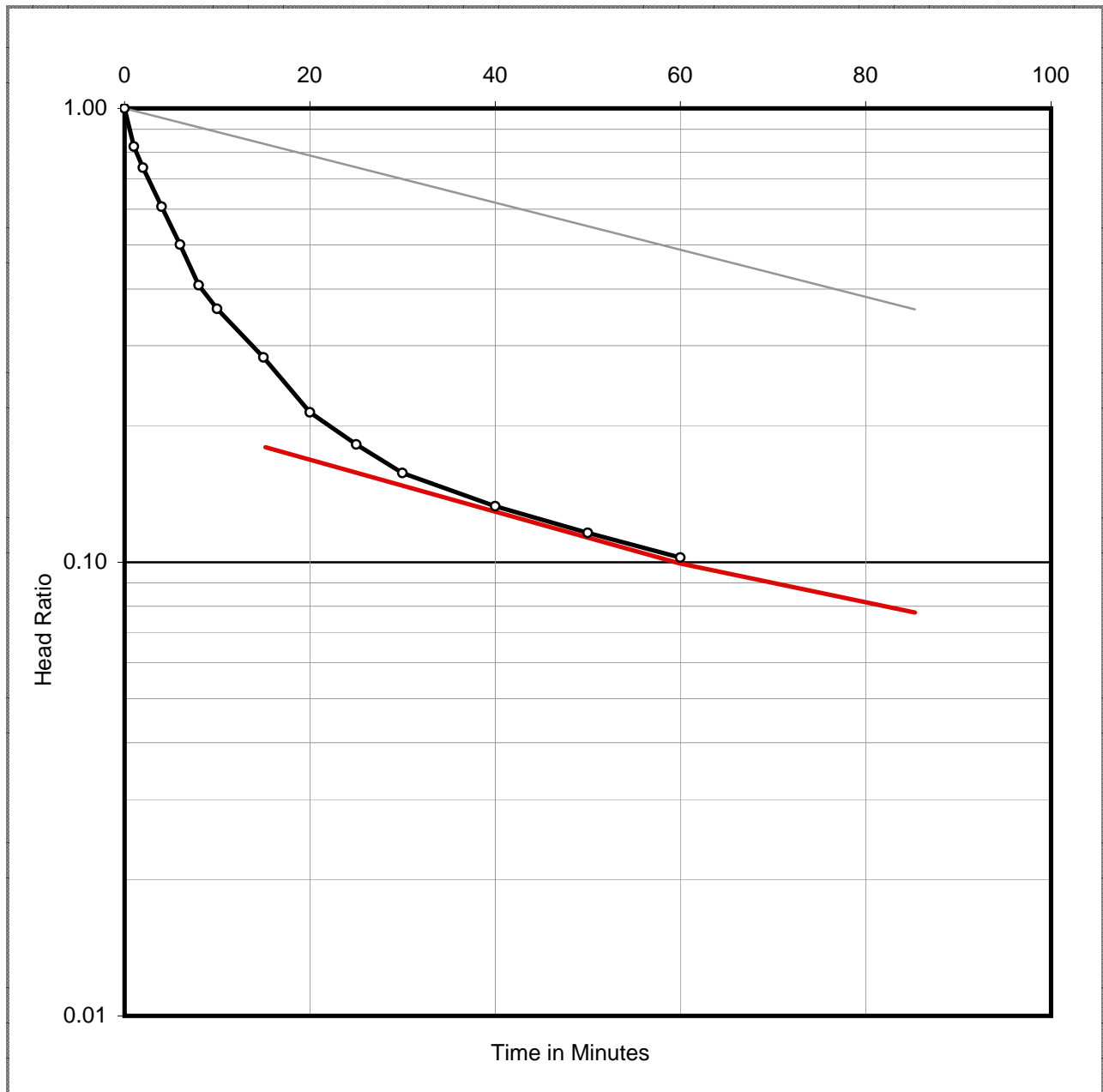

Semi-Log Plot of Head Ratio Vs Time (FPT-26)



Field Permeability Test No. : FPT-27

By Constant Head Method

IS: 5529-Part-1-1985, RA-2009

Test Details	
Borehole No. :	BH-4
Location :	Ash Pond Area
UTM Coordinates :	404203.43 m E, 2806545.85 m N
Depth of Borehole :	8.00 m = 800 cm
Depth of bottom of casing below EGL :	800 cm
Diameter of Intake Pipe :	15 cm
Depth of Water Table :	7.0 cm
Effective Height of water in Tank :	92 cm
Differential Head :	99.0 cm
Soil Classification :	Fine sand

Time, min	Q(litre)	Discharge, Q litre/min)	Q _{average} litre/min	Borehole Radius (r), mm	Differential Head (H), m	C	k, cm/s
0	174.0	0.000					
1	174.4	40.0					
2	174.7	30.0					
4	175.6	45.0					
6	176.4	40.0					
8	176.9	25.0	26.7	75	1.0	4E-03	1.1E-01
10	177.5	30.0					
15	178.9	28.0					
20	180.1	24.0					

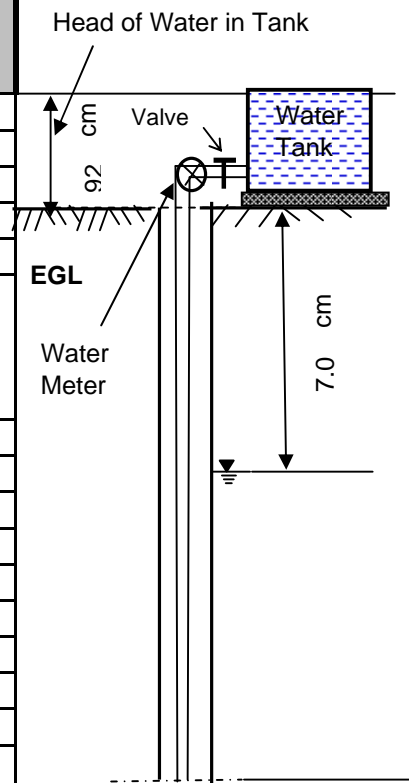

Equation used for calculation

Where:

$$k = C * \left[\frac{Q}{H} \right] \quad C = \left[\frac{1}{5.5 r} \right]$$

Q=Discharge,(litre/min)

H=Differential Head,(m)

r=radius of casing,(mm)

Determination of Coefficient of Permeability (FPT-27)



Field Permeability Test No. : FPT-28

By Constant Head Method

IS: 5529-Part-1-1985, RA-2009

Test Details	
Borehole No. :	BH-4
Location :	Ash Pond Area
UTM Coordinates :	404203.43 m E, 2806545.85 m N
Depth of Borehole :	10.0 m = 1000 cm
Depth of bottom of casing below EGL :	1000 cm
Diameter of Intake Pipe :	15 cm
Depth of Water Table :	7.0 cm
Effective Height of water in Tank :	92 cm
Differential Head :	99.0 cm
Soil Classification :	Fine sand

Time, min	Q(litre)	Discharge, Q (litre/min)	Q _{average} (litre/min)	Borehole Radius (r), mm	Differential Head (H), m	C	k, cm/s
0	190.0	0.000					
1	190.2	20.0					
2	190.4	20.0					
4	190.7	15.0					
6	191.1	20.0					
8	191.6	25.0					
10	192.0	20.0	21.3	75	1.0	4E-03	8.7E-02
15	193.1	22.0					
20	194.2	22.0					

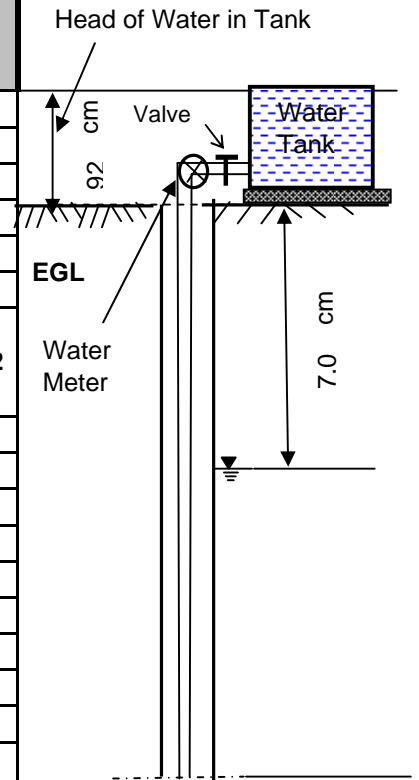

Equation used for calculation

Where:

$$k = C * \left[\frac{Q}{H} \right] \quad C = \left[\frac{1}{5.5 r} \right]$$

Q=Discharge,(litre/min)

H=Differential Head,(m)

r=radius of casing,(mm)

Determination of Coefficient of Permeability (FPT-28)



Field Permeability Test No. : FPT-29

By Constant Head Method

IS: 5529-Part-1-1985, RA-2009

Test Details	
Borehole No. :	BH-4
Location :	Ash Pond Area
UTM Coordinates :	404203.43 m E, 2806545.85 m N
Depth of Borehole :	12.0 m = 1200 cm
Depth of bottom of casing below EGL :	1200 cm
Diameter of Intake Pipe :	15 cm
Depth of Water Table :	7.0 cm
Effective Height of water in Tank :	92 cm
Differential Head :	99.0 cm
Soil Classification :	Fine sand

Time, min	Q(litre)	Discharge, Q (litre/min)	Q _{average} (litre/min)	Borehole Radius (r), mm	Differential Head (H), m	C	k, cm/s
0	195.0	0.000					
1	195.2	20.0					
2	195.4	20.0					
4	195.7	15.0					
6	196.0	15.0					
8	196.4	20.0					
10	196.7	15.0	15.0	75	1.0	4E-03	6.1E-02
15	197.4	14.0					
20	198.2	16.0					

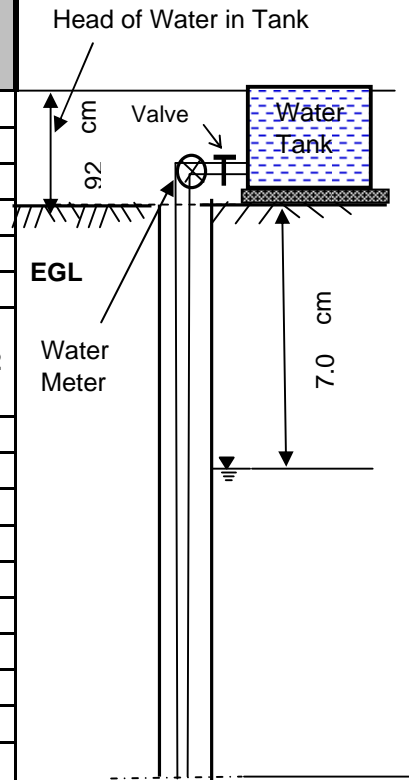

Equation used for calculation

$$k = C * \left[\frac{Q}{H} \right] \quad C = \left[\frac{1}{5.5 r} \right]$$

Where:

Q=Discharge,(litre/min)

H=Differential Head,(m)

r=radius of casing,(mm)

Determination of Coefficient of Permeability (FPT-29)



Field Permeability Test No. : FPT-30

By Constant Head Method

IS: 5529-Part-1-1985, RA-2009

Test Details	
Borehole No. :	BH-4
Location :	Ash Pond Area
UTM Coordinates :	404203.43 m E, 2806545.85 m N
Depth of Borehole :	14.0 m = 1400 cm
Depth of bottom of casing below EGL :	1400 cm
Diameter of Intake Pipe :	15 cm
Depth of Water Table :	7.0 cm
Effective Height of water in Tank :	92 cm
Differential Head :	99.0 cm
Soil Classification :	Fine sand

Time, min	Q(litre)	Discharge, Q litre/min)	Q _{average} litre/min	Borehole Radius (r), mm	Differential Head (H), m	C	k, cm/s
0	199.0	0.000					
1	199.2	20.0					
2	199.4	20.0					
4	199.9	25.0					
6	200.3	20.0					
8	200.8	25.0	25.5	75	1.0	4E-03	1.0E-01
10	201.3	25.0					
15	202.5	24.0					
20	203.9	28.0					

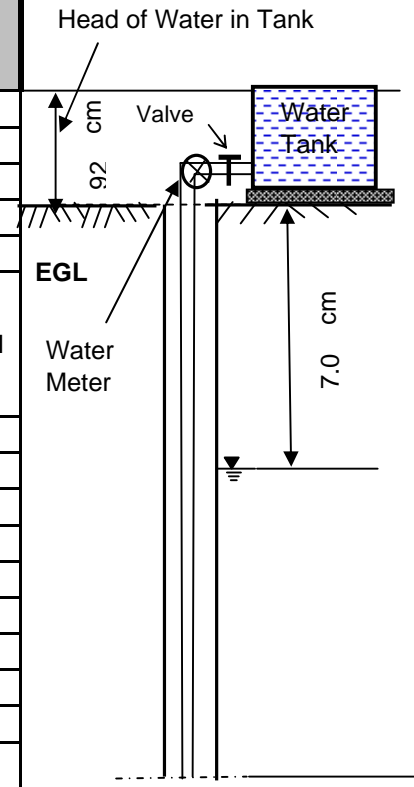

Equation used for calculation

$$k = C * \left[\frac{Q}{H} \right] \quad C = \left[\frac{1}{5.5 r} \right]$$

Where:

Q=Discharge,(litre/min)

H=Differential Head,(m)

r=radius of casing,(mm)

Determination of Coefficient of Permeability (FPT-30)



Field Permeability Test No. : FPT-31

By Constant Head Method

IS: 5529-Part-1-1985, RA-2009

Test Details	
Borehole No. :	BH-4
Location :	Ash Pond Area
UTM Coordinates :	404203.43 m E, 2806545.85 m N
Depth of Borehole :	16.0 m = 1600 cm
Depth of bottom of casing below EGL :	1600 cm
Diameter of Intake Pipe :	15 cm
Depth of Water Table :	7.0 cm
Effective Height of water in Tank :	92 cm
Differential Head :	99.0 cm
Soil Classification :	Fine sand

Time, min	Q(litre)	Discharge, Q (litre/min)	Q _{average} (litre/min)	Borehole Radius (r), mm	Differential Head (H), m	C	k, cm/s
0	204.0	0.000					
1	204.4	40.0					
2	204.7	30.0					
4	205.0	15.0					
6	205.2	10.0					
8	205.7	25.0					
10	206.0	15.0	16.3	75	1.0	4E-03	6.7E-02
15	206.9	18.0					
20	207.7	16.0					

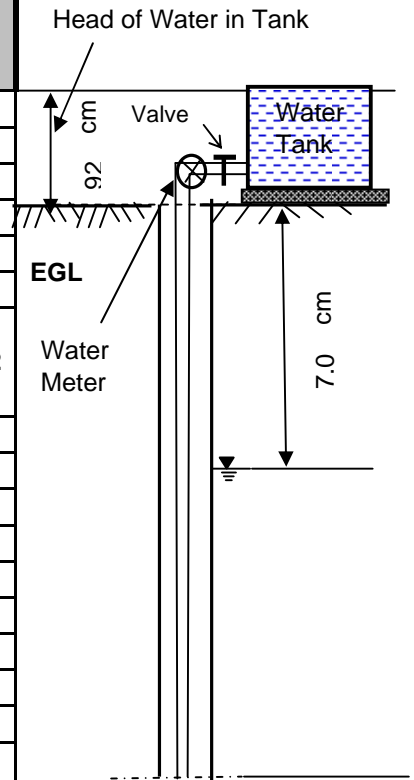

Equation used for calculation

Where:

$$k = C * \left[\frac{Q}{H} \right] \quad C = \left[\frac{1}{5.5 r} \right]$$

Q=Discharge,(litre/min)

H=Differential Head,(m)

r=radius of casing,(mm)

Determination of Coefficient of Permeability (FPT-31)



Field Permeability Test No. : FPT-32

By Constant Head Method

IS: 5529-Part-1-1985, RA-2009

Test Details	
Borehole No. :	BH-4
Location :	Ash Pond Area
UTM Coordinates :	404203.43 m E, 2806545.85 m N
Depth of Borehole :	18.0 m = 1800 cm
Depth of bottom of casing below EGL :	1800 cm
Diameter of Intake Pipe :	15 cm
Depth of Water Table :	7.0 cm
Effective Height of water in Tank :	92 cm
Differential Head :	99.0 cm
Soil Classification :	Fine sand

Time, min	Q(litre)	Discharge, Q litre/min)	Q _{average} litre/min	Borehole Radius (r), mm	Differential Head (H), m	C	k, cm/s
0	208.0	0.000					
1	208.2	20.0					
2	208.4	20.0					
4	208.7	15.0	17.3	75	1.0	4E-03	7.1E-02
6	209.0	15.0					
8	209.4	20.0					
10	209.8	20.0					
15	210.7	18.0					
20	211.5	16.0					

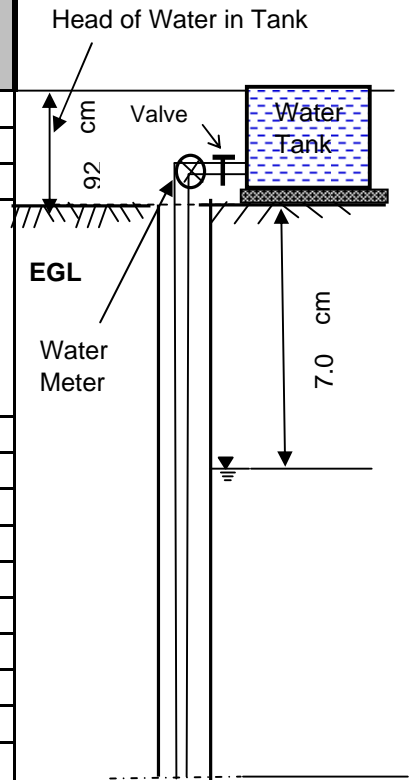

Equation used for calculation

$$k = C * \left[\frac{Q}{H} \right] \quad C = \left[\frac{1}{5.5 r} \right]$$

Where:

Q=Discharge,(litre/min)

H=Differential Head,(m)

r=radius of casing,(mm)

Determination of Coefficient of Permeability (FPT-32)



Field Permeability Test No. : FPT-33

By Constant Head Method

IS: 5529-Part-1-1985, RA-2009

Test Details	
Borehole No. :	BH-4
Location :	Ash Pond Area
UTM Coordinates :	404203.43 m E, 2806545.85 m N
Depth of Borehole :	20.0 m = 2000 cm
Depth of bottom of casing below EGL :	2000 cm
Diameter of Intake Pipe :	15 cm
Depth of Water Table :	7.0 cm
Effective Height of water in Tank :	92 cm
Differential Head :	99.0 cm
Soil Classification :	Fine sand

Time, min	Q(litre)	Discharge, Q litre/min)	Q _{average} litre/min	Borehole Radius (r), mm	Differential Head (H), m	C	k, cm/s
0	212.0	0.000					
1	212.2	20.0					
2	212.3	10.0	11.7	75	1.0	4E-03	4.8E-02
4	212.6	15.0					
6	212.9	15.0					
8	213.1	10.0					
10	213.3	10.0					
15	213.9	12.0					
20	214.4	10.0					

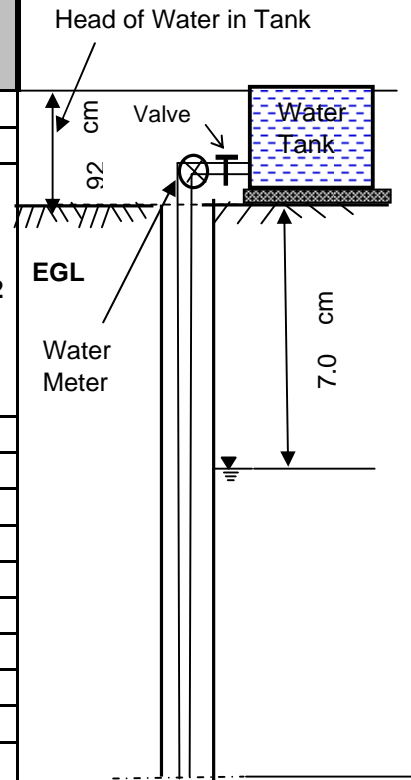

Equation used for calculation

Where:

$$k = C * \left[\frac{Q}{H} \right] \quad C = \left[\frac{1}{5.5 r} \right]$$

Q=Discharge,(litre/min)

H=Differential Head,(m)

r=radius of casing,(mm)

Determination of Coefficient of Permeability (FPT-33)



Field Permeability Test No.: FPT-34

By Falling Head Method

IS: 5529-Part-1-1985, RA-2009

Test Details	
Borehole No. :	BH : 5
Location :	Ash Pond Area
Reduced Level (RL) :	N/A
UTM Coordinates :	404597.72 m E, 2806647.28 m N
Depth of Borehole :	2.0 m
Depth of bottom of casing below EGL :	1.50 m
Diameter of Intake Pipe :	15.0 cm
Length of Test Section :	50.0 cm
Depth of Water Table :	7.0 m
Height of Casing above GL :	0.80 m
Hydraulic Head at Start of test :	255 cm
Soil Classification :	Silty fine sand

Sl. No.	Time in Minutes	Water Level in Intake Pipe, cm	Head, cm	Sl. No.	Time in Minutes	Water Level in Intake Pipe, cm	Head, cm
1	0.0	0.0	255				
2	1.0	26.0	229				
3	2.0	42.0	213				
4	4.0	78.0	177				
5	6.0	91.0	164				
6	8.0	109.0	146				
7	10.0	126.0	129				
8	15.0	150.0	105				
9	20.0	170.0	85				
10	25.0	181.0	74				
11	30.0	190.0	65				
12	40.0	199.0	56				

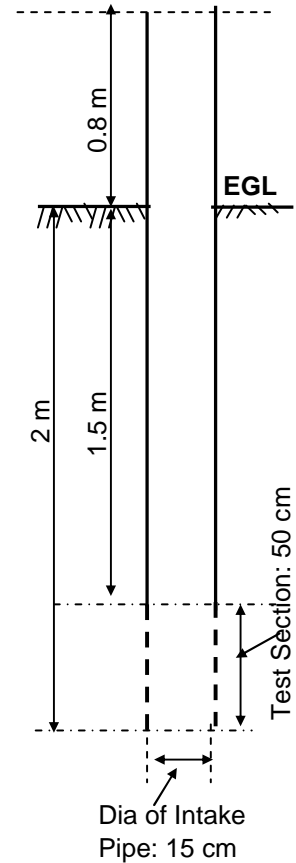

$$k = \text{Coefficient of Permeability} = \frac{d^2}{8L(t_2 - t_1)} \ln\left(\frac{2L}{d}\right) \ln\left(\frac{h_1}{h_2}\right)$$

Where:

L =	50.0 cm	d =	15.0 cm
2L/d =	6.67	R =	7.5 cm
h ₁ /h ₀ =	0.25	t ₁ =	30 minutes
h ₂ /h ₀ =	0.22	t ₂ =	39.6 minutes
h ₁ /h ₂ =	1.143		

Calculations based on semilog plot of Head Ratio vs. Time, as per IS:5529 (Part-I)

$$k = 2.5E-04 \text{ cm/sec}$$

Determination of Coefficient of Permeability (FPT-34)



Field Permeability Test No.: FPT-34

By Falling Head Method

(IS: 5529-Part-1-1985, RA-2009)

Test Details
Borehole No. : BH : 5
Location : Ash Pond Area
Reduced Level (RL) : N/A
UTM Coordinates : 404597.72 m E, 2806647.28 m N
Depth of Borehole : 2.0
Calculated value of k : 2.5E-04

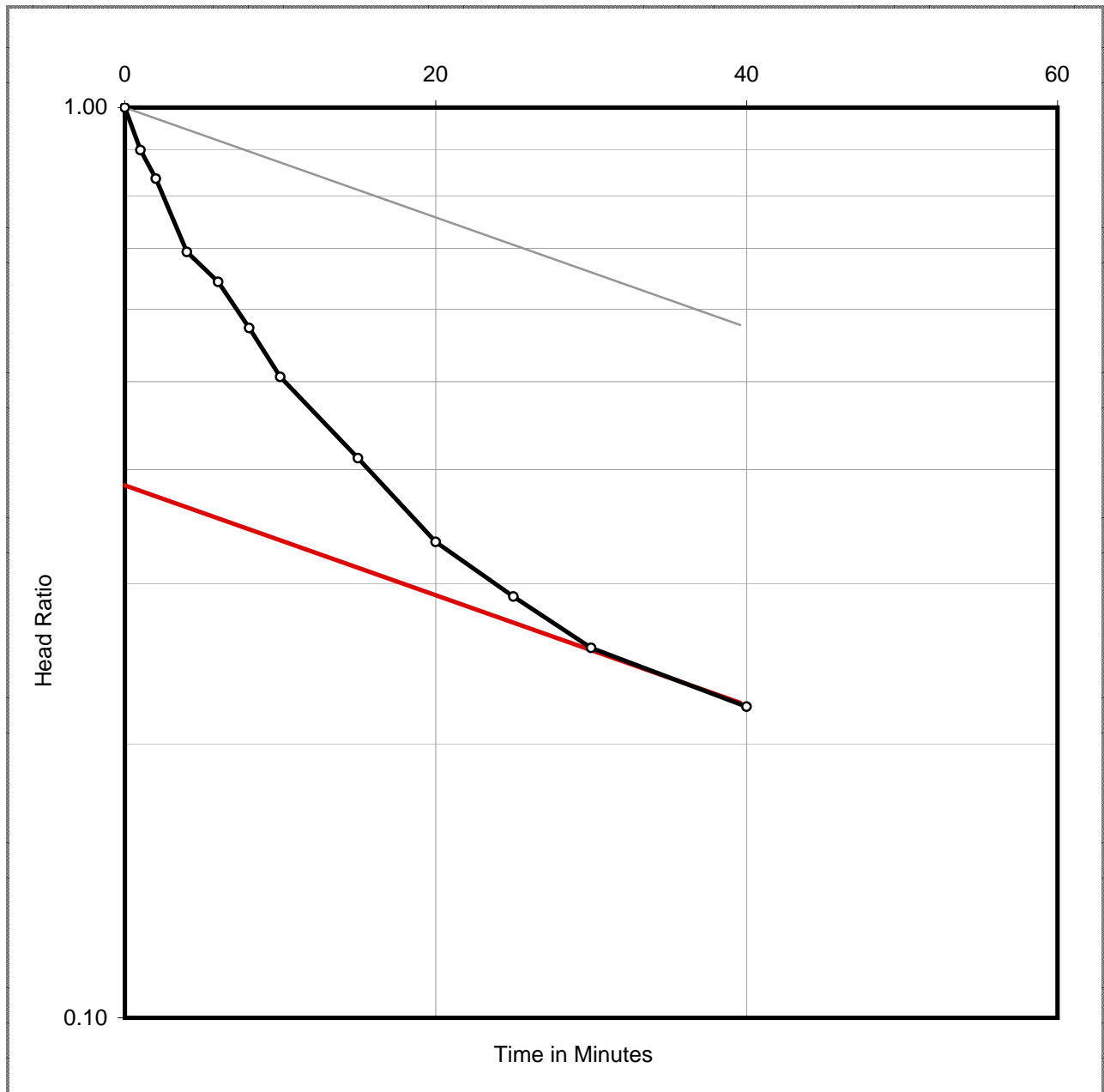

Semi-Log Plot of Head Ratio Vs Time (FPT-34)



Field Permeability Test No.: FPT-35

By Falling Head Method

IS: 5529-Part-1-1985, RA-2009

Test Details	
Borehole No. :	BH : 5
Location :	Ash Pond Area
Reduced Level (RL) :	N/A
UTM Coordinates :	404597.72 m E, 2806647.28 m N
Depth of Borehole :	4.0 m
Depth of bottom of casing below EGL :	3.50 m
Diameter of Intake Pipe :	15.0 cm
Length of Test Section :	50.0 cm
Depth of Water Table :	7.0 m
Height of Casing above GL :	0.13 m
Hydraulic Head at Start of test :	388 cm
Soil Classification :	Silty fine sand

Sl. No.	Time in Minutes	Water Level in Intake Pipe, cm	Head, cm	Sl. No.	Time in Minutes	Water Level in Intake Pipe, cm	Head, cm
1	0.0	0.0	388				
2	1.0	90.0	298				
3	2.0	139.0	249				
4	4.0	178.0	210				
5	6.0	196.0	192				
6	8.0	218.0	170				
7	10.0	236.0	152				
8	15.0	275.0	113				
9	20.0	302.0	86				
10	25.0	320.0	68				
11	30.0	334.0	54				

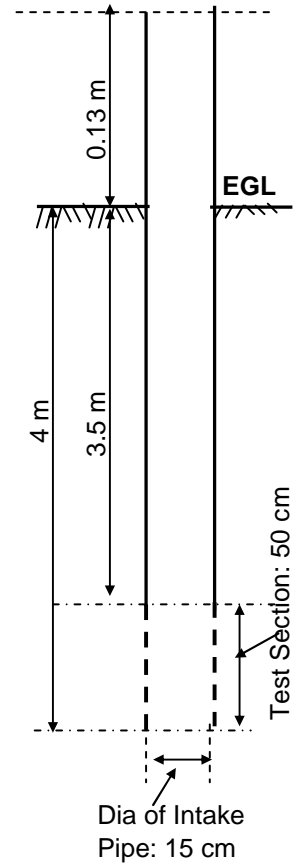

$$k = \text{Coefficient of Permeability} = \frac{d^2}{8L(t_2 - t_1)} \ln\left(\frac{2L}{d}\right) \ln\left(\frac{h_1}{h_2}\right)$$

Where:

- | | |
|--|-------------------------------|
| L = 50.0 cm | d = 15.0 cm |
| 2L/d = 6.67 | R = 7.5 cm |
| h ₁ /h ₀ = 0.14 | t ₁ = 30 minutes |
| h ₂ /h ₀ = 0.05 | t ₂ = 53.2 minutes |
| h ₁ /h ₂ = 2.940 | |

Calculations based on semilog plot of Head Ratio vs. Time, as per IS:5529 (Part-I)

$$k = 8.3E-04 \text{ cm/sec}$$

Determination of Coefficient of Permeability (FPT-35)



Field Permeability Test No.: FPT-35

By Falling Head Method

(IS: 5529-Part-1-1985, RA-2009)

Test Details
Borehole No. : BH : 5
Location : Ash Pond Area
Reduced Level (RL) : N/A
UTM Coordinates : 404597.72 m E, 2806647.28 m N
Depth of Borehole : 4.0
Calculated value of k : 8.3E-04

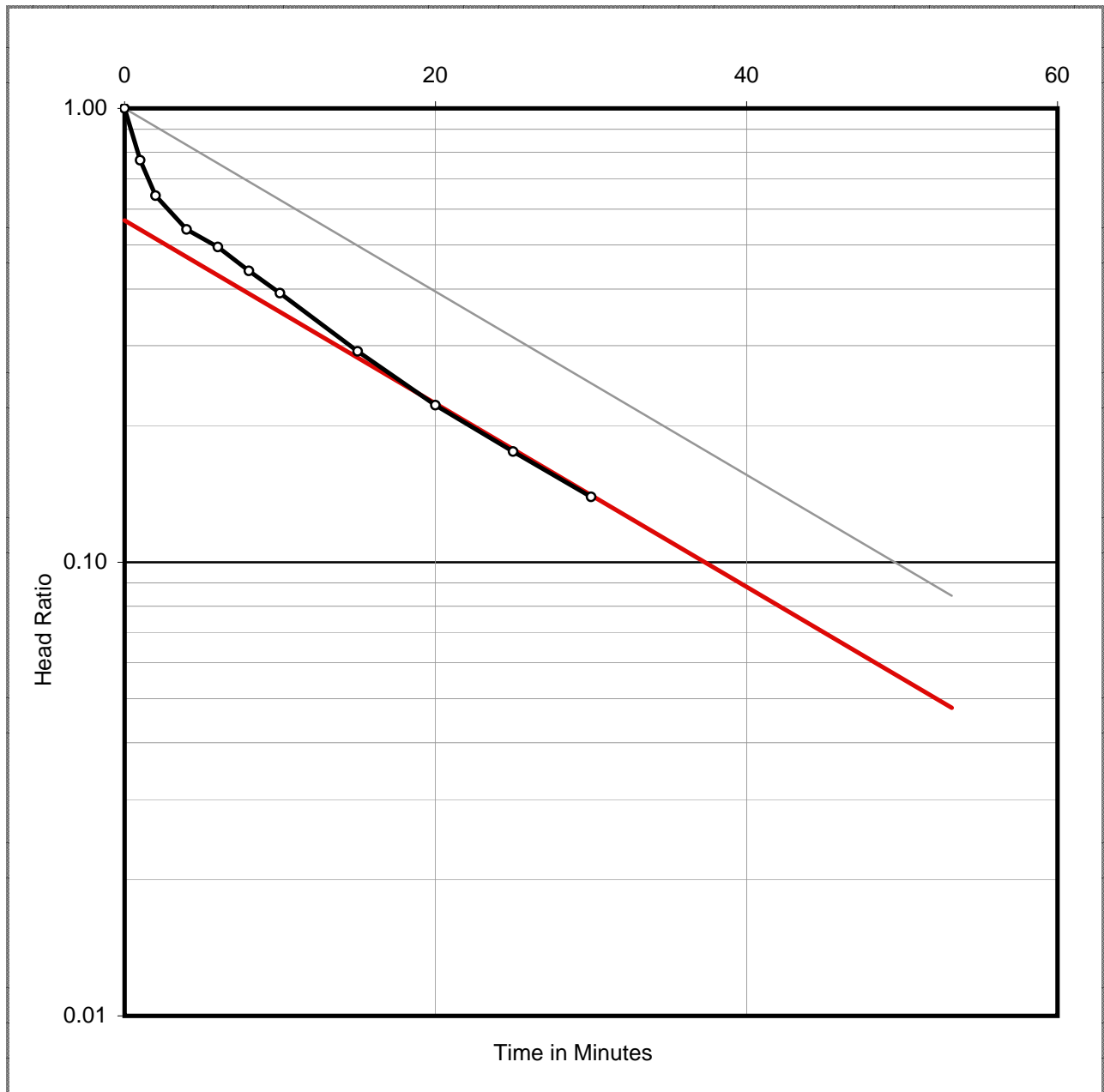

Semi-Log Plot of Head Ratio Vs Time (FPT-35)



Field Permeability Test No.: FPT-36

By Falling Head Method

IS: 5529-Part-1-1985, RA-2009

Test Details	
Borehole No. :	BH : 5
Location :	Ash Pond Area
Reduced Level (RL) :	N/A
UTM Coordinates :	404597.72 m E, 2806647.28 m N
Depth of Borehole :	6.0 m
Depth of bottom of casing below EGL :	5.50 m
Diameter of Intake Pipe :	15.0 cm
Length of Test Section :	50.0 cm
Depth of Water Table :	7.0 m
Height of Casing above GL :	0.80 m
Hydraulic Head at Start of test :	655 cm
Soil Classification :	Silty fine sand

Sl. No.	Time in Minutes	Water Level in Intake Pipe, cm	Head, cm	Sl. No.	Time in Minutes	Water Level in Intake Pipe, cm	Head, cm
1	0.0	0.0	655				
2	1.0	135.0	520				
3	2.0	180.0	475				
4	4.0	260.0	395				
5	6.0	333.0	322				
6	8.0	389.0	266				
7	10.0	441.0	214				
8	15.0	488.0	167				
9	20.0	519.0	136				
10	25.0	544.0	111				
11	30.0	556.0	99				
12	40.0	572.0	83				
13	50.0	582.0	73				
14	60.0	591.0	64				

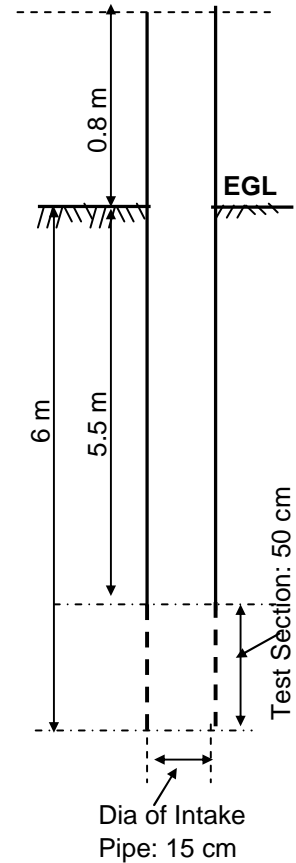

$$k = \text{Coefficient of Permeability} = \frac{d^2}{8L(t_2 - t_1)} \ln\left(\frac{2L}{d}\right) \ln\left(\frac{h_1}{h_2}\right)$$

Where:

L = 50.0 cm	d = 15.0 cm
2L/d = 6.67	R = 7.5 cm
$h_1/h_0 = 0.15$	$t_1 = 30$ minutes
$h_2/h_0 = 0.09$	$t_2 = 62.5$ minutes
$h_1/h_2 = 1.667$	

Calculations based on semilog plot of Head Ratio vs. Time, as per IS:5529 (Part-I)

$$k = 2.8E-04 \text{ cm/sec}$$

Determination of Coefficient of Permeability (FPT-36)



Field Permeability Test No.: FPT-36

By Falling Head Method

(IS: 5529-Part-1-1985, RA-2009)

Test Details
Borehole No. : BH : 5
Location : Ash Pond Area
Reduced Level (RL) : N/A
UTM Coordinates : 404597.72 m E, 2806647.28 m N
Depth of Borehole : 6.0
Calculated value of k : 2.8E-04

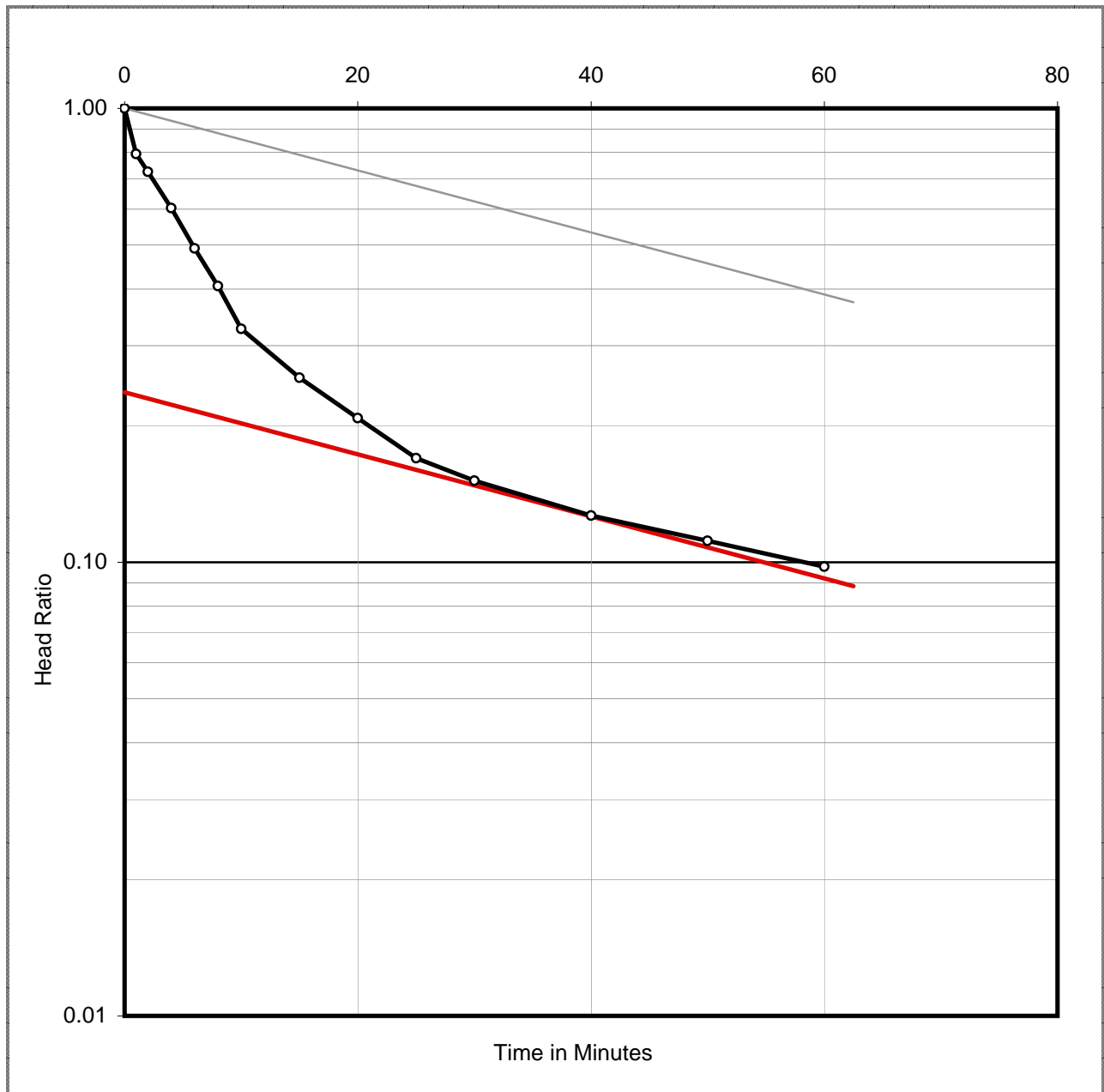

Semi-Log Plot of Head Ratio Vs Time (FPT-36)



Field Permeability Test No. : FPT-37

By Constant Head Method

IS: 5529-Part-1-1985, RA-2009

Test Details	
Borehole No. :	BH-5
Location :	Ash Pond Area
UTM Coordinates :	404597.72 m E, 2806647.28 m N
Depth of Borehole :	8.00 m = 800 cm
Depth of bottom of casing below EGL :	800 cm
Diameter of Intake Pipe :	15 cm
Depth of Water Table :	7.0 cm
Effective Height of water in Tank :	92 cm
Differential Head :	99.0 cm
Soil Classification :	Fine sand

Time, min	Q(litre)	Discharge, Q (litre/min)	Q _{average} (litre/min)	Borehole Radius (r), mm	Differential Head (H), m	C	k, cm/s
0	215.0	0.000					
1	215.4	40.0					
2	215.8	40.0					
4	216.4	30.0	30.2	75	1.0	4E-03	1.2E-01
6	216.9	25.0					
8	217.5	30.0					
10	218.1	30.0					
15	219.8	34.0					
20	221.4	32.0					

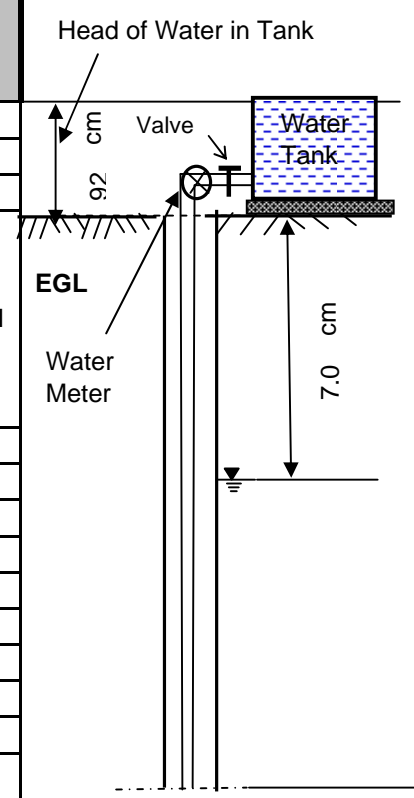

Equation used for calculation

$$k = C * \left[\frac{Q}{H} \right] \quad C = \left[\frac{1}{5.5 r} \right]$$

Where:

Q=Discharge,(litre/min)

H=Differential Head,(m)

r=radius of casing,(mm)

Determination of Coefficient of Permeability (FPT-37)



Field Permeability Test No. : FPT-38

By Constant Head Method

IS: 5529-Part-1-1985, RA-2009

Test Details	
Borehole No. :	BH-5
Location :	Ash Pond Area
UTM Coordinates :	404597.72 m E, 2806647.28 m N
Depth of Borehole :	10.00 m = 1000 cm
Depth of bottom of casing below EGL :	1000 cm
Diameter of Intake Pipe :	15 cm
Depth of Water Table :	7.0 cm
Effective Height of water in Tank :	92 cm
Differential Head :	99.0 cm
Soil Classification :	Fine sand

Time, min	Q(litre)	Discharge, Q litre/min)	Q _{average} litre/min	Borehole Radius (r), mm	Differential Head (H), m	C	k, cm/s
0	222.0	0.000					
1	222.2	20.0					
2	222.5	30.0					
4	223.0	25.0					
6	223.4	20.0	21.8	75	1.0	4E-03	8.9E-02
8	223.8	20.0					
10	224.3	25.0					
15	225.4	22.0					
20	226.5	22.0					

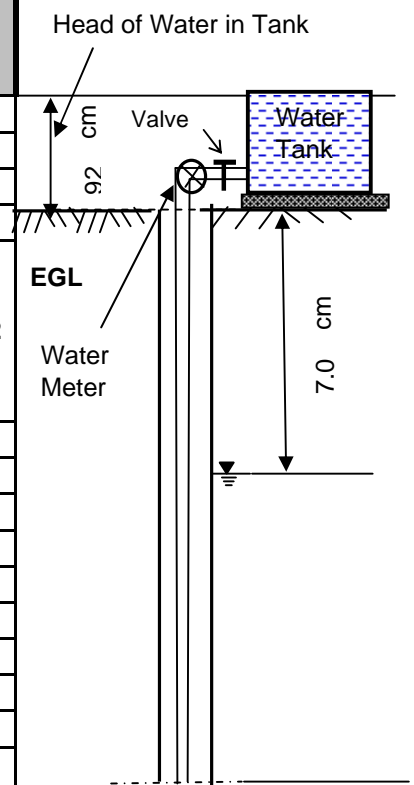

Equation used for calculation

Where:

$$k = C * \left[\frac{Q}{H} \right] \quad C = \left[\frac{1}{5.5 r} \right]$$

Q=Discharge,(litre/min)

H=Differential Head,(m)

r=radius of casing,(mm)

Determination of Coefficient of Permeability (FPT-38)



Field Permeability Test No. : FPT-39

By Constant Head Method

IS: 5529-Part-1-1985, RA-2009

Test Details	
Borehole No. :	BH-5
Location :	Ash Pond Area
UTM Coordinates :	404597.72 m E, 2806647.28 m N
Depth of Borehole :	12.00 m = 1200 cm
Depth of bottom of casing below EGL :	1200 cm
Diameter of Intake Pipe :	15 cm
Depth of Water Table :	7.0 cm
Effective Height of water in Tank :	92 cm
Differential Head :	99.0 cm
Soil Classification :	Fine sand

Time, min	Q(litre)	Discharge, Q litre/min)	Q _{average} litre/min	Borehole Radius (r), mm	Differential Head (H), m	C	k, cm/s
0	227.0	0.000					
1	227.2	20.0					
2	227.4	20.0					
4	227.7	15.0	13.0	75	1.0	4E-03	5.3E-02
6	228.0	15.0					
8	228.2	10.0					
10	228.5	15.0					
15	229.1	12.0					
20	229.7	12.0					

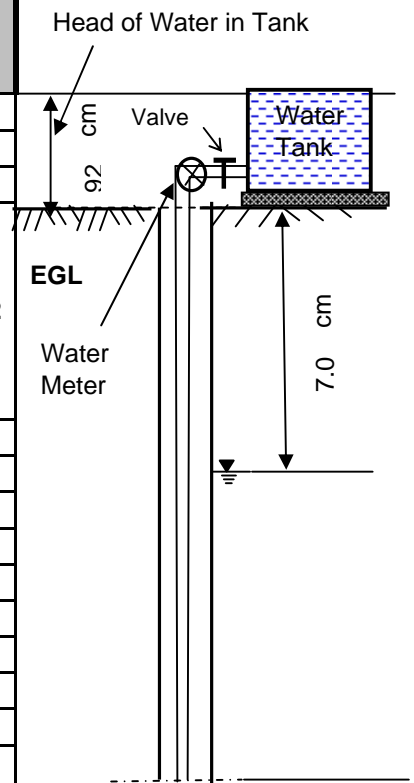

Equation used for calculation

Where:

Q=Discharge,(litre/min)

H=Differential Head,(m)

r=radius of casing,(mm)

$$k = C * \left[\frac{Q}{H} \right] \quad C = \left[\frac{1}{5.5 r} \right]$$

Determination of Coefficient of Permeability (FPT-39)



Field Permeability Test No. : FPT-40

By Constant Head Method

IS: 5529-Part-1-1985, RA-2009

Test Details	
Borehole No. :	BH-5
Location :	Ash Pond Area
UTM Coordinates :	404597.72 m E, 2806647.28 m N
Depth of Borehole :	14.00 m = 1400 cm
Depth of bottom of casing below EGL :	1400 cm
Diameter of Intake Pipe :	15 cm
Depth of Water Table :	7.0 cm
Effective Height of water in Tank :	92 cm
Differential Head :	99.0 cm
Soil Classification :	Fine sand

Time, min	Q(litre)	Discharge, Q litre/min)	Q _{average} litre/min	Borehole Radius (r), mm	Differential Head (H), m	C	k, cm/s
0	230.0	0.000					
1	230.4	40.0					
2	230.7	30.0					
4	231.4	35.0					
6	232.0	30.0	31.8	75	1.0	4E-03	1.3E-01
8	232.6	30.0					
10	233.3	35.0					
15	234.9	32.0					
20	236.5	32.0					

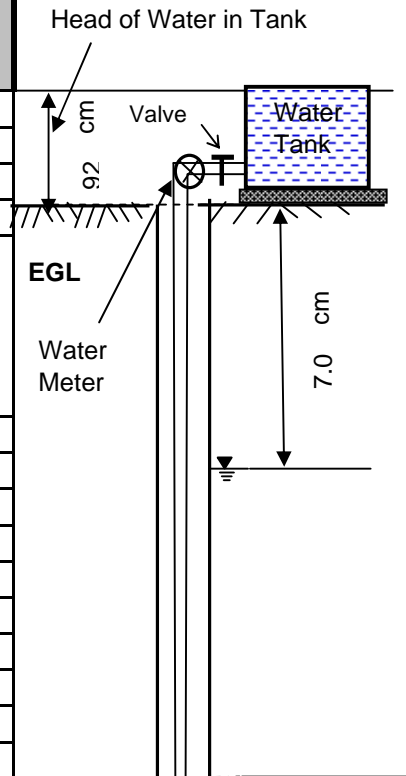

Equation used for calculation

Where:

Q=Discharge,(litre/min)

H=Differential Head,(m)

r=radius of casing,(mm)

$$k = C * \left[\frac{Q}{H} \right] \quad C = \left[\frac{1}{5.5 r} \right]$$

Determination of Coefficient of Permeability (FPT-40)



Field Permeability Test No. : FPT-41

By Constant Head Method

IS: 5529-Part-1-1985, RA-2009

Test Details	
Borehole No. :	BH-5
Location :	Ash Pond Area
UTM Coordinates :	404597.72 m E, 2806647.28 m N
Depth of Borehole :	16.00 m = 1600 cm
Depth of bottom of casing below EGL :	1600 cm
Diameter of Intake Pipe :	15 cm
Depth of Water Table :	7.0 cm
Effective Height of water in Tank :	92 cm
Differential Head :	99.0 cm
Soil Classification :	Fine sand

Time, min	Q(litre)	Discharge, Q (litre/min)	Q _{average} (litre/min)	Borehole Radius (r), mm	Differential Head (H), m	C	k, cm/s
0	237.0	0.000					
1	237.4	40.0					
2	237.7	30.0					
4	238.4	35.0					
6	238.8	20.0	20.6	75	1.0	4E-03	8.4E-02
8	239.3	25.0					
10	239.7	20.0					
15	240.6	18.0					
20	241.6	20.0					

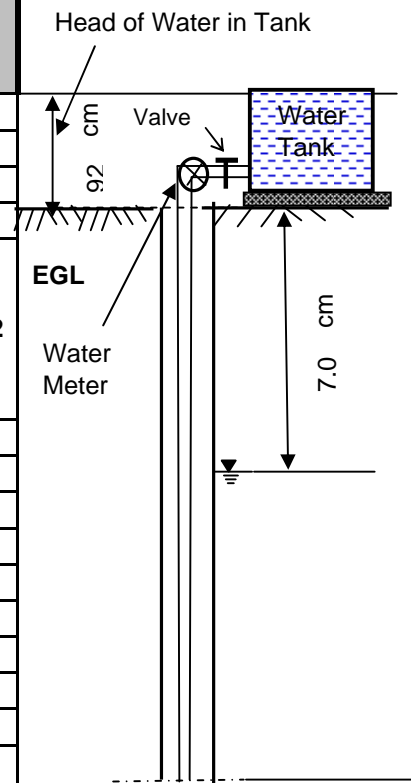

Equation used for calculation

$$k = C * \left[\frac{Q}{H} \right] \quad C = \left[\frac{1}{5.5 r} \right]$$

Where:

Q=Discharge,(litre/min)

H=Differential Head,(m)

r=radius of casing,(mm)

Determination of Coefficient of Permeability (FPT-41)



Field Permeability Test No. : FPT-42

By Constant Head Method

IS: 5529-Part-1-1985, RA-2009

Test Details	
Borehole No. :	BH-5
Location :	Ash Pond Area
UTM Coordinates :	404597.72 m E, 2806647.28 m N
Depth of Borehole :	18.00 m = 1800 cm
Depth of bottom of casing below EGL :	1800 cm
Diameter of Intake Pipe :	15 cm
Depth of Water Table :	7.0 cm
Effective Height of water in Tank :	92 cm
Differential Head :	99.0 cm
Soil Classification :	Fine sand

Time, min	Q(litre)	Discharge, Q litre/min)	Q _{average} litre/min	Borehole Radius (r), mm	Differential Head (H), m	C	k, cm/s
0	242.0	0.000					
1	242.3	30.0					
2	242.5	20.0	16.6	75	1.0	4E-03	6.8E-02
4	242.9	20.0					
6	243.2	15.0					
8	243.6	20.0					
10	243.9	15.0					
15	244.6	14.0					
20	245.2	12.0					

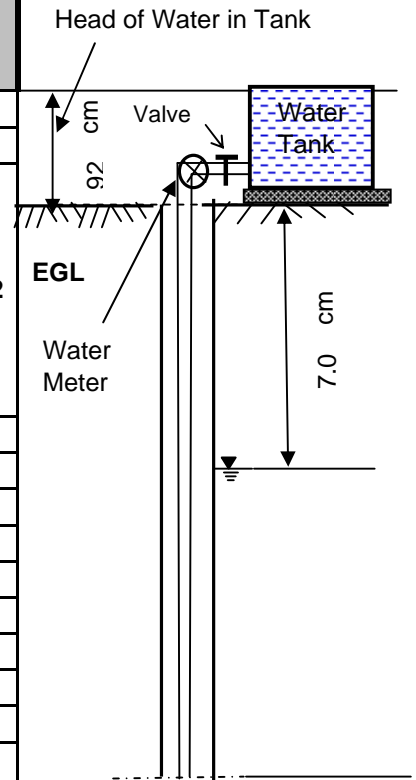

Equation used for calculation

Where:

$$k = C * \left[\frac{Q}{H} \right] \quad C = \left[\frac{1}{5.5 r} \right]$$

Q=Discharge,(litre/min)

H=Differential Head,(m)

r=radius of casing,(mm)

Determination of Coefficient of Permeability (FPT-42)



Field Permeability Test No. : FPT-43

By Constant Head Method

IS: 5529-Part-1-1985, RA-2009

Test Details	
Borehole No. :	BH-5
Location :	Ash Pond Area
UTM Coordinates :	404597.72 m E, 2806647.28 m N
Depth of Borehole :	20.00 m = 2000 cm
Depth of bottom of casing below EGL :	2000 cm
Diameter of Intake Pipe :	15 cm
Depth of Water Table :	7.0 cm
Effective Height of water in Tank :	92 cm
Differential Head :	99.0 cm
Soil Classification :	Fine sand

Time, min	Q(litre)	Discharge, Q litre/min)	Q _{average} litre/min	Borehole Radius (r), mm	Differential Head (H), m	C	k, cm/s
0	245.4	0.000					
1	245.6	20.0					
2	245.7	10.0	11.7	75	1.0	4E-03	4.8E-02
4	246.0	15.0					
6	246.3	15.0					
8	246.5	10.0					
10	246.7	10.0					
15	247.3	12.0					
20	247.8	10.0					

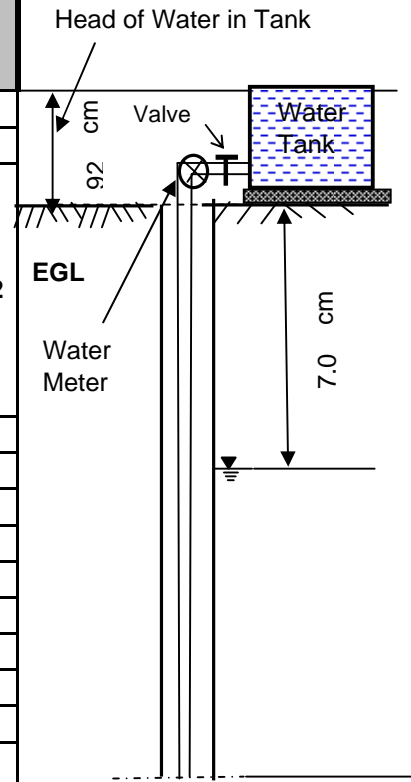

Equation used for calculation

$$k = C * \left[\frac{Q}{H} \right] \quad C = \left[\frac{1}{5.5 r} \right]$$

Where:

Q=Discharge,(litre/min)

H=Differential Head,(m)

r=radius of casing,(mm)

Determination of Coefficient of Permeability (FPT-43)



Field Permeability Test No.: FPT-44

By Falling Head Method

IS: 5529-Part-1-1985, RA-2009

Test Details	
Borehole No. :	BH : 6
Location :	Ash Pond Area
Reduced Level (RL) :	N/A
Co-ordinates :	403480.69 m E, 2805802.09 m N
Depth of Borehole :	2.0 m
Depth of bottom of casing below EGL :	1.50 m
Diameter of Intake Pipe :	15.0 cm
Length of Test Section :	50.0 cm
Depth of Water Table :	7.1 m
Height of Casing above GL :	0.16 m
Hydraulic Head at Start of test :	191 cm
Soil Classification :	Clayey silt

Sl. No.	Time in Minutes	Water Level in Intake Pipe, cm	Head, cm	Sl. No.	Time in Minutes	Water Level in Intake Pipe, cm	Head, cm
1	0.0	0.0	191				
2	1.0	17.0	174				
3	2.0	20.0	171				
4	4.0	23.0	168				
5	6.0	27.0	164				
6	8.0	30.0	161				
7	10.0	34.0	157				
8	15.0	44.0	147				
9	20.0	58.0	133				
10	25.0	70.0	121				
11	30.0	81.0	110				
12	40.0	96.0	95				
13	50.0	108.0	83				

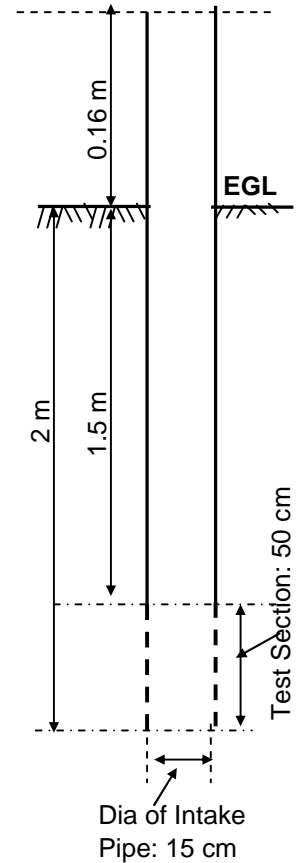

$$k = \text{Coefficient of Permeability} = \frac{d^2}{8L(t_2 - t_1)} \ln\left(\frac{2L}{d}\right) \ln\left(\frac{h_1}{h_2}\right)$$

Where:

L =	50.0 cm	d =	15.0 cm
2L/d =	6.67	R =	7.5 cm
$h_1/h_0 =$	0.58	$t_1 =$	30 minutes
$h_2/h_0 =$	0.43	$t_2 =$	49.7 minutes
$h_1/h_2 =$	1.351		

Calculations based on semilog plot of Head Ratio vs. Time, as per IS:5529 (Part-I)

$$k = 2.7E-04 \text{ cm/sec}$$

Determination of Coefficient of Permeability (FPT-44)



Field Permeability Test No.: FPT-44

By Falling Head Method

(IS: 5529-Part-1-1985, RA-2009)

Test Details
Borehole No. : BH : 6
Location : Ash Pond Area
Reduced Level (RL) : N/A
Co-ordinates : 403480.69 m E, 2805802.09 m N
Depth of Borehole : 2.0
Calculated value of k : 2.7E-04

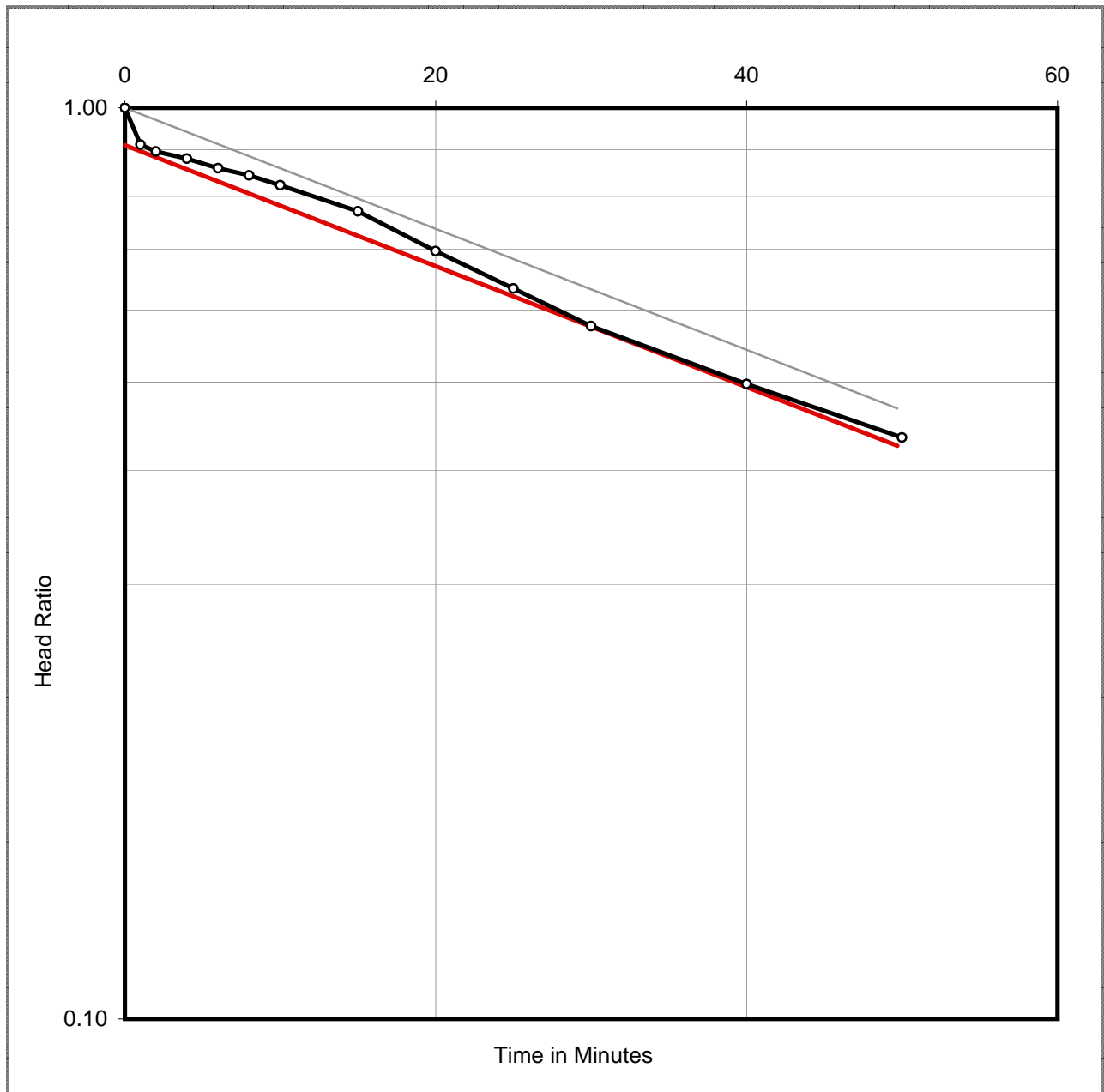

Semi-Log Plot of Head Ratio Vs Time (FPT-44)



Field Permeability Test No.: FPT-45

By Falling Head Method

IS: 5529-Part-1-1985, RA-2009

Test Details	
Borehole No. :	BH : 6
Location :	Ash Pond Area
Reduced Level (RL) :	N/A
Co-ordinates :	403480.69 m E, 2805802.09 m N
Depth of Borehole :	4.0 m
Depth of bottom of casing below EGL :	3.50 m
Diameter of Intake Pipe :	15.0 cm
Length of Test Section :	50.0 cm
Depth of Water Table :	7.1 m
Height of Casing above GL :	0.50 m
Hydraulic Head at Start of test :	425 cm
Soil Classification :	Silty fine sand

Sl. No.	Time in Minutes	Water Level in Intake Pipe, cm	Head, cm	Sl. No.	Time in Minutes	Water Level in Intake Pipe, cm	Head, cm
1	0.0	0.0	425				
2	1.0	34.0	391				
3	2.0	58.0	367				
4	4.0	106.0	319				
5	6.0	152.0	273				
6	8.0	162.0	263				
7	10.0	170.0	255				
8	15.0	193.0	232				
9	20.0	220.0	205				
10	25.0	241.0	184				
11	30.0	260.0	165				
12	40.0	291.0	134				
13	50.0	314.0	111				
14	60.0	332.0	93				

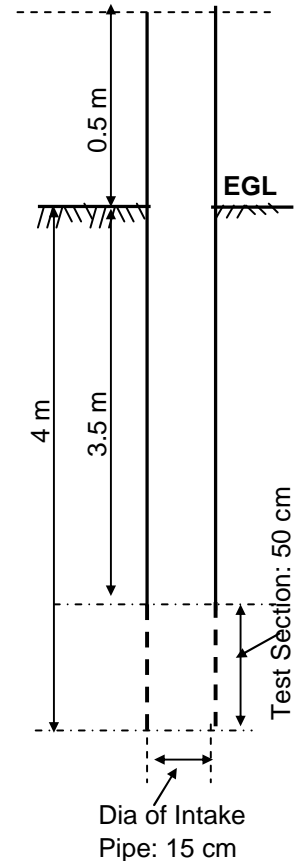

$$k = \text{Coefficient of Permeability} = \frac{d^2}{8L(t_2 - t_1)} \ln\left(\frac{2L}{d}\right) \ln\left(\frac{h_1}{h_2}\right)$$

Where:

L = 50.0 cm	d = 15.0 cm
2L/d = 6.67	R = 7.5 cm
$h_1/h_0 = 0.39$	$t_1 = 30$ minutes
$h_2/h_0 = 0.21$	$t_2 = 60$ minutes
$h_1/h_2 = 1.843$	

Calculations based on semilog plot of Head Ratio vs. Time, as per IS:5529 (Part-I)

$$k = 3.6E-04 \text{ cm/sec}$$

Determination of Coefficient of Permeability (FPT-45)



Field Permeability Test No.: FPT-45

By Falling Head Method

(IS: 5529-Part-1-1985, RA-2009)

Test Details	
Borehole No. :	BH : 6
Location :	Ash Pond Area
Reduced Level (RL) :	N/A
Co-ordinates :	403480.69 m E, 2805802.09 m N
Depth of Borehole :	4.0
Calculated value of k :	3.6E-04

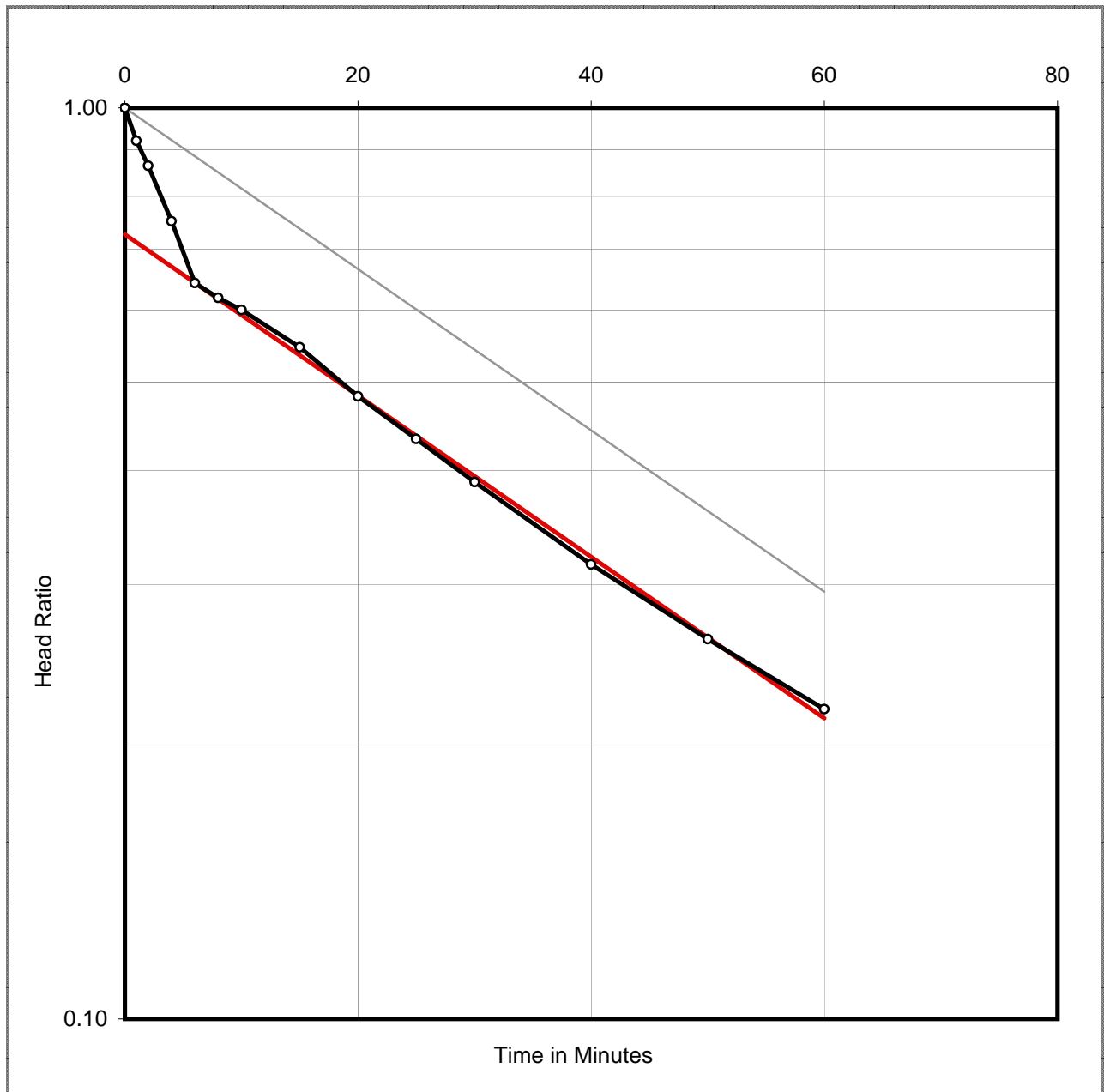

Semi-Log Plot of Head Ratio Vs Time (FPT-45)



Field Permeability Test No.: FPT-46

By Falling Head Method

IS: 5529-Part-1-1985, RA-2009

Test Details	
Borehole No. :	BH : 6
Location :	Ash Pond Area
Reduced Level (RL) :	N/A
Co-ordinates :	403480.69 m E, 2805802.09 m N
Depth of Borehole :	6.0 m
Depth of bottom of casing below EGL :	5.50 m
Diameter of Intake Pipe :	15.0 cm
Length of Test Section :	50.0 cm
Depth of Water Table :	7.1 m
Height of Casing above GL :	0.18 m
Hydraulic Head at Start of test :	593 cm
Soil Classification :	Silty fine sand

Sl. No.	Time in Minutes	Water Level in Intake Pipe, cm	Head, cm	Sl. No.	Time in Minutes	Water Level in Intake Pipe, cm	Head, cm
1	0.0	0.0	593				
2	1.0	65.0	528				
3	2.0	90.0	503				
4	4.0	175.0	418				
5	6.0	245.0	348				
6	8.0	290.0	303				
7	10.0	350.0	243				
8	15.0	420.0	173				
9	20.0	470.0	123				
10	25.0	505.0	88				
11	30.0	530.0	63				
12	40.0	550.0	43				
13	50.0	560.0	33				

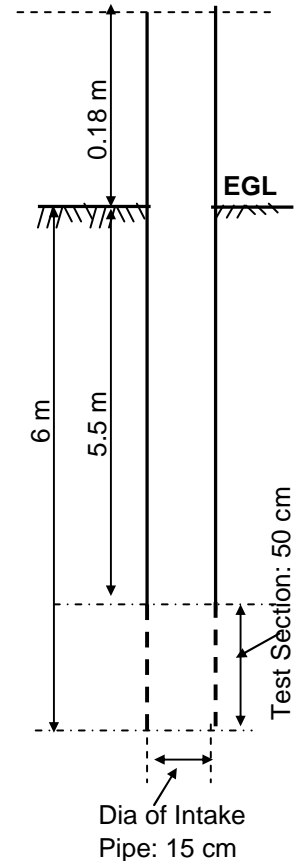

$$k = \text{Coefficient of Permeability} = \frac{d^2}{8L(t_2 - t_1)} \ln\left(\frac{2L}{d}\right) \ln\left(\frac{h_1}{h_2}\right)$$

Where:

L = 50.0 cm	d = 15.0 cm
2L/d = 6.67	R = 7.5 cm
$h_1/h_0 = 0.09$	$t_1 = 32.3$ minutes
$h_2/h_0 = 0.12$	$t_2 = 28.3$ minutes
$h_1/h_2 = 0.787$	

Calculations based on semilog plot of Head Ratio vs. Time, as per IS:5529 (Part-I)

$$k = 1.1E-03 \text{ cm/sec}$$

Determination of Coefficient of Permeability (FPT-46)



Field Permeability Test No.: FPT-46

By Falling Head Method

(IS: 5529-Part-1-1985, RA-2009)

Test Details	
Borehole No. :	BH : 6
Location :	Ash Pond Area
Reduced Level (RL) :	N/A
Co-ordinates :	403480.69 m E, 2805802.09 m N
Depth of Borehole :	6.0
Calculated value of k :	1.1E-03

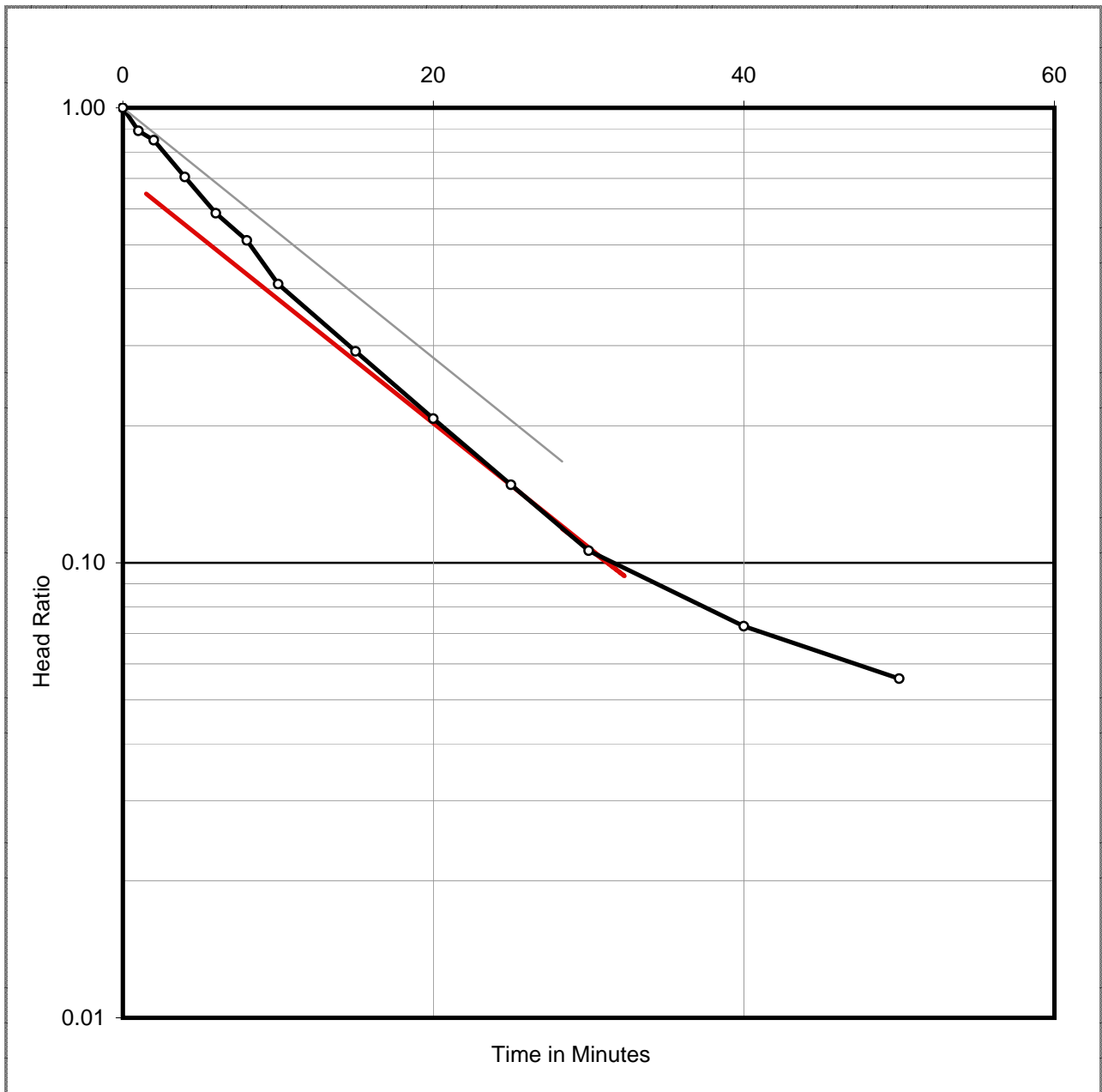

Semi-Log Plot of Head Ratio Vs Time (FPT-46)



Field Permeability Test No. : FPT-47

By Constant Head Method

IS: 5529-Part-1-1985, RA-2009

Test Details	
Borehole No. :	BH-6
Location :	Ash Pond Area
UTM Coordinates :	403480.69 m E, 2805802.09 m N
Depth of Borehole :	8.00 m = 800 cm
Depth of bottom of casing below EGL :	800 cm
Diameter of Intake Pipe :	15 cm
Depth of Water Table :	7.1 cm
Effective Height of water in Tank :	92 cm
Differential Head :	99.1 cm
Soil Classification :	Fine sand

Time, min	Q(litre)	Discharge, Q (litre/min)	Q _{average} (litre/min)	Borehole Radius (r), mm	Differential Head (H), m	C	k, cm/s
0	298.0	0.000					
1	298.3	30.0					
2	298.5	20.0					
4	298.9	20.0					
6	299.2	15.0	15.4	75.0	1.0	4E-03	6.3E-02
8	299.5	15.0					
10	299.8	15.0					
15	300.6	16.0					
20	301.4	16.0					

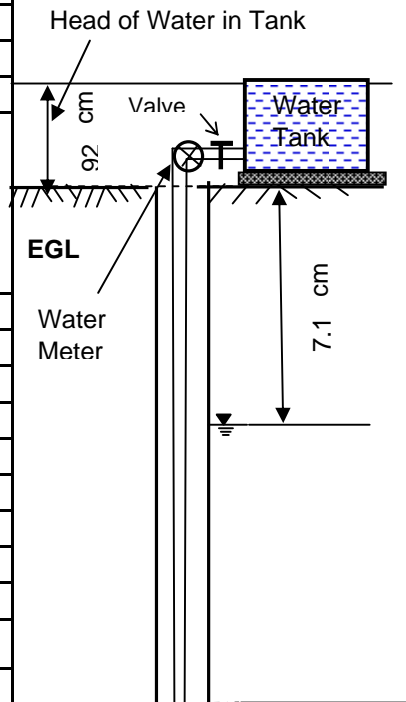

Equation used for calculation

Where:

$$k = C * \left[\frac{Q}{H} \right] \quad C = \left[\frac{1}{5.5 r} \right]$$

Q=Discharge,(litre/min)

H=Differential Head,(m)

r=radius of casing,(mm)

Determination of Coefficient of Permeability (FPT-47)



Field Permeability Test No. : FPT-48

By Constant Head Method

IS: 5529-Part-1-1985, RA-2009

Test Details	
Borehole No. :	BH-6
Location :	Ash Pond Area
UTM Coordinates :	403480.69 m E, 2805802.09 m N
Depth of Borehole :	10.00 m = 1000 cm
Depth of bottom of casing below EGL :	1000 cm
Diameter of Intake Pipe :	15 cm
Depth of Water Table :	7.1 cm
Effective Height of water in Tank :	92 cm
Differential Head :	99.1 cm
Soil Classification :	Fine sand

Time, min	Q(litre)	Discharge, Q litre/min)	Q _{average} litre/min	Borehole Radius (r), mm	Differential Head (H), m	C	k, cm/s
0	301.4	0.000					
1	301.6	20.0					
2	301.7	10.0					
4	301.8	5.0	5.3	75	1.0	4E-03	2.2E-02
6	301.9	5.0					
8	302.0	5.0					
10	302.1	5.0					
15	302.4	6.0					
20	302.7	6.0					

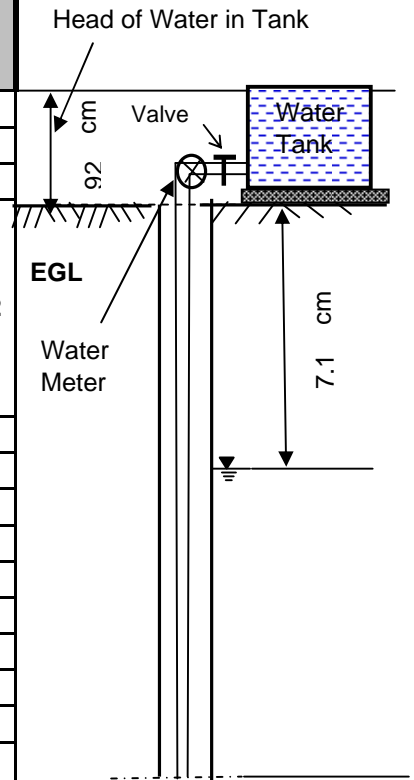

Equation used for calculation

Where:

$$k = C * \left[\frac{Q}{H} \right] \quad C = \left[\frac{1}{5.5 r} \right]$$

Q=Discharge,(litre/min)

H=Differential Head,(m)

r=radius of casing,(mm)

Determination of Coefficient of Permeability (FPT-48)



Field Permeability Test No. : FPT-49

By Constant Head Method

IS: 5529-Part-1-1985, RA-2009

Test Details	
Borehole No. :	BH-6
Location :	Ash Pond Area
UTM Coordinates :	403480.69 m E, 2805802.09 m N
Depth of Borehole :	12.00 m = 1200 cm
Depth of bottom of casing below EGL :	1200 cm
Diameter of Intake Pipe :	15 cm
Depth of Water Table :	7.1 cm
Effective Height of water in Tank :	92 cm
Differential Head :	99.1 cm
Soil Classification :	Fine sand

Time, min	Q(litre)	Discharge, Q litre/min)	Q _{average} litre/min	Borehole Radius (r), mm	Differential Head (H), m	C	k, cm/s
0	302.7	0.000					
1	302.9	20.0					
2	303.1	20.0					
4	303.4	15.0	16.5	75	1.0	4E-03	6.7E-02
6	303.7	15.0					
8	304.0	15.0					
10	304.4	20.0					
15	305.3	18.0					
20	306.1	16.0					

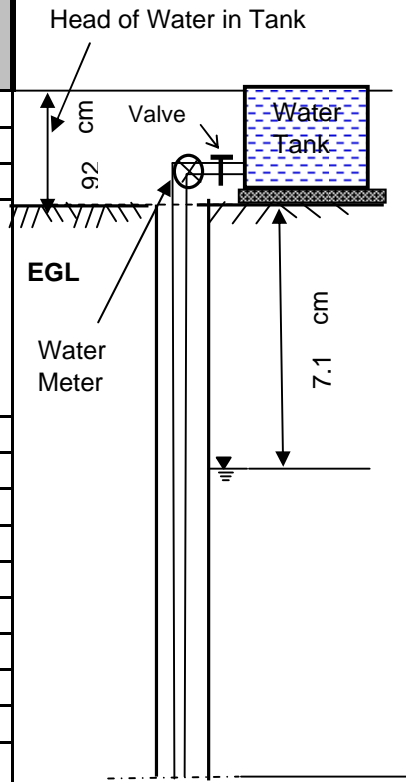

Equation used for calculation

$$k = C * \left[\frac{Q}{H} \right] \quad C = \left[\frac{1}{5.5 r} \right]$$

Where:

Q=Discharge,(litre/min)

H=Differential Head,(m)

r=radius of casing,(mm)

Determination of Coefficient of Permeability (FPT-49)



Field Permeability Test No. : FPT-50

By Constant Head Method

IS: 5529-Part-1-1985, RA-2009

Test Details	
Borehole No. : BH-6	
Location : Ash Pond Area	
UTM Coordinates : 403480.69 m E, 2805802.09 m N	
Depth of Borehole : 14.00 m = 1400 cm	
Depth of bottom of casing below EGL : 1400 cm	
Diameter of Intake Pipe :	15 cm
Depth of Water Table :	7.1 cm
Effective Height of water in Tank :	92 cm
Differential Head :	99.1 cm
Soil Classification : Fine sand	

Time, min	Q(litre)	Discharge, Q litre/min	Q _{average} litre/min	Borehole Radius (r), mm	Differential Head (H), m	C	k, cm/s
0	306.1	0.000					
1	306.3	20.0					
2	306.4	10.0	8.7	75	1.0	4E-03	3.6E-02
4	306.6	10.0					
6	306.8	10.0					
8	306.9	5.0					
10	307.1	10.0					
15	307.5	8.0					
20	307.9	8.0					

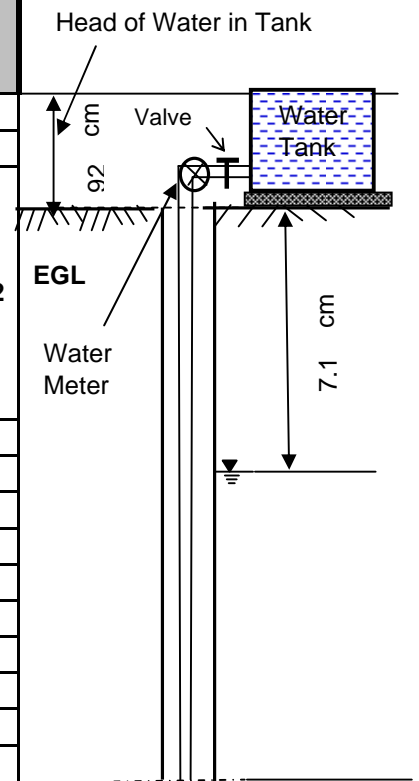

Equation used for calculation

Where:

Q=Discharge,(litre/min)

H=Differential Head,(m)

r=radius of casing,(mm)

$$k = C * \left[\frac{Q}{H} \right] \quad C = \left[\frac{1}{5.5 r} \right]$$

Determination of Coefficient of Permeability (FPT-50)



Field Permeability Test No. : FPT-51

By Constant Head Method

IS: 5529-Part-1-1985, RA-2009

Test Details	
Borehole No. :	BH-6
Location :	Ash Pond Area
UTM Coordinates :	403480.69 m E, 2805802.09 m N
Depth of Borehole :	16.00 m = 1600 cm
Depth of bottom of casing below EGL :	1600 cm
Diameter of Intake Pipe :	15 cm
Depth of Water Table :	7.1 cm
Effective Height of water in Tank :	92 cm
Differential Head :	99.1 cm
Soil Classification :	Fine sand

Time, min	Q(litre)	Discharge, Q (litre/min)	Q _{average} litre/min	Borehole Radius (r), mm	Differential Head (H), m	C	k, cm/s
0	308.0	0.000					
1	308.2	20.0					
2	308.3	10.0	7.7	75	1.0	4E-03	3.1E-02
4	308.5	10.0					
6	308.7	10.0					
8	308.8	5.0					
10	308.9	5.0					
15	309.2	6.0					
20	309.6	8.0					

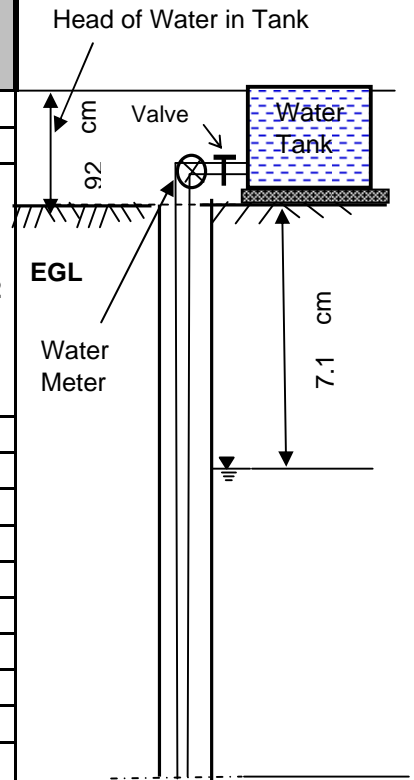

Equation used for calculation

$$k = C * \left[\frac{Q}{H} \right] \quad C = \left[\frac{1}{5.5 r} \right]$$

Where:

Q=Discharge,(litre/min)

H=Differential Head,(m)

r=radius of casing,(mm)

Determination of Coefficient of Permeability (FPT-51)



Field Permeability Test No. : FPT-52

By Constant Head Method

IS: 5529-Part-1-1985, RA-2009

Test Details	
Borehole No. :	BH-6
Location :	Ash Pond Area
UTM Coordinates :	403480.69 m E, 2805802.09 m N
Depth of Borehole :	18.00 m = 1800 cm
Depth of bottom of casing below EGL :	1800 cm
Diameter of Intake Pipe :	15 cm
Depth of Water Table :	7.1 cm
Effective Height of water in Tank :	92 cm
Differential Head :	99.1 cm
Soil Classification :	Fine sand

Time, min	Q(litre)	Discharge, Q (litre/min)	Q _{average} (litre/min)	Borehole Radius (r), mm	Differential Head (H), m	C	k, cm/s
0	309.6	0.000					
1	309.8	20.0					
2	309.9	10.0	6.4	75	1.0	4E-03	2.6E-02
4	310.1	10.0					
6	310.2	5.0					
8	310.3	5.0					
10	310.4	5.0					
15	310.7	6.0					
20	310.9	4.0					

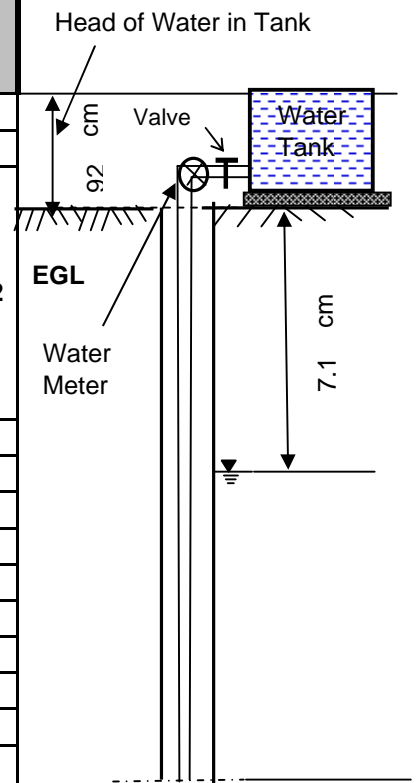

Equation used for calculation

Where:

$$k = C * \left[\frac{Q}{H} \right] \quad C = \left[\frac{1}{5.5 r} \right]$$

Q=Discharge,(litre/min)

H=Differential Head,(m)

r=radius of casing,(mm)

Determination of Coefficient of Permeability (FPT-52)



Field Permeability Test No. : FPT-53

By Constant Head Method

IS: 5529-Part-1-1985, RA-2009

Test Details	
Borehole No. :	BH-6
Location :	Ash Pond Area
UTM Coordinates :	403480.69 m E, 2805802.09 m N
Depth of Borehole :	20.00 m = 2000 cm
Depth of bottom of casing below EGL :	2000 cm
Diameter of Intake Pipe :	15 cm
Depth of Water Table :	7.1 cm
Effective Height of water in Tank :	92 cm
Differential Head :	99.1 cm
Soil Classification :	Fine sand

Time, min	Q(litre)	Discharge, Q litre/min)	Q _{average} litre/min	Borehole Radius (r), mm	Differential Head (H), m	C	k, cm/s
0	311.0	0.000					
1	311.2	20.0					
2	311.3	10.0	8.0	75	1.0	4E-03	3.3E-02
4	311.5	10.0					
6	311.7	10.0					
8	311.8	5.0					
10	311.9	5.0					
15	312.3	8.0					
20	312.7	8.0					

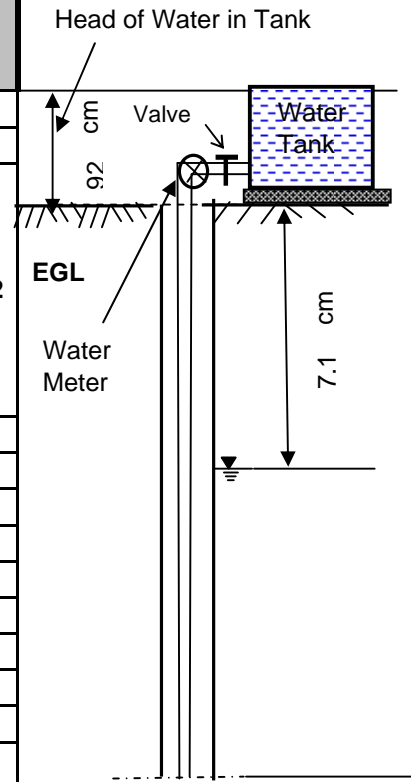

Equation used for calculation

$$k = C * \left[\frac{Q}{H} \right] \quad C = \left[\frac{1}{5.5 r} \right]$$

Where:

Q=Discharge,(litre/min)

H=Differential Head,(m)

r=radius of casing,(mm)

Determination of Coefficient of Permeability (FPT-53)



Field Permeability Test No.: FPT-54

By Falling Head Method

IS: 5529-Part-1-1985, RA-2009

Test Details	
Borehole No. :	BH : 7
Location :	Ash Pond Area
Reduced Level (RL) :	N/A
UTM Coordinates :	403506.00 m E, 2805239.00 m N
Depth of Borehole :	2.0 m
Depth of bottom of casing below EGL :	1.50 m
Diameter of Intake Pipe :	15.0 cm
Length of Test Section :	50.0 cm
Depth of Water Table :	7.1 m
Height of Casing above GL :	0.15 m
Hydraulic Head at Start of test :	190 cm
Soil Classification :	Silty fine sand

Sl. No.	Time in Minutes	Water Level in Intake Pipe, cm	Head, cm	Sl. No.	Time in Minutes	Water Level in Intake Pipe, cm	Head, cm
1	0.0	0.0	190				
2	1.0	26.0	164				
3	2.0	42.0	148				
4	4.0	62.0	128				
5	6.0	74.0	116				
6	8.0	83.0	107				
7	10.0	92.0	98				
8	15.0	108.0	82				
9	20.0	119.0	71				
10	25.0	128.0	62				
11	30.0	136.0	54				
12	40.0	147.0	43				
13	50.0	156.0	34				
14	60.0	163.0	27				

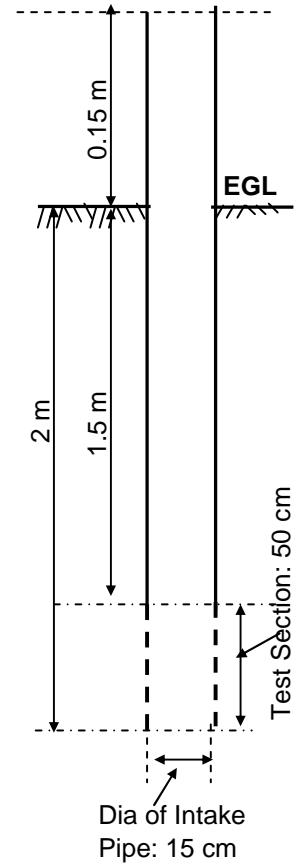

$$k = \text{Coefficient of Permeability} = \frac{d^2}{8L(t_2 - t_1)} \ln\left(\frac{2L}{d}\right) \ln\left(\frac{h_1}{h_2}\right)$$

Where:

L = 50.0 cm	d = 15.0 cm
2L/d = 6.67	R = 7.5 cm
$h_1/h_0 = 0.28$	$t_1 = 30$ minutes
$h_2/h_0 = 0.09$	$t_2 = 78.1$ minutes
$h_1/h_2 = 3.088$	

Calculations based on semilog plot of Head Ratio vs. Time, as per IS:5529 (Part-I)

$$k = 4.2E-04 \text{ cm/sec}$$

Determination of Coefficient of Permeability (FPT-54)



Field Permeability Test No.: FPT-54

By Falling Head Method

(IS: 5529-Part-1-1985, RA-2009)

Test Details
Borehole No. : BH : 7
Location : Ash Pond Area
Reduced Level (RL) : N/A
UTM Coordinates : 403506.00 m E, 2805239.00 m N
Depth of Borehole : 2.0
Calculated value of k : 4.2E-04

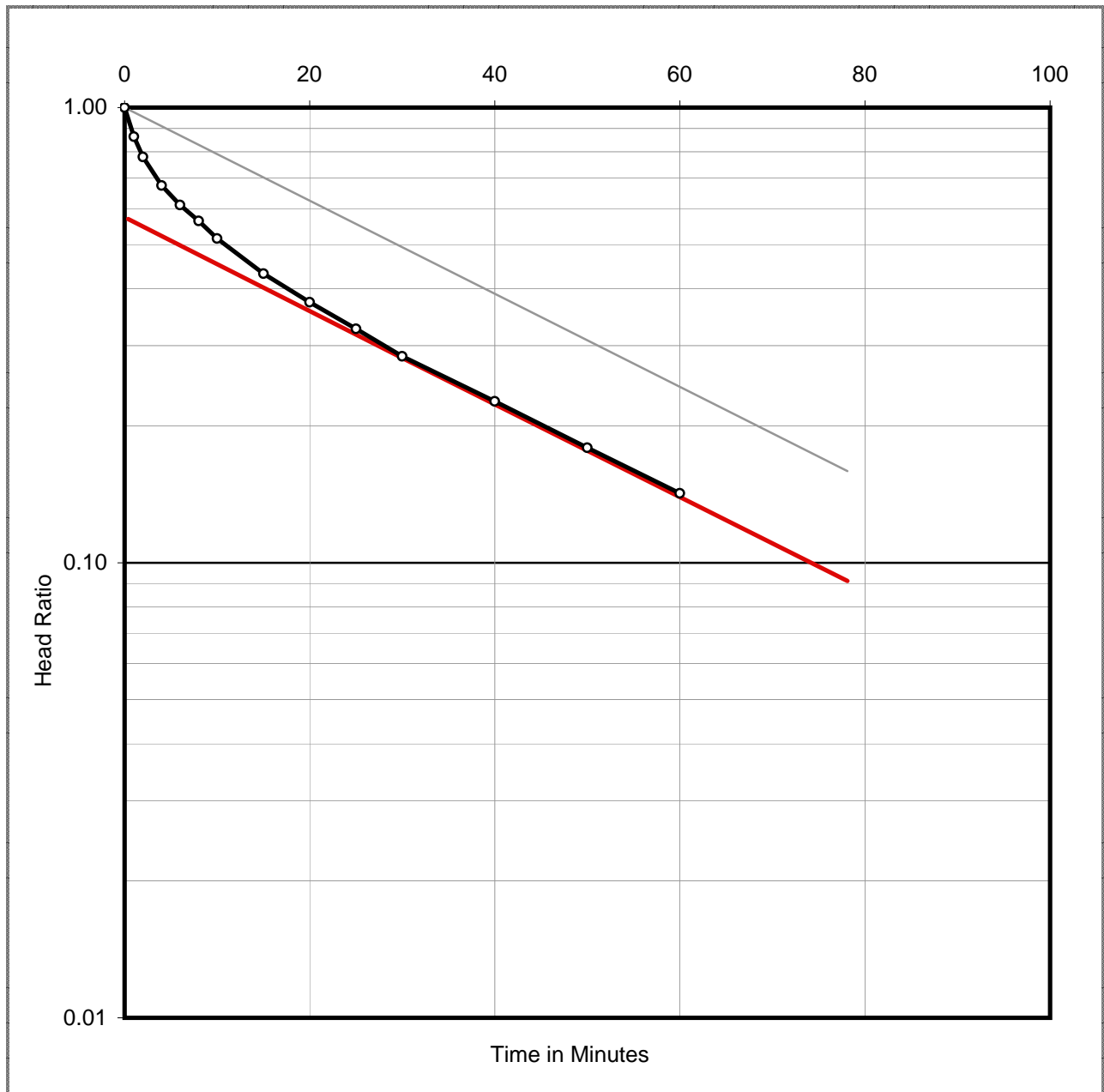

Semi-Log Plot of Head Ratio Vs Time (FPT-54)



Field Permeability Test No.: FPT-55

By Falling Head Method

IS: 5529-Part-1-1985, RA-2009

Test Details	
Borehole No. :	BH : 7
Location :	Ash Pond Area
Reduced Level (RL) :	N/A
UTM Coordinates :	403506.00 m E, 2805239.00 m N
Depth of Borehole :	4.0 m
Depth of bottom of casing below EGL :	3.50 m
Diameter of Intake Pipe :	15.0 cm
Length of Test Section :	50.0 cm
Depth of Water Table :	7.1 m
Height of Casing above GL :	0.80 m
Hydraulic Head at Start of test :	455 cm
Soil Classification :	Silty fine sand

Sl. No.	Time in Minutes	Water Level in Intake Pipe, cm	Head, cm	Sl. No.	Time in Minutes	Water Level in Intake Pipe, cm	Head, cm
1	0.0	0.0	455				
2	1.0	46.0	409				
3	2.0	65.0	390				
4	4.0	88.0	367				
5	6.0	102.0	353				
6	8.0	115.0	340				
7	10.0	128.0	327				
8	15.0	161.0	294				
9	20.0	190.0	265				
10	25.0	216.0	239				
11	30.0	238.0	217				
12	40.0	270.0	185				
13	50.0	297.0	158				
14	60.0	319.0	136				

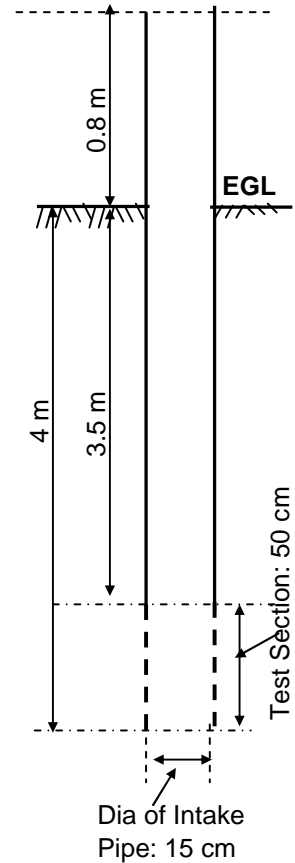

$$k = \text{Coefficient of Permeability} = \frac{d^2}{8L(t_2 - t_1)} \ln\left(\frac{2L}{d}\right) \ln\left(\frac{h_1}{h_2}\right)$$

Where:

L = 50.0 cm	d = 15.0 cm
2L/d = 6.67	R = 7.5 cm
$h_1/h_0 = 0.47$	$t_1 = 30$ minutes
$h_2/h_0 = 0.26$	$t_2 = 68.8$ minutes
$h_1/h_2 = 1.791$	

Calculations based on semilog plot of Head Ratio vs. Time, as per IS:5529 (Part-I)

$$k = 2.7E-04 \text{ cm/sec}$$

Determination of Coefficient of Permeability (FPT-55)



Field Permeability Test No.: FPT-55

By Falling Head Method

(IS: 5529-Part-1-1985, RA-2009)

Test Details
Borehole No. : BH : 7
Location : Ash Pond Area
Reduced Level (RL) : N/A
UTM Coordinates : 403506.00 m E, 2805239.00 m N
Depth of Borehole : 4.0
Calculated value of k : 2.7E-04

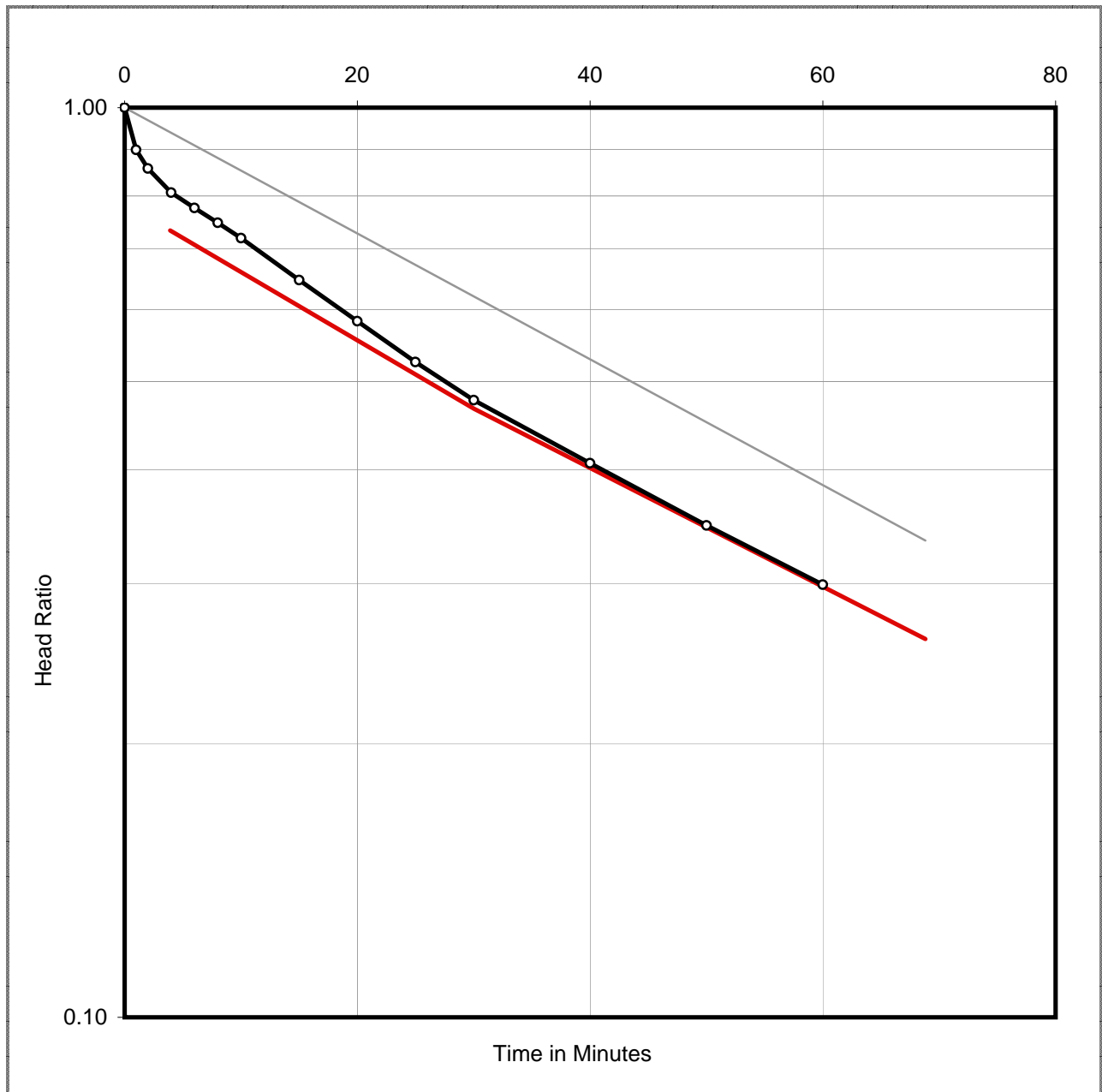

Semi-Log Plot of Head Ratio Vs Time (FPT-55)



Field Permeability Test No.: FPT-56

By Falling Head Method

IS: 5529-Part-1-1985, RA-2009

Test Details	
Borehole No. :	BH : 7
Location :	Ash Pond Area
Reduced Level (RL) :	N/A
UTM Coordinates :	403506.00 m E, 2805239.00 m N
Depth of Borehole :	6.0 m
Depth of bottom of casing below EGL :	5.50 m
Diameter of Intake Pipe :	15.0 cm
Length of Test Section :	50.0 cm
Depth of Water Table :	7.1 m
Height of Casing above GL :	0.16 m
Hydraulic Head at Start of test :	591 cm
Soil Classification :	Silty fine sand

Sl. No.	Time in Minutes	Water Level in Intake Pipe, cm	Head, cm	Sl. No.	Time in Minutes	Water Level in Intake Pipe, cm	Head, cm
1	0.0	0.0	591				
2	1.0	78.0	513				
3	2.0	130.0	461				
4	4.0	205.0	386				
5	6.0	275.0	316				
6	8.0	315.0	276				
7	10.0	351.0	240				
8	15.0	404.0	187				
9	20.0	441.0	150				
10	25.0	476.0	115				
11	30.0	499.0	92				
12	40.0	530.0	61				
13	50.0	551.0	40				

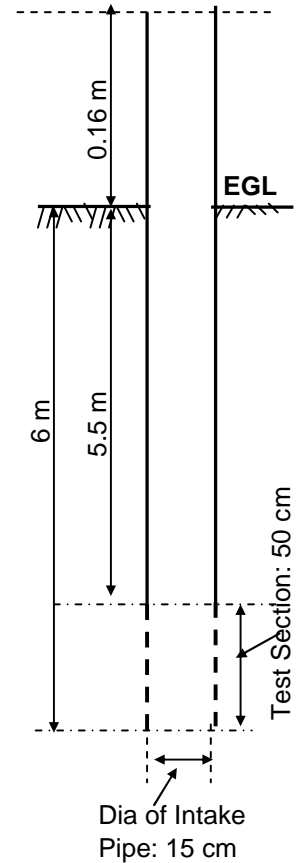

$$k = \text{Coefficient of Permeability} = \frac{d^2}{8L(t_2 - t_1)} \ln\left(\frac{2L}{d}\right) \ln\left(\frac{h_1}{h_2}\right)$$

Where:

L = 50.0 cm	d = 15.0 cm
2L/d = 6.67	R = 7.5 cm
$h_1/h_0 = 0.15$	$t_1 = 30$ minutes
$h_2/h_0 = 0.05$	$t_2 = 55.5$ minutes
$h_1/h_2 = 2.920$	

Calculations based on semilog plot of Head Ratio vs. Time, as per IS:5529 (Part-I)

$$k = 7.5E-04 \text{ cm/sec}$$

Determination of Coefficient of Permeability (FPT-56)



Field Permeability Test No.: FPT-56

By Falling Head Method

(IS: 5529-Part-1-1985, RA-2009)

Test Details
Borehole No. : BH : 7
Location : Ash Pond Area
Reduced Level (RL) : N/A
UTM Coordinates : 403506.00 m E, 2805239.00 m N
Depth of Borehole : 6.0
Calculated value of k : 7.5E-04

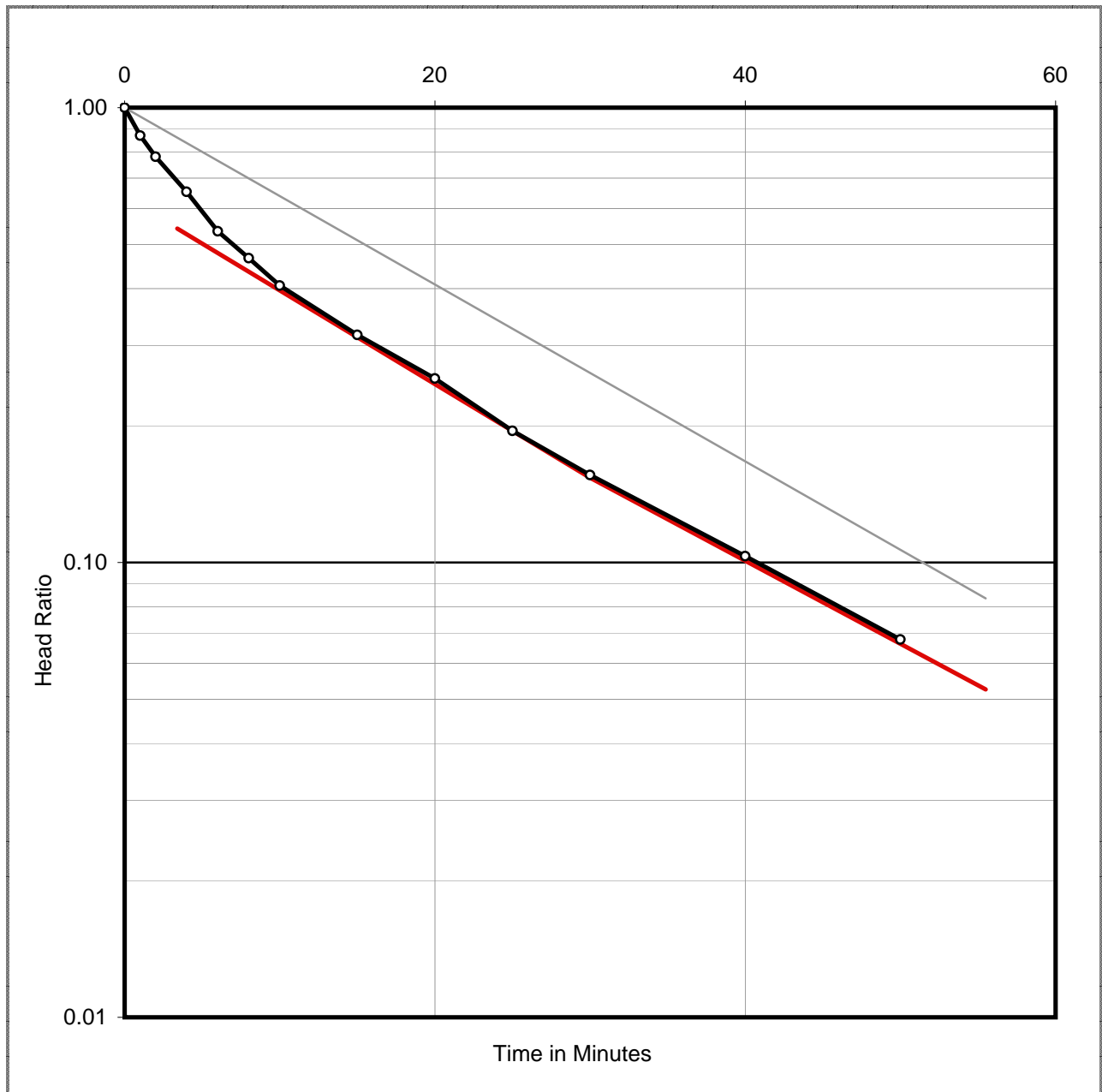

Semi-Log Plot of Head Ratio Vs Time (FPT-56)



Field Permeability Test No. : FPT-57

By Constant Head Method

IS: 5529-Part-1-1985, RA-2009

Test Details	
Borehole No. :	BH-7
Location :	Ash Pond Area
UTM Coordinates :	403506.00 m E, 2805239.00 m N
Depth of Borehole :	8.00 m = 800 cm
Depth of bottom of casing below EGL :	800 cm
Diameter of Intake Pipe :	15 cm
Depth of Water Table :	7.1 cm
Effective Height of water in Tank :	92 cm
Differential Head :	99.1 cm
Soil Classification :	Silty fine sand

Time, min	Q(litre)	Discharge, Q (litre/min)	Q _{average} (litre/min)	Borehole Radius (r), mm	Differential Head (H), m	C	k, cm/s
0	279.0	0.000					
1	279.3	30.0					
2	279.5	20.0					
4	279.9	20.0					
6	280.3	20.0					
8	280.6	15.0					
10	280.9	15.0	16.0	75	1.0	4E-03	6.5E-02
15	281.8	18.0					
20	282.6	16.0					

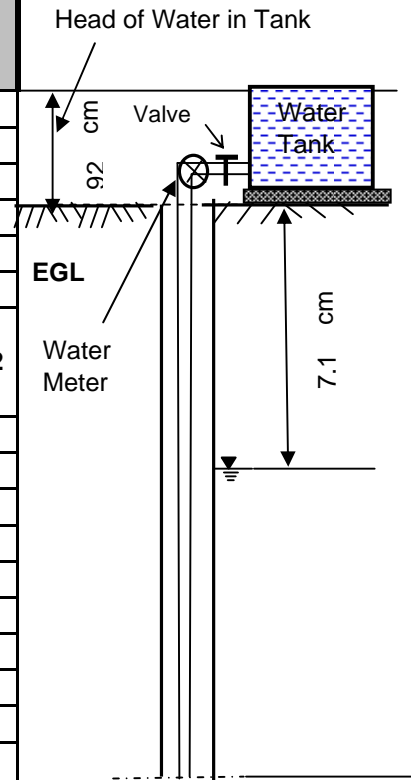

Equation used for calculation

Where:

$$k = C * \left[\frac{Q}{H} \right] \quad C = \left[\frac{1}{5.5 r} \right]$$

Q=Discharge,(litre/min)

H=Differential Head,(m)

r=radius of casing,(mm)

Determination of Coefficient of Permeability (FPT-57)



Field Permeability Test No. : FPT-58

By Constant Head Method

IS: 5529-Part-1-1985, RA-2009

Test Details	
Borehole No. :	BH-7
Location :	Ash Pond Area
UTM Coordinates :	403506.00 m E, 2805239.00 m N
Depth of Borehole :	10.00 m = 1000 cm
Depth of bottom of casing below EGL :	1000 cm
Diameter of Intake Pipe :	15 cm
Depth of Water Table :	7.1 cm
Effective Height of water in Tank :	92 cm
Differential Head :	99.1 cm
Soil Classification :	Fine sand

Time, min	Q(litre)	Discharge, Q (litre/min)	Q _{average} litre/min	Borehole Radius (r), mm	Differential Head (H), m	C	k, cm/s
0	282.6	0.000					
1	282.8	20.0					
2	282.9	10.0					
4	283.1	10.0					
6	283.3	10.0					
8	283.4	5.0					
10	283.5	5.0	6.3	75	1.0	4E-03	2.6E-02
15	283.8	6.0					
20	284.2	8.0					

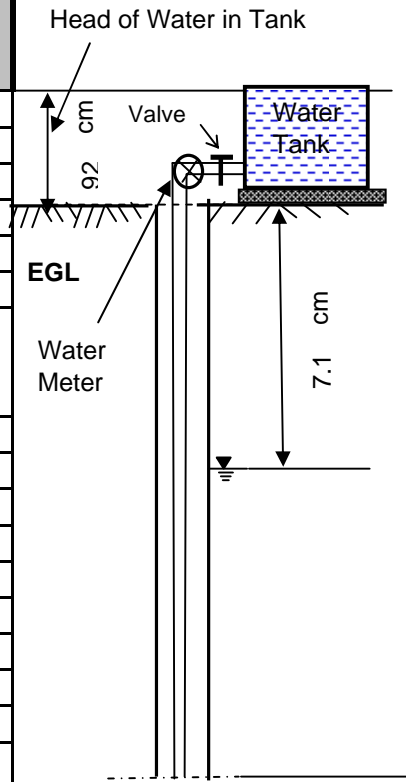

Equation used for calculation

$$k = C * \left[\frac{Q}{H} \right] \quad C = \left[\frac{1}{5.5 r} \right]$$

Where:

Q=Discharge,(litre/min)

H=Differential Head,(m)

r=radius of casing,(mm)

Determination of Coefficient of Permeability (FPT-58)



Field Permeability Test No. : FPT-59

By Constant Head Method

IS: 5529-Part-1-1985, RA-2009

Test Details	
Borehole No. :	BH-7
Location :	Ash Pond Area
UTM Coordinates :	403506.00 m E, 2805239.00 m N
Depth of Borehole :	12.00 m = 1200 cm
Depth of bottom of casing below EGL :	1200 cm
Diameter of Intake Pipe :	15 cm
Depth of Water Table :	7.1 cm
Effective Height of water in Tank :	92 cm
Differential Head :	99.1 cm
Soil Classification :	Silty fine sand

Time, min	Q(litre)	Discharge, Q litre/min)	Q _{average} litre/min	Borehole Radius (r), mm	Differential Head (H), m	C	k, cm/s
0	284.3	0.000					
1	284.6	30.0					
2	284.9	30.0					
4	285.4	25.0					
6	285.9	25.0					
8	286.3	20.0					
10	286.7	20.0	19.3	75	1.0	4E-03	7.9E-02
15	287.6	18.0					
20	288.6	20.0					

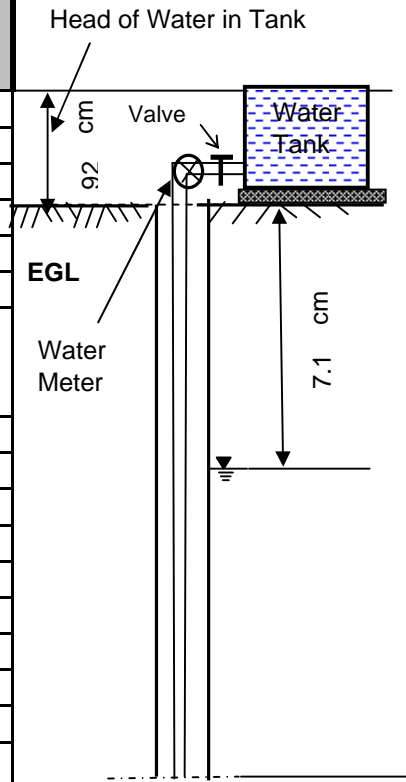

Equation used for calculation

$$k = C * \left[\frac{Q}{H} \right] \quad C = \left[\frac{1}{5.5 r} \right]$$

Where:

Q=Discharge,(litre/min)

H=Differential Head,(m)

r=radius of casing,(mm)

Determination of Coefficient of Permeability (FPT-59)



Field Permeability Test No. : FPT-60

By Constant Head Method

IS: 5529-Part-1-1985, RA-2009

Test Details	
Borehole No. :	BH-7
Location :	Ash Pond Area
UTM Coordinates :	403506.00 m E, 2805239.00 m N
Depth of Borehole :	14.00 m = 1400 cm
Depth of bottom of casing below EGL :	1400 cm
Diameter of Intake Pipe :	15 cm
Depth of Water Table :	7.1 cm
Effective Height of water in Tank :	92 cm
Differential Head :	99.1 cm
Soil Classification :	Fine sand

Time, min	Q(litre)	Discharge, Q litre/min)	Q _{average} litre/min	Borehole Radius (r), mm	Differential Head (H), m	C	k, cm/s
0	288.6	0.000					
1	288.8	20.0					
2	289.0	20.0					
4	289.3	15.0					
6	289.6	15.0					
8	289.9	15.0					
10	290.1	10.0	10.7	75	1.0	4E-03	4.3E-02
15	290.7	12.0					
20	291.2	10.0					

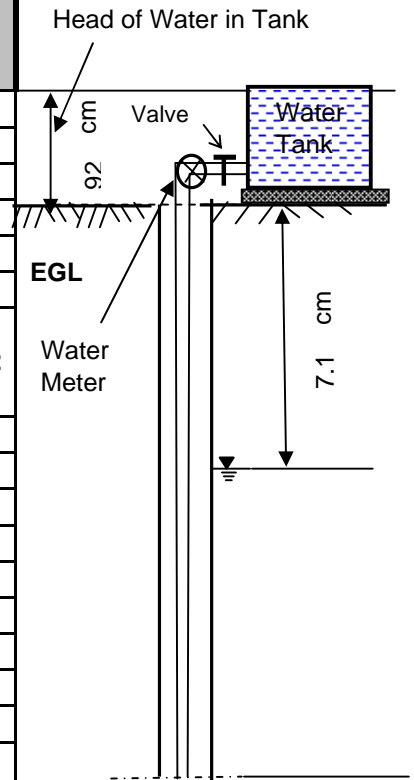

Equation used for calculation

$$k = C * \left[\frac{Q}{H} \right] \quad C = \left[\frac{1}{5.5 r} \right]$$

Where:

Q=Discharge,(litre/min)

H=Differential Head,(m)

r=radius of casing,(mm)

Determination of Coefficient of Permeability (FPT-60)



Field Permeability Test No. : FPT-61

By Constant Head Method

IS: 5529-Part-1-1985, RA-2009

Test Details	
Borehole No. :	BH-7
Location :	Ash Pond Area
UTM Coordinates :	403506.00 m E, 2805239.00 m N
Depth of Borehole :	16.00 m = 1600 cm
Depth of bottom of casing below EGL :	1600 cm
Diameter of Intake Pipe :	15 cm
Depth of Water Table :	7.1 cm
Effective Height of water in Tank :	92 cm
Differential Head :	99.1 cm
Soil Classification :	Fine sand

Time, min	Q(litre)	Discharge, Q litre/min)	Q _{average} litre/min	Borehole Radius (r), mm	Differential Head (H), m	C	k, cm/s
0	291.2	0.000					
1	291.4	20.0					
2	291.6	20.0					
4	291.9	15.0					
6	292.1	10.0	11.4	75	1.0	4E-03	4.6E-02
8	292.4	15.0					
10	292.6	10.0					
15	293.1	10.0					
20	293.7	12.0					

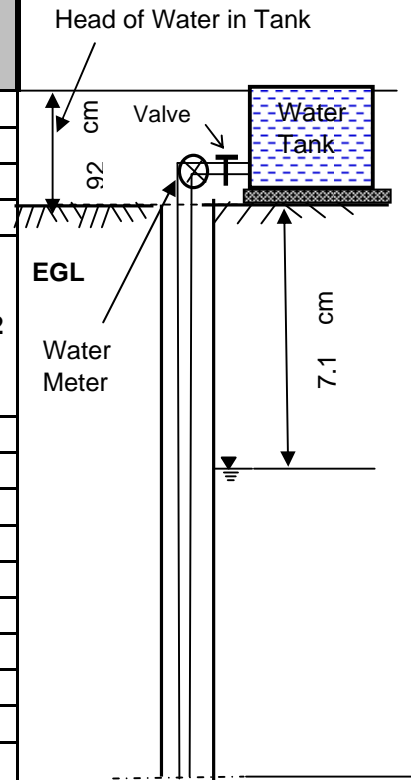

Equation used for calculation

Where:

$$k = C * \left[\frac{Q}{H} \right] \quad C = \left[\frac{1}{5.5 r} \right]$$

Q=Discharge,(litre/min)

H=Differential Head,(m)

r=radius of casing,(mm)

Determination of Coefficient of Permeability (FPT-61)



Field Permeability Test No. : FPT-62

By Constant Head Method

IS: 5529-Part-1-1985, RA-2009

Test Details	
Borehole No. :	BH-7
Location :	Ash Pond Area
UTM Coordinates :	403506.00 m E, 2805239.00 m N
Depth of Borehole :	18.00 m = 1800 cm
Depth of bottom of casing below EGL :	1800 cm
Diameter of Intake Pipe :	15 cm
Depth of Water Table :	7.1 cm
Effective Height of water in Tank :	92 cm
Differential Head :	99.1 cm
Soil Classification :	Fine sand

Time, min	Q(litre)	Discharge, Q litre/min)	Q _{average} litre/min	Borehole Radius (r), mm	Differential Head (H), m	C	k, cm/s
0	293.7	0.000					
1	293.9	20.0					
2	294.0	10.0	11.0	75	1.0	4E-03	4.5E-02
4	294.2	10.0					
6	294.4	10.0					
8	294.7	15.0					
10	294.9	10.0					
15	295.5	12.0					
20	296.0	10.0					

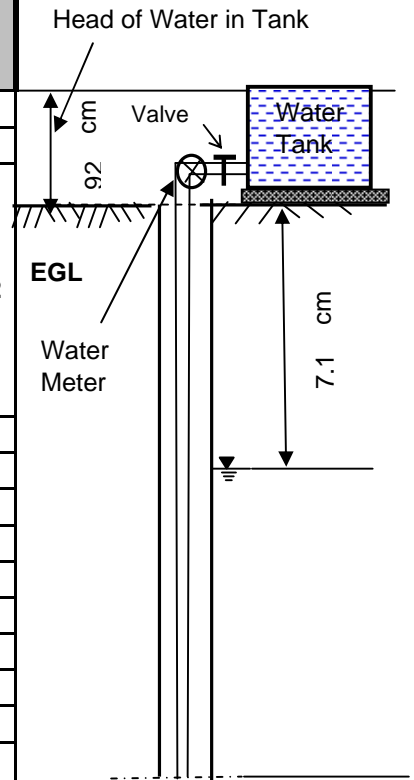

Equation used for calculation

Where:

$$k = C * \left[\frac{Q}{H} \right] \quad C = \left[\frac{1}{5.5 r} \right]$$

Q=Discharge,(litre/min)

H=Differential Head,(m)

r=radius of casing,(mm)

Determination of Coefficient of Permeability (FPT-62)



Field Permeability Test No. : FPT-63

By Constant Head Method

IS: 5529-Part-1-1985, RA-2009

Test Details	
Borehole No. :	BH-7
Location :	Ash Pond Area
UTM Coordinates :	403506.00 m E, 2805239.00 m N
Depth of Borehole :	20.00 m = 2000 cm
Depth of bottom of casing below EGL :	2000 cm
Diameter of Intake Pipe :	15 cm
Depth of Water Table :	7.1 cm
Effective Height of water in Tank :	92 cm
Differential Head :	99.1 cm
Soil Classification :	Fine sand

Time, min	Q(litre)	Discharge, Q litre/min)	Q _{average} litre/min	Borehole Radius (r), mm	Differential Head (H), m	C	k, cm/s
0	296.0	0.000					
1	296.1	10.0					
2	296.2	10.0					
4	296.4	10.0					
6	296.7	15.0					
8	296.9	10.0	10.2	75	1.0	4E-03	4.2E-02
10	297.1	10.0					
15	297.5	8.0					
20	297.9	8.0					

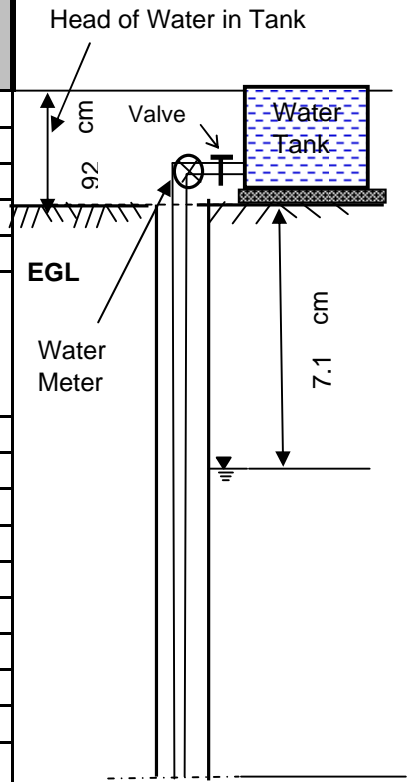

Equation used for calculation

$$k = C * \left[\frac{Q}{H} \right] \quad C = \left[\frac{1}{5.5 r} \right]$$

Where:

- Q=Discharge,(litre/min)
- H=Differential Head,(m)
- r=radius of casing,(mm)

Determination of Coefficient of Permeability (FPT-63)



Field Permeability Test No.: FPT-64

By Falling Head Method

IS: 5529-Part-1-1985, RA-2009

Test Details	
Borehole No. :	BH : 8
Location :	Ash Pond Area
Reduced Level (RL) :	N/A
UTM Coordinates :	404586.77 m E, 2805103.37 m N
Depth of Borehole :	2.0 m
Depth of bottom of casing below EGL :	1.50 m
Diameter of Intake Pipe :	15.0 cm
Length of Test Section :	50.0 cm
Depth of Water Table :	7.0 m
Height of Casing above GL :	0.20 m
Hydraulic Head at Start of test :	195 cm
Soil Classification :	Silty fine sand

Sl. No.	Time in Minutes	Water Level in Intake Pipe, cm	Head, cm	Sl. No.	Time in Minutes	Water Level in Intake Pipe, cm	Head, cm
1	0.0	0.0	195				
2	1.0	32.0	163				
3	2.0	57.0	138				
4	4.0	82.0	113				
5	6.0	101.0	94				
6	8.0	120.0	75				
7	10.0	135.0	60				
8	15.0	156.0	39				
9	20.0	169.0	26				
10	25.0	174.0	21				
11	30.0	178.0	17				
12	40.0	199.0	-4				
13	50.0						

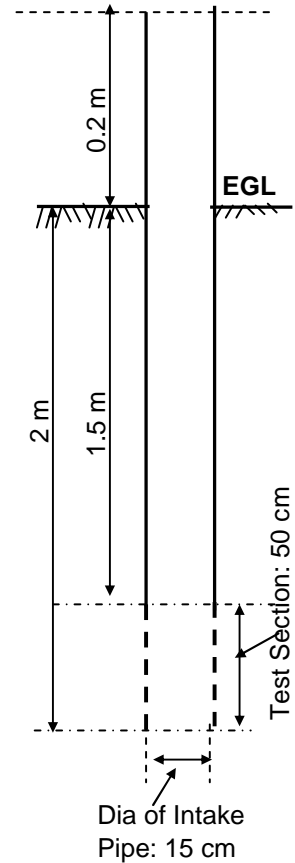

$$k = \text{Coefficient of Permeability} = \frac{d^2}{8L(t_2 - t_1)} \ln\left(\frac{2L}{d}\right) \ln\left(\frac{h_1}{h_2}\right)$$

Where:

L = 50.0 cm	d = 15.0 cm
2L/d = 6.67	R = 7.5 cm
$h_1/h_0 = 0.05$	$t_1 = 45.1$ minutes
$h_2/h_0 = 0.03$	$t_2 = 53.5$ minutes
$h_1/h_2 = 1.366$	

Calculations based on semilog plot of Head Ratio vs. Time, as per IS:5529 (Part-I)

$$k = 6.6E-04 \text{ cm/sec}$$

Determination of Coefficient of Permeability (FPT-64)



Field Permeability Test No.: FPT-64

By Falling Head Method

(IS: 5529-Part-1-1985, RA-2009)

Test Details
Borehole No. : BH : 8
Location : Ash Pond Area
Reduced Level (RL) : N/A
UTM Coordinates : 404586.77 m E, 2805103.37 m N
Depth of Borehole : 2.0
Calculated value of k : 6.6E-04

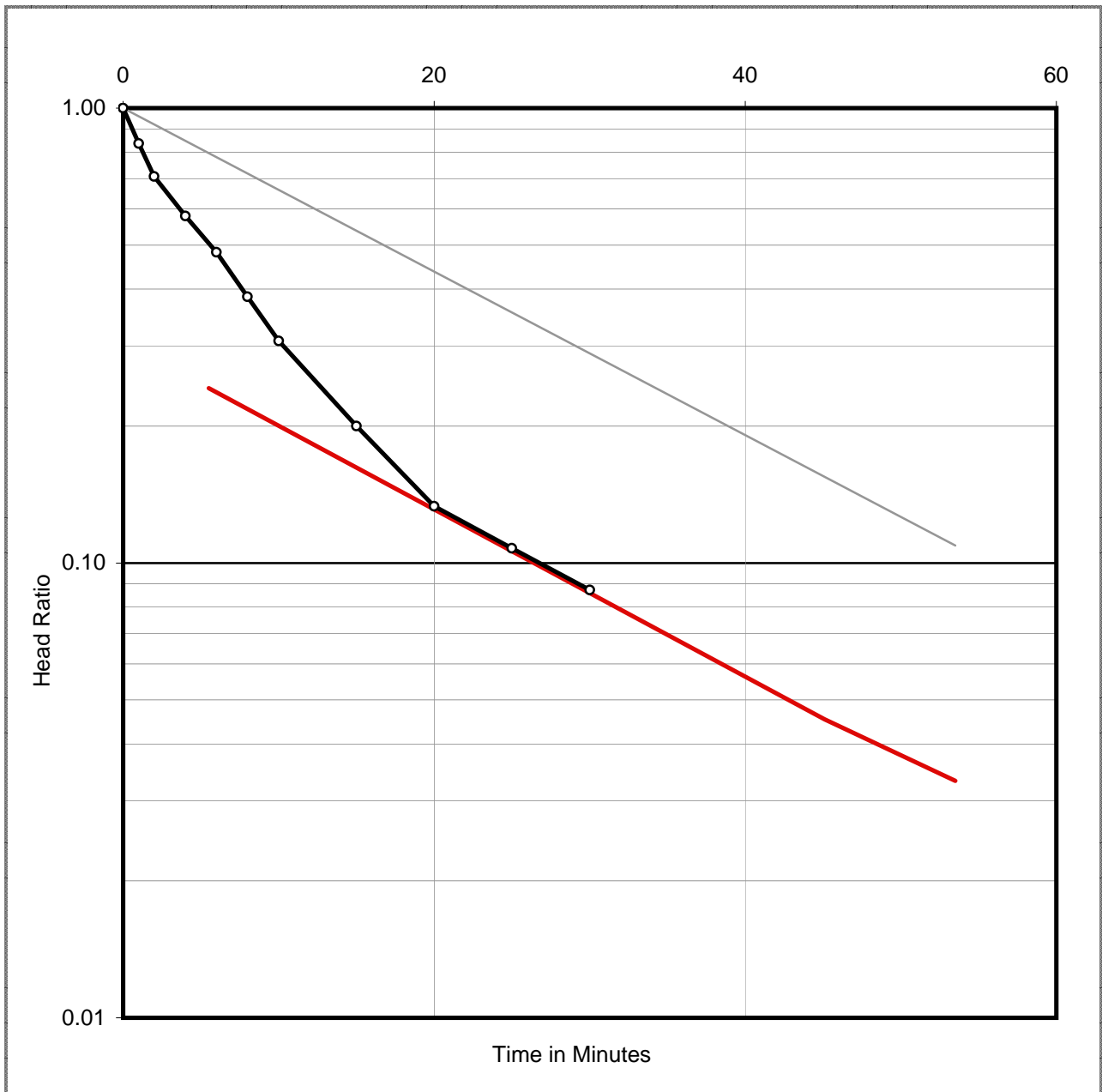

Semi-Log Plot of Head Ratio Vs Time (FPT-64)



Field Permeability Test No.: FPT-65

By Falling Head Method

IS: 5529-Part-1-1985, RA-2009

Test Details	
Borehole No. :	BH : 8
Location :	Ash Pond Area
Reduced Level (RL) :	N/A
UTM Coordinates :	404586.77 m E, 2805103.37 m N
Depth of Borehole :	4.0 m
Depth of bottom of casing below EGL :	3.50 m
Diameter of Intake Pipe :	15.0 cm
Length of Test Section :	50.0 cm
Depth of Water Table :	7.0 m
Height of Casing above GL :	0.25 m
Hydraulic Head at Start of test :	400 cm
Soil Classification :	Silty fine sand

Sl. No.	Time in Minutes	Water Level in Intake Pipe, cm	Head, cm	Sl. No.	Time in Minutes	Water Level in Intake Pipe, cm	Head, cm
1	0.0	0.0	400				
2	1.0	41.0	359				
3	2.0	69.0	331				
4	4.0	102.0	298				
5	6.0	140.0	260				
6	8.0	171.0	229				
7	10.0	198.0	202				
8	15.0	234.0	166				
9	20.0	262.0	138				
10	25.0	288.0	112				
11	30.0	310.0	90				
12	40.0	334.0	66				
13	50.0	347.0	53				

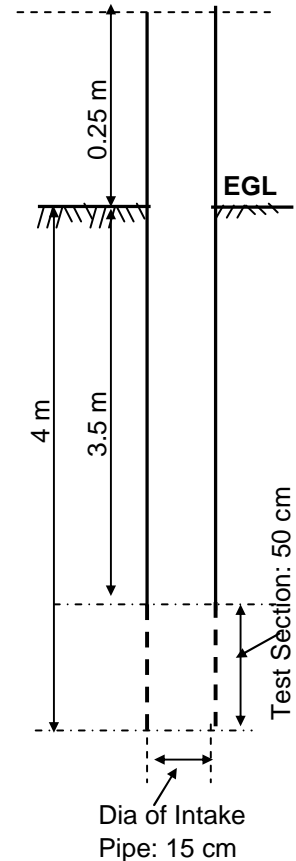

$$k = \text{Coefficient of Permeability} = \frac{d^2}{8L(t_2 - t_1)} \ln\left(\frac{2L}{d}\right) \ln\left(\frac{h_1}{h_2}\right)$$

Where:

L = 50.0 cm	d = 15.0 cm
2L/d = 6.67	R = 7.5 cm
$h_1/h_0 = 0.20$	$t_1 = 30$ minutes
$h_2/h_0 = 0.04$	$t_2 = 98.6$ minutes
$h_1/h_2 = 4.753$	

Calculations based on semilog plot of Head Ratio vs. Time, as per IS:5529 (Part-I)

$$k = 4.0E-04 \text{ cm/sec}$$

Determination of Coefficient of Permeability (FPT-65)



Field Permeability Test No.: FPT-65

By Falling Head Method

(IS: 5529-Part-1-1985, RA-2009)

Test Details
Borehole No. : BH : 8
Location : Ash Pond Area
Reduced Level (RL) : N/A
UTM Coordinates : 404586.77 m E, 2805103.37 m N
Depth of Borehole : 4.0
Calculated value of k : 4.0E-04

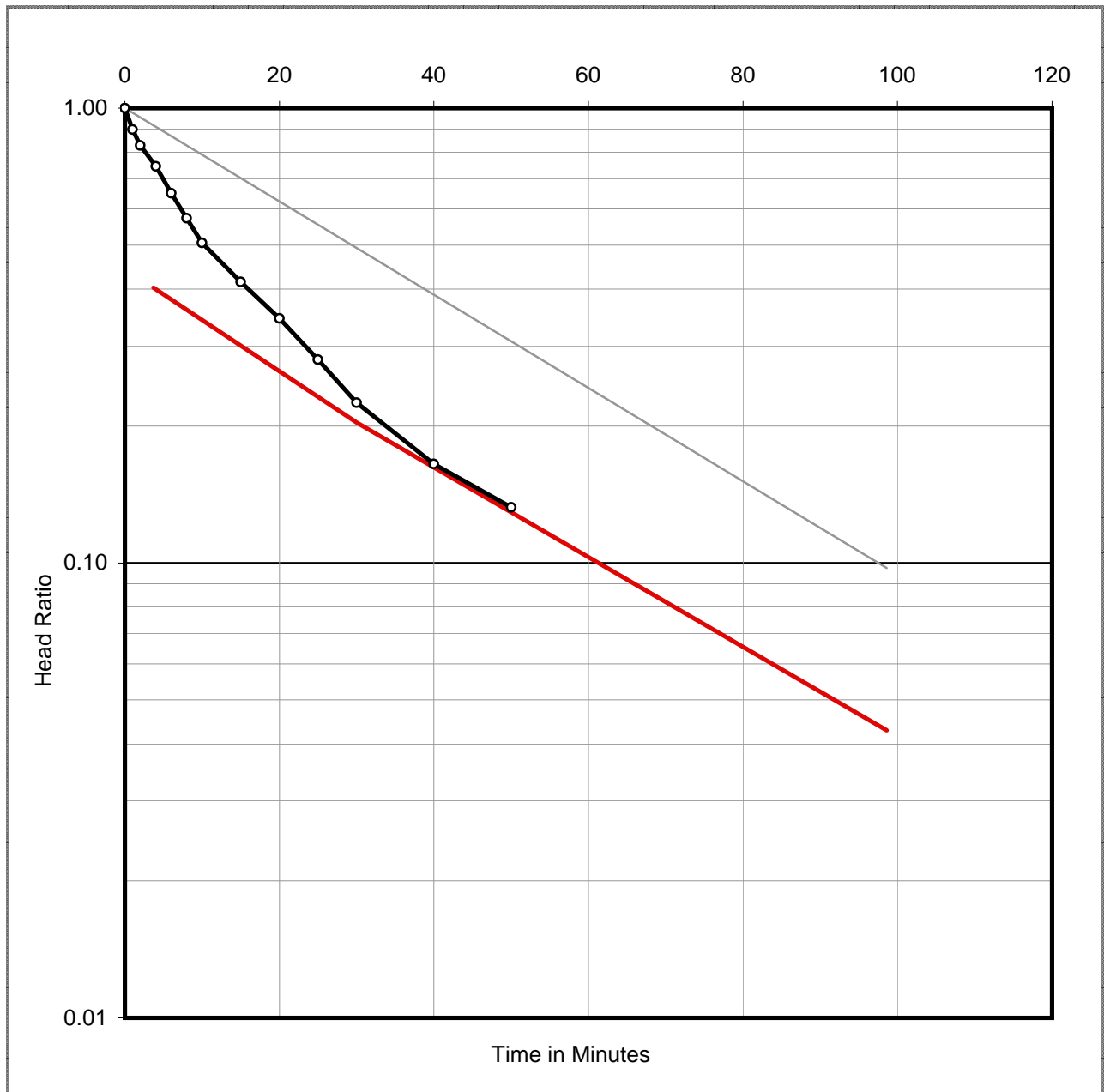

Semi-Log Plot of Head Ratio Vs Time (FPT-65)



Field Permeability Test No.: FPT-66

By Falling Head Method

IS: 5529-Part-1-1985, RA-2009

Test Details	
Borehole No. :	BH : 8
Location :	Ash Pond Area
Reduced Level (RL) :	N/A
UTM Coordinates :	404586.77 m E, 2805103.37 m N
Depth of Borehole :	6.0 m
Depth of bottom of casing below EGL :	5.50 m
Diameter of Intake Pipe :	15.0 cm
Length of Test Section :	50.0 cm
Depth of Water Table :	7.0 m
Height of Casing above GL :	0.20 m
Hydraulic Head at Start of test :	595 cm
Soil Classification :	Silty fine sand

Sl. No.	Time in Minutes	Water Level in Intake Pipe, cm	Head, cm	Sl. No.	Time in Minutes	Water Level in Intake Pipe, cm	Head, cm
1	0.0	0.0	595				
2	1.0	35.0	560				
3	2.0	60.0	535				
4	4.0	120.0	475				
5	6.0	170.0	425				
6	8.0	250.0	345				
7	10.0	300.0	295				
8	15.0	380.0	215				
9	20.0	440.0	155				
10	25.0	480.0	115				
11	30.0	515.0	80				
12	40.0	550.0	45				
13	50.0	570.0	25				

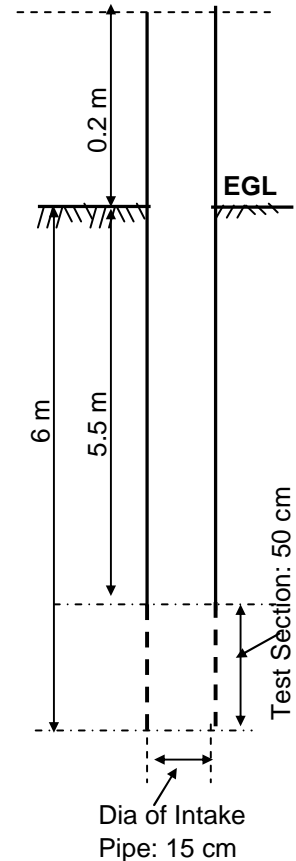

$$k = \text{Coefficient of Permeability} = \frac{d^2}{8L(t_2 - t_1)} \ln\left(\frac{2L}{d}\right) \ln\left(\frac{h_1}{h_2}\right)$$

Where:

L =	50.0 cm	d =	15.0 cm
2L/d =	6.67	R =	7.5 cm
$h_1/h_0 =$	0.11	$t_1 =$	32.3 minutes
$h_2/h_0 =$	0.05	$t_2 =$	46.9 minutes
$h_1/h_2 =$	2.352		

Calculations based on semilog plot of Head Ratio vs. Time, as per IS:5529 (Part-I)

$$k = 1.0E-03 \text{ cm/sec}$$

Determination of Coefficient of Permeability (FPT-66)



Field Permeability Test No.: FPT-66

By Falling Head Method

(IS: 5529-Part-1-1985, RA-2009)

Test Details
Borehole No. : BH : 8
Location : Ash Pond Area
Reduced Level (RL) : N/A
UTM Coordinates : 404586.77 m E, 2805103.37 m N
Depth of Borehole : 6.0
Calculated value of k : 1.0E-03

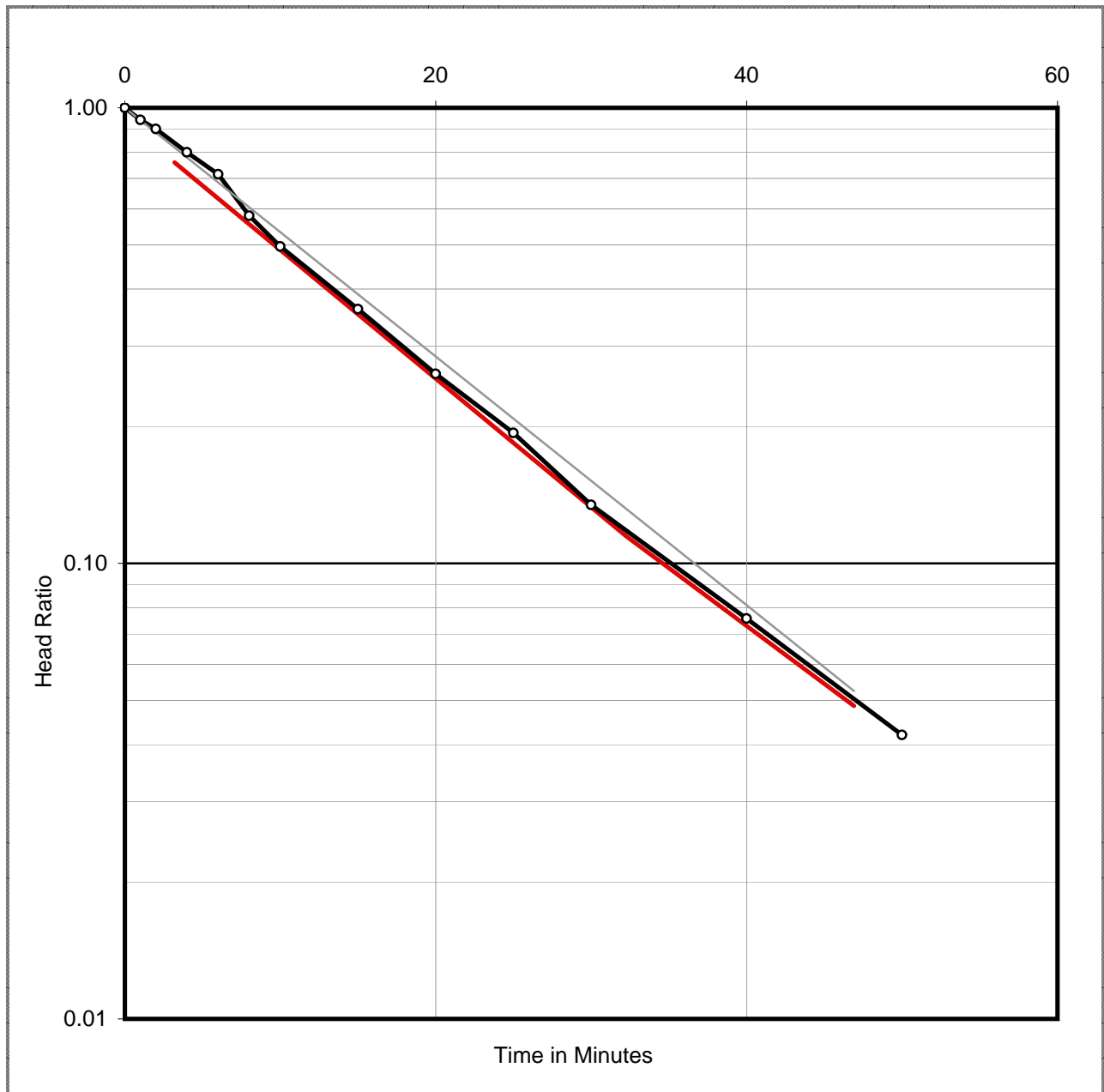

Semi-Log Plot of Head Ratio Vs Time (FPT-66)



Field Permeability Test No. : FPT-67

By Constant Head Method

IS: 5529-Part-1-1985, RA-2009

Test Details	
Borehole No. :	BH-8
Location :	Ash Pond Area
UTM Coordinates :	404586.77 m E, 2805103.37 m N
Depth of Borehole :	8.00 m = 800 cm
Depth of bottom of casing below EGL :	800 cm
Diameter of Intake Pipe :	15 cm
Depth of Water Table :	7.1 cm
Effective Height of water in Tank :	92 cm
Differential Head :	99.1 cm
Soil Classification :	Silty fine sand

Time, min	Q(litre)	Discharge, Q litre/min)	Q _{average} litre/min	Borehole Radius (r), mm	Differential Head (H), m	C	k, cm/s
0	249.0	0.000					
1	249.4	40.0					
2	249.8	40.0					
4	250.5	35.0					
6	251.1	30.0					
8	251.8	35.0					
10	252.2	20.0	23.0	75	1.0	4E-03	9.4E-02
15	252.7	10.0					
20	253.7	20.0					

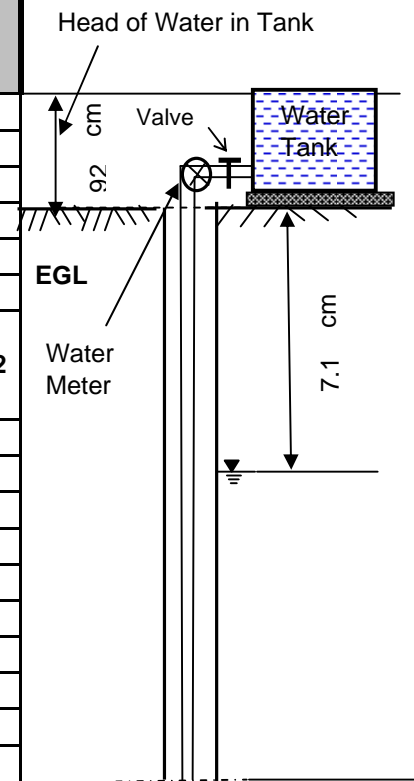

Equation used for calculation

$$k = C * \left[\frac{Q}{H} \right] \quad C = \left[\frac{1}{5.5 r} \right]$$

Where:

Q=Discharge,(litre/min)

H=Differential Head,(m)

r=radius of casing,(mm)

Determination of Coefficient of Permeability (FPT-67)



Field Permeability Test No. : FPT-68

By Constant Head Method

IS: 5529-Part-1-1985, RA-2009

Test Details	
Borehole No. :	BH-8
Location :	Ash Pond Area
UTM Coordinates :	404586.77 m E, 2805103.37 m N
Depth of Borehole :	10.00 m = 1000 cm
Depth of bottom of casing below EGL :	1000 cm
Diameter of Intake Pipe :	15 cm
Depth of Water Table :	7.1 cm
Effective Height of water in Tank :	92 cm
Differential Head :	99.1 cm
Soil Classification :	Silty fine sand

Time, min	Q(litre)	Discharge, Q (litre/min)	Q _{average} (litre/min)	Borehole Radius (r), mm	Differential Head (H), m	C	k, cm/s
0	254.0	0.000					
1	254.3	30.0					
2	254.5	20.0					
4	254.9	20.0					
6	255.3	20.0					
8	255.8	25.0					
10	256.1	15.0	20.0	75	1.0	4E-03	8.2E-02
15	257.1	20.0					
20	258.0	18.0					

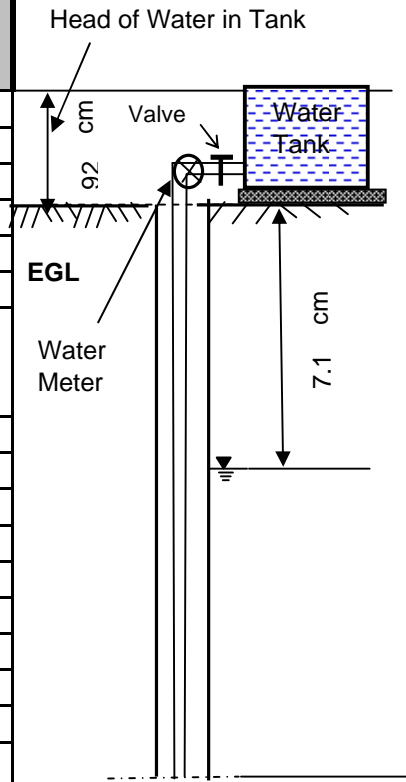

Equation used for calculation

$$k = C * \left[\frac{Q}{H} \right] \quad C = \left[\frac{1}{5.5 r} \right]$$

Where:

Q=Discharge,(litre/min)

H=Differential Head,(m)

r=radius of casing,(mm)

Determination of Coefficient of Permeability (FPT-68)

Field Permeability Test No. : FPT-69

By Constant Head Method

IS: 5529-Part-1-1985, RA-2009

Test Details	
Borehole No. :	BH-8
Location :	Ash Pond Area
UTM Coordinates :	404586.77 m E, 2805103.37 m N
Depth of Borehole :	12.00 m = 1200 cm
Depth of bottom of casing below EGL :	1200 cm
Diameter of Intake Pipe :	15 cm
Depth of Water Table :	7.1 cm
Effective Height of water in Tank :	92 cm
Differential Head :	99.1 cm
Soil Classification :	Silty fine sand

Time, min	Q(litre)	Discharge, Q litre/min)	Q _{average} litre/min	Borehole Radius (r), mm	Differential Head (H), m	C	k, cm/s
0	258.0	0.000					
1	258.4	40.0					
2	258.9	50.0					
4	259.3	20.0					
6	259.9	30.0					
8	260.4	25.0	27.5	75	1.0	4E-03	1.1E-01
10	260.9	25.0					
15	262.5	32.0					
20	263.9	28.0					

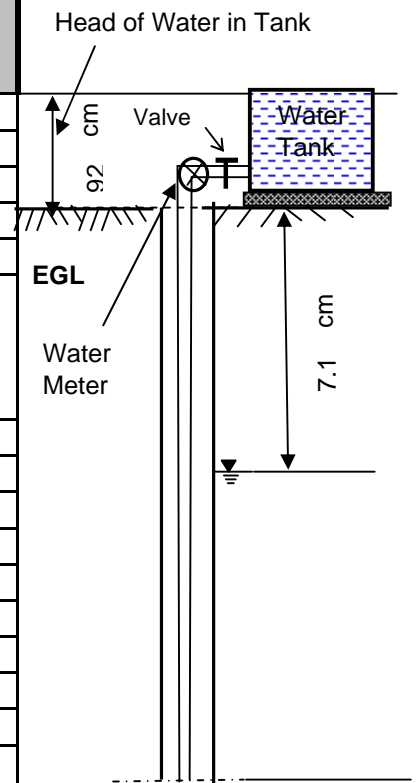

Equation used for calculation

$$k = C * \left[\frac{Q}{H} \right] \quad C = \left[\frac{1}{5.5 r} \right]$$

Where:

Q=Discharge,(litre/min)

H=Differential Head,(m)

r=radius of casing,(mm)

Determination of Coefficient of Permeability (FPT-69)



Field Permeability Test No. : FPT-70

By Constant Head Method

IS: 5529-Part-1-1985, RA-2009

Test Details	
Borehole No. :	BH-8
Location :	Ash Pond Area
UTM Coordinates :	404586.77 m E, 2805103.37 m N
Depth of Borehole :	14.00 m = 1400 cm
Depth of bottom of casing below EGL :	1400 cm
Diameter of Intake Pipe :	15 cm
Depth of Water Table :	7.1 cm
Effective Height of water in Tank :	92 cm
Differential Head :	99.1 cm
Soil Classification :	Silty fine sand

Time, min	Q(litre)	Discharge, Q (litre/min)	Q _{average} (litre/min)	Borehole Radius (r), mm	Differential Head (H), m	C	k, cm/s
0	264.0	0.000					
1	264.4	40.0					
2	264.8	40.0					
4	265.4	30.0					
6	266.1	35.0					
8	266.7	30.0					
10	267.1	20.0	20.7	75	1.0	4E-03	8.4E-02
15	268.1	20.0					
20	269.2	22.0					

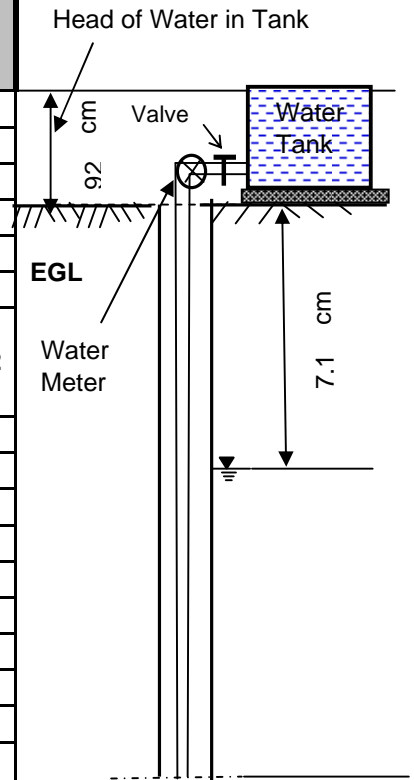

Equation used for calculation

$$k = C * \left[\frac{Q}{H} \right] \quad C = \left[\frac{1}{5.5 r} \right]$$

Where:

Q=Discharge,(litre/min)

H=Differential Head,(m)

r=radius of casing,(mm)

Determination of Coefficient of Permeability (FPT-70)



Field Permeability Test No. : FPT-71

By Constant Head Method

IS: 5529-Part-1-1985, RA-2009

Test Details	
Borehole No. :	BH-8
Location :	Ash Pond Area
UTM Coordinates :	404586.77 m E, 2805103.37 m N
Depth of Borehole :	16.00 m = 1600 cm
Depth of bottom of casing below EGL :	1600 cm
Diameter of Intake Pipe :	15 cm
Depth of Water Table :	7.1 cm
Effective Height of water in Tank :	92 cm
Differential Head :	99.1 cm
Soil Classification :	Silty fine sand

Time, min	Q(litre)	Discharge, Q (litre/min)	Q _{average} (litre/min)	Borehole Radius (r), mm	Differential Head (H), m	C	k, cm/s
0	269.2	0.000					
1	269.5	30.0					
2	269.7	20.0					
4	270.2	25.0					
6	270.6	20.0					
8	270.9	15.0					
10	271.3	20.0	18.0	75	1.0	4E-03	7.3E-02
15	272.2	18.0					
20	273.0	16.0					

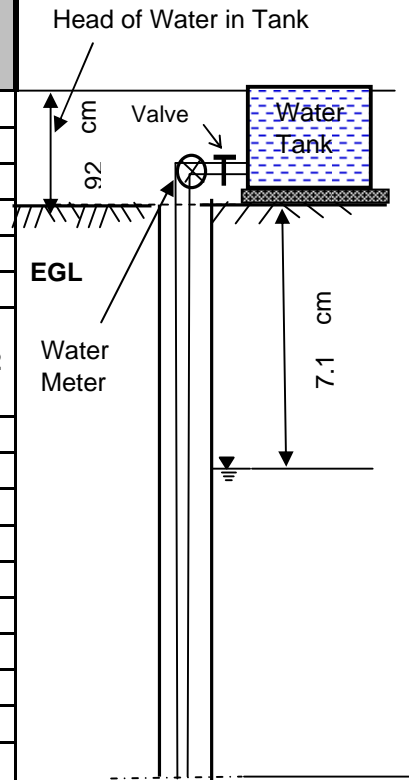

Equation used for calculation

$$k = C * \left[\frac{Q}{H} \right] \quad C = \left[\frac{1}{5.5 r} \right]$$

Where:

Q=Discharge,(litre/min)

H=Differential Head,(m)

r=radius of casing,(mm)

Determination of Coefficient of Permeability (FPT-71)



Field Permeability Test No. : FPT-72

By Constant Head Method

IS: 5529-Part-1-1985, RA-2009

Test Details	
Borehole No. :	BH-8
Location :	Ash Pond Area
UTM Coordinates :	404586.77 m E, 2805103.37 m N
Depth of Borehole :	18.00 m = 1800 cm
Depth of bottom of casing below EGL :	1800 cm
Diameter of Intake Pipe :	15 cm
Depth of Water Table :	7.1 cm
Effective Height of water in Tank :	92 cm
Differential Head :	99.1 cm
Soil Classification :	Silty fine sand

Time, min	Q(litre)	Discharge, Q litre/min)	Q _{average} litre/min	Borehole Radius (r), mm	Differential Head (H), m	C	k, cm/s
0	273.0	0.000					
1	273.2	20.0					
2	273.4	20.0					
4	273.7	15.0					
6	274.1	20.0					
8	274.4	15.0					
10	274.7	15.0	14.5	75	1.0	4E-03	5.9E-02
15	275.4	14.0					
20	276.1	14.0					

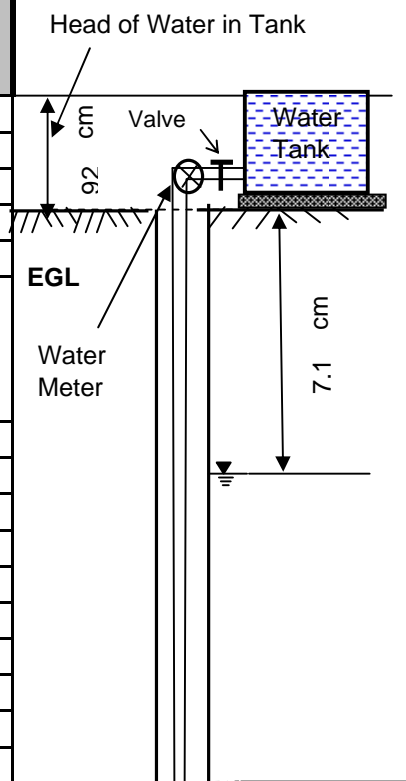

Equation used for calculation

Where:

$$k = C * \left[\frac{Q}{H} \right] \quad C = \left[\frac{1}{5.5 r} \right]$$

Q=Discharge,(litre/min)

H=Differential Head,(m)

r=radius of casing,(mm)

Determination of Coefficient of Permeability (FPT-72)



Field Permeability Test No. : FPT-73

By Constant Head Method

IS: 5529-Part-1-1985, RA-2009

Test Details	
Borehole No. :	BH-8
Location :	Ash Pond Area
UTM Coordinates :	404586.77 m E, 2805103.37 m N
Depth of Borehole :	20.00 m = 2000 cm
Depth of bottom of casing below EGL :	2000 cm
Diameter of Intake Pipe :	15 cm
Depth of Water Table :	7.1 cm
Effective Height of water in Tank :	92 cm
Differential Head :	99.1 cm
Soil Classification :	Silty fine sand

Time, min	Q(litre)	Discharge, Q litre/min)	Q _{average} litre/min	Borehole Radius (r), mm	Differential Head (H), m	C	k, cm/s
0	276.2	0.000					
1	276.4	20.0					
2	276.5	10.0					
4	276.8	15.0					
6	277.1	15.0					
8	277.3	10.0	10.5	75	1.0	4E-03	4.3E-02
10	277.5	10.0					
15	278.1	12.0					
20	278.6	10.0					

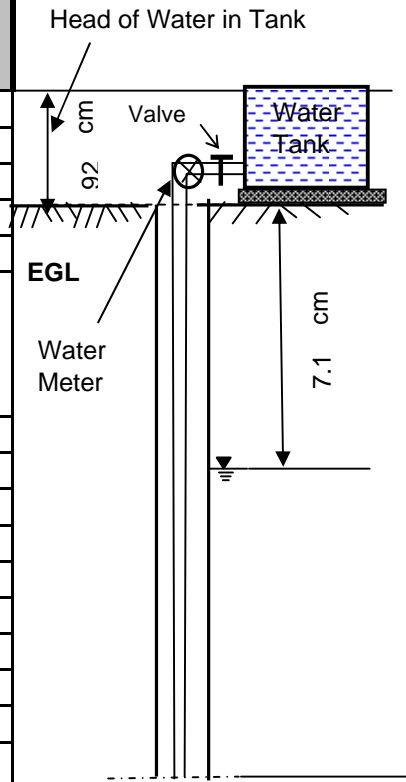

Equation used for calculation

Where:

$$k = C * \left[\frac{Q}{H} \right] \quad C = \left[\frac{1}{5.5 r} \right]$$

Q=Discharge,(litre/min)

H=Differential Head,(m)

r=radius of casing,(mm)

Determination of Coefficient of Permeability (FPT-73)



Grain Size Analysis

IS : 2720 (Part 4) - 1985, RA-2010

Sample Details			Test Results									
Borehole Number	Sample Depth, m	Sample Description	% Gravel	% Sand	% Silt	% Clay	D ₆₀	D ₅₀	D ₃₀	D ₁₀	C _u	C _c
BH-1	0.00	Sandy silt (CL)	0	17	62	20	0.021	0.016	0.005			
BH-1	1.00	Silty fine sand (SM)	0	62	35	3	0.186	0.160	0.062	0.026	7.2	0.79
BH-1	2.00	Silty fine sand (SM)	0	83	17	0	0.205	0.170	0.122			
BH-1	4.00	Silty fine sand (SM)	0	78	17	5	0.133	0.130	0.087	0.014	9.5	4.06
BH-1	5.00	Silty fine sand (SM)	0	79	16	5	0.157	0.150	0.093	0.015	10.5	3.67

Hydrometer Analysis

Sieve Analysis

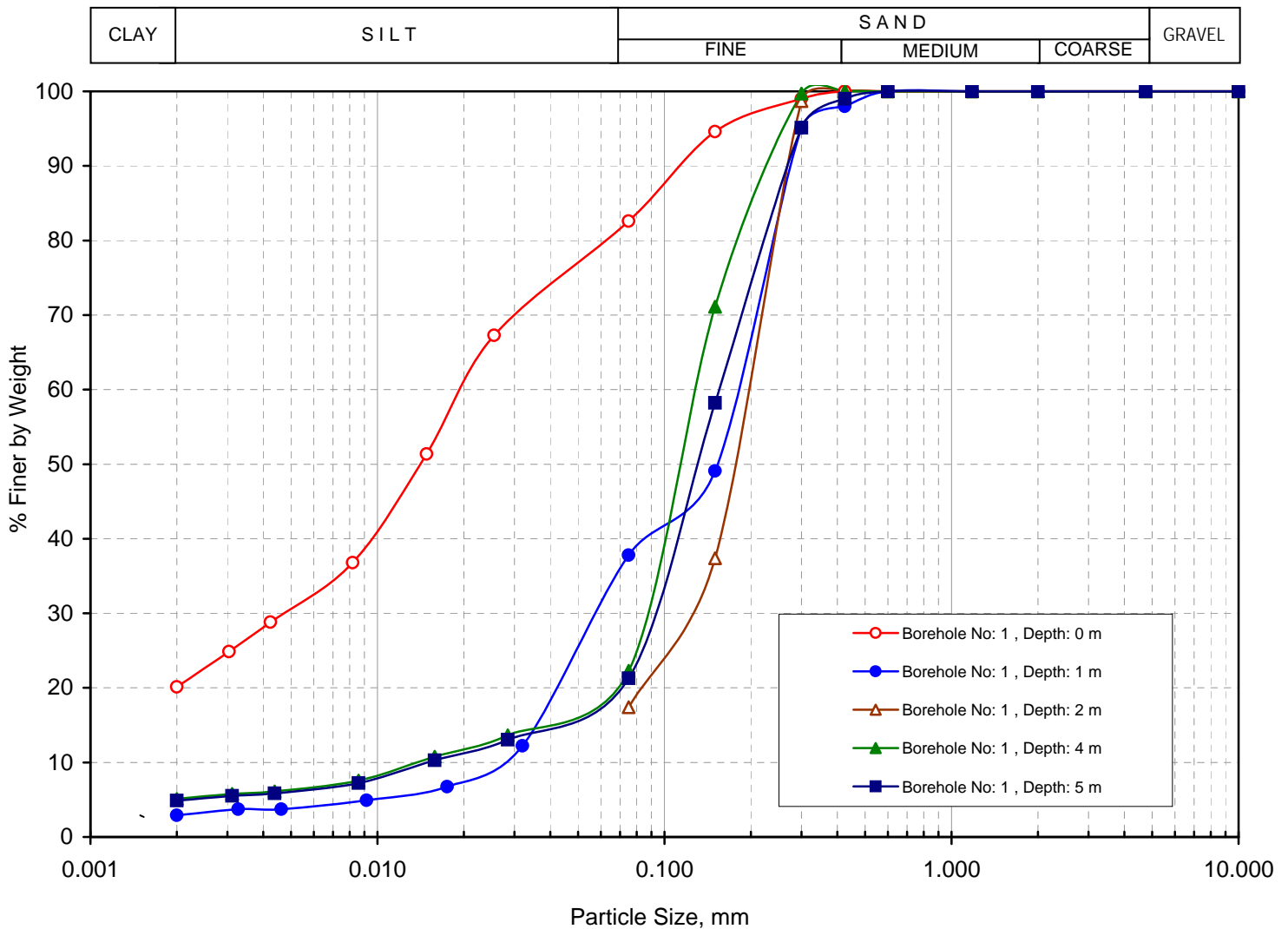

Grain Size Distribution Curve





Grain Size Analysis

IS : 2720 (Part 4) - 1985, RA-2010

Sample Details			Test Results									
Borehole Number	Sample Depth, m	Sample Description	% Gravel	% Sand	% Silt	% Clay	D ₆₀	D ₅₀	D ₃₀	D ₁₀	C _u	C _c
BH-1	8.00	Silty fine sand (SM)	0	86	14	0	0.201	0.170	0.121			
BH-1	12.00	Fine sand (SP-SM)	0	95	5	0	0.265	0.230	0.186	0.109	2.4	1.20
BH-1	14.00	Fine sand (SP)	0	96	4	0	0.293	0.250	0.203	0.129	2.3	1.09
BH-1	16.00	Fine sand (SP)	1	99	0	0	0.287	0.250	0.207	0.153	1.9	0.98

Hydrometer Analysis

Sieve Analysis

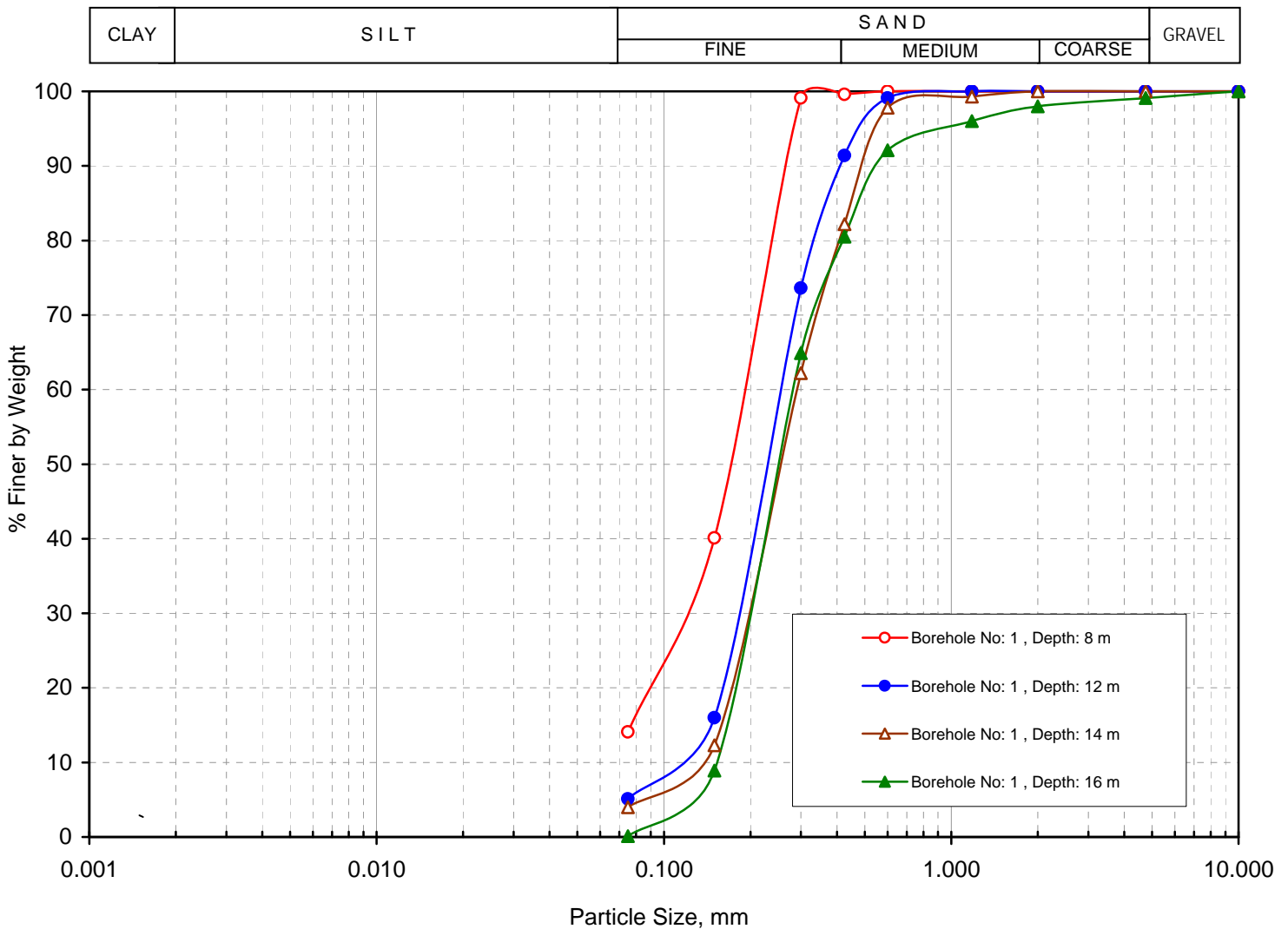

Grain Size Distribution Curve

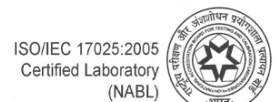

Certificate No. T-1741



Grain Size Analysis

IS : 2720 (Part 4) - 1985, RA-2010

Sample Details			Test Results									
Borehole Number	Sample Depth, m	Sample Description	% Gravel	% Sand	% Silt	% Clay	D ₆₀	D ₅₀	D ₃₀	D ₁₀	C _u	C _c
BH-1	18.00	Fine sand (SP)	0	97	3	0	0.307	0.280	0.216	0.158	1.9	0.96
BH-1	20.00	Fine sand (SP)	0	98	2	0	0.298	0.270	0.214	0.158	1.9	0.97

Hydrometer Analysis

Sieve Analysis

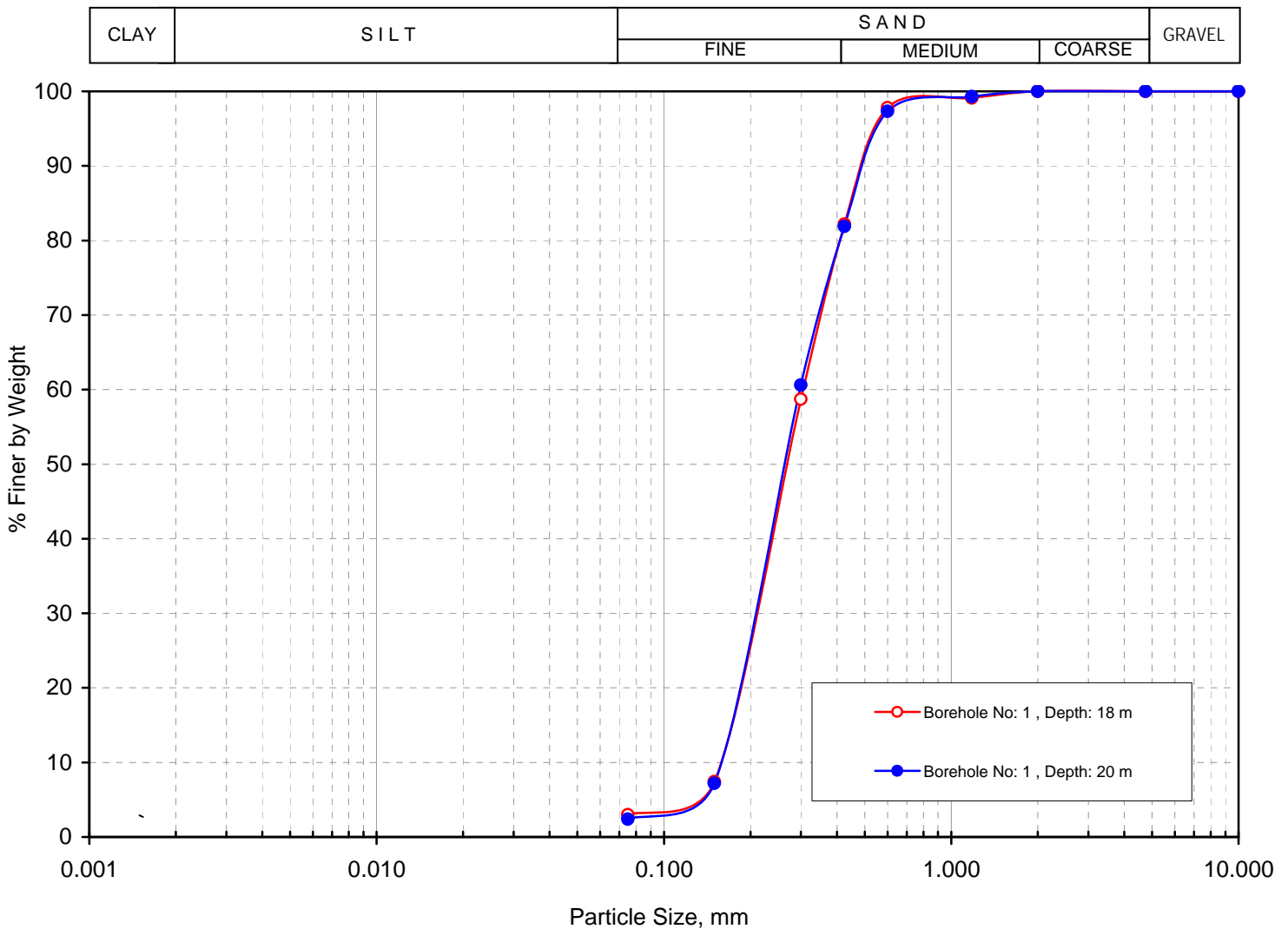

Grain Size Distribution Curve





Grain Size Analysis

IS : 2720 (Part 4) - 1985, RA-2010

Sample Details			Test Results									
Borehole Number	Sample Depth, m	Sample Description	% Gravel	% Sand	% Silt	% Clay	D ₆₀	D ₅₀	D ₃₀	D ₁₀	C _u	C _c
BH-2	0.00	Sandy silt (CL)	0	36	51	12	0.065	0.034	0.011			
BH-2	2.50	Sandy silt (CL)	0	19	61	20	0.022	0.015	0.005			
BH-2	4.50	Silty fine sand (SM)	0	80	16	4	0.188	0.160	0.102	0.017	11.1	3.26
BH-2	7.50	Silty fine sand (SM)	0	86	12	2	0.204	0.170	0.125			
BH-2	10.80	Fine sand (SP-SM)	0	95	5	0	0.228	0.200	0.170	0.101	2.3	1.25

Hydrometer Analysis

Sieve Analysis

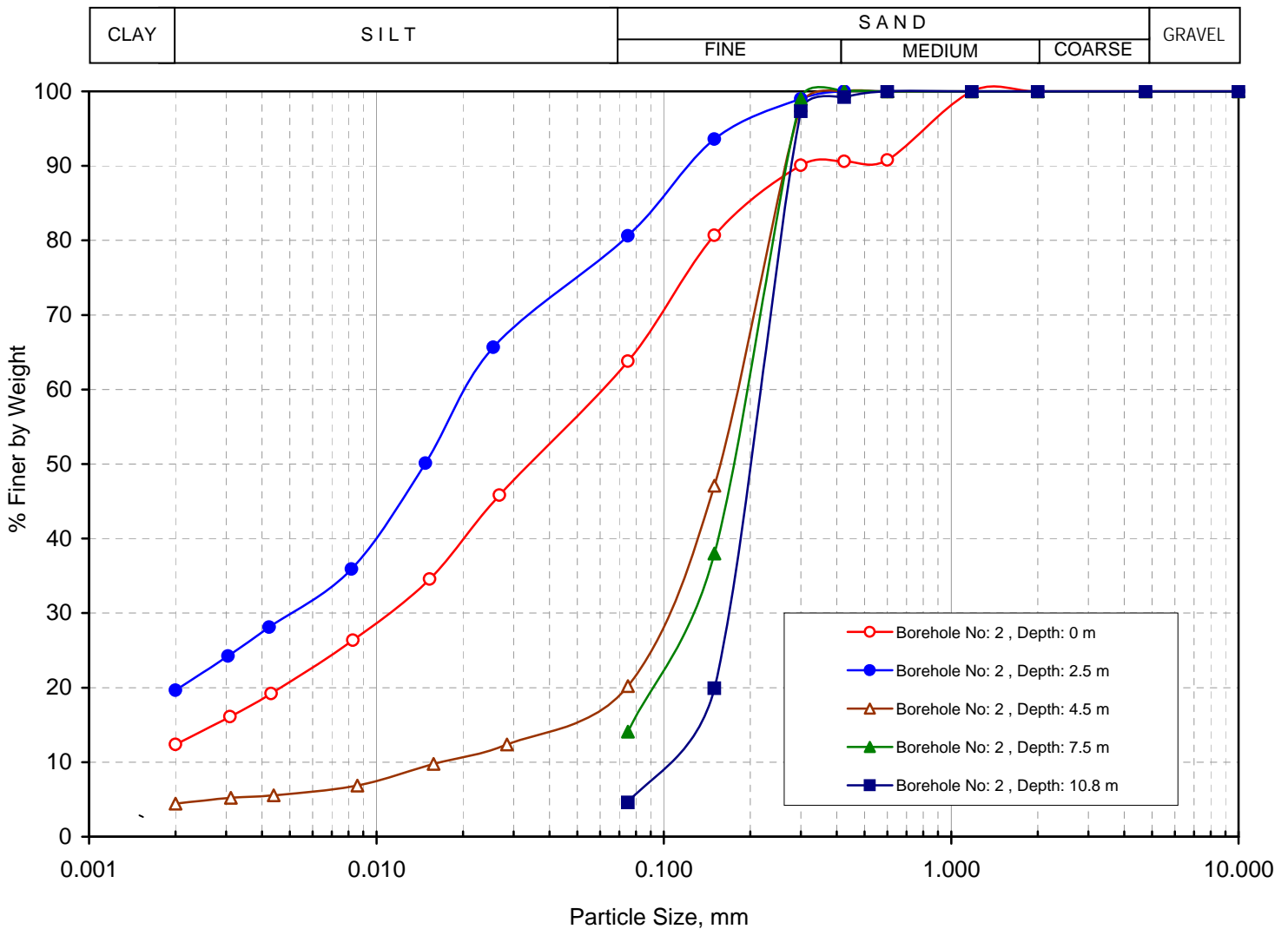

Grain Size Distribution Curve

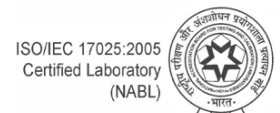

Certificate No. T-1741



Grain Size Analysis

IS : 2720 (Part 4) - 1985, RA-2010

Sample Details			Test Results									
Borehole Number	Sample Depth, m	Sample Description	% Gravel	% Sand	% Silt	% Clay	D ₆₀	D ₅₀	D ₃₀	D ₁₀	C _u	C _c
BH-2	12.00	Fine sand (SP)	0	96	4	0	0.235	0.220	0.182	0.129	1.8	1.09
BH-2	14.50	Fine sand (SP-SM)	0	93	7	0	0.297	0.270	0.205	0.119	2.5	1.19
BH-2	16.50	Fine sand (SP)	0	98	2	0	0.246	0.220	0.186	0.138	1.8	1.02
BH-2	18.50	Fine sand (SP)	0	98	2	0	0.233	0.210	0.179	0.125	1.9	1.10

Hydrometer Analysis

Sieve Analysis

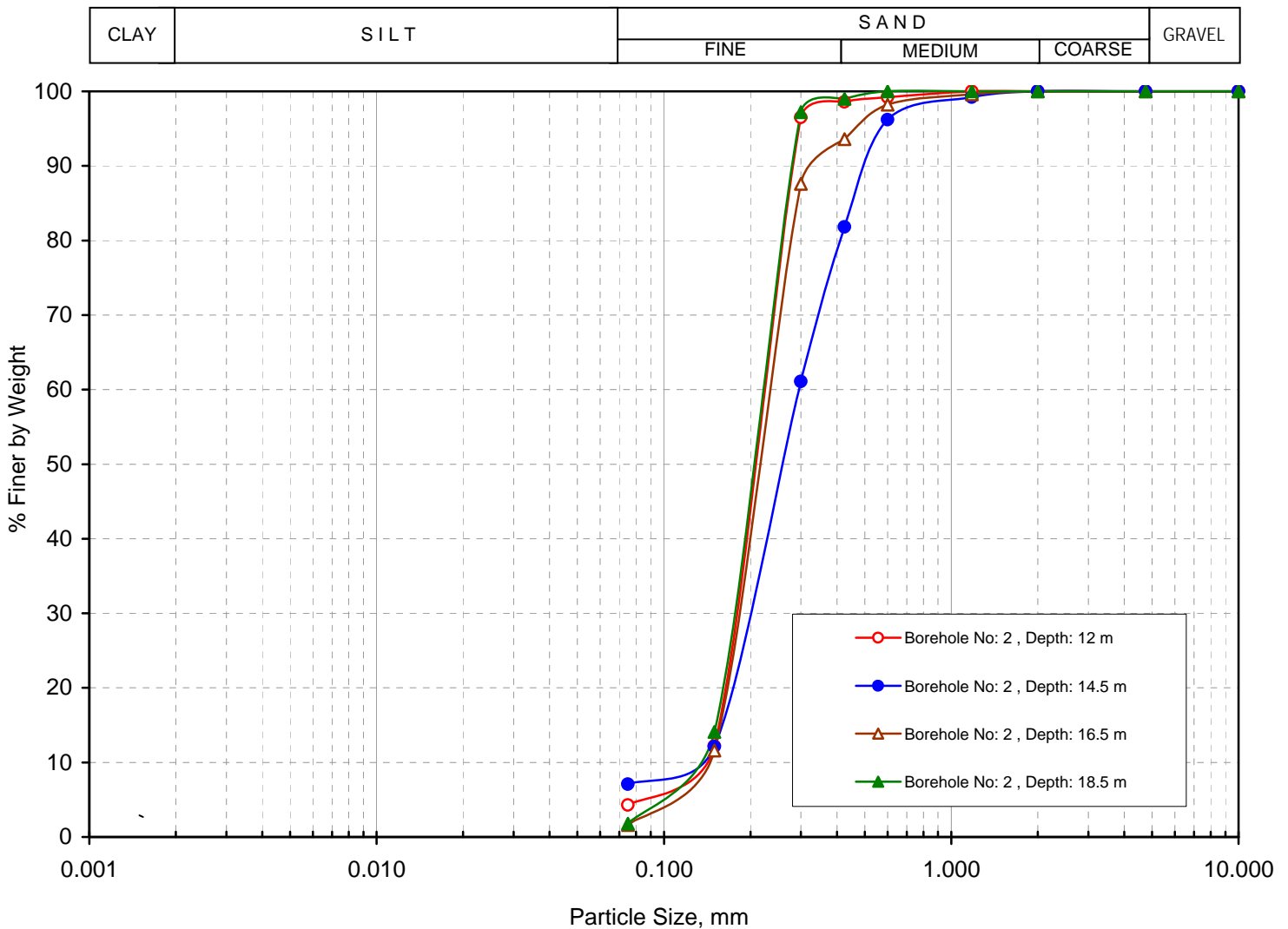

Grain Size Distribution Curve

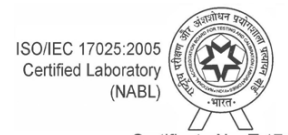



Grain Size Analysis

IS : 2720 (Part 4) - 1985, RA-2010

Sample Details			Test Results									
Borehole Number	Sample Depth, m	Sample Description	% Gravel	% Sand	% Silt	% Clay	D ₆₀	D ₅₀	D ₃₀	D ₁₀	C _u	C _c
BH-3	0.00	Sandy silt (CL)	0	25	58	17	0.038	0.022	0.008			
BH-3	1.00	Silty fine sand (SM)	0	61	36	3	0.205	0.160	0.056	0.016	12.8	0.96
BH-3	2.00	Silty fine sand (SM)	0	84	16	0	0.136	0.120	0.095			
BH-3	5.00	Silty fine sand (SM)	0	81	19	0	0.158	0.140	0.096			
BH-3	6.00	Silty fine sand (SM)	0	60	35	5	0.205	0.160	0.020	0.004	51.3	0.49

Hydrometer Analysis

Sieve Analysis

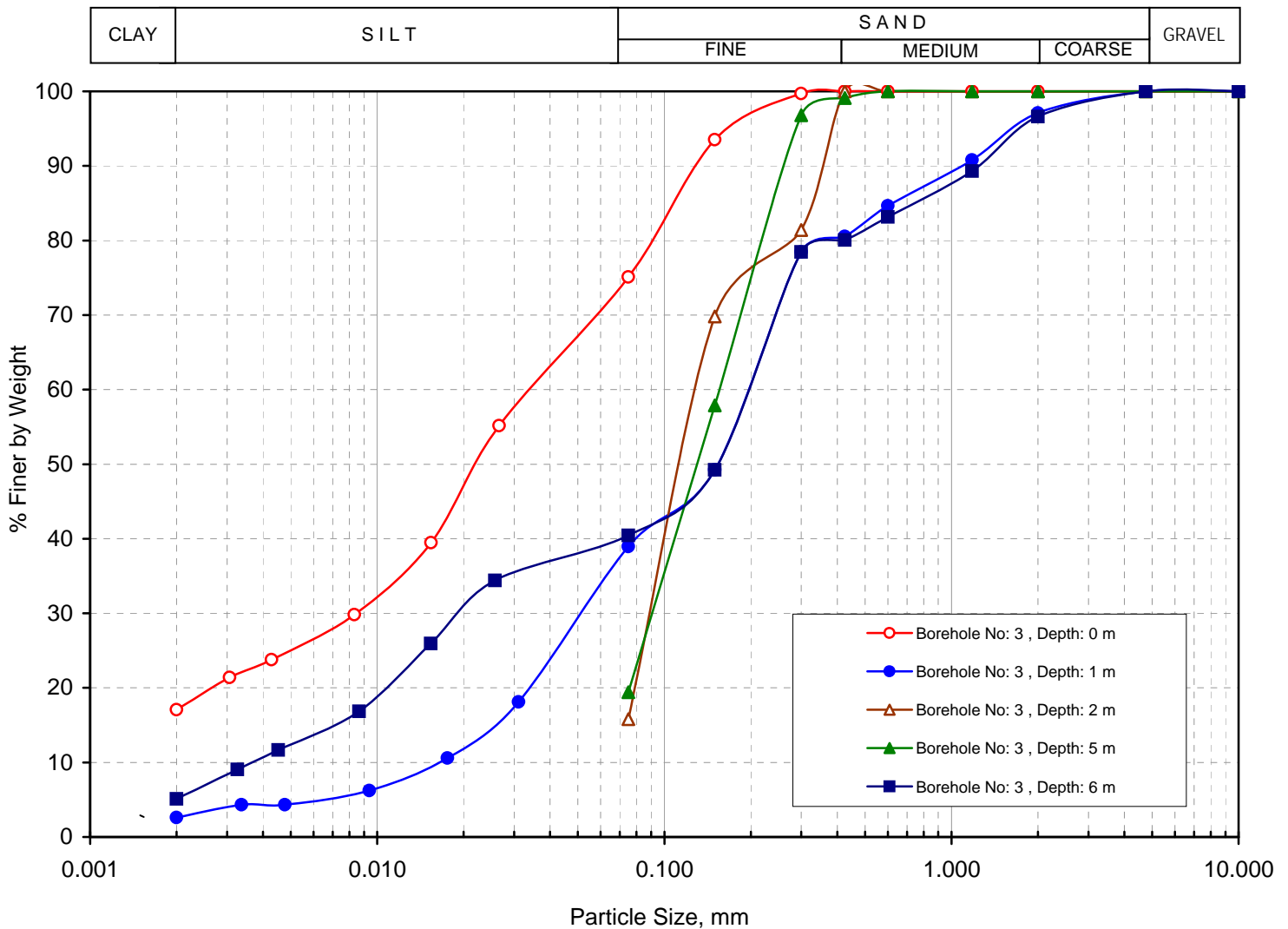

Grain Size Distribution Curve





Grain Size Analysis

IS : 2720 (Part 4) - 1985, RA-2010

Sample Details			Test Results									
Borehole Number	Sample Depth, m	Sample Description	% Gravel	% Sand	% Silt	% Clay	D ₆₀	D ₅₀	D ₃₀	D ₁₀	C _u	C _c
BH-3	8.00	Sandy silt (CL)	0	40	50	10	0.076	0.055	0.023	0.002	38.0	3.48
BH-3	12.00	Fine sand (SP-SM)	0	95	5	0	0.241	0.220	0.171	0.100	2.4	1.21
BH-3	14.00	Silty fine sand (SM)	0	82	18	0	0.182	0.150	0.103			
BH-3	16.00	Fine sand (SP)	0	99	1	0	0.361	0.320	0.243	0.166	2.2	0.99

Hydrometer Analysis

Sieve Analysis

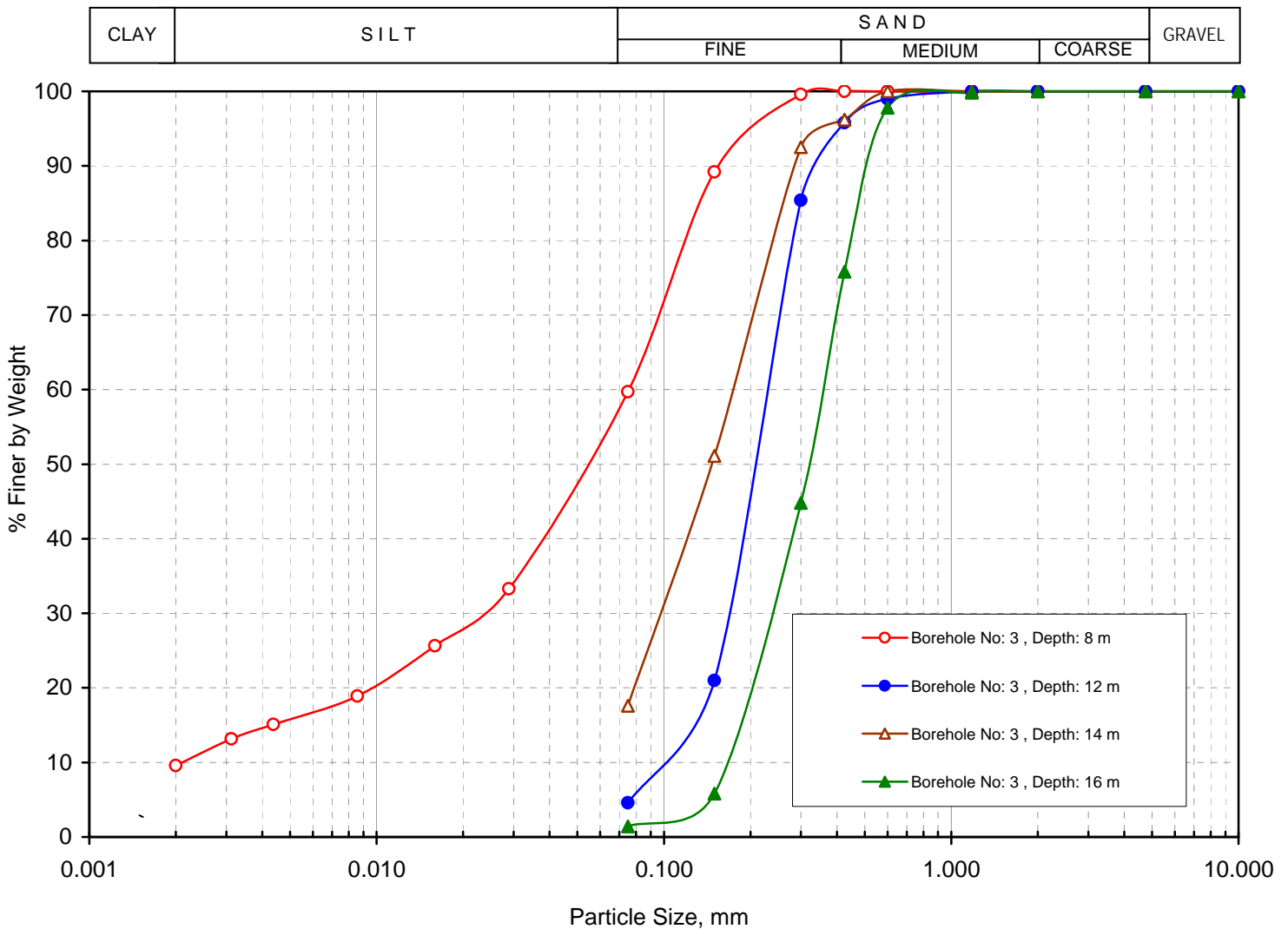

Grain Size Distribution Curve





Grain Size Analysis

IS : 2720 (Part 4) - 1985, RA-2010

Sample Details			Test Results									
Borehole Number	Sample Depth, m	Sample Description	% Gravel	% Sand	% Silt	% Clay	D ₆₀	D ₅₀	D ₃₀	D ₁₀	C _u	C _c
BH-3	18.00	Fine sand (SP)	0	99	1	0	0.354	0.310	0.242	0.170	2.1	0.97
BH-3	20.00	Fine sand (SP)	0	99	1	0	0.386	0.340	0.257	0.180	2.1	0.95

Hydrometer Analysis

Sieve Analysis

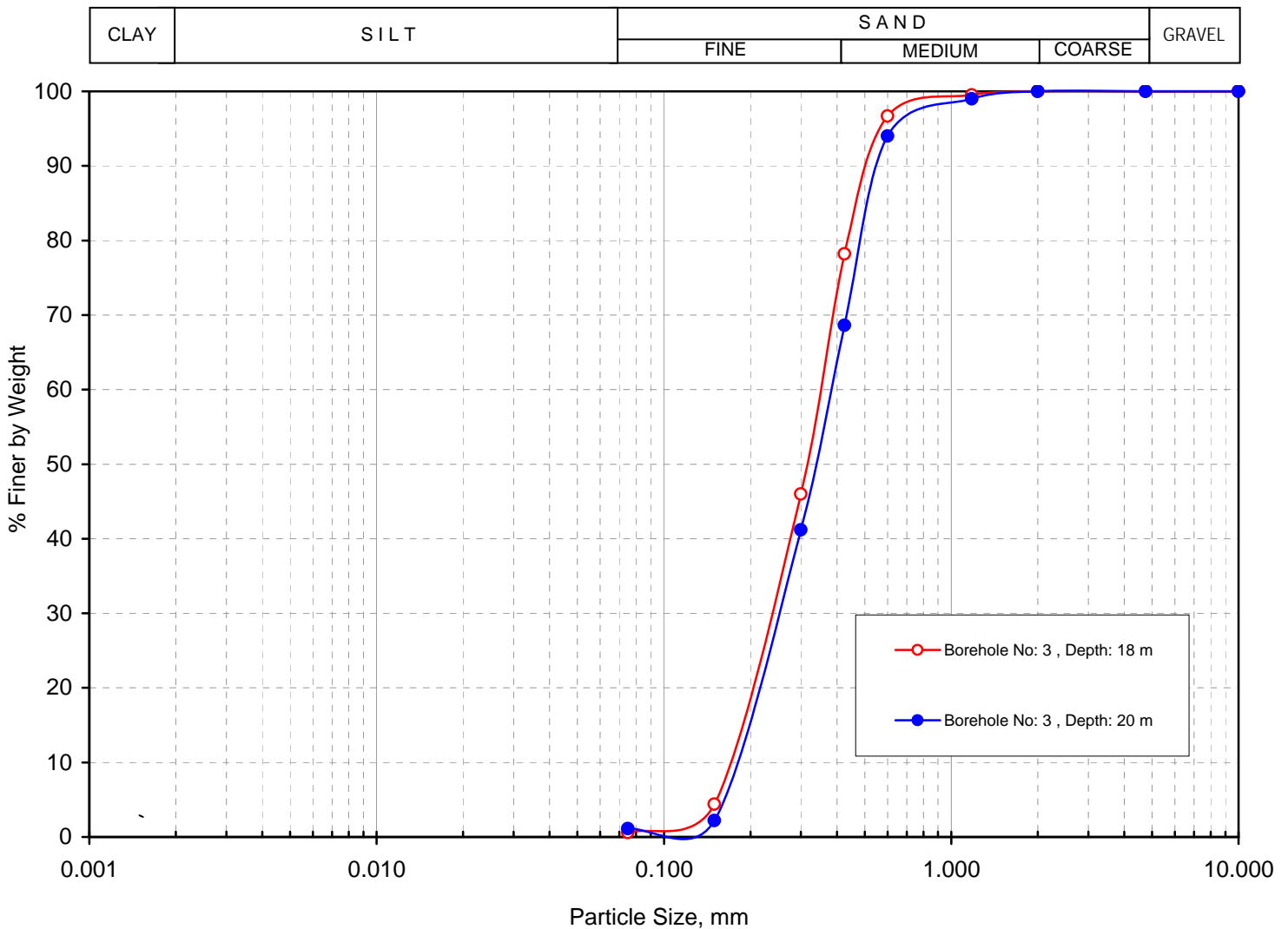

Grain Size Distribution Curve

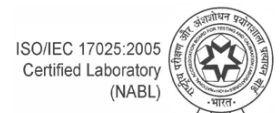

Certificate No. T-1741



Grain Size Analysis

IS : 2720 (Part 4) - 1985, RA-2010

Sample Details			Test Results									
Borehole Number	Sample Depth, m	Sample Description	% Gravel	% Sand	% Silt	% Clay	D ₆₀	D ₅₀	D ₃₀	D ₁₀	C _u	C _c
BH-4	2.50	Silty fine sand (SM)	0	56	40	4	0.102	0.085	0.050	0.016	6.4	1.53
BH-4	4.50	Sandy silt (CL)	0	4	68	27	0.016	0.012	0.003			
BH-4	6.50	Silty fine sand (SM)	3	55	37	5	0.198	0.150	0.053			
BH-4	7.50	Fine sand (SP-SM)	0	92	8	0	0.211	0.180	0.139	0.082	2.6	1.12
BH-4	8.50	Fine sand (SP-SM)	0	89	11	0	0.240	0.210	0.179			

Hydrometer Analysis

Sieve Analysis

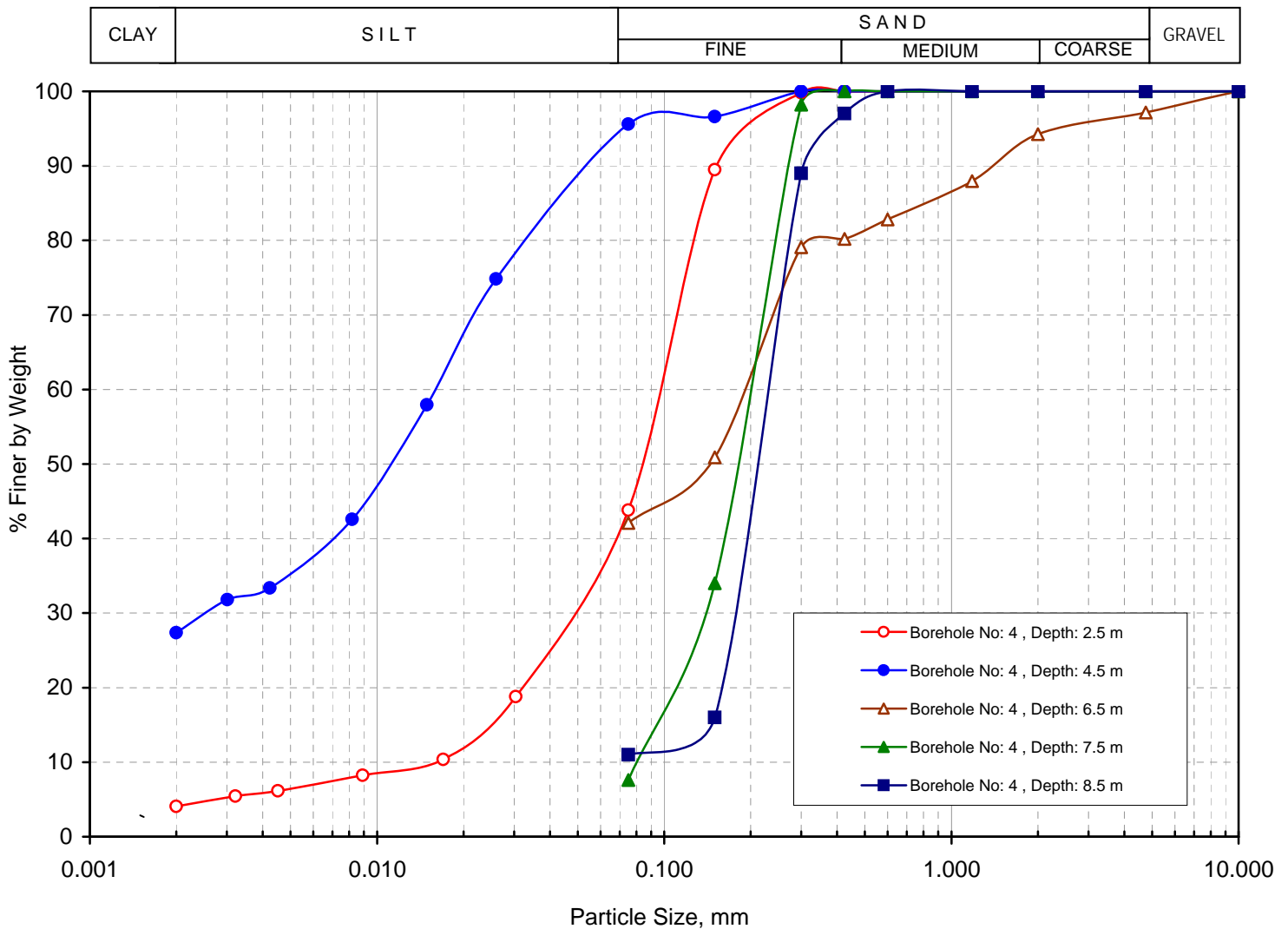

Grain Size Distribution Curve

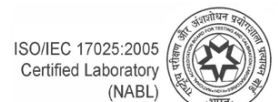

Certificate No. T-1741



Grain Size Analysis

IS : 2720 (Part 4) - 1985, RA-2010

Sample Details			Test Results									
Borehole Number	Sample Depth, m	Sample Description	% Gravel	% Sand	% Silt	% Clay	D ₆₀	D ₅₀	D ₃₀	D ₁₀	C _u	C _c
BH-4	11.50	Fine sand (SP)	0	99	1	0	0.261	0.230	0.201	0.162	1.6	0.96
BH-4	13.50	Fine sand (SP)	0	99	1	0	0.317	0.280	0.221	0.164	1.9	0.94
BH-4	15.50	Fine sand (SP-SM)	0	95	5	0	0.250	0.230	0.177	0.103	2.4	1.22
BH-4	17.50	Fine sand (SP)	0	98	2	0	0.287	0.250	0.206			
BH-4	19.50	Fine sand (SP)	0	98	2	0	0.263	0.230	0.189			

Hydrometer Analysis

Sieve Analysis

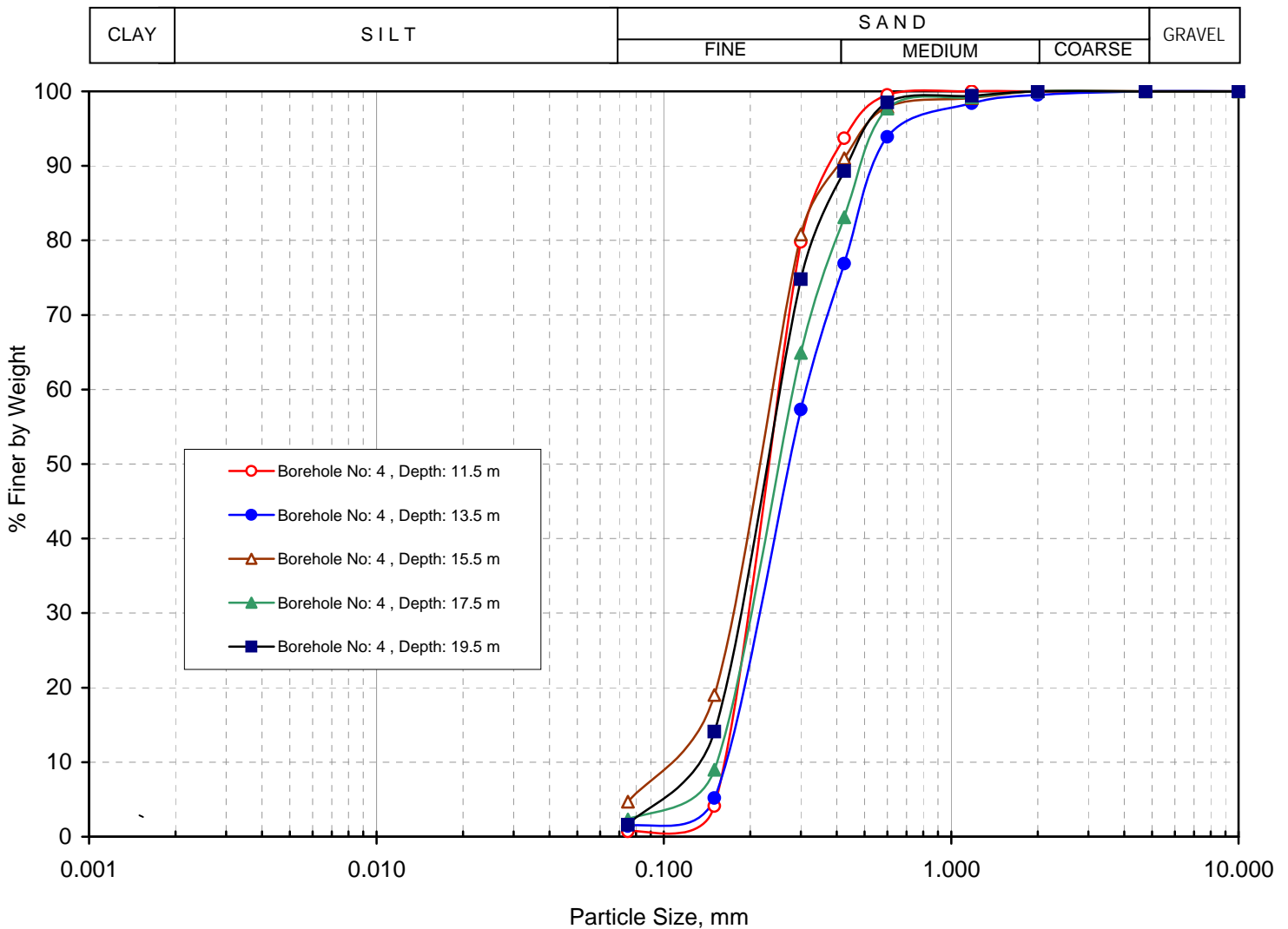

Grain Size Distribution Curve

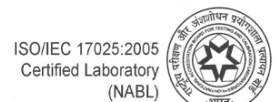

Certificate No. T-1741



Grain Size Analysis

IS : 2720 (Part 4) - 1985, RA-2010

Sample Details			Test Results									
Borehole Number	Sample Depth, m	Sample Description	% Gravel	% Sand	% Silt	% Clay	D ₆₀	D ₅₀	D ₃₀	D ₁₀	C _u	C _c
BH-5	1.00	Silty fine sand (SM)	0	62	35	3	0.186	0.150	0.062	0.026	7.2	0.79
BH-5	8.00	Fine sand (SP)	0	97	3	0	0.248	0.220	0.193	0.157	1.6	0.96
BH-5	13.00	Fine sand (SP)	0	96	4	0	0.429	0.340	0.241	0.165	2.6	0.82
BH-5	18.00	Fine sand (SP)	0	96	4	0	0.313	0.280	0.214	0.153	2.1	0.96

Hydrometer Analysis

Sieve Analysis

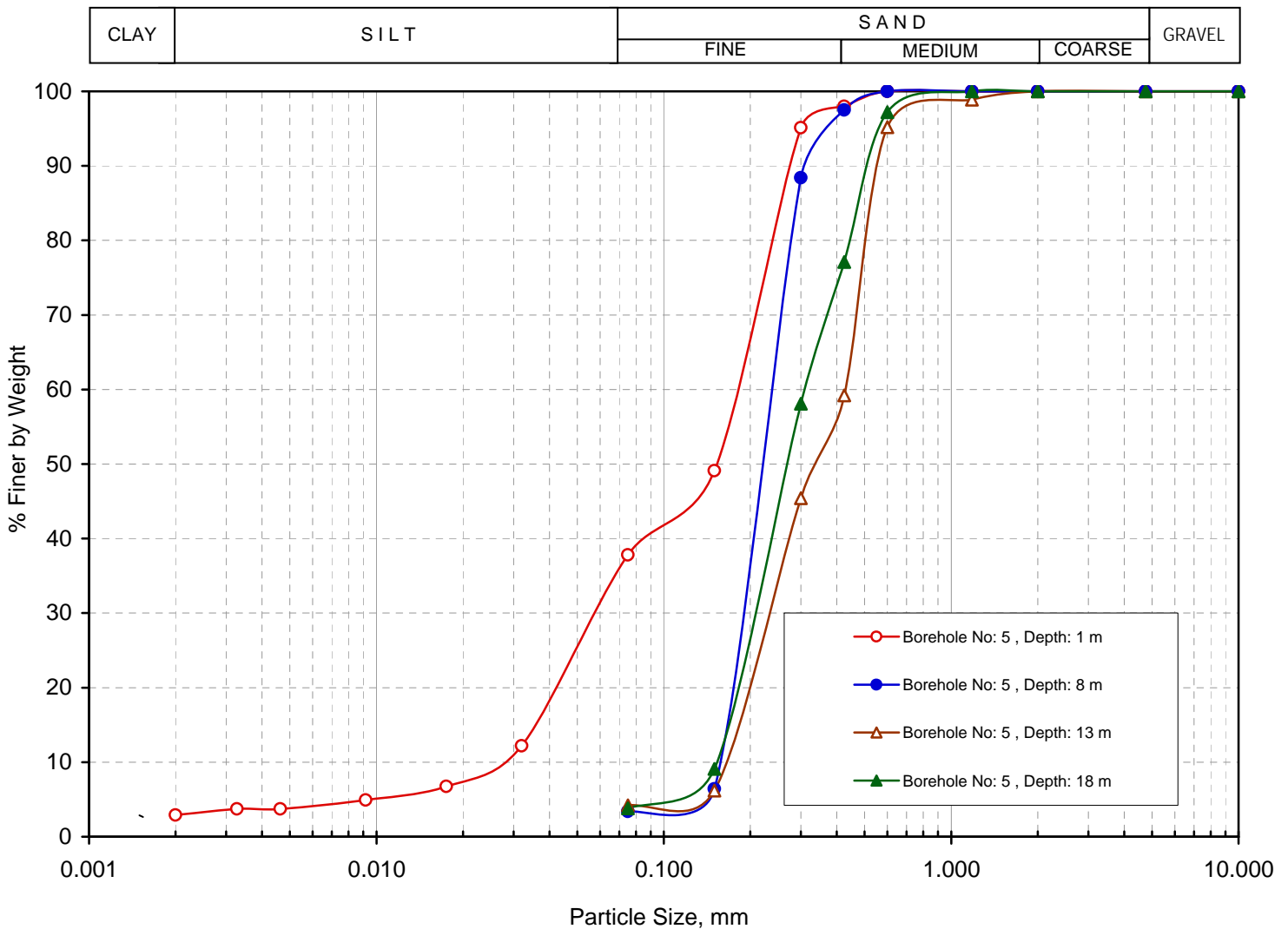

Grain Size Distribution Curve

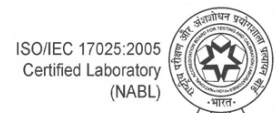

Certificate No. T-1741



Grain Size Analysis

IS : 2720 (Part 4) - 1985, RA-2010

Sample Details			Test Results									
Borehole Number	Sample Depth, m	Sample Description	% Gravel	% Sand	% Silt	% Clay	D ₆₀	D ₅₀	D ₃₀	D ₁₀	C _u	C _c
BH-6	1.00	Clayey silt (CI)	0	20	59	21	0.011	0.009	0.004			
BH-6	4.00	Silty fine sand (SM)	0	64	31	5	0.218	0.170	0.025	0.004	54.5	0.72
BH-6	5.00	Silty fine sand (SM)	0	80	20	0	0.203	0.180				
BH-6	11.00	Fine sand (SP)	0	97	3	0	0.247	0.220	0.188			

Hydrometer Analysis

Sieve Analysis

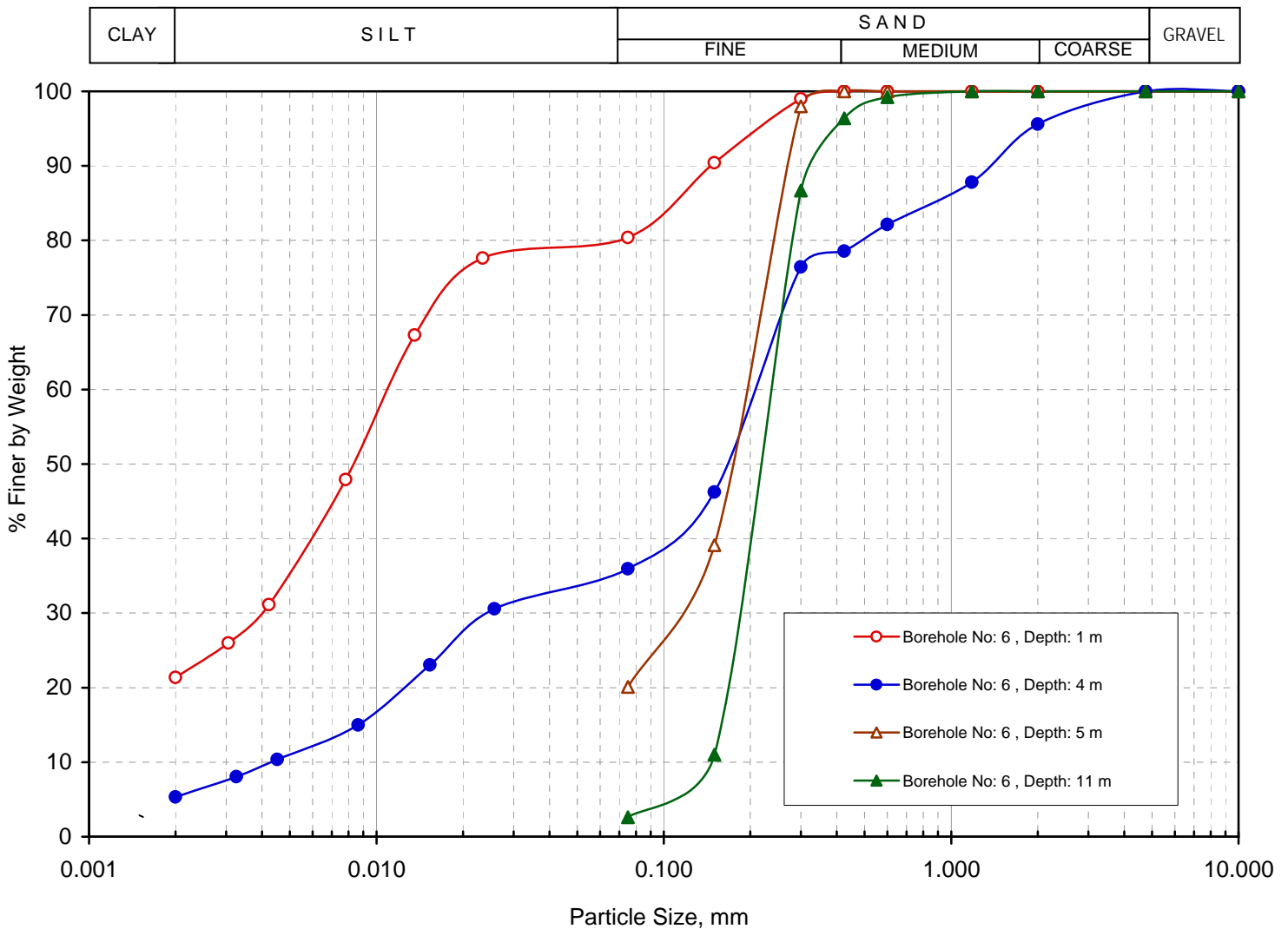

Grain Size Distribution Curve

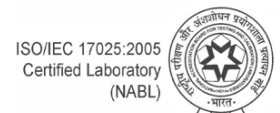

Certificate No. T-1741



Grain Size Analysis

IS : 2720 (Part 4) - 1985, RA-2010

Sample Details			Test Results									
Borehole Number	Sample Depth, m	Sample Description	% Gravel	% Sand	% Silt	% Clay	D ₆₀	D ₅₀	D ₃₀	D ₁₀	C _u	C _c
BH-6	16.00	Fine sand (SP)	0	98	2	0	0.237	0.210	0.177	0.115	2.1	1.15
BH-6	19.00	Fine sand (SP)	0	98	2	0	0.251	0.230	0.191	0.151	1.7	0.96

Hydrometer Analysis

Sieve Analysis

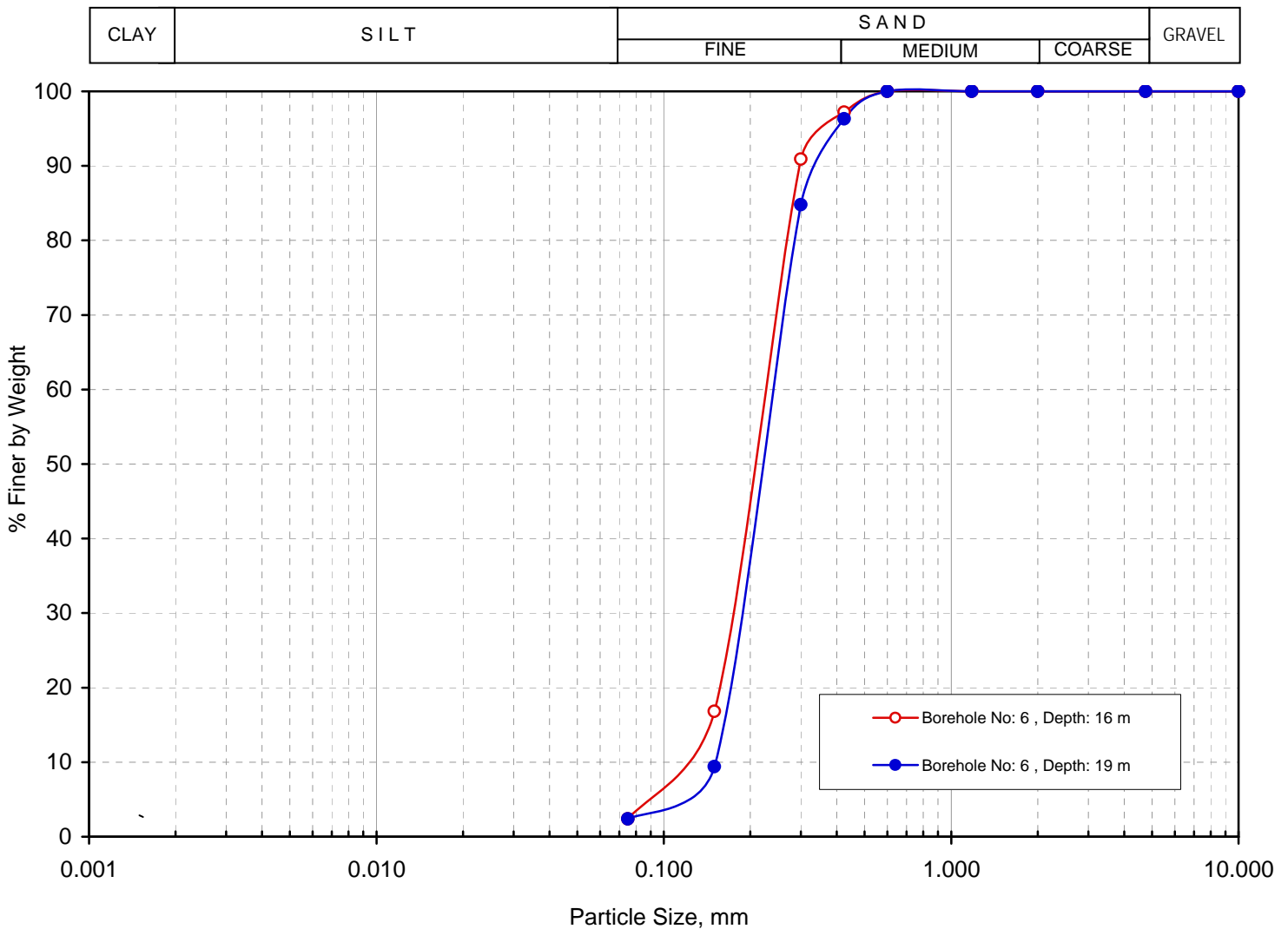

Grain Size Distribution Curve

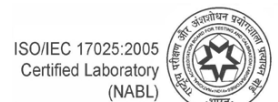

ISO/IEC 17025:2005
Certified Laboratory
(NABL)

Certificate No. T-1741



Grain Size Analysis

IS : 2720 (Part 4) - 1985, RA-2010

Sample Details			Test Results									
Borehole Number	Sample Depth, m	Sample Description	% Gravel	% Sand	% Silt	% Clay	D ₆₀	D ₅₀	D ₃₀	D ₁₀	C _u	C _c
BH-7	2.50	Silty fine sand (SM)	0	51	45	4	0.113	0.075	0.049	0.014	8.1	1.52
BH-7	5.50	Silty fine sand (SM)	0	62	35	3	0.186	0.150	0.062	0.026	7.2	0.79
BH-7	6.50	Silty fine sand (SM)	0	64	34	2	0.203	0.185	0.065	0.030	6.8	0.69
BH-7	7.50	Silty fine sand (SM)	0	85	15	0	0.237	0.220	0.172			
BH-7	10.50	Fine sand (SP-SM)	0	89	11	0	0.241	0.222	0.176			

Hydrometer Analysis

Sieve Analysis

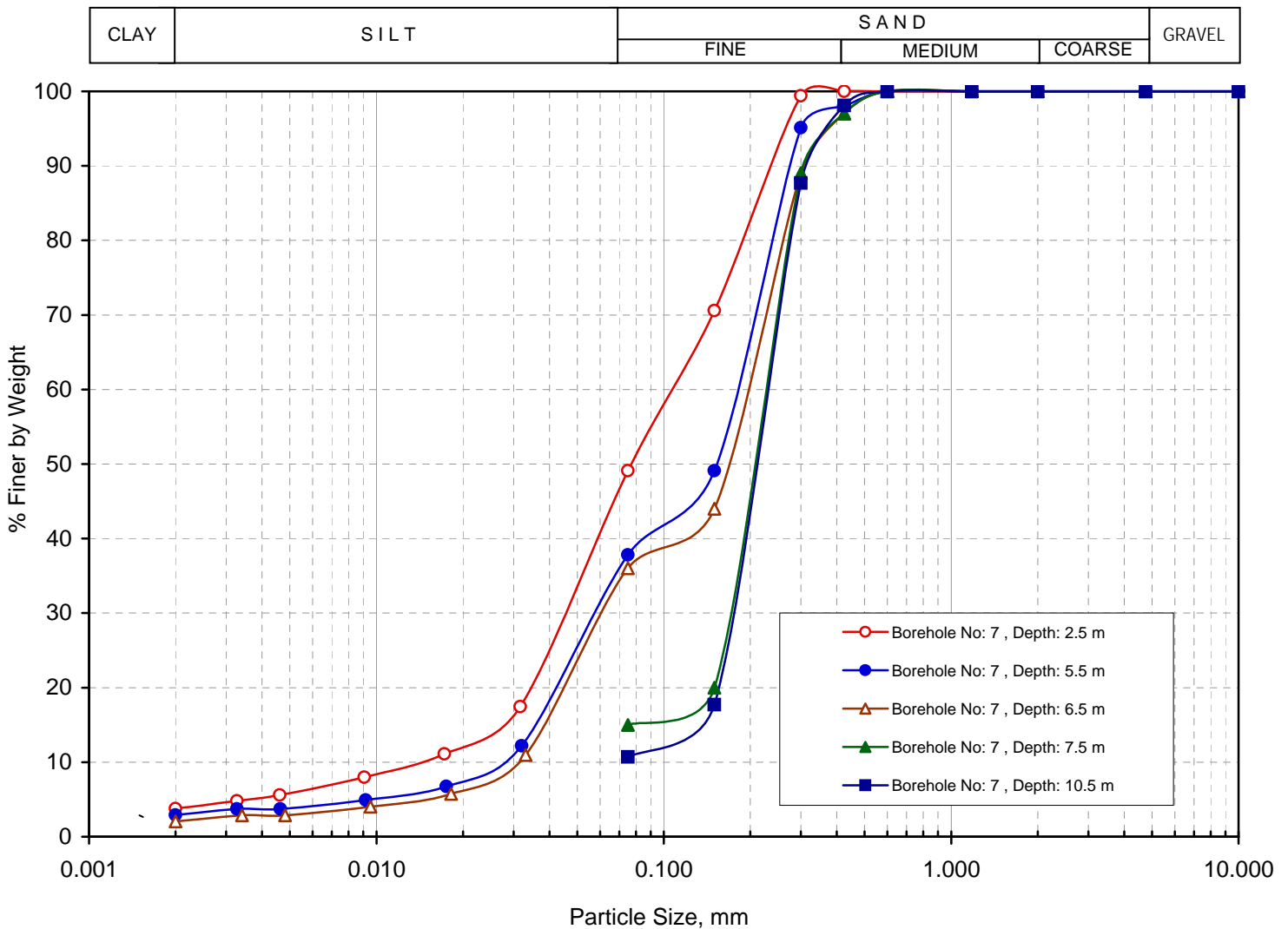

Grain Size Distribution Curve

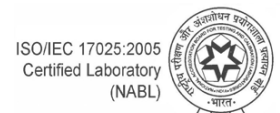

Certificate No. T-1741



Grain Size Analysis

IS : 2720 (Part 4) - 1985, RA-2010

Sample Details			Test Results									
Borehole Number	Sample Depth, m	Sample Description	% Gravel	% Sand	% Silt	% Clay	D ₆₀	D ₅₀	D ₃₀	D ₁₀	C _u	C _c
BH-7	12.00	Silty fine sand (SM)	0	65	33	2	0.190	0.160	0.064	0.024	7.9	0.90
BH-7	19.50	Fine sand (SP-SM)	0	91	9	0	0.242	0.230	0.180			

Hydrometer Analysis

Sieve Analysis

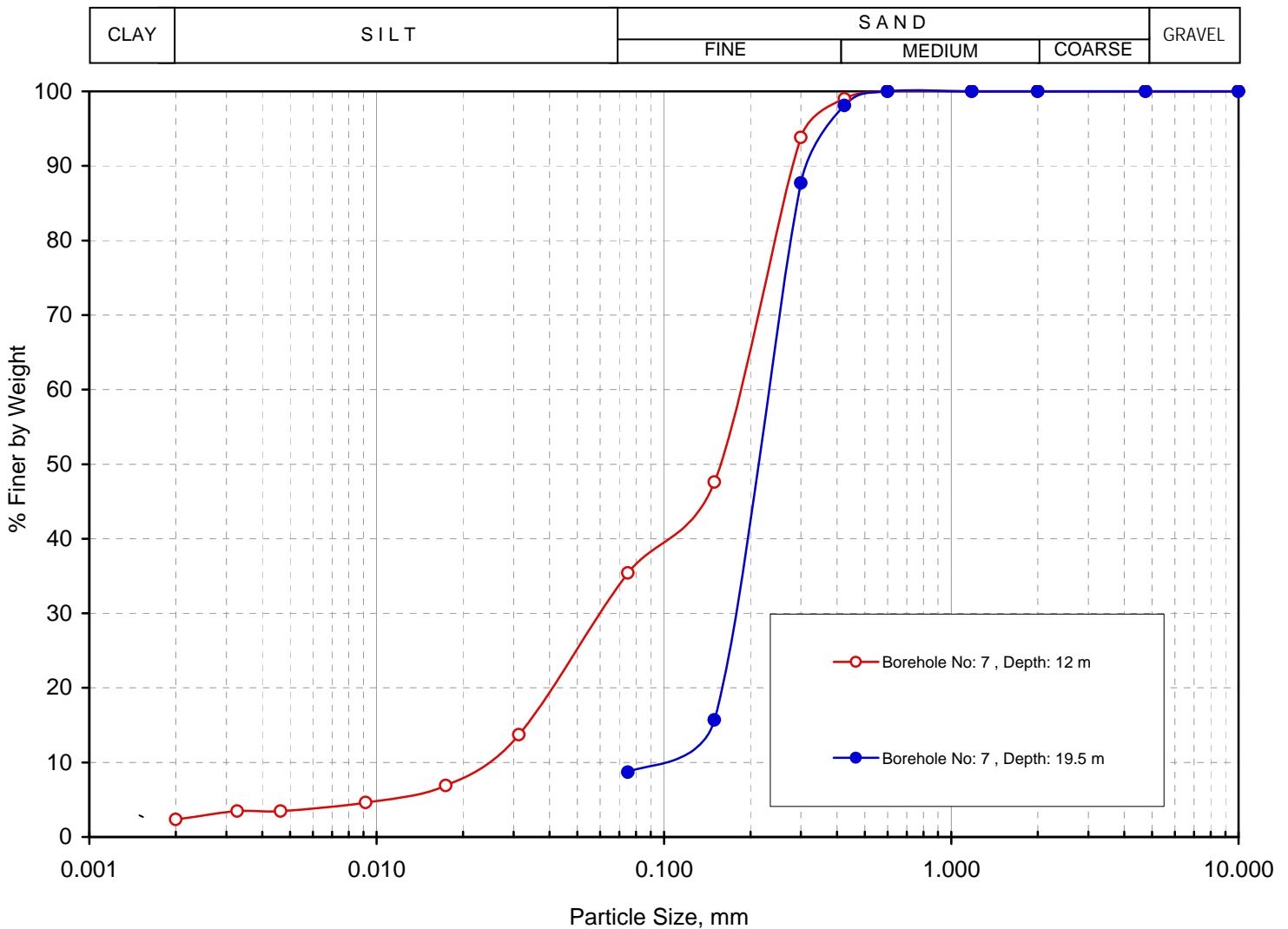

Grain Size Distribution Curve

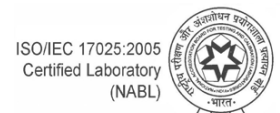

Certificate No. T-1741



Grain Size Analysis

IS : 2720 (Part 4) - 1985, RA-2010

Sample Details			Test Results									
Borehole Number	Sample Depth, m	Sample Description	% Gravel	% Sand	% Silt	% Clay	D ₆₀	D ₅₀	D ₃₀	D ₁₀	C _u	C _c
BH-8	1.00	Sandy silt (CL)	0	40	55	5	0.076	0.055	0.031	0.008	9.5	1.58
BH-8	4.00	Silty fine sand (SM)	0	64	33	3	0.190	0.160	0.065	0.028	6.8	0.79
BH-8	5.00	Silty fine sand (SM)	0	81	19	0	0.221	0.190	0.159			
BH-8	11.00	Fine sand (SP-SM)	0	90	10	0	0.223	0.190	0.163	0.077	2.9	1.55
BH-8	18.00	Silty fine sand (SM)	0	79	21	0	0.157	0.140	0.093			

Hydrometer Analysis

Sieve Analysis

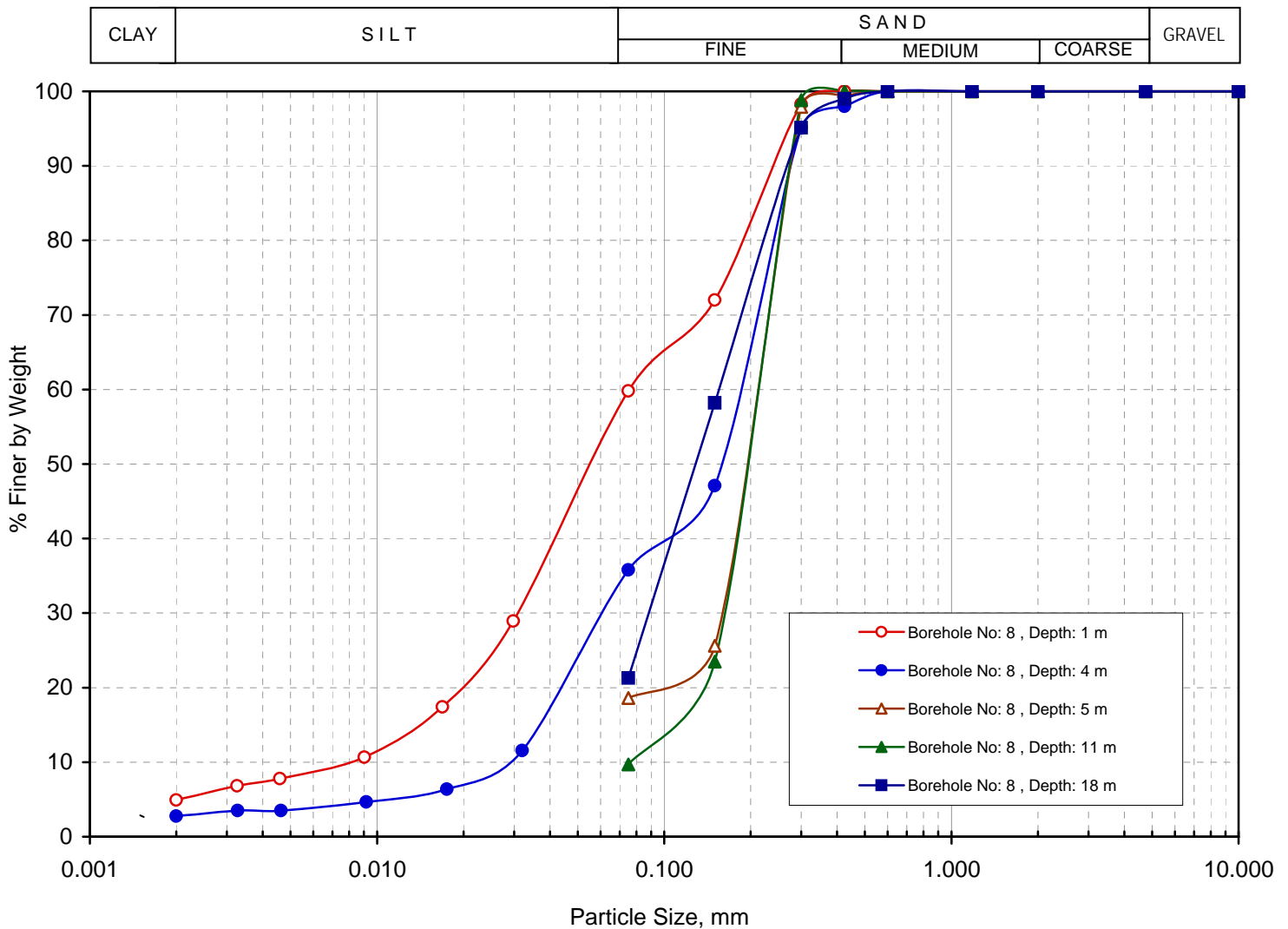

Grain Size Distribution Curve





Drained Direct Shear Test

IS : 2720 (Part-13)-1986, RA-2010

Sample Details	Borehole No.: BH-1	Sample Depth: 3 m
	Sample No.: UDS1	Sample Description: Silty fine sand
	Type of Sample:	Remoulded
	Dry Density of Soil (g/cm ³):	1.57
Test Results	Moisture Content (%):	Saturated
	Cohesion Intercept, c :	0.00 kg/cm²
	Angle of Internal Friction, ϕ :	32.1 degrees

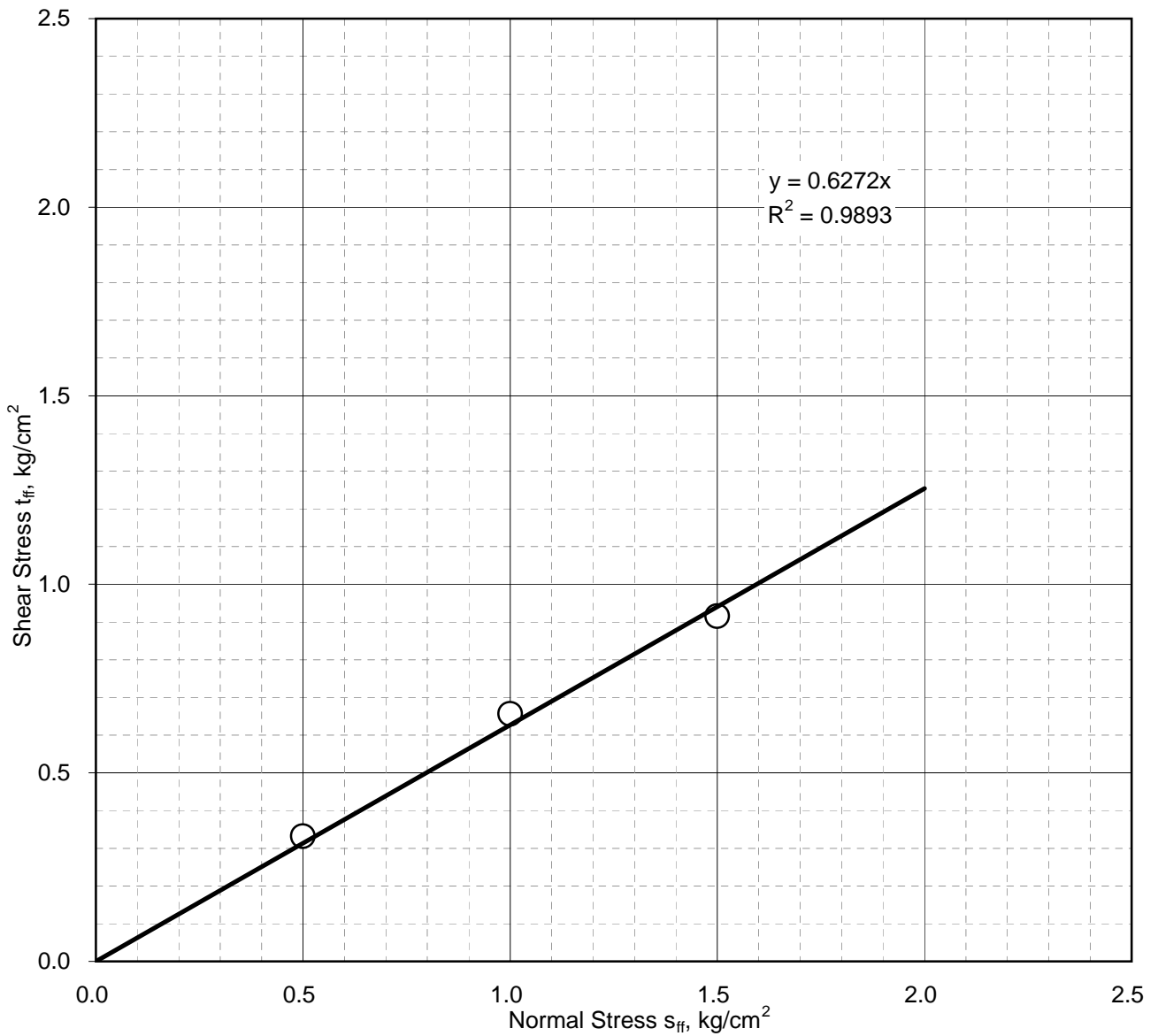

Mohr-Coulomb Failure Envelope

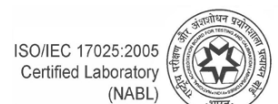

Certificate No. T-1741



Drained Direct Shear Test

IS : 2720 (Part-13)-1986, RA-2010

Sample Details	Borehole No.: BH-2		Sample Depth: 1.5 m	
	Sample No.: UDS1		Sample Description: Silty fine sand	
	Type of Sample:		Remoulded	
	Dry Density of Soil (g/cm ³):		1.59	
Test Results	Moisture Content (%):		Saturated	
	Cohesion Intercept, c :		0.00	kg/cm ²
	Angle of Internal Friction, ϕ :		32.3	degrees

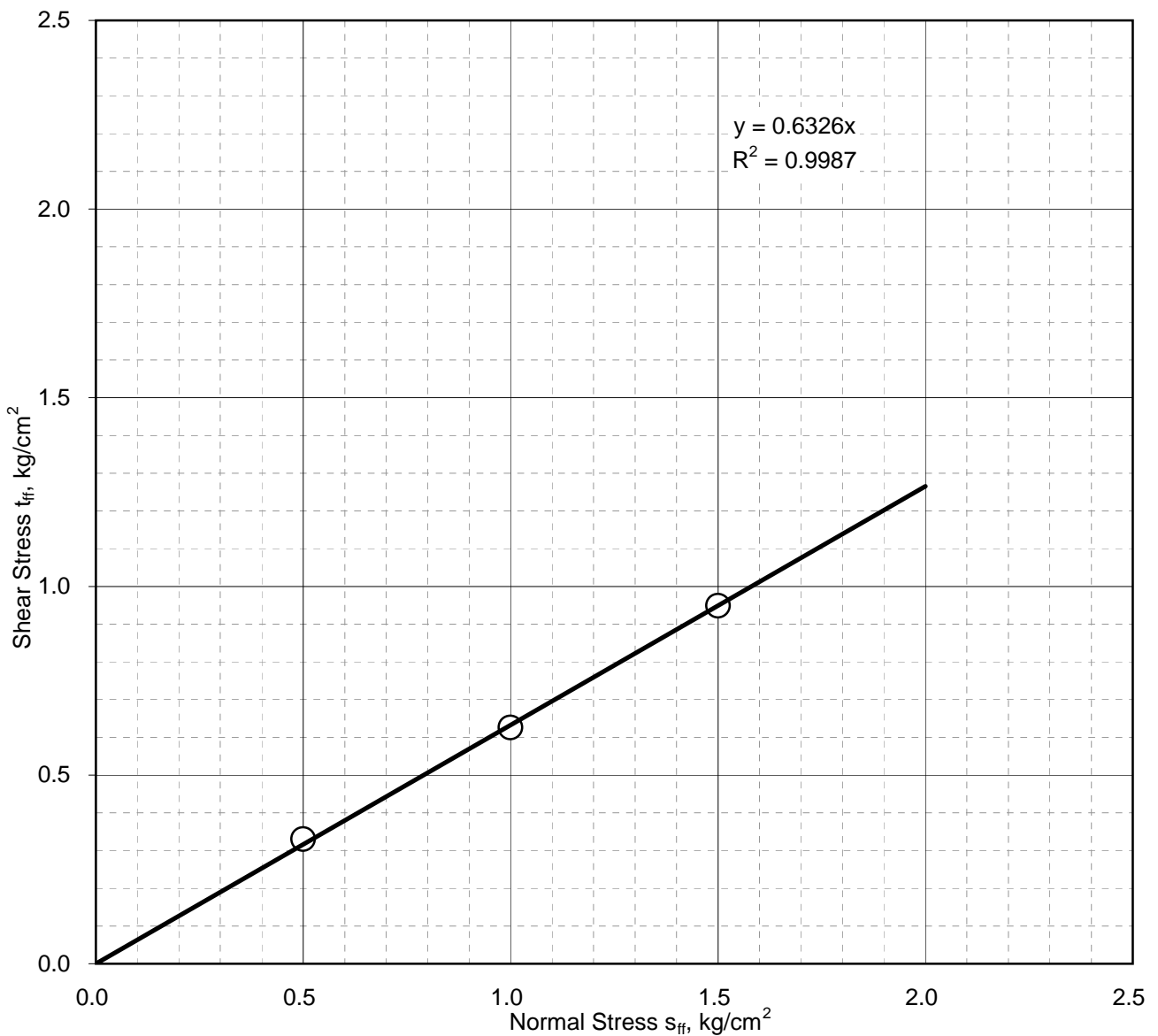

Mohr-Coulomb Failure Envelope

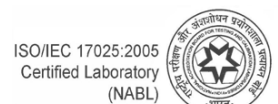

Certificate No. T-1741



Drained Direct Shear Test

IS : 2720 (Part-13)-1986, RA-2010

Sample Details	Borehole No.: BH-2		Sample Depth: 4.5 m	
	Sample No.: UDS2		Sample Description: Silty fine sand	
	Type of Sample:		Remoulded	
	Dry Density of Soil (g/cm ³):		1.57	
Test Results	Moisture Content (%):		Saturated	
	Cohesion Intercept, c :		0.00	kg/cm ²
	Angle of Internal Friction, ϕ :		30.2	degrees

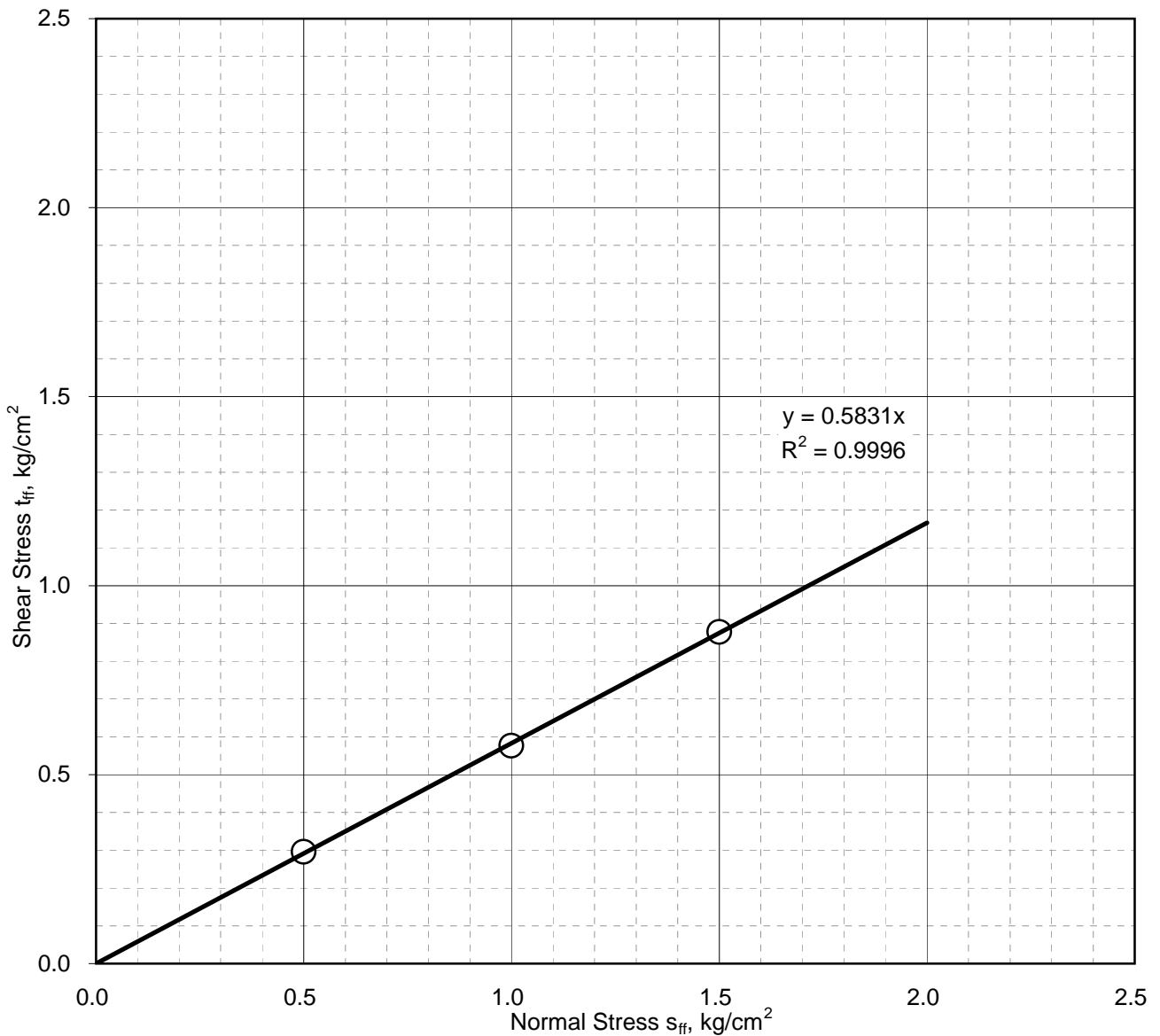

Mohr-Coulomb Failure Envelope

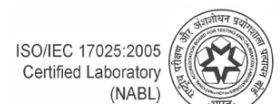

Certificate No. T-1741



Drained Direct Shear Test

IS : 2720 (Part-13)-1986, RA-2010

Sample Details	Borehole No.: BH-2	Sample Depth: 7.5 m
	Sample No.: UDS3	Sample Description: Silty fine sand
	Type of Sample:	Remoulded
	Dry Density of Soil (g/cm ³):	1.60
Test Results	Moisture Content (%):	Saturated
	Cohesion Intercept, c :	0.00 kg/cm²
	Angle of Internal Friction, ϕ :	36.2 degrees

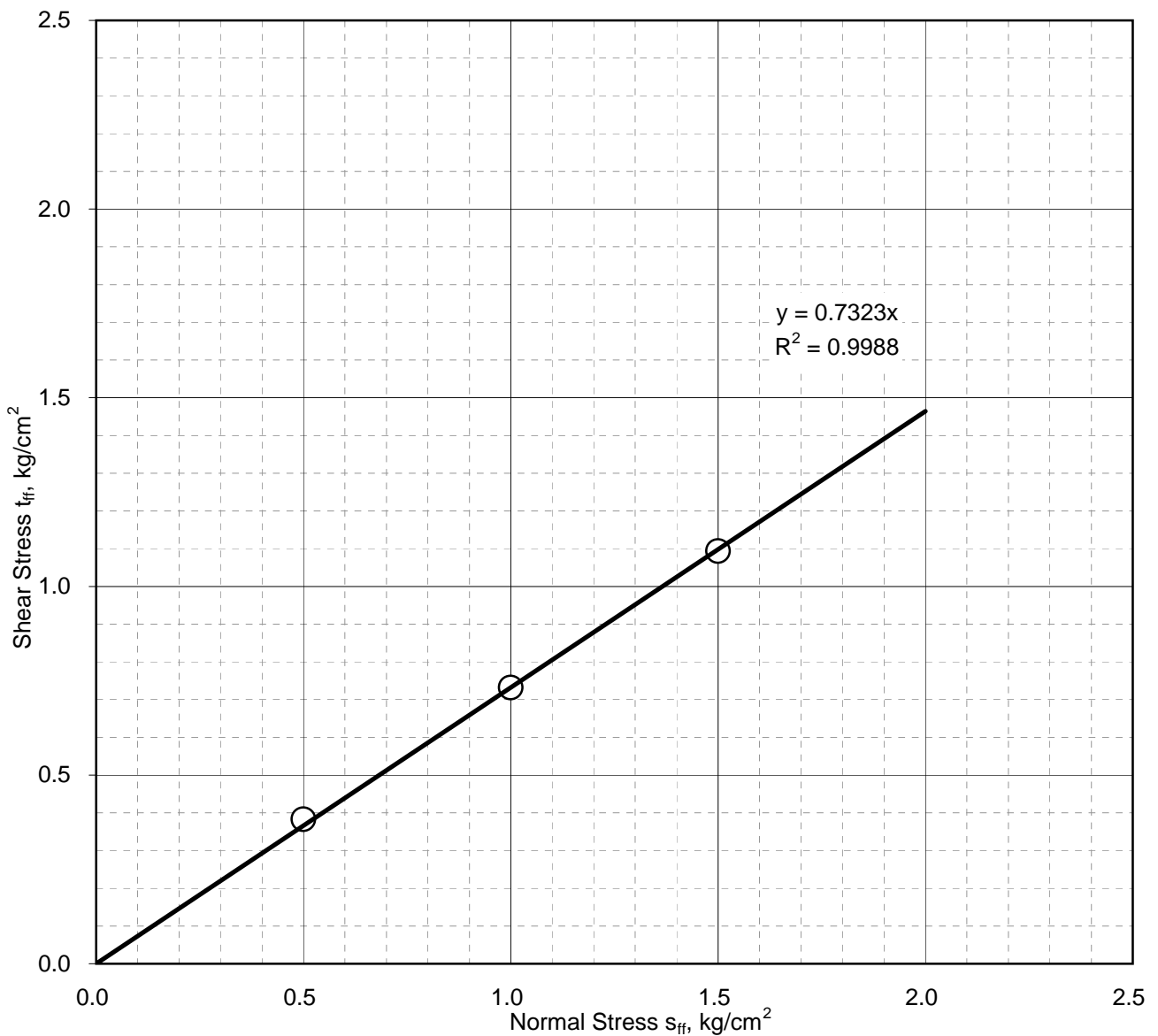

Mohr-Coulomb Failure Envelope

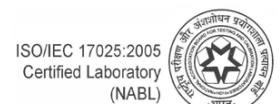

Certificate No. T-1741



Drained Direct Shear Test

IS : 2720 (Part-13)-1986, RA-2010

Sample Details	Borehole No.: BH-3		Sample Depth: 6 m	
	Sample No.: UDS1		Sample Description: Silty fine sand	
	Type of Sample:		Remoulded	
	Dry Density of Soil (g/cm ³):		1.58	
Test Results	Moisture Content (%):		Saturated	
	Cohesion Intercept, c :		0.00	kg/cm ²
	Angle of Internal Friction, ϕ :		32.3	degrees

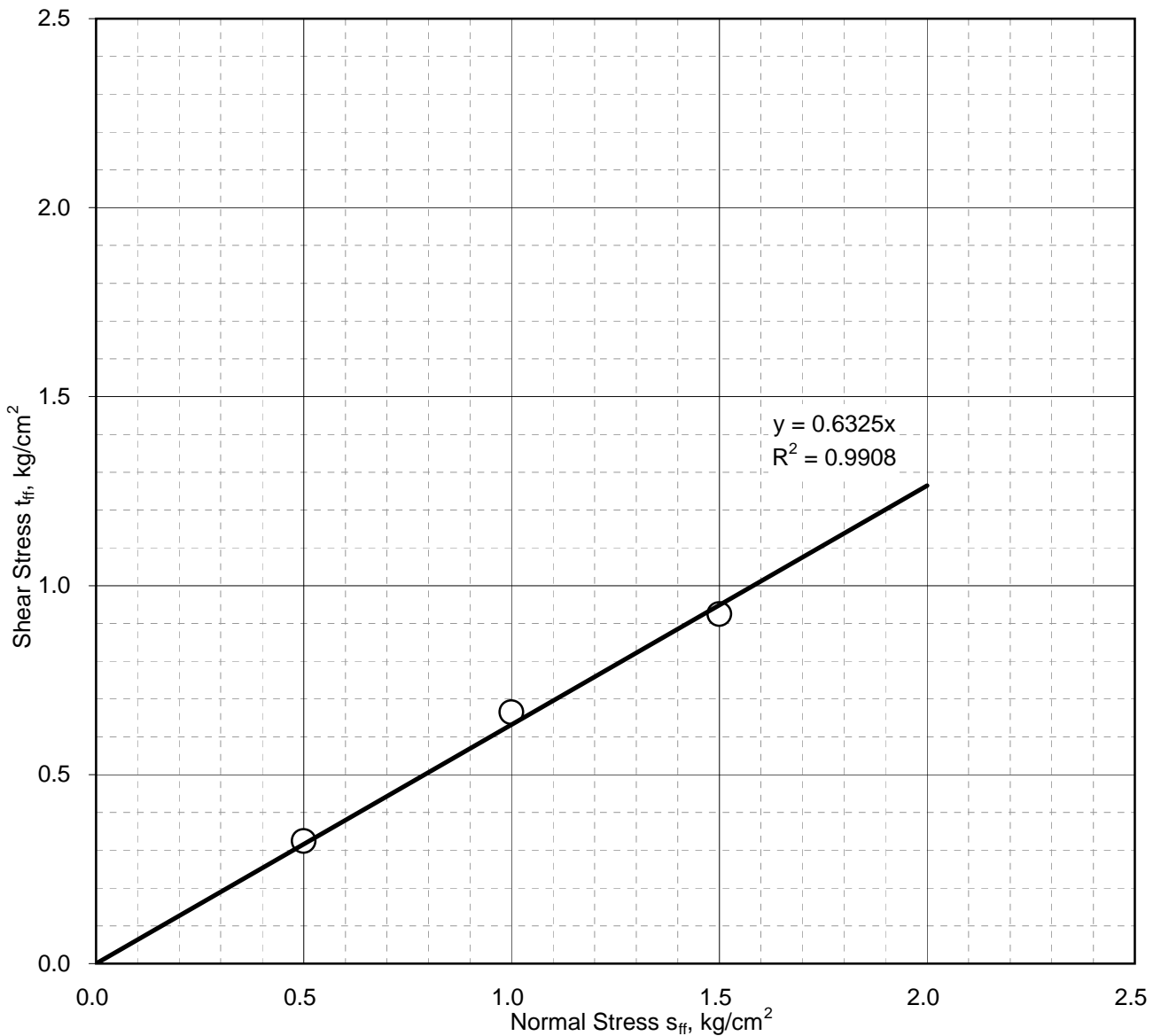

Mohr-Coulomb Failure Envelope

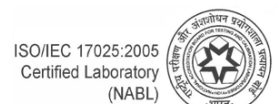

Certificate No. T-1741



Drained Direct Shear Test

IS : 2720 (Part-13)-1986, RA-2010

Sample Details	Borehole No.: BH-3		Sample Depth: 9 m	
	Sample No.: UDS2		Sample Description: Fine sand	
	Type of Sample:		Remoulded	
	Dry Density of Soil (g/cm ³):		1.58	
Test Results	Moisture Content (%):		Saturated	
	Cohesion Intercept, c :		0.00	kg/cm²
	Angle of Internal Friction, ϕ :		32.4	degrees

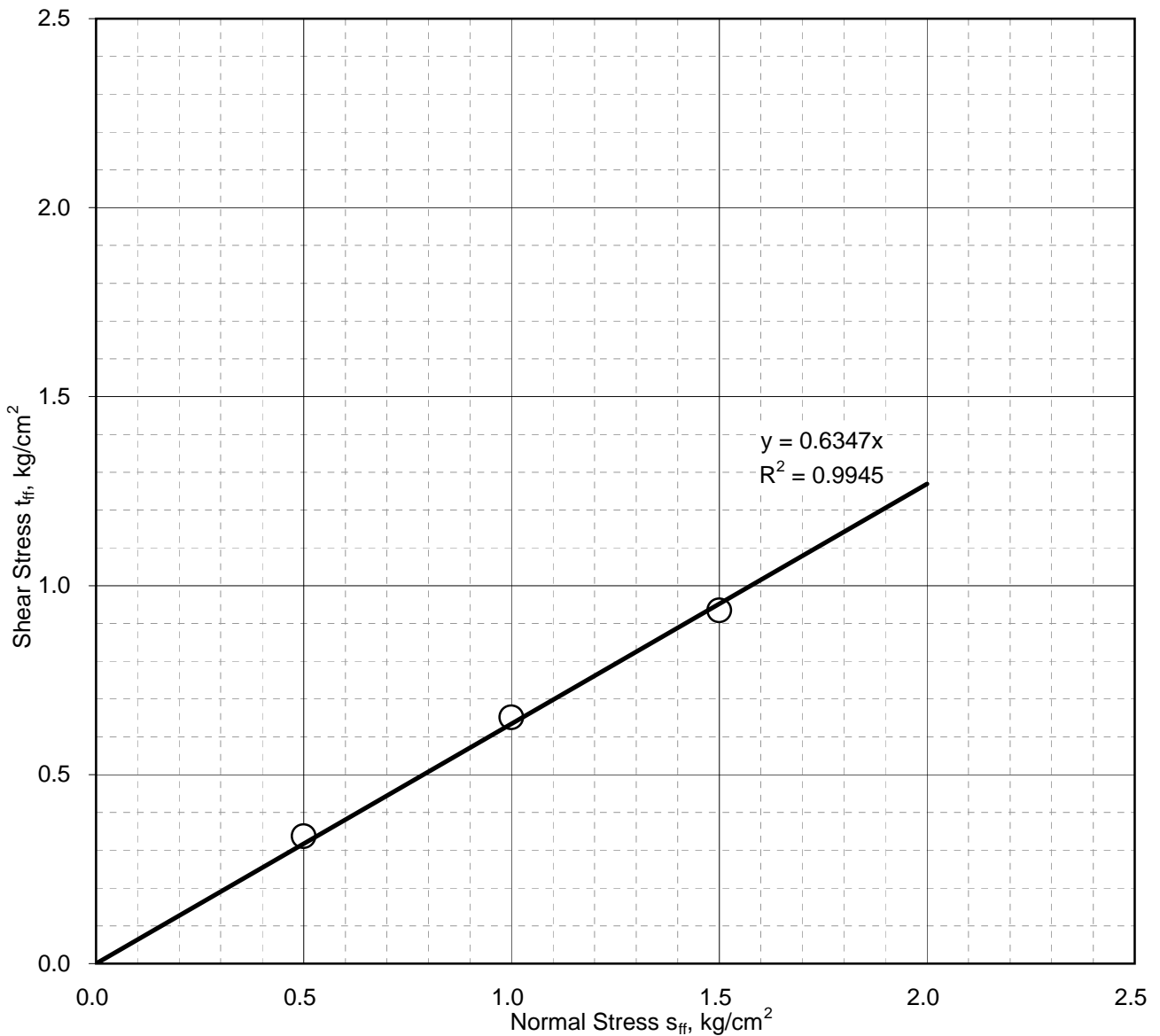

Mohr-Coulomb Failure Envelope

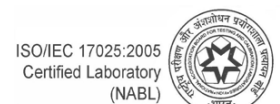

Certificate No. T-1741



Drained Direct Shear Test

IS : 2720 (Part-13)-1986, RA-2010

Sample Details	Borehole No.: BH-4		Sample Depth: 1.5 m	
	Sample No.: UDS1		Sample Description: Silty fine sand	
	Type of Sample:		Remoulded	
	Dry Density of Soil (g/cm ³):		1.59	
Test Results	Moisture Content (%):		Saturated	
	Cohesion Intercept, c :		0.00	kg/cm ²
	Angle of Internal Friction, ϕ :		30.8	degrees

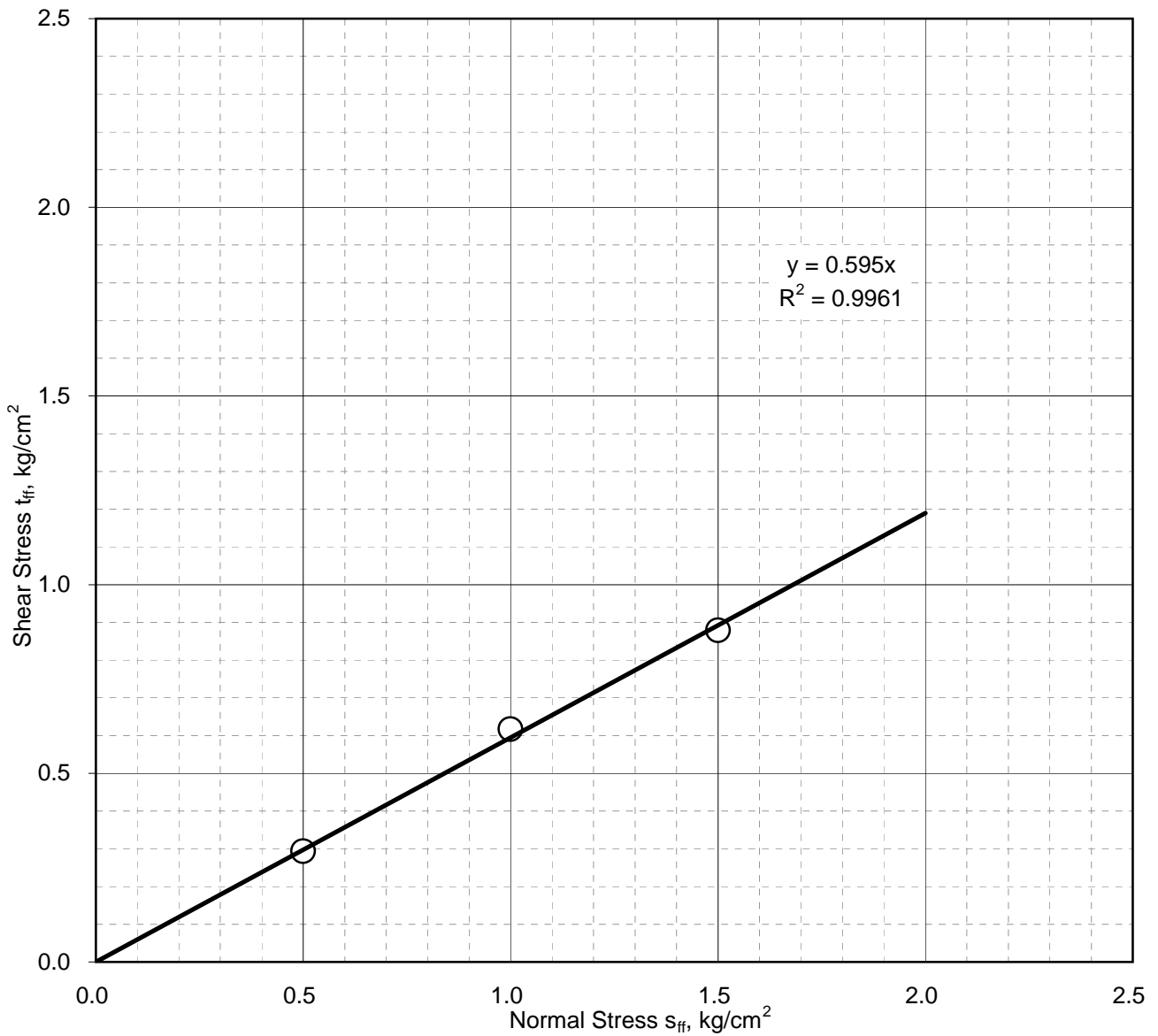

Mohr-Coulomb Failure Envelope

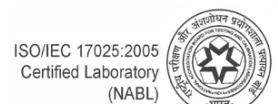

Certificate No. T-1741



Drained Direct Shear Test

IS : 2720 (Part-13)-1986, RA-2010

Sample Details	Borehole No.: BH-4		Sample Depth: 7.5 m	
	Sample No.: UDS3		Sample Description: Fine sand	
	Type of Sample:		Remoulded	
	Dry Density of Soil (g/cm ³):		1.62	
Test Results	Moisture Content (%):		Saturated	
	Cohesion Intercept, c :		0.00	kg/cm ²
	Angle of Internal Friction, ϕ :		35.1	degrees

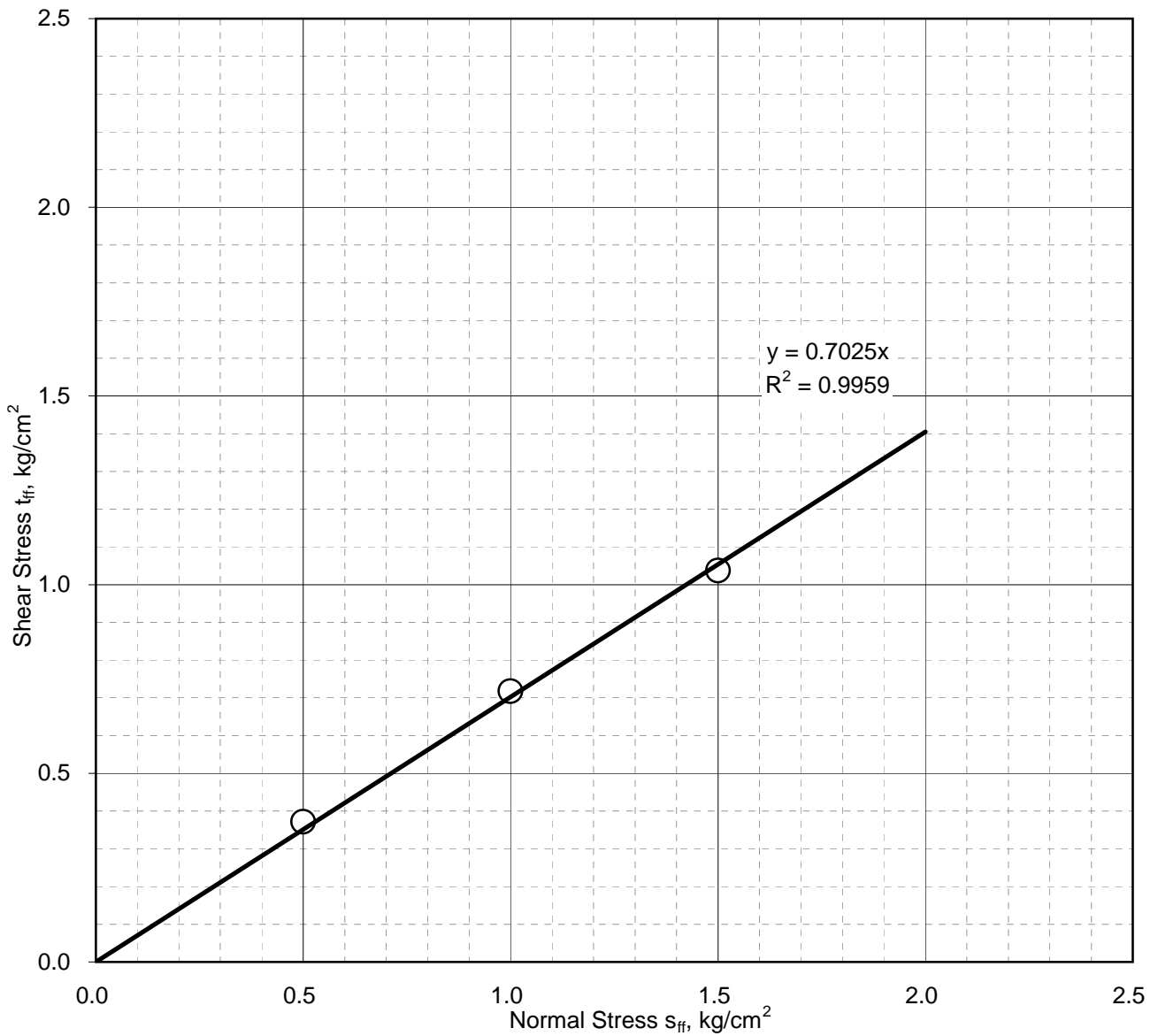

Mohr-Coulomb Failure Envelope

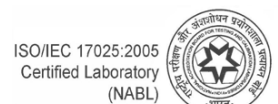

Certificate No. T-1741



Drained Direct Shear Test

IS : 2720 (Part-13)-1986, RA-2010

Sample Details	Borehole No.: BH-5	Sample Depth: 3 m
	Sample No.: UDS1	Sample Description: Silty fine sand
	Type of Sample:	Remoulded
	Dry Density of Soil (g/cm ³):	1.55
Test Results	Moisture Content (%):	Saturated
	Cohesion Intercept, c :	0.00 kg/cm²
	Angle of Internal Friction, ϕ :	29.8 degrees

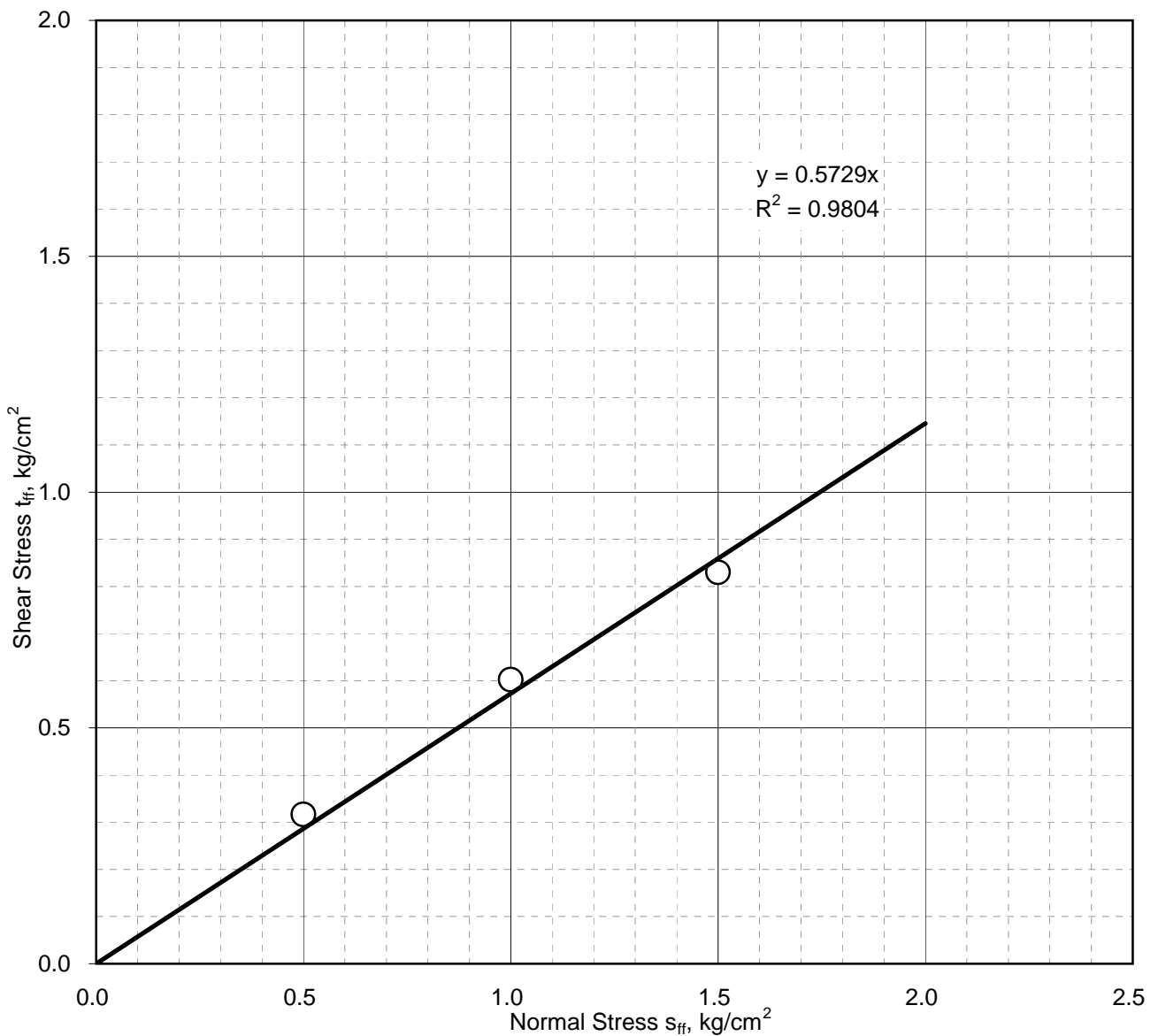

Mohr-Coulomb Failure Envelope

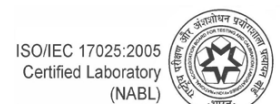

Certificate No. T-1741



Drained Direct Shear Test

IS : 2720 (Part-13)-1986, RA-2010

Sample Details	Borehole No.: BH-5		Sample Depth: 9 m	
	Sample No.: UDS-3		Sample Description: Fine sand	
	Type of Sample:		Remoulded	
	Dry Density of Soil (g/cm ³):		1.62	
Test Results	Moisture Content (%):		Saturated	
	Cohesion Intercept, c :		0.00	kg/cm ²
	Angle of Internal Friction, ϕ :		31.1	degrees

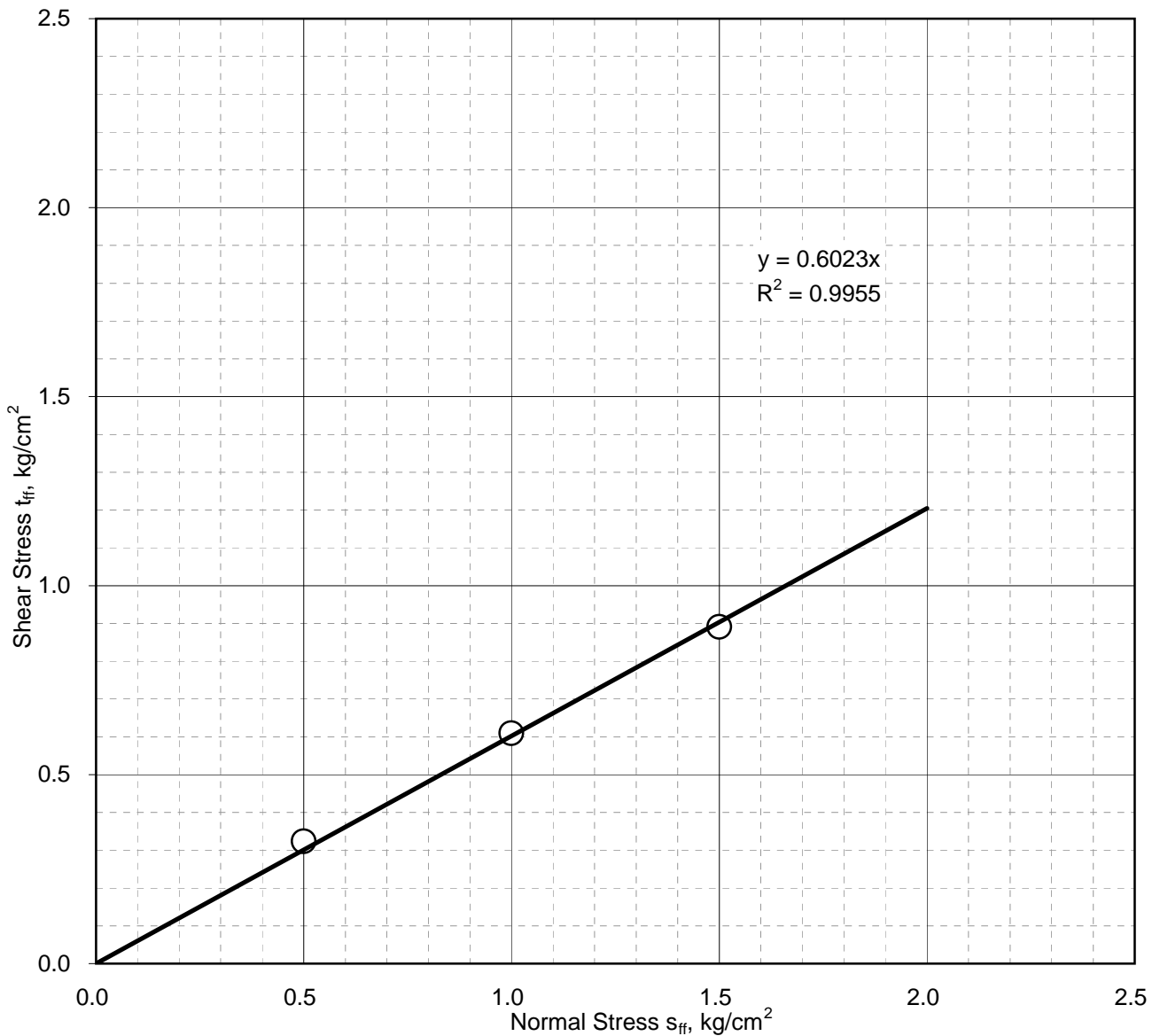

Mohr-Coulomb Failure Envelope

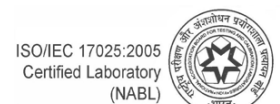

Certificate No. T-1741



Drained Direct Shear Test

IS : 2720 (Part-13)-1986, RA-2010

Sample Details	Borehole No.: BH-6		Sample Depth: 3 m	
	Sample No.: UDS1		Sample Description: Silty fine sand	
	Type of Sample:		Remoulded	
	Dry Density of Soil (g/cm ³):		1.58	
Test Results	Moisture Content (%):		Saturated	
	Cohesion Intercept, c :		0.00	kg/cm²
	Angle of Internal Friction, ϕ :		30.8	degrees

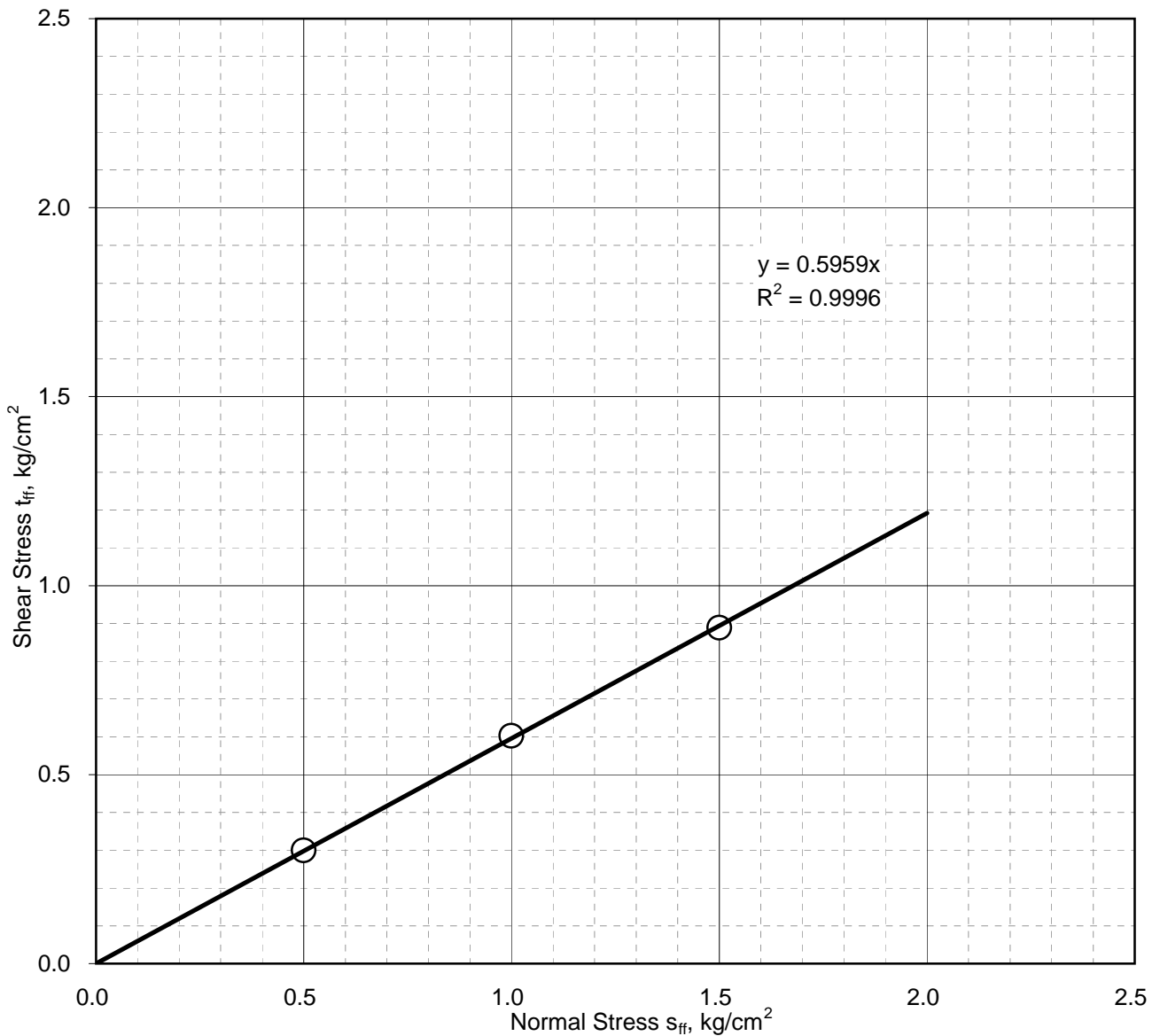

Mohr-Coulomb Failure Envelope

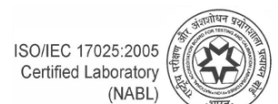

Certificate No. T-1741



Drained Direct Shear Test

IS : 2720 (Part-13)-1986, RA-2010

Sample Details	Borehole No.: BH-6	Sample Depth: 6 m
	Sample No.: UDS-2	Sample Description: Silty fine sand
	Type of Sample:	Remoulded
	Dry Density of Soil (g/cm ³):	1.59
Test Results	Moisture Content (%):	Saturated
	Cohesion Intercept, c :	0.00 kg/cm²
	Angle of Internal Friction, ϕ :	32.6 degrees

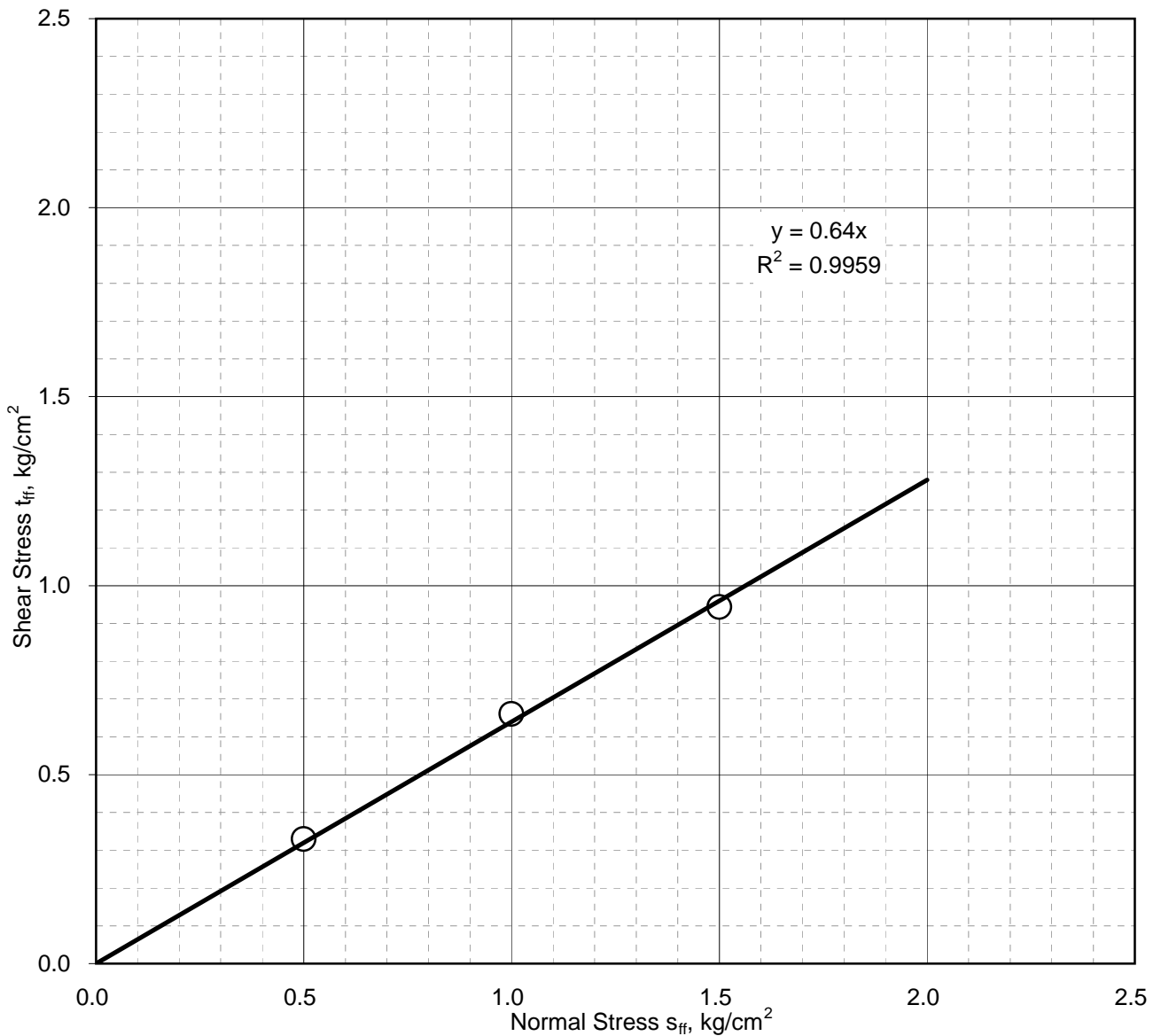

Mohr-Coulomb Failure Envelope

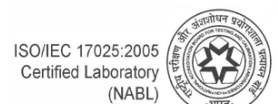

Certificate No. T-1741



Drained Direct Shear Test

IS : 2720 (Part-13)-1986, RA-2010

Sample Details	Borehole No.: BH-7	Sample Depth: 1.5 m
	Sample No.: UDS-1	Sample Description: Silty fine sand
	Type of Sample:	Remoulded
	Dry Density of Soil (g/cm ³):	1.55
Test Results	Moisture Content (%):	Saturated
	Cohesion Intercept, c :	0.00 kg/cm²
	Angle of Internal Friction, ϕ :	28.3 degrees

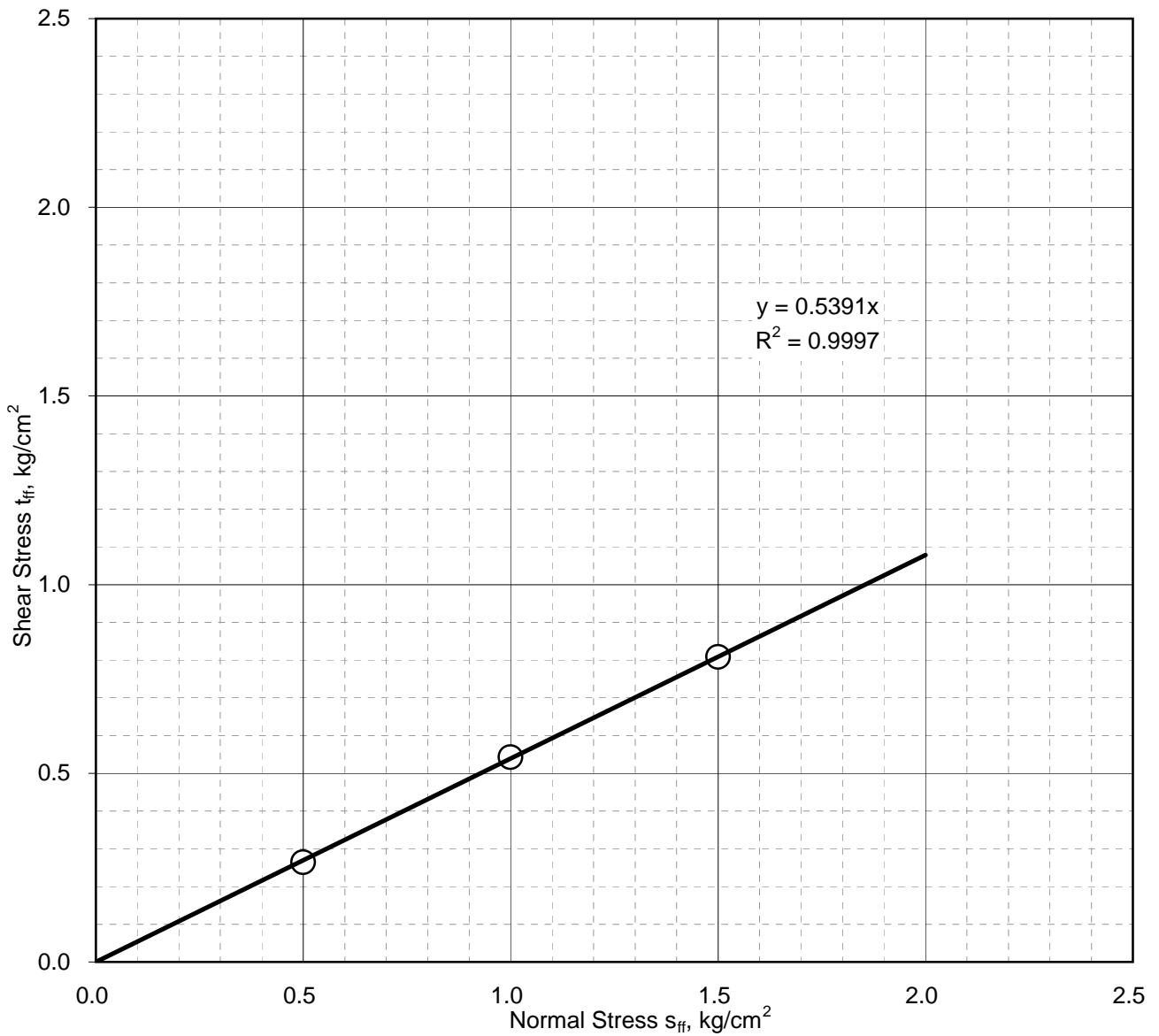

Mohr-Coulomb Failure Envelope

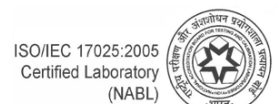

Certificate No. T-1741



Drained Direct Shear Test

IS : 2720 (Part-13)-1986, RA-2010

Sample Details	Borehole No.: BH-7		Sample Depth: 7.5 m	
	Sample No.: UDS-3		Sample Description: Silty fine sand	
	Type of Sample:		Remoulded	
	Dry Density of Soil (g/cm ³):		1.60	
Test Results	Moisture Content (%):		Saturated	
	Cohesion Intercept, c :		0.00	kg/cm ²
	Angle of Internal Friction, ϕ :		31.5	degrees

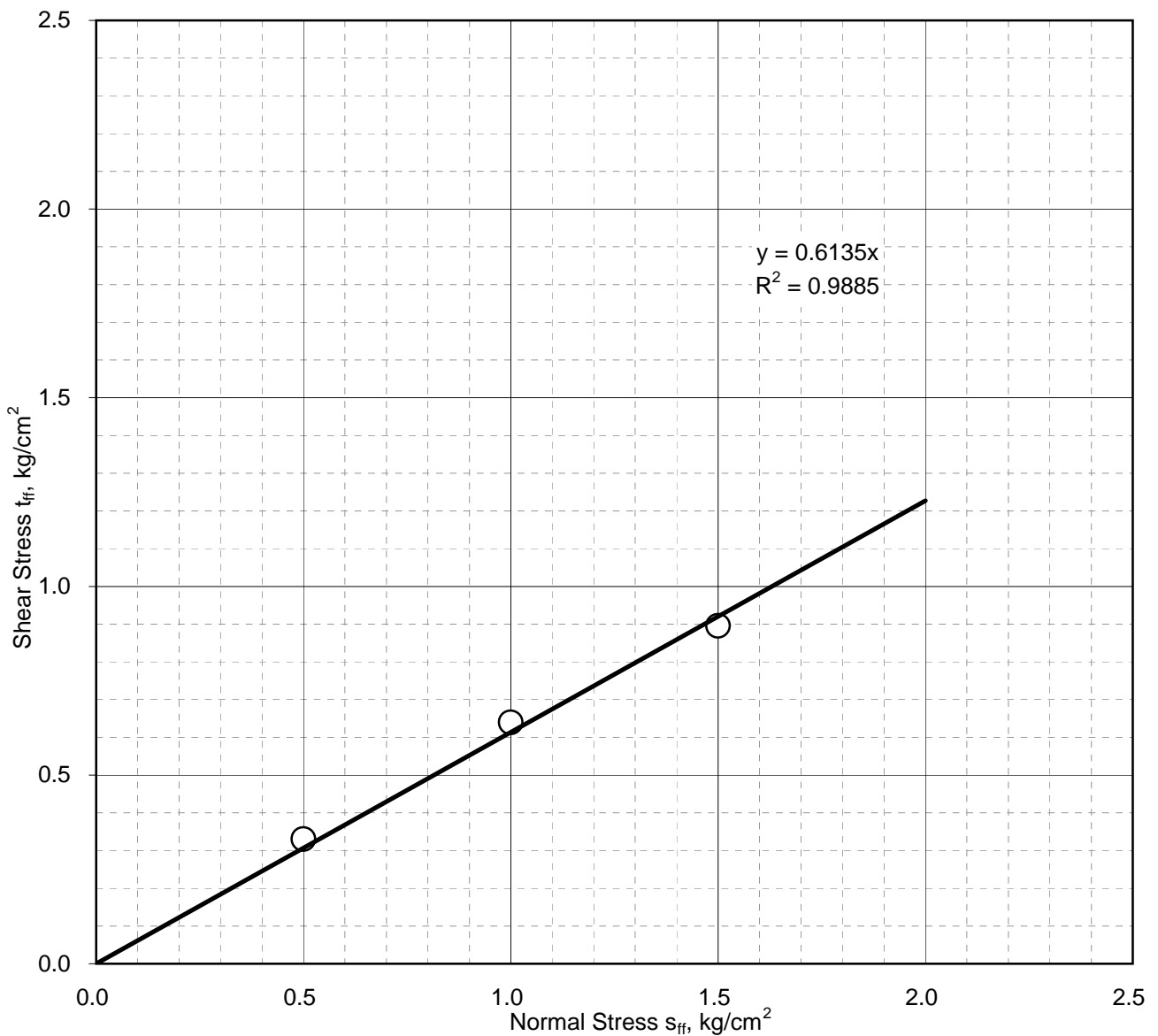

Mohr-Coulomb Failure Envelope

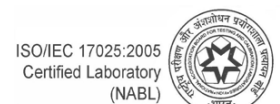

Certificate No. T-1741



Drained Direct Shear Test

IS : 2720 (Part-13)-1986, RA-2010

Sample Details	Borehole No.: BH-8	Sample Depth: 3 m
	Sample No.: UDS-2	Sample Description: Silty fine sand
	Type of Sample:	Remoulded
	Dry Density of Soil (g/cm ³):	1.56
Test Results	Moisture Content (%):	Saturated
	Cohesion Intercept, c :	0.00 kg/cm²
	Angle of Internal Friction, ϕ :	28.3 degrees

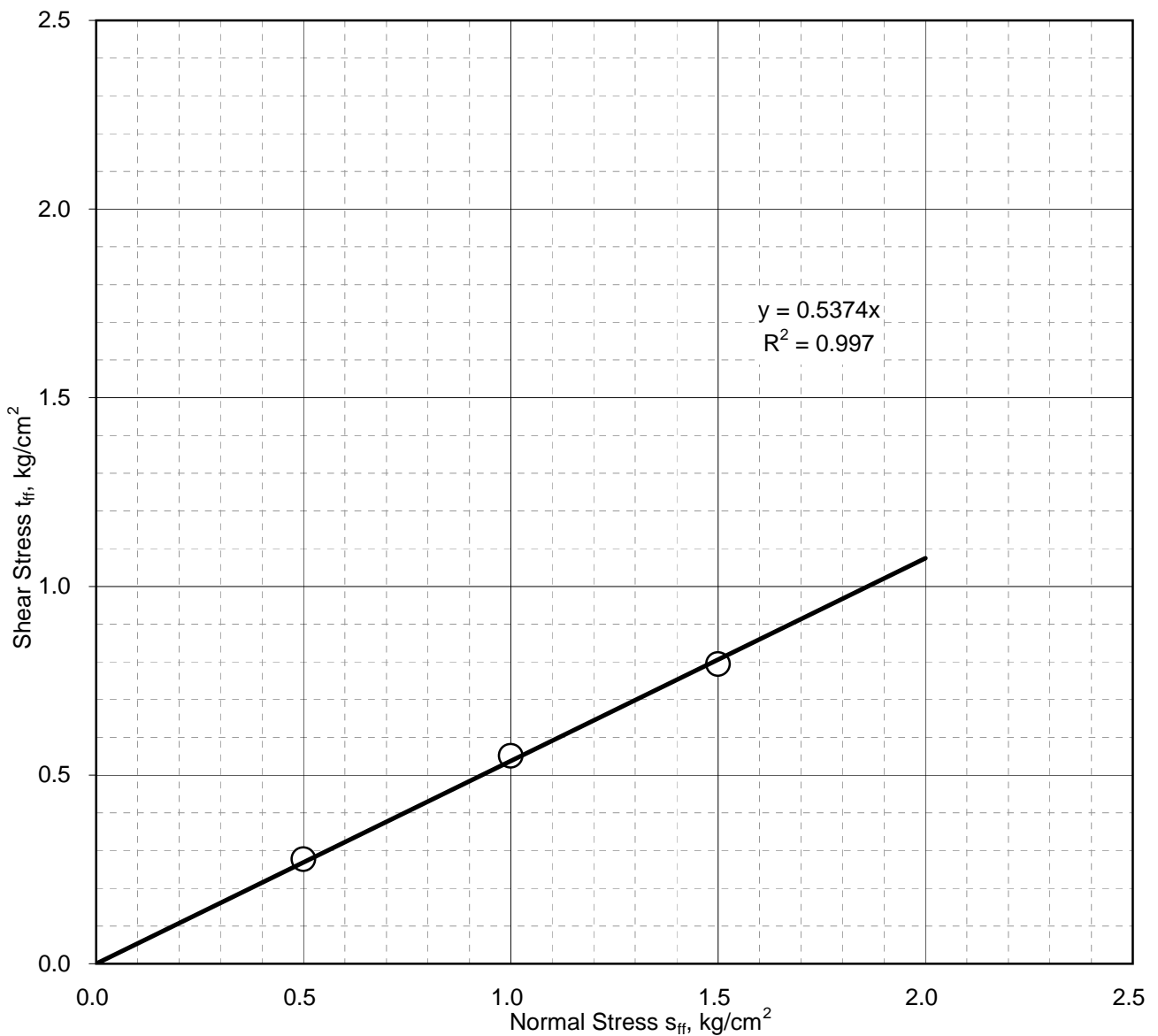

Mohr-Coulomb Failure Envelope

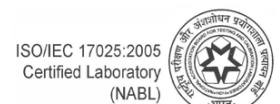

Certificate No. T-1741



Drained Direct Shear Test

IS : 2720 (Part-13)-1986, RA-2010

Sample Details	Borehole No.: BH-8	Sample Depth: 6 m
	Sample No.: UDS-3	Sample Description: Silty fine sand
	Type of Sample:	Remoulded
	Dry Density of Soil (g/cm ³):	1.61
Test Results	Moisture Content (%):	Saturated
	Cohesion Intercept, c :	0.00 kg/cm²
	Angle of Internal Friction, ϕ :	33.7 degrees

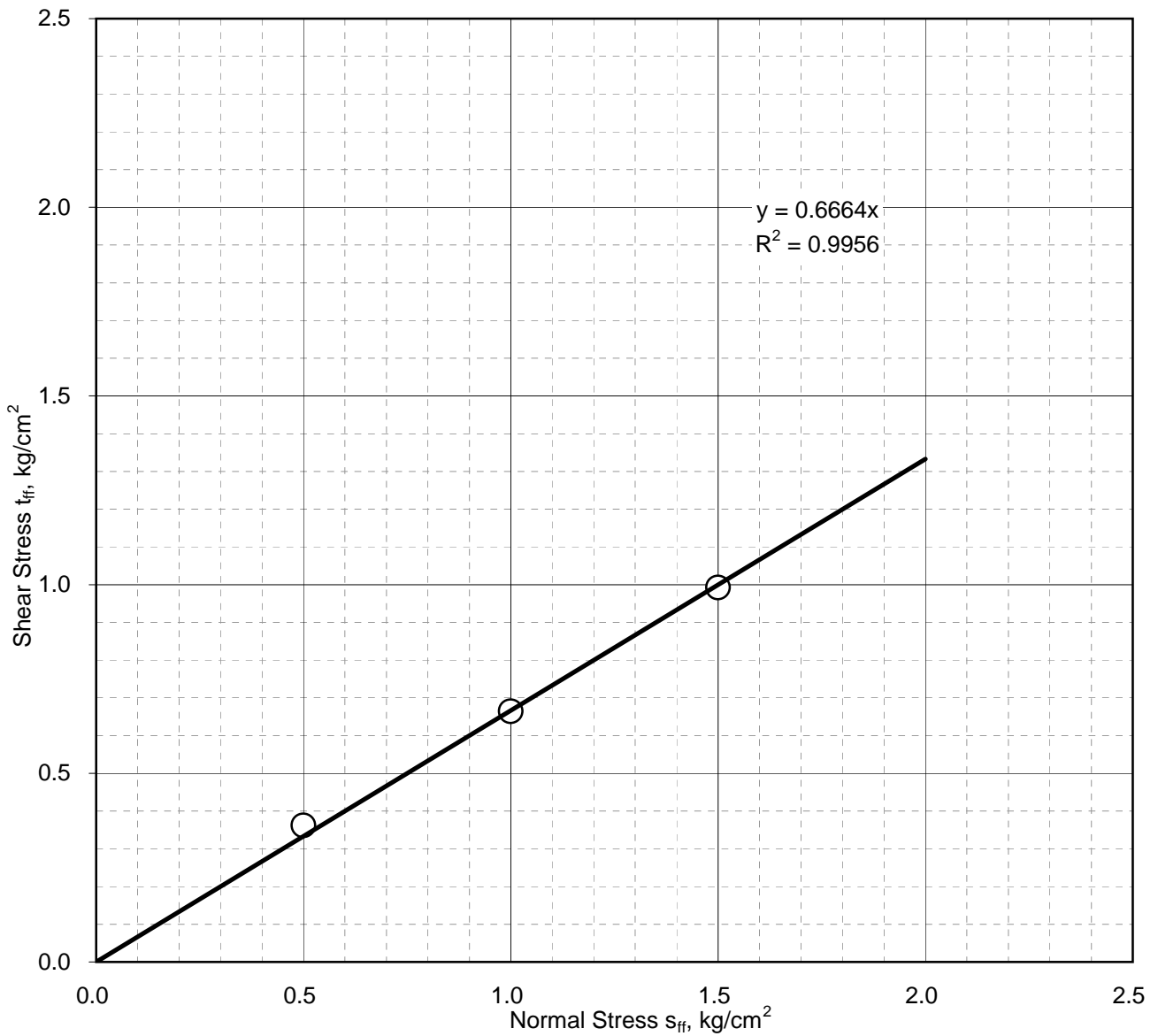

Mohr-Coulomb Failure Envelope

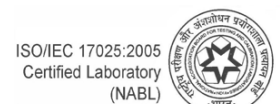

Certificate No. T-1741



TEST RESULTS

Soil-Water Extract Test Results				
Borehole No.	Depth, (m)	Sulphate Content (SO ₃), %	Chloride Content (Cl), %	pH Value
BH-2	2.50	0.11	0.03	7.3
BH-4	2.50	0.11	0.03	7.3
BH-8	1.00	0.10	0.03	7.4

Groundwater Test Results			
Borehole No.	Sulphate Content (SO ₃), mg/l	Chloride Content (Cl), mg/l	pH Value
BH-1	352	390	7.4
BH-2	359	337	7.7
BH-3	364	407	7.6
BH-4	352	330	7.6
BH-5	330	287	7.3
BH-6	342	292	7.4
BH-7	345	300	7.6
BH-8	331	320	7.4

IS : 456-2000, SPECIFICATIONS

Requirements for Concrete Exposed to Sulphate Attack as per IS : 456-2000, Clauses 8.2.2.4 and 9.1.2, Table 4, Page-19

Class	Concentration of Sulphates, expressed as SO ₃ In-Soil-Water Extract (Total) Percent	In Groundwater (mg/l)
1	Traces (<0.2)	Less than 300
2	0.2 to 0.5	300-1200
3	0.5 to 1.0	1200-2500
4	1.0 to 2.0	2500-5000
5	> 2.0	> 5000

Classification of Chloride Conditions in Groundwater*

Classification	Chloride Limits	
	Temperate Climate	Tropical Climate
Negligible	0-2000 ppm	Not Applicable
Moderate	2000-10,000 ppm	0-2000 ppm
High	More than 10,000 ppm	2000-20,000 ppm
Very High	Generally not applicable	Only if considerably in excess of 20,000 ppm

*Source : Institution of Civil Engineers, London (1979)

Chemical Test Results

APPENDIX-A
TYPICAL CALCULATIONS



Bearing Capacity Analysis for Shallow Foundations

Analysis as per IS 6403-1981

Open Foundations Ash Pond Area

The bearing capacity equation is as follows :

$$q_{\text{net safe}} = (1/FS)\{cN_c z_c d_c + q(N_q - 1)z_q d_q + 0.5B\gamma N_g z_g d_g R_w\}$$

where:

$q_{\text{net safe}}$ = safe net bearing capacity c = cohesion intercept
 q = overburden pressure B = Foundation width
 γ = Bulk density of soil below founding level
 R_w = Water table correction factor FS = Factor of safety
 N_c, N_q, N_g = bearing capacity factors, which are a function of f
 d_c, d_q, d_g = Depth factors
 z_c, z_q, z_g = Shape factors

Soil parameters :

$c = 0.00 \text{ T/m}^2$ $\phi = 30.0$ degrees GENERAL SHEAR FAILURE
 $c' = 0.00 \text{ T/m}^2$ $\phi = 21.1$ degrees LOCAL SHEAR FAILURE
 General Shear Failure : $N_c = 30.14$ $N_q = 18.40$ $N_g = 22.40$
 Local Shear Failure : $N_c' = 15.87$ $N_q' = 7.11$ $N_g' = 6.24$

Bulk Density Profile		
Depth, m		γ
From	To	T/m^3
0.0	1.5	1.70
1.5	4.0	1.80
4.0	8.0	1.85
8.0	12.0	1.90
12.0	20.0	2.00

Factor of safety = **2.5** as per **IS 1904-1986**

Design Water Table depth = **4.0** m

R_w factor: Constant value(V) for worst condition or

calculate(C) based on WT Depth ? :

V

$R_w = 0.50$

Depth factor to be considered ?

Y

For computation of Depth Factor, depth below GL to be ignored to account for loose soils, poorly compacted backfill above foundation, scour etc. =

0.0 m

FAILURE CRITERIA : **AVERAGE OF LOCAL & GENERAL SHEAR FAILURE**

Foundation Dimensions		FOUN-DATION SHAPE	Depth, m	R_w	Shape Factors			Depth factors (GSF)			Depth factors (LSF)			$q_{\text{net safe}}$, T/m^2		Safe Net Bearing Capacity T/m^2	Gross Bearing Capacity (Safe) T/m^2
B, m	L, m				z_c	z_q	z_g	d_c	d_q	d_g	d_c'	d_q'	d_g'	GSF	LSF		
3.0	3.0	Square	1.5	0.50	1.30	1.20	0.80	1.17	1.09	1.09	1.15	1.07	1.07	33.7	10.9	22.3	24.9
6.0	6.0	Square	1.5	0.50	1.30	1.20	0.80	1.09	1.04	1.04	1.07	1.04	1.04	42.7	13.4	28.1	30.6
3.0	3.0	Square	3.0	0.50	1.30	1.20	0.80	1.35	1.17	1.17	1.29	1.15	1.15	63.0	20.8	41.9	47.1
6.0	6.0	Square	3.0	0.50	1.30	1.20	0.80	1.17	1.09	1.09	1.15	1.07	1.07	69.3	22.5	45.9	51.1



Settlement Analysis for Shallow Foundation Based on N- Values

Analysis as per IS:8009 (Part 1)-1976, Clause 9.1.4

Open Foundations Ash Pond Area

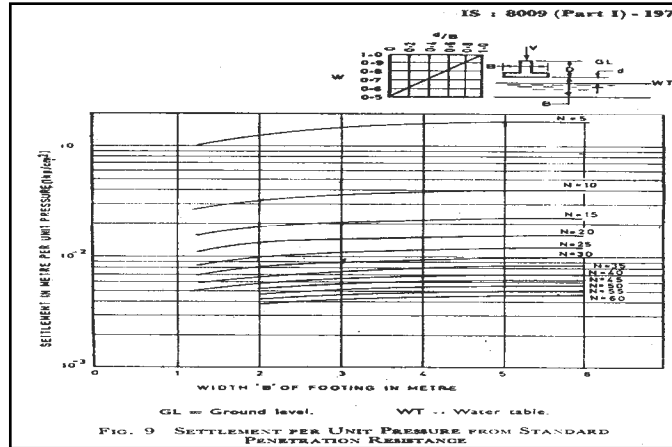

Design Water Table Depth : 4.0 m

R_w factor : Calculate (C) based on water table depth
or Fixed Value(V) for worst condition :

V Rw factor for design : 0.5

Fox's Depth Factor to be considered ? Y

Depth to be ignored in Depth Factor Computation for
loose soils, poorly compacted backfill, scour, etc. 0.0 m

Foundation Width, m	Foundation Length, m	Foundation Depth, m	Shape	Design N-Value	Design Net Bearing Pressure, T/m ²	Settlement @ 1kg/cm ² (as read off from graph).	R_w	Fox's Depth Factor, d_f	Rigidity Factor, d_r	Computed Settlement, mm
3.0	3.0	1.5	Square	18.0	9.0	15.9	0.50	0.85	1.0	24.3
6.0	6.0	1.5	Square	18.0	9.0	17.5	0.50	0.94	0.8	23.6
3.0	3.0	3.0	Square	22.0	13.0	12.6	0.50	0.73	1.0	23.8
6.0	6.0	3.0	Square	22.0	13.0	13.8	0.50	0.85	0.8	24.4



Settlement Analysis for Shallow Foundations Elastic Settlement Computed From Theory of Elasticity

Analysis as per IS : 8009 Part 1 - 1976, Clause 9.2

Open Foundations Ash Pond Area

Total settlement computed as equal to elastic/immediate settlement.

No consolidation settlement - analysis valid for granular soils, weathered rocks,
hard clays & cohesive soils above water table

ELASTIC / IMMEDIATE SETTLEMENT

$$S_i = \frac{q B' (1 - \mu^2) I}{E} d_f d_r$$

Reference : *Foundation Analysis & Design by J.E.Bowles* fifth edition (1996)

where B = Foundation width $B' = B/2$ $L' = L/2$ μ = Poisson's Ratio
 q = Applied Bearing Pressure E = Modulus of Elasticity
 d_f = Fox's Depth factor d_r = Rigidity factor
 I = Influence factor at corner of rectangular loaded area($B' \times L'$),
 computed from theory of elasticity using Steinbrenner's factors
 Settlement at centre of footing of size $B \times L = 4 \times$ Settlement at corner of area $B' \times L'$

Poisson's Ratio : 0.30

Is Rigid Layer met ? N

Layer No.	Depth, m		Soil Classification	Modulus of Elasticity, T/m ²
	From	To		
1	0.0	1.5	Sandy silt	650
2	1.5	4.0	Silty fine sand	1000
3	4.0	8.0	Silty fine sand	1200
4	8.0	12.0	Silty fine sand	1600
5	12.0	20.0	Silty fine sand	2800

Fox's Depth Factor to be considered ? Y

Depth to be ignored in Depth Factor Computation for loose soils, poorly compacted backfill, scour etc. = 0.0 m

Founda- tion Width (B), m	Founda- tion Length (L), m	Embed- ment Depth (D), m	Applied Bearing Press. T/m ²	Rigidity Factor, d_r	Fox's Depth Factor	$M = L'/B'$	$N = H/B'$	Influence Factor	E(weigh- ted ave.) T/m ²	Elastic Settle- ment mm
3.0	3.0	1.5	9.0	1.00	0.85	1.00	10.00	0.507	1753	12.1
6.0	6.0	1.5	9.0	0.80	0.94	1.00	10.00	0.507	1951	19.1
3.0	3.0	3.0	13.0	1.00	0.73	1.00	10.00	0.507	1933	13.5
6.0	6.0	3.0	13.0	0.80	0.85	1.00	10.00	0.507	2035	24.0

**GEOTECHNICAL INVESTIGATION REPORT
(VOLUME-2)**

**FOR
POWER HOUSE AREA**

**RELATED TO
THE PREPARATORY SURVEY FOR
CONSTRUCTION OF
BARAUNI SUPER CRITICAL COAL FIRED
THERMAL POWER STATION
(UNIT#10)**

OF

BIHAR STATE POWER GENERATION COMPANY LTD.

CONSULTANT

steag



STEAG Energy Services India Pvt. Ltd.

(Formerly Evonik Energy Services India Ltd.)

(A wholly owned subsidiary of Steag Energy Services GmbH, Germany)

A-29, Sector-16, NOIDA-201301, India

TABLE OF CONTENTS

		<u>Sheet No.</u>
1.0	INTRODUCTION	3
	1.1 Project Description	3
	1.2 Purposes of Study	4
	1.3 Report Format	4
	1.4 Scope of Geotechnical Investigations covered in this Report (<i>Powerhouse Area</i>)	5
2.0	FIELD INVESTIGATIONS	5
	2.1 Soil Boring	5
	2.2 Groundwater	6
3.0	LABORATORY TESTS	6
4.0	GENERAL SITE CONDITIONS	6
	4.1 Site Details	6
	4.2 Regional Geology	7
	4.3 Site Stratigraphy	7
	4.4 Groundwater	8
5.0	LIQUEFACTION SUSCEPTIBILITY ASSESSMENT	8
	5.1 Detailed Liquefaction Analysis as per NCEER Approach	8
	5.1.1 Introduction	8
	5.1.2 Calculation of Cyclic Stress Ratio (CSR)	8
	5.1.3 Calculation of Cyclic Resistance Ratio (CRR) based on SPT Values	9
	5.2 Results of Detailed Liquefaction Studies	10
6.0	CONCEPT OF FOUNDATION ANALYSIS	10
	6.1 Open Foundation	10
	6.2 Definition of Gross and Net Bearing Pressure	11
	6.3 RCC Bored Cast in-situ Piles	12
7.0	FOUNDATION ANALYSIS AND RECOMMENDATIONS	13
	7.1 General	13
	7.2 Foundation Type and Depth	13
	7.3 Design Parameters	14
	7.4 Recommended Net Allowable Bearing Pressures	14
	7.5 Pile Foundations	15
	7.6 Ground Improvement by Excavation and Replacement	16
	7.7 Ground Improvement by Rammed Stone Columns	17
	7.8 Definition of Gross and Net Bearing Pressure	18
8.0	FOUNDATION CONSTRUCTION CONSIDERATION	18
	8.1 Excavation	18
	8.2 Foundation Level Preparation	18
	8.3 Pile Construction	18
	8.4 Pile Testing Program	19
	8.5 Chemical Attack	19
9.0	RECOMMENDATIONS FOR FURTHER INVESTIGATION	20
10.0	VARIABILITY IN SUB-SURFACE CONDITIONS	20

LIST OF ILLUSTRATIONS

<u>Caption</u>	<u>Plate</u>
Layout Plan	1
Satellite Image of Site and Test Locations	2
Engineering Description of Soils	3
Uncertainty in Laboratory Measurements	4
Soil Profiles	5 to 28
Summary of Borehole Profiles	29
Standard Penetration Test Results	30 & 31
Grain Size Analysis	32 to 55
Shear Test Results	56 to 67
Chemical Test Results	68

Appendix A: Liquefaction Susceptibility Assessment

Appendix B: Typical Calculations

Appendix C: Site Photographs

DEFINITION OF ACRONYMS

USL	United Spirit Limited
UTM	Universal Transverse Mercator coordinates system
NABL	National Accreditation Board for Testing and Calibration Laboratories
ISO	International Standards Organization
BIS	Bureau of Indian Standards
EGL	Existing Ground Level
NGL	Natural Ground Level
RL	Reduced Level
SPT	Standard Penetration Test
NCEER	National Center for Earthquake Engineering Research
UUT	Unconsolidated undrained triaxial shear test
DS	Consolidated drained direct shear test

BIS REFERENCES

- Compendium of Indian Standard on Soil Engineering (Part-2, Field Testing of Soils for Civil Engineering Purposes), SP36 (Part-2:1988)-RA 2006
- Compendium of Indian Standard on Soil Engineering (Part-1, Laboratory Testing of Soils for Civil Engineering Purposes), SP36 (Part-1:1987)-RA 2006

1.0 INTRODUCTION

1.1 Project Description

Japan International Cooperation Agency (JICA) has appointed Kyushu Electric Power Co. Inc. as a consultant, to conduct the preparatory survey for construction of the Barauni Super Critical Coal Fired Thermal Power Station. Kyushu Electric Power Co. Inc. has appointed M/s. STEAG Energy Services (India) Pvt. Ltd for the preparatory survey work for the project.

This report volume (Volume-II) presents field and laboratory test results along with our geotechnical recommendations for the Power House area. An accompanying volume (Volume-I) presents results of the geotechnical investigation for the Ash Pond area. Volume-III presents all data and recommendations for the Raw Water Intake area.

1.2 Purposes of Study

The overall purposes of this study are to investigate the stratigraphy at the site, and to develop preliminary geotechnical recommendations for design and construction of foundations for the Ash Pond, Powerhouse and Raw Water Intake Areas.

To accomplish these purposes, the study was conducted in the following phases:

- (i) drilling 8 boreholes to 20m depth in the Ash Pond area, in order to evaluate the stratigraphy, and to collect soil and groundwater samples for laboratory testing;
- (ii) performing seventy three (73) field permeability tests in the Ash Pond area at eight (8) borehole locations to assess the in-situ coefficient of permeability of the strata;
- (iii) drilling 6 boreholes to 40 m depth in the Power House area in order to evaluate the stratigraphy, and to collect soil and groundwater samples for laboratory testing;**
- (iv) drilling 3 boreholes to 20m depth at the Raw Water Intake location in order to evaluate the stratigraphy, and to collect soil and groundwater samples for laboratory testing;
- (v) testing selected soil and groundwater samples in the laboratory to determine pertinent index and engineering properties; and
- (vi) analyzing all field and laboratory data to develop geotechnical recommendations for foundations.

The scope of work presented in this report volume (*Volume-II*) consists of 6 boreholes to 40m depth for the power plant facilities.

The boreholes have been done at widely spaced locations for DPR purpose. The data and recommendations in this report in this report may please be taken as preliminary for initial planning purpose only. A detailed investigation should be performed at site for all the facilities of the power plant to develop final geotechnical recommendations.

1.3 Report Format

This report is presented in three volumes. The scope of work included in each volume is as described below:

Report Volume	Proposed Structures	Scope of Work
Volume-I	Ash Pond	<ul style="list-style-type: none"> ▪ Eight (8) Boreholes ▪ Seventy three (73) field permeability tests
Volume-II	Powerhouse	<ul style="list-style-type: none"> ▪ Six (6) Boreholes
Volume-III	Raw Water Intake	<ul style="list-style-type: none"> ▪ Three (3) Boreholes

This volume, designated as Volume-II, includes field and laboratory data together with our engineering recommendations for the proposed **Powerhouse area**.

The initial sections of this volume of the report present brief descriptions of the field procedures together with a list of various laboratory tests conducted. General site conditions, including geology and stratigraphy along the cross bridge alignment, are then presented. This is followed by our foundation analysis and recommendations.

Plates of soil profiles and various laboratory tests follow the report text. The illustrations section includes a site plan, graphical plots of various field and laboratory test results, summary of borehole profiles, sectional profiles and other related sketches.

1.4 Scope of Geotechnical Investigations covered in this Report (**Powerhouse Area**)

Details of boreholes drilled on site are as follows:

Sr. No.	Structure	Borehole Designation	UTM Coordinates ⁽¹⁾ , m		Existing Ground Level ⁽¹⁾ (RL), m	Borehole Termination Depth, m
			Easting	Northing		
1	Coal Silo	BH-P-1	402227	2809110	45.5	40.32
2	Chimney	BH-P-2	401627	2808823	45.5	40.34
3	Boiler	BH-P-3	401549	2808592	45.5	40.33
4	Generator	BH-P-4	401536	2808557	45.5	40.34
5	Generator Transformer	BH-P-5	401506	2808528	45.5	40.33
6	Raw water storage tank	BH-P-6	401514	2808315	45.5	40.30

- A layout plan illustrating the various test locations covered in this report volume are presented on Plate 1.
- The test locations were given to us on the ground by the client representatives at site. The locations were marked on Google earth and a satellite image illustrating the approximate test locations (as given to us) is presented on Plate 2.

2.0 FIELD INVESTIGATIONS

2.1 Soil Boring

The borings were progressed using a shell and auger to the specified depth. The diameter of the borehole was 150 mm. Casing was used for advancing boring below water table at all borehole locations. The work was in general accordance with IS: 1892-1979.

Standard Penetration Tests (SPT) were conducted in the boreholes at 1.0 m depth interval. The test was conducted by connecting a split spoon sampler to 'A' rods and driving it by 45 cm using a 63.5 kg hammer falling freely from a height of 75 cm. The tests were conducted in accordance with IS: 2131-1981.

The number of blows for each 15 cm of penetration of the split spoon sampler was recorded. The blows required to penetrate the initial 15 cm of the split spoon for seating the sampler is ignored due to the possible presence of loose materials or cuttings from the drilling operation. Where refusal (N>100) to further penetration of the split spoon sampler is encountered in the first 15 cm seating penetration

itself, SPT test could not be completed and "Ref" is indicated in the bore logs, along with the penetration achieved. The 'N' values are presented on the soil profile for each borehole.

Disturbed samples were collected from the split spoon after conducting SPT. The samples were preserved in transparent polythene bags. Undisturbed samples were collected by attaching 75 mm diameter thin walled 'Shelby' tubes and driving the sampler using a 63.5 kg hammer in accordance with IS: 2132-1986. The tubes were sealed with wax at both ends. All samples were transported to our NABL accredited laboratory at Noida for further examination and testing.

2.2 Groundwater

Groundwater level was measured in the boreholes after drilling and sampling was completed. The measured water levels are recorded on the individual soil profiles.

3.0 LABORATORY TESTS

The laboratory testing has been carried out in our NABL accredited laboratory. The quality procedures in our laboratory conform to ISO/IEC-17025-2005.

Laboratory tests were conducted on selected soil and groundwater samples, to determine their physical and engineering properties. The testing procedures were in accordance with current applicable IS specifications. The following tests were conducted on selected soil and groundwater samples recovered from the boreholes:

Name of Test		IS Code No.
Bulk Density		IS : 2386 (Part-3)-1963
Natural moisture content		IS : 2720 (Part-2)-1973, RA-2010
Grain size analysis		IS : 2720 (Part-4)-1985, RA-2010
Specific gravity		IS : 2720 (Part-3)-1980, RA-2007
Liquid and plastic limits		IS : 2720 (Part-5)-1985, RA-2010
Unconfined compression test		IS : 2720 (Part-10)-1991, RA-2010
Unconsolidated undrained triaxial shear test		IS : 2720 (Part-11)-1993, RA-2007
Consolidated drained direct shear test		IS : 2720 (Part-13)-1986, RA-2010
Chemical analysis of soil*	pH value	IS : 2720 (Part 26)-1987, RA-2007
	Total soluble sulphates	IS : 2720 (Part-27)-1977, RA-2010
	Total soluble chlorides	IS : 3025 (Part-32)-1988, RA-2009
Chemical analysis of water*	pH value	IS : 3025 (Part-11)-1983, RA-2006
	Total soluble sulphates	IS : 3025 (Part-24)-1986, RA-2009
	Total soluble chlorides	IS : 3025 (Part-32)-1988, RA-2009

* Outside NABL Scope

Engineering terms used to describe soils are explained on Plate 3. A note on our NABL accreditation together with the uncertainty in laboratory measurements is presented on Plate 4.

4.0 GENERAL SITE CONDITIONS

4.1 Site Details

The site located in Barauni district, Bihar. Rajendra pul railway Station is located about 2.5 k m west of the site. Fly ash is present all over the site. The site is fairly leveled and ground level is RL 45.5 m.

4.2 Regional Geology

The deposits in the project area belong to the Indo-Gangetic alluvium⁽¹⁾. The alluvial tract is of the nature of a synclinal basin formed concomitantly with the elevation of the Himalaya to its North.

The Indo-Gangetic depression was formed in the later stages of Himalayan Orogeny when the Indian shield under-thrust the Asian continent. The well-consolidated crust of the shield became engulfed under the light, soft, moist sediments. As the northward drift of India continued, the more consolidated and metamorphosed older strata and the granitic magmas intrusive into them slid southwards, impelled partly by gravity and partly by compressive force.

The Pleistocene and recent deposits covering the Indo-Gangetic Basin are upto 1,000 m thick. They are composed of gravels, sands and clays with remains of animals and plants.

The older alluvium (called Bhangar) is rather dark colored and generally rich in concretions and nodules of impure calcium carbonate (kankar). It is of Middle to Upper Pleistocene age.

The Newer alluvium (called Khadar) is light colored and poor in calcareous matter. It contains lenticular beds of sand and gravel and peat beds. It merges by insensible gradations into the recent or deltaic alluvia and should be assigned an Upper Pleistocene to Recent age.

4.3 Site Stratigraphy

A surficial fill of flyash is underlain by sandy silt / clayey silty to about 5-7.5 m depth. Silty sand / fine sand is then encountered to the final explored depth of 40 m.

The stratigraphy at site may be divided into three (3) generalized strata as described below:

Stratum – I (Loose to medium dense fly ash): A loose surficial fill of flyash is present all over the site to about 4.0-4.5 m depth (RL 41.5 -41.0 m). SPT values in the flyash range from 6 to 10 indicating loose to medium dense conditions.

In this stratum, bulk density values range from 1.37 g/cm³ to 1.48 g/cm³ and moisture content values range from 30 % to 35 %. In this stratum, liquid limit values range from 24 % to 36 and plasticity index values range from 11 % to 15 %.

Stratum – II (Loose sandy silt / firm clayey silt): Below Stratum-I, loose sandy silt / firm clayey silt is encountered to about 5.0-7.5 m depth (RL 40.5-38.0). However, at the Chimney location (P-2), sandy silt / clayey silt layer extends to about 12.0 m depth (RL 33.5 m). SPT values in this stratum range from 5 to 9.

In stratum-II, bulk density values range from 1.85 g/cm³ to 1.93 g/cm³ and moisture content values range from 21 % to 26 %. In this stratum, liquid limit values range from 28 % to 46 and plasticity index values range from 13 % to 24 %.

Stratum – III (medium dense to very dense silty fine sand / fine sand): Stratum-III consists of medium dense to very dense silty fine sand / fine sand to the maximum explored depth of 40 m (RL 5.5 m). SPT values in this stratum range from 20 to 66 to about 19-23 m depth (RL 26.5-22.5 m). Below this, refusal (N >100) is encountered.

In this stratum, bulk density values range from 1.37 g/cm³ to 1.85 g/cm³ and moisture content values range from 19 % to 23 %.

⁽¹⁾ Krishnan, M.S. (1982), "**Geology of India and Burma**", CBS Publishers & Distributors, Delhi, Sixth Edition.

Detailed description of the soil encountered at the borehole locations are presented on the individual soil profiles in Plate 5 to 28. A pictorial summary of the borehole profiles is illustrated on Plate 29. Plots of field and corrected SPT values versus depth are presented on Plate 30 to 31.

4.4 Groundwater

Based on our measurements in the completed boreholes, groundwater was met at 9.4-10.1 m depth (RL 36.1- 35.4 m) during the period of our field investigation (July, 2015). Fluctuations may occur in the measured water levels due to seasonal variations in rainfall and surface evaporation rates.

5.0 LIQUEFACTION SUSCEPTIBILITY ASSESSMENT

5.1 Detailed Liquefaction Analysis as per NCEER Approach

5.1.1 Introduction

For a better evaluation of the liquefaction potential at the project site, a detailed analysis has been done as per standard procedures given in published literature. The methodology based on the simplified procedure developed by Seed and Idriss, as described in the NCEER Summary Report (2001)⁽²⁾.

As per the simplified procedure, the factor of safety (FS) against liquefaction is given by the following equation:

$$FS = \left[\frac{CRR_{7.5}}{CSR} \right] MSF$$

where,

- CSR = Cyclic Stress Ratio, generated by the earthquake shaking;
- $CRR_{7.5}$ = Cyclic Resistance Ratio for magnitude 7.5 earthquakes; and
- MSF = Magnitude Scaling Factors (*as recommended by the NCEER Summary Report*), used to scale the calculated $CRR_{7.5}$ values to the design earthquake magnitude.

Calculation, or estimation, of two variables is required for evaluation of liquefaction resistance of soils:

1. the seismic demand on a soil layer, expressed in terms of Cyclic Stress Ratio (CSR); and
2. capacity of the soil to resist liquefaction, expressed in terms of cyclic resistance ratio (CRR), based on SPT values (*Refer to Section 6.1.3*)

A Magnitude Scaling Factor (MSF) of 1.442 (based on a mean of Scaling Factors defined by various investigators recommended by the NCEER Summary Report, 2001) was applied to the $CRR_{7.5}$ value, to adjust the clean sand curves to the design earthquake magnitude of 6.7.

5.1.2 Calculation of Cyclic Stress Ratio (CSR)

In this analysis, the cyclic stress ratio (CSR) has been calculated for the selected peak horizontal ground accelerations at various depths using the following equations.

⁽²⁾ Youd, T.L., and Idriss, I.M., (2001), "*Liquefaction Resistance of Soils: Summary Report from the 1996 NCEER and 1998 NCEER/NSF Workshops on Evaluation of Liquefaction Resistance of Soils*", Journal of Geotechnical and Geo-environmental Engineering, April 2001, pp. 297-313.

$$CSR = \left(\frac{\tau_{av}}{\sigma_{vo}'} \right) = 0.65 r_d \left(\frac{\sigma_{vo}}{\sigma_{vo}'} \right) \frac{a_{max}}{g},$$

$$\text{and } \begin{cases} r_d = 1.0 - 0.00765z \text{ for } z \leq 9.15 \text{ m} \\ r_d = 1.174 - 0.0267z \text{ for } 9.15 \leq z \leq 23 \text{ m} \end{cases}$$

where:

- τ_{av} = Average horizontal shear stress acting on soil element during earthquake shaking
- r_d = Stress reduction coefficient, based on Liao and Whitman (1986b)⁽³⁾
- σ_{vo} = Total vertical overburden stresses
- σ_{vo}' = Effective vertical overburden stresses
- g = acceleration due to gravity
- a_{max} = Peak horizontal ground acceleration (PGA)

5.1.3 Calculation of Cyclic Resistance Ratio (CRR) based on SPT Values

Since SPT N-values increase with increasing effective overburden pressure, an overburden stress correction factor is applied (Seed & Idriss 1982⁽⁴⁾) to normalize N_{60} to an equivalent effective overburden pressure of approximately 1 atmosphere (100 kPa). The overburden correction on SPT values is based on the actual depth of groundwater, as measured in the field, and presented in the bore log.

Other correction factors for borehole diameter, rod length, and sampler type have also been taken into account. The SPT values have further been corrected for fines content.

The corrections used to obtain the Corrected Blow Count, $(N_1)_{60}$, were applied as follows.

$$(N_1)_{60} = N_{field} \cdot C_N \cdot C_H \cdot C_B \cdot C_R \cdot C_S$$

where,

N_{field}	=	Measured Standard Penetration Resistance
C_N	=	Factor to normalize N_{field} to a common reference effective overburden pressure of 1 atmosphere (100 kPa), restricted to 1.7
C_H	=	Correction for Hammer Energy Ratio (ER), taken as 0.75
C_B	=	Correction Factor for Borehole Diameter, taken as 1.05
C_R	=	Correction Factor for Rod Length
C_S	=	Correction for sampler type, taken as 1.20

C_N has been calculated at the middle of each layer from the following equation (Liao and Whitman, 1986a⁽⁵⁾):

⁽³⁾ Liao, S.S.C., and Whitman, R.V. (1986b), "**Catalogue of liquefaction and non-liquefaction occurrences during earthquakes**", Res. Rep., Dept. of Civil Engrg., MIT, Mass.

⁽⁴⁾ Seed, H.B., and Idriss, I.M. (1982), "**Ground motions and soil liquefaction during earthquakes**", Earthquake Engineering Research Institute Monograph, Oakland, Calif.

⁽⁵⁾ Liao, S. and Whitman, R.V. (1986a), "**Overburden correction factors for SPT in sand**", J. Geotech. Engrg., ASCE, 112(3), 373-377.

$$C_N = \left(\frac{P_o}{\sigma_{vo}'} \right)^{0.5} \leq 1.7$$

Where,

- P_o = Reference effective overburden pressure of 1 atmosphere (100 kPa);
 σ_{vo}' = Effective overburden pressure at middle of layer at the time of drilling

The corrected $(N_1)_{60}$ value thus obtained was further corrected for the influence of fines content (FC %). The clean-sand base curve for determination of CRR based on corrected SPT N-values, $(N_1)_{60}$, has been estimated by the following equation (Rauch, 1998⁶):

5.2 Results of Detailed Liquefaction Studies

For the liquefaction analysis, the design earthquake magnitude has been taken as 6.7 on the Richter scale for Zone IV. The peak ground acceleration has been considered as equal to 0.24g. The results of the analysis are presented below:

Sr. No.	Structure	Borehole No.	Liquefaction Potential Susceptibility
1	Coal silo	P1	No Liquefaction potential
2	Chimney	P2	No Liquefaction potential
3	Boiler	P3	Liquefaction potential between 10.0 to 13.5 m depth
4	Generator	P4	No Liquefaction potential
5	Generator Transformer	P5	No Liquefaction potential
6	Raw water storage tank	P6	No Liquefaction potential

According to Fig.1 of IS: 1893 (Part1)-2002, RA-2005 showing seismic zones the proposed site falls on earthquake Zone-IV. Therefore design should be done considering the earthquake parameters for Zone-IV.

6.0 CONCEPT OF FOUNDATION ANALYSIS

6.1 Open Foundation

Bearing capacity analysis for open foundations has been done in general accordance with IS: 6403-1981. The bearing capacity equation used is as follows:

$$q_{net\ safe} = \frac{1}{F} [cN_c\zeta_c d_c + q(N_q - 1)\zeta_q d_q + 0.5 B \gamma N_\gamma \zeta_\gamma d_f R_w]$$

Where:

- $q_{net\ safe}$ = safe net bearing capacity of soil based on the shear failure criterion.
 q = overburden pressure
 R_w = water table correction factor,
 F = Factor of safety, taken as equal to 2.5 in accordance with IS:1904-1986.
 $\zeta_c, \zeta_q, \zeta_\gamma$ = Shape factors. For Strip footings, $\zeta_c = \zeta_q = \zeta_\gamma = 1$
For Square footing, $\zeta_c = 1.3, \zeta_q = 1.2, \zeta_\gamma = 0.6$

⁽⁶⁾ Rauch, A. F. (1998). Personal Communication. (as cited in Youd, T. L., Idriss, I. M., Andrus, R. D., Arango, I., Castro, G., Christian, J. T., Dobry, R., Finn, W. D. L., Harder, L. F., Hynes, M. E., Ishihara, K., Koester, J. P., Liao, S. S. C., Marcuson, W. F., Martin, G. R., Mitchell, J.K., Moriwaki, Y., Power, M. S., Robertson, P. K., Seed, R. B., and Stokoe, K. H. (2001). **Liquefaction Resistance of Soils: Summary Report from the 1996 NCEER and 1998**

$d_c, d_q, d_r =$ Depth factors
 For $\phi \leq 10$, $d_c = 1 + 0.2 \tan(45 + \phi / 2) D / B$, $d_q = d_r = 1$
 For $\phi > 10$, $d_q = d_r = 1 + 0.1 \tan(45 + \phi / 2) D / B$

Appropriate values have been substituted into the bearing capacity equation given above to compute the safe net bearing capacity. The values have been checked to determine the settlement of the foundation under the safe bearing pressure. The allowable bearing pressure has been taken as the lower of the two values computed from the bearing capacity shear failure criterion as well as that computed from the tolerable settlement criterion.

Settlement analysis has been performed based on SPT values in accordance with Clause 9.1.4 of IS 8009 (Part 1) - 1976 Fig.9. The values have been cross checked with the classical theory as the sum of immediate settlement and consolidation settlement. Since sand is primarily encountered, consolidation is not likely to occur. Thus the total settlement is equal to the immediate settlement, which is computed using the following equation [Clause 9.2.3 of IS 8009 Part 1-1976]⁽⁷⁾:

$$S_i = \frac{qB'(1 - \mu^2)}{E} I d_f d_r$$

where:

S_i = immediate (elastic) settlement
 B = foundation width, $B' = B/2$
 μ = Poisson's ratio
 q = applied bearing pressure
 E = modulus of elasticity
 d_f = depth factor
 d_r = rigidity factor
 I = influence factor at corner of rectangular loaded area (B'x L')

6.2 Definition of Gross and Net Bearing Pressure

For the purposes of this report, the net allowable bearing pressure should be calculated as the difference between total load on the foundation and the weight of the soil overlying the foundation divided by the effective area of the foundation. The gross bearing pressure is the total pressure at the foundation level including overburden pressure and surcharge load.

The following equations may be used –

$$q_{net} = [(P_s + W_s) / A_f] - S_v$$

$$q_{gross} = q_{net} + S_v = (P_s + W_f + W_s) / A_f$$

where:

q_{net} = net allowable bearing pressure
 q_{gross} = gross bearing pressure
 P_s = superimposed static load on foundation
 W_f = weight of foundation
 W_s = weight of soil overlying foundation
 A_f = effective area of foundation
 S_v = overburden pressure at foundation level prior to excavation for foundation.

⁽⁷⁾ Bowles, J.E. (1996), "**Foundation Analysis and Design**", International Edition, pp. 303-317.

It may please be noted that safe bearing pressures recommended in this report refer to “**net values**”. Where filling is done, it should be treated as a surcharge over the foundation. Typical calculations are attached at the end of this report.

6.3 RCC Bored Cast in-situ Piles

The axial capacity for bored piles have been computed as per IS 2911 (Part-I/Section-2) - 2010 based on static analysis using c - ϕ values as interpreted from the site stratigraphy, SPT values and laboratory test results.

$$Q_{ult} = \left[\sum_{i=1}^n f_s A_s L_i \right] + q_u A_p$$

$$= \left[\sum_{i=1}^n (\alpha c_i + p_i k \tan \delta_i) A_s L_i \right] + \left[c_p N_c + q_p N_q + \frac{1}{2} \gamma D N_\gamma \right] A_p$$

where:

Q_{ult}	=	ultimate pile capacity
f_s	=	unit skin friction
α	=	adhesion factor
c_i	=	cohesion intercept in i^{th} layer
p_i	=	overburden pressure at centre of i^{th} layer
k	=	coefficient of lateral earth pressure
δ_i	=	angle of friction between soil and pile (taken as equal to ϕ_i) for the i^{th} layer
A_s	=	surface area of pile per m length
L_i	=	length of pile section in i^{th} layer
c_p	=	cohesion intercept in bearing strata
q_u	=	unit end bearing
q_p	=	overburden pressure in bearing strata
N_c, N_q	=	bearing capacity factors, which are a function of ϕ in the bearing strata
A_p	=	pile cross sectional area

A factor of safety of 2.5 has been used on the ultimate pile capacity as per IS 1904-1986 in order to obtain the safe pile capacities.

The overburden pressure is assumed to become constant below depth of 15 times pile diameters.

The uplift / pullout resistance has been computed from the static formula by ignoring the end bearing component and adding the effective weight of the pile to the skin friction component. A factor of safety of 3.0 has been applied to the ultimate pile pullout resistance to obtain the safe pullout capacity.

The lateral load carrying capacity of fixed head pile has been computed based on IS: 2911 (Part-I) Section-2 2010 using the following equation:

$$Q = \frac{12 \gamma E I}{(L_1 + L_r)^3}$$

where:

Q	=	lateral load
E	=	the Young's modulus of pile material
I	=	moment of inertia of pile cross section.

- L_f = depth of fixity
 L_1 = length of pile section below cut-off-level that may not contribute significantly to lateral resistance (in loose/weak soils)
 y = horizontal deflection

7.0 FOUNDATION ANALYSIS AND RECOMMENDATIONS

7.1 General

A suitable foundation for any structure should have an adequate factor of safety against exceeding the bearing capacity of the supporting soils. Also the vertical movements due to compression of the soils should be within tolerable limits for the structure. We consider that foundations designed in accordance with the recommendations herein will satisfy these criteria.

7.2 Foundation Type and Depth

As described in Section 4.3, loose to medium dense surficial fill (Fly ash) is present all over the site. It extends from ground surface to about 4.0-4.5 m depth (RL 41.5 -41.0 m). Open Foundation is not feasible in Filled up stratum.

Structure	Borehole No.	Foundation Type	Remarks
Coal silo	BH-P-1	Raft Foundation	<ul style="list-style-type: none"> Fill is met to 4.0 m depth. Open and raft foundations are feasible at 5.0 m depth. Alternatively RCC bored piles with cut off level at 1.5~2.0 m depth may be provided
		RCC Bored Cast In-situ Piles	
Chimney	BH-P-2	RCC Bored Cast In-situ Piles	<ul style="list-style-type: none"> Fill is met to 4.0 m depth and low SPT values to about 11 m depth. Open and raft Foundation are not feasible. RCC bored piles with cut off level at 1.5~2.0 m depth may be provided
Boiler	BH-P-3	RCC Bored Cast In-situ Piles	<ul style="list-style-type: none"> Fill is met to 4.5 m depth and liquefy to about 13.5 m depth. Open and raft Foundation are not feasible. RCC bored piles with cut off level at 1.5~2.0 m depth may be provided
Generator	BH-P-4	RCC Bored Cast In-situ Piles	<ul style="list-style-type: none"> Fill is met to 4.5 m depth and low SPT values to about 8.5 m depth. Open and raft foundations are not feasible. RCC bored piles with cut off level at 1.5~2.0 m depth may be provided
Generator Transformer	BH-P-5	RCC Bored Cast In-situ Piles	<ul style="list-style-type: none"> Fill is met to 4.0 m depth and low SPT values to about 7.0 m depth. Open and raft foundations are not feasible. RCC bored piles with cut off level at 1.5~2.0 m depth may be provided
Raw water storage tank	BH-P-6	Open Foundation	<ul style="list-style-type: none"> Fill is met to 4.5 m depth and low SPT values to about 6.0 m depth. Open and raft foundations are feasible at 6.5 m depth. Alternatively RCC bored piles with cut off level at 1.5~2.0 m depth may be provided
		RCC Bored Cast In-situ Piles	

Our recommended values of net allowable bearing pressure are presented in Section 7.4. Recommended safe pile capacities are presented in Section 7.5.

Lightly loaded foundations for pipe rack, small buildings, etc. may bear on the flyash after improving the ground to densify the loose flyash. Alternative methods of ground improvement suitable for the minor facilities include the following:

1. Excavation and compaction in layers (See Section 7.6), or
2. Rammed Stone Columns (See Section 7.7).

Plate load tests should be done to confirm the safe bearing capacity of the improved soils.

The current investigation is intended to give a generalized assessment of the stratigraphy and the expected foundation system. The recommendations in this report may please be treated as preliminary and applicable for structures in the vicinity of the borehole locations.

We suggest that a detailed geotechnical study be carried out on site for a better assessment of the strata conditions at the structure locations.

7.3 Design Parameters

The final design parameters as selected by us are based on the field and laboratory test results, as well as our engineering judgment; keeping in view the limited data and expected strata variations. In some cases, where the laboratory values may be inordinately high/low, we have selected design parameters based on the SPT values as well as the general strata characteristics across the site.

Structure	Depth , m		Soil Classification	Design N-Value	$\gamma, T/m^3$	c, T/m ²	ϕ , degrees
	From	To					
Coal Silo, Chimney, Generator, Generator Transformer Raw water storage tank	0.0	4.0	Fill (Fly ash)	6	1.40		
	4.0	12.0	Sandy silt / Clayey silt	9	1.65	6.5	4
	5.0	15.0	Fine sand	20	1.75	0	30
	15.0	20.0	Fine sand	35	1.85	0	31
	20.0	30.0	Fine sand	65	1.95	0	32
	30.0	40.0	Fine sand	100	2.00	0	33
Boiler	0.0	4.5	Flyash	6	1.40		
	4.5	7.5	Sandy silt	7	1.65	6.5	4
	7.5	13.0	Fine sand - liquefiable	14	1.75	0	30
	13.0	20.0	Fine sand	35	1.85	0	31
	20.0	30.0	Fine sand	65	1.95	0	32
	30.0	40.0	Fine sand	100	2.00	0	33

where:

N = Design SPT values
 γ = bulk density
 C = cohesion intercept
 ϕ = angle internal friction

7.4 Recommended Net Allowable Bearing Pressures

The following table presents our preliminary suggested net allowable bearing pressures for open and raft foundations at the Coal Silo and Raw Water Storage Tank:

Structure	Depth, m	Recommended Net Allowable Bearing Pressure, T/m ²						Suggested Modulus of Subgrade Reaction, kN/m ³
		Isolated Footing			Raft Foundations			
		Total Settlement = 12.5 mm	Total Settlement = 25 mm	Total Settlement = 40 mm	Total Settlement = 25 mm	Total Settlement = 40 mm	Total Settlement = 75 mm	
Coal Silo	5.0	5.2	10.3	16.5	10.9	17.5	32.8	4200
	6.0	7.5	15.0	24.0	15.6	25.0	46.9	6105
Raw water storage tank	6.5	5.8	11.6	18.5	12.2	19.5	36.6	4700
	7.5	8.1	16.3	26.0	16.6	26.5	49.7	6500

The above values include a bearing capacity safety factor of 2.5. The appropriate values of net bearing pressure may be selected as per the permissible settlement criterion. Net bearing pressures for foundations of intermediate widths and at intermediate depths may be interpolated linearly between the values given above. Fill placed above EGL should be treated as surcharge load.

In order to restrict the influence of adjacent footings on each other, the lateral edge-to-edge spacing between the foundations should at least be equal to "0.8B" where "B" is the width of the larger footing.

The suggested modulus of sub grade reaction (k) has been computed based on empirical relationships as given in published literature⁽⁸⁾, and is applicable for minimum 2-6 m size square footing at the center of the loaded area.

7.5 Pile Foundations

RCC bored cast-in-situ piles may be used to support structural loads. The following table presents our preliminary estimate of safe load carrying capacities for 550-600mm diameter bored piles with cut-off-level at about 2 m depth (RL 43.5 m).

Structure	Pile Diameter, mm	Pile Length below cut-off-level, m	RL of Pile Tip	Recommended Safe Load Carrying Capacities, Tonnes		
				Compression	Pullout	Lateral
Coal Silo Chimney, Generator Transformer, Raw water storage tank	550	18	25.5	71	35	9.0
		20	23.5	86	41	
		22	21.5	95	47	
		24	19.5	104	53	
		26	17.5	114	60	
	600	18	25.5	85	40	9.8
		20	23.5	102	47	
		22	21.5	113	55	
		24	19.5	124	62	
		26	17.5	135	69	

⁽⁸⁾ Bowles, J.E. (1996), "**Foundation Analysis and Design Fifth Edition**", The McGraw-Hill Companies Inc., pp. 503

Structure	Pile Diameter, mm	Pile Length below cut-off-level, m	RL of Pile Tip	Recommended Safe Load Carrying Capacities, Tonnes		
				Compression	Pullout	Lateral
Boiler	550	18	25.5	61	28	9.0
		20	23.5	75	35	
		22	21.5	85	41	
		24	19.5	95	47	
		26	17.5	105	54	
	600	18	25.5	74	33	9.8
		20	23.5	92	41	
		22	21.5	103	48	
		24	19.5	115	56	
		26	17.5	126	63	

The following points are highlighted with reference to the above capacities:

1. The above values are based on IS: 2911(Part-1): Section 2-2010 and include safety factor of 2.5 for compression and 3.0 for uplift.
2. Safe pile capacities for piles of intermediate lengths may be interpolated linearly between the values given above.
3. The lateral capacities are for fixed head pile with horizontal deflection of 5 mm at the pile head.
4. It should be ensured that the bottom of the pile bore is cleaned properly before casting the pile. This is important because the soil particles tend to settle down at the bottom of the pile bore, which may cause reduction in pile capacities.
5. The capacities given above may be taken as a guideline for initial design. Final pile capacities should be confirmed by conducting initial pile load tests as per IS: 2911 (Part 4) – 1985, RA-2010. Also, routine load tests should be conducted on sufficient working piles to ensure that the piles are safe for the design loads.
6. We recommend that pile integrity tests (PIT)⁽⁹⁾ be carried out on all working piles installed on site, in order to assess the quality of the pile construction. The PIT results may be used as a guideline to select the appropriate piles for routine load tests. In addition consideration may be given to conducting a few high strain dynamic pile load tests (HSDLT) as a quality assurance measure.

7.6 Ground Improvement by Excavation and Replacement

For lightly loaded foundation not exceeding 1 m width, we recommend as follows:

⁽⁹⁾ Sanjay Gupta, Ravi Sundaram and Sorabh Gupta (2008), “**Pile Integrity Testing for Monitoring Pile Construction**”, Proceedings, National Symposium on Geoenvironment, Geohazards, Geosynthetics and Ground Improvement-Experiences and Practices (4G) Indian Geotechnical Society (Delhi Chapter) pp 173-178.

1. Lightly loaded foundations not exceeding 1 m width may bear at 1.0 m depth on compacted structural fill.
2. Excavate to 2.0 m depth.
3. Place the flyash back in layers not exceeding 15 cm thickness and compact each layer.
4. The flyash should be placed and compacted at moisture content of ± 1 percent and should be compacted to at least 95 percent of the maximum dry density as determined by the standard proctor test (IS: 2720 Part VII).
5. A 300 mm thick gravel pad (63 mm down stones mixed with 40-20 mm size stones, blinded with flyash).
6. Foundations not exceeding 1 m width bearing on the compacted gravel pad may be designed for a net allowable bearing pressure of 5 T/m^2 . This value includes a bearing capacity safety factor of 2.5. Total settlement of foundations designed for this bearing pressure is expected to be less than 40 mm.
7. Plate load test should be performed on the improved ground to confirm the safe bearing capacity.

7.7 Ground Improvement by Rammed Stone Columns

To improve the bearing capacity of the flyash, and minimize the total and differential settlements under the anticipated loads; we suggest the use of rammed stone columns. The technique of improving the engineering properties of soil by provision of gravel piles / rammed stone columns is a cost effective system⁽¹⁰⁾.

In this scheme, 63 mm down, graded, stone aggregate mixed with 40 mm and 20 mm stones are placed and compacted in boreholes drilled to the desired depth. The borehole is filled with the stones to a height of about 1 m above the bottom of the hole and is rammed using a heavy rammer (600-1000 kg weight) till a set is obtained. Ramming is done on the gravel layer. The process is repeated till the gravel pile / stone column is constructed up to the desired depth.

The granular pile should be constructed by placing the stone aggregate in the pile with adequate ramming. The granular piles may be constructed in a triangular grid pattern, covering the entire area of the foundations. In order to ensure peripheral restraintment, at least two rows of stone column / granular piles should be provided outside the loaded areas. On top of the piles, a 50 cm thick gravel pad may be placed. Foundations may be constructed on top of this gravel pad.

The stone columns should extend to about 10 m depth below EGL. We suggest use of 400-500 mm diameter rammed stone columns spaced 1.5-2.0 m apart. The spacing may be optimized as per the required safe bearing capacity. Foundation on the improved ground may bear at 1.5-2.0 m depth. We expect that the net allowable bearing pressure of the ground after improvement may be about $12-15 \text{ T/m}^2$ for a permissible settlement of 40 mm. However, the same must be confirmed on site by constructing trial stone columns and load testing them on site.

We suggest the trial stone column be installed at site and load tested in order to assess the safe bearing capacity and developed field expectance criterion. The spacing between the stone columns may be optimized based on an acceptance criterion to be developed on site.

Load tests on single stone column and group of three stone columns on trial stone columns installed at different spacing may be used to select the suitable spacing to achieve the desired bearing

⁽¹⁰⁾ Ravi Sundaram and Sanjay Gupta (1996), "**Gravel Piles: Construction and Field Testing**", Proceedings, Seminar on Piles, Indian Geotechnical Society Delhi Chapter, pp 72-81.

capacity. The size of the test plate shall be decided based on the stone column diameter and spacing between the stone columns. Boreholes / cone penetration tests should be done in between the stone column / granular piles to assess the extent of ground improvement achieved on site.

Open foundations / raft foundations may be adopted on the improved ground, after verifying the effectiveness of the ground improvement method used on site.

7.8 Definition of Gross and Net Bearing Pressure

For the purposes of this report, the net allowable bearing pressure should be calculated as the difference between total load on the foundation and the weight of the soil overlying the foundation divided by the effective area of the foundation. The gross bearing pressure is the total pressure at the foundation level including overburden pressure and surcharge load.

The following equations may be used –

$$q_{net} = [(P_s + W_f + W_s) / A_f] - S_v$$

$$q_{gross} = q_{net} + S_v = (P_s + W_f + W_s) / A_f$$

where:

q_{net}	=	net allowable bearing pressure
q_{gross}	=	gross bearing pressure
P_s	=	superimposed static load on foundation
W_f	=	weight of foundation
W_s	=	weight of soil overlying foundation
A_f	=	effective area of foundation
S_v	=	overburden pressure at foundation level prior to excavation for foundation.

It may please be noted that safe bearing pressures recommended in this report refer to “**net values**”. Where filling is done, it should be treated as a surcharge over the foundation.

8.0 FOUNDATION CONSTRUCTION CONSIDERATION

8.1 Excavation

Temporary open cut excavations to about 6.5-7.0 m depth for foundation construction may be cut using side slopes of 1-vertical on 0.8 to 1.0 horizontal. If excessive sloughing or caving is observed, the slopes may be flattened further to ensure stability. A horizontal berm, at least 1.5 m wide, should be provided at 2.5-3.0 m depth interval for stability purpose.

The engineer should monitor the excavation of slopes. In case excessive sloughing or caving occurs, the slope may be flattened further to ensure stability.

8.2 Foundation Level Preparation

All loose soils should be removed and the exposed foundation bearing surface should be watered and compacted properly using rammers / rollers. The surface should then be protected from disturbances due to construction activities so that the foundations may bear on the natural undisturbed ground. We recommend the placement of a 75 to 100 mm thick “blinding layer” of lean concrete to facilitate placement of reinforcing steel and to protect the soils from disturbance.

In case mechanical means like excavators are deployed for excavations, the excavations should be carried out up to 0.5 m above the proposed level. The last 0.5 m depth of excavation should be carried out manually, so that the founding soils are not disturbed / loosened.

8.3 Pile Construction

For construction of piles, properly mixed drilling mud should be used to control the caving of the borehole during drilling and concreting. The concrete used for the pile construction use of tremie concreting is recommended so as to ensure that the groundwater does not mix with the fresh concrete. It should be coherent, with a minimum cement content of 400 kg/m³. It should have a slump of about 150 to 180 mm.

The piling activity should ensure minimum disturbance to the soil around the pile shaft. The piling works should be executed by a specialist agency with sufficient experience in such works.

8.4 Pile Testing Program

A program of initial and routine static pile load tests under compression, pullout and lateral loading condition should be drawn up and sufficient number of piles should be load tested in accordance with IS: 2911 (Part-IV)-1985 in order to ensure that the safe load on the pile is either equal to or greater than the working load on the piles.

We suggest that low-strain pile integrity testing (PIT) be conducted on all the working piles as a quality control measure. The integrity test results should be used as a basis for selecting the working / routine piles to be load-tested.

In addition to static pile load tests, we recommend that high strain dynamic pile load tests (HSDLT)¹¹ (preferably using 8-channel PDA equipment) be carried out on some of the test piles to quickly assess the safe pile capacity and pile integrity. HSDLT can effectively supplement static load test and may result in substantial savings in the time and cost of foundation testing.

8.5 Chemical Attack

Results of chemical test on selected soil and water samples are presented on Plate 68. The results indicate that the soils contain 0.10-0.11 percent sulphates and 0.04-0.06 percent chlorides. The groundwater contains 331- 355 mg / litre of sulphates and 112-192 mg / litre of chlorides. The pH value of soil is 7.4-8.0 and that of groundwater is 7.2-7.5 indicating nearly neutral condition.

IS: 456-2000 recommends that precautions should be taken against chemical degradation of concrete if

- sulphates content of the soils exceeds 0.2 percent, or
- groundwater contains more than 300 mg /litre of sulphates (SO₃).

Comparing the test results with these specified limits, the sulphate content of the groundwater is higher than the specified limit. Groundwater is encountered at about 9.4-10.1 m and is likely to influence foundation concrete. Therefore, strata at the site may be treated in **Class-2** category as described on IS: 456-2000.

The strata at the site may be treated in **Class 2** category as described on IS: 456-2000. In our opinion, groundwater is marginally aggressive to the foundation concrete.

We recommend the following measures to limit the potential for chemical attack:

- (1) Piles should contain at least 400 kg/m³ cement. The cement content in concrete for open foundations and pile caps should be at least 330 kg/cm³.
- (2) Water cement ratio in foundation concrete should not exceed 0.50.

¹¹⁾ ASTM D4945 - 08 Standard Test Method for High-Strain Dynamic Testing of Piles

- (3) A clear concrete cover over the reinforcement steel of at least 50 mm should be provided for all foundations.
- (4) Concrete for open foundations and pile caps should be densified adequately using a vibrator so as to form a dense impervious mass.

9.0 RECOMMENDATIONS FOR FURTHER INVESTIGATION

The current study is a preliminary investigation for DPR purpose. The boreholes drilled on site were widely spaced. The current investigation is intended to give a generalized assessment of the stratigraphy and the expected foundation system. The recommendations in this report may please be treated as preliminary and applicable for structures in the vicinity of the borehole locations.

We suggest that a detailed geotechnical study be carried out on site once the layout plan is finalized, for a better assessment of the strata conditions at the structure locations. Such an investigation may include the following:

1. **Boreholes**: Sufficient boreholes should be drilled for each structure to assess the stratigraphy and soil conditions.
2. **Static Cone Penetration Tests**: The cone penetration test provides a continuous profile of cone tip resistance versus depth. The data may be used for foundation analysis in conjunction with the borehole data.
3. **Pressuremeter Test**: The test provides superior data for foundation analysis that can be used to economize the foundation design.
4. **Cross-hole Seismic Test**: The test should be conducted in areas of dynamic loads for evaluating the primary and shear wave velocities, dynamic Young's modulus, shear modulus, etc.
5. **Electrical Resistivity Tests**: The test provides useful data for design of the electrical grounding system.
6. **Field and Laboratory CBR Tests**: The results may be used for design of the internal roads of the plant.

10.0 VARIABILITY IN SUB-SURFACE CONDITIONS

Subsurface conditions encountered during construction may vary somewhat from the conditions encountered during the site investigation. In case significant variations are encountered during construction, we request to be notified so that our engineers may review the recommendations in this report in light of these variations.

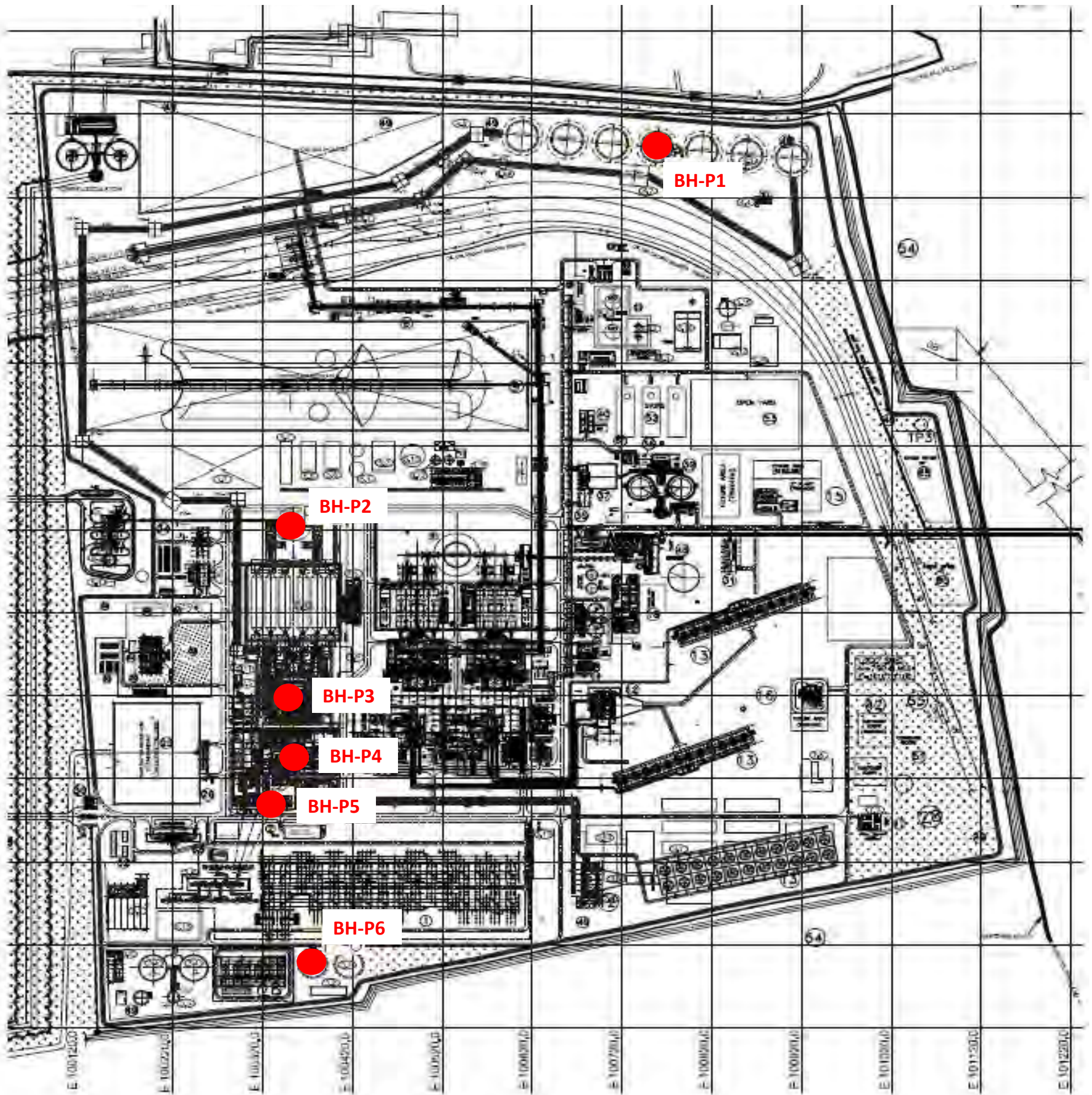

LEGEND

SYMBOL	TYPE OF TEST
	Borehole (BH)

Location: Power House Area
Plan of Field Investigations

Test No.	UTM Coordinate (Zone-45R)	
	East	North
P1	402227.78 m E	2809110.21 m N
P2	401627.08 m E	2808823.46 m N
P3	401549.02 m E	2808592.84 m N
P4	401536.16 m E	2808557.61 m N
P5	401506.00 m E	2808528.00 m N
P6	401514.17 m E	2808315.16 m N



- Satellite image taken from Google Earth®
- Test Locations marked as per GPS coordinates taken on site using hand-held Garmin® device
- Accuracy of hand-held GPS device generally ranges from 4-6m, and varies depending on the availability of satellite connection at the site

Location: Power House Area
Satellite Image of Site and Test Locations



Plasticity of Clay

Plasticity	Liquid Limit
Low Plastic	< 35
Medium Plastic	35 to 50
High Plastic	> 50

Plasticity Chart

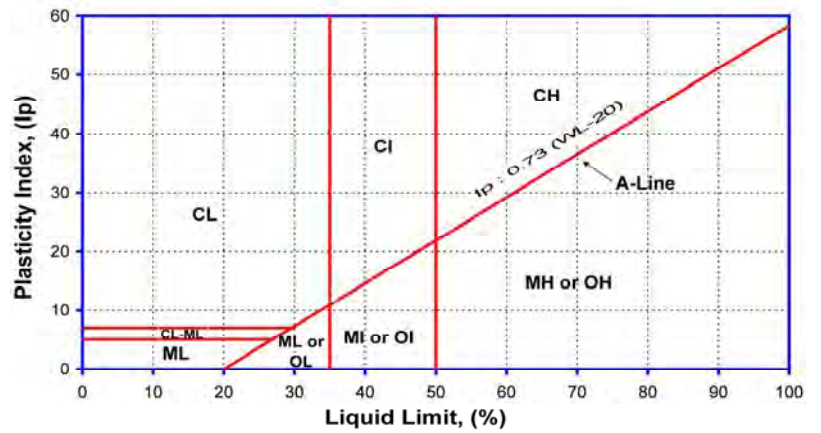

Consistency of Cohesive Soils

Consistency	Cohesion Intercept, kg/sq.cm	SPT (N) Value
Very Soft	< 0.1	0 to 2
Soft	0.1 to 0.25	2 to 4
Firm/Medium	0.25 to 0.5	4 to 8
Stiff	0.5 to 1.0	8 to 15
Very Stiff	1.0 to 2.0	15 to 30
Hard	> 2.0	> 30

Density Condition of Granular Soils

Density Descriptor	SPT (N) Value	Static Cone Tip Resistance kg/sq.cm
Very Loose	0 to 4	< 20
Loose	4 to 10	20 to 40
Medium Dense	10 to 30	40 to 120
Dense	30 to 50	120 to 200
Very dense	> 50	> 200

Degree of Expansion of Fine Grained Soils

Liquid Limit	Plasticity Index	Shrinkage Index	Free Swell Percent	Degree of Expansion	Degree of Severity
20 - 35	< 12	< 15	< 50	Low	Non-critical
35 - 50	12 - 23	15 - 30	50 - 100	Medium	Marginal
50 - 70	23 - 32	30 - 60	100 - 200	High	Critical
70 - 90	> 32	> 60	> 200	Very High	Severe

Engineering Description of Soils



NABL Accredited Laboratory

Our laboratory is accredited to **National Accreditation Board for Testing and Calibration Laboratories (NABL)**, New Delhi. The quality procedures in our laboratory conform to the International Standard **ISO/IEC: 17025-2005**.

The accreditation assures our clients of work quality in conformance with international norms and practices. It authorizes us to use the NABL logo on test results.

To maintain the necessary level of quality and reliability in all measurements on a continual basis, we indulge in the following:

- Use of calibrated equipment, regular maintenance and good housekeeping are a part of our work culture.
- Inter-laboratory comparison, proficiency testing and replicate testing, continuing education - ensure uniform quality of results.
- Internal Audit of quality procedures is done by our qualified ISO 17025 auditors to maintain the requisite standards. NABL conducts external audit.

Uncertainty

Every measurement entails an uncertainty. It is well known that no measuring instrument can determine the true value of any measurement. The cumulative effect of factors such as sensitivity of equipment, accuracy in calibration, human factors and environmental conditions will determine the overall uncertainty in the parameter determined from these measurements.

As a part of our commitment to our clients, we have worked out the uncertainty in the parameters reported by our laboratory. Although this does not form a part of our contract agreement, we present below our statistical estimate of uncertainty of various parameters based on our most recent evaluation (Feb., 2015).

Test / Parameter		Uncertainty*	Test / Parameter		Uncertainty*
Moisture Content		± 0.13 %	Free Swell Index, %		± 2.0 %
Bulk & Dry Density		± 0.0015 g/cc	Swell Pressure		± 0.43 %
Specific Gravity		± 0.014	Consolidation	c _{c1}	± 0.0003
Liquid Limit		± 0.27 %		c _{c2}	± 0.003
Plastic Limit		± 0.19 %		m _v	± 0.0003 cm ² /kg
Shrinkage Limit		± 0.30 %		p _c	± 0.15 kg/cm ²
Unconfined Compression	c	± 0.079 kg/cm ²	CD Direct Shear Test	φ	± 0.29°
UU Triaxial Test	c	± 0.42 %	Soil Gradation	Coarse grained soils	± 0.6% of particle size
	φ	± 0.2 %		Fine grained soils	± 0.5% of particle size
Std/Mod Proctor Compaction	MDD	± 0.03 g/cc	Coefficient of Permeability		± 1.3 % of value
	OMC	± 0.13 %	Rock	Crushing Strength	± 0.80 % of value
Laboratory CBR	± 0.57%	Point Load Strength Index		± 0.04 % of value	

* at 95 percent confidence level for coverage factor of 2

Uncertainty in Laboratory Measurements

Soil Profile (BH-P-1)

Location : Coal Silo #4 Site

Termination Depth : 40.32 m (RL 5.2 m)

Boring Method : Shell & Auger

UTM Coordinates : 402227.78 m E, 2809110.21 m N

Ground Water Depth : 9.60 m

Casing Depth : 39.0 m

Surface Elevation : RL 45.50 m

Boring Start : 13-Jul-15

Ground Water Level : 35.9 m

Boring Finish : 14-Jul-15

ISO/IEC 17025:2005
Certified Laboratory
(NABL)



Certificate No. T-1741

Depth, m		Sample No.	SPT ⁽¹⁾		Symbol	SOIL DESCRIPTION	Depth of Strata, (m)	Grain Size Analysis				Atterberg Limits			Density and Moisture			Specific Gravity	Shear Tests					
From	To		Field Value, N _f	Corrected Value, N _c				Gravel (%)	Sand (%)	Silt (%)	Clay (%)	Liquid (%)	Plastic (%)	Plasticity Index (%)	Bulk Density (gms/cm ³)	Dry Density (gms/cm ³)	Moisture Content (%)		Type of Test	Confining Pressures, (kg/cm ²)	Cohesion Intercept, 'c' (kg/cm ²)	Angle of Internal Friction, φ (degrees)		
0.00	0.50	DS1			[Symbol]	FILL: Flyash																		
0.50	1.00	DS2							0	21	51	28	24.6	18.5	6.0									
1.00	1.45	SPT1	12	17																				
2.00	2.45	SPT2	17	22					0	45	48	7												
3.00	3.30	UDS1					4.00								1.40	1.06	32.0		DS	0.5 ,1, 1.5	0.0	38.9		
4.00	4.45	SPT3	17	18	[Symbol]	Medium dense grey sandy silt, low plastic (CL)	5.00	0	12	81	7	30.9	Non Plastic											
5.00	5.45	SPT4	12	12	[Symbol]	Medium dense grey silty fine sand (SM)																		
6.00	6.30	UDS2						0	84	16	0			1.85	1.48	25.0		DS	0.5 ,1, 1.5	0.0	30.3			
7.00	7.45	SPT5	23	21													2.65							
8.00	8.45	SPT6	27	23				0	81	19	0													
9.00	9.45	SPT7	30	25			10.00																	
10.00	10.45	SPT8	33	27	[Symbol]	Dense grey fine sand (SP-SM)		0	93	7	0													

⁽¹⁾ SPT is outside NABL scope.

Soil Profile (BH-P-1)

Location : Coal Silo #4 Site

Termination Depth : 40.32 m (RL 5.2 m)

Boring Method : Shell & Auger

UTM Coordinates : 402227.78 m E, 2809110.21 m N

Ground Water Depth : 9.60 m

Casing Depth : 39.0 m

Surface Elevation : RL 45.50 m

Boring Start : 13-Jul-15

Ground Water Level : 35.9 m

Boring Finish : 14-Jul-15

ISO/IEC 17025:2005
Certified Laboratory
(NABL)

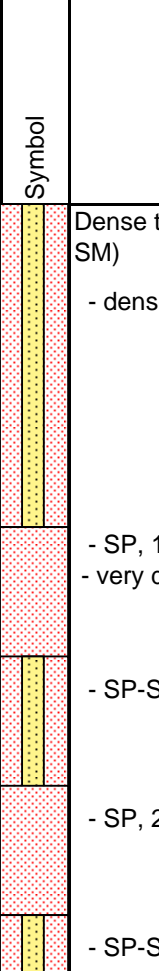

Certificate No. T-1741

Depth, m		SPT ⁽¹⁾	SPT ⁽¹⁾		Symbol	SOIL DESCRIPTION	Depth of Strata, (m)	Grain Size Analysis				Atterberg Limits			Density and Moisture			Specific Gravity	Shear Tests			
From	To		Field Value, N _f	Corrected Value, N _c				Gravel (%)	Sand (%)	Silt (%)	Clay (%)	Liquid (%)	Plastic (%)	Plasticity Index (%)	Bulk Density (gms/cm ³)	Dry Density (gms/cm ³)	Moisture Content (%)		Type of Test	Confining Pressures, (kg/cm ²)	Cohesion Intercept, 'c' (kg/cm ²)	Angle of Internal Friction, φ (degrees)
11.00	11.45	SPT9	35	28		Dense to very dense grey fine sand (SP-SM)																
12.00	12.45	SPT10	42	33		- dense, 11.0 to 16.0 m	0	90	10	0												
13.00	13.45	SPT11	46	35			0	94	6	0												
14.00	14.45	SPT12	50	38			0	94	6	0												
15.00	15.45	SPT13	44	33																		
16.00	16.45	SPT14	61	45		- SP, 16.0 to 18.0 m	0	96	4	0												
17.00	17.45	SPT15	66	48		- very dense, 16.0 to 23.0 m																
18.00	18.45	SPT16	76	54		- SP-SM, 18.0 to 20.0 m	0	95	5	0												
19.00	19.40	SPT17	100/25cm	100/25cm																		
20.00	20.41	SPT18	100/26cm	100/26cm		- SP, 20.0 to 22.0 m	0	99	1	0												
21.00	21.38	SPT19	100/23cm	100/23cm																		
22.00	22.40	SPT20	100/25cm	100/25cm	- SP-SM, 22.0 to 23.0 m	0	91	9	0													

⁽¹⁾ SPT is outside NABL scope.

Soil Profile (BH-P-1)

Location : Coal Silo #4 Site

Termination Depth : 40.32 m (RL 5.2 m)

Boring Method : Shell & Auger

UTM Coordinates : 402227.78 m E, 2809110.21 m N

Ground Water Depth : 9.60 m

Casing Depth : 39.0 m

Surface Elevation : RL 45.50 m

Boring Start : 13-Jul-15

Ground Water Level : 35.9 m

Boring Finish : 14-Jul-15

ISO/IEC 17025:2005
Certified Laboratory
(NABL)



Certificate No. T-1741

Depth, m		SPT ⁽¹⁾	SOIL DESCRIPTION	Depth of Strata, (m)	Grain Size Analysis				Atterberg Limits			Density and Moisture			Specific Gravity	Shear Tests						
From	To				Sample No.	Field Value, N _f	Corrected Value, N _c	Symbol	Gravel (%)	Sand (%)	Silt (%)	Clay (%)	Liquid (%)	Plastic (%)		Plasticity Index (%)	Bulk Density (gms/cm ³)	Dry Density (gms/cm ³)	Moisture Content (%)	Type of Test	Confining Pressures, (kg/cm ²)	Cohesion Intercept, 'c' (kg/cm ²)
23.00	23.38	SPT21	100/23cm	100/23cm	Very dense grey fine sand (SP-SM)																	
24.00	24.36	SPT22	100/21cm	100/21cm		0	91	9	0													
25.00	25.38	SPT23	100/23cm	100/23cm																		
26.00	26.35	SPT24	100/20cm	100/20cm		0	88	12	0													
27.00	27.40	SPT25	100/25cm	100/25cm																		
28.00	28.38	SPT26	100/23cm	100/23cm		0	90	10	0													
29.00	29.35	SPT27	100/20cm	100/20cm																		
30.00	30.35	SPT28	100/20cm	100/20cm		0	92	8	0													
31.00	31.38	SPT29	100/23cm	100/23cm																		
32.00	32.36	SPT30	100/21cm	100/21cm																		
33.00	33.38	SPT31	100/23cm	100/23cm		0	91	9	0													
34.00	34.35	SPT32	100/20cm	100/20cm																		

⁽¹⁾ SPT is outside NABL scope.

Soil Profile (BH-P-1)

Location : Coal Silo #4 Site

Termination Depth : 40.32 m (RL 5.2 m)

Boring Method : Shell & Auger

UTM Coordinates : 402227.78 m E, 2809110.21 m N

Ground Water Depth : 9.60 m

Casing Depth : 39.0 m

Surface Elevation : RL 45.50 m

Boring Start : 13-Jul-15

Ground Water Level : 35.9 m

Boring Finish : 14-Jul-15

ISO/IEC 17025:2005
Certified Laboratory
(NABL)



Certificate No. T-1741

Depth, m		SPT ⁽¹⁾	SOIL DESCRIPTION	Depth of Strata, (m)	Grain Size Analysis				Atterberg Limits			Density and Moisture			Specific Gravity	Shear Tests					
From	To				Sample No.	Field Value, N _f	Corrected Value, N _c	Symbol	Gravel (%)	Sand (%)	Silt (%)	Clay (%)	Liquid (%)	Plastic (%)		Plasticity Index (%)	Bulk Density (gms/cm ³)	Dry Density (gms/cm ³)	Moisture Content (%)	Type of Test	Confining Pressures, (kg/cm ²)
35.00	35.35	SPT33	100/20cm	100/20cm	Very dense grey fine sand (SP-SM)		0	91	9	0											
36.00	36.39	SPT34	100/24cm	100/24cm																	
37.00	37.33	SPT35	100/18cm	100/18cm																	
38.00	38.35	SPT36	100/20cm	100/20cm																	
39.00	39.33	SPT37	100/18cm	100/18cm																	
40.00	40.32	SPT38	100/17cm	100/17cm	40.45																

⁽¹⁾ SPT is outside NABL scope.

Soil Profile (BH-P-2)

Location : Chimney Site Termination Depth : 40.34 m (RL 5.2 m) Boring Method : Shell & Auger
 UTM Coordinates : 401627.08 m E, 2808823.46 m N Ground Water Depth : 10.10 m Casing Depth : 38.5 m
 Surface Elevation : RL 45.50 m Boring Start : 02-Jul-15
 Ground Water Level : 35.4 m Boring Finish : 06-Jul-15

ISO/IEC 17025:2005
Certified Laboratory
(NABL)



Certificate No. T-1741

Depth, m		Sample No.	SPT ⁽¹⁾		Symbol	SOIL DESCRIPTION	Depth of Strata, (m)	Grain Size Analysis				Atterberg Limits			Density and Moisture			Specific Gravity	Shear Tests				
From	To		Field Value, N _r	Corrected Value, N _c				Gravel (%)	Sand (%)	Silt (%)	Clay (%)	Liquid (%)	Plastic (%)	Plasticity Index (%)	Bulk Density (gms/cm ³)	Dry Density (gms/cm ³)	Moisture Content (%)		Type of Test	Confining Pressures, (kg/cm ²)	Cohesion Intercept, 'c' (kg/cm ²)	Angle of Internal Friction, φ (degrees)	
0.00	1.00	DS1				FILL: Flyash																	
1.00	1.45	SPT1	8	12				0	19	74	7	31.8	20.3	11.4									
2.00	2.45	SPT2	10	13																			
3.00	3.30	UDS1					4.00	0	42	44	14				1.46	1.07	35.8		DS	0.5 ,1, 1.5	0.0	30.6	
4.00	4.45	SPT3	7	8		Loose grey sandy silt, low plastic (CL)																	
5.00	5.45	SPT4	8	8				0	10	80	10							2.62					
6.00	6.30	UDS2					7.00					31.7	24.0	7.7	1.92	1.52	26.2		UC	-	1.7		
7.00	7.45	SPT5	5	5		Firm grey clayey silt, medium plastic (CI)		0	3	77	20	43.6	22.6	21.0									
8.00	8.45	SPT6	5	5								39.3	25.0	14.3									
9.00	9.45	SPT7	6	6			10.00	0	3	79	18	40.9	21.3	19.6									
10.00	10.45	SPT8	9	7		Loose to medium dense grey sandy silt, low plastic (CL)																	
11.00	11.45	SPT9	26	21		- loose, 10.0 to 11.0 m - medium dense, 11.0 to 12.0 m	12.00	0	24	61	15	30.8	20.7	10.1									

⁽¹⁾ SPT is outside NABL scope.

Soil Profile (BH-P-2)

Location : Chimney Site Termination Depth : 40.34 m (RL 5.2 m) Boring Method : Shell & Auger
 UTM Coordinates : 401627.08 m E, 2808823.46 m N Ground Water Depth : 10.10 m Casing Depth : 38.5 m
 Surface Elevation : RL 45.50 m Boring Start : 02-Jul-15
 Ground Water Level : 35.4 m Boring Finish : 06-Jul-15

ISO/IEC 17025:2005
Certified Laboratory
(NABL)



Certificate No. T-1741

Depth, m		Sample No.	SPT ⁽¹⁾		Symbol	SOIL DESCRIPTION	Depth of Strata, (m)	Grain Size Analysis				Atterberg Limits			Density and Moisture			Specific Gravity	Shear Tests			
From	To		Field Value, N _r	Corrected Value, N _c				Gravel (%)	Sand (%)	Silt (%)	Clay (%)	Liquid (%)	Plastic (%)	Plasticity Index (%)	Bulk Density (gms/cm ³)	Dry Density (gms/cm ³)	Moisture Content (%)		Type of Test	Confining Pressures, (kg/cm ²)	Cohesion Intercept, 'c' (kg/cm ²)	Angle of Internal Friction, φ (degrees)
12.00	12.45	SPT10	32	25		Dense to very dense grey fine sand (SP-SM)																
13.00	13.45	SPT11	32	24		- dense, 12.0 to 14.0 m		0	92	8	0											
14.00	14.38	SPT12	100/23cm	100/23cm		- very dense, 14.0 to 24.0 m																
15.00	15.36	SPT13	100/21cm	100/21cm				0	94	6	0											
16.00	16.34	SPT14	100/19cm	100/19cm																		
17.00	17.37	SPT15	100/22cm	100/22cm		- SP, 17.0 to 19.0 m		0	96	4	0											
18.00	18.42	SPT16	100/27cm	100/27cm																		
19.00	19.44	SPT17	100/29cm	100/29cm		- SP-SM, 19.0 to 23.0 m		0	95	5	0											
20.00	20.42	SPT18	100/27cm	100/27cm																		
21.00	21.40	SPT19	100/25cm	100/25cm				0	94	6	0											
22.00	22.43	SPT20	100/28cm	100/28cm																		
23.00	23.40	SPT21	100/25cm	100/25cm		- SP, 23.0 to 24.0 m		0	98	2	0											

⁽¹⁾ SPT is outside NABL scope.

Soil Profile (BH-P-2)

Location : Chimney Site Termination Depth : 40.34 m (RL 5.2 m) Boring Method : Shell & Auger
 UTM Coordinates : 401627.08 m E, 2808823.46 m N Ground Water Depth : 10.10 m Casing Depth : 38.5 m
 Surface Elevation : RL 45.50 m Boring Start : 02-Jul-15
 Ground Water Level : 35.4 m Boring Finish : 06-Jul-15

ISO/IEC 17025:2005
Certified Laboratory
(NABL)



Certificate No. T-1741

Depth, m		SPT ⁽¹⁾	SOIL DESCRIPTION	Depth of Strata, (m)	Grain Size Analysis				Atterberg Limits			Density and Moisture			Specific Gravity	Shear Tests				
From	To				Sample No.	Field Value, N _r	Corrected Value, N _c	Symbol	Gravel (%)	Sand (%)	Silt (%)	Clay (%)	Liquid (%)	Plastic (%)		Plasticity Index (%)	Bulk Density (gms/cm ³)	Dry Density (gms/cm ³)	Moisture Content (%)	Type of Test
24.00	24.40	SPT22	100/25cm	100/25cm	Very dense grey fine sand (SP)															
25.00	25.44	SPT23	100/29cm	100/29cm		0	96	4	0											
26.00	26.41	SPT24	100/26cm	100/26cm																
27.00	27.39	SPT25	100/24cm	100/24cm		0	96	4	0											
28.00	28.37	SPT26	100/22cm	100/22cm																
29.00	29.37	SPT27	100/22cm	100/22cm																
30.00	30.35	SPT28	100/20cm	100/20cm																
31.00	31.38	SPT29	100/23cm	100/23cm	- SP-SM, 31.0 to 34.0 m	0	95	5	0											
32.00	32.40	SPT30	100/25cm	100/25cm																
33.00	33.41	SPT31	100/26cm	100/26cm																
34.00	34.37	SPT32	100/22cm	100/22cm	- SP, 34.0 to 36.0 m - with traces of gravel, 34.0 to 35.0 m	1	95	4	0											
35.00	35.35	SPT33	100/20cm	100/20cm																

⁽¹⁾ SPT is outside NABL scope.

Soil Profile (BH-P-2)

Location : Chimney Site Termination Depth : 40.34 m (RL 5.2 m) Boring Method : Shell & Auger
 UTM Coordinates : 401627.08 m E, 2808823.46 m N Ground Water Depth : 10.10 m Casing Depth : 38.5 m
 Surface Elevation : RL 45.50 m Boring Start : 02-Jul-15
 Ground Water Level : 35.4 m Boring Finish : 06-Jul-15

ISO/IEC 17025:2005
Certified Laboratory
(NABL)



Certificate No. T-1741

Depth, m		SPT ⁽¹⁾	SOIL DESCRIPTION	Depth of Strata, (m)	Grain Size Analysis				Atterberg Limits			Density and Moisture			Specific Gravity	Shear Tests					
From	To				Sample No.	Field Value, N _r	Corrected Value, N _c	Symbol	Gravel (%)	Sand (%)	Silt (%)	Clay (%)	Liquid (%)	Plastic (%)		Plasticity Index (%)	Bulk Density (gms/cm ³)	Dry Density (gms/cm ³)	Moisture Content (%)	Type of Test	Confining Pressures, (kg/cm ²)
36.00	36.33	SPT34	100/18cm	100/18cm	 Very dense grey fine sand (SP-SM) - with gravel, 38.0 to 39.0 m - with traces of gravel, 40.0 to 40.34 m																
37.00	37.39	SPT35	100/24cm	100/24cm																	
38.00	38.38	SPT36	100/23cm	100/23cm																	
39.00	39.37	SPT37	100/22cm	100/22cm																	
40.00	40.34	SPT38	100/19cm	100/19cm	40.34																

⁽¹⁾ SPT is outside NABL scope.

Soil Profile (BH-P-3)

Location : Boiler Foundation Site

Termination Depth : 40.33 m (RL 5.2 m)

Boring Method : Shell & Auger

UTM Coordinates : 401549.02 m E, 2808592.84 m N

Ground Water Depth : 9.90 m

Casing Depth : 38.6 m

Surface Elevation : RL 45.50 m

Boring Start : 02-Jul-15

Ground Water Level : 35.6 m

Boring Finish : 24-Jul-15

ISO/IEC 17025:2005
Certified Laboratory
(NABL)



Certificate No. T-1741

Depth, m		Sample No.	SPT ⁽¹⁾		Symbol	SOIL DESCRIPTION	Depth of Strata, (m)	Grain Size Analysis				Atterberg Limits			Density and Moisture			Specific Gravity	Shear Tests				
From	To		Field Value, N _f	Corrected Value, N _c				Gravel (%)	Sand (%)	Silt (%)	Clay (%)	Liquid (%)	Plastic (%)	Plasticity Index (%)	Bulk Density (gms/cm ³)	Dry Density (gms/cm ³)	Moisture Content (%)		Type of Test	Confining Pressures, (kg/cm ²)	Cohesion Intercept, 'c' (kg/cm ²)	Angle of Internal Friction, φ (degrees)	
0.00	0.50	DS1			[Blue wavy pattern]	FILL: Flyash																	
0.50	1.00	DS2						18	28	49	5												
1.50	1.80	UDS1										1.48	1.13	30.9	DS	0.5 , 1, 1.5	0.0	28.9					
2.50	2.95	SPT1	10	12				0	41	54	5	30.0	17.1	12.8									
3.50	3.95	SPT2	11	12			4.50																
4.50	4.80	UDS2			[Green grid pattern]	Loose to medium dense brown sandy silt, low plastic (CL)		0	8	61	31			1.93	1.58	22.0							
5.50	5.95	SPT3	7	7			- loose, 4.5 to 6.5 m					32.4	20.7	11.7									
6.50	6.95	SPT4	12	11			- medium dense, 6.5 to 7.5 m - with gravel, 6.5 to 7.5 m	7.50	13	7	73	7											
7.50	7.80	UDS3			[Yellow dotted pattern]	Medium dense grey silty fine sand (SM)						1.85	1.57	18.2									
8.50	8.95	SPT5	14	12											2.67								
9.50	9.95	SPT6	14	11																			
10.50	10.80	UDS4						11.50	0	61	36	3		Non Plastic	1.90	1.53	24.0						

⁽¹⁾ SPT is outside NABL scope.

Soil Profile (BH-P-3)



Location : Boiler Foundation Site Termination Depth : 40.33 m (RL 5.2 m) Boring Method : Shell & Auger
 UTM Coordinates : 401549.02 m E, 2808592.84 m N Ground Water Depth : 9.90 m Casing Depth : 38.6 m
 Surface Elevation : RL 45.50 m Boring Start : 02-Jul-15
 Ground Water Level : 35.6 m Boring Finish : 24-Jul-15

Depth, m		SPT ⁽¹⁾	Symbol	SOIL DESCRIPTION	Depth of Strata, (m)	Grain Size Analysis				Atterberg Limits			Density and Moisture			Specific Gravity	Shear Tests				
From	To					Sample No.	Field Value, N _f	Corrected Value, N _c	Gravel (%)	Sand (%)	Silt (%)	Clay (%)	Liquid (%)	Plastic (%)	Plasticity Index (%)		Bulk Density (gms/cm ³)	Dry Density (gms/cm ³)	Moisture Content (%)	Type of Test	Confining Pressures, (kg/cm ²)
11.50	11.95	SPT7	15	12	Medium dense to dense grey fine sand (SP-SM)		0	91	9	0											
12.50	12.95	SPT8	17	13																	- medium dense, 11.5 to 14.5 m
13.50	13.95	SPT9	26	20																	- dense, 14.5 to 16.5 m
14.50	14.95	SPT10	32	24	16.50	0	89	11	0												
15.50	15.95	SPT11	38	28																	
16.50	16.95	SPT12	45	32	18.50	0	87	13	0												
17.50	17.95	SPT13	50	35																	Dense grey silty fine sand (SM)
18.50	18.95	SPT14	56	39	Very dense grey fine sand (SP-SM)	0	88	12	0												
19.50	19.95	SPT15	66	45																	
20.50	20.95	SPT16	70	47																	
21.50	21.88	SPT17	100/ 23cm	100/ 23cm																	
22.50	22.90	SPT18	100/ 25cm	100/ 25cm																	

⁽¹⁾ SPT is outside NABL scope.

Soil Profile (BH-P-3)

Location : Boiler Foundation Site

Termination Depth : 40.33 m (RL 5.2 m)

Boring Method : Shell & Auger

UTM Coordinates : 401549.02 m E, 2808592.84 m N

Ground Water Depth : 9.90 m

Casing Depth : 38.6 m

Surface Elevation : RL 45.50 m

Boring Start : 02-Jul-15

Ground Water Level : 35.6 m

Boring Finish : 24-Jul-15

ISO/IEC 17025:2005
Certified Laboratory
(NABL)



Certificate No. T-1741

Depth, m		SPT ⁽¹⁾	SOIL DESCRIPTION	Depth of Strata, (m)	Grain Size Analysis				Atterberg Limits			Density and Moisture			Specific Gravity	Shear Tests																						
From	To				Field Value, N _f	Corrected Value, N _c	Symbol	Gravel (%)	Sand (%)	Silt (%)	Clay (%)	Liquid (%)	Plastic (%)	Plasticity Index (%)		Bulk Density (gms/cm ³)	Dry Density (gms/cm ³)	Moisture Content (%)	Type of Test	Confining Pressures, (kg/cm ²)	Cohesion Intercept, 'c' (kg/cm ²)	Angle of Internal Friction, φ (degrees)																
23.50	23.89	SPT19	100/24cm 100/24cm	Very dense grey fine sand (SP-SM)		0	94	6	0																													
24.50	24.86	SPT20	100/21cm 100/21cm																																			
25.50	25.85	SPT21	100/20cm 100/20cm																																			
26.50	26.87	SPT22	100/22cm 100/22cm																																			
27.50	27.90	SPT23	100/25cm 100/25cm																																			
28.50	28.86	SPT24	100/21cm 100/21cm																																			
29.50	29.83	SPT25	100/18cm 100/18cm																																			
30.50	30.85	SPT26	100/20cm 100/20cm																		- SP, 30.5 to 32.5 m	0	96	4	0													
31.50	31.87	SPT27	100/22cm 100/22cm																																			
32.50	32.88	SPT28	100/23cm 100/23cm																		- SP-SM, 32.5 to 35.5 m	0	94	6	0													
33.50	33.86	SPT29	100/21cm 100/21cm																																			
34.50	34.31	SPT30	100/26cm 100/26cm			0	91	9	0																													

⁽¹⁾ SPT is outside NABL scope.

Soil Profile (BH-P-3)

Location : Boiler Foundation Site

Termination Depth : 40.33 m (RL 5.2 m)

Boring Method : Shell & Auger

UTM Coordinates : 401549.02 m E, 2808592.84 m N

Ground Water Depth : 9.90 m

Casing Depth : 38.6 m

Surface Elevation : RL 45.50 m

Boring Start : 02-Jul-15

Ground Water Level : 35.6 m

Boring Finish : 24-Jul-15

ISO/IEC 17025:2005
Certified Laboratory
(NABL)



Certificate No. T-1741

Depth, m		SPT ⁽¹⁾	SOIL DESCRIPTION	Depth of Strata, (m)	Grain Size Analysis				Atterberg Limits			Density and Moisture			Specific Gravity	Shear Tests					
From	To				Field Value, N _f	Corrected Value, N _c	Symbol	Gravel (%)	Sand (%)	Silt (%)	Clay (%)	Liquid (%)	Plastic (%)	Plasticity Index (%)		Bulk Density (gms/cm ³)	Dry Density (gms/cm ³)	Moisture Content (%)	Type of Test	Confining Pressures, (kg/cm ²)	Cohesion Intercept, 'c' (kg/cm ²)
35.50	35.90	SPT31	100/25cm 100/25cm	40.33	Very dense grey fine sand (SP) - SP-SM, 38.5 to 40.33 m	0	96	4	0												
36.50	36.82	SPT32	100/27cm 100/27cm																		
37.50	37.85	SPT33	100/20cm 100/20cm																		
38.50	38.80	SPT34	100/15cm 100/15cm			0	95	5	0												
40.00	40.33	SPT35	100/18cm 100/18cm																		

⁽¹⁾ SPT is outside NABL scope.

Soil Profile (BH-P-4)

Location : Generator Foundation Site Termination Depth : 40.34 m (RL 5.2 m) Boring Method : Shell & Auger
 UTM Coordinates : 401536.16 m E, 2808557.61 m N Ground Water Depth : 9.80 m Casing Depth : 37.8 m
 Surface Elevation : RL 45.50 m Boring Start : 07-Jul-15
 Ground Water Level : 35.7 m Boring Finish : 08-Jul-15

ISO/IEC 17025:2005
Certified Laboratory
(NABL)



Certificate No. T-1741

Depth, m		Sample No.	SPT ⁽¹⁾		Symbol	SOIL DESCRIPTION	Depth of Strata, (m)	Grain Size Analysis				Atterberg Limits			Density and Moisture			Specific Gravity	Shear Tests					
From	To		Field Value, N _f	Corrected Value, N _c				Gravel (%)	Sand (%)	Silt (%)	Clay (%)	Liquid (%)	Plastic (%)	Plasticity Index (%)	Bulk Density (gms/cm ³)	Dry Density (gms/cm ³)	Moisture Content (%)		Type of Test	Confining Pressures, (kg/cm ²)	Cohesion Intercept, 'c' (kg/cm ²)	Angle of Internal Friction, φ (degrees)		
0.00	0.50	DS1			[Symbol: Blue wavy pattern]	FILL: Flyash																		
0.50	1.00	DS2																						
1.50	1.80	UDS1							1	25	61	13	27.5	12.6	14.8	1.37	1.01	35.7		DS	0.5 ,1, 1.5	0.0	35.7	
2.50	2.95	SPT1	9	11																				
3.50	3.95	SPT2	13	14				4.50	0	29	57	14												
4.50	4.80	UDS2				[Symbol: Green grid pattern]	Loose grey sandy silt, low plastic (CL)						1.91	1.57	22.0					UU	0.4 ,0.6, 0.8	2.1	19.0	
5.50	5.95	SPT3	5	5				6.50	0	12	78	10	32.9	18.8	14.1				2.63					
6.50	6.95	SPT4	8	8	[Symbol: Green diagonal lines]	Firm brown clayey silt, medium plastic (CI)	7.50	0	3	82	15	40.6	20.4	20.2										
7.50	7.80	UDS3			[Symbol: Yellow dotted pattern]	Medium dense grey silty fine sand (SM)						1.85	1.57	18.0					DS	0.5 ,1, 1.5	0.0	32.3		
8.50	8.95	SPT5	24	20				0	87	13	0													
9.50	9.95	SPT6	28	23																				
10.50	10.95	SPT7	30	24				0	86	14	0													

⁽¹⁾ SPT is outside NABL scope.

Soil Profile (BH-P-4)

Location :	Generator Foundation Site	Termination Depth :	40.34 m (RL 5.2 m)	Boring Method :	Shell & Auger
UTM Coordinates :	401536.16 m E, 2808557.61 m N	Ground Water Depth :	9.80 m	Casing Depth :	37.8 m
		Surface Elevation :	RL 45.50 m	Boring Start :	07-Jul-15
		Ground Water Level :	35.7 m	Boring Finish :	08-Jul-15

ISO/IEC 17025:2005
Certified Laboratory
(NABL)



Certificate No. T-1741

Depth, m		SPT ⁽¹⁾	SOIL DESCRIPTION	Depth of Strata, (m)	Grain Size Analysis				Atterberg Limits			Density and Moisture			Specific Gravity	Shear Tests						
From	To				Sample No.	Field Value, N _f	Corrected Value, N _c	Symbol	Gravel (%)	Sand (%)	Silt (%)	Clay (%)	Liquid (%)	Plastic (%)		Plasticity Index (%)	Bulk Density (gms/cm ³)	Dry Density (gms/cm ³)	Moisture Content (%)	Type of Test	Confining Pressures, (kg/cm ²)	Cohesion Intercept, 'c' (kg/cm ²)
11.50	11.95	SPT8	38	30	Medium dense grey silty fine sand (SM)																	
12.50	12.95	SPT9	40	31			0	86	14	0												
13.50	13.95	SPT10	40	30																		
14.50	14.95	SPT11	43	32		15.50	0	87	13	0												
15.50	15.95	SPT12	44	32	Dense to very dense grey fine sand (SP-SM) - dense, 15.5 to 16.5 m - very dense, 16.5 to 18.5 m																	
16.50	16.95	SPT13	51	37		18.50	0	95	5	0												
17.50	17.95	SPT14	64	46																		
18.50	18.95	SPT15	60	42	Very dense grey silty fine sand (SM)																	
19.50	19.95	SPT16	72	50		20.50	0	87	13	0												
20.50	20.95	SPT17	76	52	Very dense grey fine sand (SP-SM)																	
21.50	21.91	SPT18	100/26cm	100/26cm		22.50	0	88	12	0												
22.50	22.89	SPT19	100/24cm	100/24cm		0	87	13	0													

⁽¹⁾ SPT is outside NABL scope.

Soil Profile (BH-P-4)

Location : Generator Foundation Site Termination Depth : 40.34 m (RL 5.2 m) Boring Method : Shell & Auger
 UTM Coordinates : 401536.16 m E, 2808557.61 m N Ground Water Depth : 9.80 m Casing Depth : 37.8 m
 Surface Elevation : RL 45.50 m Boring Start : 07-Jul-15
 Ground Water Level : 35.7 m Boring Finish : 08-Jul-15



Depth, m		SPT ⁽¹⁾	SOIL DESCRIPTION	Depth of Strata, (m)	Grain Size Analysis				Atterberg Limits			Density and Moisture			Specific Gravity	Shear Tests			
From	To				Field Value, N _f	Corrected Value, N _c	Symbol	Gravel (%)	Sand (%)	Silt (%)	Clay (%)	Liquid (%)	Plastic (%)	Plasticity Index (%)		Bulk Density (gms/cm ³)	Dry Density (gms/cm ³)	Moisture Content (%)	Type of Test
23.50	23.88	SPT20	100/23cm 100/23cm	26.50	Very desen grey silty fine sand (SM)	0	87	13	0										
24.50	24.92	SPT21	100/27cm 100/27cm																
25.50	25.90	SPT22	100/25cm 100/25cm	26.50	Very dense grey fine sand (SP-SM)	0	90	10	0										
26.50	26.86	SPT23	100/21cm 100/21cm																
27.50	27.87	SPT24	100/22cm 100/22cm	26.50	- SP, with traces of gravel, 28.5 to 32.5 m	1	96	3	0										
28.50	28.85	SPT25	100/20cm 100/20cm																
29.50	29.83	SPT26	100/18cm 100/18cm																
30.50	30.88	SPT27	100/23cm 100/23cm	26.50	- SP-SM, 32.5 to 35.5 m	0	89	11	0										
31.50	31.86	SPT28	100/21cm 100/21cm																
32.50	32.85	SPT29	100/20cm 100/20cm	26.50															
33.50	33.90	SPT30	100/25cm 100/25cm																
34.50	34.88	SPT31	100/23cm 100/23cm																

⁽¹⁾ SPT is outside NABL scope.

Soil Profile (BH-P-4)

Location : Generator Foundation Site Termination Depth : 40.34 m (RL 5.2 m) Boring Method : Shell & Auger
 UTM Coordinates : 401536.16 m E, 2808557.61 m N Ground Water Depth : 9.80 m Casing Depth : 37.8 m
 Surface Elevation : RL 45.50 m Boring Start : 07-Jul-15
 Ground Water Level : 35.7 m Boring Finish : 08-Jul-15

ISO/IEC 17025:2005
Certified Laboratory
(NABL)



Certificate No. T-1741

Depth, m		SPT ⁽¹⁾	Symbol	SOIL DESCRIPTION	Depth of Strata, (m)	Grain Size Analysis				Atterberg Limits			Density and Moisture			Specific Gravity	Shear Tests			
From	To					Field Value, N _f	Corrected Value, N _c	Gravel (%)	Sand (%)	Silt (%)	Clay (%)	Liquid (%)	Plastic (%)	Plasticity Index (%)	Bulk Density (gms/cm ³)		Dry Density (gms/cm ³)	Moisture Content (%)	Type of Test	Confining Pressures, (kg/cm ²)
35.50	35.85	SPT32	100/20cm	100/20cm	40.00	0	87	13	0											
36.50	36.87	SPT33	100/22cm	100/22cm																
37.50	37.83	SPT34	100/18cm	100/18cm																
38.50	38.85	SPT35	100/20cm	100/20cm	40.00															
40.00	40.34	SPT36	100/19cm	100/19cm	40.34	0	84	16	0											

⁽¹⁾ SPT is outside NABL scope.

Soil Profile (BH-P-5)

Location : Generator Transformer Site Termination Depth : 40.33 m (RL 5.2 m) Boring Method : Shell & Auger
 UTM Coordinates : 401506.00 m E, 2808528.00 m N Ground Water Depth : 9.85 m Casing Depth : 38.9 m
 Surface Elevation : RL 45.50 m Boring Start : 07-Jul-15
 Ground Water Level : 35.65 m Boring Finish : 09-Jul-15

ISO/IEC 17025:2005
Certified Laboratory
(NABL)



Certificate No. T-1741

Depth, m		Sample No.	SPT ⁽¹⁾		Symbol	SOIL DESCRIPTION	Depth of Strata, (m)	Grain Size Analysis				Atterberg Limits			Density and Moisture			Specific Gravity	Shear Tests					
From	To		Field Value, N _f	Corrected Value, N _c				Gravel (%)	Sand (%)	Silt (%)	Clay (%)	Liquid (%)	Plastic (%)	Plasticity Index (%)	Bulk Density (gms/cm ³)	Dry Density (gms/cm ³)	Moisture Content (%)		Type of Test	Confining Pressures, (kg/cm ²)	Cohesion Intercept, 'c' (kg/cm ²)	Angle of Internal Friction, φ (degrees)		
0.00	1.00	DS1			[Symbol]	FILL: Flyash																		
1.00	1.45	SPT1						26	18	56	35.1	20.6	14.5											
2.00	2.45	SPT2	7	9																				
3.00	3.30	UDS1					4.00	3	15	54	28		1.43	1.10	30.0		DS	0.5 , 1, 1.5	0.0			39.0		
4.00	4.45	SPT3	5	5	[Symbol]	Firm brown clayey silt, medium plastic (CI)		0	4	81	15	36.8	21.1	15.6										
5.00	5.45	SPT4	7	7	[Symbol]		6.00	0	6	71	23	46.6	22.4	24.2										
6.00	6.30	DS2			[Symbol]	Medium dense grey silty fine sand (SM)																		
7.00	7.45	SPT5	14	13													2.64							
8.00	8.45	SPT6	16	14				0	81	19	0													
9.00	9.45	SPT7	18	15																				
10.00	10.45	SPT8	21	17		- with traces of gravel, 10.0 to 12.0 m		2	84	14	0													
11.00	11.45	SPT9	28	22			12.00																	

⁽¹⁾ SPT is outside NABL scope.

Soil Profile (BH-P-5)

Location : Generator Transformer Site Termination Depth : 40.33 m (RL 5.2 m) Boring Method : Shell & Auger
 UTM Coordinates : 401506.00 m E, 2808528.00 m N Ground Water Depth : 9.85 m Casing Depth : 38.9 m
 Surface Elevation : RL 45.50 m Boring Start : 07-Jul-15
 Ground Water Level : 35.65 m Boring Finish : 09-Jul-15

ISO/IEC 17025:2005
Certified Laboratory
(NABL)



Certificate No. T-1741

Depth, m		SPT ⁽¹⁾	Symbol	SOIL DESCRIPTION	Depth of Strata, (m)	Grain Size Analysis				Atterberg Limits			Density and Moisture			Specific Gravity	Shear Tests				
From	To					Sample No.	Field Value, N _f	Corrected Value, N _c	Gravel (%)	Sand (%)	Silt (%)	Clay (%)	Liquid (%)	Plastic (%)	Plasticity Index (%)		Bulk Density (gms/cm ³)	Dry Density (gms/cm ³)	Moisture Content (%)	Type of Test	Confining Pressures, (kg/cm ²)
12.00	12.45	SPT10	30	23	19.00	Dense to very dense grey fine sand (SP-SM) - dense, 12.0 to 17.0 m	0	88	12	0											
13.00	13.45	SPT11	32	24																	
14.00	14.45	SPT12	38	29																	
15.00	15.45	SPT13	44	33			- with traces of gravel, 15.0 to 16.0 m	2	92	6	0										
16.00	16.45	SPT14	44	32																	
17.00	17.45	SPT15	51	37	- very dense, 17.0 to 19.0 m	0	95	5	0												
18.00	18.45	SPT16	58	41	23.00	Very dense grey silty fine sand (SM)	0	87	13	0											
19.00	19.45	SPT17	63	44																	
20.00	20.45	SPT18	67	46																	
21.00	21.45	SPT19	74	50																	
22.00	22.45	SPT20	76	50																	
23.00	23.41	SPT21	100/26cm	100/26cm		Very dense grey fine sand (SP)	0	98	2	0											

⁽¹⁾ SPT is outside NABL scope.

Soil Profile (BH-P-5)

Location : Generator Transformer Site Termination Depth : 40.33 m (RL 5.2 m) Boring Method : Shell & Auger
 UTM Coordinates : 401506.00 m E, 2808528.00 m N Ground Water Depth : 9.85 m Casing Depth : 38.9 m
 Surface Elevation : RL 45.50 m Boring Start : 07-Jul-15
 Ground Water Level : 35.65 m Boring Finish : 09-Jul-15

ISO/IEC 17025:2005
Certified Laboratory
(NABL)



Certificate No. T-1741

Depth, m		SPT ⁽¹⁾	Symbol	SOIL DESCRIPTION	Depth of Strata, (m)	Grain Size Analysis				Atterberg Limits			Density and Moisture			Specific Gravity	Shear Tests				
From	To					Sample No.	Field Value, N _f	Corrected Value, N _c	Gravel (%)	Sand (%)	Silt (%)	Clay (%)	Liquid (%)	Plastic (%)	Plasticity Index (%)		Bulk Density (gms/cm ³)	Dry Density (gms/cm ³)	Moisture Content (%)	Type of Test	Confining Pressures, (kg/cm ²)
24.00	24.38	SPT22	100/23cm	100/23cm	27.00	0	93	7	0												
25.00	25.40	SPT23	100/25cm	100/25cm																	
26.00	26.41	SPT24	100/26cm	100/26cm																	
27.00	27.38	SPT25	100/23cm	100/23cm	29.00	0	87	13	0												
28.00	28.36	SPT26	100/21cm	100/21cm																	
29.00	29.38	SPT27	100/23cm	100/23cm		0	98	2	0												
30.00	30.35	SPT28	100/20cm	100/20cm																	
31.00	31.38	SPT29	100/23cm	100/23cm																	
32.00	32.39	SPT30	100/24cm	100/24cm																	
33.00	33.35	SPT31	100/20cm	100/20cm		3	87	10	0												
34.00	34.36	SPT32	100/21cm	100/21cm																	
35.00	35.35	SPT33	100/20cm	100/20cm																	

⁽¹⁾ SPT is outside NABL scope.

Soil Profile (BH-P-5)

Location :	Generator Transformer Site	Termination Depth :	40.33 m (RL 5.2 m)	Boring Method :	Shell & Auger
UTM Coordinates :	401506.00 m E, 2808528.00 m N	Ground Water Depth :	9.85 m	Casing Depth :	38.9 m
		Surface Elevation :	RL 45.50 m	Boring Start :	07-Jul-15
		Ground Water Level :	35.65 m	Boring Finish :	09-Jul-15



Depth, m		SPT ⁽¹⁾	SOIL DESCRIPTION	Depth of Strata, (m)	Grain Size Analysis				Atterberg Limits			Density and Moisture			Specific Gravity	Shear Tests					
From	To				Field Value, N _f	Corrected Value, N _c	Symbol	Gravel (%)	Sand (%)	Silt (%)	Clay (%)	Liquid (%)	Plastic (%)	Plasticity Index (%)		Bulk Density (gms/cm ³)	Dry Density (gms/cm ³)	Moisture Content (%)	Type of Test	Confining Pressures, (kg/cm ²)	Cohesion Intercept, 'c' (kg/cm ²)
36.00	36.37	SPT34	100/22cm	100/22cm	Very dense grey fine sand (SP-SM) - with traces of gravel, 37.0 to 38.0 m																
37.00	37.36	SPT35	100/21cm	100/21cm			2	93	5	0											
38.00	38.33	SPT36	100/18cm	100/18cm																	
39.00	39.38	SPT37	100/23cm	100/23cm																	
40.00	40.33	SPT38	100/18cm	100/18cm	40.33	0	88	12	0												

⁽¹⁾ SPT is outside NABL scope.

Soil Profile (BH-P-6)

Location : Raw Water Storage Tank Site Termination Depth : 40.3 m (RL 5.2 m) Boring Method : Shell & Auger
 UTM Coordinates : 401514.17 m E, 2808315.16 m N Ground Water Depth : 9.40 m Casing Depth : 39.5 m
 Surface Elevation : RL 45.50 m Boring Start : 10-Jul-15
 Ground Water Level : 36.1 m Boring Finish : 11-Jul-15

ISO/IEC 17025:2005
Certified Laboratory
(NABL)



Certificate No. T-1741

Depth, m		Sample No.	SPT ⁽¹⁾		Symbol	SOIL DESCRIPTION	Depth of Strata, (m)	Grain Size Analysis				Atterberg Limits			Density and Moisture			Specific Gravity	Shear Tests				
From	To		Field Value, N _f	Corrected Value, N _c				Gravel (%)	Sand (%)	Silt (%)	Clay (%)	Liquid (%)	Plastic (%)	Plasticity Index (%)	Bulk Density (gms/cm ³)	Dry Density (gms/cm ³)	Moisture Content (%)		Type of Test	Confining Pressures, (kg/cm ²)	Cohesion Intercept, 'c' (kg/cm ²)	Angle of Internal Friction, φ (degrees)	
0.00	0.50	DS1			[Symbol]	FILL: Flyash																	
0.50	1.00	DS2						0	62	35	3												
1.50	1.80	UDS1										1.46	1.09	34.0	DS	0.5 ,1, 1.5	0.0	32.4					
2.50	2.95	SPT1	6	7				0	22	50	28	32.1	17.1	15.0									
3.50	3.95	SPT2	9	10			4.50																
4.50	4.80	UDS2					Firm brown clayey silt with traces of gravel, medium plastic (CI)		2	20	55	23		1.92	1.59	21.0	UU	0.4 ,0.6, 0.8	2.9	5.7			
5.50	5.95	SPT3	7	7				6.50				35.6	21.8	13.7									
6.50	6.95	SPT4	20	19			Medium dense brown sandy silt, low plastic (CL)	7.50	0	25	57	18	28.7	18.5	10.2								
7.50	7.95	SPT5	23	20		Medium dense to dense grey silty fine sand (SM)																	
8.50	8.95	SPT6	24	20		- medium dense, 7.5 to 10.5 m		0	81	19	0												
9.50	9.95	SPT7	27	22																			
10.50	10.95	SPT8	36	29		- dense, 10.5 to 11.5 m		0	76	24	0												

⁽¹⁾ SPT is outside NABL scope.

Soil Profile (BH-P-6)

Location : Raw Water Storage Tank Site Termination Depth : 40.3 m (RL 5.2 m) Boring Method : Shell & Auger
 UTM Coordinates : 401514.17 m E, 2808315.16 m N Ground Water Depth : 9.40 m Casing Depth : 39.5 m
 Surface Elevation : RL 45.50 m Boring Start : 10-Jul-15
 Ground Water Level : 36.1 m Boring Finish : 11-Jul-15



Depth, m		SPT ⁽¹⁾	Symbol	SOIL DESCRIPTION	Depth of Strata, (m)	Grain Size Analysis				Atterberg Limits			Density and Moisture			Specific Gravity	Shear Tests			
From	To					Sample No.	Field Value, N _f	Corrected Value, N _c	Gravel (%)	Sand (%)	Silt (%)	Clay (%)	Liquid (%)	Plastic (%)	Plasticity Index (%)		Bulk Density (gms/cm ³)	Dry Density (gms/cm ³)	Moisture Content (%)	Type of Test
11.50	11.95	SPT9	39	31	17.50	Dense to very dense grey silty fine sand (SM)	0	79	21	0										
12.50	12.95	SPT10	41	32																- dense, 11.5 to 14.5 m
13.50	13.95	SPT11	47	36																- very dense, 14.5 to 17.5 m
14.50	14.95	SPT12	51	38																- with traces of gravel, 14.5 to 15.5 m
15.50	15.95	SPT13	55	41																
16.50	16.95	SPT14	61	44																
17.50	17.95	SPT15	49	35	17.50	Dense to very dense grey fine sand (SP-SM)	0	94	6	0										
18.50	18.95	SPT16	62	44																- dense, 17.5 to 18.5 m
19.50	19.95	SPT17	72	50																- SP, 19.5 to 23.5 m
20.50	20.95	SPT18	80	55																- very dense, 19.5 to 23.5 m
21.50	21.91	SPT19	100/26cm	100/26cm																
22.50	22.89	SPT20	100/24cm	100/24cm																

⁽¹⁾ SPT is outside NABL scope.

Soil Profile (BH-P-6)

Location : Raw Water Storage Tank Site Termination Depth : 40.3 m (RL 5.2 m) Boring Method : Shell & Auger
 UTM Coordinates : 401514.17 m E, 2808315.16 m N Ground Water Depth : 9.40 m Casing Depth : 39.5 m
 Surface Elevation : RL 45.50 m Boring Start : 10-Jul-15
 Ground Water Level : 36.1 m Boring Finish : 11-Jul-15

ISO/IEC 17025:2005
Certified Laboratory
(NABL)



Certificate No. T-1741

Depth, m		SPT ⁽¹⁾	Symbol	SOIL DESCRIPTION	Depth of Strata, (m)	Grain Size Analysis				Atterberg Limits			Density and Moisture			Specific Gravity	Shear Tests			
From	To					Sample No.	Field Value, N _f	Corrected Value, N _c	Gravel (%)	Sand (%)	Silt (%)	Clay (%)	Liquid (%)	Plastic (%)	Plasticity Index (%)		Bulk Density (gms/cm ³)	Dry Density (gms/cm ³)	Moisture Content (%)	Type of Test
23.50	23.86	SPT21	100/21cm	100/21cm		0	98	2	0											
24.50	24.88	SPT22	100/23cm	100/23cm																
25.50	25.90	SPT23	100/25cm	100/25cm		0	95	5	0											
26.50	26.87	SPT24	100/22cm	100/22cm																
27.50	27.88	SPT25	100/23cm	100/23cm		0	96	4	0											
28.50	28.85	SPT26	100/20cm	100/20cm																
29.50	29.86	SPT27	100/21cm	100/21cm		2	91	7	0											
30.50	30.83	SPT28	100/18cm	100/18cm																
31.50	31.88	SPT29	100/23cm	100/23cm		0	98	2	0											
32.50	32.86	SPT30	100/21cm	100/21cm																
33.80	33.85	SPT31	100/20cm	100/20cm		1	97	2	0											
34.80	34.89	SPT32	100/24cm	100/24cm																

⁽¹⁾ SPT is outside NABL scope.

Soil Profile (BH-P-6)

Location : Raw Water Storage Tank Site Termination Depth : 40.3 m (RL 5.2 m) Boring Method : Shell & Auger
 UTM Coordinates : 401514.17 m E, 2808315.16 m N Ground Water Depth : 9.40 m Casing Depth : 39.5 m
 Surface Elevation : RL 45.50 m Boring Start : 10-Jul-15
 Ground Water Level : 36.1 m Boring Finish : 11-Jul-15

ISO/IEC 17025:2005
Certified Laboratory
(NABL)



Certificate No. T-1741

Depth, m		SPT ⁽¹⁾	SOIL DESCRIPTION	Depth of Strata, (m)	Grain Size Analysis				Atterberg Limits			Density and Moisture			Specific Gravity	Shear Tests					
From	To				Sample No.	Field Value, N _f	Corrected Value, N _c	Symbol	Gravel (%)	Sand (%)	Silt (%)	Clay (%)	Liquid (%)	Plastic (%)		Plasticity Index (%)	Bulk Density (gms/cm ³)	Dry Density (gms/cm ³)	Moisture Content (%)	Type of Test	Confining Pressures, (kg/cm ²)
35.50	35.85	SPT33	100/20cm	100/20cm	Very dense grey fine sand (SP)	0	97	3	0												
36.50	36.84	SPT34	100/19cm	100/19cm																	
37.50	37.86	SPT35	100/21cm	100/21cm			2	96	2	0											
38.50	38.83	SPT36	100/18cm	100/18cm																	
40.00	40.30	SPT37	100/15cm	100/15cm	40.30	0	97	3	0												

⁽¹⁾ SPT is outside NABL scope.

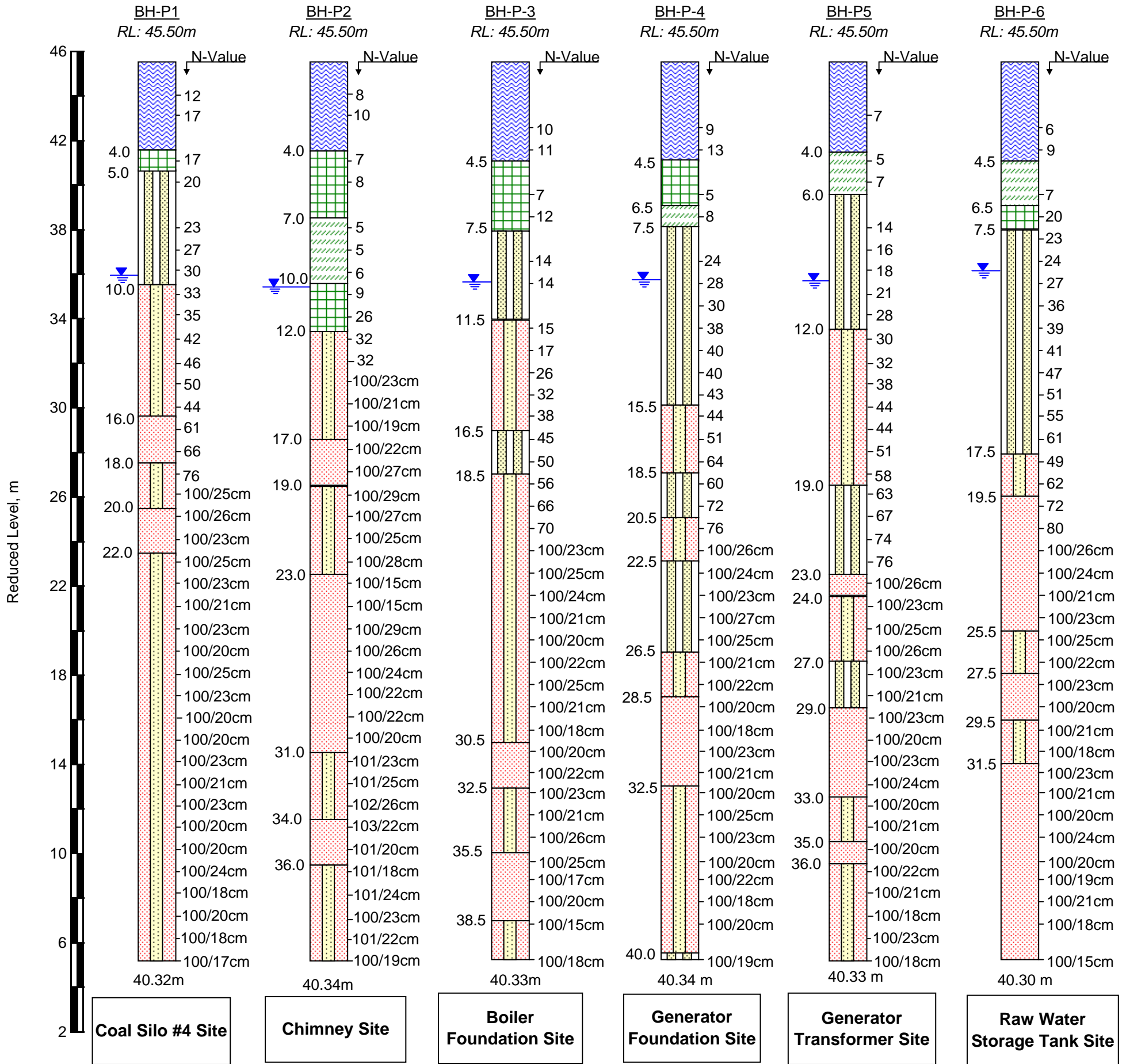

LEGEND	
SYMBOL	DESCRIPTION
	FILL: Flyash
	Sandy silt (CL)
	Clayey silt (CI)
	Silty sand (SM)
	Fine sand (SP-SM)
	Fine sand (SP)
	Water table

Summary of Borehole Profiles



Standard Penetration Test

IS : 2131-1981, RA-2007

Borehole Details			
Symbol	Borehole Number	Reduced Level,m	Location
○	BH-P-1	45.50	Coal Silo #4 Site
●	BH-P-2	45.50	Chimney Site
△	BH-P-3	45.50	Boiler Foundation Site
▲	BH-P-4	45.50	Generator Foundation Site
□	BH-P-5	45.50	Generator Transformer Site
■	BH-P-6	45.50	Raw Water Storage Tank Site

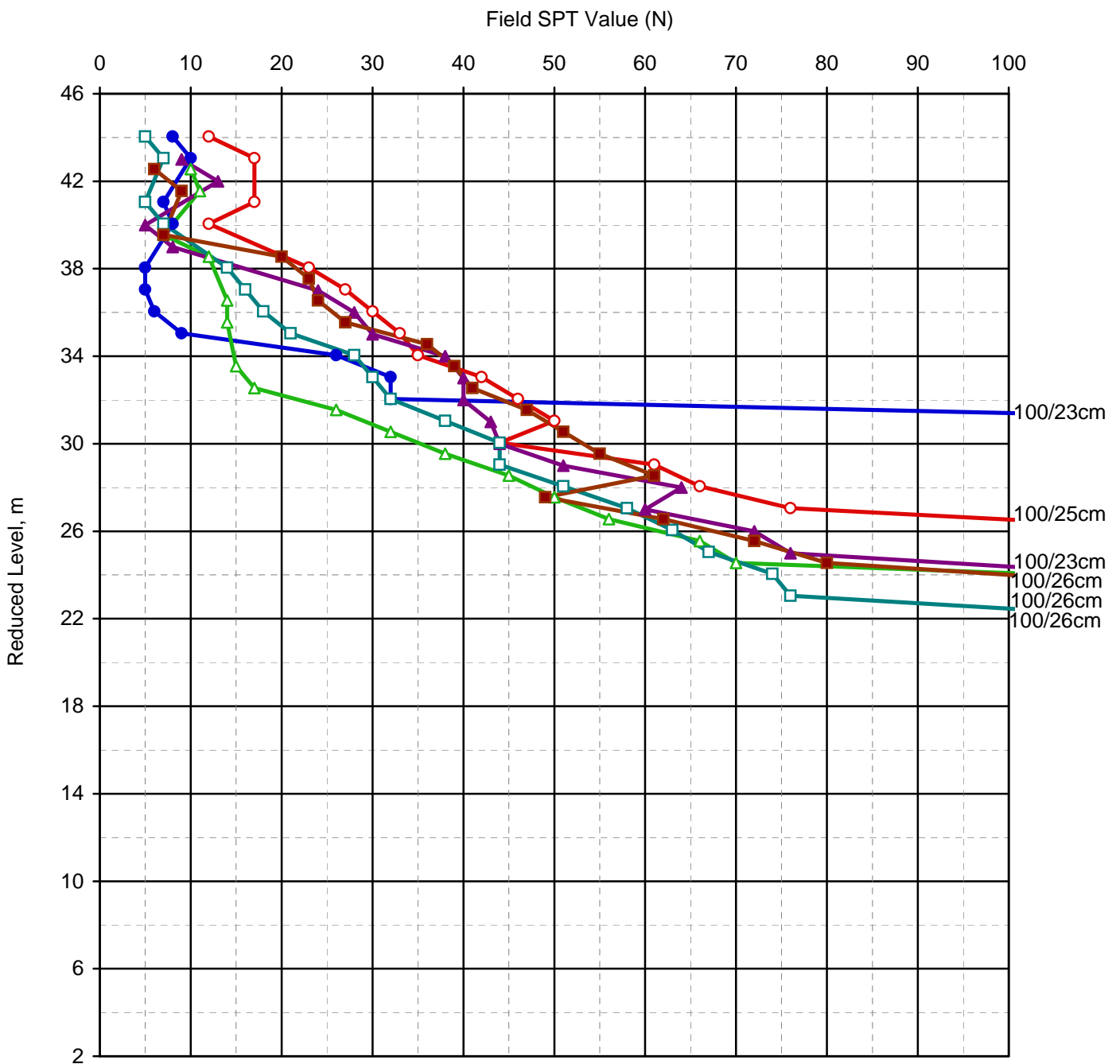

Field SPT Values versus Reduced Level



Standard Penetration Test

IS : 2131-1981, RA-2007

Borehole Details			
Symbol	Borehole Number	Reduced Level,m	Location
○	BH-P-1	45.50	Coal Silo #4 Site
●	BH-P-2	45.50	Chimney Site
△	BH-P-3	45.50	Boiler Foundation Site
▲	BH-P-4	45.50	Generator Foundation Site
□	BH-P-5	45.50	Generator Transformer Site
■	BH-P-6	45.50	Raw Water Storage Tank Site

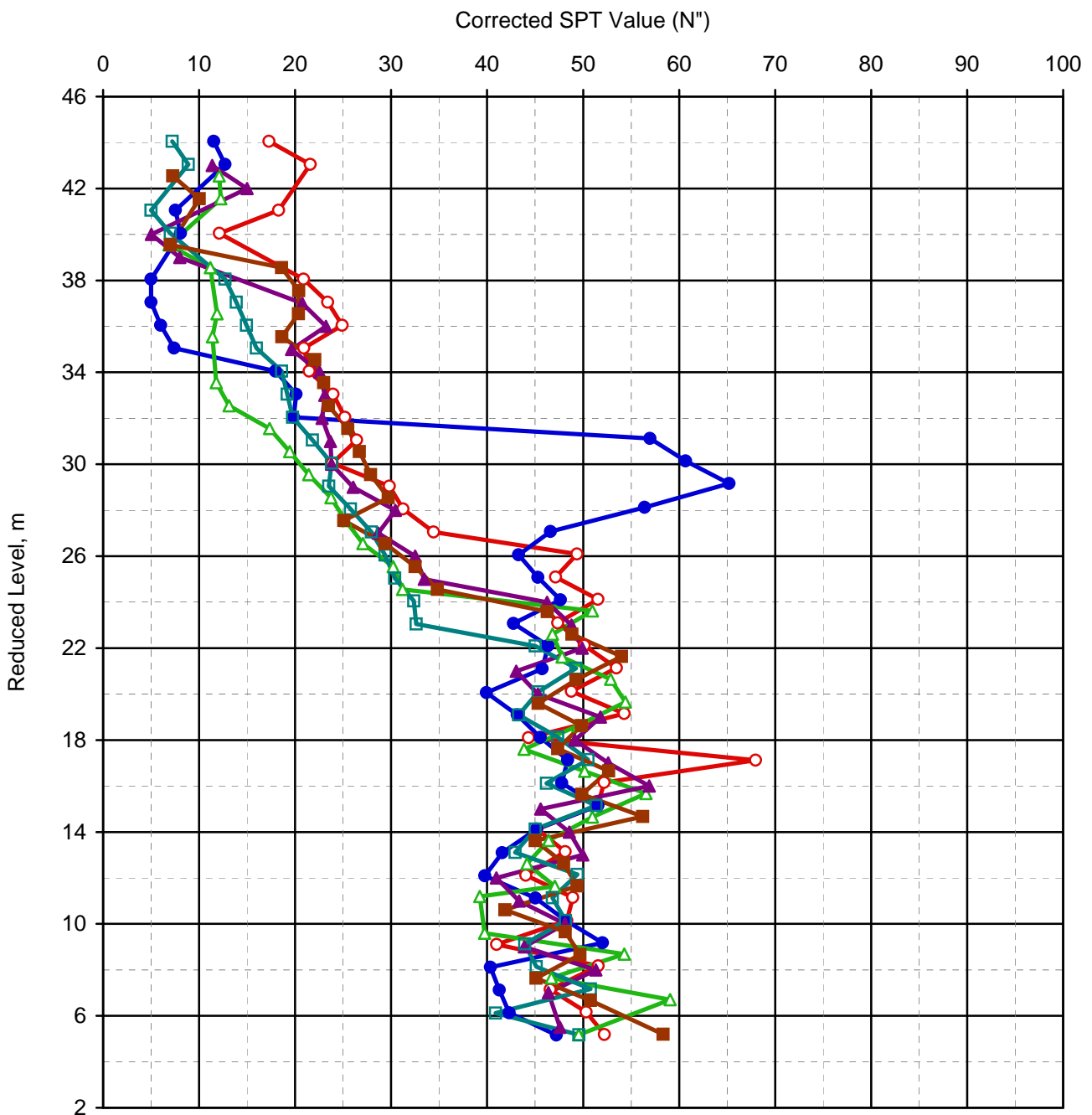

Corrected SPT Values versus Reduced Level



Grain Size Analysis

IS : 2720 (Part 4) - 1985, RA-2010

Sample Details			Test Results									
Borehole Number	Sample Depth, m	Sample Description	% Gravel	% Sand	% Silt	% Clay	D ₆₀	D ₅₀	D ₃₀	D ₁₀	C _u	C _c
BH-P-1	0.50	FILL: Flyash	0	21	51	28	0.007	0.005	0.002			
BH-P-1	2.00	FILL: Flyash	0	45	48	7	0.133	0.019	0.010	0.004	33.3	0.19
BH-P-1	4.00	Sandy silt (CL)	0	12	81	7	0.029	0.022	0.013	0.004	7.3	1.46
BH-P-1	6.00	Silty fine sand (SM)	0	84	16	0	0.220	0.200	0.158			
BH-P-1	8.00	Silty fine sand (SM)	0	81	19	0	0.205	0.180	0.122			

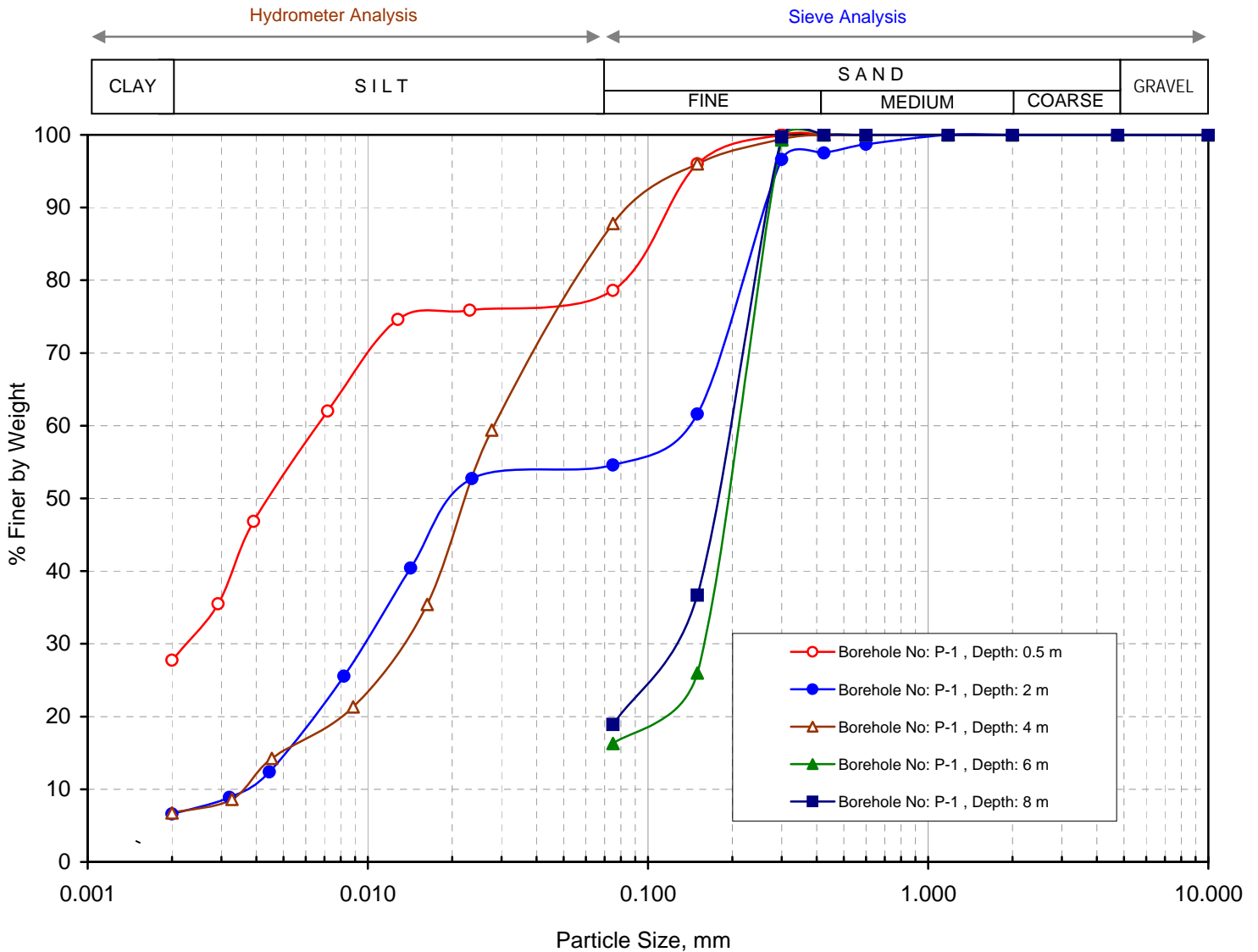

Grain Size Distribution Curve

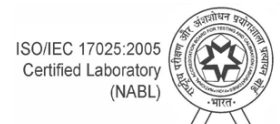

Certificate No. T-1741



Grain Size Analysis

IS : 2720 (Part 4) - 1985, RA-2010

Sample Details			Test Results									
Borehole Number	Sample Depth, m	Sample Description	% Gravel	% Sand	% Silt	% Clay	D ₆₀	D ₅₀	D ₃₀	D ₁₀	C _u	C _c
BH-P-1	10.00	Fine sand (SP-SM)	0	93	7	0	0.240	0.210	0.178	0.097	2.5	1.36
BH-P-1	12.00	Fine sand (SP-SM)	0	90	10	0	0.280	0.250	0.192	0.079	3.5	1.67
BH-P-1	14.00	Fine sand (SP-SM)	0	94	6	0	0.276	0.250	0.194	0.113	2.4	1.21
BH-P-1	16.00	Fine sand (SP)	0	96	4	0	0.288	0.260	0.205	0.150	1.9	0.97
BH-P-1	18.00	Fine sand (SP-SM)	0	95	5	0	0.280	0.250	0.206	0.157	1.8	0.97

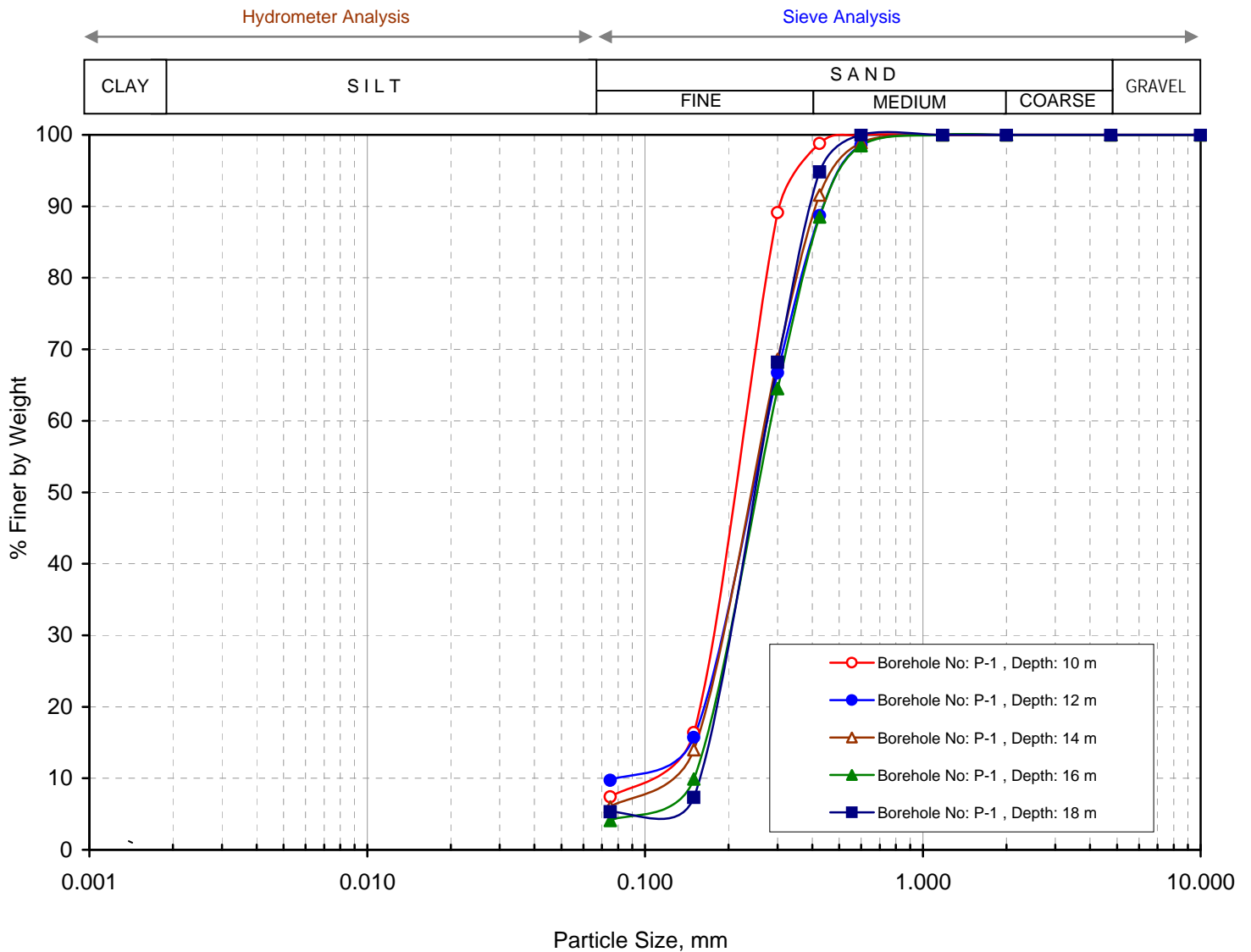

Grain Size Distribution Curve

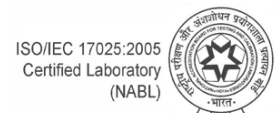

Certificate No. T-1741



Grain Size Analysis

IS : 2720 (Part 4) - 1985, RA-2010

Sample Details			Test Results									
Borehole Number	Sample Depth, m	Sample Description	% Gravel	% Sand	% Silt	% Clay	D ₆₀	D ₅₀	D ₃₀	D ₁₀	C _u	C _c
BH-P-1	20.00	Fine sand (SP)	0	99	1	0	0.282	0.250	0.210	0.162	1.7	0.97
BH-P-1	22.00	Fine sand (SP-SM)	0	91	9	0	0.276	0.240	0.183	0.085	3.3	1.43
BH-P-1	24.00	Fine sand (SP-SM)	0	91	9	0	0.286	0.240	0.188	0.080	3.6	1.54
BH-P-1	26.00	Fine sand (SP-SM)	0	88	12	0	0.263	0.220	0.163			
BH-P-1	28.00	Fine sand (SP-SM)	0	90	10	0	0.274	0.230	0.181	0.078	3.5	1.53

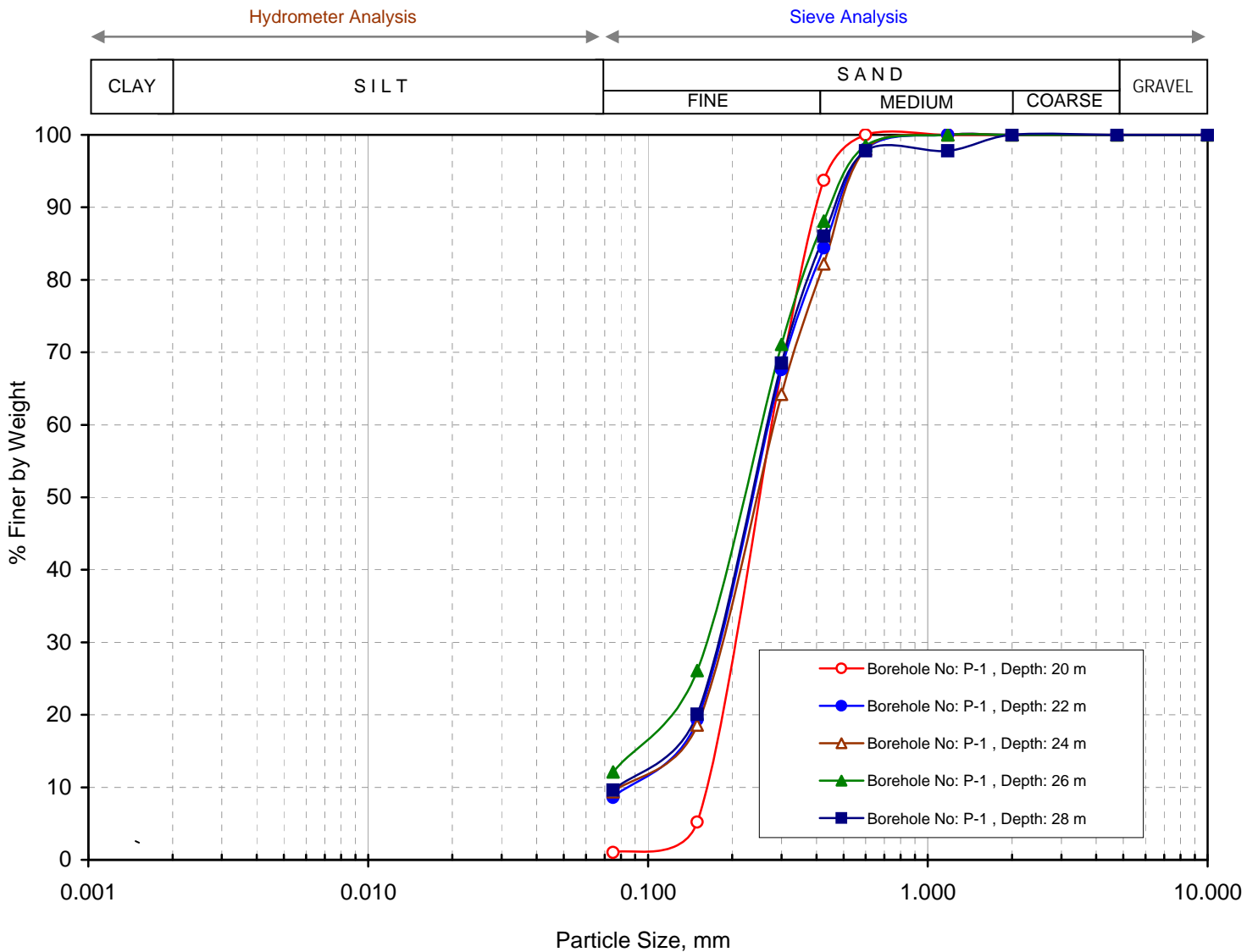

Grain Size Distribution Curve

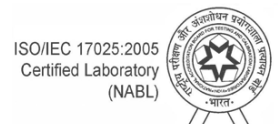



Grain Size Analysis

IS : 2720 (Part 4) - 1985, RA-2010

Sample Details			Test Results									
Borehole Number	Sample Depth, m	Sample Description	% Gravel	% Sand	% Silt	% Clay	D ₆₀	D ₅₀	D ₃₀	D ₁₀	C _u	C _c
BH-P-1	30.00	Fine sand (SP-SM)	0	92	8	0	0.271	0.230	0.190	0.098	2.8	1.36
BH-P-1	33.00	Fine sand (SP-SM)	0	91	9	0	0.266	0.230	0.186	0.085	3.1	1.53
BH-P-1	35.00	Fine sand (SP-SM)	0	91	9	0	0.275	0.240	0.192	0.083	3.3	1.62
BH-P-1	37.00	Fine sand (SP-SM)	0	92	8	0	0.288	0.250	0.198	0.102	2.8	1.33
BH-P-1	39.00	Fine sand (SP-SM)	0	92	8	0	0.273	0.240	0.192	0.099	2.8	1.36

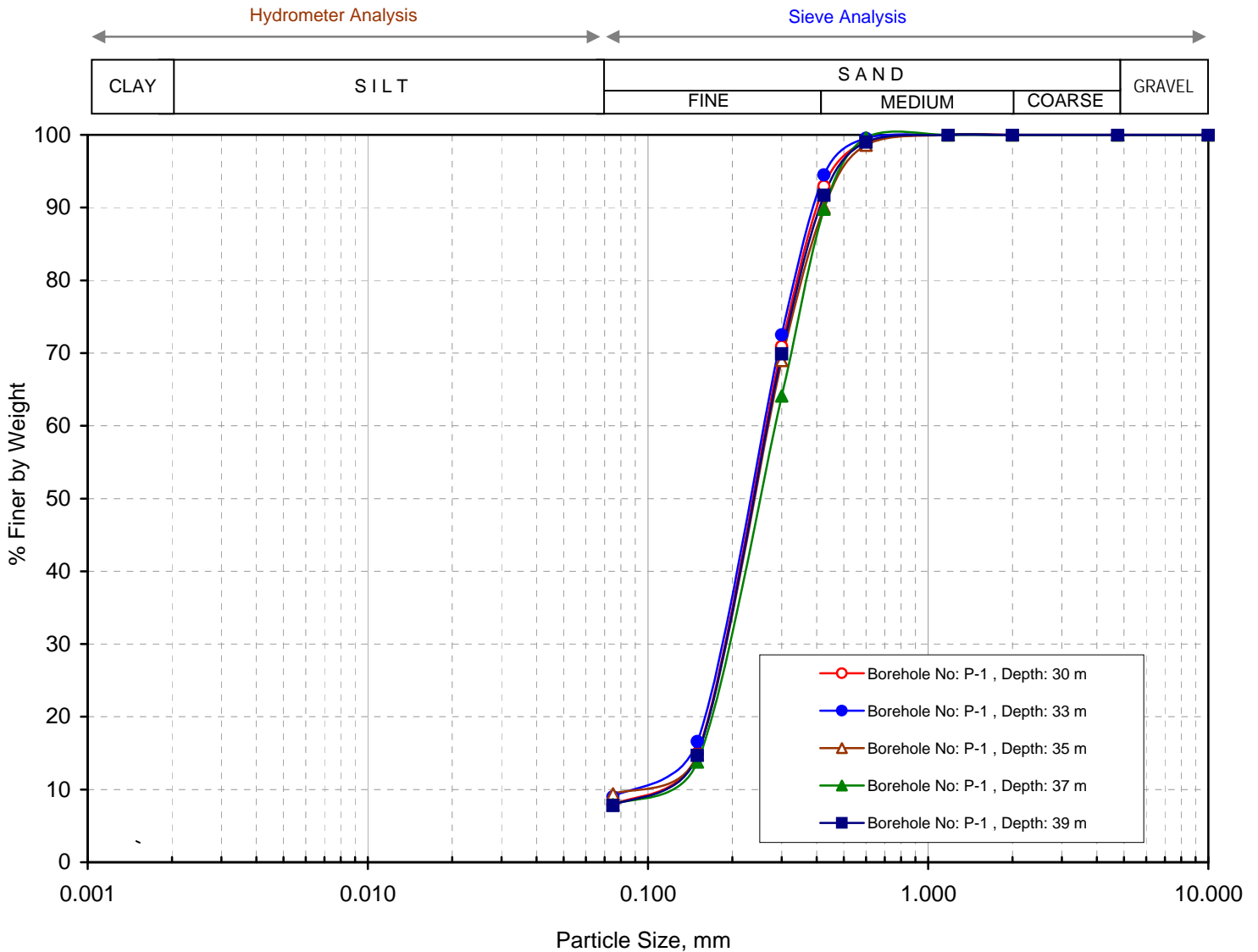

Grain Size Distribution Curve

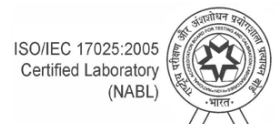



Grain Size Analysis

IS : 2720 (Part 4) - 1985, RA-2010

Sample Details			Test Results									
Borehole Number	Sample Depth, m	Sample Description	% Gravel	% Sand	% Silt	% Clay	D ₆₀	D ₅₀	D ₃₀	D ₁₀	C _u	C _c
BH-P-2	1.00	FILL: Flyash	0	19	74	7	0.044	0.029	0.016	0.003	14.7	1.94
BH-P-2	3.00	FILL: Flyash	0	42	44	14	0.091	0.020	0.008			
BH-P-2	5.00	Sandy silt (CL)	0	10	80	10	0.025	0.019	0.010	0.002	12.5	2.00
BH-P-2	7.00	Clayey silt (CI)	0	3	77	20	0.010	0.008	0.004			
BH-P-2	9.00	Clayey silt (CI)	0	3	79	18	0.012	0.009	0.004			

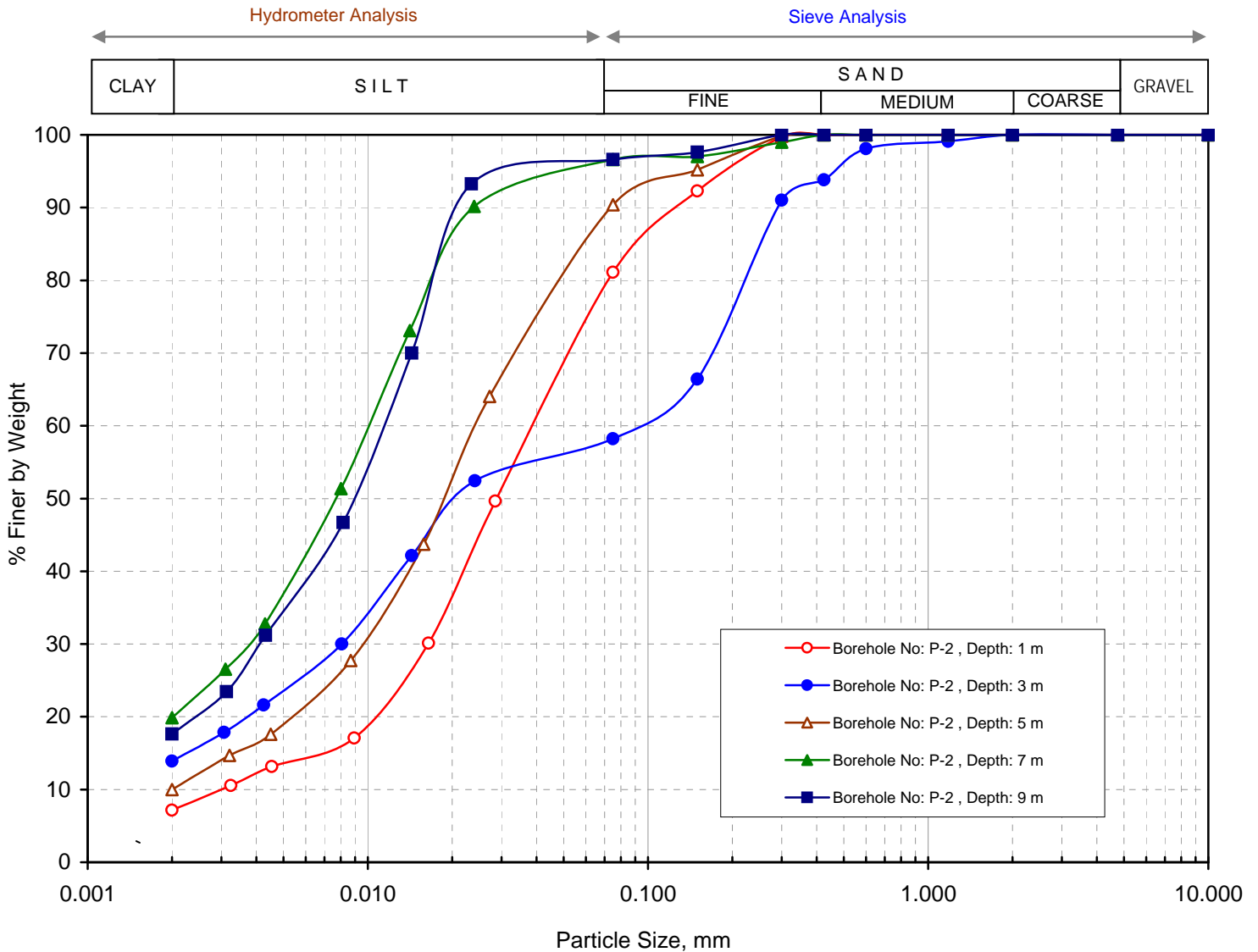

Grain Size Distribution Curve

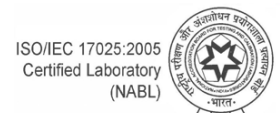

Certificate No. T-1741



Grain Size Analysis

IS : 2720 (Part 4) - 1985, RA-2010

Sample Details			Test Results									
Borehole Number	Sample Depth, m	Sample Description	% Gravel	% Sand	% Silt	% Clay	D ₆₀	D ₅₀	D ₃₀	D ₁₀	C _u	C _c
BH-P-2	11.00	Sandy silt (CL)	0	24	61	15	0.024	0.016	0.006			
BH-P-2	13.00	Fine sand (SP-SM)	0	92	8	0	0.208	0.180	0.134	0.080	2.6	1.08
BH-P-2	15.00	Fine sand (SP-SM)	0	94	6	0	0.265	0.220	0.184	0.102	2.6	1.25
BH-P-2	17.00	Fine sand (SP)	0	96	4	0	0.246	0.210	0.181	0.112	2.2	1.19
BH-P-2	19.00	Fine sand (SP-SM)	0	95	5	0	0.265	0.220	0.197	0.152	1.7	0.96

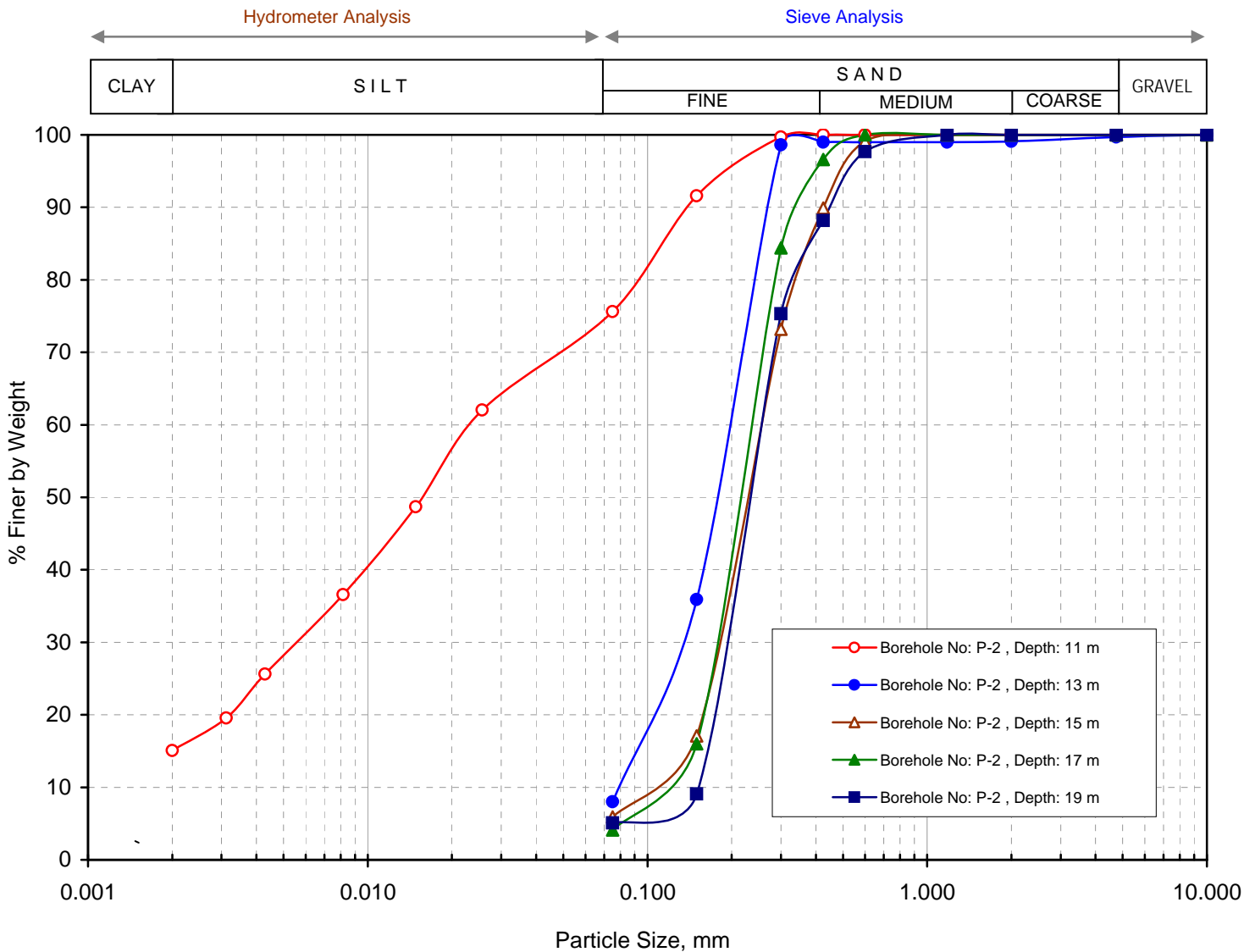

Grain Size Distribution Curve

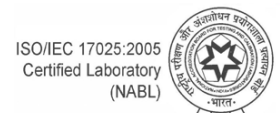

Certificate No. T-1741



Grain Size Analysis

IS : 2720 (Part 4) - 1985, RA-2010

Sample Details			Test Results									
Borehole Number	Sample Depth, m	Sample Description	% Gravel	% Sand	% Silt	% Clay	D ₆₀	D ₅₀	D ₃₀	D ₁₀	C _u	C _c
BH-P-2	21.00	Fine sand (SP-SM)	0	94	6	0	0.280	0.250	0.201	0.142	2.0	1.02
BH-P-2	23.00	Fine sand (SP)	0	98	2	0	0.295	0.260	0.212	0.157	1.9	0.97
BH-P-2	25.00	Fine sand (SP)	0	96	4	0	0.282	0.250	0.206	0.155	1.8	0.97
BH-P-2	27.00	Fine sand (SP)	0	96	4	0	0.291	0.260	0.211	0.158	1.8	0.97
BH-P-2	29.00	Fine sand (SP)	0	96	4	0	0.259	0.220	0.194	0.150	1.7	0.97

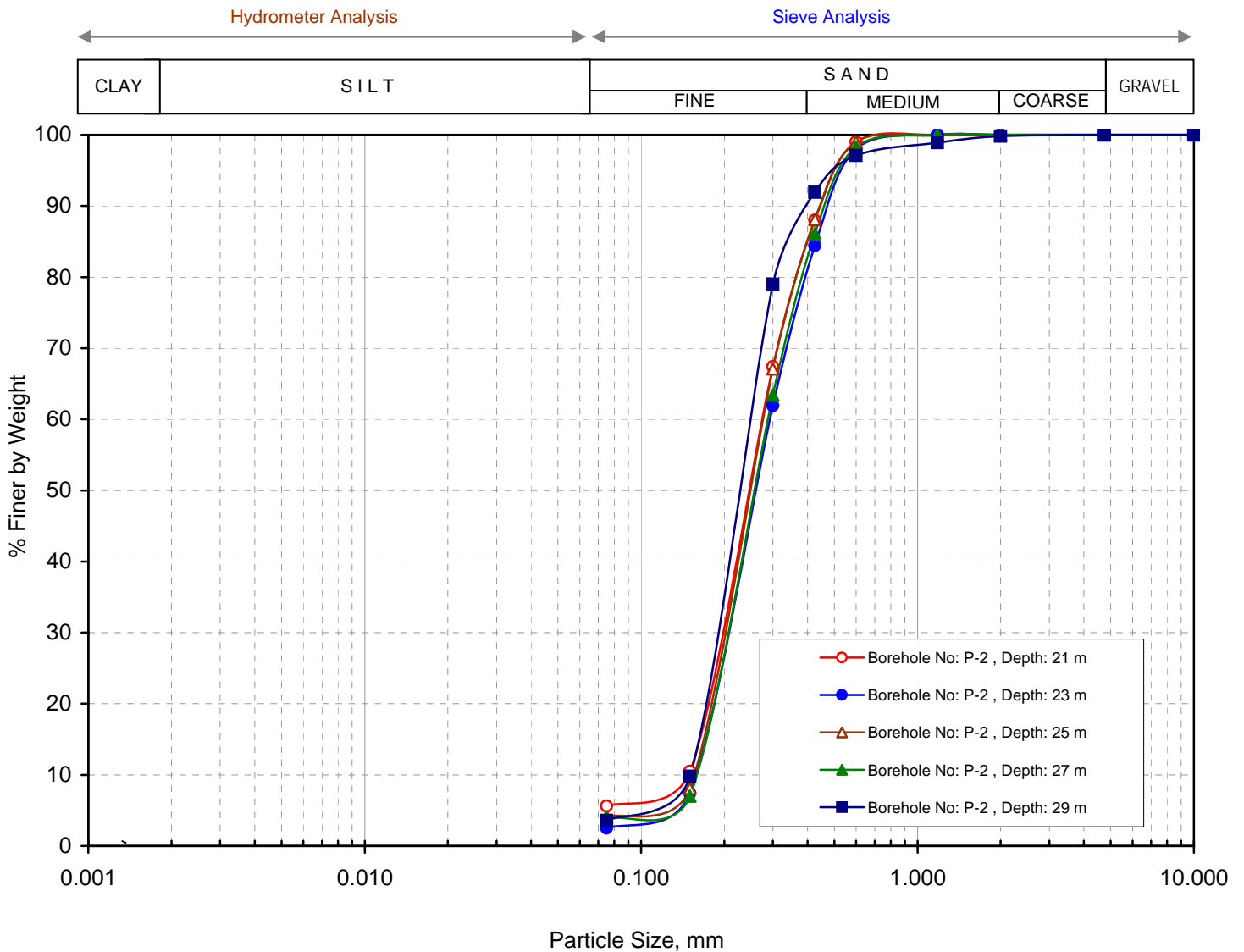

Grain Size Distribution Curve

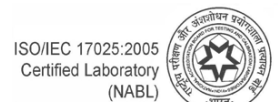

Certificate No. T-1741



Grain Size Analysis

IS : 2720 (Part 4) - 1985, RA-2010

Sample Details			Test Results									
Borehole Number	Sample Depth, m	Sample Description	% Gravel	% Sand	% Silt	% Clay	D ₆₀	D ₅₀	D ₃₀	D ₁₀	C _u	C _c
BH-P-2	31.00	Fine sand (SP-SM)	0	95	5	0	0.268	0.230	0.194	0.128	2.1	1.10
BH-P-2	34.00	Fine sand with traces of gravel (SP)	1	95	4	0	0.257	0.220	0.192	0.139	1.9	1.03
BH-P-2	36.00	Fine sand (SP-SM)	0	89	11	0	0.239	0.210	0.177			
BH-P-2	38.00	Fine sand with gravel (SP-SM)	6	89	5	0	0.259	0.220	0.187	0.113	2.3	1.19
BH-P-2	40.00	Fine sand with traces of gravel (SP-SM)	4	87	9	0	0.252	0.220	0.178	0.084	3.0	1.50

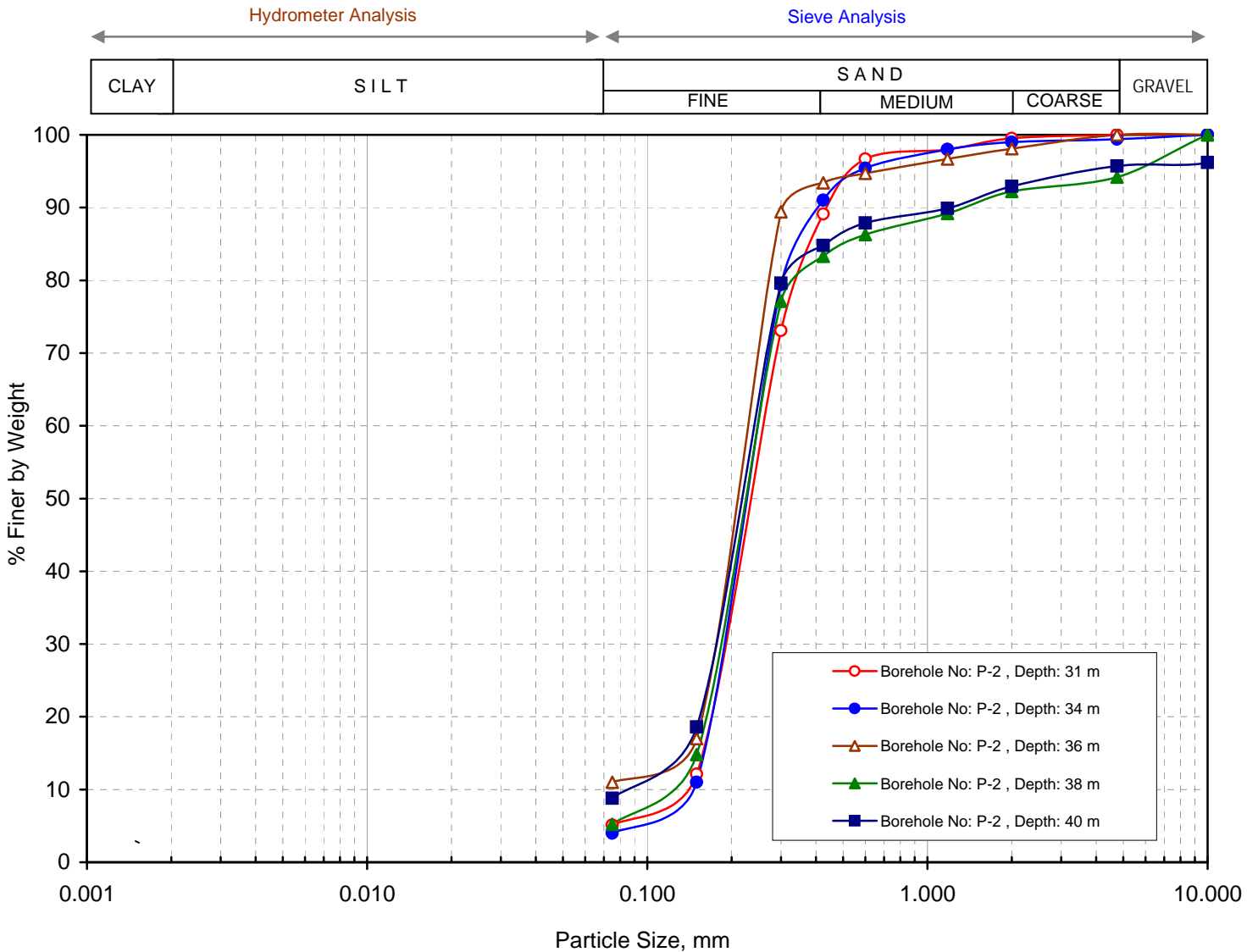

Grain Size Distribution Curve

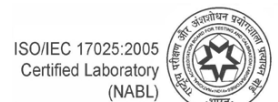

ISO/IEC 17025:2005
Certified Laboratory
(NABL)

Certificate No. T-1741



Grain Size Analysis

IS : 2720 (Part 4) - 1985, RA-2010

Sample Details			Test Results									
Borehole Number	Sample Depth, m	Sample Description	% Gravel	% Sand	% Silt	% Clay	D ₆₀	D ₅₀	D ₃₀	D ₁₀	C _u	C _c
BH-P-3	0.50	FILL: Flyash	18	28	49	5	0.127	0.060	0.025	0.004	31.8	1.23
BH-P-3	2.50	FILL: Flyash	0	41	54	5	0.082	0.052	0.025	0.004	20.5	1.91
BH-P-3	4.50	Sandy silt (CL)	0	8	61	31	0.006	0.004	0.002			
BH-P-3	6.50	Sandy silt with gravel (CL)	13	7	73	7	0.036	0.024	0.014	0.003	12.0	1.81
BH-P-3	10.50	Silty fine sand (SM)	0	61	36	3	0.111	0.090	0.056	0.014	7.9	2.02

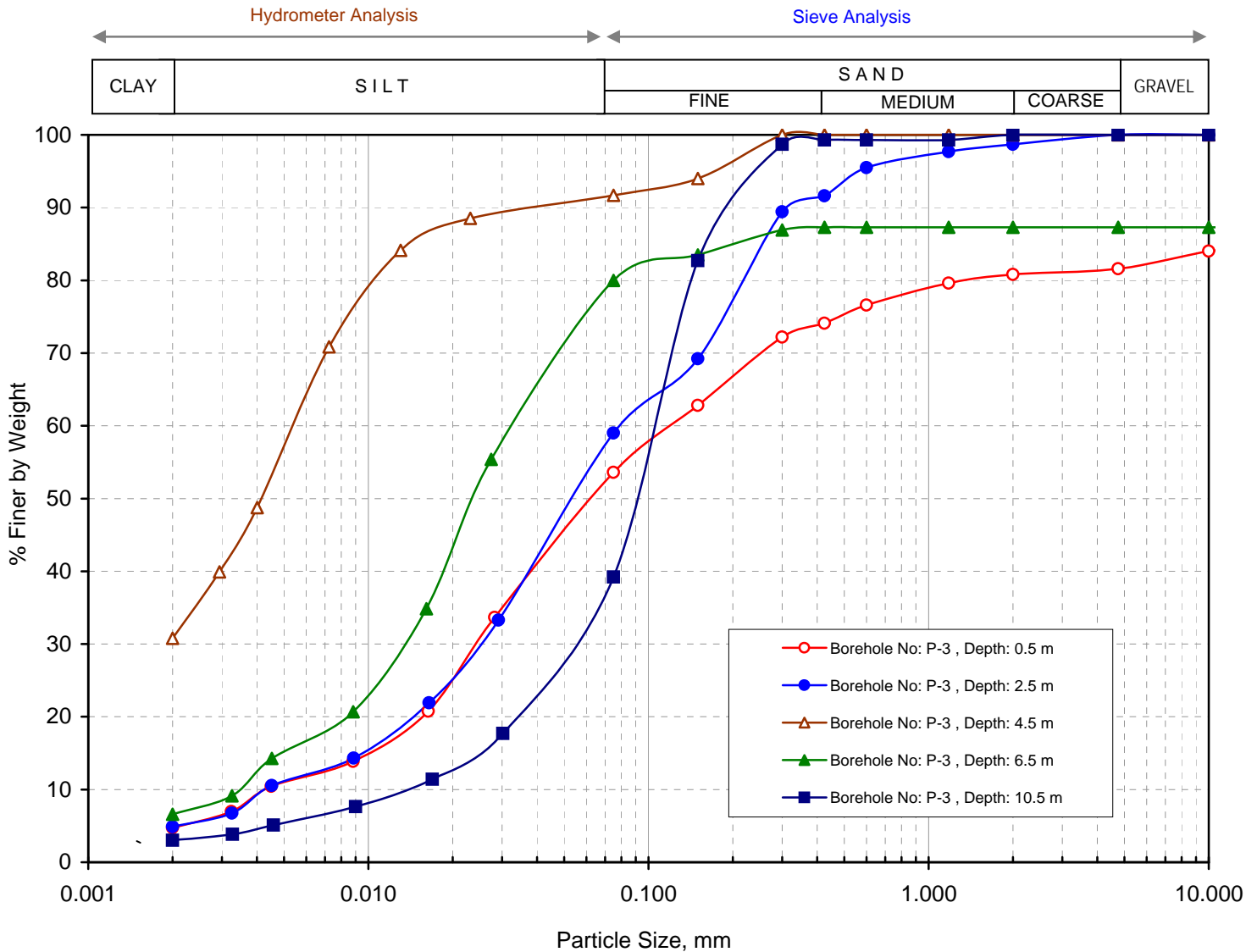

Grain Size Distribution Curve

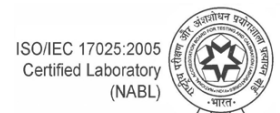

Certificate No. T-1741



Grain Size Analysis

IS : 2720 (Part 4) - 1985, RA-2010

Sample Details			Test Results									
Borehole Number	Sample Depth, m	Sample Description	% Gravel	% Sand	% Silt	% Clay	D ₆₀	D ₅₀	D ₃₀	D ₁₀	C _u	C _c
BH-P-3	12.50	Fine sand (SP-SM)	0	91	9	0	0.226	0.200	0.167	0.083	2.7	1.49
BH-P-3	14.50	Fine sand (SP-SM)	0	89	11	0	0.229	0.200	0.169			
BH-P-3	16.50	Silty fine sand (SM)	0	87	13	0	0.212	0.190	0.139			
BH-P-3	18.50	Fine sand (SP-SM)	0	88	12	0	0.204	0.180	0.124			
BH-P-3	20.50	Fine sand (SP-SM)	0	93	7	0	0.301	0.270	0.196	0.100	3.0	1.28

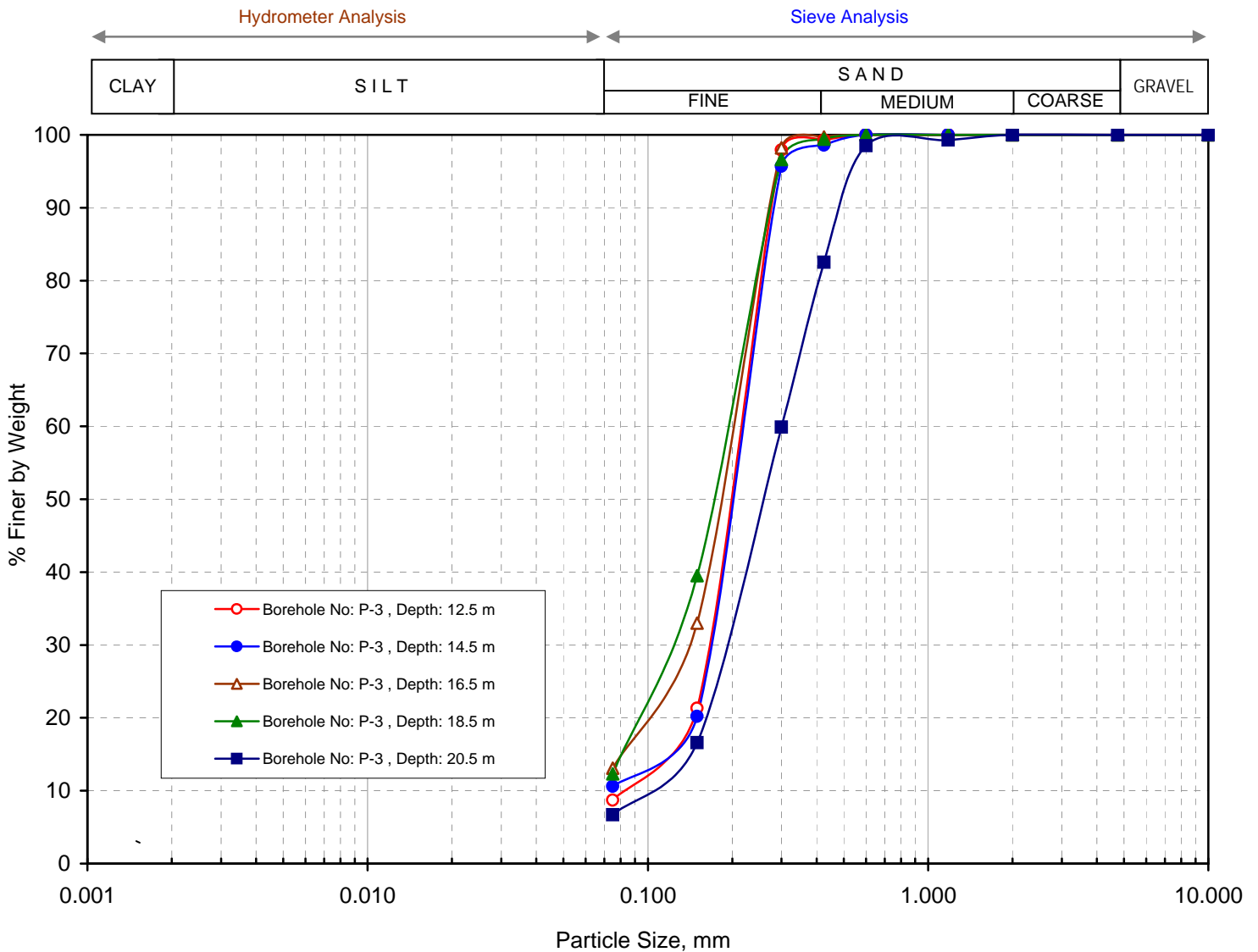

Grain Size Distribution Curve

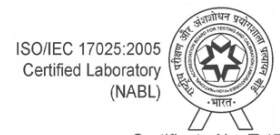



Grain Size Analysis

IS : 2720 (Part 4) - 1985, RA-2010

Sample Details			Test Results									
Borehole Number	Sample Depth, m	Sample Description	% Gravel	% Sand	% Silt	% Clay	D ₆₀	D ₅₀	D ₃₀	D ₁₀	C _u	C _c
BH-P-3	22.50	Fine sand (SP-SM)	0	90	10	0	0.314	0.280	0.199	0.078	4.0	1.62
BH-P-3	24.50	Fine sand (SP-SM)	0	94	6	0	0.307	0.280	0.206	0.116	2.7	1.19
BH-P-3	26.50	Fine sand (SP-SM)	0	92	8	0	0.253	0.230	0.187	0.100	2.5	1.38
BH-P-3	28.50	Fine sand with traces of gravel (SP-SM)	1	91	8	0	0.279	0.250	0.199	0.115	2.4	1.23
BH-P-3	30.50	Fine sand (SP)	0	96	4	0	0.268	0.240	0.198	0.152	1.8	0.96

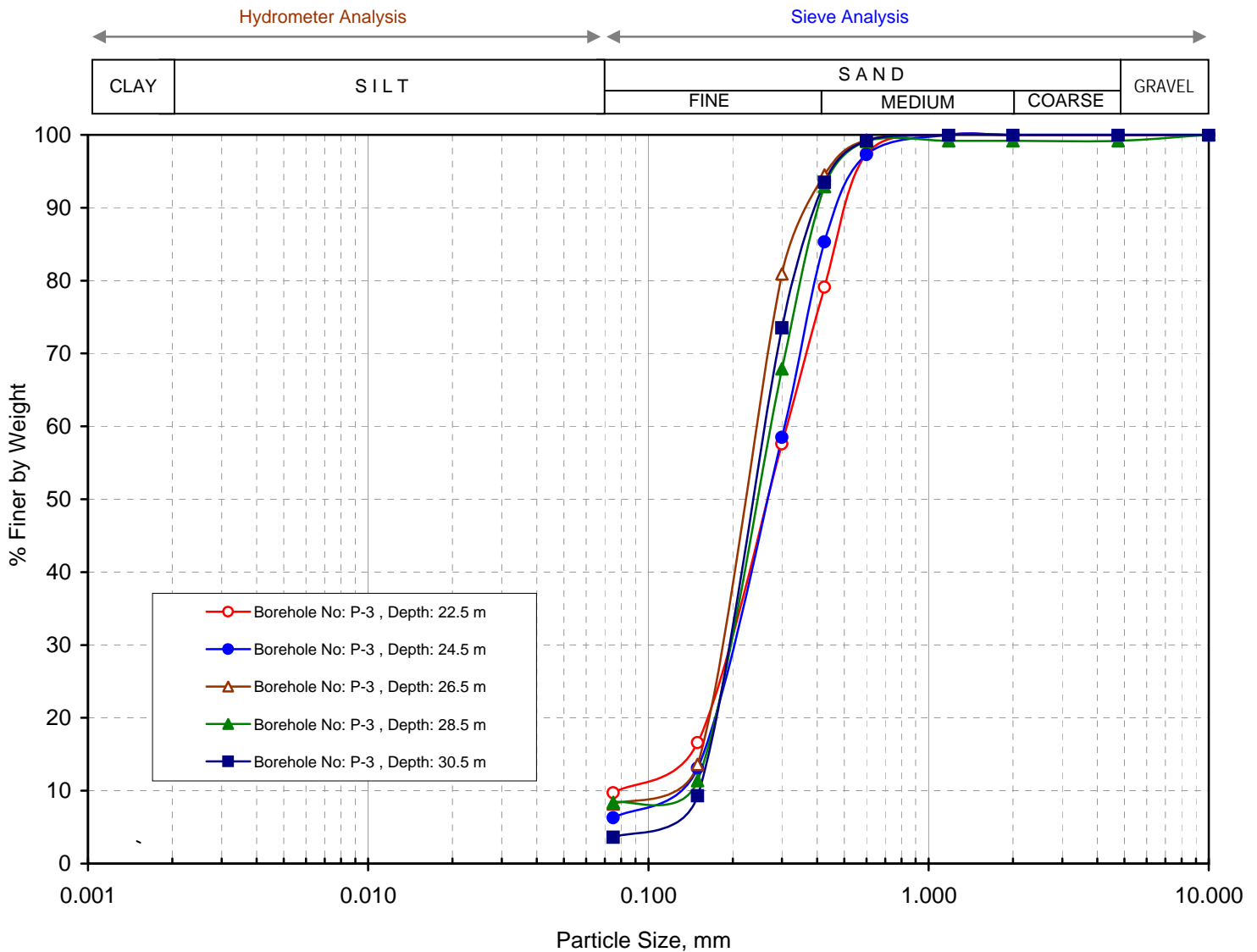

Grain Size Distribution Curve

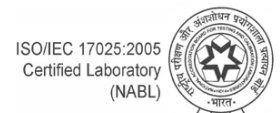

Certificate No. T-1741



Grain Size Analysis

IS : 2720 (Part 4) - 1985, RA-2010

Sample Details			Test Results									
Borehole Number	Sample Depth, m	Sample Description	% Gravel	% Sand	% Silt	% Clay	D ₆₀	D ₅₀	D ₃₀	D ₁₀	C _u	C _c
BH-P-3	32.50	Fine sand (SP-SM)	0	94	6	0	0.290	0.270	0.205	0.143	2.0	1.01
BH-P-3	34.50	Fine sand (SP-SM)	0	91	9	0	0.298	0.270	0.204	0.098	3.0	1.43
BH-P-3	36.50	Fine sand (SP)	0	96	4	0	0.259	0.230	0.195	0.153	1.7	0.96
BH-P-3	38.50	Fine sand (SP-SM)	0	95	5	0	0.267	0.240	0.199	0.154	1.7	0.96

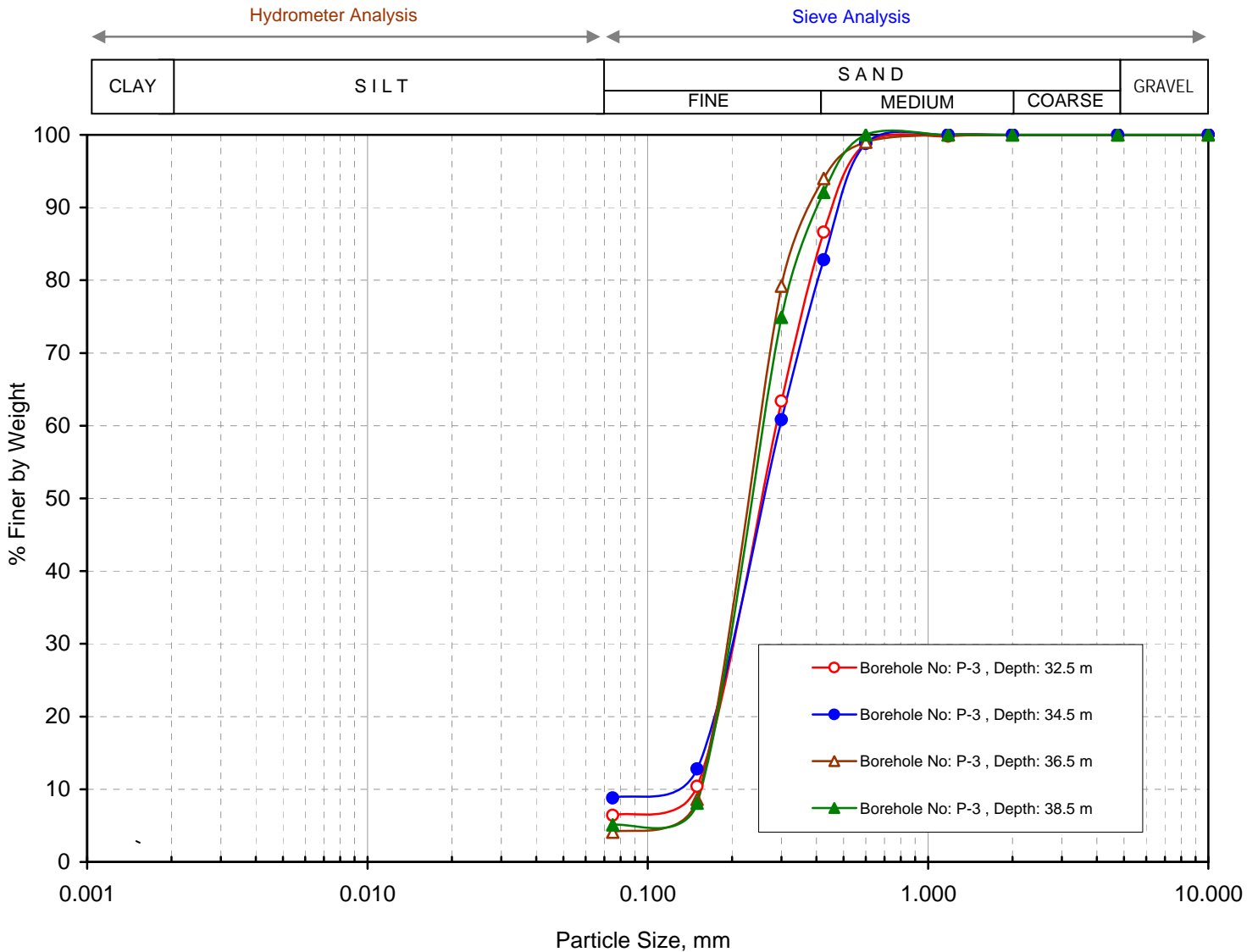

Grain Size Distribution Curve

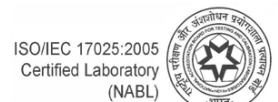

Certificate No. T-1741



Grain Size Analysis

IS : 2720 (Part 4) - 1985, RA-2010

Sample Details			Test Results									
Borehole Number	Sample Depth, m	Sample Description	% Gravel	% Sand	% Silt	% Clay	D ₆₀	D ₅₀	D ₃₀	D ₁₀	C _u	C _c
BH-P-4	1.50	FILL: Flyash	1	25	61	13	0.031	0.019	0.008			
BH-P-4	3.50	FILL: Flyash	0	29	57	14	0.043	0.022	0.009			
BH-P-4	5.50	Sandy silt (CL)	0	12	78	10	0.018	0.014	0.006			
BH-P-4	6.50	Clayey silt (CI)	0	3	82	15	0.016	0.013	0.006			
BH-P-4	8.50	Silty fine sand (SM)	0	87	13	0	0.211	0.190	0.137			

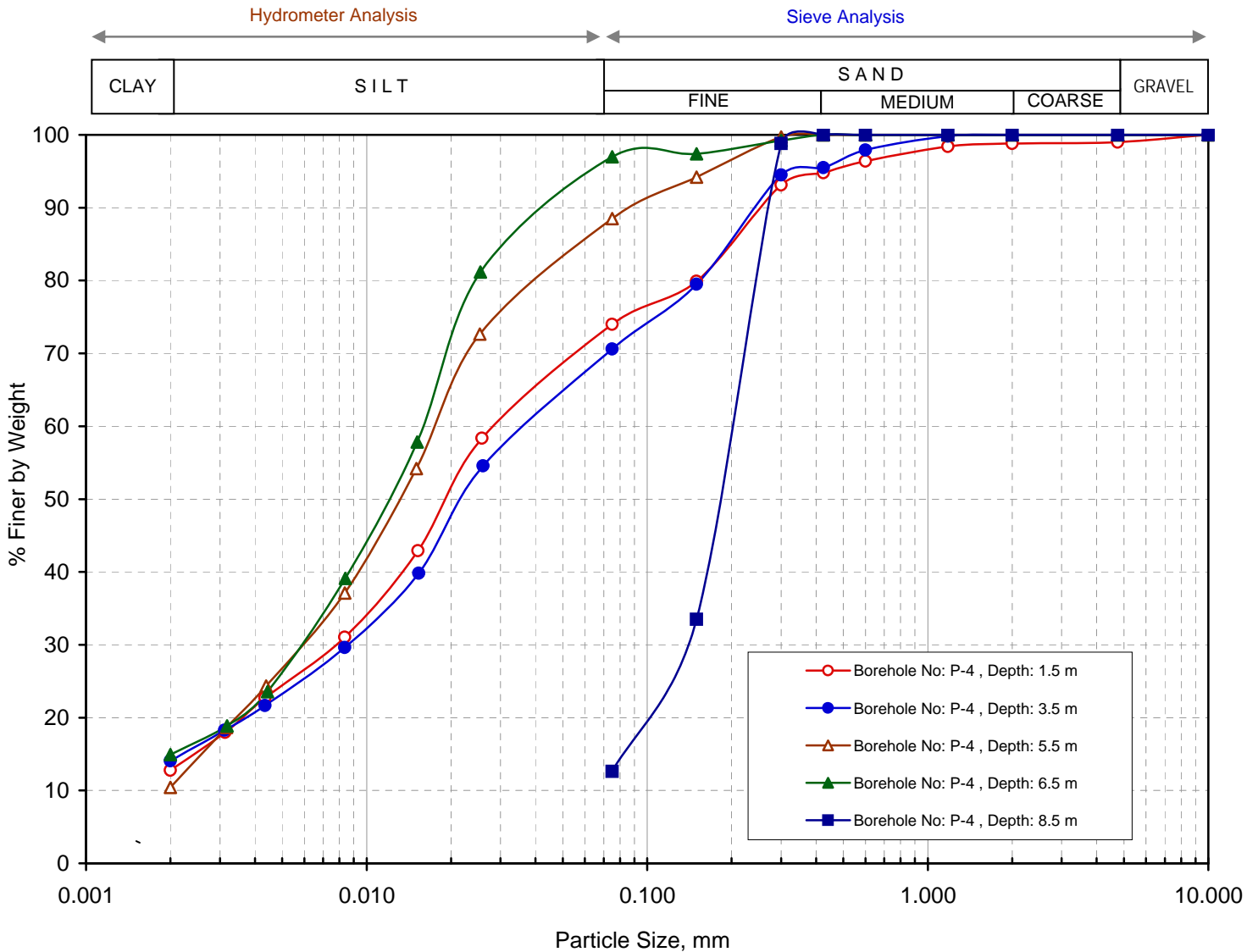

Grain Size Distribution Curve

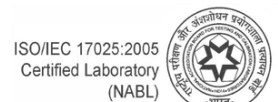

Certificate No. T-1741



Grain Size Analysis

IS : 2720 (Part 4) - 1985, RA-2010

Sample Details			Test Results									
Borehole Number	Sample Depth, m	Sample Description	% Gravel	% Sand	% Silt	% Clay	D ₆₀	D ₅₀	D ₃₀	D ₁₀	C _u	C _c
BH-P-4	10.50	Silty fine sand (SM)	0	86	14	0	0.227	0.200	0.168			
BH-P-4	12.50	Silty fine sand (SM)	0	86	14	0	0.218	0.190	0.152			
BH-P-4	14.50	Silty fine sand (SM)	0	87	13	0	0.229	0.200	0.171			
BH-P-4	16.50	Fine sand (SP-SM)	0	95	5	0	0.241	0.220	0.186	0.144	1.7	1.00
BH-P-4	18.50	Silty fine sand (SM)	0	87	13	0	0.204	0.180	0.124			

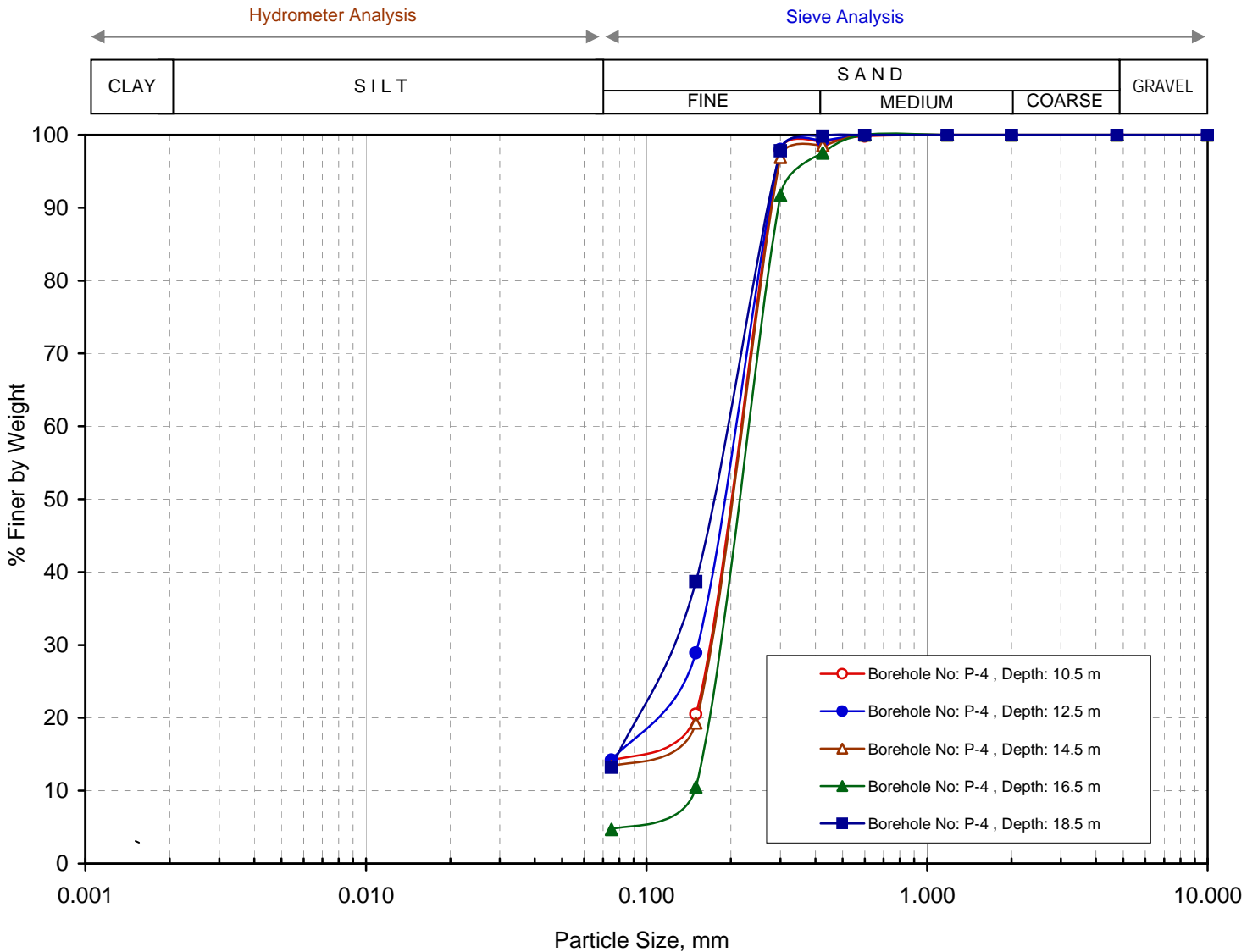

Grain Size Distribution Curve

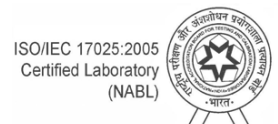

Certificate No. T-1741



Grain Size Analysis

IS : 2720 (Part 4) - 1985, RA-2010

Sample Details			Test Results									
Borehole Number	Sample Depth, m	Sample Description	% Gravel	% Sand	% Silt	% Clay	D ₆₀	D ₅₀	D ₃₀	D ₁₀	C _u	C _c
BH-P-4	20.50	Fine sand (SP-SM)	0	88	12	0	0.222	0.200	0.156			
BH-P-4	22.50	Silty fine sand (SM)	0	87	13	0	0.222	0.200	0.158			
BH-P-4	24.50	Silty fine sand (SM)	0	87	13	0	0.212	0.180	0.132			
BH-P-4	26.50	Fine sand (SP-SM)	0	90	10	0	0.249	0.220	0.176	0.077	3.2	1.62
BH-P-4	28.50	Fine sand with traces of gravel (SP)	1	96	3	0	0.278	0.250	0.202	0.152	1.8	0.97

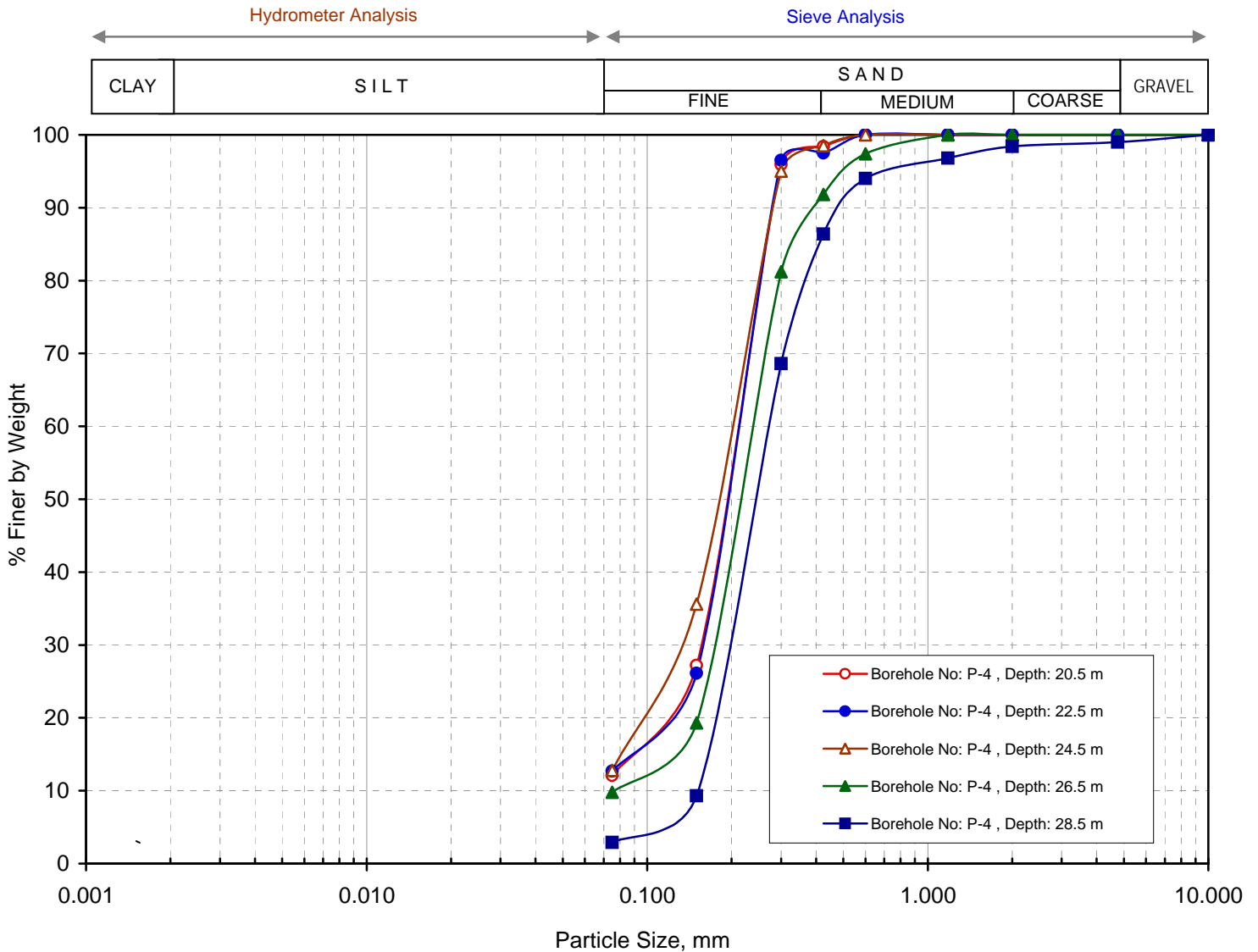

Grain Size Distribution Curve

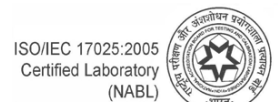

Certificate No. T-1741



Grain Size Analysis

IS : 2720 (Part 4) - 1985, RA-2010

Sample Details			Test Results									
Borehole Number	Sample Depth, m	Sample Description	% Gravel	% Sand	% Silt	% Clay	D ₆₀	D ₅₀	D ₃₀	D ₁₀	C _u	C _c
BH-P-4	30.50	Fine sand with traces of gravel (SP)	1	95	4	0	0.276	0.250	0.199	0.139	2.0	1.03
BH-P-4	32.50	Fine sand (SP-SM)	0	89	11	0	0.239	0.210	0.159			
BH-P-4	35.50	Silty fine sand (SM)	0	87	13	0	0.214	0.180	0.123			
BH-P-4	37.50	Fine sand (SP-SM)	0	91	9	0	0.244	0.210	0.163	0.078	3.1	1.40
BH-P-4	40.00	Silty fine sand (SM)	0	84	16	0	0.252	0.210	0.159			

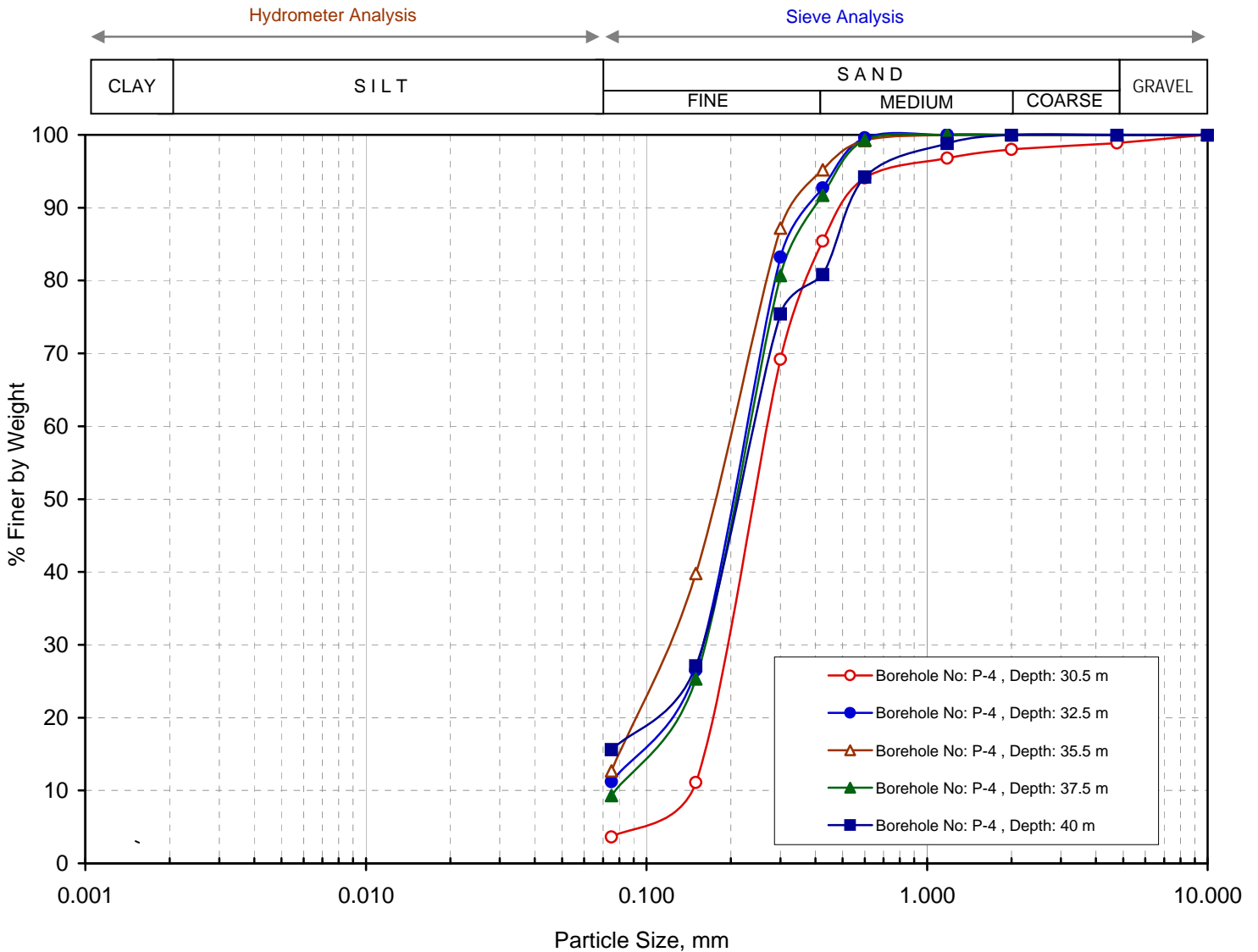

Grain Size Distribution Curve

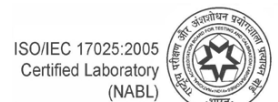

Certificate No. T-1741



Grain Size Analysis

IS : 2720 (Part 4) - 1985, RA-2010

Sample Details			Test Results									
Borehole Number	Sample Depth, m	Sample Description	% Gravel	% Sand	% Silt	% Clay	D ₆₀	D ₅₀	D ₃₀	D ₁₀	C _u	C _c
BH-P-5	1.00	FILL: Flyash	26	18	56		0.331		0.040			
BH-P-5	3.00	FILL: Flyash	3	15	54	28	0.008	0.005	0.002			
BH-P-5	4.00	Clayey silt (CI)	0	4	81	15	0.017	0.013	0.006			
BH-P-5	5.00	Clayey silt (CI)	0	6	71	23	0.009	0.007	0.003			
BH-P-5	8.00	Silty fine sand (SM)	0	81	19	0	0.216	0.190	0.137			

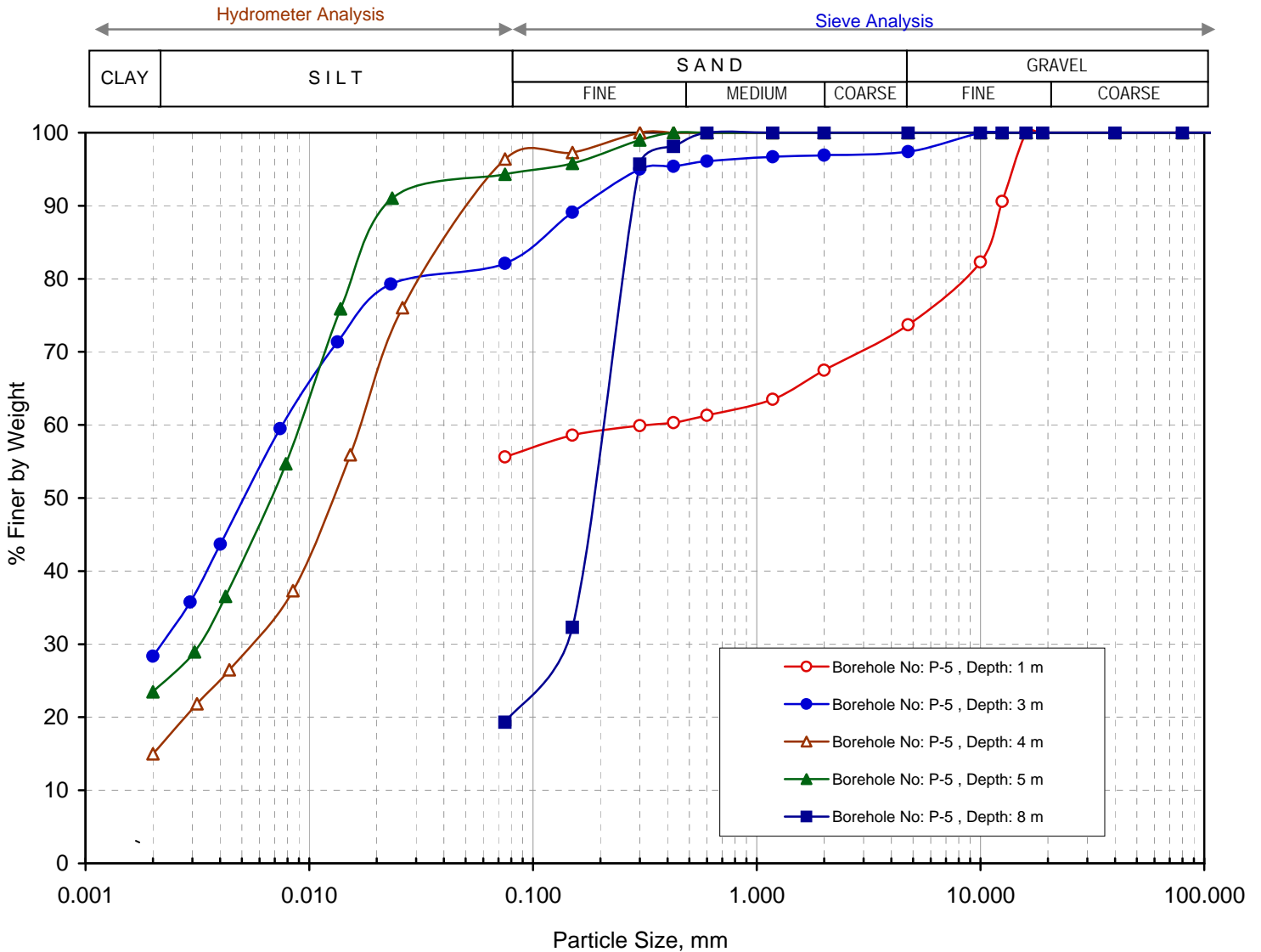

Grain Size Distribution Curve

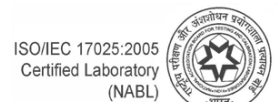

Certificate No. T-1741



Grain Size Analysis

IS : 2720 (Part 4) - 1985, RA-2010

Sample Details			Test Results									
Borehole Number	Sample Depth, m	Sample Description	% Gravel	% Sand	% Silt	% Clay	D ₆₀	D ₅₀	D ₃₀	D ₁₀	C _u	C _c
BH-P-5	10.00	Silty fine sand (SM)	2	84	14	0	0.231	0.200	0.167			
BH-P-5	13.00	Fine sand (SP-SM)	0	88	12	0	0.239	0.210	0.173			
BH-P-5	15.00	Fine sand with traces of gravel (SP-SM)	2	92	6	0	0.467	0.400	0.274	0.159	2.9	1.01
BH-P-5	17.00	Fine sand (SP-SM)	0	95	5	0	0.289	0.260	0.204	0.142	2.0	1.01
BH-P-5	19.00	Silty fine sand (SM)	0	87	13	0	0.244	0.220	0.180			

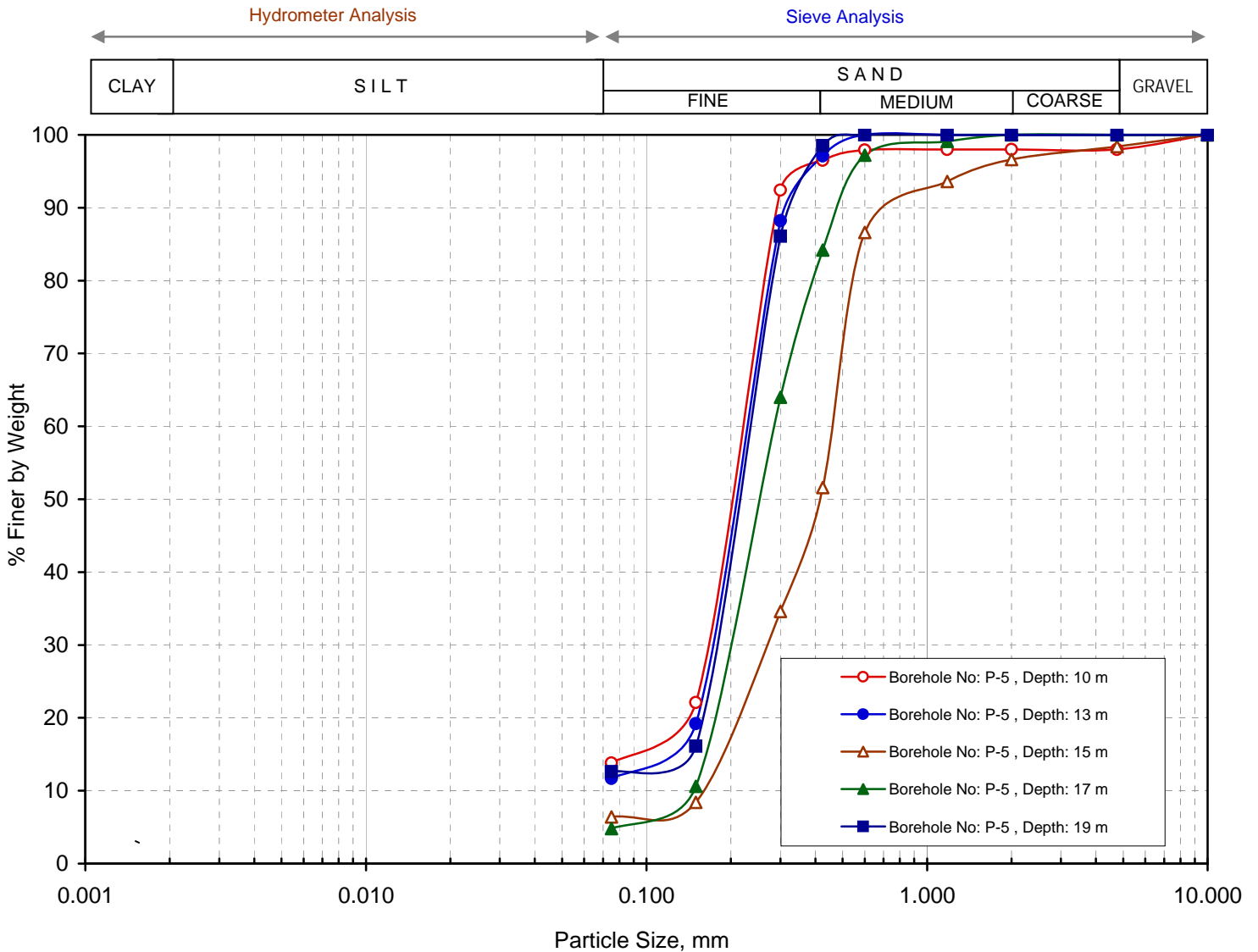

Grain Size Distribution Curve

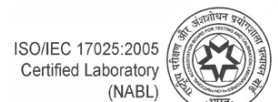

Certificate No. T-1741



Grain Size Analysis

IS : 2720 (Part 4) - 1985, RA-2010

Sample Details			Test Results									
Borehole Number	Sample Depth, m	Sample Description	% Gravel	% Sand	% Silt	% Clay	D ₆₀	D ₅₀	D ₃₀	D ₁₀	C _u	C _c
BH-P-5	21.00	Silty fine sand (SM)	0	87	13	0	0.223	0.200	0.157			
BH-P-5	23.00	Fine sand (SP)	0	98	2	0	0.297	0.270	0.212	0.156	1.9	0.97
BH-P-5	25.00	Fine sand (SP-SM)	0	93	7	0	0.317	0.280	0.213	0.140	2.3	1.02
BH-P-5	27.00	Silty fine sand (SM)	0	87	13	0	0.258	0.220	0.186			
BH-P-5	29.00	Fine sand (SP)	0	98	2	0	0.377	0.320	0.243	0.167	2.3	0.94

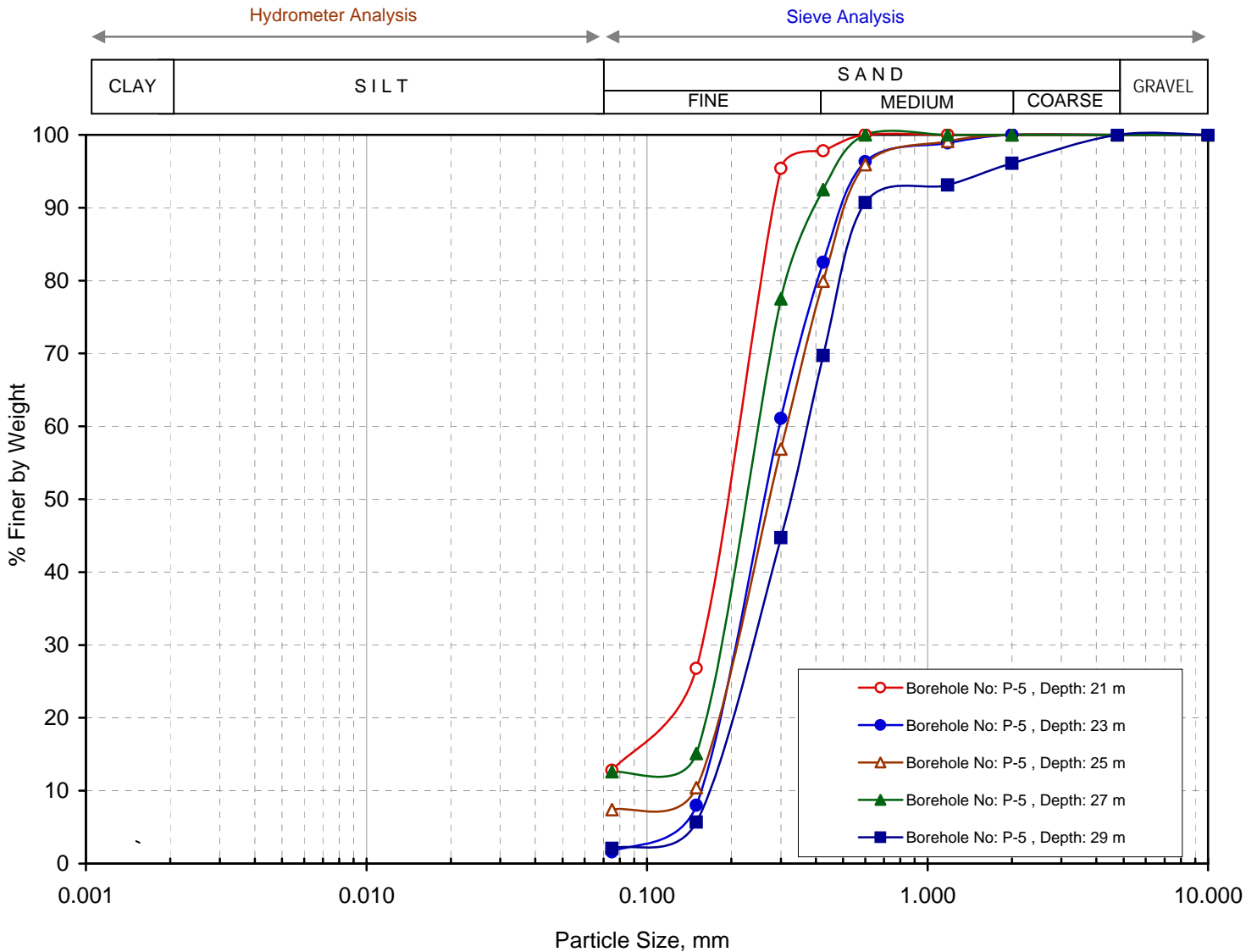

Grain Size Distribution Curve

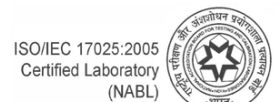

Certificate No. T-1741



Grain Size Analysis

IS : 2720 (Part 4) - 1985, RA-2010

Sample Details			Test Results									
Borehole Number	Sample Depth, m	Sample Description	% Gravel	% Sand	% Silt	% Clay	D ₆₀	D ₅₀	D ₃₀	D ₁₀	C _u	C _c
BH-P-5	31.00	Fine sand (SP)	0	99	1	0	0.419	0.360	0.256	0.175	2.4	0.89
BH-P-5	33.00	Fine sand with traces of gravel (SP-SM)	3	87	10	0	0.454	0.400	0.246	0.082	5.5	1.63
BH-P-5	35.00	Fine sand with traces of gravel (SP)	2	97	1	0	0.395	0.330	0.248	0.170	2.3	0.92
BH-P-5	37.00	Fine sand with traces of gravel (SP-SM)	2	93	5	0	0.409	0.340	0.250	0.160	2.6	0.96
BH-P-5	40.00	Fine sand (SP-SM)	0	88	12	0	0.230	0.200	0.153			

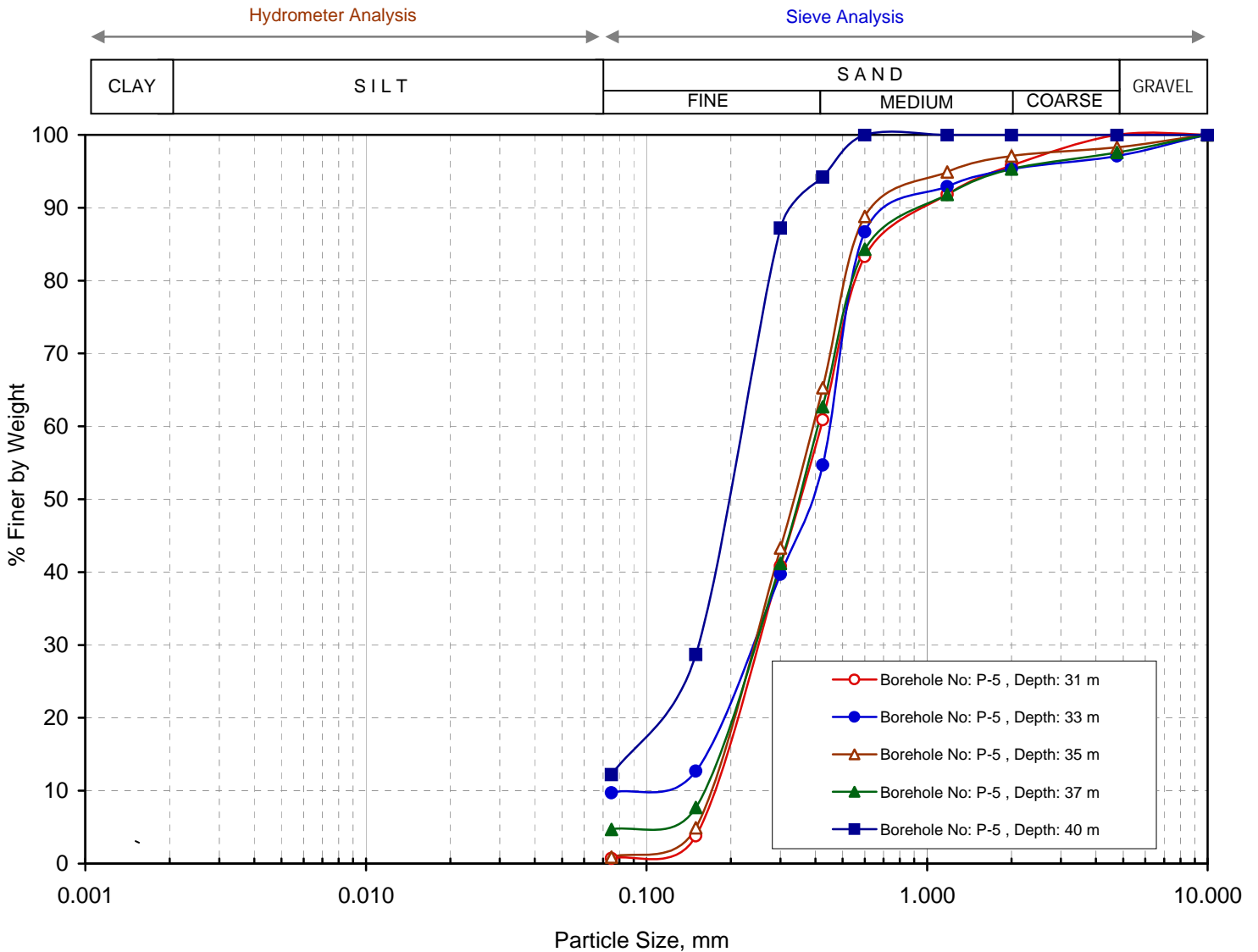

Grain Size Distribution Curve

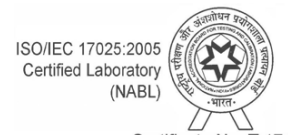



Grain Size Analysis

IS : 2720 (Part 4) - 1985, RA-2010

Sample Details			Test Results									
Borehole Number	Sample Depth, m	Sample Description	% Gravel	% Sand	% Silt	% Clay	D ₆₀	D ₅₀	D ₃₀	D ₁₀	C _u	C _c
BH-P-6	0.50	FILL: Flyash	0	62	35	3	0.133	0.110	0.056	0.012	11.1	1.96
BH-P-6	2.50	FILL: Flyash	0	22	50	28	0.010	0.006	0.002			
BH-P-6	4.50	Clayey silt with traces of gravel (CI)	2	20	55	23	0.009	0.007	0.003			
BH-P-6	6.50	Sandy silt (CL)	0	25	57	18	0.013	0.009	0.004			
BH-P-6	8.50	Silty fine sand (SM)	0	81	19	0	0.218	0.190	0.139			

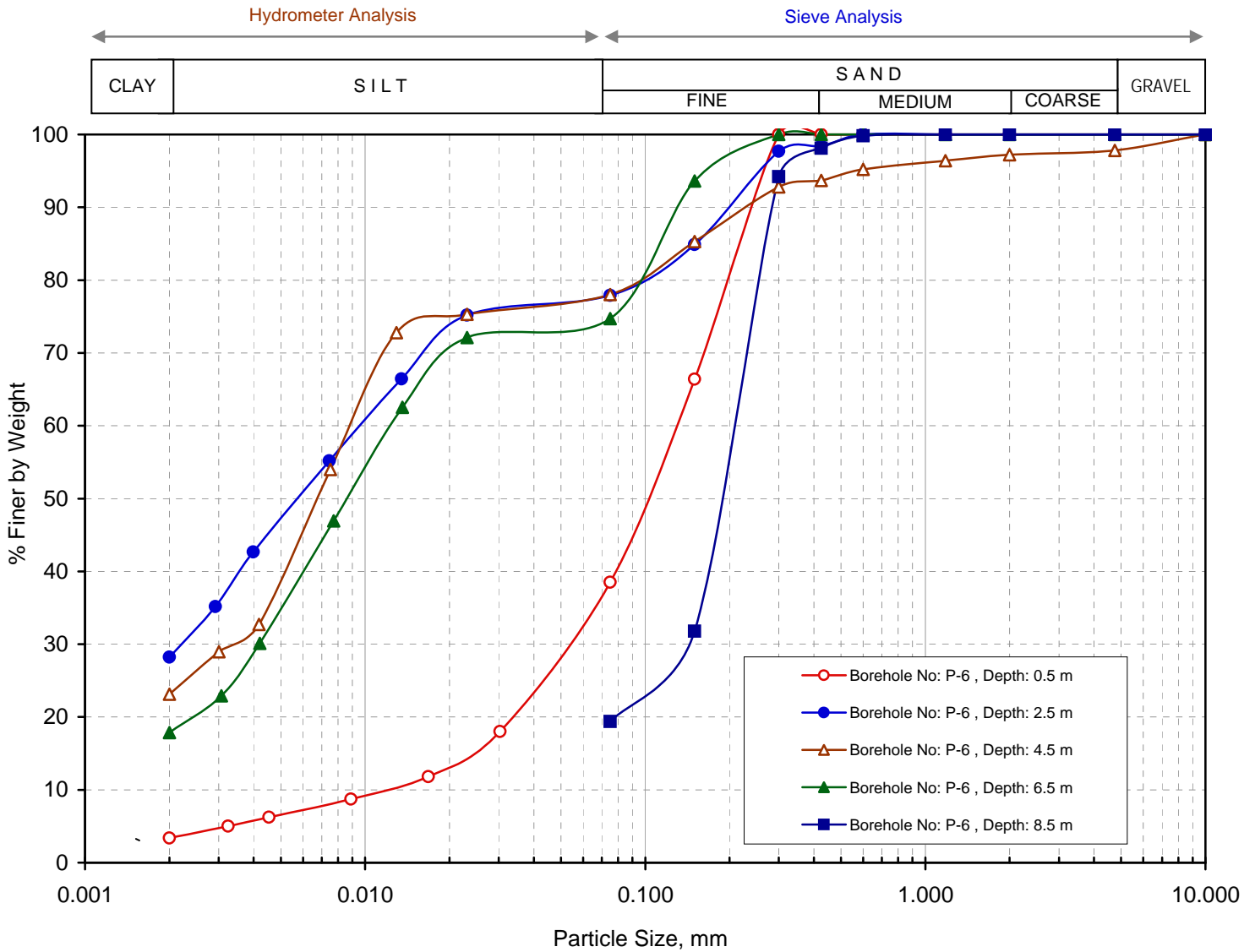

Grain Size Distribution Curve

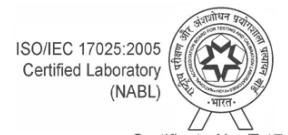



Grain Size Analysis

IS : 2720 (Part 4) - 1985, RA-2010

Sample Details			Test Results									
Borehole Number	Sample Depth, m	Sample Description	% Gravel	% Sand	% Silt	% Clay	D ₆₀	D ₅₀	D ₃₀	D ₁₀	C _u	C _c
BH-P-6	10.50	Silty fine sand (SM)	0	76	24	0	0.200	0.170	0.099			
BH-P-6	12.50	Silty fine sand (SM)	0	79	21	0	0.216	0.190	0.136			
BH-P-6	14.50	Silty fine sand with traces of gravel (SM)	1	80	19	0	0.219	0.190	0.153			
BH-P-6	17.50	Fine sand (SP-SM)	0	94	6	0	0.225	0.190	0.149	0.088	2.6	1.12
BH-P-6	19.50	Fine sand (SP)	0	98	2	0	0.368	0.220	0.234	0.148	2.5	1.01

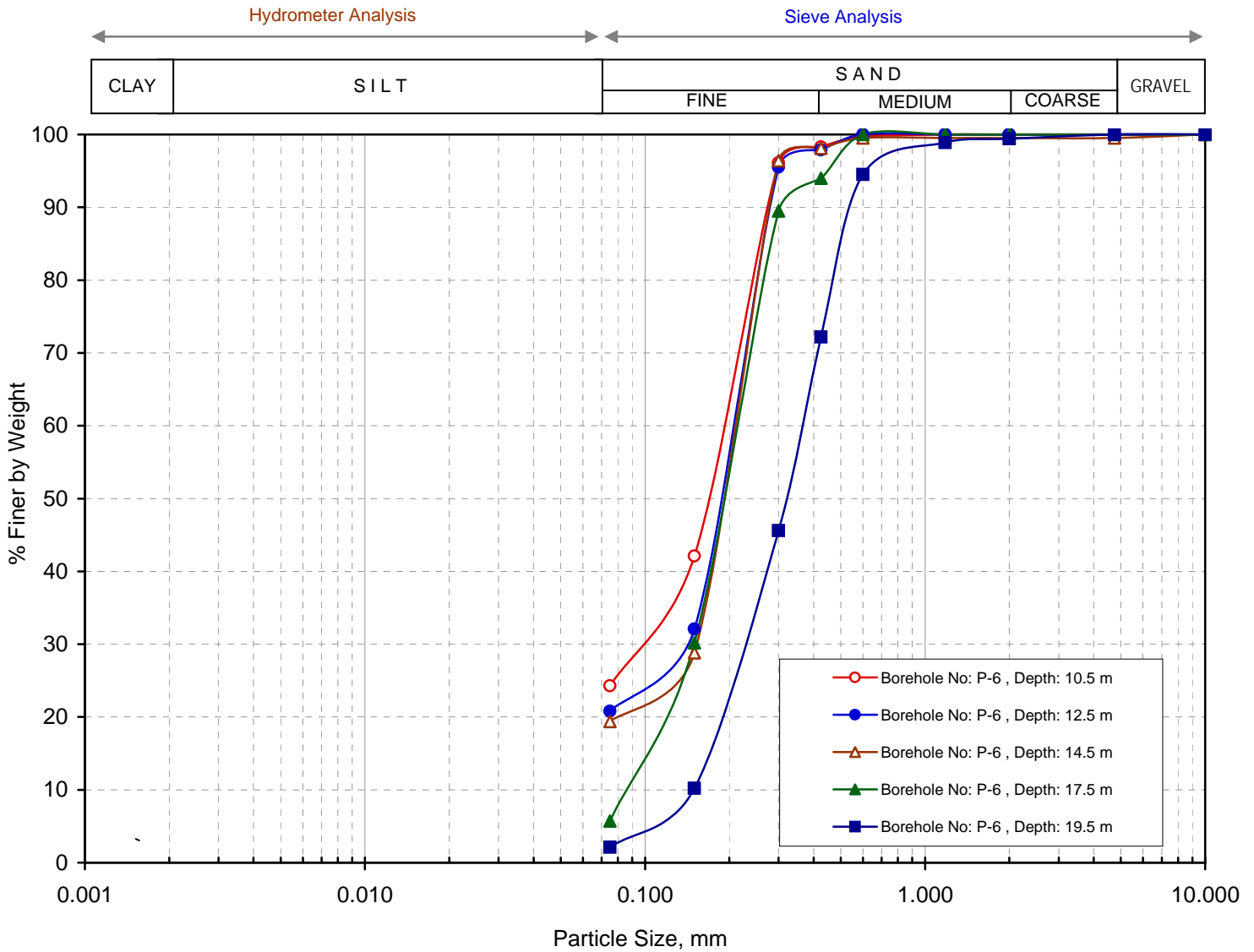

Grain Size Distribution Curve

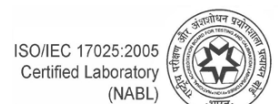

Certificate No. T-1741



Grain Size Analysis

IS : 2720 (Part 4) - 1985, RA-2010

Sample Details			Test Results									
Borehole Number	Sample Depth, m	Sample Description	% Gravel	% Sand	% Silt	% Clay	D ₆₀	D ₅₀	D ₃₀	D ₁₀	C _u	C _c
BH-P-6	21.50	Fine sand (SP)	0	97	3	0	0.410	0.350	0.242	0.160	2.6	0.89
BH-P-6	23.50	Fine sand (SP)	0	98	2	0	0.379	0.310	0.234	0.161	2.4	0.90
BH-P-6	25.50	Fine sand (SP-SM)	0	95	5	0	0.394	0.310	0.230	0.151	2.6	0.89
BH-P-6	27.50	Fine sand (SP)	0	96	4	0	0.415	0.370	0.257	0.161	2.6	0.99
BH-P-6	29.50	Fine sand with traces of gravel (SP-SM)	2	91	7	0	0.356	0.300	0.219	0.109	3.3	1.24

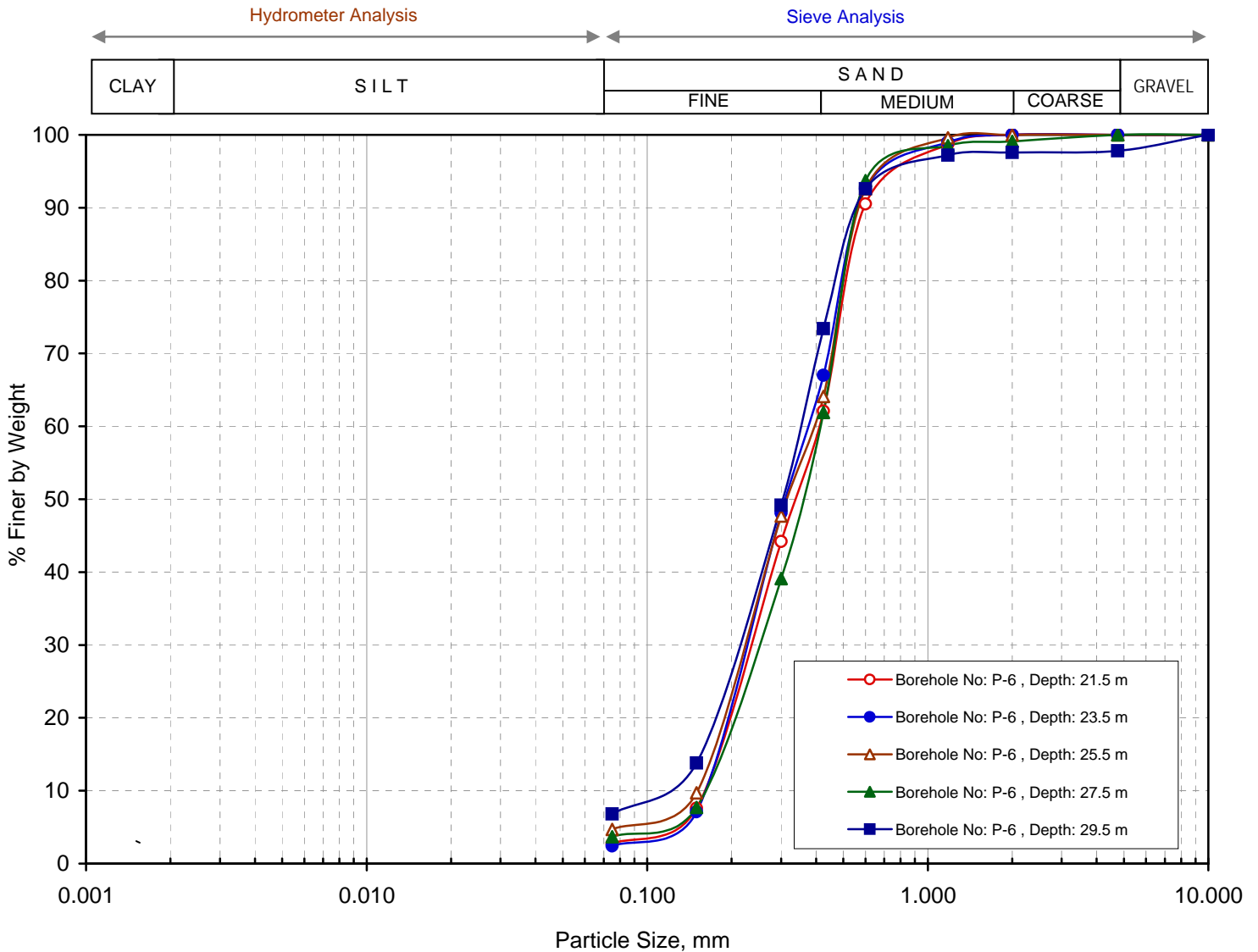

Grain Size Distribution Curve

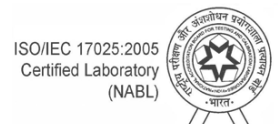



Grain Size Analysis

IS : 2720 (Part 4) - 1985, RA-2010

Sample Details			Test Results									
Borehole Number	Sample Depth, m	Sample Description	% Gravel	% Sand	% Silt	% Clay	D ₆₀	D ₅₀	D ₃₀	D ₁₀	C _u	C _c
BH-P-6	31.50	Fine sand (SP)	0	98	2	0	0.472	0.400	0.288	0.185	2.6	0.95
BH-P-6	33.80	Fine sand with traces of gravel (SP)	1	97	2	0	0.478	0.400	0.294	0.187	2.6	0.97
BH-P-6	35.50	Fine sand (SP)	0	97	3	0	0.456	0.390	0.277	0.181	2.5	0.93
BH-P-6	37.50	Fine sand with traces of gravel (SP)	2	96	2	0	0.479	0.400	0.291	0.187	2.6	0.95
BH-P-6	40.00	Fine sand (SP)	0	97	3	0	0.497	0.440	0.314	0.188	2.6	1.06

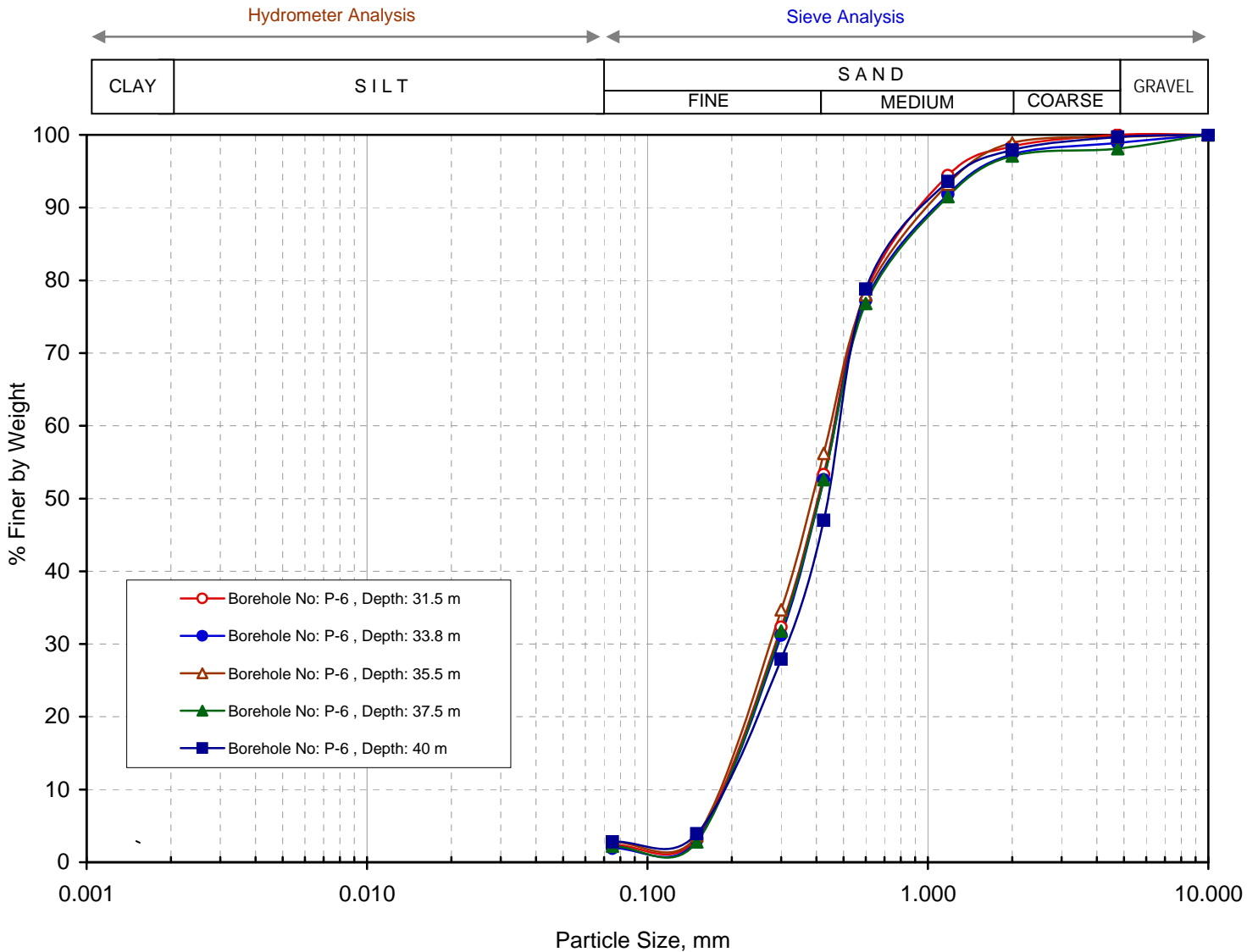

Grain Size Distribution Curve

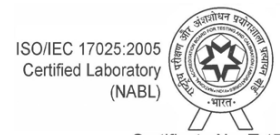



Drained Direct Shear Test

IS : 2720 (Part-13)-1986, RA-2010

Sample Details	Borehole No.: BH-P-1	Sample Depth: 3 m
	Sample No.: UDS1	Sample Description: FILL: Flyash
	Type of Sample:	Remoulded
	Dry Density of Soil (g/cm ³):	1.06
Test Results	Moisture Content (%):	Saturated
	Cohesion Intercept, c :	0.00 kg/cm²
	Angle of Internal Friction, ϕ :	38.9 degrees

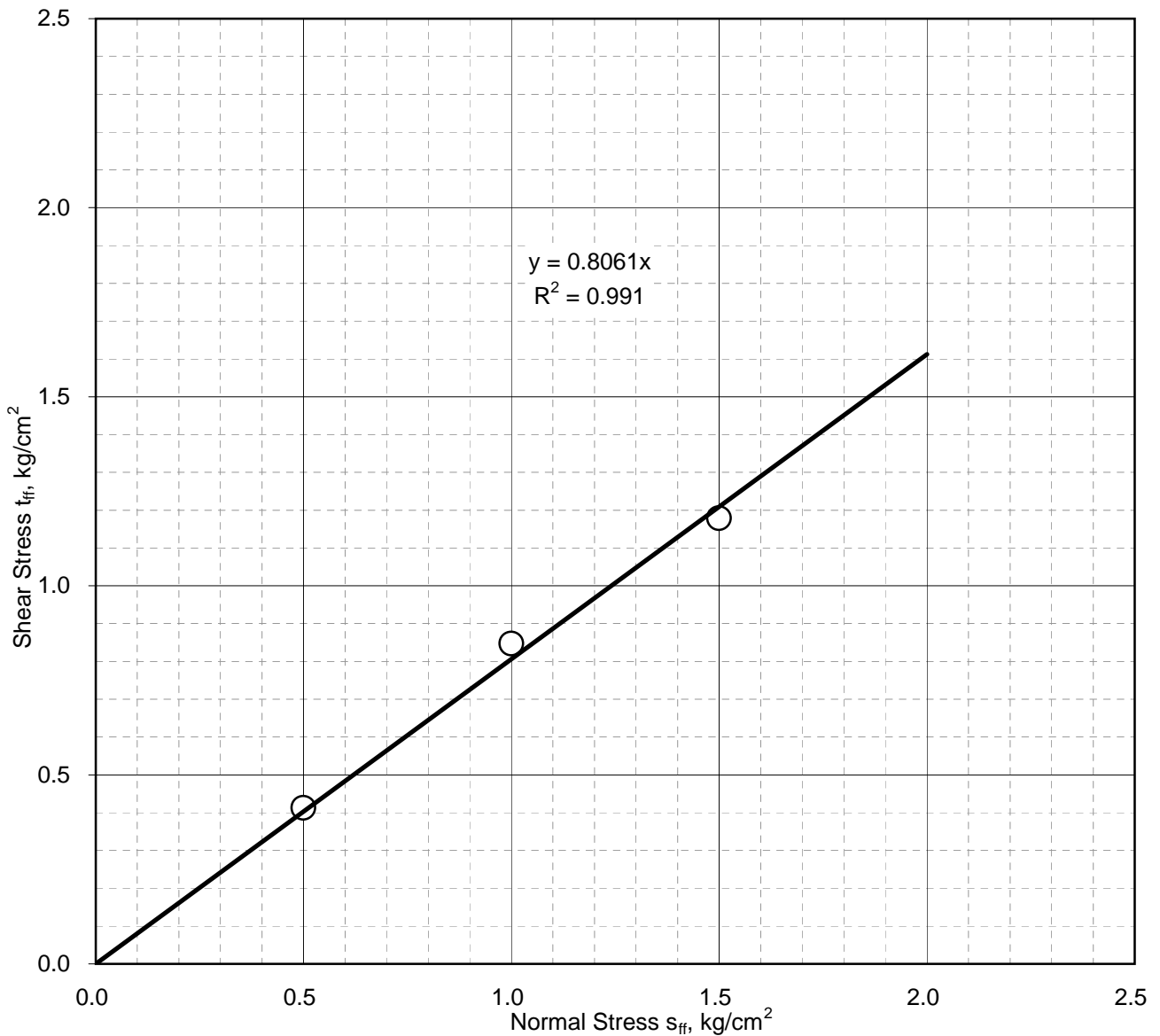

Mohr-Coulomb Failure Envelope

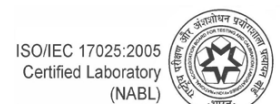

Certificate No. T-1741



Drained Direct Shear Test

IS : 2720 (Part-13)-1986, RA-2010

Sample Details	Borehole No.: BH-P-1	Sample Depth: 6 m
	Sample No.: UDS2	Sample Description: Silty fine sand
	Type of Sample:	Remoulded
	Dry Density of Soil (g/cm ³):	1.48
Test Results	Moisture Content (%):	Saturated
	Cohesion Intercept, c :	0.00 kg/cm ²
	Angle of Internal Friction, ϕ :	30.3 degrees

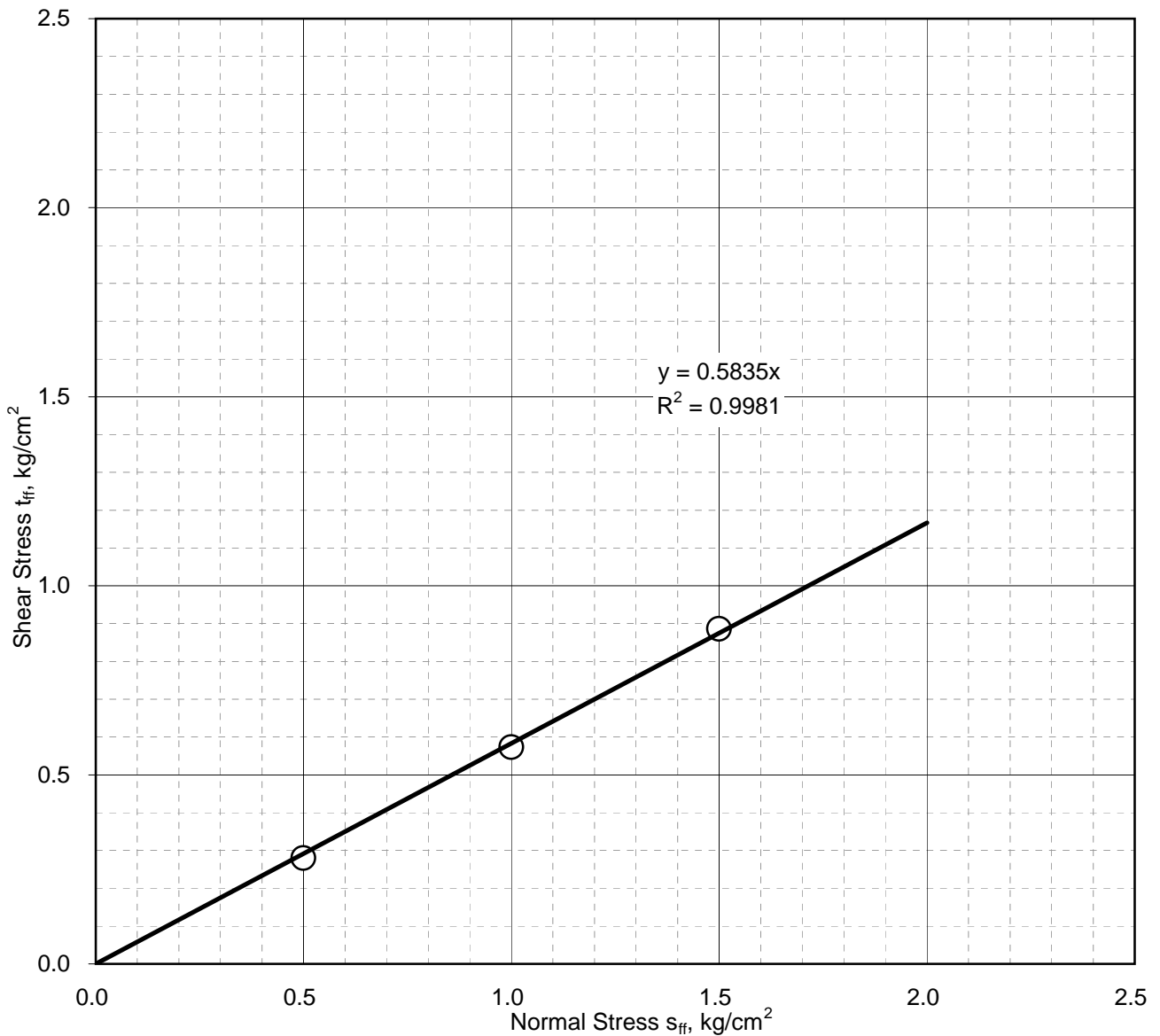

Mohr-Coulomb Failure Envelope

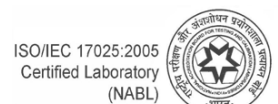

Certificate No. T-1741



Drained Direct Shear Test

IS : 2720 (Part-13)-1986, RA-2010

Sample Details	Borehole No.: BH-P-2		Sample Depth: 3 m	
	Sample No.: UDS1		Sample Description: FILL: Flyash	
	Type of Sample:		Remoulded	
	Dry Density of Soil (g/cm ³):		1.07	
Test Results	Moisture Content (%):		Saturated	
	Cohesion Intercept, c :		0.00	kg/cm ²
	Angle of Internal Friction, ϕ :		30.6	degrees

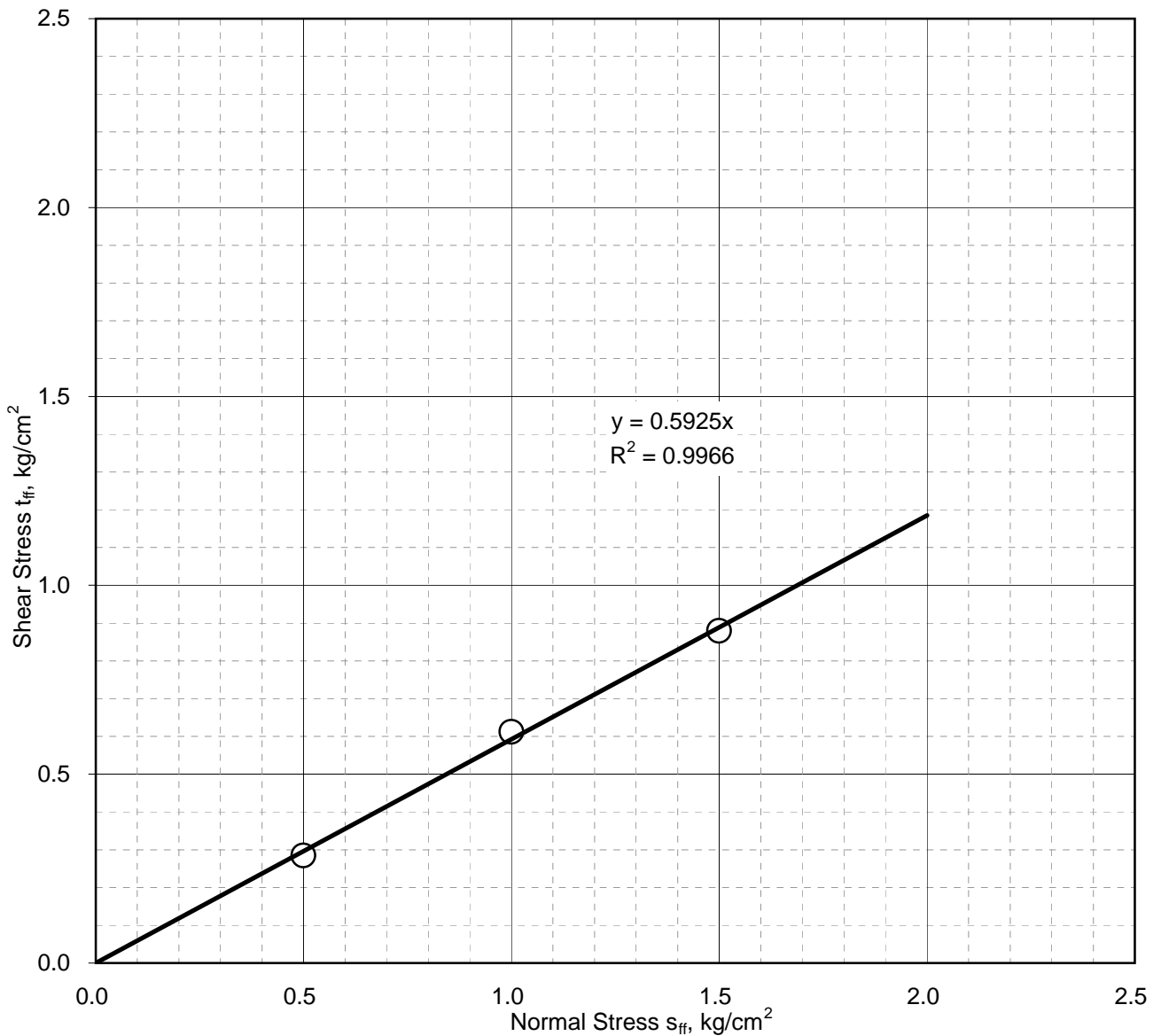

Mohr-Coulomb Failure Envelope

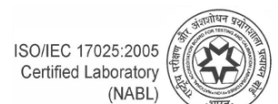

Certificate No. T-1741



Unconfined Compression Test on an Remoulded Soil Sample

IS : 2720 (Part-10)-1991, RA-2010

Borehole No.: BH-P-2		Sample Depth: 6 m	
Sample No.: UDS2		Sample Description: Sandy silt	
Sample Details		Test Results	
Sample Type:	Remoulded	Unconfined Compressive Strength, q_u (kg/cm ²):	3.4
Initial diameter (cm):	3.80	Cohesion Intercept, c (kg/cm ²):	1.7
Initial Length (cm):	7.60		
Sample Bulk Density (γ_b), g/cc	1.88	Failure Strain, ϵ_f (%):	19.7
Sample Dry Density (γ_d), g/cc	1.53	Secant Modulus, E_{50} (kg/cm ²):	23
Sample Moisture content (w), %	23.2	Initial Tangent Modulus, E_i (kg/cm ²):	34

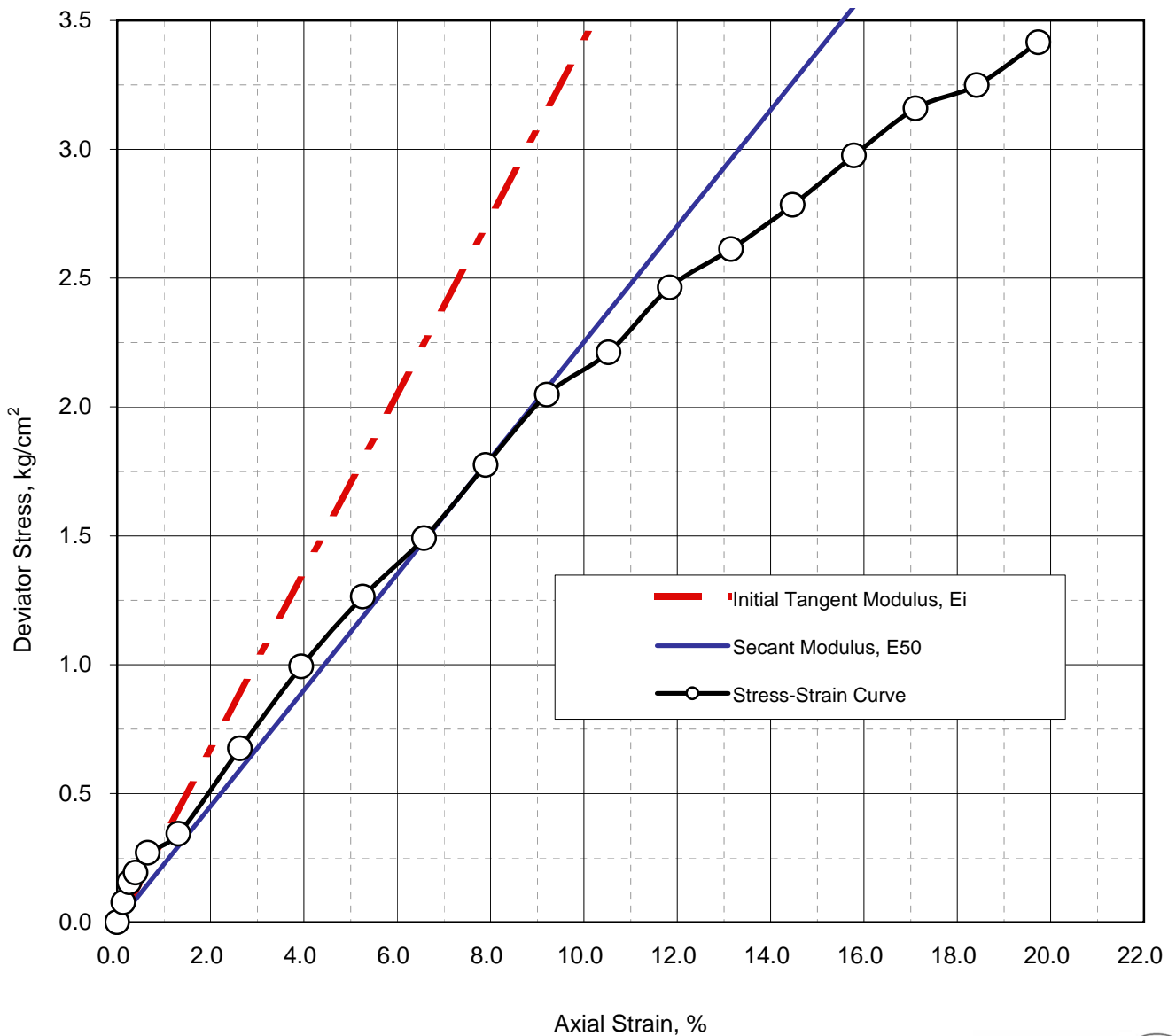

Mohr-Coulomb Failure Envelope

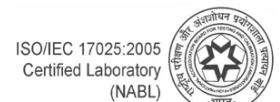

Certificate No. T-1741



Drained Direct Shear Test

IS : 2720 (Part-13)-1986, RA-2010

Sample Details	Borehole No.: BH-P-3	Sample Depth: 1.5 m
	Sample No.: UDS1	Sample Description: FILL: Flyash
	Type of Sample:	Remoulded
	Dry Density of Soil (g/cm ³):	1.13
Test Results	Moisture Content (%):	Saturated
	Cohesion Intercept, c :	0.00 kg/cm²
	Angle of Internal Friction, ϕ :	28.9 degrees

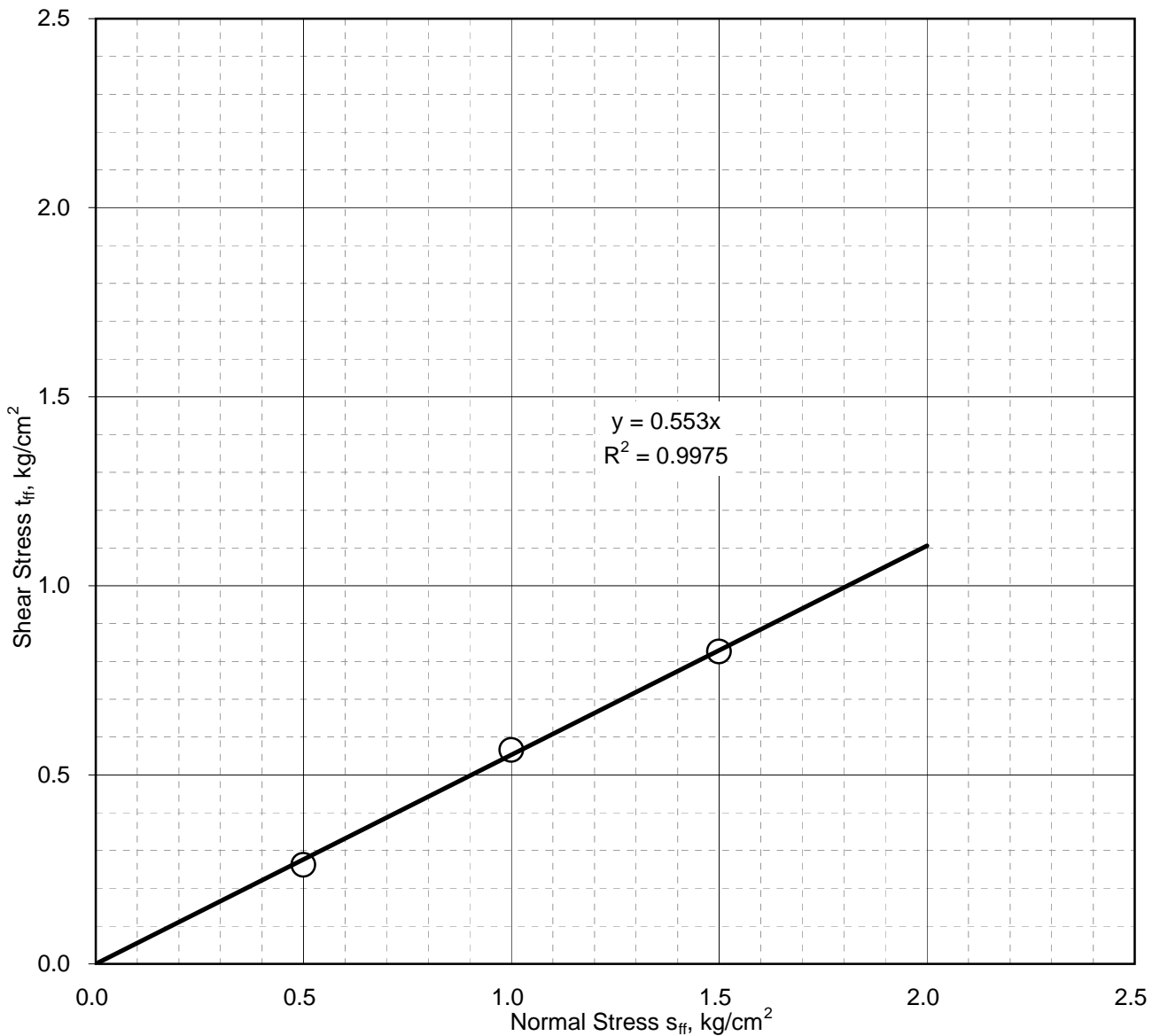

Mohr-Coulomb Failure Envelope

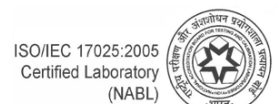

Certificate No. T-1741



Drained Direct Shear Test

IS : 2720 (Part-13)-1986, RA-2010

Sample Details	Borehole No.: BH-P-3		Sample Depth: 7.5 m	
	Sample No.: UDS3		Sample Description: Silty fine sand	
	Type of Sample:		Remoulded	
	Dry Density of Soil (g/cm ³):		1.57	
Test Results	Moisture Content (%):		Saturated	
	Cohesion Intercept, c :		0.00	kg/cm ²
	Angle of Internal Friction, ϕ :		33.0	degrees

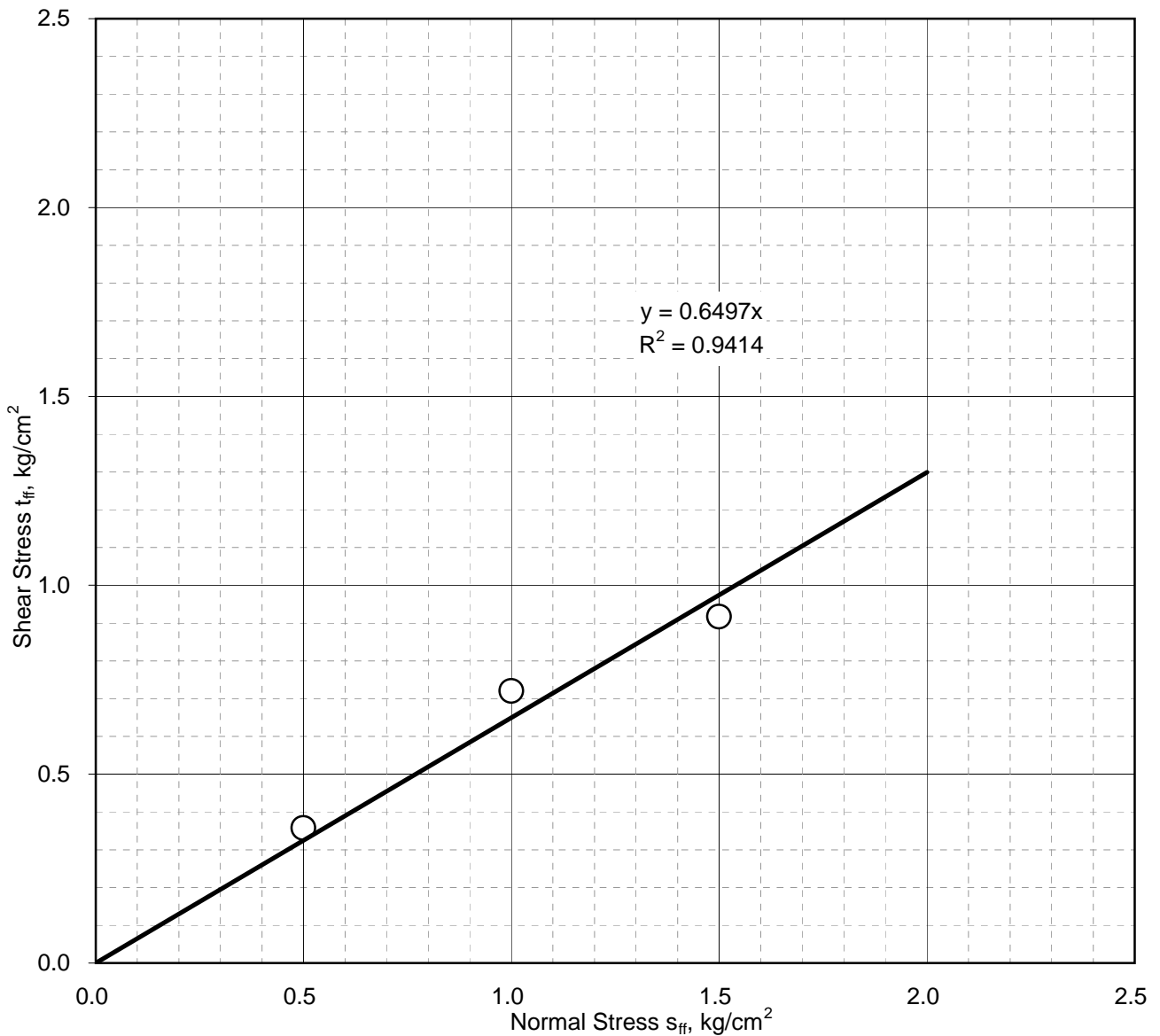

Mohr-Coulomb Failure Envelope

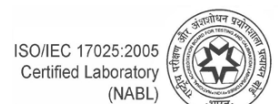

ISO/IEC 17025:2005
Certified Laboratory
(NABL)

Certificate No. T-1741



Drained Direct Shear Test

IS : 2720 (Part-13)-1986, RA-2010

Sample Details	Borehole No.: BH-P-3	Sample Depth: 10.5 m
	Sample No.: UDS4	Sample Description: Silty fine sand
	Type of Sample:	Remoulded
	Dry Density of Soil (g/cm ³):	1.53
Test Results	Moisture Content (%):	Saturated
	Cohesion Intercept, c :	0.00 kg/cm²
	Angle of Internal Friction, ϕ :	28.4 degrees

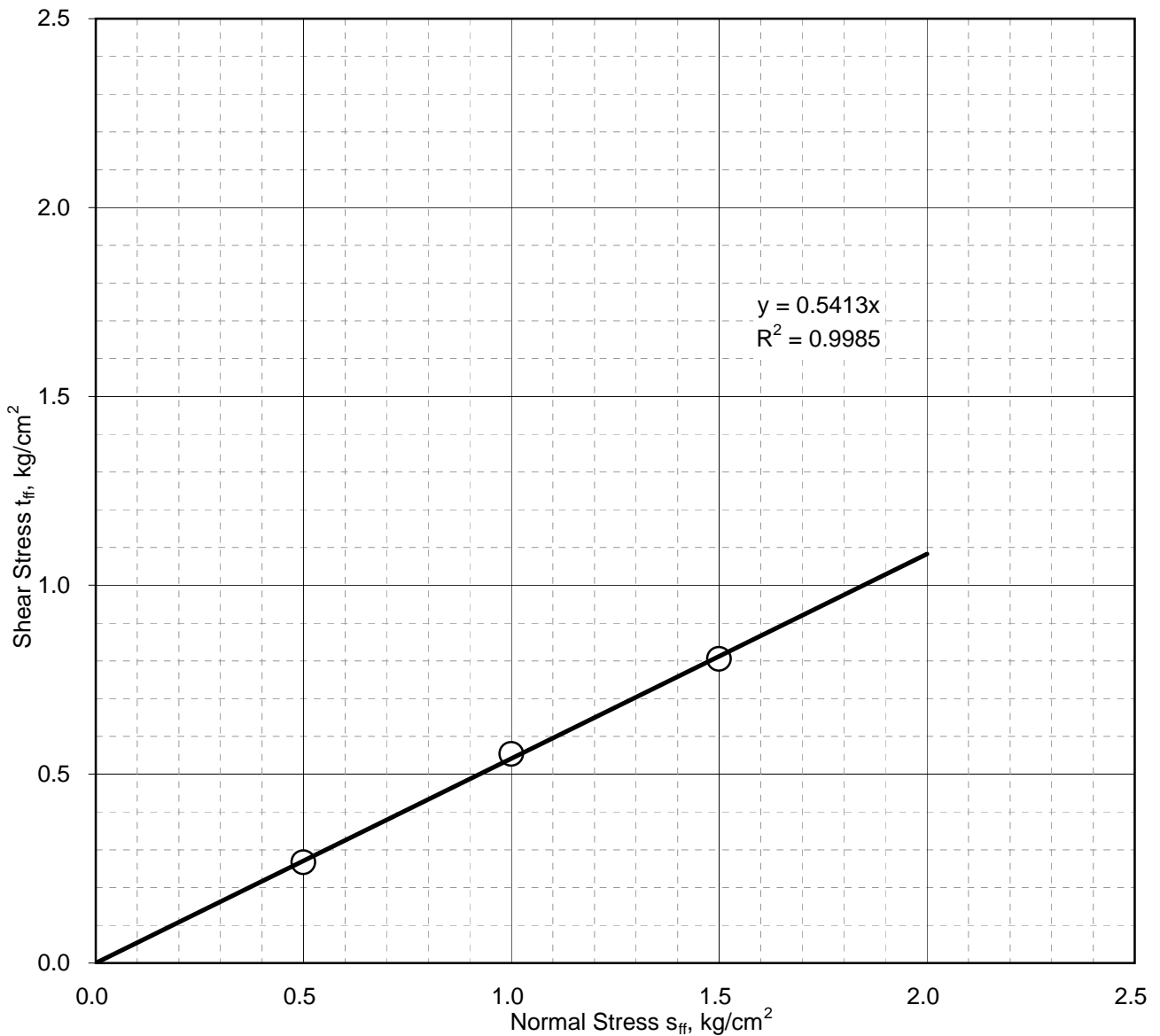

Mohr-Coulomb Failure Envelope

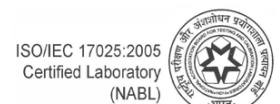

ISO/IEC 17025:2005
Certified Laboratory
(NABL)

Certificate No. T-1741



Drained Direct Shear Test

IS : 2720 (Part-13)-1986, RA-2010

Sample Details	Borehole No.: BH-P-4	Sample Depth: 1.5 m
	Sample No.: UDS1	Sample Description: FILL: Flyash
	Type of Sample:	Remoulded
	Dry Density of Soil (g/cm ³):	1.01
Test Results	Moisture Content (%):	Saturated
	Cohesion Intercept, c :	0.00 kg/cm²
	Angle of Internal Friction, ϕ :	35.7 degrees

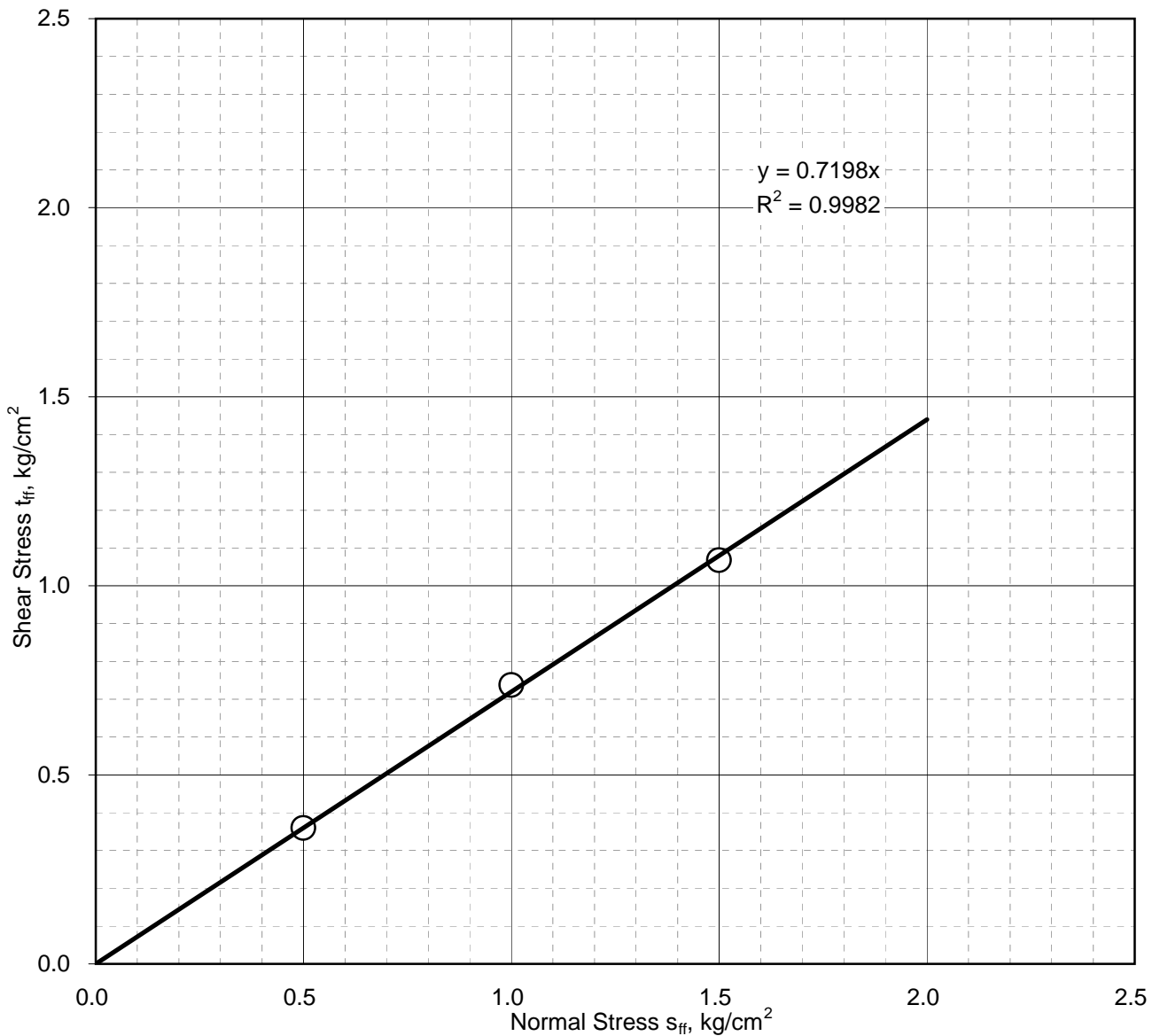

Mohr-Coulomb Failure Envelope

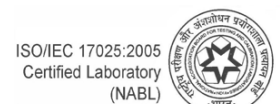

Certificate No. T-1741



Unconsolidated Undrained Triaxial Test

IS : 2720 (Part-11)-1993, RA-2007

Sample Details	Borehole No.: BH-P-4		Sample Depth: 4.5 m	
	Sample No.: UDS2		Sample Description: Sandy silt	
	Confining Pressure, σ_0 (kg/cm ²):	0.4	0.6	0.8
	Initial diameter (cm):	3.8	3.8	3.8
	Initial Length (cm):	7.6	7.6	7.6
	Bulk Density (g/cc):	1.87	1.87	1.87
	Dry Density (g/cc):	1.56	1.57	1.56
Test Results	Moisture Content (%):	19.9	19.6	19.8
	Peak Deviator Stress, $(\sigma_3 - \sigma_1)_f$ (kg/cm ²):	6.16	6.38	6.54
	Failure Strain, ϵ_f (%):	23.7	23.7	23.7
	Cohesion Intercept, c:	2.10	kg/cm²	
	Angle of Internal Friction, ϕ:	19.0	degrees	

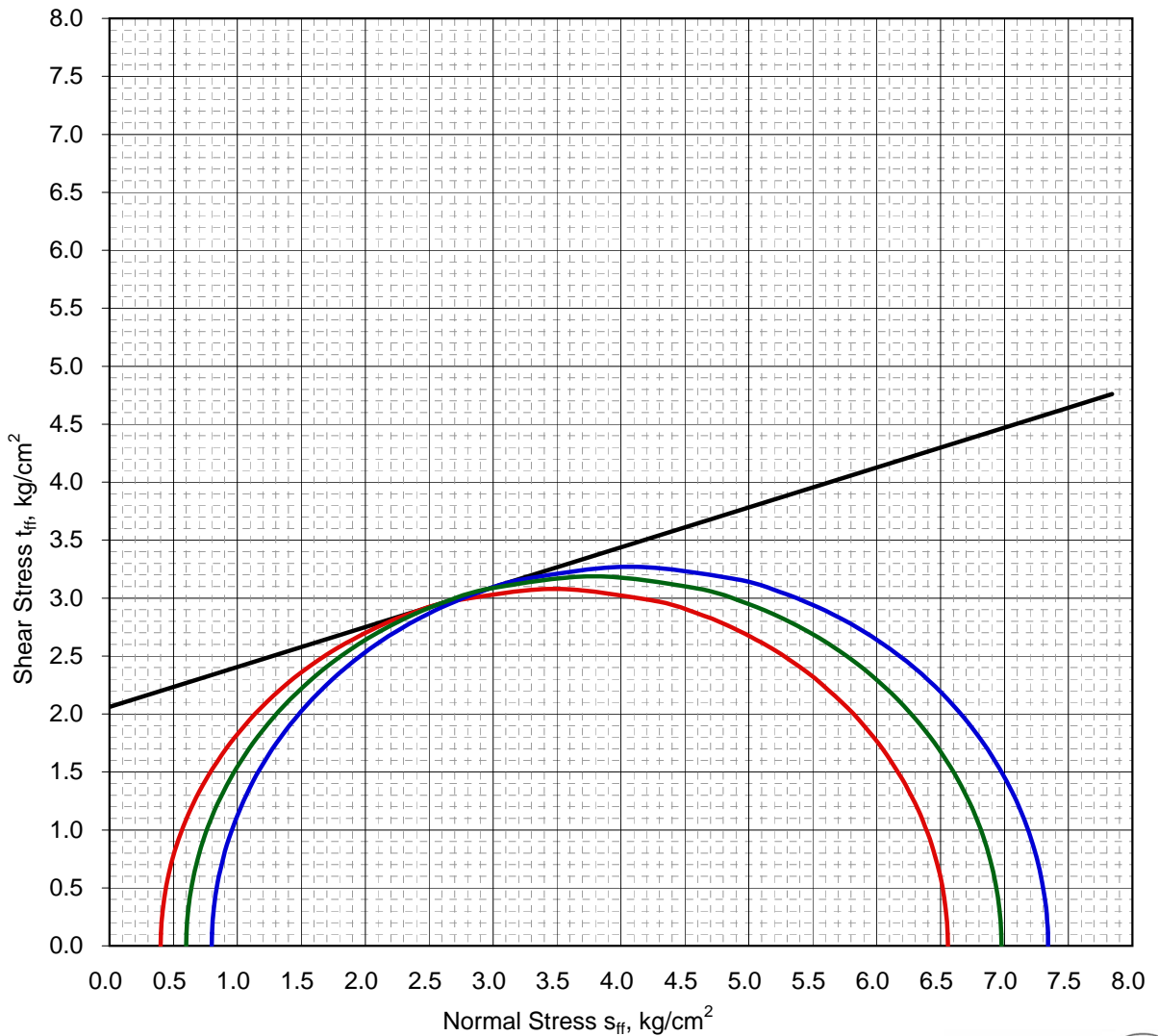

Mohr-Coulomb Failure Envelope

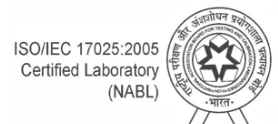



Drained Direct Shear Test

IS : 2720 (Part-13)-1986, RA-2010

Sample Details	Borehole No.: BH-P-4	Sample Depth: 7.5 m
	Sample No.: UDS3	Sample Description: Silty fine sand
	Type of Sample:	Remoulded
	Dry Density of Soil (g/cm ³):	1.57
Test Results	Moisture Content (%):	Saturated
	Cohesion Intercept, c :	0.00 kg/cm²
	Angle of Internal Friction, ϕ :	32.3 degrees

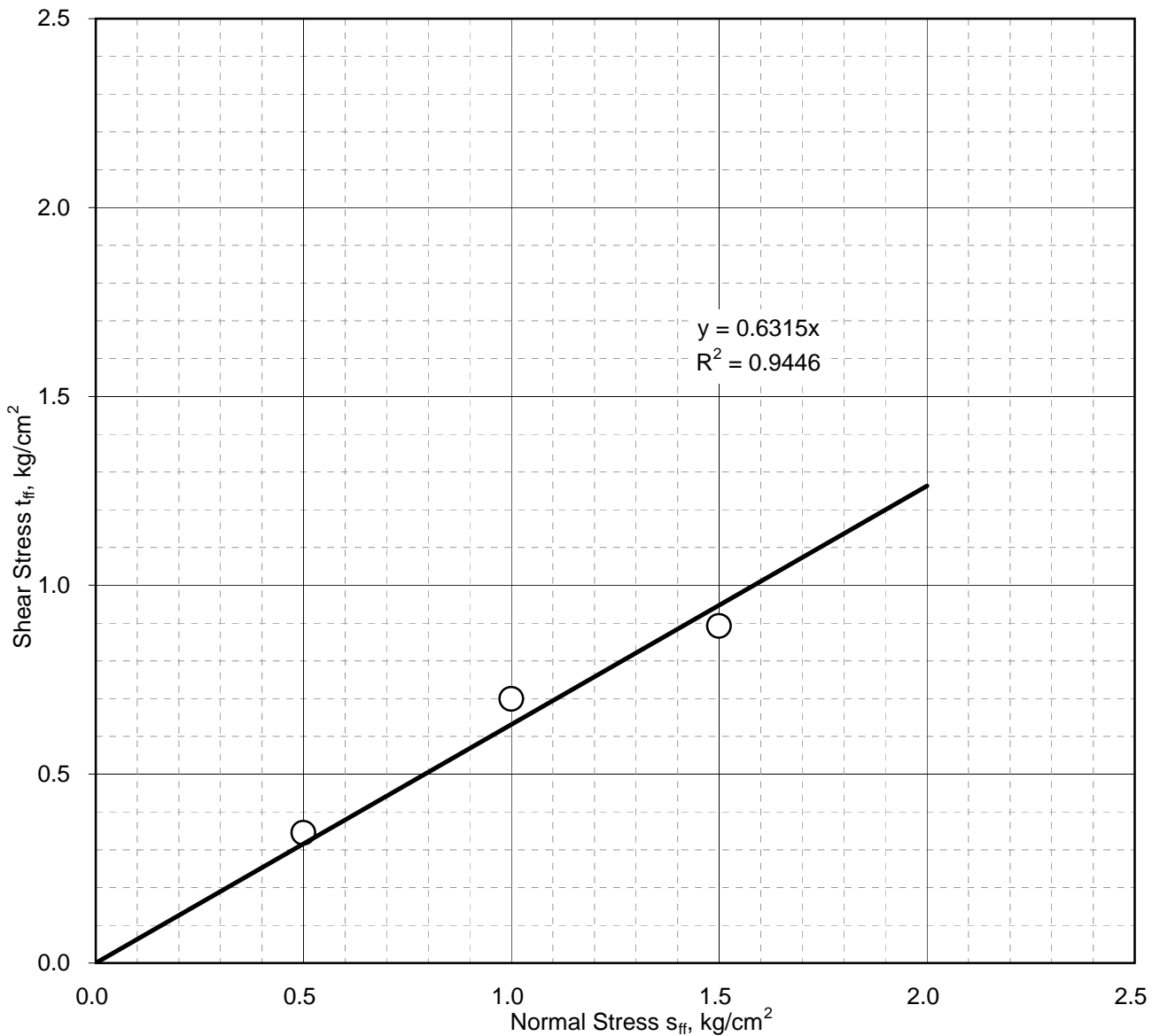

Mohr-Coulomb Failure Envelope

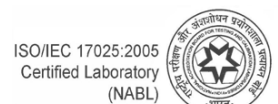

Certificate No. T-1741



Drained Direct Shear Test

IS : 2720 (Part-13)-1986, RA-2010

Sample Details	Borehole No.: BH-P-5	Sample Depth: 3 m
	Sample No.: UDS1	Sample Description: FILL: Flyash
	Type of Sample:	Remoulded
	Dry Density of Soil (g/cm ³):	1.10
Test Results	Moisture Content (%):	Saturated
	Cohesion Intercept, c :	0.00 kg/cm²
	Angle of Internal Friction, ϕ :	39.0 degrees

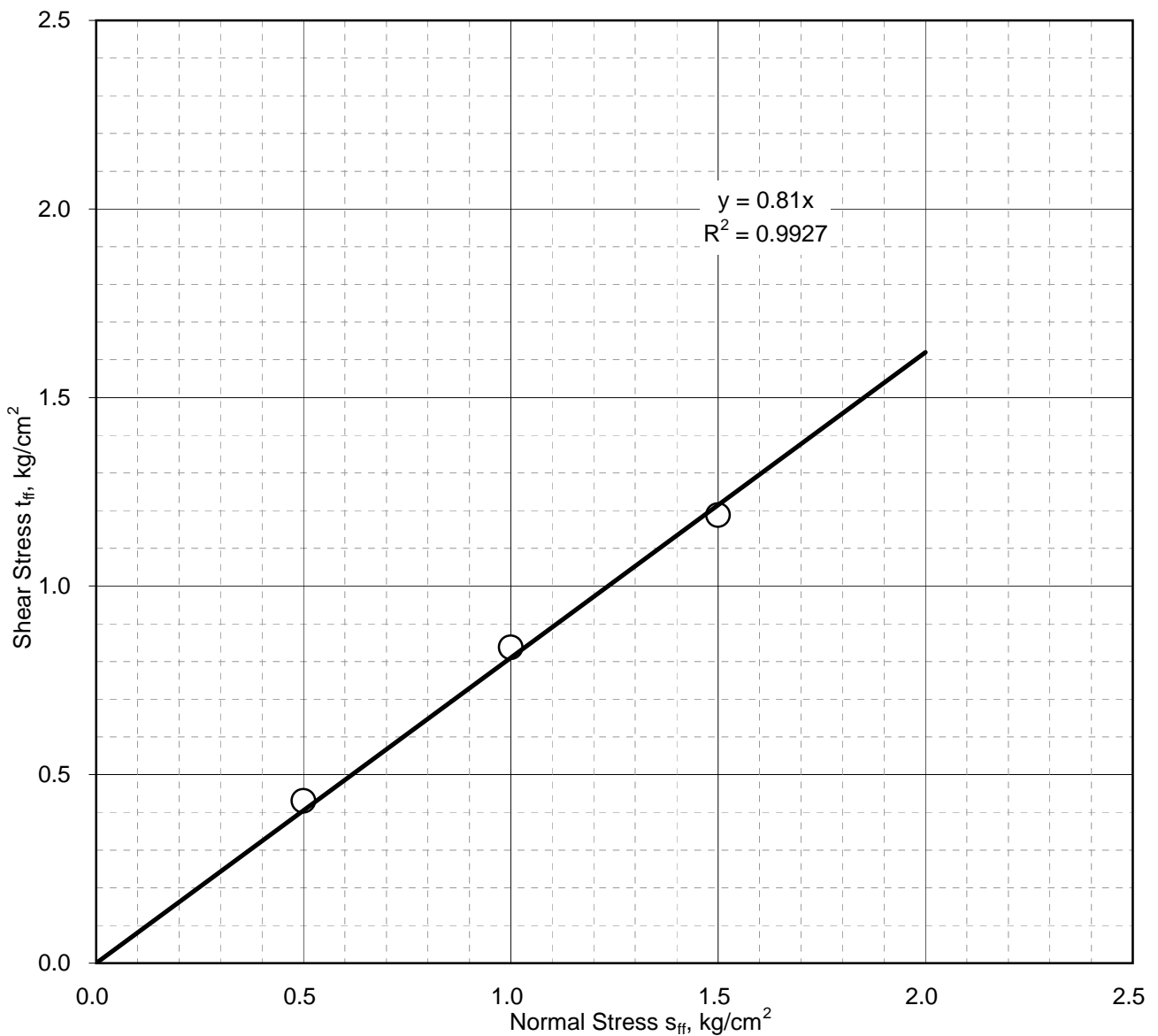

Mohr-Coulomb Failure Envelope

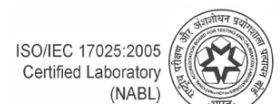

Certificate No. T-1741



Drained Direct Shear Test

IS : 2720 (Part-13)-1986, RA-2010

Sample Details	Borehole No.: BH-P-6	Sample Depth: 1.5 m
	Sample No.: UDS1	Sample Description: FILL: Flyash
	Type of Sample:	Remoulded
	Dry Density of Soil (g/cm ³):	1.09
Test Results	Moisture Content (%):	Saturated
	Cohesion Intercept, c :	0.00 kg/cm²
	Angle of Internal Friction, ϕ :	32.4 degrees

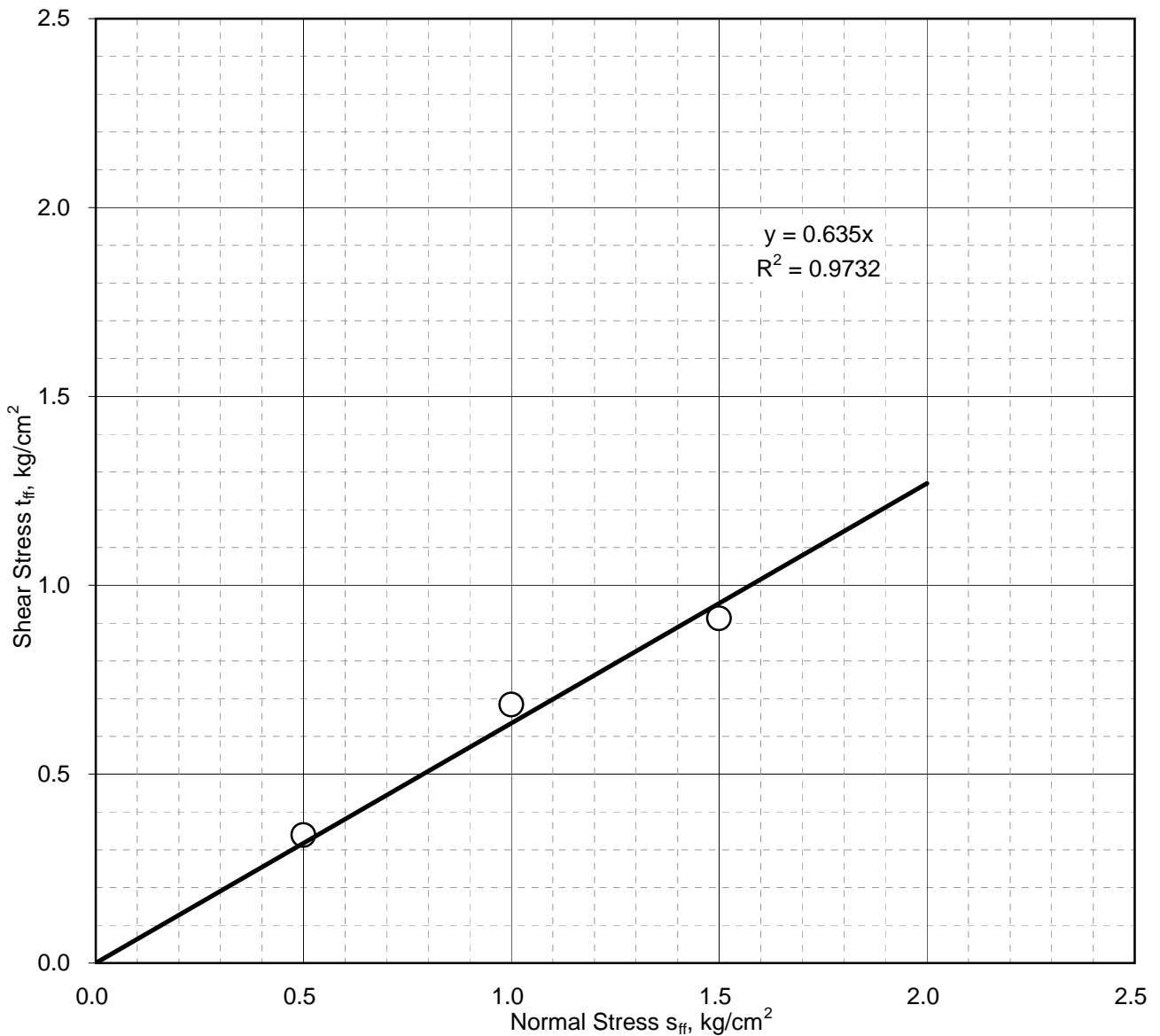

Mohr-Coulomb Failure Envelope

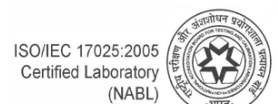

Certificate No. T-1741



Unconsolidated Undrained Triaxial Test

IS : 2720 (Part-11)-1993, RA-2007

Sample Details	Borehole No.: BH-P-6	Sample Depth: 4.5 m		
	Sample No.: UDS2	Sample Description: Clayey silt		
	Confining Pressure, σ_0 (kg/cm ²):	0.4	0.6	0.8
	Initial diameter (cm):	3.8	3.8	3.8
	Initial Length (cm):	7.6	7.6	7.6
	Bulk Density (g/cc):	1.89	1.89	1.89
	Dry Density (g/cc):	1.59	1.59	1.58
Test Results	Moisture Content (%):	18.6	19.0	19.3
	Peak Deviator Stress, $(\sigma_3 - \sigma_1)_f$ (kg/cm ²):	6.59	6.54	6.67
	Failure Strain, ϵ_f (%):	23.7	23.7	23.7
	Cohesion Intercept, c:	2.90	kg/cm²	
	Angle of Internal Friction, ϕ:	5.7	degrees	

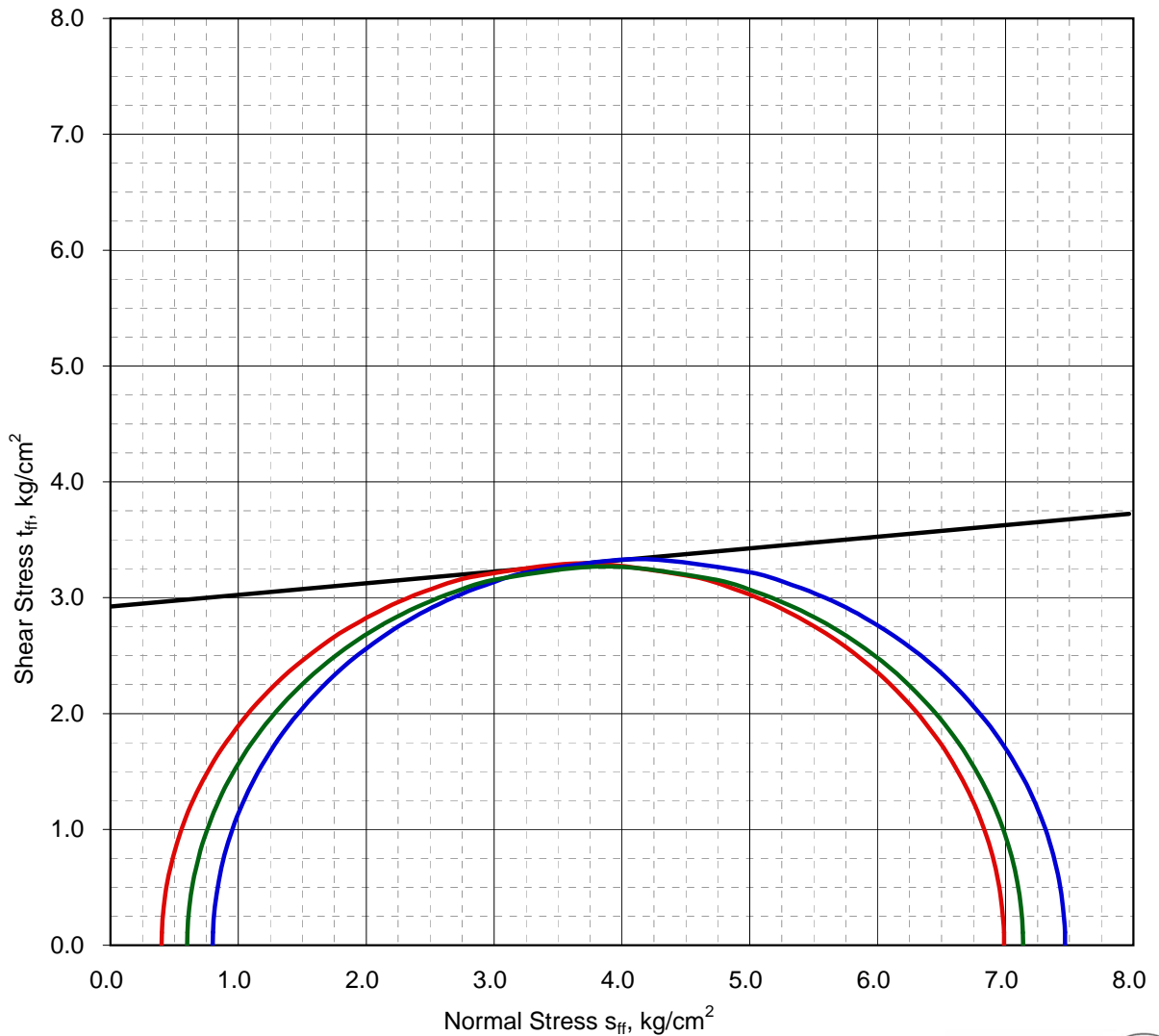

Mohr-Coulomb Failure Envelope

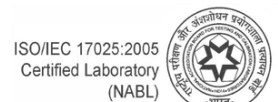

Certificate No. T-1741



TEST RESULTS

Soil-Water Extract Test Results				
Borehole No.	Depth, (m)	Sulphate Content (SO ₃), %	Chloride Content (Cl), %	pH Value
BH-P1	0.50	0.11	0.06	8.0
	3.00	0.10	0.05	7.4
BH-P2	0.50	0.11	0.05	7.7
	3.00	0.11	0.05	7.8
BH-P3	0.50	0.11	0.04	7.6
	2.50	0.11	0.04	7.5
BH-P4	1.50	0.11	0.05	7.5
	3.50	0.11	0.04	7.6
BH-P5	0.00	0.11	0.05	7.7
	2.00	0.10	0.05	7.7
BH-P6	0.50	0.11	0.06	7.9
	2.50	0.10	0.04	7.7

Groundwater Test Results			
Borehole No.	Sulphate Content (SO ₃), mg/l	Chloride Content (Cl), mg/l	pH Value
BH-P1	347	172	7.3
BH-P2	331	112	7.4
BH-P3	342	135	7.3
BH-P4	335	150	7.5
BH-P-5	355	192	7.2
BH-P6	340	127	7.4

IS : 456-2000, SPECIFICATIONS

Requirements for Concrete Exposed to Sulphate Attack as per IS : 456-2000, Clauses 8.2.2.4 and 9.1.2, Table 4, Page-19

Class	Concentration of Sulphates, expressed as SO ₃ In-Soil-Water Extract (Total) Percent	In Groundwater (mg/l)
1	Traces (<0.2)	Less than 300
2	0.2 to 0.5	300-1200
3	0.5 to 1.0	1200-2500
4	1.0 to 2.0	2500-5000
5	> 2.0	> 5000

Classification of Chloride Conditions in Groundwater*

Classification	Chloride Limits	
	Temperate Climate	Tropical Climate
Negligible	0-2000 ppm	Not Applicable
Moderate	2000-10,000 ppm	0-2000 ppm
High	More than 10,000 ppm	2000-20,000 ppm
Very High	Generally not applicable	Only if considerably in excess of 20,000 ppm

*Source : Institution of Civil Engineers, London (1979)

Chemical Test Results

APPENDIX-A
LIQUEFACTION SUSCEPTIBILITY ASSESSMENT

Liquefaction Susceptibility Assessment

Project Details

Borehole No.	P-1		
Block	N/A		
Structure	Coal Silo #4 Site		
Existing Ground Level (EGL)	45.5		
Surcharge Load, if any:	0 T/m ²		
Design Earthquake	Site Levels	Boring Details	
Seismic Zone: IV	Existing Ground Level, EGL (m): 45.5	Sampler with liner? N	
Earthquake Magnitude: 6.7	Actual GW Depth (m): 9.6	Hammer Type: WT	
PGA (g): 0.24	Design GW Depth (m): 4.0	Borehole Diameter (mm): 150	
Critical Factor of Safety (FS): 1.0	Design GW Level (m): 41.5	SPT Energy Correction (C _E): 0.75	

Theory

As per Seed and Idriss Approach, as described in the NCEER Summary Report (2001) -

$$FOS = \frac{CRR_{7.5}}{CSR} \cdot MSF$$

$$CSR = \left(\frac{\tau_{av}}{\sigma'_{vo}} \right) = 0.65 \left(\frac{a_{max}}{g} \right) \left(\frac{\sigma'_{vo}}{\sigma'_{vo}} \right) r_d$$

$$CRR_{7.5} = \frac{1}{34 - (N_1)_{60}} + \frac{(N_1)_{60}}{135} + \frac{50}{[10 \cdot (N_1)_{60} + 45]^2} - \frac{1}{200}$$

Several corrections are applied to the field N value:

Corrected SPT 'N' Value: $(N_1)_{60} = N_m \cdot C_N \cdot C_E \cdot C_B \cdot C_R \cdot C_S$

Influence of Fines Content: $(N_1)_{60,cs} = \alpha + \beta(N_1)_{60}$

Symbols and Abbreviations-

- | | | |
|---|--|--------------------------------|
| FOS = Factor of safety against liquefaction | (N ₁) ₆₀ = Corrected SPT N value | MSF= Magnitude Scaling Factors |
| CRR _{7.5} = Cyclic Resistance Ratio | N _m = Measured (field) SPT N value | |
| CSR = Cyclic Stress Ratio | α, β = Coefficients based on fines content | |
| a _{max} = Peak horizontal acceleration | C _N = Factor to normalize N _m to reference overburden stress | |
| g = Acceleration of gravity | C _E = Correction for hammer energy ratio (ER) | |
| σ' _{vo} = Effective vertical overburden stress | C _R = correction for rod length | |
| r _d = Stress reduction coefficient | C _S = correction for samplers with or without liners | |

Calculations

Layer	Soil Description	Depth to Top of Layer (m)	Layer Thickness (m)	Unit weight (T/m ³)	Total Overburden Pressure at Middle of Layer (T/m ²)	Effective Stress at Middle of Layer, based on design GWT (T/m ²)	Effective Stress at Middle of Layer, based on actual GWT (T/m ²)	N _m	Fines Content (%)	C _N	C _E	C _B	C _R	C _S	α	β	(N ₁) _{60,cs}	CRR _(7.5)	Stress Reduction Factor (r _d)	CSR	Magnitude Scaling Factor	CSR _{7.5}	Computed FOS against liquefaction	Plasticity Index (%)
1	Fly ash	0.0	1.0	1.40	0.7	0.7	0.700	10	79	1.70	0.75	1.05	0.75	1.20	5.00	1.20	19	0.21	1.00	0.16	1.442	0.11	NL	6.0
2	Fly ash	1.0	1.0	1.40	2.1	2.1	2.1	12	79	1.70	0.75	1.05	0.75	1.20	5.00	1.20	22	0.25	0.99	0.15	1.442	0.11	NL	6.0
3	Fly ash	2.0	2.0	1.40	4.2	4.2	4.2	17	55	1.54	0.75	1.05	0.75	1.20	5.00	1.20	27	0.35	0.98	0.15	1.442	0.11	NL	6.0
4	Sandy silt	4.0	1.0	1.65	6.4	5.9	6.4	17	88	1.25	0.75	1.05	0.85	1.20	5.00	1.20	25	0.30	0.97	0.16	1.442	0.11	NL	
5	Silty fine sand	5.0	2.0	1.65	8.9	6.9	8.9	20	16	1.06	0.75	1.05	0.95	1.20	2.77	1.05	23	0.25	0.95	0.19	1.442	0.13	1.92	
6	Silty fine sand	7.0	1.0	1.65	11.4	7.9	11.4	23	17	0.94	0.75	1.05	0.95	1.20	3.01	1.06	24	0.27	0.94	0.21	1.442	0.15	1.82	
7	Silty fine sand	8.0	1.0	1.65	13.0	8.6	13.0	27	19	0.88	0.75	1.05	0.95	1.20	3.43	1.07	26	0.32	0.93	0.22	1.442	0.15	2.08	
8	Silty fine sand	9.0		1.65				30	15														NL	
9																								
10																								
11																								

N/A : Not Applicable (as in the case of unsaturated soils)

NL : Not Liquefiable, e.g. if (N₁)_{60,cs}>30, PI>15%, or Fines Content>50%

Conclusion:

No Liquefaction potential

Liquefaction Susceptibility Assessment																										
Project Details										Theory																
Borehole No.	P-2									<p>As per Seed and Idriss Approach, as described in the NCEER Summary Report (2001) -</p> $FOS = \frac{CRR_{7.5}}{CSR} \cdot MSF$ $CSR = \left(\frac{\tau_{av}}{\sigma'_{vo}} \right) = 0.65 \left(\frac{a_{max}}{g} \right) \left(\frac{\sigma'_{vo}}{\sigma'_{vo}} \right) r_d$ $CRR_{7.5} = \frac{1}{34 - (N_1)_{60}} + \frac{(N_1)_{60}}{135} + \frac{50}{[10 \cdot (N_1)_{60} + 45]^2} - \frac{1}{200}$ <p>Several corrections are applied to the field N value: Corrected SPT 'N' Value: $(N_1)_{60} = N_m \cdot C_N \cdot C_E \cdot C_B \cdot C_R \cdot C_S$ Influence of Fines Content: $(N_1)_{60,cs} = \alpha + \beta(N_1)_{60}$</p> <p>Symbols and Abbreviations-</p> <p>FOS = Factor of safety against liquefaction (N1)₆₀ = Corrected SPT N value MSF= Magnitude Scaling Factors CRR_{7.5} = Cyclic Resistance Ratio N_m = Measured (field) SPT N value CSR = Cyclic Stress Ratio α, β = Coefficients based on fines content a_{max} = Peak horizontal acceleration C_N = Factor to normalize N_m to reference overburden stress g = Acceleration of gravity C_E = Correction for hammer energy ratio (ER) σ'_{vo} = Effective vertical overburden stress C_R = correction for rod length r_d = Stress reduction coefficient C_S = correction for samplers with or without liners</p>																
Block	N/A																									
Structure	Chimney Site																									
Existing Ground Level (EGL)	45.5																									
Surcharge Load, if any:	0 T/m ²																									
Design Earthquake					Site Levels					Boring Details																
Seismic Zone: IV					Existing Ground Level, EGL (m): 45.5					Sampler with liner? N																
Earthquake Magnitude: 6.7					Actual GW Depth (m): 10.1					Hammer Type: WT																
PGA (g): 0.24					Design GW Depth (m): 4.0					Borehole Diameter (mm): 150																
Critical Factor of Safety (FS): 1.0					Design GW Level (m): 41.5					SPT Energy Correction (C _E): 0.75																
Calculations																										
Layer	Soil Description	Depth to Top of Layer (m)	Layer Thickness (m)	Unit weight (T/m ³)	Total Overburden Pressure at Middle of Layer (T/m ²)	Effective Stress at Middle of Layer, based on design GWT (T/m ²)	Effective Stress at Middle of Layer, based on actual GWT (T/m ²)	N _m	Fines Content (%)	C _N	C _E	C _B	C _R	C _S	α	β	(N1) _{60,cs}	CRR _(7.5)	Stress Reduction Factor (r _d)	CSR	Magnitude Scaling Factor	CSR _{7.5}	Computed FOS against liquefaction	Plasticity Index (%)		
1	Fly ash	0.0	1.0	1.40	0.7	0.7	0.700	7	70	1.70	0.75	1.05	0.75	1.20	5.00	1.20	15	0.16	1.00	0.16	1.442	0.11	NL	11.4		
2	Fly ash	1.0	1.0	1.40	2.1	2.1	2.1	8	81	1.70	0.75	1.05	0.75	1.20	5.00	1.20	17	0.18	0.99	0.15	1.442	0.11	NL	11.4		
3	Fly ash	2.0	2.0	1.40	4.2	4.2	4.2	10	58	1.54	0.75	1.05	0.75	1.20	5.00	1.20	18	0.19	0.98	0.15	1.442	0.11	NL	11.4		
4	Sandy silt	4.0	1.0	1.65	6.4	5.9	6.4	7	88	1.25	0.75	1.05	0.85	1.20	5.00	1.20	13	0.14	0.97	0.16	1.442	0.11	NL	7.7		
5	Sandy silt	5.0	2.0	1.65	8.9	6.9	8.9	8	90	1.06	0.75	1.05	0.95	1.20	5.00	1.20	14	0.15	0.95	0.19	1.442	0.13	NL	7.7		
6	Clayey silt	7.0	1.0	1.65	11.4	7.9	11.4	5	97	0.94	0.75	1.05	0.95	1.20	5.00	1.20	10	0.11	0.94	0.21	1.442	0.15	NL	21.0		
7	Clayey silt	8.0	1.0	1.65	13.0	8.6	13.0	5	85	0.88	0.75	1.05	0.95	1.20	5.00	1.20	10	0.11	0.93	0.22	1.442	0.15	NL	14.3		
8	Clayey silt	9.0	1.0	1.65	14.7	9.3	14.7	6	97	0.83	0.75	1.05	0.95	1.20	5.00	1.20	10	0.12	0.92	0.23	1.442	0.16	NL	19.6		
9	Sandy silt	10.0	1.0	1.65	16.3	9.9	16.3	9	70	0.78	0.75	1.05	1.00	1.20	5.00	1.20	13	0.14	0.89	0.23	1.442	0.16	NL	10.1		
10	Sandy silt	11.0	1.0	1.65	18.0	10.6	16.6	26	76	0.78	0.75	1.05	1.00	1.20	5.00	1.20	28	0.37	0.87	0.23	1.442	0.16	NL	10.1		
11	Fine sand	12.0		1.65				32	8														NL			
																						N/A : Not Applicable (as in the case of unsaturated soils)				
																						NL : Not Liquefiable, e.g. if (N1) _{60,cs} >30, PI>15%, or Fines Content>50%				

Conclusion:

No Liquefaction potential

Liquefaction Susceptibility Assessment																								
Project Details												Theory												
Borehole No.		P-3										As per Seed and Idriss Approach, as described in the NCEER Summary Report (2001) -												
Block		N/A										$FOS = \frac{CRR_{7.5}}{CSR} \cdot MSF$ $CSR = \left(\frac{\tau_{av}}{\sigma'_{vo}} \right) = 0.65 \left(\frac{a_{max}}{g} \right) \left(\frac{\sigma'_{vo}}{\sigma'_{vo}} \right) r_d$ $CRR_{7.5} = \frac{1}{34 - (N_1)_{60}} + \frac{(N_1)_{60}}{135} + \frac{50}{[10 \cdot (N_1)_{60} + 45]^2} - \frac{1}{200}$												
Structure		Boiler Foundation Site										Several corrections are applied to the field N value: Corrected SPT 'N' Value: $(N_1)_{60} = N_m \cdot C_N \cdot C_E \cdot C_B \cdot C_R \cdot C_S$ Influence of Fines Content: $(N_1)_{60,cs} = \alpha + \beta(N_1)_{60}$												
Existing Ground Level (EGL)		45.5										Symbols and Abbreviations- FOS = Factor of safety against liquefaction $(N_1)_{60}$ = Corrected SPT N value MSF = Magnitude Scaling Factors $CRR_{7.5}$ = Cyclic Resistance Ratio N_m = Measured (field) SPT N value CSR = Cyclic Stress Ratio α, β = Coefficients based on fines content a_{max} = Peak horizontal acceleration C_N = Factor to normalize N_m to reference overburden stress g = Acceleration of gravity C_E = Correction for hammer energy ratio (ER) σ'_{vo} = Effective vertical overburden stress C_R = correction for rod length r_d = Stress reduction coefficient C_S = correction for samplers with or without liners												
Surcharge Load, if any:		0 T/m ²																						
Design Earthquake				Site Levels				Boring Details																
Seismic Zone:		IV		Existing Ground Level, EGL (m):		45.5		Sampler with liner?		N														
Earthquake Magnitude:		6.7		Actual GW Depth (m):		9.9		Hammer Type:		WT														
PGA (g):		0.24		Design GW Depth (m):		4.0		Borehole Diameter (mm):		150														
Critical Factor of Safety (FS):		1.0		Design GW Level (m):		41.5		SPT Energy Correction (C_E):		0.75														
Calculations																								
Layer	Soil Description	Depth to Top of Layer (m)	Layer Thickness (m)	Unit weight (T/m ³)	Total Overburden Pressure at Middle of Layer (T/m ²)	Effective Stress at Middle of Layer, based on design GWT (T/m ²)	Effective Stress at Middle of Layer, based on actual GWT (T/m ²)	N_m	Fines Content (%)	C_N	C_E	C_B	C_R	C_S	α	β	$(N_1)_{60,cs}$	$CRR_{(7.5)}$	Stress Reduction Factor (r_d)	CSR	Magnitude Scaling Factor	$CSR_{7.5}$	Computed FOS against liquefaction	Plasticity Index (%)
1	Fly Ash	0.0	2.5	1.40	1.8	1.8	1.750	8	70	1.70	0.75	1.05	0.75	1.20	5.00	1.20	17	0.18	0.99	0.15	1.442	0.11	NL	12.8
2	Fly Ash	2.5	1.0	1.40	4.2	4.2	4.2	10	55	1.54	0.75	1.05	0.75	1.20	5.00	1.20	18	0.19	0.98	0.15	1.442	0.11	NL	12.8
3	Fly Ash	3.5	2.0	1.40	6.3	6.3	6.3	11	59	1.26	0.75	1.05	0.85	1.20	5.00	1.20	18	0.20	0.97	0.15	1.442	0.10	NL	12.8
4	Sandy silt	5.5	1.0	1.65	8.5	6.6	8.5	7	92	1.08	0.75	1.05	0.95	1.20	5.00	1.20	13	0.14	0.95	0.19	1.442	0.13	NL	11.7
5	Sandy silt	6.5	2.0	1.65	11.0	7.6	11.0	12	80	0.95	0.75	1.05	0.95	1.20	5.00	1.20	17	0.18	0.94	0.21	1.442	0.15	NL	11.7
6	Silty fine sand	8.5	1.0	1.75	13.5	8.6	13.5	14	25	0.86	0.75	1.05	0.95	1.20	4.29	1.12	16	0.17	0.93	0.23	1.442	0.16	1.10	
7	Silty fine sand	9.5	2.0	1.75	16.2	9.8	16.2	14	39	0.79	0.75	1.05	1.00	1.20	5.00	1.20	17	0.19	0.89	0.23	1.442	0.16	1.17	
8	Fine sand	11.5	1.0	1.75	18.8	10.9	16.7	15	10	0.77	0.75	1.05	1.00	1.20	0.87	1.02	12	0.13	0.85	0.23	1.442	0.16	0.83	
9	Fine sand	12.5	1.0	1.75	20.5	11.7	17.5	17	9	0.76	0.75	1.05	1.00	1.20	0.56	1.02	13	0.14	0.83	0.23	1.442	0.16	0.89	
10	Fine sand	13.5	1.0	1.85	22.3	12.5	18.3	26	10	0.74	0.75	1.05	1.00	1.20	0.87	1.02	19	0.21	0.80	0.22	1.442	0.15	1.35	
11	Fine sand	14.5		1.85				32	11														NL	
N/A : Not Applicable (as in the case of unsaturated soils) NL : Not Liquefiable, e.g. if $(N_1)_{60,cs} > 30$, $PI > 15\%$, or Fines Content $> 50\%$																								

Conclusion:

Liquefaction potential 11.5 to 13.5 m depth

Liquefaction Susceptibility Assessment

Project Details								Theory																																				
Borehole No.	P-4							<p>As per Seed and Idriss Approach, as described in the NCEER Summary Report (2001) -</p> $FOS = \frac{CRR_{7.5}}{CSR} \cdot MSF$ $CSR = \left(\frac{\tau_{av}}{\sigma'_{vo}} \right) = 0.65 \left(\frac{a_{max}}{g} \right) \left(\frac{\sigma'_{vo}}{\sigma'_{vo}} \right) r_d$ $CRR_{7.5} = \frac{1}{34 - (N_1)_{60}} + \frac{(N_1)_{60}}{135} + \frac{50}{[10 \cdot (N_1)_{60} + 45]^2} - \frac{1}{200}$ <p>Several corrections are applied to the field N value: Corrected SPT 'N' Value: $(N_1)_{60} = N_m \cdot C_N \cdot C_E \cdot C_B \cdot C_R \cdot C_S$ Influence of Fines Content: $(N_1)_{60,cs} = \alpha + \beta(N_1)_{60}$</p> <p>Symbols and Abbreviations-</p> <table style="width: 100%; font-size: small;"> <tr> <td>FOS = Factor of safety against liquefaction</td> <td>$(N_1)_{60}$ = Corrected SPT N value</td> <td>MSF = Magnitude Scaling Factors</td> </tr> <tr> <td>$CRR_{7.5}$ = Cyclic Resistance Ratio</td> <td>N_m = Measured (field) SPT N value</td> <td></td> </tr> <tr> <td>CSR = Cyclic Stress Ratio</td> <td>α, β = Coefficients based on fines content</td> <td></td> </tr> <tr> <td>a_{max} = Peak horizontal acceleration</td> <td>C_N = Factor to normalize N_m to reference overburden stress</td> <td></td> </tr> <tr> <td>g = Acceleration of gravity</td> <td>C_E = Correction for hammer energy ratio (ER)</td> <td></td> </tr> <tr> <td>σ'_{vo} = Effective vertical overburden stress</td> <td>C_R = correction for rod length</td> <td></td> </tr> <tr> <td>r_d = Stress reduction coefficient</td> <td>C_S = correction for samplers with or without liners</td> <td></td> </tr> </table>																FOS = Factor of safety against liquefaction	$(N_1)_{60}$ = Corrected SPT N value	MSF = Magnitude Scaling Factors	$CRR_{7.5}$ = Cyclic Resistance Ratio	N_m = Measured (field) SPT N value		CSR = Cyclic Stress Ratio	α, β = Coefficients based on fines content		a_{max} = Peak horizontal acceleration	C_N = Factor to normalize N_m to reference overburden stress		g = Acceleration of gravity	C_E = Correction for hammer energy ratio (ER)		σ'_{vo} = Effective vertical overburden stress	C_R = correction for rod length		r_d = Stress reduction coefficient	C_S = correction for samplers with or without liners	
FOS = Factor of safety against liquefaction	$(N_1)_{60}$ = Corrected SPT N value	MSF = Magnitude Scaling Factors																																										
$CRR_{7.5}$ = Cyclic Resistance Ratio	N_m = Measured (field) SPT N value																																											
CSR = Cyclic Stress Ratio	α, β = Coefficients based on fines content																																											
a_{max} = Peak horizontal acceleration	C_N = Factor to normalize N_m to reference overburden stress																																											
g = Acceleration of gravity	C_E = Correction for hammer energy ratio (ER)																																											
σ'_{vo} = Effective vertical overburden stress	C_R = correction for rod length																																											
r_d = Stress reduction coefficient	C_S = correction for samplers with or without liners																																											
Block	N/A																																											
Structure	Generator Foundation Site																																											
Existing Ground Level (EGL)	45.5																																											
Surcharge Load, if any:	0 T/m ²																																											
Design Earthquake		Site Levels				Boring Details																																						
Seismic Zone: IV		Existing Ground Level, EGL (m): 45.5				Sampler with liner? N																																						
Earthquake Magnitude: 6.7		Actual GW Depth (m): 9.8				Hammer Type: WT																																						
PGA (g): 0.24		Design GW Depth (m): 4.0				Borehole Diameter (mm): 150																																						
Critical Factor of Safety (FS): 1.0		Design GW Level (m): 41.5				SPT Energy Correction (C_E): 0.75																																						

Calculations

Layer	Soil Description	Depth to Top of Layer (m)	Layer Thickness (m)	Unit weight (T/m ³)	Total Overburden Pressure at Middle of Layer (T/m ²)	Effective Stress at Middle of Layer, based on design GWT (T/m ²)	Effective Stress at Middle of Layer, based on actual GWT (T/m ²)	N_m	Fines Content (%)	C_N	C_E	C_B	C_R	C_S	α	β	$(N_1)_{60,cs}$	$CRR_{(7.5)}$	Stress Reduction Factor (r_d)	CSR	Magnitude Scaling Factor	$CSR_{7.5}$	Computed FOS against liquefaction	Plasticity Index (%)
1	Fly ash	0.0	2.5	1.40	1.8	1.8	1.750	8	70	1.70	0.75	1.05	0.75	1.20	5.00	1.20	17	0.18	0.99	0.15	1.442	0.11	NL	14.8
2	Fly ash	2.5	1.0	1.40	4.2	4.2	4.2	9	74	1.54	0.75	1.05	0.75	1.20	5.00	1.20	17	0.18	0.98	0.15	1.442	0.11	NL	14.8
3	Fly ash	3.5	2.0	1.40	6.3	6.3	6.3	13	71	1.26	0.75	1.05	0.85	1.20	5.00	1.20	21	0.23	0.97	0.15	1.442	0.10	NL	14.8
4	Sandy silt	5.5	1.0	1.65	8.5	6.6	8.5	5	88	1.08	0.75	1.05	0.95	1.20	5.00	1.20	11	0.12	0.95	0.19	1.442	0.13	NL	14.1
5	Clayey silt	6.5	2.0	1.65	11.0	7.6	11.0	8	97	0.95	0.75	1.05	0.95	1.20	5.00	1.20	13	0.14	0.94	0.21	1.442	0.15	NL	20.2
6	Silty fine sand	8.5	1.0	1.65	13.5	8.6	13.5	24	13	0.86	0.75	1.05	0.95	1.20	1.89	1.04	21	0.23	0.93	0.23	1.442	0.16	1.45	
7	Silty fine sand	9.5	1.0	1.65	15.1	9.2	15.1	28	15	0.81	0.75	1.05	1.00	1.20	2.50	1.05	25	0.29	0.91	0.23	1.442	0.16	1.82	
8	Silty fine sand	10.5	1.0	1.65	16.8	9.9	15.6	30	14	0.80	0.75	1.05	1.00	1.20	2.20	1.04	26	0.31	0.88	0.23	1.442	0.16	1.92	
9	Silty fine sand	11.5		1.65				38	16														NL	
10																								
11																								

N/A : Not Applicable (as in the case of unsaturated soils)
NL : Not Liquefiable, e.g. if $(N_1)_{60,cs} > 30$, $PI > 15\%$, or Fines Content $> 50\%$

Conclusion:

No Liquefaction potential

Liquefaction Susceptibility Assessment

Project Details

Theory

As per Seed and Idriss Approach, as described in the NCEER Summary Report (2001) -

$$FOS = \frac{CRR_{7.5}}{CSR} \cdot MSF$$

$$CSR = \left(\frac{\tau_{av}}{\sigma'_{vo}} \right) = 0.65 \left(\frac{a_{max}}{g} \right) \left(\frac{\sigma'_{vo}}{\sigma'_{vo}} \right) r_d$$

$$CRR_{7.5} = \frac{1}{34 - (N_1)_{60}} + \frac{(N_1)_{60}}{135} + \frac{50}{[10 \cdot (N_1)_{60} + 45]^2} - \frac{1}{200}$$

Several corrections are applied to the field N value:

Corrected SPT 'N' Value: $(N_1)_{60} = N_m \cdot C_N \cdot C_E \cdot C_B \cdot C_R \cdot C_S$

Influence of Fines Content: $(N_1)_{60,cs} = \alpha + \beta(N_1)_{60}$

Symbols and Abbreviations-

- FOS = Factor of safety against liquefaction
- CRR_{7.5} = Cyclic Resistance Ratio
- CSR = Cyclic Stress Ratio
- a_{max} = Peak horizontal acceleration
- g = Acceleration of gravity
- σ'_{vo} = Effective vertical overburden stress
- r_d = Stress reduction coefficient
- (N₁)₆₀ = Corrected SPT N value
- N_m = Measured (field) SPT N value
- α, β = Coefficients based on fines content
- C_N = Factor to normalize N_m to reference overburden stress
- C_E = Correction for hammer energy ratio (ER)
- C_R = correction for rod length
- C_S = correction for samplers with or without liners
- MSF = Magnitude Scaling Factors

Design Earthquake

Site Levels

Boring Details

Seismic Zone: **IV**

Existing Ground Level, EGL (m): **45.5**

Sampler with liner? **N**

Earthquake Magnitude: **6.7**

Actual GW Depth (m): **9.9**

Hammer Type: **WT**

PGA (g): **0.24**

Design GW Depth (m): **4.0**

Borehole Diameter (mm): **150**

Critical Factor of Safety (FS): **1.0**

Design GW Level (m): **41.5**

SPT Energy Correction (C_E): **0.75**

Calculations

Layer	Soil Description	Depth to Top of Layer (m)	Layer Thickness (m)	Unit weight (T/m ³)	Total Overburden Pressure at Middle of Layer (T/m ²)	Effective Stress at Middle of Layer, based on design GWT (T/m ²)	Effective Stress at Middle of Layer, based on actual GWT (T/m ²)	N _m	Fines Content (%)	C _N	C _E	C _B	C _R	C _S	α	β	(N ₁) _{60,cs}	CRR _(7.5)	Stress Reduction Factor (r _d)	CSR	Magnitude Scaling Factor	CSR _{7.5}	Computed FOS against liquefaction	Plasticity Index (%)
1	Fly ash	0.0	2.0	1.40	1.4	1.4	1.400	7	65	1.70	0.75	1.05	0.75	1.20	5.00	1.20	15	0.16	0.99	0.15	1.442	0.11	NL	14.5
2	Fly ash	2.0	2.0	1.40	4.2	4.2	4.2	7	56	1.54	0.75	1.05	0.75	1.20	5.00	1.20	14	0.15	0.98	0.15	1.442	0.11	NL	14.5
3	Clayey silt	4.0	1.0	1.70	6.5	6.0	6.5	5	96	1.25	0.75	1.05	0.85	1.20	5.00	1.20	11	0.12	0.97	0.16	1.442	0.11	NL	15.6
4	Clayey silt	5.0	2.0	1.65	9.0	7.0	9.0	7	94	1.06	0.75	1.05	0.95	1.20	5.00	1.20	13	0.14	0.95	0.19	1.442	0.13	NL	24.2
5	Silty fine sand	7.0	1.0	1.65	11.4	8.0	11.4	14	14	0.94	0.75	1.05	0.95	1.20	2.20	1.04	14	0.15	0.94	0.21	1.442	0.15	1.06	
6	Silty fine sand	8.0	1.0	1.65	13.1	8.7	13.1	16	19	0.87	0.75	1.05	0.95	1.20	3.43	1.07	17	0.18	0.93	0.22	1.442	0.15	1.18	
7	Silty fine sand	9.0	1.0	1.65	14.7	9.3	14.7	18	16	0.82	0.75	1.05	0.95	1.20	2.77	1.05	17	0.18	0.92	0.23	1.442	0.16	1.14	
8	Silty fine sand	10.0	1.0	1.65	16.4	10.0	15.7	21	14	0.80	0.75	1.05	1.00	1.20	2.20	1.04	19	0.20	0.89	0.23	1.442	0.16	1.26	
9	Silty fine sand	11.0		1.65				28	15														NL	
10																								
11																								

N/A : Not Applicable (as in the case of unsaturated soils)
NL : Not Liquefiable, e.g. if (N₁)_{60,cs}>30, PI>15%, or Fines Content>50%

Conclusion:

No Liquefaction potential

Liquefaction Susceptibility Assessment																								
Project Details												Theory												
Borehole No.		P-6										<p>As per Seed and Idriss Approach, as described in the NCEER Summary Report (2001) -</p> $FOS = \frac{CRR_{7.5}}{CSR} \cdot MSF$ $CSR = \left(\frac{\tau_{av}}{\sigma'_{vo}} \right) = 0.65 \left(\frac{a_{max}}{g} \right) \left(\frac{\sigma'_{vo}}{\sigma'_{vo}} \right) r_d$ $CRR_{7.5} = \frac{1}{34 - (N_1)_{60}} + \frac{(N_1)_{60}}{135} + \frac{50}{[10 \cdot (N_1)_{60} + 45]^2} - \frac{1}{200}$ <p>Several corrections are applied to the field N value: Corrected SPT 'N' Value: $(N_1)_{60} = N_m \cdot C_N \cdot C_E \cdot C_B \cdot C_R \cdot C_S$ Influence of Fines Content: $(N_1)_{60,cs} = \alpha + \beta(N_1)_{60}$</p> <p>Symbols and Abbreviations-</p> <p>FOS = Factor of safety against liquefaction $(N_1)_{60}$ = Corrected SPT N value MSF = Magnitude Scaling Factors CRR_{7.5} = Cyclic Resistance Ratio N_m = Measured (field) SPT N value CSR = Cyclic Stress Ratio α, β = Coefficients based on fines content a_{max} = Peak horizontal acceleration C_N = Factor to normalize N_m to reference overburden stress g = Acceleration of gravity C_E = Correction for hammer energy ratio (ER) σ'_{vo} = Effective vertical overburden stress C_R = correction for rod length r_d = Stress reduction coefficient C_S = correction for samplers with or without liners</p>												
Block		N/A																						
Structure		Raw Water Storage Tank Site																						
Existing Ground Level (EGL)		45.5																						
Surcharge Load, if any:		0 T/m ²																						
Design Earthquake				Site Levels				Boring Details																
Seismic Zone: IV				Existing Ground Level, EGL (m): 45.5				Sampler with liner? N																
Earthquake Magnitude: 6.7				Actual GW Depth (m): 9.4				Hammer Type: WT																
PGA (g): 0.24				Design GW Depth (m): 4.0				Borehole Diameter (mm): 150																
Critical Factor of Safety (FS): 1.0				Design GW Level (m): 41.5				SPT Energy Correction (C _E): 0.75																
Calculations																								
Layer	Soil Description	Depth to Top of Layer (m)	Layer Thickness (m)	Unit weight (T/m ³)	Total Overburden Pressure at Middle of Layer (T/m ²)	Effective Stress at Middle of Layer, based on design GWT (T/m ²)	Effective Stress at Middle of Layer, based on actual GWT (T/m ²)	N _m	Fines Content (%)	C _N	C _E	C _B	C _R	C _S	α	β	(N ₁) _{60,cs}	CRR _(7.5)	Stress Reduction Factor (r _d)	CSR	Magnitude Scaling Factor	CSR _{7.5}	Computed FOS against liquefaction	Plasticity Index (%)
1	Fly ash	0.0	2.5	1.40	1.8	1.8	1.750	5	38	1.70	0.75	1.05	0.75	1.20	5.00	1.20	12	0.13	0.99	0.15	1.442	0.11	N/A	15.0
2	Fly ash	2.5	1.0	1.40	4.2	4.2	4.2	6	78	1.54	0.75	1.05	0.75	1.20	5.00	1.20	13	0.14	0.98	0.15	1.442	0.11	NL	15.0
3	Fly ash	3.5	2.0	1.40	6.3	6.3	6.3	9	70	1.26	0.75	1.05	0.85	1.20	5.00	1.20	16	0.17	0.97	0.15	1.442	0.10	NL	15.0
4	Clayey silt	5.5	1.0	1.65	8.5	6.6	8.5	7	78	1.08	0.75	1.05	0.95	1.20	5.00	1.20	13	0.14	0.95	0.19	1.442	0.13	NL	13.7
5	Sandy silt	6.5	1.0	1.65	10.2	7.2	10.2	20	75	0.99	0.75	1.05	0.95	1.20	5.00	1.20	26	0.32	0.95	0.21	1.442	0.14	NL	10.2
6	Silty fine sand	7.5	1.0	1.65	11.8	7.9	11.8	23	16	0.92	0.75	1.05	0.95	1.20	2.77	1.05	23	0.25	0.94	0.22	1.442	0.15	1.67	
7	Silty fine sand	8.5	1.0	1.65	13.5	8.6	13.5	24	19	0.86	0.75	1.05	0.95	1.20	3.43	1.07	23	0.26	0.93	0.23	1.442	0.16	1.66	
8	Silty fine sand	9.5		1.65				27	15														NL	
9																								
10																								
11																								
N/A : Not Applicable (as in the case of unsaturated soils) NL : Not Liquefiable, e.g. if (N ₁) _{60,cs} >30, PI>15%, or Fines Content>50%																								

Conclusion:

No Liquefaction potential

PILE FOUNDATION

COAL SILO SITE

CHIMNEY SITE

GENERATOR FOUNDATION SITE

GENERATOR TRANSFORMER SITE

RAW WATER TANK SITE

APPENDIX-B
TYPICAL CALCULATIONS

PILE FOUNDATION

COAL SILO # 4 SITE

CHIMNEY SITE

GENERATOR FOUNDATION SITE

GENERATOR TRANSFORMER SITE

RAW WATER TANK SITE



Computation of Safe Axial Compressive Pile Capacity

By Static Analysis

Analysis in accordance with IS 2911 (Part 1 / Section 2) : 2010

Pile Type : **Bored Cast in Situ** RCC Pile

Loading : Axial Compression

The safe pile capacity is computed as :

$$Q_{safe} = (1/FS) \{ \sum_{1 \text{ to } n} [(\alpha c + p k \tan \delta) A_s L] + [c N_c + p N_q + 0.5 D \gamma' N_\gamma A_p] \}$$

where :

<p>Q_{safe} = Safe axial pile capacity, kN</p> <p>α = Adhesion factor (<i>function of C_u</i>)</p> <p>δ = Angle of wall friction between soil and pile, degrees</p> <p>c = Cohesion intercept, kN/m²</p> <p>γ' = Effective density of soil, kN/m³</p> <p>N_c, N_q, N_γ = Bearing capacity factors, which are a function of ϕ</p> <p>n = Number of layers</p>	<p>FS = Factor of safety</p> <p>p = Overburden pressure, kN/m²</p> <p>L = Pile segment length in selected layer</p> <p>k = Coefficient of earth pressure</p> <p>D = Pile diameter</p> <p>A_s = Pile surface area per m length</p> <p>A_p = Pile end bearing area</p>
--	---

Pile Cross section : Circle

Pile cut-off Level (COL) : 2.0 m

Pile Diameter, D : 550 mm

Pile Surface Area, A_s = 1.728 m²/m length

Pile cross-section Area, A_p = 0.238 m²

Overburden Pressure to be considered below : COL

Consider overburden pressure to 20 pile diameters, i.e. 11.0 m below 2.0 m

become constant below : i.e. 13.0 m below 0.0 m

Design Water Table Depth: 5.0 m

Factor of Safety : 2.5 as per IS 2911 (Part 1 / Section 2) : 2010

Layer No.	Depth, m		Soil Classification	c , kN/m ²	δ ($=\phi$), degrees	γ , kN/m ³	k	α	N_c	N_q	N_γ
	From	To									
1	0.0	4.0	Flyash	0	0	14.0	1.0	0.00			
2	4.0	12.0	Sandy silt	65	4	16.5	1.0	0.33			
3	12.0	15.0	Fine sand	0	30	17.5	1.0	0.00		20.95	22.40
4	15.0	20.0	Fine sand	0	31	18.5	1.1	0.00		23.93	25.99
5	20.0	30.0	Fine sand	0	32	19.5	1.1	0.00		28.88	30.21
6	30.0	40.0	Fine sand	0	33	20.0	1.2	0.00		34.86	35.19

Pile Capacity Calculation at following Pile Length(s) below cut-off Level (m)	18.0	20.0	22.0	24.0	26.0



Computation of Safe Axial Compressive Pile Capacity

By Static Analysis

Analysis in accordance with IS 2911 (Part 1 / Section 2) : 2010

Pile Type : **Bored Cast in Situ** RCC Pile

Loading : Axial Compression

Pile Dia = 550 mm

Depth Below GL, m	Pile Length below COL, m	Layer No.	Soil Parameters			Overburden Pressure kN/m ²	Unit Skin Friction kN/m ²	Skin Friction in Layer kN	Cumulative Skin Friction kN	Unit End Bearing kN/m ²	Total End Bearing kN	Ult. Pile Capacity kN	Safe Pile Capacity kN	Safe Pile Capacity MT
			C, kN/m ²	φ (=δ), degrees	γ _{eff} , kN/m ³									
0.0	-	1	0.0											
2.0	0.0	1	0.0	0	14.0	0.0								
4.0	2.0	2	65.0	4	16.5	14.0	0	0	0					
5.0	3.0	2	65.0	4	6.5	28.0	24	42	42					
5.1	3.1	2	65.0	4	6.5	36.3	25	4	46					
12.0	10.0	2	65.0	4	6.5	44.5	25	4	46					
13.0	11.0	3	0.0	30	7.5	44.8	26	314	360					
13.1	11.1	3	0.0	30	7.5	45.2	26	314	360					
15.0	13.0	3	0.0	30	7.5	67.6	54	94	454					
16.1	14.1	3	0.0	30	7.5	90.0	54	94	454					
18.9	16.9	4	0.0	31	8.5	93.8	56	10	464					
20.0	18.0	4	0.0	31	8.5	97.5	56	185	649					
		4	0.0	31	8.5	97.5	62	117	765					
		4	0.0	31	8.5	97.5	62	298	1063					
		4	0.0	31	8.5	97.5	62	117	1180	2393	569	1749	699	71



Computation of Safe Axial Compressive Pile Capacity

By Static Analysis

Analysis in accordance with IS 2911 (Part 1 / Section 2) : 2010

Pile Type : **Bored Cast in Situ** RCC Pile
Pile Dia = 550 mm

Loading : Axial Compression

Depth Below GL, m	Pile Length below COL, m	Layer No.	Soil Parameters			Overburden Pressure kN/m ²	Unit Skin Friction kN/m ²	Skin Friction in Layer kN	Cumulative Skin Friction kN	Unit End Bearing kN/m ²	Total End Bearing kN	Ult. Pile Capacity kN	Safe Pile Capacity kN	Safe Pile Capacity MT
			c, kN/m ²	φ (=δ), degrees	γ _{eff} , kN/m ³									
20.0	18.0	5	0.0	32	9.5	97.5	67	1180	2393	569	1749	699	71	
						97.5	67	127	1307	2895	688	1995	798	81
21.1	19.1	5	0.0	32	9.5	97.5	67	104	1412	2895	688	2099	840	86
						97.5	67	232	1643	2895	688	2331	932	95
22.0	20.0	5	0.0	32	9.5	97.5	67	232	1875	2895	688	2562	1025	104
						97.5	67	232	2106	2895	688	2794	1118	114
24.0	22.0	5	0.0	32	9.5	97.5	67							
						97.5	67							
26.0	24.0	5	0.0	32	9.5	97.5	67							
						97.5	67							
28.0	26.0	5	0.0	32	9.5	97.5	67							
						97.5	67							



Computation of Safe Axial Pullout Capacity of Pile

By Static Analysis

Analysis in accordance with IS 2911 (Part 1 / Section 2) : 2010

Pile Type : **Bored Cast in Situ** **RCC Pile**

Loading : Axial Pullout (Uplift)

The safe uplift capacity of pile is calculated as :

$$Q_{\text{safe}} = (1/\text{FS}) \{ \sum_{1 \text{ to } n} [(\alpha c + p k \tan \delta) A_s L] \} + W$$

where

<p>Q_{safe} = Safe axial pile capacity, kN</p> <p>α = Adhesion factor (function of C_u)</p> <p>δ = Friction angle between soil and pile, degrees (= ϕ)</p> <p>c = Cohesion intercept, kN/m²</p> <p>γ' = Effective density of soil, kN/m³</p> <p>n = Number of layers</p> <p>W = Weight of the pile</p>	<p>FS = Factor of safety</p> <p>p = Overburden pressure, kN/m²</p> <p>L = Pile segment length in selected layer</p> <p>k = Coefficient of earth pressure</p> <p>D = Pile diameter</p> <p>A_s = Pile surface area per m length</p>
--	---

Pile cross section shape : **circle** Pile cut-off Level (COL) : **2.0** m

Pile Diameter, D : **550** mm

Pile Surface Area, A_s = **1.728** m²/m length

Overburden Pressure to be considered below : **COL**

Consider overburden press. to become constant below : **20** pile diameters, i.e. **11.0** m below **2.0** m
i.e. **13.0** m below **0.0** m

Design Water Table Depth : **5.0** m

Factor of Safety : **3.0** as per IS 2911 (Part 1 / Section 2) : 2010 Clause 6.3.2

Percentage of Ultimate Shaft Resistance to be used for Ultimate Pullout Capacity: **0.7**

Layer No.	Depth, m		Soil Classification	c , kN/m ²	δ (= ϕ), degrees	γ , kN/m ³	k	α
	From	To						
1	0.0	4.0	Flyash	0	0	14.0	1.0	
2	4.0	12.0	Sandy silt	65	4	16.5	1.0	0.33
3	12.0	15.0	Fine sand	0	30	17.5	1.0	
4	15.0	20.0	Fine sand	0	31	18.5	1.1	
5	20.0	30.0	Fine sand	0	32	19.5	1.1	
6	30.0	40.0	Fine sand	0	33	20.0	1.2	

Pile Capacity Calculation at following Pile Length(s) below cut-off Level (m)	18.0	20.0	22.0	24.0	26.0



Computation of Safe Axial Pullout Capacity of Pile

By Static Analysis

Analysis in accordance with IS 2911 (Part 1 / Section 2) : 2010

Pile Type : **Bored Cast in Situ** **RCC Pile**
Pile Dia = 550 mm Bored Cast in Situ RCC Pile

Depth Below GL , m	Pile Length below COL, m	Layer No.	Soil Parameters			Overburden Pressure kN/m ²	Unit Skin Friction kN/m ²	Skin Friction in Layer kN	Cumulative Skin Friction kN	Weight of Pile kN	Ultimate Pullout Capacity kN	Safe Pullout Capacity kN	Safe Pullout Capacity MT
			c, kN/m ²	φ (-δ), degrees	γ _{eff} , kN/m ³								
0.0	-												
2.0	0.0	1	0.0	0		0.0							
4.0	2.0	1	0.0	0	14.00	14.0	0.0	0	0				
5.0	3.0	2	65.0	4	16.50	28.0	24.2	42	42				
12.0	10.0	2	65.0	4	6.50	36.3	26.3	319	360				
13.0	11.0	3	0.0	30	7.50	44.5	54.1	94	454				
15.0	13.0	3	0.0	30	7.50	67.3	56.3	195	649				
20.0	18.0	4	0.0	31	8.50	90.0	61.5	531	1180	67	893	342	
22.0	20.0	5	0.0	32	9.50	93.8	67.0	232	1412	74	1062	403	
24.0	22.0	5	0.0	32	9.50	97.5	67.0	232	1643	80	1230	464	
26.0	24.0	5	0.0	32	9.50	97.5	67.0	232	1875	87	1399	524	
28.0	26.0	5	0.0	32	9.50	97.5	67.0	232	2106	94	1568	585	
						97.5							



Lateral Load Carrying Capacity for Pile Foundations

Analysis in accordance with: IRC 78 - 2014

Pile Type : Bored Cast in Situ RCC Pile
 Pile cross-section : Circle
 Pile Dia : 550 mm
 Pile Cut-off-Level below GL : 2.0 m Pile Length : 18 m
 Pile Head : Fixed Head Condition
 Grade of Concrete : M 30 Modulus of Elasticity : 31000 MPa
 Moment of Inertia, I : 4.492E-03 m⁴
 Soil Classification: Cohesive Normally Consolidated or Preconsolidated Clays? P
 Unconfined Compression Strength (qu) = 130.0 kPa
 Saturation : Submerged

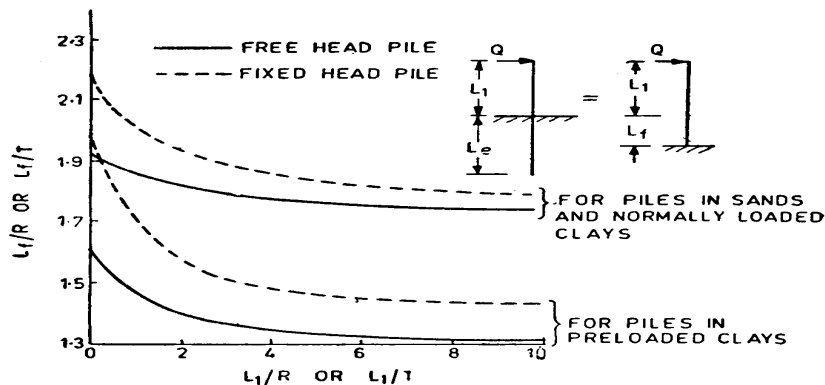

FIG. 2 DETERMINATION OF DEPTH FIXITY

$T = (EI/\eta_n)^{1/5}$ for Granular Soils and NC Clays $R = (EI/KB)^{1/4}$ for Preconsolidated Clays
Modulus of Subgrade Reaction, $k_1 = 23.4 \text{ MN/m}^3$ $R = 2.34 \text{ m}$
Free Standing Length of Pile or Length of pile below cut-off-level not contributing substantially to lateral capacity (e) : 0.0 m
$e/R = 0.0$ Reading off from graph, $z_f/R = 1.95$
Depth of Fixity, $z_f = 4.56 \text{ m}$ $e + z_f = 4.56 \text{ m}$
$\text{Deflection, } y = \frac{H (e + z_f)^3}{3 EI} \times 10^3 \quad \dots \text{ for free-head pile}$
$\text{Deflection, } y = \frac{H (e + z_f)^3}{12 EI} \times 10^3 \quad \dots \text{ for fixed-head pile}$
where : $y =$ Lateral deflection at pile top $e =$ Free-standing length of pile $H =$ Lateral load applied $z_f =$ Depth of fixity
Permissible Horizontal Deflection at top of pile, $Y = 5.0 \text{ mm}$
Computed Lateral Capacity of Pile, $H = 88 \text{ kN} = 9.0 \text{ Tonnes}$



Computation of Safe Axial Compressive Pile Capacity

By Static Analysis

Analysis in accordance with IS 2911 (Part 1 / Section 2) : 2010

Pile Type : **Bored Cast in Situ** RCC Pile

Loading : Axial Compression

The safe pile capacity is computed as :

$$Q_{\text{safe}} = (1/FS) \{ \sum_{1 \text{ to } n} [(\alpha c + p k \tan \delta) A_s L] + [c N_c + p N_q + 0.5 D \gamma' N_\gamma A_p] \}$$

where :

Q_{safe}	=	Safe axial pile capacity, kN	FS	=	Factor of safety
α	=	Adhesion factor (function of C_u)	p	=	Overburden pressure, kN/m ²
δ	=	Angle of wall friction between soil and pile, degrees	L	=	Pile segment length in selected layer
c	=	Cohesion intercept, kN/m ²	k	=	Coefficient of earth pressure
γ'	=	Effective density of soil, kN/m ³	D	=	Pile diameter
N_c, N_q, N_γ	=	Bearing capacity factors, which are a function of ϕ	A_s	=	Pile surface area per m length
n	=	Number of layers	A_p	=	Pile end bearing area

Pile Cross section : Circle

Pile cut-off Level (COL) : 2.0 m

Pile Diameter, D : 600 mm

Pile Surface Area, A_s = 1.885 m²/m length

Pile cross-section Area, A_p = 0.283 m²

Overburden Pressure to be considered below : COL

Consider overburden pressure to 20 pile diameters, i.e. 12.0 m below 2.0 m

become constant below : i.e. 14.0 m below 0.0 m

Design Water Table Depth: 5.0 m

Factor of Safety : 2.5 as per IS 2911 (Part 1 / Section 2) : 2010

Layer No.	Depth, m		Soil Classification	c , kN/m ²	δ ($=\phi$), degrees	γ , kN/m ³	k	α	N_c	N_q	N_γ
	From	To									
1	0.0	4.0	Flyash	0	0	14.0	1.0	0.00			
2	4.0	12.0	Sandy silt	65	4	16.5	1.0	0.33			
3	12.0	15.0	Fine sand	0	30	17.5	1.0	0.00		20.95	22.40
4	15.0	20.0	Fine sand	0	31	18.5	1.1	0.00		23.93	25.99
5	20.0	30.0	Fine sand	0	32	19.5	1.1	0.00		28.88	30.21
6	30.0	40.0	Fine sand	0	33	20.0	1.2	0.00		34.86	35.19

Pile Capacity Calculation at following Pile Length(s) below cut-off Level (m)	18.0	20.0	22.0	24.0	26.0



Computation of Safe Axial Compressive Pile Capacity

By Static Analysis

Analysis in accordance with IS 2911 (Part 1 / Section 2) : 2010

Pile Type : **Bored Cast in Situ** RCC Pile

Loading : Axial Compression

Pile Dia = 600 mm

Depth Below GL, m	Pile Length below COL, m	Layer No.	Soil Parameters			Overburden Pressure kN/m ²	Unit Skin Friction kN/m ²	Skin Friction in Layer kN	Cumulative Skin Friction kN	Unit End Bearing kN/m ²	Total End Bearing kN	Ult. Pile Capacity kN	Safe Pile Capacity kN	Safe Pile Capacity MT
			C, kN/m ²	φ (=δ), degrees	γ _{eff} , kN/m ³									
0.0	-	1	0.0											
2.0	0.0	1	0.0	0	14.0	0	0	0						
4.0	2.0	2	65.0	4	16.5	24	46	46						
5.0	3.0	2	65.0	4	6.5	25	9	55						
5.2	3.2	2	65.0	4	6.5	26	338	393						
12.0	10.0	3	0.0	30	7.5	55	123	517						
13.2	11.2	3	0.0	30	7.5	59	89	605						
14.0	12.0	3	0.0	30	7.5	61	114	720						
15.0	13.0	4	0.0	31	8.5	66	150	870						
16.2	14.2	4	0.0	31	8.5	66	325	1194						
18.8	16.8	4	0.0	31	8.5	66	150	1344	2578	729	2073	829	85	
20.0	18.0													



Computation of Safe Axial Compressive Pile Capacity

By Static Analysis

Analysis in accordance with IS 2911 (Part 1 / Section 2) : 2010

Pile Type : **Bored Cast in Situ** RCC Pile
Pile Dia = 600 mm

Loading : Axial Compression

Depth Below GL, m	Pile Length below COL, m	Layer No.	Soil Parameters			Overburden Pressure kN/m ²	Unit Skin Friction kN/m ²	Skin Friction in Layer kN	Cumulative Skin Friction kN	Unit End Bearing kN/m ²	Total End Bearing kN	Ult. Pile Capacity kN	Safe Pile Capacity kN	Safe Pile Capacity MT
			c, kN/m ²	φ (=δ), degrees	γ _{eff} , kN/m ³									
20.0	18.0	5	0.0	32	9.5	105.0	72	1344	2578	729	2073	829	85	
						105.0	72	163	1507	3118	882	2389	956	97
21.2	19.2	5	0.0	32	9.5	105.0	72	109	1616	3118	882	2498	999	102
						105.0	72	272	1888	3118	882	2770	1108	113
22.0	20.0	5	0.0	32	9.5	105.0	72	272	2160	3118	882	3042	1217	124
						105.0	72	272	2432	3118	882	3314	1326	135
24.0	22.0	5	0.0	32	9.5	105.0	72							
						105.0	72							
26.0	24.0	5	0.0	32	9.5	105.0	72							
						105.0	72							
28.0	26.0	5	0.0	32	9.5	105.0	72							
						105.0	72							



Computation of Safe Axial Pullout Capacity of Pile

By Static Analysis

Analysis in accordance with IS 2911 (Part 1 / Section 2) : 2010

Pile Type : **Bored Cast in Situ** **RCC Pile**

Loading : Axial Pullout (Uplift)

The safe uplift capacity of pile is calculated as :

$$Q_{\text{safe}} = (1/FS) \{ \sum_{1 \text{ to } n} [(\alpha c + p k \tan \delta) A_s L] \} + W$$

where

<p>Q_{safe} = Safe axial pile capacity, kN</p> <p>α = Adhesion factor (function of C_u)</p> <p>δ = Friction angle between soil and pile, degrees (= ϕ)</p> <p>c = Cohesion intercept, kN/m²</p> <p>γ' = Effective density of soil, kN/m³</p> <p>n = Number of layers</p> <p>W = Weight of the pile</p>	<p>FS = Factor of safety</p> <p>p = Overburden pressure, kN/m²</p> <p>L = Pile segment length in selected layer</p> <p>k = Coefficient of earth pressure</p> <p>D = Pile diameter</p> <p>A_s = Pile surface area per m length</p>
--	--

Pile cross section shape : **circle**

Pile cut-off Level (COL) : **2.0** m

Pile Diameter, D : **600** mm

Pile Surface Area, A_s = **1.885** m²/m length

Overburden Pressure to be considered below : **COL**

Consider overburden press. to

become constant below : **20** pile diameters, i.e. **12.0** m below **2.0** m

i.e. **14.0** m below **0.0** m

Design Water Table Depth : **5.0** m

Factor of Safety : **3.0** as per IS 2911 (Part 1 / Section 2) : 2010 Clause 6.3.2

Percentage of Ultimate Shaft Resistance to be used for Ultimate Pullout Capacity: **0.7**

Layer No.	Depth, m		Soil Classification	c , kN/m ²	δ (= ϕ), degrees	γ , kN/m ³	k	α
	From	To						
1	0.0	4.0	Flyash	0	0	14.0	1.0	
2	4.0	12.0	Sandy silt	65	4	16.5	1.0	0.33
3	12.0	15.0	Fine sand	0	30	17.5	1.0	
4	15.0	20.0	Fine sand	0	31	18.5	1.1	
5	20.0	30.0	Fine sand	0	32	19.5	1.1	
6	30.0	40.0	Fine sand	0	33	20.0	1.2	

Pile Capacity Calculation at following Pile Length(s) below cut-off Level (m)	18.0	20.0	22.0	24.0	26.0



Computation of Safe Axial Pullout Capacity of Pile

By Static Analysis

Analysis in accordance with IS 2911 (Part 1 / Section 2) : 2010

Pile Type : **Bored Cast in Situ** **RCC Pile**
Pile Dia = 600 mm Bored Cast in Situ RCC Pile

Depth Below GL , m	Pile Length below COL, m	Layer No.	Soil Parameters			Overburden Pressure kN/m ²	Unit Skin Friction kN/m ²	Skin Friction in Layer kN	Cumulative Skin Friction kN	Weight of Pile kN	Ultimate Pullout Capacity kN	Safe Pullout Capacity kN	Safe Pullout Capacity MT
			c, kN/m ²	φ (-δ), degrees	γ _{eff} , kN/m ³								
0.0	-												
2.0	0.0	1	0.0	0		0.0							
4.0	2.0	1	0.0	0	14.00	14.0	0.0	0	0				
5.0	3.0	2	65.0	4	16.50	28.0	24.2	46	46				
12.0	10.0	2	65.0	4	6.50	36.3	26.3	348	393				
14.0	12.0	3	0.0	30	7.50	44.5	56.3	212	605				
15.0	13.0	3	0.0	30	7.50	67.3	60.6	114	720				
20.0	18.0	4	0.0	31	8.50	97.5	66.2	624	1344	80	1021	393	
22.0	20.0	5	0.0	32	9.50	105.0	72.2	272	1616	88	1219	465	
24.0	22.0	5	0.0	32	9.50	105.0	72.2	272	1888	96	1417	536	
26.0	24.0	5	0.0	32	9.50	105.0	72.2	272	2160	103	1616	608	
28.0	26.0	5	0.0	32	9.50	105.0	72.2	272	2432	111	1814	679	



Lateral Load Carrying Capacity for Pile Foundations

Analysis in accordance with: IRC 78 - 2014

Pile Type : Bored Cast in Situ RCC Pile
 Pile cross-section : Circle
 Pile Dia : 600 mm
 Pile Cut-off-Level below GL : 2.0 m Pile Length : 18 m
 Pile Head : Fixed Head Condition
 Grade of Concrete : M 30 Modulus of Elasticity : 31000 MPa
 Moment of Inertia, I : 6.362E-03 m⁴
 Soil Classification: Cohesive Normally Consolidated or Preconsolidated Clays? P
 Unconfined Compression Strength (qu) = 130.0 kPa
 Saturation : Submerged

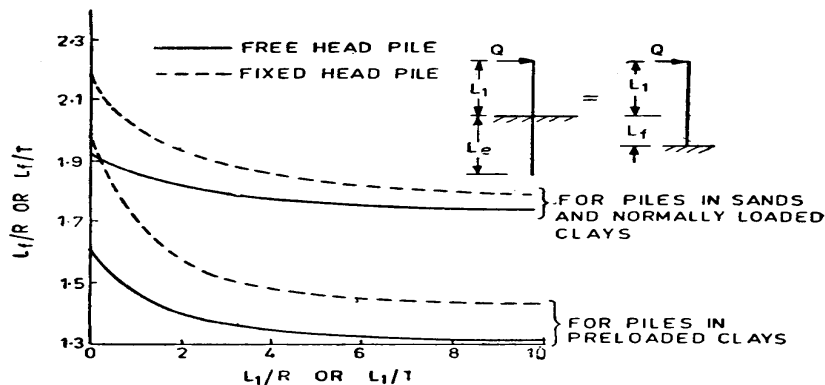

FIG. 2 DETERMINATION OF DEPTH FIXITY

$T = (EI/\eta_n)^{1/5}$ for Granular Soils and NC Clays	$R = (EI/KB)^{1/4}$ for Preconsolidated Clays				
Modulus of Subgrade Reaction, $k_1 = 23.4 \text{ MN/m}^3$	$R = 2.55 \text{ m}$				
Free Standing Length of Pile or Length of pile below cut-off-level not contributing substantially to lateral capacity (e) :	0.0 m				
$e/R = 0.0$	Reading off from graph, $z_f/R = 1.95$				
Depth of Fixity, $z_f = 4.97 \text{ m}$	$e + z_f = 4.97 \text{ m}$				
<table style="width: 100%; border-collapse: collapse;"> <tr> <td style="width: 60%; padding: 5px;">Deflection, $y = \frac{H (e + z_f)^3}{3EI} \times 10^3$</td> <td style="padding: 5px;">.... for free-head pile</td> </tr> <tr> <td style="padding: 5px;">Deflection, $y = \frac{H (e + z_f)^3}{12EI} \times 10^3$</td> <td style="padding: 5px;">.... for fixed-head pile</td> </tr> </table>		Deflection, $y = \frac{H (e + z_f)^3}{3EI} \times 10^3$ for free-head pile	Deflection, $y = \frac{H (e + z_f)^3}{12EI} \times 10^3$ for fixed-head pile
Deflection, $y = \frac{H (e + z_f)^3}{3EI} \times 10^3$ for free-head pile				
Deflection, $y = \frac{H (e + z_f)^3}{12EI} \times 10^3$ for fixed-head pile				
<table style="width: 100%; border-collapse: collapse;"> <tr> <td style="width: 50%; padding: 5px;">where : y = Lateral deflection at pile top</td> <td style="padding: 5px;">e = Free-standing length of pile</td> </tr> <tr> <td style="padding: 5px;">H = Lateral load applied</td> <td style="padding: 5px;">z_f = Depth of fixity</td> </tr> </table>		where : y = Lateral deflection at pile top	e = Free-standing length of pile	H = Lateral load applied	z_f = Depth of fixity
where : y = Lateral deflection at pile top	e = Free-standing length of pile				
H = Lateral load applied	z_f = Depth of fixity				
Permissible Horizontal Deflection at top of pile, Y = 5.0 mm					
Computed Lateral Capacity of Pile, H = 96 kN = 9.8 Tonnes					

PILE FOUNDATION

BOILER FOUNDATION SITE



Computation of Safe Axial Compressive Pile Capacity

By Static Analysis

Analysis in accordance with IS 2911 (Part 1 / Section 2) : 2010

Pile Type : **Bored Cast in Situ** RCC Pile

Loading : Axial Compression

The safe pile capacity is computed as :

$$Q_{\text{safe}} = (1/FS) \{ \sum_{1 \text{ to } n} [(\alpha c + p k \tan \delta) A_s L] + [c N_c + p N_q + 0.5 D \gamma' N_\gamma A_p] \}$$

where :

Q_{safe}	=	Safe axial pile capacity, kN	FS	=	Factor of safety
α	=	Adhesion factor (function of C_u)	p	=	Overburden pressure, kN/m ²
δ	=	Angle of wall friction between soil and pile, degrees	L	=	Pile segment length in selected layer
c	=	Cohesion intercept, kN/m ²	k	=	Coefficient of earth pressure
γ'	=	Effective density of soil, kN/m ³	D	=	Pile diameter
N_c, N_q, N_γ	=	Bearing capacity factors, which are a function of ϕ	A_s	=	Pile surface area per m length
n	=	Number of layers	A_p	=	Pile end bearing area

Pile Cross section : Circle

Pile cut-off Level (COL) : 2.0 m

Pile Diameter, D : 550 mm

Pile Surface Area, A_s = 1.728 m²/m length

Pile cross-section Area, A_p = 0.238 m²

Overburden Pressure to be considered below : COL

Consider overburden pressure to 20 pile diameters, i.e. 11.0 m below 2.0 m

become constant below : i.e. 13.0 m below 0.0 m

Design Water Table Depth: 5.0 m

Factor of Safety : 2.5 as per IS 2911 (Part 1 / Section 2) : 2010

Layer No.	Depth, m		Soil Classification	c , kN/m ²	δ ($=\phi$), degrees	γ , kN/m ³	k	α	N_c	N_q	N_γ
	From	To									
1	0.0	4.5	Flyash	0	0	14.0	1.0	0.00			
2	4.5	7.5	Sandy silt	65	4	16.5	1.0	0.33			
3	7.5	13.0	Fine sand - liquefiable	0	0	17.5	1.0	0.00			
4	13.0	20.0	Fine sand	0	31	18.5	1.1	0.00		23.93	25.99
5	20.0	30.0	Fine sand	0	32	19.5	1.1	0.00		28.88	30.21
6	30.0	40.0	Fine sand	0	33	20.0	1.2	0.00		34.86	35.19

Pile Capacity Calculation at following Pile Length(s) below cut-off Level (m)	18.0	20.0	22.0	24.0	26.0



Computation of Safe Axial Compressive Pile Capacity

By Static Analysis

Analysis in accordance with IS 2911 (Part 1 / Section 2) : 2010

Pile Type : **Bored Cast in Situ** RCC Pile

Loading : Axial Compression

Pile Dia = 550 mm

Depth Below GL, m	Pile Length below COL, m	Layer No.	Soil Parameters			Overburden Pressure kN/m ²	Unit Skin Friction kN/m ²	Skin Friction in Layer kN	Cumulative Skin Friction kN	Unit End Bearing kN/m ²	Total End Bearing kN	Ult. Pile Capacity kN	Safe Pile Capacity kN	Safe Pile Capacity MT
			C, kN/m ²	φ (=δ), degrees	γ _{eff} , kN/m ³									
0.0	-	1	0.0											
2.0	0.0	1	0.0	0	14.0	0.0								
4.5	2.5	2	65.0	4	16.5	17.5	0	0	0					
5.0	3.0	2	65.0	4	6.5	35.0								
5.6	3.6	2	65.0	4	6.5	39.1	24	21	21					
7.5	5.5	2	65.0	4	6.5	43.3	25	26	47					
8.6	6.6	2	65.0	4	6.5	47.2	25	83	130					
13.0	11.0	3	0.0	0	7.5	53.3	0	0	130					
14.1	12.1	3	0.0	0	7.5	59.5	0	0	130					
18.9	16.9	4	0.0	31	8.5	63.6	0	0	130					
20.0	18.0	4	0.0	31	8.5	67.8	64	121	251					
21.1	19.1	4	0.0	31	8.5	84.3	64	527	778					
		4	0.0	31	8.5	100.8	64	121	899	2471	587	1486	594	61
		5	0.0	32	9.5	100.8	69	132	1031	2989	710	1741	696	71
						100.8								



Computation of Safe Axial Compressive Pile Capacity

By Static Analysis

Analysis in accordance with IS 2911 (Part 1 / Section 2) : 2010

Pile Type : **Bored Cast in Situ** RCC Pile
Pile Dia = 550 mm

Loading : Axial Compression

Depth Below GL, m	Pile Length below COL, m	Layer No.	Soil Parameters			Overburden Pressure kN/m ²	Unit Skin Friction kN/m ²	Skin Friction in Layer kN	Cumulative Skin Friction kN	Unit End Bearing kN/m ²	Total End Bearing kN	Ult. Pile Capacity kN	Safe Pile Capacity kN	Safe Pile Capacity MT
			c, kN/m ²	φ (=δ), degrees	γ _{eff} , kN/m ³									
21.1	19.1	5	0.0	32	9.5	100.8	69	1031	2989	710	1741	696	71	
22.0	20.0	5	0.0	32	9.5	100.8	69	1138	2989	710	1848	739	75	
24.0	22.0	5	0.0	32	9.5	100.8	69	1378	2989	710	2088	835	85	
26.0	24.0	5	0.0	32	9.5	100.8	69	1617	2989	710	2327	931	95	
28.0	26.0	5	0.0	32	9.5	100.8	69	1856	2989	710	2566	1026	105	



Computation of Safe Axial Pullout Capacity of Pile

By Static Analysis

Analysis in accordance with IS 2911 (Part 1 / Section 2) : 2010

Pile Type : **Bored Cast in Situ** **RCC Pile**

Loading : Axial Pullout (Uplift)

The safe uplift capacity of pile is calculated as :

$$Q_{\text{safe}} = (1/\text{FS}) \{ \sum_{1 \text{ to } n} [(\alpha c + p k \tan \delta) A_s L] \} + W$$

where

<p>Q_{safe} = Safe axial pile capacity, kN</p> <p>α = Adhesion factor (function of C_u)</p> <p>δ = Friction angle between soil and pile, degrees (= ϕ)</p> <p>c = Cohesion intercept, kN/m²</p> <p>γ' = Effective density of soil, kN/m³</p> <p>n = Number of layers</p> <p>W = Weight of the pile</p>	<p>FS = Factor of safety</p> <p>p = Overburden pressure, kN/m²</p> <p>L = Pile segment length in selected layer</p> <p>k = Coefficient of earth pressure</p> <p>D = Pile diameter</p> <p>A_s = Pile surface area per m length</p>
--	---

Pile cross section shape : **circle**

Pile cut-off Level (COL) : **2.0** m

Pile Diameter, D : **550** mm

Pile Surface Area, A_s = **1.728** m²/m length

Overburden Pressure to be considered below : **COL**

Consider overburden press. to

become constant below : **20** pile diameters, i.e. **11.0** m below **2.0** m
i.e. **13.0** m below **0.0** m

Design Water Table Depth : **5.0** m

Factor of Safety : **3.0** as per IS 2911 (Part 1 / Section 2) : 2010 Clause 6.3.2

Percentage of Ultimate Shaft Resistance to be used for Ultimate Pullout Capacity: **0.7**

Layer No.	Depth, m		Soil Classification	c , kN/m ²	δ (= ϕ), degrees	γ , kN/m ³	k	α
	From	To						
1	0.0	4.5	Flyash	0	0	14.0	1.0	
2	4.5	7.5	Sandy silt	65	4	16.5	1.0	0.33
3	7.5	13.0	Fine sand - liquefiable	0	0	17.5	1.0	
4	13.0	20.0	Fine sand	0	31	18.5	1.1	
5	20.0	30.0	Fine sand	0	32	19.5	1.1	
6	30.0	40.0	Fine sand	0	33	20.0	1.2	

Pile Capacity Calculation at following Pile Length(s) below cut-off Level (m)	18.0	20.0	22.0	24.0	26.0



Computation of Safe Axial Pullout Capacity of Pile

By Static Analysis

Analysis in accordance with IS 2911 (Part 1 / Section 2) : 2010

Pile Type : **Bored Cast in Situ** **RCC Pile**
Pile Dia = 550 mm Bored Cast in Situ RCC Pile

Depth Below GL , m	Pile Length below COL, m	Layer No.	Soil Parameters			Overburden Pressure kN/m ²	Unit Skin Friction kN/m ²	Skin Friction in Layer kN	Cumulative Skin Friction kN	Weight of Pile kN	Ultimate Pullout Capacity kN	Safe Pullout Capacity kN	Safe Pullout Capacity MT
			c, kN/m ²	φ (-δ), degrees	γ _{eff} , kN/m ³								
0.0	-												
2.0	0.0	1	0.0	0									
4.5	2.5	1	0.0	0	14.00	0.0	0	0					
5.0	3.0	2	65.0	4	16.50	17.5	0.0	0					
7.5	5.5	2	65.0	4	6.50	35.0	24.4	21	21				
13.0	11.0	3	0.0	0	7.50	39.1	25.2	109	130				
20.0	18.0	4	0.0	31	8.50	43.3	0.0	0	130				
22.0	20.0	5	0.0	32	9.50	51.4	63.6	769	899	67	696	277	
24.0	22.0	5	0.0	32	9.50	59.5	69.3	239	1138	74	870	339	
26.0	24.0	5	0.0	32	9.50	80.1	69.3	239	1378	80	1045	402	
28.0	26.0	5	0.0	32	9.50	100.8	69.3	239	1617	87	1219	464	
						100.8	69.3	239	1856	94	1393	527	
						100.8							



Lateral Load Carrying Capacity for Pile Foundations

Analysis in accordance with: IRC 78 - 2014

Pile Type : Bored Cast in Situ RCC Pile
 Pile cross-section : Circle
 Pile Dia : 550 mm
 Pile Cut-off-Level below GL : 2.0 m Pile Length : 18 m
 Pile Head : Fixed Head Condition
 Grade of Concrete : M 30 Modulus of Elasticity : 31000 MPa
 Moment of Inertia, I : 4.492E-03 m⁴
 Soil Classification: Cohesive Normally Consolidated or Preconsolidated Clays? P
 Unconfined Compression Strength (qu) = 130.0 kPa
 Saturation : Submerged

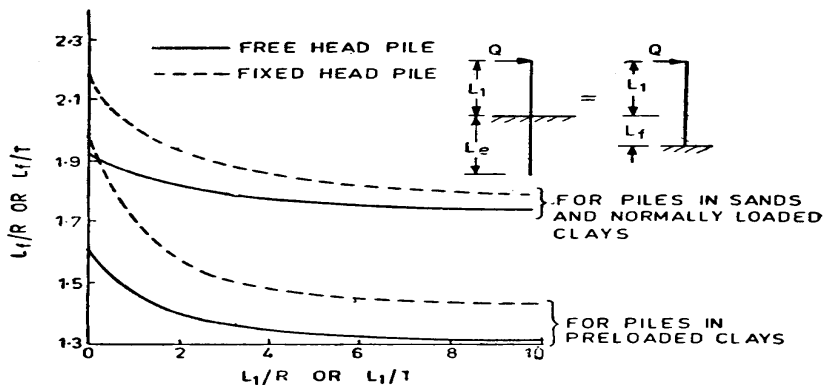

FIG. 2 DETERMINATION OF DEPTH FIXITY

$T = (EI/\eta_n)^{1/5}$ for Granular Soils and NC Clays	$R = (EI/KB)^{1/4}$ for Preconsolidated Clays
Modulus of Subgrade Reaction, $k_1 = 23.4 \text{ MN/m}^3$	$R = 2.34 \text{ m}$
Free Standing Length of Pile or Length of pile below cut-off-level not contributing substantially to lateral capacity (e) :	0.0 m
$e/R = 0.0$	Reading off from graph, $z_f/R = 1.95$
Depth of Fixity, $z_f = 4.56 \text{ m}$	$e + z_f = 4.56 \text{ m}$
$\text{Deflection, } y = \frac{H (e + z_f)^3}{3 EI} \times 10^3 \text{ for free-head pile}$	
$\text{Deflection, } y = \frac{H (e + z_f)^3}{12 EI} \times 10^3 \text{ for fixed-head pile}$	
where : $y =$ Lateral deflection at pile top	$e =$ Free-standing length of pile
$H =$ Lateral load applied	$z_f =$ Depth of fixity
Permissible Horizontal Deflection at top of pile, $Y = 5.0 \text{ mm}$	
Computed Lateral Capacity of Pile, $H = 88 \text{ kN} = 9.0 \text{ Tonnes}$	



Computation of Safe Axial Compressive Pile Capacity

By Static Analysis

Analysis in accordance with IS 2911 (Part 1 / Section 2) : 2010

Pile Type : **Bored Cast in Situ** RCC Pile

Loading : Axial Compression

The safe pile capacity is computed as :

$$Q_{\text{safe}} = (1/FS) \{ \sum_{1 \text{ to } n} [(\alpha c + p k \tan \delta) A_s L] + [c N_c + p N_q + 0.5 D \gamma' N_\gamma A_p] \}$$

where :

Q_{safe}	=	Safe axial pile capacity, kN	FS	=	Factor of safety
α	=	Adhesion factor (function of C_u)	p	=	Overburden pressure, kN/m ²
δ	=	Angle of wall friction between soil and pile, degrees	L	=	Pile segment length in selected layer
c	=	Cohesion intercept, kN/m ²	k	=	Coefficient of earth pressure
γ'	=	Effective density of soil, kN/m ³	D	=	Pile diameter
N_c, N_q, N_γ	=	Bearing capacity factors, which are a function of ϕ	A_s	=	Pile surface area per m length
n	=	Number of layers	A_p	=	Pile end bearing area

Pile Cross section : Circle

Pile cut-off Level (COL) : 2.0 m

Pile Diameter, D : 600 mm

Pile Surface Area, A_s = 1.885 m²/m length

Pile cross-section Area, A_p = 0.283 m²

Overburden Pressure to be considered below : COL

Consider overburden pressure to 20 pile diameters, i.e. 12.0 m below 2.0 m

become constant below : i.e. 14.0 m below 0.0 m

Design Water Table Depth: 5.0 m

Factor of Safety : 2.5 as per IS 2911 (Part 1 / Section 2) : 2010

Layer No.	Depth, m		Soil Classification	c , kN/m ²	δ ($=\phi$), degrees	γ , kN/m ³	k	α	N_c	N_q	N_γ
	From	To									
1	0.0	4.5	Flyash	0	0	14.0	1.0	0.00			
2	4.5	7.5	Sandy silt	65	4	16.5	1.0	0.33			
3	7.5	13.0	Fine sand - liquefiable	0	0	17.5	1.0	0.00			
4	13.0	20.0	Fine sand	0	31	18.5	1.1	0.00		23.93	25.99
5	20.0	30.0	Fine sand	0	32	19.5	1.1	0.00		28.88	30.21
6	30.0	40.0	Fine sand	0	33	20.0	1.2	0.00		34.86	35.19

Pile Capacity Calculation at following Pile Length(s) below cut-off Level (m)	18.0	20.0	22.0	24.0	26.0



Computation of Safe Axial Compressive Pile Capacity

By Static Analysis

Analysis in accordance with IS 2911 (Part 1 / Section 2) : 2010

Pile Type : **Bored Cast in Situ** RCC Pile

Loading : Axial Compression

Pile Dia = 600 mm

Depth Below GL, m	Pile Length below COL, m	Layer No.	Soil Parameters			Overburden Pressure kN/m ²	Unit Skin Friction kN/m ²	Skin Friction in Layer kN	Cumulative Skin Friction kN	Unit End Bearing kN/m ²	Total End Bearing kN	Ult. Pile Capacity kN	Safe Pile Capacity kN	Safe Pile Capacity MT
			C, kN/m ²	φ (=δ), degrees	γ _{eff} , kN/m ³									
0.0	-	1	0.0											
2.0	0.0	1	0.0	0	14.0	0.0								
4.5	2.5	2	65.0	4	16.5	17.5	0	0	0					
5.0	3.0	2	65.0	4	6.5	35.0								
5.7	3.7	2	65.0	4	6.5	39.1	24	23	23					
7.5	5.5	2	65.0	4	6.5	43.3	25	33	56					
8.7	6.7	3	0.0	0	7.5	45.5	25	86	142					
13.0	11.0	3	0.0	0	7.5	47.8	0	0	142					
14.0	12.0	4	0.0	31	8.5	53.7	0	0	142					
14.2	12.2	4	0.0	31	8.5	59.5	66	125	267					
18.8	16.8	4	0.0	31	8.5	64.0	69	26	293					
20.0	18.0	4	0.0	31	8.5	68.5	69	598	890	2680	758	1804	722	74
						84.6	69	156	1046					
						100.8								
						105.0								
						109.3								
						109.3								
						109.3								
						109.3								
						109.3								
						109.3								



Computation of Safe Axial Compressive Pile Capacity

By Static Analysis

Analysis in accordance with IS 2911 (Part 1 / Section 2) : 2010

Pile Type : **Bored Cast in Situ** RCC Pile
Pile Dia = 600 mm

Loading : Axial Compression

Depth Below GL, m	Pile Length below COL, m	Layer No.	Soil Parameters			Overburden Pressure kN/m ²	Unit Skin Friction kN/m ²	Skin Friction in Layer kN	Cumulative Skin Friction kN	Unit End Bearing kN/m ²	Total End Bearing kN	Ult. Pile Capacity kN	Safe Pile Capacity kN	Safe Pile Capacity MT
			c, kN/m ²	φ (=δ), degrees	γ _{eff} , kN/m ³									
20.0	18.0	5	0.0	32	9.5	109.3	75	1046	2680	758	1804	722	74	
						109.3	75	170	1216	3241	916	2133	853	87
21.2	19.2	5	0.0	32	9.5	109.3	75	113	1329	3241	916	2246	898	92
						109.3	75	283	1613	3241	916	2529	1012	103
22.0	20.0	5	0.0	32	9.5	109.3	75	283	1896	3241	916	2812	1125	115
						109.3	75	283	2179	3241	916	3095	1238	126
24.0	22.0	5	0.0	32	9.5	109.3	75							
						109.3	75							
26.0	24.0	5	0.0	32	9.5	109.3	75							
						109.3	75							
28.0	26.0	5	0.0	32	9.5	109.3	75							
						109.3	75							



Computation of Safe Axial Pullout Capacity of Pile

By Static Analysis

Analysis in accordance with IS 2911 (Part 1 / Section 2) : 2010

Pile Type : **Bored Cast in Situ** **RCC Pile**

Loading : Axial Pullout (Uplift)

The safe uplift capacity of pile is calculated as :

$$Q_{\text{safe}} = (1/\text{FS}) \{ \sum_{1 \text{ to } n} [(\alpha c + p k \tan \delta) A_s L] \} + W$$

where

<p>Q_{safe} = Safe axial pile capacity, kN</p> <p>α = Adhesion factor (function of C_u)</p> <p>δ = Friction angle between soil and pile, degrees (= ϕ)</p> <p>c = Cohesion intercept, kN/m²</p> <p>γ' = Effective density of soil, kN/m³</p> <p>n = Number of layers</p> <p>W = Weight of the pile</p>	<p>FS = Factor of safety</p> <p>p = Overburden pressure, kN/m²</p> <p>L = Pile segment length in selected layer</p> <p>k = Coefficient of earth pressure</p> <p>D = Pile diameter</p> <p>A_s = Pile surface area per m length</p>
--	---

Pile cross section shape : **circle**

Pile cut-off Level (COL) : **2.0** m

Pile Diameter, D : **600** mm

Pile Surface Area, A_s = **1.885** m²/m length

Overburden Pressure to be considered below : **COL**

Consider overburden press. to

become constant below : **20** pile diameters, i.e. **12.0** m below **2.0** m

i.e. **14.0** m below **0.0** m

Design Water Table Depth : **5.0** m

Factor of Safety : **3.0** as per IS 2911 (Part 1 / Section 2) : 2010 Clause 6.3.2

Percentage of Ultimate Shaft Resistance to be used for Ultimate Pullout Capacity: **0.7**

Layer No.	Depth, m		Soil Classification	c , kN/m ²	δ (= ϕ), degrees	γ , kN/m ³	k	α
	From	To						
1	0.0	4.5	Flyash	0	0	14.0	1.0	
2	4.5	7.5	Sandy silt	65	4	16.5	1.0	0.33
3	7.5	13.0	Fine sand - liquefiable	0	0	17.5	1.0	
4	13.0	20.0	Fine sand	0	31	18.5	1.1	
5	20.0	30.0	Fine sand	0	32	19.5	1.1	
6	30.0	40.0	Fine sand	0	33	20.0	1.2	

Pile Capacity Calculation at following Pile Length(s) below cut-off Level (m)	18.0	20.0	22.0	24.0	26.0



Computation of Safe Axial Pullout Capacity of Pile

By Static Analysis

Analysis in accordance with IS 2911 (Part 1 / Section 2) : 2010

Pile Type : **Bored Cast in Situ** **RCC Pile**
Pile Dia = 600 mm Bored Cast in Situ RCC Pile

Depth Below GL , m	Pile Length below COL, m	Layer No.	Soil Parameters			Overburden Pressure kN/m ²	Unit Skin Friction kN/m ²	Skin Friction in Layer kN	Cumulative Skin Friction kN	Weight of Pile kN	Ultimate Pullout Capacity kN	Safe Pullout Capacity kN	Safe Pullout Capacity MT
			c, kN/m ²	φ (-δ), degrees	γ _{eff} , kN/m ³								
0.0	-												
2.0	0.0	1	0.0	0		0.0							
4.5	2.5	1	0.0	0	14.00	17.5	0.0	0	0				
5.0	3.0	2	65.0	4	16.50	35.0	24.4	23	23				
7.5	5.5	2	65.0	4	6.50	43.3	25.2	119	142				
13.0	11.0	3	0.0	0	7.50	51.4	0.0	0	142				
14.0	12.0	4	0.0	31	8.50	59.5	66.2	125	267				
20.0	18.0	4	0.0	31	8.50	80.1	68.9	780	1046	80	812	324	
22.0	20.0	5	0.0	32	9.50	100.8	75.1	283	1329	88	1018	398	
24.0	22.0	5	0.0	32	9.50	105.0	75.1	283	1613	96	1224	472	
26.0	24.0	5	0.0	32	9.50	109.3	75.1	283	1896	103	1430	546	
28.0	26.0	5	0.0	32	9.50	109.3	75.1	283	2179	111	1636	620	
						109.3							



Lateral Load Carrying Capacity for Pile Foundations

Analysis in accordance with: IRC 78 - 2014

Pile Type : Bored Cast in Situ RCC Pile
 Pile cross-section : Circle
 Pile Dia : 600 mm
 Pile Cut-off-Level below GL : 2.0 m Pile Length : 18 m
 Pile Head : Fixed Head Condition
 Grade of Concrete : M 30 Modulus of Elasticity : 31000 MPa
 Moment of Inertia, I : 6.362E-03 m⁴
 Soil Classification: Cohesive Normally Consolidated or Preconsolidated Clays? P
 Unconfined Compression Strength (qu) = 130.0 kPa
 Saturation : Submerged

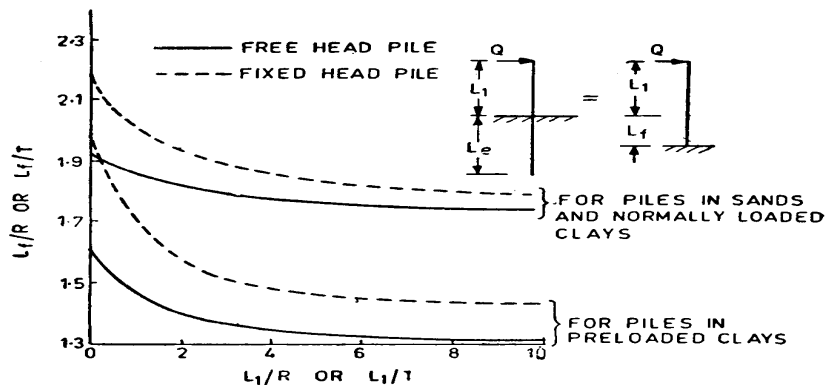

FIG. 2 DETERMINATION OF DEPTH FIXITY

$T = (EI/\eta_n)^{1/5}$ for Granular Soils and NC Clays $R = (EI/KB)^{1/4}$ for Preconsolidated Clays	
Modulus of Subgrade Reaction, $k_1 = 23.4 \text{ MN/m}^3$	$R = 2.55 \text{ m}$
Free Standing Length of Pile or Length of pile below cut-off-level not contributing substantially to lateral capacity (e) : 0.0 m	
$e/R = 0.0$	Reading off from graph, $z_f/R = 1.95$
Depth of Fixity, $z_f = 4.97 \text{ m}$	$e + z_f = 4.97 \text{ m}$
Deflection, $y = \frac{H (e + z_f)^3}{3 EI} \times 10^3$ for free-head pile Deflection, $y = \frac{H (e + z_f)^3}{12 EI} \times 10^3$ for fixed-head pile	
where : $y =$ Lateral deflection at pile top	$e =$ Free-standing length of pile
$H =$ Lateral load applied	$z_f =$ Depth of fixity
Permissible Horizontal Deflection at top of pile, $Y = 5.0 \text{ mm}$	
Computed Lateral Capacity of Pile, $H = 96 \text{ kN} = 9.8 \text{ Tonnes}$	

OPEN FOUNDATION

COAL SILO SITE



Bearing Capacity Analysis for Shallow Foundations

Analysis as per IS 6403-1981

The bearing capacity equation is as follows :

$$q_{\text{net safe}} = (1/FS)\{cN_c z_c d_c + q(N_q - 1)z_q d_q + 0.5B\gamma N_g z_g d_g R_w\}$$

where:

$q_{\text{net safe}}$ = safe net bearing capacity c = cohesion intercept
 q = overburden pressure B = Foundation width
 γ = Bulk density of soil below founding level
 R_w = Water table correction factor FS = Factor of safety
 N_c, N_q, N_g = bearing capacity factors, which are a function of f
 d_c, d_q, d_g = Depth factors
 z_c, z_q, z_g = Shape factors

Soil parameters :

$c = 0.00 \text{ T/m}^2$ $\phi = 30.0$ degrees GENERAL SHEAR FAILURE
 $c' = 0.00 \text{ T/m}^2$ $\phi = 21.1$ degrees LOCAL SHEAR FAILURE
 General Shear Failure : $N_c = 30.14$ $N_q = 18.40$ $N_g = 22.40$
 Local Shear Failure : $N'_c = 15.87$ $N'_q = 7.11$ $N'_g = 6.24$

Bulk Density Profile		
Depth, m		γ
From	To	T/m^3
0.0	4.0	1.40
4.0	5.0	1.65
5.0	15.0	1.75
15.0	20.0	1.85
20.0	40.0	1.95

Factor of safety = **2.5** as per **IS 1904-1986**

Design Water Table depth = **5.0** m

R_w factor: Constant value(V) for worst condition or

calculate(C) based on WT Depth ? :

V

$R_w = 0.50$

Depth factor to be considered ?

Y

For computation of Depth Factor, depth below GL to be ignored to account for loose soils, poorly compacted backfill above foundation, scour etc. =

4.0 m

FAILURE CRITERIA : **GENERAL SHEAR FAILURE**

Foundation Dimensions		FOUN-DATION SHAPE	Depth, m	R_w	Shape Factors			Depth factors (GSF)			Depth factors (LSF)			$q_{\text{net safe}}$, T/m^2		Safe Net Bearing Capacity T/m^2	Gross Bearing Capacity (Safe) T/m^2
B, m	L, m				z_c	z_q	z_g	d_c	d_q	d_g	d'_c	d'_q	d'_g	GSF	LSF		
3.0	3.0	<i>Square</i>	5.0	0.50	1.30	1.20	0.80	1.12	1.06	1.06				74.0		74.0	81.3
6.0	6.0	<i>Square</i>	5.0	0.50	1.30	1.20	0.80	1.06	1.03	1.03				81.7		81.7	88.9
3.0	3.0	<i>Square</i>	6.0	0.50	1.30	1.20	0.80	1.23	1.12	1.12				85.0		85.0	93.0
6.0	6.0	<i>Square</i>	6.0	0.50	1.30	1.20	0.80	1.12	1.06	1.06				90.6		90.6	98.6



Settlement Analysis for Shallow Foundation Based on N- Values

Analysis as per IS:8009 (Part 1)-1976, Clause 9.1.4

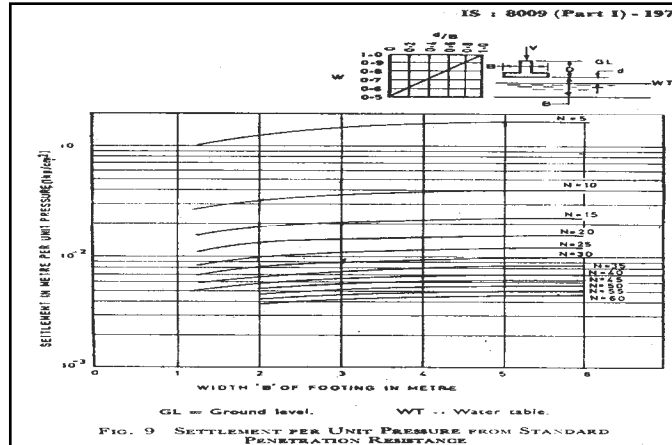

Design Water Table Depth : 5.0 m

R_w factor : Calculate (C) based on water table depth
or Fixed Value(V) for worst condition :

V Rw factor for design : 0.5

Fox's Depth Factor to be considered ? Y

Depth to be ignored in Depth Factor Computation for
loose soils, poorly compacted backfill, scour, etc. 4.0 m

Foundation Width, m	Foundation Length, m	Foundation Depth, m	Shape	Design N-Value	Design Net Bearing Pressure, T/m ²	Settlement @ 1kg/cm ² (as read off from graph).	R_w	Fox's Depth Factor, d_f	Rigidity Factor, d_r	Computed Settlement, mm
3.0	3.0	5.0	Square	21.0	16.5	13.3	0.50	0.91	1.0	39.8
6.0	6.0	5.0	Square	21.0	17.5	14.6	0.50	0.96	0.8	39.1
3.0	3.0	6.0	Square	26.0	24.0	10.4	0.50	0.80	1.0	39.8
6.0	6.0	6.0	Square	27.0	25.0	10.9	0.50	0.91	0.8	39.7



Settlement Analysis for Shallow Foundations Elastic Settlement Computed From Theory of Elasticity

Analysis as per IS : 8009 Part 1 - 1976, Clause 9.2

Total settlement computed as equal to elastic/immediate settlement.

No consolidation settlement - analysis valid for granular soils, weathered rocks,
hard clays & cohesive soils above water table

ELASTIC / IMMEDIATE SETTLEMENT

$$S_i = \frac{q B' (1 - \mu^2) I}{E} d_f d_r$$

Reference : *Foundation Analysis & Design by J.E.Bowles* fifth edition (1996)

where B = Foundation width B' = B/2 L' = L/2 μ = Poisson's Ratio
 q = Applied Bearing Pressure E = Modulus of Elasticity
 d_f = Fox's Depth factor d_r = Rigidity factor
 I = Influence factor at corner of rectangular loaded area(B' x L'),
 computed from theory of elasticity using Steinbrenner's factors
 Settlement at centre of footing of size B x L = 4 x Settlement at corner of area B' x L'

Poisson's Ratio : 0.30

Is Rigid Layer met ? N

Layer No.	Depth,m		Soil Classification	Modulus of Elasticity,T/m ²
	From	To		
1	0.0	4.0	Fill (Flyash)	500
2	4.0	5.0	sandy silt	700
3	5.0	15.0	Fine sand	1000
4	15.0	20.0	Fine sand	1800
5	20.0	30.0	Fine sand	3200
6	30.0	40.0	Fine sand	4500

Fox's Depth Factor to be considered ? Y

Depth to be ignored in Depth Factor Computation for loose soils, poorly compacted backfill, scour etc. = 4.0 m

Founda-tion Width (B), m	Founda-tion Length (L), m	Embed-ment Depth (D), m	Applied Bearing Press. T/m ²	Rigidity Factor, d _r	Fox's Depth Factor	M = L/B'	N = H/B'	Influence Factor	E(weigh-ted ave.) T/m ²	Elastic Settle-ment mm
3.0	3.0	5.0	16.5	1.00	0.91	1.00	10.00	0.507	1267	32.7
6.0	6.0	5.0	17.5	0.80	0.96	1.00	10.00	0.507	2450	30.4
3.0	3.0	6.0	24.0	1.00	0.80	1.00	10.00	0.507	1413	37.6
6.0	6.0	6.0	24.0	0.80	0.91	1.00	10.00	0.507	2567	37.6

OPEN FOUNDATION

RAW WATER STORAGE TANK SITE



Bearing Capacity Analysis for Shallow Foundations

Analysis as per IS 6403-1981

The bearing capacity equation is as follows :

$$q_{\text{net safe}} = (1/FS)\{cN_c z_c d_c + q(N_q - 1)z_q d_q + 0.5B\gamma N_g z_g d_g R_w\}$$

where:

$q_{\text{net safe}}$ = safe net bearing capacity c = cohesion intercept
 q = overburden pressure B = Foundation width
 γ = Bulk density of soil below founding level
 R_w = Water table correction factor FS = Factor of safety
 N_c, N_q, N_g = bearing capacity factors, which are a function of f
 d_c, d_q, d_g = Depth factors
 z_c, z_q, z_g = Shape factors

Soil parameters :

$c = 0.00 \text{ T/m}^2$ $\phi = 30.0$ degrees GENERAL SHEAR FAILURE
 $c' = 0.00 \text{ T/m}^2$ $\phi = 21.1$ degrees LOCAL SHEAR FAILURE
 General Shear Failure : $N_c = 30.14$ $N_q = 18.40$ $N_g = 22.40$
 Local Shear Failure : $N_c' = 15.87$ $N_q' = 7.11$ $N_g' = 6.24$

Bulk Density Profile		
Depth, m		γ
From	To	T/m^3
0.0	4.5	1.40
4.5	5.0	1.65
5.0	15.0	1.75
15.0	20.0	1.85
20.0	40.0	1.95

Factor of safety = **2.5** as per **IS 1904-1986**

Design Water Table depth = **5.0** m

R_w factor: Constant value(V) for worst condition or

calculate(C) based on WT Depth ? :

V

$R_w = 0.50$

Depth factor to be considered ?

Y

For computation of Depth Factor, depth below GL to be ignored to account for loose soils, poorly compacted backfill above foundation, scour etc. =

4.5 m

FAILURE CRITERIA : **GENERAL SHEAR FAILURE**

Foundation Dimensions		FOUN-DATION SHAPE	Depth, m	R_w	Shape Factors			Depth factors (GSF)			Depth factors (LSF)			$q_{\text{net safe}}$, T/m^2		Safe Net Bearing Capacity T/m^2	Gross Bearing Capacity (Safe) T/m^2
B, m	L, m				z_c	z_q	z_g	d_c	d_q	d_g	d_c'	d_q'	d_g'	GSF	LSF		
3.0	3.0	Square	6.5	0.50	1.30	1.20	0.80	1.23	1.12	1.12				87.3		87.3	95.6
6.0	6.0	Square	6.5	0.50	1.30	1.20	0.80	1.12	1.06	1.06				92.8		92.8	101.1
3.0	3.0	Square	7.5	0.50	1.30	1.20	0.80	1.35	1.17	1.17				99.2		99.2	108.2
6.0	6.0	Square	7.5	0.50	1.30	1.20	0.80	1.17	1.09	1.09				102.2		102.2	111.2



Settlement Analysis for Shallow Foundation Based on N- Values

Analysis as per IS:8009 (Part 1)-1976, Clause 9.1.4

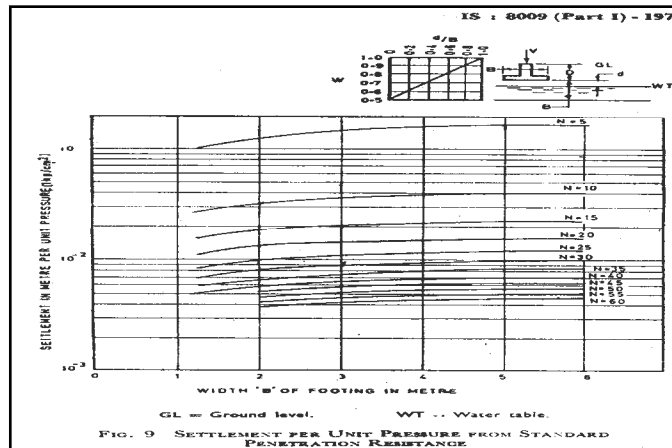

Design Water Table Depth : 5.0 m

R_w factor : Calculate (C) based on water table depth
or Fixed Value(V) for worst condition :

V Rw factor for design : 0.5

Fox's Depth Factor to be considered ? Y

Depth to be ignored in Depth Factor Computation for
loose soils, poorly compacted backfill, scour, etc. 4.5 m

Foundation Width, m	Foundation Length, m	Foundation Depth, m	Shape	Design N-Value	Design Net Bearing Pressure, T/m ²	Settlement @ 1kg/cm ² (as read off from graph).	R_w	Fox's Depth Factor, d_f	Rigidity Factor, d_r	Computed Settlement, mm
3.0	3.0	6.5	Square	21.0	18.5	13.3	0.50	0.80	1.0	39.3
6.0	6.0	6.5	Square	22.0	19.5	13.8	0.50	0.91	0.8	39.1
3.0	3.0	7.5	Square	26.0	26.0	10.4	0.50	0.73	1.0	39.4
6.0	6.0	7.5	Square	27.0	26.5	10.9	0.50	0.85	0.8	39.3



Settlement Analysis for Shallow Foundations Elastic Settlement Computed From Theory of Elasticity

Analysis as per IS : 8009 Part 1 - 1976, Clause 9.2

Total settlement computed as equal to elastic/immediate settlement.

No consolidation settlement - analysis valid for granular soils, weathered rocks,
hard clays & cohesive soils above water table

ELASTIC / IMMEDIATE SETTLEMENT

$$S_i = \frac{q B' (1 - \mu^2) I}{E} d_f d_r$$

Reference : *Foundation Analysis & Design by J.E.Bowles* fifth edition (1996)

where B = Foundation width $B' = B/2$ $L' = L/2$ μ = Poisson's Ratio
 q = Applied Bearing Pressure E = Modulus of Elasticity
 d_f = Fox's Depth factor d_r = Rigidity factor
 I = Influence factor at corner of rectangular loaded area($B' \times L'$),
 computed from theory of elasticity using Steinbrenner's factors
 Settlement at centre of footing of size $B \times L = 4 \times$ Settlement at corner of area $B' \times L'$

Poisson's Ratio : 0.30

Is Rigid Layer met ? N

Layer No.	Depth, m		Soil Classification	Modulus of Elasticity, T/m ²
	From	To		
1	0.0	4.0	Fill (Flyash)	500
2	4.0	5.0	sandy silt	700
3	5.0	15.0	Fine sand	1000
4	15.0	20.0	Fine sand	2000
5	20.0	30.0	Fine sand	3800
6	30.0	40.0	Fine sand	4500

Fox's Depth Factor to be considered ? Y

Depth to be ignored in Depth Factor Computation for loose soils, poorly compacted backfill, scour etc. = 4.5 m

Founda- tion Width (B), m	Founda- tion Length (L), m	Embed- ment Depth (D), m	Applied Bearing Press. T/m ²	Rigidity Factor, d_r	Fox's Depth Factor	$M = L'/B'$	$N = H/B'$	Influence Factor	E(weigh- ted ave.) T/m ²	Elastic Settle- ment mm
3.0	3.0	5.0	18.5	1.00	0.96	1.00	10.00	0.507	1333	36.9
6.0	6.0	5.0	19.5	0.80	0.98	1.00	10.00	0.507	2683	31.7
3.0	3.0	6.0	26.0	1.00	0.85	1.00	10.00	0.507	1520	40.2
6.0	6.0	6.0	26.5	0.80	0.94	1.00	10.00	0.507	2800	39.2

APPENDIX-C
SITE PHOTOGRAPHS



Photo: 1 Borehole No. BH-P1



Photo: 2 Borehole No. BH-P2

Site Photographs



Photo: 3 Borehole No. BH-P3



Photo: 4 Borehole No. BH-P4

Site Photographs



Photo: 5 Borehole No. BH-P5

Site Photographs

**GEOTECHNICAL INVESTIGATION REPORT
(VOLUME-3)**

FOR

RAW WATER INTAKE AREA

RELATED TO

THE PREPARATORY SURVEY FOR

CONSTRUCTION OF

BARAUNI SUPER CRITICAL COAL FIRED

THERMAL POWER STATION

(UNIT#10)

OF

BIHAR STATE POWER GENERATION COMPANY LTD.

CONSULTANT

steag



STEAG Energy Services India Pvt. Ltd.

(Formerly Evonik Energy Services India Ltd.)

(A wholly owned subsidiary of Steag Energy Services GmbH, Germany)

A-29, Sector-16, NOIDA-201301, India

TABLE OF CONTENTS

		<u>Sheet No.</u>
1.0	INTRODUCTION	4
	1.1 Project Description	4
	1.2 Purposes of Study	4
	1.3 Report Format	4
	1.4 Scope of Geotechnical Investigations covered in this Report (<i>Raw water Intake</i>)	5
2.0	FIELD INVESTIGATIONS	5
	2.1 Soil Boring	5
	2.2 Groundwater	6
3.0	LABORATORY TESTS	6
4.0	GENERAL SITE CONDITIONS	6
	4.1 Site Details	6
	4.2 Regional Geology	6
	4.3 Site Stratigraphy	7
	4.4 Groundwater	7
5.0	LIQUEFACTION SUSCEPTIBILITY ASSESSMENT	7
	5.1 Detailed Liquefaction Analysis as per NCEER Approach	7
	5.1.1 Introduction	7
	5.1.2 Calculation of Cyclic Stress Ratio (CSR)	8
	5.1.3 Calculation of Cyclic Resistance Ratio (CRR) based on SPT Values	9
	5.2 Results of Detailed Liquefaction Studies	10
6.0	FOUNDATION ANALYSIS AND RECOMMENDATIONS	10
	6.1 General	10
	6.2 Foundation Type and Depth	10
	6.3 Concept for Well Foundation Analysis	11
	6.4 Design Soil Parameters	11
	6.5 Recommended Gross Allowable Bearing Pressures	12
	6.6 Definition of Gross and Net Bearing Pressure	12
7.0	FOUNDATION CONSTRUCTION CONSIDERATION	13
	7.1 Fill Placement and Compaction	13
	7.2 Chemical Attack	13
8.0	VARIABILITY IN SUB-SURFACE CONDITIONS	14

LIST OF ILLUSTRATIONS

<u>Caption</u>	<u>Plate</u>
Layout Plan	1
Satellite Image of Site and Test Locations	2
Engineering Description of Soils	3
Uncertainty in Laboratory Measurements	4
Soil Profiles	5 to 19
Summary of Borehole Profiles	20
Standard Penetration Test Results	21 & 22
Grain Size Analysis	23 to 28
Shear Test Results	29 to 31
Chemical Test Results	32

Appendix A: Liquefaction Susceptibility Assessment

Appendix B: Typical Calculations

Appendix C: Site Photographs

DEFINITION OF ACRONYMS

USL	United Spirit Limited
UTM	Universal Transverse Mercator coordinates system
NABL	National Accreditation Board for Testing and Calibration Laboratories
ISO	International Standards Organization
BIS	Bureau of Indian Standards
EGL	Existing Ground Level
NGL	Natural Ground Level
RL	Reduced Level
SPT	Standard Penetration Test
NCEER	National Center for Earthquake Engineering Research
UUT	Unconsolidated undrained triaxial shear test
DS	Consolidated drained direct shear test

BIS REFERENCES

- Compendium of Indian Standard on Soil Engineering (Part-2, Field Testing of Soils for Civil Engineering Purposes), SP36 (Part-2:1988)-RA 2006
- Compendium of Indian Standard on Soil Engineering (Part-1, Laboratory Testing of Soils for Civil Engineering Purposes), SP36 (Part-1:1987)-RA 2006.

1.0 INTRODUCTION

1.1 Project Description

Japan International Cooperation Agency (JICA) has appointed Kyushu Electric Power Co. Inc. as a consultant, to conduct the preparatory survey for construction of the Barauni Super Critical Coal Fired Thermal Power Station. Kyushu Electric Power Co. INC has appointed M/s. STEAG Energy Services (India) Pvt. Ltd for the preparatory survey work for the project.

This report volume (Volume-III) presents field and laboratory test results along with our geotechnical recommendations for the Raw Water Intake area. Two accompanying volumes present results of the geotechnical investigation for the Ash Pond area (Volume-I) & for the Powerhouse facilities area (Volume-II).

1.2 Purposes of Study

The overall purposes of this study are to investigate the stratigraphy at the site, and to develop geotechnical recommendations for design and construction of foundations for the Ash Pond, Powerhouse and the Raw Water Intake structure.

To accomplish these purposes, the study was conducted in the following phases:

- (i) drilling 8 boreholes to 20 m depth in the Ash Pond area, in order to evaluate the stratigraphy, and to collect soil and groundwater samples for laboratory testing;
- (ii) performing seventy three (73) field permeability tests in the Ash Pond area at eight (8) borehole locations to assess the in-situ coefficient of permeability of the strata;
- (iii) drilling 6 boreholes to 40 m depth in the Powerhouse area in order to evaluate the stratigraphy, and to collect soil and groundwater samples for laboratory testing;
- (iv) drilling 3 boreholes to 50 m depth at the Raw Water Intake location in order to evaluate the stratigraphy, and to collect soil and groundwater samples for laboratory testing;**
- (v) testing selected soil and groundwater samples in the laboratory to determine pertinent index and engineering properties; and
- (vi) analyzing all field and laboratory data to develop geotechnical recommendations for foundations.

This geotechnical investigation for the raw water intake structure has been done adjacent to the River Ganga flowing in the vicinity of the power plant.

1.3 Report Format

This report is presented in three volumes. The scope of work included in each volume is as described below:

Report Volume	Proposed Structures	Scope of Work
Volume-I	Ash Pond	<ul style="list-style-type: none"> ▪ Eight (8) Boreholes ▪ Seventy three (73) field permeability tests
Volume-II	Powerhouse	<ul style="list-style-type: none"> ▪ Six (6) Boreholes
Volume-III	Raw Water Intake	<ul style="list-style-type: none"> ▪ Three (3) Boreholes

This volume, designated as Volume-III, includes field and laboratory data together with our engineering recommendations for the proposed **Raw Water Intake area**.

The initial sections of this volume of the report present brief descriptions of the field procedures together with a list of various laboratory tests conducted. General site conditions, including geology and stratigraphy along the cross bridge alignment, are then presented. This is followed by our foundation analysis and recommendations.

Plates of soil profiles and various laboratory tests follow the report text. The illustrations section includes a site plan, graphical plots of various field and laboratory test results, summary of borehole profiles, sectional profiles and other related sketches.

1.4 Scope of Geotechnical Investigations covered in this Report (*Raw water Intake*)

Details of boreholes drilled on site are as follows:

Sr. No.	Borehole Designation	UTM Coordinates, m		Existing Ground Level (RL), m	Borehole Termination Depth, m
		Easting	Northing		
1	BH-1	399001.29	2808360.28	38.838	50.17
2	BH-2	399026.35	2808311.37	38.231	50.18
3	BH-3	399055.13	2808256.66	38.246	50.20

- A layout plan illustrating the various test locations covered in this report volume are presented on Plate 1.
- The test locations were given to us on the ground by the client representatives at site. The locations were marked on Google earth and a satellite image illustrating the approximate test locations (as given to us) is presented on Plate 2.

2.0 FIELD INVESTIGATIONS

2.1 Soil Boring

The borings were progressed using a shell and auger to the specified depth. The diameter of the borehole was 150 mm. Casing was used for advancing boring below water table at all borehole locations. The work was in general accordance with IS: 1892-1979.

Standard Penetration Tests (SPT) were conducted in the boreholes at 1.0 m depth interval. The test was conducted by connecting a split spoon sampler to 'A' rods and driving it by 45 cm using a 63.5 kg hammer falling freely from a height of 75 cm. The tests were conducted in accordance with IS: 2131-1981.

The number of blows for each 15 cm of penetration of the split spoon sampler was recorded. The blows required to penetrate the initial 15 cm of the split spoon for seating the sampler is ignored due to the possible presence of loose materials or cuttings from the drilling operation. Where refusal (N>100) to further penetration of the split spoon sampler is encountered in the first 15 cm seating penetration itself, SPT test could not be completed and "Ref" is indicated in the bore logs, along with the penetration achieved. The 'N' values are presented on the soil profile for each borehole.

Disturbed samples were collected from the split spoon after conducting SPT. The samples were preserved in transparent polythene bags. Undisturbed samples were collected by attaching 75 mm diameter thin walled 'Shelby' tubes and driving the sampler using a 63.5 kg hammer in accordance with

IS: 2132-1986. The tubes were sealed with wax at both ends. All samples were transported to our NABL accredited laboratory at Noida for further examination and testing.

2.2 Groundwater

Groundwater level was measured in the boreholes after drilling and sampling was completed. The measured water levels are recorded on the individual soil profiles.

3.0 LABORATORY TESTS

The laboratory testing has been carried out in our NABL accredited laboratory. The quality procedures in our laboratory conform to ISO/IEC-17025-2005.

Laboratory tests were conducted on selected soil and groundwater samples, to determine their physical and engineering properties. The testing procedures were in accordance with current applicable IS specifications.

The following tests were conducted on selected soil and groundwater samples recovered from the boreholes:

Name of Test		IS Code No.
Bulk Density		IS : 2386 (Part-3)-1963
Natural moisture content		IS : 2720 (Part-2)-1973, RA-2010
Grain size analysis		IS : 2720 (Part-4)-1985, RA-2010
Specific gravity		IS : 2720 (Part-3)-1980, RA-2007
Liquid and plastic limits		IS : 2720 (Part-5)-1985, RA-2010
Consolidated drained direct shear test		IS : 2720 (Part-13)-1986, RA-2010
Chemical analysis of soil*	pH value	IS : 2720 (Part 26)-1987, RA-2007
	Total soluble sulphates	IS : 2720 (Part-27)-1977, RA-2010
	Total soluble chlorides	IS : 3025 (Part-32)-1988, RA-2009
Chemical analysis of water*	pH value	IS : 3025 (Part-11)-1983, RA-2006
	Total soluble sulphates	IS : 3025 (Part-24)-1986, RA-2009
	Total soluble chlorides	IS : 3025 (Part-32)-1988, RA-2009

* Outside NABL Scope

Engineering terms used to describe soils are explained on Plate 3. A note on our NABL accreditation together with the uncertainty in laboratory measurements is presented on Plate 4.

4.0 GENERAL SITE CONDITIONS

4.1 Site Details

The site located in Barauni district, Bihar. Rajendra pul railway Station is located about 2.5 k m west of the site. Ganga river is flowing about 120 m away from the site.

4.2 Regional Geology

The deposits in the project area belong to the Indo-Gangetic alluvium⁽¹⁾. The alluvial tract is of the nature of a synclinal basin formed concomitantly with the elevation of the Himalaya to its North.

The Indo-Gangetic depression was formed in the later stages of Himalayan Orogeny when the Indian shield under-thrust the Asian continent. The well-consolidated crust of the shield became engulfed under the light, soft, moist sediments. As the northward drift of India continued, the more

⁽¹⁾ Krishnan, M.S. (1982), "**Geology of India and Burma**", CBS Publishers & Distributors, Delhi, Sixth Edition.

consolidated and metamorphosed older strata and the granitic magmas intrusive into them slid southwards, impelled partly by gravity and partly by compressive force.

The Pleistocene and recent deposits covering the Indo-Gangetic Basin are upto 1,000 m thick. They are composed of gravels, sands and clays with remains of animals and plants.

The older alluvium (called Bhangar) is rather dark colored and generally rich in concretions and nodules of impure calcium carbonate (kankar). It is of Middle to Upper Pleistocene age.

The Newer alluvium (called Khadar) is light colored and poor in calcareous matter. It contains lenticular beds of sand and gravel and peat beds. It merges by insensible gradations into the recent or deltaic alluvia and should be assigned an Upper Pleistocene to Recent age.

4.3 Site Stratigraphy

The stratigraphy at site may be divided into two (2) generalized strata as described below:

Stratum – I (Stiff to firm clayey silt): A stiff to firm surficial clayey silt layer is present all over the site to about 1.0-1.5 m depth (RL 36.7-37.8 m).

Stratum – II (Loose to very dense silty fine sand / fine sand): Stratum-II consists of loose to very dense silty fine sand / fine sand to the maximum explored depth of 50 m (RL -12 m). SPT values in this stratum range from 5 to 16 to about 13-15 m depth (RL 23.2-25.2 m), indicating loose to medium dense soil conditions. SPT values range from 28 to 66 to about 26.5 m depth (RL 11.7 m). Below this, SPT values in this stratum range from 73 to 100+ (refusal) to about 30 m depth (RL 8.2 m). Below this, refusal (N >100) is encountered.

However in between 6.5 to 7.5 m depth, SPT value at this level is low at all three borehole locations suggesting that a loose zone (probably due to erosion of river in the past). We suggest that during the detailed investigation stage, static cone penetration tests also be done to reconfirm this loose zone.

In stratum-II, bulk density values range from 1.79 g/cm³ to 1.86 g/cm³ and moisture content values range from 24 % to 25 % to about 3.0 m depth (RL 35.2 m).

Detailed description of the soil encountered at the borehole locations are presented on the individual soil profiles in Plate 5 to 19. A pictorial summary of the borehole profiles is illustrated on Plate 20. Plots of field and corrected SPT values versus depth are presented on Plate 21 & 22.

4.4 Groundwater

Based on the field data of three (3) completed boreholes, groundwater was met at 3.0-3.1 m depth during the period of our field investigation (July, 2015). Fluctuations may occur in the measured water levels due to seasonal variations in rainfall and surface evaporation rates as well as flow of water in the Ganga River.

5.0 LIQUEFACTION SUSCEPTIBILITY ASSESSMENT

5.1 Detailed Liquefaction Analysis as per NCEER Approach

5.1.1 Introduction

For a better evaluation of the liquefaction potential at the project site, a detailed analysis has been done as per standard procedures given in published literature. The methodology based on the

simplified procedure developed by Seed and Idriss, as described in the NCEER Summary Report (2001)⁽²⁾.

As per the simplified procedure, the factor of safety (FS) against liquefaction is given by the following equation:

$$FS = \left[\frac{CRR_{7.5}}{CSR} \right] MSF$$

where,

- CSR = Cyclic Stress Ratio, generated by the earthquake shaking;
- CRR_{7.5} = Cyclic Resistance Ratio for magnitude 7.5 earthquakes; and
- MSF = Magnitude Scaling Factors (*as recommended by the NCEER Summary Report*), used to scale the calculated CRR_{7.5} values to the design earthquake magnitude.

Calculation, or estimation, of two variables is required for evaluation of liquefaction resistance of soils:

1. the seismic demand on a soil layer, expressed in terms of Cyclic Stress Ratio (CSR); and
2. capacity of the soil to resist liquefaction, expressed in terms of cyclic resistance ratio (CRR), based on SPT values (*Refer to Section 6.1.3*)

A Magnitude Scaling Factor (MSF) of 1.442 (based on a mean of Scaling Factors defined by various investigators recommended by the NCEER Summary Report, 2001) was applied to the CRR_{7.5} value, to adjust the clean sand curves to the design earthquake magnitude of 6.7.

5.1.2 Calculation of Cyclic Stress Ratio (CSR)

In this analysis, the cyclic stress ratio (CSR) has been calculated for the selected peak horizontal ground accelerations at various depths using the following equations.

$$CSR = \left(\frac{\tau_{av}}{\sigma_{vo}'} \right) = 0.65 r_d \left(\frac{\sigma_{vo}}{\sigma_{vo}'} \right) \frac{a_{max}}{g}$$

$$\text{and } \begin{cases} r_d = 1.0 - 0.00765z \text{ for } z \leq 9.15 \text{ m} \\ r_d = 1.174 - 0.0267z \text{ for } 9.15 \leq z \leq 23 \text{ m} \end{cases}$$

where:

- τ_{av} = Average horizontal shear stress acting on soil element during earthquake shaking
- r_d = Stress reduction coefficient, based on Liao and Whitman (1986b)⁽³⁾
- σ_{vo} = Total vertical overburden stresses
- σ_{vo}' = Effective vertical overburden stresses

⁽²⁾ Youd, T.L., and Idriss, I.M., (2001), "**Liquefaction Resistance of Soils: Summary Report from the 1996 NCEER and 1998 NCEER/NSF Workshops on Evaluation of Liquefaction Resistance of Soils**", Journal of Geotechnical and Geo-environmental Engineering, April 2001, pp. 297-313.

⁽³⁾ Liao, S.S.C., and Whitman, R.V. (1986b), "**Catalogue of liquefaction and non-liquefaction occurrences during earthquakes**", Res. Rep., Dept. of Civil Engrg., MIT, Mass.

g = acceleration due to gravity
 a_{max} = Peak horizontal ground acceleration (PGA)

5.1.3 Calculation of Cyclic Resistance Ratio (CRR) based on SPT Values

Since SPT N-values increase with increasing effective overburden pressure, an overburden stress correction factor is applied (Seed & Idriss 1982⁽⁴⁾) to normalize N_{60} to an equivalent effective overburden pressure of approximately 1 atmosphere (100 kPa). The overburden correction on SPT values is based on the actual depth of groundwater, as measured in the field, and presented in the bore log.

Other correction factors for borehole diameter, rod length, and sampler type have also been taken into account. The SPT values have further been corrected for fines content.

The corrections used to obtain the Corrected Blow Count, $(N_1)_{60}$, were applied as follows.

$$(N_1)_{60} = N_{field} \cdot C_N \cdot C_H \cdot C_B \cdot C_R \cdot C_S$$

where,

N_{field} =	Measured Standard Penetration Resistance
C_N =	Factor to normalize N_{field} to a common reference effective overburden pressure of 1 atmosphere (100 kPa), restricted to 1.7
C_H =	Correction for Hammer Energy Ratio (ER), taken as 0.75
C_B =	Correction Factor for Borehole Diameter, taken as 1.05
C_R =	Correction Factor for Rod Length
C_S =	Correction for sampler type, taken as 1.20

C_N has been calculated at the middle of each layer from the following equation (Liao and Whitman, 1986a⁽⁵⁾):

$$C_N = \left(\frac{P_o}{\sigma_{vo}'} \right)^{0.5} \leq 1.7$$

Where,

P_o = Reference effective overburden pressure of 1 atmosphere (100 kPa);
 σ_{vo}' = Effective overburden pressure at middle of layer at the time of drilling

The corrected $(N_1)_{60}$ value thus obtained was further corrected for the influence of fines content (FC %). The clean-sand base curve for determination of CRR based on corrected SPT N-values, $(N_1)_{60}$, has been estimated by the following equation (Rauch, 1998⁽⁶⁾):

⁽⁴⁾ Seed, H.B., and Idriss, I.M. (1982), "**Ground motions and soil liquefaction during earthquakes.**", Earthquake Engineering Research Institute Monograph, Oakland, Calif.
⁽⁵⁾ Liao, S. and Whitman, R.V. (1986a), "**Overburden correction factors for SPT in sand.**", J. Geotech. Engrg., ASCE, 112(3), 373-377.
⁽⁶⁾ Rauch, A. F. (1998). Personal Communication. (as cited in Youd, T. L., Idriss, I. M., Andrus, R. D., Arango, I., Castro, G., Christian, J. T., Dobry, R., Finn, W. D. L., Harder, L. F., Hynes, M. E., Ishihara, K., Koester, J. P., Liao, S. S. C., Marcuson, W. F., Martin, G. R., Mitchell, J.K., Moriwaki, Y., Power, M. S., Robertson, P. K., Seed, R. B., and Stokoe, K. H. (2001). **Liquefaction Resistance of Soils: Summary Report from the 1996 NCEER and 1998**

5.2 Results of Detailed Liquefaction Studies

For the liquefaction analysis, the design earthquake magnitude has been taken as 6.7 on the Richter scale for Zone IV. The peak ground acceleration has been considered as equal to 0.24g. The results of the analysis are presented below:

Sr. No.	Borehole No.	Liquefaction Potential Susceptibility
1	BH-1	Liquefaction potential to 9.0 m depth (RL 29.8 m)
2	BH-2	Liquefaction potential to 12.5 m depth (RL 25.7 m)
3	BH-3	Liquefaction potential to 10.0 m depth (RL 28.2 m)

For the purpose of design, we suggest that liquefaction be considered to 12.5 m depth (RL 25.7 m).

According to Fig.1 of IS: 1893 (Part1)-2002, RA-2005 showing seismic zones the proposed site falls on earthquake Zone-IV. Therefore design should be done considering the earthquake parameters for Zone-IV.

6.0 FOUNDATION ANALYSIS AND RECOMMENDATIONS

6.1 General

A suitable foundation for any structure should have an adequate factor of safety against exceeding the bearing capacity of the supporting soils. Also the vertical movements due to compression of the soils should be within tolerable limits for the structure. We consider that foundations designed in accordance with the recommendations herein will satisfy these criteria.

6.2 Foundation Type and Depth

The following points are highlighted with reference to the well foundations:

1. As per the information provided to us, well foundations are being planned at the project site to support the structural loads of the proposed Intake well.
2. Diameter or size of well, shape of well and foundation depth of well etc were not finalized at the time of this report preparation.
3. Hydrological details and maximum scour depth were not provided to us at the time of this report preparation. As suggested by Steag, we have considered the maximum scour depth at 20 m depth (RL 18.2 m).
4. Our recommended safe net and gross allowable bearing pressures for well foundation are presented in **Section 6.5**.
5. The minimum depth of the well should be decided as per the required grip length below the maximum scour level. For initial analysis, the minimum well depth has been considered as 30 m below EGL (RL 8.2 m).

As conveyed to us, sedimentation tank shall be constructed on a 20 m thick fill. Prior to placement of fill, the exposed soils at ground level should be watered and compacted by several passes of a 10 ton roller. The fill should be placed in layers and compacted thoroughly as given in Section 8.1 of this report. Detailed testing including boreholes and static cone penetration tests should be performed to assess the safe bearing capacity of the fill.

6.3 Concept for Well Foundation Analysis

The bearing capacity equation used for analyzing well foundation is as follows:

$$q_{gross\ safe} = \frac{1}{F} [cN_c \zeta_c d_c + pN_q \zeta_q d_q + 0.5 B \gamma N_\gamma \zeta_\gamma d_\gamma R_w]$$

where :

$q_{gross\ safe}$	=	safe gross bearing capacity of soil based on the shear failure criterion.
c	=	cohesion intercept
ϕ	=	angle of internal friction
γ	=	bulk unit weight of soil
p	=	overburden pressure computed below the level of maximum scour
N_c, N_q, N_γ	=	Bearing capacity factors which are a function of ϕ .
R_w	=	water table correction factor, taken as 0.5 for submerged condition
F	=	Factor of safety
$\zeta_c, \zeta_q, \zeta_\gamma$	=	Shape factors for circular wells, $\zeta_c = 1.3$ $\zeta_q = 1.2$ $\zeta_\gamma = 0.6$
d_c, d_q, d_γ	=	Depth factors (computed below level of maximum scour) For $\phi < 10$, $d_c = 1 + 0.2 \tan(45 + \phi/2) D/B$, $d_q = d_\gamma = 1$ For $\phi \geq 10$, $d_c = d_q = d_\gamma = 1 + 0.1 \tan(45 + \phi/2) D/B$

Settlement analysis has been performed as per IS 8009 (Parts 1 & 2). As per IS 1904, the tolerable total settlement is taken as 50 mm. Since dense sand is met at or below well tip, consolidation settlement is not likely to occur. The total settlement is equal to the immediate settlement.

The immediate settlement has been computed using the following equation [Clause 9.2.3 of IS 8009 Part 1-1976] as per the procedure given by Bowles⁽⁷⁾.

where :

$$S_i = \frac{qB'(1 - \mu^2)}{E} I d_f d_r$$

S_i	=	immediate (elastic) settlement
B	=	foundation width, $B' = B/2$
μ	=	Poisson's ratio
q	=	applied bearing pressure
E	=	modulus of elasticity
d_f	=	depth factor
d_r	=	rigidity factor
I	=	influence factor at corner of rectangular loaded area ($B' \times L'$)

6.4 Design Soil Parameters

Reviewing the soil characteristics, the following soil parameters have been selected for foundation analysis:

⁽⁷⁾ Bowles, J.E. (1996), "**Foundation Analysis and Design**", International Edition, pp. 303-317.

Depth, m		Stratigraphy	c, T/m ²	φ	γ, T/m ³	E, T/m ²
From	To					
0.0	1.5	Clayey silt			1.65	
1.5	12.5	Fine sand (Liquefiable)			1.70	
12.5	20.0	Fine sand (Scour)			1.85	
20.0	30.0	Fine sand	0	31	1.95	2500
30.0	40.0	Fine sand	0	32	2.00	4000
40.0	50.0	Fine sand	0	33	2.10	5000

where:

c	=	cohesion intercept
φ	=	angle of internal friction
γ	=	bulk density
E	=	modulus of elasticity ⁸

Since sand is met at or below well tip, consolidation settlement is not likely to occur. The total settlement is equal to the immediate settlement.

6.5 Recommended Gross Allowable Bearing Pressures

The following table presents our recommended values of gross bearing pressure for the well foundations:

Well Diameter, m	Depth of the Well Tip, m	RL of the Well Tip, m	Recommended Gross Bearing Pressure, T/m ²
8.0	30.0	RL 8.2 m	115.0
	32.0	RL 6.2 m	123.0
	35.0	RL 3.2 m	140.0
10.0	30.0	RL 8.2 m	99.0
	32.0	RL 6.2 m	108.0
	35.0	RL 3.2 m	125.0

This value includes a bearing capacity safety factor of 2.5. Total settlement of the well designed for this bearing pressure is expected to be about 50 mm.

6.6 Definition of Gross and Net Bearing Pressure

For the purposes of this report, the net allowable bearing pressure should be calculated as the difference between total load on the foundation and the weight of the soil overlying the foundation divided by the effective area of the foundation. The gross bearing pressure is the total pressure at the foundation level including overburden pressure and surcharge load.

The following equations may be used –

$$q_{net} = [(P_s + W_f + W_s) / A_f] - S_v$$

$$q_{gross} = q_{net} + S_v = (P_s + W_f + W_s) / A_f$$

where:

q_{net}	=	net allowable bearing pressure
q_{gross}	=	gross bearing pressure

⁸ estimated based on empirical correlations with SPT N-values

P_s	=	superimposed static load on foundation
W_f	=	weight of foundation
W_s	=	weight of soil overlying foundation
A_f	=	effective area of foundation
S_v	=	overburden pressure at foundation level prior to excavation for foundation.

It may please be noted that safe bearing pressures recommended in this report refer to “**net values**”. Where filling is done, it should be treated as a surcharge over the foundation.

7.0 FOUNDATION CONSTRUCTION CONSIDERATION

7.1 Fill Placement and Compaction

Structural fill is defined as fill that is placed in areas of built up areas, above foundations, behind retaining walls, and beneath roads. General fill refers to fill that is placed in open areas to raise site grades and in landscaped areas that does not experience any load.

The natural soils at site are suitable for use as structural fill. However, close control of moisture content and compactive effort is required to ensure adequate compaction.

Sand / silty sand is a suitable fill material. Alternatively, good earth should be used as fill material. Alternatively, good earth should be used as fill material. Good earth (silty sand or sandy silt of low plasticity) used as structural fill should contain less than 5 percent gravel and at least 30 percent sand sized particles. It should have a liquid limit of less than 35 percent and plasticity index material less than 8 percent. Sand may also be used as fill material.

In open areas, the fill may be placed in layers not exceeding 30 cm in thickness. In confined areas, the layer thickness should be restricted to 15 cm.

Structural fill placed in building areas and behind retaining walls should be placed at a moisture content equal to ± 1 percent of the optimum moisture content. Compaction should be done to at least 95% of the maximum dry density determined in accordance with IS: 2720 Part 7 (Standard Proctor Compaction Test).

Fill under roads should be compacted to at least 95% of the maximum dry density (Modified Proctor Compaction Test, IS: 2720 Part-8). The road may be designed on the basis of soaked CBR tests on specimen compacted to 95% of MDD.

General fill should be placed in layers not exceeding 40 to 50 cm in thickness and should be compacted adequately. It should be ensured that the fill does not settle under local traffic loads or water seepage.

Permanent slopes in areas outside constructed areas should not be steeper than 1-vertical on 2.5 horizontal. In the area adjacent to the river, adequate slope protection should be done by provision of stone riprap or geotextiles. Compaction along man-made slopes should be done to at least 90 percent of the maximum dry density (IS: 2720 Part-7).

7.2 Chemical Attack

Results of chemical test on selected soil and water samples are presented on Plate 32. The results indicate that the soils contain 0.11-0.12 percent sulphates and 0.03-0.09 percent chlorides. The groundwater contains 318-331mg / litre of sulphates and 75-102 mg / litre of chlorides. The pH value of soil is 7.5-7.9 and that of groundwater is 7.2, indicating nearly neutral condition.

IS: 456-2000 recommends that precautions should be taken against chemical degradation of concrete if

- sulphates content of the soils exceeds 0.2 percent, or
- groundwater contains more than 300 mg /litre of sulphates (SO₃).

Comparing the test results with these specified limits, the sulphate content of the groundwater is higher than the specified limit. Groundwater is encountered at about 9.4-10.1 m and is likely to influence foundation concrete. Therefore, strata at the site may be treated in **Class-2** category as described on IS: 456-2000.

The strata at the site may be treated in **Class 2** category as described on IS: 456-2000. In our opinion, groundwater is marginally aggressive to the foundation concrete.

We recommend the following measures to limit the potential for chemical attack:

1. Well should contain at least 400 kg/m³ cement. The cement content in concrete for well caps should be at least 330 kg/cm³.
2. Water cement ratio in foundation concrete should not exceed 0.50.
3. A clear concrete cover over the reinforcement steel of at least 50 mm should be provided for all foundations.
4. Concrete for well caps should be densified adequately using a vibrator so as to form a dense impervious mass.

8.0 VARIABILITY IN SUB-SURFACE CONDITIONS

Subsurface conditions encountered during construction may vary somewhat from the conditions encountered during the site investigation. In case significant variations are encountered during construction, we request to be notified so that our engineers may review the recommendations in this report in light of these variations.



Location: Intake Well
Plan of Field Investigations



- Satellite image taken from Google Earth®
- Test Locations marked as per GPS coordinates taken on site using hand-held Garmin® device
- Accuracy of hand-held GPS device generally ranges from 4-6m, and varies depending on the availability of satellite connection at the site

Location: Intake Well
Satellite Image of Site and Test Locations



Plasticity of Clay

Plasticity	Liquid Limit
Low Plastic	< 35
Medium Plastic	35 to 50
High Plastic	> 50

Plasticity Chart

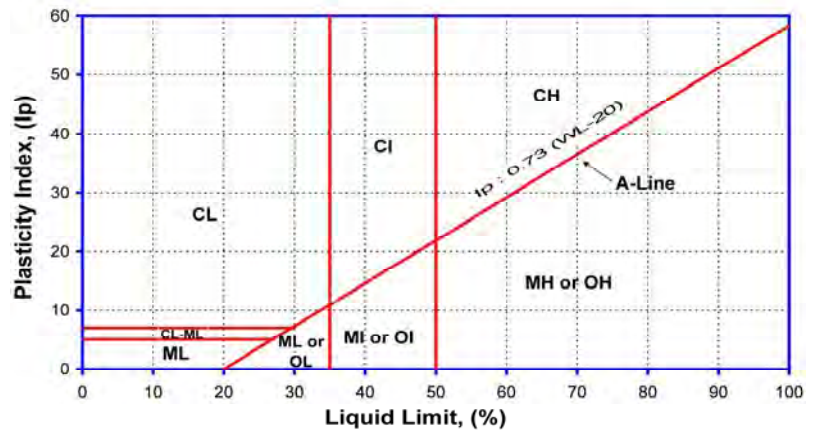

Consistency of Cohesive Soils

Consistency	Cohesion Intercept, kg/sq.cm	SPT (N) Value
Very Soft	< 0.1	0 to 2
Soft	0.1 to 0.25	2 to 4
Firm/Medium	0.25 to 0.5	4 to 8
Stiff	0.5 to 1.0	8 to 15
Very Stiff	1.0 to 2.0	15 to 30
Hard	> 2.0	> 30

Density Condition of Granular Soils

Density Descriptor	SPT (N) Value	Static Cone Tip Resistance kg/sq.cm
Very Loose	0 to 4	< 20
Loose	4 to 10	20 to 40
Medium Dense	10 to 30	40 to 120
Dense	30 to 50	120 to 200
Very dense	> 50	> 200

Degree of Expansion of Fine Grained Soils

Liquid Limit	Plasticity Index	Shrinkage Index	Free Swell Percent	Degree of Expansion	Degree of Severity
20 - 35	< 12	< 15	< 50	Low	Non-critical
35 - 50	12 - 23	15 - 30	50 - 100	Medium	Marginal
50 - 70	23 - 32	30 - 60	100 - 200	High	Critical
70 - 90	> 32	> 60	> 200	Very High	Severe

Engineering Description of Soils



NABL Accredited Laboratory

Our laboratory is accredited to **National Accreditation Board for Testing and Calibration Laboratories (NABL)**, New Delhi. The quality procedures in our laboratory conform to the International Standard **ISO/IEC: 17025-2005**.

The accreditation assures our clients of work quality in conformance with international norms and practices. It authorizes us to use the NABL logo on test results.

To maintain the necessary level of quality and reliability in all measurements on a continual basis, we indulge in the following:

- Use of calibrated equipment, regular maintenance and good housekeeping are a part of our work culture.
- Inter-laboratory comparison, proficiency testing and replicate testing, continuing education - ensure uniform quality of results.
- Internal Audit of quality procedures is done by our qualified ISO 17025 auditors to maintain the requisite standards. NABL conducts external audit.

Uncertainty

Every measurement entails an uncertainty. It is well known that no measuring instrument can determine the true value of any measurement. The cumulative effect of factors such as sensitivity of equipment, accuracy in calibration, human factors and environmental conditions will determine the overall uncertainty in the parameter determined from these measurements.

As a part of our commitment to our clients, we have worked out the uncertainty in the parameters reported by our laboratory. Although this does not form a part of our contract agreement, we present below our statistical estimate of uncertainty of various parameters based on our most recent evaluation (Feb., 2015).

Test / Parameter		Uncertainty*	Test / Parameter		Uncertainty*
Moisture Content		± 0.13 %	Free Swell Index, %		± 2.0 %
Bulk & Dry Density		± 0.0015 g/cc	Swell Pressure		± 0.43 %
Specific Gravity		± 0.014	Consolidation	c _{c1}	± 0.0003
Liquid Limit		± 0.27 %		c _{c2}	± 0.003
Plastic Limit		± 0.19 %		m _v	± 0.0003 cm ² /kg
Shrinkage Limit		± 0.30 %		p _c	± 0.15 kg/cm ²
Unconfined Compression	c	± 0.079 kg/cm ²	CD Direct Shear Test	φ	± 0.29°
UU Triaxial Test	c	± 0.42 %	Soil Gradation	Coarse grained soils	± 0.6% of particle size
	φ	± 0.2 %		Fine grained soils	± 0.5% of particle size
Std/Mod Proctor Compaction	MDD	± 0.03 g/cc	Coefficient of Permeability		± 1.3 % of value
	OMC	± 0.13 %	Rock	Crushing Strength	± 0.80 % of value
Laboratory CBR	± 0.57%	Point Load Strength Index		± 0.04 % of value	

* at 95 percent confidence level for coverage factor of 2

Uncertainty in Laboratory Measurements

Soil Profile (BH-1)

ISO/IEC 17025:2005
Certified Laboratory
(NABL)



Certificate No. T-1741

Location : Intake Well

Termination Depth : 50.17 m (RL -11.3 m) Boring Method : Shell & Auger

UTM Coordinates : 399001.29m E, 2808360.28m N

Ground Water Depth : 3.2 m Casing Depth : 49.3 m

Surface Elevation : 38.8 m

Boring Start : 01-Jul-15

Ground Water Level : 35.688 m

Boring Finish : 06-Jul-15

Depth, m		Sample No.	SPT ⁽¹⁾		Symbol	SOIL DESCRIPTION	Depth of Strata, (m)	Grain Size Analysis				Silt Factor	Atterberg Limits			Density and Moisture			Specific Gravity	Shear Tests									
From	To		Field Value, N _r	Corrected Value, N _r				Gravel (%)	Sand (%)	Silt (%)	Clay (%)		Liquid (%)	Plastic (%)	Plasticity Index (%)	Bulk Density (gms/cm ³)	Dry Density (gms/cm ³)	Moisture Content (%)		Type of Test	Confining Pressures, (kg/cm ²)	Cohesion Intercept, 'c' (kg/cm ²)	Angle of Internal Friction, φ (degrees)						
0.00	0.50	DS1				Firm brown grey clayey silt, medium plastic (CI)																							
0.50	1.00	DS2					1.00	0	4	96	2.89	39.6	23.1	16.5															
1.00	1.45	SPT1	5	7		Loose to dense grey fine sand (SP)																							
2.00	2.45	SPT2	9	11		- loose, 1.0 to 5.0 m																							
3.00	3.30	UDS1						0	97	3	0	0.82			1.86	1.49	25.3				DS	0.5 ,1, 1.5	0.0	31.1					
4.00	4.45	SPT3	9	10																									
5.00	5.45	SPT4	33	36		- dense, 5.0 to 7.0 m																							
6.00	6.45	SPT5	42	45																									
7.00	7.45	SPT6	4	4		- loose, 7.0 to 8.0 m	8.00																						
8.00	8.45	SPT7	14	14		Medium dense grey silty fine sand (SM)		0	57	40	3	0.56																	
9.00	9.45	SPT8	30	30																									
10.00	10.45	SPT9	30	29			11.00																						

⁽¹⁾ SPT is outside NABL scope.

ISO/IEC 17025:2005
Certified Laboratory
(NABL)



Certificate No. T-1741

Soil Profile (BH-1)

Location :	Intake Well	Termination Depth :	50.17 m (RL -11.3 m)	Boring Method :	Shell & Auger
UTM Coordinates :	399001.29m E, 2808360.28m N	Ground Water Depth :	3.2 m	Casing Depth :	49.3 m
		Surface Elevation :	38.8 m	Boring Start :	01-Jul-15
		Ground Water Level :	35.688 m	Boring Finish :	06-Jul-15

Depth, m		SPT (1)	SOIL DESCRIPTION	Depth of Strata, (m)	Grain Size Analysis					Atterberg Limits			Density and Moisture			Specific Gravity	Shear Tests						
From	To				Sample No.	Field Value, N _r	Corrected Value, N _c	Symbol	Gravel (%)	Sand (%)	Silt (%)	Clay (%)	Silt Factor	Liquid (%)	Plastic (%)		Plasticity Index (%)	Bulk Density (gms/cm ³)	Dry Density (gms/cm ³)	Moisture Content (%)	Type of Test	Confining Pressures, (kg/cm ²)	Cohesion Intercept, 'c' (kg/cm ²)
23.00	23.45	SPT22	56	41	Very dense grey fine sand (SP)																		
24.00	24.45	SPT23	55	40																			
25.00	25.45	SPT24	62	44																			
26.00	26.45	SPT25	59	41		0	97	3	0	0.99													
27.00	27.45	SPT26	73	50																			
28.00	28.45	SPT27	86	58																			
29.00	29.45	SPT28	102	68																			
30.00	30.45	SPT29	101	66																			
31.00	31.40	SPT30	101/ 25cm	101/ 25cm																			
32.00	32.41	SPT31	101/ 26cm	101/ 26cm																			
33.00	33.38	SPT32	102/ 23cm	102/ 23cm																			
34.00	34.37	SPT33	103/ 22cm	103/ 22cm																			

(1) SPT is outside NABL scope.



Soil Profile (BH-1)

Location : Intake Well Termination Depth : 50.17 m (RL -11.3 m) Boring Method : Shell & Auger
 UTM Coordinates : 399001.29m E, 2808360.28m N Ground Water Depth : 3.2 m Casing Depth : 49.3 m
 Surface Elevation : 38.8 m Boring Start : 01-Jul-15
 Ground Water Level : 35.688 m Boring Finish : 06-Jul-15

Depth, m		SPT (1)	SOIL DESCRIPTION	Depth of Strata, (m)	Grain Size Analysis				Silt Factor	Atterberg Limits			Density and Moisture			Specific Gravity	Shear Tests				
From	To				Sample No.	Field Value, N _r	Corrected Value, N _c	Symbol		Gravel (%)	Sand (%)	Silt (%)	Clay (%)	Liquid (%)	Plastic (%)		Plasticity Index (%)	Bulk Density (gms/cm ³)	Dry Density (gms/cm ³)	Moisture Content (%)	Type of Test
35.00	35.35	SPT34	101/20cm	101/20cm	Very dense grey fine sand (SP)	0	96	4	0	0.78											
36.00	36.34	SPT35	101/19cm	101/19cm																	
37.00	37.32	SPT36	101/17cm	101/17cm																	
38.00	38.20	SPT37	101/5cm	101/5cm																	
39.00	39.17	SPT38	100/2cm	100/2cm																	
40.00	40.14	SPT39	Ref*/14cm	Ref*/14cm																	
41.00	41.16	SPT40	100/1cm	100/1cm																	
42.00	42.15	SPT41	Ref*/15cm	Ref*/15cm																	
43.00	43.17	SPT42	101/2cm	101/2cm																	
44.00	44.17	SPT43	102/2cm	102/2cm																	
45.00	45.34	SPT44	101/19cm	101/19cm																	
46.00	46.32	SPT45	102/17cm	102/17cm																	

(1) SPT is outside NABL scope.

Soil Profile (BH-2)

ISO/IEC 17025:2005
Certified Laboratory
(NABL)



Certificate No. T-1741

Location : Intake Well

UTM Coordinates : 399026.35m E, 2808311.37m N

Termination Depth : 50.18 m (RL -11.9 m) Boring Method : Shell & Auger

Ground Water Depth : 3.1 m Casing Depth : 49.3 m

Surface Elevation : 38.2 m Boring Start : 08-Jul-15

Ground Water Level : 35.161 m Boring Finish : 11-Jul-15

Depth, m		SPT ⁽¹⁾	SOIL DESCRIPTION				Grain Size Analysis					Atterberg Limits			Density and Moisture			Shear Tests						
From	To						Sample No.	Field Value, N _r	Corrected Value, N _r	Symbol	Depth of Strata, (m)	Gravel (%)	Sand (%)	Silt (%)	Clay (%)	Silt Factor	Liquid (%)	Plastic (%)	Plasticity Index (%)	Bulk Density (gms/cm ³)	Dry Density (gms/cm ³)	Moisture Content (%)	Specific Gravity	Type of Test
11.50	11.95	SPT10	14	13																				
12.50	12.95	SPT11	16	15																				
13.50	13.95	SPT12	21	19				0	95	5	0	1.06												
14.50	14.95	SPT13	21	18																				
15.50	15.95	SPT14	23	20																				
16.50	16.95	SPT15	28	24																				
17.50	17.95	SPT16	32	26																				
18.50	18.95	SPT17	35	28																				
19.50	19.95	SPT18	40	32				4	88	8	0	1.53												
20.50	20.95	SPT19	47	37																				
21.50	21.95	SPT20	47	36																				
22.50	22.95	SPT21	53	40																				

⁽¹⁾ SPT is outside NABL scope.

Soil Profile (BH-2)

ISO/IEC 17025:2005
Certified Laboratory
(NABL)



Certificate No. T-1741

Location : Intake Well

UTM Coordinates : 399026.35m E, 2808311.37m N

Termination Depth : 50.18 m (RL -11.9 m) Boring Method : Shell & Auger

Ground Water Depth : 3.1 m Casing Depth : 49.3 m

Surface Elevation : 38.2 m Boring Start : 08-Jul-15

Ground Water Level : 35.161 m Boring Finish : 11-Jul-15

Depth, m		SPT (1)	SOIL DESCRIPTION			Grain Size Analysis					Atterberg Limits			Density and Moisture			Specific Gravity	Shear Tests						
From	To					Sample No.	Field Value, N _r	Corrected Value, N _r	Symbol	Depth of Strata, (m)	Gravel (%)	Sand (%)	Silt (%)	Clay (%)	Silt Factor	Liquid (%)		Plastic (%)	Plasticity Index (%)	Bulk Density (gms/cm ³)	Dry Density (gms/cm ³)	Moisture Content (%)	Type of Test	Confining Pressures, (kg/cm ²)
23.50	23.95	SPT22	56	41	Very dense grey fine sand (SP-SM)																			
24.50	24.95	SPT23	59	43																				
25.50	25.95	SPT24	62	44			0	93	7	0	1.09													
26.50	26.95	SPT25	68	47																				
27.50	27.95	SPT26	75	51																				
28.50	28.95	SPT27	75	50																				
29.50	29.95	SPT28	101	67																				
30.50	30.95	SPT29	101	66																				
31.50	31.89	SPT30	101/ 24cm	101/ 24cm																				
32.50	32.87	SPT31	101/ 22cm	101/ 22cm																				
33.50	33.84	SPT32	101/ 19cm	101/ 19cm	- SP, 33.5 to 35.5 m																			
34.50	34.82	SPT33	101/ 17cm	101/ 17cm			0	96	4	0	0.90													

(1) SPT is outside NABL scope.

ISO/IEC 17025:2005
Certified Laboratory
(NABL)



Certificate No. T-1741

Soil Profile (BH-2)

Location :	Intake Well	Termination Depth :	50.18 m (RL -11.9 m)	Boring Method :	Shell & Auger
UTM Coordinates :	399026.35m E, 2808311.37m N	Ground Water Depth :	3.1 m	Casing Depth :	49.3 m
		Surface Elevation :	38.2 m	Boring Start :	08-Jul-15
		Ground Water Level :	35.161 m	Boring Finish :	11-Jul-15

Depth, m		SPT ⁽¹⁾	SOIL DESCRIPTION	Depth of Strata, (m)	Grain Size Analysis				Silt Factor	Atterberg Limits			Density and Moisture			Specific Gravity	Shear Tests					
From	To				Sample No.	Field Value, N _r	Corrected Value, N _r	Symbol		Gravel (%)	Sand (%)	Silt (%)	Clay (%)	Liquid (%)	Plastic (%)		Plasticity Index (%)	Bulk Density (gms/cm ³)	Dry Density (gms/cm ³)	Moisture Content (%)	Type of Test	Confining Pressures, (kg/cm ²)
35.50	35.80	SPT34	101/15cm	101/15cm	Very dense grey fine sand (SP)																	
36.50	36.77	SPT35	102/12cm	102/12cm																		
37.50	37.70	SPT36	100/5cm	100/5cm																		
38.50	38.67	SPT37	101/2cm	101/2cm																		
39.50	39.66	SPT38	101/1cm	101/1cm																		
40.50	40.65	SPT39	Ref*/7cm	Ref*/7cm																		
41.50	41.63	SPT40	Ref*/13cm	Ref*/13cm																		
42.50	42.59	SPT41	Ref*/9cm	Ref*/9cm																		
43.50	43.57	SPT42	Ref*/7cm	Ref*/7cm																		
44.50	44.83	SPT43	101/18cm	101/18cm																		
45.50	45.83	SPT44	101/18cm	101/18cm																		
46.50	46.82	SPT45	102/17cm	102/17cm																		

⁽¹⁾ SPT is outside NABL scope.

ISO/IEC 17025:2005
Certified Laboratory
(NABL)



Certificate No. T-1741

Soil Profile (BH-2)

Location :	Intake Well	Termination Depth :	50.18 m (RL -11.9 m)	Boring Method :	Shell & Auger
UTM Coordinates :	399026.35m E, 2808311.37m N	Ground Water Depth :	3.1 m	Casing Depth :	49.3 m
		Surface Elevation :	38.2 m	Boring Start :	08-Jul-15
		Ground Water Level :	35.161 m	Boring Finish :	11-Jul-15

Depth, m		SPT ⁽¹⁾	SOIL DESCRIPTION	Depth of Strata, (m)	Grain Size Analysis					Atterberg Limits			Density and Moisture			Shear Tests							
From	To				Sample No.	Field Value, N _r	Corrected Value, N _c	Symbol	Gravel (%)	Sand (%)	Silt (%)	Clay (%)	Silt Factor	Liquid (%)	Plastic (%)	Plasticity Index (%)	Bulk Density (gms/cm ³)	Dry Density (gms/cm ³)	Moisture Content (%)	Specific Gravity	Type of Test	Confining Pressures, (kg/cm ²)	Cohesion Intercept, 'c' (kg/cm ²)
47.50	47.78	SPT46	101/13cm	101/13cm	Very dense grey fine sand (SP-SM)	50.18	0	95	5	0	1.06												
48.50	48.75	SPT47	101/20cm	101/20cm																			
49.50	49.72	SPT48	102/17cm	102/17cm																			
50.00	50.18	SPT49	101/3cm	101/3cm																			

⁽¹⁾ SPT is outside NABL scope.

Soil Profile (BH-3)

Location : Intake Well Termination Depth : 50.2 m (RL -12 m) Boring Method : Shell & Auger
 UTM Coordinates : 399055.13m E, 2808256.66m N Ground Water Depth : 3.0 m Casing Depth : 49.5 m
 Surface Elevation : 38.2 m Boring Start : 13-Jul-15
 Ground Water Level : 35.296 m Boring Finish : 15-Jul-15

ISO/IEC 17025:2005
Certified Laboratory
(NABL)



Certificate No. T-1741

Depth, m		SPT ⁽¹⁾	Symbol	SOIL DESCRIPTION	Depth of Strata, (m)	Grain Size Analysis				Silt Factor	Atterberg Limits			Density and Moisture			Specific Gravity	Shear Tests			
From	To					Field Value, N _r	Corrected Value, N _r	Gravel (%)	Sand (%)		Silt (%)	Clay (%)	Liquid (%)	Plastic (%)	Plasticity Index (%)	Bulk Density (gms/cm ³)		Dry Density (gms/cm ³)	Moisture Content (%)	Type of Test	Confining Pressures, (kg/cm ²)
23.00	23.45	SPT22	63 47	Very dens grey fine san (SP)		0	98	2	0	0.91											
24.00	24.45	SPT23	70 51																		
25.00	25.45	SPT24	66 47																		
26.00	26.45	SPT25	66 46																		
27.00	27.45	SPT26	69 48																		
28.00	28.45	SPT27	80 54																		
29.00	29.45	SPT28	91 61																		
30.00	30.45	SPT29	102 67																		
31.00	31.42	SPT30	101/ 101/ 27cm 27cm																		
32.00	32.40	SPT31	101/ 101/ 25cm 25cm																		
33.00	33.37	SPT32	101/ 101/ 22cm 22cm																		
34.00	34.36	SPT33	101/ 101/ 21cm 21cm																		

⁽¹⁾ SPT is outside NABL scope.

ISO/IEC 17025:2005
Certified Laboratory
(NABL)



Certificate No. T-1741

Soil Profile (BH-3)

Location :	Intake Well	Termination Depth :	50.2 m (RL -12 m)	Boring Method :	Shell & Auger
UTM Coordinates :	399055.13m E, 2808256.66m N	Ground Water Depth :	3.0 m	Casing Depth :	49.5 m
		Surface Elevation :	38.2 m	Boring Start :	13-Jul-15
		Ground Water Level :	35.296 m	Boring Finish :	15-Jul-15

Depth, m		SPT ⁽¹⁾	Symbol	SOIL DESCRIPTION	Depth of Strata, (m)	Grain Size Analysis				Silt Factor	Atterberg Limits			Density and Moisture			Specific Gravity	Shear Tests			
From	To					Sample No.	Field Value, N _r	Corrected Value, N"	Gravel (%)		Sand (%)	Silt (%)	Clay (%)	Liquid (%)	Plastic (%)	Plasticity Index (%)		Bulk Density (gms/cm ³)	Dry Density (gms/cm ³)	Moisture Content (%)	Type of Test
35.00	35.33	SPT34	101/18cm	101/18cm																	
36.00	36.30	SPT35	102/15cm	102/15cm		1	94	5	0	1.15											
37.00	37.27	SPT36	101/12cm	101/12cm																	
38.00	38.25	SPT37	101/10cm	101/10cm																	
39.00	39.23	SPT38	101/8cm	101/8cm																	
40.00	40.23	SPT39	101/8cm	101/8cm																	
41.00	41.20	SPT40	101/5cm	101/5cm																	
42.00	42.17	SPT41	101/2cm	101/2cm																	
43.00	43.13	SPT42	Ref*/13cm	Ref*/13cm																	
44.00	44.10	SPT43	Ref*/10cm	Ref*/10cm																	
45.00	45.08	SPT44	Ref*/8cm	Ref*/8cm																	
46.00	46.43	SPT45	101/28cm	101/28cm																	

⁽¹⁾ SPT is outside NABL scope.

ISO/IEC 17025:2005
Certified Laboratory
(NABL)



Certificate No. T-1741

Soil Profile (BH-3)

Location :	Intake Well	Termination Depth :	50.2 m (RL -12 m)	Boring Method :	Shell & Auger
UTM Coordinates :	399055.13m E, 2808256.66m N	Ground Water Depth :	3.0 m	Casing Depth :	49.5 m
		Surface Elevation :	38.2 m	Boring Start :	13-Jul-15
		Ground Water Level :	35.296 m	Boring Finish :	15-Jul-15

Depth, m		SPT ⁽¹⁾	Symbol	SOIL DESCRIPTION	Depth of Strata, (m)	Grain Size Analysis				Silt Factor	Atterberg Limits			Density and Moisture			Specific Gravity	Shear Tests			
From	To					Sample No.	Field Value, N _r	Corrected Value, N _r	Gravel (%)		Sand (%)	Silt (%)	Clay (%)	Liquid (%)	Plastic (%)	Plasticity Index (%)		Bulk Density (gms/cm ³)	Dry Density (gms/cm ³)	Moisture Content (%)	Type of Test
47.00	47.40	SPT46	101/25cm	101/25cm	50.20	0	98	2	0	1.13											
48.00	48.36	SPT47	101/21cm	101/21cm																	
49.00	49.32	SPT48	101/17cm	101/17cm																	
50.00	50.20	SPT49	101/5cm	101/5cm																	

⁽¹⁾ SPT is outside NABL scope.

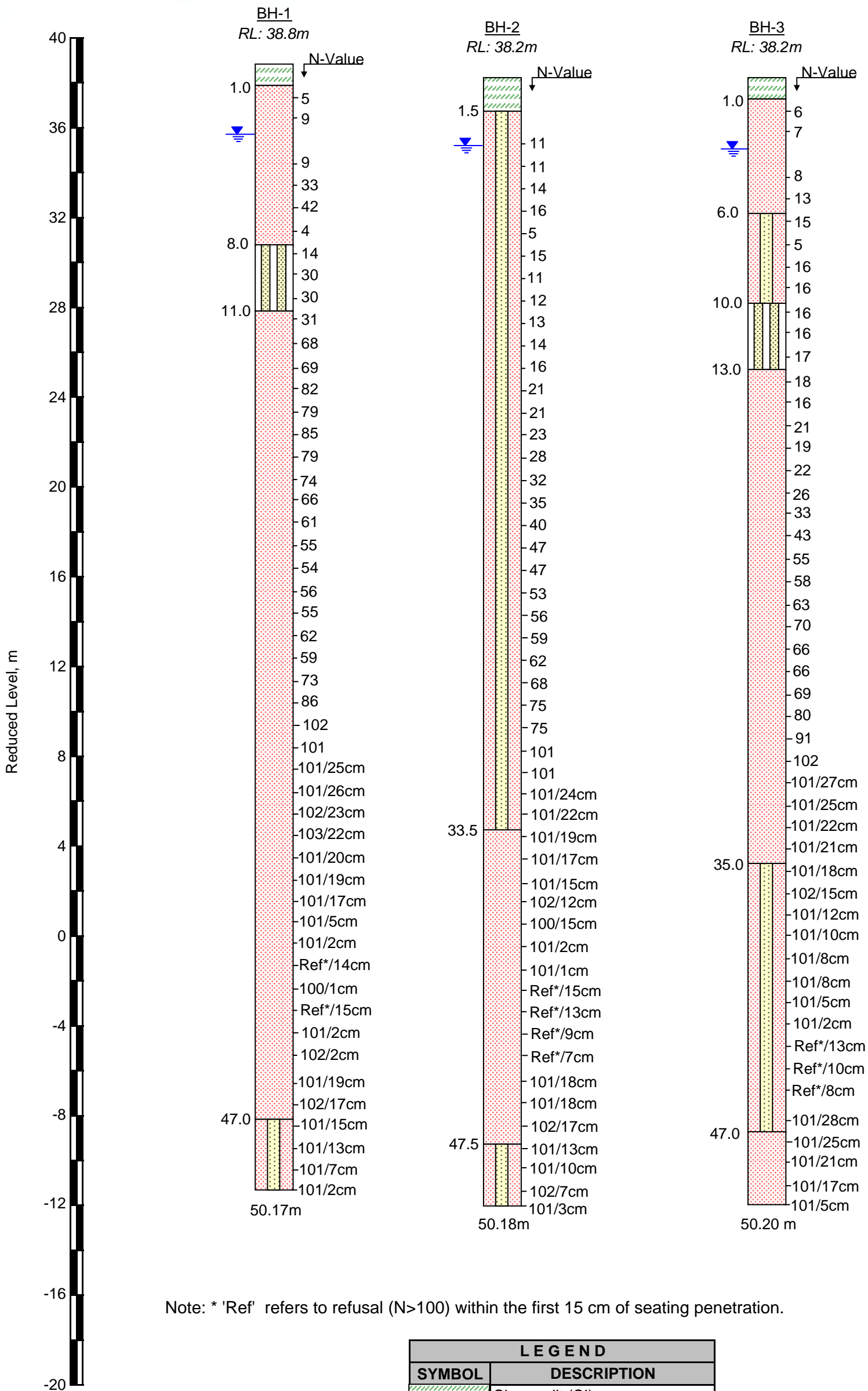

LEGEND	
SYMBOL	DESCRIPTION
	Clayey silt (CI)
	Silty sand (SM)
	Fine sand (SP-SM)
	Fine sand (SP)
	Water table

Location: Intake Well

Summary of Borehole Profiles



Standard Penetration Test

IS : 2131-1981, RA-2007

Borehole Details			
Symbol	Borehole Number	Reduced Level,m	Location
○	BH-1	38.8	Intake Well
●	BH-2	38.2	
△	BH-3	38.2	

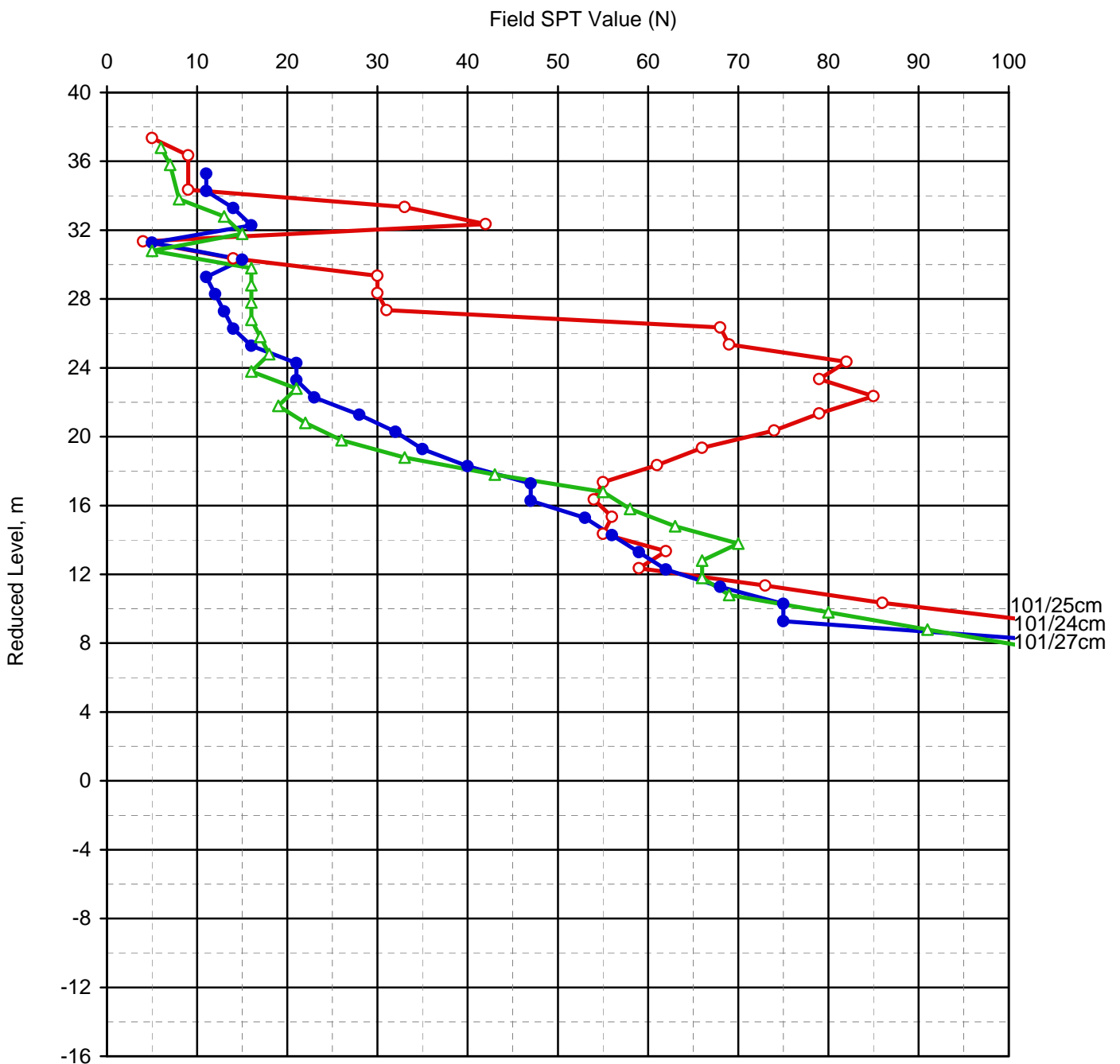

Field SPT Values versus Reduced Level



Standard Penetration Test

IS : 2131-1981, RA-2007

Borehole Details			
Symbol	Borehole Number	Reduced Level,m	Location
○	BH-1	38.8	Intake Well
●	BH-2	38.2	
△	BH-3	38.2	

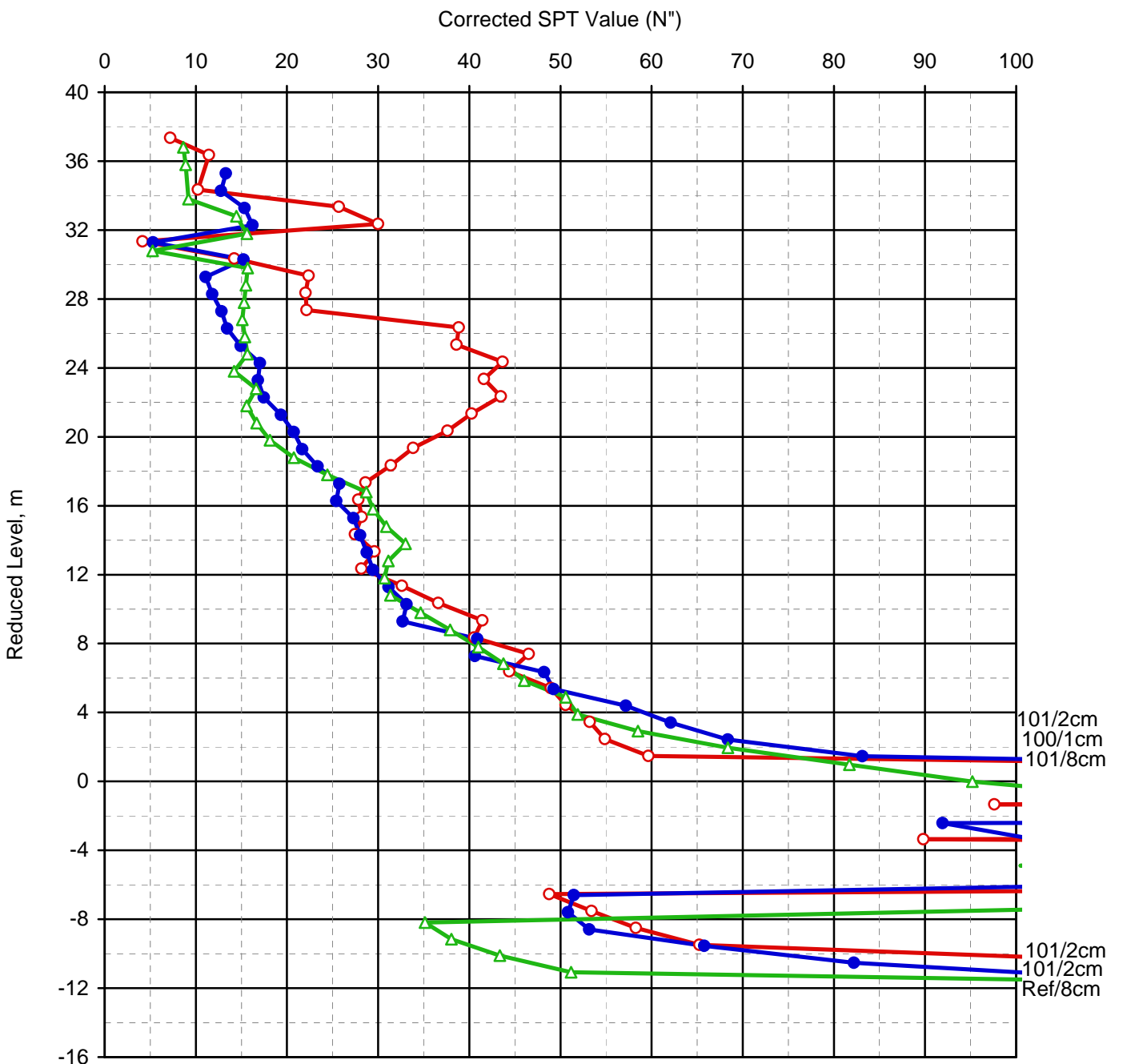

Corrected SPT Values versus Reduced Level

Grain Size Analysis

IS : 2720 (Part 4) - 1985, RA-2010

Sample Details			Test Results								
Borehole Number	Sample Depth, m	Sample Description	% Gravel	% Sand	% Silt	% Clay	D ₆₀	D ₃₀	D ₁₀	C _u	C _c
BH-1	0.50	Clayey silt (CI)	0	4	96		0.047	0.023			
BH-1	3.00	Fine sand (SP)	0	97	3	0	0.236	0.184	0.145	1.6	0.99
BH-1	8.00	Silty fine sand (SM)	0	57	40	3	0.107	0.039	0.015	7.1	0.95
BH-1	13.00	Fine sand (SP)	0	98	2	0	0.392	0.252	0.171	2.3	0.95
BH-1	19.00	Fine sand with traces of gravel (SP)	2	95	3	0	0.275	0.201	0.151	1.8	0.97

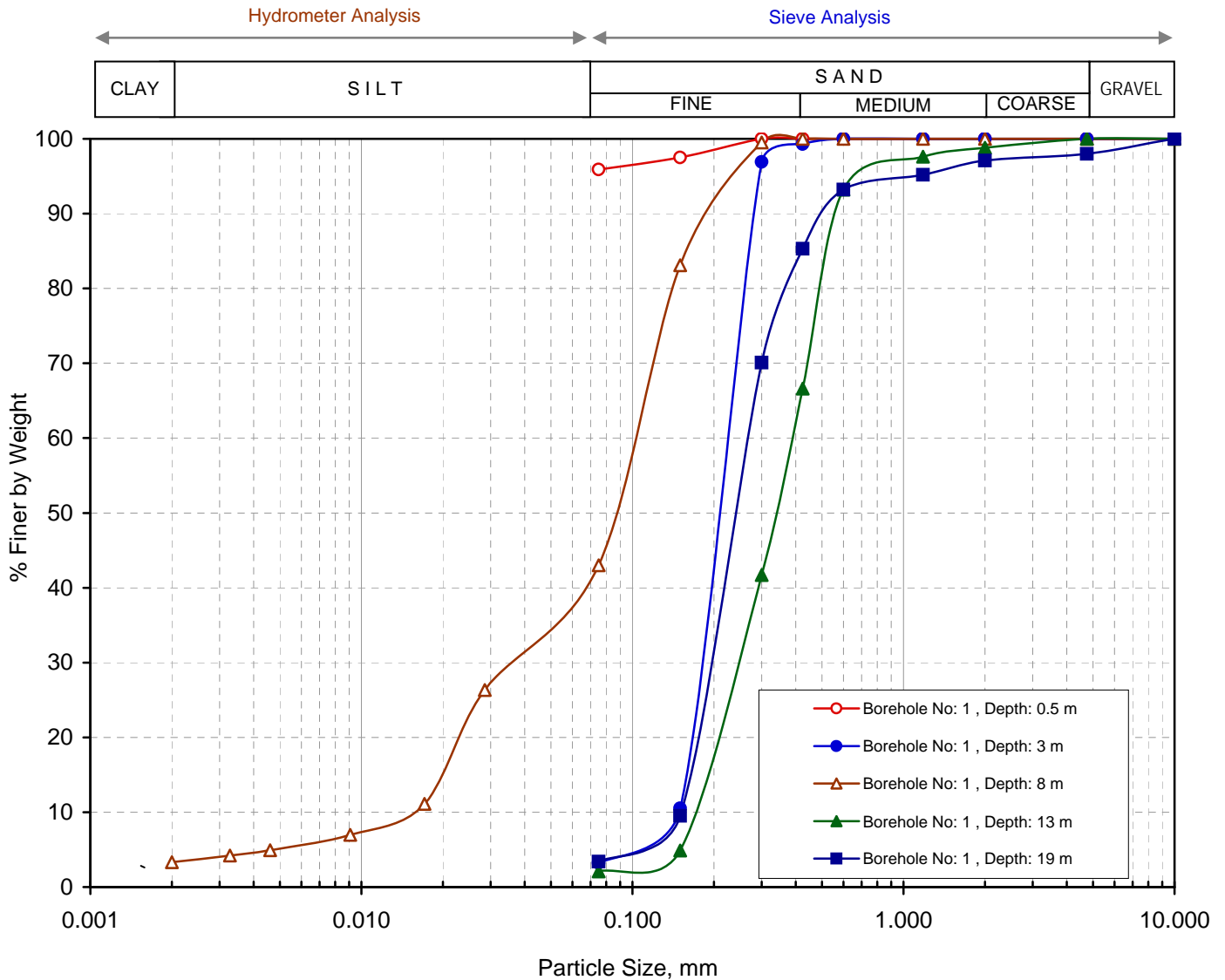

Grain Size Distribution Curve



Grain Size Analysis

IS : 2720 (Part 4) - 1985, RA-2010

Sample Details			Test Results								
Borehole Number	Sample Depth, m	Sample Description	% Gravel	% Sand	% Silt	% Clay	D ₆₀	D ₃₀	D ₁₀	C _u	C _c
BH-1	26.00	Fine sand (SP)	0	97	3	0	0.272	0.202	0.155	1.8	0.97
BH-1	35.00	Fine sand (SP)	0	96	4	0	0.223	0.164	0.099	2.3	1.22
BH-1	48.00	Fine sand (SP-SM)	0	95	5	0	0.366	0.233	0.152	2.4	0.98

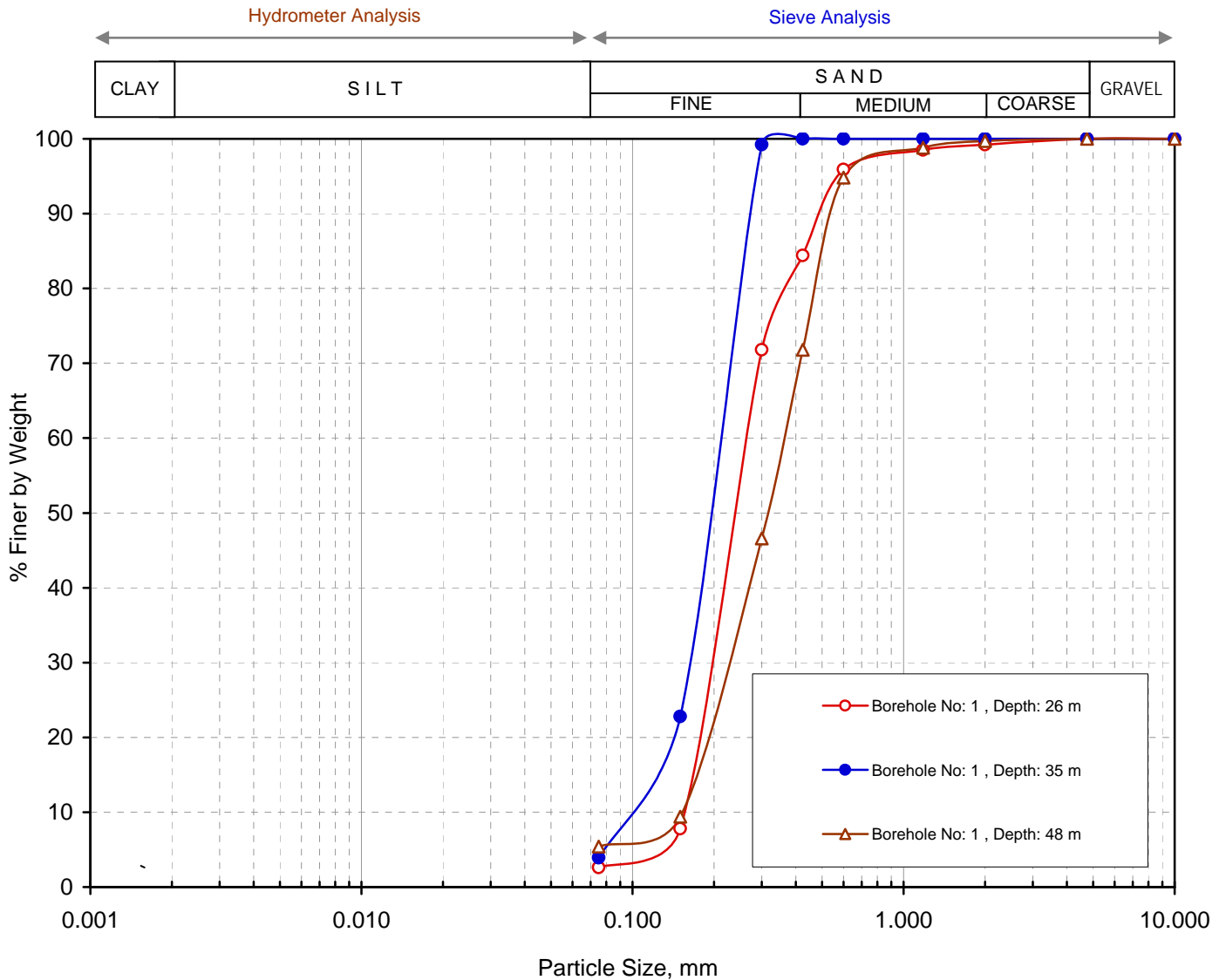

Grain Size Distribution Curve

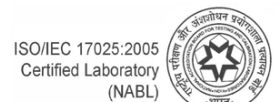

Certificate No. T-1741



Grain Size Analysis

IS : 2720 (Part 4) - 1985, RA-2010

Sample Details			Test Results								
Borehole Number	Sample Depth, m	Sample Description	% Gravel	% Sand	% Silt	% Clay	D ₆₀	D ₃₀	D ₁₀	C _u	C _c
BH-2	0.50	Clayey silt (CI)	0	5	95		0.047	0.024			
BH-2	4.50	Fine sand (SP-SM)	0	88	12	0	0.225	0.164			
BH-2	8.50	Fine sand (SP-SM)	0	92	8	0	0.228	0.166	0.085	2.7	1.42
BH-2	13.50	Fine sand (SP-SM)	0	95	5	0	0.366	0.233	0.152	2.4	0.98
BH-2	19.50	Fine sand with traces of gravel (SP-SM)	4	88	8	0	0.377	0.221	0.137	2.8	0.95

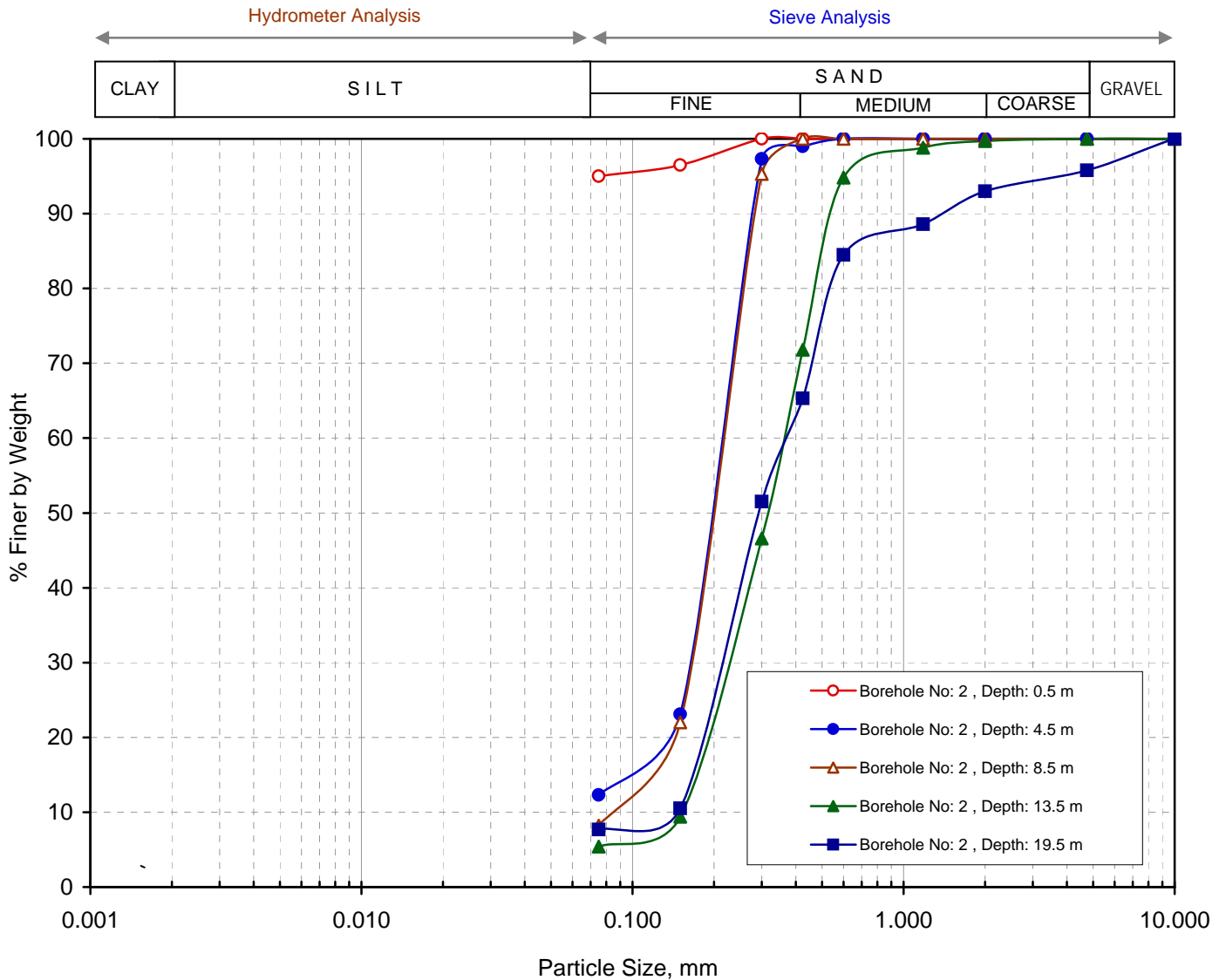

Grain Size Distribution Curve

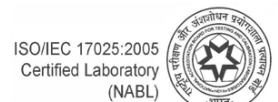

ISO/IEC 17025:2005
Certified Laboratory
(NABL)

Certificate No. T-1741



Grain Size Analysis

IS : 2720 (Part 4) - 1985, RA-2010

Sample Details			Test Results								
Borehole Number	Sample Depth, m	Sample Description	% Gravel	% Sand	% Silt	% Clay	D ₆₀	D ₃₀	D ₁₀	C _u	C _c
BH-2	25.50	Fine sand (SP-SM)	0	93	7	0	0.300	0.207	0.128	2.3	1.12
BH-2	33.50	Fine sand (SP)	0	96	4	0	0.251	0.186	0.123	2.0	1.12
BH-2	47.50	Fine sand (SP-SM)	0	95	5	0	0.366	0.233	0.152	2.4	0.98

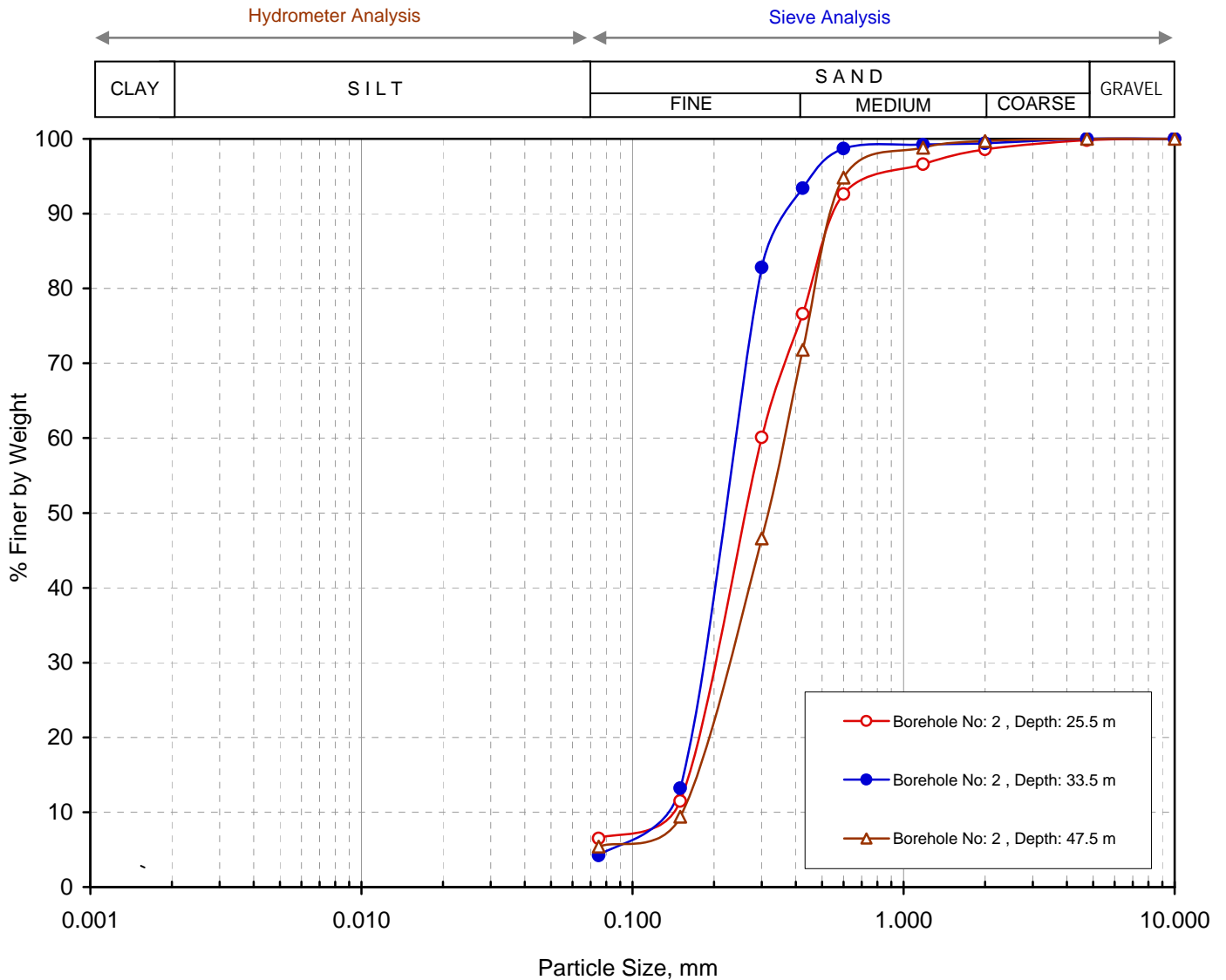

Grain Size Distribution Curve

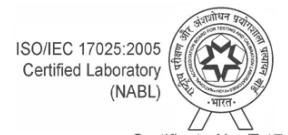



Grain Size Analysis

IS : 2720 (Part 4) - 1985, RA-2010

Sample Details			Test Results								
Borehole Number	Sample Depth, m	Sample Description	% Gravel	% Sand	% Silt	% Clay	D ₆₀	D ₃₀	D ₁₀	C _u	C _c
BH-3	0.50	Clayey silt (CI)	0	21	52	27	0.007	0.003			
BH-3	2.00	Fine sand (SP)	0	97	3	0	0.223	0.165	0.102	2.2	1.20
BH-3	6.00	Fine sand (SP-SM)	0	91	9	0	0.231	0.169	0.082	2.8	1.51
BH-3	10.00	Silty fine sand (SM)	0	61	36	3	0.115	0.053	0.019	6.1	1.29
BH-3	18.00	Fine sand (SP)	0	96	4	0	0.252	0.188	0.129	2.0	1.09

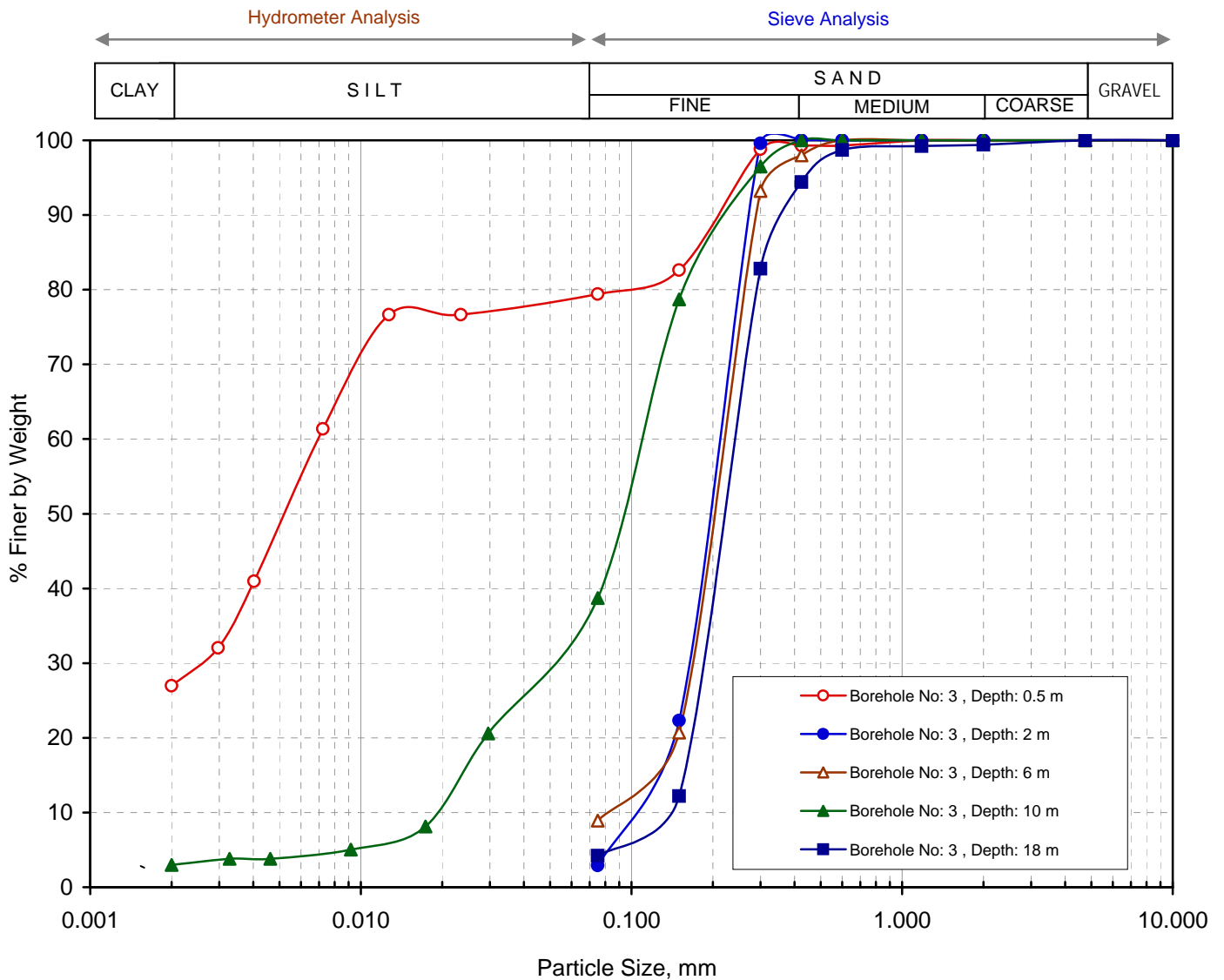

Grain Size Distribution Curve





Grain Size Analysis

IS : 2720 (Part 4) - 1985, RA-2010

Sample Details			Test Results								
Borehole Number	Sample Depth, m	Sample Description	% Gravel	% Sand	% Silt	% Clay	D ₆₀	D ₃₀	D ₁₀	C _u	C _c
BH-3	23.00	Fine sand (SP)	0	98	2	0	0.263	0.203	0.163	1.6	0.96
BH-3	36.00	Fine sand with traces of gravel (SP-SM)	1	94	5	0	0.370	0.235	0.155	2.4	0.96
BH-3	47.00	Fine sand (SP)	0	98	2	0	0.392	0.252	0.171	2.3	0.95

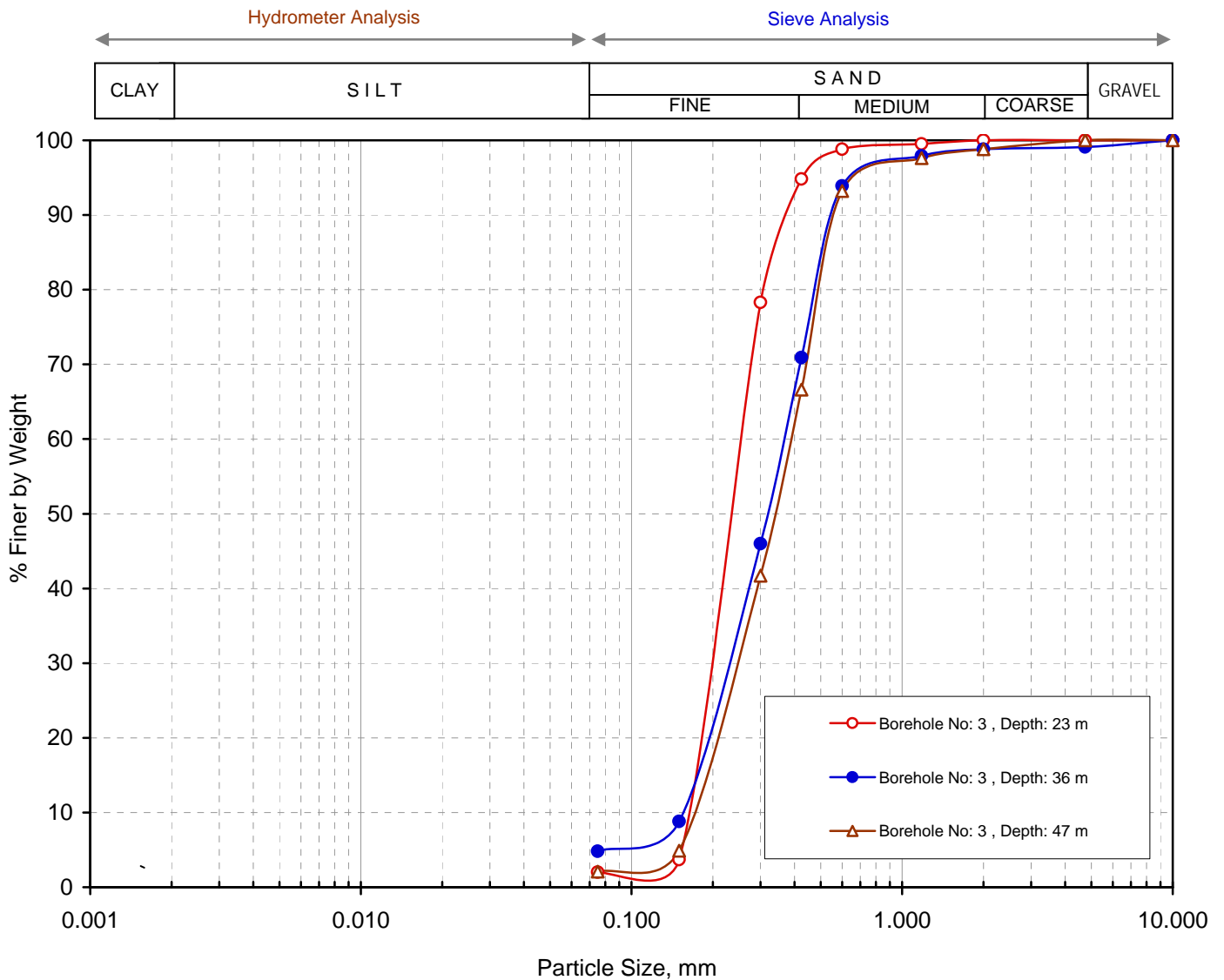

Grain Size Distribution Curve





Drained Direct Shear Test

IS : 2720 (Part-13)-1986, RA-2010

Sample Details	Borehole No.: BH-1	Sample Depth: 3 m
	Sample No.: UDS1	Sample Description: Fine sand
	Type of Sample:	Remoulded
	Dry Density of Soil (g/cm ³):	1.49
Test Results	Moisture Content (%):	Saturated
	Cohesion Intercept, c :	0.00 kg/cm²
	Angle of Internal Friction, ϕ :	31.1 degrees

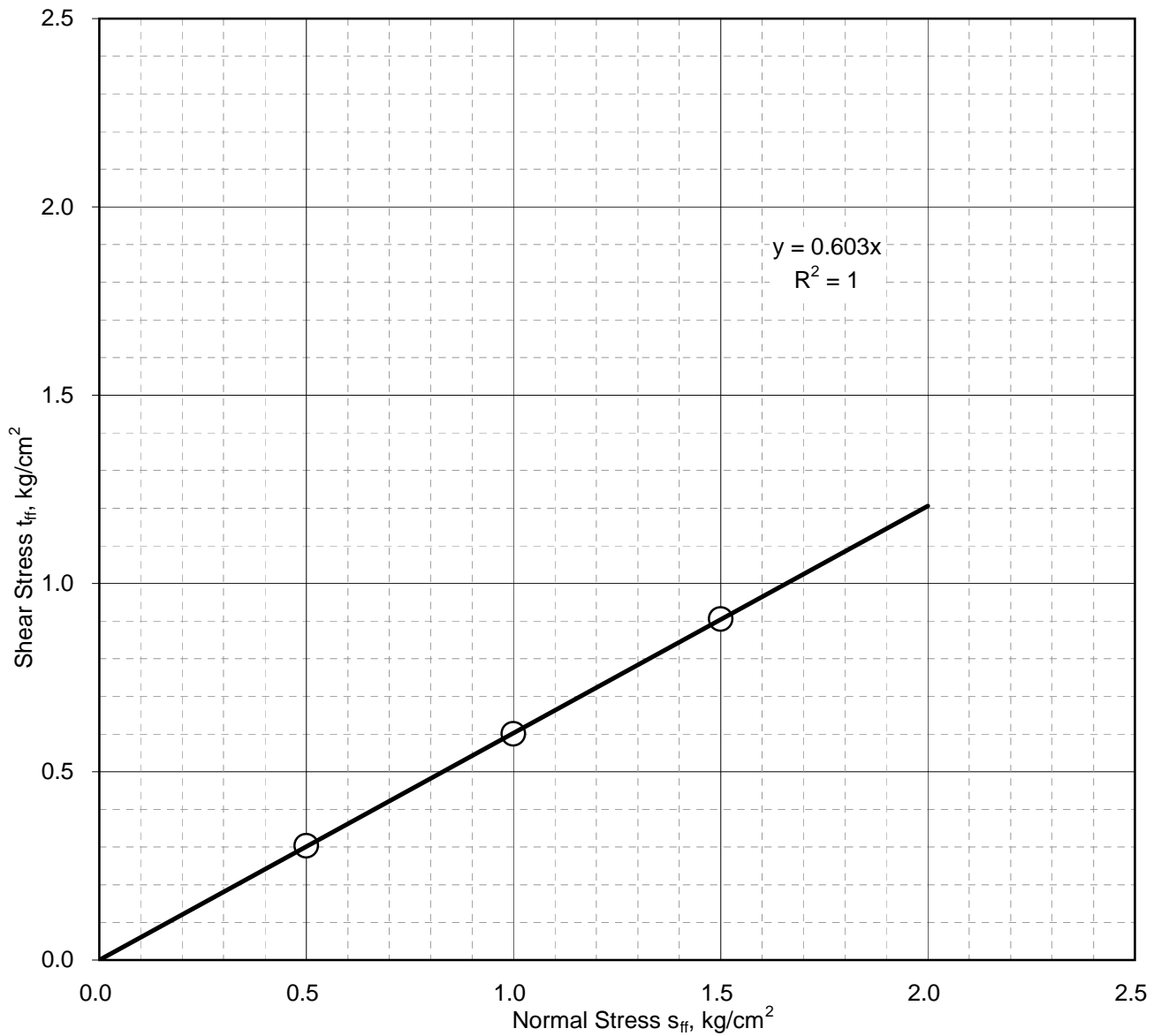

Mohr-Coulomb Failure Envelope

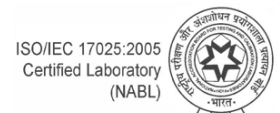

ISO/IEC 17025:2005
Certified Laboratory
(NABL)

Certificate No. T-1741



Drained Direct Shear Test

IS : 2720 (Part-13)-1986, RA-2010

Sample Details	Borehole No.: BH-2	Sample Depth: 1.5 m
	Sample No.: UDS1	Sample Description: Fine sand
	Type of Sample:	Remoulded
	Dry Density of Soil (g/cm ³):	1.60
Test Results	Moisture Content (%):	Saturated
	Cohesion Intercept, c :	0.00 kg/cm²
	Angle of Internal Friction, ϕ :	30.5 degrees

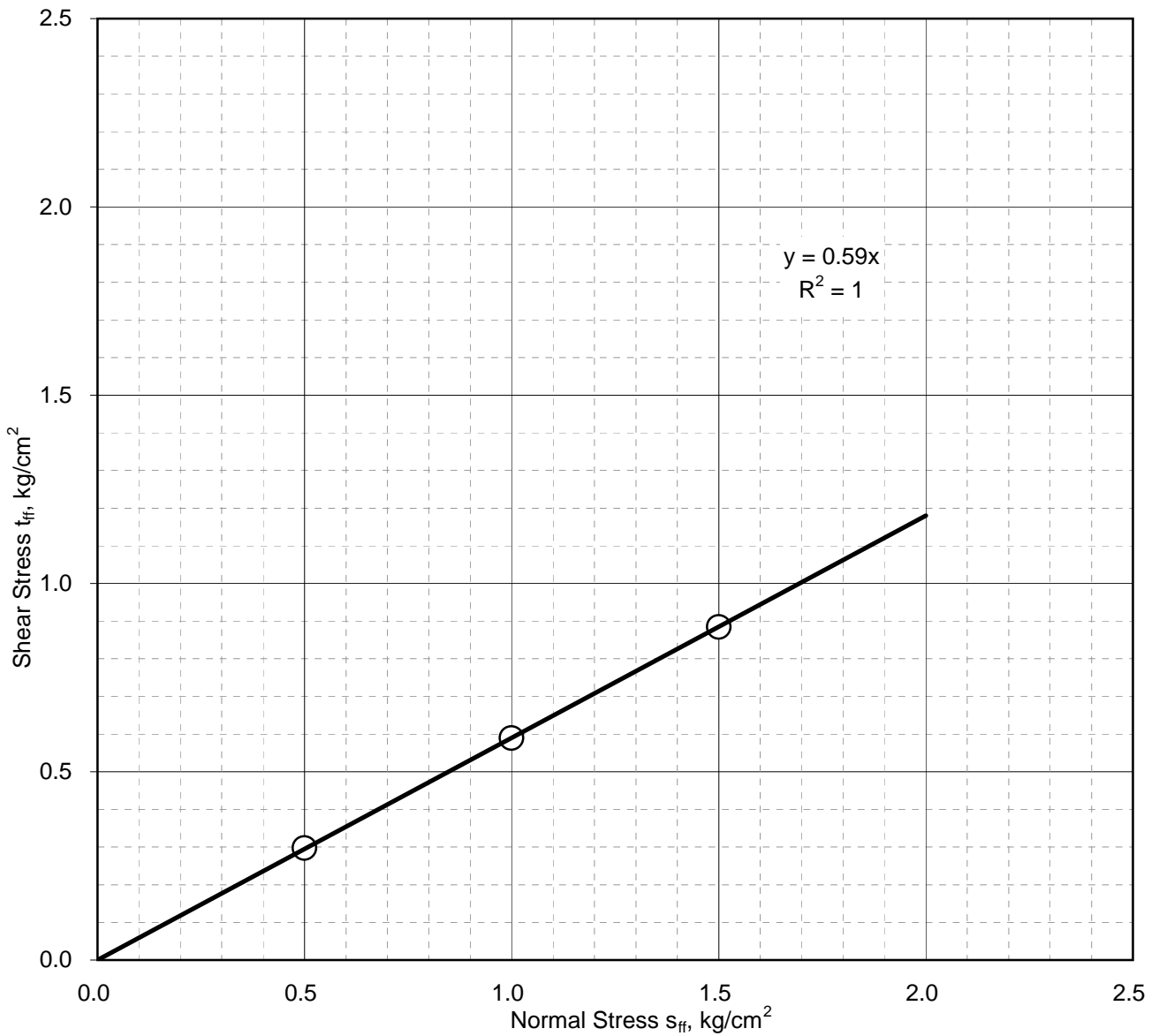

Mohr-Coulomb Failure Envelope

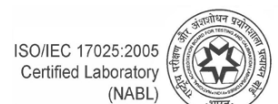

ISO/IEC 17025:2005
Certified Laboratory
(NABL)

Certificate No. T-1741



Drained Direct Shear Test

IS : 2720 (Part-13)-1986, RA-2010

Sample Details	Borehole No.: BH-3	Sample Depth: 3 m
	Sample No.: UDS1	Sample Description: Silty Fine Sand
	Type of Sample:	Remoulded
	Dry Density of Soil (g/cm ³):	1.49
Test Results	Moisture Content (%):	Saturated
	Cohesion Intercept, c :	0.00 kg/cm²
	Angle of Internal Friction, ϕ :	31.9 degrees

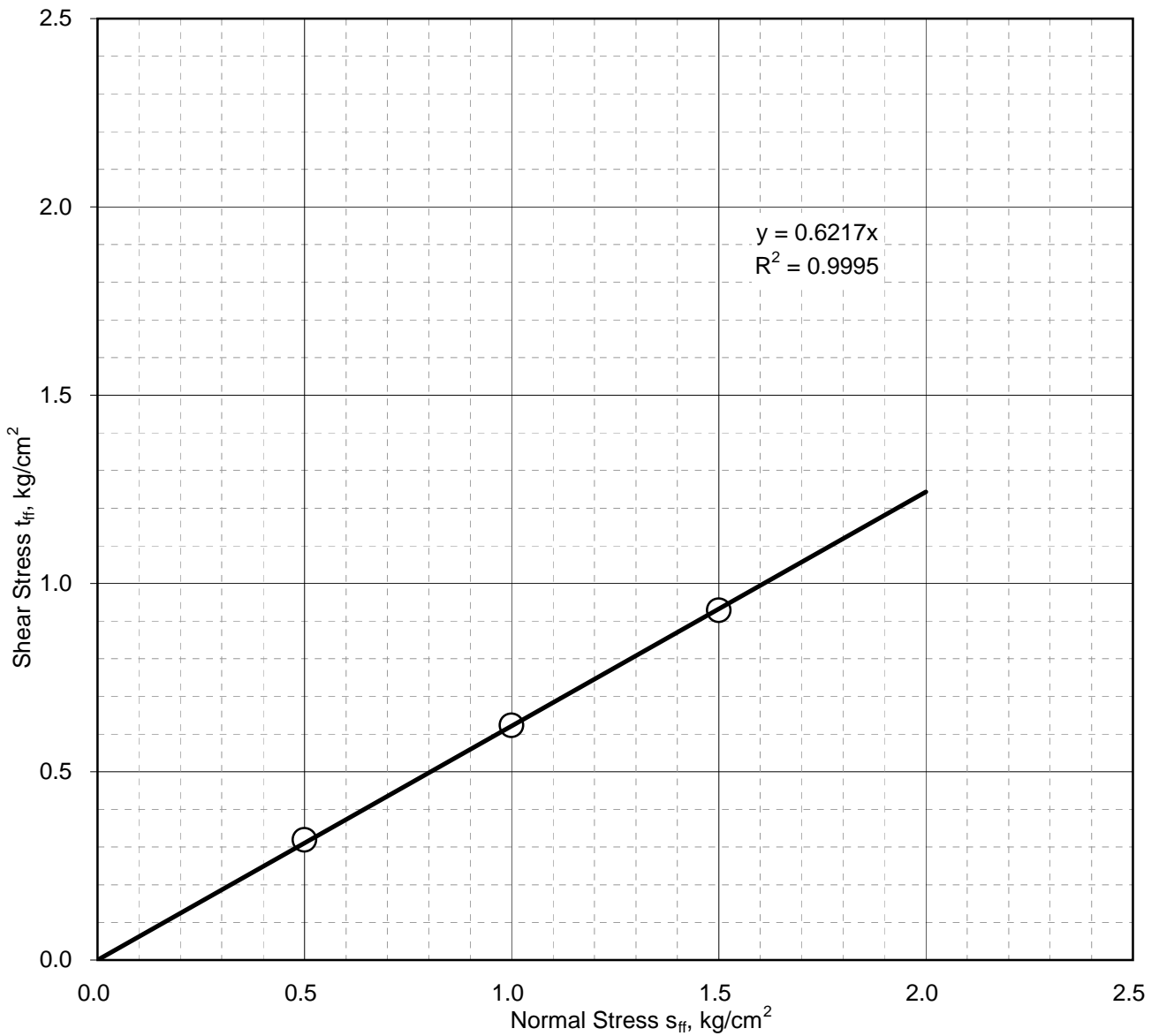

Mohr-Coulomb Failure Envelope

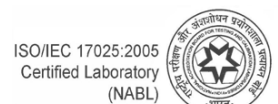

Certificate No. T-1741



TEST RESULTS

Soil-Water Extract Test Results				
Borehole No.	Depth, (m)	Sulphate Content (SO ₃), %	Chloride Content (Cl), %	pH Value
BH-1	0.50	0.11	0.04	7.9
	3.00	0.11	0.06	7.9
BH-2	0.50	0.11	0.03	7.8
	2.50	0.11	0.06	7.7
BH-3	0.50	0.12	0.04	7.5
	4.00	0.11	0.09	7.7

Groundwater Test Results			
Borehole No.	Sulphate Content (SO ₃), mg/l	Chloride Content (Cl), mg/l	pH Value
BH-1	318	102	7.2
BH-2	331	75	7.2

IS : 456-2000, SPECIFICATIONS

Requirements for Concrete Exposed to Sulphate Attack as per IS : 456-2000, Clauses 8.2.2.4 and 9.1.2, Table 4, Page-19

Class	Concentration of Sulphates, expressed as SO ₃ In-Soil-Water Extract (Total) Percent	In Groundwater (mg/l)
1	Traces (<0.2)	Less than 300
2	0.2 to 0.5	300-1200
3	0.5 to 1.0	1200-2500
4	1.0 to 2.0	2500-5000
5	> 2.0	> 5000

Classification of Chloride Conditions in Groundwater*

Classification	Chloride Limits	
	Temperate Climate	Tropical Climate
Negligible	0-2000 ppm	Not Applicable
Moderate	2000-10,000 ppm	0-2000 ppm
High	More than 10,000 ppm	2000-20,000 ppm
Very High	Generally not applicable	Only if considerably in excess of 20,000 ppm

*Source : Institution of Civil Engineers, London (1979)

Chemical Test Results

APPENDIX-A
LIQUEFACTION SUSCEPTIBILITY ASSESSMENT

Liquefaction Susceptibility Assessment																								
Project Details												Theory												
Borehole No.		BH-1										As per Seed and Idriss Approach, as described in the NCEER Summary Report (2001) -												
Block		N/A										$FOS = \frac{CRR_{7.5}}{CSR} \cdot MSF$ $CSR = \left(\frac{\tau_{av}}{\sigma'_{vo}} \right) = 0.65 \left(\frac{a_{max}}{g} \right) \left(\frac{\sigma'_{vo}}{\sigma'_{vo}} \right) r_d$ $CRR_{7.5} = \frac{1}{34 - (N_1)_{60}} + \frac{(N_1)_{60}}{135} + \frac{50}{[10 \cdot (N_1)_{60} + 45]^2} - \frac{1}{200}$												
Structure		Intake Well										Several corrections are applied to the field N value:												
Existing Ground Level (EGL)		38.8										Corrected SPT 'N' Value: $(N_1)_{60} = N_m \cdot C_N \cdot C_E \cdot C_B \cdot C_R \cdot C_S$ Influence of Fines Content: $(N_1)_{60,cs} = \alpha + \beta(N_1)_{60}$												
Surcharge Load, if any:		0 T/m ²										Symbols and Abbreviations-												
Design Earthquake				Site Levels				Boring Details				FOS = Factor of safety against liquefaction $(N_1)_{60}$ = Corrected SPT N value MSF= Magnitude Scaling Factors CRR _{7.5} = Cyclic Resistance Ratio N _m = Measured (field) SPT N value CSR = Cyclic Stress Ratio α, β = Coefficients based on fines content a _{max} = Peak horizontal acceleration C _N = Factor to normalize N _m to reference overburden stress g = Acceleration of gravity C _E = Correction for hammer energy ratio (ER) σ' _{vo} = Effective vertical overburden stress C _R = correction for rod length r _d = Stress reduction coefficient C _S = correction for samplers with or without liners												
Seismic Zone: IV		Existing Ground Level, EGL (m): 38.8		Sampler with liner? N		Earthquake Magnitude: 6.7		Actual GW Depth (m): 3.2		Hammer Type: WT		PGA (g): 0.24		Design GW Depth (m): 0.0		Borehole Diameter (mm): 150		Critical Factor of Safety (FS): 1.0		Design GW Level (m): 38.8		SPT Energy Correction (C _E): 0.75		
Calculations																								
Layer	Soil Description	Depth to Top of Layer (m)	Layer Thickness (m)	Unit weight (T/m ³)	Total Overburden Pressure at Middle of Layer (T/m ²)	Effective Stress at Middle of Layer, based on design GWT (T/m ²)	Effective Stress at Middle of Layer, based on actual GWT (T/m ²)	N _m	Fines Content (%)	C _N	C _E	C _B	C _R	C _S	α	β	(N ₁) _{60,cs}	CRR _(7.5)	Stress Reduction Factor (r _d)	CSR	Magnitude Scaling Factor	CSR _{7.5}	Computed FOS against liquefaction	Plasticity Index (%)
1	Clayey silt	0.0	1.0	1.70	0.9	0.4	0.850	5	96	1.70	0.75	1.05	0.75	1.20	5.00	1.20	12	0.13	1.00	0.37	1.442	0.25	NL	16.5
2	Fine sand	1.0	1.0	1.70	2.6	1.1	2.6	5	4	1.70	0.75	1.05	0.75	1.20	0.00	1.00	6	0.08	0.99	0.36	1.442	0.25	0.32	
3	Fine sand	2.0	2.0	1.70	5.1	2.2	5.1	9	2	1.40	0.75	1.05	0.75	1.20	0.00	1.00	9	0.10	0.98	0.36	1.442	0.25	0.42	
4	Fine sand	4.0	1.0	1.70	7.7	3.2	6.3	9	3	1.26	0.75	1.05	0.85	1.20	0.00	1.00	9	0.11	0.97	0.36	1.442	0.25	0.43	
5	Fine sand	5.0	1.0	1.75	9.4	4.0	7.1	33	3	1.19	0.75	1.05	0.85	1.20	0.00	1.00	32		0.96	0.35	1.442	0.24	NL	
6	Fine sand	6.0	1.0	1.75	11.1	4.7	7.8	42	4	1.13	0.75	1.05	0.95	1.20	0.00	1.00	43		0.95	0.35	1.442	0.24	NL	
7	Fine sand	7.0	1.0	1.75	12.9	5.5	8.6	4	3	1.08	0.75	1.05	0.95	1.20	0.00	1.00	4	0.06	0.94	0.34	1.442	0.24	0.27	
8	Silty fine sand	8.0	1.0	1.75	14.6	6.3	9.4	14	43	1.03	0.75	1.05	0.95	1.20	5.00	1.20	21	0.22	0.93	0.34	1.442	0.24	0.95	
9	Silty fine sand	9.0		1.75				30	25														NL	
10																								
11																								
N/A : Not Applicable (as in the case of unsaturated soils) NL : Not Liquefiable, e.g. if (N1) _{60,cs} >30, PI>15%, or Fines Content>50%																								

Conclusion:

Liquefaction potential to 9.0 m depth

Liquefaction Susceptibility Assessment																								
Project Details												Theory												
Borehole No.		BH-2										As per Seed and Idriss Approach, as described in the NCEER Summary Report (2001) -												
Block		N/A										$FOS = \frac{CRR_{7.5}}{CSR} \cdot MSF$ $CSR = \left(\frac{\tau_{av}}{\sigma'_{vo}} \right) = 0.65 \left(\frac{a_{max}}{g} \right) \left(\frac{\sigma'_{vo}}{\sigma'_{vo}} \right) r_d$ $CRR_{7.5} = \frac{1}{34 - (N_1)_{60}} + \frac{(N_1)_{60}}{135} + \frac{50}{[10 \cdot (N_1)_{60} + 45]^2} - \frac{1}{200}$												
Structure		Intake Well										Several corrections are applied to the field N value: Corrected SPT 'N' Value: $(N_1)_{60} = N_m \cdot C_N \cdot C_E \cdot C_B \cdot C_R \cdot C_S$ Influence of Fines Content: $(N_1)_{60,cs} = \alpha + \beta(N_1)_{60}$												
Existing Ground Level (EGL)		38.2										Symbols and Abbreviations- FOS = Factor of safety against liquefaction (N1) ₆₀ = Corrected SPT N value MSF= Magnitude Scaling Factors CRR _{7.5} = Cyclic Resistance Ratio N _m = Measured (field) SPT N value CSR = Cyclic Stress Ratio α, β = Coefficients based on fines content a _{max} = Peak horizontal acceleration C _N = Factor to normalize N _m to reference overburden stress g = Acceleration of gravity C _E = Correction for hammer energy ratio (ER) σ' _{vo} = Effective vertical overburden stress C _R = correction for rod length r _d = Stress reduction coefficient C _S = correction for samplers with or without liners												
Surcharge Load, if any:		0 T/m ²																						
Design Earthquake				Site Levels				Boring Details																
Seismic Zone:		IV		Existing Ground Level, EGL (m):		38.2		Sampler with liner?		N														
Earthquake Magnitude:		6.7		Actual GW Depth (m):		3.1		Hammer Type:		WT														
PGA (g):		0.24		Design GW Depth (m):		0.0		Borehole Diameter (mm):		150														
Critical Factor of Safety (FS):		1.0		Design GW Level (m):		38.2		SPT Energy Correction (C _E):		0.75														
Calculations																								
Layer	Soil Description	Depth to Top of Layer (m)	Layer Thickness (m)	Unit weight (T/m ³)	Total Overburden Pressure at Middle of Layer (T/m ²)	Effective Stress at Middle of Layer, based on design GWT (T/m ²)	Effective Stress at Middle of Layer, based on actual GWT (T/m ²)	N _m	Fines Content (%)	C _N	C _E	C _B	C _R	C _S	α	β	(N1) _{60,cs}	CRR _(7.5)	Stress Reduction Factor (r _d)	CSR	Magnitude Scaling Factor	CSR _{7.5}	Computed FOS against liquefaction	Plasticity Index (%)
1	Clayey silt	0.0	2.5	1.70	2.1	0.9	2.125	8	95	1.70	0.75	1.05	0.75	1.20	5.00	1.20	17	0.18	0.99	0.37	1.442	0.25	NL	22.5
2	Fine sand	2.5	1.0	1.70	5.1	2.2	5.1	11	7	1.40	0.75	1.05	0.75	1.20	0.12	1.01	11	0.12	0.98	0.36	1.442	0.25	0.49	
3	Fine sand	3.5	1.0	1.70	6.8	2.9	5.9	11	8	1.30	0.75	1.05	0.85	1.20	0.30	1.01	12	0.13	0.97	0.36	1.442	0.25	0.53	
4	Fine sand	4.5	1.0	1.70	8.5	3.6	6.6	14	12	1.23	0.75	1.05	0.85	1.20	1.55	1.03	16	0.17	0.96	0.35	1.442	0.25	0.68	
5	Fine sand	5.5	1.0	1.75	10.2	4.3	7.4	16	11	1.17	0.75	1.05	0.95	1.20	1.21	1.03	18	0.20	0.95	0.35	1.442	0.24	0.81	
6	Fine sand	6.5	1.0	1.75	12.0	5.1	8.1	5	8	1.11	0.75	1.05	0.95	1.20	0.30	1.01	5	0.07	0.95	0.35	1.442	0.24	0.31	
7	Fine sand	7.5	1.0	1.75	13.7	5.9	8.9	15	9	1.06	0.75	1.05	0.95	1.20	0.56	1.02	15	0.16	0.94	0.34	1.442	0.24	0.68	
8	Fine sand	8.5	1.0	1.75	15.5	6.6	9.7	11	8	1.02	0.75	1.05	0.95	1.20	0.30	1.01	10	0.12	0.93	0.34	1.442	0.23	0.50	
9	Fine sand	9.5	1.0	1.75	17.2	7.4	10.4	12	8	0.98	0.75	1.05	1.00	1.20	0.30	1.01	12	0.13	0.91	0.33	1.442	0.23	0.56	
10	Fine sand	10.5	1.0	1.80	19.0	8.2	11.2	13	7	0.94	0.75	1.05	1.00	1.20	0.12	1.01	12	0.13	0.88	0.32	1.442	0.22	0.59	
11	Fine sand	11.5	1.0	1.8	20.8	9.0	12.0	14	9	0.91	0.75	1.05	1.00	1.20	0.56	1.02	13	0.14	0.85	0.31	1.442	0.21	0.65	
12	Fine sand	12.5		1.8				16	5														NL	
N/A : Not Applicable (as in the case of unsaturated soils) NL : Not Liquefiable, e.g. if (N1) _{60,cs} >30, PI>15%, or Fines Content>50%																								

Conclusion:

Liquefaction potential to 12.5 m depth

Liquefaction Susceptibility Assessment																								
Project Details												Theory												
Borehole No.		BH-3										As per Seed and Idriss Approach, as described in the NCEER Summary Report (2001) -												
Block		N/A										$FOS = \frac{CRR_{7.5}}{CSR} \cdot MSF$ $CSR = \left(\frac{\tau_{av}}{\sigma'_{vo}} \right) = 0.65 \left(\frac{a_{max}}{g} \right) \left(\frac{\sigma'_{vo}}{\sigma'_{vo}} \right) r_d$ $CRR_{7.5} = \frac{1}{34 - (N_1)_{60}} + \frac{(N_1)_{60}}{135} + \frac{50}{[10 \cdot (N_1)_{60} + 45]^2} - \frac{1}{200}$												
Structure		Intake Well										Several corrections are applied to the field N value:												
Existing Ground Level (EGL)		38.2										Corrected SPT 'N' Value: $(N_1)_{60} = N_m \cdot C_N \cdot C_E \cdot C_B \cdot C_R \cdot C_S$ Influence of Fines Content: $(N_1)_{60,cs} = \alpha + \beta(N_1)_{60}$												
Surcharge Load, if any:		0 T/m ²										Symbols and Abbreviations-												
Design Earthquake				Site Levels				Boring Details				FOS = Factor of safety against liquefaction (N ₁) ₆₀ = Corrected SPT N value MSF= Magnitude Scaling Factors CRR _{7.5} = Cyclic Resistance Ratio N _m = Measured (field) SPT N value CSR = Cyclic Stress Ratio α, β = Coefficients based on fines content a _{max} = Peak horizontal acceleration C _N = Factor to normalize N _m to reference overburden stress g = Acceleration of gravity C _E = Correction for hammer energy ratio (ER) σ'vo = Effective vertical overburden stress C _R = correction for rod length r _d = Stress reduction coefficient C _S = correction for samplers with or without liners												
Seismic Zone:		IV		Existing Ground Level, EGL (m):		38.2		Sampler with liner?		N														
Earthquake Magnitude:		6.7		Actual GW Depth (m):		3.0		Hammer Type:		WT														
PGA (g):		0.24		Design GW Depth (m):		0.0		Borehole Diameter (mm):		150														
Critical Factor of Safety (FS):		1.0		Design GW Level (m):		38.2		SPT Energy Correction (C _E):		0.75														
Calculations																								
Layer	Soil Description	Depth to Top of Layer (m)	Layer Thickness (m)	Unit weight (T/m ³)	Total Overburden Pressure at Middle of Layer (T/m ²)	Effective Stress at Middle of Layer, based on design GWT (T/m ²)	Effective Stress at Middle of Layer, based on actual GWT (T/m ²)	N _m	Fines Content (%)	C _N	C _E	C _B	C _R	C _S	α	β	(N ₁) _{60,cs}	CRR _(7.5)	Stress Reduction Factor (r _d)	CSR	Magnitude Scaling Factor	CSR _{7.5}	Computed FOS against liquefaction	Plasticity Index (%)
1	Clayey silt	0.0	1.0	1.70	0.9	0.4	0.850	5	79	1.70	0.75	1.05	0.75	1.20	5.00	1.20	12	0.13	1.00	0.37	1.442	0.25	NL	17.1
2	Fine sand	1.0	1.0	1.70	2.6	1.1	2.6	6	4	1.70	0.75	1.05	0.75	1.20	0.00	1.00	7	0.09	0.99	0.36	1.442	0.25	0.35	
3	Fine sand	2.0	2.0	1.70	5.1	2.2	5.1	7	3	1.40	0.75	1.05	0.75	1.20	0.00	1.00	7	0.09	0.98	0.36	1.442	0.25	0.35	
4	Fine sand	4.0	1.0	1.70	7.7	3.2	6.1	8	4	1.28	0.75	1.05	0.85	1.20	0.00	1.00	8	0.10	0.97	0.36	1.442	0.25	0.40	
5	Fine sand	5.0	1.0	1.75	9.4	4.0	6.9	13	3	1.21	0.75	1.05	0.85	1.20	0.00	1.00	13	0.14	0.96	0.35	1.442	0.24	0.56	
6	Fine sand	6.0	1.0	1.75	11.1	4.7	7.6	15	9	1.14	0.75	1.05	0.95	1.20	0.56	1.02	16	0.17	0.95	0.35	1.442	0.24	0.72	
7	Fine sand	7.0	1.0	1.75	12.9	5.5	8.4	5	10	1.09	0.75	1.05	0.95	1.20	0.87	1.02	6	0.08	0.94	0.34	1.442	0.24	0.33	
8	Fine sand	8.0	1.0	1.75	14.6	6.3	9.2	16	11	1.04	0.75	1.05	0.95	1.20	1.21	1.03	17	0.18	0.93	0.34	1.442	0.24	0.75	
9	Fine sand	9.0	1.0	1.75	16.4	7.1	9.9	16	12	1.00	0.75	1.05	0.95	1.20	1.55	1.03	16	0.17	0.92	0.33	1.442	0.23	0.76	
10	Silty fine sand	10.0	1.0	1.75	18.1	7.8	10.7	16	39	0.97	0.75	1.05	1.00	1.20	5.00	1.20	23	0.25	0.89	0.32	1.442	0.22	1.11	
11	Silty fine sand	11.0	1.0	1.75	19.9	8.6	11.5	16	31	0.93	0.75	1.05	1.00	1.20	4.77	1.16	21	0.23	0.87	0.31	1.442	0.22	1.06	
12	Silty fine sand	12.0						17	25	N/A : Not Applicable (as in the case of unsaturated soils) NL : Not Liquefiable, e.g. if (N ₁) _{60,cs} >30, PI>15%, or Fines Content>50%												NL		

Conclusion:

Liquefaction potential to 10.0 m depth

APPENDIX-B
TYPICAL CALCULATIONS



Bearing Capacity Analysis for Well Foundations

Analysis as per IS 6403-1981

Intake Well

The bearing capacity equation for well foundations is as follows :

$$q_{\text{gross safe}} = (1/FS)\{cN_c\zeta_c d_c + qN_q\zeta_q d_q + 0.5B\gamma N_\gamma\zeta_\gamma d_\gamma R_w\}$$

where:

$q_{\text{gross safe}}$	= safe gross bearing capacity	c	= cohesion intercept
q	=	overburden pressure below scour level	
B	= Well Diameter		
γ	= Bulk density of soil below founding level		
R_w	= Water table correction factor		
N_c, N_q, N_γ	= bearing capacity factors, which are a function of ϕ		
d_c, d_q, d_γ	= Depth factors		
$\zeta_c, \zeta_q, \zeta_\gamma$	= Shape factors		
FS	= Factor of safety		

Well Foundation Shape: **Circle**

Soil Parameters :

$c = 0.0$ T/m $\phi = 32.0$ degrees

Bearing Capacity Factors $N_c = 35.49$ $N_q = 23.18$ $N_\gamma = 30.21$

Water Table Depth = **GL**

Factor of safety = **2.5** as per **IS 1904-1986**

Scour Depth below Bed Level = **20.0** m

R_w factor: Constant value(V) for worst condition or calculate(C) based on WT Depth ? :

Bulk Density Profile		
Depth, m		γ
From	To	T/m ³
0.0	1.5	Scour
1.5	12.5	
12.5	20.0	
20.0	30.0	1.95
30.0	40.0	2.00
40.0	50.0	2.1

Well Diameter, m	Depth, m	R_w	Shape Factors			Depth factors			Safe Gross Bearing Capacity T/m ²
			ζ_c	ζ_q	ζ_γ	d_c	d_q	d_γ	
8.0	30.0	0.50	1.30	1.20	0.60	1.00	1.23	1.23	165.1
8.0	32.0	0.50	1.30	1.20	0.60	1.00	1.27	1.27	199.5
8.0	35.0	0.50	1.30	1.20	0.60	1.00	1.34	1.34	255.4
10.0	30.0	0.50	1.30	1.20	0.60	1.00	1.18	1.18	167.5
10.0	32.0	0.50	1.30	1.20	0.60	1.00	1.22	1.22	199.7
10.0	35.0	0.50	1.30	1.20	0.60	1.00	1.27	1.27	251.1



Settlement Analysis for Shallow Foundations Based on N-Values

Analysis as per IS:8009(Part 1)-1976 , Clause 9.1.4 & IS8009 Part 2

Intake Well

Profile of N(SPT) Values			Bulk Density, T/m ²
Depth,m		Corrected N-value	
From	To		
0.0	1.5	6.0	1.65
1.5	12.5	12.0	1.70
12.5	20.0	20.0	1.85
20.0	30.0	32.0	1.95
30.0	40.0	50.0	2.00
40.0	50.0	70.0	2.10

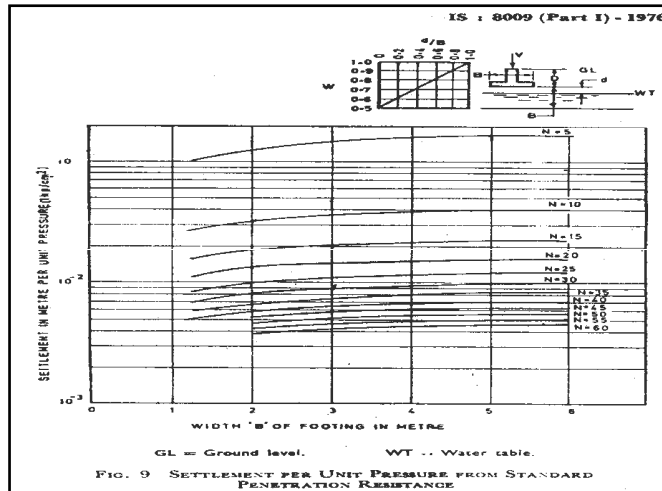

Depth below Foundation to which weighted average of SPT (N)-value is to be calculated (as function of B)

1.0 B

Design Water Table Depth : GL

Depth of loose soils to be ignored for depth factor calculations: 12.5 m

Well Shape : Circle

Maximum Scour Depth : 20.0 m

R_w factor : Calculate (C) based on water table depth or

Fixed Value(V) for worst condition : C

Poisson's Ratio : 0.33

Foundation Width,m	Foundation Depth,m	Applied Gross Bearing Pressure, T/m ²	Applied Net Bearing Pressure, T/m ²	Weighted Average N-value	Settlement @ 1kg/cm ² (as read off from graph), mm	R _w	Depth Factor	Computed Settlement, mm
8.0	30.0	115.0	90.5	50.0	5.7	0.50	0.54	45.0
8.0	32.0	123.0	96.5	50.0	5.7	0.50	0.54	47.2
8.0	35.0	140.0	110.5	55.5	5.1	0.50	0.53	47.5
10.0	30.0	99.0	74.5	50.0	5.8	0.50	0.56	38.9
10.0	32.0	108.0	81.5	51.5	5.6	0.50	0.55	40.5
10.0	35.0	125.0	95.5	58.5	4.9	0.50	0.54	40.6



Settlement Analysis for Well Foundations

Elastic Settlement Computed from Theory of Elasticity
Analysis as per IS : 8009 Parts 1 & 2 - 1976

Intake Well

Total settlement computed as equal to elastic/immediate settlement.

No consolidation settlement - analysis valid for granular soils, weathered rocks, hard clays which are not likely to consolidate

ELASTIC / IMMEDIATE SETTLEMENT

$S_i = \frac{q B' (1 - \mu^2) I}{E} d_f d_r$ <p>where</p> <p>B = Equivalent width of well</p> <p>q = Net Bearing Pressure = $q_{gross} - \gamma D$</p> <p>d_f = Fox's Depth factor</p> <p>I = Influence factor at corner of rectangular loaded area ($B' \times L'$), computed from theory of elasticity using Steinbrenner's factors</p>	<p>Reference : <i>Foundation Analysis & Design by J.E.Bowles, fifth edition (1996)</i></p> <p>$B' = B/2$</p> <p>μ = Poisson's Ratio</p> <p>E = Modulus of Elasticity</p> <p>d_r = Rigidity factor, taken as 0.8</p> <p>Settlement at centre of well of equivalent dimensions $B \times L = 4 \times$ Settlement at corner of area $B' \times L'$ (for circular well $B =$ Side of square of same area)</p>
--	--

Poisson's Ratio : **0.33**

Is Rigid Layer met ?

Y

Rigid Layer at

45.0

m depth

Layer No.	Depth, m		Soil Classification	Modulus of Elasticity, T/m ²	Bulk Density, T/m ³
	From	To			
1	0.0	1.5	Clayey silt		1.65
2	1.5	12.5	Fine sand (Liquefiable)		1.70
3	12.5	20.0	Fine sand (Scour)		1.85
4	20.0	30.0	Fine sand	2500	1.95
5	30.0	40.0	Fine sand	4000	2.00
6	40.0	50.0	Fine sand	5000	2.10

Well Shape : **Circle**

Design Water Table Depth :

GL

Depth To be ignored in computation of Depth

Factor for loose soils, fill, scour etc. :

12.5 m

Well Diameter m	Well Tip Depth, m	Gross Bearing Press. T/m ²	Net Bearing Press. T/m ²	Depth Factor	M = L/B'	N = H/B'	Influence Factor, I	E (weighted average) T/m ²	Elastic Settlement mm
8.0	30.0	115.0	90.5	0.54	1.00	4.23	0.434	4333	49.8
8.0	32.0	123.0	96.5	0.54	1.00	3.67	0.416	4385	49.6
8.0	35.0	140.0	110.5	0.53	1.00	2.82	0.378	4500	49.3
10.0	30.0	99.0	74.5	0.56	1.00	3.39	0.405	4333	49.6
10.0	32.0	108.0	81.5	0.55	1.00	2.93	0.384	4385	49.9
10.0	35.0	125.0	95.5	0.54	1.00	2.26	0.340	4500	49.4

APPENDIX-C
SITE PHOTOGRAPHS



Photo: 1 Borehole No. BH-2



Photo: 2 Borehole No. BH-3

Site Photographs