

**DATA COLLECTION SURVEY  
FOR  
DISASTER PREVENTION  
IN  
INDIA**

**FINAL REPORT**

**OCTOBER 2015**

**JAPAN INTERNATIONAL COOPERATION AGENCY  
YACHIYO ENGINEERING CO., LTD.**

ID
JR(先)
15 - 011

**DATA COLLECTION SURVEY  
FOR  
DISASTER PREVENTION  
IN  
INDIA**

**FINAL REPORT**

**OCTOBER 2015**

**JAPAN INTERNATIONAL COOPERATION AGENCY  
YACHIYO ENGINEERING CO., LTD.**

**Exchange Rate applied in this Report**

*As of September, 2015*

USD 1.00 = JPY 121.81

INR 1.00 = JPY 1.844

## **DATA COLLECTION SURVEY FOR DISASTER PREVENTION IN INDIA**

### **FINAL REPORT**

#### **TABLE OF CONTENTS**

Table of Contents  
List of Figures  
List of Tables  
Abbreviations  
Executive Summary

CHAPTER 1	BACKGROUND AND OBJECTIVE OF THE SURVEY .....	1-1
1.1	Background.....	1-1
1.1.1	Mainstreaming Disaster Risk Reduction.....	1-1
1.1.2	Disaster Management Policy in India .....	1-1
1.1.3	Japan’s Assistance Policy for Disaster Management in India.....	1-2
1.2	Objective of the Survey .....	1-2
1.3	Survey Areas .....	1-2
1.4	Survey Schedule .....	1-3
CHAPTER 2	DEVELOPMENT PLAN AND SOCIO-ECONOMIC CONDITION.....	2-1
2.1	National Development Plan .....	2-1
2.1.1	Outline of The 12th Five-Year Plan (2012-2017).....	2-1
2.1.2	Water (Flood Management) .....	2-2
2.1.3	Seismological Research .....	2-2
2.1.4	Governance (Disaster Management).....	2-2
2.2	Natural and Socio-Economic Condition .....	2-3
2.2.1	Natural Condition .....	2-3
2.2.2	Socio-Economic Condition.....	2-4
CHAPTER 3	DISASTER MANAGEMENT.....	3-1
3.1	Disaster Management Act, 2005 .....	3-1
3.2	National Policy on Disaster Management.....	3-1
3.3	National Disaster Management Plan.....	3-3
3.4	Institutional Framework of Disaster Management.....	3-3
3.4.1	Organisational Structure of the Disaster Management .....	3-3
3.4.2	Guidelines for the Disaster Management and Standard Operating Procedures ...	3-4
3.4.3	Emergency Operation Centres (EOCs) .....	3-6
3.4.4	Nodal Ministries/Departments for Management/Mitigation of Different Disasters .....	3-6
3.4.5	Review of the Disaster Management Act, 2005.....	3-7
3.5	Other Donor Assistance to Disaster Management .....	3-7
3.5.1	Project Outline of the World Bank (WB).....	3-7
3.5.2	Project Outline of the Asian Development Bank (ADB).....	3-10
3.5.3	Project Outline of the United Nations Development Programme (UNDP) .....	3-11
3.5.4	U.S. Agency for International Development (USAID).....	3-11

CHAPTER 4	NATURAL DISASTERS IN INDIA	4-1
4.1	Overview.....	4-1
4.2	Floods .....	4-4
4.2.1	Situation of Countermeasures in National Policy and Planning .....	4-4
4.2.2	Policies and Institutional Frameworks .....	4-4
4.2.3	Floods Record and Damages .....	4-7
4.2.4	Observation Systems.....	4-9
4.2.5	Risk Analysis .....	4-13
4.2.6	Preparedness and Countermeasures .....	4-15
4.2.7	Evacuation Systems .....	4-20
4.2.8	Emergency Response .....	4-21
4.2.9	Challenges to be Addressed .....	4-21
4.3	Sediment Disaster (Landslide).....	4-25
4.3.1	Situation of Countermeasures in National Policy and Planning .....	4-25
4.3.2	Policies and Institutional Frameworks.....	4-25
4.3.3	Disaster Records .....	4-29
4.3.4	Observation/Monitoring System/Early Warning.....	4-30
4.3.5	Risk Analysis .....	4-35
4.3.6	Preparedness and Countermeasures .....	4-39
4.3.7	Challenges to be Addressed .....	4-43
4.4	Cyclones .....	4-48
4.4.1	Situation of Countermeasures in National Policy and Planning .....	4-48
4.4.2	Policy and Institutional Framework.....	4-48
4.4.3	Disaster Records .....	4-52
4.4.4	Observation Systems.....	4-55
4.4.5	Risk Analysis .....	4-59
4.4.6	Preparedness and Countermeasures .....	4-61
4.4.7	Evacuation Systems .....	4-63
4.4.8	Emergency Response .....	4-64
4.4.9	Challenges to be Addressed .....	4-64
4.5	Evaluation and Prioritisation of Challenges Identified.....	4-70
4.5.1	Methodology.....	4-70
4.5.2	Evaluation Result.....	4-70
4.6	Earthquake .....	4-75
4.6.1	Situation of Countermeasures in National Policy and Planning .....	4-75
4.6.2	Policy and Institutional Framework.....	4-75
4.6.3	Disaster Records .....	4-78
4.6.4	Observation System .....	4-79
4.6.5	Risk Analysis .....	4-79
4.6.6	Preparedness and Countermeasures .....	4-81
4.6.7	Earthquake Information Dissemination System .....	4-81
4.7	Tsunami.....	4-83
4.7.1	Situation of Countermeasure in National Policy and Planning.....	4-83
4.7.2	Policy and Institutional Framework.....	4-84
4.7.3	Disaster Records .....	4-86
4.7.4	Observation System .....	4-87
4.7.5	Risk Analysis .....	4-89
4.7.6	Preparedness and Countermeasures .....	4-92
4.7.7	Emergency Communication.....	4-93
CHAPTER 5	FORECASTING AND EARLY WARNING SYSTEMS .....	5-1
5.1	Implementation Structure.....	5-1
5.2	Current Situation of the Systems .....	5-1
5.2.1	Warning Systems for Cyclones.....	5-1

5.2.2	Forecasting Systems for Floods.....	5-3
5.2.3	Warning Systems for Landslides.....	5-5
5.2.4	Warning Systems for Tsunamis.....	5-5
5.2.5	Information Flow and Communication System.....	5-8
5.3	Andaman and Nicobar Islands Case .....	5-9
5.3.1	Disaster Management Plan .....	5-9
5.3.2	Institutional Framework for Disaster Management .....	5-10
5.3.3	Risk Analysis .....	5-11
5.3.4	Preparedness and Countermeasures .....	5-13
5.3.5	Forecasting, Early Warning and Communication Systems.....	5-17
5.3.6	Emergency Response .....	5-19
5.3.7	Evacuation Systems .....	5-20
5.3.8	Disaster Risk Finance .....	5-20
5.4	Challenges to be addressed .....	5-21
5.5	Evaluation and Prioritisation of Challenges Identified.....	5-23
5.5.1	Methodology.....	5-23
5.5.2	Evaluation Result.....	5-24
<b>CHAPTER 6 DISASTER RISK FINANCE.....</b>		<b>6-1</b>
6.1	Policy and Finance Scheme .....	6-1
6.1.1	Policy on Disaster Risk Finance .....	6-1
6.1.2	Disaster Risk Finance Systems .....	6-1
6.2	Past Records of Disaster Risk Finance .....	6-5
6.3	Challenges to be addressed .....	6-9
6.3.1	Disaster Response Fund.....	6-9
6.3.2	Disaster Mitigation Fund .....	6-11
6.3.3	Challenge to be Addressed.....	6-11
<b>CHAPTER 7 PRIORITY AREA STUDY .....</b>		<b>7-1</b>
7.1	Selection of Priority Survey Areas.....	7-1
7.2	Uttarakhand State.....	7-1
7.2.1	State Disaster Management Policy and Development Plan .....	7-1
7.2.2	Institutional Framework for Disaster Management .....	7-1
7.2.3	Disaster Records .....	7-2
7.2.4	Observation Systems.....	7-5
7.2.5	Risk Analysis .....	7-6
7.2.6	Emergency Response .....	7-8
7.2.7	Evacuation Systems .....	7-13
7.2.8	Preparedness and Countermeasures .....	7-14
7.2.9	Forecasting, Early Warning and Communication Systems at State Level .....	7-21
7.2.10	Disaster Risk Finance at State Level.....	7-21
7.2.11	Challenges to be Addressed .....	7-22
7.3	Bihar State.....	7-26
7.3.1	State Disaster Management Policy and Development Plan .....	7-26
7.3.2	Institutional Framework for Disaster Management .....	7-28
7.3.3	Disaster Records .....	7-29
7.3.4	Observation Systems for Rainfall and Water Level .....	7-31
7.3.5	Risk Analysis .....	7-31
7.3.6	Emergency Response .....	7-36
7.3.7	Evacuation Systems .....	7-42
7.3.8	Preparedness and Countermeasures .....	7-43
7.3.9	Forecasting, Early Warning and Communication Systems at State Level .....	7-48
7.3.10	Disaster Risk Finance at State Level.....	7-49
7.3.11	Challenges to be Addressed .....	7-50

7.4	Andhra Pradesh State .....	7-54
7.4.1	State Disaster Management Policy and Development Plan .....	7-54
7.4.2	Institutional Framework for Disaster Management .....	7-54
7.4.3	Disaster Records .....	7-55
7.4.4	Observation Systems.....	7-58
7.4.5	Risk Analysis .....	7-60
7.4.6	Emergency Response .....	7-62
7.4.7	Evacuation Systems .....	7-68
7.4.8	Preparedness and Countermeasures .....	7-69
7.4.9	Forecasting, Early Warning and Communication Systems at State Level .....	7-73
7.4.10	Disaster Risk Finance at State Level.....	7-75
7.4.11	Challenges to be Addressed .....	7-75
7.5	Evaluation and Prioritisation of Challenges Identified .....	7-82
7.5.1	Methodology .....	7-82
7.5.2	Evaluation Result .....	7-83
CHAPTER 8	APPLICABILITY OF JAPANESE TECHNOLOGY TO CHALLENGES IDENTIFIED .....	8-1
8.1	Japan's Experience and Technology .....	8-1
8.2	Applicability of Japanese Technologies to Challenges Identified .....	8-5
8.3	Conclusion .....	8-12

## List of Figure

Figure 1.3.1	Survey Areas .....	1-2
Figure 2.1.1	Outline of The 12th Five-Year Plan (2012–2017).....	2-1
Figure 2.2.1	Average Annual Mean Temperature .....	2-4
Figure 2.2.2	Annual Rainfall in India (2013) .....	2-4
Figure 2.2.3	Allocation of GDP (Current Price in 2013).....	2-5
Figure 3.2.1	Outline of NPDM .....	3-2
Figure 3.4.1	Institutional Framework of Disaster Management in India.....	3-4
Figure 4.1.1	Natural Disaster Events in India (1955-2014).....	4-2
Figure 4.1.2	Occurrence of Natural Disaster by State (1955-2014) .....	4-3
Figure 4.2.1	Organisational Structure of MOWR.....	4-6
Figure 4.2.2	Major Meteorological, Hydrological and Flood Forecasting Stations .....	4-12
Figure 4.2.3	Flood Prone Areas in India.....	4-13
Figure 4.3.1	Map of Landslide Affected States .....	4-25
Figure 4.3.2	Organisational Structure of GSI .....	4-27
Figure 4.3.3	Monitoring System of Mansa Devi Landslide.....	4-31
Figure 4.3.4	SSR and Scanning Method.....	4-32
Figure 4.3.5	Flow of Landslide Investigation.....	4-33
Figure 4.3.6	Relation of Documents, Standards and SOP .....	4-35
Figure 4.3.7	Flow Chart of Risk Assessment.....	4-36
Figure 4.3.8	Example of Landslide Hazard Zonation Map by NRSA .....	4-37
Figure 4.3.9	Example of Landslide Susceptibility Map (Sikkim) .....	4-38
Figure 4.3.10	Examples of Countermeasures for Varnavat Landslide .....	4-42
Figure 4.3.11	Right of Way (All Types of Road).....	4-42
Figure 4.4.1	Institutional Framework of Earth System Science .....	4-49
Figure 4.4.2	Organisational Structure of IMD.....	4-50
Figure 4.4.3	Cyclone Warning Organisational Structure of IMD.....	4-51
Figure 4.4.4	Hazard Prone District Map of India .....	4-52
Figure 4.4.5	Annual Frequency of Cyclones (1891-2014) .....	4-53
Figure 4.4.6	Tracks of Cyclones during 1891-2014 .....	4-53
Figure 4.4.7	Tropical Cyclones Regional Bodies of WMO.....	4-55
Figure 4.4.8	Annual Average Track Forecast Error of Cyclones in the North Indian Ocean... 4-58	
Figure 4.4.9	Annual Average Track Forecast Error of Typhoon by JMA.....	4-59
Figure 4.4.10	Wind and Cyclone Zones in India .....	4-60
Figure 4.4.11	Probable Maximum Storm Surge above Tide Levels in India.....	4-61
Figure 4.4.12	Cyclone Risk Mitigation Framework .....	4-61
Figure 4.6.1	National Seismic Network.....	4-79
Figure 4.6.2	Seismic Zonation Map of India .....	4-80
Figure 4.6.3	General Information Dissemination .....	4-82
Figure 4.6.4	Schematic Seismological Operation including Dissemination System .....	4-82
Figure 4.7.1	Damage of the Indian Ocean Tsunami 2004 in India .....	4-84
Figure 4.7.2	Organisational Structure of INCOIS .....	4-86
Figure 4.7.3	National Seismic Network and Location of Seismic Station of INCOIS .....	4-88
Figure 4.7.4	Location of BPR and Tide Gauges .....	4-88
Figure 4.7.5	International Real Time Seismic Network (IRTSN) .....	4-89
Figure 4.7.6	Flow of Tsunami Modelling for Bulletin Dissemination .....	4-90
Figure 4.7.7	Study Area.....	4-91
Figure 4.7.8	Example of Tsunami Inundation Map and Hazard Map .....	4-91
Figure 4.7.9	Education Materials for Tsunami Preparedness prepared by INCOIS .....	4-92



Figure 4.7.10	Monitoring and Computer System of ITEWC .....	4-94
Figure 5.2.1	Distribution of Flood Forecasting Network.....	5-4
Figure 5.2.2	Bulletins Issuing for April 2012 Earthquakes .....	5-7
Figure 5.2.3	Information Flow when there is an Early Warning Signal.....	5-8
Figure 5.2.4	Information Flow when there is no Early Warning Signal.....	5-8
Figure 5.3.1	Organisational Structure of Directorate of Disaster Management.....	5-11
Figure 5.3.2	Tsunami Atlas – Andaman Sea .....	5-13
Figure 5.3.3	School Disaster Management System and School Disaster Management Plan....	5-14
Figure 5.3.4	Example of School Evacuation Map and Situation of Go-Down at School.....	5-14
Figure 5.3.5	Sea Wall and Coastal Plantation of Mangroves .....	5-16
Figure 5.3.6	Tsunami Shelter.....	5-16
Figure 5.3.7	Communication Flow of Alert/Warning (Tsunami Case) .....	5-17
Figure 5.3.8	Tsunami Sirens .....	5-18
Figure 5.3.9	Trigger Mechanism for Response to Disasters .....	5-19
Figure 5.3.10	School used for Tsunami Shelter and Location Map for Communities .....	5-20
Figure 6.1.1	Flow of State Disaster Response Fund and National Disaster Response Fund.....	6-2
Figure 6.2.1	Annual Trend of SDRF .....	6-5
Figure 6.3.1	Release of NDRF and Severe Natural Disaster Occurrence.....	6-10
Figure 7.2.1	Current Organisational Setup for Disaster Management in Uttarakhand State.....	7-2
Figure 7.2.2	Photo of Kedarnath Village before and after the Disaster in June 2013.....	7-3
Figure 7.2.3	Damages caused by the Landslide/Flooding in April 2012 in Uttarkashi District .....	7-4
Figure 7.2.4	Landslide Hazard Zone of Uttarakhand State.....	7-4
Figure 7.2.5	Small-scale Landslide (near Rudraprayag as of 17 July 2015) .....	7-5
Figure 7.2.6	Major Landslide Zones along the Char Dham Yatra Route .....	7-6
Figure 7.2.7	An Example of LHZ prepared by Technical Institute .....	7-7
Figure 7.2.8	State Disaster Response Force at Sonprayag District.....	7-9
Figure 7.2.9	Current Situation of SEOC.....	7-10
Figure 7.2.10	Emergency Community System on District Level .....	7-11
Figure 7.2.11	Equipment of DEOC .....	7-12
Figure 7.2.12	Critical Location and Evacuation Points along Kedarnath Tatra Route.....	7-16
Figure 7.2.13	Topographical Setting of Landslide Area.....	7-17
Figure 7.2.14	Typical Types of Landslide by the Field Survey Results.....	7-18
Figure 7.2.15	Situation of Debris Flow from Small Stream .....	7-18
Figure 7.2.16	Typical Method of Countermeasures for Existing Landslide.....	7-19
Figure 7.2.17	Construction of Stone Masonry and Danger Notice Signboard .....	7-19
Figure 7.2.18	Schematic Drawing of Target Roads.....	7-20
Figure 7.2.19	Communication Network in Uttarakhand State.....	7-21
Figure 7.3.1	Current Organisational Setup for Disaster Management in Bihar State.....	7-29
Figure 7.3.2	Organisational Structure of Bihar State Disaster Management Authority .....	7-29
Figure 7.3.3	Location of Hydro-Meteorological and Hydrological Stations (40 Stations) .....	7-31
Figure 7.3.4	Bihar Seismic Zones.....	7-32
Figure 7.3.5	Rivers in Bihar State.....	7-33
Figure 7.3.6	Flood Vulnerable Zones (Bihar State).....	7-33
Figure 7.3.7	Drought Prone Areas (Bihar State).....	7-34
Figure 7.3.8	An Example of Inundation Map and Flood Hazard Map (Khagaria, Bihar) .....	7-36
Figure 7.3.9	Disaster Response at L1 Level .....	7-38
Figure 7.3.10	Disaster Response at L2-L3 Level.....	7-39
Figure 7.3.11	Information Flow of Alert (Bihar State).....	7-41
Figure 7.3.12	Safety Road Map during Flood (Example of Madhubani District) .....	7-42
Figure 7.3.13	Preparing Relief and Response Materials for Preparedness (DMD) .....	7-44

Figure 7.3.14	Flood Preparedness in the Ganga River (Samastipur) .....	7-44
Figure 7.3.15	Embankment Works in the Bagmati River (Muzzafarpur).....	7-45
Figure 7.3.16	Meandering of River and Lower Ground than River Water in the Kamla River (Janjharpur District) .....	7-46
Figure 7.3.17	Adopted Structural Measures for Bank Protection.....	7-47
Figure 7.3.18	People living in the River Area (Burhi Gandak and Bagmati Rivers).....	7-47
Figure 7.3.19	Early Warning System in Bihar State.....	7-48
Figure 7.4.1	Organisation Setup for Disaster Management in Andhra Pradesh State .....	7-55
Figure 7.4.2	Land-fall Locations of Major Cyclones in the Recent Past.....	7-58
Figure 7.4.3	Automatic Weather Station and its Specification on APSDPS Website .....	7-59
Figure 7.4.4	Observation Data Browser on APSDPS Website.....	7-59
Figure 7.4.5	Example of Daily Spatial Maps by APSDPS .....	7-60
Figure 7.4.6	Vulnerability Map for Storm Surge in case of 235km/h Wind Speed.....	7-61
Figure 7.4.7	Inundation Map for 1/100 Return Period .....	7-61
Figure 7.4.8	Vulnerability Maps prepared by the GOI-UNDP Project in Vijayawada .....	7-62
Figure 7.4.9	Organisation of IRT at State Level.....	7-63
Figure 7.4.10	Cyclone Hudhud Observed Track and 24 Hour Precipitation.....	7-65
Figure 7.4.11	Semi-Real Time Cyclone Inundated Area Map.....	7-66
Figure 7.4.12	Cyclone Shelter in Andhra Pradesh State.....	7-71
Figure 7.4.13	Laying Power and Communication Cables Underground in Visakhapatnam .....	7-72
Figure 7.4.14	Coast near the Visakhapatnam Magistrate's Office .....	7-72
Figure 7.4.15	Results of Rainfall Forecast for next 24 & 48 Hours by APSDPS.....	7-73
Figure 7.4.16	Daily Possible Damaging Wind Speed in Visakhapatnam by APSDPS .....	7-73
Figure 7.4.17	Control Panel of Real Time System in APSDPS.....	7-74
Figure 7.4.18	Wire-less Communication Equipment in District.....	7-74

## List of Table

Table 2.2.1	Land Use in India (2011).....	2-3
Table 2.2.2	Distribution of Population in India (2014) .....	2-5
Table 3.1.1	Outline of the Disaster Management Act, 2005 .....	3-1
Table 3.4.1	Outline of the State Disaster Management Plan .....	3-5
Table 3.4.2	Nodal Ministries/Departments by Disaster Type .....	3-6
Table 3.4.3	Central Departments for Early Warning by Disaster Type .....	3-7
Table 3.5.1	Components of Bihar Kosi Flood Recovery Project .....	3-8
Table 3.5.2	Components of Uttarakhand Disaster Recovery Project .....	3-9
Table 3.5.3	Components of National Cyclone Risk Mitigation Project (Phase II) .....	3-10
Table 3.5.4	Summary of UNDP Projects for Disaster Risk Reduction .....	3-11
Table 4.1.1	Quinquennial Trend of Total Affected People and Damage caused by Different Disasters .....	4-4
Table 4.2.1	Major Flood Disasters in India (1990-2014) .....	4-8
Table 4.2.2	Flood Damage during 2004-2013.....	4-9
Table 4.2.3	Basin-wise Number of Meteorological Stations and Exclusive Meteorological Stations .....	4-10
Table 4.2.4	Number of Hydrological Stations from 2003 to 2012.....	4-10
Table 4.2.5	State-wise Hydrological Stations.....	4-11
Table 4.2.6	Total Flood Prone Area in India.....	4-14
Table 4.2.7	Flood Management Measures in India .....	4-15
Table 4.2.8	Achievement in Flood Management.....	4-16
Table 4.2.9	Expenditure of the 11th Five-Year Plan and Outlay of the 12th Five-Year Plan for FMP .....	4-17
Table 4.2.10	Detailed Outlays of the 12th Five-Year Plan for FMP .....	4-17
Table 4.2.11	Funding Share under FMP in the 12th Five-Year Plan .....	4-18
Table 4.2.12	Number of Critical Schemes and Funding Share under FMP in the 12th Five-Year Plan.....	4-18
Table 4.2.13	State-wise Details of Works Approved and Completed, and Funds Released (FMP) .....	4-19
Table 4.2.14	Challenges and Actions (Floods).....	4-23
Table 4.3.1	Action Plan for Landslide Risk Mitigation.....	4-25
Table 4.3.2	Departments/Organisations for Landslide Hazard Study and Activities .....	4-28
Table 4.3.3	Landslide Classification System in India .....	4-28
Table 4.3.4	Disaster Record of Landslide in India (1990-2015) .....	4-29
Table 4.3.5	Example of Landslide Inventory by GSI.....	4-37
Table 4.3.6	Prioritisation of Each Scale (Macro and Meso).....	4-39
Table 4.3.7	Outline of Contents of DPR .....	4-41
Table 4.3.8	Challenges and Actions (Landslides) .....	4-45
Table 4.4.1	Cyclone Related Policy, Plan and Guidelines by the Government of India.....	4-48
Table 4.4.2	Number of Cyclone related Staff of IMD.....	4-51
Table 4.4.3	Annual Budget of IMD.....	4-51
Table 4.4.4	Criteria for Classification of Cyclonic Disturbances over North Indian Ocean ...	4-52
Table 4.4.5	Historical Cyclonic Storms on East and West Coasts of India after 1990s.....	4-54
Table 4.4.6	Types of Bulletins (exclude aviation related bulletins) .....	4-56
Table 4.4.7	Cyclone Related Bulletins in India.....	4-56
Table 4.4.8	Observation Equipment and Systems .....	4-57
Table 4.4.9	Major Activities on NCRMP Phase 1 in Andhra Pradesh and Odisha.....	4-62
Table 4.4.10	Breakdown of Activities in Andhra Pradesh and Odisha .....	4-63
Table 4.4.11	Time Line of Early Warning and Evacuation at Event of Cyclone.....	4-63
Table 4.4.12	Time Line of Response at Event of Cyclone .....	4-64

Table 4.4.13	Challenges and Actions (Cyclones).....	4-67
Table 4.6.1	Budget Requirement.....	4-76
Table 4.6.2	Major Earthquakes that Affected India .....	4-78
Table 4.7.1	List of Tsunami Disasters (after 1900s).....	4-87
Table 4.7.2	Items of Structural and Non-Structural Measures .....	4-93
Table 5.2.1	Area of Responsibility of ACWCs and Cyclone Warning Centres.....	5-1
Table 5.2.2	Bulletins: Case of Cyclone Hudhud .....	5-2
Table 5.2.3	Number of Flood Forecasting Sites in Major Inter-state River Systems.....	5-3
Table 5.2.4	Threat Categories of Tsunami Early Warning.....	5-5
Table 5.2.5	Organisations Related to Bulletin Dissemination.....	5-5
Table 5.2.6	Threat Information Issued by ITEWC after 2007 .....	5-7
Table 5.3.1	Composition of Union Territory Disaster Management Plan.....	5-10
Table 5.3.2	Triggering of Tsunami Sirens in the Andaman and Nicobar Islands .....	5-18
Table 5.3.3	Expenditures for Response in District.....	5-21
Table 5.4.1	Challenges and Actions (Early Warning and Communication System).....	5-22
Table 6.2.1	State Disaster Response Fund (SDRF).....	6-6
Table 6.2.2	Insurance Conditions of NAIS (Rabi 1999-2000 to Kharif 2014, 30 Seasons).....	6-7
Table 6.2.3	Insurance Conditions of MNAIS (Rabi 2010-2011 to Kharif 2014, 8 Seasons)....	6-8
Table 6.2.4	Insurance Conditions of WBCIS (Kharif 2007 to Kharif 2014, 16 Seasons).....	6-8
Table 6.3.1	Financial Gap between NCCD and NCCF/NDRF .....	6-9
Table 6.3.2	Challenges to be addressed (Disaster Risk Finance).....	6-12
Table 7.1.1	States ranked by the Number of Deaths caused by Disaster (1995–2014).....	7-1
Table 7.2.1	Disaster Record of Uttarakhand State (2004-2014).....	7-2
Table 7.2.2	Damages due to the Disaster (Landslide/Flooding) in June 2013 of Uttarakhand State (Damage in Rudraprayag and Uttarkashi Districts).....	7-3
Table 7.2.3	Damages due to Landslide/Flooding in April 2012 in Uttarkashi District.....	7-4
Table 7.2.4	EOC Activation Level .....	7-8
Table 7.2.5	Brief Description of Seven Desks .....	7-15
Table 7.2.6	Allocation and Release of SDRF/NDRF in Uttarakhand State (2010-2015) .....	7-21
Table 7.2.7	Sanction and Release of SDRF in Uttarkashi District (2010-2015).....	7-22
Table 7.2.8	Challenges and Actions (Uttarakhand State).....	7-24
Table 7.3.1	Factor Risks identified in the State Disaster Management Plan.....	7-27
Table 7.3.2	Roles of DMD and BSDMA .....	7-28
Table 7.3.3	Major Earthquakes in Bihar State.....	7-30
Table 7.3.4	Flood Damage during 2004-2013 in Bihar State.....	7-30
Table 7.3.5	Earthquake Zone Classification in Bihar State.....	7-32
Table 7.3.6	Disaster Prone Districts in Bihar .....	7-35
Table 7.3.7	Classification of Disaster Level.....	7-37
Table 7.3.8	Recovery Works after Flood Events.....	7-40
Table 7.3.9	Disaster Management Expenditure.....	7-40
Table 7.3.10	Water Level during Flood and Setting Danger Water Level (Example of Madhubani District, Bihar).....	7-42
Table 7.3.11	Relief Centre and its Capacity (Madhubani District, Bihar) .....	7-43
Table 7.3.12	Flood-prone Area, Embankment Length and Protection Area (Bihar).....	7-45
Table 7.3.13	Responsible Authority/Body for Early Warning System .....	7-48
Table 7.3.14	Allocation and Release of SDRF/NDRF in Bihar State (2010-2015) .....	7-50
Table 7.3.15	Challenges and Actions (Bihar State).....	7-52
Table 7.4.1	Disaster Records in last 10 years in Andhra Pradesh State .....	7-55
Table 7.4.2	The Number of Weather and Water Level Sensors in Andhra Pradesh State .....	7-59
Table 7.4.3	Utilised Numerical Model for Risk Mapping in Andhra Pradesh .....	7-62
Table 7.4.4	Contents of DDMP on Cyclone in Visakhapatnam District.....	7-65

Table 7.4.5	Response Activities During Cyclone Hudhud.....	7-66
Table 7.4.6	Estimated Loss and Required Financial Assistance .....	7-67
Table 7.4.7	Lessons Learned from Cyclone Hudhud .....	7-68
Table 7.4.8	Warning Level and Actions taken by District Magistrate (Visakhapatnam Case).....	7-69
Table 7.4.9	Allocation and Release of SDRF/NDRF in Andhra Pradesh State (2010-2015) .	7-75
Table 7.4.10	Challenges and Actions (Andhra Pradesh State).....	7-78

### **List of Abbreviations**

ACWC	Area Cyclone Warning Centre
ADB	Asian Development Bank
AIC	Agricultural Insurance Company of India Ltd.
AICTE	All India Council for Technical Education
AIGS	All Indian General Scheme
APARD	Andhra Pradesh Academy of Rural Development
APCHMP	Andhra Pradesh Cyclone Hazard Mitigation Project
APSDMS	Andhra Pradesh State Disaster Mitigation Society
APSDPS	Andhra Pradesh State Development Planning Society
ARGS	Automatic Rain Gauge Station
AWS	Automatic Weather Station
BB	Brahmaputra Board
BCDRR	Bihar Conference of Disaster Risk Reduction
BIS	Bureau of Indian Standard
BMTPC	Building Material and Technology Promotion Council
BPR	Bottom Pressure Recorder
BRO	Boarder Roads Organisation
BSDMA	Bihar State Disaster Management Authority
BSIDM	Bihar State Institute of Disaster Management
CAT	Catchment Area Treatment
CBDMP	Community Based Disaster Management Programme
CBO	Community-based Organisations
CBRI	Central Building Research Institute
CDMC	Cyclone Distress Mitigation Committee
CDMM	Centre for Disaster Management and Mitigation
CMC	Crisis Management Committee
CMED	Centre for Management of Environment and Disasters
CMRF	Chief Minister's Relief Fund
CoA	Council of Architecture
CP	Central Plan
CPIS	Coconut Palm Insurance Scheme
CRR	Central Road Research Institute
CSIO	Central Scientific Instrument Organisation
CWC	Central Water Commission
CWDS	Cyclone Warning Dissemination System
DDGM	Deputy Director Generals of Meteorology
DDM	Directorate of Disaster Management
DDMA	District Disaster Management Authority
DDMF	District Disaster Mitigation Fund
DDMP	District Disaster Management Plan
DDRF	District Disaster Response Fund
DEOC	District Emergency Operation Centre
DM Act	Disaster Management Act
DMD	Disaster Management Department
DMMC	Disaster Mitigation and Management Centre
DOT	Department of Telecommunication
DPR	Detailed Project Report
DR2AD	Disaster Risk Reduction Investments Accounts for Development
DRMS	District-wise Rainfall Monitoring Scheme

DRR	Disaster Risk Reduction
DSC	Decision Support Centre
DSS	Decision Support System
DST	Department of Science and Technology
EOC	Emergency Operation Centre
ESCAP	United Nations Economic and Social Commission for Asia and the Pacific
ESF	Emergency Support Function
ESSO	Earth Science System Organization
ETA	Estimated Time of Wave Arrival
EWA	Estimated Maximum Wave Amplitude
EWDS	Early Warning Dissemination System
FFWS	Flood Forecasting and Warning System
FM	Flood Management
FMIS	Flood Management Information System
FMISC	Flood Management Information Support Centre
FMP	Flood Management Plan
FPZ	Flood Plain Zoning
GDP	Gross Domestic Products
GFCC	Ganga Flood Control Commission
GLOF	Glacial Lake Outburst Flood
GOI	Government of India
GTS	Global Telecommunication System
GSI	Geological Survey of India
HFL	Highest Flood Level
HFRT	High Frequency Radio Transmission
HLC	High Level Commission
IADP	Intensive Agricultural Development Programme
IAP	Incident Action Plan
ICHAM	Integrated Coastal and Marine Area Management
ICS	Incident Command System
ICT	Information and Communication Technology
ICZM	Integrated Coastal Zone Management
IEC	Information, Education and Communication
IIRS	Indian Institute of Remote Sensing
IIT	Indian Institute of Technology
IMD	Indian Meteorological Department
IMG	Inter-Ministerial Group
IMT	Incident Management Team
INCOIS	Indian National Centre for Oceanic Information Services
INDOFOS	Indian Ocean Forecasting System
INR/Rs.	Indian Rupee
IRP	Incident Response Plan
IRS	Incident Response System
IRSS	Indian Remote Sensing Satellite
IRT	Incident Response Team
IRTSN	International Real Time Seismic Network
ISET	Indian Society of Earthquake Technology
ISI	Indian Standard Institution
ISRO	Indian Space Research Organisation
ITEWC	Indian Tsunami Early Warning Centre
ITEWS	Indian Tsunami Early Warning System

IWRM	Integrated Water Resources Management
JICA	Japan International Cooperation Agency
JMA	Japan Meteorological Agency
LHZ	Landslide Hazard Zonation
MFR	Medical First Responder
MHA	Ministry of Home Affairs
MNAIS	Modified National Agricultural Insurance Scheme
MOA	Ministry of Agriculture
MOEFCC	Ministry of Environment, Forest and Climate Change
MOES	Ministry of Earth Sciences
MOM	Ministry of Mines
MOUDPA	Ministry of Urban Development and Poverty Alleviation
MOWR	Ministry of Water Resources
MSB	Monthly Seismological Bulletin
NAIS	National Agricultural Insurance Scheme
NCIP	National Crop Insurance Program
NCMC	National Crisis Management Committee
NCRMP	National Cyclone Risk Mitigation Project
NCS	National Centre for Seismology
NDMA	National Disaster Management Authority
NDMF	National Disaster Mitigation Fund
NDMP	National Disaster Management Plan
NDRF	National Disaster Response Fund
NEC	National Executive Committee
NEOC	National Emergency Operation Centre
NERMP	National Earthquake Risk Mitigation Project
NGO	Non-Governmental Organization
NH	National Highway
NIDM	National Institute of Disaster Management
NIRM	National Institute of Rock Mechanics
NPCBEERM	National Program for Capacity Building of Engineers in Earthquake Risk Management
NPDM	National Policy on Disaster Management
NPEEE	National Program on Earthquake Engineering Education
NRSA	National Remote Sensing Agency
NRSC	National Remote Sensing Centre
NWA	National Water Academy
NWP	National Water Policy
ODA	Official Development Assistance
PER	Preliminary Earthquake Report
PIU	Project Implementation Unit
PMNRF	Prime Minister's National Relief Fund
PMU	Project Management Unit
PRI	Panchayati Raj Institution
PTC	Panel on Tropical Cyclones
QRT	Quick Response Team
RBA	Rashtriya Barh Ayog (National Flood Commission in India)
RCC	Reinforced Cement Concrete
RO	Responsible Officer
RTSP	Regional Tsunami Service Provider
SAO	Seasonal Agricultural Operations
SCMC	State Crisis Management Committee



SEC	State Executive Committee
SEOC	State Emergency Operation Centre
SERC	Science and Engineering Research Council
SERI	State Earthquake Research Institute
SDMA	State Disaster Management Authority
SDMF	State Disaster Mitigation Fund
SDMP	State Disaster Management Plan
SDRF	State Disaster Response Fund
SMS	Short Message Service
SOI	Survey of India
SOP	Standard Operating Procedure
SP	State Plan
SSM	Storm Surge Model
SSR	Slope Stability Radar
TC	Tropical Cyclone
TCAC	Tropical Cyclone Advisory Centre
TOI	Times of India
ULB	Urban Local Body
UNDP	United Nations Development Programme
USAC	Uttarakhand Space Applications Centre
USAID	U.S. Agency for International Development
USD	United States Dollar
USDMA	Uttarakhand State Disaster Management Authority
USFS	United States Forest Service
UT	Union Territory
UTDMA	Union Territory Disaster Management Authority
UTDMP	Union Territory Disaster Management Plan
VMC	Vijayawada Municipal Corporation
VSAT	Very Small Aperture Terminal
WB	World Bank
WBCIS	Weather Based Crop Insurance Scheme
WHM	Wind Hazard Model
WIHG	Wadia Institute of Himalayan Geology
WMO	World Metrological Organisation
WRD	Water Resources Department

# Executive Summary

## 1. Background and Objective

### 1.1 Background

Spending on the Disaster Risk Reduction (DRR) may have often been regarded as “subservient” to the society as a whole. Especially, developing countries where priority is given to economic growth often have a limited budget for DRR and tend to allocate their DRR budget not for disaster prevention and mitigation but for the expenses of emergency response provision following a natural disaster.

The 12th Five-Year Plan (2012–2017) of India stipulates the DRR in the chapters of “Water”, “Science Technology” and “Governance”. Especially in the governance chapter, it is clearly mentioned that the prior investment in DRR for prevention and mitigation will be economically and socially more beneficial than the expenses for emergency response and reconstruction. This indicates a policy shift toward the disaster risk reduction and prevention. Moreover, National Disaster Management Authority (NDMA) established under the Disaster Management Act in 2005 (hereinafter referred to as the “DM Act”) has driven the establishment of disaster warning system in disaster prone areas, mainstreaming of DPR, and improvement of awareness on DRR in central, state and district levels.

Japan’s assistance policy to India sets reduction of poverty and improvement of environmental issues among the priority objectives, and it includes the activities considering the DRR. The policy stipulates the necessity of assistance in DRR based on the experiences and know-how on erosion and flood control and warning system in Japan. The policy also requires providing the assistance to minimise the economic losses by natural disasters and to achieve the sustainable development for the prevention and mitigation of natural disasters based on international DRR trends and continuous efforts for economic development and disaster management in India.

### 1.2 Objective

The objectives of Data Collection Survey for Disaster Prevention in India (hereinafter referred to as the “Survey”) are to collect a wide range of information regarding the DRR in India, and to analyse the necessary assistance for the DRR in India considering the current situation, issues and assistance needs in the policy, regulatory and institutional aspects of risk control and risk finance.

### 1.3 Survey Area

The information on current status, issues and assistance needs in DRR in India will be collected through national government institutions, and it is planned that detail information on DRR in each disaster type will be collected and analysed in Bihar, Uttarakhand and Andhra Pradesh states designated as the priority survey areas. In addition, the Andaman and Nicobar Islands are selected as an example of information gathering

for the tsunami early warning systems (see in Figure-1).

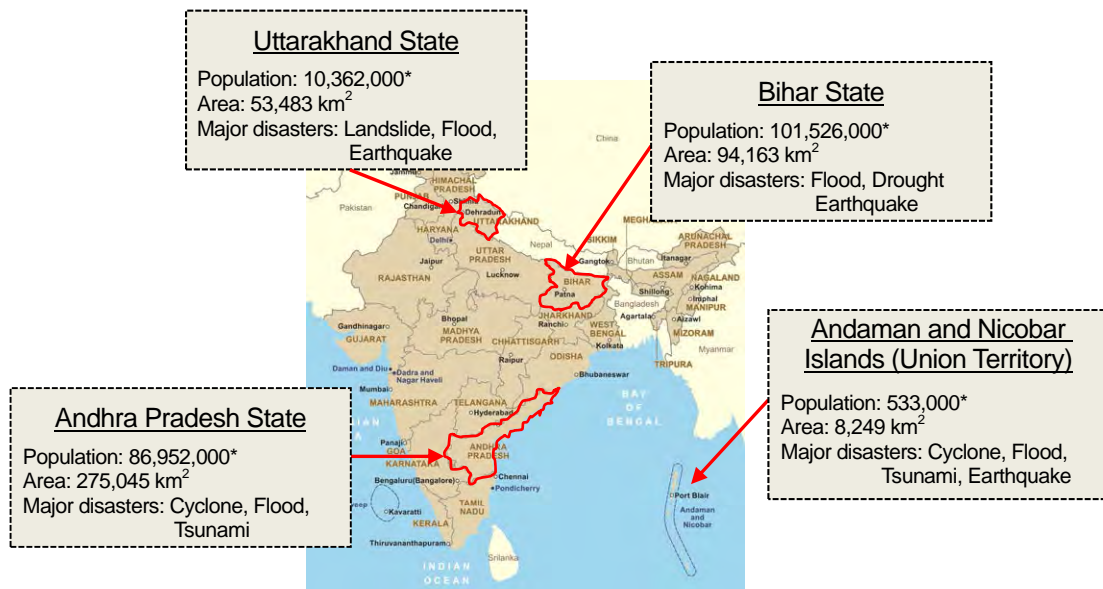

Note: Population data is estimated number in 2014 projected by the Central Statistics Office, the Ministry of Statistics and Programme Implementation.

Source: prepared by the Survey Team from the Statistic Yearbook in India (2015)

Figure-1 Survey Areas

## 2. Natural Disasters in India

### 2.1 Major Natural Disasters in India

The Indian scenario of disasters described in the “Disaster Management in India”, summarises the major disasters and damage in recent years. During the last 30 years, India has been hit by more than 400 major disasters resulting into enormous loss to life and property. During last 20 years (1995 to 2014), flood disasters have caused large-scale damage to the country. Abnormal weather, sediment disasters and cyclones (storm) have occurred once a year or more frequently. Those types of disasters have caused big damages. Regarding the earthquakes and tsunamis, although they do not have high frequency of occurrence, they have a huge impact once they occur. By reviewing the past disasters, it can be said that major natural disasters in India are “floods”, “cyclones”, “sediment disasters”, “earthquakes”, “tsunamis” and “abnormal weather”.

Floods have led to a large number of fatalities in Bihar, Himachal Pradesh and Uttarakhand states located in the middle reach and upper reach of the Ganges River. A large number of deaths caused by cyclones are recognised in Odisha, Andhra Pradesh and Gujarat states. Many people have suffered from sediment disasters and demised in Uttarakhand, Jammu and Kashmir and Himachal Pradesh states in the Himalaya mountain area. Considering the above conditions, the following three (3) states are selected as the priority survey areas to grasp and analyse the current situation of disaster management at the state level: Bihar for

floods, Andhra Pradesh for cyclones, and Uttarakhand for sediment disasters or landslides (See Figure-2 and Table-1).

**a. Occurrence**

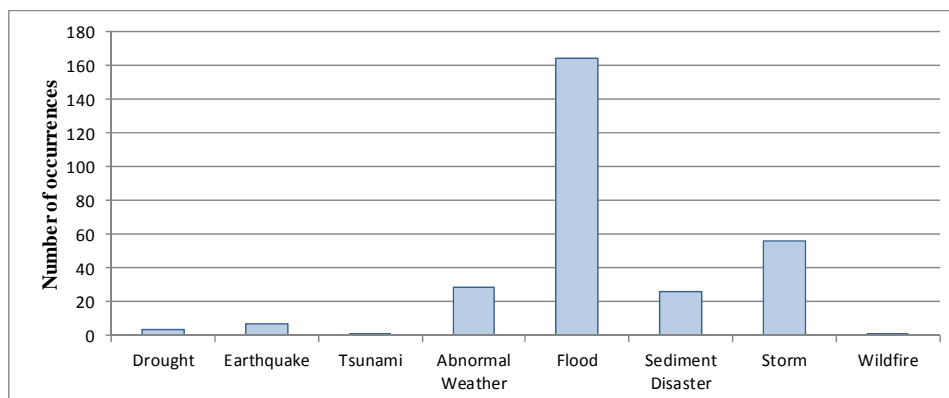

**b. Fatalities**

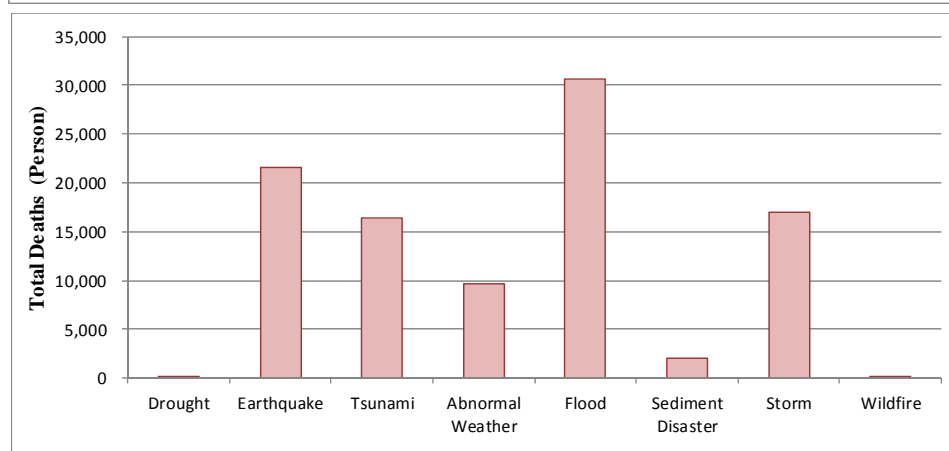

**c. Economic Loss**

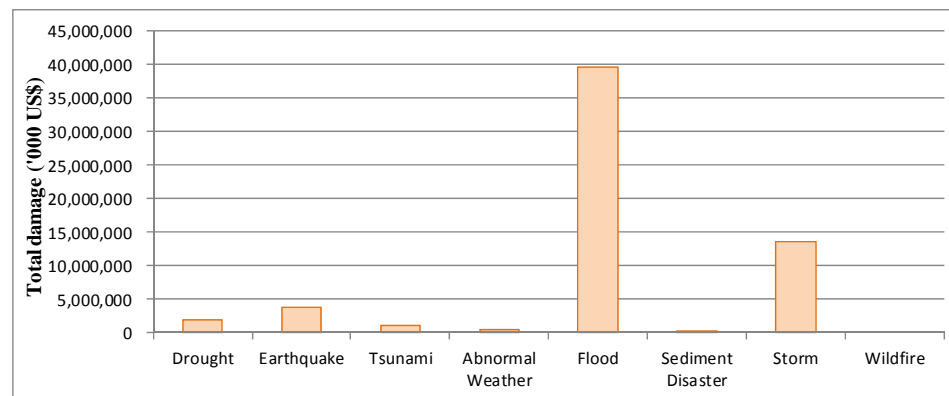

Type of Disaster	Frequency (times/year)	Average Number of Deaths (Persons/year)	Average Economic Damage (Thousand US\$/year)
Drought	0.2	1	102,056
Earthquake	0.4	1,079	189,100
Tsunami	0.1	819	51,140
Abnormal Weather	1.5	484	20,000
Flood	8.2	1,532	1,979,169
Sediment Disaster	1.3	101	2,725
Storm	2.8	852	681,656
Wildfire	0.1	0	0

Source: compiled by the Survey Team based on EM-DAT

Figure-2 Natural Disaster Events in India (1955-2014)

Table-1 Quinquennial Trend of Total Affected People and Damage caused by Different Disasters

	Total affected people			Total economic damage ('000 US\$)		
	2001-2005	2006-2010	2011-2015	2001-2005	2006-2010	2011-2015
Earthquake	6,478,634	-	634,550	3,623,000	-	120,000
Tsunami	654,512	-	-	1,022,800	-	-
Riverine flood	120,970,121	53,505,869	21,862,429	9,392,696	8,094,151	18,524,000
Flash flood	3,700,045	8,931,465	-	26,000	123,000	-
Coastal flood	-	7,200,000	-	-	275,000	-
Landslide*	5,020	-	513,673	50,000	-	1,100,000
Tropical cyclone	77,250	5,750,300	14,470,004	28,416	300,000	8,271,096

Note: The landslide event in June 2013 is classified in to “Flood” by EM-DAT.

Source: compiled by the Survey Team based on EM-DAT

## 2.2 Challenges of Disaster Management

Considering the current situation of DRR in India, challenges to be addressed can be drawn from the following perspectives:

- Institutional framework
- Risk analysis
- Preparedness
- Countermeasure
- Forecasting, early warning and communication system
- Emergency response
- Evacuation system

The following are the results of analysis:

< Disaster Type >

### Floods

A challenge identified by the Indian side is as follows:

- Reorganising the strategy for introduction of flood plain zoning

Challenges identified by the Survey Team are as follows:

- Introducing basin-wide sediment control with the concept of river basin management (RBM)
- Implementing embankment and bank protection works in consideration of basin-wide sediment control
- Planning countermeasures for water logging that could occur in the future due to shortage of flow carrying capacity caused by sedimentation in canals/channels

< Landslides >

Challenges identified by the Indian side are as follows:

- Prioritising landslide areas where countermeasures need to be implemented based on the risk assessment
- Establishing monitoring and early warning systems for landslide
- Improving the communication systems to enable rapid emergency response at the local level

Challenges identified by the Survey Team are as follows:

- Strengthening the coordination mechanism among organisations and institutions related to landslide risk reduction
- Raising awareness of and developing capacity of community inhabitants who live in landslide prone areas
- Introducing countermeasures against each type of landslide

< Cyclones >

Challenges identified by the Indian side are as follows:

- Conducting a sector-based risk analysis (for transportation and logistics)
- Conducting risk analysis for wildlife conservation area and zoological park/national park
- Planning deployment of proper materials and supplies for disaster response
- Maintaining cyclone shelters properly
- Coordinating rapid supply of essential resources during emergency response

Challenges identified by the Survey Team are as follows:

- Developing an effective Disaster Management Plan at the district level
- Securing public telecommunications systems during disasters
- Providing accurate warning at the local level by introducing reasonable systems
- Ensuring appropriate care for women, children, senior citizens, and disabled people in shelters

< Forecasting, Early Warning and Communication system >

Challenges identified by the Indian side are as follows:

- Improving last mile connectivity
- Securing redundancy of the communication systems

A challenge identified by the Survey Team is as follows:

- Planning installation of tsunami sirens with necessary facilities/structures

## 2.3 Disaster Risk Finance

In accordance with the recommendations by the Finance Commission and the task force constituted by the MHA and the analysis of current operations of disaster risk finance in India, the following actions are proposed. It is considered that the present status is during 14th FC period (2015-2016 to 2019-2020), so that all the concerned modifications might be applied from the next FC period (from 2020)

- Identifying and applying additional funding sources for NDRF
- Modifying sharing portion between central and state governments for SDRF
- Constituting NDMF and SDMF

During the course of the Survey, the disaster-related agencies in the selected priority survey areas did not express the financial needs as their challenges for the disaster management, so that the potential needs for those schemes to allocate the required funds for post-disaster recovery was not identified at present.

Depending on the future disaster damages, the GOI might consider the utilisation of those external funds for the emergency response.

## 2.4 Disaster Management in the Survey Areas

Similar to the analysis of challenges by disaster type, challenges to be addressed in the survey areas can be drawn based on the survey results:

### Priority Survey Areas

#### < Uttarakhand State >

Challenges identified by the related organisations in Uttarakhand State are as follows:

- Establishing forecasting/early warning system for landslide
- Strengthening the communication system at the time of occurrence of landslide event

Challenges identified by the Survey Team are as follows:

- Strengthening the coordination mechanism among organisations/institutions related to landslide DRR
- Reviewing and revising the landslide inventory
- Preparing evacuation maps (evacuation places and routes) for communities close to landslide prone areas
- Establishing appropriate system of planning, design and construction of countermeasures
- Strengthening the evacuation system at the time of occurrence of landslide event

#### < Bihar State >

A challenge identified by the related organisations in Bihar State is as follows:

- Reorganising the strategy for introduction of flood plain zoning

Challenges identified by the Survey Team are as follows:

- Introducing basin-wide sediment control with the concept of river basin management (RBM)
- Conducting risk analysis of riverbed aggradation and inland water drainage
- Establishing appropriate system of planning, design and construction of countermeasures to strengthen the banks
- Establishing appropriate system of planning, design and construction of measures for inland water drainage
- Establishing the early warning systems for tributaries of the Ganga River

#### < Andhra Pradesh State >

Challenges identified by the related organisations in Andhra Pradesh State are as follows:

- Establishing the institutional framework of disaster management at the district, mandal (sub-district) and village levels
- Introducing scientific tools for the cyclone and flood risk analysis

Challenges identified by the Survey Team are as follows:

- Developing capacity on disaster mitigation and preparedness at the mandal and village levels
- Developing reliable communication network for river monitoring and management facilities during cyclone

- Giving incentives to strengthen and/or retrofit individual houses and buildings to make them resilient to disaster risks
- Implementing countermeasures for coastal protection in the urban area
- Strengthening building resilience to cyclones and floods
- Strengthening the communication network tolerance to cyclones
- Strengthening the capacity of early warning for local torrential downpours in the urban area
- Constructing/renovating cyclone shelters

#### Andaman and Nicobar Islands

A challenge identified by the Survey Team is as follows:

- Planning installation of tsunami sirens with necessary facilities and structures

### **3. Applicability of Japanese Technology to Challenges Identified**

#### 3.1 Japanese Experience and Technologies

The followings are the Japanese experience and technologies that might be introduced in India to tackle the challenges identified:

- |   |                             |
|---|-----------------------------|
| ● Armor levee method for spilling                               | Floods                      |
| ● Storage facility during flood in urban area (retarding basin) | Floods                      |
| ● Comprehensive flood disaster management                       | Floods                      |
| ● Flood risk analysis   | Floods                      |
| ● Restraint work and control work                               | Landslides                  |
| ● Water control work  | Landslides                  |
| ● Rock fall countermeasure                                      | Landslides                  |
| ● Risk assessment of landslide area                             | Landslides                  |
| ● X-band phased array radar                                     | Forecasting / Early Warning |
| ● Tsunami hazard map by residential area                        | Tsunami                     |
| ● Town planning based on tsunami risk assessment                | Tsunami                     |
| ● Tsunami tower, siren  | Tsunami                     |

#### 3.2 Conclusion

The Survey followed two (2) approaches to evaluate the current situation of disaster risk reduction in India. The first approach is evaluation by major disaster type (see Chapter 4) and the other one is evaluation by state selected as priority survey area (see Chapter 7). In order to tackle the challenges, it is necessary to take some actions on a step-by-step basis. Therefore, the matrices shown in Chapter 4 and Chapter 7 describe the stepwise actions for three terms: short term (1 -2 years), medium term (3 – 5 years) and long term (5 -10 years).

The challenges identified are evaluated from three perspectives: 1) effectiveness of activities to be taken, 2) capacity of the relevant organisations (the Indian side), and 3) current situation and progress of policy and planning. As a result, it was concluded that the following are the challenges with high priority.



< Disaster Type >

Floods:

- Implementing embankment and bank protection works in consideration of basin-wide sediment control (Countermeasure)

Landslides:

- Prioritising landslide areas where countermeasures need to be implemented based on the risk assessment (Risk Analysis)
- Introducing countermeasures against each type of landslide (Countermeasure)

Cyclones:

- Securing public telecommunications systems during disasters (Countermeasure)
- Providing accurate warning at the local level by introducing reasonable systems (Forecasting, Early Warning and Communication System)
- Ensuring appropriate care for women, children, senior citizens, and disabled people in shelters (Evacuation System)

< Early Warning and Communication System >

- Securing redundancy of the communication systems

< Priority Survey Areas >

Uttarakhand State

- Reviewing and revising the landslide inventory (Risk Analysis)
- Establishing appropriate system of planning, design and construction of countermeasures (Countermeasure)

Bihar State

- Conducting risk analysis of riverbed aggradation and inland water drainage (Risk Analysis)
- Establishing appropriate system of planning, design and construction of countermeasures to strengthen the banks (Countermeasure)

Andhra Pradesh State

- Developing capacity on disaster mitigation and preparedness at the mandal and village levels (Institutional Framework)

- Implementing countermeasures for coastal protection in the urban area (Countermeasure)
- Strengthening the communication network tolerance to cyclones (Forecasting, Early Warning and Communication System)

The result shows that risk analysis and countermeasure are the major challenges with high priority. In order to mainstream disaster management in the development activities and reduce the disaster risk, risk analysis and countermeasure are a very important part. For example, the landslides risk assessment has been carried out by some Government of India's agencies and institutions such as GSI; however, the analysis measures still follow macro scale zoning. Besides, countermeasures leave much to be improved because the applied measures are very limited at the moment. Disaster mechanism varies depending on the location and local situation. Therefore, it is necessary to apply suitable measures to each type of disaster risk. As discussed in Section 8.1 and 8.2, some Japanese technologies and experience can be introduced to India in order to address the challenges. It is expected that organisations responsible for disaster management at all levels take initiative to address the challenges considering the applicability of other countries' experience and realise a society resilient to the natural disasters.



## **CHAPTER 1 BACKGROUND AND OBJECTIVE OF THE SURVEY**

### **1.1 Background**

#### **1.1.1 Mainstreaming Disaster Risk Reduction**

Spending on the Disaster Risk Reduction (DRR) may have often been regarded as “low priority” to the society as a whole. Especially, developing countries where priority is given to economic growth often have a limited budget for DRR and tend to allocate their DRR budget not for disaster prevention and mitigation but for the expenses of emergency response provision following a natural disaster.

The Sendai Framework for Disaster Risk Reduction had been adopted at the UN World Conference on Disaster Risk Reduction in March 2015 with seven (7) targets and four (4) priorities for DRR related actions for the next 15 years. International community have started their DRR related actions based on the priorities such as investigating in DRR for resilience, enhancing disaster preparedness for effective response, “Build Back Better” in recovery, rehabilitation and reconstruction. In addition, the position paper issued by Japan International Cooperation Agency (JICA) for DRR focuses on the increase of prior investment in DRR as one of the main concerns toward mainstreaming DRR. Moreover, JICA has actively made efforts for the mainstreaming DRR; it has disseminated the activities for DRR after 2015 development agenda, developed economic simulation model called as DR2AD (Disaster Risk Reduction Investments Accounts for Development) which enables to quantitatively analyse the impacts of the investment in DRR on the economic growth and development.

#### **1.1.2 Disaster Management Policy in India**

According to the 12th Five-Year Plan (2012–2017) of India, it is planned to invest approximately 51 trillion Indian Rupee (INR or Rs.) by public and private financing for the development of the social and economic infrastructures, such as power generation system, railway, water supply and sewerage system, port, airport and so on. In accordance with the development needs in India, JICA committed to JPY 311.54 billion in Fiscal Year 2013 for ODA loan projects including railway, metro and water supply projects and committed similar level of assistance in Fiscal Year 2014 for ODA loan projects.

The 12th Five-Year Plan stipulates the DRR in the chapters of “Water”, “Science Technology” and “Governance”. Especially in the governance chapter, it is clearly mentioned that the prior investment in DRR for prevention and mitigation will be economically and socially more beneficial than the expenses for emergency response and reconstruction. This indicates a policy shift toward the disaster risk reduction and prevention. Moreover, National Disaster Management Authority (NDMA) established under the Disaster Management Act in 2005 (hereinafter referred to as the “DM Act”) has driven the establishment of disaster warning system in disaster-prone areas, mainstreaming DRR, improvement of awareness on DRR in central, state and district levels.

On the other hand, even though the national government has accelerated the mainstreaming DRR, a number of large scale natural disasters have occurred in regional areas: sediment disasters in mountainous areas in Uttarakhand State in 2013 and Jammu and Kashmir State in 2014; and flood disaster in every monsoon season in Bihar, Assam, West Bengal and south-eastern states. Since the state governments do not have sufficient capabilities to respond to those disasters, the assistance of the Government of India and/or international societies is required.

### 1.1.3 Japan’s Assistance Policy for Disaster Management in India

Japan’s assistance policy to India sets reduction of poverty and improvement of environmental issues among the priority objectives, and it includes the activities considering the DRR. The policy stipulates the necessity of assistance in DRR based on the experiences and know-how on erosion and flood control and warning system in Japan. The policy also requires providing the assistance to minimise the economic losses by natural disasters and to achieve the sustainable development for the prevention and mitigation of natural disasters based on international DRR trends and continuous efforts for economic development and disaster management in India.

### 1.2 Objective of the Survey

The objectives of Data Collection Survey for Disaster Prevention in India (hereinafter referred to as the “Survey”) are to collect a wide range of information regarding the DRR in India, and to analyse and explore the probable areas that may require assistance from JICA for DRR in India considering the current situation, issues and assistance needs in the policy, regulatory and institutional aspects of risk control and risk finance.

### 1.3 Survey Areas

The information on current status, issues and assistance needs in DRR in India will be collected through the Government of India’s institutions, and detailed information on DRR in each disaster type are collected and analysed in Bihar, Uttarakhand and Andhra Pradesh states designated as the candidate states of priority survey areas (see in Figure 1.3.1).

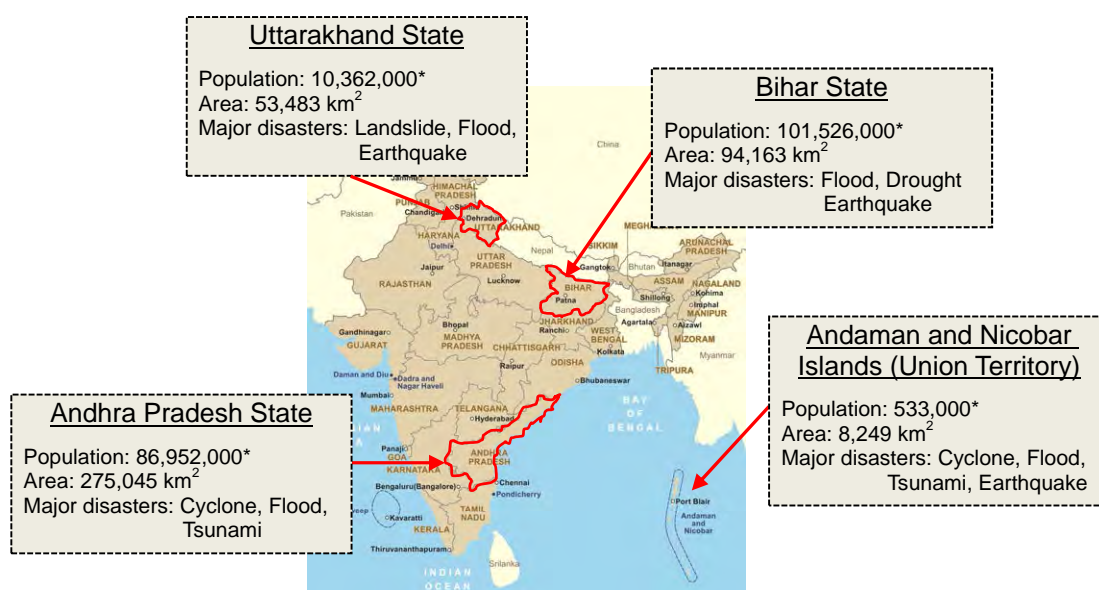

Note: Population data is estimated number in 2014 projected by the Central Statistics Office, the Ministry of Statistics and Programme Implementation.

Source: prepared by the Survey Team from the Statistic Yearbook in India (2015)

**Figure 1.3.1 Survey Areas**

Telangana State was established in 2014 as a separate new state carved out of Andhra Pradesh State with Hyderabad, as the capital city of both Andhra Pradesh and Telangana states. Thus, this change will be considered in the statistical data collection and institutional analysis. Although Hyderabad is serving as the capital city of Andhra Pradesh State, as mentioned above, it is planned to relocate the state capital from Hyderabad and develop a new capital by 2024.

As for the forecasting and early warning systems, the information about the Andaman and Nicobar Islands will be gathered as an example.

## 1.4 Survey Schedule

### < 1<sup>st</sup> Survey in India >

No.	Date	Organisation Visited/Activities
1	May 4, 2015	Arrival in New Delhi
2	May 5, 2015	JICA India Office National Institute of Disaster Management (NIDM)
3	May 6, 2015	Geological Survey of India (GSI), Ministry of Mines Central Water Commission (CWC), Ministry of Water Resources
4	May 7, 2015	India Meteorological Department (IMD), Ministry of Earth Sciences (MOES) Ministry of Earth Sciences (MOES) World Bank India Office
5	May 8, 2015	JICA India Office National Institute of Disaster Management (NIDM) JICA Expert, Department of Road Transport and Highways, Ministry of Road Transport and Highways (MORTH)
6	May 9, 2015	Leaving for Tokyo
7	May 10, 2015	Arrival in Tokyo

### < 2<sup>nd</sup> Survey in India >

No.	Date	Organisation Visited/Activities		
1	June 21, 2015	Arrival in New Delhi		
2	June 22, 2015	JICA India Office		
3	June 23, 2015	Meeting with local engineers for arrangement of meeting and site survey National Disaster Management Authority (NDMA)		
4	June 24, 2015	Data analysis		
5	June 25, 2015	National Centre for Seismology (NCS), Ministry of Earth Sciences		
6	June 26, 2015	Ministry of Road Transport and Highways (MORTH)		
7	June 27, 2015	Data analysis		
8	June 28, 2015	Data analysis		
9	June 29, 2015	Indian National Centre for Ocean Information Services (INCOIS) Ministry of Agriculture		
10	June 30, 2015	Ministry of Environment, Forest and Climate Change (MOEFCC)		
11	July 1, 2015	U.S. Agency for International Development (USAID) Asian Development Bank (ADB)		
12	July 2, 2015	Ministry of Water Resources (MOWR)		
13	July 3, 2015	JICA India Office United Nations Development Programme (UNDP)		
14	July 4, 2015	Site survey in Bihar State	Site survey in Uttarakhand State	Site survey in Andhra Pradesh State
15	July 5, 2015	Preparation	Preparation	Preparation
16	July 6, 2015	Meeting with Chief Secretary, Relief Commissioner, State Disaster Management Department, State Disaster Management Authority (BSDMA), and National Disaster Response Force	Meeting with World Bank and State Public Works Department (SPWD)	Meeting with State Development Planning Society and Planning Department

No.	Date	Organisation Visited/Activities		
17	July 7, 2015	Site survey in Bihar State	Site survey in Uttarakhand State	Site survey in Andhra Pradesh State
		Meeting with Bihar Aapda Punarwas Evam Punarnirman Society under Planning and Development Department, Water Resource Department, Flood Management Improvement Support Centre, PMU & PIU for Kosi River Flood Recovery Project	Meeting with Chief Secretary, State Public Works Department (SPWD) and Disaster Mitigation and Management Centre (DMMC)	Meeting with Transport, Road & Buildings Department
18	July 8, 2015	Meeting with Water Resources Department Move to Khagaria	Meeting with State Disaster Response Force (SDRF) and State Department of Disaster Management	Meeting with Centre of Disaster Preparedness and Water Resources Department
19	July 9, 2015	Survey on Kosi River Meeting with District Office on Flood Management	Meeting with Geological Survey of India (GSI)	Meeting with Revenue (Disaster Management) Department
20	July 10, 2015	Survey on Anti-erosion Works in Ganga Move to Patna	Meeting with District Magistrate, District Disaster Management Authority (DDMA), District Disaster Management Centre and District Emergency Operation Centre of Uttarkashi District	Meeting with Chief Secretary
21	July 11, 2015	Data analysis	Site survey on landslide areas and river conditions along NH-108	Data analysis
22	July 12, 2015	Data analysis	Data analysis	Move from Hyderabad to Visakhapatnam
23	July 13, 2015	Survey on Gandak River	Site survey on Uttarkashi-Pauthi-Mussoorie-Dehradun (NH-108-134-123), Meeting with State Emergency Operation Centre (SEOC)	Meeting with Disaster Section of Visakhapatnam District
24	July 14, 2015	Survey on Burhi Gandak River and Bagmati River Meeting with District Office on Flood Management	Site survey on Dehradun-Rishikesh-Srinagar-Rudraprayag (NH-58)	Meeting with District Magistrate and site survey in Vhemili Village
25	July 15, 2015	Survey on Khirol (Bagmati) River and Kamila (Kosi) River Meeting with BSDMA	Meeting with District Magistrate, District Disaster Management Authority and District Emergency Operation Centre of Rudraprayag District	Meeting with Disaster Section of Krishna District
26	July 16, 2015	Survey on Khirol (Bagmati) River, Bagmati River and Burhi Gandak River	Survey on landslide area and river condition along the NH-109	Site survey in Tahsaldar Mandal and meeting with Deputy Tahsaldar

No.	Date	Organisation Visited/Activities		
27	July 17, 2015	Site survey in Bihar State	Site survey in Uttarakhand State	Site survey in Andhra Pradesh State
		Survey on Ganga River (Left bank embankment) Move to Patna Meeting with DMD	Survey on Rudraprayag-Srinagar-Rishikesh-Dehradun (NH-58)	Meeting with UNDP in Vijayawada
28	July 18, 2015	Move to New Delhi	Move to New Delhi	Move to New Delhi
29	July 19, 2015	Data analysis		
30	July 20, 2015	Data analysis		
31	July 21, 2015	Data analysis		
32	July 22, 2015	JICA India Office		
33	July 23, 2015	Meeting with local engineers for arrangement of meeting and site survey in the Andaman and Nicobar Islands		
34	July 24, 2015	Ministry of Road Transport and Highways (MORTH) Leaving for Tokyo (Expert of Flood Disaster and Expert of Cyclone Disaster)		
35	July 25, 2015	Data analysis Arrival in Tokyo (Expert of Flood Disaster and Expert of Cyclone Disaster)		
36	July 26, 2015	Move to Port Blair, the Andaman and Nicobar Islands		
37	July 27, 2015	Chief Secretary, Directorate of Disaster Management (DDM)		
38	July 28, 2015	Directorate of Disaster Management (DDM) South Andaman District Emergency Operation Centre		
39	July 29, 2015	Site Survey (tsunami siren, school evacuation shelter, check dam, evacuation shelters, and relief godown) Port Management Board		
40	July 30, 2015	Public Works Department		
41	July 31, 2015	Site Survey (tsunami siren, mangrove plantation sites, sluice gate, and evacuation shelters) Directorate of Disaster Management (DDM)		
42	August 1, 2015	Data analysis		
43	August 2, 2015	Move to New Delhi		
44	August 3, 2015	Central Water Commission (CWC), Ministry of Water Resources (MOWR)		
45	August 4, 2015	National Disaster Management Authority (NDMA)		
46	August 5, 2015	Meeting with local engineers for arrangement of required data and documents		
47	August 6, 2015	JICA India Office Data analysis		
48	August 7, 2015	Leaving for Tokyo (Expert of Sediment Disaster and Expert of Disaster Risk Finance)		
49	August 8, 2015	Arrival in Tokyo (Expert of Sediment Disaster and Expert of Disaster Risk Finance)		
50	August 9, 2015	Data analysis		
51	August 10, 2015	Leaving for Tokyo (Team Leader/DRR Policy and Legislative)		
52	August 11, 2015	Arrival in Tokyo (Team Leader/DRR Policy and Legislative)		





## CHAPTER 2 DEVELOPMENT PLAN AND SOCIO-ECONOMIC CONDITION

### 2.1 National Development Plan

#### 2.1.1 Outline of The 12th Five-Year Plan (2012-2017)

The 12th Five-Year Plan is the medium term national development plan in India. The plan’s vision is “Faster, More Inclusive and Sustainable Growth.” The key areas of intervention in the plan are 1) Developing capabilities, 2) Managing natural resources and the environment, and 3) Engagement with the world. The main part of the plan consists of financing plan and sector-wise plans. The disaster management is mentioned in several parts, such as the key areas of intervention and sector-wise policy. Major plans related to the disaster management are flood damage assessment, development of basins-wise flood management models and integrated mathematical models in the water sector, implementation of seismological research and the disaster management support in the science and technology sector, establishment of the early warning systems, and mainstreaming of disaster risk reduction in all major schemes and awareness and capacity building (see Figure 2.1.1).

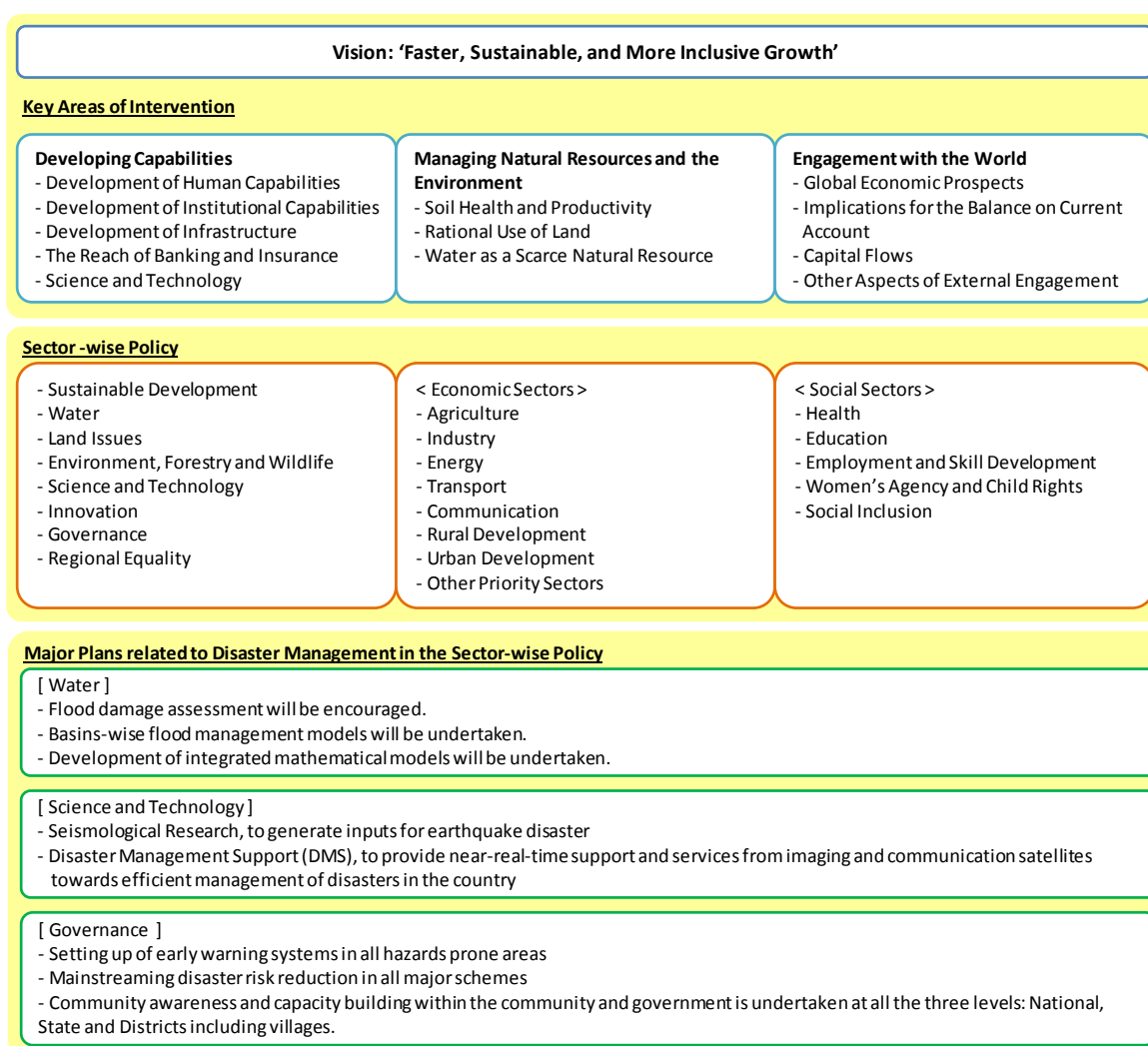

Source: compiled by the Survey Team based on “The 12th Five-Year Plan (2012–2017)”, (2013)

**Figure 2.1.1 Outline of The 12th Five-Year Plan (2012–2017)**

### **2.1.2 Water (Flood Management)**

The 12th Five-Year Plan states that, overall, 39 districts in India have been identified as chronically flood-prone. Indiscriminate development and encroachment of flood plain areas, improper planning in construction of roads and railways, inadequate and ineffective drainage in urban areas, and so on, have contributed to the increase in flood damage. Some state governments, such as Bihar State, have changed their strategy of tackling floods by placing emphasis on rehabilitation of traditional and natural drainage systems because of the limited possibilities of building more large storages and embankments. The 12th Five-Year Plan endorses such a paradigm shift taken by the state governments in flood management. Greater priority is also given to non-structural measures in the 12th Five-Year Plan. Major action plans in the 12th Five-Year Plan are as follows:

- The 12th Five-Year Plan will extend the inflow forecasting coverage of the Central Water Commission (CWC), which is currently limited to 28 reservoirs, to additional 160 reservoirs making it cover 80–90 % of the total live storage capacity.
- The NDMA will make adequate provision for development of model multipurpose flood shelters under the National Flood Risk Mitigation Project or other related programmes.
- The National Water Academy (NWA) will be developed as a centre of excellence for international training programmes on matters pertaining to flood mitigation so that up-to-date globally available know-how could be shared under such training programmes.
- Use of flood hazard zonation maps of National Remote Sensing Centre (NRSC), close contour information, river configuration & bank erosion studies, geo-spatial tools and flood mapping and flood damage assessment will be encouraged.

### **2.1.3 Seismological Research**

It is proposed to provide thrust to the earthquake-related studies and to generate inputs for earthquake disaster mitigation. The primary activities include the followings:

- Deep crustal studies across the Indian continental margin and the interior
- Paleo seismological studies and kinematics of the Himalayan region, Andaman subduction zone and active faults of India

### **2.1.4 Governance (Disaster Management)**

The 10th Five-Year Plan initiated the process of shift from relief and response centric disaster management to prevention, mitigation and preparedness as means to revert to more effective way of handling the disasters. The process of strengthening disaster preparedness was further emphasised in the 11th Five-Year Plan. The NDMA was set up at the national level. The authority formulated extensive guidelines and a national policy on disaster management. Similarly, state and district level authorities were also set up gradually. The strategy for the disaster management in the 12th Five-Year Plan is based on the achievements under the previous plans. The following programmes are undertaken:

- Early warning systems in all hazards prone areas of the country:  
Effective communication systems have to be set up at all levels to ensure timely and accurate dissemination of warning signals to vulnerable communities.
- Mainstreaming DRR in all major schemes:  
The development programmes and policies should focus on their impacts on increasing disaster risks and on the mitigation measures they propose. The DRR will need to be thus incorporated in all major schemes, specifically the flagship schemes, for reducing the vulnerability of the hazards prone areas of the country.
- Capacity Building:  
It is important that community awareness and capacity building within the community and government is undertaken at all three (3) levels: national, state and district including village.

These need to cover education and research, public sensitisation, and awareness and institutional strengthening and development.

## 2.2 Natural and Socio-Economic Condition

### 2.2.1 Natural Condition

#### (1) Topographic Condition

The Indian peninsula is separated from mainland Asia by the Himalayas. The country is surrounded by the Bay of Bengal in the east, the Arabian Sea in the west and the Indian Ocean in the south. It measures about 3,214 km from north to south and about 2,933 km from east to west. The total length of coastline of the mainland, Lakshadweep Islands and Andaman & Nicobar Islands is 7,516.6 km.

As shown in Table 2.2.1, the total geological area of India is approximately 3.3 million km<sup>2</sup>, consisting of 0.7 million km<sup>2</sup> (22 %) of forest area, 2.0 million km<sup>2</sup> (60 %) of cropped area, and 0.6 million km<sup>2</sup> (18 %) of other land use. Besides, depending on the location of the states of India, the land use trend varies; Bihar and Andhra Pradesh states are dominated by the agricultural land use, but most of the Uttarakhand State area is covered by forest since this area is mountainous.

**Table 2.2.1 Land Use in India (2011)**

Location	Total Area	Forest Area		Cropped Area		Other Areas	
	(km <sup>2</sup> )	(km <sup>2</sup> )	(%)	(km <sup>2</sup> )	(%)	(km <sup>2</sup> )	(%)
India	3,287,469	700,060	21.3	1,989,690	60.5	597,719	18.2
Bihar State	94,163	6,220	6.6	71,940	76.4	16,003	17.0
Uttarakhand State	53,483	34,850	65.2	11,700	21.9	6,933	13.0
Andhra Pradesh State	275,045	62,300	22.7	145,120	52.8	67,625	24.6

Source: Statistic Yearbook in India (2015)

#### (2) Meteorological Condition

Generally, the climate of India can be classified as tropical monsoon. In spite of much of northern part of India lying beyond the tropical zone, the entire country has a tropical climate marked by relatively high temperatures and dry winter. There are four (4) seasons in India:

- Winter: December to February
- Summer: March to June
- South-West Monsoon Season: June to September
- Post Monsoon Season: October to November

Figure 2.2.1 shows the annual average temperature in India and selected states. The lowest temperature is recorded during the winter season, and it increases toward the summer season. The months with highest temperature are May and June. Among the selected three (3) states, Uttarakhand State shows the lowest temperature during the winter season since this state is located in Himalayas.

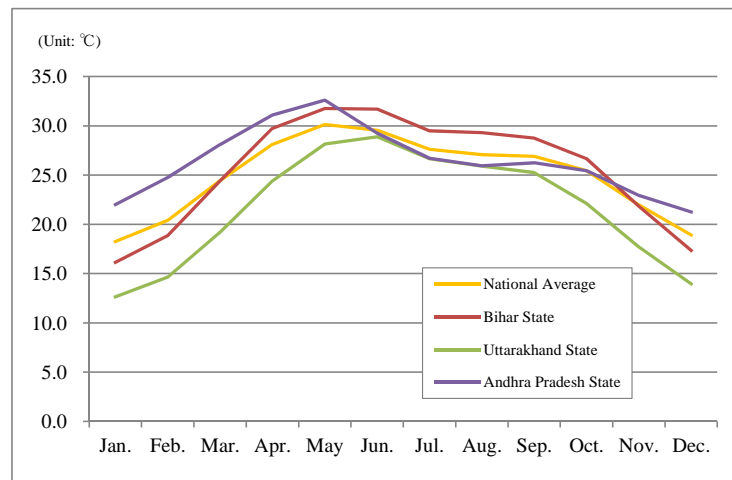

Note: Climatological information is based on monthly averages for the 50-100 years period for 1951-2000 published by IMD.  
Source: India Meteorological Department (IMD) (2015)

**Figure 2.2.1 Average Annual Mean Temperature**

The average rainfall is shown in Figure 2.2.2. During the monsoon season between June to September, the maximum rainfall occurs; approximately 14,000 mm of rainfall was recorded in July. Due to the mountainous nature, Uttarakhand State shows the highest rainfall volume of all the three (3) states.

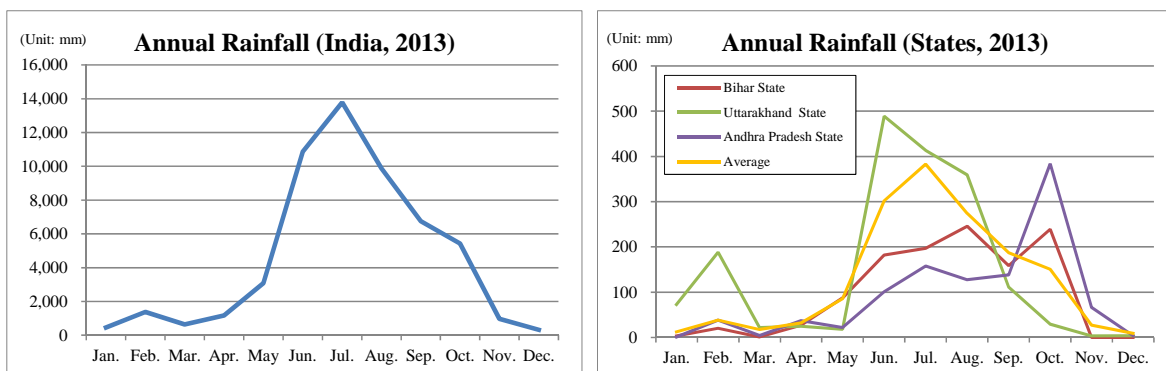

Source: Statistic Yearbook in India (2015)

**Figure 2.2.2 Annual Rainfall in India (2013)**

## 2.2.2 Socio-Economic Condition

### (1) Population

The projected population in 2014 is 1.2 billion based on the national census in 2011 as shown in Table 2.2.2 (Source: Statistic Yearbook in India (2015)). Almost 70 % of the population lives in rural area, and especially Bihar State has high ratio in the rural population. The population growth ratio is approximately 18 % over a decade, and Bihar State indicates a high population growth rate of more than 25 %.

**Table 2.2.2 Distribution of Population in India (2014)**

Location	Area (km <sup>2</sup> )	Population			Population Density (person/km <sup>2</sup> )	10-Year Growth Rate (%)
		Total ('000 persons)	Urban Area (%)	Rural Area (%)		
India	3,287,469	1,238,887	31%	69%	382	17.70%
Bihar State	94,163	101,526	11%	89%	1,106	25.42%
Uttarakhand State	53,483	10,362	29%	71%	189	18.81%
Andhra Pradesh State	275,045	86,952	28%	72%	308	10.98%

Note: Population data in 2014 are projected by the Central Statistics Office, the Ministry of Statistics and Programme Implementation.

Source: Statistic Yearbook in India (2015)

## (2) Economic Activity

The Gross Domestic Products (GDP) as of 2013 is estimated as Rs. 9,388,876 crore (equivalent to USD 1.5 trillion) consisting of the several industry sectors shown in Figure 2.2.3. Agriculture contributes a significant figure to the GDP with a proportion of 18 %, amounting to Rs. 1,645,000 crore (equivalent to USD 0.3 trillion). Considering the land use and population distribution stated above, the agriculture is unquestionably the largest livelihood provider in India in the vast rural area.

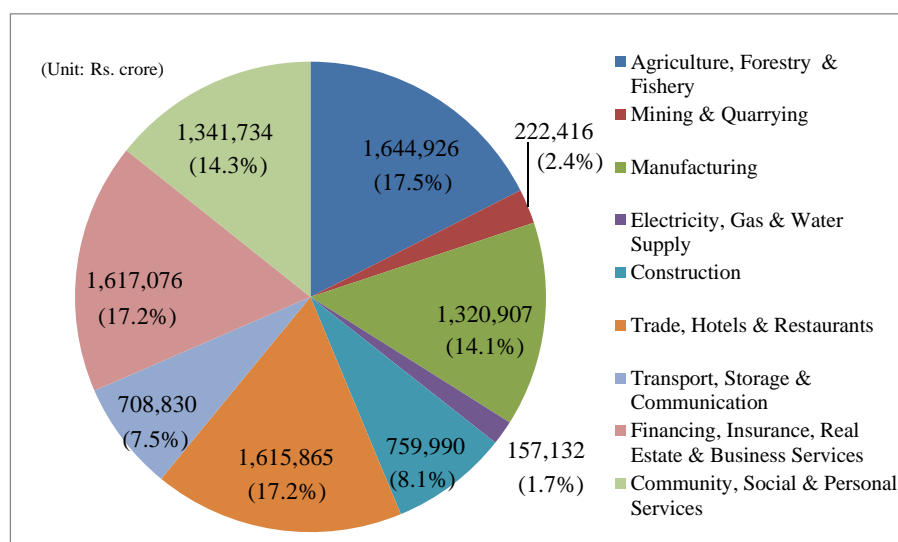

Source: Statistic Yearbook in India (2015)

**Figure 2.2.3 Allocation of GDP (Current Price in 2013)**

According to Statistic Yearbook in India in 2015, GDP per capita amounts USD 1,584.33 in 2014 and annual growth rate is approximately 5.6 %.



## CHAPTER 3 DISASTER MANAGEMENT

### 3.1 Disaster Management Act, 2005

A few states such as Uttarakhand State had enacted their own disaster management laws earlier. On 23 December 2005, the DM Act was enacted as a comprehensive law on disaster management at the national level in order to adopt a holistic and integrated approach to the disaster management in India. This important milestone was a first step to shift the paradigm from the relief-based response to a proactive prevention, mitigation and preparedness-driven approach on the disaster management. The DM Act provides the setting up of institutional structures at the national, state and district levels. Table 3.1.1 shows the structure at each administration level.

**Table 3.1.1 Outline of the Disaster Management Act, 2005**

No.	Administration Level	Institutional Setup
1	National	<ul style="list-style-type: none"> <li>- Establishment of the followings: National Disaster Management Authority (NDMA) National Executive Committee (NEC) National Institute of Disaster Management (NIDM) National Disaster Response Force</li> <li>- Preparation of a national disaster management plan (NDMP)</li> <li>- Preparation of a national plan for the disaster management by every ministry or department of the GOI</li> </ul>
2	State	<ul style="list-style-type: none"> <li>- Constitution of State Disaster Management Authority (SDMA)</li> <li>- Establishment of State Executive Committee (SEC)</li> <li>- Preparation of a state disaster management plan (SDMP)</li> </ul>
3	District	<ul style="list-style-type: none"> <li>- Constitution of District Disaster Management Authority (DDMA)</li> <li>- Preparation of a district disaster management plan (DDMP)</li> </ul>

Source: Disaster Management Act, 2005

### 3.2 National Policy on Disaster Management

The National Policy on Disaster Management 2009 (NPDM) was prepared by the NDMA and was approved by the Union Cabinet on 22 October 2009. Creation of NPDM is one of the steps to realise the paradigm shift in the disaster management. The vision and objectives of the policy are as follows:

**Vision:**

To build a safe and disaster resilient India by developing a holistic, proactive, multi-disaster oriented and technology driven strategy through a culture of prevention, mitigation, preparedness and response.

**Objectives:**

- Promoting a culture of prevention, preparedness and resilience at all levels through knowledge, innovation and education
- Encouraging mitigation measures based on technology, traditional wisdom and environmental sustainability
- Mainstreaming disaster management into the developmental planning process
- Establishing institutional and techno-legal frameworks to create an enabling regulatory environment and a compliance regime
- Ensuring efficient mechanism for identification, assessment and monitoring of disaster risks
- Developing contemporary forecasting and early warning systems backed by responsive and fail-safe communication with information technology support
- Ensuring efficient response and relief with a caring approach towards the needs of the vulnerable sections of the society



- Undertaking reconstruction as an opportunity to build disaster resilient structures and habitat for ensuring safer living
- Promoting a productive and proactive partnership with the media for disaster management

NPDM consists of ten (10) components: 1) institutional and legal arrangements, 2) financial arrangements, 3) disaster prevention, mitigation and preparedness, 4) techno-legal regime, 5) response, 6) relief and rehabilitation, 7) reconstruction and recovery, 8) capacity development, 9) knowledge management, and 10) research and development. These components describe strategic approaches, role of stakeholders, and specific actions to be taken by various institutions. However, they do not include any information about estimated cost required for the specific actions and implementation schedule. Figure 3.2.1 shows the outline of the NPDM.

<b>Institutional and Legal Arrangements</b>	<ul style="list-style-type: none"> <li>- Setting Institutional framework of disaster management by NDMA, SDMA and DDMA</li> <li>- Coordinating the existing crisis management systems, etc.</li> </ul>
<b>Financial Arrangements</b>	<ul style="list-style-type: none"> <li>- Arranging budgetary allocation to mainstream prevention and mitigation measures into the developmental plans</li> <li>- Establishing a foundation for disaster mitigation/prevention</li> </ul>
<b>Disaster Prevention, Mitigation and Preparedness</b>	<ul style="list-style-type: none"> <li>- Carrying out risk assessment and hazard/vulnerability mapping</li> <li>- Promoting climate change adaptation, Setting up forecasting and warning systems</li> <li>- Enhancing the function of emergency operation centre, etc.</li> </ul>
<b>Techno-Legal Regime</b>	<ul style="list-style-type: none"> <li>- Revising municipal regulations, land use planning, safe construction practices</li> <li>- Building compliance regime and enforcement systems</li> </ul>
<b>Response</b>	<ul style="list-style-type: none"> <li>- Clarifying roles and tasks of related organisations</li> <li>- Preparing standard operation procedures (SOP), etc.</li> </ul>
<b>Relief and Rehabilitation</b>	<ul style="list-style-type: none"> <li>- Setting up temporary relief camps</li> <li>- Managing relief supplies</li> <li>- Reviewing and revising standards of relief, etc.</li> </ul>
<b>Reconstruction and Recovery</b>	<ul style="list-style-type: none"> <li>- Promoting owner driven reconstruction</li> <li>- Linking recovery with safe development</li> <li>- Laying emphasis on livelihood restoration, etc.</li> </ul>
<b>Capacity Development</b>	<ul style="list-style-type: none"> <li>- Enhancing institutional capacity development, training of communities, professional technical education, disaster management education in schools and training of artisans and other groups</li> </ul>
<b>Knowledge Management</b>	<ul style="list-style-type: none"> <li>- Promoting synergetic application of science and technology</li> <li>- Expanding the Indian Disaster Resource Network (IDRN) and knowledge network (IDKN)</li> </ul>
<b>Research and Development</b>	<ul style="list-style-type: none"> <li>- Identifying needs and promotion of research and research partners/agencies/groups depending on their knowledge base and expertise</li> </ul>

Source: compiled by the Survey Team based on NPDM

**Figure 3.2.1 Outline of NPDM**

### **3.3 National Disaster Management Plan**

Section 11 of the DM Act makes it mandatory to prepare the National Disaster Management Plan (NDMP) for the whole country. Based on this provision, the NDMP was prepared. The NDMP consists of two parts: Part I-Basic Plan and Framework and Part II-Disaster Mitigation, Response and Function Plans. Part I was prepared by the National Executive Committee (NEC) in consultation with the state governments and expert bodies or organisations in the field of disaster management and approved by the NDMA, while Part II was prepared by the ministries or departments of the GOI. The main purpose of the NDMP is to outline the prevention, preparedness, mitigation and response measures of any situation emerging out of natural or human-induced disasters in the country. The followings are the contents of the NDMP.

- Part I: National profile, capacity building, disaster mitigation, mainstreaming of disaster risk reduction in development plan, disaster preparedness and response, disaster recovery, and financial arrangement
- Part II: Hazard specific mitigation plan, response plan, and function plans

Previously, major activities for the disaster management in India were response and rehabilitation. After the enactment of the DM Act, preparedness and mitigation were focused on to reduce the risks associated with natural disasters. The “Disaster Mitigation” section covers seven (7) components: 1) Knowledge & Research, 2) Hazard Mapping and Assessments, 3) Coordination, 4) Information Collection, Interpretation, Dissemination, and Archiving, 5) Education, Public Awareness and Outreach, 6) National/State/Local Government Mitigation Initiatives, and 7) Governance, Roles and Responsibilities.

The concept of “Mainstreaming of Disasters Risk Reduction in Developmental Plan” is still new to India. The NDMP states that the development plan of every ministry/department should incorporate elements of the DRR.

### **3.4 Institutional Framework of Disaster Management**

#### **3.4.1 Organisational Structure of the Disaster Management**

Figure 3.4.1 shows the legal-institutional framework stipulated by the DM Act and the NPDM. The disaster management system in India is composed of three (3) administrative layers: national, state and district levels. Since administrative system applied in India is the federal system, each state government has broad authorities.

The NDMA has the responsibility for laying down policies, plans and guidelines for the disaster management and coordinating the enforcement and implementation of those policies, plans and guidelines to ensure timely and effective response to disasters. The central ministries, departments and states are responsible for formulating their respective disaster management plans.

At the state level, the State Disaster Management Authority (SDMA) has the responsibility for laying down policies and plans for the disaster management in the state. The state plan should follow the guidelines laid down by the NDMA.

The District Disaster Management Authority (DDMA) plays a role as the planning, coordinating and implementing body for the disaster management at the district level. The DDMA takes necessary measures for the disaster management in accordance with the guidelines laid down by the NDMA and the SDMA.

Local authorities also need to ensure capacity building of their officers for the disaster management, carry out relief, rehabilitation and reconstruction activities in the affected areas and prepare disaster

management plans in accordance with the guidelines of the NDMA, the SDMA and the DDMA.

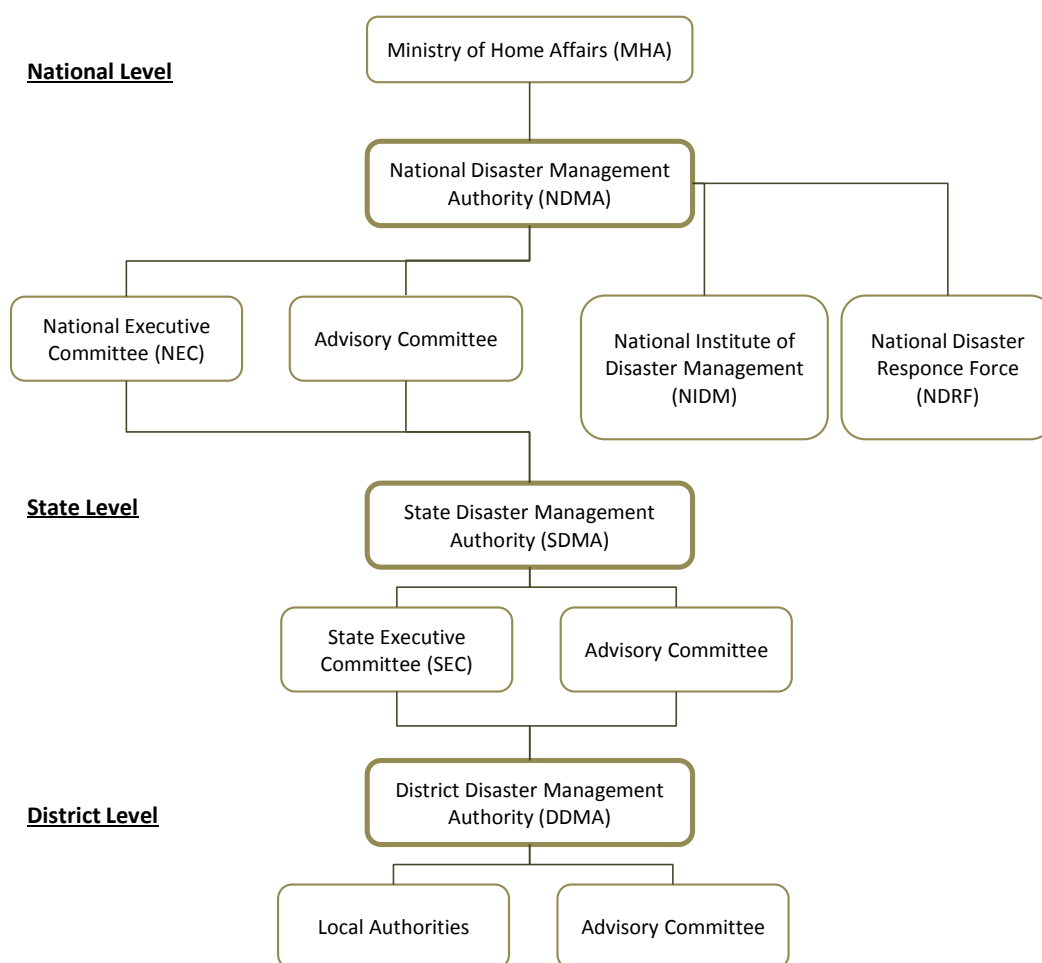

Source: compiled by the Survey Team based on NPDM

**Figure 3.4.1 Institutional Framework of Disaster Management in India**

The National Institute of Disaster Management (NIDM) is responsible for training, research, documentation and development of a national level information base.

The National Disaster Response Force works for specialised response to a threatening disaster situation or disasters/emergencies both natural and man-made. The National Disaster Response Force units maintain close liaison with the designated state governments and are available to them in the event of any serious threatening disaster situation. The National Disaster Response Force units also impart basic training to all the stakeholders identified by the state governments in their respective locations.

### **3.4.2 Guidelines for the Disaster Management and Standard Operating Procedures**

The NDMA laid down the guidelines that are expected to be utilised by the central ministries, departments, states, districts and local authorities for preparation of their respective disaster management plans. The followings are the major ones:

- Incident response system
- National disaster management information and communication system
- Management of floods
- Management of urban flooding
- Management of landslides and snow avalanches

- Management of cyclones
- Management of earthquakes
- Management of Tsunamis
- Seismic retrofitting of deficient buildings and structures
- Preparation of state disaster management plans
- Model framework for District Disaster Management Plan (DDMP)

The guidelines for preparation of state disaster management plans provide the suggested outline of the state plan as shown in Table 3.4.1. Basically, the outline follows the structure of national policy. The model framework of the DDMP also follows similar structure. According to the National Institute of Disaster Management (NIDM), state and district officers have the capacity to prepare the disaster management plans at the state and district level, while the implementation of the plans is different issue.

**Table 3.4.1 Outline of the State Disaster Management Plan**

Outline		Typical Content
Part I: General		
Chapter I	Introduction	- State profile: social, economic and demographic
Chapter II	Vulnerability Assessment and Risk Analysis	- History of vulnerability of the state to different types disasters - Hazard risk assessment and vulnerability mapping
Chapter III	Preventive Measures	- Natural disasters, specific to the state - Early warning and dissemination systems - Prevention and mitigation plans - Training needs analysis and development of state HR plan
Chapter IV	Mainstreaming DM Concerns into Developmental Plans/Programmes/Projects	- Economic and social infrastructure - Elements of impact assessment, risk reduction, and the “do no harm” approach - Classification of disasters and residual agenda
Chapter V	Preparedness Measures	- Resource availability, both national and state resources: government, private, civil society - Techno-legal regime - Fail-safe communication including last mile connectivity
Chapter VI	Response	- Incident Command System - Emergency Operation Centres - Alert mechanisms - early warnings
Chapter VII	Partnership with other stakeholders	- Roles of academic institutions and scientific and technical organisations - Media
Chapter VIII	Financial Arrangements	- Arrangements for the funding of the components of the state plan
Part II: Disaster Specific Action Plan		
Chapter IX - XVII	Floods, Cyclones, Earthquakes, Landslides, Chemical Disasters (including emphasis on off-site plans - preparation and rehabilitation), Nuclear Disasters, Biological Disasters, Oil Spills and Mine Disasters, Tsunamis	Depending on the hazard assessment result in the state
Part III: Cross-cutting Issues		
Chapter XVIII	Review and updating of plans	Schedule for submitting Action Taken Reports
Chapter XIX	Coordination and Implementation	Coordination, as between and amongst the various agencies involved in the disaster management

Source: NDMA, “National Disaster Management Guidelines, Preparation of State Disaster Management Plans”, (2007)

As discussed in Chapter 7, most part of the state disaster management plans cover the emergency operations and communication flow during disasters and other parts show only the general direction of planning at lower administration level such as district. The state government officials might be able to follow the procedure described in the plans during emergencies. However, the state disaster management plans does not cover measures needed either for mitigation or for rehabilitation/recovery of the affected people and reconstruction of the area. This means there is no comprehensive DRR plan considering prevention/mitigation and the concept of building back better.

The standard operating procedure (SOP) for responding to natural disasters was laid down by the Ministry of Home Affairs (MHA). The SOP includes specific actions to be taken by various central ministries and departments, state governments and the district administration for responding to natural disasters. SOP is mainly composed of institutional mechanism, preparedness, early warning, trigger mechanism, response and relief.

### **3.4.3 Emergency Operation Centres (EOCs)**

Emergency operation centres/control rooms are set up at national, state and district levels with requisite facilities. The followings are the functions of the EOCs/control rooms:

- Receive and process disaster alerts and warnings from nodal agencies and other sources and communicate the same to all designated authorities
- Monitor emergency operations
- Facilitate the coordination among ministries/departments/agencies that have primary and secondary emergency support functions
- Requisition additional resources during the disaster phase
- Issue disaster/incident specific information and instructions specific to all concerned
- Consolidate, analyse and disseminate damage, loss and needs assessment data
- Forward consolidated reports to all designated authorities

### **3.4.4 Nodal Ministries/Departments for Management/Mitigation of Different Disasters**

The nodal ministries/departments related to the management/mitigation of different disasters are shown in Table 3.4.2.

**Table 3.4.2 Nodal Ministries/Departments by Disaster Type**

No.	Disasters	Nodal Ministries	Department/Centre/Commission
1	Earthquakes	Ministry of Earth Sciences	National Centre for Seismology (NCS)
2	Floods	Ministry of Water Resources	Central Water Commission (CWC)
3	Landslides	Ministry of Mines	Geological Survey of India (GSI)
4	Cyclones/ Tornado/ Hurricane	Ministry of Earth Sciences	Indian Meteorological Department (IMD)
5	Tsunamis	Ministry of Earth Sciences	Indian National Centre for Oceanic Information Services (INCOIS)

Source: compiled by the Survey Team based on “Disaster Management in India”, (2011) of the MHA

Table 3.4.3 shows the central departments mandated for early warning of major natural disasters. These departments are responsible for keeping track of observations and informing the designated authorities and agencies of observed data and forecasts.

**Table 3.4.3 Central Departments for Early Warning by Disaster Type**

No.	Disasters	Agencies
1	Cyclones	Indian Meteorological Department (IMD)
2	Floods	Central Water Commission (CWC)
3	Landslides	Geological Survey of India (GSI)
4	Tsunamis	Indian National Centre for Oceanic Information Services (INCOIS)

Source: MHA, "Standard Operating Procedure for Responding to Natural Disasters", (2010)

The IMD and INCOIS are constituted under the Ministry of Earth Sciences as Earth Science System Organisations (ESSOs).

### **3.4.5 Review of the Disaster Management Act, 2005**

A Task Force was constituted in December 2010 to review the DM Act. The review report was compiled in March 2013. The following are the recommendations presented by the Task Force, which may affect the existing institutional setup:

- The functions of NEC may be assigned to the NDMA and the NEC may be discontinued.
- The National Crisis Management Committee (NCMC) may be included in the DM Act, and perform the tasks specifically related to response and coordination.
- The functions of the SEC may be assigned to the SDMA and the SEC may be discontinued.
- The State Crisis Management Committee (SCMC) may be included in the DM Act, and perform the tasks particularly relating to response and coordination
- The powers and functions of the DDMA may be vested in the District Collector.
- Chapter 6 of the DM Act may add a provision which enables the state government to constitute a Disaster Management Authority for large cities, e.g., those with municipal corporations.
- The National Disaster Response Fund (NDRF) and the National Disaster Mitigation Fund (NDMF) are a must at the national level. At the state level it is desirable to have both the SDRF and the SDMF.

## **3.5 Other Donor Assistance to Disaster Management**

### **3.5.1 Project Outline of the World Bank (WB)**

The World Bank (WB) has been implementing several projects in the sectors of education and nutrition improvement, women empowerment, infrastructure development including roads and power sector, and poverty reduction in whole India.

Regarding the disaster risk reduction, the following projects have been carried out in the priority survey areas:

- Bihar Kosi Flood Recovery Project
- Uttarakhand Disaster Recovery Project
- National Cyclone Risk Mitigation Project Phase-II

#### **(1) Bihar Kosi Flood Recovery Project**

On 18 August 2008, the Kosi River burst through its eastern embankment, 11 km upstream of the Kosi barrage in Nepal, which is 8 km north from the Indian border. In Bihar State of India, about 3.3 million people were affected; the fatalities were more than 500 people, and 1 million people

were evacuated including about 460,000 people who evacuated to temporary shelter in 360 relief camps. Houses and infrastructures also suffered from huge damages including rural roads and bridges, especially in Supaul, Saharsa, Madhepura, Araria and Purnea districts.

Under this situation, in order to support the flood recovery and future risk reduction in Bihar State, the Bihar Kosi Flood Recovery Project has been implemented from September 2010 up to June 2016 under the loan of USD 220 million. The components of the Project are summarised in Table 3.5.1.

**Table 3.5.1 Components of Bihar Kosi Flood Recovery Project**

No.	Component	Activity
Component A	Owner Driven Housing Reconstruction	- To reconstruct the damaged houses of about 100,000 households
Component B	Reconstruction of Roads and Bridges	- To reconstruct damaged rural roads (290 km length) - To reconstruct damaged bridges and newly construct bridges (90 bridges in total)
Component C	Strengthening Flood Management Capacity	- To strengthen the overall flood forecasting and flood and erosion management capacity in Bihar State by enhancing the knowledge, understanding, and capacity for flood and sediment management with three (3) subcomponents: a) knowledge management and capacity building b) flood forecasting and early warning systems c) structural investments
Component D	Livelihood Restoration and Enhancement	- To build social and financial capital, and restore and expand the livelihood opportunities of the affected people with four (4) subcomponents: a) community institution development b) community investment fund c) technical assistance fund d) project management
Component E	Improving Emergency Response Capacity	- To provide contingency funding for works, goods and services required to respond in case of future calamities and for public and private sector expenditures directly related to the emergency recovery program
Component F	Project Management and Technical Assistance	- To support project implementation through the provision of necessary offices, equipment, training and exposure visits for staff, and associated incremental cost of the state-level Project Management Unit (PMU) and its representative offices at district and block levels, and other implementing agencies - To provide the costs of related consulting services for design, planning and implementation support; management; quality, procurement, financial and third party audits; and monitoring and evaluation

Source: WB, "Project Information Document", (2010)

## (2) Uttarakhand Disaster Recovery Project

Due to the monsoon in June 2013, flash floods occurred in the Mandakini, Alakananda, Bhagirathi and other river basins and also extensive landslides were caused at various locations. In order to improve the resilience of the state's infrastructure and its communities to the impacts of future disasters and climate change, the Uttarakhand Disaster Recovery Project has started in October 2013 and scheduled to continue until December 2017 with the amount of USD 250 million loan. The Project consists of the components shown in Table 3.5.2.

**Table 3.5.2 Components of Uttarakhand Disaster Recovery Project**

No.	Component	Activity
Component 1	Resilient Infrastructure Reconstruction	- To reconstruct damaged houses and public buildings
Component 2	Rural Road Connectivity	- To restore the connectivity lost due to the disaster by reconstruction of damaged roads and bridges
Component 3	Technical Assistance and Capacity Building for Disaster Risk Management	- To enhance the capabilities of government entities and others in risk mitigation and response with the following subcomponents: a) risk assessment modelling and capacity building of Uttarakhand Space Applications Centre (USAC) b) establishment of Decision Support System (DSS) c) river morphology study and slope stabilisation study d) strengthening of Uttarakhand State Disaster Management Authority (USDMA) e) strengthening hydro-meteorological network and early warning systems and strengthening emergency response capacity
Component 4	Financing Disaster Response Expenses	- To provide financial support of eligible expenses already incurred by the State during the disaster response period (e.g. reimbursement of fuel purchased and used for helicopter rescue missions, hiring of heavy equipment for clearing of roads to restore immediate connectivity, etc.)
Component 5	Implementation Support	- To provide incremental operating costs for the Project Management Unit (PMU) and respective Project Implementation Units (PIUs) in the line agencies
Component 6	Contingency Emergency Response	- To provide financial resources from the unallocated expenditure category and/or allow the government to request the WB to re-categorise and reallocate financing from other project components to partially cover emergency response and recovery costs

Source: WB, "Project Information Document", (2013)

### **(3) National Cyclone Risk Mitigation Project Phase -II**

In order to assist the GOI in mitigating the risks and vulnerability of the people of India to natural disasters, particularly cyclones, the National Cyclone Risk Mitigation Project has been implemented. Currently the Phase-II of the project with loan amount of USD 364 million is on-going; the second phase, which was required due to the Cyclone Phailin that hit the states of Odisha and Andhra Pradesh in October 2013, started in November 2014 and will continue until October 2017. The components of the Project are summarised in Table 3.5.3.



**Table 3.5.3 Components of National Cyclone Risk Mitigation Project (Phase II)**

No.	Component	Activity
Component A	Early Warning Dissemination Systems (EWDS)	- To reduce the vulnerability of coastal communities by addressing the existing gap in dissemination of warning to the communities
Component B	Cyclone Risk Mitigation Infrastructure	- To assist the investment of strategic infrastructures for the reduction of vulnerability of coastal communities, such as multipurpose emergency shelters, up-grading roads, underground electric cabling, bridges, up-grading saline embankments and bunds
Component C	Technical Assistance for Disaster Risk Assessment and Recovery	- To improve the quality of available information on multi-hazard risks for decision making, and the assessment of strategies for risk financing with two (2) subcomponents: a) multi-hazard risk modelling and assessment b) strengthening emergency recovery capacity
Component D	Understanding and Strengthening Multi-Hazard Risk Management	- To understand and strengthen national multi-hazard risk management at a national level with three (3) subcomponents: a) enhancing capacity for disaster risk management and response in non-coastal states b) comprehensive multi-hazard risk financing strategy c) design of a national seismic risk mitigation program
Component E	Project Management and Implementation Support	- To finance the incremental operating costs of the Project Management Unit (PMU) and the State PIUs.

Source: WB, "Project Information Document", (2014)

### 3.5.2 Project Outline of the Asian Development Bank (ADB)

In accordance with the suffering from the monsoon in June 2013, the Asian Development Bank (ADB) has assisted for the implementation of the Uttarakhand Emergency Assistance Project from October 2013 with the amount of USD 200 million loan in cooperation with the WB. The Project consists of the following components.

- Reconstruction of damaged roads and bridges
- Reconstruction and upgrading of urban infrastructures including water supply facilities
- Rehabilitation and reconstruction of tourism infrastructures and trekking routes
- Improvement of capacity on disaster preparedness and management through construction of helipads, heliports, or helidromes with associated amenities for emergency evacuation and relief operations
- Project management system operation

Moreover, the technical assistance is also provided to guide and assist the implementing agency in project preparation of indicative selected subprojects, assessment of economic feasibility and financial sustainability of subprojects, procurement, safeguards, project management and financial management to ensure timely implementation of Uttarakhand Emergency Assistance Project.

In addition, Odisha State also suffered from tremendous damages by the strike of cyclone 'Phailin' in 2013; 44 people died, approximately 13 million people were affected in over 18,000 villages, and houses and infrastructures were severely damaged. According to the damage and needs assessment conducted the ADB and WB, power sector infrastructure damages totalled about USD 170 million, causing the disrupted power supply to around 75,000 households. Thus, in order to

reconstruct and rehabilitate the power sector infrastructures, Odisha Power Sector Assistance Project was proposed. To develop a cyclone resilient system, some transmission lines and distribution cables will be undergrounded. The total project cost was estimated to USD 159.7 million, and USD 100 million was requested by the GOI as loan. The project period is scheduled for 36 months from the effective date of project approval from the ADB.

### 3.5.3 Project Outline of the United Nations Development Programme (UNDP)

The United Nations Development Programme (UNDP) has carried out projects in various sectors such as poverty reduction, governance, environment and energy, and crisis prevention and recovery. The UNDP projects for the disaster risk reduction are summarised in Table 3.5.4.

**Table 3.5.4 Summary of UNDP Projects for Disaster Risk Reduction**

Period	Project Name	Project Activity
2009-2011 (completed)	Kosi Flood Recovery and Reconstruction	- To support recovery processes from the flood damages, including settlement and habitat planning to reduce disaster risk
2009-2012 (completed)	Urban Risk Reduction	- To strengthen capacities of institutions and other stakeholders such as municipal officers, planners, NGOs, etc. to manage risks in 56 cities across the country in cooperation with MHA - To raise awareness and build resilience of the communities to disaster-related risks, and to strengthen the capacities of the state and district Disaster Management Authorities to better deal with disasters and post-disaster recovery efforts in cooperation with NDMA
2011-2014 (completed)	Climate Change Adaptation	- To address a crucial dimension of vulnerabilities by supporting specific activities to enhance climate change induced risk management capacities in districts across flood-prone areas of Odisha and drought-prone areas of Madhya Pradesh
2013-2017 (on-going)	Enhancing Institutional and Community Resilience to Disasters and Climate Change (Grant with USD 6 million)	- To strengthen the capacities of government, communities and institutions to accelerate the implementation of disaster risk reduction and climate change adaptation plans

Source: UNDP (2015)

### 3.5.4 U.S. Agency for International Development (USAID)

U.S. Agency for International Development (USAID) formally started supporting the GOI after the Gujarat earthquake of 2001. Based on the bilateral agreement between the GOI and the USAID in 2002, various assistances for the disaster management have been provided in 17 states. Its primary intervention has primarily been conducted in the sector of DRR to enhance the capacity of state and district administrations and the community and shift from the relief-oriented to the preparedness-oriented disaster management.

From 2012 to 2015 (to be extended until 2016) with the grant amount of USD 1.7 million, the USAID has carried out a project for mitigation of urban flood damages in eight (8) selected cities: Bhubaneswar (Odisha State), Madurai (Tamil Nadu State), Visakhapatnam (Andhra Pradesh State), Vijayawada (Andhra Pradesh State), Thiruvananthapuram (Trivandrum) (Kerala State), Navi Mumbai (Maharashtra State), Shimla (Himachal Pradesh State) and Gangtok (Sikkim State). This project includes the capacity development for the municipality administrations regarding the risk assessment, multi-sectoral planning, strengthening of early warning system, enhancement of vulnerable people especially women, urban community preparedness and knowledge management.

Through the interviews to those donors in the Survey, the following challenges were pointed out:

**(1) Institutional Aspects:**

- In many states, the SDMAs have not been functional mainly because they are still under formulation process and lack the required resource allocation.
- Few districts have fully operational DDMA's.
- Even though the coordination among relevant departments and agencies in mitigation and preparation phases is important, it is not sufficiently conducted.

**(2) Disaster Management Planning Aspects:**

- In India, the primary activity for the disaster management is response-oriented, so the understanding and implementation of preparedness- and mitigation-related activities are still limited.
- The disaster management plans in the state and district levels need to be implementable.

**(3) Community Aspects:**

- There is a lack of awareness about disaster risk among local people even though they live in the disaster prone areas.

## **CHAPTER 4    NATURAL DISASTERS IN INDIA**

### **4.1        Overview**

The Indian scenario of disasters described in the “Disaster Management in India”, summarises the major disasters and damage in recent years. During the last 30 years, India has been hit by more than 400 major disasters resulting into enormous loss to life and property. Figure 4.1.1 shows the damage conditions (number of occurrence, number of fatalities and economic losses) caused by the natural disasters in the last 20 years (1995 to 2014). According to the figure, floods had occurred with high frequency; therefore, flood disasters have caused large-scale damage to the country. Abnormal weather, sediment disasters and cyclones (storm) have occurred once a year or more frequently. Those types of disasters have caused big damages. Regarding the earthquakes and tsunamis, although they do not have high frequency of occurrence, they have a huge impact once they occur. By reviewing the past disasters, it can be said that major natural disasters in India are “floods”, “cyclones”, “sediment disasters”, “earthquakes”, “tsunamis” and “abnormal weather”.

The occurrence of major disasters is shown in Figure 4.1.2 by the type of disaster and state. The flood prone areas are Himachal Pradesh, Uttarakhand and Bihar states located along the upper and middle reaches of the Ganga River. Storm (Cyclone) prone areas are Odisha and Andhra Pradesh states at the east coast of the country, and Gujarat State at the west coast. The sediment disasters occur in Uttarakhand, Jammu and Kashmir, Himachal Pradesh states in the Himalaya mountain area.

**a. Occurrence**

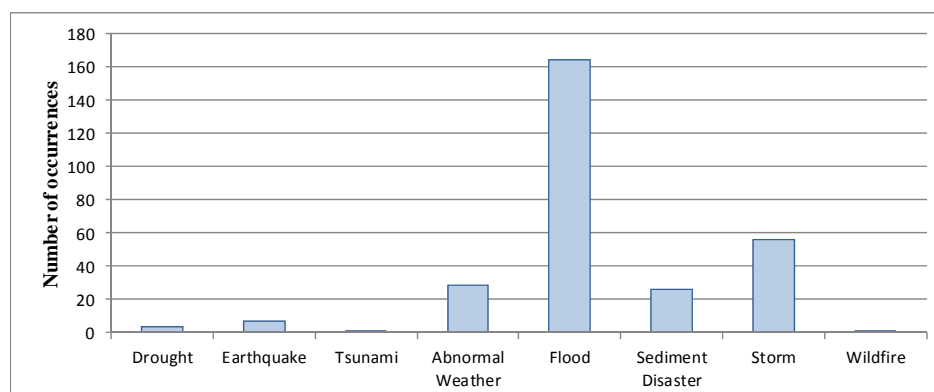

**b. Fatalities**

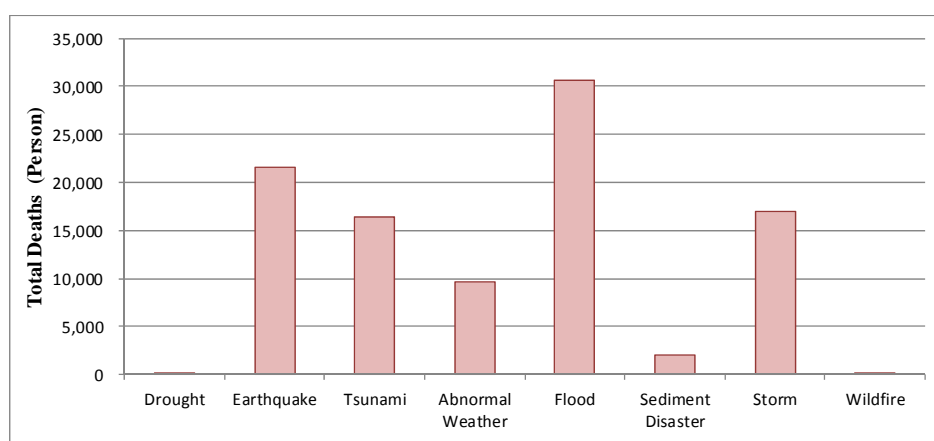

**c. Economic Loss**

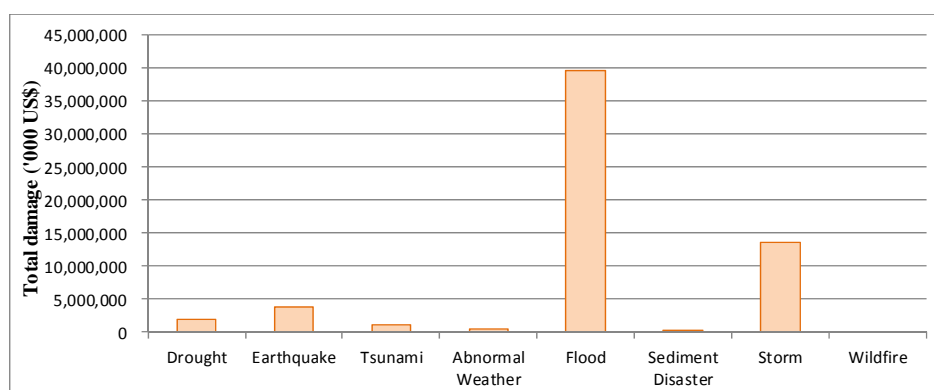

Type of Disaster	Frequency (times/year)	Average Number of Deaths (Persons/year)	Average Economic Damage (Thousand US\$/year)
Drought	0.2	1	102,056
Earthquake	0.4	1,079	189,100
Tsunami	0.1	819	51,140
Abnormal Weather	1.5	484	20,000
Flood	8.2	1,532	1,979,169
Sediment Disaster	1.3	101	2,725
Storm	2.8	852	681,656
Wildfire	0.1	0	0

Source: compiled by the Survey Team based on EM-DAT

**Figure 4.1.1 Natural Disaster Events in India (1955-2014)**

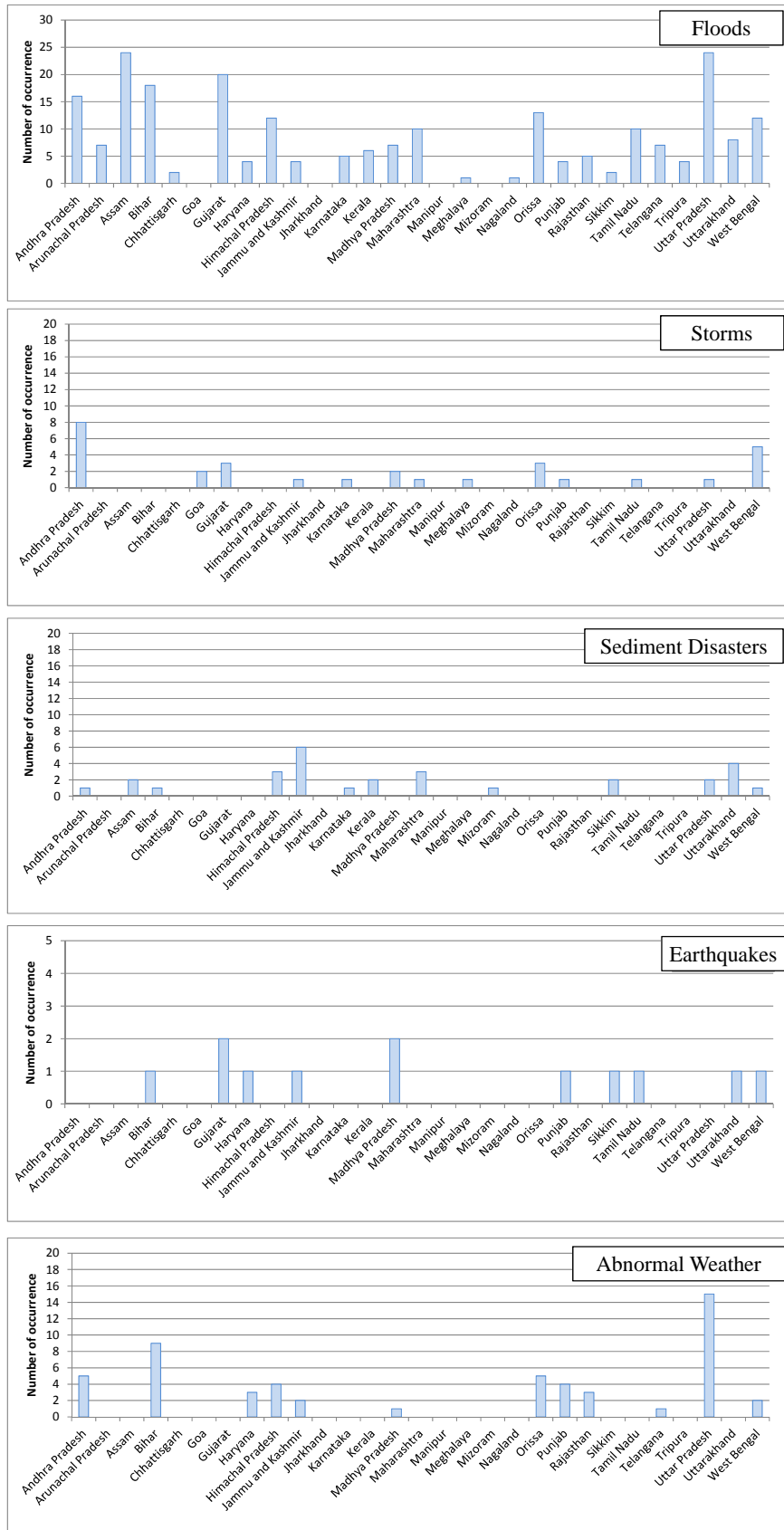

Source: compiled by the Survey Team from EM-DAT

**Figure 4.1.2 Occurrence of Natural Disaster by State (1955-2014)**

Table 4.1.1 shows the recent 15 years trend of the total number of people affected and total damage caused by different disasters. The total damage for 2011-2015 due to riverine floods increased by twice compared to that for 2001-2005, and in contrast, the total number of affected people has decreased. As for the tropical cyclones, both the total affected people and economic damage increased extremely for the latest five (5) years.

**Table 4.1.1 Quinquennial Trend of Total Affected People and Damage caused by Different Disasters**

	Total affected people			Total economic damage ('000 US\$)		
	2001-2005	2006-2010	2011-2015	2001-2005	2006-2010	2011-2015
Earthquake	6,478,634	-	634,550	3,623,000	-	120,000
Tsunami	654,512	-	-	1,022,800	-	-
Riverine flood	120,970,121	53,505,869	21,862,429	9,392,696	8,094,151	18,524,000
Flash flood	3,700,045	8,931,465	-	26,000	123,000	-
Coastal flood	-	7,200,000	-	-	275,000	-
Landslide*	5,020	-	513,673	50,000	-	1,100,000
Tropical cyclone	77,250	5,750,300	14,470,004	28,416	300,000	8,271,096

Note: The landslide event in June 2013 is classified in to "Flood" by EM-DAT.

Source: compiled by the Survey Team based on EM-DAT

## 4.2 Floods

### 4.2.1 Situation of Countermeasures in National Policy and Planning

Floods are the most common natural disaster in India. The central and state governments have been devised many ways of coping with them. However, inundations in the flood plains over the years have aggravated the flood problem, and therefore it is necessary to take effective and sustained flood management measures.

Various structural and non-structural measures have been taken by the GOI. Although considerable protection measures have been taken to protect the areas and people, further efforts are required in this direction. There is also a need to put in place a techno-legal regime to make flood-proof structures and regulate the activities in the flood plains of the rivers.

Flood forecasting and warning and decision support system will be established on a scientific basis taking into account the latest technological developments in India.

### 4.2.2 Policies and Institutional Frameworks

#### (1) Policy on Floods

The GOI while framing policy has laid significant emphasis on the management of floods which reflected in the National Water Policy (NWP). The NWP was formulated by the Ministry of Water Resources (MOWR) to govern the planning and development of water resources and their optimum utilisation. The first NWP was adopted in September 1987. It was reviewed and updated in 2002 and later in 2012. This policy also deals with the participation of farmers and voluntary agencies for the water quality improvement, water zoning, conservation of water, flood and drought management, and erosion.

The main emphasis of the NWP 2012 is to treat water as economic goods which the ministry claims to promote its conservation and efficient use. This provision also intends for the privatisation of water-delivery services is being criticised from various quarters. The policy also

does away with the priorities for water allocation mentioned in 1987 and 2002 versions of the policy.

Regarding flood management, the following two (2) concerns are identified in the NWP 2012:

- Wide temporal and spatial variation in availability of water, due to climate change, causing deepening of water crisis and incidences of water related disasters, i.e., floods and erosion.
- Characteristics of catchment areas of rivers and recharge zones of aquifers are changing because of land use and land cover changes.

In the NWP 2012, in consideration of importance of water environment, all the elements of the water cycle, i.e., rainfall, runoff, rivers, lakes and ground water are recognised as interdependent, and the basic hydrological unit is the river basin. Conservation of rivers, river corridors, water bodies and infrastructure will be undertaken in a scientifically planned manner through community participation.

Flood management policy is shown as follows:

- Through structural and non-structural measures, emphasis should be on preparedness for flood.
- In order to prevent loss of land eroded by the river, revetments, spurs and embankment should be planned, executed, monitored and maintained on the basis of morphological studies.
- Flood forecasting is very important for flood preparedness and should be expanded extensively across the country.
- Frequency based flood inundation maps should be prepared to evolve coping strategies.
- In order to increase preparedness for sudden and unexpected flood related disasters, dam/embankment break studies, disaster management plans should be evolved.

## **(2) Institutional Framework**

As per the constitutional provisions, flood management is a state subject and as such the primary responsibility for flood management lies with states. The central government has taken initiatives and set up a number of organisations dealing with the floods.

The most notable one is the enactment of the DM Act in 2005 and setting up the NDMA, which has been assigned to deal with all types of disasters, including floods. The NEC with the Secretary of GOI of the ministries or departments assists the NDMA in the discharge of its functions and ensures the compliance of the directions issued by the central government apart from preparing the NDMP.

The state governments set up the SDMA and the SEC to perform similar functions at the state level.

The GOI has set up the following organisations and various expert committees for the flood disaster management in a comprehensive manner.

### **1) Ministry of Water Resources (MOWR)**

The MORW is a nodal ministry responsible for laying down policy guidelines and programmes for the development and regulation of water resources in India. The major functions of the MORW are listed below:

- Overall planning, policy formulation, coordination and guidance in the water resources sector
- Technical guidance, scrutiny, clearance and monitoring of the irrigation, flood control and multi-purpose projects



- Formulation of national water development perspective and the determination of the water balance of different basins/sub-basins for consideration of possibilities of inter-basin transfers
- Coordination, mediation and facilitation in regard to the resolution of differences or disputes relating to inter-state rivers and in some instances, the overseeing of the implementation of inter-state projects
- Operation of the central network for flood forecasting and warning on inter-state rivers, the provision of central assistance for some state schemes in special cases and preparation of flood control master plans for the Ganga and the Brahmaputra river basins.

The organisational structure of the MOWR is shown in Figure 4.2.1. The MOWR consists of 12 functional units called wing with the different mandates. According to the Annual Report 2013-2014, there are 434 officials in the MOWR. The flood management is handled by the Flood Management Wing in cooperation with other institutions including the CWC. About 30 engineers are deployed to the Flood Management Wing (source: MOWR as of July 2015).

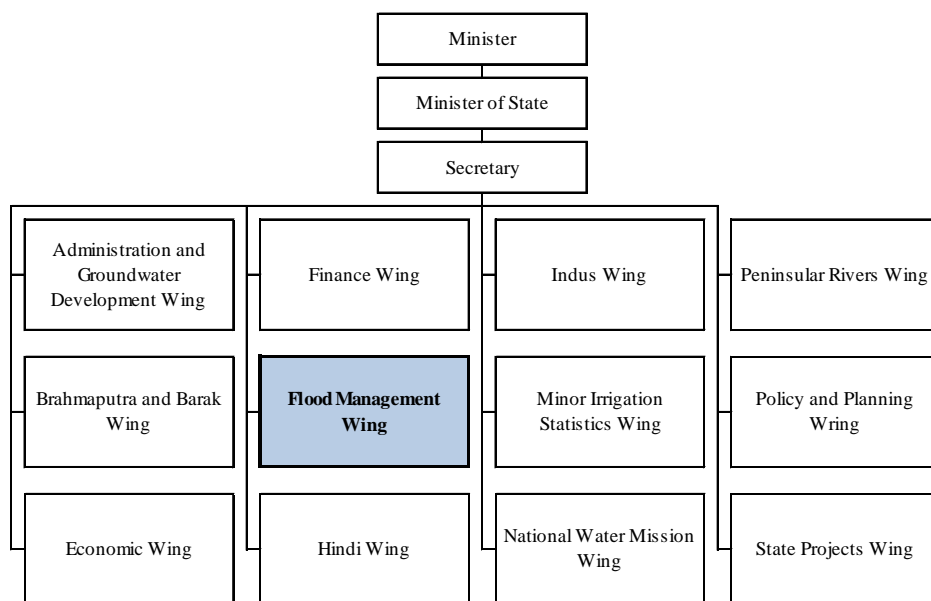

Source: compiled by the Survey Team based on the information of the MOWR (2015)

**Figure 4.2.1 Organisational Structure of MOWR**

## 2) Central Water Commission (CWC)

The GOI set up the Central Water Commission (CWC) as presently named in 1945 for achieving the goal of furthering and promoting measures of flood control, conservation and utilisation of water resources throughout the country, irrigation and hydropower generation, flood management and river conservation. According to the seniority list, there are 1,880 officials in CWC (excluding supporting staff).

## 3) Brahmaputra Board (BB)

The Brahmaputra Board (BB) was established by Brahmaputra Board Act, 1980 (No. 46 of 1980) under the former Ministry of Irrigation (present MOWR). The jurisdiction of the BB includes all North East region states in Brahmaputra and Barak Basin.

## 4) Ganga Flood Control Commission (GFCC)

The Ganga Flood Control Commission (GFCC) was constituted in 1972 for preparation of comprehensive plan of flood control for Ganga Basin and to draw out a phased coordinated program of implementation of works and monitoring & appraisal of flood management schemes of

Ganga Basin states.

The GFCC has prepared comprehensive plans of flood management of the 23 sub-basins in the Ganga Basin besides drawing out a phased program of implementation of these works to proper standards, examination and monitoring of various flood management schemes in the Ganga Basin states.

#### **5) Farakka Barrage Project Authority**

The Farakka Barrage Project Authority carries out anti-erosion and river bank protection works in its jurisdiction in near river vicinity of the barrage.

#### **6) State Level**

The state level mechanism includes the Water Resources Departments, State Technical Advisory Committee and Flood Control Board. In some states, the Irrigation Departments and Public Works Departments look after flood matters.

### **(3) Institutional Arrangement and Reforms**

The working group on flood management and region specific issues for the 12th Five-Year Plan suggested the following institutional reforms for the effective flood management in India in October 2011 report:

- Expedite setting up of river basin authorities
- Strengthening of organisation under MOWR (CWC, GFCC, BB)
- Strengthening of National Water Academy (NWA) Pune (training on DRR)
- Strengthening of the State Flood Control Department
- Dispensing with the concept of “Plan” and “Non-plan” (proper assets management after scheme)
- No restriction on recruitment of new staff
- Providing adequate infrastructural facilities on field activities (field staff and inspection vehicles)
- Capacity building programmes (preparing specific training programs and adequate funds)

#### **4.2.3 Floods Record and Damages**

Major floods after the 1990's are shown in Table 4.2.1. According to some available sources, the main reasons for flood disasters are as follows:

##### Flood in Maharashtra State, 2005

Due to the poor flood management and mitigation measures in Mumbai urban area and other areas in Maharashtra State, many vulnerable people were affected by floods caused by heavy monsoon rainfall (Source: Exposing Vulnerabilities: Monsoon Floods in Mumbai, India, UN Habitat).

##### Flood in North Bihar, 2008

Bank burst in the Kosi River caused severe flood in Nepal and India, over an area 15-20 km across and 150 km from north to south (Source: Bihar Kosi Flood (2008) Needs Assessment Report, the Government of Bihar and the World Bank).

In general, the following may be the major reasons for damage due to flood disasters in India:

- Massive flood water spreads into broader areas in the basins because of relatively flat topographical characteristics.
- Poor flood management in urban areas such as lack of proper drainage system, flood zoning, etc. contributes to increase in the number of disaster affected people.

**Table 4.2.1 Major Flood Disasters in India (1990-2014)**

Date	Location	Total Number of Deaths (persons)	Total Number of Affected People (persons)	Damage (USD)
08/07/1993	Punjab, Haryana, Himachal Pradesh, Gujarat, Jammu and Kashmir, Rajasthan, Madhya Pradesh, Chandigarh, Assam states	827	128,000,000	7,000,000
05/1994	Assam, Arunachal Pradesh, Jammu and Kashmir, Himachal, Punjab, Uttar Pradesh, Goa, Kerala, Gujarat states	2,001	12,060,050	175,000
01/09/1995	Bihar, Haryana, Punjab, Rajasthan, Himachal Pradesh, Jammu and Kashmir, Uttar Pradesh, West Bengal Maharashtra states	1,479	32,704,000	258,000
09/1997	Andhra Pradesh, Arunachal Pradesh, Assam, Bihar, Gujarat, Himachal Pradesh, Jammu and Kashmir, Karnataka, Kerala, Maharashtra, Madhya Pradesh, Orissa, Punjab, Rajasthan, Sikkim, Uttar Pradesh, West Bengal states	1,442	29,259,000	
08/1998	Assam, Arunachal, Bihar, Kerala, Meghalaya, Punjab, Sikkim, Uttar Pradesh, West Bengal states	1,811	29,227,200	
02/08/2000	Gujarat, Andhra Pradesh, Assam, Arunachal Pradesh, Bihar, Himachal Pradesh, Kerala, Madhya Pradesh, Punjab, Uttar Pradesh, West Bengal states	867	22,000,000	43,000
18/09/2000	Birbhum, Burdwan, Murshidabad, Malda districts (West Bengal), Munger, Bhalagpur, Dumka, Sahbganj, Doegarh, Mafhpur, Josidih, Sheikhpura, Banka (Bihar State)	884	24,600,000	691,500
20/06/2004	Darbhanga, Madhubani, Sitamarhi, Banka Bhagalpur, Muzzafarpur, Sheohar (Bihar State), South and West Tripura (Tripura State), Kamrup, Nalbri, Darrang, Sonitpur, Dhemaji, Lakhimpur (Assam State), Gujarat State	900	33,000,000	2,500,000
24/07/2005	Gujarat, Madhya Pradesh, Maharashtra, Goa, Orissa, Karnataka, Himachal Pradesh, Jammu and Kashmir	1,200	20,000,055	3,330,000
03/07/2007	Bihar, Uttar Pradesh, Assam, Orissa, West Bengal	1,103	18,700,000	
11/06/2008	West Bengal, Orissa, Lakhimpur, Dhemaji, Sonitpur districts (Assam), Bihar, Gujarat, Goa, Haryana, Kerala, Karnataka, Maharashtra, Madhya Pradesh, Punjab, Orissa, Rajasthan, Uttar Pradesh, Tamil Nadu, West Bengal, Arunachal Pradesh, Uttarakhand, Jharkhand	1,063	7,900,000	123,000
07/2009	Bihar, Orissa, West Bengal, Assam, Kerala, Gujarat, Karnataka states	992	1,886,000	220,000

Source: EM-DAT (2015)

According to the “Water and Related Statistics (2015)” prepared by the CWC, historical flood damage at national level due to flood and heavy rains are arranged as shown in Table 4.2.2.

**Table 4.2.2 Flood Damage during 2004-2013**

Year	Affected Area(M.ha)	Population Affected (Million)	Damage to Crops (Rs. Crore)	Damage to Housed (Rs. Crore)	Cattle Lost (Nos. ('000))	Human Live Lost (Nos.)	Damage to Public utilities (Rs. Crore)	Total Damages (Rs. Crore)	
2004	5.31	43.73	778.69	879.60	134	1,813	1,656.09	3,314.38	
2005	12.96	22.93	2,370.92	380.53	120	1,455	4,688.22	7,439.67	
2006	1.10	25.22	2,850.67	3,636.85	267	1,431	13,303.93	19,791.45	
2007	7.14	41.40	3,121.53	2,113.11	89	3,389	8,049.04	13,283.68	
2008	3.43	29.91	3,401.56	1,141.89	102	2,876	5,046.48	9,589.93	
2009	3.84	29.54	4,232.61	10,809.80	63	1,513	17,509.35	32,551.76	
2010	2.62	18.30	5,887.38	875.95	40	1,582	12,757.25	19,520.58	
2011	1.90	15.97	1,393.85	410.48	36	1,761	6,053.57	7,857.90	
2012	2.14	14.69	1,534.11	240.57	32	933	9,169.97	10,944.65	
2013	31.58	21.15	3,214.99	526.12	157	2,137	3,938.12	7,679.23	
Total	72.02	262.84	28,786	21,015	1,040	18,890	82,172	131,973	
Average	7.20	26.28	2,879	2,101	104	1,889	8,217	13,197	
Maximam Record	Damage	31.58	43.73	5,887.38	10,809.80	267	3,389	17,509.35	32,551.76
	Year	2013	2004	2010	2009	2006	2007	2009	2009

Note: Red figures indicate the largest damage over the last 10 years.

Source: CWC, "Water and Related Statistics", (2015)

From the tables above, damage characteristics over the past 10 years are summarised as follows:

- The year 2009 shows the maximum total damage amounting to Rs. 32,551 crore. In this year, states such as Andhra Pradesh, Karnataka, Odisha, Kerala and Maharashtra as well as the National Capital Territory of Delhi are affected.
- Maximum human live losses occurred in the year 2007 with 3,389 fatalities, followed by 2008 with 2,876.

#### 4.2.4 Observation Systems

##### (1) Meteorological Observation

The CWC is a premier technical organisation in the country dealing with collection and compilation of hydrological data in the river basins.

According to the "Meteorological Observation Stations in India under CWC", meteorological data are being collected at 852 stations including 76 exclusive meteorological stations, as of 2012. Observation items are follows:

- Rainfall (Rf)
- Temperature or Air Temperature (Mt)
- Humidity (Hu)
- Sunshine (Ss)
- Pan-evaporation (Pe)
- Wind speed and direction (Wv)
- Snow (Sg)

Basin-wise details of meteorological station and exclusive meteorological stations are shown in Table 4.2.3. The starting year for observation stations varies from 1950's to 2000's. The stations which started the observation of rainfall and temperature in 1956 are located at Hayaghat, Darbhanga District in the Bagmati River, Jhanjharpur, Madhubani District in the Kamla-Balan River, Sikandarpur, Muzaffarpur District in the Burhi Gandak River and Tribeni, West Camparan District, Bihar State in the Ganga River.

**Table 4.2.3 Basin-wise Number of Meteorological Stations and Exclusive Meteorological Stations**

No.	Basin Name	No. of States within Basin	No. of Met. Station	No. of Excl. Station
1.	Brahmani-Baitarni	2	15	1
2.	Cauvery Basin	4	32	0
3.	East Flowing rivers bet. Mahanado & Pennar	2	13	0
4.	East Flowing rivers bet. Pennar to Kanyakunari	3	17	0
5.	Ganga-Brahamaputra-Meghna/Barak	18	385	10
6.	Godavari	6	68	3
7.	Indus	2	15	22
8.	Krishna	3	38	9
9.	Mahanadi	2	39	5
10.	Mahi	3	38	0
11.	Narmada	2	24	2
12.	Pennar	1	8	0
13.	Sabarmati	2	13	0
14.	Subarnarekha & Burhabalang	3	12	0
15.	Tapi	3	17	7
16.	West Flowing Rivers from Tadri to Kanyakumari	3	29	0
17.	West Flowing Rivers from Tape to Tadri	4	14	0
18.	West Flowing Rivers of Kutchh & Saurashtra	2	14	0
19.	Minor Rivers	-	0	0
20.	Area Inland Drainage	-	0	0
Total		-	776	76
		-	852	

Source: CWC, "Meteorological Observation Stations in India", (2012)

## (2) Hydrological Observation

Hydrological data is also dealt with by the CWC. According to the "Hydrological Observation Stations in India under CWC", a total of 878 hydrological observation sites are being maintained by the CWC. There were 945 hydrological stations in 2003, and they reduced to 878 hydrological stations in 2012. Details on hydrological stations changes are shown in Table 4.2.4.

**Table 4.2.4 Number of Hydrological Stations from 2003 to 2012**

No.	Type of Site	Number of Stations		
		2003	2010	2012
1.	Water Level (WL) Gauge	245	272	295
2.	WL & Discharge (D)	282	157	154
3.	WL, D & Sediment (S)	41	38	33
4.	WL, D, & Water Quality (WQ)	115	129	131
5.	WL,D,S & WQ	252	246	239
6.	WL & WQ	-	38	26
Total		945	866	878

Source: CWC, "Hydrological Observation Stations in India under CWC", (2013)

Basin-wise details of hydrological station are shown in Table 4.2.5. The starting year for observation stations varies from 1940's to 1990's. The oldest observation is Hathida at Patna, Bihar State, and it started observation in the Ganga River in 1948.

**Table 4.2.5 State-wise Hydrological Stations**

No.	Basin Name	No. of States within Basin	No. of Hydrological Station (Nos)
1.	Brahmani-Baitarni	2	15
2.	Cauvery Basin	4	34
3.	East Flowing rivers bet. Mahanado & Pennar	2	13
4.	East Flowing rivers bet. Pennar to Kanyakunari	3	17
5.	Ganga-Brahamaputra-Meghna/Barak	18	445
6.	Godavari	6	77
7.	Indus	2	26
8.	Krishna	3	53
9.	Mahanadi	2	39
10.	Mahi	3	12
11.	Narmada	2	26
12.	Pennar	1	8
13.	Sabarmati	2	13
14.	Subarnarekha & Burhabalang	3	12
15.	Tapi	3	18
16.	West Flowing Rivers from Tadri to Kanyakumari	3	22
17.	West Flowing Rivers from Tape to Tadri	4	29
18.	West Flowing Rivers of Kutchh & Saurashtra	2	14
19.	Minor Rivers	-	0
20.	Area Inland Drainage	-	5
Total		-	878

Source: CWC, "Hydrological Observation Stations in India under CWC", (2013)

In view of the importance of the Ganga River in India, i.e., the scale of flood damages, and the importance of water resources developments, many observation stations have been installed, and hydrological items such as rainfall, water level and sediment are observed in this basin. The CWC meteorological, hydrological and flood forecasting stations in the Ganga Basin are shown, as an example on the networks, in Figure 4.2.2.

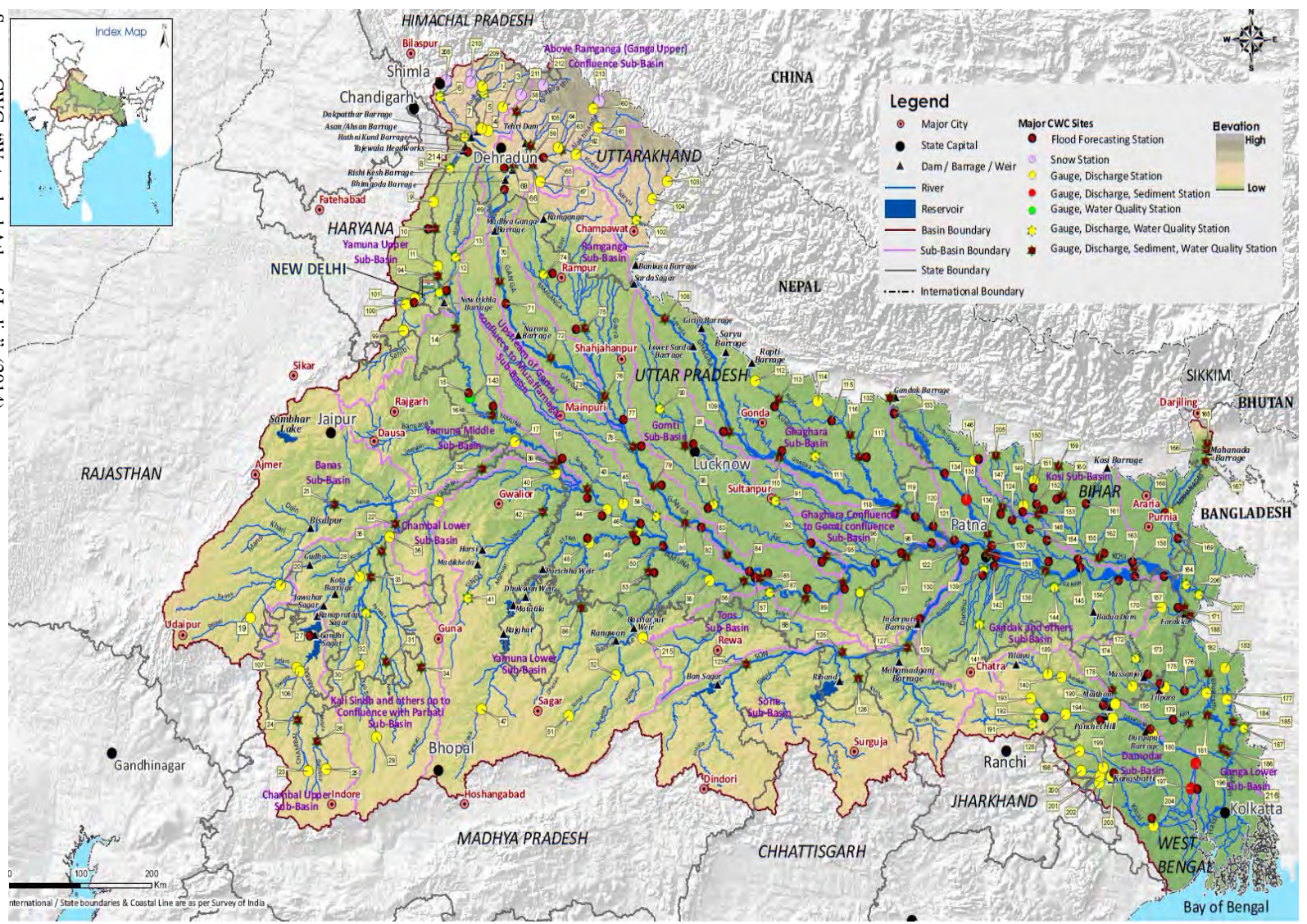

Source: CWC, "Watershed Atlas of India", (2014)

Figure 4.2.2 Major Meteorological, Hydrological and Flood Forecasting Stations

## 4.2.5 Risk Analysis

### (1) Flood Risks in India

Heavy flood damages had occurred in 1977, 1978, 1979, 1995, 2000 and 2001. On average, the floods resulted in an annual damage of more than Rs. 18 billion in addition to loss of human lives and livestock.

According to the NDMA, *Rashtriya Barh Ayog* (RBA, National Flood Commission of India) assessed 40 mha of the total flood prone area in 1980. 80 % or 32 mha of this area could be provided with reasonable degree of protection. India can be divided into four (4) regions from the flood hazard perspective: the Brahmaputra River region, the Ganga River region, the North-west river region and the Central India and Deccan region.

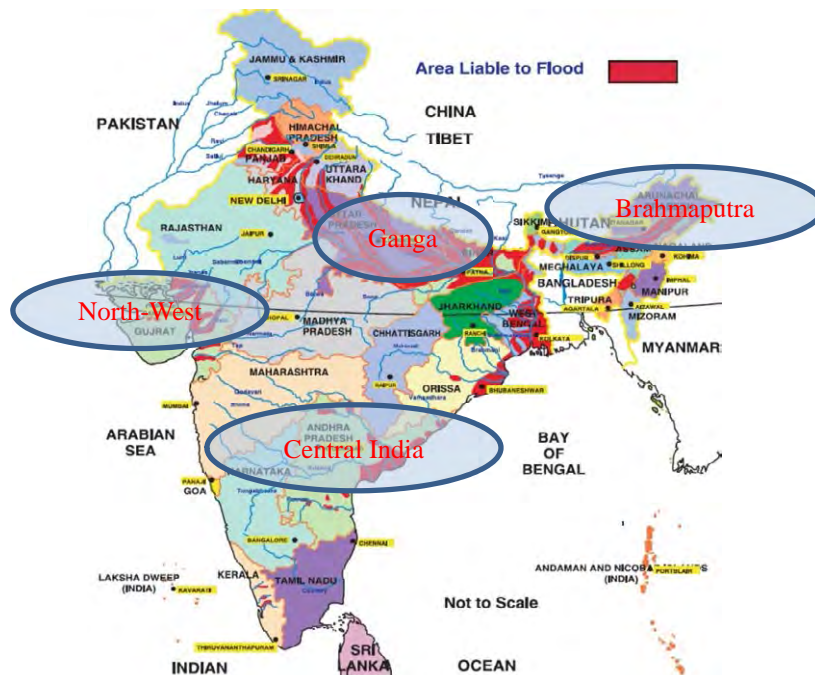

Source: NDMA, “National Disaster Management Guidelines for Management of Floods”, (2008)

**Figure 4.2.3 Flood Prone Areas in India**

### (2) Activities for Minimising Flood Risk and Losses

The National Disaster Management Guidelines for Management of Floods was published by the NDMA in January 2008 (hereinafter referred to as the “NDMA Guidelines for Floods”). The NDMA Guidelines for Floods proposes activities for minimising the flood and losses in three (3) phases as explained below.

#### 1) Phase I

The Phase I activities include identification and making maps of flood prone areas, preparation of close contour and flood vulnerability maps, and formulating plans for expansion and modernisation of Flood Forecasting and Warning (FFW) system. These activities also include identification of priority flood protection and drainage protection works, identification of reservoirs for review and modification of operation manuals and rule curves and understanding special studies on problems of river erosion. These activities are scheduled for completion by January 2010.



## 2) Phase II

The Phase II activities include the schemes for expansion and modernisation of the FFW network, execution of flood protection and drainage improvement schemes, modification and adoption of revised reservoir operation manuals and enactment of flood plain zoning regulations. The activities also include planning and preparation of Detailed Project Reports (DPRs) for storage reservoirs and implementation of the schemes for real-time hydro-meteorological data collection on rivers in Nepal, Bhutan and China. These activities are scheduled for completion by March 2012.

## 3) Phase III

These activities include construction and Catchment Area Treatment (CAT) works in India as well as neighbouring countries. It was envisioned that all feasible scheme would be completed by the year 2025.

### (3) Activities in National Remote Sensing Centre and Indian Space Research Organisation

The Indian Space Research Organisation (ISRO) is playing a vital role in supporting the flood management activities, by providing space as well as aerial remote sensing based services and products. Using satellite data from Indian Remote Sensing Satellite (IRSS) System and from foreign satellites, the impact of floods in the country has been assessed for the past one decade operationally. Its services are as follows:

- Near Real Time Flood Mapping and Monitoring
- Flood Damage Assessment
- Flood Hazard Zone Mapping
- River Bank Erosion Mapping
- Mapping changes in the river course

The National Remote Sensing Centre (NRSC) and ISRO have taken up development of Flood Hazard Zonation Maps using satellite data towards the DRR, in addition to flood response services through Decision Support Centre (DSC) under the ISRO-DMS Programme.

Over a period of time, the ISRO has created a repository of large data pertaining to the floods in different areas of the country. These historical datasets generated by NRSC/ISRO are useful for identification of the flood-prone areas and risk assessment.

### (4) Flood Prone Areas in India

As mentioned in (1), *Rashtriya Barh Ayog* (RBA) assessed the total flood prone areas in the country as 40 mha in 1980 by adding the maximum flood affected area (34 mha) and the total protected area (10 mha) as well as deducting portion (4 mha) of the total protected due to failure of protection works as shown below.

**Table 4.2.6 Total Flood Prone Area in India**

Item	Area (mha)
1) Maximum flood affected area	34
2) Total protected area	10
3) Deduction for total protected area included in the flood affected area due to failure of protection works	4
Area liable to floods=(1)+2)-3)	40

Source: Planning Commission, "Report of Working Group on Flood Management and Region Specific Issues for XII Plan", (2011)

## 4.2.6 Preparedness and Countermeasures

### (1) Flood Management Plans (FMPs)

Based on the NDMA Guidelines for Floods, the central ministries and departments concerned and the state governments are required to prepare their Flood Management Plans (FMPs). These plans focus on the community and the collective efforts of the government and NGOs.

The measures for flood prevention, preparedness and mitigation can be categorised into structural measures and non-structural measures. The structural measures aim to prevent floods from causing damages, whereas non-structural measures strive to keep the people away from floods. Flood measures adopted in India are shown in Table 4.2.7.

**Table 4.2.7 Flood Management Measures in India**

No.	Countermeasures	Line Ministries/Agencies
<b>I. Structural Measures</b>		
1.	Embankment/ Flood Walls	MOWR
2.	Dams, Reservoirs, Water Storage	MOWR
3.	Channel Improvement	MOWR
4.	Desilting and Dredging of Rivers	MOWR, CWC
5.	Drainage Improvement	States and SDMAs
6.	Diversion of Flood Water	States and SDMAs
7.	Catchment Area Treatment/Afforestation	States and SDMAs
8.	Anti-erosion Works	States and SDMAs/DDMAs
9.	Sea Walls/Coastal Protection Works	States/Port Authorities
10.	Provision of Waterway	MOSRTH, MOR, MOD, NHAI, BRO, States/SDMAs
<b>II. Non-Structural Measures</b>		
1.	Flood Plain Zoning (FPZ)	Under preparation (States/Flood Zoning Authority)
2.	Flood Proofing	States/SDMAs
3.	Flood Forecasting and Warning (FFW)	CWC
4.	Integrated Water Resources Management (IWRM)	States/SDMAs and CWC

Source: NDMA, "National Disaster Management Guidelines for Management of Floods", (2008)

Of the above measures, MOWR/CWC had prepared a Model Bill on Flood Plain Zoning (FPZ) and circulated it to state governments for enacting suitable legislature and enforcement. The state governments have reported difficulties in enactment of legislation and enforcement of laws in this regard because of constraints of land for relocating the people who are already occupying the flood plains.

In order to protect human life, land and property from floods in India, the state governments have been engaged in flood management works for the last five (5) decades and a total of 18.22 mha has been protected by the end of the 10th plan. The working group on water resources constituted by the Planning Commission has set a target to protect an additional area of 2.18 mha during the 11th Five-Year Plan (2007-2012).

The GOI has also been assisting the flood prone states in flood management and anti-erosion works for critical areas, by providing financial assistance to the state government through a number of centrally sponsored schemes.

In order to provide financial assistance to the state government for undertaking flood management works in critical areas, "Flood Management Programme" was launched by the MOWR, at a total cost of Rs. 8,000 crore. The GOI has approved continuation of this program during the 12th Five-Year Plan with an outlay of Rs. 10,000 crore.

## (2) Achievement in Flood Management by MOWR

Flood management aims at providing a reasonable degree of protection against flood damage at reasonable economic costs. In India, systematic planning for flood management commenced with the Five Year Plans, particularly with the launching of the National Program of Flood Management in 1954.

From the commencement of National Program of Flood Management in 1954, different methods of structural and non-structural flood protection measures have been adopted in different states depending upon the nature of the problem and local conditions. The structural measures include storage reservoirs, flood embankments, drainage channels, anti-erosion works, channel improvement works, detention basins etc., and non-structural measures include flood forecasting, flood plain zoning, flood proofing, disaster preparedness, etc.

Table 4.2.8 summarises the various flood management measures undertaken through the five years plans based on the flood management data of the MOWR.

**Table 4.2.8 Achievement in Flood Management**

No.	Works	Dimensions
1.	Flood embankments	34,397.61 km
2.	Drainage channels	51,317.50 km
3.	Towns protection works	2,400 Nos.
4.	Villages raised	4,721 Nos.

Source: MOWR (2014)

The reservoirs constructed exclusively for flood control storage include Maithon, Panchet, Tilaiya and Konar in Damodar Valley; Chandil Dam on the Subarnarekha River and Rengali Dam on the Brahmani River. In addition, a live storage of 177 billion m<sup>3</sup> created so far in the various reservoirs for irrigation, hydropower generation, drinking water, etc. also helps in reducing flood intensity by storing part of the flood waters in them.

## (3) Strategies and Recommendations for the 12th Five-Year Plan

The Planning Commission prepared a draft approach for strategies focusing on preparing various components of the 12th Five-Year Plan ensuring development in the key area in order to achieve the broad objectives, targets, associated with the challenges and implementation of the policies by the central and the state governments. The development plans will not be able to achieve the objectives and overall growth unless the flood management sector is given due attention and propriety.

Therefore, it will be needed to plan strategies to reduce the flood damages in India in a best techno-economically viable manner. It will also be needed effort toward reduction of the agony brought by floods to the common people.

In order to implement effective programmes addressing the problems of the floods, the following strategies are recommended:

- Modernisation of flood forecasting network and its extension
- Installation of automatic reservoir release information system
- Adoption of basin-wise integrated flood management approach
- Adoption of remote sensing based state of the art technologies
- Use of new construction materials
- Introduction of flood management programmes

Planning Commission considered allocating major portion of the plan outlay for flood management directly to the state governments as per their requirement under flood control sector and making a balanced allocation under State Sector in Central Plan for critical flood management works only.

#### (4) Budget for Flood Management Works

The plan-wise anticipated expenditure in the 11th Five-Year Plan and outlay recommended during the 12th Five-Year Plan is shown in Table 4.2.9. In a view of strengthening the river management activities based on the strategies in the 12th Five-Year Plan, outlay of the river management works as well as flood forecasting has been increased by the Working Group of the Central Commission compared to the 11th Five-Year Plan. Detailed outlays for each scheme in central sector are shown in Table 4.2.10.

**Table 4.2.9 Expenditure of the 11th Five-Year Plan and Outlay of the 12th Five-Year Plan for FMP**

(Unit: Rs. crore)

SN	Program/Scheme	Expenditure of 11th Five-Year Plan	Outlay of 12th Five-Year Plan
A	Central Plan (CP)	5,268	18,475
I	Central Sector	1,130	2,475
-i	River management activities and works	755	1,250
-ii	Flood Forecasting	106	425
-iii	Farakka Barrage project	270	800
II	State Sector	4,266	16,000
-i	Flood Management Programme (FMP)	4,268	16,000
B	State Plan (SP)	N.A.	39,100
	Grand Total (CP+SP)	N.A.	57,575

Note N.A.: Information not received from Planning Commission

Source: Planning Commission, "Report of Working Group on Flood Management and Region Specific Issues for XII Plan", (2011)

**Table 4.2.10 Detailed Outlays of the 12th Five-Year Plan for FMP**

(Unit: Rs. crore)

No.	Program/Scheme	Outlay
1.	River Management Activities	1,250
	1) Hydrological observation and flood forecasting on common border rivers with neighbouring countries	25
	2) Investigation of water resources projects in neighbouring countries (Sapta Kosi Dam (SKD), Pancheswar Multipurpose Project (PMP), Mana Multipurpose Project, etc. )	100
	3) Pre-construction activities for water resources projects in common border rivers (SKD, PMP, Sankosh Multipurpose Project)	25
	4) Grant-aid to:	1,040
	a. States for FM works on common border of rivers	340
	b. Union Territories for flood management works	700
	5) Contribution of Ganga Flood Control Commission (GFCC)	60
2.	Flood Forecasting	425
	1) Spillover works of 11th Five-Year Plan	10
	2) Installation of automatic data collection and communication system to cover FF network (234 stations).	34
	3) Extension of FF network in other areas (1,000 stations)	223
	4) Collection and dissemination of flood information to local authorities/NDMA	158
3.	Farakka Barrage Project	800
	1) Anti-erosion works	300
	2) Replacement of damaged gates	150
	3) Other works	350

No.	Program/Scheme	Outlay
Total (=1+2+3)		2,475

Source: Planning Commission, "Report of Working Group on Flood Management and Region Specific Issues for XII Plan", (2011)

The funds for the 12th Five-Year Plan released by the Ministry of Finance to the state governments show the following shares.

**Table 4.2.11 Funding Share under FMP in the 12th Five-Year Plan**

Category	Central Share (%)	State Share (%)
a. Special Category States	90	10
b. Other States	75	25

Note: Special category states: North Eastern, Himachal Pradesh, Jammu & Kashmir, and Uttarakhand  
Source: MOWR, "Flood Management Program", (2015)

Considering the request of the state government, central plan scheme is recommended to be continued during the 12th Five-Year Plan to provide central assistance to states.

As mentioned in the above table, an outlay of Rs.16,000 crore is recommended under FMP during the 12th Five-Year Plan. The schemes costing up to Rs. 100.99 crore and above may be taken up by the state. The "critical schemes" with "benefit cost (B/C) ratio" of more than 2.0 and estimated cost Rs. 100 crore and above may also be considered for funding.

The requirement of funds with tentative list of schemes (projects) under FMP during the 12th Five-Year Plan is shown in Table 4.2.12.

**Table 4.2.12 Number of Critical Schemes and Funding Share under FMP in the 12th Five-Year Plan**

(Unit: Rs. crore)

No.	State	No. of Schemes	Estimated Cost (EC)	Central Share (CS)	Ratio (CS/EC,%)
A	Balance of Central Share spilling over to the 12th Five-Year Plan			1,172.75	
B					
1.	Assam	8	1,416.21	1,274.59	90.0
2.	Bihar	3	1,513.9	1,135.45	75.0
3.	Gujarat	1	338.26	253.70	75.0
4.	Himachal Pradesh	1	200.00	180.00	90.0
5.	J & K	6	3,698.00	3,329.01	75.0
6.	Karnataka	1	291.72	218.79	75.0
7.	Kerala	3	2,536.13	1,902.10	75.0
8.	Maharashtra	1	187.60	140.70	75.0
9.	Odisha	2	1,306.73	980.05	75.0
10.	Sikkim	1	100.21	90.19	90.0
11.	Tamil Nadu	1	166.43	124.82	75.0
12.	Uttar Pradesh	1	500.00	375.00	75.0
13.	Uttarakhand	1	350.00	315.00	90.0
14.	West Bengal	4	6,208.44	4,656.33	75.0
	Total (B)	34	18,814.56	14,975.72	79.6
	Grand Total		18,814.56	16,148.07 (=16,000)	-

Note: Critical schemes have benefit cost (B/C) ratio more than 2.0 and estimated cost Rs. 100.0 crore and above  
Source: Planning Commission, "Report of Working Group on Flood Management and Region Specific Issues for XII Plan", (2011)

State-wise details of works approved, works completed and funds released under FMP are shown in Table 4.2.13.

**Table 4.2.13 State-wise Details of Works Approved and Completed, and Funds Released (FMP)**

(Unit: Rs. crore)

No.	State	Works Approved and completed in 11th & 12th Plans			Funds Released (Mar. 2014)			
		No.	Estimated Cost	Central Share	No. Of Works Complete	11th Plan	12th Plan	Total
1	Arunachal Pradesh	21	107.33	96.55	11	78.77	16.83	95.60
2	Assam	141	2,383.11	1,924.39	77	744.90	2.51	747.41
3	Bihar	47	1,818.05	1,330.30	26	680.79	143.05	823.84
4	Chattisgarh	3	31.13	23.34	0	15.57	3.75	19.32
5	Goa	2	22.73	17.05	1	9.98	2.00	11.98
6	Gujarat	2	19.79	14.84	0	2.00	0.00	2.00
7	Haryana	1	173.75	130.31	0	46.91	0.00	46.91
8	Himachal Pradesh	7	1,364.94	1,000.51	0	165.31	29.67	194.98
9	Jammu & Kashmir	42	571.40	481.61	8	243.50	67.65	311.15
10	Jharkhand	3	39.30	29.47	0	17.07	4.27	21.34
11	Karnataka	3	59.46	44.59	0	20.00	0.00	20.00
12	Kerala	4	279.74	209.80	0	63.68	0.00	63.68
13	Manipur	22	109.34	98.41	19	65.03	17.91	82.94
14	Mizoram	2	9.13	8.22	0	3.40	0.00	3.40
15	Nagaland	14	86.73	70.55	9	28.96	15.45	44.41
16	Odisha	68	231.32	173.48	60	95.64	0.00	95.64
17	Puducherry	1	139.67	104.75	0	7.50	0.00	7.50
18	Punjab	5	153.40	115.04	0	40.43	0.00	40.43
19	Sikkim	45	366.32	227.39	21	82.86	2.43	85.29
20	Tamil Nadu	5	635.54	476.66	0	59.82	0.00	59.82
21	Tripura	11	26.57	23.92	4	20.91	0.00	20.91
22	Uttara Pradesh	29	959.27	709.10	6	290.69	75.90	366.59
23	Uttarakhand	21	303.27	246.98	3	49.63	53.14	102.77
24	West Bengal	18	2,261.02	1,695.77	7	642.87	138.30	781.17
Sub-total		517	12,152.31	9,303.03	252	3,476.22	572.86	4,049.08
Spillover Works 10th Plan					0	88.79	0.00	88.79
Total		517	12,152.31	9,303.03	252	3,565.01	572.86	4,137.87

Note: Rows highlighted in red are the highest three states for the fund released.

Source: Planning Commission, "Report of Working Group on Flood Management and Region Specific Issues for XII Plan", (2011)

From the above table, the highest three states are Bihar State with Rs. 823 crore, West Bengal State with Rs. 781 crore and Assam State with Rs. 747 crore.

#### (5) Specific Issues in Regions

The working group proposed to study the specific flood related issues for the following broad regions of India in the 12th Five-Year Plan.

- Desert Region
- Coastal Saline Region
- Non-coastal Saline Region
- Himalayan Region (Ganga, Brahmaputra, Northwest River, Central India and Deccan Region)
- Water logged areas

Of these, major issues on the Ganga River are summarised as follows.

- a. Flood problem is mostly confined to the areas on the northern bank of the river Ganga.
- b. The damage is caused by the northern tributaries of the Ganga by spilling over their banks and changing their courses.
- c. Flood problem increases from the west to the east and from the south to the north.

- d. In the north western parts of the region, there is the problem of drain congestion.*
- e. The flooding and erosion problem is serious in the states of Uttara Pradesh, Bihar and West Bengal states.*
- f. In Bihar, the floods are largely confirmed to the rivers of north Bihar such as Burhi Gandak, the Bagmati, the Kamla Balan, and the Kosi River. These rivers spill over their banks.*
- g. Erosion has also been taking place along Ganga and is now prominent on the right bank immediately downstream of the Mokameh Bridge and in the vicinity of the Mansi Railway Station on the left bank.*
- h. In Uttara Pradesh, the flooding is frequent in the eastern districts, mainly due to spilling of the Rapti, the Sharada, the Ghaghra and the Gandak.*
- i. The problem of drainage congestion exists in the western and north western areas of Uttara Pradesh, particularly in Agra, Mathura and Meerut districts.*
- j. Erosion is experimented in some places on the left bank of Ganga, on the right bank of the Ghanga and on the right bank of the Gandak.*
- h. In Hayana, flooding takes place in the marginal areas along the Yamuna and the problem of poor drainage exists in some of the south western districts.*

#### **4.2.7 Evacuation Systems**

##### **(1) Evacuation System for Flood**

Evacuation is one of the prescribed measures to save people from the floods. Evacuation of area affected by flood can be one of the most difficult operations when it involves large population. Evacuation needs to be carried out as a “precautionary measure” based on the warning indicators such as Flood Forecasting and Warning System (FFWS), prior to impact, in order to move people to a safe place.

Disaster management officials are the core authorities for carrying out evacuation. The following agencies and stakeholders are generally expected to be involved in evacuation activities with coordination of the disaster management officials:

- Early warning providers (FFWS)
- Transportation authorities (road for evacuation and road connectivity)
- Health care authorities (health facilities and staff)
- Food and commodity supply to relief centres (foods, water and commodities)
- Civil societies (at Block/Gram Panchayat level)
- NGOs

The responsibilities of each authority/agency need to be fixed in accordance with Standard Operating Procedures (SOPs).

##### **(2) Evacuation Capacity of Community**

At district level, the district has got a number of resources and capacities, which are useful in emergency as well as normal situations. The resources envisioned for evacuation during the floods are listed below:

- Connecting roads for evacuation
- Helipad
- Relief centres in the district
- Shelters including temporary shelters
- Boats

### **(3) Coordination between Government and NGOs**

According to “Model Framework for District Disaster Management Plan” published by the NDMA in July 2014, community at large and NGOs have their own responsibilities in the District Disaster Management Plan. The role of each of them has been prepared with the sole objective of making the concerned organisations understand their duties and responsibilities.

Local community groups and voluntary agencies including NGOs normally help in prevention and mitigation activities under the overall direction and supervision of the district disaster management. They should be encouraged to participate in all training activities as may be organised and should familiarise themselves with their role in the disaster management.

Regarding citizens, every citizen has a duty to assist the District Collector or any other person entrusted with or engaged in the disaster management whenever demanded for the purpose of the disaster management.

#### **4.2.8 Emergency Response**

After receiving flood warning for evacuation, flood response requires coordination and effective response systems at all levels: national, state, district, local and community. The scale of response for floods and the corresponding role players will be identified and mobilised at the district, state and national levels depending on the magnitude and the severity of the flood event.

In India, based on the NDMA Guidelines for Floods, all response activities will be undertaken at each administrative level through the Incident Command System (ICS) based on the Incident Action Plan (IAP) for flood through the Emergency Operation Centre (EOC).

For formulating the community evacuation plan in the IAP, the following task/function/activity will be considered by indicating connected line agencies:

- Raise flood alarm/early warning siren
- Look out on flood data from IMD, CWC for forecast and follow up action
- Alert all emergency support functions (ESFs)
- Assess the situation, make evacuation plan and move the community to a safe zone

#### **4.2.9 Challenges to be Addressed**

According to the information gathered, the following are the challenges identified by the Indian side:

##### **< Preparedness >**

For the enhancement of preparedness against flood disaster, the state government is responsible for the preparation and implementation of Flood Plain Zoning (FPZ). On the other hand, due to difficulties for the resettlement of the people living in flood prone areas, it is not applied yet in most states. Thus, the central and state governments need to collaborate to formulate a new strategy for the introduction of FPZ.

- Challenge(s) of Preparedness:
- Reorganising the strategy for introduction of flood plain zoning

In addition, considering the current situation of flood risk reduction in India, it is worth pointing out the following as challenges to be addressed:



< Institutional Framework >

At present, the state government is mainly in charge of river management and flood control in its administrative area. However, it is considered that this mechanism on the administrative area basis may cause ineffectiveness and inefficiency of river management, especially for cross-state rivers. Moreover, the 12th Five-Year Plan recommends the application of the integrated approach for flood management. Thus, the concept of river basin management needs to be introduced for effective and efficient flood management. Since one of the causes of flood disasters is riverbed aggradation caused by sediment inflows from the upper reaches, comprehensive sediment control in river basins is also required for the flood management.

Challenge(s) of Institutional Framework:

- Introducing basin-wide sediment control with the concept of river basin management (RBM)

< Countermeasures >

As discussed in Section 7.3, major countermeasures against floods are the embankment and anti-erosion works in Bihar State. This situation is similar to the whole country. The embankment leads to riverbed aggradation. Besides, water logging may occur in the future due to shortage of flow carrying capacity caused by sedimentation in canals/channels. Therefore, it is necessary to implement embankment and bank protection works in consideration of basin-wide sediment control and to plan countermeasures against water logging caused by sedimentation.

Challenge(s) of Countermeasures:

- Implementing embankment and bank protection works in consideration of basin-wide sediment control
- Planning countermeasures for water logging that could occur in the future due to shortage of flow carrying capacity caused by sedimentation in canals/channels

According to the CWC, inundation forecasting is identified as a challenge to make the emergency response effective. A pilot project will be started by the end of 2015 in three target areas: Mahanadi basin, Brahmaputra basin and Kosi basin. As for the aspect of forecasting, early warning and communication system, other specific challenges are not identified for policy, planning and current activities at the national level.

Table 4.2.14 shows the challenges identified, actions to be taken for the improvement and organisations responsible for implementation of the actions.

**Table 4.2.14 Challenges and Actions (Floods)**

S/N	Challenges	Actions to be Taken: <u>Floods</u>		
		Short Term (1 - 2 Years)	Medium Term (3 -5 Years)	Long Term (5 - 10 Years)
<b>Challenges identified by the Indian Side</b>				
[ Preparedness ]				
DT-FL-1	Reorganising the strategy for introduction of flood plain zoning	<u>Action(s)</u> - Reviewing the past strategy to introduce the flood plain zoning - Investigating the current situation of flood plain zoning in the states - Formulating a draft strategy or concept paper to enhance the introduction of flood plain zoning	<u>Action(s)</u> - Sensitising state departments responsible for flood risk reduction to the introduction of flood plain zoning	-
		<u>Taken by</u> - MHA - NDMA	<u>Taken by</u> - MHA - NDMA	-
<b>Challenges identified by the Survey Team</b>				
[ Institutional Framework ]				
DT-FL-2	Introducing basin-wide sediment control with the concept of river basin management (RBM)	<u>Action(s)</u> - Investigating the current situation of sediment control in river basins - Analysing factors that may cause the riverbed aggradation - Formulating a concept paper to enhance the basin-wide sediment control - Preparing the guidelines and manuals for planning of basin-wide sediment control	<u>Action(s)</u> - Sensitising state departments responsible for flood risk reduction to the introduction of basin-wide sediment control	-
		<u>Taken by</u> - MOWR - CWC	<u>Taken by</u> - MOWR - CWC	-

S/N	Challenges	Actions to be Taken: <u>Floods</u>		
		Short Term (1 - 2 Years)	Medium Term (3 -5 Years)	Long Term (5 - 10 Years)
[ Countermeasure ]				
DT-FL-3	Implementing embankment and bank protection works in consideration of basin-wide sediment control	<u>Action(s)</u> - Reviewing the effectiveness of existing structural measures - Formulating a guidebook that shows the feature, typical specifications and planning methodology of measures against floods and sedimentation	<u>Action(s)</u> - Sensitising state departments responsible for flood risk reduction to the introduction of suitable measure based on the guidebook	-
		<u>Taken by</u> - MOWR - CWC	<u>Taken by</u> - MOWR - CWC	-
DT-FL-4	Planning countermeasures for water logging that could occur in the future due to shortage of flow carrying capacity caused by sedimentation in canals/channels	<u>Action(s)</u> - Reviewing the current situation of measures against water logging - Formulating a guidebook that shows the feature, typical specifications and planning methodology of countermeasures against water logging	<u>Action(s)</u> - Sensitising state departments responsible for flood risk reduction to measures against water logging	-
		<u>Taken by</u> - MOWR - CWC	<u>Taken by</u> - MOWR - CWC	-

Source: prepared by the Survey Team

### 4.3 Sediment Disaster (Landslide)

#### 4.3.1 Situation of Countermeasures in National Policy and Planning

Figure 4.3.1 shows that a wide range of land area in India is vulnerable to landslide disaster indicating approximately 15 % of India's land area might face landslide disaster. Most of the landslides occur during the monsoon period, barring a few which owe their origin to earthquake. Especially, as shown in the figure below, the northern part of the country located in the mountainous area is vulnerable to landslide disaster.

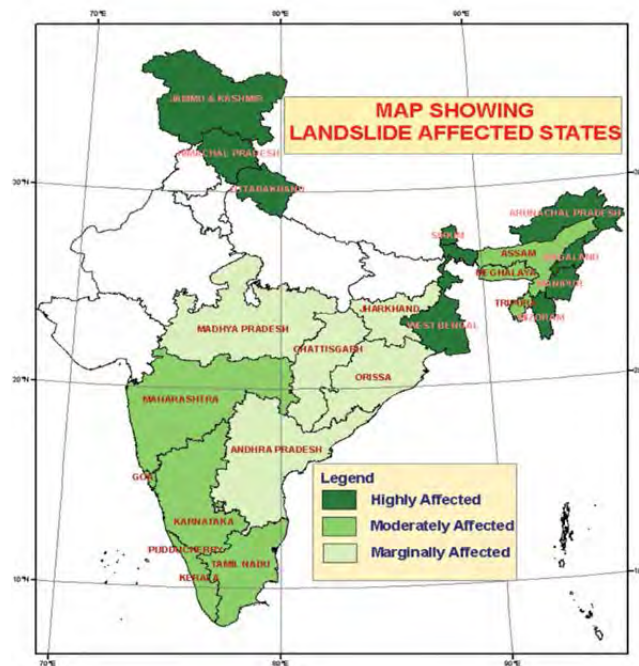

Source: NDMA, "National Policy on Disaster Management 2009", (2009)

**Figure 4.3.1 Map of Landslide Affected States**

According to the "Disaster Management in India" prepared by the MHA in May 2011, the geo-tectonic features of the Himalayan region and adjacent alluvial plains make the region susceptible to earthquakes, landslides and water erosion. It is estimated that 30 % of the world's landslides occur in the Himalayas. Therefore, the landslides are considered as one of major natural hazards in India, based on the result of hazard profiling.

#### 4.3.2 Policies and Institutional Frameworks

##### (1) Policy on Landslide (Sediment Disaster) Prevention

##### 1) Action Plan for Landslide Risk Mitigation

According to the Office Memorandum issued by the MHA in November 2004, an action plan for landslide risk mitigation is addressed. Table 4.3.1 shows the main items of the action plan.

**Table 4.3.1 Action Plan for Landslide Risk Mitigation**

(i)	(a)	Finalising uniform methodologies for landslide hazard zonation on macro and meso scales
	(b)	Developing methodologies for landslide hazard zonation on meso scales
(ii)		Landslide hazard zonation of the vulnerable area on macro scale
(iii)		Landslide hazard zonation of the identified areas on a meso scale
(iv)		Developing landslide risk mitigation plan

---

(v)	Monitoring of recurring landslides
(vi)	Rapid response to suggest immediate measures in the event of landslides
(vii)	Evolving an early warning system
(viii)	Awareness generation

Source: MHA (2004)

Landslide hazard zonation and vulnerable area zonation at macro-scale has been conducted by related organisations and GSI by applying uniformed standards, while meso-scale identification of hazard zonation area has not been conducted. Landslide monitoring and study on early warning system has been done by some technical institutions; however, the result of those works has not been applied to practical use. Comprehensive awareness and preparedness programmes for natural disaster have been implemented in the country.

## **2) National Disaster Management Guidelines for Management of Landslides and Snow Avalanches**

The National Disaster Management Guidelines for Management of Landslides and Snow Avalanches issued by the NDMA in June 2009 (hereinafter referred to as the “NDMA Guidelines for Landslides”) aims at the following points:

- To institutionalise the landslide hazard mitigation efforts
- To make the society aware of the various aspects of landslide hazards in the country
- To prepare the society to take suitable actions to reduce both risks and costs associated with landslides

### **(2) Institutional Framework**

#### **1) Related Organisations and Departments**

##### **a) National Core Group for Landslide Hazard Mitigation**

The National Core Group for Landslide Hazard Mitigation was set up with the approval of the Prime Minister. The core group comprises of the followings members:

- Secretary (BM), Ministry of Home Affairs – Chairman
- Secretary, Ministry of Defence
- Secretary, Department of Science and Technology
- Secretary, Ministry of Road Transport and Highways
- Director General, Geological Survey of India (GSI)
- Director, National Remote Sensing Agency (NRSA)
- Joint Secretary (DM), Ministry of Home Affairs

The core group has the follow functions:

- To draw up a strategy of action for monitoring the impact of landslides
- To provide advice and guidance to state governments on various aspects of landslide hazard mitigation
- To monitor the activities related to landslide hazard mitigation including landslide hazard zonation
- To evolve an early warning system and protocols for landslide hazard/ risk reduction

##### **b) Geological Survey of India (GSI)**

The Geological Survey of India (GSI) is a nodal agency for sediment disaster prevention, which falls under the Ministry of Mines (MOM). The following are GSI’s functions for the landslide risk

mitigation:

- Coordinating and undertaking geological studies for landslide hazard mitigation
- Carrying out landslide hazard zonation
- Monitoring landslides and avalanches
- Studying factors that cause sliding and suggesting precautionary as well as preventive measures

The organisational structure of the GSI is shown in Figure 4.3.2. The head office is located in Kolkata and there are six (6) regional headquarters. According to the civil list, there are 3,927 officials in the GSI.

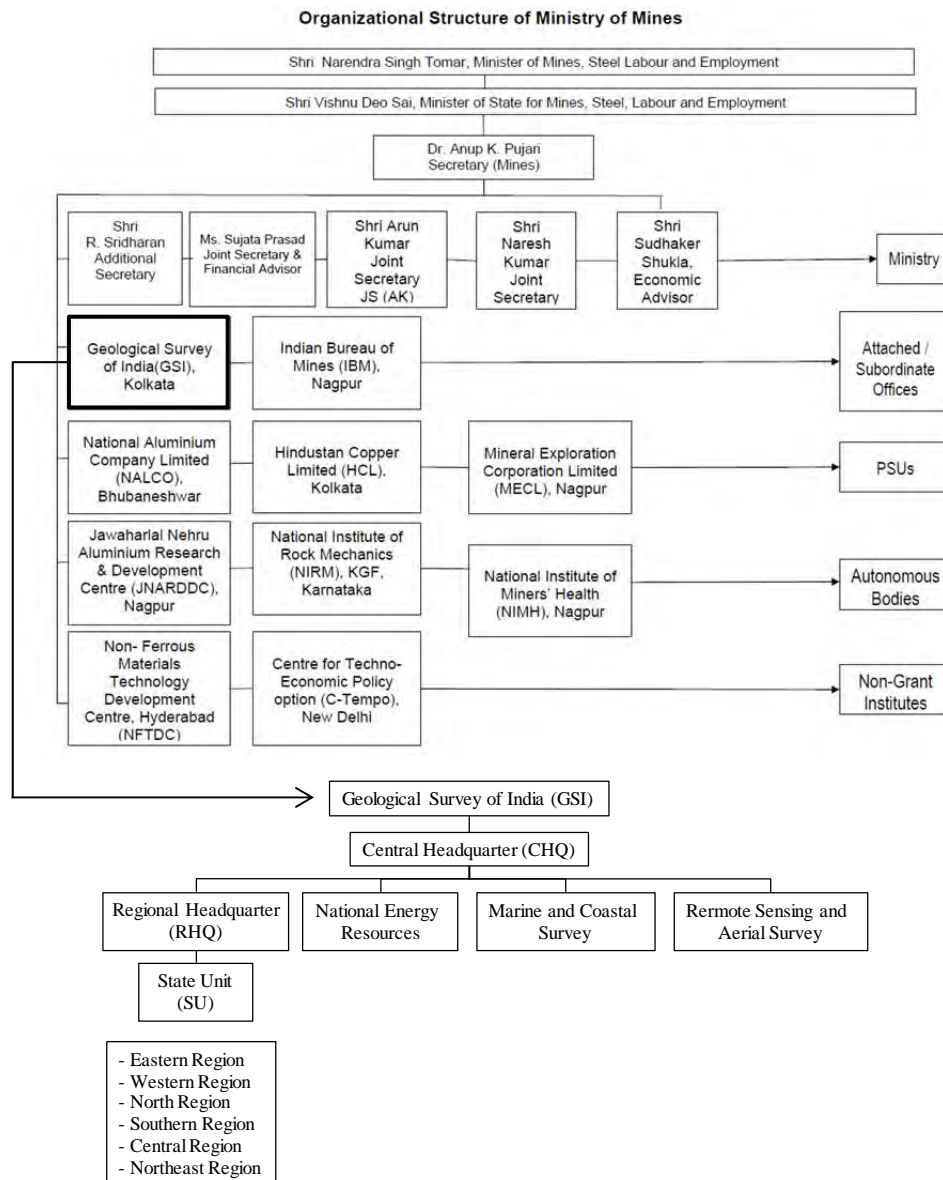

Source: prepared by the Survey Team based on the information of MOM and GSI

**Figure 4.3.2 Organizational Structure of GSI**

c) Other Organisations and Departments

Other government departments and organisations which are engaged in the study and management of landslide hazards in the country and their activities are shown in Table 4.3.2.

**Table 4.3.2 Departments/Organisations for Landslide Hazard Study and Activities**

No.	Resource Departments/ Organisations	Activities related to Landslide Mitigation
<b>Central Government Organisations</b>		
1.	Central Water Commission (CWC)	Study related to rivers and data of discharge gauges, hydrology, etc.
2.	Central Groundwater Board (CGWB)	Hydrological studies, geophysical investigation, groundwater studies, etc.
3.	Survey of India (SOI)	Preparation of topographical sheet of particular region (prepared topographical sheets are available with SOI). SOI are generating contours or doing total survey station for generation of contours.
<b>State Government Organisations</b>		
4.	State Geology and Mineral Resource Department	Investigation/study of landslide in the state and recommendations for its mitigation
5.	Public Works Department	Survey of landslide site and work on structural mitigation measures. Preparation of cost estimation on the basis of Schedule of Rates, etc.
6.	State Remote Sensing Centre/Space Application Centre (SAC)/NRSC (National Remote Sensing Centre)-ISRO (Indian Space Research Organisation)/NRSA (National Remote Sensing Agency)	Acquisition, distribution and analysis of remote sensing data Landslide hazard zonation and risk map
<b>Other Institutes</b>		
7.	CSIR- Central Road Research Institute (CIRRI)	Geological and geotechnical investigation, slope stability analysis, design of suitable remedial measures, recommendation and providing services to execution instrumentation and monitoring for suitable remedial measures
8.	National Institute of Hydrology (NIH), Roorkee	Hydrological study for landslide mitigation measures
9.	Central Water and Power Research Centre (CWPRC), Pune	Hydrology, river engineering services, hydraulics, etc. related to landslide management

Source: prepared by the Survey Team

## 2) Landslide Classification System

Landslide classification system in India is shown in Table 4.3.3. Many types of movement and materials are listed in Table 4.3.3. The main types of landslides in India are Falls, Slide and Lateral spreads. Most of the landslides occur along the existing roads.

**Table 4.3.3 Landslide Classification System in India**

Types of Movement	Types of Material			
	Soils		Bed Rock	
	Predominantly Fine	Predominantly Coarse		
Falls	Earth fall	Debris fall	Rock fall	
Topples	Earth topple	Debris topple	Rock topple	
Slides	Rotational	Earth slump	Debris slump	Rock slump
	Transitional	Earth block slide	Debris block slide	Rock block slide
		Earth slide	Debris slide	Rock slide
Lateral Spreads	Earth spread	Debris spread	Rock spread	
Flows	Earth flow	Debris flow	Rock flow	
	Slope creep		Deep creep	
Complex	Combination of two or more types of movement			

Source: BIS, "Indian Standard Landslide Control – Guideline", (1999)

### 4.3.3 Disaster Records

Table 4.3.4 shows the historical records of landslide events in India from 1990 to 2015. According to the table, many landslide events occurred during June to August of rainy (monsoon) season.

**Table 4.3.4 Disaster Record of Landslide in India (1990-2015)**

Date	Location	Total Number of Deaths (persons)	Total Number of Affected People (persons)	Damage (USD)
16/09/1990	Sikkim	30		
09/08/1992	Aizawi (Mizoram State)	60		
23/09/1993	Bombay	20	25	
16/01/1995	Kashmir Province	200	5,250	
03/06/1995	Mizoeram State	40	14,280	4,500
12/09/1995	Kulla (Himachal Pradesh)	400	1,100,000	
30/09/1996	Kamataka (Andhra Pradesh, Maharashtra)	48		
09/06/1997	Gangtok (Sikkim)	28	30	
06/08/1997	Darjeeling (West Bengal)	23	2,000	
05/03/1998	Himachal Pradesh	26		
03/06/1998	Assam	48	150	
17/08/1998	Malpa Village (Uttar Pradesh)	239	200,000	
19/08/1998	Mansuna Village (Uttar Pradesh)	37		
31/03/1998	Sikkim	24	6	
--/06/2000	Moradabad (Uttar Pradesh), Garhwal Himalaya Region)	43		
12/07/2000	Ghatlopar (Bombay)	58	7,038	
11/08/2000	Himalayan Foothills	86		
16/07/2001	Rudraprayag (Uttarakhand)	27		
14/08/2001	Chamba District (Himachal Pradesh)	16		
09/11/2001	Amboori Village (Kerala Province)	55		
03/03/2003	Himalayan (Jammu & Kashmir)	25		
15/02/2005	Verinag Ramus etc. (Jammu & Kashmir)	250	5,000	
08/02/2008	Kaoran Village (Kashmir)	37		
08/08/2009	Pithoragarh District Uttarakhand	45		
03/09/2009	Mumbai	10		
08/02/2010	Khelemarg Mountains (Kashmir)	14		
12-27/06/2013 *	Uttarakhand, Himachal Pradesh, Uttar Pradesh, Bihar, etc.	6,054	504,473	1,100,000
30/07/2014	Malin (Maharashtra)	209		

Note: Event of 06/2013 is classified into "Flood" by EM-DAT.

Source: EM-DAT (2015)



According to some available sources, main reasons for landslide disasters are as follows:

Landslide in Uttarakhand State etc. in June 2013 (fatalities: 6,054 people)

Heavy rain caused flash flooding, and a glacial lake outburst flood (GLOF) occurred due to a breach of glacial lake in the upper stream of the Mandakini River caused by heavy rain. The flash flood and GLOF triggered a huge number of landslides along the Mandakini River. Those floods and landslides directly washed out existing roads, houses and agricultural lands and caused economic losses and human casualties. Besides, huge numbers of “landslide dams” were formed by the debris of landslides. Those landslide dams were breached subsequently, and then reserved water became flood, causing debris flow and washing out existing roads, houses and agricultural land. It also caused economic losses and human casualties. Especially, many pilgrims were involved in the disaster (Source: Disaster Recovery of Disaster Uttarkashi, Uttarkashi District, Uttarakhand).

Landslide in Uttarakhand in August 2012 (fatalities: 35 people, affected agricultural land 72,000ha)

Heavy rain caused flash flooding, which flash floods triggered huge numbers of landslides along the Bhangirathi River. The flooding and landslides directly washed out existing roads, houses and agricultural land, causing economic losses and human casualties (Source: Disaster Recovery of Disaster Uttarkashi, Uttarkashi District, Uttarakhand).

In general, the following may be the major reasons for damage due to landslide disasters in India:

- Poor management of pre-evacuation, such as lack of reliable communication system, accurate information (forecasting and warning) and reliable evacuation system at particular locations, caused huge numbers of fatalities in the past events (Insufficient preparedness and non-structural measures).
- There is no appropriate countermeasure for mitigation (structural measures) in the landslide prone area (Lack of appropriate structural measures against landslides).

#### **4.3.4 Observation/Monitoring System/Early Warning**

##### **(1) Observation/Monitoring**

Effective early warning and countermeasures against landslides can be planned and implemented based on landslide mechanism information. Thus, the landslide observation and monitoring are very important activities to understand the mechanism.

In order to establish appropriate early warning system, from the view of engineering, installation of suitable monitoring equipment (instrumentation) and establishment of appropriate monitoring system are important. The following are the examples of observation/monitoring system of the landslides.

##### **1) Mansa Devi Landslide (Uttarakhand State)**

Mansa Devi landslide is located on Haridwar bypass road that joins Haridwar township in the south and village Kharkhari in the north. For this landslide, the Central Scientific Instrument Organisation (CSIO) set up a monitoring system. Figure 4.3.3 shows the outline of the network of the system. This system was installed in 2006 for the first time in India.

This system was set up for the purpose of research work and for establishment of the instrumentation network for monitoring landslides and for early prediction of landslide activities by regular continuous monitoring. The CSIO had a plan to utilise this monitoring system for early warning of landslide; however, this monitoring system was not connected to the early warning system, and early warning system was not installed.

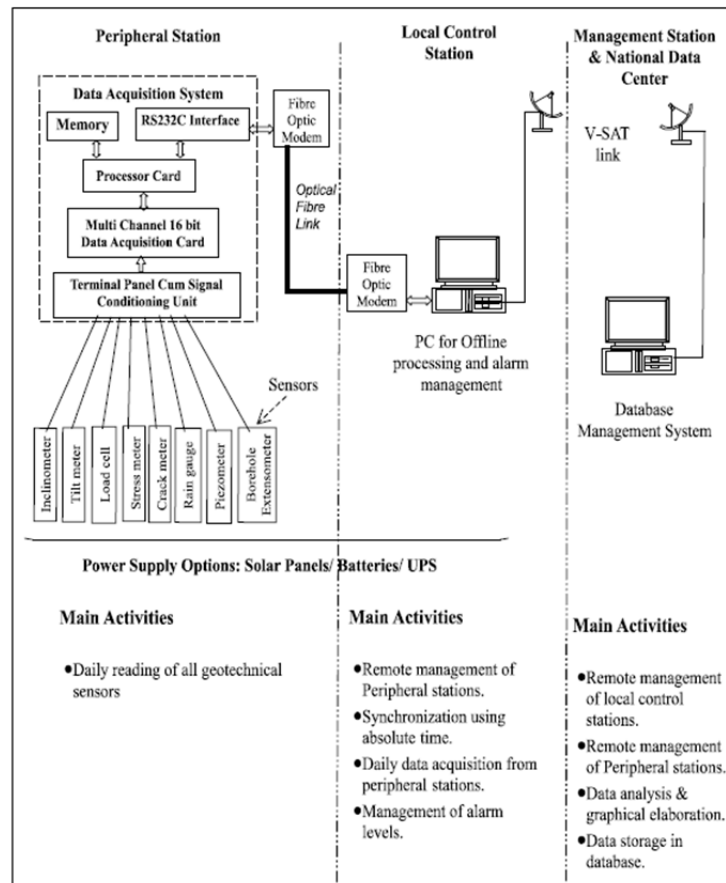

Source: CSIO (2009)

**Figure 4.3.3 Monitoring System of Mansa Devi Landslide**

## 2) Varunavat Landslide (Uttarakhand State)

Varunavat landslide is located in Uttarkashi town in Uttarakhand State and the landslide area is behind the township area. Therefore, there is high risk in case landslide becomes active. Countermeasure works against this landslide started in 2003 and completed in 2009. The countermeasure works were requested and started directly by the central government. All budgets including budget for geological investigation, monitoring and construction, etc. were allocated by the central government.

Geological investigation and construction works of the countermeasures were done by private company. Planning, design and supervision of the construction works were done by the THDC India Limited.

The National Institute of Rock Mechanics (NIRM) planned to set a Slope Stability Radar (SSR) for the monitoring/early warning of this landslide area. However, this SSR is still not installed. Figure 4.3.4 shows the SSR and slope scanning method planned by the NIRM.

Regarding the early warning system, very limited planning and research activities have been carried out. Furthermore, the result of those works has not been practically used.

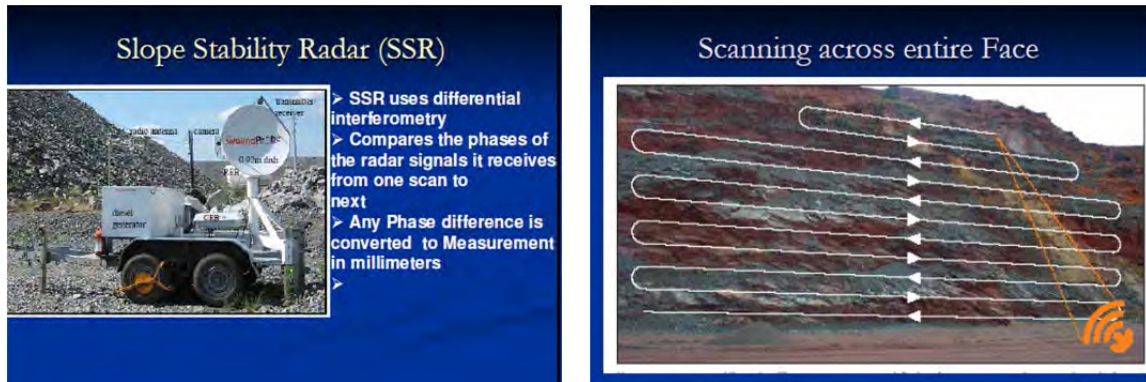

Source: NIRM, “Stabilisation of Varunavat Landslide in Uttarkashi Town, Uttarakhand Himalaya”, (2009)

**Figure 4.3.4 SSR and Scanning Method**

At present, there are no standard readymade systems for early warning of landslides. In order to establish instrument-based early warning system, the following processes are necessary:

- Preparation of guidelines/manuals for the landslide early warning system
- Conducting a pilot project in accordance with the guidelines/manuals
- Reviewing and revising the guidelines/manuals
- Dissemination of the guidelines/manuals to states which have landslide prone areas

The guidelines/manuals should cover the implementation system, i.e. responsible organisation, relationship between structure of monitoring system (i.e. type of monitoring equipment, sensor) and necessary related data such as rainfall data.

## (2) Landslide Investigation

Landslide investigation is an important stage to understand the mechanism of landslide that includes geology and geological structure of landslide, scale of landslide (area, depth of sliding surface) and groundwater distribution in the landslide area. The result of the landslide investigation is used for planning and design of landslide countermeasures. Figure 4.3.5 shows the landslide investigation flow.

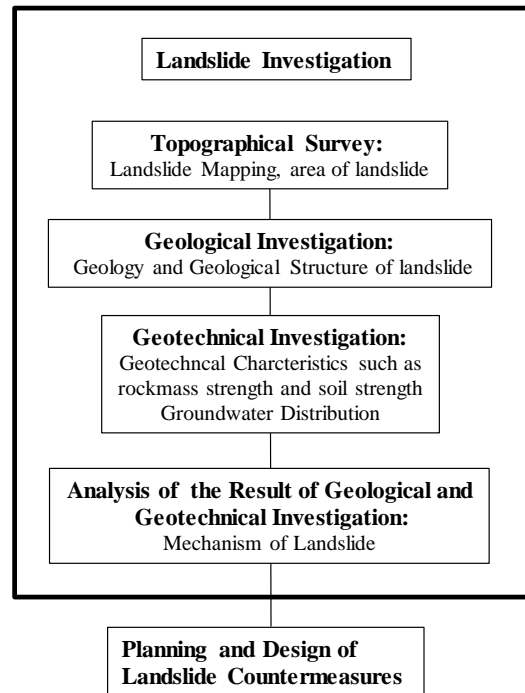

Source: prepared by the Survey Team

**Figure 4.3.5 Flow of Landslide Investigation**

The methodology of landslide investigation is indicated in the following documents:

- National Disaster Management Guidelines for Management of Landslides and Snow Avalanches (NDMA, April 2007)
- Template for Preparation of Detailed Project Report (DPR) for Site Specific Landslide Risk Mitigation (NDMA, June 2015)
- Standards for Geological and Geotechnical related Investigation

**1) National Disaster Management Guidelines for Management of Landslides and Snow Avalanches**

a) Geological Investigation

The geological investigation of landslide can be divided into different stages and these investigations proceeded sequentially from one stage to the other with some overlap. The following are the investigation stages:

- i) Preliminary geological investigation
- ii) Detailed geological investigation
- iii) Treatment implementation stage investigation
- iv) Post-implementation stage investigation/monitoring

The Guideline indicates that actions related to geological investigation are implemented by the GSI, the Department of Science and Technology (DST), GOI, Indian Institutes of Technology (IITs), universities and other academic institutions. In addition, the Bureau of Indian Standard (BIS) collaborates with these organisations.

b) Geotechnical Investigation

The geotechnical investigation of landslide includes mapping of the problematic slope at the

appropriate scale, scientific understanding of its kinetics, elucidation of the landslide boundaries, determination of representative shear strength parameters and pore pressure variations on the landslide boundaries, and finally the evaluation of the safety factor. The NDMA Guidelines for Landslides indicate that actions related to geotechnical investigation are implemented by the NIDM, GSI, DST, the Centre for Disaster Management and Mitigation, Vellore (CDMM), Central Building Research Institute (CBRI), the Central Road Research Institute (CRRI), the Wadia Institute of Himalayan Geology (WIHG), the Council of Architecture (CoA), IITs, universities and other academic institutions. In addition, the BIS collaborates with these organisations. Evaluation of investigation result is done by the GSI.

According to these descriptions, the policy of geological and geotechnical investigation for landslide is well examined.

## **2) Template for Preparation of Detailed Project Report (DPR) for Site Specific Landslide Risk Mitigation**

The investigation methods for the following types of slopes are described in the document:

- Soil/Debris Slope
  - Soil sampling
  - Conducting of soil penetration test (IS 2131, BIS)
  - Drilling borehole (IS 1892)
  - Density test
  - Soil test (grain size, density of soil, specific gravity, unit weight)
  - Liquid and plastic limit
  - Shear strength
  - Permeability
  
- Rock Slope
  - Rock sampling
  - Rock quality designation
  - Discontinuity parameter
  - Rock mass classification
  - Slope mass rating
  - Uni-axial compression strength
  - Shear properties

## **3) Standards for Geological and Geotechnical related Investigation**

As for the standards of geological and geotechnical related investigation, the following standards and SOPs are prepared by the GSI and BIS:

- GSI
  - SOP for Landslide Investigation
  - Guideline for Investigations and Explorations Required at DPR Stage of Proposed Hydroelectric Project in Hilly Terrain
  - SOP for Engineering Geology and Geotechnical Investigations
  - Quality Management & SOP for National Geological Mapping
  - Modified SOP for National Geophysical Mapping
  
- BIS
  - IS 1892- 1979 Code of practice for subsurface investigation for foundation (reaffirmed 2002)
  - IS 15686 (2006) Recommendation for preparation of geological and geotechnical maps for river valley projects

Figure 4.3.6 shows the relation of abovementioned documents, standards and SOP.

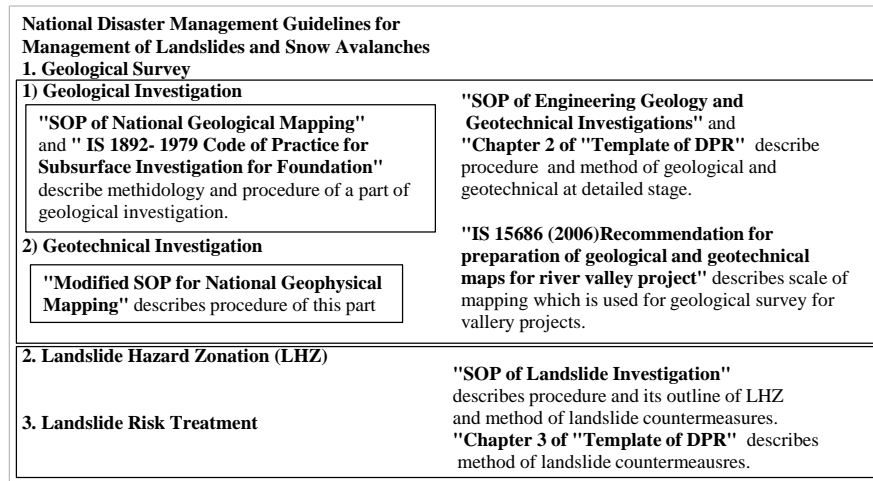

Source: prepared by the Survey Team

**Figure 4.3.6 Relation of Documents, Standards and SOP**

The NDMA Guidelines for Landslides describe the outline of landslide investigation, landslide hazard zonation (LHZ) and landslide risk treatment. The other SOPs and ISs describe procedure and method of part of the NDMA Guidelines for Landslides. For example, the SOP for Engineering Geology and Geotechnical Investigation and Chapter 2 of DPR describe part of geological and geotechnical investigation of the NDMA Guidelines for Landslides. And also Chapter 3 of DPR describes part of Landslide Risk Treatment of the NDMA Guidelines for Landslides.

#### **4.3.5 Risk Analysis**

##### **(1) Hazard Zonation Mapping**

##### **1) Flow of Risk Assessment**

Figure 4.3.7 shows a flow chart of risk assessment from landslide zone to identification of individual landslide.

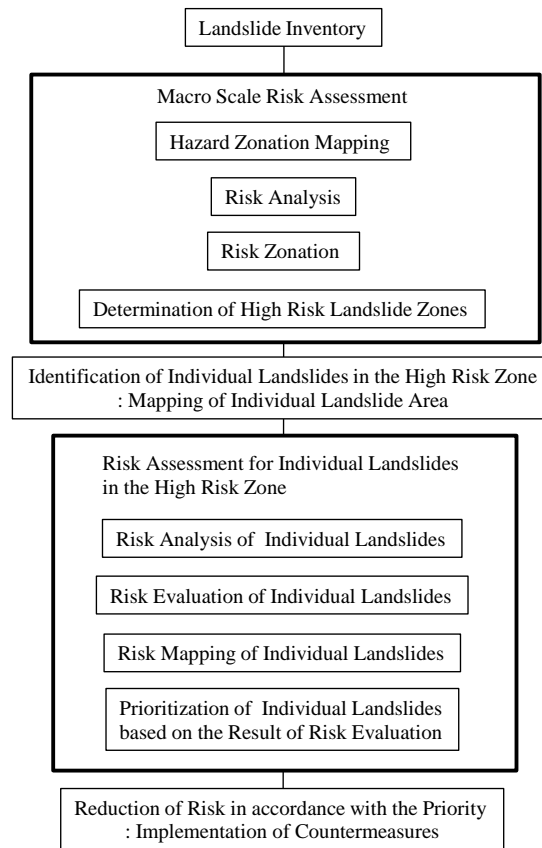

Source: prepared by the Survey Team

**Figure 4.3.7 Flow Chart of Risk Assessment**

## 2) Landslide Inventory

The NDMA Guidelines for Landslides provide the procedure and method to prepare landslide inventory. The guidelines also indicate actions related to the landslide inventory that are supposed to be implemented by the GSI, state directorates of geology and mining, WIHG, NIDM, NRSC, State Remote Sensing Centre. Landslide inventory in the disaster management plan of each state is referred to existing documents or research results which were used and carried out for different purposes. Therefore, formats/forms of landslide inventory in the disaster management plan are different in each state. The existing formats/forms are used for the following purposes:

- To assess damage due to landslide event occurrence (after reoccurrence of landslide event)
- To identify the location, dimension, mechanism (characteristics) of landslide (before reoccurrence of landslide event)
- To research relation among geological component, geological structure and location of landslide, including the location, dimension and mechanism

Table 4.3.5 shows an example of landslide inventory compiled by the GSI. This inventory form can be used for the damage assessment and the abovementioned research.

**Table 4.3.5 Example of Landslide Inventory by GSI**

State: Uttarakhand		Tehsil / Village:	
District: Pithoragarh		Date: 13/12/2013	
National/State Highway:			
Transact from km to km			

Sl. No.	Data set	Geoparameters	Details of the Landslide
1	Location detail	Slide No./ID/ Popular name	L-5
2		State/District	Uttarakhand/Pithoragarh
3		Toposheet No.	62/C/2
4		Important location/Landmark	1 Km from Charamanya (Bhubalkhola) toward Raagaah
5		Latitude, Longitude	N 29°43'41" E 80°4'25" 1064m elev.
6	Slide type	Date of occurrence	Recent during rain of June 2013
7		Type of material involved	Sheared, highly weathered thinly bedded Limestone/Dolomite of Raatgara Pithoragarh Formation)
8		Type of movement	
9		Type of slide	Rock-cum-debris slide
10		Rate of movement/activity	Rapid during rain
11	Slide morphology	History of slide	New
12		Length (m)	45m
13		Width (m)	40 m
14		Area (m <sup>2</sup> )	
15		Height (m)	35 to 40m
16		Volume (m <sup>3</sup> ) with estimated depth	
17		Run Out (distance, zone, hazard)	40 m
18		Slope angle and direction	33° to 53°, S170°
19	Geological details	Geology	
20		ix. Lithology	Limestone/Dolomite
20		x. Slope forming material	Debris
20		Structural details	S50-42°N10°E
21	Landslide causes	ix. Geomorphology and	Slope
21		x. Hydro-geological	Dry
22	Damage and risk due to landslide	Land use/ land cover	Barren to Sparsely vegetation
22		Triggering factor and cause(s)	Heavy rainfall
23	Landslide process	Landslide process	Heavy rainfall and Road cuts
23		Geological causes	Highly weathered limestone and debris movement during heavy rain.
26	Damage and risk due to landslide	Death of persons/human casualty/injury	NIL
27		People affected	NIL
28		Live stock loss	NIL
29		Buildings/houses/infrastructure damages (partially or completely)	NIL
30		Communication network	Road network
31		Agricultural/forest land	

  

Sl. No.	Remarks/ measures for the slide	Risk	Communication network
32			
33	Remedial measures (brief)		Toe wall may be constructed above the road level Existing toe wall may be extended in length
34	Rehabilitation plan (if applicable)		NIL
35	Realignment (in case of road communication network)		NIL
36	Remarks/Abstract		NIL
37	Photographs of slide		Yes
	ix. Sketches		
	x. Soft copy		
38	Slide documentation		

Source: GSI, "Report on Landslide Hazard Zonation on Macro Scale in Parts of Pithoragarh District, Uttarakhand", (2014)

### 3) Landslide Hazard Zonation (LHZ) Mapping

The existing standard for hazard mapping is "IS 14496 (Part 2): 1998 Preparation of Landslide Hazard Zonation Maps in Mountainous Terrains-Guidelines Part 2 Micro Zonation" prepared by the BIS in 1998. Figure 4.3.8 shows an example of the existing landslide hazard map. The figure is the macro-scale landslide hazard map along the main rivers in Himachal Pradesh State and Uttarakhand State, prepared by the NRSA in collaboration with the WIHG. These maps indicate individual landslide areas.

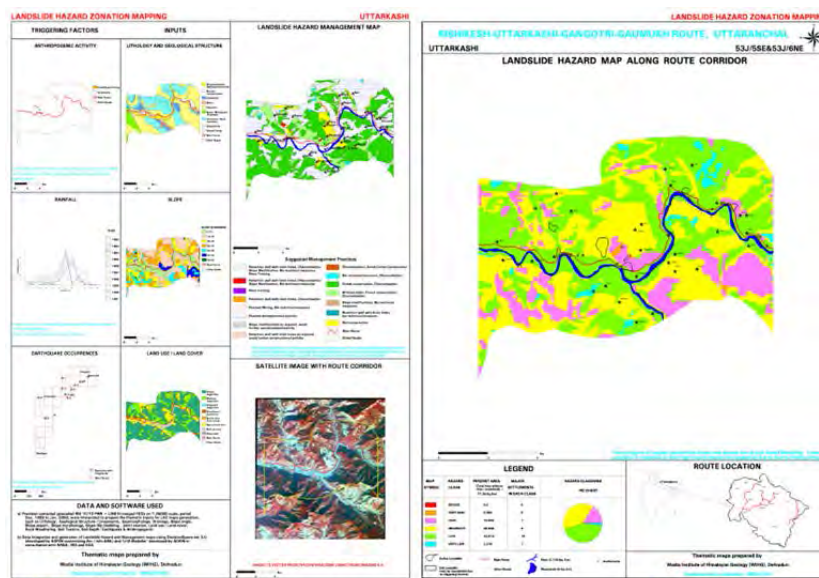

Source: NRSA (2001)

**Figure 4.3.8 Example of Landslide Hazard Zonation Map by NRSA**



There is one (1) type of multi-hazard risk vulnerability assessment as shown in Figure 4.3.9.

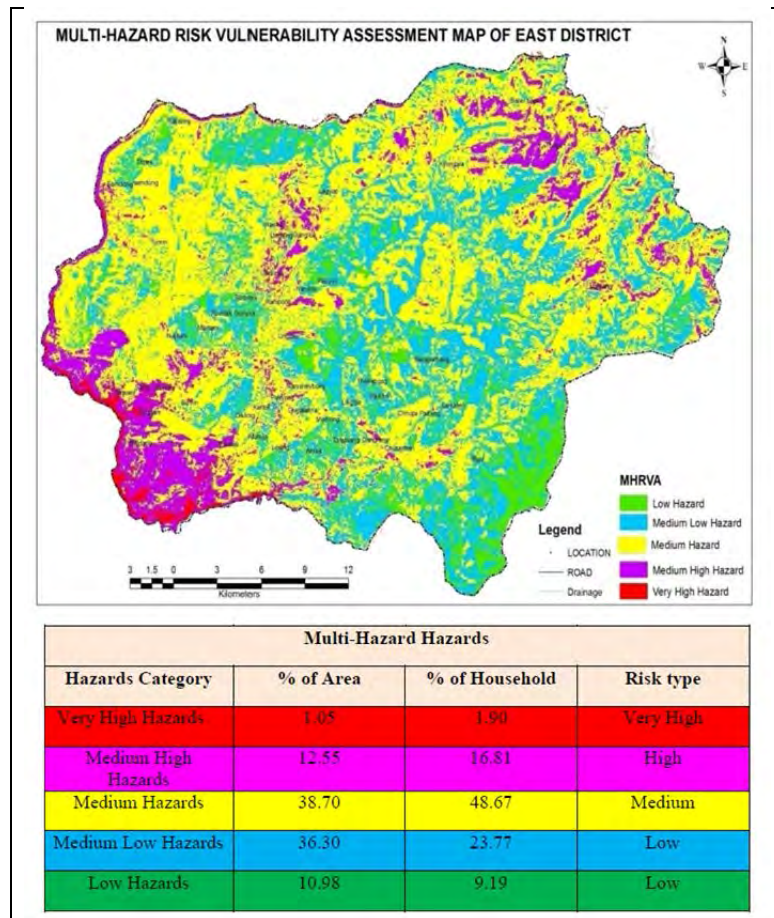

Source: CBRI Roorkee

**Figure 4.3.9 Example of Landslide Susceptibility Map (Sikkim)**

As shown above, contents and accuracy of hazard zonation maps vary because different organisations prepared the maps.

The NDMA Guidelines for Landslides describe the method of macro-scale (1:25,000 to 1:50,000) and meso-scale (1:5,000 to 1:10,000) landslide hazard zonation mapping. The mapping is implemented by the NRSC, DST, CBRI, CRRI, WIHG, and IITs. In addition, the BIS collaborates with these organisations. The NDMA Guidelines for Landslides also recommend that the existing guidelines for macro-scale hazard zonation that is prepared by the BIS should be reviewed and revised in collaboration of the BIS, GSI, IITs, etc.

#### 4) **Prioritisation of Areas for LHZ Mapping**

There are two (2) steps to prioritise areas for LHZ mapping:

- Mapping of landslide zones
- Mapping of individual landslide area

The actions related to prioritisation of area for LHZ mapping to be taken are provided in the NDMA Guidelines for Landslides and those works are implemented by GSI, NRSC, DST, CRRI, WIHG, and Boarder Roads Organisation (BRO). The GSI has a responsibility to evaluate the result of LHZ mapping conducted by other organisations. Table 4.3.6 shows the criteria of prioritisation for macro and mezzo scale mapping. However, the step taken for the LHZ mapping at present is

mainly the first one of the mapping of landslide zone, and mapping of individual landslide areas has not been conducted.

**Table 4.3.6 Prioritisation of Each Scale (Macro and Meso)**

Macro Scale	Meso Scale
<ul style="list-style-type: none"> <li>● Keeping in view the civilian in the immediate vicinity and strategic demands, areas along specified road corridors in the Himalayas and the North-East Region (NER)</li> <li>● Critical Transportation corridors in the Western Ghats and Nilgiris</li> <li>● Critical areas with inhabited towns, villages, pilgrim centres, and pilgrim route in the Western and Eastern Himalayas</li> </ul>	<ul style="list-style-type: none"> <li>● Areas around urban agglomerations, including those having high growth potential in the Himalayas and the NER</li> <li>● Critical transportation corridors in the Western Ghats</li> <li>● Critical areas in the Nilgiris having high growth/development potential</li> <li>● Areas with high potential for the siting of hydroelectric power structure in the Himalayas and NER</li> </ul>

Source: NDMA, “National Disaster Management Guidelines for Management of Landslides and Snow Avalanches”, (2009)

## (2) **Landslide Risk Assessment and Zonation**

Landslide risk assessment is very important for the formulation of landslide disaster management plan in order to execute effective landslide mitigation measures. The NDMA Guidelines for Landslides provide schematic method and procedure for landslide risk assessment (risk analysis and risk evaluation) and risk zonation as well. Some technical institutes have already carried out the landslide risk assessment. However, at present, the risk assessment by the technical institutes is still at the study level and has not been used for individual landslide area. The risk assessment generally requires four (4) types of data: environmental factor, triggering factor, historical landslide occurrence and element at risk. Except for the historical landslide occurrence based on the landslide inventory, other required data might not be studied or gathered.

### **4.3.6 Preparedness and Countermeasures**

#### **(1) Preparedness**

##### **1) Awareness**

Activities for the public awareness generation are taken by the SDMAs/state governments, GSI, district administrations and NGOs. There are two (2) types of activities for awareness raising:

- a) Creation of public awareness for landslide risk reduction
  - Handbooks, posters and handbills containing the status of landslide hazard are distributed in order to create the public awareness. These documents will be translated to local and regional languages.
- b) Awareness drives for specific target groups
  - One of the most challenging tasks in landslide preparedness and mitigation is sensitisation of all the stakeholders. Therefore, it is necessary to initiate programmes to sensitise decision makers and other important functionaries in undertaking mitigation measures in landslide affected area.

Landslide events occur frequently; however, the level of awareness about landslide risks has been quite low compared to other disasters like earthquakes, floods and cyclones. Therefore, there is an immediate need to raise public awareness about the necessity of preparedness and mitigation to

reduce the associated risk and loss.

## **2) Preparedness**

There are two (2) types of landslide preparedness at the local level.

### **a) Community Preparedness**

- Local authorities like gram panchayats with the help of NGOs and volunteer groups in the community prepare and implement community level DM plan.
- Exercise and development of programmes for each disaster prone district are essential parts of the preparedness programmes.

### **b) Medical Preparedness**

- Medical First Responders (MFRs) for administering first aid and resuscitation measures at the incident site and during the transportation of casualties are identified and trained.

Comprehensive awareness and preparedness programmes for natural disasters have been implemented in the country. However, the landslide awareness and preparedness programmes have not properly covered all the communities, especially community or people who live in/close to landslide prone area.

## **(2) Countermeasures**

### **1) Guidelines and Other Related Documents**

As mentioned above, most of the landslides occur during the monsoon period in India, barring a few which owe their origin to earthquake. Extreme water pressure plays a major role in initiating landslide events. There are also instances which toe erosion by rivers or canals and scouring of hill slope due to high velocity discharge of streams descending from the crown of the landslide gives rise to debris flow/slide or rock slide. Hence, surface and sub-surface water management from the slopes or catchments forms the most effective remediation measure for controlling many landslides. Management of surface run-off and subsurface water is done through the construction of drainage network. Reinforcing technologies like nailing, bolting, and anchoring and tie back solutions have all provided apt solutions to the bewildering varieties of civil and mining engineering problems. Numerous successful examples of stabilisation of problematic slopes and landslides, open cast mines, tunnels, road cuttings, wharf and retaining structures, etc., bear ample testimony to the great potential the reinforcing technologies hold.

The followings are the guidelines and related documents that provide countermeasures for landslide mitigation:

- IS 14680: 1999 (reaffirmed 2004) Landslide Control Guideline, BIS
- National Disaster Management Guidelines for Management of Landslides and Snow Avalanches (NDMA, June 2009)
- Template for Preparation of Detailed Project Report (DPR) for Site Specific Landslide Risk Mitigation (NDMA, June 2015)

The above documents recommend the following countermeasures:

- Restraining structures such as retaining walls
- Dry, banded and mortar masonry walls
- Gabions/sausage walls
- Concrete retaining walls

- Restraining structures
- Anchored walls
- Restraining piles
- Excavation methods
- Reconstruction of slope using reinforced earth
- Rock reinforcement
- Surface and sub-drainage
- Proper alignment of road (if applicable)
- Slope reinforcement
- Bioengineering measures, etc.

The Template for Preparation of DPR mentions not only technical method for landslide mitigation, but also measures from the view of planning and countermeasure work implementation. The contents of the DPR are outlined in Table 4.3.7. The document mentions necessity of investigation and countermeasures for individual landslide.

**Table 4.3.7 Outline of Contents of DPR**

Foreword
Preface
Introduction
Summary of Detailed Project Report
Content - I: Salient feature of the project
Content - II: Brief executive summary of the project highlighting mitigation measures for landslide including measures to avoid re-occurrences and prevention of existing and potential landslides
Content - III: Abstract cost of the project component wise, including cost of road diversion, construction of new road, rehabilitation of habitans etc. if any
Detailed Project Report (DPR)
Chapter 1 - Introduction of the area
Chapter 2 - Detailed investigation
Chapter 3- Proposed mitigation measures
Chapter 4- Time lines of various activities (post sanction) in the form of bar chart
Chapter 5- Cost estimation
List of Annexures
Activity wise details of resource departments/organisations, consultation with whom may be useful for preparation of DPRs for landslide mitigation schemes
References Useful for Preparation of DPR

Source: NDMA (2015)

## 2) Countermeasure Works

### a) Large Scale Landslides

Many types of countermeasures are applied to the large scale landslides. For example, the following works were executed for the Varnavat Landslide in Uttarkashi, based on the detailed geological and geotechnical survey:

- Geo-grid wall
- Chainlink shotcrete with drainage pipe
- Ground anchor
- Slope cutting

This landslide area is close to arterial road and town area. Figure 4.3.10 shows examples of countermeasure works.



Source: NIRM, "Stabilisation of Varunavat Landslide, in Uttarkashi Town, Uttarakhand Himalaya", (2009)

**Figure 4.3.10 Examples of Countermeasures for Varnavat Landslide**

b) Small Scale Landslides

In case of small scale landslide, mainly slope failure or rock fall along the road, the stone masonry and concrete retaining wall are applied as the major countermeasures.

The countermeasures against landslides shown in the guidelines and actually applied in India are similar to those in Japan in general. Those measures are mainly utilised for sliding-type landslides. In India, especially mountainous area, there are many landslide areas classified into the rock fall type. However, countermeasures for the rock fall type landslides, such as rock shed and rock net, are not mentioned in the guidelines and are not executed.

c) Issues in constructing countermeasures along the road

At present, the Right of Way (ROW) of India is determined as shown in Figure 4.3.11.

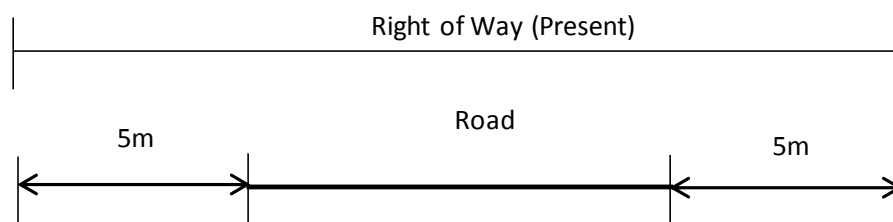

Source: compiled by the Survey Team based on information from the Public Works Department in Uttarakhand State

**Figure 4.3.11 Right of Way (All Types of Road)**

In India, road construction is executed by the Public Works Department (PWD) of the state government, even though the Ministry of Environment, Forest and Climate Change (MOEFCC) has jurisdiction over the slope of mountain side of the road and the MOWR has jurisdiction over the slopes along the river.

When slope protection work is required, it is said that the cooperation among these organisations involves difficulties. In order to construct landslide countermeasures along the road, it is necessary to ensure the smooth cooperation among these organisations.

In case there is a limitation of available land due to inappropriate coordination between PWD and MOEFCC, or PWD and MOWR, proper countermeasure work of landslide, such as slope protection work and road shoulder protection work against the river erosion cannot be conducted. This will hinder the disaster risk reduction by structural countermeasures.

#### **4.3.7 Challenges to be Addressed**

According to the information gathered, the following are the challenges identified by the Indian side:

##### **< Risk Analysis >**

Hazard and risk maps of sediment disasters (landslides) are prepared by the GSI and central technical institutes. Those maps are prepared based on macro-scale (1:25,000 to 1:50,000) and hazard zones are extracted with very rough scale. This means that the risk assessment of individual landslide areas has not been done.

In order to formulate a regional landslide disaster prevention plan and to implement effective countermeasure works for landslide disaster mitigation and reduction, it is necessary to evaluate the necessity of countermeasures against landslides and prioritise landslide areas where countermeasures need to be implemented based on the results of risk assessment. However, such evaluation of individual landslide areas based on the results of risk assessment has not been conducted yet. Director of GSI Uttarakhand Unit expressed the necessity of capacity building in terms of risk assessment and risk mapping.

- Challenge(s) of Risk Analysis:
- Prioritising landslide areas where countermeasures need to be implemented based on the risk assessment

##### **< Forecasting, Early Warning and Communication System >**

Monitoring and early warning systems of landslides have not been established in India. There are some examples of research activities related to monitoring and early warning systems of landslides. However, the results of those works have not been practically used for landslide disaster mitigation and reduction. NDMA and GSI Uttarakhand Unit pointed out necessity of the systems.

- Challenge(s) of Forecasting, Early Warning and Communication System:
- Establishing monitoring and early warning systems of landslides

##### **< Emergency Response >**

The SOP of emergency response is well prepared and organized by the State and District Governments. However, the SEOC of Uttarakhand State, the District Magistrates and the DEOCs of Uttarkashi and Rudrapurayag districts pointed out that there was an issue on the last mile connectivity among the SEOC, the DEOCs and community inhabitants at times of emergency.

- Challenge(s) of Emergency Response System:
- Improving the communication systems to enable rapid emergency response at the local level

In addition, considering the current situation of landslide risk reduction in India, it is worth pointing out the following as challenges to be addressed:

< Institutional Framework >

The GSI and some technical institutions carry out partial landslide risk assessment and give the results to related organisations. However, national and state level organisations related to landslide risk reduction do not utilise their works for landslide risk reduction well. It can be inferred that no action for coordination/communication between the GSI/technical institutes and related organisations has been taken for the purpose of landslide risk reduction. Therefore, it is necessary to strengthen the coordination mechanism among organisations and institutions to realise the landslide risk reduction based on the results of risk assessment.

Challenge(s) of Institutional Framework:

- Strengthening the coordination mechanism among organisations and institutions related to landslide risk reduction

< Preparedness >

Some organisations such as DMMC and the State Disaster Response Force conduct activities for raising public awareness. However, these should be carried out regularly and continuously to prepare the landslide disaster risk. In some communities, people are not aware of the landslide risk in their residential area. Therefore, it is necessary to raise public awareness about landslide risk and develop the capacity of community inhabitants in terms of landslide disaster risk reduction and mitigation and emergency response.

Challenge(s) of Preparedness:

- Raising awareness and developing capacity of community inhabitants who live in landslide prone areas

< Countermeasures >

Only a very limited variety of countermeasures against landslides can be found in the mountain areas. Overall, stone masonry and gabion are the major existing countermeasure works. However, there are several types of landslide and each one has its specific mechanism. Therefore, it is necessary to evaluate what measure is suitable for each case and apply the countermeasure work to the specific landslide mechanism. In Uttarakhand State, a project of countermeasure work against landslides will be carried out by the ADB fund and budget of the MORTH. During the process of project implementation, applicable measures will be considered and examined. The experience of examination and consideration on planning, design and construction should be utilised for similar projects which will be implemented in the country in the future. Therefore, the procedure of examination and consideration and the results of planning, design and construction should be compiled as guidelines and manuals.

Challenge(s) of Countermeasures:

- Introducing countermeasures against each type of landslide

Table 4.3.8 shows the challenges identified, actions to be taken for the improvement and organisations responsible for implementation of the actions.

**Table 4.3.8 Challenges and Actions (Landslides)**

S/N	Challenges	Actions to be Taken: <u>Landslides</u>		
		Short Term (1 - 2 Years)	Medium Term (3 -5 Years)	Long Term (5 - 10 Years)
<b>Challenges identified by the Indian Side</b>				
[ Risk Analysis ]				
DT-LS-1	Prioritising landslide areas where countermeasures need to be implemented based on the risk assessment	<u>Action(s)</u> - Formulating uniform landslide inventory format for risk analysis - Gathering information of existing Landslide Hazard Zonation (LHZ) maps that are prepared for landslide prone states - Gathering information of existing procedures and methods that are followed in each state - Preparing micro-zonation maps for Seismic Zone III, IV and V	<u>Action(s)</u> - Conducting risk analysis, zonation and mapping for the individual landslide area and setting criteria to evaluate the risk ranking in a pilot state - Prioritising the landslide area for implementation of countermeasures based on the risk analysis - Preparing the guidelines and manuals for risk analysis, zonation, mapping and ranking	<u>Action(s)</u> - Disseminating the guidelines and manuals to the landslide prone states - Reviewing the guidelines and manuals as appropriate
		<u>Taken by</u> - GSI - Central Technical Institutions	<u>Taken by</u> - GSI - Central Technical Institutions - State Department of Disaster Management (Pilot State)	<u>Taken by</u> - GSI
[ Forecasting, Early Warning and Communication System ]				
DT-LS-2	Establishing monitoring and early warning systems for landslide	<u>Action(s)</u> - Reviewing outputs from the past and on-going activities for observation and early warning - Investigating the observation and early warning systems to be installed based on the result of reviewing - Examining an appropriate information dissemination system for landslide forecasting and early warning	<u>Action(s)</u> - Formulating an implementation plan in a pilot state to install the observation and early warning of landslides - Installing the planned system	<u>Action(s)</u> - Expanding application of observation and early warning systems to other areas and states
		<u>Taken by</u> - GSI - Central Technical Institutions	<u>Taken by</u> - GSI - Central Technical Institutions - State Department of Disaster Management (Pilot State)	<u>Taken by</u> - GSI



S/N	Challenges	Actions to be Taken: <u>Landslides</u>		
		Short Term (1 - 2 Years)	Medium Term (3 -5 Years)	Long Term (5 - 10 Years)
[ Emergency Response ]				
DT-LS-3	Improving the communication systems to enable rapid emergency response at the local level	<u>Action(s)</u> - Evaluating the reliance of existing communication systems in emergencies among SEOC, SDRF, DEOC, related organisations and communities, especially last mile connectivity in a pilot state - Formulating an implementation plan to improve the last mile connectivity, considering applicable communication tools and redundancy of the communication systems	<u>Action(s)</u> - Implementing the plan - Evaluating the reliance, drawing lessons and summarising the effectiveness - Rolling out the improvement of communication systems to other states	-
		<u>Taken by</u> - SDMA - SEOC - DDMA - DEOC	<u>Taken by</u> - SDMA - SEOC - DDMA - DEOC	-
<b>Challenges identified by the Survey Team</b>				
[ Institutional Framework ]				
DT-LS-4	Strengthening the coordination mechanism among organisations and institutions related to landslide risk reduction	(After preparation of implementation plans for other challenges)	<u>Action(s)</u> - Taking joint actions for planning, analysis, evaluation and preparation	-
		-	<u>Taken by</u> - GSI - Central Technical Institutions - SDMA - Related State Departments	-

S/N	Challenges	Actions to be Taken: <u>Landslides</u>		
		Short Term (1 - 2 Years)	Medium Term (3 -5 Years)	Long Term (5 - 10 Years)
[ Preparedness ]				
DT-LS-5	Raising awareness of and developing capacity of community inhabitants who live in landslide prone areas	<u>Action(s)</u> - Gathering information of existing land use around the landslide prone areas - Preparing a land use plan based on the existing land use information and landslide hazard zonation maps - Preparing materials for sensitisation of community inhabitants	<u>Action(s)</u> - Implementing sensitisation workshops to raise awareness of community inhabitants about landslide risk and to make them understood first response and evacuation at landslide events	-
		<u>Taken by</u> - State Department of Disaster Management - SDMA	<u>Taken by</u> - State Department of Disaster Management - SDMA	-
[ Countermeasure ]				
DT-LS-6	Introducing countermeasures against each type of landslide	<u>Action(s)</u> - Gathering information of existing countermeasures against each type of landslide - Evaluating the applicability of countermeasures by the type of landslide - Selecting a pilot state to introduce the countermeasures against each type of landslide as a showcase of technology to be applied - Formulating an implementation plan	<u>Action(s)</u> - Implementing the "Showcase" plan - Evaluating the effectiveness of the countermeasures against each type of landslide - Formulating the guidelines and manuals to plan and design the countermeasures - Sensitising the related officials at the national and state level to diversify the methods for landslide risk reduction	<u>Action(s)</u> - Expanding application of the countermeasures against landslides to other areas and states
		<u>Taken by</u> - GSI - PWD (Pilot State) - BRO	<u>Taken by</u> - GSI - PWD (Pilot State) - BRO	<u>Taken by</u> - GSI

Source: prepared by the Survey Team

## 4.4 Cyclones

### 4.4.1 Situation of Countermeasures in National Policy and Planning

Under the 12th Five-Year Plan of India, identification of coastal vulnerability and assessment of coastal inundation are highly prioritised. In this sense, the GOI is implementing the Integrated Coastal Zone Management (ICZM) initiated by the MOEFCC for filling the gap between existing coastal management programs and actual needs. The ICZM policies should be designed to afford protection against coastal vulnerabilities. Under the ICZM, the following activities are planned: (i) modification of coastal zone regulations for construction activities, (ii) infrastructure development, and (iii) Climate Change Impact Assessment for integration of coastal process study.

Furthermore, with the assistance of the World Bank, a pilot programme for the ICZM in states of Gujarat, Odisha and West Bengal is in place.

### 4.4.2 Policy and Institutional Framework

#### (1) Policy on Cyclone Risk Mitigation

According to the NPDM formulated based on the DM Act, all stakeholders shall take actions for the disaster prevention, mitigation and preparedness. In the NPDM, general policy for disaster management is mentioned, but the policy for cyclone disasters is not specified. It only mentions the current situation of cyclone disasters in India briefly.

For disaster management related planners and implementers at all levels, the NDMA prepared the National Disaster Management Guidelines for Management of Cyclones in 2008 (hereinafter referred to as the “NDMA Guidelines for Cyclones”) which helps to strengthen preparedness and mitigation approach for cyclone disaster management. Also, the IMD, which is a nodal agency of cyclone observation, prepared the SOP for cyclone warning in India.

**Table 4.4.1 Cyclone Related Policy, Plan and Guidelines by the Government of India**

Title of Document	Published by	Month/Year
National Policy on Disaster Management	NDMA	2009
National Disaster Management Plan Basic Plan and Framework Disaster Mitigation Response and Function Plans	NDMA	-
National Disaster Management Guidelines for Management of Cyclones	NDMA	April 2008
Cyclone Warning in India Standard Operation Procedure	IMD	July 2013

Source: compiled by the Survey Team based on the various documents

#### (2) Institutional Framework

##### 1) Ministry of Earth Sciences (MOES)

The Ministry of Earth Sciences (MOES) is a nodal ministry to conduct the scientific and technical activities related to earth system science for improving forecasting of weather, monsoon, climate and hazards, exploration of polar regions, seas around India, for developing the technology of exploration and exploitation of ocean resources, and for ensuring their sustainable use.

The main functions of the MOES are as follows:

- To enhance and sustain the long-term observations of atmosphere, ocean, cryosphere and solid earth to record the vital signs of earth system and changes

- To develop forecasting capacity of atmosphere and oceanic phenomena through dynamical models and assimilation techniques and to build prediction system for weather climate and hazards
- To understand the interaction between components of earth systems and human systems at various spatial and temporal scales
- To explore polar and high seas regions for discovery of new phenomena and resources
- To translate knowledge and insight themes gained into services for societal, environmental and economic aspects

In order to fulfil those functions, the MOES has established various Earth System Science Organisations (ESSOs) designated for the specific functions including India Meteorological Department (IMD), National Centre for Seismology (NCS) and Indian National Centre for Ocean Information Services (INCOIS) (see Figure 4.4.1).

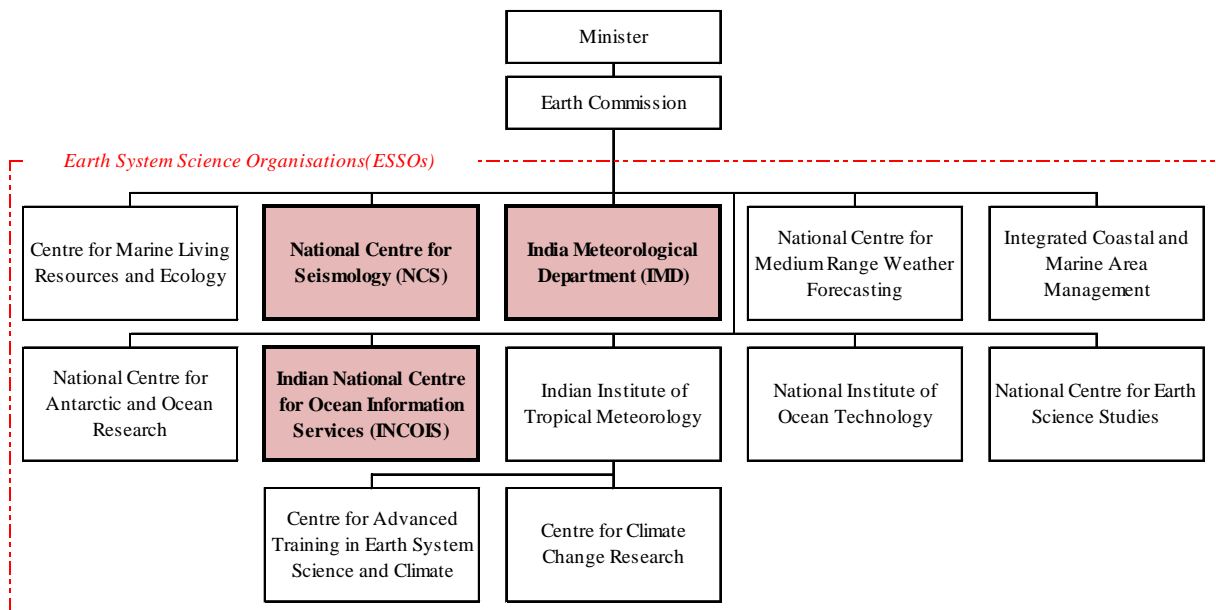

Source: compiled by the Survey Team based on the information from Ministry of Earth Sciences (2015)

**Figure 4.4.1 Institutional Framework of Earth System Science**

## 2) India Meteorological Department (IMD)

The GOI has constituted the nodal ministries/departments and organisations to provide early warnings on different natural hazards. For cyclone warnings, the IMD under the MOES is the key department as one of the ESSOs. The mandates of the IMD are as follows:

- To take meteorological observations and to provide current and forecast meteorological information for optimum operation of weather-sensitive activities like agriculture, irrigation, shipping, aviation, offshore oil explorations, etc.
- To warn against severe weather phenomena like tropical cyclones, norwesters, duststorms, heavy rains and snow, cold and heat waves, etc., which cause destruction of life and property
- To provide meteorological statistics required for agriculture, water resource management, industries, oil exploration and other nation-building activities
- To conduct and promote research in meteorology and allied disciplines
- To detect and locate earthquakes and to evaluate seismicity in different parts of the country for development projects

To implement those mandates, the IMD set up its organisation structure as shown in Figure 4.4.2. The IMD has regional meteorological centres at six (6) locations: Chennai, Guwahati, Kolkata,

Mumbai, Nagpur and New Delhi. Each regional meteorological centre controls meteorological centres at 19 locations in total. Moreover, in order to monitor the movement of cyclone and disseminate the early warning of cyclone effectively and timely, Area Cyclone Warning Centres (ACWCs) and Cyclone Warning Centres are established.

Besides, in the international context, the IMD acts as a Regional Specialised Meteorological Centre for monitoring, prediction and early warning of cyclone over the North Indian Ocean as designated by the World Meteorological Organisation (WMO). It provides advisories to the WMO/United Nations Economic and Social Commission for Asian and the Pacific (ESCAP) panel member countries.

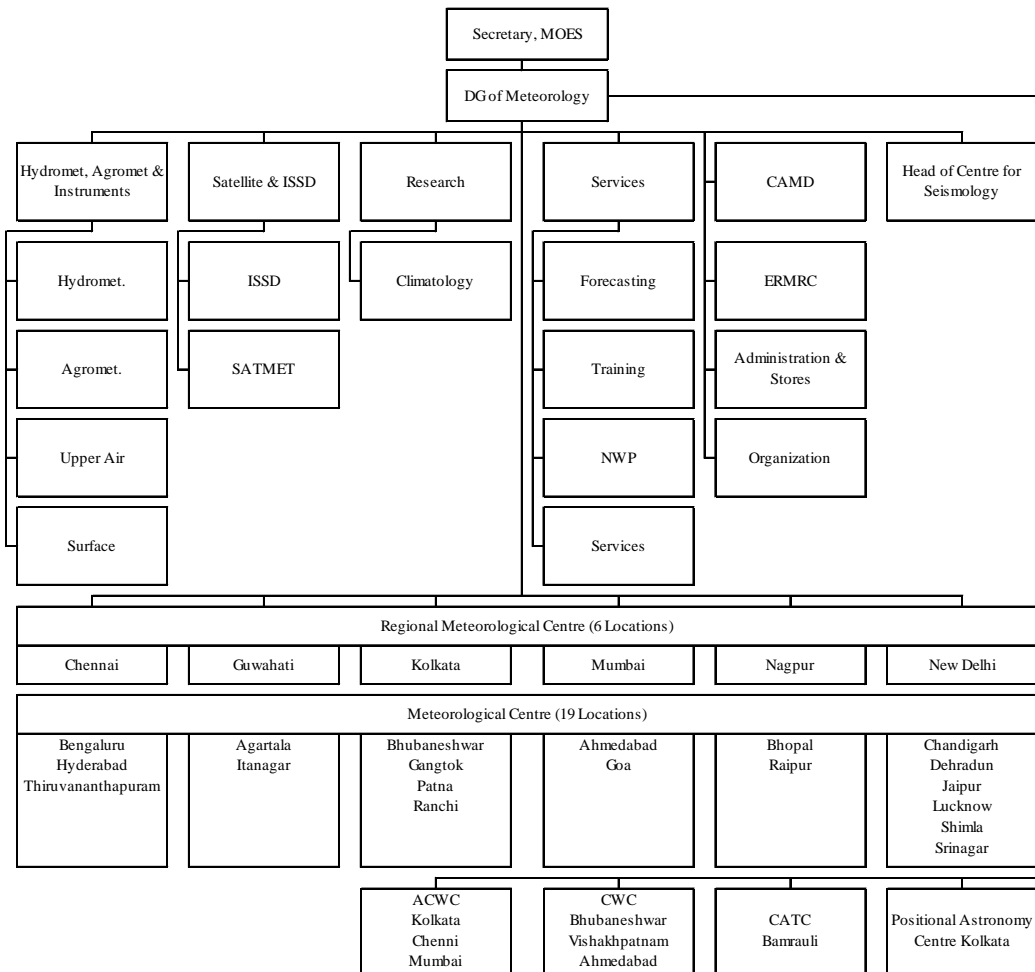

Source: IMD (2015)

**Figure 4.4.2 Organisational Structure of IMD**

With the establishment of the additional centres at Bhubaneshwar and Visakhapatnam, the Storm Warning Centres at Kolkata, Chennai and Mumbai were named as Area Cyclone Warning Centres (ACWCs), and the Storm Warning Centres at Visakhapatnam, Bhubaneshwar and Ahmedabad as Cyclone Warning Centres. The Cyclone Warning Centres in Visakhapatnam, Bhubaneshwar and Ahmedabad function under the control of the ACWCs of Chennai, Kolkata and Mumbai respectively. Meteorological Centre in Hyderabad liaises between the Cyclone Warning Centre Visakhapatnam and Andhra Pradesh government officials; warnings issued by the Cyclone Warning Centre Visakhapatnam are sent to Meteorological Centre Hyderabad also for briefing the Andhra Pradesh government officials at the state capital. Most of the cyclone related officers belong to the ACWCs and Cyclone Warning Centres at branch level.

**Table 4.4.2 Number of Cyclone related Staff of IMD**

Section	Number of Staff
Area Cyclone Warning Centre Mumbai	46
Area Cyclone Warning Centre Chennai	17
Cyclone Warning Centre Vishakhapatnam	28

Source: IMD, "Directory Search", (2015)



Source: IMD, "Cyclone Warning in India Standard Operation Procedure", (2013)

**Figure 4.4.3 Cyclone Warning Organisational Structure of IMD**

The annual budgets of IMD from 2010 to 2014 are shown in Table 4.4.3.

**Table 4.4.3 Annual Budget of IMD**

No.	Item	2010-11		2011-12		2012-13		2013-14	2014-15
		Grant	Expenditure	Grant	Expenditure	Grant	Expenditure	Budget Estimation	Budget Estimation
1.	Non-Plan Revenue Account	1.55	24.86	2.56	25.00	27.51	-	300.06	-
2.	Non-Plan Capital Account	0.25	0.02	1.10	0.01	0.03	-	3.01	-
3.	Plan Revenue Account	-	5.11	8.88	5.19	0.71	-	70.00	75.00
4.	Plan Capital Account	-	11.46	26.32	9.29	1.35	-	130.00	115.00

(Unit: Rs. crore)

Note: Revenue Account-Expenditure/Receipts: The Revenue Account deals with the proceeds of taxation and other receipts classed as revenue and expenditure met therefrom.

Note: Capital Account-Expenditure/Receipts: The Capital Account deals with expenditure incurred with the purpose of either increasing the concrete assets of durable nature or of reducing recurring liabilities.

Source: IMD, "Annual Report", (from 2010 to 2014)

### 3) Organisation for Vulnerability and Risk Assessment

The Ministry of Urban Development and Poverty Alleviation (MOUDPA) had constituted an Expert Group to examine the issues related to the identification of vulnerable areas and to workout appropriate measures for disaster reduction and mitigation. The Building Materials and Technology Promotion Council (BMTPC), MOUDPA published the Vulnerability Atlas for earthquakes, cyclones, and floods based on the advice of the Expert Group.

### 4.4.3 Disaster Records

#### (1) Classification of Cyclonic Disturbances

The criteria followed by the IMD to classify the low pressure systems in the Bay of Bengal and in the Arabian Sea as adopted by the WMO are shown in Table 4.4.4.

**Table 4.4.4 Criteria for Classification of Cyclonic Disturbances over North Indian Ocean**

No.	Type of disturbance	Associated maximum sustained wind (MSW)
1.	Low Pressure Area	Not exceeding 17 knots (<31 kmph )
2.	Depression	17 to 27 knots (31-49 kmph)
3.	Deep Depression	28 to 33 knots (50-61 kmph )
4.	Cyclonic Storm	34 to 47 knots (62-88 kmph )
5.	Severe Cyclonic Storm	48 to 63 knots (89-117 kmph )
6.	Very Severe Cyclonic Storm	64 to 119 knots (118-221 kmph )
7.	Super Cyclonic Storm	120 knots and above ( $\geq$ 222 kmph )

Source: IMD, "Cyclone Warning in India Standard Operation Procedure", (2013)

#### (2) Vulnerable Area to Cyclones

About 8 % of the country's area and one-third of its population live in 13 coastal states and Union Territories (UTs) in the country, encompassing 84 coastal districts, and they are affected by tropical cyclones. According to the result of cyclone vulnerability assessment done by the NDMA and the IMD, four (4) states (Tamil Nadu, Andhra Pradesh, Odisha and West Bengal), and one (1) UT (Puducherry) on the east coast, and one (1) state (Gujarat) on the west coast are more vulnerable to hazards associated with cyclones. The result of the assessment is shown in Figure 4.4.4.

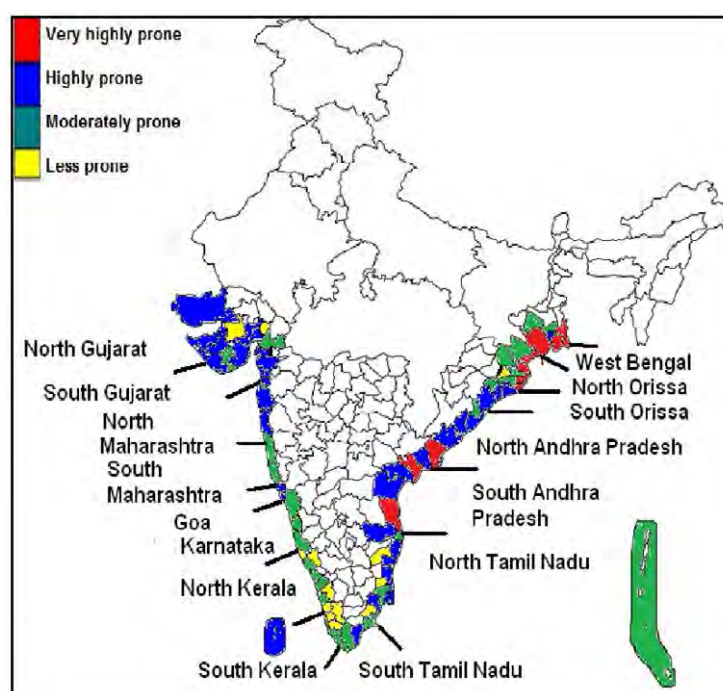

Source: IMD (2015)

**Figure 4.4.4 Hazard Prone District Map of India**

### (3) Historical Record of Cyclones

#### 1) Frequency and Location of Cyclone Occurrence in India

The average annual number of Tropical Cyclones (TC) in the North Indian Ocean (Bay of Bengal and Arabian Sea) is about 5 (5-6 % of the global annual average number of the TC). The frequency is more in the Bay of Bengal than in the Arabian Sea, and the ratio is 4:1. The monthly frequency of tropical cyclones in the North Indian Ocean shows a bi-modal characteristic with a primary peak in November and secondary peak in May (see Figure 4.4.5). The months of May-June and October-November are known to produce cyclones of severe intensity. Tropical cyclones occurring during the monsoon months (July to September) are generally not much intense. Figure 4.4.6 shows the tracks of cyclones during 1891-2014.

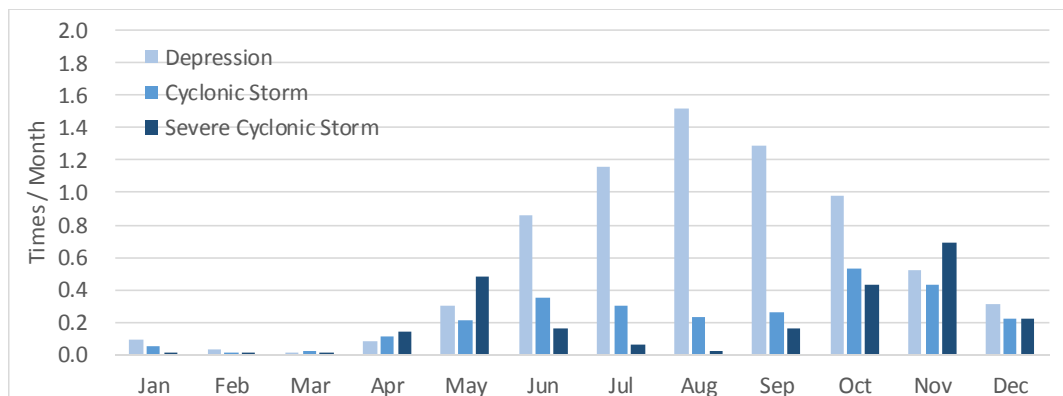

Source: IMD, "Cyclone eAtlas", (2015)

**Figure 4.4.5 Annual Frequency of Cyclones (1891-2014)**

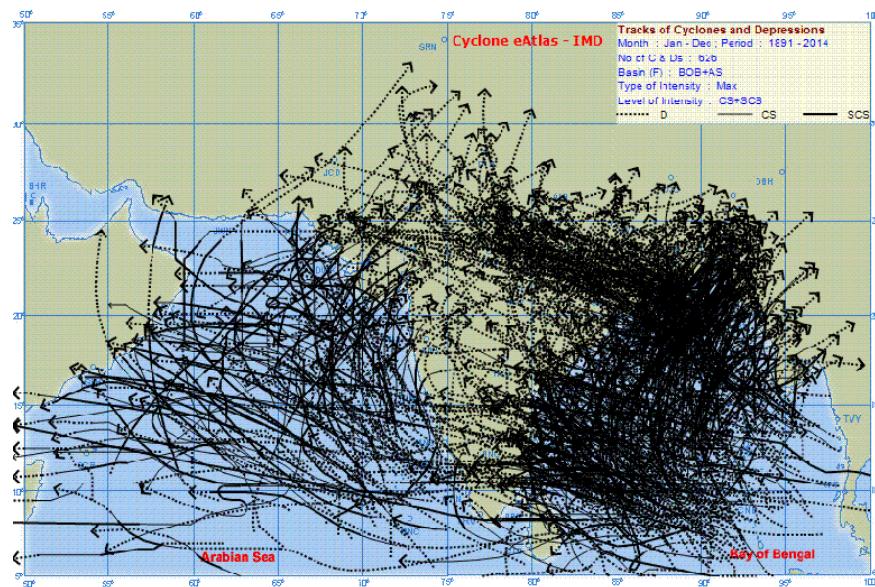

Source: IMD (2015)

**Figure 4.4.6 Tracks of Cyclones during 1891-2014**

#### 2) Historical Records of Cyclone

Historical records of devastating cyclonic storms after 1990s formed in the east and west coasts of India are shown in Table 4.4.5.



**Table 4.4.5 Historical Cyclonic Storms on East and West Coasts of India after 1990s**

No.	Date	Category of Cyclone	Landfall and Relevant Information
<b>I. Cyclonic Storm on East-Coast</b>			
1.	4–11 May 1990	Super Cyclonic Storm	Crossed Andhra Pradesh coast at about 40 km south west of Machilipatnam Maximum wind: 102 kmph (55 kts) at Machilipatnam, and 93 kmph (50 kts) at Gannavaram Maximum estimated wind speed: 235 kmph (126 kts) Surge height: 4 – 5 m Intensity: T 6.5 Loss and damage: 967 people killed, and caused about Rs. 2,248 crores crops and properties damages
2.	5–6 November 1996	Very Severe Cyclonic Storm	Crossed Andhra Pradesh coast near Kakinada Maximum wind: 200 kmph (108 kts) Surge height: 3 – 4 m Loss and damage: 2,000 people killed, 900 people missing, crops in 320,000 hectares of land destroyed, and 10,000 houses destroyed, Estimated loss of crops: Rs. 150 crores
3.	25–31 October 1999	Super Cyclonic Storm	Crossed Odisha coast near Paradip Maximum wind: 260 kmph (140 kts) Bhubaneshwar: 148 kmph (80 kts) Surge height: 6 – 7 m Intensity: T 7.0 Loss and damage: 9,885 people killed, 2,142 people injured, 370,297 cattle heads perished, paddy crops in 1,617,000 hectares and other crop in 33,000 hectares damaged.
4.	12–13 October 2013	Super Cyclonic Storm (Phailin)	Crossed Odisha coast near Brahmapur, caused landfall Loss and damage: 46 people killed, and caused economic losses of 320 million USD Number of evacuees: more than 900 thousand
5.	12 October 2014	Super Cyclonic Storm (Hudhud)	Crossed Andhra Pradesh coast near Visakhapatnam, Andhra Pradesh and caused landfall Loss and damage: 26 killed, 43 injured, 182,128 hectare of agricultural land and 7871 houses affected
<b>II. Cyclonic Storm on West-Coast</b>			
1.	17-20 June, 1996	Severe Cyclonic Storm	Crossed south Gujarat coast between Veraval and Diu in the early morning of 19 June Intensity : T 3.5 Maximum wind : Veraval recorded 86 kmph (46 kts) at 0430 hrs IST of 19 June Storm surge : 5-6 m near Bharuch Loss and damage: People killed – 46 Cattle heads perished- 2113; No. of houses damaged – 29,595, loss of property - Rs. 18.05 crores
2.	4 – 10 June 1998	Very Severe Cyclonic Storm	Crossed Gujarat coast near Porbandar between 0630 and 0730 hrs IST of 9 June Intensity : T5.0 Maximum wind : Jamnagar : 183 kmph (98 kts) at 0730 hrs IST of 9 June Surge height : 2 – 3 m above the astronomical tide of 3.2m; Loss and damage: People killed – 1173; People missing – 1774 Loss of property worth Rs. 18.65. crores

Source: compiled by the Survey Team based on “Cyclone Warning in India SOP”, (2013) of the IMD

According to some available sources, main reasons for cyclonic disasters are as follows:

Severe Cyclonic Storm in Odisha, 1999 (fatalities: 10,000 people, affected paddy field: paddy crops in 16,17,000 hectares)

Due to the violent cyclonic storm, 7m storm surge swept more than 20 km inland and brought massive destruction in Odisha State (Source: )

Cyclone Phailin in Odisha, 2013 (fatalities: 46 people, damaged standing crops: 625,408 hectares)

Due to the very severe cyclone Phailin, 900,000 people were evacuated to shelters. It was the largest pre-disaster evacuation in the country (Source: Preparing for Disaster: Lessons from Phailin Response, UNDP & Disaster relief emergency fund (DREF) India: Cyclone Phailin, IFRC)

In general, the following may be the major reasons for damage due to cyclonic disasters in India:

- Miss-management of pre-evacuation caused huge numbers of fatalities in past events. Recently, evacuation management has been improved in India.
- Due to strong winds, storm surges and heavy rainfall bring severe impact on agricultural fields, valuable buildings, etc.

#### 4.4.4 Observation Systems

##### (1) International Setups

The WMO designates the following five (5) tropical cyclones regional bodies as its regional component:

- ESCAP/WMO Typhoon Committee
- WMO/ESCAP Panel on Tropical Cyclones
- Regional Association I Tropical Cyclone Committee for the South-West Indian Ocean
- Regional Association IV Hurricane Committee
- Regional Association V Tropical Cyclone Committee for the South Pacific and South-East Indian Ocean

Each of these bodies has an operational plan or manual to share the responsibilities for the warning services and infrastructures throughout the region. India is one of the members of WMO/ESCAP Panel on Tropical Cyclones (PTC). The other members of the PTC are Bangladesh, Maldives, Myanmar, Oman, Pakistan, Sri Lanka and Thailand.

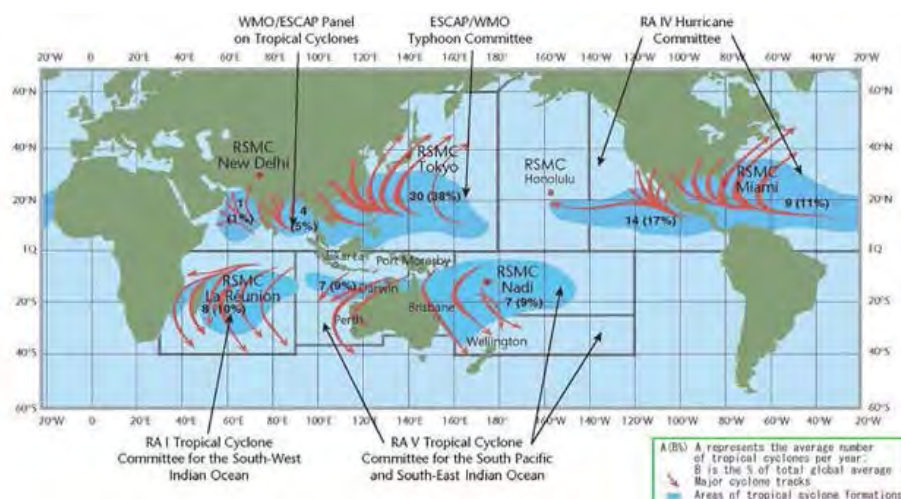

Source: WMO (2015)

**Figure 4.4.7 Tropical Cyclones Regional Bodies of WMO**

**(2) Types of Observation Records**

**1) Weather Bulletins**

The IMD observes cyclones in the North Indian Ocean. The IMD prepares and disseminates the cyclone bulletins shown in Table 4.4.6. The IMD also acts as Tropical Cyclone Advisory Centre (TCAC) and issues the bulletins for international aviation.

**Table 4.4.6 Types of Bulletins (exclude aviation related bulletins)**

Type of Bulletins	Landfall and Relevant Information
Tropical Weather Outlook	The Tropical Weather Outlook is issued daily at 0600 UTC based on 0300 UTC observations in normal weather for use of the PTC member countries.
Special Tropical Weather Outlook	The Special Tropical Weather Outlook, in addition to tropical weather outlook, a special weather outlook is issued at 1500 UTC based on 1200 UTC observations when a tropical depression lies over the North Indian Ocean.
Tropical Cyclone Advisories	Tropical cyclone advisories are issued at 3-hour intervals based on 00, 03, 06, 09, 12, 15, 18 and 21 UTC observations.

Source: compiled by the Survey Team based on IMD (2015)

**Table 4.4.7 Cyclone Related Bulletins in India**

Issuing Organisation	Name of the Bulletins
IMD New Delhi	Tropical Weather Outlook Tropical Cyclone Advisories Tropical Cyclone Advisories for Civil Aviation
INOSHAC, Pune	Global Maritime Distress Safety System (GMDSS)
Cyclone Warning Division	Bulletin for India coasts
ACWCs/Cyclone Warning Centres	Four Stage Warning Bulletin Sea Area Bulletin Coastal Weather Bulletins Warnings to Ports Warnings for Fisheries Bulletins for All India Radio (AIR) Coastal Bulletins for AIR news cycle Registered/designated warnees Press Bulletins Aviation Warnings Bulletins for Indian Navy

Source: IMD, "Cyclone Warning in India Standard Operation Procedure", (2013)

**2) Observation and Prediction Products**

The special tropical outlook and tropical weather outlook indicates discussion on current location and intensity, past movement of various diagnostic and prognostic parameters of 120 hours track and intensity forecast and associated adverse weather and sea condition from the stage of deep depression forecast. The track and intensity forecast are issued for +06, +12, +18, +24, +36, +48, +60, +72, +84, +96, +108 and +120 hours or till the system is likely to weaken into a low pressure area from the stage of deep depression onwards. It also includes the description of current location and intensity and past movement description of satellite imageries.

Tropical cyclone advisories are issued at 3-hour intervals based on 00, 03, 06, 09, 12, 15, 18 and 21 UTC observations. The time of issue is HH+03 hours. These bulletins contain the current position and intensity, central pressure of the cyclone, description of satellite imageries cloud imageries, expected direction and speed of movement, expected track and intensity of the system up to 72 hours like those in special tropical weather outlook. Storm surge guidance is also provided in the bulletin when required. Forecast of winds, adverse weather and state of the sea in and around the system are also indicated in the bulletin. Tropical cyclone advisories are transmitted to panel member countries through global telecommunication system (GTS) and are also made available on

real time basis through internet at IMD's website

### (3) Observation Equipment and Systems

The IMD has built up Cyclone Warning Systems including conventional meteorological observations, reports from ships, observations from ocean data buoys, coastal radars (conventional and Doppler) and national and international satellites (geo-stationary and polar orbiting).

**Table 4.4.8 Observation Equipment and Systems**

Type of Observation	Items	Details
Surface (Land Ocean)	Land synoptic stations	559 surface observatories in India Measuring items: surface air pressure, temperature, humidity, wind, clouds, visibility, rainfall etc.
	Ships	Number of Voluntary Observing Fleet is 203 (Merchant's ships of Indian as well as foreign ships and ships belonging to Indian navy.)
Surface (Land Ocean)	Buoys	14 active buoys in India Measuring items: wind speed & direction, atmospheric pressure, air temperature, humidity, conductivity, sea surface temperature, current speed & direction and wave parameters. Data transmission: data collected by INCOIS are sent to GTS by email through IMD
	Tide gauges	Tide gauges have been installed at Chennai, Cochin, Tuticorin, Mangalore and Port Blair along the Indian Coasts.
	Aviation meteorological offices	Airport Meteorological Offices record half hourly/hourly meteorological reports. Also, aircrafts during flight, report wind and temperature at the cruising level at certain places designated as meteorological reporting points. These observations known as AIREPS/PIREPS are transmitted by High Frequency Radio Transmission (HFRT) to communication unit of the airport authority for onward transmission to the airport meteorological office.
	Automatic Weather Stations (AWSs)	About 675 Automatic Weather Stations (AWSs) are located all over India. In addition, 1350 automatic rain gauge stations (ARGSs) are also planned. 500 ARGs will have sensors for air temperatures, relative humidity and rainfall. The remaining 850 ARGs will have only rainfall sensors. Out of 1350, about 450 AWSs have been installed till the end of 2011.
Upper Air	Pilot balloon stations	There are 62 pilot balloon observatories spread all over the country Measuring items: wind speed and direction Frequency: 2 to 4 times a day (00, 06, 12 and 18 UTC)
	GPS Sonde/ Radio-sonde/ Radio wind stations	IMD is at present using GPS sonde at 11 places and Mark IV radiosonde in other 28 places of its upper air network.
	Wind profiler stations	4 wind profilers will be added to IMD upper air observation network. (2 wind profilers are operating at Pune and Gadanki.)
Radar		Ten cyclone detection radars (10 cm –S band) are at present in operation in the country along the east and west coasts.
Satellite		At present IMD is receiving and processing meteorological data from two Indian satellites namely Kalpana-1 and INSAT-3A.

Source: compiled by the Survey Team based on "Cyclone Warning in India Standard Operation Procedure", (2013) of the IMD

**(4) Surface Observation**

In India, there are 559 surface observatories under the District-wise Rainfall Monitoring Scheme (DRMS), Intensive Agricultural Development Programme (IADP) and All India General Scheme (AIGS). Most of the surface monitoring stations are maintained by the state governments which the stations are located. For adequate monitoring, it is important to obtain the data on real time basis. Therefore, during 2007, Tamil Nadu government and IMD signed an MOU for exchange of rainfall data in real time. Similar arrangements in other coastal states are desirable.

To emphasise the observation network along the coast, cooperative cyclone reporting network of stations has been started along the coast on the recommendations of the Cyclone Distress Mitigation Committees (CDMCs). In Andhra Pradesh State, there are 13 cooperative cyclone reporting stations while Odisha State has 16 CDMC stations. These stations are located at all police stations and they deliver the metrological information to the IMD through the police wireless network and telephone.

**(5) Prediction Technique**

The IMD introduced the objective TC track forecast valid for next 24 hours over the North Indian Ocean in 2003. It further extended the validity period up to 72 hours in 2009. The track forecast has been issued by the IMD for 12, 24, 36, 48, 60 and 72 hours forecast periods. The TC forecast will be issued six (6) times a day at the interval of three (3) hours.

Currently, the IMD adopts statistical techniques and the Numerical Weather Prediction model for ensemble TC track and intensity prediction. The synoptic chart, statistical and satellite/radar products help in short range track forecast (up to 12 hours); the Numerical Weather Prediction is mainly used for 24-72 hours forecasts.

Regarding storm surge, the IMD Nomogram (Ghosh model) and the IIT Delhi Model (developed by the Indian Institute of Technology Delhi) are used for calculative prediction in India.

**(6) Forecast Errors**

According to the IMD Annual Report 2014, the forecast errors of cyclone track in the North Indian Ocean are decreasing significantly in recent years (see Figure 4.4.8). For reference, forecast error statistics of Japan by Japan Meteorological Agency (JMA) is shown in Figure 4.4.9.

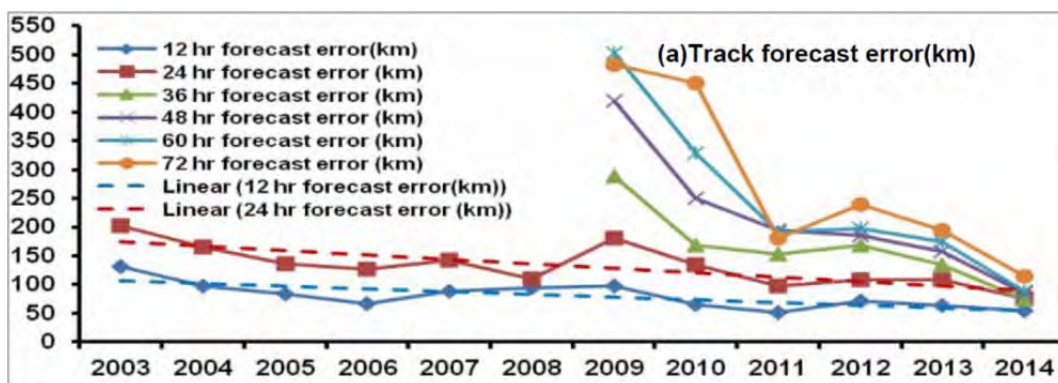

Source: IMD, "Annual Report 2014", (2015)

**Figure 4.4.8 Annual Average Track Forecast Error of Cyclones in the North Indian Ocean**

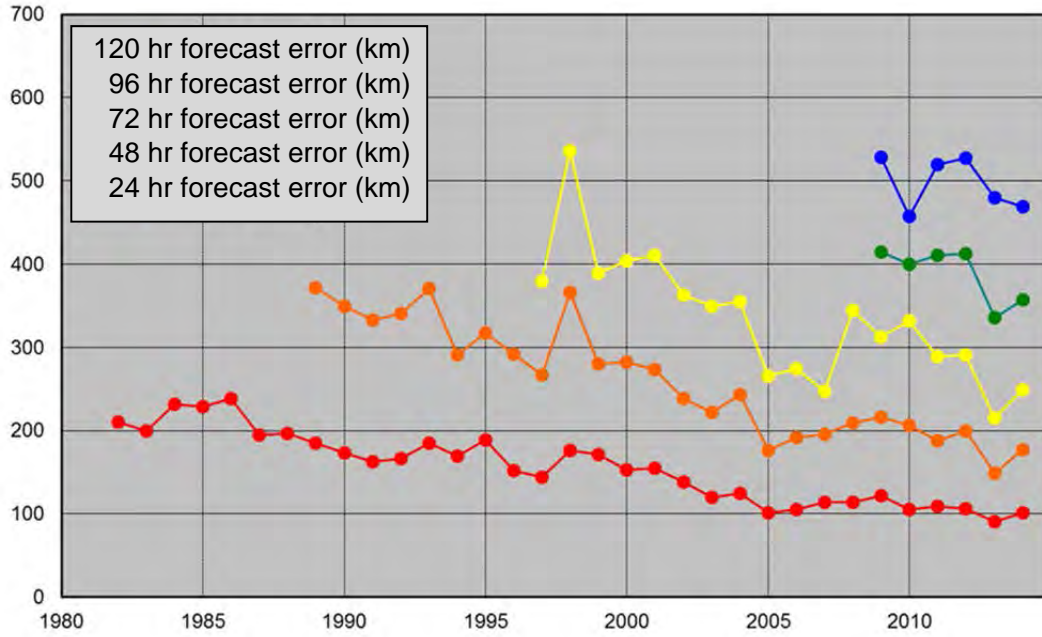

Source: compiled by the Survey Team based on the JMA data (2015)

**Figure 4.4.9 Annual Average Track Forecast Error of Typhoon by JMA**

#### 4.4.5 Risk Analysis

##### (1) Risk of Cyclone, Strong Wind and Storm Surge

The risk analysis for cyclones, strong wind and storm surge are conducted by the BMTPC, MOHUPA.

The wind velocity zoning mapping is produced based on the Indian Standard 875-1987 (3) by computing the wind pressures on various surfaces. The coastal areas of west-coast states (Tamil Nadu, Andhra Pradesh, Odisha and West Bengal) and east coast state (Gujarat) are very vulnerable to cyclone disasters. These areas are categorised as Very High Damage Risk Zone B with expected wind velocity of more than 50m/s (see Figure 4.4.10).

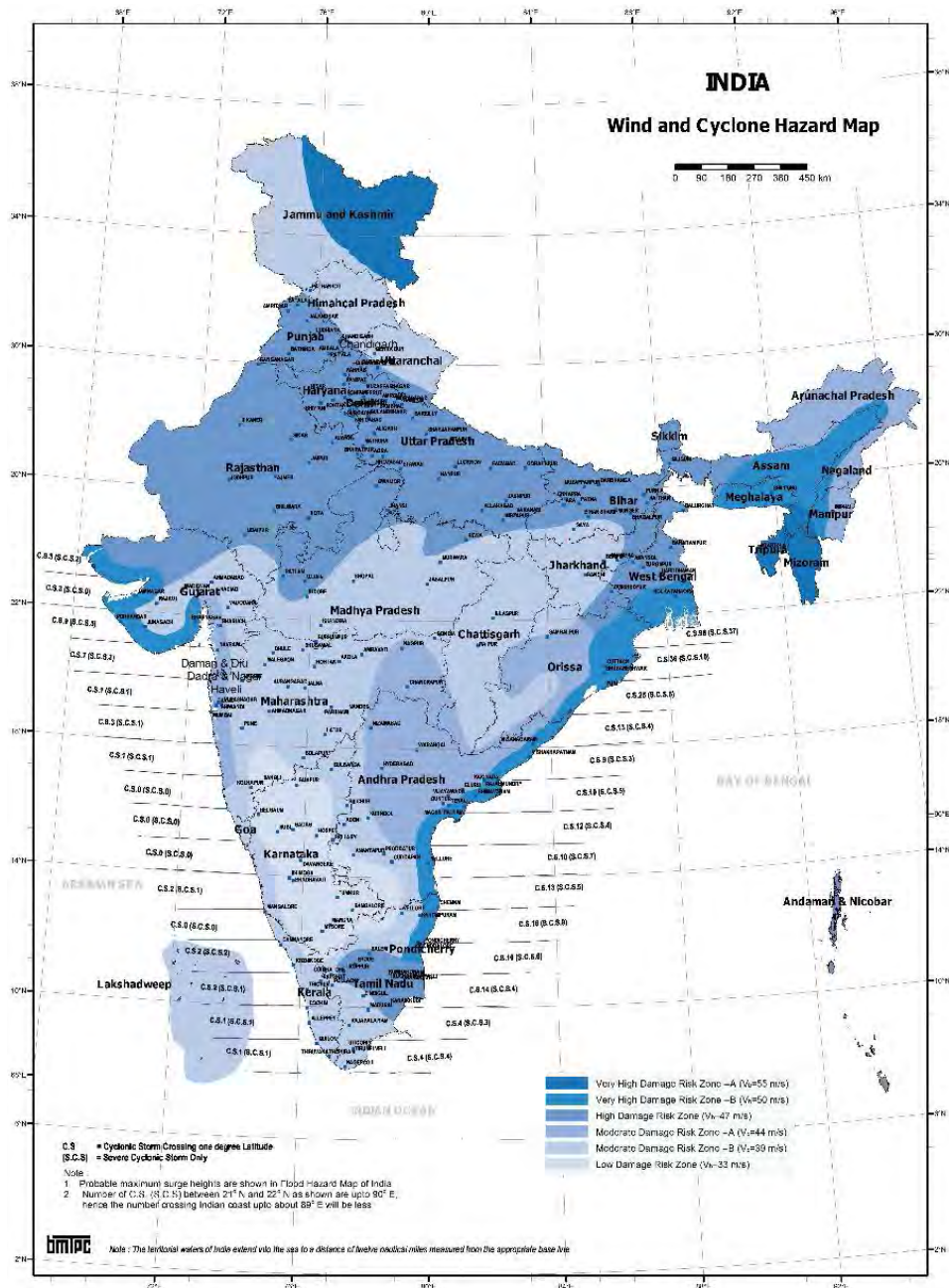

Source: BMTPC (2015)

**Figure 4.4.10 Wind and Cyclone Zones in India**

Cyclone prone areas are also prone to storm surge. From topographical feature, area located at narrow bay is more vulnerable than simple coastal line area. Probable maximum storm surge height in the coastal area of West Bengal State (east coast) is more than 10 m. Also, the central area of Andhra Pradesh State has a probable maximum storm surge of more than 8 m.

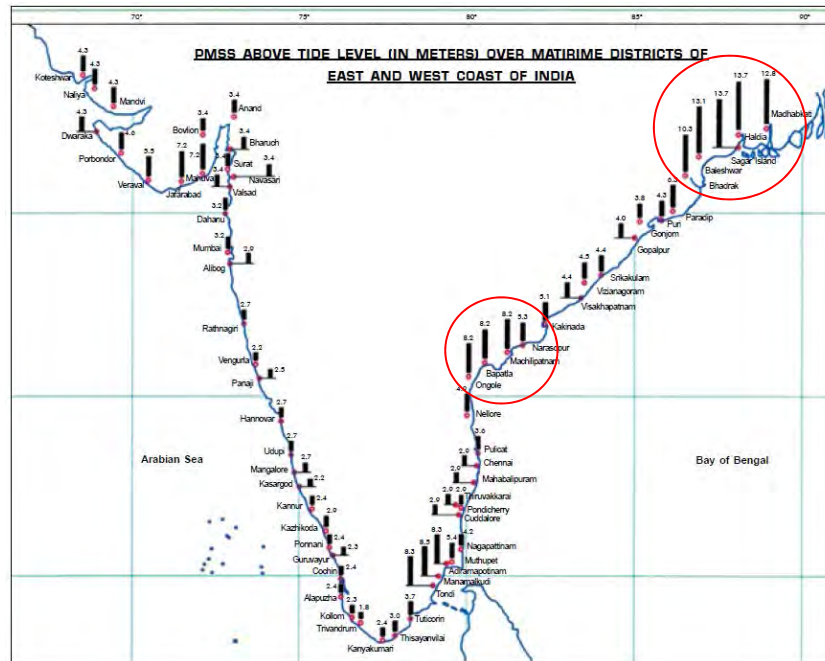

Source: compiled by the Survey Team based on “Cyclone Warning in India Standard Operation Procedure”, (2013) of the IMD

**Figure 4.4.11 Probable Maximum Storm Surge above Tide Levels in India**

#### 4.4.6 Preparedness and Countermeasures

##### (1) General Information

The risk mitigation and preparedness frameworks against cyclones are summarised in Figure 4.4.12. To reduce the risk and vulnerability to cyclones, several types of structural and non-structural measures shown in the figure can be developed.

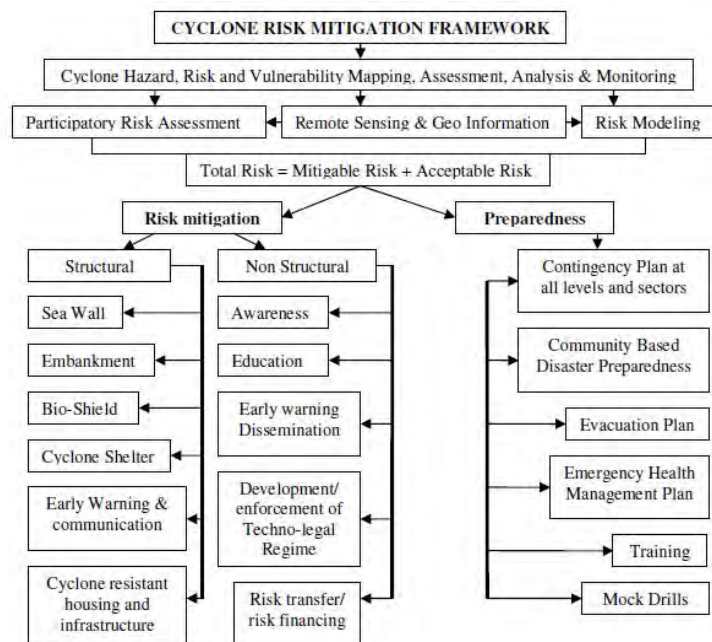

Source: SAARC Disaster Management Centre (2015)

**Figure 4.4.12 Cyclone Risk Mitigation Framework**



## (2) Structural Mitigation Measures in India

### 1) Types of Structural Measures

The design and maintenance considerations for the structural measures against cyclone are the main focal points. This will cover the following facilities:

- buildings, including multi-purpose cyclone shelters
- road links, culverts and bridges
- canals, drains, surface water tanks, etc.
- saline embankments
- communication towers and power transmission networks

### 2) Cyclone Shelter and Access Road

Safer cyclone shelter is vital to protect human lives at the time of cyclone. For the construction of new cyclone shelter, the location of site, function and structure are considered based on 100-year return period TC resistance. New cyclone shelters will be planned for multi-purpose use such as school, community hall, place of worship, etc.

Multi-purpose cyclone shelters need regular maintenance and timely repair work. In some states, a monitoring committee for shelters is established consisting of representatives of the state and local governments, NGOs, leaders of community, etc.

Cyclone shelters also need to store the amenities to be provided to large number of evacuees for few days during disaster.

### (3) National Cyclone Risk Mitigation Project

The NDMA is implementing the National Cyclone Risk Mitigation Project (NCRMP) in cyclone prone coastal states/UTs. The project is implemented with the 75 % of the cost contributed by the central government and the remaining 25 % by the state governments for the components consisting of structural and non-structural measures. In the first phase, the states of Andhra Pradesh and Odisha are being covered at an estimated cost of Rs. 1,496.71 crore. The World Bank is providing financial assistance equivalent to Rs. 1,198.44 crore.

The objectives of the project are to upgrade cyclone forecasting, tracking and warning systems and capacity building in multi-hazard risk management and to construct major infrastructures including multi-purpose cyclone shelters and embankments.

The NCRMP is monitored and implemented by the Management Unit in the NDMA at the central level and the Project Implementation Unit at the state level.

**Table 4.4.9 Major Activities on NCRMP Phase 1 in Andhra Pradesh and Odisha**

No.	Activities	Rs. crore
1.	Community mobilisation and training	72.75
2.	Cyclone Risk Mitigation Infrastructure (Construction of cyclone shelters, roads/missing links and construction/repair of Saline Embankments etc.)	1164.00
3.	Technical assistance for capacity building on Disaster Risk Management (risk assessment, damage and needs assessment)	29.10
4.	Implementation assistance (Operational cost, technical assistance cost and IEC material etc.)	95.06
5.	Others	135.80

Source: MHA, "State Level Programmes for Strengthening Disaster Management in India", (2011)

**Table 4.4.10 Breakdown of Activities in Andhra Pradesh and Odisha**

No.	Activities	Andhra Pradesh	Odisha
1.	Cyclone shelters	130 nos.	148 nos.
2.	Cyclone shelters for fishing communities	19 nos.	-
3.	Shelter-cum-godown	6 nos.	-
4.	Approach roads to proposed cyclone shelters	130 nos. (150.35 km)	206 nos. (280.00 km)
5.	Approach roads to existing cyclone shelters	61 nos. (112.8 km)	-
6.	Roads connecting habitations of less than 500 or unconnected habitations	-	272 nos. (479 km)
7.	No. of bridges	-	22 nos.
8.	No. of roads	-	3 nos. (23 km)
9.	Saline embankments	23 nos. (157 km)	2 nos. (33.6 km)

Source: MHA, "State Level Programmes for Strengthening Disaster Management in India", (2011)

#### 4.4.7 Evacuation Systems

##### (1) Responsible Organisation for Evacuation

State and local authorities have direct responsibility for the safety of the communities.

##### (2) Time Line of Evacuation Activities at Event of Cyclone

The time line of evacuation activities is shown in Table 4.4.11. Based on the weather information from the IDM, state and district governments operate evacuation activities. According to the NDMA Guidelines for Cyclones, evacuation activities should be finished before 12 hours of landfall.

**Table 4.4.11 Time Line of Early Warning and Evacuation at Event of Cyclone**

Time	Activities	Organisation
5-3 days in advance of landfall	Generation of cyclone watch	IMD, MHA, State Executive Committee(SEC)
3 days in advance of landfall	Cyclone alert	IMD, MHA, SEC
2 days in advance of landfall	Specify track, intensity of landfall location, and lead time of coastal hazard (storm surge, inundation etc.) Emergency response planning De-warning of safe areas	IMD, MHA, SEC, DDMA, Community, Civil Defence, NGOs, Media
24 hours in advance of landfall	Updating track, intensity of landfall location, and lead-time of coastal hazard (storm surge, inundation etc.) Emergency evacuation planning Relief routing Rehabilitation Planning De-warning of safe areas	Central/State Government, National/State Disaster Relief Forces (DRFs), Civil Defence Teams (CDTs)
12 hours in advance of landfall	Updating track, intensity of landfall location, and lead-time of coastal hazard (storm surge, inundation etc.) Emergency evacuation Emergency preparedness for organising relief, rescue and rehabilitation	Central/State Government, National/State DRFs, CDTs, NGOs, Local Authorities

Note SEC: State Executive Committee, DDMA: District Disaster Management Authority

Source: compiled by the Survey Team based on "National Disaster Management Guidelines for Management of Cyclones", (2008) of the NDMA

#### **4.4.8 Emergency Response**

##### **(1) Role of Ministry of Home Affairs and State Disaster Management Departments**

The central government provides financial and logistic support in the event of major disasters. A Crisis Management Committee (CMC) in the state, with senior representatives from government departments and central agencies located in the state, supervises disaster management actions and activities. In the event of approaching cyclones, the IMD informs and warns all of the concerned sectors in the government, the local population and media, through various communication channels.

For the operation, Emergency Operation Centre (EOC) in the MHA is connected to the state level EOCs based on the Department of Telecommunication (DOT) networks. In case of emergency, satellite communication system called SPACENET is provided by the Department of Space (ISRO). Currently, there are 35 SPACENET nodes being operated between the NDMA/MHA and state EOCs.

##### **(2) Role of Ministry of Defence**

The Armed Forces are the quickest to reach the affected areas for delivering timely action. The communication is often restored by the army, and it is a major contribution. The Air Force assists in search and rescue operations, evacuation and airdropping of relief supplies. The Indian Navy and Coast Guard convey the assistance in rescue operations as well.

##### **(3) Time Line of Response Activities at Event of Cyclone**

The time line of response activities is shown in Table 4.4.12. Basic data collection and assessment of the situation should be finished after 24 hours of landfall.

**Table 4.4.12 Time Line of Response at Event of Cyclone**

Time	Activities	Organisation
Up to 24 hours later	Grasping of location-specific impact of rainfall, wind, river discharge and inundation including coastal effects. Emergency rescue, relief and rehabilitation Restoration of damaged lifeline infrastructure and essential services (shelters and relief camp, human security, livestock protection)	Central/State Government, National/State DRFs, CDTs, NGOs, Local Authorities
Post Disaster (2-7 days)	Forecasting for relief and rehabilitation efforts Relief operations Facilitating the repatriation of people from shelters and camps Immediate restoration actions of damaged critical services De-warning of cyclone impact	Central/State Government, National/State DRFs, CDTs, NGOs, Local Authorities

Source: compiled by the Survey Team based on “National Disaster Management Guidelines for Management of Cyclones”, (2008) of the NDMA

#### **4.4.9 Challenges to be Addressed**

According to the information gathered, the following are the challenges identified by the Indian side:

##### **< Risk Analysis >**

The committee which drew lessons from management of Cyclone Hudhud under the directive of Prime Minister suggested the needs to secure the emergency logistics and formulate the guidelines for wildlife sanctuaries and zoological parks during disasters. Especially, for the purpose of

evacuation and material distribution, specified maps are very useful for disaster response. In India, modelling and analysing skills for cyclone risks are at high-level. Sector specialised risk map such as evacuation or material distribution maps for transportation sector are needed for effective activities for disaster response. The map should be organized on a GIS based viewer system.

- Challenge(s) of Risk Analysis:
- Conducting a sector-based risk analysis (for transportation and logistics)
  - Conducting risk analysis for wildlife conservation area and zoological park/national park

< Preparedness >

The committee, which drew lessons from management of Cyclone Hudhud under the directive of the Prime Minister, suggested the need to store an adequate quantity of foods, water, materials and energy for distribution to evacuation shelters and emergency construction works. India Disaster Resource Network, which is an interstate cooperation mechanism, functions well. However, there is a need to upgrade the list of materials and supplies stores based on past disaster experience. Updating of a checklist of the most essential activities during preparedness phase based on the actual activities during disaster is needed. Also, After Action Review is essential. Raising awareness for importance of comprehensive Mock Drill is important for DRR in schools and communities.

- Challenge(s) of Preparedness
- Planning deployment of proper materials and supplies for disaster response

< Countermeasures >

The committee, which drew lessons from management of Cyclone Hudhud under the directive of the Prime Minister, suggested the need to maintain the cyclone shelters and access roads. Cyclone shelter management is a key activity for cyclone disaster management. Development of a regular maintenance scheme of cyclone shelters and their access roads is needed.

- Challenge(s) of Countermeasures:
- Maintaining cyclone shelters properly

< Emergency Response >

Cars and drivers/operators for road clearance and information gathering are priority resources for the initial stage of disaster response. It is required to secure proper communication tools among drivers/operators during and after a cyclone hit. Procurement for providing necessary materials for emergency response such as human resources, materials for urgent construction work, foods and water for shelter, energy, etc. should be negotiated before the disaster.

- Challenge(s) of Emergency Response:
- Coordinating rapid supply of essential resources during emergency response

In addition, considering the current situation of cyclone risk reduction in India, it is worth pointing out the following as challenges to be addressed:

< Institutional Framework >

In general, a district level disaster management plan focuses on disaster response and recovery. Countermeasures against cyclone risk and damage are not well described in the plan. Moreover, recognition of the necessity of disaster mitigation is relatively low among district, mandal and village level officers responsible for disaster management. Effective disaster management plans at district level are not developed enough especially for consideration of cyclone risk mitigation and disaster preparedness. It is necessary for state governments (SDMA and state department of disaster management) to lead the formulation of disaster management plans at the district level. District Disaster Management Plans should include actual field requirements such as valuable areas,

evacuation routes, alternative route for shelters, shelter maps, etc. Municipal corporations also need to develop Disaster Management Plans in synchronisation with District Plans.

- Challenge(s) of Institutional Framework:
- Developing an effective Disaster Management Plan at the district level

< Countermeasures >

During cyclone disaster, most public telecommunications systems such as mobile and land phones are fallen and means of communication are limited only to specified wireless radio and direct oral communication. Therefore, it is necessary to develop resilient telecommunications networks including optical fibre networks.

- Challenge(s) of Countermeasures:
- Securing public telecommunications systems during disasters

< Forecasting, Early Warning and Communication System >

Cyclone forecasting and early warning is conducted by IMD on the international level. IMD is one of the international centres for cyclone detection. Development of reasonable accuracy warning capabilities at the local level is needed. Issuing/providing impact-based warning to decision makers and general public is needed for adequate actions for cyclone disasters.

- Challenge(s) of Forecasting, Early Warning and Communication System:
- Providing accurate warning at the local level by introducing reasonable systems

< Evacuation System >

In India, most residents can evacuate to cyclone shelters during disasters. However, the shelters that were visited during the survey receive huge numbers of people to narrow spaces. The living environment of the shelters is not adequate. In particular, special considerations for women, children, elder persons and disabilities are needed.

- Challenge(s) of Evacuation System:
- Ensuring appropriate care for women, children, senior citizens, and disabled people in shelters

Table 4.3.8 shows the challenges identified, actions to be taken for the improvement and organisations responsible for implementation of the actions.

**Table 4.4.13 Challenges and Actions (Cyclones)**

S/N	Challenges	Actions to be Taken: <u>Cyclones</u>		
		Short Term (1 - 2 Years)	Medium Term (3 -5 Years)	Long Term (5 - 10 Years)
<b>Challenges identified by the Indian Side</b>				
[ Risk Analysis ]				
DT-CC-1	Conducting a sector-based risk analysis (for transportation and logistics)	<u>Action(s)</u> - Gathering basic data of roads, houses, etc. for the risk analysis - Analysing the risk of during and after disasters	<u>Action(s)</u> - Mapping cyclone risk for transportation sector - Developing a GIS-based equipment distribution map with shelter locations	<u>Action(s)</u> - Keeping the transportation routes in good conditions for emergency distribution of relief materials and evacuation
		<u>Taken by</u> - SDMA - State Department of Disaster Management	<u>Taken by</u> - SDMA - State Department of Disaster Management	<u>Taken by</u> - SDMA - State Department of Disaster Management - State Public Works Department
DT-CC-2	Conducting risk analysis for wildlife conservation area and zoological park/national park	<u>Action(s)</u> - Mapping cyclone risk for conservation area and zoological park/national park	<u>Action(s)</u> - Developing risk maps and management guidelines for wildlife sanctuaries and zoological parks during disaster	<u>Action(s)</u> - Developing eco friendly DRR facilities such as wave power reduction facilities
		<u>Taken by</u> - SDMA - State Department of Disaster Management	<u>Taken by</u> - SDMA - State Department of Disaster Management	<u>Taken by</u> - SDMA - State Department of Disaster Management - State Public Works Department

S/N	Challenges	Actions to be Taken: <u>Cyclones</u>		
		Short Term (1 - 2 Years)	Medium Term (3 -5 Years)	Long Term (5 - 10 Years)
[ Preparedness ]				
DT-CC-3	Planning deployment of proper materials and supplies for disaster response	<u>Action(s)</u> - Preparing light equipment for emergency response such as cutting and road clearance equipment, diesel generator, boat, etc. - Preparing a checklist of the most essential activities during preparedness phase - Updating 'India Disaster Resource Network' data base - Preparing an "After Action Review" to accumulate the experience of disasters	-	-
		<u>Taken by</u> - SDMA - State Department of Disaster Management	-	-
[ Countermeasure ]				
DT-CC-4	Maintaining cyclone shelters properly	<u>Action(s)</u> - Conducting assessment of cyclone shelter conditions - Conducting urgent repair works for shelters	<u>Action(s)</u> - Developing regular maintenance scheme of cyclone shelters and their access roads	-
		<u>Taken by</u> - SDMA - State Department of Disaster Management	<u>Taken by</u> - SDMA - State Department of Disaster Management	-
[ Emergency Response ]				
DT-CC-5	Coordinating rapid supply of essential resources during emergency response	<u>Action(s)</u> - Making prior procurement of relief materials between government and material provider	<u>Action(s)</u> - Formulating the mechanism for pre-procurement	-
		<u>Taken by</u> - SDMA - State Department of Disaster Management	<u>Taken by</u> - SDMA - State Department of Disaster Management	-

S/N	Challenges	Actions to be Taken: <u>Cyclones</u>		
		Short Term (1 - 2 Years)	Medium Term (3 -5 Years)	Long Term (5 - 10 Years)
<b>Challenges identified by the Survey Team</b>				
[ Institutional Framework ]				
DT-CC-6	Developing an effective Disaster Management Plan at the district level	<u>Action(s)</u> - Conducting a review of existing District Disaster Management Plans	<u>Action(s)</u> - Developing District Disaster Management Plans based on the actual field requirements (valuable areas, evacuation routes, alternative routes for shelters, shelter distribution maps, etc.) - Developing City Disaster Management Plan in conjunction with the District Plans	-
		<u>Taken by</u> - SDMA - State Department of Disaster Management - DDMA - Municipal Corporations	<u>Taken by</u> - SDMA - State Department of Disaster Management - DDMA - Municipal Corporations	-
[ Countermeasure ]				
DT-CC-7	Securing public telecommunications systems during disasters	<u>Action(s)</u> - Assessing the current situation of telecommunications systems against disasters, such as redundancy and backup systems	<u>Action(s)</u> - Developing resilient facilities of telecommunications	<u>Action(s)</u> - Developing alternative lines to secure the communication during disasters
		<u>Taken by</u> - Ministry of Communications and Information Technology - State department(s) related to planning and telecommunication	<u>Taken by</u> - Ministry of Communications and Information Technology - State department(s) related to planning and telecommunication	<u>Taken by</u> - Ministry of Communications and Information Technology - State department(s) related to planning and telecommunication
[ Forecasting, Early Warning and Communication System ]				
DT-CC-8	Providing accurate warning at the local level by introducing reasonable systems	<u>Action(s)</u> - Assessing the current situation of cyclone warnings and receiver's review at the local level	<u>Action(s)</u> - Developing capabilities of state government for providing accurate warning by installing reasonable equipment such as X-band radar	<u>Action(s)</u> - Developing a system to issue/provide an impact-based warning to decision makers and general public at the local level
		<u>Taken by</u> - IMD - SDMA - State Department of Disaster Management - DDMA - Municipal Corporations	<u>Taken by</u> - SDMA - State Department of Disaster Management	<u>Taken by</u> - SDMA - State Department of Disaster Management - DDMA - Municipal Corporations



S/N	Challenges	Actions to be Taken: <u>Cyclones</u>		
		Short Term (1 - 2 Years)	Medium Term (3 - 5 Years)	Long Term (5 - 10 Years)
[ Evacuation System ]				
DT-CC-9	Ensuring appropriate care for women, children, senior citizens, and disabled people in shelters	<u>Action(s)</u> - Assessing the living environment of cyclone shelters during evacuation	<u>Action(s)</u> - Formulating guidelines for ensuring appropriate care for gender and vulnerable groups	-
		<u>Taken by</u> - SDMA - State Department of Disaster Management - DDMA - Municipal Corporations	<u>Taken by</u> - SDMA - State Department of Disaster Management - DDMA - Municipal Corporations	-

Source: prepared by the Survey Team

## 4.5 Evaluation and Prioritisation of Challenges Identified

### 4.5.1 Methodology

The challenges identified are evaluated from three perspectives: 1) effectiveness of activities to be taken, 2) capacity of the relevant organisations (the Indian side), and 3) current situation and progress of policy and planning in India. Each aspect is rated with the following criteria:

#### Effectiveness of activities to be taken

- A: The existing gap seems to be large and activities may highly contribute to filling in the gap.
- B: The existing gap seems to be relatively large and activities may contribute to filling in the gap.
- C: The existing gap seems to be relatively small and activities may contribute to filling in the gap.

#### Capacity of the relevant organisation (the Indian side)

- A: Has the ability to address based on the existing capacity, but capacity building needed in specific areas of activities
- B: Has the ability to address based on the existing capacity, but capacity building needed in some areas of activities
- C: Capacity building needed in the large area of activities

#### Current Situation and Progress of Policy and Planning

- A: Has not been addressed
- B: Has been addressed, but only partially and leaving much to be improved
- C: Has been addressed, but the need for improvement exists

Finally, each challenge is prioritised in terms of the following criteria, based on the evaluation results of each perspective:

#### Total Evaluation

- A: Needs to be implemented at an early stage
- B: Can be implemented with second priority
- C: Had better be implemented

### 4.5.2 Evaluation Results

The following are the evaluation results of challenges by disaster type:

➤ Floods

S/N	Challenges	Evaluation Aspects (Floods)			Total Evaluation	Remark
		Effectiveness	Capacity of the Indian Side	Current Situation and Progress of Policy and Planning		
<b>Challenges identified by the Indian Side</b>						
[ Preparedness ]						
DT-FL-1	Reorganising the strategy for introduction of flood plain zoning	B	C	B	C	Relatively large amount of cost needed
<b>Challenges identified by the Survey Team</b>						
[ Institutional Framework ]						
DT-FL-2	Introducing basin-wide sediment control with the concept of river basin management (RBM)	A	C	A	B	Relatively large amount of cost needed
[ Countermeasure ]						
DT-FL-3	Implementing embankment and bank protection works in consideration of basin-wide sediment control	A	B	A	A	Relatively large amount of cost needed
DT-FL-4	Planning countermeasures for water logging that could occur in the future due to shortage of flow carrying capacity caused by sedimentation in canals/channels	A	C	A	B	Relatively large amount of cost needed

➤ Landslides

S/N	Challenges	Evaluation Aspects (Landslides)			Total Evaluation	Remark
		Effectiveness	Capacity of the Indian Side	Current Situation and Progress of Policy and Planning		
<b>Challenges identified by the Indian Side</b>						
[ Risk Analysis ]						
DT-LS-1	Prioritising landslide areas where countermeasures need to be implemented based on the risk assessment	A	A	A	A	Certain amount of cost needed, but not so large
[ Forecasting, Early Warning and Communication System ]						
DT-LS-2	Establishing monitoring and early warning systems for landslide	A	C	A	B	Large amount of cost needed
[ Emergency Response ]						
DT-LS-3	Improving the communication systems to enable rapid emergency response at the local level	A	B	B	B	Relatively large amount of cost needed
<b>Challenges identified by the Survey Team</b>						
[ Institutional Framework ]						
DT-LS-4	Strengthening the coordination mechanism among organisations and institutions related to landslide risk reduction	B	B	B	B	Certain amount of cost needed, but not so large
[ Preparedness ]						
DT-LS-5	Raising awareness of and developing capacity of community inhabitants who live in landslide prone areas	B	B	B	B	Relatively large amount of cost needed
[ Countermeasure ]						
DT-LS-6	Introducing countermeasures against each type of landslide	A	B	A	A	Relatively large amount of cost needed

➤ Cyclones

S/N	Challenges	Evaluation Aspects (Cyclone)			Total Evaluation	Remark
		Effectiveness	Capacity of the Indian Side	Current Situation and Progress of Policy and Planning		
<b>Challenges identified by the Indian Side</b>						
[ Risk Analysis ]						
DT-CC-1	Conducting a sector-based risk analysis (for transportation and logistics)	A	B	B	B	Relatively large amount of cost needed
DT-CC-2	Conducting Risk analysis for wildlife conservation area and zoological park/national park	B	C	A	B	Relatively large amount of cost needed
[ Preparedness ]						
DT-CC-3	Planning deployment of proper materials and supplies for disaster response	A	A	C	B	Relatively large amount of cost needed
[ Countermeasure ]						
DT-CC-4	Maintaining cyclone shelters properly	B	A	B	B	Relatively large amount of cost needed
[ Emergency Response ]						
DT-CC-5	Coordinating rapid supply of essential resources during emergency response	A	B	C	B	Certain amount of cost needed, but not so large
<b>Challenges identified by the Survey Team</b>						
[ Institutional Framework ]						
DT-CC-6	Developing an effective Disaster Management Plan at the district level	A	B	C	B	Certain amount of cost needed, but not so large
[ Countermeasure ]						
DT-CC-7	Securing public telecommunications systems during disasters	B	A	A	A	Relatively large amount of cost needed
[ Forecasting, Early Warning and Communication System ]						
DT-CC-8	Providing accurate warning at the local level by introducing reasonable systems	A	B	A	A	Relatively large amount of cost needed
[ Evacuation System ]						
DT-CC-9	Ensuring appropriate care for women, children, senior citizens, and disabled people in shelters	A	B	A	A	Certain amount of cost needed, but not so large

According to the evaluation results, the following are the challenges with high priority (total evaluation “A”):

Floods:

- Implementing embankment and bank protection works in consideration of basin-wide sediment control (Countermeasure)

Landslides:

- Prioritising landslide areas where countermeasures need to be implemented based on the risk assessment (Risk Analysis)
- Introducing countermeasures against each type of landslide (Countermeasure)

Cyclones:

- Securing public telecommunications systems during disasters (Countermeasure)
- Providing accurate warning at the local level by introducing reasonable systems (Forecasting, Early Warning and Communication System)
- Ensuring appropriate care for women, children, senior citizens, and disabled people in shelters (Evacuation System)

## **4.6 Earthquake**

### **4.6.1 Situation of Countermeasures in National Policy and Planning**

The increasing seismic risks in the country have caused enormous damages in several states: Uttarakhand in 1991, Maharashtra in 1993, Madhya in 1997, Gujarat in 2001 and Jammu & Kashmir in 2005. Earthquakes cause consequent disasters, such as landslides on the hill slopes resulting in the blockage of river courses and flash floods. Therefore, as discussed in Chapter 2, the seismological research is highlighted as the objectives of the MOES in the 12th Five-Year Plan. The primary activities of the seismological research include (i) deep crustal studies across the Indian continental margin and the interior, (ii) Paleo seismological studies and kinematics of the Himalayan region, Andaman subduction zone, and active faults of India.

The 12th Five-Year Plan also indicates that mainstreaming the DRR in all major programmes would need to be emphasised. Therefore, the impacts of increasing disaster risks should be focused on and mitigation is proposed at the programme preparation stage for reducing the vulnerability in the hazards prone areas of the country.

In addition, after the earthquake in Nepal in April 2015, India's interest in earthquake prevention has become stronger.

### **4.6.2 Policy and Institutional Framework**

#### **(1) Policy on Earthquake Risk Mitigation**

The DM Act requires the central ministries, departments and state governments to prepare the disaster management plans regarding the concerned disasters including earthquake. The NDMA published the "National Disaster Management Guidelines for Management of Earthquakes" in April 2007 (hereinafter referred to as the "NDMA Guidelines for Earthquakes"). According to the NDMA Guidelines for Earthquakes, a typical disaster management plan shall include several aspects of earthquake disaster management as follows:

- Identification of all tasks to be undertaken before, during and after earthquake
- Outline of the response mechanism with clear defined roles and responsibilities for various stakeholders
- Identification of the available resources to ensure their effective utilisation in the event of earthquake

The required disaster management plans will spell out the strategy for addressing the various tasks relating to earthquake preparedness and awareness creation, capacity development, monitoring and enforcement of earthquake-resistant codes and building bye-laws. They will also include the emergency response, earthquake-resistant design and construction of new structure, and selective seismic strengthening and retrofitting of priority and lifeline structures in the earthquake prone area.

Moreover, according to the NDMA Guidelines for Earthquakes, the following subjects are required.

- All new structures are built in compliance with earthquake resistant building codes.
- For preparation of the town planning bye-laws, structural safety audits of existing lifeline structures and other critical structures in the earthquake prone areas, the selective seismic strengthening and retrofitting shall be conducted.

According to the NDMA, the earthquake disaster risks on account of geographical conditions in India have increased manifolds because of the lack of earthquake preparedness, unregulated construction activities, the lack of appropriate techno-legal regime and the lack of awareness

amongst general public about earthquake risk mitigation measures.

Thus, some initiatives have been undertaken to improve earthquake preparedness, to create an enabling environment for the preparation and implementation of earthquake risk management plan and to improve seismic safety in the country. However, these initiatives are at a nascent stage that a comprehensive framework for earthquake risk management is required to minimise the critical gaps. Some of the gaps indicated by the NDMA are given below:

- Inadequate monitoring and enforcement of earthquake-resistant building codes and town planning bye-laws
- Lack of formal training among professionals in earthquake resistant construction practices
- Absence of earthquake resistant features in non-engineered construction in sub-urban and rural areas
- Inadequate attention to structural mitigation measures in the education syllabus
- Lack of adequate awareness and preparedness among various stakeholder groups

To minimise those gaps, various approaches for the mitigation of earthquake disaster risks have been carried out by related agencies.

## (2) Institutional Framework

As mentioned in Chapter 3, the MOES is the nodal ministry for the management of earthquake disaster. Under the MOES, the NCS is constituted for the monitoring, detection, analysis and communication related to seismology in India. In addition, several organisations are designated for disaster risk reduction, such as the BIS and the BMTPC.

### 1) National Centre for Seismology (NCS)

Previously, the IMD had been mandated in the field of seismology. However, in order to set up a new centre of excellence in seismology, the NCS was constituted in August 2014 by bringing all seismology related activities and resources from the IMD. The main functions of the NCS are to conduct the monitoring, detection, analysis and communication related to the earthquake.

The NCS deals with earthquake which occurs in inland area of India. The major activities currently being pursued by the NCS include the followings:

- Earthquake monitoring on 24x7 basis, including real time seismic monitoring for early warning of tsunamis
- Operation and maintenance of national seismological network and local networks
- Operation of seismological data centre and information services
- Implementation of seismic hazard and risk related studies
- Implementation of field studies for aftershock/swarm monitoring, site response studies
- Execution of earthquake processes and modelling

For the activities including the construction of laboratory building, human resources recruitment, research and development activities, training and awareness related programs, the following budgets are requested for five (5) years.

**Table 4.6.1 Budget Requirement**

(Unit: Rs. crore)

Year	2012-2-13	2013-2014	2014-2015	2015-2016	2016-2017	Total
Budget	15.00	25.00	30.00	20.00	15.00	105.00

Source: MOES (2015)

## **2) Bureau of Indian Standards (BIS)**

The BIS as the national standards body has been successfully promoting and nurturing standards movement within the country since 1947. The BIS came into existence on 1 April 1987 through the Act of Parliament dated 26 November 1986. It took over the staff, assets, liabilities and functions of the former Indian Standards Institution (ISI) with an enlarged scope and enhanced powers for harmonious development of activities of standardisation, marking and quality certification of goods and for matters connected therewith or incidental thereto.

The BIS is mandated to develop national codes and practices for design and construction of housing and all infrastructure projects.

In terms of the DRR, the BIS prepared earthquake resistant building code, named “IS 1893:1984 Criteria for Earthquake Resistant Design of Structures”. This standard deals with earthquake resistant design of structures and is applicable to buildings, elevated structures, bridges, dams, etc. It also provides a map which divides the country into five (5) seismic zones based on the seismic intensity. It is composed of five (5) parts: Part I: general provisions and buildings, Part II: liquid retaining tanks - elevated and ground supported, Part III: bridges and retaining walls, Part IV: industrial structures including stack like structures, and Part V: dams and embankments. The Part II was amended in 2002 with the following major modifications:

- Revising seismic zone map with only four (4) zones, instead of five (5)
- Adopting the procedure of first calculating the actual force that may be experienced by the structure during the probable maximum earthquake
- Changing of values of seismic zone factors
- Restricting the use of foundations vulnerable to differential settlements in severe seismic zones

## **3) Building Material and Technology Promotion Council (BMTPC)**

In order to bridge the gap between research and development and large scale application of new building material technologies, the Ministry of Urban Development had established the BMTPC in July 1990.

As pro-active roles in the field of disaster mitigation and management, the BMTPC have produced the following maps and guidelines:

- Seismic Zone Map
- Vulnerability Atlas of India
- Landslide Hazard Zonation Atlas of India
- Guidelines for Improving Earthquakes

Furthermore, the BMTPC carries out a building assessment as a part of vulnerability assessment.

## **4) National Core Group for Earthquake Mitigation**

The National Core Group for Earthquake Mitigation has been constituted consisting of the following experts in earthquake engineering and administrators:

- Ministry of Home Affairs (MHA)
- Indian Institute of Technology Roorkee (IIT Roorkee)
- Indian Institute of Technology Kanpur (IIT Kanpur)
- Building Material and Promotion Council (BMTPC)
- Central Building Research Institute (CBRI)
- Science and Engineering Research Council (SERC)
- All India Council for Technical Education (AICTE)



The Group plays roles in disseminating the knowledge and technology for the earthquake mitigation with the main functions listed below:

- To draw up a strategy and a plan of action for mitigation the impact of earthquake
- To provide advice and guidance to the state governments on various aspects of earthquake mitigation
- To develop or organise the development of handbook, pamphlets, type designs for earthquake resistant construction
- To work out systems for assisting the state governments in the seismically vulnerable zones to adopt or integrate appropriate BIS Codes in their building bye-laws
- To evolve the training systems for municipal engineers and practicing architects and engineers in the salient features of the BIS Codes and the amended bye-laws
- To evolve systems of certification of architects/engineers for testing their knowledge of earthquake resistant construction

The Group has been set up having the most eminent authorities on earthquake engineering in the country as members. The states in seismic zones III, IV and V have been advised to change their building bye-laws to incorporate the BIS codes for safe construction in the seismic zones.

### (3) Projects for Earthquake Mitigation

The National Earthquake Risk Mitigation Project (NERMP) has been approved with an outlay of Rs. 24.87 crore in April 2013. This project aims at strengthening the structural and non-structural earthquake mitigation efforts and reducing the vulnerability in the high-risk districts prone to earthquake, and necessary risk mitigation measures are proposed to be put in place in the highly seismic zones through capacity building and public awareness and sensitisation. The NDMA is the implementing agency of the project. Under this project, the BIS Codes would be placed in the public domain. Necessary steps for revision of these codes would be taken. The project is being implemented in 25 states/UTs that lie in the seismic zones IV and V for the improvement of techno-legal regime in the country.

Moreover, in order to seek for the upgrading the Earthquake Hazard Maps, the Project for Preparation of Upgraded Earthquake Hazard Maps has been carried out by the BMTPC with an outlay of Rs. 76.83 lakh since 2014.

#### 4.6.3 Disaster Records

Table 4.6.2 shows the historical records of earthquake disasters with more than 6.0 magnitude from 1990s. As shown in the table, every three (3) to six (6) years a large-scale earthquake occurs mainly in Himalayan areas indicating the disaster risks of earthquake are increasing recently.

**Table 4.6.2 Major Earthquakes that Affected India**

Date	Affected State	Magnitude	Deaths	Remark
20 October 1991	Uttarakhand	6.6	768	
30 September 1993	Maharashtra	6.4	10,000	
22 May 1997	Madhya Pradesh	6.0	60	
26 January 2001	Gujarat	6.9	13,845	
8 October 2005	Jammu & Kashmir	7.6	74,500	
18 September 2011	Sikkim	6.9	6	
25 April 2015	Bihar, Uttar Pradesh, West Bengal, Sikkim and Rajasthan	7.5	72*	57 in Bihar, 12 in Uttar Pradesh, 2 in West Bengal, and 1 in Rajasthan

Note: Information from "Day 3 of the Earthquake Rescue & Relief Operations" in Reliefweb  
Source: Rajib Shaw, Hari Krishna Nibanupud, "Mountain Hazard and Disaster Risk Reduction", Springer, and the disaster information of "Reliefweb", UNOCHA

#### 4.6.4 Observation System

National Seismic Network in India was set up by the IMD as shown in Figure 4.6.1. At present, there are 82 seismic stations installed in India including Andaman & Nicobar Islands. Among these seismic stations, 17 stations are utilised by the Indian Tsunami Early Warning Centre (ITEWC), a part of the INCOIS for detection and analysis of tsunamigenic earthquake. The NCS has a plan to increase the number of seismic stations up to 140 in due course of time.

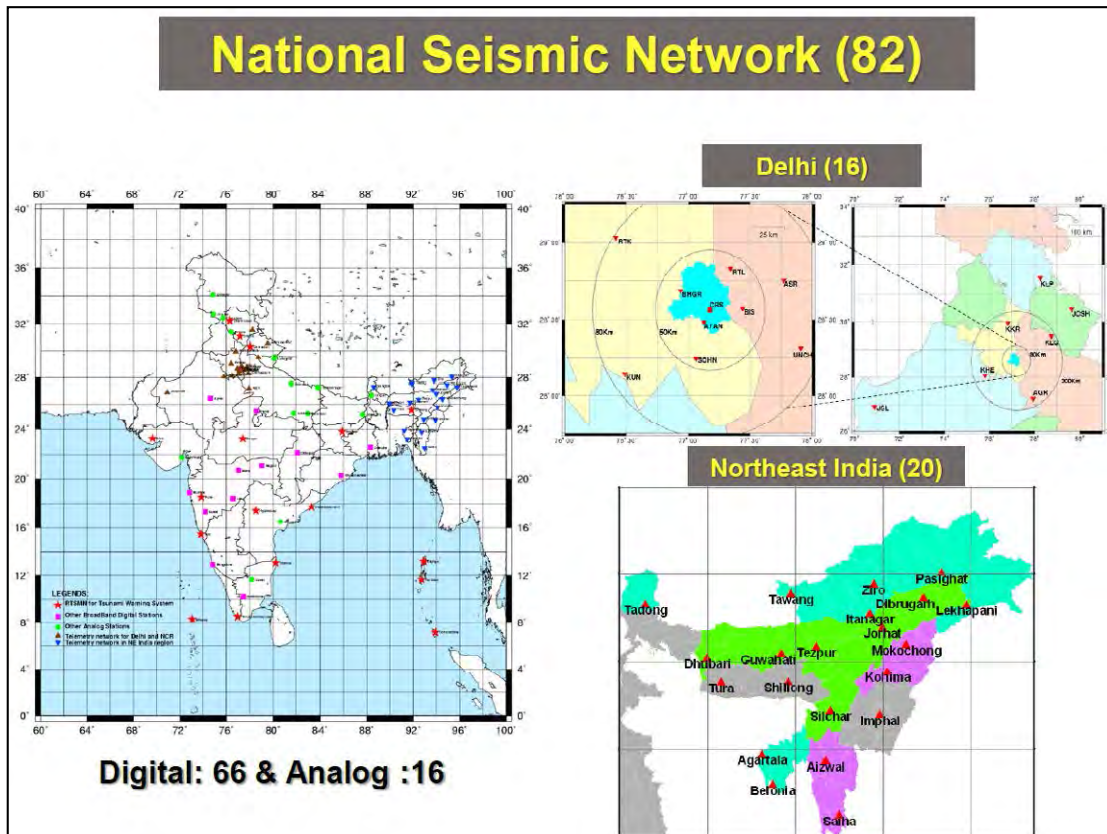

Source: R. S. Dattatrayam, (IMD) (2013)

**Figure 4.6.1 National Seismic Network**

The NCS carries out observation of earthquake with more than 4.0 magnitude. Observation of the earthquake with less than 4.0 magnitude is carried out by state governments as needed.

#### 4.6.5 Risk Analysis

##### (1) Preparation of Seismic Zonation Map

Figure 4.6.2 shows the Seismic Zonation Map in India. As described in section 4.5.2. (2), Hazard Zonation Map of India was prepared by BMTPC. According to Figure 4.6.2, 30 % of the area of India belongs to seismic zones IV and V.

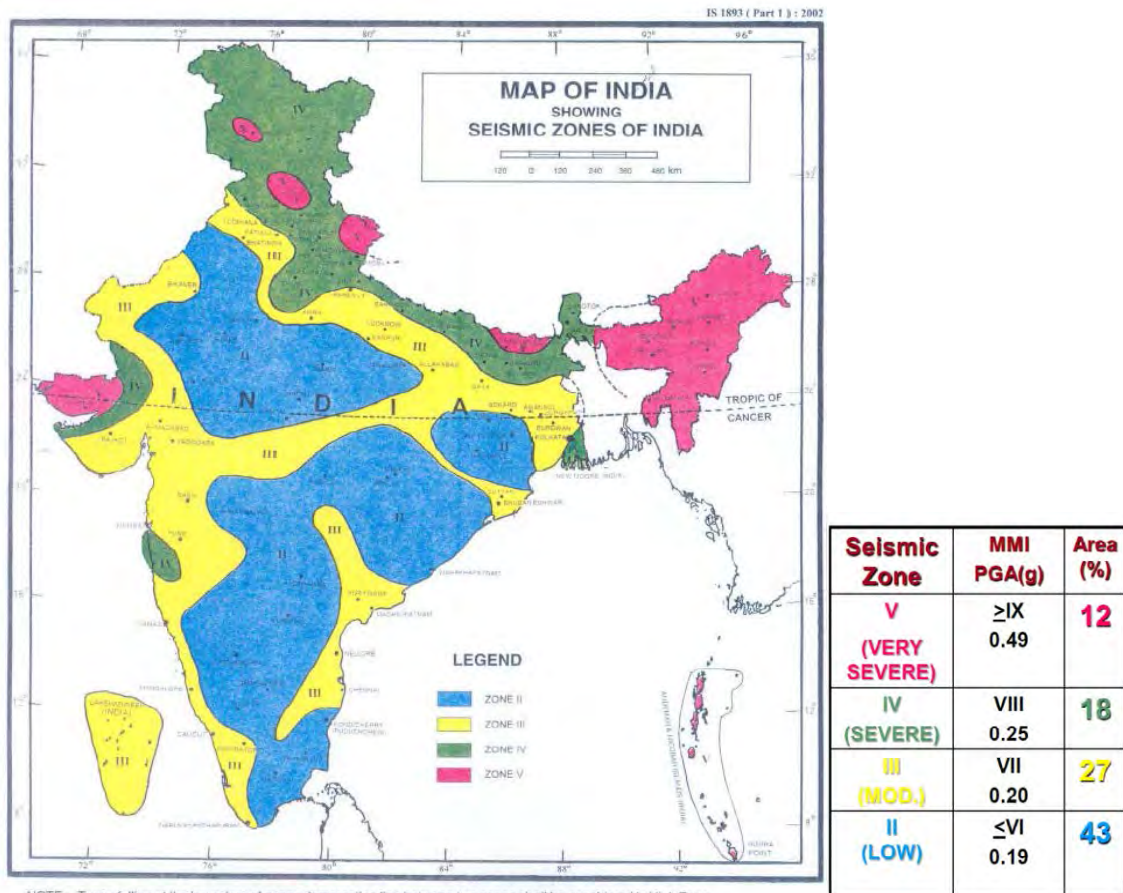

Figure 4.6.2 Seismic Zonation Map of India

## (2) Seismic Micro-Zonation

As one of the methods of seismic hazard mapping, a seismic micro-zonation has been carried out by the NCS and other related organisations.

### 1) Methodology

According to the NCS, the study for seismic micro zonation mapping follows a uniform method. For that, the following manual and handbook are prepared by Geological Science Division, MOES:

- Seismic Micro-zonation Manual (2011)
- Seismic Hazard-zonation Handbook (2011)

### 2) Progress on Preparation of Hazard Zonation Map

In India, 38 cities with more than 50 million population are located in seismic zones III, IV and V, and among these 38 cities, 10 cities are located in seismic zones IV and V.

The NCS has completed the preparation of micro-zonation maps in 8 cities at the scale of 1:10,000 including Delhi, Guwahati and Bangalore. The target area of micro-zonation mapping is 30 cities and the mapping for the remaining cities will be completed within 3 to 4 years.

## (3) Vulnerability Assessment

Vulnerability assessment for existing buildings has been executed by the BMTPC under the

MOUDPA. The NCS carries out geotechnical surveys for the vulnerability assessment.

#### **4.6.6 Preparedness and Countermeasures**

##### **(1) Preparedness**

The NDMA Guidelines for Earthquakes describe the policy which requires the earthquake preparedness.

Based on the results of the risk assessment mentioned in section 4.6.5, the following activities for the earthquake risk reduction are required in the NDMA Guidelines for Earthquakes.

- Preparation of Seismic Zoning Map
- Preparation of Seismic Micro-Zonation
- Review and revision of National Building Code of India (NBC)

In addition, recently the following activities have been taken for the seismic risk reduction.

##### **1) Capacity Building Program**

After the 2001 Bhuj earthquake (Mw 7.7), the obvious needs to include appropriate components of earthquake engineering in the civil engineering and architecture curricula were recognised. Therefore, the National Program on Earthquake Engineering Education (NPEEE) and the National Program for Capacity Building of Engineers in Earthquake Risk Management (NPCBEERM) have been launched by the MHA envisaging eleven (11) premier institutes of science and technology in India as resource institutions.

##### **2) Public Awareness**

The Indian Society of Earthquake Technology (ISET), Roorkee, NDMA and state level disaster management centres have been engaged in carrying out earthquake awareness programs for general public and disaster managers. The Assam State Disaster Management Authority released a pamphlet about reliable seismic precursors for ordinal people.

##### **(2) Countermeasures**

As described in 4.6.2 above, as for the prevention and mitigation of earthquake, the preparation of Detailed Project Report (DPR) is required in order to strengthen the structural and non-structural measures for the earthquake mitigation and to reduce vulnerability in the high-risk districts prone to earthquake.

#### **4.6.7 Earthquake Information Dissemination System**

##### **(1) Outline of Earthquake Information Dissemination System**

Figure 4.6.3 shows general information dissemination system of earthquake. Figure 4.6.4 shows schematic seismological operation including dissemination system. Along with this operation/dissemination system, the NCS will be able to disseminate the earthquake information to the related stakeholders and the public by using several media, such as internet website, short message service (SMS), telephone, fax and email.

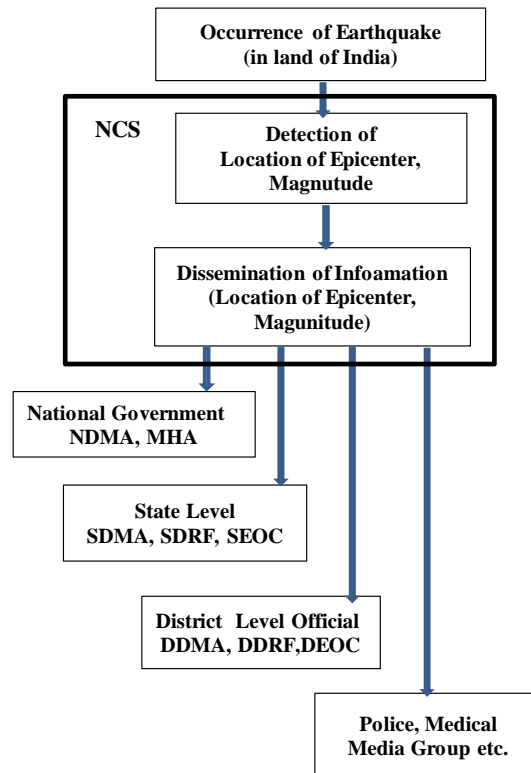

Source: prepared by the Survey Team

Figure 4.6.3 General Information Dissemination

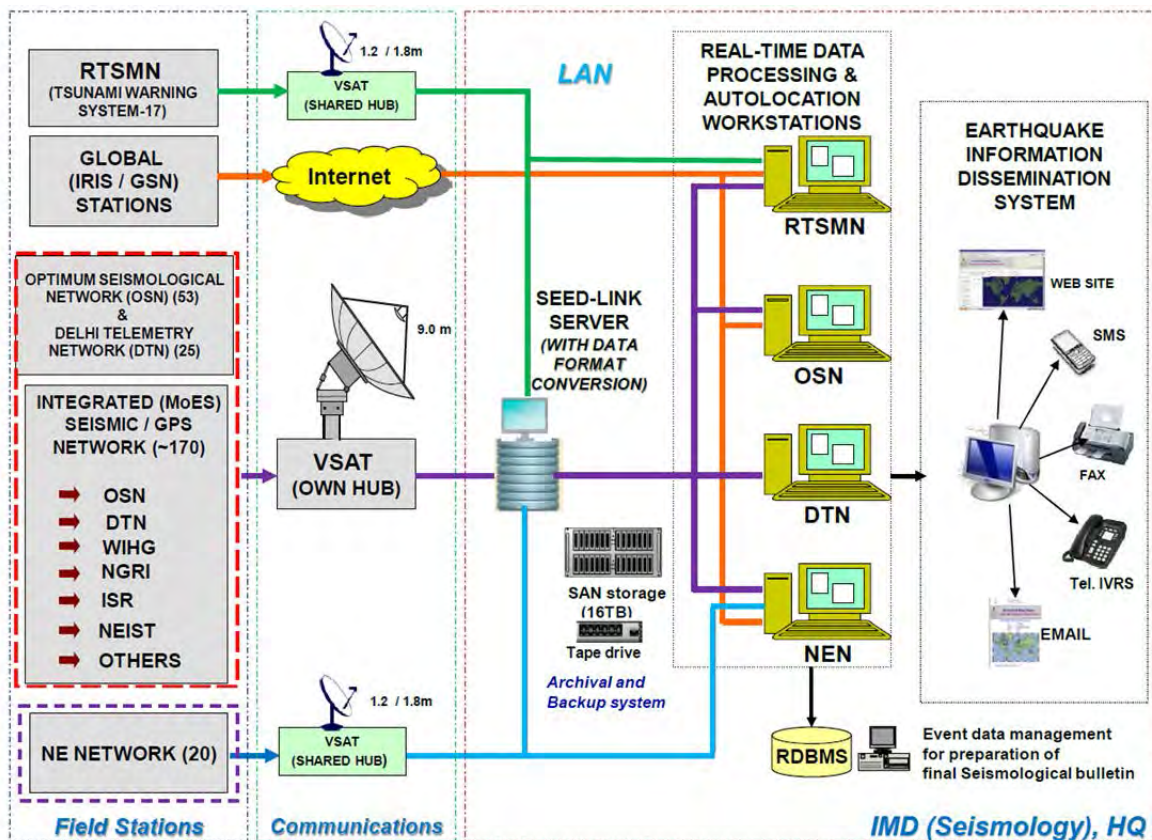

Source: NCS (2015)

Figure 4.6.4 Schematic Seismological Operation including Dissemination System

The NCS generates the following three (3) types of products to disseminate the earthquake information to the related agencies:

- Preliminary Earthquake Report (PER)
- Monthly Seismological Bulletin (MSB)
- Earthquake Catalogues

At present, the dissemination of earthquake forecasting information before the occurrence of earthquake is quite difficult. Therefore, immediately after the occurrence of earthquake, information such as epicentre and magnitude is disseminated as the Preliminary Earthquake Report (PER) to various state and central government agencies dealing with the relief and rehabilitation activities, disaster management, civil/defence authorities, etc. by electronic and print media. The PER is the first-hand information and corresponds to “Earthquake Information” in the Figure 4.6.4.

#### **(2) Preliminary Earthquake Report (PER)**

The Preliminary Earthquake Report (PER) is the first-hand information report generated in operational mode immediately after the occurrence of an earthquake (events of significance in India and the larger ones away from India) for dissemination to all concerned user agencies. The PER consists of ‘preliminary’ information on origin time, latitude and longitude of the epicentre, focal depth and magnitude of the earthquake. The information is disseminated to various state and central government agencies dealing with the relief and rehabilitation measures, disaster management, civil/defence authorities, electronic and print media, as per standard list through various modes of communication. The information is also posted on IMD’s website ([www.imd.gov.in](http://www.imd.gov.in)). The earthquake source parameters reported in the PER are subsequently refined by incorporating all available data from the network stations to form part of the final monthly seismological bulletins.

#### **(3) Monthly Seismological Bulletin (MSB)**

Each seismological station of the network prepares and sends a list of various seismic phases recorded in the daily seismograms to the NCS in a standard format every month. Based on the data from the stations and using appropriate velocity models for local, regional and teleseismic events, the earthquake source parameters are refined and published as Monthly Seismological Bulletins (MSBs). The MSBs contain refined locations of all significant earthquakes in and around the country including the phase data, etc. in standard Nordic format.

#### **(4) Earthquake Catalogues**

Earthquake catalogue contains information of origin time/date, latitude and longitude of epicentre, focal depth, magnitude, region, etc. of all earthquakes. The basic data input for comprehensive seismic hazard assessment of any given region are catalogue of past earthquakes, which is uniform and complete in both space, and time, with the time extending over sufficiently large period. For the Indian region, the earthquake catalogue covers total time span of about 200 years (first catalogue was prepared in 1869).

### **4.7 Tsunami**

#### **4.7.1 Situation of Countermeasure in National Policy and Planning**

Even though most people were not aware of the tsunami risk in India’s coastal states, the Indian Ocean Tsunami on 26 December 2004 revealed the inherent vulnerabilities of the coastal areas along 7,516 km length of the coastline.

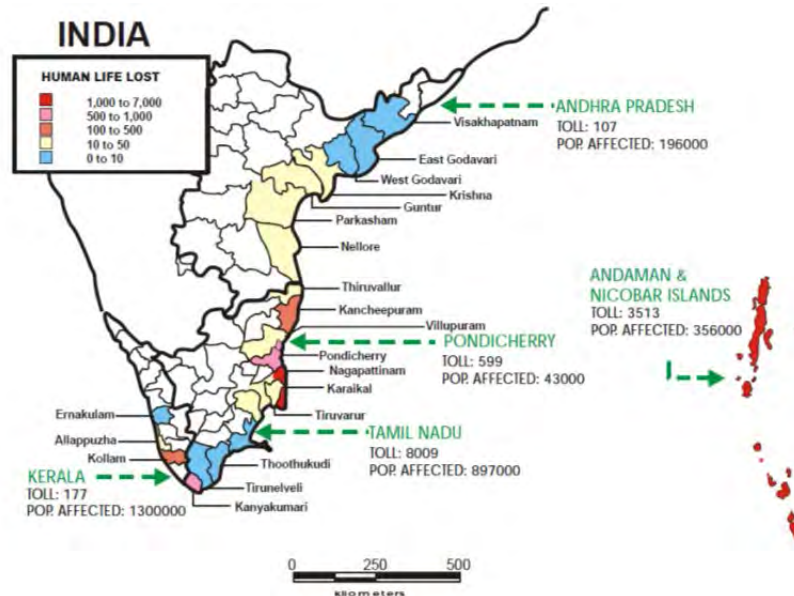

Source: Tsunami Recovery – a Joint UN Report- India (2006)

**Figure 4.7.1 Damage of the Indian Ocean Tsunami 2004 in India**

The population in the coastal area has been increasing rapidly, mostly due to the expanding economic activities propelled by urbanisation and industrialisation in the coastal districts. However, so far the efforts to strengthen the preparedness of the coastal communities to face the increasing threats of storm surges, sea level rise, coastal erosion, etc. have been often restricted with very limited impact, in spite of the increasing disaster risk and vulnerability of the coastal communities.

After the 2004 Indian Ocean Tsunami, India has developed a state-of-the-art Tsunami Early Warning System in the country. The critical gaps that now remain are the lack of public awareness on tsunami risk and vulnerability in the coastal areas, as well as the weak enforcement and compliance of town planning bye-laws, development control regulations and building codes in the coastal areas, and the challenges in implementation of appropriate technologies to disseminate and communicate the early warning to the coastal inhabitants located in the vicinity of a source of tsunami.

Besides, “National Disaster Management Guidelines for Management of Tsunamis” issued by the NDMA in August 2010 (hereinafter referred to as the “NDMA Guidelines for Tsunamis”) indicate the necessity of structural measures and lay down strategy for protecting lifelines along the seafront besides laying down the guidance for development the techno-legal regime and giving an account of various tool kits for tsunami risk management.

#### 4.7.2 Policy and Institutional Framework

##### (1) Policy on Tsunami Risk Mitigation

The Indian Ocean Tsunami on 26 December 2004 is the most destructive tsunami known to have hit India and 13 other countries in the Indian Ocean region. Because of the tsunami disaster, the following points were revealed:

- Absence of an effective Tsunami Early Warning System and last mile connectivity to disseminate alert and early warning message to the coastal communities
- Lack of public awareness
- Lack of emergency response preparedness among the various stakeholder groups

A proactive prevention, mitigation and preparedness stated in the DM Act, and led by the global best practices of strengthening preparedness and mitigation strategies are planned. Those proactive actions would considerably reduce the vulnerability of disaster prone communities and thereby reduce the risk associated with tsunami in the coastal areas. The following actions are emphasised by the NDMA Guidelines for Tsunamis in order to mitigate tsunami disaster risk:

- Implementation of Integrated Coastal Zone Management (ICZM)
- Tsunami Risk Assessment and Vulnerability Analysis
- Tsunami Warning System
- Structural Mitigation Measures
- Regulation and Enforcement of Techno-Legal Regime
- Emergency Tsunami Response
- Preparation of National Disaster Management Plan

## **(2) Institutional Framework**

Regarding the mitigation of tsunami disaster risks, the observation, risk analysis, forecast and warning are carried out by the ITEWC, which is operated by the INCOIS.

The INCOIS was established as an autonomous body in 1999 and is a unit of the ESSOs. The mandate of the INCOIS is to provide the best possible ocean information and advisory services to society, industry, government agencies and the scientific community through sustained ocean observation and constant improvement through systematic and focused research. On the other hand, the ITEWC was established in 2005 and in 2007 real-time observation network was established. The main functions of the INCOIS are listed below:

- To establish, maintain and manage systems for data acquisition, analysis, interpretation and archival for ocean information and related services
- To undertake, aid, promote, guide and coordinate research in the field of ocean information and related services including satellite oceanography
- To carry out surveys and acquire information using satellite technology, ships, buoys, boats or any other platforms to generate information on fisheries, minerals, oil, biology, hydrology, bathymetry, geology, meteorology, coastal zone management and associated resources
- To generate and provide data along with value added data products to user communities
- To cooperate and collaborate with other national and international institutions in the field of ocean remote sensing, oceanography, atmospheric sciences/meteorology and coastal zone management
- To establish Early Warning System for Tsunami and Storm Surges
- To support the research centres in conducting investigations in specified areas related to oceanic processes, ocean atmospheric interaction, coastal zone information, data synthesis, data analysis and data collection
- To organise training programmes, seminars and symposia to advance study and research related to oceanography and technology
- To publish and disseminate information, results of research, data products, maps and digital information through all technologically possible methods to users for promoting research and to meet societal needs for improvement of living standards
- To provide consultancy services in the fields of ocean information and advisory services
- To co-ordinate with space agencies to ensure continuity, consistency and to obtain state-of-the-art ocean data from satellite observations
- To encourage and support governmental and non-governmental agencies/organisations for furthering programmes in the generation and dissemination of ocean information
- To undertake other lawful activities as may be necessary, incidental or conducive to the attainment and furtherance of all or any of the above objectives of the INCOIS

Figure 4.7.2 shows the organisational structure of the INCOIS and the ITEWC.



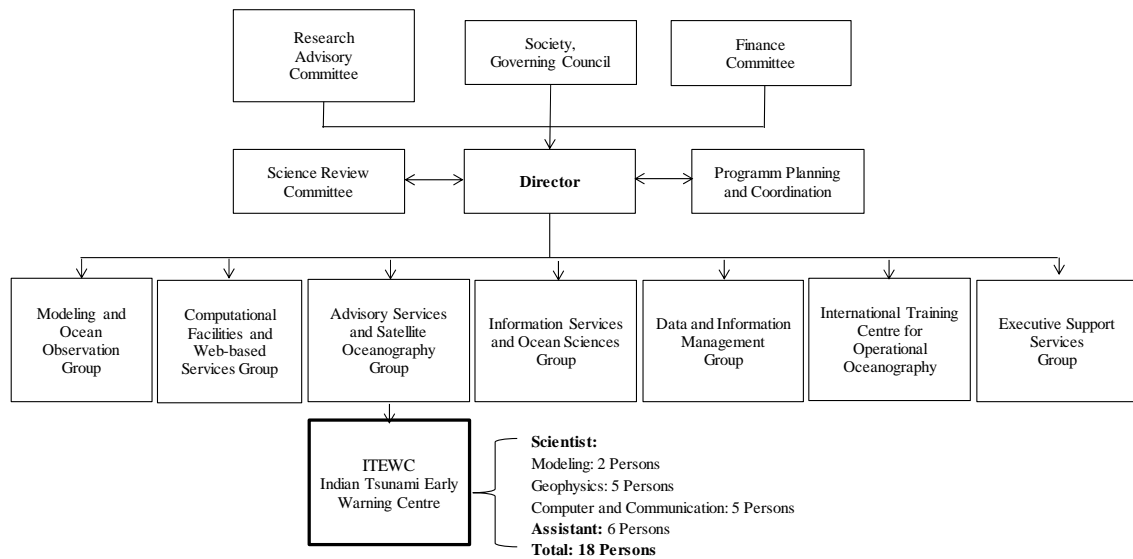

Source: INCOIS (2015)

**Figure 4.7.2 Organisational Structure of INCOIS**

The ITEWC belongs to “Advisory Services and Satellite Oceanography Group (ASP)” of the INCOIS. The total number of staff in ITEWC is 18 persons. Personnel structure of the ITEWC is as follows:

- **Modelling Team: 2 persons**  
This team mainly carries out tsunami modelling (modelling of propagation and potential run-ups and inundation).
- **Geophysics Team: 5 persons**  
This team mainly carries out earthquake detection (detection of earthquake for determination of preliminary earthquake epicentre and magnitude).
- **Computer and Communication Team: 11 persons**  
This team mainly gives decision support and carries out software development for the decision support.

### 4.7.3 Disaster Records

Table 4.7.1 shows a list of tsunamis that affected India. According to the table, tsunamis do not occur frequently, while the earthquake in December 2004 caused extensive damage to India. The lesson learnt from this tsunami event prompted the government of India to take pioneer step to establish an appropriate institutional mechanism for the effective management of the disasters in India.

**Table 4.7.1 List of Tsunami Disasters (after 1900s)**

No.	Year and Date	Remarks
1	26 June 1941	Earthquake of magnitude M8.1 occurred in the Andaman Sea at 12.90N, 92.50E. No reliable data on the resultant tsunamis on the east coast of India are available. Although there are some unverifiable reports, there are no press reports of any tsunami related damage from East Coast.
2	27 November 1945	Makran Earthquake (magnitude M8.3) and with 12 to 15 m wave height occurred in Ormara, 13 m at Pasni, and 1.37 m at Karachi (Pakistan). In Gulf of Cambay of Gujarat, the estimated wave height was 11.0 m, and 2 m at Mumbai, where boats were taken away from their moorings.
3	26 December 2004	An earthquake of high magnitude (M9.3) generated giant tsunami waves in North Indian Ocean. Tsunami extensively damaged many coastal areas of Indonesia, India, Malaysia, Maldives, Sri Lanka and Thailand. More than 200,000 people lost their lives in 14 countries in the Indian Ocean region.

Source: NDMA, "National Disaster Management Guidelines for Management of Tsunamis", (2010)

#### **4.7.4 Observation System**

##### **(1) Observation System of India**

Observation system controlled by the ITEWC is comprised of the following:

- Real time network of seismic stations: 17 locations
- Tide gauge: 21 locations
- Bottom Pressure Recorders (BPR)/tsunami buoys: 7 locations

The location of these observation systems are shown in Figure 4.7.3.

At present, India has National Seismic Network with 82 seismic stations installed by the IMD, of which 17 seismic stations are operated by the ITEWC. The tide gauges and BPRs are used for observation of sea-level.

INCOIS has a plan to install other 15 tide gauges and 35 seismic stations within 2015. The INCOIS intends to shorten the period of time from occurrence of an earthquake to the dissemination of forecast/warning information.

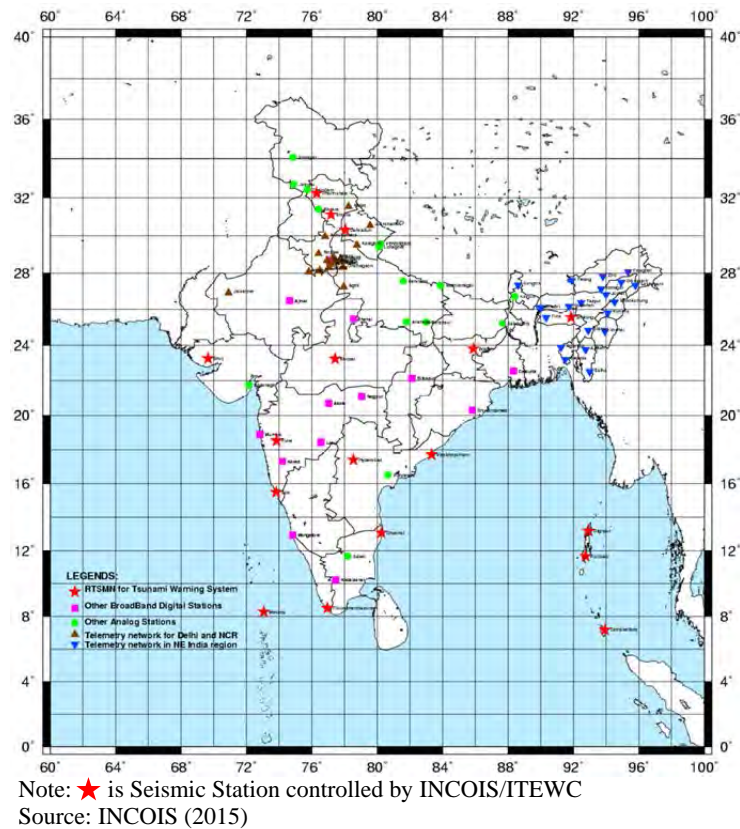

**Figure 4.7.3 National Seismic Network and Location of Seismic Station of INCOIS**

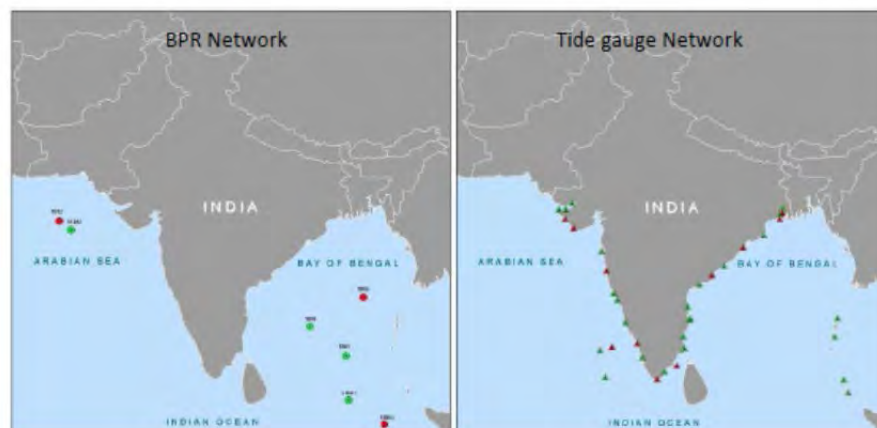

Source: INCOIS (2015)

**Figure 4.7.4 Location of BPR and Tide Gauges**

## (2) International Seismic Network

Figure 4.7.5 shows the international real time seismic network. There are around 300 seismic stations in the network. Through this network, the ITEWC is able to obtain real-time earthquake data with magnitude more than 5.5 to determine preliminary earthquake epicentres and magnitude.

In 2011, the ITEWC was designated as a Regional Tsunami Service Provider (RTSP); therefore, the ITEWC has a responsibility for providing tsunami advisories to Indian Ocean Rim Countries.

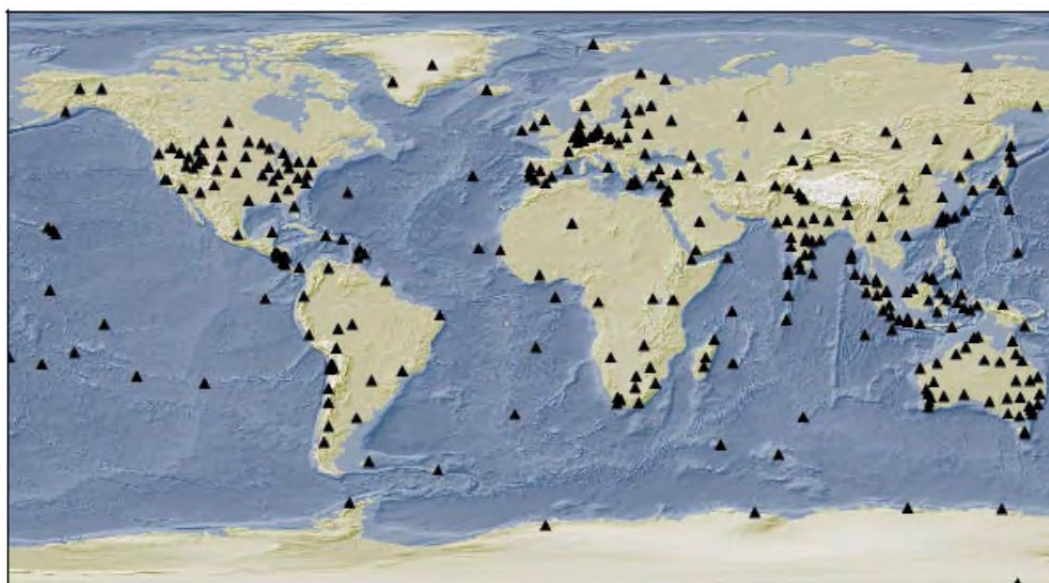

Source: INCOIS (2015)

**Figure 4.7.5 International Real Time Seismic Network (IRTSN)**

In addition, the INCOIS established integrated Indian Ocean Forecasting System (INDOFOS). This forecasting system is capable of predicting the surface and subsurface features of the Indian Ocean reasonably well in advance (5 to 7 days presently). At present, the INCOIS provides forecasts on the following items:

- Height, direction and period (of both wind waves and swell waves)
- Sea surface currents
- Sea surface temperature
- Mixed layer depth (the well mixed upper layer of the sea)
- Depth of the 20 degree isotherm (a measure of the depth of the thermocline)
- Astronomical tides
- Wind speed and direction
- Oil-spill trajectory

#### **4.7.5 Risk Analysis**

##### **(1) Tsunami Modelling**

According to the “Indian Tsunami Early Warning Centre (ITEWC) RTSP Services User Guideline” published by the INCOIS in 2011, the INCOIS has carried out tsunami modelling (run-up and inundation) by using TUNAMI N2 model (Imamura, 1996). Figure 4.7.6 shows a flow of tsunami modelling for the dissemination of bulletin. The results of the modelling (run-up, inundation) are utilised for the preparation of Tsunami Hazard Map.

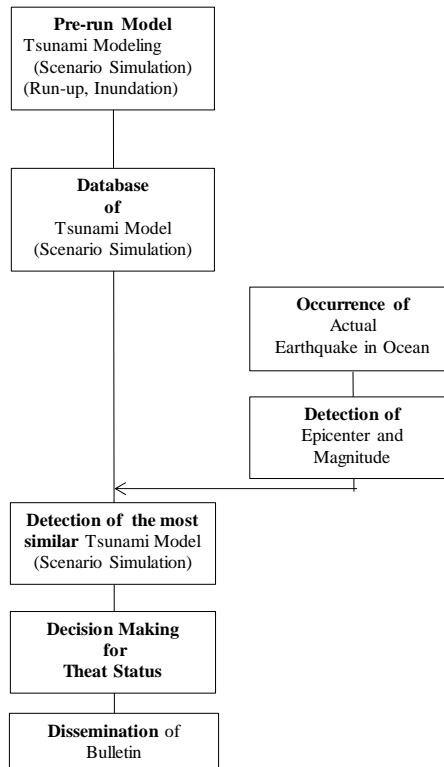

Source: prepared by the Survey Team

**Figure 4.7.6 Flow of Tsunami Modelling for Bulletin Dissemination**

## (2) Tsunami Hazard Mapping

A tsunami hazard map is prepared by the INCOIS and Integrated Coastal and Marine Area Management (ICHAM), MOES.

Based on the results of vulnerability assessment of sea level rise and inundation in the coastal area, the ITEWC is in the process of the preparation of “Tsunami Vulnerability Map” for a total of 3,600 km of the India’s coastal line (total length of coastline is more than 7,500 km including the Andaman and Nicobar Islands). So far, 500 km section has been completed, and the work of another 500 km section is now on going and the remaining sections will be completed within two (2) years. According to the ASP, this vulnerability map will include the damage estimation and evacuation suggestion.

In addition, according to the article “Modelling and Mapping of Tsunami along Indian Coast as a part of the Early Tsunami and Storm Surge Warning System” published by the ICHAM in March 2009, based on the results of run-up and inundation modelling, the ICHAM prepared a tsunami hazard map and tsunami inundation map in some study areas.

Figure 4.7.7 shows the modelling area, and Figure 4.7.8 shows example of tsunami inundation and hazard maps.

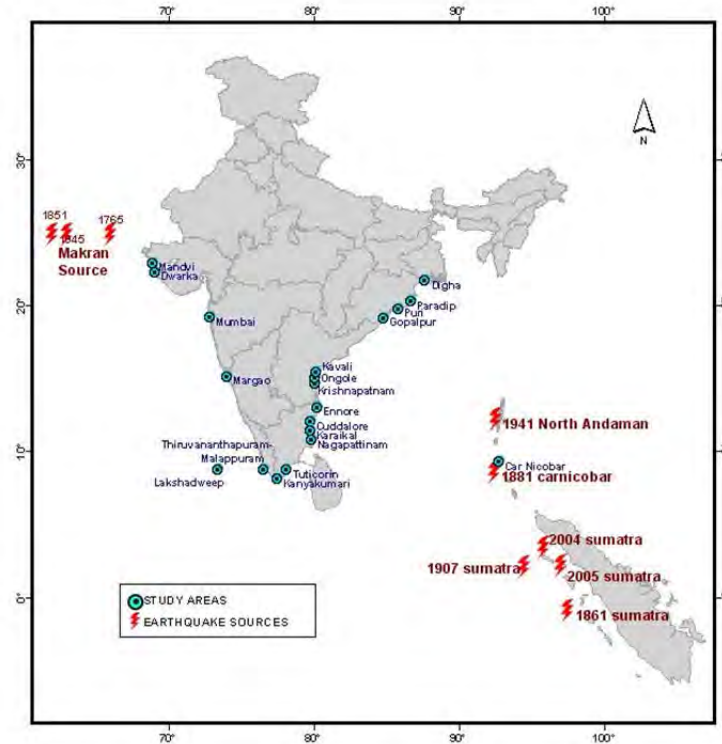

Source: ICHAM, “Modelling and Mapping of Tsunami along Indian Coast as a part of the Early Tsunami and Storm Surge Warning System”, (2009)

**Figure 4.7.7 Study Area**

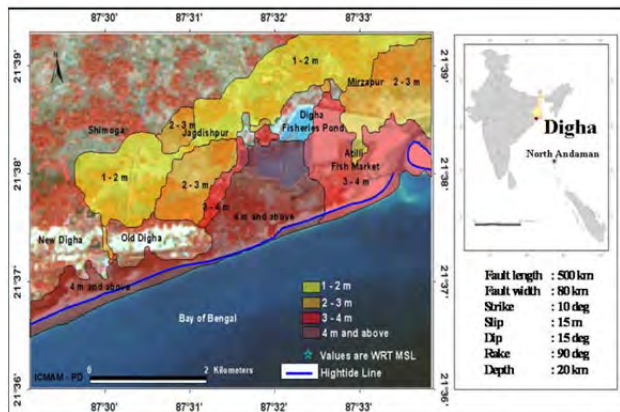

Example of Inundation Map of Digha, West Bengal  
Source: ICHAM (2009)

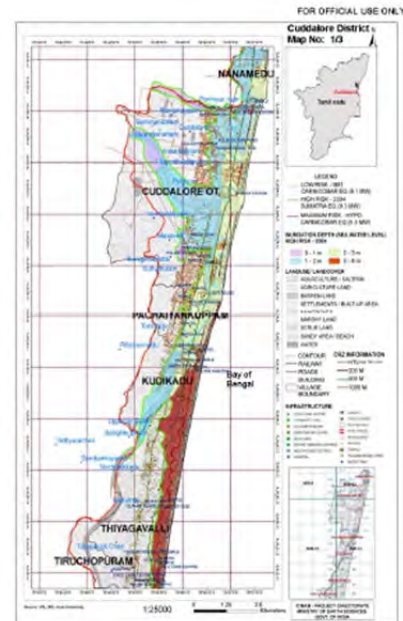

Tsunami Hazard Map, Cuddalore

**Figure 4.7.8 Example of Tsunami Inundation Map and Hazard Map**

### (3) Tsunami Vulnerability Assessment

According to the NDMA Guidelines for Tsunamis, the results of vulnerability assessment indicate the areas likely to be affected by sea water inundation and damages thereof. In the risk prone areas, information from remote sensing and field investigation shall be integrated into GIS for modelling

and mapping of inundation of seawater for the determination of setback lines and planning coastal defences, and so on.

The INCOIS carries out the vulnerability assessment and prepares vulnerability map for estimation of damage due to tsunami event and examination of evacuation route.

The guidelines for tsunami hazard mapping have not been prepared by the BIS or other central organisations.

#### 4.7.6 Preparedness and Countermeasures

##### (1) Preparedness

##### 1) General

The preparedness for tsunami disaster is stated in the NDMA Guidelines for Tsunamis. According to the guidelines, the following activities are necessary for the preparedness of tsunami:

- Preparation of Tsunami Hazard Maps
- Preparation of Coastal Vulnerability Maps

The outline of these maps is described in section 4.7.5 above.

##### 2) Preparedness by ITEWC

The INCOIS prepares the original education materials for tsunami preparedness. The content and materials are shown in Figure 4.7.9.



Source: INCOIS (2011)

Education Materials for Tsunami Preparedness (prepared by INCOIS):

- Communities test & tsunami drill manuals & reports
- Tsunami awareness films for administrators
- General public and children
- Tsunami awareness & preparedness posters
- Leaflets in multiple local languages
- Flyers, videos

**Figure 4.7.9 Education Materials for Tsunami Preparedness prepared by INCOIS**

The ITEWC uses the above materials for tsunami awareness training to government organisations and the community.

## (2) Countermeasures

The NDMA Guidelines for Tsunamis describe tsunami mitigation measures consisting of structural and non-structural measures, responsible organisation and note of each measure as summarised in Table 4.7.2.

**Table 4.7.2 Items of Structural and Non-Structural Measures**

Type	Measure	Responsible Organisation	Note
Structural Measures	Shelter for Storm Surge and Tsunami	<ul style="list-style-type: none"> <li>● State Governments</li> <li>● UT Administrations</li> </ul>	
Non-structural Measures	Mainstreaming DM in Development Planning	<ul style="list-style-type: none"> <li>● All Ministries/Departments</li> <li>● State Governments</li> <li>● UT Administrations</li> </ul>	
	Tsunami Mitigation Measures	<ul style="list-style-type: none"> <li>● State Governments</li> <li>● PRIs</li> <li>● UT Administrations</li> <li>● SDMAs and DDMAs</li> <li>● Builder and Individual Developers</li> </ul>	As for the coastal zone mitigation measures, buffer zone that consists of mangrove wetlands, coastal forest and others are recommended as an ecosystem-base countermeasures. As a reference, "Protection and Mitigation from Risk of Tsunami-A Strategy Paper" is issued by the National Disaster Management Division, MHA in 2006.
	Institutionalisation of Design and Construction for Tsunami	<ul style="list-style-type: none"> <li>● State Governments</li> <li>● UT Administrations</li> <li>● SDMAs and DDMAs</li> </ul>	
	New Standard for Protection of Structure against Tsunami	<ul style="list-style-type: none"> <li>● BIS</li> </ul>	The Guideline stipulates that the BIS has initiated a draft standard entitled "Criteria for Tsunami-Resistant Design Structure". However, this standard has not been issued by the BIS. Other standards related to tsunami disaster mitigation cannot be found at the BIS website.

Source: NDMA, "National Disaster Management Guidelines for Management of Tsunamis", (2010)

### 4.7.7 Emergency Communication

#### (1) Very Small Aperture Terminal (VSAT) aided Emergency Communication System

The INCOIS implements a fall-safe satellite-based communication system called "Very Small Aperture Terminal (VSAT) aided Emergency Communication System (VECS)" at seven (7) Emergency Operation Centres in Andaman and Nicobar Islands.

VSAT system is a two-way satellite communication system establishing information network between hubs (INCOIS and other 7 EOCs). As a result, information is exchanged among those hubs after occurrence of tsunamigenic earthquake.



**(2) Operation Room of ITEWC**

As shown in Figure 4.7.10, the ITEWC set up the monitoring facilities in the INCOIS. A large size monitoring screen is installed in the monitor room, and it displays real-time monitoring information and data delivered from seismic stations, tide gauges and bottom pressure recorders for 24 hours.



Real-time Monitoring Screen



Control Desk and Screen



Computer System

Source: INCOIS

**Figure 4.7.10 Monitoring and Computer System of ITEWC**

## CHAPTER 5 FORECASTING AND EARLY WARNING SYSTEMS

### 5.1 Implementation Structure

As discussed in Chapter 3, the following are the organisations responsible for forecasting and early warning of the different disaster:

Indian Meteorological Department (IMD):	Cyclones
Central Water Commission (CWC):	Floods
Geological Survey of India (GSI):	Landslides
Indian National Centre for Oceanic Information Services (INCOIS):	Tsunamis

### 5.2 Current Situation of the Systems

#### 5.2.1 Warning Systems for Cyclones

IMD has the SOP for cyclone warning in India. The network is composed of two Deputy Director Generals of Meteorology (DDGM), one (1) in New Delhi for Cyclone Warning, and the other in Pune for weather forecasting, three (3) Area Cyclone Warning Centres (ACWCs) located at Kolkata, Chennai and Mumbai, and three (3) Cyclone Warning Centres located at Visakhapatnam, Bhubaneshwar and Ahmedabad (see Figure 4.4-3).

The ACWCs and Cyclone Warning Centres perform the operational work of issuing the bulletins and warnings to the various users. DDGMs coordinate the work of the ACWCs and Cyclone Warning Centres, supervise their work and take necessary measures for continued improvement and efficiency of the warnings system. Table 5.2.1 shows the area of responsibility of ACWCs/ Cyclone Warning Centres. Cyclone Warning Centre Visakhapatnam and ACWC Kolkata are the centres responsible for Andhra Pradesh State and the Andaman and Nicobar Islands respectively.

**Table 5.2.1 Area of Responsibility of ACWCs and Cyclone Warning Centres**

Centre	Sea Area	Coastal Area	Maritime State
ACWC Kolkata	Bay of Bengal	West Bengal, Andaman & Nicobar Islands	West Bengal, Andaman & Nicobar Islands.
ACWC Chennai		Tamil Nadu, Pondicherry, Kerala & Karnataka	Tamil Nadu, Puducherry, Kerala, Karnataka and Lakshadweep.
ACWC Mumbai	Arabian Sea	Maharashtra, Goa	Maharashtra, Goa
Cyclone Warning Centre Bhubaneshwar		Odisha	Odisha
Cyclone Warning Centre Visakhapatnam		Andhra Pradesh	Andhra Pradesh
Cyclone Warning Centre Ahmedabad		Gujarat, Diu, Daman, Dadra and Nagar Haveli	Gujarat, Diu, Daman, Dadra and Nagar Haveli

Source: IMD, "Cyclone Warning in India Standard Operation Procedure", (2013)

There are four (4) stages for issuing warning bulletins under the cyclone warning system.

The first stage warning is "PRECYCLONE WATCH" that is issued 72 hours in advance of commencement of adverse weather, and it contains early warning about the development of a cyclonic disturbance.

The second stage warning is "CYCLONE ALERT" that is issued at least 48 hours in advance of the expected commencement of adverse weather over the coastal areas. It contains information on the location and intensity of the storm, likely direction of its movement, intensification, coastal districts likely to experience adverse weather and advice to fishermen, general public, media and disaster

managers.

The third stage warning is “CYCLONE WARNING” that is issued at least 24 hours in advance of the expected commencement of adverse weather over the coastal areas. This stage warning gives the latest position of cyclone and its intensity, likely point and time of landfall, associated heavy rainfall, strong wind and storm surge along with their impact and advice to general public, media, fishermen and disaster managers.

The fourth stage warning is “POST LANDFALL OUTLOOK” that is issued at least 12 hours in advance of expected time of landfall. This stage warning gives likely direction of movement of the cyclone after its landfall and adverse weather likely to be experienced in the interior areas.

The cyclone warnings are disseminated to various users through different means such as telephone, tele-fax, police wireless, internet (e-mail), radio/TV network, mobile phone and SMS, and they are also put on the IMD’s website, [www.imd.gov.in](http://www.imd.gov.in). As a part of state level disaster management plans, VHF set is installed at ACWC Mumbai and Cyclone Warning Centre Bhubaneswar for quick communication to state control rooms.

In addition to the above network, the IMD has installed special receivers in the vulnerable coastal areas for quick dissemination of warning against impending disaster from approaching cyclones. The dissemination system is called as Cyclone Warning Dissemination System (CWDS). This is a direct broadcast service of cyclone warning in the regional languages. There are 352 stations along the Indian coast, of which 101 CWDS are located along Andhra coast.

Table 5.2.2 shows a series of bulletins issued in the case of Cyclone Hudhud for the first 10 days. The warning information covers heavy rainfall warning, wind warning, sea condition, damage expected and actions suggested. Issuing of bulletins continued up to 14 October 2014 and the final subject was depression over east Uttar Pradesh and neighbourhood weakened into a well-marked low pressure area.

**Table 5.2.2    Bulletins: Case of Cyclone Hudhud**

No.	Date	Time	Subject
1	06.10.2014	12:30	Low pressure area over Tenasserim Coast and adjoining Andaman Sea
2	07.10.2014	12:00	Depression over north Andaman Sea, Cyclone Alert for Andaman & Nicobar Islands and Pre-cyclone Watch for north Andhra Pradesh & Odisha coasts
3	07.10.2014	14:30	Depression over north Andaman Sea, Cyclone Alert for Andaman & Nicobar Islands and Pre-cyclone Watch for north Andhra Pradesh & Odisha coasts
4	07.10.2014	20:00	Depression intensified into a Deep Depression over north Andaman Sea and neighbourhood, Cyclone Alert for Andaman & Nicobar Islands and Pre-cyclone Watch for north Andhra Pradesh & Odisha coasts
5	08.10.2014	02:00	Depression intensified into a Deep Depression over north Andaman Sea and neighbourhood, Cyclone Alert for Andaman & Nicobar Islands and Pre-cyclone Watch for north Andhra Pradesh & Odisha coasts
6	08.10.2014	08:00	Deep Depression over north Andaman Sea & adjoining southeast Bay of Bengal, Cyclone Alert for Andaman & Nicobar Islands and Pre-cyclone Watch for north Andhra Pradesh & Odisha coasts
7	08.10.2014	12:00	Cyclonic Storm, ‘HUDHUD’ over north Andaman Sea & adjoining southeast Bay of Bengal, Cyclone Warning for Andaman & Nicobar Islands and Cyclone Alert for north coastal Andhra Pradesh & south Odisha coasts
8	08.10.2014	17:30	Cyclonic Storm, ‘HUDHUD’ over southeast Bay of Bengal,

No.	Date	Time	Subject
			Cyclone Warning for Andaman & Nicobar Islands and Cyclone Alert for north coastal Andhra Pradesh & south Odisha coasts
9	08.10.2014	20:00	Cyclonic Storm, 'HUDHUD' over southeast Bay of Bengal, Cyclone Warning for Andaman & Nicobar Islands and Cyclone Alert for north coastal Andhra Pradesh & south Odisha coasts
10	08.10.2014	23:00	Cyclonic Storm, 'HUDHUD' over southeast Bay of Bengal, Cyclone Warning for Andaman & Nicobar Islands and Cyclone Alert for north coastal Andhra Pradesh & south Odisha coasts

Source: IMD (2015)

### 5.2.2 Forecasting Systems for Floods

The CWC manages the “National Flood Forecasting and Warning Network”, which is composed of 175 flood forecasting sites including 28 inflow forecasting sites as shown in Table 5.2.3 and Figure 5.2.1. Most of the forecasting systems are installed in the Ganga and its tributaries and it accounts for 50 % of the total sites. As for the number by state, 20 % of the systems are installed in Uttar Pradesh State, followed by 18 % in Bihar State and 14 % in Assam State.

The CWC issues forecasts to the various user agencies, which include agencies of the central and state governments such as irrigation, revenue, railways, public works, district magistrates, sub divisional officers besides the defence authorities involved in the flood loss mitigation work. On an average, over 6,000 forecasts are being issued every year by the CWC during the flood season. Normally, these forecasts are issued 12 to 48 hours in advance, depending upon the river terrain, the locations of the flood forecasting sites and base stations. During the flood season (May to October) in 2013, a total of 7,060 flood forecasts (5,741 level forecasts and 1,319 inflow forecasts) were issued through the flood forecasting systems operated by the CWC.

**Table 5.2.3 Number of Flood Forecasting Sites in Major Inter-state River Systems**

No.	Major Interstate River Systems	Type of Forecasting Sites		Total
		Level Forecasting	Inflow Forecasting	
1	Ganga & its tributaries	77	10	87
2	Brahmaputra & its tributaries	27	-	27
3	Barak System	5	-	5
4	Eastern Rivers	8	1	9
5	Mahanadi	3	1	4
6	Godavari	14	4	18
7	Krishna	3	6	9
8	West Flowing Rivers	9	6	15
9	Southern River System (Pennar)	1	0	1
	Total	147	28	175

Source: CWC, “Flood Forecasting and Warning Network Performance Appraisal Report”, (2011)

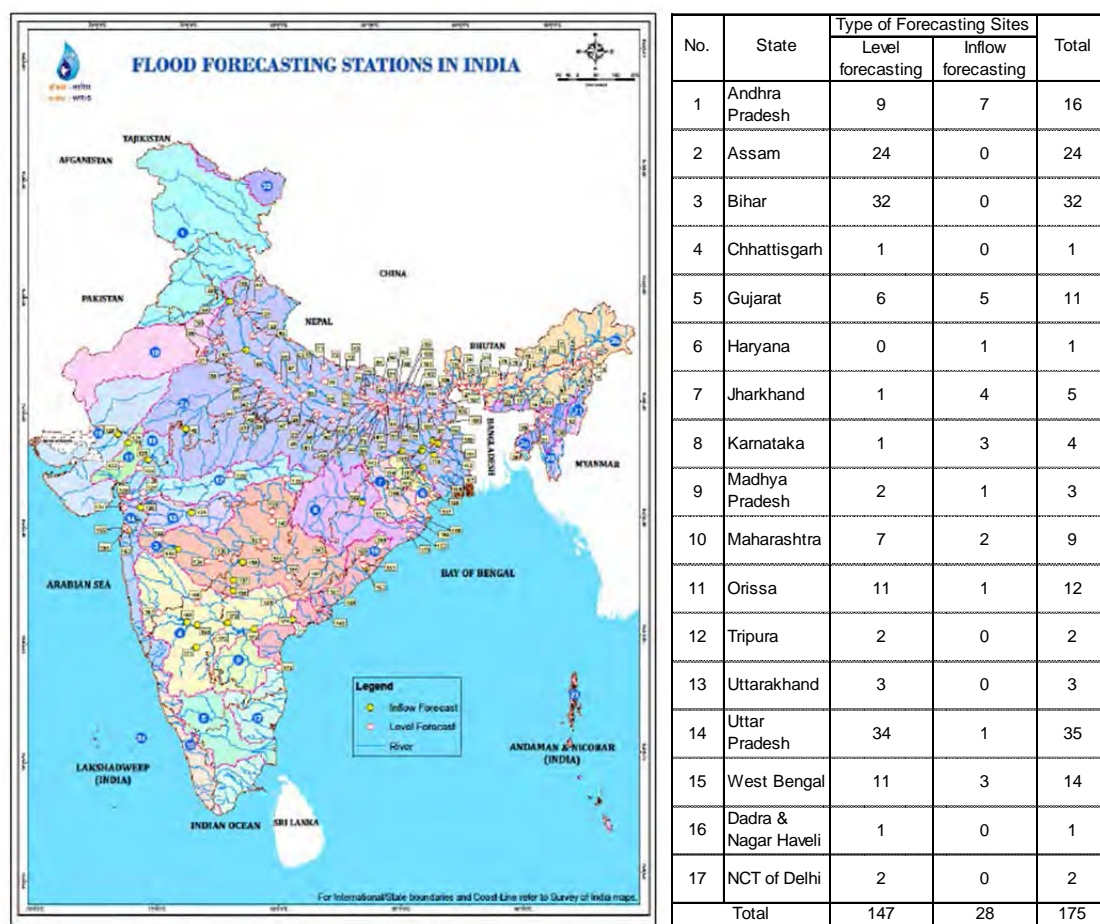

Source: CWC, “Flood Forecasting and Warning Network Performance Appraisal Report”, (2011)

**Figure 5.2.1 Distribution of Flood Forecasting Network**

There are four (4) levels of forecasts: low flood, moderate flood, high flood and unprecedented flood. The description of each level is as follows:

Low Flood:	The water level of the river touches or crosses the warning level, but remains below the danger level of the forecasting site.
Moderate Flood:	If the water level of the river touches or crosses its danger level, but remains 0.50 m below the Highest Flood Level of the site (commonly known as “HFL”).
High Flood:	If the water level of the river at the forecasting site is below the Highest Flood Level of the forecasting site but still within 0.50 m of the HFL.
Unprecedented Flood:	The water level of the river crosses the “HIGHEST FLOOD LEVEL” recorded at any forecasting site so far.

Source: CWC, “Flood Forecasting and Warning Network Performance Appraisal Report”, (2011)

In “High Flood Situations” a special “Orange Bulletin” is issued by the CWC to the user agencies which contains a “special flood message” on the high flood, based on the SOP for issuing alerts and electronic messaging in the event of disaster situations. In “Unprecedented Flood Situations” a special “Red Bulletin” is issued by the CWC to the user agencies which contains a “special flood message” on the unprecedented flood. The basic activities of data collection, the transmission and dissemination of flood forecasts to the local administration are carried out by the field divisions of the CWC. Those activities include issuing of flood forecasts to designated officers of concerned states and transmission through fax/telephone/e-mail/special messengers during monsoon every

year, and sending flood alerts through SMS on mobile phones to the concerned officers of central and state governments during high and unprecedented flood situations.

During the year 2013, 170 daily bulletins (once daily) and 102 Orange Bulletins for high flood situation (twice daily) and 82 Red Bulletins (every 3 hours) were issued as per the SOP issued by the MHA and NDMA.

### 5.2.3 Warning Systems for Landslides

The office memorandum of the MHA on Action Plan for Landslide Risk Mitigation states the need to evolve an early warning system for landslides. For effective prediction model of landslide early warning system, a landslide incident inventory is being developed by the GSI in consultation with state governments and other agencies such as the BRO. The entire framework of the early warning system to be developed and implemented will be examined by the technical committee comprising of IIT Roorkee IMD, CWC and so on and GSI is the convener of the committee.

### 5.2.4 Warning Systems for Tsunamis

The ITEWC established in the INCOIS operates the Indian Tsunami Early Warning System (ITEWS) that has the monitoring networks of 17 seismic stations, 21 tide-gauge stations, and 7 tsunami buoys. Based on the tsunami related data/information from the observation network, the ITEWC carries out tsunami forecasting and warning. The ITEWC implements the tsunami forecasting for an earthquake with magnitude more than 6.5. The INCOIS has received the certification of ISO 9001: 2008, Quality Management System, and the warning system and forecasting system is operated in accordance with the SOP. Analysis of tsunami threat is commenced whenever earthquakes are recorded with magnitudes  $\geq 6.5$  within Indian Ocean and magnitudes  $>8.0$  outside Indian Ocean. There are three threat categories for the tsunami as shown in Table 5.2.4.

**Table 5.2.4 Threat Categories of Tsunami Early Warning**

ETA < 60 minutes travel time		ETA > 60 minutes travel time	
EWA (m)	Treat Status	EWA (m)	Treat Status
> 2	Warning	> 2	Alert
0.5 to 2	Alert	0.5 to 2	Watch
0.2 to 0.5	Watch	0.2 to 0.5	Watch

Note: ETA: Estimated Time of Wave Arrival, EWA: Estimated Maximum Wave Amplitude  
Source: INCOIS

Tsunami bulletin is disseminated to central government organisations, such as the MHA, the NDMA, National Disaster Response Force, state and district governments and related organisations of coastal areas, and Andaman and Nicobar Islands through fax, email, SMS, website and Global Telecommunication System (GTS).

**Table 5.2.5 Organisations Related to Bulletin Dissemination**

Level	Organisation
International Level	All 23 Indian Ocean rim countries
National Level	MHA, NDMA, MOES, National Disaster Response Force Head Quarters, IMD & CWC
State Level	Principal Secretary (Revenue) of Andaman & Nicobar (A&N) Islands, Andhra Pradesh, Gujarat, Goa, Karnataka, Kerala, Maharashtra, Odisha, Tamilnadu, West Bengal, Lakshadweep and Piducherry
District Level	DROs of Srikakulam, Vizianagaram, Visakhapatnam, East Godavari, West Godavari, Krishna, Guntur, Prakasham, and S.P.S Nellore

Level	Organisation
Institution	1-10 NDRF battalions, all control rooms of A&N Islands, HQWNC, HQENC, HQSNC, NOIC Tamilnadu, Gujarat, West Bengal, NPCIL, Mumbai, Madras Atomic Power Station, Tarapur Atomic Power Station, Kudanlulam Atomic Power Unit, SHAR, MRCC, Coast Guard, Port officers, Coastal Industries (Reliance), Media & Public subscription

HWQNC: Headquarter Western Naval Command, HQENC: Headquarter Eastern Naval Command, HQSNC: Headquarter Southern Command, NPCIL: Nuclear Power Corporation Limited, SHAR: Satish Dhawan Space Centre, MRCC: Maritime Rescue Coordination Centre  
Source: INCOIS (2015)

ITEWC issues bulletins based on the result of analysis. For Indian Ocean earthquakes, ITEWC issues Type-I bulletin that contains preliminary earthquake information and a qualitative statement on its tsunamigenic potential. Based on preliminary earthquake parameters, the nearest matching scenario from pre-run model scenario database is selected. If pre-run model scenario indicates the estimated wave amplitude (EWA) is below 0.2 m, Type-II bulletin is issued with “NO THREAT” information. However, the monitoring of sea-level observations continues.

If the EWA exceeds 0.2 m, Type-II bulletin is issued with the estimated time of wave arrival (ETA), estimated maximum wave amplitude and threat category (WARNING / ALERT / WATCH) for each of the coastal forecast zones.

As and when the revised earthquake parameters become available, or else if earthquake elapsed time exceeds 60 minutes, before the real-time sea-level data becomes available, a supplementary to Type-II bulletin is issued with revised threat category (WARNING / ALERT / WATCH) information.

If the readings from sea level gauges confirm generation of tsunami, ITEWC issues Type-III bulletin with threat category (WARNING / ALERT / WATCH) information from model scenario as well as observed water levels. As and when subsequent real-time observations become available or after 60 minutes from the time of previous bulletin issuance, a supplementary to Type-III bulletin is issued.

The final bulletin is issued when there are no significant water level changes from multiple sea level gauges or 120 minutes after the last exceedance of 0.5 m threat threshold at last Indian coast. However, as local conditions would cause a wide variation in tsunami wave action the all clear determination is made by local authorities.

Figure 5.2.2 shows tsunami bulletins issued for the earthquakes that occurred at off west coast of Northern Sumatra in April 2012 as an example. There were two (2) earthquakes exceeded Magnitude 8.0 on the same day. A total of six (6) bulletins were issued for the first earthquake and 5 bulletins were issued for the second one.

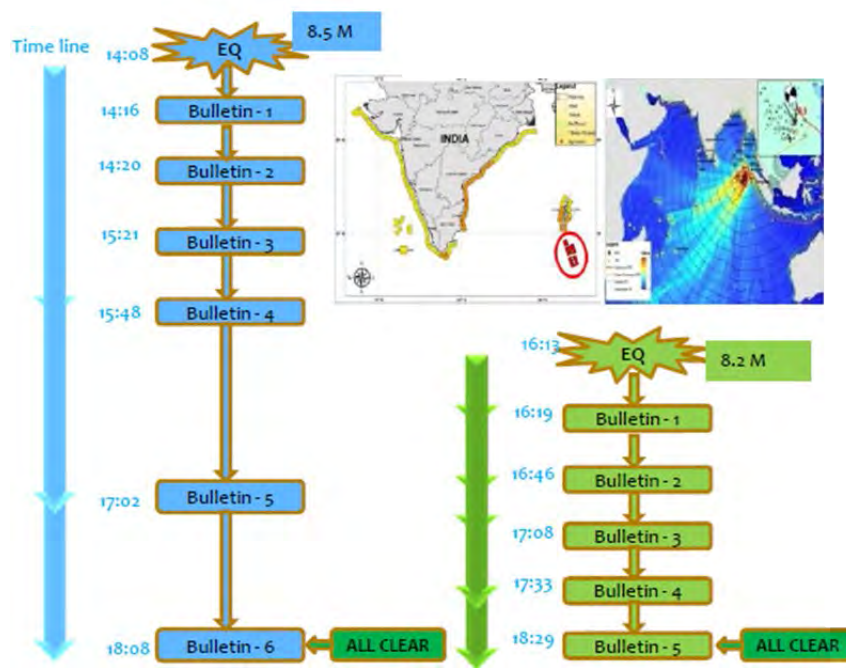

Source: INCOIS

**Figure 5.2.2 Bulletins Issuing for April 2012 Earthquakes**

Table 5.2.6 shows the history of disseminating the threat information after 2007. The threat category of the 2012 April earthquakes was “WARNING” for Indira Point, Car Nicobar, Komatra and Katchal Islands of the Andaman and Nicobar Islands, and “ALERT” for rest of the Andaman and Nicobar Islands, Tamil Nadu, and Andhra Pradesh after the first event, and “ALERT” for Nicobar Islands after the second event. As for other events, the treat category was “WATCH”.

**Table 5.2.6 Threat Information Issued by ITEWC after 2007**

No.	Date and Time (UTC)	Magnitude	Region Name	ITEWC Evaluation	Tsunami Observation
1	12-Sep-2007 11:10:26	8.5	Southern Sumatra, Indonesia	WATCH for the Andaman and Nicobar Islands, Orissa, Andhra Pradesh, Tamil Nadu, Kerala	1 m at Padang, Indonesia and 15 cm at Cocos Islands
2	30-Mar-2010 16:54:50	6.9	Andaman and Nicobar Islands, India	Tsunami WATCH for West and land fall islands, Flat islands, North Sentinel Islands, Port Blair	No tsunami
3	12-Jun-2010 19:26:47	7.5	Nicobar Island, India	Tsunami WATCH for Nicobar, Komatra and Katchal Island	3 cm at Trincomalee, Sri Lanka
4	10-Jan-2012 18:37:00	7.1	Off west coast of Northern Sumatra	Tsunami WATCH for Nicobar Islands	No tsunami
5	11-Apr-2012 08:38:36	8.5	Off west coast of Northern Sumatra	Tsunami WARNING for Indira Point, Car Nicobar, Komatra and Katchal Islands of the Andaman and Nicobar Islands ALERT for rest of the Andaman and Nicobar Islands, Tamil Nadu, Andhra Pradesh WATCH for few areas in mainland	1 m at Meulaboh and 0.35 m at Sabang, Indonesia and 0.30 m at Campbellbay



No.	Date and Time (UTC)	Magnitude	Region Name	ITEWC Evaluation	Tsunami Observation
6	11-Apr-2012 10:43:10	8.2	Off west coast of Northern Sumatra	Tsunami ALERT for Nicobar Islands, and WATCH for Andaman Islands and east coast of India.	20 cm at Meulaboh, Indonesia

Source: INCOIS

### 5.2.5 Information Flow and Communication System

Any alert and early warning will be sent to states that are likely to be affected by disasters. The SEOC receives an alert and early warning and communicates it to the DEOCs urgently. When the alert or warning is issued by the concerned agencies, the stakeholders need to follow the information flow as Figure 5.2.3 shows. When disaster occurs without any early warning, the bottom-up information flow is as shown in Figure 5.2.4.

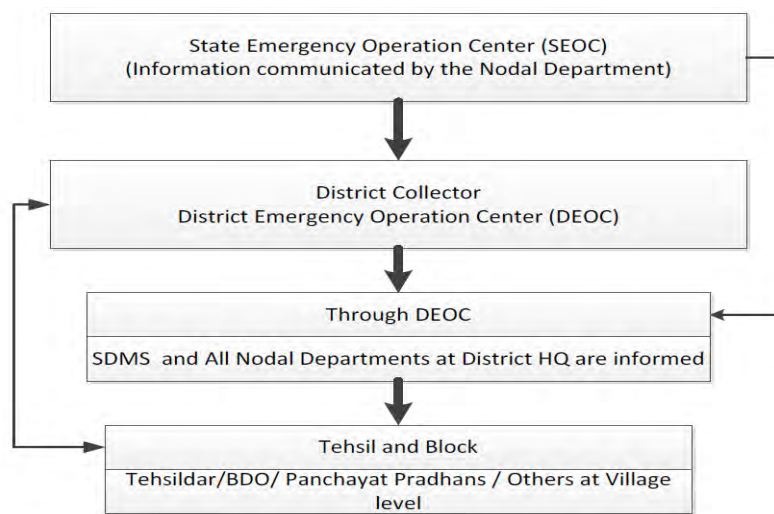

Source: NDMA, "Explanatory Notes for Preparation of District Disaster Management Plan (DDMP)"

**Figure 5.2.3 Information Flow when there is an Early Warning Signal**

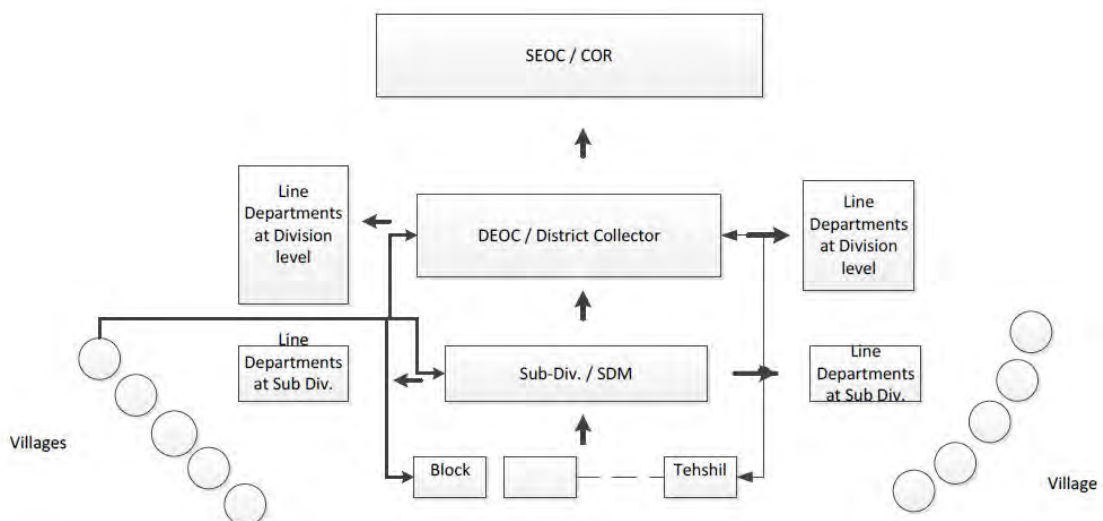

Source: NDMA, "Explanatory Notes for Preparation of District Disaster Management Plan (DDMP)"

**Figure 5.2.4 Information Flow when there is no Early Warning Signal**

Communication systems for reporting and communication among agencies/departments are established in many ways such as satellite phone, HF/VHF set, HAM radio, VSAT and SMS. The general public can receive the early warning/alert information through SMS, blasting of sirens and oral communication. However, there is a possibility of malfunction of the communication systems due to bad weather conditions such as heavy rain. Securing redundancy of the communication systems needs to be considered to ensure certainty of alerts and warnings.

### **5.3 Andaman and Nicobar Islands Case**

The Andaman and Nicobar Islands (hereinafter referred to as the “A&N Islands”) are categorised as Union Territory (UT) and one of the multi-hazard prone areas in India. Since the A&N Islands are open to sea from all the sides, they are further exposed to hydro-meteorological disaster risks, such as floods, cyclones, and so on. Moreover, the A&N Islands have suffered from various geological disasters. Since they are located in the seismically active part, they are classified in Zone V in the seismic zonation map of India. The earthquake may cause tsunami, and the Indian Ocean Tsunami on 26 December 2004 hit the A&N Islands resulting in the tremendous damages in the islands. According to the MHA’s annual report 2005-06, 3,513 persons were dead/missing in the tsunami disaster and over 9,500 families lost their homes. There was large scale destruction of ports and jetties and school and hospital buildings, damage to coconut plantations and agricultural lands, roads, bridges and water and power supply schemes and so on.

Thus, in order to reduce the multi-hazard disaster risks in A&N Islands, the Union Territory Administration of A&N Islands formulated the Union Territory Disaster Management Plan (hereinafter referred to as the “UTDMP”) in 2012 and constituted the institutional scheme for the implementation of the countermeasures to reduce the disaster risks.

#### **5.3.1 Disaster Management Plan**

In accordance with the DM Act, the Union Territory Administration of A&N Islands formulated the UTDMP for the entire A&N Islands. The UTDMP aims at providing a well-structured, participatory, multi-disciplinary, multi-departmental and systematic approach to guide administrative mechanisms at all levels of government, private sectors, NGOs and community-based organisations (CBOs) to work seamlessly and providing a quick and effective response in emergency situations. In the UTDMP, the following subjects are emphasised to be implemented:

- Prevention from danger or threat of any disasters
- Access to the existing resources and facilities available at various departments and agencies involved in the disaster management in the A&N Islands
- Identification of the requirements for institutional strengthening, technological support, up-gradation of information systems and data management for improving the quality of administrative response to disasters at the UT level
- Making the UTDMP an effective response mechanism as well as a policy and planning tool
- Making the UTDMP specifically focus on the roles of various governmental departments, agencies and the EOC in case of any of the above mentioned disasters. (This plan concentrates primarily on the response strategy.)
- Mitigation or reduction of risks of any disasters or their severity or consequences
- Capacity building and training
- Prompt response to any threatening disaster situation
- Assessment of the severity or magnitude of effects of any disasters
- Evacuation, rescue and relief
- Rehabilitation and reconstruction

The UTDMP consists of 17 chapters with the following compositions shown in Table 5.3.1.

**Table 5.3.1 Composition of Union Territory Disaster Management Plan**

Chapter	Title	Content
1.	Introduction	Outlines of administrative system and physical features
2.	Hazard Analysis	Outlines of various hazards including natural disasters especially focusing on earthquake and tsunami disasters and impacts of climate change
3.	Union Territory Disaster Management System	Objectives of UTDMP and introduction of institutional framework
4.	UT Disaster Management Executive Committee	Composition and roles of UT Disaster Management Executive Committee
5.	District Disaster Management	Composition and functions of District Disaster Management Authority and associated institutions in three (3) districts
6.	Directorate of Disaster Management	Roles of directorate of disaster management and emergency operation centre (EOC)
7.	Incident Response System	Duties and responsibilities of related agencies under incident response system
8.	Village Contingency Plan	Roles of village disaster management committee and task forces
9.	Disaster Mitigation	Responsibilities of government agencies, private sectors and community in each disaster and considerable mitigation measures
10.	Preparedness Plan	Emphasis on necessity of preparedness in village, community and school levels
11.	Response Plan	Clarification of responsibilities of each agencies for response activities
12.	Rehabilitation	Clarification of responsibility at village level for rehabilitation
13.	Appraisal, Documentation and Reporting	Required documentations on disaster records and appraisal for revision of disaster management plans in all levels
14.	Standard Operating Procedures (SOPs)	Necessary concerns for the preparation of SOPs
15.	Glossary of Terms	Glossary of related terms
16.	Explanations	Explanation of important concepts on disaster management
17.	Abbreviations	List of abbreviation

Source: Directorate of Disaster Management, A&N Island, "Disaster Management Plan 2012 Andaman & Nicobar Islands", (2012)

### 5.3.2 Institutional Framework for Disaster Management

As the institutional framework for the disaster risk reduction in line with the DM Act, the following bodies were constituted in 2008:

- A&N Islands Union Territory Disaster Management Authority
- A&N Islands Union Territory Disaster Management Executive Committee
- District Disaster Management Authorities

A&N Islands Union Territory Disaster Management Authority (hereinafter referred to as the "UTDMA") was constituted in 2008 with the following functions:

- To assess the scale of disasters
- To inform the GOI about disasters
- To require the assistance from the Defence Force to manage the disaster
- To seek the assistance/help from the GOI
- To monitor the rescue, relief and rehabilitation operations
- To recognise meritorious service rendered by persons in the disaster management
- To disseminate disaster information

In accordance with the DM Act, the A&N Islands Administration set up the A&N Islands Union Territory Disaster Management Executive Committee (hereinafter referred to as the "UT

Committee”) in 2008. The UT Committee is mainly mandated to coordinate and monitor the implementation of the disaster management plans prepared by the departments of the UT Administration and district authorities, to provide necessary technical assistance or give advice to district authorities and local authorities for carrying out their functions effectively and to advise the UT Administration regarding all financial matters in relation to disaster management.

The A&N Islands Administration also established three (3) DDMA for the South Andaman district, North and Middle Andaman district and Nicobar district in 2008. The DDMA shall act as the district planning, coordination and implementation bodies for the disaster management and take all measures for the purposes of disaster management in the district level. Thus, the DDMA are mandated to prepare and implement the District Disaster Management Plan.

In addition to the above, the Directorate of Disaster Management (hereinafter referred to as the “DDM”) primarily functions to implement the Disaster Management Action Plan includes coordination, policy-making, operations management, data collection, record keeping, Information, Education and Communication (IEC) activities, public information, preparedness, community-based disaster preparedness training to all levels of the community, establishing of adequate warning systems, uprising the situation from time to time to the UTDMA and to the NDMA, capacity building & training and mock exercise at different levels of community and constitution of various task forces at various levels including village and grass root levels of the community with a main objective to create awareness on disaster preparedness and resource management. As shown in Figure 5.3.1, the DDM consists of 24 officials and Operations Wing with State Control Room are in charge of daily operation for the disaster management.

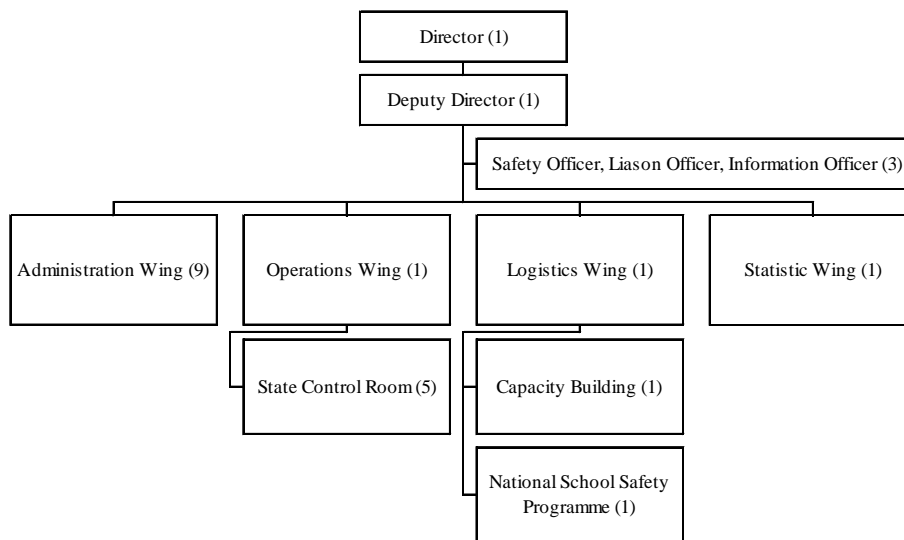

Source: compiled by the Survey Team based on information from the Directorate of Disaster Management (2015)

**Figure 5.3.1 Organisational Structure of Directorate of Disaster Management**

Besides, eight (8) EOCs were established in various islands: Port Blair, Mayabunder in North and Middle Andaman, Hut Bay, Car Nicobar, Campbell Bay and Kamorta. All these EOCs are connected with the State Control Room, DDM under a Disaster Management Emergency Communication Networking.

### 5.3.3 Risk Analysis

For each natural disaster, risk levels in the A&N Islands are summarised below:

- Earthquake: Zone V (Building Material and Technology Promotion Council, BMTPC)
- Tsunami: No map by BMTPC, Tsunamigenic Zone (INCOIS)

- Cyclone: Damage Risk Zone A (BMTPC)
- Flood: Not liable to Flood (BMTPC), low-lying adjoin areas of Port Blair and part of North and Middle Andaman are prone to floods during heavy torrential rains (UTDMP)
- Landslide: Unlikely (BMTPC)

According to above risk levels, the A&N Islands have risk of Cyclone, Earthquake and Tsunami.

The District Control Room (DCR)/Emergency Operation Centres (EOCs) in the district are in charge of the assessment of disaster vulnerability in A&N Islands. The procedures of the vulnerability assessment conducted by the DCR/EOCs are listed in the UTDMP as follows:

- The DCR/EOC assesses the general vulnerability at the district level. The assessment includes the aspects of vulnerability of the people's habitations, shelters and activities.
- The concerned organisations of the government and non-government organisations regarding the factories, industries and infrastructure establishments shall make annual primary assessment of vulnerabilities of their establishment and send Action Taken Report to the respective DDMA with copy to Assessment Commissioner and Village Level Disaster Management Control Rooms in second week of May every year.
- The assessment returns sent in various format shall be discussed and reviewed in the meeting of District Disaster Management Committee during second week of June every year. The recommendation if any, made by the Committee shall be implemented by the concerned authorities and confirmed to the DDMA, Assistant Commissioner and Village Level Disaster Management Control Rooms within stipulated time following the discussion in the District Disaster Management Committee.

Furthermore, as a part of Community Based Disaster Preparedness (CBDP), items for risk and vulnerability (socio-economic vulnerability) assessment such as the handicapped, senior citizens, children, residents of unsafe shelter, etc., are specified in the UTDMP.

As an actual activity for the tsunami risk assessment, a Tsunami Wave Traveling Atlas "Tsunami Atlas - Andaman Sea" has been prepared by INCOIS based on the scenario modelling of earthquake. Figure 5.3.2 shows the location of scenario earthquake epi-centre and traveling time in the scenario case. Based on this modelling result, the comprehensive height and traveling time of Tsunami can be understood. However, a detailed estimation map of tsunami inundation area and height has not been prepared. In order to evaluate the risk facing each town/village along the shoreline, preparation of detailed tsunami inundation map on the town/village scale is indispensable. According to the information at the fishermen village in Port Blair, tsunami height was about 1.5 m at the last event in 2004.

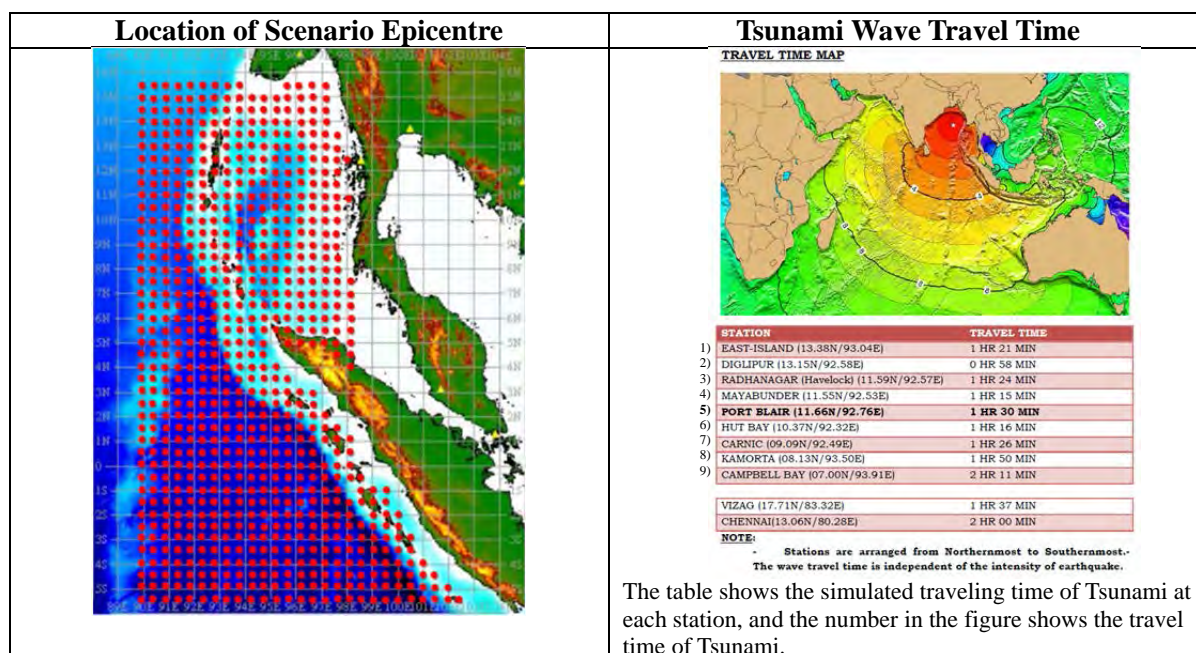

Source: State Control Room of Andaman & Nicobar Islands

**Figure 5.3.2 Tsunami Atlas – Andaman Sea**

### 5.3.4 Preparedness and Countermeasures

#### (1) Preparedness

According to the UTDMP, followings are the objects of the DDM as for preparedness.

- Preparation, formulation and finalisation of UTDMP
- Preparation, formulation and finalisation of School Safety Plan
- Identification and formulation of the Village Level Voluntary Task Force and implementation of training programmes
- Facilitation of Training of Trainers (ToTs) as master trainers
- Involvement of NGOs/agencies as per the guidelines of NDMA, MHA and GOI
- Implementation of Community-based Disaster Preparedness/training and capacity building
- Updating of tactical resources of all the line departments of A&N Islands
- Updating of link between six (6) EOCs – 24 x 7 (*currently eight (8) EOCs were set up*)
- Up keeping of identified relief go down (146 nos.) in different Islands.
- Updating of Incident Response Team (IRT) members along with their identified duties and responsibilities
- Updating of SOPs
- Execution of regular Mock Drill (a practice or a trial of emergency operations such as evacuation and response) on earthquake, False Fire Accident (Live Drill)
- Generation of public awareness on regular intervals- web base window up-linking
- Installation of SAT Phones

Due to the 2004 Tsunami in A&N Islands, almost 120 schools out of 399 were severely damaged, and the children were severely affected due to loss of school. Against this background, School Safety Plan has been developed for the purpose of the reduction of vulnerability of school children and teachers. Figure 5.3.3 shows the School Disaster Management System and contents of School Disaster Management Plan.



Source: Directorate of Disaster Management, A&N Island, “Disaster Management Plan 2012 Andaman & Nicobar Islands”, (2012)

**Figure 5.3.3 School Disaster Management System and School Disaster Management Plan**

In accordance with the School Disaster Management Plan, each school in the A & N Islands sets up evacuation routes, prepares a map of school area to secure smooth and safe evacuation, and stores stockpiles necessary for response, relief and rescue. Figure 5.3.4 shows an example of school evacuation map and stockpile at a school.



**Figure 5.3.4 Example of School Evacuation Map and Situation of Go-Down at School**

The School Disaster Management Plans have been established. However, evacuation maps, which indicate evacuation places and evacuation routes to the evacuation places, for community people/villages cannot be identified. Such evacuation maps should be prepared in the Community Based Disaster Management Programme (CBDMP) in coordination with the A&N Administration.

The community is not only a group of individuals and households living in the same location and having the same hazard exposure but also the first responder to disaster. Therefore, a community based disaster management plan (preparedness and mitigation) has been prepared by the DDM. The CBDMP will be commenced from 2016 (programme period is three years) for total 69 Gram Panchayats and 52 Tribal Village Council.

The objectives of the CBDMP are as follows:

- To enhance capacity of village community to tackle any crisis situation
- To prepare and develop Village Disaster Management Plans
- To strengthen the alert, warning and communication system in the communities at grassroots level
- To ease the escape routes in the communities
- To constitute and train village task forces for first response and use of local resources for Evacuation, Search & Rescue, First Aid and Relief Operations
- To sensitise village communities on disaster preparedness and safety measures
- To identify hazard profile of the village communities for mitigation

- To carry out Information, Education and Communication (IEC) activities in villages and associated environment
- To motivate direct participation of villagers in the disaster awareness activities that would help building towards a disaster-resilient community

A Mock Disaster Management Exercise for tsunami and earthquake was conducted by the DDM from 20 to 22 November 2013. A mock disaster management exercise in 2015 November is planned and SOP for the exercise is prepared. Preparedness for tsunami disaster risk reduction has been progressed step by step.

## **(2) Countermeasures**

Disaster mitigation measures are those to eliminate or reduce the impacts and risks of hazards through proactive measures taken prior to an emergency or disaster, while response to disaster is only temporary relief at high cost. Therefore, it is necessary to consider mitigation measures in the disaster management. Each type of disaster requires individual mitigation measures. However, certain mitigation measures are common to all disasters.

### **1) Earthquake**

Since A&N Islands are prone to earthquake, special emphasis is required for earthquake mitigation measures. According to the UTDMP, the measures which have been taken for the mitigation of earthquake effects are listed below:

- An audit committee has to be constituted for monitoring/implementation of the building policy/bye-laws.
- The Port Blair Municipal Council has initiated step (issued notices) for retrofitting of 166 buildings in Port Blair Municipal area which do not conform the building bye-laws/BIS Codes.
- The Port Blair Municipal Council has suggested amendments in its bye-laws for suitable techno legal regime.

### **2) Tsunami**

The UTDMP states that flat lands such as Car Nicobar, Chowra, Teressa, Little Andaman and Long Island, etc. are vulnerable to tsunami. In such areas, coastal plantation/mangroves and high altitude ground/building can be countermeasures to reduce the vulnerability of the people to tsunami.

As for the specific countermeasure against tsunami, APWD has constructed “Sea Wall” with a height of 3.5 m along the existing roads which are located along the shoreline. The height was set based on the experience of the last tsunami event in 2004. The sea wall has function not only to reduce the impact of tidal wave at the time of tsunami but also to protect erosion of roads by tidal wave and to protect the flow out of sediment from land (farmland and housing areas) to the sea at normal times.

Plantation of mangroves is also utilised as a countermeasures for tsunami. The reason is that at the time of the 2004 tsunami, mangrove plantation reduced the impact of the waves. Figure 5.3.5 shows photos of the currently applied sea wall and coastal plantation of mangroves.



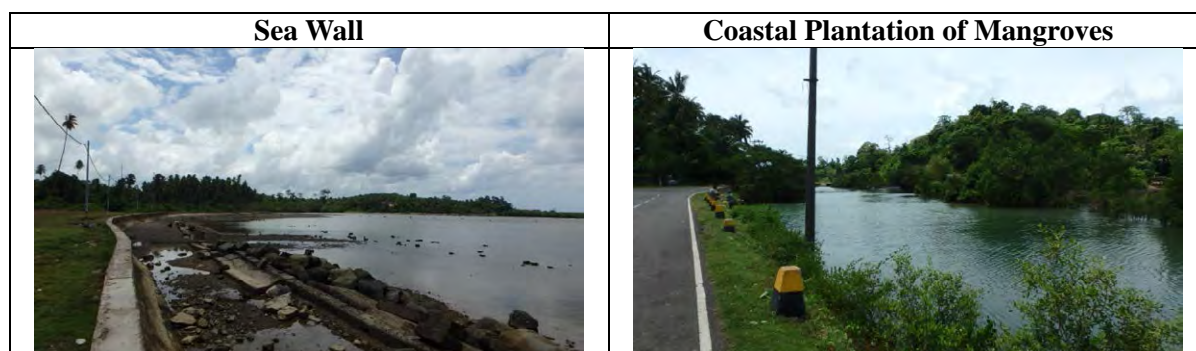

**Figure 5.3.5 Sea Wall and Coastal Plantation of Mangroves**

Sea wall of Figure 5.3.5 was constructed after 2004 Tsunami. Because the previous sea wall was destroyed by the 2004 Tsunami (remnants of previous sea wall remain in front of the newly constructed sea wall).

On the other hand, as a measure for damage mitigation of tsunami, tsunami shelters have been prepared by the A&N Administration and the related agencies. Figure 5.3.6 shows an example of tsunami shelters. Basically these shelters are used as public housing at normal times, however in case of tsunami these houses will be used for evacuation and relief camps. According to the regulation of the Andaman and Nicobar Administration, the tsunami shelters should be constructed 500m away from the coastal line and 50m above the sea level.



**Figure 5.3.6 Tsunami Shelter**

PWD has a regulation for the construction of tsunami shelters. According to the regulation for the construction of tsunami shelters, tsunami shelters should be constructed inland at a distance more than 500 m from shoreline and more than 15m above sea level.

As mentioned above, some of countermeasures for tsunami risk mitigation have been taken by the A &N Administration and the related agencies. However, in lowland areas which have low altitude of ground, it is assumed to be difficult to find locations appropriate to construct shelters. In such case, construction of a high tsunami evacuation tower or embankment will be recommendable as a tsunami risk mitigation facility.

### **3) Cyclone**

According to the UTDMP, one of the measures for mitigation of effects due to cyclone is the community relief shelter.

In addition, the following measures are listed in the UTDMP as the structural and non-structural measures for disaster.

- Preparation of hazard map
- Adoption and enforcement of land use and zoning practices
- Implementation and enforcement of building codes
- Preparation of flood plain map
- Reinforcement of tornado safe rooms

- Burying of electrical cables to prevent ice build-up
- Raising of homes in flood-prone areas

### 5.3.5 Forecasting, Early Warning and Communication Systems

#### (1) Communication Flow of Alert and Warning

The warning system ranges from alarms and high range centralised sirens in each island for earthquake and tsunami to public announcements through radio, television and other traditional modes of communications such as public address system, mega phones, ringing of bells and hoisting of flags. The state control room and the district administration are the primary agencies responsible for issuing disaster warnings after taking consent from the INCOIS. Figure 5.3.7 shows the communication flow of alert/warning in the case of tsunami.

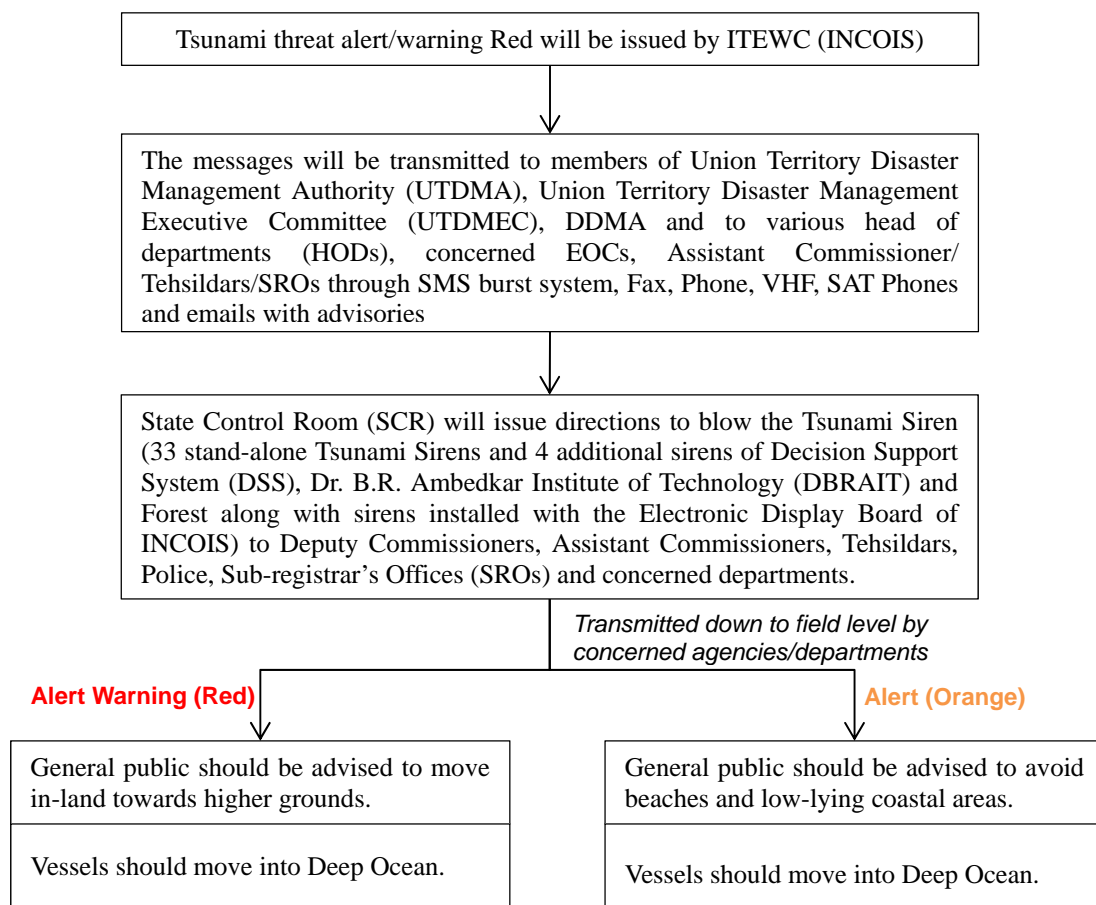

Source: Andaman and Nicobar Administration

**Figure 5.3.7 Communication Flow of Alert/Warning (Tsunami Case)**





According to the information from the A&N Administration, communication connectivity becomes very weak during heavy rain because the system is based on satellites and the rainfall may affect the connectivity of radio waves through satellites.

#### (2) Tsunami Sirens

Tsunami sirens are used in the A&N Islands to warn the general public about the tsunami risk. The DDM of the A&N Administration has authority to issue the warning and order blasting of sirens. Sirens with four types of blast range are installed in the residential area: 5 km, 8 km, 16 km and 25 km radius. Most of the siren installation sites are public buildings such as police stations, EOCs,

PWD offices and fire stations. The biggest radius siren is installed in the Secretariat. Table 5.3.2 shows triggering of tsunami sirens, advice to the general public and blasting of sirens. Mock drills are conducted to make the general public aware of the alert system with tsunami sirens. Those sirens are manually operated by the district officers. In order to warn the general public about the tsunami risk by the sirens, officers in charge of the sirens need to blast the sirens manually. Even though the initial alert can reach EOCs at the state and district level within five minutes, blasting of sirens depends on deployment of the officers. The landscape is also a factor that may affect the last mile connectivity to the general public. In addition to the manual sirens, electronic display boards equipped with an automated siren are installed in 13 locations. The electronic boards are connected with the communication systems of ITEWC, INCOIS in Hyderabad, and can be blasted automatically at ITEWC when tsunami risk is detected by ITEWC. In order to address the issue of tsunami siren operation, INCOIS is taking process to procure and install 35 automated sirens with public address system at vulnerable locations in the A&N Islands. The sirens will be installed in the same locations as GPS observatories constructed by MOES. Figure 5.3.8 shows the tsunami sirens installed and the automated one that is considered for procurement.

**Table 5.3.2 Triggering of Tsunami Sirens in the Andaman and Nicobar Islands**

Threat Status	MW* Wave Amplitude	Advice	Blasting of Sirens
	>6.5 >2.00	- People in affected areas to vacate - Vessels to move into deep ocean	Three Long Blast
	>6.5 0.5 to 2.00	- People in sea beaches and vulnerable areas to move to higher ground - Vessels to move into deep ocean	Two Long Blast
	>6.5 0.5	No immediate threat just watch	One Long Blast, if required
	All clear message will be issued by the State Control Room.		

Note: MW - Moment Magnitude

Source: SEOC, Directorate of Disaster Management, A&N Administration, “State Level Communication Exercise Manual, Suraksha Goonj-14”



Manual Siren



Electronic Display Board



Automated Siren

Source: Directorate of Disaster Management, A&N Administration and the Survey Team

**Figure 5.3.8 Tsunami Sirens**

As for observation and determination of parameters of earthquakes such as epicentre and MW, the responsible bodies in India are NCS for inland earthquakes and INCOIS for submarine earthquakes respectively.

### 5.3.6 Emergency Response

On receipt of early warning or information about occurrence of disaster, the State Control Room will activate all the control rooms/EOCs of the districts and information will be sent to the Chief Secretary, MHA Control Room and Commander-in-Chief (C-in-C), A & N Command (as deemed fit) and heads of nodal departments.

The general patterns of the response are rescue of human beings from various traps, emergency medical care to injured, rescue of domestic and farm animals and providing veterinary care to them, extrication of dead bodies and their disposal and so on. As for the rescue and search, there are two (2) ways as follows:

**Self-start mechanism:** The response operations will commence at the field level by a broad division of labour in the village to look after different tasks like water supply, catering, power supply, transportation, communication, health, etc. before help from outside arrives on occurrence of disaster at land.

**Quick start mechanism:** The core line departments will simultaneously commence response operations on receipt of information regarding occurrence of disaster.

According to the SOP for emergency response, State Disaster Response Force/specialised search and rescue teams from the Police/Fire Department will be pressed into action. Mobile units from Andaman Public Works Department (APWD) and Directorate of Health Services (DHS) will assist these teams. Figure 5.3.9 shows the trigger mechanism for response to disasters and emergency response flow.

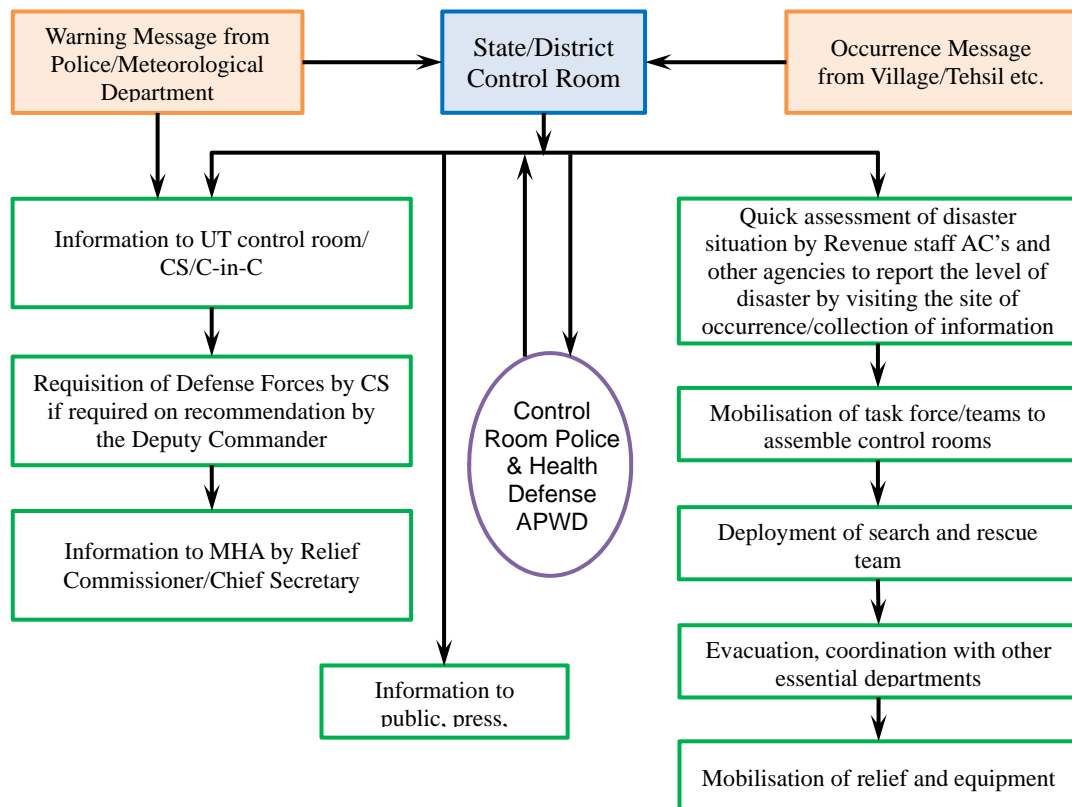

Source: Directorate of Disaster Management, A&N Administration, "Disaster Management Plan 2012 Andaman & Nicobar Islands", (2012)

**Figure 5.3.9 Trigger Mechanism for Response to Disasters**

### 5.3.7 Evacuation Systems

All evacuations are ordered only by Deputy Commissioner, Police Department and Fire Brigade and are reported to Deputy Commissioner or District Superintendent of Police Department immediately. The followings are the steps for evacuation.

- Shelter sites should be within one hour's walk or 3 miles (5 km) of dwellings.
- The evacuation routes should be away from the coastal areas.
- Evacuation routes should not include roads likely to be submerged in marshy land but may include pathways.
- Proper evacuation should be ensured by seeking community participation.
- Families should be encouraged to take along water, food, clothing and emergency supplies.
- People should listen to a battery-powered radio and follow local instructions.
- If the danger is a chemical release, then people should be instructed to evacuate immediately.

Schools are designated as evacuation areas and stockpile supplies against emergency such as blankets, batteries, candles, ropes, knives, portable radios and some plastic containers. Mock drills are carried out in residential areas, schools and government offices. The activities contribute to raising awareness of disaster risk reduction and making people understand the evacuation routes and behaviours.

In the lowland areas near the coastal line where tsunami hit at the time of 2014 Sumatera Earthquake, there are sign boards that show the inundated areas, locations of schools (tsunami shelter), rivers, distribution of houses where children live, homes of the aged and the handicapped, and emergency contact numbers such as panchayat office and police station. Figure 5.3.10 shows the school yard used for tsunami shelter and an example of location map for local communities.



School Yard used for Tsunami Shelter

Source: the Survey Team

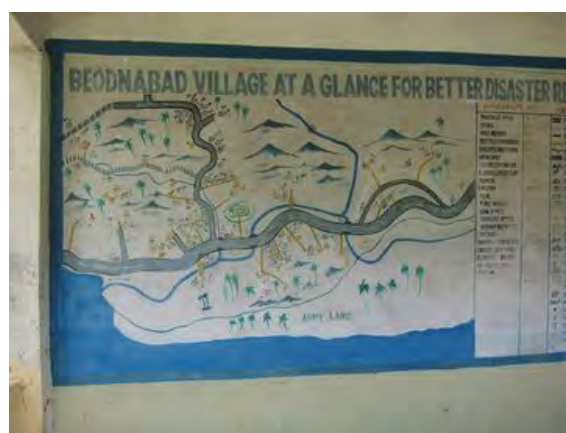

Location Map for Communities

**Figure 5.3.10 School used for Tsunami Shelter and Location Map for Communities**

### 5.3.8 Disaster Risk Finance

The SDRF was constituted in A&N Islands, and the central government approved its constitution in 2013. However, even though Rs. 10 crore of the SDRF has been sanctioned for 2015, it has not been disbursed to date. Thus, until present A&N Administration has disbursed the required expenditures for the response activities from its plan budget. The expenditures for the response activities in each district for the last three (3) years are shown in Table 5.3.3.

**Table 5.3.3 Expenditures for Response in District**

(unit: Rs. lakh)

Year	South Andaman District	North & Middle Andaman District	Nicobar District
2012-2013	25.00	38.18	N.A.
2013-2014	280.60	126.95	N.A.
2014-2015	15.27	10.40	N.A.

N.A.: not available

Source: Directorate of Disaster Management (2015)

According to the DDM, the MHA still makes clarification on the necessity of the SDRF for A&N Islands Administration. The SDRF will be shared between the central and state governments, but A&N Administration as UT fully receives annual budget from the central government. Thus, it is doubtful on the necessity of the SDRF. On the other hand, A&N Administration demands the SDRF for the following reasons:

- The SDRF can be exclusively utilised for the disaster response and mitigation activities.
- The SDRF can be an indicator to the departments related to the disaster management to let them understand the necessity of the mitigation and response activities.
- The outlays from the plan budget require a defined administrative process which will take long time even though the payments for the response will be done immediately.

#### **5.4 Challenges to be Addressed**

The forecasting and early warning systems are well established and the communication systems are well organised. The agencies/departments are improving accuracy of observation data and forecasting and early warning information. The information flow between the emergency operation centres and control rooms at the national, state and district levels is very reliable and communication tests are implemented regularly as preparedness against emergency. However, the following challenges for the early warning and communication systems are identified by the Indian side:

- Improving last mile connectivity
- Securing redundancy of the communication systems

As for the case of the A&N Islands, new automated sirens will be procured and installed by INCOIS. The automated systems will improve the emergency response against tsunami risk and last mile connectivity. However, according to the Directorate of Disaster Management, A&N Administration, 35 sirens can cover only the major residential areas while other small villages and islands are not covered and still face lack of last mile connectivity. Therefore, considering the current situation, it is worth pointing out the following as challenges to be addressed:

- Planning installation of tsunami sirens with necessary facilities/structures

**Table 5.4.1 Challenges and Actions (Early Warning and Communication System)**

S/N	Challenges	Actions to be Taken: <u>Early Warning and Communication System</u>		
		Short Term (1 - 2 Years)	Medium Term (3 -5 Years)	Long Term (5 - 10 Years)
<b>Challenges identified by the Indian Side</b>				
[ Common Issues ]				
EW-CI-1	Improving last mile connectivity	<u>Action(s)</u> - Analysing current situation of last mile connectivity in some sample sites and identifying areas, villages, communities, or spots with interruption of communication during emergency - Planning physical and non-physical measures to improve the interruption	<u>Action(s)</u> - Implementing the physical works and non-physical activities - Reviewing the improvement of last mile connectivity through test communication or drills	<u>Action(s)</u> - Taking remedy actions if necessity of further improvement for the last mile connectivity is identified through the reviewing process
		<u>Taken by</u> - MHA - NDMA - Ministry of Communications and Information Technology - SDMA - DDMA - Mucipal Corporations	<u>Taken by</u> - MHA - NDMA - Ministry of Communications and Information Technology - SDMA - DDMA - Mucipal Corporations	<u>Taken by</u> - MHA - NDMA - Ministry of Communications and Information Technology - SDMA - DDMA - Mucipal Corporations
EW-CI-2	Securing redundancy of the communication systems	<u>Action(s)</u> - Identifying the situation of malfunction of communication systems - Analysing the factors of malfunction and planning the countermeasures in cooperation with related entities such as mobile and communication companies	<u>Action(s)</u> - Establishing the redundancy systems that will work during malfunction of the ordinal systems	-
		<u>Taken by</u> - MHA - NDMA - Ministry of Communications and Information Technology - SDMA - DDMA - Mucipal Corporations - Mobile and communication companies	<u>Taken by</u> - MHA - NDMA - Ministry of Communications and Information Technology - SDMA - DDMA - Mucipal Corporations - Mobile and communication companies	-

S/N	Challenges	Actions to be Taken: <u>Early Warning and Communication System</u>		
		Short Term (1 - 2 Years)	Medium Term (3 -5 Years)	Long Term (5 - 10 Years)
<b>Challenges identified by the Survey Team</b>				
[ A&N Islands ]				
EW-AN-1	Planning installation of tsunami sirens with necessary facilities/structures	<u>Action(s)</u> - Conducting a survey of vulnerable area to tsunami risk and identifying locations where additional siren systems need to be installed - Planning tsunami siren systems required for those areas (including radio communication systems and structure for installation)	<u>Action(s)</u> - Installing the tsunami siren systems and structure in areas required - Reviewing the improvement of last mile connectivity for the tsunami early warning through test communication or drills	<u>Action(s)</u> - Taking remedy actions if necessity of further improvement for the last mile connectivity is identified through the reviewing process
		<u>Taken by</u> - DDM - SDMA - PWD - DDMA - Mucipal Corporations	<u>Taken by</u> - DDM - SDMA - PWD - DDMA - Mucipal Corporations - Villages - Communities	<u>Taken by</u> - DDM - SDMA - PWD - DDMA - Mucipal Corporations

Source: prepared by the Survey Team

## 5.5 Evaluation and Prioritisation of Challenges Identified

### 5.5.1 Methodology

The challenges identified are evaluated from three perspectives: 1) effectiveness of activities to be taken, 2) capacity of the relevant organisation (the Indian side), and 3) current situation and progress of policy and planning in India. Each aspect is rated with the following criteria:

#### Effectiveness of activities to be taken

- A: The existing gap seems to be large and activities may highly contribute to filling in the gap.
- B: The existing gap seems to be relatively large and activities may contribute to filling in the gap.
- C: The existing gap seems to be relatively small and activities may contribute to filling in the gap.

#### Capacity of the relevant organisation (the Indian side)

- A: Has the ability to address based on the existing capacity, but capacity building needed in specific areas of activities
- B: Has the ability to address based on the existing capacity, but capacity building needed in some areas of activities
- C: Capacity building needed in the large area of activities

#### Current Situation and Progress of Policy and Planning

- A: Has not been addressed
- B: Has been addressed, but only partially and leaving much to be improved
- C: Has been addressed, but the need for improvement exists



Finally, each challenge is prioritised in terms of the following criteria, based on the evaluation results of each perspective:

**Total Evaluation**

- A: Need to be implemented at an early stage
- B: Can be implemented with second priority
- C: Had better be implemented

**5.5.2 Evaluation Results**

The following table shows the evaluation results of challenges for the early warning and communication system:

S/N	Challenges	Evaluation Aspects (Early Warning and Communication System)			Total Evaluation	Remark
		Effectiveness	Capacity of the Indian Side	Current Situation and Progress of Policy and Planning		
<b>Challenges identified by the Indian Side</b>						
[ Common Issues ]						
EW-CI-1	Improving last mile connectivity	A	B	B	B	Relatively large amount of cost needed
EW-CI-2	Securing redundancy of the communication systems	A	B	A	A	Relatively large amount of cost needed
<b>Challenges identified by the Survey Team</b>						
[ A&N Islands ]						
EW-AN-1	Planning installation of tsunami sirens with necessary facilities/structures	A	B	B	B	Relatively large amount of cost needed

As a common issue for the early warning and communication system, “securing redundancy of the communication systems” is the challenges to be addressed with high priority.

As for the challenge of the Andaman and Nicobar Islands on the early warning and communication system, the total evaluation is “B”. However, the series of actions, a survey of vulnerable areas to tsunami risk and identifying locations, identification of risk level, preparation of risk maps, planning of tsunami siren and related facility location, are very important processes to formulate a mitigation plan.

## **CHAPTER 6    DISASTER RISK FINANCE**

### **6.1        Policy and Finance Scheme**

In accordance with the DM Act, disaster response fund is applied in India, as a financial source for disaster response activities. Moreover, various types of crop insurance schemes have been introduced for the farmers.

#### **6.1.1     Policy on Disaster Risk Finance**

The financial assistance for natural calamities in India has been provided to assist the people affected by the calamities to restore their economic activities. In the 9th Finance Commission (FC) period (1990-1995), the Calamity Relief Fund (CRF) was constituted with the contributions of the central and state governments; central government and state government contributed 75 % and 25 % of the fund, respectively. The 11th FC (2000-2005) recommended to establish the National Calamity Contingency Fund (NCCF) as a financial assistance provided by the central government to the disasters beyond the capacity of state government.

However, it was recognised by the 12th FC that quick response and direct intervention of the central government is required in cases of calamities of rare severity. Thus, in accordance with the issuance of the DM Act, the following two (2) financial schemes are to be constituted as the instruments for disaster risk finance:

- Disaster Response Fund at national, state and district levels
- Disaster Mitigation Fund at national, state and district levels

Due to the constitution of those schemes, the CRF was merged into the State Disaster Response Fund (SDRF) and the NCCF was merged into the National Disaster Response Fund (NDRF).

The NDRF and all SDRFs are constituted, but very few states constituted such response funds in the district level. The disaster mitigation funds in the national and district levels have not been constituted. In the state level, the State Disaster Mitigation Fund (SDMF) is constituted by some states.

#### **6.1.2     Disaster Risk Finance Systems**

##### **(1)        Disaster Response Fund**

The SDRF has been constituted by each state under the DM Act. The central government contributes 75 % and 90 % of the total annual fund allocation to general category state and special category state respectively. The remaining 25 % of the general category state and 10 % of the special category state are contributed by the respective state governments.

In the event of a severe natural calamity when the SDRF is insufficient to meet the relief requirements, additional financial assistance is provided by the NDRF. The source of fund of the NDRF is the National Calamity Contingent Duty (NCCD), which is the duty imposed on pan masala, chewing tobacco, cigarettes, motor cars, multi-utility vehicles, two wheelers and domestic crude oil with a various range of rate.

There are no criteria laid down either in the DM Act or in any guidelines issued by the GOI for deciding whether the calamity is of severe nature. No notification is formally prescribed or issued. However, according to the “Manual on Administration of SDRF and NDRF” issued by the MHA, the GOI considers a calamity to be a severe nature on a case-by-case basis taking into account of the intensity and magnitude of the calamity, level of relief assistance, coping capacity of the state

government to tackle the problem, the alternatives and flexibility of budget use available with the state plan to provide successor and relief and so on.

The general flow for the utilisation and application of the SDRF and the NDRF is shown in Figure 6.1.1.

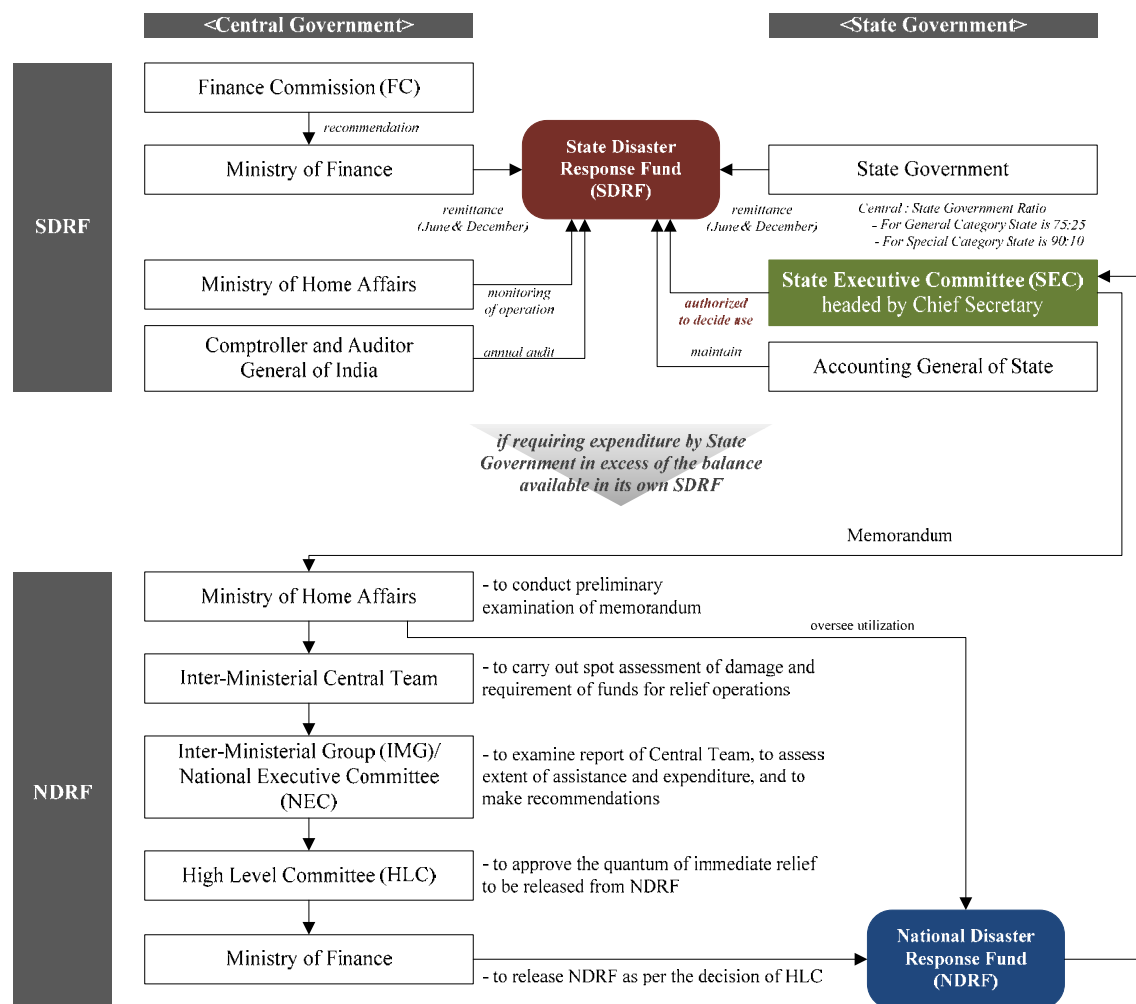

Source: compiled by the Survey Team based on “Guidelines on Constitution and Administration of the State Disaster Response Fund and National Disaster Response Fund”, (2010) of the MHA

**Figure 6.1.1 Flow of State Disaster Response Fund and National Disaster Response Fund**

**1) State Disaster Response Fund (SDRF)**

Based on the determined ratio, the share of the central government and state government shall be remitted to the SDRF in two installations in June and December in each financial year. The SEC headed by Chief Secretary is authorised to decide on all matters related to the financing of the relief expenditure from the SDRF. The MHA has responsibility to monitor the operation of the SDRF and the compliance with the prescribed processes. The accounts of the SDRF and the investment shall be maintained by the Accountant General in the state government and the Comptroller and Audit General of India would audit the SDRF every year.

**2) National Disaster Response Fund (NDRF)**

In case the NDRF is needed, the state government is required to submit a memorandum indicating the sector-wise damage and requirement of funds. On receipt of the memorandum from the state

government, Inter-Ministerial Central Team is constituted and conducts a spot assessment of damage and requirement of funds for relief operations as per present items and norms after the preliminary examination of the memorandum by the MHA. The report of the team is considered by the Inter-Ministerial Group (IMG)/NEC headed by the Home Secretary. Based on the recommendation from the IMG/NEC, the High Level Commission (HLC) consisting of the Home Minister, the Finance Minister, the Agricultural Minister and the Deputy Chairman of Planning Commission will examine those outputs and approve the quantum of assistance from the NDRF.

Both the SDRF and the NDRF are applicable to be utilised for the following disasters: avalanches, cyclone, cloud burst, drought, earthquake & tsunami, fire, flood, hailstorm, landslides, pest attack, frost and cold wave. The items and norms of the assistance from the SDRF and the NDRF are determined based on the “Items and Norms of Assistance from the SDRF and the NRDF for the period of 2015-2020” issued by the MHA. The items specified in the said guidance are listed below.

- Gratuitous Relief: payment to families of deceased persons, payment for hospitalisation, assistance for people whose livelihood is affected, etc.
- Search and Rescue Operations: cost for search and rescue measures, and cost for hiring boats
- Relief Measures: provision of temporary accommodation, food, clothing, medical care, etc.
- Clearance of Affected Areas: clearance of debris in public area, draining off flood water, etc.
- Agriculture: assistance for land and other losses, subsidies to farmers
- Animal Husbandry-Assistance to Small and Marginal Farmers: provision of fodder/feed, etc.
- Fishery: assistance for repair/replacement of boats, nets, and subsidies for fish seed farm
- Handicrafts/Handloom Assistance to Artisans: replacement of damaged tools/equipment, etc.
- Housing: payments based on damage conditions
- Infrastructure: payments for repair/replacement of damaged infrastructures including roads, bridges, telecommunication, power generation/supply, etc.
- Procurement of essential search, rescue and evacuation equipment
- Capacity Building (with cost not exceeding 5 % of the SDRF, and not from the NDRF)
- Assistance for state specific disasters within the local context in the state (not exceeding 10 % of the SDRF, not from the NDRF)

In the 14th FC period, a maximum of 5 % of the SDRF is allowed for financing the capacity building activities by the state government. This indicates that the preparedness is emphasised for the reduction of disaster risks.

### **3) Other Disaster Relief Funds**

As available relief funds, the following two (2) funds are available in India: Prime Minister’s National Relief Fund (PMNRF) on the national level and Chief Minister's Relief Fund (CMRF) on the state level. Both funds are collected through donations and are primarily intended to render immediate relief to families of those killed in natural calamities such as floods, cyclones and earthquakes, etc. and to the victims of the major accidents and riots.

#### **(2) Crop Insurance**

One of the major economic activities in India is agriculture, and a large number of people are engaged in this sector. Thus, to insure the farming community against various risks, the Ministry of Agriculture (MOA) has operated various crop insurance schemes since 1985. The following crop insurances currently operate under the National Crop Insurance Program (NCIP):

- Modified National Agricultural Insurance Scheme (MNAIS)
- Weather Based Crop Insurance Scheme (WBCIS)
- Coconut Palm Insurance Scheme (CPIS)

## 1) **Modified National Agricultural Insurance Scheme (MNAIS)**

In order to enlarge the coverage of farmers, crops and risks, the National Agricultural Insurance Scheme (NAIS) was introduced from *Rabi* 1999-2000 managed by Agricultural Insurance Company of India Ltd. (AIC). Under the NAIS, the food crops (cereals, millets and pulses) and annual commercial/horticultural crops (oilseeds, sugarcane, cotton and potato) are covered. This insurance is provided to cover yield losses due to the following risks:

- Natural fire and lightning
- Storm, hailstorm, cyclone, typhoon, tempest, hurricane, tornado, etc.
- Flood, inundation and landslides
- Drought, dry spells
- Pests/diseases, etc.

This insurance is compulsory for all farmers growing notified crops and availing Seasonal Agricultural Operations (SAO) loans from financial institutions (loanee farmers), and it is voluntary for other farmers (non-loanee farmers). The premium rates under the NAIS range from 1.5 to 3.5 %, and 50 % of the premium rates of small and marginal farmers may be subsidised and equally shared by the central and state governments.

However, in order to make the crop insurance more farmer-friendly, the restructuring of the NAIS was conducted and the Modified National Agricultural Insurance Scheme (MNAIS) was implemented as a pilot project in 2010 in 50 districts of 21 states and approved by the GOI in 2013. According to the MOA, the major improvements of MNAIS are as follows:

- Reduction in unit area of insurance to village/village panchayat
- Actuarial premium rates for insuring crops and hence claims liability is on insurance companies
- In addition to the AIC, private insurance companies have also been involved for the implementation to provide competitive services to the farmers
- Higher subsidy in premium ranging up to 75 % to all farmers
- Higher minimum indemnity level of 70 % instead of 60 % of NAIS
- Indemnity amount for prevented sowing/planting risks and for post-harvest losses due to cyclones
- On account payment of up to 25 % of likely claims as advance for providing immediate relief to farmers during adverse season
- An individual assessment of claims in case of specified localised calamity, viz. hailstorm, landslide, etc.

By introducing the MNAIS, it was decided to discontinue the NAIS from 2013. However, the state governments are still allowed to implement NAIS or MNAIS during 2014-2015 and 2015-2016 in accordance with the needs in the states.

## 2) **Weather Based Crop Insurance Scheme (WBCIS)**

The Weather Based Crop Insurance Scheme (WBCIS) was approved for implementation in 20 states on pilot basis in 2007, and started to be implemented as full-fledged component of the NICP from 2013. The WBCIS intends to provide insurance protection to the farmers against adverse weather incidence, such as deficient and excess rainfall, high or low temperature, humidity, and so on which are deemed to impact adversely the crop production. Under the WBCIS, actuarial rates of premium are being charged. However, to make the scheme affordable to the farmers, subsidy up to 50 % of the premium is provided by the central and state governments. Like the NAIS, the loanee farmers growing notified crops are covered on compulsory basis whereas for non-loanee farmers the scheme is voluntary. For more competitive services to the farmers, private insurance companies are involved in the provision of the insurance services beside of the AIC.

### 3) Coconut Palm Insurance Scheme (CPIS)

The Coconut Palm Insurance Scheme (CPIS) was started on a pilot basis from 2009 in selected coconut growing states including Andhra Pradesh, Goa, Karnataka and Kerala states, and has been implemented as a full-fledged component scheme of the NICP in 2013. The insurance compensates the insured against the likelihood of diminished net output/yield resulting from non-preventable natural factors, such as natural fire & lightning, storm, hailstorm, cyclone, typhoon, tempest, hurricane, tornado, flood, inundation, landslide and pests/diseases, etc. This scheme is administered by Coconut Development Board and the AIC is responsible for making payment for all the claims.

**Box: Private Companies enrolled in Crop Insurance Scheme**

Under the NCIP, in addition to the AIC, several private insurance companies participate for the provision of crop insurance to farmers in India.

Royal Sundaram Alliance Insurance Company Limited, which is one of the participants in the scheme, is the first private general insurance company in India to be licensed since 2001. As one of its insurance services, it provides cover for dwelling and farm produce against fire and allied perils (fire, lightning, explosion/implosion, riot, strike, malicious damage, terrorism, storm, cyclone, typhoon, tempest, tornado, flood and inundation and earthquake).

## 6.2 Past Records of Disaster Risk Finance

### (1) Disaster Response Fund

Figure 6.2.1 shows the SDRF budget allocated for the 13th FC (2010-2015) and the budget planned for 14th FC (2015-2020). In both FC periods, the annual average increase rate is approximately 5%. In addition, from the 13th FC to 14th FC, the total amount of the SDRF remarkably increases by 50% based on the financial needs for the emergency relief in case of severe calamities in the states. The SDRF for each state in the 13th and 14th FC periods is shown in Table 6.2.1.

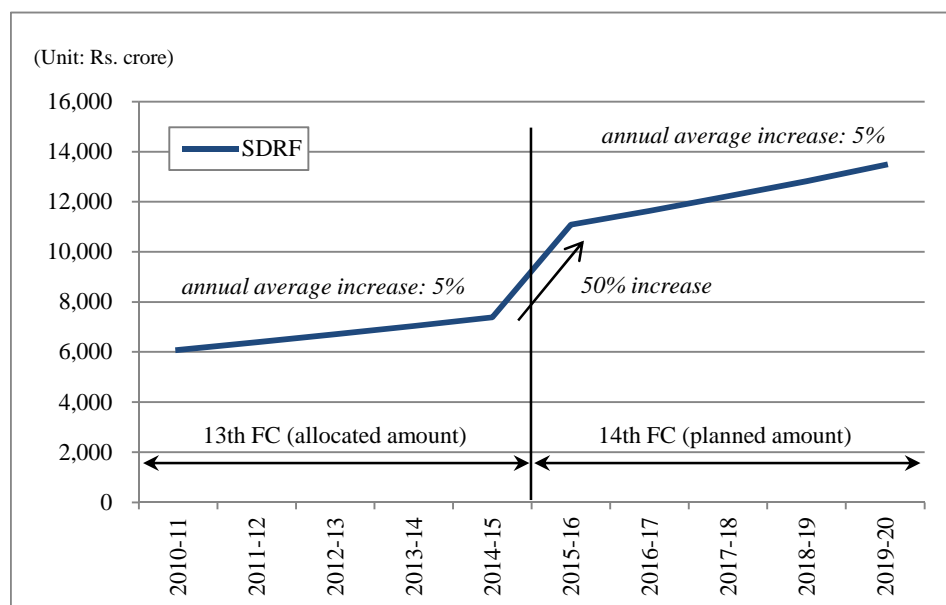

Source: compiled by the Survey Team based on "Annual Report", (from 2010-2011 to 2014-2015) of the MHA

**Figure 6.2.1 Annual Trend of SDRF**

**Table 6.2.1 State Disaster Response Fund (SDRF)**

(unit: Rs. crore)

No.	State	13th Finance Commission (13th FC)					14th Finance Commission (14th FC)					Total		
		2010-11	2011-12	2012-13	2013-14	2014-15	2015-16	2016-17	2017-18	2018-19	2019-20	13th FC	14th FC	Total
1.	Andhra Pradesh	508.84	534.28	560.99	589.04	618.49	440.00	462.00	485.00	509.00	534.00	2,811.64	2,430.00	5,241.64
2.	Arunachal Pradesh	36.74	38.58	40.51	42.54	44.67	52.00	55.00	57.00	60.00	63.00	203.04	287.00	490.04
3.	Assam	263.77	276.96	290.81	305.35	320.62	460.00	483.00	507.00	532.00	559.00	1,457.51	2,541.00	3,998.51
4.	Bihar	334.49	351.21	368.77	387.21	406.57	469.00	492.00	517.00	543.00	570.00	1,848.25	2,591.00	4,439.25
5.	Chhattisgarh	151.32	158.89	166.83	175.17	183.93	241.00	253.00	265.00	278.00	292.00	836.14	1,329.00	2,165.14
6.	Goa	2.96	3.11	3.27	3.43	3.60	4.00	4.00	4.00	4.00	4.00	16.37	20.00	36.37
7.	Gujarat	502.12	527.23	553.59	581.27	610.33	705.00	740.00	777.00	816.00	856.00	2,774.54	3,894.00	6,668.54
8.	Haryana	192.90	202.55	212.68	223.31	234.48	308.00	323.00	339.00	356.00	374.00	1,065.92	1,700.00	2,765.92
9.	Himachal Pradesh	130.76	137.30	144.17	151.38	158.95	236.00	248.00	260.00	273.00	287.00	722.56	1,304.00	2,026.56
10.	Jammu & Kashmir	172.46	181.08	190.13	199.64	209.62	255.00	268.00	281.00	295.00	310.00	952.93	1,409.00	2,361.93
11.	Jharkhand	259.45	272.42	286.04	300.34	315.36	364.00	382.00	401.00	421.00	442.00	1,433.61	2,010.00	3,443.61
12.	Karnataka	160.96	169.01	177.46	186.33	195.65	276.00	290.00	305.00	320.00	336.00	889.41	1,527.00	2,416.41
13.	Kerala	131.08	137.63	144.51	151.74	159.33	185.00	194.00	204.00	214.00	225.00	724.29	1,022.00	1,746.29
14.	Madhya Pradesh	392.75	412.39	433.01	454.66	477.39	877.00	921.00	967.00	1,016.00	1,066.00	2,170.20	4,847.00	7,017.20
15.	Maharashtra	442.69	464.82	488.06	512.46	538.08	1,483.00	1,557.00	1,635.00	1,717.00	1,803.00	2,446.11	8,195.00	10,641.11
16.	Manipur	7.22	7.58	7.96	8.36	8.78	19.00	20.00	21.00	22.00	23.00	39.90	105.00	144.90
17.	Meghalaya	14.65	15.38	16.15	16.96	17.81	24.00	25.00	27.00	28.00	29.00	80.95	133.00	213.95
18.	Mizoram	8.55	8.98	9.43	9.90	10.40	17.00	18.00	19.00	20.00	20.00	47.26	94.00	141.26
19.	Nagaland	4.97	5.22	5.48	5.75	6.04	10.00	10.00	11.00	11.00	12.00	27.46	54.00	81.46
20.	Odisha	391.58	411.16	431.72	453.31	475.98	747.00	785.00	824.00	865.00	909.00	2,163.75	4,130.00	6,293.75
21.	Punjab	222.92	234.07	245.77	258.06	270.96	390.00	409.00	430.00	451.00	474.00	1,231.78	2,154.00	3,385.78
22.	Rajasthan	600.66	630.69	662.22	695.33	730.10	1,103.00	1,158.00	1,216.00	1,277.00	1,340.00	3,319.00	6,094.00	9,413.00
23.	Sikkim	22.75	23.89	25.08	26.33	27.65	31.00	33.00	34.00	36.00	38.00	125.70	172.00	297.70
24.	Tamil Nadu	293.52	308.20	323.61	339.79	356.78	679.00	713.00	748.00	786.00	825.00	1,621.90	3,751.00	5,372.90
25.	Telangana*	-	-	-	-	-	274.00	288.00	302.00	317.00	333.00	0.00	1,514.00	1,514.00
26.	Tripura	19.31	20.28	21.29	22.35	23.47	31.00	33.00	34.00	36.00	38.00	106.70	172.00	278.70
27.	Uttara Pradesh	385.39	404.66	424.89	446.13	468.44	675.00	709.00	744.00	781.00	820.00	2,129.51	3,729.00	5,858.51
28.	Uttarakhand	117.66	123.54	129.72	136.21	143.02	210.00	220.00	231.00	243.00	255.00	650.15	1,159.00	1,809.15
29.	West Bengal	304.83	320.07	336.07	352.87	370.51	516	542.00	569.00	598.00	628.00	1,684.35	2,853.00	4,537.35
	<b>Total</b>	<b>6,077.30</b>	<b>6,381.18</b>	<b>6,700.22</b>	<b>7,035.22</b>	<b>7,387.01</b>	<b>11,081.00</b>	<b>11,635.00</b>	<b>12,214.00</b>	<b>12,825.00</b>	<b>13,465.00</b>	<b>33,580.93</b>	<b>61,220.00</b>	<b>94,800.93</b>

\* Since Telangana State was established in June 2014 to be partly independent from Andhra Pradesh State, the SDRF will be allocated starting from the 14th FC.

Source: compiled by the Survey Team based on "Annual Report", (from 2010-2011 to 2014-2015) of the MHA and the report of the 14th Finance Commission

## (2) Crop Insurance

The NAIS is the major crop insurance scheme introduced in India in *Rabi* 1999-2000 and will continue until *Kharif* 2016. As shown in Table 6.2.2, the total number of insured farmers and the area of lands covered by the NAIS until 2014 are 229 million and 339 million ha, respectively. Andhra Pradesh, Gujarat, Karnataka, Madhya Pradesh, Maharashtra, Odisha, Rajasthan, Uttara Pradesh and West Bengal states accounted for the majority of the insured farmers. Moreover, those states accounted for more than 80 % of the premium and the claims.

**Table 6.2.2 Insurance Conditions of NAIS (Rabi 1999-2000 to Kharif 2014, 30 Seasons)**

No.	State/UT	No. of Farmers Insured ('000)	Area Insured ('000 ha.)	Amount in Rs. crore				No. of Farmers Benefited ('000)
				Sum Insured	Premium	Subsidy	Claims	
1.	Andhra Pradesh	29,952	45,583.16	62,181.36	1,768.16	157.37	4,649.11	6,730
2.	Assam	396	291.13	807.21	22.54	2.34	16.53	65
3.	Bihar	6,037	7,377.70	11,904.02	303.83	27.10	2,306.15	2,431
4.	Chhatisgarh	10,425	20,991.14	11,511.43	294.44	19.46	398.57	1,706
5.	Goa	8	13.44	3.18	0.06	0.01	0.02	1
6.	Gujarat	14,870	33,886.59	44,953.82	1,788.61	160.52	6,503.47	4,946
7.	Haryana	636	769.04	834.96	24.14	0.68	43.36	129
8.	Himachal Pradesh	321	248.84	543.77	11.71	5.15	17.83	108
9.	Jharkhand	6,277	3,767.77	3,401.53	84.35	4.51	522.99	2,183
10.	Karnataka	13,150	20,872.42	16,418.06	483.98	24.01	1,949.40	5,223
11.	Kerala	461	414.74	871.66	18.82	2.52	30.63	85
12.	Madhya Pradesh	32,332	78,058.92	58,205.85	1,678.16	48.44	4,234.32	6,459
13.	Maharashtra	39,190	32,619.85	27,084.63	1,192.54	315.06	2,919.70	10,790
14.	Manipur	26	37.22	94.02	2.33	0.16	7.71	19
15.	Meghalaya	34	34.44	65.53	2.94	0.40	0.52	3
16.	Mizoram	0	0.13	0.23	0.01	0.00	0.11	0
17.	Odisha	17,313	17,018.22	27,259.92	684.03	71.63	1,830.31	3,047
18.	Rajasthan	15,059	31,379.98	16,203.09	457.54	7.38	2,621.66	5,201
19.	Sikkim	2	1.32	2.54	0.04	0.01	0.01	0
20.	Tamil Nadu	6,556	8,495.08	18,461.54	474.76	233.78	2,937.17	2,633
21.	Telengana	2	3.00	11.26	0.31	0.02	0.00	0
22.	Tripura	19	12.64	29.08	0.81	0.09	0.58	3
23.	Uttar Pradesh	23,426	31,070.39	33,537.82	684.82	52.19	1,169.38	4,518
24.	Uttarakhand	399	372.51	870.98	19.78	1.79	41.88	119
25.	West Bengal	12,364	6,223.12	14,179.98	595.47	256.49	1,122.41	2,742
26.	A & N Islands	4	5.77	16.66	0.44	0.40	1.15	1
27.	Puducherry	40	56.63	103.63	2.00	0.68	3.15	7
28.	Jammu and Kashmir	49	68.99	109.02	2.14	0.16	1.23	4
Total		229,348	339,674.18	349,666.78	10,598.76	1,392.35	33,329.35	59,153

Source: Agricultural Insurance Company of India Ltd. (2015)

The MNAIS was introduced on a pilot basis in selected districts from *Rabi* 2010-2011. Table 6.2.3 shows that during the eight (8) seasons of its implementation, the MNAIS has covered 9 million farmers and 10 million ha lands. Thus, so far the MNAIS has been operated on a much smaller scale than the NAIS. The main participants are from Andhra Pradesh, Bihar, Karnataka, Rajasthan, Tamil Nadu, Uttara Pradesh and West Bengal states accounting for 97 % and 94 % of the premium and the claims respectively.



**Table 6.2.3 Insurance Conditions of MNAIS (Rabi 2010-2011 to Kharif 2014, 8 Seasons)**

No.	State/UT	No. of Farmers Insured ('000)	Area Insured ('000 ha.)	Amount in Rs. Crore				No. of Farmers Benefited ('000)
				Sum Insured	Premium	Subsidy	Claims	
1.	Andhra Pradesh	1,342	1,428.91	5,189.07	539.84	292.75	774.46	524
2.	A&N Islands	0	0.00	0.00	0.00	0.00	0.00	0
3.	Assam	17	12.67	49.54	2.09	0.86	0.63	1
4.	Bihar	1,223	1,370.07	2,266.79	479.39	343.52	153.90	62
5.	Chhatisgarh	0	0.03	0.05	0.00	0.00	0.00	0
6.	Goa	0	0.18	0.26	0.01	0.00	0.00	0
7.	Gujarat	0	0.59	2.61	0.28	0.17	0.17	0
8.	Haryana	102	210.98	853.04	34.18	14.68	26.07	22
9.	Jharkhand	12	6.05	14.61	1.32	0.73	0.03	0
10.	Karnataka	1,026	1,656.61	2,439.94	295.34	176.23	77.89	115
11.	Madhya Pradesh	79	150.79	197.23	7.60	2.99	0.22	0
12.	Maharashtra	52	49.62	76.21	13.62	9.80	0.00	0
13.	Mizoram	1	0.49	0.99	0.06	0.03	0.09	1
14.	Odisha	120	87.32	297.07	11.32	4.43	65.10	56
15.	Rajasthan	3,256	4,010.01	3,292.80	350.26	199.77	119.80	346
16.	Tamil Nadu	476	522.47	1,283.39	140.22	83.22	204.58	180
17.	Tripura	3	2.91	67.32	0.00	0.00	0.00	0
18.	Uttar Pradesh	747	765.57	1,896.76	86.69	36.57	219.75	246
19.	Uttarakhand	70	62.30	209.99	5.86	1.73	3.35	11
20.	West Bengal	1,149	488.47	3,185.97	393.11	275.12	73.62	91
Total		9,675	10,826.04	21,323.64	2,361.19	1,442.60	1,719.66	1,655

Source: Agricultural Insurance Company of India Ltd. (2015)

The WBCIS has been operated by the AIC and private insurance companies since 2007, and 33 million farmers and 45 million ha area of lands are insured by the WBCIS (see in Table 6.2.4). The amount of claims payment is Rs. 4,000 crore, against the premium received which is Rs. 5,843 crore. The major states participating in the WBCIS are Andhra Pradesh, Bihar, Maharashtra and Rajasthan states.

**Table 6.2.4 Insurance Conditions of WBCIS (Kharif 2007 to Kharif 2014, 16 Seasons)**

No.	State/UT	No. of Farmers Insured ('000)	Area Insured ('000 ha.)	Amount in Rs. Crore				No. of Farmers Benefited ('000)
				Sum Insured	Premium	Subsidy	Claims	
1.	Andhra Pradesh	2,881.83	4,697.05	11,814.59	1,178.49	725.48	875.03	2,016.44
2.	Assam	4.74	2.66	16.16	1.66	0.83	0.00	0.00
3.	Bihar	6,471.29	6,815.36	15,631.47	1,344.04	934.28	832.45	3,944.00
4.	Chhatisgarh	202.21	372.31	726.98	57.28	43.42	61.12	148.52
5.	Gujarat	497.66	413.13	223.95	22.39	19.88	8.57	170.58
6.	Haryana	70.43	119.77	440.61	38.39	29.67	33.88	40.10
7.	Himachal Pradesh	98.70	39.39	510.46	58.76	29.38	48.99	75.71
8.	Jharkhand	225.13	170.60	318.31	29.59	22.01	17.84	186.37
9.	Karnataka	696.08	820.52	1,513.27	171.30	98.37	78.87	482.89
10.	Kerala	116.48	82.63	256.12	26.37	16.92	14.56	59.03
11.	Madhya Pradesh	428.55	843.12	1,798.31	164.42	115.01	97.43	377.70
12.	Maharashtra	1,413.13	1,581.43	3,830.59	438.86	260.49	259.39	458.82
13.	Odisha	214.43	309.60	389.35	38.93	29.20	19.69	123.53
14.	Punjab	0.02	0.10	0.19	0.02	0.01	0.00	0.00
15.	Rajasthan	20,241.37	29,071.66	23,654.23	2,217.82	1,537.31	1,603.77	10,600.09
16.	Tamil Nadu	76.04	72.67	171.98	16.70	11.26	14.35	39.46
17.	Uttar Pradesh	64.27	24.39	68.66	6.28	4.42	2.19	27.98
18.	Uttarakhand	77.62	25.74	233.08	27.85	13.92	36.76	45.79
19.	West Bengal	36.07	19.76	48.17	4.69	3.29	4.45	27.84
Total		33,816.05	45,481.90	61,646.48	5,843.84	3,895.15	4,009.34	18,824.85

Source: Agricultural Insurance Company of India Ltd. (2015)

### 6.3 Challenges to be addressed

The 14th FC was constituted under the Constitution to make recommendations on the financial distribution between the central and state governments for the period of 2015-2020 by taking into account the fiscal consolidation roadmap recommended by the previous FC. According to the report of the 14th FC, the major challenges related to the Disaster Response Fund are stated. In addition, the MHA constituted a task force to carry out the review study of the DM Act and published the report named “A Review of the Disaster Management Act, 2005” in March 2013 (hereinafter referred to as the “MHA Task Force Report”) describing various recommendations on the financing provisions of the DM Act. Those recommendations are summarised below.

#### 6.3.1 Disaster Response Fund

##### (1) National Disaster Response Fund

As a financial source for the NDRF, the NCCD has been levied. However, as shown in Table 6.3.1, the total collection through the NCCD was Rs. 28,382 crore for the period from 2002-2003 to 2013-2014 while the fund released under the NCCF/NDRF in the same period was Rs. 30,806 crore. This fact indicates that Rs. 2,423 crore in total, or Rs. 202 crore annually on average, was not met through the budgetary resources.

**Table 6.3.1 Financial Gap between NCCD and NCCF/NDRF**

(unit: Rs. Crore)

Year	NCCD Collection	NCCF/NDRF Release	Financial Gap
2002-2003	1,648.45	1,600.00	48.45
2003-2004	1,740.13	1,587.42	152.71
2004-2005	1,484.44	2,583.12	(1,098.68)
2005-2006	1,274.67	3,061.44	(1,786.77)
2006-2007	1,727.88	1,962.05	(234.17)
2007-2008	2,268.36	373.38	1,894.98
2008-2009	2,319.73	2,279.92	39.81
2009-2010	2,619.56	3,261.52	(641.96)
2010-2011	2,966.51	4,179.25	(1,212.74)
2011-2012	3,246.16	2,458.12	788.04
2012-2013	3,540.67	2,810.29	730.38
2013-2014	3,546.07	4,649.94	(1,103.87)
<b>Total</b>	<b>28,382.63</b>	<b>30,806.45</b>	<b>(2,423.82)</b>
<b>Average</b>	<b>2,365.22</b>	<b>2,567.20</b>	<b>(201.99)</b>

Source: compiled by the Survey Team based on “the report of 14th Finance Commission” and “Finance Accounts” (from 2002-2003 to 2013-2014) of Ministry of Finance

The gap between the NCCD collection and NCCF/NDRF release happens depending on the occurrence of severe natural disasters and emergency needs of financial support from the central government for immediate reliefs. Figure 6.3.1 shows the correlations between the NCCF/NDRF releases and occurrence of severe natural disasters. The localised disaster events such as landslide and earthquake cause severe damage in limited areas, but they still require large scale emergency activities. The cyclonic disasters affect various locations and cause the natural disasters including floods and landslides.

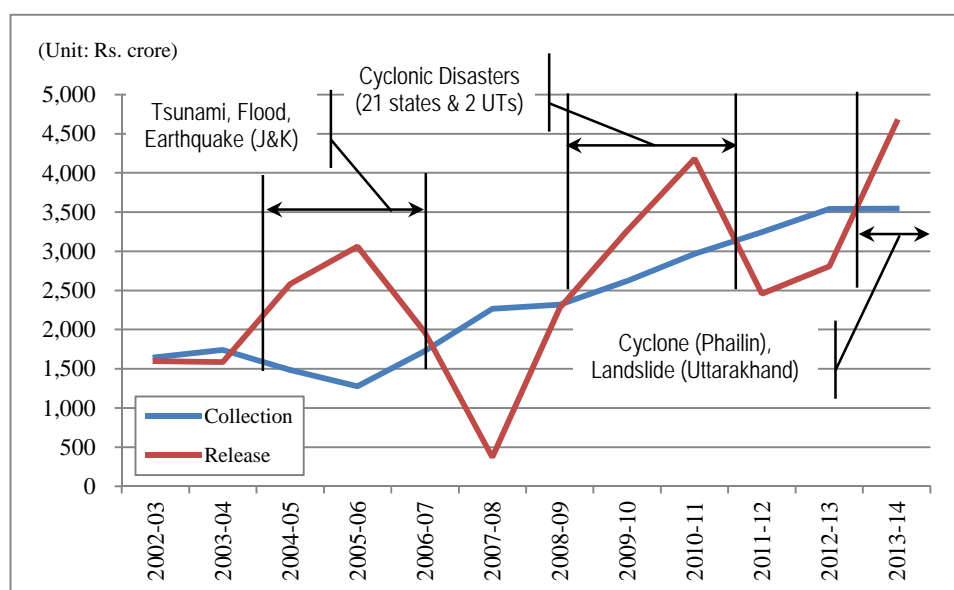

\* J&K: Jammu & Kashmir state, UT: Union Territory

Source: compiled by the Survey Team based on "Finance Accounts" (from 2002-2003 to 2013-2014) of Ministry of Finance and "Annual Reports" (from 2002-2003 to 2013-2014) of the MHA

**Figure 6.3.1 Release of NDRF and Severe Natural Disaster Occurrence**

Since it is essential to secure the timely availability and release of adequate funds under the NDRF to meet the requirements of disasters of rare severity, the 14th FC has recommended the central government to consider ensuring an assured source of funding for the NDRF such as the goods and services tax (GST).

Moreover, the World Bank and JICA operate a type of contingent credit line that provides immediate liquidity in the aftermath of a natural disaster called "Development Policy Loan with a Catastrophe Deferred Drawdown Option (CAT-DDO)" and "Stand-by Emergency Credit for Urgent Recovery (SECURE)" respectively. Those loans aim to respond promptly to the temporary financial requirements of post-disaster recovery activities when liquidity constraints are usually highest. However, during the course of the Survey, the disaster-related agencies in the selected priority survey areas did not express financial needs as their challenges for disaster management, so that the potential needs for those schemes to allocate required funds for post-disaster recovery were not identified at present. Depending on future disasters, the GOI might consider the utilisation of those external funds for emergency responses.

## (2) State Disaster Response Fund

According to the report of 14th FC, the state governments requested the followings regarding the SDRF and the NDRF:

- To increase substantially the SDRF corpus based on expenditures incurred on calamity relief because they are compelled to spend funds in excess of the SDRF from their own resources
- To increase the central government's share from the present level of 75 %

In line with the financial needs of the state governments in the form of the SDRF, the central government increased the SDRF by 50 % from the 14th FC as shown in Figure 6.2.1. On the other hand, according to the "Explanatory Memorandum as to the Action taken on the Recommendations made by the Fourteenth Finance Commission in its Report submitted to the President on December 15, 2014" issued by the Ministry of Finance dated 24 February 2015, the central government will retain the present shares, i.e. 75 % and 25 % for general category states and 90 % and 10 % for special category states by central and state governments respectively.

### **(3) District Disaster Response Fund**

On the funding and operationalisation of the District Disaster Response Fund (DDRF), the general view among the state governments is that they should have flexibility in its constitution as well as financing. They argued that they already have a well-established mechanism for the timely transfer of the funds to the district level when required. Constituting the DDRF and routing funds to them from the SDRF will result in funds being thinly spread across districts and becoming locked in areas not necessarily affected by a natural calamity, as well as the state government losing its flexibility to pool funds for disaster management. Accordingly, they urged that constituting the DDRF shall not be made mandatory. States which have already constituted the DDRF asked for the provision of additional grants-in-aid over and above the SDRF.

In accordance with the present situation as stated above, the 14th FC recommends that in view of the federal administrative system in the country, the constitution of the DDRF is best left to the wisdom of the state governments so that the separate grants for financing the DDRF is not recommended.

#### **6.3.2 Disaster Mitigation Fund**

According to the MHA Task Force Report, it is recommended that the NDMF be constituted due to the significance of setting up a fund exclusively for the purpose of disaster mitigation and also as the legal requirement under the DM Act. The following positive impacts on the constitution of the NDMF are expected:

- The NDMF would help the system develop an overall mechanism for monitoring the percentage and the manner of financial resources being spent on disaster mitigation.
- The NDMF would help the national economy in saving scarce financial resources (e.g. if the NDMF could be used for insurance which is a risk transfer mechanism, it would help reduce the tendency of devoting precious financial resources of the state in post-disaster phase.).
- The NDMF would ensure better outcomes to cross-sectoral activities such as capacity building and community awareness generation.

In addition, the MHA Task Force Report also recommends to constitute the SDMF to accelerate the implementation of disaster mitigation activities such as capacity building, enforcement of various codes and regulations, studies and analyses cutting across various districts, activities and sectors. On the other hand, same as the DDRF, it is mentioned in the report that the state governments may decide whether the state governments will establish the DDMF for timely access to financial resources by district authorities.

#### **6.3.3 Challenge to be addressed**

In accordance with the recommendations by the Finance Commission and the task force constituted by the MHA and the analysis of current operations of disaster risk finance in India, several actions are proposed to be taken in the following phases. It is considered that the present status is during 14th FC period (2015-2016 to 2019-2020), so that all the concerned modifications might be applied from the next FC period (from 2020) which are described as long-term challenges in Table 6.3.2.

Moreover, for the improvement of disaster risk finance in India, the further analysis will be required on the following subjects:

- SDRF: major disasters for utilisation of the SDRF in each state, policy direction including modification of central government share and its fund source
- NDRF: financial gap between requested and disbursed amounts in each state, issues on approval process, policy direction to ensure the additional fund sources to fulfil the gap
- Future policy and challenges on establishment of the NDMF

**Table 6.3.2 Challenges to be addressed (Disaster Risk Finance)**

	Short Term (1-2 Years)	Medium Term (3-5 Years)	Long Term (5-10 Years)
Disaster Response Fund <ul style="list-style-type: none"> <li>• Identification and application of additional funding sources for NDRF</li> <li>• Modification of sharing portion between central and state governments for SDRF</li> </ul>	<ul style="list-style-type: none"> <li>• Examination and discussion for the identification and application of additional funding source for NDRF</li> <li>• Examination and discussion for modification of sharing portion between central and state governments for SDRF</li> </ul>	<ul style="list-style-type: none"> <li>• Application of additional funding source for NDRF if applicable</li> <li>• Modification of sharing portion between central and state governments for SDRF, if applicable</li> </ul>	
Disaster Mitigation Fund <ul style="list-style-type: none"> <li>• Constitution of NDMF</li> <li>• Constitution of SDMF</li> </ul>	<ul style="list-style-type: none"> <li>• Examination and discussion for constitution of NDMF</li> <li>• Examination and discussion for constitution of SDMF</li> </ul>	<ul style="list-style-type: none"> <li>• Constitution of NDMF, if applicable</li> <li>• Constitution of SDMF, if applicable</li> </ul>	

## CHAPTER 7 PRIORITY AREA STUDY

### 7.1 Selection of Priority Survey Areas

Table 7.1.1 summarises the number of fatalities caused by the major natural disasters. Floods have led to a large number of fatalities in Bihar, Himachal Pradesh and Uttarakhand states located in the middle reach and upper reach of the Ganges River. A large number of deaths caused by cyclones are recognised in Odisha, Andhra Pradesh and Gujarat states. Many people have suffered from sediment disasters and demised in Uttarakhand, Jammu and Kashmir and Himachal Pradesh states in the Himalaya mountain area. Considering the above conditions, the following three (3) states are selected as the priority survey areas to grasp and analyse the current situation of disaster management at the state level: Bihar for floods, Andhra Pradesh for cyclones, and Uttarakhand for sediment disasters or landslides.

**Table 7.1.1 States ranked by the Number of Deaths caused by Disaster (1995–2014)**

Rank	Name of State: Higher Rank of the Number of Deaths caused by Disaster				
	Flood	Cyclone	Sediment Disaster	Earthquake	Abnormal Weather
1	Himachal Pradesh	Odisha	Uttarakhand	Gujarat	Andhra Pradesh
2	Bihar	Gujarat	Jammu & Kashmir	TamilNadu	Odisha
3	Uttarakhand	Andhra Pradesh	Himachal Pradesh	Madhya Pradesh	Uttar Pradesh
4	West Berngal	Karnataka	Bihar	Punjab	Bihar
5	Gujarat	West Bengal	Maharashtra	Uttarakhand	Himachal Pradesh

Source: EM-DAT (2015)

### 7.2 Uttarakhand State

#### 7.2.1 State Disaster Management Policy and Development Plan

The Government of Uttarakhand State prepared the SDMP. The plan aims at localising the disaster impact to the extent possible and to contain its impact on human interests and environment. The focus of the plan can be outlined as follows:

- Establishing constructive and continuously updated and tested disaster preparedness, response and recovery plans
- Ensuring prompt, efficient and coordinated response
- Bringing forth maximum community participation in all disaster management related activities during every phase of the disaster management cycle
- Ensuring high priority to all disaster management initiatives in the planning process at all levels so as to mainstream disaster management into development
- Promoting a culture of prevention and preparedness so as to ensure disaster resilience in the state

The plan covers the comprehensive components related to disaster management: organisational setup, assessment of vulnerable areas, preparedness, prevention and mitigation, early warning, evacuation, mainstreaming disaster management into development, and response. Most of the contents are similar to the SOP and include the communication diagram for early warning, items to be included in the evacuation plan, task allocation matrix, response mechanism and lists of information for emergency response such as contact information of officials, locations of helipads, primary health centre and go-downs.

#### 7.2.2 Institutional Framework for Disaster Management

Uttarakhand State is the first state to have separate Department of Disaster Management and set up a dedicated autonomous institution, Disaster Mitigation and Management Centre (DMMC), for

various disaster management related studies, capacity building and policy interventions. After the enactment of the DM Act, the organisational setup for the disaster management in Uttarakhand State follows the institutional framework provided by the DM Act. SDMA and SEC were constituted by the state government in 2007 and 2008 respectively. The State Disaster Response Force was also formed under the Police Department. Currently, research and study, preparedness, capacity building and management of SEOC are carried out by DMMC with financial allocation from the state government. Currently, DMMC has about 80-90 staff including 15 operators of SEOC (permanent 10 and additional). The state government is planning to integrate those functions into SDMA. Figure 7.2.1 shows the current organisational setup for the disaster management in the state.

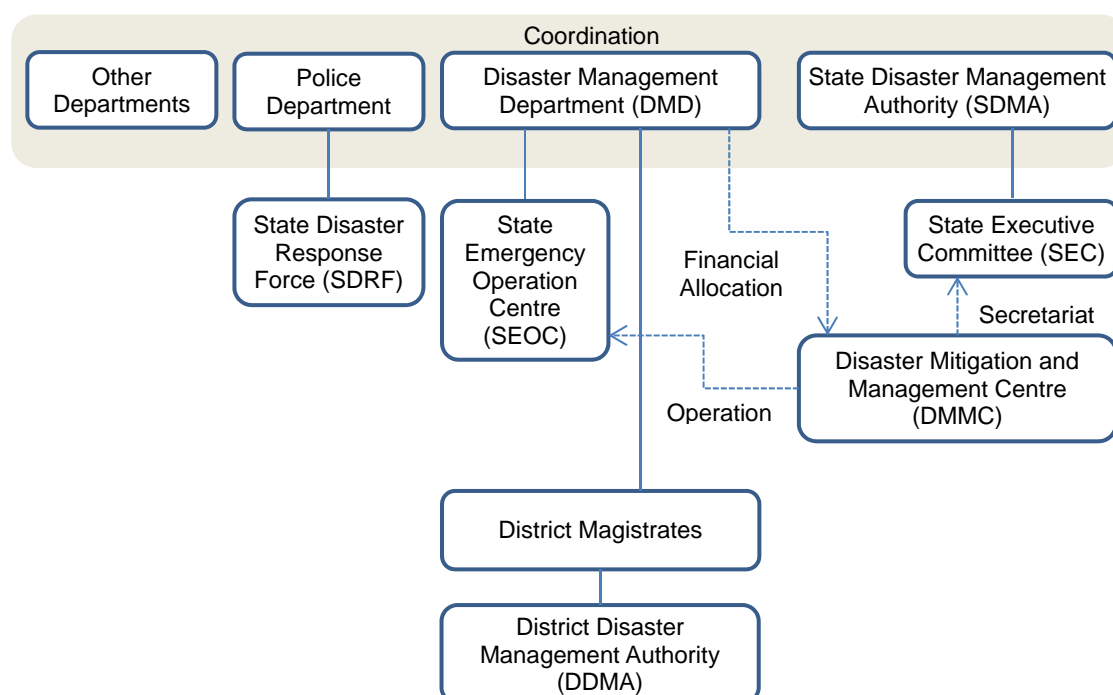

Source: prepared by the Survey Team

**Figure 7.2.1 Current Organisational Setup for Disaster Management in Uttarakhand State**

### 7.2.3 Disaster Records

#### (1) State Level

Disaster records in the past 10 years (2004–2014) are summarised in the SDMP as shown in Table 7.2.1. Natural disasters in Uttarakhand State in the past 10 years are mainly due to landslide and flooding. Heavy rain induces flooding and landslides.

**Table 7.2.1 Disaster Record of Uttarakhand State (2004-2014)**

Year	Description (Damage)
2004	Amparav Landslide: 3 persons died
2004	Sundardgung Landslide: 5 persons up in the mountains for tracking died
2004	Lambagar Landslide: 7 persons died together with other 9 missing
2004	KalindiParvat Landslide (Uttarkashi District): 6 person died
2004	Landslide at Jakholi in Tehri Garhwal and Devaldhar in Chamoli District: 32 persons died
2005	Ramlolsari Landslide: massive damage to agricultural field, no human casualties
2005	Govindghat Landslide in Chamoli District: Killed 11 persons and causes heavy damage to property
2005	Agstyamuni Landslide in Rudraprayag District: 4 persons killed and heavy loss of infrastructure
2008	Landslides at a Amru Band : 17 persons died

Year	Description (Damage)
2009	Landslides at La Jhakela in Munisyari Tehsil: 43 persons died
2010	Landslides at many places across state: 220 persons died
2012	Landslides/ Flooding in Uttarkashi and Rudraprayag District: 164 persons died
2013	Landslides/ Flooding in Uttarkashi and Rudraprayag District: more than 4,000 persons missing

Source: State Disaster Management Authority Uttarakhand, "State Disaster Management Plan", (2014)

Landslide/flooding disasters in June 2013 caused huge damages to Uttarkashi and Rudraprayag districts. Damage due to this disaster in Uttarakhand State is shown in Table 7.2.2.

**Table 7.2.2 Damages due to the Disaster (Landslide/Flooding) in June 2013 of Uttarakhand State (Damage in Rudraprayag and Uttarkashi Districts)**

Affected persons	5 lakhs (approximately)
Affected villages	4,200
Severely affected villages	over 200
Persons injured	4,463
Number of dead persons	over 900
Number of missing persons	5,748
Number of pukka houses damaged	2,679
Number of kuccha houses damaged	681
Number of animals lost	8,716
Numbers of roads destroyed	2,302
Number of bridges washed away	145
Number of drinking water schemes damaged	1,418
Number of villages without power	3,750

Source: DMMC, IAG, UNDMT, Internet

Damage caused by this disaster in Rudraprayag District was larger than in Uttarkashi District. Especially in Kedarnath and the section between Kedarnath and Sonprayag along the Mandakini River (along the NH-109), there was devastating damage and many pilgrims suffered direct and indirect damage. Figure 7.2.2 shows the photo of Kedarnath Village before and after the disaster in June 2013.



Source: PWD Uttarkashi Field Office

**Figure 7.2.2 Photo of Kedarnath Village before and after the Disaster in June 2013**

## (2) District Level

A landslide/flooding in April 2012 caused huge damage to Uttarkashi District. Table 7.2.3 and Figure 7.2.3 show the records and situation of damage due to the disaster respectively.



**Table 7.2.3 Damages due to Landslide/Flooding in April 2012 in Uttarkashi District**

Dead	35 persons
Injured	20 persons
Affected families	2,383 families
Affected population	12,115 persons
Affected agricultural land	71,788 hectare
Public properties damage	6144.72 lakh
Full damaged houses	132
Severely damaged houses	149
Partially damaged houses	313
Villages affected	192
Bridges damaged	14
Highway bridges damaged	2

Source: Uttarkashi Disaster Management Centre

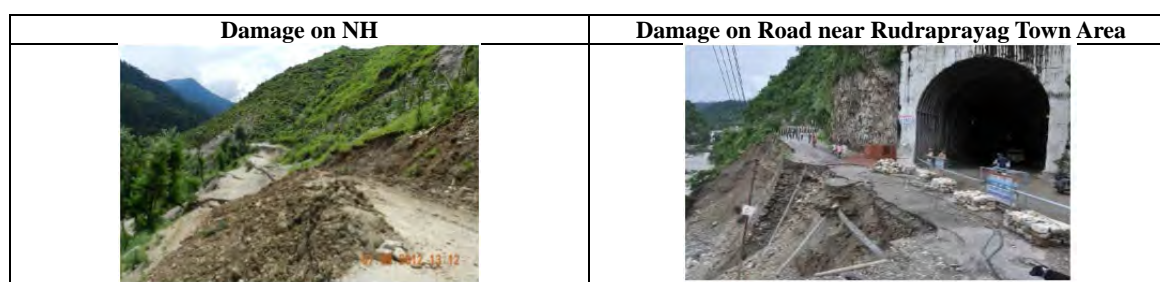

Source: DDMA Uttarkashi District

**Figure 7.2.3 Damages caused by the Landslide/Flooding in April 2012 in Uttarkashi District**

Figure 7.2.4 shows a landslide hazard zonation map prepared by DMMC. The geological, topographical and climatic conditions of the area and human factors such as deforestation, unscientific road construction (blasting for road cuttings), construction of dams or reservoirs, housing schemes, roads, and intensive agricultural practices on the steep slopes, etc., without proper environmental impact assessment have increased the intensity and frequency of landslides. Around 30 % of areas in the state are classified into severe to very high landslide hazard zones.

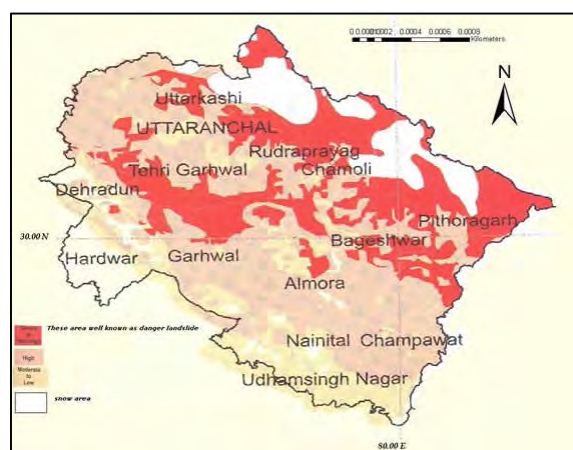

Source: DMMC

**Figure 7.2.4 Landslide Hazard Zone of Uttarakhand State**

Landslides shown in Table 7.2.2 and Table 7.2.3 are relatively huge. However, in every monsoon season around 200 landslide events occur in Uttarakhand State. Most of those landslides have occurred along the existing National Highways (NH) and other roads. Figure 7.2.5 shows an example of occurrence of small-scale landslide at the time of field survey. As shown in the figure, small-scale landslide, which triggers traffic failure and harm to people in some cases, frequently

occur in the monsoon season.

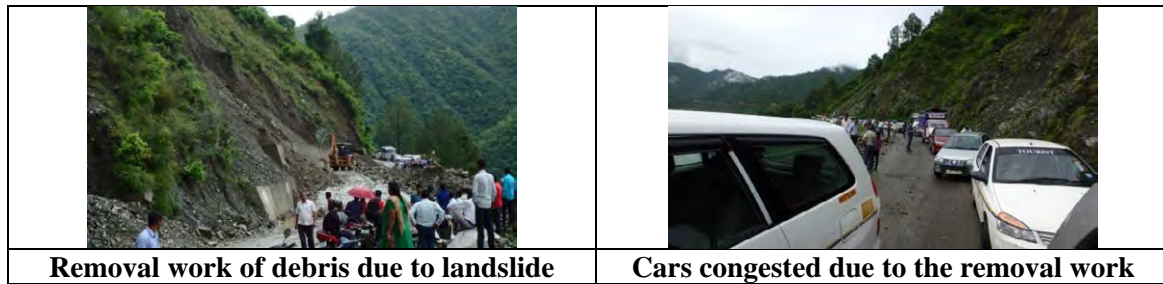

Source: prepared by the Survey Team

**Figure 7.2.5 Small-scale Landslide (near Rudraprayag as of 17 July 2015)**

## 7.2.4 Observation Systems

### (1) State Level

#### 1) Observation for Landslide Area

The SDMP does not indicate responsible authority to observation of landslide; however DMMC has a mandate to carry out scientific studies of disasters.

As discussed in the section 4.3.4, there were a few cases of installation of observation system for the Mansa Devi landslide and Varnavat landslide in Uttarakhand State for the purpose of monitoring and construction countermeasure work. Observation of the Mansa Devi landslide was carried out by CSIO and the Varnavat landslide was carried out by a private company advised by GSI. However, those observation systems have not been used for practical use, and in the Varnavat landslide, observation is not implemented by any organisations at present.

#### 2) Observation of Rainfall

Almost all landslide events have occurred in the monsoon season due to heavy and continuous rainfall. Uttarakhand SEOC receives seven or eight weather forecasts/warnings from IMD in a day. The weather forecast/warning information is sent to the DEOC. There is no rainfall observation network or stations controlled and managed by Uttarakhand State.

In order to disseminate forecasting/warning of the occurrence of landslide at local (river basin) level, it is necessary to examine and estimate the relation between rainfall and initiation of landslide at river basin level. For that, establishment of rainfall gauge network at river basin level is recommended.

### (2) District Level

Landslide observation has not been carried out at the district level. Observation of river water level has been carried out by using river water level gauges which are installed by CWC in Uttarkashi and Rudraprayag districts. The river water level gauges are installed in Bhagrahi in Uttarkashi District and Alkananda and Mandikini River in Rudeaprayag District. The observation data is sent to DEOC three times a day.

## 7.2.5 Risk Analysis

### (1) State Level

#### 1) Responsible Organisation for Risk Analysis at the State Level

DMMC is responsible for hazard risk and vulnerability assessment at the state level. GSI supports their activity.

#### 2) Landslide Inventory

Landslide inventory was prepared by DMMC and is shown in the Annex 7 of the SDMP. Furthermore, DMMC prepared a landslide inventory for specific districts, such as Rudraprayag District, based on field investigation.

On the other hand, after the disaster in 2013, GSI Uttarakhand State Unit prepared a landslide inventory of all the 419 landslides in the State. GSI has a responsibility to carry out post-disaster assessment of landslide areas in order to understand the mechanism of occurrence of landslides, evaluate stability of landslide areas and suggest appropriate method for reconstruction/recovery of landslide areas.

#### 3) Landslide Hazard Zonation Map (LHZ)

For Uttarakhand State, the major landslide zone map prepared by DMMC is shown in the SDMP and Figure 7.2.6. In addition, DMMC has carried out slope instability study for the area around Mussoorie and Nainital.



Source: DMMC

**Figure 7.2.6 Major Landslide Zones along the Char Dham Yatra Route**

As discussed in the section 4.2.5, NRSA has prepared landslide hazard zonation maps for along the rivers of Uttarakhand State based on GIS. Further, research of LHZ mapping for specialised areas such as tributary of upstream of the Mandakini River has been conducted by technical institute.

Figure 7.2.7 shows the example of LHZ map by Wadia Institute of Himalayan Geology (WIHG).

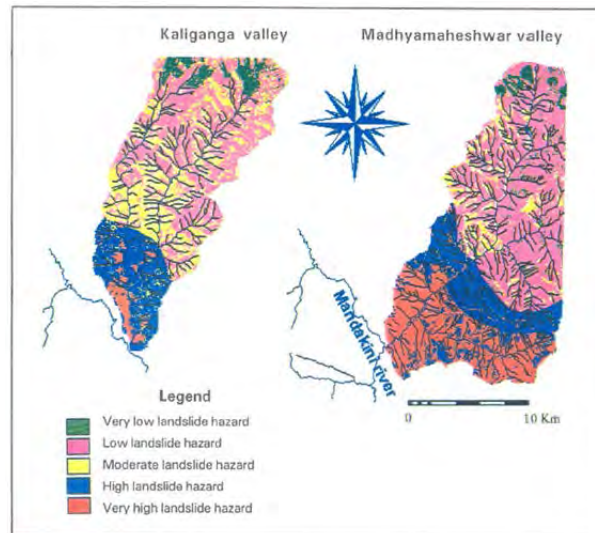

Source: WIHG

**Figure 7.2.7 An Example of LHZ prepared by Technical Institute**

#### **4) Risk Analysis**

As a basic part of risk mapping, hazard zonation map by using predictive modelling such as susceptibility modelling has been under research by GSI. Hazard zonation map by susceptibility modelling only shows the slope on which landslides are likely to occur.

For the risk analysis of landslide, in addition to hazard zonation map by susceptibility modelling, examination of element at risk and damage estimation, etc. are required. Landslide inventory is utilised for examination of susceptibility modelling. Thus, risk analysis and risk mapping of landslide has been at research level and have not prepared for practical use.

Regarding the existing landslide hazard zonation (LHZ) maps, they have been made in macro-scale. In order to identify the risk of individual landslides, meso-scale or micro-scale risk maps should be prepared.

#### **(2) District Level**

Risk analysis of landslide has not been conducted on the district level.

According to the SDMP, the DDMA has a function to ensure that the areas in the district vulnerable to disaster are identified. However, risk analysis has been carried out by national level and state level organisations, authorities and other technical institutes. And in the DDMP, location map and list of existing landslide areas are prepared. As discussed in previous section, landslide risk map by meso-scale or micro-scale by technical organisations and institutes have not reached the practical use level, therefore, the DDMA cannot use such meso-scale or micro-scale landslide risk map, and the DDMA uses landslide location maps and lists that are prepared on the district level to disseminate landslide related information to community people. From this point, the preparation of meso-scale or micro-scale landslide risk maps is required.

## 7.2.6 Emergency Response

### (1) State Level

#### 1) Emergency Response System at State Level

In order to ensure specialised response during disasters, as a specialised force that is well-versed with local terrain conditions and other ground realities, the state government has established the the State Disaster Response Force through Government Order No.2086/XX-1/13-11904) 2013 dated 09 October 2013.

On the other hand, the SEOC is set up for taking communication on the state level, district level and community level to cope with emergency situations.

According to the SDMP, level of emergency and activation guideline of EOC are given as shown in Table 7.2.4. And also the SDMP has lists of “Post-disaster responsibilities of departments as to the intended action” and “Task and responsibility matrix for emergency phase” (action to be taken for response within 72 hours and responsible authorities for the action).

**Table 7.2.4 EOC Activation Level**

Level of Emergency	Activation
L1	Minimum level of activation. This level may be used for situations that initially require only a few people
L2	This level of activation is normally achieved as an increase from Level 1 or a decrease from Level 3. This activation level is used for emergencies or planned events that would require more than a minimum staff but do not call for a full activation of all organisational elements, or less than full staffing
L3	This level of activation involves a complete and full activation with all organisational elements at full staffing. Level 3 is normally the initial activation during any major emergency.

Source: State Disaster Management Authority Uttarakhand, “State Disaster Management Plan”, (2014)

#### 2) State Disaster Response Force

Under the SDMA, the State Disaster Response Force is set up as an operational wing. The State Disaster Response Force is under the Police Department and started its operation in February 2014. The headquarters of State Disaster Response Force is set up in Dehradun and has some camp areas for pre-position teams. Camp areas are set up in the disaster prone districts such as Pithoragarh, Chamoli, Rudraprayag, Bagesgwar and Uttarkashi. The State Disaster Response Force has one battalion with six companies; each company consists of three teams and 156 officers. Out of six companies only three companies are functional at present and the other three are yet to be formed as of the end of 2015.

During disasters, the DDMA send a request to the State Disaster Response Force for deploying teams and pre-position teams.

Main function of State Disaster Response Force is to carry out emergency response and rescue activities during a disaster. Capacity building for the rescue team is conducted to prepare the emergency operations. The State Disaster Response Force also provides awareness campaigns and training programmes for community people and schools.

The State Disaster Response Force has the following equipment:

- Cutter
- Extraction equipment

- Reduction equipment; light detector, victim location detector, etc.
- Thermometer, pulse detecting equipment, first aid kit
- Basic medicines, etc.

After the disaster in June 2013, one company of State Disaster Response Force (104 persons: as of 2014) has been positioned at Sonprayag in Rudraprayag District as a pre-position team from 24 June 2014, during monsoon season.

Figure 7.2.8 shows the camp site of State Disaster Response Force and situation of State Disaster Response Force's training at Sonprayag in Rudraprayag District.

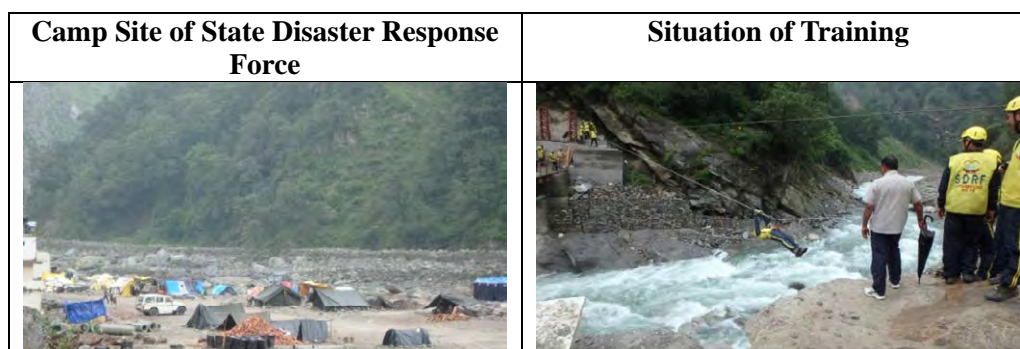

Source: prepared by the Survey Team

**Figure 7.2.8 State Disaster Response Force at Sonprayag District**

### 3) State Emergency Operation Centre (SEOC)

SEOC is set up on the premises of SDMA. SEOC is operated by DMMC.

There are 10 permanent staffs. An additional five staffs who belong to other related authorities work in the monsoon season. These staffs work in eight (8)-hour shifts. The composition of permanent staffs is as follows:

- SEOC in charge (1 person)
- Operators (Junior assistants: 4 persons)
- Office assistants (4 persons)
- Other (1 person)

The following are the main activities of SEOC:

- Forwarding weather forecasting and early warning information, which is sent by IMD (seven to eight times in a day), to DEOC
- Updating contact details of all the related persons in the data bank, such as district head, block head, media, life department, communities, village head and NGOs, etc.
- Forwarding the disaster information sent from DEOC to SDMA and DMD for further action

SEOC has the following communication equipment:

- Satellite Phone
- Radio Phone (Wireless phone)
- Phone (Land line)
- Fax and Computer
- Video call system (network station: SEOC, Dehradun, Pithoragarh (Kumaun region), Badrinath (Garhwal region), Guptkashi (Garhwal region))

Figure 7.2.9 shows the current situation of SEOC.

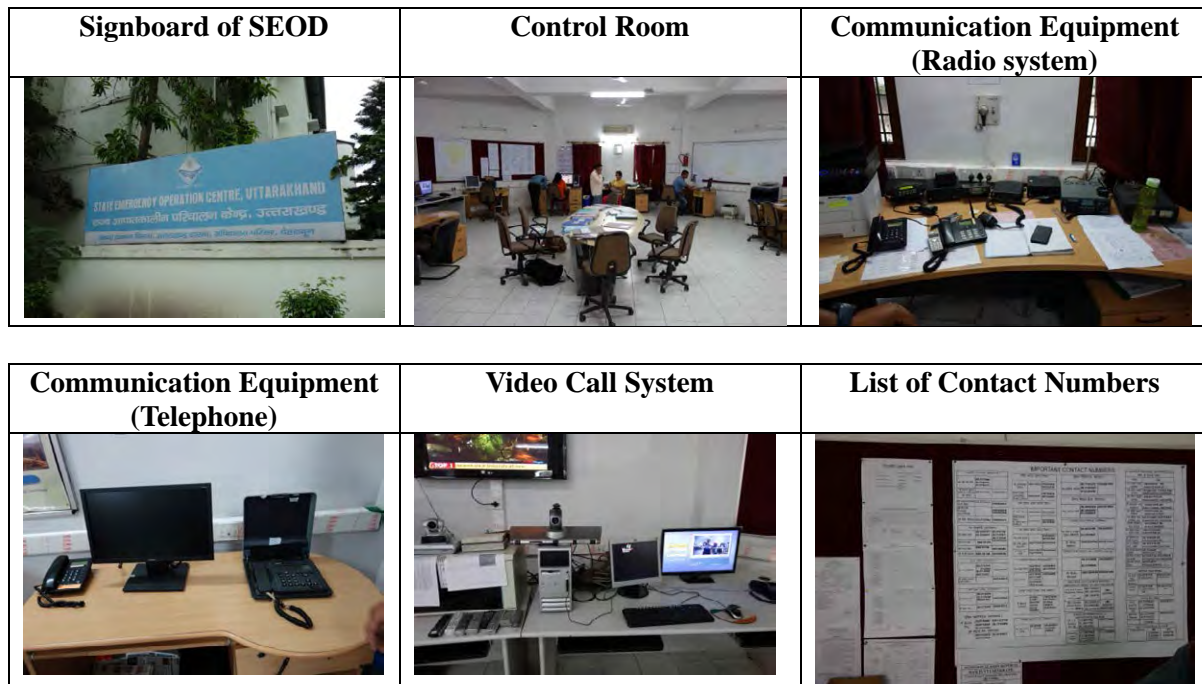

Source: prepared by the Survey Team

**Figure 7.2.9 Current Situation of SEOC**

At present, periodical communication between villages/districts and state is conducted two times per day. However, SEOC officers think that there should be more frequent calls on daily basis and DEOC should send status reports to SEOC at least every two to three hours especially in the monsoon season.

**(2) District Level**

**1) Emergency Response System at the District Level**

Emergency response system at the district level in case of landslide occurrence is shown in Figure 7.2.10.

The emergency response will be taken by the district government for the ordinal case, whilst the District Magistrate will request assistance of related state authorities and the State Disaster Response Force for abnormal situations.

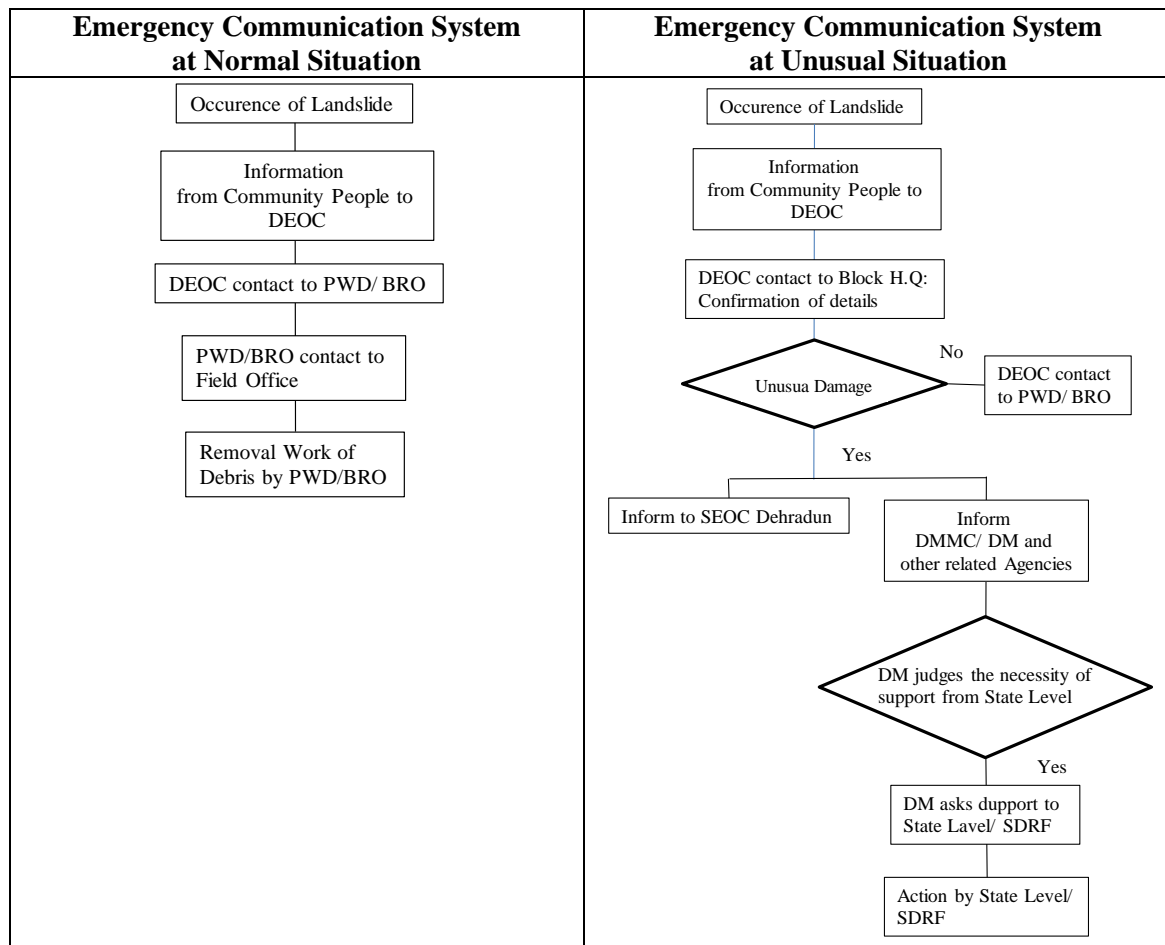

Source: prepared by the Survey Team

**Figure 7.2.10 Emergency Community System on District Level**

The SOP for daily basis periodical communication to communities is prepared and conducted. The daily basis communication with communities is conducted two or three times a day.

## 2) District Emergency Operation Centre (DEOC)

### a) Staffs

The staff number of DEOC is 10 for Uttarkashi District and 18 for Rudraprayag District. Both DEOC staffs work in eight (8)-hour shifts.

In normal situations, their key tasks are to gather information of rainfall and river water level from various locations of the district via communication equipment, to disseminate the information to communities, and to communicate with communities periodically to grasp the local situation.

### b) Equipment

The followings are the equipment owned by DEOC Uttarkashi and Rudraprayag.

DEOC Uttarkashi: <ul style="list-style-type: none"> <li>● Radio Phone (Wireless phone)</li> <li>● Phone (Land line)</li> <li>● Fax</li> </ul>	DEOC Rudraprayag: <ul style="list-style-type: none"> <li>● Radio Phone (Wireless phone)</li> <li>● Phone (Land line)</li> <li>● Fax and Desktop Computer</li> </ul>
---	---



Figure 7.2.11 shows equipment of DEOC of Uttarkashi and Rudraprayag districts, respectively. DEOC Uttarkashi does not have any personal computer. Therefore, all information received from sites is recorded in notebooks by handwriting, while DEOC Rudraprayag has a personal computer.

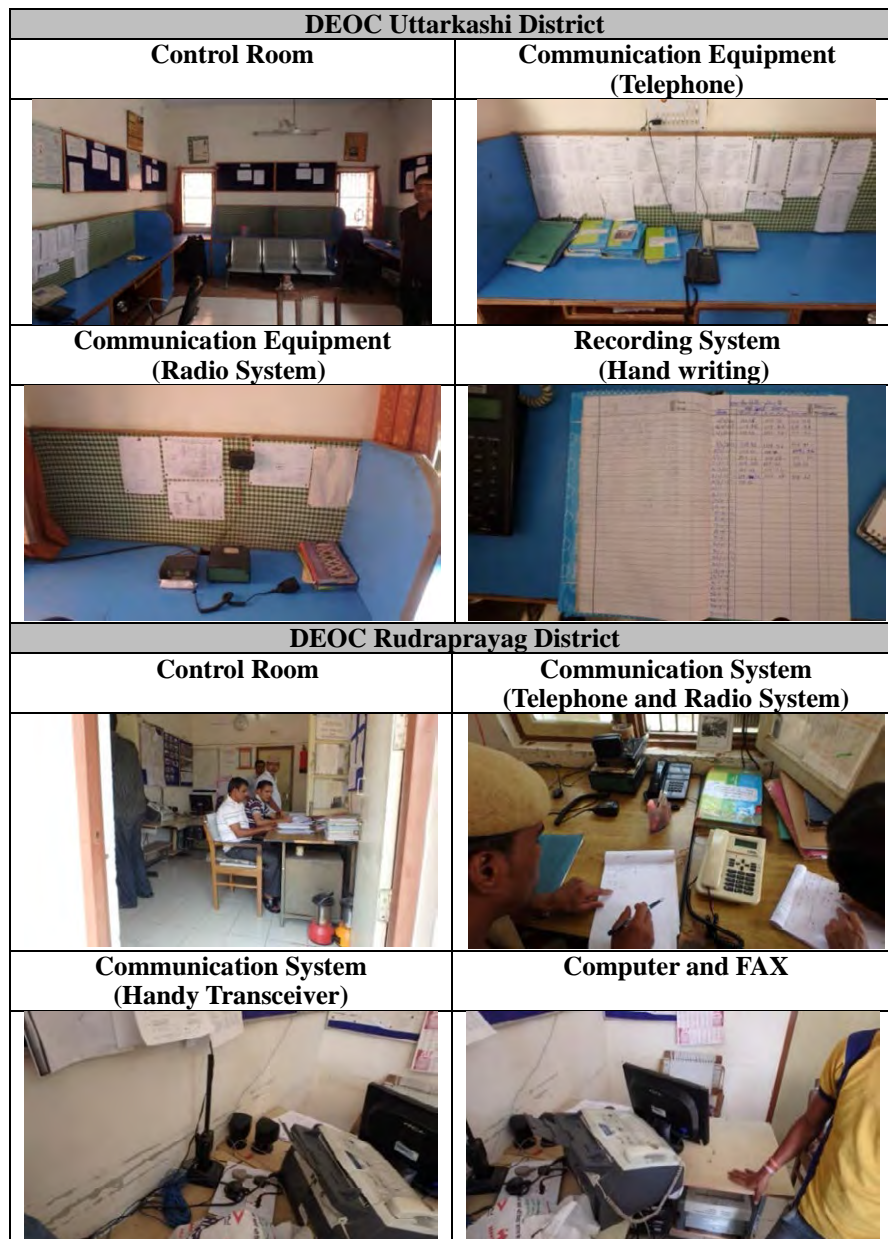

Source: prepared by the Survey Team

**Figure 7.2.11 Equipment of DEOC**

Disaster management officer of Uttarkashi District and District Magistrate of Rudraprayag expressed that there is an issue on procedure and equipment for the communication with communities. In Rudraprayag, all district government authorities including DDMA and DEOC are gathered in one area that is located around 3 km from the town centre.

### (3) Community Level

For emergency response, Village Disaster Management Committee, Tehsil Disaster Management Committee and Quick Response Teams (QRTs) have been formed which are responsible to act immediately for search and rescue, and relief operations. The roles and responsibilities and the members of the committee are defined.

Furthermore, during the disaster events, the neighbours and the people from nearby villages come for rescuing people and providing the first aid and food. This means that a “Mutual assistant system” is well established based on their experiences of disaster.

According to community people, generally it takes 24 hours for rescue team to reach to the place of incident, however it depends on distance from the district centre and can take up to 48 hours.

### **7.2.7 Evacuation Systems**

#### **(1) State Level**

##### **1) Outline**

In the SDMP, in order for appropriate provision of the DM Act, an evacuation plan is prepared. This evacuation plan lists items and policies. Basically, the DDMA's would be responsible for preparing, practicing/rehearsing, updating and revising the evacuation plan in case of any emergency.

##### **2) Contents of Evacuation Plan**

The evacuation plan covers the following contents:

- Identification of vulnerable areas
- Risk communication
- Identification of safe place
- Information exchange
- Warning dissemination
- Air evacuation and alternative routes
- Traffic regulation

This evacuation plan does not describe a landslide specific evacuation plan.

#### **(2) District and Community Level**

In the DDMP, a clear definition of evacuation system at the district and community level is not stated. However, as discussed in Section 7.2.6, each district has DEOC and a communication system between DEOC and communities. The roles and responsibilities and the members of the committee for the emergency situation are defined.

Further, there is not a specific evacuation system for landslide at the district and community level at present. Therefore, as an actual situation, if a blockage/interruption of roads occurs due to landslides, community people just stay in their villages, and wait for rescue or provision of foods.

On the other hand, Rudraprayag District experienced a huge landslide disaster in June 2013, and learned many lessons from the disaster. Therefore, Rudraprayag District has prepared the Kedarnath Evacuation Action Plan in order to reduce the damage of disaster along the Kedarnath Yatra Route.

## **7.2.8 Preparedness and Countermeasures**

### **(1) Preparedness**

#### **1) State Level**

##### **a) Outline**

According to the SDMP preparedness is classified into the following three (3) types:

- Preparedness for Mitigation:
  - ◆ Identification of Hazard
  - ◆ Ensuring Structural and Non-structural Safety Measures
  - ◆ Generation of Accurate, Authentic and Reliable Warning
- Preparedness for Response
  - ◆ Risk Transfer Mechanism, e.g. Insurance
  - ◆ Preparation of Department Plan
  - ◆ Preparation of Village, District and State Disaster Management Plan
- Preparedness for Awareness
  - ◆ Human Resource Development
  - ◆ Mass Awareness
  - ◆ Mock Drill

The State Disaster Management Plan describes items/activities to be taken during disaster and policies for them. And also the plan includes a list of tasks and the responsible authorities of each item/activity are mentioned.

On the other hand, the Uttarakhand State Disaster Management Action Plan describes preparedness measures. This action plan focuses on community based disaster management.

Components of community based preparedness in the State Disaster Management Action Plan are as follows:

- Hazard Awareness to Community
- Disaster Response by Community
- Participatory Approach (Active Involvement of Community)
- Local Knowledge in Measures
- Physical Environment
- Community Organised Preparedness
- Recovery Ability of Community

##### **b) Seven Desks System**

The seven desks system is a response structure to deal with disaster situations during calamities. Officers in charge supervise seven areas i.e. operations, logistics, communication, resources, health, services and infrastructure, sit together to make a plan and allot specific responsibilities for efficient management. The roles and responsibilities of each officer and co-workers are laid down so that they do not have to wait for orders to act and immediately follow their roles and responsibilities for immediate relief operations. This also reduces the possibility of gaps in operations due to misunderstanding among various agencies. The use of Information & Communication Technology (ICT) and the rapid advancement and development of various technologies can precisely alarm before the occurrence of such types of disasters. Brief description of each desk is shown in Table 7.2.5.

**Table 7.2.5 Brief Description of Seven Desks**

Name of Desk	Brief Description
Operation Desk	<ul style="list-style-type: none"> <li>- Disaster management and rescue operation supervision and inspection</li> <li>- Finalising the relief funds for affected persons, keeping records of the people associated with the relief work, demanding rescue and other related resources from state or central government, etc.</li> </ul>
Service Desk	<ul style="list-style-type: none"> <li>- Organising and coordinating relief and rescue work</li> <li>- Conducting search and fixing the need requirements as per the rescue operation</li> <li>- Fixing the relief amount to be disbursed</li> </ul>
Infrastructure Desk	<ul style="list-style-type: none"> <li>- Conducting temporary restoration of infrastructure such as electricity, water and transportation, etc. after disaster</li> <li>- Constructing facilitative structures such as clean living places</li> <li>- Providing and constructing hand pumps and wells</li> </ul>
Health Desk	<ul style="list-style-type: none"> <li>- Decanting dead bodies</li> <li>- Implementing medical checks of injured and patient people</li> <li>- Checking medical availability related to common and endemic disasters, ambulances and required numbers.</li> </ul>
Logistics and Agricultural Desk	<ul style="list-style-type: none"> <li>- Checking supply of the necessary resources as per information and requesting resources form other districts or villages</li> <li>- Providing the relief materials collected from the NGOs and other organisations directly to the affected people</li> </ul>
Communication and Information Desk	<ul style="list-style-type: none"> <li>- Disseminating information such as weather, rainfall, etc. from concerned departments to the district disaster management authority (DDMA)</li> <li>- Preparing and maintaining a communication list such as chief secretaries, secretaries, etc. and their contact numbers, and list of lifeline facilities such as alternative routes, sources of water, electricity and others which can be destroyed due to disaster</li> </ul>
Resource Desk	<ul style="list-style-type: none"> <li>- Accounting for the cash received from various sources and its expenditure</li> <li>- Maintaining a repository of food commodities, its utilisation and dead stock log book for all relief related commodities.</li> <li>- Accounting for all expenditure associated with relief workers</li> <li>- Maintaining all the expenditures related to administration and relief works.</li> </ul>

Source: DDMA Uttarkashi (2015)

Each DDMA and SDMA apply the Seven Desks System to the disaster management in the monsoon season.

## 2) District Level

DDMPs include the following preparedness items/actions for DRR:

- Preparedness for Mitigation:
  - ◆ Disaster mitigation and management plan (works to be taken)
  - ◆ Ensuring structural and non-structural safety measures
  - ◆ Generation of accurate, authentic and reliable warning, etc.
- Preparedness for Response:
  - ◆ List of authorities, human resources and their contact numbers
  - ◆ List of equipment for response and persons in charge for disaster events
  - ◆ List of NGOs, etc.
- Preparedness for Awareness:
  - ◆ Location map of landslide prone areas
  - ◆ Description of critical areas for natural disaster

The DDMPs do not state specific items/activities for landslides, except for landslide location maps.

On the other hand, the “National School Safety Programme” has been conducted by the GOI. For this programme, 2 out of 22 districts have been selected and Rudraprayag District is one of the target districts in Uttarakhand State. Trainer from SDMA gives training on TOT, mock drills and

preparation of disaster management plan of schools. Budget of this programme is allocated by the GOI. And also training for capacity building of communities is provided by NGOs.

The huge disaster in June 2013 caused enormous damage to Uttarakhand State, especially Rudraprayag District was heavily affected during the disaster. Rudraprayag DDMA learned many lessons from this disaster. Based on these lessons, Rudraprayag District has prepared the Kedarnath Evacuation Action Plan and several safety measures have been set and installed based on the action plan. Main safety measures along the Kedarnath Yatra Route are as follows:

- Deploying one company of the State Disaster Response Force at Sonprayag in the monsoon season
- Setting up four pilgrim registration and verification centres at Guptkashi, Phata, Sonprayag and Kedarnath
- Constructing helipads at all critical locations for rescue and evacuation
- Restoring power supply

Figure 7.2.12 shows critical location and evacuation points along the Kedarnath Yatra Route.

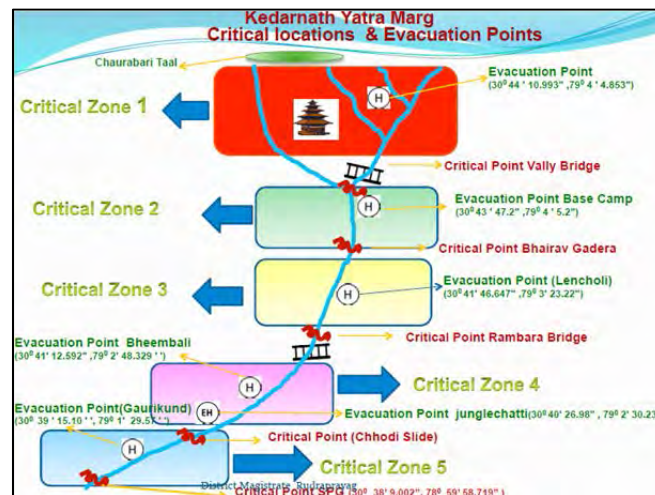

Source: DDMA Rudraprayag

**Figure 7.2.12 Critical Location and Evacuation Points along Kedarnath Tatra Route**

Some training and awareness programmes have been provided to community by State Government and BRO, etc. in Uttarkashi District. However, District authorities do not provide any training to community people.

## (2) Countermeasures

### 1) Responsible Organisation to deal the Countermeasure Work

Construction work of countermeasures is carried out by PWD Uttarakhand and BRO. Also PWD and BRO are responsible for carrying out maintenance of roads and road slopes. For the planning of countermeasures, GSI and DMMC give technical advice/suggestions to PWD and BOR.

PWD Uttarakhand divides the operation area into two zones and there are total 16 field offices. In case of occurrence of landslide, PWD field office and BRO carry out the removal work of debris accumulated onto the road. BRO is in charge of some NHs (NH-108, 58) in Rudraprayag and Uttarkashi districts.



Budget for construction countermeasures, removal of debris and maintenance of roads is allocated by MORTH.

If the scale of landslide is large and/or PWD has technical difficulty conducting countermeasure work such as in the case of Varnavat Landslide in Uttarkashi, national level technical organisations and institutes deal with countermeasure work.

**2) Outline of Situation of Landslide in the Surveyed District**

**a) Topographical Setting of Landslide Area**

Topographical setting of landslide area is mainly divided into two categories. One is the landslides which are located on slopes with high relative height from rivers, and the other one is landslides which are located on slopes along the rivers or near river beds. The latter is overwhelmingly common and causes greater damage to traffic compared to the former case. The topographical settings of landslides depend on alignment of roads. Figure 7.2.13 shows the example of above-mentioned topographical setting of landslide area.



<b>Landslide Area with High Relative Height from River</b>	<b>Landslide Area along the River</b>
	
It does not suffer an influence of tow erosion by river stream	It suffers an influence of tow erosion by river stream (Sonprayag Landslide; Rudraprayag)



Source: prepared by the Survey Team

**Figure 7.2.13 Topographical Setting of Landslide Area**

**b) Types of Landslide**

Based on the field survey in Uttarkashi and Rudraprayag districts, the landslides can be classified into four types. Figure 7.2.14 shows each typical type of landslide.

<b>(a) Rock Fall Type</b> Some part of rock mass fall down on the road	<b>(b) Lateral Spread (Debris Spread) Type</b> Debris/alluvial cone on the tow of slope is spread onto roads due to loosening by rainfall
	

<p><b>(c) Combination of Rock Fall and Lateral Spread</b> Loosened rock mass due to weathering and debris/alluvial cone are spread onto roads due to loosening by rainfall</p>	<p><b>(d) Slide (Rotational) Type</b> Landslide which has sliding surface caused by loosening materials of slope or increase of pore water pressure due to groundwater level rise. It is assumed that sliding surface of this type extends to river side.</p>
	

Source: prepared by the Survey Team

**Figure 7.2.14 Typical Types of Landslide by the Field Survey Results**

The type of landslide mainly depends on the geological condition. Many landslide areas are classified into type (b).

As shown in Figure 7.2.15, accumulation of soils and stones on the road due to debris flow from small stream can be seen in places. The reasons for this phenomena are mainly due to inappropriate size (dimensions) of box culverts that are constructed underneath the road or no construction of box culverts for down-flow of stream water in the monsoon season.

<p><b>Debris Flow from Small Stream</b></p>	
<p>Debris flows from mountain side of small stream onto roads due to inappropriate size of box culverts and no construction of box culverts</p>	
	

Source: prepared by the Survey Team

**Figure 7.2.15 Situation of Debris Flow from Small Stream**

### 3) Existing Countermeasures for Landslide Risk Mitigation

#### a) In case of Large Scale Landslide (Varnavat Landslide in Uttarkashi)

As discussed in Section 4.3.4 and 4.3.6, countermeasure works were implemented from 2003 to 2009. Major components of countermeasure are as follows:

- Geo grid wall
- Chainlink shotcrete with drainage pipe
- Ground anchor
- Slope cutting

Photos of these countermeasures are shown in section 4.3.6.



According to the latest information by Times of India (TOI) on 21 July 2015, a crack was observed on a part of the treated area of countermeasures. TOI reports that poor slope treatment methods caused this crack.

**b) Typical Countermeasure Method used for other Landslide Area**

Typical countermeasures methods constructed by PWD and BRO are as follows:

- Stone Masonry
- Gabion

Figure 7.2.16 show the typical countermeasures along the existing NHs.

<b>Stone Masonry</b>	<b>Gabion</b>
	
<b>NH-97 Bukki Landslide Uttarlashi District</b>	<b>NH-107 Kakdagad Landslide Rudraprayag District</b>



Source: prepared by the Survey Team

**Figure 7.2.16 Typical Method of Countermeasures for Existing Landslide**

Some of the countermeasures are effective; however, most of countermeasure are ineffective and inappropriate as fundamental landslide measures. Due to reoccurrence of landslide, those countermeasures are partially destroyed. Furthermore, there are many landslides which have no countermeasures, therefore, debris spreads onto road surface every time rain falls in such areas.

Measures for protection from weathering and erosion of landslide zone and countermeasures appropriate to the type of landslide are required. Re-alignment of road to avoid landslide area should be taken into consideration.

Figure 7.2.17 shows condition of construction of stone masonry by BRO and installation situation of danger notice signboard of landslide.

<b>Construction of Stone Masonry by BRO NH-97 (Uttarkashi District)</b>	<b>Danger Notice Signboard NH-97 (Uttarkashi District)</b>
	

Source: prepared by the Survey Team

**Figure 7.2.17 Construction of Stone Masonry and Danger Notice Signboard**



**c) Rehabilitation and Upgrading Road Project in Uttarakhand State**

At present, a road rehabilitation and upgrading project is in progress by MORTH. The DPRs for this project were prepared and tender process for the implementation of works is underway. The following are the main features of this project:

- Total length of the Project: 899km
- Total cost of the Project: Rs. 12,000 crores
- Target NH: NH-58, 74, 94, 108, 109, 119, 121 and 125 in the Uttarakhand State
- Planned Project Period: 3 to 4 years, commenced from the beginning of 2016
- To re-align/stabilise all major landslide locations
- To keep the re-alignments away from rivers both horizontally and vertically
- To provide long bridges/viaducts/tunnels (2 tunnels, 5km and 500m)/to bypass landslide hazard zones
- To improve all geometric deficiencies of the existing roads
- To enhance the road safety measures, as per the site specific conditions
- To reconstruct all narrow/distressed bridges
- To provide bypasses/re-alignments for congested towns/built-up areas
- To provide way-side amenities including parking areas and helipads depending on the land availability

Schematic drawing of target road is shown in Figure 7.2.18. Blue, orange and red coloured roads on the map are the target roads of this project. All NH are covered by this project. Each colour line shows main support authorities other than NH (MORTH).

- Orange coloured line: NH and State PWD (State Public Works Department)
- Red coloured line: NH and NHAI (National Highways Authority)
- Blue coloured line: NH and BRO (Border Roads Organisations)



Source: MORTH (2015)

**Figure 7.2.18 Schematic Drawing of Target Roads**

DPR of the project was prepared in coordination with the following organisations:

- Geological Survey of India (GSI)
- Survey of India (SOI)
- Indian Institute of Remote Sensing (IIRS)
- Central Water Commission (CWC)
- State government departments such as DMMC, Civil Aviation, Tourism, Police, Revenue, Forest Irrigation, etc.

MORTH plans to apply latest technology to these project components such as slope stabilisation. Therefore, the procedure and method used for the planning, design and construction work of this project should be summarised as guidelines/manuals as a reference for similar works in the future.

### 7.2.9 Forecasting, Early Warning and Communication Systems at State Level

The SEOC is responsible for disseminating warning upon receiving early warning information from IMD, CWC and GSI. The figure below shows the communication network in Uttarakhand State. VSAT is used for communicating with the central organisations and the districts, while the satellite phone is the local communication tool.

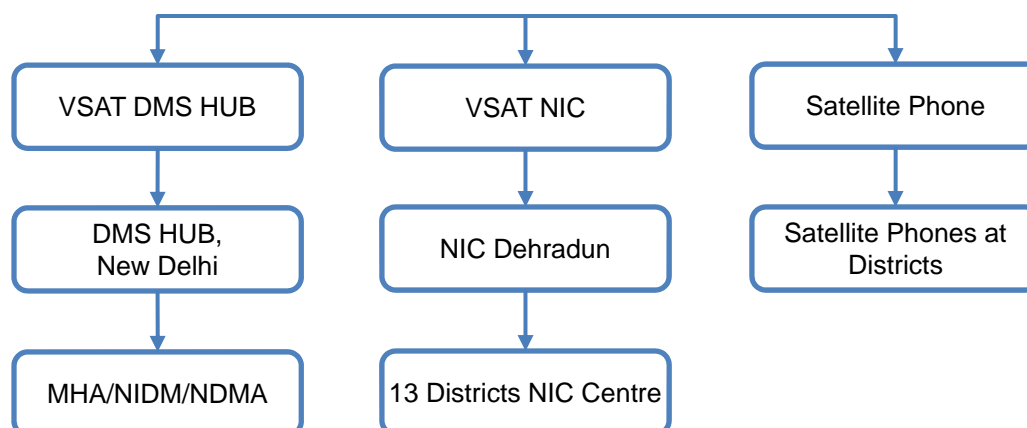

Source: State Disaster Management Authority Uttarakhand, "State Disaster Management Plan", (2014)

**Figure 7.2.19 Communication Network in Uttarakhand State**

### 7.2.10 Disaster Risk Finance at State Level

#### (1) Disaster Risk Finance Scheme in Uttarakhand State

The DMD has authority to handle the SDRF under the approval of the SEC. The SDRF is distributed among the districts in the state uniformly before the onset of the monsoon every year. The additional funds are also provided during the emergency operation if demanded by the District Magistrate. Moreover, the District Magistrate is allowed to utilise the allocated SDRF for the purpose of disaster preparedness if the SDRF remains.

#### (2) Operation of Disaster Risk Finance in Uttarakhand State

The allocations and amounts released of the SDRF and the NDRF in Uttarakhand State during the 13th FC period are summarised in Table 7.2.6.

**Table 7.2.6 Allocation and Release of SDRF/NDRF in Uttarakhand State (2010-2015)**

Year	SDRF Allocated	SDRF Released	NDRF Released
2010-2011	117.66	105.89	517.66
2011-2012	123.54	-	-
2012-2013	129.72	205.60	-
2013-2014	136.22	145.00	329.50
2014-2015	143.02	-	172.33

Source: MHA, "Annual Report", (2010-2011 to 2014-2015)

During the monsoon period of 2010, the entire state was overwhelmed with landslides, flash floods and floods causing more than 200 fatalities. In 2012, Uttarkashi and Rudraprayag districts were hit by flash floods, debris flows and landslides. As the latest huge disaster, Uttarakhand State was

severely hit by heavy rain-induced flash floods and landslides in June 2013. On the occasions of those disasters, the SDRF and NDRF were utilised for the response and relief activities. Uttarkashi District suffered from severe flood and landslide disasters in 2012 and 2013 respectively. The expenditures of the SDRF in this district during the 13th FC period are shown in Table 7.2.7.

**Table 7.2.7 Sanction and Release of SDRF in Uttarkashi District (2010-2015)**

(unit: Rs. lakh)			
Year	Sanctioned Amount	Released Amount	Balance
2010-2011	505.61	500.88	4.73
2011-2012	82.50	69.73	12.77
2012-2013	425.71	409.05	16.66
2013-2014	406.66	406.66	0
2014-2015	42.64	40.66	1.98

Source: Uttarkashi District Disaster Management Authority (2015)

### 7.2.11 Challenges to be Addressed

According to the information gathered, the following are the challenges identified by the related organisations in Uttarakhand State:

#### < Forecasting, Early Warning and Communication System >

As discussed in Subsection 4.3.7, monitoring and early warning systems of landslides have not been established in India. There are some examples of research activities related to monitoring and early warning systems of landslides. However, the results of those works have not been practically used for landslide disaster mitigation and reduction. NDMA and GSI Uttarakhand Unit pointed out the necessity of the systems.

Challenge(s) of Forecasting, Early Warning and Communication System:

- Establishing forecasting/early warning system for landslide

#### < Emergency Response >

As discussed in Subsection 4.3.7, the SEOC of Uttarakhand State, the District Magistrates and the DEOCs of Uttarkashi and Rudrapurayag districts pointed out that there was an issue on the last mile connectivity among the SEOC, the DEOCs and community inhabitants at times of emergency.

Challenge(s) of Emergency Response System:

- Strengthening the communication system at the time of occurrence of landslide event

In addition, considering the current situation of landslide risk reduction in Uttarakhand State, it is worth pointing out the following as challenges to be addressed:

#### < Institutional Framework >

As discussed in Subsection 4.3.7, the GSI and some technical institutions have carried out partial landslide risk assessment and given the results to related organisations. However, national and state level organisations related to landslide risk reduction do not utilise their works for landslide risk reduction well. Therefore, it is necessary to strengthen the coordination mechanism among organisations and institutions to realise landslide risk reduction based on the results of risk assessment.

Challenge(s) of Institutional Framework:

- Strengthening the coordination mechanism among organisations/institutions related to landslide DRR

< Risk Analysis >

Past records of updating the landslide inventory at the state level were not found. Reviewing and revising the landslide inventory at the state level is important to assess the risk level of landslides and also is required for the risk analysis by central technical organisations/institutes.

Challenge(s) of Risk Analysis: ● Reviewing and revising the landslide inventory

< Preparedness >

An evacuation map that shows the evacuation route and area is essential for the preparedness of community inhabitants against landslides. However, such maps were not found during the survey. It can be inferred that the evacuation maps have not been prepared. In order to raise the public awareness of landslide risk and make the community inhabitants prepared, it is necessary to prepare the evacuation maps for communities alongside or close to landslide prone areas.

Challenge(s) of Preparedness: ● Preparing evacuation maps (evacuation places and routes) for communities close to landslide prone areas

< Countermeasures >

As discussed in Subsection 4.3.7, only a very limited variety of countermeasures against landslides can be found in the mountain areas. Therefore, it is necessary to evaluate what measures are suitable for each case and apply the countermeasure work to the specific landslide mechanism.

Challenge(s) of Countermeasures: ● Establishing appropriate system of planning, design and construction of countermeasures

< Evacuation System >

State and district governments did not mention this point as a challenge. Rudraprayag District was heavily affected during the landslide disaster in 2013. Rudraprayag DDMA learned many lessons from this disaster. Based on these lessons, Rudraprayag District has prepared the Kedarnath Evacuation Action Plan as a specific plan and several safety measures have also been set and implemented based on the action plan. Preparation of such a specific evacuation plan for areas with high risk is useful to reduce/mitigate the landslide risk for districts that have landslide prone areas.

Challenge(s) of Evacuation System: ● Strengthening the evacuation system at the time of occurrence of landslide event

Table 7.2.8 shows the challenges identified, actions to be taken for the improvement, and organisations responsible for implementation of the actions.

**Table 7.2.8 Challenges and Actions (Uttarakhand State)**

S/N	Challenges	Actions to be Taken: Uttarakhand State		
		Short Term (1 - 2 Years)	Medium Term (3 -5 Years)	Long Term (5 - 10 Years)
<b>Challenges identified by the Indian Side</b>				
[ Forecasting, Early Warning and Communication System ]				
PA-UK-1	Establishing forecasting/early warning system for landslide	<u>Action(s)</u> - Reviewing the output of existing observation systems conducted as experimental basis	<u>Action(s)</u> - Planning the forecasting/early warning system to be developed for landslide risk reduction - Preparing the national guidelines and manual for the system development	<u>Action(s)</u> - Establishing reliable forecasting/early warning system for landslide risk reduction in accordance with the national guidelines and manual
		<u>Taken by</u> - GSI - SDMA - DMD	<u>Taken by</u> - GSI - SDMA - SEOC - DEOC	<u>Taken by</u> - GSI - SDMA - SEOC - DEOC
[ Emergency Response ]				
PA-UK-2	Strengthening the communication system at the time of occurrence of landslide event	<u>Action(s)</u> - Reviewing the existing procedures and equipment used for emergency response - Planning the communication systems to be established	<u>Action(s)</u> - Establishing the communication system among SDRF, SEOC, DEOC, related organisations and communities at the time of disaster (Equipment installation)	-
		<u>Taken by</u> - SDMA - SEOC - DEOC	<u>Taken by</u> - SDMA - SEOC - DEOC - Communities	-
<b>Challenges identified by the Survey Team</b>				
[ Institutional Framework ]				
PA-UK-3	Strengthening the coordination mechanism among organisations/ institutions related to landslide DRR	<u>Action(s)</u> - Reviewing the current situation of coordination mechanism and identifying the gap - Formulating an action plan to improve the coordination mechanism	<u>Action(s)</u> - Establishing the coordination mechanism among organizations related to planning of landslide risk reduction at the state and district level	-
		<u>Taken by</u> - GSI - Government of India's Institution - BRO - PWD	<u>Taken by</u> - GSI - Government of India's Institution - BRO - PWD	-

S/N	Challenges	Actions to be Taken: Uttarakhand State		
		Short Term (1 - 2 Years)	Medium Term (3 -5 Years)	Long Term (5 - 10 Years)
<b>Challenges identified by the Indian Side</b>				
[ Risk Analysis ]				
PA-UK-4	Reviewing and revising the landslide inventory	<u>Action(s)</u> - Reviewing and revising landslide inventory (event basis) for the risk analysis	<u>Action(s)</u> - Reviewing and revising landslide inventory (event basis) for the risk analysis	<u>Action(s)</u> - Reviewing and revising landslide inventory (event basis) for the risk analysis
		<u>Taken by</u> - GSI - DMD - SDMA	<u>Taken by</u> - GSI - DMD - SDMA	<u>Taken by</u> - GSI - DMD - SDMA
[ Preparedness ]				
PA-UK-5	Preparing evacuation maps (evacuation places and routes) for communities close to landslide prone areas	<u>Action(s)</u> - Conducting vulnerability assessment for infrastructure and communities - Preparing a land use plan in accordance with the national land use guidelines	<u>Action(s)</u> - Preparing evacuation maps (showing evacuation places and routes) in high landslide risk areas in cooperation with community inhabitants who lives in or close to landslide prone areas - Conducting training to community inhabitants for community based disaster management	-
		<u>Taken by</u> - SDMA - DMD	<u>Taken by</u> - SDMA - DMD - DDMA - Communities	-
[ Countermeasure ]				
PA-UK-6	Establishing appropriate system of planning, design and construction of countermeasures	(The action can be effective after establishment of coordination mechanism among the related organisations)	(The action can be effective after establishment of coordination mechanism among the related organisations)	<u>Action(s)</u> - Implementing countermeasures for the landslide with high risk rank which is set up by the National level organisations - Preparing DPR for the construction of countermeasures against landslides - Implementing the project
		-	-	<u>Taken by</u> - PWD - BRO

S/N	Challenges	Actions to be Taken: Uttarakhand State		
		Short Term (1 - 2 Years)	Medium Term (3 -5 Years)	Long Term (5 - 10 Years)
[ Evacuation System ]				
PA-UK-7	Strengthening the evacuation system at the time of occurrence of landslide event	<u>Action(s)</u> - Reviewing the existing procedures and equipment used for evacuation - Planning the evacuation system among the State Disaster Response Force, SEOC, DEOC, related organizations and communities	<u>Action(s)</u> - Establishing the evacuation system for communities at the time of disaster (formulation of procedures and equipment installation if necessary)	-
		<u>Taken by</u> - SDMA - DMD - SEOC - State Disaster Response Force - DDMA - DEOC	<u>Taken by</u> - SDMA - DMD - SEOC - State Disaster Response Force - DDMA - DEOC - Communities	-

Source: prepared by the Survey Team

### 7.3 Bihar State

#### 7.3.1 State Disaster Management Policy and Development Plan

The Government of Bihar State prepared an approach to the 12th Five-Year Plan. This shows the state plan during the 12th Five-Year Plan period and includes the component of disaster management. The Vision in the 12th Five-Year Plan for disaster management sector in Bihar State is “DRR for all”. The 12th Five-Year Plan aims at reducing areas susceptible to different kinds of disasters through appropriate risk reduction measures, planning of responses and adequate public awareness campaigns. The followings are the key areas for the disaster management:

- Regular studies, research and workshops vulnerability analysis and existing coping mechanisms
- Reforms in the existing administrative, legal, techno-legal and institutional systems for mainstreaming DRR in all the development policies
- Capacity building of communities through pro-active role of Panchayati Raj Institutions (PRIs)/Urban Local Bodies (ULBs)
- Mainstreaming DRR in development policy

The Government of Bihar State also prepared the SDMP consisting of two (2) parts: disaster risk management and disaster crisis management. The first part, disaster risk management, deals with prevention, mitigation, preparedness and capacity building, while the second part mainly describes response and relief, recovery, rehabilitation and livelihood resettlement. The objectives of the plan are set as follows:

- Treating community as the primary stakeholder and first respondent in the SDMP, focusing on disaster risk reduction, prevention, mitigation and preparedness measures
- Emphasising preparedness at the community level and readiness at the local bodies level
- Facilitating the role played by the administration and government departments and other stakeholders through the institutional mechanism

- Creating specialised institutions to make disaster management an inclusive exercise and to wed it to development initiatives
- Creating a dependable early warning system to warn people and activate other stakeholders
- Ensuring quick response and providing relief with care and attention to those belonging to marginalised sections
- Undertaking rehabilitation with “Build Back Better” motif

The first part is composed of four (4) sections: 1) disaster prevention and mitigation, 2) disaster preparedness, 3) Sankalp Kendra (community-based disaster management), and 4) awareness generation and capability building. The plan describes the factors at risk by typical disaster type in the state as shown in Table 7.3.1.

**Table 7.3.1 Factor Risks identified in the State Disaster Management Plan**

Disaster Type	Factors at Risk
Flood	<ul style="list-style-type: none"> <li>- The flood-prone zone is around 74 % and highly flood affected area is around 36 %.</li> <li>- The agriculture affected in Bihar every year by floods covers up to 16,258 hectares.</li> <li>- In 36 % of the highly affected areas of the State, apart from agriculture, stored agri-products, 70 % of Kutchha dwellings, where around 42 % of the poor people live, and a host of infrastructure are liable to be badly affected.</li> </ul>
Earthquake	<ul style="list-style-type: none"> <li>- Around 13 million habitations of all sorts are in the severe earthquake prone area of 78.9 %.</li> <li>- The infrastructure in the 78.9 % area of the state consists of 75,000 km of national highways to link roads with numerous large infrastructures, like Gandhi Setu and Rajendra Bridge, and small bridges in numerous numbers.</li> </ul>
Drought	<ul style="list-style-type: none"> <li>- The population and livestock affected would be approximately 47 million persons out of which around 22 million would be women and about 8 million children of 0-6 years. Age group SC/ST and minorities affected would be around 15,853,044.</li> </ul>

Source: Disaster Management Department, “The State Disaster Management Plan”

The disaster preparedness described in the plan covers the following three (3) activities:

- Research and study: hazard mapping
- Meticulous planning: creation of special setups and programme and activities at each administration level
- Capacity development at each administration level

The second part of the plan is mainly composed of three (3) sections: 1) disaster response, 2) build back better, and 3) roles and responsibilities of and guidelines for government departments and other stakeholders. This part is similar to the SOP for disaster response. The disaster response section outlines the disaster management system, response plan including incident command structure and emergency support functions, and relief operation. The “build back better” section describes the concept. The followings are the examples of policy statement:

- The rehabilitation, reconstruction and recovery efforts shall aim at restoring the affected structures to a condition better than what existed before the disaster.
- All construction work-houses, infrastructure, roads and bridges shall be built hazard-resistant.

In addition, Bihar State has taken initiative to organise the Bihar Conference of Disaster Risk Reduction (BCDRR) on Post Sendai Development Framework. This initiative aims to create a conducive environment for stakeholders to participate in framing the DRR road map for Bihar-2020. Key outcomes of the BCDRR are to draft a road map for mainstreaming the DRR in each sectoral development programme and to develop indicators for monitoring and evaluation of progress made to achieve the set goals.



### 7.3.2 Institutional Framework for Disaster Management

The Disaster Management Department (DMD) and Bihar State Disaster Management Authority (BSDMA) are the primary bodies responsible for disaster management in Bihar State. Roles of those organisations are shown in Table 7.3.2.

**Table 7.3.2 Roles of DMD and BSDMA**

Organisation	Role
Disaster Management Department (DMD)	<ul style="list-style-type: none"> <li>- Coordinating with the department of state government</li> <li>- Analysing information and gaps for the people of Bihar during natural and human emergencies</li> <li>- Operating the state emergency operation centre</li> <li>- Commanding and coordinating disaster response operation</li> <li>- Dispatching the National Disaster Response Force and BSDRF to the incident sites</li> <li>- Allocating resources to districts for combating disaster situations</li> </ul>
Bihar State Disaster Management Authority (BSDMA)	<ul style="list-style-type: none"> <li>- Laying down policies on disaster management, and guidelines to be followed by the district authorities in drawing up the district plan and by the different state departments for the purpose of integrating the measures for prevention of disaster or the mitigation of its effects in their development plans and projects</li> <li>- Approving plans prepared by the departments of the state government in accordance with the state plan</li> <li>- Coordinating the enforcement and implementation of the policy and plans for disaster management</li> <li>- Recommending provision of funds for the purpose of mitigation</li> <li>- Taking such other measures for the prevention of disaster, or mitigation, or preparedness and</li> <li>- Capacity building for dealing with threatening disaster situations or disasters as it may consider necessary</li> </ul>

Source: compiled by the Survey Team from the information of DMD and BSDMA

DMD is mainly responsible for disaster crisis management (immediate response-centric) stated in the SDMP, while BSDMA is engaged in the disaster risk management such as prevention and mitigation, preparedness and capacity building. Figure 7.3.1 shows the current organisational setup for the disaster management in the state. At present, 65 officials are working for the DMD, including supporting staff. However, there are no permanently deployed officials for the disaster management. On the other hand, senior advisers for several fields are deployed in BSDMA. Figure 7.3.2 show the organisational structure of BSDMA. Currently, more than 20 officials are deployed to BSDMA.

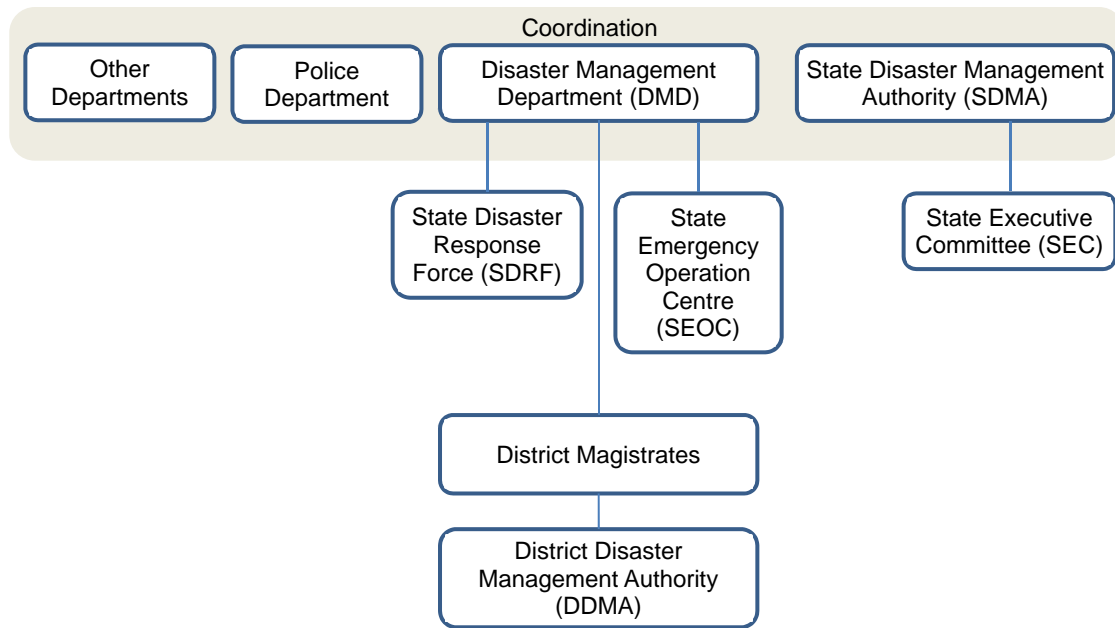

Source: prepared by the Survey Team

**Figure 7.3.1 Current Organisational Setup for Disaster Management in Bihar State**

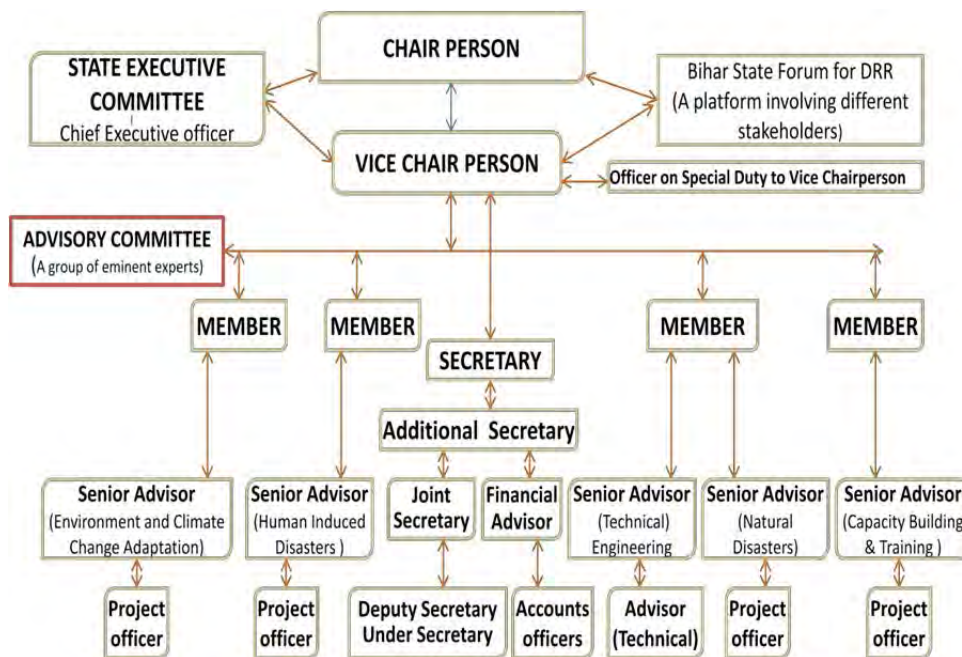

Source: BSDMA (2015)

**Figure 7.3.2 Organisational Structure of Bihar State Disaster Management Authority**

### 7.3.3 Disaster Records

#### (1) Multi-Hazard Profile of Bihar State

The geographical complexion of Bihar, its boundaries, its land, its water bodies, the climate and, above all, its location makes it the “Home state of hazards”. Major hazards in the state are earthquakes, floods and droughts.

## (2) Earthquake

The major earthquake records in Bihar are shown in Table 7.3.3. The earthquakes in Bihar range from 5.5 to 8.3 on the Richter scale from 1900s onwards. The latest earthquake was reported on 18 September 2011 at 6.12 pm with magnitude of 6.8 on the Richter scale with epicentre being Sikkim-Nepal region. Only 10 casualties were reported in the state. The worst earthquake was in 1934, when about 10,500 people lost their lives. Munger in Bihar was completely ruined. Large parts of Patna, Muzaffarpur and Dharhanga in Bihar were also destroyed. The isoseismic covered an area of about 36,000 km<sup>2</sup> with an average length of about 300 km from the epicentre.

**Table 7.3.3 Major Earthquakes in Bihar State**

No.	Date	Epicentre	Scale	Casualties	Districts Affected
1	7 October 1920	Bihar-Uttar Pradesh-Bihar	5.5	-	
2	15 January 1934	Indo-Nepal Border	8.3	10,500	Patna, Gaya, Shahabad, Saran, Muzaffarpur, Dharhanga, Bhagaipur, Munger, Purnia
3	11 January 1962	Indo-Nepal Border	6.0	-	
4	21 August 1988	Indo-Nepal Border	6.8	1,000	Mudhubani, Dharhanga
5	18 September 2011	Sikkim-Nepal Border	6.8	10	

Source: Disaster Management Department, Government of Bihar, "The State Disaster Management Plan (Part 1)"

## (3) Floods

Bihar State is the most flood-prone state in India. There are 28 flood-prone districts identified in Bihar. Out of these, 15 are categorised as the most flood-prone districts and remaining 13 are flood-prone districts. The flood affected area accounts for 73 % (about 68,800 km<sup>2</sup>) of total geographical area (94,163 km<sup>2</sup>). The total area affected by floods increased during these years. The flood damage data in Bihar is shown in Table 7.3.4.

**Table 7.3.4 Flood Damage during 2004-2013 in Bihar State**

Year	Affected Area (Lakh.ha)	Population Affected Lakh)	Damageg Crops (Rs. Lakh)	Damaged Houses (Rs. Lakh)	Human Live Lost (Nos.)	Animal Live Lost (Nos.)	Damaged Public Utilities (Rs. Lakh)	Total Damages (Rs. Lakh)	
2004	27.00	212.99	52,205.64	75,809.51	885	3,272	103,049.60	231,064.75	
2005	4.60	21.04	1,164.50	382.79	58	4	305.00	1,852.29	
2006	1.81	10.89	706.63	1,225.03	36	31	8,456.17	10,387.83	
2007	18.83	244.42	76,837.82	83,144.52	1287	2,423	64,241.52	224,223.86	
2008	8.82	49.95	3,420.25	8,451.40	258	878	9,771.96	21,643.61	
2009	11.05	22.03	2,182.57	528.15	97	2	530.10	3,240.82	
2010	1.99	7.18	311.92	704.87	32	0	189.20	1,205.99	
2011	39.20	71.43	10,295.70	6,904.44	249	183	153.67	17,353.81	
2012	1.07	2.40	300.00	159.52	15	0	162.20	621.72	
2013	20.00	69.00	10,572.00	2,506.00	231	6,464	1,661.00	14,739.00	
Total	134.38	711.33	157,997	179,816	3,148	13,257	188,520	526,334	
Average per year	13.44	71.13	15,800	17,982	315	1,326	18,852	52,633	
Maximam Record	Damage	27	244.42	76,837.82	83,144.52	1287	3,272	103,409.60	231,064.75
	Year	2004	2007	2007	2007	2007	2004	2004	2004

Source: Flood Management Information Support Centre, "Flood Report 2013", (2014)

The largest flood disaster occurred in 2007. It was reported that 1,287 people and 2,423 animals were killed and damaged houses were worth Rs. 83,144 lakh. Damaged crops and public utilities were estimated at Rs. 76,837 lakh and 64,241 lakh respectively.

The second largest one was in the year 2004 and the damage of a death of 885 human lives and 3,272 animals was reported. Crop damage was worth Rs. 52,205 lakh and loss of public utilities was worth Rs. 103,049 lakh.

**(4) Drought**

Bihar State often faces drought situations at different scales/levels that intrinsically lead to famine situations. This situation occurs when the summer monsoon gets weak and the rainfall is less than that of the normal seasons. The widespread drought occurred in 2009, resulting in a reduction in paddy production in Bihar by 28 %. In 2013, taking into account deficit rainfall, the government of Bihar State declared 33 out of 38 districts in the state as drought-hit.

**7.3.4 Observation Systems for Rainfall and Water Level**

The government of Bihar State finds its genesis in the brainstorming meeting in 2006 introducing the extensive use of modern information technologies developing and implementing a comprehensive Flood Management Information System (FMIS) in priority areas. Flood Management Information Support Centre (FMISC) was established under Monitoring and Planning, Water Resources Department (WRD). FMISC collects hydrological and hydro-meteorological data from other government agencies.

As shown in figure below, there are 40 observation stations consisting of 20 daily rainfall, 13 daily rainfall and water level, and 7 water level stations. Of these, 17 stations are located in Nepal and observation data is obtained through website of the Government of Nepal. Locations of river gauging and rainfall gauging stations in the basins are shown in Figure 7.3.3.

Daily rainfall is also observed at all 38 districts and reported to the related departments such as irrigation, public works and water resources.



Source: Flood Management Information Support Centre, “Flood Report 2013”, (2014)

**Figure 7.3.3 Location of Hydro-Meteorological and Hydrological Stations (40 Stations)**

**7.3.5 Risk Analysis**

Major hazards in Bihar State are earthquake, flood and drought. Profiles of earthquake, flood and drought are summarised as follows.

## (1) Earthquake

As described in section 7.3.3, there are six (6) sub-surface fault lines penetrating in Bihar State through its Ganga planes in four directions (see Figure 7.3.4).

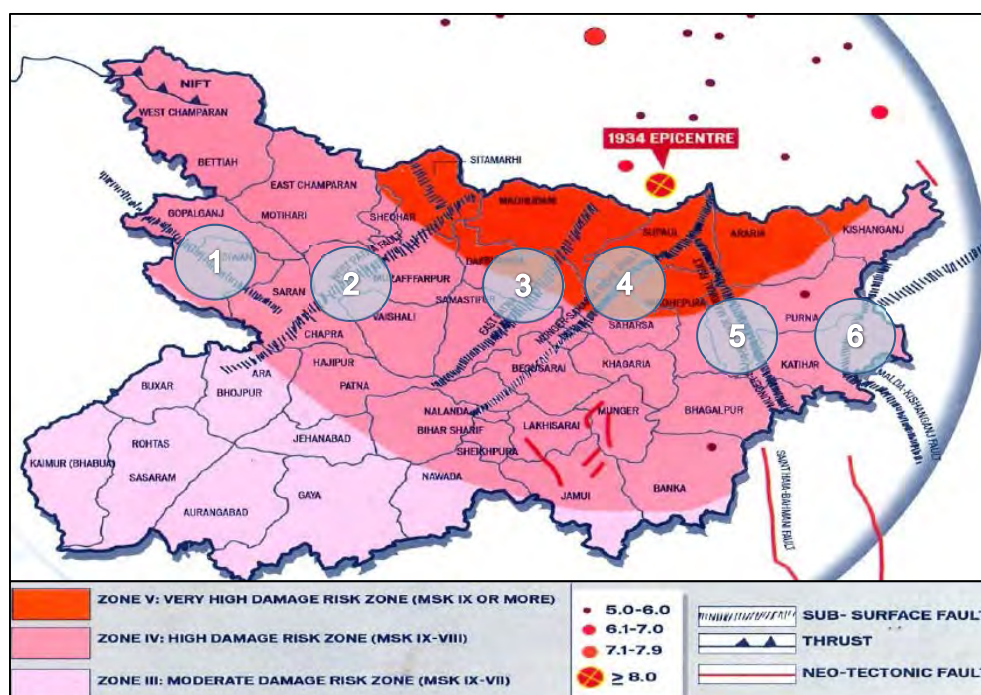

Source: Disaster Management Department, Government of Bihar, “The State Disaster Management Plan (Part 1)”

**Figure 7.3.4 Bihar Seismic Zones**

Zone classification in Bihar State is shown in Table 7.3.5. Out of 11 districts in Zone V, the percentage of the highest risk area is 100 % for two (2) districts, Madhubani and Supaul, more than 85 % for two (2) districts, Araria and Sitamarhi, above 45 % for three (3) districts, Dhargbhanga, Madhepura and Saharsa, and less than 10 % for the remaining four (4) districts. In total, Zone V area accounts for 15 % of the total area of Bihar State, while 64 % in Zone IV and 21 % in Zone III.

**Table 7.3.5 Earthquake Zone Classification in Bihar State**

No.	Seismic Zones	Percentage in Area (%)	Name of Districts Belonged
1	Zone V	15.2	Madhubani, Supaul, Araria, Sitamarhi, Dhargbhanga, Madhepura, Saharsa, Kishanganj, Muzaffarpur, Purniam Sheohar
2	Zone IV	63.7	
3	Zone III	21.1	
Total		100	

Source: Disaster Management Department, Government of Bihar, “The State Disaster Management Plan (Part 1)”

## (2) Floods

The plains of Bihar State, adjoining Nepal, are drained by a number of rivers that have their catchments in the steep and geologically nascent Himalayas. As shown in Figure 7.3.5, Kosi, Gandak, Burhi Gandak, Bagmati, Kamla Balan, Mahananda and Adhwara groups of rivers originate in Nepal, carry high discharge and very high sediment load which they discharge in the plains of Bihar State. About 65 % of catchments area of these rivers falls in Nepal/Tibet and only 35 % of catchments area lies in Bihar State. The plains of north Bihar State recorded the highest

number of floods during the last 30 years. The years 1978, 1987, 1998, 2004 and 2007 witnessed high magnitudes of flood in the state.

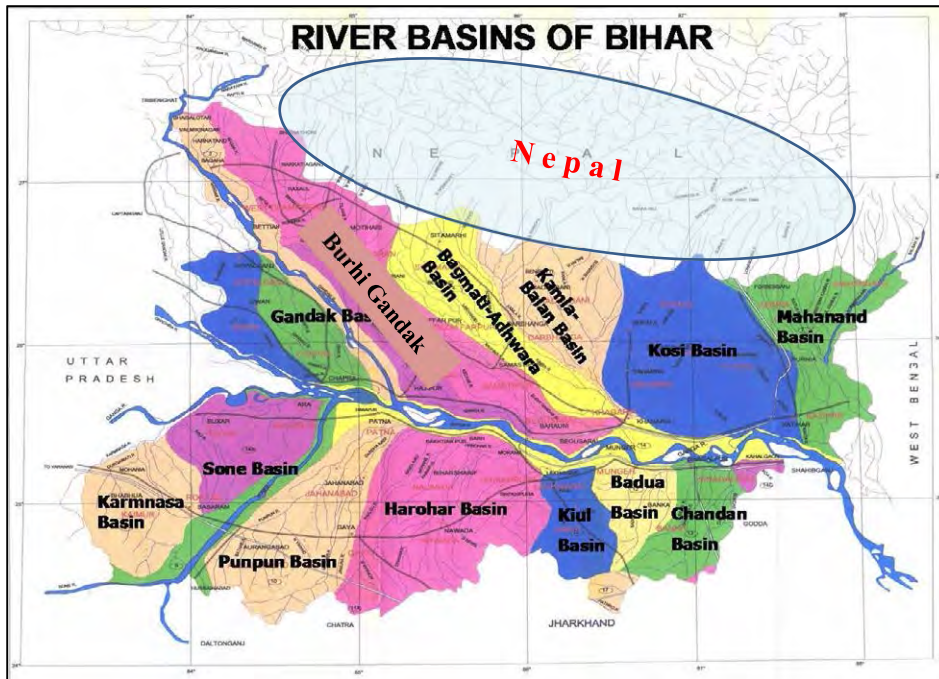

Source: Water Resources Department, Government of Bihar (2015)

**Figure 7.3.5 Rivers in Bihar State**

Figure 7.3.6 shows the flood vulnerability zone in Bihar State. Highlighted zones shown in red are the “most vulnerable” districts such as East Champaran, Muzaffarpur and Darbhanga. 15 districts are designated as the most vulnerable areas. Zones shown in pink are vulnerable districts such as Siwan, Patna and Nalanda. 13 districts are designated as vulnerable areas.



Source: Disaster Management Department, Government of Bihar, “The State Disaster Management Plan (Part 1)”

**Figure 7.3.6 Flood Vulnerable Zones (Bihar State)**

### (3) Drought

Climatically, Bihar State lies on the cross-roads of the west eastern plains and is on the threshold of transition zone that has regional variation in rainfall distribution as well as rainfall variability. Average annual rainfall in Bihar State is 1,120 mm, but considerable variations occur with 2,000 mm in the extreme eastern and northern parts and less than 1,000 mm in the western and south-western parts of the state. As a result, 33 % of the state receives less than 750 mm rainfall, making the southern part of Bihar State vulnerable to drought. Severe affected areas are shown in Figure 7.3.7.

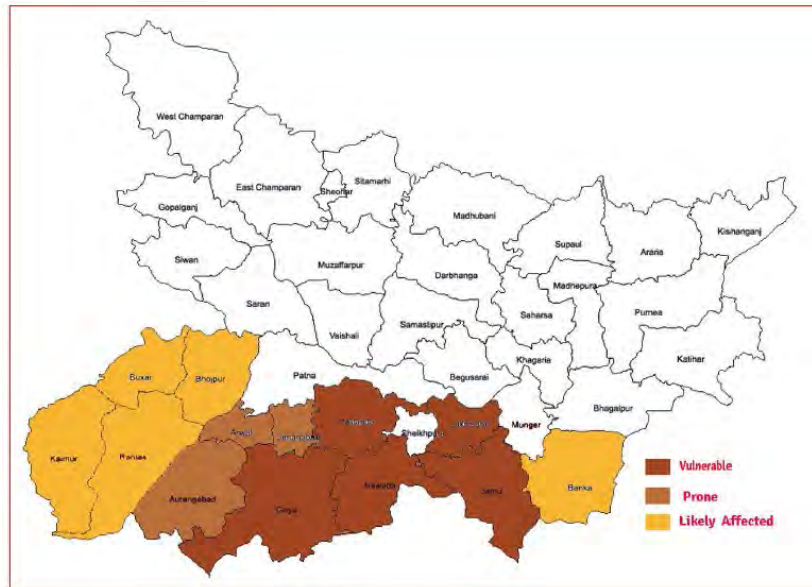

Source: Disaster Management Department, Government of Bihar, “The State Disaster Management Plan (Part 1)”

**Figure 7.3.7 Drought Prone Areas (Bihar State)**

Even 35 % of north-eastern part of Bihar State receives around 1,120 mm rainfall, and the state suffers drought once in four to five years due to scanty rains. The north part of Bihar State receives plenty of rainfall, but when the annual rainfall is less than 25 % of the normal, drought situations prevail. Quite often the problem of drought and floods prevails simultaneously in the state.

### (4) Disaster Prone Districts

Based on the disaster risk analysis including other natural disasters such as fire and cyclone storm, DMD prepared vulnerability profile for each district shown in Table 7.3.6.

**Table 7.3.6 Disaster Prone Districts in Bihar**

Sl. No.	District	Earthquake		Flood	Drought	Fire	Cyclonic Storm
		High	Medium				
1	Araria	H		F			CY
2	Arwal				D		
3	Aurangabad				D		
4	Banka		M		D		CY
5	Begusarai		M	F	D		
6	Bhagalpur		M	F	D		CY
7	Bhojpur			F	D		CY
8	Buxar			F	D	Intensive	CY
9	Darbhangha	H		F	D	Intensive	CY
10	East Champaran		M	F	D		CY
11	Gaya		M		D		
12	Gopalganj		M	F			CY
13	Jamui				D		
14	Jehanabad				D		CY
15	Kaimur(Bhabua)				D		CY
16	Katihar		M	F		Intensive	CY
17	Khagaria			F			CY
18	Kishanganj		M	F			CY
19	Lakhisarai			F	D		CY
20	Madhepura	H		F			CY
21	Madhubani	H		F	D	Intensive	CY
22	Munger		M		D		CY
23	Muzaffarpur			F	D	Intensive	CY
24	Nalanda		M	F	D	Intensive	CY
25	Nawada				D		
26	Patna		M	F	D		CY
27	Purnia		M	F			CY
28	Rohtas				D		CY
29	Saharsa	H		F			CY
30	Samastipur		M	F	D		CY
31	Saran		M	F	D	Intensive	CY
32	Sheikhpura		M	F	D		CY
33	Sheohar			F	D		CY
34	Sitamarhi	H		F	D		CY
35	Siwan		M	F	D	Intensive	CY
36	Supaul	H	M	F			CY
37	Vaishali		M	F	D	Intensive	CY
38	West Champaran			F		Intensive	CY

**Legends**

EARTHQUAKE	H	DROUGHT	D
	M		FIRE
FLOOD	F	CYCLONIC STORM	CY

Source: Disaster Management Department, Government of Bihar, “The State Disaster Management Plan (Part 1)”

**(5) Flood Hazard Map of Bihar State**

Over a period of time, NRSC has created a repository of large data pertaining to floods in different areas of the country. These historical datasets, generated by NRSC, are useful for identification of the flood-prone areas and risk assessment. NRSC has prepared district-wise flood hazard zonation maps for Bihar State using the available historical satellite datasets spanning over 13 years and annual flood variations from 1998 to 2010.

The flood hazard maps prepared from satellite data were reviewed by a committee constituted by the NDMA, which includes CWC, IMD and BSDMA. The flood hazard maps were also validated on ground by the BSDMA through its district administration. An example of inundation map and flood hazard map is show in Figure 7.3.8.



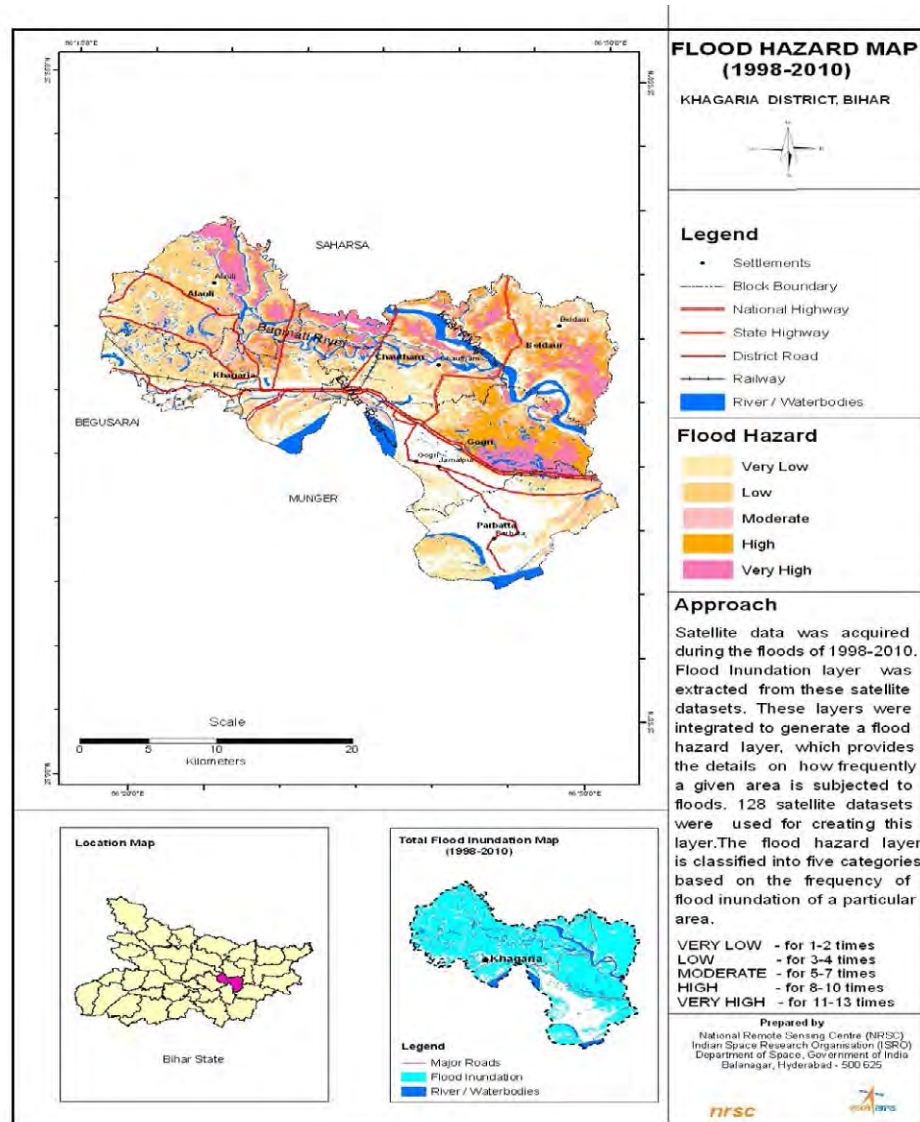

Source: BSDMA

**Figure 7.3.8 An Example of Inundation Map and Flood Hazard Map (Khagaria, Bihar)**

### 7.3.6 Emergency Response

The response mechanism has been based on worst case scenario and orchestrated hazard-wise lead support roles of the government department with DMD's presence. The response has been coupled with the relief distribution and support services to be rendered through the National Disaster Response Force, the State Disaster Response Force, and other stakeholders and local bodies.

In reference to "L concept" or the definition of disaster level and area, based on the impact of the disasters, disasters are classified into four categories as shown in Table 7.3.7.

**Table 7.3.7 Classification of Disaster Level**

Level	Explanation
L0 Level	Denote normal time when there is no disaster like situation
L1 Level	Disasters which can be handled at the district level
L2 Level	Disasters which are beyond existing capabilities of the district authorities and need active support from the state agencies
L3 Level	Disasters which are beyond existing capabilities of district and state. It needs active support from the national level agencies.

Source: Madhubani District, "District Disaster Management Plan"

Disaster response requires coordinated and concerted efforts of three main functionaries at the state, district and community levels. The three functionaries are the government machinery, the NGOs and the affected communities.

Disaster response requires relief materials and logistics management, carrying out search and rescue operation, providing shelters and relief camps, caring for health and sanitations, communicating to host stakeholders, documenting and reporting. These functions are highly specialised and require professionals to perform these roles. But the irony of the situation is that such professionals are few and far between. This is a necessity as well as a compulsion for the state. Therefore, in line with the thinking of the state, specialised institutions, like the State Disaster Response Force and Bihar State Institute of Disaster Management (BSIDM) have been included in the state disaster management system.

Disaster response plan structures the channelling of response down to the site of incident and from site to command centre.

**(1) Incident Response**

For L1 Level disaster, DDMA has the primary responsibility for the incident response and DEOC becomes a command centre. For L1 Level incident, the disaster response activities are implemented at the district level. The main respondents are DDMA, DEOC, Block and Anchal. In this case the state government agencies remain in the state preparedness. The response flow for L1 Level incident is shown in Figure 7.3.9.

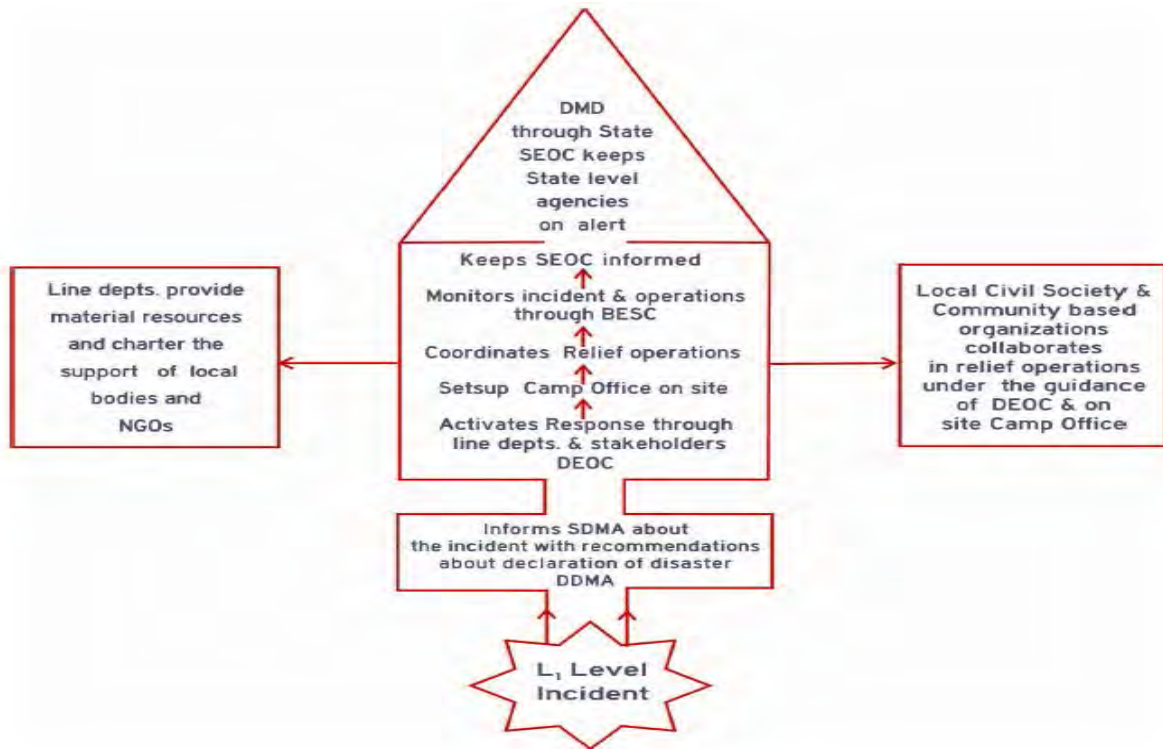

Source: Disaster Management Department, Government of Bihar, “The State Disaster Management Plan (Section-III)”

**Figure 7.3.9 Disaster Response at L1 Level**

In case of L2 Level incident, disaster response activates at the state level. The main respondents include DMD, SEC, the State Disaster Response Force and the National Disaster Response Force. In this case, DMD becomes overall coordinator in charge, but Chief Secretary as chief of SEC/Principal Secretary, DMD manages the operations. The central government agencies are in preparedness to respond.

In case of L3 Level incident, response activates at the state level and the respondents include NDMA, the National Disaster Response Force, Defence Ministry, MHA and other central ministries. The response flow for L2-L3 Level incidents is shown in Figure 7.3.10. There are two incident response systems (IRS), namely the systems applied within 6 hrs and after 6 hrs. In the flow for within 6 hours, SEC sends the State Disaster Response Force groups for rescue and relief operations, and formulates the incident management team (IMT). After 6 hours, formulated IMT starts activities.

DMD coordinates the operations and liaises with NGOs, corporate houses, professional bodies on donation and relief issues. DMD also coordinates with various governmental departments on response related issues and damage assessment with the assistance of SDMA. SEC gathers information, keeps in touch with all centres, passes on directions to all concerned and provides feedback from the field to the IMT.

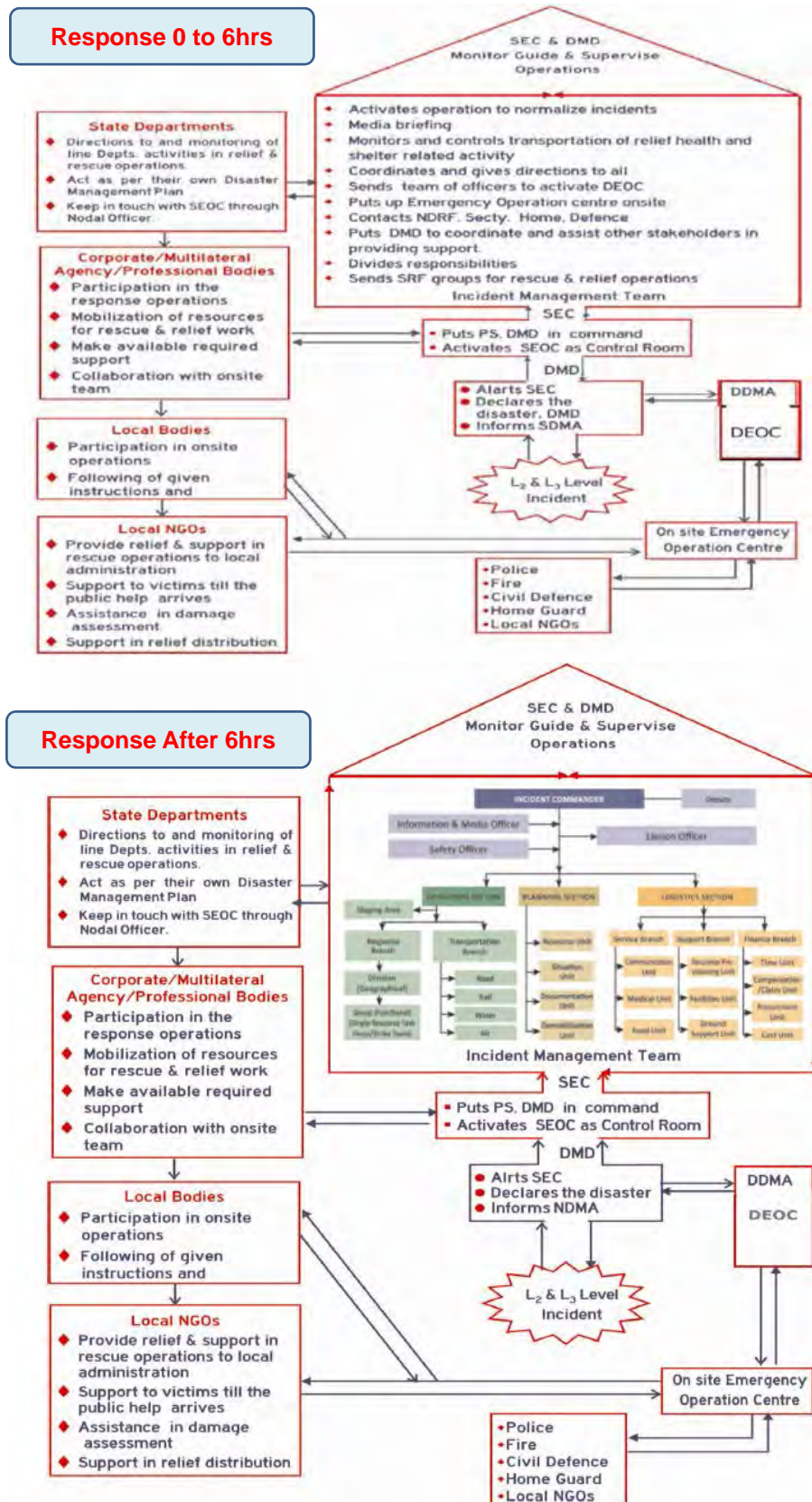

Source: Disaster Management Department, Government of Bihar, "The State Disaster Management Plan (Section-III)"

Figure 7.3.10 Disaster Response at L2-L3 Level

The disaster response covers state, district, block and Gram Panchayat and consists of five (5) main respondents:

- i) Crisis management group
- ii) Incident management team
- iii) Emergency support groups
- iv) Emergency operation centres
- v) Block/Anchal/ emergency support centre

## (2) Recovery Works for Floods

According to the SDMP, contents of recovery works for flood in major departments such as WRD and Department of Rural Works are summarised in Table 7.3.8.

**Table 7.3.8 Recovery Works after Flood Events**

Department	Contents of Recovery Works
Water Resource Department (WRD)	1) Survey and study of the factors of flooding for taking long-term preventive measures 2) Providing for upkeep and maintenance
Agricultural Department (AD)	1) Providing support in the implementation of alternative cropping program 2) Damage assessment for crops
Public Health Engineering Department (PHED)	1) Survey and study for the rehabilitation of victims 2) Working out layout plan for sanitation and drinking water supply in consultation with agency involved in construction of houses.
Department of Road Construction (DORC)	Making approach road to resettlement site.
Department of Building Construction (DBC)	Support in the construction of safe houses for resettlement of victims
Department of Energy (DOE)	Power supply and lighting arrangements in rehabilitation areas
Department of Rural Works (DORW)	1) Repair and maintenance of the damaged roads, bridges and culverts 2) Construction of roads, and culverts to connect the rehabilitation site

Source: Disaster Management Department, Government of Bihar, "The State Disaster Management Plan"

## (3) Final Outlay and Expenditure for Disaster Management

Final outlay and expenditure for disaster management in Bihar State are shown in Table 7.3.9. In response to the damages caused by flood in 2007, the expenditure of 2008-09 reaches Rs. 30,660 lakh.

**Table 7.3.9 Disaster Management Expenditure**

Item	2007-2008	2008-2009	2009-2010	2010-2011	2007-2011
1) Revised Outlay	5,500.00	15,600.00	1,146.70	1,129.42	23,376.12
2) Expenditure	2,919.26	30,659.82	1,124.88	916.82	35,620.78
3) Balance (1-2)	2,580.74	-15,059.82	21.82	212.60	-12,244.66

Source: Bihar Statistical Hand Book (2012)

## (4) Communication Flow and its System

Figure 7.3.11 shows the alert procedures in the state. DMD activates in close-relation with IMD, CWC and WRD of Bihar State to get the prior information of monsoon-rainfall, cyclone and water level rise in different rivers. During monsoon season, DMD is the nodal department for response and rescue, monitors and checks the daily reports of IMD, CWC and WRD, and issues alerts/warning to concerned district authorities if required. Rainfall reports from every district are

checked by DMD to make strategy of disaster management.

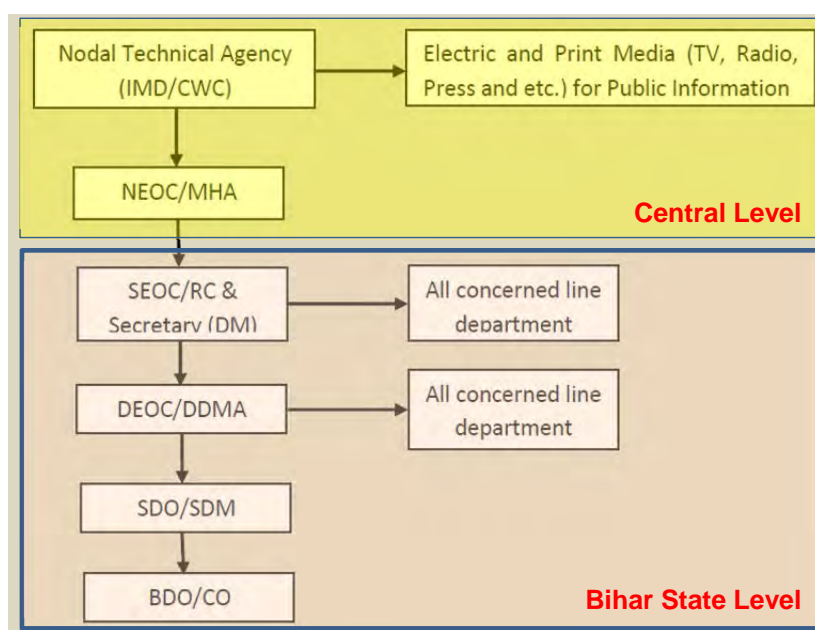

Notes: SDO: Sub-Divisional Officer, / BDO: Block Development Officer  
Source: Disaster Management Department, Government of Bihar, "State Disaster Management Plan"

**Figure 7.3.11 Information Flow of Alert (Bihar State)**

As for the communication system between central government and state, various methods are adopted such as VSAT, VHF, SW, GSM, etc., depending on communication conditions. Hotline, LAN system and fax are the common communication systems. Mobile phone is commonly used for alert from DEOC to block level. In case of no mobile phone network, vocal communication is used.

### **(5) Activities of DMD**

In Bihar State, DMD executes activities in line with the SOP on the basis of day-to-day emerging needs through a web portal to know the status of flood response. Materials and information related preparedness of floods are disseminated on the DMD's website that covers the following items:

- a. Rainfall data
- b. Area which would be affected by flood
- c. Country boat
- d. Storage sites of grain
- e. Storage sites of motor boats, tents, jackets, polythene sheets, bleaching powder, etc.
- f. Storage of medicine and drinking water for human beings
- g. Storage of medicine for cattle
- h. Rate fixation for essential items

DMD is involved in providing the relief and rescue training of volunteers (generally 7 days) as State Disaster Response Force while providing food and travel allowances at the focal districts, and those trained volunteers are responsible for training programmes at the community level. Around 45 to 50 volunteers are trained by the state governments throughout a year except during the monsoon season.

DMD has been working with the help of Water Aid since 2007 on disaster management especially preparedness in Samstipur, Darbangha, Muzaffarpur and Madhubani districts, focusing on water sanitation and providing emergency kits, which comprise basic relief materials like life jackets, medicines, food, etc.

### 7.3.7 Evacuation Systems

Danger water level for evacuation is specified by the Flood Management Plan for each river based on the previous historical floods as well as situation after implementation of river improvement works. Table 7.3.10 shows an example of water level during floods and danger water level settings for Madhubani District.

**Table 7.3.10 Water Level during Flood and Setting Danger Water Level  
(Example of Madhubani District, Bihar)**

River	Kamla Galan (Jhanjharpur)		Bhuri (Ekma Saifan)		Kamla Jay Nagar	
	WL	Danger Level	WL	Danger Level	WL	Danger Level
1987	54.34	50.00	72.10	69.50	70.40	69.31
2004	54.30		71.90		70.65	
2007	53.30		69.81		69.35 Up 69.70 Down	

Note: WL: Water Level

Source: Madhubani District, "District Disaster Management Plan"

When a warning or alert is issued by organisations in charge, DDMA disseminates a warning or alert in the most prone areas through the Disaster Management Teams and block level officials. People living in the prone areas evacuate to designated relief camp by means of cars, agricultural vehicles trucks and walking.

DDMA shows roads with safety and low possibility for inundation during floods in the DDMP (see Figure 7.3.12). Relief operations and evacuated people can use these roads.

Evacuation activity is carried out, in principle, at Panchayat level under the command of deputy officers in-charge after receiving an alert at block level.

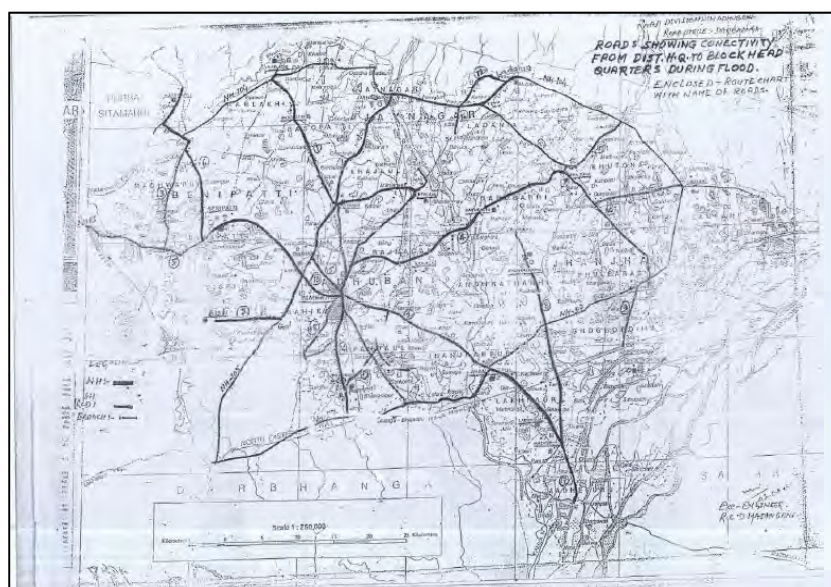

Source: Madhubani District, "District Disaster Management Plan"

**Figure 7.3.12 Safety Road Map during Flood (Example of Madhubani District)**

To prevent casualties by floods, people move to relief centres prepared by DDMA, and stay there for a few days. The relief centres are located at high schools or community centres in Panchayat. Their capacity varies from 20 families to 200 families in case of Madhubani District as shown in Table 7.3.11. Water and food supply as well as toilets are also equipped at the centres.

**Table 7.3.11 Relief Centre and its Capacity (Madhubani District, Bihar)**

S. No.	Name of Block	Name & Place of Relief Centre	Available Resources		Concern Panchayat	Name and Designation of Deputed Officer-In Charge	Capacity of Shelter	Name of Identified Shelter
			Drinking Water	Toilet				
1.	Rahika	High School, Rahika	Yes	Yes	Rhika	Shri Basant Jha, Incharge Gram Panchayat Moderator	200 Family	1. Saurath sabha gachhi 2. N. College, Madhubani 3. Madarsa, Bhachchhee 4. Unch Vi., Kapileshwar Sthan 5. Unch Vi., Malangiya 6. Vi.Velam 7. Gandhvaree, Durgasthan
					Satlakha			
					Hussainpur			
					North Kakraul			
		High School, Shambhuar	Yes	Yes	Maksuda	Shri Raman Roy, Block Investigator, Rahika	200 Family	
					Sanaur			
					Laxmipur			
					Balia			
					Khajuri			
		Panchayat Bhawan, Kakraul	Yes	Yes	Basauri	Shri Dev Prasad Bachhan, Block Education officer	20 Family	
					Ajra			
					Maglia			
					South Kakraul			
		High School, Jitwapur	Yes	Yes	Jagatpur	Shri Subash Prasad Singh, Block Vetnary Officer	200 Family	
					Najirpur			
Saurath								
	Panchayat Bhawan, Bahuara	Yes	Yes	Bhachhi	Shri Ajay K Jha, Block Agriculture Officer	20 Family		
				Bahuara				
				Basuara				
2.	Rajnagar Zone 1	Panchayat Bhawan, Sugauna South	Yes	Yes	Shivpatti	S. K Mahto Block Statistical Officer	100 Family	
					Karhiya West			
					Karhiya East			
					Parharpur			
					Raghunai			
					Dehat			
					Bhariyavishnupur			
					Mangrauni East			
					Mangrauni South			
					Pilakhwar			
					Ranti			
					Mahinathpur			
Rampatti								
Raghopur Blat								

Source: Madhubani District, "District Disaster Management Plan"

### 7.3.8 Preparedness and Countermeasures

#### (1) Flood Preparedness in Bihar State

To prevent floods, various measures have been implemented by the Government of Bihar and peoples in the community as flood preparedness. DMD checks preparation of country boats, tents, life jackets, polythene sheets, bleaching powder, drinking water and medicine for cattle at storage sites for each district. Based on the SOP for floods, every DDMA prepares disaster management plan before the start of the monsoon season.



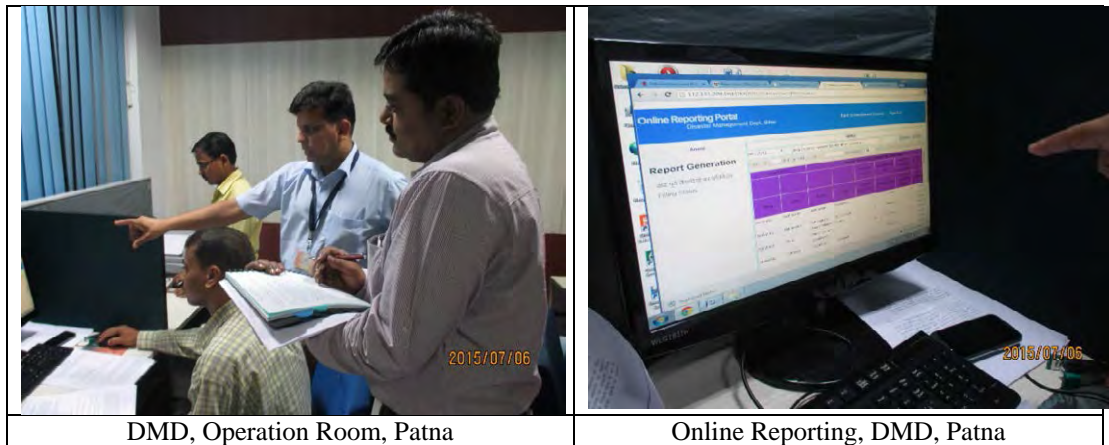

DMD, Operation Room, Patna

Online Reporting, DMD, Patna

Source: prepared by the Survey Team

**Figure 7.3.13 Preparing Relief and Response Materials for Preparedness (DMD)**

Home guards are deployed to monitor the water level for 24 hours at the critical portions from the middle of June to the middle of October every year. They also monitor the bank conditions and send the information to the River Office, if an accident is expected or occurs. Sand bags are prepared for flood fighting activities in the Ganga (see Figure 7.3.14).



Staff Gauge for Water Level Monitoring

Sand Bags for Flood Fighting

Source: prepared by the Survey Team

**Figure 7.3.14 Flood Preparedness in the Ganga River (Samastipur)**

## (2) Flood Management Works

Flood management works implemented so far comprise construction and maintenance of embankments, revetment in selected portions of river banks, land spurs and other flood protection works. All the rivers excluding the Burhi Gandak joining the Ganga on its left bank in Bihar State flow through a considerable length in Nepal. A large part of their catchments falls in the glacial regions of the Great Himalayas. Thus, the countermeasures against floods in Bihar State acquire international dimensions. As a long-term measure, construction of storage reservoirs and extensive water shed treatment in upper catchments of river is essential.

## (3) Embankment Works

As a short-term protective measure, construction of embankments along rivers has been adopted. By constructing about 3,732 km of embankment, around 34 lakh ha of area has been brought under reasonable protection as shown in Table 7.3.12.

**Table 7.3.12 Flood-prone Area, Embankment Length and Protection Area (Bihar)**

No.	River	Length (km)	Catchment Area (lakh ha)	Flood Prone Area (lakh ha) (A)	Length of Embankment (km)	Area under Protection (lakh ha) (B)	Ratio (B/A)
1	Gandak	260	4	3.35	511.66	6.24	1.86
2	Burhi Gandak	320	10	8.21	779.26	6.73	0.82
3	Kosi	260	11.41	10.15	451.21	9.72	0.96
4	Bagmati	394	6.5	4.44	650.34	1.67	0.38
5	Baduaa	130	2.215	1.05	64.95	*	*
6	Kamla-Balan	120	4.488	3.7	190	5.62	1.52
7	Mahananda	376	6.15	5.15	225.33	1.01	0.20
8	Chaghra	83	2.995	2.53	132.9	0.79	0.31
9	Punpun	235	9.026	6.13	37.62	0.2	0.03
10	Ganga	445	19.322	12.92	596.92	2.44	0.19
11	Sone	202	15.82	3.7	59.54	0.21	0.06
12	Kiul-Harohar	-	17.225	6.34	14	0	0.00
13	Chandan	118	4.093	1.13	18.23	0.06	0.05
	<b>TOTAL</b>	<b>2,943</b>	<b>113.033</b>	<b>68.8</b>	<b>3,731.96</b>	<b>34.69</b>	<b>0.50</b>

Source: WRD, Government of Bihar

The protected area for the Gandak and Kamla-Balan rivers is larger than the flood-prone area. This indicates that the effect of flood management has appeared. Meanwhile, concerning most rivers except those two rivers, the protected area is smaller than the prone area. In these areas, flood management works need to be carried out continuously in the future.

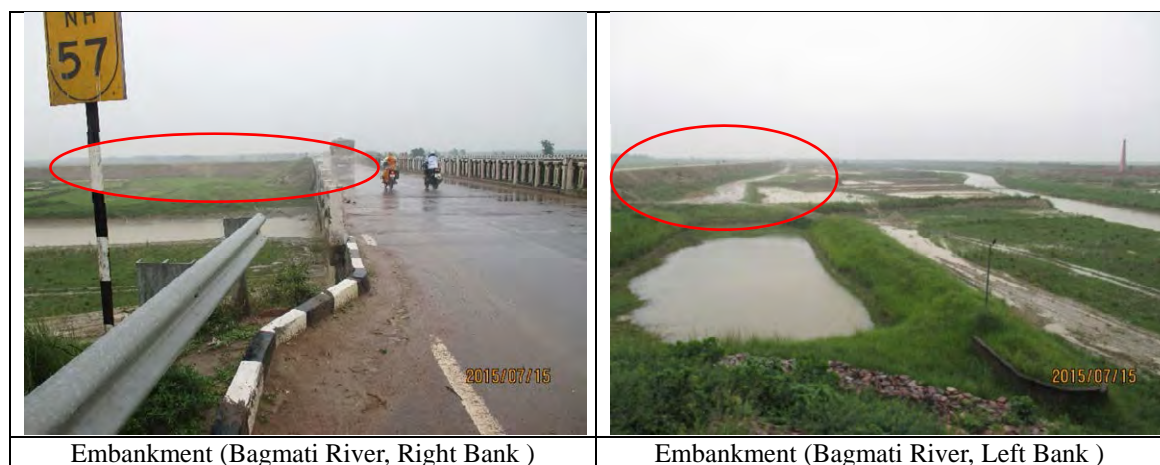

Source: prepared by the Survey Team

**Figure 7.3.15 Embankment Works in the Bagmati River (Muzzafarpur)**

The existing embankments are under increasing pressure due to raising bed level of rivers caused by transported heavy silts from Nepal. Raising bed level makes abnormal changes in river courses; in consequence, anti-erosion works for protection of embankment and some flood fighting works become essential in monsoon season every year.

These examples are shown in the Kamla River. Country side elevation is lower than flood level of Kamla River.



Source: prepared by the Survey Team

**Figure 7.3.16 Meandering of River and Lower Ground than River Water in the Kamla River (Janjharpur District)**

#### **(4) Anti-Erosion Works**

Various anti-erosion works are adopted in Bihar State. These works are planned and designed in accordance with the “Handbook for Flood Management, Anti-Erosion & River Training Works” (CWC, 2012). The following are the typical examples for works adopted in the rivers in Bihar State:

- 1) Reinforced Cement Concrete (RCC) porcupine (Buhri Gandak, Kosi River)
- 2) Bank (Boulder) pitching (Kosi River)
- 3) Bank protection by geo-textile bags (Buhro Gandak River)
- 4) Spurs and groins (Kosi River)

As for the Kosi River, RCC porcupine, groin works and boulder pitching works for protection of bank with boulders are carried out in Saharsa District. Using geo-textile bags is the most common method for bank protection in the state from the viewpoint of cost and effect for flood water. Spurs are adopted to protect banks by keeping flow away from banks.

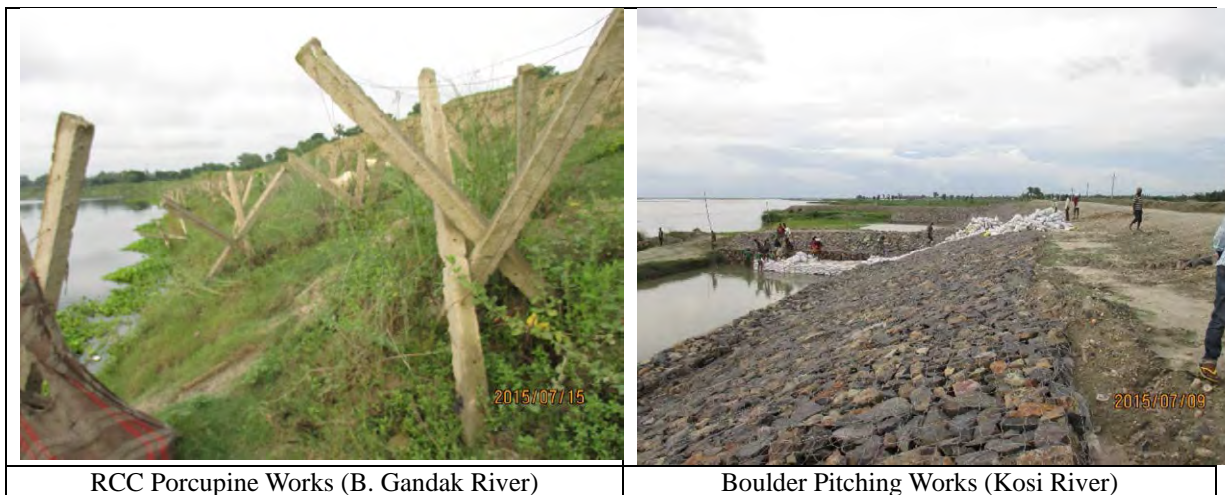

RCC Porcupine Works (B. Gandak River)

Boulder Pitching Works (Kosi River)



Source: prepared by the Survey Team

**Figure 7.3.17 Adopted Structural Measures for Bank Protection**

**(5) Critical Issues in the River of Bihar**

Many people live in and near the river and river area. For example, 60 people have lived in between the Burhi Gandak River and the embankment of road along with the river (Madhubankanty Panchayat, Minapur Village, Muzaffasrapur District) from 2008 onwards. They shifted their houses nine times during thirty years because the river changes its path every year in the monsoon season. The same scenes can be seen around the Bagmati River.



Source: prepared by the Survey Team

**Figure 7.3.18 People living in the River Area (Burhi Gandak and Bagmati Rivers)**

### 7.3.9 Forecasting, Early Warning and Communication Systems at State Level

The responsible authorities/bodies for early warning are shown in Table 7.3.13. The authority to permit issue of early warnings and approve their wording and frequency is the Incident Commander, namely, Chief Secretary, for L2 and L3 level disaster, and District Magistrate for the L1 level disaster respectively. SEOC and DEOC convey the warning statements in simple and local language. The authorisation to issue warnings is given in writing.

**Table 7.3.13 Responsible Authority/Body for Early Warning System**

Step	Authority
Permit issue of early warning and approve the wordings and its frequency	L2 and L3 level disaster: Incident Commander (Chief Secretary)
	L1 level disaster: District Magistrate
Convey warning statement	SEOC at the state level DEOC at the district level

Source: Disaster Management Department, Government of Bihar, “The State Disaster Management Plan (Part 1)”

Figure 7.3.19 shows the early warning systems set up in the state. The SEOC is linked with the DEOC through two-way audio-video communication and data collection (VSAT), two-way audio communication and data collection (VHF) and processing system and one-way communication system (short wave/HAM radio).

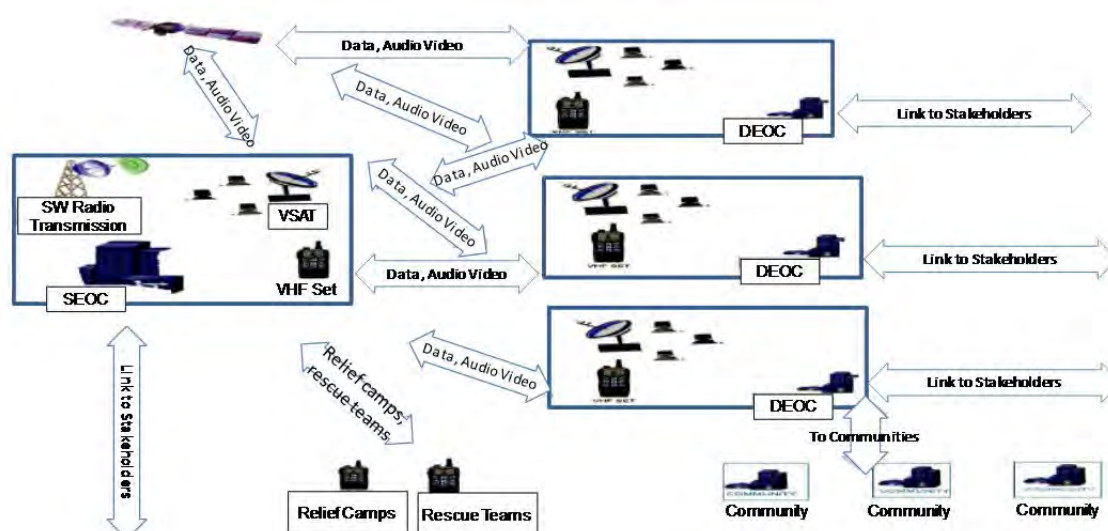

Source: Disaster Management Department, Government of Bihar, “The State Disaster Management Plan (Part 1)”

**Figure 7.3.19 Early Warning System in Bihar State**

SEOC and DEOC communicate with the following related organisations for giving early warnings.

- For Earthquakes:
  - IMD
  - State Earthquake Research Institute (SERI)
  - GSI
- For Floods:
  - IMD
  - Water Resources Department
  - Local Flood Forecasting Unit of CWC
  - Disaster Management Department

- For Cyclones:
  - IMD
  - Disaster Management Department

### **7.3.10 Disaster Risk Finance at State Level**

#### **(1) Disaster Risk Finance Scheme in Bihar State**

In accordance with the DM Act, the government of Bihar State constituted and has operated the following two (2) disaster risk finance schemes.

- State Disaster Response Fund (SDRF)
- State Disaster Mitigation Fund (SDMF)

The DMD is authorised to manage the SDRF as a short-term fund to be utilised for the preparation of emergency response and the immediate funding for emergency response activities. The SDRF can be utilised in accordance with the guidance named “Items and Norms of Assistance from the SDRF and the NDRF 2015-2020” issued by the MHA.

Besides, the SDMF was constituted in 2012 and is managed by the BSDMA as a long-term investment for the purpose of mitigation activities related to disasters. According to the BSDMA Rules 2012, the major activities funded from the SDMF are listed below:

- Research and development activities for disaster risk reduction including climate change adaption and mitigation
- Activities for awareness generation, knowledge dissemination, capacity building and training activities/programmes
- Activities to strengthen the existing educational, technical or professional organisations in the field of disaster reduction and to establish new institutions
- Facilitation of research and project works by research scholars, students and interns of educational, technical or professional organisations
- Promotional activities and involvement of different stakeholders such as community based organisations, civil societies/NGOs, corporate sector, volunteers and youth organisations
- Development of Information, Education and Communication (IEC) including training materials

On the other hand, the Bihar state government has not constituted the DDMF. According to the BSMDA, the nodal departments of the district government are obliged to implement their mandated works considering the mitigation measures against the natural disasters and the required budgets for those works are allocated. Thus, since it is considered that the required budgets for mitigation measures are included in the annual budget of the district government, the constitution of the DDMF is not required as independent fund in the state.

#### **(2) Operation of Disaster Risk Finance in Bihar State**

The allocated and released amounts of the SDRF/NDRF during 13th FC period are summarised in Table 7.3.14. The SDRF allocation fully covers the required budget for the response activities except in 2010-2011.

**Table 7.3.14 Allocation and Release of SDRF/NDRF in Bihar State (2010-2015)**

(unit: Rs. crore)

Year	SDRF Allocated	SDRF Released	NDRF Released
2010-2011	334.49	250.88	368.01
2011-2012	351.21	-	-
2012-2013	368.77	138.29	-
2013-2014	387.21	290.41	-
2014-2015	406.57	152.47	-

Source: Bihar State Government, "Financial Provisions of Disaster Management: NDRF & SDRF" (2015), MHA, "Annual Report" (2010-2011 to 2014-2015)

The SDMF has been established as non-lapsable fund by Bihar state government. Rs. 5 crore will be allocated every year to implement the activities for disaster mitigation. The district governments also have access to the SDMF for their mitigation plans.

### 7.3.11 Challenges to be Addressed

According to the information gathered, the following are the challenges identified by the related organisations in Bihar State:

#### < Preparedness >

As described in Section 4.3.7, reorganising the strategy for introduction of flood plain zoning is a challenge for flood management in the country. The flood affected area accounts for 73 % of the total geographical area in Bihar State. Therefore, institutionalising the techno-legal regime is an urgent issue to be tackled in the state. Under these circumstances, the government of Bihar classified the flood prone area with different flood probability (return period): 2 years, 5 years, 10 years and 20 years, and conducted the asset evaluation survey in the Bagmati and Kosi river areas. Based on the output, draft regulations on the flood plain zoning will be formulated.

- Challenge(s) of Preparedness:                      ● Reorganising the strategy for introduction of flood plain zoning

In addition, considering the current situation of flood risk reduction in India, it is worth pointing out the following as challenges to be addressed:

#### < Institutional Framework >

The riverbed aggradation is remarkable in the rivers flowing through Bihar State because of sediment inflow (silting) from the upper reaches of rivers. However, main countermeasures against floods identified through the site survey and interviews are embankment and anti-erosion works only. The state government should consider the basin-wide sediment control with the concept of river basin management.

- Challenge(s) of Institutional Framework:                      ● Introducing basin-wide sediment control with the concept of river basin management (RBM)

#### < Risk Analysis >

No challenge is identified in the general sense of policy, planning and current activities at the state level. However, in order to realise the countermeasures described in the following part, risk analysis of riverbed aggradation in the rivers and inland water drainage in the urban areas need to be carried out because those risks are not considered in the existing flood risk maps.

- Challenge(s) of Risk Analysis:                      ● Conducting risk analysis of riverbed aggradation and inland water drainage

< Countermeasures >

In some areas along the rivers in Bihar State, the ground elevation seems to gradually become lower than the high flood level (HFL) because the sediment inflow from the upper reaches aggrades the riverbed. The riverbed aggradation may cause difficulty of inland water drainage. Therefore, it is necessary to establish appropriate system of planning, design and construction of countermeasures to strengthen the banks because the major cause of damages due to floods is bank burst. Measures to drain the inland water such as pumping system and land raising need to be considered to reduce the damage/impact due to flooding water.

- Challenge(s) of Countermeasures:
- Establishing appropriate system of planning, design and construction of countermeasures to strengthen the banks
  - Establishing appropriate system of planning, design and construction of measures for inland water drainage

< Forecasting, Early Warning and Communication System >

Observation, forecasting and early warning systems are well established along the Ganga River and managed by WRD. However, there is no state observation facility in the tributaries such as Burhi Gandak, Bagmati, Kamla and Kosi rivers even though the most vulnerable areas are located in the catchment areas of those rivers (see Figure 7.3.6). Therefore, the observation systems should be expanded to the tributaries to reduce the flood risk in the catchment area of tributaries.

- Challenge(s) of Forecasting, Early Warning and Communication System:
- Establishing the early warning systems for tributaries of the Ganga River

Table 7.3.15 shows the challenges identified, actions to be taken for the improvement, and organisations responsible for implementation of the actions.



**Table 7.3.15 Challenges and Actions (Bihar State)**

S/N	Challenges	Actions to be Taken: <u>Bihar State</u>		
		Short Term (1 - 2 Years)	Medium Term (3 -5 Years)	Long Term (5 - 10 Years)
<b>Challenges identified by the Indian Side</b>				
[ Preparedness ]				
PA-BH-1	Reorganising the strategy for introduction of flood plain zoning	<u>Action(s)</u> - Reviewing the output of past surveys related to the flood plain zoning - Reviewing the prevailing land use regulations at the state level - Investigating the current situation of land use in each river basin	<u>Action(s)</u> - Formulating a draft zoning plan including examination of possible strategic land use such as introduction of retarding basin and cost estimate of implementation and compensation - Implementing the zoning in a model area as a showcase - Drawing lessons and reviewing the draft plan	<u>Action(s)</u> - Institutionalising the flood plain zoning as a state regulation - Rolling out the zoning in other model areas
		<u>Taken by</u> - SDMA - WRD - Planning Department	<u>Taken by</u> - SDMA - WRD - Planning Department	<u>Taken by</u> - SDMA - WRD - Planning Department
<b>Challenges identified by the Survey Team</b>				
[ Institutional Framework ]				
PA-BH-2	Introducing basin-wide sediment control with the concept of river basin management (RBM)	<u>Action(s)</u> - Investigating the current situation of sediment control in the river basins - Analysing factors that may cause riverbed aggradation - Formulating an implementation plan for a pilot river basin	<u>Action(s)</u> - Implementing the basin-wide sediment control plan	-
		<u>Taken by</u> - WRD	<u>Taken by</u> - WRD	-

S/N	Challenges	Actions to be Taken: <u>Bihar State</u>		
		Short Term (1 - 2 Years)	Medium Term (3 -5 Years)	Long Term (5 - 10 Years)
[ Risk Analysis ]				
PA-BH-3	Conducting risk analysis of riverbed aggradation and inland water drainage	<u>Action(s)</u> - Investigating the current situation of sediment inflow from the upper reaches of rivers - Investigating the current situation of water logging in the urban areas - Analysing the risk area of riverbed aggradation and inland water drainage - Preparing risk maps based on the result of analysis	<u>Action(s)</u> - Sensitising the departments related to flood risk reduction to the result of risk analysis on the riverbed aggradation and inland water drainage	-
		<u>Taken by</u> - WRD - Urban Development Department	<u>Taken by</u> - WRD - Urban Development Department	-
[ Countermeasure ]				
PA-BH-4	Establishing appropriate system of planning, design and construction of countermeasures to strengthen the banks	<u>Action(s)</u> - Reviewing the existing countermeasures to strengthen the banks - Investigate prospective measures that can strengthen the banks and have not been introduced in the country - Formulating a implementation plan to introduce the measures	<u>Action(s)</u> - Implementing the plan as a showcase to disseminate the effectiveness for flood risk reduction - Formulating a guidebook that shows the feature, typical specifications and planning methodology of countermeasures	<u>Action(s)</u> - Sensitising state departments responsible for flood risk reduction to the introduction of measure to strengthen the banks
		<u>Taken by</u> - MOWR - CWC - WRD	<u>Taken by</u> - MOWR - CWC - WRD	<u>Taken by</u> - MOWR - CWC
PA-BH-5	Establishing appropriate system of planning, design and construction of measures for inland water drainage	<u>Action(s)</u> - Reviewing the existing countermeasures against inland water drainage - Investigating prospective measures that can solve the problem of inland water drainage - Formulating a implementation plan to introduce the measures with pumping system	<u>Action(s)</u> - Implementing the plan as a showcase to disseminate the effectiveness to solve the problem of inland water drainage - Formulating a guidebook that shows the feature, typical specifications and planning methodology of countermeasures against inland water drainage	<u>Action(s)</u> - Sensitising state departments responsible for flood risk reduction to the introduction of measures to solve the inland water drainage
		<u>Taken by</u> - Ministry of Urban Development - Urban Development Department	<u>Taken by</u> - Ministry of Urban Development - Urban Development Department	<u>Taken by</u> - Ministry of Urban Development

S/N	Challenges	Actions to be Taken: <u>Bihar State</u>		
		Short Term (1 - 2 Years)	Medium Term (3 -5 Years)	Long Term (5 - 10 Years)
[ Forecasting, Early Warning and Communication System ]				
PA-BH-6	Establishing the early warning systems for tributaries of the Ganga River	<u>Action(s)</u> - Analysing the locations of telemetric stations to be set up - Selecting a model sub river basin for the setting up - Formulating a implementation plan	<u>Action(s)</u> - Implementing the plan as a showcase to expand the early warning system to the tributaries - Examining integration of the system for model sub river basin into the state-wise system - Preparing operational guidelines and manuals of the sub river basin system - Formulating a rolling out plan of the systems to other sub river basins	-
		<u>Taken by</u> - WRD	<u>Taken by</u> - WRD	-

Source: prepared by the Survey Team

## 7.4 Andhra Pradesh State

### 7.4.1 State Disaster Management Policy and Development Plan

The former Andhra Pradesh State was separated into two (2) states: Andhra Pradesh State and Telangana State in June 2014. The former government of Andhra Pradesh State prepared an approach to the 12th Five-Year Plan. The document shows the state approach and strategy during the 12th Five-Year Plan period. Natural disasters such as frequent floods and droughts are considered as negative factors that affect the growth of agriculture sector. However, no specific strategy or measure for enhancement of disaster management is described in the document.

After the division of state territory, the new Andhra Pradesh State proceeds for the preparation of a new SDMP.

### 7.4.2 Institutional Framework for Disaster Management

The department that organise the disaster management activities at the state level is Revenue (Disaster management) Department in Andhra Pradesh State. The SDMP was prepared by the department in 2010. The new SDMP is in process of preparation by the department in collaboration with Planning Department. The organisational structure for disaster management in Andhra Pradesh State can be illustrated as shown in Figure 7.4.1.

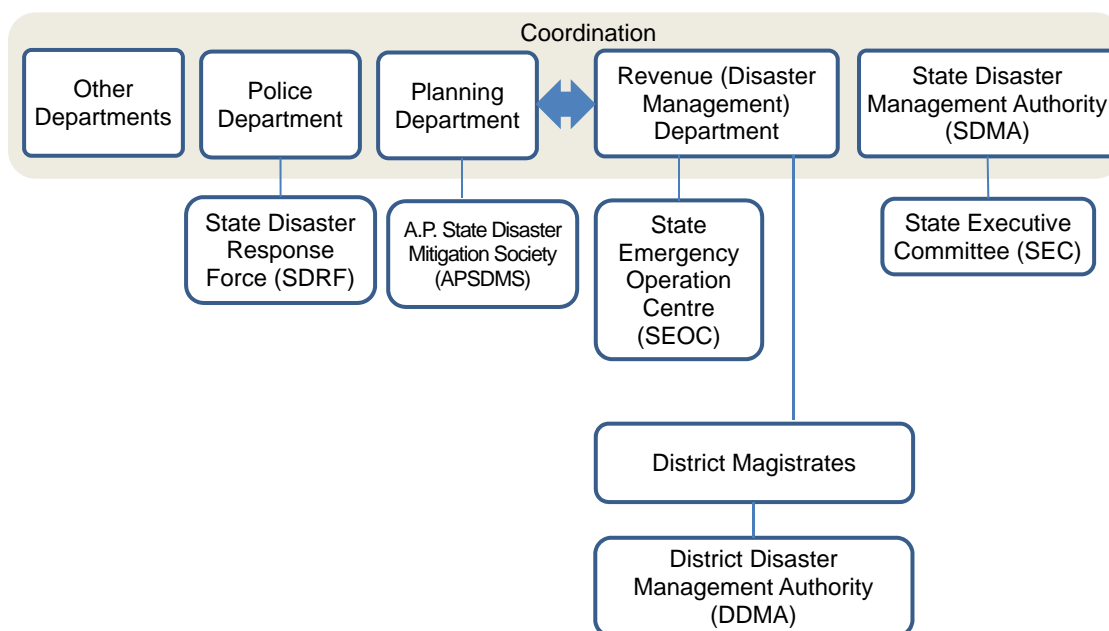

Source: prepared by the Survey Team

**Figure 7.4.1 Organisation Setup for Disaster Management in Andhra Pradesh State**

### 7.4.3 Disaster Records

Disaster records in last 10 years in Andhra Pradesh State are show in Table 7.4.1. Most of the districts have been affected by cyclone and flood in the last 10 years. The most costly disaster in the last 10 years is Cyclone Hudhud in 2014. Hudhud was the first cyclone to hit a major coastal city in Andhra Pradesh State.

**Table 7.4.1 Disaster Records in last 10 years in Andhra Pradesh State**

No.	Year	Date of Occurrence	Location (District in AP State)	Affected Area (ha.)	Population		Estimated Value of Damage (Rs. in crore)
					Affected	Lost	
<b>Cyclone Disasters</b>							
1	2008	14 to 16 Nov. (Cyclone Khaimuk), 25 to 30 Nov. (Cyclone Nisha)	Srikakulam, Vizianagaram, Visakhapatnam, East Godavari, West Godavari, Krishna, Guntur, Prakasam, and Nellore	279,287	200,000	9	116.00
2	2010	17 to 22 May (Cyclone Laila) 29 Oct – 8th Nov. (Cyclone Jal)	Srikakulam, Vizianagaram, Visakhapatnam, East Godavari, West Godavari, Krishna, Guntur, Prakasam, Nellore, Chittoor, Kadapa and Ananthapur	456,481	3,446,000	84	3973.86
3	2011	25 to 31 Dec. (Cyclone Thane)	Srikakulam, Vizianagaram, Visakhapatnam, East Godavari, West Godavari,	62,883	-	0	56.92

No.	Year	Date of Occurrence	Location (District in AP State)	Affected Area (ha.)	Population		Estimated Value of Damage (Rs. in crore)
					Affected	Lost	
			Krishna, Prakasam, Nellore and Chittoor.				
4	2012	29 Oct. to 6 Nov. (Cyclone Nilam)	Srikakulam, Vizianagaram, Visakhapatnam, East Godavari, West Godavari, Krishna, Guntur, Prakasam, Nellore, Chittoor, Kadapa, Ananthapur and Kurnool	836,093	2,039,000	56	4038.6
5	2013	10 to 13 Oct. - (Cyclone Phailine)  19 to 28 Nov. (Cyclone Helen and Leher)	Srikakulam, Vizianagaram, Visakhapatnam, East Godavari, West Godavari, Krishna, and Guntur	287,518	1,071,000	11	838.88
6	2014	11 to 13 Oct. (Cyclone Hudhud)	Srikakulam, Vizianagaram, Visakhapatnam and East Godavari	325,839	9,277,000	61	21,908.49
<b>Flood Disasters</b>							
1	2007	1 Jun., 7 Sep., Oct. & Nov.	Vizianagaram, Visakhapatnam, East Godavari, West Godavari, Krishna, Guntur, Prakasam, Chittoor, Kurnoo, Kadapa and Ananthapur	143,365	1,500,000	126	2652.48
2	2008	9 to 13 Feb., 3 to 11 Aug.	Srikakulam, Visakhapatnam, East Godavari, West Godavari, Krishna, Guntur, Prakasam, Nellore, Kadapa and Kurnool	624,593	1,532,000	66	1373.92
3	2009	29 Sep. to 4 Oct.	Srikakulam, Vizianagaram, West Godavari, Guntur, Krishna, Kadapa, Ananthapur and Kurnool	167,395	1,426,000	54	8476.49
4	2010	South West Monsoon, 5 - 8 Dec.	Srikakulam, Vizianagaram, Visakhapatnam, East Godavari, West Godavari, Krishna, Guntur, Prakasam, Nellore,	1,171,005	1,518,000	44	5614.83

No.	Year	Date of Occurrence	Location (District in AP State)	Affected Area (ha.)	Population		Estimated Value of Damage (Rs. in crore)
					Affected	Lost	
			Chittoor, Kadapa, Ananthapur, and Kurnool				
5	2013	21 to 27 Oct.	Srikakulam, Vizianagaram, Visakhapatnam, East Godavari, West Godavari, Krishna, Guntur, Prakasam, Kadapa, Ananthapur and Kurnool,	684,489	513,000	39	6928.77
<b>Drought Disasters</b>							
1	2009	-	Srikakulam, Vizianagaram, Visakhapatnam, EG, WG, Krishna, Guntur, Prakasam, Nellore, Chittoor, Kadapa, Ananthapur, and Kurnool	314,519	470,000	0	871.06
2	2011	-	Entire the State	1,441,655.5	1,914,000	0	3210.06
3	2012	-	Guntur, Prakasam, Nellore, Chittoor, Kadapa, Ananthapur and Kurnool	1,131,564	1,176,000	0	2069.83
4	2013	-	Vizianagaram, Chittoor and Kadapa, Ananthapur	803,412	790,000	0	1061.89
5	2014	-	Guntur, Prakasam, Nellore, Chittoor, Kadapa, Ananthapur & Kurnool	730,355	829,000	0	2929.40
6	2015	-	Entire the State	1,441,655.5	1,914,000	0	3210.06

Note: The figures before reorganisation of Andhra Pradesh State in 2014 include the figures in Telangana area (Telangana State).  
Source: APSDPS (2015)

The land-fall locations of cyclone in recent past are shown in Figure 7.4.2. This figure shows all of the coastal areas of Andhra Pradesh that have high possibility of cyclone land fall.

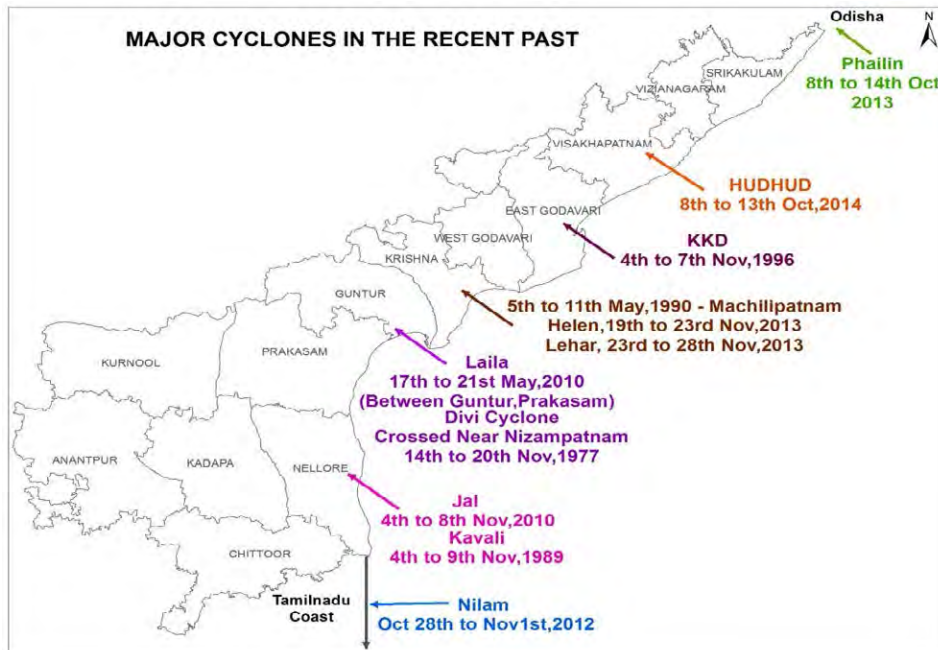

Source: APSDPS, "Cyclone and Flood Event Management In Andhra Pradesh", (2015)

**Figure 7.4.2 Land-fall Locations of Major Cyclones in the Recent Past**

#### 7.4.4 Observation Systems

##### (1) Organisation

Andhra Pradesh State Development Planning Society (APSDPS) has initiative for disaster-related observation and data analysis in Andhra Pradesh State and Telangana State.

AP State Disaster Mitigation Society (APSDMS) was established after the Andhra Pradesh Hazard Mitigation and Emergency Cyclone Recovery Project that was funded by the World Bank got over in 2003 under the administrative control of Planning Department. In 2012, after almost 10 years of the establishment of APSDMS, it was restructured and re-named as APSDPS.

APSDPS has the following two divisions, (1) the Development Planning Division, and (2) the Disaster Mitigation Division. The Development Planning Division is initiating sector-wise studies, research, reviews, appraisals and data based on key growth parameters in the state. The Disaster Mitigation Division is analysing disaster risks and providing warnings of disasters to AP state government agencies and the public based on the hydro-meteorological observation data by APSDPS and central government.

##### (2) Observation Stations/Sensors

Instrument Unit of APSDPS maintains the weather and water level sensors shown in Table 7.4.2 and updates the observation data to its website. All of the sensors even in remote areas work on battery backup with solar panels and transmit data through GSM mobile network. The location and details of the sensors (see Figure 7.4.3) are listed on the website of APSDPS.

**Table 7.4.2 The Number of Weather and Water Level Sensors in Andhra Pradesh State**

No.	Weather Station's Sensors and Water Level Sensors	Number
1	Rainfall sensors	1203
2	Air temperature sensors	1173
3	Humidity sensors	1173
4	Wind speed sensors	1173
5	Wind direction sensors	1173
6	Pressure sensors	713
7	Global radiation sensors	86
8	Soil moisture sensors	59
9	River water level sensors	93
10	Reservoir water level sensors	76
11	Coastal station with tidal gauge	5

Source: APSDPS (2015)



Source: APSDPS (2015)

General		Image View																		
Station ID	10281	Date Of Installation	06/07/2009																	
Site Type	AWS	Instrument type	AWS																	
Agency	APSDPS																			
Location	Machilipatnam																			
Mandal	Machilipatnam																			
District	Krishna																			
State	Andhra Pradesh																			
Country	India																			
Address Details	132KV substation, Machilipatnam, Machilipatnam(M), Krishna; Ph:08672- 223358; AE-9490154742																			
		<table border="1"> <thead> <tr> <th></th> <th>Deg</th> <th>Min</th> <th>Sec</th> </tr> </thead> <tbody> <tr> <td>Longitude</td> <td>16.0°</td> <td>10'</td> <td>59.021"</td> </tr> <tr> <td>Latitude</td> <td>81.0°</td> <td>8'</td> <td>19.19"</td> </tr> <tr> <td>Elevation</td> <td colspan="3">8</td> </tr> </tbody> </table>				Deg	Min	Sec	Longitude	16.0°	10'	59.021"	Latitude	81.0°	8'	19.19"	Elevation	8		
	Deg	Min	Sec																	
Longitude	16.0°	10'	59.021"																	
Latitude	81.0°	8'	19.19"																	
Elevation	8																			
		Email Id	awsaps@gmail.com																	
		Phone No	NA																	

**Figure 7.4.3 Automatic Weather Station and its Specification on APSDPS Website**

**(3) Data Collection, Analysis and Storage**

Based on the observed data, APDPS disseminates the real time observation data through the website with maps, tables and CSV files. All of the visitors to the website can select the particular location of the observation site and display current status. The example of the web browsing system on APSDPS website is shown in Figure 7.4.4.

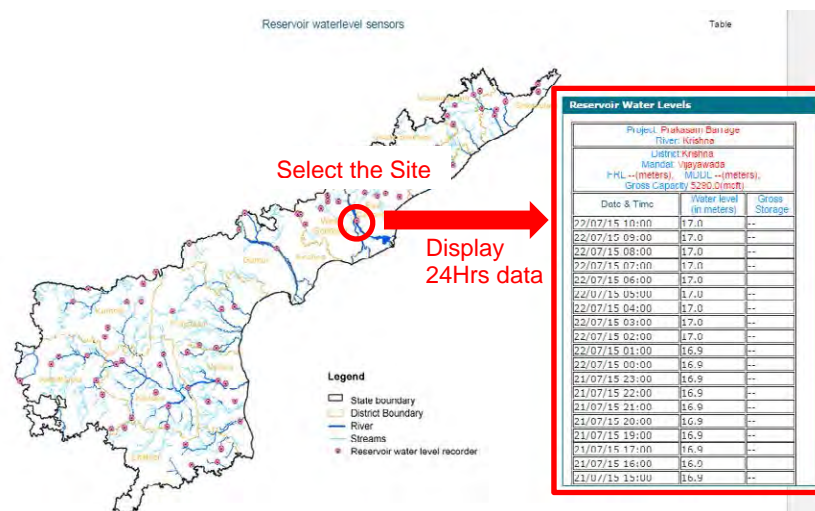

Source: APSDPS (2015)

**Figure 7.4.4 Observation Data Browser on APSDPS Website**



APSDPS develop and publish spatial maps such as daily rainfall distribution, daily cumulative rainfall, deviation of actual rainfall from normal rainfall, etc. based on the daily observation data. These data also available on the APSDPS website. The example of the published spatial maps are shown in Figure 7.4.5. These maps are used for mainly disaster prevention and agricultural purposes.

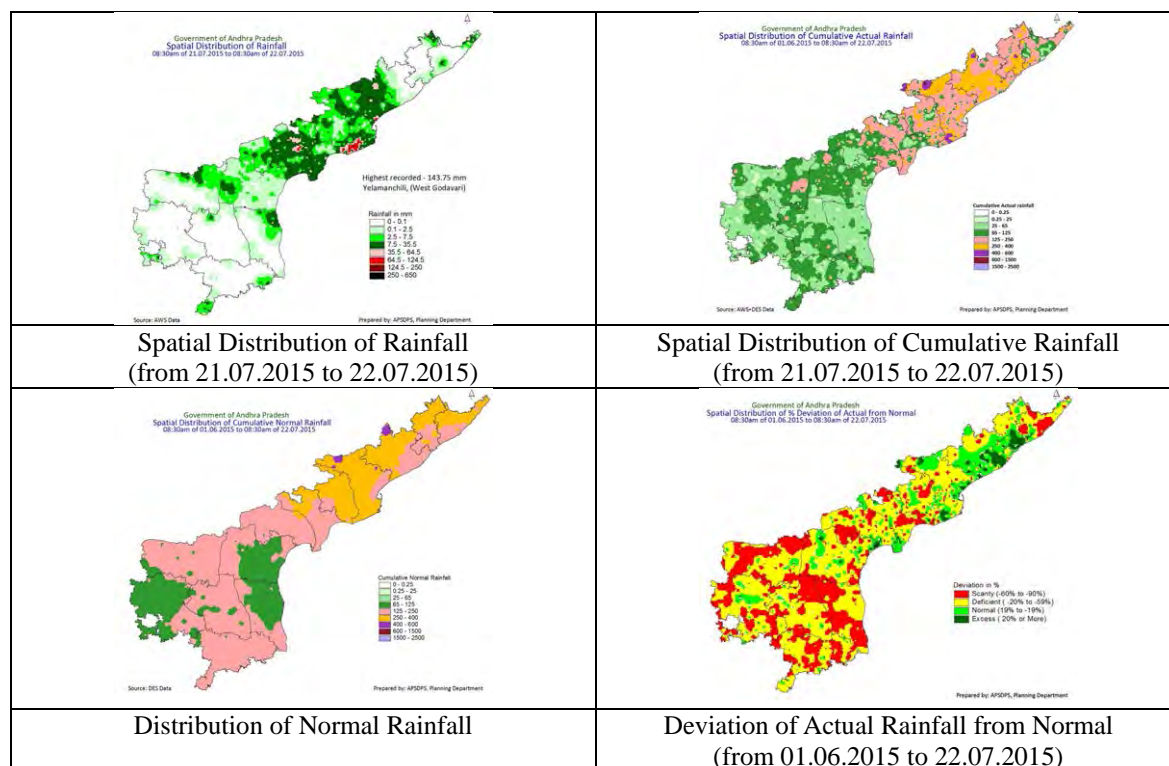

Source: APSDPS (2015)

**Figure 7.4.5 Example of Daily Spatial Maps by APSDPS**

## 7.4.5 Risk Analysis

### (1) Risk Mapping

APSDPS provides vulnerability maps for cyclone (height of storm surge and wind), flood and drought. These maps are available on the website.

The cyclone vulnerability maps are provided in two wind intensity cases, 65 km/h (18 m/s) and 235 km/h (65 m/s). The cyclone vulnerability maps are prepared for indicated magnitude of storm surge and damage to buildings and crops by strong wind.

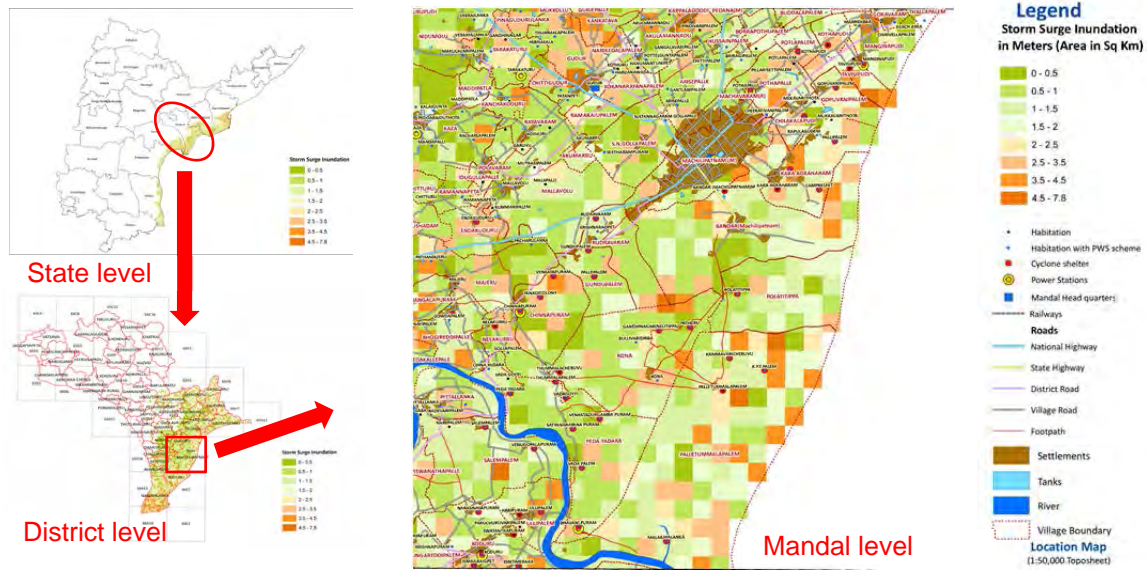

Source: APSDPS (2015)

**Figure 7.4.6 Vulnerability Map for Storm Surge in case of 235km/h Wind Speed**

The flood inundation maps are prepared for 1 in 100 year return period event along the major rivers and inundation depth is not identified.

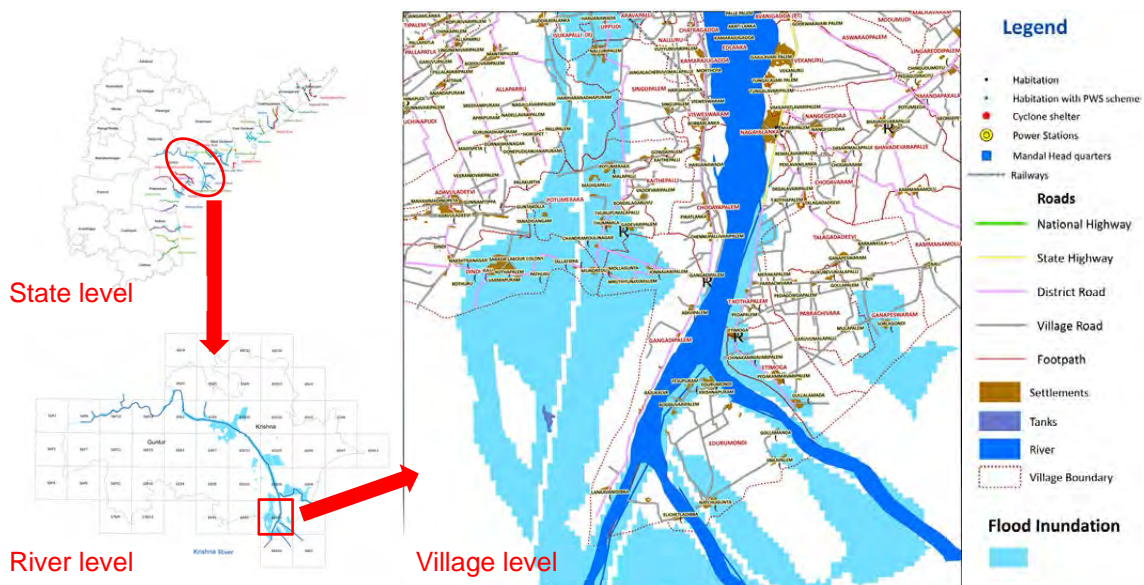

Source: APSDPS (2015)

**Figure 7.4.7 Inundation Map for 1/100 Return Period**

## (2) Types of the Models for Risk Analysis

APSDPS has prepared risk maps for cyclone, flood and drought based on the observation and analysed data in Andhra Pradesh State. The numerical model for risk analysis has been developed with the help of research institutes and universities. Table 7.4.3 shows the numerical models for risk analysis with developers. These models are also installed into the real time system for decision support system. These models can provide real time calculation results based on real time monitoring data.

**Table 7.4.3 Utilised Numerical Model for Risk Mapping in Andhra Pradesh**

No.	Name	Purpose of the Model	Developer(s)
1	Storm Surge Model (SSM)	Computing storm surges in 20km inside the coastline of AP including the entire area of Krishna, Godavari and Pennar deltas.	Delft 3D (Deltares, Netherland)
2	Wind Hazard Model (WHM)	Computing wind damage assessment includes all the mandals (sub district) within 60km from coast and delta area.	Indian Institute of Technology Chennai
3	Rainfall-Runoff Model	Calculating a run-off volume from rainfall and land conditions such as soil moisture and underground water level.	Water Resources Systems Research Laboratory, Newcastle, U.K.
4	Flood Model	Calculating river discharge in each sections and generating inundation maps based on topography data.	MIKE 11 (DHI)

Source: compiled by the Survey Team based on the website of APSDPS

### (3) Disaster Risk Analysis in Major City

The GOI-UNDP’s project, Enhancing Institutional and Community Resilience to Disasters and Climate Change (2013-2017) is implementing in 10 cities including Vijayawada and Visakhapatnam Municipal Corporation, Andhra Pradesh State. Under the project, hazard risk and vulnerability assessment is carried out in city area.

Vijayawada is located aside of Krishna River, which is one of the major two rivers in Andhra Pradesh. Vijayawada is prone for multi hazard such as flood from Krishna river, strong wind by cyclones, inland flood, rock slide and heat wave. The vulnerability maps prepared by the GOI-UNDP project are shown in Figure 7.4.8.

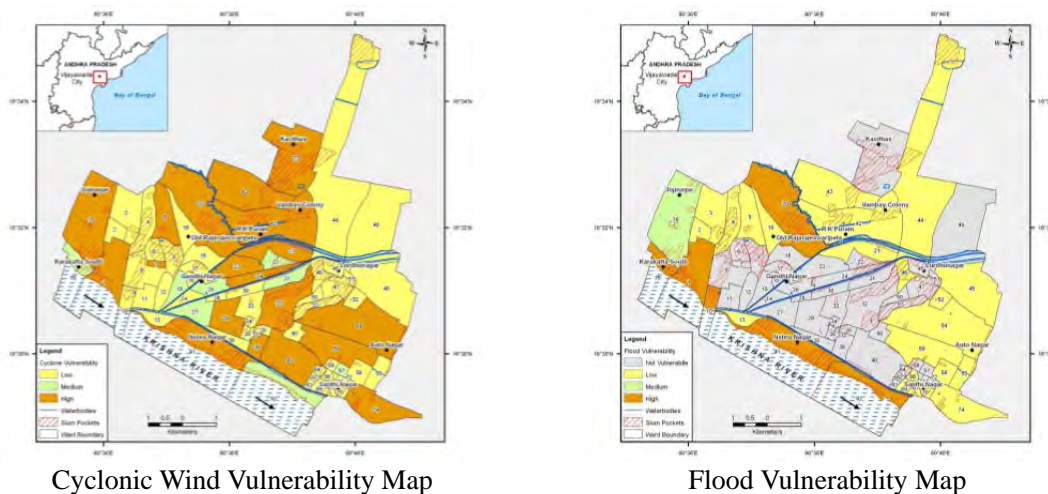

Source: UNDP “Hazard Risk and Vulnerability Analysis (HRVA) City of Vijayawada, Andhra Pradesh Multi-hazard Risk Atlas” (2014)

**Figure 7.4.8 Vulnerability Maps prepared by the GOI-UNDP Project in Vijayawada**

## 7.4.6 Emergency Response

### (1) State Level

The A.P Disaster Management Rules-2007, G.O Ms.No.1436, Rev. (DM.III) Dept., dt.14.11.2007. regulates to constitute the SDMA, SEC and DDMA for disaster management in Andhra Pradesh State. Besides, in 2015, based on G.O Ms.No.4, Rev. (DM) Dept., dt.07.05.2015., the Incident Response System (IRS) is constituted for emergency response in Andhra Pradesh State.

The IRS is considered to be a useful mechanism and the same is discussed in draft SDMP. Establishment of IRT on state and district level is one of the key actions mentioned in National Disaster Management Guidelines for Incident Response System in 2010 published by the NDMA.

In any disaster response, the initial efforts would always be taken by the district administration. However, when districts are overwhelmed in any situation, the support necessarily has to come from the state and national level. While the IRS is mainly relevant at the basic functional level, it is absolutely necessary that the support functionaries from the state and the national level also conform to the principles of IRS in the emergency support duties. This will be greatly beneficial for the proper coordination of the various response efforts at the national and state level with that of the district. It is therefore necessary to clearly understand the structure of the IRS in the context of state response. The hierarchical representation of Responsible Officer (RO) with SEOC, Headquarters IRT and its lower level of IRTs at district level are shown in Figure 7.4.9.

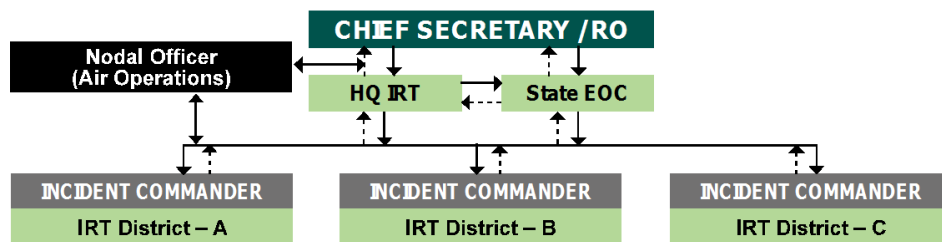

Source: NDMA, “National Disaster Management Guidelines for Incident Response System”, (2010)

**Figure 7.4.9 Organisation of IRT at State Level**

## (2) District Level

The model frame of the DDMP which has been prepared by the state government suggests to review the situation/condition of climate, economy, infrastructure, administrative system, equipment, human resources and related organisations, and to develop following plans and forms for disaster response:

- Shelter Management Plan
- Evacuation Plan
- Media Management Plan
- Medical and Hospital Management Plan
- Formats for post disaster damage, loss, needs and capacity assessment

Actual situation of emergency response varies from one district to another. The Survey Team investigated two districts, Krishna and Visakhapatnam. In Krishna District, the section named “D-Section” mainly manages emergency response. The human resources in the D-Section is limited. They cover several issues such as land management, disaster management, etc. Only one officer is working for disaster management in normal situation. On the other hand, in Visakhapatnam District, there is the Disaster Section. The section is designated only for disaster management in the district.

### 1) Krishna District

Krishna District is located on the delta area of Krishna River. The District has 7 cyclone prone mandals (sub districts) and 12 flood prone mandals. The population of the district is 4.5 million (census in 2011). There are two major cities, Machilipatnam and Vijayawada. Machilipatnam is capital of the district and Vijayawada is located near the area of new capital of Andhra Pradesh State.

### Institutional Setup of Disaster Management in Krishna District

Krishna District formulated the DDMA in 2007. The DDMA convenes periodical meetings with all the line departments and reviews the plans of pre- and post-disaster measures of departments. The special officer for natural calamities was appointed for each and every mandal.

The action plans for village/mandal levels were prepared. The main items of the action plan are implementation team for each village, list of related telephone numbers and available facilities and equipment, and form of damage assessment.

### Standard Operating Procedure (SOP) for Disaster Management in Krishna District

The DDMA prepared the SOP for disaster management in Krishna District. The SOP figures out the activities of district departments for implementation of disaster response.

The example of description in the SOP is shown below. The SOP covers activities most of all department-related disaster management, but the descriptions of activities are quite simple, general and response-oriented. Besides, the timing/time line of activities and framework of inter-departments cooperation are not mentioned in the SOP.

#### Example of Description of SOP in Krishna District

##### Police Dept. –

- To provide bundobast and patrol at the evacuated areas and also at the relief camps rescue operation places and also to alert the people
- To make standby arrangements for providing sufficient number of VHF sets (Wireless sets) to meet the emergencies

##### Irrigation –

- To prepare the list of weak bunds and flood banks of irrigation sources and to strengthen and to repair it immediately
- To put in place teams to watch the bunds and ensure their safety

Source: Standard Operating Procedure for Disaster Management in Krishna District

## **2) Visakhapatnam District**

Visakhapatnam District, which is located in the East Indian coastal area, has the major port city named Visakhapatnam. The population of the district is 4.3 million (census in 2011). Visakhapatnam is capital of the district and one of the big cities in Andhra Pradesh State.

Visakhapatnam District has not formulated the DDMA yet. Under the chairmanship of district collector, the district level high power standing committee for implementation of disaster management is formulated.

The DDMP on Cyclone is formulated for integrated disaster management plan in the district and updated annually. The action plan figures out the cyclone-prone mandals and flood-prone mandals. Besides, the plan identifies the responsibilities of each district department and disaster management procedures for each district department. The contents of the plan are shown in Table 7.4.4.

**Table 7.4.4 Contents of DDMP on Cyclone in Visakhapatnam District**

Chapter	Description	Pages
1	Contingency Plan to meet a Cyclone Situation	1-9
2	Visually of Natural Calamities, Cyclone Forecasting and Warning	10-18
3	Action Immediately Before and during the Occurrence of a Cyclone	19-27
4	Action after receipt of Second Warning	28-30
5	Post-Cyclone Measures Convening of the Committees	31-36
6	Community Preparedness –Mass Publicity	37-42
7	Visual Natural Calamities Flood Warning	43-45
8	Measures to be taken by state Government Irrigation Department	46-52
9	Cyclone Stores	53-54
10	Department-wise Action Plans	55-85
11	Action Plans and Profiles of all the Vulnerable Mandals of the District	86-167
12	Statistical Information of the District	168-176
13	List of Important Phone Numbers	177-180

Source: Visakhapatnam District, “District Disaster Management Plan on Cyclone 2014-2015” (2014)

The SOP for disaster management are also described in the DDMP in Visakhapatnam.

### (3) Emergency Operations During Cyclone ‘Hudhud’ in 2014

#### 1) Outline of Cyclone

‘Hudhud’ crossed over Visakhapatnam District coast between 12:00AM and 1:00PM on 12 October 2014. Visakhapatnam, Srikakulam, Vizianagaram and East Godavari Districts received heavy rainfall. The highest cumulative rainfall of 527.27 mm (from 8:30AM on 12 to 8:30 AM on 13 October 2014) was recorded in Atchutapuram Mandal.

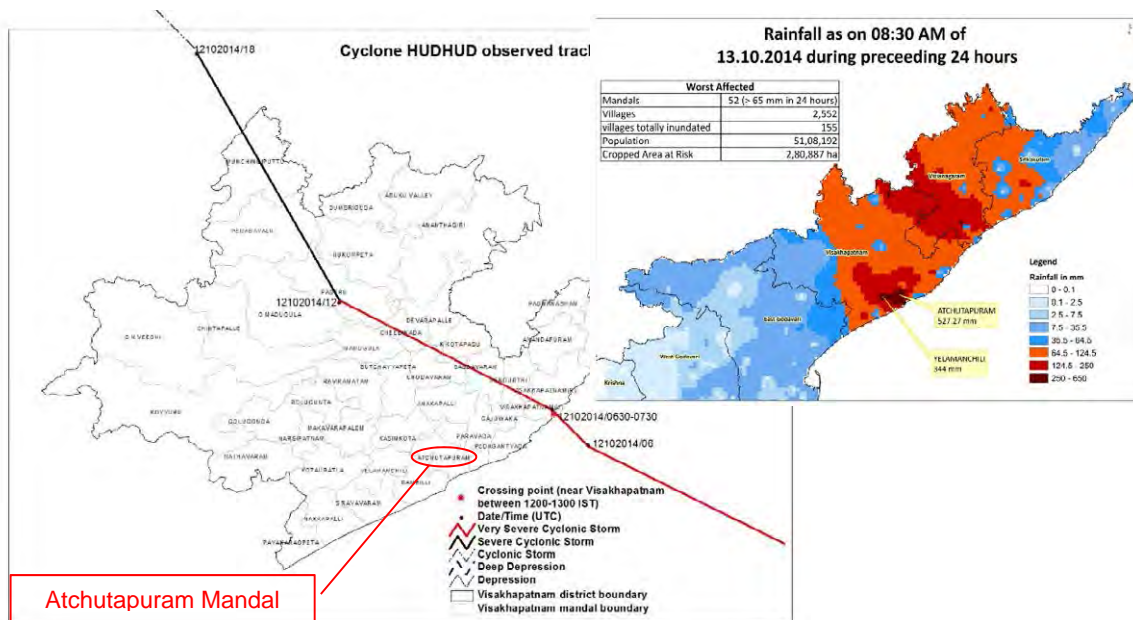

Source: APSDPS

**Figure 7.4.10 Cyclone Hudhud Observed Track and 24 Hour Precipitation**

#### 2) Time Line of Response Activities

The disaster response activities during Cyclone Hudhud are shown in Table 7.4.5.

**Table 7.4.5 Response Activities During Cyclone Hudhud**

Term/Item	Activities
Pre-Disaster	<ul style="list-style-type: none"> <li>Control rooms were opened by the government at state headquarters and district headquarters (24 hours opened during disaster)</li> </ul>
Early Warnings	<ul style="list-style-type: none"> <li>Wide publicity about the intensity of cyclone disseminated through television / radio / print media regarding the progress of cyclone from time to time. 15 satellite phones were provided to the district administration</li> <li>All fishermen in the coastal districts were alerted through the mobile phone.</li> </ul>
Deployment of Officers	<ul style="list-style-type: none"> <li>40 senior AIS officers were posted to supervise rescue &amp; relief operations in the field.</li> <li>Senior officers were deputed as a Special Officers to all affected mandals to monitor and assist the mandal administration.</li> </ul>
Rescue & Relief Teams	<ul style="list-style-type: none"> <li>24 teams of the National Disaster Response Force, 1 State Disaster Response Force team, 4 columns of army personnel (4x110) and 30 navy teams (30x3) were deployed for rescue &amp; relief operations.</li> </ul>
Equipment for Rescue & Relief	<ul style="list-style-type: none"> <li>17 ships, 2 dornier, 4 transport aircrafts and 20 helicopters were deployed for rescue &amp; relief operations.</li> </ul>
Evacuation	<ul style="list-style-type: none"> <li>2.23 Lakh people were evacuated from low lying areas under precautionary measures and 310 relief camps were organised</li> <li>29.05 lakh food packets were distributed in the relief camps.</li> <li>16,24,572 persons were provided with food and drinking water outside of relief camps.</li> </ul>
Emergency Rehabilitation	<ul style="list-style-type: none"> <li>7073 fallen trees were cleared and normalcy was restored in transportation.</li> <li>Ensured restoration of normalcy in drinking water supply through tankers by drawing tankers and personnel from neighbouring districts.</li> <li>Monitored the restoration of power supply to cyclone hit areas by drafting about 2000 technical staff from other districts of the state.</li> <li>Monitored the activities of cell tower operators for restoration of communication system.</li> </ul>
Damages	<ul style="list-style-type: none"> <li>Due to falling trees / wall collapse / electrical pole collapse, 61 deaths were reported in 3 districts (Ex-gratia of Rs.5.00 lakh to the kin of the deceased.)</li> </ul>

Source: Visakhapatnam District, "Presentation for DEA Joint Mission"

### 3) Provision of Observation and Analysed Data for Decision Making

During the cyclone, APSDPS provided the observation and analysed data for cyclone such as rainfall, wind speed, course of cyclone, inundation area based on analysis of satellite image, etc.

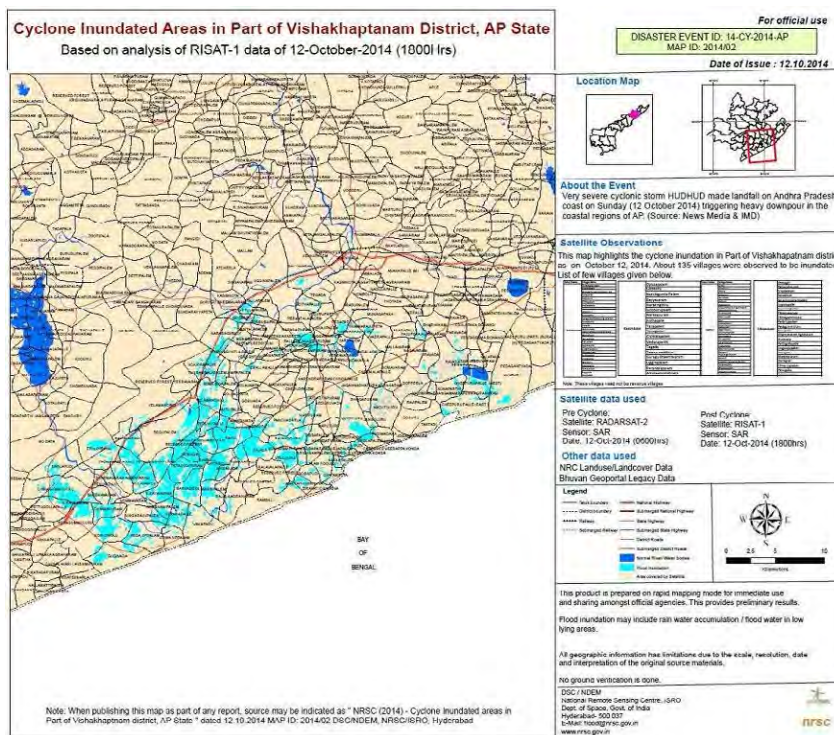

**Figure 7.4.11 Semi-Real Time Cyclone Inundated Area Map**

#### 4) Damages caused by the Cyclone

The result of post-cyclone damage assessment is shown in Table 7.4.6. All of the damage data was collected by the Mandal Revenue Officers through the Village Revenue Officers.

**Table 7.4.6 Estimated Loss and Required Financial Assistance**

Department (Sector)	Damages	Estimated Loss
Agriculture	● Total cropped area damaged: 2,37,854.00 ha	Rs. 947.9 Cr
Horticulture	● Horticultural lands affected: 87984 Ha	Rs. 1339.23 Cr
Sericulture		Rs. 1.73 Cr
Animal Husbandry	● Big animals: 1406 ● Small animals: 4468 ● Poultry: 4634706	N/A
Fisheries	● No of boats and nets Lost: 956	Rs.98.29 Cr
Road & Buildings Department	● Damages to R&B roads: 3880km ● No. of buildings damaged: 53	Rs. 1111.80 Cr
Panchayat Raj Department	● No. of PR roads damaged: 2274 ● No. of PR buildings damaged: 375	Rs. 995.20 Cr
Gram Panchayat Roads	● GP internal roads damaged: 4831km ● No of GP buildings damaged: 1108 ● No of street lights & fixtures: 2.5 Lakhs	Rs. 410.00 Cr
Municipal Administration and Urban Development Department	● Municipal roads damaged: 1345km ● No of municipal buildings damaged: 24138 ● No of municipal street lights/etc. damaged: 40614	Rs. 3621.56 Cr.
House Damages	● Total no. of houses damaged: 200673	Rs.3236.32 Cr.
Rural Water Supply & Sanitation	● Total no. of works damaged: 1163	Rs.126.9 Cr.
Irrigation	● No of irrigation sources damaged: 3180 ● Damages to flood banks: 59 ● Damages to buildings: 51	Rs. 317.05 Cr
School Education	● No of classrooms damaged: 1269	Rs. 51.29 Cr
Social Welfare	● No. of hostel buildings damaged: 156	Rs. 4.93 Cr
BC Welfare	● No. of hostel buildings damaged: 117	Rs. 40.87 Cr
Tribal Welfare	● No. of hostel buildings damaged: 253	Rs. 52.01 Cr
Intermediate Education	● No. of Govt. Jr. colleges damaged: 38	Rs. 1.02 Cr
Health Infrastructure		Rs. 308.79 Cr
Power Sector		Rs. 1290.08 Cr.
AP Housing Corporation Ltd	● No. of house buildings damaged: 15303	Rs. 5.07 Cr.
Revenue Infrastructure (Visakhapatnam)	● No. of buildings damaged: 4	Rs. 3.60 Cr
Forest Department		Rs. 315.00 Cr.
Fire Services		Rs. 1.39 Cr
Commandant 5th Btn, APSP		Rs. 3.89 Cr
AP Beverage Corporation Ltd		Rs. 0.80 Cr
Industries (Pvt):	● Damages to APIIC parks ● Damages to Private Industries	Rs. 1275.00 Cr Rs. 6136.20 Cr
(Other)	● Push carts damaged: 824 ● Rickshaws damaged :3635 ● No of auto rickshaws damaged: 160	N/A
	Total	Rs. 21,908 Cr

Source: AP State, "Presentation for DEA Joint Mission", (2014)



## 5) Lessons Learned from Cyclone Hudhud

According to Visakhapatnam District Magistrate, lessons learned from Cyclone Hudhud can be summarised as shown in Table 7.4.7.

During the response phase of Cyclone Hudhud, deployment of skilled officials and equipment went well. Also, the basic information for damage assessment were well prepared. On the other hand, communication systems were damaged and took long time for rehabilitation.

**Table 7.4.7 Lessons Learned from Cyclone Hudhud**

Went Well	Went Badly
<ul style="list-style-type: none"> <li>● Huge quantity of vegetables were supplied form other districts without inflation</li> <li>● Under AP State “Skills Development Mission”, skilled electricians, plumbers, carpenters, etc. were supplied to necessary households for free (managed by call centre)</li> <li>● Power saws were supplied to villages to help them to cut the fallen trees</li> <li>● “National Rural Employment Guarantee Scheme (NREGA)” contributed to evaluate the value for fallen trees on district level.</li> <li>● The insurance companies regularly reviewed on the claim settlements</li> </ul>	<ul style="list-style-type: none"> <li>● Telecom companies took long time to resume the communications due to the insufficient storage of fuel.</li> <li>● Bank ATMs took time to restore the service due to the disconnection of online service.</li> </ul>

## 6) Evaluation of Activities during Cyclone Hudhud by APSDPS

APSDPS drew lessons from the experience of Cyclone Hudhud from the perspective of “Build Back Better”, scientific input and governance. Resilience to cyclone impact needs to be improved for the core infrastructures, such as:

- Road/rail network, water supply, communication, aviation, power lines/energy systems
- Shelters and other key facilities (hospital, police, financial service, civil supplies)

The following scientific inputs are also considered for cyclone and flood response:

- Detailed spatial databases up to habitation level
- LiDAR surveys for finer topographic data
- Advance modelling facilities to simulate future intensities of cyclones

Besides, the following are the governance issues to be addressed:

- Establishment of EOCs at state, district and mandal levels
- Detailed operational manuals for disasters
- Pre-defined roles and responsibilities and triggering points for all levels
- Revision of building codes with higher specs for key and core infrastructures
- Retrofitting key and core structures to comply with building standards

### 7.4.7 Evacuation Systems

#### (1) State Level

According to the AP SDMP (2011), activities related to evacuation are listed as follows:

- Preparation and communication of village level evacuation plans, especially for the most

- vulnerable villages
- Early warning to most vulnerable villages of impending disaster as declared by competent authorities
- Coordination with civil defence/NGOs/gram panchayats and local police departments
- Alerting villages/communities on earmarked boats and vehicles for evacuation; arranging boats and vehicles to most vulnerable villages/mandals
- Evacuation of people from areas most affected and administering of emergency relief
- Training and organising of village level task force for emergencies; identifying NGOs to take up the responsibility of training the task force
- Drafting local cable operators to broadcast alerts as running flashes on TV
- State-wide amber alerts
- Deploying police to maintain law and order; peacekeeping during evacuation
- Identifying disaster shelters (such as high ground/schools if not affected or other such places) and managing people mobility to these shelters
- Deployment of power boats/country boats as needed

The primary responsibility of issuing an evacuation order is given to the District Magistrate. The District Magistrate gathers the information of evacuation status, and reports the same to the Division. The information about evacuation status is compiled by the division revenue officer and forwarded to the state.

## (2) District Level

The District Magistrate activates the actions shown in Table 7.4.8 when the warning is received.

**Table 7.4.8 Warning Level and Actions taken by District Magistrate (Visakhapatnam Case)**

Type of Warning	Actions
First Warning	<ul style="list-style-type: none"> <li>● Taking communication with divisional officers, all heads of districts and departments through telephones/wireless or SMS.</li> <li>● Concerned officials should communicate to the village committees and officials.</li> <li>● Village officials give wide publicity to the vulnerable areas such as low lying area.</li> <li>● In case of the area has no accessible by the road, the people should be evacuated to safer place.</li> <li>● All the district officials who are away on tours should immediately return to Headquarters and contact the magistrate.</li> <li>● District and Division should open the control room till the receipt of de-warning.</li> </ul>
Second Warning	<ul style="list-style-type: none"> <li>● Revenue Department sends lorries and buses to the villages if needed.</li> <li>● Revenue Department arranges food, water and medical items for shelters.</li> <li>● The people should be evacuated to safer places such as cyclone shelters/ schools/ temples/ churches / mosques and other public buildings with assistance of police department and mandal and village revenue officers.</li> </ul>

Source: Visakhapatnam District, "District Disaster Management Plan on Cyclone 2014-2015", (2014)

## (3) Situation of Cyclone Shelters

In Andhra Pradesh State, there are more than 1,100 cyclone shelters. The mandals list cyclone shelters in their Disaster Management Plans with name, place and condition of the cyclone shelters. The condition of cyclone shelters has not been sufficient till now. According to the Mandal Disaster Management Plan in Visakhapatnam, many of the shelters require minor (fixing window, doors, etc.) / major (fixing of roof etc.) repairs.

### 7.4.8 Preparedness and Countermeasures

#### (1) State Level

AP SDMP defines the basis of prevention and mitigation measures for disasters in Andhra Pradesh

State. The main mitigation strategy of disaster mitigation includes the following:

- Risk assessment and vulnerability analysis
- Applied research and technology transfer
- Public awareness and training
- Promoting intuitional mechanisms
- Incentives and resources for mitigation
- Mainstreaming land use planning and regulations to disaster management

Risk assessment is implemented by APSDPS, national institutions and universities. Based on these measurements and assessments, concrete projects such as construction of embankment, cyclone shelters, etc. are implemented.

The state government established the facilities to provide training courses, for example, AMR-Andhra Pradesh Academy of Rural Development (AMR APARD). The Academy has specialised centres for particular sectors. The Centre for Management of Environment and Disasters (CMED) provides the training programmes for disaster management. Currently, the facilities are under the administration of Telangana State. The new training facilities for Andhra Pradesh State will be established.

APSDMP emphasises the importance of pre-event planning and stable funding mechanism as incentive for mitigation measures. In this sense, APSDMP pointed out the mitigation measures will include the following:

- Developing mechanisms to provide stable sources of funding for preparedness and mitigation activities at all levels of government. State Disaster Mitigation Fund being set up will be the primary source of funding government initiatives.
- Review of current incentives and disincentives for undertaking both pre- and post-disaster mitigation action will determine what additional incentives and disincentives are required to ensure sustainable development of DM concerns.
- Providing resources for state and local governments to ensure adequate levels of coordination and effective implementation of mitigation activities
- Introducing disaster insurance, based on community rating systems that recognise adoption and enforcement by communities of building codes that contain all-hazard building standards
- Credit finance and housing finance companies will be encouraged to mandate new constructions to follow specified building codes or zoning regulations as part of loan requirements.

### **1) Measures for Cyclones**

Many of the public buildings and transport infrastructure are vulnerable to damage from earthquakes, cyclones, winds and other hazards. Departments like Roads and Buildings Department, Municipal Administration and Urban Development, Panchayati Raj Engineering, etc. are responsible for construction and maintenance of critical infrastructure, public buildings and installations in the state. As part of mitigation strategy, these departments will consider both structural design and material standards to ensure strengthening and protection of these structures and installations.

Different departments such as Panchayati Raj, Roads & Buildings and other agencies have built cyclone shelters in the nine coastal districts of Andhra Pradesh. Under the project of the World Bank's National Cyclone Risk Mitigation Project, Andhra Pradesh State has developed the Multi-Purpose Cyclone Shelters.



Source: prepared by the Survey Team

**Figure 7.4.12 Cyclone Shelter in Andhra Pradesh State**

## 2) Flood Control Measures

Andhra Pradesh has strong flood monitoring and management system. The office of Engineer-in-Chief, Water Resources Department implements flood control measures for major rivers in Andhra Pradesh State. The main methods of flood control measures undertaken in Andhra Pradesh are as follows:

### (Structural Measures)

- Development of embankment, flood walls
- Construction of dams and reservoirs
- Development of natural detention basin
- Improvement of channel and drainage
- Diversion of flood waters

### (Non-Structural Measures)

- Flood plain zoning

## (2) District Level Measures

In case of Visakhapatnam District, the Director General of Information and Public Relations in consultation with radio stations in Andhra Pradesh will arrange suitable programmes for educating the public about possible hazards of cyclone and the steps to mitigate the distress due to cyclone.

Before the cyclone season, the nodal department should survey all the works in its charge every year. Irrigation department should keep the adequate capacity of drain system and embankments for maximum flood discharge. The A.P. Transco (Electric Department) should store enough restoration supplies for cables. Road and Bridge Department also should store the materials for temporary repairs.

In Visakhapatnam, under the World Bank's National Cyclone Risk Mitigation Project, power and communication cable are laid underground instead of on electrical poles along the coast area.



Source: prepared by the Survey Team

**Figure 7.4.13 Laying Power and Communication Cables Underground in Visakhapatnam**

Coastal line of Visakhapatnam is affected by high waves and part of the coastal protection facilities are damaged. The gap between sea water level and town side ground level is high, so waves not cause severe damage to the town side right now, but some protection measures are needed for the coast in the future.



Source: prepared by the Survey Team

**Figure 7.4.14 Coast near the Visakhapatnam Magistrate's Office**

### **(3) UNDP Urban Climate Risk Mitigation Project in Vijayawada**

The UNDP project was prepared the Disaster Management Plan -2015 in Vijayawada Municipal Corporation (VMC). The plan includes assessment of vulnerability for natural and man-made disasters, standard operating procedure for disaster response, and action plan for disaster risk mitigation measures with cost information for the projects. The proposed mitigation initiatives to be conducted by VMC are as follows:

- Focusing implementation of building codes and building by-laws in the city
- Identifying old structures/dilapidated buildings and alerting during emergency by Town Planning
- Development of EOC at VMC
- Establishment of IRS and provision of officers trained for emergency response
- SMS package will be established to broadcast emergency SMS based on category of hazard
- Identifying secure landslide/rock slide pockets and low lying areas
- Development of knowledge products/films/poster on DRR/CCA for enhancing capacities of population
- Focusing to reduction of vector borne disease focusing malaria, dengue, filarial

- Solid waste management in collaboration with two agencies for conversion into energy
- Tracking disasters during emergency and alerting public/focusing vulnerable divisions and wards [IMD, CWC, NGRI, INCOSIS & NDMA]

### 7.4.9 Forecasting, Early Warning and Communication Systems at State Level

#### (1) Forecasting and Early Warning

The Cyclones and Storm Surge Forecast Unit of APSDPS provides early warning for cyclone and rainfall based on forecasts. Also, Cyclone Warning Centre, IMD provides the bulletins for cyclones and heavy rains.

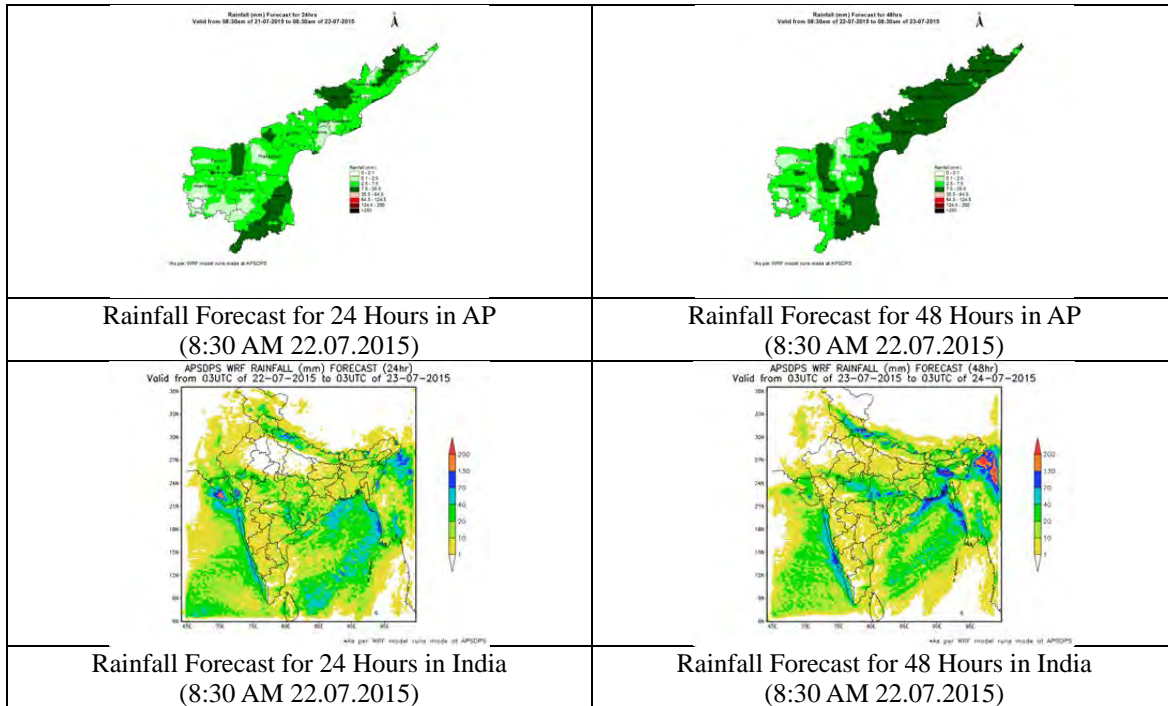

Source: APSDPS (2015)

**Figure 7.4.15 Results of Rainfall Forecast for next 24 & 48 Hours by APSDPS**

Based on the real time monitoring and forecast data, APSDPS provides real time information of possible damages through the real time system. Figure 7.4.16 shows mandal level real time possible damaging wind speed predictions.

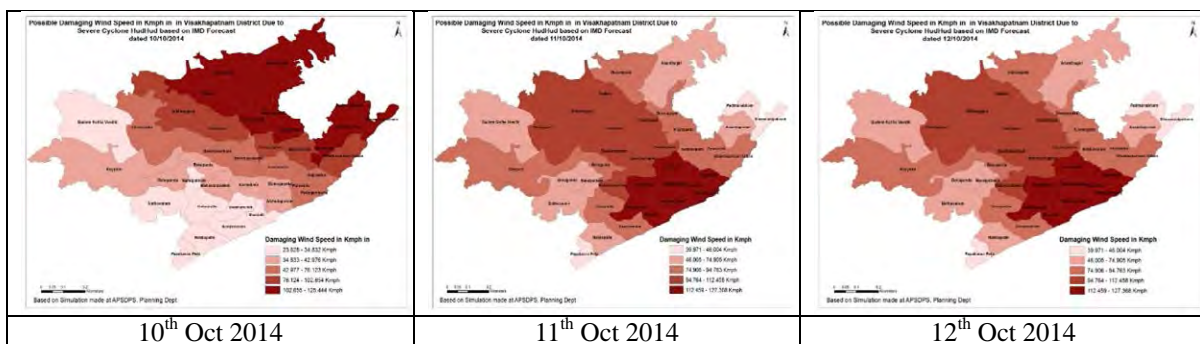

Source: APSDPS, "Cyclone and Flood Event Management in Andhra Pradesh", (2015)

**Figure 7.4.16 Daily Possible Damaging Wind Speed in Visakhapatnam by APSDPS**

The flow diagram of the real time system is shown in Figure 7.4.17. The system was composed of the numerical models for risk mapping. The outputs of the system are sent to decision makers such as Chief Minister, head of state departments, etc. Also, part of the results are put into the public domain immediately after the calculation. The system was developed in the Andhra Pradesh Cyclone Hazard Mitigation Project (APCHMP).

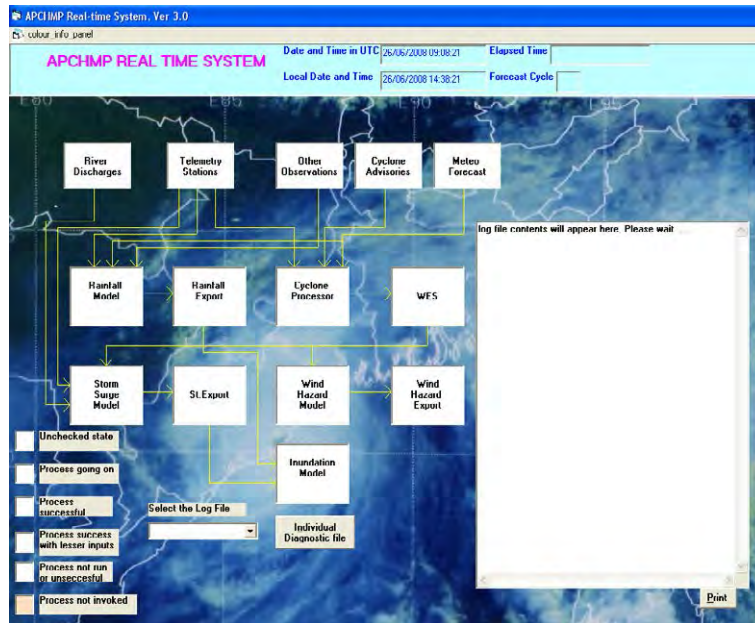

Source: APSDPS, “Cyclone and Flood Event Management in Andhra Pradesh”, (2015)

**Figure 7.4.17 Control Panel of Real Time System in APSDPS**

**(2) Communication Systems**

For communication between state and districts, there is TV meeting system. Also, mobile, land phone, ham radio, VHF and police wire-less can use for disasters. Mandal and village revenue officers also use the system in the offices.

Communication system between village revenue officers and community people is limited to mobile and oral communication. In case of mobile communication failure, community people cannot receive any information from the government.

Mobile carriers provide SMS base data dissemination system based on the agreement of licensing. SMS can be disseminated to people based on the requests from the District Magistrates.



Source: prepared by the Survey Team

**Figure 7.4.18 Wire-less Communication Equipment in District**

### 7.4.10 Disaster Risk Finance at State Level

#### (1) Disaster Risk Finance Scheme in Andhra Pradesh State

The DM Act mandates the constitution of the disaster response fund and the disaster mitigation fund at the state level. The government of Andhra Pradesh State is at the forefront of utilising the SDRF efficiently in mitigation, relief and rehabilitation works. Thus, in order to operationalise the SDRF, the state government constituted the Andhra Pradesh Disaster Response and Mitigation Fund (APDRMF). The APDRMF is facilitated for the sustained development of capacities, response and mitigation mechanisms to meet disasters/emergencies in the state by enabling government departments and other local entities to have access to capital.

Moreover, the funds from the Chief Minister's Fund are also accessed when natural disasters strike the state.

#### (2) Operation of Disaster Risk Finance in Andhra Pradesh State

The allocation and release of the SDRF and the NDRF in Andhra Pradesh State during the 13th FC period are summarised in Table 7.4.9.

**Table 7.4.9 Allocation and Release of SDRF/NDRF in Andhra Pradesh State (2010-2015)**

(unit: Rs. crore)

Year	SDRF Allocated	SDRF Released	NDRF Released
2010-2011	508.84	481.63	374.78
2011-2012	534.28	100.36	257.61
2012-2013	560.99	420.74	-
2013-2014	589.04	520.89	763.53
2014-2015*	323.62	230.86	427.06

Note: The allocation of SDRF between Andhra Pradesh and newly carved state of Telangana has been divided in the ratio of 59.38:40.62 for the year of 2014-2015.

Source: MHA, "Annual Report", (2010-2011 to 2014-2015)

Except during year 2012-2013, the NDRF was released from the central to the state government. As mentioned in section 7.4.3 above, Andhra Pradesh State has suffered from various natural disasters such as cyclones, floods and droughts every year with large estimated damaged values. It seems that the funding demands for the disaster response may exceed the financial capability of the state government due to the regular outlays of the NDRF.

### 7.4.11 Challenges to be Addressed

According to the information gathered, the following are the challenges identified by the related organisations in Andhra Pradesh State:

< Institutional Framework >

Review/revision of SDMP for new Andhra Pradesh State is still under the process at the state level. Some districts do not formulate effective DDMPs and SOPs due to the lack of human resources for disaster management section. Therefore it is necessary to establish the institutional framework of disaster management at the district, mandal and village levels with an effective Disaster Management Plan at the district level that cover the task allocation among the stakeholders.

Challenge(s) of Institutional Framework:

- Establishing the institutional framework of disaster management at the district, mandal and village levels



< Risk Analysis >

The state department has the engineering skills for risk analysis such as wind velocity, inundation, etc. For improvement of accuracy on risk analysis including real time analysis, detailed topographical data (LiDAR data) and engineering knowledge to manage them are needed. However, currently the detailed topographical data is not used for the risk analysis.

- Challenge(s) of Risk Analysis:
- Introducing scientific tools for the cyclone and flood risk analysis

In addition, considering the current situation of cyclone risk reduction in India, it is worth pointing out the following as challenges to be addressed:

< Institutional Framework >

DRR activities are limited to response and rehabilitation at the mandal and village levels. No official is made responsible for disaster preparedness and mitigation at the district, mandal and village levels. Besides, mandal and village level offices are not aware of challenges and issues on disaster management. Therefore, it is necessary to develop capacity on disaster mitigation and preparedness at the mandal and village levels in order to reduce the disaster risk at the local level.

- Challenge(s) of Institutional Framework:
- Developing capacity on disaster mitigation and preparedness at the mandal and village levels

< Preparedness >

During cyclones, due to the fall of mobile and land phone networks, there are no means of private telecommunication. Therefore, lack of communication with vehicle drivers/operators for evacuation and material distribution makes it difficult to conduct disaster response activities. There are no action plans to substantiate the disaster mitigation and preparedness at district, mandal and village levels. Also, there is no system of subsidies to encourage the disaster preparedness such as reinforcement of roof/windows. The concept of “Build back better” is not well understood. Therefore, it is necessary to develop reliable communication networks for river monitoring and management facilities during cyclone and to give incentives to strengthen and/or retrofit individual houses and buildings to make them resilient to disaster risks in order to improve the situation of preparedness.

- Challenge(s) of Preparedness
- Developing reliable communication network for river monitoring and management facilities during cyclone
  - Giving incentives to strengthen and/or retrofit individual houses and buildings to make them resilient to disaster risks

< Countermeasures >

The urban coastal area needs to be protected from wave actions, high tides and storm surges, but there are almost no countermeasures along the coast. Individual countermeasures such as retrofitting of houses, protection of electric poles, etc. are important for cyclone risk reduction. But, there are no suitable building codes and design guidelines for cyclone and flood proof structures. The urban area along the Krishna River, the area for a new capital, needs to be protected from inland flood and flash flood. Therefore, countermeasures for coastal protection in the urban area should be planned and implemented. Building resilience to cyclones and floods also has to be strengthened to reduce the damage due to those disaster risks.

- Challenge(s) of Countermeasures:
- Implementing countermeasures for coastal protection in the urban area
  - Strengthening building resilience to cyclones and

floods

< Forecasting, Early Warning and Communication System >

AP State WRD can obtain all hydro-metrological data from observation stations through the GSM mobile network except during cyclone due to disconnection of mobile network. However, during a cyclone, WRD cannot obtain the data because of the collapse of mobile networks. Securing redundancy of communications for data transmission during cyclone and automatising gate operations can be considered as the major challenges for the river management during cyclone events. Beside, measurement of local torrential downpours for inland flood warning in urban areas and flash flood warning in small river basins is still insufficient in the state. Therefore, it is necessary to strengthen the communication network tolerance to cyclones and the capacity of early warning for local torrential downpours in the urban area in order to reduce the disaster risk due to cycles.

- |  |  |
|--|--|
| Challenge(s) of Forecasting, Early Warning and Communication System: | <ul style="list-style-type: none"><li>● Strengthening the communication network tolerance to cyclones</li><li>● Strengthening the capacity of early warning for local torrential downpours in the urban area</li></ul> |
|--|--|

< Evacuation System >

Evacuation system including communication between state, district, mandal and village level officers is functioning well. Most of the people can evacuate to safer places during cyclone and flood. However, the condition of shelters is unsatisfactory. Many shelters need to be repaired in order to make them durable to cycles and usable as evacuation areas at any time.

- Challenge(s) of Evacuation System: ● Constructing/renovating cyclone shelters

In Andhra Pradesh State, most of the disaster response activities including compensation for the disaster victims are functioning well. Mandal and village officers did not point out specific issues on disaster response. After Cyclone Hudhud, a major rehabilitation project is being implemented in Visakhapatnam, funded by the World Bank. Therefore, it can be inferred that assistance for response and rehabilitation is relatively low priority.

Table 7.4.10 shows the challenges identified, actions to be taken for the improvement, and organisations responsible for implementation of the actions.

**Table 7.4.10 Challenges and Actions (Andhra Pradesh State)**

S/N	Challenges	Actions to be Taken: <u>Andhra Pradesh State</u>		
		Short Term (1 - 2 Years)	Medium Term (3 -5 Years)	Long Term (5 - 10 Years)
<b>Challenges identified by the Indian Side</b>				
[ Institutional Framework ]				
PA-AP-1	Establishing the institutional framework of disaster management at the district, mandal and village levels	<u>Action(s)</u> - Constituting District Disaster Management Authority in all districts	<u>Action(s)</u> - Formulating practical Disaster Mitigation & Preparedness Action Plan at the mandal and village levels	-
		<u>Taken by</u> - State Department of Revenue - SDMA - District Magistrates - District Department of Disaster Management	<u>Taken by</u> - SDMA - DDMA - Mandals - Villages	-
[ Risk Analysis ]				
PA-AP-2	Introducing scientific tools for the cyclone and flood risk analysis	<u>Action(s)</u> - Conducting a detail aerial topographical survey (LiDAR data survey) for urban/important area - Improving existing numerical models for inundation and cyclone prediction	<u>Action(s)</u> - Developing the capacity of officials in charge on data management of LiDAR data - Implementing the detail aerial topographical survey in the entire state of Andhra Pradesh	<u>Action(s)</u> - Developing the impact-based cyclone risk prediction system based on the detail topographical and structures data
		<u>Taken by</u> - APSDPS	<u>Taken by</u> - APSDPS	<u>Taken by</u> - APSDPS
<b>Challenges identified by the Survey Team</b>				
[ Institutional Framework ]				
PA-AP-3	Developing capacity on disaster mitigation and preparedness at the mandal and village levels	<u>Action(s)</u> - Providing training on disaster mitigation and preparedness at the mandal and village levels	<u>Action(s)</u> - Reorganising the institutional setup at the mandal and village levels (deployment of permanent officials for disaster management)	-
		<u>Taken by</u> - State Department of Revenue - SDMA - District Department of Disaster Management - DDMA - Mandals - Villages	<u>Taken by</u> - State Department of Revenue - SDMA - District Department of Disaster Management - DDMA - Mandals - Villages	-

S/N	Challenges	Actions to be Taken: <u>Andhra Pradesh State</u>		
		Short Term (1 - 2 Years)	Medium Term (3 -5 Years)	Long Term (5 - 10 Years)
[ Preparedness ]				
PA-AP-4	Developing reliable communication network for river monitoring and management facilities during cyclone	<u>Action(s)</u> - Conducting needs assessment for river information system including development of optical fibre networks	<u>Action(s)</u> - Developing optical fibre networks and ad-hock networks among measurement stations along a river and cloud DB for O&M - Installing of atomized gate operation system for river management facilities	<u>Action(s)</u> - Developing automatized river operation and monitoring networks and integrated operation centre
		<u>Taken by</u> - State Department of Revenue - SDMA - WRD	<u>Taken by</u> - State Department of Revenue - SDMA - WRD	<u>Taken by</u> - State Department of Revenue - SDMA - WRD
PA-AP-5	Giving incentives to strengthen and/or retrofit individual houses and buildings to make them resilient to disaster risks	<u>Action(s)</u> - Formulating an action plan for raising awareness of DRR - Training facilitators for a workshop for raising awareness of DRR - Conducting a workshop at mandal and village levels	<u>Action(s)</u> - Formulating disaster education programmes in schools - Developing schemes for subsidies for cyclone and flood resilient houses	<u>Action(s)</u> - Developing proper system for disaster insurance and incentives for housing loans
		<u>Taken by</u> - State Department of Revenue - SDMA - District Department of Disaster Management	<u>Taken by</u> - State Department of Revenue - SDMA - District Department of Disaster Management	<u>Taken by</u> - State Department of Revenue - SDMA - District Department of Disaster Management
[ Countermeasure ]				
PA-AP-6	Implementing countermeasures for coastal protection in the urban area	<u>Action(s)</u> - Conducting needs assessment of coastal protection in the urban area that is likely to be affected - Formulating action plans	<u>Action(s)</u> - Implementing the coastal protection works	<u>Action(s)</u> - Improving all buildings and infrastructures in the state against flood and cyclonic strong wind
		<u>Taken by</u> - State Department of Revenue - Planning Department - SDMA	<u>Taken by</u> - State Department of Revenue - Transport, Roads and Buildings Department	<u>Taken by</u> - State Department of Revenue - Transport, Roads and Buildings Department

S/N	Challenges	Actions to be Taken: <u>Andhra Pradesh State</u>		
		Short Term (1 - 2 Years)	Medium Term (3 -5 Years)	Long Term (5 - 10 Years)
PA-AP-7	Strengthening building resilience to cyclones and floods	<u>Action(s)</u> - Analysing resilience of important buildings and infrastructures - Identifying gaps between existing building codes and actual situation of authorized structure	<u>Action(s)</u> - Improving the structure of important buildings and infrastructures (from the viewpoint of disaster management) to make them resilient to cyclones and floods	<u>Action(s)</u> - Improving all public buildings and infrastructures in the state to make them resilient to floods and cyclonic strong wind
		<u>Taken by</u> - State Department of Revenue - Planning Department - SDMA	<u>Taken by</u> - State Department of Revenue - Transport, Roads and Buildings Department	<u>Taken by</u> - State Department of Revenue - Transport, Roads and Buildings Department
[ Forecasting, Early Warning and Communication System ]				
PA-AP-8	Strengthening the communication network tolerance to cyclones	<u>Action(s)</u> - Conducting needs assessment for strengthening communication systems including mobile networks during cyclone - Planning the reinforcement	<u>Action(s)</u> - Reinforcing the mobile communication networks in cooperate with private mobile carriers	<u>Action(s)</u> - Providing mobile network base stations to resume services quickly
		<u>Taken by</u> - State Department of Revenue - SDMA - District Department of Disaster Management - DDMA - Municipal Corporations	<u>Taken by</u> - State Department of Revenue - SDMA - District Department of Disaster Management - DDMA - Municipal Corporations - Private mobile carriers	<u>Taken by</u> - State Department of Revenue - SDMA - District Department of Disaster Management - DDMA - Municipal Corporations - Private mobile carriers
PA-AP-9	Strengthening the capacity of early warning for local torrential downpours in the urban area	<u>Action(s)</u> - Assessing the current situation and risk of local torrential downpours in the urban area - Formulating an action plan	<u>Action(s)</u> - Installing radar systems such as X-band phased array radar that can observe local torrential downpours - Formulating operation procedures of early warning for local torrential downpours in the urban area based on the radar systems	-
		<u>Taken by</u> - APSDPS - SDMA - WRD - Municipal Corporations	<u>Taken by</u> - APSDPS - SDMA - WRD - Municipal Corporations	<u>Taken by</u> - APSDPS - SDMA - WRD - Municipal Corporations

S/N	Challenges	Actions to be Taken: <u>Andhra Pradesh State</u>		
		Short Term (1 - 2 Years)	Medium Term (3 -5 Years)	Long Term (5 - 10 Years)
[ Evacuation System ]				
PA-AP-10	Constructing/ renovating cyclone shelters	<u>Action(s)</u> - Conducting repair works for damaged shelters - Constituting a local group for maintain cyclone shelters at the village level	<u>Action(s)</u> - Formulating an action plan to reduce evacuees during cyclone - Upgrading a living quality of cyclone shelters (improvement of housing capacity, electricity, etc.)	-
		<u>Taken by</u> - State Department of Revenue - SDMA - District Department of Disaster Management - DDMA - Mandals - Villages	<u>Taken by</u> - State Department of Revenue - SDMA - District Department of Disaster Management - DDMA - Mandals - Villages	-

Source: prepared by the Survey Team

## **7.5 Evaluation and Prioritisation of Challenges Identified**

### **7.5.1 Methodology**

The challenges identified are evaluated from three perspectives: 1) effectiveness of activities to be taken, 2) capacity of the relevant organisation (the Indian side), and 3) current situation and progress of policy and planning in India. Each aspect is rated with the following criteria:

#### Effectiveness of activities to be taken

- A: The existing gap seems to be large and activities may highly contribute to filling in the gap.
- B: The existing gap seems to be relatively large and activities may contribute to filling in the gap.
- C: The existing gap seems to be relatively small and activities may contribute to filling in the gap.

#### Capacity of the relevant organisation (the Indian side)

- A: Has the ability to address based on the existing capacity, but capacity building needed in specific areas of activities
- B: Has the ability to address based on the existing capacity, but capacity building needed in some areas of activities
- C: Capacity building needed in the large area of activities

#### Current Situation and Progress of Policy and Planning

- A: Has not been addressed
- B: Has been addressed, but partially and leaving much to be improved
- C: Has been addressed, but the need for improvement exists

Finally, each challenge is prioritised in terms of the following criteria, based on the evaluation result of each perspective:

#### Total Evaluation

- A: Needs to be implemented at an early stage
- B: Can be implemented with second priority
- C: Had better be implemented

## 7.5.2 Evaluation Results

The following are the evaluation results of challenges in the priority survey areas:

### ➤ Uttarakhand State

S/N	Challenges	Evaluation Aspects (Uttarakhand State)			Total Evaluation	Remark
		Effectiveness	Capacity of the Indian Side	Current Situation and Progress of Policy and Planning		
<b>Challenges identified by the Indian Side</b>						
[ Forecasting, Early Warning and Communication System ]						
PA-UK-1	Establishing forecasting/early warning system for landslide	A	C	A	B	Large amount of cost needed
[ Emergency Response ]						
PA-UK-2	Strengthening the communication system at the time of occurrence of landslide event	A	B	B	B	Relatively large amount of cost needed
<b>Challenges identified by the Survey Team</b>						
[ Institutional Framework ]						
PA-UK-3	Strengthening the coordination mechanism among organizations/institutions related to landslide DRR	B	B	B	B	Certain amount of cost needed, but not so large
[ Risk Analysis ]						
PA-UK-4	Reviewing and revising the landslide inventory	A	A	B	A	Certain amount of cost needed, but not so large
[ Preparedness ]						
PA-UK-5	Preparing evacuation maps (evacuation places and routes) for communities close to landslide prone areas	B	B	A	B	Relatively large amount of cost needed
[ Countermeasure ]						
PA-UK-6	Establishing appropriate system of planning, design and construction of countermeasures	A	B	A	A	Relatively large amount of cost needed
[ Evacuation System ]						
PA-UK-7	Strengthening the evacuation system at the time of occurrence of landslide event	A	B	B	B	Certain amount of cost needed, but not so large



➤ Bihar State

S/N	Challenges	Evaluation Aspects (Bihar State)			Total Evaluation	Remark
		Effectiveness	Capacity of the Indian Side	Current Situation and Progress of Policy and Planning		
<b>Challenges identified by the Indian Side</b>						
[ Preparedness ]						
PA-BH-1	Reorganising the strategy for introduction of flood plain zoning	B	C	B	C	Relatively large amount of cost needed
<b>Challenges identified by the Survey Team</b>						
[ Institutional Framework ]						
PA-BH-2	Introducing basin-wide sediment control with the concept of river basin management (RBM)	A	C	A	B	Relatively large amount of cost needed
[ Risk Analysis ]						
PA-BH-3	Conducting risk analysis of riverbed aggradation and inland water drainage	A	B	A	A	Relatively large amount of cost needed
[ Countermeasure ]						
PA-BH-4	Establishing appropriate system of planning, design and construction of countermeasures to strengthen the banks	A	B	A	A	Relatively large amount of cost needed
PA-BH-5	Establishing appropriate system of planning, design and construction of measures for inland water drainage	A	C	A	B	Large amount of cost needed
[ Forecasting, Early Warning and Communication System ]						
PA-BH-6	Establishing the early warning systems for tributaries of the Ganga River	B	B	A	B	Relatively large amount of cost needed

➤ Andhra Pradesh State

S/N	Challenges	Evaluation Aspects (Andhra Pradesh State)			Total Evaluation	Remark
		Effectiveness	Capacity of the Indian Side	Current Situation and Progress of Policy and Planning		
<b>Challenges identified by the Indian Side</b>						
[ Institutional Framework ]						
PA-AP-1	Establishing the institutional framework of disaster management at the district, mandal and village levels	A	B	B	B	Certain amount of cost needed, but not so large
[ Risk Analysis ]						
PA-AP-2	Introducing scientific tools for the cyclone and flood risk analysis	A	B	B	B	Relatively large amount of cost needed
<b>Challenges identified by the Survey Team</b>						
[ Institutional Framework ]						
PA-AP-3	Developing capacity on disaster mitigation and preparedness at the mandal and village levels	A	B	A	A	Certain amount of cost needed, but not so large
[ Preparedness ]						
PA-AP-4	Developing reliable communication network for river monitoring and management facilities during cyclone	A	C	A	B	Relatively large amount of cost needed
PA-AP-5	Giving incentives to strengthen and/or retrofit individual houses and buildings to make them resilient to disaster risks	A	C	A	B	Relatively large amount of cost needed
[ Countermeasure ]						
PA-AP-6	Implementing countermeasures for coastal protection in the urban area	A	B	A	A	Large amount of cost needed
PA-AP-7	Strengthening building resilience to cyclones and floods	B	B	A	B	Large amount of cost needed
[ Forecasting, Early Warning and Communication System ]						
PA-AP-8	Strengthening the communication network tolerance to cyclones	B	A	A	A	Relatively large amount of cost needed
PA-AP-9	Strengthening the capacity of early warning for local torrential downpours in the urban area	A	C	A	B	Relatively large amount of cost needed
[ Evacuation System ]						
PA-AP-10	Constructing/renovating cyclone shelters	B	A	B	B	Relatively large amount of cost needed

According to the evaluation results, the following are the challenges with high priority (total evaluation “A”):

Uttarakhand State

- Reviewing and revising the landslide inventory (Risk Analysis)
- Establishing appropriate system of planning, design and construction of countermeasures (Countermeasure)

Bihar State

- Conducting risk analysis of riverbed aggradation and inland water drainage (Risk Analysis)
- Establishing appropriate system of planning, design and construction of countermeasures to strengthen the banks (Countermeasure)

Andhra Pradesh State



- Developing capacity on disaster mitigation and preparedness at the mandal and village levels (Institutional Framework)
- Implementing countermeasures for coastal protection in the urban area (Countermeasure)
- Strengthening the communication network tolerance to cyclones (Forecasting, Early Warning and Communication System)





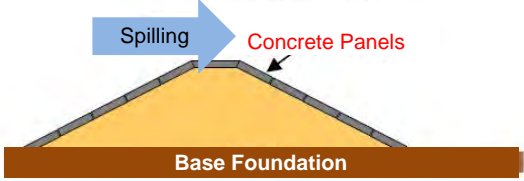

According to the contents of the national and state disaster management plans and result of site surveys and interviews, it can be inferred that no priority is set among aspects of disaster management such as institutional framework, risk analysis, preparedness, countermeasure, early warning and communication system, emergency response and evacuation system under the current disaster management system in each state. Each aspect should be addressed simultaneously.

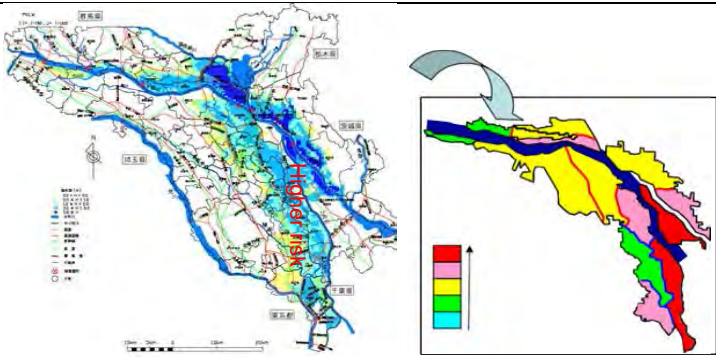

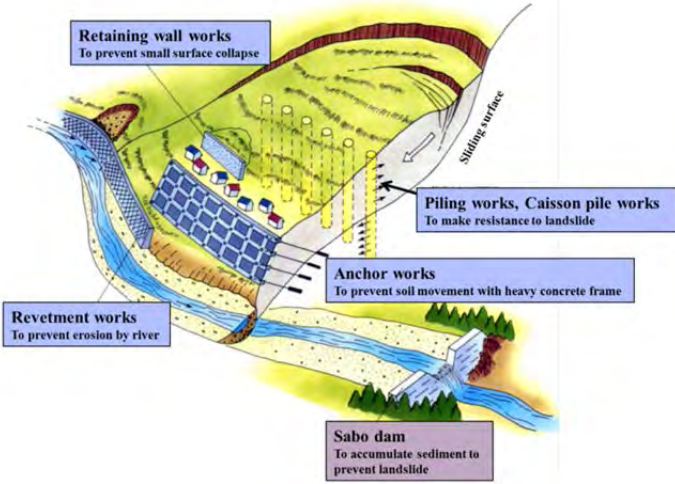
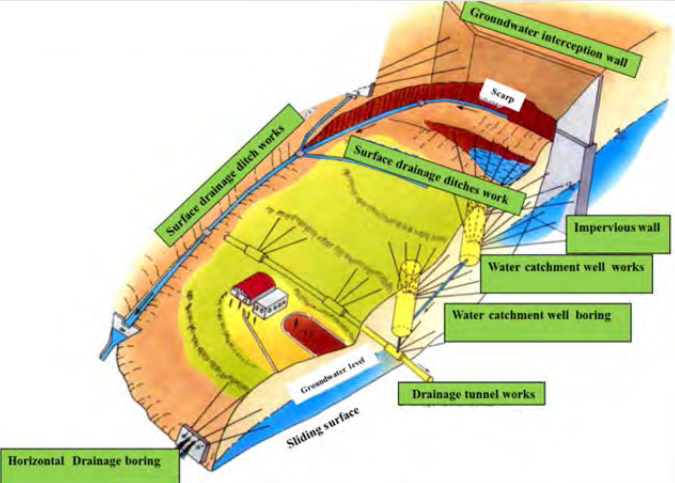

APPLICABILITY OF JAPANESE TECHNOLOGY TO CHALLENGES IDENTIFIED

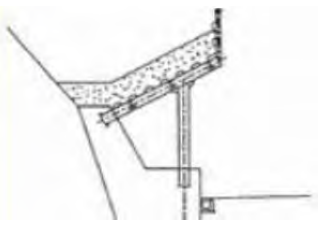

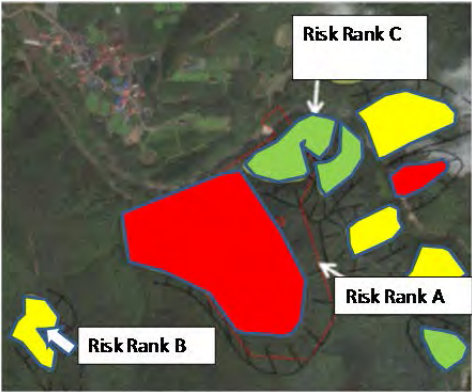

8.1 Japan's Experience and Technology

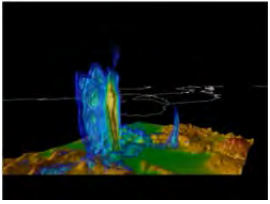
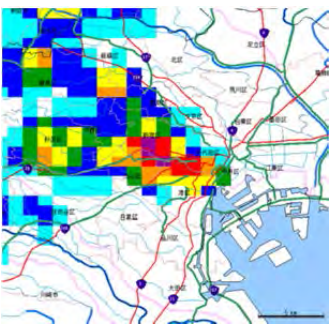
Japan is prone to natural disasters such as floods, landslides, typhoons, earthquakes, tsunamis and so on. In order to reduce the disaster risk, investments in disaster countermeasures have been promoted. Disaster prevention and preparedness through countermeasures against those disasters is one of the major pillars of disaster management in Japan. Therefore, tangible countermeasures are described in the disaster management plans at the local government level with clear task allocation among stakeholders. The following part shows Japan's experience and technology that might be introduced in India to tackle the challenges identified.

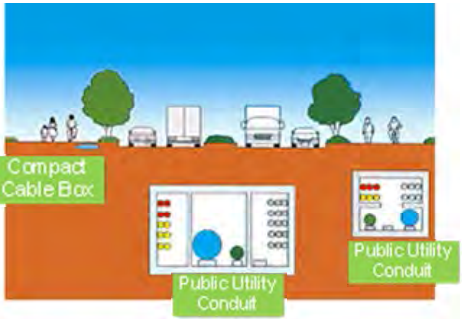
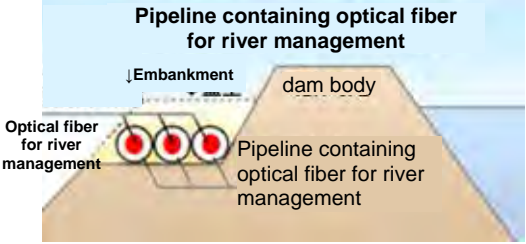
Japan's Experience and Technology	
Floods	<p><u>Armor levee method for spilling</u></p> <p>Protecting the river banks from spilling/overflowing and erosions that are major causes of flood disasters</p>  <p>(Source: Ministry of Land, Infrastructure, Transport and Tourism, Japan)</p>
Floods	<p><u>Storage facility during flood in urban area (retarding basin)</u></p> <p>Normal time: Used for tennis courts During floods: Change to retarding basin to store the flood water</p>  <p>(Source: Ministry of Land, Infrastructure, Transport and Tourism, Japan)</p>
Floods	<p><u>Comprehensive flood disaster management</u></p> <p>Incorporating the following components in the flood disaster management:</p> <ul style="list-style-type: none"> <li>- River improvement such as river channel improvement, construction of retarding basins, etc.</li> <li>- Measures in river basins, such as maintenance of urbanization control areas</li> <li>- Measures to alleviate damage, such as early warning systems and awareness raising</li> </ul>  <p>(Source: Ministry of Land, Infrastructure, Transport and Tourism, Japan)</p>
Floods	<p><u>Flood risk analysis</u></p> <p>Review of past floods</p> <p>Runoff analysis and inundation analysis</p> <p>Zoning into inundation blocks</p>  <p>(Source: Ministry of Land, Infrastructure, Transport and Tourism, Japan)</p>

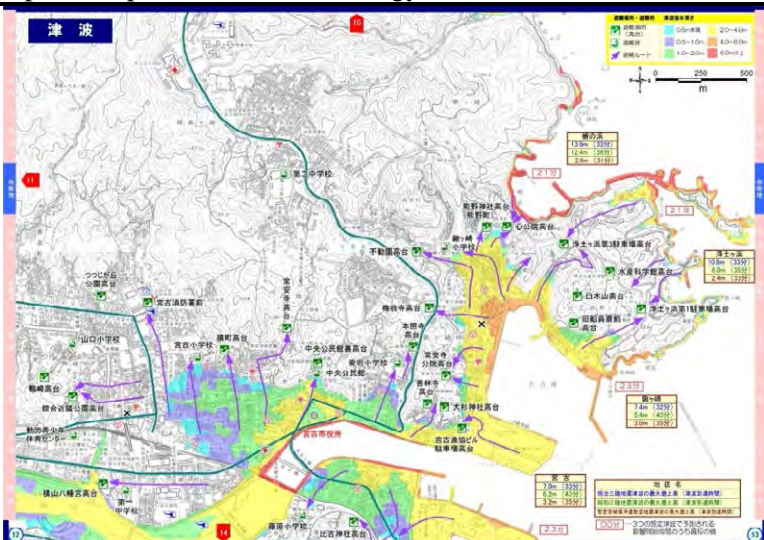
Japan's Experience and Technology	
Landslide	<p><u>Restraint work and control work</u></p> <ul style="list-style-type: none"> <li>- Retaining wall</li> <li>- Revetment</li> <li>- Pilling</li> <li>- Anchor</li> <li>- Sabo dam (check dam)</li> </ul>  <p>(Source: compiled by the Survey Team based on materials of Sabo &amp; Landslide Technical Centre (STC), Japan)</p>
Landslide	<p><u>Water control work</u></p> <ul style="list-style-type: none"> <li>- Groundwater interception wall</li> <li>- Surface drainage ditches</li> <li>- Impervious wall</li> <li>- Water catchment well</li> <li>- Drainage tunnel</li> <li>- Horizontal drainage boring</li> </ul>  <p>(Source: compiled by the Survey Team based on the material of Sabo &amp; Landslide Technical Centre (STC), Japan)</p>
Landslide	<p><u>Rock fall countermeasure</u></p> <div style="display: flex; justify-content: space-around;"> <div style="text-align: center;">  <p>Covering Type Prevention Net</p> </div> <div style="text-align: center;">  <p>Catchment Type Prevention Net</p> </div> <div style="text-align: center;">  <p>Prevention Barrier</p> </div> </div> <div style="display: flex; justify-content: space-around; margin-top: 20px;"> <div style="text-align: center;">  <p>Prevention Barrier (Rock Keeper)</p> </div> <div style="text-align: center;">  <p>Prevention Retaining Wall</p> </div> <div style="text-align: center;">  <p>Rock Shed</p> </div> </div> <p>(Source: Japan Association for Slope Disaster Management)</p>

Japan's Experience and Technology	
Landslides	<p><u>Risk assessment of landslide area</u></p> <p>Prioritising the landslide area based on the severity of risk</p> <p>Carrying out the measures in the order of descending priority</p>  <p>(Source: Survey Team)</p>
Forecasting / Early Warning	<p><u>X-band phased array radar</u></p> <p>Detailed and real-time observation of local heavy rain is possible though the observable area is small.</p> <ul style="list-style-type: none"> <li>- High resolution</li> <li>- High real-time performance</li> <li>- Wind observation</li> </ul> <p>In contrast to C-band radar (observation radius of 120 km), which is suited for broad-area precipitation observations, with X-band radar (e.g. observation radius of 60 km), detailed and real-time observation of local heavy rain is possible though the observable area is small.</p>   <p>Observation Result (Source: Toshiba Corporation)</p> <div style="display: flex; justify-content: space-around;"> <div style="text-align: center;"> <p>C-band Radar</p>  </div> <div style="text-align: center;"> <p>X-band Radar</p>  </div> </div> <p>(Source: Ministry of Land, Infrastructure, Transport and Tourism, Japan)</p>
Communication	<p><u>Optical fibre communication</u></p> <p>Stable communication is possible with no influence of electromagnetic induction noise.</p> <p>Transmission loss is very small and long distance transmission is possible without relay stations.</p> <p>Laying underground</p>  <p>Laying along with embankment</p>  <p>(Source: Ministry of Land, Infrastructure, Transport and Tourism, Japan)</p>

Japan's Experience and Technology	
Tsunami	<p><u>Tsunami hazard map by residential area</u></p> <p>Showing the following:</p> <ul style="list-style-type: none"> <li>- Inundation depth</li> <li>- Location of evacuation area</li> <li>- Evacuation routes</li> <li>- Estimated arrival time of tsunami by scenario</li> <li>- Location of public facilities such as helipads, hospitals and fire stations</li> </ul>  <p>(Source: Miyako-shi government office)</p>
Tsunami	<p><u>Town planning based on tsunami risk assessment</u></p> <ul style="list-style-type: none"> <li>- Designation of hazard area</li> <li>- Structural measures to protect residential areas</li> <li>- Evacuation facilities and their distribution</li> <li>- Building control</li> <li>- Improvement of existing infrastructure</li> </ul>  <p>(Source: Ministry of Land, Infrastructure, Transport and Tourism, Japan)</p>
Tsunami	<p><u>Tsunami tower, siren</u></p> <ul style="list-style-type: none"> <li>- Tsunami tower</li> </ul> <p>Structure/building for those who fail to evacuate from tsunami</p> <ul style="list-style-type: none"> <li>- Tsunami siren</li> </ul> <p>Communication system for blasting of siren and public announcement</p> <div style="display: flex; justify-content: space-around;"> <div style="text-align: center;">  <p>Tsunami Siren</p> <p>(Source: Sendai City)</p> </div> <div style="text-align: center;">  <p>Tsunami Tower</p> <p>(Source: Ishinomaki City)</p> </div> </div>

## 8.2 Applicability of Japanese Technologies to Challenges Identified

Japanese technologies and experiences including those shown in Section 8.1 are evaluated in terms of applicability to the challenges identified in Chapter 4 for disaster type and Chapter 7 for priority survey areas. The applicability is rated with the following criteria:

- A: Highly applicable and effective
- B: Applicable and effective
- C: Can be addressed with local technologies and experience

The following are the evaluation results of challenges by disaster type and survey area and early warning and communication system:

< Disaster Type >

### Floods

S/N	Challenges	Evaluation Aspects (Floods)			Total Evaluation	Applicability of Japanese Technology and Experience	Remark
		Effectiveness	Capacity of the Indian Side	Current Situation and Progress of Policy and Planning			
<b>Challenges identified by the Indian Side</b>							
[ Preparedness ]							
DT-FL-1	Reorganising the strategy for introduction of flood plain zoning	B	C	B	C	C	Relatively large amount of cost needed
<b>Challenges identified by the Survey Team</b>							
[ Institutional Framework ]							
DT-FL-2	Introducing basin-wide sediment control with the concept of river basin management (RBM)	A	C	A	B	A	Relatively large amount of cost needed
[ Countermeasure ]							
DT-FL-3	Implementing embankment and bank protection works in consideration of basin-wide sediment control	A	B	A	A	B	Relatively large amount of cost needed
DT-FL-4	Planning countermeasures for water logging that could occur in the future due to shortage of flow carrying capacity caused by sedimentation in canals/channels	A	C	A	B	A	Relatively large amount of cost needed



## Landslides

S/N	Challenges	Evaluation Aspects (Landslides)			Total Evaluation	Applicability of Japanese Technology and Experience	Remark
		Effectiveness	Capacity of the Indian Side	Current Situation and Progress of Policy and Planning			
<b>Challenges identified by the Indian Side</b>							
[ Risk Analysis ]							
DT-LS-1	Prioritising landslide areas where countermeasures need to be implemented based on the risk assessment	A	A	A	A	A	Certain amount of cost needed, but not so large
[ Forecasting, Early Warning and Communication System ]							
DT-LS-2	Establishing monitoring and early warning systems for landslide	A	C	A	B	A	Large amount of cost needed
[ Emergency Response ]							
DT-LS-3	Improving the communication systems to enable rapid emergency response at the local level	A	B	B	B	B	Relatively large amount of cost needed
<b>Challenges identified by the Survey Team</b>							
[ Institutional Framework ]							
DT-LS-4	Strengthening the coordination mechanism among organisations and institutions related to landslide risk reduction	B	B	B	B	B	Certain amount of cost needed, but not so large
[ Preparedness ]							
DT-LS-5	Raising awareness of and developing capacity of community inhabitants who live in landslide prone areas	B	B	B	B	A	Relatively large amount of cost needed
[ Countermeasure ]							
DT-LS-6	Introducing countermeasures against each type of landslide	A	B	A	A	A	Relatively large amount of cost needed

## Cyclones

S/N	Challenges	Evaluation Aspects (Cyclone)			Total Evaluation	Applicability of Japanese Technology and Experience	Remark
		Effectiveness	Capacity of the Indian Side	Current Situation and Progress of Policy and Planning			
<b>Challenges identified by the Indian Side</b>							
[ Risk Analysis ]							
DT-CC-1	Conducting a sector-based risk analysis (for transportation and logistics)	A	B	B	B	B	Relatively large amount of cost needed
DT-CC-2	Conducting Risk analysis for wildlife conservation area and zoological park/national park	B	C	A	B	A	Relatively large amount of cost needed
[ Preparedness ]							
DT-CC-3	Planning deployment of proper materials and supplies for disaster response	A	A	C	B	C	Relatively large amount of cost needed
[ Countermeasure ]							
DT-CC-4	Maintaining cyclone shelters properly	B	A	B	B	C	Relatively large amount of cost needed
[ Emergency Response ]							
DT-CC-5	Coordinating rapid supply of essential resources during emergency response	A	B	C	B	B	Certain amount of cost needed, but not so large
<b>Challenges identified by the Survey Team</b>							
[ Institutional Framework ]							
DT-CC-6	Developing an effective Disaster Management Plan at the district level	A	B	C	B	C	Certain amount of cost needed, but not so large
[ Countermeasure ]							
DT-CC-7	Securing public telecommunications systems during disasters	B	A	A	A	A	Relatively large amount of cost needed
[ Forecasting, Early Warning and Communication System ]							
DT-CC-8	Providing accurate warning at the local level by introducing reasonable systems	A	B	A	A	A	Relatively large amount of cost needed
[ Evacuation System ]							
DT-CC-9	Ensuring appropriate care for women, children, senior citizens, and disabled people in shelters	A	B	A	A	B	Certain amount of cost needed, but not so large

< Early Warning and Communication System >

S/N	Challenges	Evaluation Aspects (Early Warning and Communication System)			Total Evaluation	Applicability of Japanese Technology and Experience	Remark
		Effectiveness	Capacity of the Indian Side	Current Situation and Progress of Policy and Planning			
<b>Challenges identified by the Indian Side</b>							
[ Common Issues ]							
EW-CI-1	Improving last mile connectivity	A	B	B	B	B	Relatively large amount of cost needed
EW-CI-2	Securing redundancy of the communication systems	A	B	A	A	B	Relatively large amount of cost needed
<b>Challenges identified by the Survey Team</b>							
[ A&N Islands ]							
EW-AN-1	Planning installation of tsunami sirens with necessary facilities/structures	A	B	B	B	A	Relatively large amount of cost needed

< Priority Survey Area >

Uttarakhand State

S/N	Challenges	Evaluation Aspects (Uttarakhand State)			Total Evaluation	Applicability of Japanese Technology and Experience	Remark
		Effectiveness	Capacity of the Indian Side	Current Situation and Progress of Policy and Planning			
<b>Challenges identified by the Indian Side</b>							
[ Forecasting, Early Warning and Communication System ]							
PA-UK-1	Establishing forecasting/early warning system for landslide	A	C	A	B	A	Large amount of cost needed
[ Emergency Response ]							
PA-UK-2	Strengthening the communication system at the time of occurrence of landslide event	A	B	B	B	B	Relatively large amount of cost needed
<b>Challenges identified by the Survey Team</b>							
[ Institutional Framework ]							
PA-UK-3	Strengthening the coordination mechanism among organizations/ institutions related to landslide DRR	B	B	B	B	B	Certain amount of cost needed, but not so large
[ Risk Analysis ]							
PA-UK-4	Reviewing and revising the landslide inventory	A	A	B	A	A	Certain amount of cost needed, but not so large
[ Preparedness ]							
PA-UK-5	Preparing evacuation maps (evacuation places and routes) for communities close to landslide prone areas	B	B	A	B	A	Relatively large amount of cost needed
[ Countermeasure ]							
PA-UK-6	Establishing appropriate system of planning, design and construction of countermeasures	A	B	A	A	A	Relatively large amount of cost needed
[ Evacuation System ]							
PA-UK-7	Strengthening the evacuation system at the time of occurrence of landslide event	A	B	B	B	B	Certain amount of cost needed, but not so large

**Bihar State**

S/N	Challenges	Evaluation Aspects (Bihar State)			Total Evaluation	Applicability of Japanese Technology and Experience	Remark
		Effectiveness	Capacity of the Indian Side	Current Situation and Progress of Policy and Planning			
<b>Challenges identified by the Indian Side</b>							
[ Preparedness ]							
PA-BH-1	Reorganising the strategy for introduction of flood plain zoning	B	C	B	C	B	Relatively large amount of cost needed
<b>Challenges identified by the Survey Team</b>							
[ Institutional Framework ]							
PA-BH-2	Introducing basin-wide sediment control with the concept of river basin management (RBM)	A	C	A	B	C	Relatively large amount of cost needed
[ Risk Analysis ]							
PA-BH-3	Conducting risk analysis of riverbed aggradation and inland water drainage	A	B	A	A	B	Relatively large amount of cost needed
[ Countermeasure ]							
PA-BH-4	Establishing appropriate system of planning, design and construction of countermeasures to strengthen the banks	A	B	A	A	B	Relatively large amount of cost needed
PA-BH-5	Establishing appropriate system of planning, design and construction of measures for inland water drainage	A	C	A	B	A	Large amount of cost needed
[ Forecasting, Early Warning and Communication System ]							
PA-BH-6	Establishing the early warning systems for tributaries of the Ganga River	B	B	A	B	B	Relatively large amount of cost needed

**Andhra Pradesh State**

S/N	Challenges	Evaluation Aspects (Andhra Pradesh State)			Total Evaluation	Applicability of Japanese Technology and Experience	Remark
		Effectiveness	Capacity of the Indian Side	Current Situation and Progress of Policy and Planning			
<b>Challenges identified by the Indian Side</b>							
[ Institutional Framework ]							
PA-AP-1	Establishing the institutional framework of disaster management at the district, mandal and village levels	A	B	B	B	C	Certain amount of cost needed, but not so large
[ Risk Analysis ]							
PA-AP-2	Introducing scientific tools for the cyclone and flood risk analysis	A	B	B	B	A	Relatively large amount of cost needed
<b>Challenges identified by the Survey Team</b>							
[ Institutional Framework ]							
PA-AP-3	Developing capacity on disaster mitigation and preparedness at the mandal and village levels	A	B	A	A	B	Certain amount of cost needed, but not so large
[ Preparedness ]							
PA-AP-4	Developing reliable communication network for river monitoring and management facilities during cyclone	A	C	A	B	A	Relatively large amount of cost needed
PA-AP-5	Giving incentives to strengthen and/or retrofit individual houses and buildings to make them resilient to disaster risks	A	C	A	B	C	Relatively large amount of cost needed
[ Countermeasure ]							
PA-AP-6	Implementing countermeasures for coastal protection in the urban area	A	B	A	A	B	Large amount of cost needed
PA-AP-7	Strengthening building resilience to cyclones and floods	B	B	A	B	B	Large amount of cost needed
[ Forecasting, Early Warning and Communication System ]							
PA-AP-8	Strengthening the communication network tolerance to cyclones	B	A	A	A	A	Relatively large amount of cost needed
PA-AP-9	Strengthening the capacity of early warning for local torrential downpours in the urban area	A	C	A	B	A	Relatively large amount of cost needed
[ Evacuation System ]							
PA-AP-10	Constructing/renovating cyclone shelters	B	A	B	B	C	Relatively large amount of cost needed

### 8.3 Conclusion

The Survey followed two (2) approaches to evaluate the current situation of disaster risk reduction in India. The first approach is evaluation by major disaster type (see Chapter 4) and the other one is evaluation by state selected as priority survey area (see Chapter 7). In order to tackle the challenges, it is necessary to take some actions on a step-by-step basis. Therefore, the matrices shown in Chapter 4 and Chapter 7 describe the stepwise actions for three terms: short term (1 -2 years), medium term (3 – 5 years) and long term (5 -10 years). Basically, the evaluation results by disaster type cover the challenges at the national level. Therefore, most of the actions entail preparation of guidelines and manuals and sensitisation of related organisations on those materials because the central ministries, departments and authorities are not made responsible for the implementation of individual activities at local level. On the other hand, the evaluation results by priority survey area show the individual measures to reduce the disaster risk at the local level. Major actions to be taken in each state are a series of disaster management activities: risk assessment, planning of mitigation measures, implementation, drawing lessons and accommodating them to further mitigation measures, sensitisation and so on.

The challenges identified are evaluated from three perspectives: 1) effectiveness of activities to be taken, 2) capacity of the relevant organisations (the Indian side), and 3) current situation and progress of policy and planning in India. As a result, it was concluded that the following are the challenges with high priority.

< Disaster Type >

#### Floods:

- Implementing embankment and bank protection works in consideration of basin-wide sediment control (Countermeasure)

#### Landslides:

- Prioritising landslide areas where countermeasures need to be implemented based on the risk assessment (Risk Analysis)
- Introducing countermeasures against each type of landslide (Countermeasure)

#### Cyclones:

- Securing public telecommunications systems during disasters (Countermeasure)
- Providing accurate warning at the local level by introducing reasonable systems (Forecasting, Early Warning and Communication System)
- Ensuring appropriate care for women, children, senior citizens, and disabled people in shelters (Evacuation System)

< Early Warning and Communication System >

- Securing redundancy of the communication systems

< Priority Survey Areas >

#### Uttarakhand State

- Reviewing and revising the landslide inventory (Risk Analysis)
- Establishing appropriate system of planning, design and construction of countermeasures (Countermeasure)

#### Bihar State

- Conducting risk analysis of riverbed aggradation and inland water drainage (Risk Analysis)
- Establishing appropriate system of planning, design and construction of countermeasures to strengthen the banks (Countermeasure)

Andhra Pradesh State

- Developing capacity on disaster mitigation and preparedness at the mandal and village levels (Institutional Framework)
- Implementing countermeasures for coastal protection in the urban area (Countermeasure)
- Strengthening the communication network tolerance to cyclones (Forecasting, Early Warning and Communication System)

The result shows that risk analysis and countermeasures are the major challenges with high priority. In order to mainstream disaster management in the development activities and reduce the disaster risk, risk analysis and countermeasure are a very important part. The risk assessment has been carried out by some Government of India's agencies and institutions such as GSI; however, the analysis measures still follow macro scale zoning. Besides, countermeasures leave much to be improved because the applied measures are very limited at the moment. Disaster mechanism varies depending on the location and local situation. Therefore, it is necessary to apply suitable measures to each type of disaster risk. As discussed in Section 8.1 and 8.2, some Japanese technologies and experience can be introduced to India in order to address the challenges. It is expected that organisations responsible for disaster management at all levels take initiative to address the challenges considering the applicability of other countries' experience and realise a society resilient to the natural disasters.





# APPENDICES



## Appendix 1: Minutes of Meeting



Meeting:	National Disaster Management Authority (NDMA)
Date:	23 June 2015
Venue:	CWC Office, New Delhi
Attendance:	<p>NDMA: Ms. Neelkamal Darbari, IAS, Joint Secretary &amp; Advisor Mr. Rajesh Kumar Singh, Director Dr. Monika Gupta, Senior Research Officer</p> <p>JIAC India Office: Ms. Ai TACHIKAWA, Representative Mr. Vineet Sahai Sarin, Principal Development Specialist</p> <p>Survey Team: Mr. Akihiro SHIMOMURA, Mr. Toru TAKAHASHI, Mr. Nobuyuki IJIMA, Mr. Hajime WATANABE, Mr. Naoki UEHATA, Ms. Lalita Joshi</p>
Discussion:	<p>1. All the states in India have formulated the State Disaster Management Authority (SDMA) and State Disaster Management Plan (SDMP). However, the structure for the SDMA and SDMP may be different in each state depending on state policies and priorities.</p> <p>2. Approach to disaster management in India has shifted from the reactive to proactive and includes preparedness, prevention, mitigation, response and recovery.</p> <p>3. There are a number of ministries, departments, agencies and other stakeholders involved in disaster management in India.</p> <p>4. National Policy on Disaster Management was formulated in 2009 and there is a possibility of policy review. The Ministry of Home Affairs is responsible for amendment of the DM Act and review of policy. Further details on policy review can be discussed with them. Earlier, a task force was set up in 2011 and suggested certain recommendations on the policy.</p> <p>5. For mainstreaming of disaster management, the capacity building of departments and agencies involved in disaster management is the primary activity by NDMA. The preparedness level has increased with respect to response, rescue and providing immediate medical relief.</p> <p>6. It is observed that the number of fatalities due to natural disaster has reduced considerable over time because of 1) robust early warning system, 2) regular mock drills conducted by NDMA, and 3) community training programmes conducted by various disaster management agencies.</p> <p>7. Disaster management planning in India is done at various levels. The national plan is prepared by the National Executive Committee, the disaster and domain-specific plans are to be made by the respective central ministries and departments. In addition, there are disaster management plans at state and district levels as well as school disaster management plan.</p> <p>8. NDMA has taken up a project on school disaster involving 22 states and two districts from each state.</p> <p>9. There are periodic meetings between different agencies working on disaster management. The meetings are also catalysed by certain events.</p> <p>10. Different ministries and line departments have their own specific budget for the disaster management in India.</p> <p>11. In addition to the fixed budget allocation for disaster management, there are supports from multinational donor agencies such as World Bank and UNDP.</p> <p style="text-align: right;">End</p>

Meeting:	Indian Meteorological Department (IMD), Ministry of Earth Sciences (MOES)
Date:	3 August 2015
Venue:	IMD Office, New Delhi
Attendance:	<p>IMD: Mr. M. Mohapatra, Cyclone Warning Division</p> <p>Survey Team: Mr. Akihiro SHIMOMURA, Mr. Nobuyuki IIJIMA, Mr. Naoki UEHATA, Ms. Lalita Joshi, Ms. Sugandha Rastogi</p>
Discussion:	<p>1. IMD is the nodal agency regarding the early warning system for cyclones and other hazards.</p> <p>2. IMD maintains disaster records related to cyclones since 1891. Most reports and records of cyclones are digitised and uploaded on the website, so that all the data are available and accessible to the public.</p> <p>3. Two types of data are generated by IMD; 1) basic data which are collected through monitoring such as rainfall intensity, track of cyclone, etc., and 2) derived data which are the reports on cyclones, books, etc.</p> <p>4. Important information and data are shared with concerned agencies in India and with other countries. It is also available on the website.</p> <p>5. Future plan for improving observation systems is in terms of 1) Radar network, 2) AWS (Automatic Weather Stations), 3) ARG (Automatic Rain Gauge), 4) high wind speed records, and 5) GPS-based radiosonde.</p> <p>6. Once observatories for monitoring are installed, digitised forecasting workstations are being planned to be installed at all workstations. Presently, they are installed at few places only.</p> <p>7. At present, satellites are the major sources for cyclone monitoring. The cyclogenesis parameters need to be derived through satellite.</p> <p>8. INSAT 3D needs to be developed for better accumulation of information and data processing.</p> <p>9. Advanced Dvorak techniques need to be developed for better understanding of approaching cyclone which will help advanced preparedness.</p> <ul style="list-style-type: none"> <li>• Satellite-based forecasting techniques</li> <li>• Simulation of satellite data in the model</li> <li>• Improvement of satellite data assimilation</li> </ul> <p>10. For cyclone monitoring, data and information are required at local, state and national levels. Moreover, information from neighbouring countries is required as well.</p> <p>11. SOPs to transfer the global telecommunications system (GTS) and non-GTS data have been developed by WMO.</p> <p>12. For the management of equipment, handbook for maintenance of surface observatory and manual for Radar handling have been prepared and followed. Satellites are maintained by the Indian Space Research Organisation (ISRO) but SOP for obtaining information from satellites and its interpretation is laid down and followed.</p> <p>13. In every cyclone season, pre-cyclone exercises are conducted in all cyclone-prone regions of the country. In the exercises, working conditions of instruments, personal availability, etc. are assessed. Telecommunication department is requested to maintain telecommunication facilities, and inspection of observatories is done.</p> <p>14. Pre-event exercises are conducted just before cyclones. Meetings with concerned personnel and headquarters are conducted, and all other preparations are made and rechecked for better preparedness.</p> <p>15. Post-cyclone activities are taken after the cyclone has passed. A team is dispatched to affected areas to conduct post-cyclone survey to assess not only the damage but also ground tracing on exact track, intensity and other related information. District Magistrate and local agencies will be confirmed whether the information from IMD is reached to them well before strike or not. A preliminary report is prepared within a week and from such report</p>

further areas of improvement and learnings are outlined for better preparedness for next cyclone.

16. A blue book for Cyclone Hudhud is prepared by disaster management division of Ministry of Home Affairs. Lessons learned are always documented and based on that further precautionary actions are taken. IMD contributes on the preparedness part. These documents related to lessons learned include both technical and operational aspects.
17. State governments take care of budgetary and administrative aspects during any disasters.
18. There is a future plan to improve the modelling system, observatories, analysis, prediction system like the Hurricane Weather Research and Forecast (HWRF) coupled model and warning dissemination.
19. The Ministry of Earth Sciences (MOES) has updated the computational system and now all departments can utilise this resource.
20. Various means are used for disseminating cyclone bulletin, such as;
  - The following information are transferred to local authorities such as district heads and village heads who further deliver information to tehsildars: 1) genesis forecast, 2) 5-day forecast, and 3) cyclone associated weather forecast including rainfall, its intensity, etc.
  - Special bulletins are issued 3 times a day when cyclone is formed and when depression is formed; 3 hourly bulletins are issued and information is sent to district head via email and SMS. State chief secretary is contacted and is briefed about the situation orally.
  - Press conferences are conducted to brief media about the situation and the public are informed through press releases.
  - All information is also transmitted through mass media such as radio and TV.
  - Regarding the last mile connectivity;
    - Cyclone warning dissemination system is also satellite-based. The bulletin is disseminated in three languages: English, Hindi and local language. These bulletins are repeated and updated hourly.
    - SMS is also sent to private registered users (those who are registered with IMD and INCOIS).
  - AGROMET also has cyclone warning system.
21. IMD is not responsible for last mile connectivity but there is some redundancy.
22. There are some issues with early warning system:
  - Observations and information from the core of cyclone cannot be collected.
  - Modelling
  - Technical issues; track forecasting is easier than intensity forecasting.
  - Models fail when there is rapid intensification of cyclone.
23. GOI formulated National Cyclone Risk Mitigation Project (NCRMP). Hazard analysis has been carried out in 96 districts along the coast. Coastal districts are classified on the basis of their vulnerability to cyclones (4 classes).
24. NDMA and SDMAs are responsible for disaster risk analysis. Risk will depend on hazard and vulnerability, and vulnerability will vary in districts.
25. All cyclone-prone states are working with IMD and early warning for disaster is done by IMD and is shared with the states.

End



Meeting:	National Centre for Seismology (NCS), Ministry of Earth Sciences (MOES)
Date:	25 June 2015
Venue:	NCS Office, New Delhi
Attendance:	<p>NCS: Dr. Swati Basu, Advisor/Scientist Dr. K.J. Ramesh, Advisor/Scientist</p> <p>Survey Team: Mr. Akihiro SHIMOMURA, Mr. Toru TAKAHASHI, Mr. Nobuyuki IJIMA, Mr. Hajime WATANABE, Mr. Naoki UEHATA, Ms. Lalita Joshi</p>
Discussion:	<p>1. NCS was formally established as an independent organisation in August 2014 which was divided from IMD. The main responsibilities of NCS are monitoring, detection and communication on earthquake related activities.</p> <p>2. After a major seismic activity, the first bulletin on earthquake related information is issued within 15 minutes. The information is sent to the Ministry of Home Affairs, disaster management authorities, crisis management authorities and other designated persons.</p> <p>3. For online monitoring of seismic activity in the country, the following infrastructures are provided:</p> <ul style="list-style-type: none"> <li>• 80-82 broad band stations for real time seismic monitoring, which NCS plans to expand to 140 in due course of time.</li> <li>• High Density Observation Network (HDON) comprising of 20 sensors have been provided in two regions in the country for detailed information on seismic activities in the region. HDON is set up at Delhi and Shillong region.</li> <li>• Laboratories for multi parametric observations has been set up in 4/5 places in India, including Andaman &amp; Nicobar, North East India, Himalayas (Dehradun) and Koyna in Maharashtra.</li> <li>• Currently, the borehole physical laboratories are placed in depth of 1.5 km. NCS plans to set up a laboratory at 5 km.</li> <li>• All communication systems are currently Broadband Based System (BBS). All stations are connected by VSAT-based seismic telemetry network which is established for real time monitoring and reporting of seismic activity.</li> <li>• All seismological networks in the country are maintained by NCS. Both INCOIS and NCS receive the data from various seismological networks. The communication on land related activity is done by NCS and the communication on Tsunami is done by INCOIS.</li> </ul> <p>4. Offline activities done by NCS include;</p> <ul style="list-style-type: none"> <li>• NCS has completed seismic micro zonation of 8 cities in India at the scale of 1:10,000. The cities include Delhi, Guwahati and Bangalore.</li> <li>• Standard methodology to finalise seismic micro zonation of different areas in India has been established, and NCS has developed a seismic micro zonation manual and handbook.</li> <li>• Micro zonation for important and seismic vulnerable areas is being done on priority basis and 30 cities should be covered in the next 2-3 years.</li> <li>• NCS plans to conduct micro zonation studies for all the cities with more than 0.1 million population. However, many technical groups are not available in the country for taking up the task.</li> <li>• Fund allocation has not been an issue with various seismic activities. Sufficient budgetary provision has been made in the last five year plan for doing micro zonation studies in 30 cities.</li> <li>• In addition, research activities including national programme for earthquake pre-cursor (NPEP) studies has been conducted. Multi parametric seismic laboratories were set up as a part of this programme.</li> </ul>

- Other activities include pre-cursory services, geophysical characteristics analysis, and dissemination of standard for earthquake resistant buildings.
5. Some of the state governments are proactive and put 1 or 2 seismometers other than the seismometric network done by NCS.
  6. Programme like rapid visual mapping of vulnerable structures has been initiated by Delhi government. Under the programme, Delhi Municipal Corporation has deployed approximately 150 staffs to identify vulnerable building in Delhi.
  7. Micro zonation activity is also done by GSI; however, the purpose of GSI micro zonation is different from that of NCS and is primarily for mineral and metal resources.
  8. There are other organisations working on seismic safety of different structures which include Atomic Energy Regulatory Board working on seismic safety for nuclear structure. Central Water Commission (CWC) works on seismic safety of reservoir.
  9. The task to make all public lifeline infrastructure earthquake resistance has been put on priority by GOI.

End

Meeting:	Indian National Centre for Oceanic Information Services (INCOIS), Ministry of Earth Sciences (MOES)
Date:	29 June 2015
Venue:	INCOIS Office, Hyderabad
Attendance:	INCOIS: Dr. Srinivasa Kumar Tummala, Scientist & Head, Advisory Services & Satellite Oceanography Group (ASG), In-Charge, Indian Tsunami Warning Centre (ITEWC)  Survey Team: Mr. Akihiro SHIMOMURA, Mr. Nobuyuki IJIMA, Ms. D. Svega
<p>Discussion:</p> <ol style="list-style-type: none"><li>1. INCOIS was established in 2001.</li><li>2. Currently, 17 seismic stations, 21 tidal gauges, and 7 tsunami buoys have been installed.</li><li>3. Continuous tsunami monitoring has been carried out and monitoring data are delivered and transmitted to related agencies.</li><li>4. Standard Operation Procedures (SOPs) for observations are for:<ul style="list-style-type: none"><li>• Reporting the seismic activities</li><li>• Monitoring daily events</li><li>• Measuring tide gauges by GPRS &amp; through satellite</li></ul></li><li>5. 16 tsunami events have been recorded.</li><li>6. For dissemination of tsunami information to the communities, warnings are given by INCOIS and general public should be advised to move. When sirens are blasted, people should respond for evacuation.</li><li>7. Site specific evacuation plans are prepared for vulnerable coastal zones.</li><li>8. Research and modelling of mathematical models are also carried out to be used for ocean state forecasts, prediction of tsunami waves, storm surges, etc. along the coast.</li><li>9. National network (Indian Seismic and Global Navigation Satellite System (GNSS) Network (ISGN)) that integrates seismic and GNSS stations are established and provide high quality data.</li><li>10. INCOIS generates ocean analysis data using mathematical models and observations on a daily basis.</li></ol> <p style="text-align: right;">End</p>	

Meeting:	Ministry of Road Transport and Highways (MORTH)
Date:	26 June 2015
Venue:	MORTH Office, New Delhi
Attendance:	<p>MORTH: Mr. Rohit Kumar Singh, Joint Secretary Mr. Rajneesh Kapoor</p> <p>Survey Team: Mr. Akihiro SHIMOMURA, Mr. Toru TAKAHASHI, Mr. Nobuyuki IJIMA, Mr. Hajime WATANABE, Mr. Naoki UEHATA, Ms. Lalita Joshi</p>
Discussion:	<p>1. Indian Road Congress (IRC) and Bureau of Indian Standards (BIS) have codes and standards with details on disaster prevention and engineering intervention in design of road structures to make them strong enough to withstand the impact of natural hazard. All the construction works necessarily follow these codes and standards.</p> <ul style="list-style-type: none"> <li>• In MORTH, Standards &amp; Research Unit is responsible for design of standards and applicability.</li> <li>• Separate design codes for construction on hills and plain area; similarly codes for construction of bridges and terminals</li> </ul> <p>2. The feasibility report and the Detailed Project Report prepared for any road projects take into account of the risk assessment and susceptibility to earthquake and other disasters. During the feasibility stage, 4-5 different alignments are analysed for their suitability including susceptibility to disaster. In case the alignment with high susceptibility to disaster is selected, suitable preventive measures are taken during the design and construction stage of the project.</p> <p>3. Disaster preventive measure in road sector is also done using technological interventions which include</p> <ul style="list-style-type: none"> <li>• Road Asset Management System (RAMS) is a strategic and systematic process of maintaining, upgrading and operating road assets effectively. Currently RAMS is implemented by National Highway Authority of India (NHAI) with support from World Bank aiming to create centralised road database for national highways (NHs) in the country. Information collected and made available through this system will be useful for the agencies responsible for road development and maintenance, investors, as well as road users. Currently work of 3,000 km of NH is completed and 97,000 km is to be done.</li> <li>• MORTH and NHAI are also using light detection and ranging (LiDAR) technology to conduct feasibility studies for all highway projects.</li> <li>• The installation of Intelligent Transportation System (ITS) along with close-circuit TV cameras is planned for Eastern Peripheral Expressway to record incidents and provide information on the physical condition of the road along with highway advisory radio system.</li> </ul> <p>4. MORTH does not have any specific budgets for disaster management. All the funds are allocated in either plan head or non-plan head. The plan head is for increment in the capacity and the non-plan head is for maintenance which includes preventive maintenance, regular maintenance and emergency response. INR 3,000 million has been allocated for emergency response head, which has been sufficient so far. In case of requirement beyond the allocated money, the money can be diverted from the plan head.</p> <p style="text-align: right;">End</p>

Meeting:	Central Water Commission (CWC), Ministry of Water Resources (MORW)
Date:	3 August 2015
Venue:	CWC Office, New Delhi
Attendance:	CWC: Mr. V D Roy, CWC Survey Team: Mr. Akihiro SHIMOMURA, Mr. Nobuyuki IJIMA, Mr. Naoki UEHATA, Ms. Lalita Pant Joshi, Ms. Sugandha Rastogi
<p>Discussion:</p> <ol style="list-style-type: none"> <li>1. Main issues with flood forecasting and early warning system are as follows; <ul style="list-style-type: none"> <li>• Additional installation of forecast and warning systems is demanded by state and district administrators.</li> <li>• Enhancement of data collection and analysis such as information related to river course, area to be inundated within next 24 hours, and so on</li> <li>• Digital Elevation Model (DEM) is not available for all areas.</li> </ul> </li> <li>2. Pilot projects for inundation forecasts are planned in: <ul style="list-style-type: none"> <li>• Mahanadi basin: flood plain is 8,000 to 10,000 km<sup>2</sup>. Hirakund dam was built on the upper reach of the river more than 50 years ago, which is the longest earth dam (27 km of total length).</li> <li>• Brahmaputra basin in north eastern India</li> <li>• North Kosi River</li> </ul> </li> <li>3. These areas are selected mainly because DEM are available for these areas which are frequently suffered from flood.</li> <li>4. The main component of those pilot projects is 2D hydrodynamic modelling.</li> <li>5. The learnings and outcomes from these pilot projects will be utilised to plan and cover all flood plains for better inundation forecasting.</li> <li>6. Another limitation is to improve flood warning time. Now flood warning time is very less. To overcome, rainfall runoff model is made. 3-day and 4-day hydrographs can be prepared using this rainfall runoff model.</li> <li>7. Until recently, flood warning was dependent on gauge information.</li> <li>8. Rainfall runoff model helps in well advanced forecast of flood so that the National Disaster Response Force/State Disaster Response Force can be deployed with minimum loss.</li> <li>9. GIS-based flood risk map is not yet available.</li> <li>10. National Remote Sensing Centre (NRSC) prepared a district-wise flood risk maps.</li> <li>11. Information can be extracted from such NRSC and Ganga Flood Control (GFC) publications.</li> <li>12. As per the Constitution, disaster management is the responsibility of state government; thus, it is not responsible for the CWC to provide active support and cooperation to the state governments for disaster management.</li> <li>13. Flood occurrence depends on the operation of control structures on the rivers which are mostly operated by state governments except a few under central government.</li> <li>14. The control structures such as dam decrease the flood frequency to manifold in downstream areas which further lead to encroachment in such areas and this also becomes a problem.</li> <li>15. Structural countermeasures are; <ul style="list-style-type: none"> <li>• Most common short/medium term measures are flood embankments.</li> <li>• In earlier days, few reservoirs/dams were constructed with specific flood cushions for flood moderation (e.g. Hirakund, Damodar, Bhakra, etc.).</li> </ul> </li> <li>16. Construction of big dams/provision of flood cushions is also opposed by many environmentalists.</li> <li>17. Non-structural countermeasures are:</li> </ol>	

- Flood forecasting and early warning system
  - Flood plain zoning
18. Flood plain zoning and implementation of regulation of these zones are also very important. However, because of political constraints, it is very difficult to implement it.
  19. Flood plain zoning might be implemented by passing and enacting flood plain zoning bill. Only 3 states have enacted: Manipur, Rajasthan and Uttarakhand states.
  20. Chronically, flood-prone states like Uttar Pradesh, West Bengal and Bihar states do not enact this bill and say that they already have similar plans at state level.
  21. Issues related to flood plain zoning are to be dealt by Revenue Department, SDMA and DDMA. Disaster management authorities in the state and district levels should take leading roles on this subject.

End

Meeting:	United Nations Development Programme (UNDP)
Date:	3 July 2015
Venue:	UNDP Office, New Delhi
Attendance:	<p>UNDP:  Mr. G. Padmanabhan, Emergency Analysis  Mr. Lal Arun Kumar Shahdeo, Coordinator – Disaster Risk Reduction, GOI-UNDP DRR-CCA Programme  Ms. Abha Mishra, National Project Coordinator, GOI-INDP Project (CRM in Urban Areas)</p> <p>Survey Team:  Mr. Akihiro SHIMOMURA, Mr. Toru TAKAHASHI, Mr. Nobuyuki IJIMA, Mr. Hajime WATANABE, Mr. Naoki UEHATA, Ms. Lalita Joshi</p>
Discussion:	<p>1. From 2002 to 2009, UNDP was involved in community-based disaster risk management programme and totally worked in almost 150,000 villages, 176 districts in 17 states in India.</p> <ul style="list-style-type: none"> <li>• The programme included the public awareness improvement and the preparation of disaster management plans at state, district and sub-district levels.</li> <li>• Training of personnel and formulation of disaster mitigation task forces at state and district levels</li> <li>• Establishment of India Disaster Resource Network</li> <li>• Formulation of response and emergency database</li> <li>• The programme in total for approximately 300 billion people</li> <li>• Intervention to state government projects</li> </ul> <p>2. From 2009 to 2013, Disaster Risk Reduction ( DRR) Programmes</p> <ul style="list-style-type: none"> <li>• Creating awareness on risk reduction in 17 states</li> <li>• Strengthening SDMAs and DDMAs</li> <li>• In some of the states, SDMAs are only on papers. However, at the district, the situation seems to be better with relief department being renamed as DDMA.</li> </ul> <p>3. 2013- onwards – working on four areas</p> <p>A. Mainstreaming Disaster Risk Reduction</p> <p>B. Disaster management considering climate change risks and impacts in selected urban areas</p> <ul style="list-style-type: none"> <li>• Working with nodal ministries on policy level and capacity building for integration of disaster management components in their policies</li> <li>• UNDP works in close relation with the Ministry of Home Affairs and provides technical inputs on disaster related issues to the central government, such as the Ministry of Home Affairs and NDMA.</li> <li>• Urban disaster risk reduction work is done through state level and municipal corporation level.</li> </ul> <p>C. Early Warning System</p> <ul style="list-style-type: none"> <li>• Training for municipal corporation and community by introducing the incident response system (IRS)</li> <li>• Assistance for state to develop the training modules</li> <li>• Knowledge sharing between different states</li> </ul> <p>D. Community Resilience</p> <ul style="list-style-type: none"> <li>• Identification of indicator to improve resilience</li> <li>• Development of baseline in terms of resilience</li> <li>• Capacity building</li> </ul> <p>4. Disaster risk reduction policy guidelines have been formulated by some states</p> <ul style="list-style-type: none"> <li>• States like Assam, Maharashtra, Odisha, Gujarat, Mizoram and Nagaland</li> </ul> <p>5. State and District Level Disaster Management Systems</p> <p>a. Currently, some of the units are relatively better at the district level than at the state</p>

- level.
- b. Coordination between DMA and other departments at state level is weak; however, it seems better at district level.
  - c. Some state governments are proactive in disaster risk reduction programme, for example;
    - Uttar Pradesh State Government has training of mason including the component of disaster risk reduction at the design and construction stage.
    - The government of Odisha State launched the scheme of Biju pucca houses.
  - d. Only one or two states have a kind of platform similar with National Platform for Disaster Risk Reduction.
  - e. Uttarakhand State is one of the proactive states for disaster management.
    - It was one of the first states to establish a technical cell for disaster management.
    - Disaster Management and Mitigation Centre (DMMC) in Dehradun is proactive agency in disaster management activities.
    - First state to come up with seven desk emergency support system
6. There is a periodic meeting among NDMA and other agencies. However, NDMA needs to carry out various tasks to fulfil its mandate.
  7. UNDP works with local NGOs to conduct specific activities, such as:
    - Creating awareness
    - Capacity building
  8. Hazard Risk Vulnerability Assessment (HRVA) of urban cities is a key requirement. HRVA forms a critical part of the disaster risk reduction program and it has the potential to instruct the necessary authorities to prepare for emergencies.
  9. City Disaster Management Programme
    - a. Early warning system and strengthening forecasting mechanism
      - To review the early warning system and to do it as multi-hazard approach
      - SMS-based system is developing.
      - In some of the cases where the expense is not highly sufficient, UNDP makes investment in the seed money. UNDP has done it for SMS-based system for 600 people in selected cities. GOI now plans to upgrade it to 60,000 people.
      - 2/3 states has set up emergency operation centres.
    - b. IRS is a modified version of US Incident Command System (ICS) and has been adopted by certain states in India.
      - States like Assam, Andhra Pradesh and Meghalaya have announced the IRS system. Few others have done the training.
      - Basic survival skills are emphasised in case of disaster.
  10. UNDP primarily works on the soft skills which include institutional capacity building, awareness and advocacy.
  11. Government funds for disaster management are adequate in India. In the past, UNDP invested in some of the schemes. However, currently GOI is able to invest and UNDP is requested to provide the supports for project implementation.
    - USD 6.9 million was provided by GOI for DRR.
    - In addition, bilateral funds from USAID and DFID are for a few programmes.
  12. Disaster management is primarily state government responsibility and central government only supports when the state government cannot manage disaster situation.
  13. State supports each other in case of post disaster reconstruction. In addition, coordination also happens in between central and state government.
    - Odisha State sent rescue team to Andhra Pradesh State during the cyclone in 2013.
    - Maharashtra State supported Tamil Nadu in post disaster reconstruction works after Tsunami in 2004.
    - Post disaster operation is well structured in India; however, recovery part is still weak.
    - Currently the development of the recovery framework is emphasised.
  14. There are two types of fund available for disaster management in India: response fund and mitigation fund.



- Response funds are created at the central and state levels (NDRF and SDRF), but mitigation fund has not been created.
  - It was a deliberate decision by the central government not to create mitigation fund and mainstream it in the regular developmental activity. And the same has been highlighted in the 14th Finance Commission recommendation.
  - National Disaster Response Fund (NDRF) and State Disaster Response Fund (SDRF) are available for specific post disaster actions.
    - On the ratio of the shares of the central and state governments in the SDRF, the Ministry of Home Affairs advocated retaining the present 75:25 ratio for general category states and 90:10 for special category states.
  - 15% of SDRF allocation can be utilised for preparedness, capacity building and purchase of emergency equipment.
15. Areas where support can be provided by an external funding agency are considered as:
- Data system development for multi-hazard
  - Investment on DRR
  - Establishment of Hazard Vulnerability and Risk Assessment system

End

Meeting:	Asian Development Bank (ADB)
Date:	1 July 2015
Venue:	ADB Office, New Delhi
Attendance:	<p>ADB: Mr. Pushakar Srivastava, Urban Expert, India Resident Mission Mr. Prabhash Sahu, Associate Project Officer, India Resident Mission Mr. Saurav Majumdar, Associate Project Officer, India Resident Mission</p> <p>Survey Team: Mr. Akihiro SHIMOMURA, Mr. Toru TAKAHASHI, Mr. Nobuyuki IJIMA, Mr. Hajime WATANABE, Mr. Naoki UEHATA, Ms. Lalita Joshi</p>
Discussion:	<ol style="list-style-type: none"> <li>1. ADB assistance for disaster management in India started after the Gujarat earthquake of 2001, where ADB intervention to the tune of USD 500 million was provided. The project closed in 2007 with USD 350 million of assistance.</li> <li>2. ADB supported GOI after the Tsunami in December 2004, for which USD 200 million was provided to the states of Tamil Nadu and Kerala with USD 100 million as loan and USD 100 million as grant. The project period was from 2004 to 2009 and prime sectors of interventions were: <ol style="list-style-type: none"> <li>a. water supply</li> <li>b. roads and bridges</li> <li>c. ports and harbours</li> <li>d. rural electrification</li> </ol> </li> <li>3. After the disaster in Uttarakhand State in June 2013, damage assessment was exercised jointly by ADB, the World Bank and other partners and components for support were identified. ADB is supporting state government of Uttarakhand in water supply, roads and bridges, tourism and civil aviation sector; whereas components like livelihood, forestry and related areas are being supported by the World Bank. The total assistance provided by ABD for Uttarakhand State is USD 200 million loan and 2 million for technical assistance.</li> <li>4. ADB provides emergency assistance for short-term reconstruction and rehabilitation after a major disaster which is normally 3 to 5 years.</li> <li>5. For ADB assistance, one of the conditions is that SDMA should be in operation. In many states, SDMA is not effectively functional. Adequate resource allocation needs to be done for strengthening of these organisations. Also, the coordination mechanism among different authorities and line departments during any major disasters need to be well established.</li> <li>6. Discussions were held on landslide disaster management in Uttarakhand State. The state government of Uttarakhand has identified 200 chronic zones in the state. For landslide disaster management, chronic zone treatment is one of the key activities to be done by the state government. The state government has already made a priority list for different chronic zones in the state. The state government of Uttarakhand has addressed the issue of Varnavat landslide. However, ADB considers that the piece-meal approach for working on disaster management in the region may not be the effective approach and an integrated approach will be required. The state government of Uttarakhand is planning to develop a master plan for chronic zoning in the state. However, the idea is still in the discussion phase and no actual work has been commenced.</li> <li>7. Institutes working on research for disaster management in Uttarakhand State include Wadia Institute, Forest Research Institute and National Remote Sensing Agency (NRSA).</li> <li>8. After a major disaster, needs assessment study is conducted and immediate, short-term and long-term needs are identified. ADB does not provide support on the immediate relief measures.</li> <li>9. Regarding the urban flood guidelines, it is more related to the drainage situation in the cities. ADB objective in the flood management programme is not to stop the flood completely, but minimise its damages. Also, substantial investment is required for</li> </ol>

construction, operation and maintenance.

10. ADB does not have any specific budget similar to the catastrophe risk deferred drawdown option (CAT-DDO) by the World Bank.

End

Meeting:	U.S. Agency for International Development (USAID)
Date:	1 July 2015
Venue:	USAID Office, New Delhi
Attendance:	<p>USAID: Ms. Balaka Dey, Project Management Specialist, Disaster Management</p> <p>Survey Team: Mr. Akihiro SHIMOMURA, Mr. Toru TAKAHASHI, Mr. Nobuyuki IJIMA, Mr. Hajime WATANABE, Mr. Naoki UEHATA, Ms. Lalita Joshi</p>
Discussion:	<p>1. USAID formally started supporting the GOI for the disaster management after the Gujarat earthquake in 2001. In 2002, bilateral agreement was signed with the GOI, and USAID has supported the disaster management activities since then; the support has primarily been on community-based disaster.</p> <p>2. Until 2001, disaster management was responsible under the Ministry of Agriculture (MOA); flood and cyclone were considered prime disaster and disaster management was primarily response related activity. Preparedness was not a part of disaster management activity and there was no discussion on pre-disaster aspects.</p> <p>3. To date, USAID has supported 17 states in India. Strengthening the community and the district administration is recognised as the key interventions.</p> <p>4. USAID intervention has primarily been in the sector of disaster risk reduction, enhancement of the capacity for the community, state and district administrations to shift from relief phase to preparedness.</p> <p>5. Training programme for mason, architects and engineering to develop disaster resilient buildings is one of the activities of USAID. USAID had tried to build the disaster resilience component in various programmes like Indira Awas Yojna, which supports housing for poor.</p> <p>6. In most of the states, relief commissioner is renamed as SDMA and very few districts have fully operational disaster management authorities.</p> <p>7. USAID is of the opinion that any disaster management response, mitigation and preparedness are cross cutting subjects and require the involvement of various departments. However, the coordination of different departments is a big challenge. The target for 2015-2030 is to make the disaster management plan more implementation friendly.</p> <p>8. USAID has conducted a demonstration project for retrofitting of public building in Delhi with support from Geohazard International. Five (5) public buildings were selected including schools, hospitals and other public buildings.</p> <p>9. USAID provides training supports to National Institute of Disaster Management (NIDM) for the development of training manuals. USAID also supports UNDP in their training initiative by providing monetary support.</p> <p>10. USAID conducts vulnerability and risk assessment at 8 selected cities in India including Bhubaneshwar, Madurai, Vizag, Vijayawada, Trivandrum, Navi Mumbai, Shimla and Gangtok. These cities were identified by the Ministry of Home Affairs in consultation with individual cities. Other criteria for selection of cities were vulnerability of the cities to disaster and city size (mid-size, not very large).</p> <p>11. Another challenge in disaster management in India is that city administrations normally headed by urban local bodies such as Municipal Corporation, Municipality, etc. are not included as a part of the information flow channel during disaster events, and their preparedness level is low. Disaster management information passes from the central to the state and the district levels. However, the information fails to reach to the city level or reaches late to cities. As a result, city administrations do not have the sufficient lead time to prepare. USAID through its various programmes has conducted training of city administrations, worked on early warning and disaster response system for city level. In addition, the introduction of SMS-based information system for city administrations has</p>

been implemented.

12. ICS-based disaster management started in early 2005-06. This capacity building initiative provides ICS training to government and non-government disaster managers to develop a coordinated disaster response plan. ICS is implemented in India under the name of Incident Response System (IRS). USAID support has primarily been on the development of training module and guidelines and the dissemination of information. Currently, seven (7) states in India have developed response activities based on the IRS.
13. In case of any disasters, preliminary assessment is done to verify the scope and magnitude of the event; in case of declaration of disaster, immediate relief of USD 100,000 is provided by USAID. USAID does not have bilateral agreement for response with the GOI. The GOI does not request for external help in response.

End

Meeting:	World Bank (WB), Dehradun, Uttarakhand State
Date:	6 July 2015
Venue:	Hotel Softel Plaza, Dehradun
Attendance:	World Bank: Mr. Deepak Malik, Operations Specialist  Survey Team: Mr. Akihiro SHIMOMURA, Mr. Nobuyuki IIJIMA, Mr. Naoki UEHATA, Ms. Daya Handa, Mr. Lovekush Shah
Discussion:	<ol style="list-style-type: none"> <li>1. Before the constitution of the DM Act at central level, Disaster Mitigation and Management Centre (DMMC) was set up under Disaster Management Department (DMD) for state of Uttarakhand. DMD works under Revenue Department.</li> <li>2. After the formulation of the DM Act in 2005, it became mandatory for state government to form State Disaster Management Authority (SDMA) headed by Chief Minister of the state. However, in case of Uttarakhand, SDMA was formed but not in function as of now. All the disaster-related works and relief operations are undertaken by DMMC.</li> <li>3. WB is pursuing state government to make SDMA a functional body which is in paper form as of now and needs to be approved from cabinet.</li> <li>4. DMMC performs all the functions of SDMA currently and funds dispersed from central government for disaster management are utilised by DMMC.</li> <li>5. Initially DMMC was one of the leading organisations for disaster management in Uttarakhand and has done exemplary work for disaster management. However, over the period of time, it has become more of awareness agency, organising small scale training like community level training, creating voluntary during emergency period, etc. DMMC is not much active currently.</li> <li>6. WB pursued the state government to form the State Disaster Response Force, as a result the State Disaster Response Force was formed which was one of the key achievements of WB.</li> <li>7. SDRF has two companies with 6 battalions with approximate 48 people, location of these battalions is fixed, people are deployed and WB has supported them with equipment. SDRF has worked on their human resources and equipment capacity required with the support of WB.</li> <li>8. Hi-tech vehicle and emergency hazmat vehicle still lacks in the state. WB has already asked for the support from the Government of Japan to supply a few Hazmat Vehicles. They were also planning to have a discussion with JICA if they can fund one or two vehicles.</li> <li>9. WB initiatives: <ol style="list-style-type: none"> <li>. Coordination between the departments such as irrigation department, CWC, PWD etc. is one of the key issues as all the department works in their own domain and there is no coordinating body. WB is still struggling to suggest some structure to coordinate these departments and all the activities.</li> <li>a. WB has allocated USD 155 million for building roads and bridges but there are technical issues for construction of roads and bridges, as the planning and design system with government is still very primitive and based on rough estimates only. There is tendering process for the new construction which takes a lot of time and causes delay. As suggested by WB, new designs should include concepts of retaining walls, slope stabilisation and same aspects have been assured by WB that preparation of Detailed Project Report (DPR) should cover them. This will result into resilience of the roads, less road accidents and sustainability. Earlier WB took up almost 2,000-2,500 km of roads to be developed in the state; however, to make the roads resilience USD 155 million was not sufficient. Hence, currently they are focusing on 1,400 to 1,600 km of roads. Same has been done with bridges. WB is assuring that all the new bridges are designed as per the IRC codes so that they remain stable and sustainable.</li> </ol> </li> </ol>

- b. WB had discussion with JICA in the area of slope stabilisation. Two of the identified slopes are given to Japanese company for the preparation of DPR, and later on these might be given to WB for funding and implementation. Along with that, WB has floated consultancy services for the study of 5 critical slope zones for which contract will be signed in a few days. The study will include solutions and strategies to manage the critical zones and as per the availability of finances work will be initiated by WB.
  - c. After the flood of 2013, the river course changed drastically and the morphology changes completely. There might be more hazards related to this which are still unknown to government or to people. To study that and understand the risks, WB studies some critical riverine and river morphology.
  - d. For early warning system, WB has commissioned a study on hydrometeorology to understand the meso level network required in terms of AWS, RWS, radar stations and locations to install. WB is also supporting a system to convert data into decision support system. Government and people are still not able to understand the quantum and calculation of risk, vulnerable population, threats. After the formation of hydrometeorology system, all the information will go into the system and will be helpful in identifying the measures and vulnerable places.
  - e. The decision support system will be the first of its kind in India for risk assessment. The state government does not have the capacity to operate this system; therefore, the project also includes assessment of the existing capacities of the government and measures to upgrade. This is in conceptual stage as of now. This project will also tell about the initiative needs to be taken up at state level and district level and training of the officials to run the system. WB also plans to run the decision support system through consultancy for one year and later on transfer to state government. This practice will give more time to state government to understand the process of the system. The system will also support the officials to have early warning system in case of flash floods.
  - f. Retrofitting is another key aspect WB concerns. The existing government and schools buildings (5,000 to 6,000 schools) are not earthquake resistance.
  - g. Community level and household level disaster preparedness is totally lacking which is another key area.
  - h. WB's primary focus is to upgrade government's capacity because spreading awareness and capacity building at micro level is a long term task and it can only be done if the government itself is capable of doing that.
  - i. During the flood, there were five worse effected districts namely Rudraprayag, Bageshwar, Chamoli, Uttarkashi and Pithoragarh. Road construction work undertaken by WB will primarily focus on these five districts.
10. Currently the state government is dealing with disaster risks at local level in a scattered and isolated manner. There is no comprehensive plan to deal with them.
  11. DMMC publishes various articles for disaster management. UNDP has supported state government to form District Disaster Management Authority (DDMA).
  12. There is urgent need to make SDMA a functional body so that all the efforts can be brought under single umbrella.
  13. DMMC along with GSI is also a part of technical team formed for risk assessment at state level.
  14. Alert system at state level is not proper; e.g. information regarding the probable rain quantity in the regions can only be utilised if it is converted to assess the risk for which decision support system is required.
  15. There are approximately 6,000 landslide zones in the state which have already been mapped by the state government; out of those 50 landslide areas are very critical. Mapping at state level is done; however, at micro level or community level, no such kind of mapping is available.
  16. The state government has assured that people do not stay in most critical landslide prone areas.

17. There is total lack of awareness among local people. Lots of people are still staying in flood prone zones.

End



Meeting:	Disaster Management Department (DMD), Uttarakhand State
Date:	8 July 2015
Venue:	DMD Office, Dehradun
Attendance:	<p>DMD: Mr. R. Meenakshi Sundram, Relief Commissioner and Secretary Disaster Management</p> <p>Survey Team: Mr. Akihiro SHIMOMURA, Mr. Nobuyuki IIJIMA, Mr. Naoki UEHATA, Ms. Daya Handa, Mr. Lovekush Shah</p>
<p>Discussion:</p> <ol style="list-style-type: none"> <li>1. Landslide disaster in Uttarkashi District <ul style="list-style-type: none"> <li>• In Uttarkashi District, there is a hillock named Varnavat, where there was a huge landslide in 2004 and 2005. There is township below this hill and lives of the people are at threat due to landslide risk. Landslide treatment programme was organised by the GOI. The hill is currently stable and was not affected during 2013 flood.</li> <li>• Another critical landslide prone area is Thanbakhani zone. GSI suggested that landslide treatment is not possible in this zone as the slope is very steep. Hence, bypassing of route was done by constructing the tunnel.</li> <li>• Another landslide area is above Gangotri temple called Bhirojhap Nallah. Some treatments are done for this zone; however it is not sufficient as there are number of cases when debris flows happen. In Gangotri near the national highway, there is landslide zone called Bhatwadi which is a tehsil head quarter. The whole area is under landslide zone which is continuously sinking due to frequent landslides. There are incidents of entire road washed away and destruction of buildings.</li> </ul> </li> <li>2. Landslide in Rudraprayag District <ul style="list-style-type: none"> <li>• Two key slide zones in Rudraprayag are in Sonprayag and Gauri Kund where huge slides happen frequently.</li> </ul> </li> <li>3. Funding for disaster <ul style="list-style-type: none"> <li>• Uttarakhand State gets funds from central government i.e. NDRF and state government fund i.e. SDRF. There is regular flow of funds for both the line departments and districts.</li> <li>• Before NDMA came into force, Uttarakhand was the first state in the country to have its own State Disaster Management Act.</li> <li>• After coming up of the DM Act, the state government act was repealed and replaced.</li> <li>• At state level, SDMA is headed by Chief Minister (CM) and at district level by District Magistrate who is chairman of the DDMA.</li> <li>• DDMA has sufficient authorities during emergency operations.</li> <li>• Funds received from central and state governments are distributed among the districts uniformly before onset of the monsoon. In 2015, every district obtains Rs. 2 crore. Additional funds are given to districts in case of emergency if demanded. The District Magistrate has also been given the power to withdraw money from treasury during the emergency under Treasury Rules No. 24 without taking permission of the state. After the money is spent, the District Magistrate sends the expenditure statement and state government makes the adjustments in the budget accordingly.</li> <li>• The amount of Rs. 2 crores per district varies every year.</li> <li>• If the calamity is very large, assistance is sought from the central government.</li> <li>• Funds are spent for disaster preparedness in case it is not utilised for relief works and disasters and if DM thinks it to be required.</li> </ul> </li> <li>4. Currently the state is in the process of re-modifying SDMA and it is expected to work as full time organisation. As of now, by mandate the CM is head of the SDMA and various secretaries from departments are the members; but they become active only for conducting</li> </ol>	

some meetings or taking decisions. After the modification, there will be a Chairman (Chief Minister) and full time vice chairman (some ex-officials).

5. There will be a crisis management group consisting of secretary and crisis advisory group having group of ministers. There will be a permanent vice chairman under whom there will be a certain member allocated different responsibility. This body will be totally independent and will take charge in case of major calamity.
6. It is still under discussion, but it is considered that Disaster Mitigation and Management Centre (DMMC) and State Emergency Operation Centre (SEOC) will be merged with SDMA, and the State Disaster Response Force will also become part of SDMA.
7. District Emergency Operation Centres are also set up at district level.
8. Currently the state has the World Bank sponsored programme under which state of the art building are planned to construct for SDMA and DDMA with hi-tech communication facilities.
9. For training programmes, there is Uttarakhand emergency assistance programme assisted by ADB and Uttarakhand disaster training programme assisted by the World Bank.
10. There is no particular guideline available for Disaster Risk Reduction at state level. Although the District Disaster Action Plan has all the inputs required for human and material resources. At state level, there is also State Disaster Action Plan.
11. After the functionalisation of SDMA in Uttarakhand, DMD will act more as administrative body.
12. After SDMA establishment, funds will be routed to SDMA and SDMA will distribute the funds to DDMA. DMD role will be reduced after SDMA became full time functional body.
13. Monitoring in landslide areas – apart from Varnavat hill, no other landslide zones have been treated as of now. Varnavat was given priority due to the settlements present below the hill whereas in other areas road block is the only issue. There are future plans to take up other landslide areas for treatment.
14. Roads repair and maintenance works due to disaster are taken up by concerned road authority only such as the Public Works Department (PWD) and Border Road Organisation (BRO). Tunnels are also constructed by PWD and BRO. Budgetary support is given by the DMD but the plan has to be executed by concerned authority.
15. Generally plain areas are affected by flood, not the hilly areas. In Rishikesh and Haridwar, there is probability of floods as water immediately goes down and flows into the river along the towns.
16. There are efforts to create embankments in the critical areas along the rivers; some of them have already been constructed and some are in pipelines.
17. Special consideration for Disaster Risk Reduction Plan is to build by-laws to take care of the planning and design criteria for buildings.
18. There is no separate plan for Disaster Risk Reduction. State level and District level Action Plans include risk reduction strategies and programme.

End

Meeting:	Public Works Department (PWD), Uttarakhand State
Date:	6 July 2015
Venue:	PWD Office, Dehradun
Attendance:	<p>PWD: Mr. Arvind Singh Hyanki, Additional Secretary</p> <p>Survey Team: Mr. Akihiro SHIMOMURA, Mr. Nobuyuki IIJIMA, Mr. Naoki UEHATA, Ms. Daya Handa, Mr. Lovekush Shah</p>
Discussion:	<p>1. PWD is responsible not only for construction of new roads but also for maintenance and protection works of existing roads. Maintenance includes periodical repairs and periodical protection works.</p> <p>2. After the disaster at Kedarnath region in 2013, PWD approached the World Bank and ADB for restoration of connectivity and improvement of roads damaged by the disaster.</p> <p>3. Consultants are also appointed to study those areas where heavy landslides occurred during the disaster. One of the consultants is Tehri Hydro Development Corporation (THDC), which has identified more than 40 different sites which PWD proposed to study to identify the reasons of landslide and measures which need to be taken to prevent such events in future. THDC has already prepared DPRs of the projects to prevent landslides in future and submitted to state government. These projects will be considered under Externally Aided Projects (EAP) to be funded by ADB.</p> <p>4. During the planning and design stage, risk assessment is done and preventive measures are detailed out in the DPR. IRC codes are followed while project design.</p> <p>5. Seven (7) to eight (8) critical zones have been identified by the consultants where landslides are quite common. Consultants have proposed activities such as diverting the alignment and treatment work on the hill as well on the river side to prevent future landslide events. More than Rs. 120 billion is allocated for these projects. DPRs have been prepared and tender process for the implementation work is underway currently.</p> <p>6. The Ministry of Road Transport and Highways (MORTH) of the central government classifies some of the roads as National Highways (NHs). For NHs, the GOI is responsible for funds. A separate unit within PWD takes care of the implementation and maintenance of the NHs. Works such as widening, strengthening and slope stabilisation are being taken up by this unit within PWD.</p> <p>7. PWD is headed by Secretary, who is IAS rank officer. Engineer in Chief (EIC) heads the implementation side for National Highways &amp; State Roads for all the implementation and maintenance of the projects. There are two Chief Engineers (One for Gadhwal region and another for Kumau region) for National Highways under EIC and six Chief Engineers for state roads. Each CE has jurisdiction of about 2-3 districts. Every district has one Superintending Engineer (SE) who reports to CE. There are 3-6 divisions in each district, where Executive Engineers (EE) operates.</p> <p>8. State PWD takes care of the funding for all state roads (all roads except National Highways). PWD also gets funds under State Disaster Response Fund for the roads damaged during natural calamity. These funds are routed through DMD to the State Disaster Response Force and DM to various departments including PWD at district level.</p> <p>9. Irrigation department is responsible agency for any restoration work related to river floods. In the event roads are affected by these floods, PWD gets involved to restore the road.</p> <p>10. There is a system in place to monitor the condition of roads and bridges. PWD maintains a road register to record the condition of the road periodically.</p> <p>11. No issues are identified in inter-departmental coordination. District Magistrate works as the focal point for all agencies involved in the event of a disaster in the region.</p>

12. Under the DM Act, District Magistrate has the powers to allow all restoration and protection works in the event of a disaster without having to take permissions from the other involved agencies (for example forest department, irrigation department) for compliances.
13. Inter-departmental issues are also resolved by involvement of state government and secretaries of the relevant departments.
14. Along the NH, land can be of revenue department, forest department or private land. Land acquisition process is different for every case, which is followed by the PWD for the respective cases.
15. Road side land control act empowers PWD to have rights on either sides of the road (normally 120m on either side) for the roads which are notified under this act. The land owners need to take no objection certificate (NOC) from PWD before starting any activity such setting up of shop, construction, etc.

End

Meeting:	State Disaster Management Authority (SDMA), Bihar State
Date:	6 July 2015
Venue:	SDMA Office, Patna
Attendance:	SDMA: Mr. A.K. Singh, Vice Chairman  Survey Team: Mr. Toru TAKAHASHI, Mr. Alok Kumar Pal
Discussion:	<ol style="list-style-type: none"> <li>1. Bihar State is the second largest state in respect of population and ninth in area in India and is the most flood-affected state in the entire country. The northern part of the state is mostly affected by the floods.</li> <li>2. The Vice Chairman (VC) emphasised that there are needs to focus on not only flood but also natural calamities like earthquake and drought. Moreover, as the northern part of Bihar State is categorised under seismic zone V and generally drought and flood disasters occur simultaneously every year.</li> <li>3. The National Commission on Floods has stated that the continued rise of riverbeds has created problems of seepage and drainage, aggravating water logging apart from embankments, transportation networks like railways and highways with inadequate provision for waterways have played a major role in aggravating the problem.</li> <li>4. All major roads and railways running from east to west cut across the natural flow and drainage of the rivers in north Bihar.</li> <li>5. Inadequate waterways and bridges build up the volume and velocity of flood waters resulting in the rivers attacking the banks at the upstream and even the downstream with added fury eroding its banks and inundating the country side.</li> <li>6. The VC suggested that there should be a detailed discussion on preparedness measures in all the areas and the contact information should be made available. It is recalled about the severity of Kosi flood and showed his deep concern about those people who have suffered due to lack of awareness on disaster preparedness. The VC also talked about imparting the preparedness message through mock drills and related awareness programmes.</li> <li>7. One of the issues is on the education of children even after the occurrence of destruction. To ensure better preparedness, the district risk reduction groups are working according to the task force umbrella planned by them. The task force umbrella's prime goal is to ensure the safety of the respective village during crisis.</li> <li>8. A multi-hazard approach is recommended as 80% of the area in the state falls under highest seismic zone in addition to drought and floods happening simultaneously.</li> <li>9. In north Bihar, the important rivers namely Ghaghra, Gandak, Buri-Gandak, Kosi and Mahananda fall into the Ganga River, the main stream flowing from west to east, whereas Bagmati-Adhwara, Kamla-Balan, etc. rivers into the Ganga River through the Kosi River. Due to lack of planned initiatives on mitigation and preparedness measures, the vulnerability of the state to the flood has further increased.</li> <li>10. The State Government of Bihar has identified the improvement of flood control as a priority area for the World Bank engagement in the state. The World Bank-Government of Bihar Partnership Matrix (2006) prioritises the improvement of the institutional capacity for delivering better flood management and drainage services as a key action for accelerating agriculture productivity in north Bihar.</li> <li>11. The VC emphasises on flood modification apart from reducing drainage congestion. Some measures enumerated to minimise floods to be applied; <ol style="list-style-type: none"> <li>a. A suitably modified agronomic practice</li> <li>b. Rescheduling of agricultural operations</li> </ol> </li> </ol>

- c. Flood plain zoning
  - d. Implementation of land reforms
  - e. Extensive utilisation of ground water resources creating the capacity for ground water storage of excess run-off water
  - f. Providing suitable technology for flood-proof housing in the affected areas
  - g. Elimination of middlemen in flood protection schemes
  - h. Reducing the interference from politicians and local political pressure groups
12. Apart from structural mitigation measures, it is also worth to consider the social and economic aspects to deal with flood hazards.
  13. Improvement of flood management to protect the poor farmers and tribal groups located in the low value lands in the flood plains is also in line with the World Bank/DFID partnership policy of extending support to state reforms that could lead to lasting poverty reduction.
  14. The technical approaches in flood forecasting, inundation modelling and warning and embankment management are also coupled with expanded institutional and community linkages and expanding geographic coverage, especially in north Bihar. The fourth stage aims to develop integrated flood/drainage/irrigation management through upgrading Flood Management Information System into Water Resources Information System, implementing operational community based flood management and operationalising regional flood knowledge base and management plans.
  15. Providing and disseminating information tools have moved sector agencies capacity from disaster response to disaster preparedness and to effectively support flood control and management in the flood prone areas of the state.
  16. A substantive effort is required for planning the development and rehabilitation of the flood and drainage control infrastructure, in the short term, there is a compelling need for adopting new technological approaches to improve the decision process before, during and after the flood events

End

Meeting:	Water Resource Department (WRD), Bihar State
Date:	6 July 2015
Venue:	WRD Office, Patna
Attendance:	SDMA: Mr. Vipin Kumar Rai, Officer on Special Duty (OSD)  Survey Team: Mr. Toru TAKAHASHI, Mr. Alok Kumar Pal
Discussion:	<ol style="list-style-type: none"> <li>1. The functions of the WRD include major and medium irrigation projects, flood management, drainage management and command area development and water management. WRD undertakes projects in developing major and medium irrigation schemes, constructing reservoirs, interlinking of rivers, participatory irrigation management, construction and management of flood protection structures, anti-erosion works, developing flood management information systems, development of drainage systems, construction of water ways and associated areas.</li> <li>2. Bihar State is one of the most disaster prone states in the county. Floods, droughts, earthquakes, heat/cold waves, river erosions, fire incidence etc. are various forms of disasters prevalent in the state. Among natural disasters, flood is the most common and a regular phenomenon in the state resulting in enormous loss of life and property. In addition to floods, the seismic vulnerability of the state to earthquakes is another constant danger. Increasing population pressure, high density of buildings and their poor construction quality, the settlement in vulnerable areas and inadequate or no investment on mitigation/preparedness measures have further increased the vulnerability of the population to these natural hazards. In addition to extensive damage to life and property, these disasters over the years have also adversely affected economic development in the state.</li> <li>3. The mean annual rainfall for the state is about 1,300 mm. Most of the rainfall (80% to 90%) is received from mid-June to mid-October. The late September-October rains (locally known as 'Hathia'), though only 75 to 100 mm in quantity, are very crucial to agriculture in the region and their timing and distribution make all the difference between plenty and scarcity.</li> <li>4. Total flood prone area of the state is about 70.0 lakh hectares which accounts for 75% of its total geographical area.</li> <li>5. The state has witnessed devastating floods in recent years. In fact, south west monsoon rain has become a synonym of floods in north Bihar plains resulting in enormous loss of life and property and bringing untold human miseries and sufferings to the people.</li> <li>6. It is articulated about one of the very profound ideas to focus on not only disaster like flood but also natural calamities like earthquake, drought and fire, etc. and there should be a preparedness plan for each situation.</li> <li>7. Focusing on the Kosi embankment at Beerpur, Supaul, if it breaks, the water flow will hit the areas like at Supaul, Madhepura, Saharsa, etc. It is ensured that the state has prepared to deal with the disaster situation, so it is recommended that the state preparedness plan should be developed keeping in view of the existing situations. The multi-sectoral issues shall be focused arising during the flood. Needs of vulnerable groups should be taken care of as a priority and planning should be done accordingly.</li> <li>8. An issue on the availability of drinking water, medicines and toilet facilities etc. during the emergencies is identified and the facilities of mobile aid will start in June end. The mobile aid team has great importance not only in health camps but also in many others contexts.</li> <li>9. WRD has been involved in providing the relief and rescue training of volunteers (generally 7 days) at the district with about 45 to 50 volunteers.</li> <li>10. WRD started working with the help of Water Aid since 2007 on disaster management</li> </ol>

pecially preparedness in Samstipur, Darbangha, Muzaffarpur and Madhubani districts focusing on water sanitation and providing emergency kits, which comprise of basic relief materials like life jackets, medicines, food, etc.

11. Important rivers namely Ghaghra, Gandak, Burhi Gandak, Kosi and Mahananda etc. drain directly into the Ganga River, the main stream flowing from west to east, whereas Bagmati-Adhwara, Kamla-Balan etc. stream into the Ganga River through the Kosi River.
12. The Ghaghra, Gandak and Burhi Gandak rivers of north Bihar are now more or less stabilised. The Gandak River has travelled from near Burhi Gandak on the east to its present course on the west in course of last several hundred years, whereas the Bagmati, Adhwara group of rivers, Kamla-Balan and Kosi are still very unstable due to steep slopes and high silt charges and are always exerting tremendous pressure on the embankments.
13. There have been many technical studies into the practicalities of flood control in north Bihar. Various feasibility studies have looked at building dams, embankments along the river shoreline, etc. Efforts have been ongoing to control the devastating consequences of flooding in the successive years with an alarming regularity.
14. The major rivers of north Bihar have generally Himalayan origin and considerable portion of their catchments lie in the glacial region. They are snow-fed and perennial in flow. These rivers have catchments in the Himalayan region in Nepal. Some of them have catchments even in Tibet. They receive very copious rainfall during monsoon which causes rise in discharge of these rivers by more than 75-80 times higher than fair weather flows which causes frequent flooding of north Bihar during monsoon.
15. It was generally found that early flood takes place during the month of June in Bagmati, Kosi and Kamla rivers. Thereafter flood generally comes in the Burhi Gandak River in the month of mid or last July. During these months the Ganga River generally remains low but by September, the Ganga River also rises making the flood problem more acute.
16. The flood problem was accentuated due to ever increasing encroachments on the flood plains by the growing population to meet its requirements of food and fibre. The destruction of forests for reclaiming areas for occupation and for obtaining fuel for domestic requirements had also caused changes in river regime. All these have resulted in an anomalous situation.
17. A substantive effort is required for planning the development and rehabilitation of the flood and drainage control infrastructure, in the short term, there is a compelling need for adopting new technological approaches to improve the decision process before, during and after the flood events.
18. The technical assistance are required for strengthening flood knowledge base and analysis, the dissemination and outreach of operational flood management information and the improvement of flood preparedness.
19. There is one Standard Operating Procedure followed for flood response plans which are designed and executed on the basis of day-to-day emerging needs through a web portal to know the status of the flood mitigation. There are eight different web pages consisting of:
  - a. Rain gauge data
  - b. Flood prone areas
  - c. Country boat
  - d. Storage point of the grains (pre-flood situation)
  - e. Storage of motors boats, tent, jackets, polythene sheets, bleaching powder, etc.
  - f. Storage of medicine, drinking water for human beings
  - g. Storage of medicine for cattle
  - h. Rate fixation of essential items

End



Meeting:	Andhra Pradesh State Development Planning Society (APSDPS), Andhra Pradesh State
Date:	6 July 2015
Venue:	APSDPS Office, Hyderabad
Attendance:	<p>APSDPS: Mr. Sanjay Kumar, Chief Executive Officer Mr. Ramana Murthy, Deputy Executive Engineer</p> <p>Survey Team: Mr. Hajime WATANABE, Ms. D. Svega</p>
<p>Discussion:</p> <ol style="list-style-type: none"> <li>1. APSDPS plays a role as scientific advisory for disaster management. APSDPS also maintains automatic weather stations and manages the gauge and weather data.</li> <li>2. APSDPS installed the following equipment: <ul style="list-style-type: none"> <li>• 2000 AWSs</li> <li>• 50 telemetry rain gauges</li> <li>• 44 telemetry river gauges</li> </ul> </li> <li>3. Vulnerability maps for cyclone are generated by APSDPS.</li> <li>4. APSDPS also focuses on decision support system with GIS database.</li> <li>5. APSDPS intends to improve topographic and spatial databases, advance modelling facilities and forecast maps on real time basis.</li> <li>6. APSDPS developed the models of Krishna Floods in 2009 and completed mapping for Cyclone Hudhud at Vizag in October 2014.</li> <li>7. IMD and APSDPS have the MOU to analyse temperature and humidity profiles for seasonal conditions.</li> <li>8. The data maintained at APSDPS are accessible by Chief Minister.</li> <li>9. APSDPS intends to improve data management and dissemination: <ul style="list-style-type: none"> <li>• to improve the data accuracy and better topographic mapping</li> <li>• to maintain the network from top level to bottom level, i.e. state level to village level</li> </ul> </li> <li>10. Andhra Pradesh State has strong monitoring network in radar system and vulnerability mapping.</li> <li>11. Three issues that APSDPS want to improve in Andhra Pradesh State are: <ol style="list-style-type: none"> <li>a) Soil moisture</li> <li>b) Terrain mapping in urban areas</li> <li>c) Establishment of weather control room on database management</li> </ol> </li> <li>12. Building should be constructed with cement concrete and infrastructure shall be properly constructed and managed.</li> <li>13. Terrain mapping is costly, so it is welcome if JICA can provide funding.</li> <li>14. District Collector is authorised to control all other departments at time of cyclones.</li> </ol> <p style="text-align: right;">End</p>	

Meeting:	Water Resources Department (WRD), Andhra Pradesh State
Date:	8 July 2015
Venue:	WRD Office, Hyderabad
Attendance:	<p>WRD:            Mr. M. Venkateshwar Rao, Engineer In Chief            Mr. Srinivas, Deputy Chief Engineer            Mr. Ravi Babu, Executive Engineer            Mr. Nagaraju, Deputy Chief Engineer</p> <p>Survey Team:            Mr. Hajime WATANABE, Ms. D. Svega</p>
Discussion:	<ol style="list-style-type: none"> <li>1. Whenever cyclone warning is given, rescue teams and the State Disaster Response Force are dispatched to areas where will be affected.</li> <li>2. For the emergency response, Chief Minister will make coordination among all departments.</li> <li>3. WRD has a limited role such as flood management, protection of water resource, and preparation of flood management plan.</li> <li>4. At the time of first warning, all officials get alerted and reported, and they will reach to the river banks.</li> <li>5. Superintend engineers will check the conditions of embankment and take the protection measures if required.</li> <li>6. District Collector is responsible for the flood management.</li> <li>7. Reservoirs are maintained by Irrigation Department.</li> <li>8. APSDPS provides the rainfall data to related departments and bodies during monsoon season.</li> <li>9. IMD gives data of expected rainfall for cyclones.</li> <li>10. Guidelines for flood management are available at WRD.</li> <li>11. Some of issues at the time of floods are: 1) more gauging stations, 2) automatic sensor, 3) real time data collection, and 4) communication network will be disrupted.</li> <li>12. For the rehabilitation from the disaster, Revenue Department will take initiatives.</li> <li>13. The State Government will provide required funds for the rehabilitation works.</li> <li>14. It is planned to install optical fibre within 1 year.</li> <li>15. Drainage facility and canals shall be properly maintained to secure the flow capacity.</li> <li>16. To protect the crop area, tidal embankments are established to stop the intrusion of water along the coastal line.</li> </ol> <p style="text-align: right;">End</p>

Meeting:	Directorate of Disaster Management (DDM), Andaman & Nicobar Islands Union Territory
Date:	27 July 2015
Venue:	DDM Office, Port Blair
Attendance:	<p>DDM: Mr. Sanjay Balan, Deputy Director Mr. T.K.S. Ajayan, Assistant Director</p> <p>JICA India Office Ms. Ai TACHIKAWA, Representative Mr. Vineet Sahai Sarin, Principal Development Specialist</p> <p>Survey Team: Mr. Akihiro SHIMOMURA, Mr. Nobuyuki IJIMA, Mr. Naoki UEHATA, Mr. Lovekush Shah</p>
Discussion:	<p>1. In 2011, there was a depression called Thane. In 2013 there was Cyclone Phailin, and in 2014 there was Cyclone Hudhud. Andaman &amp; Nicobar Islands Union Territory observes 2-3 cyclones every year. Apart from cyclones, depressions are also observed in the Andaman seas.</p> <p>2. Information Dissemination:</p> <ul style="list-style-type: none"> <li>• From national level (MHA, NDMA, INCOIS (ITEWC) and IMD) to State Emergency Operation Centre (SEOC), to 8 DEOCs and to local community via various media</li> </ul> <p>3. Emergency Communication:</p> <ul style="list-style-type: none"> <li>• For cyclones, current systems allow sufficient time for rescue. In case of earthquakes, SEOC finds more difficulty because of very less time to react after the warnings.</li> </ul> <p>4. Currently SEOC has the following facilities/equipment:</p> <ul style="list-style-type: none"> <li>• 13 satellite phones</li> <li>• 11 electric display boards</li> <li>• Video conferencing with centre</li> <li>• VOIP linkage</li> <li>• Push messaging for instant messages</li> <li>• VHF connectivity</li> <li>• 36 tsunami sirens</li> <li>• 35 GPS strong motion accelerometers</li> <li>• 2 Doppler weather radars</li> <li>• Automated weather station</li> </ul> <p>5. Preparedness:</p> <ul style="list-style-type: none"> <li>• Current State Disaster Management Plan was prepared in 2012 and is under review.</li> <li>• SEOC has the following equipment and implemented the following activities: <ul style="list-style-type: none"> <li>○ SOPs for all departments for disasters</li> <li>○ 140 relief shelters</li> <li>○ 45 State Disaster Response Force personnel deployed</li> <li>○ 412 schools under National School Safety Programme</li> <li>○ Implementation of mock drill exercises and community based disaster risk reduction programmes</li> <li>○ 198 trainings in total</li> </ul> </li> </ul> <p>6. Needs:</p> <ul style="list-style-type: none"> <li>• Following needs were highlighted for the improvement of disaster management: <ul style="list-style-type: none"> <li>○ Capacity building of the SEOC officials and other staff involved</li> <li>○ Installation of remote operation warning/sirens</li> </ul> </li> </ul>

○ Advancements in new SEOC

7. No major disasters were reported in the last 3-4 years.

8. Funds:

- Rs. 10 crores of the SDRF has been sanctioned but not released by the Ministry of Home Affairs as of now. Currently, required funds for the disaster response are used from the plan budget of the Andaman and Nicobar Islands Union Territory.

End

Meeting:	Public Works Department (PWD), Andaman & Nicobar Islands Union Territory
Date:	30 July 2015
Venue:	PWD Office, Port Blair
Attendance:	PWD: Mr. Bimal Sinha, Chief Engineer  Survey Team: Mr. Akihiro SHIMOMURA, Mr. Nobuyuki IJIMA, Mr. Naoki UEHATA, Mr. Lovekush Shah
Discussion:	<ol style="list-style-type: none"><li>1. Considering tsunami risks, tsunami shelters are constructed 500m away from the coastal line and 50m above the sea level.</li><li>2. Approximately 5,000 houses are constructed and rehabilitated after tsunami in 2004.</li><li>3. Approximately 50 check dams are constructed in A&amp;N for the purpose of water supply. Around 7 sluice gates are planned out of which 4 gates are already constructed and 3 are under construction.</li><li>4. A master plan to protect paddy fields from erosion between Mayabunder and Diglipur is under preparation.</li><li>5. Dhanikhari dam is the major source of water supply with the capacity of 8,500 million litres.</li></ol> <p style="text-align: right;">End</p>

## Appendix 2: Photos



New Delhi



Meeting at NDMA



Meeting at MOWR



Meeting at MORTH



Meeting at MOES



Meeting at UNDP









Meeting at MOEFCC



**Uttarakhand State**

	
Uttarkashi District Disaster Management Centre	Varnavat Landslide Area (Uttarkashi District)
	
Houses wrecked by Slope Failure along a River (Uttarkashi District)	Rudraprayag District Disaster Management Centre
	
Landslide by the flood 3013 (at Sonprayag, Rudraprayag District)	Area eroded by the flood 2013 (at Khagaria, Rudraprayag District)

**Bihar State (1/2)**

	
<p>Ganga River (at Patna)</p>	<p>Bridge on the Ganga River (Pajendra Bridge, at Begasarai)</p>
	
<p>Bihar SDMA (Vice Chairman &amp; Project Officer)</p>	<p>RCC Porcupine Works along the Kosi River</p>
	
<p>Houses Located in the River Area (Kosi River)</p>	<p>Bank Protection Works along the Buhri Gandak River (at Khagaria)</p>

**Bihar State (2/2)**



Staff Gauge at Banibad Water Level Station  
(Bagmati River)



Burhi Gandak River (Samastipur Bridge)









Protection Works by Sand Bags at Dhamaun  
(Ganga River)



Protection Works by Boulder Pitching Works at  
Dhamaun (Ganga River)

Andhra Pradesh State (1/2)

	
<p>Exterior view of old cyclone shelter (not in use) in Vhemili Village, Visakhapatnam</p>	<p>Interior view of old cyclone shelter (not in use) in Vhemili Village, Visakhapatnam</p>
	
<p>School used as Shelter in Vhemili Village, Visakhapatnam</p>	<p>Cyclone Shelter (used as nursery) in Vhemili Village, Visakhapatnam</p>
	
<p>Doppler Weather Ladder Station in Visakhapatnam</p>	<p>Doppler Weather Ladder Station in Visakhapatnam</p>

**Andhra Pradesh State (2/2)**



Krishna River



View of urban coast in Visakhapatnam



Emergency Operation Room  
in Krishna District Office



View of Krishna Manda, Krishna District  
(from the roof top of cyclone shelter)

Andaman and Nicobar Islands (1/2)



Damage by Natural Disasters in the Andaman and Nicobar Islands



South Andaman District Emergency Operation Centre (Port Blair)



Andaman and Nicobar Union Territory Emergency Operation Centre (Port Blair)



Fishing Port (Port Blair)



Check Dam near Beadonabad Village



Materials stored in Godown (Port Blair)

**Andaman and Nicobar Islands (2/2)**

 A photograph showing a dense mangrove plantation with lush green trees and a body of water in the foreground.	 A photograph showing a road with a concrete barrier and a body of water, illustrating rehabilitation works along NH4 after the 2004 tsunami.
<p>Mangrove Plantation near Corbyn's Cove (Eastern Coast of Port Blair)</p>	<p>Rehabilitation Works along NH4 after Tsunami Disaster 2004</p>
 A photograph showing a concrete sluice gate structure with a body of water in the foreground.	 A photograph showing a large body of water with a small boat in the distance, illustrating an inundated area after the 2004 tsunami.
<p>Sluice Gate near Mitha Khari</p>	<p>Inundated Area after Tsunami Disaster 2004</p>