

A6-1 対象浄水場のPIデータ

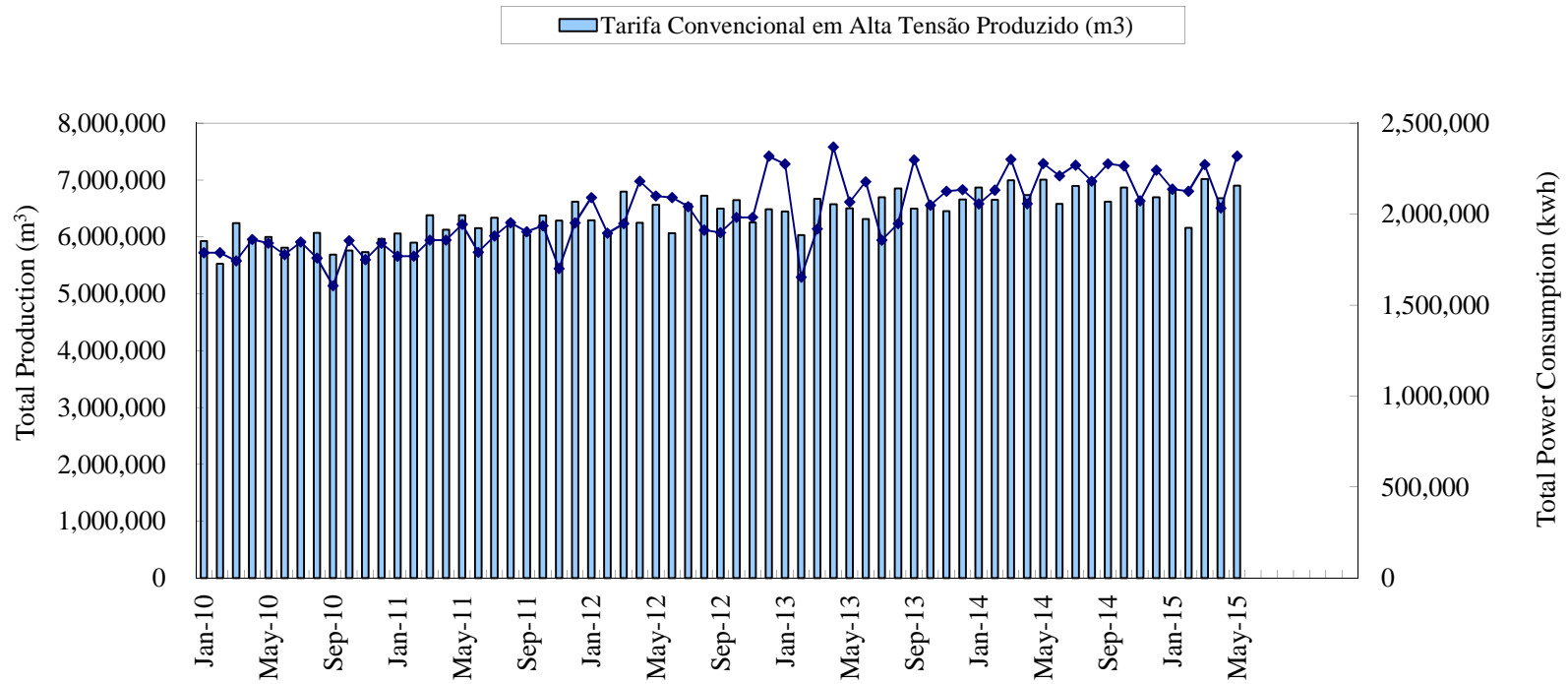

Total Production (m³) and Total Power Consumption (kWh) (2010- onward) - Irai

Ref.	Leitura	Produção (Mz)	Dias em Operação	Consumo - Fora Ponta			Consumo - Ponta			Demanda - Fora Ponta			Demanda - Ponta			Ultrap - Fora Ponta		Ultrap - Ponta		CER - Fora Ponta		CER - Ponta		DER - Fora Ponta		DER - Ponta		Dem. Isenta ICMS(R\$)	Tx. Ium. (R\$)	Encarg. (R\$)	Outros (R\$)	Total (R\$)	Total power consumption (kWh)	Total billed electricity (R\$)							
				Médio (kwh)	Faturado (R\$)	Importe (R\$)	Médio (kwh)	Faturado (R\$)	Importe (R\$)	Média (kwh)	Faturada (R\$)	Importe (R\$)	Média (kwh)	Faturada (R\$)	Importe (R\$)	Faturada (R\$)	Importe (R\$)	Faturada (R\$)	Importe (R\$)	Faturada (R\$)	Importe (R\$)	Faturada (R\$)	Importe (R\$)	Faturada (R\$)	Importe (R\$)	Faturada (R\$)	Importe (R\$)								Faturada (R\$)	Importe (R\$)					
Feb-10	2010/1/8		32	70,762	70,762	10,029.47	6454.0	6454	7,376.53	294.0	294.0	2,860.20	291.0	291	RS 0.00	0.0	RS 0.00	0.0	RS 0.00	1,958.0	149.95	125.0	142.80	0.0	0.0	0.0	0.0	0.0	0.0	0.0	0.0	20,559.01	77,216.00	20,559.01							
Mar-10	2010/2/8	491,793	30	60,955	60,955	2,032.84	8426.0	8426	9,627.07	263.0	275.0	2,656.65	262.0	275	RS 0.00	0.0	RS 0.00	0.0	RS 0.00	1,223.0	159.12	173.0	197.44	0.0	0.0	0.0	0.0	0.0	0.0	0.0	0.0	0.0	0.0	21,277.74	69,301.00	21,277.74					
Apr-10	2010/3/5	389,264	30	50,254	50,254	1,717.77	4250.0	4250	4,856.31	264.0	275.0	2,611.75	263.0	275	RS 0.00	0.0	RS 0.00	0.0	RS 0.00	929.0	107.47	131.0	92.4	0.0	0.0	0.0	0.0	0.0	0.0	0.0	0.0	0.0	0.0	0.0	14,948.50	45,948.50					
May-10	2010/4/6	228,353	32	34,214	34,214	4,847.85	1608.0	1608	1,837.28	201.0	275.0	2,453.92	155.0	275	RS 0.00	0.0	RS 0.00	0.0	RS 0.00	821.0	116.32	37.0	42.27	0.0	0.0	0.0	0.0	0.0	0.0	0.0	0.0	0.0	0.0	0.0	9,297.64	35,822.00	9,297.64				
Jun-10	2010/5/5	101,866	30	23,852	23,852	3,678.67	1189.0	1189	1,386.96	202.0	275.0	2,456.90	37.0	275	RS 0.00	0.0	RS 0.00	0.0	RS 0.00	491.0	103.47	32.0	37.52	0.0	0.0	0.0	0.0	0.0	0.0	0.0	0.0	0.0	0.0	0.0	7,667.34	24,841.00	7,667.34				
Jul-10	2010/6/7	167,107	32	29,398	29,398	4,572.37	1190.0	1190	1,388.07	204.0	275.0	2,462.86	149.0	275	RS 0.00	0.0	RS 0.00	0.0	RS 0.00	1,166.0	181.35	14.0	16.35	0.0	0.0	0.0	0.0	0.0	0.0	0.0	0.0	0.0	0.0	0.0	8,620.96	30,588.00	8,620.96				
Aug-10	2010/7/5	314,735	28	45,166	45,166	7,607.30	4162.0	4162	5,106.51	209.0	275.0	2,577.71	195.0	275	RS 0.00	0.0	RS 0.00	0.0	RS 0.00	1,721.0	298.29	158.0	193.84	0.0	0.0	0.0	0.0	0.0	0.0	0.0	0.0	0.0	0.0	0.0	0.0	15,783.67	49,328.00	15,783.67			
Sep-10	2010/8/6	230,276	32	37,584	37,584	6,977.67	2759.0	2759	3,029.68	199.0	275.0	2,743.40	194.0	275	RS 0.00	0.0	RS 0.00	0.0	RS 0.00	1,058.0	196.42	127.0	164.04	0.0	0.0	0.0	0.0	0.0	0.0	0.0	0.0	0.0	0.0	0.0	0.0	13,691.23	40,343.00	13,691.23			
Oct-10	2010/9/3	116,499	28	24,775	24,775	4,608.04	1394.0	1394	1,826.14	209.0	275.0	2,182.62	187.0	275	RS 0.00	0.0	RS 0.00	0.0	RS 0.00	675.0	101.20	52.0	68.12	0.0	0.0	0.0	0.0	0.0	0.0	0.0	0.0	0.0	0.0	0.0	0.0	9,396.44	26,149.00	9,396.44			
Nov-10	2010/10/6	222,527	33	34,733	34,733	6,460.18	1566.0	1566	2,051.46	241.0	275.0	2,888.87	193.0	275	RS 0.00	0.0	RS 0.00	0.0	RS 0.00	886.0	164.79	51.0	66.81	0.0	0.0	0.0	0.0	0.0	0.0	0.0	0.0	0.0	0.0	0.0	0.0	11,632.11	36,299.00	11,632.11			
Dec-10	2010/11/3	400,624	27	30,499	30,499	5,672.68	1817.0	1817	2,380.27	206.0	275.0	2,771.56	206.0	275	RS 0.00	0.0	RS 0.00	0.0	RS 0.00	713.0	132.61	38.0	49.78	0.0	0.0	0.0	0.0	0.0	0.0	0.0	0.0	0.0	0.0	0.0	0.0	0.0	11,606.96	32,319.00	11,606.96		
Jan-11	2010/12/3	271,639	30	39,226	39,226	6,703.99	1606.0	1,606	2,062.09	251.0	275.0	2,922.39	136.0	275	0.0	0.0	0.0	0.0	0.0	1,469.0	251.06	93.0	119.41	0.0	0.0	0.0	0.0	0.0	0.0	0.0	0.0	0.0	0.0	0.0	0.0	0.0	12,058.94	40,832.00	12,058.94		
Feb-11	2011/1/3	465,678	31	58,536	58,536	10,004.21	5196.0	5,196	6,671.63	334.0	275.0	3,002.82	274.0	275	0.0	0.0	334.0	2276.02	0.0	2,009.0	343.35	154.0	197.73	0.0	0.0	0.0	0.0	0.0	0.0	0.0	0.0	0.0	0.0	0.0	0.0	0.0	22,495.76	63,732.00	22,495.76		
Mar-11	2011/2/3	630,462	31	40,154	40,154	6,862.66	4797.0	4,797	6,159.32	254.0	275.0	2,932.44	217.0	275	0.0	0.0	0.0	0.0	0.0	10,951.0	1,871.60	181.0	234.3	0.0	0.0	0.0	0.0	0.0	0.0	0.0	0.0	0.0	0.0	0.0	0.0	0.0	20,160.26	45,951.00	20,160.26		
Apr-11	2011/3/3	282,077	28	15,120	15,120	2,584.11	1689.0	1,689	2,168.64	92.0	400.0	3,335.44	68.0	400	0.0	0.0	0.0	0.0	0.0	7,474.0	1,267.20	104.0	176.49	0.0	0.0	0.0	0.0	0.0	0.0	0.0	0.0	0.0	0.0	0.0	0.0	0.0	0.0	9,531.90	16,809.00	9,531.90	
May-11	2011/4/4	283,220	32	29,655	29,655	5,074.13	2245.0	2,245	2,687.67	234.0	450.0	3,817.67	139.0	400	0.0	0.0	0.0	0.0	0.0	5,141.0	873.24	56.0	95.26	0.0	0.0	0.0	0.0	0.0	0.0	0.0	0.0	0.0	0.0	0.0	0.0	0.0	0.0	12,748.19	31,880.00	12,748.19	
Jun-11	2011/5/4	133,068	30	12,997	12,997	2,315.80	995.0	995	782.78	198.0	275.0	2,740.86	0.0	0.0	0.0	0.0	0.0	0.0	0.0	4,568.0	661.13	198.0	26.44	0.0	0.0	0.0	0.0	0.0	0.0	0.0	0.0	0.0	0.0	0.0	0.0	0.0	6,549.23	12,992.00	6,549.23		
Jul-11	2011/6/6	113,406	30	20,258	20,258	3,784.28	979.0	979	1,288.00	198.0	275.0	2,760.90	0.0	0.0	0.0	0.0	0.0	0.0	0.0	1,423.0	242.30	67.0	11.44	0.0	0.0	0.0	0.0	0.0	0.0	0.0	0.0	0.0	0.0	0.0	0.0	0.0	0.0	8,086.88	21,237.00	8,086.88	
Aug-11	2011/7/6	162,567	30	25,353	25,353	4,769.42	1344.0	1,344	1,788.89	200.0	275.0	2,654.99	0.0	0.0	0.0	0.0	0.0	0.0	0.0	335.0	472.74	32.0	5.84	0.0	0.0	0.0	0.0	0.0	0.0	0.0	0.0	0.0	0.0	0.0	0.0	0.0	0.0	9,511.43	26,699.00	9,511.43	
Sep-11	2011/8/5	182,732	30	24,753	24,753	4,708.30	1050.0	1,050	1,416.66	196.0	275.0	2,953.29	0.0	0.0	0.0	0.0	0.0	0.0	0.0	919.0	163.31	43.0	7.64	0.0	0.0	0.0	0.0	0.0	0.0	0.0	0.0	0.0	0.0	0.0	0.0	0.0	9,259.31	25,803.00	9,259.31		
Oct-11	2011/9/5	89,330	31	20,307	20,307	3,900.58	1082.0	1,082	1,474.18	184.0	275.0	2,945.69	0.0	0.0	0.0	0.0	0.0	0.0	0.0	869.0	155.94	50.0	8.97	0.0	0.0	0.0	0.0	0.0	0.0	0.0	0.0	0.0	0.0	0.0	0.0	0.0	8,485.36	21,389.00	8,485.36		
Nov-11	2011/10/5	173,456	30	25,063	25,063	4,814.12	2252.0	2,252	3,068.27	196.0	275.0	2,987.25	0.0	0.0	0.0	0.0	0.0	0.0	0.0	1,144.0	295.29	199.0	32.12	0.0	0.0	0.0	0.0	0.0	0.0	0.0	0.0	0.0	0.0	0.0	0.0	0.0	0.0	11,107.07	27,315.00	11,107.05	
Dec-11	2011/11/7	160,675	32	16,635	16,635	3,195.26	794.0	794	1,081.79	182.0	275.0	2,936.10	0.0	0.0	0.0	0.0	0.0	0.0	0.0	3,249.0	583.04	182.0	32.66	0.0	0.0	0.0	0.0	0.0	0.0	0.0	0.0	0.0	0.0	0.0	0.0	0.0	7,828.88	17,429.00	7,828.88		
Jan-12	2011/12/8	177,013	28	11,715	11,715	2,062.09	670.0	670	894.39	96.0	275.0	2,619.54	0.0	0.0	0.0	0.0	0.0	0.0	0.0	4,434.0	795.69	317.0	56.88	0.0	0.0	0.0	0.0	0.0	0.0	0.0	0.0	0.0	0.0	0.0	0.0	0.0	6,429.62	12,395.00	6,429.59		
Feb-12	2012/1/5	511,591	31	38,704	38,704	6,816.40	4038.0	4,038	5,300.42	321.0	275.0	3,832.46	321.0	RS 1,301.84	0.0	0.0	0.0	0.0	0.0	7,577.0	1,359.12	662.0	118.74	0.0	0.0	0.0	0.0	0.0	0.0	0.0	0.0	0.0	0.0	0.0	0.0	0.0	0.0	18,619.64	42,744.00	18,619.61	
Mar-12	2012/2/6	614,121	32	65,455	65,455	11,527.09	8371.0	8,371	11,174.45	270.0	275.0	3,262.26	270.0	RS 0.00	0.0	0.0	0.0	0.0	0.0	3,446.0	618.39	407.0	73.03	0.0	0.0	0.0	0.0	0.0	0.0	0.0	0.0	0.0	0.0	0.0	0.0	0.0	0.0	26,655.44	73,826.00	26,655.42	
Apr-12	2012/3/6	357,215	29	49,879	49,879	8,784.05	4052.0	4,052	5,409.11	279.0	279.0	3,317.96	0.0	0.0	0.0	0.0	0.0	0.0	0.0	2,311.0	41.45	7.0	1.29	0.0	0.0	0.0	0.0	0.0	0.0	0.0	0.0	0.0	0.0	0.0	0.0	0.0	0.0	0.0	17,573.83	53,931.00	17,573.82
May-12	2012/4/5	402,787	30																																						

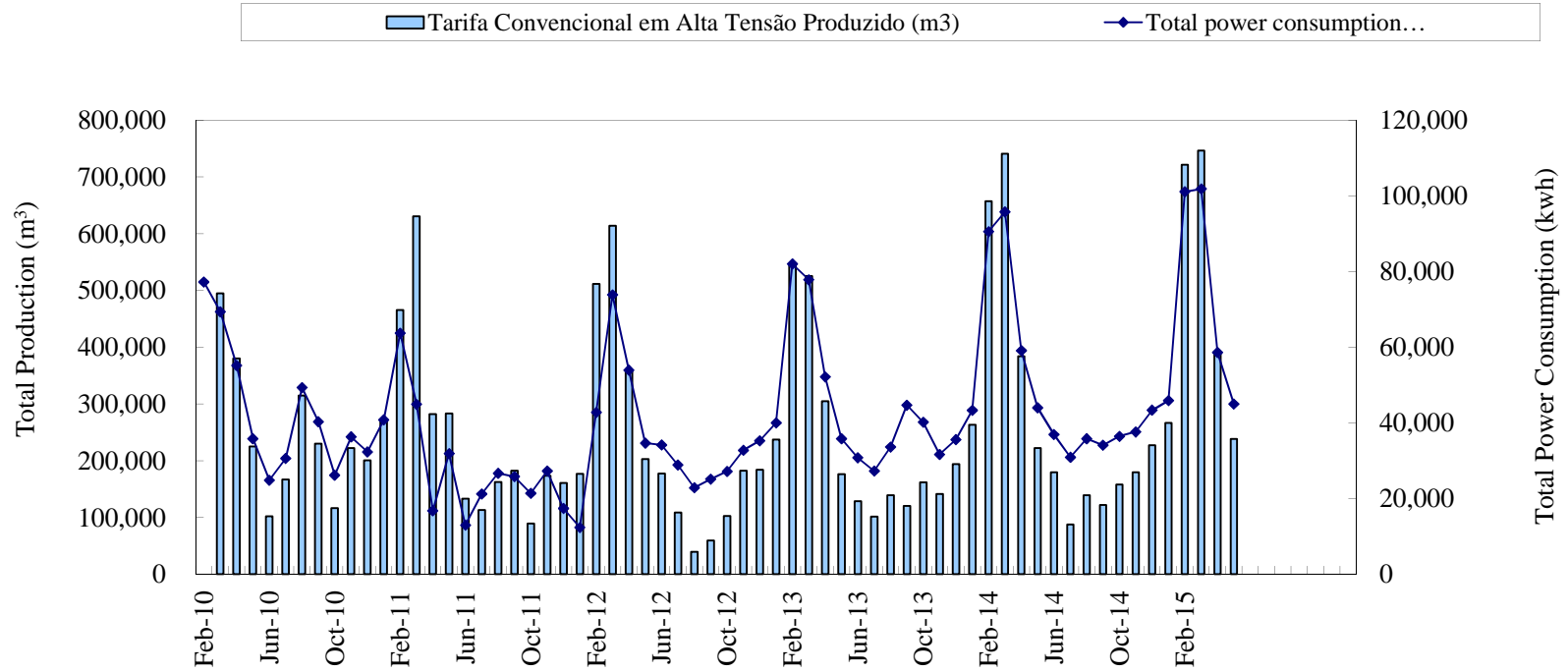

Total Production (m³) and Total Power Consumption (kWh) (2010- onward) - Praia de Leste

Power - Morretes																						
Ref.	Leitura	Produzido (m3)	Dias Cons	Consumo			Demanda			Ultrapassagem		CER		DER		Dem. Isenta ICMS(R\$)	Tx Ilum. (R\$)	Encarg	Outros (R\$)	Total (R\$)	Total power consumption (kWh)	Total billed electricity (R\$)
				Medido (kwh)	Faturado (kwh)	Importe (R\$)	Medida (kva)	Faturada (kva)	Importe (R\$)	Faturada (kva)	Importe (R\$)	Faturado (kvar)	Importe (R\$)	Faturado (kvar)	Importe (R\$)							
Feb-10	2010/1/23		31	4400	4400	1.390,09	0	0	0,00	0	0,00	0	0,00	0	0,00	0,00	30,72	0	0,00	1.420,81	4.400,00	1.420,81
Mar-10	2010/2/23	73.926,0	31	4.240	4.240	1.339,54	0	0	0,00	0	0,00	0	0,00	0	0,00	0,00	50,00	0	0,00	1.389,54	4.240,00	1.389,54
Apr-10	2010/3/23	62.996,0	28	4,080	4,080	1,288,99	0	0	0,00	0	0,00	0	0,00	0	0,00	0,00	50,00	0	0,00	1,338,99	4,080,00	1,338,99
May-10	2010/4/23	64.858,0	31	4,240	4,240	1,339,54	0	0	0,00	0	0,00	0	0,00	0	0,00	0,00	50,00	0	0,00	1,389,54	4,240,00	1,389,54
Jun-10	2010/5/23	57.274,0	30	4,200	4,200	1,326,90	0	0	0,00	0	0,00	0	0,00	0	0,00	0,00	50,00	0	0,00	1,376,90	4,200,00	1,376,90
Jul-10	2010/6/23	68.537,0	31	9,440	9,440	2,982,37	0	0	0,00	0	0,00	0	0,00	0	0,00	0,00	50,00	0	0,00	3,032,37	9,440,00	3,032,37
Aug-10	2010/7/23	59.529,0	30	3,640	3,640	1,323,32	0	0	0,00	0	0,00	0	0,00	0	0,00	0,00	50,00	0	0,00	1,373,32	3,640,00	1,373,32
Sep-10	2010/8/23	69.198,0	31	5,640	5,640	2,052,48	0	0	0,00	0	0,00	0	0,00	0	0,00	0,00	50,00	0	0,00	2,102,48	5,640,00	2,102,48
Oct-10	2010/9/23	64.990,0	31	5,360	5,360	1,952,20	0	0	0,00	0	0,00	0	0,00	0	0,00	0,00	50,00	0	0,00	2,002,20	5,360,00	2,002,20
Nov-10	2010/10/23	62.034,0	29	4,880	4,880	1,777,38	0	0	0,00	0	0,00	0	0,00	0	0,00	0,00	50,00	0	0,00	1,827,38	4,880,00	1,827,38
Dec-10	2010/11/23	64.470,0	31	5,280	5,280	1,923,07	0	0	0,00	0	0,00	0	0,00	0	0,00	0,00	50,00	0	0,00	1,973,07	5,280,00	1,973,07
Jan-11	2010/12/23	68.448,0	30	5,880	5,880	2,141,60	0	0	0,00	0	0,00	0	0,00	0	0,00	0,00	50,00	0	0,00	2,191,60	5,880,00	2,191,60
Feb-11	2011/1/23	80.732,0	31	5,360	5,360	1,952,20	0	0	0,00	0	0,00	0	0,00	0	0,00	0,00	50,00	0	0,00	2,002,20	5,360,00	2,002,20
Mar-11	2011/2/23	77.256,0	31	5,520	5,520	2,010,48	0	0	0,00	0	0,00	0	0,00	0	0,00	0,00	50,00	0	0,00	2,060,48	5,520,00	2,060,48
Apr-11	2011/3/23	66.180,0	28	8,120	8,120	2,958,80	0	0	0,00	0	0,00	0	0,00	0	0,00	0,00	50,00	0	0,00	3,008,80	8,120,00	3,008,80
May-11	2011/4/23	75.896,0	31	5,640	5,640	2,063,01	0	0	0,00	0	0,00	0	0,00	0	0,00	0,00	50,00	0	-231,22	1,881,79	5,640,00	1,881,79
Jun-11	2011/5/20	65.375,0	27	5,760	5,760	2,106,93	0	0	0,00	0	0,00	0	0,00	0	0,00	0,00	50,00	0	-37,95	2,118,98	5,760,00	2,118,98
Jul-11	2011/6/21	72.737,0	32	5,880	5,880	2,150,82	0	0	0,00	0	0,00	0	0,00	0	0,00	0,00	50,00	0	0,00	2,200,82	5,880,00	2,200,82
Aug-11	2011/7/21	67.965,0	30	2,520	2,520	948,27	0	0	0,00	0	0,00	0	0,00	0	0,00	0,00	50,00	0	0,00	998,27	2,520,00	998,27
Sep-11	2011/8/22	74.873,0	32	5,480	5,480	2,082,92	0	0	0,00	0	0,00	0	0,00	0	0,00	0,00	50,00	0	0,00	2,132,92	5,480,00	2,132,92
Oct-11	2011/9/22	67.601,0	31	5,480	5,480	2,090,60	0	0	0,00	0	0,00	0	0,00	0	0,00	0,00	50,00	0	0,00	2,140,60	5,480,00	2,140,60
Nov-11	2011/10/24	65.228,0	31	5,480	5,480	2,090,60	0	0	0,00	0	0,00	0	0,00	0	0,00	0,00	50,00	0	0,00	2,140,60	5,480,00	2,140,60
Dec-11	2011/11/22	70.343,0	29	3,000	3,000	1,144,49	0	0	0,00	0	0,00	0	0,00	0	0,00	0,00	50,00	0	0,00	1,194,49	3,000,00	1,194,49
Jan-12	2011/12/20	63.223,0	28	5,360	5,360	2,044,82	0	0	0,00	0	0,00	0	0,00	0	0,00	0,00	50,00	0	0,00	2,094,82	5,360,00	2,094,82
Feb-12	2012/1/20	76.078,0	31	5,320	5,320	2,029,56	0	0	0,00	0	0,00	0	0,00	0	0,00	0,00	50,00	0	0,00	2,079,56	5,320,00	2,079,56
Mar-12	2012/2/18	73.368,0	29	1,280	1,280	488,31	0	0	0,00	0	0,00	904	162,22	0	0,00	0,00	50,00	0	0,00	700,54	1,280,00	700,53
Apr-12	2012/3/21	85.769,0	32	4,960	4,960	1,892,22	0	0	0,00	0	0,00	0	0,00	0	0,00	0,00	50,00	0	-23,78	1,918,44	4,960,00	1,918,44
May-12	2012/4/20	79.105,0	30	4,680	4,680	1,785,40	0	0	0,00	0	0,00	0	0,00	0	0,00	0,00	50,00	0	0,00	1,835,40	4,680,00	1,835,40
Jun-12	2012/5/22	78.141,0	32	5,320	5,320	2,029,56	0	0	0,00	0	0,00	245	43,96	0	0,00	0,00	50,00	0	0,00	2,123,53	5,320,00	2,123,52
Jul-12	2012/6/20	66.018,0	29	4,560	4,560	1,739,62	0	0	0,00	0	0,00	0	0,00	0	0,00	0,00	50,00	0	-128,48	1,661,14	4,560,00	1,661,14
Aug-12	2012/7/20	69.989,0	30	4,440	4,440	1,707,55	0	0	0,00	0	0,00	0	0,00	0	0,00	0,00	50,00	0	0,00	1,757,55	4,440,00	1,757,55
Sep-12	2012/8/21	69.496,0	32	5,600	5,600	2,155,59	0	0	0,00	0	0,00	0	0,00	0	0,00	0,00	50,00	0	0,00	2,205,59	5,600,00	2,205,59
Oct-12	2012/9/20	69.646,0	30	4,640	4,640	1,786,02	0	0	0,00	0	0,00	0	0,00	0	0,00	0,00	50,00	0	0,00	1,836,02	4,640,00	1,836,02
Nov-12	2012/10/22	75.713,0	32	4,560	4,560	1,755,25	0	0	0,00	0	0,00	0	0,00	0	0,00	0,00	50,00	0	0,00	1,805,25	4,560,00	1,805,25
Dec-12	2012/11/21	79.208,0	29	8,320	8,320	3,202,59	0	0	0,00	0	0,00	0	0,00	0	0,00	0,00	50,00	0	0,00	3,252,59	8,320,00	3,252,59
Jan-13	2012/12/20	73.922,0	29	4,920	4,920	1,893,84	0	0	0,00	0	0,00	0	0,00	0	0,00	0,00	50,00	0	-12,73	1,931,11	4,920,00	1,931,11
Feb-13	2013/1/21	86.168,0	32	4,880	4,880	1,862,17	0	0	0,00	0	0,00	0	0,00	0	0,00	0,00	50,00	0	0,00	1,912,17	4,880,00	1,912,17
Mar-13	2013/2/20	77.978,0	30	600	600	188,78	0	0	0,00	0	0,00	0	0,00	0	0,00	0,00	28,31	0	-191,21	25,88	600,00	25,88
Apr-13	2013/3/21	67.497,0	29	4,800	4,800	1,488,35	0	0	0,00	0	0,00	0	0,00	0	0,00	0,00	50,00	0	0,00	1,538,35	4,800,00	1,538,35
May-13	2013/4/19	47.380,0	29	5,920	5,920	1,835,64	0	0	0,00	0	0,00	0	0,00	0	0,00	0,00	50,00	0	0,00	1,885,64	5,920,00	1,885,64
Jun-13	2013/5/21	88.938,0	32	7,680	7,680	2,381,37	0	0	0,00	0	0,00	0	0,00	0	0,00	0,00	50,00	0	0,00	2,431,37	7,680,00	2,431,37
Jul-13	2013/6/20	72.622,0	30	5,080	5,080	1,559,30	0	0	0,00	0	0,00	0	0,00	0	0,00	0,00	50,00	0	0,00	1,609,30	5,080,00	1,609,30
Aug-13	2013/7/22	74.126,0	32	5,120	5,120	1,709,66	0	0	0,00	0	0,00	0	0,00	0	0,00	0,00	50,00	0	0,00	1,759,66	5,120,00	1,759,66
Sep-13	2013/8/19	65.118,0	28	12,640	12,640	4,258,01	0	0	0,00	0	0,00	0	0,00	0	0,00	0,00	50,00	0	0,00	4,308,01	12,640,00	4,308,01
Oct-13	2013/9/18	74.991,0	30	5,760	5,760	1,940,36	0	0	0,00	0	0,00	0	0,00	0	0,00	0,00	50,00	0	-157,38	1,832,98	5,760,00	1,832,98
Nov-13	2013/10/18	80.187,0	30	5,760	5,760	1,940,36	0	0	0,00	0	0,00	0	0,00	0	0,00	0,00	50,00	0	0,00	1,990,36	5,760,00	1,990,36
Dec-13	2013/11/19	89.482,0	31	5,960	5,960	2,007,73	0	0	0,00	0	0,00	0	0,00	0	0,00	0,00	50,00	0	-36,49	2,021,24	5,960,00	2,021,24
Jan-14	2013/12/18	81.552,0	29	5,760	5,760	1,940,36	0	0	0,00	0	0,00	0	0,00	0	0,00	0,00	50,00	0	0,00	1,990,36	5,760,00	1,990,36
Feb-14	2014/1/17	86.119,0	30	8,320	8,320	2,802,74	0	0	0,00	0	0,00	1683	353,98	0	0,00	0,00	50,00	0	0,00	3,206,73	8,320,00	3,206,72
Mar-14	2014/2/18	90.632,0	32	6,120	6,120	2,061,63	0	0	0,00	0	0,00	0	0,00	0	0,00	0,00	50,00	0	-126,57	1,985,06	6,120,00	1,985,06
Apr-14	2014/3/19	79.729,0	29	6,560	6,560	2,209,85	0	0	0,00	0	0,00	0	0,00	0	0,00	0,00	50,00	0	0,00	2,259,85	6,560,00	2,259,85
May-14	2014/4/16	77.731,0	28	7,560	7,560	2,546,72	0	0	0,00	0	0,00	881	185,30	0	0,00	0,00	0,00	0	-0,35	2,731,67	7,560,00	2,731,67
Jun-14	2014/5/19	95.150,0	33	6,880	6,880	2,317,65	0	0	0,00	0	0,00	0	0,00	0	0,00	0,00	0,00	0	0,00	2,317,65	6,880,00	2,317,65
Jul-14	2014/6/17	78.770,0	29	6,800	6,800	2,290,70	0	0	0,00	0	0,00	0	0,00	0	0,00	0,00	0	0	0,00	2,290,70	6,800,00	2,290,70
Aug-14	2014/7/17	83.220,0	30	4,920	4,920	1,657,39	0															

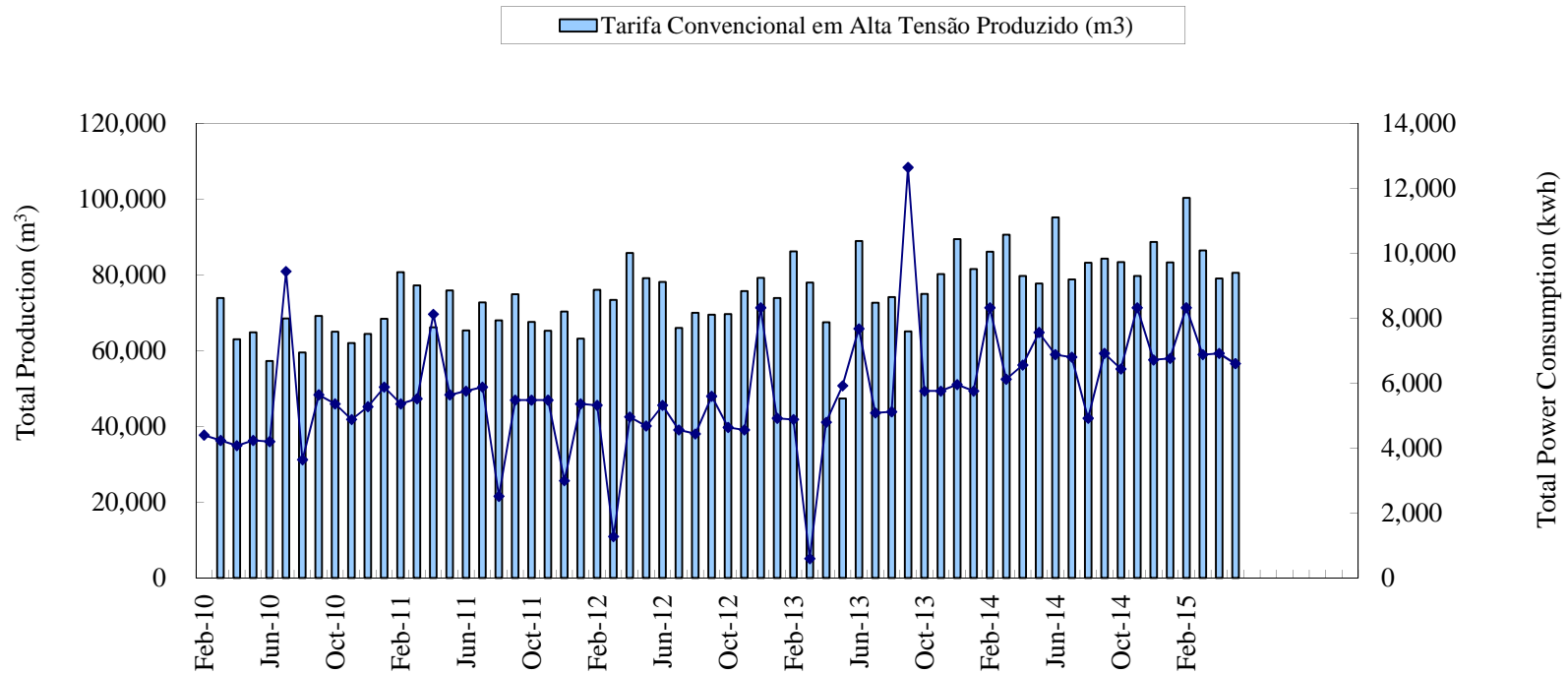

Total Production (m³) and Total Power Consumption (kWh) (2010- onward) - Morretes

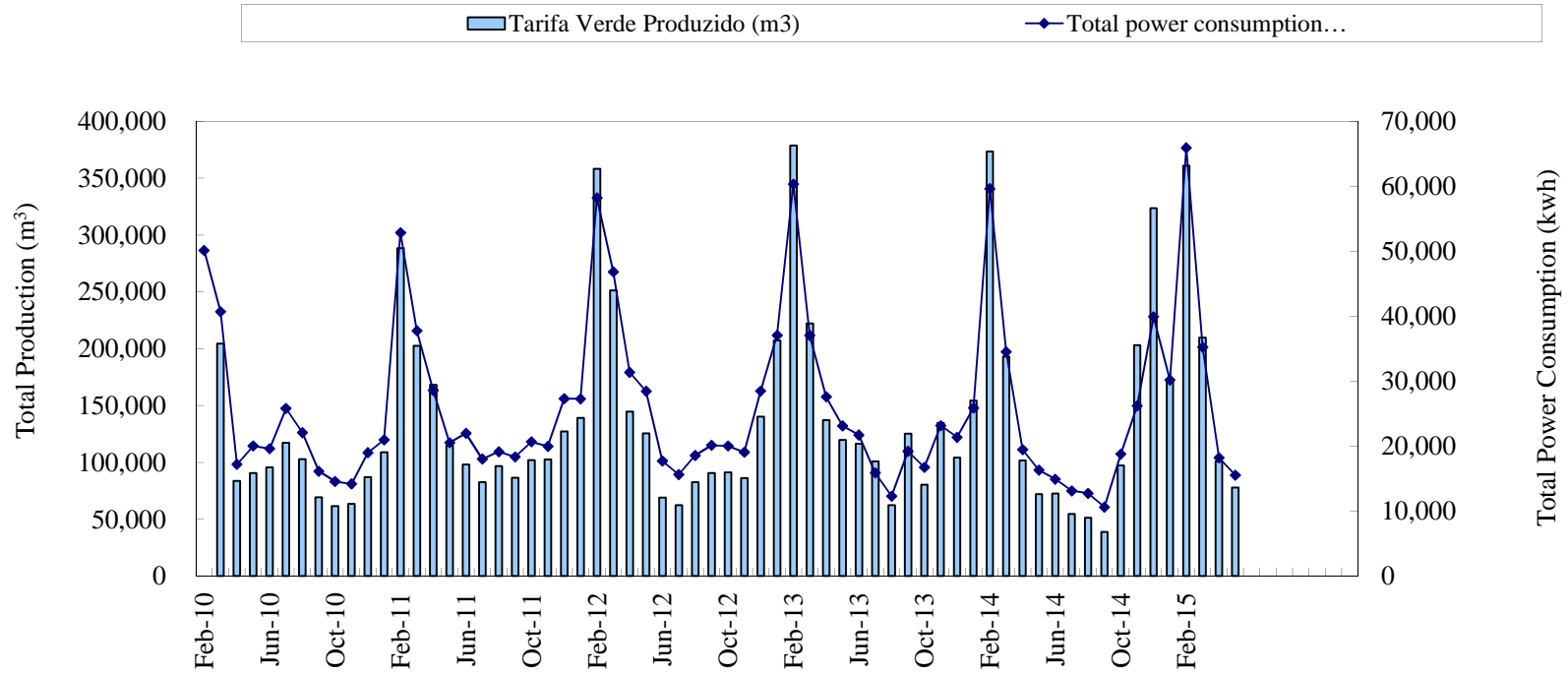

Total Production (m³) and Total Power Consumption (kWh) (2010- onward) - Saíguaçu

Power - Guaraquecaba

Ref.	Leitura	Produzido (m3)	Dias Cons	Consumo			Demanda			Ultrapassagem		CER		DER		Dem. Isenta ICMS(R\$)	Tx Ilum. (R\$)	Encarg	Outros (R\$)	Total (R\$)	Total power consumption (kWh)	Total billed electricity (R\$)
				Medido (kwh)	Faturado (kwh)	Importe (R\$)	Medida (kva)	Faturada (kva)	Importe (R\$)	Faturada (kva)	Importe (R\$)	Faturado (kvar)	Importe (R\$)	Faturado (kvar)	Importe (R\$)							
Jan-10																					0.00	0.00
Feb-10	2010/1/14		31	1,320	1,320	R\$ 417.02	0	0	R\$ 0.00	0	R\$ 0.00	0	R\$ 0.00	0	R\$ 0.00	0	R\$ 0.00	0	R\$ 0.00	R\$ 417.02	1,320.00	417.02
Mar-10	2010/2/14	14,517.0	31	1,240	1,240	R\$ 391.75	0	0	R\$ 0.00	0	R\$ 0.00	0	R\$ 0.00	0	R\$ 0.00	0	R\$ 0.00	0	R\$ 0.00	R\$ 391.75	1,240.00	391.75
Apr-10	2010/3/15	14,376.0	29	1,400	1,400	R\$ 442.30	0	0	R\$ 0.00	0	R\$ 0.00	0	R\$ 0.00	0	R\$ 0.00	0	R\$ 0.00	0	-R\$ 1.96	R\$ 440.34	1,400.00	440.34
May-10	2010/4/16	15,200.0	32	1,240	1,240	R\$ 391.75	0	0	R\$ 0.00	0	R\$ 0.00	0	R\$ 0.00	0	R\$ 0.00	0	R\$ 0.00	0	-R\$ 0.44	R\$ 391.31	1,240.00	391.31
Jun-10	2010/5/18	14,671.0	32	1,000	1,000	R\$ 315.92	0	0	R\$ 0.00	0	R\$ 0.00	0	R\$ 0.00	0	R\$ 0.00	0	R\$ 0.00	0	-R\$ 2.59	R\$ 313.33	1,000.00	313.33
Jul-10	2010/6/18	15,001.0	31	960	960	R\$ 303.29	0	0	R\$ 0.00	0	R\$ 0.00	0	R\$ 0.00	0	R\$ 0.00	0	R\$ 0.00	0	R\$ 0.00	R\$ 303.29	960.00	303.29
Aug-10	2010/7/18	14,336.0	30	1,200	1,200	R\$ 426.73	0	0	R\$ 0.00	0	R\$ 0.00	0	R\$ 0.00	0	R\$ 0.00	0	R\$ 0.00	0	R\$ 0.00	R\$ 426.73	1,200.00	426.73
Sep-10	2010/8/18	11,526.0	31	1,480	1,480	R\$ 538.43	0	0	R\$ 0.00	0	R\$ 0.00	0	R\$ 0.00	0	R\$ 0.00	0	R\$ 0.00	0	R\$ 0.00	R\$ 538.43	1,480.00	538.43
Oct-10	2010/9/18	11,023.0	31	1,320	1,320	R\$ 480.76	0	0	R\$ 0.00	0	R\$ 0.00	0	R\$ 0.00	0	R\$ 0.00	0	R\$ 0.00	0	R\$ 0.00	R\$ 480.76	1,320.00	480.76
Nov-10	2010/10/18	10,217.0	29	1,200	1,200	R\$ 437.06	0	0	R\$ 0.00	0	R\$ 0.00	0	R\$ 0.00	0	R\$ 0.00	0	R\$ 0.00	0	R\$ 0.00	R\$ 437.06	1,200.00	437.06
Dec-10	2010/11/18	11,395.0	31	1,040	1,040	R\$ 378.78	0	0	R\$ 0.00	0	R\$ 0.00	0	R\$ 0.00	0	R\$ 0.00	0	R\$ 0.00	0	R\$ 0.00	R\$ 378.78	1,040.00	378.78
Jan-11	2010/12/18	11,442.0	30	1,240	1,240	R\$ 451.63	0	0	R\$ 0.00	0	R\$ 0.00	0	R\$ 0.00	0	R\$ 0.00	0	R\$ 0.00	0	R\$ 0.00	R\$ 451.63	1,240.00	451.63
Feb-11	2011/1/18	14,045.0	31	1,440	1,440	R\$ 524.47	0	0	R\$ 0.00	0	R\$ 0.00	0	R\$ 0.00	0	R\$ 0.00	0	R\$ 0.00	0	-R\$ 25.68	R\$ 498.79	1,440.00	498.79
Mar-11	2011/2/18	12,387.0	31	1,320	1,320	R\$ 480.76	0	0	R\$ 0.00	0	R\$ 0.00	0	R\$ 0.00	0	R\$ 0.00	0	R\$ 0.00	0	-R\$ 54.71	R\$ 426.05	1,320.00	426.05
Apr-11	2011/3/18	11,989.0	28	1,120	1,120	R\$ 407.92	0	0	R\$ 0.00	0	R\$ 0.00	0	R\$ 0.00	0	R\$ 0.00	0	R\$ 0.00	0	-R\$ 121.66	R\$ 286.26	1,120.00	286.26
May-11	2011/4/18	12,977.0	31	920	920	R\$ 336.42	0	0	R\$ 0.00	0	R\$ 0.00	0	R\$ 0.00	0	R\$ 0.00	0	R\$ 0.00	0	R\$ 0.00	R\$ 336.42	920.00	336.42
Jun-11	2011/5/17	11,050.0	29	960	960	R\$ 351.15	0	0	R\$ 0.00	0	R\$ 0.00	0	R\$ 0.00	0	R\$ 0.00	0	R\$ 0.00	0	-R\$ 73.37	R\$ 277.78	960.00	277.78
Jul-11	2011/6/16	10,822.0	30	1,120	1,120	R\$ 409.68	0	0	R\$ 0.00	0	R\$ 0.00	0	R\$ 0.00	0	R\$ 0.00	0	R\$ 0.00	0	R\$ 0.00	R\$ 409.68	1,120.00	409.68
Aug-11	2011/7/18	11,411.0	32	1,160	1,160	R\$ 434.52	0	0	R\$ 0.00	0	R\$ 0.00	0	R\$ 0.00	0	R\$ 0.00	0	R\$ 0.00	0	R\$ 0.00	R\$ 434.52	1,160.00	434.52
Sep-11	2011/8/17	10,912.0	30	1,080	1,080	R\$ 409.92	0	0	R\$ 0.00	0	R\$ 0.00	0	R\$ 0.00	0	R\$ 0.00	0	R\$ 0.00	0	R\$ 0.00	R\$ 409.92	1,080.00	409.92
Oct-11	2011/9/19	12,773.0	33	1,240	1,240	R\$ 473.05	0	0	R\$ 0.00	0	R\$ 0.00	0	R\$ 0.00	0	R\$ 0.00	0	R\$ 0.00	0	R\$ 0.00	R\$ 473.05	1,240.00	473.05
Nov-11	2011/10/19	11,955.0	29	1,080	1,080	R\$ 412.01	0	0	R\$ 0.00	0	R\$ 0.00	0	R\$ 0.00	0	R\$ 0.00	0	R\$ 0.00	0	R\$ 0.00	R\$ 412.01	1,080.00	412.01
Dec-11	2011/11/18	11,731.0	30	1,080	1,080	R\$ 412.01	0	0	R\$ 0.00	0	R\$ 0.00	0	R\$ 0.00	0	R\$ 0.00	0	R\$ 0.00	0	R\$ 0.00	R\$ 412.01	1,080.00	412.01
Jan-12	2011/12/16	10,796.0	28	880	880	R\$ 335.71	0	0	R\$ 0.00	0	R\$ 0.00	0	R\$ 0.00	0	R\$ 0.00	0	R\$ 0.00	0	-R\$ 8.27	R\$ 327.44	880.00	327.44
Feb-12	2012/1/17	13,451.0	32	1,240	1,240	R\$ 473.05	0	0	R\$ 0.00	0	R\$ 0.00	0	R\$ 0.00	0	R\$ 0.00	0	R\$ 0.00	0	R\$ 0.00	R\$ 473.05	1,240.00	473.05
Mar-12	2012/2/15	12,104.0	29	1,120	1,120	R\$ 427.27	0	0	R\$ 0.00	0	R\$ 0.00	0	R\$ 0.00	0	R\$ 0.00	0	R\$ 0.00	0	-R\$ 20.12	R\$ 407.15	1,120.00	407.15
Apr-12	2012/3/16	14,094.0	30	1,080	1,080	R\$ 412.01	0	0	R\$ 0.00	0	R\$ 0.00	0	R\$ 0.00	0	R\$ 0.00	0	R\$ 0.00	0	R\$ 0.00	R\$ 412.01	1,080.00	412.01
May-12	2012/4/17	13,038.0	32	1,000	1,000	R\$ 381.49	0	0	R\$ 0.00	0	R\$ 0.00	0	R\$ 0.00	0	R\$ 0.00	0	R\$ 0.00	0	R\$ 0.00	R\$ 381.49	1,000.00	381.49
Jun-12	2012/5/17	11,431.0	30	840	840	R\$ 320.45	0	0	R\$ 0.00	0	R\$ 0.00	0	R\$ 0.00	0	R\$ 0.00	0	R\$ 0.00	0	R\$ 0.00	R\$ 320.45	840.00	320.45
Jul-12	2012/6/16	11,189.0	30	880	880	R\$ 335.71	0	0	R\$ 0.00	0	R\$ 0.00	0	R\$ 0.00	0	R\$ 0.00	0	R\$ 0.00	0	R\$ 0.00	R\$ 335.71	880.00	335.71
Aug-12	2012/7/17	11,871.0	31	800	800	R\$ 307.32	0	0	R\$ 0.00	0	R\$ 0.00	0	R\$ 0.00	0	R\$ 0.00	0	R\$ 0.00	0	R\$ 0.00	R\$ 307.32	800.00	307.32
Sep-12	2012/8/16	12,344.0	30	560	560	R\$ 215.55	0	0	R\$ 0.00	0	R\$ 0.00	39	R\$ 7.96	0	R\$ 0.00	0	R\$ 0.00	0	-R\$ 11.61	R\$ 203.94	560.00	203.94
Oct-12	2012/9/16	13,119.0	31	1,000	1,000	R\$ 384.90	0	0	R\$ 0.00	0	R\$ 0.00	0	R\$ 0.00	0	R\$ 0.00	0	R\$ 0.00	0	R\$ 0.00	R\$ 384.90	1,000.00	384.90
Nov-12	2012/10/17	12,943.0	31	1,040	1,040	R\$ 400.30	0	0	R\$ 0.00	0	R\$ 0.00	0	R\$ 0.00	0	R\$ 0.00	0	R\$ 0.00	0	R\$ 0.00	R\$ 400.30	1,040.00	400.30
Dec-12	2012/11/16	12,704.0	30	1,280	1,280	R\$ 492.70	0	0	R\$ 0.00	0	R\$ 0.00	0	R\$ 0.00	0	R\$ 0.00	0	R\$ 0.00	0	R\$ 0.00	R\$ 492.70	1,280.00	492.70
Jan-13	2012/12/16	13,189.0	30	1,360	1,360	R\$ 523.50	0	0	R\$ 0.00	0	R\$ 0.00	0	R\$ 0.00	0	R\$ 0.00	0	R\$ 0.00	0	R\$ 0.00	R\$ 523.50	1,360.00	523.50
Feb-13	2013/1/16	15,590.0	31	1,520	1,520	R\$ 581.38	0	0	R\$ 0.00	0	R\$ 0.00	0	R\$ 0.00	0	R\$ 0.00	0	R\$ 0.00	0	R\$ 0.00	R\$ 581.38	1,520.00	581.38
Mar-13	2013/2/16	14,682.0	31	1,400	1,400	R\$ 455.79	0	0	R\$ 0.00	0	R\$ 0.00	0	R\$ 0.00	0	R\$ 0.00	0	R\$ 0.00	0	-R\$ 41.20	R\$ 414.59	1,400.00	414.59
Apr-13	2013/3/17	12,518.0	29	1,440	1,440	R\$ 446.50	0	0	R\$ 0.00	0	R\$ 0.00	0	R\$ 0.00	0	R\$ 0.00	0	R\$ 0.00	0	R\$ 0.00	R\$ 446.50	1,440.00	446.50
May-13	2013/4/15	12,268.0	29	1,200	1,200	R\$ 372.08	0	0	R\$ 0.00	0	R\$ 0.00	0	R\$ 0.00	0	R\$ 0.00	0	R\$ 0.00	0	-R\$ 111.45	R\$ 260.63	1,200.00	260.63
Jun-13	2013/5/15	13,578.0	30	1,160	1,160	R\$ 359.68	0	0	R\$ 0.00	0	R\$ 0.00	0	R\$ 0.00	0	R\$ 0.00	0	R\$ 0.00	0	-R\$ 102.29	R\$ 257.39	1,160.00	257.39
Jul-13	2013/6/16	14,391.0	32	1,160	1,160	R\$ 356.96	0	0	R\$ 0.00	0	R\$ 0.00	0	R\$ 0.00	0	R\$ 0.00	0	R\$ 0.00	0	R\$ 0.00	R\$ 356.96	1,160.00	356.96
Aug-13	2013/7/17	13,746.0	31	1,120	1,120	R\$ 369.33	0	0	R\$ 0.00	0	R\$ 0.00	0	R\$ 0.00	0	R\$ 0.00	0	R\$ 0.00	0	R\$ 0.00	R\$ 369.33	1,120.00	369.33
Sep-13	2013/8/18	11,344.0	32	920	920	R\$ 309.91	0	0	R\$ 0.00	0	R\$ 0.00	0	R\$ 0.00	0	R\$ 0.00	0	R\$ 0.00	0	R\$ 0.00	R\$ 309.91	920.00	309.91
Oct-13	2013/9/17	11,092.0	30	1,080	1,080	R\$ 363.81	0	0	R\$ 0.00	0	R\$ 0.00	0	R\$ 0.00	0	R\$ 0.00	0	R\$ 0.00	0	-R\$ 43.11	R\$ 320.70	1,080.00	320.70
Nov-13	2013/10/17	11,339.0	30	1,240	1,240	R\$ 417.71	0	0	R\$ 0.00	0	R\$ 0.00	0	R\$ 0.00	0	R\$ 0.00	0	R\$ 0.00	0	R\$ 0.00	R\$ 417.71	1,240.00	417.71
Dec-13	2013/11/19	12,369.0	32	1,320	1,320	R\$ 444.66	0	0	R\$ 0.00	0	R\$ 0.00	0	R\$ 0.00	0	R\$ 0.00	0	R\$ 0.00	0	R\$ 0.00	R\$ 444.66	1,320.00	444.66
Jan-14	2013/12/17	11,712.0	28	1,240	1,240	R\$ 417.71	0	0	R\$ 0.00	0	R\$ 0.00	0	R\$ 0.00	0	R\$ 0.00	0	R\$ 0.00	0	R\$ 0.00	R\$ 417.71	1,240.00	417.71
Feb-14	2014/1/18	16,648.0	32	1,600	1,600	R\$ 538.98	0	0	R\$ 0.00	0	R\$ 0.00	0	R\$ 0.00	0	R\$ 0.00	0	R\$ 0.00	0	R\$ 0.00	R\$ 538.98	1,600.00	538.98
Mar-14	2014/2/18	15,569.0	31	1,720	1,720	R\$ 579.41	0	0	R\$ 0.00	0	R\$ 0.00	0	R\$ 0.00	0	R\$ 0.00	0	R\$ 0.00	0	-R\$ 43.59	R\$ 535.82	1,720.00	535.82
Apr-14	2014/3/18	14,062.0	28	1,200	1,200	R\$ 404.24	0	0	R\$ 0.00	0	R\$ 0.00	0	R\$ 0.00	0	R\$ 0.00	0	R\$ 0.00	0	-R\$ 62.67	R\$ 341.57	1,200.00	341.57
May-14	2014/4/16	13,448.0	29	1,000	1,000	R\$ 336.86	0	0	R\$ 0.00	0	R\$ 0.00	0	R\$ 0.00	0	R\$ 0.00	0	R\$ 0.00	0	R\$ 0.00	R\$ 336.86	1,000.00	336.86
Jun-14	2014/5/16	14,062.0	30	880	880	R\$ 296.44	0	0	R\$ 0.00													

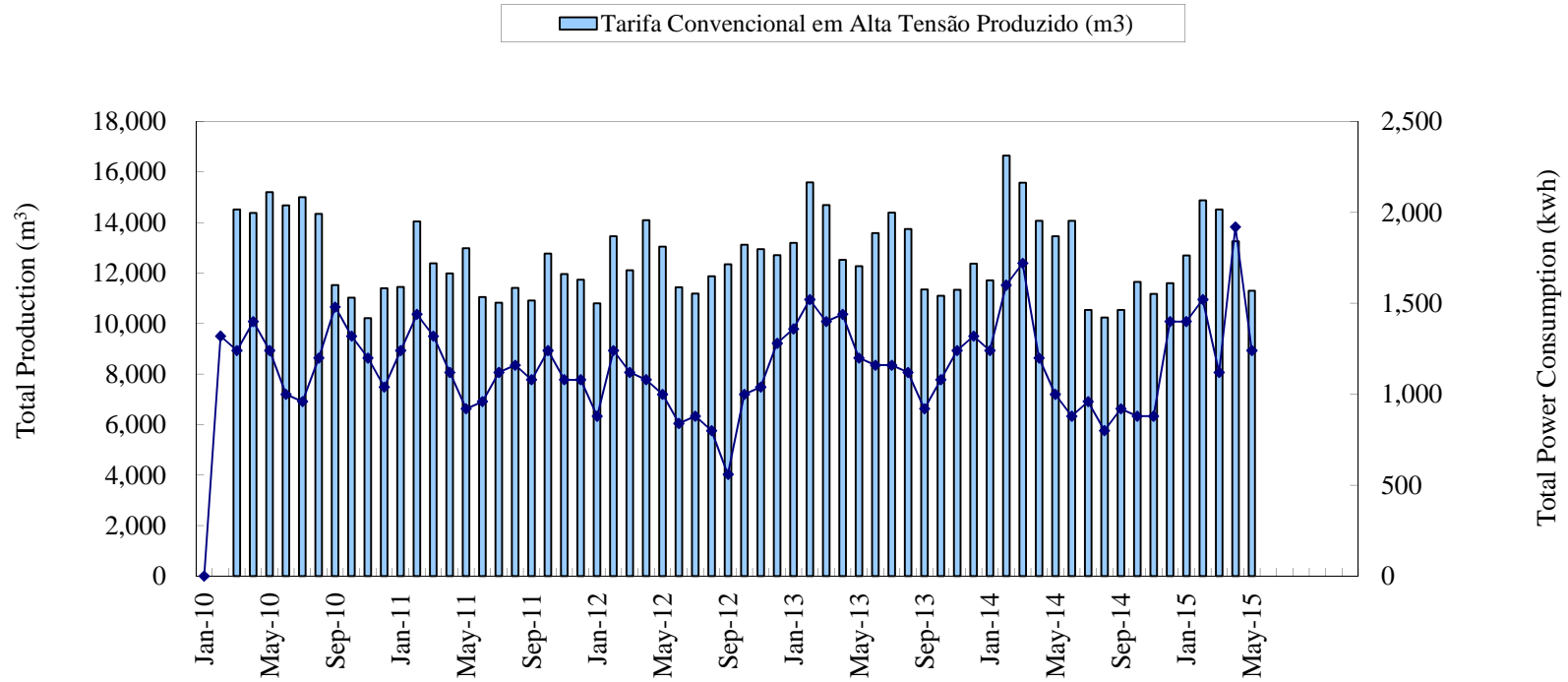

Total Production (m³) and Total Power Consumption (kWh) (2010- onward) - Guaraqueçaba

Irai Chemical Consumption

Month	Production	Total Payment																					
		SULFATO DE ALUMINIO. LIQ. (CG 12)		POLICLORETO DE ALUMINIO (CG 37)		HIDROXIDO DE CALCIO EM SUSPENSÃO 20%		CLORO LIQUIDO 900 KG (CG 16)		ACIDO FLOUSSILICICO (CG 32)		POLIMERO ANIONICO (CG 38)		POLIMERO CAT. GRAN. (CG 18A)		POLIMERO CAT. MEDIO FRACO (CG 55)		ORTO POLIFOSFATO (CG 22)		Total Payment			
		m ³	Aplicado (kg)	Custo Aplicado	Aplicado (kg)	Custo Aplicado	Aplicado (kg)	Custo Aplicado	Aplicado (kg)	Custo Aplicado	Aplicado (kg)	Custo Aplicado	Aplicado (kg)	Custo Aplicado	Aplicado (kg)	Custo Aplicado	Aplicado (kg)	Custo Aplicado	Aplicado (kg)	Custo Aplicado	R\$	R\$/m3	
Jan-10	Jan	5,967,600	397,461	106,758			341,952	133,361	18,900	75,600	28,403	6,626	301	2,519			478	4,417	3,613	45,159	374,440	0.06274557	
Feb-10	Feb	5,560,150	360,878	96,932			322,437	132,199	25,200	100,800	23,028	7,408	395	3,301			359	3,323	3,363	19,036	362,998	0.06528570	
Mar-10	Mar	6,309,650	369,077	118,105			359,929	140,372	18,900	68,229	26,369	8,483	406	3,397			494	4,567	3,821	22,162	365,314	0.05789770	
Apr-10	Apr	5,973,152	335,719	108,001			309,237	126,787	18,900	75,600	25,901	6,043	267	2,236			317	2,932	3,311	18,736	340,336	0.05697760	
May-10	May	6,089,168	344,309	110,764			309,049	126,710	18,900	75,600	23,286	5,433	229	1,371			378	3,497	3,483	19,679	343,053	0.05633830	
Jun-10	Jun	5,824,800	250,518	80,166			205,451	80,126	19,638	70,893	22,100	10,100	251	2,100			365	3,373	3,377	42,213	288,971	0.04961038	
Jul-10	Jul	5,954,673	246,241	79,216			247,823	101,607	19,649	78,596	22,990	5,364	40	238			567	5,243	3,373	22,092	292,356	0.04909685	
Aug-10	Aug	6,145,960	270,541	87,033			225,788	92,573	19,771	79,084	23,439	10,711	197	1,181			434	4,014	3,431	19,421	294,017	0.04783911	
Sep-10	Sep	5,713,043	242,959	78,160			213,583	87,569	20,747	87,967	23,188	8,278	275	1,652			429	3,967	678	3,837	271,431	0.04751074	
Oct-10	Oct	5,705,750	205,007	65,951	42,056	24,199	172,486	70,719	19,898	84,368	22,664	8,091	287	1,721			242	2,243		0	257,292	0.04509338	
Nov-10	Nov	5,806,023			234,725	135,061	82,962	34,014	19,193	81,378	21,843	7,798	320	1,920			223	2,059		508	2,877	0.04566074	
Dec-10	Dec	6,044,328	274,292	88,240	28,433	16,360	199,932	81,972	20,746	87,962	22,809	8,143	309	1,855			528	4,888		3,484	19,718	309,139	0.05114524
Jan-11	Jan	6,150,073	317,781	102,230			202,422	78,945	20,281	73,214	23,618	8,432			285	2,605		3,395	42,438	307,863	0.05005840		
Feb-11	Feb	5,977,816	273,359	87,940	16,541	9,518	151,811	62,161	18,881	80,055	23,121	8,254	800	6,693				3,362	19,028	273,649	0.04577736		
Mar-11	Mar	6,481,730	215,283	69,257			129,282	53,006	20,747	87,967	28,008	9,999	196	1,636			437	4,043	3,716	21,031	246,939	0.03809763	
Apr-11	Apr	6,244,211	232,944	74,938			133,037	54,545	18,548	78,644	27,867	9,949	192	1,606			387	3,575	3,585	20,290	243,547	0.03900362	
May-11	May	6,501,809	203,616	65,503			47,899	19,639	16,421	69,625	24,902	8,890	71	597			324	3,000	3,242	18,351	185,605	0.02864668	
Jun-11	Jun	6,248,200	209,407	67,366			56,303	23,084	16,890	71,571	22,731	8,115	129	1,078			481	4,449	2,983	192,545	192,545	0.03081600	
Jul-11	Jul	6,405,123	240,805	77,403			107,491	44,071	19,610	83,146	23,344	8,334	279	517			517	4,782	3,059	17,314	237,381	0.03706106	
Aug-11	Aug	6,361,718	251,524	80,915			118,950	48,770	17,048	72,284	29,755	10,623	232	1,938			490	4,533	83	469	218,530	0.03450792	
Sep-11	Sep	6,117,932	203,372	65,486			131,330	53,845	16,655	70,617	24,335	8,688	211	1,765			557	5,152	2,797	15,831	221,385	0.03618618	
Oct-11	Oct	6,505,352	231,360	74,498			158,294	64,901	19,420	82,341	25,482	9,097	93	778			606	5,604	3,067	17,359	254,577	0.03913352	
Nov-11	Nov	6,402,801	208,823	67,241			118,450	48,565	19,021	80,649	28,339	10,117	107	895			679	6,277	3,050	17,261	231,005	0.03607868	
Dec-11	Dec	6,751,199	247,262	79,618			189,557	77,718	23,321	98,881	29,082	10,382	136	1,140			560	5,176	3,279	18,559	291,476	0.04317392	
Jan-12	Jan	6,292,596	253,257	81,473			219,001	85,410	21,778	78,619	27,297	9,745	166	1,386			514	5,397	2,696	33,695	295,725	0.04699573	
Feb-12	Feb	6,034,681	247,716	84,223			239,302	107,447	24,989	110,201	25,292	7,469	129	805			564	5,922	3,057	14,265	330,332	0.05473890	
Mar-12	Mar	6,797,481	287,873	97,877			293,968	131,992	27,634	121,866	30,445	8,990	39	243			604	6,341	3,344	15,605	382,914	0.05633171	
Apr-12	Apr	6,247,706	284,527	96,739			235,102	105,561	22,491	99,185	29,805	8,801	170	1,063			521	5,472	3,188	14,876	331,697	0.05309097	
May-12	May	6,564,917	243,768	82,881			267,304	120,019	22,482	100,135	24,294	7,174	41	256			608	6,388	3,173	14,807	331,661	0.05052025	
Jun-12	Jun	6,066,530	282,414	96,021			269,639	121,068	17,556	78,194	24,382	7,200					510	5,355	3,114	14,531	322,369	0.05313889	
Jul-12	Jul	6,581,770	230,046	78,216			190,181	85,391	19,706	87,771	24,650	7,279					632	6,636	3,578	16,696	281,988	0.04284381	
Aug-12	Aug	6,721,260	233,412	79,360			37,138	16,675	21,419	95,400	24,400	9,943	98	609			568	5,962	4,052	60,089	268,038	0.03987915	
Sep-12	Sep	6,498,330	240,289	81,698			179,441	80,569	19,983	89,004	24,963	10,172	160	998			499	5,240	4,026	59,704	327,385	0.05037993	
Oct-12	Oct	6,648,606	242,784	82,547			192,465	86,417	24,164	107,626	20,772	8,465	203	1,267			556	5,838	3,306	49,026	341,185	0.05131684	
Nov-12	Nov	6,251,297	144,205	60,350			48,360	22,536	26,386	117,523	27,694	11,285	282	2,153			280	2,940	3,434	50,925	267,712	0.04282498	
Dec-12	Dec	6,486,806	175,036	73,253			69,280	32,284	36,438	162,295	22,409	9,132	333	2,542			480	4,282	3,663	54,320	338,108	0.05212243	
Jan-13	Jan	6,448,744	247,575	70,683			51,758	24,119	31,403	142,884	23,647	9,636	601	4,589			330	2,944	3,157	46,817	301,671	0.04677980	
Feb-13	Feb	6,029,688	142,794	119,810			59,063	27,523	27,415	124,738	20,408	8,316	362	2,764			309	2,756	2,731	40,499	326,408	0.05413342	
Mar-13	Mar	6,667,265	312,955	137,124			290,881	135,551	27,471	124,993	25,836	10,812	5	38			311	2,774	3,365	17,397	428,689	0.06429759	
Apr-13	Apr	6,573,372	255,113	87,040			192,898	89,890	29,156	132,660	23,754	9,680	263	2,008			211	1,882	3,252	49,333	372,493	0.05666690	
May-13	May	6,504,984	248,025	109,229			169,037	83,504	25,569	116,339	20,972	8,546	342	2,611			208	1,855	3,196	48,483	370,568	0.05696673	
Jun-13	Jun	6,315,809	325,001	107,065			248,530	122,774	23,004	104,668	23,865	9,725	305	2,329			221	1,971	1,539	23,347	371,878	0.05888058	
Jul-13	Jul	6,696,776	323,510	165,087			227,204	112,239	19,577	89,075	24,240	9,878	331	3,661			302	2,694			382,634	0.05713699	
Aug-13	Aug	6,850,253	244,269	146,084			153,804	75,979	21,663	98,567	32,431	13,216	317	3,506			403	3,595			340,946	0.04977128	
Sep-13	Sep	6,499,290	274,948	143,239			168,954	83,463	21,418	97,452	21,247	11,452	347	3,838			163	1,454			340,898	0.05245162	
Oct-13	Oct	6,591,491	275,987	126,298			153,412	75,786	20,697	94,171	20,605	11,106	530	5,862			273	2,435			315,658	0.04788864	
Nov-13	Nov	6,450,455	320,093	169,260			147,233	72,733	17,290	78,668	20,753	11,186	440	4,866			289	2,578			339,291	0.05259961	
Dec-13	Dec	6,655,502	311,000	128,253			169,326	83,647	18,482	84,093	25,635	13,817	377	4,170			264	2,355			316,335	0.04752980	
Jan-14	Jan	6,982,200	370,202	179,374			208,990	103,241	20,830	96,860	31,818	17,150	120	1,327			252	2,245			400,197	0.05731675	
Feb-14	Feb	6,751,700	327,943	182,827			213,122	105,282	22,238	103,405	26,275	14,162	231	2,549			256	2,283			410,509	0.06080079	
Mar-14	Mar	7,105,300	335,440	136,562			229,135	113,193	23,245	108,009	26,314	14,183	172	1,546			284	2,530			376,104	0.05293142	
Apr-14	Apr	6,781,300	291,070	163,836			185,785	91,778	26,318	122,380	21,652	11,670	207	1,860			189	1,686			393,210	0.05798453	
May-14	May	7,119,418	274,925	150,394			179,099	88,475	28,774	133,799	28,185	15,192	363	3,267			256	2,281			393,408	0.05525846	
Jun-14	Jun	6,607,501	318,290	150,478			206,916	102,217	24,513	113,985	20,717	11,166	168										

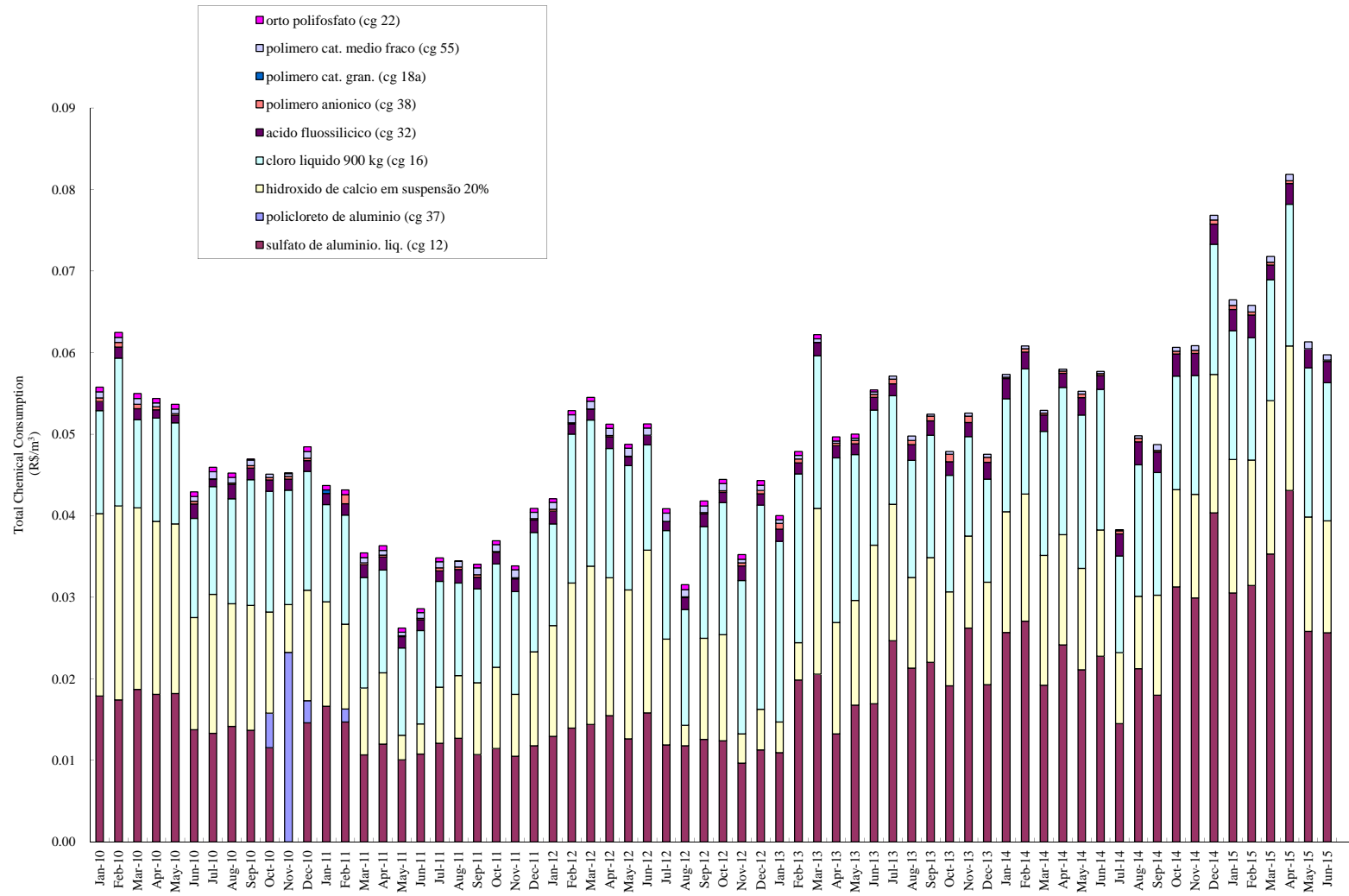

Proportion of Individual Chemical Consumption to Total Consumption (R\$/m³, 2010 - 2013) - Irai WTP

P de Leste		Chemical Consumption															Total Payment											
Month	Produção	POLIURETANO DE ALUMÍNIO - PAC			HIDRÓXIDO DE CÁLCIO			ÁCIDO FLUOSSULFÚICO			PURATE			ÁCIDO SULFÚRICO 78%			CLORO GILINDRO 800 KG			POLÍMERO AMÔNIO			BENTONITA		Total Payment			
		m ²	Aplicado (kg)	Unit price (R\$/kg)	Quanto Aplicado	Aplicado (kg)	Unit price (R\$/kg)	Quanto Aplicado	Aplicado (kg)	Unit price (R\$/kg)	Quanto Aplicado	Aplicado (kg)	Unit price (R\$/kg)	Quanto Aplicado	Aplicado (kg)	Unit price (R\$/kg)	Quanto Aplicado	Aplicado (kg)	Unit price (R\$/kg)	Quanto Aplicado	Aplicado (kg)	Unit price (R\$/kg)	Quanto Aplicado	Aplicado (kg)	Unit price (R\$/kg)	Quanto Aplicado	R\$	R\$/m ²
Jan-10	Jan	599,683	84,884	0,58	48,808	154,835	0,41	63,482	2,602	0,36	929	3,693	5,99	22,120	5,117	2,29	11,717	2,435	4,24	10,324	69	6,00	415	725	0,82	594	158,391	0,26412418
Feb-10	Feb	382,885	49,881	0,58	28,681	66,815	0,41	27,394	1,705	0,36	609	2,392	5,99	14,325	3,314	2,29	7,588	1,556	4,24	6,598	43	6,00	260	375	0,82	308	85,763	0,22395084
Mar-10	Mar	216,214	23,138	0,58	13,305	34,601	0,41	14,187	947	0,36	338	1,758	5,99	10,589	2,448	2,29	5,609	878	4,24	3,727	16	6,00	94	0	0,82	0	47,849	0,22130252
Apr-10	Apr	131,126	16,772	0,58	9,684	20,566	0,41	8,342	598	0,36	198	1,068	5,99	6,386	1,477	2,29	3,382	528	4,24	2,236	15	6,00	89	0	0,82	0	30,359	0,23819853
May-10	May	117,848	8,655	0,58	4,977	19,064	0,41	7,816	463	0,36	162	943	5,99	5,648	1,306	2,29	2,992	474	4,24	2,017	14	6,00	83	0	0,82	0	23,684	0,20105768
Jun-10	Jun	324,679	23,654	0,58	13,601	45,029	0,41	18,462	1,028	0,36	367	2,490	5,99	14,913	3,448	2,29	7,897	1,310	4,24	5,552	35	6,00	211	0	0,82	0	61,004	0,18789071
Jul-10	Jul	262,794	17,929	0,58	10,309	37,265	0,41	15,278	710	0,36	253	2,008	5,99	12,034	2,783	2,29	6,374	1,062	4,24	4,804	28	6,00	166	0	0,82	0	48,916	0,18613918
Aug-10	Aug	117,407	7,285	0,58	4,185	13,639	0,41	5,592	352	0,36	125	929	5,99	5,554	1,287	2,29	2,947	475	4,24	2,014	12	6,00	70	0	0,82	0	20,501	0,17681721
Sep-10	Sep	206,398	11,952	0,58	6,872	20,700	0,41	8,487	707	0,36	252	1,462	5,99	8,756	2,025	2,29	4,638	841	4,24	3,565	22	6,00	130	0	0,82	0	32,701	0,15843274
Oct-10	Oct	201,418	22,010	0,58	12,656	27,109	0,41	11,115	701	0,36	250	1,473	5,99	8,824	2,041	2,29	4,674	811	4,24	3,438	33	6,00	199	0	0,82	0	41,156	0,20433287
Nov-10	Nov	280,532	33,648	0,58	19,348	40,714	0,41	16,693	1,047	0,36	374	1,836	5,99	10,998	2,544	2,29	5,826	1,132	4,24	4,800	49	6,00	291	0	0,82	0	58,329	0,20792312
Dec-10	Dec	406,512	68,752	0,58	39,533	75,955	0,41	31,146	967	0,36	345	2,814	5,99	15,656	3,521	2,29	8,293	1,656	4,24	7,021	82	6,00	491	2,059	0,82	1,681	104,165	0,25924063
Jan-11	Jan	685,015	99,612	0,58	57,277	148,412	0,41	60,849	2,228	0,36	796	4,508	5,99	27,001	6,246	2,29	14,303	2,774	4,24	11,760	106	6,00	636	6,75	0,82	554	173,174	0,25280307
Feb-11	Feb	299,457	43,220	0,58	24,852	45,270	0,41	18,561	1,097	0,36	392	2,623	5,99	15,709	3,634	2,29	8,321	1,214	4,24	5,147	31	6,00	183	0	0,82	0	73,165	0,24432579
Mar-11	Mar	282,041	25,182	0,58	14,480	29,221	0,41	11,981	962	0,36	344	2,287	5,99	13,697	3,168	2,29	7,255	1,144	4,24	4,851	30	6,00	182	0	0,82	0	52,790	0,18717173
Apr-11	Apr	143,253	11,884	0,58	6,833	13,778	0,41	5,849	496	0,36	177	1,245	5,99	7,456	1,725	2,29	3,949	580	4,24	2,459	14	6,00	85	0	0,82	0	26,698	0,18574513
May-11	May	84,786	4,447	0,58	2,557	7,425	0,41	3,044	298	0,36	106	747	5,99	4,478	2,98	2,29	682	343	4,24	1,454	9	6,00	53	0	0,82	0	12,372	0,14592422
Jun-11	Jun	157,670	6,463	0,58	3,716	12,838	0,45	5,764	520	0,36	186	1,154	5,99	6,910	1,586	2,29	3,860	637	4,24	2,702	17	6,00	100	0	0,82	0	23,039	0,14611959
Jul-11	Jul	185,875	18,892	0,75	14,169	24,703	0,45	11,091	673	0,45	240	1,904	5,99	11,406	2,638	2,29	6,042	754	4,41	3,325	20	6,24	124	0	0,82	0	46,397	0,24961381
Aug-11	Aug	112,489	13,352	0,75	10,014	15,537	0,45	6,976	428	0,36	153	1,198	5,99	7,173	1,659	2,29	3,800	455	4,41	2,007	12	6,24	74	0	0,82	0	30,197	0,26843971
Sep-11	Sep	139,376	16,772	0,75	10,714	20,657	0,45	9,186	603	0,30	179	1,093	5,99	6,389	1,481	2,29	3,869	529	4,41	2,759	16	6,24	97	0	0,82	0	21,399	0,21810743
Oct-11	Oct	68,184	17,038	0,75	12,779	19,146	0,45	8,597	595	0,30	176	1,280	5,99	7,670	1,774	3,20	5,677	664	4,41	2,926	17	6,24	107	0	0,82	0	37,930	0,55629576
Nov-11	Nov	180,007	17,056	0,75	12,972	21,571	0,45	9,685	738	0,30	218	2,093	5,99	12,539	2,900	3,20	9,281	728	4,41	3,739	20	6,24	105	0	0,82	0	47,830	0,26571258
Dec-11	Dec	393,638	58,631	0,75	43,973	69,104	0,45	31,028	1,548	0,30	457	6,571	5,99	39,393	9,104	3,20	29,134	1,594	4,41	6,930	42	6,24	265	2,378	0,82	1,948	153,196	0,38898075
Jan-12	Jan	670,525	92,303	0,75	69,225	116,673	0,45	57,212	2,744	0,30	744	7,642	5,99	45,778	10,589	3,20	33,384	2,716	4,41	11,978	62	6,24	447	0	0,82	0	215,399	0,32180743
Feb-12	Feb	388,908	33,550	0,75	25,012	49,072	0,45	22,034	1,581	0,30	467	3,837	5,99	22,986	5,317	3,20	17,014	1,569	4,41	7,920	41	6,24	255	0	0,82	0	94,691	0,24354338
Mar-12	Mar	233,183	20,167	0,75	15,125	35,587	0,45	15,978	914	0,30	270	2,183	5,99	13,074	3,024	3,20	9,677	931	4,41	4,107	27	6,24	155	2,125	0,82	1,743	60,130	0,25786662
Apr-12	Apr	175,344	21,170	0,64	13,582	36,631	0,45	16,447	671	0,30	198	1,818	5,99	10,878	2,516	3,20	8,052	701	4,41	3,092	21	6,24	132	0	0,82	0	52,381	0,29874092
May-12	May	102,346	12,632	0,64	8,105	18,917	0,45	8,494	394	0,30	116	1,338	5,99	8,013	1,954	3,20	5,931	411	4,41	1,812	14	6,24	85	0	0,82	0	32,555	0,31009255
Jun-12	Jun	58,745	7,276	0,64	4,668	15,239	0,45	6,842	233	0,30	69	762	5,99	4,566	1,056	3,20	3,380	235	4,41	1,036	7	6,24	42	0	0,82	0	20,604	0,35074237
Jul-12	Jul	47,414	4,594	0,64	2,947	6,590	0,45	2,918	193	0,30	57	565	5,99	3,386	783	3,20	2,506	208	4,41	9,283	4	11,06	41	0	0,82	0	12,783	0,26961166
Aug-12	Aug	83,936	6,467	0,64	4,149	8,677	0,49	4,286	296	0,30	88	804	5,99	4,818	1,115	3,20	3,566	328	4,45	1,460	6	11,06	60	0	0,82	0	18,435	0,21962929
Sep-12	Sep	291,422	13,693	0,64	8,785	23,478	0,49	11,598	3,869	0,41	437	839	5,99	5,028	2,432	3,20	7,781	809	4,45	3,604	15	11,06	165	0	0,82	0	38,398	0,19032374
Oct-12	Oct	192,724	15,782	0,64	10,126	22,654	0,49	11,191	693	0,41	278	2,547	6,25	15,919	3,528	3,20	11,292	656	4,45	2,920	13	11,06	147	0	0,82	0	51,872	0,31877708
Nov-12	Nov	240,369	36,948	0,64	23,706	56,788	0,49	28,053	789	0,41	321	5,633	6,25	35,209	7,805	3,95	30,831	971	4,45	4,325	18	11,06	202	0	0,82	0	122,647	0,51024505
Dec-12	Dec	505,041	100,528	0,64	64,499	126,715	0,49	62,597	1,779	0,41	725	11,700	6,25	73,127	16,211	3,95	64,034	2,047	4,45	9,116	41	11,06	448	2,500	0,82	2,050	176,595	0,54766871
Jan-13	Jan	586,350	136,894	0,64	87,825	154,679	0,49	76,412	2,168	0,41	884	13,452	6,25	84,078	18,639	3,95	73,622	2,381	4,45	10,605	53	11,06	581	0	0,82	0	334,004	0,56963303
Feb-13	Feb	338,356	63,712	0,64	40,877	71,324	0,49	35,234	1,223	0,41	498	7,062	6,25	44,140	9,785	3,95	38,652	1,339	4,45	5,923	25	11,06	285	0	0,82	0	165,695	0,50944568
Mar-13	Mar	197,731	25,300	0,64	16,252	27,203	0,49	13,438	760	0,41	286	1,849	6,25	11,556	2,562	3,95	10,120	789	4,45	3,512	14	11,06	155	2,125	0,82	1,743	57,062	0,28858173
Apr-13	Apr	96,148	7,687	0,64	4,932	13,200	0,49	6,521	353	0,41	144	928	6,25	5,798	1,285	3,95	5,077	392	4,45	1,745	7	11,06	72	0	0,82	0	24,288	0,25261073
May-13	May	103,703	6,417	1,05	6,738	10,450	0,49	5,162	350	0,41	135	917	6,25	5,730	1,270	3,95	5,018	427	4,45	1,903	7	11,06	81	0	0,82	0	24,768	0,23881607
Jun-13	Jun	151,316	15,203	1,05	15,963	17,050	0,49	8,423	499	0,41	203	1,365	6,25	8,716	1,932	3,95	7,532	615	4,55	2,798	11	11,06	123	0	0,82	0	43,854	0,28982026
Jul-13	Jul	105,908	10,759	1,05	11,292	12,760	0,49	6,303	340	0,54	183	946	6,25	5,913	1,310	3,95	5,176	431</										

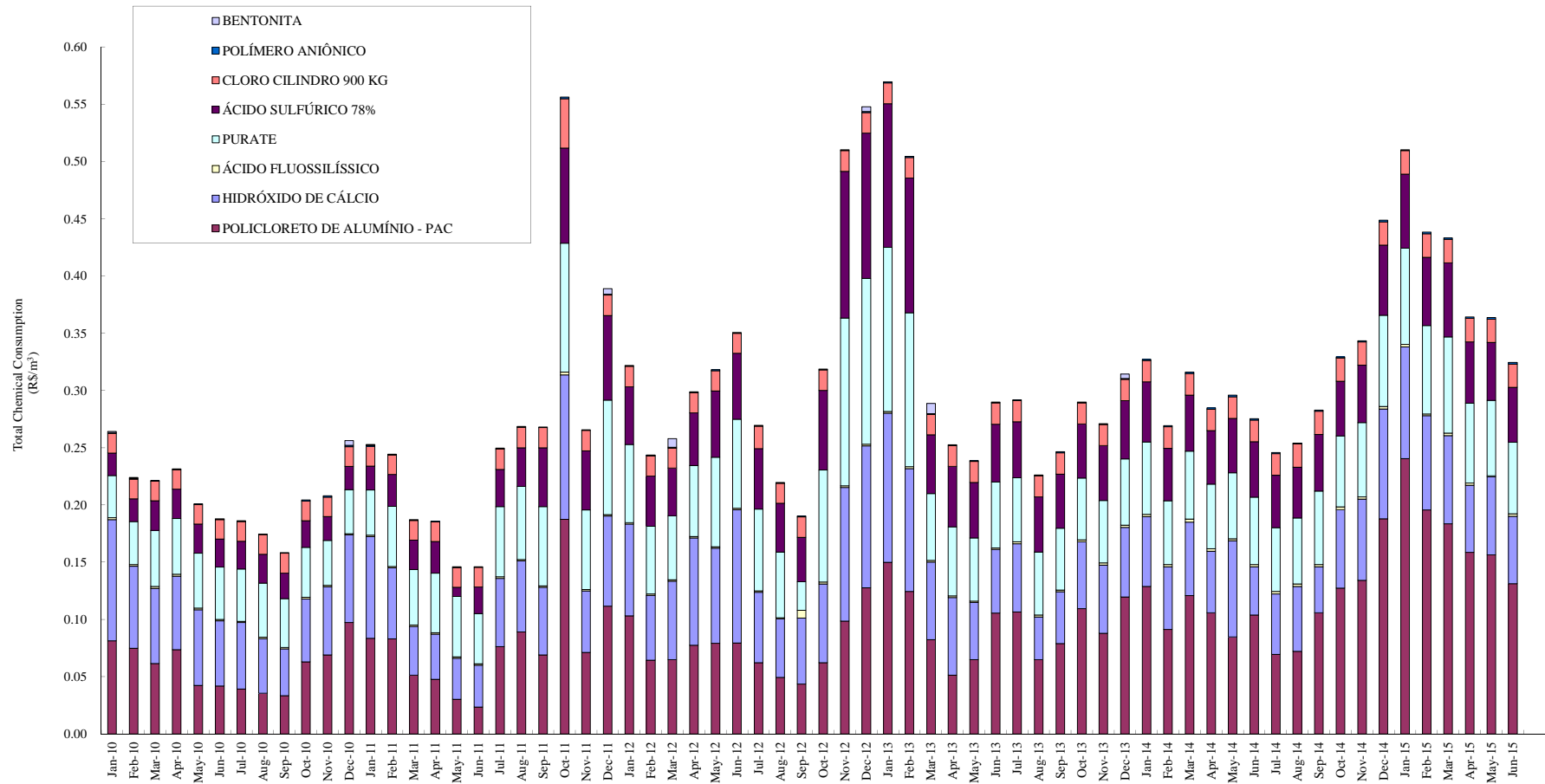

Proportion of Individual Chemical Consumption to Total Consumption (R\$/m³, 2010 - 2013) - Praia de Leste WTP

Morretes Chemical Consumption

Month	Production	POLICLORETO DE ALUMÍNIO - PAC																		FLUOSSILICATO DE SÓDIO			BARRILHA (Na2O03)			GLORETO DE SÓDIO			HIPOCAL			CLORO CILINDRO 88 KG			Total Payment	
		m ³	Aplicado (kg)	Unit price (R\$/kg)	Custo Aplicado	Aplicado (kg)	Unit price (R\$/kg)	Custo Aplicado	Aplicado (kg)	Unit price (R\$/kg)	Custo Aplicado	Aplicado (kg)	Unit price (R\$/kg)	Custo Aplicado	Aplicado (kg)	Unit price (R\$/kg)	Custo Aplicado	Aplicado (kg)	Unit price (R\$/kg)	Custo Aplicado	Aplicado (kg)	Unit price (R\$/kg)	Custo Aplicado	R\$	R\$/m ³											
Jan-10	Jan	72,389	2,182	0.58	1,255	100	3.27	327	320	1.35	431	1,875	0.46	863	180	5.49	988	0	4.84	0	3,864	0.05338186														
Feb-10	Feb	65,849	1,246	0.58	717	100	3.27	327	207	1.35	279	1,750	0.46	805	70	5.49	384	0	4.84	0	2,512	0.03815249														
Mar-10	Mar	70,683	1,902	0.58	1,093	75	3.27	245	282	1.35	379	1,475	0.46	679	50	5.49	275	0	4.84	0	2,671	0.03779310														
Apr-10	Apr	60,395	1,451	0.58	834	100	3.27	327	296	1.35	399	1,325	0.46	610	0	5.49	0	0	4.84	0	2,170	0.03592459														
May-10	May	58,287	1,333	0.58	767	75	3.27	245	239	1.35	322	1,350	0.46	621	0	5.49	0	0	4.84	0	1,955	0.03354268														
Jun-10	Jun	63,849	760	0.58	437	75	3.27	245	300	1.35	404	1,250	0.46	575	100	5.49	549	0	4.84	0	2,211	0.03462247														
Jul-10	Jul	61,738	870	0.58	500	50	3.27	164	375	1.35	506	1,200	0.46	552	50	5.49	275	0	4.84	0	1,996	0.03233163														
Aug-10	Aug	68,542	440	0.58	253	50	3.27	164	300	1.35	404	1,400	0.46	644	0	5.49	0	0	4.84	0	1,465	0.02136882														
Sep-10	Sep	62,751	641	0.58	369	75	3.27	245	325	1.35	438	1,500	0.46	690	40	5.49	220	0	4.84	0	1,962	0.03126002														
Oct-10	Oct	63,428	1,226	0.58	705	100	3.27	327	225	1.35	303	1,075	0.46	495	180	5.65	1,017	0	4.84	0	2,847	0.04488712														
Nov-10	Nov	62,633	1,638	0.58	942	135	3.27	442	375	1.35	506	425	0.46	196	190	5.65	1,074	0	4.84	0	3,158	0.05041643														
Dec-10	Dec	77,198	1,321	0.58	759	100	3.27	327	525	1.35	708	450	0.46	207	240	5.65	1,356	0	4.84	0	3,357	0.04348772														
Jan-11	Jan	77,642	2,214	0.58	1,273	100	3.27	327	550	1.35	741	350	0.46	161	370	5.65	2,091	0	4.84	0	4,593	0.05915333														
Feb-11	Feb	70,812	1,788	0.58	1,028	100	3.27	327	500	1.33	665	300	0.79	237	260	5.65	1,469	0	4.84	0	3,726	0.05262293														
Mar-11	Mar	74,654	1,867	0.58	1,074	106	3.27	347	425	1.33	565	375	0.79	296	220	5.65	1,243	0	4.84	0	3,525	0.04721786														
Apr-11	Apr	72,496	2,599	0.58	436	75	3.27	245	475	1.33	632	350	0.79	277	320	5.65	1,808	0	4.84	0	3,398	0.04687176														
May-11	May	73,915	222	0.58	300	100	3.27	327	375	1.33	499	225	0.79	178	350	5.65	1,978	0	4.84	0	3,281	0.04439248														
Jun-11	Jun	69,166	253	0.58	148	100	3.27	327	150	1.33	200	975	0.79	770	565	5.65	3,192	0	4.84	0	4,635	0.06700850														
Jul-11	Jul	68,062	567	0.75	425	125	3.27	409	100	1.33	133	0	0.79	0	540	5.65	3,051	0	4.84	0	4,018	0.05903551														
Aug-11	Aug	73,581	1,021	0.75	766	0	3.27	0	200	1.33	266	0	0.79	0	600	5.65	3,390	0	5.10	0	4,422	0.06009772														
Sep-11	Sep	63,703	686	0.75	515	100	3.27	327	150	1.33	200	0	0.79	0	460	5.65	2,599	0	5.10	0	3,640	0.05714205														
Oct-11	Oct	68,184	1,507	0.75	1,130	175	3.27	572	275	1.33	366	0	0.79	0	460	6.27	2,884	0	5.10	0	4,953	0.07263669														
Nov-11	Nov	71,632	1,382	0.75	1,036	125	3.27	409	275	1.33	366	0	0.79	0	580	6.27	3,637	0	5.10	0	5,447	0.07604667														
Dec-11	Dec	72,968	1,788	0.75	1,341	100	3.56	356	325	1.33	432	0	0.79	0	540	6.27	3,386	0	5.10	0	5,515	0.07558176														
Jan-12	Jan	74,984	3,363	0.75	2,522	150	3.56	534	475	1.33	632	0	0.79	0	600	6.27	3,762	0	5.10	0	7,450	0.09935253														
Feb-12	Feb	77,887	2,215	0.75	1,661	150	3.56	534	499	1.33	632	0	0.79	0	580	6.27	3,637	0	5.10	0	6,331	0.08127833														
Mar-12	Mar	82,521	1,503	0.75	1,128	100	3.56	356	275	1.33	366	0	0.79	0	570	6.27	3,574	0	5.10	0	5,423	0.06571903														
Apr-12	Apr	77,288	1,733	0.64	1,112	150	3.56	534	275	1.33	366	0	0.52	0	510	6.27	3,198	0	5.10	0	5,209	0.06740004														
May-12	May	70,713	1,432	0.64	919	100	3.56	356	350	1.33	466	0	0.52	0	440	6.27	2,759	0	5.10	0	4,499	0.06362620														
Jun-12	Jun	69,069	2,356	0.64	1,512	118	3.56	418	275	1.33	366	0	0.52	0	445	6.27	2,790	0	5.10	0	5,086	0.07363375														
Jul-12	Jul	89,878	712	0.64	457	125	3.56	445	200	1.33	266	0	0.52	0	480	6.27	3,010	0	5.10	0	4,177	0.04647949														
Aug-12	Aug	66,169	261	0.64	168	100	3.56	356	188	1.48	278	0	0.52	0	430	6.27	2,696	34	5.10	173	3,871	0.05548054														
Sep-12	Sep	70,407	625	0.64	401	100	3.90	390	838	1.48	1,240	0	0.52	0	10	6.27	63	0	5.29	0	2,093	0.02973091														
Oct-12	Oct	76,780	1,258	0.64	807	100	3.90	390	775	1.48	1,147	0	0.52	0	0	6.27	0	272	5.29	1,439	3,783	0.04927165														
Nov-12	Nov	77,669	1,772	0.64	1,137	100	3.90	390	825	1.48	1,221	0	0.52	0	0	6.27	0	60	5.29	317	3,066	0.03946970														
Dec-12	Dec	83,036	1,789	0.64	1,148	125	3.90	488	850	1.48	1,258	0	0.52	0	0	6.27	0	272	5.29	1,439	4,332	0.05216949														
Jan-13	Jan	78,393	2,113	0.64	1,355	100	3.90	390	950	1.48	1,406	0	0.52	0	0	6.27	0	340	5.29	1,799	4,950	0.06314396														
Feb-13	Feb	75,341	1,717	0.64	1,102	125	3.90	488	925	1.48	1,369	0	0.52	0	0	6.27	0	272	5.29	1,439	4,397	0.05836141														
Mar-13	Mar	74,332	1,804	0.64	1,158	75	3.90	293	900	1.48	1,332	0	0.55	0	0	6.27	0	266	5.29	1,407	4,189	0.05635730														
Apr-13	Apr	81,565	902	0.64	579	100	3.90	390	875	1.48	1,295	0	0.55	0	0	6.27	0	240	5.29	1,270	3,533	0.04331911														
May-13	May	81,662	1,266	1.05	1,329	125	3.90	488	925	1.48	1,369	0	0.55	0	0	6.49	0	248	5.29	1,312	4,498	0.05507727														
Jun-13	Jun	71,578	1,736	1.05	1,823	125	3.90	488	800	1.48	1,184	0	0.55	0	0	6.49	0	240	5.29	1,270	4,764	0.06655537														
Jul-13	Jul	71,405	1,132	1.05	1,188	150	3.90	585	775	1.48	1,147	0	0.55	0	0	6.49	0	227	5.53	1,255	4,175	0.05847437														
Aug-13	Aug	70,381	483	1.05	507	100	3.90	390	600	1.48	898	0	0.55	0	0	6.49	0	150	5.53	829	2,614	0.03714525														
Sep-13	Sep	77,771	847	1.05	899	125	3.90	488	750	1.48	1,110	0	0.55	0	0	6.49	0	150	5.53	829	3,316	0.04293691														
Oct-13	Oct	84,572	1,575	1.05	1,654	150	4.48	672	875	1.48	1,235	0	0.55	0	0	6.49	0	250	5.53	1,382	5,003	0.05915936														
Nov-13	Nov	85,506	1,899	1.05	1,994	125	4.48	560	1,075	1.48	1,591	0	0.55	0	0	6.49	0	300	5.53	1,659	5,804	0.06787734														
Dec-13	Dec	88,353	2,500	1.05	2,625	75	4.48	336	1,275	1.48	1,887	0	0.55	0	0	6.49	0	310	5.53	1,714	6,563	0.07427806														
Jan-14	Jan	86,604	2,216	1.05	2,326	125	4.48	560	1,200	1.48	1,776	0	0.55	0	0	6.49	0	310	5.53	1,714	6,377	0.07362875														
Feb-14	Feb	78,417	1,029	1.05	1,080	100	4.48	448	925	1.48	1,369	0	0.55	0	0	6.49	0	278	5.53	1,537	4,434	0.05654823														
Mar-14	Mar	85,785	2,129	1.05	2,235	125	4.48	560	1,000	1.48	1,480	0	0.62	0	0	6.49	0	310	5.53	1,714	5,989	0.06981633														
Apr-14	Apr	86,269	2,129	1.05	2,235	125	4.48	560	950	1.48	1,406	0	0.62	0	0	6.80	0	300	5.53	1,659	5,860	0.06792585														
May-14	May	86,445	780	1.19	904	100	4.48	448	850	1.48	1,258	0	0.62	0	0	6.80	0	310	5.53	1,714	4,324	0.05002248														
Jun-14	Jun	82,410	1,298	1.19	1,544	125	4.48	560	875	1.48	1,295	0	0.62	0	0	6.80	0	284	5.53	1,570	4,970	0.06030524														
Jul-14	Jul	83,470	1,124	1.19	1,337	125	4.48	560	925	1.45	1,341	0	0.62	0	0	6.80	0	242	5.53	1,338	4,577	0.05482892														
Aug-14	Aug	83,676	759	1.19	903	150	4.48	672	1,050	1.45	1,523	0	0.62	0	6	6.80	41	248	5.86	1,453	4,592	0.05487583														
Sep-14	Sep	80,776	1,740	1.19	2,071	125	4.48	560	750	1.45	1,088	0	0.62	0	4	6.80	27	240	5.86	1,406	5,152	0.06377761														
Oct-14	Oct	84,074	1,590	1.19	1,892	100	4.48	448	950	1.45	1,378	0	0.62	0	30	6.80	204</																			

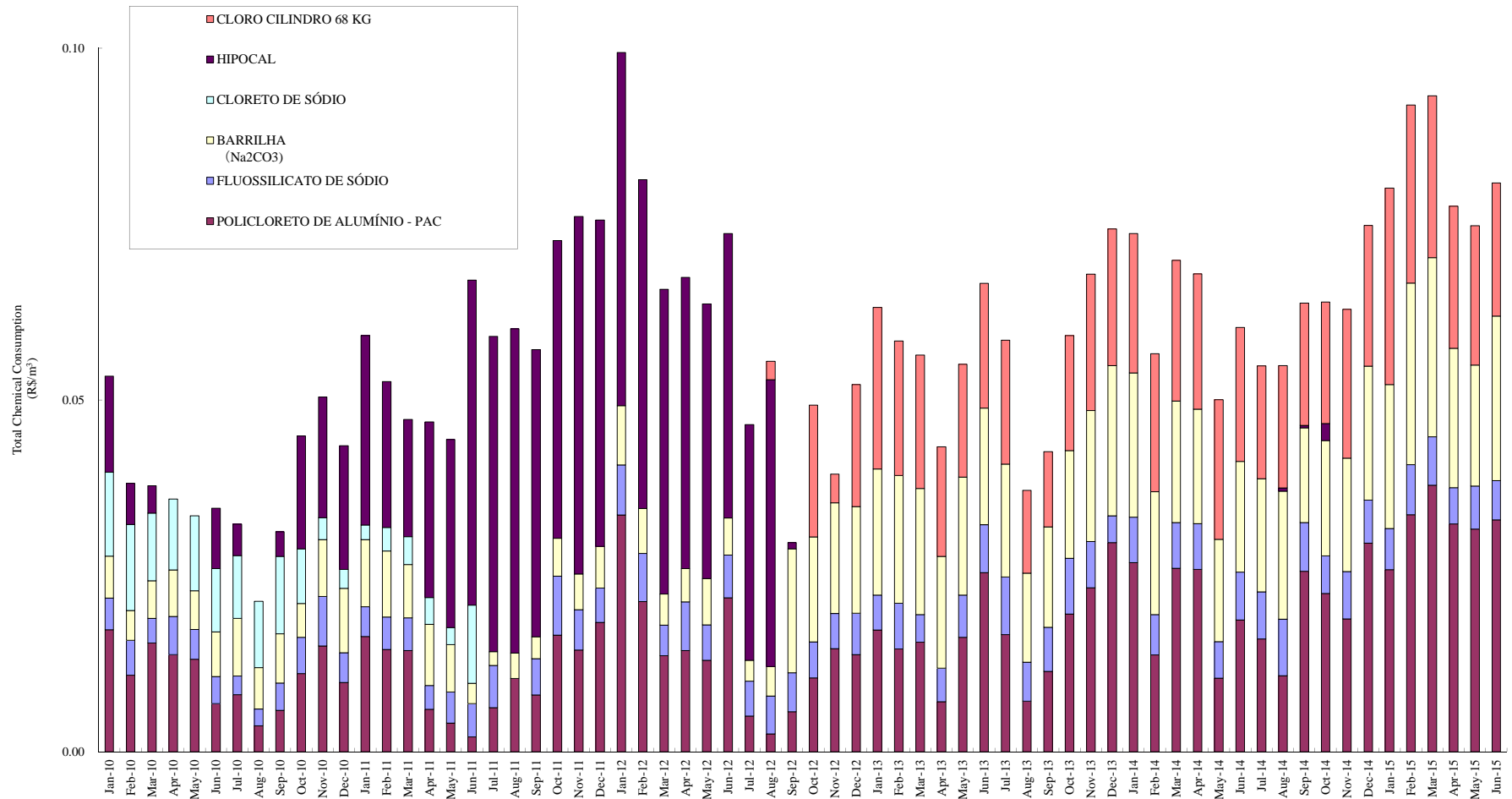

Proportion of Individual Chemical Consumption to Total Consumption (RS/m³, 2010 - 2013) - Morretes WTP

Saguacú		Chemical Consumption																								Total Payment																					
Month	Producción	POLICLORURO DE ALUMÍNIO - PAC						BARRILLA						ÁCIDO FLUOSULFÚRICO						PURATE						ÁCIDO SULFÚRICO 78%						CLORO GILINDRO 800 KG						HIDRÓXIDO DE CÁLCIO						POLÍMERO ANIÓNICO		R\$	R\$/m3
		m ²	Aplicado (kg)	Unidad precio (R\$/kg)	Cuanto Aplicado	Aplicado (kg)	Unidad precio (R\$/kg)	Cuanto Aplicado	Aplicado (kg)	Unidad precio (R\$/kg)	Cuanto Aplicado	Aplicado (kg)	Unidad precio (R\$/kg)	Cuanto Aplicado	Aplicado (kg)	Unidad precio (R\$/kg)	Cuanto Aplicado	Aplicado (kg)	Unidad precio (R\$/kg)	Cuanto Aplicado	Aplicado (kg)	Unidad precio (R\$/kg)	Cuanto Aplicado	Aplicado (kg)	Unidad precio (R\$/kg)	Cuanto Aplicado	Aplicado (kg)	Unidad precio (R\$/kg)	Cuanto Aplicado	Aplicado (kg)	Unidad precio (R\$/kg)	Cuanto Aplicado	R\$	R\$/m3													
Jan-10	Jan	246.024	46.499	0.58	26.737	9.074	1.35	12.232	2.086	0.36	745	2.292	5.99	14.329	3.315	2.29	7.590	512	4.24	2.171	0	0.41	0	26	6.00	156	63.860	0.25997282																			
Feb-10	Feb	173.467	31.964	0.58	18.379	5.477	1.35	7.383	1.477	0.36	527	1.576	5.99	9.441	2.184	2.29	5.001	358	4.24	1.518	0	0.41	0	18	6.00	105	42.355	0.24416708																			
Mar-10	Mar	83.679	15.624	0.58	8.994	3.293	1.35	4.421	647	0.36	231	930	5.99	4.794	1.108	2.29	2.539	190	4.24	906	0	0.41	0	9	6.00	56	21.832	0.23304609																			
Apr-10	Apr	84.365	15.211	0.58	8.734	3.276	1.35	4.416	574	0.36	231	930	5.99	4.308	1.071	2.29	2.330	171	4.24	736	0	0.41	0	5	6.00	30	20.863	0.24671293																			
May-10	May	106.740	19.369	0.58	11.137	3.004	1.35	4.049	664	0.36	237	959	5.99	5.745	1.329	2.29	3.043	220	4.24	934	0	0.41	0	5	6.00	32	25.176	0.23586742																			
Jun-10	Jun	109.301	18.853	0.58	10.841	2.368	1.35	3.192	637	0.36	227	958	5.99	5.735	1.327	2.29	3.038	220	4.24	932	0	0.41	0	17	6.00	101	24.067	0.22019025																			
Jul-10	Jul	102.399	16.416	0.58	9.438	2.258	1.35	3.043	616	0.36	220	869	5.99	5.207	1.204	2.29	2.758	209	4.24	885	0	0.41	0	8	6.00	49	21.801	0.21955350																			
Aug-10	Aug	73.193	9.887	0.58	5.225	1.389	1.35	1.860	391	0.36	140	617	5.99	3.698	855	2.29	1.359	149	4.24	631	0	0.41	0	5	6.00	32	13.544	0.18504624																			
Sep-10	Sep	64.688	5.110	0.58	2.938	1.327	1.35	1.789	277	0.36	99	468	5.99	2.742	634	2.29	1.452	108	4.24	456	0	0.41	0	3	6.00	21	9.497	0.17366270																			
Oct-10	Oct	74.832	11.978	0.58	6.887	2.443	1.35	3.294	376	0.36	134	668	5.99	4.003	926	2.29	2.120	153	4.24	647	0	0.41	0	12	6.00	74	17.159	0.22829852																			
Nov-10	Nov	99.029	17.965	0.58	10.330	2.220	1.35	2.993	475	0.36	170	1.038	5.99	6.223	1.439	2.29	3.296	201	4.24	833	0	0.41	0	23	6.00	132	23.996	0.24230963																			
Dec-10	Dec	191.715	35.264	0.58	20.277	3.665	1.35	4.941	947	0.36	338	1.833	5.99	10.977	2.727	2.29	6.244	389	4.24	1.649	0	0.41	0	52	6.00	312	44.737	0.23335856																			
Jan-11	Jan	272.249	55.881	0.58	32.132	0	1.35	0	1.226	0.36	437	2.866	5.99	17.166	3.971	2.29	9.092	554	4.24	2.349	6.308	0.41	2.586	73	6.00	437	64.200	0.23581207																			
Feb-11	Feb	145.319	31.021	0.58	17.837	0	1.33	0	684	0.36	244	1.377	5.99	8.250	1.908	2.29	4.370	295	4.24	1.251	2.024	0.41	8.307	15	6.00	88	32.870	0.22819545																			
Mar-11	Mar	198.442	40.973	0.58	23.560	0	1.33	0	805	0.36	287	1.849	5.99	11.055	2.557	2.29	5.856	402	4.24	2.455	0.41	1.800	17	6.00	105	43.575	0.21955350																				
Apr-11	Apr	100.721	15.230	0.58	8.757	0	1.33	0	400	0.36	143	842	5.99	5.041	1.166	2.29	2.670	204	4.24	867	8.229	0.41	340	26	6.00	155	17.972	0.17846151																			
May-11	May	85.062	19.368	0.58	11.137	0	1.33	0	457	0.36	163	705	5.99	4.223	1.047	2.29	1.047	174	4.24	736	8.877	0.41	364	24	6.00	143	17.814	0.20725083																			
Jun-11	Jun	69.574	18.853	0.58	10.840	0	1.33	0	332	0.36	119	533	5.99	3.194	739	2.29	1.692	141	4.24	598	7.02	0.45	315	19	6.00	112	16.871	0.24248575																			
Jul-11	Jul	95.632	16.936	0.75	12.702	0	1.33	0	462	0.36	165	743	5.99	4.451	1.030	2.29	2.358	194	4.41	857	6.736	0.45	3.024	28	6.24	174	23.730	0.24814339																			
Aug-11	Aug	79.791	15.718	0.75	11.768	0	1.33	0	390	0.36	139	654	5.99	3.993	807	2.29	2.076	160	4.41	703	5.422	0.45	2.435	24	6.24	147	21.209	0.26580199																			
Sep-11	Sep	97.034	17.721	0.75	13.295	0	1.33	0	408	0.36	120	723	5.99	4.627	1.071	3.20	3.424	199	4.41	869	6.532	0.45	2.924	29	6.24	175	24.624	0.24620810																			
Oct-11	Oct	105.937	18.222	0.75	13.667	0	1.33	0	541	0.30	160	731	5.99	4.381	1.013	3.20	3.243	215	4.41	948	5.807	0.45	2.607	20	6.24	125	25.130	0.23721873																			
Nov-11	Nov	120.190	24.195	0.75	18.146	0	1.33	0	595	0.30	176	888	5.99	5.318	1.230	3.20	3.936	245	4.41	1.080	7.726	0.45	3.469	29	6.24	179	32.304	0.26877708																			
Dec-11	Dec	196.026	41.853	0.75	31.240	0	1.33	0	924	0.30	273	1.314	5.99	7.874	1.820	3.20	5.825	439	4.41	1.667	15.553	0.45	6.983	38	6.24	235	54.092	0.29077718																			
Jan-12	Jan	349.218	79.696	0.75	59.897	0	1.33	0	1.843	0.30	694	3.843	5.99	17.028	3.929	3.20	12.824	715	4.41	3.141	29.042	0.45	12.594	120	6.24	751	105.598	0.30499297																			
Feb-12	Feb	216.077	51.051	0.75	38.288	0	1.33	0	1.295	0.30	382	1.749	5.99	10.477	2.423	3.20	7.755	438	4.41	1.938	15.522	0.45	6.969	74	6.24	461	66.270	0.30665153																			
Mar-12	Mar	146.724	33.617	0.75	25.213	0	1.33	0	1.055	0.30	311	1.239	5.99	4.720	1.716	3.20	5.492	299	4.41	1.317	11.859	0.45	5.325	50	6.24	309	45.388	0.30934388																			
Apr-12	Apr	122.021	28.163	0.64	18.071	0	1.33	0	779	0.30	230	1.028	5.99	6.145	1.421	3.20	4.548	248	4.41	1.095	10.468	0.45	4.700	42	6.24	259	35.047	0.29722000																			
May-12	May	73.047	17.346	0.64	11.125	0	1.33	0	407	0.30	120	664	5.99	3.379	782	3.20	2.501	149	4.41	658	5.479	0.45	2.460	26	6.24	163	20.411	0.27941749																			
Jun-12	Jun	58.675	14.362	0.64	9.214	0	1.33	0	313	0.30	92	444	5.99	2.661	615	3.20	1.969	116	4.41	509	4.364	0.45	1.959	20	6.24	125	15.531	0.29167182																			
Jul-12	Jul	86.652	19.890	0.64	12.762	0	1.33	0	444	0.30	131	685	5.99	4.105	950	3.20	3.039	177	4.45	786	6.109	0.45	2.750	27	11.06	294	23.867	0.27545622																			
Aug-12	Aug	86.823	18.251	0.64	11.710	0	1.48	0	468	0.30	138	675	5.99	4.040	935	3.20	2.990	177	4.45	790	5.122	0.49	2.530	21	11.06	233	22.432	0.25836860																			
Sep-12	Sep	88.439	16.350	0.64	10.460	0	1.48	0	442	0.41	180	652	5.99	4.088	946	3.20	3.028	180	4.45	801	5.535	0.49	2.734	18	11.06	198	21.517	0.24529535																			
Oct-12	Oct	102.292	19.704	0.64	12.642	0	1.48	0	512	0.41	209	707	6.25	4.981	1.104	3.20	3.534	208	4.45	927	2.655	0.49	3.781	27	11.06	296	28.371	0.25778889																			
Nov-12	Nov	139.122	32.517	0.64	20.863	0	1.48	0	715	0.41	291	1.101	6.25	6.882	1.526	3.95	6.026	284	4.45	1.266	14.119	0.49	6.975	46	11.06	507	42.809	0.30770931																			
Dec-12	Dec	281.692	50.483	0.64	32.900	0	1.48	0	1.247	0.41	508	2.114	6.25	13.214	2.929	3.95	11.571	532	4.45	2.371	22.532	0.49	11.131	72	11.06	800	71.984	0.27507008																			
Jan-13	Jan	337.794	71.811	0.64	45.945	0	1.48	0	1.531	0.41	624	3.031	6.25	18.943	4.200	3.95	16.888	690	4.45	3.072	39.627	0.49	19.578	92	11.06	1.021	105.788	0.31314131																			
Feb-13	Feb	200.576	40.291	0.64	25.851	0	1.48	0	894	0.41	364	1.808	6.25	11.208	2.505	3.95	9.993	409	4.45	1.823	21.557	0.49	10.839	51	11.06	561	60.428	0.30127471																			
Mar-13	Mar	149.224	35.787	0.64	22.961	0	1.48	0	761	0.41	310	1.200	6.25	7.499	1.662	3.95	6.666	305	4.45	1.357	21.023	0.49	10.385	43	11.06	474	49.551	0.33260687																			
Apr-13	Apr	121.830	24.856	0.64	15.848	0	1.48	0	564	0.41	230	920	6.25	5.747	1.274	3.95	5.032	248	4.45	1.105	14.182	0.49	4.706	32	11.06	349	35.416	0.29070378																			
May-13	May	108.325	11.576	1.05	12.154	0	1.48	0	443	0.41	180	887	6.25	5.541	1.228	3.95	4.852	220	4.45	469	9.451	0.49	4.669	22	11.06	244	28.623	0.26423192																			
Jun-13	Jun	101.173	15.104	1.05	15.853	0	1.48	0	418	0.41	170	831	6.25	5.195	1.152	3.95	4.549	206	4.55	937	10.448	0.49	5.161	19	11.06	212	32.694	0.31712480																			
Jul-13	Jul	81.724	15.081	1.05	15.838	0	1.48	0	332	0.54	179	680	6.25	4.252	943	3.95	3.723	167	4.55	796	10.391	0.49	5.133	20	11.06	219	30.102	0.36833621																			
Aug-13	Aug	107.198	15.367	1.05	16.138	0	1.48	0	383	0.54	206	8																																			

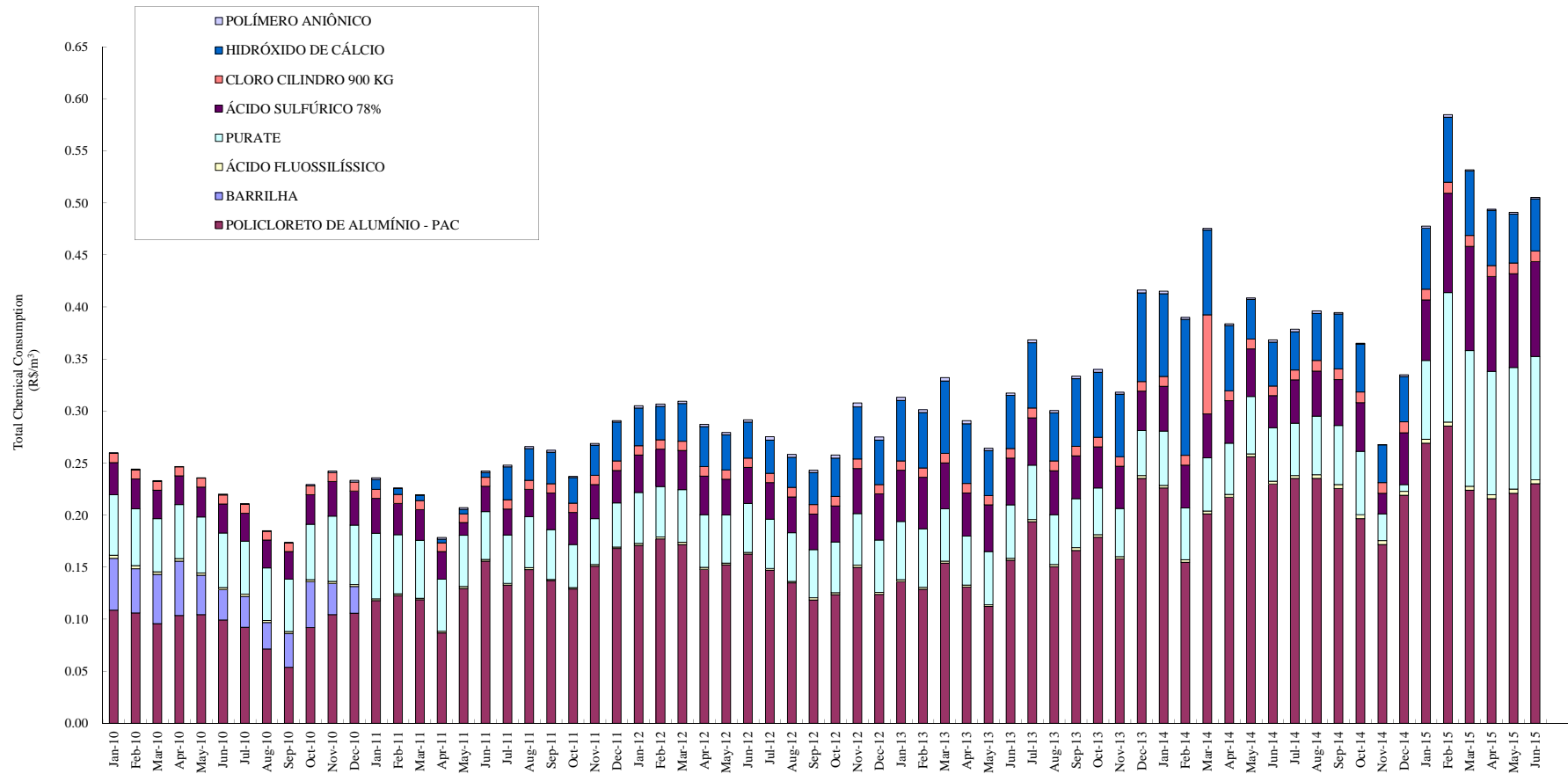

Proportion of Individual Chemical Consumption to Total Consumption (R\$/m³, 2010 - 2013) - Saiguacu WTP

G'quecaba Chemical Consumption

Month	Production m ³	Sulfato de Alumínio																								Total Payment	
		Sulfato de Alumínio			Barrilha			Cloreto de Sódio			Fluosilicato de Sódio			Ácido Fluossilícico			Hifocal			R\$	R\$/m ³						
		Aplicado (kg)	Unit price (R\$/kg)	Custo Aplicado	Aplicado (kg)	Unit price (R\$/kg)	Custo Aplicado	Aplicado (kg)	Unit price (R\$/kg)	Custo Aplicado	Aplicado (kg)	Unit price (R\$/kg)	Custo Aplicado	Aplicado (kg)	Unit price (R\$/kg)	Custo Aplicado	Aplicado (kg)	Unit price (R\$/kg)	Custo Aplicado			Aplicado (kg)	Unit price (R\$/kg)	Custo Aplicado			
Jan-10	Jan	13.639	154	0.64	98	104	1.35	140	247	0.46	114	53	3.27	173	60	5.49	329	855	0.06265614								
Feb-10	Feb	13.639	154	0.64	98	104	1.35	140	247	0.46	114	53	3.27	173	60	5.49	329	855	0.06265230								
Mar-10	Mar	15.363	200	0.64	127	200	1.35	270	400	0.46	184	25	3.27	82	0	5.49	0	662	0.04311528								
Apr-10	Apr	13.735	150	0.64	95	200	1.35	270	485	0.46	223	15	3.27	49	0	5.49	0	637	0.04637918								
May-10	May	14.034	100	0.64	64	150	1.35	202	550	0.46	253	10	3.27	33	0	5.49	0	551	0.03929115								
Jun-10	Jun	14.418	100	0.64	64	100	1.35	135	475	0.46	219	12	3.27	39	0	5.49	0	456	0.03163091								
Jul-10	Jul	14.101	100	0.64	64	175	1.35	236	550	0.46	253	10	3.27	33	0	5.49	0	585	0.04149436								
Aug-10	Aug	10.585	50	0.64	32	75	1.35	101	325	0.46	150	50	3.27	164	10	5.49	55	501	0.04731412								
Sep-10	Sep	10.452	150	0.64	95	125	1.35	169	250	0.46	115	10	3.27	33	10	5.49	55	466	0.04462036								
Oct-10	Oct	10.653	175	0.64	111	100	1.35	135	350	0.46	161	45	3.27	147	10	5.65	57	611	0.05731991								
Nov-10	Nov	11.234	75	0.64	48	87	1.35	118	217	0.46	100	28	3.27	90	0	5.65	0	355	0.03163384								
Dec-10	Dec	13.176	107	0.70	75	46	1.35	62	375	0.46	173	15	3.27	48	0	5.65	0	357	0.02705792								
Jan-11	Jan	13.315	75	0.70	53	150	1.35	202	400	0.46	184	45	3.27	147	20	5.65	113	699	0.05248997								
Feb-11	Feb	11.437	192	0.70	134	69	1.33	92	348	0.79	275	23	3.27	76	20	5.65	113	690	0.06030091								
Mar-11	Mar	13.081	150	0.70	105	125	1.33	166	375	0.79	296	52	3.27	170	10	5.65	57	794	0.06070655								
Apr-11	Apr	11.410	150	0.70	105	125	1.33	166	254	0.79	201	18	3.27	59	10	5.65	57	587	0.05147166								
May-11	May	11.182	29	0.70	20	53	1.33	70	143	0.79	113	16	3.27	52	0	5.65	0	256	0.02290281								
Jun-11	Jun	10.569	47	0.70	33	98	1.33	130	116	0.79	91	12	3.27	39	0	5.65	0	293	0.02774389								
Jul-11	Jul	11.265	103	0.70	72	101	1.33	135	124	0.79	98	19	3.27	62	0	5.65	0	366	0.03249120								
Aug-11	Aug	11.220	200	0.70	140	150	1.33	200	143	0.79	113	50	3.27	164	10	5.65	57	673	0.05994029								
Sep-11	Sep	12.258	150	0.70	105	175	1.33	233	225	0.79	178	50	3.27	164	0	5.65	0	679	0.05539729								
Oct-11	Oct	11.841	50	0.70	35	50	1.33	67	125	0.79	99	25	3.27	82	0	6.27	0	282	0.02381809								
Nov-11	Nov	11.929	75	0.70	53	88	1.33	116	217	0.79	171	28	3.27	90	10	6.27	63	493	0.04132569								
Dec-11	Dec	12.793	50	0.70	35	100	1.33	133	125	0.79	99	25	3.56	89	0	6.27	0	356	0.02780818								
Jan-12	Jan	12.510	100	0.70	150	125	1.33	150	200	0.79	0	25	3.56	86	0	6.27	0	573	0.03089448								
Feb-12	Feb	13.207	100	0.70	132	175	1.33	132	150	0.79	0	50	3.56	173	0	6.27	1,057	573	0.11306126								
Mar-12	Mar	13.510	50	0.70	324	200	1.33	324	150	0.79	0	25	3.56	86	0	6.27	0	573	0.05438416								
Apr-12	Apr	11.761	100	0.70	247	150	1.33	247	150	0.52	0	25	3.56	86	10	6.27	118	573	0.05933356								
May-12	May	11.729	150	0.70	141	125	1.33	141	125	0.52	0	25	3.56	86	10	6.27	117	573	0.04135984								
Jun-12	Jun	11.356	75	0.70	114	75	1.33	114	150	0.52	0	50	3.56	172	20	6.27	114	573	0.04519021								
Jul-12	Jul	12.573	125	0.70	101	50	1.33	63	75	0.52	0	25	3.56	86	50	6.27	251	573	0.03985994								
Aug-12	Aug	12.798	100	1.04	128	75	1.48	128	0	0.52	0	50	3.56	172	50	6.27	256	573	0.05347867								
Sep-12	Sep	13.195	50	1.04	132	50	1.48	66	0	0.52	0	50	3.90	173	60	6.27	396	573	0.05807313								
Oct-12	Oct	13.259	100	1.04	133	75	1.48	106	0	0.52	0	10	3.90	35	40	6.27	265	573	0.04060201								
Nov-12	Nov	13.029	100	1.04	130	100	1.48	130	0	0.52	0	50	3.90	173	70	6.27	391	573	0.06323970								
Dec-12	Dec	14.628	50	1.04	88	75	1.48	102	0	0.52	0	25	3.90	86	30	6.27	585	573	0.05889623								
Jan-13	Jan	15.048	100	1.04	104	100	1.48	148	0	0.52	0	50	3.90	195	60	6.27	376	823	0.05470494								
Feb-13	Feb	12.304	150	1.04	156	100	1.48	148	0	0.52	0	50	3.90	195	80	6.27	502	1,001	0.08132315								
Mar-13	Mar	13.278	250	1.04	260	150	1.48	222	0	0.55	0	25	3.90	98	70	6.27	439	1,018	0.07669830								
Apr-13	Apr	13.336	100	1.04	104	100	1.48	148	0	0.55	0	25	3.90	98	40	6.27	251	600	0.04501350								
May-13	May	13.881	50	1.04	52	25	1.48	37	0	0.55	0	50	3.90	195	50	6.49	325	609	0.04383690								
Jun-13	Jun	13.780	100	1.04	104	50	1.48	74	0	0.55	0	75	3.90	293	50	6.49	325	795	0.05769231								
Jul-13	Jul	11.566	50	1.04	52	25	1.48	37	0	0.55	0	35	3.90	137	30	6.49	195	420	0.03633062								
Aug-13	Aug	10.749	50	1.04	52	25	1.48	37	0	0.55	0	50	3.90	195	50	6.49	325	609	0.05660992								
Sep-13	Sep	11.197	50	1.04	52	25	1.48	37	0	0.55	0	25	3.90	98	40	6.49	260	446	0.03984103								
Oct-13	Oct	11.746	0	1.04	0	0	1.48	0	0	0.55	0	25	3.90	98	50	6.49	325	422	0.03592712								
Nov-13	Nov	12.166	50	1.04	52	25	1.48	37	0	0.55	0	25	4.48	112	60	6.49	369	590	0.04852869								
Dec-13	Dec	14.745	50	1.04	52	50	1.48	74	0	0.55	0	50	4.48	224	40	6.49	260	610	0.04134283								
Jan-14	Jan	15.534	50	1.04	52	50	1.48	74	0	0.55	0	0	0	0	80	0.54	43	60	389	0.03595983							
Feb-14	Feb	14.178	50	1.04	52	100	1.48	148	0	0.55	0	0	0	0	48	0.54	26	100	649	0.06170969							
Mar-14	Mar	15.273	50	1.04	52	75	1.48	111	0	0.62	0	0	0	0	55	0.54	30	50	649	0.03388368							
Apr-14	Apr	14.697	0	1.04	0	50	1.48	74	0	0.62	0	0	0	0	60	0.54	32	60	680	0.03500034							
May-14	May	12.268	50	1.04	52	50	1.48	74	0	0.62	0	0	0	0	36	0.54	19	70	680	0.05065536							
Jun-14	Jun	10.075	0	1.04	0	25	1.48	37	0	0.62	0	0	0	0	43	0.54	23	60	680	0.04647345							
Jul-14	Jul	10.632	0	1.04	0	25	1.45	36	0	0.62	0	0	0	0	67	0.54	36	40	680	0.03239560							
Aug-14	Aug	11.138	50	1.04	52	25	1.45	36	0	0.62	0	0	0	0	52	0.75	39	50	680	0.04195098							
Sep-14	Sep	10.920	0	1.04	0	0	1.45	0	0	0.62	0	0	0	0	39	0.75	29	60	680	0.04004121							
Oct-14	Oct	11.392	50	1.04	52	0	1.45	0	0	0.62	0	0	0	0	60	0.75	45	70	680	0.05029846							
Nov-14	Nov	11.610	50	1.04	52	0	1.45	0	0	0.62	0	0	0	0	102	0.75	77	70	680	0.05206718							
Dec-14	Dec	14.182	0	1.04	0	0	1.45	0	0	0.62	0	0	0	0	66	0.75	50	90	680	0.04664363							
Jan-15	Jan	15.644	100	1.04	104	0	1.45	0	0	0.62	0	0	0	0	49	0.75	37	60	680	0.03507735							
Feb-15	Feb	12.509	50	1.04	52	0	1.98	0	0	0.62	0	0	0	0	52	0.75	39	80	945	0.06771125							
Mar-15	Mar	12.962	0	1.04	0	75	1.98	149	0	0.62	0	0	0	0	112	0.75	84	50	945	0.05438975							
Apr-15	Apr	11.224	50	1.04	52	0	1.98	0	0	0.62	0	0	0	0	52	0.75	39	60	945	0.05862438							
May-15	May	11.403	0	1.04	0	0	1.98	0	0	0.62	0	0	0	0	52	0.75	39	50	945	0.04485662							
Jun-15	Jun	12.065	50	1.04	52	50	1.98	99	0	0.62	0	0	0	0	50	0.75	38	54	945	0.05823291							

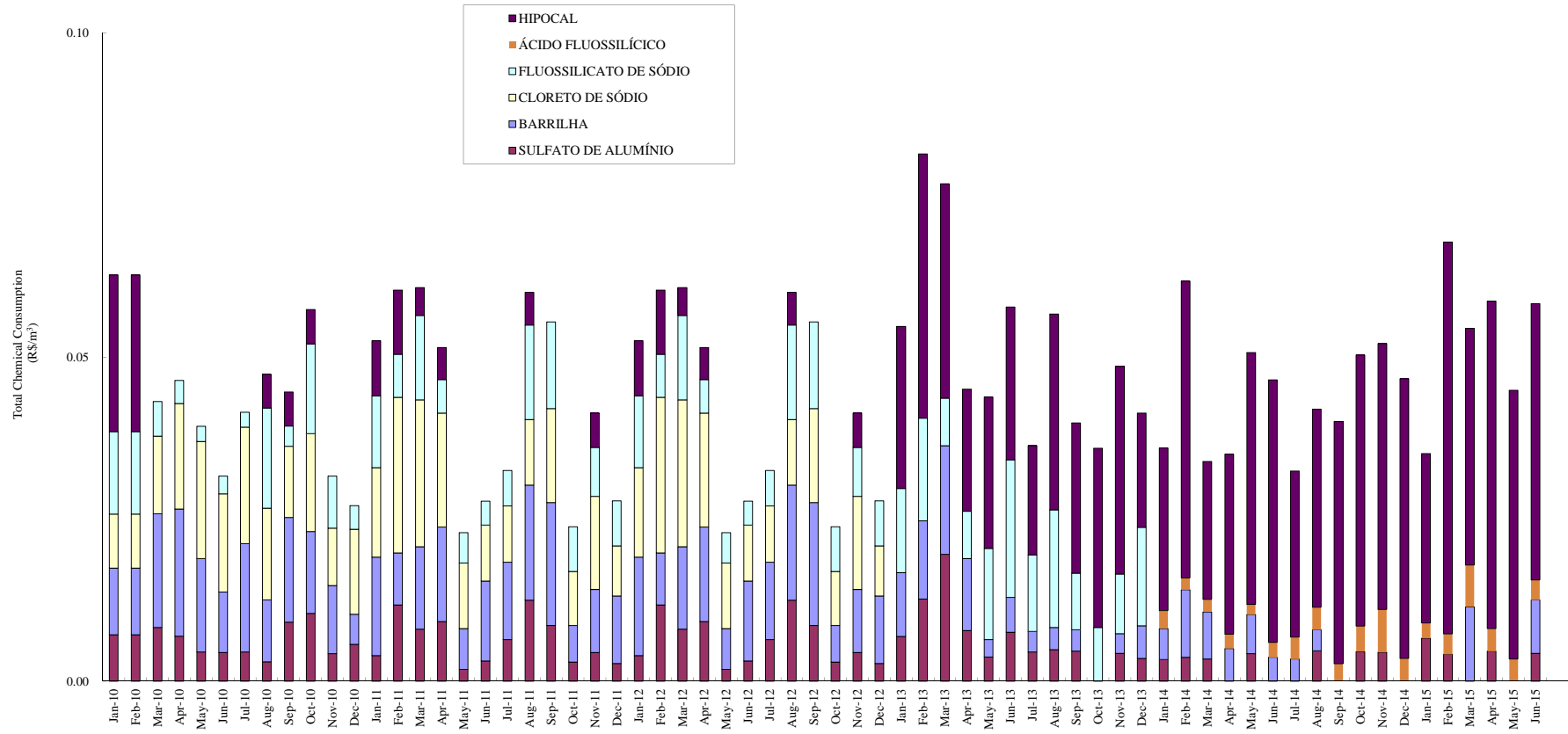

Proportion of Individual Chemical Consumption to Total Consumption (R\$/m³, 2010 - 2013) - Guaraquecaba WTP

Water Quality Standard Compliance Rate – Irai

Month	Total Number of Sample						Number of Sample Not Conform to Standard						Compliance rate (%)
	Physical		Chemical		Biological		Physical		Chemical		Biological		
	Turbidity	Color	Residual Chlorine	Fluoride	Total Coliform	E-Coli	Turbidity	Color	Residual Chlorine	Fluoride	Total Coliform	E-Coli	
Jan-10	758	758	758	758	13	13	1	0	0	0	0	0	99.99%
Feb-10	688	688	688	688	16	16	0	0	0	0	0	0	100.00%
Mar-10	758	758	758	758	15	15	0	0	0	0	0	0	100.00%
Apr-10	736	737	737	737	17	17	4	0	0	0	0	0	99.95%
May-10	742	742	742	742	16	16	0	0	0	0	0	0	100.00%
Jun-10	721	721	721	721	7	7	10	0	0	0	0	0	99.86%
Jul-10	745	745	745	745	10	10	17	0	0	0	0	0	99.77%
Aug-10	753	753	753	753	9	9	4	0	0	0	0	0	99.95%
Sep-10	727	727	727	727	8	8	3	0	0	0	0	0	99.96%
Oct-10	748	748	748	748	8	8	0	0	0	0	0	0	100.00%
Nov-10	727	726	727	728	10	10	5	0	0	0	0	0	99.93%
Dec-10	759	759	759	759	18	18	13	0	0	0	0	0	99.83%
Jan-11	752	752	752	752	10	10	4	0	0	0	0	0	99.95%
Feb-11	682	682	682	682	10	10	0	0	0	0	0	0	100.00%
Mar-11	749	749	749	749	10	10	0	0	0	0	0	0	100.00%
Apr-11	736	736	736	736	16	16	0	0	0	0	0	0	100.00%
May-11	758	758	758	758	18	18	0	0	0	0	0	0	100.00%
Jun-11	735	735	735	735	18	18	0	0	0	0	0	0	100.00%
Jul-11	762	762	762	762	17	17	15	8	0	0	0	0	99.70%
Aug-11	753	753	753	753	17	17	0	0	0	0	0	0	100.00%
Sep-11	735	735	735	735	17	17	0	0	0	0	0	0	100.00%
Oct-11	761	761	761	760	16	16	2	0	0	0	0	0	99.97%
Nov-11	728	729	729	729	17	17	0	0	1	3	0	0	99.92%
Dec-11	759	759	759	759	16	16	0	0	0	0	0	0	100.00%
Jan-12	757	757	756	756	17	17	0	0	0	0	0	0	100.00%
Feb-12	708	705	708	707	12	12	0	0	1	0	0	0	99.98%
Mar-12	760	760	759	757	13	13	0	0	0	0	0	0	100.00%
Apr-12	732	732	732	730	17	17	0	0	1	1	0	0	99.96%
May-12	761	761	761	759	18	18	3	0	0	0	0	0	99.96%
Jun-12	713	713	712	712	12	12	15	7	0	0	0	0	99.69%
Jul-12	762	713	762	760	18	18	0	0	0	5	0	0	99.90%
Aug-12	759	759	759	759	14	14	0	0	0	13	0	0	99.74%
Sep-12	732	732	732	732	16	16	0	0	0	1	0	0	99.98%
Oct-12	760	760	760	757	18	18	0	0	0	0	0	0	100.00%
Nov-12	736	736	736	731	17	17	4	3	0	0	0	0	99.90%
Dec-12	758	758	758	755	18	18	0	0	2	0	0	0	99.96%
Jan-13	742	742	741	742	16	16	0	0	0	0	0	0	100.00%
Feb-13	688	688	688	685	16	16	2	0	0	0	0	0	99.97%
Mar-13	752	752	752	749	18	18	0	0	0	2	0	0	99.96%
Apr-13	719	719	719	719	17	17	0	0	0	0	0	0	100.00%
May-13	759	759	759	758	16	16	0	0	0	0	0	0	100.00%
Jun-13	731	731	731	731	17	17	27	0	0	0	0	0	99.63%
Jul-13	762	762	762	762	18	18	6	0	0	0	0	0	99.92%
Aug-13	762	762	762	760	18	18	0	0	0	0	0	0	100.00%
Sep-13	719	719	719	719	18	18	3	0	0	0	0	0	99.96%
Oct-13	734	734	734	734	15	15	0	0	2	0	0	0	99.96%
Nov-13	717	359	717	717	16	16	0	0	0	0	0	0	100.00%
Dec-13	740	740	740	740	18	18	0	0	0	0	0	0	100.00%
Jan-14	759	759	759	759	15	15	0	0	0	0	0	0	100.00%
Feb-14	672	672	672	672	15	15	0	0	0	0	0	0	100.00%
Mar-14	758	758	758	758	14	14	7	4	0	2	0	0	99.82%
Apr-14	698	698	698	698	13	13	0	0	0	0	0	0	100.00%
May-14	744	744	744	744	17	17	0	0	0	0	0	0	100.00%
Jun-14	738	738	738	738	18	18	16	0	0	0	0	0	99.78%
Jul-14	744	744	744	744	18	18	0	0	0	0	0	0	100.00%
Aug-14	745	745	746	746	18	18	0	0	0	0	0	0	100.00%
Sep-14	717	717	717	717	15	15	0	0	0	0	0	0	100.00%
Oct-14	746	746	746	746	13	13	12	0	0	0	0	0	99.84%
Nov-14	707	707	707	707	9	9	0	0	0	0	0	0	100.00%
Dec-14	743	379	743	743	14	14	44	0	0	0	0	0	99.22%
Jan-15	744	371	744	744	11	11	0	0	0	0	0	0	100.00%
Feb-15	673	337	673	673	12	12	0	0	0	0	0	0	100.00%
Mar-15	742	370	742	742	13	13	0	0	0	0	0	0	100.00%
Apr-15	718	361	718	718	14	14	0	0	0	0	0	0	100.00%
May-15	743	374	743	743	13	13	0	0	0	0	0	0	100.00%
Jun-15	700	350	700	700	13	13	0	0	0	0	0	0	100.00%

Weighing rate in calculation for water quality guideline compliance rate:
 - For physical item: 20%
 - For chemical item: 30%
 - For microbiological item: 50%

Water Quality Standard Compliance Rate – Praia de Leste

Month	Total Number of Sample						Number of Sample Not Conform to Standard						Compliance rate (%)
	Physical		Chemical		Biological		Physical		Chemical		Biological		
	Turbidity	Color	Residual Chlorine	Fluoride	Total Coliform	E-Coli	Turbidity	Color	Residual Chlorine	Fluoride	Total Coliform	E-Coli	
Jan-10	407	406	403	404	9	9	10	0	1	1	0	0	99.68%
Feb-10	263	263	263	262	8	8	4	0	1	0	0	0	99.79%
Mar-10	185	184	184	184	9	9	2	0	0	0	0	0	99.89%
Apr-10	63	63	63	63	9	9	0	0	0	0	0	0	100.00%
May-10	117	117	117	116	8	8	0	0	0	0	0	0	100.00%
Jun-10	291	291	291	287	9	9	1	0	0	0	0	0	99.97%
Jul-10	21	221	220	220	9	9	0	0	0	0	0	0	100.00%
Aug-10	118	118	118	118	8	8	4	0	0	0	0	0	99.66%
Sep-10	184	185	183	183	8	8	3	0	0	0	0	0	99.84%
Oct-10	166	167	167	167	9	9	2	0	1	0	0	0	99.79%
Nov-10	215	214	214	212	9	9	0	0	0	0	0	0	100.00%
Dec-10	294	296	292	292	8	8	13	0	0	0	0	0	99.56%
Jan-11	520	520	518	517	8	8	7	0	0	0	0	0	99.87%
Feb-11	250	247	246	246	8	8	2	0	0	0	0	0	99.92%
Mar-11	233	233	234	234	7	7	2	0	0	0	0	0	99.91%
Apr-11	121	121	120	120	8	8	1	0	0	0	0	0	99.92%
May-11	93	93	93	93	8	8	0	0	0	0	0	0	100.00%
Jun-11	143	143	143	143	7	7	7	0	0	0	0	0	99.51%
Jul-11	121	121	121	121	9	9	0	0	0	0	0	0	100.00%
Aug-11	73	73	73	73	9	9	3	0	0	0	0	0	99.59%
Sep-11	94	94	94	94	8	8	0	0	0	0	0	0	100.00%
Oct-11	99	99	99	99	8	8	0	0	0	0	0	0	100.00%
Nov-11	115	115	115	115	9	9	0	0	0	0	0	0	100.00%
Dec-11	261	261	261	261	9	9	13	0	0	0	0	0	99.50%
Jan-12	441	440	438	439	9	9	2	0	0	1	0	0	99.92%
Feb-12	228	228	228	228	8	8	1	0	1	0	0	0	99.89%
Mar-12	115	115	115	115	10	10	1	0	0	0	0	0	99.91%
Apr-12	99	99	99	99	8	8	2	0	0	0	0	0	99.80%
May-12	66	66	66	66	10	10	1	0	0	0	0	0	99.85%
Jun-12	34	34	34	34	5	5	0	0	0	0	0	0	100.00%
Jul-12	36	36	36	36	7	7	0	0	0	0	0	0	100.00%
Aug-12	46	46	46	46	9	9	0	0	0	0	0	0	100.00%
Sep-12	146	146	146	146	9	9	0	0	0	0	0	0	100.00%
Oct-12	97	97	97	97	11	11	0	0	0	0	0	0	100.00%
Nov-12	149	150	150	149	8	8	0	0	0	0	0	0	100.00%
Dec-12	312	312	312	312	10	10	25	0	0	0	0	0	99.20%
Jan-13	417	417	417	417	9	9	53	25	0	0	0	0	98.13%
Feb-13	226	227	227	226	9	9	0	0	0	0	0	0	100.00%
Mar-13	135	135	135	135	10	10	1	0	0	0	0	0	99.93%
Apr-13	63	63	63	63	8	8	0	0	0	0	0	0	100.00%
May-13	74	74	74	74	10	10	0	0	0	0	0	0	100.00%
Jun-13	122	122	122	122	8	8	1	0	0	0	0	0	99.92%
Jul-13	74	74	74	74	9	9	0	0	0	0	0	0	100.00%
Aug-13	128	128	128	128	9	9	0	0	0	0	0	0	100.00%
Sep-13	106	106	106	106	10	10	1	0	0	0	0	0	99.91%
Oct-13	114	114	114	114	10	10	0	0	0	0	0	0	100.00%
Nov-13	188	188	188	188	10	10	0	0	0	0	0	0	100.00%
Dec-13	329	329	329	329	9	9	10	0	0	2	0	0	99.60%
Jan-14	508	508	508	508	9	9	18	0	2	0	0	0	99.59%
Feb-14	258	258	258	258	8	8	0	0	0	0	0	0	100.00%
Mar-14	195	195	195	195	8	8	0	0	0	0	0	0	100.00%
Apr-14	120	120	120	120	9	9	0	0	0	0	0	0	100.00%
May-14	71	71	71	71	7	7	0	0	0	0	0	0	100.00%
Jun-14	91	91	90	91	9	9	0	0	0	0	0	0	100.00%
Jul-14	74	74	74	74	9	9	0	0	0	0	0	0	100.00%
Aug-14	97	97	97	97	8	8	0	0	0	0	0	0	100.00%
Sep-14	110	110	109	110	9	9	0	0	0	0	0	0	100.00%
Oct-14	121	121	121	121	9	9	1	0	0	0	0	0	99.92%
Nov-14	152	152	152	153	9	9	0	0	0	0	0	0	100.00%
Dec-14	431	431	431	431	10	10	1	0	0	0	0	0	99.98%
Jan-15	554	554	554	554	7	7	7	0	0	0	0	0	99.87%
Feb-15	280	280	280	280	8	8	0	0	0	0	0	0	100.00%
Mar-15	142	142	142	142	9	9	0	0	0	0	0	0	100.00%
Apr-15	142	142	142	142	9	9	0	0	0	0	0	0	100.00%
May-15	111	111	111	111	8	8	0	0	0	0	0	0	100.00%
Jun-15	57	57	57	57	9	9	0	0	0	0	0	0	100.00%

Weighing rate in calculation for water quality guideline compliance rate:
 - For physical item: 20%
 - For chemical item: 30%
 - For microbiological item: 50%

Water Quality Standard Compliance Rate – Morretes

Month	Total Number of Sample						Number of Sample Not Conform to Standard						Compliance rate (%)
	Physical		Chemical		Biological		Physical		Chemical		Biological		
	Turbidity	Color	Residual Chlorine	Fluoride	Total Coliform	E-Coli	Turbidity	Color	Residual Chlorine	Fluoride	Total Coliform	E-Coli	
Jan-10	561	295	561	561	8	8	0	0	0	0	0	0	100.00%
Feb-10	508	280	508	508	8	8	0	0	0	0	0	0	100.00%
Mar-10	550	292	550	550	9	9	0	0	0	0	0	0	100.00%
Apr-10	484	266	486	487	8	8	0	0	0	0	0	0	100.00%
May-10	505	271	505	505	8	8	0	0	0	0	0	0	100.00%
Jun-10	533	289	532	533	8	8	0	0	0	0	0	0	100.00%
Jul-10	502	260	501	505	9	9	0	0	0	0	0	0	100.00%
Aug-10	515	276	516	516	8	8	0	0	0	0	0	0	100.00%
Sep-10	464	254	463	463	9	9	0	0	0	0	0	0	100.00%
Oct-10	459	246	445	437	9	9	0	0	0	0	0	0	100.00%
Nov-10	461	246	463	463	8	8	0	0	0	0	0	0	100.00%
Dec-10	533	282	534	534	9	9	0	0	0	0	0	0	100.00%
Jan-11	598	320	598	598	8	8	0	0	0	0	0	0	100.00%
Feb-11	527	288	531	531	8	8	0	0	0	0	0	0	100.00%
Mar-11	544	302	545	545	9	9	1	0	0	0	0	0	99.98%
Apr-11	562	295	551	535	8	8	0	0	0	3	0	0	99.92%
May-11	565	565	565	565	9	9	0	0	0	0	0	0	100.00%
Jun-11	503	269	505	503	8	8	0	1	0	0	0	0	99.97%
Jul-11	496	273	498	494	9	9	2	0	25	1	0	0	99.16%
Aug-11	528	291	531	514	8	8	19	2	7	2	0	0	99.23%
Sep-11	509	277	510	511	10	10	2	1	0	0	0	0	99.92%
Oct-11	512	379	512	513	8	8	1	1	0	1	0	0	99.93%
Nov-11	535	282	533	535	8	8	2	0	3	0	0	0	99.87%
Dec-11	561	295	555	562	8	8	2	0	6	3	0	0	99.71%
Jan-12	574	305	571	575	9	9	0	0	2	0	0	0	99.95%
Feb-12	602	318	597	600	8	8	0	0	0	0	0	0	100.00%
Mar-12	591	314	591	591	9	9	2	0	0	0	0	0	99.96%
Apr-12	559	295	556	559	8	8	2	0	0	0	0	0	99.95%
May-12	485	257	486	469	9	9	0	0	0	0	0	0	100.00%
Jun-12	489	268	494	496	8	8	0	0	0	0	0	0	100.00%
Jul-12	511	269	512	517	9	9	0	0	0	0	0	0	100.00%
Aug-12	586	308	588	587	9	9	0	0	0	0	0	0	100.00%
Sep-12	581	311	585	585	7	7	0	0	0	0	0	0	100.00%
Oct-12	601	324	601	601	9	9	0	0	0	0	0	0	100.00%
Nov-12	587	338	589	589	6	6	5	9	0	1	0	0	99.67%
Dec-12	648	349	644	644	8	8	0	0	0	0	0	0	100.00%
Jan-13	614	340	613	613	7	7	0	0	0	0	0	0	100.00%
Feb-13	602	402	596	599	7	7	0	0	0	0	0	0	100.00%
Mar-13	503	415	563	563	9	9	0	0	0	1	0	0	99.97%
Apr-13	627	332	623	623	9	9	0	0	0	0	0	0	100.00%
May-13	660	390	660	660	9	9	0	0	0	1	0	0	99.98%
Jun-13	621	374	622	622	7	7	0	0	0	0	0	0	100.00%
Jul-13	624	407	624	621	9	9	0	0	0	0	0	0	100.00%
Aug-13	614	372	614	615	8	8	0	0	0	2	0	0	99.95%
Sep-13	664	359	659	659	8	8	0	0	0	0	0	0	100.00%
Oct-13	608	335	1206	1211	9	9	0	0	0	0	0	0	100.00%
Nov-13	544	347	544	544	9	9	0	0	0	1	0	0	99.97%
Dec-13	663	373	665	665	9	9	0	0	0	2	0	0	99.95%
Jan-14	666	370	667	666	9	9	0	0	1	0	0	0	99.98%
Feb-14	588	329	1162	1163	8	8	0	0	0	0	0	0	100.00%
Mar-14	691	373	1380	1380	8	8	0	0	0	0	0	0	100.00%
Apr-14	645	394	1282	1278	9	9	0	0	0	0	0	0	100.00%
May-14	648	357	1286	1285	10	10	0	0	0	0	0	0	100.00%
Jun-14	636	347	1266	1266	8	8	0	0	0	0	0	0	100.00%
Jul-14	640	416	1271	1271	9	9	0	0	0	0	0	0	100.00%
Aug-14	626	409	1245	1244	9	9	0	0	0	0	0	0	100.00%
Sep-14	708	351	1228	1229	9	9	0	0	0	0	0	0	100.00%
Oct-14	652	418	1295	1295	9	9	0	0	0	0	0	0	100.00%
Nov-14	616	399	1225	1225	9	9	0	0	0	3	0	0	99.96%
Dec-14	697	377	1364	1321	10	10	0	0	0	0	0	0	100.00%
Jan-15	658	389	1308	1295	8	8	0	0	0	0	0	0	100.00%
Feb-15	618	395	1228	1219	8	8	0	0	0	0	0	0	100.00%
Mar-15	665	614	1309	1053	9	9	0	0	0	0	0	0	100.00%
Apr-15	670	555	1262	1126	9	9	0	0	0	0	0	0	100.00%
May-15	688	560	689	689	8	8	0	0	0	0	0	0	100.00%
Jun-15	616	442	617	616	9	9	0	0	0	0	0	0	100.00%

Weighing rate in calculation for water quality guideline compliance rate:

- For physical item: 20%
- For chemical item: 30%
- For microbiological item: 50%

Water Quality Standard Compliance Rate – Saiguacu

Month	Total Number of Sample						Number of Sample Not Conform to Standard						Compliance rate (%)
	Physical		Chemical		Biological		Physical		Chemical		Biological		
	Turbidity	Color	Residual Chlorine	Fluoride	Total Coliform	E-Coli	Turbidity	Color	Residual Chlorine	Fluoride	Total Coliform	E-Coli	
Jan-10	436	233	436	435	8	8	12	1	0	0	0	0	99.61%
Feb-10	303	158	303	303	8	8	0	0	0	0	0	0	100.00%
Mar-10	138	80	137	137	9	9	2	0	0	0	0	0	99.82%
Apr-10	112	67	112	112	9	9	0	0	0	0	0	0	100.00%
May-10	142	85	148	148	9	9	0	0	0	1	0	0	99.90%
Jun-10	167	82	167	167	9	9	1	0	0	0	0	0	99.92%
Jul-10	142	87	140	140	8	8	1	0	0	1	0	0	99.81%
Aug-10	97	59	97	97	9	9	0	0	0	0	0	0	100.00%
Sep-10	68	45	67	67	8	8	0	0	0	0	0	0	100.00%
Oct-10	93	59	93	93	8	8	6	1	0	1	0	0	98.92%
Nov-10	130	81	130	130	9	9	0	0	0	0	0	0	100.00%
Dec-10	339	192	339	339	9	9	7	0	0	1	0	0	99.69%
Jan-11	480	258	480	480	8	8	3	0	0	0	0	0	99.92%
Feb-11	239	136	239	239	8	8	8	0	0	0	0	0	99.57%
Mar-11	329	182	329	329	9	9	12	0	0	9	0	0	99.12%
Apr-11	129	79	129	129	9	9	0	0	0	0	0	0	100.00%
May-11	109	65	109	109	9	9	0	0	0	0	0	0	100.00%
Jun-11	99	57	99	99	9	9	3	0	0	0	0	0	99.62%
Jul-11	144	85	144	144	8	8	1	0	0	0	0	0	99.91%
Aug-11	110	99	111	111	9	9	0	0	0	0	0	0	100.00%
Sep-11	136	81	136	136	8	8	0	0	0	0	0	0	100.00%
Oct-11	152	87	152	152	8	8	2	0	0	0	0	0	99.83%
Nov-11	172	96	172	172	9	9	0	0	1	3	0	0	99.65%
Dec-11	242	140	242	291	9	9	1	0	4	7	0	0	99.33%
Jan-12	567	302	567	567	9	9	0	0	0	0	0	0	100.00%
Feb-12	307	168	307	307	8	8	0	0	0	0	0	0	100.00%
Mar-12	181	110	181	181	9	9	0	0	0	0	0	0	100.00%
Apr-12	161	93	161	161	8	8	0	0	0	0	0	0	100.00%
May-12	97	58	97	97	10	10	0	0	0	0	0	0	100.00%
Jun-12	73	43	73	73	8	8	0	0	0	0	0	0	100.00%
Jul-12	113	67	113	113	9	9	0	0	0	0	0	0	100.00%
Aug-12	113	68	113	113	9	9	0	0	0	0	0	0	100.00%
Sep-12	116	66	116	116	8	8	0	0	0	0	0	0	100.00%
Oct-12	136	79	136	136	8	8	0	0	0	0	0	0	100.00%
Nov-12	195	107	195	195	9	9	1	1	1	0	0	0	99.79%
Dec-12	379	203	379	376	8	8	6	3	1	0	0	0	99.65%
Jan-13	563	288	563	563	9	9	5	2	0	0	0	0	99.84%
Feb-13	329	178	329	329	8	8	0	0	0	0	0	0	100.00%
Mar-13	219	116	219	219	8	8	2	0	0	0	0	0	99.88%
Apr-13	219	116	219	219	8	8	2	0	0	0	0	0	99.88%
May-13	176	94	176	176	9	9	0	0	0	1	0	0	99.91%
Jun-13	94	59	94	94	8	8	0	0	0	0	0	0	100.00%
Jul-13	83	47	83	83	9	9	0	0	0	1	0	0	99.82%
Aug-13	152	82	152	152	8	8	0	0	0	0	0	0	100.00%
Sep-13	109	61	109	109	9	9	0	0	0	0	0	0	100.00%
Oct-13	149	82	149	149	7	7	0	0	0	0	0	0	100.00%
Nov-13	119	64	119	119	8	8	0	0	0	0	0	0	100.00%
Dec-13	301	158	301	301	9	9	0	0	0	0	0	0	100.00%
Jan-14	554	287	554	554	9	9	0	0	0	0	0	0	100.00%
Feb-14	165	94	165	165	8	8	0	0	0	0	0	0	100.00%
Mar-14	135	75	136	136	7	7	1	1	0	0	0	0	99.81%
Apr-14	77	44	77	77	9	9	0	0	0	0	0	0	100.00%
May-14	103	61	103	103	8	8	0	0	0	0	0	0	100.00%
Jun-14	31	23	31	31	9	9	0	0	0	0	0	0	100.00%
Jul-14	23	19	23	23	9	9	1	0	0	0	0	0	99.52%
Aug-14	75	46	75	75	9	9	6	0	0	0	0	0	99.01%
Sep-14	168	94	168	168	8	8	0	0	0	0	0	0	100.00%
Oct-14	502	261	503	503	10	10	0	0	0	0	0	0	100.00%
Nov-14	410	221	410	410	7	7	0	0	0	0	0	0	100.00%
Dec-14	386	208	386	386	9	9	0	1	0	2	0	0	99.89%
Jan-15	602	319	602	602	9	9	0	0	0	0	0	0	100.00%
Feb-15	351	187	351	351	8	8	0	0	0	0	0	0	100.00%
Mar-15	183	101	183	183	9	9	0	0	0	0	0	0	100.00%
Apr-15	134	79	134	134	9	9	0	0	0	0	0	0	100.00%
May-15	123	72	123	123	8	8	0	0	0	0	0	0	100.00%
Jun-15	93	55	93	93	9	9	0	0	0	0	0	0	100.00%

Weighing rate in calculation for water quality guideline compliance rate:
 - For physical item: 20%
 - For chemical item: 30%
 - For microbiological item: 50%

Water Quality Standard Compliance Rate – Guaraquecaba

Month	Total Number of Sample						Number of Sample Not Conform to Standard						Compliance rate (%)
	Physical		Chemical		Biological		Physical		Chemical		Biological		
	Turbidity	Color	Residual Chlorine	Fluoride	Total Coliform	E-Coli	Turbidity	Color	Residual Chlorine	Fluoride	Total Coliform	E-Coli	
Jan-10	302	302	302	302	8	8	0	0	0	0	0	0	100.00%
Feb-10	240	240	240	240	8	8	0	0	0	0	0	0	100.00%
Mar-10	278	278	278	278	8	8	0	0	0	0	0	0	100.00%
Apr-10	270	270	270	270	8	8	0	0	0	0	0	0	100.00%
May-10	281	281	281	281	8	8	0	0	0	0	0	0	100.00%
Jun-10	250	250	250	250	8	8	1	0	0	0	0	0	99.96%
Jul-10	264	264	264	264	8	8	0	0	0	0	0	0	100.00%
Aug-10	277	277	277	277	8	8	0	0	0	0	0	0	100.00%
Sep-10	272	272	272	272	9	9	0	0	0	0	0	0	100.00%
Oct-10	263	263	263	263	8	8	0	0	0	0	0	0	100.00%
Nov-10	255	255	255	255	9	9	0	0	0	0	0	0	100.00%
Dec-10	285	285	285	285	8	8	0	0	0	0	0	0	100.00%
Jan-11	255	255	255	255	8	8	0	0	0	0	0	0	100.00%
Feb-11	241	241	241	241	8	8	0	0	0	0	0	0	100.00%
Mar-11	277	277	277	277	9	9	0	0	0	0	0	0	100.00%
Apr-11	279	279	279	279	8	8	0	0	0	0	0	0	100.00%
May-11	262	262	262	262	8	8	0	0	0	0	0	0	100.00%
Jun-11	276	276	276	276	8	8	0	0	0	0	0	0	100.00%
Jul-11	244	244	244	244	9	9	0	0	0	0	0	0	100.00%
Aug-11	246	246	246	246	8	8	0	0	0	0	0	0	100.00%
Sep-11	250	250	250	250	8	8	0	0	0	0	0	0	100.00%
Oct-11	246	246	246	246	7	7	0	0	0	0	0	0	100.00%
Nov-11	252	252	252	252	8	8	0	0	0	0	0	0	100.00%
Dec-11	252	252	252	252	10	10	0	0	0	0	0	0	100.00%
Jan-12	288	288	288	288	9	9	0	0	0	0	0	0	100.00%
Feb-12	268	268	268	268	6	6	0	0	0	0	0	0	100.00%
Mar-12	278	278	278	278	9	9	0	0	0	0	0	0	100.00%
Apr-12	256	256	256	256	8	8	0	0	0	0	0	0	100.00%
May-12	281	281	281	281	10	10	0	0	0	0	0	0	100.00%
Jun-12	246	246	246	246	7	7	0	0	0	0	0	0	100.00%
Jul-12	252	252	252	252	9	9	0	0	0	0	0	0	100.00%
Aug-12	256	256	256	256	9	9	0	0	0	0	0	0	100.00%
Sep-12	267	267	267	267	8	8	0	0	0	0	0	0	100.00%
Oct-12	251	251	251	251	7	7	0	0	0	0	0	0	100.00%
Nov-12	249	249	249	249	6	6	0	0	0	0	0	0	100.00%
Dec-12	349	349	349	349	8	8	0	0	0	0	0	0	100.00%
Jan-13	472	472	472	451	7	7	0	0	0	0	0	0	100.00%
Feb-13	406	406	406	406	7	7	0	0	0	0	0	0	100.00%
Mar-13	415	415	415	415	8	8	0	18	0	3	0	0	99.46%
Apr-13	468	468	468	468	9	9	0	0	0	0	0	0	100.00%
May-13	481	481	481	481	9	9	0	0	0	0	0	0	100.00%
Jun-13	468	468	467	468	8	8	0	0	0	0	0	0	100.00%
Jul-13	455	455	455	454	7	7	0	0	0	0	0	0	100.00%
Aug-13	445	445	445	445	8	8	0	0	0	0	0	1	96.88%
Sep-13	462	462	451	462	8	8	0	0	0	0	0	0	100.00%
Oct-13	411	411	410	411	8	8	0	0	0	0	0	0	100.00%
Nov-13	423	424	413	388	9	9	2	0	1	2	0	0	99.84%
Dec-13	442	442	437	417	10	10	0	0	0	4	0	0	99.86%
Jan-14	450	450	450	450	9	9	1	0	0	0	0	0	99.98%
Feb-14	457	464	465	465	8	8	0	0	0	4	0	0	99.87%
Mar-14	503	503	503	502	8	8	0	0	0	34	0	0	98.99%
Apr-14	466	466	509	510	9	9	0	0	0	9	0	0	99.74%
May-14	459	466	495	495	10	10	0	0	0	7	0	0	99.79%
Jun-14	427	427	461	462	8	8	0	0	0	4	0	0	99.87%
Jul-14	419	419	447	447	10	10	0	0	0	2	0	0	99.93%
Aug-14	443	445	473	473	8	8	0	0	0	0	0	0	100.00%
Sep-14	447	447	470	469	9	9	0	0	0	2	0	0	99.94%
Oct-14	508	509	541	541	9	9	0	0	0	1	0	0	99.97%
Nov-14	433	433	460	461	9	9	0	0	0	4	0	0	99.87%
Dec-14	464	465	482	482	9	9	0	0	1	0	0	0	99.97%
Jan-15	475	475	480	479	8	8	0	0	0	0	0	0	100.00%
Feb-15	451	451	461	461	8	8	0	0	0	0	0	0	100.00%
Mar-15	441	442	475	475	9	9	0	0	0	0	0	0	100.00%
Apr-15	445	445	484	486	8	8	0	0	0	2	0	0	99.94%
May-15	456	456	490	492	8	8	0	0	0	1	0	0	99.97%
Jun-15	414	414	434	436	9	9	0	0	0	0	0	0	100.00%

Weighing rate in calculation for water quality guideline compliance rate:

- For physical item: 20%
- For chemical item: 30%
- For microbiological item: 50%

A11-1 下水管路の補修・更新計画

JAPAN INTERNATIONAL COOPERATION AGENCY (JICA)

PARANA STATE SANITATION COMPANY (SANEPAR)

**PROJECT
FOR
IMPROVEMENT OF OPERATION AND MAINTENANCE
OF
WATER SUPPLY AND SEWERAGE SYSTEMS
IN
PARANA STATE**

**REHAVILITATION, RENEWAL AND IMPROVEMENT
PLAN OF SEWAGE PIPE NETWORK**

(Pilot Area at CMA)

DRAFT

January 2015

**JAPAN INTERNATIONAL COOPERATION AGENCY
(JICA)**

NIHON SUIDO CONSULTANTS Co., Ltd

**PROJECT FOR IMPROVEMENT OF OPERATION AND MAINTENANCE OF
WATER SUPPLY AND SEWERAGE SYSTEMS IN PARANA STATE, BRAZIL**

(Third Fiscal Year)

**REHAVILITATION, RENEWAL AND IMPROVEMENT PLAN OF SEWAGE
PIPE NETWORK (Pilot Area at CMA)**

TABLE OF CONTENTS

1.	Basic Policy for the Establishment of the Plan	1
1-1	Selection of the Pilot Area.....	1
1-2	Investigation and Diagnosis of Sewage Pipe Network	1
1-3	Investigation of illegal connection using Dying test (VTA) and measures for them.....	1
1-4	Size-up Plan of the Sewage Pipe.....	1
2.	Study Area	2
3.	Investigation and Diagnosis of Sewage Pipe Network	4
3-1	Investigation and Diagnosis method	4
3-2	Criteria for the Diagnosis of sewage Pipe.....	4
3-3	Results of Investigation and Diagnosis of Sewage Pipe Network	5
4.	Investigation of Illegal Connection	13
4-1	Dying Test (VTA).....	13
4-2	Smoke Test.....	14
5.	Size-up Plan of Sewage Pipe Network.....	17
5-1	Actual Condition and Measures.....	17
5-2	Identifying of Rain Water Inflow by Flow Rate Investigation	18
5-3	Evaluation of the Capacity of Existing Sewage Pipe Network	18
6.	Activities of Urban River Revitalization Plan (PRRU) and Environmental Education.....	21
6-1	Activities of Urban River Revitalization Plan (PRRU)	21
6-2	Activities of Environmental Education (River School).....	22
7.	Rehabilitation, Renewal, and Improvement Plan of Sewage Pipe Network.....	23
7-1	Size-up Plan of Sewage Pipe	23
7-2	Renewal Plan of Sewage Pipe Network.....	25

7-3 Rehabilitation Plan of sewage Pipe network.....	25
8. Challenges and Proposal	26
8-1 Process of Investigation and Diagnosis of Sewage Pipe Network	26
8-2 Diagnosis of Sewage Pipe Network.....	26

1. Basic Policy for the Establishment of the Plan

Comprehensive improvement plan including measures for illegal connection and size-up of sewers with insufficient capacity will be established in addition to the structural rehabilitation of sewers base on the investigation and diagnosis of sewers using TV camera.

1-1 Selection of the Pilot Area

Areonzinho River basin was selected as a pilot area in CMA which satisfied the conditions beneath.

- ✓ To have an average condition in CMA
- ✓ To be an area where water quality of the river can be monitored
- ✓ To be an area with jurisdiction of URCT-L only

The pilot area was enlarged and the area was doubled considering access to the river for monitoring. Investigation of sewage pipe network and VTA was implemented at the whole area and the smoke test was implemented at the original area.

1-2 Investigation and Diagnosis of Sewage Pipe Network

All the sewage pipe lines was investigated and diagnosed preliminary by a simple TV camera and selected pipe lines to be diagnosed by an insert-type TV camera considering that this work is a pilot project for implementing the diagnosis in the whole CMA area. Sewage pipes were diagnosed to ranking using criteria on breakage, crack, misalignment and slackening etc. Pipe line by a unit of inter manholes was scored and selected to the line to be rehabilitated all the line or those rehabilitated partially.

1-3 Investigation of illegal connection using Dying test (VTA) and measures for them

VTA was implemented at all the pilot area and smoke test was implemented at the one part of it (the original area – area 1) VTA was implemented by a method that SANEPAR has been done. Smoke test was implemented by the method that was newly developed to find illegal connections or breakage of sewers.

1-4 Size-up Plan of the Sewage Pipe

More than 90% of the sewage pipes have a dimension of 150mm. Especially at the section with relatively large catchment area the sewage pipe has an almost full-flow even in a dry weather. In a wet weather infiltration will be added to it and overflow to the road or spouting to the ground through broken part by water pressure easily. On the other hand in the level of trunk sewers studied by elaboration of the master plan a section with insufficient capacity was not identified.

2. Study Area

The study area is shown at **Figure 1-1** and the outline of it is shown in **Table 1-1**.



Figure 1-1 Study Area

Table1-1 Outline of the Pilot Area

	Area 1	Area 2	Total Area
Area	122ha	157ha	279ha
Extension of Sewge Pipes	31,618m	33,106m	64,562m
Number of manholes	573	732	1,305
Number of House Connections	2,414	2,144	4,558

3. Investigation and Diagnosis of Sewage Pipe Network

3-1 Investigation and Diagnosis method

The flow diagram of the investigation and diagnosis is shown in **Figure 3-1**. It is necessary to investigate and diagnose the sewage pipe network effectively and efficiently because the total length of it in whole CMA area reaches more than 9,000km. Consequently the primary diagnosis will be implemented firstly to select the sections to be investigated and diagnosed secondarily by an insert-type TV camera.

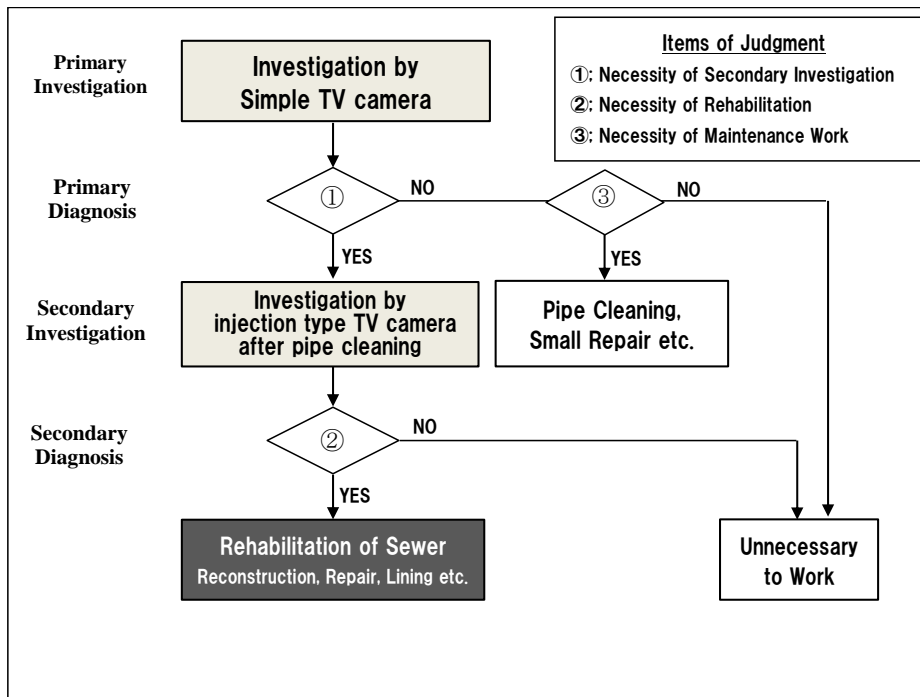

Figure 3-1 Flow Diagram of the Investigation and Diagnosis of Sewage Pipe Network

The selected sewage pipes will be investigated secondarily by an insert-type TV camera and diagnosed to decide to be rehabilitated wholly or partially based on the criteria in the next section.

3-2 Criteria for the Diagnosis of sewage Pipe

The criteria for the diagnosis of sewage pipe were established based on the criteria in Japan and the brain-storming of SDT.

3-2-1 Preliminary Diagnosis by Simple TV Camera

The purpose of the preliminary diagnosis by a simple TV camera is to judge the necessity of a secondary diagnosis by an insert-type TV camera and to judge the necessity of repairs at a man hole or connection part of manhole. At the same time a sighting survey will be implemented to find a road depression or a breakage of a house inlet. The criteria to judge the necessity of a secondary diagnosis by an insert type (Evaluation ① in the **Figure 3-1**) are shown as follows.

- Pipe is submerged.

- Sewage flow volume at the outlet of the pipe is smaller than that of inlet.
- Breakage of pipe or projecting of house connection pipe is verified by TV camera etc.

3-2-2 Secondary Diagnosis by an Insert-type TV Camera

In the secondary diagnosis by an insert-type TV sites with structural problem or problem in maintenance on will be identified. In case of structural problems each problem will be classified by the items of corrosion, breakage and infiltration and evaluated by 4 stages. Each stage has a weighted point, for example A; 5 points, B; 3points, C; 1point ,D; 0 point, and these points will be sum-upped for each span inter manholes. The section with more than 21 points will be targeted to be rehabilitated or renewed wholly. The section with less than 20 points will be targeted to be repaired partially. Even in case with more than 21 points, partial repairmen can be applied considering the state of problems. The criteria for the secondary diagnosis are shown in **Table 3-1**.

Table 3-1 Criteria for Secondary Diagnosis by Insert-type TV Camere

DIAGNÓSTICO DA REDE COLETORA DE ESGOTO			
TABELA PARA CRITÉRIOS DE CLASSIFICAÇÃO DE ANORMALIDADES			
PROBLEMAS ESTRUTURAIS			
Nº	ANORMALIDADES	AE	BE
1	Corrosão da tubulação	Exposição do vergalhão	Exposição do material do gravel
2	Avaria (Trinca, Deslocado, Quebrado)	Depressão (rachadura / colapso)	Fissura de forma geral
3	Infiltração	Água jorrando	Água minando/escorrendo
4	Desalinhamento da junção da tubulação	Totalmente desalinhada	Pouco Desalinhada
5	Invasão da raiz de árvore	Acima de 50% da seção transversal	Menor que 50% da seção transversal
6	Sifonamento da tubulação	Maior que 50% da seção cheia	Menor que 50% da seção cheia
7	Vazamento para a GAP/Rio	Grande intensidade	Pequena intensidade
PROBLEMAS DE MANUTENÇÃO			
Nº	ANORMALIDADES	AM	BM
11	Ligação irregular	Acima de 50% do diâmetro	Menor que 50% do diâmetro
12	Gordura	Maior que 30 % da seção transversal	Menor que 30% da seção transversal
13	Sujo com areia e terra	Acima de 50%	Menor que 50%
14	Sujo com bucha	Acima de 50%	Menor que 50%
15	Seção da Tubulação	Afogado	Entre 100% e 75% da seção
LEGENDA			
A = REPARO EMERGENCIAL		B = REPARO PLANEJADO	C = OBSERVAÇÃO CONTINUA
5 pontos		2 pontos	0 pontos

Versão R1 (Novembro/2014)

3-3 Results of Investigation and Diagnosis of Sewage Pipe Network

3-3-1 Results of Primary Investigation and Diagnosis

The results of investigation by a simple TV camera were summarized 1,168 reports in the format illustrated in **Figure 3-2**. The summary table is shown in **Table 3-2**. **Photograph 3-1** shows field



Photograph 3-1 Field Investigation by Simple TV camera

survey of the primary investigation.

Figure 3-2 Example of Report of Primary Investigation

The summary of the sections where secondary diagnosis is needed are shown in Table 3-2.

Table 3-2 The summary of the sections where secondary diagnosis is needed

	Number of Spans	Total Extension(m)
Sections with need of Secondary Diagnosis	158	7,605m

Table 3-3 shows points with need of repair of manhole or pipe connection section of manhole and removal of blockage. Beyond that 9 illegal house connection were identified. These points with problems will be repaired in the maintenance work.

Table 3-3 Problems Found by Primary Investigation

Items	Number(2012)	Number(2013)	Number(2014.7)
Repair of Manhole	35	106	114

Repair of Pipeline	21	84	256
Removal of blockage	141	182	119
Removal of blockage (house connection)	40	59	36
Total	237	431	525

Points with problems at manholes were plotted in the ledger and shown in **Figure 3-3**. Data were sum-upped and are shown in **Table 3-4**.

Table 3-4 Number of the Problems of Manhole

	A	B	C	D
Number	109	375	146	506

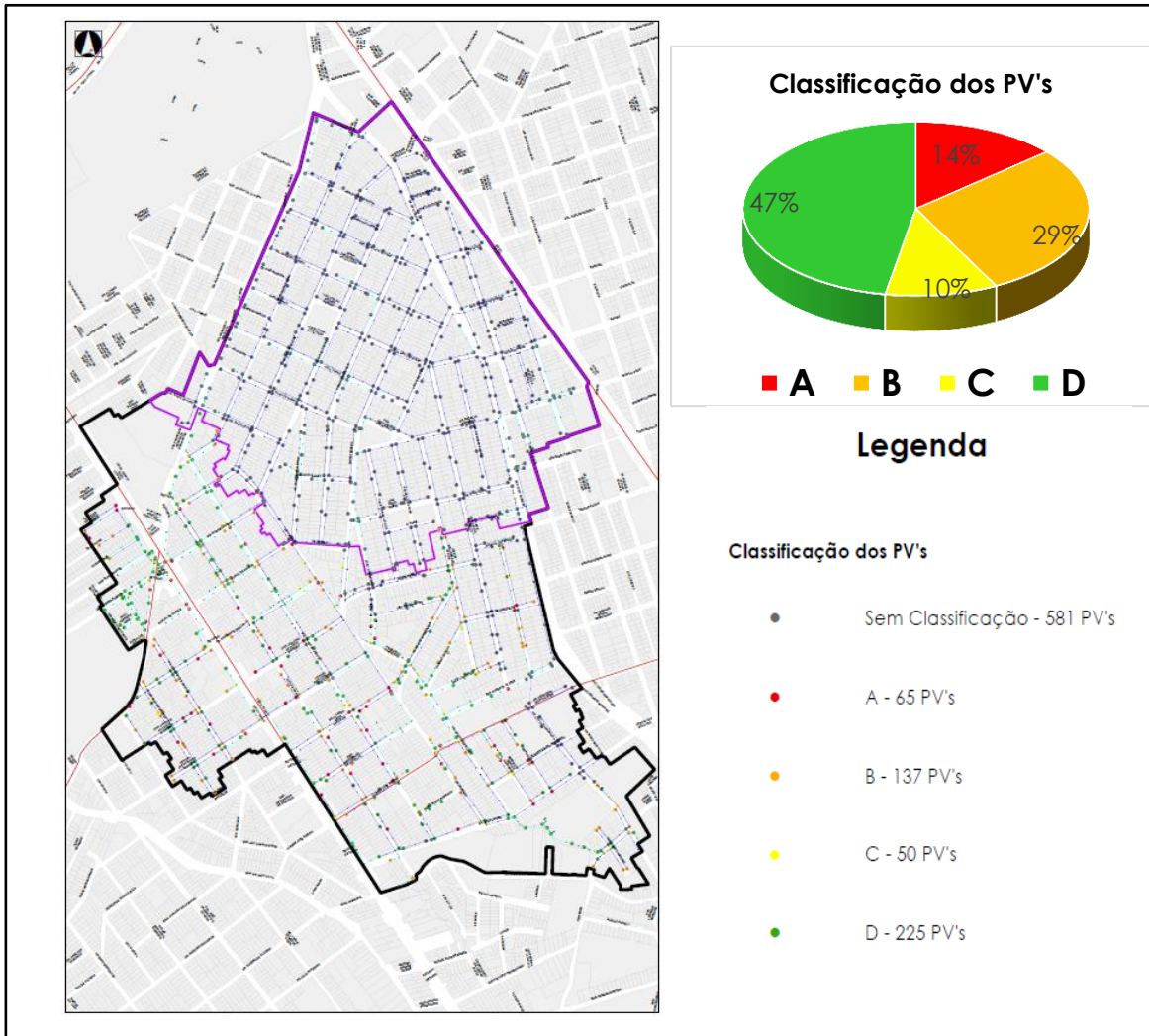

Figure 3-3 Results of Diagnosis of manholes

3-3-2 Results of Secondary Investigation and Diagnosis

The results of the investigation by an insert-type TV camera will be diagnosed by the criteria shown in **Table 3-1** and classified by the categories of structural problem or problem on maintenance and evaluated into 4 ranks, A to D. The points with problems found by an insert-type TV camera were summed and shown in **Table 3-5**. All the results are shown in **Table 3-7**, and illustrated in **Figure 3-4**.

Table 3-5 Problems found by Insert-Type TV Camera

	Structural Plomlem			
	A	B	C	D
Number	29	23	76	27



Photograph 3-2 Field Investigation by Insert-Type TV Camera

The results of summing-up of weighted points for section inter manholes for each rank are shown in **Table 3-6**. The highest point shows 49 point and 14% is ranked A which are targeted to be rehabilitated wholly. The most frequent rank is C which shares 55%. On the whole it was rated as relatively sound.

Table 3-6 Results of Diagnosis of Sewage Pipes by Ranking

	A	B	C	D
	More than 21	20—11	11—1	0
Extension (m)	2,096	1,473	4,330	1,327

Table 3-7.1 Result of Secondary Diagnosis by Insert-type TV camera

	ENDEREÇO	CÓD_RCE	A	B	C	D	EXTENSÃO FILMADA	EXTENSÃO CADASTRADA	NOTA PONTUAÇÃO	REALIZADO POR
1	Rua José Lucas	1_82346				7	53.10	53.62	0	Abatê
2	Rua Cónego Januário de Cunha Barbosa	1_82015				4	69.00	69.00	0	Abatê
3	Rua Franklin Soares Gomes	1_119538				1	12.80	12.62	0	Abatê
4	Rua General Setembrino de Carvalho	1_81536				1	12.80	13.60	0	Abatê
5	Rua Marechal Cardoso Junior	1_82141				6	61.10	65.00	0	Abatê
6	Rua Comendador Pinto Bandeira	1_81559				1	15.60	16.32	0	Abatê
7	Avenida Comendador Franco	1_674816				1	53.00	63.00	0	Abatê
8	Avenida Comendador Franco	1_635939				3	80.00	89.38	0	Abatê
9	Avenida Comendador Franco	1_598186				6	58.40	55.70	0	Abatê
10	Rua Doutor Brasílio Ferreira da Luz	1_81497				1	16.40	12.85	0	Abatê
11	Rua Doutor Brasílio Ferreira da Luz	1_81510				3	13.00	13.83	0	Abatê
12	Rua Blasco Ibanez	1_81549				4	17.20	43.00	0	Abatê
13	Rua Blasco Ibanez	1_81548				5	37.80	59.90	0	Abatê
14	Rua Ivo Ferro	1_373385				1	1.90	10.80	0	Abatê
15	Rua Luigi Romano	1_557591				2	34.90	67.74	0	Abatê
16	Rua João Doetzer	1_338515				1	13.70	34.00	0	Abatê
17	Rua Nossa Senhora de Lourdes	1_82262				3	34.10	55.00	0	Abatê
18	Rua Frei Francisco Sampaio	1_81546				2	30.12	88.50	0	Manutenção - Teste de Fumaça
19	Rua André Petrelli	1_81817				3	53.04	39.00	0	Manutenção - Teste de Fumaça
20	Rua Tenente Brigadeiro Francisco Assis Correa de Mello	1_81916				3	44.60	90.00	0	Manutenção - Teste de Fumaça
21	Rua Eduardo Couture	1_81931				3	48.21	99.33	0	Manutenção - Teste de Fumaça
22	Rua Almirante Dídio Costa	1_81936				7	48.74	60.00	0	Manutenção - Teste de Fumaça
23	Rua Frei Francisco Sampaio	1_452069				2	37.59	38.00	0	Manutenção - Teste de Fumaça
24	Rua Frei Francisco Sampaio	1_737174				12	56.05	68.40	0	Manutenção - Teste de Fumaça
25	Rua Frei Francisco Sampaio	1_737175				12	56.05	2.75	0	Manutenção - Teste de Fumaça
26	Rua Frei Francisco Sampaio	1_737176				9	54.20	62.80	0	Manutenção - Teste de Fumaça
27	Rua Comendador Pinto Bandeira	1_694350				3	41.34	42.90	0	Manutenção - Teste de Fumaça
28	Rua João Iliberê	1_296528			1	1	16.70	15.00	1	Abatê
29	Rua Eduardo Couture	1_81932			1	5	57.79	90.00	1	Manutenção - Teste de Fumaça
30	Rua Doutor Hugo de Barros	1_324142			2	1	26.69	35.00	2	Manutenção
31	Rua Frei Vicente Salvador	1_82302			2	4	68.90	70.20	2	Abatê
32	Rua Bandeirantes	1_729759			2	9	97.90	117.00	2	Abatê
33	Rua Doutor Constante Coelho	1_324161			3	3	19.19	25.46	3	Manutenção
34	Rua Almirante Dídio Costa	1_81921			3	8	88.60	73.67	3	Abatê
35	Rua Da Capitania	1_84091		1		1	2.00	3.80	3	Abatê
36	Rua Luigi Romano	1_81835		1		1	31.30	34.00	3	Abatê
37	Rua Eduardo Couture	1_81945		1		4	50.38	60.00	3	Manutenção - Teste de Fumaça
38	Rua Frei Francisco Sampaio	1_452067		1		3	32.83	34.50	3	Manutenção - Teste de Fumaça
39	Rua Herculano de Souza	1_292026		1	1	4	34.00	65.00	4	Manutenção
40	Rua Professor João Doetzer	1_81846		1	1	8	100.40	81.90	4	Abatê
41	Rua José de Mello Braga Junior	1_81864		1	1		14.70	17.32	4	Abatê
42	Rua Heitor de Andrade	1_81482			4	5	48.50	45.36	4	Abatê
43	Rua Coronel Joaquim Lacerda	1_82349		1	1	3	35.24	30.00	4	Manutenção - Teste de Fumaça
44	Rua Durval de Moraes	1_82025	1			2	37.70	95.00	5	Abatê
45	Rua General Setembrino de Carvalho	1_81535	1			5	72.90	76.10	5	Abatê
46	Rua José de Mello Braga Junior	1_557095	1			1	19.70	21.00	5	Abatê
47	Avenida Comendador Franco	1_598218	1			2	49.90	41.00	5	Abatê
48	Avenida Comendador Franco	1_615829	1			4	155.60	95.00	5	Abatê
49	Rua Doutor Brasílio Ferreira da Luz	1_81511	1			2	22.00	37.83	5	Abatê
50	Rua Frei Francisco Sampaio	1_81545	1				15.00	15.75	5	Abatê
51	Rua Lima Barreto	1_749125	1			1	11.40	12.00	5	Abatê
52	Rua Lima Barreto	1_748481	1				8.50	111.00	5	Abatê
53	Rua João Doetzer	1_81826	1			2	31.10	29.38	5	Abatê
54	Rua João Doetzer	1_81925	1			4	56.60	21.61	5	Abatê
55	Rua Antônio Pace	1_82294	1			4	35.80	35.00	5	Abatê
56	Rua Antônio Pace	1_82290	1			1	43.40	46.00	5	Abatê
57	Rua Antônio Pace	1_82289	1			4	57.00	58.50	5	Abatê
58	Rua Antônio Pace	1_82288	1			1	16.50	20.70	5	Abatê
59	Rua Antônio Pace	1_82287	1			2	37.10	39.10	5	Abatê
60	Rua Professor João Doetzer	1_338519	1				0.50	36.90	5	Abatê
61	Rua Tenente Brigadeiro Francisco Assis Correa de Mello	1_81904	1			5	39.69	74.00	5	Manutenção - Teste de Fumaça
62	Rua Tenente Brigadeiro Francisco Assis Correa de Mello	1_81912	1			3	46.48	102.29	5	Manutenção - Teste de Fumaça
63	Rua Eduardo Couture	1_303036	1			2	29.86	88.00	5	Manutenção - Teste de Fumaça
64	Rua Comendador Pinto Bandeira	1_694349	1	1		2	41.06	40.60	5	Operação - Teste de Fumaça
65	Rua Comendador Pinto Bandeira	1_694347	1			1	41.43	40.70	5	Operação - Teste de Fumaça
66	Rua João Iliberê	1_479086	1			1	12.29	16.70	6	Manutenção
67	Rua Heitor de Andrade	1_82200	1			1	40.90	47.53	6	Abatê
68	Rua Frei Francisco Sampaio	1_81543	1	2		4	77.00	87.62	6	Abatê
69	Rua Coronel Alfredo Ferreira Costa	1_81491	1			1	15.60	20.83	6	Abatê
70	Rua Barão de Monte Alegre	1_81909	1			1	51.62	86.00	6	Manutenção - Teste de Fumaça
71	Rua Almirante Dídio Costa	1_81917	1			1	44.48	60.00	6	Manutenção - Teste de Fumaça
72	Rua Rodolpho Serff	1_82424	1			2	51.78	56.42	7	Manutenção
73	Rua Franklin Soares Gomes	1_119518	1			2	25.70	30.00	7	Abatê
74	Rua José de Mello Braga Junior	1_81896	1	2		1	14.10	14.90	7	Abatê
75	Rua Ivo Ferro	1_324885	1			2	13.80	14.50	7	Abatê
76	Rua Heitor de Andrade	1_324137	1	1		4	63.24	660.00	7	Manutenção - Teste de Fumaça
77	Rua Doutor Constante Coelho	1_496589	1	1		1	8.25	12.90	8	Manutenção
78	Rua Senador Batista de Oliveira	1_82427	1	1		2	29.56	80.72	8	Manutenção
79	Rua Doutor Brasílio Ferreira da Luz	1_81496	1	1		6	47.00	55.55	8	Abatê
80	Rua Bandeirantes	1_83796	1	1			3.50	11.77	8	Abatê

Table 3-7.2 Result of Secondary Diagnosis by Insert-type TV camera

81	Rua Lima Barreto	1_749117	1	1			61.80	64.00	8	Abail
82	Rua João Doetzer	1_737386	1	1			0.30	16.00	8	Abail
83	Rua Tenente Brigadeiro Francisco Assis Correa de Mello	1_81914	1	1		8	83.73	90.00	8	Manutenção - Teste de Fumaça
84	Rua José Lucas	1_82321	1	1		7	51.33	50.00	8	Manutenção - Teste de Fumaça
85	Rua Maestro Antonello	1_82331		1	5	5	50.26	50.00	8	Operação - Teste de Fumaça
86	Rua Comendador Pinto Bandeira	1_694348	1	1		3	38.82	42.20	8	Manutenção - Teste de Fumaça
87	Rua Rodolpho Senif	1_82091		3		4	53.50	98.00	9	Manutenção
88	Rua Senador Batista de Oliveira	1_82434		3		1	35.60	84.85	9	Manutenção
89	Rua Heitor de Andrade	1_82201	1		4	5	40.10	45.00	9	Abail
90	Rua Heitor de Andrade	1_82385	1	1	1	6	47.11	56.30	9	Operação - Teste de Fumaça
91	Rua Heitor de Andrade	1_82390	1	1	1	6	56.19	69.94	9	Manutenção - Teste de Fumaça
92	Rua Eduardo Couture	1_81944		3			48.03	48.03	9	Operação - Teste de Fumaça
93	BR 277	1_82335	1	1	2	2	55.00	50.00	10	Abail
94	Rua Pedro Demeterco	1_414914	2				11.50	12.81	10	Abail
95	Rua José de Mello Braga Junior	1_81895	1	1	2	2	45.70	50.00	10	Abail
96	Rua Cônego Januário da Cunha Barbosa	1_81554	2				22.00	62.06	10	Abail
97	Avenida Comendador Franco	1_737331	2			3	91.60	35.00	10	Abail
98	Avenida Comendador Franco	1_737332	2			3	91.60	41.00	10	Abail
99	Rua Bandeirantes	1_680030	2				15.00	8.00	10	Abail
100	Rua João Doetzer	1_737388	2			2	18.00	19.00	10	Abail
101	Rua Nossa Senhora de Lourdes	1_82259	2				23.00	19.19	10	Abail
102	Rua Câmara Junior	1_82280	2			4	51.80	57.37	10	Abail
103	Rua Frei Francisco Sampaio	1_81959	2			2	43.15	53.00	10	Manutenção - Teste de Fumaça
104	Rua Heitor de Andrade	1_82383	2			1	14.60	16.91	10	Operação - Teste de Fumaça
105	Rua Comendador Pinto Bandeira	1_82237	2		1	4	44.80	48.00	11	Abail
106	Rua Câmara Junior	1_82313	1	2		3	72.50	70.00	11	Abail
107	Rua Bandeirantes	1_729761	1	2		11	98.90	125.00	11	Abail
108	Rua Nossa Senhora de Lourdes	1_82261	1	2		4	55.30	60.00	11	Abail
109	Rua Eduardo Couture	1_81933	2		1	5	85.98	90.00	11	Manutenção - Teste de Fumaça
110	Rua Maestro Antonello	1_82330		1	10	6	46.05	53.87	13	Operação - Teste de Fumaça
111	Rua Tenente Brigadeiro Francisco Assis Correa de Mello	1_81913	2	1	1	12	101.00	101.00	14	Manutenção - Teste de Fumaça
112	Rua Tenente Brigadeiro Francisco Assis Correa de Mello	1_81915	1	3		10	80.00	80.00	14	Manutenção - Teste de Fumaça
113	Rua Câmara Junior	1_82343		2	8		63.72	63.83	14	Operação - Teste de Fumaça
114	Rua Doutor Hugo de Barros	1_82204	1	3	1	2	47.50	30.98	15	Abail
115	Rua Targino da Silva	1_737283	2	1	2	10	65.40	39.00	15	Abail
116	Rua Targino da Silva	1_737284	2	1	2	10	65.40	35.00	15	Abail
117	Rua Cônego Januário da Cunha Barbosa	1_82022	3			3	47.20	50.00	15	Abail
118	Rua Antônio Paça	1_82292	3				10.60	10.25	15	Abail
119	Rua Coronel Joaquim Lacerda	1_81485	3			3	33.84	39.55	15	Manutenção - Teste de Fumaça
120	Rua Cônego Januário da Cunha Barbosa	1_736733	2	2		1	36.40	38.10	16	Abail
121	Rua Rodolpho Senif	1_82430	3		1	4	30.96	63.31	16	Manutenção - Teste de Fumaça
122	Rua Heitor de Andrade	1_81483	1	2	6	6	69.00	65.38	17	Abail
123	Rua Dona Saza Lattes	1_120169	1	3	3	3	45.60	79.40	17	Abail
124	Rua Nossa Senhora de Lourdes	1_82260	1	4		1	54.90	45.35	17	Abail
125	Rua Câmara Junior	1_82342		4	6	4	59.41	39.00	18	Operação - Teste de Fumaça
126	Rua Sinke Ferreira	1_737457	2	2	3	4	46.10	121.50	19	Abail
127	Rua Barão de Monte Alegre	1_81910	3	1	1	4	54.94	80.00	19	Manutenção - Teste de Fumaça
128	Rua General Setembrino de Carvalho	1_81538	4			1	42.30	44.00	20	Abail
129	Rua Frei Francisco Sampaio	1_82066		6	3	5	85.30	105.00	21	Abail
130	Rua Frei Francisco Sampaio	1_748888	3	2		2	28.15	30.10	21	Manutenção - Teste de Fumaça
131	Rua Comendador Pinto Bandeira	1_82236	3	2	1	3	49.60	50.78	22	Abail
132	Rua Barão de Monte Alegre	1_82251	3		8		79.00	79.48	23	Operação - Teste de Fumaça
133	Rua Sinke Ferreira	1_81799		7	3	7	78.20	84.00	24	USEG - Teste de Fumaça
134	Rua Frei Vicente Salvador	1_82303	4	1	2	4	66.10	69.00	25	Abail
135	Rua Almirante Didio Costa	1_81922	4	2	0	1	18.10	13.11	26	Abail
136	Rua Herculano de Souza	1_414907	5		2	1	35.50	72.84	27	Abail
137	Rua Pedro Demeterco	1_81487	3	4	1	6	59.20	68.82	28	Abail
138	Rua General Setembrino de Carvalho	1_81537	6			2	34.50	54.00	30	Abail
139	Rua Sinke Ferreira	1_81798		10		5	58.46	71.51	30	USEG - Teste de Fumaça
140	Rua São Tomé	1_81950	5	2		7	69.66	73.36	31	Manutenção - Teste de Fumaça
141	Rua Sinke Ferreira	1_737163	4	3	3	6	112.06	59.00	32	Manutenção
142	Rua Sinke Ferreira	1_737164	4	3	3	6	112.06	66.00	32	Manutenção
143	Rua Câmara Junior	1_82314	2	6	4	3	84.70	83.00	32	Abail
144	Rua Ivo Ferro	1_324879	6	1			29.50	31.80	33	Abail
145	Rua Câmara Junior	1_82344	3	4	7	4	54.44	57.11	34	Operação - Teste de Fumaça
146	Rua Câmara Junior	1_82344	3	4	7	4	54.44	57.11	34	Operação - Teste de Fumaça
147	Rua Cônego Januário da Cunha Barbosa	1_81998	4	5		4	76.90	64.90	35	Abail
148	Rua Doutor Hugo de Barros	1_82205	6	2			28.60	40.00	36	Abail
149	Rua Rodolpho Senif	1_82431	6	2	3		69.30	69.30	39	Operação - Teste de Fumaça
150	Rua Tasso Azevedo da Silveira	1_82268	2	3	22	1	64.27	70.00	41	Operação - Teste de Fumaça
151	Rua Barão de Monte Alegre	1_82250	4	4	10		113.77	119.00	42	Operação - Teste de Fumaça
152	Rua Nossa Senhora de Lourdes	1_634655	9			6	97.09	100.00	45	Manutenção - Teste de Fumaça
153	Rua Iseo Dizari	1_120170	6	5	1	6	85.70	100.00	46	Abail
154	Rua Tasso Azevedo da Silveira	1_82266	1	8	17	6	79.43	87.07	46	Operação - Teste de Fumaça
155	Rua João Iliberé	1_296520	6	6	1	10	82.02	82.82	49	Manutenção
156	Rua Tasso Azevedo da Silveira	1_82267	4	5	17	1	81.96	76.00	52	Operação - Teste de Fumaça
157	Rua Sinke Ferreira	1_324150	10	2	1	6	77.72	88.00	57	USEG - Teste de Fumaça
158	Rua Tasso Azevedo da Silveira	1_82269	8	1	16	4	83.66	73.00	59	Operação - Teste de Fumaça
			226	177	231	534	7604.81	9225.44		

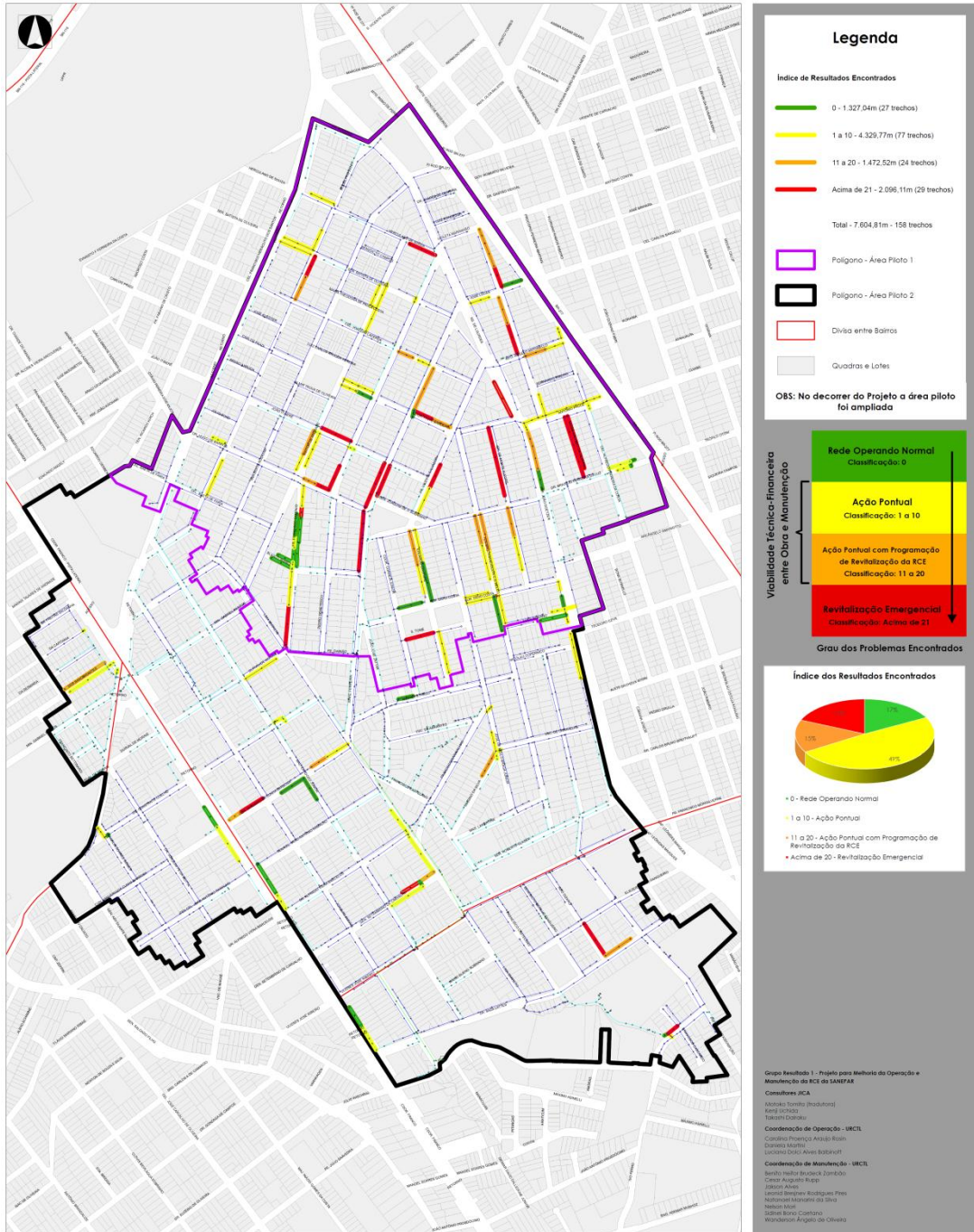

Figure 3-4 Results of Diagnosis by Insert-type TV camera plotted on the Ledger

4. Investigation of Illegal Connection

4-1 Dying Test (VTA)

SANEPAR has been implementing the dying test to find an illegal house connection from previous. The surveyed number is higher than the number of connection in CMA. The newly connected housings are investigated by this method and the condition of the connection is checked. In this project all the connections were checked by previous VTA and additional VTA. The results of the VTA are shown in **Table 4-1** and illustrated in **Figure 4-1**. 91% have no problem and illegal connection shares 3%, 159cases. ③ in the table shows the cases without sewage pipe at the road in front of the house. To construct a new sewage pipe there is a case that inhabitants need to pay one part of construction cost. Even in such case SENEPAR decided to prepare fund of it and new sewage pipes are under construction. The extension of constructing sewage pipe reaches 985m. ④ shows the case that the connection is difficult because the ground level of the house is lower than the sewage pipe. Although in this moment the connection in this case is difficult, the institutional measures should be considered such as subsidy system for install of a pump of personal property by referring the Japanese case.

Table 4-1 Results of Dying Test (VTA)

Items	Number
① Connection without Problem	4,182
② Connection with Problems	159
③ No Connection	106
④ No Connection by elevation	16
⑤ To be not Visited	59
⑥ Visit is Prolonged	36

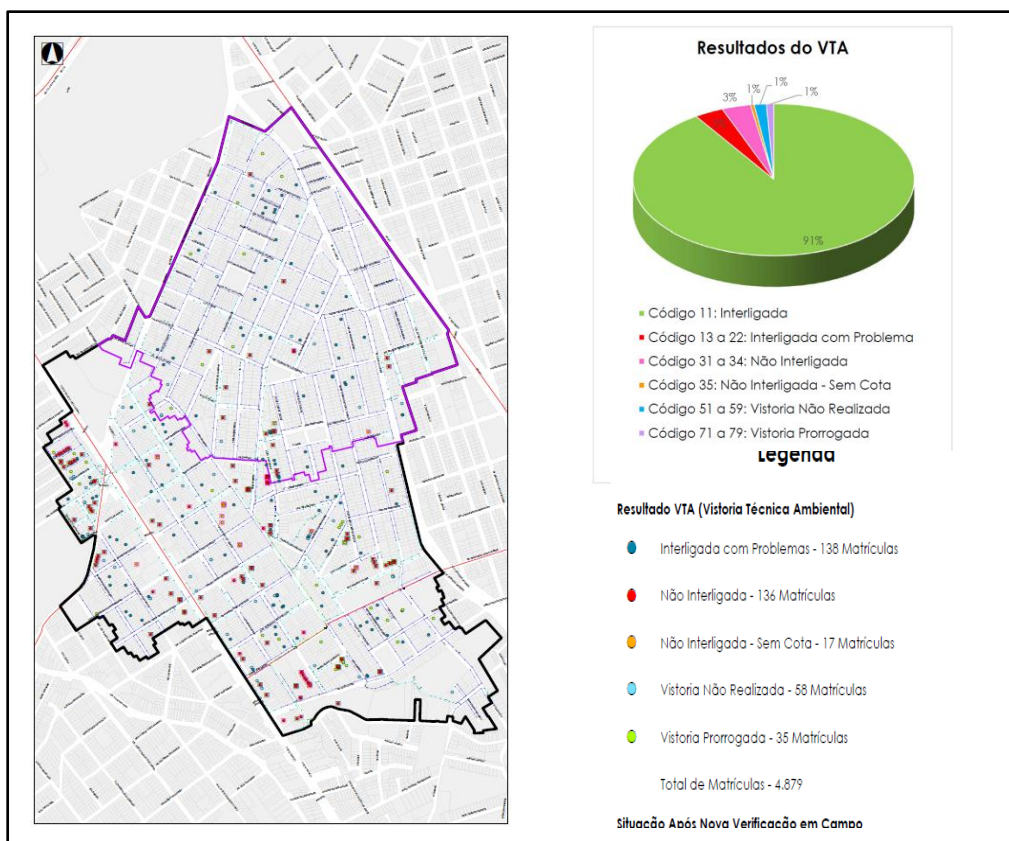

Figure 4-1 Results of Dying Test (VTA)

4-2 Smoke Test

A new method to generate smoke combusting the substance mixed of glycerin and water was developed and a smoke test using this equipment has been implementing from 2013. This method seems to be effective as a preliminary test although there is a problem of accuracy because smoke by this method will vanish in a short time compared with that by a smoke candle. Smoke test was implemented in the pilot area. The area of test was limited to the Area 1 122ha because of the budget. The result of this test is shown in **Table 4-2** and illustrated in **Figure 4-2**.

66 problems in total were identified of which 76% caused by a sewage pipe including cases with problem in a house connection also. These points will be checked by insert-type TV camera and repaired. Illegal house connections will be coped with by visit and encouragement of SANEPAR and will be coped with by the city government which is a authority in this problem.

Table 4-2 Results of Smoke Test

Encountered Irregularity	Number	%
Irregularity of Sewage Pipe	45	68
Irregularity of Residence	16	24
Irregularity of Sewage Pipe and Residence	5	8
Total	66	100



Photograph 4-1 Implementation of Smoke Test

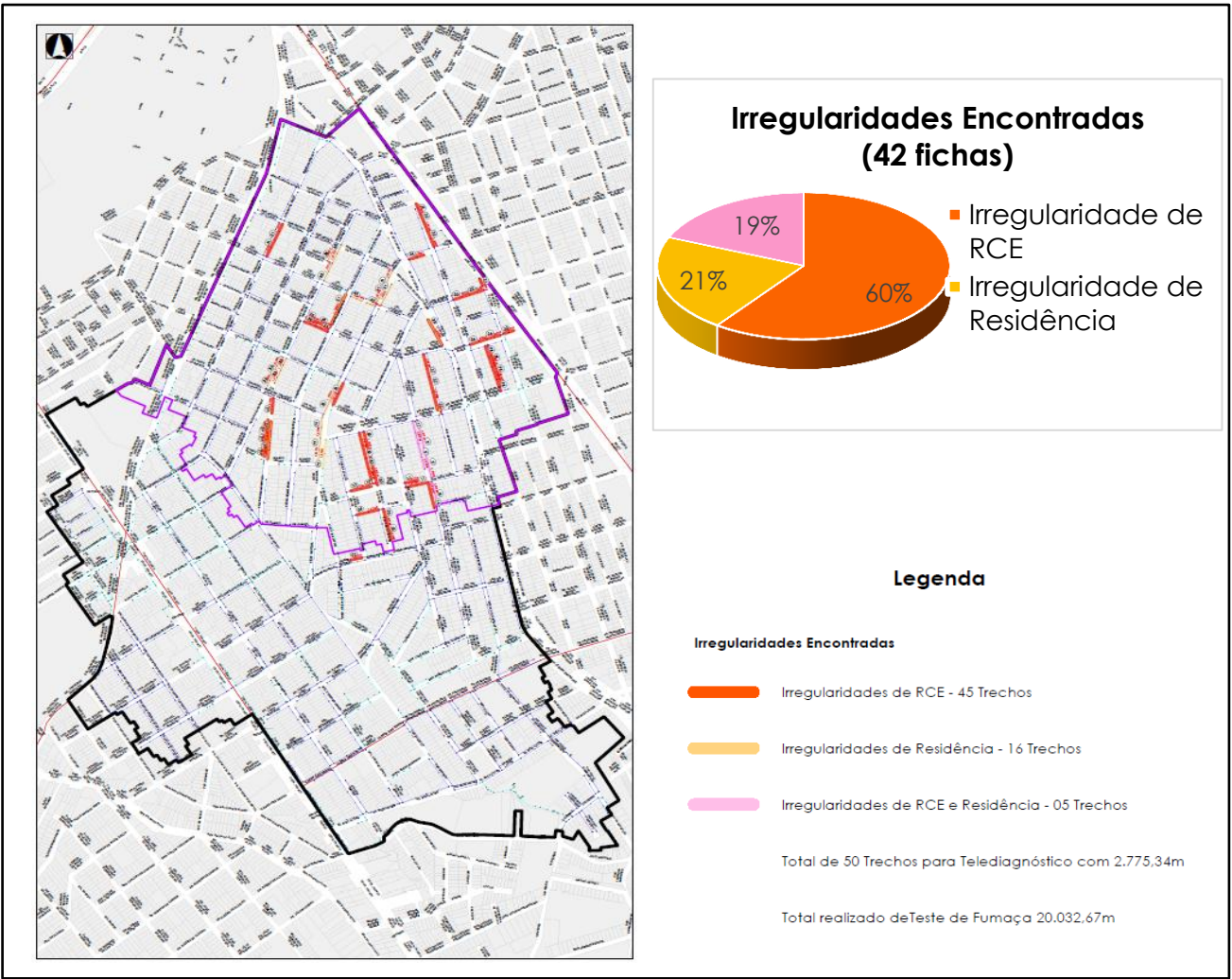

Figure 4-3 Result of Smoke Test

5. Size-up Plan of Sewage Pipe Network

5-1 Actual Condition and Measures

SANEPAR adopted diameter of 150mm as the minimum dimension of sewage pipe. Furthermore because of little reserve factor for sewage flow volume, almost all the sewage pipes are composed of 150mm and the share of 150mm in the pilot area exceeds 90%. On the other hand in wet weather much infiltration of rain water into sewage pipe is observed, as explained in the next section, that causes overflow of sewage to road and backflow to housing easily even without blockage of the pipe. There was a case that in the section, where once a leakage of sewage was repaired, another leakage occurred once more at the point different from repaired point. It is assumed that the sewage pipe has a full flow and the sewage spurted out though broken point by water pressure and enlarge it. Photograph 5-1 shows the sewage flow volume comparing before repair and after repair. The photograph after repair shows the sewage pipe is in full flow and in wet weather infiltration of rain water will be added to it, that provokes the pipe in a condition with pressure. And also it will be imagined easily that this condition with pressure will be extending to the upstream region.



Size-up of sewage pipe is planned for the purpose to protect the overflow to road or backflow to housing of sewage and breakage of sewage pipe by water pressure. It is not a good solution to size-up all the pipes with dimension of 150mm from the view point of cost/benefit, so that a critical section will be selected to size-up and the size-up plan will be elaborated. The critical section will be selected where a margin of capacity is small, there is much flow volume in dry weather and a leakage occurs frequently.

5-2 Identifying of Rain Water Inflow by Flow Rate Investigation

Investigation of flow rate of a trunk sewer with diameter of 500 mm at the downstream of the pilot area was implemented using an ultrasonic flow meter which is procured equipment. Result of investigation is illustrated in **Figure 5-1**. Compared with at the time of dry weather 3 times of flow volume was observed. That is, infiltration of rain water corresponded with 2 times of sewage.

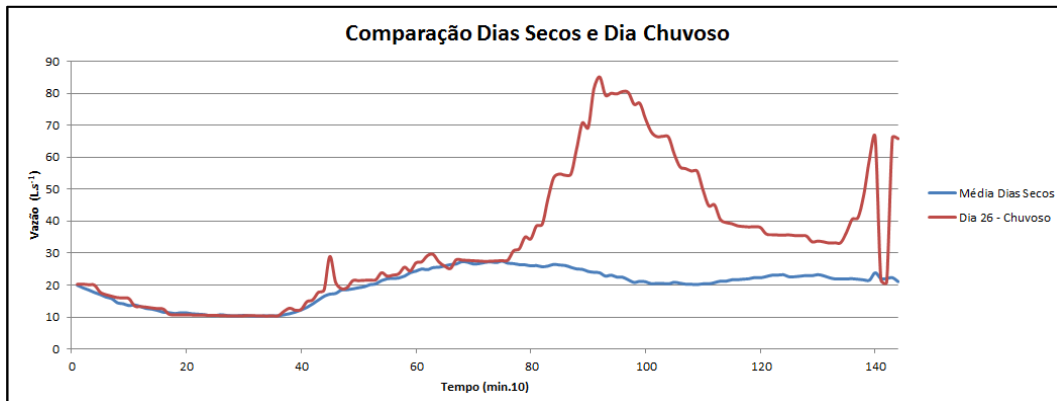

Figure 5-1 Result of Investigation of Flow Rate at Wet Weather

5-3 Evaluation of the Capacity of Existing Sewage Pipe Network

The flow rate of sewage pipe network of the pilot area was calculated and the capacity of the existing sewage pipe network was evaluated. To calculate the water consumption, which is basic data, actual consumption of water supply was adopted to improve the accuracy not using per capita consumption at the time of elaborating a master plan. Results are shown in **Table 5-1** and illustrated in **Figure 5-2**. The capacity of existing network is sufficient in case of adding the value used in the master plan as infiltration volume. There is no problem in the trunk sewer described in the master plan and the margin of a pipe is smaller at the downstream section with diameter of 150mm.

Table 5-1 Results of the Calculation of Flow Rate in the Pilot Area

POLÍGONO	INTERRELAÇÃO POLÍGONOS	VAZÃO TOTAL DE CADA POLÍGONO (L/s)	EXTENSÃO (M)	COTA FUNDO PV MONTANTE	COTA FUNDO PV JUSANTE	DECLIVIDADE I (m/m)	DIÂMETRO (mm)	MATERIAL	COEFICIENTE DE MANNING	LÂMINA %	LÂMINA PARA i: 0,0026
1	1	0.614	13.00	897.302	897.300	0.00015	150	Cerâmica	0.013	40	19
2	2, 1, 3, 4	4.868	13.00	898.650	898.410	0.01846	150	PVC	0.01	29	49
3	3	1.726	12.00	898.020	897.810	0.01750	150	Cerâmica	0.013	20	32
4	4	0.482	27.92	912.490	899.420	0.46812	150	Cerâmica	0.013	5	17
5	5	0.826	18.00	896.153	896.000	0.00850	150	Cerâmica	0.013	16	22
6	6, 5, 18	6.188	17.00	906.290	906.250	0.00235	250	Cerâmica	0.013	31	30
7	7, 6	7.699	39.00	904.040	903.420	0.01590	250	PVC	0.01	19	30
8	8, 9	11.109	18.00	903.789	903.204	0.03250	150	Cerâmica	0.013	44	>90
9	9, 2, 10	9.416	16.70	900.740	899.890	0.05090	150	PVC	0.01	31	76,5
10	10, 11	2.201	11.00	897.669	897.440	0.02082	150	Cerâmica	0.013	21	36
11	11	0.462	13.00	898.803	898.400	0.03100	150	Cerâmica	0.013	9	16
12	12	0.906	21.00	913.400	912.560	0.04000	150	PVC	0.01	10	20
13	13, 12, 23	4.562	12.75	895.750	894.650	0.08627	150	PVC	0.01	19	47
14	14, 13	6.406	11.00	899.156	898.550	0.05509	150	Cerâmica	0.013	29	69
15	15, 7, 8	23.295	10.00	897.300	897.140	0.01600	300	Cerâmica	0.013	29	48
16	16, 17	5.286	68.20	98.900	98.480	0.00616	250	PVC	0.01	20	25
17	17	2.627	14.00	898.275	898.000	0.01964	250	Cerâmica	0.013	12	20
18	18	2.190	20.70	910.550	910.500	0.00242	250	Cerâmica	0.013	19	18
19	19	4.484	104.00	900.478	897.460	0.02902	150	Cerâmica	0.013	28	55
20	20, 15, 16, 19	36.296	114.00	889.030	888.710	0.00281	400	Concreto	0.013	40	40
21	21, 14, 22	12.297	14.00	900.410	900.300	0.00786	150	Cerâmica	0.013	75	>90
22	22, 25	3.102	17.00	897.002	896.800	0.01188	150	Cerâmica	0.013	29	44
23	23, 24	1.447	22.00	907.963	907.528	0.01977	150	PVC	0.01	15	25
24	24	1.398	25.00	908.388	907.963	0.01700	150	PVC	0.01	16	26
25	25	0.393									
26	26, 21	13.876	125.50	887.870	883.040	0.03849	150	PVC	0.01	41	>90
27	27, 20	36.879	12.00	888.320	888.020	0.02500	400	Concreto	0.013	23	41
28	28	0.963	14.37	893.990	893.250	0.05150	150	Cerâmica	0.013	11	24
29	29	0.485	64.60	905.790	902.480	0.05124	150	Cerâmica	0.013	8	17
30	30	1.000	14.86	903.140	902.640	0.03365	150	Cerâmica	0.013	13	24
31	31, 30	4.472	14.40	891.090	891.020	0.00486	150	Cerâmica	0.013	45	55
32	32, 26, 27, 28, 29, 31	60.067	88.00	882.030	878.050	0.04523	500	Concreto	0.013	18	39

TRECHO	INTERRELAÇÃO POLÍGONOS	VAZÃO TOTAL DE CADA POLÍGONO (L/s)	EXTENSÃO (M)	COTA FUNDO PV MONTANTE	COTA FUNDO PV JUSANTE	DECLIVIDADE I (m/m)	DIÂMETRO (mm)	MATERIAL	COEFICIENTE DE MANNING	LÂMINA %	LÂMINA PARA i: 0,0026
A	2,1,3,4	4.868	56.00				150	PVC	0.01		49
B	2,1,3,4	4.868	69.00				150	PVC	0.01		49
C	10,11	2.201	77.00	101.44	99.15	0.02974	200	PVC	0.01	12	22
D	9,2,10	9.416	86.20	899.89	898.34	0.01798	150	PVC	0.01	41	76
E	6,5,18	6.188	51.60	906.25	904.98	0.02461	250	Cerâmica	0.013	18	30
F	6,5,18	6.188	30.60	904.98	904.19	0.02582	250	Cerâmica	0.013	17	30
G	6,5,18	6.188	17.76	904.19	904.04	0.00845	250	Cerâmica	0.013	23	30
H	7,6,8,9	18.808	57.20		901.03		300	Cerâmica	0.013		43
I	7,6,8,9	18.808	22.40	901.03	900.78	0.01116	300	Cerâmica	0.013	29	43
J	7,6,8,9	18.808	88.50	900.78	899.45	0.01503	300	Cerâmica	0.013	27	43
K	23,24	1.447	102.54				150	PVC	0.01		26
L	13,12,23	4.562	95.55	897.2	895.75	0.01518	150	PVC	0.01	29	47
M	14,13	6.406	30.00				150	Cerâmica	0.013		70
N	14,13	6.406	66.93				150	Cerâmica	0.013		70
O	15,7,8,16,17	28.581	84.70	897.14	896.79	0.00413	300	Cerâmica	0.013	47	54
P	15,7,8,16,17	28.581	101.62	896.79	895.42	0.01348	300	Cerâmica	0.013	34	54
Q	22,25	3.102	64.15				150	Cerâmica	0.013		44
R	22,25	3.102	40.00				150	Cerâmica	0.013		44
S	27,20,28	37.84	86.10				400	Concreto	0.013		41
T	27,20,28	37.84	21.4				400	Concreto	0.013		41
U	27,20,28	37.84	34.00				400	Concreto	0.013		41

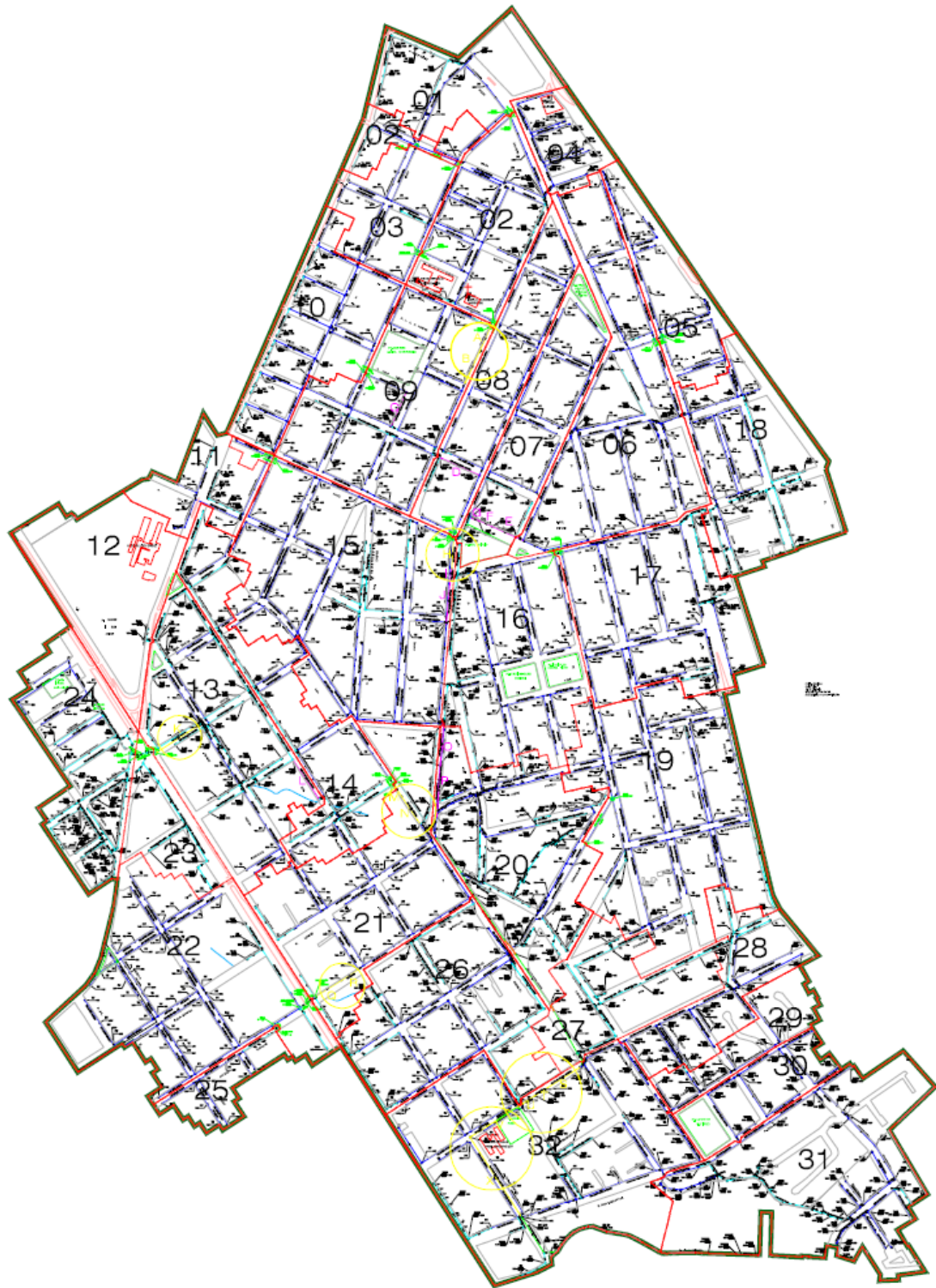

Figure5-2 The Rout Map for Calculation of Flow Rate

6. Activities of Urban River Revitalization Plan (PRRU) and Environmental Education

6-1 Activities of Urban River Revitalization Plan (PRRU)

SANEPAR has been implementing the project “Urban River Revitalization Plan” to cope with the water pollution of a river water cause by leakage or overflow of sewage. In this project targeting 5mg/ℓ of Oxygen Demand water quality is monitored and the leakage of sewage is found out by surveying sewage pipe network and the result is informed to the O&M sector.

In 2013 Areozinho River Basin, that is also the pilot area of this project, was selected for the activities of PRRU. As the result of the activities problems of sewage leakage were pointed out in the sections shown in **Figure 6-1**. The investigation using TV camera in this project also pointed out problems ranking them to A category. On the other hand in these sections the leakage occurred once more in the same section and at another point after repair of it. So that it is needed to consider rehabilitate them or size-up them.

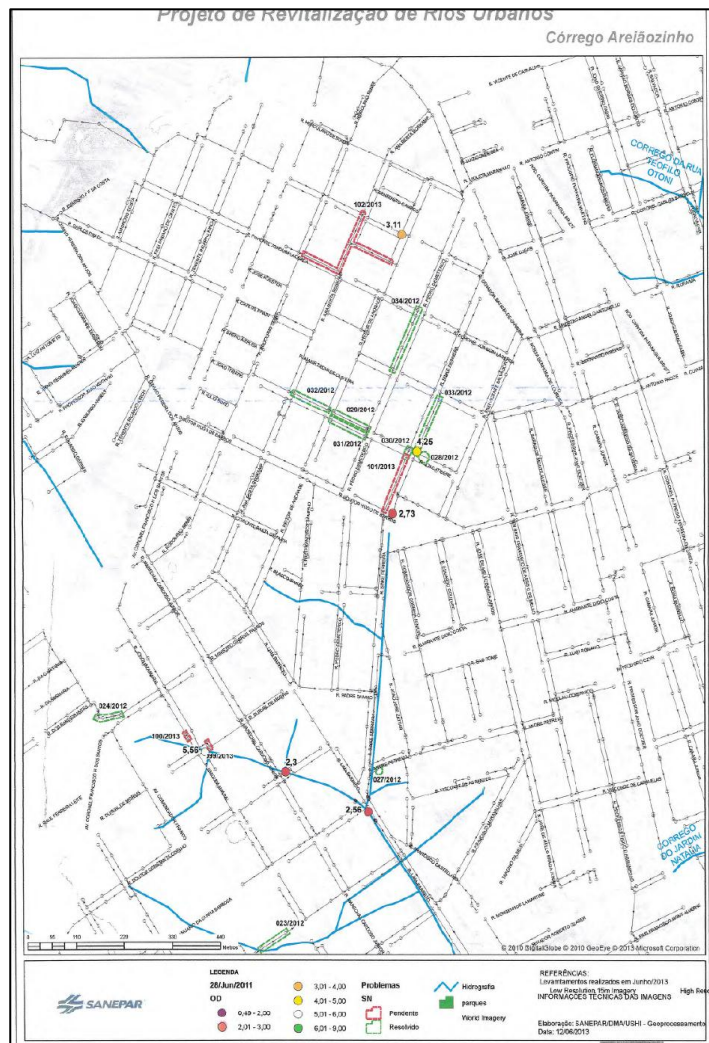

Figure 6-1 Points of Problems Pointed out by PRRU

6-2 Activities of Environmental Education (River School)

SANEPAR has been implementing the activities of environmental activities setting Environmental Education Division. In these activities 23 rivers were selected in Parana State and “River School” has been held, which monitors the river environment cooperating with inhabitants and schools in each basin. The purposes of this project are sustainable protection of water quality and water resource, improvement of the skill of students to analyse water quality, monitoring of the state of trash at the margin of the river and community participation to environmental protection. In the area of URCT-L Areonzinho River, which is the pilot area in CMA of this project, has selected to cooperate with this project and the activities has been implemented from 2013. The entity to cooperate with is the school having the faculty of environmental technology in this basin. The activities are monitoring of water quality of the river by students using the kits to analyze water quality, monitoring of trashes in the margin of the river, the grasp of secular change of water quality, planting of seedlings around the river, distribution of enlightenment leaflets to local residents and presentation meeting of the activities at the end of the year intending sustainable activities to next year.



7. Rehabilitation, Renewal, and Improvement Plan of Sewage Pipe Network

Rehabilitation, renewal, and improvement plan of sewage pipe network contains newly installation, size-up, rehabilitation and renewal and repair at the point with need of urgent work of sewage pipe. The newly installation is under construction as mentioned in the section 4.

7-1 Size-up Plan of Sewage Pipe

The sections to be size-upped were selected considering following items;

- ✓ Actual state and distribution of existing sewage pipe
- ✓ Results of evaluation of existing sewage pipe by estimation of flow volume
- ✓ Results of diagnosis of sewage pipe by TV camera
- ✓ Sections with problems found by activities of PRRU
- ✓ Flow volume in dry weather by visual observation

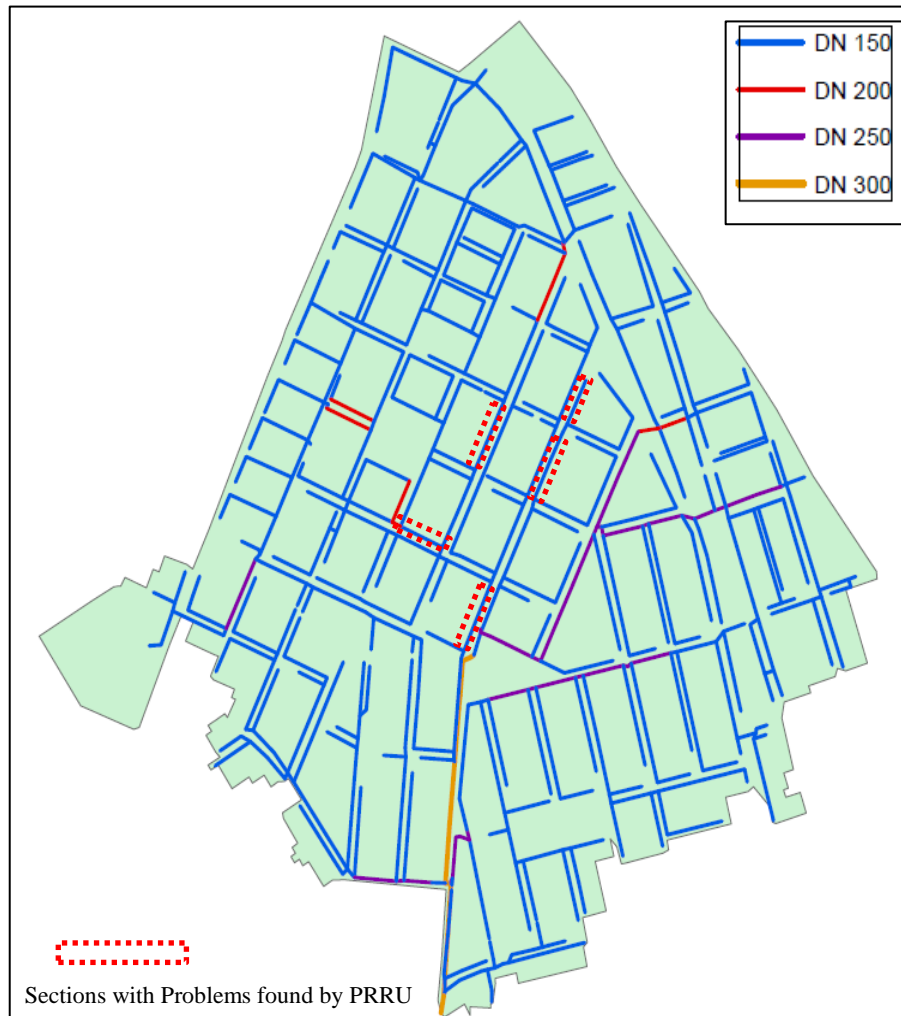

Figure 7-1 Sewage Pipe Network by Each Diameter in the Pilot Area and Section with Problems

Figure 7-1 shows the sewage pipe network in the pilot area colored by each diameter and the sections with problems. The sections with problems have a diameter of 150mm that connect to the pipes with a diameter of 250mm and there are not sections with 200mm. The sections to be size-upped from 150mm to 200mm are selected, which is shown in **Figure 7-2** considering with the results of the evaluation of existing sewage pipe network by estimation of flow volume. The sections with 1,129m will be size-upped as shown in **Table 7-1**.

Table 7-1 Extension of Sewage Pipe to be Size-upped

Diameter of Existing Pipe	Diameter after size-up	Extension (m)
150 mm	200 mm	1,129m

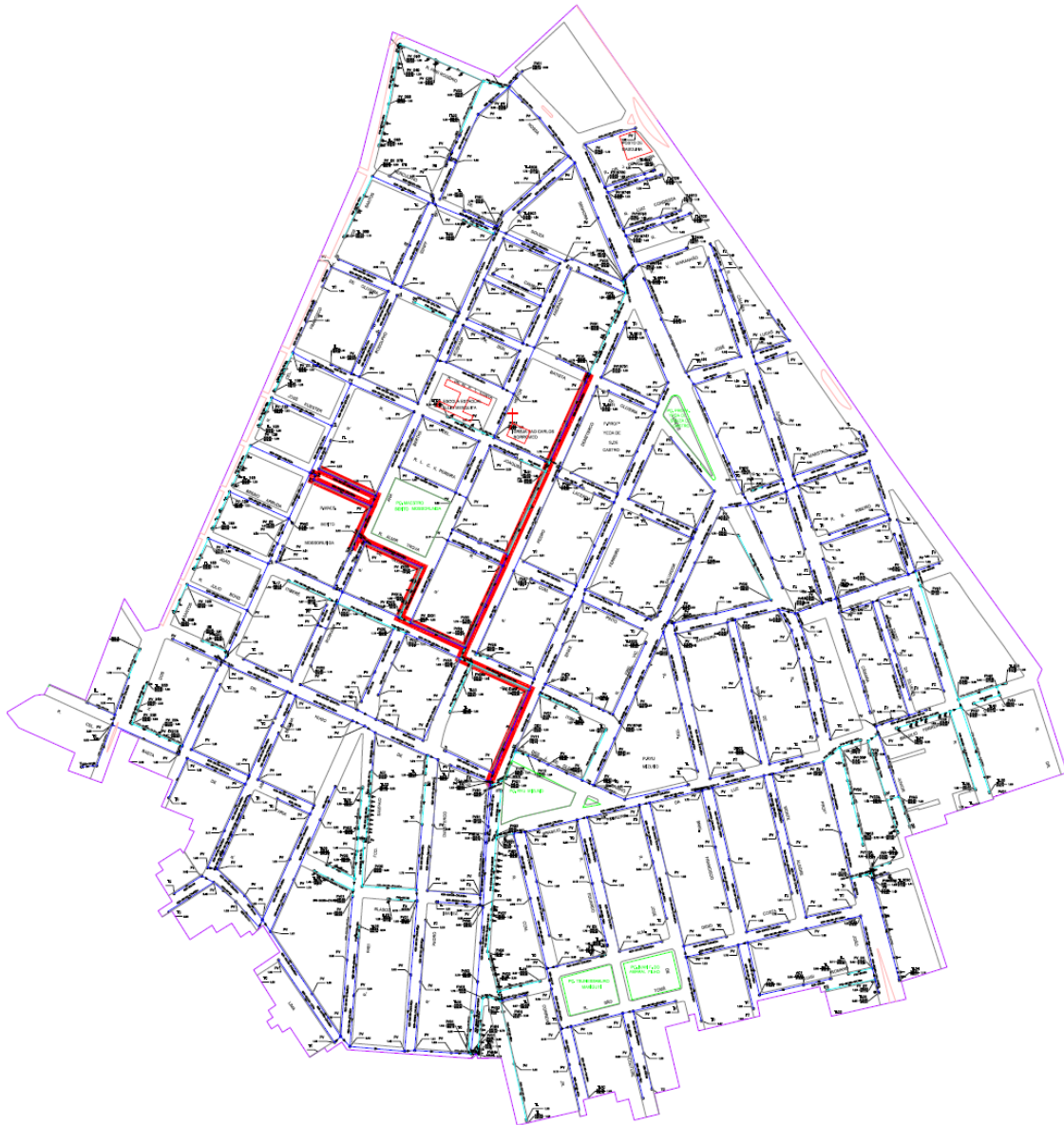

Figure7-2 Sections to be Size-upped

7-2 Renewal Plan of Sewage Pipe Network

The renewal of the sewage pipe will be implemented in the whole interval between manholes by reconstruction or pipe lining. Targeted sections, with extension shown in **Table 7-2**, will be the sections diagnosed to be rank A subtracting the sections to be size-upped.

Table 7-2 Extension of Sewage Pipe to be Renewed

Diameter	Extension(m)
150 mm	1,841m

7-3 Rehabilitation Plan of sewage Pipe network

The points with structural problems identified by diagnosis using inset-type TV camera will be selected for the rehabilitation plan of sewage pipes. The points with problems identified by a simple TV camera will be repaired daily maintenance work. The problems of illegal connection will be treated separately including administrative directives. Items and number of the points to be rehabilitated are shown in **Table 7-3**.

Table 7-3 Items and Number of the Points to be Rehabilitated

	A	Notes
Number	102points	Crack, damage, gap of the coupling, slack,etc

8. Challenges and Proposal

In this project at first investigation and diagnosis of sewage pipe network by TV camera was planned and implemented. Secondary additional works such as investigation of illegal house connection, study on the size-up of them and investigation of water quality were implemented. Finally through these works a comprehensive improvement plan of sewage pipe network has elaborated. This works were carried out by try and error because process of investigation was not perfect or elaboration of criteria for diagnosis was delayed. The procedure of this works will be reviewed and improved method will be proposed for next works as mentioned below. The improved method of procedure and criteria of diagnosis will be proposed in the diagnosis plan for project area. In the future more efficient and effective method will be elaborated by PDCA cycle.

8-1 Process of Investigation and Diagnosis of Sewage Pipe Network

Firstly investigation method of sewage pipe network in the pilot area was planned being based on the usage of a simple TV camera and an insert-type TV camera. Later activities of PRRU and newly developed smoke test were implemented. For instance a smoke test was implemented after an investigation of TV camera in some sections where additional investigations by TV camera were implemented. Based on the results of the works in the pilot area, the procedure of investigation and so on was reviewed comprehensively and improved procedure was obtained as follows; ① Investigation of water quality of river, ② Dying test and smoke test, ③ Investigation by simple TV camera. Results of ①, ②, ③ will be estimated comprehensively and sections to be investigated by an insert-type TV camera will be selected. The new flow chart will be elaborated and will be used in the investigation and diagnosis of all the area of CMA. On the other hand it is desired that study on the size-up of the pipes will be implemented in the early stage.

8-2 Diagnosis of Sewage Pipe Network

The criteria being used for the diagnosis in the pilot area was elaborated based on that in Japan for an auto-propelled TV camera and it is too detailed for an insert-type TV camera which can be used in everywhere in Parana State that it is difficult to estimate by obtained data. More simplified criteria will be proposed that will be used in the sewage pipe diagnosis in the all area of CMA in future.

JAPAN INTERNATIONAL COOPERATION AGENCY (JICA)

PARANA STATE SANITATION COMPANY (SANEPAR)

**PROJECT
FOR
IMPROVEMENT OF OPERATION AND MAINTENANCE
OF
WATER SUPPLY AND SEWERAGE SYSTEMS
IN
PARANA STATE**

**REHAVILITATION, RENEWAL AND IMPROVEMENT
PLAN OF SEWAGE PIPE NETWORK**

(Pilot Area at Coastal Area)

DRAFT

January 2015

**JAPAN INTERNATIONAL COOPERATION AGENCY
(JICA)**

NIHON SUIDO CONSULTANTS Co., Ltd

**PROJECT FOR IMPROVEMENT OF OPERATION AND MAINTENANCE OF
WATER SUPPLY AND SEWERAGE SYSTEMS IN PARANA STATE, BRAZIL**

(Third Fiscal Year)

**REHAVILITATION, RENEWAL AND IMPROVEMENT PLAN OF SEWAGE
PIPE NETWORK (Pilot Area at Coastal Area)**

TABLE OF CONTENTS

1. Basic Policy for the Establishment of the Plan	1
1-1 Selection of the Pilot Area.....	1
1-2 Investigation and Diagnosis of Sewage Pipe Network	1
1-3 Pilot Area.....	1
2. Investigation and Diagnosis of Sewage Pipe Network	2
2-1 Investigation and Diagnosis method	2
2-2 Criteria for the Diagnosis of Sewage Pipe Network	3
2-3 Results of Diagnosis of Sewage Pipe Network	3
3. Rehabilitation and Renewal Plan of Sewage Pipe Network	6
3-1 Sections to be Rehabilitated and Renewed	6
3-2 Imprementation of the Renewal Plan.....	6

1. Basic Policy for the Establishment of the Plan

In the rehabilitation and renewal plan of sewage pipe network the structural function will be rehabilitated being based on the diagnosis by TV camera.

1-1 Selection of the Pilot Area

In the coastal area the pilot area was selected from the areas where ceramic pipes are installed. At the one part of the districts of Matinhos and Morretes ceramic pipes are installed. The total extension is 19.3km. From these 2 districts all the area with ceramic pipes in Matinhos district, where problems occur frequently, was selected as the pilot area. The extension of sewage pipes in pilot area is 14.7km.

1-2 Investigation and Diagnosis of Sewage Pipe Network

In the coastal area points of problems are concentrated in the ceramic pipe installed sections. And so implementation of diagnosis of sewage pipe will be defined to these sections, which have not much extension. The investigation by a simple TV camera will be omitted and only that by an insert-type TV camera will be implemented for diagnosis. Each problem will be classified by the items of corrosion, breakage and infiltration, and evaluated to ranking. Each stage has a weighted point and these points will be sum-upped for each span between manholes. The section targeted to be renewed wholly or rehabilitated by partial repairs will be selected by this point.

1-3 Pilot Area

Figure 1-1 shows the study area and **Table 1-1** shows the outline of the sewage pipe facilities.

Table 1-1 Outline of the Pilot Area

	Area 1	Area 2	Area 3	Total
Area (ha)	45.3	4.7	134.6	184.6
Extension of pipe (m)	3,236	248	11,095	14,579
Number of manholes	139	5	47	191
Number of House Connections	635	14	402	1,051



Figure 1-1 Pilot Area

2. Investigation and Diagnosis of Sewage Pipe Network

2-1 Investigation and Diagnosis method

Flow diagram of the investigation and diagnosis is shown in Figure 2-1.

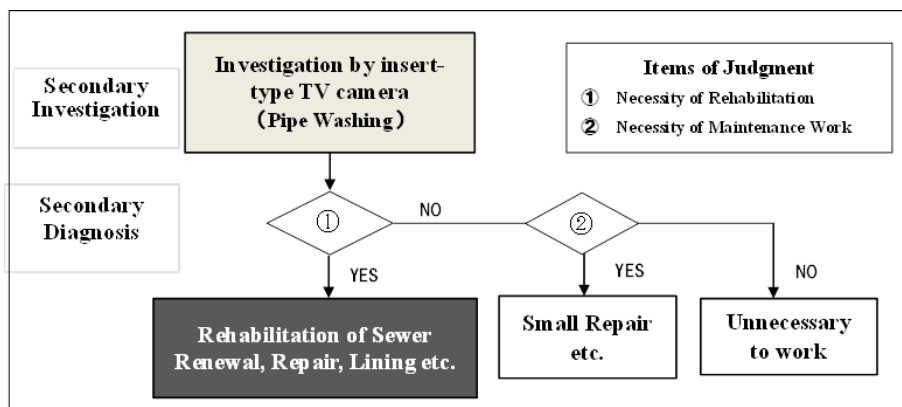

Figure 2-1 Flow Diagram of Investigation and Diagnosis in Coastal Area

2-2 Criteria for the Diagnosis of Sewage Pipe Network

Although it was considered to apply the criteria developed in the works of the pilot area in CMA, in the diagnosis in the coastal area the criteria was simplified experimentally because structurally important problems such as breakages, cracks and slackening occur very often. Investigated pipes were diagnosed by the score between manholes based on the criteria shown in **Table 2-1**.

Table 2-1 Investigated pipes were diagnosed by the score between manholes based on the criteria

Structurally Important Problem	Intrusion of Root of Tree	Extrusion of House Connection Pipe etc.	Problem on Maintenance
5 points	3points	1 point	0 point

2-3 Results of Diagnosis of Sewage Pipe Network

2-3-1 Results of Secondary Diagnosis by Insert-type TV Camera

Table 2-2 shows the results in total and **Table 2-3** shows the results for each section. The results of the pilot area in the coastal area are very different from that in CMA. Number of structurally important problems is very high. This number attains to 3,965 and 26 per 100m. In the works of the pilot area in CMA sections with more the 21 points will be rehabilitated wholly. Structurally Important Problem gets 5 points and highest points attain 460 points and most of the diagnosed section gets more than 21 points.

Table 2-2 Results of Diagnosis of Sewage Pipe Network in total

Structurally Important Problem	Intrusion of Root of Tree	Extrusion of House Connection Pipe etc.	Problem on Maintenance
3,965	286	44	3,082

Table 2-3 Results of Diagnosis for each Section

DATA	ENDEREÇO	QTDE. OCORRÊNCIAS				EXTENSÃO REAL DA REDE	NOTA
		RCE/BOJO/T/D	RAÍZES	LIG. F. PAD	ARE/GOR/SIN		
10/06/14	Rua Ipirangua	92			80	90.00	460
21/07/14	Rua Paranaguá	82		1	66	89.10	411
25/07/14	Rua Parana	82			3	80.00	410
18/07/14	Rua Londrina	81			79	94.00	405
04/06/14	Rua Jaguariava	74			60	171.00	370
14/05/14	Rua Aglio de Leao	65	12		8	80.00	361
15/10/14	Rua João Ignacio Freire	70			17	100.00	350
15/09/14	Rua João Ignacio Freire	70			17	50.00	350
04/06/14	Rua Castro	68			81	80.00	340
25/07/14	Rua Paranaguá	66	2	1	105	83.00	337
21/07/14	Tv caiobá	65			60	84.00	325
09/10/14	Rua Itaporã	64			36	80.40	320
24/04/14	Rua Uniflor	62	2	1	29	140.00	317
11/04/14	Rua Uniflor	62	2	1	29	140.00	317
16/09/14	Rua José Meduna	61			12	70.00	305
30/09/14	Rua Ceciliano Tavares	61			18	70.80	305
15/09/14	Rua Itacolomi	59			28	95.00	295
21/07/14	Rua Ponta Grossa	56	1		5	20.00	283
10/06/14	Rua Rio Branco	56			2	132.00	280
28/04/14	Rua Manoel Paranhos	53	5		52	78.00	280
14/10/14	Rua União	54			51	118.75	270
16/07/14	Av Atlantica	53			141	100.00	265
17/05/13	Av Atlantica	53			131	170.00	265
08/08/13	Rua Porto rico	44	14	1	7	106.70	263
30/09/14	Rua Bandeirantes	50			12	88.00	250
22/10/13	Rua Manoel Paranhos	50			53	66.00	250
17/10/14	Rua Pablo Luis do Rosário	46			55	80.00	230
28/05/14	Rua Passeio das Palmeiras	44	2		6	126.00	226
08/05/14	Rua Jaguariava	41			98	74.05	205
08/05/14	Rua Cambara	39		4	29	74.00	199
15/01/14	Rua Jardim Alegre	23	26		42	91.65	193
14/05/14	Rua Ipirangua	35	4	4	2	84.00	191
23/09/14	Rua União	38			4	92.10	190
17/05/13	Av Atlantica	34	4		20	57.70	182
24/07/14	Rua Aglio de Leao	36		1	24	61.00	181
14/05/14	Rua Aglio de Leao	36		1	24	55.00	181
02/08/13	Rua Aglio de Leao	33	3	2	13	85.00	176
04/12/13	Rua Manoel Ribas	25	16	1	16	100.87	174
21/07/14	Rua Ponta Grossa	32	3			30.00	169
21/10/14	Rua Valdir Muller	33			23	71.00	165
27/08/14	Rua João Ignacio Freire	32		1	10	60.55	161
28/05/14	Rua Passeio das Palmeiras	32			9	150.00	160
16/05/14	Rua Rio Branco	31	1		1	68.50	158
02/08/13	Rua Aglio de Leao	21	17		3	87.00	156
09/08/13	Rua Manoel Ribas	28	5		6	81.00	155
31/10/13	Rua Passeio das Palmeiras	31			12	150.00	155
20/10/14	Rua União	31				51.00	155
24/04/14	Rua Manoel Paranhos	30		1	50	75.00	151
21/10/14	Rua Itaporã	30		1	9	80.40	151
30/07/13	Rua Urai	26	7		3	51.27	151
21/07/14	Rua Ponta Grossa	30			2	21.00	150
21/01/14	Rua Manoel Ribas	20	16	1	31	102.85	149
27/11/13	Rua Manoel Ribas	19	16		16	64.00	143
02/12/13	Rua Jaguariava	28			43	80.00	140
09/07/14	Rua Roque Vernalha	28			2	40.20	140
15/09/14	Rua João Ignacio Freire	28			6	40.00	140
13/06/14	Rua Uniflor	27			10	120.78	135
22/04/14	Rua Uniflor	27			10	120.78	135
02/10/14	Rua Bandeirantes	27			6	50.00	135
13/06/14	Rua Uniflor	27			10	120.78	135
27/11/13	Rua Manoel Ribas	26		1	17	81.65	131
31/10/14	Rua Itacolomi	26			25	95.00	130
03/11/14	Rua Roque Vernalha	26			8	80.00	130
30/09/14	Rua José Meduna	26			4	72.00	130
16/09/14	Rua Itacolomi	26			25	75.00	130
04/11/14	Av atlantica prainha	23	4			30.00	127
13/01/14	Rua Jardim Alegre	15	15	1	26	116.00	121
20/08/14	Rua João Ignacio Freire	21	3	1	20	28.50	115
14/08/14	Rua Sereias	21	2	2		28.00	113
17/09/14	Rua José Meduna	22			18	93.00	110
17/07/14	Rua Jaguariava	22			10	53.00	110
05/12/13	Rua Aglio de Leao	15	10		1	111.00	105
31/10/14	Helen B. Laurindo	21				57.00	105
09/07/14	Rua Helen B Laurindo	21				57.00	105
20/01/14	Rua Manoel Ribas	18	4	1	25	94.00	103
31/10/14	Tv das Pedras	20		1	1	24.00	101
31/10/14	Rua Jacinto Mesquita	19			9	44.50	95
03/11/14	Rua Roque Vernalha	19			2	81.40	95
23/01/14	Rua Cel Azul	19			19	67.70	95
14/01/14	Rua Jardim Alegre	13	9		14	84.00	92
04/11/14	Av atlantica prainha	14	7		6	38.00	91
07/10/14	Rua Sereias	18				67.40	90
20/10/14	Rua Bandeirantes	18			1	38.00	90
16/10/14	Rua José Felinto	18			17	45.00	90
21/07/14	Rua Ponta Grossa	18				20.00	90
21/05/14	Rua Aglio de Leao	15	2	1		48.00	82
16/06/14	Rua Manoel Paranhos	15	2		3	9.00	81
16/05/13	Av Atlantica	16			12	55.50	80
03/11/14	Rua Roque Vernalha	16			2	34.00	80
03/11/14	Rua Reinhold Scheffer	16			7	78.00	80
06/12/13	Rua Aglio de Leao	13	4		14	111.00	77
07/01/14	Rua Marechal Rondón	14	2		26	83.10	76
21/11/13	Rua Aglio de Leao	15				65.00	75
24/10/13	Rua Cambara	15			100	110.00	75

13/01/14	Rua Cel Azul	12	5		12	58.65	75
11/04/14	Rua Uniflor	15			22	140.00	75
31/10/14	Rua Roque Vermelha	15			8	35.60	75
04/11/14	Av atlantica prainha	12	5			38.00	75
23/09/14	Rua Bandeirantes	14	1		18	51.00	73
08/04/14	Rua Ipirangua	14			24	100.00	70
25/02/14	Rua Presidente Kenedy	14			29	62.24	70
24/01/14	Rua Presidente Kenedy	14			4	90.00	70
20/10/14	Rua Bandeirantes	14			8	50.00	70
21/01/14	Rua Agilio de Leao	13		3	9	85.00	68
15/01/14	Rua Jardim Alegre	11	3		14	70.00	64
22/01/14	Rua Agilio de Leao	11	2		1	102.00	61
10/04/14	Rua Nova Esperança	12			30	105.00	60
10/02/14	Rua Nova Esperança	12			30	105.00	60
10/05/13	Rua Jaguaraiava	12			16	80.00	60
08/09/14	Rua João Ignacio Freire	12			4	33.00	60
03/12/13	Rua Andirá	11	1		9	92.95	58
17/01/14	Rua Passeio das Palmeiras	9	4	1	4	49.00	58
07/01/14	Rua Marechal Rondón	11			28	75.20	55
27/11/13	Rua Avelino Vieira	11			1	75.99	55
02/10/14	Rua Bandeirantes	11			36	34.80	55
07/08/13	Rua Manoel Ribas	9	2		7	52.50	51
16/04/14	Rua Alvorada	9	2		6	55.70	51
30/07/14	Rua Alm Tamandaré	9	2		7	52.50	51
08/01/14	Rua Manoel Ribas	7	5		14	110.00	50
17/04/14	Rua Presidente Kenedy	10			22	80.60	50
24/07/14	Rua Agilio de Leao	10			1	48.00	50
14/01/14	Rua Porto rico	6	6	1	3	68.85	49
17/01/14	Rua Assis Chateaubriand	6	6		13	80.00	48
31/10/14	Av das Pedras	9				29.00	45
09/08/13	Rua Porto rico	9			3	13.33	45
17/10/14	Rua José Felinto	9			8	31.00	45
27/11/14	Rua Agilio de Leao	8	1		1	100.00	43
09/04/14	Av Maringá	8	1		3	29.00	43
16/06/14	Rua Agilio de Leao	8			2	60.00	40
17/01/14	Rua Passeio das Palmeiras	8				39.90	40
09/07/14	Rua Roque Vermelha	8			3	40.00	40
04/11/14	Av atlantica prainha	7	1			70.00	38
21/01/14	Rua Bom Jardim	7			14	65.79	35
14/08/14	Rua João Ignacio Freire	6	1			48.70	33
02/12/13	Rua Andirá lado esquerdo	6		1	19	92.45	31
20/05/14	Rua Urai	5	2		7	30.00	31
15/01/14	Rua Jardim Alegre	6		1	5	52.00	31
04/06/13	Av Atlantica	6			11	52.60	30
07/01/14	Rua Presidente Kenedy	6			15	99.50	30
31/10/14	Rua Sereias	5			11	21.30	25
05/06/14	Rua Andirá	4		1	22	89.20	21
29/05/14	Rua Andirá	4			21	72.90	20
27/06/14	Rua Alm Tamandaré	4			3	71.50	20
23/09/14	Rua Bandeirantes	4			5	37.00	20
16/06/13	Rua Agilio de Leao	4				48.00	20
18/06/13	Rua Agilio de Leao	4				10.62	20
09/07/14	Rua Roque Vermelha	3			8	55.00	15
21/01/14	Rua Assis Chateaubriand	2	1	2	3	42.95	15
24/01/14	Rua Uniflor	3			1	41.40	15
07/05/14	Rua Andirá	1	2	2	38	64.00	13
23/01/14	Rua Cel Azul	2		1	16	92.20	11
11/06/14	Rua Jacarezinho	2			16	86.00	10
18/07/14	Rua Jaguaraiava	2			14	36.00	10
15/07/14	Rua Apucarana	1			10	92.55	5
14/06/13	Rua Manoel Paranhos	1			31	60.00	5
04/12/13	Rua Marechal Rondón	1			14	57.70	5
17/10/14	Av Maringá	1			7	29.30	5
09/05/13	Av Atlantica	14			10	98.00	70
15/05/13	Av Atlantica				2	99.10	
16/10/14	Rua Ceciliano Tavares				29	96.00	
17/06/13	Av Atlantica	9			8	80.00	45
29/10/14	Rua Sereias				9	66.00	
07/06/13	Av Atlantica	13	3		1	68.55	74
18/06/13	Rua Ipirangua				3	84.00	
21/07/14	Av Caioba				6	80.00	
14/05/13	Av Atlantica		1		4	124.85	3
07/06/13	Av Atlantica	12		1	8	62.65	61
14/05/13	Av Atlantica	1			7	117.00	5
23/05/13	Av Atlantica					50.00	
29/05/13	Av Atlantica	11	5		12	40.00	70
21/07/14	Rua Ponta Grossa				5	51.70	
23/05/13	Av Atlantica	6			2	50.00	30
06/06/13	Av Atlantica	4			5	52.60	20
17/05/13	Av Atlantica	12			11	70.00	60
23/05/13	Av Atlantica	11			9	20.00	55
06/06/13	Av Atlantica	16	1		9	52.22	83
17/06/13	Av Atlantica	19	1		1	56.00	98
18/07/14	Rua Ponta Grossa				23	143.80	
15/10/14	Rua João Ignacio Freire				10	87.00	
11/02/14	Rua Das Palmeiras PVC					124.50	
14/06/13	Av Atlantica	6			9	13.85	30
17/10/14	Av Maringá				5	24.70	
21/07/14	Rua Ponta Grossa					11.00	
26/06/13	Rua Castro				14	108.20	
TOTAL:		3,965.00	286.00	44.00	3,082.00	13,223.17	

3. Rehabilitation and Renewal Plan of Sewage Pipe Network

3-1 Sections to be Rehabilitated and Renewed

As shown in **Table 3-1** sections with more than 21 points will be wholly renewed by reinstallation or lining etc. Sections with points fewer than 20 will be repaired partially at the A ranked points and will be up observation. In these sections 39 points were identified the structural problems.

Table 3-1 Results of Diagnosis of Sewers

Rank	Extension(m)	Remarks
I . More than 21 points	10,985	To be Renewed
II . Under 20 points	1,139	Partial Repair and Observation
III. 0 point	970	Do nothing
計	13,223	

3-2 Implementation of the Renewal Plan

Among the methods of renewal of sewage pipes open cut method is recommended in the point of view of cost. Considering the condition of the pilot area being urban area and also a tourist spot, it is needed to study a non-did construction method. As available methods in Brazil pipe lining method and pipe burst method, which constructs new pipe after destroying existing old pipe, are listed. In Brazil there are not many construction records and they need higher cost. It is recommended to respond carefully by implementation of experimental construction and so on. Period of implementation is supposed to be 5 years from 2015.

A11-2 クリチバ首都圏及び沿岸部の下水管路診断計画案

BRAZIL

PARANA STATE SANITATION COMPANY (SANEPAR)

**PROJECT FOR IMPROVEMENT OF
OPERATION AND MAINTENANCE OF
WATER SUPPLY AND SEWERAGE
SYSTEMS IN PARANA STATE, BRAZIL
(Third Fiscal Year)**

**Sewage Pipe Network Diagnosis Plan in
CMA and Coastal Area (Draft)**

JANUARY 2015

(2015)

**JAPAN INTERNATIONAL COOPERATION
AGENCY (JICA)**

NIHON SUIDO CONSULTANTS CO., LTD.

**PROJECT FOR IMPROVEMENT OF OPERATION AND MAINTENANCE OF
WATER SUPPLY AND SEWERAGE SYSTEMS IN PARANA STATE, BRAZIL**

(Third Fiscal Year)

Sewage Pipe Network Diagnosis Plan in CMA and Coastal Area (Draft)

TABLE OF CONTENTS

1. Policy for Sewage Pipe Network Diagnosis Plan	2
1-1 Actual Condition of Sewage Pipe Network in CMA and the Coastal Area	2
1-2 Targeted Area for Sewage Pipe Network.....	3
1-3 Concept for the Priority.....	7
1-4 Improvement of the Method of Sewage Pipe Diagnosis	7
2. Method to Diagnose Sewage Pipe Network	8
2-1 Flow Diagram of Diagnosis	8
2-2 Criteria for Diagnosis	8
3. Study for Priority	10
3-1 Analysis of the Results of the Flow Rate Investigation	10
3-2 Priority based on the River Water Quality.....	13
3-3 Decision of Priority	13
4. Task Forth for Central Area	14
4-1 Actual Activities	14
4-2 Future Activities	15

5. Diagnosis Plan in the Coastal Area	15
5-1 Diagnosis Plan in the Morretes District	15
6. Data Base of the Results of Investigation and Diagnosis.....	16
7. Implementation Plan of Sewage Pipe Diagnosis	17
7.1 Implementation Plan of sewage Pipe Diagnosis in CMA.....	17
7.2 Implementation Plan of sewage Pipe Diagnosis in the coastal area.	17
7.3 Proposal for the Implementation of the Sewage Pipe Network Diagnosis Plan.....	17

1. Policy for Sewage Pipe Network Diagnosis Plan

1-1 Actual Condition of Sewage Pipe Network in CMA and the Coastal Area

Length of sewage pipes for each material is shown in **Table 1-1**. Sewage pipes constructed in the early time adopted ceramic for its material which accounts 35% of total length. In CMA the problems of ceramic pipes have been pointed out. According to the results of the diagnosis of sewage pipes in the pilot area 14% of them are proposed to be rehabilitated totally between manholes. On the other hand in the coastal area troubles have occurred intensively in the sewage pipes constructed early time with ceramic material. According to the results of the diagnosis of sewage pipes in the pilot area 83% of them are proposed to be rehabilitated totally between manholes. This percentage is much higher than that in the pilot area in CMA. Both in CMA and the coastal area ceramic sewage pipes should be investigated and diagnosed.

Table1-1 Length of Sewage Pipe for each Material

Material	Length (km)	%
PVC	5,165.4	60.6
Ceramic	2,999.6	35.2
Concrete	249.7	2.9
Others	112.5	1.3
Total	8,527.3	98.7

※ SEIC is the Area for Sewage Master Plan

1-2 Targeted Area for Sewage Pipe Network

Sewered area in CMA is shown in **Figure 1-1**. Area shown in red in the figure is the subject of this diagnostic plan.

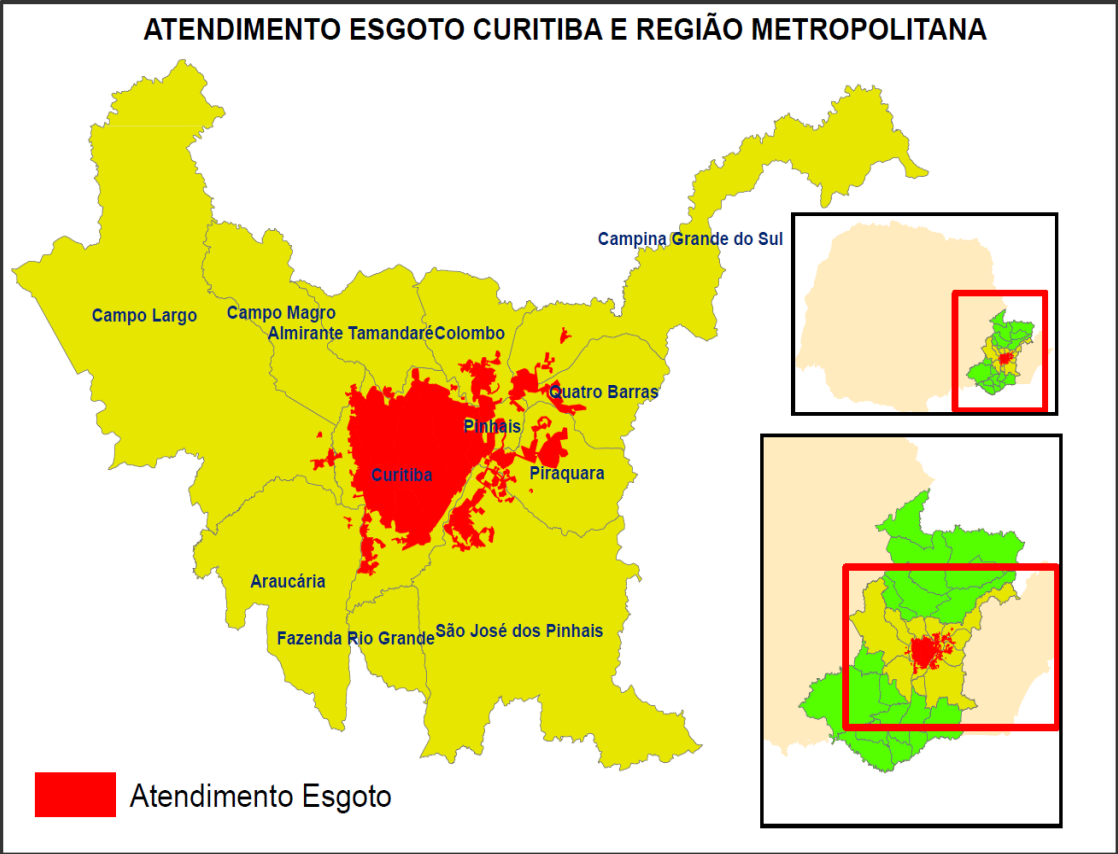

Figure 1-1 CMA Area and Sewered Area

The sewered area in CMA is divided to the areas for 22 STPs basins. In this figure the blue colored area is the areas of 5 STPs that constructed in relatively early time and ceramic pipe area is almost included in this area. And also area of these 5 STPs corresponds to the area, called SEIC, for establishing the Sewage Master Plan and had been decided to be the targeted area of this diagnosis plan. The area of SEIC is illustrated in **Figure 1-2** and actual capacities of 22 STPs are shown in **Table 1-1**.

Table 1-1 STPs and Capacity in CMA

Local	ETE	Média de Vazão Atual (L/s)
Agudos do Sul	ETE Agudos do Sul	2
Almirante Tamandare	ETE São Jorge	44
Araucária 1	ETE Cachoeira	57
Araucária 2	ETE Iguaçu	20
Araucária 3	ETE Passaúna	
Balsa Nova	ETE Balsa Nova	15
Campina Gde. Do Sul	ETE Engenho	9
Campo Largo 1	ETE Cambui	64
Campo Largo 2	ETE Itaqui	10
Cerro Azul	ETE Vila Eliane	1
Colombo 1	ETE Colombo Sede	3
Contenda	ETE Contenda	20
Curitiba 46	ETE Padilha Sul	302
Curitiba 5	ETE Atuba Sul	1.098
Curitiba 54	ETE Santa Candida	1
Curitiba 55	ETE Santa Quitéria	397
Curitiba 65	ETE CIC Xisto	423
Curitiba 9	ETE Belém	1.209
Fazenda Rio Grande	ETE Faz. Rio Grande	94
Itaperuçu	ETE Buqueirinho	20
Lapa	ETE Rodovia do Xisto	45
Mandirituba	ETE Moradias Barcelona	2
Quitandinha	ETE Quitandinha	8
Rio Negro	ETE Estação Nova	12
São José dos Pinhais 3	ETE Iguaçu I	50
São José dos Pinhais 4	ETE Martinópolis	30
São José dos Pinhais 5	ETE Volkswagen	10

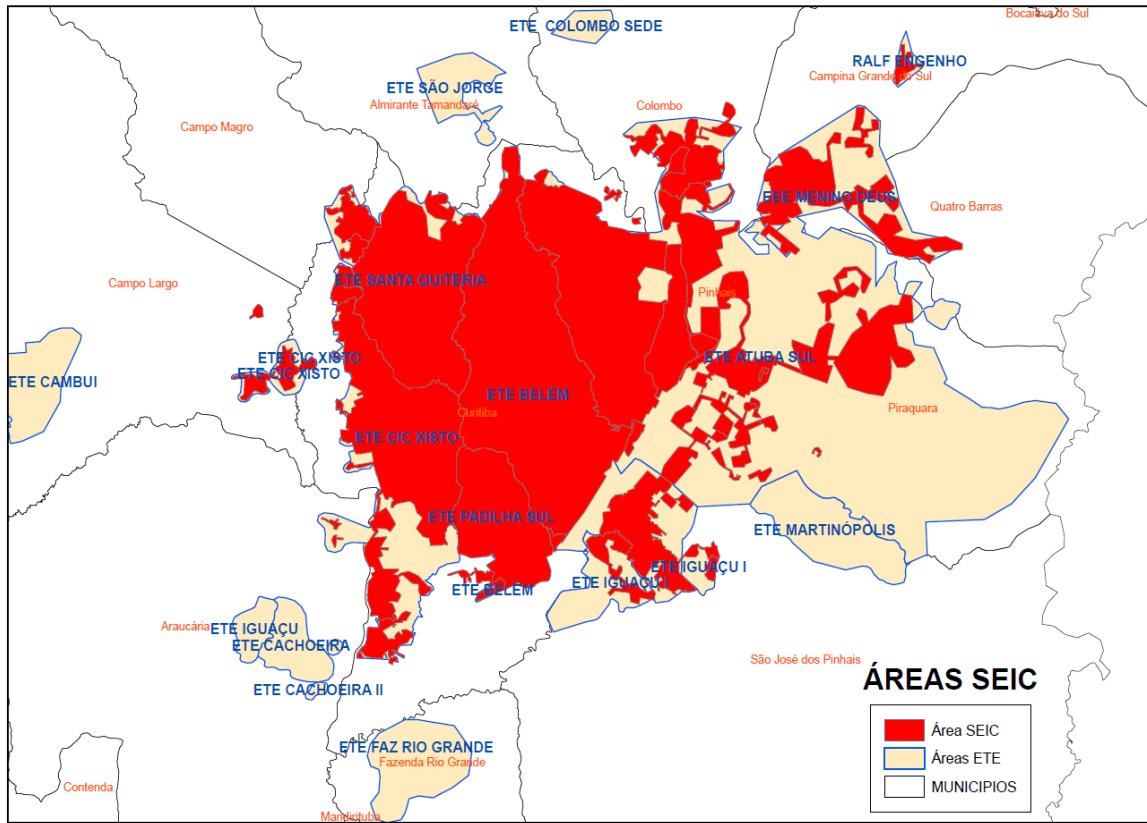

Figure 1-2 SEIC Area and Sewered Area

The length of sewage pipes in each STP area is shown in **Table 1-2** and the area with ceramic pipes is illustrated in **Figure 1-3**.

Table 1-2 Length of sewage pipes and ceramic pipes in each STP area (km)

Name of ETE	Length of Sewage Pipe (km)	Length of Ceramic Pipe(km)
Padilha Sul	705.9	80.4
Atuba Sul	2,277.5	614.3
Santa Quitéria	779.8	249.4
CIC Xisto	1,350.1	275.8
Belém	2,118.2	1,487.9
Total	7,231.5	2,707.8

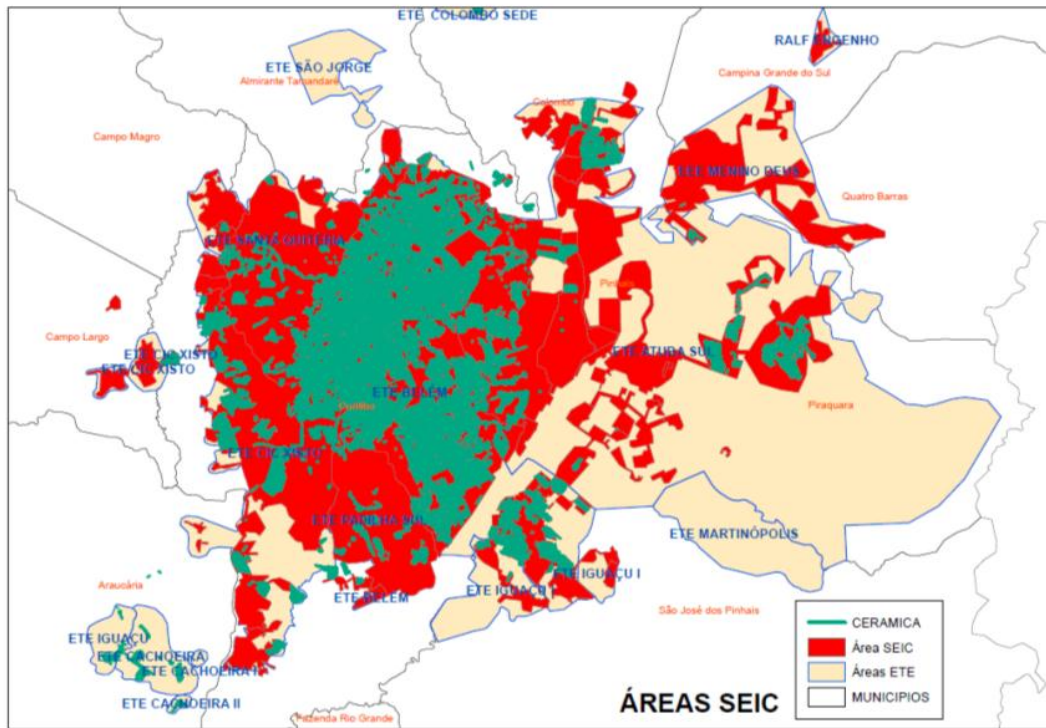

Figure 1-3 Area of Ceramic Pipes

As for the coastal area, only in the districts of Matinhos and Morretes ceramic pipes are used. These two districts are to be the targeted area of the diagnosis plan of the sewage pipe network. Meanwhile because in the district of Matinhos all the ceramic pipes have diagnoses as the pilot area, only the area with ceramic pipes in Morretes district will be the target area of this diagnosis plan, whose length is 4.6km. The length of the pipes with ceramic pipes in both areas are shown in **Table 1-3** and targeted area in Morretes district is illustrated in **Figure 1-4**.

Table 1-3 Length of Ceramic Pipes in Matinhos and Morretes Districts

Districts	Length of Ceramic Pipes (km)
Matinhos	14.7
Morretes	4.6
Total	19.3

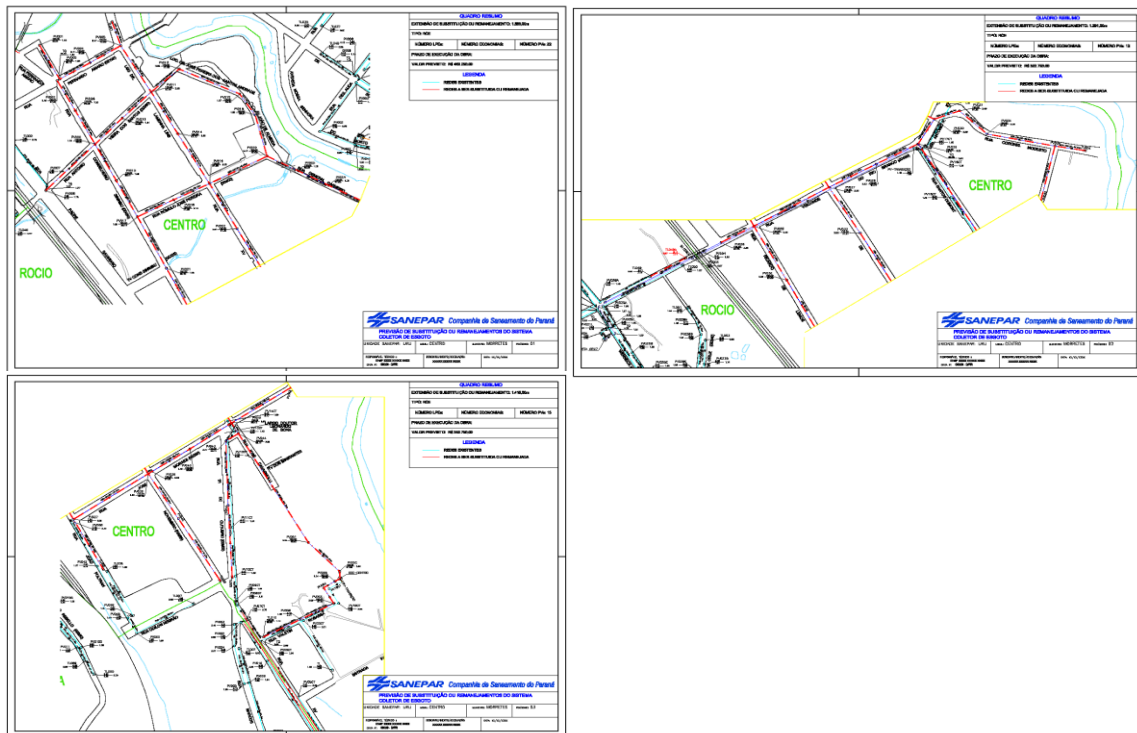

Figure 1-4 Area with Ceramic Pipes in Morretes District

1-3 Concept for the Priority

In CMA there constructed so big amount of sewage pipes that it needs long term for the investigation and diagnosis of them. And so there is a need to carefully consider on the order of the implementation. As criteria to decide the order of the implementation, importance in two aspects was adopted. The first one is the importance judged from infiltration to sewage pipes in wet weather and leakage of sewage in dry weather. The second one is the importance on the implementation of the urban river rehabilitation plan. The priority for this diagnosis plan by each area will be decided by considering these two criteria.

1-4 Improvement of the Method of Sewage Pipe Diagnosis

In the diagnosis of sewage pipe network in the pilot area an investigation by TV camera was planned firstly and secondly a check of illegal connection by smoke test, a study for size-up of a pipe and activity of PRRU were added. Because the order of the implementation was not ideal, in this diagnosis plan the method implemented in the pilot project is revised and it will be implemented in the ideal method. The criteria for diagnosis also are revised by improving the criteria that established in the pilot project.

2. Method to Diagnose Sewage Pipe Network

2-1 Flow Diagram of Diagnosis

To investigate and diagnose sewage pipes by screening sewage pipes those that will have problems are selected and investigated by TV camera. As much as possible the order of ① smoke test, ② simple TV camera is desirable, and in parallel with those investigations ③ activity of PRRU is implemented. Summing up results of those 3 investigations sections of sewage pipes to be investigated by TV camera are selected. Particularly sections selected by PRRU to have a doubt of the leakage of sewage in dry weather should be investigated by TV camera. The flow-diagram of the investigation and diagnosis method is shown in **Figure 2-1**.

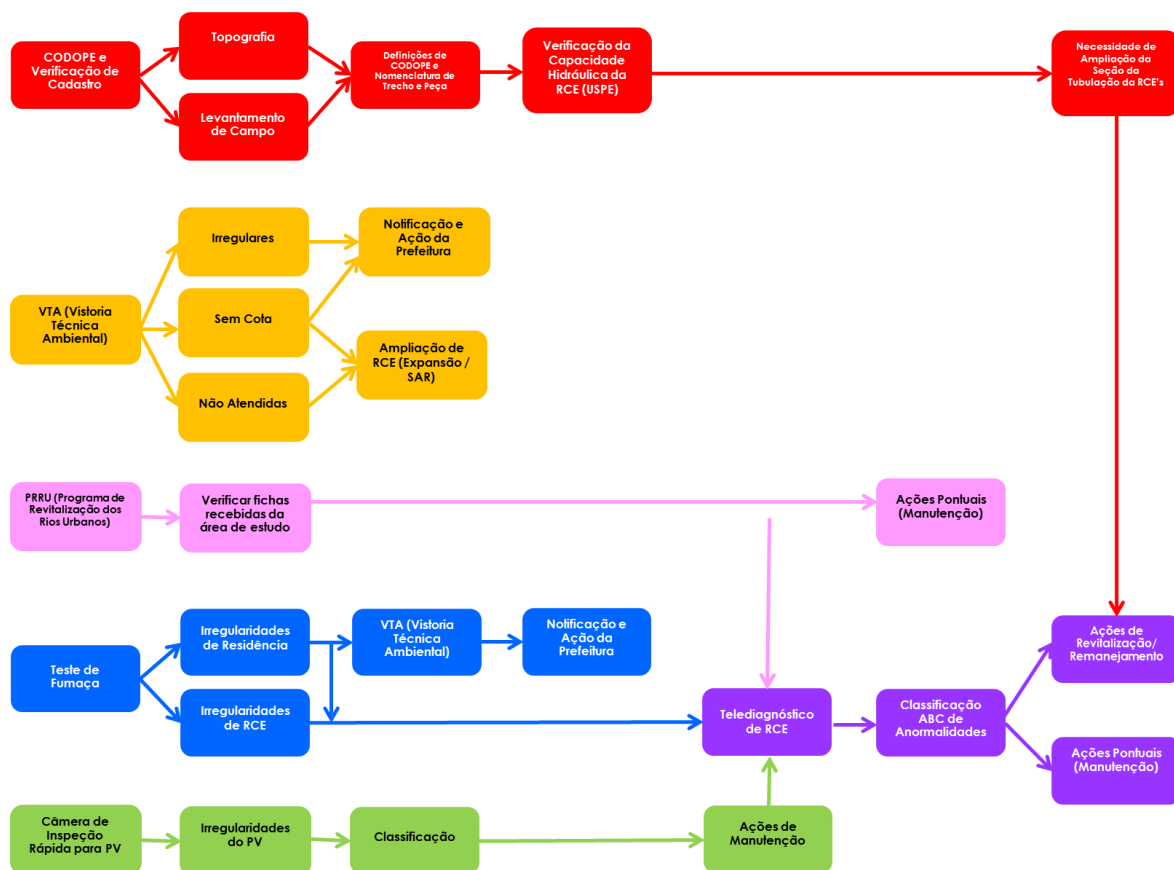



Figure 2-1 Flow-Diagram of Investigation and Diagnosis

In the coastal area all the targeted pipe are investigated by TV camera.

2-2 Criteria for Diagnosis

The criteria for diagnosis were reviewed and the new criteria shown in **table 2-1** were established. In this diagnosis plan the new criteria will be used and sewage pipes will be diagnosed.

Table 2-1 Reviewed Criteria for Diagnosis of Sewage Pipe

 DIAGNÓSTICO DA REDE COLETORA DE ESGOTO TABELA PARA CRITÉRIOS DE CLASSIFICAÇÃO DE ANORMALIDADES				
PROBLEMAS ESTRUTURAIS				
Nº	ANORMALIDADES	AE	BE	CE
1	Corrosão da tubulação	Exposição do vergalhão	Exposição do material do gravel	Monitoramento contínuo
2	Avaria (Trinca, Deslocado, Quebrado)	Depressão (rachadura / colapso)	Fissura de forma geral	Monitoramento contínuo
3	Infiltração	Água jorrando	Água minando/escorrendo	Monitoramento contínuo
4	Desalinhamento da junção da tubulação	Totalmente desalinhada	Pouco Desalinhada	Monitoramento contínuo
5	Invasão da raiz de árvore	Acima de 50% da seção transversal	Menor que 50% da seção transversal	Monitoramento contínuo
6	Sifonamento da tubulação	Maior que 50% da seção cheia	Menor que 50% da seção cheia	Monitoramento contínuo
7	Vazamento para a GAP/Rio	Grande intensidade	Pequena intensidade	Monitoramento contínuo
PROBLEMAS DE MANUTENÇÃO				
Nº	ANORMALIDADES	AM	BM	CM
11	Ligação irregular	Acima de 50% do diâmetro	Menor que 50% do diâmetro	Monitoramento contínuo
12	Gordura	Maior que 30 % da seção transversal	Menor que 30% da seção transversal	Monitoramento contínuo
13	Sujo com areia e terra	Acima de 50%	Menor que 50%	Monitoramento contínuo
14	Sujo com bucha	Acima de 50%	Menor que 50%	Monitoramento contínuo
15	Seção da Tubulação	Afogado	Entre 100% e 75% da seção	Monitoramento contínuo
LEGENDA				
A = REPARO EMERGENCIAL		B = REPARO PLANEJADO	C = OBSERVAÇÃO CONTINUA	
5 pontos		2 pontos	0 pontos	

Versão R1 (Novembro/2014)

3. Study for Priority

Considering the priority for each sewage basin by the evaluation the infiltration in wet weather and the leakage in dry weather based on the investigation of flow rate of sewage pipes, and the priority for the river (or branch) basin decided by discussion with the environmental bureau of the City Government, the priority of the diagnosis of sewage pipes will be decided. The diagnosis method for the coastal area will be decided separately.

3-1 Analysis of the Results of the Flow Rate Investigation

Infiltration in wet weather and leakage in dry weather based on the results of flow rate investigation were analyzed and each basin were evaluated and pointed. The leakage in dry weather was evaluated with more weighted points considering it is more important than the infiltration. Targeted 5 STPs basin were prioritized as in **Table 3-1**. Belem STP has gotten higher points and higher priority. Atuba Sur STP has gotten low points which are matched with the results of investigation of the flow rate balance in this project that shows the relatively small leakage in dry weather.

Table 3-1 Evaluation of 5 Targeted STP Basins

ETE	Seco	Fator 0,6	Chuva	Fator 0,4	Soma dos Fatores	Extensão da RCE	Soma dos Fatores / Extensão da RCE	Curva ABC	
Belém	2791,92	1675,152	437,99	175,196	1850,348	2.118.243,86	0,000873529	36,81721677	36,81722
Padilha	466,52	279,912	225,28	90,112	370,024	705.939,40	0,000524158	22,09204745	58,90926
Cic Xisto	812,18	487,308	512,24	204,896	692,204	1.350.069,38	0,000512717	21,60983806	80,5191
Santa Quitéria	232,81	139,686	102,91	41,164	180,85	779.776,15	0,000231926	9,775119167	90,29422
Atuba Sul	700,65	420,39	260,21	104,084	524,474	2.277.545,60	0,00023028	9,705778545	100
							0,002372611		

Then the sewage pipe network of the Belem basin was divided into small basins. These small basins were prioritized. The small basins of the Belem basin are illustrated in **Figure 3-1** and the result of the evaluation is shown in **Table 3-2**.

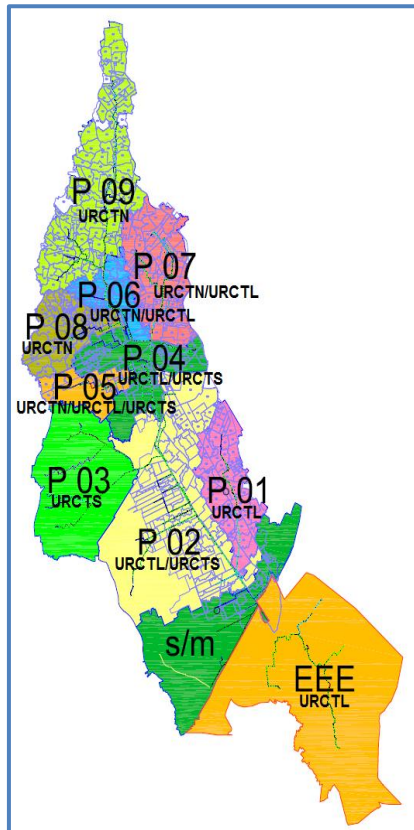

Figure 3-1 Small Basins of Sewage Pipe Network of Belem STP

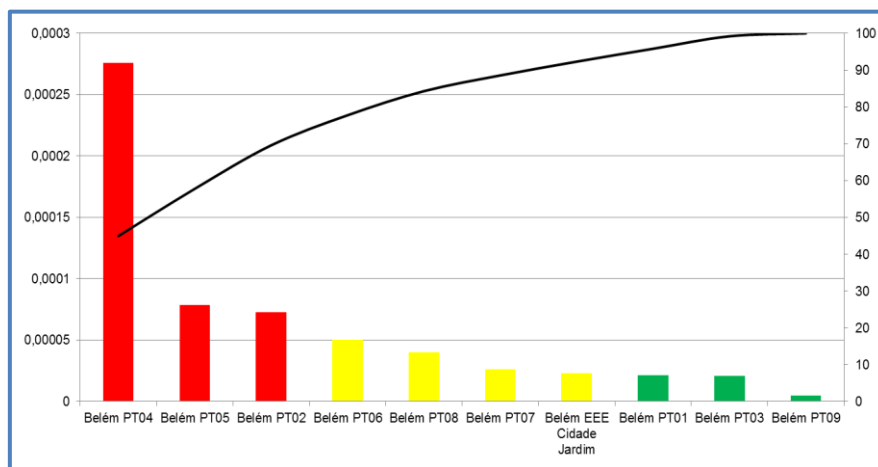

Figure 3-2 Priority of Small Basins of Sewage Pipe Network

PT04, PT05 and PT02 colored in red have high priority. PT04 and PT05 are located in the city center area, where the priority of the diagnosis is high. Connection flow of existing sewage pipe network is shown in Figure 3-3 which shows the inflow rate and leakage rate. Actual implementation order of diagnosis is supposed considering the sewage flow as follows; PT05→PT08→PT06→PT07→PT04→PT02. As for the basins other than Belem STP it will be studied later including the flow rate investigation in detail.

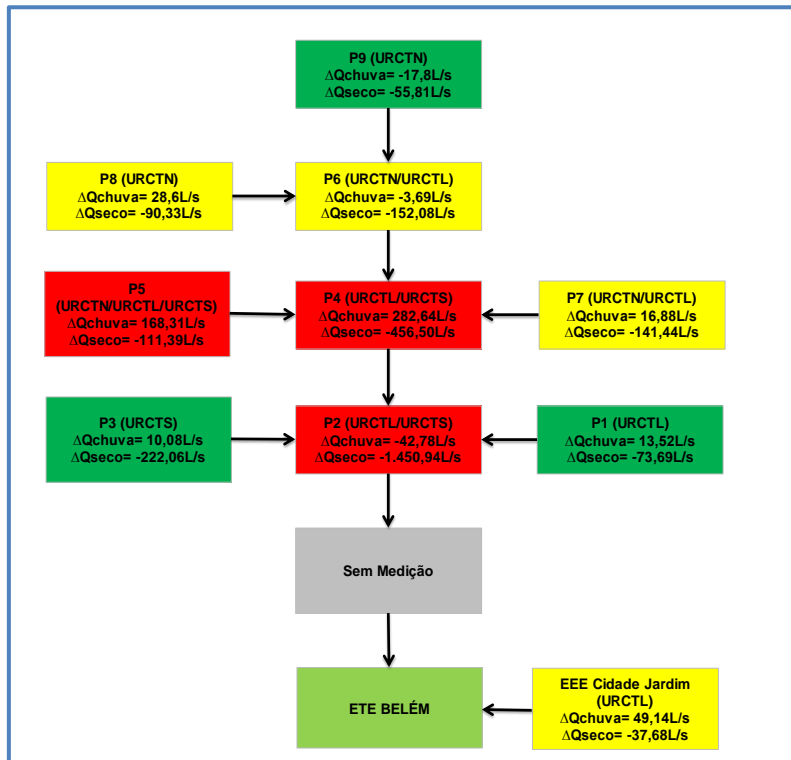

Figure 3-3 Sewage Pipe Network of Belem STP Basin

3-2 Priority based on the River Water Quality

The priority of the activity of PRRU for small basins of the rivers is shown in **Table 3-2** which was decided on the discussion with the Environmental Bureau of the City Government.

Table 3-2 The priority of the activity of PRRU for small basins of the rivers

Nº	Sub-Bacia	Bacia	UR
1	Córrego Tapajós	Belém	SUL
2	Ludovico Bauml	Barigui	SUL
3	Córrego Hermes Fontes	Barigui	NORTE
4	Córrego do Gava	Belém	NORTE
5	Córrego Taruma / Marumbi	Atuba	LESTE
6	Córrego Areãozinho	Belém	LESTE
7	Córrego Duque de Caxias	Atuba	NORTE
8	Córrego Campina do Siqueira	Barigui	NORTE
9	Córrego Três Marias	Passaúna	NORTE
10	Córrego Evaristo da Veiga	Belém	SUL E LESTE
11	Arroio Pinheirinho	Padilhas	SUL
12	Arroio Boa Vista	Padilhas	SUL
13	Bacacheri Mirim	Atuba	NORTE
14	Rio Vila Formosa	Barigui	SUL
15	Rio Uvu	Barigui	NORTE
17	Rio Pinheirinho	Belém	SUL E LESTE
21	Rio Bacacheri	Atuba	NORTE E LESTE
22	Rio Vila Guaíra / Córrego do Cortume	Belém	SUL
28	Córrego Itatiaia (Córrego dos Muller)	Barigui	NORTE
	Rio Quero-Quero	Barigui	NORTE
	Rio Belém – norte	Belém	NORTE
	Rio Ivo	Belém	NORTE E LESTE
	Rio Vila Izabel	Barigui	SUL E NORTE
	Rio Vila Guaíra	Belém	SUL
	Córrego Juvevê	Belém	NORTE E LESTE
	Rio Água Verde	Belém	SUL / LESTE / NORTE
	Rio Timbu	Iraí	NORTE
	Rio Canguiri	Iraí	NORTE
	Rio Curralinho	Iraí	NORTE
	Rio Cerrado	Iraí	NORTE
	Rio Iraizinho	Iraí	LESTE
	Córrego Capão da Imbuia	Atuba	LESTE
	Córrego do Aviário (atrás da UFPR)	Belém	LESTE
	Córrego Alto Boqueirão / Córrego Jardim Paranaense	Alto Iguaçu	SUL
	Rio Ponta Grossa	Alto Iguaçu	SUL
	Rio Ressaca		LESTE
		Belém	SUL
			NORTE
			LESTE

3-3 Decision of Priority

As shown in **Table 3-2** the 12 branches of Belem River have been nominated in 36 rivers that are more than that of other rivers and are consistent with the result of 3-1 section from the point of view of O&M of sewage pipe network. Because to diagnose a sewage pipe network it is effective to implement by a unit of small sewage pipe network, the order of diagnosis will be implemented by the priority shown in 3-3 section. The priority of the river branches in PRRU is consistent with that of small basin of the sewage pipe network.

4. Task Forth for Central Area

4-1 Actual Activities

In principal this diagnosis plan will be implemented by the method used in the pilot project. in case of the that of the central area that method will not be effective because of the issues as follows;

- Big quantity of leakage of sewage in dry weather is supposed.
- Underground infrastructure facilities are congested and measures for them are difficult.
- One measure is the additional construction of a trunk sewer.
- There are so many aged pipes that it cannot be effective the screening by simple TV camera. So that there is a possibility to investigate almost all the pipes by TV camera.
- There are so many traffics that make the investigation more difficult.

To cope with these issues SANEPAR established the Central Area Task Forth and JICA expert supports it. In September 2014 the persons of the units shown in **Table 4-1** joined and established the Team and began to act. The targeted area is shown in **Figure 4-1**.

表4-1 Member of Central Area Task forth Team

Task Forth Team Member
USEG
URCT-L
URCT-N
URCT-S
USHI
USPE
JICA Expert (Advisor)

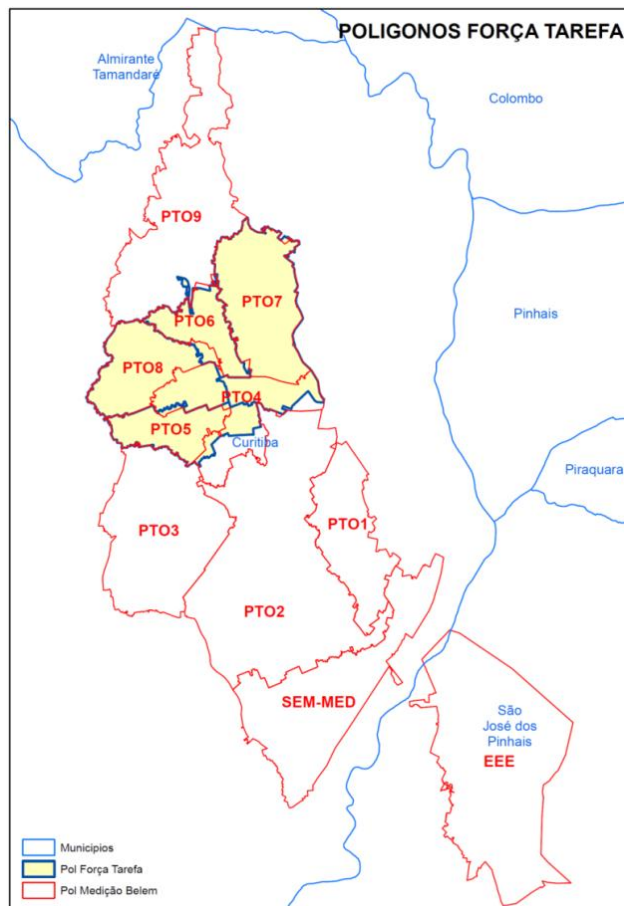

Figure 4-1 Targeted Area of Task Forth for Central District

4-2 Future Activities

Identification of sites the leakage problem by PRRU, check of the section with poor capacity pointed by the Master Plan and putting on the drawings will be implemented. In parallel a brain-storming will be conducted for the identification of the issues and sharing of the by the members.

5. Diagnosis Plan in the Coastal Area

5-1 Diagnosis Plan in the Morretes District

In the coastal area the targeted area will be the area with ceramic pipes in Morretes District. All the sections will be investigated and diagnosed by TV camera.

6. Data Base of the Results of Investigation and Diagnosis

In future according to the progress of the diagnosis the big amount of data will be obtained that urged us database them. SANEPAR has been developing a system by which results of diagnosis or rehabilitation can be contained in the ledger system that SENEPAR developed and the needed data can be taken off from it. It will be attempted by the data of pilot project. Because it is difficult to database all the data, the narrow dawn of the data has been discussed. Then this system can be used all area of Parana State. One example of the system is shown in **Figure 6-1**.

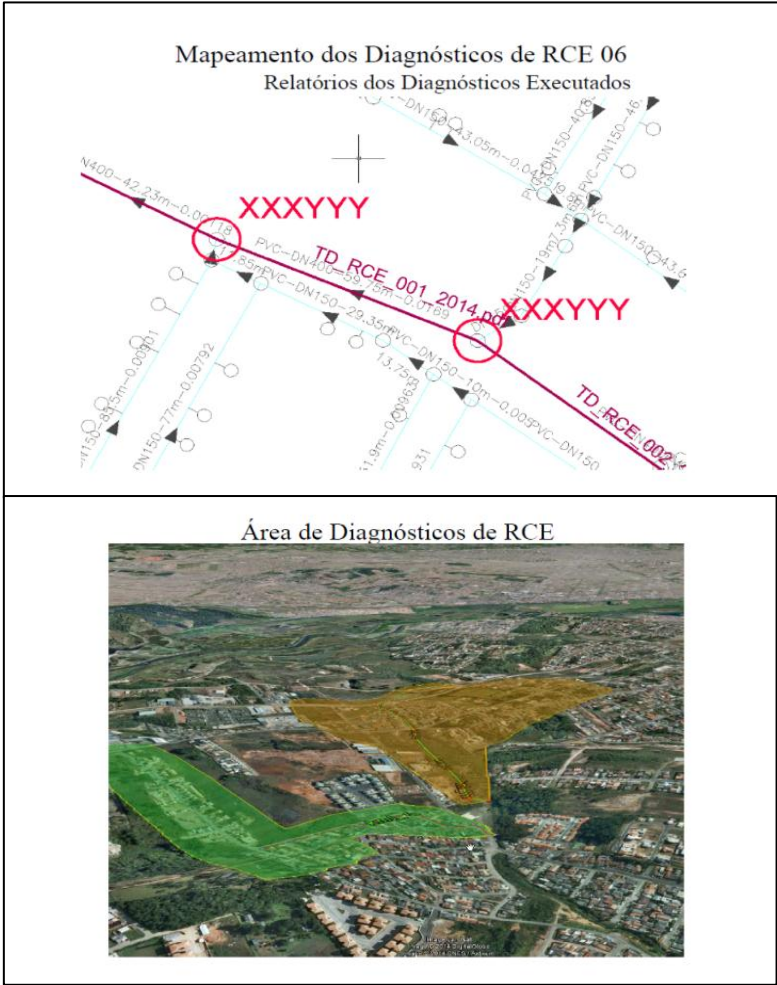

Figure 6-1 Example of Data Base System in Development

7. Implementation Plan of Sewage Pipe Diagnosis

7.1 Implementation Plan of sewage Pipe Diagnosis in CMA

The sewage pipe diagnosis in the pilot project needed about 1 year to implement. It is supposed to be big amount of period to implement the diagnosis plan in CMA. In this diagnosis plan the road map will be presented as an example only for the Belem STP basin where the priority of the small basins is decided and is shown in **Figure 7-1**. Small basins of PT04, PT05, PT06, PT07 and PT08 are in the area of central area. PT02 with high priority was included to them to form the road map.

Small Basin	Length of Ceramic Pipe	Year			
		2015	2016	2017	2018
PT05	62.8	■			
PT08	101.0		■		
PT06	54.7		■		
PT07	159.5		■	■	
PT04	100.8			■	
PT02	329.9				■

Figure 7-1 Road Map of the Sewage Pipe Network Diagnosis Plan in Belem STP Basin (Example)

7.2 Implementation Plan of sewage Pipe Diagnosis in the coastal area.

The targeted pipes of the sewage pipe network diagnosis plan in the coastal area have only length of 4.6km, and so the plan started in 2014 and will be finished within 1 year. Smoke test will be implemented which was not implemented in the pilot project in the coastal area.

7.3 Proposal for the Implementation of the Sewage Pipe Network Diagnosis Plan

It needs enhanced organization, sufficient equipment and secure of budget to convert the treat specific O&M method to the premeditated and preventive method. It is desired that each regional office will make a plan document and procured budget and the implement it. However it is important to recognize that temporal increase of the budget and personnel are the investment to reduce the budget in future by diminishing points with problem.

A11-3 下水処理場の運転維持管理マニュアル

PARANÁ SANITATION COMPANY



SERVICE UNITS - CURITIBA



MANUAL – OPERATIONAL PROCEDURES

ATUBA SUL WWTP

Location

ATUBA SUL WASTEWATER TREATMENT PLANT

CURITIBA

2015

INFO

Summary

1. INTRODUCTION	6
1.1. ADDRESS	6
1.2. PUBLIC SEWERS	6
1.3. TREATMENT PROCESS AND STRUCTURE	7
1.3.1. RAW SEWAGE PUMPING STATION (RSPS)	8
1.3.2. PRELIMINARY TREATMENT	8
1.3.3. BIOLOGICAL TREATMENT	9
1.3.4. PHYSICAL-CHEMICAL TREATMENT	11
1.3.5. SLUDGE DEWATERING AND INERTIZATION	12
1.3.6. CONTROL OF BAD ODORS	14
1.3.7. FINAL EFFLUENT OUTFALL	15
1.3.8. RECEPTOR BODY	15
2. QUALITY CONTROL	15
2.1. ANALYTICAL AND OPERATIONAL CONTROL PLANS (ACP AND OCP)	15
2.2. COLLECTIONS	15
2.3. ANALYSES	15
2.4. PARAMETERS AND FREQUENCY OF COLLECTIONS	16
1. CHANGE OF SHIFT	17
1.1. ARRIVAL AT THE PLANT	17
1.2. VERIFICATION OF THE WWTP PREMISES	17
1.3. OPERATIONAL CONTROL BULLETINS (OCB)	17
1.4. CHECKLIST OF ATUBA SUL WWTP	18
2. FOLLOW-UP AND FILL OUT OF SPS AND SUPERVISORY SYSTEM	19
2.1. PUMPING STATIONS PANEL	19
2.2. PRELIMINARY TREATMENT WWTP PANEL	22
2.2.1. CONTROL OF ALTERNATION OF THE PRELIMINARY TREATMENT SCREW PUMPS 22	
2.3. ACTUATION ON ALERT	23
3. PRELIMINARY TREATMENT	24
3.1. OPERATION OF THE RSPS'S SCREW PUMPS	24
3.2. USE OF RSPS'S SLUICES	25
3.2.1. ACTUATION AND MANEUVERS OF THE AUTOMATIC RSPS'S SLUICES	25

3.2.2.	MANEUVERS OF MANUAL SLUICES	25
3.3.	DISCHARGE FOLLOW-UP AND CONTROL	25
3.4.	UTILIZATION OF THE RAW SEWAGE BYPASS (via channel downstream the flap valve) 26	
3.5.	CLEANING OF THE PRIMARY GRATING (rough)	26
3.6.	OPERATION OF THE SECONDARY GRATING (automated).....	27
3.6.1.	COMMAND PANEL OF THE MECHANIZED GRATES	27
3.6.2.	MAN MACHINE INTERFACE (MMI)	28
3.7.	GRIT CHAMBER	32
3.7.1.	GRIT CHAMBER INSPECTION	32
3.7.2.	INSPECTION AND CLEANING OF THE SAND CLASSIFYING SCREW	33
3.7.3.	UTILIZATION AND CLEANING OF THE GRIT CHAMBER BYPASS CHANNEL	33
3.8.	CLEANING OF THE FLOW DISTRIBUTOR (Grease chamber)	34
3.9.	CHANGE OF CONTAINERS	34
3.10.	SERVICES SCHEDULING	35
4.	BIOLOGICAL TREATMENT - AFBR	36
4.1.	VERIFICATION – BIOGAS BURNERS	36
4.2.	VERIFICATION – LEVELING OF SPILLWAYS.....	37
4.3.	CLEARANCE OF DISCHARGE DIFFUSER BEAKS	37
4.4.	CLEANING OF CIRCULARS' SPILLWAYS	39
4.5.	REMOVAL OF SAND FROM THE CENTRAL DISCHARGE DIFFUSERS	39
4.6.	REMOVAL OF FROTH	40
4.7.	CLEANING OF SPILLWAYS OF PRIMARY GUTTERS	40
4.8.	MEASUREMENT OF THE SLUDGE LAYER.....	41
4.9.	SLUDGE DISPOSAL	41
4.10.	FLAME-TRAP DEVICES MAINTENANCE	42
4.11.	AFBR SERVICES SCHEDULING	43
5.	ELIMINATION OF BAD ODORS	44
5.1.	BEHAVIOR OF SULFIDE IN THE ATUBA SUL WWTP – AFBR EFFLUENT	44
5.2.	HYDROGEN PEROXIDE – H ₂ O ₂	46
5.2.1.	OPERATION OF THE HYDROGEN PEROXIDE APPLICATION SYSTEM.....	47
5.2.2.	PEROXIDE DOSING	48
5.2.3.	REQUEST OF HYDROGEN PEROXIDE.....	49
5.2.4.	RECEPTION OF THE HYDROGEN PEROXIDE LOAD.....	49

5.3.	CHLORINE GAS - Cl	50
5.3.1.	SAFETY	50
5.3.2.	OPERATION OF THE CHLORINE GAS APPLICATION SYSTEM	50
5.3.3.	FIRST AIDS.....	54
5.4.	SULFIDE ANALYSIS	55
5.4.1.	RESPONSIBILITY FOR COLLECTION AND ANALYSES	56
6.	PHYSICAL-CHEMICAL TREATMENT – DISSOLVED AIR FLOATATION	56
6.1.	DESCRIPTION OF THE PROCESS	57
6.2.	ROUTINE OF FLOATATION OPERATOR	59
6.3.	CHECKLIST OF FLOATATION	60
6.4.	AIR COMPRESSORS	60
6.5.	EMPTY/CHARGE FLOATERS.....	62
6.6.	DEFINITION OF FLOATERS OPERATION DISCHARGE	63
6.6.1.	REGULATING THE OPERATION DISCHARGE VIA SUPERVISORY	64
6.7.	RECIRCULATION WATER SATURATION SYSTEM	66
6.7.1.	FUNCTIONING OF THE SATURATION TANK	66
6.7.2.	OPERATION AND MONITORING RANGE OF THE SATURATION TANK LT	69
6.7.3.	LEVEL AND PRESSURE REGULATION IN THE SATURATION TANK	69
6.7.4.	INITIAL PROCESS REGULATION	70
6.8.	COAGULANT DOSING SYSTEM	72
6.8.1.	COAGULANT RESERVOIR.....	72
6.8.2.	DOSING PUMPS	74
6.8.3.	FERRIC CHLORIDE COAGULATION AND DOSING	74
6.8.4.	PROCEDURE TO DOSE FERRIC CHLORIDE	75
6.8.5.	INITIAL DOSING ADJUSTMENT	76
6.8.6.	FINE DOSING ADJUSTMENT	76
6.8.7.	RECEPTION AND UNLOAD OF FERRIC CHLORIDE.....	77
6.9.	SLUDGE SCRAPERS	77
6.9.1.	TURN ON/OFF SCRAPERS	78
6.9.2.	ADJUSTMENT OF THE SCRAPING TIME.....	79
6.10.	ANALYTICAL MONITORING OF THE FLOATATION SYSTEM	80
6.10.1.	MONITORING PARAMETERS	80
6.11.	PROBLEMS AND SOLUTIONS.....	81
6.12.	SERVICES SCHEDULING	84

7.	SLUDGE DEWATERING AND INERTIZATION	85
7.1.	WORK ROUTINE MANAGEMENT	85
7.2.	FILLING THE DEWATERING AND INERTIZATION SYSTEM OPERATIONAL BULLETIN	85
7.3.	SLUDGE DESTINATION FLOWCHART	87
7.4.	LAYOUT OF THE SLUDGE DEWATERING AND INERTIZATION PROCESS	88
7.5.	DESCRIPTION OF THE PROCESS	88
7.6.	OPERATION OF THE SLUDGE DEWATERING AND INERTIZATION SYSTEM	90
7.6.1.	HOW TO TURN ON THE SYSTEM	90
7.6.2.	STAGES OF THE PROCESS ACTUATION	90
7.6.3.	TURN OFF THE SYSTEM	95
7.6.4.	DETERMINATION OF THE POLYMER DOSING	96
7.6.5.	DETERMINATION OF THE COMPACTED SLUDGE DISCHARGE	100
7.6.6.	DETERMINATION OF LIME DOSING	103
7.7.	IMPORTANT CALCULATIONS	108
7.7.1.	LIME QUANTITY PER CONTAINER IN ORDER TO OBTAIN THE PERCENTAGE OF 58% OF DM	109
7.8.	VERIFICATION OF THE SLUDGE LEVEL IN THE COMPACTOR	110
7.8.1.	MEASUREMENT WITH THE SLUDGE JUDGE	110
7.8.2.	MEASUREMENT WITH THE ELECTRONIC INTERFACE MEASURER	110
7.9.	VERIFICATION OF THE LEVEL OF THE UTILITIES WATER RESERVOIR	111
7.10.	MONITORING OF THE LIME INVENTORY	111
7.10.1.	RECEPTION OF LIME	111
7.11.	MONITORING OF THE POLYMER INVENTORY	112
7.11.1.	RECEPTION OF POLYMER	112
7.11.2.	CLEANING OF THE POLYMER SOLUTION PREPARATION AREA	112
7.12.	COLLECTION AND ANALYSIS OF SAMPLES	112
7.12.1.	ANALYSIS OF TOTAL SOLIDS	113
7.12.2.	OPERATION OF THE SARTORYUS AUTOMATIC SCALE	113
7.12.3.	COLLECTION OF CURED SLUDGE TO BE SENT TO THE LABORATORY	114
7.13.	REGULATING THE CENTRIFUGE PARAMETERS	115
7.13.1.	REGULATING THE COMB HEIGHT AND CLEANING	115
7.13.2.	CLEANING OF ADJUSTMENT COMBS	117
7.13.3.	CLEANING OF THE CLARIFIED MATTER POINTER COUPLING	117
7.13.4.	REGULATION OF THE COMB HEIGHT	117

7.14.	CENTRIFUGATION VERIFICATION AND FOLLOW UP	118
7.15.	SERVICES SCHEDULING	119
8.	EMERGENCY SITUATIONS	121
8.1.	POWER OUTAGE AT THE WWTP:	121
8.2.	FLOODING IN FLOATERS	121

CHAPTER I

1. INTRODUCTION

This manual details the responsibilities of professionals, technicians and agents of Atuba Sul WWTP. The theoretical functioning of each of these processes is described in MN/OPE/0032, this document and others that will be mentioned here can be viewed on the Intranet through Sanepar's Normative System (SNS).

1.1. ADDRESS

The Atuba Sul Wastewater Treatment Plant (WWTP) is located at Rua Miguel Pedro Abib, number 179, at the corner with Luiz Oranje Fernandes da Penha street, Jardim Acrópole/Cajuru, Curitiba/PR – Postal Code 82 980-410.

1.2. PUBLIC SEWERS

The Atuba Sul Wastewater Treatment Plant receives the sanitary effluent collected from part of the Atuba River basin by the trunk sewers (TS) Bacacheri, Cajuru, and Maria Antonieta, also serving the systems of the Sewage Pumping Stations (SPS) Weissópolis and Piraquara. There are twenty nine pumping stations, and one of them is actually inside the WWTP.

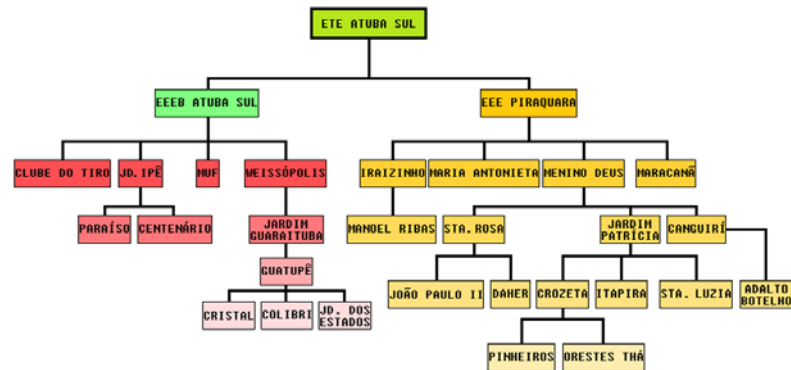

Image 1 - Flowchart of the Iraí U.I.'s SPSS. .

1.3. TREATMENT PROCESS AND STRUCTURE

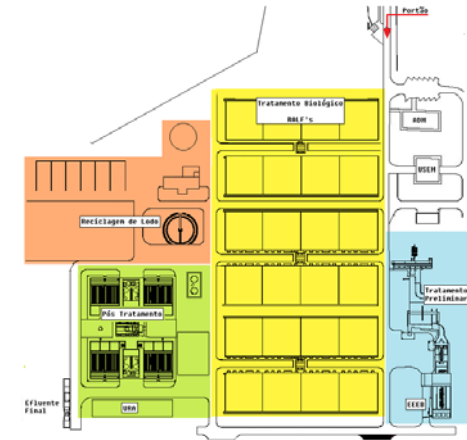

Image 2 - Layout of Atuba Sul WWTP

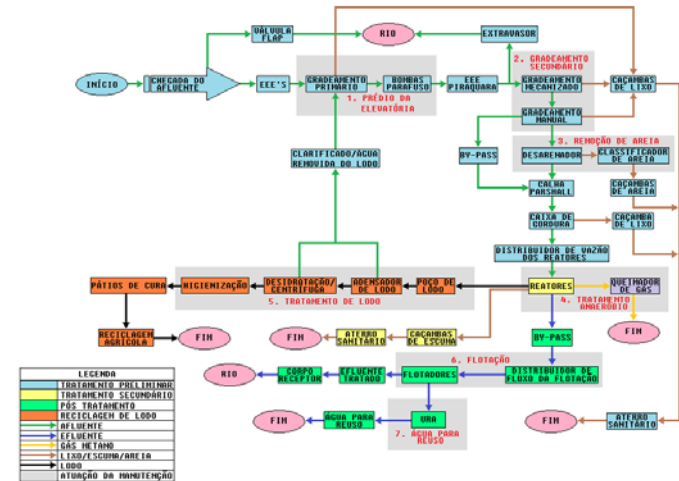

Image 3 - Operational Flowchart of Atuba Sul WWTP

To better visualize the Atuba Sul WWTP system, see Figure 03 that shows an operational flowchart of Atuba Sul WWTP illustrating all the treatment stages. The theoretical functioning of each of the stages shown as follows can be seen on MN/OPE/0032.

Note: The detailed flowcharts of Atuba Sul WWTP are part of the *Internal Supplementary Document: specification 6.252* that can be consulted in the Sanepar's Normative System (SNS).

1.3.1. RAW SEWAGE PUMPING STATION (RSPS)



Image 4 - RSPS

It consists of raising the sanitary sewage coming to the plant, by gravity or pumping of several outfalls, to start the treatment process. The Atuba Sul WWTP RSPS also has a rough grating installed to remove undesired materials of bigger size. The operating system has the following components:

- Four electromechanical actuation sluices;
- Manual rough grating of 80 mm;
- Single-girder overhead bridge crane;
- Pumping: 03 Helicoid Pumps, diameter 1830 mm, gradient 38°, elevation 7.50 m, approximate discharge 700 L/s each;
- 03 automatic greasing machines of the helicoid pumps pillow blocks;
- Command and power supply panels;
- Added to the Piraquara SPS discharge, average of 450 L/s.

1.3.2. PRELIMINARY TREATMENT

The Preliminary Treatment aims to render the sewage adequate for the biological treatment to be performed. This is done by grating and desanding. The first procedures aim to remove the rough material, generally garbage. The second one aims to remove sand and similar materials, such as stones, little stones, gravels, pebbles, among others. The Preliminary Treatment comprises the following:

- Mechanical grating of the belt type with 10 mm spacing, with helicoid conveying thread, and 05 m³ trash container;
- Mechanical grating by-pass channel with manual grating of 80 mm;
- "Door Oliver" type 140 m² square sand box, and 0.97 m spillway brim with removal system through scraping bridge and conveying thread, two 05 m³ trash containers;
- Desanding treatment by-pass channel;
- Grease trap;



Image 5 - Preliminary Treatment

- Discharge measurement by a 213.5 cm (7') throat Parshall Flume with ultrasound sensor and discharge totalizer;
- Flow directing box between sets (H's);

Wastes: garbage retained in the grids and sand removed from the sand box.

1.3.3. BIOLOGICAL TREATMENT



Image 6 - RALF

The biological treatment of Atuba Sul WWTP is performed through the Anaerobic Fluidized Bed Reactors, the AFBRs', which main purpose is to remove the organic matter.

Basically, the AFBR corresponds to a tank where the sewage is introduced to the bottom, flowing upwards until leaving through the surface. The sedimentation of the sewage solid material occurs until a sludge layer is formed at the lower part of the tank. This layer is composed of microorganisms that eat the organic matter in the sewage.

Gravity acts on the solid particles in the sewage flow, depositing them as sediments. On the other hand, the upward flow drags the solids again upward. The anaerobic activity generates an also upward flowing gas. This combination of contrary flows continuously moves the sludge layer, producing the so-called fluidized effect of the AFBR.

Several independent and simultaneous reactions occur inside the reactor. Briefly speaking, the organic matter is hydrolyzed, fractioning the long chains into smaller chains. Then, acidogenic bacteria transform these acids into acetates. The methanogenic bacteria use acetate to produce methane gas. With this set of reactions the organic matter is converted into carbon gas, methane gas and water. Concurrently, sulfate-reducing bacteria convert sulfate into sulfides, producing hydrogen sulfide gas that has to be treated to prevent unpleasant odors.

Sewage treatment through AFBR results in three products: treated effluent, sewage sludge and biogas. The sewage sludge is the residual solid mass retained in the reactor, the biogas is a mix of gases in which methane is the main component.

The sewage sludge produced in a treatment plant has to be periodically disposed of. Considering a stable system, i.e., with a biomass amount balanced with the amount of organic matter available in the raw sewage to be consumed, the disposal volume should be proportional to the volume of sludge produced. This means that the surplus sludge formed, which is not required to maintain the biological treatment at the plant, should be removed from the process.

Let's remember that this manual does not include the 08 new reactors that were still under construction. At the moment of this manual elaboration, Atuba Sul WWTP has 04 lines with 04 AFBRs each, totaling 16 reactors, with the following characteristics:

- 2008 m³ parallelepiped shape (21 m x 21 m x 4.55 m);
- Rated discharge of each reactor is 70 L/s;
- Water detention time (WDT) of 7.96 hours;
- Discharge speed (m³/m²/h) varies from 0.35 m/h to 0.73 m/h, to discharges between 600 L/h to 1440 L/h, respectively. For an average discharge of 1,00 L/s, the average speed will be 0.56 m/h;
- The sewage flow distribution is done by 90 DN 75 HDPE diffusing pipes. With the long DN 75 90 degrees curve located to the end to direct the sewage inlet flow against the reactor floor;
- Height of the sludge layer between 2 – 2.5 m from the bottom;
- Height of sludge mattress is less than 0.8 m.
- Effluent junction box of 4 lines.

- Wastes: garbage removed in final grids, foam retained in the gas chamber and in the decanter, biological sludge and biogas.
- Biogas treatment: gas lines with flame arrester valve, flow interruption valves, and burner with automatic sparking, one for each of the AFBR's lines.

1.3.3.1. STUDY ON THE BEHAVIOR OF SOLIDS IN THE AFBR

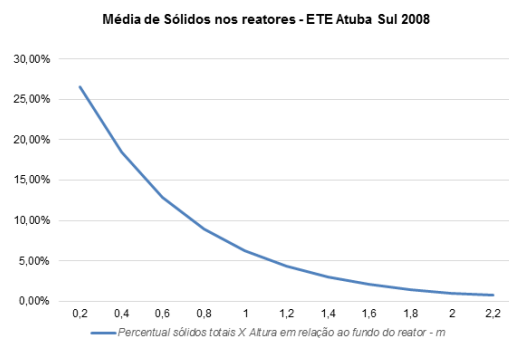

Graph 1 - Average of solids in the AFBRs of Atuba Sul WWTP - 2008

We observe in the above graph that the concentration of sludge is stratified in the reactor's profile. And this is higher at the bottom, with over 20% of Total Solids (TS). That is, the sludge at the bottom of the reactor is more concentrated than the centrifuged sludge.

The sludge with concentration higher than 10% TS is usually called the sludge mattress, and is found at approximately 0.8 m from the reactor's bottom.

Totalização média de sólidos nos reatores - ETE Atuba Sul - 2008

Altura (metro)	Volume reator (m³)	% sólidos	Kg/m³	Kg ST
0,1	44	31,88	319	14061
0,2	44	26,61	266	11733
0,3	44	22,2	222	9791
0,4	44	18,53	185	8170
0,5	44	15,46	155	6818
0,6	44	12,9	129	5689
0,7	44	10,77	108	4747
0,8	44	8,98	90	3962
0,9	44	7,5	75	3306
1	44	6,26	63	2759
1,1	44	5,22	52	2302
1,2	44	4,36	44	1917
1,3	44	3,63	36	1599
1,4	44	3,03	30	1335
1,5	44	2,53	25	1114
1,6	44	2,11	21	929
1,7	44	1,76	18	775
1,8	44	1,47	15	647
1,9	44	1,23	12	540
2	44	1,02	10	451
2,1	44	0,85	9	376
2,2	44	0,71	7	314
Total	969	8,59 *	Total	83334

* - Média

Table 1 - Total solids in the reactors

In the above table, we can observe that the typical sludge amount, for each reactor of the Atuba Sul WWTP, is approximately 83,000 kg of Total Solids in average.

By dividing this amount of 83,000 kg of sludge by the total volume of reactors found in these 2.2 m, we will reach the amount of 85 kg/m³, i.e., 8.5% of Total Solids. This is the average concentration, typical of the Atuba Sul AFBR's sludge profile, at the bottom of the reactor until the sludge/clarified interface – near the height of 2.2m.

The AFBRs of Atuba Sul WWTP have a junction in the opening of the gas chamber with the three-phase separator, and this is the differential concept in regard to the UASB (Upflow Anaerobic Sludge Blanket).

1.3.4. PHYSICAL-CHEMICAL TREATMENT



Image 7 – Floaters

The physical-chemical treatment, or post-treatment, of the Atuba Sul WWTP is performed through the Dissolved Air Flotation (DAF) system.

In the DAF system, a coagulating agent is added to the affluent sewage, in case of the Atuba Sul WWTP, the Ferric Chloride (FeCl_3) is used, and the dose is calculated in Jar-Test. Serial flocculation chambers, with decreasing rotation speeds, mix the chemical product to the sewage. At the end of such chambers, the before suspended solids must be agglutinated in bigger flakes. In the flotation chambers, water saturated with air is added in the vertical flow, with the purpose of suspending flakes in the tank. The floated sludge remains on the tank surface and is removed through a surface scraper.

The objective of the floatation is to suspend solid particles, removing them from the sewage. In order to do that, water saturated with air is injected at the bottom of the tank, releasing micro bubbles. They flow upward until the surface of the tank, leaving to the atmosphere. In their way to the surface, those micro bubbles find a physical barrier, which are the solids that were agglutinated with the help of FeCl_3 , and suspend such material until the surface. In the surface, such solids are removed with a scraper.

The DAF system of Atuba Sul WWTP comprises the following:

- Discharge distributing box with by-pass to regulate the flow by an electromechanical actuation sluice, and a 213.5 cm (7') throat Parshall flume, with ultrasound sensor and discharge totalizer;
- 04 pneumatic actuation sluices for flow interruption, one per floatation module;
- Coagulation: by ferric chloride, with two 75 m³ tanks for storage, an intermediary 05 m³ tank, 04 dosing pumps, and fast mechanical mix;
- Flocculation: 04 systems with 03 flocculation tanks of 5.2 x 5.2 x 3.4 (92 m³) and mechanical agitation for each system.
- Dissolved Air Flotation – DAF: 04 systems with two modules of 10 x 7.95 x 3.8 m (302 m³), with capacity of 110 L/s (120 m³/m².d) each;
- Recirculation: 01 submersible recirculation motor-pump assembly of 56 L/s and 75 HP for each DAF system;
- Air saturation: 04 sets with 5 HP compressor for 0.52 Nm³/min, pressure tank for 8.0 bar, and saturation tank of 2.0 m x 2.0 m (6.3 m³) with filling, and automated control by a Supervision and Control system, 01 for each DAF system;
- Saturated water distribution: 11 DN 60 PP pipes per DAF module, with pressure reduction by manual valve, and distribution in 09 orifices with diameter 10 mm. Currently of the 11 pipes, three are closed, 08 are working per floatation module (A/B);
- Sludge removal: mechanical scraping, directed to the floated sludge well, and elevated by helicoid pump 14 m³/h (two per well, but one remains in stand-by);
- Cleaning of the bottom: drained by a valve at the bottom, directed to the central floaters well, and the central well has two submersible pumps with maneuver valve, sent to the compactor or to the RSPS;
- Wastes: floated sludge and bottom sludge go to the sludge compactor. The occasional foam in the flocculators is removed by a suction truck, and then sent to the WWTP Belém.

1.3.5. SLUDGE DEWATERING AND INERTIZATION

For being a waste that should be properly disposed of in order to prevent damages to the environment, and considering that such disposal has a considerable cost, the reduction of the sludge volume is fundamental. At the Atuba Sul WWTP the centrifuge system is used to remove moisture and consequently to reduce the volume of sludge coming from the floaters and AFBRs.

In centrifuges, the sludge is previously flocculated, and then it is inserted into a high rotation rotating drum. The centrifuge force pushes the sludge against the drum walls, separating it from the liquid. Independent pipes remove the sludge and the water from the centrifuge continuously. After dewatered, the sludge now has solids contents between 15% to 30%.



Image 8 - Dewatering building

- Disposal of the sludge from the Anaerobic Fluidized Bed Reactor (AFBR): 12 valves per AFBR, 06 valves 0.3 m high, called valves "B" (low), and 06 valves 0.9m high, called "A" (high). All valves directed to a channel per line, and communicating with the AFBRS' sludge well located in the sludge dewatering shed;
- Floated sludge: directed to the sludge compactor by an helicoid booster pump;
- Sludge at the bottom of the floaters: directed to the sludge compactor, through 02 submersible pumps located in the central floaters well, with automatic actuation by a level electrode;
- Sludge well of the AFBRS: 2.30 m x 2.30 m x 5.5 m;
- Pumping from the AFBRS' sludge well to the compactor: 02 submersible engine sets, with automatic actuation by a level electrode;
- Compactor: 14.6 m of diameter x 3.0 m of height at the brim (502.25 m³), rotating bridge of 0.75 hp. Floating material returns to the RSPS (Raw Sewage Pumping Station) and the compacted sludge is sent to be dewatered. Two helicoid engine sets to direct it to the centrifuge, discharge capacity of 15m³/h, with variator through a frequency inverter, with an electro-magnetic discharge measurer at the PP (Pressurized Pipeline) for each dewatering machine. Remarks: works as equalizer of the reactor's sludge and compactor of the floated sludge;
- Dewatering: 02 centrifuge decanters with capacity up to 700 kgTS/h (10 m³/h sludge with 07 % TS);
- Polymer: Two 4000 liters tanks to dilute polymer/water, one to prepare with mechanical agitation, and the other for application working alternately. Dosing done by 02 helicoid pumps, discharge measurement by flow meter with capacity of 1400 L/h;
- Lime storage: 01 15 m³ silo with disaggregation done by a compressed air and mechanical vibrator system;
- Lime dosing thread: maximum capacity of 320 kg/h with dosing variator;
- Sludge-lime mix: 01 mechanical mixer with capacity for 3500 kg of viscous sludge per hour (20%);
- Cure and storage: approximately 1000 m² of a covered yard with concrete floor and drainage done through a crushed stone channel, 2000 m² of asphalted yard without drain, and 1400 m² of compacted gross sand yard without drain;
- Waste: the dewatered and limed sludge remains curing for a period in the sludge drying yard, the clarified effluent and the drained liquid of the yard return to the start of the sewage treatment process.
- The Sludge Management Unit (SMU) of the Atuba Sul WWTP is responsible for the formation of monthly batches, and the elaboration of sketches mapping the drying yard.

1.3.6. CONTROL OF BAD ODORS

Wastewater treatment plants and the neighboring community have to live together in harmony. Therefore, the odors of a WWTP shall be carefully controlled.

Bad odors resulting from the sewage treatment mainly come from sulfur and nitrogen compounds. Among the sulfur compounds, the hydrogen sulfide gas and the mercaptans are the main ones, while among the nitrogen compounds, the main ones are the ammonia and the amines;

In terms of volume, the hydrogen sulfide gas represents less than 1% of the gases generated, however for having a threshold of olfactory detection in very reduced concentrations, it is the main agent causing bad odors at the WWTPs.

In general, the odor fight activities should follow three lines: monitoring, capturing and treatment of gases, and control of AFBRs' effluents.

Monitoring actions are performed by following up the weather conditions, sulfide measurements in liquid mean, and identification of possible complaints.

The production of hydrogen sulfide gas occurs naturally in the organic matter fermentation phase, and a higher volume is produced in the AFBR. Concurrently, sulfates are reduced to sulfides, in a process called sulfidogenesis. Thus, the sulfide remains contained not in a gaseous form, but in a liquid mean, being sent along with the AFBR's effluent. Therefore, it is important to monitor the amount of total sulfides in liquid mean. To further details on odor control methods, please refer to *MN/OPE/0035*.

At the Atuba Sul WWTP, the control of the release of gases dissolved in the reactors' effluent is done through the oxidation of sulfides by using chemicals. Such as the Hydrogen Peroxide and Chlorine.

1.3.6.1. HYDROGEN PEROXIDE

The treatment with hydrogen peroxide (H_2O_2) consists of reducing sulfides in the liquid mean through oxidation. With its high contents of active oxygen and the high oxidative power, the hydrogen peroxide promotes the oxidation of dissolved sulfides, reducing the H_2S concentration in liquid mean, and consequently the corrosion and generation of toxic and odoriferous vapors.



Image 9 - Peroxide Application System

- Application of 50% hydrogen peroxide distributed in the AFBRs' gutters, with the supplier's proprietary system;
- Storage of chemicals: 02 tanks of 28 m³;
- Dragging water: polypropylene (PP) water container of 1000 liters with buoy, consumption measured by a water meter, and dragging by a centrifuge pump;
- Peroxide dosing: 04 stainless steel individual distribution lines 316 1/2" (one per reactor line) controlled by a sphere valve, and discharge measured by a flow meter up to 100 L/h.
- Peroxide-water mix: injection point with vortex-like mix and retention valve of the little door type at the potable water line;

- Distribution: 07 dosing points per reactor, 28 per line, with sphere valve and dosing nozzle. Totalizing 112 application points.

1.3.6.2. CHLORINE



Image 10 - Chlorine Application System

The treatment with gaseous chlorine (Cl_2) aims to oxidize the total sulfides in the liquid mean to elementary sulfur, precipitating this compound in the liquid mean, and thus preventing the release of odor to the atmosphere.

- Chlorine stored in liquid form in 12 cylinders of 900 Kg;
- Cylinders support berth;
- Centrifuge pump for dragging fluid;
- Venturi Type chlorine – dragging fluid mixer;
- Manifold connecting all the cylinders.

1.3.7. FINAL EFFLUENT OUTFALL



Image 11 - Final Effluent Outfall

- Concrete channel 3 m wide and 43 m long discharging into Atuba river;
- Discharge measurer by a 213.5 cm (7') throat Parshall Flume with ultrasound sensor and discharge totalizer with sonar;
- Sample collection point: after the Parshall flume.

1.3.8. RECEPTOR BODY

- Atuba River

2. QUALITY CONTROL

2.1. ANALYTICAL AND OPERATIONAL CONTROL PLANS (ACP AND OCP)

Analytical Control Plan (ACP) and Operational Control Plan (OCP) pursuant to *PF/OPE/0158* and *IT/OPE/1728*, respectively.

2.2. COLLECTIONS

Collections should be performed pursuant to *IT/LAB/1538*. The ACP analyses should be collected and sent to the USAV (Compliance Evaluation Service Unit) – Curitiba or Belém WWTP, as applicable; OCP analyses should be done at the Atuba Sul WWTP Laboratory.

2.3. ANALYSES

The analyses laboratory should comply with the *IT/LAB/1554* in regard to the facility and cares. The following analyses should be performed to comply with the Operational Control Plan – OCP:

- Analysis of Dissolved Oxygen (DO) - *IT/LAB/1233*;
- Analysis of Settleable Solids (SED.S) - *IT/LAB/1453*;
- Analysis of Total Suspended Solids (TSS) - *IT/LAB/1146*;

1.4. CHECKLIST OF ATUBA SUL WWTP

The form is a detailed checklist for the Atuba Sul WWTP. It includes sections for: VALVULA FLAP (Valve status), COMPORTAS AUTOMATIZADAS (Automated gates), GRADEAMENTO PRIMARIO (Primary grading), DOBRAS ESES (Screens), NIVEL GRAXA (Grease level), CAÇAMBAS (Skimmer), GRADES AUTO (Automatic gates), QUEIMADORES (Burners), TRANSFERENCIA (Transfer), BOMBAS DE RESERVA (Reserve pumps), BOMBAS DE DRENAGEM (Drainage pumps), POÇO DE LODO CENTRIFUGA (Centrifuge sludge tank), BARRAS MECANICAS (Mechanical bars), ADESTRADOR (Screw), and ILUMINAÇÃO (Lighting). Each section contains multiple rows for different shifts (07:00, 13:00, 19:00) and columns for status indicators like 'OK', 'Deslig', 'Falha', etc.

Image 12 - Checklist of Atuba Sul WWTP

The filling out of the checklist (IA/OPE/1526) is obligatory, and shall be done daily at 7:00 am and 11:00 pm by the operator of the support 6x4 scale operator, and in the absence of this operator, by the floatation operator. This document is very important and will be the guideline for the activities to be performed, as well as for monitoring the operation conditions of the WWTP and the need request services.

The operator should personally check all the WWTP sectors described in the document, and the operation conditions of the equipment. The document shall be filled out with blue or black pen, following the instructions:

- Check if there is sewage overflow through the FLAP valve, observing whether the valve is open or closed;
- check if the automated sluices of the RSPS are working. open and close the sluice by the command panel, keeping it in the position it originally was. If any of them is in maintenance, count the days;
- check the situation and need of cleaning the primary grating;
- write down the situation of the RSPS pumps;
- Grease level of the pumps. Beneath the RSPS building staircase and beside the sand classifying Screw.
- check the trash containers, and write down as requested by the document. arrange for the change of trash container if needed pursuant *item 3.9*;
- check the mechanized grates functioning. If it is not possible keep them in operation, deviate the flow the second manual grate, as described in *Item 3.6*;
- check if the AFBRS' biogas burners are lit. If they are not lit and the ignition candles are not working, make a torch light them;
- check the grit chamber and the sand classifying screw. If they are working properly, write down OK, otherwise count the maintenance days and deviate the flow the grit chamber bypass. As described in *Item 3.7.3*;
- check the grit chamber By-Pass sluices, remembering that if the grit chamber and the sand classifying screw are under maintenance, the by-pass should be obligatorily open;
- check whether the discharge measurer is working. It is located beneath the grease chamber staircase;
- check in the Hs of the AFBRS if there is any closed reactor, and write down the number;
- Check the situation of the Chlorine and Peroxide dosing. If the pumps are turned off, the operator should make sure he/she knows the reason, and resume the dosing as soon as possible;
- check the centrifuge water reservoir pump. Its command panel is located at the Line 04, near AFBR 16. Take notes as instructed in the document;
- test the Rainwater Drainage Pump, its command panel is near the Parshall flume of the Final Effluent. Turn it on test its functioning, and then turn it off. If it does not turn on, request maintenance USEM;

- Centrifuge sludge well: check the well level, the pump status, and whether it is managing to pull the sludge. In this case there are some particularities, if the well is low, the pump cannot be on, working dry. If the well is high, the pump should turn on, and if this does not occur, you should check the reason. And, at last, if the pump is on, you should check whether it is pulling the sludge, and for that you should check visually if the sludge is coming near the shaft of the compactor blades.
- visually check if the compactor blades are turned on and spinning. Fill out the document as requested;
- observe the lighting situation of the WWTP;
- The shift operators of the three shifts should read their e-mails, the Occurrences Books, and the bulletins pertaining to their sector of the WWTP, in the beginning of their shifts, and they should initiated the Checklist, certifying to be aware of the instructions and situations therein described.

The morning shift operator should also fill out the Hour Meters Control of the Atuba Sul WWTP (IA/OPE/1537) and the Peroxide Consumption Control (IA/OPE/1521).

2. FOLLOW-UP AND FILL OUT OF SPS AND SUPERVISORY SYSTEM

The filling out of the Pumping Stations Control and Monitoring (IA/OPE/1524) via supervisory system is daily performed at 00:00, 03:00, 05:00, 07:00, 10:00 am, and 1:00, 3:00, 5:00, 7:00, 9:00 pm, and is the responsibility of the operator in the 6x4 support shift, and if absent, of the floater operator. This is a document that should be carefully filled out, through it the functioning, overflow and maintenance of the Pumping Stations of the Irai UI system are supervised.

Whenever an abnormal situation is observed, take note of this in the WWTP Occurrences Book. The referral and resolution of such situations is priority above other services, except for discharge regulation.

2.1. PUMPING STATIONS PANEL

In the computer where the supervisory is installed, it is possible to access and to follow up the functioning of various SPSs that composed the Atuba Sul WWTP system. In the upper part of the screen there is the button UNIDADES that provides access to the SPSs, sectors of the Atuba Sul WWTP, and one general screen that allows visualizing all SPSs available in the system.

The entering of data should follow the standards of the legend:

<u>SITUATION OF THE PUMP</u>		<u>SITUATION OF THE LEVEL</u>
A – Automatic	SC – W/o communication	N – Normal
M – Manual	SE – W/o energy	NB – Low level
L – Local	PN – Pump turned off for Level	NA – Level too high
PID – Manual PID	PNN – Failure, does not turn off for low level	E – Overflowing
AF/LF/MF – Failure	PV – Discharge limitation downstream	
Ma01 - Maintenance	PE – Electrical grid limitation	
MaP – Maintenance , on duty at the site		

Icons:

Image 13 - Icons of pumps in the supervisory

- **Turned On / Off** – Green icon: pump turned on, red icon: pump turned off;
- **Automatic** – Pump operates with no intervention from operation. Working according to the well level, by a measurer or electrodes. It is possible to access commands for remote operation.
- **Local** – Pump operates directly in the site, with commands via command panel, and working according to the level. It is not possible to access commands for remote operation.
- **Manual** – In this way, the pump works uninterruptedly, i.e., it does not turn off/on because of the level. Commands for remote operation are available.
- **Manual PID**– In the PID mode, the amperage of the pump is remotely defined, this mode is generally used to control discharge in the SPS.
- **Failure** – When the pump is in failure, a blinking yellow square will appear around the icon of the pump. In this case, it is necessary to access the pump menu, and click on the reset button.
- **Maintenance** – The pump under maintenance stays remotely inaccessible, a static yellow square appears around the icon. In this case, it is advisable to contact the field operator and to confirm the information.
- **Main/Supplementary** - White box appearing to the left of the pump icon. P for main, and C for supplementary, this indication shows the pump functioning system, the main will always be the first to be turned on and the last to be turned off. The supplementary will only start operation if the well level is too high.

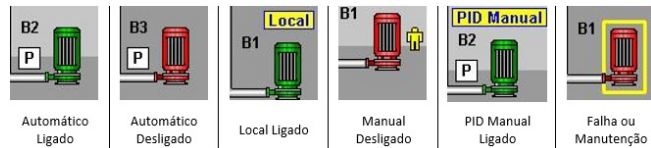

Image 14 - SPS Panel

Information on the SPS screen:

- **Actual overflowing level:** It facilitates the level monitoring, in order to prevent overflowing;
- **No-break:** The SPSs are equipped with no-break equipment so that we can have time to act in case of power outage. When its icon, on the upper left corner, is red this means that there is no power supply, and in this case the time of power available will lower, when it is zeroed it means that there is no power at all at the SPS.
- **Area/Name:** Upon clicking on this field, a menu will be opened where it is possible to change the pumps operation system, the main and supplementary pumps, and the alternation time.
- **Clock setup:** Operation field exclusive to the automation/maintenance staff.

- **Status:** In the figure where we can read SPS Turned for minimum level, the messages Level Too High and Overflowing can also appear, and these are level status. There is also communication status that can show the messages W/o communication and SPS Interlocked.
- **LT:** Level Transmitter, measurer of the SPS well level, on the screen it will appear followed by the identification number. Upon clicking on where LT is written, a menu will be opened where it is possible to reset LT, change the SPS functioning levels, and some other configurations which are the responsibility of the automation/maintenance team. Upon directly clicking on the box showing the level, a graph will be opened where it will be possible to analyze the level track records. When LT is correctly working, this box appears in orange, and it will be yellow when there is a failure, and in this case the LT letters should be clicked on, and then the Reset button should be clicked on.
- **Amperage:** It shows the amperage in which the pump is operating, upon clicking the box, a graph with the amperage track records will be opened.
- **SPS Enabled / Disabled:** It enables or disables the remote operation of the Pumping Station.
- **Electrical:** It shows the voltage of the three power feeding phases at the WWTP (RST). Each box of the three phases generates a graph. It is important to always pay attention to this field to prevent overflowing to occur due to the pumping station being turned off because of power outage.
- **Pumps:** The information shown in the pumps icons were detailed described above. Upon clicking on the icon, the following menu will be opened:

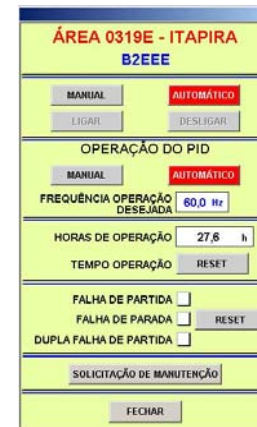

Image 15 - Pump menu

- **Manual/Automatic/Turn On/Turn Off:** It defines whether the pump will operate in automatic or manual mode. When in manual mode, the turn on/off buttons will be activated.
- **Pid Operation:** In Automatic mode, the pump will modulate its frequency according to the well level. If it is defined in Manual mode, it will be possible to enter the desired operation frequency.
- **Operation Hour/Time:** Hour meter and hour meter reset.
- **Failures panel:** Indication of pump failure which might occur, and reset for correction.
- **Maintenance request:** Yet to be implemented.

Attention

- **Pumps or discharge/level measures with failure:** To open the menu of the faulty equipment, and click on the reset button, waiting for some time. If there is no solution, to inform the field operator (in business hours), or the USEG on alert, and to record it in the book of occurrences.
- **High level/overflowing:** The SPS should be operating in its maximum capacity. If not, try to reset the pumps and level measures as described above.
- **Low level:** to monitor and, if necessary, to check the amperage graphs to see if the pumps are turning off. If pumps continue to operate with the dry well, open the pumps menu and click on the reset button, do the same in the LT menu. Wait for some time. If there is no solution, to inform the field operator (in business hours), or the USEG on alert.
- **Electric power:** In case of lack of energy, it is obligatory to communicate COPEL through the phone 0800 64 37 575, informing the local client code (which is available in the invitations to bid), and to record the

occurrence and the service protocol on the WWTP's book of occurrences. Follow up the case, and if the energy supply is not resumed within one hour, contact COPEL again, and with the field/alert operator, to record again in the book of occurrences. If the problem persists, repeat the contact with COPEL, Field/Alert Operator each 30 minutes.

- **Interlocked SPS:** It generally occurs when the SPS is not enabled, in this case click on the Enable button that is above the electrical power counter. The second option to solve the problem is to rest the level pumps and LT. If not solved, call the USEG in alert.

2.2. PRELIMINARY TREATMENT WWTP PANEL

On this screen, among other information, there are three fields requiring the attention from the operator: FT01A, FT01, and LT01.

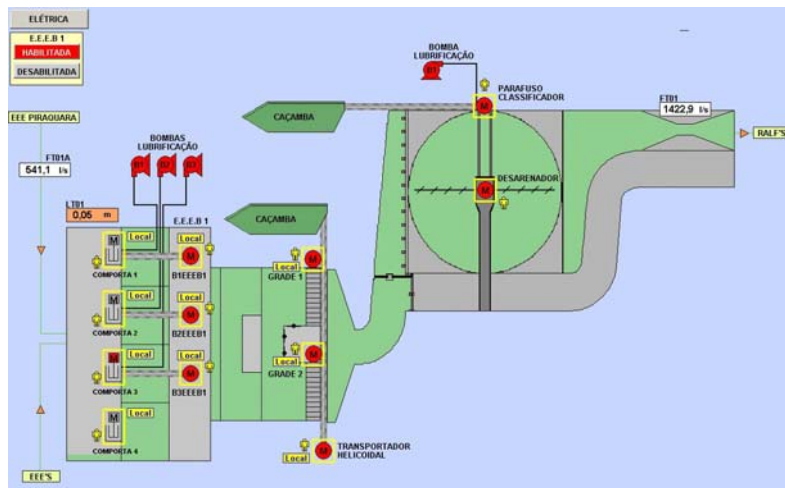

Image 16 – Preliminary treatment WWTP screen

- **FT01A** – Measurer of the discharge coming from Piraquara SPS, which is the biggest pumping station of the system.
- **FT01** – Measurer of Atuba Sul WWTP discharge
- **LT01** – Measurer of the flap valve well level (spillway). Whenever this level is above 1.58, there will be overflow. This occurrence is only acceptable when the Atuba Sul WWTP inflow discharge (FT01) is between 1600 and 1650 L/s.

2.2.1. CONTROL OF ALTERNATION OF THE PRELIMINARY TREATMENT SCREW PUMPS

With the aim of preventing mechanical jamming, the RSPS screw pumps should be alternated. The instructions for alternation are further detailed in *Item 3.1*, but are basically the following:

- The Pump B2 and B3 should be the main ones, and B1 will be the alternating pump.
- The alternation and maintenances shall be recorded in the Operational Bulletin of Pumping Stations (IA/OPE/1524).

- This change shall be performed in an alternate way, i.e., if in this week B2 was turned off to turn on B1, next week B3 should be turned off.

The follow-up of RSPS (Raw Sewage Pumping Station) functioning of Atuba Sul WWTP in the Operational Bulletin of Pumping Stations shall follow the following model:

- Take note of information according to the situation of each pump, writing down “A” for pump in operation in the automatic mode via supervisory. “L” for pump turned on in local mode, directly in the command panel in the field; “M” for operation in manual mode via supervisory; “P” for turned off pump, in standby.
- In the field corresponding to the last pump alternating with B1, an “R” should be written down for the control of which pump will be the next to be changed. For instance, if the pump is turned on in local mode in the field, and was turned off last Monday for alternation, in the corresponding field the information “LR” will be written down
- In case of pump under maintenance, count the days it is unavailable for use, and for that write down “Ma01” for the first day, “Ma02” for the second day, “Ma03” for the third day, and thus successively until the pump is released for use.
- For pump in manual mode in the supervisory, write down “M-LIG” for when it is turned on or “M-DESL” for when it is turned off.

2.3. ACTUATION ON ALERT

The alert system solves the problems that might occur in the SPS, and cannot be corrected directly by the supervisory system, always in weekends, holidays and non business hours. In business hours, the field operators of the East UI should be called.

In addition to the already mentioned situations, the alert system should be activated when:

- It is verified a defective pump that does not work when the reset is activated.
- When the pump is in failure and does not reset, try to turn it on in Manual mode, and follow up the well level graph to prevent the risk of the pump working with the empty well. In this case, in addition to record in the WWTP's book of occurrences, inform the situation via e-mail to the East UI manager, with copy for the Irai UI manager for knowledge. If the pump does not turn on even in manual mode, call the USEG under alert.
- One or more pumping stations having Communication Failure, record in the book of occurrences, and via e-mail to the managers of East UI and Irai UI;
- Sps that have discharge measurer (FT) which, free from failure, do not register even with the pumps on.

occurring. Overflowing is only allowed when the WWTP discharge is between 1600 and 1650 L/s. In such case, if the overflowing level is observed and the discharge is below **1600 L/s**, the operator should give total priority to correct this situation.

The follow-up can also be done in the field, through the discharge measurer located beneath the grit chamber staircase (*Image 20*), the overflowing of the flap valve can be visually inspected in the well beside the RSPS.

The data on the overflowing, either because of excess, outage of electric power, or any other reasons, should be recorded in the *WWTP's Book of Occurrences*. Obligatory.

Instructions:

- The discharge adjustment is exclusively done through automatic sluices located before the screw pumps. Opening or closing the sluices, as described in *item 3.2.1*;
 - Do not regulate the inflowing discharge through the mechanized grading sluices, because it can overflow to the plant's street.
 - Record it in the Bulletin of Pumping Stations Monitoring (*IA/OPE/1524*);
- For situations of energy outage and flooding of the WWTP, please refer to *topic 8* of this chapter.



Image 20 – Field discharge measurer

3.4. UTILIZATION OF THE RAW SEWAGE BYPASS (via channel downstream the flap valve)

- In case of excess discharge, i.e., discharge over **1650 L/s**:
 - keep 02 screw pumps working;
 - let the sewage inflowing between **1600 L/s and 1650 L/s**, varying the height of mechanized sluices that stay in the well upstream (before) the screw pumps. Do not regulated the inflowing discharge through the mechanized grading sluices, because it can overflow to the plant's street. According to instructions in *item 3.3*.
- In case of discharge restriction to prevent overflowing in the floaters, due to flood in the plant via advance of Atuba river, that strangulates the final effluent flow (*see Item 8.2 – Flood in the Floaters*);
- Accidents, among other extraordinary cases. According to superior orientation and authorization;
- Electric power outage at the Atuba Sul WWTP (*see Item 8.1 – Electric Power Outage at the WWTP*).

3.5. CLEANING OF THE PRIMARY GRATING (rough)

The rough grating stays upstream (before) the screw pumps. In order to clean the manual grates *GM01*, *GM02*, and *GM03*, follow the following instructions:

- Use of PPE (Personal Protection Equipment) – safety boots, nitrile gloves, goggles, and respirator – is obligatory;
- check whether the discharge allows clean the grates, and clean them if the volume is below the floor level, preferably early in the morning when the WWTP discharge is reduced;
- pick up necessary tools; shovel, rake, bucket, hose;

- remove the garbage accumulated in the grate using the rake, initially putting the material inside the bucket, and then in one of the trash containers;
- remove materials hanging on the guardrails, and put them in the *trash container 001*;
- clean the floor of the area surrounding the grating using a shovel and a hose;
- Cleaning should be done in the morning shift on a daily basis;
- Cleaning is performed by an outsourced team:
- check the service compliance, if negative, record the noncompliance in the bulletin of occurrences (BDO);

3.6. OPERATION OF THE SECONDARY GRATING (automated)

In order to perform the maintenance in the mechanical grates *GA01*, *GA02*, and use of *GM04* (Manual grate between mechanical grates):

- Use of PPE (Personal Protection Equipment) – safety boots, nitrile gloves, goggles, and respirator – is obligatory;
- Turn off the mechanical grates and the Helicoid Conveying Thread when performing any kind of service in the equipment;
- Inspection should be done twice a day through the checklist (*IA/OPE/1526*);
- The cleaning of wastes accumulating in the water runoff gutter of the helicoid conveyer should be done on a daily basis, by the business hours operator. In order to do that, open the lid at the end of the conveying screw, and throw away the water, with a hose or a bucket;
- The cleaning of the sieve should be performed on a weekly basis with water jet. Activity to be performed by the operators in business hours;
- Whenever necessary to interrupt or start the operation of grates, check whether the corresponding sluices are in the correct position, open or closed;
- If any grate cannot work because of a failure, maintenance, among others, deviate the flow to the *GM04* manual grate.

3.6.1. COMMAND PANEL OF THE MECHANIZED GRATES



Image 21 – Command panel of automated grates

Man Machine Interface (MMI) – Touch screen where there are the commands and parameters of grate operation, helicoid thread and water pumps for washing (*BA01 and BA02*);

Powered Command – Indicates that the panel is powered, and that the equipment is ready to operate;

In Operation – It remains lit whenever grates or the helicoid thread are working. It turns off when the equipment is in standby;

Defect – Indicates failure in the equipment;

Manual/Automatic Selection – Equipment operation mode;

Command On/Off Buttons;

Emergency Key;

Master Switch.

3.6.2. MAN MACHINE INTERFACE (MMI)

Initial screen of the grating system, being possible to access the setup screens of the equipment and general parameters.



Image 22 – Initial screen MMI

On the initial screen of the Man Machine Interface, it is possible to access clock set, the flowchart, the setup screens and alarms.

- **Clock set** – By pressing the Clock Set button on the Initial Screen, a window will open, click on the date/time fields to set the clock, and then click on close.

a) Setup

On the Initial Screen, press the Setup button and a screen will appear to set up the functioning times according to the equipment work modes.

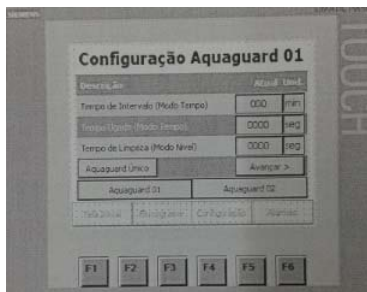

Image 23 – MMI configuration I

On this screen, we program the following setups:

- **Interval Time (Time Mode)** – When the equipment operates in the time mode, this will be the time of the interval between actuations. It is set up in minutes.
- **Time On (Time Mode)** – When the equipment operates in the Time Mode, this is the time when the equipment is on. It is defined in seconds;
- **Cleaning Time (Level Mode)** – When the equipment is set up to operate in the Level Mode, this is the time when the equipment will be on after reaching the minimum level to be cleaned. It is set up in seconds.
- **Single Aquagard Button** – Button accessible only by the maintenance team using a password.

After the setups, by clicking on Advance, we go to the next setup screen:

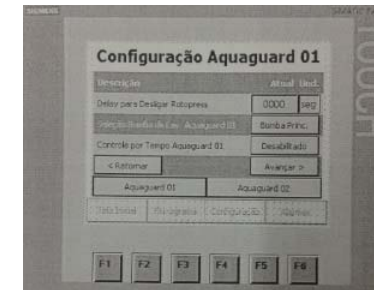

Image 24 - MMI configuration II

On this screen, we program the following parameters:

- **Delay to turn off the Rotopress** – In this field, the time when the washing system will remain on after the end of the mechanized grate cycle is defined. It is set up in seconds.
- **Selection of the Aquagard 01/02 Washing Pump** – Definition of which water pump will be used, the main pump or the standby one (reserve).
- **Control per the Aquagard 01/02 time** – If the command is Disabled, the equipment will work in the Level Mode. If it is enabled, the work will be in the Time Mode, according to the setups done in the previous screen.

After the setups, by clicking on Advance, we go to the next setup screen:

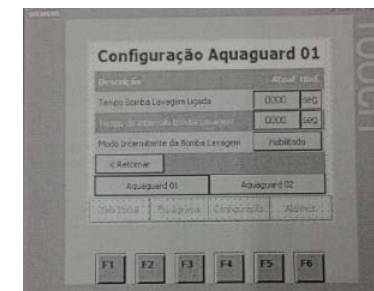

Image 25 - MMI configuration III

On this screen, we program the following parameters:

- **Time of washing pump on** – If the washing water pump is in the intermittent mode on, this parameter will define the time when the pump will be on. It is set up in seconds.
- **Time of washing pump interval** - If the washing water pump is in the intermittent mode on, this parameter will define the time of interval of the pump operation. It is set up in seconds.
- **Intermittent Mode of the Washing Pump** – It defines whether the pump will work in the Intermittent Mode, i.e., when the mechanized grate is on, it will follow the times defined above to turn on and off intermittently.

To leave this setup, choose one of the options of the screen lower bar – *Initial Screen, Flowchart, Setup or Alarms*.

In the case of the mechanized grating system installed at the Atuba Sul WWTP, there are two mechanized grates and two washing water pumps. The same parameters should be set up for the two grates by clicking on the selection buttons: *Aquagard 01/Aquagard 02*.

b) Flowchart



Image 26 – MMI flowchart

This screen shows the machine and the devices status, the total system current, the worked hours, and the engines status. On the lower bar, there are buttons to select between *Aquagard 01* and *Aquagard 02*.

On the upper right side of the screen, there is a button indicating whether the system is operating in automatic or manual mode, the selection is done through the selecting key on the door of the command panel. By pressing this button, the following menus will be opened.

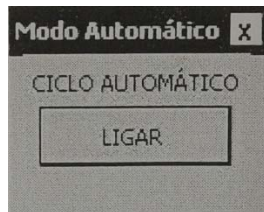

Image 27 – MMI automatic cycle

In automatic mode, to turn on/off the cycle.

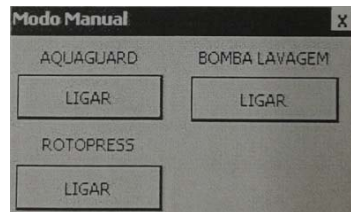

Image 28 – MMI manual cycle

In manual mode, to individually actuate each process.

c) Alarms

To access the alarms, click on the alarms button on the lower bar, the following screen will be exhibited.

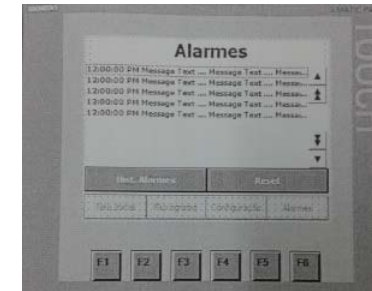

Image 29 – MMI alarms

- If the system shows any failure, the MMI will generate an alarm. In order to recognize it, press the Reset button. If the problem is solved, the alarm message will disappear, cleaning the screen.
- If the failure is not solved, it will remain being shown on the screen, and in this case it will be necessary to call the maintenance team to check the problem.
- On the alarms screen, it is also possible to visualize the history of generated alarms by clicking the Hist. button. Alarms.

d) Remarks

- Whenever there is an outage or oscillation of the power supply, the grates will turn off. In such cases, it is immediately necessary to rest the failures on the Man Machine Interface, by pressing the Turn On Command button so that the Powered Command indicator is lit. After that, resume the operation of the system on the MMI according the instructions mentioned above.
- Always pay attention to the possible failures and stoppages of the grates. When this occurs, garbage accumulates in the grates raising the sewage level, and then there is the risk of sewage overflowing to the streets of the WWTP.
- Grates *GA01*, *GA02*, and the *helicoid Conveyor* should remain always on in the automatic mode. Grate *GM04* should only be used when one or two mechanized grates are halted for maintenance or because of failure;
- In order to use the manual grate *GM04*, its sluices should be opened (*CM03*, *CM04*, *CM07*, *CM08*, *CM13*, *CM14*, *CM15*, and *CM16* according to *Figure 17*), and the sluices of the Automatized grate under maintenance should be closed;
- When the grate *GM04* is being used, the manual cleaning should also be done, and for that a rake should be used to remove the garbage, and a bucket to transport and dispose it onto the *trash container 01*;
- The garbage that might be stuck in the mechanical grates and which might be prevented to leave because of the grate's own scraping mechanism should be cleaned. Cleaning is manual by using a bucket to transport and dispose the garbage onto the trash container 001;

3.7. GRIT CHAMBER



Image 30 - Grit Chamber

3.7.1. GRIT CHAMBER INSPECTION

The verification of the grit chamber functioning conditions is performed twice a day, through the Checklist of Atuba Sul WWTP (IA/OPE/1526). If it is observed that the grit chamber has the hydraulic flow, and the scraping bridge and/or conveyance screw halted, the following procedures should be performed:

- a) check in the command panel whether the actuation handle is in the on position, and if not, turn it on immediately;
- b) check the field switch. If it is in the on position, and even though the equipment does not work, the inflowing flow should be deviated the grit chamber bypass, according *Item 3.7.3*, and the UI Iraí manager should be informed in order to actuate the USEM, and make arrangements for the operation resumption;
- c) If it is not possible to resume the operation because of damage or jamming of the equipment, it will be necessary to keep the grit chamber bypass open;
- d) The manager should schedule the maintenance along with USEM;
- e) After fixing it, the USEM Manager and UI Iraí Manager shall authorize the resumption of the operation. In this evaluation, it will be observed if it is necessary to completely drain, turn on again the scraping bridge or the conveyance screw.
- f) completely drain the grit chamber, open the grit chamber runoff valve (see the location of *Image 17*);
- g) remove sand from the grit chamber after the draining. The equipment should be turned off for every service to be done there in order to prevent accidents;
- h) remove sand from the grit chamber, it will be necessary to have the following tools: shovels, buckets, ropes;
- i) A trash container should be put near the grit chamber area;
- j) A team inside the grit chamber fills the buckets, while another one pulls them outside with a rope, and discharges the contents into the trash container located near the grit chamber;
- k) The manager should define the team, and schedule the day for cleaning;
- l) If the classifying screw is working during the grit chamber cleaning, it could be used to discharge the sand, instead of the buckets.
- m) Use of PPE (Personal Protection Equipment) – gloves, goggles, respirator, waterproof boots – is obligatory.

3.7.2. INSPECTION AND CLEANING OF THE SAND CLASSIFYING SCREW

The verification of the operation conditions is performed twice a day, through the Checklist of Atuba Sul WWTP (IA/OPE/1526). If it is observed any strange noise or any abnormal situation, this should be informed to the UI Iraí manager, so that the request is passed through to the USEM, and the problem should be registered in the Atuba Sul WWTP Book of Occurrences.



Image 31 – Central bearing

The central bearing of the conveyance screw should be cleaned every day to prevent the wear and tear caused by the attrition with sand, thus extending the useful life of the equipment. Therefore, do the following:

- a) Turn off the conveyance screw in the command panel and in the power cut button, which is in the screw gutter. Every service should be done with the equipment turned off to prevent accidents;
- b) The bearing is cleaned manually with the help of a small size rake;
- c) In order to clean the sand exit duct, use a hose with water and HDPE. Insert the HDPE in the duct through the little door installed in the duct funnel, and repeatedly beat the compacted sand that is obstructing it.
- d) After the clearance/cleaning, turn the equipment on in the command panel by putting the button in the “local” position, and the switch in the “on” position;
- e) Dispose of the removed material into the sand containers;
- f) Clean the surrounding floor if dirty;
- g) Use of PPE (Personal Protection Equipment) – safety boots, nitrile gloves, goggles, and respirator – is obligatory;

3.7.3. UTILIZATION AND CLEANING OF THE GRIT CHAMBER BYPASS CHANNEL

The Bypass is used to deviate the sewage flow from the grit chamber when it is being cleaned or under maintenance. In order to perform this maneuver, follow the following procedures:

- a) Open the sluices of the bypass channel exit (CM23 and CM24), located near the Parshall flume;
- b) Open the sluices at the entrance of the bypass (CM21 and CM22);
- c) Close the sluices of the grit chamber entrance (CM19 and CM20);

In order to resume the grit chamber operation:

- a) Open the sluices of the grit chamber entrance (CM19 and CM20);
- b) Close the sluices at the entrance of the bypass (CM21 and CM22);
- c) Close the sluices at the exit of the bypass (CM23 and CM24);
- d) Open the Bypass Channel Runoff Valve, located outside the channel, with the maneuver key;

Cleaning of the grit chamber bypass channel:

- a) After performing the procedure to resume the grit chamber operation, above mentioned;
- b) Wait for the channel to dry, preferably after a short drought period (2 to 3 days), to clean it;
- c) Remove the sandbanks located in the channel with the help of hoes, shovels, buckets and wheelbarrow, and throw the wastes into the sand container;
- d) Wash the walls and floor with the water jet truck.

For all the procedures listed up, the use of PPE (Personal Protection Equipment) – safety boots, nitrile gloves, goggles, and respirator – is obligatory.

3.8. CLEANING OF THE FLOW DISTRIBUTOR (Grease chamber)

After the RSPS Parshall, there is the flow distributor where usually grease and other debris accumulate. For this reason, this distributor is weekly cleaned. This service is performed by an outsourced team. In order to perform this service, follow these instructions:

- a) A septic tank cleaning truck or bucket and shovel should be used;
- b) To clean with the septic tank cleaning truck, its hose should be positioned in the region where the grease accumulates inside the chamber, and then turn on the truck to suck up the material, pulling the minimum possible of water;
- c) The removed material should be taken to the Belém WWTP;
- d) In order to clean using a bucket and a shovel, the shovel should be used to remove the grease layer and put the material in a bucket, for then discharging it into the *trash container 01*;
- e) The service is performed on a weekly basis by an outsourced company;
- f) To check the service compliance, if negative, to record the noncompliance in the bulletin of occurrences.
- g) Use of PPE (Personal Protection Equipment) – safety boots, nitrile gloves, goggles, and respirator – is obligatory;

3.9. CHANGE OF CONTAINERS

- When one of the sand containers is full:
 - a) In the morning, the 6x4 shift operator of floaters will perform the Atuba Sul WWTP Checklist (*IA/OPE/1526*), on observing the need to change the container, the operator should inform the administrative facilitator or the Ul Iraí manager, and they will pass through the demand to the manager of the contract with the outsourced company.
 - b) The operator should be alert so that the reserve container is always empty in weekends and holidays, when the change service is not performed.
- In relation to trash containers, from the mechanized grating:
 - a) The outsourced company with contract in force will periodically send a vehicle to perform the transference to the Atuba Sul WWTP.
 - b) The operator does not have to request the service, and also it is not necessary to send an e-mail;
 - c) If the change of containers is not scheduled, do as described for the sand containers.
- The responsible operator should fill out the removal control form on the operators table, following the instructions below:
 - a) Fill out all the fields carefully and properly. When it is about the periodical changes of trash containers, it is not necessary to fill out the field Call;
 - b) The 1st copy (white) should be left on the administrative facilitator desk, to be forwarded to the contract manager;
 - c) The 2nd copy (yellow) should be delivered to the outsourced company truck driver.
 - d) The 3rd copy (pink) should remain in the writing pad, and should have annexed to it the control yellow copy that the truck driver will deliver.

3.10. SERVICES SCHEDULING



Table 4 – Daily scheduling of Preliminary Treatment services



Table 5 - Weekly scheduling of Preliminary Treatment services



Table 6 - Monthly scheduling of Preliminary Treatment services

4. BIOLOGICAL TREATMENT - AFBR

The use of PPE (Personal Protection Equipment) – safety boots, nitrile gloves, goggles, and respirator – is obligatory. The reactors cleaning services are performed by an outsourced team, and the business hours operators are responsible for monitoring and inspecting such services.

VERIFICATION – PLATES, GRATES AND GUARDRAILS

- a) check the preservation conditions of reactors' concrete plates identifying possible curving points, cracks, or even lack of parts;
- b) check the preservation conditions of grids of access the discharge distributors, identifying possible corrosion points, or even lack of parts;
- c) check the preservation conditions of guardrails of the whole set of reactors, identifying possible corrosion points, cracks at the base, lack of screws, folded or loosen screws, or even the lack of parts;
- d) check the preservation conditions of partition plates of the discharge central diffusers;
- e) Such procedure should be performed on a daily basis during the filling out of the plant checklist (IA/OPE/1526);
- f) In case of poor conservation conditions, and if there is a risk to the safety of employees and/or visitors, isolate the area with proper signaling, and restrict the access;
- g) Communicate the manager, administrative facilitator or the CIPA (Internal Accident Prevention Commission) representative for the due procedures;
- h) Report the situations in the Atuba Sul WWTP Book of Occurrences.

4.1. VERIFICATION – BIOGAS BURNERS



Image 32 – Biogas burner

To visually check the existence of flame in the burner;

If there is not, check the possible causes; Causes might be: strong winds, rain*, obstructed pipelines (valves closed, flame-trap devices dirty), pipeline with air inside, electric equipment problems;

Check the functioning of the automatic igniter; Check whether the circuit breaker in the command panel is on.

- a) Check whether there is any visible wire disconnected.
- b) Check the functioning of sparking plugs and/or electrodes;
- c) Check if there is sparkles in the set of sparking plugs;
 - Check whether the sparking plugs are connected to the shanks.
 - Check the level of corrosion of the sparking plugs.
- d) If any of these items has problems, communicate the manager or administrative facilitator to arrange for the respective maintenance;
- e) Light it with a torch until the maintenance is performed in the system.

* In rainy periods, the effluent dilution is normal generating the low production of methane gas.

4.2. VERIFICATION – LEVELING OF SPILLWAYS

- a) Visually check on a monthly basis the leveling conditions of the reactors' spillways, observing whether the flow distribution is regular throughout the extension of gutters, in the moment of smaller discharge;
- b) If unlevelness is verified, immediately communicate this to the manager or responsible person, so that maintenance is provided;
- c) Register the information on the Atuba Sul WWTP Book of Occurrences.

4.3. CLEARANCE OF DISCHARGE DIFFUSER BEAKS

Material needed:

- Dn 40 PVC or ¼ PEAD (water) pipe approximately 10 meters long;
- Submersible pump with 1" hose; *
- Water jet truck; **

* The service can be done using a submersible pump with 1" hose instead of PVC or HDPE pipe.

** The service can be also done with a water jet truck when available or necessary.

- a) Prepare the DN 40 PVC or ¼ PEAD (water) pipe approximately 10 meters long;
- b) Introduce the pipe into the beak that needs to be cleared, closing the upper end with the hand;
- c) Pull it down, and then remove the hand palm from the pipe in order to expel the retained air (as if opening and closing the upper end of the pipe);
- d) Do that until it is cleared;
- e) If necessary, it can be cleared by using a water jet truck or submersible pump;
- f) When the use of a water jet truck or submersible pump is possible, introduce the hose already with water pressure, and then pull it until it is cleared.



Image 33 – Diffuser beak obstructed

Atenção: Para utilização de caminhão de hidrojateamento no serviço, são necessários, no mínimo, dois operadores treinados. Devido à vibração do equipamento e a forte pressão de água, tomar muito cuidado para que a mangueira não escape da tubulação, o que poderia causar sérios acidentes.

Inspection:

- Cleaning information should be written down in the AFBR's Maintenance Daily Follow-Up Form (IA/OPE/1518);
- The service is performed on a weekly basis by an outsourced company;
- Check the service compliance, if negative, record the noncompliance in the bulletin of occurrences.
- Use of PPE (Personal Protection Equipment) – safety boots, nitrile gloves, goggles, and respirator – is obligatory;

4.4. CLEANING OF CIRCULARS' SPILLWAYS
Material needed:

- Bucket with handle;
- Harrow or rake;

- a) Wastes should be thrown onto the *Trash Container 001*;
- b) It is not necessary to halt the system;
- c) Using the rake, pull the wastes stuck to the diffusers' partition plates;
- d) Remove all the waste preventing their entrance through the distributing beaks;
- e) Put the material into the bucket;
- f) Dispose of the material into the container.

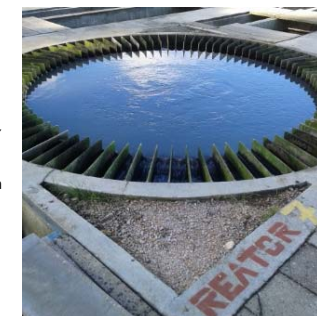

Image34 - Circular distributor of the AFBR

Inspection:

- Cleaning information should be written down in the AFBR's Maintenance Daily Follow-Up Form (IA/OPE/1518);
- The service is performed on a weekly basis by an outsourced company;
- Check the service compliance, if negative, record the noncompliance in the bulletin of occurrences;
- Use of PPE (Personal Protection Equipment) – safety boots, nitrile gloves, goggles, and respirator – is obligatory;

4.5. REMOVAL OF SAND FROM THE CENTRAL DISCHARGE DIFFUSERS
Materials needed:

- Shovel, wheelbarrow and container;
- Little hose or pump to drain the diffuser;
- Minimum team: 02 people;

Before cleaning:

- Place the container in the street between AFBR's lines by using a proper truck;
- The sluice related to the AFBR to be cleaned should be closed;
- Lower the circular level, with a pump or siphon, until the water drainage;

Cleaning of the circular:

- A shovel should be used to remove sand from the circular, initially depositing it into the wheelbarrow, and then into the froth container;
- Open the sluice at the end of the AFBR cleaning;

Inspection:

- Cleaning information should be written down in the AFBR's Maintenance Daily Follow-Up Form (IA/OPE/1518);

- The service is performed from 8:00 am to 5:00 pm once each 2 months per AFBR;
- This service is performed by an outsourced team;
- Check the service compliance, if negative, record the noncompliance in the bulletin of occurrences;
- Use of PPE (Personal Protection Equipment) – safety boots, nitrile gloves, goggles, and respirator – is obligatory

4.6. REMOVAL OF FROTH

Materials:

- Materials needed: Skimming ladle, wheelbarrow and container;
- Little hoses or pump to lower the AFBR level;
- Minimum team: 04 people.

Before cleaning:

- The sluice related to the AFBR to be cleaned should be closed;
- Lower the AFBR level until the end of the slab (gas chamber) by using a pump or siphons;

Removal of froth:

- A skimming ladle should be used to remove the froth from the AFBR, initially putting it into the wheelbarrow, and then in to the froth container that was placed in the street between AFBR's lines;
- Open the sluice at the end of the AFBR cleaning;
- After opening the sluice, the froth accumulated between the spillway and the deflector should be removed, according to *Item 4.8*;
- At the end of the cleaning day, clean the floor, dirty with froth, by using a water jet truck or pump.

Inspection:

- Cleaning information should be written down in the AFBR's Maintenance Daily Follow-Up Form (IA/OPE/1518);
- The service is performed from 8:00 am to 5:00 pm once each 2 months per AFBR;
- This service is performed by an outsourced team;
- Check the service compliance, if negative, record the noncompliance in the bulletin of occurrences;
- Use of PPE (Personal Protection Equipment) – safety boots, nitrile gloves, goggles, and respirator – is obligatory

4.7. CLEANING OF SPILLWAYS OF PRIMARY GUTTERS

Materials needed:

- Small skimming ladle, wheelbarrow and container;
 - Necessary team: 02 people.
- a) After performing the froth removal service, and reopening the AFBRs;
 - b) After raising the AFBR level again, clean the froth that will be accumulated in the primary gutters' spillways with the help of a skimming ladle;
 - c) Put the froth into the wheelbarrow;
 - d) Discharge it into the froth container placed in the street between the AFBRs lines.

Inspection:

- Cleaning information should be written down in the AFBR's Maintenance Daily Follow-Up Form (IA/OPE/1518);
- The service is performed from 8:00 am to 5:00 pm once each 2 months per AFBR;
- This service is performed by an outsourced team;
- Check the service compliance, if negative, record the noncompliance in the bulletin of occurrences;
- Use of PPE (Personal Protection Equipment) – safety boots, nitrile gloves, goggles, and respirator – is obligatory

4.8. MEASUREMENT OF THE SLUDGE LAYER

Materials needed:

- Sludge judge or automatic measurer (light sign/Japanese model);
- Paper and pen.

Measurement with the Sludge Judge:

- a) In order to measure, the equipment should be introduced into the inspection point (PV);
- b) Remove the equipment quite quickly, creating a liquid hammer to brake the valve;
- c) Check the value shown in the interface between sludge and water;
- d) Count the number of markings with the clarified liquid, each marking on the tube ruler is equal 0.3 m, then the number of clarified markings x 0.3 is the clarified liquid height;
- e) The difference between the clarified liquid height and 4.5 meters is the sludge layer height;
- f) Take notes of the values in the Monitoring of the Sludge Layer Expansion and Growth (IA/OPE/1523);

Measurement with the light sign measures (Japanese model):

- a) Adjust the sensor for minimum sensitiveness;
- b) In order to measure, the equipment should be slowly introduced into the inspection point (PV);
- c) Introduce it until the trigger of the sound sign. The sound sign will trigger when there is the interruption of the emitter LED light emission into the detector LED, i.e., the sludge layer does not allow the passage of light between the emitter and the detector;
- d) Check in the thread marking the distance until finding the sludge layer;
- e) Count in the marking that is equal to 1 m, and estimate it;
- f) The difference with 4.5 m is the height of the sludge layer;
- g) Take notes of the values in the Monitoring of the Sludge Layer Expansion and Growth (IA/OPE/1523);

4.9. SLUDGE DISPOSAL

Material needed:

- Maneuver key;
 - 1.0 meter ruler.
- a) When the height of the sludge layer in the sludge compactor is below 0.7 meters, check in the IA/OPE/1523 which AFBR has a sludge layer height above 2.0 m. Select for disposal the reactor with the biggest difference of sludge layer height IA/OPE/1523;
 - b) Once the reactor with the highest sludge layer is chosen, dispose of the sludge until it is 2.0m;
 - c) Interrupt the discharge flow by closing the inflowing sluice of the AFBR;
 - d) Wait for 1 hour;

- e) Open the "A" flow valves of sludge disposal; if it is clogged, open the "B", arranging for its clearance.
- f) Lower the reactor level, regarding the difference of the sludge layer height to reach 2.0m. For instance, if the reactor was a sludge layer height of 2.4 m, then 40 cm of sludge should be disposed of to reach the height of 2.0 m;
- g) Collect 3 samples in the sludge compactor entrance pipeline, the first one 1 hour after the start of the disposal, the second one in the middle of the disposal, and the last one when the valves are closed. Collect at the compactor entrance, in the pipeline corresponding to the AFBR disposal;
- h) The registration of disposal data, for future counting, is done in the *solids bulletin of the laboratory*. It is obligatory to write down in the bulletin board the following information: which AFBR had the disposal done and when (day). This is to guide if there is any unpredicted event during the night shift, regarding the disposal network.
- i) In Atuba Sul WWTP, the experience shows that the AFBR sludge disposal does not promote significant improvements in the AFBR effluent quality, and because of that the priority should be the destination of the sludge generated in the Floaters, and it should be evaluated, even if there is little sludge in the compactor (height lower than 0.7 m), the availability of yard area.

Sludge analysis:

- Perform the determination of total solids pursuant to *IT/LAB/1551*.
- Take note of the data on the *IA/OPE/1019* – Bulletin of AFBRs Sludge Disposal Control.

4.10. FLAME-TRAP DEVICES MAINTENANCE

Material needed:

- Screwdriver;
- Flat wrench No. 17;
- Flat wrench No. 19;
- Steel brush;
- Bee hive drawing tool;
- Clearing solution;
- Industrial Vaseline;
- Hose with compressed air outlet.

Verification of the burners system:

- a) Visually check the conditions of the gas conveying pipelines;
- b) Carefully check for the existence of leaks, cracks and/or splitting, obstructions, or folded pipes;
- c) If any of those problems is verified, immediately communicate this to the manager or responsible person, so that maintenance is provided;
- d) Register the information on the Atuba Sul WWTP Book of Occurrences.

Maintenance:

- a) Prepare tools: steel brush, bee hive drawing tool, clean bee hive, screwdriver and flat wrench;
- b) Stop the sewage flow in the reactor which valve will undergo maintenance;
- c) Lower the AFBR level five centimeters below the gas chamber;
- d) Close the valve that is above the mentioned valve, or turn off the automatic lighter;
- e) Open the compartment where the bee hive use by using the flat wrench no. 17;
- f) Remove the flame arrester by using the drawing tool, if necessary;
- g) Take care to prevent damages to the bee hive (it can unroll during the operation);
- h) Do not beat on the bee hive support because it is made of fragile material;
- i) Brush the bee hive support removing all the encrusting and rusting;

- j) Pass pasty lubricant (industrial Vaseline) on the valve structure;
- k) Install the clean bee hive;
- l) Close the compartment where the bee hive is again;
- m) Open the gas valve that is above the valve, or turn on the automatic lighter;
- n) Put the reactor into operation;
- o) Register the maintenance into Atuba Sul WWTP Book of Occurrences.

Cleaning:

- a) Brush the bee hives and remove all the crusting and rusting;
- b) Put the bee hives into a clearing solution for 12 hours;
- c) After such period, remove and dry them up with the help of a compressed air hose, in the compressors located beside the centrifuge big shed;
- d) Keep it in a proper place, in the workshop beside the centrifuge big shed;

4.11. AFBR SERVICES SCHEDULING

Programação Diária				
O que?	Quem?	Quando?	Como?	Porque?
Limpeza do Gradeamento Grosseiro	Empresa terceirizada com supervisão do operador no horário comercial	Das 08:00 às 10:00 horas.	Item 4.1.1 do MN/OPE/0037	Evitar o estrangulamento de fluxo.
Manutenção do Gradeamento Mecanizado	Empresa terceirizada com supervisão do operador no horário comercial	A cada duas horas.	Item 4.1.2 do MN/OPE/0037	Evitar o estrangulamento de fluxo.
Limpeza do Gradeamento Fino	Empresa terceirizada com supervisão do operador no horário comercial	A cada duas horas.	Item 4.1.3 do MN/OPE/0037	Evitar o estrangulamento de fluxo.
Limpeza do Gradeamento Mecanizado	Empresa terceirizada com supervisão do operador no horário comercial	A cada duas horas.	Item 4.1.2 do MN/OPE/0037	Evitar o estrangulamento de fluxo.
Controle de Vazão	Empresa terceirizada com supervisão do operador no horário comercial	A cada duas horas.	Item 4.2.1 do MN/OPE/0037	Acompanhamento
Limpeza de Vertedores da Circular	Empresa terceirizada com supervisão do operador no horário comercial	A cada duas horas.	Item 4.2.2 do MN/OPE/0037	Evitar o estrangulamento de fluxo.
Limpeza de Circular	Empresa terceirizada com supervisão do operador no horário comercial	A cada duas horas.	Item 4.2.7 do MN/OPE/0037	Evitar o estrangulamento de fluxo.

Table 4 - Daily scheduling of AFBR services

Programação Semanal				
O que?	Quem?	Quando?	Como?	Porque?
Limpeza da caixa de distribuição	Empresa terceirizada com supervisão do operador no horário comercial	01 vez por semana	Item 4.1.5 do MN/OPE/0037	Diminuir o acúmulo de material (gordura) nos reatores
Troca de caçambas	Empresa terceirizada com supervisão do operador no horário comercial	Sempre que se verificar necessário	Item 4.1.7 do MN/OPE/0037	Evitar vetores

Table 5 – Weekly scheduling of AFBR services

Programação Mensal				
O quê?	Quem?	Quando?	Como?	Porque?
Retirada de escuma	Empresa terceirizada com supervisão do operador no horário comercial	Bimestral	Item 4.2.3 do MN/OPE/0037	Melhorar desempenho do reator
Medição do manto de lodo	Operador do horário comercial	Mensal	Item 4.2.4 do MN/OPE/0037	Verificação
Manutenção queimadores	Empresa terceirizada com supervisão do operador no horário comercial	Mensal	Item 4.2.6 do MN/OPE/0037	Evitar acúmulo de gás nos reatores.

Table 6 - Monthly scheduling of AFBR services

5. ELIMINATION OF BAD ODORS

5.1. BEHAVIOR OF SULFIDE IN THE ATUBA SUL WWTP – AFBR EFFLUENT

The concentration of sulfides in the AFBR (Anaerobic fluidized bed reactor) effluent follows the behavior patterns typical and similar to the COD and turbidity behaviors.

The graph below shows the behavior of sulfide in liquid environment at Atuba Sul WWTP.

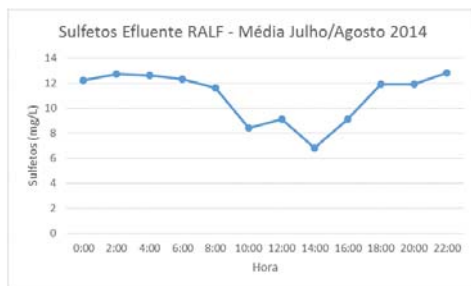

Graph 2 - AFBR Effluent Sulfides

Similarly to the following parameters: COD and Suspended Solids and turbidity. The increase of sulfide concentration is observed at night, and this behavior is similar to what occurs to the COD, Suspended Solids and Turbidity, with the concentration peak at 12:00 pm. Sulfide reaches a concentration of approximately 12 mg/L on this time, and on the other side, there is a reduction of sulfide concentration around noon, with an average concentration of 7 mg/L.

Therefore, we can identify three characteristic periods of behavior:

- High concentration period: 9:00 pm - 3:00 am;
- Intermediary concentration period: 3:00 pm – 9:00 pm; 3:00 am – 9:00 am;
- Low concentration period: 9:00 am – 3:00 pm;

We can conclude that during the night period there will be a higher consumption of chemicals to fight the sulfides in the liquid phase. Consequently, in the morning period, around noon, there will be the smallest consumption.

HORA	MÉDIA		
	Sulfetos (mg/L)	Vazão afluente (L/s)	Sulfetos (Kg/hora)
0:00	12,2	1343	59
2:00	12,7	1177	54
4:00	12,6	931	42
6:00	12,3	809	36
8:00	11,6	809	34
10:00	8,4	954	31
12:00	9,1	1272	42
14:00	6,8	1442	36
16:00	9,1	1513	50
18:00	11,9	1482	64
20:00	11,9	1431	61
22:00	12,8	1398	65
	11,0	1216,8	47,8

Table 7 - AFBR Effluent Sulfides

HORA	MÉDIA		
	Sulfetos (mg/L)	Vazão afluente (L/s)	Sulfetos (Kg/hora)
0:00	2,9	1352	15
2:00	2,2	1177	9
4:00	1,9	945	6
6:00	1,4	809	4
8:00	1,1	747	3
10:00	1,1	1017	4
12:00	1,1	1272	5
14:00	1,4	1467	6
16:00	1,6	1513	8
18:00	2	1463	11
20:00	2,4	1425	13
22:00	2,4	1398	12
	1,8	1218,3	8,0

Table 8 - Final Effluent Sulfides

The formula to measure the efficiency of sulfide removal in the liquid environment when using the peroxide is the following:

$$(\text{Sulfide } w/o \text{ H}_2\text{O}_2 - \text{Sulfide } w \text{ H}_2\text{O}_2) \div \text{Sulfide } w/o \text{ H}_2\text{O}_2 = \text{REMOVAL EFFICIENCY}$$

By applying the values obtained in laboratory, we obtain the removal efficiency of 83%: $(47.8 - 8) \div 47.8 = 83\%$

In Table 12, we observe that the average concentration of sulfides in the AFBR effluent, after applying the peroxide, is 2.7 mg/L. This happens after a contact time of approximately 10 minutes. The average

HORA	MÉDIA		
	Sulfetos (mg/L)	Vazão afluente (L/s)	Sulfetos (Kg/hora)
0:00	4,4	1352	21
2:00	3,1	1177	13
4:00	2,3	951	8
6:00	1,6	813	5
8:00	1,9	747	5
10:00	1,8	1017	7
12:00	2,2	1272	8
14:00	2,2	1467	13
16:00	2,5	1513	13
18:00	3,4	1482	18
20:00	3,7	1431	19
22:00	3,7	1398	19
	2,7	1218,3	12,4

remaining load of sulfide is around 12.3 kg/hour. Table 9 - Sulfides after H₂O₂. The residual peroxide obtained in the inlet of floaters was 1.9 PPM. Therefore, the conclusion is that increasing the peroxide dose to totally eliminate sulfides is not effective. In short, there is residual peroxide even after the contact time (19 PPM), and even though the sulfide in the liquid environment is not entirely eliminated. The residual peroxide obtained in the Final Effluent was 1.5 ppm, showing that results do not improve when the detention, and consequently the contact time is increased. The average consumption of peroxide (July 2014) was 98 L/hour.

- The average removal (oxidation) of July 2014 was $47.8 - 8 = 39.8$ kg/hour.
- The application relation is $98 \text{ L} / 39.8 \text{ kg} = 2.5$ L of peroxide per kg of sulfide.

Therefore, the use of chlorine gas as complement to the hydrogen peroxide aiming to eliminate the residual sulfide not eliminated by the hydrogen peroxide is justified.

5.2. HYDROGEN PEROXIDE – H₂O₂



Image 35 - Storage tanks

The Hydrogen Peroxide is a clear, clean liquid, with a characteristic odor and mixable with water in all the proportions.

The Hydrogen Peroxide solutions, even those highly pure, have as specific feature a slow, although continuous decomposition, forming water and oxygen gas, and releasing heat.

5.2.1. OPERATION OF THE HYDROGEN PEROXIDE APPLICATION SYSTEM

In order to better visualize the hydrogen peroxide application system in Atuba Sul WWTP, a flowchart of this system will be presented as follows.

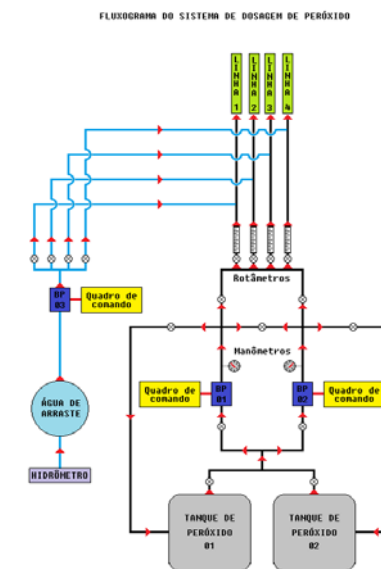

Image 36 - Peroxide flowchart

- Use of PPE (Personal Protection Equipment) – nylon jumpsuit, safety boots, nitrile gloves, and colorless facial protector – is obligatory;
- This manual predefines that the *BPO1 pump* will operate as the main pump, and *BPO2* will be the reserve pump, and shall be turned on in case of failure or maintenance of the *BPO1*;
- Use the contents of one tank each time.
- Use the peroxide of one tank until reaching to the 2.0 m³ level, then the flow should be deviated to another tank. When this happens, the operator should inform the manager or administrative facilitator in order to order a new delivery of the chemical product;
- The follow-up of the chemical product level in the tanks, consumption and dosage, should be done every morning by the 6x4 scale operator. Data should be taken note of in the Peroxide Consumption Control (IA/OPE/1521).

In order to turn on the H₂O₂ application system:

- a) Open the water meter valve and wait until the water cistern for dragging is full;
- b) Open the outlet valve of the peroxide tank to be used;
- c) Open the valve before the *BPO1* pump, make sure that the valve before the *BPO2* pump is closed;
- d) Open the valve that is located before the flow meters, and make sure that the valves of return to the storage tanks are closed;
- e) Open the valves after the dragging water pump *BPO3*;

- f) Close all the valves that are in the dosing beaks above the AFBRs, left open only the last valve of each line, i.e., the valve that is most distant from the storage tanks. This procedure is performed to eliminate the air in the peroxide dosing pipeline;
- g) Turn on the dragging water pump *BP03*;
- h) Turn on the peroxide dosing pump *BP01* (see *Image 39*);
- i) Through the valves located immediately before the flow meters, adjust the dosing to 40 L/h per line (see *Image 40*). This adjustment is transitory, and is done to expel the air that might be trapped inside the dosing line;
- j) Open the valves located in the dosing beaks above the AFBRs, from the last to the first. The valves should stay slightly opened, allowing the dosing of just a little peroxide;
- k) After all valves of dosing beaks are opened, reduce the dosing to 20 L/h per line;



Image 37 - Peroxide command cabinet



Image 38 - Peroxide flow meters

In order to turn off the H₂O₂ application system:

- a) Turn off the *BP03* and *BP01* pumps;
- b) Close the valve at the outlet of the storage tank being used.

5.2.2. PEROXIDE DOSING

The dosing control is done based on the residual peroxide analysis in the inlet of floaters. It is checked every two hours by the 6x4 scale operator of the flotation, using a Peroxide Test Tape:

- a) Collect samples of the AFBR Effluent (flotation inlet) and of the Final Effluent, without agitate them;
- b) Use the test tape for each sample;
- c) Put the test tape for 01 second into the sample;
- d) Wait the reaction for 15 seconds;
- e) Compare the blue shade that has appeared on the test tape with the table printed in the tape package, this is the residual value of hydrogen peroxide;
- f) The residual value of peroxides in the AFBR effluent and the final effluent should be written down in the electronic spreadsheet and in the *IA/OPE/1520*;
- g) If there is no tape available, let the dose fixed in 80 L/h (20 L/h per line).

Based on the result obtained in the test tape, we define the alterations in the peroxide dosing based on the AFBR Effluent sample value (floater inlet):



Image 39 - Test tape for residual peroxide

- **0.5 to 01 PPM (estimate):** does not change the dosing;
- **Above 01 PPM:** reduce the dosing by 10 L/h in each line, for instance, if the dosing is 30 L/h, then reduce it to 20 L/h;
- **Below 0.5 PPM:** increase the dosing by 10 L/h in each line.

In order to increase or reduce the peroxide dosing, open or close the flow meters valve, as needed;

- a) Does not change the valves of AFBRs. The team of Peróxidos do Brasil keep them already pre-regulated;
- b) When the froth cleaning is performed, close the valve of the flow meter corresponding to this line where the service is performed. Never close more than one line;
- c) The team of Peróxidos do Brasil performs the maintenance in the system every Friday;

5.2.3. REQUEST OF HYDROGEN PEROXIDE

When filling out the Checklist (*IA/OPE/1526*), the level of hydrogen peroxide in the storage tanks is verified. Whenever this level is equal or lower than 2 m³, the tank being used should be changed, and the WWTP manager or administrative facilitator should be warned to request a new load of the chemical product.

5.2.4. RECEPTION OF THE HYDROGEN PEROXIDE LOAD

- a) The request for chemical products should be done through the Materials Administration Service (SAM) of USMA by the administrative facilitator or manager at least 48 hours beforehand;
- b) Before receiving the product, the invoice should be checked for the delivery place, requested amount and received product;
- c) The plant operator should guide and follow up the truck driver in unloading the product, informing in which tank the product should be discharged in, as well the due care with the place (lawn, sidewalks, curbs, fences);
- d) Two samples should be collected, directly from the truck, in plastic flasks to be sent for compliance analysis at the USMA laboratory, pursuant to *IA/MAT/0003*;
- e) After unloading the material, the invoice and the carrier's bill should be signed.
- f) The invoice counterpart staying with the operator should be put in the "Invoices" pigeonhole at Atuba Sul WWTP office, after duly stamped and signed. This invoice should be sent to USMA, along with the collected sample.
- g) In case of delay or no service at all, the BDO should be issued and sent to the contract manager for the due procedures.

5.3. CHLORINE GAS - Cl



Image 40 - Chlorination

Chlorine is found in nature, combined with several elements, mainly sodium and potassium. In its elementary form, it is a greenish gas that can be easily compressed into a clear amber liquid.

In water, chlorine acts in two ways: as a disinfectant, destroying and inactivating pathogenic microorganisms, algae, bacteria and free life, and as oxidant of organic and inorganic compounds present in the water. This action depends on the concentration, of the form it has, of the contact time, temperature, turbidity, and water pH, and of the type of microorganism to destroy.

5.3.1. SAFETY

- a) Personal Protection Equipment (PPE)
 - Use a nylon protection coat, with elastic in the cuffs and hem;
 - Rubber cap (swimming cap);
 - Face mask against chlorine gas, with chemical filter or equipped with compressed or natural air hose;
 - Latex gloves;
 - Safety boots;
 - The operator should not wear beards or big sideburns, because it can allow the infiltration of gases through the mask, reaching the respiratory system.

Remarks: The rubber cap should cover the ears and part of the forehead, and it should be carefully worn to prevent the cap having folds or wrinkles. The coat should be worn over the clothing, and the blouse should be put inside the trousers. The gloves cuffs should be beneath the coat sleeves. The face mask should be worn on the rubber cap, and above these, the coat hood.

- b) Collective Protective Equipment (CPE)
 - Emergency Kit – Equipment used in emergency situations in case of leaks in 68 Kg or 900 Kg chlorine cylinders;
 - Sound Alarm – Sound equipment to be manually actuated when complete evacuation from the area is needed.

Todos os operadores devem receber treinamento acerca de operação e situações de emergência sobre gás cloro. De acordo com a IT/RHU/0068 (Plano de Ação para Situações de Emergência e Vazamento de Gás Cloro) e IT/OPE/0143 (Instalação e Manutenção de Kit de Emergência de Gás Cloro).

5.3.2. OPERATION OF THE CHLORINE GAS APPLICATION SYSTEM

In order to better view the chlorine gas application system installed at Atuba Sul WWTP, a flowchart of the chlorination system will be shown as follows.

SISTEMA DE DOSAGEM DE CLORO

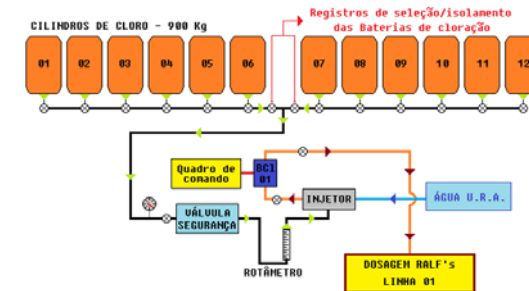

Image 41 - Chlorination flowchart

- A trained operator is necessary for the execution of this activity.
- Use of PPE (Personal Protection Equipment) – nylon protection coat; rubber cap, face mask against chlorine gas; latex gloves; safety boots;
- The operator should not wear beards or big sideburns, because it can allow the infiltration of gases through the mask, reaching the respiratory system.
- This manual pre-defines that a battery of chlorine tanks will be used each time. I.e., if we used the cylinders 01 to 06, the cylinders 07 to 12 will be the reserve. When the chlorine of the first battery of tanks ends, the utilization is alternated;
- When the contents of a battery of chlorine tanks (06 tanks) end, the administrative facilitator or the manager of the WWTP should be informed to make a new order for the delivery of the chemical product;

5.3.2.1. VERIFICATION

Verify in the beginning of the shift, when filling the Atuba Sul WWTP Checklist (IA/OPE/1526), the operation and maintenance situation of the chlorination system equipment and components:

- Manifold
- Valves
- Diaphragm
- Flow meter
- Injector
- Chlorine pump
- Pipelines and fittings

- a) Check the supply of dragging water coming from the URA (Water Recuperation Unit);
- b) Check the functioning of the chlorine pump and dosing;
- c) Evaluate the availability of chlorine in the Piston cylinders;
- d) Change the cylinder if necessary;
- e) Request new cylinders if necessary;
- f) Keep the cylinders storage place clean and organized;
- g) Record the abnormalities in the Book of Occurrences of Atuba Sul WWTP, and inform them to the WWTP manager;

MANIFOLD

Yellow pipeline interconnecting all the chlorine cylinders to the dosing system. In this pipeline, the presence of damages such as rust, wrinkled parts, and any other situation putting operators at risk should be verified.



Image 42 – Valve

VALVES

There are several valves installed in the chlorination system. We should always check whether they are opening and closing easily, whether they are sealed, and whether their thread is stripped or not. Especially the chlorine cylinders and Manifold valves.



Image 43 - Diaphragm

DIAPHRAGM

The diaphragm installed in the chlorine cylinders makes a characteristic squeaking when functioning, which can also be taken into consideration when checking the equipment. If the diaphragm is not making such noise, it means that chlorine is not being applied, and in this case there is a pressure relief system, which will slowly eliminate the gas contained in the Manifold.



Image 44 - Flow meter

FLOW METER

The flow meter is a graduated device graduated in kg/day that indicates the chlorine dosing being applied by the dosing pump. Its graduation goes from 0 to 2000 kg/day. The dosing is increased or reduced as needed, through the opening of the valve. When the chlorination system is functioning, the counter is kept suspended inside the flow meter in a stable manner, indicating the amount of injected chlorine. When it oscillates, this indicates that the pump is no longer applying chlorine.



Image 45 - Injector

INJECTOR

The injector is the part mixing the gas chlorine with dragging water. It should be paid attention to cracks and damages that can create leaks. In order to check for leaks, spray out the air inside the ammonia flask, if there is leak, a white smoke will form.



Image 46 - Pump

CHLORINE PUMP

Chlorine pumps can be easily checked, because they make a characteristic noise when functioning. Furthermore, their shaft can be seen moving when actuated for operation. Attention should be also paid to the sealing of pipelines connected to the pump.

PIPELINES AND FITTINGS

Due to the exposure to climatic conditions, and to the presence of corrosive gases such as the H₂S, the chlorination system parts undergo a great wear and tear, and could also stop the application of chlorine in certain cases. It is important to regularly check the existing pipelines and fittings conditions, since those parts in addition to being fragile are too much manipulated.

5.3.2.2. TURN ON THE CHLORINATION SYSTEM

- Be correctly wearing the PPEs mentioned in *Item 5.3.1*;
- Be sure that the supply of dragging water coming from the URA is normally occurring;
- Turn on the chlorination pump (*BCL01*) in its command panel;
- Select one of the batteries to be used;
- Break the seals, and open ¼ of the turn of the chlorine gas cylinders valves, spraying ammonia in the fittings in order to detect possible leaks, pursuant to *Item 5.3.2.5*;
- Open ¼ of the turn of the Manifold valves of the battery to be used, again spraying ammonia;
- Slowly open the valve of the chlorine battery to be used;
- Check the manometer, the registered pressure should be between 6 and 8 atm, according to the room temperature, the heater the higher pressure;
- Slowly open the valve located before the diaphragm;
- Check and adjust the dosing in the flow meter.

5.3.2.3. CHANGE OF CHLORINE CYLINDERS BATTERY

This change will be performed whenever the 06 cylinders of the battery in use end, and this will be evidenced in the following ways:

- Manometer will register pressure 0 atm;
- The flow meter dosing counter will stay still in the bottom;
- The injector will make a noise, as if there were stones being agitated inside it. This equipment generally operates quietly.

To make the change:

- Keep the pump (*BCL01*) on;
- Close the valves of empty chlorine cylinders;
- Wait until the pressure in the pipeline is relieved, this will be visible in the manometer that will register pressure of 0 atm;
- After relieving the pressure in the pipeline, close the valve before the diaphragm;
- Close the valve of the empty battery;
- It is not necessary to close the Manifold valves;
- Break the seals, and open ¼ of the turn of the chlorine gas cylinders valves, spraying ammonia in the fittings in order to detect possible leaks;

- h) Open ¼ of the turn of the Manifold valves of the battery to be used, if they are closed, again spraying ammonia;
- i) Slowly open the valve of the chlorine battery to be used;
- j) Check the manometer, the registered pressure should be between 6 and 8 atm, according to the room temperature, the heater the higher pressure;
- k) Slowly open the valve located before the diaphragm;
- l) Check and adjust the dosing in the flow meter.

5.3.2.4. TURN OFF THE CHLORINATION SYSTEM

- a) Keep the pump (BCL01) on;
- b) Close the valves of the chlorine cylinders;
- c) Wait until the pressure in the pipeline is relieved, this will be visible in the manometer that will register pressure of 0 atm;
- d) After relieving the pressure in the pipeline, close the valve before the diaphragm;
- e) Close the valve of the chlorine battery that was being used;
- f) It is not necessary to close the Manifold valves;
- g) Turn off the pump (BCL01);

5.3.2.5. VERIFICATION OF LEAKS

In order to locate a chlorine leak, a spraying flask containing diluted ammonia is used. The approximation of ammonia vapors in the leak place will form a white mist that will allow the quick location of the escape point. The contact between the ammonia and brass should be prevented. Never throw the ammonia directly into the leak place.

- a) Only spray the air inside the ammonia solution flask on the cylinders, near the points with possible leaks in the fittings of pipelines and valves;
- b) Check the formation of the white mist, if positive, there are leaks;
- c) After identifying the leak, if possible, isolate the place. Communicate the waterway team to fix it;
- d) The contact between the ammonia and brass should be prevented. Never throw the ammonia directly into the leak place.

5.3.2.6. REQUEST OF CHLORINE GAS

- a) The request for chemical products should be done through the Materials Administration Service (SAM) of USMA by the administrative facilitator or manager at least 48 hours beforehand;
- b) The operator should inform to the administrative facilitator or the manager, after changing the chlorination battery, the amount of material to be requested to the USMA, preventing the intervention of suppliers and others;
- c) The request should be registered in the materials order form, if any.
- d) In case of delay or no service at all, the BDO should be issued and sent to the contract manager for the due procedures.

5.3.2.7. RECEPTION OF CHLORINE GAS CYLINDERS

- a) Before receiving the product, the invoice should be checked for the delivery place, requested amount and received product;
- b) The plant operator should follow up the cylinders deliver determining the correct positions for unloading. In addition, it is important to check the cylinders conditions (seals, wrinkles, valves), and cares with the unloading area (lawn, sidewalks, curbs, fences).
- c) After unloading the material, the invoice and the carrier's bill should be signed.

5.3.3. FIRST AIDS

5.3.3.1. POTENTIAL EFFECTS ON HEALTH

- a) Routes of entrance in the organism: Inhalation, skin and eyes;
- b) Affected Systems and Organs: Airways, skin and eyes;
- c) Irritations: Strong in airways, skin and eyes;
- d) Capacity of Sensitization: No effect is known;
- e) Carcinogenic effects: No effect is known;
- f) Effects in reproduction: No effect is known;

5.3.3.2. EFFECTS OF SHORT TIME EXPOSURE

- a) Inhalation: Cough, mucosa irritation, headache, restlessness, and feeling of suffocation. Exposures to high concentrations might cause pneumonia and pulmonary edema;
- b) Eyes: High concentrations in the air or direct contact might cause burns;
- c) Skin: Contact might cause burns and destruction of tissues. Contact with liquid chlorine can cause burns by freezing as the result of low temperature.
- d) Ingestion: Ingestion of chlorine is unlikely to occur. Above the established exposure limits, it can cause reduction of respiratory capacity.

5.3.3.3. FIRST AID MEASURES

Always prioritize to treat the effects caused by the product inhaling.

- a) Inhalation:
 - Take the victim to the fresh air, and keep her/him warm.
 - If breathing is difficult, give humid oxygen at the rate of 6 liters/min. The victim should be seated, in the angle of 45 to 60 degrees between the thorax and lower limbs.
 - Call for medical help immediately.
 - Important remark: Keep people trained at all times to administer oxygen and artificial breathing.
- b) Eyes:
 - Immediately wash the eyes, continuously, with a direct flow of water, for at least 20 minutes.
 - When washing, eyelids should be opened to ensure the entire irrigation of eyes and ocular tissues.
 - Wash the eyes a few seconds after exposure, this is key to reach maximum efficiency.
 - Call for medical help immediately.
- c) Skin:
 - Take off the contaminated clothing under the shower.
 - Continuously wash the affected part with cold water, for at least 20 minutes. Washing can be done with water and soap.
 - If the skin becomes irritated after washing, call for medical help.
- d) Ingestion:
 - Never administrate any substance orally to an unconscious person.
 - If chlorine is ingested, DO NOT INDUCE VOMITING.
 - If the victim is conscious, give her/him lots of water.
 - If there is spontaneous vomiting, keep the air circulating in the environment and give more water to the victim.
 - CALL FOR MEDICAL HELP IMMEDIATELY.

5.4. SULFIDE ANALYSIS

The sulfide analysis is performed pursuant to *IT/LAB/0733*, samples should be collected in the following points, the analyses results should be registered in the Oxidants Monitoring Spreadsheet (*IA/OPE/1520*):

- **AFBR (with no peroxide application):** In AFBR 12, at the end of any primary gutter, immediately before cascading into the secondary gutter. If AFBR 12 is closed, collect in AFBR 11;
- **Inlet of floaters** (if contamination of ferric chloride);
- **Final Effluent.**

5.4.1. RESPONSIBILITY FOR COLLECTION AND ANALYSES

- When the floatation system and the centrifuge are simultaneously halted, the support will perform the analysis. If there is no operator in the support scale, do not make analyses;
- When the floatation and the centrifuge are halted, the operator will perform the analysis.

6. PHYSICAL-CHEMICAL TREATMENT – DISSOLVED AIR FLOATATION

In order to better understand the steps of the dissolved air flotation system, *Images 49 and 50* show a flowchart of the steps and a schematic drawing of the floater functioning.

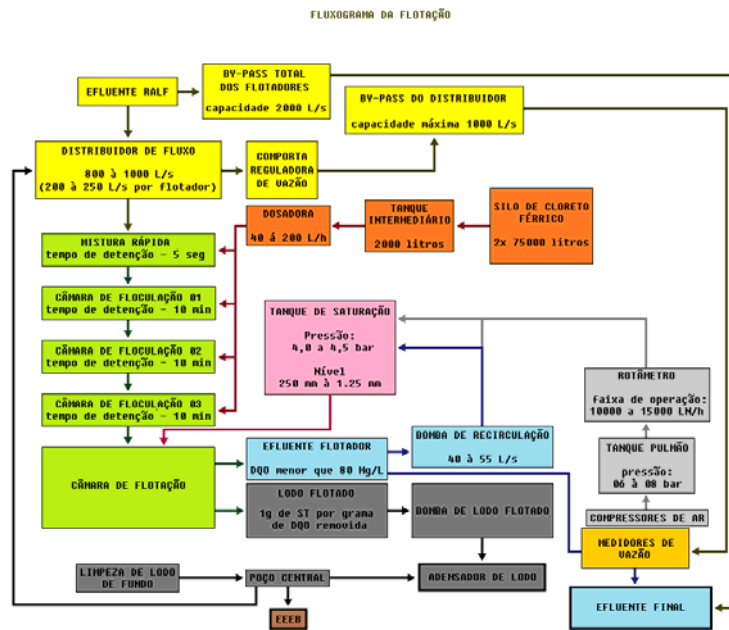

Image 47 - DAF system flowchart

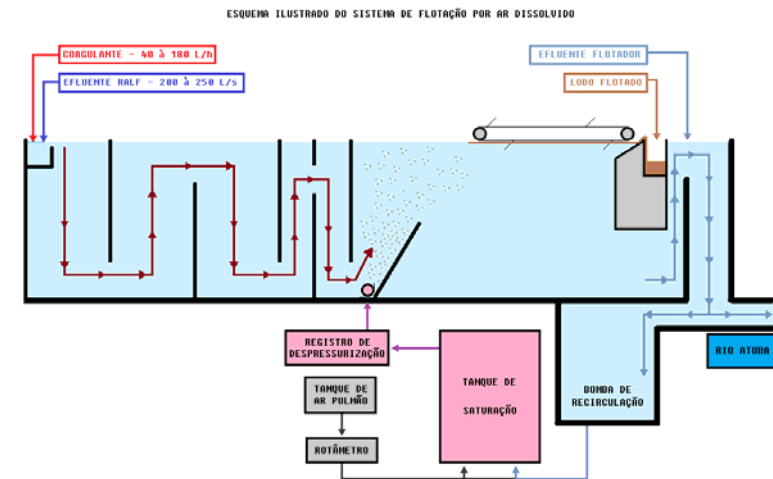

Image 48 - DAF schematic drawing

6.1. DESCRIPTION OF THE PROCESS

- The effluent comes from the AFBRs and passes through the Floaters Flow Distributor. Each floater has the capacity to operate with a discharge between 200 and 250 L/s per module, and the excess will be disposed off through the Sluice of the Flow Distributor Bypass. In order to determine the discharge that should be admitted in the floaters, refer to the procedure to determine the floatation discharge (*item 3.6.2.3*);
- The portion of the AFBRs effluent that is discarded in the Flow Distributor Bypass Sluice is mixed in the Parshall flume with the effluent from floaters. The sample to check the quality of the Treated Effluent is collected after the Parshall flume of the WWTP Final Effluent;
- After passing through the discharge distributor, the coagulant is added to the AFBRs Effluent, in case of Atuba Sul WWTP, ferric chloride (FeCl_3) is used, but there are other chemicals that can be used for the same purpose. The monthly average dosing of ferric chloride is of 110 L/h;
- The FeCl_3 dosing varies according to the period of the day, and also to the climatic conditions. In rainy days, the dose is reduced, and can reach 40 L/h. In drought days, and between 10:00 pm and 2:00 am, the dosing can reach 180 L/h;
- Dosing is defined based on the pH variation between the AFBR Effluent with and without the addition of FeCl_3 , also taking into consideration the turbidity of the AFBRs Effluent. See the procedure for chloride dosing *Item 6.8.4* for more details;
- The addition of FeCl_3 takes place in the flocculation chamber, the AFBR Effluent then goes through one or three chambers, according to where the application will be done. Flocculators should have the mixers on;
- After flocculation, the flow goes to the flotation chamber, where flakes receive micro air bubbles, and these adhere to the sludge flakes and carry them to the tank surface. The accumulated sludge is then removed by the sludge scrapers;
- The effluent already without the sludge due to flotation gets out through the bottom of the floater, and goes to the Parshall flume of the Final Effluent;
- Micro bubbles are formed through the process of air saturation in the recirculation water. Recirculation water is collected from the floater effluent, and pumped by the recirculation water pump. The recirculation water goes to the saturation tank, where it gets air under high pressure. The water saturated with air is

unpressurized, and forms nano and micro bubbles, this water is then injected in the bottom of floatation chambers;

- Micro bubbles coming from the saturated water adhere to the coagulated sludge, taking it to the surface of the floatation chamber;
- The sludge removed by the Sludge Scrapers accumulates in the well of the Floated Sludge Pump Station, in this place the sludge is pumped to the Centrifuge Sludge Well, and from there to the Compactor.
- The effluent from the flocculation chamber partially goes to the WWTP final effluent, and partially to the recirculation well that feeds the saturation tank.
- In the Final Effluent outfall, the mix with part of the effluent that did not go through floaters occurs, it then goes through the Parshall flume where the discharge is measured, and finally goes to Atuba River.

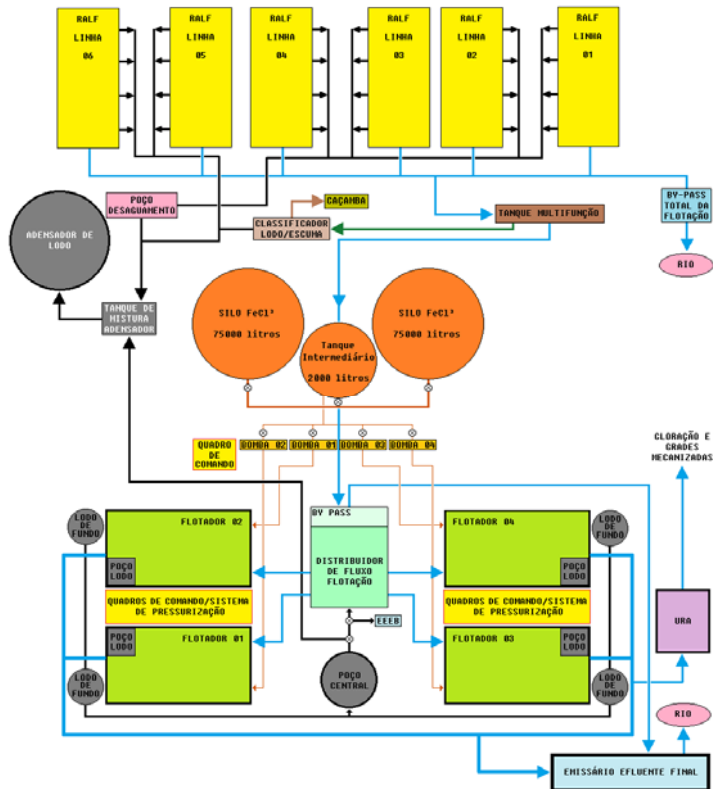

Image 49 - Floatation Layout

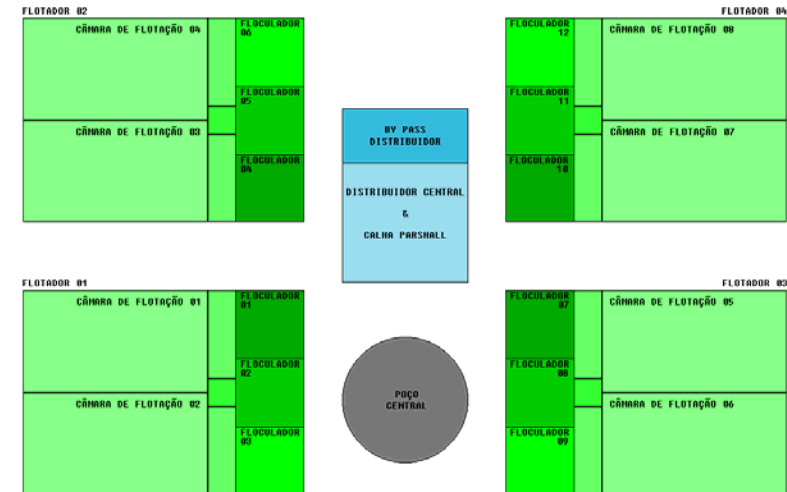

Image 50 - Floaters map

6.2. ROUTINE OF FLOATATION OPERATOR

- Check the Floatation Book of Occurrences and the e-mail;
- Analyze the track records of Atuba Sul WWTP discharge graphs and the floaters inlet in the supervisory;
- Fill the intermediate chlorine tank, carefully to prevent overflow;
- Make the Checklist of the floaters equipment (Item 6.3);
- Turn on air compressors (Item 6.4);
- Charge or empty the floater, according to the demand (Item 6.5);
- Define the floatation discharge according to the height of the sludge layer in the compactor, see information in the operation bulletin of the sludge inertization system (IA/OPE/1527), pursuant to Item 6.6;
- Turn on the air saturation system: recirculation pump, and open the compressed air valves (Item 6.7);
- Turn on mixers of the flocculation chambers;
- Turn on the coagulant dosing system (Item 6.8);
- Turn on the sludge scraper (Item 6.9);
- Evaluate the time of the sludge scrapers:
 - In rainy season, the little sludge, increase the time of scrapers halt;
 - In dry season, reduce the halt time. The functioning time should be always 5 minutes;
- Regulate the chlorine dosing, as well as its fine adjustment (Item 6.8.7);
- Collect samples to perform the analytical process control (Item 6.10);
- Perform the compound collection of samples if any (samples for the Belém WWTP/USAV);
- Take notes in the Floatation Operational Bulletin (IA/OPE/1652).

6.3. CHECKLIST OF FLOATATION

Check it at 8:30 am and register the information in the Floatation Operational Bulletin (IA/OPE/1652):

- Level of O2 tanks of ferric chloride storage;
- Hour counters of 06 air compressors;
- Hour counters of 04 floated sludge pumps;

Information to be registered in the Floatation Occurrences Book:

A princípio estas informações não são registradas no Boletim Operacional da Flotação (IA/OPE/1652). Independente disto, o operador deverá fazer as verificações no início do turno e a cada duas horas no seu decorrer.

- a) Air pressure registered in the lung tanks manometer should be between 06 to 08 bar;
- b) Saturation tanks level should be between 250 mm to 1250 mm;
- c) Saturation tanks pressure with the system on should be between 4 and 4.5 bar;
- d) Compressed air flow with the system off, between 10000 and 15000 LN/h;
- e) Recirculation flow with the system on should be higher than 50 L/s;
- f) Check the functioning of scrapers, and if crackling sounds, lack of alignment, lack lubricants is noticed, the equipment is not working or other relevant information, and inform the USEM team or the shift, weekends and holidays team immediately;
- g) Check whether the containment tank sluice of chloride tanks is closed, if not, close it immediately;
- h) Check the corrosion situation in coagulant tanks;
- i) Simulate the containment tank pump functioning, if it does not turn on or has noise, request maintenance to the USEM team.

6.4. AIR COMPRESSORS

The air system is fed by 06 compressors, the three first supplying the 01 and 02 floaters, and the other compressors providing air to the 03 and 04 floaters.

To turn on the compressor, press the green button in the panel. There is also a selecting switch of the compressors operation mode.



Image 51 - Air compressors



Image 52 - Compressor panel

Compressors work in automatic mode, and can all be turned on simultaneously. When the Lung Tank reaches the pressure between 06 and 08 bar, compressors get into the standby mode, automatically turning on when the pressure goes down. Be alert during electric power outages and oscillations, because in such case compressors had to be manually turned on.

As already described, three compressors of the set can be turned on simultaneously. In case of maintenance, turn on two compressors simultaneously, this means that only one compressor can be halted for maintenance per set.

The compressed air in the lung tank has the role of saturating the recirculation water, which will then create micro bubbles that will promote the sludge floatation. It also serves to actuate the pneumatic sluices of the flow distributor, the air feeding such sluices passes through air drier.

In the beginning of each shift, and at each two hours, check the pressure in the manometer of the lung tank, remembering that such pressure should be between 06 and 08 bar.



Image 53 - Lung Tank Manometer

In the beginning of each shift, check:

- Functioning conditions, and no more than one compressor can be under maintenance;
- Oil leaks and strange noise;
- Register abnormalities in the Floatation Occurrences Book;
- Inform abnormalities to UI Irai management, in order to request maintenance to the USEM team.

6.5. EMPTY/CHARGE FLOATERS

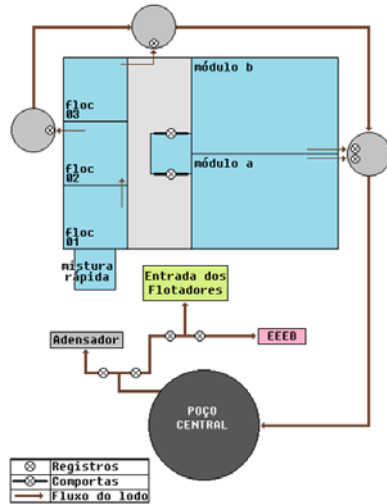

Image 54 - Bottom clean-up layout

To empty and clean a floater:

- One module is charged and the other is emptied, and the corresponding sluice should be closed to interrupt the water flow;
- If necessary to empty both floater modules, it will be necessary to lower the pneumatic sluice of the corresponding floater flow distributor. In this case, the following will be also necessary:

Periodically, floaters should be emptied to clean up the sludge accumulated in the bottom of the reactor, tanks should also be emptied for maintenance.

In order to clean, the flow of one of the floater modules should be stopped by manually lowering the corresponding sluice at the end of the third flocculator. One floater module will always be charged, while the other will be in standby, maintenance or cleaning. The operation of the two modules will only be stopped when there is need of a general halt for maintenance.

Floaters tanks are emptied by maneuvering the valves. Firstly, the clarified liquid that should be sent back to the RSPS (Raw Sewage Pumping Station) will come out through the maneuver of valves near the central well. When the liquid is totally drained, the sludge accumulated in the bottom of the tanks will start to flow, and the flow should be deviated from the RSPS to the compactor.

The cleaning and service execution halt is performed by the shift operator of floaters.



Image 55 - Command panel of pneumatic sluices

- Interrupt the ferric chloride dosing of the floater, close the valve behind the dosing pump to prevent the occurrence of gravity dosing, the valve is inside the ferric chloride containment tank;
 - After thirty minutes, turn off the recirculation pump;
 - Close the inlet pneumatic sluice of the floater to be emptied;
 - Close the valves of the compressed air feeding the saturation tank;
 - Turn off the floated sludge scrapers;
- Close the valve of the central well pumps outlet located between floater 01 and floater 03, which sends sludge or effluent to the compactor, open the valve beside floater 03, which is inside the valves box, because it will send the floater effluent directly to the pumping station. When lowered until reaching the

sludge in the bottom of the floater, invert the valve to open the valve beside floater 01, as well as close the valve beside floater 03, because the sludge has to be sent to the compactor. See the schematic drawing.

- Partially open the valves beside the module A or module B Inspection Point until the water level inside the tank is below the street level. After lowering to this level, completely open the valve, this will prevent overflowing;
- When the tank level lowers and it is possible to see the sludge at the bottom of the floater, the manual sluice of the floater module should be completely closed, this will occur approximately 6 hours after starting the cleaning;
- When the sludge is more diluted in the bottom of the tank, use the little blue hose to help cleaning. Connect it to the "filter Y", and turn on the recirculation pump. Does not allow too much liquid to accumulate in the bottom, so that emptying it does not take too much time;
- After washing and closing the valves of *modules a and b*, open the valve of the Inspection Point (PV) of *flocculator 3*, after emptying it make the cascading, opening and closing the pneumatic sluice of the floater inlet, when the sludge is diluted, use the little blue hose to finish cleaning, and then close the PV valve;
- At last, open the PV valve of *flocculators 1 and 2*, and repeat the procedure of the previous item;
- The priority is to keep the floater charged, floating or not, using it as a decanter. Floater should not be kept too long halted for cleaning, or even clean and empty;

To charge the floater:

- Check whether all the PVs valves around the floater are closed;
- Open the sluices:
 - Floater effluent outlet (manual);
 - Manual sluices of flocculators outlet, floating chamber inlet;
 - Open the pneumatic sluice of the floater flow distributor;

If the above described sluices are not sufficiently opened, there will be overflowing to the street;

- Regulate the floaters operation discharge according to *item 6.6*;
- If it is not possible to turn on the floater because of excess sludge in the compactor, or for any mechanical problem, then let it only as passage. In case of mechanical problem, call the USEM team;
- Turn on the saturation system, ferric chloride dosing, flocculators and scrapers, make the adjustments, and proceed with the operation normally.

6.6. DEFINITION OF FLOATERS OPERATION DISCHARGE

In order the floating system operates more efficiently and with low loss of solids in its effluent, it is necessary to operate with discharge between 200 and 250 L/s in each floatation module. Hydraulically, each floater can stand the maximum discharge of 400 L/s, being necessary to level the sill of the floater effluent.

Floaters operation can be interrupted for the following reasons:

- Corrective maintenance;
- Preventive maintenance;
- Cleaning;
- Standby due to discharge demand.

Because of the limitation of the saturated water discharge, it is not possible to satisfactorily operate both modules of the same floater with discharge of 200 L/s each, totalizing 400 L/s in the floater. In this case, only one module is operated with discharge of 200 L/s, while the other remains turned off.

With 04 operating modules (one module of each floater), it is possible to reach the total discharge of 1000 L/s, i.e., 250 L/s per module.

The floating discharge is determined according to the demand of sludge dewatering, and the sludge layer height in the compactor. The record of such information is found in the Operational Bulletin of the Sludge Dewatering and Inertization System (IA/OPE/1527).

The sludge layer height is checked every day by the centrifuge operator at 8:00 am. The floater operator should search for this information every morning in order to determine the floaters discharge, as shown in Image 51, below.

Determinação de vazão dos flotores	
Altura do manto de lodo no adensador	Vazão dos flotores
De 2,8 m até 3,0 m	Se a centrífuga estiver parada, não operar a flotação. Com a centrífuga ligada, a vazão da flotação deve ser de 200 L/s, ou seja, apenas um flotor operando. Não fazer limpeza de lodo de fundo.
De 2,5 m até 2,8 m	Vazão no sistema flotação deve ser de 400 L/s, ou seja, dois flotores funcionando. Não fazer limpeza de lodo de fundo.
De 2,3 m até 2,5 m	Vazão no sistema flotação deve ser de 600 L/s, ou seja, três flotores funcionando. Não fazer limpeza de lodo de fundo.
De 0,5 até 2,3 m	Vazão no sistema de flotação deve ser a máxima possível, todos os flotores operando. Verificar a possibilidade de fazer limpeza de fundo do flotor.
Abaixo de 0,5 m	Além de vazão máxima no flotor, é necessário descartar o lodo do RALF. Avisar responsável pelo descarte. Caso ocorra no final de semana, o operador do sistema de desaguamento deve realizar o descarte. Considerar a possibilidade de limpeza de lodo de fundo do flotor.

Table 10 - DAF discharge determination

- If the floating system is halted because of excess sludge in the compactor, **floating operators** should measure the compactor in the beginning of their shifts.
- If dewatering is halted because of lack of sludge in the compactor, **centrifuge operators** should measure the compactor in the beginning of their shifts.
- Dewatering operator: If the dewatering system is halted because of lack of sludge, at each shift beginning.

6.6.1. REGULATING THE OPERATION DISCHARGE VIA SUPERVISORY

The adjustment of floaters discharge can be done automatically, through the sluice automation. In order to do that, follow the following steps:

- In the command panel located above the flow distribution box of floaters, turn the red selection switch to the Automatic position (Image 56);
- In the computer of the supervisory system, open the screen of any of the floaters;
- In the upper right side of the screen, located the icon illustrated in Image 57, and click on it.



Image 56 - Bypass sluice panel



Image 57 - Bypass sluice icon

ETE ATUBA SUL
OPERAÇÃO COMP. BY-PASS

MANUAL AUTOMÁTICO

ABRIR FECHAR

SP TEMPO ESPERA PASSO 30,0 s

SP TEMPO DE PASSO 2,00 s

SP VAZÃO FLOTADOR 01 275, l/s

SP VAZÃO FLOTADOR 02 0,00 l/s

SP VAZÃO FLOTADOR 03 275, l/s

SP VAZÃO FLOTADOR 04 0,00 l/s

FLOTADORES EM OPER. SETPOINT SOMADO 550, l/s

EMERGÊNCIA ATUADA

FECHAR

Image 58 - Bypass sluice operation

The menu on the side will show up, and it will allow the following:

MANUAL/AUTOMATIC: Defines the operation mode, in the manual mode it is possible to OPEN/CLOSE the sluice via supervisory;

SP STEP WAITING TIME: In automatic mode, this value will define the waiting time to actuate the sluice, in seconds;

SP STEP TIME: In automatic mode, this value will define how long the sluice will work, opening or closing, according to the discharge adjustment need, defined in seconds;

SP FLOATER 01/02/03/04 DISCHARGE: In automatic mode, these fields should be defined as discharges to be practiced in each floater, in L/s;

OPERATING FLOATERS SUMMED UP SET POINT: Summed up value of all defined discharges. This value is the discharge the system will try to keep, opening or closing the sluice according to the times previously defined;

ACTUATED EMERGENCY: Indicates whether the emergency button is actuated in field.

6.7. RECIRCULATION WATER SATURATION SYSTEM

RESUMO DO SISTEMA DE SATURAÇÃO DA ÁGUA

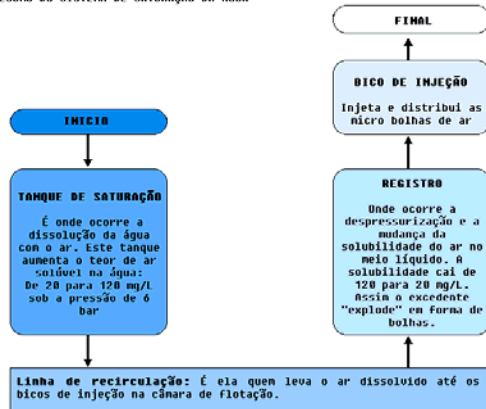

Image 59 - Stages of the saturation process

The success of the floatation system depends on the injection of small air bubbles, nano and micro (10-9 and 10-6 meters respectively). The adhesion of the finely divided air into the sludge flakes makes the sludge float in the floatation chamber of Atuba Sul WWTP DAF.

The micro bubbles production system is summarized into three states, as illustrated on the left.

6.7.1. FUNCTIONING OF THE SATURATION TANK

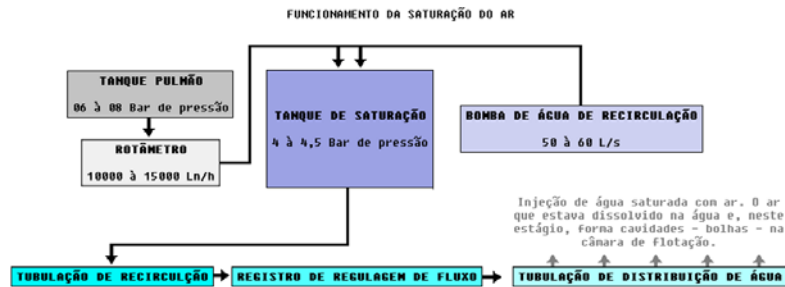

Image 60 - Saturation of water with air

The saturation tank does not form micro bubbles by itself, it promotes the solubilization of air into the recirculation water according to Henry's law, i.e. the constant solubility is directly proportional to pressure.

$$\text{Air solubilization} = \text{Constant solubility} \times \text{Pressure}$$

In virtue of Henry's law:

- There is a high air transference rate in the liquid mass in short detention time, thus requiring little volume of saturation tank. That is why such systems are called high rate;

- It is possible through air pressurization and the respective afterward abrupt depressurizing to form micro bubbles and nano bubbles of air where such depressurizing occurs, as illustrated in the next Image:

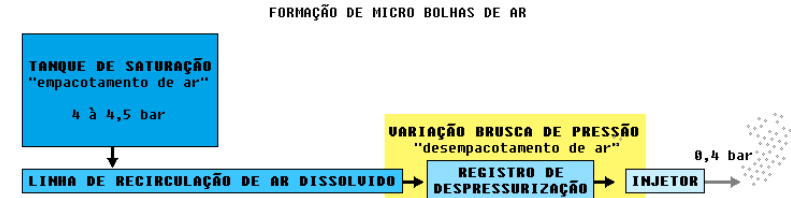
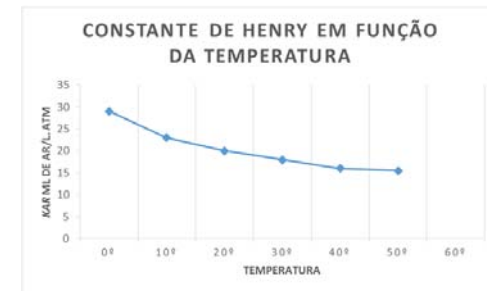

Image 61 - Formation of air micro bubbles

The effluent temperature is also a variable for the solubilization of air in water. In days when the effluent temperature is lower, the air solubility increases in comparison to days with warmer effluent and under the same pressure, as shown in the graph below:



Graph 3 - Constant of Henry in function of temperature (Literature review and data compilation, Squiba 2012 – data not published)

Based on the above graph, in the conditions of Atuba Sul WWTP, considering the effluent at 20°C, and the saturation tank working with 06 bar of pressure, we have:

This means that 120 ml/L of air, under a 6-bar pressure, gets into a state of perfect solution in the liquid mean, and thus, when depressurized in the injection beak to 1 bar, then 120 - 20 = 100 ml/L of air that will go back to the dispersion or suspension (micro bubbles) state, i.e. 100 ml/L of air will become microscopic air bubbles. **LEVEL MEASUREMENT IN THE SATURATION TANK**

- The right side of the LT measures the sum of pressure: water column + tank pressure;

- The left side only measures the air pressure in the tank.

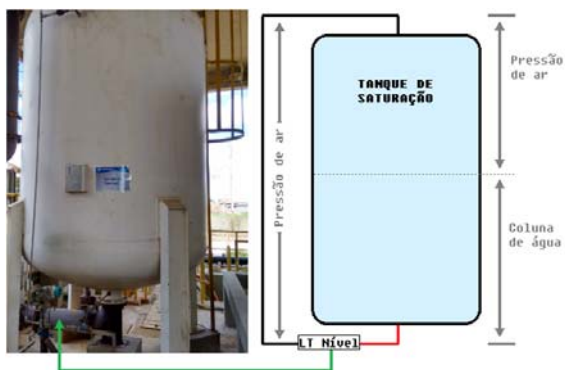

Image 62 - LT scheme in the saturation tank

The LT (level transmitter) measures the level of the liquid inside the saturation tank through the pressure difference between extremities.

Considering the pressure unit in *mwc* (meters of water column), air pressure in the tank of *60 mwc* (*06 bar*) and water column of one meter (*01 mwc*). Based on the above figure, the left side of the LT will measure *60 mwc*, and the right side will measure the tank pressure + water column ($60 + 1 = 61mwc$), then the level measures calculates the difference $61 - 60 = 1 meter$. As a conclusion, the tank has *01 meter* of water level inside, and that is how the LT measures and shows it.

Still regarding the LT of the saturation tank level, it is important to know that due to foam problems, spatters and possible debris inside the tank pressure pipeline (left side of the LT), there might occur distortions of the level measured. As a solution, the technical team has decided to solve the problem by supplementing water in the pipeline of this side of the LT, recalibrating the LT to obtain the actual measurement.

GAUGING AND CALIBRATION OF THE LT

Due to the above described water problem on the left side of the LT, it is necessary to inspect the LT whenever the tank is empty and depressurized, and for that the manometer just after the saturation tank should be verified.

It is necessary to check if the LT is marking the level value in the interval between -100 mm to $+100\text{ mm}$, because if the system is turned off there should be no level. If the level is outside the described range, the management should be informed and this should be taken note of in the Floaters Occurrence Book. Management will in turn forward the demand to the automation team, in order to perform the calibration.

This level verification will be done every time the system is turned off for cleaning or maintenance, or even when atypical values are observed. When this happens, the system should be halted.

6.7.2. OPERATION AND MONITORING RANGE OF THE SATURATION TANK LT

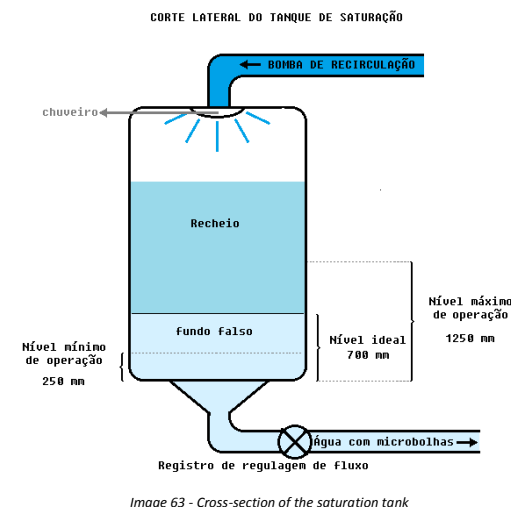

Image 63 - Cross-section of the saturation tank

According to the above figure, we can understand that the water level in the saturation tank should be kept:

- **Above 250 mm:** because below that air can leave the tank, going to the floatation chamber, and prejudicing floatation;
- **Below 1250 mm:** Above that, there is excessive drowning of the filling, and prejudice to the air saturation that does not occur satisfactorily.

It is observed that in some cases, in order to reach the ideal level of 700 mm, the saturated water discharge has to be excessively reduced, and because of this discharge reduction, the worsening of the process is observed. It can happen that some floater is working with saturated water discharge near the limit of 55 L/s with the pump in the 56 Hz frequency. The level tank will be around 1250 mm, and the pressure between 4 and 4.5 bar, and thus a situation closer to the ideal is found.

Remark: The goal should be the maximum level of 700 mm, since it is the ideal situation, however the frequency of the recirculation pump should not be lowered to less than 54 Hz in order to not jeopardize the recirculation discharge.

Check the saturation tank level via supervisory each two hours by evaluating the graphs, where the level variation should be observed, as well as whether it fits the specification given. If such information is not shown in the supervisory, request maintenance via e-mail to the Manager, and write it down in the Floatation Occurrences Book. If this information is not available via supervisory, check the field LT. Measurer is near the base of the respective saturation tank.

6.7.3. LEVEL AND PRESSURE REGULATION IN THE SATURATION TANK

In order to regulate the height of the saturation tank level, the following variables should be taken into consideration:

- **Recirculation discharge:** High recirculation discharge tends to increase the height of the tank level, as well as a low discharge tends to lower the level. Discharge is regulated by:
 - Frequency inverter;
 - Flow regulating valve, at the outlet pipeline of the saturation tank. In this case, the discharge and pressure of the tank are changed.
- Air discharge: High air discharge reduces the level, as well as a low air discharge increases the level;
- Tank Pressure: High pressure tends to reduce the tank level, as well as low pressure tends to increase the level. In order to change the tank pressure:
 - Open/close the flow regulating valve, at the outlet pipeline of the saturation tank;
 - Increase/reduce the recirculation discharge;
 - Increase/reduce the air discharge.

Always regulate to the highest saturated water discharge possible, i.e. higher recirculation pump frequency trying to keep the pressure within the range of 4 to 4.5 BAR, and the air discharge between 10000 and 15000 LN/h.



Image 64 – Manometer of the air system

6.7.4. INITIAL PROCESS REGULATION

- a) Totally open the valve that regulates the saturated water flow;
- b) Turn on the recirculation pump at the maximum frequency; 60 Hz;
- c) Open the air through valves, searching for a discharge between 10000 and 15,000 LN/h;
- d) Gradually close the saturated water injection valve, until the pressure of the saturation tank is stabilized between 4 and 4.5 BAR;
- e) It will be necessary to readjust the air discharge to 10000 to 15000 LN/h;
- f) Check the LT, and if the level is:

Below 250 mm and the recirculation pump in 60 Hz:

- Gradually close the flow regulating valve (¼ of the turn each time).
- Check the saturation tank pressure, in the air system panel. If it is above 4.5 bar, it will be necessary to gradually reduce the recirculation pump frequency.
- Repeat the procedure until the level is between 250 and 1250 mm, and the tank pressure is between 4 and 4.5 BAR;
- Readjust the air discharge to the range between 10000 and 15000 LN/h.

Below 250 mm and saturation tank pressure below 4 BAR:

- Gradually increase the recirculation pump frequency;
- If the recirculation pump reaches 60 Hz (maximum frequency) and the pressure is kept low, gradually close the flow regulating valve (¼ of the turn each time);
- Readjust the air discharge to the range between 10000 and 15000 LN/h.

Below 250 mm and saturation tank pressure above 4.5 BAR:

- Gradually increase the recirculation pump frequency;
- Probably the tank pressure will increase even more, and in this case gradually open the flow regulating valve (¼ of the turn each time);
- Readjust the air discharge to the range between 10000 and 15000 LN/h.

Above 1250 mm and saturation tank pressure below 4 BAR:

- Gradually close the flow regulating valve (¼ of the turn each time);
- After some time, when the pressure is within the range of 4 to 4.5 BAR, and if the level stays above 1250 mm, the recirculation pump frequency should be gradually reduced until the level is within this operation range;
- Check, in the air system panel, the saturation tank pressure will be reduced due to the pressure caused by the pump. Then, gradually close the flow regulating valve (¼ of the turn each time);

Above 1250 mm and saturation tank pressure above 4.5 BAR:

- Gradually open the flow regulating valve (¼ of the turn each time);
- If the pressure is within the range between 4 and 4.5 BAR and the level remains high, gradually reduce the recirculation pump frequency until the level is below 1250 mm;
- After reducing the recirculation pump frequency, readjust the tank pressure by closing the flow regulating valve so that the pressure is between 4 and 4.5 BAR;
- Do not operate with the recirculation pump frequency below 54 Hz.

Notes:

- Do not work with the recirculation pump frequency below 54 Hz, in order to not excessively reduce the saturated water discharge.
- In the beginning of the process, with the recirculation valve entirely opened, the level above 1250 mm will hardly occur;
- It should also be considered that with the valve entirely opened, the tank pressure will probably not exceed 4 BAR;

Para regulagem de nível do tanque e manutenção de processo, verificar a cada duas horas o nível e pressão do tanque que devem ficar entre 250 e 1250 mm e 4 e 4,5 BAR, respectivamente.

6.8. COAGULANT DOSING SYSTEM

LAYOUT DE ESTRUTURA DE DOSAGEM DE CLORETO FÉRRICO

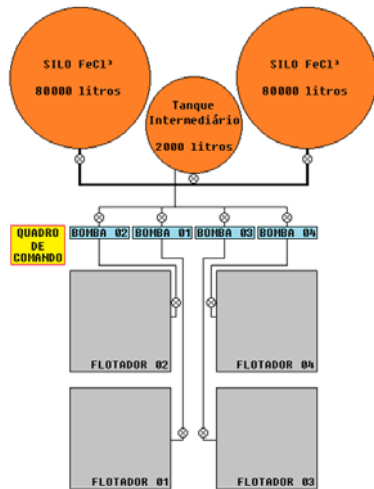

Image 65 - Coagulant structure

The coagulant used in the Atuba Sul WWTP is the Ferric Chloride ($FeCl^3$), the dosing system structure is composed of:

- Two storage tanks with 80 m³ capacity each;
- One intermediary 2 m³ tank to relief the hydrostatic pressure;
- 04 dosing pumps;
- Command panel with 04 frequency inverters;
- Flow meter.
- One quick mix tank per floater;
- Three flocculation tanks for each floater.

6.8.1. COAGULANT RESERVOIR

- There are two coagulant reservoirs installed at the Atuba Sul WWTP, called Tank I and Tank II, each one with 80000-liter capacity;
- The reading of the tank level should be done by the floatation operator every day in the morning, at 8:00 am. The data should be written down in the Floatation Bulletin (*IA/OPE/1652*);
- Use one tank each time. For instance, when tank I is used, tank II should wait for recharge or be in standby, if full;
- The tank in use should have a plate indicating this;
- A schedule should be organized for recharging the tanks;
- When one of the tanks is empty, a new charge should be requested to the plant's administrative facilitator or to the manager, and the request should be registered in *folder number 10 – Chemical Products*.
- The plant's administrative facilitator or manager requests the recharge to the USMA (Service Unit of Materials) through the REM (extra remittance of material). In general, several recharge requests are made to fill the tank, as in a schedule. The recharge schedule is elaborated by the administrative/manager with the information from the morning shift operator when one of the tanks is empty.

INTERMEDIARY CHLORIDE TANK

2000-L capacity tank that serves as hydrostatic pressure relief, because the 80000-L tanks when full has high manometric height causing high pressure in the dosing pumps valves, prejudicing the dosing accuracy.

- Always keep the intermediary tank level above ¼ of its capacity;
- The recharge of the intermediary tank should be monitored by the operator in person to prevent overflowing. In order to fill the intermediary tank, check which of the 80000-L tanks is in use, and slowly open its valve;
- Change shifts always with the tank full. Never change shifts with the tank in filling process, with the valve open;
- If there is overflowing to the leak containment tank, check if the sluice is sealed, if not, close it immediately, write this down in the Book of Occurrences (black book), and warn the manager.

LEAK CONTAINMENT TANK

Tank with the aim of containing leaks of chemicals, preventing them to flow to the street and to the rainwater galleries. This tank has a slide gate sluice and should be always closed.

In the place, there is a containment tank draining pump. Through it, it is possible to return the coagulant to the 80 m³ tank or to another destination, by installing a quick hook hose.

It is necessary to keep the containment tank clean, because if it is necessary to pressurize the flow to the 80 m³ tank, the dirt will contaminate the tank, and might damage the dosing pumps. The business hours operator is responsible for cleaning.

Make the checklist:

- The draining pump of the containment tank at 8:30 am. If the pump does not turn on/or shows any noise or abnormality, warn the USEM team. Write this down in the Floatation Occurrences Book;
- Clean the tank;
- Presence of overflowing;
- Register abnormalities in the Floatation Occurrences Book.

6.8.2. DOSING PUMPS

There are 4 dosing pumps installed, one for each floater, being actuated by a switch, containing a frequency inverter to adjust the dosing for each dosing pump;

There are two types of dosing pumps, namely:

- Helicoid pump;
- Diaphragm pump (nemo).

Vazão da bomba nemo							
Hz	L/s	Hz	L/s	Hz	L/s	Hz	L/s
14	49	26	91	38	133	50	175
14,5	50	26,5	92	38,5	134	50,5	176
15	52	27	94	39	136	51	178
15,5	54	27,5	96	39,5	138	51,5	180
16	56	28	98	40	140	52	182
16,5	57	28,5	99	40,5	141	52,5	183
17	59	29	101	41	143	53	185
17,5	61	29,5	103	41,5	145	53,5	187
18	63	30	105	42	147	54	189
18,5	64	30,5	106	42,5	148	54,5	190
19	66	31	108	43	150	55	192
19,5	68	31,5	110	43,5	152	55,5	194
20	70	32	112	44	154	56	196
20,5	71	32,5	113	44,5	155	56,5	197
21	73	33	115	45	157	57	199
21,5	75	33,5	117	45,5	159	57,5	201
22	77	34	119	46	161	58	203
22,5	78	34,5	120	46,5	162	58,5	204
23	80	35	122	47	164	59	206
23,5	82	35,5	124	47,5	166	59,5	208
24	84	36	126	48	168	60	210
24,5	85	36,5	127	48,5	169		
25	87	37	129	49	171		
25,5	89	37,5	131	49,5	173		

Table 11 - Conversion of the nemo pump discharge

If the dose is not working as usual, i.e., the known discharge does not correspond to a given frequency, then:

- Check the intermediary tank load, this should always be higher than ¾ of the tank capacity;
- Check if the valves are closed or not;
- Check if the pipeline is broken;
- Make the primer of the pump head, both of the helicoid as well as the diaphragm types;
- Clean the diaphragm pump valves;
- If there is no solution, request maintenance to the USEM team;
- Any abnormality should be written down in the Floatation Occurrences Book and pass through by e-mail.

6.8.3. FERRIC CHLORIDE COAGULATION AND DOSING

The coagulant dosing adjustment in the floaters is done in two stages:

- Initial adjustment: It is a rough adjustment visually done;
- Fine adjustment: It is a quantitative adjustment, done based on the pH difference;

The ferric chloride, when dosed in the AFBR's effluent, consumes its alkalinity, i.e. by using ferric chloride the effluent pH is reduced.



Graph 4 - pH variation in regard to FeCl₃ - Atuba Sul



Graph 5 - COD in relation to FeCl₃

The pH difference before and after Ferric Chloride dosing is called pH Consumption Range.

The periods of higher Ferric Chloride consumption are determined according to the changes of the plant's Affluent characteristics. It changes the characteristics of the AFBR's Effluent that, as consequence, change the pH Consumption Range according to its buffering capacity, which is how a solution resists to the pH changes.

Graph 5 is the result of a Jar Test performed with samples of the Atuba Sul WWTP AFBR's Effluent, where after the flocculation the sample was filtered, and the soluble COD was analyzed. We have noticed that there is a fast initial conversion of soluble COD into suspended COD (coagulation and flocculation), and then a deceleration for higher doses of FeCl₃, reaching a point where the conversion is null, and this point is $Dx/Dt=0$, the point of the best dosing result.

Under such conditions, the AFBRs Effluent was with a turbidity of 170, and the pH Consumption Range with better result was 0.65, shown in Graph 5. The dosing done in such conditions was 145 L/hour of ferric chloride, and the discharge equivalent to 200 L/s in the floaters.

In the graph below we can observe the variations of the AFBR's effluent characteristics according to the time, we can notice a high correlation between turbidity and the period of the day.



Graph 6 - Daily variation of ER turbidity

Turbidity also varies according to climatic conditions, in rainy periods a drop in the turbidity values is clearly observed in the field. In dry days, there is a significant worsening of the turbidity value at midnight, and the best time is at noon. This behavior is repeated in the results Sulfides and COD analyses.

6.8.4. PROCEDURE TO DOSE FERRIC CHLORIDE

Let's remember that the pH difference before and after Ferric Chloride dosing is called *pH Consumption Range*, and before verifying the following should be done:

- Checklist of the flocculation conditions in the field, visually;

- Visual adjustment of the dosing, i.e., an initial adjustment. This is necessary not to waste time classifying the pH range, which is a fine adjustment, if the flocculation is visually inappropriate.

6.8.5. INITIAL DOSING ADJUSTMENT

- Analyze the recent history of dosing conditions in the Floatation Bulletin (IA/OPE/1652), perform the recorded dosing;
- Adjust the floater's discharge to the range between 200 and 250 L/s, observe the history in the Floatation Bulletin and try to operate in the discharge recently entered in the bulletin;
- Check the operation conditions of the ferric chloride pump, i.e. if there is flow interruption of excessive discharge;
- After analyzing the previous items, see the aspect of the flake at the flocculation chamber inlet, which should be slightly light brown, consistent aspect and good separation of the flake from the clarified liquid, thus:
 - If flakes are grayish and ill-formed, it will be necessary to increase the $FeCl_3$ dosing, and wait for 15 minutes to make a new evaluation. In such case, there will be no clear separation between flakes and the clarified liquid;
 - If the flake is orange, this is because of excess ferric chloride, and thus the dosing should be reduced and wait for 15 minutes to redo the evaluation.
- See the aspect of the floatation chamber sludge, it should be slightly brown when peroxide is not used, and lead-grey to dark beige when peroxide is used. If it is:
 - Black, then chloride is lacking, and the dose should be increased and wait for 15 minutes to redo the evaluation;
 - With the orange color, then reduce the dose, wait for 15 minutes to redo the evaluation;
- Once the rough adjustment is done, perform the fine regulation based on the next item.

6.8.6. FINE DOSING ADJUSTMENT

- Collect a sample from the AFBR's Effluent and analyze the turbidity twice per shift, as recommended in the Floatation Bulletin (IA/OPE/1652);
- Based on the turbidity analysis result, check the *pH consumption range* to be performed as indicated in *table 12*. Take note of such values in the Floatation Bulletin;

/Image 66 - Collection points for pH Analysis
- Collect samples from the AFBR's Effluent with and without the application of ferric chloride for the pH analysis, the collection points are indicated in the *Image 66*, beside;
- Perform the pH analysis of collected samples;
- Calculate the pH consumption Range according to the following formula:
- Check whether the pH consumption range found matches the turbidity value, according to the values shown in *Table 12*, and if the consumption range is:

Parâmetros para ajuste de dosagem de coagulante	
Turbidez Efluente RALF	Faixa de consumo de pH
Menor que 45	Não dosa $FeCl_3$
45 - 100	0,36 - 0,45
100 - 170	0,45 - 0,55
Maior que 170	0,55 - 0,65

Table 12 - Parameters for the coagulant dosing adjustment

- Take note of the chloride dosing in the Floatation Bulletin (IA/OPE/1652);
 - It can happen to find a very low turbidity in rainy days, in this case the pump should be turned off and the coagulant should be applied only by gravity, opening/closing the valve before the pump to regulate the ferric chloride dosing.
 - Keep the intermediary ferric chloride tank always full to prevent infiltration of air in the dosing pipeline.

6.8.7. RECEPTION AND UNLOAD OF FERRIC CHLORIDE

- The request for chemical products should be done through the Materials Administration Service (SAM) of USMA by the administrative facilitator or manager at least 48 hours beforehand;
- Before receiving the product, the invoice should be checked for the delivery place, requested amount and received product;
- The floatation operator should guide and follow up the truck driver in unloading the product, informing in which tank the product should be discharged in, as well the due care with the place (lawn, sidewalks, curbs, fences);
- Two samples should be collected, directly from the truck, in plastic flasks to be sent for compliance analysis at the USMA laboratory, pursuant to IA/MAT/0003;
- Maneuver the valves to unload the product into the silo being recharged, only unload it into the silo being used when the other one is already full or is under maintenance;
- Check if there are leaks in the unload hose couplings, if yes, the unload should be interrupted and the leak contained;
- Release the unload;
- After unloading the material, the invoice and the carrier's note should be signed.
- The copy of the invoice stays with the operator and should be placed in the "Invoices" pigeonhole at the Atuba Sul WWTP office, after duly stamped and signed. This invoice will be forwarded to the USMA, along with the collected sample.
- In case of delay or non fulfillment of the request, the BDO should be issued and forwarded to the contract manager for the due procedures.

6.9. SLUDGE SCRAPERS

The function of scrapers is to remove the sludge layer formed on the floatation tank surface, and to prevent that it gets loose and comes out with the floaters effluent. The sludge removed by scrapers is sent to the sludge well of the centrifuge building, and then to the sludge compactor, and subsequently to the dewatering and inertization process.

The handles to actuate the scrapers are in the third door of each side of the floaters' central command panels, and each handle actuates the respective number scraper, as follows:

- Floater 01 → Scrapers 01 and 02
- Floater 02 → Scrapers 03 and 04
- Floater 03 → Scrapers 05 and 06
- Floater 04 → Scrapers 07 and 08

There are also two command panels near the scrapers of each floatation module, and scrapers automation devices (*Zelio*) are installed in them. These devices are responsible for:

- Programming the functioning time and the scrapers halt time;
- Equipment breakdown prevention system.

The concentration of floated sludge varies according to the floatation rate (which in turn varies according to the effluent characteristics), and to the functioning/waiting time of scrapers. See *item 6.9.2*.

Also in the *Zelio* command panel, it is possible to select if the scrapers will operate in the temporized or continuous mode.

It is necessary to grease scrapers every week, which is the responsibility of the business hours operator. It is also necessary to clean the beaches on a daily basis, to prevent the accumulation of sludge, and this activity is performed by the operator of the respective shift.

6.9.1. TURN ON/OFF SCRAPERS

- a) In the central command panel, rotate the handle of the scraper to be actuated to the "on" position;



Image 67 - Scraper emergency button

- b) In the field, near the scrapers engine, check if the emergency buttons are on or off. If they are on, rotate the button to unlock it. There is a button for each floatation module;

- c) Open the door of the *Zelio* command panel and check for failures. If yes, reset the equipment by pushing the first button on the left side of the equipment (arrow to the left);



Image 68 - Zelio command panel



Image 69 - Inside Zelio command panel

- If there is no movement in the scraper conveying belt, turn off and on the equipment. For that, turn off the circuit breaker appearing to the left in *Image 69*, and wait for 5 seconds until turn it on;
- If the system works again, observe if the failure occurs again, following the full cycle and, if the failure repeats, call the USEM team. Register in the occurrences book and in the Floatation Bulletin;

- If there is sludge accumulation because of lack of scraping, and it becomes too much consistent, change the position of the key, beneath the panel so that it works in the continuous mode. After normalizing the situation, get it back to the temporized mode, see the image below:

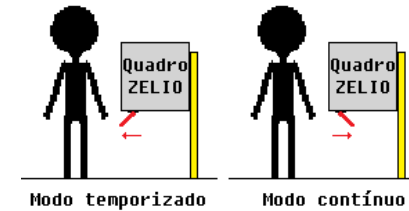

Image70 - Selection of the Zelio operation mode

Use the emergency button, or turn it off in the central command panel, when you notice that the scraper is:

- Misaligning the blades;
- With the sheaves getting out of the rails;
- Broken sheaves;
- Making clicks.
- Broken sheaves.

In such cases, inform the USEM team and register it in the Occurrences Book and in the Floatation Bulletin.

6.9.2. ADJUSTMENT OF THE SCRAPING TIME

Because of maintenance, the functioning time of floated sludge scrapers is fixed in 5 minutes, and the halt time might vary according to the operational need. The more the scrapers stay halt, the higher the floated sludge solids concentration will be, and vice-versa.

The halt time should be enough to produce sludge with consistence between 3 and 3.5% of total solids (TS), because:

- Floated sludge with high concentration (more than 3.5% TS): Overload the sludge scrapers, increasing the wear and tear, and causing the equipment breakdown.
- Floated sludge with low concentration (less than 3% TS): Generates an excessive floated sludge discharge, causing hydraulic overload in the compactor, expanding the sludge layer, and making the sludge coming out through the spillways in the compactor.

In order to facilitate the comprehension about the importance of producing sludge with the correct concentration of solids, we can observe the impacts caused in the sludge dewatering and inertization system, because when the compacted sludge has consistency:

- Smaller than 2% TS, the sludge centrifugation is impossible;
- 2 to 4% TS, centrifuged sludge with consistency below 17% TS is produced, an undesired situation;
- 4 to 7% TS, is the ideal situation for dewatering;
- Over 7% TS, centrifuged sludge with consistency higher than 21% TS is produced, and constantly, jamming the Helicoid fan guard.

In order to keep the sludge concentration at the specified range, in rainy days the waiting time of scrapers should be reduced, because the sludge production rate is smaller. In dry days, with the AFBR's effluent more concentrated, there is an increase in the sludge production rate, and then the halt time should be adjusted.

In order to check the solids contents, analyze the Total Solids, using an automatic scale for analyzing the dewatering solids in the lab, pursuant to the *IT/LAB/1146*. If the result is:

- More than 3.5% TS: Reduce the scraper halt time;
- Less than 3% TS: increase the scraper halt time.

Remembering that the scrapers functioning time should be always fixed in 5 minutes;

To change the scrapers functioning time:



Image 71 - Zelio Display

- Press MENU/OK (green button);
- Press the arrows \uparrow or \downarrow until finding the item *PARAMETER* that will be blinking in the display;
- In the *PARAMETER* position, press again MENU/OK (enter);
- Press the arrows \leftarrow or \rightarrow to select A or B, where:
 - A = scraper functioning time;
 - B = halt time.
- The functioning time (A) should be fixed in 5 minutes (upon USEM request);
- The halt time (B) varies according to the operational conditions. It should be enough to produce sludge with consistence between 3 and 3.5% of solids.
- Press the arrows \uparrow or \downarrow to reduce or increase the time;
- Once the time is adjusted, press the green button MENU/OK to complete the programming.

6.10. ANALYTICAL MONITORING OF THE FLOATATION SYSTEM

The laboratory analyses of the DAF system monitor the process, and guide operators in performing actions throughout the process, and the samples for such analyses should be collected in the following locations:

- Afbr Effluent
- Floater 01
- Floater 02
- Floater 03
- Floater 04
- Final Effluent

Analyses should follow the schedule proposed the Floatation Bulletin (*IA/OPE/1652*), the analyses times are described in such document, but follow the following pattern:

pH, temperature, turbidity and settleable solids	COD
0:00 am	
4:00 am	
8:00 am	0:00 am
12:00 am	8:00 am
4:00 pm	4:00 pm
8:00 pm	

6.10.1. MONITORING PARAMETERS

- a) pH
- Serves to define and monitor the coagulant dosing, pursuant to *Item 6.8.6*.

- In order to monitor the coagulation, the result of the AFBR Effluent Turbidity is also needed, to then calculate the *pH consumption range* between the effluent with and without the application of ferric chloride. This range might vary between 0.36 and 0.65, and the 0.65 range is for the effluent with higher turbidity.
 - It is a legal parameter, i.e. to discharge the Atuba Sul WWTP effluent into the river complying with the environmental legislation, the pH should be between 5 and 8;
 - The analysis is performed twice per shift in order to monitor the coagulant dosing;
 - The collection should also be done whenever the dosing should be adjusted;
 - Monitoring in regard to the legislation is done based on the composed sample.
- b) Temperature
- It influences the air saturation capacity, and this parameter is necessary to compose the history and to help in the theoretical estimate of the air saturation capacity in water;
 - Temperature is also a parameter related to the final effluent discharge pattern, and the limit temperature to discharge it into the river is 40°C.
 - For the composed collection, which will be sent to the central laboratory (Belém WWTP), take note of the temperature in the form coming with the samples. Take note of the temperature on the collection day in the Floatation Bulletin (*IA/OPE/1652*);
- c) Turbidity
- It serves to estimate the concentration of the AFBR effluent to be coagulated. The more turbid, the higher the dirt load is in the effluent. Based on this parameter, the pH consumption range is determined in order to determine the ferric chloride dosing;
 - The collection is done in the AFBR effluent to check the dosing, and in the Floater effluent to check the efficiency;
 - Turbidity is not a control parameter related to the legislation.
- d) COD (Chemical Oxygen Demand)
- The oxygen chemical demand estimates the total potential that a given pollutant has of consuming oxygen when discharged into the environment. COD is generally something around the double of the Biochemical Demand; The COD analysis serves to check the post-treatment pollutants capture yield.
 - COD is a legal parameter, and the COD discharge standard is determined by the National Agency of Water (ANA) and the Environmental Institute of Paraná (IAP);
 - The collection is:
 - Punctual: in the AFBR effluent and the Floater outlet. Verification performed by the floatation system operator, once at each shift beginning, with the aim of checking the floater performance;
 - Composed: to be sent to the central laboratory (Belém WWTP), according to the collection schedule.
- e) Settleable SOLIDS
- Checks the loss of sludge in the system. It is a standard parameter in regard to the final effluent discharge standard, and the maximum allowed value is 1 ml/L;
 - The collection is done in the AFBR effluent and the Floater outlet;
 - This analysis is also done based on the composed collection, at the central laboratory (Belém WWTP).

6.11. PROBLEMS AND SOLUTIONS

- **Depressurized air tank / compressors**
 - Flow meter does not show the discharge even opening the valves;
 - Pressure indicated in the manometer of the air tank is below 7 BAR;
 - Pneumatic sluices do not work.

- a) Check/turn on compressors: Compressors work in automatic mode, i.e.: they turn on/off according to the pressure.
- When there is a drop or oscillation in the power supply, compressors should be again turned on in the control panel located in the equipment itself.
 - In every shift beginning, compressors and compressed air tank pressure should be checked.
- b) Check valves: Check if there is any valve closed throughout the line.



Image 72 - Valves of the compressed air pipeline

- c) If there is power and the compressors do not work again, it will be necessary to:
- Turn off the chloride dosing;
 - Close the air regulating valve in the flow meter, in the air system panel;
 - Inform the occurrence to the USEM team;
 - Describe the problem and actions done in the Floatation Occurrences Book;
 - **Note:** The recirculation pump should be working, unless the problem continues for longer.
- **Failure in scrapers**
- a) Check whether the equipment is really on in the central command panel;
 - b) Check whether the emergency button is not actuated. If they it is on, rotate the button to unlock it;
 - c) Follow the steps in *Item 6.9.1.c*, i.e.: Open the door of the Zelio command panel and check for failures. If yes, reset the equipment by pushing the first button on the left side of the equipment (arrow to the left);
 - If there is no movement in the scraper conveying belt, turn off and on the equipment. For that, turn off the circuit breaker to the left, and wait for 5 seconds until turning it on again;
 - If the system works again, observe if the failure occurs again, following the full cycle and, if the failure repeats, call the USEM team. Register in the occurrences book and in the Floatation Bulletin;
 - d) If there is sludge accumulation because of lack of scraping, and it becomes too much consistent, change the position of the key, beneath the panel so that it works in the continuous mode. After normalizing the situation, get it back to the temporized mode,
- **Scraper beach full of sludge**
- a) Check whether the sludge pump is not off;
 - b) Check whether the electrodes are dirty, if yes, clean them;
 - c) Check whether there is excess discharge in the floaters inlet, this will raise the level inside flocculation tanks, and will make the water overflowing over the beach;
 - d) If there is the same problem with the sludge pump, call the USEM team;

- e) Write this down in the Floatation Occurrences Book.

- **Sludge pump does not turn off automatically**
 - a) Check the actuation buttons: on/off key, and emergency buttons;
 - b) Check whether the electrodes are dirty, if yes, clean them;
 - c) If after cleaning the system does not go back to work, then call the USEM team, and write this down in the Floatation Occurrences Book.
- **Automatic sluice, distributor of floaters flow is not working**
 - a) Check whether it is in the automatic position of the sluice panel, located near the bypass sluice;
 - b) Check whether there is communication between the supervisory system and the floatation. If not, inform the manager in order to request maintenance to the Instrumentation USEM team. In such case, operate floatation with discharge regulation in the manual mode;

Let's remember that the floatation bypass has the maximum capacity of 1000 L/s. Therefore, the discharge in the floaters should be calculated with the discharge received by the WWTP.
- **Coagulant is not dosed**
 - a) Check whether there is ferric chloride in the intermediary tank;
 - b) Check whether the inlet valve of the dosing pump is open, as well as the valves along the pipeline that extends until the application point;
 - c) Check whether the dosing pump is on;
 - d) Check whether the inverter is working;
 - e) Clean the inlet and outlet valves of the peristaltic pump;
 - f) Prime the pump;
 - g) If this does not work, call the USEM team;
 - h) Write it down in the Floatation Occurrences Book, and send an e-mail.
- **Pneumatic sluices do not respond to commands**
 - a) Check whether the pressure in the lung tank is above 6 BAR;
 - b) Check whether the air compressors are closed;
 - c) If there is pressure in the tank and sluices does not work, check whether the valves in the line near the air drier are closed, if yes, open them;
 - d) If the problem is not solved after performing the previous items, inform the USEM team;
 - e) Write it down in the Floatation Occurrences Book, and send an e-mail.
- **Compressors do not turn on**
 - a) Check the master switch;
 - b) Check whether the cutout fuse is actuated;
 - c) With no power in the distribution grid;
 - d) Inform the USEM team;
 - e) Write it down in the Floatation Occurrences Book, and send an e-mail.

DATA: ____/____/____

HORA	MOTIVOS DAS PARADAS
08:00	
09:00	
10:00	
11:00	
12:00	
13:00	
14:00	
15:00	
16:00	
17:00	
18:00	
19:00	
20:00	
21:00	
22:00	
23:00	

TRANSBORDO			NÍVEL DO RESERVIATÓRIO DE ÁGUA DA PRENSA (EXTRAVASANDO; MÉDIO; BAIXO)			
HORARIO	QUANT.	ROMANEJO	HORA	% SÓLIDOS CENTR.	% SÓLIDOS CALEADO	% CAL
			03:00			
			09:00			
			13:00			
			17:00			
			21:00			

03:00 = _____
IA/OPE/1527-002

Image 74 - IA/OPE/1527 back

The role of the Dewatering and Inertization System Operational Bulletin (IA/OPE/1527) is basically to:

- Gather information of the process and the equipment operation conditions;
- Manage the operation routine of the sludge dewatering system;
- Control the sludge production;
- Control the operation: Process conduction state, equipment under maintenance, equipment in use, operation discharge;
- Direct the process resumption in cases of halt, through the operation history;
- Control of products inventory;
- Provide data to the information systematization such as:
 - Average discharge;
 - Working hours per day;
 - Percentage of lime applied to the sludge;
 - Proportion of polymers used per the amount of dry matter produced;
 - Yield of the centrifuge per hour.

7.3. SLUDGE DESTINATION FLOWCHART

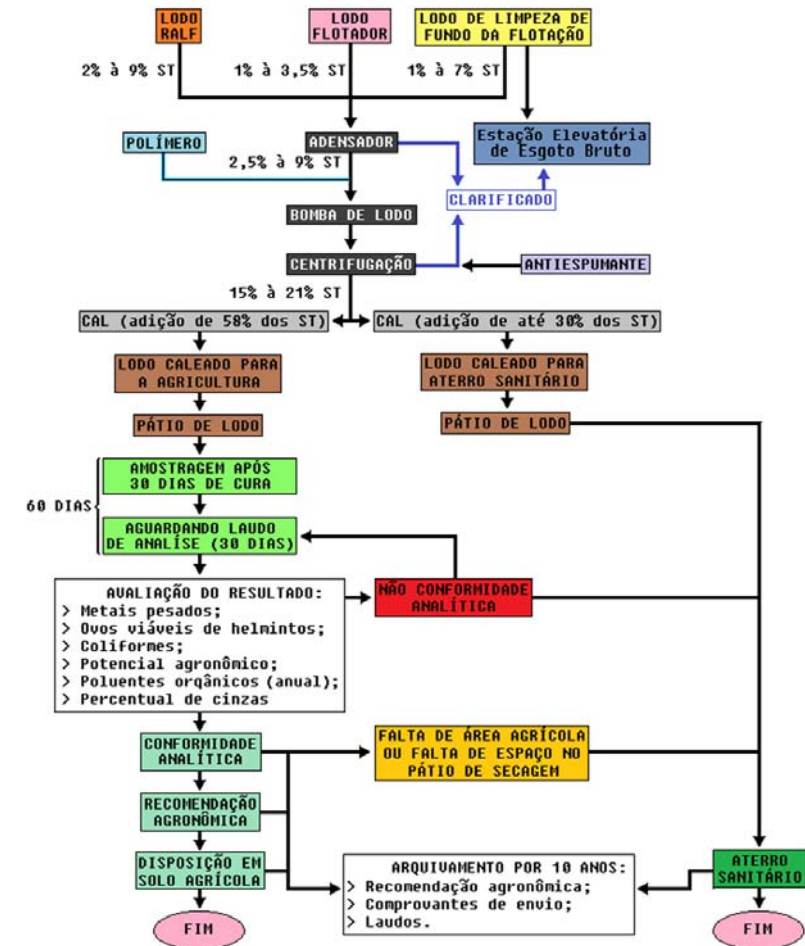

Image 75 - Sludge destination flowchart

and then a new sample is collected and sent to the outsourced laboratory, and if the sample is again not approved, the sludge is sent to the sanitary landfill.

It is common that in cultivating seasons there are no agricultural areas available to receive the sludge generated by the Atuba Sul WWTP. In such case, when there is no more space in the sludge drying yard, the production with reduced lime dosing should be done, to be subsequently sent to the sanitary landfill.

7.6. OPERATION OF THE SLUDGE DEWATERING AND INERTIZATION SYSTEM

7.6.1. HOW TO TURN ON THE SYSTEM

The operation of the dewatering and inertization system is summarized as follows:

- Search for prior information of the process by reading the Centrifuge Occurrences Book, and e-mails. Analysis of information of the Operational Bulletin (IA/OPE/1527);
- Turn on the air compressor, the air is used to prevent lime compacting inside the silo;
- Turn on the centrifuge;
- Make the checklist of valves, pipelines, and equipment;
- Turn on the sludge and polymer pump, and regulate their discharges;
- Turn on the antifoaming pump;
- Ten minutes after turning on the sludge pump, collect the compacted sludge sample to analyze the percentage of solids, pursuant to *Item 7.12.1*;
- Turn on the lime dosing system, regulate this dosing based on the history, and pay attention to any obstacle that should be registered in the Centrifuge Occurrences Book;
- Based on the analysis of the compacted sludge solids percentage, recalculate the sludge discharge;
- Readjust the polymer dosing;
- Fill the Operational Bulletin (IA/OPE/1527);
- At 00:00 pm of each day, the dewatering system operator should:
 - Read the hour counters;
 - Read the accumulated discharge;
 - Survey the inventory of chemicals;
 - Fill this information in the Operational Bulletin (IA/OPE/1527);

Através deste manual fica estabelecido que:

- A centrífuga 01 opera como principal, ficando a centrífuga 02 como equipamento reserva;
 - Sempre que possível utilizar os equipamentos correspondentes, ou seja, centrífuga 01 com bomba de lodo 01 e bomba polímero 01;
 - Utilizar os equipamentos de numeração 02 caso os de número 01 estejam em manutenção;
 - No Boletim Operacional, em caso de manutenção, anotar Ma01, Ma02, etc. no campo do referido equipamento;
- Toda segunda-feira, da 09:30 às 09:30 horas do dia seguinte, operar o sistema com os equipamentos reservas para evitar emperramento mecânico.
- Toda segunda-feira é realizado reposição de graxa na centrífuga e nos mancais das helicoidais. Aproveitar a abertura da tampa de proteção da centrífuga e limpar os resíduos de cloreto férrico, conforme *Item 7.13*.

7.6.2. STAGES OF THE PROCESS ACTUATION

The stages here described take into consideration that the system is off and starting the operation. The detailed instructions about the polymer, sludge and lime dosing and discharge are described in *Items 7.6.4, 7.6.5, and 7.6.6*.

7.6.2.1. TURN ON THE AIR COMPRESSOR



Image 78 - Actuation button of compressors



Image 79 - Air drier

- In the *Command Panel 01* in the operation room, turn on the *Air Compressor 01*.
 - In case of failure or maintenance of the *Compressor 01* turn on *Compressor 02* (reserve equipment), also in the *Command Panel 01*, changing the handle as indicated in the command panel itself;
 - Turn on the *Air Drier* by pushing the green button;
 - Check the air manometer in the compressor, the indicated pressure should be higher than 4 Kg/cm²;
 - If compressors do not turn on or the manometer indicates a pressure lower than 4 Kg/cm², then call the USEM (Unit of Electromechanical Service) maintenance service;
- Every Monday operate with the *Air Compressor 02* (reserve equipment), from 9:30 am to the 9:30 of the following day.

7.6.2.2. TURN ON THE CENTRIFUGE

- A. Polymer pump inverter;
- B. Indicator on/failure of polymer pump;
- C. Indicator off/failure of sludge pump;
- D. Indicator on/failure of centrifuged sludge thread;
- E. Sludge pump inverter;
- F. Buttons to change the sludge pump frequency;
- G. Local/remote selection of the polymer potentiometer;
- H. Compressors command;
- I. Indicator on/failure washing pump;
- J. Turn on/off washing pump;
- K. Turn on/off polymer pump;
- L. Turn on/off sludge pump;
- M. Turn on/off centrifuged sludge thread;
- N. Local potentiometer of the polymer pump.



Image 80 – Command panels I and II



Image 81 - Command panel III

- A. Indicator on/failure of the polymer mixer 01;
- B. Indicator on/failure of the polymer mixer 02;
- C. Indicator on/failure of the limed sludge thread;
- D. Turn on/off polymer mixer 01;
- E. Turn on/off polymer mixer 02;
- F. Turn on/off sludge/lime mixer (deactivated);
- G. Turn on/off limed sludge thread;
- H. Indicator on/failure of the lime thread;
- I. Indicator on/failure of the lime dispenser;
- J. Turn on/off lime;
- K. Turn on/off lime dispenser;
- L. Turn on/off lime agitator;

Centrifuge command panel

- A. General power switch
- B. Hour counter;
- C. Ihm Display;
- D. Alarm;
- E. Centrifuge on/off button;
- F. Reset
- G. Turn on/off sanitizing pump
- H. Emergency button.



Image 82 – Command panels IV and V

Turn on the centrifuge by pressing the green button at the panel door. *Command panel 04 for Centrifuge 01, and Command Panel 05 for Centrifuge 02;*

- a) If the centrifuge does not turn on:
 - Check the emergency buttons located in the *Command Panels 04 or 05*, and on the cages near the centrifuges. If they are blocked, unlock them by rotating them clockwise;
 - Check if there is any failure signaling or alarm in *Command Panels 04 or 05*. If yes, request maintenance to the USEM team.

While the centrifuge accelerates the rotation, make the checklist of maneuver valves in sludge and polymer pumps pipelines.

7.6.2.3. CHECKLIST OF VALVES, PIPELINES, AND EQUIPMENT

- a) Make sure that the valves of the sludge pump pipeline are open, there is valve just after the sludge pump, and another at the centrifuge inlet;



Image 83 - Sludge pipeline valve

- If the *Sludge Pump 02* is used to feed the *Centrifuge 01*, or vice-versa, it will be necessary to open the pipeline valve between the sludge pumps, and this open valve will make a communicating bridge between sludge pumps. When this maneuver is performed, close the valve at the centrifuge inlet that will not be in use, under the risk of causing the pipeline rupture.

- b) Make sure that the valves of the *polymer pump* to be used are with maneuver bypass to the sludge pump in operation;

- c) Check the valves before and after the *polymer pump* to be used;
- d) Make sure that the inlet valve of the *sludge pump* to be used is open, and the valve of the standby *sludge pump* is closed;
- e) Do not close the outlet valves of *sludge pump*. Such valves are only closed when the pump is removed for maintenance;
- f) Still while the centrifuge accelerates rotation, clean the spillway of the centrifuge sludge thread, and in order to that following the following steps: Turn on the *service water pump* and use a hose, with the *centrifuge sludge thread* off, clear the spillway that is near the centrifuge thread moto-reducer;
- g) Once the cleaning is done, Turn on the *Centrifuge Sludge Thread in the Command Panel 01/02*, according to the centrifuge in operation. Visually check in the field whether the equipment turned on;
- If there is a drop of the circuit breaker, call the USEM team.
- h) Wait until the centrifuge reaches the speed of 2970 RPM (check in the display of the *Command Panel 04/05*, according to the centrifuge in use), it takes approximately 10 minutes to reach such speed;
- i) Check the level of the antifoaming agent drum. Write it down in the Operational Bulletin (*IA/OPE/1527*). If it is below 5 cm, then change it. The empty drum should be placed upside down in a proper place to drip off the remaining antifoaming agent;
- j) Turn on the antifoaming agent pump;

7.6.2.4. TURN ON THE SLUDGE AND POLYMER PUMPS

- a) After the centrifuge reaches the rotation of 2970 RPM turn on the *Sludge Pump 01/02 in the Command Panel 01/02*;
- b) Soon after that, turn on the *Polymer Pump 01/02 in the Command Panel 01/02*;
- c) The two *Polymer Pumps* can be turned on at the same time if the polymer discharge needs to be supplemented;

Através deste manual fica estabelecido que:

- a) A centrífuga 01 opera como principal, ficando a centrífuga 02 como equipamento reserva;
- b) Sempre que possível utilizar os equipamentos correspondentes, ou seja, centrífuga 01 com bomba de lodo 01 e bomba polímero 01;
- c) Utilizar os equipamentos de numeração 02 caso os de número 01 estejam em manutenção;

7.6.2.5. REGULATING SLUDGE, POLYMER AND LIME DISCHARGE

Just remembering, the stages here described take into consideration that the system is off and starting the operation. The detailed instructions about the polymer, sludge and lime dosing and discharge are described in Items 7.6.4, 7.6.5, and 7.6.6.

- a) Soon after turning on the *sludge pump*, adjust its discharge according to the following instructions:
 - In the first minutes of operation, repeat the sludge discharge practiced in the last time of production according to the registration made in the Operational Bulletin. If the system is halted for more than one day, then start with the discharge of 9 m³/h, to then make adjustments after analyzing the percentage of solids of the compacted sludge;
- b) Soon after turning on the *Sludge Pump*, turn on the *Polymer Pump*
 - Likewise practiced with the sludge dosing, in the first minutes of operation, the dosing should be repeated according to the registration done in the Operational Bulletin. If the dewatering system is halted for more than two days, or if there is no polymer dosing history, start the dosing with discharge of 1200 L/h;

- c) Turn on the *Antifoaming Agent Pump*;



Image 84 - Antifoaming agent pump panel

- d) As soon as the sludge starts to drop into the *Centrifuged Sludge Thread*, start the lime dosing, see details in *Item 7.6.6*;
- e) In the *Command Panel 03* turn on: *Lime Silo Agitator, Lime Thread, and Lime Dispenser*;
 - At first, practice the lime dosing based on the last one, according to the Registration done in the Operational Bulletin. It is noteworthy that the maximum dosing is always search for, and if the registration of last dosing is lost, information about possible restrictions should be searched for in the *Centrifuge Occurrences Book*, and the *Dewatering Team Leader* guidance should be asked.
- f) Check the lime dosing variator near the lime silo. Check whether the dosing value is according to the proposed value;
- g) In the system of air injection into the lime silo, make a quick bypass of the solenoid valve and of the temporizer to promote air decompression. See *Item 7.6.6.2*;
- h) After 10 minutes of the system operation, collect a compacted sludge sample in the sludge pump inlet valve (20 mm valve). According to *Item 7.12.1*
- i) Analyze the total solids of the compacted sludge (*IT/LAB/1551*), this analysis will serve to define the sludge, polymer and lime discharges to be practiced;
- j) Adjust to the appropriate sludge, polymer and lime dosing;
- k) Take notes in all the fields of the Operational Bulletin (*IA/OPE/1527*) according to the time.
- l) Even if the dewatering and inertization system is halted, the operation bulletin should be filled.

7.6.3. TURN OFF THE SYSTEM

- a) Turn off the sludge and polymer pumps, keep the centrifuge on;
- b) Wait for one minute, and turn off the centrifuge sludge thread and the lime dosing;
- c) Clean the spillway of the centrifuge sludge thread, and in order to that following the following steps:
 - Turn on the *Utilities Water Pump* in the *Command Panel 01/03*, and use a hose;
 - With the centrifuge sludge thread off, clear the spillway that is near the centrifuge thread moto-reducer;
 - Turn on again the *Centrifuge Sludge Thread*.
- d) Open the valve at the junction of polymer preparation water pipelines with the polymer injection network, this valve is behind the polymer tanks. This procedure will interconnect the polymer

- preparation water with the polymer dosing network, and through this polymer dosing network, water will be injected in the sludge pump inlet being used;
- e) Close the inlet valve of the *sludge pump*. Do not close the outlet valve of the sludge pump, because this will break the pipeline.
 - f) Close the outlet valves of the polymer pump to prevent reflow to the polymer tanks;
 - g) Check whether the valves of the polymer injection line are open, allowing the washing water flow to the *sludge pump*;
 - h) Make sure that the water inlet valves in the polymer tanks are closed. Then, turn on the *utilities water pump* to be used in the *Command Panel 01/02*. Make sure that the water inlet valves in the polymer tanks, to dilute the polymer, are closed;
 - i) Soon after interconnecting the utilities water into the polymer networks, as above:
 - Turn on the sludge pump being used;
 - Regulate the sludge pump discharge to 5 m³/h.
 - j) Let the flow pass through the Centrifuge for 15 minutes, to wash it;
 - k) After these 15 minutes of washing, turn of the centrifuge by pressing the red button in the *Command Panel 04/05*. With the aim of washing the centrifuge drum with a different rotation (wash with the centrifuge slowing down). Keep the *utilities water pump* on, as well as the sludge pump;
 - l) When the drum rotation comes to a halt, turn on the centrifuge again, pushing the green button on the *Command Panel 04/05*, according to the centrifuge being used;
 - m) When the centrifuge reaches 1000 RPM, turn off the sludge pump and the utilities water;
 - n) Close the valve of the centrifuge washing water, at the junction with the polymer network;
 - o) Open the inlet valve of the sludge pump and the outlet valve of the polymer pump;
 - p) After one minute, turn off the centrifuge by pushing the red button in the *Command Panel 04/05*;
 - q) Turn off the centrifuge sludge thread, in the *Command Panel 01/02*, according to the centrifuge being used;
 - r) Turn off the limed sludge thread in the *Command Panel 03*;
 - s) Turn off the compressor being used in the *Command Panel 01*;
 - t) Make notes in the fields of the Operational Bulletin of the Dewatering and Inertization of Sludge (IA/OPE/1527);

7.6.4. DETERMINATION OF THE POLYMER DOSING

The sludge dewatering process in the centrifuge is considerably improved when polymer is added. At the Atuba Sul WWTP, the cationic high load polymer is applied after being diluted in water. This should follow this technical specification, but the polymer brand can vary according to the purchase bidding done by the Materials Service Unit (USMA).

The polymer is provided in 25-kg bags, and the product inventory is monthly replaced by USMA through a request via Sanepar computer system. The request is done by the administrative facilitator or by the WWTP manager in the beginning of the month through the ICL (Local Consumption Indicator) or when the polymer load via ICL shows to be insufficient, the request is done through the REM (Extra Materials Request). The request done through the ICL is delivered after scheduled, and in general takes place at the end of every month. When the request is done through the REM, the material has to be taken at the USMA. The scheduling of the amount to be delivered is done by this process leader, and is part of the monthly work scheduling.

The inventory count is done every day at 0:00 pm by the dewatering system operator. It should be taken note of in the Operational Bulletin (IA/OPE/1527);

7.6.4.1. PREPARATION OF THE POLYMER SOLUTION (DILUTION)



Image 85 - Polymer tank



Image 86 - Polymer inventory



Image 87 - Application point

The ideal concentration of polymer found after several tests performed at the Atuba Sul WWTP was 0.3% (12 kg of polymer for 4000 liters of water). In order to perform this dilution, follow these instructions:

- a) In the polymer inventory room, pick a polymer bag, and if the pack is not open, cut one of the edges with a scissors, and transfer the polymer from the bag into a determined bucket, taking care to prevent spilling it on the floor. Make this transference in a place specially defined for that, within the containment box. Transfer 12 kg of already graduated polymer to the bucket;
- b) After transferring it to the bucket, clean the floor with a broom;
- c) After weighting the polymer, climb the tank stairs and open the water valve of the tank to be filled;
- d) Turn on the *Utilities Water Pump* in the *Command Panel 01/03*;
- e) Fill approximately 75% of the tank, this should be done to prevent the agglutination of the polymer when poured into the tank;
- f) When the level reaches approximately 75% of the tank, turn on the mixer corresponding to the tank in the *Command Panel 03*, using the actuation handle to select the mixer. The green light will light up.
- g) Install the funnel in the polymer tank;
- h) Orient the funnel to the water jet, and slowly pour the polymer inside the funnel to dilute it.
- i) Once the polymer is diluted, fill the tank with water closely looking to prevent overflowing;
- j) With the tank full, turn off the utilities water pump;
- k) Close the utilities water valve located in the polymer tank;
- l) Sweep the polymer preparation floor and around it;
- m) Wash the floor, especially of the polymer weighting surrounding area. Eliminate any remains of polymer on the floor, because it becomes extremely slippery in contact with water, and can cause accidents;
- n) The polymer bag is not recyclable, and should be thrown away in the trash container that is taken to the sanitary landfill. Whenever the bag is emptied, the operator should throw it away in the trash container near the sludge compactor. Under no circumstances whatsoever, the bag might be left empty in the polymer preparation premises.

7.6.4.2. REGULATING THE POLYMER DOSING

INITIAL DOSING

- Make the checklist of the polymer pump inlet and outlet valves, as well as of the flow meters, in the injection line and at the inlet of the sludge pump being used. Do not dose the polymer at the outlet of the sludge pump, this valve should be closed.
- After turning on the centrifuge and its reaches the speed of 2970 RPM, turn on the sludge pump, and soon after turn on the polymer pump respective to the inlet of the sludge pump being used, i.e., if you are using the *Sludge Pump 01*, then use the *Polymer Pump 01*.
- In the first minutes of operation, the dosing should be repeated according to the registration done in the Operational Bulletin. If the dewatering system is halted for more than two days, or if there is no polymer dosing history, start the dosing with discharge of 1200 L/h;

- Cada bomba de polímero dosa: 1100 L/h quando se utiliza o conteúdo do *Tanque 01* e 900 L/h quando se utiliza o *Tanque 02*.

- Caso seja necessário maior vazão de polímero, por exemplo: 1400 L/h, ligar a *Bombas de Polímero 01 e 02* juntas;

- Como já citado no *Item 7.7.1*, a *Bomba de Polímero 01* irá operar como principal, ficando a *Bomba de Polímero 02* em espera como equipamento reserva, devendo ser ligada todas as segundas-feiras das 09:30 até as 09:30 do dia seguinte.

- Caso for utilizar a *Bomba de Lodo 02* para alimentar a *Centrífuga 01*, ou vice versa, será necessário abrir o registro da tubulação entre as bombas de lodo FOTO, este registro aberto fará uma ponte comunicante entre as bombas de lodo. Quando for feita esta manobra, fechar o registro de entrada da centrífuga que não estará em uso, sob o risco de ocasionar o rompimento da tubulação.



Image 88 - Detail of the command panel



Image 89 - Polymer flow meters

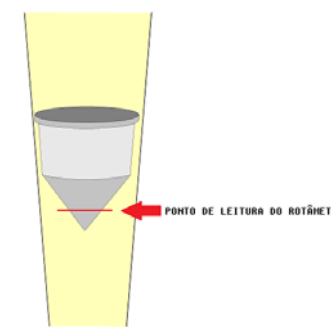

Image 90 - Instruction to read the flow meter



Image 91 - Polymer potentiometer

In the potentiometer, on the wall behind the *Polymer Tank 01*, regulate the discharge according to the instructions in *Item C*, the current discharge can be read in the flow meters.

MONITORING AND REGULATING

The procedure to monitor and regulate the polymer dosing is obligatorily performed in three situations during the dewatering process:

- In the beginning of the process, 10 minutes after turning on the sludge and polymer pumps;
- Whenever the tank level of polymer being used reaches half of its height;
- Whenever the polymer tank being used has to be changed.

In order to monitor, follow the following steps:

- a) Collect a sample of the “clarified” water from the centrifuge, and transfer it to a 100 ml beaker to observe the sample turbidity:
 - If it is excessively turbid or black, increase the polymer, wait for 05 minutes, and redo *Item a*;
 - When the centrifuge outlet liquid is clear, perform the fine test of the dose, and for that follow the steps described as follows.
- b) Put the “clarified” water in a 100 ml beaker.
- c) Using a stick, add a little diluted polymer from the tank being used.
- d) If when adding the polymer there is flocculation, it will be necessary to increase the polymer dose by 50 ml, wait for 05 minutes, and redo the test;
- e) If there is no reaction (flakes), there are two possibilities: the dose is correct or excessive.
- f) In order to check whether there is excess polymer, add to the clarified water a little sludge from the compactor with the help of a stick;
- g) Note: If there is flocculation, reduce the dose by 50 l/h, waiting for 05 minutes, and redo the test;
- h) If there is no coagulation, the dose is correct;

7.6.5. DETERMINATION OF THE COMPACTED SLUDGE DISCHARGE

In the first minutes of operation, repeat the sludge discharge practiced in the last production time according to the registration done in the Operational Bulletin (IA/OPE/1527). If the system is halted for more than one day, then start with the discharge of 9 m³/h.

After 10 minutes of the sludge pump operation, collect the compacted sludge as described in *Item 7.12.1*. This verification should also be done at 0:00, 4:00, 8:00, 12:00 am, and 4:00, 6:00 and 8:00 pm, as requested in the operational bulletin.

The times of 2:00, 6:00, 10:00 am, and 2:00, 6:00 and 10:00 pm are only to monitor the discharge already established in the analyses, in order to check whether there was oscillation in the discharge measurer, and if yes, to readjust the discharge according to the established one.

Variação da vazão de lodo e percentual de sólidos em relação à carga desaguada		
Vazão da bomba de lodo m ³ /hora	Percentual de sólidos do lodo adensado	Kg de Sólidos Totais/hora
18,05	2,5	440
15,04	3,0	440
12,89	3,5	440
11,27	4,0	440
10,02	4,5	440
9,02	5,0	440
8,19	5,5	440
7,52	6,0	440
6,94	6,5	440
6,44	7,0	440
6,01	7,5	440

Table 15 - Variation of the sludge discharge and solids percentage

The above table shows that if the compacted sludge is diluted, it will be necessary to increase the sludge pump discharge to keep the same dewatered load (Kg ST/hour).

$$ST = Total Solids = MS = Dry Matter$$

After defining how many kilos of lime per hour (*Item 3.7.7.6*), the following calculation should be done to obtain the sludge pump discharge to be used: $\frac{Lime\ dosing\ in\ Kg/hor}{TS\ of\ the\ compacted\ sludge}$

Multiply the obtained result by: *Sludge for Agriculture*: 0.167965 *Sludge for sanitary landfill*: 0.4454740 The multiplication result is the value of sludge discharge without the polymer discharge, then add the polymer, to that: Firstly, convert the polymer discharge from liters/hours to

$$m^3/hour: \frac{Discharge\ in\ liters/hour}{1000} = Discharge\ in\ m^3/hour. Then\ calculate: Sludge\ discharge\ in\ m^3/hour + Polymer\ discharge\ in\ m^3/hour = SLUDGE\ PUMP\ DISCHARGE$$

Through the frequency inverter of the sludge pump, adjust the discharge found in *item c*; To calculate the dewatered sludge volume in Kg MS/h:

$$\left(Sludge\ discharge\ in\ m^3/hours - Polymer\ discharge\ in\ m^3/hour \right) \times ST\ of\ compacted\ sludge = YY \times 9.76 = VOLUME\ OF\ DEWATERED\ SLUDGE\ IN\ KgST/hour$$

Where 9.76 is the value of the centrifuge efficiency (0.976) multiplied by 10 (to convert solids of percentage to Kg/m³).

- a) In order to obtain the value of lime percentage in the sludge, calculate the following:

$$\left(\frac{Lime\ dosing\ in\ Kg/hour}{Volume\ of\ dewatered\ sludge\ KgMS/hour} \right) \times 100 = Percentage\ of\ lime\ in\ sludge$$

The resulting percentage of lime in the sludge should be:

- 61% for agricultural use;
- 23% when the destination is the sanitary landfill.

Take note of the results in the Dewatering and Inertization Operational Bulletin (IA/OPE/1527).

7.6.5.1. MAINTENANCE OF THE SLUDGE PUMP

The maintenance of the sludge pump should be performed when one of the following situations occur:

- Discharge smaller than 8 m³/h with electrical frequency above 43 Hz;
- Discharge smaller than 9.5 m³/h with electrical frequency above 50 Hz;
- Pump does not turn on, presenting a current failure.

When the sludge pump presents the situation described above, do the following procedures:

- a) Check the actual functioning of the sludge pump:
 - Check if the pump actuation handle is turned on in the *Command Panel 01/03*;
 - Check in the field, near the pump, if:

- The pump inlet valve is not closed;
 - Behind the pump, if the shaft is actually rotating. If not, operate the system with the reserve pump. If the reserve pump is not available for use, call the USEM team, and warn the manager.
 - If this happens in no business hours, request the electromechanical maintenance shift, and warn the USEG alert team.
- b) Prime the sludge pump:
- With the sludge pump off, open the valve of the water pipeline located at the wall near the sludge pump;
 - Open the valve located at the pump inlet, located in the sludge pipeline, a 3/4' sphere valve. Wait until the air comes out, until water also comes out from this valve;
 - If water does not come out from the valve as above described, check:
 - If there is water in the water network;
 - If the valve is not clogged. If yes, remove the tow from the valve inlet using a wire;
- c) If the prime does not work, then abruptly increase the discharge in the sludge pump:
- In the *Command Panel 01/03* of the sludge pump, in the pump frequency inverter, put the maximum pump discharge (60 Hz) for some seconds, if it does not work, turn on another sludge pump at 60 Hz.
- d) If the pump is not starting, and in the *Machine Man Interface* of the frequency inverter the following message appear: "*current limit*":
- When there is a failure because of current limit, it is because the pump is overloaded, the pump amperage is above 8.5 A. Possibly because of stator obstruction due to dirty inverter ramp. Direct start should be done, eliminating the inverter. In such case, follow the procedure below:
 - Make the checklist of valves, pursuant to *Item 7.7.2.3*;
 - Prime the sludge pump;
 - In the *Command Panel 01/03*, according to the sludge pump being used, keep the on/off switch of the sludge pump in the manual position;
 - In the selecting key "*operation mode of the sludge pump*", in the lower left corner of the panel, change the handle to the central position, and let it in this position for 5 seconds, and the *Machine Man Interface* of the sludge pump inverter will turn off. After that, return the selection key to the "*Direct Start*" position;
 - Let the pump turned on for 15 seconds;
 - After these 15 seconds, return the key to the central position for 5 seconds, and then change it to the frequency inverter position.
- e) If the maneuvers described in this item does not solve the problem, it will be necessary to clean the sludge pump inlet pipeline, doing as follows:
- With the pump off, close the valve of the sludge pump inlet pipeline;
 - Wash the pump for 2 minutes, according to the centrifuge cleaning (*item 3.7.7.3*), if there is no pump start failure;
 - Close the network water, and open the primer valves of the pump for 30 seconds;
 - Turn off the sludge pump;
 - With the help of a current key, let the fittings loose;
 - The disassembling, as well as the consequent assembling of the pipeline, should be done with the help of the business hours operators, and at the end of the day or during the weekends, with the help of the operator of another shift.
 - Make the inspection and remove rough materials from the fittings curves;
 - After cleaning, remake the sludge pipeline installation, starting by the L-shaped pipeline. Tighten the fittings the less as possible (slight tight);
 - After tightening the fittings, open the network water to check whether there are leaks in such fittings; Tighten the fittings again if necessary;
 - Open the sludge inlet valve of the sludge pump;

- Make the primer of the sludge pump, according to item "A" of this procedure;
 - Once the primer is done, close the network water valve, and turn on the sludge pump.
 - Wash the floor of the place.
 - Write down this in the Centrifuge Occurrences Book and in the Operational Bulletin.
- f) Turn on the reserve pump
- If the above described actions do not solve the problem, turn on the reserve pump, and request maintenance to USEM. Note: Make the bypass maneuvers in the pipeline;
 - If the reserve pump is not available, call USEM team to replace the pump, and inform Atuba Sul WWTP management.

7.6.6. DETERMINATION OF LIME DOSING

Liming is a method of sludge chemical sanitization, adding lime to the sludge causes a sudden alkalization of the mean, raising the pH to values above 12, and releasing large amounts of ammonia, factors resulting in the destruction or inactivation of most of the pathogenic organisms present in the sludge. Depending on the sludge humidity, temperature can raise above 50°C with the liming process, increasing the process efficiency.

The percentage of lime to be added to the centrifuged sludge varies according to the lime specification, and the sludge final disposal. Such doses were defined according to studies performed by the APD (Research and Development Area).

Liming for agriculture:

- DOLOMITIC LIME: 58 kg of virgin lime for 100 kg of dry sludge matter, i.e. 58%;
- CALCICTIC LIME: 50 kg of virgin lime for 100 kg of dry sludge matter, i.e. 50%;

For agricultural use, the sludge still needs a curing period of 30 days after adding lime. After this period, samples are collected from the sludge for analyses at an outsourced laboratory, and this analysis checks whether pathogenic organisms were reduced. Collection is done every beginning of the month, and is the responsibility of the Atuba Sul WWTP laboratory chief.

At the Atuba Sul WWTP, dolomitic lime is used, therefore as already explained the dosing defined to use the dolomitic lime is 58%. At Atuba Sul WWTP, because of convention, the dosing used is 61%;

The lime request is done at USMA (Materials Service Unit), by the leader of the dewatering and inertization team.

Liming to dispose of in sanitary landfill:

When the sludge destination is the sanitary landfill, the lime dosing used is 23%, or according to the determination of the leaders of this process, also being possible to produce sludge with no lime.

7.6.6.1. REGULATING THE LIME DOSING

The load of solids of the sludge and lime mix should be enough to produce a 7m³ container at each 2.5 hours by using a centrifuge. This was the best performance obtained taking into consideration a safe production in regard to the capacity of conveying threads, without jamming the equipment.

Dewatering 410 kg of dray matter per hour, approximate 7m³ of "tart" is obtained at each 2.5 hours, therefore the regulating target should be 410 kg DM/h. As we dosed 60% of lime, then: $410 \times 0.6 = 246 \text{ Kg/h of lime}$

The lime dosing should be started with the discharge of 246 kg/h, however there is the risk of strangling the sludge flow, and jamming the limed sludge helicoid. If this happens, the lime dosing should be reduced to 227 kg/hour, if the problem remains, the dose should be reduced to 208 kg/hour and then successively: 189, 170, 151 kg/hour, until there is a safe flow. The calculation of the dewatered sludge (kilogram of dry matter per hour) is done based on the lime dosing. Thus, if there is variation in the lime dosing, the amount of dry matter produced per hour is also varied aiming to keep the percentage of 61% of lime for the agricultural sludge, and 23% for the sanitary landfill sludge. When the specification

the low dewatering performance is solved (problem at the helicoid, polymer pump, etc.), the lime dose should be reestablished to 246 kg/h, or to as high as possible. When it is necessary to work with a dewatering smaller than 410 kg DM/h, i.e. lime amount smaller than 246 kg/h, the reason for this discharge reduction should be written down in the Centrifuge Occurrences Book. This should be done every beginning of shift. When the low dosing problem is solved, this should be likewise written down in the Centrifuge Occurrences Book. **Practice of solids load regulation (kg DM/h), and lime dose (kg/h)**

medidor de vazão lodo (M ³ /H)	% Sólidos aden.	KG MS/H (matéria seca por hora)	DOSE DE CAL KGH	% DE CAL
00:00				
02:00				
04:00				
06:00				
08:00				
10:00				
12:00				
14:00				
16:00				
18:00				
20:00				
22:00				

Image 92 - Detail of the analyses filed of the Operational Bulletin

Start the sludge, polymer and lime dosing according to the last value recorded in the history of the operational bulletin, if the system has remained turned off for more than two days, the sludge discharge should start at 9 m³/h or lower if there is any strangling or restriction, and such information should be written down in the Centrifuge Occurrences Book.

Long process halts, for more than one day, cause a higher compaction of the sludge in the sludge compactor and consequently promotes higher contents of solids in the compacted sludge. Therefore, the observation of the quality and quantity of the tart should be intensified when starting the process in this situation to prevent overloading the centrifuge and the helicoids.

Does not register the initial discharge in the operational bulletin, before that the collection and analysis of the solids percentage in the compacted sludge should be done, for then calculating the discharge and writing down the information.

See in the Centrifuge Occurrences Book if there is any restriction in regard to the lime dosing, if not, keep the last dosing practiced.

If for any reason the dry matter load was defined as being smaller than 410 kg/hour, i.e. the lime dose smaller than 246 kg/h, the reason should be read in the occurrences bulletin, and repeat the justification of this.

In the operational bulleting, take note of the lime dose in the forth column of the spreadsheet shown in *Image 93*. In the field LIME %, the value recorded should always be 61% when producing agricultural sludge, and 23% when producing sludge for the landfill. If the values obtained are different from this determination, then there is possibly a calculation mistake, being necessary to check and recalculate.

See in the table which value (N) of the lime dosing results in the desired (close) amount.

Conversão de dosagem de cal	
Número no redutor	Kg/h
6,00	94
5,75	104
5,50	113
5,25	123
5,00	132
4,75	142
4,50	151
4,25	161
4,00	170
3,75	179
3,50	189
3,25	198
3,00	208
2,75	217
2,50	227
2,25	236
2,00	246
1,75	255
1,50	265
1,25	274
1,00	284
0,75	293
0,50	302
0,25	312
0	321

Table 16 - Conversion of the lime discharge



Image 93 - Lime reducer

7.6.6.2. LIME DISPENSER

Located in the lower part of the silo, the lime dispenser is composed of a moto-reducer, an helicoid, and a compressed air injection system.

The compressed air injection is important to improve the functioning and precision of the dispenser, it prevents compacting lime in the bottom of the silo, which causes the interruption of the dosing. The air injection system is composed of: air compressor, air drier, line filters, temporizer, and solenoid valve. In the beginning of each shift, a checklist should be done of these equipment functioning state:

- Check if the air drier is on;
- Check if there is air pressure in the manometer in the compressor, the indicated pressure should be higher than 4 Kg/cm²;
- Check if there is no obstruction in the air injection hose valves in the silo and dispenser, of blue color.
- If the compressor produced pressurized air, even being on for some minutes, and/or the solenoid valve does not actuate, request inspection to the USEM team, and describe the problem in the Centrifuge Occurrences Book.
- Check the lime dispenser, if the N value matches the pre-established value, do this in every shift beginning. If not, make the adjustment.
- The gauging and calibration of the dispenser are performed on a monthly basis, by the operator of business hours.
- Decompression of lime dispenser:
 - Make a bypass of the solenoid valve for some seconds, in order to promote air injection in large amounts, this serves to clear the air injection pipeline, breaking preferential paths inside the silo, and decompressing the lime inside the silo.

- This maneuver is performed by opening the parallel valve between the solenoid valve inlet and the outlet. The valve is beside the lime silo.
- The solenoid inlet valve is always open. This valve is only closed during maintenance in the solenoid valve and in the temporizer.

7.6.6.3. GAUGING AND CALIBRATION OF THE LIME DOSING

Every beginning of the month, the operator of the business hours gauges and calibrates the lime dispenser, and for that he follows the instructions and uses the bucket, stopwatch, and scale:

- a) With the lime dispenser and thread on, make collections for each N in the dispenser;
- b) Take note of each collection time;
- c) Weight the samples;
- d) Make a spreadsheet to obtain the hourly dose for each "N";
- e) Plot the dose in relation to the "N" in the graph;
- f) Make the correlation for linear graph (first degree equation), or obtain the equation from the graph, and the correlation index;
- g) If the correlation index is smaller than 95%, redo the collections and weighting;
- h) Gauge again and if there is still no correlation higher than 95%, then the mechanical dosing system is not working properly, inform the USEM team.
- i) Based on the equation, recalculate the dose for each "N";
- j) Make the dosing table;
- k) The dosing table is a SI (Support Instruction), then change the version in the normative system.
- l) Provide this SI in the dewatering system bulletin board;
- m) The dosing should be done based on this SI.

7.6.6.4. MAINTENANCE OF THE LIME DOSING PROCESS

Due to the discharge of the sludge removal from the bottom of the compactor to feed the centrifuge, there is a reduction of the compacted sludge solids concentration throughout the process. Thus, the sludge load should be constantly adjusted, according to the times defined in the operational bulletin (IA/OPE/1527) which are: 2:00, 6:00, 10:00 am, and 2:00, 6:00, and 10:00 pm.

Readjust the compacted sludge following the discharge adjustment procedure shown in *Item 7.6.5.*

a) Monitoring of the lime percentage based on solids

We can observe in the table and in the graph below, that the dry matter contents vary linearly according to the lime dosing. Due to this excellent correlation, the liming process control is promising when analyzing the centrifuged sludge and limed sludge solids in a short period of time. It is noteworthy that this is not appropriate to control the sludge in the year, because the dry matter increases because of the water evaporation process performed by the climate.

Percentual de cal	Dosagem de cal e variação da matéria seca				Média
	09/05/2013	18/12/2013	12/02/2014	28/04/2014	
	% MS	%MS	%MS	%MS	
0	18,35	26,01	18,42	17,60	20,10
28	23,44	31,77	23,44	22,96	25,40
38	25,26	33,83	25,24	24,78	27,28
48	27,08	35,89	27,03	26,61	29,15
58	28,90	37,95	28,82	28,25	30,98
68	30,72	40,01	30,61	29,84	32,80

MS = Matéria Seca = Sólidos Totais

Table 17 - Lime dosing and Dry Matter variation

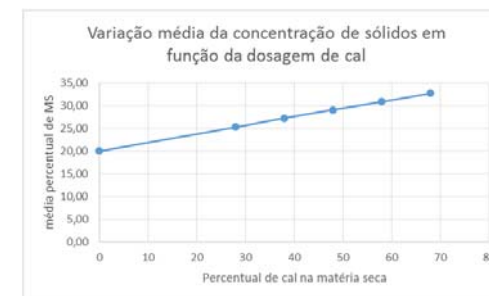

Graph 7 - Average variation of the solids concentration in function of the lime dosing

The ratio of the solids concentration increase is found by dividing the solids contents of the limed sludge by of the centrifuged sludge (with 0% of lime). Based on the values shown in the above table, in order to obtain 58% of lime, the ratio should be dosing

$$\frac{30,98}{20,09} = 1,54$$

Therefore, for closing the liming at 58% it is necessary to observe this 1.54 ratio between the solids of the lime sludge and of the sludge with no lime.

For the other doses, we check the following ratios:

Razão do acréscimo de sólidos pela adição de cal ao lodo			
% de Cal	Razão do lodo calado/centrifugado	% de Cal	Razão do lodo calado/centrifugado
1	-	60	1,56
20	1,18	61	1,57
21	1,19	62	1,575
22	1,20	63	1,585
23	1,21	64	1,59
24	1,22	65	1,59
25	1,23	66	1,61
26	1,24	67	1,62
27	1,25	68	1,63
28	1,26	69	1,64
29	1,27	70	1,65
30	1,28	71	1,66
31	1,29	72	1,67
32	1,30	73	1,68
33	1,31	74	1,69
34	1,316	75	1,70
35	1,325	76	1,71
36	1,33	77	1,715
37	1,34	78	1,72
38	1,35	79	1,73
39	1,36	80	1,74
40	1,37	81	1,75
41	1,38	82	1,76
42	1,39	83	1,77
43	1,40	84	1,78
44	1,41	85	1,79
45	1,42	86	1,80
46	1,43	87	1,81
47	1,44	88	1,82
48	1,445	89	1,83
49	1,455	90	1,84
50	1,46	91	1,845
51	1,47	92	1,85
52	1,48	93	1,86
53	1,49	94	1,87
54	1,50	95	1,88
55	1,51	96	1,89
56	1,52	97	1,90
57	1,53	98	1,91
58	1,54	99	1,92
59	1,55	100	1,93

Table 18 - Ratio of the solids addition by adding lime to the sludge

To interpret the result:

- **ABOVE 1.54:** excess lime, see lime dosing in the lime dispenser, whether "N" is adequate our if there was a reduction of the sludge discharge;
- **EQUAL TO 1.54:** liming percentage equal to 58% of lime, ideal situation;
- **BELOW 1.54:** sub-dosing of lime, i.e. the lime percentage is below 58%. See if there is obstruction in the lime dispense, or if "N" in the dispenser variator is according to the specification. Check if the air compressor is working.
- Register the problem occurred and the corrective actions in the Centrifuge Occurrences Book.

Collect samples and make analysis according to the time written on the back of the Operational Bulletin (IA/OPE/1527), take notes in this same table.

Collect sample of the limed sludge pursuant to Item 7.12.1, and the collection should necessarily be done in the outlet of the limed sludge thread, when dropping into the container, for the following reasons: work safety; better mix since the sludge/lime mixer is not use.

If there is no liming, it is not necessary to analyze the limed sludge.

7.7. IMPORTANT CALCULATIONS

PROPORTION OF THE DRY SLUDGE TO THE HUMID

$$\text{SLUDGE} \frac{\text{KgMs}}{\text{hour}} = \text{hourly sludge discharge} \times \text{sludge concentration then: } \frac{\text{m}^3}{\text{h}} \times \frac{\text{KgDM}}{\text{m}^3} \rightarrow \text{KgDM/hour}$$

Thus, we observe that the dewatered sludge load is the result of the multiplication of the sludge discharge by its concentration. The discharge measurer reads in the sludge discharge added to the polymer discharge in m³/h. As the analysis of the compacted sludge is done without considering the polymer dosing, then the polymer discharge should be discounted. This discharge is shown in the flow meter in L/h, in order to calculate the value in m³/h is needed,

$$\text{and for that: } \frac{\text{Discharge } \text{L/h}}{1000} = \text{Discharge } \text{m}^3/\text{h}$$

The concentration is the result of converting the solids percentage in kg/m³, to perform this conversion: 1000 liters equals 1 m³; The sludge density is 1030 kg/m³, in actual terms the value of 1000 kg/m³ is used; in order to calculate the solids percentage, this value is divided by 1000. Then, for 1% of solids: 1 kg of dry sludge – 100 kg of humid sludge. As density is 1.000 kg/m³: 100 kg = 0.1 m³. By replacing 100 kg of humid sludge by 0.1 m³, we have:

$$1\% \text{ of dry solids}$$

$$1 \text{ Kg of dry sludge} = 100 \text{ Kg of humid sludge}$$

1 Kg of dry sludge = 0.1 m³. Therefore, we have proportionally: 10 Kg of dry sludge = 1 m³

We conclude that in order to transform the percentage of Total Solids in Kg/m³, we just have to multiply the value of solids percentage by 10, however we should take into consideration the efficiency of solids capture in the centrifuge, which is 97.6%. Then, we actually multiply the percentage of Total Solids by 9.76 to obtain the value in Kg/m³.

7.7.1. LIME QUANTITY PER CONTAINER IN ORDER TO OBTAIN THE PERCENTAGE OF 58% OF DM

- To a full container, we consider the weight of 7000 Kg;
- If the Total Solids of the limed sludge are 26.78%, we have:

$$7000 \times 0.2678 = 1874 \text{ Kg of Dry Matter of the limed sludge} \text{ Therefore:}$$

$$\text{Dry sludge} + \text{lime at 58\%} = \text{DM of the limed sludge}$$

$$\text{Dry sludge} + 0.58 \times \text{Dry sludge} = 1874 \text{Kg}$$

$$\text{Dry sludge} (1 + 0,58) = 1874 \text{Kg}$$

$$\text{Dry sludge} \times 1.58 = 1874 \text{Kg}$$

$$\text{Dry sludge} = 1874 \div 1,58$$

$$\text{Dry sludge} = 1186 \text{Kg} \quad \text{Then:} \quad \text{Kg of limed sludge} - \text{Kg of dry} = \text{Kg of lime}$$

$$1874 \text{Kg} - 1186 = \text{Kg of lime}$$

$$\text{Kg of lime} = 688 \text{Kg for a } 7\text{m}^3 \text{ container with limed sludge at } 26.78\% \text{ of DM}$$

We should consider some variables caused by lime dosing error, by the container weight not being exactly 7000 Kg, among others. That is why there is an error margin of 15% for more or for less. Therefore, for the limed sludge with 26.78% of DM where we calculate 688 Kg of lime for a 7000 Kg container, considering the error margin, we find a minimum and maximum weight of 598 and 791 Kg, respectively.

Kg DE CAL PARA UMA CAÇAMBA DE 7 TONELADAS				
Percentual de ST do lodo centrifugado	Percentual de ST do lodo calado	Kg de cal por caçamba		
		mínimo	ideal	máximo
15	23,1	469	551	634
15,3	23,6	478	562	647
15,6	24,0	487	573	659
15,9	24,5	497	584	672
16,2	24,9	506	595	685
16,5	25,4	515	606	697
16,8	25,9	525	617	710
17,1	26,3	534	628	723
17,4	26,8	543	639	735
17,7	27,3	553	650	748
18,0	27,7	562	661	761
18,3	28,2	572	672	773
18,6	28,6	581	683	786
18,9	29,1	590	694	799
19,2	29,6	600	706	811
19,5	30,0	609	717	824
19,8	30,5	618	728	837
20,1	31,0	628	739	849
20,4	31,4	637	750	862

ton container

Table 19 - Kg of lime for a 7-

$$\text{LIME PERCENTAGE} \frac{\text{Kg of lime per hour}}{\text{Kg of dry matter}} \times 100 = \text{Percentage of lime}$$

The conversion factor for the sludge intended agriculture is 0.167965. In order to calculate the solids percentage, we also consider the following equation:

$$\text{Kg of dry matter} = \text{discharge} \times \text{concentration of compacted sludge}$$

Replacing the variables, we have:

$$\frac{\frac{\text{Kg of lime per hour}}{\text{sludge discharge} \times \text{concentration of compacted sludge}} \times 100 = \text{Percentual de cal}}{\frac{\text{Kg of lime per hour}}{\text{sludge discharge} \times \text{percentage of DM of the compacted sludge}} \times 9.76^*} = 61\%$$

* In order to convert the solids percentage into Kg/m³ multiply it by 10, but we actually use 9.76 that is the centrifuge efficiency value (97.6%).

$$\text{Discharge} = \frac{\text{Kg of lime per hour}}{0.61 \times 9.76 \times \text{percentage of solids of the compacted sludge}}$$

$$\text{Discharge} = \frac{\text{Kg of lime per hour}}{5.9535 \times \text{percentage of solids of the compacted sludge}} \quad \text{Discharge} = \frac{1}{5.9536} \times \text{discharge (m3/h)} =$$

1	x	kg / h lime	5.9536	%	% of compacted solids discharge (m3/h)
= 0.167966	x	kg / h lime			% de sólidos adensado

INACABADO!?

7.8. VERIFICATION OF THE SLUDGE LEVEL IN THE COMPACTOR

The verification should be obligatorily done every day at 8:00 am by the 6x4 shift operator of dewatering. This verification will determine the floaters functioning discharge.

As already described in *Item 6.2.3*, the sludge layer measurement should also be done in the following situations:

- If the floating system is halted because of excess sludge in the compactor, floating operators should measure the compactor in the beginning of their shifts.
- If dewatering is halted because of lack of sludge in the compactor, centrifuge operators should measure the compactor in the beginning of their shifts.
- Dewatering operator: If the dewatering system is halted because of lack of sludge, at each shift beginning.

7.8.1. MEASUREMENT WITH THE SLUDGE JUDGE

- a) Go to the sludge compactor near the footbridge opposed to the staircase;
- b) Introduces the measurement equipment enough to check the interface;
- c) Count on the sludge judge ruler how many marks of clarified matter appeared in the ruler. In the sludge judge, each ruler mark equals approximately 30 cm;
- d) Subtract the result found by 3 meters, which is the depth of the compactor at the brim;
- e) This difference is the sludge interface height in the compactor.
- f) Take note of the height found, in the field called "Height of the sludge layer in the Compactor" in the Operational Bulletin of the Sludge Dewatering and Inertization System (IA/OPE/1527).

7.8.2. MEASUREMENT WITH THE ELECTRONIC INTERFACE MEASURER

- a) Go to the sludge compactor near the footbridge opposed to the staircase;
- b) Regulate the equipment sensitivity to the smaller possible;
- c) Introduce the sensor stick until sounding a sound alarm;
- d) When the alarm sounds, count in the sensor ruler the meters presented in the device stick.
- e) Subtract the result found by 3 meters, which is the depth of the compactor at the brim;
- f) This difference is the sludge interface height in the compactor.
- g) Take note of the height found, in the field called "Height of the sludge layer in the Compactor" in the Operational Bulletin of the Sludge Dewatering and Inertization System (IA/OPE/1527).

7.9. VERIFICATION OF THE LEVEL OF THE UTILITIES WATER RESERVOIR



Image 94 - Hatchway of the utilities water well

The verification of the level of the utilities water reservoir is performed every day: 8:00 am, the information should be registered on the back of the Operational Bulletin (IA/OPE/1527).

In the reservoir, inside the dewatering equipment shed, open the hatchway at the feet of the utilities water pumps, and check the level situation:

- **Overflowing:** Nappe leveled with the spillway. Keep the rainwater drainage pump that is at the AFBR 16 wall on, even if there is overflow. If there is another power source, then turn it off.
- **Medium:** Nappe until approximately 30 cm from the spillway. This is the ideal situation, with no action necessary.
- **Low:** Nappe below 30 cm from the spillway. It should be verified if the rainwater drainage pump is properly working, if situations of vandalism or theft have occurred, and if there is another source of power, if it is working. Request the service from the USEM team, if applicable.

7.10. MONITORING OF THE LIME INVENTORY

It is performed on a daily basis by the leader of the sludge dewatering and inertization system team;

- Performed based on the lime dispenser hour counters, multiplied by the average hourly dosing, according to the "N" used in the lime dispenser variator. This is the daily consumption.
- The initial inventory, less the daily consumption, is the final inventory;
- Lime is requested by the administrative facilitator or by the manager of the WWTP, through the REM (Request for Extra Material).

7.10.1. RECEPTION OF LIME

- a) Before unloading, check the invoice and all the safety requirements, such as the truck conditions, PPE use, materials used to unload, etc.
- b) With the help of a bucket and a sampler, collect samples from all the truck unload compartments. Collect samples until obtaining a mass of more or less 5 Kg. Collect samples from the diagonals of the cross-section, in equidistant points on the vehicle load using the indicated samples, in the upper part of the load, and with at least 30 cm of depth;
- c) Before releasing the unload:
 - Check the conditions of the unloading hose;
 - Check if the lime dispenser sluice is not opened.
- d) Being ok, release the unload;

- e) Transfer all the fractions of the collected sample to the same recipient and homogenize;
- f) Divide the sample after homogenized into two fractions of 200g (proof and counterproof), and put the two fractions into proper collection packages (plastic);
- g) Identify the samples pursuant to *IA/MAT/0003 (Identification Labels and Situation of Chemical Products)*;
- h) Stamp the invoice in the upper left corner of the back and sign;
- i) Send the samples and the invoice to the Atuba Sul WWTP Laboratory every Friday, via motoboy, to the Chemicals Quality Control Laboratory, acting as stipulated in the *IT/MAT/0019*.

7.11. MONITORING OF THE POLYMER INVENTORY

Performed by the operator of the dewatering 6X4 scale, daily at 0:00 am, as follows:

- Count the number of woven sacks layers according to the stacking scheme shown in the figure below;

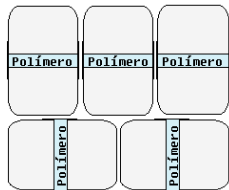

Image 95 - Example of the polymer inventory organization

- In the stacking, each layer inverts the illustrated scheme shown beside;
- Each layer should have 05 sacks;
- If it is not in this standard stacking format, it should be stacked as in the model showed beside;
- Multiply the number of layer by 05, and then by the weight of each sack (25 kg);
- Open sack should be estimated according to the amount being above or below half the sack.

- The counting is performed at 0:00 am, and this is the closing of the final polymer inventory. The difference between the initial and final inventory is the daily consumption of polymer. Take note of the result in the operational bulletin (*IA/OPE/1527*);
- Starting the following page of the bulletin, at 0:00 am, the result is the initial inventory.

7.11.1. RECEPTION OF POLYMER

- a) In the case of polymer, lots coming from the Materials Management Service Unit – USMA, i.e. from SANEPAR itself, do not need to be sampled, because they were already analyzed, and when issued by that area, are already in conditions approved for use.
- b) The centrifuge 6x4 scale operation is responsible for monitoring the unload, and should provide guidance so that the polymer sacks are stacked up, in such a way to allow the stability of the stack, as well as to allow counting the inventory afterwards. For such a purpose, the polymer sacks should be woven, each layer, pursuant to *Item 7.11*.
- c) According to the above scheme, each new layer of polymer sacks should invert the drawing to provide the stack with stability, forming a kind of braid, which facilitates counting the inventory afterwards.

7.11.2. CLEANING OF THE POLYMER SOLUTION PREPARATION AREA

- After the whole polymer preparation, the (polymer) deposit surrounding, as well as the way until the dilution tank, should be washed.
 - When changing shifts, the floors should be sludge-free.
- Use the *Utilities Water Pump 1/2*, which will be turned on in the *Command Panel 1/3*. To do that:
- Turn on the *Utilities Water Pump* to be used in the respective command panel;
 - Open the hose tap that is near the press screens washing pump.

7.12. COLLECTION AND ANALYSIS OF SAMPLES

7.12.1. ANALYSIS OF TOTAL SOLIDS

The analysis of total solids should be done on a daily basis according to the times set in the *Operational Bulletin (IA/OPE/1527)*.

The samples that should be collected are as follows:

- Compacted Sludge;
- Centrifuged Sludge;
- Limed Sludge;
- Clarified Matter.

A simple sampling should be performed, and is expressly forbidden to collect in the following points, because of work safety and homogenization:

- In the helicoids: of limed sludge and centrifuged sludge;
- In the centrifuge outlet fume hood.

a) Collection of compacted sludge

The percentage of total solids of the compacted sludge is the parameter of the centrifuge operation for dosing lime and for calculating the flow of solids do be practiced in the dewatering process.

- The collection is done without adding polymer, at the inlet of the compacted sludge pump.
- Collections are performed 10 minutes after starting the sludge dewatering process, besides the times defined in the *Operational Bulletin (IA/OPE/1527)*;
- In order to collect, follow the sequence below:
 - Turn off the polymer, and wait for 10 seconds;
 - Turn off the sludge pump, and go immediately to the collection valve at the inlet of the sludge pump;
 - Open the valve, and collect 100 ml of sample, and thrown it away;
 - Collect again another 100 ml of sample;
 - Turn on the sludge and polymer pumps again;

b) Collection of centrifuged sludge

The percentage of total solids of the centrifuged sludge is the parameter to check the dewatering yield of the centrifuge, and to gauge the lime dosing.

- The collection is done at the fume hood near the end of the limed sludge helicoid. Open the vertical door of such fume hood, through the wing nut.

For safety, it is strictly forbidden to:

- Collect at the fume hood of the Centrifuge;
- Collect at the sludge drop of the fume hood for the limed sludge helicoid.

c) Collection of limed sludge

The percentage of total solids of the limed sludge is parameter to check the lime dosing.

- The collection is done at the outlet of the limed sludge thread, when the sludge falls into the containers, using a shovel.

For safety and for the fact that there is not time to homogenize the sample, never collect samples at the helicoid of the limed sludge.

d) Collection of the centrifuge clarified matter

The analysis of the centrifuge clarified matter serves to estimate the equipment loss of solids, as well as the sludge capture efficiency.

- After regulating the centrifuge, collect the sample at the outlet of the clarified matter;

7.12.2. OPERATION OF THE SARTORYUS AUTOMATIC SCALE

- a) Turn on the scale in the plug socket;



Image 96

- b) Push the on/off button;



Image 97

- c) Open the scale lid;

- d) Check whether the temperature is 105°C in the display.
 e) If this configuration is not shown, change parameters through the selection key until entering PRG. Push Enter, change the programs through the selection keys, then press Enter until returning to the main menu.



Image 98 - Scale display

- f) After turning on the scale, put the aluminum capsule, wait until stabilizing, and press Enter to fix the capsule weight.
 g) The icon to insert the sample will appear, remove the capsule from the scale, and put between 2 and 5 grams of the sample spreading them well in the capsule;
 h) Put the aluminum capsule with the sample again;
 i) Close the scale lid, the measurement will start automatically;
 j) The result will automatically appear after 20 or 30 minutes, according to the air humidity. Wait until END appears, the presented value is the result of solids. In the display, besides the value the "%S" icon should also appear;
 k) If the icon "%M" (% of humidity) appear in the display, it will be necessary to do the following calculation to obtain the percentage of solids:

$$\%S = \%M - 100$$

 l) If the "S/M" icon appear, this means the Solids/Humidity relation, it should be changed to "S".
 m) If the result is not appearing in % of Solids (S%), then go to PRG (PRG appears in the scale display), and leave it in S.
 n) For further details, check the equipment manual: Manual Sartorius Moisture Analyzer – MA35 – available at >> http://www.sartorius.es/fileadmin/fm-dam/sartorius_media/Lab-Products-and-Services/Lab-Weighing/Moisture-Analyzer/Manuals/MAN-MA35-s.pdf << or in the locker of the centrifuge Laboratory.

7.12.3. COLLECTION OF CURED SLUDGE TO BE SENT TO THE LABORATORY

This collection is performed every beginning of the month, and is the responsibility of the laboratory technician. Procedure:

- Check which lot has already gone through the 30-day curing period in the sludge yard;
- Check which parameter and company is contracted with the person responsible for the analytical contract in the GATI.
- Fill out the collection form;
- Schedule the delivery and removal of the sample with the outsourced laboratory. The deadline cannot exceed 24 hours;

- Locate the lot in the sketch;
- For being a collection for microbiological analysis, it should be done with the profile collector and clean buckets, new gloves. Collect at least 15 samples in the profile, zigzagging the ridge;
- In the laboratory, homogenize the sample, and remove two 1-kg samples (proof and counterproof). Put them in a transparent plastic bag, fold the edges and staple them. Put them in another plastic bag, together with the collection form filled out. Take another 1-kg sample;
- Put it in a thermal box with ice;
- Two collection forms are filled out and serve as document of delivery, control, and archiving, one of them is the receipt that should stay at WWTP after getting the signature in the removal/delivery moment. If there are two laboratories, there will be 4 forms.
- Wash the bucket and the profile collector.

7.13. REGULATING THE CENTRIFUGE PARAMETERS

In the liquid-solid separation performed by the centrifuge, the optimization of each product operation and the concerned process should be performed pursuing the balance between the following:

- Low contents of solid substance in the clarified matter – liquid phase (high capture of sediment);
- Low contents of liquid in the centrifuged solid (high concentration of solids).

Such process requirements can be influenced by the operational parameters of the machine, as well as by the process parameters, as indicated in Table 23.

The possibility of separating liquid-solid is also conditioned by the formation of the solid layer in the space between the drum and the thread. For several products and some operations with solid substances, but granulometrically very fine, this layer might be difficult to form. If this happens, there should be an intervention, replacing one product by another during a short period of the machine initial functioning, if possible the same type of product, but with bigger grains.

In general, the layer so formed inside the drum becomes consistent and stable, even after the machine washing operations.

Along with the centrifuge decanter, a series of combs is provided, which allows to vary the liquid level inside the drum. This regulating depends on the type of product to be treated, and the results intended to reach.

In order to vary the drum speed and the drum-thread differential speed, the USEM asks for FAST Technical Assistance.

AÇÕES PARA MELHORAR A PERFORMANCE DA CENTRIFUGA						
AÇÃO	Velocidade do Tambor	Velocidade diferencial tambor/rosca	Avanço tubo de entrada de lodo	Altura do pente	Vazão de lodo	Adição de polímero
Diminuir a turbidez do clarificado	Aumentar	Diminuir	Aumentar	Diminuir	Diminuir	Aumentar
Maior teor de sólidos na torta (aumentando o lodo seco)	Aumentar	Diminuir	Diminuir	Aumentar	Aumentar	Aumentar

Table 20 - Table of actions

7.13.1. REGULATING THE COMB HEIGHT AND CLEANING

Every maintenance, incrustation cleaning, and regulation should be done with the machine turned off.

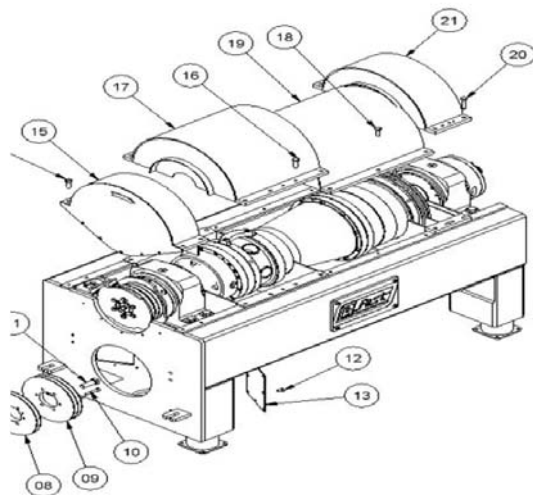

20 - parafuso
21 - carcaça superior do líquido

Image 99 - Centrifuge layout

The clarified matter outlet spillway is in portion 21, removing the carcass 21 (lid), through the screws 20.

Removing the lid, it is possible to observe the sluices, as shown in the drawing below.

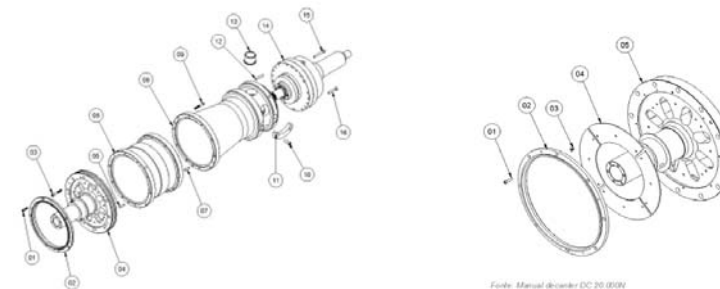

04 - ponteira do clarificado - na lateral os orifícios de saída de clarificado
Image 100

05 - ponteira do clarificado
04 - pontes de ajustes (comportinhas)
Image 101

7.13.2. CLEANING OF ADJUSTMENT COMBS

Due to splash of chemical sludge (remains of ferric chloride), incrustation of sludge/ferric oxide is formed in the regulation combs, and this incrustation dams the outlet of the clarified matter, harming the tart drying.

Every Monday, during the disassembling for greasing (done by USEM), the crusts should be cleaned out. Use an spatula to remove crusts.

7.13.3. CLEANING OF THE CLARIFIED MATTER POINTER COUPLING

Clean the coupling of the clarified matter pointer every Monday, during the disassembling for greasing done by the USEM.

In this place, there is an accumulation of wastes, making difficult to move the drum, see *Drum blocked when manually actuated in Item 7.14.*

7.13.4. REGULATION OF THE COMB HEIGHT

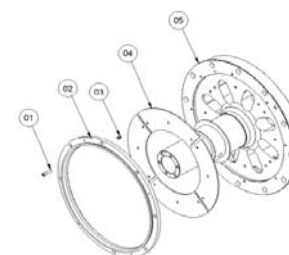

Fonte: Manual decanter DC 20 000N

05 - ponteira do clarificado
04 - pontes de ajustes (comportinhas)

Image 102

Disassembling:

- Remove the protection lid of the liquid pointer;
- Unscrew the combs support ring (02);
- Unscrew the regulating combs (04).

Assembling:

- After cleaning the flat surfaces and the threads, assemble it reversely;
- The regulating combs should all have the same internal diameter.

7.14. CENTRIFUGATION VERIFICATION AND FOLLOW UP

Source: Manual Decanter DC 20.000 N. For further details, refer to the maker's manual.

- a) Drum blocked when manually actuated:
 - Main bearings jammed: replace bearings by original parts;
 - Existence of incrustations between the carcass and the drum: wash and drain inside the machine.
- b) Drum-thread set clogged, causes:
 - Excessive discharge in feeding;
 - Low differential speed between drum-thread;
 - Excessive contents of solid substances in the feeding fluid;
 - Loosen belts.

Perform the following operations:

- Inject hot water into the drum, through the feeding tube;
- Remove the belts;
- Move the pulley manually, grabbing the reducer;
- Check if the thread is free through the dehydrated matter discharge holes;
- If the thread is free, rotate the pulley one time;
- Turn on and off the main engine 2-3 times briefly;
- Check whether the thread discharges the solids in the drum;
- If it is not possible to release the thread manually, disassemble it, asking if necessary the help of FAST Technical Assistance.

Attention: do not try to release the drum by disassembling the safety device and forcing the inlet shaft in the reducer. This can seriously harm the reducer.

- c) Machine with vibrations
 - A limited vibration usually occurs during the start and stop phases, due to the critical speed: no procedure needed;
 - Wear and tear of the drum and thread bearings: identify the worn out bearings and replaced them by original parts;
 - Unbalancing of rotating parts, because of:
 - Loss of elasticity of broken rubber vibration isolators: replace them;
 - Imperfect cleaning inside the rotor: clean again;
 - Wrong assemblage, damaged rotor parts, wear and tear, and holes in the thread: Check which part of the machine was wrongly assembled, and make corrections. Otherwise, as for FAST Technical Assistance.
- d) Noise in transmission parts
 - Bearings: replace them by original parts;
 - Reducer: wear and tear of gears and bearings, and presence of metallic waste in the lubricant oil. Ask for FAST Technical Assistance;
 - Worn out or loosen belts: control the tension or replace them.
- e) Rotor speed excessively low and/or start time excessively slow
 - Low voltage in the power grid or nominal voltage of the grid below the motor voltage: check the voltages and correct the defects;
 - Defective motor: fix or replace it.
- f) Excessive absorption of electric energy in the main engine
 - Dirt or partial clogging between the drum and the carcass: wash and drain inside the carcass.
- g) Too sudden start
 - Inverter parameters not programmed – Reprogram correct values in the inverter.
- h) The solid sediment does not splic
 - Improper regulating comb: replace by another with convenient diameter;

- Worn out thread: check the radial drum-thread clearance (normal clearance 1.3 mm). Ask for FAST Technical Assistance;
- There is no formation of solid layer inside the drum in the space between the drum and the thread: act on the drum and thread variables, and in the liquid layer inside the drum. Ask for FAST Technical Assistance.

7.15. SERVICES SCHEDULING

Programação dos Serviços				
O que?	Quem?	Quando?	Como?	Porque?
Avaliação do andamento do processo	Operador da escala 6x4 da centrífuga	Início de turno/processo	Leitura e análise de e-mail e Livro de Ocorrências	Gerenciamento da rotina de trabalho
Nível do lodo do adensador	Operador da escala 6x4 da centrífuga	Diariamente, às 08:00 horas		Determinar a vazão de operação dos flotas e necessidade de descartar lodo dos RALF's
Ligar centrífuga	Operador da escala 6x4 da centrífuga	Início do processo		Reduzir o volume e preparar o lodo para o destino final
Check-List dos registros da tubulação de lodo	Operador da escala 6x4 da centrífuga	Início do processo		Impedir rompimento da tubulação e consequente parada do processo
Ligar/verificar compressores e secador de ar	Operador da escala 6x4 da centrífuga	Início de turno		Impedir interrupção da caleação
Check-List da dosagem de cal	Operador da escala 6x4 da centrífuga	Início de turno		Impedir interrupção da caleação
By-Pass do injetor de ar no dosador de cal	Operador da escala 6x4 da centrífuga	Início de turno		Impedir interrupção da caleação
Ligar as bombas de lodo e polímero	Operador da escala 6x4 da centrífuga	Início do processo		Iniciar o processo
Verificar nível de antiespumante na bombona	Operador da escala 6x4 da centrífuga	Início do turno		Impedir transbordamento de espuma
Ligar dosadora de antiespumante	Operador da escala 6x4 da centrífuga	Início do processo		Impedir transbordamento de espuma
Ajuste da vazão e caleação do lodo	Operador da escala 6x4 da centrífuga	Várias vezes durante o turno		Reduzir parasitas e eliminar agente catagénicos do lodo
Preparo, aferição e dosagem de polímero	Operador da escala 6x4 da centrífuga	Várias vezes durante o turno		Melhorar a eficiência do desaguamento e reduzir a espuma no efluente da centrífuga
Coleta de lodo adensado e análise de sólidos	Operador da escala 6x4 da centrífuga	Várias vezes durante o turno		Ajuste da carga desaguada e percentual da cal
Coleta de lodo centrifugado e análise de sólidos	Operador da escala 6x4 da centrífuga	Várias vezes durante o turno		Verificação da dosagem de cal e performance da centrífuga
Coleta de lodo caído e análise de sólidos	Operador da escala 6x4 da centrífuga	Várias vezes durante o turno		Verificação da dosagem de cal e performance da centrífuga
Verificação do nível de água na sistema	Operador da escala 6x4 da centrífuga	Diariamente, às 08:30 horas		Água usada para preparo de polímero e lavagem do galpão. Caso não haja água não é possível operar a desaguadora.
Manutenção de vazão da bomba de lodo	Operador da escala 6x4 da centrífuga com auxílio do op. Comercial ou op. Flotador.	Determinação e verificação de vazão: horário; Esconer: diária; limpeza: quando necessário conforme procedimento operacional.		Manter o regime de funcionamento
Descarte de lodo do RALF	Operador da escala 6x4 da centrífuga	Manta de lodo no adensador estiver menor que 1 metro		Dar continuidade no processo de desaguamento
Troca de caçamba	Operador da escala 6x4 da centrífuga	Completar 7m³ de lodo caído ou 6m³ de lodo sem cal		Evitar transbordamento
Análise de sólidos totais do adensado, centrifugado, caído e clarificado	Operador da escala 6x4 da centrífuga	Conforme horário estabelecido no Boletim Operacional		Controle analítico do processo
Levantamento do estoque de cal	Lider da equipe do sistema de desaguamento	Diariamente, às 08:30 horas		Controle de desempenho, consumo e peddo
Levantamento do estoque de polímero	Operador da escala 6x4 da centrífuga	Diariamente, às 00:00 horas		Controle do desempenho, consumo e peddo
Recebimento de cal virgem	Operador da escala 6x4 da centrífuga	Entre 07:00 e 19:00 horas		Orientação de descarga, coleta de amostra, carimbo de nota fiscal e encaminhamento para o laboratório
Recebimento de polímero	Operador da escala 6x4 da centrífuga	Entre 07:00 e 19:00 horas		Ajuda e orientar a carga e descarga
Limpeza do entorno da área do polímero e do galpão	Operador da escala 6x4 da centrífuga	Após preparar polímero e ao final do turno		Manutenção e higiene do galpão e prevenção de acidentes
Registro de horímetros	Operador da escala 6x4 da centrífuga	Diariamente, às 00:00 horas		Rendimento e acompanhamento dos equipamentos
Preenchimento do Boletim Operacional	Operador da escala 6x4 da centrífuga	Várias vezes durante o turno		Informação para a troca de turno e gerenciamento da rotina de trabalho

Table 21 - Daily scheduling of centrifuge services

Programação Semanal				
O que?	Quem?	Quando?	Como?	Porque?
Engraxar centrífuga	USEM	Todas as segundas-feiras, pela manhã	De acordo com o manual do equipamento.	Manutenção preventiva
Engraxar mancais da helicoidal transportadora de cal	USEM	Todas as segundas-feiras, pela manhã	De acordo com o manual do equipamento.	Manutenção preventiva
Limpeza do extravisor do clarificado da centrífuga	Operador da escala 6x4 da centrífuga	Todas as segundas-feiras, pela manhã		Limpeza dos resíduos gerados pelo Cloreto Férrico que emperram a comporta comprometendo a performance da centrífuga.
Limpeza do acoplamento do tambor com a carcaça da centrífuga	Operador da escala 6x4 da centrífuga	Todas as segundas-feiras, pela manhã		Limpeza dos resíduos gerados pelo Cloreto Férrico que podem impedir a partida da centrífuga
Preenchimento das planilhas do boletim operacional - produção de lodo	Líder da equipe do sistema de desaguamento	Todas as segundas-feiras	Digitação de dados em planilha	Sistematização de informação
Preenchimento das planilhas do boletim operacional - motivo das paradas	Líder da equipe do sistema de desaguamento	Todas as segundas-feiras	Digitação de dados em planilha	Sistematização de informação
Solicitação de mistura de lodo no páteo, acompanhamento da formação de lotes	Líder da equipe do sistema de desaguamento	Todas as quartas-feiras	Solicitação e acompanhamento de serviço terceirizado	Otimizar a estocagem
Complementação da aplicação de cal	Líder da equipe do sistema de desaguamento	Todas as quartas-feiras	Solicitação de carga extra de cal	Evitar reprovação de lotes nos testes laboratoriais
Programar trambordo das caçambas de lodo aos domingos	Operador da escala 6x4 da centrífuga	Todas as sextas-feiras, pela tarde	Verificar possibilidade com o pessoal da ETE Belém, caso não seja possível verificar com o GATI (Luiz)	Evitar a parada do processo

Table 22 - Weekly scheduling of centrifuge services

Programação Mensal				
O que?	Quem?	Quando?	Como?	Porque?
Coleta de amostra de lodo caledado, passado 30 dias de cura no páteo, para envio para análise	Laboratorista	Até o dia 10 de cada mês	Com coletor de perfil, amostra feita em 15 pontos diferentes no páteo de lodo	Análise de caracterização do lote
Solicitação de retirada de lodo	Líder da equipe do sistema de desaguamento	Até o dia 10 de cada mês	Solicitação via e-mail para o GATI	Evitar parada do processo por falta de espaço no páteo de lodo
Elaboração do Croqui de localização dos lotes de lodo	Líder da equipe do sistema de desaguamento	Até o dia 10 de cada mês	Elaboração por computador	Localização e organização dos lotes
Anexação dos romaneios, fechamentos de envio de lodo e arquivamento de documentos	Líder da equipe do sistema de desaguamento	Entre os dias 20 e 30 de cada mês	Serviço administrativo	Documentação do processo
Levantamento da situação dos arquivos e documentos de análise e envio de lodo	Líder da equipe do sistema de desaguamento	Entre os dias 20 e 30 de cada mês	Elaboração de relatório	Documentação do processo
Fechamento de relatório do Monitoramento do Desaguamento	Líder da equipe do sistema de desaguamento	Entre os dias 20 e 30 de cada mês	Preenchimento em planilha do excel	Acompanhamento da performance do processo
Limpeza do entorno da área do polímero no barracão da centrífuga com hidrojateamento	Equipe terceirizada com supervisão do operador da centrífuga	Até o dia 10 de cada mês	Solicitação de serviço terceirizado	Evitar acidentes de trabalho
Verificação da tensão e desgaste das correias da centrífuga	USEM	Primeira semana de cada mês	Inspeção de acordo com o manual do equipamento	Evitar o desgaste da peça e parada do equipamento

Table 23 - Monthly scheduling of centrifuge services

Programação Semestral				
O que?	Quem?	Quando?	Como?	Porque?
Aperto dos parafusos	USEM	Janeiro e Agosto	Com ferramenta adequada	Manutenção preventiva
Arruela de alumínio	USEM	Janeiro e Agosto	Inspeção	Manutenção preventiva
Verificação do bocal de saída de sólidos	USEM	Janeiro e Agosto	Inspeção	Manutenção preventiva
Corrosão da carcaça	USEM	Janeiro e Agosto	Inspeção	Manutenção preventiva
Troca de óleo do redutor epicicoidal	USEM	Janeiro e Agosto	Conforme manual do equipamento	Manutenção preventiva
Amortecedores de vibração	USEM	Janeiro e Agosto	Verificação do estado da peça	Manutenção preventiva

Table 24 - Semestral scheduling of centrifuge services

8. EMERGENCY SITUATIONS

8.1. POWER OUTAGE AT THE WWTP:

- Walk around the WWTP and check the poles with a cutout fuse (poles with Trafo transformer), check visually if there is a disarmed fuse, in this case the power outage is located inside the WWTP). If there is no abnormality, probably the power outage is general, and affects the whole plant neighborhood.
- If the situation remains unchanged for more than thirty minutes, inform the manager (business hours), or the USEG alert team (other times), and USEM alert team. Follow the instructions given;
- After one hour without power, inform the manager, or USEG and USEM alert teams again, according to the instructions above. Contact COPEL again informing the service protocol taken not of in the first call.



Image 103 - Pole with cutout fuse (floater 01)

8.2. FLOODING IN FLOATERS

Use this maneuver only in rainy seasons, only when there is overflow over floaters caused by the high river level.

- Firstly, turn off the general power switches of the floaters, if it is safe to get to the command panels.
- Inform the WWTP manager (in business hours) or the USEG alert team (in other times).
- Reduce the discharge letting only one screw pump on at the RSPS.

- Restrict the inlet of sewage by lowering the mechanic actuation sluices (CA01, CA02, CA03, CA04), located before the screw pumps, until the sewage level covers only the beginning of the pump, according to the illustration:



Image 104 - Example RSPS level

- Turn off B1 and B3 of Piraquara SPS via supervisory, i.e. only let B2 working. In the second case, let only B1. The discharges of Piraquara SPS pumps are in general configure for B1 = 300 L/s, B2 = 200 L/s, and B3 = 80 L/s. If it is not possible to turn off the pumps via supervisory, inform this to the USEG alert team.
- In doing as mentioned above, the WWTP discharge will be approximately 1100 L/s. The next step is to regulate the flow to 600 L/s, through the sluices of the upper part of the pumping station. Open CM03, CM04, CM07, and CM08, which access the manual grate GM04, open CM05 and CM06 which access the spillway. If you see that the sluices CM13, CM14, CM15, and CM16 after the manual grate GM04 are closed, then, regulate the discharge to 600 L/s. You thus relief the flow and prevent overflowing to the streets by the lateral walls of the pumping station.
- Do not regulate the discharge through the sluices CM01, CM02, CM09, and CM10, located before the mechanized grates GA01 and GA02. This action might cause overflowing by the lateral walls of the pumping station.
- Immediately after normalizing the overflow situation in floaters, undo the maneuvers, go back to operate the two screw pumps, and regulate the discharge to 1600 L/s.
-