

Title

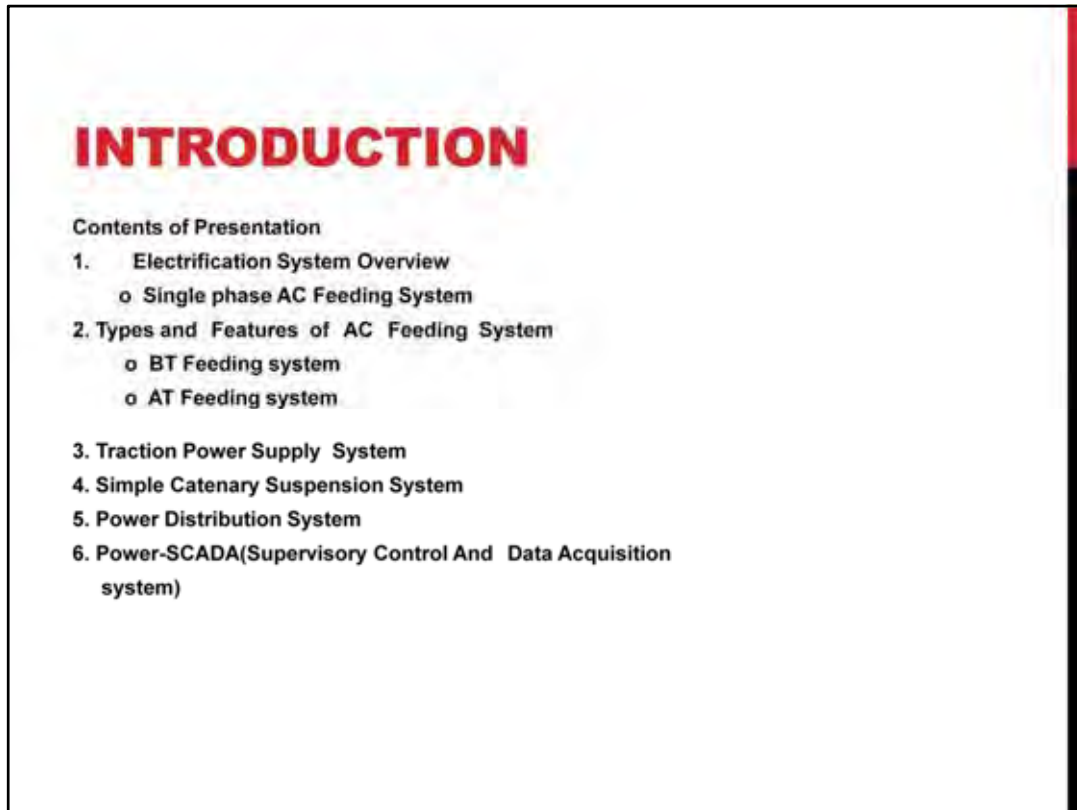

This is contents of the presentation. As you can see here, I am going to explain these six (6) points.

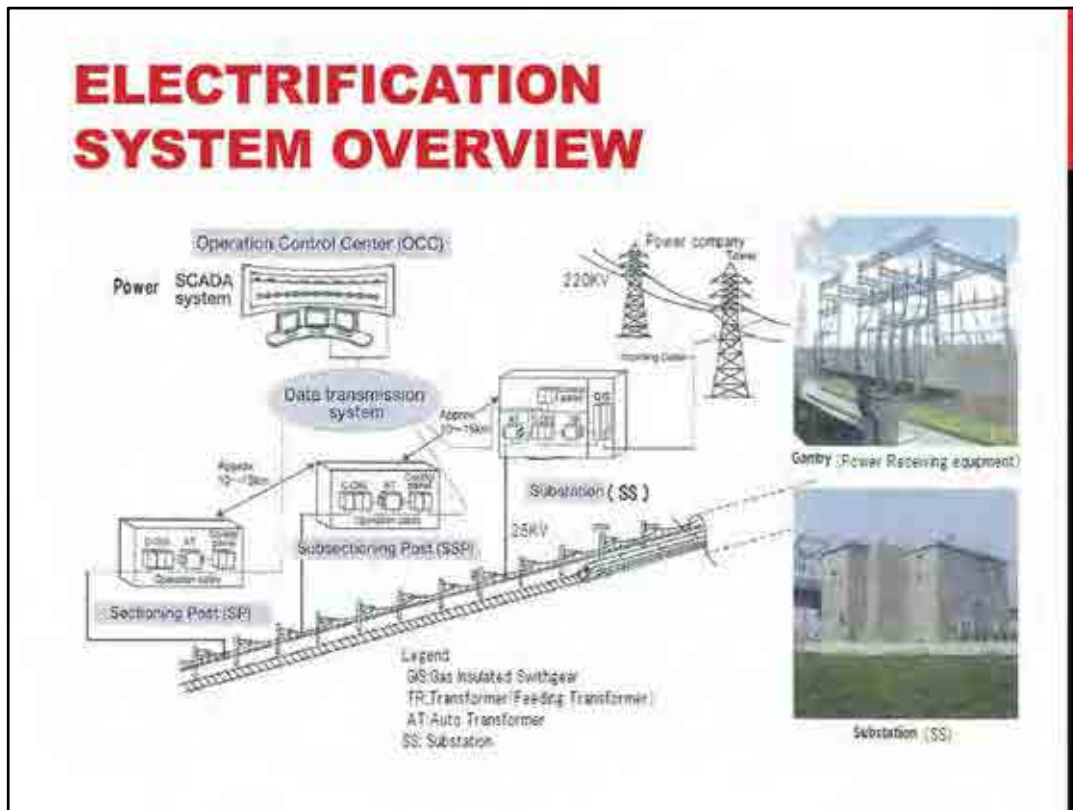

I am going to explain about the view of electrification.

First, we need to receive electric power from Ultra-High Voltage Grid of power company to traction substation for railway. EVN(Electric of Vietnam) supplies 500KV,220KV and 110KV ultra high voltage grids. We recommend to use the 220KV grid.

At this substation, three phase lines are converted to two sets of single phase line. We need to convert three phase to single phase. At the same time, 220KV voltage is converted to 25KV. I will explain about SP and SSP later.

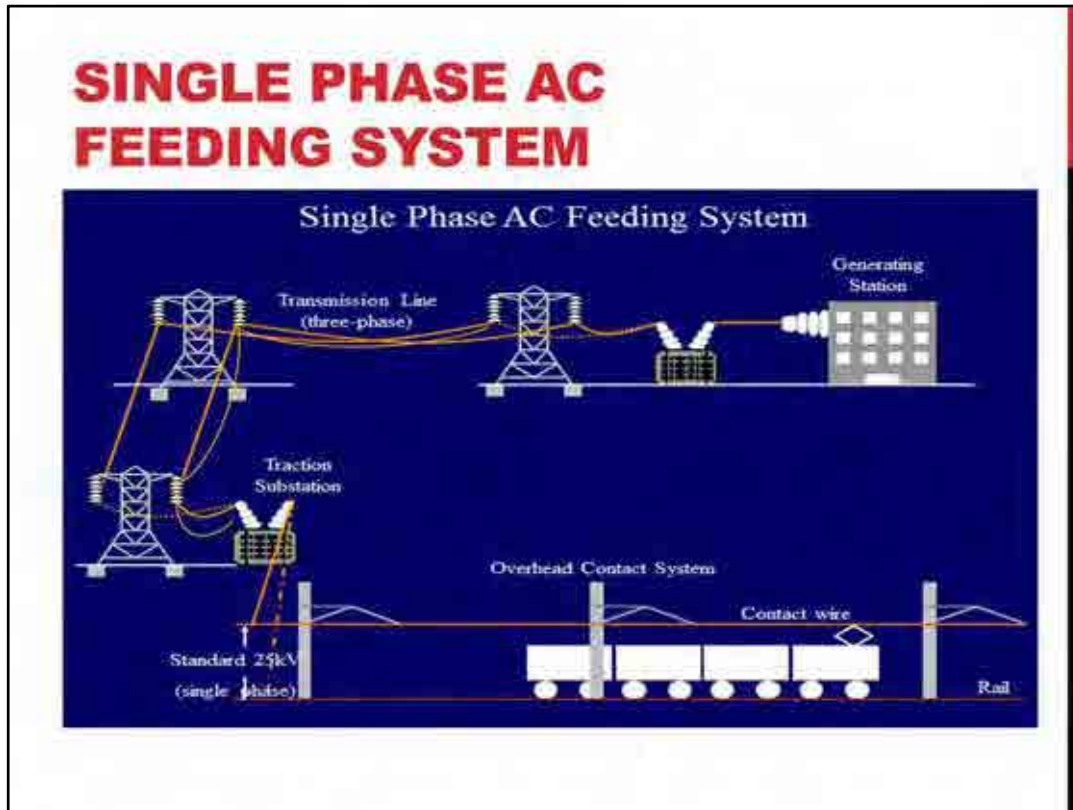

This figure is single phase AC (Alternative Current) feeding system.  
Rolling stock needs single phase electric power.  
As I explained in previous slide, this traction transformer converts the phase from three phase to two sets of single phase.

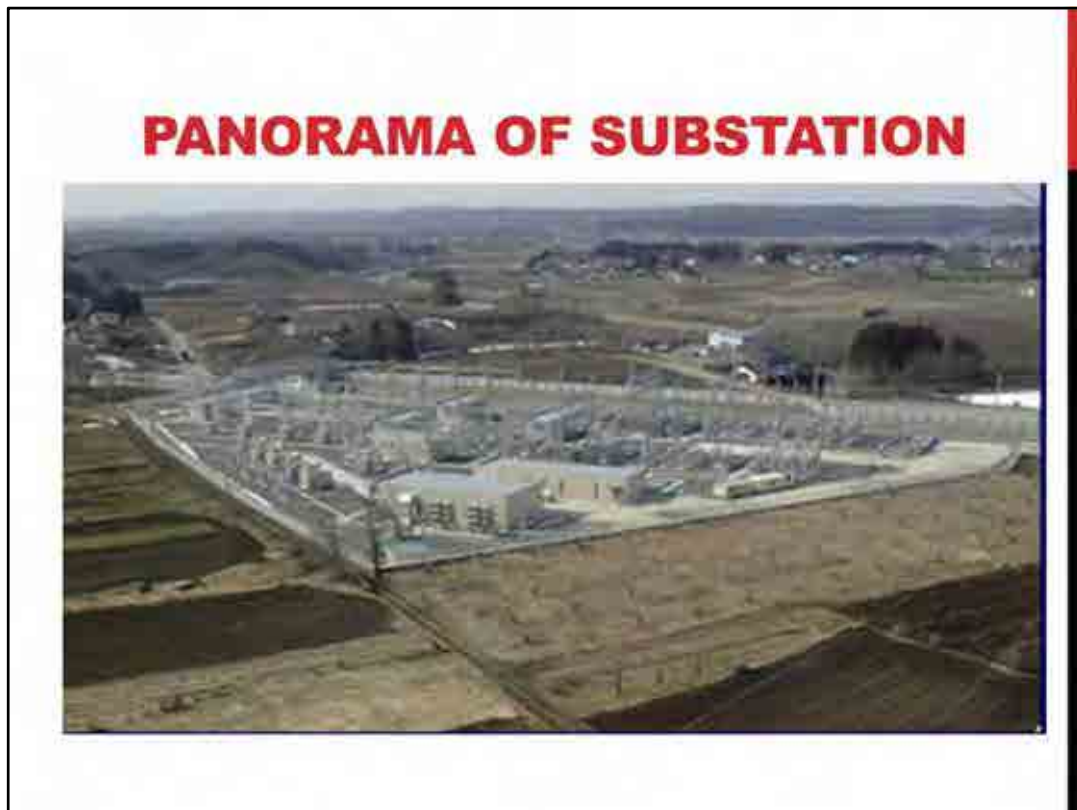

This is a panoramic view of Substation. We need a very large vast land, about 18,000m<sup>2</sup>, 90m by 200m.

## **FEEDING TRANSFORMER**



Again, this is a panoramic view of Traction Substation and Feeding Transformer.

## **AT ( AUTO TRANSFORMER)**



This is the exterior of Auto Transformer (AT).  
I will explain about AT later.





This is a transformer called Modified Wood-Bridge Transformer. This is used as a standard transformer for Shinkansen in Japan. Because of characteristics of this transformer, electric power from a pair (A phase and B phase) of single phases is not even. So we need to put the Step Up Transformer on one of the Single Phase (B phase). The transformer on the right in this picture is Step Up Transformer.







In order to improve this situation (Modified Wood-Bridge connected Transformer needs Step up transformer), this Roof Delta connected Transformer was completed after research and development started in 1999. This transformer has no Step up transformer. This transformer was used for Japanese Tohoku Shinkansen which started its operation in December 2010.

As you can see, this transformer is small and light. The construction cost is also cheaper than the other transformers.

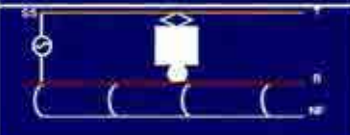
## TYPES AND FEATURES OF SINGLE-PHASE AC FEEDING SYSTEM

Types and Features of Single-phase AC Feeding System			
Title	System Diagram	Application	
		In Japan	Others
Simple Feeding System With NF			France, England, Russia, Etc
BT Feeding System With NF		Conventional Line	England, France, Sweden, etc
AT Feeding System		Shinkansen Conventional Line	France, etc

As you can see in this chart, there are 3 methods to feed electric power to a train and each country uses different method.

The first one is Simple Feeding System. This is very simple and just allocates single phase transformers along railway lines. Merit is that construction cost is cheap. Demerit is that number of transformers increases. Also, return current leaks into the ground and causes Inductive interference to the communication lines along the railway .

The second one is Booster transformer Feeding System. This reduces Inductive interference because Booster Transformers absorb return current. However, in order to insert BT (booster transformers), Air Section needs to be installed. Demerit is that electric arc occurs when a train passes each air section and damages contact wires. It also causes noise.

The third one is Auto Transformer Feeding System. Merit is that we can make feeding voltage from transformers twice the volume of contact wire Voltage, and as a result, we can make the distance between transformers longer. In addition, inductive interference doesn't occur and we don't have problems with electric arc. The only demerit is that construction cost is expensive.

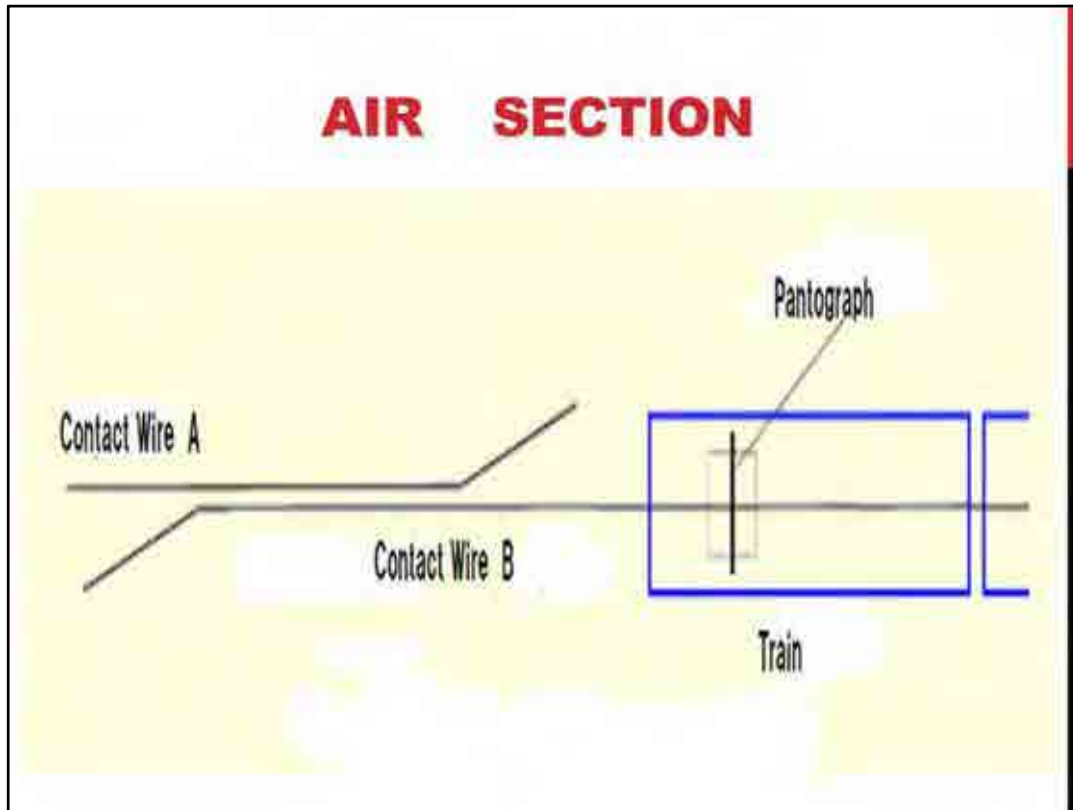

I would like to explain about Air Section here.

In this figure, we are looking at a train and wires from above. As you can see, contact wire A and contact wire B are not connected and there is some space between contact wire A and contact wire B. Because of this space, electric power is cut off. When a train comes into this section from the right side, a pantograph touches contact wires and electric power will be supplied from contact wire B to contact wire A.

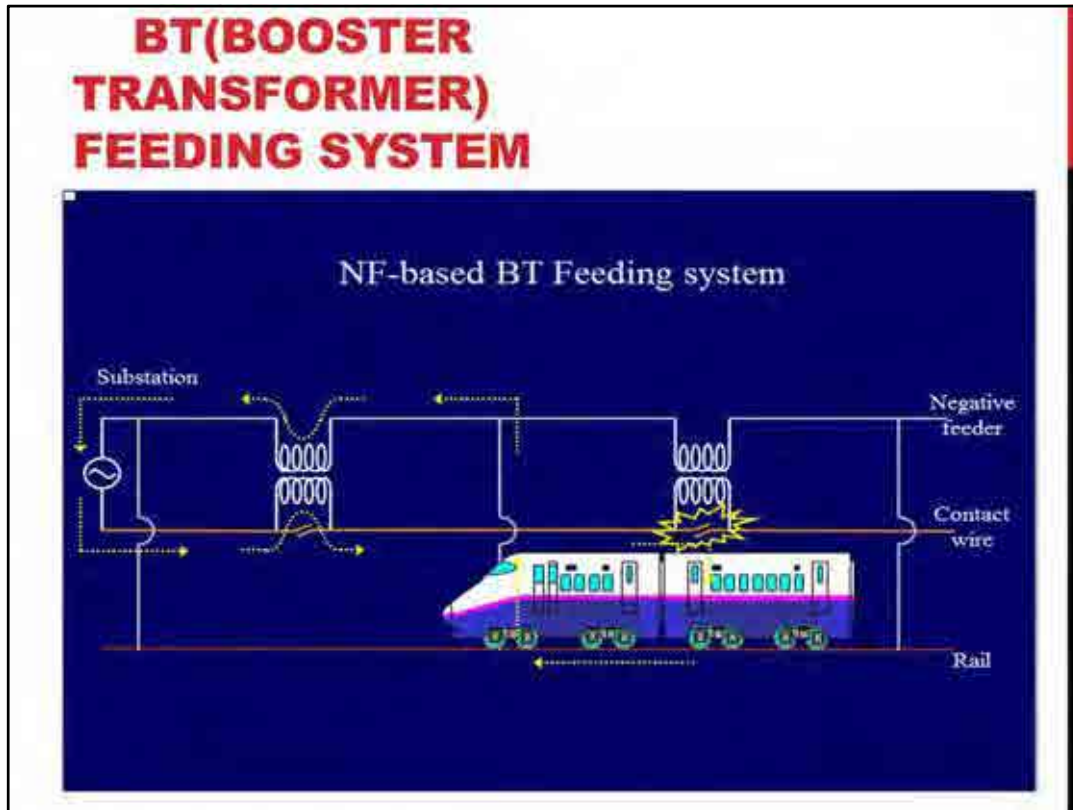

This is an illustration of Booster Transformer Feeding System. As you can see, electric arc occurs at booster section.

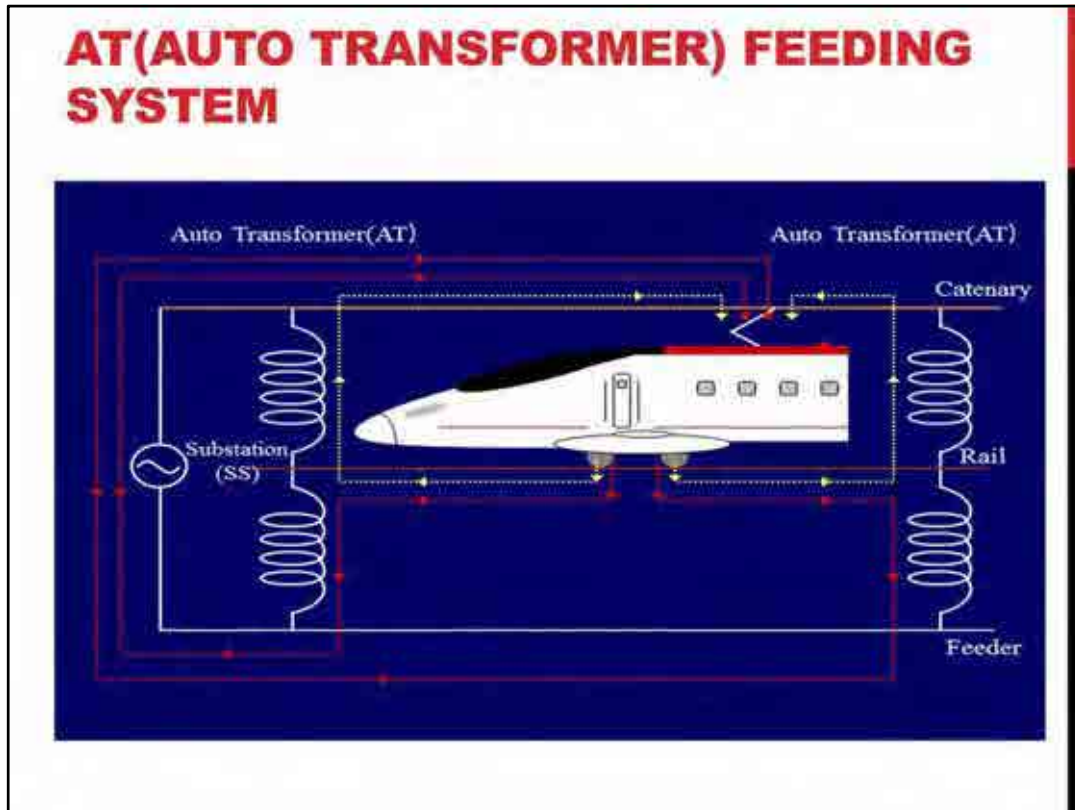

This is an illustration of Auto Transformer Feeding System.

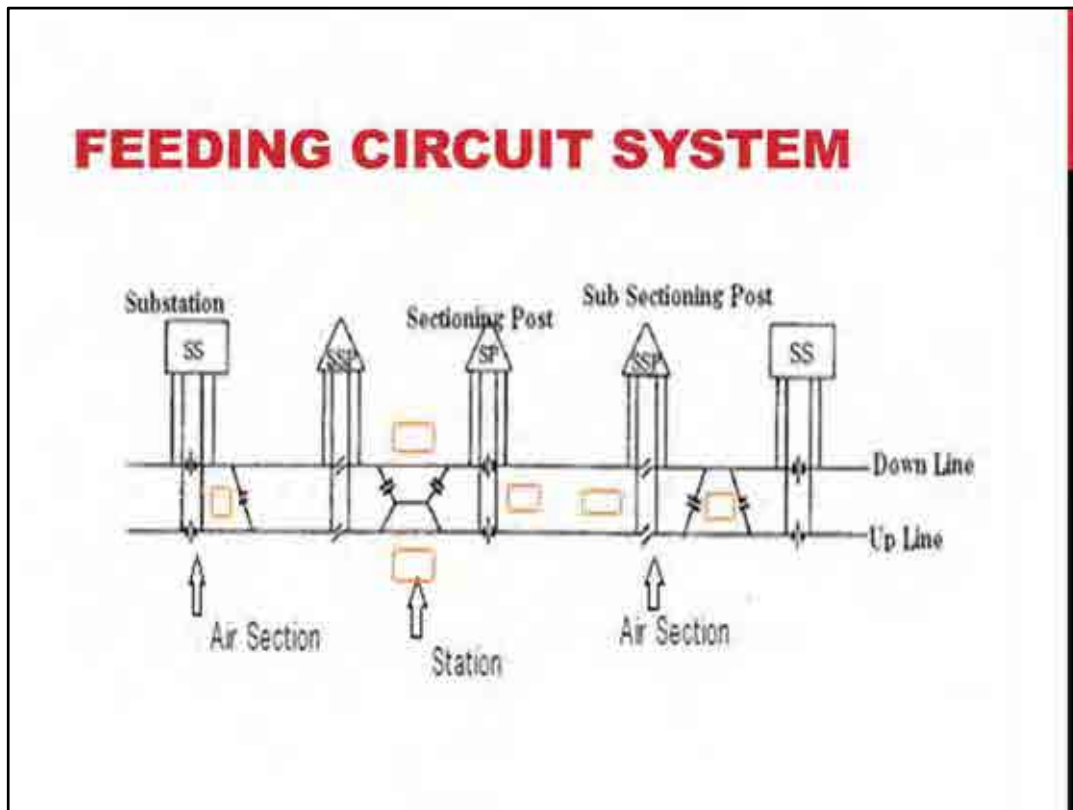

We have to install a sectioning post between substations ,because we cannot connect different power sources with each other. At this post, we need Air Section in order to separate different power sources. This post is called Sectioning Post. We want to minimize sections to cut electric power during accidents and maintenance. In case of accidents and maintenance, we install Sub Sectioning Posts for our convenience.

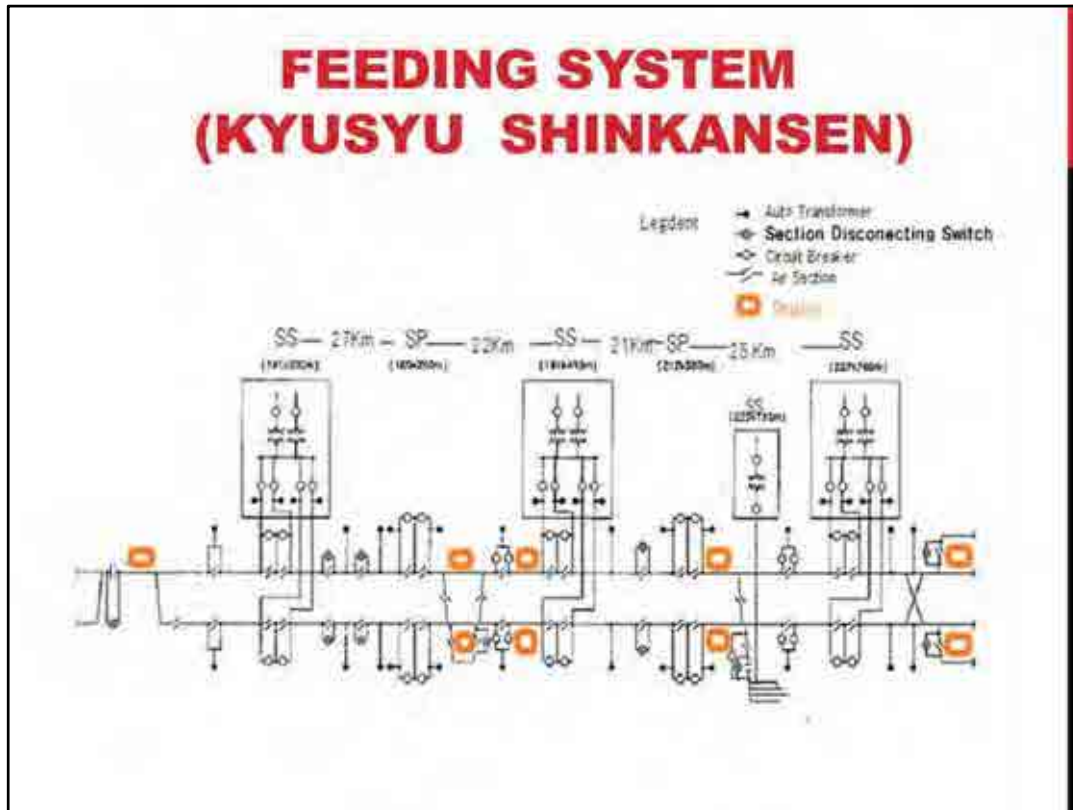

This is the actual distribution of Substation (SS), Sectioning Post (SP) and Sub-sectioning Post (SSP) in Kyusyu Shinkansen.

The distance between SS and SS is about 50 Km. The distance between SS and SP is about 25 Km.



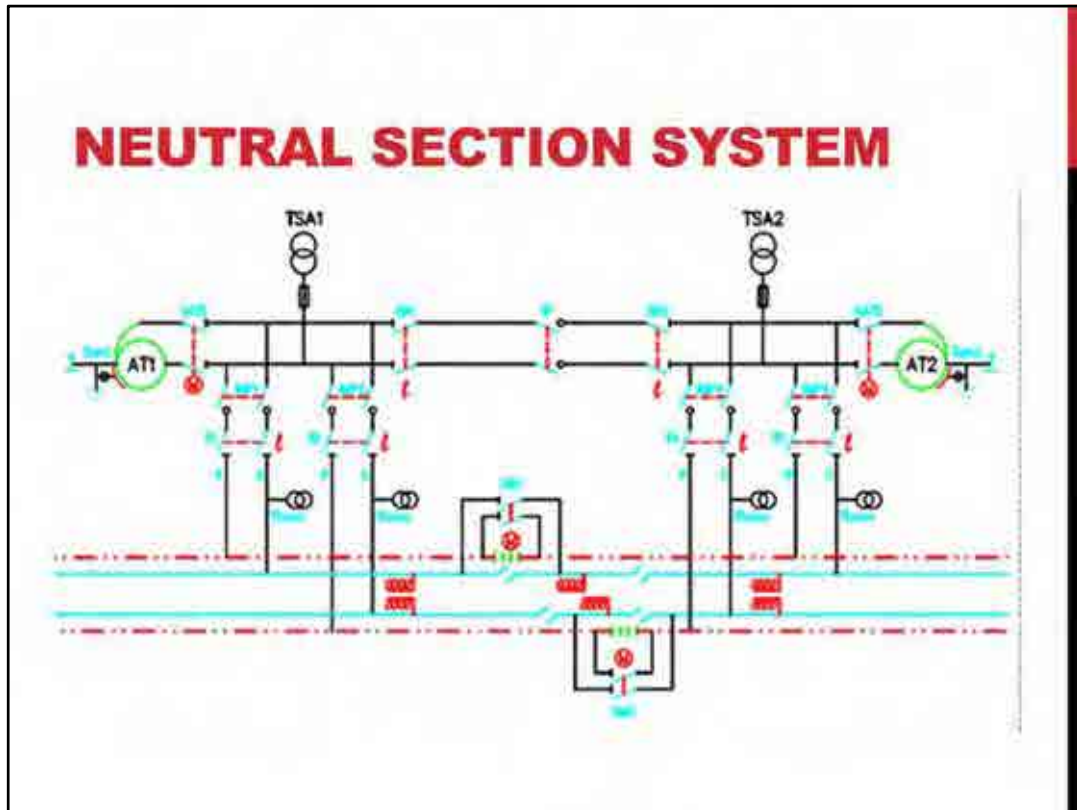

This is an example of a certain country system . This is a point where different power sources meet. There is a neutral section . The neutral section is not fed electric power. The train runs in coasting driving. The train slows down a little bit.

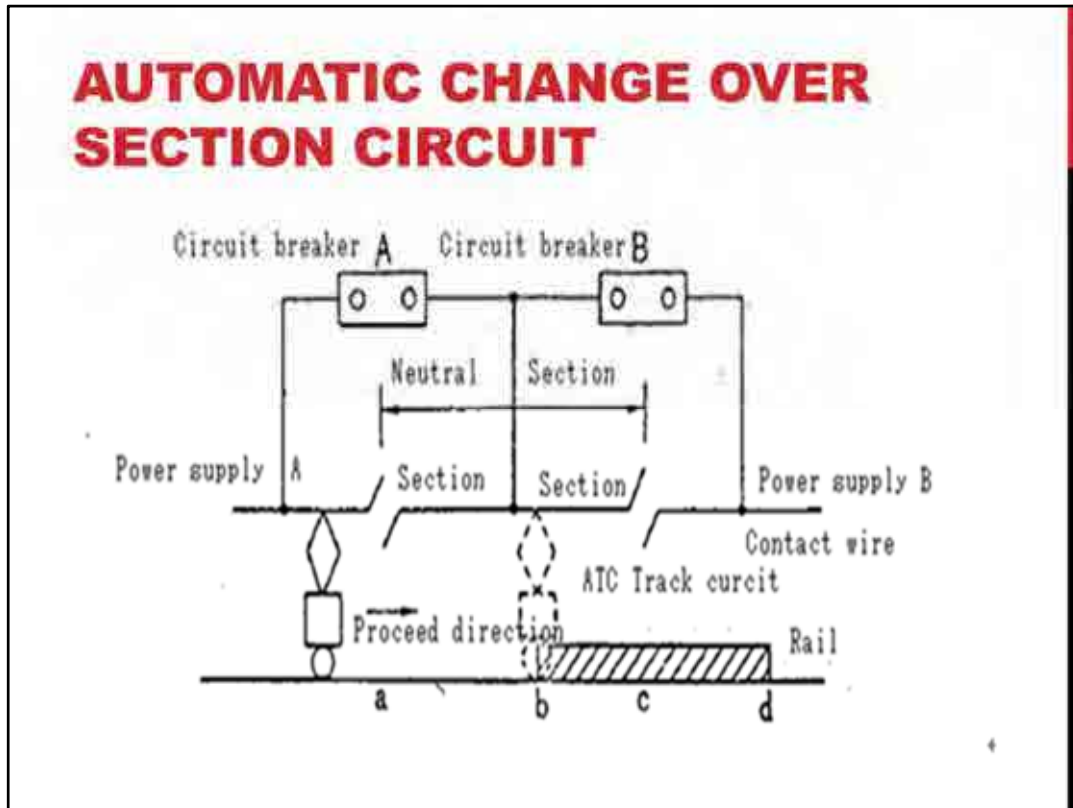

This is a sample of Japanese Shinkansen system. In the condition of no train, circuit breaker A is closed and B is open. When a train is moving into neutral section, and passes "b" point, the track circuit detects it, and A is open, B is closed. After a train passes "d" point, track circuit detects no train in the neutral section, and B is open, A is closed. This system automatically switches from power source A to power source B. It only takes 0.3 seconds to switches from power source A to power source B. In neutral section, a train can run in power running.

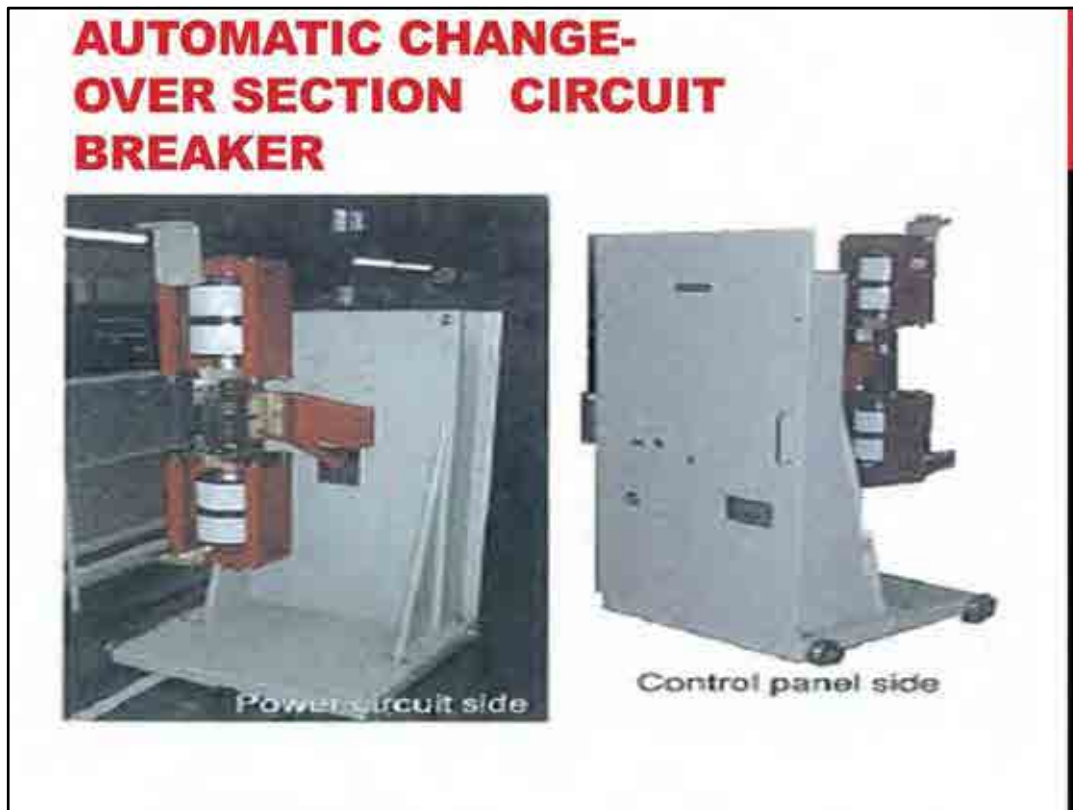

This is a picture of Circuit Breaker.

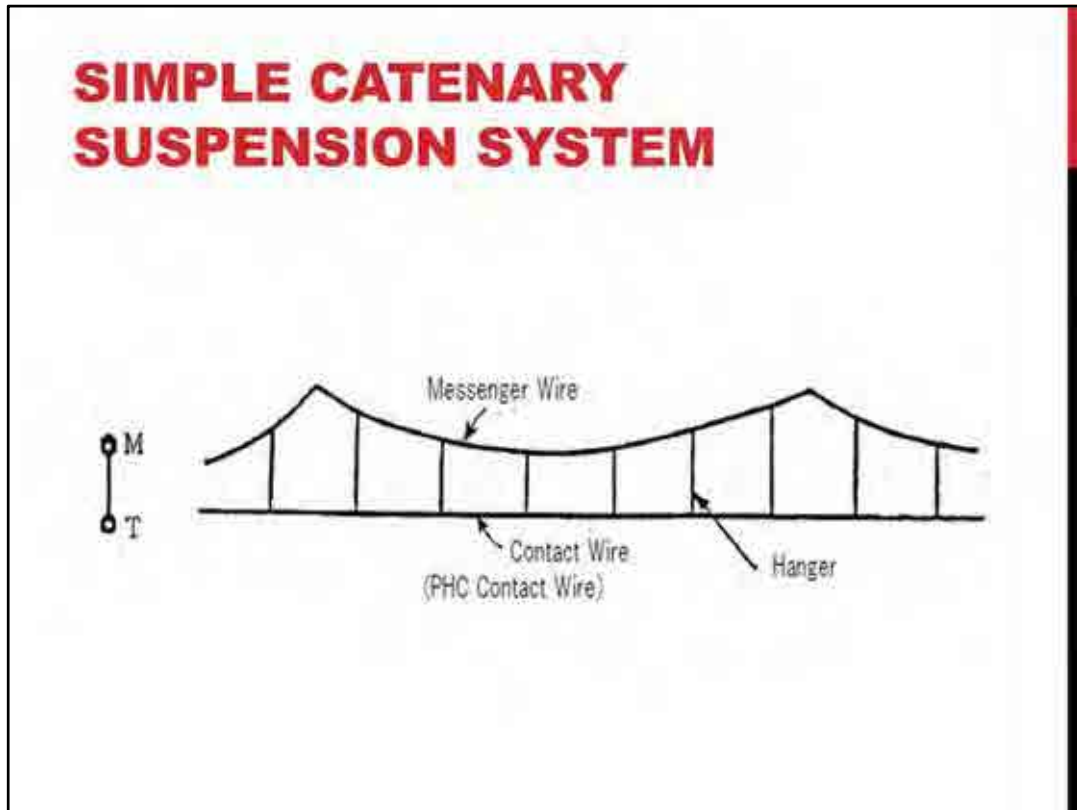

This is Simple Catenary system and we are proposing to use this system in this project. This Simple Catenary consists of Messenger Wire, Hanger and Contact Wire.

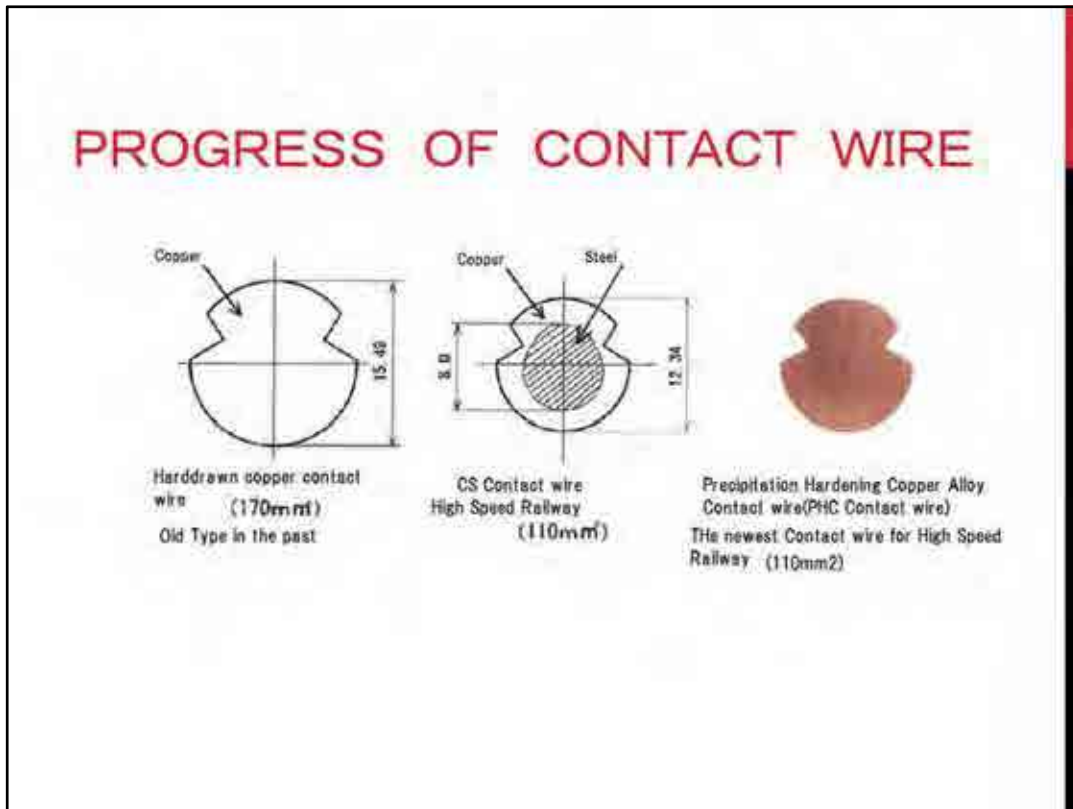

This shows how contact wire has progressed. This contact wire called PHC (Precipitation Hardening Copper) is developed with the latest technology. PHC contact wire is made of alloyed metal with a small amount of chrome and zirconium. This has an excellent performance in general satisfying tension, anti-wear agent and conductivity.

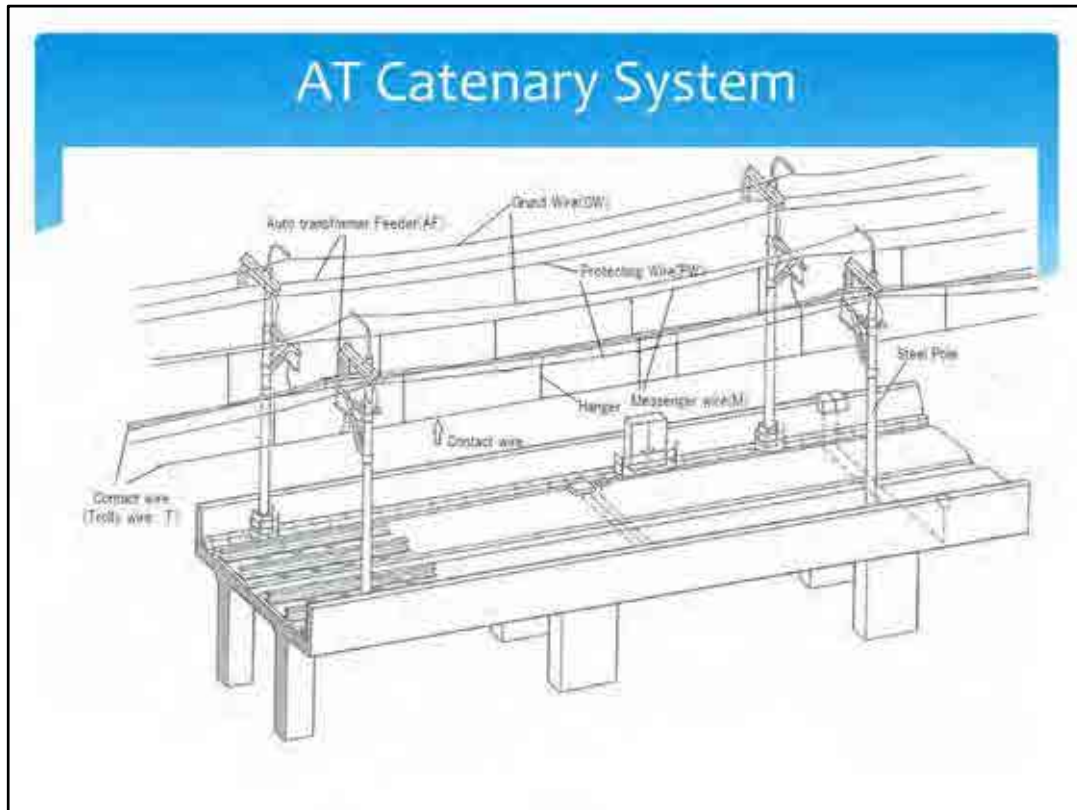

This is an image of elevated section. When the construction is completed, Simple Catenary system will look like this.  
Protecting wire (PW) is used for lightning protection.

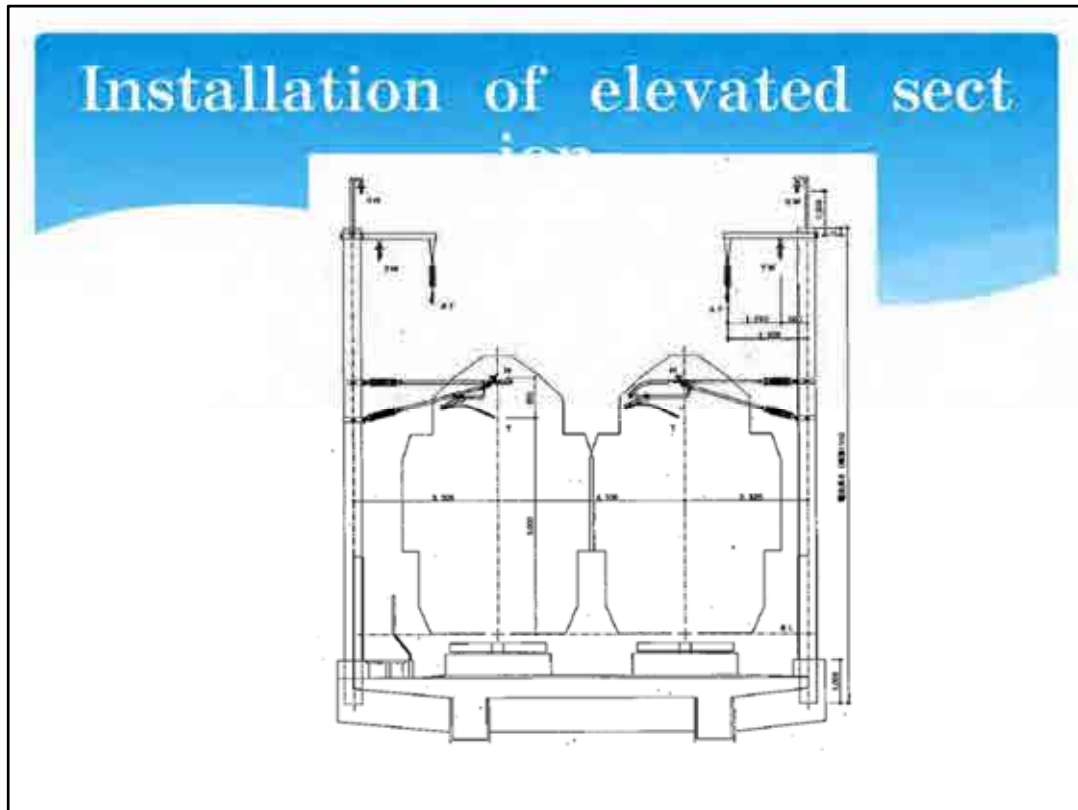

This is a cross-sectional view of elevated section.





This is a cross sectional view in tunnel .

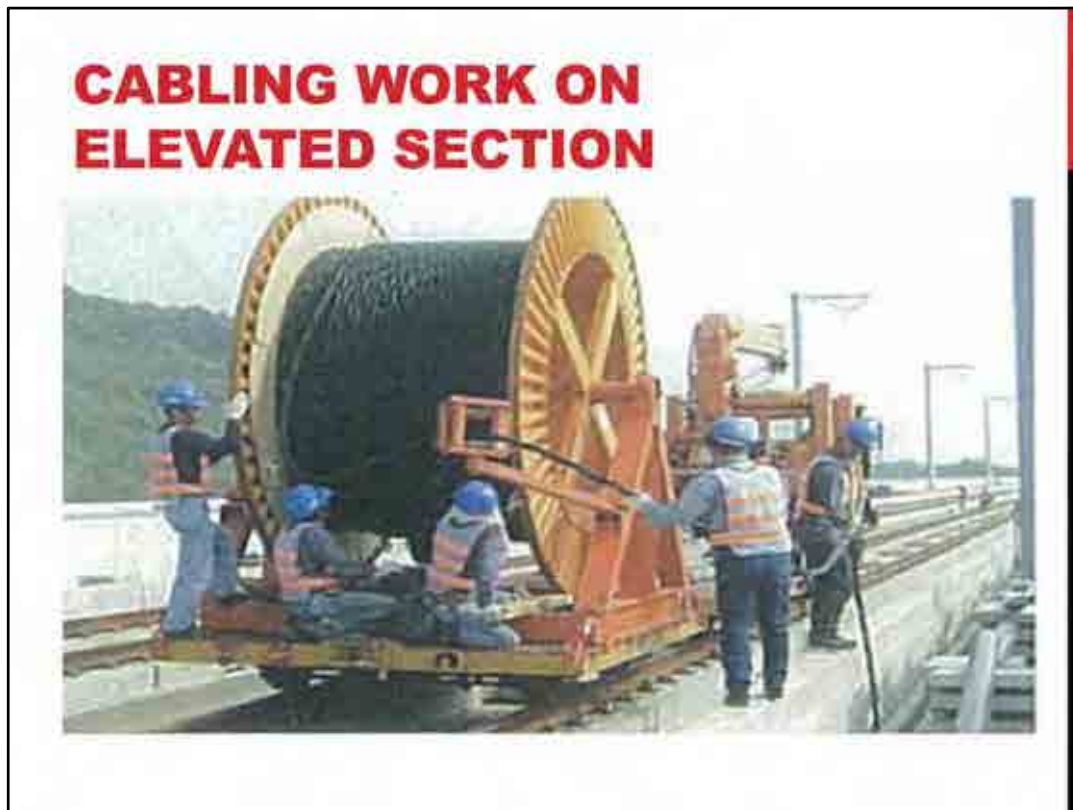

This is a picture of cabling work. They are using a catenary wiring car here.

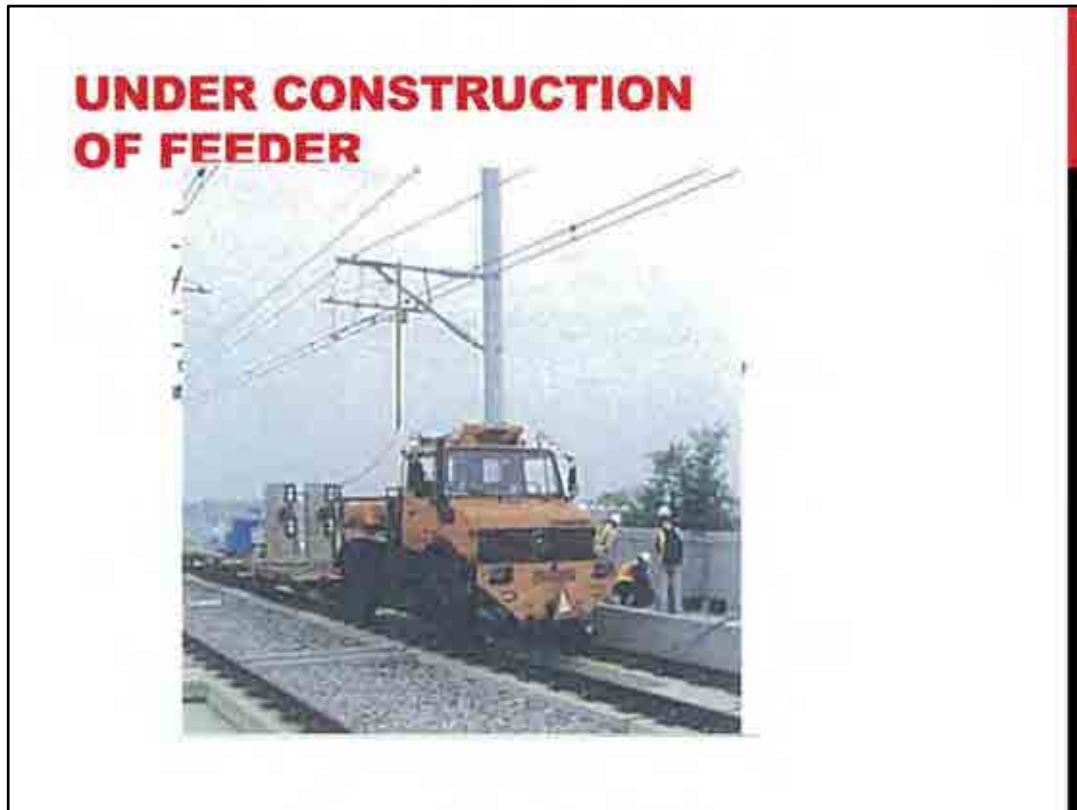

This is a picture of construction and the height of contact wire is measured.

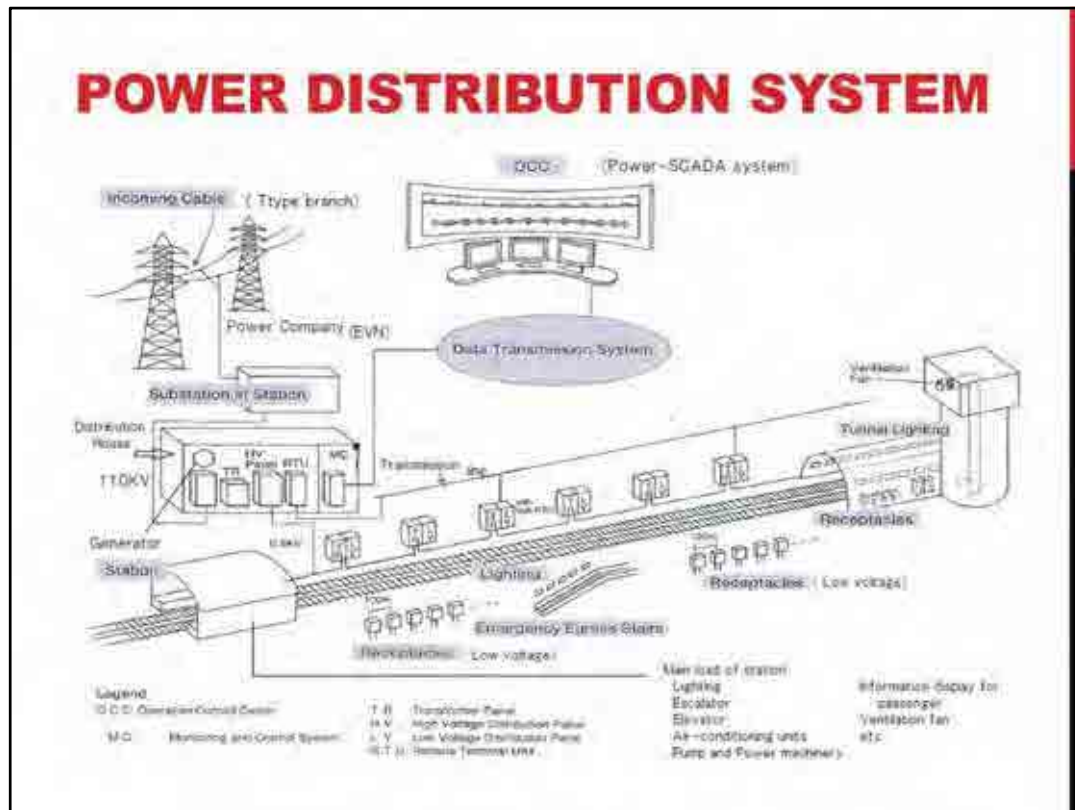

All electric power but for train running, is supplied from this power distribution system. For example, power in stations such as lightings , escalators, elevators, pumps for plumbing, electric power source for air-conditioners, message boards, electrical outlets and signal & telecommunication is supplied. We build a distribution house close to a station, and convert electric power supplied from a power company here before distributing electric power to the station.

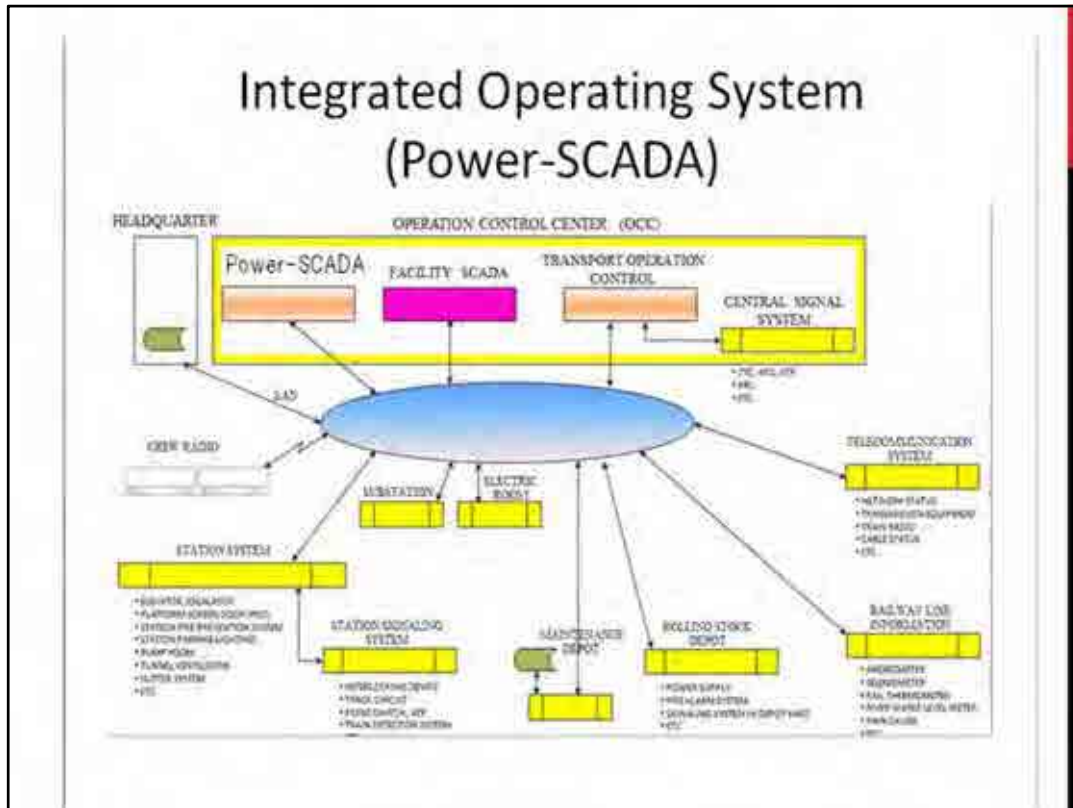

Power-SCADA system is the system which monitors and controls equipment at substations and sectioning post. This system should be installed in the same room as a part of integrated operating system. Especially in case of accident, all sub-systems in the OCC room must cooperate with each other.



This is the image of Operating Control Center room.



This is the picture of dispatcher desk for Power-SCADA system for a Japanese Shinkansen.



## COMPARISON OF MODIFIED WOOD-BRIDGE AND ROOF-DELTA CONNECTED TRANSFORMER

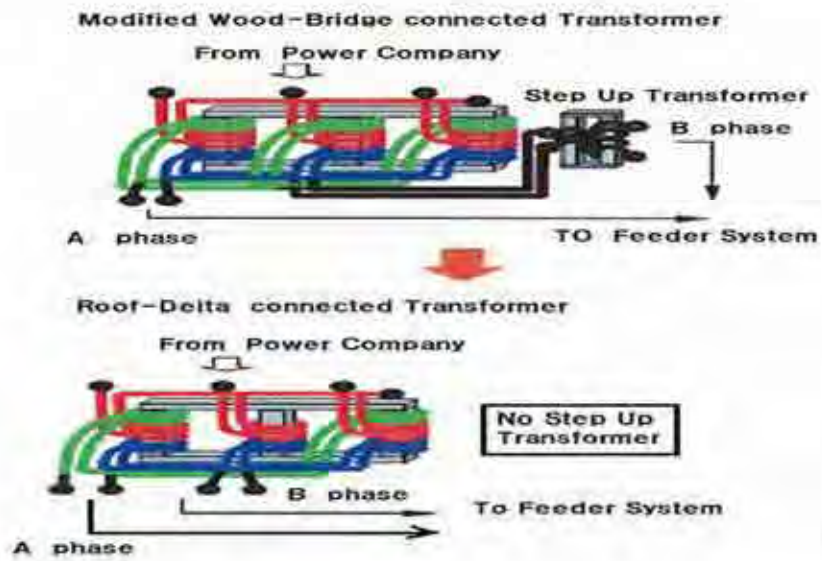

Fabrication of Roof-Delta transformer is more difficult than Modified Wood-Bridge transformer.

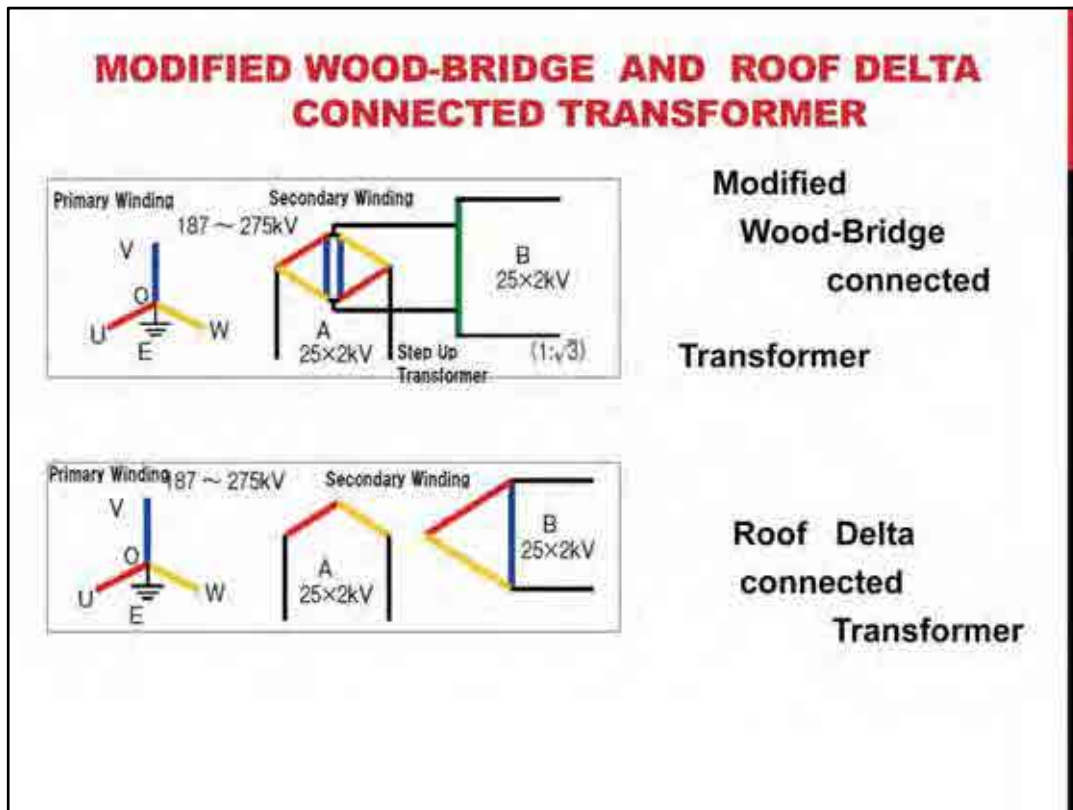

This is the comparison of Modified Wood-Bridge connected Transformer and Roof Delta connected Transformer.

Roof-Delta connected transformer can omit step-up transformer.

## Wave Propagation Velocity

C: Wave Propagation Velocity

$$C = \sqrt{T/\rho}$$

T: Tension of contact wire tension (KN)

$\rho$  : Contact wire weight (kg/m)

$$\beta = V/C$$

V : Train speed (km/h)

C : Wave Propagation Velocity (km/h)

When  $\beta$  exceeds 70-80 % , current collection performance drops extremely.

This is the formula of Wave Propagation Velocity.  
The rate of V by C indicates the current collection performance.

## Example of Applicable Train Speed based on Wave Propagation Velocity

Wave Propagation Velocity : C ( Km/h )

$$C = \sqrt{T/\rho}$$

T : Tension of Contact Wire (kN)

$\rho$  : Contact Wire Weight (kg/m)

Numerical Calculation

T: 19.6kN (PHC Contact Wire)

$\rho$ : 0.991Kg/m (PHC Contact Wire)

$$C = \sqrt{\frac{19.6\text{KN}}{0.991\text{kg/m}}} = \sqrt{\frac{19.6 \cdot 1000\text{Kg.m/s}^2}{0.991\text{Kg/m}}} = 140\text{m/s} = 506\text{Km/h}$$

$\beta = V/C$

V: Train Speed ( Km/h)

$$\beta = 350(\text{Km/h})/506(\text{Km/h}) = 0.69 < 0.7$$

**350Km/h is applicable !**



THANK YOU FOR YOUR  
ATTENTION

# Signaling Overview of Signal and Communications Technology in the Railway sector

4 Dec 2013

JICA Study Team

Makito MURAKAMI



Japan International Consultants for Transportation Co.,Ltd. (JIC)

Today, we will explain the outline of the signal systems and telecommunications technologies used in railways.

## Contents

### 1. Overview of railway signaling and communication facilities

- 1 Block Signals (signal, track circuit)
- 2 Automatic Train Protection (ATS, ATC)
- 3 Train Operation Control
- 4 Communication

### 2. Main factors of which control train speed

- 1 Signal
- 2 Level Crossing

Today, we will focus on the following two topics:

1. Signal systems and communication facilities used in the railway transport sector
2. Major factors that control the train speed

First, we would like to discuss the signal systems and communication facilities that are used in the railway transport sector.



1 Overview of railway signaling and communication facilities		3
The signal and communication systems of "North-South line"		
<b>【SIGNAL】</b>		
Block signaling system	Semi-automatic operation system	
Signal system	Colored signal	
Train detection system	Axle counter	
Interlocking	Relay interlocking , Electronic interlocking	
<b>【COMMUNICATION】</b>		
Wired communication	Fiber cable transmission system , Bare wire information system	
Wireless communication	Narrowband microwave system	
<b>【LEVEL CROSSING】</b>		
1,048 crossings (269 automatic warning , 376 boards , 403 guarded crossing)		
<b>【TRAIN OPERATION CONTROL SYSTEM】</b>		
Not installed (Operation Staff of each station to manage train operations.)		

This slide summarizes our understanding from the past study results on the signal communication systems that are currently used in the existing line that connects between Hanoi and Ho Chi Minh (hereafter, we call it "North-South line").

Regarding the signal systems,

- The block system is semi-automatic,
- The signaling system uses colored signals,
- The train detector system uses axle counters, and
- The interlocking devices are mainly relay interlocking devices, and electronic interlocking devices are introduced in some principal stations.

In the field of communication,

- For wired telecommunications, bare wires are mainly used and some sections are implemented with Fiber cables.
- Regarding wireless telecommunications, some sections are implemented with narrowband microwave system.

Regarding railway level crossing facilities,

- Out of the total of 1,048 railway level crossings, 269 are with automatic warning systems, 376 are with boards, and 403 are guarded crossing.

No traffic operation control systems have been introduced. Route setup is made by the operators positioned at each station, and telephone communication is used between stations as well as between station and train control center.

1-1 Block Signals 4

Type of block signaling system

Single / Double	Type	Note
Single track	Staff block system	
	tablet instrument block system	
	Token less block system	
	Semi-automatic block system	Track circuit system , Electronic codes Verification
Double track	Automatic block system	
	Automatic block system	

While a number of block systems are in use as shown in the table, the semi-automatic block system of the North-South line, shown in the blue frame, and the automatic block system popularly used in Japanese railways, shown in the red frame, will be discussed in this presentation.

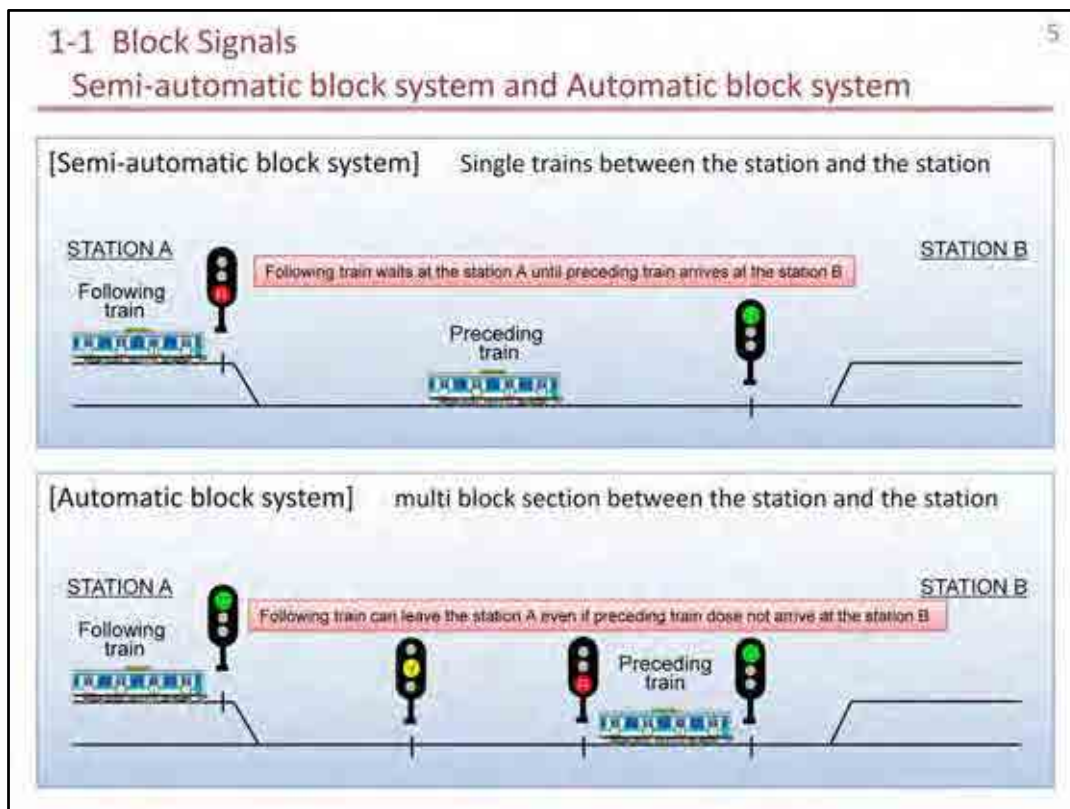

First, we will discuss the semi-automatic block system.

The semi-automatic block system allows only one train to run in a block, i.e., between two adjacent stations, at a time.

This figure shows the case when a preceding train is running in between the stations A and B. In this case, the following train at Station A is not allowed to depart from the station until the preceding train arrives at Station B.

The next one is the automatic block system.

The automatic block system allows two or more trains to run in between two adjacent stations, by dividing the section between two adjacent stations into two or more blocks.

As shown in this figure, the following train can run up to the point just before the block in which the preceding train is running, i.e., even when the preceding train is in between the two stations.

The advantage of the automatic block system is that the number of train operations can be increased by increasing the number of blocks.

From the next page, we will discuss the details of the automatic block system.

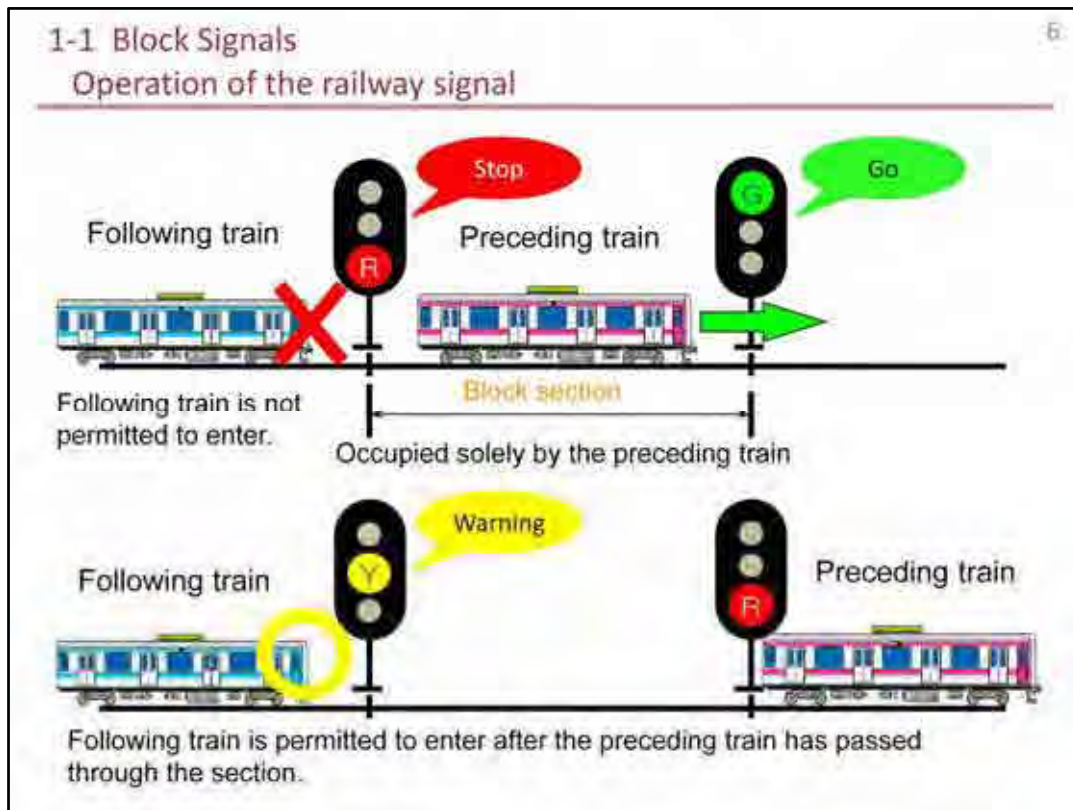

This slide explains the outline of how the signal works.

When the preceding train is in a block, the following train is not allowed to enter the block according to the "one block one train" principle. Accordingly, the signal shows the "red" stop signal to stop the following train before the block section.

When the preceding train has entered the next block section, the signal indicates the "yellow" caution signal, which allows the following train to enter the block section. However, because the "yellow" caution signal is indicated, the following train is to run at a reduced speed.

Then, the next slide will explain the mechanism of detecting the existence of a train in a block.

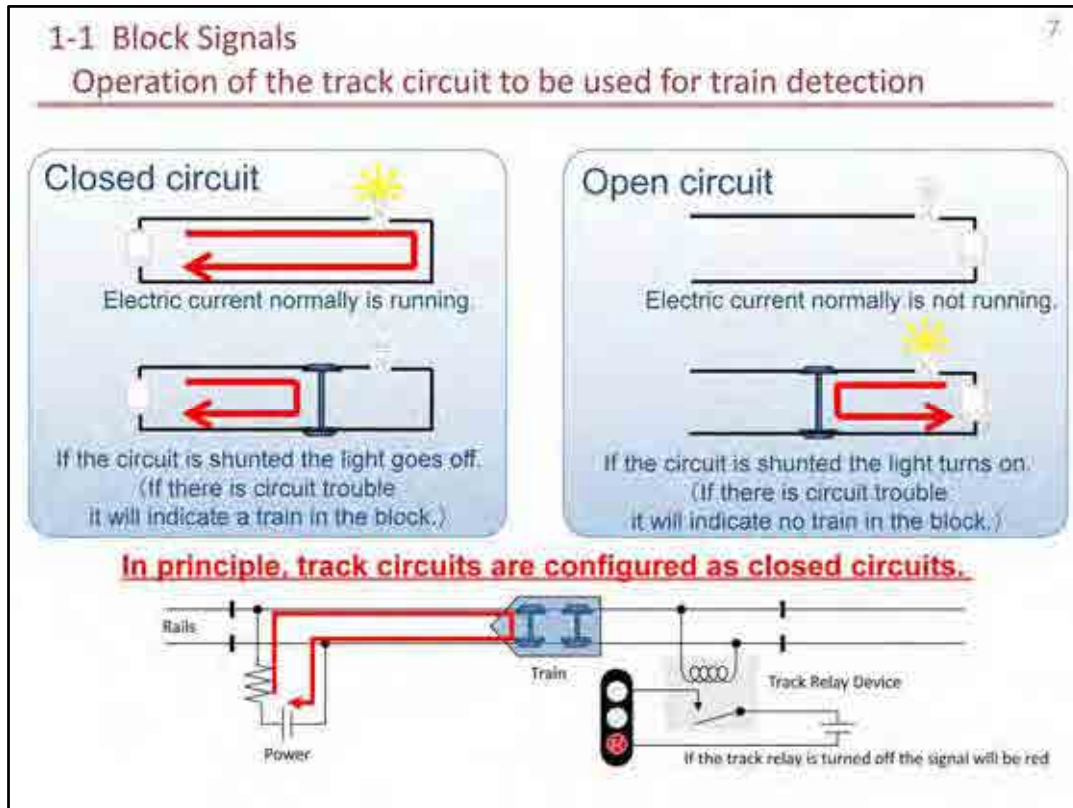

This slide outlines the operation of a track circuit, which is a device used to detect the existence of a train in a block.

A track circuit uses the right and left rails as components of an electric circuit. When a train enters the section, the circuit will be shunted by the axle, and the resulting change is detected to indicate the existence of the train.

There are two types of track circuit -- one is the closed circuit type as shown to the left and the other is the open circuit type shown to the right.

In the case of the closed circuit type, the electric circuit is always closed, and shunting by the train's axle turns off the light bulb.

In the case of the open circuit type, the electric circuit is normally open, and shunting by the train's axle closes the circuit and turns on the light bulb.

While the figure is showing a light bulb as the device to indicate the existence of a train, the actual system uses a device called "track relay," of which contact making and breaking is used to detect the existence of a train.

In the case of the closed circuit type, any other failure such as power interruption, relay failure, or rail breakage will also indicate "existence of a train" by the making of relay contact. As such, it accords with the "fail safe" concept, and so the term "track circuit" normally refers to the closed type track circuit.

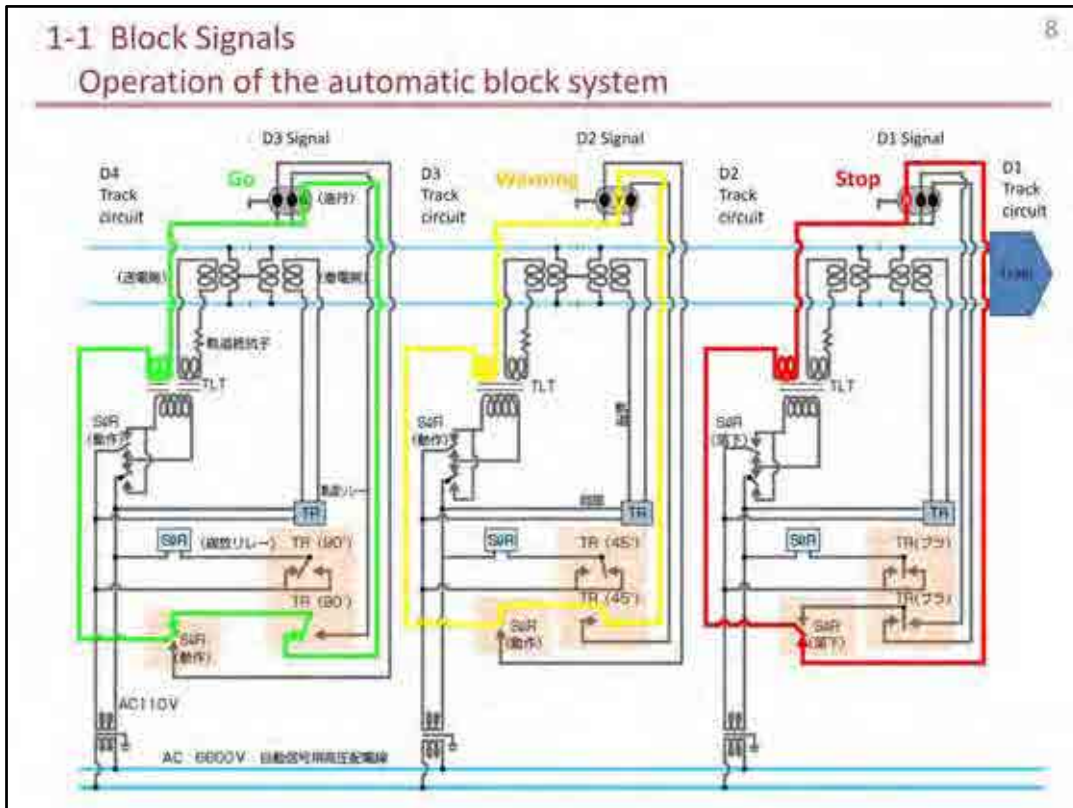

This slide shows the operation of the track circuit and the associated signal in an automatic block section.

When a train is on the D1 track circuit, the track relay of the D1 track circuit drops (i.e., breaks contact) to close the electrical circuit shown by the red line, and the D1 signal indicates the red "stop" signal.

Next, as no train exists in the section D2, the SIR relay is energized and makes contact to close the electrical circuit shown by the yellow line, and the D2 signal indicates the yellow "warning" signal.

As no train exists in the D3 section, the SIR relay is energized and makes contact. Because there is also no train in the forward section D2, the TR relay is set to the phase of 90 degrees to close the electrical circuit shown by the green line, and the D2 signal indicates the green "go" signal.

As in the above, the electrical circuits for the "warning" signal and "go" signal can be configured by changing the polarity of the power supply.



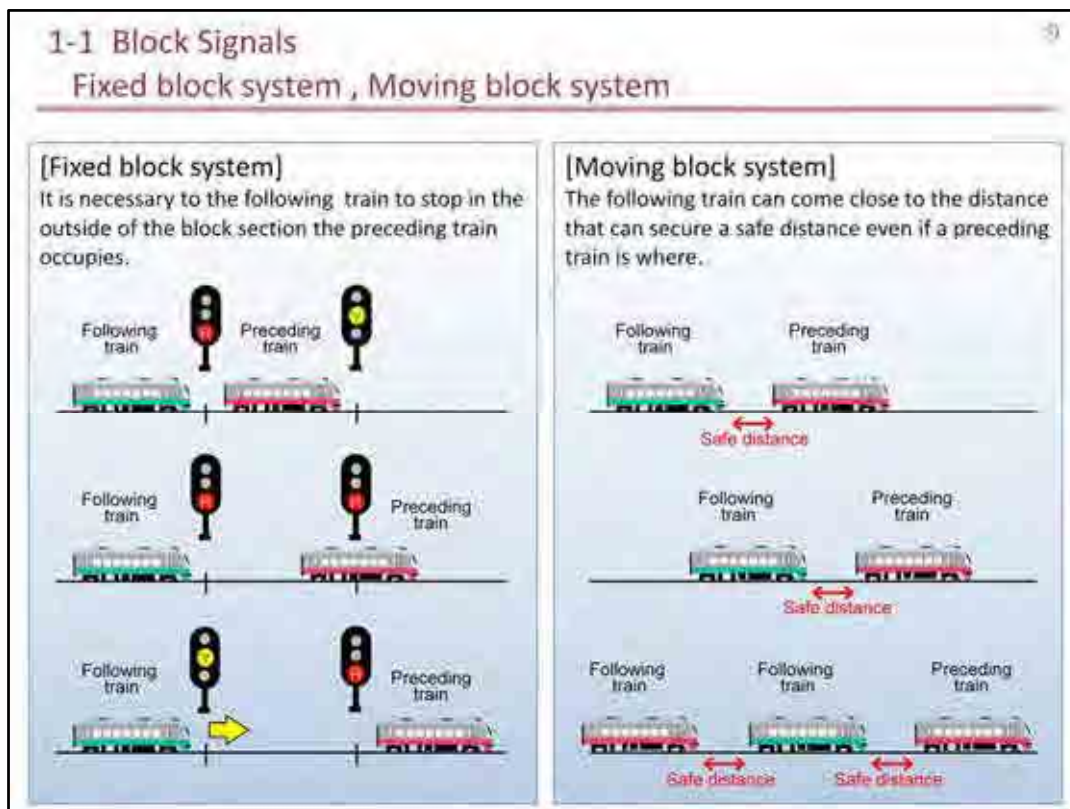

There are different types of block system besides the above-described ones that use ground facilities such as track circuits to set the block section.

The previously described ones are called "fixed block system," which is shown on the left side. In the fixed block system, the block sections are determined by the associated track circuits and signals, and the following train is required to stop at a position outside the block section occupied by the preceding train. As such, because the maximum number of trains is equal to the number of track circuits, the transport capacity is limited by the ground facility.

On the other hand, the "moving block" system shown to the right is a system that allows the following train to freely approach the preceding train regardless of the position of the preceding train, on condition that the minimum safe distance can be maintained between the trains. Thus, it means that the train separation can be reduced as necessary to increase the traffic capacity if the safe distance can be maintained.

The moving block system is mainly used for the railway sections that are required to carry a high traffic volume, such as urban commuter rail lines.

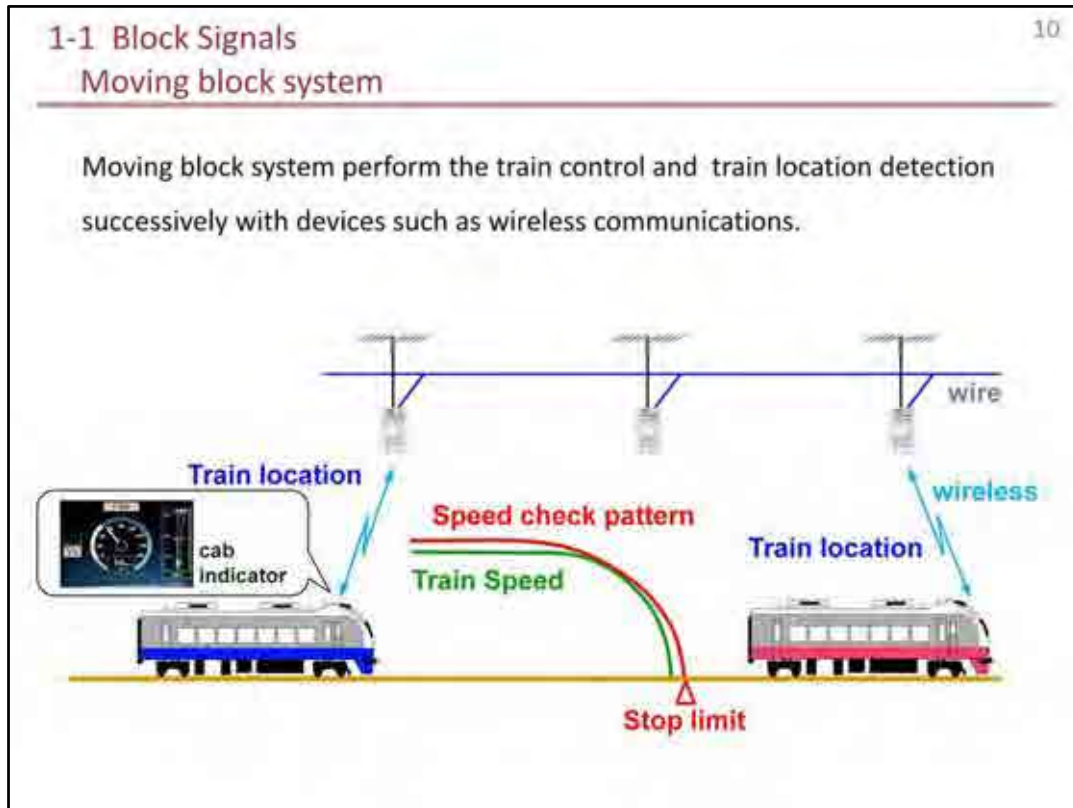

This slide explains the mechanism of the moving block system.

The currently used moving block systems are effectively using train radio systems and other facilities to continuously detect and control train positions.

Let's discuss the operation in a more specific manner.

- The preceding train transmits the own position to the shared network with wireless communications.
- Upon receiving this information, the following train calculates the stopping limit position and the braking pattern, i.e., speed check pattern (red line in the figure) to be used to control the train to stop before reaching the stopping limit position, according to the safe distance to be maintained, own position, and the position of the preceding train received.
- By continuously comparing the actual speed of the own train (green line) against the calculated speed given by the speed check pattern, the system performs automatic braking whenever the own speed has exceeded the speed of the speed check pattern.

The mechanism ensures proper train separation as required from time to time, by continuously updating the train position information through radio communication.

The features of the moving block system are that:

- Lean facilities can be realized, as track circuits and other associated devices become unnecessary.
- Traffic capacity can be expected to increase significantly, being not limited by the ground facility.



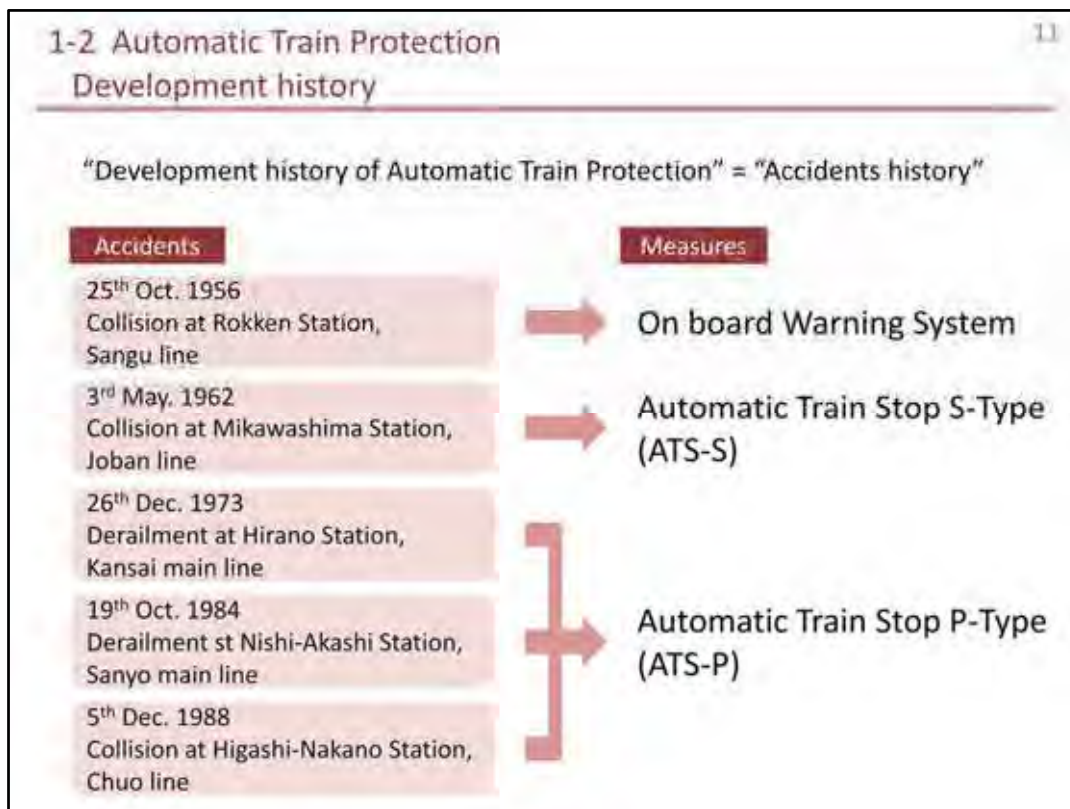

Next, we will explain the automatic train protection systems.

It can be said that the development history of automatic train protection systems is the history of railway accidents in Japan.

The automatic train protection system has been developed and continuously improved as recurrence prevention measures for past accidents.

First of all, we will explain the “on board warning system”, which is an early-stage implementation of the automatic train protection system.

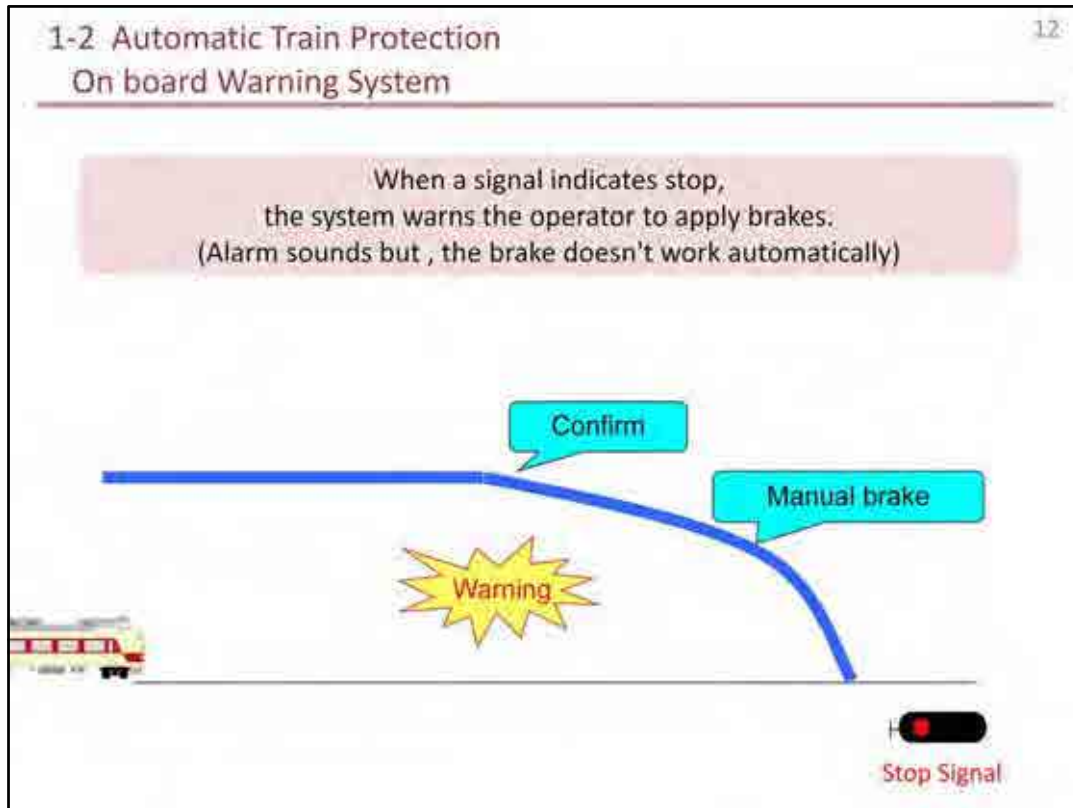

A on board warning system is a warning device to alert the train driver that the signal ahead of the train is indicating "stop".

The information to indicate the state of the signal ahead is carried in the form of signal current that flows in the right and left rails, which is detected by onboard detectors of the train for alerting the driver.

Note that this device only provides a warning indication without performing automatic braking. Accordingly, the train driver is required to manually control the brake when the warning is noted.

1-2 Automatic Train Protection 13  
Accident at Mikawashima and ATS-S System

[Overview of Accident]

Date	3 <sup>rd</sup> May 1962
Fatality	160
injuring	296
Cause	Signal Passed At Danger (SPAD)



[Problem of On Board Warning System]

The system can't stop the train when operator overlooking the warning



**Introduction of ATS-S System**



Next, we would like to introduce the accidents that triggered the introduction of the automatic train stop system.

This train crash accident occurred at the Mikawashima station on the Joban line on May 3, 1962. This devastating accident killed 160 people and injured 296 people. The cause was an over-run due to a failure of the train driver to overlook the stop signal.

The problem was that the on board warning systems implemented at that time did not have an automatic braking function. So, once the warning signal was overlooked, the train could not be stopped.

As a solution to the problem, i.e., to automatically stop the train, the automatic train stop system (ATS-S) was introduced after the accident.

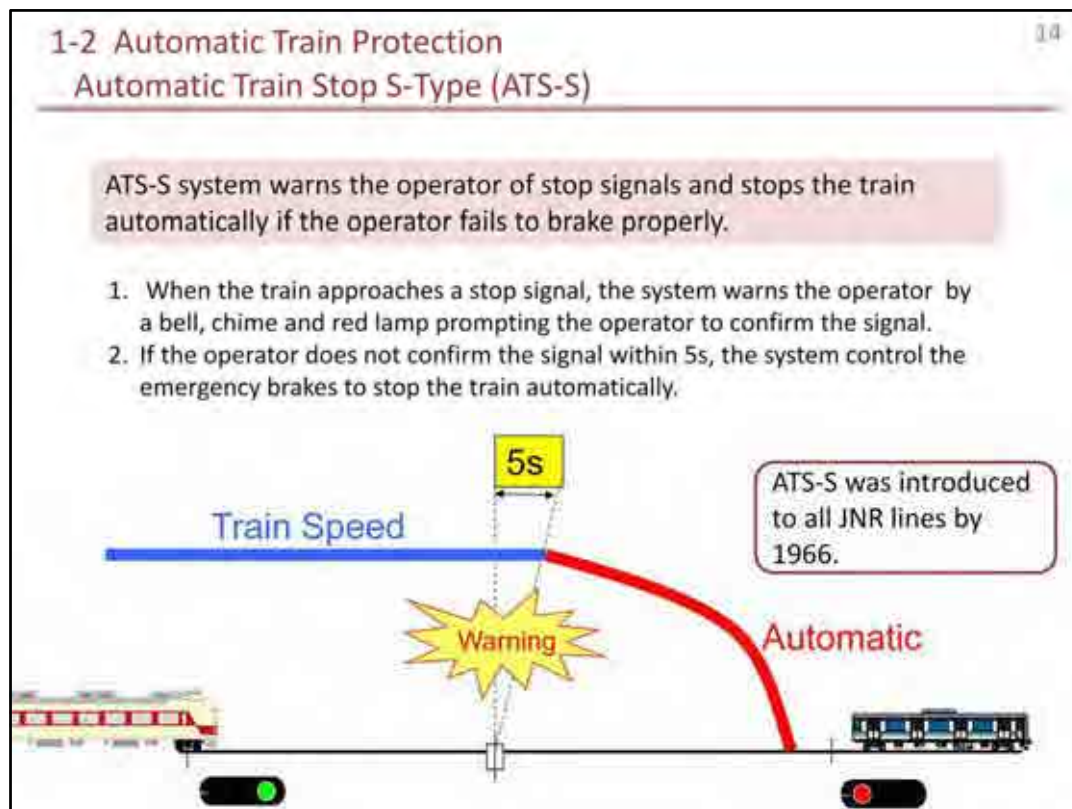

Now, we will have a look at the details of the automatic train stop system (hereafter referred to as "ATS-S").

The ATS-S system first warns the driver that the signal ahead is indicating "stop". If the driver does not properly operate the brake within 5 seconds after the alert, the ATS-S system will automatically control the brake to stop the train.



The stop signal information ahead of the train can be transferred to the train in various ways. One of the typical methods is to transmit the signal information from a ground coil installed on the track to the on-board antenna mounted on the bottom of the train.

For your information, implementation of the ATS-S system was completed by 1966 in all sections of the Japanese National Railways (JNR).

1-2 Automatic Train Protection  
Accident at Hirano and ATS-P System 15

[Overview of Accident]

Date	26 <sup>th</sup> Dec 1973
Fatality	3
injuring	156
Cause	Over speed -> Derailment



Although the ATS-S system had been implemented in all sections of JNR, it was unable to prevent an accident.

This train derail accident occurred at the Hirano station on the Kansai-Honsen line on December 26, 1973.

The disaster, which was caused by over speeding, killed 3 people and caused 156 injuries.



1-2 Automatic Train Protection 16

Accident at Higashi-Nakano and ATS-P System

[Overview of Accident]

Date	5 <sup>th</sup> Dec 1988
Fatality	2
injuring	116
Cause	Over speed -> Derailment



[Problem of ATS-S]

- No ability to check train speed
- After train operator confirmed warnings within 5 seconds, safety entirely is dependent on the operator's attention.



**Introduction of ATS-P System**

This train rear-end collision accident occurred at the Higashi-Nakano station on the Chuo line on December 5, 1988.

The accident, which killed 2 people and caused 116 injuries, was caused by the failure of the driver by entering the stop signal area despite the stop signal, without taking proper actions.

From these two accidents, it can be readily understood that the ATS-S system has the following problems to be solved:

- It does not have the function to check the train speed.
- Once the warning status is acknowledged by the driver within 5 seconds after the alert, the automatic train stopping function will be disabled and thus the safety becomes totally dependent on the attentiveness of the driver.

To solve these problems, a newly improved automatic train stop system, called ATS-P, was introduced.

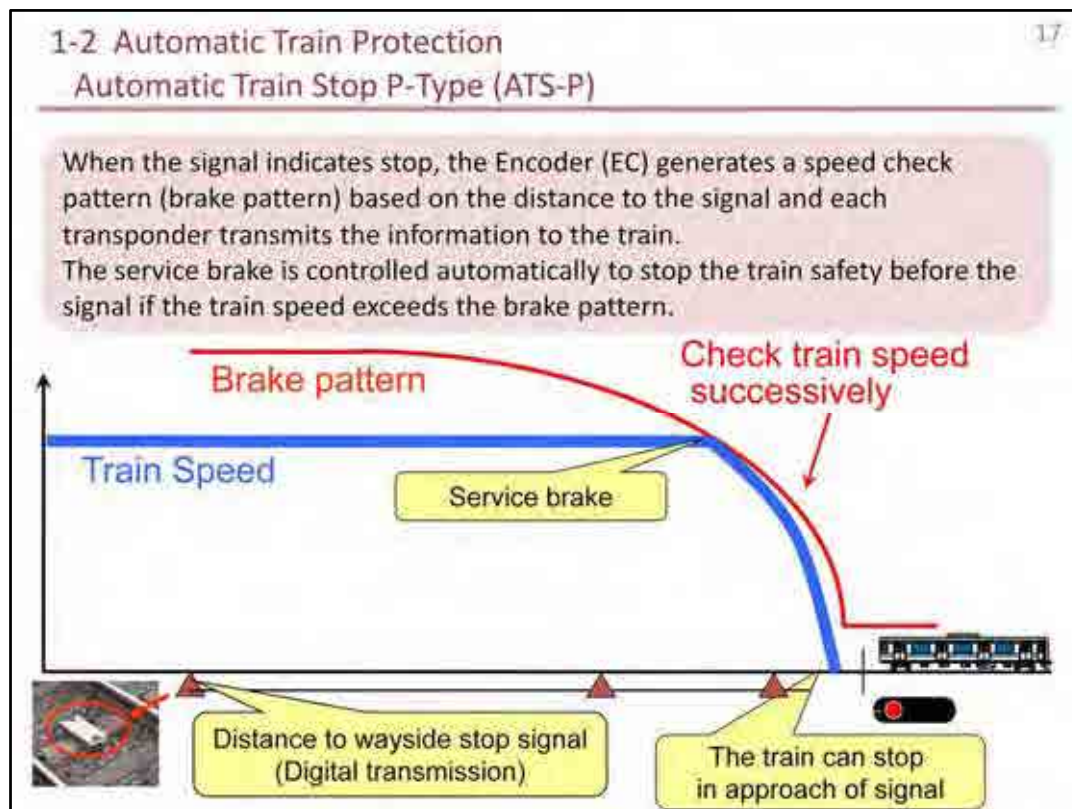

This slide illustrates the general operation of the ATS-P system.

1. A transponder which is installed on the ground transmits the state of the wayside stop signal and the distance to the signal to the train.
2. After receiving the information sent from the transponder using an on-board antenna attached on the bottom of the train, the on-board system generates a braking pattern according to the information received.
3. If the train speed exceeds the speed defined by the braking pattern (speed-check pattern), the system automatically controls the brake to stop the train before reaching the wayside stop signal.

The ATS-P system can not only prevent the driver's ignorance to the signal, but also prevent excessive speed when the train passes a switch, curve, down slope, or other speed-limit sections.

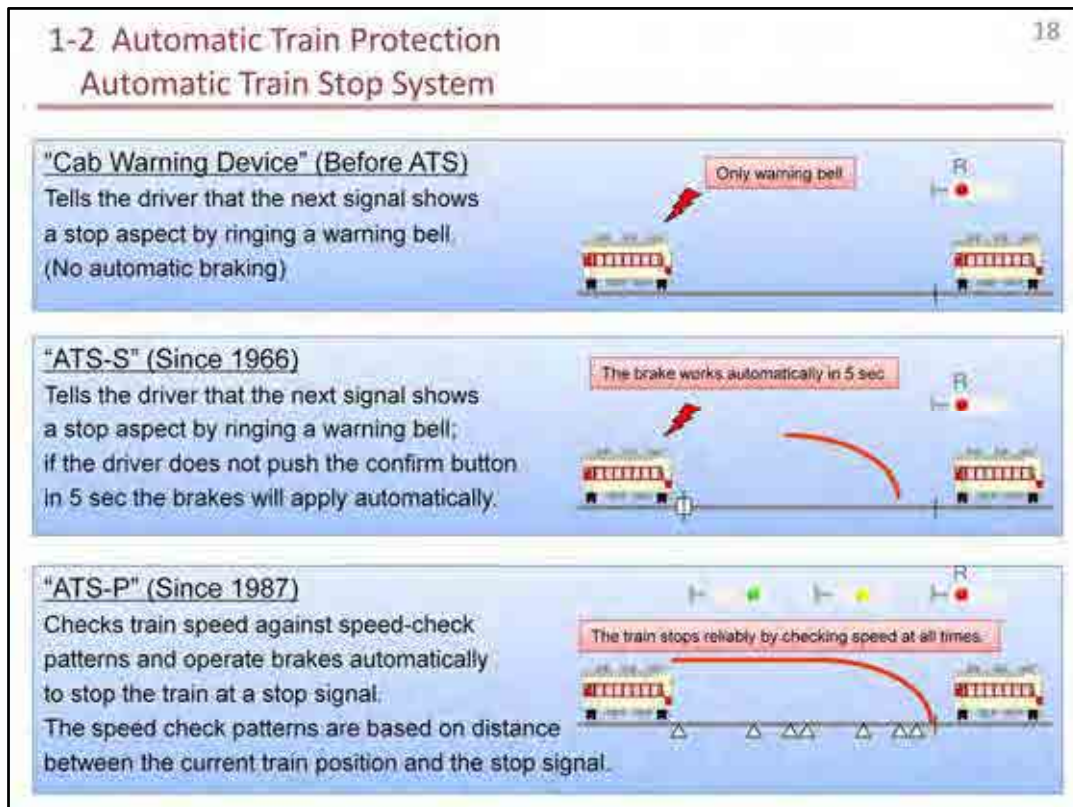

This page provides a comparison of major parameters between the Cab Warning Device, ATS-S system, and ATS-P system.

No detailed explanation is given here, as it has been detailed in the previous slides.



## 1-2 Automatic Train Protection

19

### Introduction of Automatic Train Control System(ATC)

The ATS system is a kind of "back-up" system in that it automatically stops the train when it enters or is likely to enter the stop signal area due to lack of attentiveness or ignorance of the driver.

[In the case of High-Speed Railway of which train speed exceeds 200 km/h]

- The braking distance becomes very long and may exceed the visual range to the wayside signals.
- A short delay in braking action the moment causes a serious accident



***The conventional ATS system that depends on the driver's braking action after his recognition of the wayside signal indication is considered very risky.***

As it is understood from the previous explanation, the ATS system is a kind of "back-up" system in that it automatically stops the train when it enters or is likely to enter the stop signal area due to lack of attentiveness or ignorance of the driver.

In the case of a high speed railway of which train speed exceeds 200 km/h, the braking distance becomes very long and may exceed the visual range to the wayside signals, and a short delay in the braking action can result in a significant effect. As such, the conventional ATS system that depends on the driver's braking action after his recognition of the wayside signal indication is considered very risky.

1-2 Automatic Train Protection 20

**Introduction of Automatic Train Control System(ATC)**

---

[In the case of High-Speed Railway of which train speed exceeds 200 km/h]

- The braking distance becomes very long and may exceed the visual range to the wayside signals.  
*>>> On-board signal system*
- A short delay in braking action the moment causes a serious accident  
*>>>Operating speed is displayed in numbers .*  
*The brake is controlled automatically to stop the train safety if the train speed exceeds the operating speed.*



**Introduction of Automatic Train Control System (ATC)**

So, for the high speed railways of which train speed exceeds 200 km/h, a decision was made to adopt a new on-board signal system that indicates the signal state in the cab, i.e., it displays the signal information in the form of numeric values (i.e., operating speed), compares the operating speed against the actual speed, and automatically controls the brake to reduce the train speed down to the operating speed. This system, the Automatic Train Control (ATC) system, was thus developed and introduced.

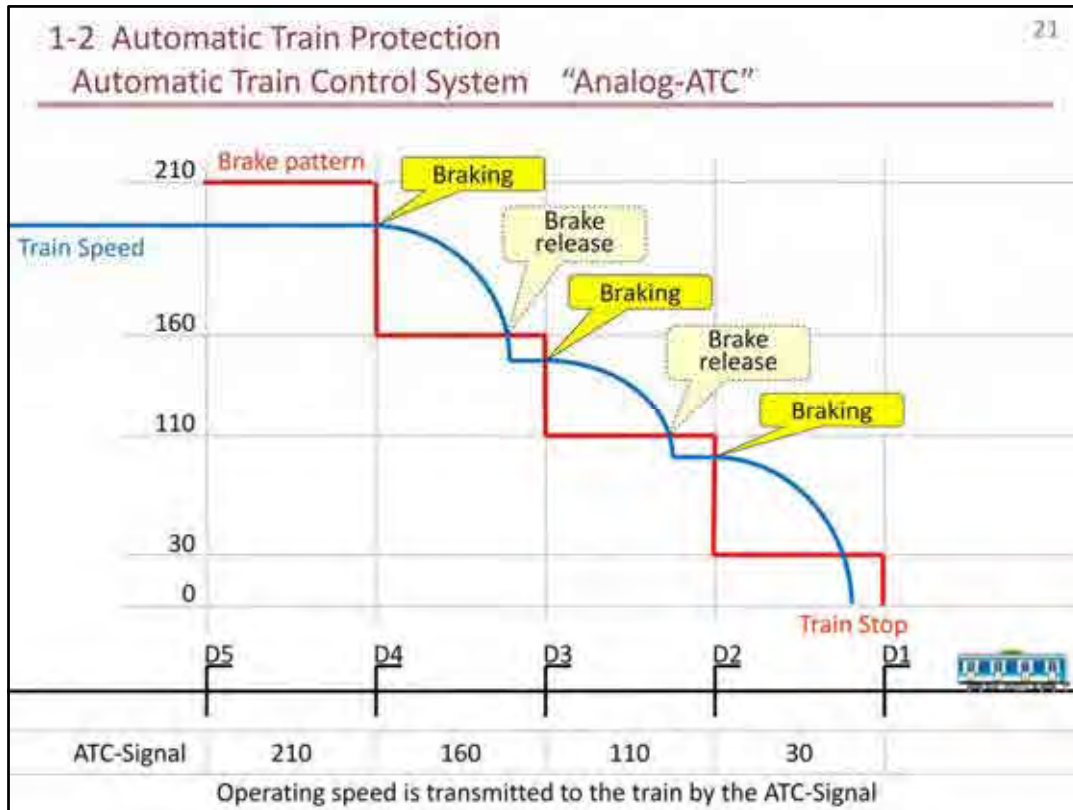

The earlier ATC systems are called "Analog ATC" -- the train control functions are mainly implemented in the ground system, as the speed signal to control the train is transmitted from the ground system to the on-board system.

Here, the outline of the analog ATC operation is presented using an animation.

- The ATC signal is an analog signal. In this system, an allowable operating speed for each block is determined based on the position of the preceding train and transmitted to the following train.
- The signal current flows in the right and left rails, and the train receives the information through the wheels.
- If the actual train speed exceeds the operating speed specified for the block, the on-board system automatically controls the brake to reduce the speed. Then, after the speed becomes sufficiently lower than the operating speed, it releases the brake.
- By repeating the above described braking actions, the system stops the train before entering the block section in which the preceding train is present.

As the ATC signal current is always flowing in the rails, the train can continuously receive the constantly changing operating speed.

Although this system is considered a safe and proven system based on the technology originally developed for the Tokaido Shinkansen (which started the service in 1964), it also has the following problems:

- As the speed reduction is performed in steps according to the operation speed specified for each track circuit, the repetition cycle of applying and releasing the brake can give bad effects on the ride comfort of passengers.
- As the operating speed of a track circuit is determined to be suitable to the train type with the worst braking performance, the trains have to reduce the speed for a long distance, to lead to a significant time loss.
- Although the driver can check the operating speed of the section the train is currently in, the operating speed of the section ahead cannot be checked.

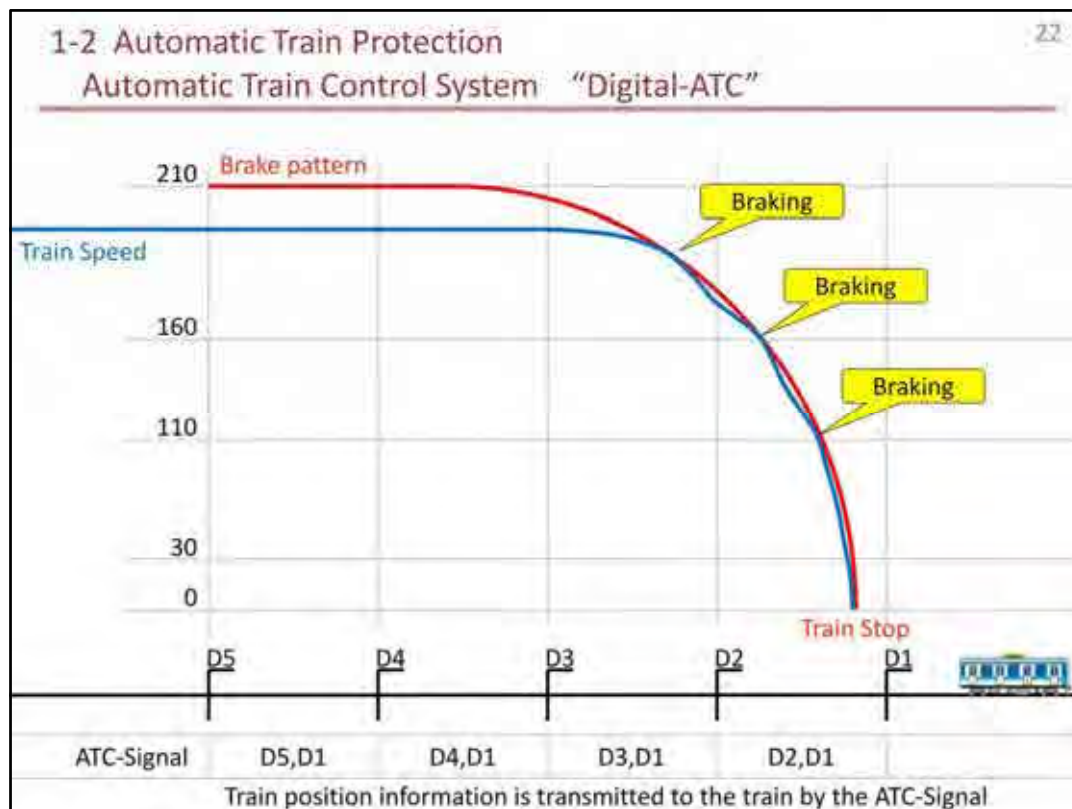

To solve the problems with the analog ATC system, a new "digital ATC" system was developed.

Here, the outline of the digital ATC operation is presented using an animation.

- In the digital ATC system, the position of the preceding train as well as the position of the own train is received as digital data.
- Then, the on-board system generates the braking pattern (speed check pattern) using the information received.
- If the train speed exceeds the speed defined by the braking pattern, the system automatically controls the brake to stop the train before the block section in which the preceding train is present.

The features of the digital ATC system are listed below:

- Digital signals are used to enable exchange of a large amount of data between the ground system and the on-board system.
- Smooth braking control is realized through the use of an optimum braking (speed check) pattern, as generated by the on-board system from the position of the preceding train and the position and speed of the own train.
- The braking control can be optimized for each train type, leading to the reduction of the running time between stations.

1-2 Automatic Train Protection 23

Differences of ATS and ATC

Compare items	ATS	ATC
Signal system	Ground-based Signal system	On-board Signal system
Information transmission	The intermittent transmission by transponder etc.	Continuously transmission with rails
Control method	Intermittent control	Continuous control
Speed checking	(ATS-S) absence (ATS-P) presence	presence
Safety	Low	High

This table shows the differences between ATS and ATC.

In terms of the type of the signal system, ATS is compatible to the ground-based signal system, and ATC is an on-board signal system.

Regarding the method of ground to train information transfer, ATS uses ground coils or transponders to intermittently transfer the information while ATC uses both rails to continuously transfer the data without interruption.

The difference in the information transfer method also affects the braking control. As the information is obtained intermittently, the braking control decision of ATS is made only when the information is obtained. On the other hand, as the necessary information is always available, the braking control decision of ATC can be made at any time.

While the ATS system has the speed check function only after Type P, the ATC system has the same function from the first, in principle.

From the above differences, it can be said that ATC has relatively higher degree of protection than ATS.

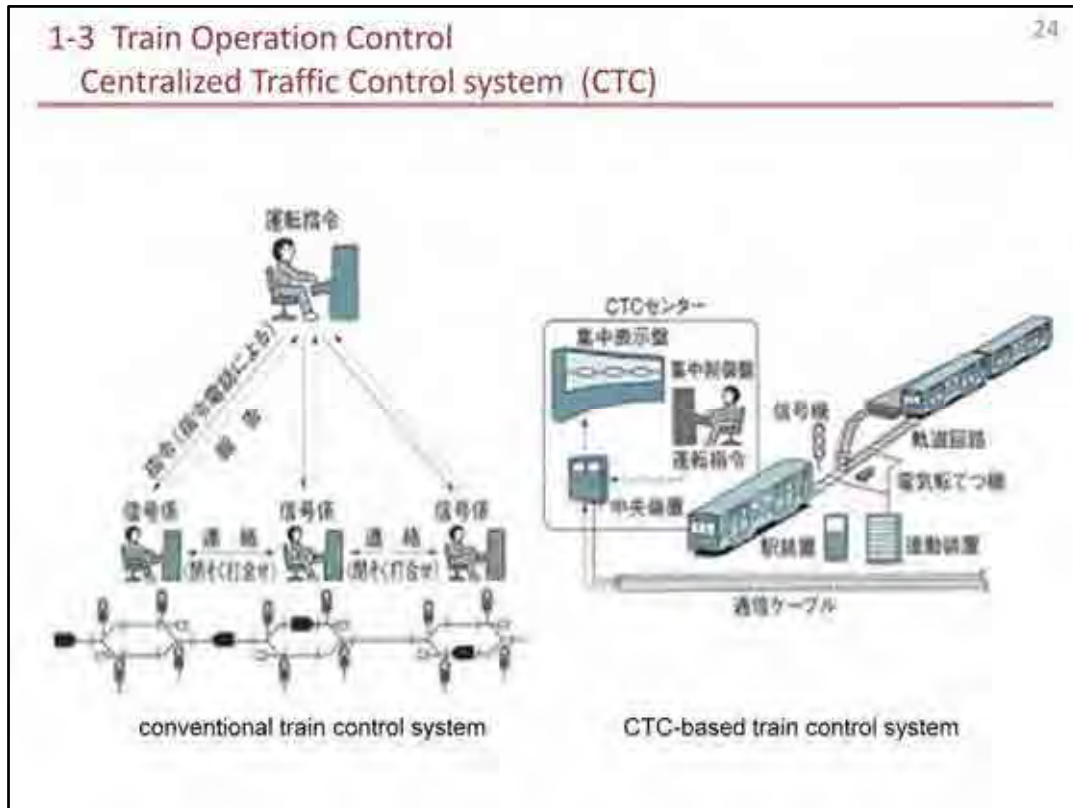

Now, let's have a look at the train operation control system.

The Centralized Traffic Control system (hereafter referred to as "CTC") enables train dispatchers to grasp the overall status of train operation in the railway section and has the function to directly remote control the signals of each station.

In a conventional train control system, some operating personnel positioned at each station are to control the signal systems according to the train schedule. Telephone lines are used for voice communication between stations as well as between stations and the central dispatcher to exchange the departure and arrival information.

In the CTC-based train control system, the CTC center and the stations are equipped with information transfer devices, the status of track circuits and signals is obtained at the CTC center, and the dispatcher controls the signals of each station based on the status information obtained.



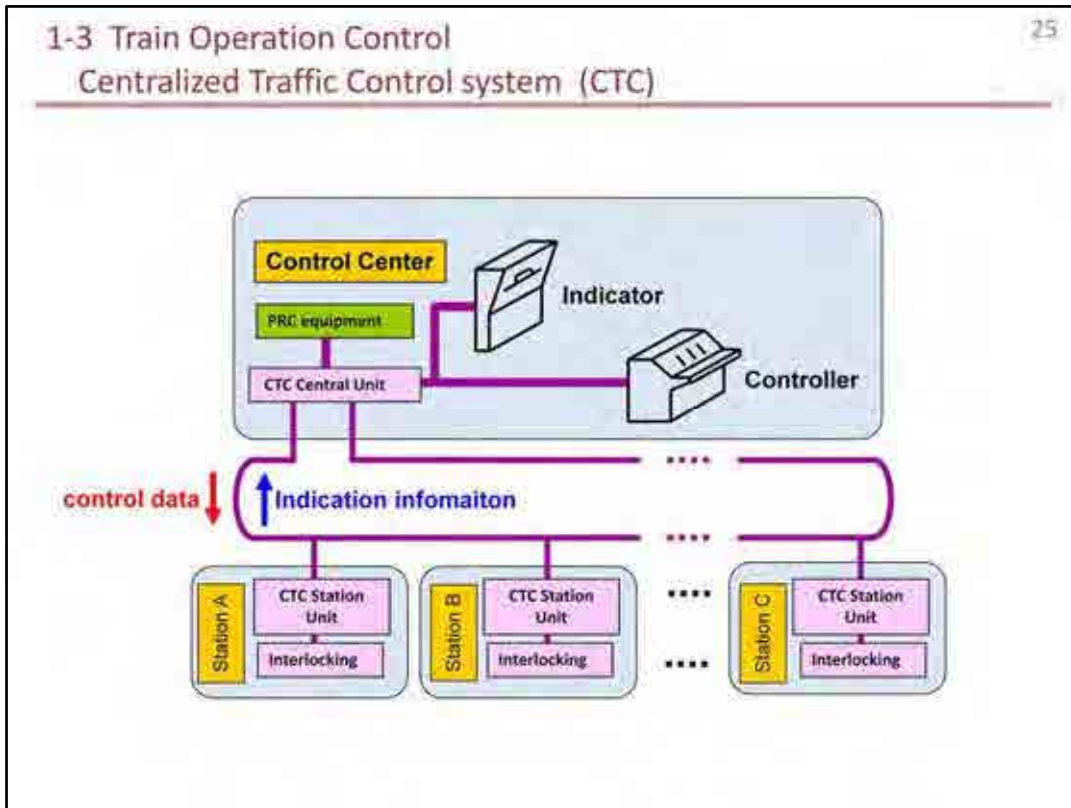

This figure illustrates the outline of the system.

- A network is implemented to connect the control center and the stations via optical fiber cables.
- Using this network, each station transmits the status of signals and other display data to the control center.
- In the control center, the status of every station is displayed on a display panel according to the display data obtained.
- The dispatcher controls the signals of each station from the control console according to the information on the display panel.
- The control information entered from the control console is sent to each station via the network.
- At each station, the signals and switches are operated according to the control information received.

The positive effects of the implementation of CTC are as follows:

- Through the use of the centralized operating status monitoring and route control functions, it will no longer be required to position operating personnel at each station, and it leads to possible reduction of personnel.
- As the exchange of reports and instructions among the stations and the control center will no longer be required, quick and speedy dispatching services can be realized.

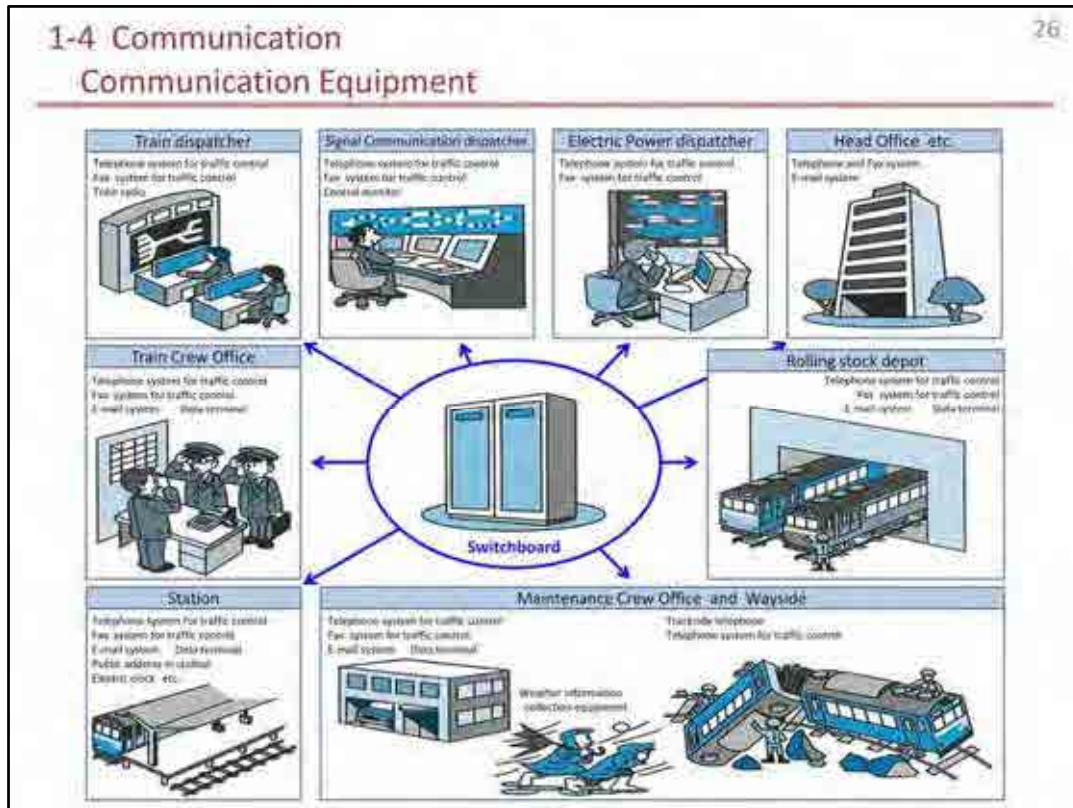

The role of communication in a railway system is as described below:

(1) Train operation and communication

Ensuring the safety and the accuracy of operation are the essential factors of train operation. To this end, and in order to be able to promptly deal with possible train delays, the train dispatchers are positioned to always keep track of the status of train operation, collect necessary information, and provide commands. Telephone systems are used for the traffic control communication with each station, train radio systems are used to communicate with trains, and ITV systems are installed on station platforms to monitor the movement of passengers. Furthermore, such devices as railway bridge wind monitors are also regarded as communications equipment.

(2) Passenger service and communication

At a station, reserved seat tickets as well as air tickets are issued promptly. This is because the terminals at the station are connected to the central management computer via a communication network. Furthermore, the broadcasting systems for passenger guidance on train departure/arrival are also categorized as communications equipment.

(3) Other communication facilities

The dedicated telephone lines to connect various locations of the railway, communications network and exchanges to connect telephone terminals, and automatic fire alarm systems are also categorized as communications equipment.



## Contents

### 1. Overview of railway signaling and communication facilities

- 1 Block Signals (signal, track circuit)
- 2 Automatic Train Protection (ATS, ATC)
- 3 Train Operation Control
- 4 Communication

### 2. Main factors of which control train speed

- 1 Signal
- 2 Level Crossing

While the previous slides were used to explain the signal systems and communication facilities used in the railway transport sector,  
The following slides are used to explain the major factors that control the train speed, from the viewpoints of signals and railway level crossings.

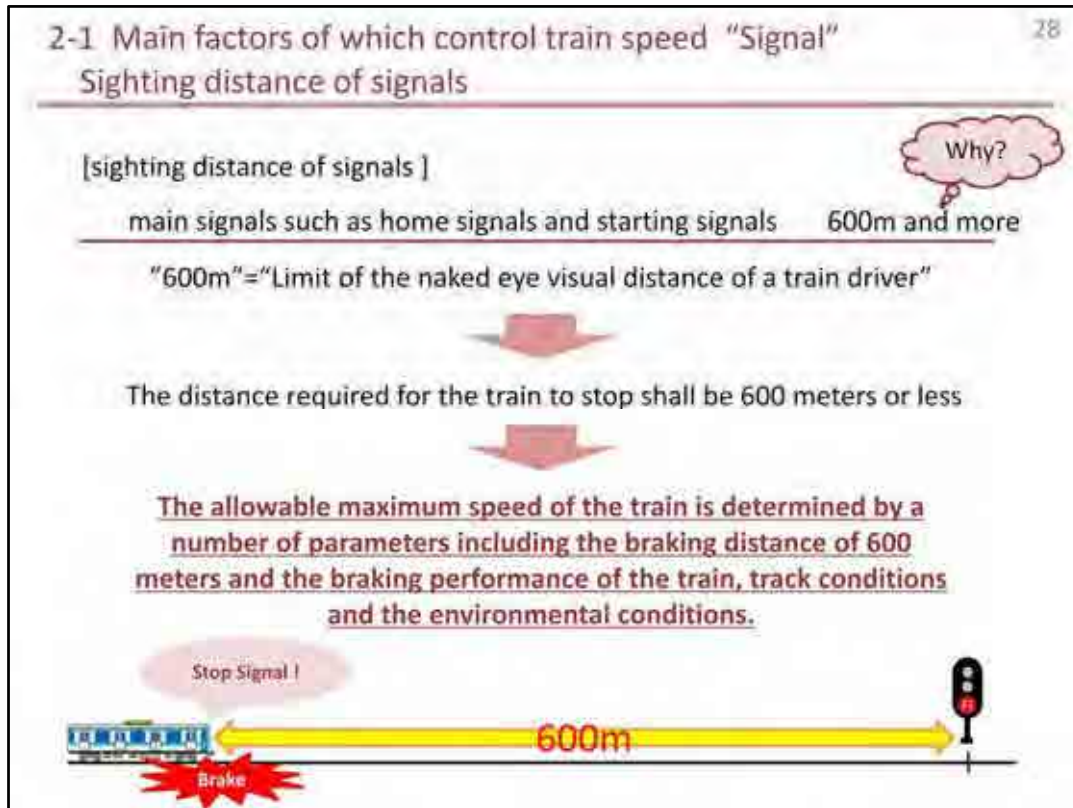

First, we will talk about the sighting distance of signals.

In Japan, the sighting distance of 600 meters or more shall be ensured in principle, for the main signals such as home signals and starting signals. Now, why the 600 meters or more distance is required?

The sighting distance of 600 meters has been specified based on the idea that the maximum naked eye visual distance of a train driver is about 600 meters.

Accordingly, it is understood that the distance required for the train to stop shall be 600 meters or less, i.e., as measured from the point a stop signal or obstacle is recognized by the driver up to the point the train is completely stopped by the emergency brake.

Accordingly, the allowable maximum speed of the train is determined by a number of parameters including the braking distance of 600 meters and the braking performance of the train, as well as the curve, cant, and other track conditions and the environmental conditions.

2-1 Main factors of which control train speed "Signal" 29  
Extension of the emergency braking distance

The allowable maximum train speed is limited by the emergency braking distance of 600 meters.



The maximum train speed should be able to be increased if the emergency braking distance can be increased.

The emergency braking distance can be increased if the following conditions can be satisfied:

- An effective train protection system, such as the train protection radio, that does not depend on visual recognition by the driver is adopted.
- There are no level crossings, e.g., long tunnel sections or elevated sections

[case examples in Japan]  
The emergency braking distance has been increased to 1,100 meters for the Hokuetsu Express line and Narita Rapid Rail Access line to realize the train operation at 160 km/h.

As the allowable maximum train speed is limited by the emergency braking distance of 600 meters, the maximum train speed should be able to be increased if the emergency braking distance can be increased.

The emergency braking distance can be increased if the following conditions can be satisfied:

- An effective train protection system, such as the train protection radio, that does not depend on visual recognition by the driver is adopted;
- There are no level crossings, e.g., long tunnel sections or elevated sections

In some cases, it may be required to take some actions to assist the driver to extend the visual range.

As case examples in Japan, the emergency braking distance has been increased to 1,100 meters for the Hokuetsu Express line and Narita Rapid Rail Access line to realize the train operation at 160 km/h.

## 2-1 Main factors of which control train speed "Signal" 30

### The visibility of a signal in the case of a High-Speed Railway

A train running at the speed of 200km/h will run about 55 meters per second.

A very long braking distance will be required and the resulting emergency braking distance would considerably exceed the visual range of the driver to visually recognize a ground signal, an emergency braking operation by the operator after a signal or obstacle on the track is visually recognized will not be able to bring the train to full stop before the train reaches the signal or obstacle.



conditions shall be specified for the signal equipment of any railway of which trains are to run at a speed exceeding 200 km/h:

- Adoption of an on-board signal system to display the signal inside the cab
- Elimination of any possible obstacle, such as the ones for level crossings

Next, we will discuss the visibility of a signal, assuming the case of a high speed railway of which train speed exceeds 200 km/h.

For example, a train running at the speed of 200km/h will run about 55 meters per second.

As such, as a very long braking distance will be required and the resulting emergency braking distance would considerably exceed the visual range of the driver to visually recognize a ground signal, an emergency braking operation by the operator after a signal or obstacle on the track is visually recognized will not be able to bring the train to full stop before the train reaches the signal or obstacle.

Accordingly, from the viewpoint of signal visibility, the following conditions shall be specified for the signal equipment of any railway of which trains are to run at a speed exceeding 200 km/h:

- Adoption of an on-board signal system to display the signal inside the cab
- Elimination of any possible obstacle, such as the ones for level crossings.

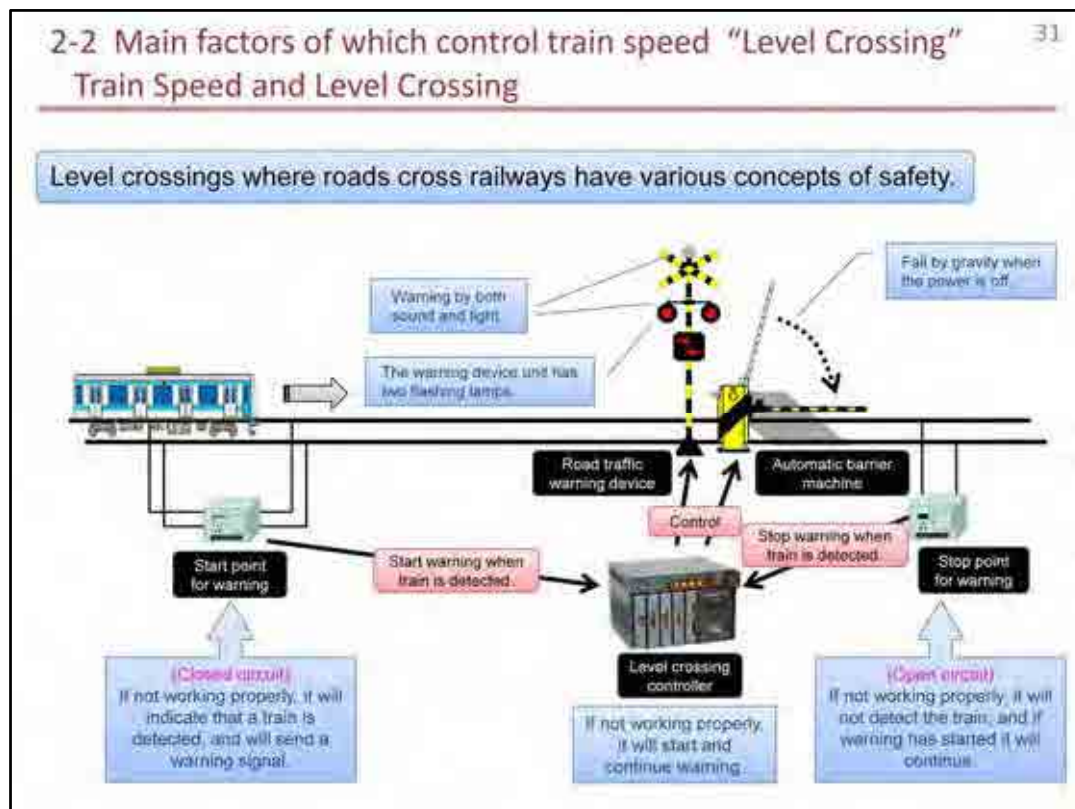

Next, we will explain the issue of train speed in relation to level crossings.

In Japanese railways, so called "automatic level crossing" is commonly used to automatically display alarms and open/close the level crossing gate. In these automated systems, various ideas are employed to ensure the safety of the automatic level crossings.

The figure shows the basic components of an automatic level crossing system as listed below:

- A start point to detect an approaching train and a stop point to detect the passing of the train;
- A controller that controls the start/stop operation of the warning device and automatic barrier machine;
- A warning device to provide audible and visible alarms to the passers-by;
- An automatic barrier machine to prevent entry from the road using crossing rods or other device; and
- Control cables used for the interconnection between subsystems



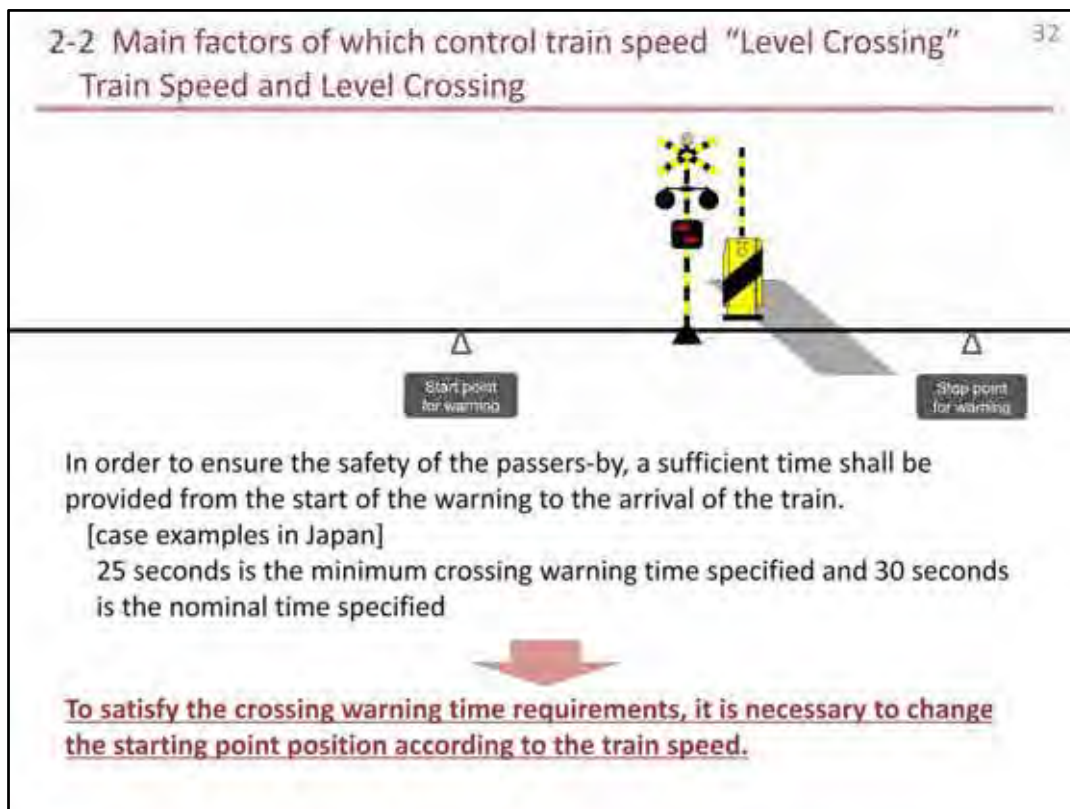

Here, the operational flow of the automatic level crossing system is presented using an animation, from train approach to warning/gating at the level crossing.

- (1) When the train approaches the level crossing and passes the start point, the train approach information is sent from the start point to the controller.
- (2) When the train approach information is received, the controller commands the road traffic warning device and the automatic barrier machine to start providing the warning signal and closing the gate, respectively.
- (3) The road traffic warning device and the automatic barrier machine start to operate as commanded.
- (4) When the train passes the crossing and runs over the stopping point, the stopping point will transmit the train passing information to the controller.
- (5) When the train passing information is received, the controller commands the road traffic warning device and the automatic barrier machine to stop providing the warning signal and open the gate, respectively.
- (6) The road traffic warning device and the automatic barrier machine will complete the operation as commanded.

In order to ensure the safety of the passers-by, a sufficient time shall be provided from the start of the warning to the arrival of the train. Here, this time period is called "crossing warning time". According to the applicable ministerial ordinance of Japan, 25 seconds is the minimum crossing warning time specified and 30 seconds is the nominal time specified. To satisfy the crossing warning time requirements, it is necessary to change the starting point position according to the train speed.

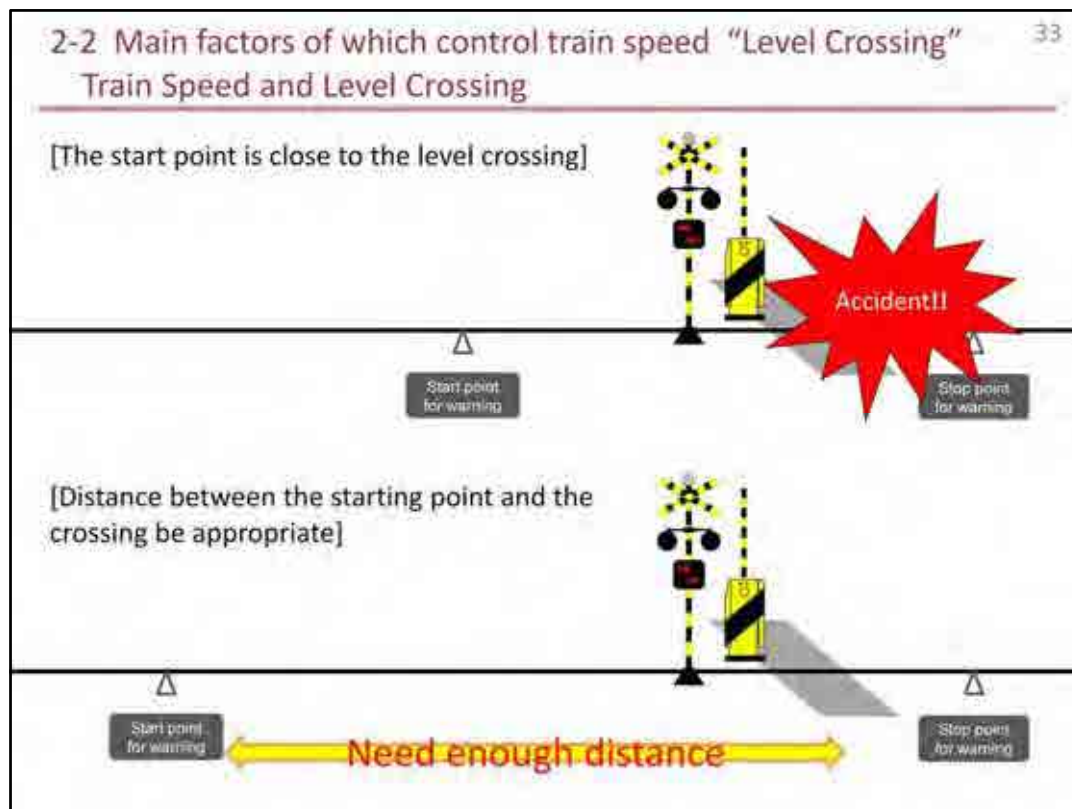

If the train speed is excessively high and the distance between the crossing and the start point is too short, a sufficient crossing warning time may not be provided. In such a case, the train may reach the crossing point before the gating operation is completed. In the worst case, it could cause an accident.

The faster the train speed, the more distance is required between the crossing and the start point.

However, using a longer distance between the crossing and the start point has some disadvantages:

The cost will increase due to the longer control cable to connect between the start point and the crossing.

If trains of different speed levels are to use the same section, the start point shall be set up to be suitable to the faster train. As a result, the crossing warning time for the slower train will become longer than the optimal time, to possibly cause traffic congestion.

2-2 Main factors of which control train speed "Level Crossing" 34  
Train Speed and Level Crossing

A train running at the speed of 200km/h will run about 55 meters per second.

- In such a case, as the distance between the start point and the level crossing will exceed 1,600 meters, the cost of cable installation will significantly be increased.
- It should be pointed out from the standpoint of the driver's visibility that it is very difficult for the emergency braking to stop the train in time if the braking is performed only after an obstacle is recognized.



**It is concluded that it is difficult to implement level crossings for a high speed railway of which train speed exceeds 200 km/h.**

That it is very rare in the world that a level crossing is implemented in a railway section of which train speed exceeds 160 km/h.

Next, we will discuss the issue of level crossings for the case of a high speed railway of which train speed exceeds 200 km/h.

As mentioned earlier, a train running at the speed of 200km/h will run about 55 meters per second.

In such a case, as the distance between the start point and the level crossing will exceed 1,600 meters, the cost of cable installation will significantly be increased. In addition, it should be pointed out from the standpoint of the driver's visibility that it is very difficult for the emergency braking to stop the train in time if the braking is performed only after an obstacle is recognized.

As such, it is concluded that it is difficult to implement level crossings for a high speed railway of which train speed exceeds 200 km/h.

Note that it is very rare in the world that a level crossing is implemented in a railway section of which train speed exceeds 160 km/h.



35

## 2 Main factors of which control train speed

### Relationship of the signal system and train speed of world railways

Country	Japan	France SNCF	Germany DB AG	Italy FS	Austria ÖBB	Switzerland SBB	UK Rail Network BR
maximum speed(km/h)	160	220	200	230	160	160	200
Automatic Train Protection	ATS	ATC	ATC	ATC	ATC	ATC	ATS
Signal System	Ground Signal	On-board signal	On-board signal	On-board signal	On-board signal	On-board signal	Ground Signal
Block System	Automatic	Automatic	Automatic	Automatic	Automatic	Automatic	Automatic
train detection	Track Circuit	Track Circuit	Track Circuit	Track Circuit	Track Circuit	Track Circuit	Track Circuit
Train Operation Control	Yes	Yes	Yes	Yes	Yes	Yes	Yes
Level Crossing	No	No	No	Yes	No	No	Yes

**The signal system to be used in a railway system of which operational train speed is about 200 km/h**

[Automatic Train Protection]	ATC System
[Signal System]	On-board Signal System
[Block System]	Automatic Block System
[Train detection]	track circuit
[train operation system]	Yes
[Level Crossing]	No

This table summarizes the major parameters of signal systems of world railways that are operated at the train speed of around 200 km/h.

It is considered the mainstream to use ATC, which is with a higher degree of protection, as an automated train protection system for the sections of which train speed exceeds 200 km/h. Although the British Rail in UK is using ATS for their operation, they are employing two train drivers to run the train when the train speed is to exceed 175 km/h, in order ensure a higher degree of protection.

Also, level crossings are mostly avoided in the sections of which train speed exceeds 160 km/h. For the cases where level crossing is used, automatic level crossing systems are installed and it is also mandated to take proper measures to prevent accidents, such as positioning of security personnel and installation of monitor cameras.

From the current situation of other countries, it is reasonably understood that the signal system to be used in a railway system of which operational train speed is about 200 km/h should use:

- Automatic Train Control (ATC) system for automated train protection;
- On-board signal system to display the operating speed value;
- Automatic block system;
- Track circuits for train detection;
- Train operation control systems;
- No level crossing facilities.

# Structure 1

1. Comparison of High-Speed Rail and Freight Rail
2. Comparison of Japanese and Global High-Speed Rail

4 Dec 2013

JICA Study Team

Kenji OHISHI



Japan International Consultants for Transportation Co.,Ltd. (JIC)

1/30

I am Ohishi from Japan International Consultants for Transportation Co., Ltd., and the subject of my presentation today is comparing high-speed rail with freight rail and Japanese high-speed rail with other high-speed rail around the world.

Thank you for being here.

## Contents

### 1. Comparison of High-Speed Rail and Freight Rail

- (1) What's a High-Speed Rail?
- (2) What's a Freight Rail?
- (3) Differences on Line Specifications
- (4) Differences on Axle Load
- (5) Differences on the Structural Cross-Sections (Case of PC-girder)
- (6) Differences on Track Layout Plan
- (7) Differences on Maintenance Windows
- (8) Approaches to operating high-speed passenger trains and freight trains on the same line, which is being considered for the Seikan Tunnel
- (9) Conclusion

### 2. Comparison of Japanese and Global High-Speed Rail

- (1) Differences on Track Spacing and Formation Level Width
- (2) Differences on the Structure Ratios
- (3) Differences on Structural Cross-Sections (Tunnel)
- (4) Differences on the Approach to Tunnel Fire Countermeasures
- (5) Tunnel Buffering Hoods
- (6) Differences on the Approach to the Air Tightness of Rolling Stock
- (7) Differences on the Concept of Track Layouts
- (8) Differences on Maintenance Approach
- (9) Conclusion

2/30

The details of today's presentation are shown here.

1. Comparing high-speed rail and freight rail
2. Comparing Japanese high-speed rail with other high-speed rail around the world

I will provide an explanation of these two topics.

## 1. Comparison of High-Speed Rail and Freight Rail

3/30

First, I would like to compare high-speed rail and freight rail.

## (1) What's a High-Speed Rail?

- UIC defines high-speed rail as trains running at a maximum speed of 250km/h or more (In Japan, trains run at 200km/h or more on the main sections of the line).
- At present, the maximum operating speed in the world is 320km/h.



Example of multiple-unit system train  
(Japan, Tohoku Shinkansen E5 series)



Example of power concentrated system train  
(France, TGV-R)

Source: High-speed railway in the world, JARTS

4/30

I will begin with the definition of a high-speed rail.

The International Union of Railways (UIC) defines this as a rail system on which trains run at a maximum speed of 250km/h or more.

In Japan, however, it is defined as a rail system on which trains run at 200km/h or more on the main sections of the line.

This is known as a “Shinkansen” or bullet train in Japan.

In Japan, an electric multiple-unit system is used for high-speed rail.

An example of an electric multiple-unit system train is Japan’s Tohoku Shinkansen E5 series.

In Europe, meanwhile, the power concentrated system is also used for high-speed rail.

An example of a power concentrated system train is France’s TGV-R.

At the present time, the maximum operating speed among high-speed trains worldwide is 320km/h.

## (2) What's a Freight Rail?

- Railway for the purpose of transport of cargo such as containers and bulk goods



The world's first Multiple-unit system container cargo train (Japan, popular name "SUPER RAIL CARGO")  
Maximum operating speed: 130km/h



Electric Locomotive to pull the container (Japan)  
Maximum operating speed: 110km/h

Source: Japan Freight Railway Company

5/30

Next, I will explain a definition of a freight train.

A freight train refers to a train whose purpose is to transport cargo such as containers and bulk goods.

The photo on the left is a freight train commonly known as the Super Rail Cargo, which was developed as the world's first-ever electric multiple-unit system container freight train in Japan. Its maximum operating speed is 130km/h.

The photo on the right is an electric locomotive for transporting containers in Japan, with a maximum operating speed of 110km/h.

### (3) Differences on Line Specifications

#### ➤ High Speed Railway

Item	Shinkansen (Japan)			TGV (France)	
	Tokaido	Tohoku	Kyushu	Paris – Lyon	Paris – Baudrecourt
Design Speed	210km/h	260km/h	260km/h	270km/h	350km/h
Maximum Operating Speed	270km/h	320km/h	260km/h	300km/h	320km/h
Vertical Curve Radius	10,000m	15,000m	25,000m	25,000m	25,000m
Minimum Horizontal Curve Radius	2,500m	4,000m	4,000m	4,000m	6,000m
Maximum Gradient (‰)	20	20	35	35	N/A

Source: JICA Study Team

#### ➤ Freight Railway

- Classification by maximum design speed

Maximum design speed	Steepest gradient
110km/h or more	10/1000
More than 90km/h and less than 110km/h	20/1000
Speed of 90km/h or less	35/1000

- Classification by train pulled by locomotive (Maximum gradient 35‰ by electric trains)

Design traction weight	Steepest gradient
1200 tons or more	15/1000
More than 1,000 tons and less than 1200 tons	20/1000
Less than 1000 tons	25/1000

Source: JICA Study Team

Now, to compare high-speed trains and freight trains, I will first explain differences on line specifications.

The shinkansen began with the Tokaido Shinkansen, and has since been expanded with the Tohoku Shinkansen and Kyushu Shinkansen.

The structural maximum design speed was 210km/h at opening time, but thanks to advances in technology development of rolling stocks, the current maximum operating speed is 270km/h.

In relation to TGV of French high speed train between Paris and Lyon, in the same way, the structural maximum design speed was 270km/h at opening time, the current maximum operating speed is up to 300km/h.

In terms of specific advances in rolling stocks technology, besides improved acceleration and maximum speed running stability, there has also been development of rolling stocks with first cars designed to control tunnel-micro pressure wave, the introduction of car body inclining devices and so on.

Japan's Tohoku Shinkansen and France's TGV (Paris-Baudrecourt) run at 320km/h, which is currently the maximum operating speed among high-speed trains in the world.

When it comes to freight rail, on the other hand, many freight trains in Japan use the same tracks as passenger lines, so the railway structure is based on passenger train standards.

Freight trains are categorized based on the maximum design speed, which depends on the importance of the line, and the horizontal curve radius and maximum gradient are determined based on the speed.

In the railway section of only electric trains, the maximum gradient is 35%.



## (4) Differences on Axle Load

### ➤ High Speed Railway

Item	Shinkansen (Japan)			TGV (France)	
	Tokaido	Tohoku	Kyushu	Sub-Est	North Europe
Maximum axle load (Actual load of vehicle)	11.4tf	13.1tf	11.4tf	17tf	17tf

Source: JICA Study Team

### ➤ Freight Railway

Item	Japan			Vietnam
	Container Electric train	Container Locomotive	Tank Locomotive	D16E
Maximum axle load (Actual load of vehicle)	10tf	14.6tf	15tf	21tf

Source: JICA Study Team

7/30

This slide explains differences on axle load.

For Japan's high-speed Shinkansen trains, the maximum axle load ranges from around 11 to 13 tons. The maximum axle load for France's high-speed trains is 17 tons.

For freight trains, on the other hand, the axle load varies depending on the transported cargo, but the maximum axle load is usually determined based on the locomotive.

In the case of Japan, it ranges from around 10 to 15 tons. In the case of Vietnam, if we take the D16E as an example, it is 21tf.

### (5) Differences on the Structural Cross-Sections (Case of PC-girder)

#### ➤ Design condition

- High-speed passenger train ... Maximum operating speed 350km/h, Axle load 16tf
- Freight train\* ...Maximum operating speed 100km/h, Axle load 21tf
- Method for calculating the impact factor in accordance with latest Shinkansen structure design criteria and UIC standard.

\* Freight train was assumed D16E as an example.

#### ➤ Target structure

- Simple T-PC 4-main girder L=35m



Simple T-PC girder  
 Source: JICA Study Team

Item	High-speed rail	Freight rail (D16E)
Vmax	350km/h	100km/h
Axle load	16tf (Design)	21tf (Actual load)
Train length	25.0m	16.92m
Girder height (Japan)	2.6m	2.8m
Girder height (UIC)	2.6m	3.5m

Source: JICA Study Team

8/30

To compare structural cross-sections, JICA study team roughly approximated the effect of differences on maximum speed and axle load on girder height by performing simple calculations for both a high-speed passenger train (axle load: 16 tons) with a maximum design speed of 350km/h and a freight train (Vietnam's D16E electric diesel locomotive; axle load: 21 tons) with a maximum design speed of 100km/h on simple PC girders for a 35m long bridge.

The results of this analysis showed that with the Japanese shinkansen's structural design standards, the PC girder height increases 0.2m more when running a freight train compared to a high-speed train.

On the other hand, with the UIC's standards, which do not take the effect of speed into account, the results of analysis using larger and smaller axle loads show that the PC girder height increases 0.9m more when running a freight train compared to a high-speed train.

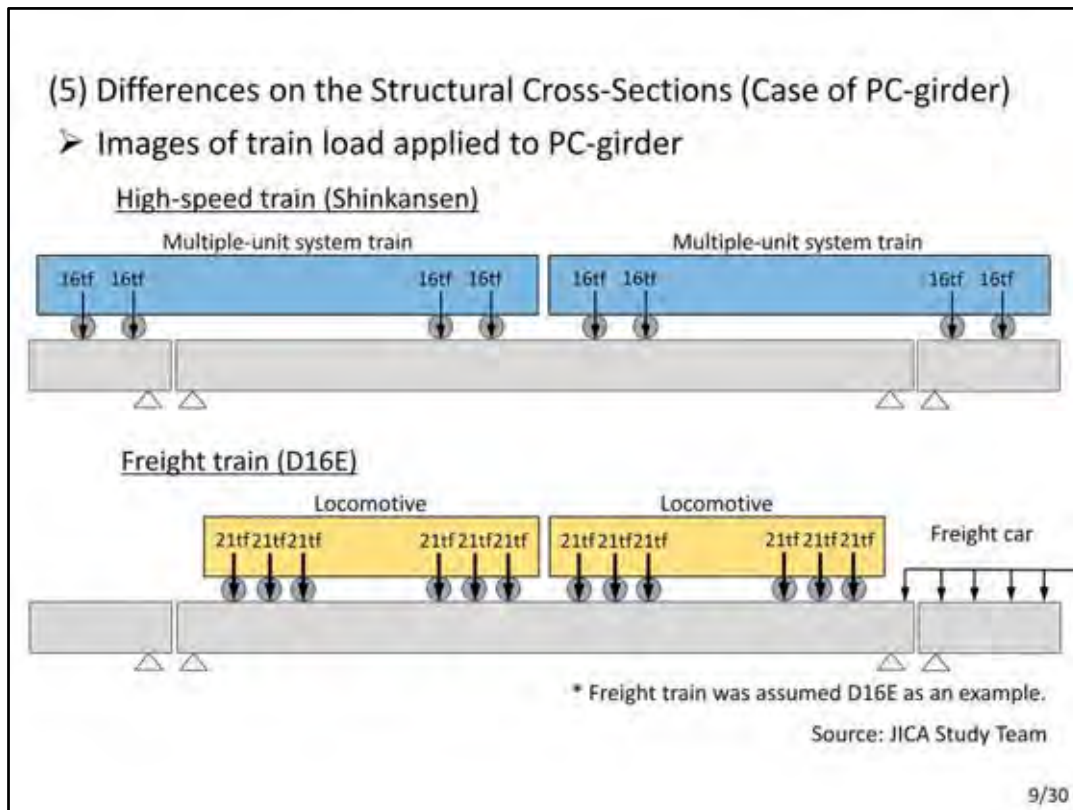

Using PC girders as an example, the images in this slide show train load applied to PC-girder.

First, for a high-speed passenger train (Shinkansen), based on the relationship of the car length and wheelbase to the girder length, 16tf is applied to four axles on a 35m girder.

On the other hand, for a freight train (here, the D16E is used as an example), 21tf is applied to 12 axles on a 35m girder.

As you can understand from looking at these images, a freight train applies a significantly higher train load to girders than a high-speed passenger train does.

## (6) Differences on Track Layout Plan

### ➤ High Speed Railway

- High-speed railway can basically be operated with simple track layout plans.

### ➤ Freight Railway

- Since facilities for handling freight are required and freight handling takes time, tracks are laid for freight-handling purposes.
- Since freight trains are longer than passenger trains, it is necessary to have a longer effective track length at freight stations.
- Since freight trains are not suited to running at high speed, facilities are required for high-speed trains to overtake freight trains.



Freight Station (Japan, Kyoto Freight Station)

Source: Japan Freight Railway Company

10/30

This slide explains differences on track layout plans.

High-speed railway can basically be operated with simple track layout plans.

Track layout plans for freight rails, on the other hand, are distinctive due to the transportation of cargo.

Since facilities for handling freight are required and freight handling takes time, tracks are laid for freight-handling purposes.

What's more, since freight trains are longer than passenger trains, it is necessary to have a longer effective track length at freight stations.

If operating high-speed trains and freight trains on the same line, since freight trains are not suited to running at high speed, facilities are required for high-speed trains to overtake freight trains.

## (7) Differences on Maintenance Windows

- High Speed Railway
  - Due to noise and vibration issues, Japan's Shinkansen trains cannot run during the night. Maintenance work at night only in principle.
- Freight Railway
  - If freight trains were running during the night, night-time maintenance of shinkansen tracks would not be possible.
  - Night-time maintenance is performed daily after shinkansen tracks close, and a confirmation car is run before the first train of the day.



When operating high-speed passenger trains and freight trains on the same line, various questions arise, for example,

- ✓ How will maintenance windows be handled?
- ✓ Will the track structure be a parallel single-track system?
- ✓ How will safety be ensured during maintenance work?

11/30

This slide explains differences on maintenance windows.

Due to noise and vibration issues, Japan's Shinkansen trains cannot run during the night.

When shinkansen trains and freight trains are operated on the same line, night-time maintenance of shinkansen tracks would not be possible, if freight trains were running during the night.

Night-time maintenance is performed daily after shinkansen tracks close, and a confirmation car is run before the first train of the day.

When operating high-speed passenger trains and freight trains on the same line, various questions arise, for example,

- ✓ how will maintenance windows be handled?
- ✓ Will the track structure be a parallel single-track system?
- ✓ How will safety be ensured during maintenance work?

**(8) Approaches to operating high-speed passenger trains and freight trains on the same line, which is being considered for the Seikan Tunnel**

**Review some technical issues related to operating high-speed passenger trains and freight trains on the same line**

The main focal point when operating freight trains on a high-speed rail line is **whether high-speed passenger trains and freight trains will pass each other or not** (The reason for this is that it is **impossible to completely eliminate the risk of scattering of cargo, load collapse and abnormal yawing of wagons**) .

**1) If the high speed trains and freight trains do not pass each other**

• Separation of operating time zone

⇒ If high-speed passenger trains operate in the daytime and freight trains in the night time, securing periods for maintenance windows is an issue.

12/30

I would now like to explain the approaches to operating high-speed passenger trains and freight trains on the same line, which is being considered for the Seikan Tunnel.

Before that, I would like to review some technical issues related to operating high-speed passenger trains and freight trains on the same line.

The main focal point when operating freight trains on a high-speed rail line is whether high-speed passenger trains and freight trains will pass each other or not. The reason for this is that it is impossible to completely eliminate the risk of scattering of cargo, load collapse and abnormal yawing of wagons.

If the high speed trains and freight trains do not pass each other, the following a method is considered:

• Separation of operating time zone

→ If high-speed passenger trains operate in the daytime and freight trains in the night time, securing periods for maintenance windows is an issue.

Even with parallel single tracks, freight trains need to operate at reduced speed during maintenance work for safety reasons.



(8) Approaches to operating high-speed passenger trains and freight trains on the same line, which is being considered for the Seikan Tunnel

**2) If the high speed trains and freight trains pass each other**

• Reducing the speed of high-speed passenger trains

⇒ If this is implemented along the whole line, there will be a loss of rapidity for high-speed passenger trains. If high-speed passenger train speed is reduced only when passing freight trains, technological development of a new signaling system will be required.

• Increasing the track spacing (widening of civil structure)

⇒ This will increase construction costs. Furthermore, the safety of freight trains will still remain doubtful.

• Designing freight cars able to pass each other and run at high speed

⇒ It will be necessary to consider the axle load and bogie structure, maintenance frequency, center of gravity height, derailment/rollover threshold, etc. and conducting running tests. These take development costs and time.

• Using train cars with a similar structure to high-speed passenger trains

⇒ Transportation of containers will not be possible. When it comes to transported goods, it will only be possible to handle small quantities and high added-value items.

13/30

If the high speed trains and freight trains pass each other, the following four methods are considered:

• Reducing the speed of high-speed passenger trains

→ If this is implemented along the whole line, there will be a loss of rapidity for high-speed passenger trains.

If high-speed passenger train speed is reduced only when passing freight trains, technological development of a new signaling system will be required.

• Increasing the track spacing (widening of civil structure)

→ This will increase construction costs. Furthermore, the safety of freight trains will still remain doubtful.

• Designing freight cars able to pass each other and run at high speed

→ It will be necessary to consider the axle load and bogie structure, maintenance frequency, center of gravity height, derailment/rollover threshold, etc. and conducting running tests. These take development costs and time.

• Using train cars with a similar structure to high-speed passenger trains

→ Transportation of containers will not be possible. When it comes to transported goods, it will only be possible to handle small quantities and high added-value items.

Based on the above, I will explain what is being considered in terms of methods for operating both high-speed passenger trains and freight trains in the Seikan Tunnel.



Japan's Seikan Tunnel connects Hokkaido to the main island of Honshu along the sea floor. The tunnel's total length is around 53.9km. The underground section on the Honshu side extends for about 13.6km, the sea floor section extends for 23.3km, and the underground section on the Hokkaido side extends for about 17km.

The following slides provide a simple explanation of four proposals under consideration.

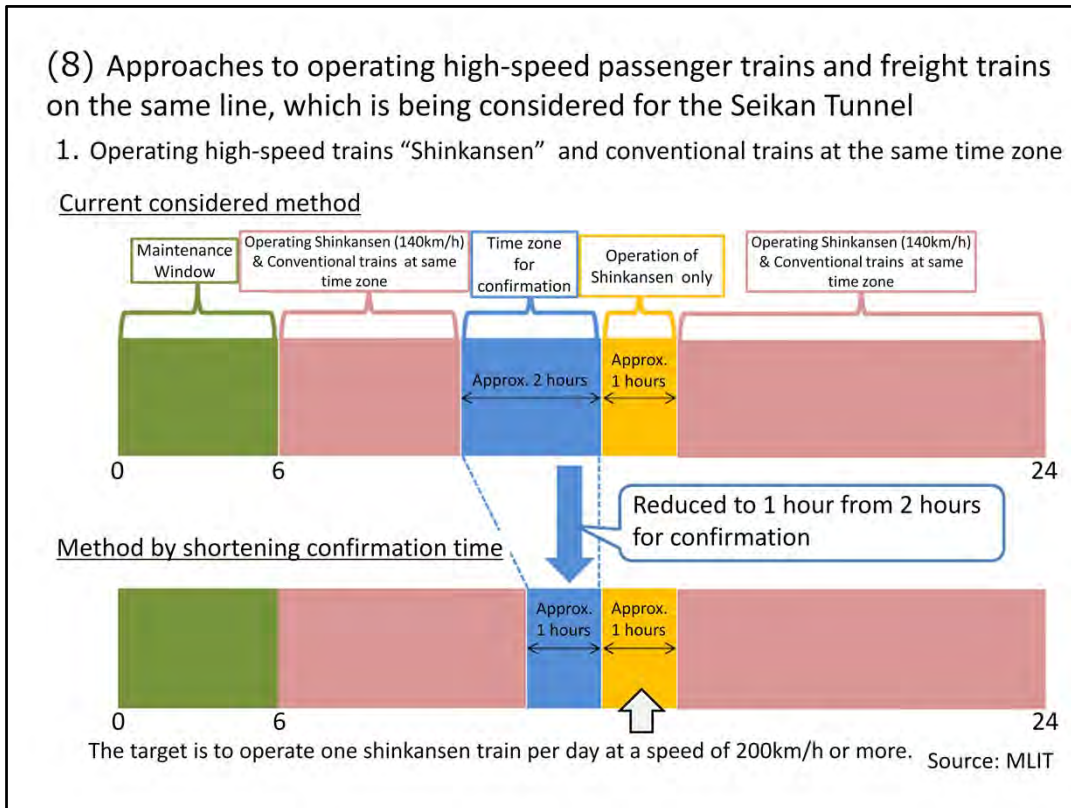

The first method is operating high-speed trains “Shinkansen” and conventional trains at the same time zone.

With this method, time for maintenance work is secured by making maintenance windows separate from the times when shinkansen and conventional trains (including freight trains) operate at the same time zone.

However, with this method, due to safety issues when high speed trains and freight trains pass each other, it would not be possible to run shinkansen trains at speeds exceeding 140km/h.

Therefore, another method that is being considered is to set specific time periods during which only shinkansen trains will run. This would enable trains to run at 260km/h during this time zone only.

The target is to operate one shinkansen train per day at a speed of 200km/h or more.

With this method, however, track confirmation time before running shinkansen trains is an issue.

In other words, with existing shinkansen lines, after maintenance work is completed, a confirmation car run along the tracks in order to verify their safety so that shinkansen cars can run at high speed. With this method, it has been argued that after maintenance work or simultaneous operation of freight trains and shinkansen trains (140km/h), time is needed to confirm that trains can run at high speed.

At this point, let me explain about track confirmation cars.

When the Tokaido Shinkansen opened, confirmation cars were not utilized. However, at that time there were large-scale maintenance work and other tasks requiring a lot of manpower, and work tools and the like were often left behind, so confirmation cars were introduced.

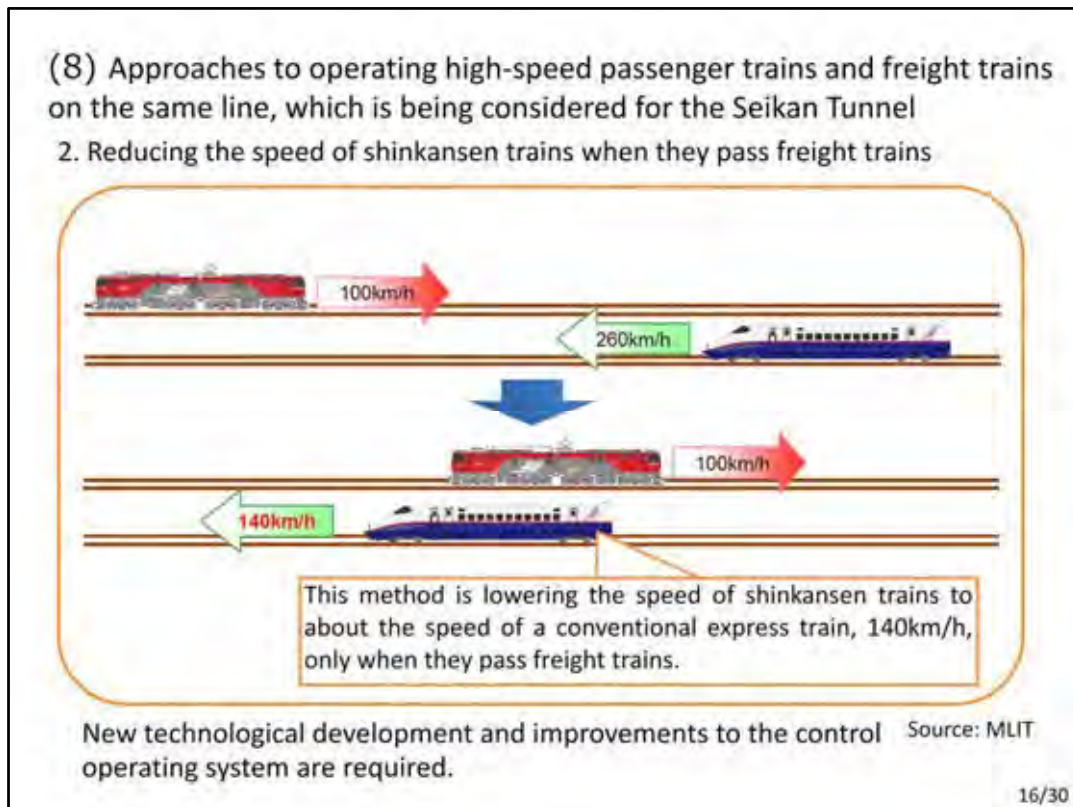

Next, the second method is reducing the speed of shinkansen trains when they pass freight trains.

This method is lowering the speed of shinkansen trains to about the speed of a conventional express train, 140km/h, only when they pass freight trains. Since it is necessary to control the speed of the shinkansen train based on the other train's position, speed, and so on, the safety system will differ from existing signal indications.

As a result, new technological development and improvements to the control operating system are required.

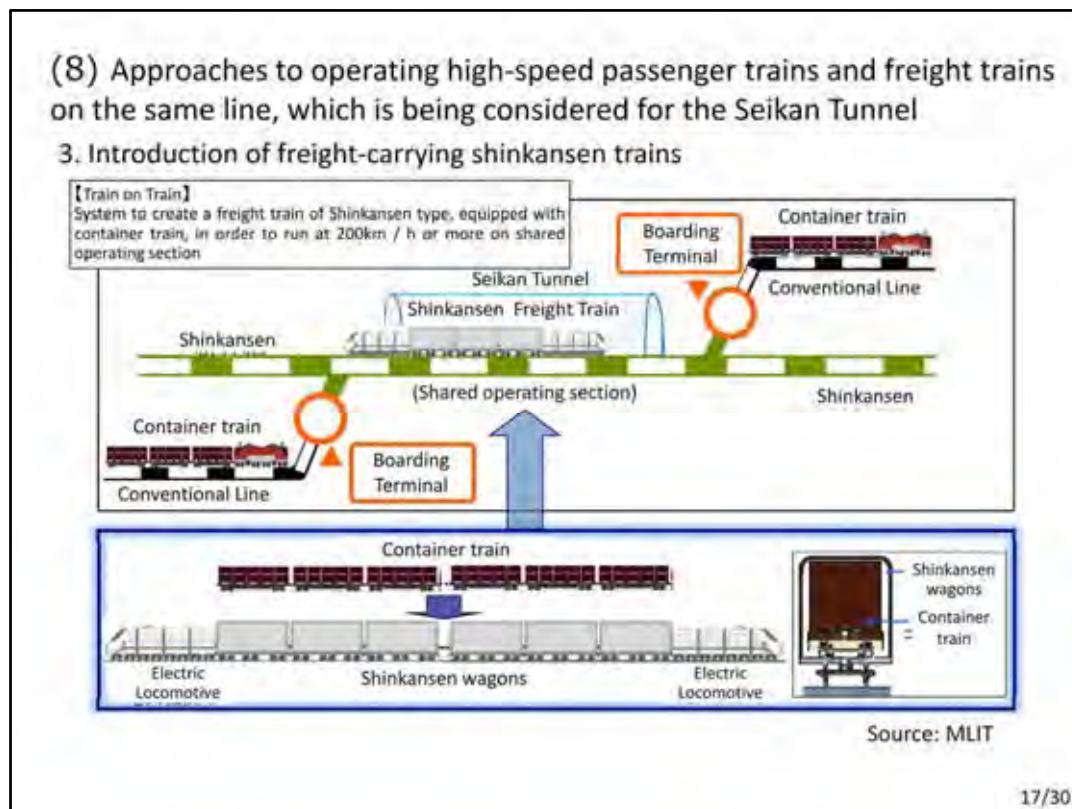

Next, the third method is the introduction of freight-carrying shinkansen trains. This concept is known as “Train on Train,” with development being led by JR Hokkaido mainly.

This method would load the container freight train that was running on a conventional line into shinkansen-size freight wagons at a boarding terminal, then run them at 200km/h through the Seikan Tunnel by coupling them to shinkansen electric locomotives. Since it involves a freight-carrying shinkansen wagon, this method would ensure safety equivalent to a shinkansen. It is anticipated that the boarding terminal operations would take about 10 minutes at each station. Assuming that the Seikan Tunnel section can be traversed in 40 minutes, the total required time would be 60 minutes, which is no worse than the 64 minutes currently needed for freight trains.

If this freight wagon is realized, it would be the first freight wagon in the world able to operate at high speed.



(8) Approaches to operating high-speed passenger trains and freight trains on the same line, which is being considered for the Seikan Tunnel

4. Installing dividing walls between the up and down tracks.



Installing dividing walls

Source: MLIT

It would be necessary to proceed with construction during downtime on the tracks, which are already in use.

18/30

Next, the fourth method is installing dividing walls between the up and down tracks. This method would install walls between the up and down tracks inside the tunnel to physically separate conventional lines that are passed by high-speed shinkansen trains.

In order to ensure the stability of the dividing walls with respect to wind pressure and so forth, it is necessary to reinforce them by driving in anchors or the like.

It would therefore be necessary to proceed with construction during downtime on the tracks, which are already in use.

Therefore, it is considered that construction will require a considerable amount of time.



(8) Approaches to operating high-speed passenger trains and freight trains on the same line, which is being considered for the Seikan Tunnel

Japan's policies for the time being

1. Operation at same time zone of high-speed shinkansen lines (running at 140km/h) and conventional lines.

⇒ Assuming that testing of the technology needed to ensure safety proceeds smoothly, the aim is to enable high-speed running for one round trip per day.

Meanwhile, the technological feasibility of the following will be considered more seriously and the direction of future development will be determined:

2. Plan to implement operation at same time zone based on a system to reduce the speed of high-speed trains when they pass freight trains.

3. Plan to introduce freight-carrying shinkansen trains.

19/30

This slide explains Japan's policies for the time being with respect to operating both shinkansen trains and freight trains inside the Seikan Tunnel.

1. Operation at same time zone of high-speed shinkansen lines (running at 140km/h) and conventional lines

⇒ Assuming that testing of the technology needed to ensure safety proceeds smoothly, the aim is to enable high-speed running for one round trip per day.

Meanwhile, the technological feasibility of the following will be considered more seriously and the direction of future development will be determined:

2. Plan to implement operation at same time zone based on a system to reduce the speed of high-speed trains when they pass freight trains.

3. Plan to introduce freight-carrying shinkansen trains.

Each of these plans involves passenger trains running at high speed operating on the same line as container freight trains, and once realized, each is expected to represent an achievement without precedent around the world.

## (9) Conclusion

- When it comes to operating high-speed trains and freight trains on the same line, there are various issues that must be considered and addressed such as maximum gradient, girder and tunnel structural cross-sections, track layout plan, maintenance windows and so on.
- In Japan, the Seikan Tunnel was constructed under the assumption that both shinkansen trains and freight trains would use it, so further development and research will be conducted going forward with the aim of opening the Hokkaido Shinkansen line.
- As can be seen with the Seikan Tunnel, even if high-speed trains and freight trains will be operated together only on one section of a line, time and money is needed to carry out sufficient analysis and development.

20/30

When it comes to operating high-speed trains and freight trains on the same line, there are various issues that must be considered and addressed such as maximum gradient, girder and tunnel structural cross-sections, track layout plan, maintenance windows and so on.

In Japan, the Seikan Tunnel was constructed under the assumption that both shinkansen trains and freight trains would use it, so further development and research will be conducted going forward with the aim of opening the Hokkaido Shinkansen line.

As can be seen with the Seikan Tunnel, even if high-speed trains and freight trains will be operated together only on one section of a line, time and money is needed to carry out sufficient analysis and development.

## 2. Comparison of Japanese and Global High-Speed Rail

21/30

Next, I would like to compare Japanese high-speed rail with other high-speed rails around the world.

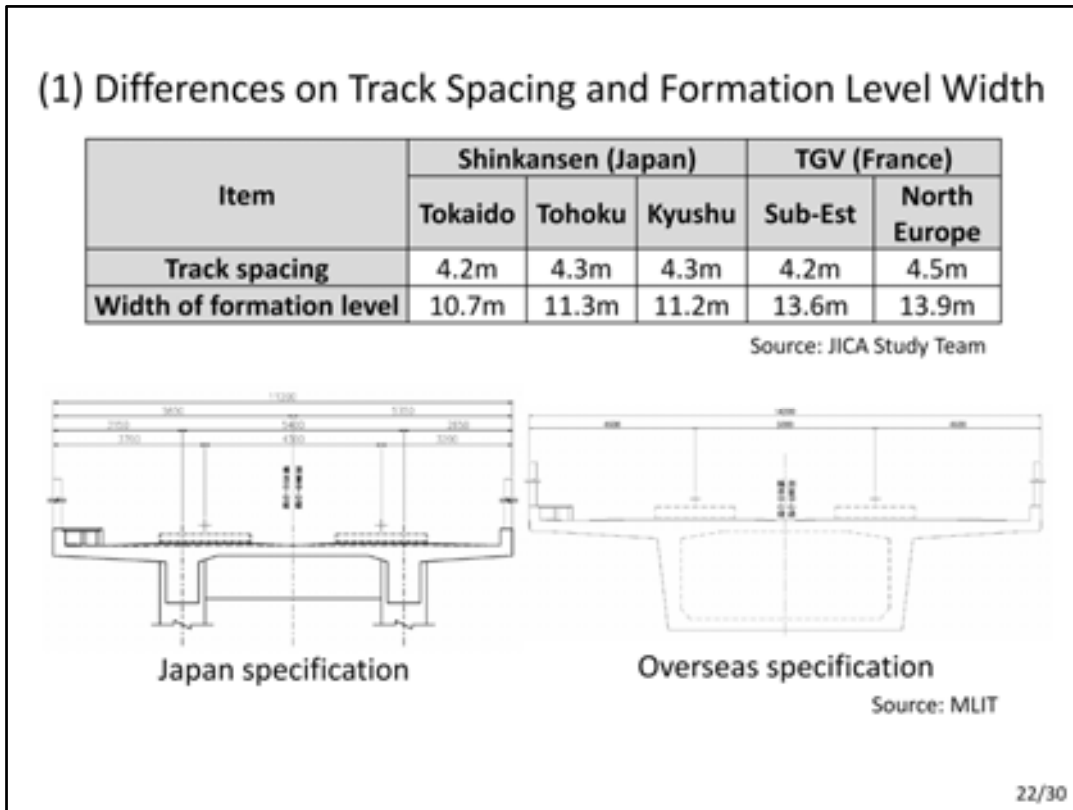

First, I will explain differences on track spacing and formation level width.

Track spacing and formation level width are determined based on the vibration from running trains, wind pressure when trains pass each other, amount of maintenance space, amount of evacuation space needed during emergencies, construction precision, and so on.

In the case of Japan, it is possible to use smaller figures compared to other countries due to the superior aerodynamic characteristics of shinkansen trains, the secure and complete separation of maintenance times from train operating times, differences in the approach to evacuating passengers when accidents occur, installation sites for ancillary equipment such as cables based on agreements with maintenance sides, etc.

Therefore it is possible to narrow the width of the structure, as a result of which the site width is narrower. The fact that it is possible to reduce the quantity of construction materials for the structure helps to reduce construction costs.

## (2) Differences on the Structure Ratios

Structure	Shinkansen (Japan)			TGV (France)	
	Tokaido	Tohoku	Kyushu	Sub-Est	Atlantic
Earthworks	53%	8%	8%	99%	93%
Bridge & Viaduct	34%	57%	42%	1%	1%
Tunnel	13%	35%	50%	0%	6%

Source: JICA Study Team



Extradosed Bridge, Tohoku Shinkansen

Source: JICA Study Team



Earthworks, TGV Sub-Est

Source: <http://www.railteam.eu/en/high-speed-travel/high-speed-trains/tgv/>

23/30

This slide explains differences on the structure ratios.

### Japan

- In Japan, where 73% of the land is mountainous terrain, if you want to provide high-speed rail lines that enable rapid travel between major cities, there is no way to avoid having numerous tunnel sections.
- Since the Tokaido Shinkansen line runs near the coast, the ratio of tunnel sections is less than for the Tohoku and Kyushu Shinkansen lines.

### France

- It is possible to have lines that make use of the country's comparatively extensive flatlands.
- Tunnel sections represent only a small ratio of the total track length.

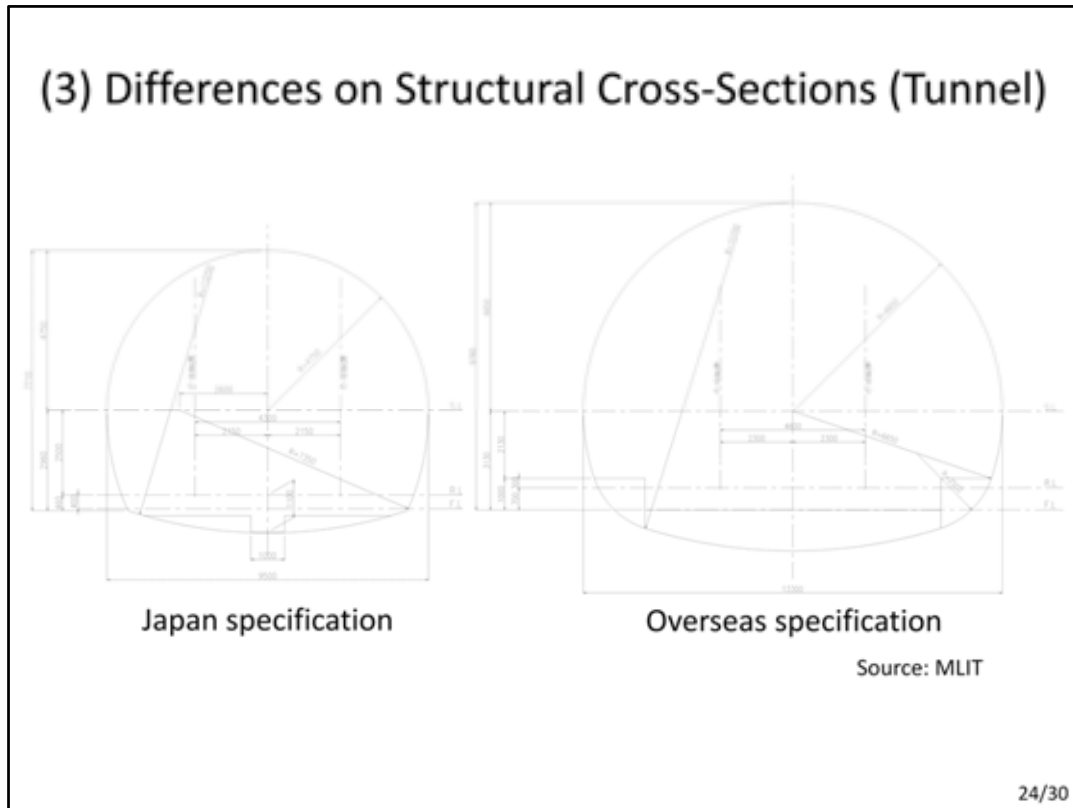

Using tunnels as an example, I will now explain differences on structural cross-sections.

#### Japan

- One of the distinctive features of Japanese shinkansen structures is that the tunnel inner section is extremely narrow while accommodating double tracks.

As already mentioned, in Japan, where 73% of the land is mountainous terrain, if you want to provide high-speed rail lines that enable rapid travel between major cities, there is no way to avoid having numerous tunnel sections.

Therefore, lowering tunnel construction costs is an extremely effective way to reduce overall shinkansen construction costs, and in Japan, tunnel sections are designed so as to make them as small as possible.

#### France

Due to the fact that tunnel sections represent only a small ratio of the total track length and other factors, there was no need to shrink tunnel cross-section size to the same extent as in Japan.



#### (4) Differences on the Approach to Tunnel Fire Countermeasures

Items	Japan	Europe
<b>Tunnel Cross Section (Single or Double Line)</b>	Double Line Cross Section	Single Line Cross Section over 5km (Two Single Tunnels)
<b>Tunnel Cross Section</b>	About 64m <sup>2</sup>	About 45m <sup>2</sup> *2=90m <sup>2</sup>
<b>Fire Counter-measure</b>	<ul style="list-style-type: none"> <li>• Non Stop in Tunnel</li> <li>• Stop and Refuge at Station or Appointed place out of Tunnel</li> </ul>	<ul style="list-style-type: none"> <li>• Stop in Tunnel and Use of Refuge Passage</li> </ul>
<b>Operation at Fire</b>	<ul style="list-style-type: none"> <li>• Secure of Refuge Passage by Operation Stop of Other Line of Double Lines</li> </ul>	<ul style="list-style-type: none"> <li>• Bi-directional Operation of Other Line of Double Lines</li> </ul>
<b>Construction Cost</b>	<ul style="list-style-type: none"> <li>• Low Cost by Small Cross Section</li> <li>• Large influence due to so many Tunnels</li> </ul>	<ul style="list-style-type: none"> <li>• High Cost of Two Single Tunnels</li> </ul>
<b>Difference of Rolling Stock</b>	<ul style="list-style-type: none"> <li>• Escape Possibility out of Tunnel due to Electric Multiple Unit (EMU)</li> </ul>	<ul style="list-style-type: none"> <li>• Safety Measure and Operation at Fire on the Assumption of Stop in Tunnel due to Locomotive type</li> </ul>

Source: JICA Study Team

25/30

This slide explains differences on the approach to tunnel fire countermeasures.

If a tunnel fire should occur, in Japan, based on the lessons learned from the Hokuriku Tunnel train fire accident, the operating regulations have been revised so that the train will continue to run without stopping and exit the tunnel. In many European countries, on the other hand, it is stipulated that the train should stop inside the tunnel and the passengers be evacuated.

Since the approach in Europe differs from Japan in this way, the tunnel cross-section for the TGV or ICE is around 1.5 times larger than for the shinkansen.

As a result, evacuation space is obtained by either 1) constructing two parallel single-track tunnels and making one of them an evacuation tunnel by setting up connecting passages between the two tunnels at fixed intervals, or 2) widening the track spacing in double-track cross-section tunnels.

If the track spacing is wide, it is harder for the tunnel-micro pressure wave effect to be produced, but all else being equal, the excavation and construction costs will naturally increase.

### (5) Tunnel Buffering Hoods

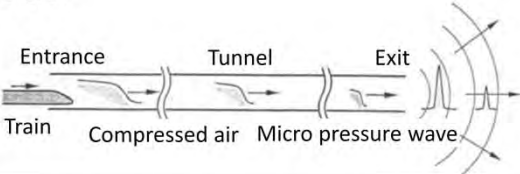
Tunnel length (km)	Tunnel section (m <sup>2</sup> )	Length of a buffer structure (m)
5	63	90
	80	62
1	63	57
	80	40

Source: JR East

Source: JICA Study Team

**Note;**

- According to the survey conducted by Railway Technical Research Institute (RTRI)
- To keep the micro-pressure wave less than 50 Pa at 20m from the tunnel exit when E5 series run the tunnel (slab track) at 350km/h.
- The tunnel buffering hoods technology developed in Japan is adopted not only Japan but also Germany.

26/30

A unique aspect of Japan’s shinkansen tunnels, which have a small cross-section area, is the presence of the tunnel buffering hoods installed at the front of the tunnel entrance and exit for the purpose of reducing tunnel-micro pressure wave effect.

The effect on the surrounding environment of tunnel-micro pressure wave, which occurs when the train enters the tunnel at high speed, is solved by installing the tunnel buffering hoods at the front of the tunnel entrance and exit based on various parameters.

With regard to the body of the rolling stock, the designs are being developed that reduce the incidence of micro pressure waves by optimizing the shape of the first car while at the same time preserving passengers’ comfort by controlling pressure variation inside the train by making the body of the rolling stock more airtight.

This shows the length of the buffer structure.

The buffer structure is constructed to reduce the micro pressure wave. This occurs on the opposite side of the entrance when the train enters the tunnel.

The micro pressure wave goes to the opposite side of the tunnel. At that time, a large sound is created.

In order to eliminate or reduce such noise, we adopt the buffer.

The tunnel buffering hoods technology developed in Japan is adopted not only Japan but also Germany.

#### (6) Differences on the Approach to the Air Tightness of Rolling Stock

- ✓ Since the tunnel cross-section area is small, Japan's high-speed rolling stocks are designed to be more airtight than European rolling stocks.
- ✓ When the tunnel cross-section area is small, it is easier for tunnel-micro pressure wave to occur due to high-speed operation, causing significant pressure variation inside the tunnel, which hurts passengers' eardrums.



Source: JICA Study Team

27/30

This slide explains differences on the approach to the air tightness of rolling stock.

Since the tunnel cross-section area is small, Japan's high-speed rolling stocks are designed to be more airtight than European rolling stocks.

When the tunnel cross-section area is small, it is easier for tunnel-micro pressure wave to occur due to high-speed operation, causing significant pressure variation inside the tunnel, which hurts passengers' eardrums.

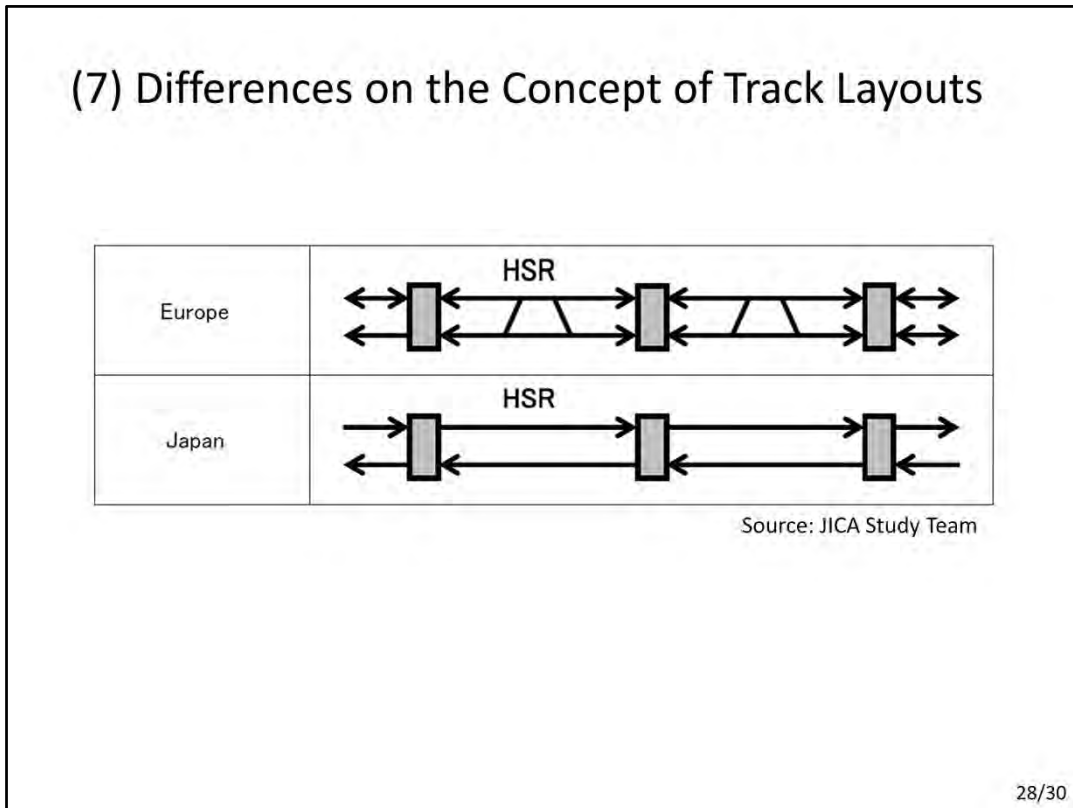

This slide explains differences on the concept of track layouts.

The high-speed rail lines in France and Germany are based on a system of parallel single-track operation, with crossovers laid between stations to connect the up- and down-tracks, to allow trains to run in two directions on a single track, in case the other track has failed.

In contrast, the shinkansen rail lines in Japan operate up- and down-trains separately on the track dedicated to a particular direction. In case one track has failed, both tracks in the section that includes the failed point are completely closed, with train operation resumed in principle after the section has been restored.

More than 300 trains are operated everyday on the Tokaido or Tohoku shinkansen railway. Therefore, only two or three trains can be operated on a track under the single-track operation system, in case the other track has become inoperative.

If feeding were stopped only for the defective track for the purpose of recovery work, it will endanger the life of workers due to mistaken electric shock. For this reason, power supply is stopped for the whole section, with priority placed on the recovery work.

### (8) Differences on Maintenance Approaches

➤ Maintenance of High Speed Rail Line in the World

	Italy	Spain	France	Belgium	Taiwan	Korea	Japan	
Length of Line (km)	640	N/A	389	210	345	212	714	
Daily service (trains/day)	290	N/A	N/A	N/A	123	N/A	176	
Track type(%)	Ballast	100	95	100	100	1.2	8	
	Slab	0	5	0	0	98.5	86	
	Embedded rail	0	0	0	0	0.3	6	
Maintenance bases	Number	14	9	7	3	5	17	
	Average coverage (km)	46	N/A	78	71	69	70	42
Sweep train	(Y/N)	No	Yes	N/A	Yes	Yes	Yes	No
	Operation speed (km/h)		200			170		70-110 (Confirmation car)
Maintenance approach	moving from time-based maintenance to condition-based maintenance in terms of defect detection	time-based / condition-based	actual: time-based future: condition-based	time-based / condition-based	time-based / condition-based	time-based / condition-based	time-based / condition-based	

Source: JICA Study Team  
29/30

This slide explains differences on maintenance approaches.

The table shows maintenance approaches for high-speed rail in countries that possess such rail lines.

However, please note that it does not show maintenance conditions for all lines in each country.

The distance between maintenance depots is around 50km in Japan and Italy, while in Spain, France, Belgium, Taiwan, and South Korea it is around 70km.

Maintenance approaches include time-based and condition-based maintenance, and broadly speaking, all of these countries implement both approaches. France, however, currently uses time-based maintenance but plans to use a condition-based approach in future.

#### Sweep Train:

On the high-speed rail lines of many countries a sweep train is utilized for confirmation that the line is clear and no obstacles remain after maintenance work. The first train of the day will be operated as “sweep train” with a maximum speed of 170km/h to 200km/h.

On Japanese high-speed rail lines a designated “confirmation car” is utilized after maintenance work during the working window.

The confirmation car has a lighting device and CCTV to identify the obstacles and it is operated at 70km/h to 110km/h.

## (9) Conclusion

- There are differences in the specifications for high-speed rail in Japan and in other countries, based on differences in the development process, terrain conditions, approach to tunnel fire countermeasures, performance of operated rolling stocks and approach to maintenance.
- It is necessary to properly understand these differences in specifications before deciding what specifications are required for your own country.

30/30

There are differences in the specifications for high-speed rail in Japan and in other countries, based on differences in the development process, terrain conditions, approach to tunnel fire countermeasures, performance of operated rolling stocks and approach to maintenance.

It is necessary to properly understand these differences in specifications before deciding what specifications are required for your own country.

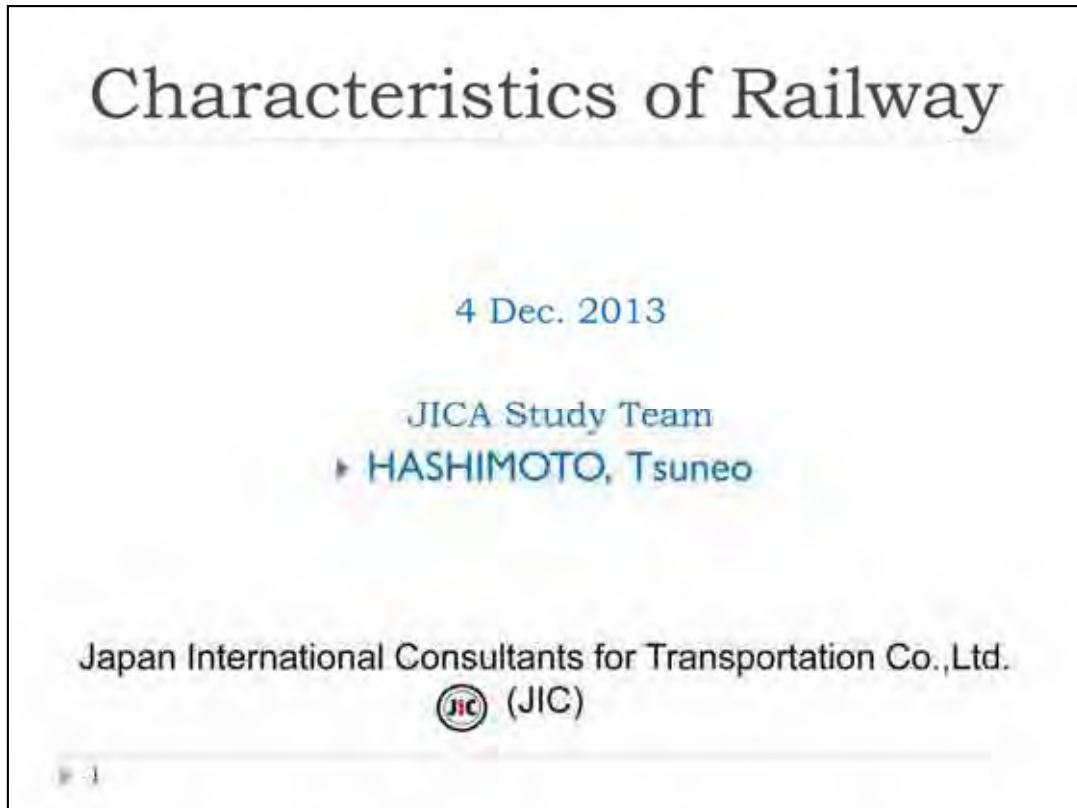

My name is Hashimoto. I am a railway civil engineer. I had engaged in Japanese National Railways. I had also engaged in Japanese National Railways Settlement Corporation for decrease the debt of JNR by selling surplus land. Now I am working in JIC.



## Contents

1. History of Railway
2. Characteristic of Railway
3. Merit of Railway
4. Shares of Transportation Modes
5. Favorable condition for railway
6. Characteristics of Japanese Railways
7. Basic Statistics of Japanese Railways
8. Overview Diagram of New Shinkansen Lines
9. Management Improvement of JNR
10. Japanese Thought about Railway
11. Effort for Rational Railway
12. Tokyo Urban Rail Example

Railway is the main transport measures from more than 100years ago. Railway is not always proper transport means in every transport category. In these years, railways have seen many technological breakthroughs in various fields, including intercity transport, urban transport, and high-speed train service. In addition to that, Japan has also had experience in railway management on privatizing its national railway. Today, I'm going to talk about characteristics of railway..

## History of Railway

**1825 Commencement of Railway Operation in England**

**1872 Railway Operation in Japan (Shinbashi – Yokohama) 29km**

**1881 Railway Operation in Vietnam (Saigon – Mitho) 71km**

**1936 Railway Operation (Hanoi-Saigon) 1726km**

**1964 Japanese Shinkansen Operation (Tokyo - Shin.Osaka) 515km**

▶ 3

As you know, Railway operation had commenced on 1825 in England. After 35 years of it, Japan started the construction of Railway.

On 1872, the railway operation had commenced from Shinbashi, Tokyo to Yokohama only 29km.

After world war II, World tendency moved to road transport from railway transport. Railway becomes a declining industry in the world. Under such circumstances, Japanese National Railway began the construction of High speed railway (Shinkansen). Some people said it is stupid act like the construction of Great Wall in China or Japanese battleship Yamato. Do you know battleship Yamato? It was extremely large battle ship sunk by airplane at Okinawa battle of world war II. It could not fight against ship at all. It was stupid investment.

Shinkansen generates much profit. Currently, Shinkansen and urban commuter lines are the major earning bodies. After Shinkansen commenced the operation on 1964, world tendency changed to adoption of high speed railway.

Although the operation of Shinkansen was successful, the finance situation of Japanese National Railway was getting worse caused by burden of local line service. Politicians had urged to construct the railway line on their territory region without considering the demand. Though, JNR had many deficit operation lines.

The speed up of Japanese convention line is executed by adding acceleration with electrified and strength of track /turnout structures, curve radius enlargement at the disaster prevention route change etc.

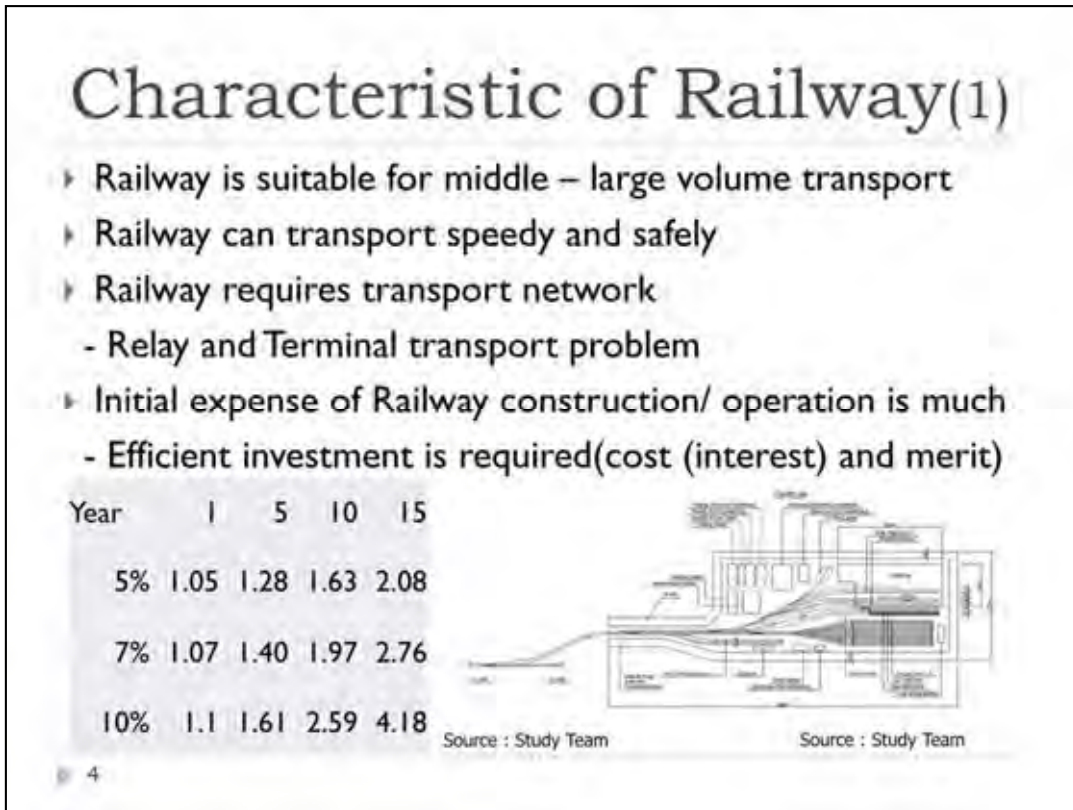

Railways are suitable for middle to large-volume transportation of passengers and goods, which they transport speedily and safely while conserving energy. When the volumes of freight or passengers do not reach certain levels or when there are relay and terminal transport problems, however, railway transportation is not suitable.

•During the construction of railways, the initial costs are high; therefore efficient investment strategies that take profitability into account are required. In regard to investment interest rates, attention needs to be paid to specific rates, because even an interest rate of 7% will yield double the initial investment after 10 years. This means, therefore, that after 10 years, it would be as if the investor had only committed half the initial capital.

When investing in railways, it is necessary to carefully choose and allocate facilities and to secure sites suitable for the railway business for a minimum of 30 to 50 years in order to negate the need for reinvestment. Regarding the introduction of real facilities, with the exception of those whose costs that would balloon if construction were delayed, only such facilities deemed necessary for five to 10 years should be constructed. When we take car depots into consideration, for example, railway companies need to secure the sites necessary to construct enough storage tracks for 30 years, but should actually manufacture only the amounts of storage tracks estimated to be necessary for the immediate future. The same goes for railcars, which should be purchased as necessary.

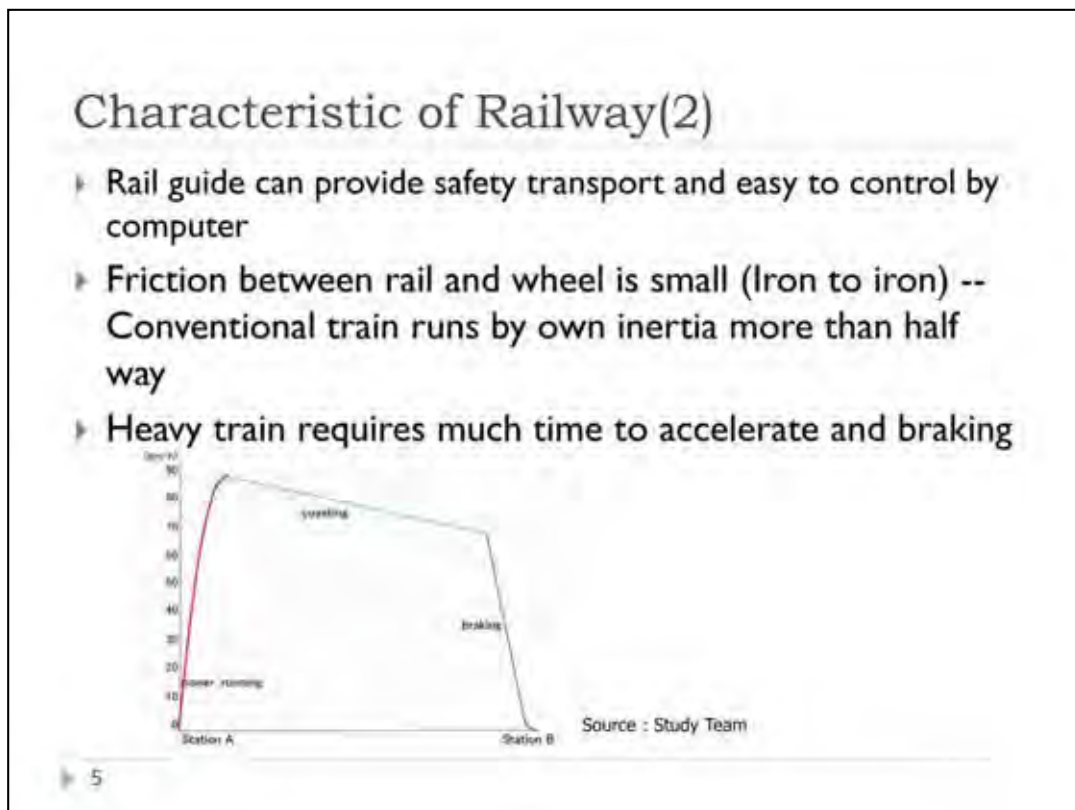

Guiding rail causes easy control and provide high safety.

The level of friction between rails and wheels is low because they are both made of steel. Conventional trains, therefore, coast for more than half the distance between stations (the figure shows the run curve as trains travel between stations).

Depending on the usage of railcars, some locomotives and electrically powered units provide better acceleration performance at low speeds, while others provide acceleration rates that do not decline, even at high speeds.

Regular passenger and freight trains coast once they have reached their optimum speeds, which lowers energy costs; whereas limited express trains accelerate constantly to maintain required speeds.

Heavy trains, naturally, require longer acceleration and braking times with the result that freight trains need to accelerate and brake for longer periods than passenger trains.

## Merit of Railway

- ▶ With narrow space It transports large volume passenger  
- - 10m width – 50,000 pas/hour
- ▶ Flexible for increasing demand 20,000 – 90,000 pas/hour
- ▶ Environmental friendly by electric operation
- ▶ High speed operation is possible with safety
- ▶ No parking space is required at city center area
- ▶ Underground operation is easy because no exhaust gas
- ▶ Little operation staff can transport large volume passengers of freight
- ▶ Economical transport is possible when it treats large volume

### Merit of Railway

With narrow space It transports large volume passenger

- - 10m width – 50,000 pas/hour

Flexible for increasing demand 20,000 – 90,000 pas/hour

Environmental friendly by electric operation

High speed operation is possible with safety

No parking space is required at city center area

Underground operation is easy because no exhaust gas

Little operation staff can transport large volume passengers of freight

Economical transport is possible when it treats large volume

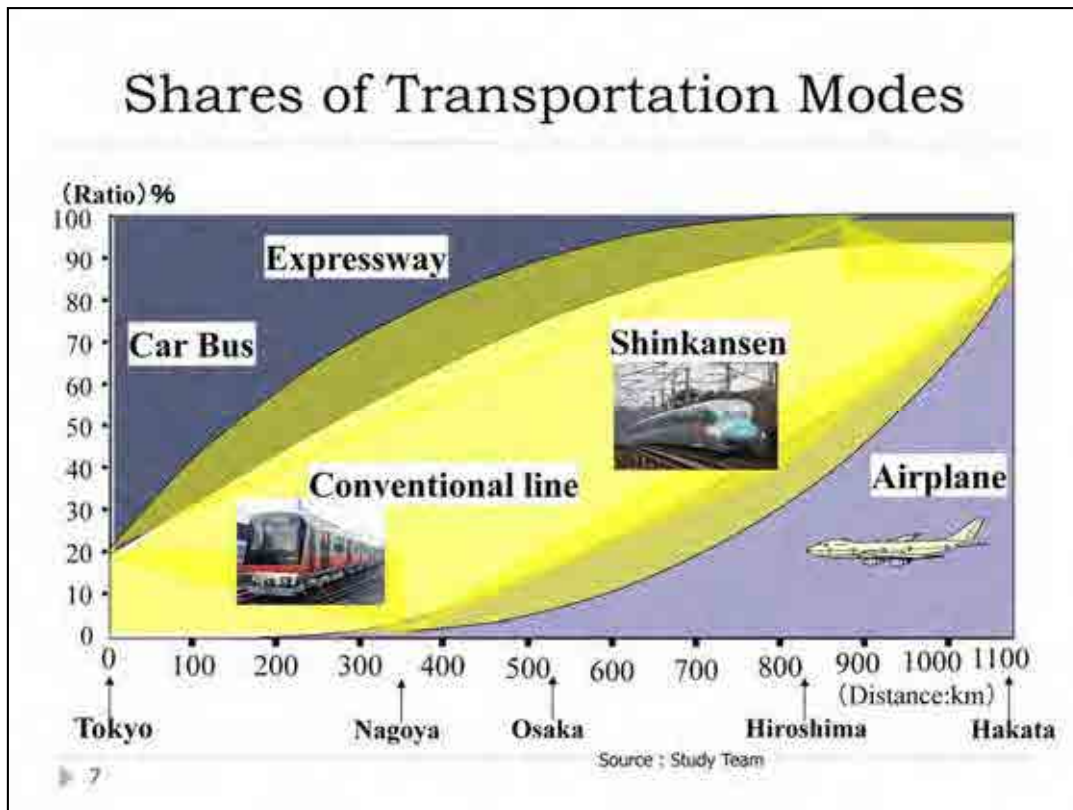

This is a representation of transportation mode shares in Japan. As can be seen, for short distances cars take the largest share, along with urban railways. For medium- to long-distance travel, the share of high-speed railways increases.

When, for example, railway travel times are three hours or less, railways generally prove to be more convenient than airlines.

The shares of railways and airlines change as train speeds increase, access times to stations are cut, and punctuality is improved.

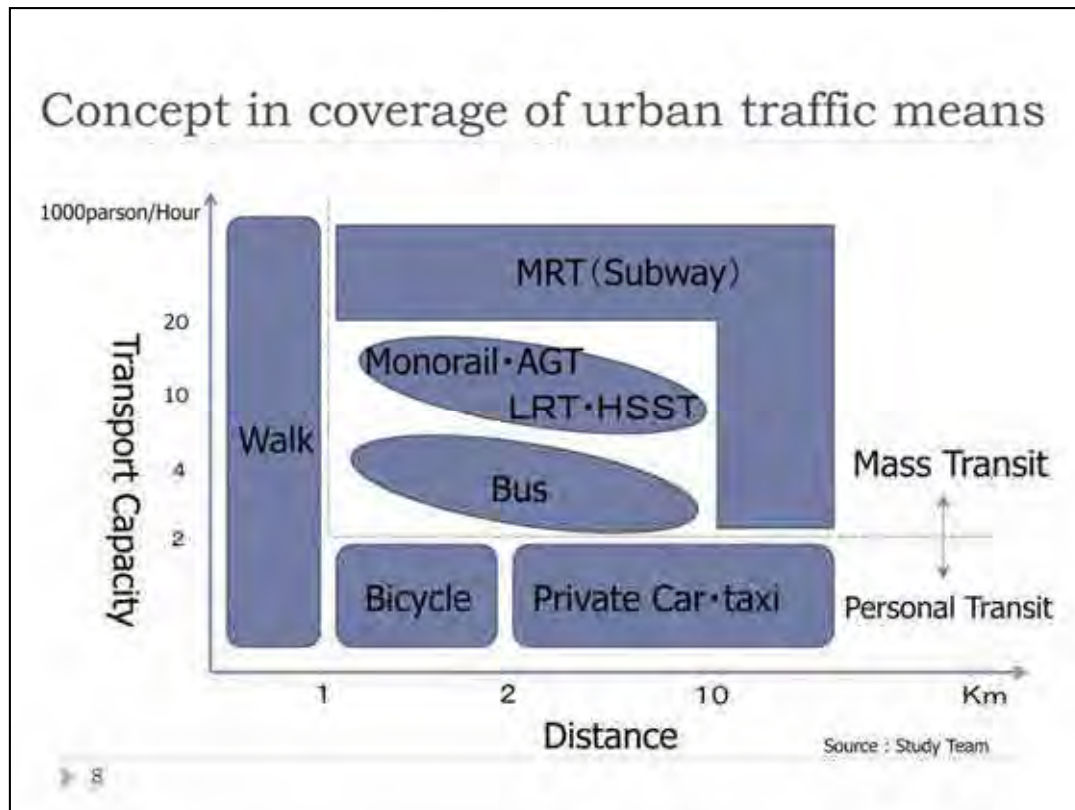

#### Urban Traffic Means

This graphic shows urban travel system divisions. Generally, for trips less than 1 km, people walk. For journeys of approximately 2 km, bicycles are favored. If destinations are less than 10 km, buses, trams, and monorails can be effective. And for distances of 10 km and above, and when passenger volume exceeds 20,000 people per hour, urban railways are the best.



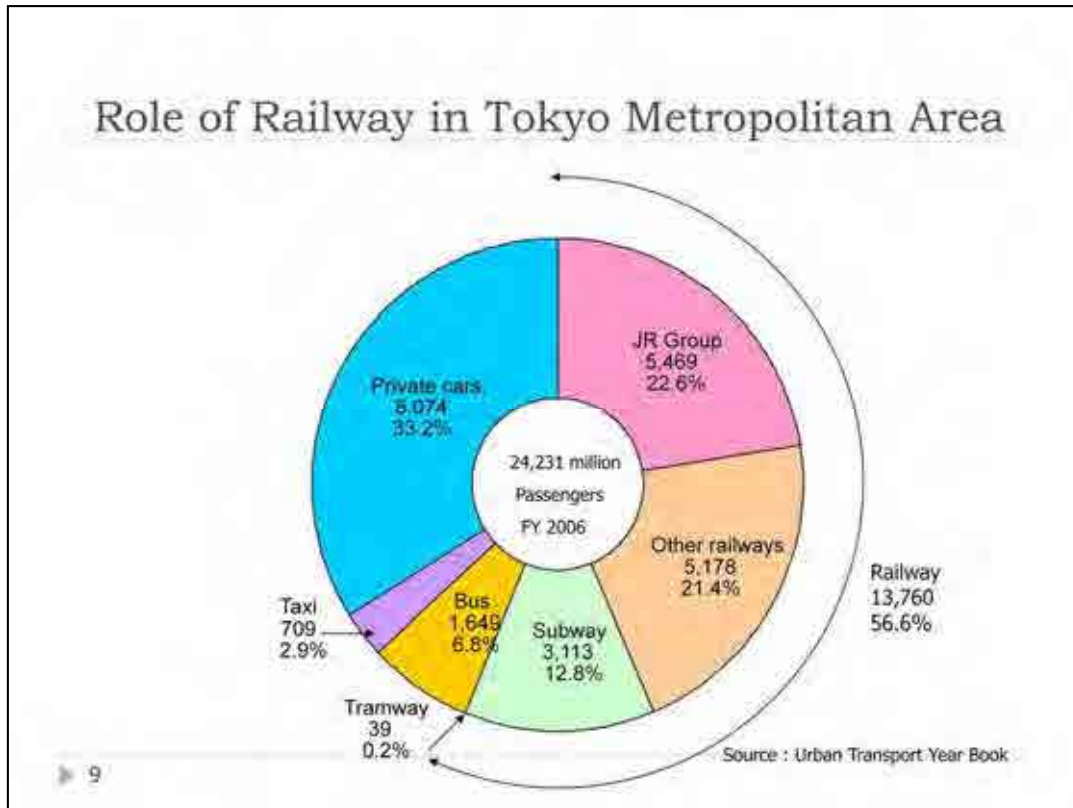

#### Role of Railways in Greater Tokyo

In cities, railways account for more than 50% of passenger journeys, for which two reasons can be cited: (1) car travel requires longer times to be allowed due to differing levels of congestion, etc. and (2) the difficulty of finding parking spaces in urban areas. If land usage efficiency is taken into account, it is, of course, wasteful to construct parking lots in city centers where real estate prices are high.

In metropolis area, the urban plan should be “Railway oriented urban plan” on the assumption that passenger transport depends on railway transportation.

## Favorable condition for railway (Features of Japan )

- ▶ Land cost is expensive at flat area
- ▶ Poor Progress of Road Transport in the Past
- ▶ Progress of Urban Area mainly at sea side or river side
- ▶ Continuous of High Density Population Cities
- ▶ Metropolitan area grows gigantic

10

- Japan is islands country and mountainous country. There is little flat space.
- Japan has large population. So the population density is rather high especially at flat area.
- The Japanese population is concentrated on the plains, which make up approximately 33% of the country (the remaining 70% is mountainous).
- Ground has much up and down. It is not convenient to use vehicle. So in Japan, transportation by vehicle did not progress. Formerly cargos were mainly transported by ship.
- People lives at limited flat area along the sea side or river side. High density population cities locate at sea side continuously. (plain area density is 1,600 persons/square kilometer) It is convenient for railway transport.
- Tokyo metropolitan area extends almost 50km radius area.
- The commuting distance of 30km from home to office is not rare. At such case railway commuting is indispensable. This is the reason why Japanese urban railway had remarkably progressed.

## Characteristics of Japanese Railways

- ▶ Many people use railways especially in the urban areas and on the inter-city lines.



Source : Study Team

- ▶ Passenger train service is main , freight train service is minor.

▶ 11

### Characteristics of Japanese Railways

Two of the most salient characteristics of Japanese railways are that many people use urban railways and inter-city railways and the fact that the volume of passenger train services is considerably higher than that of freight train services.

### Basic Statistics of Japanese Railways

FY2011	JR Group		Other Railways		Total	
	Shinkansen		Subway			
Number of enterprises	7	4	193	10	200	
Route length (km)	20,124	2,620	7,335	719	27,459	
Electrified section (km)	12,248	2,620	5,330	719	17,578	
	Ratio	60.8%	100%	72.7%	100%	64.0%
Number of Stations	4,660	81	5,056	628	9,716	
Track gauge (mm)	1,067	1,435	762~1,435		-	
Traffic volume	bil. passenger-km	244.6	76.9	149.0	34.9	393.6
	bil. tons-km	20.2	0.0	0.2	0.0	20.4

Source : Study Team

▶ 12

#### Japanese Railways: Basic Statistics

This table shows statistics regarding Japanese railways.

Many inter-city lines, including the Shinkansen, are electrified, as are other surface lines and subways in urban areas. When electricity is used as the motive source, it becomes easier to generate large volumes of power, and environmental damage decreases as there are no exhaust gas emissions. What is more, since electricity can be generated by various methods, it becomes easier to respond to oil shortages.

Japanese railways operate on various line gauges. The predominant gauges are 1,067 mm and 1,435 mm, and although it is inconvenient that through operations are not possible along tracks of differing width, the actual gauges are chosen according to specific line circumstances.

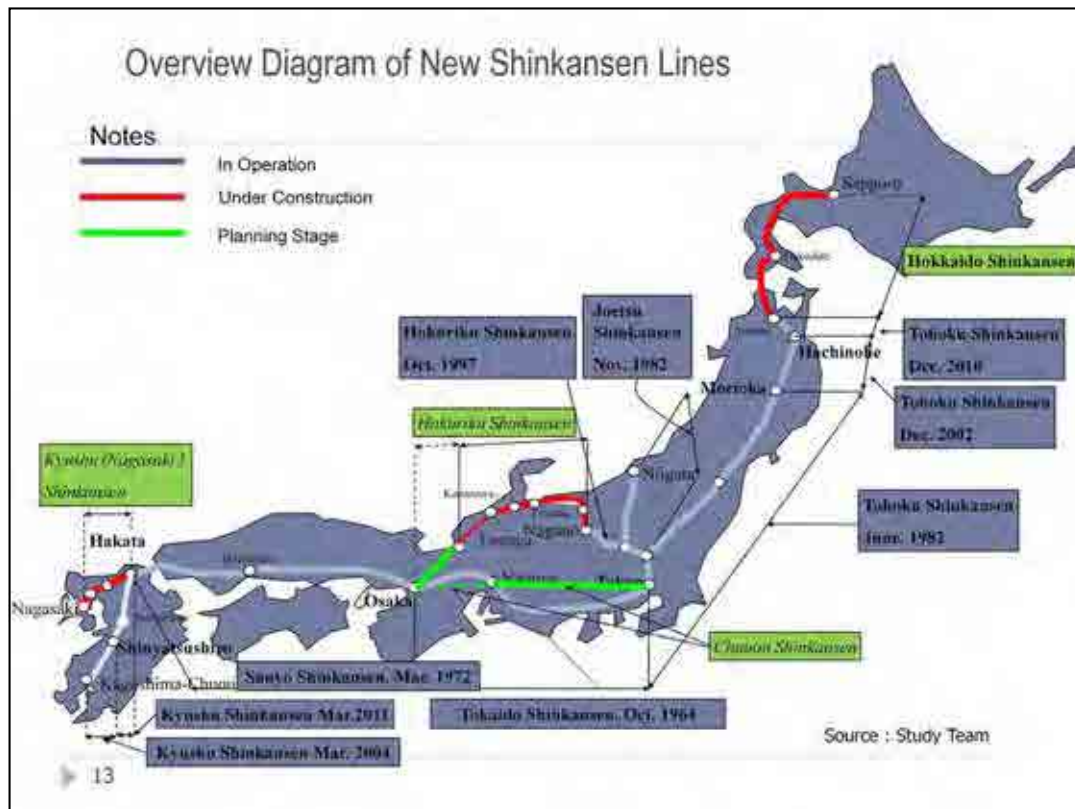

- Shinkansen in operation, under construction and authorized plan line.
- Tokaido Shinkansen started the operation on October 1964.
- Sanyo Shinkansen started the operation March 1972.
- Tohoku started the operation on July 1982 from Omiya to Morioka. On March 1985 the operation between Ueno and Omiya had started. The operation between Tokyo and Ueno started on July 1991. Then passengers could transfer from Tokaido Shinkansen to Tohoku Shinkansen at Tokyo station.
- Joetsu Shinkansen started the operation on November 1982.
- Hokuriku Shinkansen started the operation on November 1997 from Takasaki to Nagano.
- Kyushu Shinkansen started the operation on March 2004 from ShinYatsusiro to Kagoshima.chuou.
- Some extension work continue at Kyushu, Hokuriku and Aomori Hakodate area.

## Shinkansen Network

### In Operation

Line	Section	Route Length	Opening date	Maximum Speed	Travel Time
Tokaido	Tokyo-Shin.Osaka	515.4km	Oct.1964	270km/h	2h25m
Sanyo	Shin.Osaka-Hakata	553.7km	Mar.1975	300km/h	2h30m
Tohoku	Tokyo-Shin.Aomori	674.9km	Dec.2010	320km/h	2h59m
Joetsu	Omiya-Niigata	269.5km	Nov.1982	300km/h	1h37m
Nagano	Takasaki-Nagano	117.4km	Oct.1997	260km/h	1h27m
Kyuusyu	Hakata-Kagoshima.Chuo	256.8km	Mar.2011	260km/h	1h28m

### Under Construction

Source : Study Team

Line	Section	Route Length	Scheduled Opening
Hokkaido	Shin.Aomori-Shin.Hakodate	149km	Mar.2016
Hokuriku	Nagano-Kanazawa	228km	Mar.2015
Kyuusyu	TakeoOnsen-Nagasaki	67km	
Chuo	Tokyo(Shinagawa)-Nagoya	286km	2027

Source : Study Team

▶ 14

Maximum operation speed is 320km/h.

### Shinkansen Network

When the Tokaido Shinkansen commenced operations in 1964, the maximum speed was set at 210 km/h and although the same tracks are still used today, the maximum speed has now been increased to 300 km/h by reducing the burden on the rails and suppressing noise and vibration levels through the introduction of lighter railcars. As a further countermeasure to aerodynamic drag and the problems of shock waves inside tunnels, a variety of head shapes have been devised for lead railcars.

The Tohoku Shinkansen E5 series has been operating at speeds of up to 320 km/h since spring 2013. There are also plans for a maglev superconducting Chuo Shinkansen capable of operating at speeds up to 500 km/h.

## Results of New Shinkansen Lines

- (1) Significant reduction in time required**
- (2) Considerable increase in passengers**
- (3) Significant benefit to regional development**
- (4) Reduction in CO<sub>2</sub>**



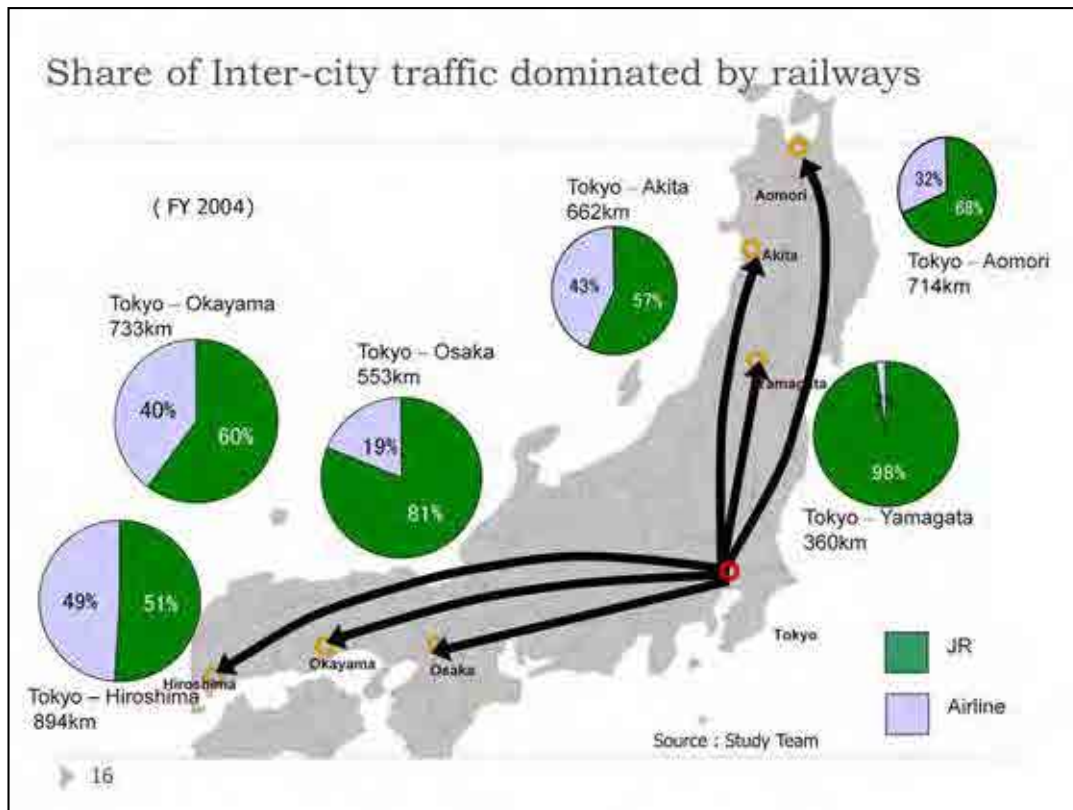

. Inter-city Traffic Railway Share

This table shows the transport shares of the Shinkansen and airlines.

For journeys between large cities on Japan’s main island, Honshu, up to distances of approximately 700 km, the Shinkansen is dominant. Particularly for trips of up to three hours, trains are seen as having a distinct advantage over airlines.

## Time Competition of Railway and Aviation

### Loss time of using aviation

- ▶ Access time to airport
- ▶ Proceeding time for boarding
- ▶ Predicted delay time caused runway congestion or wind direction

### Railway countermeasure against aviation

- ▶ Station should be located at city center
- ▶ Punctual train operation
- ▶ Frequent operation

## Management Improvement of JNR

- ▶ Abolition of Red Figure lines • • • <2000pas/day
  - Bus is better • • <4000pas/day,
  - Rail is indispensable • • >8000pas/day
- ▶ Direct Transport of Freight Cargo
  - - Abolition of large relay yards
- ▶ Intensive freight station distribution
  - - Average station interval 30km (max 50km )
- ▶ Development of new business (under market economy)
  - Public project - - Governmental preferential treatment (Subsidies etc.)
  - Profit-making project (Private)- - Fair competition

18

### Management Improvements since JNR

At the time of the reform of the former publicly owned Japanese National Railways, a distinction was made between journeys better suited to railway transport and others where car transport was deemed to be more efficient.

Railway lines with passenger volumes of less than 2,000 per day were closed.

When railway lines had passenger volumes of less than 4,000 per day, road transport was deemed to be more efficient.

When railway lines had passenger volumes of 8,000 or more per day, a total reliance on road transport was deemed to be inefficient.

One ton of freight is taken to equal one passenger, and can be converted as such.

Intensive freight distribution was improved, with the focus changing to direct freight transportation between hubs, and freight train relays and train make-up yards abolished.

Management effort to get income from out of transportation. Under the market economy, profit gain project should keep fairness of competition.

## Japanese Thought about Railway

- ▶ Safety is first...Fail-safe Principle ...Stop the train if doubt
- ▶ Railway should connect with city center as far as possible • • • Compete with aviation
- ▶ Station square is indispensable for intercity railway transport
- ▶ Transfer loss should be decreased to minimum.
- ▶ Barrier free
- ▶ Ease the congestion of commuter train
- ▶ Railway Station as the landmark...Railway oriented City-plan

▶ 19

- “Safety first” means trains may stop in case of little confidence.
- Stop the train if earthquake or heavy rain or strong wind is observed. After it, checking the track or slow operation or normal operation shall start depending on the intensity of the disaster.
- Rash hour congestion of commuter train in Japan had been terrible situation.
- Run-through service among suburban railway and metro.
- Shinkansen should be connected at Tokyo station.

## Effort for Rational Railway

- ▶ Selection of construction position  
(Underground, Viaduct, On ground)
- ▶ Avoid level crossing • • • weak point of railway
- ▶ Introduce one-man operation, CTC train control
- ▶ Maintenance free facilities
- ▶ The demand forecast and train operation plan is the basic matter of railway project.
- ▶ Future railway network plan should be considered at the time of first line planning.

■ 20

- Level crossing is the weak point of the railway
- Grade separation among railway and road/ Fly over construction and Continuous grade separation project for existing railway
- On time alarm and shutting barrier should be installed to make short the shut down time.
- The planning of railway is deeply concerned with train operation plan that is how much cars for one train, how much speed, how much frequency and how to maintain the facilities/ equipment.
- That includes connecting station structure with other lines/ mode, additional lines/ cars for increasing demand and innovation of railway technology.

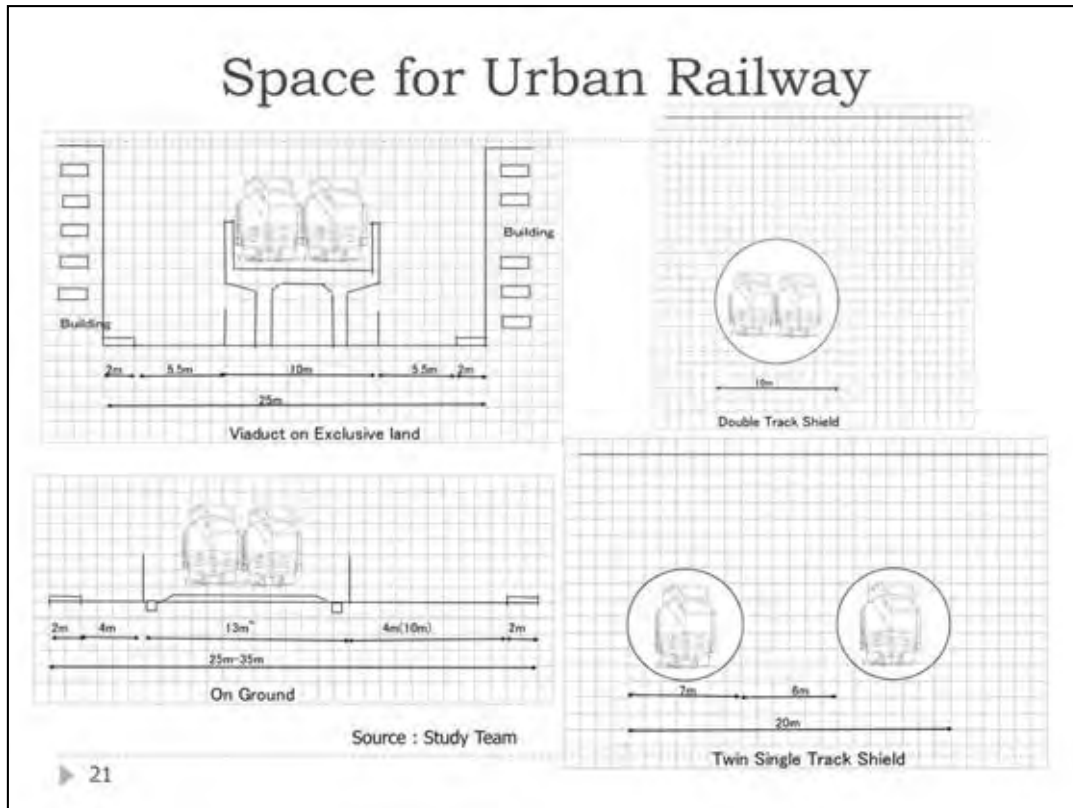

- At urban area, some space between railway and building is required.
- It is recommendable to keep more than 6 meter road between railway and buildings.
- In future, reform to viaduct track may be required. Road width of 10m for one side is useful to construct the viaduct. After one single track viaduct complete, additional one track shall be constructed at the removed track.
- Cost and necessary space for viaduct, on ground and subway. The rate of their track structure construction cost are 5:1:25. (10thousand dollar/m), (2thousand dollar/m), (50thousand dollar/m).
- Station is the center of the town
- On foot area from the station is variable(400m radius from the station at busyness area (5min. Walking) and 1.2km radius area at residential area(15 min. walking))

## Tokyo Urban Rail Example

							(2006)
	Chuo Line	Chiyoda Line	Nanboku Line	Ginza Line	Oedo Line	Haneda Monorail	Yuri-kamome
Operater	JR East	Tokyo Metro	Tokyo Metro	Tokyo Metro	Tokyo Municipality	Tokyo Monorail	Tokyo Rinkai
Route length	53.1km	24.0km	21.3km	14.3km	40.7km	17.8km	14.7km
Train consist	10*20.0m	10*20.0m	8*20.0m	6*16.0m	8*16.5m	6*15.6km	6*8.55m
Train capacity	1,400	1,424	886	608	780	584	352
Minimum headway	2'00"	2'07"	4'00"	2'00"	3'10"	3'33"	3'00"
Traffic volume (peak 1hour, each way)	87,260	74,220	19,560	30,122	23,403	9,852	5,121
Notes	Ordinary Rail	Subway Through operation	Subway Through operation	Subway	Subway Linear motor	Monorail	AGT

Source : Study Team

### Example of Mass transport of Tokyo

JR Chuo line was constructed at ground level and elevated one by one between stations. It had made enlarge the transport capacity.

Subway Chiyoda Line, Nanboku Line etc. are executed mutual trackage operation.

Oedo Line adopted liner- motor subway.

Haneda Airport Line adopted monorail system.

Yurikamome Line adopted new transit system of rubber tire guideway system.



## Histories of Urban Railway Development in Tokyo

1870~ Develop the main long distance lines

1945~ Reconstruct them after the world war II

1950~ Construct the second subway line

1960~ Replace electric cars with new ones

1970~ Increasing transport capacity to ease congestion rate

1975 ~ Continuous grade separation at traffic congestion section



▶ 23

Source : Study Team

### The History of Urban Railway Development in Tokyo

Prior to World War II, the main form of rail transportation in central Tokyo was by tram, with only a single subway line (Ginza Line) in operation.

Most suburban railways were also above ground. However, because level crossings caused traffic jams, a program to introduce grade separate crossings was carried out in areas of high traffic volume.

## Tokyo Metro Subway Construction

Year	Line	Length(km)	mil.\$/km	Total cost (100mil.¥)
1941	Ginza	14.3	1.4	0.858
1961	Marunouchi	27.4	4.9	482
1964	Hibiya	21.1	8.8	671
1969	Tozai	31.8	12	1320
1978	Chiyoda	23.0	32	1617
1988	Yurakucho	29.4	145	5554
1989	Hanzomon	10.9	180	2552
2000	Nanboku	21.4	253	5964
2008	Fukutoshin	8.9	286	2550

Source : Study Team

▶ 24

### Tokyo Metro Construction

Since the 1960s, subway construction has been carried out—initially by the Teito Rapid Transit Authority.

Indicated in dollar rates at the time 1931: ¥3.1 = \$1 1940: ¥4.3 = \$1 1950–1970: ¥360 = \$1

Because of price rises and the need to construct deeper lines, construction costs are burgeoning.

Huge sums of money are needed to construct subways. Recently the cost has risen to approximately ¥25 billion to ¥30 billion per kilometer. Subsidies are available for the construction of railways and, in the specific case of subways, subsidies of up to 70% of the cost of construction are offered by central and local government bodies. For railway development in new towns and airport access lines, subsidies of approximately 40% of the cost of construction are offered by central and local government bodies.

### Regional Share of Trip Mode for Commuting

	Railway	Bus	Automobile	Walk, Bicycle
Urban center	66.9%	2.8%	11.2%	19.1%
Fringe of Urban	41.0	3.6	29.5	25.9
Suburb	29.5	1.4	42.4	26.7
Rural	8.6	1.3	70.8	19.3

Source : Study Team

▶ 25

#### Commuting Modes

Railways account for a large share of commuting journeys in urban areas, but the roles of urban railways differ according to the population of each city.

In rural cities with low population densities, train services are less frequent and railway networks thin, so cars are deemed to be more convenient.

END



Source : Study Team

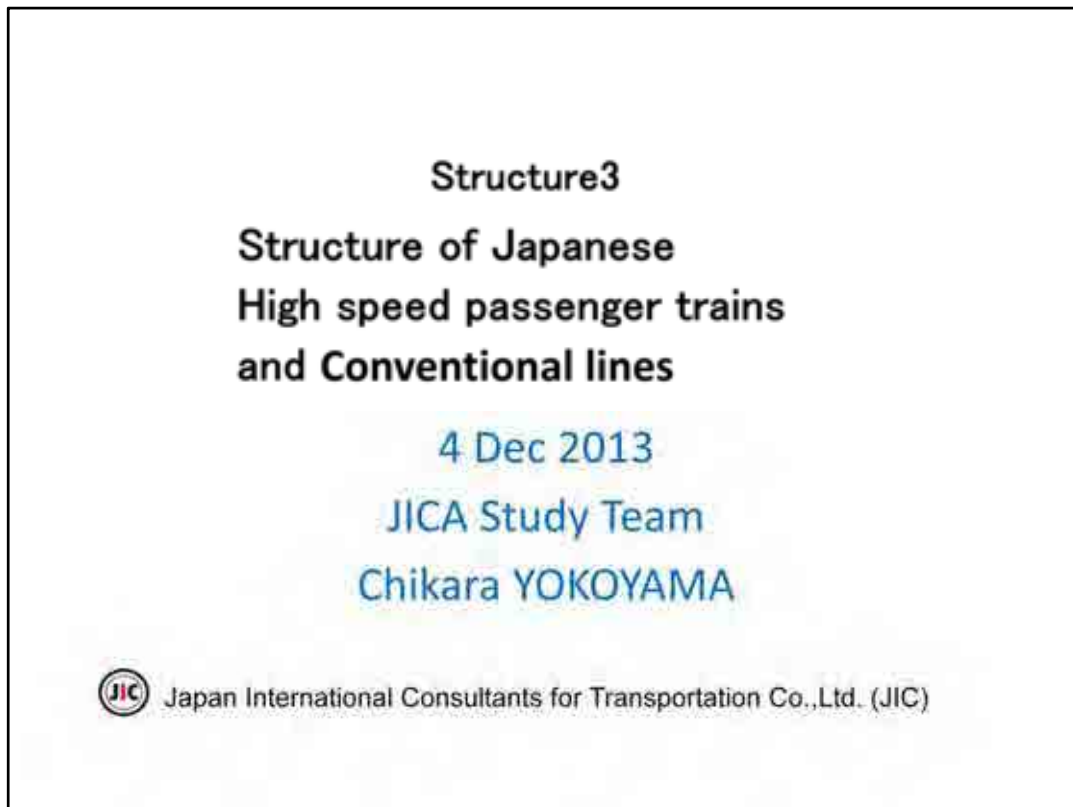

In this presentation, I will be talking about Shinkansen—that is to say, high-speed rail—and conventional rail structures in Japan.

# Contents

- 1. Shinkansen and conventional lines in Japan**
  - 1) Current Shinkansen Network in Japan**
  - 2) Conventional lines in overview**
  
- 2. Differences in train loads**
  - 1) Load comparison**
  - 2) Differences in structures due to mixed traffic**
  - 3) Special facilities for high-speed rail freight**
  
- 3. Train scheduling example (Tokyo-Morioka)**
  - 1) Timetable comparison**
  - 2) Expansion of facilities**
  
- 4. Maintenance**
  - 1) Conventional line maintenance**
  - 2) Shinkansen line maintenance**
  
- 5. Conclusion**

2

Here you see the contents.

1. Shinkansen and conventional lines in Japan
  - 1) The Shinkansen network in overview
  - 2) Conventional lines in overview
2. Differences in train loads
  - 1) Load comparison
  - 2) Differences in structures due to mixed traffic
  - 3) Special facilities for high-speed rail freight
3. Train scheduling example (Tokyo-Morioka)
  - 1) Timetable comparison
  - 2) Expansion of facilities
4. Maintenance
  - 1) Conventional line maintenance
  - 2) Shinkansen line maintenance
5. Conclusion

# 1. Shinkansen and conventional lines in Japan

3

Let's begin with an overview of Japan's Shinkansen and conventional line networks.



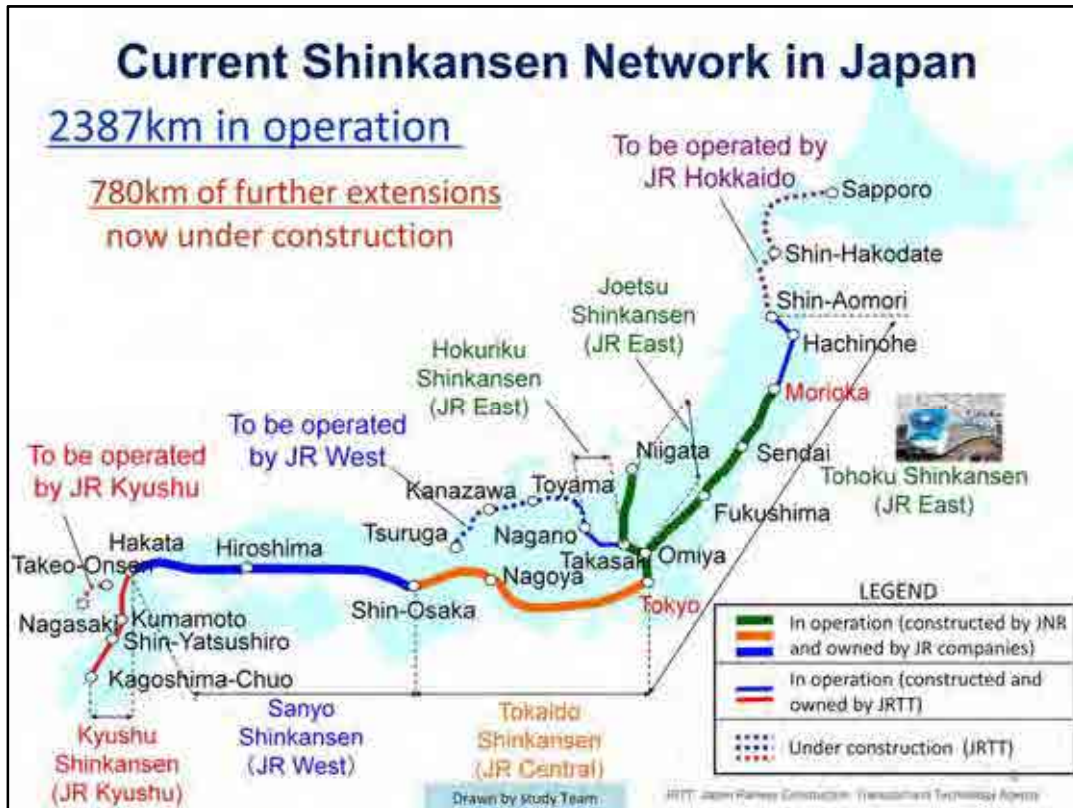

This is current status Shinkansen network in entire Japan.

We have 2,387km in operation.

The companies which have Shinkansen are JR East, JR central, JR west and JR Kyushu.

Shinkansen has been constructed with various scheme.

Heavy solid lines show Shinkansen lines constructed by Japan National Railway, JNR and owned by current Japan Railway, JR.

Thin solid lines show Shinkansen lines constructed by Japan Railway Construction, Transport and Technology Agency, JRJT and owned by JRJT.

You can see these dot lines are under construction plan by JRJT.

### A variety of Train Formation

Series	N700	E5	E4	E3	800
<b>Maximum Speed</b>	300( km/h)	320	240	275	260
<b>Starting Acceleration</b>	2.6(km/h/s)	1.7	1.6	1.6	2.5
<b>Configuration</b>	14M2T	8M2T	4M4T	4M2T	6M
<b>Train length</b>	404.5 (m)	252.5	201	128	154.7
<b>Car length</b>	25(m)	25	25	20.5	25
<b>Body width</b>	3360(mm)	3350	3380	2945	3380
<b>Capacity</b>	1323	731	817	338	392
<b>Motor power</b>	305kw × 54 (17080kw)	300kw × 32 (9600kw)	420kw × 16 (6720kw)	300 × 16 (4800kw)	275kw × 24 (6600kw)

Drawn by study Team

Various train models operate on Japan's Shinkansen network.

The maximum speeds of the models shown here range from 240 km/h to 320 km/h.

The E4 series is bi-level.

The E3 series has Shinkansen-gauge bogies but cars of a width suited to conventional lines.

There are other models too.

Later on, I'll explain about the E5 series that operates on the Tohoku Shinkansen.

The E5 series is used by the East Japan Railway Company, or JR East, and runs northwards from Tokyo.

Its top speed is 320 km/h.

## Conventional lines (Passenger)



- Conventional lines are narrow gauge with a track width of 1,067 mm.
- Limited express services travel at a maximum speed of 130 km/h.
- Trains run at 160 km/h on some sections of conventional line.

Conventional lines are narrow gauge with a track width of 1,067 mm.

On conventional lines, limited express services travel at a maximum speed of 130 km/h.

Although trains run at 160 km/h on some sections of conventional line, freight trains do not use these sections.

## Conventional lines(Freight)

- Freight is carried on narrow gauge.
- The total length of freight line in service is 8,340 km.
- The top speed is generally 110 km/h,



Freight is carried on conventional track, which is all narrow gauge.  
The total length of freight line in service is 8,340 km.  
The top speed is generally 110 km/h, though electric container freight trains can travel at up to 130 km/h on some sections of track.

Trains also run at night.

As well as containers and tank cars, freight trains also transport earth and sand.  
There are also some lines that are freight only.



Trains on high-speed container lines travel at 130 km/h.

Freight of this kind is commonly known as “Super Rail Cargo.”

The car bodies used on these trains are lighter and designed so that locomotive power is dispersed and containers can be carried in the middle of them.

They cover the approximately 500 km between Tokyo and Osaka in about 6 hours.

## 2. Differences in train loads

9

Now I would like to talk about the differences in train loads.





This slide shows the relationship between train load and axle load.  
Many locomotives bear the load on six axles.  
In the case of Shinkanen and tank cars, the load is often borne on four axles.  
Because wheels and rails are in contact with each other, axle load can be calculated by dividing the weight of the car by the number of axles.



## Train load and axle load

- Load differences are summarized in this table.

	Passenger	Passenger	Freight				
Gage	1435mm	1067mm	1067mm	1067mm	1067mm	1067mm	1067mm
Model	E5	E259	M250	EF510	コキ100	タキ1000	ホキ1000
Max Speed	320km/h	130km/h	130km/h	110km/h	110km/h	95km/h	75km/h
Net weight	52.4t	46.2t	21.0t	100.8t	18.5t	15.0t	18.8t
Loading capacity			19.0t	-	40.0t	45.0t	35.0t
Axle	4	4	4	6	4	4	4
Axle load	13.1t	11.6t	10.0t	16.8t	14.6t	15.0t	13.5t
Year	2011	2009	2002	2002	1987	1993	1990
							

Drawn by study Team

Load differences are summarized in this table.

As you can see, electric locomotives are the heaviest.

Electric container trains are designed for speed by dispersing loads and reducing axle weight.

Shinkansen tracks are not designed with freight locomotive loads in mind.

### Differences in structures due to mixed traffic

	HSR only	HSR + freight trains
Passing loops	Normally	Additional Passing loops
Maintenance costs	Normally	Additional costs
Freight trains speed	Conventional lines	Freight trains are slowed by having to stop to allow passenger trains to pass.
Freight trains depots	Conventional lines	High-speed freight trains require special depots.
Diagram	Normally	complex
Tunnel requirements	Normally	Normally
Construction costs	Normally	Additional costs

Drawn by study Team

This shows the changes in civil engineering structures necessitated by mixed traffic.

Passing loops are sections of track used by freight trains to allow faster passenger trains to overtake.

Because of their greater weight, freight trains cause more wear to the rails and lead to higher maintenance costs if allowed to use high-speed rail lines.

More points also have to be provided for passing loops, and these too cost more to maintain.

Freight trains are slowed by having to stop to allow passenger trains to pass.

They consequently take that much longer to reach their final destinations.

High-speed freight trains require special depots.

The presence of freight trains complicates things for passenger services.

Provided there are no changes in cross-section, tunnel requirements are the same.

More viaduct and bridge configurations and so forth are needed because of the greater train loads that have to be borne. Construction costs therefore increase commensurately.

## Special facilities for high-speed rail freight

- Special locomotive inspection facilities for high-speed freight.
- Special depots for high-speed freight.



From <http://www.jrfreight.co.jp/>

Special facilities are required for high-speed freight.  
New locomotive inspection facilities and special terminals for high-speed freight must be built.

## Construction costs

- Construction costs will increase.
- Maintenance costs will also increase.



From <http://www.jreast.co.jp/>

As concrete viaducts are in themselves very heavy structures, they should not change much in shape even if train load increases a little. Construction costs will also increase a little, but will not go up by an inordinate amount.

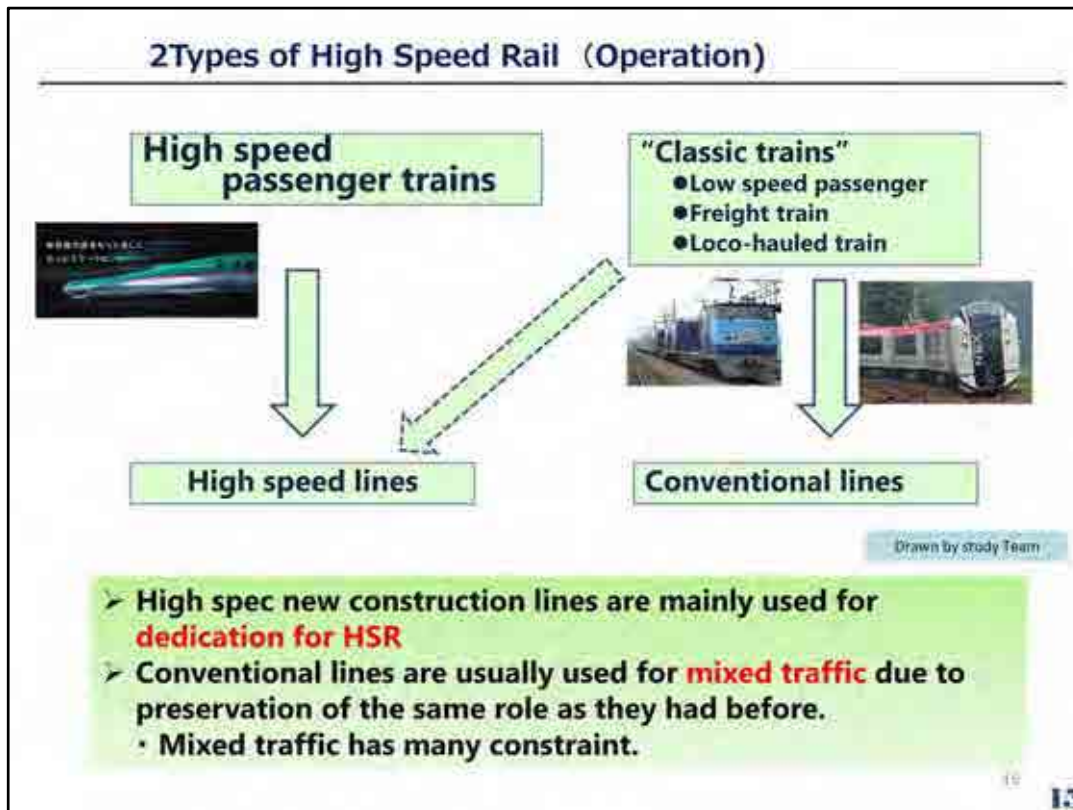

## Disadvantages of Mixed Traffic

### Disadvantages of Mixed traffic

- **Higher construction & maintenance cost.**
  - heavy axel-load
  - robust infrastructure
  - gentler gradient
  - wider distance between track centers
- **Constrain in traffic capacity**
  - due to long-time occupation of line for slow-speed conventional trains

**Shinkansen**, the world first High speed railway system, is typical of **High spec new line & dedication** for High speed passenger train.



### 3. Train scheduling example (Tokyo-Morioka)

17

As an illustration, let us look at the situation regarding services between Tokyo and Morioka in Japan.



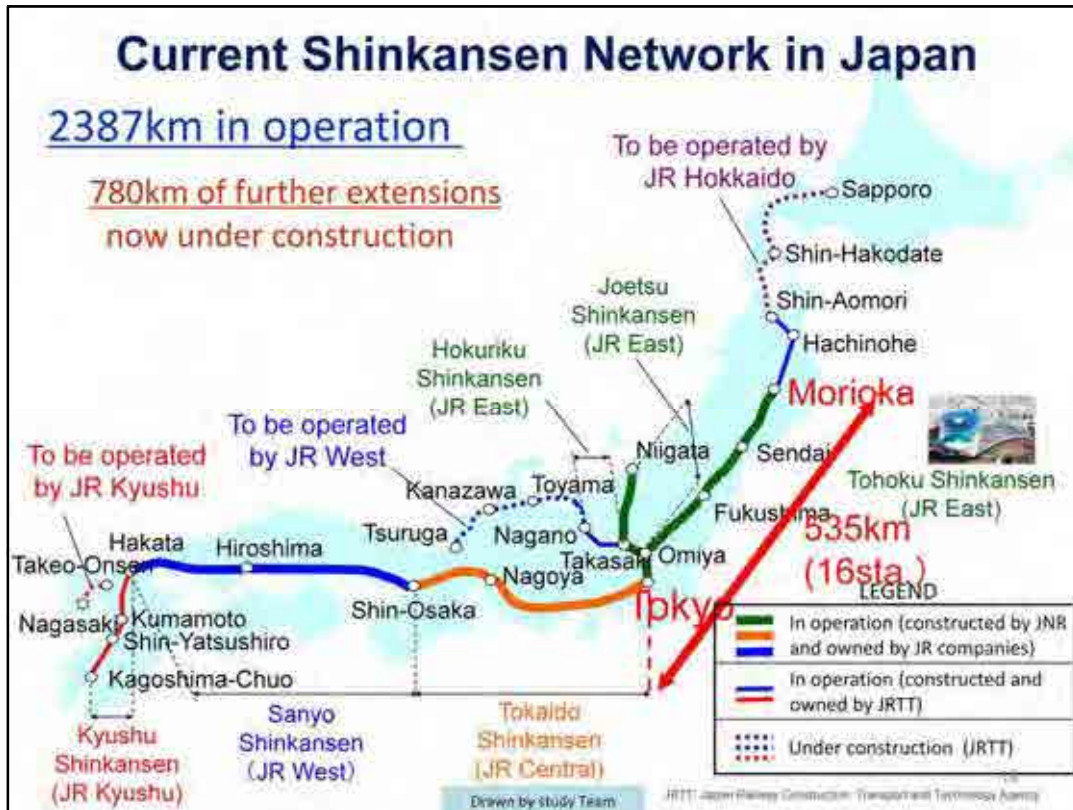

This is current status Shinkansen network in entire Japan.

The distance between Tokyo and Morioka is 535 km.

There are 16 stations along the way.

This section consists of conventional line and Shinkansen line.

## Shinkansen & Freight

### Tokyo ~ Morioka (535km)



From <http://www.jreast.co.jp/>



From <http://www.jrfreight.co.jp/>

- Shinkansen track width is 1,435 mm.
- Maximum speed is 320 km/h
- Journey time by the fastest service is 2.25 hours.
- Schedule speed is 535 km / 2.25 h, which equals 238 km/h.
- There are 16 Shinkansen stations.
- The conventional track is 1,067 mm wide.
- Maximum speed is 110 km/h.
- Assuming that schedule speed equals 110 km x 0.7, i.e., about 70 km/h,
- Estimated journey time is about 7 hours.
- There are approximately 100 stations

Shinkansen track width is 1,435 mm.

Maximum speed is 320 km/h

Journey time by the fastest service is 2.25 hours.

Schedule speed is 535 km / 2.25 h, which equals 238 km/h.

There are 16 Shinkansen stations along the way.

The conventional track is 1,067 mm wide.

Maximum speed is 110 km/h.

Assuming that schedule speed equals 110 km x 0.7, i.e., 77 km/h, estimated journey time is 7 hours.

There are approximately 100 stations along the way on the conventional line.

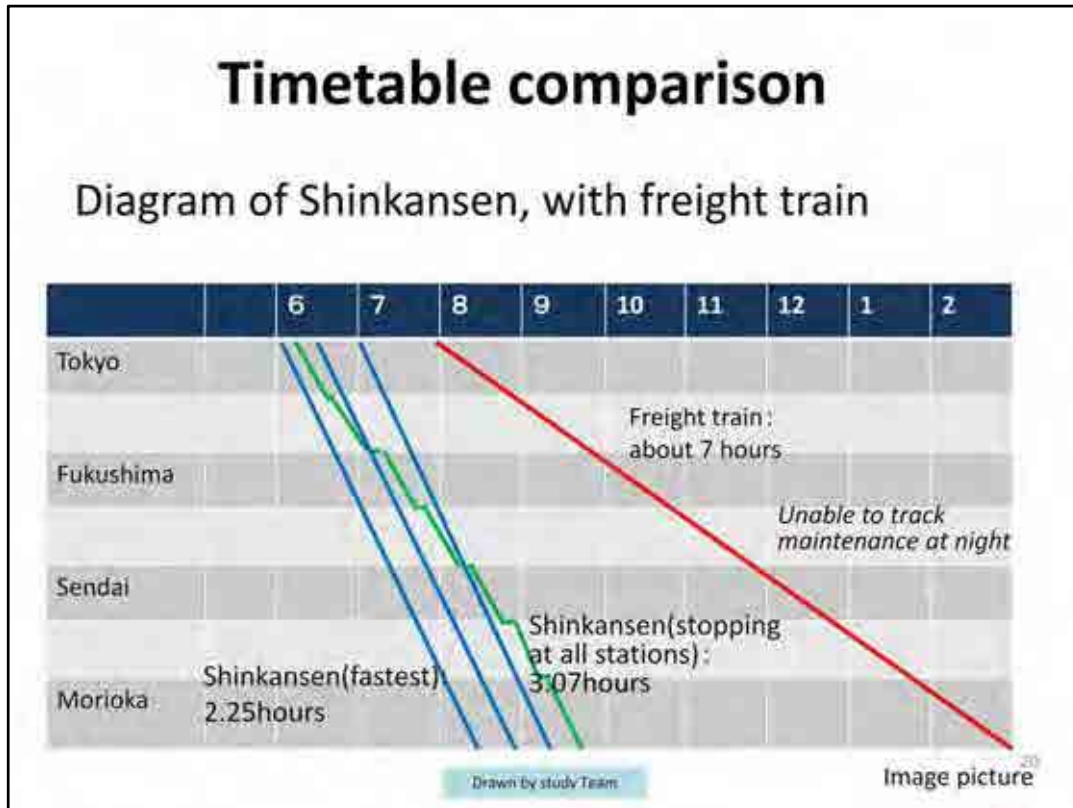

This is what a Shinkansen timetable might look like with freight trains incorporated into the schedule.

The journey time from Tokyo to Morioka is 2.25 hours at maximum speed.

Services are assumed to run at 30-minute intervals.

If the Shinkansen stops at every station, the journey time works out at 3.07 hours.

The journey time for freight trains is approximately 7 hours.

In the timetable, the fastest Shinkansen are shown in blue, Shinkansen services stopping at all stations are shown in green, and freight is shown in red

As you can see, the steeper the line, the faster the service.

The slope for freight is gentler.

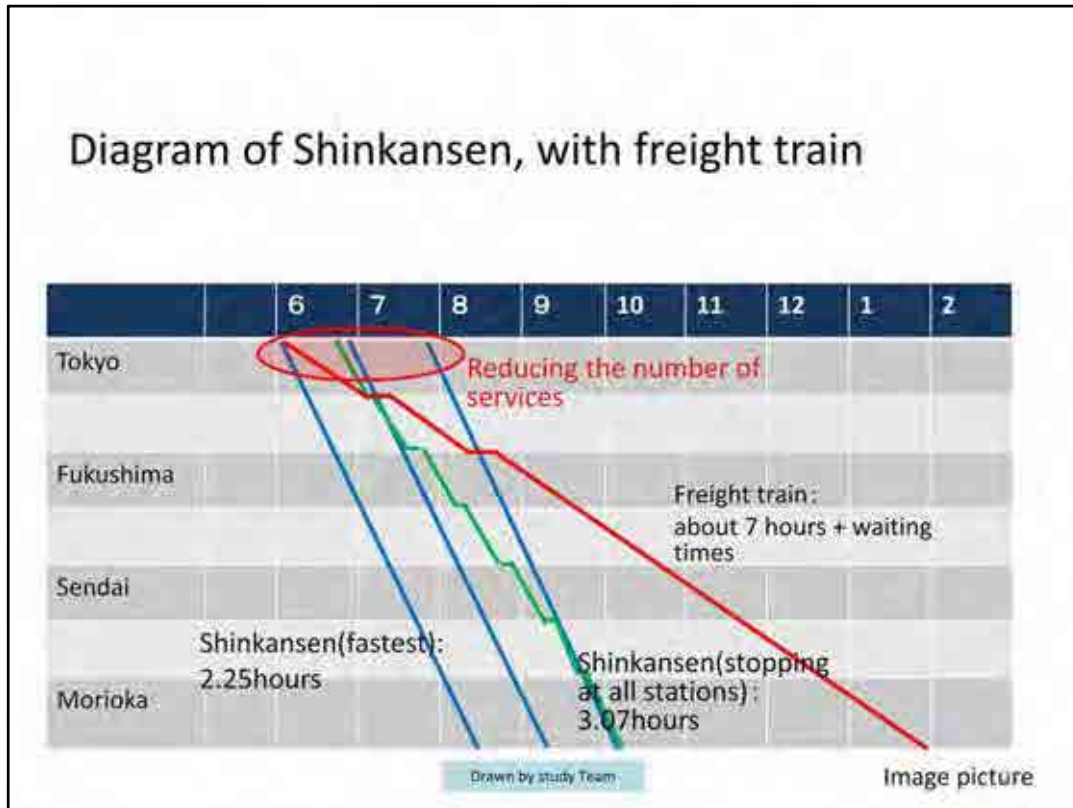

If freight trains are added to the Shinkansen timetable, passenger services will immediately catch up because freight trains are slower. Shinkansen trains therefore have to be spaced out more, which means reducing the number of services.



If the intervals between Shinkansen services are not to be reduced, freight trains will have to use passing loops to allow passenger trains to overtake them. Many new passing loops will have to be built between stations. Freight trains' journey times will also get longer and longer due to the frequency with which they have to be diverted onto passing loops to wait for other trains to pass.

Furthermore, if freight trains use the line at night after other services have finished, there will be less time for maintenance work to be performed on it.



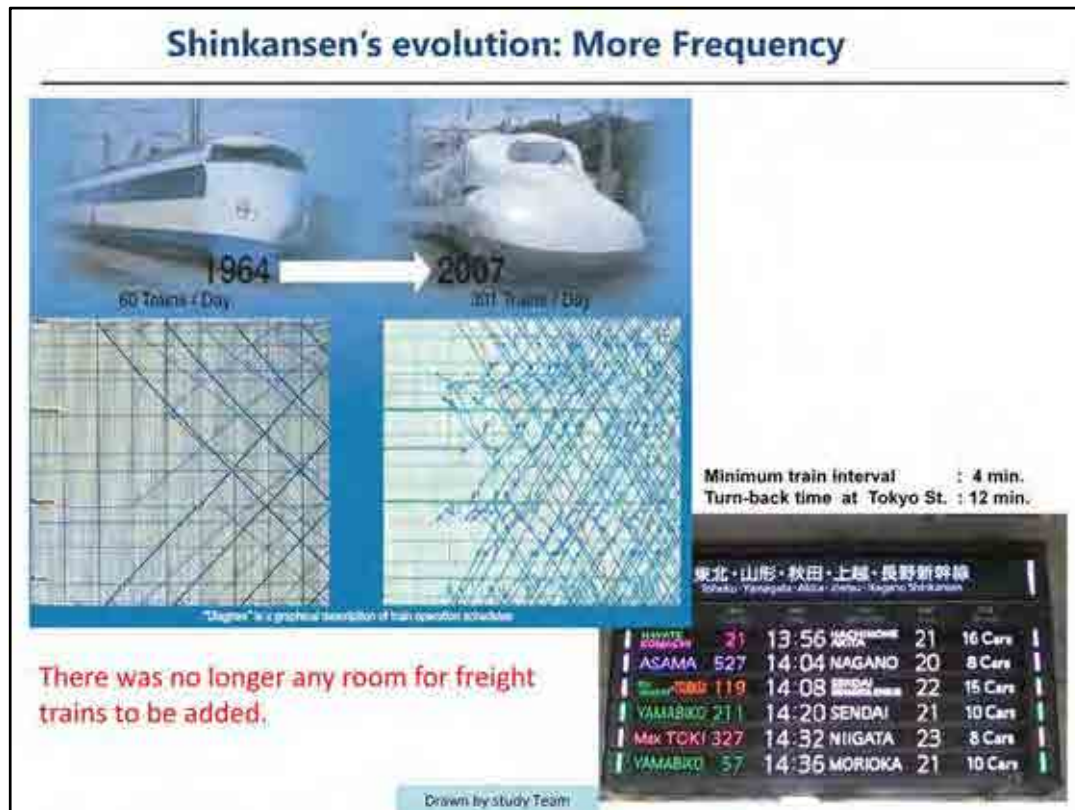

If we take the Tokaido Shinkansen as an example, services were well spaced when the line first opened in 1964, but in 2007 they were running at 4-minute intervals and there was no longer any room for freight trains to be added.

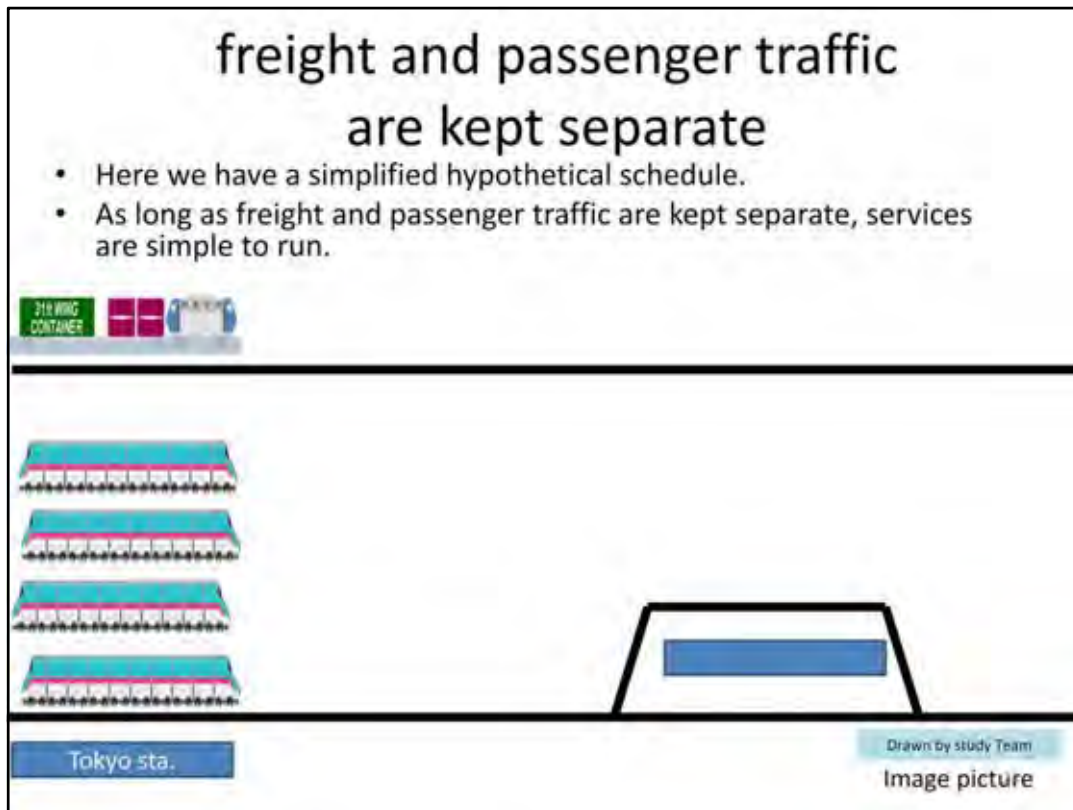

Here we have a simplified hypothetical schedule.

As long as freight and passenger traffic are kept separate, services are simple to run.

Freight train journeys also do not take longer than necessary, as they do not have to be shunted aside to let passenger trains pass.



## Mixed Traffic with Conventional locomotive-hauled train (Freight )

- Construction costs rise accordingly.
- Passing facility points also need to be maintained, which pushes up maintenance costs.

Tokyo sta.

Drawn by study Team  
Image picture

Because freight trains are slower, numerous passing facilities are required. Construction costs rise accordingly. Passing facility points also need to be maintained, which pushes up maintenance costs. Freight trains have to move aside frequently, and so take longer to reach their destinations.

## Expansion of facilities

- **Mixed Traffic with Conventional locomotive-hauled train (Freight )**

**Disadvantages**

- **Higher construction & operation cost.**  
due to
  - additional Crossover
  - a complicated operation system, enable to bi-direction
  - a complicated power supply system, enable to supply & block on one by one side
  - over night train operation
- **Constrain in traffic capacity**

26

Mixed Traffic with Conventional locomotive-hauled train  
(Freight )

Disadvantages

Higher construction & operation cost.

due to ▪ additional Crossover

▪ a complicated operation system, enable to bi-direction

▪ a complicated power supply system, enable to supply & block on one by one side

▪ over night train operation

Constrain in traffic capacity

## 4. Maintenance

## Conventional line maintenance<sup>1</sup>

- Maintenance basically takes place at night.
- Heavy machinery has been brought in to improve efficiency, but some work still has to be performed manually the old way.



Some sections on the outskirts of Tokyo are even becoming quadruple tracked. Maintenance basically takes place at night. Heavy machinery has been brought in to improve efficiency, but some work still has to be performed manually the old way. Conventional lines are used by freight trains and also sleeper trains at night. To provide opportunities for maintenance work to be carried out, freight and sleeper trains are routed along other lines on some days.

## Conventional line maintenance2

Large-scale track-switching work.



From <http://www.daiichi-kensetsu.co.jp/>

Time for large-scale track-switching work, etc. is created by ending services for the day earlier or starting them later than usual, and in some cases by laying on buses or other alternative means of transport.

## Shinkansen line maintenance

- Shinkansen maintenance is not as a rule performed during the day.



Shinkansen maintenance is not as a rule performed during the day.  
As there are no services at night, there is time for maintenance then.  
Before the first Shinkansen service of the day, a track confirmation car goes along the track to inspect the line and confirm safety.

## 4. CONCLUSION



## CONCLUSION

- Operating freight trains alongside high-speed passenger trains increases loads, changes the cross-sections of structures, and so pushes up construction costs.
- The high frequency of passenger services on Shinkansen lines in Japan means that the addition of freight trains would reduce passenger transportation capacity.
- Shinkansen lines in Japan are maintained at night rather than during the daytime. Allowing their use at night for freight would make it difficult to set aside time for maintenance work.

32

In Japan,

- Operating freight trains alongside high-speed passenger trains increases loads, changes the cross-sections of structures, and so pushes up construction costs.
- The high frequency of passenger services on Shinkansen lines in Japan means that the addition of freight trains would reduce passenger transportation capacity.
- Shinkansen lines in Japan are maintained at night rather than during the daytime. Allowing their use at night for freight would make it difficult to set aside time for maintenance work.

## Minutes of Workshop

### <1st Day>

(A preliminary address, Mr. Takahashi)

- The purpose of this workshop is to convey the experience of Japan in railways as a whole, thereby aiming at contributing to the development of railways in Vietnam, by focusing on the two issues: (1) speedup of trains and (2) use of the new railway for a mixed-train operation of passengers and freights using the same tracks, with explanations on these issues given by the experts in planning, civil engineering, rolling stock, train operation, signals and electric engineering.
- As the discussion time prepared is rather long, I wish that views/opinions be actively exchanged between those from Vietnam and Japan.
- Participants from Vietnam are those from MOT, VNRA, VNR, universities, consulting firms and other related organizations, while those from Japan are Mr. Kubo (JICA) and study team members.

(Mr. Kubo, JICA)

- Thank you very much for attending this workshop. JICA has promoted a number of projects including those on the construction of urban railways in the Hanoi and Ho Chi Minh areas. These projects are all to strengthen the capacity of railways, which is an indispensable element for the development of Vietnamese economy. I believe that an issue simultaneously to be discussed for Vietnam is to construct a new railway and run high-speed trains. Regarding the control and management of the construction of a high-speed railway, however, there are factors in quantities to be discussed, when compared with the control and management of existing railways. At this workshop, I wish that explanations be provided by the railway experts in Japan and discussions be offered by those from Vietnam. I will highly appreciate it, if active discussions and studies take place. Thank you.

(Mr. Nguyen Huu Thang – Chairman of VNRA)

- I wish to express my sincere gratitude on behalf of MOT and VNRA.
- Railways, roads, airways and shipping are taking important roles in society. Whereas the railways in Vietnam claim a 100-year-long history, they are still behind those in other countries in various aspects, with the transport capacity being low and management/control

and safety insufficient. What is the most important issue for Vietnamese railways at present is how to quickly develop by introducing advanced technologies in the world. The points now arousing the greatest attention among railway experts in Vietnam is how to operate passenger trains and freight trains on the new railway and to what extent the maximum train speed can be raised.

- This workshop is held under the approval of MOT.
- Japan is a railway country most advanced in the world that has developed railway technologies by itself. Its records of failure and success may also be valuable experiences.
- Vietnam has received great cooperation extended from the government of Japan in the field of infrastructure construction, in particular.
- This workshop provides a valuable opportunity for those from relevant organization in Vietnam to be able to listen to the presentation by Japanese experts and acquire widely-ranged information/know-how.
- On behalf of the Vietnamese side, I wish to express my deepest gratitude for cooperation extended from Japan. Thank you.

Question and Answer (1st Day: Planning, Rolling Stock and Train Operation)

Question	Answer
<p>Questions on railway laws.</p> <p>1) Are there general railway laws and high-speed railway laws existing in Japan?</p> <p>2) Were laws enacted before or after construction of railways?</p> <p>3) Have laws been observed after enactment? How severe is the penalty against violation?</p> <p>(Mr. Nguyen Huu Thang – VNRA)</p>	<p>1) In the case of Tokaido Shinkansen, laws were not enacted in particular, as the construction work was regarded as one to add tracks to the narrow-gauge Tokaido line, JNR.</p> <p>2) To ensure safety for Shinkansen, a special law for Shinkansen was put in force, before its inauguration. After Tokaido Shinkansen was recognized as a useful transport means; a special law on projected Shinkansen railways was enacted to construct a nationwide Shinkansen network. As a process stipulated in the projected Shinkansen law, opinions of a deliberation committee and third parties are heard on where and when a Shinkansen railway shall be constructed. The law also prescribes that construction of a Shinkansen railway shall be promoted based on the opinion of the operator nominated in advance. The prior nomination of an operator guarantees convenience and profitability of the Shinkansen railway after completion.</p> <p>3) As railways are constructed based on the consensus among stakeholders, there are no cases of violation or penalties. (Mr. Hashimoto)</p> <p>(Supplementary explanations)</p> <p>A supplementary explanation on legislation is as follows. In the past, the legislation for railway operation is based on the Japanese National Railways law. There were also a law on railway operation (Railway Operation Law) and a law on the construction of narrow-gauge railways (Railway</p>

Question	Answer
	<p>Construction Law).</p> <p>At the privatization of the National Railways in 1987, the Railway Enterprise Law was enacted in place of the Japanese National Railway Law, with the Railway Construction Law abolished simultaneously. However, the Railway Operation Law is still in effect.</p> <p>For Shinkansen railways, the Shinkansen Railway Construction Law was enacted in 1970, which stipulates that cooperation of local autonomous bodies and opinions of the operator shall be esteemed in constructing a Shinkansen railway.</p> <p>The basis of the railways in Japan is the Railway Enterprise Law, which prescribes that the operator shall nominate a chief engineer in operating the railway and determines detailed corporate regulations. This means that the government delegates discretionary power to a great extent to private companies.</p> <p>The Railway Operation Law sets forth the specifications of rolling stock and transport charges, under which technical standards are in force. This Law was added with a Ministerial Ordinance on Shinkansen in 1964. (Mr. Takahashi)</p>
<p>Questions on stations and level crossings with roads</p> <p>1) Stations are mostly located at the city center in consideration of the convenience of passengers and connection with roads and other traffic means. When road vehicles enter a station, don't they affect the traffic situation on the road?</p>	<p>1) As Shinkansen is completely separated from roads, there are no level crossings with Shinkansen. Grade-separated crossings don't disturb the traffic on roads at all.</p> <p>Narrow-gauge railways are elevated as far as possible to eliminate crossings with roads in urban areas in particular. Therefore, there are no requirements to relocate stations for the reason of disturbance.</p> <p>At city centers, however, noise is a problem. To solve this problem, there are some people living close to Shinkansen who require railway operators to restrict train speed. (Ms. Nakano)</p>

Question	Answer
<p>In case they do, how is it dealt with? Isn't relocation of the stations at city centers required?</p> <p>2) Level crossings with roads still exist with narrow-gauge railways in Japan. At these crossings, do traffic jams take place? How are they dealt with?</p> <p>3) What is the ratio of grade-separated crossings of narrow-gauge railways? How about the ratio of crossings that have been closed? (As there are a number of level crossings with roads that frequently cause traffic jams in Vietnam, there are claims to relocate stations to suburban areas. Are there similar claims in Japan?)</p> <p>(Mr. Nguyen Huu Thang – VNRA)</p>	<p>2) There are some crossings in Japan normally called “an all-the-time closed crossing.” Autonomous bodies are making effort to elevate railways having such crossings with subsidies from the government. Although railway operators are cooperative, this movement makes very small progress. Because there are so many crossings to be addressed. (Ms. Nakano)</p> <p>3) Although I don't have concrete figures at the moment, crossings with roads are a serious problem not only in Vietnam but also in Japan. Based on the Road Crossings Remodeling Law, grade separation work has been promoted in Japan. Although grade separation entails an enormous amount of costs, it brings about little advantages for railway operators. Therefore, the cost to eliminate crossings is partly borne by the government and autonomous bodies.</p> <p>As everybody uses railways running in cities in Japan, it is socially accepted that railways are more important than roads. Therefore, there are no claims that railways shall be rerouted. On the contrary, railways may be regarded as a cumbersome and remote existence in Vietnam only because few people use it.</p> <p>In Thailand as well, railways were treated as a nuisance, and the entry of trains into urban areas was limited in the morning and evening. (Mr. Takahashi)</p>

Question	Answer
<p>Freight transport by HSR</p> <p>1) In the case of Tokaido Shinkansen, it was reported that mixed operation of passenger trains and freight trains had been discussed at the planning stage. Is the mixed operation now in practice?</p> <p>2) In Vietnam, the mixed operation is now the object of attention. What is the maximum speed allowed for passenger trains and for freight trains in mixed operation? What sort of danger is anticipated for mixed operation?</p>	<p>1) Some passenger trains are running through Shinkansen and the remodeled conventional railways of which gauge was expanded into standard gauge. But mixed operation with passenger trains and freight trains is not implemented. It is discussed now to run passenger trains and freight trains in the future on the same tracks through the approximately 50 km-long Seikan submarine tunnel. To ensure safety and guarantee a sufficient transport capacity, it is now under coordination that Shinkansen trains run at a maximum speed of 140 km/h and freight trains at conventional 100 km/h. Although Shinkansen trains can run at 320 km/h according to their performance, the above-mentioned 140 km operation is deemed to be safe, in view of the fact that the limited express trains are now crossing freight trains at 140 km/h on narrow-gauge railways.</p> <p>2) Guarantee of safety and a sufficient transport capacity are two important challenges of mixed operation of freight trains and high-speed passenger trains. The safety level of Shinkansen in Japan is high enough. It has recorded no derailment accident in revenue service operation except one that was caused by a seismic motion at the Niigata Chuetsu Earthquake. On the other hand, freight trains on narrow-gauge railways experience derailment not frequently but several times a year. In the case of containers, it is not deniable that doors potentially open to scatter or collapse freights inside. Suppose a freight train causes an accident. In this situation, it is a problem whether the train running in the opposite direction on an adjacent track can stop safely after getting the accident information. In Japan, it is supposed that passenger and freight trains can stop within a distance of 600 m after applying an emergency brake at the maximum speed. The distance of 600 m means a distance for conventional trains to stop after the train driver detects a stop signal, including idle</p>



Question	Answer
	<p>running distance and actual braking distance.</p> <p>In the case of Shinkansen in contrast, as trains require a distance of 3 km or over to stop after application of emergency brakes at the maximum speed, it is too late for train drivers to apply emergency brakes after sighting a red signal. This is a reason why 140 km/h operation is now being discussed for Shinkansen trains to run through the Seikan Tunnel.</p> <p>In Europe, passenger trains and freight trains are allowed to pass each other at 200 km and 160 km, respectively, setting aside the question whether it is safe or not. In conjunction with the crossing speed, I hear that train operation diagrams are drawn to avoid two-train crossings or the operation time zone is separately specified for passenger trains and freight trains.</p> <p>Regarding the track capacity, operation of low-speed freight trains substantially reduces the number of operable trains.</p> <p>As there is no overtaking equipment between stations, the transportation capacity sharply decreases, unless efficient use of permanent ways is contrived.</p> <p>Increases in the frequency of train operation necessitate increases in the number of siding stations and in the operation/construction costs.</p> <p>Therefore, operation of freight trains is applicable only to sections where the transportation volume is low.</p> <p>A conceivable solution may be the operation of high-speed container trains, as smaller speed differences between passenger and freight trains eliminate the problem of transportation capacity.</p> <p>However, there are a number of subjects to be addressed in the way of high-speed container freight trains, on which I will make explanations in the afternoon session. (Mr. Kawasaki)</p>
<p>3) By what means freight is transported</p>	<p>3) Large-size freights are transported by ships in Japan as it is surrounded by the sea, which seems to be the same as in</p>

Question	Answer												
<p>(Mr. Ngo Trung Kien – VNR)</p>	<p>Vietnam.</p> <p>In Japan, highway networks are more densely constructed than those of railways.</p> <p>Railways in Japan transport a great number of passengers and only little freight. Freights are mainly transported by roads and ships, though there are a certain volume of air freights. (Mr. Hashimoto)</p> <p>(Reference)</p> <p>Freight transport share in Japan (%)</p> <table border="1" data-bbox="627 757 1353 904"> <thead> <tr> <th>Year</th> <th>Railway</th> <th>Highway</th> <th>Ship</th> </tr> </thead> <tbody> <tr> <td>1965</td> <td>31</td> <td>26</td> <td>43</td> </tr> <tr> <td>2005</td> <td>4</td> <td>59</td> <td>37</td> </tr> </tbody> </table>	Year	Railway	Highway	Ship	1965	31	26	43	2005	4	59	37
Year	Railway	Highway	Ship										
1965	31	26	43										
2005	4	59	37										
<p>Questions on demand forecasting</p> <p>1) In calculating the number of trains, what are the preconditions for demand forecasting? In my view, remodeling of the National Road No. 1 will be completed in 2020 to 2030 to form a road network, with transport demands shared between railways and other transport means. Therefore, I want to know the preconditions for the future transport demands.</p>	<p>1) A precondition is that different transport modes (railways, roads, waterways and airways) will have been improved by the respective time limits according to each master plan. (Mr. Takahashi)</p> <p>The basis of demand forecasting is placed in VITRANSS2 that prescribes a predicted figure in 2030, but not those in 2015 and 2020. The study team hears that figures not shown have been introduced from the figure in 2030 in VITRANSS2, but doesn't know the concrete method of calculation.</p> <p>As VITRANSS2 doesn't show definite figures predicted for bulk or container freights, it seems difficult to discuss the transport volumes shared between HSR and existing railways.</p> <p>Furthermore, it seems that VITRANSS2 doesn't consider the master plan on the urban railways in Hanoi or in Ho chi Minh City.</p> <p>As container transport is implemented also by roads and waterways, demand forecasting shall deliberately be discussed. (Mr. Edo)</p>												

Question	Answer
<p>2) Demand forecasting is related to the investment amounts in the plan and in alternative plans A1, A2, B1, and B2. My question is whether predicted figures are correct or not.</p> <p>As the data of VITRANSS2 cited as preconditions is too old. Isn't it necessary to update the data?</p> <p>(Mr. Phan Manh Cuong (TDSI))</p>	<p>2) As I referred to above, the figure predicted for 2020 has been calculated based on the figure predicted for 2030 in VITRANSS2. (Mr. Edo)</p> <p>It is desirable to modify the basic data over time if possible. In Vietnam, however, it is difficult to update data continuously. Furthermore, it will be impossible to correctly foresee the future, even if 100% correct data is available. As a matter of course, precision is limited for demand forecasting. Therefore, cost performance shall also be taken into consideration. (Mr. Takahashi)</p>
<p>The Seikan Tunnel</p> <p>The Seikan Tunnel is said to have been constructed to Shinkansen specifications. As it is a narrow-gauge railway, does it really deserve the naming of Shinkansen?</p> <p>(Mr. Luong Van Vinh – VNR)</p>	<p>Passenger and freight trains are now running on the narrow-gauge tracks. When Shinkansen trains are to be operated in the future, we will use a three-rail track structure to compose 1,435 mm- and 1,067 mm-gauge tracks. It may be a practical idea to run container freight trains of Shinkansen specifications on the tracks of three-rail structure.</p> <p>(Mr. Matsumoto)</p> <p>Shinkansen trains run at a reduced speed in the 54 km-long Seikan Tunnel section. In this sense, it certainly doesn't deserve the name of Shinkansen when trains are in the Seikan Tunnel. (Mr. Hashimoto).</p>
<p>The Hai Van Pass</p> <p>I've heard the story of Seikan Tunnel. Is the concept of Hai Van</p>	<p>Regarding the method to remodel the Hai Van Pass section, the Japan side hasn't finalized its policy yet. In relation to the survey this time, there may be an idea to use the Hai Van</p>

Question	Answer
<p>Pass the same as that of Seikan Tunnel? The information source is JICA FR (June 2013). (Mr. Ngo Trung Kien – VNR)</p>	<p>Pass tunnel section for high-speed tests and freight train operation.</p> <p>It is difficult to excavate another tunnel in parallel to the 54 km-long submarine Seikan Tunnel. However, the scenario is different with the Hai Van Pass tunnel, as it is shorter than 10 km.</p> <p>In my personal view, it may be possible to construct two tunnels through the Hai Van Pass, one for Shinkansen and another for a narrow-gauge railway or construct a Shinkansen tunnel first and use it for tests and construct another for a narrow-gauge railway when narrow-gauge trains shall run separately in the future. In this manner, it is recommended to run passenger and freight trains separately. (Mr. Hashimoto)</p> <p>The Hai Van Pass section is not included in the sections for which a high-speed railway survey was conducted this time. Although it hasn't officially been finalized yet, JICA will possibly implement a survey to improve the existing railways between Hanoi and HCMC. In relation to this movement, a number of personal views will sprout, including one to adopt a Seikan Tunnel method to construct the Hai Van Pass tunnel section designed to have a sectional area equivalent to that of Shinkansen tunnels. In any event, as there are no finalized policies, surveys in the future will determine whereabouts in the future. (Mr. Takahashi)</p>
<p>Curve Radius</p> <p>I hear that 320 km/h operation is possible thanks to the adoption of the maximum radius of curve 4,000 m (R 4,000). The JICA Report cites a radius of curve R 6,000 and KOICA</p>	<p>As 320 km/h operation was not assumed at the initial stage, there are some curves having a radius of R 4,000 m with the Tohoku Shinkansen railway. However, we are recommending curves of R 6,000 m or over in this case, as the target speed is 300 km/h.</p> <p>The car body tilting system naturally pushes up the cost of rolling stock. Furthermore, the system may potentially cause failures depending on the condition of operation due to its complicated structure.</p>

Question	Answer
<p>Report R 5,000 in place of R 4,000 in this regard. How shall we interpret these differences?</p> <p>(Mr. Nguyen Van Doanh – VNRA)</p>	<p>We are forced to use the above mentioned complicated system, therefore, for particular sections to meet the circumstantial conditions.</p> <p>In contrast, Vietnam is going to construct a high-speed railway from scratch. Therefore, don't rely on such complicate systems. Our proposal is that: adopt simple systems as far as possible and make the radius of curve as large as possible. (Mr. Kawasaki)</p> <p>For reference, the magnetically levitated railway (linear motor railway) in Japan will run trains at 500 km/h on curves of R 8,000 m. The train speed specified at the beginning determines the radius of curve. (Mr. Takahashi)</p>
<p>Travelling distance</p> <p>1) According to available information, HSR is more competitive than other means of transportation for the travelling distance of 300 to 700 km. But the share of railways is 10% for the distances over 900 km. Do you have Shinkansen lines longer than 1,000 km?</p> <p>2) If Hanoi and Ho Chi Minh are connected with a Shinkansen railway, it will take six to seven hours to travel 1,400 to 1,500</p>	<p>1) The line length of Shinkansen is 1069km from Tokyo and 257km from Hakata to Kagoshima.</p> <p>It is possible to run trains up to Kagoshima from Tokyo via Hakata, but there is no direct train between Tokyo and Kagoshima at the moment.</p> <p>At the initial stage after inauguration up to Hakata, it took approximately seven hours to travel by Shinkansen trains at 210 km/h between Tokyo and Hakata. A large number of passengers used to take these trains. There will be passenger demands for travelling for seven hours or so.</p> <p>For longer distances, it may be a subject to discuss introduction of overnight trains.</p> <p>However, overnight trains don't run in Japan, as the permanent way is subject to maintenance services at night (Mr. Hashimoto).</p> <p>2) The line may not be competitive against planes. As there are no high-speed railways that are longer than 1,700 km in the world, it still belongs to anybody's guess how large travelling demands emerge for the high-speed railway. (Mr. Takahashi)</p>

Question	Answer
<p>km between these two cities. I want to know if it is competitive against airplanes.</p> <p>I studied about the high-speed railway plans in Russia and the US. It seems that passengers can endure travelling for maximum two to three hours. For travelling longer distances, they require bed accommodations, whereas there are no beds on Shinkansen railways in Japan.</p> <p>(Mr. Nguyen Huu Thang – VNRA)</p>	
<p>Freight Train</p> <p>There are three categories of freights for transport: bulk, normal and container. I've heard the story of mixed operation of passenger and container freight trains.</p> <p>What do you think of the transport of bulk and normal freights? Suppose container</p>	<p>Safety and the transport capacity will be the main challenges for rapid freight transportation by the high-speed railway which will be newly constructed.</p> <p>It is rather difficult to manufacture rolling stock to transport normal freights, such as bulk freight cars, open wagons and covered wagons, which allow speedup of freight trains.</p> <p>If high-speed passenger trains and freight trains are operated on the same tracks, the line capacity will not be used efficiently, unless freight train speed can be raised.</p> <p>We believe, therefore, it is a best policy to transport bulk and normal freights by existing railways while keeping them intact. A possibility of high-speed transport may be application to container transport. This means a proposal of the</p>

Question	Answer
<p>freight trains run at a maximum speed of 160 km/h. What is the approximate maximum speed of passenger trains in that situation?</p> <p>(Mr. Luong Van Vinh – VNR)</p>	<p>aforementioned power distributed high-speed container freight trains. When freight cars loaded with bare containers are used, the maximum speed allowed for opposite passenger trains is less than 200 km/h. Although strict verification is required for the above-cited subjects, a conceivable bottleneck is whether containers can withstand wind pressure. As it is rather difficult to rely only on the efforts of the railway operator, the approximate maximum speed allowed for crossing passenger trains may be 200 km/h. Of course, it may be possible to raise train speed more, if a verification test proves it as affirmative.</p> <p>To raise train speed further, there may be no alternatives than housing containers inside the body of freight cars, which is referred to as “a body mount container system.” For freight car operation through the Seikan Tunnel, this system is being discussed under the name of “a train on train system.” The target speed is 260 km/h for passenger trains and 200 km/h for high-speed container freight trains, which is still under development.</p> <p>I think such levels of train speed are practical in Vietnam as well. However, axle loads shall strictly be controlled to avoid derailment. Despite the limited volume of freights to be transported by a train, this system requires incomparably large freight terminal facilities. Thus, it shall be fully discussed where a trade-off point exists in regard to the cost incurred.</p> <p>(Mr. Kawasaki)</p>
<p>Air-conditioning system</p> <p>Among the important systems of rolling stock, those for ventilation and air-conditioning are to guarantee convenience and make passengers feel</p>	<p>I don't think any particular type air-conditioning systems are used in Japan. As a railway car is normally equipped with two sets of air-conditioners, one set can cope with the air-conditioning requirement even in case the other has failed. When both sets have failed, passengers are requested to move to other cars. In case all air conditioners on a train set have failed, the train set is removed from service, with another train set prepared to accommodate the suffering</p>



Question	Answer
<p>relaxed.</p> <p>I have heard a case in Germany where a high-speed train was forced to cancel operation as the cabin temperature had arisen to 50°C due to the failure of air conditioning system.</p> <p>What types of air conditioning system are used in Japan? Aren't there any problems?</p> <p>(Mr. Vu Kim Ngoc – TEDI)</p>	<p>passengers.</p> <p>A serious problem with the air conditioning system is a stoppage of power supply. Trains cannot run. The air-conditioning system doesn't function. Windows don't open. We have experienced several cases in Japan where passengers were put to trouble as a result. A relief train is quickly arranged or passengers are requested to alight from the train for evacuation. Although a trouble-free air-conditioning system is important, what is far more important is a manual to deal with the situation.</p> <p>What is the most important to prevent failures of air-conditioning system is maintenance services. In midsummer, it is hotter sometimes in Japan than in Vietnam. The air-conditioning system fails frequently due to improper cleaning. JR East provides cleaning services sufficiently before summer every year to prevent failures of air-conditioning system. Even household air conditioners will lose normal performance or cause failures, if they are spoiled. This also holds true with the air-conditioning system on railway cars. (Mr. Kawasaki)</p>
<p>ATC and CBTC</p> <p>Which system do you use more frequently in Japan, ATC or CBTC?</p> <p>(Mr. Vu Kim Ngoc – TEDI)</p>	<p>The Shinkansen railways in Japan are all dependent on track circuits. I hear that the Ho Chi Minh line 1 and the Hanoi line 2 are planned to adopt the CBTC system.</p> <p>Whereas systems of the track circuit type can detect rail breakage, the wireless type CBTC system cannot, unless conditions for that purpose are set separately. Despite that there is a movement to introduce the CBTC system into narrow-gauge railways in Japan, there are only a few cases where the system has already been introduced. Please confirm the situation with the experts of signal systems next week. (Mr. Matsumoto)</p>

## Minutes of Workshop

<2nd Day>

(A preliminary address, Mr. Takahashi)

This is the 2nd session of the workshop. The power supply system and signal/telecommunication systems will be dealt with in the morning and structures in the afternoon. Like in the previous session, I have secured as much time as possible for discussions. I hope active discussions be repeated among you. Thank you.

( Mr. Nguyen Van Doanh, VNRA)

Thank your very much for having such a seminar to follow the one held last week, when we sat for lectures on Shinkansen data, rolling stock and train operation. I am expecting much today from the lectures on electric engineering, signal/telecommunication systems and civil engineering structures. The contents of these lectures will be extremely valuable for the future of this country. I wish to express my gratitude for the related organizations in Vietnam and those from VNRA, VNR and educational institutions who have victimized their precious time to attend this workshop. Thank you.

Question and Answer

(2nd Day: Electric Engineering, Signal/Telecommunication Systems and Structures)

Morning Session

Question	Answer
<p>ATC and CBTC</p> <p>1) I want to know your views on CBTC. How is it used for practical purposes in Japan?</p> <p>2) Which do you think is better to introduce into Vietnam, ATC or CBTC?</p> <p>(Mr. Vu Kim Ngoc –TEDI)</p>	<p>1) The CBTC system, which relies on the wireless telecommunication technology, can be composed without using track circuits. The system enables a rational moving block system; therefore it will become a major signal system in the future.</p> <p>There are many types of CBTC in the world, In Japan, JR East has introduced in one line. There, a train continuously calculates its position, using its speed meter and wayside radio beacon to compensate its position in place of track circuit. It communicates the exact position, speed, travel direction and braking distance etc. via radio with the wayside equipment distributed along the line for the operation of the succeeding train.</p> <p>2) Japan has developed the ATC system with track circuit. Both ATC and CBTC have their advantages and disadvantages. CBTC is applied mainly to the urban railways, which operate unified train sets frequently.</p> <p>On the other hand, there is no application for high speed railways, freight railways and interurban railways.</p> <p>Therefore ATC with track circuits is the best choice for the HSR, considering a nearly 50-year-long history.</p> <p>Furthermore, the ATC system has an advantage to detect rail breakage, a function specific to the systems dependent on track circuits. A rail breakage possibly causes a serious accident for HSR.</p> <p>What is important to discuss the signal system is the train operation plan required.</p> <p>(Mr. Murakami)</p>

<p>Crossing obstruction</p> <p>1) What countermeasures shall be taken for pedestrians who have entered a level crossing?</p> <p>(Mr. Nguyen Van Doanh - VNRA)</p>	<p>1) In case a car has been captured on a level crossing, for example, the obstacle detecting system, being installed at the crossing, detects the car. Then, a signal called “the obstruction warning indicator”, being installed at a point 600 m ahead of the crossing, issues a warning to stop trains before the crossing. Nowadays, this system is widely applied in Japan. (Mr. Murakami)</p>
<p>Japanese CBTC</p> <p>1) What are the differences between ATC and ATP?</p> <p>2) I want to know such systems as CBTC developed in Japan</p> <p>(Mr. Nguyen Dinh Dong - TRICC)</p>	<p>1) ATC is a system to continuously receive the information on the position and speed of the preceding train through rails. What is called ATP in Europe includes both ATC and ATS in Japan. ATP that has been introduced under the name of ETCS is divided into Level 1, Level 2 and Level 3. ATS is equivalent to ETCS level 1 and ATC to ETCS level 2. (Mr. Murakami)</p> <p>2) In Japan, JR East has developed a CBTC system called ATACS (Advanced Train Administration and Communications System) and applied it to one line. The line length is 18km with 8 radio stations controlling 20 trains with the minimum headway of 5 minutes. JR East decided recently to apply it another line. ATCS aims at not only urban railway but also intercity railway.(Mr. Murakami)</p>
<p>Backup system of ATC</p> <p>1) Is there any backup system that makes its debut, in case ATC has failed?</p> <p>(Mr. Doan Quang Dang - TEDI)</p>	<p>1) ATC constitutes a duplex system of itself. This exerts a backup function first. In case ATC has failed, a substitute block system, or a human system, is additionally deployed. Trains run while changing information with a person in charge assigned at each station. Unlike under the normal bock system, only one train is allowed in principle to enter the section between stations. (Mr. Murakami)</p>

<p>1) The dimensions on the drawings, Page 22, Power, are invisible. Can you offer drawings with visible dimensions? Are there rules on such dimensions?</p>	<p>1) Of course, dimensions are specified; the height of trolley wires is 5.1 m from the rail head, for example. I will present drawings clearly indicating dimensions. (Mr. Kunizawa)</p>
<p>Crossing warning 1) I want to hear about the crossing warning system, Page 32, Signal. The warning time is 25 to 32 sec long. Do crossing barriers start descending immediately at the start of warning? (Mr. Nguyen Van Hiep, Railway College)</p>	<p>1) There is a time gap between the starts of warning and descending motion of barriers. The time gap is set considering the time length required for the pedestrian who has entered the crossing at the start of warning to escape therefrom. The figure of 25 seconds is a sum of the time lengths required for warning and closing the crossing. If you need detailed figures, I can offer those specified in the ministerial ordinance in Japan. (Mr. Murakami)</p>

Afternoon Session

Question	Answer
<p>Rationalization 1) According to the slide, Page 18, by Mr. Hashimoto, railways having 2,000 passengers or less per day are to be abolished. Isn't it possible, however, to cut the</p>	<p>1) We have cut some trains running during off-peak hours. As the frequency of train operation is an important service factor for passenger, it is better to reduce the number of cars in each train set and keep the frequency of train operation intact. (Mr. Hashimoto)</p>

Question	Answer
<p>running costs of these railways for survival by cancelling trains early in the morning and late in the evening?</p> <p>2) I feel it is pitiful to recklessly abolish unprofitable sections. Wasn't it necessary to continue train operation in such sections in Japan even by reducing the number of cars composing each train set?</p> <p>3) There are similar problems in Vietnam as well. For example, rails in the Đa Lat – Thap Cham section were all removed, as the number of passengers had decreased. It is sacrilegious to scrap railways that have once been constructed. It can't be totally deniable that the railways to be constructed in the future would end in the same destiny.</p> <p>(Mr. Luong Van Vinh – VNR)</p>	<p>2) We abolish sections that remain unprofitable even after the number of cars in each train set has been cut. As a result, two- to three-car train sets are running in Japan. In case a section is still unprofitable after those drastic measures have been taken, it is advantageous to run buses from the viewpoint of national economy. We have changed the transport means from trains to buses in unprofitable sections. (Mr. Hashimoto)</p> <p>3) It holds true with Japan as well. Politicians tend to adhere to the construction of new railways in their constituency in particular. As a result, a problem of railways in deficit has arisen. Carefully select object railway sections where funds shall be invested in Vietnam. Railways will potentially run into deficit through business operation alone. VNR shall not easily accept the construction of unprofitable railways. (Mr. Hashimoto)</p> <p>(Supplementary explanations)</p> <p>As explained by Mr. Hashimoto, there were similar problems with the local lines in Japan. At the time of JNR's privatization and division, it was known that there were sections with meagre transport demands. All these sections were not necessarily abolished. A mechanism was created, therefore, to make privatized railway companies having a number of local lines compensate for the deficit with the interest from the funds provided in advance. This mechanism was thought to function satisfactorily at the initial stage.</p>

Question	Answer
	<p>But the mechanism becomes insufficient due to the unexpected low interest rates.</p> <p>Systems shall be contrived to meet the conditions specific to the country. (Mr. Takahashi)</p>
<p>Reasonable train speed</p> <p>1) Although it may be different for passenger trains and freight trains, what is the appropriate train speed when these trains of different categories use the same tracks in Vietnam?</p> <p>2) In Vietnam, it is planned to construct new railways but not to improve existing ones. What design maximum speed is reasonable in that case? (Mr. Le Thanh Hai, Railway Engineering, Hanoi Transport University)</p>	<p>1) To raise the speed of freight trains on the existing railways in Vietnam, the performance of locomotives and freight cars shall be improved</p> <p>In the case of meter-gauge railways, how about aiming at a maximum speed of approximately 100 km/h for passenger trains and 70 km/h for freight trains for the time being? When the permanent way and rolling stock have been upgraded in the future, 130 km/h operation may be possible even on meter-gauge railways. EMU container freight trains may be able to run at 130 km/h like in Japan. (Mr. Hashimoto)</p> <p>2) It is not reasonable to shift both passenger and freight trains to the new permanent way. If the existing tracks were upgraded, freight trains may be able to run immediately at approximately 70 km/h and 100 km/h.</p> <p>It is advantageous, therefore, for freight trains to run on the existing meter-gauge tracks, even after the completion of new standard gauge tracks.</p> <p>Once a new permanent way has been constructed, exclusively use it for passenger trains. It is more efficient and economical. (Mr. Hashimoto)</p>
<p>Long distance HSR</p> <p>1) It is stated that Shinkansen is an effective traffic means for a distance of 700 km or less. In Vietnam, however, the distance between Hanoi and Ho</p>	<p>1) If a high-speed railway were constructed immediately to connect Hanoi and Ho Chi Minh City, it would not be economical.</p> <p>As a matter of fact, the high-speed railway study team has never recommended construction along the whole route, but proposed it merely as a future plan.</p> <p>I support the opinion heard at the Vietnamese Diet that</p>



Question	Answer
<p>Chi Minh City is longer than 1,700 km. Is it reasonable to construct a Shinkansen railway longer than 1,700 km?</p> <p>2) It may be reasonable for passenger trains and freight trains to run on different tracks. If they run on the same tracks, what is the most efficient maximum speed?</p> <p>(Mr. Tran Minh Phuong, Investment Planning Department, MOT)</p>	<p>it is premature.</p> <p>Nevertheless, it will certainly become a burden in the future. The timing to construct a full-fledged high-speed railway shall be discussed while watching the developments of economy and the country as a whole.</p> <p>(Mr. Hashimoto)</p> <p>2) Effectively use the existing permanent way as far as possible. Then, construct a high-speed railway anew, when high-speed operation is required. Upgrade, electrify and remodel the existing permanent way into a double-track structure, then trains will be able to run at 130 km/h.</p> <p>It has been confirmed in Japan that passenger and freight trains can safely run up to this speed.</p> <p>I don't support the idea to construct a new permanent way while abandoning the existing one. Far more efficient train operation may be possible using the existing permanent way, if the bottlenecks such as those of Hai Van and Khe Net Passes have been eliminated. (Mr. Hashimoto)</p> <p>(Supplementary explanations 1)</p> <p>The question is on the train speed when passenger and freight trains run on the same tracks, the answer for which may be summarized as follows.</p> <p>A similar case is the Seikan Tunnel in Japan, which we shall address in the near future. If passenger trains run at 140 km/h and freight trains at 100 km/h on the Shinkansen tracks, two-train crossings may be possible.</p> <p>In Europe, two-train crossings are in practice, with passenger trains running at 200 km/h and freight trains at 100km/h, setting aside the question whether it is safe or not.</p> <p>The two-train crossing speed may be raised in the future. I am sorry but the information available so far is</p>

Question	Answer
	<p>limited to this extent. (Mr. Takahashi)</p> <p>(Supplementary explanations 2)</p> <p>Let me speak based on my experience involved in the FS and bidding stage of ES (Engineering Service) for a 1,400 km-long rapid freight corridor in India.</p> <p>At the basis of the planning for railway freight transport, there is a survey of physical distribution, or a commodity-wise (bulk or container freights) origin-destination survey.</p> <p>When I take an extensive view over the transport businesses in the world, I feel that a means to quickly transport freights is to use containers or rely on bulk freight transport on narrow-gauge railways. However, rapidity is not the only one important requirement for container transport.</p> <p>Suppose manufactured products to be sent from the Hanoi industrial park to Ho Chi Minh City, for example. A survey on the output from workshops, required raw materials and methods of storage will indicate the speed required for railway freights.</p> <p>When viewed from a global viewpoint, container transport is monopolized by shipping companies but not by railway companies. Survey the status of the deployment of container ships and movement of railway freights first. After that comes the discussion on the number and speed of freight trains.</p> <p>In the survey for the high-speed freight railway in India, I spent one year for a survey on physical distribution. If you really want to implement freight transportation, a survey on the status of both bulk and container traffic is required before drawing a blue print.</p> <p>(Mr. Edo)</p> <p>(Supplementary explanations 3)</p> <p>Regarding freight transport, there is a question: which is more important, rapidity or punctuality? It is said in</p>

Question	Answer
	Japan that delivery just on time is more important than delivery earlier than scheduled. (Mr. Takahashi)

(Mr. Nguyen Van Doanh, VNRA)

- I wish to express my sincere gratitude to Mr. Takahashi and JICA team members for their laborious preparation and implementation of presentation for a whole day and for their highly valuable answers for questions. The workshop has been really profound for both the audience and speakers.
- This workshop was held to follow the first seminar held last week. A number of extremely useful views and opinions were presented from various angles before the audience on passenger transport, freight transport and speedups.
- In Vietnam, we are also discussing on the same agenda. We will discuss construction of new railways on one hand and upgrading the existing ones on the other. At this seminar, we heard about a number of important experiences in Japan and have been provided with extremely precious know-how. On behalf of the attendants from Vietnam, I wish to express my gratitude to JICA members, speakers and others who have kindly extended heartily cooperation until this day. Through this seminar, annoying points for Vietnam have been clarified to some extent. I hope discussions be continued after this seminar among those concerned in Vietnam. At the end of my acknowledgment, I repeat my appreciation once again for the fruitful two-day workshop. Thank you.

### Questions and Answers

The team received questions from the related agency and gave them the answers as listed below.

	Question	Answer
1	Are there any difficulties to make the train schedule for mixed-train operation? Please provide the optimal alternatives?	(See Page II -31)
2	What is the reason that the number of seats /100m of E5 is less than N700? (E5=289; N700=327)	The reasons why the number of seats of E5 is less than N700 is as follows; 1) E5 has longer nose which means that the length of the cabin of the first and the end cars are shorter. 2) E5 has a first class car named "Gran Class" which has only 18 seats in one cabin. (See Page III-327 Table 1)
3	What is the process of designing and modeling of Shinkansen at the beginning stage? (The beginning stage means the timing when technical report and computer simulations are not available)	When the development of the Shinkansen started, engineers used only mechanical calculator or abacus. Therefore they first applied a graphical solution and approximate analysis, and analytically solved differential equations, combining with model tests, and then certified their estimation through field tests at high speed test line.
4	What design do you recommend for the model?	Just like Japanese Shinkansen, the Vietnamese high speed train shall have light weight and wide car body and the power distributed system.
5	1) What are the percentage of train obstruction which is necessary to relieve and the relief countermeasures of Shinkansen train? 2) In the workshop documents, the power distributed system has a lot of advantages. However, the power	1) (See Page III-327 Tables 2 and 3) 2) As you have pointed out, there are also several advantages in power centralized system, but in our opinion, power distributed system is more advantageous because in recent years, by adoption of VVVF control system and AC motors, motor cars do not require much maintenance. As

	centralized system also has a lot of advantages (for example of European train).	a matter of fact, Germany has introduced power distributed system from the 3rd generation of ICE, and the latest AGV of France also employs power distributed system. The power distributed system is the mainstream of the high speed rolling stock now.
6	The train model same as Shinkansen is currently used in the Ngoc Hoi - Yen Vien urban railway project in Vietnam (25Kv, power distributed system), but the line length is only over 10km. According to JICA study team, is it reasonable? And how about the possibility to connect to other urban railway lines?	AC 25kv electrification makes it possible to reduce the number of substations desirable for inter-regional railway, and is compatible with urban railways. Hanoi urban railway No.2 and No.3 adapted the DC 750V third rail system considering smaller tunnel section, which is reasonable. However, the section between Ngoc Hoi – Yen Vien is to be shared by Hanoi urban railway No.1 and inter-regional railway, so AC 25kv system is recommendable.
7	What is theoretical maximum speed of narrow gauge, provided that alignment is straight and leveling crossings removed or grade separated?	There is no clear theory on the speed limit of meter gauge, but usually it is discussed from the viewpoints of (1) Relatively low stability of vehicle overturning caused by higher gravity center compared to standard gauge and (2) Hunting motion. Through these studies, the possible maximum speed of 1067mm gauge is understood to be 200 - 250km/h. Just for reference, Japanese speed record is 179.5km/h in 1985 and the world record is 245km/h of South Africa in 1978.
8	The maximum propagation velocity of electric wire wave is $C=506\text{km/h}$ so the maximum train speed is $V_{\text{max}}=70\% \times C=350\text{km/h}$ . However, Japan tested high speed train with $V_{\text{max}}=443\text{km/h}$ . What kind of electric wire was used?	For the test driving, stronger tensile force was applied temporarily considering wave propagation velocity.
9	ATS-P system was used in Japan in 1987 but the accident still occurred on 05 Dec, 1988. Why?	The development of the ATS-P started after the accident of Hirano station on the Kansai Line that occurred in 1973. ATS-P was first introduced to 4 stations of Japanese National Railways in 1987,

		and has been introduced gradually from the main lines with higher priority. The accident in 1988 occurred in Higashi-Nakano Station which has not yet introduced the ATS-P.
10	In Japan, there was a study for freight transportation on high speed rail with the section of 500kmduring the midnight from 10pm to 5 am. It seems applicable for Vietnam HSR with the length of 1570km. The running time of freight train will be 3 days (72 hours), which is equivalent to the current running time of freight train on the existing N-S line. Therefore, applying the mixed-train operation in N-S HSR line in Vietnam seems effective.	There are several problems for operating freight trains on high speed rail. First, due to the difference of section running time between high-speed passenger trains and low speed freight trains, track capacity will be limited. Second, since high-speed passenger trains meet with freight trains of opposite direction on the way, passenger trains need to reduce their speed to guarantee safety. Third, having freight trains operating at night time, in some section, it is difficult to secure track possession period. Fourth, there is room for discussion on how to maintain running stability of freight train itself. Fifth, high speed freight cars for standard gauge (1,435mm) and cargo work equipment need to be developed. In our opinion, it is reasonable to operate freight trains on the existing line, since the existing line will have capacity margin when express passenger trains are shifted to high speed rail.
11	In order to be convenience for freight transportation, stations should be on the ground. Therefore, the level crossings will be created and have impacts on other activities? How to deal with it?	The desirable location of freight stations are near main road but outside of congested urban area. It will be built at the ground level but it will not affect the road traffic while the frequency of freight train is kept low. However, when it is judged likely to affect traffic, the main road will be elevated to create grade separate crossing.
12	According to the Japanese Statistics, JR group has 60.8% of 1067mm track gauge which was electrified. Please explain the problems being caused by mixed use of electric and diesel traction. We suppose there may be	According to the number released by Ministry of Land, Infrastructure, Transport and Tourism of Japan in 2012, the total operating distance of electrified 1067 gauge is 15,224km and JR group occupies 9,744km of them, which is 64% in ratio. (We could not find the bases of 60.8 %.)

	difficulties in the signaling system and the influence by elevated electric cable on the Diesel traction train. Are there any regulations for these matters?	There are many lines being used by not only electric but also diesel traction. There is no difficult problem in commoditizing, so there is no regulation.
13	In Japan, are there any lines expanded from track gauge 1067mm to 1435mm? What is the cost for expansion in comparison with construction of new line with track gauge 1435mm?	In 1999, the gauge of Ou line was expanded from narrow gauge (1067mm) to standard gauge (1435mm) for Yamagata Shinkansen going through the conventional line. The cost of expanding the gauge is about 0.5 billion Yen/km which is 1/10 of constructing the new line of HSR. However, in this case, Shinkansen was operated as conventional train with under 130 km/h in the section because the other facilities such as tunnels, bridges, platforms, crossings, signaling haven't changed for HSR. Therefore, it is difficult to compare the cost of constructing new line and expanding the narrow gauge because there is no example completely expanded for the HSR in Japan. Furthermore, disadvantage of expanding the narrow gauge is that we have to prepare the alternative transportation by buses during the construction term so that we continue passenger service.
14	Please provide more information on Transformer network Roof Delta?	Following websites are useful to obtain the related information. <a href="http://www.uic.org/cdrom/2008/11_wcrr2008/pdf/1.3.3.6.4.pdf">http://www.uic.org/cdrom/2008/11_wcrr2008/pdf/1.3.3.6.4.pdf</a> <a href="http://ieeexplore.ieee.org/xpl/login.jsp?tp=&amp;arnumber=5385659&amp;url=http%3A%2F%2Fieeexplore.ieee.org%2Fxppls%2Fabs_all.jsp%3Farnumber%3D5385659">http://ieeexplore.ieee.org/xpl/login.jsp?tp=&amp;arnumber=5385659&amp;url=http%3A%2F%2Fieeexplore.ieee.org%2Fxppls%2Fabs_all.jsp%3Farnumber%3D5385659</a> <a href="http://www.meidensha.co.jp/review/ereview-201203/article-201203-0015.pdf">http://www.meidensha.co.jp/review/ereview-201203/article-201203-0015.pdf</a>
15	What are the measures to ensure the safety for the none-electrified train running into the electrified section?	There is no obstacle for none-electrified rolling stock going into electrified section, as long as they are smaller than rolling stock gauge, which

	(Electrified 25Kv)	means about 4100mm of maximum height and 3200 mm of maximum width.
16	Regarding to Shinkansen, for new line construction, which is better to use the wireless communication system to transfer the information between the train and ground installations and vice versa or using the leakage coaxial cable? Please clarify the advantages and investment costs of these two methods and give us the recommendation for HSR in Vietnam.	<p>Both leakage coaxial cable and wireless communication systems use radio waves to transmit information between train and ground installation. Therefore, it can be said that coaxial cable takes part of the wireless communication systems.</p> <p>When the Shinkansen started its business, space wave system using the antenna was adopted in the section where there is nothing to shield radio waves, and leakage coaxial cable (LCX) system was adopted in a section with tunnels and other obstacles.</p> <p>Now, digital LCX radio system is used in most of the areas because of its high capacity, quality, and stability. LCX system provides good channel quality without being affected by the terrain or other obstacles, but it needs radio repeater installed at regular intervals to amplify the signal, and LCX cable laid at wayside, which makes its construction cost higher than the space wave system.</p> <p>In order to determine which method to transmit information in HSR of Vietnam, it is necessary to grasp the line environment and the type of information that is required to be transmitted.</p>
17	<p>Regarding to Shinkansen, is it necessary to construct new signaling and control system to ensure the 2-direction operation in the single track line?</p> <p>- Does Japanese Shinkansen prepare for 2-direction operation system in the single track line considering a track of double track line is obstructed or in</p>	<p>There is no single track in Japanese Shinkansen line. Also, each track does not have 2-direction operation system because the frequency of the train is so high that we can't operate by 2-direction operation system with single track.</p> <p>It is possible to execute 2-direction operation using staff block system if it is necessary, however, it has never been executed before because it needs to be operated in lower speed</p>



	<p>case of extra maintenance or not? If not, why?</p> <ul style="list-style-type: none"> <li>- Are there HSR which adopt 2-direction operation in single track line?</li> <li>- How many percentages of investment cost will be increased for the facilities for 2-direction operation? Are there many facilities necessary to be installed?</li> </ul>	<p>and is difficult to meet enough capacity.</p> <p>TGV in France and ICE in Germany are the examples of 2-direction system. Supported by low train frequency, it is used in case of accidents and track maintenance. There, sidings and turnouts are installed at every 10-20 km.</p> <p>It is difficult to clarify the percentages of investment cost for the facilities for 2-direction operation because there is no such case in Japan. However, the initial cost is assumed to be double or more because they need not only the signals for both directions, but also equipment to control 2-direction operation. In our opinion, it is more efficient to spend money on investment for upgrading reliability of each system and maintenance for stable operation rather than on 2-direction system.</p>
18	<p>What are the viewpoints of JIC for applying the ATO system for HSR? Does Japanese HSR apply ATO? In the world, are there any countries applying ATO for HSR?</p>	<p>There is no application of ATO for any HSR in the world.</p> <p>The main purpose of ATO is to reduce the labor costs for drivers applying unattended or one-man operation. ATO is introduced mainly to the low-speed railway where is no level crossing such as subway, monorail and new transportation system.</p> <p>The reasons why ATO is not suitable for HSR is as follows;</p> <ol style="list-style-type: none"> <li>1) The installation of ATO requires platform screen door for the safety of passenger. This means that ATO costs not only for the installation of ATO itself, but also for platform screen doors on every station.</li> <li>2) In HSR, station spacing is so large that it takes long time for reserve drivers to arrive at the site and move the train in case of system breakdown. To avoid the situation, drivers are required to stay</li> </ol>

		on the train. Thus, ATO doesn't reduce labor costs for drivers in HSR.
19	In the future, it is supposed that a double-track electrified line will be constructed for mixed-train operation in Vietnam ( $V \leq 150 \text{ km/h}$ ). According to your opinions, which safety ensuring system should be used (ATS-P, ATC, CBTC...) to fit with economic and technical conditions in Vietnam?	<p>ATS-P is a system for wayside signal, and ATC and CBTC are systems for cab signal. From the viewpoints of safety, economic efficiency and technical aspects, we recommend ATS-P system on the conventional line used for mixed train operation because of following reasons.</p> <p>1) CBTC system uses radio to detect the speed and distance between the train and its preceding train. When the train length is not constant such as freight train, two sets of positioning devices are required at front and back of train for CBTC. Installing such device is easy for locomotives, but difficult for freight cars.</p> <p>2) On the other hand, track circuit can detect front and back of train continuously. So ATS-P is convenient for freight train.</p> <p>3) When CBTC and ATS-P are applied for passenger train and freight train respectively, it is costly double investment.</p>
20	<p>Electric circuit is a device to recognize the "obstruction-safety". In addition, it is also able to recognize the broken track and no similar systems have this ability. However, the structure of electric circuit is very complicated and dependent on the track structure and high cost of maintenance.</p> <p>The questions are;</p> <ul style="list-style-type: none"> <li>- How is the electric circuit developed to limit the above disadvantages?</li> <li>- How many rail breakages do you have per year in Japan, and how do you detect them?</li> <li>- Is the requirement for recognizing the</li> </ul>	<p>The main objective of the electric circuit is train detection. It is one of the important equipment for safe and stable operation. Therefore, regular maintenance and usage of the parts with high reliability are necessary for stable operation.</p> <p>We tend to introduce the unified system rather than using many types of systems for the reduction of the maintenance work and early restoration from the trouble.</p> <p>In one of the major operator in Japan which maintains railways including conventional lines and Shinkansen lines, there were 8 broken tracks a year in 2010 fiscal year. The main reasons of the broken tracks are shelling, improper field welding, electric corrosion, and internal defects in</p>

	<p>rail breakage the mandatory requirement to ensure the safety for HSR?</p>	<p>rail.</p> <p>As written in the question, there is no equipment to detect broken tracks other than the electric circuit. Therefore, it would be detected by track patrols or driver's detection from an unusual sound when passing a breakage. This means it is difficult to find out broken tracks before the train passing with CBTC system.</p> <p>In our opinion, electric circuit is necessary for high speed rail to detect broken tracks which leads to the terrible accident</p>
21	<p>If we upgrade and improve the existing N-S lines (narrow gauge 1m) to allow mixed-train operation with the speed <math>\leq</math> 120km/h, according to your opinions, which signaling system should be installed to ensure the safety? (It is supposed that the projects of modernization of signaling system and infrastructure are implemented as scheduled).</p> <p>- Is it possible to install ATS-S or ATS-P to upgrade the current Diesel rolling stocks of Vietnam railways?</p>	<p>Both ATS-S and ATS-P are available if the operating speed is less than 120km/h. Comparing them from the view point of safety, ATS-P is safer because it has the speed check function and it can prevent SPAD (signal passed at danger). Even if ATS-S or ATS-P is introduced, we need equipment on the train car, such as automatic braking system and information transmission system between the wayside and on-board.</p>
22	<p>In urban railway:</p> <p>In Vietnam, there are many studies for urban railway lines. Of them, the demand forecast for some lines provided that the operation headway during the rush hours should be about 10-15 minutes. However, it is desired to select the most modern signaling and control system (CBTC) which increases the investment cost. How should we select the signaling and control system to meet the operation</p>	<p>The minimum headway is affected mainly by track layout rather than signal system. To meet the operation with 10-15 minutes headway in urban railway, either system is sufficed. The reason we hesitate to apply only CBTC is that the detection of rail breakage is difficult without applying track circuit. When deciding the signaling system, we have to choose the most suitable system considering initial cost, maintenance cost, maintainability, and interoperability with other lines which provides through service.</p>

	demand (in consideration of technical views, economic views and expandability for the future?)	
23	If Urban railway applies CBTC, it is necessary to install the 2nd system for contingency to keep the operation even in the case that the CBTC doesn't totally work. The 2nd system should be the small system considering the construction cost and maintenance works both for ground system and track circuit.	The main advantage of CBTC is reducing the equipment. If electric track circuits or wayside signals are installed for backup system of CBTC, initial construction cost will be increased and the advantage of CBTC would be reduced. In many cases the track circuits are installed as backup system of CBTC to make much of safety and stable operation. On the other hand, ATACS which is installed in Japan doesn't need the backup system.
24	Please compare the investment cost for signaling and control system for urban railway if using ATS-P and track circuit and automatic block system/ATC/CBTC for a line.	It is difficult to compare the investment cost without clear precondition.
25	Please clarify the unbalanced centrifugal acceleration applied for Japan Railway conventional line ( $V_{max}=130$ & $160\text{km/h}$ for passenger train and $110\text{km/h}$ for freight train). The unbalanced centrifugal acceleration in Vietnam currently is $0.5\text{m/s}^2$ . In the near future, when upgrading the existing railway line to increase the speed, the centrifugal acceleration will be increased. According to your opinion, in consideration of infrastructure and rolling stocks in Vietnam, what is the appropriate value of the centrifugal acceleration?	The unbalanced centrifugal acceleration is in proportion to the cant deficiency which is the difference between the equilibrium cant and the real cant. Permissive cant deficiency is defined from the 3 viewpoints, overturn to outside of the curve, overturn by the wind, and the ride quality. From the view point of ride quality, $0.8\text{m/s}^2$ of unbalanced centrifugal acceleration is accepted both in Shinkansen line and conventional line by Japanese technical standard. Furthermore, we need to consider tolerance limit of lateral force that means the strength of track.  In Vietnam, if you increase the speed of existing line, you need correction of cant or extending the radius of the curve not to increase the unbalanced centrifugal acceleration. If it would be increased, you have to strengthen the tracks by changing the PC sleeper or prolongation of rail

		<p>length with welding etc.                  (Reference: Technical Regulatory Standards on Japanese Railway P.15)  <a href="http://www.mlit.go.jp/english/2006/h_railway_bureau/Laws_concerning/14.pdf">http://www.mlit.go.jp/english/2006/h_railway_bureau/Laws_concerning/14.pdf</a></p>
26	<p>The track gauge of 1067mm is still used in Japan or not? For passenger transportation or freight transportation? Maximum speeds? The percentages of level crossings? Is there any Diesel traction used on 1067mm gauge or not and the line capacity of this 1067mm?</p>	<p>In Japan, the gauge of conventional JR line is 1067mm, and that of Shinkansen is 1435mm. We use 1067mm gauge both for passenger and freight, and 1435mm gauge only for high speed passenger.</p> <p>On the conventional line, electric car trains, diesel car trains, and electric locomotive hauling trains and diesel locomotive hauling trains are operated. The electrified length is around 60% of conventional line.</p> <p>Train frequency is 50 to 130 on single track line, and 300 to 650 on double track line.</p> <p>The maximum train speed is 130km/h on electrified lines and about 100km/h on non-electrified lines.</p> <p>There are 34,000 level crossings. About 45% of the crossing of road and railway are grade separated. For almost all level crossings, alarms or barriers are equipped. The blocking time of road traffic is about one minute for one train passing.</p>
27	<p>Is the effective length for HSR operation 700km (&lt;700km) in comparison with airway?                  Please provide recommendations for railway development strategy in Vietnam with track gauge of 1435mm (HN-HCM)? Please give the detailed explanation on train speed in each section?</p>	<p>In Japan, the number of passenger of aviation and high speed railway is even on 700 - 800km distance. There are many passengers to select railway transport for longer distance transfer depending on fare, service, safety, punctuality and the number of operation trains. This shows that service level is also an important factor to choose transportation means.</p> <p>The long term vision is required for the standard gauge between Hanoi and HCMC. The Vietnam</p>

		<p>Government has announced the strategy to change gauge for conventional lines without any time schedule. There was a heated discussion in Japan on the track gauge expansion and changing the gauge has been rejected 90years ago. In our opinion, the last chance for VNR to change the gauge may be at track doubling work of existing line.</p> <p>It is recommended that you make maximum use of existing line. As suggested in the JICA Study on the existing line improvement, VNR should improve the line gradually selecting the sections in which investment efficiency is assured to be high.</p>
28	<p>Please clarify the comparison on the land price and environment in Slide 20 - Characteristics of Railways</p>	<p>Sakudaira used to be a quiet village with paddy fields. But after the opening of Shinkansen station, the area around the station has changed to an urban district with offices, houses and hotels. The land price is nearly tripled compared to other area.</p>
29	<p>Please clarify the comparison (advantages and disadvantages) of Direct current (DC) and Alternating current (AC) electrification?</p> <p>In case of using AC and DC for urban railway and HSR, please compare the advantages and disadvantages of the track circuit and axle counter.</p>	<p>AC is suitable for HSR which needs higher power than urban railway. On the other hand, DC is suitable for subway which requires small tunnel cross section and DC cars are cheaper.</p> <p>Power feeding system has no relation with signaling system such as track circuit or axle counter.</p>
30	<p>Why is JICA study for HN-HCM existing railway line (track gauge 1m, alternative A2) with only <math>V_{max}=90\text{km/h}</math> instead of speeding up to <math>120\text{km/h}</math>?</p>	<p>Alternative A2 is considered to maximize the capacity of single track line, rather than speed up.</p> <p>When you improve the existing railways, it's better to give the priority to the sections with the high demand, or which has the bottle necks than upgrading all the line at the same time. We need more study for deciding where to upgrade immediately for speed up to <math>120\text{ km/h}</math> or</p>

	constructing double tracks.
--	-----------------------------

Table 1 Comparison of N700 and E5

Series	Number of the cars/train	Number of the seats/train	Length of the train set	Number of the seats/100m
N700	16.0	1323.0	404.7	326.9
E5	10.0	731.0	253.0	288.9

Source: Study Team

Table 2 Traffic Accident of Shinkansen

Traffic Accident in 2011										
Category	Train Collision	Derailment	Train Fire	Level Crossing Accident	Traffic Accident	Injury Accident	Material Damage	Total	Number of Accident/ Mil. Train km	Train km (Mil.km)
JR East								0	0.00	39.94
JR Central								0	0.00	56.62
JR West						1		1	0.02	41.00
JR Kyushu								0	0.00	10.12
Total	0	0	0	0	0	1	0	1	0.02	147.68

(Source: MLIT)

Table 3 Transport Disorder of Shinkansen

Transport Disorder in 2011											
Cause	Inside					Outside			Total	Number of Accident/ Mil. Train km	Train km (Mil.km)
	Person in Charge	Rolling Stock	Fixed Installation of Railway	Sub Total	Numbers/ Mil. Train km	Other than Railway	Disaster				
JR East	3	14	4	21	0.53	2	11	34	0.85	39.94	
JR Central		1	2	3	0.05	11	16	30	0.53	56.62	
JR West	3	2	3	8	0.20	3	6	17	0.41	41.00	
JR Kyushu			1	1	0.10	1	14	16	1.58	10.12	
Total	6	17	10	33	0.22	17	47	97	0.66	147.68	

Remark: "Transport Disorder" means train service cancellation and delay of trains more than 30 minutes. (Source: MLIT)

## Question from VNR

### Question 1

There is a recommendation in the summary 5-1 of Final Report that Japanese HSR be adopted since it saves construction cost due to its compact infrastructure.

Please explain how we can save cost comparing with TGV or conventional standard gauge railway.

---

### Answer

#### 1. Comparison of concentrated and distributed traction systems

Distributed traction system can decrease the train weight by 10-20 %.

We estimate the proportion of both systems as follows, based on the German ICE which has both traction systems.

ICE2 was applied concentrated system with a passenger capacity of 368 and train weight of 453 ton.

ICE3 was applied distributed system with a passenger capacity of 429 and train weight of 440 ton.

The train weight per passenger is;

$$\text{ICE2 (Concentrated system)} \quad 453/368=1.23 \text{ t/passenger}$$

$$\text{ICE3 (Distributed system)} \quad 440/429=1.03 \text{ t/passenger}$$

The proportion of the two systems is;

$$\text{ICE3/ICE2}=1.03/1.23=0.84$$

Therefore, we can roughly estimate that the train weight per passenger of distributed system be 84% of that of concentrated system.

#### 2. Effect of train weight reduction

(1) Generally, the track irregularity I is estimated by the following equation.



$$I = aT^{0.3}$$

Where I: Track irregularity

a: Constant

T: Passing tonnage

Passing tonnage is the total train weight passing by, and track maintenance cost is considered to be proportional to I: Track irregularity.

Therefore, to decrease the train weight is effective to save track maintenance cost.

Decreasing the maximum axle load is effective to reduce the maintenance cost as well.

- (2) There is estimation that lightening the axle load of 1 ton saves about 1 % of the construction cost of ordinary PC girder.

### 3. Track center distance and Formation width

- (1) Narrow formation width saves construction cost because of the smaller land acquisition area and compact railway facilities.

- (2) Comparison between Shinkansen and TGV

- 1) We suggest following Shinkansen standards;

Track center distance      4.3 m    Formation width    11.3m

- 2) The standards in Europe are shown in the Table.

Table 1 European HSR

		Track center distance	Formation width
1	Lines under construction	4.5-5.0 m	12.1-14.2m
2	TGV South-East line	4.2m	13.6m
3	TGV North European line	4.5m	13.9m

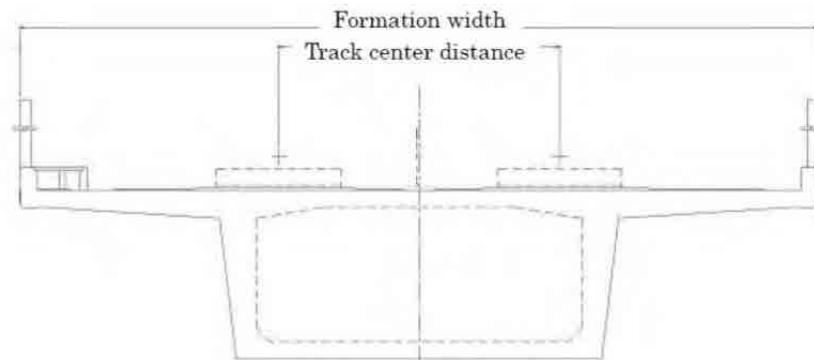

Figure 1 Cross section of Box Girder

The standards in Europe are not unified; therefore we compare Shinkansen with TGV North European line (Paris – Calais Section).

Table2 Comparison of Cross Section

	Shinkansen	TGV North
Formation width	11.3 m	13.9 m
Track center distance	4.3 m	4.5 m

For reference, the rolling stock width is 2,814 to 2,904 mm with TGV, while the corresponding figure with Shinkansen is 3,350 to 3,380 mm.

This indicates a feature that Shinkansen is operating rolling stock of larger widths on a smaller formation.

(3) Comparison of construction cost

1) The land acquisition cost is proportional to the Formation width. The ratio is;

$$\text{Shinkansen/TGV} = 11.3/13.9 = 81\%$$

2) The embankment construction cost is proportional to the Formation width. The ratio is;

$$\text{Shinkansen/TGV} = 11.3/13.9 = 81\%$$

3) The cutting earth work cost is less than proportional, so it becomes less than 80 % of bigger one. Because, the slope becomes higher and soil cutting volume increases when the Formation width is bigger.

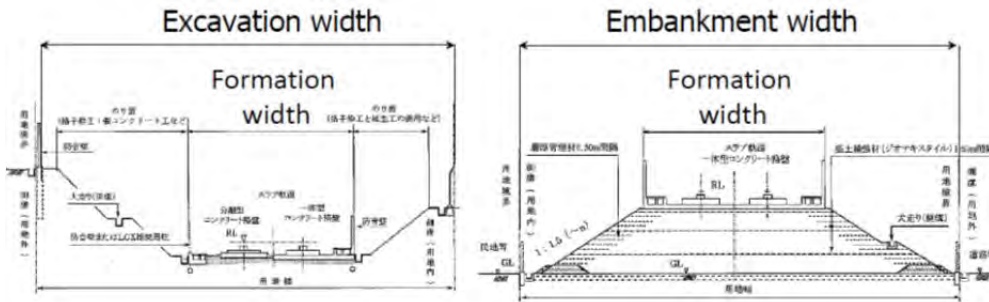

Figure 2 Formations and Construction Work

4) In the case of viaducts, the slab width becomes narrower when the Formation width becomes narrower.

The cost estimation based on the virtual design proved that the increase rate of construction cost is 3.4 % per 1 m of Formation width.

The Formation width of Japanese specification is 2.6m narrower than that of TGV North. (a difference between 13.9 and 11.3 m).

Therefore the cost ratio is;

$$100\% - 3.4\% \times 2.6\text{m} = 90\%$$

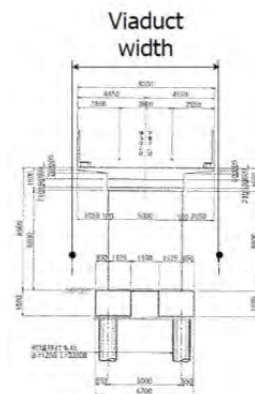

Figure 3 Viaduct width

5) We propose a tunnel cross section of 63.4 m<sup>2</sup>, considering the Formation width and the fluctuation of air pressure.

On the other hand, 107 m<sup>2</sup> of tunnel section area is applied in Europe.

The tunnel construction cost is thought to be proportional to the tunnel cross section.

Therefore, the cost ratio is;

$$63.4/107=60\%$$

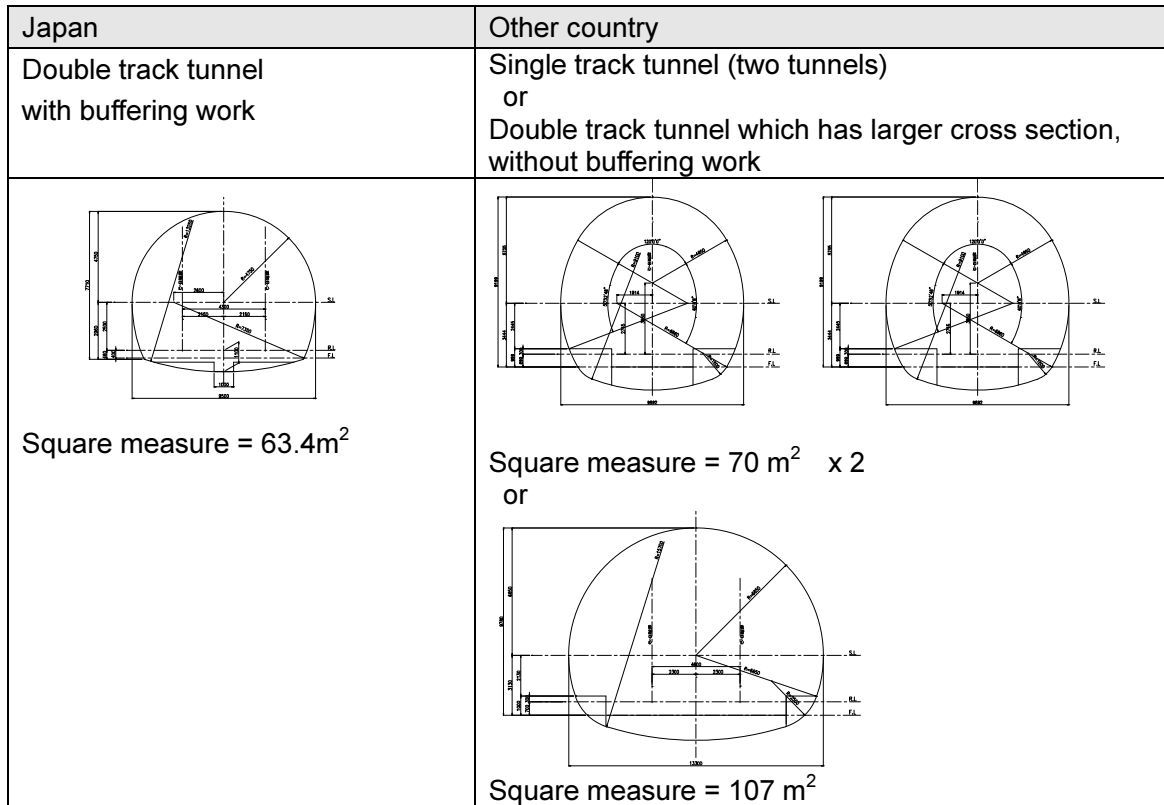

Figure 4 Cross section of Tunnel

Table3 Comparison of Tunnel Cross Section

	Japan	Others	Note
Tunnel Cross Section (m <sup>2</sup> )	63.4	107.0	Tunnel construction cost is in proportion to cross section.
%	60	100	

#### 4. Unidirectional train operation

Unidirectional train operation requires simple signaling system and track layout. Therefore the construction cost and maintenance cost is approximately half of bidirectional operation system, which requires two sets of signal equipment and turnouts.

## Question 2

Please show us the reasons and data which explain why and how the upgrade of the conventional railway to HSR is not reasonable.

Here, the conventional railway means the line which will be newly constructed with the gauge of 1435mm operating both passenger and freight trains.

Regarding to the non-efficiency of the following concept

- 1) The construction of conventional standard gauge railway which operates freight and passenger trains.
- 2) The upgrading to HSR from conventional railways in the future

---

## Answer

### 1. Consideration from the view point of train speed

(1) When you construct a standard gauge railway for passenger and freight trains, it is reasonable to adopt a line alignment matching to the maximum train speed. That is because you can control the construction cost depending on the design speed.

When you run high speed trains on the newline in the future, the alignment must be upgraded (Minimum curve radius is 6000 m for 350 km/h). The upgrade requires additional land acquisition and investment.

As a matter of fact, a drastic speed upon the once-completed conventional railway is far from realistic, because it requires vast investment and efforts.

If level crossings were installed on the conventional railway assuming the maximum train speed was less than 120km/h of maximum train speed, the investment for the grade separation becomes indispensable at the upgrading stage.

- (2) There will be no extra investment for upgrading in the future if you construct the conventional line adopting an alignment matching to high speed operation without any level crossing.

But the construction cost for the conventional line is more expensive than that of the proposed HSR since the conventional line requires the solid structures enough to support freight trains with heavy axle load.

## 2. Regarding the access to the existing station at city center applied to European HSR

- (1) The high-speed trains can show their high performance only on the dedicated line, and they have to speed down on the conventional line with the curves of small radius and level crossings.

Therefore the length of approach line between the dedicated line and conventional line shall be as short as possible.

- (2) There is the fact that a few train accidents occurred around the joining section between the dedicated line and conventional line.

## 3. Upgrade from the conventional line to the dedicated HSR line.

- (1) Useless freight approach line between main line and freight terminal after converting the gauge of the existing line to standard gauge.

The new conventional line needs common use freight terminals with the existing narrow gauge line, for the handling of freight with trucks and the existing line.

If the new conventional line is constructed on a viaduct, an approach line is required between the main line and the freight terminal.

When the new conventional line is upgraded to the HSR line in the future, and if the existing narrow gauge line is converted to standard gauge line, the approach line becomes useless.

(2) Useless standard gauge rolling stock after the upgrade of the conventional line

If the existing meter-gauge tracks are kept intact and the conventional line is shifted to HSR line, standard-gauge freight rolling stock become useless and narrow -gauge rolling stock are required.

(3) The increase in construction cost and extra maintenance cost of the freight equipment on the existing line.

The construction cost of the conventional line is comparatively expensive, because the structure is required to support freight trains with heavier axle load than that of HSR trains. Even while freight trains run on the conventional line, the minimum-level maintenance of the freight equipment on the existing line will be required considering the future freight transportation services on the existing line.

4. Extra work of transshipment until the completion of the whole conventional line

The direct freight volume between Hanoi and HCMC is larger than the freight between midsections.

The whole conventional line cannot be constructed in a short period. Therefore, the freight has to be transshipped between the conventional and existing lines during the construction of the conventional line.

The transshipment requires time and labor cost using large scale facilities, and it will lead to the loss of railway's competitiveness against other transportation modes.