

ベトナム社会主義共和国
運輸省 道路総局

ベトナム国
道路維持管理能力強化
プロジェクト
プロジェクト業務完了報告書

ITS 技術基準 (QCVN/TCVN) 策定支援

平成 26 年 4 月
(2014 年 4 月)

独立行政法人
国際協力機構 (JICA)

株式会社 片平エンジニアリング・インターナショナル
株式会社 オリエンタルコンサルタンツ
中日本高速道路 株式会社

基盤
JR
14-082(3)

目次

本文

1. 業務実施の背景	1
2. 業務の目的	1
3. 技術基準の定義	1
4. JICA 専門家派遣での課題と実施した対応	3
5. JICA 専門家によるドラフト QCVN/TCVN のレビュー結果	4
6. QCVN/TCVN 策定に向けた今後の課題と必要な対応	4

添付資料

1. LOW ON STANDARDS AND TECHNICAL REGULATIONS	
2. RECOMMENDATIONS AND REVIEWEDED RESULTS BY JICA EXPERT	
3. DRAFT QCVN OF TRAFFIC MONITORING AND MANAGEMENT FOR EXPRESSWAYS	
4. DRAFT QCVN OF CCTV CAMERA SYSTEM FOR EXPRESSWAYS	
5. DRAFT QCVN OF VMS SYSTEM FOR EXPRESSWAYS	
6. DRAFT QCVN OF COMMUNICATION SYSTEM FOR EXPRESSWAYS	
7. DRAFT QCVN OF ETC SYSTEM FOR EXPRESSWAYS	
8. MANAGEMENT CENTER/OFFICE FOR EXPRESSWAYS	
9. QCVN SCHEDULE	

ITS 技術基準 (QCVN/TCVN) 策定支援

1. 業務実施の背景

ベトナムでは高速道路網が区間ごとに異なるドナーからの資金で建設されているため、分割された道路ネットワークをいかにして統合的に運用管理するかが大きな課題になっている。この課題に注目し、ベトナムにおける ITS 統合プロジェクトの実施と ITS 技術基準の策定を目指して、「ベトナム国 ITS 技術基準・運用計画の策定支援調査業務」と「ベトナム国国道 3 号線およびハノイ大都市圏における ITS 統合プロジェクト案件実施支援調査 (SAPI)」が、2012 年までの 2 年間にわたって実施された。

この一連の調査では、ITS マスタープランでベトナムにおける ITS に対するニーズとして整理した ITS 利用者サービスに対し、最適なシステムアーキテクチャとシステム方針を論理的に導き出し、それに基づく形で ITS 技術基準案を策定した。

その後の時間の経過に伴い、現在建設中の高速道路の ITS の統合や、今後建設予定の高速道路を含めた統合的な ITS 整備方法の確立は、ますますその緊急性を増しており、ベトナム政府は ITS の技術基準を策定することを 2012 年末に決定した。JICA に対しては、その支援が求められていた。

さらに、ITS 統合プロジェクトの実施予定機関になったものの、SAPI に至る一連の調査に参画していないために ITS 技術基準案についての理解が不足していたため、ベトナム道路総局 (DRVN) の担当者の理解向上に向けた支援も併せて求められていた。

2. 業務の目的

SAPI で策定した ITS 技術基準案について、技術基準案の作成を担当する各 Sub-Group および DRVN を含むベトナム側 ITS 関係者の理解の深化を支援し、それを踏まえた技術基準の策定を支援することが、本業務の目的である。

3. 技術基準の定義

技術基準については、ベトナムの法律 (No: 68/2006/QH11: On standards and technical regulations、Appendix-1) で下記の 2 種類が規定されており、ITS の各分野の QCVN (または TCVN) の策定に向けて 8 つの Sub-Group が立ち上げられた。

- QCVN (National Technical Regulation)
- TCVN (National Technical Standards)

法律での記述は必ずしも明確ではないが、QCVN は技術基準の最上位に位置し全てのプロジェクトが準拠すべき基本要件を規定するものである。それに対して、TCVN はプロジェクトが参照すべき規定であり必ずしも準拠する必要はない。このような定義から、TCVN には、QCVN の詳細規定として策定されるケースの他に、QCVN 策定の準備段階として試作的に策定されるケースがあることも考慮するものとした。

表 1 各 Sub-Group のリーダーへの説明の実施経過

		Sub-Group Leader & Other Member	1 st Dispatch		2 nd Dispatch		3 rd Dispatch		4 th Dispatch	
			Meeting	Sending Letter	Meeting	Sending Letter	Meeting	Sending Letter	Sending Letter	Meeting
MOT		Dr. Hoang Ha (MOT/DOST) Hoangha@mt.gov.vn	(5) '13/09/16					'14/01/21		
		Mr. Nguyen Van Ich (MOT/DOST) ichnv@mt.gov.vn			(3) '13/12/18		(1) - (8) All	'14/01/21		
		Mr. Nguyen Tuan Anh (MOT/DOST) anhnt@mt.gov.vn	(8) '13/09/23		(3) '13/12/18		(1) - (8) All	'14/01/21	'14/03/05	(2),(4) '14/03/14 '14/03/18
Sub-group 1	TCVN on ITS System Architecture	Mr. Nguyen Dinh Khoa (ITST) nguyendinh_khoa@yahoo.com.vn	(3) '13/09/13	'13/09/18			(6) '14/01/22		'14/03/10	(1) '14/03/13
Sub-group 2	QCVN on Traffic Monitoring & Management for Expressways	Mr. Pham Hong Quang (CadPro) quang@cadpro.vn	(4) '13/09/13	'13/09/18		'13/12/18	(1) '14/01/20		'14/03/10	
Sub-group 3	QCVN on Traffic Database and Message System for Expressways	Mr. Van Van Trung (MOT/ITC) chungvv@mt.gov.vn		'13/09/18		'13/12/18	(8) '14/01/23		'14/03/10	
Sub-group 4	QCVN on CCTV Camera System for Expressways	Mr. Chu Quang Trung (MOT/ITC) trung@mt.gov.vn	(6) '13/09/19	'13/09/18	(2) '13/12/17		(2) '14/01/20		'14/03/10	
Sub-group 5	QCVN on VMS System for Expressways	Nguyen Anh Tuan (ITST) anhtuan.itst@gmail.com		'13/09/18	(4) '13/12/19		(5) '14/01/22		'14/03/10	(1) '14/03/13
Sub-group 6	QCVN on Communication System for Expressways	Mr. Le Thanh Tung (MOT/ITC) tunglt@mt.gov.vn	(1) '13/09/10	'13/09/18	(2) '13/12/17		(4) '14/01/22		'14/03/10	
Sub-group 7	QCVN on ETC System for Expressways	Mr. Pham Duc Long (ITD) long.pham@itd.com.vn	(2) '13/09/11	'13/09/18	(1) '13/12/16		(7) '14/01/23		'14/03/10	(3) '14/03/14
Sub-group 8	QCVN on Management Centers/Offices for Expressways	Mr. Ta Tuan Anh (CadPro) tuananh@cadpro.vn		'13/09/18		'13/12/18	(3) '14/01/20		'14/03/10	
Others		Dr. Nguyen Quang Tuan (ITST)	(7) '13/09/19				(6) '14/01/22			

4. JICA 専門家派遣での課題と実施した対応

第1～4回の JICA 専門家派遣の中で、つぎの課題を抽出し、その解決のために以下の通り必要な対応を実施した。

- (1) QCVN/TCVN の記述作成に際しては、DOST から各 Sub-Group のリーダー (前掲の表 1 参照) に対して、SAPI で作成した ITS 技術基準案の内容に基づくよう (下図の(a)) 指示が出されていたものの、各 Sub-Group で作成された QCVN/TCVN の第一ドラフトは SAPI の成果から外れた内容を数多く含むもの (下図の(b))となっていた。

図 1 QCVN/TCVN の作成イメージ

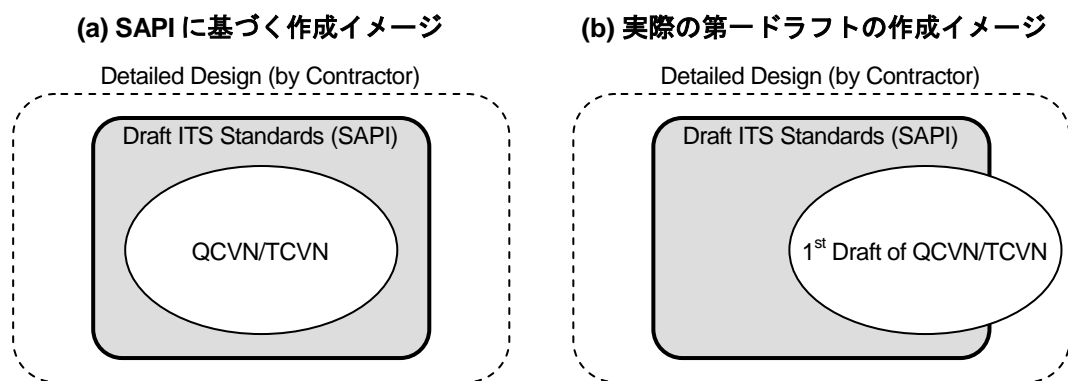

これは、Sub-Group のリーダーの過半数が SAPI を含む一連の調査に参画していないために生じたものであり、その結果として、SAPI の成果に含まれず必要性の根拠が不明確でベトナム国内での採用事例もない内容について QCVN/TCVN への記述の適否を判断しなくてはならないという、極めて困難な状況となった。

実施した対応→ JICA 専門家が各 Sub-Group の第一ドラフトに記述されるべき主な事項を示し、さらに、ドラフトの記述内容をレビューし、その結果を各 Sub-Group のリーダーに直接説明した。レビュー結果は次項に示す。

- (2) 各 Sub-Group が作成した第一ドラフトの中に、基本要件を示す QCVN に相応しくない著しく細かい記述内容が多数含まれていた。

実施した対応→ JICA 専門家が各 Sub-Group のリーダーに対して、個別に、著しく細かいと判断される記述内容を例示し、DOST から該当する記述を削除するよう指示が出された。

- (3) Sub-Group 1 でのシステムアーキテクチャの検討準備に時間を要し、2014 年 4 月以降に先送りされたため、ITS の全体構成が不明確なまま各 Sub-Group での検討が進む形となった。そのため、Sub-Group 1 で作成されるシステムアーキテクチャの成果と SAPI の検討成果との整合性、および各 Sub-Group の検討成果との整合性の確認が課題となっていた。

実施した対応→ JICA 専門家からの指摘を考慮し、DOST が Sub-Group 2 の第一ドラ

フトに示される「Figuration Map of Components in Traffic Monitoring and Management System for Expressways」の図を簡素化し、ベトナムの高速道路 ITS のシステムアーキテクチャの代用とすることとした。これと並行して、Sub-Group 1 の成果を TCVN とすることが DOST および MOT により決定された。

5. JICA 専門家によるドラフト QCVN/TCVN のレビュー結果

各 Sub-Group で作成されたドラフト QCVN/TCVN を英訳 (Appendix-3~8)、その内容をレビューして、前掲の表に示した日程で DOST、各 Sub-Group リーダーとのミーティングを行い、レビュー結果として以下の事項を提示 (Appendix-2)、説明した。

- (1) 各 Sub-Groups の検討範囲
- (2) QCVN/TCVN に記載すべき主要項目
- (3) 交通情報・管制に不可欠な地域メインセンターの下での統合
- (4) QCVN/TCVN 第一ドラフトのレビューテーブル
- (5) QCVN/TCVN に基本要件として記述すべき内容

6. QCVN/TCVN 策定に向けた今後の課題と必要な対応

現在は Sub-Group 2, 4, 5, 6, 7, 8 が担当する QCVN の第一ドラフトが出揃った段階であり、以下の課題およびそれに対して必要な対応が残されている。

- (1) ドラフトの最終化作業が比較的順調に進んでいる Sub-Group 2, 7, 8 については、3 月末までに、MOT 関係機関からの意見収集を終える予定 (Appendix-9) となっている。

必要な対応→ 3 月末以降のできる限り早い時期に、第 4 回 JICA 専門家派遣時に提示した上記のレビュー結果を反映したドラフト修正結果を確認し、引続いて MOT 関係機関からの指摘への対応の過程で SAPI との整合性を損なう修正が為されていないかを確認、それに基づいた JICA 専門家としてのコメントを提示する必要がある。

- (2) TCVN に降格された Sub-Group 1 を除く各 Sub-Group のドラフトについては、3 月末以降 8 月末までに、他省庁からの意見収集を終え、最終化する予定 (Appendix-9) となっている。

必要な対応→ Sub-Group 2, 7, 8 以外の第一ドラフトに対しても (1)と同様の対応を実施し、他省庁に送られる前に、全ての Sub-Group のドラフトに対する JICA 専門家の指摘について修正が完了したことを確認する必要がある。さらに、他省庁からの指摘および対応の過程で SAPI との整合性を損なう修正が為されていないことを確認し、JICA 専門家としてのコメントを提示する必要がある。

8 月末までに他省庁からの意見収集を終える QCVN/TCVN 最終化の予定に鑑みて、(1)と(2)に必要な対応は 7 月までに終える必要があり、JICA 専門家として 4 月以降できる限り空白期間のない対応が必要である。

添付資料-1

LOW ON STANDARDS AND TECHNICAL REGULATIONS

Law

On standards and technical regulations

(No. 68/2006/QH11)

Pursuant to the 1992 Constitution of the Socialist Republic of Vietnam, which was amended and supplemented under December 25, 2001 Resolution No. 51/2001/QH10 of the Xth National Assembly, the 10th session;

This Law provides for standards and technical regulations.

Chapter I

GENERAL PROVISIONS

Article 1.- Scope of regulation

This Law provides for the formulation, announcement and application of standards; the formulation, promulgation and application of technical regulations; and the assessment of conformity with standards and technical regulations.

Article 2.- Subjects of application

This Law applies to Vietnamese and foreign organizations and individuals and overseas Vietnamese carrying out activities related to standards and technical regulations in Vietnam.

Article 3.- Interpretation of terms

In this Law, the terms below are construed as follows:

1. Standard means regulation on technical characteristics and management requirements used as standard for classifying and appraising products, goods, services, processes, the environment and other objects in socio-economic activities with a view to improving the quality and effectiveness of these objects.

A standard shall be published in a written form by an organization for voluntary application.

2. Technical regulation means regulation on the limits of technical characteristics and management requirements which products, goods, services, processes, the environment and other objects in socio-economic activities must comply with in order to ensure safety, hygiene and human health; to protect animals, plants and the environment; to safeguard national interests and security, consumer interests and other essential requirements.

A technical regulation shall be promulgated in a written form by a competent state agency for

mandatory application.

3. Activities in the domain of standard means formulation, announcement and application of standards and assessment of conformity with standards.

4. Activities in the domain of technical regulation means formulation, promulgation and application of technical regulations and assessment of conformity with technical regulations.

5. Conformity assessment means determination as to whether objects of activities in the domain of standard or objects of activities in the domain of technical regulation are conformable with technical characteristics and management requirements in relevant standards or technical regulations.

Conformity assessment covers testing, calibration, inspection and certification of standard or technical regulation conformity; announcement of standard or technical regulation conformity; and accreditation of the capacity of testing laboratories, calibration laboratories, conformity certification organizations and inspection organizations.

6. Certification of standard conformity means certification that objects of activities in the domain of standard conform with relevant standards.

7. Certification of technical regulation conformity means certification that objects of activities in the domain of technical regulation conform with relevant technical regulations.

8. Announcement of standard conformity means announcement by an organization or individual of the conformity of objects of activities in the domain of standard with relevant standards.

9. Announcement of technical regulation conformity means announcement by an organization or individual of the conformity of objects of activities in the domain of technical regulation with relevant technical regulations.

10. Accreditation means certification that a testing laboratory, calibration laboratory, conformity certification organization or inspection organization has the capacity conformable with relevant standards.

Article 4.- Application of laws

1. In case of disparity between the provisions of this Law and those of other laws concerning standards and technical regulations, the provisions of this Law shall prevail.

2. When a treaty to which the Socialist Republic of Vietnam is a contracting party contains provisions different from those of this Law, the provisions of that treaty shall prevail.

Article 5.- Objects of activities in the domain of standard and objects of activities in domain of technical regulation

1. Objects of activities in the domain of standard and objects of activities in the domain of technical regulation include:

- a/ Products, goods;
- b/ Services;
- c/ Processes;
- d/ Environment;
- e/ Other objects in socio-economic activities.

2. The Government shall stipulate in detail objects of activities in the domain of standard and objects of activities in the domain of technical regulation.

Article 6.- Fundamental principles for activities in the domain of standard and the domain of technical regulation

1. Standards and technical regulations must ensure improvement of the quality and efficiency of socio-economic activities and raising of the competitiveness of products, goods and services on domestic and international markets.
2. Standards and technical regulations must meet requirements on safety, national security, hygiene, human health, legitimate rights and interests of related parties, protection of animals, plants and the environment, and rational use of natural resources.
3. Activities in the domain of standard and the domain of technical regulation must ensure publicity, transparency, non-discrimination and no unnecessary obstacles to production, business and commercial activities. The formulation of standards must ensure involvement and consensus of related parties.
4. The formulation of standards and technical regulations must:
 - a/ Be based on scientific and technological advances, practical experience, present-day needs and socio-economic development trends.
 - b/ Use international standards, regional standards and foreign standards as the basis, except for those not suitable to Vietnam's geographical, climatic, technical and technological characteristics or those affecting national interests;
 - c/ Prioritize requirements on the utility of products and goods while restricting requirements on descriptive characteristics or detailed design;
 - d/ Ensure uniformity of Vietnam's standard system and technical regulation system.

Article 7.- State policies on development of activities in the domain of standard and the domain of technical regulation

1. To attach importance to investment in building material-technical foundations and training human resources for the state management of activities in the domain of standard and the domain of technical regulation.

2. To support and promote scientific research and application and technological development in service of activities in the domain of standard and the domain of technical regulation.

3. To encourage domestic and foreign organizations and individuals as well as overseas Vietnamese to participate in formulating and applying standards and technical regulations, invest in developing activities in the domain of standard and the domain of technical regulation in Vietnam, and training in standard and technical regulation knowledge for econo-technical branches.

Article 8.- International cooperation on standards and technical regulations

1. The State shall encourage expansion of cooperation with other countries, territories, international organizations, regional organizations, foreign organizations and individuals on standards and technical regulations and making use of their assistance on the principle of respect for the principles of independence, sovereignty, territorial integrity, equality and mutual benefit.

2. The State shall facilitate and adopt measures to promote the signing of bilateral and multilateral agreements on mutual recognition of conformity assessment results in order to facilitate the development of trade between Vietnam and other countries and territories.

Article 9.- Prohibited acts

1. Taking advantage of activities in the domain of standard and the domain of technical regulation to impede, trouble and hassle production, business and commercial activities of organizations and individuals.

2. Disseminating false information and advertisements and committing other deceitful acts in activities in the domain of standard and the domain of technical regulation.

3. Abusing activities in the domain of standard and the domain of technical regulation to infringe upon national interests, defense, security, social order and safety.

Chapter II

FORMULATION, ANNOUNCEMENT AND APPLICATION OF STANDARDS

Article 10.- System of standards and standard symbols

The Vietnamese system of standards and standard symbols consists of:

1. National standards, symbolized by TCVN;
2. Manufacturer standards, symbolized by TCCS.

Article 11.- Responsibility for formulating, evaluating and announcing standards

1. Ministers, heads of ministerial-level agencies and heads of government-attached agencies shall organize the drafting of national standards and request the evaluation and announcement

of national standards.

2. The Minister of Science and Technology shall organize the evaluation of draft national standards and announce national standards.

3. Organizations formulating and announcing manufacturer standards include:

a/ Economic organizations;

b/ State agencies;

c/ Non-business organizations;

d/ Socio-professional organizations.

Article 12.- Types of standards

1. Fundamental standards stipulate characteristics and requirements of general application on a large scale or contain general requirements for a particular domain.

2. Terminology standards stipulate names and definitions for objects of activities in the domain of standard.

3. Technical requirement standards stipulate levels, criteria and requirements for objects of activities in the domain of standard.

4. Testing method standards stipulate methods of sampling, methods of measurement, methods of identification, methods of analysis, methods of checking, methods of assay and methods of inspection of levels, criteria and requirements for objects of activities in the domain of standard.

5. Labeling, packing, transportation and preservation standards stipulate requirements on labeling, packing, transportation and preservation of products and goods.

Article 13.- Grounds for standard formulation

Standards shall be formulated on one or more of the following grounds:

1. International, regional and foreign standards;

2. Scientific and technological research results, technical advances;

3. Practical experience;

4. Results of evaluation, assay, testing, checking and inspection.

Article 14.- Plannings and plans on formulation of national standards

1. Plannings and plans on formulation of national standards include five-year plannings and

plans and annual plans which are elaborated on the following grounds:

a/ Socio-economic development requirements;

b/ Requests of organizations and individuals.

2. The Ministry of Science and Technology shall assume the prime responsibility for, and coordinate with other concerned ministries, ministerial-level agencies and government-attached agencies in, elaborating plannings and plans on formulation of national standards and publish them for public comment before approving them.

The Ministry of Science and Technology shall approve plannings and plans on formulation of national standards and publish them within thirty days after the date of approval thereof.

3. In case of necessity, plannings and plans on formulation of national standards may be revised under decisions of the Minister of Science and Technology. The revision of plannings and plans on formulation of national standards shall comply with the provisions of Clause 2 of this Article.

Article 15.- Rights of organizations and individuals to participate in formulating national standards

1. To propose and give comments on plannings and plans on formulation of national standards.

2. To assume the prime responsibility for, or participate in, compiling draft national standards for the Ministry of Science and Technology to evaluate and announce.

3. To give comments on draft national standards.

Article 16.- Technical boards for national standard

1. A technical board for national standard is a technical advisory body set up by the Ministry of Science and Technology for each domain of standard.

2. Members of a technical board for national standard include representatives of state agencies, scientific and technological organizations, associations, unions, enterprises and other concerned organizations, consumers and specialists.

3. A technical board for national standard has the following tasks:

a/ To propose plannings, plans, options and measures to formulate national standards;

b/ To compile draft national standards based on the drafts proposed by organizations or individuals; to directly prepare draft national standards; to participate in compiling and commenting on draft international standards, draft regional standards; to participate in evaluating draft national standards formulated by ministries, ministerial-level agencies or government-attached agencies;

c/ To join in counseling on and disseminating national standards and other standards;

d/ To participate in formulating draft technical regulations upon request.

Article 17.- Order and procedures for formulating, evaluating and announcing national standards

1. The order and procedures for formulating, evaluating and announcing national standards with respect to draft national standards formulated by ministries, ministerial-level agencies or government-attached agencies are as follows:

a/ Ministries, ministerial-level agencies or government-attached agencies draft national standards on the basis of the approved plans on formulation of national standards;

b/ Ministries, ministerial-level agencies or government-attached agencies organize public gathering of opinions of concerned organizations and individuals on draft national standards; hold symposiums for related parties to give comments on the drafts. The duration for submission of opinions on a draft shall be at least sixty days; in urgent circumstances related to health, safety or environment, this duration may be shorter;

c/ Ministries, ministerial-level agencies or government-attached agencies study and take opinions of organizations and individuals into account for finalizing draft national standards, make dossiers of draft national standards and send them to the Ministry of Science and Technology for evaluation;

d/ The Ministry of Science and Technology organizes the evaluation of draft national standards in accordance with the provisions of Article 18 of this Law. The evaluation duration must not exceed sixty days from the date of receipt of valid dossiers;

e/ The Minister of Science and Technology announces national standards within thirty days after obtaining evaluation opinions agreeing with draft national standards;

f/ When there are evaluation opinions disagreeing with the draft national standard, the Ministry of Science and Technology shall forward such evaluation opinions to the national standard-drafting ministry, ministerial-level agency or government-attached agency for finalization of the draft national standard. After receiving the finalized draft, the Ministry of Science and Technology shall announce the national standard in accordance with the provisions of Point e of this Clause. If no agreement can be reached between two parties, the Ministry of Science and Technology shall report the case to the Prime Minister for consideration and decision.

2. The order and procedures for formulating, evaluating and announcing national standards with respect to draft national standards proposed by organizations or individuals are as follows:

a/ The organization or individual compiles a draft standard or proposes an existing standard to the Ministry of Science and Technology for consideration;

b/ The Ministry of Science and Technology assigns the technical board for national standard to compile a draft national standard on the basis of the draft proposed by the organization or

individual; organizes public gathering of opinions of concerned organizations and individuals on the draft; holds symposiums for related parties to give comments on the draft. The duration for submission of opinions on a draft shall be at least sixty days; in urgent circumstances related to health, safety or environment, this duration may be shorter;

c/ The technical board for national standard studies and takes opinions of organizations and individuals into account for finalizing the draft national standard, makes a dossier of the draft and submits it to the Ministry of Science and Technology for consideration;

d/ The Ministry of Science and Technology organizes the evaluation of the draft national standard under the provisions of Article 18 of this Law. The time limit for evaluation and announcement of national standards shall comply with the provisions of Point d and e, Clause 1 of this Article.

3. The order and procedures for formulation, evaluation and announcement of national standards with respect to draft national standards formulated by the Ministry of Science and Technology are as follows:

a/ On the basis of the approved plan on formulation of national standards, the Ministry of Science and Technology assigns a relevant technical board for national standard to formulate the draft national standard under the provisions of Points b and c, Clause 2 of this Article;

b/ The Ministry of Science and Technology organizes the evaluation of the draft national standard under the provisions of Article 18 of this Law. The time limit for evaluation and announcement of national standards shall comply with the provisions of Point d and e, Clause 1 of this Article.

4. The Government shall issue specific regulations on dossiers of draft national standards.

Article 18.- Contents of evaluation of draft national standards

1. Conformity of standards with scientific and technological advances, socio-economic conditions and development demands.

2. Conformity of standards with relevant technical regulations, legal provisions and international commitments and the requirement on harmonization with international standards.

3. Uniformity and consistency within the national standard system, adherence to the principles of consensus and harmonization of interests of related parties.

4. Observance of technical requirements, the order and procedures for formulation of national standards.

Article 19.- Review, amendment, supplementation, replacement and cancellation of national standards

1. The Ministry of Science and Technology shall assume the prime responsibility for, and coordinate with other ministries, ministerial-level agencies and government-attached agencies in, reviewing national standards once every three years or at an earlier time when necessary,

counting from the date of announcement of such standards.

2. Amendment, supplementation and replacement of national standards shall be effected in the order and according to the procedures specified in Article 17 of this Law on the basis of national standard review results or at the proposal of organizations or individuals.

3. Cancellation of national standards shall be effected on the basis of national standard review results or at the proposal of ministries, ministerial-level agencies, government-attached agencies, organizations or individuals.

The Ministry of Science and Technology shall evaluate dossiers of cancellation of national standards and announce the cancellation of national standards after obtaining written agreement of other ministries, ministerial-level agencies or government-attached agencies which have drafted such national standards.

Article 20.- Formulation and announcement of manufacturer standards

1. Manufacturer standards shall be formulated under the guidance of the heads of organizations specified in Clause 3, Article 11 of this Law and announced for application to manufacturers' activities.

2. Manufacturer standards shall be formulated on the basis of scientific and technological achievements, demands and practical capabilities of manufacturers. The use of national standards, international standards, regional standards and foreign standards as manufacturer standards shall be encouraged.

3. Manufacturer standards must not contravene relevant technical regulations and provisions of law.

4. The order and procedures for formulation and announcement of manufacturer standards shall comply with the guidance of the Ministry of Science and Technology.

Article 21.- Publishing and distribution of standards

1. The Ministry of Science and Technology shall hold the right to publish and distribute national standards.

2. Vietnamese representative agencies participating in international or regional standardizing organizations shall publish and distribute international standards or regional standards according to regulations of such organizations.

The publishing and distribution of standards of international or regional organizations of which Vietnam is not a member and foreign standards shall be as agreed with organizations promulgating those standards.

3. Organizations announcing manufacturer standards shall hold the right to publish and distribute those manufacturer standards.

Article 22.- Notification and dissemination of national standards

The Ministry of Science and Technology has the following responsibilities:

1. To make public the announcement of national standards, the amendment, supplementation, replacement or cancellation of national standards within thirty days after the date of issuance of relevant decisions;
2. To assume the prime responsibility for, and coordinate with other ministries, ministerial-level agencies and government-attached agencies in, disseminating and guiding the application of national standards;
3. Annually, to distribute the list of national standards.

Article 23.- Principles for application of standards

1. Standards shall be applied on the principle of voluntariness.

The application of part or the whole of a specific standard shall become mandatory when it is invoked in a legal document or technical regulation.

2. Manufacturer standards shall be applied within the scope of management of organizations that announce them.

Article 24.- Modes of application of standards

1. Standards shall be directly applied or invoked in another document.
2. Standards shall be used as the basis for conformity assessment activities.

Article 25.- Funding sources for formulation of standards

1. Funding sources for formulation of national standards include:

- a/ State budget allocated according to approved annual budget estimates;
- b/ Voluntary supports of organizations and individuals at home and abroad;
- c/ Other lawful sources of revenues.

2. Manufacturer standards shall be formulated with organizations' or individuals' own funds, which shall be accounted as reasonable expenses.

3. The Government shall stipulate the management and use of funds for formulation of national standards.

Chapter III

FORMULATION, PROMULGATION AND APPLICATION OF TECHNICAL REGULATIONS

Article 26.- System of technical regulations and symbols of technical regulations

The system of technical regulations and symbols of technical regulations of Vietnam consists of:

1. National technical regulations, symbolized by QCVN;
2. Local technical regulations, symbolized by QCDP.

Article 27.- Responsibilities for formulating, evaluating and promulgating technical regulations

1. Responsibilities for formulating, evaluating and promulgating national technical regulations are as follows:

a/ Ministers and heads of ministerial-level agencies shall formulate and promulgate national technical regulations within the scope of branches or domains under their assigned management;

b/ The Minister of Science and Technology shall organize evaluation of draft national technical regulations;

c/ The Government shall stipulate the formulation, evaluation and promulgation of national technical regulations of inter-branch nature and national technical regulations for objects of activities in the domain of technical regulation falling under the management of government-attached agencies.

2. Responsibilities for formulating, evaluating and promulgating local technical regulations are as follows:

a/ People's Committees of provinces or centrally run cities shall formulate and promulgate local technical regulations for application within the scope of local management to specific products, goods, services and processes of each locality and in response to specific environmental requirements suitable to local geographical, climatic, hydrological characteristics and socio-economic development levels;

b/ Local technical regulations shall be promulgated after they are approved by competent state agencies defined at Point a, Clause 1 of this Article.

Article 28.- Types of technical regulations

1. General technical regulations include technical and managerial regulations applicable to a management domain or a group of products, goods, services or processes.

2. Safe technical regulations include:

a/ Regulations on levels, norms and requirements related to bio-safety, fire and explosion safety, mechanical safety, industrial safety, construction safety, thermal safety, chemical safety, electricity safety, medical equipment safety, electro-magnetic compatibility, radiation

and nuclear safety;

b/ Regulations on levels, norms and requirements related to food safety and hygiene, pharmaceutical and cosmetic safety for human health;

c/ Regulations on levels, norms and requirements related to hygiene and safety of animal feeds, fertilizers, plant protection drugs, veterinary drugs, bio-products and chemicals used for animals and plants.

3. Environmental technical regulations provide for levels, norms and requirements on environmental quality and waste.

4. Technical regulations of processes provide for requirements on hygiene and safety in the processes of production, exploitation, processing, preservation, operation, transportation, use and maintenance of products and goods.

5. Technical regulations of services provide for requirements on hygiene and safety in business, trading, post, telecommunications, construction, education, financial, scientific and technological, healthcare, tourist, entertainment, cultural, sport, transport, environmental services and services in other domains.

Article 29.- Plannings and plans on formulation of technical regulations

1. Plannings and plans on formulation of technical regulations include five-year plannings and plans and annual plans elaborated on the following grounds:

a/ Socio-economic development requirements;

b/ State management requirements;

c/ Proposals of organizations and individuals.

2. Plannings and plans on formulation of technical regulations shall be elaborated by technical regulation-promulgating agencies in coordination with the Ministry of Science and Technology and concerned agencies and put up for public comment before they are approved.

Technical regulation-promulgating agencies shall approve plannings and plans on formulation of technical regulations and make them public within thirty days after approval.

3. In case of necessity, plannings and plans on formulation of technical regulations may be amended and supplemented under decisions of the heads of technical regulation-promulgating agencies and in accordance with Clause 2 of this Article.

Article 30.- Grounds for formulation of technical regulations

Technical regulations shall be formulated on one or more of the following grounds:

1. National standards;

2. International standards, regional standards and foreign standards;
3. Scientific and technological research results, technical advances;
4. Results of evaluation, assay, test, supervision and inspection.

Article 31.- Rights of organizations and individuals to participate in formulating technical regulations

1. To propose and give comments on plannings and plans on formulation of technical regulations.
2. To compile draft technical regulations and propose them to technical regulations-promulgating agencies for consideration and promulgation.
3. To participate in compiling draft technical regulations at the request of technical regulations-formulating agencies.
4. To give comments on draft technical regulations.

Article 32.- Order and procedures for formulation, evaluation and promulgation of technical regulations

1. The order and procedures for formulation, evaluation and promulgation of national technical regulations are as follows:

a/ On the basis of the approved plan on formulation of technical regulations, the national technical regulation-promulgating agency defined in Article 27 of this Law organizes the formulation of the national technical regulation with the participation of representatives of state agencies, scientific and technological institutions, enterprises, other related organizations, consumers and specialists;

b/ The national technical regulation-promulgating agency organizes public gathering of opinions of concerned organizations and individuals on the draft national technical regulation; holds symposiums for related parties to give comments on the draft. The duration for submission of opinions on the draft shall be at least sixty days; in urgent circumstances related to health, safety or environment, this duration may be shorter as decided by the national technical regulations-promulgating agency;

c/ The national technical regulation-promulgating agency studies and takes opinions of organizations and individuals into account for finalizing the draft national technical regulation, makes a dossier of the draft national technical regulation after consulting concerned ministries and branches on the contents of the draft and transfers the draft to the Ministry of Science and Technology for evaluation;

d/ The Ministry of Science and Technology organizes the evaluation of the draft national technical regulation in accordance with the provisions of Article 33 of this Law. The time limit for evaluation shall not exceed sixty days from the date of receipt of the valid dossier;

e/ The national technical regulation-promulgating agency finalizes the draft and promulgates

the national technical regulation within thirty days after the date of obtaining the agreement of the evaluating agency. In case of disagreeing with the evaluation opinions, the national technical regulation-promulgating agency shall report the case to the Prime Minister for consideration and decision.

2. The order and procedures for formulating, evaluating and promulgating local technical regulations are as follows:

a/ On the basis of the approved plan on formulation of technical regulations, the provincial/municipal People's Committee organizes the formulation of local technical regulation;

b/ The provincial/municipal People's Committee organizes public gathering of opinions of concerned organizations and individuals on the draft local technical regulation; holds symposiums for related parties to give comments on the draft. The duration for submission of opinions on the draft shall be at least sixty days; in urgent circumstances related to health, safety or environment, this duration may be shorter as decided by the provincial/municipal People's Committee;

c/ The provincial/municipal People's Committee studies and takes opinions of organizations and individuals into account for finalizing the draft local technical regulation, makes a dossier of the draft and sends it to the competent state agency defined at Point a, Clause 1, Article 27 of this Law for comment;

d/ The provincial/municipal People's Committee promulgates the local technical regulation within thirty days after the date of obtaining the agreement of the competent state agency defined at Point a, Clause 1, Article 27 of this Law.

3. The Government shall issue specific regulations on dossiers of draft technical regulations.

Article 33.- Contents of evaluation of draft national technical regulations

1. Conformity of technical regulations with relevant legal provisions and international commitments;

2. Uniformity and consistency within the system of national technical regulations;

3. Observance of professional requirements, the order and procedures for formulation of technical regulations.

Article 34.- Implementation effect of technical regulations

1. Technical regulations take effect at least six months after the date of promulgation, except for the case defined in Clause 2 of this Article.

2. In emergency circumstances related to health, safety or environment, a technical regulation may take effect earlier as decided by the technical regulation-promulgating agency.

3. National technical regulations take effect nationwide; local technical regulations take effect in localities under the management of the promulgating provincial/municipal People's

Committees.

Article 35.- Review, amendment, supplementation, replacement and cancellation of technical regulations

1. Technical regulation-promulgating agencies shall organize reviews of technical regulations once every five years or at an earlier time when necessary, counting from the date of promulgation of such technical regulations.

2. Amendment, supplementation and replacement of technical regulations shall be effected in the order and according to the procedures specified in Article 32 of this Law on the basis of review results or at the request of organizations or individuals.

3. Technical regulation-promulgating agencies may cancel technical regulations in the following order:

a/ On the basis of review results or at the request of organizations or individuals, the national technical regulation-promulgating agency organizes the compilation of a dossier of cancellation of the national technical regulation in question; examines the dossier and makes a decision to cancel the national technical regulation after obtaining the evaluation opinion of the Ministry of Science and Technology;

b/ On the basis of review results or at the request of organizations or individuals, the provincial/municipal People's Committee organizes the compilation of a dossier of cancellation of the local technical regulation in question; examines the dossier and makes a decision to cancel the local technical regulation after obtaining the evaluation opinion of the competent state agency defined at Point a, Clause 1, Article 27 of this Law.

Article 36.- Notification, dissemination, registration, publishing and distribution of technical regulations

1. Technical regulation-promulgating agencies have the following responsibilities:

a/ To make public the promulgation, amendment, supplementation, replacement or cancellation of technical regulations within thirty days after the date of issuance of relevant decisions;

b/ To organize dissemination, guidance and application of technical regulations;

c/ To send technical regulation documents to the Ministry of Science and Technology for registration;

d/ To publish and distribute technical regulations.

2. Annually, the Ministry of Science and Technology shall distribute a list of technical regulations.

Article 37.- Responsibility for applying technical regulations

1. Organizations and individuals shall apply relevant technical regulations.
2. In the course of application of technical regulations, organizations and individuals shall promptly report problems or point out inappropriate contents to the technical regulation-promulgating agencies for consideration and settlement.

Technical regulation-promulgating agencies shall respond in writing within thirty days after receiving reports or recommendations of organizations and individuals.

Article 38.- Principles for and methods of application of technical regulations

1. The application of technical regulations to production, business and other socio-economic activities is mandatory.
2. Technical regulations shall be used as the basis for conformity assessment activities.

Article 39.- Funding sources for formulation of technical regulations

1. Funding sources for formulation of technical regulations include:
 - a/ State budget allocated according to approved annual budget estimates;
 - b/ Voluntary supports of organizations and individuals at home and abroad.
2. The Government shall detail the management and use of funds for formulation of technical regulations.

Chapter IV

ASSESSMENT OF CONFORMITY WITH STANDARDS AND TECHNICAL REGULATIONS

Section 1. GENERAL PROVISIONS ON CONFORMITY ASSESSMENT

Article 40.- Fundamental requirements on conformity assessment

1. Keeping related parties informed of the conformity assessment order and procedures in a public and transparent manner.
2. Keeping confidential information and data of organizations for which conformity assessment is conducted.
3. Ensuring non-discrimination against production and business organizations and individuals or the origin of products, goods, services or processes.
4. The conformity assessment order and procedures shall comply with regulations promulgated by related international organizations.

Article 41.- Forms of conformity assessment

1. Assessment of conformity with standards or technical regulations shall be conducted by conformity assessment organizations or conformity announcement organizations or individuals themselves.
2. Assessment of conformity with standards shall be conducted on a voluntary basis at the request of organizations or individuals in the form of testing, inspection, standard conformity certification or standard conformity announcement.
3. Assessment of conformity with technical regulations shall be conducted on a mandatory basis according to state management requirements in the form of testing, inspection, technical-regulation conformity certification or technical-regulation conformity announcement.

Article 42.- Requirements for standards and technical regulations used for conformity assessment

Standards and technical regulations used for conformity assessment must be those that stipulate specific technical characteristics and managerial requirements that can be assessed with methods and means available at home or abroad.

Article 43.- Standard conformity marks, technical-regulation conformity marks

1. Standard conformity marks and technical-regulation conformity marks are proof of conformity of products or goods with relevant standards or technical regulations.
2. Standard conformity marks shall be granted to products or goods after their standard conformity is certified.
3. Technical-regulation conformity marks shall be granted to products or goods after their technical-regulation conformity is certified and announced.

Section 2. ASSESSMENT OF CONFORMITY WITH STANDARDS

Article 44.- Certification of standard conformity

1. Certification of standard conformity shall be effected under the agreement between organizations or individuals requesting certification and conformity certification organizations defined in Article 50 of this Law.
2. Standards used for certification of standard conformity must be national standards, international standards, regional standards or foreign standards satisfying requirements specified in Article 42 of this Law.

Article 45.- Announcement of standard conformity

1. Organizations and individuals shall announce the conformity of products, goods, services, processes or environment with relevant standards on the basis of the results of certification of standard conformity conducted by conformity certification organizations or the results of their self-assessment of conformity.

2. Organizations and individuals announcing standard conformity shall register their written standard conformity announcements with competent state agencies.

Article 46.- Rights and obligations of organizations and individuals requesting certification of standard conformity

1. Organizations and individuals requesting certification of standard conformity have the following rights:

a/ To select standard conformity certification organizations;

b/ To be granted standard conformity certificates for their products, goods, services, processes and environment already certified to be standard-conformable;

c/ To use standard conformity marks for products and goods already certified to be standard-conformable, packings thereof, and in documents on such products and goods;

d/ To lodge complaints about results of standard conformity certification conducted or breaches committed by conformity certification organizations in relation to standard conformity certification contracts.

2. Organizations and individuals requesting certification of standard conformity have the following obligations:

a/ To ensure conformity of products, goods, services, processes and environment with standards used for standard conformity certification;

b/ To display accurately information written in standard conformity certificates on products and goods and packings thereof and in documents on objects already certified to be standard-conformable;

c/ To notify standard conformity certification organizations of change or addition of standards used for standard conformity certification;

d/ To pay expenses for standard conformity certification.

Section 3. ASSESSMENT OF CONFORMITY WITH TECHNICAL REGULATIONS

Article 47.- Certification of technical-regulation conformity

1. Certification of technical-regulation conformity is mandatory for products, goods, services, processes and environment which are objects defined in relevant technical regulations.

2. Technical regulations used for certification of technical-regulation conformity are national or local technical regulations meeting the requirements specified in Article 42 of this Law.

3. Ministries, ministerial-level agencies and provincial/municipal People's Committees defined in Clause 1 and Clause 2, Article 27 of this Law shall designate organizations to certify conformity with technical regulations issued by themselves on the basis of considering

and selecting conformity certification organizations defined in Article 50 of this Law.

4. Conformity certification organizations may be designated to conduct regulation conformity certification by modes prescribed by competent state agencies.

Article 48.- Announcement of technical-regulation conformity

1. Production and business organizations and individuals subject to application of technical regulations shall announce the conformity of products, goods, services, processes and environment with relevant technical regulations on the basis of results of certification of technical-regulation conformity by conformity certification organizations designated under the provisions of Clause 3, Article 47 of this Law or results of their self-assessment conducted on the basis of testing results of accredited or designated testing laboratories.

2. Organizations and individuals announcing technical-regulation conformity shall register their technical-regulation conformity announcement documents with competent state agencies.

Article 49.- Rights and obligations of organizations and individuals requesting certification of technical-regulation conformity

1. Organizations and individuals requesting certification of technical-regulation conformity have the following rights:

a/ To select conformity certification organizations already designated under the provisions of Clause 3, Article 47 of this Law;

b/ To be granted technical-regulation conformity certificates for their products, goods, services, processes and environment already certified as such;

c/ To use technical-regulation conformity marks for products and goods already certified or announced to be technical regulation-conformable, packings thereof, and in documents on such products and goods;

d/ To lodge complaints about results of technical-regulation conformity certification conducted or breaches committed by conformity certification organizations in relation to contracts on technical-regulation conformity certification.

2. Organizations and individuals requesting certification of technical-regulation conformity have the following obligations:

a/ To ensure conformity of products, goods, services, processes and environment with relevant technical regulations;

b/ To display accurately information written in technical-regulation conformity certificates and announcement documents on products and goods and packings thereof and in documents on objects already certified and announced to be technical regulation-conformable;

c/ To supply, upon request of a competent state agency or conformity certification organization, documents evidencing the assurance of the conformity of products, goods,

services, processes and environment with relevant technical regulations;

d/ To suspend the provision of products, goods, services or processes failing to conform with relevant technical regulations according to decisions of competent state agencies;

e/ To pay a fee for technical-regulation conformity certification.

Section 4. CONFORMITY CERTIFICATION ORGANIZATIONS

Article 50.- Conformity certification organizations

1. Non-business units providing technical services.
2. Enterprises.
3. Vietnam-based branches of foreign certification organizations.

Article 51.- Operation conditions of conformity certification organizations

A conformity assessment organization must satisfy the following conditions:

1. Having an organizational apparatus and capability meeting requirements in national standards and international standards for conformity certification organizations;
2. Having established and maintained a management system meeting requirements in national and international standards.
3. Having registered standard conformity and technical-regulation conformity activities with a competent state agency.

Article 52.- Rights and obligations of conformity certification organizations

1. Conformity certification organizations have the following rights:

a/ To grant standard conformity or technical-regulation conformity certificates for products, goods, services, processes and environment conformable to standards or technical regulations;

b/ To assign the right to use standard conformity or technical-regulation conformity marks to organizations and individuals having products and goods already certified to be standard- or technical regulation-conformable;

c/ To withdraw granted standard conformity or technical-regulation conformity certificates and the assigned right to use standard conformity or technical-regulation conformity marks.

2. Conformity certification organizations have the following obligations:

a/ To certify standard conformity or technical-regulation conformity in the registered domains under contracts signed with certification-requesting organizations or individuals;

- b/ To ensure objectivity and fairness in standard conformity or technical-regulation conformity certification activities; to refrain from giving consultancy to certification-requesting organizations or individuals;
- c/ To keep confidential information collected in the course of conducting certification;
- d/ To supervise certified objects in order to ensure their sustained conformity with relevant standards or technical regulations;
- e/ To take responsibility before law for their activities;
- f/ To widely announce on the mass media the withdrawal of standard conformity or technical-regulation conformity certificates and the right to use standard conformity or technical-regulation conformity marks.

Section 5. MUTUAL ACCREDITATION AND RECOGNITION

Article 53.- Accreditation

1. Accreditation shall be conducted with respect to the following organizations:
 - a/ Testing laboratories;
 - b/ Calibration laboratories;
 - c/ Conformity certification organizations;
 - d/ Inspection organizations.
2. Accreditation shall be conducted on the basis of national standards and international standards.
3. Accreditation shall be conducted by accreditation organizations specified in Article 54 of this Law.

Article 54.- Accreditation organizations

1. Accreditation organizations are non-business scientific units conducting assessment and accreditation of the capabilities of organizations defined in Clause 1, Article 53 of this Law.
2. Accreditation organizations must meet the following conditions:
 - a/ Having an organizational apparatus and capability satisfying requirements in national standards and international standards for accreditation organizations; having been recognized by international and regional accreditation organizations;
 - b/ Operating in accordance with requirements in national standards and international standards for accreditation organizations;
 - c/ Having established and maintained a management system meeting requirements in national

standards and international standards;

d/ Operating in an independent and objective manner.

3. The Minister of Science and Technology shall stipulate organization and operation of accreditation organizations.

Article 55.- Rights and obligations of accreditation organizations

1. Accreditation organizations have the following rights:

a/ To grant accreditation certificates to organizations defined in Clause 1, Article 53 of this Law;

b/ To withdraw accreditation certificates.

2. Accreditation organizations have the following obligations:

a/ To carry out accreditation at the request of organizations or individuals;

b/ To ensure objectivity and fairness in accreditation activities; refrain from giving consultancy to accreditation-requesting organizations specified in Clause 1, Article 53 of this Law;

c/ To keep confidential information collected in the course of conducting accreditation;

d/ To supervise accredited organizations in order to ensure their sustained capabilities in conformity with relevant standards;

e/ To take responsibility before law for their activities.

Article 56.- Rights and obligations of accredited organizations:

1. Accredited organizations have the following rights:

a/ To propose competent state agencies to use results of conformity assessment activities with respect to certification, testing, calibration and inspection already accredited to serve state management requirements;

b/ To lodge complaints about accreditation results issued by accreditation organizations or their breaches of the undertaking to conduct accreditation;

c/ Conformity certification organizations specified at Point c, Clause 1, Article 53 of this Law shall also have the rights provided in Clause 1, Article 52 of this Law.

2. Accredited organizations have the following obligations:

a/ To ensure conformity of their accredited organizational apparatus and capability with requirements in relevant national standards and international standards;

b/ To maintain a management system meeting requirements in relevant national standards and international standards;

c/ To ensure objectivity and fairness in conformity assessment activities;

d/ Conformity certification organizations specified at Point c, Clause 1, Article 53 of this Law shall also perform the obligations defined in Clause 2, Article 52 of this Law;

e/ To pay a fee for accreditation.

Article 57.- Mutual recognition agreements

1. Mutual recognition agreements include:

a/ The recognition by Vietnam and other countries or territories of one another's conformity assessment results shall comply with treaties to which the Socialist Republic of Vietnam is a contracting party;

b/ The recognition by Vietnamese conformity assessment organizations and conformity assessment organizations of other countries or territories of one another's conformity assessment results shall be effected on their agreements.

2. The Ministry of Science and Technology shall assume the prime responsibility for, and coordinate with other concerned ministries and ministerial-level agencies in, organizing the implementation of mutual recognition agreements mentioned in Clause 1 of this Law.

Chapter V

RESPONSIBILITIES OF AGENCIES, ORGANIZATIONS AND INDIVIDUALS OPERATING IN THE DOMAIN OF STANDARD AND THE DOMAIN OF TECHNICAL REGULATION

Article 58.- Responsibilities of the Government

The Government shall perform the unified state management of activities in the domain of standard and the domain of technical regulation.

Article 59.- Responsibilities of the Ministry of Science and Technology

1. The Ministry of Science and Technology shall take responsibility to the Government for performing uniform state management of activities in the domain of standard and the domain of technical regulation.

2. The Ministry of Science and Technology has the following responsibilities:

a/ To formulate and promulgate or submit to competent state agencies or persons for promulgation, and organize the implementation of, policies and strategies on activities in the domain of standard and the domain of technical regulation; organize the elaboration and approval of plannings and plans on formulation of national standards and national technical

regulations in the domains under their assigned management;

b/ To formulate and promulgate or submit to competent state agencies or persons for promulgation legal documents on standards and technical regulations, and organize the implementation thereof;

c/ To evaluate and announce national standards; organize formulation and announcement of national standards in the domain under its assigned management; to promulgate organization and operation regulations of technical boards for national standards; to guide the formulation and application of national standards; to guide the formulation and announcement of manufacturer standards; to guide the application of international, regional and foreign standards;

d/ To evaluate national technical regulations; to guide the formulation of technical regulations; to organize the formulation and promulgation of national technical regulations in the domain under its assigned management;

e/ To manage and guide conformity assessment activities;

f/ To build and develop human resources for activities in the domain of standard and the domain of technical regulation; to organize scientific research and technological development related to standards and technical regulations;

g/ To manage international cooperation on standards and technical regulations;

h/ To organize and manage activities of the national network of notification and enquiry points related to standards, technical regulations and conformity assessment;

i/ To conduct propaganda about and guidance on the observance of the law on standards and technical regulations; to make statistics on the domain of standard and the domain of technical regulation;

j/ To supervise and inspect the observance of law on standards and technical regulations; to handle violations in accordance with law; to settle complaints and denunciations related to activities in the domain of standard and the domain of technical regulation in accordance with the law on complaints and denunciations.

Article 60.- Responsibilities of ministries, ministerial-level agencies and government-attached agencies

1. Ministries and ministerial-level agencies, within the scope of their respective tasks and powers, have the following responsibilities:

a/ To formulate and promulgate or submit to competent state agencies or competent persons for promulgation legal documents on relevant standards and technical regulations;

b/ To organize the elaboration and approval of plannings and plans on formulation on national technical regulations; to organize the formulation and promulgation of national technical regulations in the domains under their respective management;

c/ To propose plannings and plans on formulation of national standards; to organize the formulation of draft national standards in the branches or domains under their respective management;

d/ To manage the formulation and promulgation of local technical regulations; to give comments on draft local technical regulations;

e/ To manage activities of announcement of technical-regulation conformity and certification of technical-regulation conformity;

f/ To make statistics on activities of formulation, promulgation and application of technical regulations issued by themselves;

g/ To participate in international cooperation on standards and technical regulations;

h/ To disseminate, and guide the application of, standards and technical regulations;

i/ To supervise and inspect activities in the domain of technical regulation; to handle violations in accordance with law;

j/ To settle complaints and denunciations related to activities in the domain of technical regulation in accordance with the law on complaints and denunciations;

2. Government-attached agencies, within the scope of their tasks and powers, have the following responsibilities:

a/ To formulate and submit to competent state agencies or persons for promulgation legal documents on relevant standards and technical regulations;

b/ To elaborate and submit to competent state agencies or persons for approval plannings and plans on formulation of national technical regulations;

c/ To organize the formulation of draft national technical regulations; to guide the formulation of local technical regulations; to give comments on draft local technical regulations;

d/ To propose plannings and plans on formulation of national standards; to organize the formulation of draft national standards in the domains under their assigned management;

e/ To disseminate, and guide the application of, standards and technical regulations;

f/ To participate in international cooperation on standards and technical regulations;

g/ To supervise and inspect activities in the domain of technical regulation; to handle violations in accordance with law;

h/ To settle complaints and denunciations related to activities in the domain of technical regulation in accordance with the law on complaints and denunciations.

Article 61.- Responsibilities of provincial/municipal People's Committees

Provincial/municipal People's Committees, within the scope of their tasks and powers, have the following responsibilities:

1. To propose plans on formulation of national standards and national technical regulations; to organize the elaboration and implementation of plans on formulation of local technical regulations.
2. To promulgate, and guide the application of, local technical regulations.
3. To build necessary material and technical foundations for activities in the domain of standard and domain of technical regulation in localities.
4. To organize the implementation of, propaganda about and education in the law on standards and technical regulations.
5. To supervise and inspect the observance of the law on standards and technical regulations; to handle violations in accordance with law.
6. To settle complaints and denunciations related to activities in the domain of standards and the domain of technical regulation in accordance with the law on complaints and denunciations.

Article 62.- Responsibilities of production and business organizations and individuals

1. To announce standards applicable to products, goods, services, processes and environment.
2. To announce products, goods, services, processes and environment conformable with relevant technical regulations.
3. To ensure conformity of products, goods, services, processes and environment with announced technical regulations and standards.

Article 63.- Responsibilities of associations and unions

1. To give opinions on the formulation of relevant legal documents, national standards and technical regulations.
2. To disseminate and train their members in the knowledge about and provide necessary information on activities in the domain of standard and the domain of technical regulation among their members and competent state agencies in accordance with law.

Chapter VI

INSPECTION, HANDLING OF VIOLATIONS, SETTLEMENT OF COMPLAINTS AND DENUNCIATIONS AND DISPUTES RELATED TO ACTIVITIES IN THE DOMAIN OF STANDARD AND THE DOMAIN OF TECHNICAL REGULATION

Article 64.- Inspectorate of activities in the domain of standard and the domain of technical

regulation

1. The inspectorate of activities in the domain of standard and the domain of technical regulation is a specialized inspectorate.
2. Inspection of activities in the domain of standard and the domain of technical regulation shall be conducted in accordance with the law on inspection.
3. The Government shall issue detailed regulations on the organization and operation of the inspectorate of activities in the domain of standard and the domain of technical regulation.

Article 65.- Handling of violations of the law on standards and technical regulations

1. Persons who commit acts of violating the law on standards and technical regulations shall, depending on the nature and severity of their violations, be disciplined, administratively sanctioned or examined for penal liability; if causing damage, they must pay compensation therefor in accordance with law.
2. Organizations that violate the law on standards and technical regulations shall, depending on the nature and severity of their violations, be administratively sanctioned or suspended from operation; if causing damage, they must pay compensation therefor in accordance with law.

Article 66.- Complaints and denunciations related to activities in the domain of standard and the domain of technical regulation

1. Organizations and individuals are entitled to lodge complaints with competent state agencies or persons about the latter's administrative decisions or administrative acts which they deem illegal or about acts of infringing upon their legitimate rights and interests in activities in the domain of standard and the domain of technical regulation in accordance with law.
2. Individuals are entitled to denounce to competent state agencies or competent persons acts of violation of the law on standards and technical regulations.

Article 67.- Settlement of complaints and denunciations related to activities in the domain of standard and the domain of technical regulation

State agencies and persons competent to settle complaints and denunciations shall consider and settle complaints and denunciations related to activities in the domain of standard and the domain of technical regulation in accordance with the law on complaints and denunciations.

Article 68.- Resolution of disputes in activities in the domain of standard and the domain of technical regulation

The State shall encourage parties to disputes in activities in the domain of standard and the domain of technical regulation to resolve their disputes through conciliation; in case of conciliation failure, the parties may initiate lawsuits at a court or an arbitration in accordance with law.

Chapter VII

IMPLEMENTATION PROVISIONS

Article 69.- Transition provisions

1. Vietnam standards and branch standards already promulgated under the 1999 Ordinance on Goods Quality and under other laws and ordinances shall be reviewed and converted into national standards or national technical regulations.
2. Technical regulations, processes, rules, standards and documents already promulgated for mandatory application in service of state management shall be reviewed and converted into technical regulations.
3. The Government shall provide for the conversion of branch standards into national standards or national technical regulations defined in Clause 1 of this Article and the conversion of technical regulations, processes, rules, standards and documents subject to mandatory application into technical regulations defined in Clause 2 of this Article.

Article 70.- Implementation effect

This Law takes effect on January 1, 2007.

Article 71.- Implementation guidance

The Government shall detail and guide the implementation of this Law.

This Law was passed on June 29, 2006, by the XIth National Assembly of the Socialist Republic of Vietnam at its 9th session.

**THE NATIONAL
ASSEMBLY
CHAIRMAN**
(signed)

Nguyen Phu Trong

添付資料-2

**RECOMMENDATIONS AND
REVIEWEDE RESULTS
BY JICA EXPERT**

Recommendations and Reviewed Results by JICA Expert

We, JICA Expert, will present in the meeting our recommendations and the reviewed results of 1st Draft QCVN/TCVN prepared respectively by the Sub-Groups as below.

1. Recommended Scopes of Work of Sub-Groups
2. Primary Items to be Described in QCVN/TCVN
3. Requisite Integration on Traffic Information/Control under Regional Main Center
4. Reviewed Results of 1st Draft QCVN/TCVN
5. Items to be Described as Basic Requirements in QCVN/TCVN.

In the following, the pages shown in the table below are to be referred to by each Sub-Group.

Sub-Group	Output	Reference Pages
1	TCVN on ITS System Architecture	→ Pages 2 to 5, and pages 6 to 7
2	QCVN on Traffic Monitoring & Management for Expressways	→ Pages 2 to 5, and pages 8 to 11
3	QCVN on Traffic Database and Message System for Expressways	→ Pages 2 to 5, and pages 12 to 15
4	QCVN on CCTV Camera System for Expressways	→ Pages 2 to 5, and pages 16 to 19
5	QCVN on VMS System for Expressways	→ Pages 2 to 5, and pages 20 to 23
6	QCVN on Communication System for Expressways	→ Pages 2 to 5, and pages 24 to 26
7	QCVN on ETC System for Expressways	→ Pages 2 to 5, and pages 27 to 33
8	QCVN on Management Centers/Offices for Expressways	→ Pages 2 to 5, and pages 34 to 40

1. Recommended Scopes of Work of Sub-Groups

The scopes of work are recommended for respective Sub-Groups as shown in the figure below and the table in the following page based on the elemental functions of ITS.

Scopes of Work of Sub-Groups based on Elemental Functions of ITS

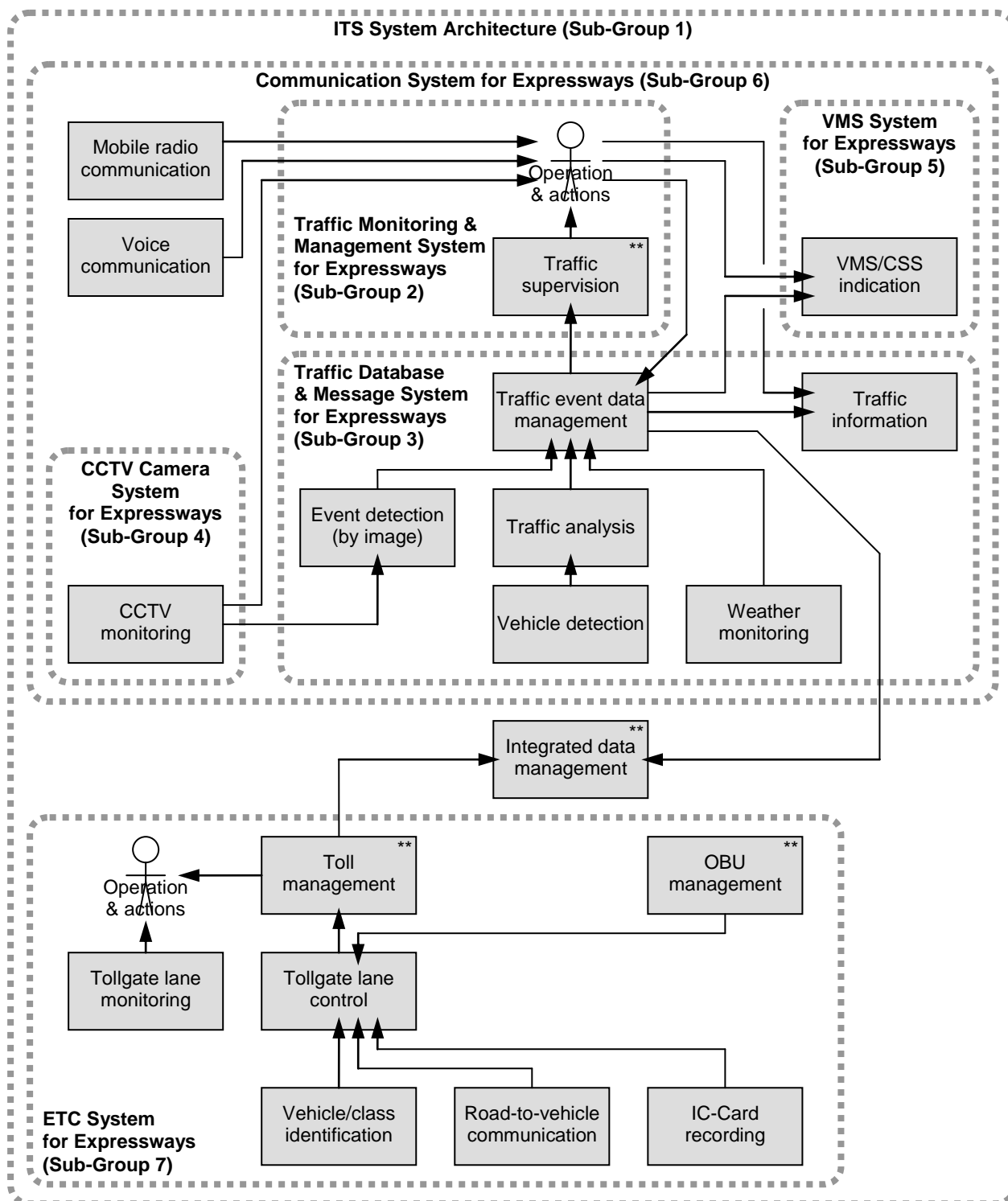

Note, ** : Elemental functions related to Management Centers/Offices to be discussed in Sub-Group 8.

Elemental Functions of ITS for Discussion in Each Sub-Group

Elemental Functions	Sub-Group 1	Sub-Group 2	Sub-Group 3	Sub-Group 4	Sub-Group 5	Sub-Group 6	Sub-Group 7	Sub-Group 8
(1) Voice communication	X					X		
(2) CCTV monitoring	X			X				
(3) Event detection (by image)	X		X					
(4) Vehicle detection	X		X					
(5) Traffic analysis	X		X					
(6) Weather monitoring	X		X					
(7) Traffic event data management	X		X					
(8) Traffic supervision	X	X						(X)
(9) VMS/CSS indication	X				X			
(10) Mobile radio communication	X					X		
(11) Traffic information	X		X					
(12) Integrated data management	X							(X)
(13) Tollgate lane monitoring	X						X	
(14) Vehicle/class identification	X						X	
(15) Tollgate lane control	X						X	
(16) Road-to-vehicle communication	X						X	
(17) IC-Card recording	X						X	
(18) Toll management	X						X	(X)
(19) OBU management	X						X	(X)

If the scopes of work of Sub-Groups remain unclear and overlapped, that will cause ITS engineers unreasonable difficulties in referring to and understanding QCVN/TCVN.

2. Primary Items to be Described in QCVN/TCVN

Primary items and basic organization of QCVN/TCVN is recommended as shown below.

Basic Organization of QCVN/TCVN Proposed for Sub-Groups

1.	General Regulation
1.1	Scope
1.2	Application Object
1.3	Reference Materials
1.4	Terminology and Definition
1.5	Abbreviations
2.	Technical Regulation
2.1	Primary Objectives of System
2.2	Elemental Functions
2.3	Each Function 1
2.3.1	Basic Requirements
2.3.2	Location of System
2.3.3	Other Requirements on Function
2.4	Each Function 2
2.4.1	Basic Requirements
:	:
2.X	Requirements on Major Components
2.X.1	Each Major Component 1
2.X.2	Each Major Component 2
:	:
3.	Regulation on Management
4.	Implementing Organization

If the titles of important clauses in QCVN/TCVN are not standardized among different Sub-Groups, that will cause ITS engineers needless difficulties in referring to QCVN/TCVN.

3. Requisite Integration on Traffic Information/Control under Regional Main Center

Traffic data acquired in the Road Management Office shall be shared with and integrated/prioritized in the Regional Main Center. The following two ways shall be secured for traffic information/control:

- (1) Prompt action by the Road Management Office responding to incidents/events based on sectional data
- (2) Integrated/prioritized information provision from the Regional Main Center.

Under normal condition, the Road Management Offices can select either way for controlling VMS. However, at the occurrence of prioritised incident/event, the Regional Main Center shall enforce the VMS control in the way (2) in order to perform the most effective control over the whole expressway network and to achieve the advantages below. This is the requisite integration in the results of SAPI.

Integration of Traffic Information/Control under Regional Main Center

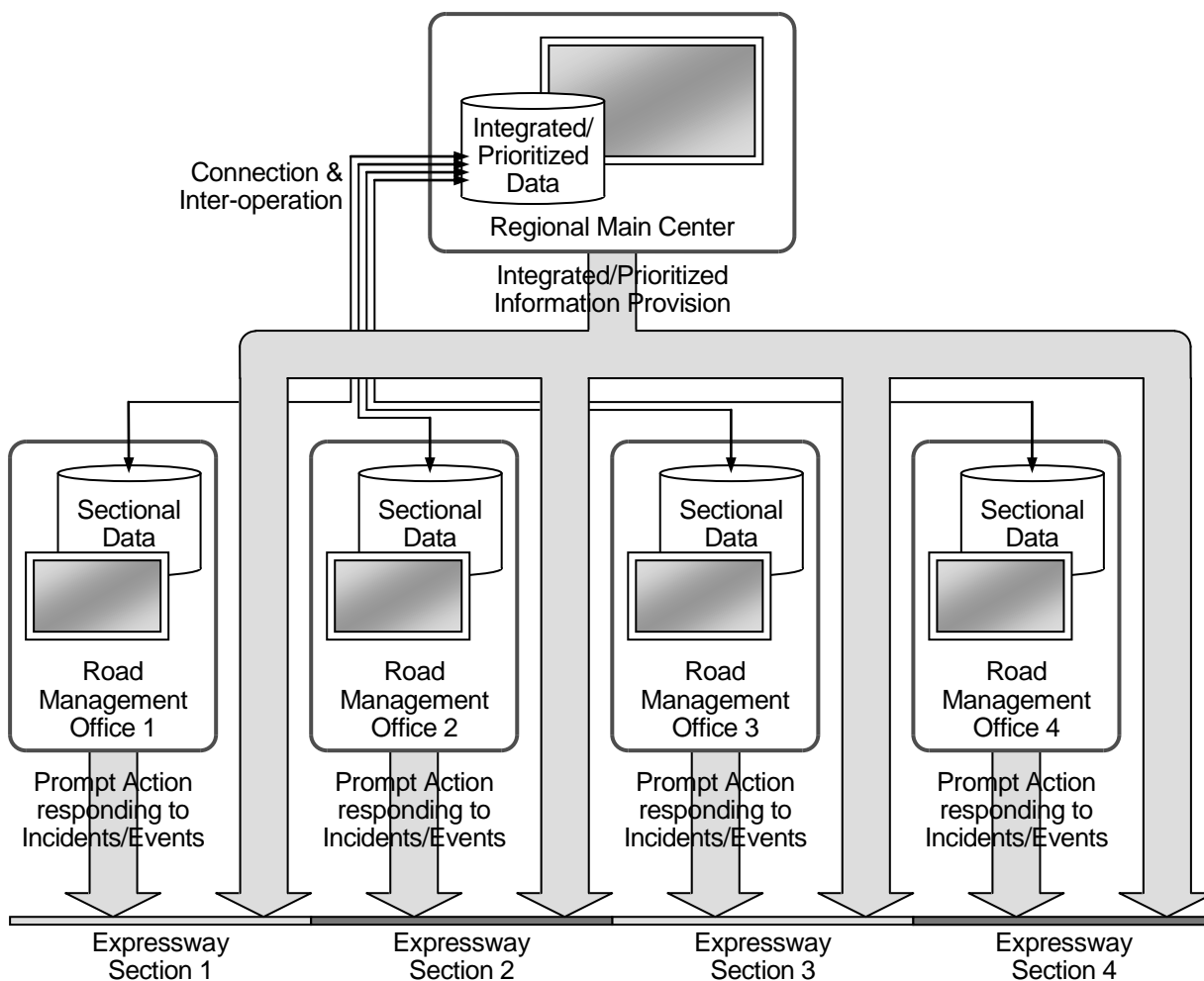

- **Reduction of system implementation/maintenance cost** : Integrated implementation of the system for processing traffic data allows the investors to eliminate overlapped implementation among many Road Management Offices placed for the different expressway sections and to reduce the system implementation/ maintenance cost.
- **Optimal traffic information provision by VMS** : the integration allows the system, in the case incidents, congestion and traffic restrictions take place on the different expressway sections at

the same time, to define priority of each event based on its relative location to the installed point of VMS and traffic volume and to indicate the optimal information on each VMS.

- **Reduction of operation cost by saving man-power** : 24-hour automatic operation of the optimal information provision aforementioned allows the Road Management Office Staff to concentrate on clearing incidents or enforcing traffic restrictions, and to operate at low cost by saving man-power.
- **Realization of system back-up** : In the case a system for VMS control has been installed in a Road Management Office, it can be utilized for system back-up for the case of system down in the Regional Main Center and other unusual cases.

4. Reviewed Results of 1st Draft QCVN/TCVN

JICA Expert received the following six 1st Draft QCVNs prepared by the respective Sub-Groups:

- Sub-Group 2: QCVN on Traffic Monitoring & Management for Expressways
- Sub-Group 4: QCVN on CCTV Camera System for Expressways
- Sub-Group 5: QCVN on VMS System for Expressways
- Sub-Group 6: QCVN on Communication System for Expressways
- Sub-Group 7: QCVN on ETC System for Expressways
- Sub-Group 8: QCVN on Management Centers/Offices for Expressways.

These 1st draft QCVNs were reviewed in accordance with the system policies which were concluded as the major opinion in the 17 times Working Groups with attendance of the persons responsible in MOT, VEC, DRVN and other organizations and the Study Team Members for the following three JICA Studies:

- Study for ITS Master Plan Development in VITRANSS2
- Study for Supporting ITS Standards & Operation Plan Development in Vietnam
- Study of Special Assistance for Project Implementation (SAPI) for ITS Integration Project on New National Highway No.3 & Northern Area of Vietnam.

The reviewed results by the JICA Expert are to be shown in the tables later being classified into the following five groups:

- Definitions inconsistent with SAPI
- Definitions in the scope of other QCVN/TCVN
- Definitions improper for QCVN
- Dropout of essential contents
- Not standardized title of clause.

The items of 1st Draft QCVN grouped as “Definitions inconsistent with SAPI” shall be revised in accordance with the system policies in SAPI, which is to be applied to the ITS Integrated Project, or shall be removed from the Draft. The items grouped as “Definitions in the scope of other QCVN” shall be revised or removed as well. That are necessary to resolve the disagreement with JICA Expert.

5. Items to be Described as Basic Requirements in QCVN/TCVN

Finally in the following pages, recommendations were made on the items to be described in QCVN/TCVN respectively for eight Sub-Groups.

Sub-group 1 : ITS System Architecture

<1> Reviewed Results of 1st Draft TCVN

The 1st Draft TCVN is still under preparation; hence, the reviewed results have not been prepared.

Article Number in 1st Draft TCVN	Classification of Reviewed Result	Corresponding Item Number in <2> & Comments

<2> Items to be Described as Basic Requirements in TCVN

The following items are recommended to be described as basic requirements in TCVN by Sub-Group 1.

1. General Regulation

1.1 Scope

1.2 Application Object

This regulation shall be applied to any organizations and individuals in charge of planning, design, construction, operation, management and maintenance of ITS for any expressways over the country.

1.3 Terminology and Definition

→Under discussion in Sub-Group 1.

1.4 Abbreviations

→To be discussed in Sub-Group 1 including the followings:

CCTV: Closed Circuit Television

CSS: Changeable Speed-limit Signs

ITS: Intelligent Transportation System

UML: Unified Modelling Language

VMS: Variable Message Signs.

2. Technical Regulation

2.1 Primary Objectives of System Architecture

System Architecture shall present the whole picture of ITS by a set of diagrams using simple graphical symbols and texts in order to share the correct understanding among all persons in charge of planning, designing, implementing and operating ITS; and to form the basis of Technical Regulations and Standards of ITS to establish compatibility of equipment component, connectability of communication interface and interoperability of data.

2.2 Element for Specifying System Architecture

System Architecture shall be specified based on elemental functions including the followings, which compose ITS and are the units of implementation and upgrading of ITS:

- (1) Voice communication
- (2) CCTV monitoring
- (3) Event detection (by image)
- (4) Vehicle detection
- (5) Traffic analysis
- (6) Weather monitoring
- (7) Traffic event data management
- (8) Traffic supervision
- (9) VMS/CSS indication
- (10) Mobile radio communication
- (11) Traffic information
- (12) Integrated data management
- (13) Tollgate lane monitoring
- (14) Vehicle/class identification
- (15) Tollgate lane control
- (16) Road-to-vehicle communication
- (17) IC-Card recording
- (18) Toll management
- (19) OBU management.

2.3 Types of System Architecture

2.3.1 Logical System Architecture: Functions of ITS shall be planned and basically designed based on the Logical System Architecture in order to achieve its performance totally, even in the case it consists of several equipment components installed in different locations respectively and operated/managed by different organization.

2.3.2 Physical System Architecture: Communication system of ITS shall be planned and basically designed based on the Physical System Architecture in order to clarify the harmonization of communication protocols including lower layers and the adequacy of capacity for data traffic to be exchanged.

2.4 Notation of System Architecture

In ITS planning and designing, System Architecture including the Use Case Diagrams, the Communication Diagrams (in other word, the Collaboration Diagrams) and the Sequence Diagrams shall be described basically according to the notation of UML standardized as ISO/IEC19505.

2.5 Diagrams of ITS System Architecture

→Shown in the Results of SAPI

3. Regulation on Management

→To be discussed in Sub-Group 1.

4. Implementing Organization

→To be discussed in Sub-Group 1.

Sub-group 2 : Traffic Monitoring & Management System for Expressways

<1> Reviewed Results of 1st Draft QCVN

Reviewed results of the 1st Draft QCVN are shown on the table below.

Article Number in 1st Draft QCVN	Classification of Reviewed Result	Corresponding Item Number in <2> & Comments
1		→
1.1	Not standardized title of clause	→See 1.1 in <2> shown later.
1.2		→
1.3	Definitions improper for QCVN	→ QCVN including reference to TCVN and TCCS needs to be reissued every time when these materials are revised. Definitions of QCVN shall never depend on such lower grade materials.
1.4		→
1.5		
2		→
2.1	Definitions improper for QCVN Definitions inconsistent with SAPI	→The figuration map shall be defined in the TCVN for ITS System Architecture by Sub-Group 1. →Emergency telephones along section shall be removed; because, that have been rejected by DOST/MOT and VEC in the discussion of SAPI. See 2.1 and 2.3.1 in <2> shown later.
2.2		→
2.3		→
2.3.1	Definitions improper for QCVN	→See 2.3.3, 2.3.4, 2.3.5, 2.3.6 and 2.3.7 in <2> shown later. All procedures by operator shall be defined clearly.
2.3.2	Definitions improper for QCVN	→See 2.3.4, 2.3.8, 2.3.9, 2.3.10 and 2.3.11 in <2> shown later. All processing on traffic information shall be defined clearly.
2.3.3	Definitions improper for QCVN	→The words “24 hours a day, 7days a week and 365 days a year” shall be removed. Because, in the international definitions, these words means “anytime including the time for maintenance” and requires the completely duplexed system.
2.4		→
2.4.1	Definitions in the scope of other QCVN Dropout of essential contents	→Digital transmission system shall never be defined in this QCVN, but in the QCVN on Communication System for Expressways to be prepared by Sub-Group 6. →Surging caused by lightening shall be considered for deciding use of fiber optic transmission.
2.4.2	Definitions in the scope of other QCVN	→Traffic monitoring system shall never be defined in this QCVN, but in the QCVN on CCTV Camra System for Expressways to be prepared by Sub-Group 4.
2.4.3	Definitions in the scope of other QCVN	→Vehicle detection system shall never be defined in this QCVN, but in the QCVN on Traffic Database & Message System for Expressways to be prepared by Sub-Group 3.

	Definitions improper for QCVN Definitions improper for QCVN	→Vehicle speed shall be calculated by using the formula of harmonic mean value. →The accuracy of vehicle speed recognition shall defined using percentage such as $\pm 10\%$; because, it is difficult to secure $\pm 5\text{km}$ at a high speed of the vehicle.
2.4.4	Definitions in the scope of other QCVN	→Automated event recognition system shall never be defined in this QCVN, but in the QCVN on Traffic Database & Message System for Expressways to be prepared by Sub-Group 3.
2.4.5		→
2.4.6	Definitions in the scope of other QCVN	→Traffic information provision system shall never be defined in this QCVN, but in the QCVN on Traffic Database & Message System for Expressways to be prepared by Sub-Group 3.
2.4.7	Definitions in the scope of other QCVN	→Communication system shall never be defined in this QCVN, but in the QCVN on Communication System for Expressways to be prepared by Sub-Group 6.
2.4.8		→
2.4.9		→
2.4.10		→
2.4.11	Definitions in the scope of other QCVN	→Toll collection system shall never be defined in this QCVN, but in the QCVN on ETC System for Expressways to be prepared by Sub-Group 7.
3		→
4		→
APPENDIX A		→
A.1	Definitions improper for QCVN	→Description of technological evaluation on Ultrasonic Vehicle Detectors shall be revised; because, Dual Type Ultrasonic Vehicle Detector can detect vehicle speed and congestion.
A.2		→
APPENDIX B		

<2> Items to be Described as Basic Requirements in QCVN

The following items are recommended to be described as basic requirements in QCVN by Sub-Group 2.

1. General Regulation

1.1 Scope

This National Technical Regulation provides basic requirements for Traffic Monitoring and Management System to be installed in the centers/offices for traffic management of expressway including some components to be installed fixedly on the expressways.

1.2 Application Object

This regulation shall be applied to any organizations and individuals in charge of planning,

design, construction, operation, management and maintenance of Traffic Monitoring & Management System for any expressways over the country.

1.3 Terminology and Definition

→Under discussion in Sub-Group 2.

1.4 Abbreviations

→To be discussed in Sub-Group 2 including the followings:

VMS: Variable Message Signs.

2. Technical Regulation

2.1 Primary Objectives of System

Traffic Monitoring & Management System shall achieve operation for remotely identifying and recognizing an occurrence incident or other event, checking situation and severity of the event, making decisions to dispatch patrol crews to the site of event and to enforce/remove the traffic restrictions, instructing the patrol crews, defining and prioritizing information of the event and disseminating the information to the drivers en route and other road users.

2.2 Elemental Functions

Traffic Monitoring & Management System shall include the following functions:

- Traffic supervision (in combination with traffic event data management)

2.3 Traffic Supervision

2.3.1 Basic Requirements: The System shall allow the operators in the regional Main Center and the Road Management Office to supervise totally and visually the current traffic condition on the expressways and exchange information for traffic control.

2.3.2 Location of System: The System of traffic supervision shall be installed in the Regional Main Centers.

2.3.3 Incident Identification by Telephone: The System shall allow the operator to receive an emergency call in the Regional Main Center through a special number from the driver who has identified an occurrence of incident or other event or receiving a call in Road Management Office responsible for the expressway section of the incident site from the police, the ambulance service or the patrol crew.

2.3.4 Automatic Incident Identification: The System shall make it possible to initially identify an occurrence of incident or other event at the bottleneck spot on the expressway network, where the traffic can be stuck easily by an incident, remotely in the Regional Main Center and Road Management Office responsible for the section of the incident site without any call from the driver, the police, ambulance service or the patrol crew.

2.3.5 Incident Monitoring: The System shall allow the operator to monitor the situations and severities of identified event and the traffic conditions at any place on the expressway network remotely in the Regional Main Center and Road Management Office.

2.4.6 Main Monitor Screen: The main monitor screen of the System shall have the function to notify

the occurred/existing traffic events to the operators in the traffic control room by indicating their classes and locations graphically on the map, which covers the expressway network of northern, middle or southern region of Vietnam, concurrently overlaid with the indications of video images from CCTV cameras and other information/data.

2.3.7 Administrative Information and Directives: The System shall allow operators to exchange information and distribute directives through the telephone among the Regional Main Center and Road Management Offices.

2.3.8 Manual Input of Traffic Information: The System shall make it possible to receive input and store the information of identified or detected events in unified and organized form in the Regional Main Center and Road Management Office.

2.3.9 Automatic Generation of Traffic Information: The System shall make it possible to automatically detect actual traffic volume, vehicle speed, other traffic conditions, rainfalls, wind speed, visibility and temperature on the expressway.

2.3.10 Validity Check of Traffic Information: The System shall allow the operator to check and share the information of the occurrence, situations and severity of an event among the regional Main Center, Road Management Office and the patrol crews in order to address the events or to enforce and remove traffic restrictions.

2.3.11 Dissemination of Traffic Information: The System shall make it possible to disseminate stored information through VMS to the drivers en route and through the Internet to other road users being operated in the Regional Main Center.

2.4 Requirements on Major Components

2.4.1 XXXXXXX (=Major Component 1)

→To be discussed in Sub-Group 2.

2.4.2 XXXXXXX (=Major Component 2)

→To be discussed in Sub-Group 2.

3. Regulation on Management

→To be discussed in Sub-Group 2.

4. Implementing Organization

→To be discussed in Sub-Group 2.

Sub-group 3 : Traffic Database & Message System for Expressways

<1> Reviewed Results of 1st Draft QCVN

The 1st Draft QCVN is still under preparation; hence, the reviewed results have not been prepared.

Article Number in 1st Draft QCVN	Classification of Reviewed Result	Corresponding Item Number in <2> & Comments

<2> Items to be Described as Basic Requirements in QCVN

The following items are recommended to be described as basic requirements in QCVN by Sub-Group 3.

1. General Regulation

1.1 Scope

This National Technical Regulation provides basic requirements for Traffic Database & Message System to be installed in the centers/offices for traffic management of expressway including some components to be installed fixedly on the expressways.

1.2 Application Object

This regulation shall be applied to any organizations and individuals in charge of planning, design, construction, operation, management and maintenance of Traffic Database & Message System for any expressways over the country.

1.3 Terminology and Definition

→Under discussion in Sub-Group 3.

1.4 Abbreviations

→To be discussed in Sub-Group 3 including the followings:

CCTV: Closed Circuit Television

IP: Internet Protocol

TCP: Transmission Control Protocol

VMS: Variable Message Signs.

2. Technical Regulation

2.1 Primary Objectives of System

Traffic Database & Message System shall achieve identification of incidents, other events, traffic conditions and weather conditions on the expressway; generation of data in a unified/integrated form for sharing it among the Regional Main Center, relevant Road Management Offices and patrol crews and for disseminating it to the drivers en route and other road users.

2.2 Elemental Functions

Traffic Database and Message System shall include the following functions:

- Event detection (by image)
- Vehicle detection
- Traffic analysis
- Weather monitoring
- Traffic event data management
- Traffic information.

2.3 Event Detection (by Image)

- 2.3.1 Basic Requirements:** The System shall achieve detection of events on traffic by automatically recognizing the occurrence of slowing-down/stopped/reversing vehicle and left obstacle at bottleneck spots on the expressway network by analysing video images captured by camera.
- 2.3.2 Location of Cameras:** The cameras shall be installed appropriately at locations, where possibility of incident occurrence is high, on the expressway.
- 2.3.3 Image Recognition:** A CCTV camera for automatic event detection shall function being combined with image recognition which can be established by hardware/software to be installed at roadside with camera or in the center.
- 2.3.4 Interface Protocols of System:** A detector for traffic data shall be connected and controlled through the interface in conformity with TCP/IP protocol based on the unified numbering system.

2.4 Vehicle Detection

- 2.4.1 Basic Requirements:** The System shall achieve measurement of actual traffic volume by automatically detecting vehicle passage on the through lanes of the expressway and at the tollgates, and to track vehicle speed, heavy vehicle ratio and other traffic conditions by analysing the detected data.
- 2.4.2 Location of Detectors:** The detectors shall be installed at the mid-point between a pair of adjacent interchanges, entrance gate and exit gate of the expressway.

2.5 Traffic Analysis

- 2.5.1 Basic Requirements:** The System shall achieve keeping track of traffic conditions on the expressway, such as vehicle velocity and crowdedness, by processing/analysing the data captured by vehicle detectors.
- 2.5.2 Interface Protocols of System:** A detector for traffic data shall be connected and controlled through the interface in conformity with TCP/IP protocol based on the unified numbering system.

2.6 Weather Monitoring

- 2.6.1 Basic Requirements:** The System shall acquire data by automatically detecting rainfalls, wind speed, visibility and temperature by sensors to estimate/classify dangerous conditions for traffic on the expressway.
- 2.6.2 Location of Sensors:** The sensors shall be installed at roadside of the expressway appropriately for obtaining meteorological observation data for expressway operation.

2.6.3 Interface Protocols of System: A detector for traffic data shall be connected and controlled through the interface in conformity with TCP/IP protocol based on the unified numbering system.

2.7 Traffic Data Management

2.7.1 Basic Requirements: The System shall allow traffic data generated/input/stored in a unified form with adequate identification and classification; shared/checked among operators in the centers and offices; and correlated/prioritized/organized for disseminating to the drivers en route and other road users.

2.7.2 Location of System: The System of traffic data management shall be installed in all of the Regional Main Centers and Road Management Offices securing harmonization by standardized function sharing, cooperation and data communication among them.

2.7.3 Data Acquisition: The System shall acquire data through an event detector, a vehicle detector or a weather sensor or by input of the information of an incident or other event by an operator in the Regional Main Center or a Road Management Office.

2.7.4 Generation of Traffic Event Data: The System shall make it possible to define, unify and store the information as a traffic event by its location, time and classification which includes items of traffic accident, incident in tunnel, reversing vehicle, broken-down vehicle, left obstacle, natural disaster, vandalism, construction work, heavy rain, high wind, dense fog, high temperature, traffic congestion, traffic restriction and special event.

2.7.5 Direct input of Special Event: The System shall allow the operator to input directly a special event as a traffic event to be disseminated through VMS and other ways of information.

2.7.6 Shared Use of Data: The System shall generate the data of a traffic event based on the rule unified and shared among the Regional Main Center and Road Management Offices for defining its location, time and classification.

2.7.7 Validity Check of Data: The System shall allow the operator to check validity of the information of the traffic event at both the Regional Main Center and Road Management Office responsible for the site of event and to share the checked information among the Regional Main Center, the relevant Road Management Office and the patrol crews.

2.7.8 Correlation of Traffic Events: The System shall make it possible to organize information by correlating a traffic event to the other traffic event which caused it.

2.7.9 Prioritization of Traffic Events: The System shall make it possible to organize information by prioritizing the traffic events automatically based on the class of correlated traffic events for disseminating information through VMS, the Internet and other ways.

2.7.10 Organization of Information: The System shall make it possible to organize information, for disseminating information through VMS, by prioritizing the traffic events automatically based on the distance from VMS to the site of the traffic event and on the traffic volume that will stumble across the traffic event.

2.8 Requirements on Major Components

2.8.1 XXXXXXX (=Major Component 1)

→To be discussed in Sub-Group 3.

2.8.2 XXXXXXX (=Major Component 2)

→To be discussed in Sub-Group 3.

3. Regulation on Management

→To be discussed in Sub-Group 3.

4. Implementing Organization

→To be discussed in Sub-Group 3.

Sub-group 4 : CCTV Camera System for Expressways

<1> Reviewed Results of 1st Draft QCVN

Reviewed results of the 1st Draft QCVN are shown on the table below.

Article Number in 1st Draft QCVN	Classification of Reviewed Result	Corresponding Item Number in <2> & Comments
1		
1.1	Dropout of essential contents	→See 1.1 in <2> shown later. The words “access roads” and “centers/offices” shall be clearly described as the installation places of cameras and its control components.
1.2	Not standardized title of clause	→See 1.2 in <2> shown later.
1.3		→
1.4		→
2	Not standardized title of clause Definitions inconsistent with SAPI Dropout of essential contents	→The title of clause is not unified with other Sub-Groups. →See 2.1.1, 2.1.2, 2.1.3, 2.3.3 and 2.3.4 in <2> shown later. CCTV camera installation “continuous along expressway” and camera control from both Regional Main Center and Road Management Office shall be clearly described. →See 2.3.5 in <2> shown later. Enhancement of compatibility of camera control using NVR is to be clearly described.
3		→
4		→
4.1	Definitions improper for QCVN	→It is impossible to monitor image clearly “at any time”; hence, the words “at any time” shall be removed. See 2.3.1 in <2> shown later.
4.2		→
4.3	Dropout of essential contents	→See 2.3.8 in <2> shown later. For securing competitive condition among suppliers, MPEG-2 and MPEG-4 shall be described in addition to H.264 and Motion JPEG in this clause.
4.4		→
4.5	Definitions improper for QCVN	→QCVN including definitions based on other TCVN needs to be reissued every time when the TCVN are revised. In fact, 22TCN 272-05 has been issued as the revision of TCVN 2737:1995, and TCVN5729:2012 has been issued as the revision of TCVN4054: 2005. Descriptions in QCVN shall never depend on such materials.
5	Dropout of essential contents Definitions improper for QCVN	→See 2.3.8 in <2> shown later. For securing compatibility with cameras manufactured by different suppliers, MPEG-2 and MPEG-4 shall be described in addition to H.264 and Motion JPEG in this clause. →The function of processing images shall never described in this clause, because it will interfere the wider selectivity of NVR for

		securing competitiveness.
6		→
7		→
8		→
8.1		→
8.2		→
8.3		→
8.4		→
8.5		→
8.6		→
9		→
9.1		→
9.2		→
9.3		→
9.4		→
9.5		→
9.6		→
10		→
11		→
12		→
13		→
14		→

<2> Items to be Described as Basic Requirements in QCVN

The following items are recommended to be described as basic requirements in QCVN by Sub-Group 4.

1. General Regulation

1.1 Scope

This National Technical Regulation provides basic requirements for CCTV Camera System to be installed fixedly on the expressways and their access roads including control components to be installed in the centers/offices for traffic management of expressway.

1.2 Application Object

This regulation shall be applied to any organizations and individuals in charge of planning, design, construction, operation, management and maintenance of CCTV Camera System for any expressways over the country.

1.3 Terminology and Definition

→Under discussion in Sub-Group 4.

1.4 Abbreviations

→To be discussed in Sub-Group 4 including the followings:

CCTV: Closed Circuit Television

IP: Internet Protocol

JPEG: Joint Photographic Experts Group

MPEG: Motion Picture Experts Group

TCP: Transmission Control Protocol.

2. Technical Regulation

2.1 Primary Objectives of System

2.1.1 Continuous along Expressway: The System shall allow the situation and severity of an incident or other event at any place on the expressways monitored remotely in the Regional Main Center and the Road Management Office in response to an emergency call from the driver who has identified it or a call from the police, the ambulance service or the patrol crew.

2.1.2 At Bottleneck Spot: The System shall allow the occurrence of incident or other event at a bottleneck spot on the expressway, where the traffic can be stuck easily by an incident, initially identified remotely in the Regional Main Center and a Road Management Office without any phone call.

2.1.3 At Tollgate: The System shall allow the occurrence of incident or other event at a tollgate initially identified remotely in a toll office without any phone call.

2.2 Elemental Functions

CCTV Camera System shall include the following functions:

- CCTV monitoring.

2.3 CCTV Camera Monitoring

2.3.1 Basic Requirements: The System shall achieve capture of the current situation of traffic accidents, broken-down vehicles, left obstacles, reversing vehicles, vandalism, natural disaster and other traffic conditions on the expressway.

2.3.2 Location of Cameras: Cameras shall be installed basically at regular intervals along the expressway with consideration of the blind angles caused by horizontal/vertical curves and obstacles; additionally at bottleneck spots on the expressway network and tollgates.

2.3.3 Camera Control under Normal Conditions: A camera installed at a regular interval or a bottleneck spot shall be controlled from both the Regional Main Center and the Road Management Office responsible for the expressway section where the camera installed.

2.3.4 Camera Control at Occurrence of Incident: A camera shall be controlled exclusively from the Road Management Office for addressing the incident.

2.3.5 Enhancing Compatibility of Camera Control: Camera control shall be established through a Network Video Recorder (NVR) installed in a Road Management Office in order to enhance the compatibility among many different cameras installed on the expressway.

2.3.6 PTZ Function of Camera: Camera which needs to cover a wider range shall be equipped with the functions of panning/tilting/zooming.

2.3.7 Resolution of Camera: Camera shall achieve a sufficient resolution for indicating captured images, including a vehicle and an obstacle, clearly on the monitor screen in the center covering the full range of an installation interval along the expressway, the bottleneck spot or the tollgate.

2.3.8 Compression Method of Video Data: Camera shall transmit the video data through the interface using standardized compression method of MPEG-4 Part 2, MPEG-4 Part 10 (H.264) or Motion JPEG.

2.3.9 Interface Protocols of Camera: Camera shall be connected and controlled through the interface in conformity with TCP/IP protocol based on the unified numbering system.

2.4 Requirements on Major Components

2.4.1 XXXXXXX (=Major Component 1)

→To be discussed in Sub-Group 4.

2.4.2 XXXXXXX (=Major Component 2)

→To be discussed in Sub-Group 4.

3. Regulation on Management

→To be discussed in Sub-Group 4.

4. Implementing Organization

→To be discussed in Sub-Group 4.

Sub-group 5 : VMS System for Expressways

<1> Reviewed Results of 1st Draft QCVN

Reviewed results of the 1st Draft QCVN are shown on the table below.

Article Number in 1st Draft QCVN	Classification of Reviewed Result	Corresponding Item Number in <2> & Comments
1		
1.1	Dropout of essential contents	→See 1.1 in <2> shown later. The words “access roads” and “centers/offices” shall be clearly described as the installation places of cameras and its control components.
1.2	Not standardized title of clause	→See 1.2 in <2> shown later.
1.3		→
1.4		→
2		→
2.1	Not standardized title of clause Dropout of essential contents Definitions inconsistent with SAPI	→The title of clause is not unified with other Sub-Groups. →See 2.1, 2.3.1 and 2.3.2 in <2> shown later. The primary objectives of system and the basic requirements on VMS/CSS shall be clearly described →See 2.3.5, 2.3.6, and 2.3.7 in <2> shown later. VMS control from Regional Main Center in normal conditions and direct control at emergency shall be clearly described.
2.2		→
2.2.1		→
2.2.2		→
2.2.3		→
2.3		→
2.3.1		→QCVN including definitions based on other TCVN needs to be reissued every time when the TCVN are revised. In fact, 22TCN331-05 in the preparation for revision in near future. Descriptions in QCVN shall never depend on such materials.
2.3.2		→
2.4		→
2.4.1		→
2.4.2		→
2.5		→
2.5.1		→
2.5.2		→
2.6		→
2.6.1	Definitions improper for QCVN	→ “Red” shall be used for both commands and warnings; because “blue” does not good visibility for the drivers. Additionally, most of VMS indications are for providing information and there are very small variety of indications for commands; hence, it is not so important to discriminate commands from warning.
2.6.2		→
2.6.3		→

2.7		→
2.8		→
2.9		→
2.10		→
2.11		→
2.12		→
2.13		→
2.14		→
3		→
3.1		→
3.2		→
3.3		→
3.4		→
3.5		→
4		→
4.1		→
4.2		→
4.3		→
4.4		→
5		→

<2> Items to be Described as Basic Requirements in QCVN

The following items are recommended to be described as basic requirements in QCVN by Sub-Group 5.

1. General Regulation

1.1 Scope

This National Technical Regulation provides basic requirements for VMS System to be installed fixedly on the expressways and their access roads including control components to be installed in the centers/offices for traffic management of expressway.

1.2 Application Object

This regulation shall be applied to any organizations and individuals in charge of planning, design, construction, operation, management and maintenance of VMS System for any expressways over the country.

1.3 Terminology and Definition

→Under discussion in Sub-Group 5.

1.4 Abbreviations

→To be discussed in Sub-Group 5 including the followings:

CSS: Changeable Speed-limit Signs

IP: Internet Protocol

TCP: Transmission Control Protocol

VMS: Variable Message Signs.

2. Technical Regulation

2.1 Primary Objectives of System

The System shall achieve disseminating information on the traffic events on the expressway network to the drivers en route in order to assist their route selection and on the speed limit responding to driving conditions on the expressway in order to secure safety.

2.2 Elemental Functions

VMS system shall include the following functions:

- VMS/CSS indication

2.3 VMS/CSS Indication

2.3.1 Basic Requirements on VMS: The System shall allow information of the traffic events, such as incidents and traffic restrictions, in the sections ahead on the expressway network disseminated by text indication to the drivers en route.

2.3.2 Basic Requirements on CSS: The System shall allow information of the speed limit responding to the driving conditions, such as heavy rains and traffic restrictions, disseminated by text indication to the drivers en route.

2.3.3 Location of VMS: VMS shall be installed at the place back from the diverging point on the access road to the entrance gate of the expressway; at a mid-point between a pair of adjacent interchanges; at the tollgate; and at the places on the expressway back from the junction and from the diverging point to the exit gate to connected arterial road.

2.3.4 Location of CSS: CSS shall be installed at behind of a merging point on the expressway and a mid-point between a pair of adjacent interchanges.

2.3.5 VMS Control under Normal Conditions: A VMS shall be controlled remotely from the Regional Main Center to indicate the information of a traffic event of the highest priority among different traffic events which occur on the expressway network at the same time or to indicate the information directly input.

2.3.6 CSS Control under Normal Conditions: A CSS shall be controlled from remotely from the Regional Main Center to indicate the information of speed limit considering the existing traffic events.

2.3.7 VMS/CSS Control at Emergency: In case of an emergency, a VMS and a CSS shall be controlled directly by the patrol crew at the site of event using a mobile terminal

2.3.8 Characters of VMS/CSS Indication: Indication of characters and other figures on VMS and CSS shall be input/controlled using the font and other codes for computers.

2.3.9 Character Size of VMS/CSS Indication: VMS and CSS shall indicate characters in the size which can be recognized by the driver in a sufficient distance for him to understand the information prior to his vehicle passing by the VMS or CSS at high speed about 120 km/hour.

2.3.10 Character Number and Lines of VMS Indication: VMS shall indicate sufficient number of characters required for disseminating information which consists of a traffic events, a name of the place where it occurs; and an additional line needed for a subsidiary traffic event caused by it.

2.3.11 Abbreviation for VMS Indication: VMS shall indicate the traffic event and its location

based on the rule of abbreviation unified and shared among the Regional Main Center and Road Management Offices.

2.3.12 Interface Protocols of VMS/CSS: A VMS and a CSS shall be connected and controlled through the interface in conformity with TCP/IP protocol based on the unified numbering system.

2.4 Requirements on Major Components

2.4.1 XXXXXXX (=Major Component 1)

→To be discussed in Sub-Group 5.

2.4.2 XXXXXXX (=Major Component 2)

→To be discussed in Sub-Group 5.

3. Regulation on Management

→To be discussed in Sub-Group 5.

4. Implementing Organization

→To be discussed in Sub-Group 5.

Sub-group 6 : Communication System for Expressways

<1> Reviewed Results of 1st Draft QCVN

Reviewed results of the 1st Draft QCVN are shown on the table below.

Article Number in 1st Draft QCVN	Classification of Reviewed Result	Corresponding Item Number in <2> & Comments
1		→
1.1	Not standardized title of clause	→See 1.1 in <2> shown later.
1.2		→
1.3	Definitions improper for QCVN, Definitions inconsistent with SAPI	→The words "Section Main Center" shall be unified to "Road Management Office" in conformity with other QCVNs and SAPI.
1.4		→
2		→
3		→
4		→
4.1	Definitions inconsistent with SAPI Definitions improper for QCVN	→See 2.3.1 and 2.3.2 in <2> shown later. Basic requirements shall be defined clearly with a distinction between the administrative telephones and the directive telephones. →The words "losing the call signal" shall be unified to "calling loss".
4.2		→
4.3		→
4.4		→
4.5		→
4.6		→
5		→
5.1		→
5.2		→
5.3	Definitions improper for QCVN	→4th and 5th items shall be deleted; because, most of existing transmission equipment components are not able to be applied with IP address and these items are covered in the definitions of switching equipment.
5.4		→
5.5	Definitions improper for QCVN	→The word "switch" shall be replaced with the word "transmission".
5.6		→
6		→
6.1		→
6.2		→
6.3		→
6.4		→
6.5		→
6.6		→
7		→
7.1		→
7.2		→
7.3		→
7.4		→
7.5		→
7.6		→

7.7		→
8		→
9		→
10		→
11		→
12		→

<2> Items to be Described as Basic Requirements in QCVN

The following items are recommended to be described as basic requirements in QCVN by Sub-Group 6.

1. General Regulation

1.1 Scope

This National Technical Regulation provides basic requirements for Communication System to be installed fixedly on the expressways and their access roads and in the centers/offices for traffic management of expressway.

1.2 Application Object

This regulation shall be applied to any organizations and individuals in charge of planning, design, construction, operation, management and maintenance of Communication System for any expressways over the country.

1.3 Terminology and Definition

→Under discussion in Sub-Group 6.

1.4 Abbreviations

→To be discussed in Sub-Group 6 including the followings:

IP: Internet Protocol

NMS: Network Management System

2. Technical Regulation

2.1 Primary Objectives of System

The System shall achieve message/data exchange between the operators, the systems, functional packages or equipment components with a sufficient capacity and quality even in the case these entities are in the different locations such as in the Regional Main Center, in the Road Management Office, roadside or in-vehicle.

2.2 Elemental Functions

Communication System shall include the following functions:

- Voice communication
- Mobile radio communication.

2.3 Voice Communication

2.3.1 Basic Requirements on Administrative Telephone: The System shall allow the operators

to perform a voice communication through the administrative telephone with an appropriate numbering system securing sufficient quality even in the case they are in the different locations in the Regional Main Center or the Road Management Office.

2.3.2 Basic Requirements on Directive Telephone: The System shall allow an operator in the Regional Main Center to deliver his directive to all operators in the Regional Main Center and concerned Road Management Office at the same time through the directive telephone with an appropriate numbering system securing sufficient quality.

2.3.3 Location of System: The system of voice communication shall be installed at appropriate place in the Regional Main Center and the Road Management Office.

2.4 Mobile Radio Communication

2.4.1 Basic Requirements: The System shall allow the operators to perform a voice communication by simultaneous transmission and reception using mobile radio communication with sufficient frequency band of VHF or UHF between the different locations in the Road Management Office or roadside.

2.4.2 Location of System: The system of mobile radio communication shall be installed in the Road Management Office and in the form of mobile terminals.

2.4.3 Radio Frequency: A specific radio frequency bandwidth shall be allocated for mobile radio communication under the license from Radio Frequency Directorate in the Ministry of Information and Communication in order to use it exclusively for the purpose and to prevent interference.

2.5 Requirements on Major Components

2.5.1 Fiber Optic Cable Network

(1) Transmission Capacity: The System shall secure a sufficient transmission capacity of ITS data communication including video images from large number of cameras and the bandwidth guarantee for the administrative or directive telephone call in case of an emergency by applying the protocol of IP over G-Ethernet onto the fiber optic cable network.

(2) Network Management: The System shall be managed by NMS with the functions of resource management, testing, performance monitoring, error notification/alert and switching for redundancy.

2.5.2 XXXXXXX (=Major Component 2)

→To be discussed in Sub-Group 6.

3. Regulation on Management

→To be discussed in Sub-Group 6.

4. Implementing Organization

→To be discussed in Sub-Group 6.

Sub-group 7 : ETC System for Expressways

<1> Reviewed Results of 1st Draft QCVN

Reviewed results of the 1st Draft QCVN are shown on the table below.

Article Number in 1st Draft QCVN	Classification of Reviewed Result	Corresponding Item Number in <2> & Comments
1		→
1.1	Not standardized title of clause	→See 1.1 in <2> shown later.
1.2		→
1.3	Definitions improper for QCVN	→QCVN including reference to TCVN needs to be reissued every time when these materials are revised. Definitions of QCVN shall never depend on such lower grade materials.
1.4		→
1.5		→
2		→
2.1		→
2.2		→
3		→
3.1	Definitions inconsistent with SAPI Definitions inconsistent with SAPI Definitions improper for QCVN Definitions improper for QCVN	→ In the figure, the words “OBU Issuance” shall be changed to “OBU and IC-Card Issuance” and the words “ OBU account refilling” shall be changed to “ETC payment account refilling.” →The words “recorded on OBU” shall be changed to “recorded on OBU or IC-Card.” →The words “define vehicle’s mileage” shall be changed to “define a pair of entrance/exit tollgates” for conformity with the definitions of the toll rate table in clause 2.2, which will depend on the policies of the investors. →The words “The system automatically count the toll rate” shall be changed to “The system automatically pick up the toll rate from the table in clause 2.2.”
3.2		→
3.3		→
3.4	Definitions improper for QCVN	→Troubles will be caused by the comparison and mutual checking between the toll collection system and the bank system. Hence, the procedure shall be performed sequentially and simply: to claim a toll amount to the bank system by the toll collection system first and then to transfer the toll amount from the bank system to the toll collection system. See 2.4, 2.5 and 2.7 in <2> shown later.
3.5		→
4		→
4.1		→
4.2	Dropout of essential contents	→See 2.5 in <2> shown later. Tollgate lane arrangement shall be defined corresponding to the scale of tollgate.

4.3	Dropout of essential contents	→See 2.6 in <2> shown later. Figures of radio frequency for DSRC shall be defined clearly in this clause.
4.4	Definitions improper for QCVN	→Troubles will be caused by the comparison and mutual checking between the toll collection system and the bank system. Hence, the procedure shall be performed sequentially and simply: to claim a toll amount to the bank system by the toll collection system first and then to transfer the toll amount from the bank system to the toll collection system.
4.5		→
5		→
6		→
7		→
APPENDIX 1		→
APPENDIX 2		→
APPENDIX 3		→
APPENDIX 4		→
APPENDIX 5	Definitions improper for QCVN, Definitions inconsistent with SAPI	→The description "USA Standard ISO/IEC 18000-6 RFID" is inconsistent with other clauses in this QCVN; hence, these words shall be deleted.
APPENDIX 6		→

<2> Items to be Described as Basic Requirements in QCVN

The following items are recommended to be described as basic requirements in QCVN by Sub-Group 7.

1. General Regulation

1.1 Scope

This National Technical Regulation provides basic requirements for ETC System to be installed at tollgates including some components to be installed in the centers/offices for toll management of expressway.

1.2 Application Object

This regulation shall be applied to any organizations and individuals in charge of planning, design, construction, operation, management and maintenance of ETC System for any expressways over the country.

1.3 Terminology and Definition

→Under discussion in Sub-Group 7.

1.4 Abbreviations

→To be discussed in Sub-Group 7 including the followings:

DSRC: Dedicated Short Range Communication

ETC: Electronic Toll Collection

OBU: On-board Unit.

2. Technical Regulation

2.1 Primary Objectives of System

2.1.1 ETC: The System shall achieve a large processing capacity of toll collection at about 800 vehicles/hour by non-stop passage without cash payment at the tollgate in order to reduce the number of lanes and the land of the tollgate.

2.1.2 Touch&Go: The System shall achieve the toll collection without cash payment at the tollgate using simple/cheap roadside equipment for one-stop passage, which allows combined use with ETC, in order to reduce the system implementation cost.

2.2 Elemental Functions

ETC System shall include the following functions:

- Tollgate lane monitoring
- Vehicle/class identification
- Tollgate lane control
- Road-to-vehicle communication
- IC-Card recording
- Toll management
- OBU management.

2.3 Tollgate Lane Monitoring

2.3.1 Basic Requirements: A camera shall be installed to initially identify the occurrence of incident or other event at a tollgate remotely in a toll office without any phone call.

2.3.2 Location of System: The System of tollgate lane monitoring shall be installed at the tollgates on the expressways.

2.3.3 Compression Method of Video Data: Camera shall transmit the video data through the interface using standardized compression method of MPEG-4 Part 2, MPEG-4 Part 10 (H.264) or Motion JPEG.

2.3.4 Interface Protocols of Camera: Camera shall be controlled through the interface in conformity with TCP/IP protocol based on the unified numbering system.

2.4 Vehicle/Class Identification

2.4.1 Basic Requirements: The System shall achieve identification of individual vehicle and its class at a tollgate for calculating the toll rate for driving on the expressway and indication of the identified results for ascertainment by the toll collector and the driver.

2.4.2 Location of System: The System of vehicle/class identification shall be installed at the tollgates on the expressways.

2.4.3 Toll Rate System: ETC shall be applicable to both the distance proportional toll rate system and the fixed toll rate system based on the vehicle classification, which is defined for the expressways and road sections in Vietnam, by using a single OBU.

2.4.4 Toll Payment Method: Prepayment shall be adopted as the toll payment method for ETC in order to serve any road users independently from the membership of credit.

2.4.5 Prepaid Balance Check: Sufficiency/shortage of prepaid balance shall be checked by each driver using only OBU with a prepaid IC-card anywhere, such as at a tollgate or a parking on the expressways, independently from telecommunication failures.

2.5 Tollgate Lane Control

2.5.1 Basic Requirements: The System shall allow the road operator to eliminate vehicle passages at a tollgate on the expressway without collecting adequate amount of toll.

2.5.2 Location of System: The System of tollgate lane control shall be installed at the tollgates on the expressways.

2.5.3 Tollgate Lane Arrangement of Large Tollgate: At a tollgate where stand three or more incoming lanes, or three or more outgoing lanes, in a line, one or more lanes of them from the left-hand side shall be equipped with ETC for exclusive use, one lane shall be equipped with Touch&Go for concurrent use with manual toll collection and others are to be the lanes of manual toll collection.

2.5.4 Tollgate Lane Arrangement of Small Tollgate: At a tollgate where stand two incoming lanes, or two outgoing lanes, in a line, both lanes shall be equipped with Touch&Go for concurrent use with manual toll collection.

2.5.5 Roadside Equipment Arrangement: Devices of roadside equipment of ETC shall be arranged on the toll island adequately for securing capability of safe vehicle stopping without any collisions with the car in front or the barrier.

2.5.6 Tollgate Lane Operation: Flexible tollgate lane operation shall be established for ETC, such as incoming by ETC to outgoing by Touch&Go or incoming by Touch&Go to outgoing by ETC, regardless of the limitation a vehicle which came in by manual toll collection is to go out by manual.

2.5.7 Check of Passage without Payment: Unlawful vehicle passage, at a tollgate lane for ETC or Touch&Go, without adequate toll payment with the amount based on the vehicle class identified by scanning the license plate shall be prevented by using signs and a barrier.

2.5.8 Check of Re-installed OBU: Unlawful vehicle passage, at a tollgate lane for ETC, with re-installed OBU shall be checked by making comparison between the scanned result of the license plate and the data of short range communication and shall be prevented by using signs and a barrier.

2.6 Road-to-vehicle Communication

2.6.1 Basic Requirements: The System shall achieve data exchange for toll collection and other services on the expressways by using short range radio communication between roadside antennas and OBUs.

2.6.2 Location of System: The System of road-to-vehicle communication shall be installed at the tollgates on the expressways and in vehicles.

2.6.3 Radio Frequency of DSRC: ETC shall be established by Road-to-vehicle communication using DSRC by radio frequency around 5.8GHz, which band width shall be equal to or less than 4.4 MHz for effective use of radio frequency.

2.6.4 Channels of DSRC: DSRC for ETC shall be capable of providing two or more channels in order to avoid crosstalk or interference between adjacent tollgates even in the case these are operated by different road operators.

2.6.5 Security of DSRC: Data exchange on DSRC shall be established with the application of enhanced security system.

2.6.6 Validity Check of Equipment for DSRC: Validity of an OBU of ETC and a prepaid IC-card for ETC/Touch&Go shall be checked by the data of short range communication at the tollgate and the passage with invalid equipment or IC-card shall be prevented by using signs and a barrier.

2.7 IC-Card Recording

2.7.1 Basic Requirements: The System shall allow the prepaid balance in an IC-card deducted for collecting adequate amount of toll at a tollgate.

2.7.2 Location of System: The System of IC-Card recording shall be installed at the tollgates on the expressways.

2.7.3 IC-card Issuance/Operation: The prepaid IC-card shall be issued/reloaded/operated by the system prepared by a bank or the cooperation of banks.

2.7.4 Touch&Go Processing by Driver: Touch&Go shall be established by the driver making a touch of the prepaid IC-card to the roadside equipment for short range communication.

2.7.5 Common Use of IC-card: A common prepaid IC-card which is issued by a bank or the cooperation of banks shall be shared by ETC and Touch&Go systems installed at any expressways or road sections.

2.8 Toll Management

2.8.1 Basic Requirements: The System shall allow the road operator to store all data on toll collection; to manage the Invalidation list on the usage of on-board units and IC-cards; and to manage toll revenue of the road operators with a high reliability.

2.8.2 Location of System: The System of toll management shall be installed in the toll office at a tollgate on the expressway.

2.9 OBU Management

2.9.1 Basic Requirements: The System shall achieve registrations of OBUs for issuance and management of the registration list and the invalidation list of OBUs

2.9.2 Location of System: The System of OBU management shall be installed in the OBU Management Center in Vietnam Register.

2.9.3 Common Use of OBU: A common OBU, which is managed/inspected by the Vietnam Register, shall be shared by ETC systems installed at any expressways or road sections.

2.10 Requirements on Major Components

2.10.1 XXXXXXX (=Major Component 1)

→To be discussed in Sub-Group 7.

2.10.2 XXXXXXX (=Major Component 2)

→To be discussed in Sub-Group 7.

3. Regulation on Management

→To be discussed in Sub-Group 7.

4. Implementing Organization

→To be discussed in Sub-Group 7.

Sub-group 8 : Management Centers/Offices for Expressways

<1> Reviewed Results of 1st Draft QCVN

Reviewed results of the 1st Draft QCVN are shown on the table below.

Article Number in 1st Draft QCVN	Classification of Reviewed Result	Corresponding Item Number in <2> & Comments
1		
1.1	Dropout of essential contents	→See 1.1 in <2> shown later. The words “offices” shall be included for clauses on the road management offices and toll offices.
1.2	Dropout of essential contents	→See 1.2 in <2> shown later. The words “offices” shall be included for clauses on the road management offices and toll offices.
1.3	Definitions improper for QCVN	→QCVN including reference to TCVN needs to be reissued every time when these materials are revised. Definitions of QCVN shall never depend on such lower grade materials.
1.4		→
1.5		→
2		→
2.1		→
2.1.1	Definitions inconsistent with SAPI	→See 2.1 and 2.5.1 in <2> shown later. The task “to disseminate traffic information through VMS and the Internet” is outside scope of Road Management Office, but shall be implemented in the Regional Main Center.
2.1.2	Definitions inconsistent with SAPI	→See 2.5.1 and 2.5.2 in <2> shown later. Road Management Office shall be equipped with vehicles and ITS, which are the tools for patrol and incident clearance. Incident site at any part of its jurisdiction shall be covered by about 1 hour’s drive from the Office. Hence, Location and jurisdiction of Road Management Office shall be defined in conformity to SAPI.
2.2		→
2.2.1	Definitions inconsistent with SAPI	→See 2.1 and 2.4.1 in <2> shown later. The tasks “to monitor traffic through cameras and detectors” and “to disseminate traffic information through VMS and the Internet” shall be clearly described.
2.2.2	Dropout of essential contents	→See 2.4.1 and 2.4.2 in <2> shown later. Location of Regional Main Center shall not depend on convenience of sending security patrol onto expressway sections, but shall be defined in conformity to SAPI; because, the patrol is to be sent from Road Management Office.
2.3		→
2.3.1		→
2.3.2		→
2.3.3	Definitions in the scope of other QCVN	→The requirements for main monitor screen shall never be defined in this QCVN, but in the QCVN on Traffic Monitoring & Management

		System for Expressways to be prepared by Sub-Group 2. See 2.4.6 in <2> for Sub-Group 2.
2.3.4	Definitions in the scope of other QCVN Dropout of essential contents	→The requirements for communication system shall never be defined in this QCVN, but in the QCVN on Communication System for Expressways to be prepared by Sub-Group 6. →The Description shall be revised as “Command telephones are essential means to and exchange information with one or more departments in a single step.”
2.3.5	Definitions in the scope of other QCVN	→The requirements for data transmission network shall never be defined in this QCVN, but in the QCVN on Communication System for Expressways to be prepared by Sub-Group 6.
2.3.6		→
2.4		→
2.4.1	Definitions in the scope of other QCVN Definitions inconsistent with SAPI	→The requirements for exchange of traffic image data shall never be defined in this QCVN, but in the QCVN on CCTV Camera System for Expressways to be prepared by Sub-Group 4. →The following descriptions shall be inserted in the top of itemization: “- Under normal condition, camera control shall be shared between the Road Management Office and the regional Main Center through NVR (Network Video Recorder) - At the occurrence of an incident/event, camera control shall be conducted exclusively by the Road Management Office”
2.4.2	Definitions in the scope of other QCVN	→The requirements for exchange of vehicle detection data, which will be performed using messages between databases, shall never be defined in this QCVN, but in the QCVN on Traffic Database & Message System for Expressways to be prepared by Sub-Group 3.
2.4.3	Definitions in the scope of other QCVN	→The requirements for exchange of weather data, which will be performed using messages between databases, shall never be defined in this QCVN, but in the QCVN on Traffic Database & Message System for Expressways to be prepared by Sub-Group 3.
2.4.4	Definitions in the scope of other QCVN	→The requirements for exchange vehicle license plate code data, which will be performed using messages between databases, shall never be defined in this QCVN, but in the QCVN on Traffic Database & Message System for Expressways to be prepared by Sub-Group 3.
2.4.5	Definitions in the scope of other QCVN	→The requirements for exchange of traffic event information, which will be performed using messages between databases, shall never be defined in this QCVN, but in the QCVN on Traffic Database & Message

		System for Expressways to be prepared by Sub-Group 3.
2.4.6	Definitions in the scope of other QCVN Definitions inconsistent with SAPI	→The requirements for exchange of information indication and traffic control, which will be performed using messages between databases, shall never be defined in this QCVN, but in the QCVN on Traffic Database & Message System for Expressways to be prepared by Sub-Group 3. →See 2.4.4 in <2> shown later. The requirement of integration on traffic information/control under Regional Main Center shall be described in this clause.
2.4.7	Definitions in the scope of other QCVN	→The requirements for exchange of toll collection data shall never be defined in this QCVN, but in the QCVN on ETC System for Expressways to be prepared by Sub-Group 7.
2.4.8	Definitions in the scope of other QCVN	→The requirements for communication standards among centers shall never be defined in this QCVN, but in the QCVN on Communication System for Expressways to be prepared by Sub-Group 6.
2.5		→
2.5.1	Definitions in the scope of other QCVN	→The requirements for management software shall never be defined in this QCVN, but in the QCVN on Traffic Database & Message System for Expressways to be prepared by Sub-Group 3.
2.5.2		→
2.5.3		→
3		→
4		→

<2> Items to be Described as Basic Requirements in QCVN

The following items are recommended to be described as basic requirements in QCVN by Sub-Group 8.

1. General Regulation

1.1 Scope

This National Technical Regulation provides basic requirements for Management Centers/ Offices to be installed fixedly for operating expressways.

1.2 Application Object

This regulation shall be applied to any organizations and individuals in charge of planning, design, construction, operation, management and maintenance of Management Centers/ Offices for any expressways over the country.

1.3 Terminology and Definition

→Under discussion in Sub-Group 8.

1.4 Abbreviations

→To be discussed in Sub-Group 8 including the followings:

CCTV: Closed Circuit Television

IP: Internet Protocol

ITS: Intelligent Transportation System

OBU: On-board Unit

TCP: Transmission Control Protocol.

2. Technical Regulation

2.1 Primary Objectives of Centers/Offices

For implementing ITS in a unified and integrated form, the following management centers and offices shall be established and operated:

- Expressway Management Office: to monitor traffic through cameras and detectors, integrate Road Management Offices for implementing traffic control and disseminate traffic information through VMS, the Internet and other ways
- Regional Main Centers: to implement traffic control and to disseminate traffic information, integrating Road Management Offices for respective jurisdictions, through VMS, the Internet and other ways
- Road Management Offices: to perform the patrol, monitor traffic through cameras and detectors, address the incidents and enforce/remove traffic restrictions
- Toll Offices: to monitor/integrate tollgate lanes and perform toll management
- OBU Management Center: to issue and manage OBU for ETC.

2.2 Required Centers/Offices

The following management centers/offices are required for ITS implementation:

- Expressway Management Office (for integrated data management)
- Regional Main Center (for traffic supervision)
- Road Management Office (for traffic supervision)
- Toll Office (for toll management)
- OBU Management Center (for OBU management).

2.3 Expressway Management Office

2.3.1 Basic Requirements: The System for integrated data management shall be installed in Expressway Management Office to manage the Regional Main Centers and expressways, utilize the data acquired through ITS and check the validity of toll revenue in comparison with traffic data.

2.3.2 Security of Data Exchange: Exchange of data for toll collection/settlement with other center shall be established with the application of enhanced security system.

2.3.3 Interface Protocols of System: Components of the System shall be connected and controlled through the interface in conformity with TCP/IP protocol based on the unified numbering system.

2.4 Regional Main Center

2.4.1 Basic Requirements and Location: Regional Main Centers shall be installed in the locations of Ha Noi, Da Nang and HCMC to monitor traffic through cameras and detectors, integrate

Road Management Offices for implementing traffic control and disseminate traffic information through VMS, the Internet and other ways.

2.4.2 Installed System: Regional Main Center shall be equipped with the System for traffic supervision which includes a main monitor screen, a traffic supervising/control console, CCTV monitoring screens, CCTV control consoles, traffic event data input devices, VMS control consoles and other equipment to be used for traffic analysis, traffic supervision, traffic data management and traffic information dissemination.

2.4.3 Interface Protocols of System: Screens and other components of the System shall be connected and controlled through the interface in conformity with TCP/IP protocol based on the unified numbering system.

2.4.4 Integration on Traffic Information/Control under Regional Main Center: Traffic data acquired in the Road Management Office shall be shared with and integrated/prioritized in the Regional Main Center. The following two ways shall be secured for traffic information/control:

- (1) Prompt action by the Road Management Office responding to incidents/events based on sectional data
- (2) Integrated/prioritized information provision from the Regional Main Center.

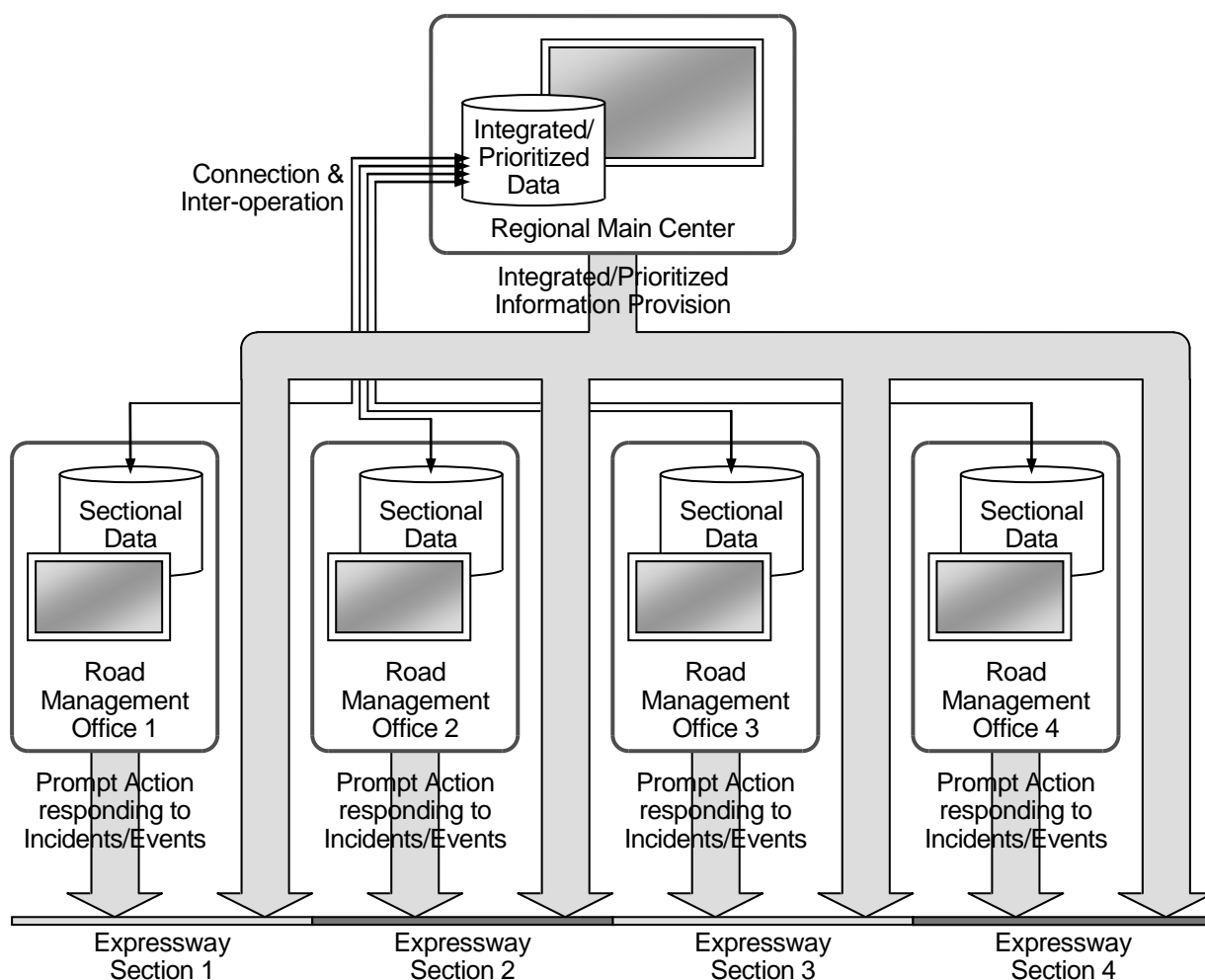

Under normal condition, the Road Management Offices can select either way for controlling VMS. However, at the occurrence of prioritised incident/event, the Regional Main Center shall

enforce the VMS control in the way (2) in order to perform the most effective control over the whole expressway network and to achieve the advantages below. This is the requisite integration in the results of SAPI.

2.5 Road Management Office

2.5.1 Basic Requirements and Location: A Road Management Office shall be installed in each expressway section, which is a jurisdiction covered by about an hour's drive from the office, to perform the patrol, monitor traffic through cameras and detectors, address the incidents and enforce/remove traffic restrictions.

2.5.2 Installed System: Road Management Office shall be equipped with the System for traffic supervision which includes CCTV control consoles, traffic event data input devices and other equipment for traffic control in cooperation with the patrol crews and vehicles, the police and ambulance service.

2.5.3 Interface Protocols of System: Screens and other components of the System shall be connected and controlled through the interface in conformity with TCP/IP protocol based on the unified numbering system.

2.6 Toll Office

2.6.1 Basic Requirements and Location: A Toll Office shall be set up in each tollgate, which has two or more tollgate lanes and booths, to monitor/integrate tollgate lanes and perform toll management.

2.6.2 Installed System: Toll Office shall be equipped with the System which executes toll management.

2.6.3 Security of Data Exchange: Exchange of data for toll collection/settlement with roadside and other center shall be established with the application of enhanced security system.

2.6.4 Interface Protocols of System: Components of the System shall be connected and controlled through the interface in conformity with TCP/IP protocol based on the unified numbering system.

2.7 OBU Management Center

2.7.1 Basic Requirements and Location: OBU Management Center shall be set up in the Vietnam Register to issue and manage OBU for ETC.

2.7.2 Installed System: OBU Management Center shall be equipped with the System for OBU management which issues OBU and manages registration/invalidation data of OBU.

2.7.3 Security of Data Exchange: Exchange of data for validation check of OBU with toll office and other center shall be established with the application of enhanced security system.

2.7.4 Interface Protocols of System: Components of the System shall be connected and controlled through the interface in conformity with TCP/IP protocol based on the unified numbering system.

2.8 Requirements on Major Components

2.8.1 XXXXXXX (=Major Component 1)

→To be discussed in Sub-Group 8.

2.8.2 XXXXXXX (=Major Component 2)

→To be discussed in Sub-Group 8.

3. Regulation on Management

→To be discussed in Sub-Group 8.

4. Implementing Organization

→To be discussed in Sub-Group 8.

添付資料-3

**DRAFT QCVN
OF
TRAFFIC MONITORING AND
MANAGEMENT FOR EXPRESSWAYS
(SUB-GROUP 2)**

1ST DRAFT
(Sub-Group 2)
2014.03.30



SOCIALIST REPUBLIC OF VIETNAM

QCVN XX:2014/BGTVT

**NATIONAL REGULATION ON TRAFFIC
MONITORING AND MANAGEMENT SYSTEM FOR
EXPRESSWAYS**

*Quy chuẩn Kỹ thuật về Hệ thống Điều hành Giao thông
Đường cao tốc*

HA NOI - 2014

Foreword

QCVN XX:2014/BGTVT was compiled by the Drafting Department for National Technical Regulation on Traffic Monitoring and Management System for Expressways (established under the Decision No. 2251/QĐ-BGTVT on July 31st 2013 of MOT), approved by the Ministry of Science and Technology, and issued by Ministry of Transportation in accordance with the Circular No./2014/TT - BGTVT on 2014.

NATIONAL TECHNICAL REGULATION ON TRAFFIC MONITORING AND MANAGEMENT SYSTEM FOR EXPRESSWAYS

National technical regulation on Trung tâm Quản lý Giao thông Đường cao tốc

1	GENERAL REGULATION	5
1.1	Scope	5
1.2	Application Object.....	5
1.3	Reference Materials.....	5
1.4	Terminology and Definition	5
1.5	Abbreviations.....	6
2	TECHNICAL REGULATION	7
2.1	Figuration of TMM System.....	7
2.2	Requirements on Design	10
2.3	System Operation Procedure	10
2.3.1	Procedure of Traffic Monitoring and Management	10
2.3.2	Procedure of Automatic Data Collection and Processing	12
2.3.3	Procedure of Equipments Surveillance and Maintenance	12
2.4	Technical Requirements on Sub-systems.....	12
2.4.1	Digital Transmission System.....	12
2.4.2	CCTV Camera System for Traffic Monitoring	13
2.4.3	System for Vehicle Detection	14
2.4.4	System for Event Management.....	16
2.4.5	System for Vehicle Axle Load Control.....	17
2.4.6	System for Traffic Information Provision	18
2.4.7	Communication System.....	20
2.4.8	Emergency Telephone System.....	20
2.4.9	Equipment Surveillance System	21
2.4.10	Traffic Operation and Management Center	22
2.4.11	Toll Collection System	23
3	REGULATION ON MANAGEMENT	24
4	IMPLEMENTING ORGANIZATION.....	24

APPENDIX A: TECHNOLOGY OF VEHICLE DETECTION	25
A.1. Vehicle Detection by Ultrasonic Type	25
A.2. Vehicle Detection by Image Recognition Type	25
APPENDIX B: TECHNOLOGY OF WEIGH IN MOTION	27

1 GENERAL REGULATION

1.1 Scope

This technical regulation provides basic requirements and directions on function, component figuration, operation method for infrastructure and equipments system of traffic monitoring and management system on expressway sections. Compulsory and optional sub-systems shall be regulated to secured the unification, integration, communication connection and data exchange among components within the system and among systems which are developed highway traffic network.

1.2 Application Object

The technical regulation is applied for related individuals, organizations during development, investment, control and operation of expressway monitoring and management system.

1.3 Reference materials

1.3.1. ISO 14813-1:2007 - Intelligent transport systems – Reference model architecture(s) for the ITS sector – Part 1: ITS service domains, service groups and services

1.3.2. QCVN 41:2012/BGTVT - National technical regulation on Highway Signs

1.3.3. QCVN ...:2014/BGTVT - National technical regulation on Expressway Management Center

1.3.4. QCVN ...:2014/BGTVT - National technical regulation on Automated Traffic Signs on Expressways

1.3.5. QCVN ...:2014/BGTVT - National technical regulation on CCTV Camera System for Expressways

1.3.6. QCVN ...:2014/BGTVT - National technical regulation on Communication System for Expressways

1.3.7. QCVN ...:2014/BGTVT - National technical regulation on Automatic Toll Collection for Expressways

1.3.8. TCCS 01:2008/VRA – Basic Standards on Road One-stop Tollgates using Barcode Prints

1.3.9. TCVN 8665:2011 - Fiber optics for Telecommunications Network - General Technical Requirements

1.3.10. TCVN 8698:2011 - Telecommunication network - bronze-strand information cable CAT.5, Cat.5e - Technical Requirements

1.4 Terminology and Definition

All terminologies in this regulation shall be defined as below:

1.4.1. *Blind spot*

The area out of site where operator shall not be capable of monitoring by captured images from CCTV camera..

1.4.2. Vehicle detectors

This equipment shall be capable of measuring vehicle volume, speed and road occupancy at one place on expressway in order to analyze congestion condition as well as to automatically recognize highway incidents.

1.4.3. Vehicle volume

The vehicle volume shall be calculated on the basic of counted number passing one fixed point within a period of time T - vehicle counting cycle. The measured volume shall be listed by lane and by classification in vehicle counting cycles..

1.4.4. Average speed

The average value of all measured vehicle speeds in vehicle counting cycle.

1.4.5. Road occupancy

The ratio between the time for a detector to recognize vehicle in area and the time of vehicle counting cycle.

1.4.6. Event

The situation affecting to traffic condition included traffic incidents, dangerous weather, traffic congestion, maintenance work and traffic restrictions.

1.4.7. Incident

An unusual event without in advance affecting or interrupting traffic condition included traffic accidents, broken down vehicles, obstacles, reversing vehicles, vandalism or natural disaster on road

1.4.8. Weigh in Motion

The equipment to measure axle load and total vehicle while moving normally and nonstop at weigh station.

1.4.9. Electronic Vehicle Identification Equipment

The equipment shall be installed on board with an identity encode of vehicle so that a reader can automatically read through radio wave communication.

1.4.10. Procedure of Close Toll Collection

The toll shall be calculated based on actual distance the vehicle travels by controlling information since the vehicle access to the entry, and it shall be collected at the exit on expressway.

1.5 Abbreviations

QCVN National Technical Regulation (according to Law on Technical Standard and Technical Regulation)

TCVN	National Standard (according to Law on Technical Standard and Regulation)
GSDHGT	Traffic Monitoring and Management System
QLĐHGT	Traffic Management Center
PTZ	Pan Tite Zoom (Quay, quét, thu phóng)
DB	Data Base
IP	Internet Protocol (Giao thức mạng Internet)
MTBF	Mean Time Between Failures (thời gian trung bình lỗi hoạt động)
MTTR	Mean Time Between Failures (thời gian trung bình để sửa chữa)
VMS	Variable Message Sign (Biển chỉ dẫn thông tin thay đổi được)

2 TECHNICAL REGULATION

2.1 Figuration of TMM System

2.1.1. Traffic monitoring and Management System shall be developed to support the operation, control and maintenance for expressways which are put in utilization. The system shall have functions of collecting, processing, determining and transmitting information and demand to competent authorities and road users, with the aim of properly understanding the operation status and cooperating to secure traffic safety, improve quality and effectiveness in highway management.

2.1.2. The figuration of TMM System shall be defined on the basic of Necessary Services for User in reference architecture of Intelligent Transportation System (ISO 14813-1:2007) with below compulsory equipment packages and optional equipment packages:

a) Compulsory equipment packages included:

1. *Digital transmission System*: shall secure communication between roadside monitoring equipments and operation center, and shall connect among road management offices/centers.
2. *CCTV Monitoring System*: shall help operators remotely monitor traffic images; shall supervise traffic flows through screens or large-size screen wall in operation office; and shall provide video images to authorities and public.
3. *Vehicle Detection*: shall collect, analyse, report and store datas on condition description and performance of road system, shall recognize traffic congestion or incidents in order to notify road users.
4. *System for Event Management*: shall provide equipments to automatically generating data from system for vehicle detection, system for vehicle axle load measurement, weather information system so that output data can be used for automatically notifying and managing traffic events which may affect to highway traffic safety.

5. *System for Vehicle Axle Load Measurement*: shall use weigh in motion to control heavy trucks, overload and oversized vehicle on expressways; shall automatically notify if any violation on load and size to apply measurements as prescribed.
6. *System for Traffic Information Provision*: shall provide information on expressway conditions and traffic status to road users by using roadside message signs, changeable velocity limitation signs, FM station, bandwidth network or Internet.
7. *Communication System*: shall connect information among expressway operation parts by using wire or wireless telephones.
8. *Emergency Telephone System*: the system shall arrange telephone to receive and respond emergency calls from individuals and organizations; record the call and properly transmit information to competent authorities so that they can handle in case of accidents or incidents.
9. *Equipments Surveillance System*: shall be capable of automatically surveilling the performance of whole system for traffic monitoring and management included power supply; information notification in case of unusual incident or broken parts and error maintenance recording or equipments replacement.
10. *Traffic Management Center*: shall be capable of processing and storing general data; providing communication methods; implementing the tasks of traffic monitoring and management at road management offices or regional main center.

b) Additional equipment packages included:

1. *Toll collection System*: shall help to collect the toll on road promptly and effectively, to implement statistic, control finance and secure toll collection safety. Toll collection system could be taken into consideration of investment on expressway which depends on government policy. As being invested to implement, this system shall be integrated with traffic monitoring and control system in order to create a mechanism of utilizing information for launching the most effective expressway operation.
2. *Weather monitoring System*: shall measure/collect information on weather condition and shall forecast weather varies within a range of section in order to warn road users/competent authorities if any bad weather condition. Thanks to the difference between Vietnam and other countries in temperate and frigid region, Vietnam highway surface has not been frozen, therefore road users can use weather forecast for expressway prepared by hydrometeorological forecast agencies..
3. *Signals at Expressway entry*: Signals system shall be installed on ramps accessing to sections with high traffic density and without tollgates, aiming to control vehicle in front of ramp meter and reduce possibility of accidents or congestion at merging points on expressway.

2.1.3. Connection figuration of sub-system shall be integrated in a general Traffic Monitoring and Management System as Figure 1 below.

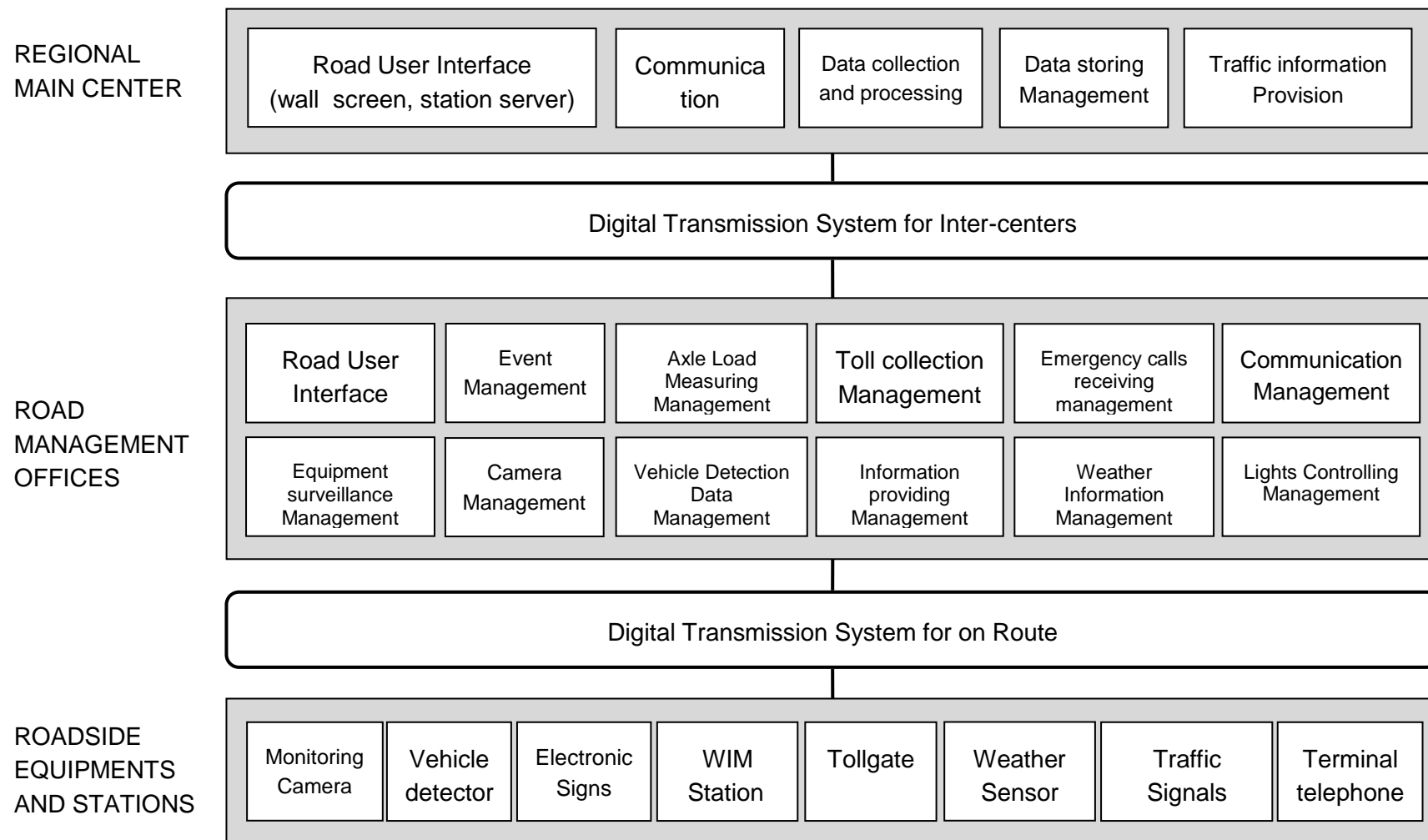

Figure 1. Figuration Map of Components in Traffic Monitoring and Management System for Expressways

2.2 Requirements on Design

2.2.1. The design of TMC system shall secure integration among component equipment systems. The scale and number of equipments in system shall be calculated and selected based on design scale, vehicle volume and the importance of section within the regional traffic network.

2.2.2. The design development to arrange and select equipments shall meet the requirements on operation and utilization according to System Operation Procedure regulated in the Article 2.3.

2.2.3. The technology selected in the design shall be modern, open, easy to be enhanced and shall be effective in using and reducing investment cost

2.2.4. The number and technical specification of equipments and supporting constructions shall be calculated on the basic of designed traffic volume on expressway within at least:

- a) 5 years for roadside and indoor equipments
- b) 20 years for civil infrastructure constructions

2.3 System Operation Procedure

2.3.1 *Procedure of Traffic Monitoring and Management*

2.3.1.1. The traffic operation and control for expressway shall be prepared with supporting from TMM system included 5 major tasks:

a) Monitoring and collecting event information by manual methods or by supporting devices through following activities/technologies:

- Traffic patrol
- Manually supervising at tollgates and interchanges on expressways
- Receiving incident information at management offices from all emergency calls
- Visually monitoring traffic images by using camera
- Automatically detecting events by images
- Measuring vehicle volume and analyzing traffic conditions
- Notifying roadside weather;
- Other methods.

b) Compiling event data when detecting incidents (Ex. accidents, broken vehicles, obstacles), traffic congestion, dangerous weather (Ex. heavy rain, strong wind, dense fog) and planned road maintenance (Ex. construction work, depressed road..).

c) Based on severity level of events, person in charge shall determine regulations on traffic restriction (Ex. road closure, lane closure, speed limitation) and other traffic directions to drivers.

d) Displaying event informations and traffic regulation on automated traffic signs or FM Radio. Communicating with collaboration organizations to rescue in case of incident occurrence.

e) Stimutaneously monitoring events by using equipments as step (a) to remove invalid event and traffic restriction.

2.3.1.2. Basic map on Traffic Monitoring and Management Procedure described as Figure 2.

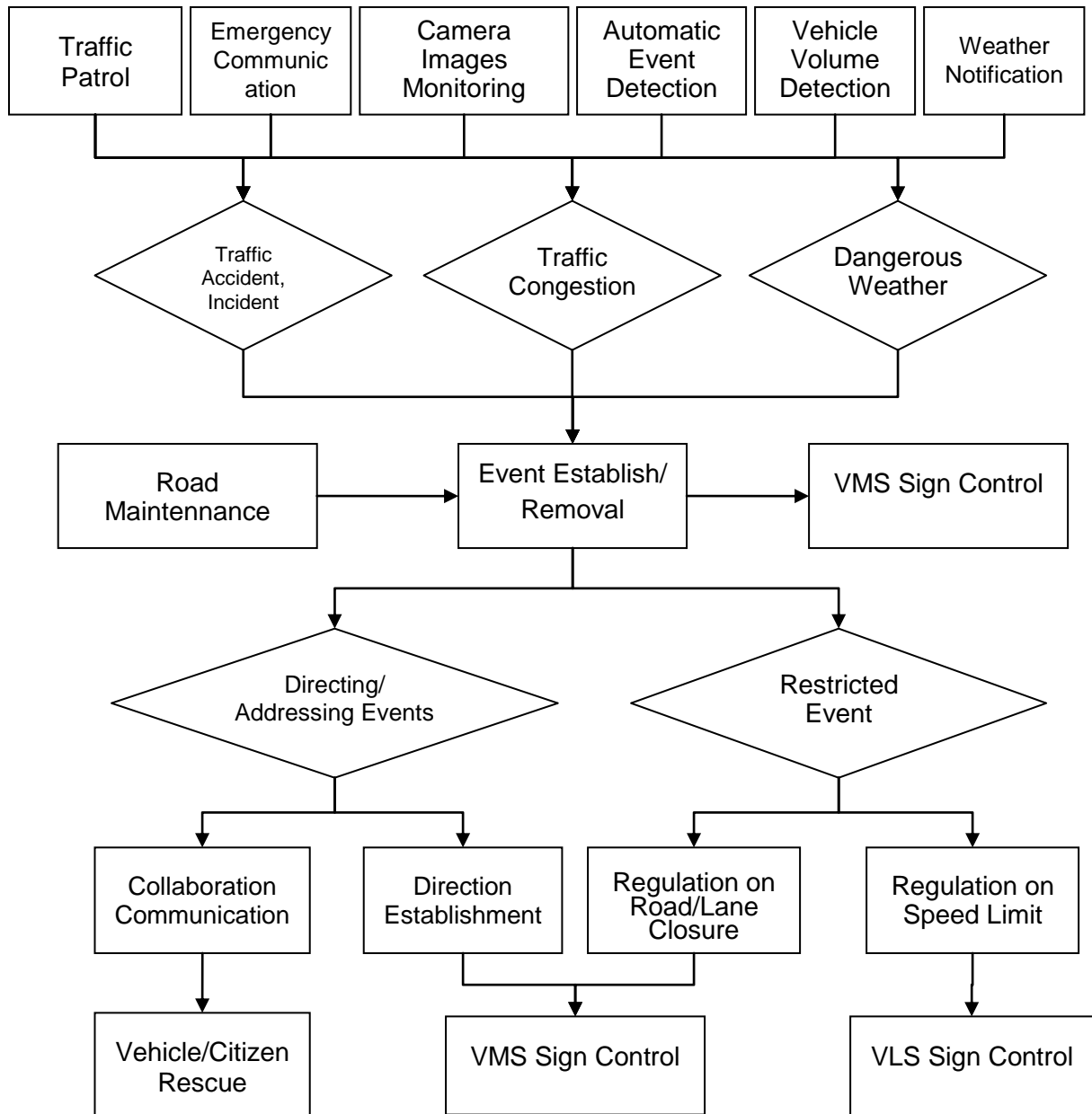

Figure 2: Traffic Monitoring and Management Procedure for Expressway

2.3.1.3. Conditions and competent jurisdiction to regulate or remove traffic restriction shall be applied in full accordance with legal documents of National Regulation on Highway Traffic management, operation, control and utilization.

2.3.2 Procedure of Automatically Collecting and Processing Traffic Data

2.3.2.1. Traffic data collection shall be implemented at stations on expressway in order to continuously record the traffic flow distribution and change in disconnected time (Ex. 5 mins, 15mins, every hour per day, every day per week, monthly, annually). Processors at center shall automatically analyze the data and provide event notification on prone traffic congestion on each section.

2.3.2.2. Event Management System shall collect data from system for axle load measurement, system for vehicle detection, weather information system in order to automatically provide notification on congestion, bad weather and violation affecting to traffic safety on expressways. The system shall capture images of violated vehicle, identify license plate and automatically store data to transmit for competent authorities to handle as regulation.

2.3.2.3. Expressway traffic data shall be collected continuously 24 hours a day, 7 days a week and 365 days a year. These data shall be stored and provided to responsible organization for compiling reports on section plan, traffic operation and distribution policies, settling measurements to avoid highway accidents and congestion.

2.3.3 Procedure of Equipment Maintenance

2.3.3.1. All the equipments for power supplying, sensing and information processing in traffic monitoring and management system shall be managed, checked and kept under usual operation status within 24 hours a day, 7 days a week and 365 days a year

2.3.3.2. Equipment surveillance system shall collect data on operation supervision of equipment and power supply to generally manage at a DataBase center. Surveilling software shall process and automatically evaluate data to recognize and notify in case of failure or unusual condition of those equipments.

2.3.3.3. The technician at Traffic Management Center shall continuously surveil the operation of equipment system by using software; taking note in diary on operation status of equipments and make maintenance plan in accordance with regulation by manufacturer.

2.4 Technical requirements on Sub-systems

2.4.1 Digital Transmission System

2.4.1.1. Digital transmission system shall be developed to secure connection among equipments on roadside, at tollgate, in service office and traffic management center. System design shall use fiber optic transmission methods for distance over 100m, twisted-pair cable for the device at a close distance or radio transmission at specific locations. Transmission network in the system should be built on the basic o.f Ethernet protocol.

2.4.1.2. Digital transmission system shall be designed in layer structure including:

a) Backbone layer shall connect among stations on section, Road management

offices/centers. The bandwidth for this layer shall be $\geq 10\text{Gbps}$.

b) Boundary layer shall connect among equipment groups on roadside, at stations or centers. The bandwidth for this layer shall be $\geq 1000\text{Mbps}$.

c) Equipment layer shall connect among equipments within scope of an office or a installing location on roadside. The bandwidth for this layer shall be $\geq 100\text{Mbps}$.

2.4.1.3. Digital transmission system shall be designed with application of Ring topology with backup feature to automatically recover in case of cable interruption at a connection point on circuit.

2.4.1.4. Digital transmission system shall be installed with system for administration, Quality of Service (QoS) so that it can monitor the appearance and recovering of incidents, record and repair network system figuration, estimate the location of incident and switch to backup cables.

2.4.1.5. The construction for the cable of transmission system shall comply with general standard for telecommunication network infrastructure and highway design. In where, optical cable shall be used in accordance with the standard TCVN 8665:2011 and twisted-pair cable in accordance with the minimum standard for Cat5 in TCVN 8698:2011.

2.4.2 *CCTV System for Traffic Monitoring*

2.4.2.1. The system shall provide visual image of road condition and traffic flow on route around the location of camera, which help operator to clearly understand the road conditions. Traffic monitoring camera shall be in used with two aims of:

- a) Visually supervise traffic flow and recognize accidents and incidents on section
- b) Visually recognize the dangerous conditions of weather such as fog or heavy rain to provide notification for drivers to prevent accidents

2.4.2.2. The monitored locations:

- a) Entrance/exit spots, interchanges between expressway sections and other roads
- b) Highly congestion and incident-prone sections, flood or erosion-prone spots on expressway
- c) On backbone expressway with high volume of mass vehicle, monitoring camera shall be covered continuously along the main section, minimizing the length of the blind spots..

2.4.2.3. System Architecture

a) Monitoring cameras shall be installed at entrance/exit points, interchanges; overall cameras shall be installed at highly incident-prone points, whose function of remotely panning and titing (PTZ).

b) Monitoring cameras along major roads in the expressways shall be installed to monitor continuously step by step, with the gap between two cameras is approximately $50 \div 1000\text{m}$. Captured images from monitoring cameras along the section shall consist of all road lanes on both directions within monitored range.

c) The data from the camera should be compressed as well as removed static images (feature of automatically detecting new radio motion) to minimize the amount of communication data and to process at center, then transmitted to the center by using the digital data transmission system.

d) Roadside equipments shall have components to install (poles or brackets) and power supply protector.

e) At management offices, radio datas shall be automatically recorded, enencoded and displayed on central monitoring screens and processed to achieve outputs of vehicle detection as requirements.

2.4.2.4. Image data protocol: based on IP, which remotely monitor from far distance on IP network to support standards of Open Network Video Interface Forum (ONVIF).

2.4.2.5. Basic technical requirements on equipments in system shall comply with QCVN ...:2014/BGTVT “National technical regulation on traffic monitoring CCTV camera system on expressway”.

2.4.3 System for Vehicle Detection

2.4.3.1. System for vehicle detection shall be installed to automatically collect traffic data with below parameters:

a) Vehicle volume shall be categorized by the length of vehicle (L) including:

- Ordinary vehicle includes car, bus and light truck with the length: $L \leq 6m$

- Large vehicle includes large bus, truck with the length: $6m < L \leq 12m$

- Extra-large vehicle includes traler truck, overload and oversize vehicle with the length: $L > 12m$.

b) The average speed shall be calculated by using this formula (1)

$$V_{tb} = (V_1 + V_2 + \dots + V_n) / N \quad (1)$$

Where: V_i is speed of vehicle No. i , N is the number vehicle in cycle T .

c) Road Occupancy shall be calculated by using this formula (2)

$$OC = (L_1/V_1 + L_2/V_2 + \dots + L_n/V_n) / T * 100 \quad (2)$$

Where: L_i , V_i is correspondent to the length and the speed of vehicle No. i in vehicle counting cycle T

2.4.3.2. Policies for vehicle arrangement shall be implemented with the aims of:

a) Control entrance/exit vehicle on expressway

Vehicle detectors shall be arranged on entrance/exit ramps, on the main expressway section near by interchanges to calculate the number of entrance/exit vehicles on each expressway section. For sections with close toll collection, it shall be capable of using counting data at tollgates to control the number of entrance/exit vehicles on each expressway.

b) Define the traffic speed, congestion of each expressway section

To get clear understanding the traffic status on a section, vehicle detectors shall be installed

in a continuously specified distance on the main expressway. The more vehicle detectors are installed, it could be more exactly and it take shorter time to recognize congestion. Requirement on installation is the system must recognize the congestion within maximum 10 minutes.

c) Automatic Event Recognition by Images

Systems for Vehicle detection by image shall be capable of recognizing by video analyzation on violations that badly affect to traffic safety on expressways, on incidents such as obstacles so as to notify road users.

d) Vehicle Encode Identification

Automatically recognize vehicle encode identification when passing vehicle detecting point by optical license plate identifying equipment or electronic vehicle identifying equipment on board

2.4.3.3. Technology for Vehicle Detection Equipment

Technology for vehicle detection equipment shall be the type of being installed on roadside without requirement to be buried underground, not destroy the road surface infrastructure during equipment installation and operation. These two following technologies shall be considered to select in design: Vehicle detection by ultrasonic type and Vehicle detection by Image Recognition type which are described in Appendix A.

2.4.3.4. Vehicle detectors which operate in normal condition of weather (without rain) shall provide the result of traffic volume with maximum tolerance:

a) Vehicle volume $\pm 5\%$

b) Vehicle speed $\pm 5\text{km/h}$

2.4.3.5. Vehicle detection data at all equipment installed points shall be transmitted to server at center continuously or in cycle at least 5 mins per time so as to be processed in accordance with below principles:

a) Cumulation and average calculation

Vehicle detection data server shall automatically calculate and generate the data at different time and counting cycle (5 mins, 15 mins, hourly, daily, monthly, annually). The procedure of cumulation and average calculation shall include interruption time when no data collected from detectors.

b) Supervision of Data Quality

Before using the vehicle detector to transmit data, it shall be checked and evaluated to supervise failure status. Collected data shall be compared with the threshold of traffic volume parameters and measurement values at being time. In case of unusual mutation in collected data, the equipment shall be marked to check. The processing procedure shall be recovered as normal if no errors or failures in collected data.

c) Data storage

Vehicle detection data shall be restored in DataBase to support statistics within validation time of at least 3 years.

d) Service level on expressway

Center server shall analyze and evaluate average vehicle speed and congestion that may occur on sections between the two installed detectors. The conditions for this analysis and evaluation shall be regulated as in Table 1.

Table 1: Criterias of evaluating traffic conditions

Traffic condition	Evaluation Criterias
Usual	No mild congestion or congestion
Mild congestion	Average speed $\leq \frac{1}{2}$ limited speed continuously in 5 minutes
Congestion	Vehicle queuing up over 1km with vehicles distance $\leq 10m$ in 5 minutes

2.4.3.6. The map for monitoring traffic volume is graphic interface which helps operators in center to overall supervise traffic volume status on the whole expressway. The map includes these informations:

- a) Measured vehicle volume by categories and average speed at measured locations on route
- b) Congestion and average traelling time on expressway sections
- c) Signals on date and time of reports

2.4.4 System for Event Management

2.4.4.1. Event Management System shall collect and monitor the condition and status of events occurred at each location on expressways. These events shall be categorized by:

- a) Traffic condition (if congestion);
- b) Bad weather (heavy rain, strong wind, thick fog, snow)
- c) Accidents, incidents (vehicle, road)
- d) Vi phạm trật tự an toàn giao thông
- e) Construction site
- f) Traffic restriction (road/lane closure, speed limitation)

2.4.4.2. Information on event can be manually managed by operator, be notified and input automatically by software system through data from vehicle detection system on traffic condition; from weather information system on bad weather condition; from vehicle detection by images; from vehicle axle load measurement system and notifications on accidents, incidents, traffic safety violations.

2.4.4.3. Vehicle detection system shall be recommended to apply on expressways to collect data on detecting traffic violations as description in Appendix A. Image of violated vehicle shall be captured, license plate shall be recognized for storage in DB in order to support

official handling and secure traffic safety.

2.4.4.4. The license plate of special vehicle shall be monitored as priority vehicle, overload or oversize vehicle, hazardous material vehicle, vehicle in black list stored in Database of event management server. When a plate in this database is detected by image recognition, the system shall automatically compile an event to notify the occurrence of object at the location of monitoring camera.

2.4.5 *System for Vehicle Axle Load Control*

2.4.5.1. System configuration

a) Equipments at WIM station:

- Automated sensor for measuring axle load, signal amplification device, measurement data processing and recording device;
- Device for measuring axle gap, vehicle speed and category;
- Device for recognizing license plate and capturing vehicle through measurement sensor;
- ID Reader for automatic vehicle identification;
- Power supplier, lightning protection and security device and other supporting devices;
- Digital communication device to center.

b) Equipments at operation center:

- Digital communication system shall receive information from weighing in motion station;
- System for recording and storing data, statistic;
- Software for recognizing violation in loading, making the minute and handling as regulation.

2.4.5.2. WIM stations shall automatically provide these datas if a vehicle passes by:

- Axle load and Axles load group
- Total weight of vehicle
- Velocity
- The distance between middle points of axles
- Vehicle category (by axle)
- License plate number
- Image of license plate and overall image of vehicle passig by sensor
- Station code/location code
- Lane and direction of vehicle
- Time of vehicle passing by
- Weight violation code

2.4.5.3. Weighing in motion might be installed at entrance/exit toll lane on expressway (average speed) or on the backbone expressway high speed as described in Appendix B. The location of WIM, operation regulation, supervision, handling the violating vehicles shall be implemented as regulated by competent authorities.

2.4.5.4. Measurement equipments (axle load scale) shall be used in system in accordance with technical requirements on measurement and be approved by competent authorities.

2.4.6 *System for Traffic information Provision*

2.4.6.1. Classification of provided information

a) Information when controlling vehicles

Based on the characteristics of driving on the highway to give the information to remind drivers to adhere to traffic rules, avoid driving in tiredness to secure traffic safety when driving.

b) Information at the specified time

Based on the specific time, such as sunset, early morning, night mode, time of high temperature, easy to sleep, peak traffic on holidays, foggy weather, etc, to put out the information to remind of safe driving.

c) Information on road condition

Providing expressway users with traffic condition on route, unusual prone-incidents included traffic accidents, road construction, flood or erosion-prone spots and other information related to handling directions.

d) Weather forecast information

Provide information on the possibility of strong wind, rain, fog, haze, dust storms, etc .

e) Other informations

Based on the different characteristics of the highway, other useful informatin shall be provided to the road users.

2.4.6.2. Procedure of information provision

a) The highway information collection, transmission, cancellation and updating shall be integrated.

b) The entire procedure of collecting, processing, transmitting, cancelling and updating highway information shall be implemented with strict managing measurement which is effective, sequenced, practical and feasible. The information shall be collected in a large range, processed in legally order, accurately displayed, promptly cancelled and updated.

2.4.6.3. Information shall be collected from:

- Equipments of Traffic monitoring and management system;
- Road managing organizations;
- Traffic police;

- Road implementing and maintaining organizations;
- Service area, tollgates;
- Expressway operating organizations;
- Other information providers.

2.4.6.4. Information processing

If there is no error when inspecting collected information on road and weather conditions, the information shall be notified on basic of regulation and procedure by competent authorities to disseminate information.

2.4.6.5. Sending information

a) The operator should use corresponding information stored in repository to send initially, or edit the necessary information at being time to send based on the actual situation.

b) When the operators send the necessary information for driving and information at specific time, they should take consideration of geographic location of the displaying screen, sub-buildings and road shape as well as the work of displaying from groups of transmission equipments.

c) Based on location and jurisdiction of the event, the notification on road condition and weather shall be defined with code so that operator can choose corresponding information to send.

d) When much information needs to be sent at the same time, it should be managed and followed as the below priority sequence of disseminating information:

- i. Information on road condition, priority for traffic incidents;
- ii. Information on weather;
- iii. Information at specific time;
- iv. Necessary information for driving;
- v. Other information.

2.4.6.6. Information cancellation and updating

a) Both necessary information for driving and information at specific time are usual information to be sent, cancellation and updating shall be followed as regulation.

b) For information on road condition and weather, operators should pay more attention to the course of the events so as to promptly cancel or update new information, and report as regulated sequence.

2.4.6.7. Variable message shall be provided by:

- a) Electronic traffic signs
- b) FM Radio
- c) Loudspeaker

d) Other information systems (Internet, mobile equipments, etc)

2.4.6.8. Electronic traffic signs shall be installed and operated in accordance with National technical regulation on Electronic traffic signs on expressways (QCVN ...:2014/BGTVT).

2.4.7 *Communication System*

2.4.7.1. The communication system shall be developed with two components::

a) Fixed telephone system shall be used to connect internal offices, stations and other fixed points.

b) Mobile radio communication system shall be used to connect operational vehicles and mobile objects on the highway.

2.4.7.2. Terminal equipments in communication system shall be installed at locations depending on application objects:

a) Traffic management center;

b) Stations and toll lanes;

c) Service area;

d) Expressway managing, implementing and maintaining organizations;

e) Mobile vehicle of patrol crew, rescue team and traffic police.

2.4.7.3. Terminal equipments shall be separated into 2 types depending on using purpose:

a) Command telephone shall be used for managing the expressway implementation and maintenance.

b) Administration telephone communication shall be used for normal activities. The priority for connection of administration phone is always lower than the command one..

2.4.7.4. Communication system should be designed with connection throughout the system to sure internal communications between traffic management center with stations, service areas and mobile vehicles The system must allow any terminal equipment from to be capable of making external call through the public switched telephone network.

2.4.7.5. The coverage area for mobile radio communication system should be designed with capability of connecting to all points along expressway included road management offices, toll collection area, rest area, parking area and all other areas. The system shall be protected with measures against interference when extending coverage area.

2.4.7.6. Equipments of communication system shall be installed in accordance with regulations in National technical regulation on Communication system for expressways QCVN ...:2014/BGTVT).

2.4.8 *Emergency Telephone System*

2.4.8.1. Emergency telephone system shall be used for receiving notification on accidents,

incidents on expressways from individuals and organizations. The system shall consist of:

- a) System of direction signs with emergency telephone number along the road or emergency telephone booths installed at the area without mobile network coverage.
- b) The telephone shall receive emergency calls at Traffic management center to collect and process information with the aim of properly dispatching rescue team if accidents or incidents to cooperate with patrol crew, traffic police and ambulance.

2.4.8.2. Direction signs with Emergency telephone number

Direction signs with Emergency telephone number shall be installed along two sides of road in accordance with regulation on Road signals QCVN 41:2012/BGTVT. The distance between signs is 500m. The information on signs shall include emergency telephone number and the location of sign in order for road user to easily locate on the highway

2.4.8.3. Emergency telephone Booths

At the installed location, emergency telephone booths shall be arranged at both two sides of the highway with a maximum spacing of 1000m. Transmission line connection is established directly from the Emergency telephone booths to the telephone which receives emergency calls in the center.

2.4.8.4. Emergency call receiving telephone

The arrangement and operation of Emergency call receiving telephone shall comply with regulations on design in Technical regulation on Traffic management center on expressways (QCVN ...:2014/BGTVT).

2.4.9 *Equipment Surveillance System*

2.4.9.1. Equipment surveillance system shall integrate information to assist monitoring overall operation of all types of equipments in traffic monitoring and management system as below:

- a) Switch devices and network of digital transmission system;
- b) CCTV Camera and image storing devices of Traffic monitoring system;
- c) Sensors and data processors of Vehicle detection system;
- d) Weigh in motion of Axle load measurement system;
- e) Electronic signs and other devices of Traffic information providing system;
- f) Telephone, call center and broadcast station of Communication System and emergency telephone system;
- g) Server for processing data;
- h) Power supplier (UPS battery, solar power);
- i) Power monitoring equipment and operating ambient;
- j) Equipmetns of Toll collection system;

- k) Sensors of Weather information system;
- l) Other equipments.

2.4.9.2. Equipment surveillance software

The surveillance of equipment operation shall be implemented through software interface at Traffic Management center. This interface can be a combination of software from many different sub-systems. The role of the implementing organization is to integrate the function of managing the devices in sub-systems on a unified interface, briefly describing the system status, making timely notification to the system operator.

2.4.9.3. Monitored information

Monitoring information should be collected periodically and continuously but not interrupt the operation of equipments. The layout for monitored information shall be classified with priority as following order:

- a) Failure status or operation error of equipment shall be evaluated according to different severity levels;
- b) Notification on unusual activities of equipments;
- c) Detailed parameters on equipment performance..

2.4.9.4. Inspection and Notification

Different measures shall be used based on each system and equipment. Typically, the normal operation will be verified periodically monitoring system by sending a request command. The time period required will be adjusted for each system and equipment parts. However, if the system detects parts of any discrepancy, the alarm signal will be switched on immediately on system components and related equipment to minimize obstruction.

2.4.9.5. Operation diary of equipments

Equipment surveillance system shall save the record of system operation and status of the system, different devices under a unified format in the database. All incidents and events must be recorded. Data tracking software will be installed to track and display the logs for the operation of systems and equipment identified. Therefore, the database is stored will be used in the calculation of the reliability index system and equipment including MTBF (mean time between failures) and MTTR (mean time to repair).

2.4.9.6. Power supply monitoring and operation ambient

All devices shall work properly only when the power supply is stable and fully standard operation ambient. The sensors should be installed at appropriate locations to monitor the power supply and operation ambient through measured values such as voltage, usage power and temperature around equipments.

2.4.10 Traffic Operation and Management Center

2.4.10.1. Traffic Monitoring and Management on expressways shall be organized by two levels:

a) Road management offices shall directly operate, monitor and control the performance of equipments which are installed for traffic management on route. The office shall be capable of self-operating: information, data in Traffic monitoring and management system shall be processed at office and be reported to higher organization.

b) Regional Main Center shall receive information and data from Road management offices to get understanding of traffic operation and utilization on expressways whin regional network. Main Center shall function directing, managing and cooperating with road offices.

2.4.10.2. Requirements on design, equipment installation and operation in Traffic Management Centers on expressways shall be implemented in accordance with National Technical Regulation QCVN ...:2014/BGTVT.

2.4.11 Toll collection System

2.4.11.1. Toll collection system for expressways shall be established as close type. Toll fare shall be defined by the proportional distance of driving and the vehicle classification.

2.4.11.2. System figuration

a) The sub-stations at highway intersections with other roads, including the entrance and exit ramps of toll freeway.

b) Section toll collection system: shall be installed in Traffic Surveillance and Control Center on expressway, in where data of different sub-stations in a close toll collection network.

c) Settlement center (Control center) is the agency with responsibility of integrating and processing data on traffic toll settlement for vehicle with automated prepaid account.

2.4.11.3. Two following methods of toll collection shall be applied at tollgates on expressways:

a) Toll collection by cash: Driver stops to receive control card at entry lane, pay back the card and toll fare by cash at exit lane on expressways.

b) Automated toll collection: The equipments for automatic toll collection shall be installed on board, driver passes the entry and exit lanes without stopping. The process of toll collection shall be automatically deducted from road user's account when registering the equipment.

2.4.11.4. The toll lanes using cash shall be builtd and operated basd on one-stop toll collection procedure in accordance with Basic Standard TCCS 01:2008/VRA issued by DRVN.

2.4.11.5. The toll lanes using automated or mixed toll collection (both automatic and cash) shall be builtd and operated in accordance with National technical regulation on Automated toll collection on expressways (QCVN ...:2014/BGTVT).

3 REGULATION ON MANAGEMENT

3.1. Traffic Monitoring and Management System plays an essential role which shall be well prepared to develop on expressway network in accordance with the Government Plan.

3.2. The operation and maintenance for Traffic Monitoring and Management System on expressway should be implemented in accordance with the procedure which is developed by design consultants, and approved by the investor or the owner, on the basis of:

- a) National regulation on Procedure of highway management, operation and maintenance;
- b) Traffic operation methods on expressways approved by competent authorities;
- c) Cooperation provision between all staffs working on expressways;
- d) System construction design documents.

3.3. Annual training on expressway operation, management and utilization with application of Traffic Monitoring and Management System for operators should be implemented under the general direction from Directorate of Road in Vietnam.

3.4 Contractor shall be assigned to manage expressway section, to operate and maintain the Traffic Monitoring and Management System, using the expense withdrawn from the road management fund which was approved by Ministry of Transportation.

4 IMPLEMENTING ORGANIZATION

4.1. Organizations and individuals in charge of planning, design, construction, operation and management of Traffic Monitoring and Management System on expressways should comply with all terms in this Technical Regulation and other related legal documents.

4.2. In case technical regulations, standards and documents in this Technical Regulation have been changed, added or replaced, it is required to comply with the new ones.

4.3. Directorate of Road in Vietnam shall be responsible:

- a) Developing General Regulation on management, operation and control highway traffic as the foundation for establishing specific procedure for each section to serve highway management, operation and maintenance.
- b) Checking and supervising the procedure of development and utilization for Traffic Monitoring and Management System in accordance with existing regulation.

4.4. Directorate of Road in Vietnam shall take control and cooperate with Department of Scientific and Technology (Ministry of Transportation) and other related authorities to guide, execute and organize this Technical Regulation implementation./.

APPENDIX A: TECHNOLOGY OF VEHICLE DETECTION

A.1. Vehicle Detection by Ultrasonic Type

A.1.1. The ultrasonic type detects vehicles passing by using arrival time difference of ultrasonic waves reflected from objects on the road and from the road. Number of vehicles can be counted with relatively high accuracy even at night mode, but not the vehicle speed and length. Vehicle detection by ultrasonic type shall be applied properly if necessity to accurately control the traffic volume on expressways at anytime.

A.1.2. Vehicle Detection by Ultrasonic Type shall work within a radius of tens of meters. Thus this technology shall provide data on vehicle counting, vehicle speed in a short expressway section. With this technology, the detection of congestion on a road section can only be based on the vehicle accumulation between two spots to speculate average distance between two vehicles on the highway. The higher the equipment installation density is, the shorter the time to detect congestion is. Table A1 gives out the relationship between the distance among vehicle detectors and the average time of server system would notify congestion signals when using Vehicle Detection by Ultrasonic Type.

Table A1: The average time to detect congestion by Ultrasonic Type (mins)

Distance Volume	1km	2km	3km	4km
600 vehicle/h	10.0	20.0	30.0	40.0
800 vehicle/h	7.6	15.0	22.6	30.0
1000 vehicle/h	6.0	12.0	18.0	24.0
2000 vehicle/h	5.0	10.0	15.0	20.0

A.2. Vehicle Detection by Image Recognition Type

A.2.1. The image recognition type detects moving objects in images captured from video cameras to identify the vehicle code, length and speed, even plate number. This technology depends much on outdoor conditions such as rain, fog or sunlight and day/night mode. It is difficult to accurately identify the length and speed of vehicle at night mode.

A.2.2. At daytime mode, camera shall be capable of detecting vehicle, measuring speed and the distance between vehicles within hundreds of meters (depends on the height of camera installed location), therefore, the distance of camera in this type shall be larger than the ultrasonic type to secure the same time to notify congestion. Table A1 gives out the relationship between the distance among vehicle detectors and the average time of server system would notify congestion signals when using Vehicle Detection by Image Recognition Type.

Table A2: The average time to detect congestion by Image Recognition Type (mins)

Distance Volume	1km	2km	3km	4km
600 vehicle/h	5.0	10.0	15.0	20.0
800 vehicle/h	3.8	7.5	11.3	15.0
1000 vehicle/h	3.0	6.0	9.0	12.0
2000 vehicle/h	2.5	5.0	7.5	10.0

A.2.3. System figuration for Vehicle Detection by image includes:

- IP Camera with high resolution and features of automatically detecting movement;
- Light supporting lamps for camera at nightmode;
- Equipment to secure resources and control the safety for equipment at site;
- Data communication equipment (data digital transmission network);
- Recorder and processors for automated detection recognition by image;
- The softwares for notifying incidents and events to traffic monitoring staff;
- Vehicle detection storing database.

A.2.4. Vehicle Detection by Image Recognition Type shall be capable of supervising traffic safety on expressways, optical identification of number plate and detection of vehicle violations such as:

- Illegally parking;
- Driving on wrong lane;
- Reversing;
- Driving on restricted road;
- Driving with illegal speed;
- Driving without complying traffic signals.

A.2.5. Vehicle Detection by Image Recognition Type shall be capable of providing parameter with the accuracy/tolerance as in Table A3.

Table A3: Accuracy/tolerance of Vehicle Detection by Image Recognition Type

Parameter	Daytime	Nighttime
Detection Coverage	300m	50m
Vehicle accounting	±2%	±10%

Classification of vehicle size	±5%	±20%
Identification of plate number	90%	70% (with supporting light)
Identification of Speed	±3km/h	±10km/h

APPENDIX B: TECHNOLOGY OF WEIGH IN MOTION

B.1. Either scale with high speed or scale with average speed, or both of them can be installed on expressways in accordance with basic principles applied in Article 6.1.2 QCVN 66:2013/BGTVT - National technical regulation on Vehicle Axle Load Station. Items in this Article shall be developed on the basis of reference to STM E1318. Requirements on basic operation functions of WIM shall be described in table B1 (referring to Standard ASTM E1318).

Table B1: Các yêu cầu chức năng vận hành của các hệ thống cân tải trọng động

Performance Parameter	Type of weight (classification to ASTM E1318)		
	Scale with high speed (Type III)	Scale with average speed (Type IV)	
Checked speed band (km/h) ^A	16-130	3-16	
Maximum axle load (ton)	30		
Overload capacity	150%		
Degree band with tolerance	0 ~ +50 degree Celcius		
Humidity band with tolerance	0~95%		
Measuring function	Allowance tolerance with reliability 95% ^B		
	Measured parameter	Parameter kg	± kg
Wheel load	±20%	2300	100
Axle load	±15%	5400	200
Axles group load	±10%	11300	500
Total weight of vehicle	±6%	27200	1100
Speed	±2km/h		

Axle gap	$\pm 0,15$ m
----------	--------------

^A: Theo quy định vận hành đường cao tốc, tốc độ 16 Km/h được coi là giới hạn dưới trên trục chính và là giới hạn trên trong làn thu phí đối với xe khi đi qua cân động.

^B: Với độ tin cậy 95%, các mục dữ liệu hệ thống đưa ra cần đáp ứng sai số cho phép quy định trong bảng.

B.2. Yêu cầu hạ tầng lắp đặt để đảm bảo độ chính xác của cân động

B.2.1. Độ dài làn cân

60m ahead and 30m back of high-speed lane.

30m ahead and 30m back of high-speed lane.

B.2.2. Linear dimension

Horizontal curve of lane must have a minimum radius of 1.7 km.

B.2.3. Vertical Geodetic

For high-speed lane (main lane) is 2%

For average-speed lane (toll lane) is 1%

B.2.4. Horizontal Geodetic

For high-speed lane (main lane) is 3%

For average-speed lane (toll lane) is 1%

B.2.5. Lane width

The lane width to install sensor of WIM system shall be about 3,6 – 4,3 m. A space of 1m shall be added to each side of lane for cumbersome trucks.

B.2.6. Road surface structure

Road surface structure and surface smoothness shall be developed and maintained in accordance with WIM sensor during operation, responding the requirements of manufacturer.

Kết cấu mặt đường và độ nhẵn bề mặt cần được xây dựng và duy trì phù hợp với hoạt động của các bộ cảm biến cân động trong suốt thời gian vận hành, đáp ứng theo yêu cầu của nhà sản xuất cân. The surface structure made of hard cement concrete shall be capable of maintaining smoothness much longer than asphalt texture. It can be considered about reinforced concrete pavement (CRCP) with 90 m in length or precast concrete pavement (JCP) with the width ≤ 5 m at the WIM lanes. The surface of the rigid pavement should be smooth after maintenance and before the installation of the WIM sensor.

添付資料-4

**DRAFT QCVN
OF
CCTV CAMERA SYSTEM
FOR EXPRESSWAYS
(SUB-GROUP 4)**

**1ST DRAFT
(Sub-Group 4)
2014.02.07**



SOCIALIST REPUBLIC OF VIETNAM

QCVN XX : 2014/BGTVT

**NATIONAL TECHNICAL REGULATION ON HIGHWAY CAMERA
MONITORING SYSTEM**

Hệ thống Camera Giám sát Giao thông trên Đường Cao tốc

HA NOI - 2014

1ST DRAFT (Sub-Group 4) 2014.02.07
--

Foreword

QCVN XX : 2014/BGTVT was compiled by Drafting Board for National Technical Regulation on Highway Camera Monitoring System under the Information Technology Center, Ministry of Transportation, approved by Department of Science Technology and issued in accordance with Circular No./2014/TT – BGTVT on, 2014 by the Minister of MOT.

NATIONAL TECHNICAL REGULATION ON HIGHWAY CAMERA MONITORING SYSTEM

*Quy chuẩn Kỹ thuật Quốc gia về Hệ thống Camera Giám sát Giao thông
trên Đường cao tốc*

1	General Regulation	3
1.1	Scope.....	3
1.2	Application Objects.....	3
1.3	Terminology and Definition	3
1.4	Abbreviations.....	3
2	General Requirements on System	5
3	System Architecture.....	5
4	Roadside Camera System.....	6
4.1	Requirements on Function	6
4.2	Structure	7
4.3	Technical Requirements	7
4.4	Human-Machine Interfaces	8
4.5	Installation	9
5	Network Video Recorder (NVR)	10
6	Video Image Displaying Device	11
7	Image Transmitter.....	12
8	Central CCTV Controller	12
8.1	Function	12
8.2	Structure	13
8.3	Performance	13
8.4	Human-Machine Interfaces	13
8.5	Communication Interfaces.....	13
8.6	Installation	15
9	Monitoring Camera Controller	14
9.1	Function	14
9.2	Structure	14
9.3	Performance	14
9.4	Human-Machine Interfaces	15
9.5	Communication Interfaces.....	15
9.6	Installation	15
10	Ambient Conditions	15
11	Power Supply	16
12	Maintenance	16
13	Regulation on Management	16
14	Implementing Organization	17

1 General Regulation

1.1 Scope

This technical regulation provides basic requirements on equipment components, performance and interface of Cameras installed on expressways which help operators in monitoring highway traffic activities such as: traffic accident, broken-down vehicle, left obstacle, reversing vehicle, vandalism, natural disaster and expressway conditions.

1.2 Application Objects

This regulation shall be applied to any organizations and individuals in charge of planning, design, construction and operation of highway camera monitoring systems.

1.3 Terminology and Definition

Road Management Office: is under management of contractor to monitor and control traffic on Expressways. This office shall be operated along with support from automatic technology, communication and control equipments in the investment package for traffic monitoring and management system.

Regional Main Center: is responsible for monitoring, managing Road Management Offices within jurisdiction. Regional Main Center can connect to Road Management Offices by using Intelligent Transportation System – ITS.

Operator: is the person securing the operation of Intelligent Transportation System ITS at both Road Management Office and Regional Main Center.

Traffic Event: is the situation affecting to traffic condition included traffic incidents, dangerous weather, traffic congestion, construction work, violation of drivers, traffic restrictions and other special events.

Incident: is the unusual event without in advance affecting or interrupting traffic condition included traffic accidents, broken-down vehicles, obstacles on road or natural disasters.

Station: is the area in where operation centers of tollgate, rest area and service on route locate.

Camera IP: the digital camera which is capable of transceiving and encoding images, then transmitting signals over IP/Ethernet protocol network.

Network Video Recorder (NVR): Network Video Recorder – Digital image capturing equipment for IP camera system.

Power over Ethernet (PoE): is the method of supplying one-way power at low voltage over the shared Ethernet network cable connected to equipment.

HD Standard: image with high resolution which is transceived from digital cameras. Resolution levels for HD standard should be 720p (1280x720), 1080p (1920x1080), 2160p (3840x2160), 4320p (7680x4320) respectively.

ONVIF: is an incorporated innovation between global IP camera manufactures with the goal to facilitate the development of a common standard for IP camera interfaces based on Web services.

Digital Panning Tilting Zooming (DPTZ): is the feature of changing view of a virtual image. The scope of digital panning, tilting and zooming depends on the view and resolution of original image transceived from the camera.

Video Management Software: is the application creating user interface, which allows general operation for all equipments used in monitoring CCTV system.

1.4 Abbreviations

ITS	Hệ thống giao thông thông minh (Intelligent Transportation System)
TMC	Traffic Management Center
VMS	Biển báo có thông tin thay đổi (Variable Message Sign)
CCTV	Truyền hình mạch đóng (Closed Circuit Television)
PTZ	Quay, quét, thu phóng (Pan Tilt Zoom)
DPTZ	Quay quét thu phóng số (Digital PTZ)
DB	Data Base
IP	Giao thức mạng Internet (Internet Protocol)
VPN	Mạng riêng ảo (Virtual Private Network)

2 General Requirements on System

Traffic surveillance camera system shall secure the requirement of being remotely managed by Main Regional Center to enhance safety and convenience for traffic vehicle.

Traffic surveillance cameras shall be installed at all important interchanges, road sections with high-congestion and accident-prone spots. The equipment shall be capable of viewing the traffic flow in day and night conditions.

The design of system should be modernized along with the application of hi-tech equipments in accordance with the development all over the world.

The system should be open, easily extensible and intergrated with other component systems which are being in use at Regional Main Center.

The video image storage system shall be generally managed and be secured to have appropriate capacity and high availability to avoid missing image during specified storage period.

The administration for camera system shall be synchronized through a unified user interface. Hardware and software must have high security and implement respective functions within specified jurisdiction with every application object in different levels.

The feasibility and consistence with economic conditions, infrastructure and traffic features in Vietnam shall be secured during the implementation of the system.

The system shall be capable of operating continuously 24 hours a day, 365 days a year excluding time for regular maintenance.

3 System Architecture

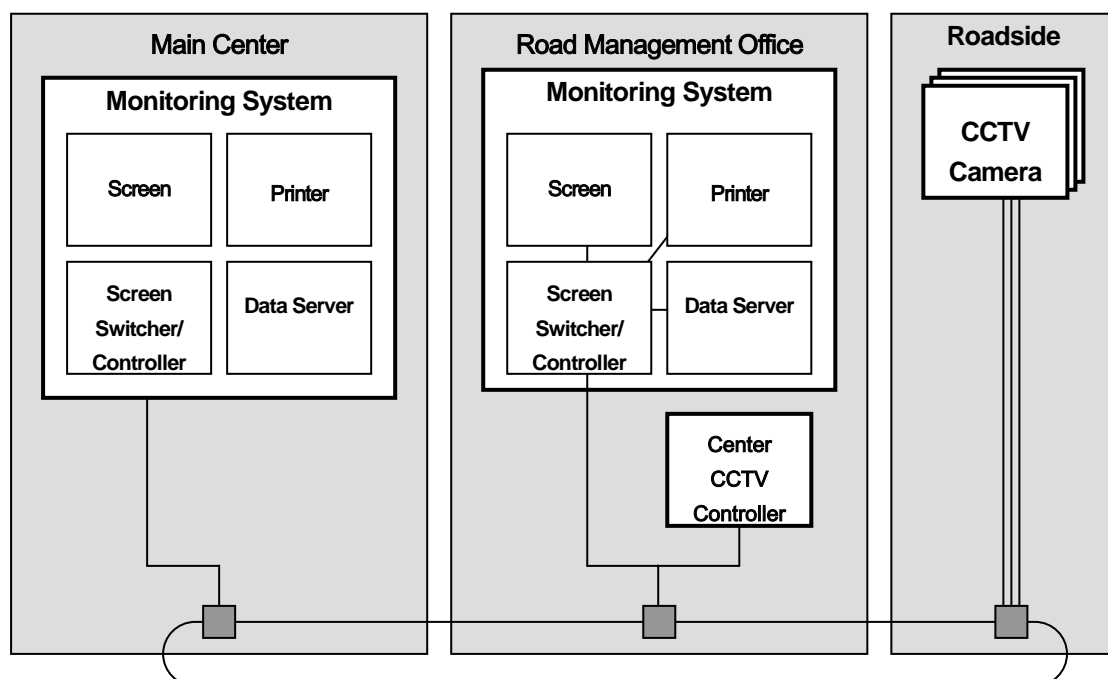

Figure: Highway Camera Monitoring System Architecture

System Architecture includes 3 main factors:

- CCTV system and other supporting devices shall be installed on expressways for monitoring highway incidents and events.
- Controller system at Road management office shall be applied for monitoring and controlling CCTV system within jurisdiction of the office.
- Controller system at Regional Main Center shall be applied for monitoring and controlling CCTV system within jurisdiction of the center.

4 Roadside Camera System

4.1 Requirements on Function

Traffic monitoring cameras shall be installed on roadside under outdoor conditions to transceive images monitoring traffic vehicle flows. Capturing images from cameras should be black/white or colour images.

Cameras shall be capable of working continuously 24 hours a day, 365 days a year excluding time for regular maintenance. Transceived images could be clearly monitored with or without light supporting equipment at anytime.

Depending on capability of controlling surveillance angle, CCTV Cameras shall be divided into two types:

Camera allows adjusting the viewing angle as remote requirement by panning, tilting and zooming the lens. PTZ camera shall be usually installed at interchanges or road sections with large range of observation in different directions from near to far distance.

+ Fixed camera shall allow surveilling with a single angle at the initial installation place. The camera shall be commonly used to monitor on the road section with fixed view according to the direction of vehicle flow.

Digital cameras with high-resolution images in accordance with HD standard shall be selected to install. Each camera shall be identified by an IP address in the connection network.

The cameras shall be supported with the intelligent processing feature to secure good image quality and adapt to operation conditions such as the change of light, the shaking of camera by strong wind.

After operation recovery from the power failure, to automatically switch on the equipment components and the software.

4.2 Structure

The equipment components shall have adequate structure, shape, size, lightweight and robustness. The components shall be protected with the measures against typhoon, fire, earthquake, sandstorm and lightning.

The equipment components shall be protected with the measures against water, rust, dust, salt water in case equipment components are installed outdoors.

The chassis of equipment components shall have adequate structure which allows maintenance works from the sides and/or back, but not from lane direction, in order to minimize the influence to traffic activities on lanes.

The Chassis of equipment shall be capable of dissipating temperature rising from inside equipment and radiant solar heat.

The equipment components shall be protected with the measures against interference from other electronic devices.

CCTV camera shall be protected against dust and water ingress if it will be installed outdoors (excluding tunnels) in accordance with IP66 of the international standards IEC 60529 or equivalent.

The system shall be capable of fully meeting the requirements even under night conditions.

4.3 Technical Requirements

IP Camera for traffic monitoring shall be required to achieve minimum general specifications as follows:

- a) CCTV camera shall be capable of surveilling in day mode and night mode with the minimum illumination of 0.5 lux.
- b) The minimum resolution under HD Standard for images shall be 720p (1280x720) and 25fps.
- c) CCTV camera shall provide output monitoring video flow which is capable of encoding images in H.264 and Motion JPEG.
- d) CCTV camera shall have the focal length of lens in accordance with surveilling angle, the width of sensor reaches a minimum of a quarter;
- e) CCTV camera can autofocus image;
- f) CCTV camera shall be capable of manually controlling and automatic aperture to match the brightness of the object for the best video image.
- g) CCTV camera shall have functions of automatically processing the transceived images such as auto gain control (kiểm tra độ lợi sáng), auto white balance (cân bằng ánh sáng trắng) and backlight compension (bù ánh sáng ngược);

- h) CCTV camera shall be protected by the chassis to prevent rain/sunlight and dust, in accordance with IP66 at least;
- i) CCTV camera can operate stably in Vietnam ambient conditions: at -15 to 50 degrees with humidity range from 20 to 90%.

PTZ cameras shall have dome structure (dạng vòm). The specifications should be required as follows

- a) CCTV camera must be capable of panning at least 350 degrees and tilting 100 degrees;
- b) The minimum optical PTZ of camera must be at x10 times
- c) The maximum surveillance range of camera must be greater than 1000m

The fixed IP cameras with resolution $\geq 1080p$ (1920x1080) shall function creating virtual images so that user can simultaneously monitor different locations in the camera frame. User can function digital panning, tilting and zooming (DPTZ) on each created virtual image.

IP camera shall be used to support the installation of intelligent features such as automatically detecting image motion, warning blurred or obscured images. A signal gateway shall be prepared for warning from camera.

The camera shall use the power supply over Ethernet network cable (PoE). The equipment shall have the feature of saving energy and consume power less than 50W to fixed camera, 100W to PTZ camera.

The camera should provide an interface to configure and view online images on Web. The equipments at center shall be capable of remotely control camera over IP network according to ONVIF standard.

The camera location shall be selected to secure traffic monitoring at the highest effectiveness, to avoid being out of sight in curves or construction works; with the aim of minimizing blind spots on road sections.

Depending on the construction site of the installation location, the camera can be installed on brackets, on roadside pole with or without handgrip. The installation height of camera must secure the minimum safety space in road traffic.

The installation structure for roadside cameras shall be designed with the measures against straight lightning and strong wind at 40mps or equivalent.

4.4 Human-Machine Interfaces

CCTV camera shall have the function to output test image to personal computers at site so that installation staff may adjust the direction of CCTV camera.

The system shall have video image output interface to adjust angle of view of camera and receiving control signal interface to check camera operation at installation at installation site.

4.5 Installation

CCTV camera installation has the following general requirement:

Roadside equipment shall be installed so as not to obstruct the vertical clearance on expressways.

CCTV camera installed at Toll Island in where the camera can capture the front of vehicle (including license plate).

Horizontal and vertical angle of CCTV camera shall be capable of being adjusted and fixed appropriately at the installation site.

CCTV camera shall be capable of being vertically and horizontally adjusted during installation at roadside.

The equipment components shall have adequate robustness against the wind of speed according to TCVN 2737:1995.

CCTV camera shall be installed so that images may not swing by strong wind.

CCTV camera shall be installed so that images may not swing by strong wind. In case the equipments to be located at outdoor, the screw for attachment should be antitheft type.

In case the equipments to be located at outdoor, the screw for attachment should be antitheft type.

CCTV camera with panning, tilting and zooming functions shall be installed at intervals of 2 km or less along through lanes so as to monitor situations such as incidents, broken vehicles, traffic congestions, and bad weather through day and night.

One or two fixed CCTV cameras shall be installed on the ramp so as to monitor situations such as incidents, broken vehicles, traffic congestions, and bad weather through day and night.

CCTV cameras shall be installed so as to get images of the road within one kilometer range without influence of obstacles such as plane curve, longitudinal slope, roadside cutting slope, overbridges, buildings, trees, lighting poles, traffic signs, and VMS.

CCTV camera shall be installed so that images may not swing by strong wind.

In case of more than one camera are attached on the same pole, each camera shall be attached with at least 1m height interval.

The angle of view of a camera shall be adjusted for monitoring the road continuously in consideration of the field of investigation.

In case the equipments to be located at outdoor, the screw for attachment should be antitheft type.

CCTV camera installation is divided into three categories:

- Installation of PTZ type camera on through lanes: should be installed along the expressway at least every 2km as follows:

+ One PTZ type camera for monitoring inbound lane.

+ One PTZ type camera for monitoring outbound lane.

PTZ type camera need to be additionally installed In case of disrupting vision obstacles such as flyover-bridge, longitudinal gradient of road, roadside cutting slope, tollgates, trees, buildings or inquiring of many surveilling screens.

In ideal condition, PTZ type camera should be capable of monitoring the road continuously.

- Installation of PTZ type camera for monitoring junction/interchange including tollgate.

PTZ type cameras should be installed according to junction and interchange type. Each type requires different PTZ camera location to monitor the whole area.

In ideal condition, PTZ type camera should be capable of monitoring junction/interchange including tollgate.

- Installation of Fixed type camera on ramp.

Fixed type camera should be installed to monitor each ramp of the junction or interchange.

Fixed type cameras shall be installed attached on roadside around the diverging/merging point of ramp with the maximum surveillance area possible.

Fixed type camera should be installed 6-7m above ground level in accordance with the limit construction clearance in accordance with TCVN 4054:2005 and TCVN 5729.

Fixed type camera need to be installed in case of disrupting vision obstacles such as flyover bridge, longitudinal gradient of road, roadside cutting slope, overbridges, buildings, trees, lighting poles, traffic signs, VMS, alignment of road, tollgate, etc.

5 Network Video Recorder (NVR)

Video images from IP cameras shall be transmitted to Network Video Recorder (NVR) in order to store for searching and reviewing as request of users.

NVR used in traffic monitoring system shall have minimum functions as follows:

- a) Recording images as video data file with H264 encoding standard
- b) Recording images along with multi video streams in the same connection network
- c) Managing the continuous recording, fixed time recording or preset recording as the activation of external events.
- d) Replaying video images recorded in different time on IP network in accordance with RTSP protocol, and quickly searching an image recorded at random time

- e) Shifting video images recorded from cameras at being time
- f) Managing storage capacity of each camera, of automatically organizing old video data for recording new data
- g) Automatically controlling and warning on recording errors, loss of image signal, storage disk or full limit.

Many NVR equipments can be operated at the same time to assign the video data storage capacity for a large number of cameras. The parallel equipment shall be capable of taking a role of backup device which can replace the main one in case of errors. The management for balancing the number of recording camera in NVR equipment shall be automatically done by Network Video Management Software.

Besides the function of storing, recording equipments shall be capable of integrating or extending intelligent functions of processing images for traffic management such as traffic volume measurement, event detection and vehicle identification by video image.

6 Video Image Displaying Device

The images of all traffic surveillance cameras shall be managed on monitoring screen of each operator and large wall screen (if any) at management office.

In case the number of monitoring cameras is larger than the installed screens, image displaying equipment shall be capable of organizing as follows:

- a) Multi images of different cameras shall be separately displayed on the splitting window Screen as a matrix form.
- b) Images of cameras in group shall be displayed on the same Monitor Screen in defined rotating interval.

For PTZ cameras, displaying equipment at operator position shall be installed with dedicated camera controller or computer software. The camera should be setup with preset angles so that user can quickly adjust camera to special locations or to automatically control the camera at different locations in cyclical time.

Image displaying wall screen shall be applied with the technology of combining multiple physical screens to a large wall screen or dividing into multiple virtual screens. Video images from cameras shall be controlled to display on virtual screen of wall screen.

The remote controller of wall screen shall be used to function the following tasks:

- a) The equipment shall be capable of organizing matrix on virtual screen which is displayed on wall screen;
- b) The equipment shall be capable of setting the content to display on each virtual screen including video image from camera and interface of application software;

- c) The equipment shall be capable of storing common configuration to quickly shift the content displayed on wall screen to different views;
- d) The equipment shall be capable of managing timing schedule with preset contents displayed on wall screen.

7 Image Transmitter Equipment

Image transmission network for traffic monitoring camera system shall secure the transmission bandwidth of at least one video stream from each IP camera to center with HD 720p resolution.

The accessing equipment for radio transmission network shall meet the following requirement on specifications:

- a) The frequency range 2400 ÷ 2483.5 Mhz, 5150 ÷ 5350 Mhz, 5470 ÷ 5725 Mhz, 5725 ÷ 5850 Mhz
- b) The minimum channel width 20 MHz, the minimum channel distance 10 MHz
- c) The transeiving distance between camera and base station ≤ 20 km, between the two 2 base stations ≤ 30 km
- d) The transmission speed from camera to base station 04 Mbps, and between the two base stations 100 Mbps
- e) Transmission protocol Ethernet/IP

Switching equipment component for wire network using optic cable shall meet the following requirement on specifications:

- a) The architecture for network design shall include 3 layers: core network, external network, accessing network
- b) The transmission speed in core network 10 Gbps, external network 1000 Mbps, accessing network 100 Mbps
- c) The distance among nodes in core network ≤ 40 km, external network ≤ 10 km, accessing network ≤ 2 km
- d) Transmission protocol Ethernet/IP

8 Central CCTV Controller

8.1 Function

The central CCTV controller shall be capable of controlling CCTV cameras functions such as zooming, panning and tilting.

The CCTV camera shall be capable of being controlled from Regional Main Center or Road Management Office depending on the given.

8.2 Structure

The equipment components shall have adequate structure, shape, size, lightweight and robustness; be protected with the measures against lightning.

Chassis of equipment shall be capable of dissipating temperature rising from inside equipment.

The equipment components shall be protected with the measures against interference from other electronic devices.

8.3 Performance

The function of encoding data of central CCTV controller complies with H.264, MPEG-4 Part 2.

The central CCTV controller shall operate with less than 6Mbps bit rate and over 25 fps frame rate.

The central CCTV controller may have recording unit with: At least 1 mega pixel resolution; more than 1 fps frame rate. This unit should be capable of recording continuously 24 hours.

8.4 Human-Machine Interfaces

Operators shall use CCTV monitoring console for setting the functions of Central CCTV Controller.

The operators at the Regional Main Center and Road Management Offices shall use keyboards and joysticks to function panning, tilting and zooming of cameras to monitor the images taken by CCTV cameras

The system shall be equipped with the functions so that operator sitting at the console 5m away from the main screen at Regional Main Center may confirm such situations as incidents, broken vehicles, traffic congestions, and bad weathers on the expressways through day and night by indicating images taken by CCTV cameras on the main screen of Regional Main Center.

8.5 Communication Interfaces

The system shall be capable of controlling the signal for images transmitted over TCP/IP.

The system shall have 100BASE, 1GBASE Ethernet and RJ-45 connectors.

The system shall be capable of working with Ethernet protocols such as: IP, UDP, RTP, multicast

The following information shall be disclosed for communication interfaces among the equipment components to control CCTV and accessible to CCTV video images from another equipment / console:

- The name of implementation software
- Bit allocation, which is needed for designing data transmission between transmission devices

- Transmission data format
- Timing chart and other details of the standard interfaces

Necessary information or specification of equipment components shall be capable of being disclosed in order to secure the interoperability of devices.

8.6 Installation

The equipment of components shall be installed at Road Management Offices.

Software shall be capable of being installed on an operating system such as Microsoft Windows or Linux.

The total number of equipments depends on the number of cameras and the number of interfaces on equipment.

9 CCTV Monitoring Console

9.1 Function

The system shall be controlled remotely by using such equipments as joystick, keyboard, trackball in the Regional Main Center. CCTV camera control shall be conducted using IP address corresponding to CCTV camera identification number.

9.2 Structure

The equipment components shall have adequate structure, shape, size, lightweight and robustness.

The equipment components shall be protected with the measures against lightning.

The chassis of equipment components which is capable of dissipating temperature arising from inside equipment, shall not be opened easily, and its door shall be opened/closed with a lock.

The equipment components shall be protected with the measures against interference from other electronic devices.

9.3 Performance

The system shall be capable of controlling the zooming and horizontally/vertically panning functions of cameras.

The system shall be capable of displaying the selected camera image on the designated monitor screen.

Recommended size of monitor screen shall be at least 20 inches.

All camera images shall be capable of being displayed on Monitor Screen. In case the number of cameras is more than which of screens, it should be organized as follows:

- Multi images shall be separately displayed on the same Monitor Screen.
- Images shall be displayed on the same Monitor Screen in defined rotating interval.

The system shall be capable of capturing CCTV images as still pictures.

9.4 Human-Machine Interfaces

The equipment components shall have human-machine interface such as keyboard, joystick, or track ball, so that the Traffic Information Operator can operate CCTV camera system.

The system shall be capable of printing captured still pictures by using A4 printer.

The monitor in the console shall be greater than 20 inches so that operators at Regional Main Center and Road Maintenance Office may confirm incidents, broken vehicles, traffic congestions, and bad weathers on the expressways through day and night by indicating images taken by CCTV cameras on the main screen.

9.5 Communication Interfaces

The system shall be capable of controlling the signal for images transmitted over TCP/IP.

The equipment components shall have the following communication interfaces and information in order to ensure that equipment components are controllable by CCTV, and accessible to CCTV video images from another equipment / console.

- The name of implementation software
- Bit allocation, which is needed for designing data transmission between transmission devices
- Transmission data format
- Timing chart and other details of the standard interfaces

Necessary information or specification of equipment components shall be capable of being disclosed in order to secure the interoperability of devices.

9.6 Installation

The equipment shall be installed in Road Management Offices and Regional Main Center.

Software shall be capable of being installed on the operating system such as Microsoft Windows or Linux.

10 Ambient Conditions

The equipment components shall be installed in the offices and protected by the measures against interferences of other electronic devices.

The equipment component shall be capable of normally operating under the following ambient conditions:

For Regional Main Center, Toll Management Center, and Toll Office

Temperature: 25 +/- 3 degree C in average

Relative humidity: between 20 and 80 % in average

For outside

Temperature: between - 0 and +50 degree C

Relative humidity: below 95 %

11 Power Supply

The main power supply shall be AC 220 volts single phase and 50 Hz frequency.

System shall have Uninterrupted Power Supply (UPS) against power failure. UPS must be capable of providing power for the system for at least 30 minutes.

12 Maintenance

The system shall be capable of being checked and maintained easily and simply.

The system shall be capable of identifying faulty parts easily in case equipment fault is detected, and the replacement of the parts shall be simple.

The spare parts of the equipment components shall be available at least five (5) years after the equipment component is handed over to the road management authority, and the manufacturer shall guarantee this spare parts supply period.

13 Regulation on Management

Traffic Monitoring System takes an essential part which should be invested in the projects of developing ITS on expressway

The operation and maintenance for Highway Camera Monitoring System should be implemented in accordance with the procedure which is approved by Ministry of Transportation or the investor on the basis of:

- Government Regulation on highway management, utilization and maintenance;
- Traffic arrangement plan for expressways has been approved by competent authorities;
- Cooperation provision between all staffs working on expressways;

Contractor shall be assigned to manage expressway section, to operate and maintain the Traffic Monitoring and Management System, using the expense withdrawn from the road management fund which was approved by Ministry of Transportation.

14 Implementing Organization

Organizations and individuals in charge of planning, design, construction, operation and management of Traffic Monitoring and Management System on expressways should comply with all terms in this Technical Regulation and other related legal documents.

In case technical regulations, standards and documents in this Technical Regulation have been changed, added or replaced, it is required to comply with the new ones.

Directorate of Road in Vietnam shall be responsible for:

- Developing provisions on cooperating, utilizing and applying Intelligent Transportation System – ITS included Traffic Monitor and Management System into expressway operation, management and maintenance.
- Inspecting, surveilling the process of investing, building and utilizing Traffic Monitoring and Management Systems in accordance with regulated provisions.

Directorate of Road in Vietnam shall take control and cooperate with Department of Scientific and Technology (Ministry of Transportation) and other related authorities to guide, execute and organize this Technical Regulation implementation./.

添付資料-5

**DRAFT QCVN
OF
VMS SYSTEM FOR EXPRESSWAYS
(SUB-GROUP 5)**

MINISTRY OF TRANSPORT

DRAFT 1
(Sub-Group 5)
2014.01.22

QUY CHUẨN KỸ THUẬT QUỐC GIA
VỀ BIỂN BÁO GIAO THÔNG ĐIỆN TỬ
TRÊN ĐƯỜNG CAO TỐC

National Technical Regulation on Electronic Signs
on Expressway

QC13315

Chair agency: Institute of Transport Science and Technology

Implementation unit: Center of Automation and Measurement

Compile head: M.A Nguyen Anh Tuan

Hanoi 01/2014

1	GENERAL REGULATION	2
1.1	Scope	2
1.2	Application Object.....	2
1.3	Abbreviations	2
1.4	Terminology and Definition	2
2	TECHNICAL REGULATION	3
2.1	General regulation on Electronic signs on Expressway	3
2.2	Material regulation	4
2.3	Shape and Size of Signs.....	5
2.4	Content Format on Signs	5
2.5	Font Size and Style.....	6
2.6	Color of Signs	8
2.7	Brightness (Luminance)	10
2.8	Observation Feature	10
2.9	Controller of Signs	10
2.10	Requirements on Power Supply and Related Problems	11
2.11	Ambience.....	12
2.12	Checking and Maintenance.....	12
2.13	Label and Labeling.....	12
2.14	Installation.....	13
3	REGULATION ON TEST AMD CHECK.....	15
3.1	Testing/Checking Conditions	15
3.2	External Check and Technical Check.....	15
3.3	Power Supply and Related Issues	15
3.4	Color Test and Check	16
3.5	Information Transmitting Inspection	16
4	REGULATION ON MANAGEMENT.....	16
4.1	Management Principles.....	16
4.2	Regulation Conformation Certification and Announcement	16
4.3	Responsibility of Road Management Agency.....	17
4.4	Responsibility of Road Users	17
5	IMPLEMENTING ORGANIZATION	18

1. GENERAL REGULATION

1.1. Scope

1.1.1 This national technical regulation (hereinafter referred to as technical regulation) regulates on electronic signs which are fixed installed on Expressway.

1.1.2 The electronic signs on Expressway are the electronic signs using illuminating LED to show the content.

1.1.3 The electronicsigns which are fixed installed on Expressway are mentioned in this technical regulation include: changeble information indicating Electronic signs (information signs), changable speed limit electronic signs (speed limit signs).

The electronicwhich installed outside Expressway are recommended to apply this regulation.

1.1.4 The information shown on information signs is in two types: letters and figures.

1.2 Application Objects

This regulation applies to all organizations and individuals involved in the design, construction, management, exploitation and maintenance of electronic signs on Expressway in the whole country.

1.3 Abbreviations

ITS: Intelligent Transportation System

LED: Light Emitting Diode

ES (signs): Electronic signs

Exw: Expressway

1.4 Terminology and Definition

1.4.1 Electronic sign: is an electronic device providing instructions for traffic control, on which displayed contents are changeable, provides traffic information for road users.

1.4.2 Traffic information: The information on speed limit, traffic jam, traffic accident, maintenance, weather condition, road condition, event holding, or other expressway features (road open/closure, tollgate, weight station...);

1.4.3 Traffic restriction: A means to restrict traffic on roads, such as road closure, lane restriction, speed limit and warnings;

1.4.4 Incident: An unusual unpredictable event casing affect or inpede on traffic, for example traffic accident, broken vehicle, obstacle, reversing vehicle, vandalism, unusual weather and

disaster on road.

1.4.5 Pixel: A basic unit of illuminating display composed by one or more LEDs.

1.4.6 Pixel distance: the distance between 2 center points of 2 adjacent pixels.

1.4.7 Character width: is the distance measured from the center of the leftmost column and outside right column of the matrix, in mm.

1.4.8 Character height: is the distance measured from the center of the top line and bottom line of the matrix, in mm.

1.4.9 Brightness (luminance): concept of light that human eyes can observe at the area of light or light source. Brightness (luminance) is measured by Candela per m² (Cd/ m²);

1.4.10 Still observation distance: The maximum distance that the observer (normal person, visual acuity is adjusted as 10/10 or more) when standing still can clearly read in daytime condition;

1.4.11 Moving observation distance: The maximum distance that the observer (normal person, visual acuity is adjusted as 10/10 or more) when moving in the speed of 120km/h can clearly read in daytime condition;

1.4.12 Half-intensity angle: The angle of the fiber axis of the maximum intensity and the fiber axis of half maximum intensity of LED.

2. TECHNICAL REGULATION

2.1 General regulation on Electronic Signs on Expressway

2.1.1 Signs are to be able to provide information in Vietnamese and English, the contents of the information must be short, understandable, and suitable with the size of signs.

2.1.2 Signs are to be able to update information when it's required to change the information displayed from "traffic monitoring/control server".

2.1.3 Content of displayed information on the surface: do not flicker, not the type of running characters;

2.1.4 Signs are to be able to operate continuously, to ensure sufficient durability and reliability in ambient conditions of the roadside installation;

2.1.5 Signs are to be protected by the prevention from big storm, fire, earthquake, sandstorm and lightning, water, being rusted, dust, salt water, avoiding interference from other electronic devices ...

2.2 Materials Requirement

2.2.1 Structure of signs

Signs include hard parts: display board, controller, frame, casing, connection gates, connection parts,...Amongst, display board composes illuminating LED elements and hanging frame.

2.2.2 Requirements on LED elements

2.2.2.1 Display board is composed by illuminating LEDs ensuring the requirements on color defined in 2.6;

2.2.2.2 Information signs are to be made with couple modules, with the size of 8x16 or 16x32 pixels.

2.2.2.3 The LED to be selected are to ensure the uniform on color and brightness of signs; LEDs when not illuminating is in black or no color;

2.2.2.4 The half-intensity angle is not less than $11,5^{\circ}$;

2.2.2.5 Uniform illuminating: the ununiform in illuminating in the condition of rated operation line of illuminating points on the whole sign and normal direction of the surface not more than 5%, in case that pixel includes many LEDs, the ununiform in illuminating in a pixel is not over 10%;

2.2.2.6 Stable average operation time of LED is not lower than 50000 hours. Stable average operation time of other electronic components and devices is not lower than 30000 hours.

2.2.3 Signs' casings

2.2.3.1 Signs and all structural assemblies, accessories are designed from sustainable materials to ensure the best performance when long-term used in the actual atmospheric conditions during normal long period in the places to use signs.

2.2.3.2 Signs' casings and other parts of signs are to be completed, assembled closely, structured stably, out holes of casing are to be suitable, neatly, outside angles and edges are not is not sharp or caused to stand out., the connection between out line and the case is to be close and tight;

2.2.3.3 Signs' casings are to be designed to adjust observation angle for signs;

2.2.3.4 Signs' casings are to have suitable structure for not being easily opened and the caps are to be locked.

2.3 Shape and Size of Signs

2.3.1 Information signs

2.3.1.1 In case information displayed is in characters, using the following to decide the shape and size of information signs:

- + contents of data message defined in National Regulations on data message system on expressway.
- + The method for presenting the displayed content on signed is defined in 2.4.1 for information signs of characters;
- + Font Size and Style are defined in 2.5.1 for information signs.

2.3.1.2 In case information displayed is in figures, information signs are to be in suitable shape and size with figures needed to be displayed which is defined in 22TCN 331-05 and observation distance is defined in 2.8;

2.3.1.3 The thickness of information signs are to be designed in accordance with its size.

2.3.2 Speed Limit Signs

2.3.2.1 Speed limit signs are to be in suitable shape and size for the display board to display outside edge circle of LED edge of 1200mm diameter;

2.3.2.2 The thickness of speed limit signs are to be designed in accordance with its size.

2.4 Display content on signs

2.4.1 Information signs

2.4.1.1 Information signs include maximum 3 lines of information

2.4.1.2 Each line is located in the center of the signs;

2.4.1.3 Distance among lines is not less than half of the height of letters which is defined in 2.5.1;

2.4.1.4 The space above, below of signs is not less than half of the height of letters which is defined in 2.5.1;

2.4.1.5 Distance among words in a line is not less than half of the height of letters;

2.4.1.6 Distance among letters in a line is not less than half of the width of letters;

2.4.1.7 The space on the left, right of signs is at least not less than half of the height of letters which is defined in 2.5.1;

2.4.1.8 In case the information is displayed in figures, the figures is to be in center of the display area.

2.4.2 Speed limit signs

2.4.2.1 Speed limit signs display just one line;

2.4.2.2 Display Line includes not more than 3 digits;

2.4.2.3 Distance among digits in a line is not less than half of the width of letters;

2.4.2.4 Display line is to be in center of the sign.

2.5 Font Size and Style

2.5.1 Information Signs

2.5.1.1 Letters and digits displayed on signs comply with 22TCN331-05;

2.5.1.2 The height of letters and digits is specified not less than 400mm;

2.5.1.3 The thickness of handwriting on signs displayed by 10-15% of their height (40-60mm);

2.5.1.4 The width of the text displayed by 20-75 % of their height (80 - 300mm) as described in Table 1 and Table 2.

Table 1. Letter's width

Letter	Letter's width (mm)	Letter's Height Percentage (%)
A	240	60
Â	240	60
Ă	240	60
B	240	60
C	240	60
D	240	60
Đ	260	65
E	240	60
Ê	240	60
F	240	60
G	240	60
H	240	60
I	80	20
J	240	60
K	240	60
L	200	50
M	240	60
N	240	60

O	240	60
Ô	240	60
Ơ	280	70
P	240	60
Q	240	60
R	240	60
S	240	60
T	200	50
U	240	60
Ư	300	75
V	240	60
W	240	60
X	240	60
Y	220	55
Z	240	60
Average	236	59

Table 2. Digit's width

Digit	Digit's width(mm)	Digit's Height Percentage (%)
1	80	20
2	240	60
3	200	50
4	220	55
5	200	50
6	200	50
7	200	50
8	200	50
9	200	50
0	200	50
Average	194	49

2.5.2 Speed Limit Signs

2.5.2.1 Digits displayed on signs comply with QCVN 41:2012/BGTVT;

2.5.2.2 The height of displayed digits is not less than 440mm.

2.5.2.3 The thickness of digits' handwriting is 10-15% of the height (40-60mm).

2.5.2.4 The width of displayed digits is 18-59% of the height (80-260mm), specified in Table 3.

Table 3. Digit's width

Digit	Digit's width(mm)	Digit's Height Percentage (%)
1	80	18
2	240	55
3	220	50
4	260	59
5	220	50
6	220	50
7	220	50
8	220	50
9	220	50
0	220	50
Average	212	48

2.6 Color of Signs (ES)

2.6.1 Information Signs of character type

2.6.1.1 Letters and digits on signs are in red, blue, yellow

- +Red indicates commands;
- + Blue indicates providing information;
- + Yellow indicates warnings

2.6.1.2 Background of signs is the surface that not includes illuminating letters, digits or else. This background is black.

2.6.1.3 Coordinate of colors is to be in the CIE 1931, defined as in table 4.

Table 4 Coordinate values of color areas

Color	Color coordinate				
	Angle =>	1	2	3	4
Red	x	0.660	0.680	0.735	0.721
	y	0.320	0.320	0.265	0.259
Yellow	x	0,536	0,547	0,613	0,593
	y	0,444	0,452	0,387	0,387
White	x	0,300	0,440	0,440	0,300
	y	0,342	0,432	0,382	0,276
Blue	x	0,009	0,310	0,310	0,284
	y	0,720	0,684	0,562	0,520
Green	x	0,109	0,173	0,208	0,149
	y	0,087	0,160	0,125	0,025

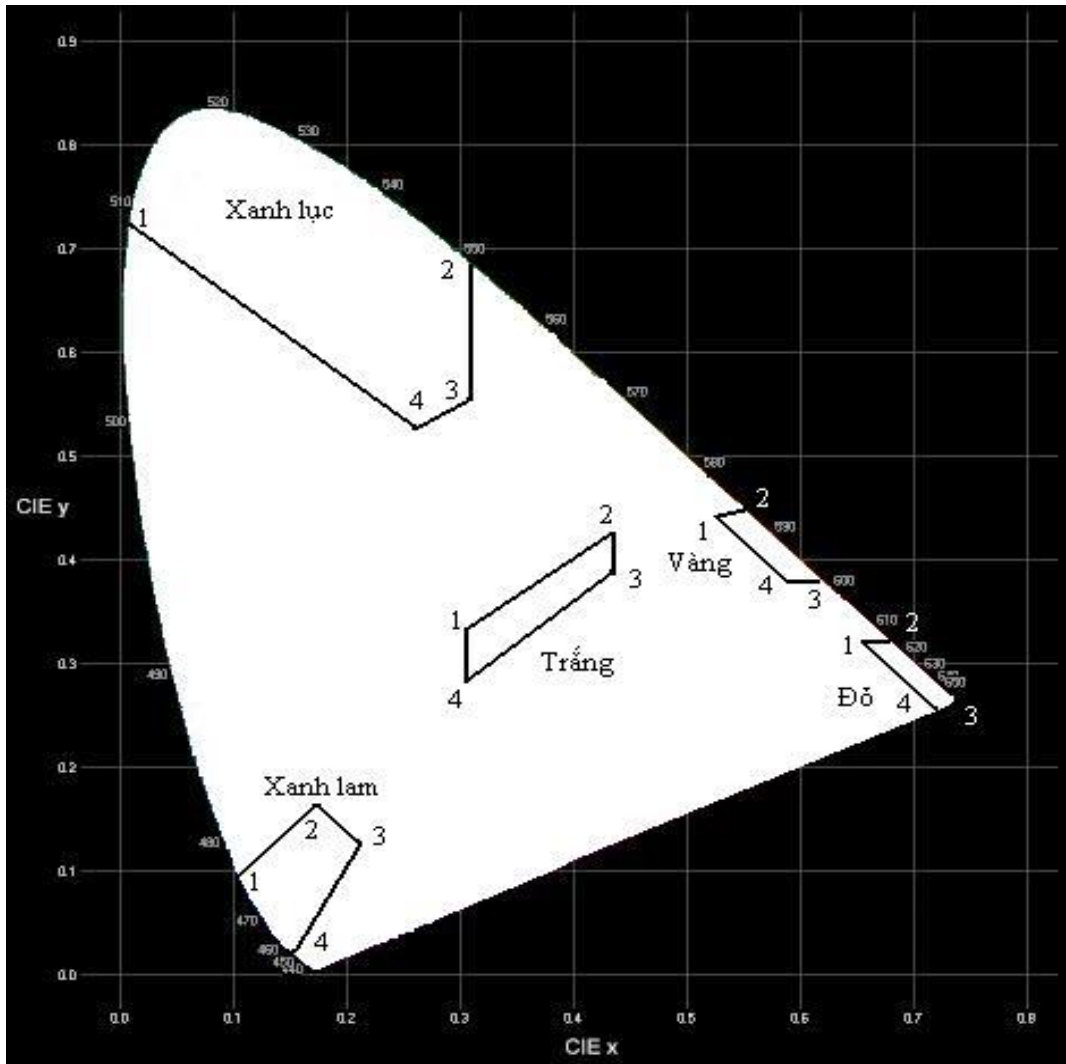

Figure1: Defined color area

2.6.2 Information Signs of figure type

2.6.2.1 Colors on signs are in red, green, blue, yellow and white;

2.6.2.2 The coordinate of colors is to be in CIE 1931, defined in table 4.

2.6.3 Speed Limit Signs

2.6.3.1 Digits for maximum speed limit is defined to be in white;

2.6.3.2 Background of signs is the surface that not includes illuminating digits or LED edge. This background is black;

2.6.3.3 LED edge is red, whose thickness is not over 60mm;

2.6.3.4 The coordinate of colors is to be in CIE 1931, defined in table 4.

2.7 Brightness (Luminance)

2.7.1 The brightness of each color displayed daytime is shown in table 5;

Table 5. *Brightness of each color in daytime*

Color displayed	Brightness when displayed
Blue	500cd/m ² or more
Red	1600cd/m ² or more
Green	2200cd/m ² or more
White	4300cd/m ² or more
Yellow	3800cd/m ² or more

2.7.2 The brightness of each color displayed night-time is shown in table 6;

Table 6. *Brightness of each color in night-time*

Color displayed	Brightness when displayed
Blue	25cd/m ² or more
Red	85cd/m ² or more
Green	120cd/m ² or more
White	230cd/m ² or more
Yellow	205cd/m ² or more

2.8 Observation Feature

2.8.1 The signs is to be able to provide instructions for road users in words clearly readable while driving at speeds up to 120km/h.

2.8.2 The distance that the drivers can see the contents of electronic signs is 150m.

+ Stable observation distance is not less than 250m;

+ Moving observation distance is not less than 210m;

2.8.3. Electronic signs are to be able to be clearly readable all the displayed information in the angle of +/- 10⁰ of the vertical line of the signs.

2.9 Controller of Signs

2.9.1 Requirements

2.9.1.1 The controller is able to control the LED lamps to display the required information from traffic monitoring and control system on expressway

2.9.1.2 The controller is able to adjust the colors to be suitable with article 2.6;

2.9.1.3 The controller is able to adjust the brightness to be suitable with article 2.7;

2.9.1.4 When there is an outage the controller is able to send signals to the traffic monitoring/control system on expressway;

2.9.1.5 The controller is to be equipped with security, avoiding impact from outside;

2.9.1.6 The controller is able to operate continuously 24 hours per day, 365 days per year, except for the duration of the maintenance and repairing.

2.9.2 Communication process and port

The controller are to be able to operate on the data transmitting with communication gate, ...

2.9.3 Structure

2.9.3.1 The controller is to have a part to convert the grid power supply into required ones, providing to inside components and modules of signs.

2.9.3.2 The controller is to have the power protection device, overvoltage protection device;

2.9.3.3 The controller is to have the ON/OFF switch allowing ON/OFF LED on the whole signs.

2.9.3.4 The controller is to have connectivity gate, functional modules for the connection, information transferring with traffic monitoring/control system.

2.9.3.5 The controller is to have a standard COM 9 port connector for the connection, information transferring with the computer when testing and checking.

2.9.3.6 The controller is to be solid, in suitable size, and placed in protecting box.

2.9.4 Clock of signs

2.9.4.1 The controller is to have real clock, whose function is to provide date and time, specifically, year, month, day, hour, minute, second, and tenths of second;

2.9.4.2 Accuracy of the real clock is ± 1 second in a week. Real clock are to be synchronized simultaneously by all monitoring, control systems.

2.10 Requirements on Power Supply and Related Problems

2.10.1 Main power supply is an AC source, single phase, valuable operating voltage of about 220VAC $\pm 15\%$, frequency 52Hz ± 2 Hz.

2.10.2 Signs should have backup power supply to prevent outages. The backup power supply should be capable of powering the system for 2 hours.

2.10.3 In the case of using backup power supply, signs are to send feedback to the control center for it to notice and to repair the power supply.

2.10.4 Insulating resistance is not allowed to be less than 100MΩ;

2.10.5 Ground safety: Signs are to be designed with safe grounding ends. Grounding ends and frames are to be stable, reliable. The resistance between grounding ends and frame is less than 0.1Ω;

2.10.6 Signs and surrounding areas are to be installed overvoltage and lightning protection system; devices, connecting ends and protection solutions are suitable with related standards.

2.11 Ambience

2.11.1 Ambient temperature: 0 ÷ 55°C.

2.11.2 Air humidity: up to 80%. It's necessary to consider preventing the effects of high humidity including condensation droplets in the ambient air

Surface solar projection withstands: 1000w/m².

2.11.3 Equipment should be appropriate stable, not being affected by wind speeds of 37m/s (level 12) or equivalent, not affecting the usage feature of signs.

2.11.4 All signs are to have surround protective casing of at least IP65. The controller is IP45.

2.12 Checking and Maintenance

2.12.1 Parts of signs are to be inspected and maintained are: display board, the controller, frame, casing, connection gates, installed connecting parts;

2.12.2 Parts of signs are to be inspected and maintained periodically or whenever there is an error to occur, according to the documents of the provider;

2.12.3 Signs are to be easily defining the type of errors when detecting them, and the replacement of parts is implemented easily.

2.13 Label and Labelling

2.13.1 All labels are to be fixed on observable places, not affecting the observation of the displayed information on the signs.

made clear, fixed and weather resistant.

2.13.2 All labels are to be protected from being tearing, blurring, broken.

2.13.3 The size of the labels are to be suitable with their contents.

2.13.4 Content and the way to label goods are to comply with regulations for goods of electric electronic products at the decree 89/2006/ND-CP dated 30/8/2006 by Government on goods' labels.

2.14 Installation

2.14.1 Signs must be placed so that drivers are not embarrassed with the information and are not prevented from clear visibility.

2.14.2 Signs are placed on the expressway with Long men tripod, roadside pole and other similar structures just above the lanes as Figure 2 and 3. Still space since the below edge of signs (if the signs are hung below) or the lowest point of the cross girder of the sign hung structure (if the signs are hung above) to road surface is not less than 5,5m.

2.14.3 Structures hanging signs are to be enduring for their own weight, weight of signs and in the level 12 storm.

2.14.4 Locations to install signs are shown in table 7;

Table 7. *Position and installation condition of signs*

Location	Condition	Method
At entrance of Exw	Tollgate at entrance and no turning back	On pole roadside
Before Tollgate on main rout	Volume of vehicles on each toll lane over 2000vehicles/whole day and turning back point before tollgate	On long men tripod
Before interchange	Always installed	On long men tripod
Between two adjacent intersections	Distance t o next signs over 10km and volume of vehicles on each lane over 5000vehicles/whole day	On long men tripod
At exit of Exw	Cross with another Exw section	On pole roadside

2.14.5 Speed limit signs are usually installed: after the ..point of expressway, between two adjacent interchanges.

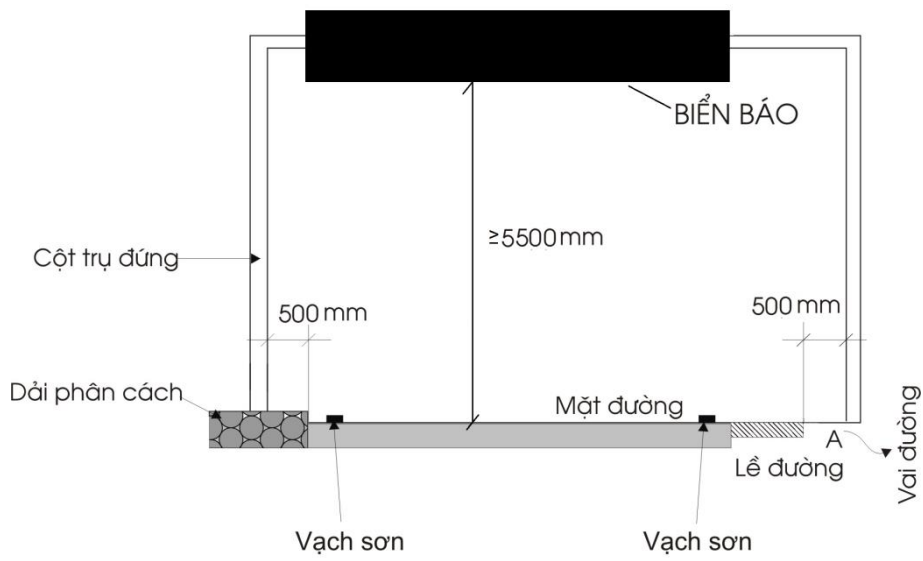

Figure 2: Giá long môn treo biển báo điện tử

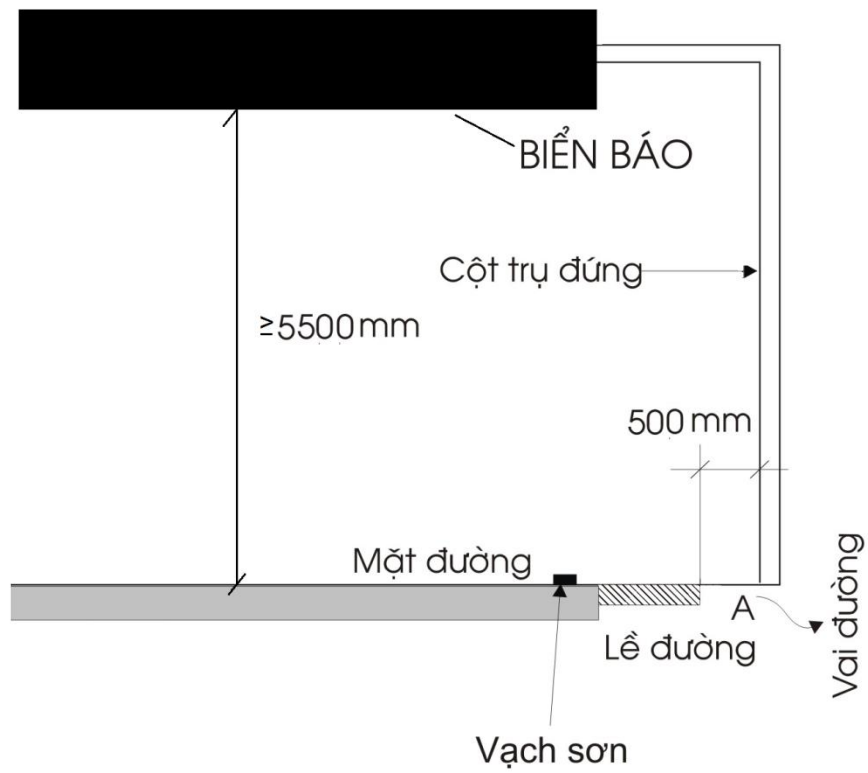

Figure 3: Cột trụ đứng treo biển báo điện tử

3. REGULATION ON TESTING AND CHECKING

3.1 Testing/Checking Conditions

3.1.1 Testing ambient condition is corresponding to the working condition of electronic signs in normal working conditions.

3.1.2 Testing places are to be clean and in fresh air.

3.1.3 Signs are to be cleaned before testing.

3.1.4 In addition, the test conditions must be consistent with each testing, checking.

3.2 External and Technical Checking

3.2.1 External Checking

3.2.1.1 Labels which include information of the product are to be checked, signs are to be labelled: labels are placed in a visible position, no tearing, blurring, lacking of information, the information on labels is specified in 2.13;

3.2.1.2 Shape, size, and accessories (if any) must be consistent with the accompanying technical documentation of the manufacturers

3.2.1.3 Board displayed, the controller, frame, casing, connection gates, connection parts are not warped, cracked;

3.2.1.4 The controller is to contain full parts, components, connectors gates, as defined for controller in Section in 2.9;

3.2.2 Technical Checking

3.2.2.1 Check the LED, LED module: brightness, brightness half angle, ...as in the accompanying technical documentation of the manufacturers.

3.2.2.2 After providing power supply, turn the ON/OFF switch into ON for the entire LED to be illuminated, check whether any LED is broken or off or not. Entire LEDs are required to function properly.

3.2.2.3 Display in turns all information on signs, The whole information is to be clearly displayed when being observed at required still distances defined in 2.8;

3.3 Power Supply and Related Issues

3.3.1 Check the function of fitting to the voltage and fluctuation frequency with level of voltage and frequency as defined in 2.10;

3.3.2 Check the operation of signs with backup power supply;

3.3.3 Check insulating resistance of signs;

3.3.4 Check grounding safety.

3.4 Color Testing and Checking

Measure and check values of colors as defined for each type of signs in conditions, procedures, equipment to test and check the colors; compare the results with the color coordinates defined in 2.6 to check whether the colors are in suitable limit or not.

3.5 Information Transmitting Check

3.5.1 Check information transmitting and updating of signs in case of using AC power supply;

3.5.2 Check information transmitting and updating of signs in case of using backup power supply;

3.5.3 Check information transmitting and updating of signs in case of power failure;

4. REGULATION ON MANAGEMENT

4.1 Management Principles

4.1.1 The expressway sections when coming into operation are to provide fully signs in accordance with the provisions of this regulation.

4.1.2 On the expressway sections in operation progress, the current signs which are not in accordance with this regulation is to be gradually adjusted, replaced to avoid waste; the new added signs must comply with the provisions of this regulation.

4.1.3 When new designing or upgrading expressway, the system of must comply with this regulation.

4.1.4 It is forbidden to plan trees, build constructions, install equipment causing obscuring, reducing of recognition distance or fainting of expressway signs.

4.2 Certification and Legal Announcement

4.2.1 All electronic signs manufactured, assembled and traded both domestically and importedly require the announcement of regulations conformity, in accordance with the provisions of this regulation. Organization, individual violate the announcement or registration of regulations conformity, behaviour and degree of the violation will be punished by the law;

4.2.2 Method, order and procedures for announcement of regulations conformity of signs comply with the "Regulation on Certification of standard conformity, certification of regulations conformity and announcements of standard conformity, regulations conformity"

issued together with circular No. 28/2012/TT-BKHHCN dated 12/12/2012 of the Ministry of Science and Technology and the provisions of law; applicable in detail as follows:

Applying the method 1, (testing of typical samples for the goods) in the Appendix II together with circular No. 28/2012/TT-BKHHCN above. Contents of testing of samples comply with the provisions of Chapter II of this regulation.

4.2.3 The organization to implement the testing and judgment of the conformation with the regulation together with circular No. 28/2012/TT-BKHHCN is to have the certificate of registration of business activities as prescribed in Circular No. 08/2009/TT-BKHHCN dated 8/4/2009 of Ministry of Science and Technology and Circular No. 10/2011/TT-BKHHCN to change, add some provisions of Circular No. 08/2009/TT-BKHHCN dated 30/6/2011 of Minister of Ministry of Science and Technology and is to be appointed by Ministry of Transport. The organization to implement the testing and judgment of the conformation with the regulation is responsible according to Article 20 of Law on quality of products and goods and other related regulations.

4.3 Responsibility of Road Management Agency

4.3.1 Expressway Management Agency is responsible for executing this regulation, ensuring the sufficient, consistent and clear sign system on the expressway. In case the signs are lost, damaged, faint or do not comply with the provisions of the regulation, it's necessary to provide additional measures, reparations or replacement to ensure traffic safety.

4.3.2 Officials and employees in charge of road management tasks within their authorities are to promptly detect any damage, loss and invasive behaviour of sign system, report to the expressway management agency, or make records or handle those violations of this regulation by their responsibilities and under the provisions of the law. If not promptly solve, causing damage to life or serious damage to health and property of others, they must be punished by the law.

4.4 Responsibility of Road Users

4.4.1 Signs are State's property. All users of expressway, the participants in traffic and drivers of all types of vehicles on expressway must protect well the signs on expressway, is not allowed himself to move, possess, damage or reduce the effect and usefulness of signs on roads, is responsible for detecting, informing to management agency of expressway the damage, loss, other problems of the signs on expressway

4.4.2 The person who causes damage or loss of signs on Expressway, are to be responsible for any loss due to the damage, loss and to pay damages. In case of causing damage, loss

without report, once being revealed, the behaviour is regarded as damaging State property and will be punished by the law.

5. Implementing Organization

5.1 Department of Science and Technology is responsible for management of product quality and check the regulations conformity announcements of signs in accordance with this regulation and other current related regulations;

5.2 Department of Science and Technology chairs and coordinates with Directorate of Road for Vietnam, and related agencies to implement and inspect the implementation of this regulation;

5.3 During implementation, if there is any difficulties or problems, report to the Ministry of Transport for consideration and decision to amend accordingly.

添付資料-6

**DRAFT QCVN
OF
COMMUNICATION SYSTEM
FOR EXPRESSWAYS
(SUB-GROUP 6)**

1ST DRAFT
(Sub-Group 6)
2014.02.28



SOCIALIST REPUBLIC OF VIETNAM

QCVN XX: 2014/BGTVT

**QUY CHUẨN KỸ THUẬT QUỐC GIA
VỀ HỆ THỐNG THÔNG TIN LIÊN LẠC
TRÊN ĐƯỜNG CAO TỐC**

*National Technical Regulation on Communication System on
Expressway*

HA NOI - 2014

Foreword

QCVN XX: 2014/BGTVT is compiled by Compiling board of National Regulation on Expressway Communication System, by Information technology Center, Ministry of Transport; evaluated by Department of Science and Technology and issued by Minister of Ministry of Transport in Circular No. xx/2013/TT-BGTVT dated..... 2014.

1ST DRAFT
(Sub-Group 6)
2014.02.28

**NATIONAL TECHNICAL REGULATION ON COMMUNICATION SYSTEM
ON EXPRESSWAY**

QUY CHUẨN KỸ THUẬT QUỐC GIA VỀ HỆ THỐNG THÔNG TIN LIÊN LẠC TRÊN ĐƯỜNG CAO TỐC

1	General Regulations	4
1.1	Scope	4
1.2	Application Object	4
1.3	Terminology and Definations	4
1.4	Abbreviations.....	4
2	Requirements	5
3	System Architecture.....	6
4	Switch Equipment Components.....	7
4.1	Functions.....	7
4.2	Structure.....	7
4.3	Performance.....	8
4.4	Human-machine Interface.....	8
4.5	Communication Interface.....	8
4.6	Installation	9
5	Transmission Equipment	9
5.1	Functions.....	9
5.2	Structure.....	10
5.3	Performance.....	10
5.4	Human-machine Interface.....	10
5.5	Communication Interface.....	10
5.6	Installation	10
6	Fiber Optic Cable.....	11
6.1	Functions.....	11
6.2	Structure.....	11
6.3	Performance.....	11
6.4	Human-machine Interface.....	12

6.5	Communication Interface.....	12
6.6	Installation	12
7	Network Management System.....	13
7.1	General.....	13
7.2	Functions.....	13
7.3	Structure.....	13
7.4	Performance.....	14
7.5	Human-machine Interface.....	14
7.6	Communication Interface.....	14
7.7	Installation	14
8	Ambient Conditions.....	15
9	Power Supply	15
10	Maintenance.....	15
11	Rules on Management.....	16
12	Implementation Organization	16

1. General provisions

1.1 Scope

This package allows road operator to exchange ITS data between Regional main center and Section main centers, and roadside equipment using backbone network between centers, including fiber optic network installed along expressways and communication nodes and network access between communication nodes with terminals on road.

1.2 Application Object

The regulations apply to organizations and individuals involved in the process of construction and operation of communication systems of expressway ITS system.

1.3 Terminology and Definitions

Section main center: under management of contractor to carry out supervision and administration of expressway on the section. The Center is operated with the help of information technology communications and automatic control equipment, of the investment package of monitoring and control traffic.

Regional main center: Responsible supervision and operation of the center line of traffic operating in the area of management. Traffic Operations Center area connected to the center line of traffic operating through Intelligent Transport System - ITS.

Operators: operational staff to ensure the operation of intelligent transportation systems in ITS Traffic Operations Center Operations Center routing and traffic areas.

Event traffic: Situations once occur affect on traffic operations including traffic incidents, hazardous weather, congestion, and roadwork there, the traffic violation of driving vehicles, the traffic restrictions and other special events.

Incident: An event of unusual and unforeseen impact or impede traffic includes traffic accidents, vehicle breakdown, road incidents, obstacles on the road, disasters happen.

Station: sector operator of the charging stations, stops, expressway services.

Toll system: System devices were installed at the toll plaza and at traffic control centers to ensure operational line toll collection on expressways.

1.4 Abbreviations

ITS	Intelligent Transportation System
TMC	Traffic Main Center
VMS	Variable Message Sign
CCTV	Closed Circuit Television
PTZ	Pan Tilt Zoom
DPTZ	Digital PTZ
IP	Internet Protocol
VPN	Virtual Private Network

2 Requirements

System is capable to exchange data (including video image) among roadside equipment on expressway, Regional TMC, Section TMC and toll office.

System is capable to transmit conversations among Regional TMC, Section TMC and toll office.

System is capable to simultaneously transmit instructions to the relevant units with the highest priority at any time for handling incident, implementing traffic regulations.

The system is capable to determine the location of the incidents on the network communications and recovery by automatic switching. The system is capable of operating 24 hours a day, 365 days a year thanks to the backup system and required durability/reliability of equipment.

3 System Architecture

Communication system architecture as follows:

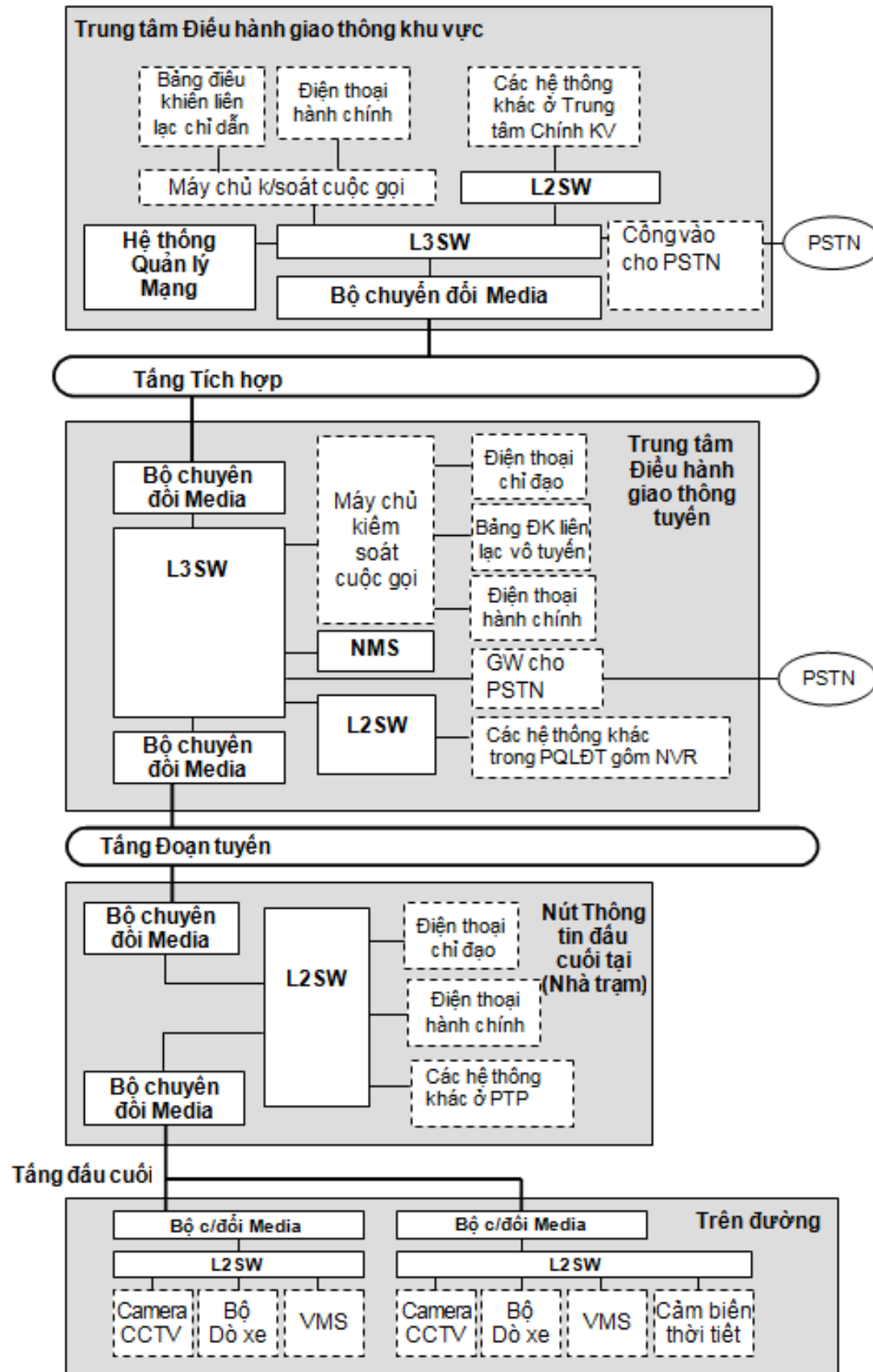

System architecture includes 3 layers:

Terminal layer

Section layer

Integrated layer

4 Switch Equipment Components

4.1 Functions

Switch equipment components is capable to change all contact flows related to ITS data.

Switch equipment components shall ensure all connections for directions as needed without losing the call signal.

Switch equipment components for Integrated Layer Network and National Layer Network is capable to use IP 6.

Switch equipment components shall not be incompatible with connection interfaces with transmission equipment components.

Various directions from Main Center like overall directions and directions to the Management Office and specific offices such as Toll Office. Switch equipment component shall be able to perform different directions under the guidance of road operator with contact instruction panel.

Switch equipment components shall the ability to control the quality of transport services contact ITS. In addition, the latency-sensitive data such as voice information shall be controlled by specific performance.

Error switch equipment components shall be able to detect and notify operations staff. During the recovery process after the fault detection, ensure continuous operation does not interrupt the backup device components.

Switch equipment components have usefulness in units operated the road, vendors or services operated under the national dialogue not produce products.

4.2 Structure

Switch equipment components shall be capable to continuously operate 24/7/365.

Switch equipment components shall be designed to be installed in the buildings or chassis.

Switch equipment Components shall be able to replace in a simple and easy way the errors once detected.

Switch equipment Components shall be capable to perform periodical operation check and cleaning.

4.3 Performance

Performance of switch equipment components shall be ensure to be able to switch and connect required information in an appropriate period as specified in the related specifications.

Voice communications for directive and administrative call shall be included in the condition Class 0 of Recommendation ITU-T, Y.1541 in ITS communication network.

Directive call from the Regional main Center shall be uninterruptedly connected. For administrative call, disconnection is allowed only at 10%.

Voice quality in voice communication shall correspond to the quality of fixed line telecommunications service provider. However, it's necessary to comply at least with the following performance:

Directive communications:

From the directive control panel to terminal equipment components to receive directive calls: approximately 18dB

Administrative call:

From one end of the terminal equipment to the other end of its: approximately 26dB

The equipment is capable of operating 24/7/365. During the period of maintenance and repair, operation shall be maintained by the backup devices.

4.4 Human-machine Interface

Switch equipment components shall be equipped with human-machine Interface for the operation and maintenance (O&M) staff to monitor and judge system, enter the necessary commands, and perform the necessary operation and maintenance activities.

Switch equipment components shall be able to detect the error of equipment components. Upon detecting an error, the system shall be able to perform such error warnings as buzz or flashing on the display to inform the O&M staff.

Switch equipment components shall include human-machine interface for the operator to input the necessary commands into the system.

The data traffic server shall be capable to manage by remote control.

4.5 Communication Interface

Communication interface of switch equipment components shall comply with international standards

Communication interface of switch equipment components shall not impede the transmission of video, data, and signals and voice.

4.6 Installation

Installation works including tax, local/domestic transportation, and installation of components of equipment, software installation, setting up, configuration, testing/inspection and equipment operation. Primitive instructions, handing over the equipment and submitting the required documents such as drawings, data and manuals by the project implementation shall be considered as a part of the installation.

Switch equipment components shall be installed in the air-conditioned room in the Regional Main Center, Road Management Office, Toll Office and other necessary locations.

If the switch equipment components are required outdoor installation at the terminal nodes, the proper equipment or protective casing shall be selected to be against the ambient conditions specified as below.

The contractor shall prepare equipment layout drawings considering existing facilities. Detail drawings including cabling and wiring diagram.

The necessary material shall be painted and completed in line with the relevant codes and standards. Quality paint and application methods shall conform to standards and can withstand ambient conditions specified as below.

Equipment shall be protected to prevent direct lightning strikes and lightning propagation. Maximum land resistance is 10ohm, and the equipment shall be protected of general grounding, connected to the grounding system of other nearby construction.

Security/guarding system shall be needed to prevent unauthorized persons from entering the field during installation process.

5 Transmission Equipment

5.1 Functions

Transmission equipment components shall be capable to transmit of all communication traffic related to ITS.

Transmission equipment components shall be ensured to transmit the directive communications in cases of emergency.

Transmission equipment components shall comply with international standards.

Transmission equipment components shall be capable to control the quality of ITS communication traffic services. Also, for such traffic delays as voice communications shall be controlled by specific performance.

Errors of switch equipment components shall be detected and notified to an operator. During the recovery process after the detection, it's required to ensure continuous operation of the backup equipment components without interrupting.

The data transmission through communication network shall be capable to guarantee security conditions.

Switch equipment components shall be useful kinds that road operators or providers of telecommunications services in other countries verify more than that of original manufacturing countries.

5.2 Structure

Equipment components shall be capable to continuously operate 24/7/365.

Transmission equipment components shall be designed to be installed in the buildings or chassis.

Transmission Equipment Components shall be able to replace in a simple and easy way the errors once detected.

Transmission Equipment Components shall be capable to perform periodical operation check and cleaning.

5.3 Performance

Performance of the component transmission equipment shall be able to transmit and connect with required communication traffic in an appropriate period specified in the related specifications.

Voice communications serving to directive and administrative calls shall be included in the conditions of the Type 0 of Recommendation ITU-T, Y.1541 in ITS network communications.

Equipment components are to be capable of continuous operation 24/7/365. During maintenance and repair, equipment is continued to be operated by backup equipment components.

5.4 Human-machine Interface

Transmission equipment components shall be equipped with human-machine Interface for the operation and maintenance (O&M) staff to monitor and judge system, enter the necessary commands, and perform the necessary operation and maintenance activities.

When the transmission equipment components errors are detected by Network Management system, error alert function by buzz or flashing on the display informs the O&M staff.

Transmission equipment components shall include human-machine interface for the operator to input the necessary commands into the system.

The data traffic server shall be capable to manage by remote control.

5.5 Communication Interface

Communication interface of switch equipment components shall comply with international standards.

Communication interface of switch equipment components shall comply with international standards, and not impede the transmission of data, signals and voice.

5.6 Installation

Installation works including tax, local/domestic transportation, and installation of components of equipment, software installation, setting up, configuration, testing /inspection and equipment operation. Primitive instructions, handing over the equipment and submitting the

required documents such as drawings, data and manuals by the project implementation shall be considered as part of the installation.

Transmission equipment components shall be installed in the air-conditioned room in the Regional Main Center, Road Management Office, Toll Office and other necessary locations.

If the transmission equipment components are required outdoor installation at the terminal nodes, the proper equipment or protective casing shall be selected to be against the ambient conditions specified as below.

The contractor shall prepare equipment layout drawings considering existing facilities. Detail drawings including cabling and wiring diagram.

The necessary material shall be painted and completed in line with the relevant codes and standards. Quality paint and application methods shall conform to standards and can withstand ambient conditions specified as below.

Equipment shall be protected to prevent direct lightning strikes and propagation. Maximum land resistance is 10ohm, and the equipment shall be protected of general grounding, connected to the grounding system of other nearby construction.

Security/guarding system shall be needed to prevent unauthorized persons from entering the field during installation process.

6 Fiber Optic Cable

6.1 Functions

Optic cable used in ITS communication network shall basically be of transmission distance far beyond the distance of copper cable.

Single mode optic cable shall be used in the ITS communication network, and it shall comply with ITU-T G652.D.

Optic cable error shall be detected by the management system and shall be capable to be detected and notified to the operator. During the recovery process after detection, ensure continuous operation without interrupting by the backup equipment components.

Data transmitted in the communication network shall be capable to ensure proper operating conditions.

Optic cable shall be useful kinds that road operators or providers of telecommunications services in other countries verify more than that of original manufacturing countries.

6.2 Structure

Basically fiber optic cable is inserted in conduit.

Optic cable shall be with sufficient corrosion resistance.

6.3 Performance

Optic cable which is selected shall be capable to transmit required communication specified requirements in the related specifications.

Performance of optical fiber shall comply with the provisions specified in ITU-T G.652.D.

The instrumentations to detect the position of optic cable errors, and other equipment for its operation and maintenance shall be provided by fiber optics cable manufacturers. Also they offer training how to use the equipment for O&M staffs. However, if it is outsourced to another unit, the detail requirements shall be specified in contracts.

The necessary equipment used in Fiber Cable replacing and connection equipment or materials of cable shall be provided by manufacturer to O&M unit for proper installation and maintenance.

The necessary training shall also be provided to the staffs of O&M units from the manufacturers, that meets the communications system. However, if it is outsourced to another unit, the detail requirements shall be specified in contracts.

6.4 Human-machine Interface

When the optic cable errors are detected by Network Management system, error alert function shall be equipped with whistle or flashing on the display to inform the O&M staff.

The instrumentations used for routine maintenance or optic cable error detection as Optical Time Domain Reflectometer (OTDR), a suitable size display screen shall be equipped.

6.5 Communication Interface

Optical Fiber Interface communication interface shall comply with international standards, and not impede the transmission of data, signals and voice.

6.6 Installation

Installation works including tax, local/domestic transportation, and installation of components of equipment, software installation, setting up, configuration, testing /inspection and equipment operation. Primitive instructions, handing over the equipment and submitting the required documents such as drawings, data and manuals by the project implementation shall be considered as part of the installation.

Optic cable shall be installed in among media switch sets in the Regional Main Center, Road Management Office, Toll Office and other necessary locations.

If the transmission equipment components are required outdoor installation at the terminal nodes, the proper equipment or protective casing shall be selected to be against the ambient conditions specified as below.

The contractor shall prepare equipment layout drawings considering existing facilities. Detail drawings including cabling and wiring diagram.

The necessary material shall be painted and completed in line with the relevant codes and standards. Quality paint and application methods shall conform to standards and can withstand ambient conditions specified as below.

Equipment shall be protected to prevent direct lightning strikes and propagation. Maximum land resistance is 10ohm, and the equipment shall be protected of general grounding, connected to the grounding system of other nearby construction.

Security/guarding system shall be needed to prevent unauthorized persons from entering the field during installation process.

7 Network Management System

7.1 General

Network Management Systems located in Road Management Office shall be capable to monitor section and terminal layer under that Road Management Office. NMS system located in Regional Main Center shall the ability to monitor Integrated Layer Network under Regional Main Center.

All equipment components shall be monitored by at least one Network Management Systems mentioned above.

7.2 Functions

Network Management System (NMS) shall be equipped with the following functions;

(1) Function of monitoring, alert and notification

Function of defining the source and recovery many types of alerts and monitoring L3SW, Switch Layer 2, equipment/ transmission line, roadside equipment. The function of log for warning is needed, and display and print functions are also required when necessary. Other necessary function is to notify operating staff by buzz or flashing.

(2) Source Management Function

Function of operation for monitoring condition Layer 3 Switch, Layer 2 Switch, equipment/ transmission line, roadside equipment connected in a required network. When system configuration is adjusted, functions also required to be equipped include: system supplementation, equipment component registration and adjust. In the process of replacing equipment components, it shall have a distinction between "Operating Conditions" and "being installed".

(3) Performance Monitoring Function

Monitoring function on network communication flow is required.

(4) Check Function

Check function for communication lines and connection of the equipment status shall be equipped.

(5) Function of switching to the backup equipment components

The function of automatically switching to the backup equipment components shall basically be equipped to detect the error, and this function can also distinguish operating status of equipment components like: "Normal" or "abnormal" for both and backup operating equipment components. Without this function, NMS is required to be equipped to switch manually or optional.

7.3 Structure

NMS shall be durable enough for continuous operation 24/7/365.

NMS shall be designed to be installed in buildings, office equipment and cabinets.

Structural NMS shall be able to replace a simple and easy way to share error detection.

Structural NMS shall be able to perform inspection activities and periodically cleaned.

Transmission equipment shall be capable of radiating heat from inside the device.

NMS shall be durable enough for continuously operating 24/7/365.

NMS shall be designed to be installed in the buildings, offices or chassis.

NMS shall be able to be replaced in a simple and easy way the error parts once detected.

NMS shall be capable to perform periodical operation check and cleaning.

Equipment casing shall be capable of heat emission internally.

7.4 Performance

Performance of the NMS shall be ensured for immediately detecting errors, so that NMS operator can understand the communication network errors before the operator of Traffic Information/Control detects errors of equipment components, if the errors belong to communication network.

The goals of NMS monitoring are switches, transmission equipment components, communication cables, and necessary monitoring content shall be selected to clearly define error location and status. Equipment components shall be capable of continuous operation 24/7/365.

7.5 Human-machine Interface

NMS shall be equipped with human-machine Interface for the operation and maintenance (O&M) staff to monitor and judge system, enter the necessary commands, and perform the necessary operation and maintenance activities.

When errors are detected, NMS shall be capable of error alert by buzz or flashing on the display to inform the O&M staff.

7.6 Communication Interface

Communication interface NMS shall comply with international standards.

7.7 Installation

Installation works including tax, local/domestic transportation, and installation of components of equipment, software installation, setting up, configuration, testing /inspection and equipment operation. Primitive instructions, handing over the equipment and submitting the required documents such as drawings, data and manuals by the project implementation shall be considered as part of the installation.

Information of NMS alert installation shall be shared in traffic management room in the Regional Main Center for the operator of traffic control to detect.

The contractor shall prepare equipment layout drawings, considering existing facilities. Detail drawings including cabling and wiring diagram.

Software shall be capable of being installed on such operating systems as Microsoft Windows or Linux or the ones are popular used in many countries.

The necessary material shall be painted and completed in line with the relevant codes and standards. Quality paint and application methods shall conform to standards and can withstand ambient conditions specified as below.

Equipment shall be protected to prevent direct lightning strikes and propagation. Maximum land resistance is 10ohm, and the equipment shall be protected of general grounding, connected to the grounding system of other nearby construction.

Security/guarding system shall be needed to prevent unauthorized persons from entering the field during installation process.

8 Ambient Conditions

Equipment components shall be protected from interference from other electronic devices and electronic noise on the project site.

Equipment components of transmission, switch and NMS shall be placed in air-conditioned clean rooms or equivalent frame with IP65 standards to ensure good working condition of the equipment.

Equipment components shall be installed outdoor with the possibility of performance in ambient conditions such as natural conditions, meteorological conditions, electronic noise and other environmental conditions at the project site in Vietnam. The contractor should inspect the environmental conditions around the project site and has appropriate protection plans designed for each individual equipment components.

Spare parts of equipment components of switch, transmission and NMS shall be stored in air-conditioned clean rooms to maintain good performance. Storage room conditions depend on the requirements for each of equipment in the storage environment.

9 Power Supply

Main power supply is AC 220V, single phase and 50 Hz frequency

Power supply is 220V AC power, phase and frequency of 50 Hz

Power Supply for Information Center/Roadside information system shall be equipped with backup power supply to ensure the equipment to operate 24/7/365.

10 Maintenance

The system shall be capable to allow check and maintenance in simple and convenient way.

The system shall be capable to easily identify the errors once they are detected, and the replacement of parts shall be able to be done easily.

Spare parts for the equipment should be provision for a minimum of five (5) years since the equipment has been handed over to the road management agency, and manufacturers shall ensure the supply of spare equipment during this period.

Manufacturers of transmission equipment and fiber optic cable shall be required to submit the necessary documents relating to operation and maintenance, such as manuals and test equipment list, also provide necessary training for O&M personnel of related equipment.

Manufacturers of transmission equipment and fiber optic shall be required to sign a contract with the road management agency on technical support services for operation and maintenance related to the supplied equipment, and provides necessary services under this contract contents.

11 Rules of Management

The system of traffic monitoring camera is an essential component to be prepared to invest in the project on ITS construction on expressways.

The operation and maintenance of expressway monitoring camera shall be done according to the Ministry of Transportation or investor approval on the basis of compliance:

- Regulation of the Government on management, exploitation and maintenance of expressways;
- Plans on expressways traffic is approved by authorized level;
- The coordination scheme among operating units on expressways;

The contractor assigned to manage expressway maintenance work performed operation and maintenance of traffic monitoring camera by taking funding from sources online management costs according to the Ministry of Transportation approval.

12 Implementation Organization

The organizations and individuals involved in the planning for development, construction investment, management, operation and maintenance of expressway monitoring camera system shall comply with the technical standards specified in this regulation and other relevant legal documents.

In case of technical regulations, standards, technical documents cited in this technical regulation have got change; supplement or replacement, it's to comply with the provisions in the new documents.

Directorate for Road of Vietnam (DRVN) is responsible for:

- Develop rules on coordination, operation of the intelligent traffic system - ITS including traffic monitoring camera system in operation management, exploitation and maintenance of expressways.
- Check and supervise the construction process and put into use monitoring camera systems strictly according to regulations issued.

DRVN shall preside and coordinate with the Department of Science and Technology (Ministry of Transport) and authorities to deploy guide and organize the implementation of this Technical Regulation./.

添付資料-7

**DRAFT QCVN
OF
ETC SYSTEM FOR EXPRESSWAYS
(SUB-GROUP 7)**

1ST DRAFT
(Sub-Group 7)
2014.03.30



SOCIALIST REPUBLIC OF VIETNAM

QCVN xx: 2014/BGTVT

**QUY CHUẨN KỸ THUẬT QUỐC GIA
VỀ THU PHÍ ĐIỆN TỬ TRÊN ĐƯỜNG CAO TỐC**
National Technical Regulation on Electronic Toll Collection (ETC)
for Expressway

HANOI - 2014

TABLE CONTENT

	Page
PREFACE	
1. GENERAL REGULATION	
1.1 Scope	5
1.2 Application Object.....	5
1.3 Reference Materials.....	5
1.4 Terms and Definitions.....	6
1.5 Abbreviations	7
2. REGULATIONS ON TOLL COUNTING.....	9
2.1 Defining Type of Vehicle.....	9
2.2 Defining Mileage of Vehicle	9
3. TOLL COLLECTION PROCEDURE	12
3.1 General Procedure	12
3.2 OBU Issuance.....	13
3.3 Account Refilling	13
3.4 Tollgate Processing	13
3.5 Bank Settlement System Processing.....	18
4. TECHNICAL REQUIREMENTS.....	19
4.1 General Requirements.....	19
4.2 Tollgate Structure	19
4.3 System Equipment.....	22
4.4 System Software.....	28
4.5 Transaction of Information	31
4.6 Model of Connection and Settlement among Tollgates and Bank	36
5. REGULATIONS ON REPORTS	39

6. REGULATIONS ON MANAGEMENT 39

7. IMPLEMENTATION..... 40

APPENDIX 1: Samples of arranging equipment on Touch & Go lane 40

APPENDIX 2: Samples of arranging equipment on ETC lane 42

APPENDIX 3: Samples of arranging equipment on combination of Touch & Go and ETC lanes 43

APPENDIX 4: Operation steps at ETC lane 44

APPENDIX 5: Basic Specifications of main equipment 50

APPENDIX 6: Samples of standard reports 52

FOREWORD

QCVN XX: 2013/BGTVT – National technical regulation on Electronic Toll Collection (ETC) for Expressway is compiled by Compiling committee of National technical regulations for electronic toll collection for expressway (established under Decision No. 2250/QD-BGTVT dated 31/07/2013 of Ministry of Transport), evaluated by Ministry of Science and Technology and issued by Ministry of Transport in line with Circular No. xx/2014/TT-BGTVT dated..... 2014 of Ministry of Transport.

NATIONAL TECHNICAL REGULATION QCVNXX: 2014/BGTVT

Quy chuẩn kỹ thuật Quốc gia về thu phí điện tử trên đường cao tốc
*National Technical Regulation on Electronic Toll Collection System (ETC) for Expressway***1. GENERAL PROVISIONS****1.1 Scope**

- This national regulation regulates basic requirements on ETC system installed at tollgates collecting toll of using expressways, including parts of system installed in centers/office of managing toll collection.

1.2 Application Object

- This national regulation applies for organizations and individuals related in investment construction, operation, management and maintenance of Electronic toll collection on expressway.

1.3 Reference Materials

- Draft ITS design standard (Revised version). Japan International Cooperation Agency (JICA), April 2013.
- QCVN 41:2012/BGTVT. National Technical Regulation on road signs and signals.
- Circular No. 159/2013/TT-BTC dated 14/11/2013 of the Ministry of Finance guiding the regime of collection, payment, management and road usage toll for ROI (Return On Investment) of road construction.
- TCVN 4054-05. Highway - Design requirements.
- CEN/TC278/5.8GHz DSRC: European standards for dedicated short range communications (DSRC) band 5.8GHz passive.
- ARIB STD-T75: Japanese Standard for dedicated short range communications (DSRC) band 5.8GHz active.

- ISO/IEC 18000-6C: American Standard RFID frequency range of 860 MHz to 960 MHz.

1.4 Terms and Definitions

In this regulation, terms and definitions are explained as follows:

- “Electronic Toll Collection (ETC) on expressway”: is understood as a closed method, including touch & go lanes and ETC lanes, moreover, it can be combined touch & go and ETC on one lane.
- “Toll collection method”: is the method to collect toll on lanes, in this regulation, there are two types of toll collection: T&G and ETC.
- “Close toll collection”: is the method to collect toll that vehicle (car) is to pay a toll rate in line with its type and mileage on toll road section.
- “Toll procedure” is an obligated procedure to follow when road toll is collected.
- “Entry lanes”: Are the lanes at tollgate where vehicles enter expressway, for defining the entering point of vehicles.
- “Exit lanes” is the lanes at tollgate where vehicles leave expressway, for defining the exit point of vehicles, defining their mileage, based on that due toll is counted.
- “ETC toll collection”: is the method of automatic toll collection allowing vehicles passing through tollgate to pay toll without stopping, combined using of IC card and OBU (if they are separated) or only OBU (IC card is integrated in OBU).
- “Touch & Go toll collection” is the method of toll collection that drivers are to stop when passing through tollgate, using prepaid IC card to touch or insert in reading area of card reader installed at entry and exit lanes for executing toll payment.
- “IC card”: is an electronic card for reading/writing and storing of vehicle owner’s account information data, serving for toll rate counting at ETC lane.
- “On Board Unit”: is an electronic equipment placed on vehicle to communicate with roadside equipment, also called toll collection equipment on vehicle, serving for toll rate counting at ETC lane.

- “Exit toll rate receipt”: is a receipt for exit gates, printed following sample as soon as Ministry of Finance and Tax Bureau have approved, providing for drivers after their toll payment at the exit for (manual lane), as valued as an receipt.
 - “Special card”: is the type of card for opening barrier, letting vehicle to pass through in special cases under tollgate regulations.
 - “Toll collector”: is tollgate’s staff, in the duty of collecting toll, working in cabin or commuter ticket selling place.
 - “Monitoring person” is tollgate’s staff, in the duty of monitoring toll collection process, work process in monitoring office
 - “Technical person”: the staff of tollgate, who has sufficient technical major ability, understands toll collection equipment system in tollgate, is assigned to maintain, repair this system under tollgate regulations.
 - “Bank settlement system”: is a system for road usage toll payment through customer’s account in settlement units (settlement units are able to be bank or other organization having settlement function).
 - “Control center for banking” is the center of management and transaction of toll collection processing as well as related operations (control, settlement of toll revenue ...) among banks and toll collection units, and among banks.
 - “Section road management center”: is an agency to manage and control traffic of an expressway, road section.
 - “Regional road management center”: is an agency to manage and control traffic of expressway, road sections in a specific region.
- “Transceiver”: is the short signal receiver and transmitter to exchange message for ETC toll collection between equipment of section management unit (road operator) and OBU on customer vehicle using nonstop toll collection services.

1.5 Abbreviations

- QCVN: National regulation.
- TCVN: National Standard.
- MOT: Ministry of Transport.

- ISO: International Organization for Standardization (An organization for setting up International Standards, with many representatives from many National Standards Bodies).
- ITS: Intelligent Transport Systems (support human and good transportation with information and communication technology for using traffic infrastructure and traffic means safely and effectively).
- DSRC: Dedicated Short Range Communications (allow high speed communication between vehicle and roadside, or among lanes, in this document it is for ITS).
- ETC: Electronic Toll Collection (is an electronic toll collection method, excluding cash, travel card or credit card are used at cabins).
- OBU: On Board Unit (equipment placed on vehicle to communicate with road side equipment, so called as toll collection equipment on vehicle).
- ALPR: Automatic License Plate Recognition.
- IC: Integrated Circuit
- ID: Identifier.
- RFID (Radio-frequency identification).
- T&G: Touch & Go
- CPU: central processing unit.

2. REGULATION ON TOLL COUNTING

Electronic Toll Collection (ETC) on expressway is close toll collection system; toll is defined based on vehicle's types and mileage that the vehicle moved on expressway.

2.1 Defining Type of Vehicle

Defining type of vehicle based on following rules:

- Defining type of vehicle according to toll rate by Ministry of Finance: based on Circular No. 14/2012/TT-BTC of Ministry of Finance as the following table 3.1

Table 2.1 Defining type of vehicle according to toll rate for expressway

No.	Vehicle to pay toll
1	Vehicle of less than 12 seats, less than 2 ton truck, public bus
2	Vehicle of from 12 to 30 seats, 2 to 4 ton truck
3	Vehicle of more than 30, 4 to 10 ton truck
4	10 to 18 ton truck, Container transporter of 20 fit
5	More than 18 ton truck, Container transporter of 40 fit

- Defining the vehicle by data in OBU: For ETC system, once driver register for using OBU, the vehicle type information (according to the defining type of vehicle by Ministry of Finance) is required to be recorded on OBU. This information on OBU when registered shall not be changed during tollgate passage.

2.2 Defining Mileage of Vehicle

- The mileage of the vehicle moving is defined based on the information recorded at coming and out-going lane. For ETC lane, at entry lane, system automatically read OBU information and write entry lane information on OBU, at lane, system shall read again the information. For manual toll lane, the system shall define the mileage of the vehicle by "coming card" issued at coming lane and reading the card at out-going lane. For T&G lane, this

defining is by the read/write of IC card at coming/out-going lanes through card reader/writer.

- Each tollgate on expressway is provided with a tollgate ID, each tollgate itself provides coming lane ID and outgoing lane ID. The toll shall be defined for each couple of tollgate (coming lane to outgoing lane) on the whole system of tollgate on expressway. The following figures give the example of a ID table for defining mileage of moving vehicle on all expressway network, based on that suitable toll rate shall be defined. Figure 2.2 show the base of defining toll rate on expressway.

Figure 2.2 Table defining toll rate on expressway

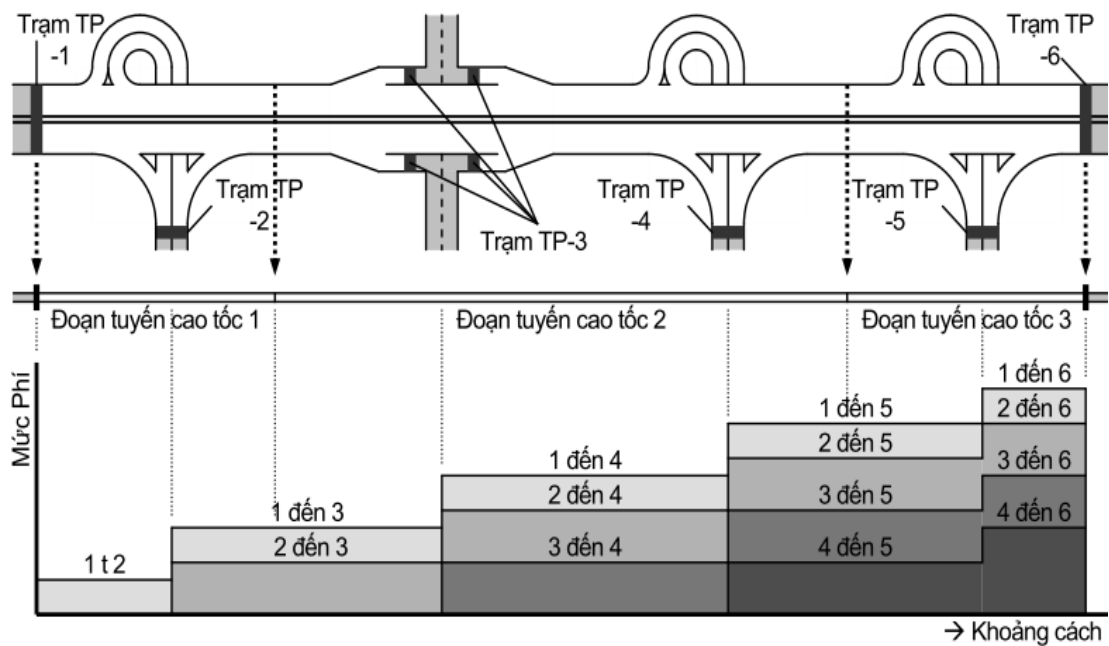

Toll rate table		Exit					
		Tollgate-1	Tollgate-2	Tollgate-3	Tollgate-4	Tollgate-5	Tollgate-6
Entry	Tollgate -1	-	1 to 2	1 to 3	1 to 4	1 to 5	1 to 6
	Tollgate -2	2 to 1	-	2 to 3	2 to 4	2 to 5	2 to 6
	Tollgate -3	3 to 1	3 to 2	-	3 to 4	3 to 5	3 to 6
	Tollgate -4	4 to 1	4 to 2	4 to 3	-	4 to 5	4 to 6
	Tollgate -5	5 to 1	5 to 2	5 to 3	5 to 4	-	5 to 6

	Tollgate -6	6 to 1	6 to 2	6 to 3	6 to 4	6 to 5	-
--	----------------	--------	--------	--------	--------	--------	---

- Toll rate for vehicles comply with the provisions of the competent authority for each expressway sections.

3. PROCEDURE OF TOLL COLLECTION

3.1 General Procedure

Electronic toll collection system on expressways ETC operate under the general procedure as follows:

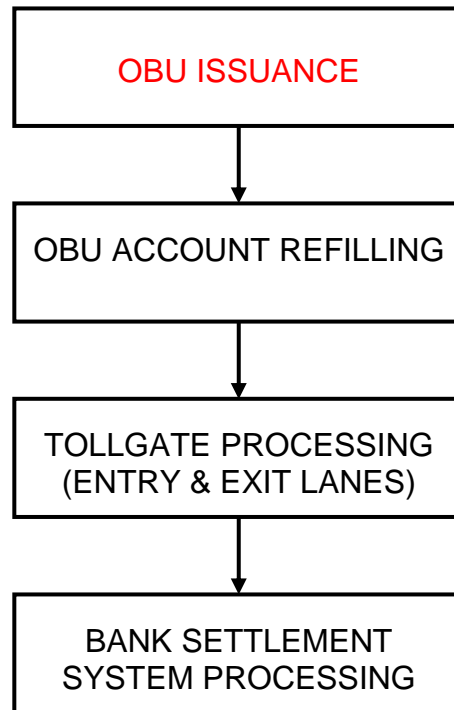

Hình 3.1 General procedure in toll collection

- Each vehicle when using ETC system is to be equipped with OBU and placed properly on it.
- Information of the vehicle, account value for payment of road usage toll are recorded on OBU and in database of settlement system.
- When vehicle enter expressway, approaching ETC lane (entry lane), the system shall check the validity of OBU and write necessary information (such as entry lane ID, lane ID, time...) as a base to define vehicle's mileage.
- When vehicle leaves expressway, approaching ETC lane (exit lane), the system shall automatically read the information, then, define vehicle's mileage, comparing with the vehicle type. The system will automatically count the toll rate and write new value (deducted toll) on OBU and IC-Card.

- Transactions are processed and saved as database of tollgate, later on, it is transmitted to bank settlement to compare and check to ensure proper and sufficient toll collection for each vehicle passing tollgate.
- The comparing, settlement, and balancing for related units are processed by bank settlement system based on transaction reports at tollgates.

3.2 OBU Issuance

- The issuing of OBU using for ETC lane can be done by toll collection management unit, or through bank (bank branches or other channels of bank).
- When issuing and distribution of OBU to driver, his/her information and his/her vehicle's information shall be collected based on the vehicle registration files and recorded on OBU, in database of tollgate and of the bank settlement.
- Information to be recorded on OBU: regulations on OBU data sets and data components in 4.5.2

3.3 Account Refilling

- When using OBU, the vehicle owner can get an account with the information to be recorded in IC card or OBU using for paying for road usage toll. Vehicle owner are to refill the account, the value of refilled money is recorded in the account to pay toll automatically when the driver pass through tollgates.
- Moreover, customer can use an account opened at bank (personal account, ATM account...) to refill into the account for paying road usage toll or update the time to use the account after that, in equivalent with the refilled amount.
- Accounts using for paying for the vehicle owner's road usage toll is to be updated on OBU/IC-Card when the vehicle moving through automatic ETC toll lanes. After refilling (into personal account, ATM account...) for next times the value shall automatically be recorded on the account when OBU vehicle pass through tollgates.

3.4 Toll Processing

3.4.1 Toll process at Touch & Go lane (for vehicles using Touch & Go toll collection)

- When vehicle enter expressway, approaching T&G tollgate and to the IC card reader, the reader shall record necessary information such as entry tollgate ID, entry lane ID, entry duration, card amount...as a base to define mileage and charge toll for vehicle.
- For valid transactions, barrier shall automatically open for the driver to drive the vehicle into expressway, it automatically close when the vehicle has passed through barrier.
- For invalid transaction (account is not sufficient, the information on the card is not fit the vehicle etc ...), the system shall validate the invalid transaction and stored in a database. To pass through tollgate, vehicle is to buy tickets at the cabins according to semi-automatic/manual toll collection.
- At expressway exit, vehicle approaches Touch & Go lanes and IC-Card reader, the driver scan IC-Card into a card reader, the system shall read the information in the card and process extract an amount from card account, write new value into the IC-Card account.
- The Automatic License Plate Recognition shall recognize license plate and take a picture of the vehicle, transmit and save it on the server at operation centers for managing and post auditing.
- Barrier shall automatically open for the driver to drive out of expressway, it automatically close when the vehicle has passed through barrier.
- Transaction (data and image) is processed and saved as database of tollgate, later on, it is transmitted to bank settlement to compare and check to ensure proper and sufficient toll collection for each vehicle passing tollgate. The comparing, settlement, and balancing for related units are processed by bank settlement system based on transaction reports at tollgates.

3.4.2 Procedure to process at ETC lane (for vehicles using electronic toll collection)

a) Processing at entry lane

Procedure to process at ETC entry lane is described as the following figure 3.2:

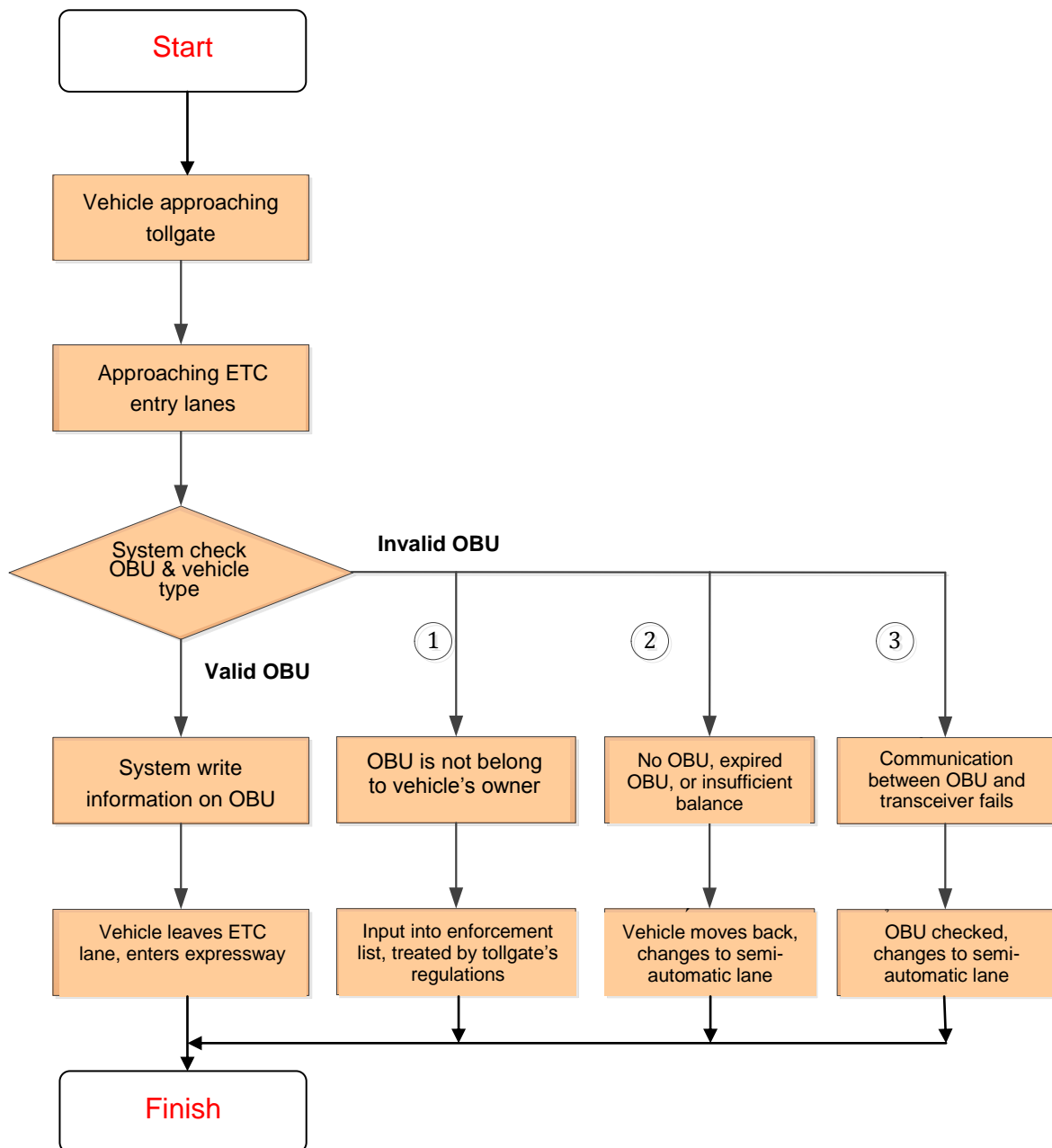

Figure 3.2. Processing procedure at entry lane for ETC on expressway

When OBU included vehicle approach tollgate, it is to go to entry lane for ETC, the system shall automatically communicate with OBU and automatically check the validity of OBU (OBU ID, vehicle type, and term of usage...). There are two following cases:

- Case 1: OBU is defined to be valid, the system shall automatically write information on OBU (including entry tollgate ID, entry lane ID, duration...),

the, barrier shall automatically open for the vehicle to go through tollgate to enter expressway. Simultaneously, all images, data in OBU are transmitted to operation center to store and provide information for counting toll at the exit.

- Case 2: OBU is defined to be invalid, that is 3 following situations:
 - 1) The vehicle is equipped with OBU but not belong to the vehicle owner, the license plate recorded in OBU is not the same with the result recognized by system of Automatic License Plate Recognition, this case is to be record in enforcement list and to be treated according into regulations of tollgate.
 - 2) Vehicle without OBU or with OBU but the account for road usage toll is expired or not sufficient for the vehicle to go through the longest distance: The system shall not allow vehicle to pass through, the staff requires it to change to be processed in manual lane. For this case, the system shall not handle the car over; the employee should ask the driver to move through the toll lane semi-automatic / manual.
 - 3) The communication between OBU and transceiver is not successful (reason is: location of OBU on vehicle is not proper; OBU is in low battery, OBU is broken): Staff needs to check OBU location and adjust it, or borrow OBU to scan the communication of transceiver. If it's still not successful, the staff informs the driver to get to the place of issuing OBU to check again the OBU, requires it to change to be processed in semi-automatic/manual lane.

b) Processing at exit lane

Processing procedure for settlement transaction at exit lanes for ETC in each tollgate on expressway is as the following figure 3.3:

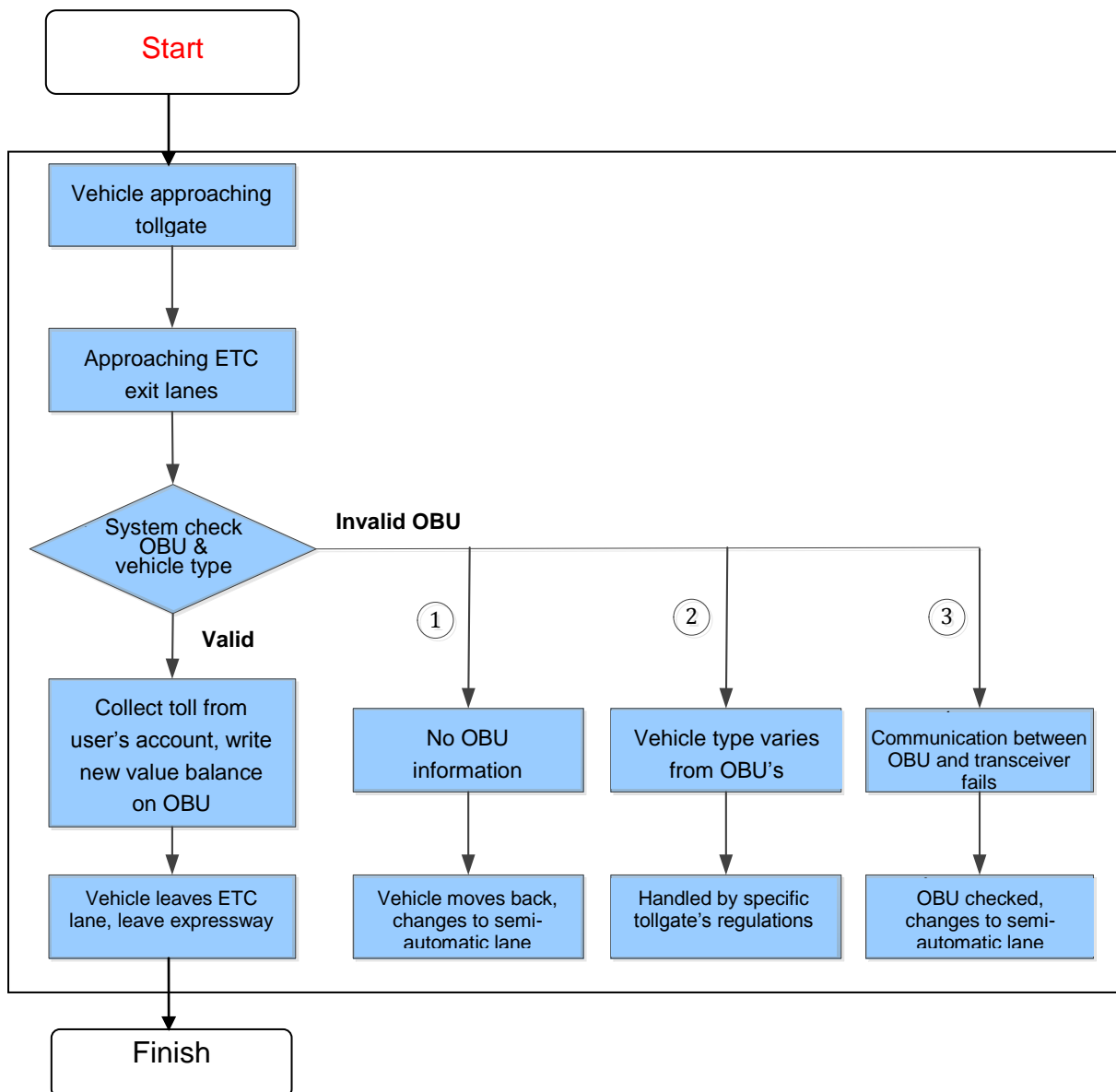

Figure 3.3. Processing procedure for settlement transaction at exit lanes for ETC on expressway

When the vehicle with OBU approach tollgate, it is to get to ETC exit lane, system shall automatically communicate with OBU and check the validity of OBU (vehicle type, information on OBU recorded at the entry of expressway...).

- Case 1: If OBU is define to be valid, system shall automatically count the toll to be paid (by mileage and vehicle type), system automatically deduct an amount and write a new account value on OBU (after deducted).

After that, barrier automatically opens for vehicle to pass through tollgate and go out of expressway. At the same time, at the toll collection office saves transaction, synchronize and exchange information with bank settlement system. In this place post auditing, transaction data comparing and checking, are also conducted.

- Case 2: If the system defines that OBU is invalid, solutions are as follows:
 - a) OBU has no recording information at entry lane: in this situation, staff requires drivers to change to half-automatic lane, and to be processed manually.
 - b) Vehicle type is not fit with type of OBU: this case is to be record in enforcement list and to be treated according into regulations of tollgate.
 - c) The communication between OBU and transceiver is not successful (reason is: location of OBU on vehicle is not proper; OBU is in low battery, OBU is broken): Staff needs to check OBU location and adjust it, or use customer's OBU to scan the communication of transceiver. If it's still not successful, the staff informs the driver to get to the place of issuing OBU to check again the OBU, requires it to change to be processed in manual lane.

Detailed operating procedure in entry and exit lanes of toll collection process of ETC toll lanes as in Appendix 4.

3.5 Bank Settlement System Processing

Bank system performs the following operations:

- Checking and doing payment for transactions of ETC/Touch & Go of the whole electronic toll collection system, implementing control (compare and check), toll balancing, etc.
- Synchronizing, information exchanging with operation center of tollgates and saving transactions.

4. TECHNICAL REGULATIONS

4.1 General Requirements

ETC system for expressway is to ensure general technical requirements as follows:

- Toll collection equipment system is integrated into an automatic system, creating a sequence of road usage toll collection when vehicles move through tollgates. Main functions of the system is supporting transaction and management of toll collection at lanes and at the tollgate operating center, supporting negative combatage surveillance, ensuring proper and fullfill collection. Locations of tollgates on expressways are regulated by the competent authority.
- ETC toll collection equipment system is to be designed to ensure vehicle speed through the lane is at least 20 km/hour.
- Equipment system is to be highly reliable, having suitable backup equipment to ensure continuous operation 24/24, not causing entire system down.
- Equipment system at lane is to operate independently when losing connection with the center.
- It can be upgraded and expanded, also ready to connect with section management center, regional management center, bank settlement center.
- The system is capable to connect traffic payment service on expressway for users through bank accounts.

4.2 Tollgate Structure

4.2.1 Layout of Lanes

- Criteria for layout of toll lane is defined corresponding to designed traffic flow through tollgates and following the basic requirements of large vehicles shall pass through the tollgate in the rightmost lane of each traffic direction. The scale and layout of toll lanes are at the request of competent authority to decide.
- ETC lane allows vehicles to pass through it at high speed, so it's prioritized for the allocation of ETC lanes in the leftmost lane of each traffic direction. Only the vehicles equipped with OBU devices are able to get into ETC lane. If the processing capacity can not meet the traffic flow, it's necessary for additional ETC lanes in adjacent lanes (allocating of ETC additional lanes on the principles from the left to the right station, in the direction that vehicles are heading to).
- Sample layout of lanes at the tollgates, with 4 lanes for each direction as shown in Figure 4.1 below:

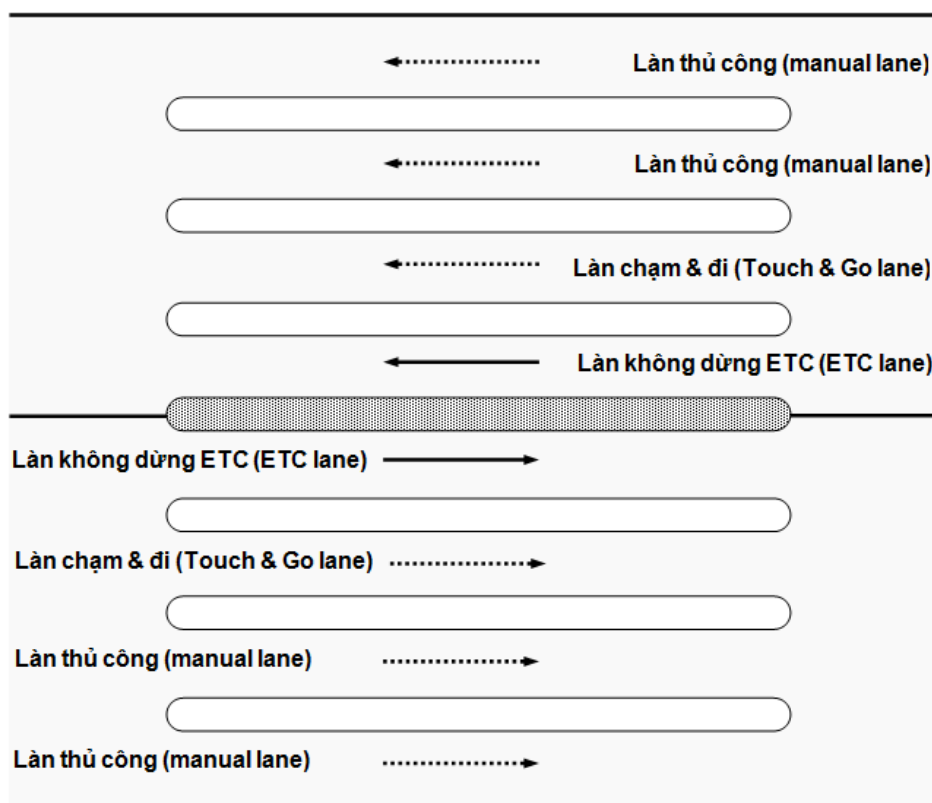

Figure 4.1 Sample layout of lanes with 4 lanes for each direction

4.2.2 Toll Plaza

- Toll plaza size: For new built tollgate, toll plaza size is to comply with TCVN 4054-05. Specifically length is of 30 m and width is of 2 m.

- Safety providing on the toll plaza: Toll plaza have a safe crash against dock at both ends of its. The shape and color of the dock comply with current standards. Moreover, around the control cabin located on the toll plaza, crash against pillars with the same height with lane control cabin are necessary. Those pillars are to be painted alternating white - red and placed on the toll plaza, forming a solid frame to safely protect the cabin.

4.2.3 Pavement, Deceleration Bar

- The structure of pavement at tollgates is to be the type of rigid reinforced concrete pavement to ensure the load capacity of complicated static/dynamic working conditions, maintain long-term durability. The pavement structure is designed in line with current regulations.

- The area in front of tollgates in the direction that vehicles are heading to is to be painted deceleration lines designed by level to remind drivers to slow down to safe level when passing through tollgates. Technical requirements of deceleration lines in front of tollgates comply with QCVN 41:2012/BGTVT.

4.2.4 Traffic Signs

- In front of each tollgate, lane dividing signs are required to inform for drivers the location of tollgates' lanes of manual, T&G, ETC. Depending on number of lane in each tollgate, signs shall be adjusted properly. Size of characters on signs is to comply with National Technical Regulation on road signs and signals QCVN 41:2012/BGTVT.
- Sample of lane dividing signs in front of tollgate, with 3 lanes for each direction is as follows.



Figure 4.2. Sample of lane dividing signs in front of tollgate

- In front of ETC lane, arrange the sign showing “ETC electronic toll collection lane” fixedly to inform driver the position of ETC lane. This boards uses suitable lighted LED, so as to drivers can see from 100m distance.



Figure 4.3. Sample of signs for ETC lane

- In front of the ETC lane toll plazas, signs number 121 and 127 complying with National Technical Regulation on road signs and signals QCVN 41:2012/BGTVT, are to be placed to control minimum distance between adjacent vehicles to ensure safety during passing through tollgates.



Figure 4.4 Signs controlling max speed and min distance
between two vehicles

4.2.5 Arrangement of Equipment on Touch & Go Toll Lanes

- Is the method of toll collection that vehicles, when passing through tollgate, is to stop once at the control gates of entry lanes and exit lanes through an automatic card reading system to collect toll.
- Arranging equipment at T&G lane at entry lanes and exit lanes as in APPENDIX 1.

4.2.6 Arrangement of Equipment on Electronic Toll Collection (ETC) Lanes

- Is the method of toll collection allowing vehicles to pay without any stop at tollgate, combining IC card with OBU (if IC card and OBU are separated), or only OBU.
- Diagram of arranging equipment at ETC lane is the same in entry lanes and exit lanes as in APPENDIX 2.

4.3 System Equipment

4.3.1 Road - Vehicle Communication Equipment

- a) OBU on vehicle
 - OBU on vehicle is an equipment used for automatic nonstop toll collection, information of customer's road toll account shall be kept in this equipment (created when customer buy or rent OBU).
 - When the vehicle move to the beginning of land toll plaza, OBU shall communicate with Transceiver at the lane, toll is paid automatically by road toll account. The whole progress is fast to ensure nonstop passing of vehicle.
- b) Transceiver at lane
 - Transceiver is functioned to implement transaction with the equipment of toll collection (OBU) installed on users' vehicles. It's installed on a hanger in front of lane, with suitable position and height complying with manufacturers' designs to avoid impeding on clearance of lane.
 - When vehicle move into lane, Transceiver and OBU shall continuously transmit signal and exchange data, that is in short time with main

information like: OBU ID, ID of intelligent card, account information, account's valid term, registered license plate, etc. to count, deduct toll in customer's account in OBU, also write new account value (deducted) on OBU.

4.3.2 Equipment at Lane

- a) Vehicle detector
 - Vehicle detector is used to count vehicles and support to close barrier automatically after passing through. One single method or combination of several methods of vehicle detection as follows:
 - Induction loops;
 - Infrared columns;
 - Video image processing.
- b) Lane computer
 - Is industrial computer, including CPU, monitor, keyboard, mouse, outside speaker and network connection equipment. The computer is to have suitable configuration with whole network system and is able to be operated normally continuously in high temperature and humidity.
- c) Lane control equipment: contains lane control cabinet, automatic barrier, traffic signal lights, and electronic signs controlling connected with general computer network. Specifically requirement is as follows:
 - Lane control cabinet: is the place to connect, integrate controlling of all equipment at lane to general computer network. It is used to control directly barrier to open/close (not through computer system) for solving special incidents. The cabinet is to have automatic vehicle counting module independently and can store continuous data within 2 weeks. It is to be closed, locked, ventilated, fusty-proof and ensuring durability in operation of high temperature and humidity.
 - Automatic barrier: is used to allow or stop vehicles to or not to pass through toll lanes, controlled by toll collection computer at lane through lane control cabinet. Automatic barrier is the type of barrier that automatically open or close with the controller suitable with operating computer. Barrier is to have

hinge opened automatically to avoid being harmful when being crashed by vehicles. The bar is to be made of stable material and to be painted in light reflecting white and red to be recognizable.

- Traffic signal lights: are for informing and instructing vehicles to move in lanes, controlled by toll collection computer through lane control cabinet. Traffic signal lights are installed near automatic barrier for being recognizable by drivers, controlled synchronously with automatic barrier. They include one red light, one green light; those light are long duration life LED, suitable brightness. They contain 2 phases: “stop” (red light is on, green light is off) and “go” (green light is on, red light is off).
- Electronic board: is used to show the notice of information of toll collection transaction and lane condition. It’s controlled by lane computer and displays standard notices, including:
 - (1) VEHICLE TYPE x/ TOLL RATE yyyyy VND (x, yyyyy: vehicle type and toll rate to pay)
 - (2) OBU EXPIRED
 - (3) NOT ENOUGH OBU BALANCE
 - (4) VEHICLE TYPE WRONG
 - (5) GO AHEAD
 - (6) LANE CLOSED

Electronic board contains at least 22 characters on 2 lines. Size of each character is to be big enough for drivers of all age can read clearly in eyesight when reaching toll lanes (10m to 20m). Character set is in Vietnamese. Color and brightness are suitable for visually in both daytime and nighttime, both sunny and rainy days.

- d) Monitoring equipment: contains lane monitoring camera, License Plate Recognition camera, panorama camera, whose requirements as follows:
- Lane monitoring camera: monitors and records the image of all vehicles passing through lanes, allocated so that it can see head and body of vehicles. Using color high resolution type of camera to be effective. The camera is to be protected from weather with casing, humidity and dust prevention, ensuring long term stability.

- License Plate Recognition camera: for capturing license plate when vehicle entering toll collection lane, automatically provide for license plate detecting software whose result of data shall be compared with those on OBU. This process support monitoring, post auditing of vehicles passing through toll lane. Camera for Recognition of License Plate is a specialized camera for license plate recognition by computer reach high accuracy, in both daytime and nighttime. It's to be located at proper locations to capture license plates clearly.
- Panorama camera: All history and status of tollgate is monitored by road operator through panorama camera. Thanks to it, monitoring person can give out comments to device suitable flow, avoiding traffic congestion. Camera is to have casing for weather (sunlight, rain, dust) protection; zooming glass for observing clearly half of tollgate activities, is able to monitor both daytime and nighttime. Camera location is to be chosen the most effective ones.
- e) Other equipment: manual barrier, toll plaza front indicator light, lane status indicator light, whistle and alarm light, UPS, specifically required as follows:
 - Manual barrier: a type of stop bar in front of lane, opened/closed manually, preventing vehicles from entering when the volume is low or serving for checking, maintenance, repairing. On the barrier, prohibit sign is to be installed (Sign number 101 of QCVN 41:2012/BGTVT) with reduced size of 0.6 to 0.8 basic sign's size. At the hinge, it's necessary to fit an automatic switch of lane close/open lighting line with status of lane opening so as to be proper with the status between barrier and flash lights. Moreover, in order to reduce occupying space of open-barrier (less occupying space on toll plaza); fold hinge is needed to reduce the length of barrier.
 - Toll plaza front indicator light: is for alarming obstacle for vehicle owners in bad weather, unclear vision, installed in front of lane toll plaza. To do that, light is designed with continuous yellow flash light to attract drivers. The brightness is moderate to avoid flaring at night.
 - Lane status indicator light: is for informing lane status being close/open (or function/stop). It's located on tollgate's roof, the vehicle coming direction. It contains two phases: "closed", in equivalent with X red lamp, and "opened", in

equivalent with ↓ green lamp. Two lamps can be used separately, each lamp each phase or combined usage for both phases. Light control is by the switch placed on open/close hinge of manual barrier. An example of combined usage of one light for both phases is in Figure 4.5 below:

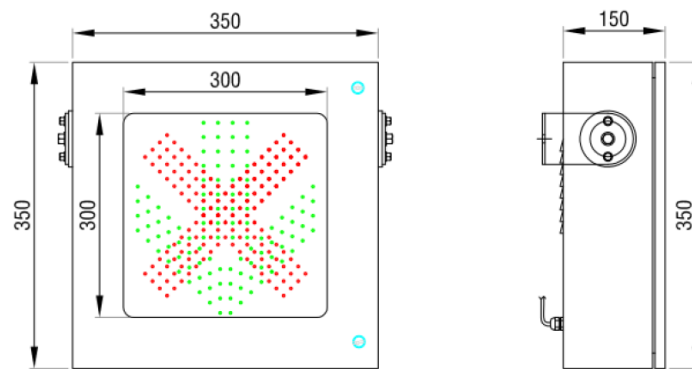

Figure 4.5 Sample of indicator light of combined usage of one light for both phases

- Whistle and alarming lamp: a set equipment to warn of violation at lane to call for support of guardsmen to enforce violated vehicles. This set is controlled by lane computer in special situations.
- UPS: supplying power for lane computer and other equipment in cabin in case of blackout. Capacity and volume of this equipment are to be chosen to be suitable with continuous working of above equipment during waiting time for power supply to operate.

4.3.3 Equipment in Operation Office

- a) Toll data server
 - It is the place to install database and small parts of toll collection software. Due to system has to work continuously as well as the importance of data; the toll collection data server is to be a specialized and strong configuration device.
 - The server is to have enough capability for all computers and terminals in the computer network of toll collection system. Its configuration is to be chosen complying with design requirement of toll collection system and storage ability, as well as modern gates and storage dishes.
- b) Computer connecting data of bank settlement

- Serving for toll collection data connection at tollgate with bank settlement system. Computers are to be chosen the type of suitable stability and quantity, to ensure reliability and stability.
- c) Other equipment
 - Monitoring computer: contain monitoring and post auditing program for operation staffs, monitoring toll collection activities at tollgates as well as post auditing for unusual matters, reducing negatives. Number of monitoring computers depends on number of lanes. Monitoring computer is to be one set monitor, printer, and supplement devices, connected with internet. Configuration is to be chosen complying with design requirement of toll collection system and image processing capability is to be higher. For stability, it's required to choosing the type that can work continuously and long-term. Monitor's size is at least 17 inch and high resolution for clear vision and avoiding eye tiredness for monitoring person
 - Data storage device: can be provided additionally to widen system's possibility of storing data and image. The latest and most popular technology should be taken, but, ensuring safe and long term storage. It's necessary to consider fixed storage capacity for storage device to ensure storage possibility before changing into storage CDs or tapes.
 - Digital recorder: Allocated in operation room, serving for recording of lane cameras, panorama cameras, and other cameras in operation room.
 - Monitor: Monitor in center is to be the type that of compatible digital image signals, suitable with monitoring equipment system's output signal which has been processed. It's in the size of at least 32 inches, high resolution to be easily observed.

Minimum specifications of main equipment is as in APPENDIX 5

4.3.4 Supplement Equipment System

- Other supplement equipment such as: lightning prevention system, internal communication system, backup generator, UPS, fire prevention system are stipulated and are to comply with related regulations.

4.3.5 Reliability and Backup Equipment

- Toll collection system is operated 24/24, therefore it's required to have high reliability and have suitable backup equipment to ensure continuous operation, not causing stop of the whole system.

4.3.6 Network System and Transmission Line

- Network equipment system and transmission line are to comply with total system and compatible with other system equipment. Connection plugs are to ensure durability and safety. Connection boxes are close and fire prevention. Also network equipment system and transmission line are to be designed with open feature to be available to connect with bank settlement center, bank control center, section and regional management offices (centers) by current regulations.

4.3.7 Power Supply System

- Power supply system is to be industrial 3 phase one (3 phases, 4 lines), sufficient capacity with each tollgate, and other specific supplement system on expressway and to comply with current regulations.

4.4 System Software

4.4.1 General Requirement

- Software system is to meet the requirements in above toll collection functions, meet requirements on operation and situations of toll collection procedure (T&G and ETC. Software is to connect controlling all system of equipment including computer network equipment, lane control equipment, monitoring equipment of various kinds, etc. as mentioned above. It's recommended to apply new automatic technology in human-machine interface and dialogue as well as other preeminent functions. Software system is to be able to independently work when losing connection with the server.
- Besides, it is to have other functions as: transmitting and exchanging all toll collection data to expressway operation centers, section and regional management centers, bank control center for executing management, control and other operations.

4.4.2 Processing Software at Lane

Processing software at toll lane is installed on lane computer; the software shall operate and solve situations of the procedures for manual; T&G, ETC toll collection. Moreover, software at T&G, ETC toll collection lanes is to be added following automatic capabilities:

- Reading and writing data on IC-Card, or OBU, check the validity of IC card or OBU
- Controlling equipment system at automatic toll collection lane
- Capturing vehicle entering automatic toll collection lane
- License plate Recognition or categorized type of vehicle
- Providing signals and OBU control information to operation center

Moreover, the software is to meet with processing requirement for the following situations:

- Vehicle with valid OBU
- Vehicle with insufficient balance OBU or locked OBU
- Vehicle with OBU but can't communicate
- Vehicle without OBU or with wrong OBU entering lane
- Independently operation capability when losing connection with operation center

4.4.3 Management Software in Center at Tollgate

Management software in center is the combination of software or software modules installed on toll collection data servers and computers in operation office.

This software is to contain modules functioning as follows:

- Manage, copy toll collection data
- Report, statistic: Provide Reports, statistics of system operation
- Accounting: the purpose is to manage and control accounting activities, serving for accounting business. Supporting management, storage in and selling of OBU, as well as stocking, reports.
- Monitoring, post auditing: provide functions to Monitor and post auditing toll collection transaction as well as toll collection staffs
- Sending information, data from main center to toll lane and settlement units

- Security: managing security function such as : password, group of passwords, orders, demarcation. For storage data, data security is executed by 5 following levels:
 - (1) Toll collection staff
 - (2) Monitoring person, technical person, accountant
 - (3) Shift head, tollgate leader
 - (4) Inspector/company's director,
 - (5) Top head

4.4.4 Software Connecting Settlement/Control through Bank

Software connecting bank settlement/control between bank settlement and ETC toll collection at tollgate, with following functions: Connecting toll payment services for traffic on expressways for users through bank account. Processing toll collection transactions as well as the operations associated (control, toll revenue settlement ...). Saving transactions and exchanging information with tollgates. Comparing revenue report and transaction data between tollgates and bank system; assuring the security communication in the connection from banks to tollgates.

- Synchronization of data between bank settlement server at bank and ETC toll collection system server at tollgate is done periodically (offline), priority level belongs to each data flow and PUSH scheme (the side obtaining data to be synchronized shall positively push data to the receiver).
- All data executed and processed at bank settlement system and server of ETC toll collection is log stored during exchange, serving for information exploitation for reports, evidence when there is any dispute.

Beside, software also has the functions of connecting to and sharing toll collection data with the server at section and regional management centers to generate data in use in management according to regulations. Section and regional management centers are capable to send query or register of receiving toll collection information reports by day including: section, time, the number of vehicles and toll amount defined by section, vehicle type; numbers vehicles applied electronic toll collection according to current regulations.

4.5 Transaction of Information

4.5.1 Data Set for Managing IC-Card

Data set for managing IC-Card is regulated as in the following Table 4.1:

Table 4.1:Main data set for managing IC-Card

Data set	Data component
IC-Card issuance data set	<ul style="list-style-type: none"> - Issuance unit ID - Issuance equipment ID - IC-Card ID - IC-Card owner ID - Deposit - Issuance time/date - Expire time/date
IC-Card refilling dataset	<ul style="list-style-type: none"> - Issuance unit ID - Refilling equipment ID - Deposit - Prepaid account - Time/date
Invalid IC-Card data set	<ul style="list-style-type: none"> - Issuance unit ID - Issuance equipment ID - Invalid IC-Card ID - IC-Card owner ID - Deposit - Issuance time/date - Expire time/date - Time/date

4.5.2 Data Set for Managing OBU

- Management of OBU is executed in OBU issuing center. Main message for OBU during registration, dissemination, and effect management shall be exchanged according to data flow as the following Figure 4.6:

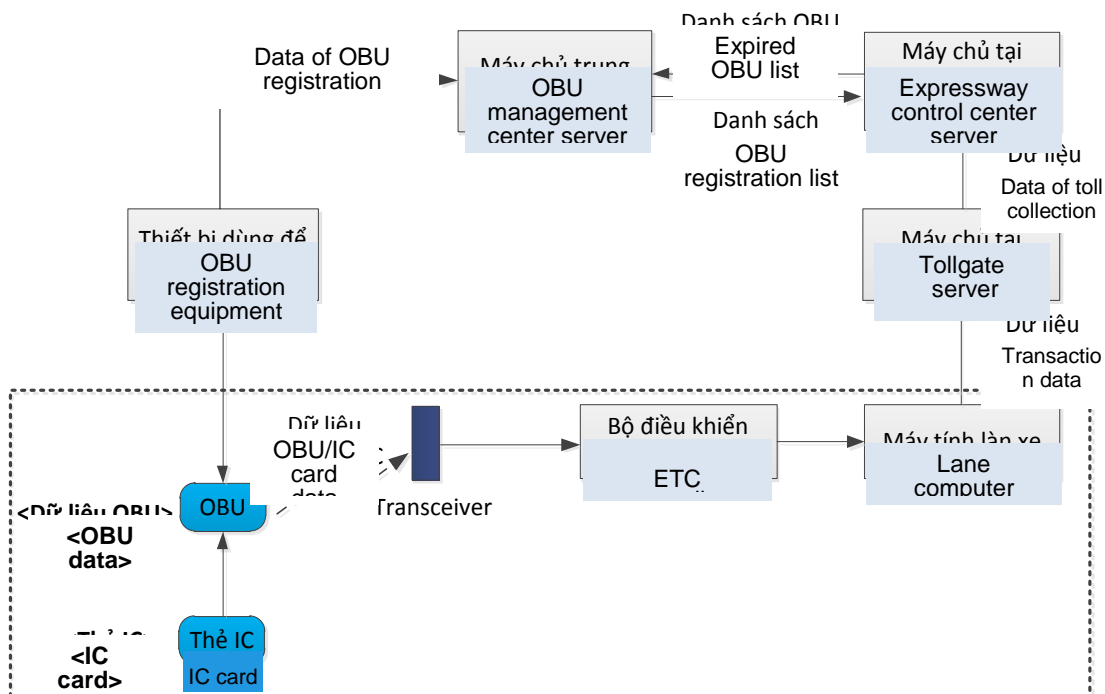

Figure 4.6. Main message exchange for OBU control

- Data set and main main data components recorded on OBU, defined as follows:

Table 4.2. Data set and data component of OBU

Data set	Data component
OBU registration data set	Management organization ID
	OBU ID
	OBU owner ID
	License plate
	Vehicle type
	Date of issue
	Expired date
OBU passing tollgate data set	Toll office ID
	Tollgate ID
	Lane ID
	IC card ID
	Toll
	Prepaid account
	Date/Time
Invalid OBU data set	Management agency ID
	Invalid OBU ID
	OBU owner ID
	License plate
	Vehicle type
	Date of issue
	Date of expired
	Date/Time

4.5.3 Data Set for Lane Control

- At ETC lane, main message for lane control at ETC lane shall be exchanged according to the following flow in figure 4.7

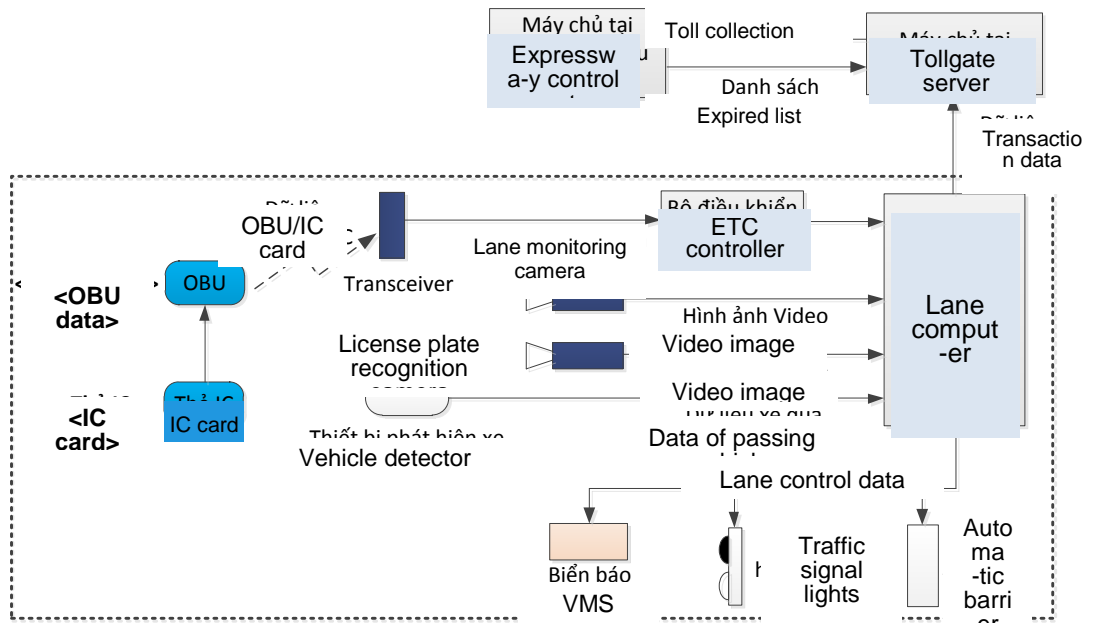

Figure 4.7. Main message exchange for lane control

- Data structure and main data component for lane control are specified in the following table 4.3:

Table 4.3. Data set for lane control

Data set	Data component
Transaction Data set	Toll office ID
	Tollgate ID
	Lane ID
	OBU ID
	Vehicle type in OBU
	License plate in OBU
	IC card ID
	Toll
	Prepaid account
	Transaction status
	Vehicle ID
	Date/Time
	Invalid IC card list Data set
Issuing equipment ID	
Invalid IC card ID	
IC card owner ID	
Deposit	
Issuing Date/Time	
Expired Date/Time	
Invalid OBU list Data set	Management agency ID
	Invalid OBU ID

	OBU owner ID
	License plate
	Vehicle type
	Date of issue
	Date of expired
	Date/Time

4.5.4 Data Set for Monitoring and Post Auditing

Monitoring and post auditing for detecting violation, cheating are executed through the following sources:

- Video image of outside shape of vehicle obtaining from CCTV
- Data receiving from OBU through Transceiver placed at ETC lanes.
- License plate data collected from License plate detecting system.
- Vehicle passing data collected from vehicle detector

Procedure of checking, comparing data for monitoring, post auditing (verification) is to be integrated on tollgate server. Main message is exchanged following data flow as in figure 4.8

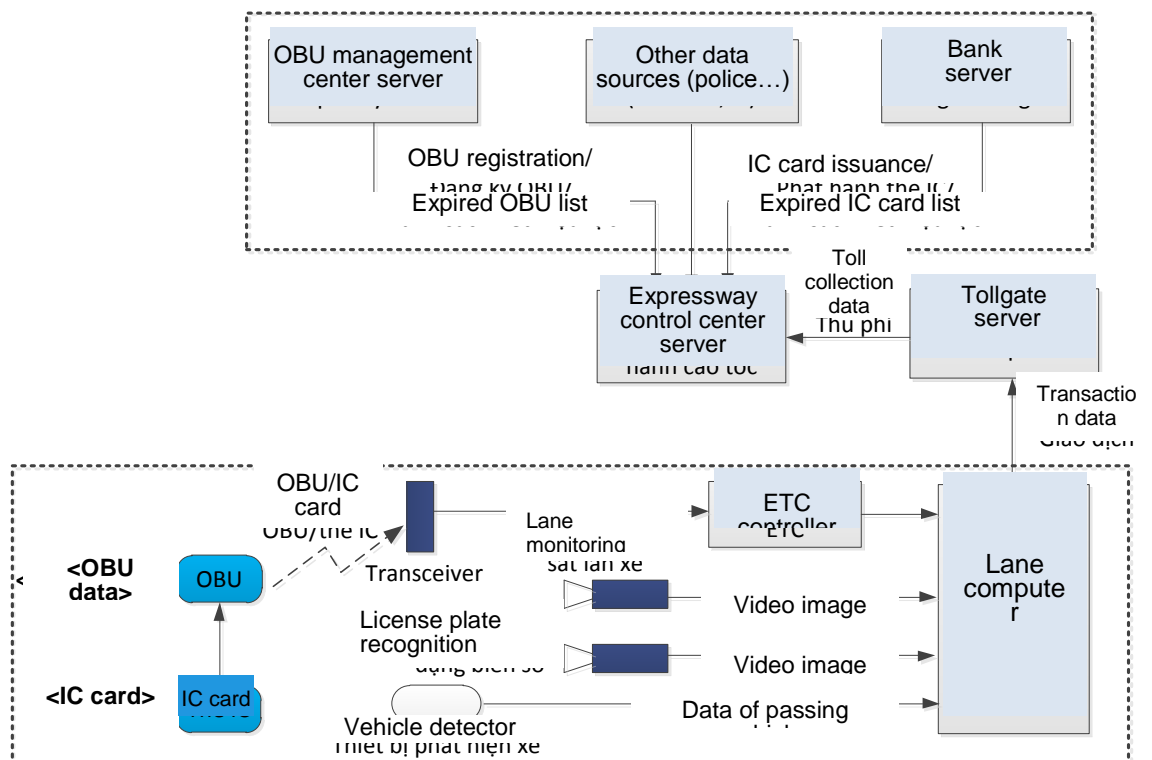

Figure 4.8. Main message exchange supporting for monitoring, post auditing

- Data set and main data components supporting for monitoring, post auditing are stipulated as Table 4.4 follows:

Table 4.4. Data set and data components for monitoring, post auditing

Data set	Data components
Passing IC card Data set	Toll office ID
	Tollgate ID
	Lane ID
	Toll
	Prepaid account
	Date/Time
Passing OBU Data set	Toll office ID
	Tollgate ID
	Lane ID
	IC card ID
	Toll
	Prepaid account
	Date/Time
Transaction Data set	Toll office ID
	Tollgate ID
	Lane ID
	OBU ID
	Vehicle type in OBU
	License plate in OBU
	IC card ID
	Toll
	Prepaid account
	Transaction status
	Vehicle ID
	Date/Time
Toll Collection Data set	Road owner ID
	Tollgate ID
	Toll date
	Total toll amount
	Number of passing vehicle
	Transaction Data set
	Enforcement status
	Date/Time

4.5.5 Data Set for Toll Collection Management

- The system allows operator of toll collection system to store all the toll collection data to manage list using OBU and IC-Card; manage toll revenue on expressways with high reliability by using computer and software system at tollgate operation office.
- The system allows operator to check the expired list of IC-Card and OBU, check validity of using license plates
- At the same time, it is able to transfer and exchange entire database on expressway operation centers, section and regional management centers, bank control center for executing management, control and other operations

- Data set for toll collection management is regulated as in the following table 4.5:

Table 4.5. Main data components for toll collection management

Data set	Data component
Toll collection data set	<ul style="list-style-type: none"> - Road owner ID - Toll office ID - Toll amount date - Total toll amount - Number of passing vehicles - Transaction data set - Enforcement status - Date/time
By hour Toll collection data set	<ul style="list-style-type: none"> - Road owner ID - Toll office ID - Recorded date - Total toll amount - Number of passing vehicles - Total toll amount of vehicle type 1 - Number of vehicle type 1 - Total toll amount of vehicle type 2 - Number of vehicle type 2 - Total toll amount of vehicle type 3 - Number of vehicle type 3 - Total toll amount of vehicle type 4 - Number of vehicle type 4 - Total toll amount of vehicle type 5 - Number of vehicle type 5 - ... - Date/time
Toll revenue data set	<ul style="list-style-type: none"> - Road owner ID - Settlement by month - Toll revenue by month/week - Number of passing vehicles - Total toll amount of vehicle type 1 - Number of vehicle type 1 - Total toll amount of vehicle type 2 - Number of vehicle type 2 - Total toll amount of vehicle type 3 - Number of vehicle type 3 - Total toll amount of vehicle type 4 - Number of vehicle type 4 - Total toll amount of vehicle type 5 - Number of vehicle type 5 - ... - Date/time

4.6 Model of Connection and Settlement among Tollgates and Bank

- System is capable to connect between tollgate operator on different expressway sections, banks and control center, allowing management and processing of toll

collection transactions as well as operations associated (control, settlement of toll revenue ...) among banks and toll collection units, and among banks, and between bank and control center. Beside, it also has the functions of connecting to and sharing toll collection data with the server at section and regional management centers to generate data in use in management according to regulations. Section and regional management centers are capable to send query or register of receiving toll collection information reports by day including: section, time, the number of vehicles and toll amount defined by section, vehicle type; numbers vehicles applied electronic toll collection according to current regulations.

- Model of connecting and settlement for inter-tollgates, inter-bank is in the structure as the following Figure 4,9:

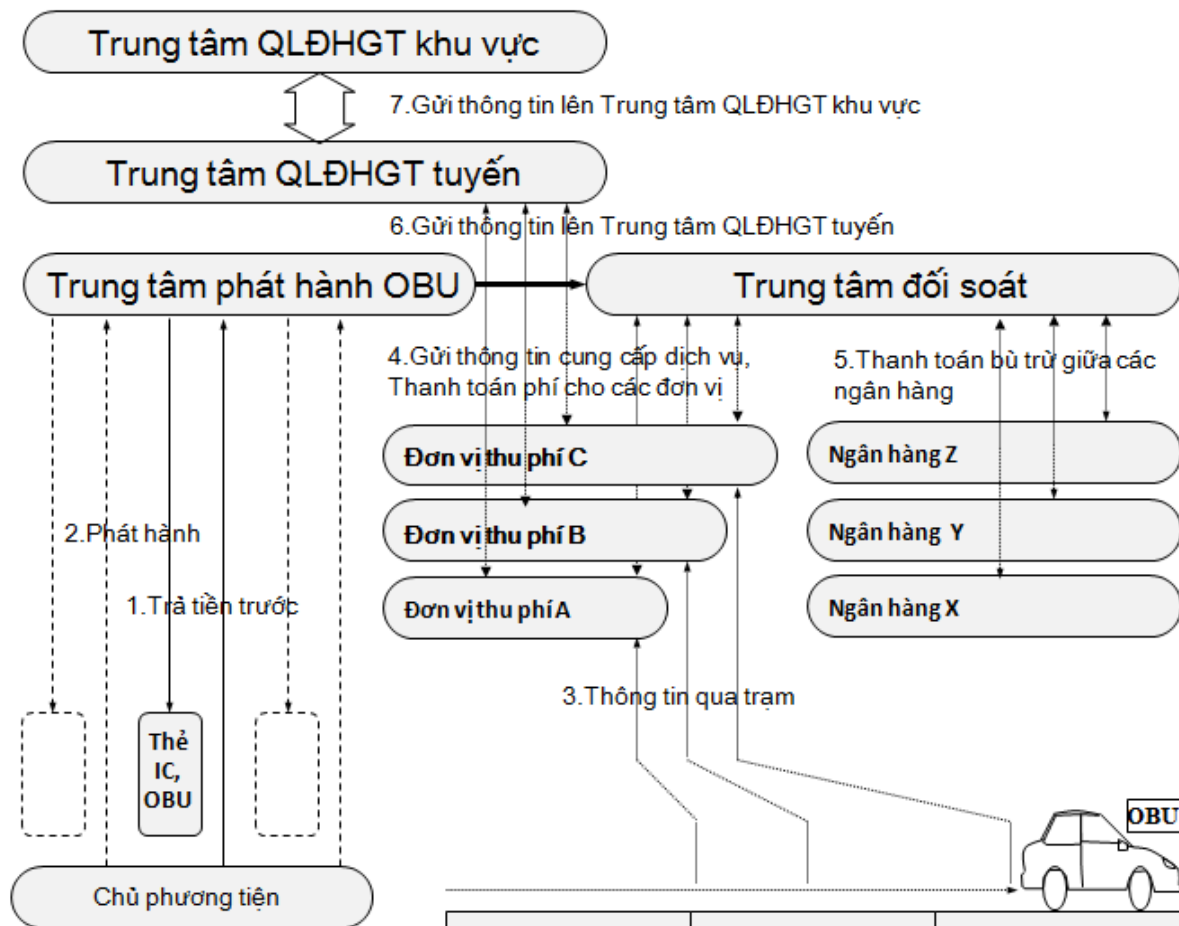

Figure 4,9. Model of connecting and settlement for inter-tollgates, inter-bank

- Design of data transferring networks being appropriate for digital reabsfering system is defined in National Technical Regulation on expressway management,

monitoring and control system.

- VLAN division is set up to divide types the transmission network and various equipment groups in network system.
- Firewall device system devices needs to be used to ensure security for connecting out to Internet.
- Other regulations on structure of transmission network and transmission standard among centers are required to comply with current related regulations.

5. REGULATIONS ON REPORTS

Standard reports are to be extracted by requirement for management and check, inspection for electronic toll collection on the whole nationwide expressways, including:

- Collective toll collection report at center
- List sheet of collective 1 part of toll collection ticket at tollgate
- Center Toll collection report (by the receipt quantity)
- Statistic of vehicle volume of lane passing

Beside, other reports complying with quality of each tollgate and expressway may included, such as : staff shift handling over report, collective handling over report, nationwide free vehicle report and ticket vehicle report. Detail report samples are in APPENDIX 6.

6. REGULATIONS ON MANAGEMENT

- Toll management, usage and accounting are applied according to Article 8, Circular No. 159/2013/TT-BTC dated 14/11/2013 of the Ministry of Finance guiding the regime of collection, payment, management and road usage toll for ROI (Return On Investment) of road construction.
- Toll collection invoice and receipts are applied according to Article 9, Circular No. 159/2013/TT-BTC dated 14/11/2013 of the Ministry of Finance guiding the regime of collection, payment, management and road usage toll for ROI (Return On Investment) of road construction.
- Electronic toll collection system on the entire of expressways shall be managed, exploited and operated by the investor or road operator, operator maintenance organization under regulations of competent agency.
- Expressway management agency under Ministry of Transport is to be responsible for management, monitoring the investment construction and operation Electronic toll collection system on the entire of expressways in its authorities.
- Connection between toll collection operation center, section management center, regional management center is executed under the roadmap and instruction by expressway management agency.

7. IMPLEMENTATION

- Organizations, individuals related to planning of development, construction investment, management, operation, and maintenance of tollgates that have electronic toll collection lane, are to follow regulations in this specifications and other related documents.
- In case specifications, standards, technical documents mentioned in 1.4 of this specifications may change, with supplement or replacement, follow the latest one.
- DRVN is responsible for building up general procedure on ETC operation and maintenance as a base for building the detail operation and maintenance procedure for each tollgate.
- DRVN chair, cooperate with Department of Infrastructure, Department of Science and Technology (MOT) and other functional agencies to instruct implementation and organization of executing this regulation.

APPENDIX 1: Sample of arranging equipment on T&G toll lane

Sample of arranging equipment on T&G toll lane is as the following figure:

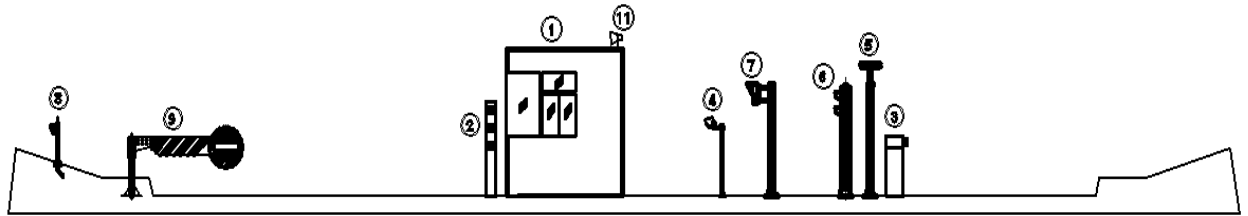

MẶT ĐỨNG

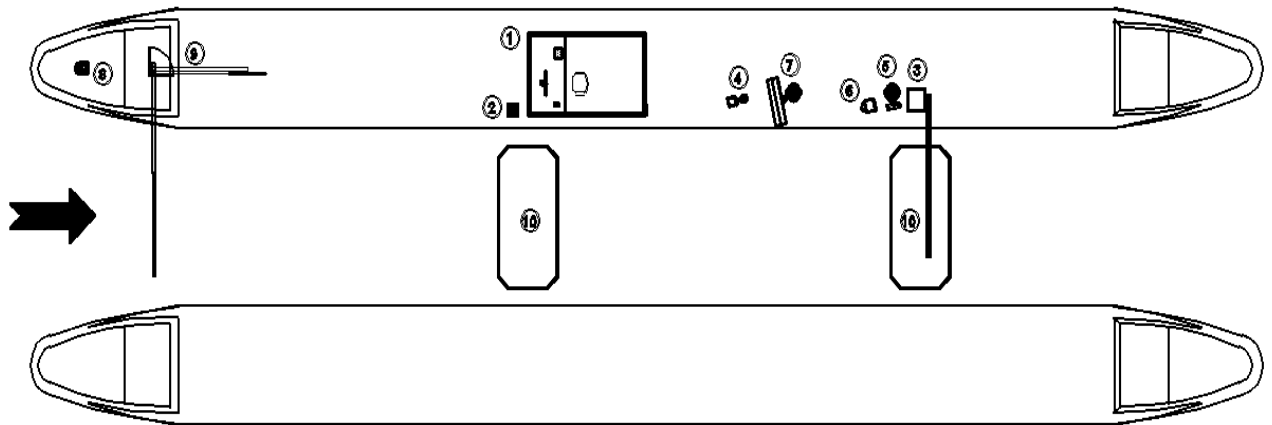

MẶT BẰNG

KÝ HIỆU	DANH MỤC THIẾT BỊ
①	Cabin thu phí
②	Đầu đọc thẻ IC không tiếp xúc
③	Ba-ri-e tự động
④	Camera dò đọc biển số xe
⑤	Camera giám sát làn xe
⑥	Đèn tín hiệu giao thông
⑦	Bảng báo điện tử
⑧	Đèn cảnh báo đầu đảo
⑨	Ba-ri-e thủ công
⑩	Vòng từ
⑪	Còi và đèn báo hiệu

APPENDIX 2: Sample of arranging equipment on ETC toll lane

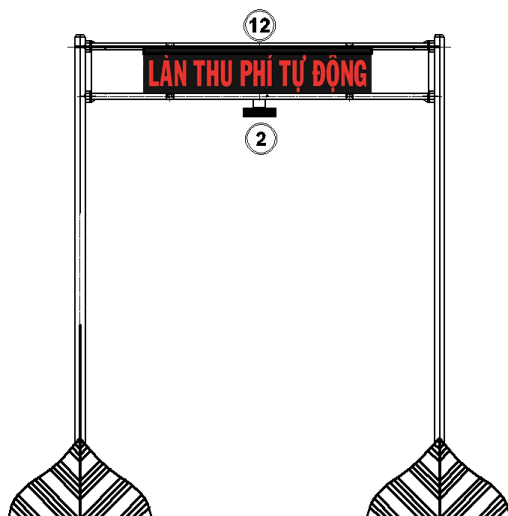
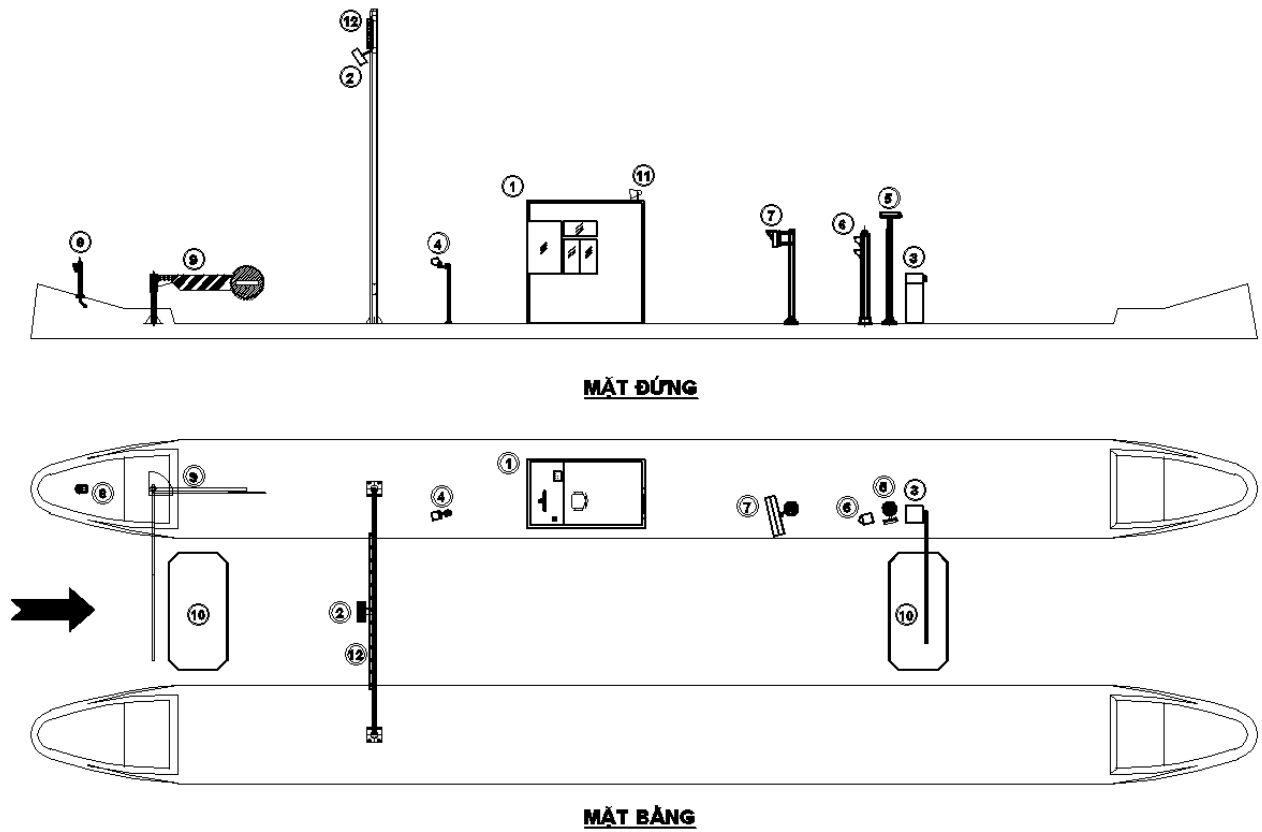

KÝ HIỆU	DANH MỤC THIẾT BỊ
①	Cabin thu phí
②	Tranceiver
③	Ba-ri-e tự động
④	Camera dò đọc biển số xe
⑤	Camera giám sát làn xe
⑥	Đèn tín hiệu giao thông
⑦	Bảng báo điện tử
⑧	Đèn cảnh báo đầu đảo
⑨	Ba-ri-e thủ công
⑩	Vòng từ
⑪	Còi và đèn báo hiệu
⑫	Biển báo làn thu phí tự động

APPENDIX 3: Sample of arranging equipment on combination of Touch & Go and ETC toll lane

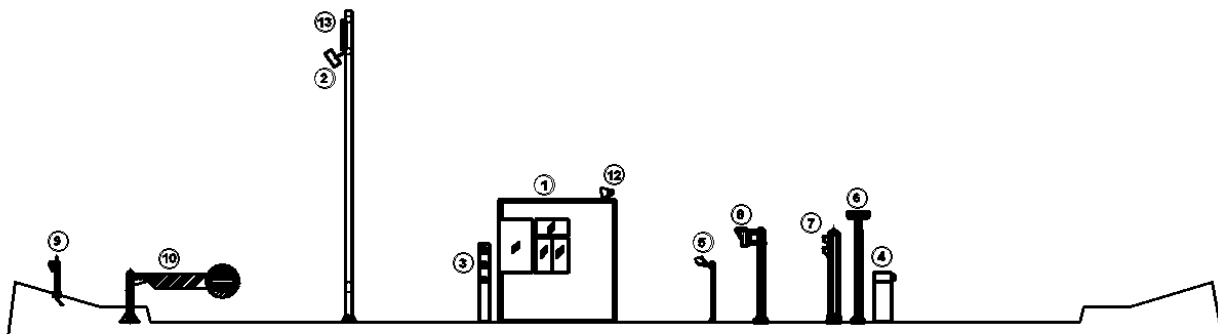

MẶT ĐỨNG

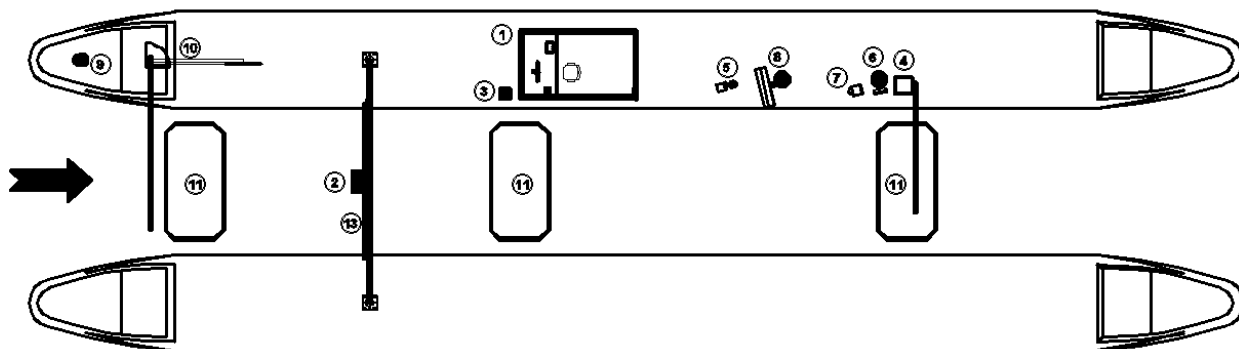

MẶT BẰNG

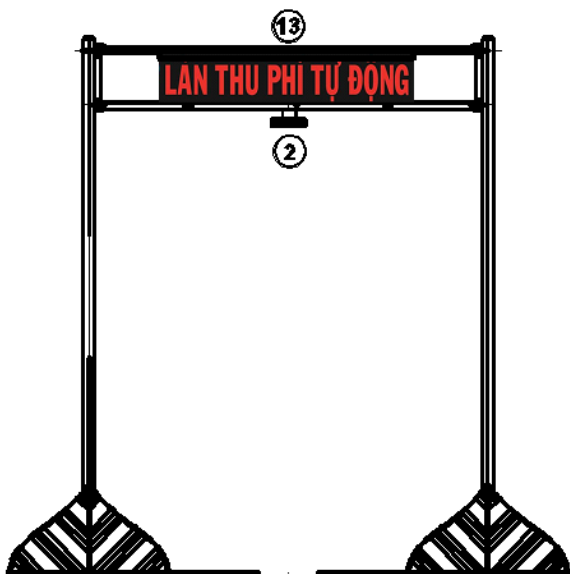

MẶT TRƯỚC

APPENDIX 4: Operation steps in ETC toll lane

APPENDIX 4.1 Operation steps at entry lane

Step	Objective	Activity		Result
1	Driver	Slow down to “entry lane” of expressway tollgate.		Speed reduced.
2	Automatic toll collection communication system (Transceiver & OBU) & license plate Recognition	<ul style="list-style-type: none"> - Recognizing OBU through communication with Transceiver. - Recognizing license plate through license plate Recognition camera - System checks OBU & license plate in database. System shall automatically communicate with OBU and automatically check the it’s validity (OBU ID, vehicle type, expired date...) 		
		- Case 1: Checking result of valid OBU	System shall automatically write information on OBU (entry tollgate ID, entry ID, entry time...)	+ Barrier opened, signal light is green, board and toll collection display license plate and expired date, system captures the vehicle image, toll collection data is insert on video signal.
		- Case 2: Checking result of invalid OBU	<u>Case 1:</u> OBU is available but not belong to vehicle owner. At that time, license plate recorded in OBU is not the same with detecting result. This case is to be listed in enforcement	Barrier closed, signal light is red, board and toll collection display inform “not right OBU”, and toll collection data is insert on video signal. + Require driver to

Step	Objective	Activity	Result
		<p>list and to be treated by tollgate regulations.</p>	<p>stop for processing by tollgate regulation.</p> <p>+ Require driver to get IC card to enter expressway.</p>
		<p><u>Case 2:</u> Vehicle without OBU, or with OBU but the account for road usage toll is expired or not sufficient for the vehicle to go through the longest distance: The system shall not allow vehicle to pass through, the staff requires it to change to semi-automatic lane to buy daily ticket</p>	<p>+ Barrier closed, signal light is red, board and toll collection display inform “no OBU”</p> <p>“Expired OBU” or “not sufficient balance”, toll collection data is insert on video signal</p> <p>+ Require drivers to move to semi-automatic lane</p> <p>+ Require drivers to get IC card to enter expressway</p>
		<p><u>- Case 3:</u> The communication between OBU and transceiver is not successful (reasons are: location of OBU on vehicle is not proper; OBU is in low battery, OBU is broken): Staff needs to check OBU location and adjust it, or borrow OBU to scan the</p>	<p>Barrier closed, signal light is red, board and toll collection display inform “no OBU signal”, toll collection data is insert on video signal</p> <p>+ Require drivers to stop for checking, if not functioned, require driver to move</p>

Step	Objective	Activity		Result
			communication of transceiver. If it's still not successful, the staff informs the driver to get to the place of issuing OBU to check again the OBU, requires it to change to be processed in semi-automatic lane to buy daily ticket	to semi-automatic lane + Require drivers to get IC card to enter expressway
3	Driver	Driver leaves ETC lane and enters expressway. All data and image of communication is transmitted to server in Center for counting toll at exit and other tasks		Barrier automatically open for vehicle to enter and close when it pass over

APPENDIX 4.2 Detail operation steps at exit lane

Step	Object	Activity		Result
1	Driver	Slow down the vehicle to "exit lane"		Speed down
2	Communication system automatically fare collection (Transceiver & OBU) & number plate recognition	<ul style="list-style-type: none"> - Recognize auto-toll collection equipment (OBU) via transceiver communications. - Recognize license plate via camera - The system checks OBU & license plate in database. The system shall automatically communicate with OBU and check the validity of the OBU (OBU ID, vehicle type, expiry date, ...) 		
		<p>- Case 1: OBU validity check result validity</p>	<p>System shall automatically count the toll to be paid (by mileage and vehicle type), system automatically deduct an amount and write a new account value on OBU (after deducted).</p>	<p>Barrier opened, signal light is green, board and toll collection display license plate and expired date, system captures the vehicle image, toll collection data is insert on video signal</p> <p>At the same time, at the toll collection management office, transactions are saved; information is synchronized and exchanged with bank settlement system. Also, post auditing, transaction data comparing and</p>

Step	Object	Activity		Result
				checking... are also conducted here.
		- Case 2: Result show invalid OBU	<p><u>Case 1:</u> OBU has no recording information at entry lane: in this situation, staff requires drivers to change to half-automatic lane, and to be processed manually.</p>	<p>+ Barrier closed, signal light is red, board and toll collection display informs “no OBU” recorded at entry lane</p> <p>+ Require driver to move to semi-automatic lane to be processed manually.</p>
			<p><u>Case 2:</u> Vehicle type is not fit with type of OBU: When communicating with OBU on road, the information of type at lane shall not fit with type in OBU, this case is to be recorded in enforcement list and to be treated according into regulations of tollgate.</p>	<p>+ Barrier closed, signal light is red, board and toll collection display informs “vehicle type is not the same with the one in OBU”.</p> <p>+ Require driver to stop and be handled by tollgate regulation.</p>
			<p>- Case 3: The communication between OBU and transceiver is not successful (reasons are: location of OBU on vehicle is not</p>	<p>+ Barrier closed, signal light is red, board and toll collection display inform “no OBU signal”.</p> <p>+ Require drivers to stop for checking, if OBU still does not function, require</p>

Step	Object	Activity	Result
		<p>proper; OBU is in low battery, OBU is broken): Staff needs to check OBU location and adjust it, or borrow OBU to scan the communication of transceiver. If it's still not successful, the staff informs the driver to get to the place of issuing OBU to check again the OBU, requires it to change to be processed in manual lane.</p>	<p>driver to move to semi-automatic lane. + Require drivers to get entry/exit expressway card.</p>
3	Driver	<p>Driver leads the vehicle out of ETC lane and leaving expressway. At the same time, at the toll collection management office, transactions are saved, information is synchronized and exchanged with bank settlement system. Also, post auditing, transaction data comparing and checking... are also conducted here.</p>	<p>Barrier automatically opens for vehicle to pass through and automatically closes when it is out of lane.</p>

APPENDIX 5: Minimum specifications of main equipment

No.	Equipment name	Minimum specifications
I	Lane equipment	
1	Transceiver	<p>Meet one of following Standards:</p> <ul style="list-style-type: none"> - CEN/ TC 278/5.8GHz DSRC: European standards for Dedicated Short Range Communications (DSRC), 5.8GHz band passive, speed (500k Down, 250k Up), 10-20m communication distance, 20MHz bandwidth. - ARIB STD—T75: Dedicated Short Range Communications (DSRC), 5.8GHz band active, 1Mbps transfer rate, plot ways of communicating to 30m, 80MHz band. - American Standard ISO/IEC 18000-6: RFID frequency range 860 MHz to 960 MHz.
2	Toll collection computer	<ul style="list-style-type: none"> - Industrial computer - Processor: Core 2 Duo 2.8 GHz or equivalent - RAM: 2GB - Hardware: 500G HDD - Connection gate: RJ-45 10/100/1000Mbps - Operation temperature: 0 to 60°C
4	IC-Card Reader	<ul style="list-style-type: none"> - Card reading/writing complying with ISO14443A or ISO18092 - Transmission speed 9.600 ~ 115.200 bps - Communication: RS232/ USB - Reading distance: 60 mm - Operation temperature : -25° to 60°C
5	Lane control cabinet	<ul style="list-style-type: none"> - Using specialized industrial controller. - Labeling, numbering clearly connections, cables for convenient installation, maintenance, and incident solving. - Using separated switch for each equipment component.
6	Manual control table	<ul style="list-style-type: none"> - On/Off alarming whistle key when vehicle pass tollgate - Barrier open key for 1 vehicle to pass - Barrier open/close key for many vehicles to pass
7	Alarming whistle and lamp	Ensuring clear sound within tollgate
8	Automatic Barrier	<ul style="list-style-type: none"> - Open/close duration: 0,9 s - bar length: 3m - There is automatic opened hinge to protect bar when crashed - Protection level: IP 44 - Operation temperature: -20° C to +60° C
9	Vehicle detector	- Ensuring error of 1/1000

10	Manual barrier	<ul style="list-style-type: none"> - 3m bar to stop vehicle - Bar installed prohibited sign for entering vehicle following QCVN 41:2012/BGTVT. - Automatic on/off light switch for lane status
11	Toll plaza front alarming light	<ul style="list-style-type: none"> - Light parameter: 100 mm. - Flashing automatically off to attract notice - Duration life: >20.000 hours.
12	lane status light	<ul style="list-style-type: none"> - Parameter: 300 mm - Duration life: >20.000 hours.
13	Traffic signal light	<ul style="list-style-type: none"> - Parameter: 200 mm - Duration life: >20.000 hours.
14	Electronic board	<ul style="list-style-type: none"> - Display 2 Vietnamese lines, 12 characters/line. - Color and brightness ensure clear visibility both daytime and nighttime. - Duration life: >20.000 hours.
II Monitoring camera		
1	Lane monitoring camera	<ul style="list-style-type: none"> - Sensor: CCD 1/3-inch - Light sensitiveness: 0,01 lux - Shutter release speed: 1/60 - 1/500.000. - Observation distance: 3-20 m. - Protection level: IP 66
2	License plate recognition camera	<ul style="list-style-type: none"> - Sensor: CMOS 1/3-inch - Shutter release speed: 1/100-1/30000 s - Infrared LED: 850 nm - Observation distance: 3-12 m - Protection level: IP 65
3	panorama camera	<ul style="list-style-type: none"> - High speed Camera Doom PTZ - Shutter release speed: 1/1 - 1/10.000 - Pan Range: 360°, Tilt Angle 180° - Protection level: IP 66
III Operation equipment		
1	Toll collection data server	<ul style="list-style-type: none"> - Processor: Intel Xeon E5-2620 2.0Ghz or equivalent - RAM: 8GB - Hard driver: 2x500GB - Raid Controller: 0,1,10 - Connection gate: RJ-45 10/100/1000Mbps
2	Monitoring, post auditing computer	<ul style="list-style-type: none"> - Processor: Core 2 Duo 2.8 GHz or equivalent - RAM: 2GB - Hard driver: 500G HDD - Connection gate: RJ-45 10/100/1000Mbps
3	Camera recorder	<ul style="list-style-type: none"> - Storage duration: 60 days - Compress standard: H264 - Supporting camera PTZ control

APPENDUX 6: Standard report samples

Appendix 6.1 Report sample BC-1:

COMPANY
TOLLGATE.....

THE SOCIALIST REPUBLIC OF VIETNAM
Independence - Freedom - Happiness

SUMMARY REPORT OF TOLL REVENUE AT TOLLGATES

From date:, to date:

Type	TG 1		TG 2		TG 3		TG 4		TG 5	
	Time	Total amo- unt	Time	Total amount	Time	Total amount	Time	Total amount	Time	Total amount
TG 1										
Vehicle type 1										
Vehicle type 1										
Vehicle type 1										
...										
Vehicle type 1										
TG 2										
Vehicle type 1										
Vehicle type 1										
...										
Vehicle type 1										
TG 3										
Vehicle type 1										
Vehicle type 1										
...										
Vehicle type 1										
TG 4										
Vehicle type 1										
Vehicle type 1										
...										
Vehicle type 1										
TG 5										
Vehicle type 1										
Vehicle type 1										
...										

Vehicle type 1										
-------------------	--	--	--	--	--	--	--	--	--	--

Total:

Total amount:.....

In word:.....

Prepared by

(Day).....(month)(year).....
Tollgate director

添付資料-8

**DRAFT QCVN
OF
MANAGEMENT CENTER/OFFICE
FOR EXPRESSWAYS
(SUB-GROUP 8)**

1ST DRAFT
(Sub-Group 8)
2014.03.30



SOCIALIST REPUBLIC OF VIETNAM

QCVN XX : 2014/BGTVT

**NATIONAL REGULATION ON TRAFFIC
MANAGEMENT CENTER FOR EXPRESSWAYS**

*Quy chuẩn Kỹ thuật về Trung tâm Quản lý Điều hành Giao thông
Đường cao tốc*

HA NOI - 2014

Foreword

QCVN XX:2014/BGTVT was compiled by the Drafting Department for National Technical Regulation on Traffic Monitoring and Management System for Expressways (established under the Decision No. 2252/QĐ-BGTVT on July 31st 2013 of MOT), approved by the Ministry of Science and Technology, and issued by Ministry of Transportation in accordance with the Circular No./2014/TT - BGTVT on 2014

NATIONAL TECHNICAL REGULATION
O HIGHWAY TRAFFIC MANAGEMENT CENTER

Quy chuẩn Kỹ thuật Quốc gia về Trung tâm Quản lý Điều hành Giao thông Đường cao tốc

1	GENERAL REGULATION.....	5
1.1	Scope	5
1.2	Application Object.....	5
1.3	Reference Materials.....	5
1.4	Terminology and Definition	5
1.5	Abbreviations	6
2	TECHNICAL REGULATION.....	6
2.1	Road Management Offices	6
2.1.1	Performance of Functions	6
2.1.2	Technical Infrastructure System.....	7
2.2	Regional Main Center	8
2.2.1	Performance of Functions	8
2.2.2	Technical Infrastructure System.....	9
2.3	Requirements on Design and Development for Equipment at Traffic Management centers	9
2.3.1	Design Scope	9
2.3.2	Equipment Room	9
2.3.3	Traffic Operation Room.....	10
2.3.4	Telephone System	11
2.3.5	Data Transmission Network.....	12
2.3.6	Supporting Device Systems	13
2.4	Exchanged Information and Data among Traffic Management Centers	14
2.4.1	Exchange of Traffic Image Data.....	14
2.4.2	Exchange of Vehicle Detection Data.....	15
2.4.3	Exchange of Weather Data	15
2.4.4	Exchange of Vehicle License Plate Data.....	16
2.4.5	Exchange of Traffic Event Information	16

2.4.6	Exchange of Indication Information and Traffic Control	17
2.4.7	Exchange of Toll Collection Information	17
2.4.8	Communication Standards among Centers.....	18
2.5	Requirements on Management Software	18
2.5.1	Management Software at Road Management Offices	18
2.5.2	Management Software at Regional Main Center	19
2.5.3	Software for Providing Traffic Information through Internet	19
3	REGULATION ON MANAGEMENT	19
4	IMPLEMENTING ORGANIZATIONS	20

1 GENERAL REGULATION

1.1 Scope

This Technical regulation shall provide requirements on function, technical infrastructure system and exchange of information, data among traffic operation and management centers on expressway.

1.2 Application Object

This Technical regulation shall be applied for related individuals, organizations during development, investment and operation of expressway operation and management center in accordance with Regulations on Management, utilization and maintenance on Expressway section.

1.3 Reference Materials

1.3.1. TCVN 9250:2012 – National Technical Standards: Data Center – Requirements on telecommunication Infrastructure.

1.3.2. QCVN 32:2011/BTTTT – National Technical Regulations on lightning protection for telecommunication stations and extra telecommunication cable network.

1.3.3. QCVN 9:2010/BTTTT - National Technical Regulations on earthing for telecommunication stations.

1.3.4. TCVN 7161-2009: National Technical Standards: Gas fire extinguishing System – Physical characteristics and system architecture.

1.3.5. TCVN 3890:2009 - National Technical Standards: Fire protection extinguishers for buildings and infrastructure – Preparation, arrangement, inspection and maintenance

1.3.6. QCVN 06:2010/BXD - National Technical Regulations on fire safety for buildings and infrastructure.

1.3.7. QCVN xx:2014/BGTVT - National Technical Regulations on traffic monitoring and management system for expressways.

1.4 Terminology and Definition

In this Technical Regulation, these following vocabularies should be defined as below:

1.4.1. Area traffic management center is the organization responsible for managing, operating traffic on expressways and road sections within determined area.

1.4.2. Road traffic management center is the organization responsible for managing, operating traffic on an expressway or a road section.

1.4.3. Traffic monitoring and management system is the system of equipments, the application of high scientific technology to manage and monitor traffic on expressway shall be installed during investment, development or utilization process.

1.4.4. Traffic images data is the data of video images from cameras installed on roadside to monitor expressway traffic condition.

1.4.5. Vehicle detection data is the data of vehicle volume, velocity from vehicle detectors installed on expressway.

1.4.6. Weather data is the data of temperature, rainfall, vision, wind velocity from weather sensors installed on expressway.

1.4.7. Vehicle license plate code data is the data of recognizing license plate, supervising vehicle flows which are automatically processed in images from cameras on expressway.

1.4.8. Traffic event information describes accidents, incidents and provides notification on securing traffic safety on expressway.

1.4.9. Traffic indication is changeable information which is displayed on electronic traffic signs on expressway.

1.4.10. Traffic control information is regulation on speed limitation on lanes and shall be remotely controlled through electronic signs on expressway.

1.4.11. Toll collection information is the integrated information of toll collection which is applied for vehicles accessing to expressway section.

1.4.12. Data queries requirement is the form of exchanging data which sender shall respond the data receiver requires (Pull mechanism).

1.4.13. Data receiving registration: is the form of exchanging data in cycle or in case of new data arising from sender to register (Push mechanism).

1.5 Abbreviations

TM	Traffic Management
PSTN	Public Switchboard Telephone Network
VLAN	Virtual Local Area Network – mạng nội bộ ảo

2 TECHNICAL REGULATION

2.1 Road Management Offices

2.1.1 Performance of Functions

The investors or operating and maintaining organization should develop and manage Road Management Offices in order to surveil, control and secure traffic safety on expressway within jurisdiction. The office shall be responsible for operating Traffic Monitoring and Management System for Expressway to implement these below tasks:

- a. Collecting and processing all types of traffic information on expressways including camera images, vehicle detection data, roadside weather, recognition alert on accidents, incidents and traffic violations of drivers.
- b. Monitoring and managing information on related events occurred on expressway, resulted in traffic congestion, accident, incident, dangerous weather and planned events such as work site, special holiday.
- c. Providing changeable indications by time such as weather condition, traffic crowdedness, travelling consultation, planned travelling time, notification on incidents, accidents, work site and information related to traffic on expressway.
- d. Receiving and timely processing information on accident, broken vehicle, work site on expressway which shall be notified to Office from different sources (automatic information collection system; patrol crew, security patrol on expressway; residence and road users) to assign patrol crew, respond traffic condition and to report the police, the rescue teams and concerned forces so that they urgently arrive at the site and function the tasks as regulation..
- e. Proactively performing measures to regulate traffic remotely in order to secure traffic safety such as adjusting lanes or restricting vehicle velocity on expressway in accordance with actual traffic condition.
- f. Gathering information on toll collection and heavy truck control (if any) on expressway to monitor on expressway.
- g. Connecting and fully transmitting traffic information, data to Area TMO Center to control and operate in accordance with regulations of Article 2.4 in this Technical Regulation.
- h. Receiving and providing information, managing the implementation of special traffic organizing methods under the direct guidance of Area TMO Center in case of unexpected difficult situation.
- i. Monitoring the performance and maintaining equipments in traffic monitor management system on expressways.

2.1.2 *Technical Infrastructure System*

Road Management Offices on Expressway shall be equipped with technical infrastructure system including following primary components:

- a. Operation room at office shall consist of Equipment Room, Traffic Operation Room and Working Room for organizational mechanism at Road Management Offices.
- b. Equipments at office shall consist of servers of sub-systems of traffic monitoring and management system for expressways as regulated in QCVN xx:2014/BGTVT – National technical regulation on traffic monitoring and management system for expressways.
- c. Station computers and displaying screens shall be used for traffic monitoring and management for expressways.

- d. Communication system shall receive emergency calls, to connect information with higher authorities, functional forces who contribute to secure traffic safety and handle accidents, incidents on expressway in accordance with regulations.
- e. Transmission network system shall connect information between Offices and roadside equipments in road traffic monitor management system, and shall secure data connection with Regional Main Center.
- f. Necessary equipments and devices (purchasing or borrowing) shall be used in periodical maintenance for roadside equipments in traffic monitor management system.

Technical infrastructure system shall be developed at Road Management Offices, based on design scale, the system should be utilized to operate and manage in one or many different expressway sections.

2.2 Regional Main Center

2.2.1 Performance of Functions

Regional Main Center is the primary unit of Expressway Management Organization whose responsibility for monitoring, controlling the performance of Road Management Offices and controlling area traffic condition within jurisdiction. Regional Main Center shall function these following tasks:

- a. Gathering and managing traffic information which are transmitted from Road Management Offices to Regional Main Center with the aim to monitor, manage and secure highway traffic safety within jurisdiction.
- b. Directly assigning the operation and maintenance organization of expressway section in area to solve serious accidents and incidents. Supervising the information provided from Road Management Offices during rescuing procedure.
- c. Coordinating traffic of area highway system by special traffic organizing methods under the approval of competent authorities in case of emergency situations, natural disasters or national security.
- d. Disseminating information to Road Management Offices so as to regulate and avoid traffic congestion among sections within the area.
- e. Implementing highway security patrol so as to check, monitor and surveil the patrol task on expressway; process or cooperate to process violations in accordance with regulations on expressway management.
- f. Providing consultation on travelling route and traffic condition of sections in an area to road users.
- g. Managing and storing data related to highway traffic within the area where is in use to serve plan managing, development and utilization planning for expressway by Expressway Management Office.
- h. .

2.2.2 *Technical Infrastructure System*

Regional Main Center shall be operated with requirement of securing technical infrastructure system included these below major components:

- a. Head office shall be prepared with equipment room, area traffic operation room and other working rooms in accordance with structure, function and managing responsibility of Regional Main Center.
- b. All servers, computers and large-size displays shall secure the performance of traffic monitor management system at Regional Main Center.
- c. Communication system shall be used to indicate and operate the performance of Road Management Offices, the operating and maintaining organizations, and to cooperate with other functional organizations.
- d. Transmission network system shall secure connection and exchange of traffic information, data among Road Management Offices within jurisdiction.
- e. Other necessary tools and equipments shall be used for security patrol on expressway sections.

The location of Regional Main Center shall be appropriate and convenient for security patrol on expressway sections within jurisdiction. It is preferred to select the locations which are prepared with communication infrastructures by telecommunication carriers so as to easily implement communication system and high-speed Data Transmission Network for Center.

2.3 **Requirements on Design and Development for Equipment at Traffic Management centers**

2.3.1 *Design Scope*

Requirements on design shall be applied for both Road Management Offices and Regional Main Center. Design Scope for Traffic Management Centers shall be required to achieve that level 2 of Data Integration Center in accordance with National Standards TCVN 9250:2012 and be approved by competent authorities of investing.

The design scale shall be secured to arrange some areas such as center building, parking area, area for the backup generator.

The building design shall separate the area of Equipment Room and Traffic Operation Room with other areas such as reception area, working room, meeting room, hall, etc.

2.3.2 *Equipment Room*

Equipment room shall be designed according to Standards for Machine Room at Data Integration Center. This room shall have adequate utilities for equipment arrangement as below:

- The rack and UPS system shall be arranged on electric static floor. The separating distance between equipments shall be secured so as to easily maintain equipments during utilization.
- Network cable and power cable system shall be conducted in cable trap or under the static floor.
- Fixed control panel should be arranged to ensure aesthetics and convenience during equipment maintenance.
- Technical electric distribution cabinet should be arranged to ensure power source safety for devices.
- The room should be designed sound insulation, heat insulation and dust insulation in accordance with standards of Machine Room at Data Integration Center.

2.3.3 Operation Room

Operating room shall be designed with large square and adequate space for necessary working positions to operate traffic monitor and management in accordance with regulations of Expressway Management Organization. Based on jurisdiction and demand of Center, equipments shall be arranged at operating room as following.

a) Large-scale display screen system

It shall be recommended to design and install the large-scale display screen system, suitable with using level at Traffic Management Center and responding to technical requirements:

- Hi-tech shall be applied in using display screen system to secure power save, clear colour and high image resolution.
- Multi-screens connection shall be allowed to display images on a fully united wall screen. The size of coupling contour between screens is less than 1 cm.
- The size of wall screen shall be large enough for operator to clearly view details of information on the map from any position in operation room. The operation room should be located at appropriate height so as to install and to create a space for viewing large-size wall screen.
- The wall screen controller can be remotely managed to changbly select and arrange information from many different sources: plan/map updated with traffic condition information on jurisdiction section or area; images from traffic monitoring cameras; other information dumped from traffic monitoring and management system.

b) Working table for operator

Each operator of the traffic monitor management system shall be arranged a working space at operating room in Center. Based on function and task of each one, the working table shall be prepared with necessary equipments, such as:

- Station computer shall be setup functional softwares which are used in traffic operation and management.

- Screen shall display interfaces of functional softwares or images from traffic supervising cameras. Number and size of screens shall be calculated in accordance with the volume of required information for road users;
- Remote controller for traffic supervising cameras shall be installed at the location with task of monitoring traffic by images;
- Terminal equipment in Communication System shall be installed at the location with task of receiving and processing information on traffic operation.
- Other essential office equipments and devices which are used for printing and marking information.

2.3.4 Telephone System

a) Telephone for receiving Emergency calls

All Road Management Offices shall establish a hotline number to receive urgent information on accidents, broken vehicles, and worksite from residence, traffic users or functional forces.

At least 02 telephones shall be installed parallel at operation room in Center to receive urgent calls from hotline. Hotline shall be configured at the highest connection mode.

Recorder is used to record the date and time automatically and the voice for each conversation. Voice recorder must have enough capacity to record conversations within a month. The conversation was recorded over a month or so will be overwritten without prior notice.

b) Command telephone and Administration telephone

Command telephones are essential means to transmit commands and information exchanged between departments, competent forces in the management process to secure traffic safety and handle traffic accidents and incidents on expressways.

The design of Communication System at Traffic Management Centers should separate between command telephone which is used in traffic operation management and administration telephone. Command telephone is always setup with priority in higher connection lever compared with administration telephone.

Equipment used for command telephone shall have separate function keys to quickly communicate with different functional forces such as traffic police, road patrol, rescue team, etc. The telephone receiving demand calls shall have warning function by signal with sirens or flashing lights.

Command communication shall be required to have high connection quality with no disconnection. It is required to prepare backup equipments so as to replace immediately when a command telephone is broken.

c) Call Center

Call Center shall be used to connect managing internal communication at Traffic Management Center. Call Center is connected to the public switched telephone (PSTN). The

number of trunks shall be designed to have redundancy to ensure high availability level for the communication connection to the outside.

When operating, it is necessary to use for monitoring performance of equipment at call center. Equipment errors shall be detected and timely notified to operator. During repairing system errors, it shall be ensured that the backup device works well so as not to interrupt the operation of the communication system..

2.3.5 Data Transmission Network

Data Transmission Network at TOM Center shall consist of two types of systems:

- Internal connection network for equipments at Traffic management center
- Connection network between Road Management Offices to roadside equipments
- Connection network between Road Management Offices and Regional Main Center
- Connection network between Traffic management center to outside of Internet

The structure of information connection among Traffic management centers through Data Transmission Network shall be shown in Figure 1.

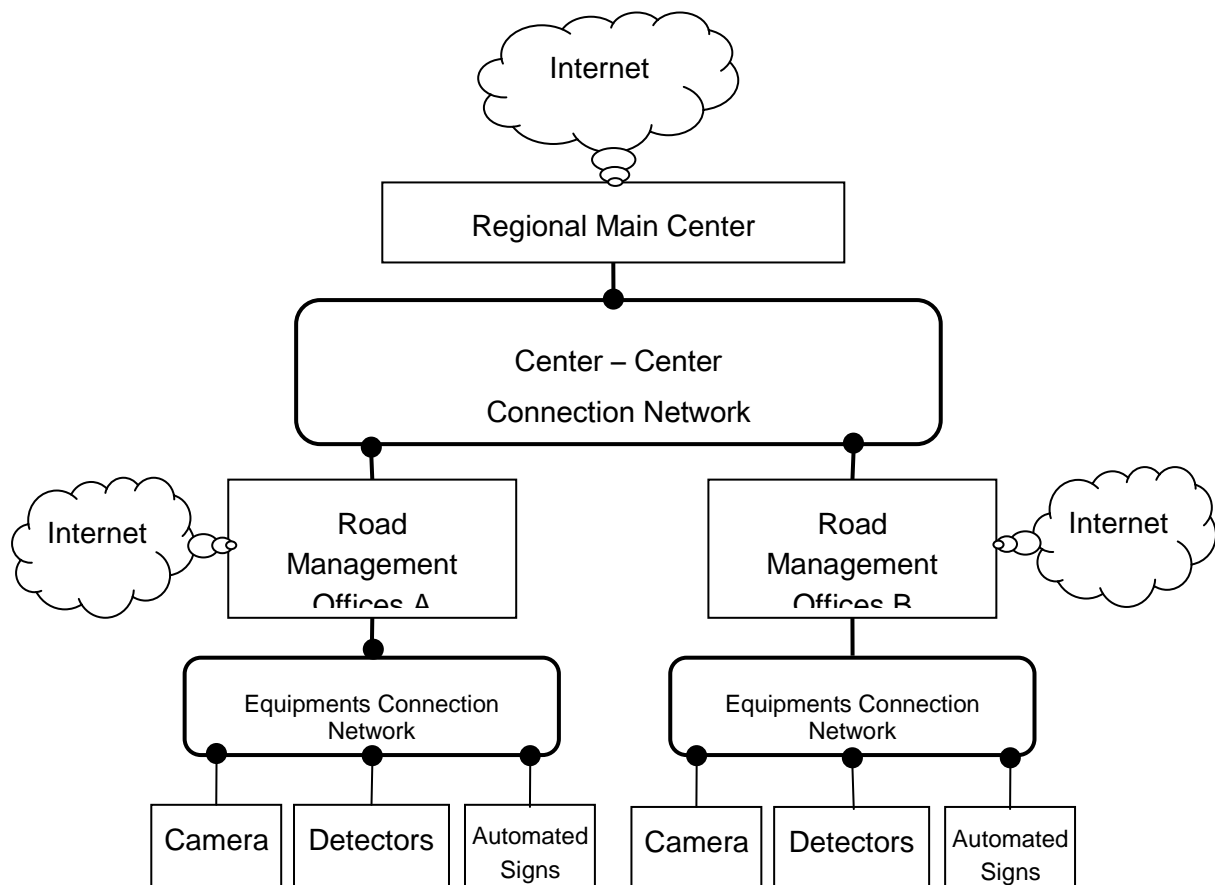

Figure 1. Map of communication connection network among Traffic management centers

The design for Data Transmission Network shall comply with digital transmission system in National Technical Regulation on Traffic monitoring and management system.

VLAN partitions shall be set up to separate the transmission network types and different groups of devices in the network.

Firewall device system shall be used to ensure network security for the connection out of Internet.

2.3.6 Supporting Device Systems

a) Backup engine generator

Traffic Management centers shall be equipped with backup engine generator which is stably connected to the power network at station and automatically start right after electricity loss. Time for starting, closing circuit and generating shall last only 02 minutes right after electricity loss. The engine capacity must be calculated in accordance with the additional charge for system of main equipments and other necessary devices at Center. The generator should be kept in good condition with redundant fuel amount for at least continuously 6-hour operation.

b) UPS device

UPS device shall be used to continuously supply power to system of main equipments with the aim of securing stable operation in case of electricity loss. The performance and capacity should be calculated to keep supplying to all equipment for at least 10 minutes.

c) Cooling device

The equipment room should be equipped with cooling system so as to keep performance environment at approximately 20-25⁰C, moisture at 40-45%, highest congealing point at 21⁰C, largest variation velocity at 5⁰C per hour and functioning 24 hours a day, 365 days a year.

The cooling device at other working room shall have adequate capacity to remain the inner temperature at 27⁰C and moisture at 50%..

d) Security Equipment

Traffic Management centers shall be designed with security lock system in Equipment Room and Traffic Operation Room. Security cameras should be installed to control tracking, recording activities and persons accessing the operating room and at the entrance to the center .

e) Fire Protection Extinguishers

Fire protection System of Traffic Management centers shall meet the regulations in QCVN 06:2010/BXD and TCVN 3890:2009

It is encouraged to prepare automatic fire bell and gas fire extinguisher complying with National Regulation TCVN 7161-2009 for equipment room in Traffic Management centers in order to keep computer system in safety if any incident.

f) Grounding and Lightning Protection

In accordance with regulations in QCVN 9:2010/BTTTT and QCVN 32:2011/BTTTT.

2.4 Exchanged Information and Data among Traffic Management Centers

2.4.1 Exchange of Traffic Image Data

Image data from highway monitoring camera system shall be shared among Road Management Offices shared in Regional Main Center with the aims of:

- Testing, confirming and reporting on condition of traffic congestion, incident occurrence on highway sections;
- Cooperating to handle and monitor serious accidents, incidents on route within jurisdiction by images;
- Providing to public visual image of highway traffic monitor on Traffic Information Website of the Center.

Regional Main Center can require item data of traffic monitoring cameras managed by Road TOM Centers. The responding data shall consist of camera code, installed location (section, direction, travelling route), attached with information on technical features such as PTZ control capability, image data identification, and maximum image resolution.

Regional Main Center can login to receive periodical notification on being time connection condition and performance error (if any) of monitoring cameras.

Regional Main Center can require pursuing the latest image data from one traffic monitoring camera. Captured images from Road Management Offices shall be formed in accordance with common archived standards such as JPEG or PNG.

Regional Main Center Center can require pursuing the data of live video from traffic monitoring cameras. When receiving requirement, Road Management Offices shall compile video in accordance with HTTP/MJPEG or RTSP/H246 standard to transmit to Regional Main Center through Data Transmission Network.

Regional Main Center can require remotely controlling cameras under Road Management Offices in order to change the view angle or other specifications. The process of remotely camera control shall follow these below basic steps:

- Regional Main Center shall send camera control requests in which consists of minimal information on code and changed specifications such as position of PTZ view angle, focal length, aperture of the camera;
- Road Management shall receive camera control requests and determine which one should be implemented immediately, which one should be waiting or be rejected based on priority decentralization level which has been set up in the system;
- Regional Main Center shall be capable of checking result of implementing camera control requests or cancelling if any request undone.

2.4.2 Exchange of Vehicle Detection Data

Data on traffic volume which Road Management Offices collect from vehicle sensors shall be reported to Area TOM Center with the aims of:

- Automatically monitoring, analyzing and evaluating traffic congestion on sections of highway network;
- Making statistic and defining congestion-prone points in order to operate and manage highway system effectively;
- Making assess on the effect of traffic monitor management system in securing traffic safety and processing accidents, incidents;
- Generating data on actual vehicle volume on route which shall be used to develop propriate traffic management policies.

Regional Main Center shall be capable of requiring data on location list of vehicle detectors managed by Road Management Offices. Responding data shall consist of information on code, location (section, direction, and travelling route) of vehicle detecting points.

Regional Main Center shall be capable of requiring or logging to receive period vehicle counting data included vehicle detecting point code; beginning time and ending time; the number of vehicle by lanes, by small size vehicle (length \leq 6m), large size vehicle (length \leq 12m) ad extra-large size vehicle (length $>$ 12m); vehicle speed shall be averaged for each lane.

Regional Main Center shall be capable of requiring data on operating history of each vehicle detector such as installation time, adjusting time, normally active or inactive period.

2.4.3 Exchange of Weather Data

Weather data which Road Management Offices collect from sensor stations on roadside shall be transmitted to Area TOM Center with the aims of using:

- Notifying extremely dangerous weather condition, therefore Regional Main Center shall be required to direct and implement special traffic alternatives;
- Providing the weather information on expressway to public on traffic information Website of Center.

Regional Main Center shall be capable of requiring data on location list of weather sensors managed by Road Management Offices. Responding data shall consist of information on code, location (section, direction, and travelling route) of observing points.

Regional Main Center shall be capable of requiring searching or login to receive period weather notification collected from observing points included information on: observing point code, beginning time and ending time of measuring period; average, minimum and maximum temperature; average, minimum and maximum rainfall.

Regional Main Center shall be capable of requiring data on operating history of each vehicle detector such as installation time, adjusting time, normally active or inactive period.

2.4.4 Exchange of Vehicle License Plate Data

Vehicle license plate monitoring and identifying cameras could be installed in traffic monitor management system on route. Data on collect from monitoring cameras shall be transmitted to *thập từ các camera giám sát được truyền về* Regional Main Center , in order to be used for travelling surveillance of which objects pass by checkpoints on highway, and for the purposes of security and defense.

Regional Main Center shall be capable of requiring data on location list of license plate monitoring and identifying cameras managed by Road Management Offices. Responding data shall consist of information on code, location (section, direction, and travelling route) of the cameras.

Regional Main Center shall be capable of requiring or logging to receive latest data on vehicle license plate code included information on: monitoring camera code; license plate and time of identifying vehicle; measured values of speed, axle load, violation of traffic regulation (if any); panoramic images and plate number of vehicles.

Regional Main Center shall be capable of requiring data on operating history of each monitoring camera such as installation time, adjusting time, normally active or inactive period.

2.4.5 Exchange of Traffic Event Information

Information of all events occurred on expressway shall be managed, supervised at Road Management Offices and be reported to Regional Main Center with the aims of using:

- Timely noticing information on existing accidents, incidents and traffic congestion condition in order to cooperate with functional forces to secure highway traffic safety;
- Automatically generating statistics about the work of ensuring traffic safety on highways within jurisdiction
- Providing traffic event information to public through private information channels in Center such as Internet.

Regional Main Center shall be capable of requiring or logging to receive notification on newly established events or to update information at Road Management Offices. Event discription included: event code, time, location (section, direction, and travelling route) of event site; classification and reason description; serious level, result of clearance and Event information shall be automatically collected, managed, updated and processed to eliminate duplication in the system at Regional Main Center.

2.4.6 *Exchange of Indication Information and Traffic Control*

Traffic indication and control information which Road Management Offices display on automated signs shall be transmitted to Regional Main Center with the aims of using:

- Monitoring the changeable information provision and traffic control which Road Management Offices shall be responsible to execute in accordance with regulations;
- Indicating Road Management Offices to provide special information or to adjust lane speed in unexpectedly difficult situations;
- Providing indications and traffic control information to public through traffic information Website in Center.

Regional Main Center shall be capable of requiring data on list of installed electronic traffic signs (including information signs and speed limitation) which shall be managed by the Road Management Offices. Responding data must contain information on number and installation location (route, direction, project management, lanes) of electronic traffic signs attached to the parameters of size and maximum length of the message being displayed on the signs.

Regional Main Center shall be capable of requiring data or logging to receive information about subscription information updated instructions on the electronic traffic signs. All messages contain the following information: number of electronic signs, time status updates and operation of the device, the content of instruction, traffic control being displayed on electronic signs.

Regional Main Center shall be capable of requiring data or login to receive notification on indications which shall be updated on automated traffic signs. The requirement procedure of disclosing indications and remotely traffic controlling shall follow these basic steps:

- Regional Main Center shall send requirement including indications and control information attached with sign code and validity of information;
- Road Management Offices shall receive and determine which one should be implemented immediately, which one should be waiting or be rejected based on priority decentralization level which has been set up in the system;
- Regional Main Center shall be capable of checking result of implementing camera control requests or cancelling if any request undone.

2.4.7 *Exchange of Toll Collection Information*

Toll collection information managed and monitored at Road Management Offices shall be reported to Regional Main Center with the aim of generating data for management in accordance with regulation. Information on rate of fee and collection methods on sections shall be disclosed on the traffic information Website of Regional Main Center.

Regional Main Center shall be capable of requiring or logging to receive daily notification on toll collection report included: section, collecting time; the number of vehicle and the amount of fee by tariff, vehicle classification; the number of vehicle using automatic collection method.

2.4.8 *Communication Standards among Centers*

Communication standards shall be unified in exchange of information, data between Regional Main Center and Road Management Offices. Equipments and softwares in traffic monitor management systems on expressways shall be willing to connect in accordance with general communication standards.

Communication standards shall be developed on the basic of communication rules between Center-Center which is applied in Intelligent Transportation Systems. The standards shall be required to secure compliance with the transmission network based on Ethernet protocol which is established among Traffic Management Centers.

2.5 **Requirements on Management Software**

2.5.1 *Management Software at Road Management Offices*

At Road Management Offices, the management software shall create interface for user to do the following tasks:

- Manage, monitor image, PTZ control, set the record mode, search and view photos of the CCTV traffic;
- - Subscribe online charts, statistics about traffic flow collected from parking lots located on the highway;
- - To monitor and handle the alerts generated by the system detects events analyzed by automated image;
- Set up and manage public information through electronic traffic signs on highway signs include instruction information, speed limit signs are changed and other information provision systems;
- Manage the setup and removal of traffic events taking place on the highway includes the group of incidents (accidents, vehicle damage incidents, road incidents, lost / damaged equipment, natural/ disaster graphics), the offense of traffic safety rules, the location of traffic jams, dangerous weather, roadworks, the traffic restrictions (closed roads, vehicle speed limit) and other special events;
- Manage, monitor traffic flow in and out at the toll booths, aggregating collected fees from time to time and post-inspection of the image turn charge;
- Monitor and handle the information on overload, oversized vehicle confirmed by checking the system load vehicles.

2.5.2 *Management Software at Regional Main Center*

At Regional Main Center, the management software shall create interface for user to do the following tasks:

- Supervise CCTV images of traffic were selected points in the region;
- Monitor traffic, the traffic situation on the area map, receive information about the accidents and incidents occurred on the highway;
- Test and certification data reports from the Road Management Offices through a system of information technology applications;
- Manage the provision of information and traffic operation to Road Traffic Management Offices;
- General information, reporting periodically operated exploit the situation to ensure safe transportation highways within the region;
- Manage the storage of various kinds of traffic data for using in planning and development.

2.5.3 *Software for providing traffic information through Internet*

Regional Main Center shall be responsible for managing and operating Website to provide to public about traffic information services within the region, including:

- Traffic information map which identifies the location congestion, accidents, incidents, construction, or traffic restrictions;
- Consultion for the road user about expected travelling time, and transportation fees;
- The important guidance information is published via electronic traffic signs on the highway;
- Images taken from CCTV traffic monitoring on expressways.

3 REGULATION ON MANAGEMENT

3.1 Road Management Offices shall be organized, operated and managed on all highway sections and roads during utilization.

3.2 Expressway Management Agency under Ministry of Transportation shall be responsible for arranging, investing, developing and operating Regional Main Center as plan.

3.3 The connection between Road Management Offices shall Regional Main Center Center shall follow the procedure and direction of Expressway Management Organization.

4 IMPLEMENTING ORGANIZATIONS

4.1 The organizations and individuals related to the planning, development, investment, construction, management and operation of executive management highway traffic center must comply with the provisions of this technical Regulation and relevant legal documents..

4.2 In case of technical regulations, standards, technical documents cited in this Technical Regulation have been changed; supplement or replacement shall comply with the provisions in the new text.

4.3 Directorate of Road in Vietnam shall be in charge of establishing regulations on management and inspecting the work of organization, operation and management at Highway Traffic Management Center.

4.4 Directorate of Road in Vietnam shall take responsibility and cooperate with Department of Science and Technology (Ministry of Transportation) and other competent agencies to guide, execute and implement this Technical Regulation./.

添付資料-9

QCVN SCHEDULE

QCVN Schedule

No.	Title of Standard / Regulation	Drafting Organization / Drafting Time	Planning time to Disclose	Implementation
1	National Technical Regulation on Vehicle Axle Load Weighing Station	Directorate of Road in Vietnam /2013	2013	National Technical Regulation 66:2013/BGTVT issued
2	National Technical Regulation on Traffic Monitoring & Management System for Expressways	QCVN Technical Working Group under MOT 2013 - 2014	2014	<ul style="list-style-type: none"> - Submitted to receive comments from professional departments (1st time), the deadline to receive comments is on March 31st 2014. - Planning meeting at the beginning of April 2014, then asking for comments from related Ministries, Agencies (2nd time) - The Draft was sent to JICA Consultors.
3	National Technical Regulation on Management Centers for Expressways	QCVN Technical Working Group under MOT 2013 - 2014	2014	<ul style="list-style-type: none"> - Submitted to receive comments from professional departments (1st time), the deadline to receive comments is on March 31st 2014. - Planning meeting at the beginning of April 2014, then asking for comments from related Ministries, Agencies (2nd time) - The Draft was sent to JICA Consultors.
4	National Technical Regulation on Electronic Toll Collection (ETC) System for Expressways	QCVN Technical Working Group under MOT 2013 - 2014	2014	<ul style="list-style-type: none"> - Submitted to receive comments from professional departments (1st time), the deadline to receive comments is on March 31st 2014. - Planning meeting at the beginning of April 2014, then asking for comments from related Ministries, Agencies (2nd time) - The Draft was sent to JICA Consultors.
5	National Technical Regulation on Variable Message Signs	Institute of Transport Science	2014	Having been drafted Planning to be submitted for

	(VMS) System for Expressways	and Technology 2013 - 2014		comments at the end of March or beginning of April 2014
6	National Technical Regulation on CCTV Camera System for Expressways	Information Technology Center 2013 - 2014	2014	Having been drafted Planning to be submitted for comments at the end of March or beginning of April 2014
7	National Technical Regulation on Traffic Database and Message System for Expressways	Information Technology Center 2013 - 2014	2014	Having been drafted Planning to be submitted for comments at the end of March or beginning of April 2014
8	National Technical Regulation on Communication System for Expressways	Information Technology Center 2013 - 2014	2014	Having been drafted Planning to be submitted for comments at the end of March or beginning of April 2014
Schedule for 2014				
9	National Standard on Architecture for Intelligent Transportation System (ITS)	Institute of Transport Science and Technology Planning in 2014	2014 (1 st quarter 2015)	Under preparation of TOR statement for approval
10	National Standard on Design for Expressway Traffic Operation Center	Information Technology Center Planning in 2014	2014 (1 st quarter 2015)	Under preparation of TOR statement for approval
11	National Standard on Weather Monitoring System for Expressways	Information Technology Center Planning in 2014	2014 (1 st quarter 2015)	Under preparation of TOR statement for approval