

**6. MANUAL GUIDING BUILDING FACILITY  
MAINTENANCE PROCEDURES (Activity-5)**

**Guideline for the Preparation of Maintenance  
Procedure Manuals for Building Facilities**

JICA Project Team

## **1.1 BACKGROUND**

Under the current Law on Construction in Vietnam, building facility owners are obliged to conduct maintenance after facility construction is completed. However, facility owners are in general said to be nonprofessional in building facility maintenance, so that the regulation stipulates the measure that design consultants develop maintenance procedure manuals and then project owners implement facility maintenance following procedures shown in the manual.

This Guideline for the Preparation of Maintenance Procedure Manuals for Building Facilities will support design consultants to develop maintenance procedure manuals for building facilities.

## **1.2 OBJECTIVES**

The Guideline for the Preparation of Maintenance Procedure Manual for Building Facilities (Hereinafter called as “the Guideline”) aims to show guidelines to building facility design consultants who develop maintenance procedure manuals for building facility owners. The Guideline shows not only the regulations relevant to building facility maintenance, but also general procedures and technical guidelines for developing Maintenance Procedure Manuals (Hereinafter called as “Maintenance Manuals”) for facility owners.

In developing Maintenance Manuals, design consultants should fully understand the stipulations of Decree 114 and other relevant regulations and develop Maintenance Manuals following this Guideline. Also, building facility owners should implement maintenance for their building facilities, observing regulations concerned and the contents shown in the maintenance Manuals..

In developing Maintenance Manuals following this Guideline, the stipulations of relevant regulations are to be preferentially treated if inconsistency is detected between regulations and this Guideline.

## **1.3 STRUCTURE OF THIS GUIDELINE**

The Guideline consists of the following two parts. Outline of each part is briefly explained bellow.

**1) Part-1: Outline of the current regulations regarding building facility maintenance**

In this part, interpretation is made focusing on regulations relevant to facility maintenance. Design consultants are requested to fully understand all the provisions in the the regulations and to develop maintenance manuals for building facilities.

**2) Part-2: Components of the maintenance manuals for building facilities**

In this part, step-by-step explanation to develop maintenance procedure manuals is made in line with contents shown below.

- a. Objectives
- b. Author information
- c. Regulations, technical standards and technical specifications to be applied
- d. Formulation, appraise, approval and adjustment of construction facility maintenance procedure manual
- e. Selection of inspection facilities (*Recommendation*)
- f. Development of maintenance plans
- g. Facility check, maintenance and repair (*Recommendation*)
- h. Types of inspection (*Recommendation*)
- i. Frequencies of inspection (*Recommendation*)
- j. Quality inspection for maintenance
- k. Inspection items (Focuses of inspection) (*Recommendation*)
- l. Inspection methods (*Recommendation*)
- m. Criteria of diagnosis on inspection results (*Recommendation*)
- n. Check list and data preservation (*Recommendation*)
- o. Construction facility monitoring
- p. Quality management of maintenance
- q. Construction facility maintenance for facilities which do not have maintenance procedure manuals
- r. Use of facilities that expire life expectancy
- s. Reporting of construction facility maintenance
- t. Treatment of facilities that show quality degradation and unable to ensure safety for operations
- u. Consultation with qualified agencies or competent state authorities (*Recommendation*)
- v. Labor safety during facility maintenance (*Recommendation*)



## **1.4 REGULATIONS RELEVANT TO BUILDING FACILITY MAINTENANCE**

### **1.4.1 Regulations and technical standards to be applied**

Design consultants should fully understand the stipulations of Construction Law, Decree 114 and Circular 02, other relevant regulations and technical standards.

#### **(1) Major regulations**

- Construction Law No.16 /2003/QH11, dated on November 26, 2003

This Law prescribes construction activities; and rights and obligations of organizations and individuals that invest in the construction of works and conduct construction activities.

- Decree No. 114/2010/ND-CP, dated on December 6, 2010

This Decree guides the implementation of the Construction Law on maintenance of construction facilities; applies to all organizations, individuals involving in management, exploitation and utilization of construction facilities (hereafter referred to as facilities) in the territory of Vietnam.

- Circular No. 02/2012/TT-BXD, dated on June 12, 2012

The Circular guides the Article 26 of the Decree No. 114/2010/NĐ-CP on persons in charge of maintenance; constructions, construction part subject to compulsory measurement during the utilization; considering and making decisions on continuing to use constructions of which the designed life expectancy has expired; handling constructions with deteriorated quality and unsafe to be used; handling problems during the utilization and inspecting the construction maintenance.

#### **(2) Other relevant regulations**

- Law on Organization of the Government, No. 32/2001/QH10, December 25, 2001
- Law on Standards and Technical Regulations No. 68/2006/QH11, June 29, 2006
- Law on Housing No. 56/2005/QH11, November 29, 2005
- Decree No. 62/2013/ND-CP on defining the functions, tasks, powers and organizational structure of the Ministry of Construction, dated on June 25, 2008

- Decree No. 71/2010/ND-CP, June 23, 2010 on detailing and guiding the implementation of the Law on Housing

### **(3) Technical standards**

All technical standards which are selected and applied to the planning, the survey, the design and the construction of the building facilities concerned should be described in the Maintenance Manuals. Technical standards which are selected in the stages of planning, survey, design and construction need to be observed even in the maintenance stage. Design consultants are allowed to add the technical standards which conform with Article 6 (2 a) of Decree 114. In addition, it is encouraged to apply the following technical standards;

- Concrete and reinforced concrete – Guideline to maintenance (TCVN 9343:2012)
- Investigation, evaluation of existing situation of masonry houses and structures (TCVN 9378:2012)

## **1.4.2 Decree No: 114/2010/ND-CP, Hanoi, December 6, 2010 on Maintenance of construction facilities**

### **(1) Sequence of implementing maintenance (Article 4)**

- a. Establish and approve facilities' maintenance procedure manual.
- b. Formulate plan and cost estimation for maintenance of facilities.
- c. Regular, periodic and unscheduled facilities' inspection.
- d. Conduct monitoring with facilities that need monitoring.
- e. Facility maintenance.
- f. Quality inspection when necessary (similar to detail survey)
- g. Periodic and unscheduled repair.
- h. Prepare and manage facility maintenance records.

### **(2) Formulation of construction facility maintenance procedure manual (Article 6)**

- a. Design consultants should be responsible for preparing and submitting maintenance procedure manual to PO together with their dossier;
- b. Equipment suppliers should be responsible for preparing and submitting maintenance procedure manual to PO before the equipment is installed in the facility;
- c. In case that design consultants or equipment suppliers fail to prepare maintenance procedure manual, they shall provide finance to PO to hire other consultants for this work.

- d. Maintenance procedure manuals are not required for building works of grade IV, individual dwelling house, and temporary facilities.
- e. If technical standards on maintenance or Maintenance procedure manuals of similar facility are available, facility owners can decide to use them without preparing their own maintenance procedure manual.

**(3) Formulation, verification, approval and adjustment of construction facility maintenance procedure manual (Article 6, 7)**

- a. POs are responsible for receiving maintenance procedure manuals provided by design consultants and equipment suppliers; conducting appraisal and approval before putting facilities into use.
- b. POs can hire consultants to check a part or the whole maintenance procedure manual before appraisal, approval.

**(4) Adjustment construction facility maintenance procedure manual (Article 8)**

- a. During maintenance implementation, facility owners or authorized persons are entitled to adjust the manual in case irrationalities that may affect facility quality, operation are detected.
- b. Consultants, suppliers who prepared maintenance procedure are responsible for revision, supplement or changes over their faults.

**(5) Plan of Construction facility maintenance (Article 10)**

- a. Maintenance plan is prepared yearly based on approved maintenance procedure manual and actual status of facilities.
- b. The facility owner or authorized person shall be responsible for preparing and approving the maintenance plan.
- c. The maintenance plan can be revised, supplemented during implementation process.

**(6) Facility check, maintenance, repair works (Article 11)**

- a. Facility owner or authorized person shall conduct facility check, maintenance and repair works according to maintenance plan if they are capable enough, or hire qualified agencies to do this job.

- b. Facility check may be done on regular or periodical manner by observation, regular monitoring, specialized equipment when necessary to evaluate actual status and promptly discover signs of degradation, damages and equipment.

**(7) Quality inspection for maintenance (Article 12)**

- a. Cases of quality inspection for maintenance:

- Regular inspection according to approved maintenance procedure manual;
- In case damages, degradation, unsafe are detected.
- When evaluation on facility actual status is required for preparing maintenance procedure manual regarding facilities without maintenance procedure manual.
- For making rationale for prolong life cycle for expired facilities, or for renovation.

- b. Sequence of quality inspection

- Facility owner or authorize person selects eligible inspection entity.
- Inspection entity prepares work plan.
- Facility owner or authorize person approves work plan
- Inspection entity conducts quality inspection.

**(8) Construction facility monitoring (Article 13)**

Facility monitoring is conducted in case observation of facility operation is required in order to prevent incidents that may cause disaster against human, properties, environment and other cases required by PO, facility owner or authorize person.

**(9) Quality management of the maintenance (Article 14)**

The facility owner or authorized person should conduct supervision over facility monitoring, inspection, maintenance implementation; acceptance on repair works; preparation, management and archive quality management dossiers.

**(10) Conducting of construction facility maintenance for under-operation facilities but without maintenance procedure manual (Article 15)**

For building facilities of grade IV, individual dwelling house and temporary facilities, the facility owner or authorized person shall carry out maintenance according to regulations in Item 4, Article 6 of this Decree.

**(11) Handling for facilities that expire their designed life expectancy but are needed for continued utilization (Article 16)**

Regarding expired facilities, but being needed for continued use, the facility owner or authorized person should undertake following activities including inspection, detail survey, repair works and:

- Decide continuing utilization for facilities of grade III, IV.
- For facilities of grade II and above, they shall report the result of inspection, repair works (if any) to state authorities.

**(12) Report, check over the implementation of construction facility maintenance (Article 17)**

The facility owner or authorized person shall prepare annual report on the implementation of facility maintenance and state of facility safety for those of grade II and above and facilities that may cause disasters when incidents occur to state authorities.

**(13) Article 18. Handling with facilities that show signs of quality degradation, safe operation is not ensured (Article 18)**

When quality degradation, unsafe operation is detected, facility owner or authorized person shall:

- Conduct checking or quality inspection;
- Decide safety measures such as operation restriction, suspending, evacuation of people and properties and immediately report to state authorities.

**1.4.3 Structure and contents of maintenance procedure manuals for building works**

**(1) Objectives**

Objectives of Maintenance Procedure Manual should be clearly defined in this section. Maintenance procedure manual means regulation on order, content and guidance for conducting of construction facility maintenance activities.

**(2) Author information**

Author information should be recorded in this section, including the name of design consultant and author, date of edition, date of facility owner's approval, the name of facility, address, facility owner's name, telephone number and other relevant information.

**(3) Regulations, technical standards and technical specifications to be applied**

All regulations which facility owners must follow, including regulations, technical standards and technical specifications, should be described in this section.

**(4) Formulation, appraise, approval and adjustment of construction facility maintenance procedure manual**

The Maintenance Procedure Manual should stipulate the following:

- Responsibility of project owners and authorized persons to appraise, approve and adjust Maintenance Procedures Manual.
- Right of project owners and authorized persons to hire consultants for check Maintenance Procedure Manuals
- Responsibility of design consultants or equipment suppliers to formulate , submit and revise maintenance Procedure Manual.
- Building facilities which do not require Maintenance Procedure Manuals

**Table 1.4.1 Regulations**

Regulations	Articles	Contents
Decree 114	Article 4	Maintenance procedure manual of construction facilities
	Article 6	Formulation of construction facility maintenance procedure manual
	Article 7	Verification and approval of construction facility maintenance manual
	Article 8	Adjustment of construction facility maintenance procedure manual

**(5) Selection of inspection facilities (*RECOMMENDATION*)**

Facility inspection which Decree 114 Article 6 stipulates should be selected from those listed in the following table. However, it should be noted that design consultants can change inspection facilities with explanation, taking account of the scales and the functions of building facilities. Appendix-1 elaborates the details of these inspection facilities.

**Table 1.4.2 Inspection Facilities**

Inspection facilities	Inspection points	Members & facilities
Building Structures	Foundation, Main structural members, Exterior walls	Foundation, RC (SS) columns , Wooden Columns, RC (SS) girders and beams, Wooden girders and beams, RC(SS) braces, RC floor slabs, RC roof slabs, External walls, Windows, Doors, Projections
	Roof	Flat roof, Pitched roof
	Interior	Walls facing to interior space,

Inspection facilities	Inspection points	Members & facilities
		windows, floors, ceilings, lighting
	Evacuation facilities	Passage, doorways, stairs, evacuation ladders, smoke exhaust equipment
	Others	
Ventilation	Rooms equipped with ventilation facilities, kitchen etc. which need ventilation equipment	Visual inspection, operation test
Smoke exhaust	Smoke exhaust fans, emergency power, engines coordinated with smoke fans	Visual inspection, operation test
Emergency lighting	Lighting equipment, standby battery	
Sanitary facilities	Water supply, drainage equipment, water supply equipment	Water quality, drainage pipes, water pumps, boilers, etc.
Electrical facilities	Wiring, emergency generator	Circuit breaker, distribution board, visual inspection, operation test
Elevators and Escalators	Elevators	Door, interior, maintenance records
	Escalators	Steps, handrails, maintenance records
Firefighting equipment	Firefighting equipment	Fire extinguishers. Sprinklers, hydrant
Others	LPG gas facilities	Location, Piping, etc.

#### (6) Development of maintenance plans

The Maintenance Procedure Manual should stipulate the following:

- Maintenance plan is prepared yearly based on approved maintenance procedure manual
- Responsibility of facility owners or authorized persons for preparing and approving the maintenance plan.
- The maintenance plan can be revised, supplemented during implementation process.
- Information to be stated in the maintenance plans
  - Name of activities to be undertaken;
  - Implementation time duration;
  - Implementation method;
  - Implementation expenses.

**Table 1.4.3 Regulation**

Regulations	Articles	Contents
Decree 114	Article 10	Plan of construction facility maintenance

#### (7) Facility check, maintenance and repair (*RECOMMENDATION*)

##### 1) The Maintenance Procedure Manual should stipulate the following;

- Responsibility of facility owners or authorized persons

- Right to hire qualified agencies to do check, maintenance and repair jobs
- Methods of facility check; Regular or periodical manner by observation, regular monitoring, specialized equipment when necessary

**2) Qualified inspection agency (RECOMMENDATION)**

Periodic inspection, unscheduled inspection and detailed surveys should be implemented by qualified inspection agencies hired by facility owners or authorized persons. Qualified inspection agencies hired by facility owners or authorized persons should formulate inspection or survey plans and submit them to facility owners or authorized persons for approval.

**Table 1.4.4 Regulation**

<b>Regulations</b>	<b>Articles</b>	<b>Contents</b>
Decree 114	Article 11	Facility check, maintenance and repair

**(8) Types of inspection (RECOMMENDATION)**

Inspection falls into routine inspection, periodic inspection and unscheduled inspection, which also includes detailed surveys and monitoring of facilities. Outline of the inspection is briefly described as follows;

**a. Routine inspection**

Routine inspection is a daily inspection to quickly find out any unusual incidents and defects on the building facilities. It generally consists of visual inspections while walking in and around building facilities.

**b. Periodic inspection**

Periodic inspection is applied to the following cases;

- To survey damages including deterioration and defects
- To diagnose deterioration and defects
- To select the suitable repair methods for light damages and deteriorations.

Also, it should make judgment on the need of a further survey on the heavy damages and deterioration. With this, it is carried out at a fixed interval. The periodic inspection provides base information to the planning of maintenance and repair works.

**c. Unscheduled inspection**

Unscheduled inspection is applied to the following cases;



- To survey and evaluate the effects of unexpected incidents occur such as floods, strong wind, fires, typhoons, earthquakes and other natural disasters which are given to building facilities.

**d. Detailed survey**

Survey and design is applied to the following cases;

- To further specify causes of structural defects and damages
- To find out the most suitable repair works for the damages
- To evaluate the performance of repair works
- To survey unidentified incidents arising after repair works and a final inspection
- To ensure structural safety when facilities are to be used with loading conditions more than the design conditions
- To evaluate structural safety when facilities are to be used more than design periods.

The survey and design is in general carried out by qualified engineers.

**(9) Frequencies of inspection (Recommendation)**

**a. Building structures**

It is recommended to apply the frequencies of periodic inspections in the following table as standard values to the building facilities in the table. Building structures include foundations, main structures, outside walls, roofs, interiors and evacuation facilities. However, it should be noted that design consultants can change inspection frequencies with explanation, taking account of the scales and the functions of building facilities.

**Table 1.4.5 Inspection Frequency for Periodic Inspection**

<b>Inspection Frequency</b>	<b>Inspection facilities</b>
Every 3 years	Theaters, cinemas, circuses, schools, hospitals, stadiums, gymnasiums, supermarkets and construction facilities with similar functions, and facilities which are greatly affected by the environment
Every 5 years	High-rise condominiums, hotels, government offices, working offices, construction-industrial facilities and urban technical infrastructure facilities
Every year	National or world cultural relics

**b. Facilities**

Facilities include ventilation facilities, smoke exhaust facilities, emergency lighting, sanitary facilities, electric facilities, elevators and escalators, firefighting facilities and

other facilities including LPG facilities. The table below shows the standard inspection frequencies. However, it should be noted that design consultants can change inspection frequencies with explanation, taking account of the scales and the functions of facilities.

**Table 1.4.6 Inspection Frequency for Facility**

Inspection frequencies	Inspection items (objective of inspection)	
	Categories	Description of applicable items
Every month	Elevators and escalators	- Regular check items for safe operation
Every 6 months	Fire-fighting equipment	- Simple check items to keep ready condition
Every year	Safety devices that are quickly degraded or that are required to be operational anytime.	- Clearance of evacuation routes - Standby batteries for emergency lighting, - Supply water quality - Emergency generators - LPG gas cylinders
Every 3 years	Others	-

**(10) Quality inspection for maintenance**

The Maintenance Procedure Manual should stipulate construction facility quality inspection procedures:

- Facility owners or authorized persons shall hire capable organizations to conduct quality inspection
- Inspection organizations formulate inspection plans
- Facility owners or authorized persons shall approve the inspection plans
- Inspection organizations implement inspections

**Table 1.4.7 Regulation**

Regulations	Articles	Contents
Decree 114	Article 12	Quality inspection for maintenance

**(11) Inspection items (Focuses of inspection)**

Representing inspection items to be focused on in the routine, periodic and unscheduled inspections and detailed surveys are shown in the **Table**. However, it should be noted that design consultants can change inspection items with explanation, taking account of the scales and the functions of facilities.

**Table 1.4.8 Inspection Items**

Inspection Items (Focuses of Inspection)
--

Bulging, reduction in capacity and function, status of cleaning, color change, status of connection, corruptions, cracks, deformation, degradation, deterioration, Fungi, gaps, inclination, water leakage, loose fasting, obstacles, operation status., position, quantity, sagging, spalling, split voltage, wiring and connection

### **(12) Inspection methods (*RECOMMENDATION*)**

Inspection methods can be selected from the list shown below. However, it should be noted that design consultants can change inspection methods with explanation, taking account of the scales of building facilities.

- Visual inspection
- Operation tests
- Check of embedded pressure gauge
- Check by tapping with a test hammer
- Check by touching
- Check with crack scales
- Check with dossiers of drawings and measurement with steel tapes, etc.
- Check with plummet,
- Non-destructive equipment, etc.
- Interlocking function test
- Measurement with a Voltmeter
- Measurement with steel tapes, etc.
- Visual inspection and check by touching
- Visual inspection with binoculars, etc., as needed

### **(13) Criteria of diagnosis on inspection results (*RECOMMENDATION*)**

The Maintenance Procedure Manual should stipulate the following;

- Responsibility of qualified inspection agencies hired by facility owners or authorized persons to diagnose the results of inspection. The diagnosis is to be made for each structure and facility. When serious defects or deterioration such as degradation in function and capacity is detected, facility owners or authorized persons should hire qualified agencies and implement detailed surveys in order to formulate repair work plans.
- Responsibility of facility owners and authorized persons to immediately take safety measures and report to state authorities, If detected damages so serious that could give negative effects on surrounding environment or on public safety.
- Responsibility of facility owners or authorized persons to conduct surveys, if they find defects or deteriorations other than those prescribed in the Manual, but which may possibly cause problems.

**(14) Check list and data preservation (RECOMMENDATION)**

The Maintenance Procedure Manual should stipulate the following;

- Responsibility of qualified inspection agencies which are hired by facility owners or authorized persons and which implement inspection to diagnose the results of inspection. The diagnosis is to be made for each structure and facility. Qualified inspection agencies should record the information on facility selection, inspection items, inspection methods, inspection results and diagnosis into check sheets whose formats are shown in APPENDIX.
- Responsibility of facility owners or authorized persons to preserve maintenance records including the above check sheets during maintenance periods.
- Responsibility of facility owners and authorized persons to hire qualified agencies and implement detailed surveys in order to formulate repair work plans, when serious defects or deterioration such as degradation in function and capacity is detected.

**(15) Construction facility monitoring**

The Maintenance Procedure Manual should stipulate the following;

- Responsibility of facility owners or authorized persons to conduct facility monitoring, if observation of facility operation is required. The facilities which need monitoring are stipulated in the Article 3 of Circular 02 and shown in Table.
- Responsibility of qualified agencies which undertake monitoring to prepare monitoring plans and submit them to facility owners or authorized persons for approval. Maintenance Procedure Manual should stipulate capacity requirements for the qualified agencies.

**Table 1.4.9 Regulation**

Regulations	Articles	Contents
Decree 114	Article 13	Construction facility monitoring
Circular 02	Appendix	Monitoring facilities

**Table 1.4.10 Monitoring Facility**

No.	Kind of construction	Grade
<b>I</b>	<b>Building facilities</b>	
1	Housing	
1.1	Apartment facility	Grade I
2	Public constructions	
2.1	School	Grade I
2.2	Hospital	Grade I

No.	Kind of construction	Grade
2.3	Indoor or outdoor stadium	Special grade, Grade I
2.4	Convention center, theatre, cultural house, club, cinema, circus	Special grade, Grade I
2.5	Museum, library, exhibition center, display center	Special grade, Grade I
2.6	Shopping mall, supermarket	Special grade, Grade I
2.7	Television, radio, telecommunication antenna tower	Special grade, Grade I
2.8	Post office, communication installation, control tower	Special grade
2.9	Train station, airport terminal, ferry terminal, railway station, bus terminal,	Special grade, Grade I
2.10	Versatile house, hotel, dorm, guest-house	Special grade, Grade I
2.11	State administrative facility	Special grade, Grade I
2.12	Working offices of non-business units, enterprises, socio-political organizations and other organizations	Grade I

(Source) Circular 02

### (16) Quality management of maintenance

The Maintenance Procedure Manual should stipulate the following;

- Responsibilities for facility owners or authorized persons to conduct supervision over facility monitoring, inspection, maintenance implementation including acceptance on repair works; preparation, management and archive quality management dossiers.

**Table 1.4.11 Regulation**

Regulations	Articles	Contents
Decree 114	Article 14	Quality management of maintenance

### (17) Construction facility maintenance for facilities which do not have construction facility maintenance procedure manuals

The Maintenance Procedure Manual should stipulate the following;

- Responsibilities for facility owners or authorized persons to carry out maintenance for building facilities of grade IV, individual dwelling house and temporary facilities, according to regulations in the Article 6 of Decree 114.

**Table 1.4.12 Regulation**

Regulations	Articles	Contents
Decree 114	Article 15	Conducting of construction facility maintenance for in-operation facilities which do not have construction facility maintenance procedure manuals

### (18) Use of facilities that expire life expectancy

The Maintenance Procedure Manual should stipulate the following;

- Responsibility of facility owners or authorized persons to conduct inspections, detailed surveys and repair works for expired facilities, but being needed for continued use, and to decide continuing utilization for facilities of grade III, IV. For facilities of grade II and above, facility owners or authorized persons shall report the result of inspection, repair works (if any) to state authorities.

**Table 1.4.13 Regulation**

Regulations	Articles	Contents
Decree 114	Article 16	Treatment for facilities that expire their life expectancy but are needed for continued utilization

**(19) Reporting of construction facility maintenance**

The Maintenance Procedure Manual should stipulate the following:

- Responsibility of facility owners or authorized persons to prepare annual report on the implementation of facility maintenance and state of facility safety for those of grade II and above and facilities that may cause disasters when incidents occur to state authorities.

**Table 1.4.14 Regulation**

Regulations	Articles	Contents
Decree 114	Article 17	Report and check of the implementation of construction facility maintenance

**(20) Treatment of facilities that show quality degradation and unable to ensure safety for operation**

The Maintenance Procedure Manual should stipulate the following:

- Responsibility of facility owners or authorized persons to take actions shown below, when quality degradation, unsafe operation is detected.
  - Conduct checking or quality inspection;
  - Decide safety measures such as operation restriction, suspending, evacuation of people and properties and immediately report to state authorities.

**Table 1.4.15 Referential Regulation**

Regulations	Articles	Contents
Decree 114	Article 18	Treatment of facilities that show signs of quality delegation and unable to ensure safety for operation and use.

**(21) Consultation with qualified agencies or competent state authorities**

The Maintenance Procedure Manual should stipulate the following:

- Responsibility of facility owners or authorized persons to consult with qualified agencies or competent state authorities when they face difficulties in making judgment on inspection results and in selecting repair works.

**(22) Labor safety during facility maintenance**

The Maintenance Procedure Manual should stipulate the following:

- Responsibility of facility owners or authorized persons to take appropriate safety measures for facility environment and public safety during inspection, maintenance and repair works.
- Responsibility of qualified agencies which conduct inspection, maintenance and repair works to take appropriate safety measures for inspection, maintenance and repair work staff.

## APPENDIX-1

### Inspection Facilities

<b>Architectural</b>	
<b>The items on Building lot</b>	
Ground	
Site	
Passageways in the site for emergency evacuation	
Fence	Foundation
	Masonry work
Retaining wall	
<b>Foundation, prime structural members and items on elevations</b>	
Foundation	
RC columns	
SS columns	
Wooden columns	
RC girders and beams	
SS girders and beams	
Wooden girders and beams	
RC or other bearing walls	
RC braces	
SS braces	
RC floor slabs	
RC roof slabs	
SS roof support structure	
Exterior wall	Masonry work
	Other structural members
	Exterior finishing material, etc.
	Sign boards, outdoor units of A/Cs, etc. attached to the exterior wall
Windows	Sashes/frames
	Gaskets
	Windowpane
Doors	
Projections	Structural parts (balconies, eaves, protruding rooms)
	Fixtures (handrails, brackets for A/C outdoor units, etc.)
<b>Roof</b>	
Flat roof	
Circumference of the flat roof	
Pitched roof	
Equipment and fixtures (cooling towers and sign towers, etc.)	
<b>Interior</b>	
Walls facing to the interior space	Masonry work
	Other structure
	Finish
Windows	Sashes/frames
	Gaskets
	Windowpane
Floors	Structure, etc.
Ceilings	Finish
Lightings and hanging items, etc.	
<b>Evacuation facilities, etc.</b>	
Passageways	
Doorways	
Stairs	Handrails
	Steps, landings, etc.
	Evacuation
Evacuation Ladders	
Smoke exhaust equipment /assembly	Smoke exhaust equipment
<b>Others</b>	
Particular structures, etc.	Membrane members and the fittings parts of membrane structure
	Seismic base isolation equipment and the trench
Lightning protection system	
Chimneys	Chimneys for building service
	Other chimneys



<b>Ventilation</b>	
<b>Habitable rooms installed with ventilation equipment (excluding kitchens, etc.)</b>	
Mechanical driven ventilation equipment	Appearance of the equipment
	Performance (including centrally controlled HVAC system)
Centrally controlled HVAC system	Capital equipment and appearance of piping
<b>Kitchen, etc. required to be installed with ventilation equipment</b>	
Passive ventilation system or mechanical driven ventilation equipment	
Mechanical driven ventilation equipment	
<b>Habitable rooms installed with ventilation equipment</b>	
Fire dampers, etc.	
<b>Smoke exhaust</b>	
<b>General</b>	
Smoke exhaust fans	Appearance
	Performance
Others	Appearance of smoke vents for mechanical smoke exhaust system
	Performance of smoke vents for mechanical smoke exhaust system
	Ducts for mechanical smoke exhaust system (excluding concealed parts)
	Fire dampers
<b>Emergency power</b>	
Emergency generator	Appearance
	Performance
Engines directly coupled with smoke exhaust fans	Appearance
	Performance
<b>Emergency Lighting</b>	
<b>Lighting equipment</b>	
Emergency lighting equipment	
<b>Standby battery (built-in or not built-in) and emergency generator</b>	
Standby batteries	
<b>Standby battery (not built-in) and emergency generator</b>	
Changeover circuit	
<b>Standby battery (built-in)</b>	
Wiring and pilot lamp for charging	
<b>Standby battery (not built-in)</b>	
Standby battery	Appearance of the battery room
	Capacity
	Charger
<b>Sanitary</b>	
<b>Water supply and drainage equipment</b>	
Water supply and drainage piping(excluding concealed parts)	
Quality of water	
<b>Water supply equipment</b>	
Reservoir tanks and supply pumps	
Boilers (including circulation pumps)	
<b>Drainage equipment</b>	
Sump pits	
Waste water recycle system	
Others	Sanitary fixtures
	Drainage traps
	Interceptors for grease, hair, and so on
	Drainage
<b>Electrical</b>	
Wiring, etc.	Outlet/wiring/switch
	Wall plates for switch and outlet
	Circuit Breaker
	Circuit Breaker /distribution board
	wiring
Building management system / integrated instrument	
Emergency generator	Appearance
	Performance

<b>Elevators and escalators</b>	
Elevators	Sill grooves
	Doors and interior condition
	Whole
	Maintenance records
Escalators	Steps, landing, handrails
	Whole
	Maintenance records
<b>Fire fighting equipment</b>	
Fire fighting equipment	Fire extinguishers
	Sprinkler
	Hydrant
<b>Others</b>	
LPG gas cylinders	Location
LPG gas	Cylinders
	Piping

## APPENDIX-2

### Check List Format

Form - 001 (technical check list)						
TECHNICAL CHECK LIST (SAMPLE)						
NO.	INSPECTION ITEMS	FOCUSED POINTS	INSPECTION METHODS	DIAGNOSIS CRITERIOR	RESULT	
					ELIGIBILITY (Y/N)	
<b>Elevators and escalators</b>						
1	Elevators	Sill grooves	Obstacle for operation	Visual inspection - Caution - Checking and removing obstacles shall be done safely after confirmation that the doors and the car will not move suddenly (refer to manufacturers' or suppliers' manual) so to avoid accidents to get involved in the doors, sheared between the floor/door frame and the car (there have been such accidents in the past)	No obstacle for smooth operation of doors, such as, pebbles in the sill grooves	N
2		Doors and interior condition	Corrosion and deformation	Visual inspection	Significant deformation or corrosion for smooth operation or safe use	Y
3		Whole	Maintenance service organization	Interview with managers or check with records	- Note - Wearing of the ropes, malfunction of the controll system and malfunction of the safety device may induce significant accidents	Y
4		Maintenance records	Maintenance implementation condition	Interview with managers or check with inspection records	Maintenance is not implemented as instructed in the maintenance supporting documents in designated period according to the documents and ordinances  - Note - Default of the maintenance including proper lubrication, periodical check for wearing status of the ropes, malfunction of the controll system, malfunction of the safety device, etc. may induce significant accidents	Y
5	Escalators	Steps	Obstacle for operation	Visual inspection - Caution - Checking and removing obstacles shall be done safely after confirmation that the escalator has stopped completely and will not move suddenly (refer to manufacturers' or suppliers' manual) so to avoid accidents to get entangled in the steps (there have been such accidents in the past)	No obstacle for smooth operation, such as, pebbles in the sill grooves	Y
6		Steps, landing, handrails	Corrosion and deformation	Visual inspection	Significant deformation or corrosion for safe use	N
7		Whole	Maintenance organization	Interview with managers or check with records	Not having been organized for maintenance service (periodical and ad-hoc in emergency)	Y
<b>INELIGIBLE ITEMS (POINTED OUT WITH "N" IN "RESULT" COLUMN)</b>						
NO.	INSPECTION ITEMS	PROBLEM		SCHEDULE OF FURTHER INSPECTION OR REPAIRING / RECTIFICATION		
		DESCRIPTION	WHERE	HOW	WHEN	
1	Elevator / Sill grooves	Obstacle stuff was stuck in the groove	The EV shaft door on the 3rd floor	Removing	done	
6	Escalator / Steps, landing, handrails	A deformed fin on a step sometimes strongly scratches other steps.	The escalator between 2nd and 3rd floor	Having escalator maintenance company repair/modulate the point	Dec.2013	
For detail please use "Remarks / description" columns on Form-003 "Photos".						
<b>OTHER REMARKS</b>						
Reaction of the floor selector buttons is blunt. It should be examined at the next EV periodical maintenance.						

APPENDIX-3

Sample Check List

INSPECTION ITEMS, FOCUSED POINTS, INSPECTION METHOD and DIAGNOSIS CRITERIOR						Importance on collapse (C) / fire safety /evacuation (F) others (O)
No.	INSPECTION ITEMS	FOCUSED POINTS	INSPECTION METHODS	DIAGNOSIS CRITERIOR	INSPECTION FREQUENCY	
Architectural						
1 The items on Building lot						
1	Ground	Unevenness, inclination, etc. due to soil subsidence and so on	Visual inspection	Subsidence remarkably endangering the facility	3Y	C
2	Site	Water drainage in site	Visual inspection	Overflow or leakage of waste water from the drainage due to choking, etc. which is problematic in terms of sanitary conditions	3Y	O
3	Passageways in the site for emergency evacuation	conditions of passageways	Visual inspection	Passageways are not secured properly	3Y	F
4		Effectual widths of the passageways	Check with dossiers of drawings and measurement with steel tapes, etc.	If the effectual widths of the passageways is secured properly as per the dossiers	3Y	F
5		Obstacles	Visual inspection	Obstacles on the passageways	3Y	F
6	Fence	Subsidence, etc. of the foundation	Visual inspection	Remarkable crack due to subsidence of the ground	3Y	C
7		Degradation and damage	Visual inspection	Gap in foundation alignment or exposure of steel bars, remarkable cracks, spalling, etc., on the concrete surface	3Y	C

1/44 (PAGES OF THIS TABLE)

INSPECTION ITEMS, FOCUSED POINTS, INSPECTION METHOD and DIAGNOSIS CRITERIOR						
No.	INSPECTION ITEMS	FOCUSED POINTS	INSPECTION METHODS	DIAGNOSIS CRITERIOR	INSPECTION FREQUENCY	Importance on collapse (C) /fire safety /evacuation (F) /others (O)
8	Fence	Cracks	Visual inspection	Cracks throughout the work	3Y	C
9	Masonry work	Gaps	Visual inspection	Gaps over multiple units	3Y	C
10		Spalling	Visual inspection	Dangerous situation to drop down pieces or serious loss on the work endangering stability of the work	3Y	C
11		Joints	Visual inspection	Degradation of joint mortar endangering stability of the work	3Y	C
12		Inclination	Visual inspection with plummet, etc., if needed	Inclination endangered to collapse	3Y	C
13		Bulging	Visual inspection with plummet, etc., if needed	Bulging endangered to collapse	3Y	C
14		Vegetation	Visual inspection	Tree root pressing to endanger to collapse	3Y	C
15		Degradation and damage on lintels over gates	Visual inspection or check by tapping with a test hammer, if needed	Remarkable cracks, corrosion, or other damages decreasing the proof stress	3Y	C
16	Retaining wall	Degradation and damage of the retaining walls	Visual inspection with binoculars, etc., as needed	Remarkable inclination, cracks or soil spillage from joints	3Y	C
17		if the weep holes are maintained properly to function	In addition to visual inspection, to be checked with: - binoculars, etc., as needed for inaccessible parts - steel bars, etc. to poke holes for accessible parts	Croking of holes with obstacles	3Y	C

INSPECTION ITEMS, FOCUSED POINTS, INSPECTION METHOD and DIAGNOSIS CRITERIOR						
No.	INSPECTION ITEMS	FOCUSED POINTS	INSPECTION METHODS	DIAGNOSIS CRITERIOR	INSPECTION FREQUENCY	Importance on collapse (C) / fire safety /evacuation (F) /others (O)
<b>2</b>	<b>Foundation, prime structural members and items on elevations</b>					-
1	Foundation	Subsidence, etc. of the foundation	Visual inspection, operation conditions of doors and windows, etc.	Remarkable crack due to subsidence of the ground or interference in operation of doors and windows	3Y	C
2		Degradation and damage	Visual inspection	Gap in foundation alignment or exposure of steel bars, remarkable cracks, spalling, etc., on the concrete surface	3Y	C
3	RC columns	Bulging or other deformation	Visual inspection, measuring with steel tapes, plummets, levels, etc., if needed	Any deformation that may affect structural strength (except for slight deformation originally formed due to construction deviation)	3Y	C
4		Cracks	Visual inspection with clack scales	Crack width is over 0.1mm (exterior) / 0.2mm (interior)	3Y	C
5		Spalling	Visual inspection or check by tapping with test hammers	Spallings over 1cm depth	3Y	C
6		Exposure of reinforcement	Visual inspection	Any exposure	3Y	C
7	SS columns	Bulging, buckling or other deformation	Visual inspection, measuring with steel tapes, plummets, levels, etc., if needed	Any deformation that may affect structural strength	3Y	C
8		Rupture	Visual inspection	Any rupture that may affect structural strength (welded lines/points shall be especially well checked)	3Y	C
9		Corrosion	Visual inspection or check by touching	Corrosion that may extend or affect structural strength	3Y	C
10		loose fastening, loss or looseness of bolts	Visual inspection or check by touching	Any looseness	3Y	C

INSPECTION ITEMS, FOCUSED POINTS, INSPECTION METHOD and DIAGNOSIS CRITERIOR						
No.	INSPECTION ITEMS	FOCUSED POINTS	INSPECTION METHODS	DIAGNOSIS CRITERIOR	INSPECTION FREQUENCY	Importance on collapse (C) /fire safety /evacuation (F) /others (O)
11	Wooden columns	Bulging, buckling or other deformation	Visual inspection, measuring with steel tapes, plummets, levels, etc., if needed	Any deformation that may affect structural strength	3Y	C
12		Split	Visual inspection	Any split that may affect structural strength	3Y	C
13		Corrosion	Visual inspection or check by touching	Any corrosion that may affect structural strength	3Y	C
14		loose fastening, loss or looseness of hardware	Visual inspection or check by touching	Any looseness	3Y	C
15	RC girders and beams	Sagging or other deformation	Visual inspection, measuring with steel tapes, plummets, levels, etc., if needed	Any sagging that may affect structural strength (except for slight sagging originally formed due to construction deviation )	3Y	C
16		Cracks	Visual inspection with crack scales	Crack width is over 0.1mm (exterior) / 0.2mm (interior)	3Y	C
17		Spalling	Visual inspection or check by tapping with test hammers	Spallings over 1cm depth	3Y	C
18		Exposure of reinforcement	Visual inspection	Any exposure	3Y	C

INSPECTION ITEMS, FOCUSED POINTS, INSPECTION METHOD and DIAGNOSIS CRITERIOR						
No.	INSPECTION ITEMS	FOCUSED POINTS	INSPECTION METHODS	DIAGNOSIS CRITERIOR	INSPECTION FREQUENCY	Importance on collapse (C) / fire safety /evacuation (F) /others (O)
19	SS girders and beams	Sagging, buckling or other deformation	Visual inspection, measuring with steel tapes, plummets, levels, etc., if needed	Any deformation that may affect structural strength	3Y	C
20		Rupture	Visual inspection	Any rupture that may affect structural strength (welded lines/points shall be especially well checked)	3Y	C
21	Wooden girders and beams	Corrosion	Visual inspection or check by touching	Corrosion that may extend or affect structural strength	3Y	C
22		loose fasting, loss or looseness of bolts	Visual inspection or check by touching	Any looseness	3Y	C
23		Sagging or other deformation	Visual inspection, measuring with steel tapes, plummets, levels, etc., if needed	Any deformation that may affect structural strength	3Y	C
24		Split	Visual inspection	Any split that may affect structural strength	3Y	C
25		Corrosion	Visual inspection or check by touching	Any corrosion that may affect structural strength	3Y	C
26		loose fasting, loss or looseness of hardware	Visual inspection or check by touching	Any looseness or insufficient supporting condition	3Y	C



INSPECTION ITEMS, FOCUSED POINTS, INSPECTION METHOD and DIAGNOSIS CRITERIOR						
No.	INSPECTION ITEMS	FOCUSED POINTS	INSPECTION METHODS	DIAGNOSIS CRITERIOR	INSPECTION FREQUENCY	Importance on collapse (C) /fire safety /evacuation (F) /others (O)
27	RC or other bearing walls	Bulging or other deformation	Visual inspection, measuring with steel tapes, plummets, levels, etc., if needed	Any deformation that may affect structural strength (except for slight deformation originally formed due to construction deviation)	3Y	C
28		Cracks	Visual inspection with crack scales	Crack width is over 0.1mm (exterior) / 0.2mm (interior)	3Y	C
29		Spalling	Visual inspection or check by tapping with test hammers	Spallings over 1cm depth	3Y	C
30		Exposure of reinforcement	Visual inspection	Any exposure	3Y	C
31	RC braces	Deformation	Visual inspection, measuring with steel tapes, plummets, levels, etc., if needed	Any deformation that may affect structural strength (except for slight deformation originally formed due to construction deviation)	3Y	C
32		Cracks	Visual inspection with crack scales	Crack width is over 0.1mm (exterior) / 0.2mm (interior)	3Y	C
33		Spalling	Visual inspection or check by tapping with test hammers	Spallings over 1cm depth	3Y	C
34		Exposure of reinforcement	Visual inspection	Any exposure	3Y	C

INSPECTION ITEMS, FOCUSED POINTS, INSPECTION METHOD and DIAGNOSIS CRITERIOR						
No.	INSPECTION ITEMS	FOCUSED POINTS	INSPECTION METHODS	DIAGNOSIS CRITERIOR	INSPECTION FREQUENCY	Importance on collapse (C) /fire safety /evacuation (F) others (O)
35	SS braces	Relaxation (in case of tension rod)	Visual inspection or check by touching	Any relaxation	3Y	C
36		Deformation	Visual inspection, measuring with steel tapes, plummets, levels, etc., if needed	Any deformation that may affect structural strength	3Y	C
37		Rupture	Visual inspection or check by touching	Any rupture that may affect structural strength (welded lines/points shall be especially well checked)	3Y	C
38		Corrosion	Visual inspection or check by touching	Corrosion that may extend or affect structural strength	3Y	C
39		loose fasting, loss or looseness of bolts	Visual inspection or check by touching	Any looseness	3Y	C
40	RC floor slabs	Sagging	Visual inspection, measuring with steel tapes, plummets, levels, etc., if needed	Any sagging that may affect structural strength (except for slight sagging originally formed due to construction deviation )	3Y	C
41		Cracks	Visual inspection with crack scales	Crack width is over 0.1mm (exterior) / 0.2mm (interior)	3Y	C
42		Spalling	Visual inspection or check by tapping with test hammers	Spallings over 1cm depth	3Y	C
43		Exposure of reinforcement	Visual inspection	Any exposure	3Y	C

INSPECTION ITEMS, FOCUSED POINTS, INSPECTION METHOD and DIAGNOSIS CRITERIOR						
No.	INSPECTION ITEMS	FOCUSED POINTS	INSPECTION METHODS	DIAGNOSIS CRITERIOR	INSPECTION FREQUENCY	Importance on collapse (C) /fire safety /evacuation (F) /others (O)
44	RC roof slabs	Sagging	Visual inspection, measuring with steel tapes, plummets, levels, etc., if needed	Any sagging that may affect structural strength (except for slight sagging originally formed due to construction deviation )	3Y	C
45		Cracks	Visual inspection with crack scales	Crack width is over 0.1mm (exterior) / 0.2mm (interior)	3Y	C
46		Spalling	Visual inspection or check by tapping with test hammers	Spallings over 1cm depth	3Y	C
47		Water Leakage	Visual inspection, check by touching, interview with users	Any water leakage	3Y	C
48		Exposure of reinforcement	Visual inspection	Any exposure	3Y	C
49	SS roof support structure	Deformation	Visual inspection, measuring with steel tapes, plummets, levels, etc., if needed	Any deformation that may affect structural strength	3Y	C
50		Rupture	Visual inspection or check by touching	Any rupture that may affect structural strength (welded lines/points shall be especially well checked)	3Y	C
51		Corrosion	Visual inspection or check by touching	Corrosion that may extend or affect structural strength	3Y	C
52		loose fasting, loss or looseness of bolts	Visual inspection or check by touching	Any looseness	3Y	C

INSPECTION ITEMS, FOCUSED POINTS, INSPECTION METHOD and DIAGNOSIS CRITERIOR						
No.	INSPECTION ITEMS	FOCUSED POINTS	INSPECTION METHODS	DIAGNOSIS CRITERIOR	INSPECTION FREQUENCY	Importance on collapse (C) /fire safety /evacuation (F) /others (O)
53	Exterior wall	Cracks	Visual inspection	Cracks throughout the work	3Y	C
54	Masonry work	Gaps	Visual inspection	Gaps over multiple units	3Y	C
55		Spalling	Visual inspection	Dangerous situation to drop down pieces or serious loss on the work endangering stability of the work	3Y	C
56		Joints	Visual inspection	Degradation of joint mortar endangering stability of the work	3Y	C
57		Inclination	Visual inspection with plummet, etc., if needed	Inclination endangered to collapse	3Y	C
58		Bulging	Visual inspection with plummet, etc., if needed	Bulging endangered to collapse	3Y	C
59		Vegetation	Visual inspection	Tree root pressing to endanger to collapse	3Y	C

INSPECTION ITEMS, FOCUSED POINTS, INSPECTION METHOD and DIAGNOSIS CRITERIOR						
No.	INSPECTION ITEMS	FOCUSED POINTS	INSPECTION METHODS	DIAGNOSIS CRITERIOR	INSPECTION FREQUENCY	Importance on collapse (C) /fire safety /evacuation (F) /others (O)
60	Exterior wall	Masonry work	Degradation and damage on lintels over windows or doors	Visual inspection or check by tapping with a test hammer, if needed	Remarkable cracks, corrosion, or other damages decreasing the proof stress	3Y C
61	Other structural members		Degradation and damage of the structure of the exterior walls (in the case of wooden structure)	Visual inspection with binoculars, etc., as needed	Remarkable rot, damage, damage by insects on timber or remarkable corrosion on metal fittings	3Y C
62			Degradation and damage of the structure of the exterior walls (in the case of reinforced hollow concrete block masonry structure)	Visual inspection with binoculars, etc., as needed	Remarkable spalling of joint mortar or deformation of structure	3Y C
63			Degradation and damage of the structure of the exterior walls (in the case of steel structure)	Visual inspection with binoculars, etc., as needed	Remarkable corrosion on steel structure	3Y C
64			Degradation and damage of the structure of the exterior walls (in the case of reinforced concrete structure or steel encased reinforced concrete structure)	Visual inspection with binoculars, etc., as needed	Exposure of steel bar, remarkable efflorescence, cracks or spalling on concrete surface	3Y C

INSPECTION ITEMS, FOCUSED POINTS, INSPECTION METHOD and DIAGNOSIS CRITERIOR						
No.	INSPECTION ITEMS	FOCUSED POINTS	INSPECTION METHODS	DIAGNOSIS CRITERIOR	INSPECTION FREQUENCY	Importance on collapse (C) /fire safety /evacuation (F) /others (O)
65	Exterior wall Exterior finishing material, etc.	Degradation and damage of the tiles, stones, etc. (excluding dry construction method) and mortar finish, etc.	Check by tapping with test hammers, etc. for accessible part around corners of openings, concrete construction joints, slant walls, etc. and visual inspection with binoculars, etc., as needed, for other parts. In the case of defects, all the part that may harm pedestrians by dropping tiles shall be checked by tapping with test hammers, etc.	Flaking, remarkable efflorescence, crack or spalling on tiles, etc.	3Y	C
66		Degradation and damage of the tiles and stones, etc. (in the case of dry construction method)	Visual inspection with binoculars, etc., as needed	Cracks or spalling on tiles, etc.	3Y	C
67	Exterior wall Exterior finishing material, etc.	Degradation and damage of the metal finished panels (including the case of curtain wall)	Visual inspection with binoculars, etc., as needed	Deformation of panel surface or part around the joints due to corrosion, etc.	3Y	C
68		Degradation and damage of the concrete panels (including the case of curtain wall)	Visual inspection with binoculars, etc., as needed	Cracks accompanying rust fluid or spalling, etc.	3Y	C
69	Sign boards, outdoor units of A/Cs, etc. attached to the exterior wall	Degradation and damage of the body	Visual inspection with binoculars, etc., as needed	Remarkable corrosion	3Y	C
70		Degradation and damage of the fastener, bracket or suspension, etc.	Visual inspection with binoculars, etc., as needed, or check by tapping with test hammers, etc. for accessible parts	Fastening defect or remarkable corrosion	3Y	C

INSPECTION ITEMS, FOCUSED POINTS, INSPECTION METHOD and DIAGNOSIS CRITERIOR						
No.	INSPECTION ITEMS	FOCUSED POINTS	INSPECTION METHODS	DIAGNOSIS CRITERIOR	INSPECTION FREQUENCY	Importance on collapse (C) /fire safety /evacuation (F) /others (O)
71	Windows Sashes/frames	Corrosion, degradation or deformation	Visual inspection or operation - Caution - Take care not to drop the window during the inspection	Corrosion, degradation or deformation of the rails, hinges or frames to endanger the window to drop	3Y	C
72		loose fasting	visual inspection or check by touching - Caution - Take care not to drop the window during the inspection	Loosening of the screws to endanger the window to drop	3Y	C
73		Smooth operation	Visual inspection and operation test - Caution - Take care not to drop the window during the inspection	Harmful obstacles/sand on the rails, hinges, or frames to hamper smooth operation and endanger the window to drop during operation	3Y	C
74	Windows Gaskets	deterioration	Visual inspection and check by touching - Caution - Take care not to drop the window during the inspection	Degradation of the gasket endangering the window pane to drop	3Y	C
75		Cracks	Visual inspection	Having cracks	3Y	C

INSPECTION ITEMS, FOCUSED POINTS, INSPECTION METHOD and DIAGNOSIS CRITERIOR						
No.	INSPECTION ITEMS	FOCUSED POINTS	INSPECTION METHODS	DIAGNOSIS CRITERIOR	INSPECTION FREQUENCY	Importance on collapse (C) /fire safety /evacuation (F) others (O)
76	Doors	Smooth operation	Check by operation	Stuck or obstructed	3Y	O
77		Handle operation	Check by operation	The ratchet cannot be operated in interlocking with the handle	3Y	O
78		Locking	Check by operation	Malfuction (in case of evacuation route, the lock shall be able to open without keys by evacuees)	3Y	F
79	Projections (Structural parts (balconies, eaves, protruding rooms))	Cracks/spalling/deflection	Visual inspection with binoculars or steel tapes if needed	Having cracks around the joint of the structure  - Note - Cantilever structure is liable to break down suddenly without symptom. Observance of officially designed usage and avoiding overload are important.	3Y	C
80	Fixtures (handrails, brackets for A/C outdoor units, etc.)	Degradation/loose connection	Visual inspection and check by touching if accessible	Loose fastening, degradation or corrosion endangering to fall down  - Note - Inspection shall be carried out safely	3Y	O



INSPECTION ITEMS, FOCUSED POINTS, INSPECTION METHOD and DIAGNOSIS CRITERIOR						
No.	INSPECTION ITEMS	FOCUSED POINTS	INSPECTION METHODS	DIAGNOSIS CRITERIOR	INSPECTION FREQUENCY	Importance on collapse (C) / fire safety /evacuation (F) others (O)
3	Roof					-
1	Flat roof	Degradation and damage of the roofs	Visual inspection	Remarkable cracks, warp, degradation or flourished plants	3Y	C
2	Circumference of the flat roof	Degradation and damage of the vertical surfaces of the parapets	Visual inspection and check by tapping with test hammers, etc.	Remarkable efflorescence, cracks, and other degradation on mortar finish, etc. or spalling of panel	3Y	C
3		Degradation and damage of the copings in mortar, etc. on the parapets	Visual inspection and check by tapping with test hammers, etc.	Remarkable cracks or spalling	3Y	O
4		Degradation and damage of the metal copings on the parapets	Visual inspection and check by tapping with test hammers, etc.	Remarkable corrosion or partial deformation on copings due to loosening of joints	3Y	O
5		Degradation and damage of the ditches and drains	Visual inspection and check by tapping with test hammers, etc.	Remarkable cracks or spalling	3Y	O
6		Pitched roof	Degradation and damage	Visual inspection with binoculars and so on as needed or check by tapping with test hammers, etc.	Remarkable cracks, warp, degradation or flourished plants, corrosion on fasteners for roof material or frames, etc.	3Y
7	Equipment and fixtures (cooling towers and sign towers, etc.)	Degradation and damage of the body and the joints	Visual inspection and check by tapping with test hammers, etc.	Remarkable corrosion on body and joints	3Y	O
8		Degradation and damage of the fasteners, stands, etc.	Visual inspection and check by tapping with test hammers, etc.	Remarkable corrosion on the fasteners or loosening on fastener or stand, or remarkable cracks, spalling, etc. on the concrete foundation and so on	3Y	C

INSPECTION ITEMS, FOCUSED POINTS, INSPECTION METHOD and DIAGNOSIS CRITERIOR						
No.	INSPECTION ITEMS	FOCUSED POINTS	INSPECTION METHODS	DIAGNOSIS CRITERIOR	INSPECTION FREQUENCY	Importance on collapse (C) /fire safety /evacuation (F) /others (O)
4	Interior					-
1	Walls facing to the interior space	Cracks	Visual inspection	Cracks throughout the work	3Y	C
2		Gaps	Visual inspection	Gaps over multiple units	3Y	C
3		Spalling	Visual inspection	Dangerous situation to drop down pieces or serious loss on the work endangering stability of the work.	3Y	C
4		Joints	Visual inspection	Degradation of joint mortar endangering stability of the work.	3Y	C
5		Inclination	Visual inspection with plummet, etc., if needed	Inclination endangered to collapse	3Y	C
6		Bulging	Visual inspection with plummet, etc., if needed	Bulging endangered to collapse	3Y	C
7		Vegetation	Visual inspection	Tree root pressing to endanger to collapse	3Y	C
8		Degradation and damage on lintels over windows or doors	Visual inspection or check by tapping with a test hammer, if needed	Remarkable cracks, corrosion, or other damages decreasing the proof stress	3Y	C

INSPECTION ITEMS, FOCUSED POINTS, INSPECTION METHOD and DIAGNOSIS CRITERIOR						
No.	INSPECTION ITEMS	FOCUSED POINTS	INSPECTION METHODS	DIAGNOSIS CRITERIOR	INSPECTION FREQUENCY	Importance on collapse (C) /fire safety /evacuation (F) /others (O)
9	Walls facing to the interior space Other structure	Degradation and damage of the structure of the walls facing to the interior space (in the case of wooden structure)	Visual inspection with binoculars, etc., as needed	Remarkable rot, damage, damage by insects on timbers or remarkable corrosion on metal fittings	3Y	C
10		Degradation and damage of the structure of the walls facing to the interior space (in the case of reinforced hollow concrete block masonry structure)	Visual inspection with binoculars, etc., as needed	Remarkable spalling of mortar joints or deformation of masonry structure	3Y	C
11		Degradation and damage of the structure of the walls facing to the interior space (in the case of steel structure)	Visual inspection with binoculars, etc., as needed	Remarkable corrosion	3Y	C
12		Degradation and damage of the structure of the walls facing to the interior space (in the case of reinforced concrete structure or steel encased reinforced concrete structure)	Visual inspection with binoculars, etc., as needed	Exposure of steel bars, remarkable efflorescence, cracks or spalling on concrete surface	3Y	C
13	Finish	Spalling	Visual inspection and tapping with a test hammer	Possibility of spalling off to endanger occupants	3Y	C
14		Fungi	Visual inspection	Fungi or plants (in terms of sanitary and symptom of hidden problem on water proofing, etc.)	3Y	O

INSPECTION ITEMS, FOCUSED POINTS, INSPECTION METHOD and DIAGNOSIS CRITERIOR						
No.	INSPECTION ITEMS	FOCUSED POINTS	INSPECTION METHODS	DIAGNOSIS CRITERIOR	INSPECTION FREQUENCY	Importance on collapse (C) /fire safety /evacuation (F) /others (O)
15	Windows Sashes/frames	Corrosion, degradation or deformation	Visual inspection or operation - Caution - Take care not to drop the window during the inspection	Corrosion, degradation or deformation of the rails, hinges or frames to endanger the window to drop	3Y	C
16		loose fastening	visual inspection or check by touching - Caution - Take care not to drop the window during the inspection	Loosening of the screws to endanger the window to drop	3Y	C
17		Smooth operation	Visual inspection and operation test - Caution - Take care not to drop the window during the inspection	Harmful obstacles/sand on the rails, hinges, or frames to hamper smooth operation and endanger the window to drop during operation	3Y	C
18	Gaskets	deterioration	Visual inspection and check by touching - Caution - Take care not to drop the window during the inspection	Degradation of the gasket endangering the window pane to drop	3Y	C
19	Windowpane	Cracks	Visual inspection	Having cracks	3Y	C

INSPECTION ITEMS, FOCUSED POINTS, INSPECTION METHOD and DIAGNOSIS CRITERIOR						
No.	INSPECTION ITEMS	FOCUSED POINTS	INSPECTION METHODS	DIAGNOSIS CRITERIOR	INSPECTION FREQUENCY	Importance on collapse (C) /fire safety /evacuation (F) /others (O)
20	Floors	structure, etc.	Degradation and damage of the structure of the floor (in the case of wooden structure)	Visual inspection	Remarkable rot, damage, damage by insects on timber or remarkable corrosion on metal fittings	3Y C
21			Degradation and damage of the structure of the floor (in the case of steel structure)	Visual inspection	Remarkable corrosion	3Y C
22	Ceilings	Finish	Degradation and damage of the interior finish	Visual inspection with binoculars and so on, as needed, or check by tapping with test hammers, etc.	blistering, sagging, degradation, damage or spalling on finish	3Y C
23			Spalling	Visual inspection and tapping with a test hammer	Possibility of spalling off to endanger occupants	3Y C
24			Fungi	Visual inspection	Fungi or plants (in terms of sanitary and symptom of hidden problem on water proofing, etc.)	3Y O
25			Lightings and hanging items, etc.	Prevention of dropping	Visual inspection with binoculars and so on as needed or check by touching	3Y C
5	<b>Evacuation facilities, etc.</b>					
1	Passageways	Availability		Visual inspection	Obstacles for evacuation or occupied	1Y F
2	Doorways	obstacles		Visual inspection	Interference to operate doorways	3Y F
3		Lock on doors		Operation test	Impossible to open without keys to the evacuation direction	1Y F
4		Smooth operation		Operation test	Difficulty in operation	3Y F
5		Handle operation		Operation test	Handles are not well linked to the latches (difficulty in opening)	3Y F

INSPECTION ITEMS, FOCUSED POINTS, INSPECTION METHOD and DIAGNOSIS CRITERIOR						
No.	INSPECTION ITEMS	FOCUSED POINTS	INSPECTION METHODS	DIAGNOSIS CRITERIOR	INSPECTION FREQUENCY	Importance on collapse (C) /fire safety /evacuation (F) /others (O)
6	Stairs	Degradation or damage	Visual inspection	Remarkable corrosion, deformation or damage	3Y	C
7		Installation on handrail, etc.	Visual inspection and checking by touching	Loose fastning	3Y	C
8	Steps, landings, etc.	Spalling, degradation or damage	Visual inspection and check by tapping with a test hammer	Remarkable spalling, deformation, degradation, slip of bricks	3Y	C
9	Evacuation	Obstacles	Visual inspection	Obstacles for evacuation	1Y	F
10	Evacuation Ladders	Installation	Visual inspection and check by touching	Loose installation, serious damage or corrosion (Installation of evacuation ladders is recommended. Bottom of the ladder can be withdrawn for crime prevention)	1Y	F
11	Smoke exhaust equipment /assembly	Operation	Operation test of capital smoke exhaust equipment on each floor	Malfunction	3Y	F
12		Smoke outlet	Visual inspection and operation test (open and close)	Malfunction or obstacles for smoke exhaust	1Y	F

INSPECTION ITEMS, FOCUSED POINTS, INSPECTION METHOD and DIAGNOSIS CRITERIOR						
No.	INSPECTION ITEMS	FOCUSED POINTS	INSPECTION METHODS	DIAGNOSIS CRITERIOR	INSPECTION FREQUENCY	Importance on collapse (C) /fire safety /evacuation (F) /others (O)
6	Others					-
1	Particular structures, etc. Membrane members and the fittings parts of membrane structure	Degradation or damage on membrane members and the fittings parts	Visual inspection with binoculars, etc., as needed	Tears, pools of rain water, separations of members at binding joint	3Y	O
2		Tension of cables and membrane members	Visual inspection with binoculars, etc., as needed	Tension drop on cables or membrane members	3Y	O
3	Seismic base isolation equipment and the trench	Degradation or damage on seismic base isolation equipment (only in the case that the equipment is visible)	Visual inspection and comparison to the records of prior inspections held within 3 years, if any	Remarkable corrosion on steel parts	3Y	C
4		Mobility of superstructure	Visual inspection	Interference of sliding of superstructure or obstacles for the system	3Y	C
5	Lightning protection system	Installation and corrosion of lightning rods (air terminals)	Visual inspection or check by touching	Loose installation or significant corrosion	3Y	O
6		Fastening and corrosion of supporting wires	Visual inspection or check by touching	Loose fastening or significant corrosion	3Y	O
7		Installation and corrosion of supports	Visual inspection or check by touching	Loose installation or significant corrosion	3Y	O
8	Wiring and connection		Visual inspection, check by touching or check with a tester, if needed	Snapping, loose connection or significant corrosion	3Y	O
9		Grounding resistance	Measure with an earthing resistor	Out of the designed range	3Y	O

INSPECTION ITEMS, FOCUSED POINTS, INSPECTION METHOD and DIAGNOSIS CRITERIOR						
No.	INSPECTION ITEMS	FOCUSED POINTS	INSPECTION METHODS	DIAGNOSIS CRITERIOR	INSPECTION FREQUENCY	Importance on collapse (C) /fire safety /evacuation (F) others (O)
10	Chimneys for building service	Degradation or damage on connecting parts of chimneys and building bodies	Visual inspection with binoculars, etc., as needed	Remarkable cracks, spalling, etc.	3Y	C
11		Degradation or damage on metal parts	Visual inspection with binoculars, etc., as needed	Remarkable corrosion, etc.	3Y	C
12	Other chimneys	Degradation or damage on chimneys	Visual inspection with binoculars, etc., as needed	Exposure of steel bars, corrosion, rust, fluid, cracks, spalling on chimneys	3Y	C
13		Degradation or damage on metal parts	Visual inspection with binoculars, etc., as needed	Remarkable corrosion, loose clamping, etc. on anchor bolts and so on	3Y	C



INSPECTION ITEMS, FOCUSED POINTS, INSPECTION METHOD and DIAGNOSIS CRITERIOR						
No.	INSPECTION ITEMS	FOCUSED POINTS	INSPECTION METHODS	DIAGNOSIS CRITERIOR	INSPECTION FREQUENCY	Importance on collapse (C) / fire safety /evacuation (F) /others (O)
<b>Ventilation</b>						
<b>Habitable rooms installed with ventilation equipment</b>						
1	Mechanical driven ventilation equipment	Prevention of leaking of rain water, etc. on outdoor air intake system and exhaust air outlet system	visual inspection	Prevention function for rain water, rals, vermin, dust, etc. on outdoor air intake system and exhaust air outlet system as stipulated in the ordinances	3Y	O
2		Installation of outdoor air outlet port and exhaust air port	visual inspection or check by touching	looseness, remarkable corrosion or damage	3Y	C
3		Position of supply air ports and exhaust air ports in every room	visual inspection with air current detector	remarkable bias of air current	3Y	O
4		Installation of supply air ports and exhaust air ports	visual inspection or check by touching	looseness, remarkable corrosion or damage	3Y	C
5		Installation of ducts	visual inspection or check by touching	looseness of installation, air leakage due to damage at joints	3Y	C
6		Installation of supply fan and exhaust fan	visual inspection or check by touching	loose installation, remarkable corrosion or damage	3Y	C
7		Ventilation condition by ventilation fan	visual inspection	remarkable inferiority of ventilation Performance due to out door air current	3Y	O

INSPECTION ITEMS, FOCUSED POINTS, INSPECTION METHOD and DIAGNOSIS CRITERIOR						
No.	INSPECTION ITEMS	FOCUSED POINTS	INSPECTION METHODS	DIAGNOSIS CRITERIOR	INSPECTION FREQUENCY	Importance on collapse (C) /fire safety /evacuation (F) /others (O)
8	Mechanical driven ventilation equipment	Ventilation volume	Measure air flow velocities with anemometer and calculate the ventilation volume (velocity multiplied by the section area is ventilation volume)	Short volume of ventilation	3Y	O
9		Control and status monitoring by centrally controlled system	Operation test	Functioning of control and status monitoring system in central control room	3Y	O
10	Centrally controlled HVAC	Installation	Visual inspection or check by touching	loose installation, remarkable corrosion or damage	3Y	C
11	Capital equipment and appearance of piping	Degradation or damage on the equipment and the piping	Visual inspection	deformation, damage or remarkable corrosion on the equipment and the piping	3Y	O
12		Operation	Visual inspection or check by touching	abnormal noise, vibration or heat during operation	3Y	O
13		Air filters	Visual inspection	Thick dust covering filters	3Y	O

INSPECTION ITEMS, FOCUSED POINTS, INSPECTION METHOD and DIAGNOSIS CRITERIOR						
No.	INSPECTION ITEMS	FOCUSED POINTS	INSPECTION METHODS	DIAGNOSIS CRITERIOR	INSPECTION FREQUENCY	Importance on collapse (C) /fire safety /evacuation (F) /others (O)
<b>2</b>	<b>Kitchen, etc. required to be installed with ventilation equipment</b>					-
1	Passive ventilation system or Mechanical driven ventilation	Installation of exhaust duct, exhaust hood and chimney	visual inspection or check by touching	loose installation, remarkable corrosion or damage	3Y	C
2		Function of supply air inlet and duct, exhaust outlet and flue, exhaust hood and chimney	visual inspection or check by touching	interference of air supply or exhaust due to bird's nest, etc.	3Y	O
3		Risk to catch fire due to grease	visual inspection or check by touching	Plenty of grease on filters, grills, hoods, ducts or grease cups	3Y	O
4		Insulation of exhaust flue and chimney	visual inspection or check by touching	Dropping or damage of insulation material	3Y	O
5	Mechanical driven ventilation equipment	Ventilation condition with ventilation fans	visual inspection	Being remarkably subject to wind to decrease ventilation capacity due to configuration and structure of the fan	3Y	O
6		Ventilation volume	Measure air flow velocities with anemometer and calculate the ventilation volume (velocity multiplied by the section area is ventilation volume)	Short volume of ventilation	3Y	O

INSPECTION ITEMS, FOCUSED POINTS, INSPECTION METHOD and DIAGNOSIS CRITERIOR						
No.	INSPECTION ITEMS	FOCUSED POINTS	INSPECTION METHODS	DIAGNOSIS CRITERIOR	INSPECTION FREQUENCY	Importance on collapse (C) /fire safety /evacuation (F) /others (O)
3	Habitable rooms installed with ventilation equipment					-
1	Fire dampers, etc.	Function of fire dampers	Operation test	Smooth motion	3Y	F
2		Degradation and damage of fire dampers	visual inspection or check by touching	Damage or remarkable corrosion	3Y	F
3		Interlocking of fire dampers with smoke detectors, heat detectors and smoke/heat detectors	Interlocking function test with testing apparatus such as, smoke generators, heaters. Provided, if the item has been inspected after the last regular inspection, check of the inspection record can substitute the inspection.	No function in conjunction with a sensor.	3Y	F

INSPECTION ITEMS, FOCUSED POINTS, INSPECTION METHOD and DIAGNOSIS CRITERIOR						
No.	INSPECTION ITEMS	FOCUSED POINTS	INSPECTION METHODS	DIAGNOSIS CRITERIOR	INSPECTION FREQUENCY	Importance on collapse (C) / fire safety /evacuation (F) others (O)
<b>Smoke exhaust</b>						
<b>1</b>	<b>General</b>					-
1	Appearance	Installation	Visual inspection or check by touching	Loose installation of the foundation, remarkable corrosion or damage	3Y	C/F
2		Connection with smoke exhaust ducts	Visual inspection	Damage or deformation on fittings	3Y	F
3		Condition of outdoor exhaust ports	Visual inspection	Possibility of influence of drafted smoke to other areas	3Y	F
4		Circumference of outdoor exhaust ports	Visual inspection	Obstacles for smoke exhaust	3Y	F
5		Rain water prevention at outdoor exhaust ports	Visual inspection	Rain water penetration or discharging failure of rain water	3Y	F
6	Performance	Interlocking starting at opening of smoke vents	Operation test	Malfunction of operation in conjunction with smoke vents	3Y	F
7		Running state	Check by touching or monitoring noise	Abnormal noise or vibration on the motor or fan	3Y	F
8		Operation with the standby power	Operation test with the standby power	Malfunction of operation with the standby power	3Y	F
9		Airflow	Measure air flow velocities with anemometer and calculate the ventilation volume (velocity multiplied by the section area is ventilation volume)	Short volume of ventilation	3Y	F

INSPECTION ITEMS, FOCUSED POINTS, INSPECTION METHOD and DIAGNOSIS CRITERIOR						
No.	INSPECTION ITEMS	FOCUSED POINTS	INSPECTION METHODS	DIAGNOSIS CRITERIOR	INSPECTION FREQUENCY	Importance on collapse (C) /fire safety /evacuation (F) /others (O)
10	Smoke exhaust fans Performance	Status monitoring and system control with central control system	Monitoring of the status	Malfunction of monitoring the status or controlling the system from the central control station	3Y	F
11	Others Appearance of smoke vents for	Circumference of smoke vents	Visual inspection	Obstacles for smoke exhaust	3Y	F
12		Installation of smoke vents	visual inspection or check by touching	looseness, remarkable corrosion or damage	3Y	C/F
13	Performance of smoke vents for mechanical smoke	State of smoke vents	Check by touching or monitoring noise during operation	Closing or remarkable vibration by airflow when it is open	3Y	F
14		Airflow	Measure air flow velocities with anemometer and calculate the ventilation volume (velocity multiplied by the section area is ventilation volume)	Short volume of ventilation	3Y	F
15		Status monitoring and system control with central control system	Monitoring of the status	Malfunction of monitoring the status or controlling the system from the central control station	3Y	F
16	Ducts for mechanical smoke exhaust system	Degradation and damage of ducts	visual inspection	Deformation, damage or remarkable corrosion	3Y	F
17		Installation of ducts	visual inspection or check by touching	loose installation, remarkable corrosion or damage on fittings and suspension bolts	3Y	C/F

INSPECTION ITEMS, FOCUSED POINTS, INSPECTION METHOD and DIAGNOSIS CRITERIOR						
No.	INSPECTION ITEMS	FOCUSED POINTS	INSPECTION METHODS	DIAGNOSIS CRITERIOR	INSPECTION FREQUENCY	Importance on collapse (C) / fire safety /evacuation (F) /others (O)
18	Others	Installation of fire dampers	visual inspection or check by touching	loose installation	3Y	C/F
19	Fire dampers	Operation of fire dampers	Operation test (to release the latch)	Malfunction of smooth closing	3Y	F
20		Degradation and damage of ducts	visual inspection or check by touching	Damage or remarkable corrosion on the body	3Y	F
21		Interlocking operation with heat detectors	To be tested with heat source	Malfunction of operation in conjunction with detectors	3Y	F
<b>2</b>	<b>Emergency power</b>					-
1	Appearance	Generator capacity	Comparison on capacity of generators and connected equipment with dossiers of drawings	Generator capacity is smaller than connected equipment and incapable of running for the period designated in the design	3Y	F
2		Generator/magnetos and engine	Visual inspection or check by touching	Looseness of terminal connections, damage on gauges or indicators, or oil leakage and so on around the engine or fuel tank	3Y	F
3		Fuel, lubricant and cooling water	visual inspection	Shortage of the fuel or cooling water to run for required period in design or the lubricant amount is out of the range indicated on the equipment	3Y	F
4		Pressure in the air tank for generator starter	Check of pressure gauge and alarm	Air pressure is out of the range designated in the design or no alarm given in the case of pressure relief	3Y	F

INSPECTION ITEMS, FOCUSED POINTS, INSPECTION METHOD and DIAGNOSIS CRITERIOR						
No.	INSPECTION ITEMS	FOCUSED POINTS	INSPECTION METHODS	DIAGNOSIS CRITERIOR	INSPECTION FREQUENCY	Importance on collapse (C) /fire safety /evacuation (F) /others (O)
5	Emergency generator Appearance	Electrolytic solution and wiring contact for the battery for the starting motor	Visual inspection for the electrolytic solution and voltage measurement for the battery with voltmeter	Insufficient voltage to meet the rating, short electrolytic to satisfy the required amount shown on the equipment, loose connection of wiring, or liquid leakage	3Y	F
6	Emergency generator Appearance	Leakage of the fuel and cooling water	visual inspection	Leakage from the piping around fittings, etc.	3Y	F
7		Installation	Visual inspection or check by touching	Loose installation, remarkable corrosion or damage on the base frame	3Y	C/F
8		Connection of grounding wiring	Visual inspection	Looseness or remarkable corrosion on the terminal connections	3Y	F
9		Insulation resistance	Test with insulation resistance tester	Insufficient insulation resistance to meet the rating as per the design	3Y	F
10	Performance	Changeover of the power source	Operation test	Malfunction of changeover to the generator	3Y	F
11		Ignition and hat	Operation test	Failure of ignition with compressed air starter or motor starter, or failure of establishment of rated voltage within the moment designated in the design after starting	3Y	F
12		Operation	Visual inspection, check by touching or monitoring of noise	Abnormal noise or vibration	3Y	F
13		Exhaust	Visual inspection	Leakage of exhaust due to deformation, damage, cracks, etc. on the exhaust pipes, silencers and so on	3Y	F



INSPECTION ITEMS, FOCUSED POINTS, INSPECTION METHOD and DIAGNOSIS CRITERIOR						
No.	INSPECTION ITEMS	FOCUSED POINTS	INSPECTION METHODS	DIAGNOSIS CRITERIOR	INSPECTION FREQUENCY	Importance on collapse (C) / fire safety /evacuation (F) /others (O)
14	Emergency generator	Performance	Running condition of ancillary equipment such as compressors, fuel pumps, cooling water pumps, and so on	Operation test	Abnormal noise or vibration	3Y F
15			Indication and lighting of instruments such as pilot lamps, gauges and other indicators	Visual inspection	Indication failure or damage on indicators and gauges for switchboards for the generator or control instruments and so on, or lighting failure of pilot lamps	3Y F
16	Engines directly coupled with smoke exhaust fans	Appearance	Installation	Visual inspection or check by touching	Loose installation, remarkable corrosion on anchor bolts, etc. or insufficient ventilation of the room	3Y C/F
17			Fuel, lubricant and cooling water	visual inspection	Shortage of the fuel or cooling water to run for required period in design or the lubricant amount is out of the range indicated on the equipment	3Y F
18			Electrolytic solution and wiring contact for the battery for the starting motor	Visual inspection for the electrolytic solution and voltage measurement for the battery with voltmeter	Insufficient voltage to meet the rating, short electrolytic to satisfy the required amount shown on the equipment, loose connection of wiring, or liquid leakage	3Y F
19			Installation of pipes for air intake and exhaust	visual inspection	Deformation, damage or cracks	3Y C/F
20			V-belts	Visual inspection or check by touching	Damage, cracks, unreasonable deflection	3Y F
21			Connection of grounding wiring	Visual inspection	Looseness or remarkable corrosion on the terminal connections	3Y F

INSPECTION ITEMS, FOCUSED POINTS, INSPECTION METHOD and DIAGNOSIS CRITERIOR						
No.	INSPECTION ITEMS	FOCUSED POINTS	INSPECTION METHODS	DIAGNOSIS CRITERIOR	INSPECTION FREQUENCY	Importance on collapse (C) /fire safety /evacuation (F) /others (O)
22	Engines directly coupled with smoke exhaust fans	Appearance Insulation resistance	Tested with insulation resistance tester	Insufficient insulation resistance to meet the rating as per the design	3Y	F
23		Performance Ignition and hat	Operation test	Failure of ignition, halt or interlocking operation in conjunction with opening of smoke vents	3Y	F
24		Operation	Visual inspection, check by touching or monitoring of noise	Abnormal noise or vibration	3Y	F
25		Indication and lighting of instruments such as pilot lamps, gauges and other indicators	Visual inspection	Indication failure or damage on indicators and gauges for switchboards and so on, or lighting failure of pilot lamps	3Y	F
3	other points to check (if any)					
<b>Emergency lighting</b>						
<b>1 Lighting equipment</b>						
1	Emergency lighting equipment	Bulbs, lamps, etc.	Visual inspection	Unconformity with the specification on emergency lighting equipment designated in the design	3Y	F
<b>2 Standby battery (built-in or not built-in) and emergency generator</b>						
1	Standby batteries	Power source changeover to the standby batteries	Operation test with checking lighting	Malfunction of automatic changeover system of emergency lighting equipment	3Y	F
2		Capacity	To check the lighting duration	Unconformity with the required duration of lighting designated in the design	3Y	F

INSPECTION ITEMS, FOCUSED POINTS, INSPECTION METHOD and DIAGNOSIS CRITERIOR						
No.	INSPECTION ITEMS	FOCUSED POINTS	INSPECTION METHODS	DIAGNOSIS CRITERIOR	INSPECTION FREQUENCY	Importance on collapse (C) /fire safety /evacuation (F) /others (O)
<b>3</b>	<b>Standby battery (not built-in) and emergency generator</b>					-
	Changeover circuit	Changeover from the ordinary power to the standby battery	Operation test	Failure of automatic changeover. From the ordinary power to the standby battery; From the standby battery to the ordinary power (when the ordinary power recover)	3Y	F
<b>4</b>	<b>Standby battery (built-in)</b>					-
1	Wiring and pilot lamp for charging	Lighting of the pilot lamp for charging	Visual inspection	Failure of lighting of the charging pilot lamp when the test switch is turned off	3Y	F
2		Exclusiveness of circuits for equipment for double use of emergency lighting and emergency exit/guide light	Visual inspection	Not exclusive	3Y	F
<b>5</b>	<b>Standby battery (not built-in)</b>					-
1	Appearance of the battery room	Battery	Visual inspection or check by touching	Deformation, damage, corrosion, leakage, etc.	1Y	F
2	Capacity	Voltage	Measurement with a Voltmeter	Abnormal voltage	1Y	F
3		Specific gravity of electrolytic solution	Measurement with a hydrometer	Improper specific gravity	1Y	F
4	Charger	Installation of cubicles	Visual inspection or check by touching	Loose installation	1Y	F
<b>6</b>	<b>other points to check (if any)</b>					-

INSPECTION ITEMS, FOCUSED POINTS, INSPECTION METHOD and DIAGNOSIS CRITERIOR						
No.	INSPECTION ITEMS	FOCUSED POINTS	INSPECTION METHODS	DIAGNOSIS CRITERIOR	INSPECTION FREQUENCY	Importance on collapse (C) / fire safety /evacuation (F) /others (O)
<b>Sanitary</b>						
<b>1</b>	<b>Water supply and drainage equipment</b>					
1	Water supply and drainage piping (installation (excluding concealed parts))		Visual inspection	Not installed safely against every kind of load such as, wind load, soil pressure, water pressure, seismic load and other impact	3Y	C
2		Corrosion or leakage	Visual inspection	Corrosion or leakage on piping	3Y	O
3		Fittings	Visual inspection	Not prevented from damage on piping due to expansion, contraction, or transformation; in case damage is prospected, pipes shall be taken effective measures such as, installation of expansion joints or flexible joints	3Y	O
4		Prevention of cross connection	Visual inspection	Unconformity with the requirements on prevention of cross connection: - pipes for potable water shall not be connected to other systems directly - air gap between the faucet and rim of the fixture shall be secured.	3Y	O
5		Suspension of hot water supply piping and expansion relief piping	Visual inspection	Hanger bolts, rubber cushions, etc. are not installed in terms of alleviation of impact and absorption of expansion or contraction	3Y	O

INSPECTION ITEMS, FOCUSED POINTS, INSPECTION METHOD and DIAGNOSIS CRITERIOR						
No.	INSPECTION ITEMS	FOCUSED POINTS	INSPECTION METHODS	DIAGNOSIS CRITERIOR	INSPECTION FREQUENCY	Importance on collapse (C) / fire safety /evacuation (F) /others (O)
6	Quality of water	Color	Visual inspection of the water sampled at a tap	Colored	1Y	O
7		Smelling and tasting	Smelling and tasting test of the water sampled at a tap or interview with the users	Foul smell or taste	1Y	O
<b>2</b>	<b>Water supply equipment</b>					-
1	Reservoir tanks and supply pumps	Corrosion or leakage	Visual inspection	Unconformity with the requirements on structure of tanks as stipulated in the ordinances for building design/construction: - proof against dust or other harmful stuff in terms of sanitary - rust prevention in case of metal material	3Y	O
2		Safety devices for pressure tanks for water supply	Operation test	Unconformity with the requirements on pressure tanks and boilers as stipulated in the ordinances for building design/construction; pressure tanks and boilers shall be equipped with safety devices	3Y	O
3		Operation of supply pumps	Check of pressure gauge and operation test	Abnormal noise or vibration, insufficient voltage to meet the rating.	3Y	O

INSPECTION ITEMS, FOCUSED POINTS, INSPECTION METHOD and DIAGNOSIS CRITERIOR						
No.	INSPECTION ITEMS	FOCUSED POINTS	INSPECTION METHODS	DIAGNOSIS CRITERIOR	INSPECTION FREQUENCY	Importance on collapse (C) /fire safety /evacuation (F) /others (O)
4	Reservoir tanks and supply pumps	Installation of tanks, pumps, etc.	Visual inspection or check by touching	Unconformity with the requirements on supports, frames, fasteners for tanks, pumps etc. as stipulated in the ordinances for building design/construction: - Parts subject to corrosion shall be taken measured for corrosion - Equipment extruding from the rooftop shall be tightly fastened to the primary structural members	3Y	C
5	Boilers (including circulation pumps)	Electric boilers	Visual inspection	Corrosion, loose support, malfunction of safety valve or water leakage, etc.	1Y	C
3	<b>Drainage equipment</b>					
1	Sump pits	Leakage	Visual inspection	Detection of leakage	3Y	O
2	Waste water recycle system	Tanks and pumps	Visual inspection	Loose installation, remarkable corrosion or damage, etc.	3Y	C
3		Disinfection device	Visual inspection	Shortage of antiseptic solution	3Y	O

INSPECTION ITEMS, FOCUSED POINTS, INSPECTION METHOD and DIAGNOSIS CRITERIOR						
No.	INSPECTION ITEMS	FOCUSED POINTS	INSPECTION METHODS	DIAGNOSIS CRITERIOR	INSPECTION FREQUENCY	Importance on collapse (C) /fire safety /evacuation (F) /others (O)
	Others					
4	Sanitary fixtures	Installation	Visual inspection	Loose installation, damage, or un conformity with the requirements on installation of sanitary fixtures as stipulated in the ordinances for building design/construction, air gap between the faucet and rim of the fixture shall be secured.	3Y	C
5	Drainage traps	Seal water	Visual inspection, smelling check and measurement with steel tapes, etc. as needed	Seal water is not kept properly to prevent odor or pests from the drainage system (sealing depth should be 5-10cm)	3Y	O
6	Interceptors for grease, hair, and so on	Seal water	Visual inspection and measurement with steel tapes, etc. as needed	Seal water is not kept properly to prevent odor or pests from the drainage system (sealing depth should be no less than 5cm)	3Y	O
7		Cleaning	Visual inspection	Full of trapped material	3Y	O
8	Drainage	Connection to sewer	Visual inspection	The end of drainage is not connected to public sewer services or a septic tank effectively	3Y	O
9		Drainage condition	Visual inspection	No pitch or malfunction of flow	3Y	O
10		Vent pipes	Visual inspection or odor check	- odor is given out except from the vent - vent piping is not set effective to avoid trap seal loss - vent piping is not set properly so that its air flow will not be obstructed with waste water	3Y	O

INSPECTION ITEMS, FOCUSED POINTS, INSPECTION METHOD and DIAGNOSIS CRITERIOR						
No.	INSPECTION ITEMS	FOCUSED POINTS	INSPECTION METHODS	DIAGNOSIS CRITERIOR	INSPECTION FREQUENCY	Importance on collapse (C) /fire safety /evacuation (F) /others (O)
11	Others Drainage	Vents of vent pipes	Visual inspection	Vents are not opened directly to the outdoor air, or special devices to confine the air in the piping are not set to the vent piping	3Y	O
4	other check points					
<b>Electrical</b>						
1	Wiring, etc.	Outlet/wiring/switch	Visual inspection	Overloading due to large-capacity appliances or octopus connection	3Y	F
2		Scorch/deformation	Visual inspection	Scorch or deformation endangering safe use	3Y	F
3		Dust/Grease	Visual inspection	Covered with dust or grease	1Y	F
4	Wall plates for switch and outlet	Installation	Visual inspection or check by touching	loose installation, slippage or dropdown	3Y	F
5	Circuit Breaker	Function	Visual inspection	Obstruction for the switches	3Y	F
6	Circuit Breaker /distribution board	Damage	Visual inspection	Scorch or deformation	3Y	F
7	wiring	Insulation	Visual inspection	Naked point or part without insulation	1Y	F
8	Building management system /	Function	Test, interview with operators/manager	Multifunction on monitoring, communication, operation, etc.	1Y	F
9		Error report	Test, interview with operators/manager	Unknown error is reported	1Y	F



INSPECTION ITEMS, FOCUSED POINTS, INSPECTION METHOD and DIAGNOSIS CRITERIOR						
No.	INSPECTION ITEMS	FOCUSED POINTS	INSPECTION METHODS	DIAGNOSIS CRITERIOR	INSPECTION FREQUENCY	Importance on collapse (C) /fire safety /evacuation (F) /others (O)
10	Emergency generator Appearance	Generator capacity	Comparison on capacity of generators and connected equipment with dossiers of drawings	Generator capacity is smaller than connected equipment and incapable of running for the period designated in the design	1Y	F
11		Generator/magnetos and engine	Visual inspection or check by touching	Looseness of terminal connections, damage on gauges or indicators, or oil leakage and so on around the engine or fuel tank	1Y	F
12		Fuel, lubricant and cooling water	visual inspection	Shortage of the fuel or cooling water to run for required period in design or the lubricant amount is out of the range indicated on the equipment	1Y	F
13		Pressure in the air tank for generator starter	Check of pressure gauge and alarm	Air pressure is out of the range designated in the design or no alarm given in the case of pressure relief	1Y	F
14		Electrolytic solution and wiring contact for the battery for the starting motor	Visual inspection for the electrolytic solution and voltage measurement for the battery with voltmeter	Insufficient voltage to meet the rating, short electrolytic to satisfy the required amount shown on the equipment, loose connection of wiring, or liquid leakage	1Y	F
15		Leakage of the fuel and cooling water	visual inspection	Leakage from the piping around fittings, etc.	1Y	F
16		Installation	Visual inspection or check by touching	Loose installation, remarkable corrosion or damage on the base frame	1Y	C/F

INSPECTION ITEMS, FOCUSED POINTS, INSPECTION METHOD and DIAGNOSIS CRITERIOR							
No.	INSPECTION ITEMS	FOCUSED POINTS	INSPECTION METHODS	DIAGNOSIS CRITERIOR	INSPECTION FREQUENCY	Importance on collapse (C) /fire safety /evacuation (F) /others (O)	
17	Emergency generator	Appearance	Ventilation (in case of indoor installation)	Visual inspection and operation test	Insufficient ventilation to raise the room temperature too high or malfunction of ventilation fans to run independently or in conjunction with the generator	1Y	F
18		Connection of grounding wiring	Visual inspection	Looseness or remarkable corrosion on the terminal connections		1Y	F
19		Insulation resistance	Test with insulation resistance tester	Insufficient insulation resistance to meet the rating as per the design		1Y	F
20		Changeover of the power source	Operation test	Malfunction of changeover to the generator		1Y	F
21		Ignition and hat	Operation test	Failure of ignition with compressed air starter or motor starter, or failure of establishment of rated voltage within the moment designated in the design after starting		1Y	F
22		Operation	Visual inspection, check by touching or monitoring of noise	Abnormal noise or vibration		1Y	F
23		Exhaust	Visual inspection	Leakage of exhaust due to deformation, damage, cracks, etc. on the exhaust pipes, silencers and so on		1Y	F
24		Running condition of ancillary equipment such as compressors, fuel pumps, cooling water pumps, and so on	Operation test	Abnormal noise or vibration		1Y	F

INSPECTION ITEMS, FOCUSED POINTS, INSPECTION METHOD and DIAGNOSIS CRITERIOR						
No.	INSPECTION ITEMS	FOCUSED POINTS	INSPECTION METHODS	DIAGNOSIS CRITERIOR	INSPECTION FREQUENCY	Importance on collapse (C) / fire safety /evacuation (F) /others (O)
25	Emergency generator	Performance	Indication and lighting of instruments such as pilot lamps, gauges and other indicators	Visual inspection	Indication failure or damage on indicators and gauges for switchboards for the generator or control instruments and so on, or lighting failure of pilot lamps	1Y F
<b>Elevators and escalators</b>						
1	Elevators	Sill grooves	Obstacle for operation	Visual inspection - Caution - Checking and removing obstacles shall be done safely after confirmation that the doors and the car will not move suddenly (refer to manufacturers' or suppliers' manual) so to avoid accidents to get involved in the doors, sheared between the floor/door frame and the car (there have been such accidents in the past)	No obstacle for smooth operation of doors, such as, pebbles in the sill grooves	1M O
2	Doors and interior condition	Corrosion and deformation		Visual inspection	Significant deformation or corrosion for smooth operation or safe use	1M O
3	Whole	Maintenance service organization		Interview with managers or check with records	Not having been organized for maintenance service (periodical and ad-hoc in emergency) - Note - Wearing of the ropes, malfunction of the control system and malfunction of the safety device may induce significant accidents	1M O

INSPECTION ITEMS, FOCUSED POINTS, INSPECTION METHOD and DIAGNOSIS CRITERIOR						
No.	INSPECTION ITEMS	FOCUSED POINTS	INSPECTION METHODS	DIAGNOSIS CRITERIOR	INSPECTION FREQUENCY	Importance on collapse (C) /fire safety /evacuation (F) /others (O)
4	Elevators Maintenance records	Maintenance implementation condition	Interview with managers or check with inspection records	Maintenance is not implemented as instructed in the maintenance supporting documents in designated period according to the documents and ordinances  - Note - Default of the maintenance including proper lubrication, periodical check for wearing status of the ropes, malfunction of the control system, malfunction of the safety device, etc. may induce significant accidents	1Y	O
5	Escalators Steps	Obstacle for operation	Visual inspection  - Caution - Checking and removing obstacles shall be done safely after confirmation that the escalator has stopped completely and will not move suddenly (refer to manufacturers' or suppliers' manual) so to avoid accidents to get entangled in the steps (there have been such accidents in the past)	No obstacle for smooth operation, such as, pebbles in the sill grooves	1M	O
6	Steps, landing, handrails	Corrosion and deformation	Visual inspection	Significant deformation or corrosion for safe use	1M	O
7	Whole	Maintenance organization	Interview with managers or check with records	Not having been organized for maintenance service (periodical and ad-hoc in emergency)	1Y	O

INSPECTION ITEMS, FOCUSED POINTS, INSPECTION METHOD and DIAGNOSIS CRITERIOR						
No.	INSPECTION ITEMS	FOCUSED POINTS	INSPECTION METHODS	DIAGNOSIS CRITERIOR	INSPECTION FREQUENCY	Importance on collapse (C) /fire safety /evacuation (F) others (O)
8	Escalators Maintenance records	Maintenance implementation condition	Interview with managers or check with inspection records	Maintenance is not implemented as instructed in the maintenance supporting documents in designated period according to the documents and ordinances  - Note - Default of the maintenance including proper lubrication, periodical check may induce significant accidents	1Y	O
<b>Fire fighting equipment</b>						
1	Fire fighting equipment	Position	Visual inspection	Improper positioning, such as, located behind obstacles with difficulty to find out or take out, put on a inaccessible high shelf, etc.	0.5Y	F
2		Corrosion and degradation	Visual inspection and check by touching  - Note - Check shall be done with care not to initialize the extinguishers	Corrosion or degradation to interrupt smooth operation	0.5Y	F

INSPECTION ITEMS, FOCUSED POINTS, INSPECTION METHOD and DIAGNOSIS CRITERIOR						
No.	INSPECTION ITEMS	FOCUSED POINTS	INSPECTION METHODS	DIAGNOSIS CRITERIOR	INSPECTION FREQUENCY	Importance on collapse (C) / fire safety /evacuation (F) /others (O)
3	Fire fighting equipment	Obstacles	Visual inspection	Obstacles around sprinkler heads to sprinkle water	0.5Y	F
4		Static pressure of filled water	Check with installed pressure gauge	Out of the designed range of water pressure	0.5Y	F
5	Hydrant	Function	Operation test with test valves (depends on the system constitution)	Multifunction of water supply with required flow rate for required time by the design	1Y	F
6		Quantity of stored water	Visual inspection	Insufficient for design requirement	0.5Y	F
7		Obstacles	Visual inspection	Obstacles to find out and operate		0.5Y
8		Function	Operation test, such as, pressure check during pump operation with all valves closed (depends on the system constitution)	Multifunction of pumping with required pressure for required time by the design	1Y	F
9		Quantity of stored water	Visual inspection	Insufficient for design requirement		0.5Y

INSPECTION ITEMS, FOCUSED POINTS, INSPECTION METHOD and DIAGNOSIS CRITERIOR						
No.	INSPECTION ITEMS	FOCUSED POINTS	INSPECTION METHODS	DIAGNOSIS CRITERIOR	INSPECTION FREQUENCY	Importance on collapse (C) /fire safety /evacuation (F) /others (O)
<b>Others</b>						
1	LPG gas Cylinders	Location	Visual inspection	Too close to the fire, positioned above the fire or in closed compartment (preferably to be located outside the building with steel roof and lifted nonflammable floor to avoid damp and fire)	1Y	F
2		Quantity	Visual inspection	More than 2 cylinders	1Y	F
3	Piping	Connection	Visual inspection and check by touching, etc.	Loose connection or degradation of connecting material from the cylinders to the burners	1Y	F

## **7. SAFETY AND HEALTH MANUAL IN CONSTRUCTION**

**(Activity-6)**





MINISTRY OF CONSTRUCTION  
Project for Capacity Enhancement in Construction Quality Assurance



# SAFETY AND HEALTH MANUAL IN CONSTRUCTION



HANOI, SEPTEMBER 2012

**MINISTRY OF CONSTRUCTION**  
**Project for Capacity Enhancement in Construction Quality Assurance**

**SAFETY AND HEALTH  
MANUAL IN CONSTRUCTION**

**HANOI, SEPTEMBER 2012**

---

Note: Illustrations and contents used in the manual are extracted/ modified from a Safety Support Manual issued by the Chubu Regional Development Bureau.

## FOREWORD

The cooperation between Vietnamese Government and Japanese Government is being enhanced and reinforced during the past years. Being strategic counterparts in many sectors, Viet Nam and Japan has cooperated in many projects including construction and infrastructure development in Viet Nam. Japanese ODA fund has been making significant contribution to improvement of infrastructure system, economic growth and amelioration of people's living condition in Viet Nam.

An illustration for the close and efficient cooperation between the two countries is the Project "Capacity Enhancement in Construction Quality Assurance" being implemented with assistance of Vietnamese and Japanese experts. Among the Activities of the Project, "**Safety and Health Manual in Construction**" and "**Case Studies on Accidents and Near Misses in Construction**" is one of the important outputs with high applicability on construction sites.

It was indicated in statistics on annual labor accidents nationwide by MOLISA that "violation against safety methods/rules" caused by the workers is the major cause for accident occurrence for the years from 2008 to 2011. For this reason, entities participating in the activities on construction site must grasp the common procedures, labor safety measurements before commencement.

The Manual is prepared with a view to improving awareness and knowledge about safety for superintendants/workers on construction site, identifying the causes behind the circumstances of high possibly leading to accidents (near misses) and preventing the accidents on construction site.

This Manual is very useful for prevention of potential accidents and injuries on construction site. This Manual and Case studies on Accidents and Near Misses in Construction are expected to be popularly disseminated to minimize labor accidents in Vietnam, especially in construction.

Sincerely,



Dr. Le Quang Hung

Director of Project Management Unit (PMU)

General Director of State Authority for Construction Quality Inspection (SACQI)

Ministry of Construction

Socialist Republic of Viet Nam

## FOREWORD

According to statistics on annual labor accidents occurring nationwide which is publicized by MOLISA, accident occurrences stemming from “violation of procedures/ measures for labor safety” is of the highest frequencies. The fact is that labor accidents can occur from routine activities on the construction site if workers are not aware of the sources of accidents and proactively prevent them. The occurrence of accidents not only affects the health, and even the lives of the labors, but also slows down the progress of the projects, causes economic loss and decreases social benefits of the projects. Therefore, prevention of labor accidents should be paid special attention during the whole construction project.

During the implementation of the Technical Cooperation Project for Capacity Enhancement in Construction Quality Assurance supported by JICA, the SACQI and Japanese experts have compiled **“Safety and Health Manual in Construction”** and **“Case Studies on Accidents and Near Misses in Construction”** with the hope that Japanese know-how and experience which are presented in this manual can help prevent and minimize the occurrence of labor accidents, contribute to build an efficient and safety working environment for everyone.

On the occasion of this publication, I would like to wish more successful cooperation between JICA and the MOC, as well as between Japan and Vietnam, as strategic partners.



Motonori Tsuno

Chief Representative, JICA Vietnam Office



# CONTENTS

	<b>Page</b>
Foreword	3
<b>I. INTRODUCTION OF MANUAL</b>	
I.1. Purpose of Manual	11
I.2. Terminologies (POs, PMU, Contractor, etc.)	
<b>II. REGULATIONS AND STANDARD ON OCCUPATIONAL SAFETY AND HEALTH AND SAFETY MANAGEMENT</b>	
II.1 An outline of safety/health regulations:	12
II.2 Rights and obligations of the Employer and the Worker. Responsibility of Client (POs), PMU, Consultant, Contractors on field of labour safety and health.	12
II.2.1 Rights and obligations of the Employer and the Worker.	21
II.2.1.1 Rights and obligations of the Employer.	21
II.2.1.2 Rights and obligations of the Employer and the Worker.	22
II.2.2 Client (POs):	22
II.2.3 PMU and Consultant:	23
II.2.4 Contractor:	23
II.3 General issues on safety	25
II.3.1 Safety management system (Safety policy/strategy/guidelines, Organization), safety induction	25
II.3.2 Regular safety management and safety education:	26
II.3.3 Working wear and protective equipment	27
II.3.4 Keeping things tidy and in order	27
II.3.5 Walkways at site	27
II.3.6 First-aid tools	27
II.3.7 Signage for hazards	27
II.3.8 Strict requirements of employment (License, Age, Sex, Previous illness, Medical check, etc.)	28

II.3.9 Application for construction permit - specific work	28
II.3.10 Signals	29
<b>III. INDIVIDUAL SAFETY AND HEALTH MANAGEMENT</b>	
III.1. Prevention of falling	31
III.1.1 Pipe Footing	31
III.1.2 Scaffolding	32
III.1.3 Opening section	33
III.1.4 Safety belt	34
III.1.5 Ascent and Descent	35
III.1.6 Safety walkway	36
III.2. Prevention of danger caused by falling/littering	37
III.2.1 Facilities to prevent littering	37
III.2.2 Chute	38
III.3. Prevention of danger caused by collapse/rolling	39
III.3.1 Assembling/Disassembling Supports	39
III.3.2 Retaining Wall Works	40
III.3.3 Excavation of natural ground	41
III.4. Prevention of danger caused by general construction equipment	42
III.4.1 Leveling, Hauling, Loading machines	42
III.4.2 Excavation machine	43
III.4.3 Foundation Works Machines	44
III.4.4 Compaction machine	45
III.4.5 Concreting machine	46
III.4.6 Breaking machine	47
III.4.7 Mobile crane	48
III.4.8 Slinging works	49
III.4.8 Slinging works - Detailed Check points	50
III.4.9 Electric circular saw (Hand tool type)	51
III.4.10 Grinder	52
III.4.11 Winch	53
III.4.12 Compressor (Engine and motor type)	54
III.5. Prevention of danger caused by electricity	55
III.5.1 Electric substation facilities	55
III.5.2 Distribution board, earth leakage breaker	56
III.5.3 Temporary electric cables	57



III.5.4	Lighting	58
III.5.5	Welding	59
III.5.6	Operations on near a live cable	60
III.6.	Prevention of danger caused by hauling, loading and unloading	61
III.6.1	Hauling, loading and unloading	61
III.7.	Prevention of danger to public	62
III.7.1	Signs of Keep out	62
III.7.2	Vibration, Noise	63
III.7.3	Works near buried objects	64
III.8.	Prevention of danger caused by fire and explosion	65
III.8.1	Fire extinguishing	65
III.8.2	Handling hazardous materials	66
III.8.3	Gas welding, Gas cutting	67
III.9.	Prevention of danger caused by tunnel and underground works	68
III.9.1	Rock falling, Ground collapse	68
III.9.2	Explosion, Fire	69
III.9.3	Evacuation	70
III.9.4	Steel Supports	71
III.9.5	Rescue	72
III.9.6	Walkways in tunnels and working environment	73
III.9.7	Quarrying	74
III.10.	Prevention of danger caused by offshore operation	75
III.10.1	Pump type dredger	75
III.10.2	Grab dredger	76
III.10.3	Ground improvement ship	77
III.10.4	Piling ship	78
III.11.	Prevention of health disorder of workers	79
III.11.1	Oxygen deficiency	79
III.11.2	Dust	81
III.11.3	Vibration, Noise	82

## **APPENDIX**

1.	Safety check lits	85
2.	Works license required	97
3.	Format of Occupational Safety and Health Card	98





## I. INTRODUCTION OF MANUAL

### I.1. Purpose of Manual

- This manual will be used by the management staff at the office/site where they manage.
- The almost system of safety rules such as law, knowledge and common sense that everyone at construction sites must obey are summarized in this manual.
- Especially when management staffs conduct a safety patrol at site, it is recommended that they understand the contents of Chapter III in this manual and will advise contractors/consultants to rectify/correct/improve safety and health matters that are against this manual and/or law.
- Also this manual can be used for self-study and as a text for workshop and/or seminar.

### I.2. Terminologies (POs, PMU, Contractor, etc.)

- Project Owner (POs): A capital owner or a person who is authorized to manage and to utilize the construction investment project capital.
- PMU: Project management unit shall perform the tasks assigned and powers authorized by investors and take responsibility before POs and law for these tasks and powers.
- Consultant: organization or individual who provides professional or expert advice and has a wide knowledge of the construction matter
- Contractor (Include main contractor, sub-contractor): organization or individual implements construction work. He has enough capacity and professionalism in construction
- Safety Unit: the unit advise and help the Employer on implementation, inspection, supervision the labour safety and health operations

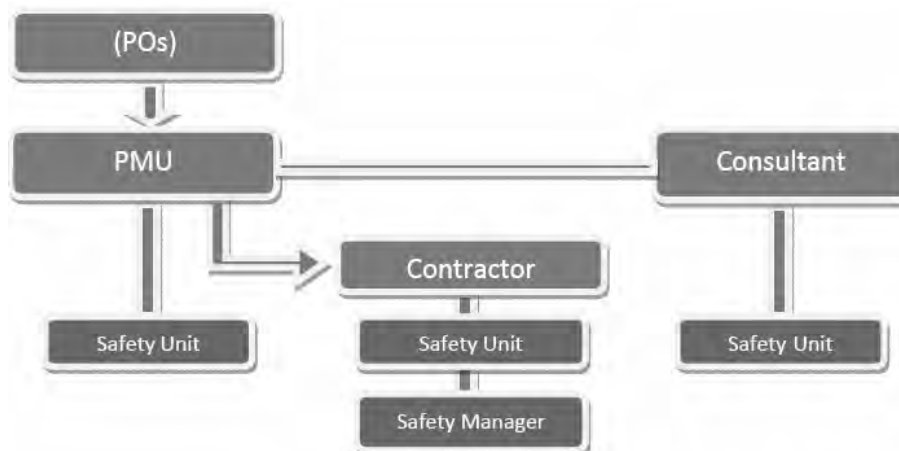

## II. REGULATIONS AND STANDARD ON OCCUPATIONAL SAFETY AND HEALTH AND SAFETY MANAGEMENT

### II.1 An outline of safety/health regulations:

- 1.1 Labour Code Chapter 9
- 1.2 Articles 95 - 108
- 1.3 Decree, circular and standard: TCVN 5308-1991, Circular No. 22/2010/TT-BXD, Circular No. 01/2011/TTLT-BLĐTĐBXH-BYT...

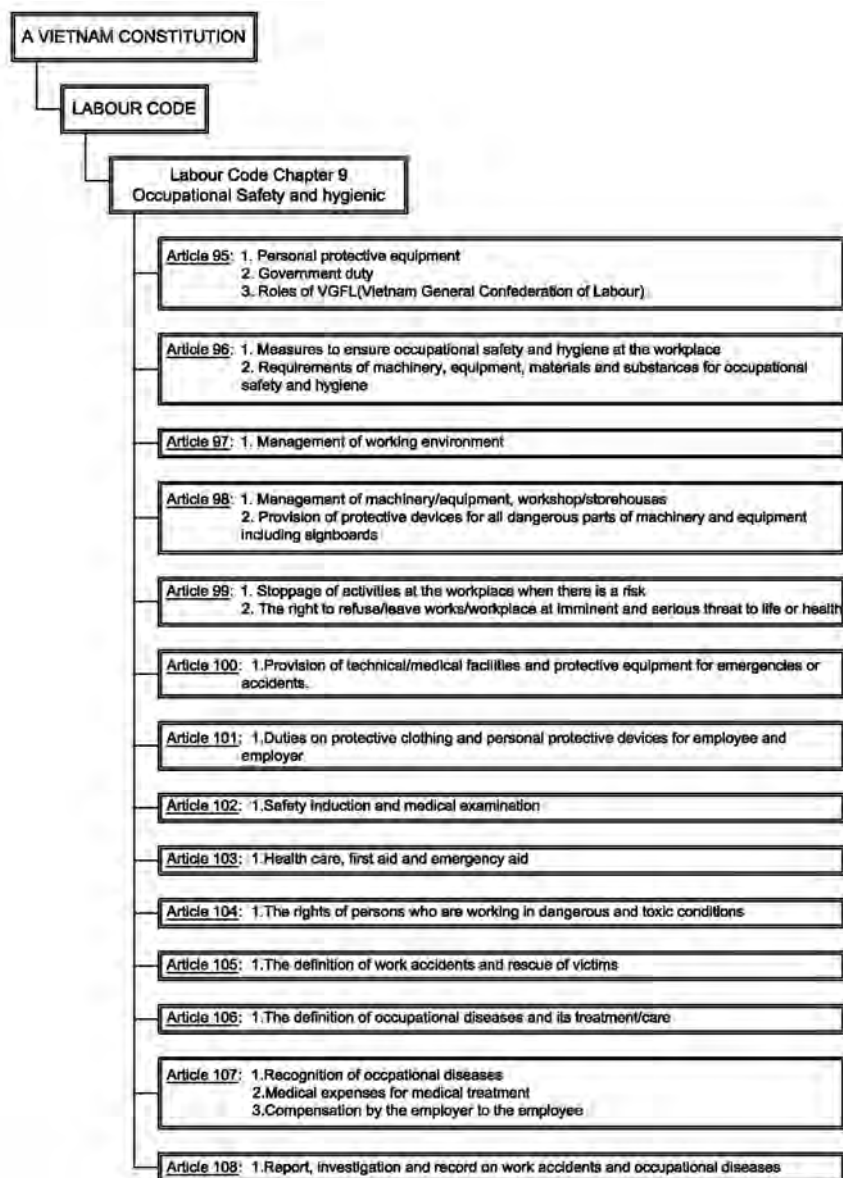

NOTE: Many decrees, circular and standards are stipulated under articles.

Contents (Refer to: - <a href="http://www.chinhphu.vn">http://www.chinhphu.vn</a> , - Current regulation on safety and health - MOC internal document - List of TCVN on Safety provided by STAMEQ		Vietnamese Governmental Safety and health regulations		Ministrial Safety and health regulations		
		Articles (Vietnam Labour laws)	Decree (ND) Decision (QĐ) Order (CT)	Circular (TT) Decision (QĐ) Code (QCVN)	Vietnam standard (TCVN)	Vietnam standard on construction (TCXDVN)
<b>A. General regulation application in safety and health in construction</b>						
A-1	Personal protective equipment	95.1	•10/2008/CT-TTg •23/2009/NĐ-CP	•10/1998/TT-BLĐTBXH	•TCVN 2291:1978 •TCVN 1598:1974 •TCVN 1841:1976 •TCVN 2606~2610:1978 •TCVN 3154~3156:1979 •TCVN 3579~3581:1981 •TCVN 3740~3742:1982 •TCVN 2603:1987 •TCVN 5039:1990 •TCVN 5082~5083:1990 •TCVN 5586~5589:1991 •TCVN 6407~6412:1998 •TCVN 6515~6520:1999 •TCVN 6689~6694:2000 •TCVN 6875~6878:2001 •TCVN 6880~6881:2001 •TCVN 7204-1~8:2002 •TCVN 7205:2002 •TCVN 7312~7314:2003 •TCVN 7544~7547:2005	
A-2	Government duty	95.2	•ND 06/CP			
A-3	Roles of VGFL (Vietnam General Confederation of Labour)	95.3	•ND 06/CP			
A-4	Measures to ensure occupational safety and hygiene at the workplace	96.1	•ND 06/CP •110/2002/NĐ-CP •23/2009/NĐ-CP	•01/2011/TTLT - BLĐTBXH-BYT •45/2011/TT-BGTVT •3/2011/TT-BXD •43/2010/TT-BCT	•TCVN 2288~2294:1978	

Contents (Refer to: - <a href="http://www.chinhphu.vn">http://www.chinhphu.vn</a> , - Current regulation on safety and health - MOC internal document - List of TCVN on Safety provided by STAMEQ		Vietnamese Governmental Safety and health regulations		Ministrial Safety and health regulations		
		Articles (Vietnam Labour laws)	Decree (ND) Decision (QĐ) Order (CT)	Circular (TT) Decision (QĐ) Code (QCVN)	Vietnam standard (TCVN)	Vietnam standard on construction (TCXDVN)
A-5	Requirements of machinery, equipment, materials and substances for occupational safety and hygiene	96.2	•39/2009/NĐ-CP •110/2002/NĐ-CP •12/2009/NĐ-CP	•37/ 2010/TT-BLĐTBXH •20/2011/TT-BTTTT 44/2011/TT- BNNPTNT •41/2011/TT-BGTVT •37/2011/TT-BGTVT •36/2011/TT-BGTVT •35/2011/TT-BGTVT •8/2011/TT- BLĐTBXH •33/2011/TT-BGTVT •31/2011/TT-BGTVT •30/2011/TT-BGTVT •14/2011/TT-BCT •23/2009/TT-BGTVT	•TCVN 2290:1978	
A-6	Management of working environment	97.1	•20/2004/CT-TTg •ND 06/CP •12/2009/NĐ-CP	•22/2010/TT-BXD •3/2011/TT-BCT •1/2011/TTLT- BLĐTBXH- BYT •20/2009/TT-BCT •16/2008/TT-BXD •505/BYT-QĐ	•TCVN 7437~7439:2004	
A-7	Management of machinery/equipment, workshop/storehouses	98.1	•93/1998/QĐ/TCKT	•01/2010/TT - BLĐTBXH •34/2010/TT-BCT •3/2010/TT-BCT	•TCVN 2290:1978	
A-8	Provision of protective devices for all dangerous parts of machinery and equipment including signboards	98.2			•TCVN 6719-2000 •TCVN 6719-2008 •TCVN 6720-2000 •TCVN 6721-2000	

Contents (Refer to: - <a href="http://www.chinhphu.vn">http://www.chinhphu.vn</a> , - Current regulation on safety and health - MOC internal document - List of TCVN on Safety provided by STAMEQ		Vietnamese Governmental Safety and health regulations		Ministrial Safety and health regulations		
		Articles (Vietnam Labour laws)	Decree (ND) Decision (QĐ) Order (CT)	Circular (TT) Decision (QĐ) Code (QCVN)	Vietnam standard (TCVN)	Vietnam standard on construction (TCXDVN)
A-9	Stoppage of activities at the workplace when there is a risk	1	•47/2010/NĐ-CP			
A-10	The right to refuse/leave works/workplace at imminent	2	•ND 06/CP			
A-11	Provision of technical/medical facilities and protective equipment or emergencies or accidents.	11	•ND 06/CP	•10/1998/TT- LĐTĐBXH		
A-12	Duties on protective clothing and personal protective devices for employee and employer	1011	•ND 06/CP	•68 /2008/ QĐ- BLĐTĐBXH •2753/ BLĐTĐBXH - BHLĐ		
A-13	Safety induction and medical examination	102.1	•ND 06/CP	•09/TT-LB •03/TTLB •21/1999/TT- BLĐTĐBXH •19/2011/TT-BYT	•TCVN 5111:1990	
A-14	Health care, first aid and emergency aid	103.1	•195/CP •188/1999/QĐ-TTg •109/2002/NĐ-CP •94/2008/NĐ-CP	•34/2007/TTLT/BTC - BLĐTĐBXH-UBTĐTT •15/2003/TT- BLĐTĐBXH •16/LĐTĐBXH-TT- BLĐTĐBXH •19/2011/TT-BYT		
A-15	The rights of persons who are working in dangerous and toxic conditions	104.1	•ND 06/CP	•16/LĐTĐBXH-TT- BLĐTĐBXH •10/1999/TTLT- BLĐTĐBXHBYT •2753/ BLĐTĐBXH - BHLĐ		
A-16	The definition of work accidents and rescue of victims	1.	•ND 06/CP •110/2002/NĐ-CP	•01/2007/TTLT/ BLĐTĐBXH- CA-VKSNDTC		



Contents (Refer to: - <a href="http://www.chinhphu.vn">http://www.chinhphu.vn</a> , - Current regulation on safety and health - MOC internal document - List of TCVN on Safety provided by STAMEQ		Vietnamese Governmental Safety and health regulations		Ministerial Safety and health regulations		
		Articles (Vietnam Labour laws)	Decree (ND) Decision (QĐ) Order (CT)	Circular (TT) Decision (QĐ) Code (QCVN)	Vietnam standard (TCVN)	Vietnam standard on construction (TCXDVN)
A-17	The definition of occupational diseases and its treatment/care	106.1	•94/2008/NĐ-CP	•08/1998/TTLT-BYT-BLĐTBXH •29/2000/TTLT- BLĐTBXH - BYT •21/1999/TT- BLĐTBXH •13/BYT •29/2000/TTLT- BLĐTBXH - BYT •27/2006/QĐ-BYT		
A-18	Recognition of occupational diseases	107.1	•122/2008/NĐ-CP	•12/2006/TT-BYT •13/2007/TT-BYT •19/2011/TT-BYT		
A-19	Medical expenses for medical treatment	107.2	•122/2008/NĐ-CP •94/2008/NĐ-CP	•19/2011/TT-BYT		
A-20	Compensation by the employer to the employee	107.3	•ND 06/CP •110/2002/NĐ-CP	•29/TT-LB •10/1999/TTLT- BLĐTBXH-BYT •10/2003/TT- BLĐTBXH •08/2003/TT- BLĐTBXH •10 /2006/TTLT - BLĐTBXH - BYT		
A-21	Report, investigation and record on work accidents and occupational diseases	108.1	•906/2005/TLĐ-BHLĐ •110/2002/NĐ-CP	•12/2012/TTLT/ BLĐTBXH - BYT - TLĐLĐVN •01/2011/TTLT- BLĐTBXH - BYT - TLĐLĐVN •01/2007/TTLT- BLĐTBXH-BCA-VKSNDTC		

Contents (Refer to: - <a href="http://www.chinhphu.vn">http://www.chinhphu.vn</a> , - Current regulation on safety and health - MOC internal document - List of TCVN on Safety provided by STAMEQ		Vietnamese Governmental Safety and health regulations		Ministrial Safety and health regulations		
		Articles (Vietnam Labour laws)	Decree (ND) Decision (QĐ) Order (CT)	Circular (TT) Decision (QĐ) Code (QCVN)	Vietnam standard (TCVN)	Vietnam standard on construction (TCXDVN)
<b>B. Regulation application in individual safety and health in construction</b>						
B-1	Prevention of Falling					
	1. Pipe footing				•TCVN 4431-1987	•TCXDVN 296-2004
	2. Scaffolding				•TCVN 6002-1995	•TCXDVN 296-2004
	3. Opening section				•TCVN 5308-1991	
	4. Safety belt				•TCVN 5308-1991 •TCVN 8206-2009	
	5. Ascent and Decent				•TCVN 5308-1991	
	6. Safety walkway				•TCVN 4431-1987	•TCXDVN 296-2004
B-2	Prevention of danger caused by falling/littering					
	1. Facilities to prevent littering				•TCVN 5308-1991	
	2. Chute				•TCVN 5308-1991	
B-3	Prevention of danger caused by collapse/rolling					
	1. Assembling/Disassembling supports				•TCVN 5308-1991 •TCVN 5178:2004	
	2. Earth retaining work				•TCVN 5308-1991 •TCVN 5178:2004	
	3. Excavation of natural ground			•1338/2006/QĐ-BXD	•TCVN 5308-1991 •TCVN 5178:2004	
B-4	Prevention of danger caused construction equipment					
	1. Leveling, Hauling, Loading machines				•TCVN 5308-1991	
	2. Excavation machine				•TCVN 5308-1991	
	3. Foundation works machine				•TCVN 5308-1991	
	4. Compaction machine				•TCVN 5308-1991	
	5. Concreting machine				•TCVN 5308-1991	
	6. Breaking machine				•TCVN 5308-1991	

Contents (Refer to: - <a href="http://www.chinhphu.vn">http://www.chinhphu.vn</a> , - Current regulation on safety and health - MOC internal document - List of TCVN on Safety provided by STAMEQ		Vietnamese Governmental Safety and health regulations		Ministrial Safety and health regulations		
		Articles (Vietnam Labour laws)	Decree (ND) Decision (QĐ) Order (CT)	Circular (TT) Decision (QĐ) Code (QCVN)	Vietnam standard (TCVN)	Vietnam standard on construction (TCXDVN)
	7. Mobile crane			•66/2008/QĐ- BLĐTBXH •04/2006/QĐ- BLĐTBXH	•TCVN 4244-1986 •TCVN 7549-1:2005	
	8. Slings works				•TCVN 4244-2005 •TCVN 5206-1990 •TCVN 5207-1990 •TCVN 5208-1990 •TCVN 5209-1990 •TCVN 5863-1995 •TCVN 5864-1995	
	9. Circular saw				•TCVN 4725~4726:1989 •TCVN 5308-1991	
	10. Grinder				•TCVN 3152:1979 •TCVN 4163-1985	
	11. Winch				•TCVN 4114~4115:1985 •TCVN 5180-1990 •TCVN 3620:1992	
	12. Air Compressor			•67/2008/QĐ- BLĐTBXH •64/2008/BLĐTBXH	•TCVN 5181-1990	
B-5	Prevention of danger caused by electricity			•12/2008/QĐ-BCT •QCVN 1:2008/BCT		•TCXDVN 394-2007
	1. Electric substation facilities				•TCVN 2295:1978 •TCVN 3145:1979 •TCVN 3259-1992	
	2. Distribution board, earth leakage breaker				•TCVN 3145-79 •TCVN 7447-2005	•TCXDVN 314-2004
	3. Temporary electric cables				•TCVN 5308-1991	
	4. Lighting				•TCVN 5308-1991	

Contents (Refer to: - <a href="http://www.chinhphu.vn">http://www.chinhphu.vn</a> , - Current regulation on safety and health - MOC internal document - List of TCVN on Safety provided by STAMEQ		Vietnamese Governmental Safety and health regulations		Ministrial Safety and health regulations		
		Articles (Vietnam Labour laws)	Decree (ND) Decision (QĐ) Order (CT)	Circular (TT) Decision (QĐ) Code (QCVN)	Vietnam standard (TCVN)	Vietnam standard on construction (TCXDVN)
	5. Welding			•20/2011/TT-BLĐTBXH •QCVN 3: 2011/BLĐTBXH	•TCVN 3146-1986 •TCVN 4741:1989 •TCVN 5331:1991 •TCVN 4245:1996	
	6. Operations on near a live wire			•QCVN 1:2008/BCT		
B-6	Prevention of danger caused by hauling, loading and				• TCVN 5308-1991	
	1. Hauling				• TCVN 5308-1991	
	2. Loading and unloading				•TCVN 3147-1990	
B-7	Prevention of danger to public					
	1. Signs of keep out				• TCVN 5308-1991	
	2. Vibration, Noise				• TCVN 5308-1991	
	3. Works near buried objects				• TCVN 5308-1991	
B-8	Prevention of danger caused by fire and explosion					
	1. Fire extinguishing equipment				•TCVN 5040-1990 •TCVN 5739~5740:1993 •TCVN 5760:1993 •TCVN 6100~6103:1996	
	2. Handling hazardous materials			•16/2007/QĐ-BKHCN •64/2008/QĐ- BLĐTBXH •51/2008/QĐ-BCT•QCVN 1:2007/BKHCNMT•QCVN 1:2008/BLĐTBXH •QCVN 2:2008/BCT	•TCVN 3890:1984 •TCVN 4245-1986 •TCVN 4245-1996	
	3. Gas welding, gas cutting				• TCVN 5308-1991	

Contents (Refer to: - <a href="http://www.chinhphu.vn">http://www.chinhphu.vn</a> , - Current regulation on safety and health - MOC internal document - List of TCVN on Safety provided by STAMEQ		Vietnamese Governmental Safety and health regulations		Ministrial Safety and health regulations		
		Articles (Vietnam Labour laws)	Decree (ND) Decision (QĐ) Order (CT)	Circular (TT) Decision (QĐ) Code (QCVN)	Vietnam standard (TCVN)	Vietnam standard on construction (TCXDVN)
B-9	Prevention of danger caused by tunnel and underground					
	1. Rock falling, Ground collapse				• TCVN 5308-1991	
	2. Explosion, Fire		•39/2009/NĐ-CP	•QCVN 06:2010/BXD	•TCVN 3890:1984 •TCVN 3255:1986 •TCVN 4878~4879:1989 •TCVN 3254:1989 •TCVN 5279:1990 •TCVN 5739~5740:1993 •TCVN 5760:1993 •TCVN 2622:1995 •TCVN 6100-6103:1996 •TCVN 6553-1~4:1999	
	3. Evacuation				•TCVN 5308-1991	
	4. Steel supports				•TCVN 5308-1991	
	5. Rescue				•TCVN 5308-1991	
	6. Working environment		•505/BYT-QĐ		•TCVN 6780-:2000	
	7. Quarrying		•18/2008/CT-TTg		•TCVN 5178-1990	
B-10	Prevention of danger caused by offshore operation					
	1. Pump type dredger				•TCVN 5585:1991	
	2. Grab dredger				•TCVN 5585:1991	
	3. Ground improvement ship				•TCVN 5585:1991	
	4. Piling ship				•TCVN 5585:1991	
B-11	Prevention of health disorder of worker		•505/QĐ-BYT •13/TT-BYT			
	1. Oxygen deficiency				•TCVN 3288:1979	
	2. Dust				•TCVN 3288:1979	
	3. Vibration, Noise				•TCVN 7335:2004	

## **II.2 Rights and obligations of the Employer and the Worker. Responsibility of Client (POs), PMU, Consultant, Contractors on field of labour safety and health.**

### **II.2.1 Rights and obligations of the Employer and the Worker.**

#### **II.2.1.1 Rights and obligations of the Employer.**

The employer is obliged:

*(Refer to: Decree 06/1995/NĐ-CP, Chapter IV, Article 13)*

- To include a plan of action for ensuring occupational safety and health and for working conditions improvement into annual plan for development of production and business of the undertaking;
- To provide the workers with sufficient personal protective devices and to carry out other measures ensuring occupational safety and health for them in conformity with laws and regulations;
- To assign an officer to supervise the implementation of regulations, work rules and measures ensuring occupational safety and health in the undertaking; to coordinate with the undertaking's Trade Union in setting up and maintaining a network of worker's safety and health representatives;
- To draw up appropriate rules and processes of occupational safety and health for different kinds of machinery, equipment and material, even in the case of change in technology, machinery, equipment, material and workplace in conformity with the national standards;
- To undertake, education and training for the workers on standards, regulations and measures ensuring occupational safety and health;
- To provide the workers with periodical medical examinations, in accordance with State standards and regulations;
- To strictly observe the regulations on declaration and investigation of all the cases of occupational accidents and diseases and duly submit the mid-year and annual reports on the actual status of occupational safety and health matters in the undertaking to the local Department of Labour, Invalids and Social Affairs.

The employer has the rights:

*(Refer to: Decree 06/1995/NĐ-CP, Chapter IV, Article 14)*

- To compel the worker to observe regulations, work rules and measures ensuring occupational safety and health;
- To accord praises and rewards to those who duly observe, and to sanction those who fail to observe regulations, work rules and measures on occupational safety and health;
- To appeal to competent authorities for reconsideration of the decisions imposed by State Labour Inspectors" Committee, while duly observing them in practice.

### II.2.1.2 Rights and obligations of the Employer and the Worker.

The Worker is obliged:

*(Refer to: Decree 06/1995/NĐ-CP, Chapter IV, Article 15)*

- To observe regulations and rules on occupational safety and health while performing work or task assigned to him/her
- To use and maintain provided protective clothing and personal protective devices, and other protective equipment at the workplace, and to compensate for the losses or damage incurred;
- To report in time to the persons in charge on the risks of industrial accidents, occupational diseases or of harmful and dangerous hazards, and to take part in the emergency aid and the activities to overcome the consequences of an accident under the directives of the employer.

The Worker has the rights:

*(Refer to: Decree 06/1995/NĐ-CP, Chapter IV, Article 16)*

- To request the employer to ensure safe and healthy working conditions, to improve labour conditions, to provide sufficient personal protective devices and training, and to implement measures ensuring occupational safety and health.
- To refuse to perform the work or leave the workplace that clearly presents an imminent and serious threat to life or health, and has the obligation to report immediately to the persons directly in charge; and to refuse to return to the workplace in question if the danger is not eliminated.
- To complain or to expose to the competent authorities any act of the employer breaching the provisions of law and regulations or failing to implement duly his/her obligation on occupational safety and health committed in labour contracts or in collective agreements.

### II.2.2 Client (POs):

*(Reference law: Circular 22/2010/TT-BXD, Chapter III, Article 5.)*

- Set up a full-time or part-time division for examining the observance of labour safety rules by the construction contractor at the construction site.
- Select a capable contractor suitable to the jobs he/she/it will perform under the construction law.
- Suspend the construction and request the contractor to take remedies, when detecting the contractor's violations of labour safety rules. If the contractor fails to take remedies, stop the construction or terminate the contract.
- Coordinate with the contractor in taking handling measures in case of labour incidents or accidents and concurrently report on the labour safety situation of the project or work to functional agencies

### II.2.3 PMU and Consultant:

(Reference law: Circular 22/2010/TT-BXD, Chapter III, Article 7.)

- Supervise contractors' observance of approved construction and safety measures and compliance with technical regulations on construction safety.
- Notify POs of dangers that might affect construction safety in order to take remedies and change construction measures as appropriate.
- Examine, and report to POs for handling violations, stop construction and request remedies when construction contractors violate safety rules at the construction site.

### II.2.4 Contractor:

(Refer to: - MOC Circular No. 22/2010/TT-BXD

- MOLISA-MOH Joint Circular 01/2011/TTLT-BLĐTBXH-BYT

- MOLISA-MOH-VGCL Joint Circular 14/2005/TTLT-BLĐTBXH-BYT-TLĐLĐVN

- MOIT National technical code QCVN 01:2008/BCT)

ITEMS	POINTS	REFERENCE LAW
1. Make and approve a design of construction measures/statement	Make and approve a design of construction measures, indicating safety measures/statement for workers, machines, equipment and the work. Periodically or extra ordinarily examine developments at the construction site to modify construction and labour safety measures as appropriate.	Circular 22 /2010/TT-BXD, Chapter III, Article 6, Clause 1
2. Select and arrange technical workers at the construction site	Select and arrange technical workers at the construction site according to their professional qualifications, capacity and health conditions under law. Furnish sufficient personal safety equipment for workers.	Circular 22 /2010/TT-BXD, Chapter III, Article 6, Clause 2
3. Establish a safety committee	A safety committee shall be established and members of committee are nominated. It shall be opened periodically.	Circular 22 /2010/TT-BXD, Chapter III, Article 6, Clause 3
4. Organizes periodical safety meeting	A safety meeting among a client, consultant, contractor and sub- contractor (if any) shall be organized at regular interval	
5. Organize a daily site inspection	A daily site inspection shall be conducted by a contractor at least once a day	



ITEMS	POINTS	REFERENCE LAW
6. Safety induction to newly employees	Provide safety training for safety work personnel and workers under their management under regulations.	Circular 22 /2010/TT-BXD, Chapter III, Article 6, Clause 4
7. Unification of signals for warning/evacuation/crane	Signal for warning, evacuation and crane shall be unified at the site and shall be notified to all persons concerned with site works.	Standard TCVN 5053:1990
8. Prepare signboard and safety regulations	Examine the observance of labor safety rules according to approved measures and the compliance with relevant technical regulations and standards. Prepare and install signboard to notice people the work area.	Circular 22 /2010/TT-BXD, Chapter III, Article 6, Clause 5 Law on Construction, Article 74
9. Notice a commencement of work and method statement	The following information shall be reported to authorize before commencement of works <ul style="list-style-type: none"> <li>• Type of work, location, title of work</li> <li>• Name of sub-contractor and its address</li> <li>• The name of safety manager.</li> </ul>	Law on Construction, Article 68, Clause 2
10. Accident record	Assume the prime responsibility for, and coordinate with investors in, overcoming consequences, declaring, investigating, and making records on, incidents or labour accidents at the construction site.	Joint Circular 12/2012/TTLT-BLĐTBXH-BYT-TLĐĐVN
11. At debris flow potential area/zone	<ul style="list-style-type: none"> <li>• Investigation of upstream river</li> <li>• Check the amount of rainfall and its records</li> <li>• Install of warning signal</li> <li>• Preparation of evacuation facilities</li> <li>• Conduct evacuation drills</li> </ul>	Standard TCVN 5308:1991, Article 2.13, 12
12. Construction machine	To inspect, register (if any) and maintain construction machines and equipment in order to ensure safety for workers and works under regulations.	Circular 22 /2010/TT-BXD, Chapter III, Article 6, Clause 7
13. Electric cables	Install and usage of electricity	Technical Code QCVN 01:2008/BCT

### II.3 General issues on safety

#### II.3.1 Safety management system (Safety policy/strategy/guidelines, Organization), safety induction:

The following points for safety management system must be confirmed.

ITEMS TO BE CHECKED	REMARKS	REFERENCE LAW
1. Is the safety and health management plan prepared?		Circular 22 /2010/TT-BXD, Chapter II
2. Is the safety and health management plan submitted to the client?		
3. Is the safety and health management organization established? <ul style="list-style-type: none"> <li>• Safety and health committee</li> <li>• Safety and health director (client side)</li> <li>• Safety and health manager (contractor)</li> <li>• Fine control</li> <li>• Self fire-fighting</li> <li>• Emergency contact</li> <li>• First-aid</li> </ul>		Circular 01/2011/TTLT-BLĐTBXH-BYT, Article 4

#### II.3.2 Regular safety management and safety education:

The following points for daily safety management and safety education must be confirmed

ITEMS TO BE CHECKED	REMARKS	REFERENCE LAW
1. Is the safety matters for individual activity discussed among the team before starting?	Procedure, method and safety of those should be discussed /confirmed.	
2. Are following activities implemented based on the safety and health management plan? <ul style="list-style-type: none"> <li>• Daily Morning meeting before starting works</li> <li>• Inspection of machines, equipment and working circumstances before starting works.</li> <li>• If shift work applied, the meeting will be held before shift work.</li> </ul>		Circular 22 /2010/TT-BXD, Chapter II Article 10  Circular 01/2011/TTLT-BLĐTBXH-BYT Appendix 2

ITEMS TO BE CHECKED	REMARKS	REFERENCE LAW
<ul style="list-style-type: none"> <li>• Weekly Weekly meeting for schedule Weekly safety meeting</li> <li>• Monthly Safety patrol As needed Safety induction for new employees</li> </ul>		
3. Are billboards/signs/posters well installed/exhibited?		Standard TCVN 5308:1991, Article 2.1.6~2.1.9
4. Is a safety health diary recorded everyday?		
5. Is a special induction for dangerous/hazardous materials conducted?		

### II.3.3 Working wear and protective equipment

ITEMS TO BE CHECKED	REMARKS	REFERENCE LAW
1. Are wear for workers reasonably good?	<ul style="list-style-type: none"> <li>• Cut of trousers/shirts</li> <li>• Shoes</li> <li>• Not naked</li> </ul>	Standard TCVN 5308:1991, Article 1.12
2. Do workers wear helmet?		Decree 06/CP (20/1/1995), Chapter IV, Article 15
3. Do worker use safety belt where it is necessary?	The site of opening Working place is more than 2m height	Decree 06/CP (20/1/1995), Chapter IV, Article 15
4. Do worker use protective equipment where it is necessary/required?	<ul style="list-style-type: none"> <li>• Protective mask for welding.</li> <li>• Insulation gloves</li> <li>• Protective mask for grinder</li> <li>• Earplug</li> <li>• Glasses</li> <li>• Gas mask</li> </ul>	Decree 06/CP (20/1/1995), Chapter IV, Article 15
5. Are number of protective equipment prepare enough?		Circular 10/1998/ TT-BLĐT BXH, Chapter IV, Article 2
6. Are protective equipment are kept tidy and in order?	Maintenance	Circular 10/1998/ TT-BLĐT BXH, Chapter IV, Article 9

### II.3.4 Keeping things tidy and in order

ITEMS TO BE CHECKED	REMARKS	REFERENCE LAW
1. Are things are kept tidy and in order?		Circular 22/2010/TT-BXD, Chapter II Article 3, Clause 2
2. Are walkways well maintenance?		Standard TCVN 5308:1991, Article 2.3
3. Are dangerous/hazardous materials stocked at the safe place?		Standard TCVN 5308:1991, Article 2.3.5~2.3.8
4. Is accident prevention measure for third person taken?		

### II.3.5 Walkways at site

ITEMS TO BE CHECKED	REMARKS	REFERENCE LAW
1. Are walkway at site kept clean and safe?	<ul style="list-style-type: none"><li>• The location of walkway must be well planned.</li><li>• The lighting for walkway must be arranged</li><li>• The walkway between machines must be more than 80cm</li><li>• Slip prevention</li></ul>	Standard TCVN 5308:1991 Article 1.19

### II.3.6 First-aid tools

ITEMS TO BE CHECKED	REMARKS	REFERENCE LAW
1. Are first-aid tool arranged?	<ul style="list-style-type: none"><li>• Stretchers/An oxygen mask</li></ul>	Decree 06/CP (20/1/1995), Chapter II, Article 5
2. Are first-aid kits arranged?	<ul style="list-style-type: none"><li>• Bandages, tweezers, disinfectant, antipyretic tourniquet, splint</li></ul>	Circular 19/2011/TT-BYT

### II.3.7 Signage for hazards

ITEMS TO BE CHECKED	REMARKS	REFERENCE LAW
1. Are billboard and signs well shown to people?	<ul style="list-style-type: none"><li>• A permission to build</li><li>• Business license of contractor</li><li>• Road occupation permit</li></ul>	Law on Construction, Article 74 Standard TCVN 5053:1990
2. Are signs for dangerous/hazardous materials well shown to people?		Standard TCVN 5053:1990

### II.3.8 Strict requirements of employment (License, Age, Sex, Previous illness, Medical check, etc.)

ITEMS TO BE CHECKED	REMARKS	REFERENCE LAW
1. Do labours go into contract with the contractor	Labour contract	Labour code Article 26~29
2. Are eligible persons assigned to the job which needs license/certificate?	<ul style="list-style-type: none"> <li>• License holder, qualified technical personal, certificated personal after special seminar</li> </ul>	Circular 22 /2010/TT-BXD, Chapter II Article 4, Clause 4 Circular 37/ 2005/ TT-BLĐTĐBXH Chapter VI
3. Are young people and female workers employed correctly by law?		Labour code Chapter X, XI Circulars: - 21/1999/TT- BLĐTĐBXH - 09/1995/TT- BLĐTĐBXH - 03/1997/TT- BLĐTĐBXH
4. Are old persons engagement/ assignment considered?		Labour code Chapter IX Article 102
5. Are medical examination conducted to employees?	<ul style="list-style-type: none"> <li>• A previous illness</li> <li>• Subjective symptom</li> <li>• Height, weight, eyesight, hearing</li> <li>• A check X-ray</li> <li>• Urine analysis</li> <li>• Blood pressure</li> </ul>	Joint Circular 19/2011/TT- BYT

### II.3.9 Application for construction permit - specific work

ITEMS TO BE CHECKED	REMARKS	REFERENCE LAW
1. Was notification submitted to the relevant authorities?	<ul style="list-style-type: none"> <li>• Authority supervision of road, electric, water system...</li> <li>• Police</li> <li>• Fire-station</li> </ul>	Standard TCVN 5308:1991, Article 2.1.1 TCVN 5178:1990 2.6.1.1

### II.3.10 Signals

ITEMS TO BE CHECKED	REMARKS	REFERENCE LAW
1. Are common signs for safety at sign determined?	<ul style="list-style-type: none"> <li>• Signs for such as evacuation, up and down for crane, forward and back for dozer, stop and go for passengers and so on must be determined and hared by supervisors/operators/workers at site.</li> </ul>	Standard TCVN 5308:1991 Article 2.1.6~2.1.9 Standard TCVN 5053:1990

### **III. INDIVIDUAL SAFETY AND HEALTH MANAGEMENT**



## 1. Prevention of falling

### 1.1 Pipe Footing

Pipe footing is composed of vertical pipes, horizontal pipes, planks, cramps, joints, metal bases and so on

**Check points** (Refer to TCXDVN 296-2004: Scaffolding - Safety Requirements)

- (1) Is maximum loading capacity of footing shown at the conspicuous place?
- (2) Are metal fittings to wall used? (TCXDVN 296-2004, Article 5.1.2.4.9)
- (3) Are metal bases for pipes used as base jack? (TCXDVN 296-2004, Article 4.2.1)
- (4) Are horizontal pipes near metal base installed?
- (5) Are metal bases located at the right space?

(TCXDVN 296-2004, Article 5.1.2.4.2~4)

Load type	Pipe cross section	a (m)	b (m)
Light load (125kg/m <sup>2</sup> )	Φ 50mm	3,0	1,2
Average load (250kg/m <sup>2</sup> )	Φ 50mm	2,4	1,0
	Φ 64mm	2,4	1,8
Heavy load (375kg/m <sup>2</sup> )	Φ 64mm	1,5	1,5

- (6) Is the height of first footing step less than 2m? (TCXDVN 296-2004, Article 4.4.4)
- (7) Is the total width of scaffold planks more than 30cm?  
Is the gap between scaffold planks less than 1cm?
- (8) Are cross bracing used to reinforce the footing?  
(TCXDVN 296-2004, Article 5.1.2.4.9)
- (9) Are handrail fixed, height is 0,9~1,15m? (TCXDVN 296-2004, Article 4.5.2)

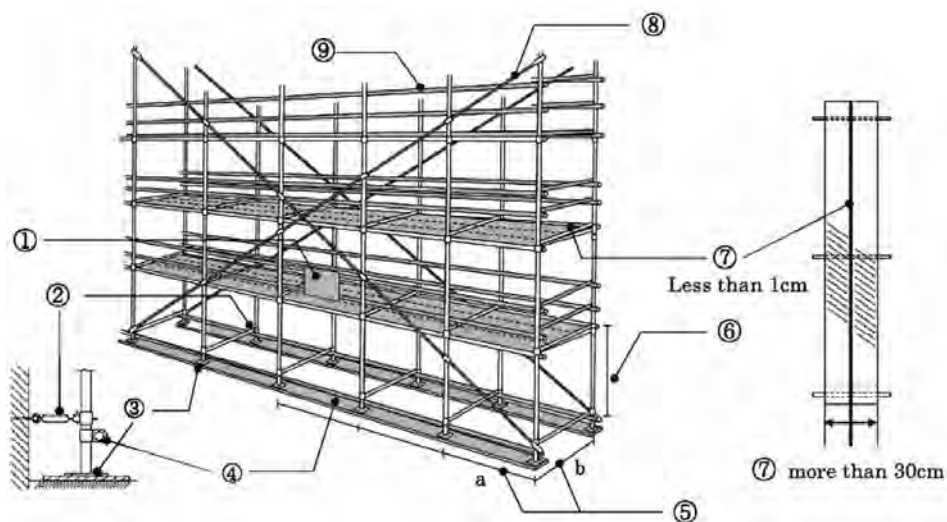



## 1. Prevention of falling

### 1.2 Scaffolding

Scaffolding is composed of frames (\*1), bracings, base joints, jack bases and so on.

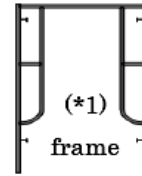

**Check points:** (Referenced from TCXDVN 296-2004: Scaffolding - Safety Requirements)

- (1) Is maximum loading capacity of footing shown at the conspicuous place?
- (2) Are metal fittings to wall used? (TCXDVN 296-2004, Article 5.1.2.4.9)
- (3) Are jack bases for pipes used? Are jack bases settled on the board? (TCXDVN 296-2004, Article 5.1.2.5.2)
- (4) Are horizontal pipes near metal base installed?
- (5) Are metal bases located at the right space? (less 1.5m, less 1.85m)
- (6) Is the total width of scaffold planks more than 30cm?  
Is the gap between scaffold planks less than 1cm?  
(TCXDVN 296-2004, Article 4.4.4)
- (7) Are bracings installed at all sides? (TCXDVN 296-2004, Article 5.1.2.4.13)
- (8) Are handrails fixed? (TCXDVN 296-2004, Article 4.5.2)

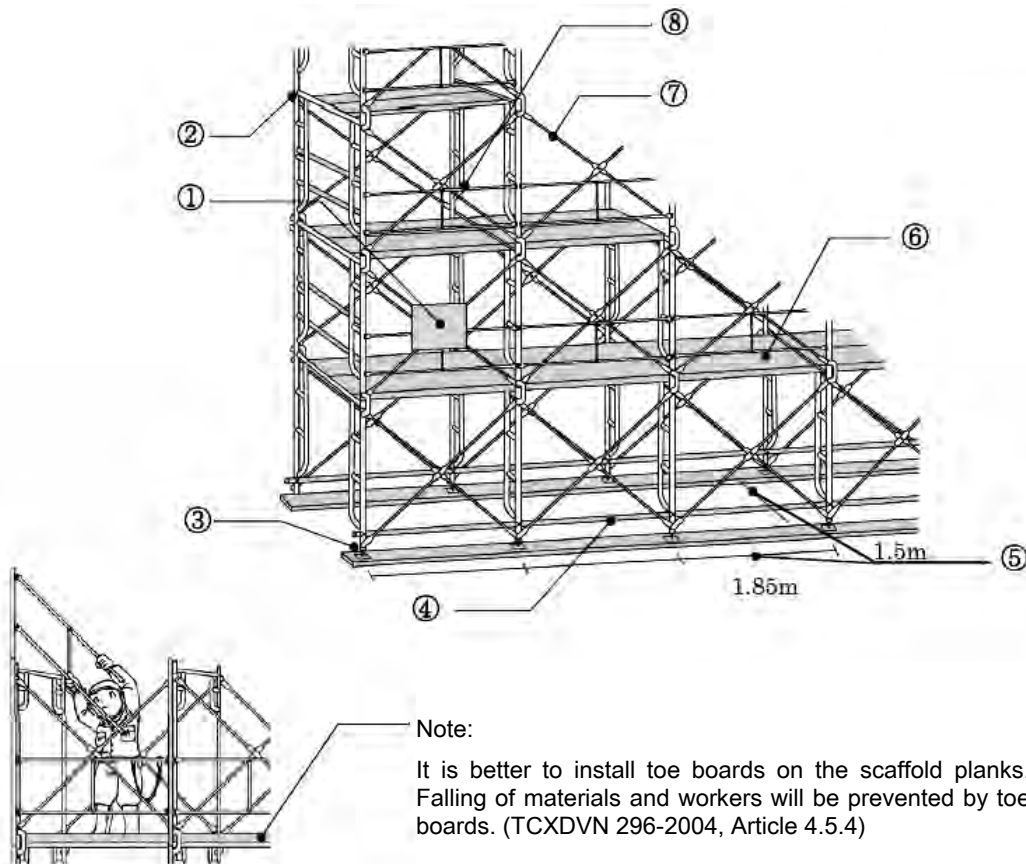

## 1. Prevention of falling

### 1.3 Opening section

Fence, handrail and cover must be set up at the potential area of workers falling.

**Check points:** (Refer to TCXDVN 296-2004: Scaffolding - Safety Requirements; TCVN 5308-1991: Code of practice for building safety technique)

- (1) Is there any facility to tie safety belt?
- (2) Is the height of handrail more than 1m? Is there extra pipe between handrail and ground? (TCXDVN 5308-1991, Article 2.1.6)
- (3) Are toe boards installed around the opening? (TCXDVN 296:2004, Article 4.5.4)
- (4) Is a caution sign shown at the opening?

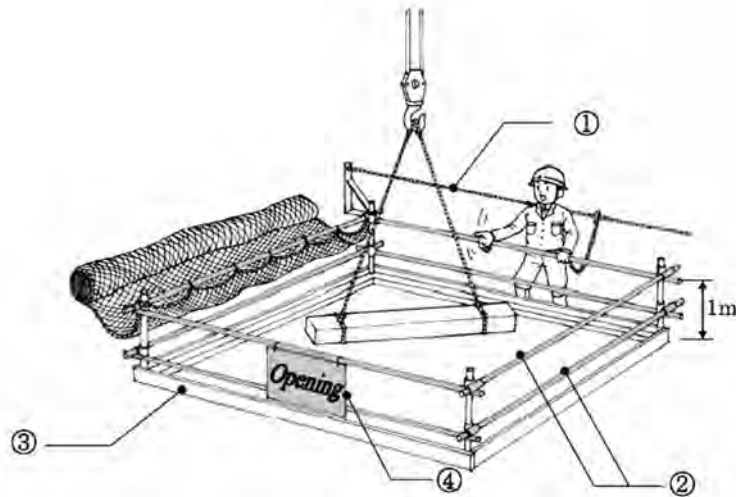

- (5) Is the height of handrail more than 0,9~1,15m? (TCXDVN 296:2004, Article 4.5.2)
- (6) Is the safety net spread out between planks And structure/framework where spacing is more than 30cm?

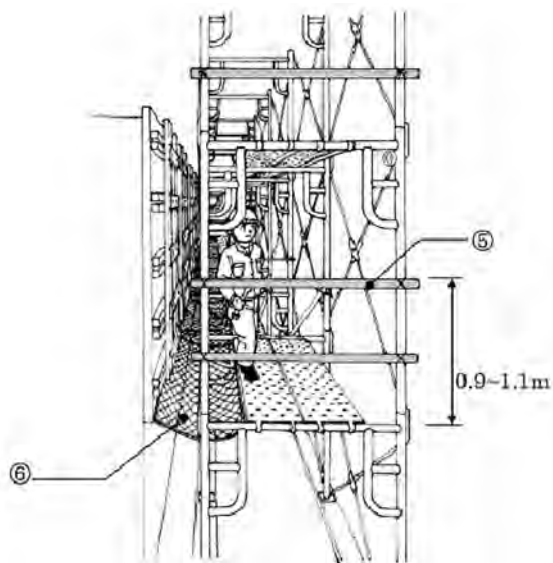

## 1. Prevention of falling

### 1.4 Safety belt

Worker must use with safety belts and/or harness when they work in high place where handrails are difficult to install.

**Check points:** (Refer to TCXDVN 296-2004: Scaffolding - Safety Requirements; TCVN 8206:2009: Personal protective equipment for protection against falls from a height. Flexible horizontal lifeline systems)

- (1) Is the main rope for hook tightened? (TCXDVN 296:2004, Article 3.19)
- (2) Is the location of hook higher than the waist? (TCXDVN 296:2004, Article 3.18)
- (3) Are spacing of supports adequate?

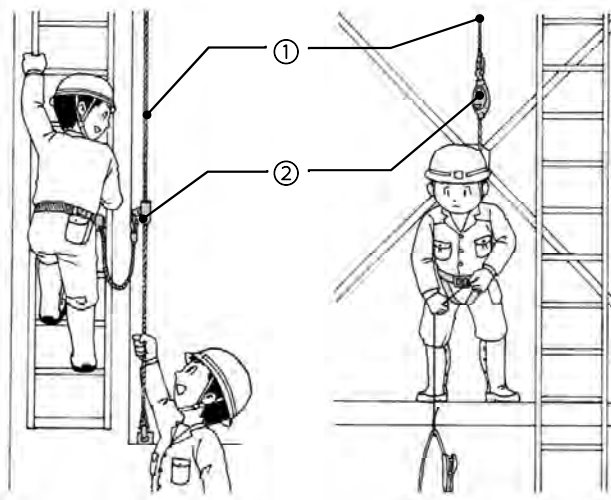
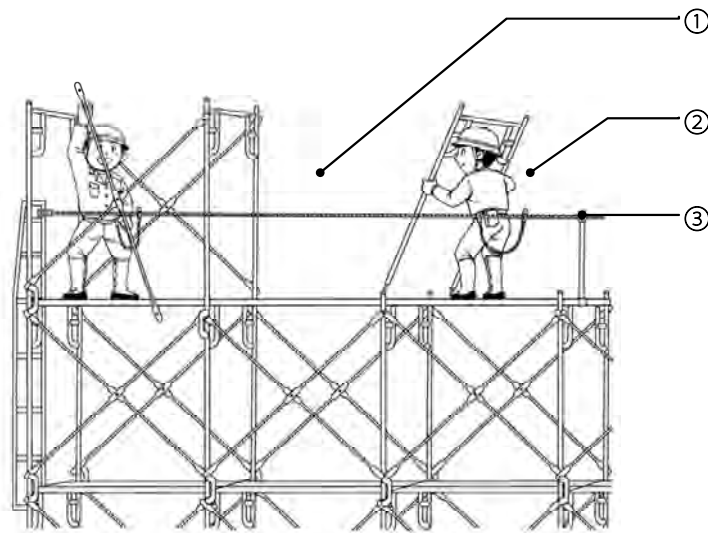

## 1. Prevention of falling

### 1.5 Ascent and Descent

Facilities shall be prepared at the place for ascent and descent where the height (or depth) is more than 1.5m.

**Check points:** (Refer to TCVN 5308:1991: Code of practice for building safety technique; TCVN 4431:1987: Safety handrail. Technical requirement)

- (1) The length of upper end must be more than 60cm
- (2) Device to prevent transposition must be taken (TCVN 5308:1991, Article 8.7.5)
- (3) Is there any damage and rot with material? (TCVN 5308:1991, Article 8.7.4)
- (4) Is slip stopper attached to the ladder?
- (5) Is the width of ladder more than 30cm?
- (6) Is the length of ladder less than 9m?
- (7) Is the height of handrail 0,9~1,15m?  
Is there extra pipe under handrail? (TCVN 4431:1987, Article 2.4; 2.5)
- (8) Are pipes fixed to the stable support? (TCVN 4431:1987, Article 2.9)
- (9) Are traps installed at same spacing?
- (10) Is a sign of stairs shown at the right place?

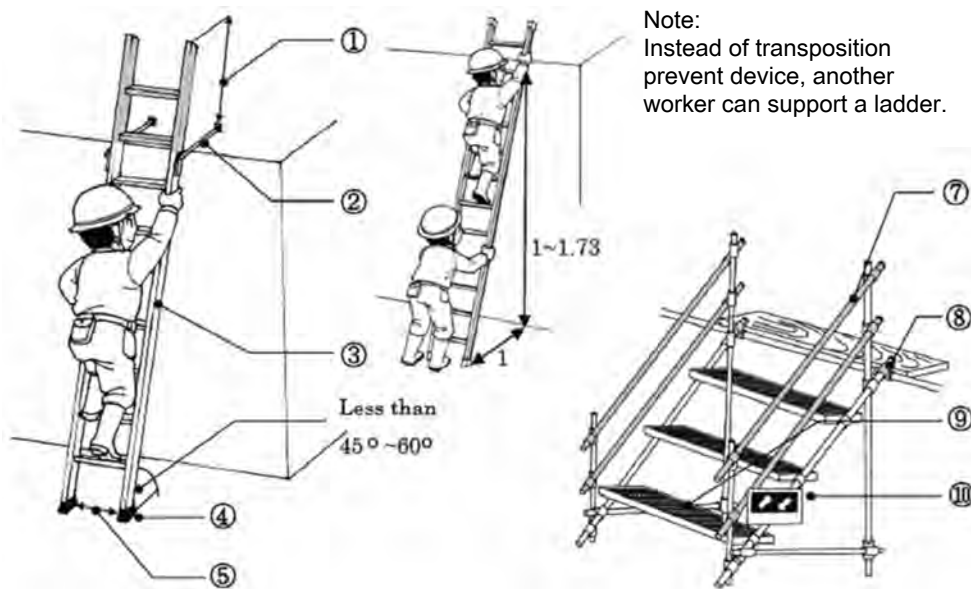

## 1. Prevention of falling

### 1.6 Safety walkway

Safety walkways must be arranged at the site to prevent falling and to prevent hit by machines.

**Check points:** (Refer to TCVN 5308:1991 Code of practice for building safety technique)

- (1) Is the height of handrail 0,9~1,15m? Is there extra pipe under handrail?  
(TCVN 5308:1991, Article 2.2.2.6)
- (2) Is the anti-slip installed?
- (3) Are pipes fixed to the stable support?
- (4) Is the width of walkway enough?  
(Example: more than 40cm in Japan)
- (5) Is the sign of walkway shown at the right place?
- (6) Is the width of walkway kept for intended purpose? (TCVN 5308:1991, Article 2.2.7)
- (7) Materials shall not be stored in the walkway. (TCVN 5308:1991, Article 2.2.3)
- (8) Is lights installed by walkway? (TCVN 5308:1991, Article 1.19)

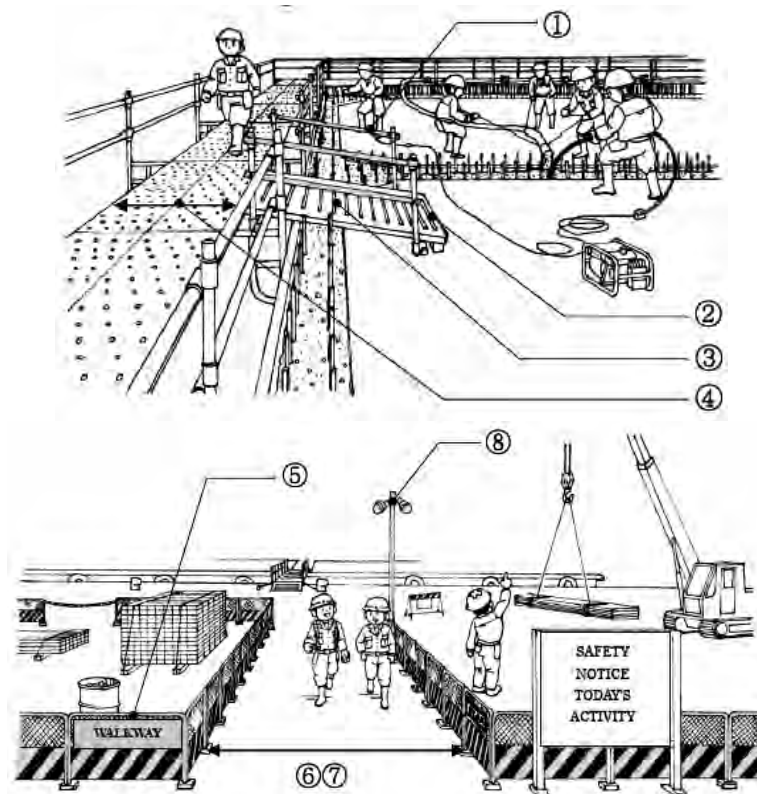

## 2. Prevention of danger caused by falling/littering

### 2.1 Facilities to prevent littering

Blue sheets and protect nets are required to install at potential unsafe area where dropped litters will be fallen.

(Note: Blue sheets - The sheets to prevent littering from building site and it is commonly known as blue sheets)

**Check points:** (Referenced from TCVN 5308:1991 Code of practice for building safety technique)

- (1) Are blue sheets tied up less than 45cm spacing?
- (2) Are blue sheets and pipes tied up less than 45cm spacing?
- (3) Potential area to be hit by dropped litters must be protected by net.
- (TCVN 5308:1991, Article 2.1.8)
- (4) Materials should be covered or tied up with ropes to prevent not to be blown by wind.
- (5) Workers must wear helmet.
- (6) Notice of "Keep Out"

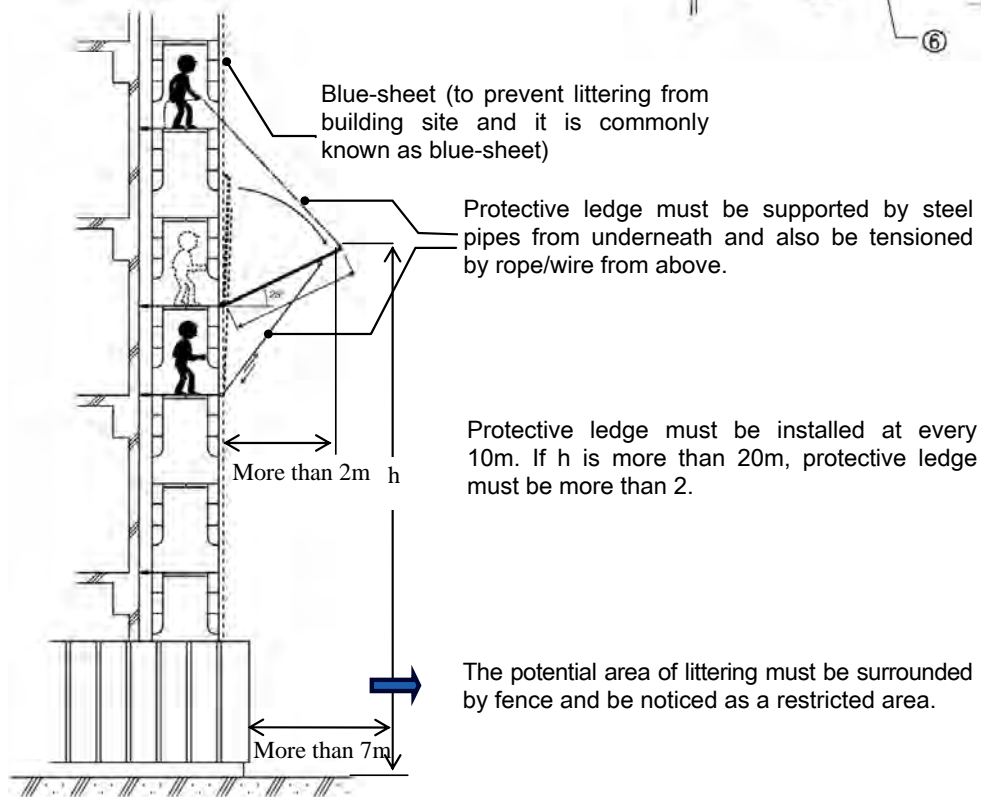
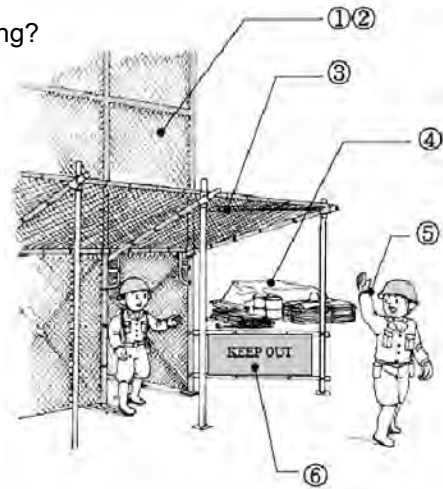

## 2. Prevention of danger caused by falling/littering

### 2.2 Chute

It is necessary to prepare chuting equipments/device when materials are dropped from the high place.

**Check points:** (Refer to TCVN 5308:1991 Code of practice for building safety technique)

- (1) Put up a "Keep Out" sign or arrange a watchman  
(TCVN 5308-1991, Article 2.1.7)
- (2) Chuting device must be used when chuting point is higher than 3m,  
dropping height is less than 1m  
(TCVN 5308-1991, Article 2.1.7)
- (3) Are ropes and bags used when loading and unloading materials?

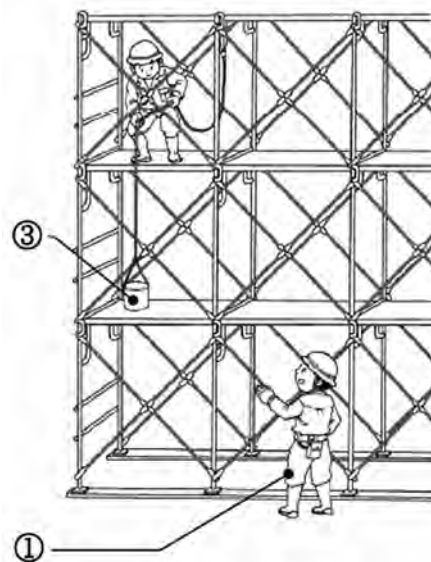
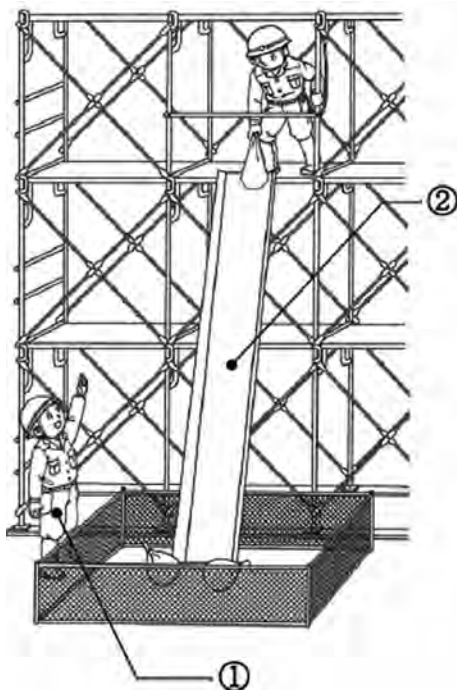

### 3. Prevention of danger caused by collapse/rolling

#### 3.1 Assembling/Disassembling Supports

The following points are required to check before assembling/disassembling formworks.

**Check points:** *(Refer to TCVN 5308-1991 Code of practice for building safety technique; TCVN 4453-1995 Monolithic concrete and reinforced concrete structures - Codes for construction, check and acceptance)*

- (1) Are drawings for assembling prepared before starting erection?
- (2) Is a chief supervisor appointed for supporting works?
- (3) Are actions taken to prohibit people from entering working area without permission? (TCVN 5308-1991, Article 2.1.9)
- (4) Works shall be stopped in inclement weather.
- (5) Pins must be used to fix the length of supports.
- (6) Are horizontal pipes near metal base installed to prevent slips of metal bases? (TCVN 4453-1195, Article 3.5.1)
- (7) Extra horizontal pipes must be added at every 2m when the height of support is higher than 3.5m.
- (8) Working platform must be set up at the top of scaffold
- (9) A diagonal brace must be set up (TCVN 4453-1195, Article 3.5.1)
- (10) A stair must be set up to the place higher than 1.5m
- (11) All braces must be set up at the right place. (TCVN 4453-1195, Article 3.5.1)

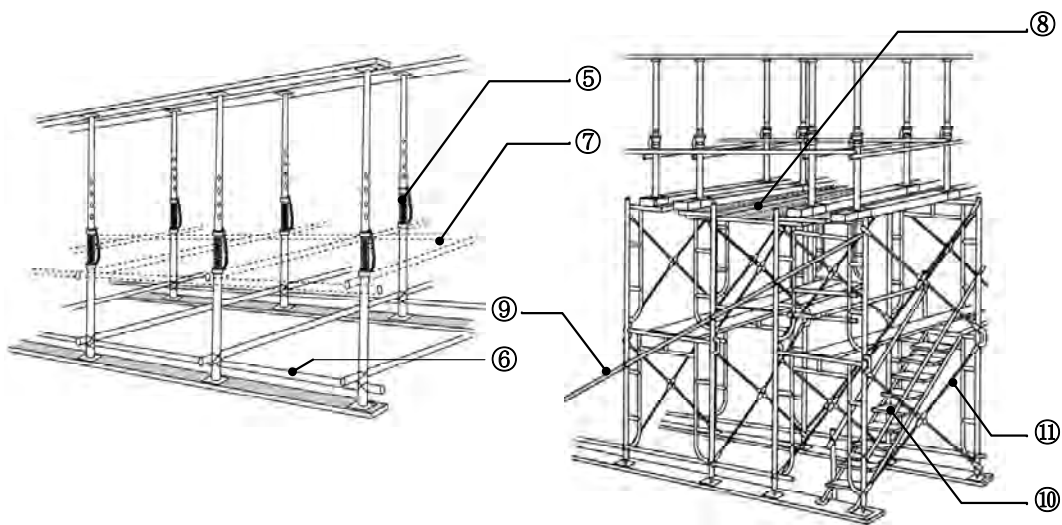



### 3. Prevention of danger caused by collapse/rolling

#### 3.2 Retaining Wall Works

Earth retaining work is to prevent deformation of excavation shape, collapse of excavation face and to keep excavation area stable.

**Check points:** (Refer to Decision 1338/2006/QĐ-BXD, TC 49-05: Technical guideline retaining and keeping excavation area; TCVN 5308-1991: Code of practice for building safety technical)

- (1) Are drawings for construction prepared before starting?  
(1338/2006/QĐ-BXD, TC 49-05, Article 4.4.1)
- (2) Is a chief supervisor appointed for supporting works?
- (3) Are actions taken to prohibit people from entering working area without permission? (TCVN 5308:1991, Article 12.1.7)
- (4) Deformation and damage of materials shall be checked before its use.
- (5) Are stairs set up?
- (6) Is the periphery of opening surrounded by handrails?  
(TCVN 5308:1991, Article 2.1.6)
- (7) Deformation of retaining shall be always monitored. (1338/2006/QĐ-BXD, TC 49-05, Article 4.4.5)
- (8) No weight shall be on struts
- (9) The type of joint for struts shall be butt joint
- (10) Strut and waling shall be fixed to lagging tightly (TCVN 5308:1991, Article 12.3.1)

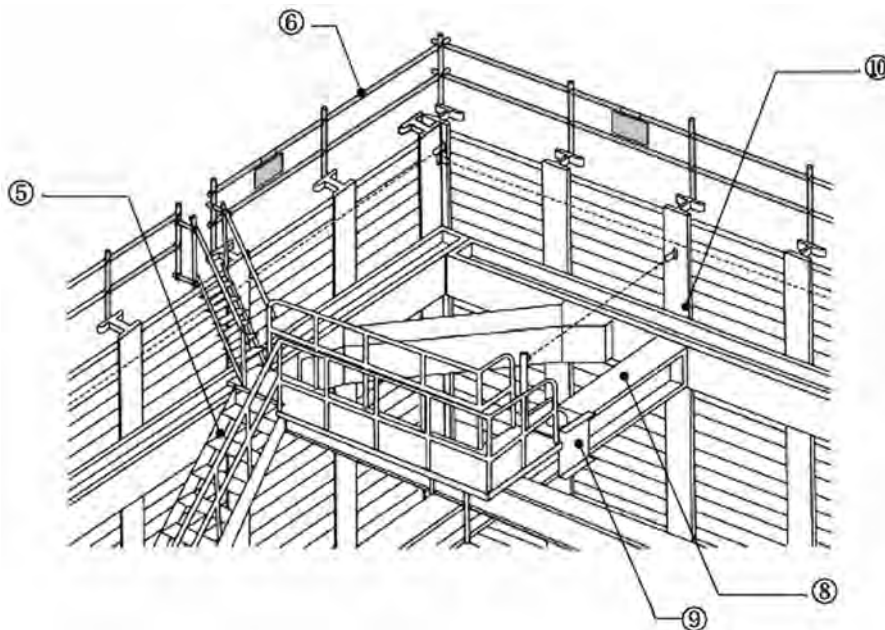

### 3. Prevention of danger caused by collapse/rolling

#### 3.3 Excavation of natural ground

The following points are required to check before excavation of natural ground. Excavation for tunnel and quarry are not subject of this item.

**Check points:** (Refer to Decision 1338/2006/QĐ-BXD, TC 49-05: Technical Guideline for retaining and keeping excavation; TCVN 5308-1991: Code of practice for building safety technique; TCVN 5178-1990: Technical safety regulation for open-pit mining and processing.)

- (1) Following points must be surveyed before excavation.  
(1338/2006/QĐ-BXD, TC 49-05, Article 4.1.1)
  - Condition of geological and geological formation
  - Existence of cracks, water leakage, high temperature gas/steam in soil
  - Existence of buried objects and its condition
- (2) Is a chief supervisor appointed for excavation more than 2m deep?
- (3) Existence and condition of loose rocks, cracks and leakage must be checked before starting excavation and/or after an earthquake with a seismic intensity of moderate. (TCVN 5308:1991, Article 12.1.11)
- (4) Collapse potential area must be protected by supports and/or protection nets. "Keep Out" sign must be set up. (TCVN 5308:1991, Article 12.1.7)
- (5) Lightings must be set up for night works. (TCVN 5308:1991, Article 1.19)
- (6) A safety slope must be kept. (TCVN 5178:1990, Article 1.3)
- (7) Overhang excavation is prohibited. (TCVN 5308:1991, Article 12.1.13)
- (8) Are drainage facilities and surface drainage set up? (TCVN 5178:1990,

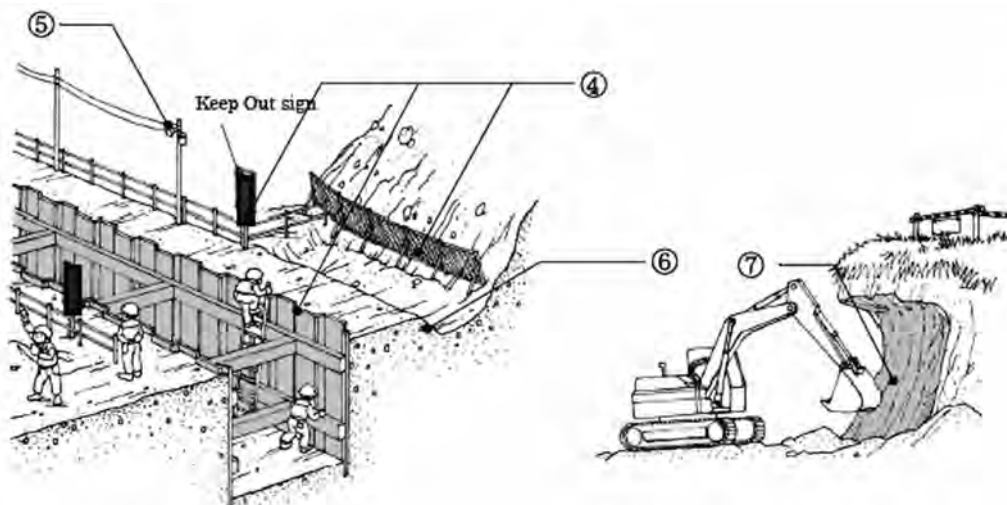

#### 4. Prevention of danger caused by general construction equipment

##### 4.1 Leveling, Hauling, Loading machines

Self-propelled machines such as bulldozer, motor grader, tractor shovel, wheel loader, backhoe and scraper are the subjects of this item.

**Check points:** (Refer to TCVN 3147-1990: Safety code for loading and unloading works-General requirements)

- (1) Worker shall not ride on machine except operator sheet
- (2) Headlights must be equipped with a machine (TCVN 3147:1990, Article 4.1.1)
- (3) When the operator leaves a machine, he must lay down the blade, set the brake and remove the key. (TCVN 3147:1990, Article 4.3.1)
- (4) Damage of canopy must be checked before starting operation. (TCVN 3147:1990, Article 4.1.1)
- (5) An observer must be arranged at the place where risks of rolling/falling exist.
- (6) Working area must be marked clearly to prevent unauthorized people to enter. (TCVN 3147:1990, Article 4.1.3)

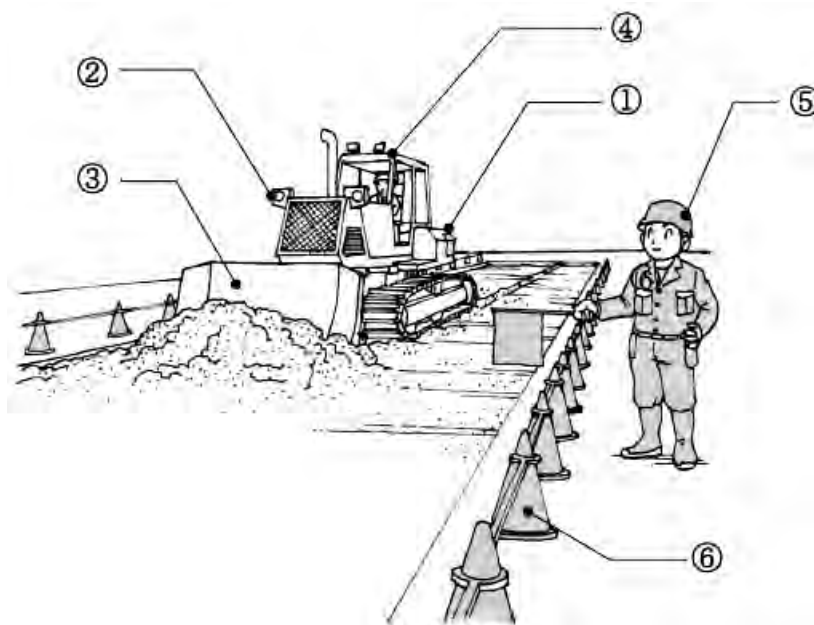

#### 4. Prevention of danger caused by general construction equipment

##### 4.2 Excavation machine

Such as power shovel, drag shovel, dragline crane, clam shell, bucket excavator and trencher are the subjects of this item.

**Check points:** (Refer to TCVN 5308:1991 Code of practice for building safety technique)

- (1) Worker shall not ride on machine except operator sheet
- (2) When the operator leaves a machine, he must lay down the blade, set the brake and remove the key. (TCVN 5308:1991, Article 12.5.2.6)
- (3) Workers shall not stay in the swinging area of machine during operation. (TCVN 5308:1991, Article 12.5.2.2)
- (4) An observer must be arranged at the right place. "Keep Out" sign must be set up where necessary. (TCVN 5308:1991, Article 6.9)
- (5) Machines must be used only for their rightful purpose. (Machines are sometimes used for lifting loads.) (TCVN 5308:1991, Article 6.11)
- (6) The ground condition must be checked before starting excavation. (TCVN 5308:1991, Article 12.1.14)

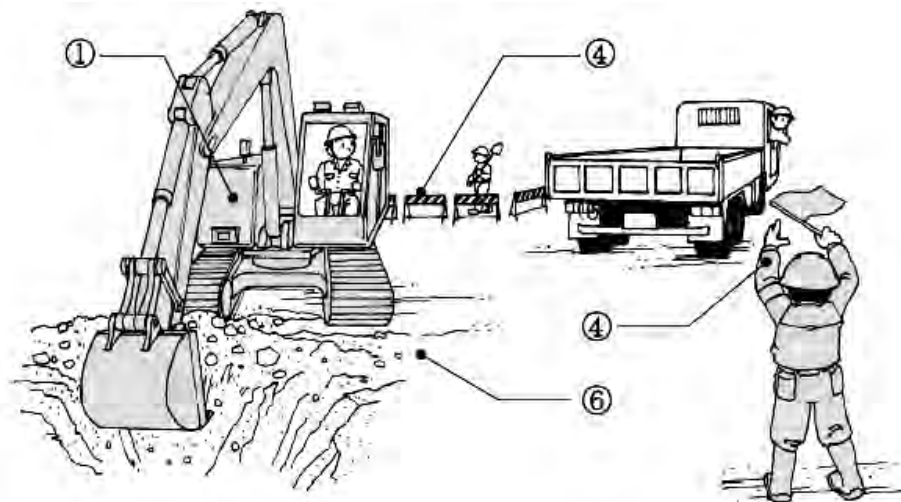

#### 4. Prevention of danger caused by general construction equipment

##### 4.3 Foundation Works Machines

Such as pile driver, pile extractor, earth drill, reverse circulation drill, earth auger, cast-in-place pile and all casing machine are the subjects of this item.

**Check points:** (Refer to TCVN 5308:1991 Code of practice for building safety technique)

- (1) Worker shall not ride on machine except operator sheet
- (2) When a person ascend and descend the lead, he must wear a safety belt which ties to the main safety line. (TCVN 5308:1991, Article 7.8)
- (3) "Keep Out" sign must be set up at the right place. (TCVN 5308:1991, Article 6.9)
- (4) The deformation and wear of wire rope must be checked.
- (5) A winding gear must be free of weight when the operator leaves a machine. (TCVN 5308:1991, Article 6.19)
- (6) A machine must be placed at level on the stable ground. (TCVN 5308:1991, Article 6.14)
- (7) A person nominated as a signal man can send pre-determined signals to the operator.

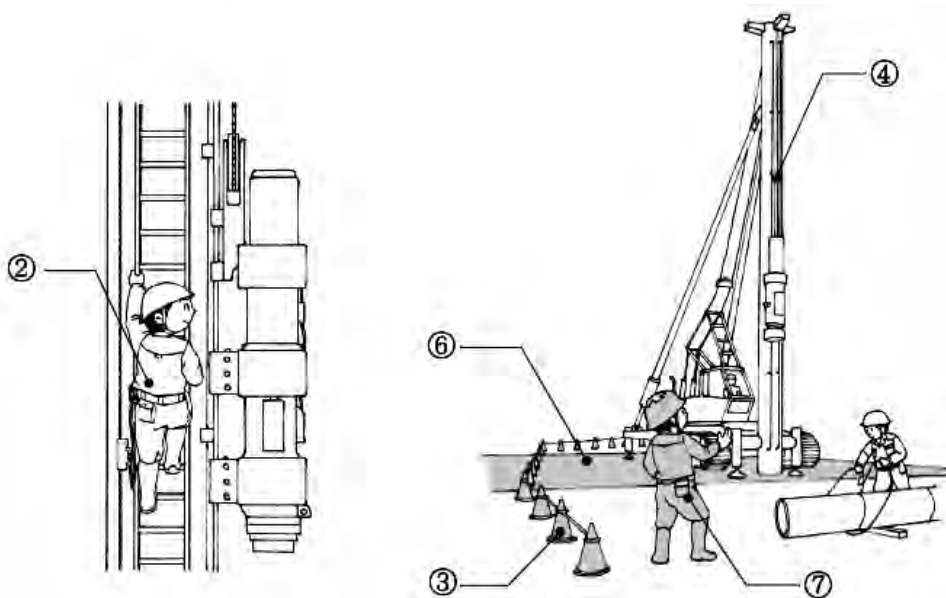

#### 4. Prevention of danger caused by general construction equipment

##### 4.4 Compaction machine

Rollers are usually used as compacting equipment for roads and grounds.

**Check points:** (Refer to TCVN 5308:1991 Code of practice for building safety technique)

- (1) Worker shall not ride on machine except operator seat
- (2) Headlights and alarm must be equipped with machine in good condition. (TCVN 5308:1991, Article 6.9)
- (3) A flagman must be arranged at the place where risks of rolling/falling exist.
- (4) No worker can stand at the blind spot.
- (5) When the operator leaves a machine, he must stop the engine, put on the break and remove the key. (TCVN 5308:1991, Article 6.19)

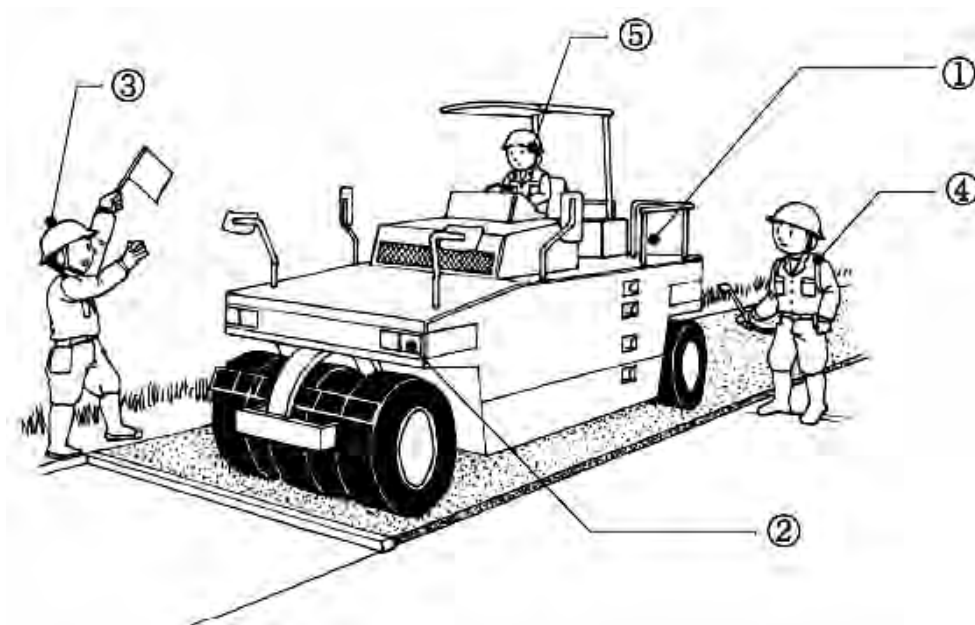

#### 4. Prevention of danger caused by general construction equipment

##### 4.5 Concreting machine

Precaution to use a concrete pump is highlighted in this clause.

**Check points:** (Refer to TCVN 5308:1991 Code of practice for building safety technique)

- (1) Worker shall not ride on machine except operator sheet
- (2) Concrete hoses must be fastened tightly and anti-swing device for concrete hoses should be arranged. (TCVN 5308:1991, Article 16.6.5)
- (3) No person is allowed to work under the boom during concreting. (TCVN 5308:1991, Article 16.6.6)
- (4) Workers at nozzle and a concrete pump operator must determine common signals between them for operation.
- (5) Outriggers must be extended to the maximum length position.
- (6) A concrete pump car must be placed at level on the stable ground. (TCVN 5308:1991, Article 6.14)
- (7) Concrete boom can be used only for concreting. Don't use it for lifting loads. (TCVN 5308:1991, Article 6.11)
- (8) No worker can stay at the outlet point of concrete hose.

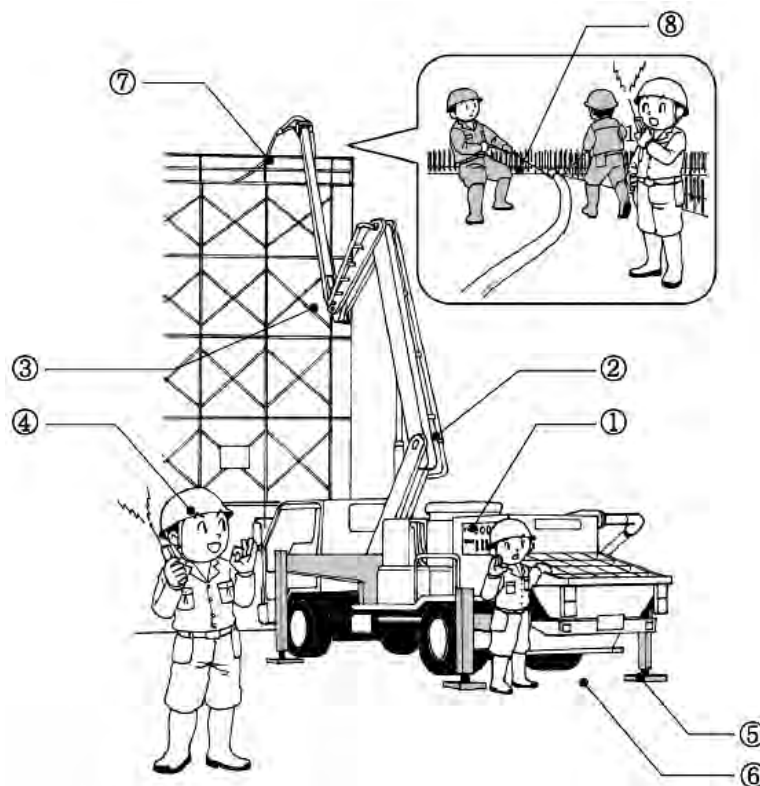

#### 4. Prevention of danger caused by general construction equipment

##### 4.6 Breaking machine

Precaution to use a breaker is highlighted in this clause.

**Check points:** (Refer to TCVN 5308:1991 Code of practice for building safety technique)

- (1) Worker shall not ride on machine except operator sheet
- (2) A flagman must be arranged at the place where risks of rolling/falling exist.
- (3) Headlights must be equipped with a machine (TCVN 5308:1991, Article 6.9)
- (4) When the operator leaves a machine, he must lay down the blade, set the brake and remove the key. (TCVN 5308:1991, Article 6.19)
- (5) The tempered glass must be used at the front glass of operator sheet or wire/steel mesh protection must be installed. (TCVN 5308:1991, Article 6.7)
- (6) "Keep Out" sign must be set up where necessary. (TCVN 5308:1991, Article 6.9)
- (7) Works must be stopped in the inclement weather.

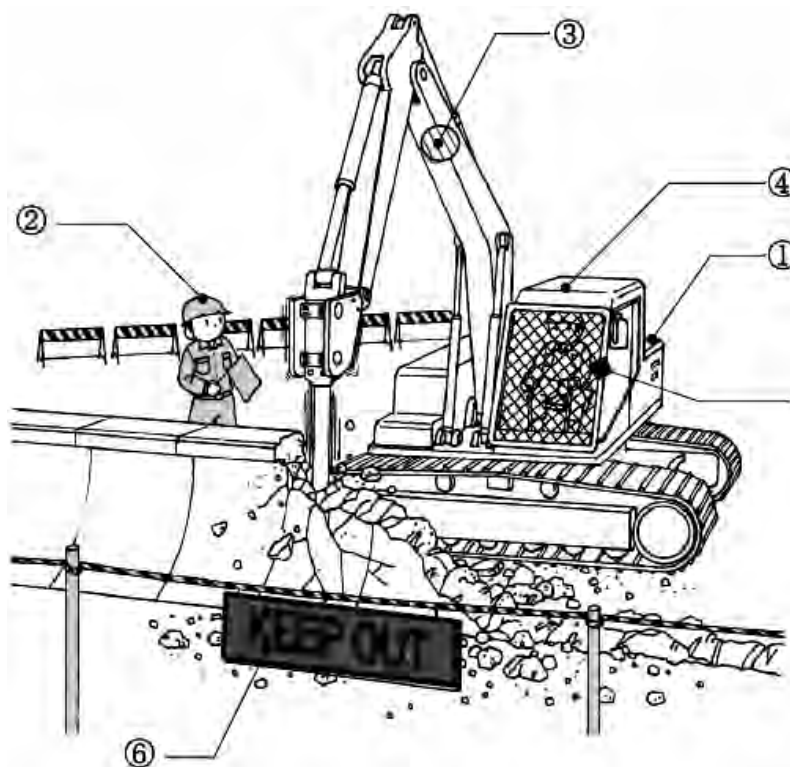



#### 4. Prevention of danger caused by general construction equipment

##### 4.7 Mobile crane

Precautions to use a mobile crane and/or other type of cranes are highlighted in this clause.

**Check points:** (Refer to TCVN 4244:1986 Code for the safe technique of crane. Equipment; TCVN 5308:1991 Code of practice for safety building technique)

- (1) Worker shall not ride on machine except operator sheet  
(TCVN 4244:1986, Article 6.5.15, n)
- (2) An over-winding prevention device is working correctly or not.
- (3) The weight of loads must be less than the safe working load  
(TCVN 4244:1986, Article 6.4.7)
- (4) No person can stand under the loads. (TCVN 4244:1986, Article 6.5.14, g)
- (5) A lead rope must be used to handle the long load.
- (6) A signalman must be arranged for the crane works. (TCVN 4244:1986, Article 6.4.7)
- (7) Outriggers must be extended to the maximum length position.
- (8) "Keep Out" sign must be set up where necessary. (TCVN 5308:1991, Article 6.9)
- (9) A mobile crane must be placed at level on the stable ground.
- (10) An overloading prevention device is working correctly or not.  
(TCVN 4244:1986, Article 5.11.3.11)
- (11) A safe working load must be exhibited at the crane.
- (12) Is the latch of hook working well (TCVN 4244:1986, Article 5.1.10)
- (13) Crane works must be stopped when the wind speed from 5 grade  
(TCVN 5308:1991, Article 17.1.5)

- (14) While hanging the load, the operator cannot leave a machine.  
(TCVN 4244:1986, Article 6.5.15,a)

- (15) Steel plates must be laid down under the outriggers at the soft ground.

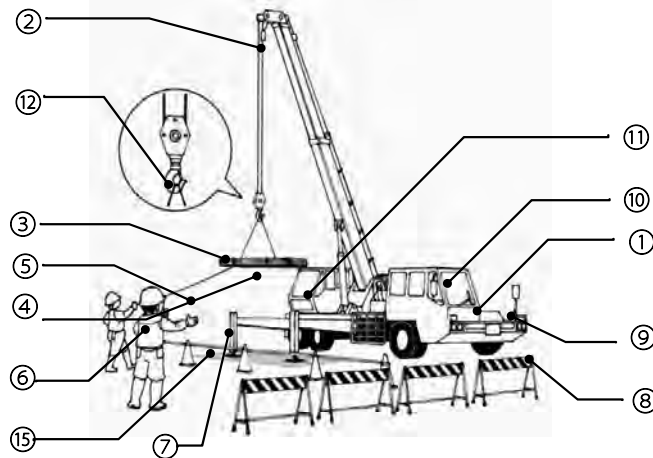

#### 4. Prevention of danger caused by general construction equipment

##### 4.8 Slinging works

Precaution for slinging works is highlighted in this clause. The most suitable slinging tools must be chosen based on the weight and shape of load.

**Check points:** (Refer to: TCVN 4244:1986 Code for the safe technique of crane. Equipment; TCVN 5308:1991 Code of practice for the building safety technique)

- (1) Check the damage of sling wire such as shapeless and cut  
(TCVN 4244:1986, Appendix 4)
- (2) Unifilar wire is not recommended to hang loads. Prural wires should be used.  
(TCVN 4244:1986, Article 5.2.12~14)
- (3) When load off the ground, lifting must be stopped and keep the load stable. Cannot lift and move horizontally at the same time.  
(TCVN 4244:1986, Article 6.5.14, e)
- (4) Sling wires must be protected by pads at the acute angle corner of loads.  
(TCVN 4244:1986, Article 5.2.2)
- (5) Sleepers must be laid down under the loads. (TCVN 4244:1986, Article 6.5.14, j)
- (6) No person can stand under the loads. (TCVN 4244:1986, Article 6.5.14, g)
- (7) A lead rope must be used to handle the long load. (TCVN 5308:1991, Article 17.1.10)
- (8) A signalman must be arranged for the crane works.(TCVN 4244:1986, Article 6.4.7)
- (9) An angle between two wires must be less than  $60^\circ$  (TCVN 4244:1986, Appendix 3)
- (10) Check the damage of hook, shackle and other metal attachments  
(TCVN 4244:1986, Article 6.4.18)

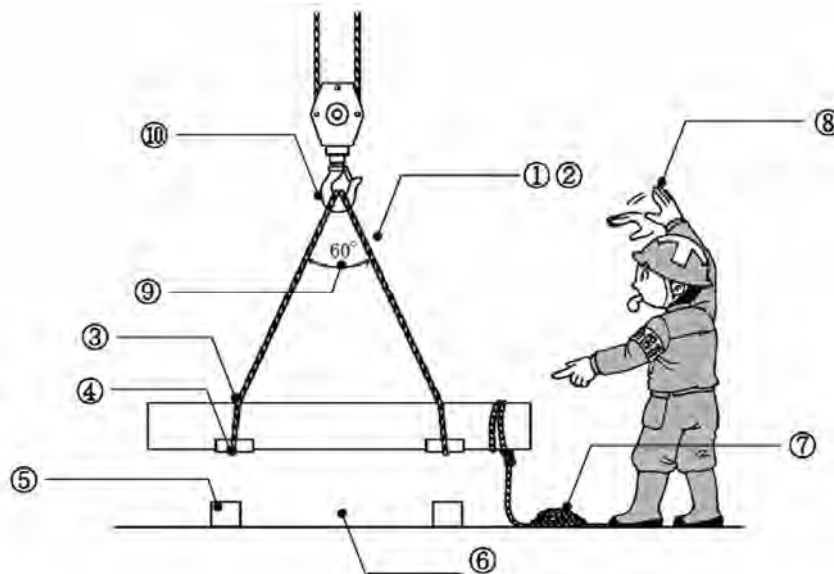

#### 4. Prevention of danger caused by general construction equipment

##### 4.8 Slinging works - Detailed Check points

Detailed Check points

###### (1) Actions prohibited

- Lifting by hooker
- Lifting by one cramp
- One point lifting
- Free fall

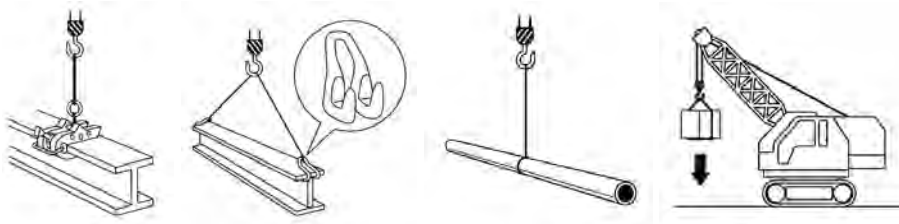

- Lifting un-combined loads

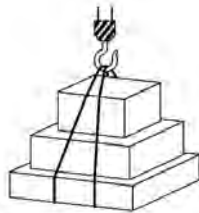

- Using unsuitable hook, shackle and other metal attachments

Bended hook

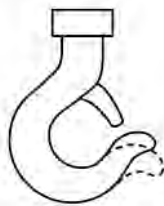

Oval shaped ring

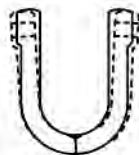

Deformed shackle

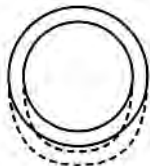

- Using unsuitable wire

Wire with strands are damaged more than 10% in one ply



Wire kinked



Wire which strands are damaged at bending portion



Wire which diameter decrease more than 7% of official diameter



Wire which has considerable deformation/ corrosion



#### 4. Prevention of danger caused by general construction equipment

##### 4.9 Electric circular saw (Hand tool type)

Be careful not to be caught your clothes and gloves in a saw when you use an electric circular saw.

**Check points:** *(Refer to TCVN 4756:1989 Code of Practice of ground connection and "O" connection of electrical equipments; TCVN 4730:1989 Production of clay bricks and tiles-General safety requirements)*

- (1) Do not wear gloves which are easily caught in saw.
- (2) Do not put on clothes which are easily caught in saw.
- (3) Adequate working area should be secured.
- (4) A Protection cover for the teeth of a saw should be well functioned.  
(TCVN 4730:1989, Article 8.6.2)
- (5) An "O" connection cord with cover of machine, stop device and fastening teeth of a saw must be checked before starting an electric circular saw.  
(TCVN 4756:1989, Article 1.5)

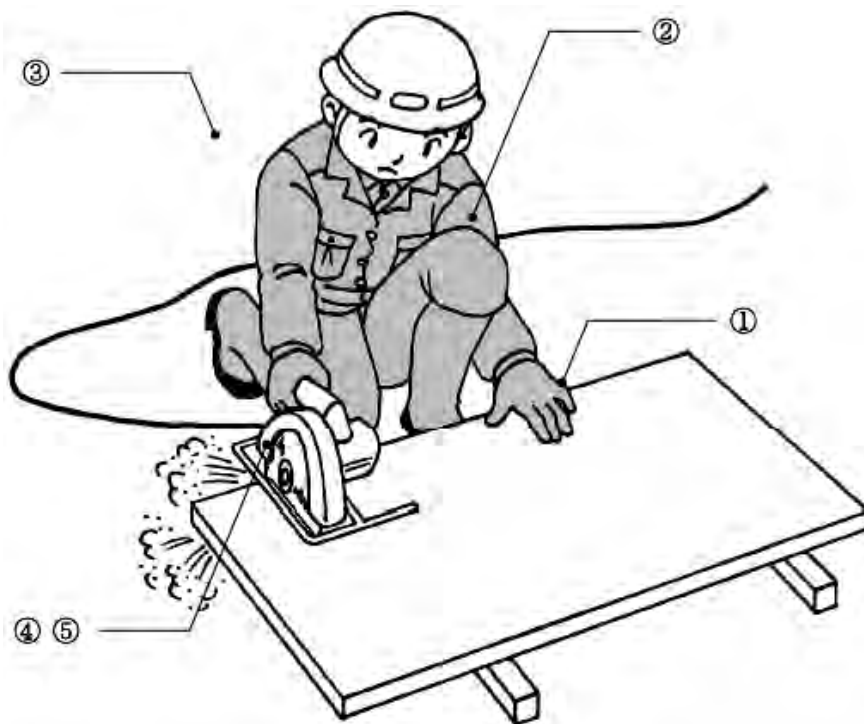

## 4. Prevention of danger caused by general construction equipment

### 4.10 Grinder

A grinder must be checked before its operation whether it is in good condition or not. Also an operator must pay attention to protect him from the litter.

**Check points:** (Refer to TCVN 5308:1991 Code of practice for building safety technique; TCVN 4730:1989 Production of clay bricks and tiles- General safety requirements)

- (1) The speed of grinder blade must not exceed the maximum allowable circumferential velocity.
- (2) An operator must wear a dust mask and dustproof goggles.  
(TCVN 4730:1989, Article 8.4.4)
- (3) A protective cover must be equipped with a grinder blade.  
(TCVN 4730:1989, Article 8.4.4)
- (4) A trial operation of grinder is recommended. (TCVN 4730:1989, Article 8.4.2)
- (5) The side face of blade shall not be used.
- (6) A certified person of grinder can replace a new blade and trial operation of grinder.  
(TCVN 5308:1991, Article 5.7)

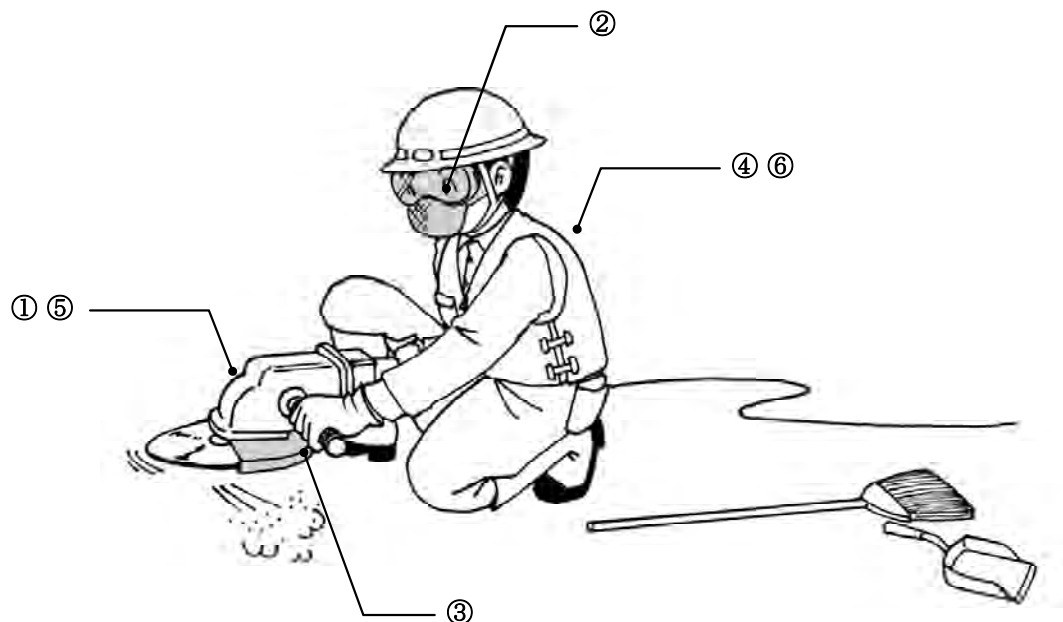

## 4. Prevention of danger caused by general construction equipment

### 4.11 Winch

A winch must be checked before its operation whether it is in good condition or not. Also an operator must pay attention to protect him not to be caught in a winch.

**Check points:** (Refer to TCVN 5308:1991 Code of practice for building safety technique)

- (1) A protective cover must be equipped with a motor and pivot.  
(TCVN 5308:1991, Article 6.7)
- (2) A wire rope must be checked before operation and if kink and wear are found don't start a winch.
- (3) The condition of an over-winding prevention device, a power cutoff device and other safety devices must be checked before its operation.  
(TCVN 5308:1991, Article 6.8)
- (4) Fences must be built around a winch and a "Keep Out" sign must be installed.  
(TCVN 5308:1991, Article 6.9)
- (5) A signalman must be designated and only he can send a starting signal of winch.
- (6) An operator must set the brake and turn off the engine before leaving the operator's seat.  
(TCVN 5308:1991, Article 6.19)
- (7) An operator must put on suitable clothes which are not caught in winch easily.

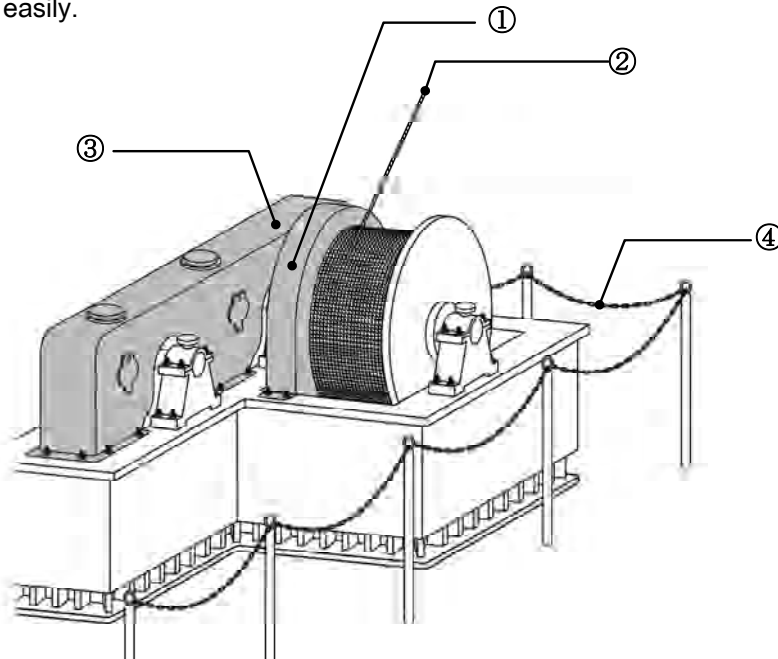

#### 4. Prevention of danger caused by general construction equipment

##### 4.12 Compressor (Engine and motor type)

A compressor is sometimes used for the impact wrench and underwater works.

**Check points:** *(Refer to QCVN 01-2008/BLĐTBXH National technical regulations on safety of boilers and pressure vessels)*

- (1) A valve of compressor is working properly or not.  
(QCVN1-2008/BLĐTBXH, Article 5.1.11)
- (2) An air inlet should be located as high as possible.
- (3) Toxic gases such as exhaust gas shall be disposed properly.
- (4) The temperature of shaft bearing shall be normal.
- (5) The temperature of cooling water for motor and the amplitude range of ammeter indicator shall be checked. (QCVN 1-2008/BLĐTBXH, Article 5.1.7.2)
- (6) All facilities including a compressor must be checked before underwater works.
- (7) A special induction of valves/cocks operation for the underwater works is necessary.

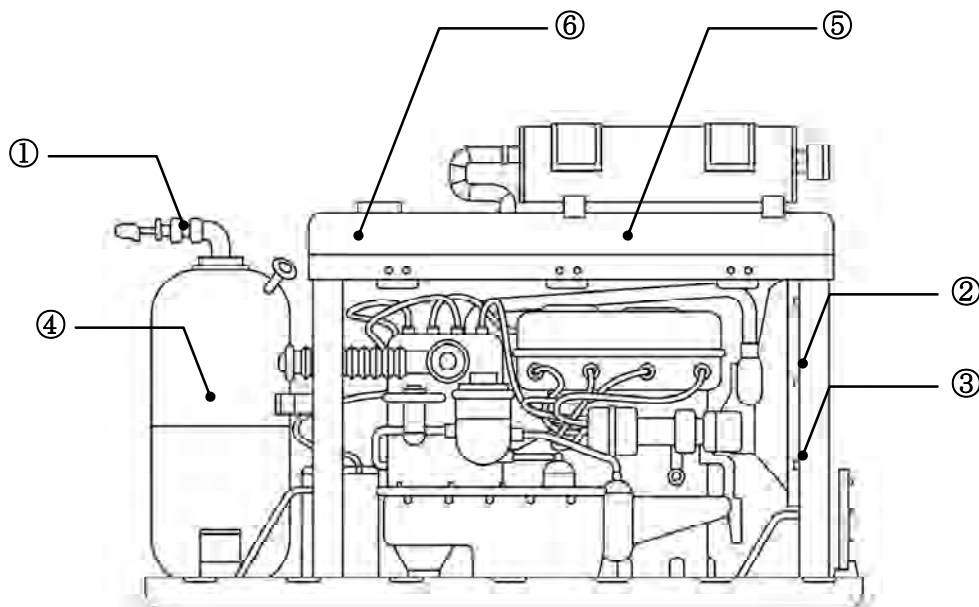

## 5. Prevention of danger caused by electricity

### 5.1 Electric substation facilities

Electric substation shall be fenced and prevent ordinary people to enter into inside.

**Check points:** (Refer to QCVN 01-2008/BCT National regulations on electrical safety)

- (1) The name of person in charge must be notice onto a (bulletin) board.
- (2) No entry fence shall be installed around facilities and put up a "Keep Out" sign. (QCVN 01-2008/BCT, Chapter II, Article 5~8)
- (1) Electric substation facilities should be inspected regularly, at least once a month.
- (2) Electric substation facilities installed at outdoors shall be waterproof type.
- (3) The substation must equip the necessary luminous intensity for the operation and inspection. (QCVN 01-2008/BCT, Chapter II, Article 10)
- (1) Regular inspections that are specified in the law (such as weekly and annual inspections) must be carried out. (QCVN 01-2008/BCT, Chapter XIII, Article 122, Clause 4)

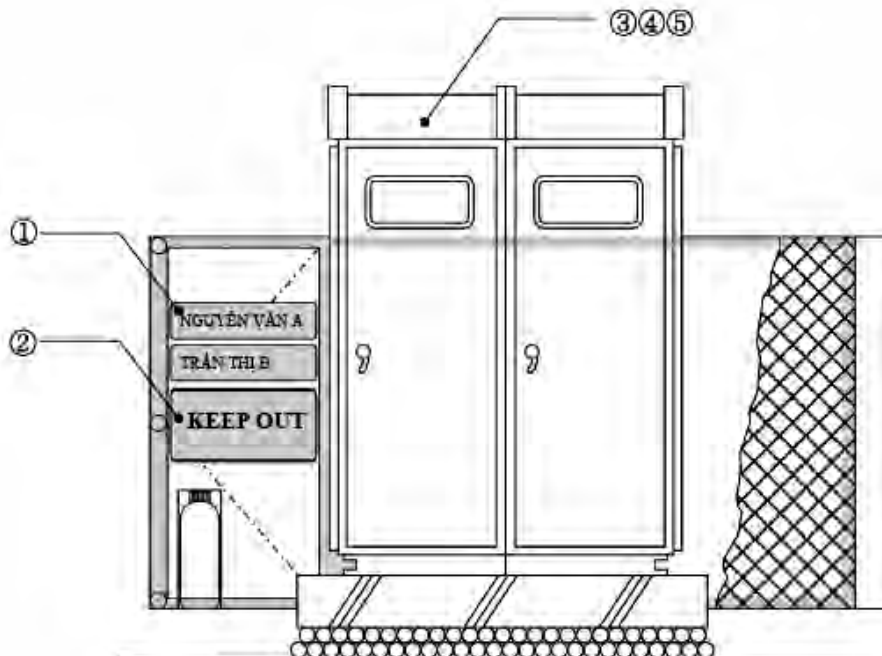



## 5. Prevention of danger caused by electricity

### 5.2 Distribution board, earth leakage breaker

Distribution boards and earth leakage breakers must be managed by a person in charge for electric works.

**Check points:** (Refer to QCVN 01-2008/BCT National technical regulations on electrical safety)

- (1) A person in charge for distribution board must be appointed.
- (2) A tag of "Under Repair" must be hanged at the distribution board and be locked while repairing facilities. (QCVN 01-2008/BCT, Chapter II, Article 5~8)
- (3) No obstacle shall be placed near the distribution board.
- (4) Electric cables shall be wired through the holes at the bottom of distribution board.
- (5) An earth leakage breaker must work properly.
- (6) A ground wire shall be connected to the right place properly. (QCVN 01-2008/BCT, Chapter VII, Article 76)
- (7) An electric circuit should be displayed.
- (8) The installation height of electric distribution board shall be more than 1.5m at site and more than 2.5m at public road from ground level.
- (9) Regular inspections that are specified in the law (such as inspection before in use, inspection of fences at least once a month, etc.) must be carried out. (QCVN 01-2008/BCT, Chapter XIII, Article 122, Clause 4)

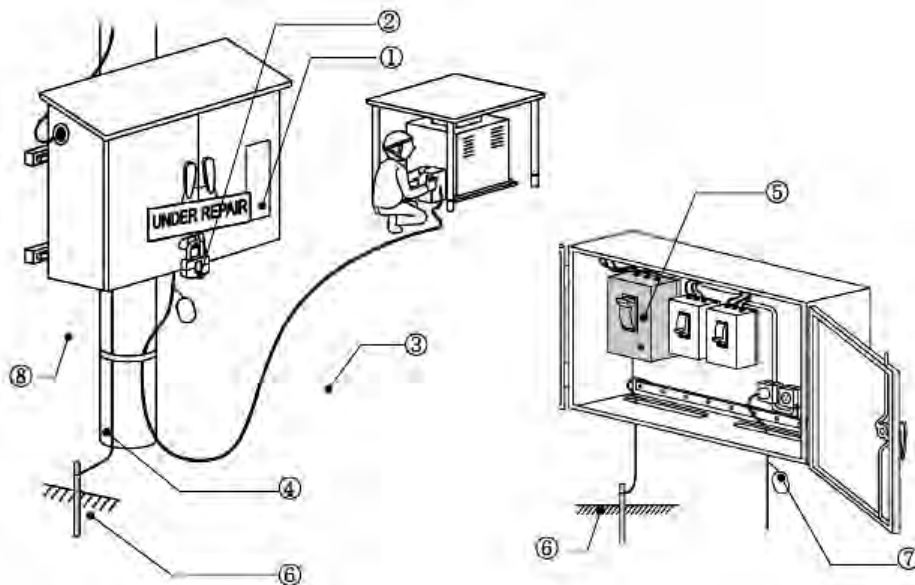

## 5. Prevention of danger caused by electricity

### 5.3 Temporary electric cables

Electric movable cables on the roads/passages shall be protected from vehicles and passengers. These cables shall be managed well to avoid damages.

**Check points:** (Refer to TCVN 4086:1995 Electrical safety in construction □  
General requirements)

- (1) Electric cables should not touch with high temperature articles.
- (2) A cable on the road/passagage shall be protected properly.  
(TCVN 4086:1995, Article 2.13)
- (3) Covering materials of cable should not be damaged.
- (4) Cabtyre (Cabtire) cable shall be used as movable cables on the roads/passages.
- (5) No load shall be placed on the cable at the floor.
- (6) Waterproof type cables and connectors shall be used at the wet place.
- (7) The edge of live wire shall not leave without any protection.
- (8) Cables and wiring shall be checked before in use.

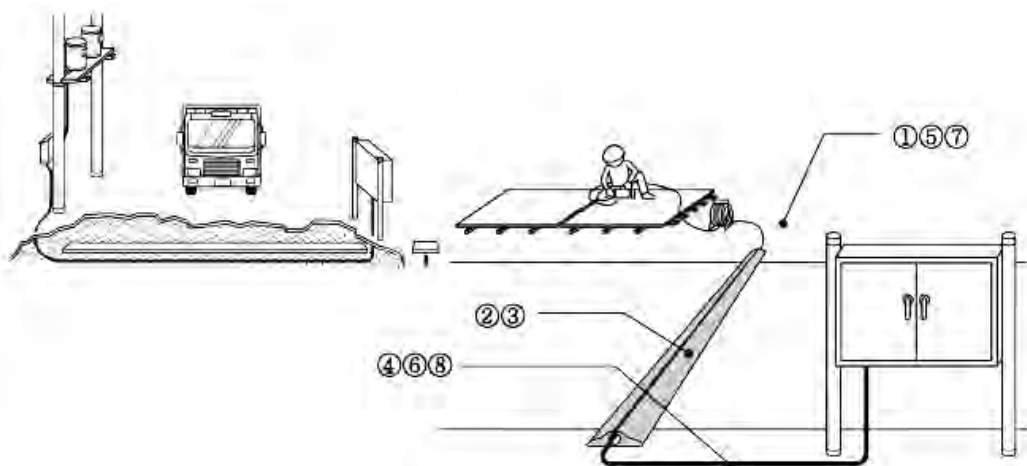

Note: Cabtyre cable

Cables are covered by vinyl or rubber and they are very strong against the weight of a load.



## 5. Prevention of danger caused by electricity

### 5.4 Lighting

Damage of bulbs, sockets and wiring must be checked carefully when the lighting is used.

**Check points:** *(Refer to TCVN 4086:1995 Electrical safety in construction - General requirements)*

- (1) Damage of bulbs and socket
- (2) Damage of wiring
- (3) Is there any heated connecting portion at the electric circuit?  
(TCVN 4086:1995, Article 2.12)
- (4) Portable and/or hanged lights must equip bulb-guards
- (5) Damaged cable shall not be used. (TCVN 4086:1995, Article 2.13)

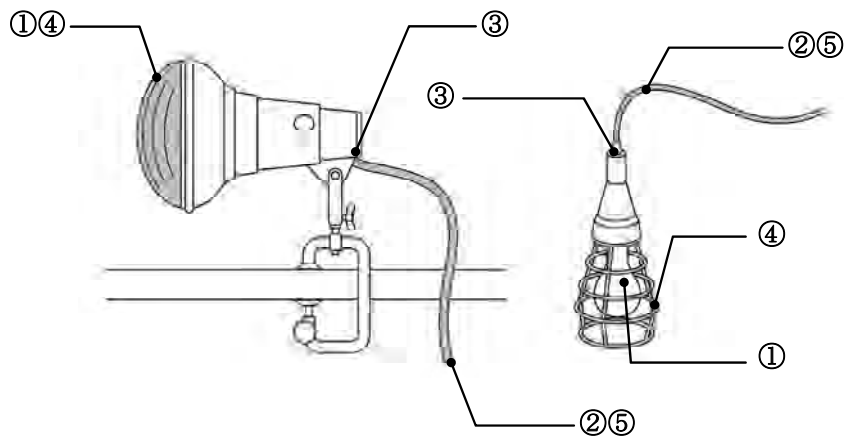

## 5. Prevention of danger caused by electricity

### 5.5 Welding

It is necessary to check the welding cable (such as the existing of leakage, damage of insulating coating, an electric shock) before using welding machine.

**Check points:** (Refer to TCVN 3146:1986 Electric welding works-General safety requirements; TCVN 4086:1985 Electrical safety in construction-General requirements)

- (1) A welder must wear welding mask, gloves and mask. (TCVN 3146:1986, Article 8)
- (2) The condition of voltage reduction device must be checked before in use. (TCVN 4086:1985, Article 2.6)
- (3) Connect the ground wire of the welding machine to the terminal. (TCVN 3146:1986, Article 2.4)
- (4) Only persons who completed a special seminar/induction of welding including practical skills test can be engaged in welding works. (TCVN 3146:1986, Article 7)
- (5) Damage of insulating coating of welding cable. (TCVN 4086:1985, Article 2.22)
- (6) No welding is allowed at the wet place nor by wet body. (TCVN 3146:1986, Article 6.7)
- (7) A welding holder for welding rod must meet the standard requirements. (TCVN 4086:1985, Appendix 2)
- (8) A regular periodical inspection for welding machine is necessary according to the law.

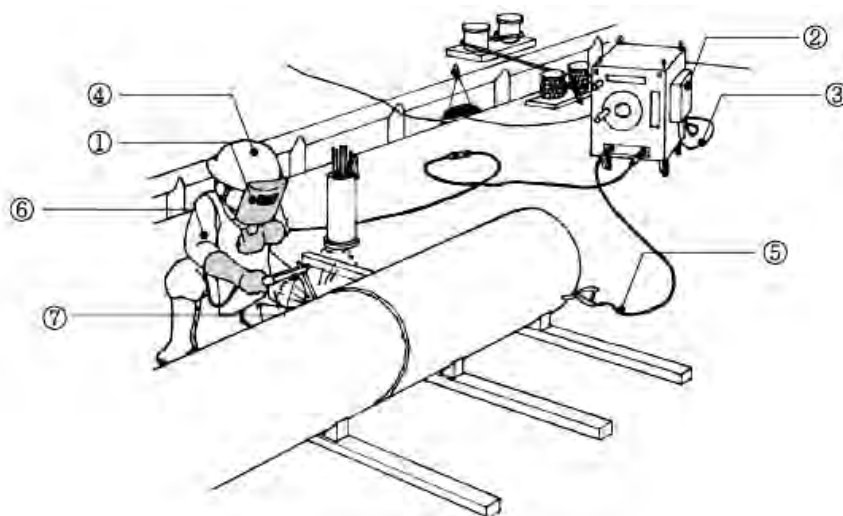

## 5. Prevention of danger caused by electricity

### 5.6 Operations on near a live cable

When electric works will be executed near live cables, necessary measures should be taken to protect an electric shock accident.

**Check points:** (Refer to QCVN 01-2008/BCT National technical regulations on electrical safety)

- (1) \* Keep enough distance from the live cables.  
(QCVN 01-2008/BCT, Chapter II, Article 8)
- (2) A full-time work supervisor must be arranged.  
(QCVN 01-2008/BCT, Chapter III, Article 15)
- (3) Workers for inspection and repair of the low voltage circuit, they must use insulation protective gears. (QCVN 01-2008/BCT, Chapter VIII, Article 85)
- (4) When a mobile crane and a piling machine are used near overhead cables, a staff of an electric power company should attend at site.  
(QCVN 01-2008/BCT, Chapter III, Article 17)
- (5) Measures for operation on live cables:  
High voltage cables: Must be protected by protective pipes  
Special high voltage cables: Must be relocated or arrange a supervisor who will watch the special high voltage electric works.  
(QCVN 01-2008/BCT, Chapter VIII, Article 88)

\* Safety distance (follow voltage grade)  
from the live cables

Line voltage (kV)	Minimum allowed distance (m)
Less than 15	0,7
From 15 to 35	1,0
From 35 to 110	1,5
From 110 to 220	2,5
From 220 to 500	4,5

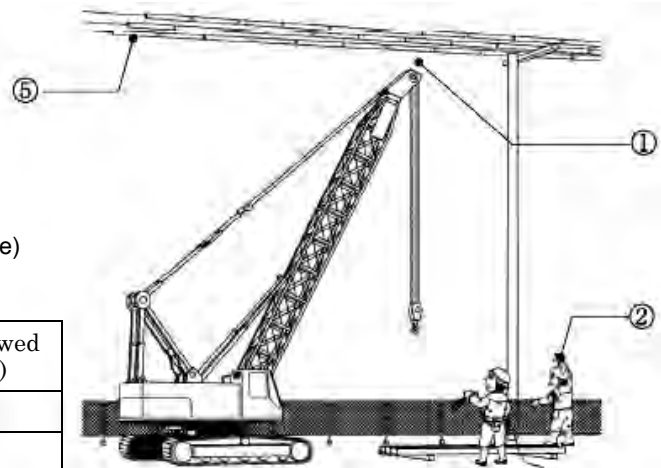

## 6. Prevention of danger caused by hauling, loading and unloading

### 6.1 Hauling, loading and unloading

Attention shall be paid to the speed limit and maximum load of vehicles when vehicles are used for hauling and loading.

**Check points:** (Refer to TCVN 3147:1990 Safety Code for loading and unloading works - General requirements)

- (1) Proper speed limit must be determined based on the shape of ground and ground condition.
- (2) The driving route will be secured from subsidence of the ground and collapse of shoulder. (TCVN 3147:1990, Article 3.1.1)
- (3) Ingress to approach places where hauling machines have risks to contact machines and materials are prohibited.
- (4) Signals must be determined between operators and flagman. (TCVN 3147:1990, Article 3.2.4)
- (5) Loads must be placed equally and well balanced on the trucks. Ropes and sheets will be used to prevent loads from collapsing. (TCVN 3147:1990, Article 3.2.2)
- (6) A vehicle must be loaded/unloaded at the flat ground. A board/plate to be used for loading/unloading must equip enough length, width and strength. A board/plate must be used at the proper angle. (TCVN 3147:1990, Article 4.1.4)
- (7) Worker shall not ride on machine except operator sheet.

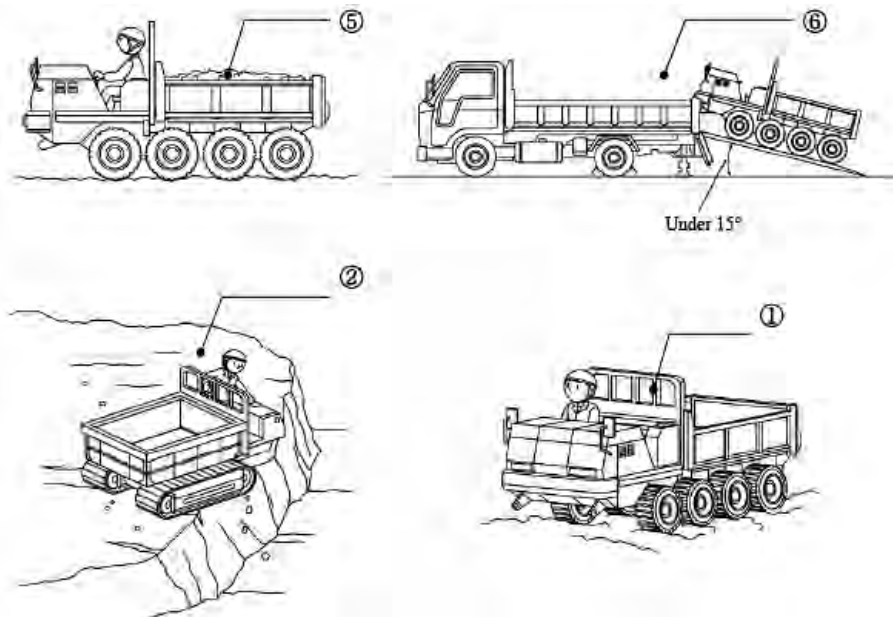

## 7. Prevention of danger to public

### 7.1 Signs of Keep out

It is necessary to install fences and notice boards to prevent third persons not to go inside of site.

**Check points:** *(Refer to Construction Law; TCVN 5308:1991 Code of practice for building safety technique)*

- (1) Publicity of works to the neighbor residents must be conducted.  
(Construction Law, Article 74)
- (2) Fences must be installed around a site to protect the possibility of accident on third persons.  
(TCVN 5308:1991, Article 2.1.1)
- (3) The entrance of site must be locked if necessary.
- (4) The structure of entrance and measures to prevent people not to enter into the site must be checked whether it is proper or not.
- (5) The fences must equip enough strength not to be destroyed by a strong wind.
- (6) A notice of "Keep out" must be displayed at the proper position.

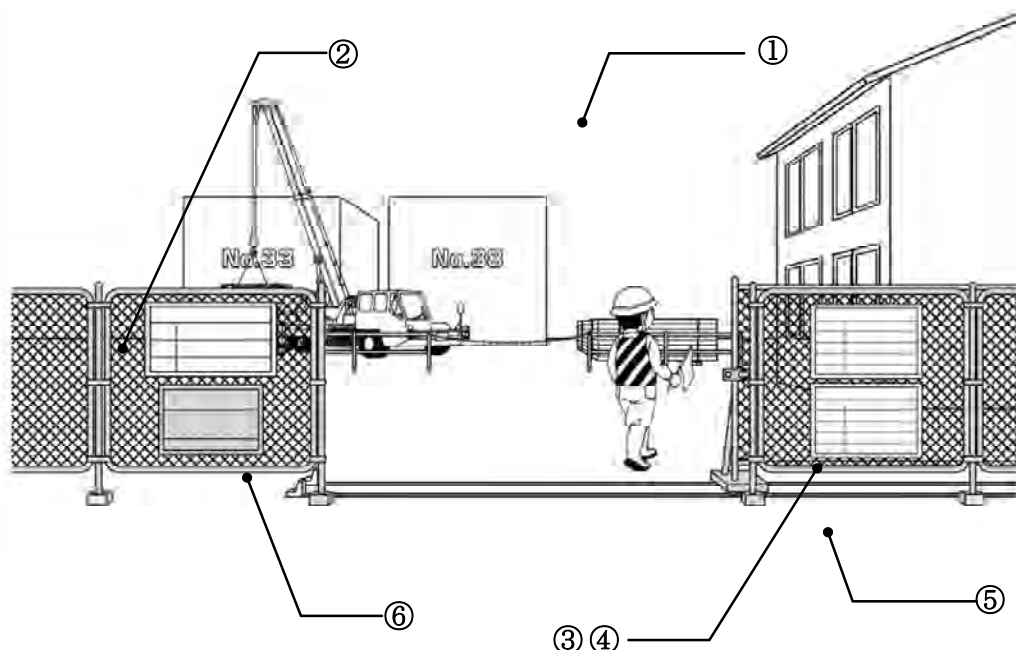

## 7. Prevention of danger to public

### 7.2 Vibration, Noise

It is necessary to prepare countermeasures not to disturb the living circumstance of residents around site.

**Check points:** (*Refer to QCVN 26:2010/BTNMT - Noise code; QCVN 27:2010/BTNMT - Vibration code*)

- (1) The noise and vibration shall not exceed the criterion levels which are specified by the vibration/noise regulation law in Vietnam.  
(QCVN 26:2010/BTNMT, QCVN 27:2010/BTNMT Chapter 2, Article 2.1)
- (2) A notification of \*designated construction work shall be submitted to the concerned government offices.
- (3) Vibration/noise regulations of concerned municipalities must be checked before starting construction.  
(QCVN 26:2010/BTNMT, QCVN 27:2010/BTNMT Chapter 4, Article 4.3)

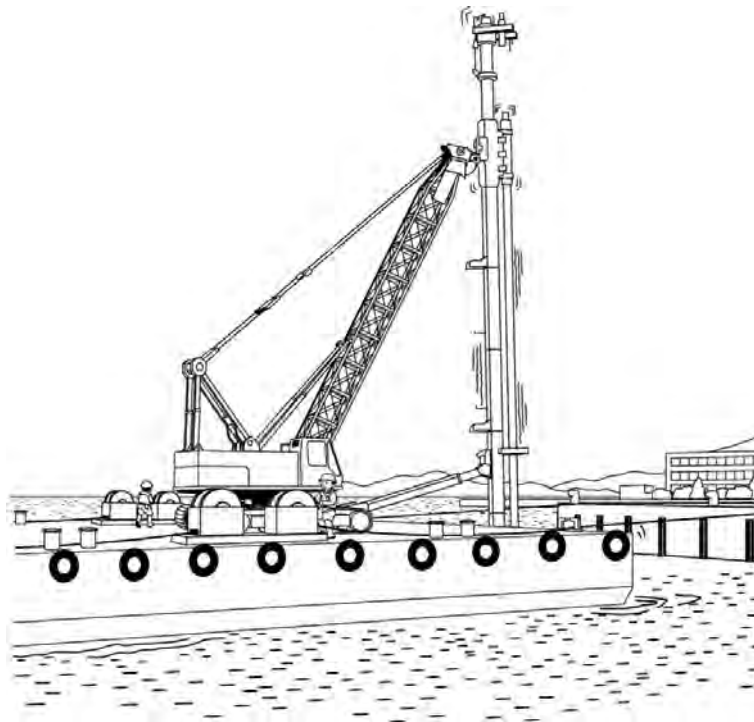

\* Designated construction work means that construction work which will cause considerable vibration and/or noise at site.



## 7. Prevention of danger to public

### 7.3 Works near buried objects

Locations of service lines for gas, electricity, telephone, internet and so on, must be checked and confirmed with concerned companies before construction.

**Check points:** (Refer to TCVN 5308:1991 Code of practice for building safety technique)

- (1) A contractor must arrange a meeting before construction with concerned companies and explain outlines of works. The method of joint inspection and security also should be discussed.  
(TCVN 5308:1991, Article 12.1.3)
- (2) Buried objects at the shallow depth must be checked by the hand test excavation. Attention must be paid not to damage buried objects at the time of test excavation. After locations of buried objects are confirmed, locations must be marked by stakes, flags or paint.  
(TCVN 5308:1991, Article 12.1.4)

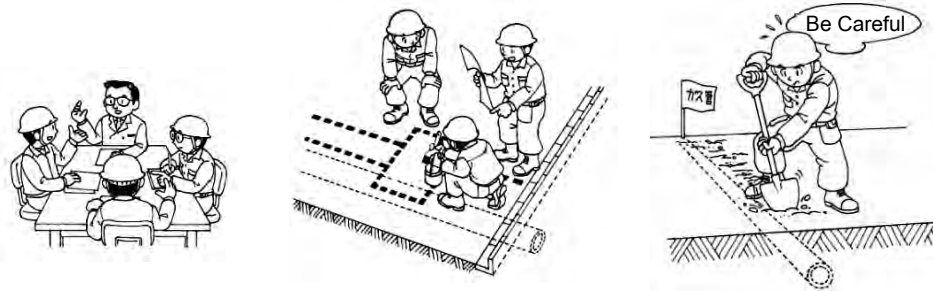

- (3) An inspector dispatched by a concerned company should attend the site when construction starts.  
(TCVN 5308:1991, Article 12.1.3)
- (4) Measures to prevent an explosion and a fire must be taken when works are close to gas pipes.
- (5) When contractor excavates near buried objects, buried objects must be reinforced or relocated if there is a possibility to be damaged.  
(TCVN 5308:1991, Article 12.1.13)

- (6) Appropriate measures must be prepared and/or taken to prevent the public disaster which may be caused by the damage of buried objects.  
(TCVN 5308:1991, Article 12.1.2)





## 8. Prevention of danger caused by fire and explosion

### 8.2 Handling hazardous materials

Appropriate management is necessary for fuel storing and for hazardous materials store. Special arrangement is required to handle such material.

**Check points:** (Refer to Decree 35/2003/NĐ-CP The detail regulations on executing some articles of Prevent and fire fighting law, TCVN 5308:1991 Code of practice for building safety technique)

- (1) Signs such as "Keep out" and "Danger: Flammable" must be installed.  
(Decree 35/2003/NĐ-CP, Chapter II, Article 9, Clause a)
- (2) A name of person in charge must be noticed at the site where fuel and hazardous materials are handled.  
(Decree 35/2003/NĐ-CP, Chapter II, Article 9, Clause b)
- (3) Ventilation is necessary at the storage house to prevent fire and explosion which may be caused by a combustible.  
(TCVN 5308:1991, Article 2.3.6)
- (4) Special attention is necessary when inflammability and combustible liquid is poured into drums.
- (5) Drums used for gasoline must be cleaned before pouring kerosene or diesel oil.

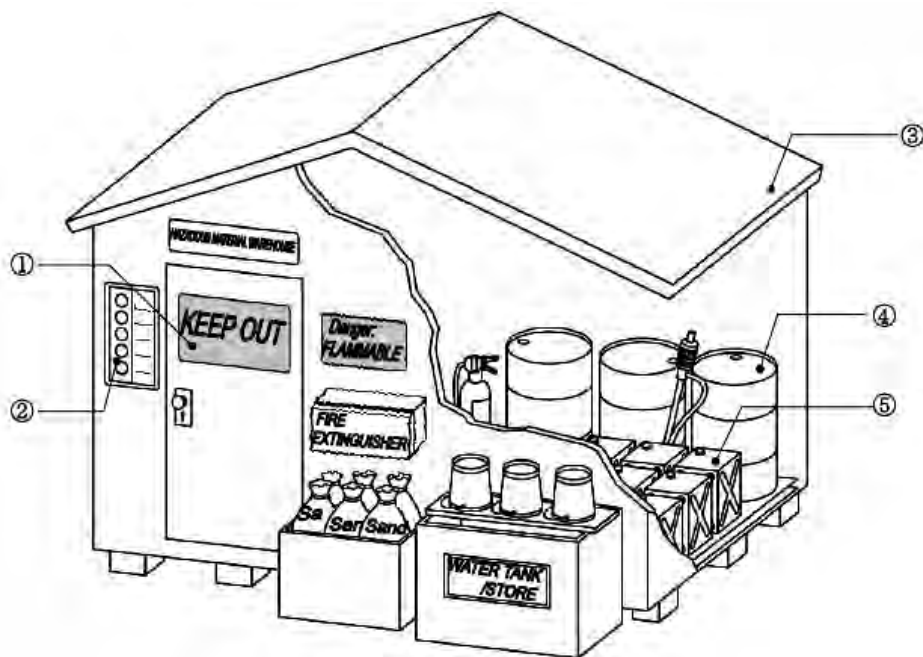

## 8. Prevention of danger caused by fire and explosion

### 8.3 Gas welding, Gas cutting

A welder must wear appropriate clothes and equipment for gas welding and cutting to protect him. Working places should be well-ventilated places..

**Check points:** *(Refer to Decree 35/2003/NĐ-CP The detail regulations on executing some articles of Prevent and fire fighting law, TCVN 5308:1991 Code of practice for building safety technique)*

- (1) A gas cutting apparatus must equip a flashback arrester.
- (2) A name of person in charge must be noticed at the site where gas cutting apparatus are used.  
(Decree 35/2003/NĐ-CP, Chapter II, Article 9, Clause b)
- (3) Indication of fill and empty must be shown on the gas/oxygen cylinders. (TCVN 5308:1991, Article 9.3.7)
- (4) Fire extinguisher must be arranged at site where gas apparatus are used.
- (5) Check the damage and crack of hoses before use. Also check gas leakage from the hoses and connection between hoses and apparatus.
- (6) Check the damage and disorder of gas apparatus's relief valves and pressure gages. (TCVN 5308:1991, Article 9.3.8)
- (7) Only qualified persons for gas apparatus can use gas apparatus.
- (8) Protection against welding litter/spark must be considered. Goggles are useful. (TCVN 5308:1991, Article 9.1.9)
- (9) Danger areas of fire and explosion must be signed as "Danger: Flammable". (Decree 35/2003/NĐ-CP, Chapter II, Article 9, Clause a)



## 9. Prevention of danger caused by tunnel and underground works

### 9.1 Rock falling, Ground collapse

It is necessary to support the stability of the tunnel portal area including tunnel entrance to prevent from rock falling and ground collapse. It is necessary to take "Keep out" measures from the portal area.

**Check points:** (Refer to TCVN 5308:1991 Code of practice for building safety technique)

- (1) Steel supports, Rockbolts and/or Shotcrete (sometimes all of them) must be used at the tunnel/portal of soft ground to prevent rocks/nature-ground from falling and collapsing. (TCVN 5308:1991, Article 21.2.3)
- (2) Protective nets against rock falling must be installed at the tunnel entrance.
- (3) Only nominated workers can work for steel supports, rockbolts and shotcrete in the tunnel. (TCVN 5308:1991, Article 21.2.6)
- (4) A ventilation system must be established in the tunnel to ventilate the exhaust gas and to keep the good visibility. (TCVN 5308:1991, Article 21.5)
- (5) Illuminance in the tunnel must be more than 70 lux at level and more than 20 lux at the passage. (TCVN 5308:1991, Article 21.4)
- (6) Driving paths for tunnel machines must be kept and well maintained in the tunnel. (TCVN 5308:1991, Article 21.3)
- (7) Watch men for tunnel machines must be arranged for its operation. (usually a tunnel worker can work as a watch men when tunnel machine moves.)
- (8) Workers in the tunnel must wear helmets (TCVN 5308:1991, Article 21.1.6)



## 9. Prevention of danger caused by tunnel and underground works

### 9.2 Explosion, Fire

It is prohibited not to bring unnecessary fire starter or high inflammable materials in the tunnel and try to prevent tunnel from explosion and fire.

**Check points:** (Refer to TCVN 5308:1991 Code of practice for building safety manual; TCVN 3254:1989 Fire safety-General requirements; TCVN 3255:1986 Explosion safety-General requirements)

- (1) Flammables, matches and lighters are prohibited to bring in the tunnel. (TCVN 3254:1989, Article 2.3)
- (2) Signs of "No carrying flammables" must be shown at the entrance of tunnel or prominent places.
- (3) Prevention measures for explosion caused by inflammable gases and prevention measures for fire must be decided by the contractor. Such measures must be known by workers as common knowledge of workers. (TCVN 3255:1986, Article 2 - 4)
- (4) If there is a possibility inflammable gas to be blown during tunnel excavation, degasification is necessary before excavation. (TCVN 5308:1991, Article 21.2.9)
- (5) Inflammable materials such as rags, chips of wood and papers must be removed from the tunnel as much as possible or will be covered by nonflammable sheets. (TCVN 3254:1989, Article 3.2)
- (6) Extinguishers must be prepared at the place of arc welding and gas cutting/welding places. The location of extinguishers must be noticed to the all workers. (TCVN 3254:1989, Article 4.5)



## 9. Prevention of danger caused by tunnel and underground works

### 9.3 Evacuation

Installation of alarm devices, the method/route of evacuation and reservation of evacuation goods must be known by workers as common knowledge of workers.

**Check points:** (Refer to TCVN 5308:1991 Code of practice for building safety manual; TCVN 3254:1989 Fire safety-General requirements)

- 1) If there are probabilities of rock falling and flushing underground water, stop all activities immediately and leave the area.

(TCVN 5308:1991, Article 21.2.5)

- 2) When the density of inflammable gas reaches 30% of the lowest limit of explosion, all workers must evacuate the site.

(TCVN 5308:1991, Article 21.2.9)

- 3) Warning devices such as siren and alarm must be installed in the tunnel if the distance between face to outside became more than 100meters. All people working in the tunnel must know the location of warning devices..

- 4) In addition to the warning devices, an intercommunication system must be installed in the tunnel if the distance between face to outside became more than 500meters.All people working in the tunnel must know the location of communication system.

(TCVN 5308:1991, Article 21.1.3)

- 5) Inflammable materials such as rags, chips of wood and papers must be removed from the tunnel as much as possible or will be covered by nonflammable sheets.

(TCVN 3254:1989, Article 3.2)

- 6) Warning devices must be maintained well at the all-time. (TCVN 3254:1989, Article 3.10)

- 7) The standby power for warning devices must be prepared.

- 8) Emergency evacuation goods must be prepared in the tunnel.



## 9. Prevention of danger caused by tunnel and underground works

### 9.4 Steel Supports

Steel supports must be prepared based on the geological formations, the nature of soil/rock, the groundwater condition, cracks and so on. Appropriate erection and disassembly is necessary according to the condition of ground.

**Check points:** (Refer to TCVN 5308:1991 Code of practice for building safety technique)

- (1) Steel supports must be not deformed, not damaged, not corroded.  
(TCVN 5308:1991, Article 21.2.12~13)
- (2) Steel supports must be designed based on the information of geological formations, the nature of soil/rock, the groundwater condition, cracks, loose stones and so on.  
(TCVN 5308:1991, Article 21.1.3)
- (3) Steel supports must be installed in the tunnel based on the erection drawing.  
(TCVN 5308:1991, Article 21.2.6)
- (4) A set of steel support must be installed in the same plane.
- (5) The condition of steel supports such as the existence of damage, pressure from the ground and the condition of joints must be checked everyday.  
(TCVN 5308:1991, Article 21.2.4)

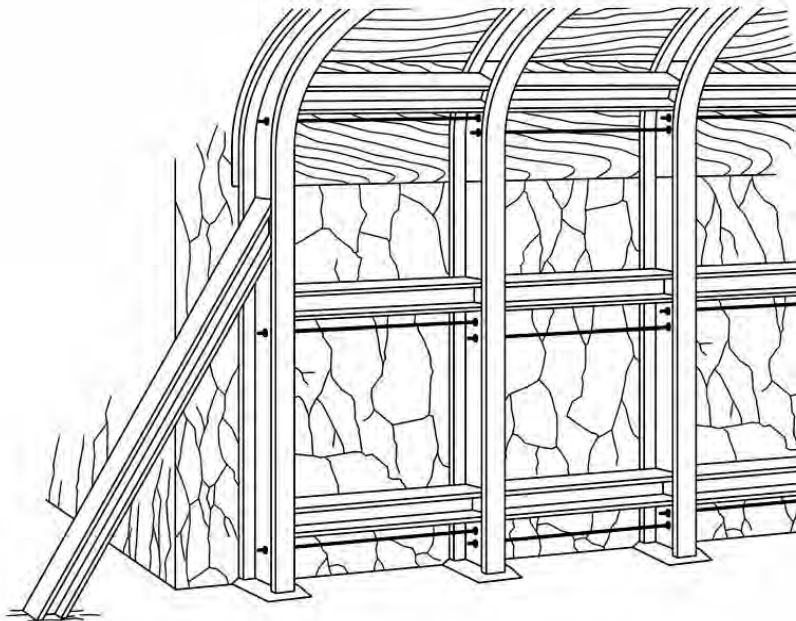



## 9. Prevention of danger caused by tunnel and underground works

### 9.5 Rescue

The following check points apply to ① the tunnel which length is more than 1,000 meters, ② the shaft which depth is more than 50 meters, ③ the pneumatic method area which pressure is more than 0.1Mpa.

**Check points:** (Refer to TCVN 5308:1991 Code of practice for building safety technique)

- (1) Oxygen masks must be equipped at site (TCVN 5308:1991, Article 21.1.6)
- (2) Measuring instruments for methane, hydrogen sulfide, carbon monoxide and oxygen density must be equipped at site.  
(TCVN 5308:1991, Article 21.2.9)
- (3) Portable lights must be equipped at site.
- (4) Ladders and rope must be equipped at site.
- (5) Drills how to use oxygen masks, measuring instruments, ladders and rope must be arranged at site. (TCVN 5308:1991, Article 21.1.9)
- (6) Drills of resuscitation and first aid must be arranged at site.  
(TCVN 5308:1991, Article 21.1.9)
- (7) Names of participants for drills, intervals of drills and contents of drills must be recorded at least for 3 years.
- (8) Names of workers and number of workers to work at above mentioned areas (①, ②, ③) must be grasped/confirmed by the supervisor at all times. (TCVN 5308:1991, Article 21.2.2)
- (9) A person in charge for resuscitation and first aid must be designated at site. (TCVN 5308:1991, Article 21.1.8)



A sample of poison gases detector (can detect methane, hydrogen sulfide, carbon monoxide and oxygen density)

## 9. Prevention of danger caused by tunnel and underground works

### 9.6 Walkways in tunnels and working environment

Walkways in tunnels must be well ventilated and keeps working environment in good condition.

**Check points:** (Referto TCVN 5308:1991 Code of practice for building safety technique)

- (1) The length of Ladder must be less than 8 meters. If the gap of height is more than 8 meters, a landing shall be arranged on the way to upper place. (TCVN 5308:1991, Article 21.3.5)
- (2) The angle of ladder must be less than 80. (TCVN 5308:1991, Article 21.3.5)
- (3) Machines operated on engine can't be used in tunnel where the ventilation is insufficient. (TCVN 5308:1991, Article 21.3.14)
- (4) Measures such as water spray must be arranged in tunnel to prevent dust scattering.
- (5) A density of carbon dioxide gas ( $\text{CO}_2$ ) in tunnel must be less than 1.5%.
- (6) Places where a density of carbon dioxide gas ( $\text{CO}_2$ ) is over 1.5% and a density of oxygen ( $\text{O}_2$ ) is less than 18% are prohibited to enter. (TCVN 5308:1991, Article 21.5.2)
- (7) A density of carbonic acid gas ( $\text{CO}_2$ ) in tunnel must be measured every month and be recorded for 3 years.
- (8) A ventilation system in tunnel must be checked at least twice a month and be recorded for 3 years.
- (9) The temperature in tunnel must be under 30 and be measured at least twice a month and be recorded for 3 years.

(TCVN 5308:1991, Article 21.5.2)

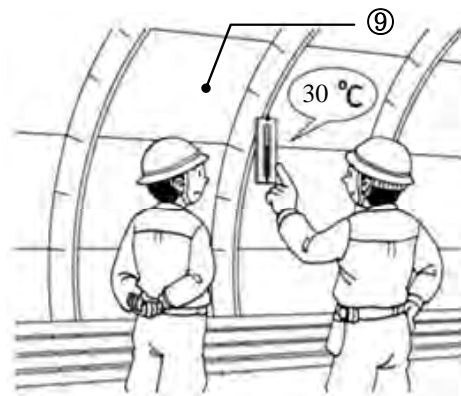
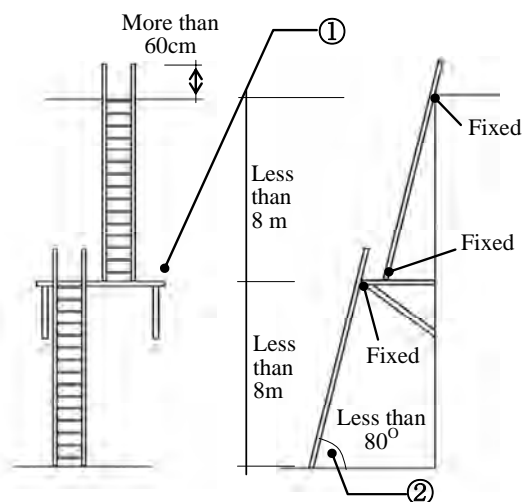

## 9. Prevention of danger caused by tunnel and underground works

### 9.7 Quarrying

Quarry means a place where large amounts of stone, etc. are dug out of the ground. Quarrying means excavation/digging at quarries, crushing stones, transportation in quarry, processing stones/rocks and so on. Appropriate management for quarrying is necessary.

**Check points:** *(Refer to TCVN 5178:1990; TCVN 5178:2004 Safety technical rules for stone explosion and processing in the open-cast mines)*

- (1) The shape of ground, geological formations and the nature of soil/rock must be checked and be recorded. (TCVN 5178:1990, Appendix 1, Article 2, 3)
- (2) \*A work plan must be prepared for quarrying.  
(TCVN 5178:1990, Appendix 1, Article 5)
- (3) A person in charge for quarrying must be designated.  
(TCVN 5178:2004, Article 3.2; 3.8)
- (4) Blasting notice must be notified the relevant personnel around a quarry.  
(TCVN 5178:2004, Article 4.6.5)
- (5) Work places at quarry must equip sufficient lighting.  
(TCVN 5178:1990, Article 2.6.1.3)
- (6) A slope of excavation must be kept within the limit slope.  
(TCVN 5178:2004, Article 4.2)
- (7) Counter measures for collapse and cave-in accidents must be arranged.
- (8) All person authorized to enter the quarry must wear safety helmets.
- 9) A controller for construction machines/vehicles must be designated and he directs traffic of machines/vehicles.  
(TCVN 5178:1990, Article 2.7; 2.8)

Note:\*A work plan

Contents of a work plan

- Types of excavation, Height of excavation, Slope of excavation  
(TCVN 5178:2004, Article 4.2)
- Locations of step, Depth of step  
(TCVN 5178:2004, Article 4.2)
- Prevention measures for cave-in  
(TCVN 5178:2004, Article 4.3)
- Type and capacity of machines  
(TCVN 5178:2004, Article 4.6.7~9)
- Disposal measures for spring
- Methods of blasting, method of crushing stones
- Methods of loading and transportation



(TCVN 5178:2004, Article 4.6; 5)  
(TCVN 5178:2004, Article 4.8)

## 10. Prevention of danger caused by offshore operation

### 10.1 Pump type dredger

Points to note for the pump type dredger are shown below.

#### Check points:

- (1) Contents of work must be notified to all people concerned with the project. (2) A qualified person for dredging must be assigned.
- (3) A signaller must be assigned and common signals must be shared among workers.
- (4) Workers must wear appropriate clothing, safety protective equipment and life preservers for dredging works.
- (5) Safety walkways must be arranged.
- (6) Winches and wire ropes must be checked regularly.
- (7) Operators and workers cannot stand at the inside of wire's interior angle.
- (8) At least two workers are required to work together for night operation on deck.
- (9) Condition of mooring must be checked.
- (10) Necessary measures must be taken according to weather and ocean phenomena.
- (11) The condition of a brake and a stopper of each winch must be checked before starting operation.

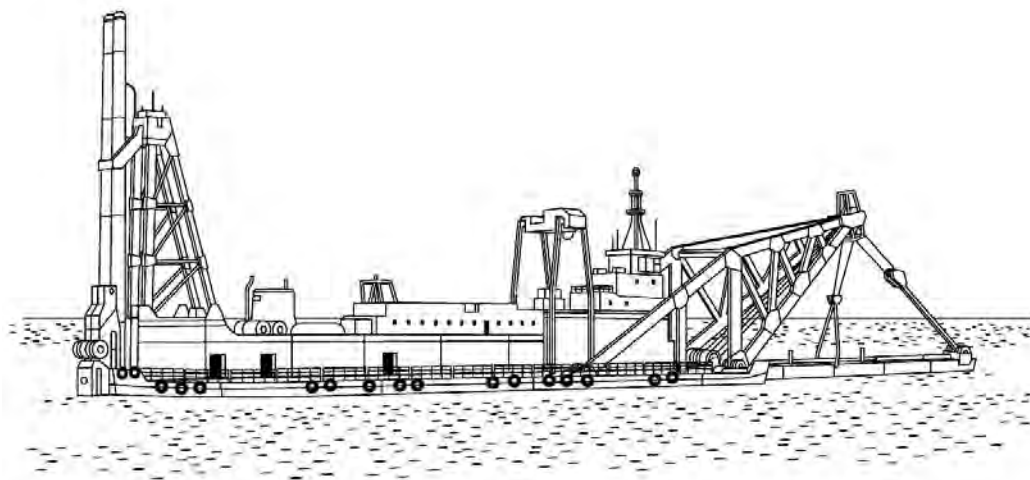

## 10. Prevention of danger caused by offshore operation

### 10.2 Grab dredger

Points to note for grab bucket dredger are shown below.

#### Check points:

- (1) Contents of work must be notified to all people concerned with the project.
- (2) A qualified person for dredging must be assigned.
- (3) A signalman must be assigned and common signals must be shared among workers.
- (4) Workers must wear appropriate clothing, safety protective equipment and life preservers for dredging works.
- (5) Safety walkways must be arranged.
- (6) Winches and wire ropes must be checked regularly.
- (7) Operators and workers cannot stand at the inside of wire's interior angle.
- (8) No worker can enter into the swing radius of dredging machine.
- (9) When the operator leaves a machine, he must lay down the grab hopper, set the brake and remove the key.
- (10) Excavated material must be loaded onto a barge equally. Overload is prohibited.
- (11) Condition of mooring must be checked.
- (12) Necessary measures must be taken according to weather and ocean phenomena.
- (13) The condition of a brake and a stopper of each winch must be checked before starting.

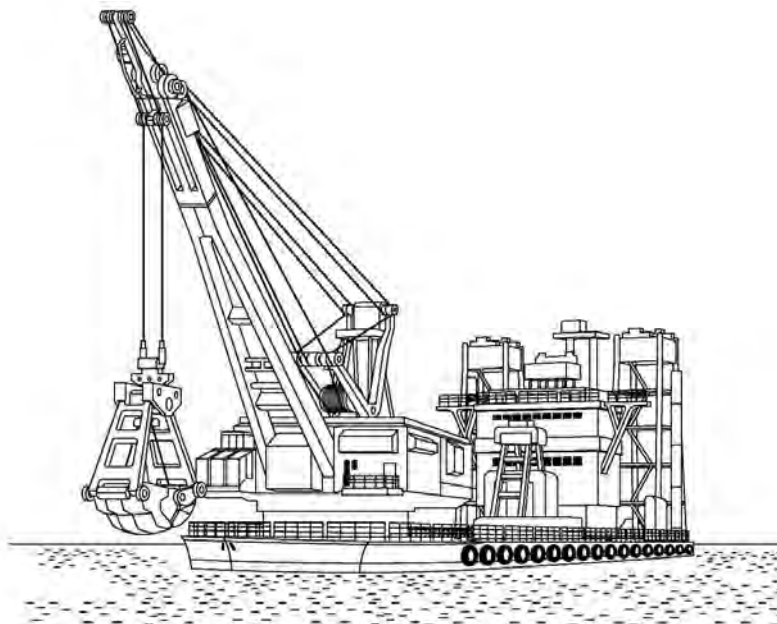

## 10. Prevention of danger caused by offshore operation

### 10.3 Ground improvement ship

Points to note for the ground improvement ship are shown below.

#### Check points:

- (1) Contents of work must be notified to all people concerned with the project.
- (2) A qualified person for ground improvement must be assigned.
- (3) A signalman must be assigned and common signals must be shared among workers.
- (4) Workers must wear appropriate clothing, safety protective equipment and life preservers on ship.
- (5) Safety walkways must be arranged.
- (6) Winches and wire ropes must be checked regularly.
- (7) Operators and workers cannot stand at the inside of wire's interior angle. (8) Safety belts must be used for works in high places.
- (9) Hoppers must be cleaned and inspected according to procedures.
- (10) Condition of mooring (main ship and work boat) must be checked.
- (11) Necessary measures must be taken according to weather and ocean phenomena.
- (12) The condition of a brake and a stopper of each winch must be checked before starting operation.

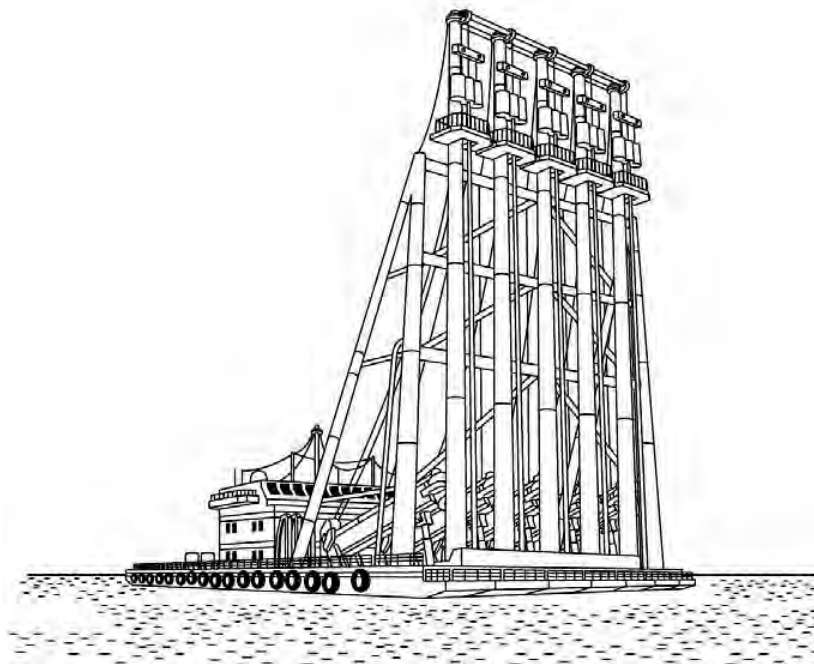

## 10. Prevention of danger caused by offshore operation

### 10.4 Piling ship

Points to note for the piling ship are shown below.

#### Check points

- (1) Contents of work must be notified to all people concerned with the project.
- (2) A qualified person for piling works must be assigned.
- (3) A signalman must be assigned and common signals must be shared among workers.
- (4) Workers must wear appropriate clothing, safety protective equipment and life preservers on ship.
- (5) Safety walkways must be arranged.
- (6) Winches and wire ropes must be checked regularly.
- (7) Appropriate anti rolling measures of piles must be arranged.
- (8) Operators and workers cannot stand at the inside of wire's interior angle. (9) Safety belts must be used for works in high places.
- (10) Nobody can work under suspended loads.
- (11) Condition of mooring must be checked.
- (12) Necessary measures must be taken according to weather and ocean phenomena.
- (13) The condition of a brake and a stopper of each winch must be checked before starting operation.

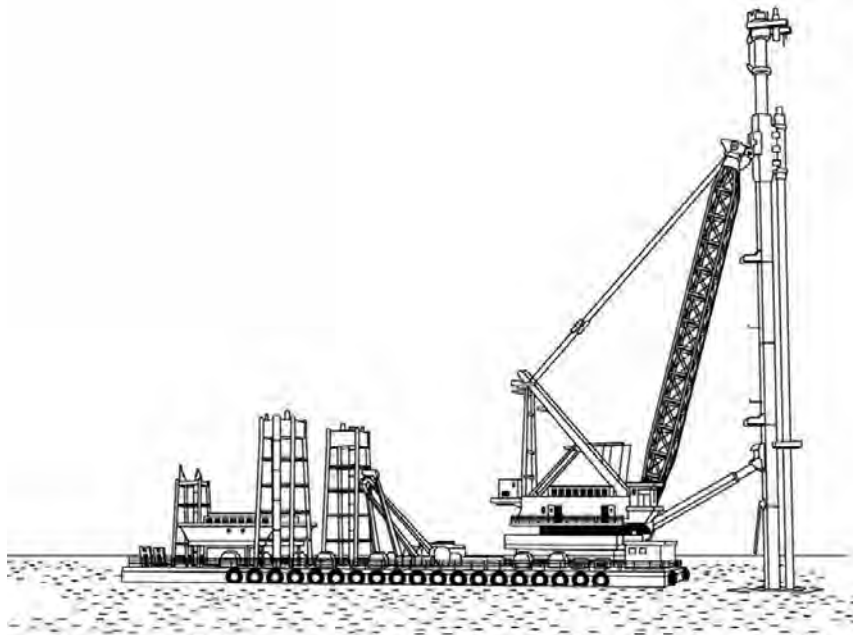

## 11. Prevention of health disorder of workers

### 11.1 Oxygen deficiency

An oxygen deficiency sometimes will happen at old wells, manholes and ship's holds where are kept airtight for a long time. Appropriate care and measures must be taken to prevent oxygen deficiency.

**Check points:** (Refer to TCVN 5308:1991, Code of practice for building safety manual)

- (1) A person in charge must be designated. (TCVN 5308:1991, Article 21.2.2)
- (2) The oxygen content at above mentioned work places must be measured before work. (TCVN 5308:1991, Article 21.2.9)
- (3) Safety belts must be used for works at high places. (TCVN 5308:1991, Article 1.14)
- (4) Working areas must be ventilated. (TCVN 5308:1991, Article 21.5.1)
- (5) Apparatus more than workers must be arranged at site. Workers must use the apparatus when and where it's required. TCVN 5308:1991, Article 21.5.5)
- (6) Apparatus must be checked every day before starting works.
- (7) At places where possibility of oxygen deficiency will happen, a number of persons must be counted before and after works. (TCVN 5308:1991, Article 21.2.2)
- (8) People who are not involved in works can't allow entering sites.
- (9) All workers must stop work immediately and evacuate site when the possibility of oxygen deficiency happens. (TCVN 5308:1991, Article 21.5.6)
- (10) A oxygen deficiency site must prepare emergency equipment (oxygen masks, ladders, ropes, etc.). TCVN 5308:1991, Article 21.1.6)

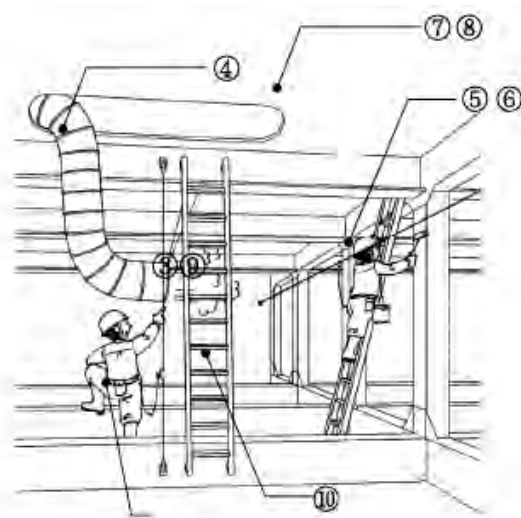



**Reference:**

Oxygen content and condition of oxygen deficiency are shown below.

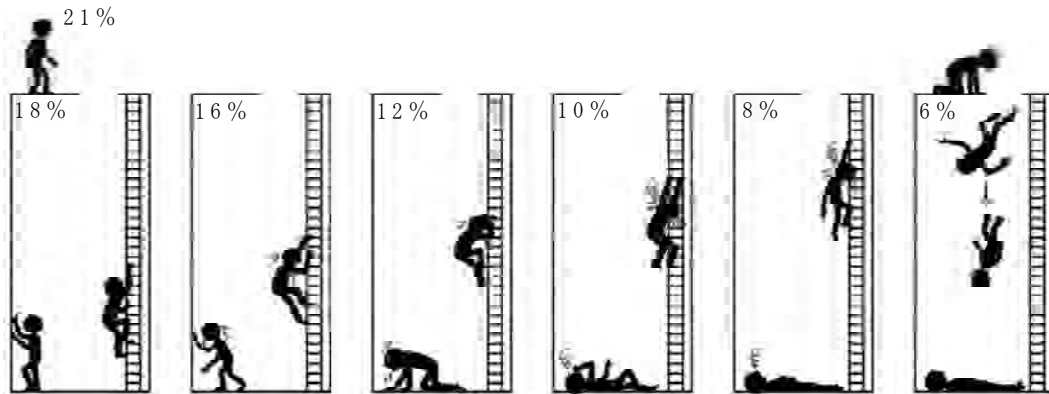

21%: Above the ground

8%: Safe limit but need continuous ventilation

6%: Breath and pulse increase, headache, nausea

2%: Dizziness, nausea, loss in muscle strength, can't support his own weight and fall (→ be killed in a fall)

10%: Facial pallor, unconsciousness, vomiting (→ an airway obstruction → death by suffocation)

8%: Faint, coma, death within 7-8 minutes

6%: Coma, cessation of breathing, convulsion, death within 6 minutes

## 11. Prevention of health disorder of workers

### 11.2 Dust

Dust will be occurred by excavation, loading materials, shotcreting, concreting and so on. Protective measures must be taken for such occasions.

**Check points:** (Refer to TCVN 5937:1995 Air Quality-Ambient air quality standards, TCVN 2291:1978 Means of labor protection-Classification)

- (1) Dust masks must be used at the dusty work place.  
(TCVN 2291:1978; Appendix 1.1)
- (2) Ventilation is required at the dusty work place.  
(TCVN 2291:1978; Appendix 2.4)

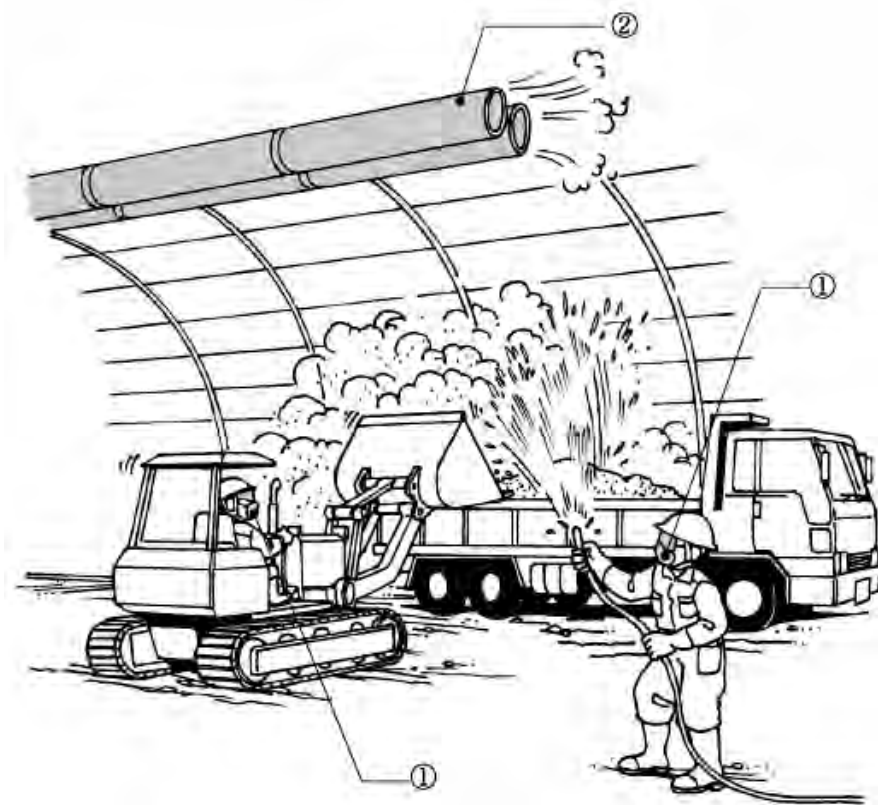

## 11. Prevention of health disorder of workers

### 11.3 Vibration, Noise

Vibration and noise will be occurred by breaking work, drilling work, bolt fastening work and so on when vibrating machine is used. White finger disease is one of the sick caused by vibration works.

**Check points:** (Refer to TCVN 2291:1978 Means of labor protection-Classification)

- (1) Personal protective equipment (vibration protective gloves, earplugs) must be worn by workers who are involved vibration and noisy works.  
(TCVN 2291:1978; Appendix 2.7)
- (2) Low vibration and low noise type machines are recommended to use.
- (3) Workers must have medical checkup for vibrating and noisy works.
- (4) Safety induction must be conducted for workers who are involved in vibrating and noisy works.
- (5) Limited working hours must be specified for vibrating works and noisy. Workers are not able to work beyond such limited working hours.

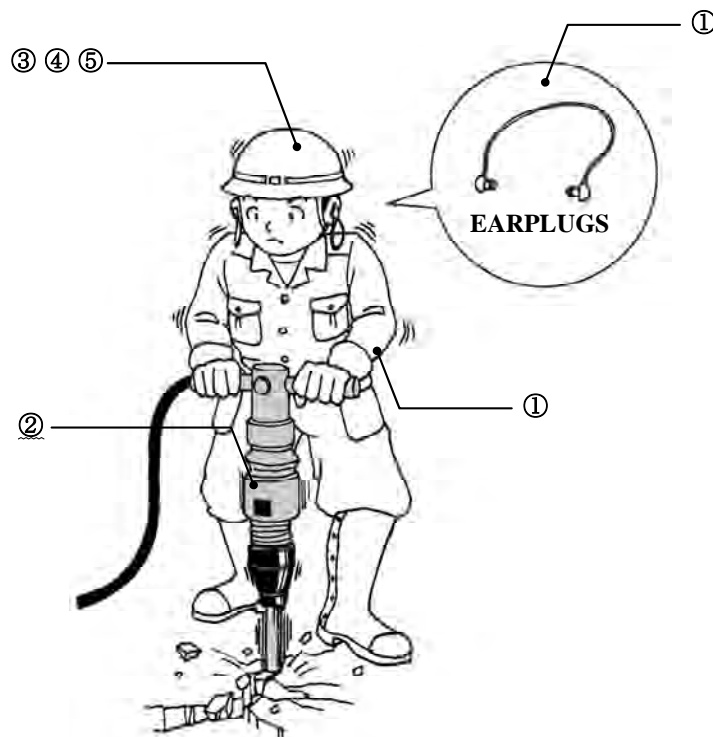

## **APPENDIX**



## **Appendix I**

### **SAFETY CHECK LIST**

*(Attached to Safety and Health Manual in Construction,  
published by Construction publishing House)*

Only 11 samples are attached for each potential risk mentioned on Chapter III of this Manual. Electric data of other 39 samples are stored in the attached CD. Users can develop the check list by themselves

Safety Check List		Footing		
Project Title		Date of Inspection	Date, Month, Year	
Construction period	Date, Month, Year ~ Date, Month, Year	Inspector	Office	
Contractor			Name	
Inspection Items		Inspection Result	Counter Measures	After measure Good/Bad
Pipe	(1) Is maximum loading capacity of footing shown at the conspicuous place?	Good • Bad		
	(2) Are metal fittings to wall used?	Good • Bad		
	(3) Are metal bases for pipes used?	Good • Bad		
	(4) Are horizontal pipes near metal base installed?	Good • Bad		
	(5) Are metal bases located at the right space? (less 1.5m, less 1.85m)	Good • Bad		
	(6) Is the height of first footing step less than 2m?	Good • Bad		
	(7) Is the total width of scaffold planks more than 40cm?	Good • Bad		
	Is the gap between scaffold planks less than 3cm?	Good • Bad		
	(8) Are cross bracing used to reinforce the footing?	Good • Bad		
	(9) Are handrails fixed?	Good • Bad		
Scaffolding	(1) Is maximum loading capacity of footing shown at the conspicuous place?	Good • Bad		
	(2) Are metal fittings to wall used?	Good • Bad		
	(3) Are metal bases for pipes used? Are metal bases settled on the board?	Good • Bad		
	(4) Are horizontal pipes near metal base installed?	Good • Bad		
	(5) Are metal bases located at the right space? (less 1.5m, less 1.85m)	Good • Bad		
	(6) Is the total width of scaffold planks more than 40cm?	Good • Bad		
	Is the gap between scaffold planks less than 3cm?	Good • Bad		
	(7) Are bracings installed at all sides?	Good • Bad		
	(8) Are handrails fixed?	Good • Bad		

Safety Check List		Facilities to prevent littering		
Project Title		Date of Inspection	Date, Month, Year	
Construction period	Date, Month, Year ~ Date, Month, Year	Inspector	Office	
Contractor			Name	
Inspection Items		Inspection Result	Counter Measures	After measure Good/Bad
	(1) Are protective sheets tied up less than 45cm spacing?	Good • Bad		
	(2) Are protective sheets and pipes tied up less than 45cm spacing	Good • Bad		
	(3) Potential area to be hit by dropped litters must be protected by net.	Good • Bad		
	(4) Materials should be covered or tied up with ropes to prevent not to be blown by wind	Good • Bad		
	(5) Workers must wear helmet	Good • Bad		
	(6) Notice of "Keep Out"	Good • Bad		



Safety Check List		Asembling/Disassembling supports		
Project Title		Date of Inspection	Date, Month, Year	
Construction period	Date, Month, Year ~ Date, Month, Year	Inspector	Office	
Contractor			Name	
Inspection Items		Inspection Result	Counter Measures	After measure Good/Bad
Assem./Disassem.	(1) Are drawings for assembling prepared before starting erection?	Good • Bad		
	(2) Is a chief supervisor appointed for supporting works?	Good • Bad		
	(3) Are actions taken to prohibit people from entering working area without permission?	Good • Bad		
	(4) Works shall be stopped in inclement weather.	Good • Bad		
Scaffold	(5) Sole use pins must be used to fix the length of supports.	Good • Bad		
	(6) Are horizontal pipes near metal base installed to prevent slips of metal bases?	Good • Bad		
	(7) Extra horizontal pipes must be added at every 2m when the height of support is higher than 3.5m.	Good • Bad		
	(8) Working platform must be set up at the top of scaffold.	Good • Bad		
	(9) A diagonal brace must be set up.	Good • Bad		
	(10) A stair must be set up to the place higher than 1.5m.	Good • Bad		
	(11) All braces must be set up at the right place.	Good • Bad		

Safety Check List		Leveling, Hauling, Loading machinesing		
Project Title		Date of Inspection	Date, Month, Year	
Construction period	Date, Month, Year ~ Date, Month, Year	Inspector	Office	
Contractor			Name	
Inspection Items		Inspection Result	Counter Measures	After measure Good/Bad
(1)	Worker shall not ride on machine except operator sheet	Good • Bad		
(2)	Headlights must be equipped with a machine	Good • Bad		
(3)	When the operator leaves a machine, he must lay down the blade, set the brake and remove the key.	Good • Bad		
(4)	Damage of canopy must be checked before starting operation.	Good • Bad		
(5)	An observer must be arranged at the place where risks of rolling/falling exist.	Good • Bad		
(6)	Working area must be marked clearly to prevent unauthorized people to enter.	Good • Bad		

Safety Check List		Electric substation		
Project Title		Date of Inspection	Date, Month, Year	
Construction period	Date, Month, Year ~ Date, Month, Year	Inspector	Office	
Contractor			Name	
Inspection Items		Inspection Result	Counter Measures	After measure Good/Bad
(1) The name of person in charge must be noticed onto a (bulletin) board.		Good • Bad		
(2) No entry fence shall be installed around facilities and put up a "Keep Out" sign.		Good • Bad		
(3) Electric substation facilities should be inspected regularly, at least once a month.		Good • Bad		
(4) Electric substation facilities installed at outdoors shall be waterproof type.		Good • Bad		
(5) The substation must equip the necessary luminous intensity for the operation and inspection.		Good • Bad		
(6) Regular inspections that are specified in the law (such as weekly and annual inspections) must be carried out.		Good • Bad		

Safety Check List		Haulin		
Project Title		Date of Inspection	Date, Month, Year	
Construction period	Date, Month, Year ~ Date, Month, Year	Inspector	Office	
Contractor			Name	
Inspection Items		Inspection Result	Counter Measures	After measure Good/Bad
	(1) Proper speed limit must be determined based on the shape of ground and ground condition.	Good • Bad		
	(2) The driving route will be secured from subsidence of the ground and collapse of shoulder.	Good • Bad		
	(3) Ingress to approach places where hauling machines have risks to contact machines and materials are prohibited.	Good • Bad		
	(4) Signals must be determined between operators and flagman.	Good • Bad		
	(5) Loads must be placed equally and well balanced on the trucks. Ropes and sheets will be used to prevent loads from collapsing.	Good • Bad		
	(6) A vehicle must be loaded/unloaded at the flat ground. A board/plate to be used for loading/unloading must equip enough length, width and strength. A board/plate must be used at the proper angle.	Good • Bad		
	(7) Worker shall not ride on machine except operator sheet.	Good • Bad		

Safety Check List		Signs of Keep out		
Project Title		Date of Inspection	Date, Month, Year	
Construction period	Date, Month, Year ~ Date, Month, Year	Inspector	Office	
Contractor			Name	
Inspection Items		Inspection Result	Counter Measures	After measure Good/Bad
(1)	Publicity of works to the neighbor residents must be conducted.	Good • Bad		
(2)	Fences must be installed around a site to protect the possibility of accident on third persons.	Good • Bad		
(3)	The entrance of site must be locked if necessary.	Good • Bad		
(4)	The structure of entrance and measures to prevent people not to go into the site must be checked whether it is proper or not.	Good • Bad		
(5)	The fences must equip enough strength not to be destroyed by a strong wind.	Good • Bad		
(6)	A notice of "Keep out" must be displayed at the proper position.	Good • Bad		



Safety Check List		Rock falling, Ground collapse		
Project Title		Date of Inspection	Date, Month, Year	
Construction period	Date, Month, Year ~ Date, Month, Year	Inspector	Office	
Contractor			Name	
Inspection Items		Inspection Result	Counter Measures	After measure Good/Bad
(1)	Steel supports, Rockbolts and/or Shotcrete (sometimes all of them) must be used at the tunnel/portal of soft ground to prevent rocks/nature-ground from falling and collapsing.	Good • Bad		
(2)	Protective nets against rock falling must be installed at the tunnel entrance.	Good • Bad		
(3)	Only nominated workers can work for steel supports, rockbolts and shotcrete in the tunnel.	Good • Bad		
(4)	A ventilation system must be established in the tunnel to ventilate the exhaust gas and to keep the good visibility.	Good • Bad		
(5)	Illuminance in the tunnel must be more than 70 lux at level and more than 20 lux at the passage.	Good • Bad		
(6)	Driving paths for tunnel machines must be kept and well maintained in the tunnel.	Good • Bad		
(7)	Watch men for tunnel machines must be arranged for its operation. (usually a tunnel worker can work as a watch men when tunnel machine moves.	Good • Bad		
(8)	A worker in the tunnel must were helmets	Good • Bad		

Safety Check List		Rock falling, Ground collapse		
Project Title		Date of Inspection	Date, Month, Year	
Construction period	Date, Month, Year ~ Date, Month, Year	Inspector	Office	
Contractor			Name	
Inspection Items		Inspection Result	Counter Measures	After measure Good/Bad
(1)	Contents of work must be notified to all people concerned with the project.	Good • Bad		
(2)	A qualified person for dredging must be assigned.	Good • Bad		
(3)	A signalman must be assigned and common signals must be shared among workers.	Good • Bad		
(4)	Workers must wear appropriate clothing, safety protective equipment and life preservers for dredging works.	Good • Bad		
(5)	Safety walkways must be arranged.	Good • Bad		
(6)	Winches and wire ropes must be checked regularly.	Good • Bad		
(7)	Operators and workers cannot stand at the inside of wire's interior angle.	Good • Bad		
(8)	At least two workers are required to work together for night operation on deck.	Good • Bad		
(9)	Condition of mooring must be checked.	Good • Bad		
(10)	Necessary measures must be taken according to weather and ocean phenomena.	Good • Bad		
(11)	The condition of a brake and a stopper of each winch must be checked before starting operation.	Good • Bad		



Safety Check List		Oxygen deficiency		
Project Title		Date of Inspection	Date, Month, Year	
Construction period	Date, Month, Year ~ Date, Month, Year	Inspector	Office	
Contractor			Name	
Inspection Items		Inspection Result	Counter Measures	After measure Good/Bad
	(1) A person in charge must be designated.	Good • Bad		
	(2) The oxygen content at above mentioned work places must be measures before work.	Good • Bad		
	(3) Safety belts must be used for works at high places.	Good • Bad		
	(4) Working areas must be ventilated.	Good • Bad		
	(5) Apparatus more than workers must be arranged at site. Workers must use apparatus when and where it's required.	Good • Bad		
	(6) Apparatus must be checked every day before starting works.	Good • Bad		
	(7) At places where possibility of oxygen deficiency will happen, a number of persons must be counted before and after works.	Good • Bad		
	(8) People who are not involved in works can't allow entering sites.	Good • Bad		
	(9) All workers must stop work immediately and evacuate site when the possibility of oxygen deficiency happens.	Good • Bad		
	(10) An oxygen deficiency site must prepare emergency equipment (oxygen masks, ladders, ropes, etc.).	Good • Bad		

## Appendix II

### LIST OF JOBS WITH STRICT REQUIREMENTS ON OCCUPATIONAL SAFETY, LABOR HYGIENE

*"(Reference Appendix 1, Circular No. 37/2005/TT-BLDTBXH*

*Dated on December 29, 2005 by*

*Ministry of Labour - Invalids and Social Affairs)"*

ACTIVITIES	No. <i>(Follow Circular)</i>	WORD DESCRIPTION
Work environment	1	The work carried out in an environment with toxic elements such as chemicals, radiation, pathogenic microorganisms ....
	5	The work carried out in high noise, high humidity environments.
	7	The work on high level, where the dangerous cliff, offshore, diving under the water.
	14	Working in areas with high temperatures easily cause an accident such as working on top of coke oven, repair coke oven. steel milling and refining ore, coking. cooking, casting fused metal. cement clinker kiln firing , kiln refractory.
Electricity	2	The work frequently contacts with main electric and electrical equipments which is accidents-prone work.
Explosion and fire	3	Production, using, storage and transportation of explosives and blasting means (detonator, detonating cord, fuse delayed ...).
	4	The ability to work with fire and explosion.
Exploitation	6	Drilling, digging excavation, deep excavation, quarrying, mining.
	11	Exploit forest products, aquatic product and exploitation, production oil and gas.
Boiler	8	Operating and repair boilers, modulation system and aeration, pressure vessels, cooling systems, steam pipe system, gas pipe system. transporting compressed gas, liquefied gas, dissolved gas.
Lifting	9	Operation and repair of lifting equipment, all kinds of excavators, forklifts, lifting equipment without cables or chains, elevators and escalators.
Construction machine	10	Operation and repair of saws, cutting and punching, crushed, mixed machines ... accidents - prone as caught hair, arms, legs, clamps, impact ....
Tunnel and underground	12	Operation, repair and maintenance of machines and equipment in the cave, tunnels, hatch.
	13	Painting, welding in closed containers, underground caves, tunnels, train tunnels.
Dangerous entertainment project	15	Operation, maintenance and inspection equipment such as carousel entertainment, cable car, the equipment to create a strong feeling of the recreation and entertainment project.

**Appendix III**

**FORMAT OF OCCUPATIONAL SAFETY AND HEALTH CARD**

*(Follow Appendix III, Circular No. 41/2005/TT-BLĐTBXH*

*dated on December 28<sup>th</sup> 2011 by*

*Ministry of Labour - Invalids and Social Affairs)*

(Size 60mm × 90mm)

FRONT SIDE

BACK SIDE

Front side	Back side
<p>(1)..... (2).....</p> <p style="text-align: center;"><b>SAFETY LABOUR CARD</b></p> <div style="border: 1px solid black; width: 150px; height: 100px; margin: 20px auto; text-align: center;"> <p>Photo 3 x 4, affixed seal or stamp on adjoining edges</p> </div> <p>No.: ...../(3)...../TATLĐ</p>	<p style="text-align: center;"><b>THE SOCIALIST REPUBLIC OF VIETNAM</b> <b>Independence - Freedom - Happiness</b></p> <p style="text-align: center;"><b>SAFETY LABOUR CARD</b></p> <p>Name .....</p> <p>Date of birth: ...../...../.....</p> <p>Job: .....</p> <p>.....</p> <p>Completed the Training course: .....</p> <p>.....</p> <p>From date ...../...../20.... to date ...../...../20.... ....., Date ...../...../..... (Sign, Name, Job title and seal)</p> <p>This card is valid to date ...../...../.....</p>

(1) Name of governing body of issue card authority (uppercase, font 10).

(2) Name of issue card authority (bold, uppercase, font 10).

(3) Year of issue card

**8. CASE STUDIES ON ACCIDENTS AND NEAR MISSES IN  
CONSTRUCTION (Activity-6)**



# CASE STUDIES ON ACCIDENTS AND NEAR MISSES IN CONSTRUCTION



**MINISTRY OF CONSTRUCTION**  
**Project for Capacity Enhancement in Construction Quality Assurance**

**CASE STUDIES ON ACCIDENTS  
AND NEAR MISSES IN CONSTRUCTION**

**HANOI, SEPTEMBER 2012**

---

Vote: Illustrations used in the manual are extracted from a case study of accident by JIHOSH (Japan International Center for Occupational Safety and Health) and by MHLW (The Ministry of Health Labour and Welfare) of Japan.

## FOREWORD

*The cooperation between Vietnamese Government and Japanese Government is being enhanced and reinforced during the past years. Being strategic counterparts in many sectors, Viet Nam and Japan has cooperated in many projects including construction and infrastructure development in Viet Nam. Japanese ODA fund has been making significant contribution to improvement of infrastructure system, economic growth and amelioration of people's living condition in Viet Nam.*

*An illustration for the close and efficient cooperation between the two countries is the Project "Capacity Enhancement in Construction Quality Assurance" being implemented with assistance of Vietnamese and Japanese experts. Among the Activities of the Project, "**Safety and Health Manual in Construction**" and "**Case Studies on Accidents and Near Misses in Construction**" is one of the important outputs with high applicability on construction sites.*

*It was indicated in statistics on annual labor accidents nationwide by MOLISA that "violation against safety methods/rules" caused by the workers is the major cause for accident occurrence for the years from 2008 to 2011. For this reason, entities participating in the activities on construction site must grasp the common procedures, labor safety measurements before commencement.*

*The Manual is prepared with a view to improving awareness and knowledge about safety for superintendants/workers on construction site, identifying the causes behind the circumstances of high possibly leading to accidents (near misses) and preventing the accidents on construction site.*

*This Manual is very useful for prevention of potential accidents and injuries on construction site. This Manual and Case studies on Accidents and Near Misses in Construction are expected to be popularly disseminated to minimize labor accidents in Vietnam, especially in construction.*

*Sincerely,*



*Dr. Le Quang Hung  
Director of Project Management Unit (PMU)  
General Director of State Authority for Construction  
Quality Inspection (SACQI)  
Ministry of Construction  
Socialist Republic of Viet Nam*





## FOREWORD

*According to statistics on annual labor accidents occurring nationwide which is publicized by MOLISA, accident occurrences stemming from “violation of procedures/ measures for labor safety” is of the highest frequencies. The fact is that labor accidents can occur from routine activities on the construction site if workers are not aware of the sources of accidents and proactively prevent them. The occurrence of accidents not only affects the health, and even the lives of the labors, but also slows down the progress of the projects, causes economic loss and decreases social benefits of the projects. Therefore, prevention of labor accidents should be paid special attention during the whole construction project.*

*During the implementation of the Technical Cooperation Project for Capacity Enhancement in Construction Quality Assurance supported by JICA, the SACQI and Japanese experts have compiled **“Safety and Health Manual in Construction”** and **“Case Studies on Accidents and Near Misses in Construction”** with the hope that Japanese know-how and experience which are presented in this manual can help prevent and minimize the occurrence of labor accidents, contribute to build an efficient and safety working environment for everyone.*

*On the occasion of this publication, I would like to wish more successful cooperation between JICA and the MOC, as well as between Japan and Vietnam, as strategic partners.*



Motonori Tsuno  
Chief Representative, JICA Vietnam Office



# Content

	Page
<b>I. Case studies from Accidents</b>	9
I.1. Falling down	11
I.2. Buried/ Crushed by objects	21
I.3. Collapse/ Rolling	27
I.4. Construction vehicles	37
I.5. Hauling/ Loading and Unloading	41
I.6. Fire and Explosion	47
I.7. Health disorder	49
I.8. Electricity	53
I.9. Other	61
<b>II. Near Misses</b>	65



## **I. C**ase studies from Accidents



## 1.1. **F**alling down

---



## What kind of accident happened?

### A worker fell from the scaffold while working for roofing and he died

The accident happened during the inspection of scaffolding for roofing works. The day of accident, a person in charge, Mr.(A), and 2 workers, Mr.(B) and (C), arrived at site at 7am. They went up onto the roof after they changed clothes and wore rubber-soled shoes. Mr.(A) explained to Mr.(B) and (C) the work of day and instructed them to inspect scaffold before they used it. Following instructions by Mr.(A), Mr.(C) went to the edge of the eaves then he jumped on the plank of scaffold. The plank was not tied with other plank by wire. So the plank of his side dropped and tipped the other side of plank. He lost his balance and dropped onto the ground 5.5m below with the plank. He died.

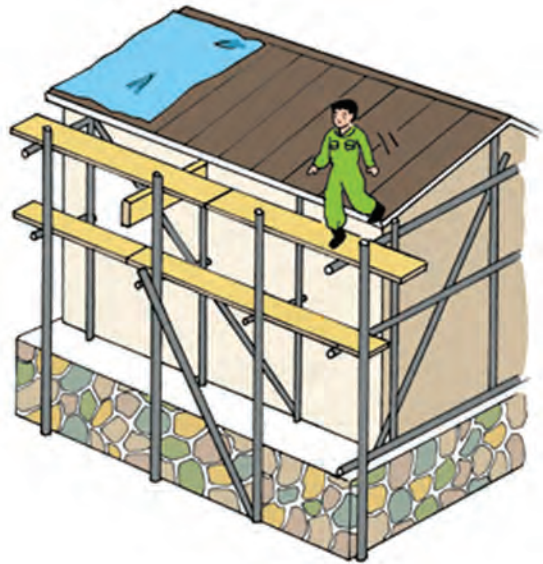

Mr.(C) didn't wore a helmet nor a safety belt. No handrail was equipped with the scaffolding. No necessary measure was taken at the eaves for fall prevention.

## The cause of the accident

1. Mr.(C) jumped on the plank of scaffold which was not tied with other planks.
2. No handrail was equipped with the scaffolding.
3. No necessary measure was taken at the eaves for fall prevention though it was roofing works at high place.
4. Mr.(C) didn't wear a helmet nor a safety belt.

## Tips for preventing similar accidents

1. A plank must be tied up with other planks by wires. Materials of scaffolding, handrails and fitting parts of planks must be checked before working. If some abnormalities are found at the scaffoldings, defects must be repaired immediately before starting works.
2. Handrails must be installed with scaffoldings.
3. Measure for fall prevention at the eaves must be arranged.
- 4.. All workers must wear helmets at site. Workers on the roof and at the eaves must wear safety belts and use it.

## What kind of accident happened?

**A worker fell from the steel pipe frame when he removed protective sheets. He died.**

The accident happened during the demolition work of 6 stories concrete building. The day of accident happened, removal of protective sheets (to prevent littering of dust/noise) and disassembling steel pipes were scheduled. A foreman, Mr.(A), and 4 workers (Mr.B, C, D, E) were dispatched from the secondary sub-contractor for the removal work of protective sheets. Mr.(A) instructed Mr.(B) to stay on the ground to receive the sheets removed. Then Mr.(A) climbed pipes with other workers and started removal of protective sheets. When Mr.(A) was removing sheets on the east face after removing sheets on the south face, Mr.(A) found that Mr.(B) was working on the frame pipe to help Mr.C~E. So Mr.(A) instructed (B) to return to the ground. When Mr.(B) tried to move to the ground, he lost his footing on the pipe and fell the ground 8m below. He was moved to the hospital immediately but he died.

The scaffolding was not put up but only pipe frame was assembled around the building due to the narrow space between the buildings surrounded. However, no scaffolding was prepared for the removal work of protective sheets because this work was scheduled only in one day. Mr.(A) didn't instruct other workers to use safety belts though they wore belts. Mr.(B) didn't use it when he fell.



## The cause of the accident

1. No scaffolding nor fall prevention device was arranged though workers worked in high place.
2. Workers wore safety belts but they didn't use them because the strict instruction using safety belts was not given to workers. Decision was left to individual workers.
3. Management for safety and health was not sufficient. The contract was stratified contract and the contractor, sub-contractor and secondary contractor were working together. The necessity of scaffolding for removal of sheets was not described in the method statement. The instruction and supervision by the foreman for safety matters was not sufficient.

## Tips for preventing similar accidents

1. When people work in high places, scaffolding and fall prevention measures must be arranged. If the scaffolding is difficult to install, the thoroughgoing instruction of wearing/using safety belts must be given to all workers. And all workers must obey such instruction.
2. The system to manage safety and health on site must be established. Especially the site stratified contract adopted, a person who has authority to control safety and health matters on site must appointed.

## What kind of accident is about to happen?

When trying to attach furring strips (the base materials for a wall) to a steel frame, the worker is extending his reach from an aerial lift while working alone.

Can you predict what's about to happen?

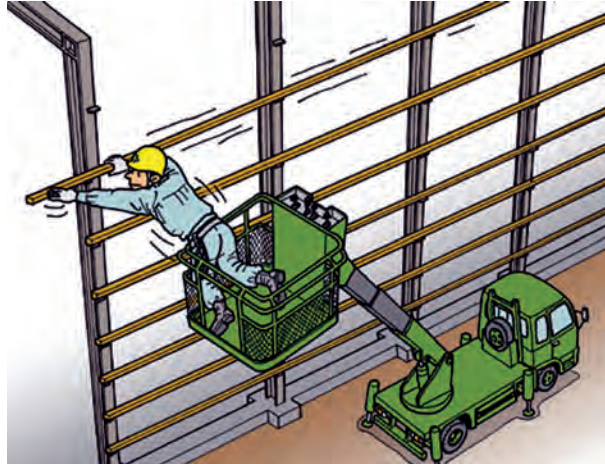

## Look what happened!

The worker reached out too far from the work platform, allowed his upper body to extend beyond the handrail, and fell out of the bucket.

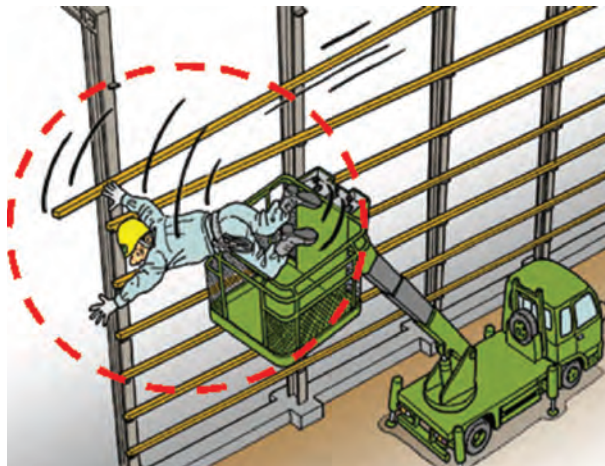

## Tips for preventing similar accidents

1. Place the aerial lift at a height and location where work can be performed comfortably, and ensure that work can be performed safely from that location.
2. Always use a safety belt when performing aerial work, even on the working platform.
3. Ensure that all relevant workers are familiar with the work procedures for performing aerial work.

## What kind of accident happened?

When a worker passed at the reconstruction site of an underground tank, he fell to the pit of the old tank and he died.

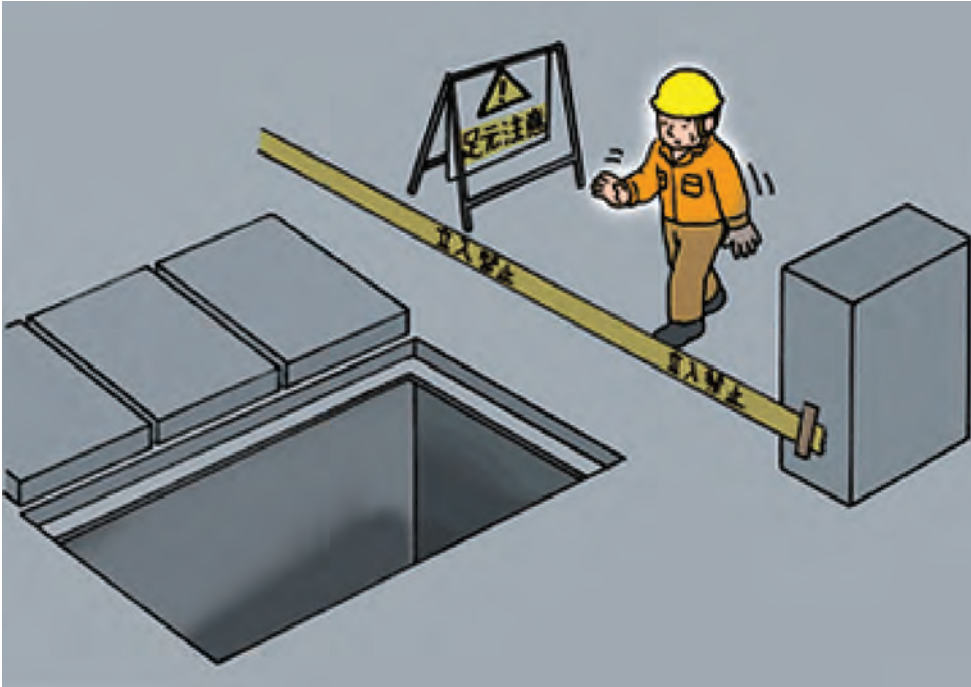

## The cause of the accident

1. Fall prevention measures were not taken.
2. Working circumstances were not checked/confirmed by the employer.
3. Reconstruction of underground tank was scheduled only for one day. So a matter of safety was treated lightly and fall prevention measures were not confirmed by the employer.

## Tips for preventing similar accidents

1. Prevention measures against falling accident such as a fence, a safety net, lights and covers must be taken.
- 2.. Working circumstances must be checked/confirmed by the employer.

## What kind of accident happened?

When the worker was painting the steel beam at the level of 4th floor, he missed his footing on the beam and he fell on the concrete at the 3rd floor. He was badly injured. He wore a safety belt and helmet while working and the safety belt was connected to the lifting piece of the beam. However, the rope of safety belt was cut at the 20cm from the hook by the shock of falling. The safety belt was a unifilar type and 6 years had passed since the safety belt was manufactured/used. The rope of safety belt was made by 8 strands but the some of them were damaged.

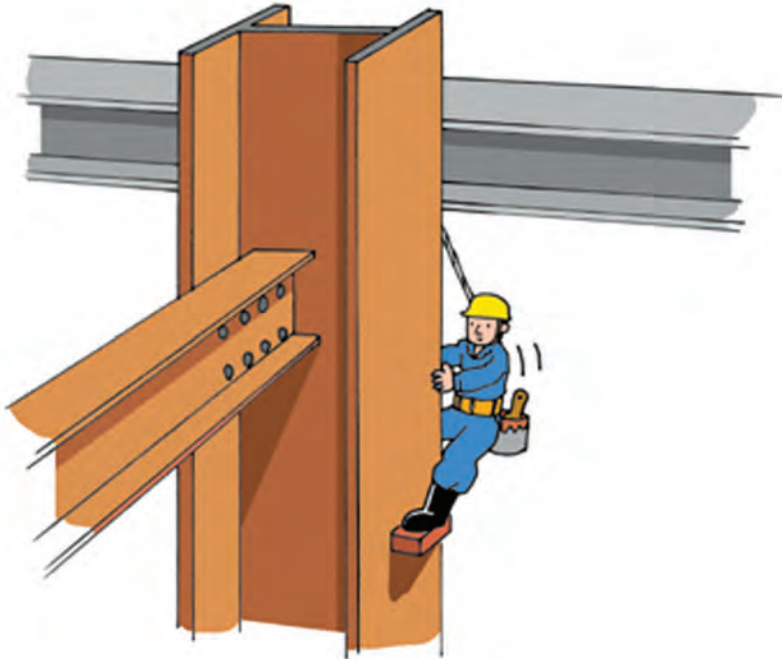

## The cause of the accident

1. The worker put his foot on the protuberance which size was not enough as a foothold.
2. The safety net was not spread out though a working platform was not constructed.
3. A checking manual/standard of safety equipment such as safety belts was not prepared. The checking was left to workers own choice.

## Tips for preventing similar accidents

1. A working platform must be arranged when workers work in high places.
2. If workers are compelled to work with safety belts when no platform is arranged, safety nets must be spread out at the work place.
3. A Checking manual/standard of safety equipment must be prepared. The results of checking must be confirmed by the supervisor.



## What kind of accident happened?

A worker fell from the H-beam onto the ground and he died. The working stage was constructed on the slope of a mountain using H-beams and steel plates. A person in charge, Mr.A, and his 4 workers (Mr.B, C, D, E) were removing materials of stone masonry under beams in the morning. After a lunch break, a representative of main contractor, Mr.F, had a meeting with Mr.A to discuss the works in the afternoon and tomorrow. They decided to remove sewage pipes from the site tomorrow. When the afternoon works started, Mr.F told Mr.B that sewage pipes were scheduled to be removed from the site tomorrow. However, Mr.B misunderstood that sewage pipes removing works would start from the afternoon. Mr.B conveyed this information to Mr.C. Mr.C thought that sewage pipes would be removed in the afternoon. So Mr.C got over a handrail from the stairs then walked on the beam (H-beam, 300mm width) toward the pipes. But he lost his balance and he fell from the beam onto the ground. Mr.C wore a safety helmet and a safety belt. However, no anchor for a safety belt arranged on the beam. A person in charge of sub-contractor, Mr.A, confirmed tomorrow's activities but he did not prepared a work plan for tomorrow nor he did not inform tomorrow's works to workers (B, C, D, E).

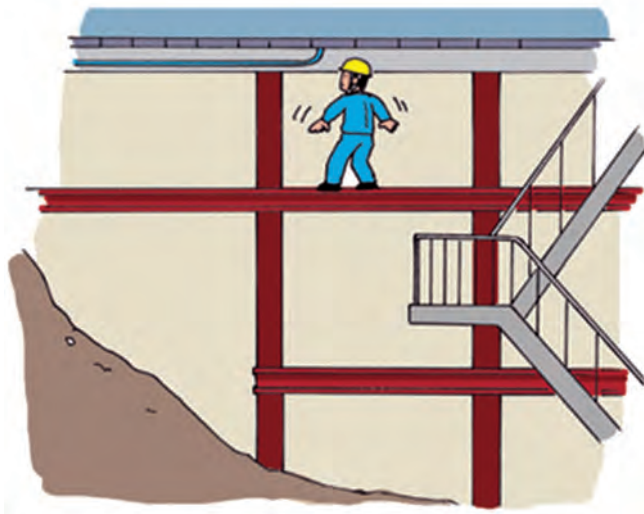

## The cause of the accident

1. No measures were taken to prevent workers from getting on the beams because nobody approached the beam for regular work. (A worker, Mr.C, could easily get over a handrail from stairs and could approach the beam.)
2. The communication between the main contractor and the sub-contractor was insufficient. Mr.F instructed Mr.A what to do next in the afternoon and tomorrow. But no direct instruction was given by Mr.A to Mr.C.
3. The safety induction was not conducted.

## Tips for preventing similar accidents

1. Fences to prevent workers from entering dangerous places shall be set up. Also signs to show "No entry" shall be displayed.

## What kind of accident happened?

The accident happened when the worker applied shotcrete on the vertical slope (almost 90 degrees). He wore a safety helmet and a safety belt. He tied a fall arresting device to a main rope (d=8mm, L=20m). After he climbed to the top of the slope, he made a knot in a main rope and put a hook of safety belt on the knot. Then he started shotcreting after he took off a fall arresting device from the main rope. A few minutes after shotcrete started, the hook of safety belt was unfastened from the main rope and he fell onto the road. He was sent to the hospital but he died.



*Main rope*



*A fall arresting device*

## The cause of the accident

1. Though a worker put a hook of safety belt on the knot, the latch of hook just closed in on main rope from both sides, but not be caught tightly with the main rope. So the hook was off from the main rope. The fall arresting device was also off by him at this moment. He fell.
2. Safety induction for the steep slope was insufficient though fall risks are lots.

## Tips for preventing similar accidents

1. A fall arresting device must be used all times at the high place. A hook of the safety belt must be fastened properly. Such manners must be trained to all workers through the safety induction and also be checked on site at the timing of actual work.
2. A safety induction for the steep slope must be conducted before works. Detail technique to fasten a safety belt and a fall arresting device to the main rope must be known by all workers. Handling the hoses of shotcrete also must be known by workers.

## What kind of accident happened?

This accident happened while the scaffold of boring works was erected. A worker fell from the scaffold because the hook of safety belt came off. The scaffold was 40 meters height and the shape of quadrangular pyramid was formed by pillars, diagonal braces and horizontal braces. Each stair of scaffold was pre assembled on the ground. It was hung by a crane and it was fastened with bolts and nuts to the stair which had had been installed before.

A worker Mr.(A) used two clamps as foothold which were installed at the 1st stair. When he started to fasten bolts and nuts, a hook of safety belt was off from the karabiner of tool holder. He fell on the ground. He was sent to the hospital but he died. The type of safety belt he used was an unifilar suspension type, it was not for the U suspension type. A person in charge was nominated for this project but he didn't perform his duties. His duties were to confirm working procedures, location of workers, a direct commander on site, condition of safety belts, the proper manner of safety belt, and so on.

## The cause of the accident

1. A karabiner of tool holder was used as an anchor of safety belt's hook.
2. A safety belt of unifilar type was used as a safety belt of U shape suspension type.
3. A person in charge who was nominated for this works didn't perform his duties.

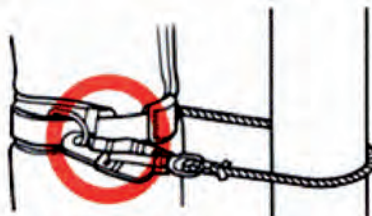
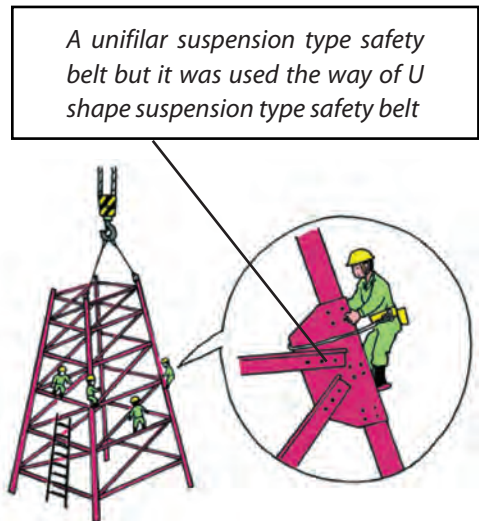

Note:  
The way to use  
the U shape  
suspension  
type safety belt

## Tips for preventing similar accidents

1. The proper usage manner of safety belt must be well known by all workers. Prohibit to use a karabiner of tool holder as an anchor of safety belt's hook.
2. A proper type of safety belt must be selected for the individual type of works.
3. A person in charge must (1) determine the procedure of works and location of workers, (2) check all tools and personal safety gears, (3) supervise the proper manner of safety belt and helmet.



## What kind of accident happened?

**3 workers fell onto the ground with the bracket which was bolted to the side concrete of highway. 1 died, 2 injured.**

The accident happened when concrete of noise-blocking walls was poured at the side edge of highway. While concreting, workers heard several loud deep sounds from the bracket type foothold. They realized something strange but they thought these sounds came from the concrete forms. (Actually, these sounds were caused when the bracket type foothold fell downward.)

Workers stopped concrete pumping. When they tried to check the bottom of forms, they fell with the bracket onto the ground. 1 died, 2 injured.

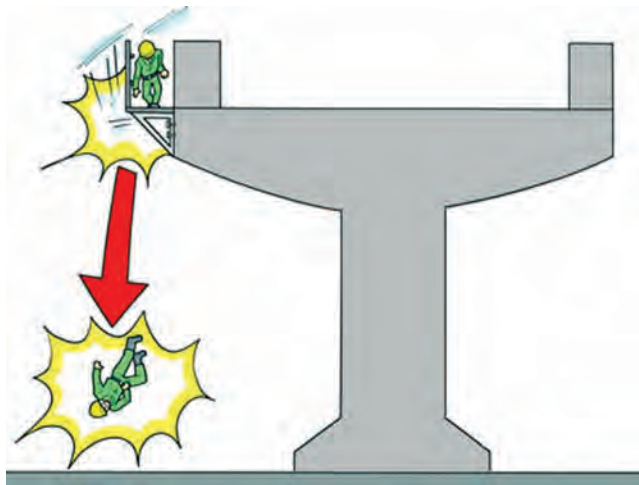

## The cause of the accident

1. The bracket was designed to be supported by bolts and inserts which were embedded in the concrete. When bolts were retrieved from the ground after the accident, it was found that different standard bolts were mixed. If the different standard bolts and inserts are used together, the design strength can not be obtained. So the standard of bolts and the standard of inserts were compared. The standard of bolt was inch basis and the standard of insert was millimeter basis. In addition, fragments of the insert's screw thread adhered to the bolt's screw thread.
2. From the above, it is assumed that the screw thread of inserts were damaged when bolted. Therefore the scaffold was supported by the strength much less than the design strength.

## Tips for preventing similar accidents

1. Use bolts which are specified by the supplier of inserts.
2. Instruct workers to use safety belts at high-place work.
3. When obvious abnormality is found with the scaffold, consolidate the countermeasure to avoid the accident before starting the work.
4. The allowable load of insert must be checked when the design is changed.

## 1.2. **B**uried/Crushed by objects

---

## What kind of accident is about to happen?

A hydraulic excavator is loading crushed stones on a truck in a material stockyard. In between the hydraulic excavator and the truck a worker is collecting the spilt crushed stones with a shovel.

Can you predict what's about to happen?



## Look what happened!

The hydraulic excavator swung all of sudden. Then he was caught between the counterweight of the machine and the truck's rear gate, and killed..

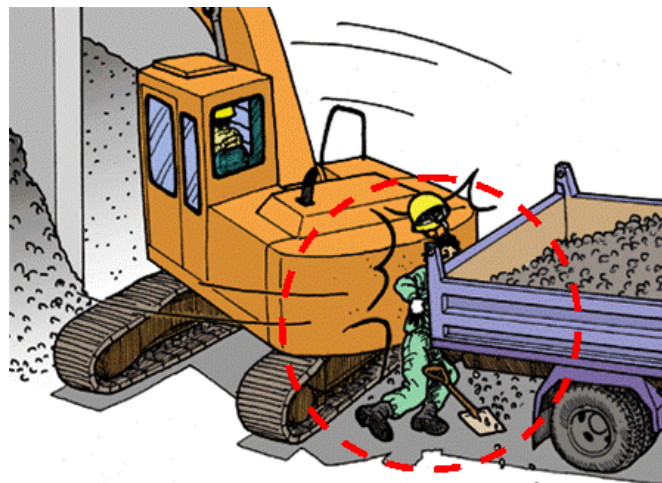

## Tips for preventing similar accidents

1. Make sure that nobody gets within the reach of the swinging upper structure.
2. If it becomes unavoidable for a worker to enter the reach, let the operator and the worker thoroughly confirm safety signals.

## What kind of accident is about to happen?

In a material stock yard, an operator worker A and another worker B are working in pair using a hydraulic excavator. Their job is to paint the surfaces of the I-beams one by one that are stacked up there. First the topside of an I- beam is painted. Then it is turned over with a lateral slinging clamp hung to a hook fixed to the bucket of the hydraulic excavator and the rear side is painted. After painting on both sides, it is stacked up using the same clamp.

The operator A has finished a special training course for operating movable type cranes, but has yet to finish a training course for operating construction vehicles, and so far has little experiences with them.

Now what accident do you anticipate from this picture?

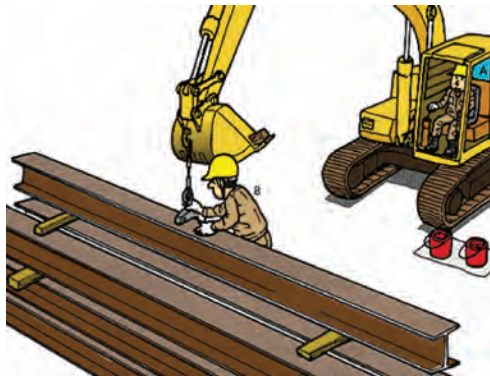

## Look what happened!

The worker B was trying to unfasten the clamp from an I-beam that has finished painting, when the inexperienced operator A moved the bucket control lever by mistake. The bucket hit the worker B hard on the chest and killed him.

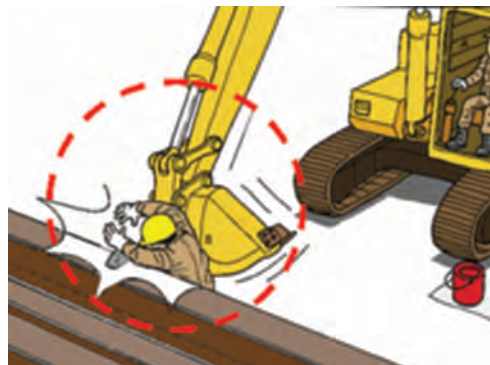

## Tips for preventing similar accidents

1. Do not allow any worker to operate construction vehicles without the required license.
2. Post a signalman where a job obliges a worker to enter and there is the danger of bodily injuries to him/her by a possible contact with a construction machine in operation.
3. Do not allow a construction machine to be used for any other purpose than its primary application.

## What kind of accident is about to happen?

A worker is standing in the bucket of a shovel loader to perform some painting repairs on a wall. He is telling the shovel loader operator to move forward and raise the bucket just a little bit.

Can you predict what's about to happen?



## Look what happened!

When the shovel loader operator released the side brake, the shovel loader lurched forward because it was located on a slight incline. The painting worker was injured when he was crushed between the wall and the bucket.

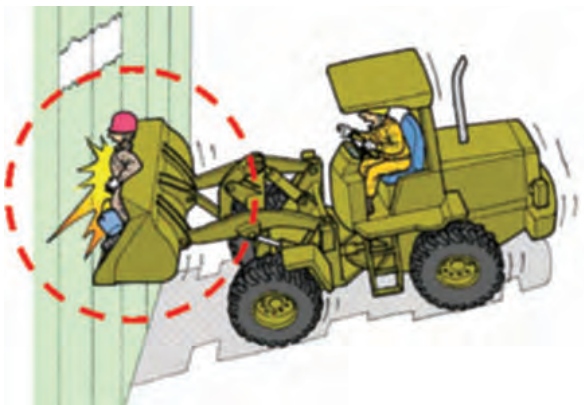

## Tips for preventing similar accidents

1. Ensure that all workers are aware that shovel loaders are not to be ridden in any location other than the operator's seat.
2. Even when performing impromptu work, create and follow a plan that includes using the appropriate equipment for the work, such as scaffolding (including ladders or stepladders) or an aerial work platform.
3. Ensure that all workers have undergone safety training regarding activities that are prohibited for the sake of preventing accidents, the use of necessary equipment, and the necessity of due diligence.

## What kind of accident is about to happen?

After removing concrete forms of a girder, one of the workers tried to shorten the boom of lift. However, he had an operational error of switch and he extended the boom instead. He was crushed between the concrete and the frame of lift.



## The cause of the accident

1. Unqualified person operated the switch. A certificate of boom lift had not checked by the company before he was engaged in such works.
2. A person in charge for high place works was not appointed but works have continued.
3. The work plan was not prepared.

## Tips for preventing similar accidents

1. Only certified workers can operate the boom lift for the high place works.
2. Provide clear instructions/rules in accordance with the predetermined work plan and ensure that all workers involved follow those instructions/rules.
3. Preliminary discussion of works must be arranged every day before starting works.



## What kind of accident is about to happen?

*A worker died when he was wedged between the bucket and a wall.*

The accident happened when concrete was poured into the form of retaining wall. A worker, Mr.(A), was connecting a concrete bucket to the excavator. An operator of backhoe was watching his works. When he extended his left hand to open the door of operator's seat, his arm touched the control lever. This action moved the bucket of crane forward. So Mr.(A), who was working at the narrow space was wedged between the bucket and a wall. He died. The excavator was planned to use it to lift the concrete bucket. But no lifting function was equipped with the excavator.

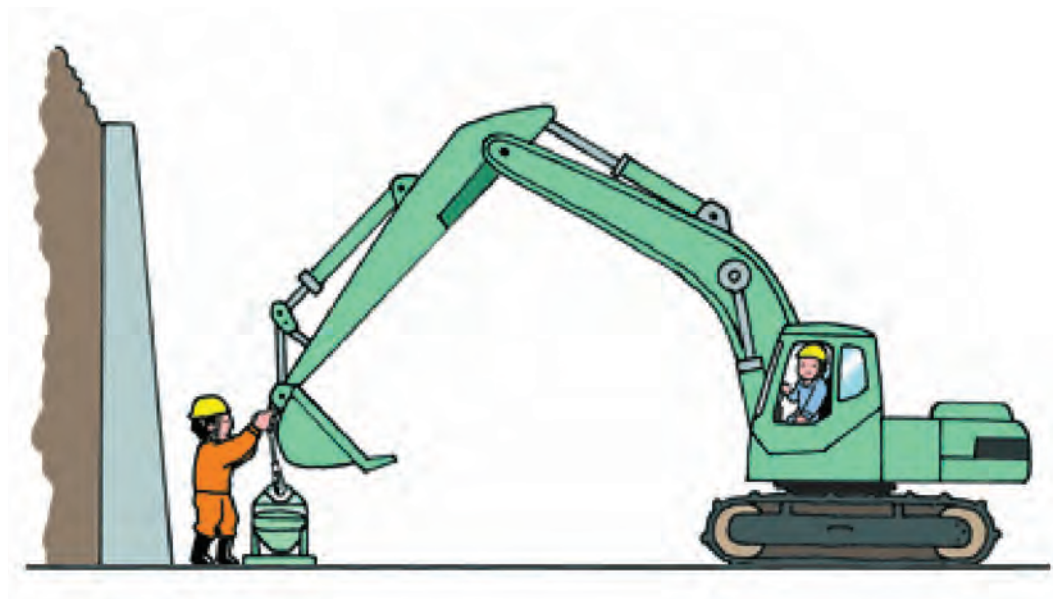

## The cause of the accident

1. The excavator was used for inappropriate purpose.
2. An operator of excavator didn't use the lock function of lever when he opened the door. So the bucket moved forward when he touched the lever unintended.
3. Mr.(A) was working in the operation range of excavator. In addition, he stayed at the narrow space where it was difficult to escape.

## Tips for preventing similar accidents

1. The work plan which describe the safety details must be prepared before starting works. For example, if crane work is necessary, a mobile crane should be arranged to lift the load (concrete bucket). Don't use a excavator as a crane.
2. A safety education to operators must be conducted. Thoroughly instruction must be given to them to use the lock function of lever when they leave a machine.

## 1.3. **C**ollapse/ Rolling

---



## What kind of accident is about to happen?

A worker is trying to offload a roller at a work site from the bed of a truck. The work site runs along a waterway.

Can you predict what's about to happen?



## Look what happened!

When trying to offload the roller, the retaining wall of the site collapsed, causing the truck to tip over and the roller to slide off the back. The operator fell into the waterway with the roller and was pinned beneath it.



## Tips for preventing similar accidents

1. Unloading activities should only be performed on flat, solid surfaces.
2. If a vehicle must be parked near a shoulder where the ground is weaker, check the ground and the shoulder area, assign someone to serve as a guide, and park as far away as possible from the shoulder.
3. Be sure to place chock blocks during offloading.
4. When offloading a machine, keep an eye on its center of gravity, and perform all necessary hazard prediction activities in advance.

## What kind of accident is about to happen?

Dirt has been produced at a nearby construction site and is going to be reused at a rock quarry. A wheel loader is therefore being used to smooth out the piled up dirt.

Can you predict what's about to happen?

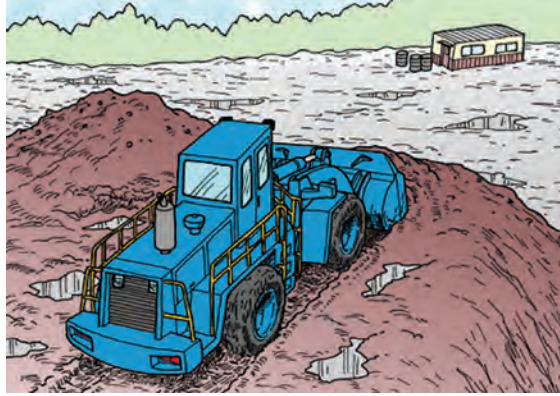

## Look what happened!

The weight of the vehicle caused the edge of the pile to collapse. The vehicle tires came off of the shoulder and the vehicle tumbled down from the top of the pile.



## Tips for preventing similar accidents

1. Machinery operators should know shoulders are unstable. Before starting work, check the shoulders and perform a safety inspection of the footing.
2. If dirt is in danger of collapsing, halt work immediately and take appropriate safety measures. For example, workers should place a flag, pole or other sign showing the location of the shoulder.
3. The driver should check the positions of the forward and reverse levers, and work perpendicular to edges when performing dirt pushing work.
4. Select the appropriate vehicle (e.g. crawler-type) for the ground and other conditions of the earthwork being performed.

## What kind of accident happened?

*The operator of breaker was caught in the landslide when he was splitting boulders into small pieces by a machine*

The accident happened at the quarry when the operator of breaker was splitting boulders into small pieces. The quarry products crushed aggregates from sandstone. Boulders which are produced by blasting are crushed by the crusher and selected by the feeder based on size. The height of each bench was 10m and the slope was 75 degrees according to the working plan prepared by the business owner.

The day of accident, a foreman Mr.(A) and 5 workers (B), (C), (D), (E), (F) arrived at site in the morning for work. They started works after Mr.(A) explained to others the work of day. Mr.(C) operated the breaker and Mr.(D) operated the backhoe at the bottom of bench. One hour after the afternoon work started, the large size of landslide suddenly happened at upper bench. Mr.(C) was swallowed by the landslide with the breaker. Mr.(C) died. The backhoe was also swallowed by the landslide but Mr.(D) could escape from it.

There were many cracks at the bedrock. And it rained very heavily, more than 60mm, from the day before accident until the morning of accident. In addition to the rain, some bedrock was loosen by the blasting that happened yesterday. This site didn't inspect the site conditions after heavy rain nor blasting to protect the landslide or collapse. 6 workers, (A) ~ (F), took technical course for quarry but nobody was appointed as the chief worker for quarry works. Also the safety and health induction was not conducted for 6 people before works.



## The cause of the accident

The direct causes of disaster were percolation of water down through the bedrock and the looseness of bedrock caused by the blasting. However, the following points seem to become indirect causes.

1. The slope of bench was 75 degrees. The degree of slope was stipulated in the law that it was less than 60 degrees. However, the slope of bench was kept 75 degrees at site though the height of bench was 10m and there were many cracks on the rock.
2. The chief worker of quarry was not appointed though workers took technical course of quarry works. So the location of responsibility was not clear.
3. No inspection was conducted. The risk of landslide shall be checked especially after heavy rain and blasting. However, nobody inspected the site on the day of accident.
4. The safety and health induction was not conducted for workers before work.

## Tips for preventing similar accidents

1. The degree of slope must be less than 60 at the quarry where cracks exist and the height of bench is more than 6m.
2. A chief worker of quarry must be appointed. He must take responsibilities for the following.
  - \* Decide the method of works and supervise works directly.
  - \* Inspect machines, materials and tools. If defects found, it must be settled or removed.
  - \* Usage status of helmet and safety belt must be checked.
  - \* Instruct the means of evacuation means on the site at the disaster.
3. The site must be inspected after heavy rain and blasting but before starting works.

## What kind of accident is about to happen?

To load a drag shovel onto a transport vehicle, the bucket is being used as a support to lift the body of the shovel onto the bed of the truck.

Can you predict what's about to happen?

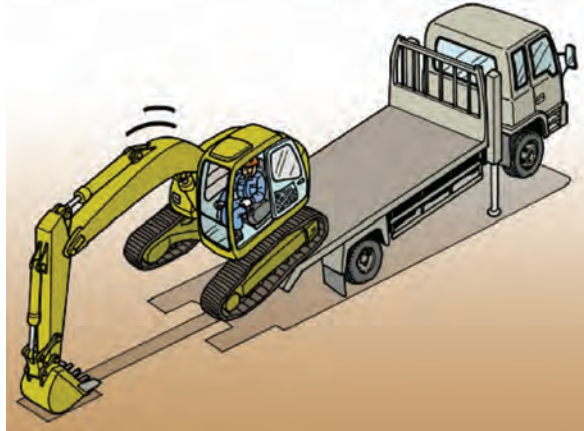

## Look what happened!

The crawler tracks of the drag shovel slipped from the transport truck bed, causing the drag shovel to topple over. The operator was pinned beneath it.

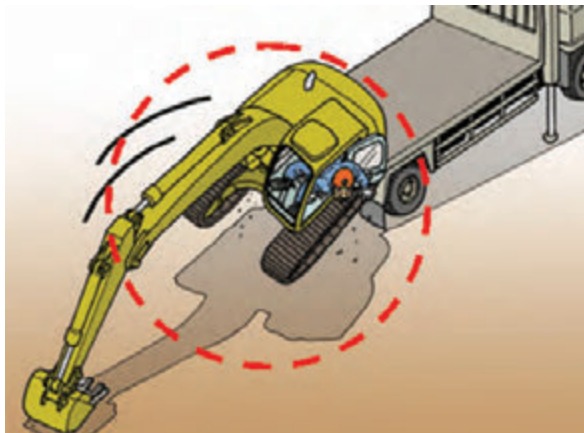

## Tips for preventing similar accidents

1. Load machinery using proper methods and procedures, such as using gangplanks.
2. Assign a worker to serve as a guide and confirm signals in advance.
3. Ensure that everyone involved undergoes safety training (on proper work procedures) before the work starts.
4. Ensure that a transport vehicle is appropriate for the size and weight of the machine to be transported, and inspect that vehicle upon arrival.



## What kind of accident is about to happen?

During earth pushing work, the operator has stopped his bulldozer on a 15° incline, has risen from his seat, and is stepping on a crawler.

Can you predict what's about to happen?



## Look what happened!

The bulldozer unexpectedly moved, and the worker lost his balance and fell hard on his chest against the blade.

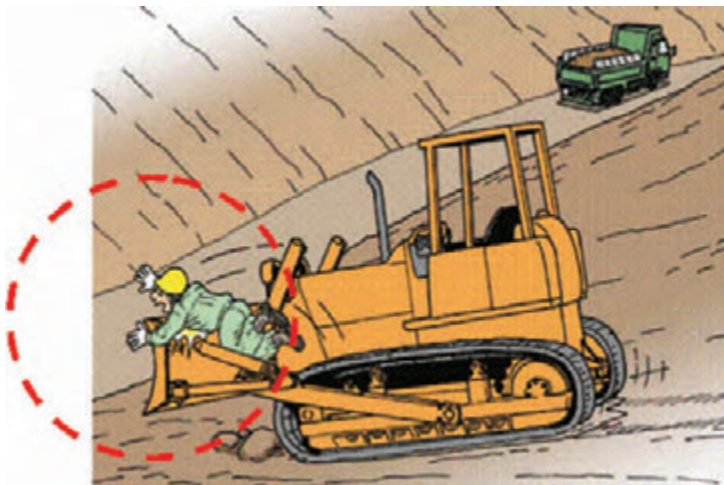

## Tips for preventing similar accidents

1. When stopping a machine and getting out of the operator's seat, be sure to shut off the engine and take measures to ensure that the vehicle does not move, such as setting the side brake.
2. Stop vehicles on surfaces that are as flat as possible. When you must stop a bulldozer on an incline, place the blade in a downward position against the ground

## What kind of accident is about to happen?

A hydraulic excavator was employed in an underground construction work. Workers are trying to pull it up with another hydraulic excavator. The former weighs 2.7 tons and the latter 11.5 tons.

Now what accident do you anticipate from this picture?

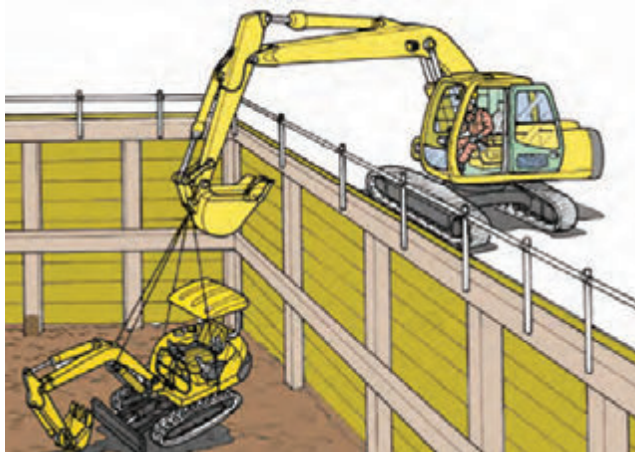

## Look what happened!

The larger hydraulic excavator lifted up the small one and tried to swing, when the former lost balance all of sudden and fell off the ground. The lifting operator jumped out of the machine to escape the danger in vain. He was killed, sandwiched between the fallen machine and the wall.

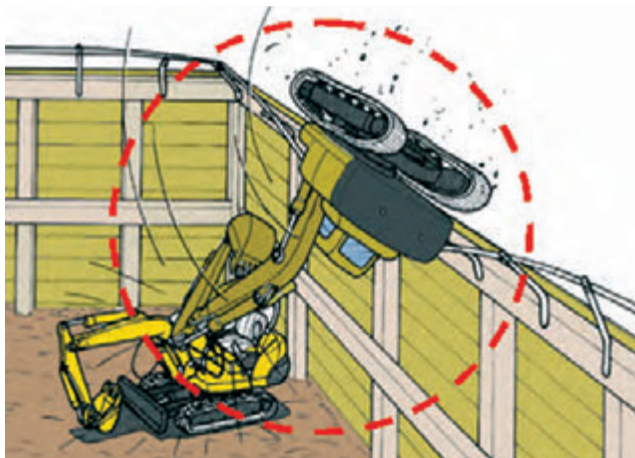

## Tips for preventing similar accidents

1. If an object weighing over 1 ton is to be lifted up, be sure to use a crane, not a hydraulic excavator.
2. When lifting up an object under 1 ton using a hydraulic excavator, observe the instructions set forth in the TCVN 4244:1986 Code for the safe technique of crane

## What kind of accident is about to happen?

An operator worker is about to load a mini excavator on a truck at the construction site of a housing complex. Because ordinary ramps are not available, he uses two plates originally used as concrete formwork. One of them is 17 cm in width x 1.6 m in length in size and the other is 17 cm in width x 1.45 m in length.

Meanwhile another worker is collecting the scattered shreds of construction materials to clean the site.

Now what accident do you anticipate from this picture?



## Look what happened!

A moment before the mini hydraulic excavator finished climbing over the edge of the truck, it suddenly lost balance and fell off on the ground on the right side. The operator jumped out of the machine unhurt in time, but the worker was crushed under the fallen machine.



## Tips for preventing similar accidents

1. Choose ramps best suited to construction vehicle, when loading and unloading them on a truck or trailer, and install them securely in the truck/trailer at an angle lower than 15 degrees.
2. Post a conductor for the work, while off-limiting the working area.
3. Determine working procedures as well as method for the work beforehand, and make sure that they are disseminated among those concerned.

## What kind of accident happened?

### *The wheel crane lifting a load rolled down due to the land subsidence at the construction site*

The day of accident, a wheel crane (the safety lifting load=50ton) was planned to lift and move sediment by a wire cargo net. When the first load was lifted, the operator started to turn the boom to the right. But the warning signal at 90% of overturning moment sounded suddenly. Then the warning signal at 100% of overturning moment sounded and the overload protective device was working. Some functions of crane were stopped after the overload protective device was working. However, the boom still could move. So the operator turned the boom to the right. But the crane fell down forward. The ground under outriggers subsided about 10-15 centimeters though the operator put steel plates and timbers under outriggers.

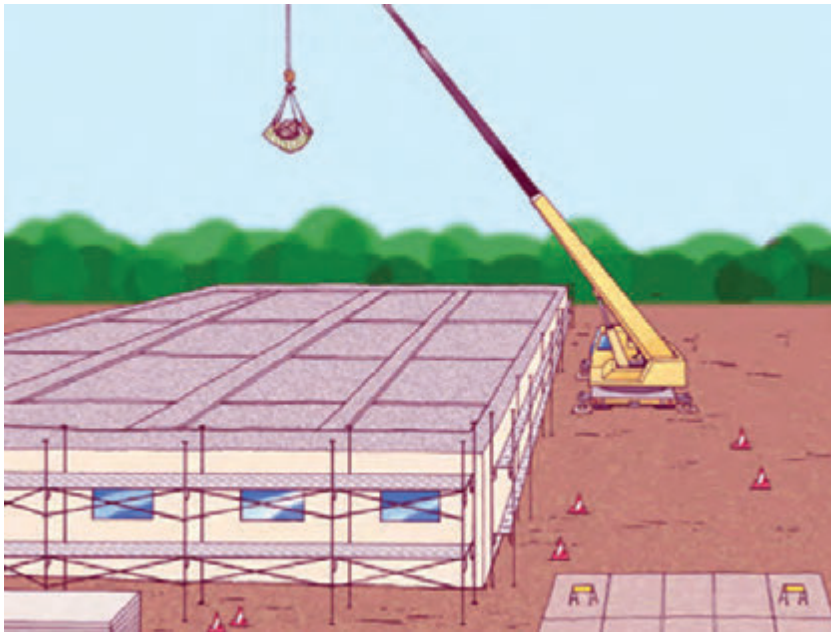

## The cause of the accident

1. Though steel plates and timbers were laid down under outriggers, the strength of back-filled soil was not strong enough to support the weight. The ground where the crane parked was backfilled area.
2. The operator didn't stop its turning after the warning signal at 100% of overturning moment sounded.

## Tips for preventing similar accidents

1. Try not to park the crane at the backfilled area. If no place can be found except the back-filled area, the strength of foundation and the condition of ground must be checked before crane works.
2. It must be noticed all workers that a crane must stop when the overload protective device is working. Such instruction must be repeated in meetings.



## What kind of accident happened?

***A bulldozer fell down from the shoulder of steep slope at 90m high when it push down soil to the bottom of slope. An operator died.***

The day of accident, the bulldozer push down soil to the slope to prepare the bench at the quarry. The width of bench was 14m. To prevent falling accident of machine, it was instructed an operator that a heap of soil always had to be kept at the end of bench.

The exact circumstances of the accident were unknown because the operator worked alone and nobody watched the accident. However, it was assumed that the bulldozer fell down from the shoulder directly to the slope. Because no soil remained at the end of the slope and the trace of crawler was left on the shoulder.

This work was operated in the foggy night. Therefore the visibility was less than 5m though the light of bulldozer was working.

Always keep a heap of soil at the end of bench

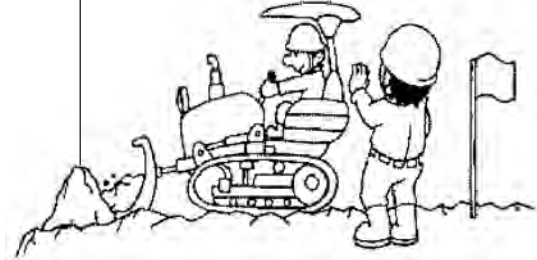

## The cause of the accident

1. No guide was arranged to show the limit of working area though the bulldozer worked at the shoulder of very steep slope.
2. No foreman was at site for the excavation work at the deep place of quarry.  
An operator worked in the foggy night. Necessary illuminance level was not discussed.
3. An exhaustive safety education for the risk of fall accident was not conducted.

## Tips for preventing similar accidents

1. Measures to prohibit machines entering in the risky area of falling accident must be taken. Or arrange a guide to instruct an operator the limit of working area.
2. Nominate a person in charge at site and let him to supervise a work directly.
3. Prepare a standard to stop works in relation to weather conditions.
4. In general, no night work accepted. If a night work is necessary, sufficient lights must be arranged as site.
5. A safety education for a quarry work must be conducted.

## 1.4. **C**onstruction vehicles

---

## What kind of accident is about to happen?

A worker is performing repairs on a water catchment square (60 x 60 x depth 66 cm) at a site where pavement work is being done. A roller is performing surface compaction in the same area.

Can you predict what's about to happen?

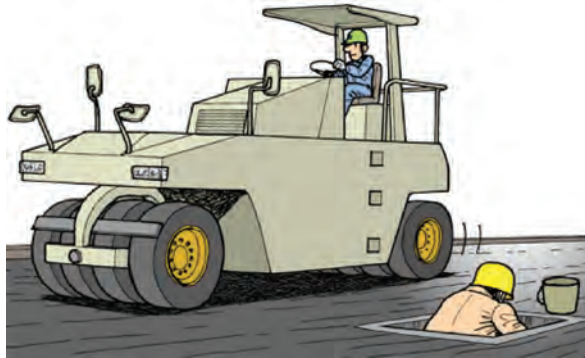

## Look what happened!

The roller operator did not notice the worker in the water catchment square. Another worker yelled out to warn him and signaled him to stop, but the rear tires of the roller ran over the top of the worker in the water catchment square.

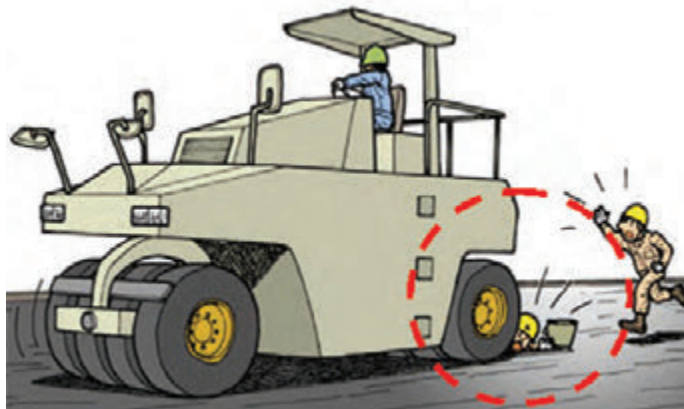

## Tips for preventing similar accidents

1. Do not undertake multiple projects in the same location.
2. If multiple projects must be undertaken in the same location, take safety measures such as the following, and be sure that everyone is aware of them:
  - a) Avoid performing work at the same time.
  - b) Divide and set up barricades between work areas.
3. Assign someone to serve as a guide in areas in which the work areas are close to one another.

## What kind of accident is about to happen?

The accident happened during the survey works at the farmland. The day of accident, a person in charge of main-contractor, Mr.(A), instructed workers on the each assignment such as survey, removing stones, leveling of ground hauling earth and sand,etc. at the field. Just after starting field works, Mr.(A) found that some materials for survey works were missing. So he left the site to bring missing materials. Before leaving the site, Mr.(A) instructed a worker (B) to prepare the hauling works. Mr.(B) judged that the rough terrain hauler was better than dump truck to haul earth and sand on the day because it was raining. So Mr.(B) went to the next section of the project to bring the machine which was used for the leveling of ground yesterday. Mr.(B) got a seat of the rough terrain hauler and reversed it into the field. Suddenly a worker (C) screamed. Mr.(B) stopped the machine because he also felt strangely as if the machine run over something. Mr.(B) got out the machine and found that a worker (D) was run over by the machine. (D) was rescued immediately and sent to the hospital. But he died at the hospital. Though there was a space for the turnaround in the field, (B) was lazy to turn the machine around and he reversed it. (B) didn't have a liscense of rough terrain hauler. The key of machine was hung at the wall of office and everybody could approach the key. A safety education to workers was not conducted well at the site. All workers were instructed by Mr.(A) verbally because the contents of work plan was not notified to workers.



## The cause of the accident

1. The management to prevent to drive machines by unqualified persons was not well established. The key was not kept in good manner and everybody could easily approach the key.
2. The operator of the rough terrain hauler didn't check behind/around for workers.
3. A safety education to workers was not conducted well. Works started without notifying the contents of work plan to workers.

## Tips for preventing similar accidents

1. Thoroughgoing management to prevent operating machines by unqualified person must be established.
2. The rough terrain hauler must drive forward as a general rule. When the machine is forced to reverse, the operator must check behind/around of machines before reversing and/or arrange an assistant to help to check behind/around.
3. A safety education/induction to workers must be conducted. The contents of work plan must be informed to workers and the work procedures must be confirmed in the daily meeting everyday.



## 1.5. **H**auling/ Loading and Unloading

---

## What kind of accident is about to happen?

Workers at a construction site are trying to offload steel plates from a truck using slinging clamps and a drag shovel with a crane attachment.

Can you predict what's about to happen?



## Look what happened!

Because the slinging clamp was not attached at the center of the steel plate, the plate slipped from the bed of the truck, crushing the worker between the drag shovel and the steel plate.

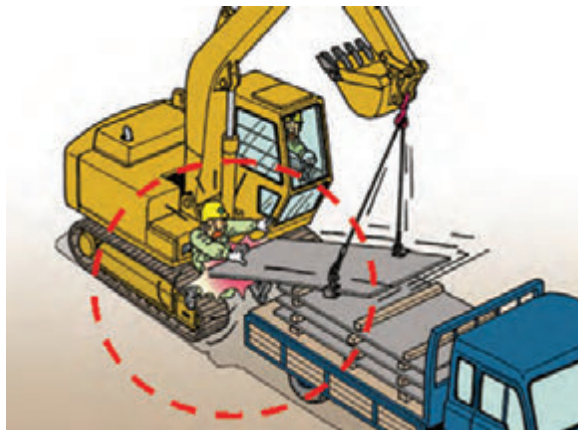

## Tips for preventing similar accidents

1. Conduct preliminary inspections and ensure that proper slinging equipment is used.
2. When steel plates are slung horizontally (parallel to the ground), use four slinging clamps.
3. Assign someone to serve as a guide, provide instructions in accordance with the pre-determined work plan, and ensure that all workers involved follow those instructions.
4. After confirming that the slinging clamps have been properly attached, the worker should move away from the suspended load and then signal the operator.

## What kind of accident is about to happen?

In preparations for transport, an operator worker is trying to lift up an iron-made grid, a product, with a lift truck so that another worker can put wooden blocks beneath it.

Now what accident do you anticipate from this picture?

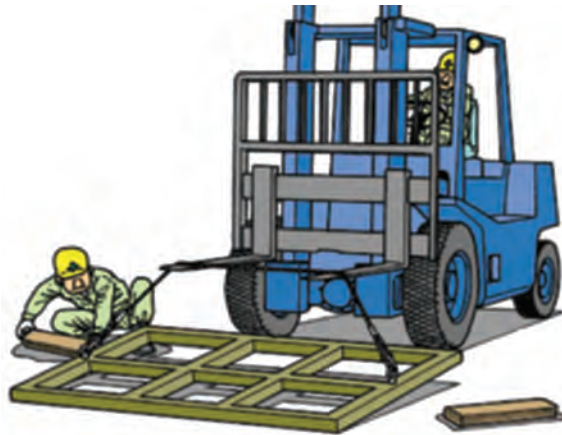

## Look what happened!

Just as the worker tried to put wooden blocks beneath the grid, one end of the wire rope slipped off from the fork tine tip, letting fall the grid, and he was wounded.

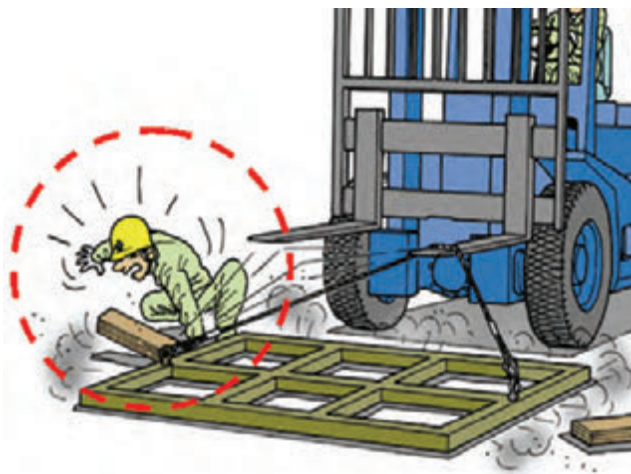

## Tips for preventing similar accidents

1. Do not bring any part of the body under lifted cargos.
2. Use a special attachment, when lifting up a cargo with a lift truck.
3. Compile working procedures corresponding with types and configurations of cargos to be handled and see that they are followed. Use of cranes will be a good solution.



## What kind of accident is about to happen?

Accident happened while unloading steel beams from the truck. Beams were loaded on the truck as shown in the sketch below.

Unloading started from the right to left. Beam 1 and 2 were unloaded first. When beam 3 was lifted, the beam 4 turned onto its side then a sling man beside beam 4 fell on the ground with a beam 4.

He was crushed by a beam 4 and he died.

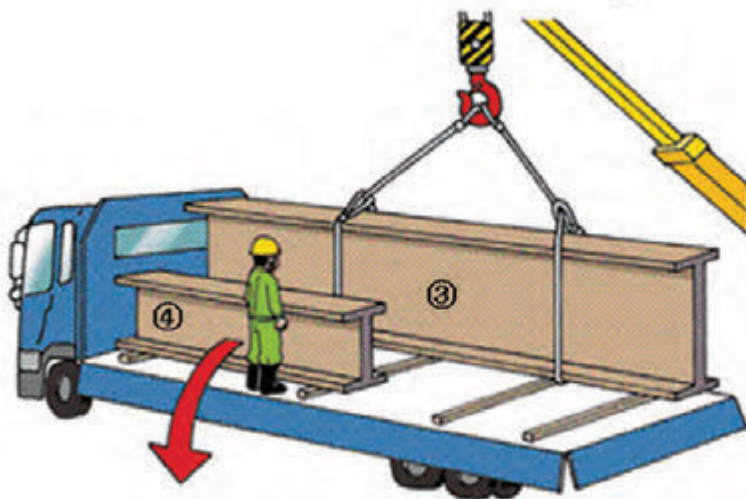
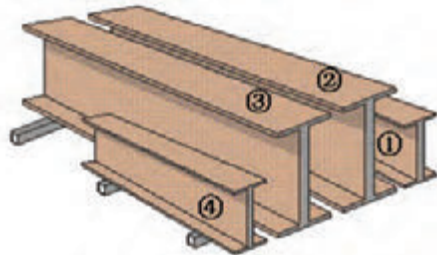

## The cause of the accident

1. Steel beam were unstable when beams arrived at site. The position of timbers shifted by vibration that was caused by transportation.
2. The stability of loads was not confirmed/checked before unloading started.
3. A sling man stood near the beam and he could not escape when the beam turned onto its side.

## Tips for preventing similar accidents

1. The vibration caused by transportation must be taken into account when the loading method is prepared/considered.
2. The order of unloading must be studied. For this case, the common order is unload beam 1 first, next beam 4, next beam 2, next beam 3.
3. Unloading can start only after the stability of loads and condition of loads are confirmed.
4. A sling man always stays at safe place when crane lift the loads.

## What kind of accident is about to happen?

This accident happened while the overhead travelling crane (safe loading load=2.8ton) was lifting and moving H-shape beams. A person in charge of sub-contractor, Mr.A, was preparing the working space for regular welding of H-shape beams. A worker, Mr.B, bundled 3 beams and hanged it by a single sling wire. Though Mr.A thought it was dangerous using only a single wire, but he didn't order to stop sling works because he wanted to start the regular welding works as soon as possible. Instead of stopping hoist works, Mr.A instructed Mr.B to keep distance from the hanged beams then lifted beams to 2m height. The

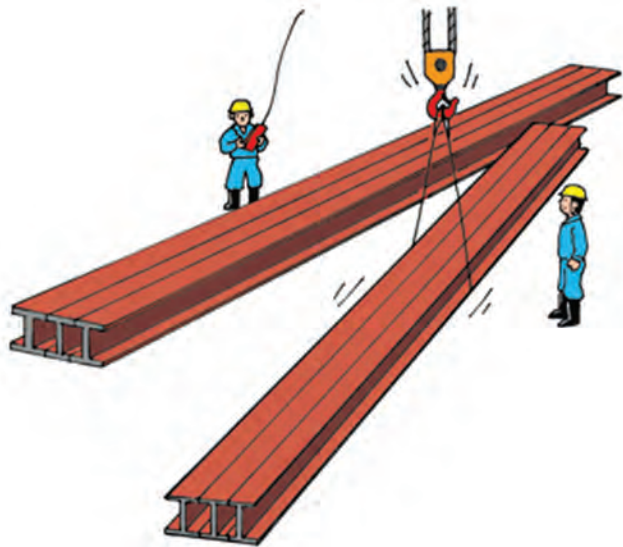

The sling wire was suddenly cut and beams were dropped on to Mr.B. Mr.B was injured and he had 2 months suspension of business. The main contractor didn't organize a regular inspection for wires. So the sub-contractor used the unsuitable wire which was kinked and lost its shape. Mr.A took a course of sling work but Mr.B didn't take. The company didn't check the license holders.

## The cause of the accident

1. The damaged wire was used. Though the wire was kinked and lost its shape, the wire was used because this wire was not inspected at the beginning of works.
2. The single wire was used for the lifting. Though Mr.A forecasted the risks caused by lifting beams, he didn't stop the lifting.
3. Mr.B was standing too close to the load.
4. Mr.B slung beams though he didn't take a course of sling works.
5. The main contractor didn't conduct a safety and health induction to workers and the contractor didn't check the number of license holders.

## Tips for preventing similar accidents

1. Not to use damaged wire.
2. The load must be checked its stability after slinging. Plural wires are recommended to be used.
3. Workers must keep distance from the load.
4. All workers who sling loads must finish the course of sling works.
5. The main contractor must conduct a safety and health induction to all workers at the site.



## 1.6. Fire and Explosion

---

## What kind of accident is about to happen?

This accident happened when a worker cut a waste drum by a grinder. A worker took a waste drum from the storage space of waste drums and brought to his original work place. He wanted to make a waste container from the drum. When he tried to cut the drum by a grinder, the drum was exploded and he suffered burns by the flames caused by the explosion.



## The cause of the accident

1. Cutting waste drums was not prohibited. This injured worker cut waste drums several times before. However, the company did not issue any work instructions related to the waste drums to him.
2. A disposal method of waste drums was not stipulated by the company. Accordingly drums with remaining hazardous materials were disposed at inappropriate place.
3. Potential risks of explosion and fires caused by the waste drums was not studied. And the prevention measures for explosion and fire was not discussed.

## Tips for preventing similar accidents

1. The possibility of cutting waste drums must be discussed whether it is accepted or not. The result of discussion must be known by all workers.
2. If the cutting works of waste drums is accepted, the following notice must be published to all workers and be recorded in writing.
  - a. Inside of waste drums must be thoroughly cleaned before works such as welding, gas/oxygen cutting, fusion cutting, etc.
  - b. A person in charge for waste drums shall be nominated. And he has to manage the number of drums, the origin of drums.
3. The safety committee of the project must study hazardous works which may cause explosion and/or fire. And if necessary, the committee must set up the prevention measures of accident against explosion/fire and notice to all workers.

## 1.7. Health disorder

---

## What kind of accident is about to happen?

The concrete hose was bursted when the ready-mixed slurry concrete was poured. Slurry concrete was sprayed on faces of workers and workers were taken to a hospital immediately after the accident.



## The cause of the accident

1. The concrete hose was bursted. The hose was damaged by handling, moving and stamping. In addition to the unaware damages, pumping pressure caused the bursting.
2. The concrete hose was not inspected before starting concrete works.

## Tips for preventing similar accidents

1. Handle concrete hose carefully and try not to be damaged.
2. A concrete hose must be checked before pouring.

## What kind of accident happened?

***A worker died from lack of oxygen which was caused by the blowout of gas when he was plumbing in the ditch.***

LPG (Liquefied petroleum Gas) pipes for the centralized gas supply services in a residential area became older. So main pipes and service pipes in this area were decided to be replaced with new pipes. After replacing all pipes, it was found that the gas was off at one house. Therefore the connection spot where the service pipe and the pipe to the private house were met was excavated to check the condition of pipe connection.

The day of accident, a sales manager of client, who had a certificate of “LPG mechanic” and a “Small gas-supply handling service”, left the site after he showed the place to be excavated. Workers excavated the place where they were instructed and they exposed the pipes at the connection.



## The cause of the accident

1. A sales manager changed old gas pipes by himself without stopping gas supply. Normally gas supply would be stopped when gas pipe fitting works started. But in this case, the sales manager didn't stop gas supply because he believed that he could finish plumbing in a short time without gas leakage.

If he stopped main gas pipes, gas supply to all houses in this residential area would be stopped. If he stopped service pipes, gas supply to 3 houses would be stopped. So he didn't stop gas supply to give priority to the convenience of customers.

2. He could complete plumbing works in a short time without stopping gas supply under the ideal condition. But actually he couldn't finish works smoothly. So a lot of gas was flew out in the ditch and oxygen-deficient air was filled in the confined space.

## Tips for preventing similar accidents

1. Instruct all workers to stop gas supply when gas pipes are changed. This rule must be known by all workers and they have to comply with it.
2. Notice all workers that gas works have risk of oxygen-deficiency. A watchman must be arranged and solo work shall be prohibited.
3. A safety education of gas works must be conducted to workers





## 1.8. Electricity

---

## What kind of accident happened?

The electrician was assembling switchboards and control panels into the high voltage sub-station facility(cubicle). Due to the insufficient brightness in the cubicle, he wanted to turn on the light in the cubicle. Therefore, he brought a cable from outside(100-volt) into the cubicle and he inserted the naked wires into the socket in the cubicle. So the light was working and he started his work. However, he did not turn off the breaker in the cubicle. The accident happened when he touched the circuit in the cubicle. The voltage of circuit was boosted to 6,600-volt by the transformer of cubicle because the circuit breaker was not turned off. He died by an electric shock.

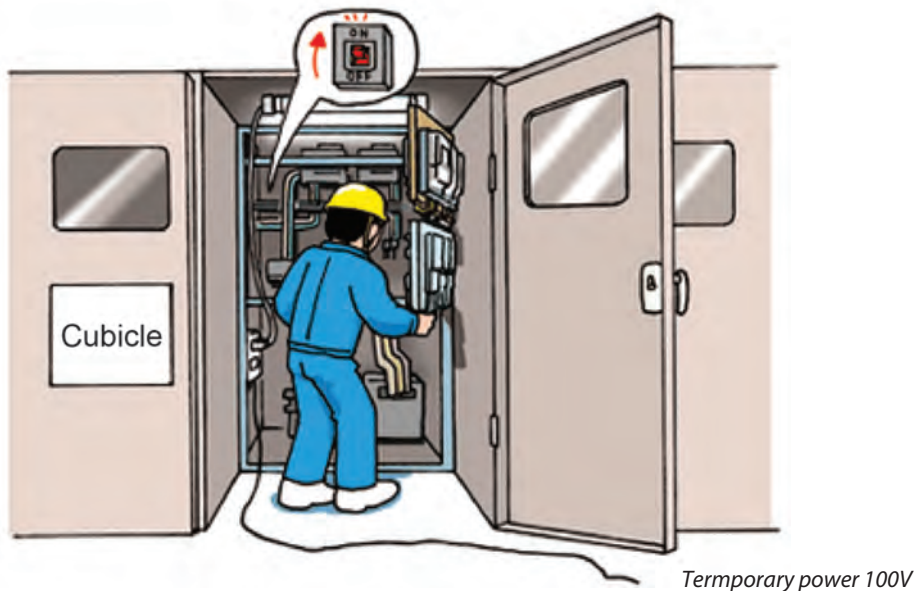

## The cause of the accident

1. The electrician didn't bring a light and he tried to use a light which was fixed with the cubicle.
2. Though he was a qualified electrician, he did not check the condition of circuit breaker.
3. As shown in his action such as inserting naked wires into the socket, his safety conscience was low.
4. A work plan was not prepared/predetermined.

## Tips for preventing similar accidents

1. Prepare a sufficient light at work place.
2. Never use a light fixed in the cubicle while assembling a cubicle.
3. Don't send an electric current to the cubicle during assembling/preparation cubicle.
4. A work plan must be prepared and a safety education must be conducted to all workers involved.

## What kind of accident happened?

The accident happened when the heat-insulating material at the ceiling was inspected.

The installation of heat-insulating materials at the ceiling completed the day before accident. The source of electricity for lighting and tools were arranged on the ceiling before but it was removed after installation works. Therefore, two workers, Mr.(A) and (B), brought the extension cable (30m) onto the ceiling to provide the electricity for the light. The plug of extension cable was inserted in the socket at the 2nd floor. On the way of inspection, the length of extension cable became insufficient. So they brought 4 additional extension cables (10m each) on the ceiling and connect them sequentially according to the progress.

After inspection finished, they started to remove extension cables from the ceiling one by one. When Mr.(A) removed the 3rd extension cable and inserted the plug of light into the 2nd extension cable, there was a shower of sparks and Mr.(A) fell on the ceiling. He was sent to the hospital but he died. The body of 2nd socket was damaged and the part of wiring was exposed without the cover. Mr.(A) tried to insert the plug into the socket in a dark. But he touched the wire exposed and got an electric shock.

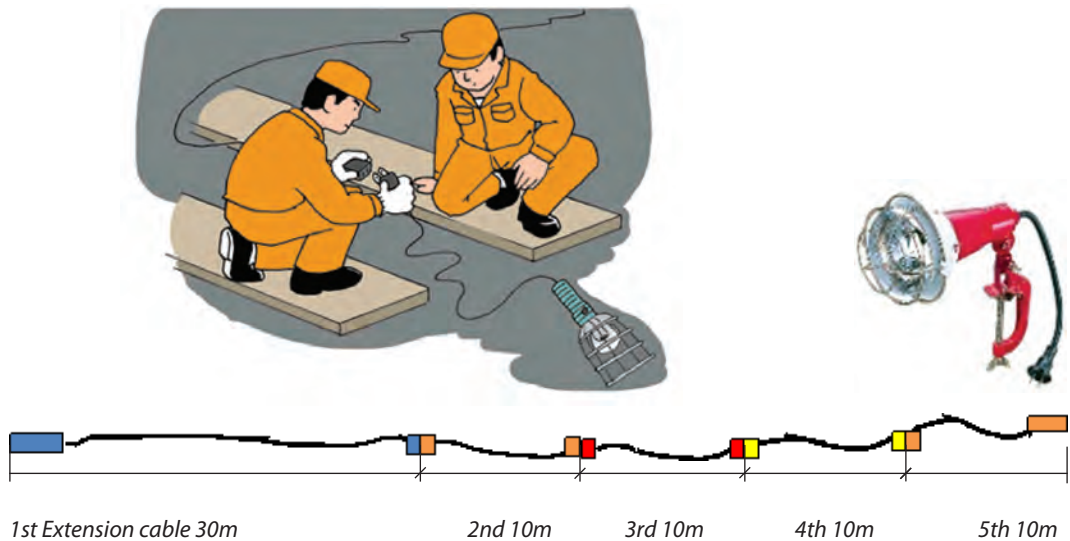

## The cause of the accident

1. The socket of extension cable was damaged.
2. Mr.(A) touched the live-wire exposed. Mr.(A) and (B) worked in a dark for a short time when a cable was extended/removed.
3. Workers didn't recognize that there was a risk of electric shock because no safety education of electric shock was conducted.

## Tips for preventing similar accidents

1. All electric appliances must be checked before they are used at site. If defects were found, don't use them until they are repaired or changed.
2. Keep lights through all work period including inspection period.
3. A safety education of electricity must be conducted. Even a low voltage circuit, it will cause death.

## What kind of accident happened?

### *3 men got an electric shock at the underground car park.*

4 workers of sub-contractor started to install angle bars at the underground car park. There was a little leakage from the wall but a worker, Mr.(A), used an arc welding machine in the morning. When Mr.(A) started his work in the afternoon, leakage formed puddles on the floor. Mr.(A) thought that it was dangerous to continue welding works under such circumstance. So he stopped welding works and he put a welding holder on the bracing of scaffold. When he went up the stairs holding the scaffold by hands, he and 2 colleagues working on the floor got an electric shock. All of them went to the hospital and stayed for 3 days. The power source of arc welding machine was "ON" when Mr.(A) put a welding holder on the bracing. The arc welding machine that Mr.(A) used equipped the auto electric shock prevention device. However, the device was not working and the machine was 20 years old. Mr.(A) joined the company 6 months ago but he didn't receive a training course of welding. He just earned his skills fro watching other people. The company didn't confirm his welding certification nor his training record of welding.

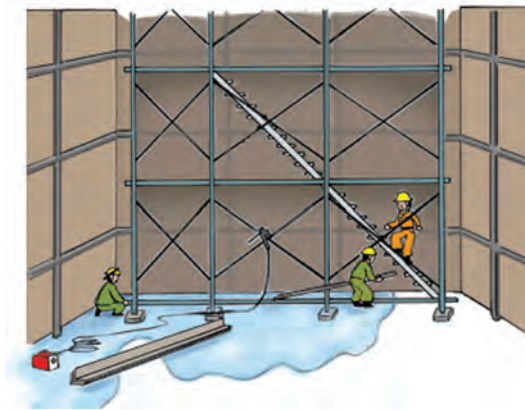

## The cause of the accident

1. Mr.(A) put a welding holder on the bracing of scaffold without turning off the switch of welding machine. So the following circuit was opened and 3 workers were shocked.

An arc welding machine -> A welding holder -> Scaffold -> Workers -> Scaffold -> Puddles of water ->An arc welding machine

2. The auto electric prevention device didn't work. Mr.(A) didn't check the welder before he used it.

3. The company didn't check the welding license of Mr.(A) nor his training record of welding. But the company didn't stop his welding works.

## Tips for preventing similar accidents

1. Instruct all workers to turn off the electric power when they stop arc welding works.

2. The function of auto electric shock prevention device must be checked before its use. Also the insulation properties of welding holder and cables must be checked. If the damage are found, they must be replaced.

3. The company must check the welding license of workers for welding works. Or the will conduct the training course of welding to workers.

## What kind of accident happened?

*4 men got an electric shock when they relocated the existing pipes.*

The day of accident, 2 workers used an aluminum stepladder for the high-place pipeworks. But accidentally, a stepladder trod on the 200V electric cable. The coating of electric cable was came off and the electric wire was exposed. So two workers got an electric shock via the stepladder. They shouted and nearly fell off the stepladder. Therefore, 2 colleagues approached the stepladder to try to rescue them. But they also got an electric shock when they touched the stepladder. The rescue manual for the victims of electric shock was not prepared for this project.

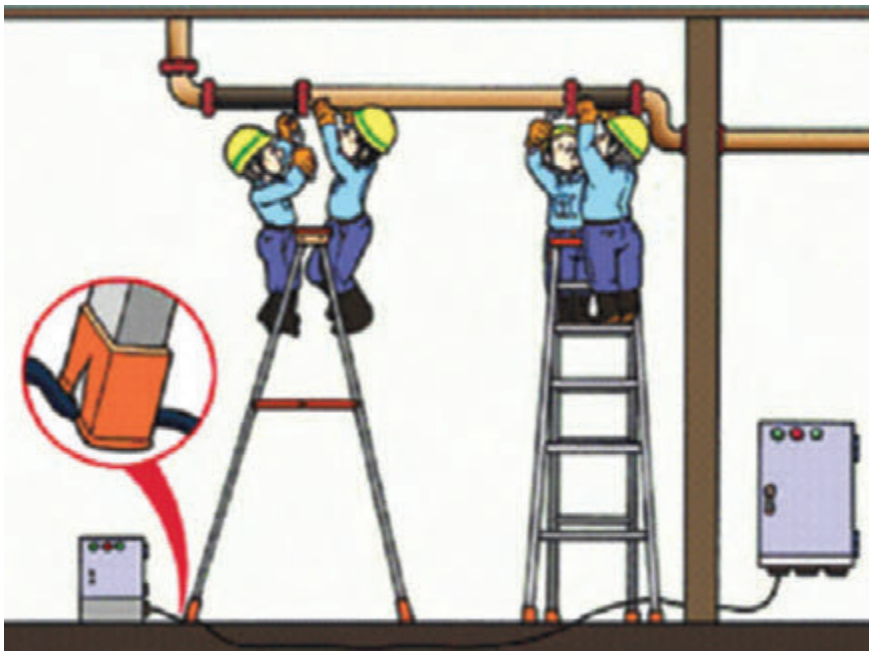

## The cause of the accident

1. The coating of electric cable was not perfect. That was the reason why the coating came off so easily.
2. No measure was taken to protect the 200V electric cable near the stepladder.

## Tips for preventing similar accidents

1. The coating condition of electric cable must be checked before works to confirm the insulation of cables.
2. Prevention measures to protect electric cables at work place must be arranged.
3. A rescue manual for victims of electric shock must be prepared.

## What kind of accident happened?

### *The crane was struck by lightning during concrete works at the slope of river.*

The day of accident, concreting was started in the afternoon. After 2nd batch of concrete was poured, it rained heavily. So the foreman instructed workers to put sheets on concrete to cover it. 15minutes later, the foreman stopped concreting because the rain was getting heavier. 30minutes after stopping concrete works, the rain eased up and the weather looked improving. Therefore, the foreman decided to start concreting again. When 3rd batch concrete was poured, suddenly the crane was struck by lightning. 3 workers for hopper, 1 vibrator operator and 1 concrete plasterer were injured by electric burn.

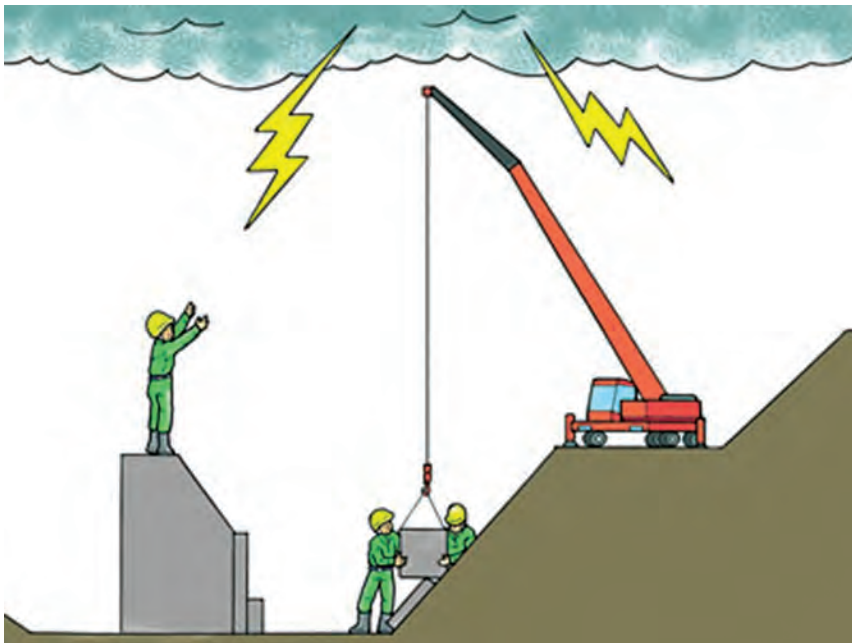

## The cause of the accident

1. The foreman resumed concreting though there was the possibility of lightning occurrence. The signs of lightning were (1) there was a rumbling of thunder in the distance, (2) the tip of boom was 24.8 meters high and it was higher than other buildings around.
2. The foreman decided to resume concrete works easily.

## Tips for preventing similar accidents

1. The following factors must be considered before commencement/resumption of works. (1) raining or not, (2) rumbling of thunder or not, (3) the height of crane, (4) the height of other buildings
2. When the possibility of lightning occurrence is high, a foreman shall consider more carefully whether the concrete works will be stopped or resumed. To contact a meteorological observatory is one of the effective means.

## What kind of accident happened?

### *An electrician died when he repaired the wiring of air conditioning on ceiling*

This accident happened in the hospital. The day of accident, a nurse in the ward complained to the electrician, Mr.(A), that a fan-coil unit of one room was noisy though the electric power was off. A person in charge for the building maintenance, Mr.(B), judged that a motor valve to supply water to the fan-coil unit couldn't close completely. So water was always running in the pipe and it caused the noise. Mr.(A) and (B) went to the noisy bedroom and confirmed the location of fan-coil unit and the motor valve. Firstly, Mr.(A) turned off the remote switch of fan-coil unit then Mr.(B) went to the ceiling. Mr.(A) sit astride the outer box of fan-coil unit and he cut the wire of motor valve. He stripped the insulating coating of wire and inserted it to the crimp contact for connection. He got an electric shock when he pressed the crimp contact by the crimp pliers. Mr.(B) watched this accident. Mr.(A) was rescued immediately and was treated at the hospital. But he died after 90minutes from the accident.

It was found after an investigation of accident that the crimp contact was connected to the wire but the insulating coating was broken and the core wire was exposed. Mr.(A) wore a long-sleeved clothes and sneakers but barehanded. It was assumed that the following circuit was opened with Mr.(A). Right hand-the trunk of the body-knees-ground.

## The cause of the accident

1. A person in charge, Mt.(B), turned off the remote switch of fan-coil unit before Mr.(B) started his work on the ceiling. But the power source of fan-coil unit was not turned off. So the unit was still continued to be charged at 100V. At hospital, the same type of electric works happened several times but it always operated with the live-wire because the hospital did not like to stop electricity for other bed rooms. Like to stop electricity for other bed rooms.
2. The posture of electrician was inappropriate. He sit astride the outer box of fan-coil unit which was made from conductive galvanized steel plate. The outer box was grounded. So the electric circuit was opened through his body.
3. Tools he used was inappropriate. The pliers he used was not insulated type. And he used it with barehands.
4. A chain of instruction for the safety management was not clear.



## Tips for preventing similar accidents

1. The method and procedure of repair work must be determined before electric work. Because there is always a risk of electric shock in electrical work even the voltage is low, such as 100-200V.
2. As a general rule, an electric current must be cut off for an electric work. If it is difficult to cut off an electric current, an earth leakage breaker must be set up in a circuit.
3. Instruct electricians to use insulated type of tools and gloves.
4. A special safety induction of electric work must be conducted to workers who are engaged in electric works.





1.9. Other



## What kind of accident happened?

### *The jib of crane at the construction site of apartment hit the prefabricated scaffold and was bent*

The day of accident, it was scheduled that steel bars would be unloaded from the trailer after concrete pouring. However, the concrete works was delayed so much. Therefore the unloading steel bars from the trailer started 30 min before sunset without lighting. The crane was operated by the radio-control. A crane operator slinged steel bars 2m from the trailer then turned and unload it on the ground. But he wanted to move steel bars slightly to the left. Therefore, he winded cable 50cm up then he tried to turn the jib to the left. But steel bars didn't up but down. He found that the jib touched with the prefabricated scaffold and bent down. The inclination angle of jib was within the acceptable range.



*Prefabricated scaffold*

## The cause of the accident

1. The jib touched with the prefabricated scaffold though the inclination angle of jib was within the acceptable range. The incident was caused by the lack of extension length of mast.
2. The time of crane operation was just before sunset. It was difficult to see and check the location of jib without lighting. But the crane operator still drove a crane from the ground using a radio-control switch.

## Tips for preventing similar accidents

1. The location of jib's fulcrum shall be jacked up or the height of prefabricated scaffold shall be lowered. And the trial operation of jib crane must be practiced after installation of jib crane and scaffold. No contact between jib and scaffold must be confirmed when the inclination angle of jib is within the acceptable range.
2. No crane work in the dark is accepted. If the crane work in the dark is necessary, the lighting must be arranged at the site.

## What kind of accident happened?

*When workers were marking the center line, the 8ton truck entered into the working area and hit 3 workers. 1 of 3 died.*

When paint material was running low, all workers (A~E) stopped marking and moved to the footpath. After filling paint, a worker (A) returned to his position and started to control the traffic from the West. Then B,C and D started the marking again. A worker (F) also started to control the traffic from the East. But when he returned to his position, the 8 ton truck already entered into the lane. So he didn't stop the truck. The truck run the lane but it suddenly cross the centerline and hit 3 workers. The permission to occupy the road was issued based on the following conditions.

1. Alternate one way traffic
2. Set up a protective car to guard workers

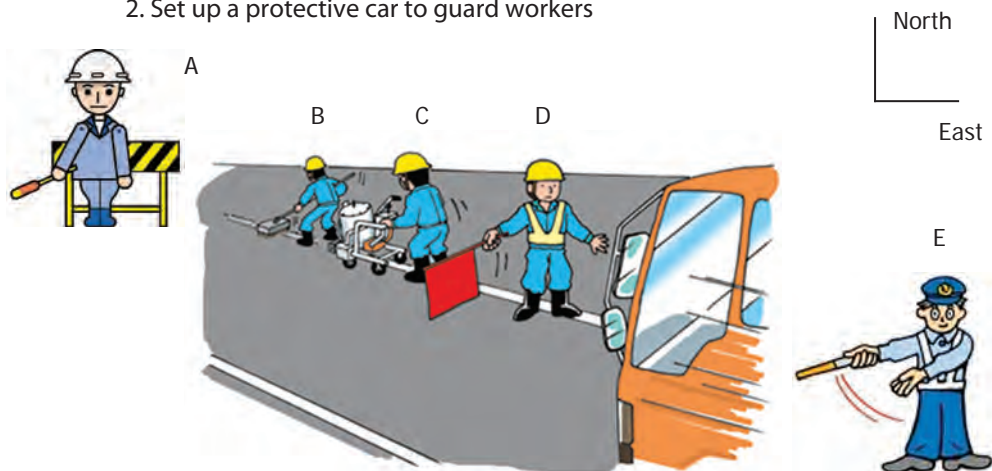

## The cause of the accident

1. The conditions of permission to occupy the road were not obeyed. Though "Alternate one way traffic" was the condition of works, two way traffic happened. And no protective car was set up.
2. A project manager of main contractor didn't instruct the detail construction method of marking to workers.
3. The work plan was not prepared nor safety induction to workers were achieved.

## Tips for preventing similar accidents

1. Setting up a protective car to guard workers is an indispensable condition.
2. Traffic controllers must be arranged at the both ends and "Alternate one way traffic" must be kept.
3. Notice boards "Road works ahead" shall be installed before at the both end of working area.
4. The work plan must be prepared before operation. And such work plan must be well known by all workers.

## What kind of accident happened?

A worker was removing the burr from the edge of cast-metal using the air operated grinder. After working several hours, he tried to change the whetstone which was worn. He removed the worn whetstone from the grinder and he tried to throw it into the disposal bin. When he approached to the bin, he found the another whetstone. He checked the condition of this whetstone and he judged it still usable. Therefore he fitted it to the grinder and started test working. However the whetstone suddenly burst and he injured.

The external diameter of whetstone was 100mm, the thickness was 6mm, and the condition of fitting to the flange was good. Also the air pressure and the peripheral velocity of grinder was within the normal range. The burst whetstone was thrown away by someone into the bin but maybe it was jumped out. No cover with the bin and no indication was shown on the whetstone which told that it was disposed whetstone. The opening space of grinder was 240 degrees. A worker did not take a training course for exchanging a whetstone of grinder.



## The cause of the accident

1. A worker fitted the used-whetstone to the grinder which was thrown away.
2. No cover with the bin and no indication shown on the whetstone which told that it was disposed whetstone.
3. The opening space which was not covered by the casing was 240 degrees.

## Tips for preventing similar accidents

1. A new whetstone must be used when it is changed. Confirm that the maximum peripheral velocity shown on the whetstone match the rotating speed of grinder.
2. A disposal bin must equip the cover. Some indication must be put on the disposed whetstone to identify it as disposal.
3. A training course for exchanging the whetstone of grinder must be arranged for workers who are engaged grinder works.

## II. **N**ear Misses

---

## Examples of Near Misses and Near Accidents

A mechanic stopped a wheel loader on a bit inclined ground to wash it clean. He got off the machine after applying the parking brake.



### What happened!

The machine began to move slowly, as the parking brake was not applied firmly.

### Corrective Action

1. Before leaving the operator's seat, be sure to set the lock brake and shut off the engine.

## Examples of Near Misses and Near Accidents

Remembering he has forgotten to support the boom cylinder on a wheel loader.



### What happened!

A mechanic has come back to it and pulled the connecting pin. Then the cylinder dropped and nearly hit him.

### Corrective Action

Ensure that the boom cylinder is supported by the props or bracing before pulling off the connecting pin.



## Examples of Near Misses and Near Accidents

Workers A and B are replacing oxygen cylinders in a cylinder installation yard. Worker A is now taking down an empty cylinder weighing 50 kg, while Worker B is kicking off a new cylinder to move it to the yard. It is charged with oxygen at the pressure ratio of 150 kg/square cm.



### Various Points of Hazard

1. The two workers do not use a special cart for transporting gas cylinders. There is the danger of damage to both the workers and the cylinders alike.
2. If a highly pressurized gas cylinder is rolled over the ground, there is always the danger of gas leakage.