

## **4. FORMULATION AND EVALUATION**

### **4.1 Definition of the Assessment Horizon of the Project**

The Project's assessment horizon will be of 15 years, same as the one applied on the Program Profile Report. The Annex-10 of SNIP regulation stipulates that the assessment horizon should be basically 10 years; however the period can be changed in case that the project formulator (DGIH in this Project) admits the necessity of change. DGIH adopted 15 years in the Program Profile Report and OPI and DGPM approved it in March 19, 2010. In JICA's development study it should be generally 50 years, so the JICA Study Team inquired on the appropriate period to DGIH and OPI, they directed JICA Study Team to adopt 15 years. And the social evaluation in case of 50 years assessment horizon is described in Annex-14 Implementation Program of Japanese Yen Loan Project.

### **4.2 Supply and Demand Analysis**

The theoretical water level was calculated considering flowing design flood discharge based on river cross sectional survey executed with a 500m interval, in each Watershed, considering a flood discharge with a return period of 50 years. Afterwards, the dike height was determined as the sum of the design water level plus the freeboard of dike.

This is the dike height required to prevent damages caused by design floods and represents the local community demand indicator.

The height of the existing dike or the height of the present ground is that required to prevent present flood damages, and represents the present supply indicator.

The difference between the design dike (demand) and the height of the present dike or ground represents the difference or gap between demand and supply.

Table 4.2-1 shows the averages of flood water level calculated with a return period of 50 years in "3.1.9 Run-off Analysis"; of the required dike height (demand) to control the discharge adding the design water level plus the freeboard dike; the dike height or that of the present ground (supply), and the difference between these last two (difference between demand-supply) of the river. Then, Table 4.2-2 shows the values of each point in Chincha river. The dike height or that of the present ground is greater than the required dike height, at certain points. In these, the difference between supply and demand was considered null.

**Table 4.2-1 Watershed Demand and Supply**

Basin	Present Height of Embankment or Ground(supply)		Flood Water Level of 1/50 Year Probability	Freeboard of Embankment	Required Height of Embankment (demand)	Supply and Demand Gap	
	Left Bank	Right Bank				Left Bank	Right Bank
	①	②				③	④
Chincha River							
Chico River	144.81	145.29	144.00	0.80	144.80	0.40	0.45
Matagente River	133.72	133.12	132.21	0.80	133.01	0.29	0.36

**Table 4.2-2 Demand and Supply according to calculation (Chico River)**

Watershed	Dike Height / current land (supply)		Theoretical water level with a return period of 50 years	Dike Freeboard	Required dike's height (demand)	Diff. demand/supply	
	Left bank	Right bank				Left bank	Right bank
	①	②				③	④
0.0	3.71	4.12	2.94	0.80	3.74	0.03	0.00
0.5	6.72	8.25	6.38	0.80	7.18	0.47	0.00
1.0	10.89	10.80	10.30	0.80	11.10	0.21	0.30
1.5	15.17	20.55	14.98	0.80	15.78	0.61	0.00
2.0	19.56	19.55	19.83	0.80	20.63	1.06	1.08
2.5	24.95	24.12	24.62	0.80	25.42	0.46	1.29
3.0	30.48	30.30	29.93	0.80	30.73	0.25	0.43
3.5	34.82	35.29	35.11	0.80	35.91	1.09	0.62
4.0	40.27	42.10	39.92	0.80	40.72	0.45	0.00
4.5	46.38	48.59	47.57	0.80	48.37	1.99	0.00
5.0	53.20	51.85	50.96	0.80	51.76	0.00	0.00
5.5	58.00	58.31	55.93	0.80	56.73	0.00	0.00
6.0	62.36	62.11	60.00	0.80	60.80	0.00	0.00
6.5	65.97	67.28	65.23	0.80	66.03	0.07	0.00
7.0	70.68	71.22	70.31	0.80	71.11	0.43	0.00
7.5	76.17	75.60	75.78	0.80	76.58	0.41	0.98
8.0	81.79	82.51	81.44	0.80	82.24	0.45	0.00
8.5	87.91	88.23	87.25	0.80	88.05	0.14	0.00
9.0	92.69	92.27	92.44	0.80	93.24	0.56	0.97
9.5	98.27	99.23	98.58	0.80	99.38	1.10	0.14
10.0	104.25	103.92	103.88	0.80	104.68	0.43	0.75
10.5	110.34	109.64	109.72	0.80	110.52	0.18	0.89
11.0	117.19	116.83	115.78	0.80	116.58	0.00	0.00
11.5	122.77	122.32	122.43	0.80	123.23	0.46	0.91
12.0	130.13	128.13	128.06	0.80	128.86	0.00	0.73
12.5	134.47	135.27	134.81	0.80	135.61	1.14	0.33
13.0	141.10	143.66	141.36	0.80	142.16	1.06	0.00
13.5	147.52	148.33	147.93	0.80	148.73	1.21	0.40
14.0	155.34	154.91	153.81	0.80	154.61	0.00	0.00
14.5	159.29	160.51	159.98	0.80	160.78	1.49	0.28
15.0	166.80	173.71	168.06	0.80	168.86	2.06	0.00
15.5	174.12	173.81	173.49	0.80	174.29	0.17	0.48

Preparatory study on the protection program for  
valleys and rural communities vulnerable to floods in Peru  
*Profile Study Report (Pre-feasibility level), Chincha River*

16.0	180.87	182.06	180.83	0.80	181.63	0.76	0.00
16.5	188.22	187.95	187.27	0.80	188.07	0.00	0.12
17.0	194.87	193.23	194.08	0.80	194.88	0.01	1.66
17.5	202.01	200.70	202.04	0.80	202.84	0.83	2.13
18.0	209.54	208.18	208.22	0.80	209.02	0.00	0.83
18.5	217.27	217.43	216.16	0.80	216.96	0.00	0.00
19.0	224.75	225.09	224.00	0.80	224.80	0.05	0.00
19.5	232.65	233.30	231.65	0.80	232.45	0.00	0.00
20.0	240.35	254.51	238.42	0.80	239.22	0.00	0.00
20.5	250.05	246.58	247.29	0.80	248.09	0.00	1.51
21.0	256.42	254.14	255.38	0.80	256.18	0.00	2.04
21.5	263.72	263.40	261.89	0.80	262.69	0.00	0.00
22.0	271.34	270.77	271.53	0.80	272.33	0.99	1.57
22.5	280.04	284.63	279.11	0.80	279.91	0.00	0.00
23.0	289.05	290.36	287.73	0.80	288.53	0.00	0.00
23.5	295.99	294.21	294.76	0.80	295.56	0.00	1.35
24.0	304.42	306.21	303.34	0.80	304.14	0.00	0.00
24.5	315.48	314.46	312.07	0.80	312.87	0.00	0.00
25.0	324.92	319.10	319.40	0.80	320.20	0.00	1.11
Average	144.81	145.29	144.00	0.80	144.80	0.40	0.45

**Table 4.2-3 Demand and supply according to calculation (Matagente River)**

Watershed	Dike Height / current land (supply)		Theoretical water level with a return period of 50 years	Dike Freeboard	Required dike's heigth (demand)	Diff. demand/supply	
	Left bank	Right bank				Left bank	Right bank
	①	②				③	④
0.0	2.58	2.16	2.22	0.80	3.02	0.44	0.85
0.5	3.40	4.85	5.26	0.80	6.06	2.66	1.21
1.0	6.55	6.50	7.22	0.80	8.02	1.47	1.52
1.5	10.00	10.11	10.17	0.80	10.97	0.97	0.85
2.0	13.43	15.09	13.71	0.80	14.51	1.08	0.00
2.5	17.07	20.06	17.69	0.80	18.49	1.43	0.00
3.0	22.03	24.12	21.63	0.80	22.43	0.39	0.00
3.5	27.56	27.50	26.13	0.80	26.93	0.00	0.00
4.0	31.51	31.24	30.47	0.80	31.27	0.00	0.04
4.5	35.58	35.32	34.51	0.80	35.31	0.00	0.00
5.0	41.98	40.32	40.01	0.80	40.81	0.00	0.49
5.5	45.86	45.19	44.84	0.80	45.64	0.00	0.45
6.0	50.08	48.81	49.14	0.80	49.94	0.00	1.13
6.5	54.35	55.04	53.40	0.80	54.20	0.00	0.00
7.0	59.08	57.82	58.08	0.80	58.88	0.00	1.06
7.5	63.40	62.51	62.98	0.80	63.78	0.38	1.27
8.0	68.88	67.69	67.28	0.80	68.08	0.00	0.39
8.5	73.29	72.83	72.72	0.80	73.52	0.23	0.69
9.0	78.20	77.68	78.60	0.80	79.40	1.20	1.72
9.5	83.40	82.77	83.25	0.80	84.05	0.66	1.28

Preparatory study on the protection program for  
valleys and rural communities vulnerable to floods in Peru  
*Profile Study Report (Pre-feasibility level), Chíncha River*

10.0	89.48	89.30	88.98	0.80	89.78	0.29	0.48
10.5	96.85	95.26	95.01	0.80	95.81	0.00	0.55
11.0	101.96	101.83	100.37	0.80	101.17	0.00	0.00
11.5	107.51	106.67	106.03	0.80	106.83	0.00	0.16
12.0	115.71	113.02	112.27	0.80	113.07	0.00	0.05
12.5	120.34	120.84	120.40	0.80	121.20	0.86	0.36
13.0	126.80	126.53	126.68	0.80	127.48	0.69	0.95
13.5	133.51	133.18	133.00	0.80	133.80	0.29	0.62
14.0	139.51	138.84	139.07	0.80	139.87	0.36	1.03
14.5	146.29	146.59	145.46	0.80	146.26	0.00	0.00
15.0	152.42	153.14	152.17	0.80	152.97	0.55	0.00
15.5	158.48	157.91	158.34	0.80	159.14	0.67	1.24
16.0	166.41	165.40	164.64	0.80	165.44	0.00	0.04
16.5	171.68	171.66	170.82	0.80	171.62	0.00	0.00
17.0	178.50	178.55	177.38	0.80	178.18	0.00	0.00
17.5	185.97	184.93	184.22	0.80	185.02	0.00	0.09
18.0	193.35	191.73	190.81	0.80	191.61	0.00	0.00
18.5	199.11	198.68	197.79	0.80	198.59	0.00	0.00
19.0	206.87	205.53	204.36	0.80	205.16	0.00	0.00
19.5	214.30	214.28	213.56	0.80	214.36	0.06	0.09
20.0	222.43	221.28	220.84	0.80	221.64	0.00	0.36
20.5	229.93	230.02	228.96	0.80	229.76	0.00	0.00
21.0	237.01	236.42	234.90	0.80	235.70	0.00	0.00
21.3	238.88	240.30	238.30	0.80	239.10	0.22	0.00
21.8	246.95	250.05	245.04	0.80	245.84	0.00	0.00
22.3	255.59	256.42	253.48	0.80	254.28	0.00	0.00
22.8	267.12	263.72	261.25	0.80	262.05	0.00	0.00
23.3	275.04	271.34	270.12	0.80	270.92	0.00	0.00
23.8	279.22	280.04	278.31	0.80	279.11	0.00	0.00
24.3	299.88	289.05	285.93	0.80	286.73	0.00	0.00
24.8	303.56	295.99	293.62	0.80	294.42	0.00	0.00
25.3	304.42	306.21	303.29	0.80	304.09	0.00	0.00
Average	133.72	133.12	132.21	0.80	133.01	0.29	0.36

## 4.3 Technical Planning

### 4.3.1 Structural Measures

As structural measures it was necessary to prepare a flood control plan for the whole Watershed. The later section 4.12 “Medium and Long Term Plan” and 4.12.1 “General Flood Control Plan” details results on the analysis. This plan proposes the construction of dikes for flood control in the entire Watershed. However, in the case of the Watershed of Chíncha river, a big project needs to be set up investing very high costs, far beyond those considered in the budget of the present Project, what makes it difficult to take this proposal. Therefore, supposing the flood control dikes in the whole Watershed are built progressively within a medium and long term plan, they would be focused on the study of more urgent and priority works for flood control.

**(1) Design flood discharge**

1) Guideline for flood control in Peru

The Methodological Guide for Projects on Protection and/or Flood Control in Agricultural or Urban Areas prepared by the Public Sector Multiannual Programming General Direction (DGPM) of the Economy and Finance Ministry (MEF) recommends to carry out the comparative analysis of different return periods: 25 years, 50 years and 100 years for the urban area, and 10 years, 25 years and 50 years for rural area and agricultural lands.

Considering that the present Project is focused on the protection of rural and agricultural areas, the design flood discharge should be the discharge with return period of 10year to 50-year.

2) Maximum discharge in the past and design flood discharge

The yearly maximum discharge in Chincha river is as shown in Figure-4.3.1-1. Based on the figure, the maximum discharge in the past can be extracted as shown in the Table- 4.3.1-1 together with the flood discharges with different return periods.

The maximum discharge in the past in the watershed occurred two times of which scale is more than the flood discharge with return period of 50-year. And it is true that the flood discharges of same scale as the flood discharge with return period of 50-year caused large damages in the past. The maximum discharge in the past in Chincha watershed occurred before 1960s, and the maximum discharges in recent 40 years are less than the discharge with return period of 50-year.

Since the flood control facilities in Peru not well developed, it is not necessary to construct the facilities for more than the maximum discharge in the past, however it is true that the past floods caused much disaster so that the facilities should be safe for the same scale of flood, therefore the design flood discharge in this Project is to be the discharge with return period of 50-year.

**Table - 4.3.1-1 Flood discharge with different return period(m<sup>3</sup>/sec)**

<b>Watershed</b>	<b>2-year</b>	<b>10-year</b>	<b>25-year</b>	<b>50-year</b>	<b>100-year</b>	<b>Max. in the Past</b>
Chincha	203	580	807	917	1,171	1,269



**Figure- 4.3.1-1 Yearly Max. Discharge (Chincha)**

### 3) Relation among probable flood, Damage and inundation area

The relation among probable flood, Damage and inundation area in Chincha river are shown in the Figure-4.3.1-2.

Based on the figures the following facts can be expressed.

- ① The more increase probable flood discharge, the more increase inundation area (green line in the figure).
- ② The more increase probable flood discharge, the more increase damage (red line in the figure).
- ③ According to increase of probable flood discharge, the damage with project increase gently (blue line in the figure).
- ④ According to increase of probable flood discharge, damage reduction (difference between red line and blue line) increase steadily, and it reaches maximum at the probable flood of 50- year within the scope of study.

The damage reduction amount in the design discharge is largest among the probable flood discharge less than with return period of 50-year, and economic viability of the design flood is confirmed.

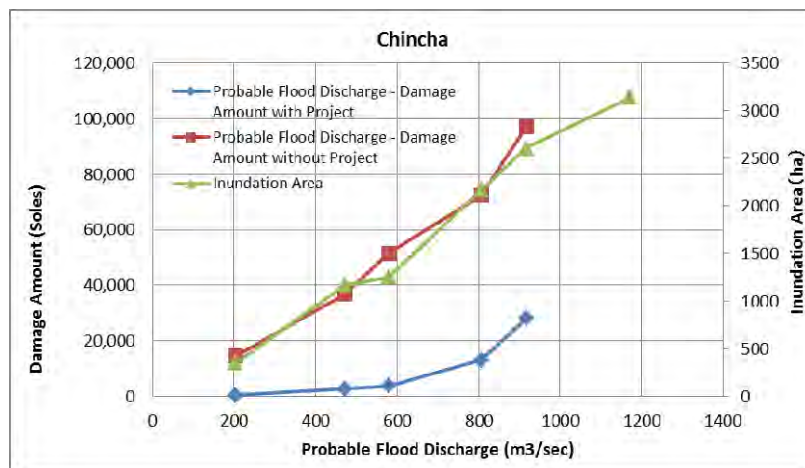

**Figure—4.3.1-2 Probable Flood Discharge, Damage Amount and Inundation Area (Chincha river)**

## (2) Topographical survey

The topographical survey was carried out in selected places for the execution of structural measurements (Table 4.3.1-1). The preliminary design of control works was based on these topographical survey results.

**Table 4.3.1-1 Summary of Topographical Survey**

River	Location (No.)	Installations	Topo lift.	Transversal Lifting (S=1/200)		
			(ha)	Line No.	Middle length (m)	Total length (m)
Chincha	Chico-1	Dike	15.0	32	50.0	1,600
	Chico-2	Reservoir	21.0	8	300.0	2,400
	Chico-3	Reservoir	5.0	4	200.0	800
	Ma-1	Dike	15.0	32	50.0	1,600
	Ma-2	Dike & excavation	24.0	13	200.0	2,600
Sub Total			80.0	89		9,000

## (3) Selection of flood protection works with high priority

### 1) Basic Guidelines

For the selection of priority flood protection works, the following elements were considered:

- Demand from the local community (based on historical flood damage)
- Lack of discharge capacity of river channel (including the sections affected by the scouring)
- Conditions of the adjacent area (conditions in urban areas, farmland, etc.).
- Conditions and area of inundation (type and extent of inundation according to inundation analysis)
- Social and environmental conditions (important local infrastructures)

Based on the river survey, field investigation, discharge capacity analysis of river channel, inundation analysis, and interviews to the local community (irrigation committee needs, local governments, historical flood damage, etc...) a comprehensive evaluation was made applying the five evaluation criteria listed above. After that we selected a total of five (5) critical points (with the highest score in the assessment) that require flood protection measures.

Concretely, since the river cross sectional survey was carried out every 500m interval and discharge capacity analysis and inundation analysis were performed based on the survey results, the integral assessment was also done for sections of 500 meters. This sections have been assessed in scales of 1 to 3 (0 point, 1 point and 2 points) and the sections of which score is more than 6 were selected as prioritized areas. The lowest limit (6 points) has been determined also taking into account the budget available for the Project in general

Table 4.3.1-3 details evaluated aspects and assessment criteria.

**Table 4.3.1-3 Assessment Aspects and Criteria**

Assessment Aspects	Description	Assessment Criteria
Demand of local population	<ul style="list-style-type: none"> <li>● Flood damages in the past</li> <li>● Demand of local population and producers</li> </ul>	<ul style="list-style-type: none"> <li>• Flooding area with big floods in the past and with great demand from local community (2 points)</li> <li>• Demand of local population (1 point)</li> </ul>
Lack of discharge capacity (bank scouring)	<ul style="list-style-type: none"> <li>● Possibility of river overflow given the lack of discharge capacity</li> <li>● Possibility of dike and bank collapse due to scouring</li> </ul>	<ul style="list-style-type: none"> <li>• Extremely low discharge capacity (discharge capacity with return period of 10 years or less) (2 points)</li> <li>• Low discharge capacity (with return period of less than 25 years) (1 point)</li> </ul>
Conditions of surrounding areas	<ul style="list-style-type: none"> <li>● Large arable lands, etc.</li> <li>● Urban area, etc.</li> <li>● Assessment of lands and infrastructure close to the river.</li> </ul>	<ul style="list-style-type: none"> <li>• Area with large arable lands (2 points)</li> <li>• Area with arable lands mixed with towns, or big urban area (2 points)</li> <li>• Same configuration as the previous one, with shorter scale (1 point)</li> </ul>
Inundation conditions	<ul style="list-style-type: none"> <li>● Inundation magnitude</li> </ul>	<ul style="list-style-type: none"> <li>• Where overflow extends on vast surfaces (2 points)</li> <li>• Where overflow is limited to a determined area (1 point)</li> </ul>
Socio-environmental conditions (important structures)	<ul style="list-style-type: none"> <li>● Intake of the irrigation system, drinking water, etc.</li> <li>● Bridges and main roads (Carretera Panamericana, etc.)</li> </ul>	<ul style="list-style-type: none"> <li>• Where there are important infrastructures for the area (2 points)</li> </ul> <p>Where there are important infrastructures (but less than the first ones) for the area (regional roads, little intakes, etc.) (1 point)</p>

## 2) Selection results

Figure 4.3.1-3 and Figure 4.3.1-4 detail assessment results of the river, as well as the selection results of flood protection priority works.



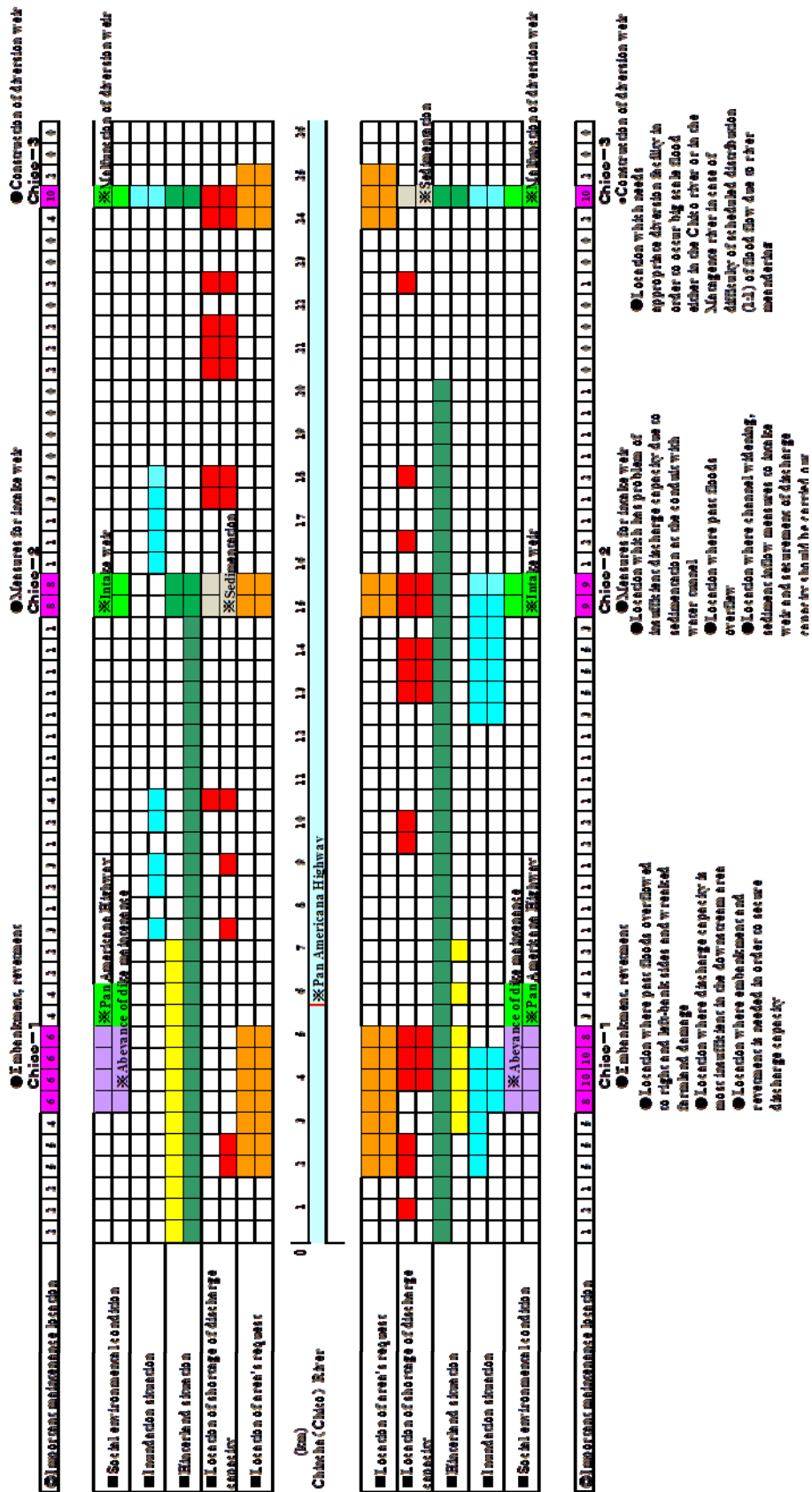

Figure 4.3.1-3 Selection results of prioritized flood protection works in Chincha-Chico river

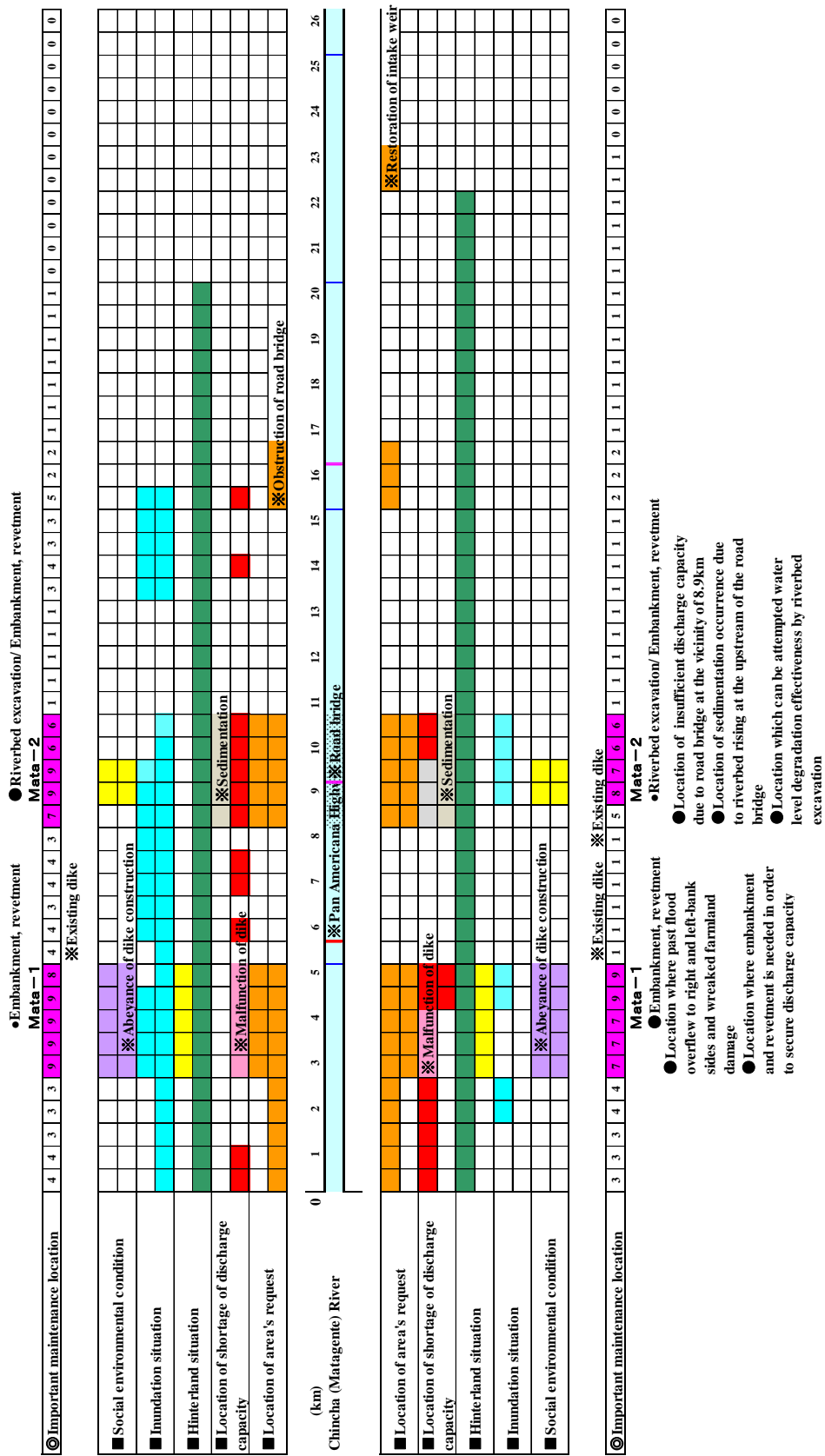

Figure 4.3.1-4 Selection results of prioritized flood protection works in Chinchá-Matagente river

### 3) Basis of Selection

The characteristics of Chincha river is that in case of unequal diversion of flood water to Chico river and Matagente river, the flooding water inflow unevenly to one river causing heavy damage in all section of that river due to insufficient discharge capacity. Even when the water is adequately distributed among rivers Chico and Matagente in a 1:1 relation, Chico River may overflow at Km 15 and Km 4 causing great damages on the left bank, and Matagente River may overflow at Km 9 and Km 3, flooding great areas from right bank.

Therefore, the basic policy of flood prevention is to build the diversion weir and embankment with bank protection in the section where inundation areas in the past due to insufficient discharge capacity. The flood prevention works are planned on the condition that the water diversion is properly implemented (in case of execution of No.③ ).

**Table 4.3.1-4 Selected sections bases to execute works (Chincha River)**

No	Location	Basis of Selection
①	<p><b>Chico river</b></p> <p>3.0km~5.1km (both banks)</p>	<p>The embankment with bank protection is required in this section where the discharge capacity is lowest in the lower reach of Chico river, especially for the left bank to prevent the damage increasing. And in case that the flood protection work is constructed in the upstream section, inundation occurs and enlarges in the right bank. Therefore the embankment at both banks is required.</p> <p>[Characteristics of the section]</p> <ul style="list-style-type: none"> <li>●Section in which the past inundations on both banks have caused damages on crops, etc</li> <li>●Section only the left bank dike is partially built. If dikes are constructed in upstream sections, this may lead to inundation in this section</li> <li>●The section with the lowest discharge capacity in the lower reach</li> </ul> <p>[Elements to protect]</p> <ul style="list-style-type: none"> <li>○Vast agricultural lands that go beyond both banks of this section (especially on the left bank)</li> </ul> <p>[Method of Protection]</p> <ul style="list-style-type: none"> <li>▼Inundation occurs at the flood with return period of 5-year and the damage become heavily at the flood with return period of 50-year, so that the flood protection work is implemented for the latter flood flowing down safely.</li> <li>▼Embankment with bank protection is built for securing the discharge capacity utilizing the existing dike partially</li> </ul>
②	<p>Chico river</p> <p>14.8km~15.5km (widening the river with to left bank)</p>	<p>This section has the problem of accumulating great amounts of sediments in the intakes and has an absolute lack of discharge capacity already mentioned. So, it is a very important section where the control of sediments to the intake (construction of a derivation work that distributes the flow correctly) and ensuring the required discharge capacity are the main tasks.</p> <p>[Characteristics of the section]</p> <ul style="list-style-type: none"> <li>●Section that inundated due to former floods</li> <li>●Section that requires widening river, control of sediments in the intake and keeping the necessary discharge capacity</li> <li>●Section where a water channel tunnel exists, in which sediments have deposited, and stops the function of tunnel.</li> </ul> <p>[Elements to protect]</p> <ul style="list-style-type: none"> <li>○Intake</li> <li>○Left bank crop lands</li> </ul> <p>[Method of Protection]</p>

		<p>▼Inundation occurs at the flood with return period of 5-year and the damage become heavily at the flood with return period of 50-year, so that the flood protection work is implemented for the latter flood flowing down safely.</p> <p>▼Widening river width and preventing the concentration of flow to the intake</p>
③	<p><b>Chico river</b></p> <p>Km24.2-km24.5 (total)</p>	<p>This section is a diversion point of Chincha river to Chico river and Matagente river, and the most important section in the flood prevention plan for Chincha river (Base of flood prevention plan).</p> <p>The diversion weir exists at the section; however it was built in 1954, and heavily devastated. And in flooding the flow meanders in the upstream of the weir and water flows in the one of two rivers, which means diversion is not well functioned. Therefore the construction of diversion weir to distribute the flood evenly is indispensable in the flood control in Chincha river</p> <p>[Characteristics of the section]</p> <ul style="list-style-type: none"> <li>● Section that requires a proper derivation work because in case that it is not possible to distribute stream in a relation 1:1 due to the river meandering. This will cause great flooding in one of both rivers: Chico or Matagente</li> </ul> <p>[Elements to protect]</p> <ul style="list-style-type: none"> <li>○ Every district of Chico and Matagente (because if the overflow stream is not adequately distributed, great damage will happen in one of both rivers)</li> </ul> <p>[Method of Protection]</p> <p>▼The diversion weir which can divert the flow steadily is constructed.</p>
④	<p><b>Matagente 川</b></p> <p>2.5km~5.0km (both banks)</p>	<p>This section is past inundation area with tendency of spreading widely to the right bank. And the irregular embankment was implemented for preventing the past damage. If the flood prevention work in the upstream is executed, inundation occurs in left bank also so that the embankment is required at both banks.</p> <p>[Characteristics of the section]</p> <ul style="list-style-type: none"> <li>●Section with lowest discharge capacity in downstream</li> <li>●Section in which the past floods have caused inundation on both banks causing great damages to croplands, etc.</li> <li>●Section where dikes were irregularly constructed.</li> </ul> <p>[Elements to protect]</p> <ul style="list-style-type: none"> <li>○ Vast agricultural lands that spreads beyond both banks of this section (specially on the right bank)</li> </ul> <p>[Method of Protection]</p> <p>▼Construction of dike to improve insufficient discharge capacity and bank protection to covering slope and end of slope</p> <p>▼Inundation occurs at the flood with return period of 5-year and the damage become heavily at the flood with return period of 50-year, so that the flood protection work is implemented for the latter flood flowing down safely.</p>
⑤	<p><b>Matagente 川</b></p> <p>8.0km~10.5km (both banks)</p>	<p>This section is the past inundation area. In this narrow section (where the bridge is built), the discharge capacity is insufficient and the river bed has raised 4 – 5 m during past 50 years. The river bed needs to be excavated to increase the discharge capability (taking the proper precautions in order not to damage the bridge's base) and a dike must be built on both banks.</p> <p>[Characteristics of the section]</p> <ul style="list-style-type: none"> <li>●Section where sediments deposited upstream of the bridge due to its damming up effect</li> </ul>

		<p>●Section in which the discharge capacity is very reduced due to the river's narrowness at km 8.9 (where the bridge is)</p> <p>[Elements to protect]</p> <ul style="list-style-type: none"> <li>○ Vast agricultural lands that go beyond both banks of this section (especially on the right bank)</li> </ul> <p>[Method of Protection]</p> <p>▼This section has tendency of riverbed raising so that riverbed excavation is to be executed for keeping discharge capacity and lowering upstream water level.</p> <p>▼Inundation occurs at the flood with return period of 5-year and the damage become heavily at the flood with return period of 50-year, so that the flood protection work is implemented for the latter flood flowing down safely.</p>
--	--	--

**(4) Location of prioritized flood control works**

Figure 4.3.1-5 shows the location of priority works on flood control in the Chincha river, and The Table 4.3.1-5 shows the summary of the priority works.

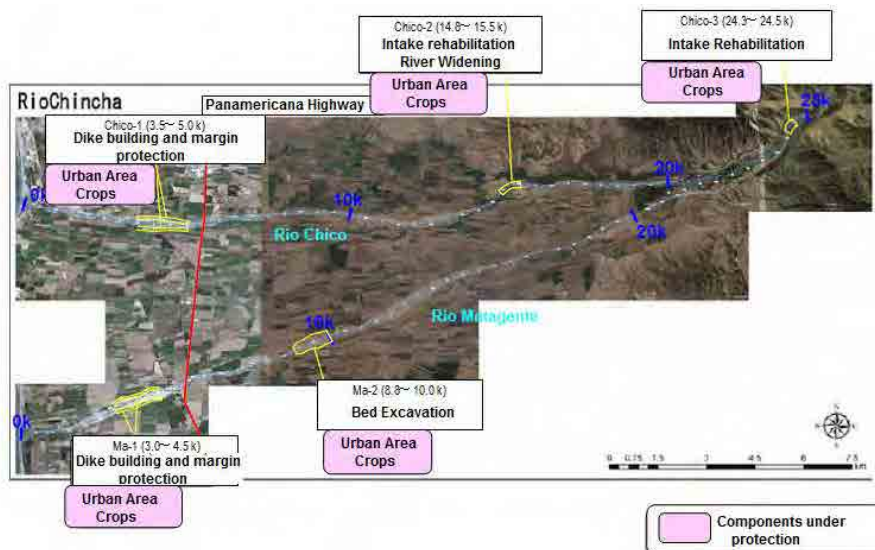

**Figure 4.3.1-5 Priority Works on flood control in the Chincha River**

**Table 4.3.1-5 Summary of priority works**

Basin	Location		Preservation Object	Counter Measure	Summary of Facility	Objective Section	
Chincha	1	C-3.5~5.0k	Inundation	Crop land (Cotton Grape)  Urban area	Dike (no dike section) Revetment	Top W; 4.0m H; 2.0m Slope; 1:3 L; 3,000m (1,500+1,500)	3.0km~5.1km(total)
	2	C-15k	Intake		Intake Widening river width	Weir W; 100m H; 3.0m T; 2.0m	14.8km~15.5km (total)
	3	C-24k	Diversion weir		Rehabilitation of diversion weir (rehabilitation of existing weir, channel and training dike)	Weir w; 70m H; 3.0m T; 2.0m	24.2km~24.5km (total)
	4	M-3.0k~4.5k	Inundation		Dike (no dike section) Revetment	Top W; 4.0m H; 2.0m Slope; 1:3 L; 3,000m (1,500+1,500)	2.5km~5.0km(total)
	5	M-8.9k	Narrow Section		Riverbed excavation	Ex. width; 100m Ex. depth; 1.0m L; 1,200m	8.0km~10.5km (total)

### (5) Standard section of the dike

#### 1) Width of the crown

The width of the dike crown was defined in 4 meters, considering the dike stability when facing design overflows, width of the existing dike, and width of the access road or that of local communication.

#### 2) Dike structure

The dike structure has been designed empirically, taking into account historic disasters, soil condition, condition of surrounding areas, etc.

Dikes are made of soil in all the Watersheds. Although there is a difference in its structure varying from area to area, this can be summarized as follows, based on the information given by the administrators interviewed:

- ① The gradient of the slope is mainly 1:2 (vertical: horizontal relationship); the form may vary depending on rivers and areas.
- ② Dike materials are obtained from the river bed in the area. Generally these are made of sand/gravel ~sandy soil with gravel, of reduced plasticity. As to the resistance of the materials, we cannot expect cohesiveness.
- ③ The Watershed of the Cañete River is made of loamy soil with varied pebble, relatively compacted.
- ④ The lower stretch of the Sullana weir of the Chira River is made of sandy soil mixed with silt. Dikes have been designed with a “zonal-type” structure where material with low permeability is placed on the riverside of the dike and the river; material with high permeability is placed on landside of the dike. However, given the difficulty to obtain material with low permeability, it has been noticed that there is lack of rigorous control of grain size distribution in supervision of construction.
- ⑤ When studying the damaged sections, significant differences were not found in dike material or in the soil between broken and unbroken dike. Therefore, the main cause of destruction has been water overflow.
- ⑥ There are groins in the Chira and Cañete rivers, and many of them are destroyed. These are made of big rocks, with filler material of sand and soil in some cases, what may suggest that destruction must be caused by loss of filler material.
- ⑦ There are protection works of banks made of big rocks in the mouth of the Pisco River. This structure is extremely resistant according to the administrator. Material has been obtained

from quarries, 10 km. away from the site.

Therefore, the dike should have the following structure.

- ① Dikes will be made of material available in the zone (river bed or banks). In this case, the material would be sand and gravel or sandy soil with gravel, of high permeability. The stability problems forecasted in this case are as follows.
  - i) Infiltrate destruction caused by piping due to washing away fine material
  - ii) Sliding destruction of slope due to infiltrate pressure

In order to secure the stability of dike the appropriate standard section should be determined by infiltration analysis and stability analysis for sliding based on unit weight, strength and permeability of embankment material.

- ② The gradient of the slope of the dike will be between  $30^\circ \sim 35^\circ$  (angle of internal friction) if the material to be used is sandy soil with low cohesiveness. The stable gradient of the slope of an embankment executed with material with low cohesiveness is determined as:  $\tan\theta = \tan\phi/n$  (where “ $\theta$ ” is gradient of the slope; “ $\phi$ ” is angle of internal friction and “ $n$ ” is 1.5 ,safety factor).

The stable slope required for an angle of internal friction of  $30^\circ$  is determined as: V:H=1:2.6 ( $\tan\theta=0.385$ ).

Taking into consideration this theoretical value, a gradient of the slope of 1:3.0 was considered, with more gentle inclination than the existing dikes, considering the results of the discharge analysis, the prolonged time of the design flood discharge (more than 24 hours), the fact that most of the dikes with slope of 1:2 have been destroyed, and the relative resistance in case of overflow due to unusual flooding.

The infiltration analysis and stability analysis of dike based on the soil investigation and martial tests are not performed in this Study so that the slope is determined by simple stability analysis assuming the strength factors of dike material estimated by field survey of material and by adding some safety allowance.

And the slope of dike in Japan is generally 1:2.0 in minimum, however the average slope will be more than 1:3.0 because the dike has several steps in every interval of 2m~3m of height.

- ③ The dike slope by the riverside must be protected for it must support a fast water flow given the quite steep slope of the riverbed. This protection will be executed using big stones or big rocks easily to get in the area, given that it is difficult to get connected concrete blocks.

The size of the material was determined between 30cm and 1m of diameter, with a minimum protection thickness of 1m, although these values will be determined based on flow speed of each river.

### 3) Freeboard of the dike

The dike is made of soil material, and as such, it generally turns to be an extremely weak structure when facing overflow. Therefore, it is necessary to prevent water overflow, to a lower water rise than the design overflow. So it is necessary to keep a determined freeboard when facing a possible increase in water level caused by the waves produced by the wind during water rise, tidal, hydraulic jump, etc. Likewise, it is necessary that the dikes have sufficient height to guarantee safety in surveillance activities and flood control, removal of logs and other carryback material, etc.

Table 4.3.1-5 shows guidelines applied in Japan regarding freeboard. Although in Peru there is

a norm on freeboard, it has been decided to apply the norms applied in Japan, considering that rivers in both countries are alike.

**Table-4.3.1-5 Discharge of design overflows and freeboard**

Discharge of design overflows	Height to be added to the level of design overflows
Less than 200 m <sup>3</sup> /s	0,6m
More than 200 m <sup>3</sup> /s, less than 500 m <sup>3</sup> /s	0,8m
More than 500 m <sup>3</sup> /s, less than 2,000 m <sup>3</sup> /s	1,0 m
More than 2,000 m <sup>3</sup> /s, less than 5,000 m <sup>3</sup> /s	1,2 m
More than 5,000 m <sup>3</sup> /s, less than 10,000 m <sup>3</sup> /s	1,5 m
More than 10,000 m <sup>3</sup> /s	2,0 m

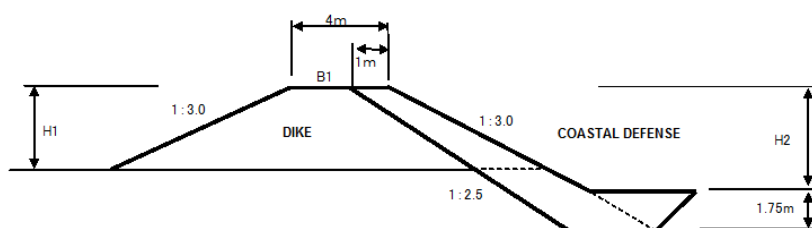

**Figure 4.3.1-4 Standard dike section**

#### 4.3.2 Nonstructural measures

##### 4.3.2.1 Reforestation and vegetation recovery

###### (1) Basic policies

The Reforestation and Vegetation Recovery Plan satisfying the goal of the present Project can be classified in: i) reforestation along fluvial works; and ii) reforestation in the high Watershed. The first one contributes directly to flood control and expresses its effect in short time. The second one demands a huge investment and an extended time, as detailed in the later section 4.12 “Medium and long term Plan”, 4.12.2 “Reforestation Plan and Vegetation Recovery”, what makes not feasible to implement it in the present Project. Therefore, the analysis is here focused only in option i).

###### (2) Reforestation plan along river structures

Policies for the afforestation plan along river structure is as shown below. The conceptual diagram of the afforestation scheme are shown in Figures 4.3.2.1-1.

- a) Objective: Reduce impact of river overflow when water rise occurs or when river narrowing is produced by the presence of obstacles, by means of vegetation borders between the river and the elements to be protected.
- b) Methodology: Create vegetation borders of a certain width between river structures and the river.
- c) Work execution: Plant vegetation at a side of the river structures (dikes, etc.) is to be a part of construction work of river structures, and which is carried out by the same contractor as for the river structures. The reasons are i) plant vegetation is to be certain for the withered damage just after plantation and ii) The same contractor for the river structures is appropriate due to the parallel work of plantation and structure construction.
- d) Maintenance post reforestation: The maintenance will be assumed by irrigation commissions by own initiative. In the past project, it is usually performed that the agreement is made between the irrigation committee and DGIH on the following two



items.

- i) The ownership of plantation belongs to the irrigation committee.
- ii) Operation and maintenance cost of the plantation is born by the committee

Therefore the plantation is not private property but public one in the committee.

- e) Plantation section : Since the purpose of plantation is mitigation of damage in overflowing of flood, the plantation is to be made in the preventive side of dike. In case that the plantation is made in the section without dike, the trees are knocked down directly by flood water, and they flow down along river causing the choke in the bridges etc. resulting in secondary damage, and as the length without dike is long , the cost of construction and land acquisition increases.

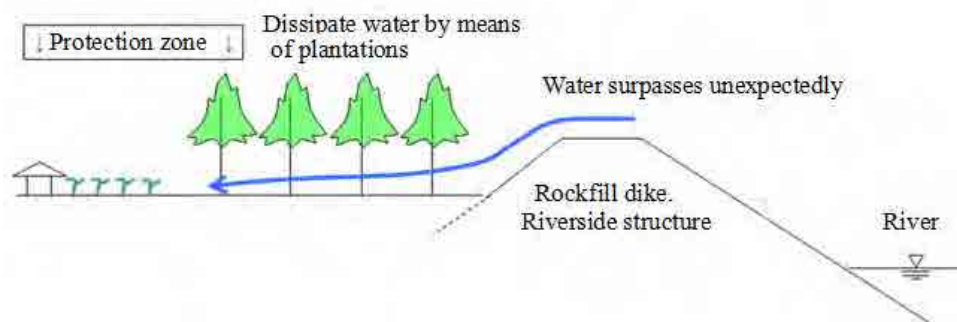
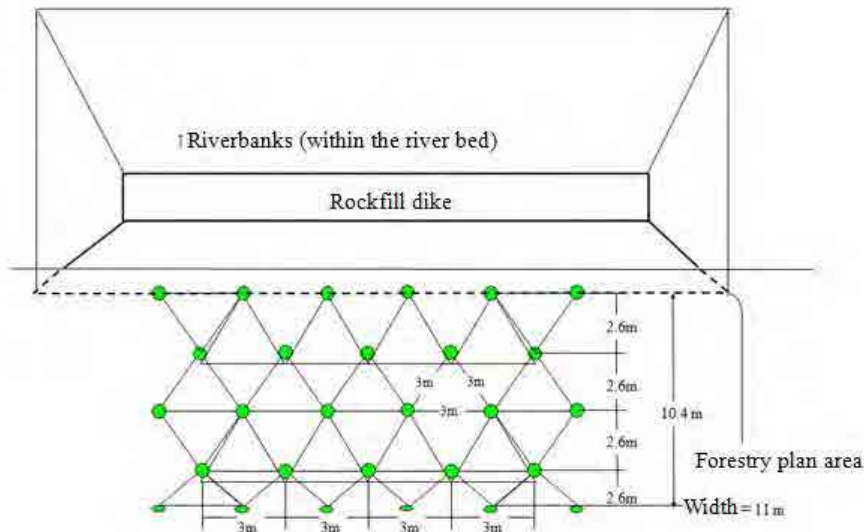

**Figure 4.3.2.1-1 Conceptual Diagram Afforestation in the Riverside structures**  
source: JICA Study Team)

### (3) Reforestation Plan

#### 1) Structure (plantation arrangement)

In Peru the most common pattern for afforestation is with equilateral triangles. This project also uses this model by planting trees with 3-meter intervals (Figure 4.3.2.1-2). If this method is used, the interval of trees vertical to the dike will be 2.6m and in the case of zigzag arrangement, the width will be 1.3m of which interval can stop the bolder with diameter of 1m or dissipate the energy of the boulder. And 4 lines of trees can increase the effect. Thus the width of plantation zone will be 11 m adding the allowance to 10.4 m.



(Source: JICA Study Team)

**Figure 4.3.2.1-2 Arrangement of plantation along river structure**

## 2) Species to be forested

The following list of forestry species has been developed for selecting the species to be planted.

- Forestry species for production (information obtained by forest nursery companies): see Table 4.3.2.1-1
- Forestry species verified in situ: see Table 4.3.2.1-2.

The mentioned species are selected for afforestation in bank structures. For selecting them, an evaluation was conducted considering certain criteria. In Table 4.3.2.1-3 shows the details of the selection, in Table 4.3.2.1-4 you can find the Table with the selection criteria.

Evaluation criteria used for selection:

1. Species with adequate properties to grow and develop in the riverside (preferably native)
2. Possibility of growing in plant nurseries
3. Possibility of wood and fruit use
4. Demand of local population
5. Native species (preferably)

After making a field survey, a list of planted or indigenous species of each zone was firstly made. Then, a list of species whose plants would grow in seedbeds, according to interviews made to plant growers, was prepared.

Priority was given to the aptitude of local conditions and to plant production precedents, leaving as second priority its usefulness and demand or if they were native species or not. Table 4.3.2.1-4 shows the assessment criterion.

**Table 4.3.2.1-1 List of seedlings that may be produced**

Watershed	Producers	Seedlings production sites	Commonly produced species	Sporadic produced species
Chincha	AGRORURAL	Lima	Pino, Molle, Eucalipto, Huarango ( <i>Prosopis limensis</i> )	Ciprés, Tara
	Fomeco	Lima	Tara, Molle, Huarango ( <i>Prosopis limensis</i> )	
	AGRORURAL	Ica	Aliso, Algarrobo, Caña, Tamarix, Bambú, Pino, Casuarina, Eucalipto	

(Source: Information gathered by the forestry seedlings producers)

**Table 4.3.2.1-2 List of Verified Tree Species in the Field (for Riparian Forestation)**

Location	Tree Species	Characteristics
Chincha	Molle	It has good track record in plantation/forestation, its characteristics shows high adequateness.
	Eucalipto	Common along the river, and its characteristics shows high adequateness.

(Source: JICA study team)

**Table 4.3.2.1-3 Results of Planting Species Selection (Details)**

River Basin	Tree Species	Adequateness to evaluation items*						Total**	Remarks
		1	2	3	4	5			
Chincha	Aliso	C	B	A	C	A	--	Adequate for high elevation areas rather as Similar to Huarango ( <i>Prosopis limensis</i> ), Prosopis is selected in the southern areas Grass Adequate for high elevation areas rather as Adequate for high elevation areas rather as Its characteristics shows high adequateness in the Northern areas, but unknown in the southern areas Recently, fruit was found as effectiveness, becomes popular for plantation Unknown for forestation record Adequate for high elevation areas rather as It is said as its root grows in deep Adequate for high elevation areas rather as Adequate for high elevation areas rather as Its characteristics shows high adequateness in the area near to the sea or dry area	
	Algarrobo	B	A	C	B	A	--		
	Canya (Cariso)	A	C	B	B	A	--		
	Quinual	C	C	B	C	A	--		
	Colle	C	D	D	B	A	--		
	Tamalix	B	A	B	B	B	--		
	Tara	D	A	A	B	A	-		
	Bamboo	A	A	B	B	A	+		
	Pine	B	D	B	B	B	-		
	Molle	B	A	B	B	A	+		
	Casuarina	A	B	C	B	B	+		
Eucalyptus	A	B	B	A	B	++			
Huarango ( <i>Prosopis limensis</i> )	A	A	D	A	A	++			

\* Evaluation criteria are shown above, \*\* ++: Selected, +: second, -: nominated but not so good, --: not be selected

(Source: JICA Study Team based on hearing from the seedling providers)

**Table 4.3.2.1-4 Assessment criterion for forest species selection**

		Assessment Criterion				
		1	2	3	4	5
Assessment points	A	In situ testing (natural or reforested growth)	Major production	Possible use as wood or for fruit production	Water demand by the Users Committee, among others	Local specie
	B	Growth has not been checked in situ, however it adapts in the zone	Sporadic production	Possible use as wood or for fruit production	There is NO water demand by the Users Committee	No local specie
	C	None of the above	Possible reproduction but not usual	No use as wood nor fruit	—	—
	D	Unknown	Not produced	Unknown	—	—

(Source: JICA Study Team)

Table-4.3.2.1-5 shows a list of selected species applying these assessment criterion. ◉ marks main species, ○ are those species that would be planted with a proportion of 30% to 50%. This proportion is considered to avoid irreversible damages such as plagues that can kill all the trees.

**Table 4.3.2.1-5 Selection of forest species**

Watershed	Forest species
Chíncha	Eucalipto (◉), Huarango (○), Casuarina (○)

In the Chíncha Watershed the main forestry specie is Eucalyptus. This specie adapts very well in this area, it adapts to the zone and has high demand by the Water User's Committees. Huarango (*Prosopis limensis*: is how this plant is known in the northern region of Peru, comes from another seed) is a native specie form the southern region of Peru. It is planted along the Panamericana Highway. Casuarina specie has been planted in this area to protect from wind and sand, moreover for the lands near farms.

### 3) Quantity of reforestation Plan

The forestry plan has been selected as it is mentioned in the location and type of species plan, in the bank protection and embankment wells along the riverside.

Following Table 4.3.2.1-3 shows the construction estimating for the Forestry and Recovery of Vegetation Cover Plan for Chíncha Watershed.

**Table 4.3.2.1-6 Amount of Afforestation/Vegetation Recovery Plan (Riparian Afforestation)**

No.	Side	Length (m)	Width (m)	Forestation Area (ha)	No. of Planting Stocks (No.)	Number of planting stocks for each Species (No.)			
						Eucalyptus	Hurango	Casuarina	Total
Chico-1	Both	2,100	22	4.6	13,616	6,808	4,085	2,723	13,616
Chico-2				0.0	0	—	—	—	—
Chico-3				0.0	0	—	—	—	—
Ma-4	Both	2,500	22	5.5	16,280	8,140	4,884	3,256	16,280
Ma-5				0.0	0	—	—	—	—
Total Chíncha		4,600		10.1	29,896	14,948	8,969	5,979	29,896

(Source: JICA Study Team)

In Table 4.3.2.1-7 shows the percentage according to forest species and the explanation in each bank structure.

**Table 4.3.2.1-7 Ratios of Number of Planting Stocks by Species for each Construction**

Serial No.	No.	Ratio of No. by Species			Remarks
		Eucalyptus	Casuarina	Huarango	
12	Chico-1	5	2	3	Eucalyptus is main species, and Hurango is sub. Huarango is the native species, it is expected that its characteristics has much adequateness than Casuarina. Then, Huarango is planted with prior than Casuarina
15	Ma-4	5	2	3	

(Source: JICA Study team)

### 4) Plan location and execution

The location of the vegetation recovery area and afforestation plan for every bank structure is the same. It is worth mentioning that the vegetation recovery area and afforestation plan will take place once finished the construction of bank structures.

#### (4) Reforestation and Vegetation Recovery Plan cost (short term)

##### 1) Unitary cost for the forestation plan and vegetation recovery

Direct costs for the forestation plan and vegetation recovery are formed by the following elements:

- Planting unitary cost (planting unitary cost + transportation)
- Labor cost
- Direct costs (tool costs: 5% labor)

##### (a) Planting unitary cost

The supply of seedlings can be divided between private and agro-rural companies. The seedlings for afforestation upstream of the Chincha river watershed is acquired by AFRORURAL, in the case of plants for the river banks private companies will be the providers. The cost of plants for afforestation is detailed in Table 4.3.2.1-8. The price of different plants has been consulted in different private companies, just as with the means of transportation. (For more information see Appendix 7-Table 2)

**Table 4.3.2.1-8 Unit Price of Seedling (for Riparian Forestation)**

River Basin	Species	Unit Price (Sol./seedling)
Chincha,	Eucalyptus	1.4
	Huarango	1.8
	Casuarina	2.2

Note: Unit price of seedling = (Seedling price + transportation fee)  
(Source: Hearing from suppliers)

##### (b) Labor cost

Criteria to assign labor costs come from the information obtained from AGRORURAL and the Water users board, cost assigned by forestation of 40 seedling a day. So, 33.6 Soles/man-day is assigned for the workers foresting in river banks.

##### (c) Direct costs

In direct costs the costs of the required tools are considered for the forestation project, instruments to dig holes for plants, plant transportation from its reception to the project area. Planting costs increase in 5%

##### (d) Work cost calculation for forestation and vegetation recovery in bank structures

The work costs for the forestry plan and vegetation recovery in bank structures are indicated in Table 4.3.2.1-9. The total work cost is 144,148 soles.

To carry out the afforestation the contractor is needed to execute bank works. Just like the cost of construction works, 88% of direct costs is destined to indirect costs.

**Table 4.3.2.1-9 Cost Estimation of Afforestation along River Protection Constructions (Riparian Afforestation)**

No.	No. of Construction	Cost of Afforestation (Sol)					
		Direct Cost				Indirect Cost	Total
		Seedlings	Planting works	Direct Expense	Sub Total		
12	Chico-1	22,875	11,437	572	34,884	30,768	65,652
13	Chico-2				0	0	0
14	Chico-3				0	0	0
15	Ma-4	27,350	13,675	684	41,709	36,787	78,496
16	Ma-5				0	0	0
Chincha River Basin		50,225	25,113	1,256	76,594	67,555	144,148

Source: JICA Study Team)

### (5) Implementation process planning

The Process Plan of afforestation works in riverbanks is part of the river structure, thus the same will be considered for the Construction Plan of the River Structure. Afforestation works should generally start at the beginning of the rainy season or just before, and must end approximately one month before the season finishes. However, there is scarce rain in the coastal area; therefore there is no effect of dry and rainy seasons. For the sake of afforestation, it is most convenient is to take advantage of water rise, but according to the Construction Schedule of the river structure there are no major afforestation issues in seasons where water level is low. The simple gravity irrigation system can be used to irrigate just planted plants during approximately the first 3 months until water level rises. This irrigation is performed using perforated horse which is a field technique actually carried out in Poechos dam area

### 4.3.2.2 Sediment Control Plan

#### (1) Importance of the Sediment Control Plan

Below flood control issues in selected Watersheds are listed. Some of them relate to sediment control. In the present Project an overall flood control plan covering both the high and the low Watershed is prepared. The study for the preparation of the Sediment Control Plan comprised the whole Watershed.

- Water rise causes overflow and floods.
- Rivers have a steep slope of 1/30 to 1/300. The flow speed is high, as well as the sediment transport capacity.
- The accumulation of large quantities of dragged sediment and the consequent elevation of the river bed aggravate flood damages.
- There is a great quantity of sediment accumulated on the river bed forming a double sandbank. The water route and the spot of greater water impact are unstable, causing route change and consequently, change of spot of greater water impact.
- Riverside is highly erodible, causing a decrease of adjacent farming lands, destruction of regional roads, etc., for what they should be duly protected.
- Big stones and rocks cause damages and destruction of water intakes.

#### (2) Sediment Control Plan (structural measures)

The sediment control plan suitable for the present sediment movement pattern was analyzed. Table 4.3.2.2-1 details basic guidelines.

**Table 4.3.2.2-1 Basic guidelines of the Sediment Control Plan**

Conditions	Typical year	Precipitations with 50-year return period
Sediment dragging	Bank erosion and river bed change	Bank erosion and river bed change Sediment flow from ravines
Measures	Erosion control → Bank protection  Control of riverbed variation → compaction of ground, bands (compaction of ground in the alluvial cone, bands)	Erosion control → bank protection Riverbed variation control → compaction of ground, bands (compaction of ground in the alluvial cone, bands) Sediment flow → protection of slopes, sediment control dams

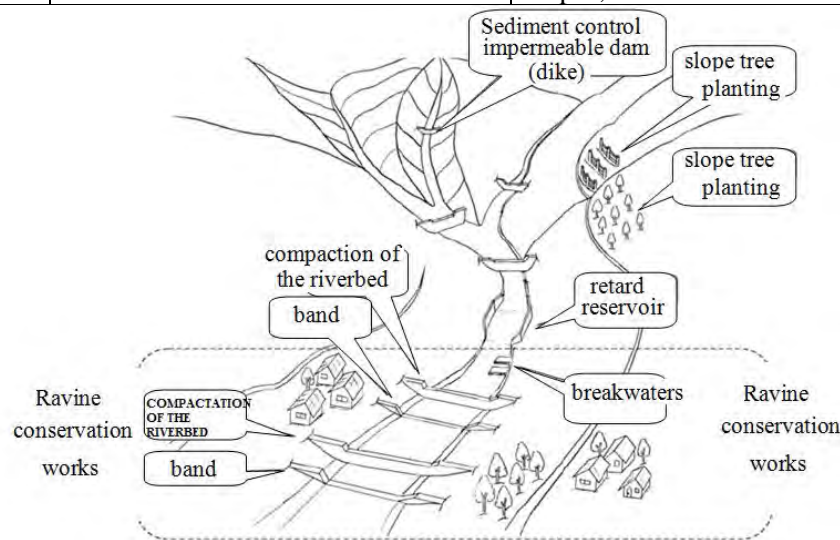

**Figure 4.3.2.2-1 Sediment control works**

1) Sediment control plan in the high Watershed

The next section 4.12 “Medium and long term Plan” 4.12.3 “Sediment Control Plan” details the sediment control plan covering the whole high Watershed. This plan will require an extremely long time with huge costs, what makes it quite not feasible. Therefore, it must be executed progressively within the medium and long term.

2) Sediment control plan in the low Watershed

We observed that building sediment control dams covering the whole Watershed will demand huge costs. Therefore, the same calculation was done but reducing its scope to just the lower Watershed of the river. In this process, analysis results on riverbed variation were taken into consideration, also included in the present study.

i) Bed variation analysis results

- The analysis results of river bed fluctuation are described below. The average riverbed raising shows the average of raising in the objective section in future 50 years. The average bed height has been increasing, so basically it is concluded that this is the general trend.

Total sediment inflow	5,759,000 m <sup>3</sup>
Average annual sediment inflow	115,000m <sup>3</sup>
Total riverbed fluctuation volume	2,610,000m <sup>3</sup>
Average Riverbed fluctuation height	0.5m/ 50 years

- The Chinchá river is susceptible to the accumulation of sediment. This tendency coincides to the field hearing results and actual riverbed conditions.
- According to the results of the analysis of variation of the river bed, Chinchá river is more susceptible to the accumulation of sediments carried, so sediment control works must be done in their respective alluvial fan. However the sediment disaster will happen suddenly and locally so that the required river channel maintenance work will be examined for all rivers with monitoring of river bed sedimentation.

While the variation of the bed (volume of sediment) is great too, looking at the average height of the bed, only 0.5 meters has changed in 50 years, and is therefore considered that the entry of sediments won't affect much the river downstream. Therefore, it is considered that it is not necessary to take a special sediment control measure.

ii) Sediment control plan in the alluvial fan

To control sediments within this fan there are ravine conservation works, combined with sand reservoirs, riverbed consolidation, groin or a combination of these. These do not only work for sediment control, but as river structures.

It is also planned to build a diversion weir in Chinchá River. This includes stabilizing of the flow and training longitudinal dyke which serve to control the sediments.

These structures are more economical and yield better cost benefit compared with structures designed to cover the entire watershed. It is much more profitable even when the cost of maintenance includes removal of stones and rocks.

Whereas the main objective of this project is in mitigating flood damage, the most effective option would be to control sediment in the alluvial fan.

#### **4.3.3 Technical Assistance**

Based on the proposals on flood control measures, a component on technical assistance is proposed in order to strengthen risk management capabilities in the Program.

**(1) Component objective**

The component objective in the Program is the "Adequate capability of local population and professionals in risk management application to reduce flood damages in Watersheds".

**(2) Target area**

The target area for the implementation of the present component is the Chinchá watershed.

In the execution stage, the implementation has to be coordinated with local authorities in the watershed. However, each authority has to execute those activities related with the characteristics of the watershed to carry out an adequate implementation.

**(3) Target population**

Target populations will represent irrigator associations and other community groups, provincial, district and local community governments and local people in the watershed, considering the limited capacity to receive beneficiaries of this component.

Participants are those with skills to widespread technical assistance contents of local populations in the watershed.

Besides, the participation of women has to be considered because currently only few ones participate in technical assistance opportunities.

**(4) Activities**

In order to achieve the above purpose, the following 3 components of study and training is to be carried out.



**Component 1: Knowledge on River Bank Protection Actions in consideration of Agriculture and Natural Environment**

Course	a) River Bank Operation and Maintenance b) River Bank Plant Management c) Erosion Prevention and Mitigation Natural Resource Management
Objectives	a) In this project, local populations learn suitable technology to operate and give maintenance to constructions and works from prior projects. b) Local populations learn suitable technology on river bank plants and vegetation for flooding control purposes. c) Local populations learn suitable technology on erosion and natural resources for flooding control purposes.
Participants	a) Engineers and / or technicians from local Governments b-c) Engineers and / or technicians from local Governments and Water Users Associations, Community representatives
Times	a) 12 times in all (every six (6) hours) b) 12 times in all (every five (5) hours) c) 26 times in all (every three (3) hours)
Lecturers	a) Contractors of constructions and works, Engineers from MINAG and / or the Regional Government b-c) Engineers from MINAG and / or the Regional Government, College professors (From universities, institutes, NGOs, etc.)
Contents	a-1) Suitable operation and maintenance technology for constructions and works from prior projects a-2) Suitable operation and maintenance technology for constructions and works in this project b-1) River bank protection with the use of plants b-2) The importance of river bank vegetation in flooding control b-3) Types of river bank plants and their characteristics c-1) Evaluation of the erosion conditions c-2) Evaluation of natural resource conditions c-3) Erosion approach for flooding control c-4) Natural resource approach for flooding control c-5) Environmental consideration approach c-6) Use of water resources c-7) Alternatives for suitable farming crops

**Component 2: Preparation of Community Disaster Management Plan for Flood Control**

Course	a) Risk management Plan Formulation b) Detailed Risk management Plan Formulation
Objectives	a) Local populations gain knowledge and learn technology to prepare a flooding control plan b) Ditto
Participants	a-c) Engineers and / or technicians from local Governments and Water Users Associations, Community representatives
Times	a) 19 times in all (every four (4) hours) b) 34 times in all (every five (5) hours) c) 24 times in all (every five (5) hours)
Lecturers	a-c) Engineers from MINAG and / or the Regional Government, Community Development Expert, Facilitator (local participation )
Contents	a-1) Flooding control plan preparation manuals a-2) Current condition analyses for flooding control a-3) Community development alternatives by means of local participation a-4) Workshop for flooding control plan preparation b-1) Community activity planning in consideration of ecological zoning b-2) Risk management b-3) Resource management c-1) Preparation of community disaster management plan

	c-2) Joint activity with local governments, users' association, etc.
<b>Component 3: Basin Management for Anti – River Sedimentation Measures</b>	
Courses	a) Hillside Conservation Techniques b) Forest Seedling Production c) Forest Seedling Planting d) Forest Resource Management and Conservation
Objectives	a) Local populations learn suitable technology on hillside conservation for flooding control purposes b) Local populations learn suitable technology on forest seedling production c) Local populations learn suitable technology on forest seedling planting d) Local populations learn suitable technology on forest resource management and conservation
Participants	a-d) Engineers and / or technicians from local Governments and Water Users Associations, Community representatives and Local People
Times	a) 12 times in all (every five (5) hours) b-d) 40 times in all for three (3) "Courses on Basin Management for Anti - River Sedimentation Measures" (every five (5) hours)
Lecturers	a-d) Engineers from MINAG and / or the Regional Government, College professors (From universities, institutes, NGOs, etc.)
Contents	a-1) Soil characteristics and conservation on hillsides a-2) Hillside agroforestry system a-3) Animal herding system on hillsides a-4) Reforestation with traditional vegetation and plants a-5) Hillside conservation and alleviation alternatives b-1) A selection of plants that are suitable to the local characteristics b-2) Forest seedling production technology  b-3) Control carried out by the local population's involvement c-1) Candidate areas for forestation c-2) Forest plantation control technology c-3) Forest plantation soil technology c-4) Control carried out by the local population's involvement d-1) Forestation for flooding control purposes d-2) Forest plantation control technology d-3) Forest plantation output technology d-4) Control carried out by the local population's involvement

**(5) Direct cost and period**

The direct cost for the above activities is as shown in the Table 4.3.3-1. The total cost for the objective basin is estimated at soles, and the brake down of the unit cost is as shown in the Annex-12, Appendix No.5. And the period required for study and training is assumed to be as same as the construction period of 2 years.

**Table 4.3.3-1 Contents of technical assistance and direct cost**

Item	Activities	Unit	Unit price(soles)	No.of basin	Amount(soles)
1.0	<b>Knowledge on river bank protection action in consideration of agriculture and natural environment</b>				
1.1	Workshop on operation and maintenance of facilities	event	9,300	1	9,300
1.2	Workshop on river bank plantation management	event	9,300	1	9,300
	Prevention and mitigation for erosion	event	9,300	1	9,300
	Natural resources management	event	9,300	1	9,300
2.0	<b>Preparation of community disaster management plan for flood control</b>				
2.1	Workshop on risk management plan	event	8,370	1	8,370
2.2	Details of 2.1	event			
	Community activity planning in consideration of ecological zoning	event	12,200	1	12,200
	Risk management	event	12,200	1	12,200
	Resource management	event	12,200	1	12,200
	Preparation of community disaster management plan	event	12,200	1	12,200
2.3	Preliminary flood forecasting and warning	event			
	Risk management and early warning system	event	9,300	1	9,300
	Joint activity with local government, users' association, etc.	event	5,580	1	5,580
3.0	<b>Hillside management for river sedimentation prevention</b>				
3.1	Field works for hillside conservation technique	event	7,500	1	7,500
	Forest seedling productions	event	7,900	1	7,900
	Forest plantation setting up	event	7,900	1	7,900
	Forest resource management and conservation		7,900	1	7,900
3.2	Difusion of posters and leaflet		3,600	1	3,600
	<b>Total</b>				<b>144,050</b>

## (6) Implementation Plan

The Hydraulic Infrastructure General Direction (DGIH-MINAG) executes this component as the executing unity in cooperation with the Agriculture Regional Direction (DRA), the Board of Users and related Institutions. In order to execute the activities efficiently the following has to be considered:

- For the implementation of the present component, the DGIH-MINAG will coordinate actions with the Central Management Unit responsible for each Watershed, as well as with Regional Managements of Agriculture (DRA).
- For the Project administration and management, the DGIH-MINAG will coordinate actions with PSI-MINAG (Sub-sector Irrigation Program with extensive experience in similar projects).
- Considering there are some local governments that have initiated the preparation of a similar crisis management plan through the corresponding civil defense committee, under the advice of the National Institute of Civil Defense (INDECI) and local governments, the DGIH-MINAG must coordinate so that these plans be consistent with those existing in each Watershed.
- Training courses will be managed and administered by irrigator associations (particularly the unit of skills development and communications) with the support of local governments in each Watershed, to support timely development in each town.

- Experts in disaster management departments in each provincial government, ANA, AGRORURAL, INDECI, etc., as well as (international and local) consultants will be in charge of course instruction and facilitation.

## 4.4 Costs

### 4.4.1 Cost Estimate (at private prices)

#### (1) Project Costs Components

Project costs include the following:

- ① Work direct costs = total number of works by type × unit price
- ② Common provisional works = ① × 10%
- ③ Construction cost -1 = ① + ②
- ④ Miscellaneous = ③ × 15%
- ⑤ Benefits = ③ × 10%
- ⑥ Construction cost -2 = ③ + ④ + ⑤
- ⑦ Tax = ⑥ × 18% (IGV)
- ⑧ Construction cost = ⑥ + ⑦
- ⑨ Environmental measures cost = ⑧ × 1%
- ⑩ Detailed design cost = ⑧ × 5%
- ⑪ Works supervision cost = ⑧ × 10%
- ⑫ Project Cost = ⑧ + ⑨ + ⑩ + ⑪

#### (2) Work direct costs

On table 4.4.1-1 a summary table of direct costs for structural measures is presented for the Chincha River basin.

#### (3) Project Costs

The project cost is estimated in 44.0 million of soles as shown in Table 4.4.1-2. It includes reforestation and vegetation recovery costs, construction of early warning system and technical assistance. The annual operation and maintenance cost of completed works is approximately 0.5% of the project's cost.

**Table 4.4.1-1 Summary Table of the work's direct cost (at private prices)**

Watershed 流域名	Critical Points クリティカル・ポイント		Measures 対策		Direct Cost 直接工事費計 (1)
Chincha	1	C-3.5~5.0k	Dike building + coastal defense	築堤・護岸工	5,134,000
	2	C-15K	Flow desilting	築堤・護岸工	3,366,000
	3	C-24K	Distributor+Floor Consolidation	分流堰・床止工	8,510,800
	4	M-3.0K~4.5K	Dike building + coastal defense	築堤・護岸工	5,134,000
	5	M-8.9K	Flow desilting	河床掘削・護岸工	1,030,000
<b>SUB TOTAL</b>					<b>23,174,800</b>

**Table 4.4.1-2 Construction cost (at private prices)**

Basin	Direct Cost			Indirect Cost								Structure Cost Total	Reforestation Cost	Technical Assistance Cost	Total Project Cost
	Work Cost	Temporary Work Cost	Direct Cost Total	Overhead Cost	Profit	Structure Cost	Tax	Construction Cost	Environment Cost	Detail Design Cost	Construction Supervision Cost				
	(1)	(2) = 0.1 x (1)	(3) = (1) + (2)	(4) = 0.15 x (3)	(5) = 0.1 x (3)	(6) = (3)+(4)+(5)	(7) = 0.18 x (6)	(8) = (6)+(7)	(9)=0.01 x (8)	(10) = 0.05 x (8)	(11) = 0.1 x (8)				
CHINCHA	23,174,800	2,317,480	25,492,280	3,823,842	2,549,228	31,865,350	5,735,763	37,601,113	376,011	1,880,056	3,760,111	43,617,291	128,676	219,105	43,965,072

#### 4.4.2 Cost Estimate (at social prices)

##### (1) Work direct costs

In Table 4.4.2-1 a summary table of direct costs for structural measures is presented for the Chincha River basin. The works' direct cost at private prices was turned into social prices applying the conversion factor.

##### (2) Project Costs

The project cost is estimated in 35.4 million of soles as shown in Table 4.4.2-2. It includes reforestation and vegetation recovery costs, construction of early warning system and technical assistance, before converting from private prices.

**Table 4.4.2-1 Summary Table of the work's direct cost (at social prices)**

Watershed 流域名	Critical Points クリティカル・ポイント	Measures 対策	Private Prices 民間価格 (PP)	Correction Factor 係数 (fs)	Social Price 社会価格 (PS) (C) x (fs)
Chincha	1	C-3.5~5.0K Dike building+coastal defense	5,134,000	0.804	4,127,736
	2	C-15K Flow desilting	3,366,000	0.804	2,706,264
	3	C-24K distributor + Floor consolidation	8,510,800	0.804	6,842,683
	4	M-3.0K~4.5K Dike building+coastal defense	5,134,000	0.804	4,127,736
	5	M-8.9K Flow desilting	1,030,000	0.804	828,120
<b>合計</b>			<b>23,174,800</b>		<b>18,632,539</b>

**Table 4.4.2-2 Construction cost at (social prices)**

Basin	Direct Cost			Indirect Cost								Structure Cost Total	Reforestation Cost	Technical Assistance Cost	Total Project Cost
	Work Cost	Temporary Work Cost	Direct Cost Total	Overhead Cost	Profit	Structure Cost	Tax	Construction Cost	Environment Cost	Detail Design Cost	Construction Supervision Cost				
	(1)	(2) = 0.1 x (1)	(3) = (1) + (2)	(4) = 0.15 x (3)	(5) = 0.1 x (3)	(6) = (3)+(4)+(5)	(7) = 0.18 x (6)	(8) = (6)+(7)	(9)=0.01 x (8)	(10) = 0.05 x (8)	(11) = 0.1 x (8)				
CHINCHA	18,632,539	1,863,254	20,495,793	3,074,369	2,049,579	25,619,741	4,611,553	30,231,295	302,313	1,511,565	3,023,129	35,068,302	101,629	189,759	35,359,690

## 4.5 Social Assessment

### 4.5.1 Private prices

#### (1) Benefits

Flood control benefits are flood loss reduction that would be achieved by the implementation of the Project and is determined by the difference between the amount of loss with and without Project. Specifically, in order to determine the benefits that will be achieved by the

works' construction. First, the flood amount per flood loss of the different return periods (between 2 to 50 years) is calculated; assuming that the flood control works have a useful life of 50 years. To finish, determine the annual average amount of the loss reduction from the loss amount of different return periods. The Methodological Guideline for Protection and/or Flood Control Projects in agricultural or urban areas, 4.1.2p-105) establishes similar procedures.

Above find the description of the procedures to determine concrete benefits

- Determine the flood loss amount in the flood area by analyzing the magnitude of overflow that occurs without the Project for each return period (between 2 and 50 years)
- After, determine the amount of flood loss in the flood area by analyzing the magnitude of overflow that occurs when flood control priority works are built (Chico 1 to 13, Matagente 1 to 12).
- Determine the difference between ① and ②. Add the benefits of other works different than dikes (intakes, roads and dams protection, etc.) in order to determine the total profits

“Benefits of the Project” are considered as the sum of direct loss amount caused by overflow and indirect loss caused by the destruction of structures in vulnerable sections (farmland loss, interruption of traffic, etc.)

#### 1) Method of loss amount calculation

In this study, the amount of loss from direct and indirect damages to the variables listed in Table 4.5.1-1 was determined.

**Table 4.5.1-1 Flood loss amount calculation variables**

Loss	Variables	Description
(1) Direct	① Crops	<ul style="list-style-type: none"> <li>• Crops in flooding season The amount of crop loss by flooding is determined by multiplying the damage % regarding water depth and the number of days flooded</li> <li>• Agricultural land and infrastructure (channels, etc.)</li> <li>• Crop loss amount is determined by multiplying the damage % regarding water depth and the number of days flooded</li> </ul>
	② Hydraulic Works	<ul style="list-style-type: none"> <li>• Loss amount due to hydraulic structures destruction (intakes, channels, etc.).</li> </ul>
	③ Road Infrastructures	<ul style="list-style-type: none"> <li>• Flood damage related to road infrastructure is determined by the damage in transport sector</li> </ul>
	④ Housing	<ul style="list-style-type: none"> <li>• Residential and industrial buildings It is calculated applying the loss coefficient depending on the flood depth Housing: residential and industrial buildings; household goods: furniture, household appliances, clothing, vehicles, etc. Flood damages in housing, commercial buildings, assets and inventories (buildings and assets) is determined applying the loss coefficient according to the flood depth</li> </ul>

	⑤ Public Infrastructures	<ul style="list-style-type: none"> <li>• Determine the loss amount in roads, bridges, sewers, urban infrastructures, schools, churches and other public facilities</li> <li>• Determine the loss amount in public works by applying the correspondent coefficient to the general assets loss amount</li> </ul>
	⑥ Public Services	<ul style="list-style-type: none"> <li>• Electricity, gas, water, rail, telephone, etc.</li> </ul>
(2) Indirect	① Agriculture	<ul style="list-style-type: none"> <li>• Estimate the loss caused by irrigation water interruption due to the damage of hydraulic structures</li> <li>• Determine the construction and repair costs of hydraulic structures such as direct year costs</li> </ul>
	② Traffic Interruption	<ul style="list-style-type: none"> <li>• Estimate the loss lead by traffic interruption due to damages on flooded roads</li> <li>• Determine road's repair and construction costs as damage direct cost</li> </ul>

#### A. Direct loss

Direct loss is determined by multiplying the damage coefficient according to the flood depth as the asset value.

#### B. Indirect Loss

Indirect loss is determined taking into account the impact of intakes and damaged roads. Below, calculation procedures are described.

##### a. Dams damage

The loss amount due to dam damage is calculated by adding the direct loss (dam's rehabilitation and construction) and the indirect loss amount (harvest loss due to the interruption of irrigation water supply)

##### ① Calculating the infrastructure cost

Works Cost = construction cost per water unit taken × size (flow, work length)

Unit cost of the work: for intakes and channels, it is required to gather information on the water intake volume of the existing work and the works' execution cost (construction or repair). The unit cost is calculated by analyzing the correlation among them both.

It was estimated that the work will be completely destroyed by the flow with a return period of 10 years.

##### ② Crop loss

Annual earnings are determined according to the crops grown in the correspondent irrigation district.

Annual Profit = (crops selling - cost) × frequency of annual harvest

Crop Sale = planted area (ha) × yield (kg/ha) × transaction unit price

Cost = unit cost (s/ha) × planted area (ha)

##### b. Road infrastructure damage

Determine the loss due to traffic interruption.



Amount of loss = direct loss + indirect loss

Direct loss: road construction cost (construction, rehabilitation)

Indirect Loss: opportunity loss cost due to road damage (vehicle depreciation + staff expenses loss)

Then, a 5 days period takes place of non-trafficability (usually in Peru it takes five days to complete the rehabilitation of a temporary road)

2) Loss estimated amount according to disasters in different return periods

In table 4.5.1-2 the amounts of loss with and without Project are shown. These are estimated for disasters of different return periods in the Chincha River.

**Table 4.5.1-2 Loss Estimated Value (at private prices)**

		千ソールレス
Case ケース	t 確率年	Chincha
Without Project 事業を実施 しない場合	2	14,576
	5	36,902
	10	51,612
	25	72,416
	50	96,886
	Total	272,392
With Project 事業を実施 した場合	2	423
	5	2,731
	10	3,904
	25	13,140
	50	28,112
	Total	48,311

3) Loss amount (annual average) expected to be reduced by the Project

The annual average loss amount that is expected to be reduced by the Project by the total annual average loss amount occurred as flow multiplying the amount of loss reduction occurred as flow for the corresponding flood probabilities.

Considering that floods happen probabilistically, the annual benefit is determined as the annual average amount of loss reduction. Next find the procedures of calculation.

**Table 4.5.1-3 Loss reduction annual average amount**

Probabilities	Loss Amount			Average path's loss	Paths' Probabilities	Loss reduction annual average amount
	Without Project	With Project	Loss Reduction			
1/1			$D_0 = 0$			
1/2	$L_1$	$L_2$	$D_1 = L_1 - L_2$	$(D_0 + D_1)/2$	$1 - (1/2) = 0,500$	$d_1 = (D_0 + D_1)/2 \times 0,67$
1/5	$L_3$	$L_4$	$D_2 = L_3 - L_4$	$(D_1 + D_2)/2$	$(1/2) - (1/5) = 0,300$	$d_2 = (D_1 + D_2)/2 \times 0,300$
1/10	$L_5$	$L_6$	$D_3 = L_5 - L_6$	$(D_2 + D_3)/2$	$(1/5) - (1/10) = 0,100$	$d_3 = (D_2 + D_3)/2 \times 0,100$
1/20	$L_7$	$L_8$	$D_4 = L_7 - L_8$	$(D_3 + D_4)/2$	$(1/10) - (1/20) = 0,050$	$d_4 = (D_3 + D_4)/2 \times 0,050$
1/30	$L_9$	$L_{10}$	$D_5 = L_9 - L_{10}$	$(D_4 + D_5)/2$	$(1/20) - (1/30) = 0,017$	$d_5 = (D_4 + D_5)/2 \times 0,017$
1/50	$L_{11}$	$L_{12}$	$D_6 = L_{11} - L_{12}$	$(D_5 + D_6)/2$	$(1/30) - (1/50) = 0,013$	$d_6 = (D_5 + D_6)/2 \times 0,013$
1/100	$L_{13}$	$L_{14}$	$D_7 = L_{13} - L_{14}$	$(D_6 + D_7)/2$	$(1/50) - (1/100) = 0,010$	$d_7 = (D_6 + D_7)/2 \times 0,010$
Foreseen average annual amount of loss reduction			$d_1 + d_2 + d_3 + d_4 + d_5 + d_6 + d_7$			

In Table 4.5.1-4 Results of loss amount calculus are presented (annual average), which are expected to be reduced when implementing the Project in the Chincha River Basin.

**Table 4.5.1-4 Annual average of loss reduction amount (Private prices)**

s/1000

流域 Watershed	流量規模 Return Period	超過確率 Probability	被害額 (Total damage - thousands of S/.)			区間平均被害額 ④ Damage Averagare	区間確率 ⑤ Probability incremental value	年平均被害額 ④×⑤ Average value of the damages flow	年平均被害額の 累計=年平均被害 軽減期待額 Annual Medial Damage
			事業を実施し ない場合①	事業を実施し た場合②	軽減額 ③=①-②				
			Without Project ①	With Project	Mitigated damages ③=①-②				
CHINCH A	1	1.000	0	0	0		0	0	
	2	0.500	14,576	423	14,153	7,076	0.500	3,538	3,538
	5	0.200	36,902	2,731	34,171	24,162	0.300	7,249	10,787
	10	0.100	51,612	3,904	47,708	40,939	0.100	4,094	14,881
	25	0.040	72,416	13,140	59,276	53,492	0.060	3,210	18,090
	50	0.020	96,886	28,112	68,774	64,025	0.020	1,281	19,371

## (2) Social Assessment

### 1) Assessment's objective and indicators

The social assessment's objective in this Study is to evaluate investment's efficiency in structural measures using the analysis method of cost-benefit (C/B) from the national economy point of view. For this, economic assessment indicators were determined (relation C/B, Net Present Value - NPV and IRR). The internal return rate (IRR) is an indicator that denotes the efficiency of the project's investment. It is the discount rate to match the current value of the project's generated cost regarding the benefit's current value. It is the discount rate necessary so the Net Present Value (NPV) equals zero and the relation C/B equals one. It

also indicates the percentage of benefits generated by such investment. The internal return rate used in the economic assessment is called “economical internal return rate (EIRR)”. The market price is turned into the economical price (costs at social prices) eliminating the impact of market distortion.

The IRR, C/B relation and NPV are determined applying mathematical expressions shown in the Table below. When IRR is greater than the social discount rate, the relation C/B is greater than one and NPV is greater than zero, it is considered that the project is efficient from the national economic growth point of view.

**Table 4.5.1-5 Analysis assessment indicators of cost-benefit relation**

Indicators	Definition	Characteristics
Net Present Value (NPV)	$NPV = \sum_{i=1}^n \frac{B_i}{(1+r)^i} - \sum_{i=1}^n \frac{C_i}{(1+r)^i}$	<ul style="list-style-type: none"> <li>- Allows comparing net benefit magnitude performed by the project</li> <li>- It varies depending on the social discount rate</li> </ul>
Cost-Benefit Relation (C/B)	$B/C = \sum_{i=1}^n \frac{B_i}{(1+r)^i} / \sum_{i=1}^n \frac{C_i}{(1+r)^i}$	<ul style="list-style-type: none"> <li>- Allows comparing the investment efficiency by the magnitude of benefit per investment unit</li> <li>- Varies depending on the social discount rate</li> </ul>
Economical Internal Return Rate (EIRR)	$\sum_{i=1}^n \frac{B_i}{(1+r)^i} = \sum_{i=1}^n \frac{C_i}{(1+r)^i}$	<ul style="list-style-type: none"> <li>- Allows knowing the investment efficiency comparing it to the social discount rate</li> <li>- Does not vary depending on the social discount rate</li> </ul>
Where Bi: benefit per “i” year / Ci: cost per “i” year / r: social discount rate (11 %) / n: years of assessment		

## 2) Assumptions

Next, find the assumptions of every indicator used from the economical assessment

### i) Assessment Period

The assessment period is set between 2013 and 2027 (15 years after construction works started). This Project implementing schedule is the following:

- 2012: Detailed Design
- 2013-2014: Construction
- 2013-2027: Assessment Period

### ii) Standard Conversion Factor (SCF)

The standard conversion factor (SCF) is the relationship between socioeconomic prices established along the border and national private prices of all goods in a country’s economy. It is used to convert goods and services prices purchased in the local market at affordable prices. In this Study the following SCF values were used:

- Dams 0.804
- Gabions 0.863
- Intakes 0.863

TAX (Peruvians use IGV) is not taken into account in the conversion of market prices to

socioeconomic prices.

iii) Other preliminary conditions

Price level: 2010

Social discount rate: 10%

Annual maintenance cost: 0.5% of construction cost

3) Cost-benefit relation analysis (C/B)

A comparison of the total cost and total benefit of flood control works converted to present values applying the social discount rate was performed. In this case, the total cost is the addition of construction, operation and maintenance costs. The total benefit is the loss amount that was reduced due to the works. For this, a base year was established for the conversion into the current value at the moment of the assessment, and the assessment period was set for the next 15 years from the beginning of the Project. The total cost was determined adding-up the construction, operation and maintenance costs of the works converted into present values; and the total benefit adding-up the annual average loss amount turned into current values.

In table 4.5.1-6 results of calculations C/B, NPV and IRR to private prices is shown.

**Table 4.5.1-6 Social Assessment (C/B, NPV, IRR) (at private prices)**

流域名	年平均被害軽減額 Accumulated Average Annual Benefit	評価期間被害軽減額(15年) Accumulated Average Annual Benefit (in 15 years)	事業費 Project's Cost	維持管理費 O&M Cost	C/B Cost/Benefit Relation	Net Present Value (NPV) NPV	Internal Rate of Return (IRR) IRR
Chincha	251,818,212	113,716,113	43,965,072	2,444,072	2.88	74,212,307	35%

**4.5.2 Costs at social prices**

(1) Benefits

1) Estimated loss amount according to different return periods

In table 4.5.2-1 the amounts of loss with and without Project are shown. These are estimated for disaster of different return periods in the Chincha River Watershed.

**Table 4.5.2-1 Estimated loss amount (at social prices)**

(s./1,000)

Case	t	Chincha
Without Project	2	16,283
	5	42,375
	10	70,525
	25	95,769
	50	125,742
	Total	350,693
With Project	2	430
	5	4,507
	10	6,449
	25	17,698
	50	33,329
	Total	62,414

2) Loss amount (annual average) is expected to be reduced with the Project

In table 4.5.2-2 results of loss amount calculation (annual average) that are expected to reduce to implement the Project in the Chincha River are shown.

**Table 4.5.2-2 Annual average of loss reduction amount (at social prices)**

s/1000

流域 Watershed	流量規模 Return Period	超過確率 Probability	被害額 (Total damage - thousands of S./)			区間平均被害 額 ④ Damage Averagare	区間確率 ⑤ Probability incremental value	年平均被害額 ④×⑤ Average value of the damages flow	年平均被害額の 累計=年平均被 害軽減期待額 Annual Medial Damage
			事業を実施し ない場合①	事業を実施し た場合②	軽減額 ③=①-②				
			Without Project ①	With Project	Mitigated damages ③=①-②				
CHINCHA	1	1.000	0	0	0		0	0	
	2	0.500	16,283	430	15,852	7,926	0.500	3,963	3,963
	5	0.200	42,375	4,507	37,868	26,860	0.300	8,058	12,021
	10	0.100	70,525	6,449	64,076	50,972	0.100	5,097	17,118
	25	0.040	95,769	17,698	78,070	71,073	0.060	4,264	21,383
	50	0.020	125,742	33,329	92,413	85,242	0.020	1,705	23,088

(2) Social Assessment

In table 4.5.2-3 results of the calculation C/B, NPV and IRR at social prices are shown.

**Table 4.5.2-3 Social Assessment (C/B, NPV, IRR) (at social prices)**

流域名	年平均被害軽減額 Accumulated Average Annual Benefit	評価期間被害軽減額(15年) Accumulated Average Annual Benefit (in 15 years)	事業費 Project's Cost	維持管理費 O&M Cost	C/B Cost/Benefit Relation	Net Present Value (NPV) NPV	Internal Rate of Return (IRR) IRR
Chincha	300,137,698	135,536,235	35,359,690	1,965,034	4.27	103,764,959	50%

### 4.5.3 Social assessment conclusions

The social assessment shows that the Project in Chincha River watershed has a high economic impact on private and social prices. Also, the following economical non-quantifiable positive impacts are shown:

- Contribution to local economic development when soothing the fear due to economic activities suspension and damage
- Contribution by increasing local employment opportunities for the construction of the project
- Strengthening the local population's awareness for floods damage and other disasters
- Income increase contributions due to an stable agricultural production because flood damages are soothed
- Increase of agricultural land price

For the economic assessment results previously presented, it is considered that this Project will contribute substantially to the local economic development.

### 4.6 Sensitivity Analysis

#### (1) Objective

A sensitivity analysis was made in order to clarify the uncertainty due to possible changes in the future of the socioeconomic conditions. For the cost-benefit analysis it is required to foresee the cost and benefit variation of the project, subject to assessment, to the future. However, it is not easy to perform an adequate projection of a public project, since this is characterized for the long period required from planning to the beginning of operations. Also because of the long useful life of works already in operation and the intervention of a number of uncertainties that affect the future cost and benefit of the project. So, analysis results are obtained frequently and these are discordant to reality when the preconditions or assumptions used do not agree with reality. Therefore, for the uncertainty compensation of the cost-benefit analysis it should be better to reserve a wide tolerance-bank, avoiding an absolute and unique result. The sensitivity analysis is a response to this situation.

The objective of the sensitivity analysis is to provide the cost-benefit analysis results a determined bank that will allow a proper managing of the project's implementation, give numbers to the population and achieve greater accuracy and reliability of the project's assessment results.

## (2) Sensitivity Analysis

### 1) General description of the sensitivity analysis

There are three methods of the sensitivity analysis, as indicated in Table 4.6-1.

**Table 4.6-1 Sensitivity Analysis Methods**

Methods	Description	Products
Variables sensitivity analysis	It consists in changing only one predetermined variable (precondition or hypothesis), to assess how the analysis result is affected	Bank values from the analysis when a precondition or hypothesis varies
Better and worst alternatives	It consists in defining the cases in which the analysis results are improved or worsen when changing the main pre-established preconditions or hypothesis to assess the analysis result bank	Bank values from the analysis when the main precondition or hypothesis vary
Monte Carlo	It consists in knowing the probability distribution of the analysis results by simulating random numbers of Monte Carlo simulation of pre-established preconditions and hypothesis	Probable results distribution when all main precondition or hypothesis vary

### 2) Description of the sensitivity analysis

In this project the sensitivity analysis method of the variables usually used in public works investments was adopted. Next, the scenarios and economic indicators used in the sensitivity analysis are shown.

**Table 4.6-2 Cases subjected to the sensitivity analysis and economic indicators**

Indicators	Variation bank according to factors	Economic indicators to be evaluated
Construction cost	In case the construction cost increases in 5 % and 10 %	IRR, NPV, C/B
Benefit	In case of reducing the benefit in 5 % and 10 %	IRR, NPV, C/B
Social discount rate	In case of increase and reduction of the discount social rate in 5 % respectively	NPV, C/B

### 3) Results of the sensitivity analysis

In table 4.6-3 the results of the sensitivity analysis of each assessed case to private and social prices is shown.

**Table 4.6-3 Results of the sensitivity analysis of IRR, C/B and NPV**

	Basin	Item	Basic Case	Case 1 Cost increase 5%	Case 2 Cost increase 10%	Case 3 Benefit decrease 5%	Case 4 Benefit decrease 10%	Case 5 Discount rate increase 5%	Case 6 Discount rate decrease 5%
PRIVATE PRICE	CHINCHA	IRR (%)	35%	34%	32%	34%	32%	35%	35%
		B/C	2.88	2.74	2.62	2.73	2.59	2.22	3.87
		NPV(s)	74,212,307	72,237,117	70,261,927	68,526,502	62,840,696	44,893,501	122,434,010
SOCIAL PRICE	CHINCHA	IRR (%)	50%	48%	46%	48%	46%	50%	50%
		B/C	4.27	4.06	3.88	4.05	3.84	3.29	5.74
		NPV(s)	103,764,959	102,176,396	100,587,832	96,988,148	90,211,336	67,804,372	162,443,112

(3) Assessment of the sensitivity analysis

As to the sensitivity analysis of the Project, the socio economic conditions change do not affect the project viability within the scope of examination at both private price and social price.



## 4.7 Sustainability Analysis

This project will be co-managed by the central government (through the DGIH), irrigation committees and regional governments. Also, the project cost will be covered with the respective contributions of the three parties. Usually the central government (in this case, the DGIH) takes the 80%, irrigation commissions 10% and regional governments 10%. However, the percentages of the contributions of these last two are decided through discussions between both parties. On the other hand, the operation and maintenance (O & M) of the completed works is assumed by the irrigation committee. So, the sustainability of the project depends on the profitability of the Project and the ability of the irrigation committees for O & M.

Table 4.7-1 presents the data of the budget for irrigation committees in recent years.

Table 4.7-1 Project Budget of the irrigation commissions

Rivers	Annual Budget				(In soles)
	2007	2008	2009	Average of three years	
Chincha	1.562.928,56	1.763.741,29	1.483.108,19	1.603.259	

### (1) Profitability

The project in Chincha river Watershed is sufficiently profitable and highly sustainable. The investment amount in this watershed is estimated in 44.0 million soles at private prices. However, the C/B relation is 4.27, the internal return rate is high (approx. 50%), and the NPV is estimated in 103.7 million soles in 15 years.

### (2) Cost of operation and maintenance

The annual cost of operation and maintenance required for the project, having as a base year 2008 is estimated at 188,006 soles, corresponding to 0.5% of the project construction cost of the Project in the Chincha Watershed. On the other hand, the average operating expenses in the last 4 years of the irrigation commissions is 1,603,259 soles.

When considering that the annual operation and maintenance cost represents 11.7% of the annual irrigation commissions, the project would be sustainable enough according to the financial capacity of these committees to maintain and operate the constructed works.

## 4.8 Environmental Impact

### 4.8.1 Procedure of Environmental Impact Assessment

Projects are categorized in three scales, based on the significance level of the negative and positive impacts, and each sector has an independent competence on this categorization. The following table shows the environmental management instruments that are required for each

category. The Project holder should submit the Environmental Impact Statement (DIA, in Spanish) for all Projects under Category I. The project holder should prepare an EIA-sd or an EIA-d if the Project is categorized under Category II or III, respectively, to be granted the Environmental Certification from the relevant Ministry Directorate.

**Table 4.8.1-1 Project Categorization and Environmental Management Instruments**

	Description	Required Environmental Management Instrument
Category I	It includes those Projects that when carried out, they cause no significant negative environmental impacts whatsoever.	PEA that is considered a DIA after the assessment for this category
Category II	It includes those Projects that when carried out, they can cause moderate environmental impacts, and their negative effects can be removed or minimized through the adoption of easily applicable measures.	Semi-Detailed Environmental Impact Assessment (EIA-sd)
Category III	It includes those Projects than can cause significant quantitative or qualitative negative environmental impacts because of their characteristics, magnitude and/or location. Therefore, a deep analysis is required to revise those impacts and set out a relevant environmental management strategy.	Detailed Environmental Impact Assessment (EIA-d)

Source: Prepared by the JICA Study Team based on the SEIA Law (2001)

The next graph shows the Environmental Document's Classification, the Environmental Document's Assessment, and the Environmental Certification.

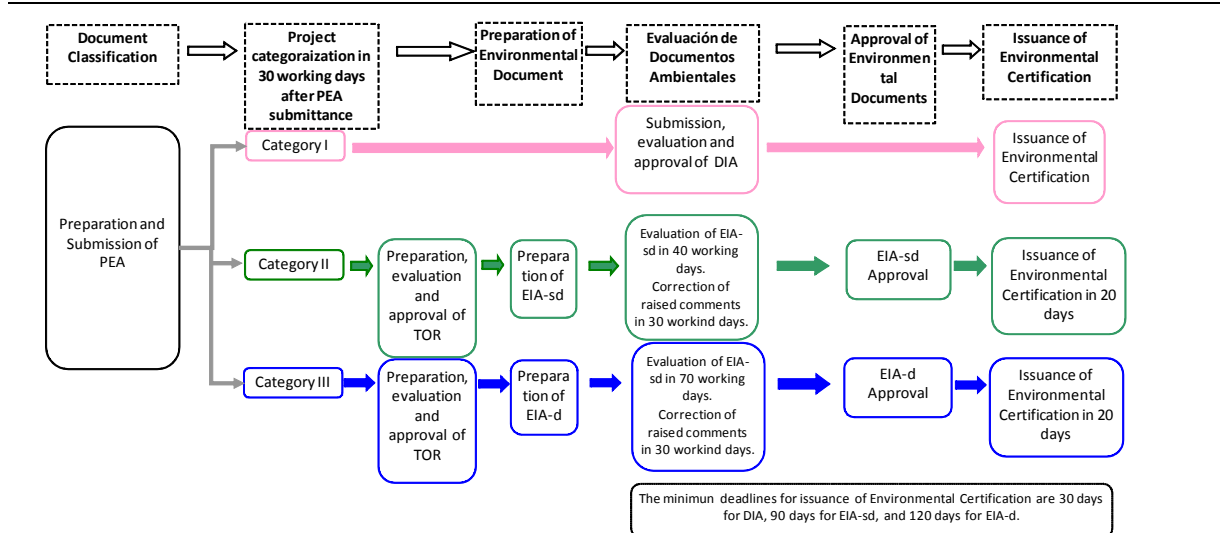

Source: Prepared by the JICA Study Team based on the SEIA Regulations (2009)

**Figure 4.8.1-1 Process to Obtain the Environmental Certification**

First, the Project holder applies for the Project classification, by submitting the Preliminary Environmental Assessment (PEA). The relevant sector assesses and categorizes the Project within the next 30 working days after the document's submission. The Project's PEA that is categorized under Category I becomes an EID, and those Projects categorized under Category II or III should prepare an EIA-sd or EIA-d, as applicable. There are cases in which the relevant sector prepares the Terms of Reference for these two studies, and submits them to the holder. There are other cases in which the holder prepares the Terms of Reference and these are approved by the relevant sector, based on the interview with DGAA. Number of working days required for EIA-sd revision and approval is 90, and number of working days required for EIS-d is 120; however, these maximum deadlines may be extended.

The progress of the environmental impact study is as shown below.

The JICA Study Team subcontracted a local Consultant (CIDE Ingenieros S.A.), and a Preliminary Environmental Assessment (PEA) was carried out, from December 2010 to January 2011 for Chincha river.

EAP for the Chincha river was submitted to DGIH from JICA on January 25, 2011. DGIH submitted the EAP to DGAA on July 19, 2011.

EAP for Chincha river was examined by DGAA, and DGAA issued their comments on EAP to DGIH. JICA Study Team revised EAP upon the comments and submitted it to DGAA on September 21, 2011. DGAA completed examination on the revised EAP and issued approval letter on Chincha river in which DGAA classified Chincha river into Category I. Therefore the additional environmental impact analysis for Chincha river is not required.

The positive and negative environmental impact associated with the implementation of this project was confirmed and evaluated, and the plan for prevention and mitigation measures are prepared by EAP results, field investigation and hearing by JICA Study Team.

The proposed works in this project include: the reparation of existing dikes, construction of new dikes, riverbed excavation, bank protection works, repair and improvement of the derivation and intakes works, and also river expansion. Table 4.8.1-2 describes “working sites” to be considered in the Environmental Impact section for Chíncha river.

**Table 4.8.1-2 Works Description**

Basin	Location		Preservation Object	Counter Measure	Summary of Facility	Objective Section	
Chíncha	1	C-3.5~5.0k	Inundation	Crop land (Cotton Grape)  Urban area	Dike (no dike section) Revetment	Top W: 4.0m H: 2.0m Slope: 1:3 L: 3,000m (1,500+1,500)	3.0km~5.1km(total)
	2	C-15k	Intake		Intake Widening river width	Weir W: 100m H: 3.0m T: 2.0m	14.8km~15.5km (total)
	3	C-24k	Diversion weir		Rehabilitation of diversion weir (rehabilitation of existing weir, channel and training dike)	Weir w: 70m H: 3.0m T: 2.0m	24.2km~24.5km (total)
	4	M-3.0k~4.5k	Inundation		Dike (no dike section) Revetment	Top W: 4.0m H: 2.0m Slope: 1:3 L: 3,000m (1,500+1,500)	2.5km~5.0km (total)
	5	M-8.9k	Narrow Section		Riverbed excavation	Ex. width; 100m Ex. depth; 1.0m L: 1,200m	8.0km~10.5km (total)

Source: JICA Study Team

## 4.8.2 Methodology

In order to identify environmental impacts of the works to be executed in the different watersheds, we developed identification impact matrixes for watershed.

First, the operation and activities for each project based on typical activities of “hydraulic works” construction were determined. Afterwards, the concrete activities type was determined which will be executed for each work that will be developed in the watersheds. Then, to evaluate Socio-environmental impacts the Leopold matrix was used.

**Table 4.8.2-1 Evaluation Criterion - Leopold Matrix**

Index		Description	Valuation
"Na" nature		It defines whether change in each action on the means is positive or negative	Positive (+) : beneficial
			Negative (-): harmful
Probability of Occurrence "P.O."		It includes the probability of occurrence of the impact on the component	High (>50 %) = 1.0
			Medium (10 – 50 %) = 0.5
			Low (1 – 10 %) = 0.2
Magnitude	Intensity (In)	It indicates the magnitude of change in the environmental factor. It reflects the degree of disturbance	Negligible (2)
			Moderate intensity (5)
			Extreme Disturbance (10)
	Extension "Ex"	It indicates the affected surface by the project actions or the global scope on the environmental factor.	Area of indirect influence: 10
			Area of direct influence: 5
			Area used up by the works: 2
	Duration "Du"	It refers to the period of time when environmental changes prevail	> 10 years: 10
			5 – 10 years : 5
			1 – 5 years: 2
	Reversibility "Rev"	It refers to the system's capacity to return to a similar, or an equivalent to the initial balance.	Irreversible: 10
			Partial return: 5
			Reversible: 2

Source: Prepared based on PEAs of 6 Basins

**Table 4.8.2-2 Impact Significance Degrees**

SIA	Extent of Significance
≤ 15	Of little significance
15.1 - 28	Significant
≥ 28	Very significant

Source: Prepared based on PEAs of 6 Basins

### 4.8.3 Identification, Description and Social Environmental Assessment

#### (1) Identification of social environmental impacts

In the following matrix (construction/operation stages) in the watershed, elaborated based on the report analysis of the Preliminary Environmental Assessment.

**Table 4.8.3-1 Impact Identification Matrix (Construction and Operation Stage) – Chincha River**

Construction Stage			Work	1-5	1-5	1-5	2,3	1,4,5	1-4	1-5	1-5	1-5	1-5		
Environment	Component	Environmental Factors	Activity												
			Labor Recruitment	Site Preparation work (Clearing, land grading, levee bed)	Dredging of the river (Coffee dams)	Dredging and filling in the river	Dredging and filling in the river	Civil Work (Concrete)	ISO of the pipe and materials production plant	DME ISO	Camps work ISO	Carriage Staff	Transportation of materials, equipment, materials and supplies	Total Negative	Total Positive
Physical	Air	PM10 (Particulate matter)		N	N	N	N	N	N	N	N	N	N	8	0
		Gas emissions		N	N	N	N	N	N	N	N	N	N	9	0
	Noise	Noise		N	N	N	N	N	N	N	N	N	N	10	0
		Soil fertility		N										3	0
	Water	Land Use		N										3	0
		Calidad del agua superficial			N	N	N							4	0
Physiography	Cantidad de agua superficial							N			N		2	0	
	Morfología fluvial				N	N	N						4	0	
Biotic	Rora	Morfología terrestre		N							N		2	0	
		Terres Mal flora		N									2	0	
	Ruina	Aquatic flora			N	N	N				N		4	0	
		Terres Mal fauna		N									2	0	
Socio-economic	Esthetic	Aquatic fauna			N	N	N				N		4	0	
		Visual landscape									N	N		2	0
	Social	Quality of life	P											3	1
		Vulnerability - Security										N	N		0
Economic	PEA	P												0	1
	Current land use													0	0
Total				2	8	7	7	7	3	10	9	3	4	62	2
Percentage of positive and negative														97%	3%

Environment	Component	Environmental Factors	Values	Operation Stage					Total Negative	Total Positive
				Dike Cubo 1	Intake Cubo 2	Partidor Cubo 3	Dike MB 4	Revised without Sliding MSC		
Physical	Air	PM10 (Particulate matter)							0	0
		Gas emissions							0	0
	Noise	Noise							0	0
		Soil fertility							0	0
	Water	Land Use							0	0
		Calidad del agua superficial		P	P				0	1
Physiography	Cantidad de agua superficial		P	P	P	P	P	0	5	
	Morfología fluvial		N		P	N	N	3	1	
Biotic	Rora	Morfología terrestre							0	0
		Terres Mal flora							0	0
	Ruina	Aquatic flora							0	0
		Terres Mal fauna							0	0
Socio-economic	Esthetic	Aquatic fauna							4	0
		Visual landscape		P	P	P	P	P	0	4
	Social	Quality of life		P	P	P	P	P	0	5
		Vulnerability - Security		P	P	P	P	P	0	5
Economic	PEA							0	0	
	Current land use		P	P	P	P	P	0	5	
Total				7	6	7	7	7	26	
Percentage of positive and negative								21%	79%	

N: Negative, P:Positive  
Source: Prepared by the JICA Study Team

On the Chincha River basin, based on the impact identification results for the construction stage, a total number of 64 interactions have been found. 62 of these interactions (97 %) correspond to impacts that will be perceived as negative, and 2 (3 %) correspond to impacts that will be perceived as positive. In addition, 33 interactions have been found for the operation stage; 7 of these interactions (21 %) correspond to impacts that will be perceived as negative, and 26 (79 %) correspond to impacts that will be perceived as positive.

## (2) Environmental and Social Impact Assessments

Environmental and social impacts are assessed with the methodology that was explained in 4.8.2 Methodology. The following tables show the environmental and social assessment results for the basin, during the construction and operation stages.

**Table 4.8.3-2 Environmental Impact Assessment Matrix – Chincha River**

		The Chincha River Basin																		
Medio	Componente	Acciones del proyecto	Construction Stage										Operation Stage							
			Labor Recruitment	Site preparation work (Clearing, land grading, Levelled)	Diversion of riverbed (Cofferdams)	Digging and refilling in riverside	Digging and refilling in riverbed	Civil Work (Concreting)	I&O of stone pits and material production plants	DME I&O	Camps work I&O	Carnage Staff	Transportation of machinery, equipment, materials and supplies	Chico1	Chico2	Chico3	Ma1	Ma2		
			Puntos de Obras:		Todos	Todos	Todos	Chico 2 y 3	Chico 1, Ma 1 y 2	Chico 1, 2, 3, Ma1	Todos	Todos	Todos	Todos	Todos	Todos	Todos	Todos	Todos	Todos
Factores Ambientales		Todos	Todos	Todos	Chico 2 y 3	Chico 1, Ma 1 y 2	Chico 1, 2, 3, Ma1	Todos	Todos	Todos	Todos	Todos	Todos	Todos	Todos	Todos	Todos	Todos		
Physique	Air	PM-10 (Particulate matter)	0.0	-12.0	-12.0	-12.0	-12.0	0.0	-18.0	-18.0	0.0	-12.0	-12.0	0.0	0.0	0.0	0.0	0.0	0.0	
		Gas emissions	0.0	-11.5	-11.5	-11.5	-11.5	-11.5	-11.5	-11.5	-11.5	0.0	-11.5	-11.5	0.0	0.0	0.0	0.0	0.0	0.0
	Noise	Noise	0.0	-15.0	-15.0	-15.0	-15.0	-15.0	-15.0	-15.0	-15.0	-15.0	-15.0	-15.0	0.0	0.0	0.0	0.0	0.0	0.0
		Soil fertility	0.0	-11.5	0.0	0.0	0.0	0.0	0.0	-14.2	-14.2	0.0	0.0	0.0	0.0	0.0	0.0	0.0	0.0	0.0
	Soil	Land Use	0.0	-14.2	0.0	0.0	0.0	0.0	0.0	-15.0	-15.0	0.0	0.0	0.0	0.0	0.0	0.0	0.0	0.0	0.0
		Calidad del agua superficial	0.0	0.0	-17.5	-12.0	-23.0	0.0	-15.0	0.0	0.0	0.0	0.0	0.0	0.0	28.0	0.0	0.0	0.0	0.0
	Water	Cantidad de agua superficial	0.0	0.0	0.0	0.0	0.0	-9.0	0.0	0.0	-15.0	0.0	0.0	0.0	26.0	31.0	26.0	26.0	31.0	
Morfología fluvial		0.0	0.0	-12.0	-20.0	-31.0	0.0	-23.0	0.0	0.0	0.0	0.0	0.0	-25.5	0.0	26.0	-25.5	-30.5		
Physiography	Morfología terrestre	0.0	-33.0	0.0	0.0	0.0	0.0	0.0	-28.0	0.0	0.0	0.0	0.0	0.0	0.0	0.0	0.0	0.0		
	Terrestrial flora	0.0	-28.0	0.0	0.0	0.0	0.0	0.0	-22.5	0.0	0.0	0.0	0.0	0.0	0.0	0.0	0.0	0.0		
Biotic	Flora	Aquatic flora	0.0	0.0	-12.0	-14.5	-14.5	0.0	-14.5	0.0	0.0	0.0	0.0	0.0	0.0	0.0	0.0	0.0	0.0	
		Terrestrial fauna	0.0	-24.2	0.0	0.0	0.0	0.0	0.0	-22.5	0.0	0.0	0.0	0.0	0.0	0.0	0.0	0.0	0.0	
	Fauna	Aquatic fauna	0.0	0.0	-12.0	-14.5	-22.5	0.0	-15.0	0.0	0.0	0.0	0.0	0.0	-25.5	0.0	-25.5	-25.5	-30.5	
		Visual landscape	0.0	0.0	0.0	0.0	0.0	0.0	-12.0	-12.0	0.0	0.0	0.0	0.0	36.0	0.0	36.0	36.0	36.0	
Socio-economic	Social	Quality of life	17.0	0.0	0.0	0.0	0.0	0.0	0.0	0.0	-17.5	-17.5	-17.5	36.0	31.0	36.0	36.0	36.0		
		Vulnerability - Security	0.0	0.0	0.0	0.0	0.0	0.0	0.0	0.0	0.0	0.0	0.0	0.0	36.0	31.0	36.0	36.0	36.0	
	Economic	PEA	17.0	0.0	0.0	0.0	0.0	0.0	0.0	0.0	0.0	0.0	0.0	0.0	0.0	0.0	0.0	0.0	0.0	
Current land use		0.0	0.0	0.0	0.0	0.0	0.0	0.0	0.0	0.0	0.0	0.0	0.0	36.0	36.0	36.0	36.0	36.0		

Source: Prepared based on PEAs of 6 Basins

It must be pointed out that in the Chincha River basin only 15 out of a total of 62 negative impacts have been quantified as significant, and 2 have been quantified as very significant, during the construction stage. Meanwhile, out of a total of 7 negative impacts, only 5 have been quantified as significant, and 2 have been quantified as very significant, during the operation stage.

During the construction stage, the works site preparation component will significantly affect the land morphology. At the same time, the Riverbed Excavation and Filling component will affect the “Chico1”, “Ma1”, and “Ma2” points. During the operation stage, river morphology and aquatic fauna will be significantly affected at the “Ma3” points, where the river basin will be unclogged.

During the construction stage, actions that will generate most significant negative impacts along the basin include: “Site Works Preparation and Clearance”, “Riverbed Excavation and

Filling”, and “Surplus Material Deposits Operation (DME, in Spanish).” “Site works Preparation and Clearance” will bring about a significant modification to the land morphology, whereas “Riverbed Excavation and Filling” will bring about a significant modification to river morphology.

During the operation stage, hydraulic infrastructure works that will bring about most significant negative environmental impacts include “Riverbed excavation and embankment” that will cause a modification to the river morphology and subsequently, decreased river habitability conditions that will directly impact the aquatic fauna.

Most significant positive impacts are related to all works to be constructed along the river basins, and are directly related to improve the quality of the lives of the population around the area of influence, improve the “Current Use of land / soil”, improve the security conditions, and reduce vulnerability at social and environmental levels.

#### **4.8.4 Socio-Environmental Management Plans**

The objective of the Socio-Environmental Plans is to internalize both positive and negative significant and very significant environmental impacts that are related to the Project’s construction and operation stages, so that prevention and/or mitigation of significant and very significant negative impacts, preservation of environmental heritage, and Project sustainability are ensured.

During the construction stage, Project of Cañete river has set out the following measures: “Local Hiring Program”, “Works Sites Management and Control Program”, “Riverbed Diversion Program”, “Riverbank Excavation and Filling Management”, “Riverbed Excavations and Filling Management”, “Quarry Management”, “DME Management”, “Camp and Site Residence Standards”, and “Transportation Activity Management.” During the operation stages, Project for the basin has considered the development of activities with regard to “Riverbed and Aquatic Fauna Management”. These activities should develop riverbed conditioning downstream the intervention points, for erosion probabilities to be reduced, and habitability conditions to be provided for aquatic fauna species. The following are measures related to those negative impacts to be mitigated or those positive impacts to be potentiated. Overall measures have been established for the basin, based on the impacts.



**Table 4.8.4-1 Environmental Impact and Prevention/Mitigation Measures**

Item	Impact	Counter Measures	Period
Natural environment	Water quality of surface water	Management of river diversion and coffering	Construction period
		Management of bank excavation and banking	
		Management of riverbed excavation and back filling	
	River topography	Management of bank excavation and banking	
		Management of riverbed excavation and back filling	
		Management of quarry site	
	Other topography	Management of construction site	
		Management of large amount of excavated or dredged material	
Dust	Management of construction site		
	Management of large amount of excavated and dredged material		
Biological environment	Aquatic fauna	Management of riverbed excavation and back filling	O/M period
	Terrestrial fauna	Management of construction site	Construction period
		Management of large amount of excavated and dredged material	
	Terrestrial flora	Management of construction site	
Management of large amount of excavated and dredged material			
Social environment	Quality of life	Management of labor and construction office	Construction period
		Management of traffic of construction vehicle	
		Employment plan of local people	
	Population of economic activity	Employment plan of local people	

Source: JICA Study Team

#### 4.8.5 Monitoring and Control Plan

##### (1) Follow up and monitoring plan

The follow-up plan has to implement firmly the management of environmental plan. The monitoring plan is to be carried out to confirm that the construction activity fulfill the environmental standard such as Environmental Quality Standards (EQS) either or Maximum Permissible Limits (MPL). And the monitoring and control must be carried out under the responsibility of the project's owner or a third party under the supervision of the owner.

##### · Construction stage

During the construction period of the projects to be done in the watershed, the Monitoring and Control Plan will be directed to the verification of the fulfillment measures designed as part of the environmental monitoring plan and the verification of the fulfillment of laws and regulation of the Peruvian Legislation. The following aspects will also be monitored:

##### Water Quality and Biological Parameters:

Water quality and biodiversity parameters control shall be performed at downstream of these works must be monitored. In the following table the profile of this plan is shown.

**Table 4.8.5-1 Monitoring to Water Quality and Biological Parameters**

Item	Unit	Measured Value (Mean)	Measured Value (Max.)	Country's Standards
pH	pH			"National Standard for Water Quality" D.S. No. 002-2009 MINAM
TSS	mg/l			
BOD/COD	mg/l			
DO	mg/l			
Total Nitrogen	mg/l			
Heavy Metals	mg/l			
Temperature	°C			
Biological Diversity indices: Shannon; Pielou; richness and abundance				

[Measurement Points]

-50 meters upstream the intervention points

-50 meters downstream the intervention points

-100 meters downstream the intervention points

[Frequency]

Quarterly

[Person in charge of Implementation]

DGIH-MINAG, or a third party under the project holder's supervision

Source: JICA Study Team

Air Quality:

During impact analysis, in the projects to be developed in the watershed no significant impacts will be seen in the activities related to hydraulic infrastructure works. However, the generation of dust and atmospheric contaminant emissions always affects the working area and the workers and inhabitants health. So, it is recommended to monitor air quality.

**Table 4.8.5-2 Monitoring to Air Quality**

Item	Unit	Measured Value (Mean)	Measured Value (Max.)	Peruvian Standards (D.S. No 074-2001-PCM)	Referred International Standards
SO <sup>2</sup>				"National Standard for Air Quality" D.S. No.074-2001-PCM	National Ambient Air Quality Standards (NAAQS) (Updated in 2008)
NO <sup>2</sup>					
CO					
O <sup>3</sup>					
PM-10					
PM-2.5					

[Measurement Points]

\*02 stations per monitoring point: Windward and downwind (upwind and against the wind direction)

-1 point at the working zones

-1 point at a quarry, away from the river (the largest and / or the closest point to a populated area)

-1 point at a D.M.E. (the largest and / or the closest point to a populated area)

[Frequency]

Quarterly

[Person in charge of the Implementation]

DGIH-MINAG, or a third party under the project holder's supervision

Source: JICA Study Team

Noise Quality

Likewise, it is proposed to perform a noise monitoring at the potential receptors located near the noise emission spots towards the working sites, in the next table 4.8.5-3, the terms are described.

**Table 4.8.5-3 Monitoring to Noise Quality**

Item	Unit	Measured Value (Mean)	Measured Value (Max.)	Country's Standards	Referred International Standards
Noise level	LAeqT (dB(A))			National Environmental Quality Standards for noise (EQS) - S.N. N° 085-2003-PCM	-IEC 651/804 - International -IEC 61672- New Law: Replaces IECs 651/804 -ANSI S 1.4 - America

[Measurement Point]

Monitoring to acoustic contamination levels will be carried out at the potential receivers that are located around the noise emission points per work front.

01 point per potential receiver will be monitored.

[Frequency]

Every two months during construction phase  
 [Person in charge of the Implementation]  
 DGIH-MINAG, or a third party under the project holder's supervision  
 Source: JICA Study Team

· Operation Stages

Regarding works impact of all projects, it is mainly recommended to monitor biologic parameters and water quality as river topography and the habitat of aquatic life.

**Table 4.8.5-4 Monitoring to Water Quality (Operation Stage)**

Item	Unit	Measured Value (Mean)	Measured Value (Max.)	Country's Standards
pH	pH			"National Standard for Water Quality" D.S. No. 002-2009 MINAM
TSS	mg/l			
BOD/COD	mg/l			
DO	mg/l			
Total Nitrogen	mg/l			
Heavy Metals	mg/l			
Temperature	°C			
Biological Diversity indices: Shannon; Pielou; richness and abundance				

[Measurement Points]  
 -50 meters upstream the intervention points  
 -50 meters downstream the intervention points  
 -100 meters downstream the intervention points  
 [Frequency]  
 Quarterly in first two years of operation phase  
 [Person in charge of Implementation]  
 DGIH-MINAG, or a third party under the project holder's supervision  
 Source: JICA Study Team

(2) Closure or Abandon Plan

Closure or abandon plans have been made for each watershed. These will be executed at the end of construction activities and involves the removal of all temporary works and restoration of intervened and/or affected areas as a result of the works execution. The restoration includes the removal of contaminated soil, disposal of waste material, restoration of soil morphology and restoration with vegetation of intervened sites.

(3) Citizen Participation

Citizen participation plans have been made for each watershed, which must be executed before and during construction and when the works are completed. The recommended activities are:

- Before works: Organize workshops in the surrounding community's area near the project and let them know what benefits they will have. Informative materials in communities, which

will explain the profile, lapse, objectives, benefits, etc. of the Project

- During works execution: Give out information on the construction progress. Responding complaints generated from the local community during works execution. For this, a consensus wants to be previously achieved with the community in order to determine how claims will be met
- When works are completed: Organize workshops to inform about works completion. Works delivery to the local community inviting local authorities for the transfer of goods, which means the work finished.

#### 4.8.6 Cost for the environmental impact management

The direct costs of previously mentioned measures to mitigate environmental impacts in the Chincha River Watershed is as shown in the Table 4.8.6-1. In any case, it is necessary to determine in detail these measures' budget for each watershed in the detailed design stage.

**Table 4.8.6-1 Direct costs of measures to manage environmental impact**

Actions	Unit	Qty	Unitary price (S/.)	Subtotal (S/.)	Total (s/.)
Sign for vehicles entrance	Month	6	S/. 1.400,0	S/. 8.400,0	S/. 8.400,0
Industrial waste transportation	Month	6	S/. 4.200,0	S/. 25.200,0	S/. 25.200,0
Project sites landscape protection measures	Month	6	S/. 2.800,0	S/. 16.800,0	S/. 16.800,0
Operation and maintenance of construction equipment	Month	6	S/. 1.960,0	S/. 11.760,0	S/. 11.760,0
Measures for staff noise protection	Month	6	S/. 1.120,0	S/. 6.720,0	S/. 6.720,0
Functioning expenses to implement environmental impact mitigation measures	Month	6	S/. 4.480,0	S/. 26.880,0	S/. 26.880,0
Soil and air contaminant prevention capacity development	Month	6	S/. 2.520,0	S/. 15.120,0	S/. 15.120,0
Bed and aquatic fauna monitoring					S/. 11.239,2
Diversity indicators monitoring	times	3	S/. 672,0	S/. 2.016,0	
Water flow monitoring	times	3	S/. 588,0	S/. 1.764,0	
T°, pH, OD monitoring	times	3	S/. 571,2	S/. 1.713,6	
DBO monitoring	times	3	S/. 638,4	S/. 1.915,2	
Total solids dissolve monitoring (SDT)	times	3	S/. 638,4	S/. 1.915,2	
Total suspended solids monitoring (SST)	times	3	S/. 638,4	S/. 1.915,2	
Air and noise quality monitoring					S/. 37.500,0
Gas emissions monitoring	times	3	S/. 4.500,0	S/. 13.500,0	
Dust monitoring	times	3	S/. 5.000,0	S/. 15.000,0	
Noise monitoring	times	3	S/. 3.000,0	S/. 9.000,0	
Total					S/. 159.619,2

## **4.8.7 Conclusions and Recommendations**

### **(1) Conclusions**

According to the Preliminary Environmental Appraisals to Chincha basin, most impacts identified during the construction and operation stages were found out to be of little significance. Significant and very significant negative impacts can be controlled or mitigated, as long as suitable Environmental Management Plans are carried out. In addition, the Project will be implemented in the short term, as environmental conditions will be quickly restored. However, the execution of a follow – up and monitoring plan is important, and in the event that unexpected impacts are generated, immediate mitigation measures must be taken.

In addition, significant positive impacts are also present, especially during the operation stage. These positive impacts include: An enhanced security / safety and a decreased vulnerability at social and environmental levels; an improved quality of life among the population in the area of influence, and an improved “Current use of land / soil”.

### **(2) Recommendations**

1) We mainly recommend that the beginning of the construction activities coincides with the beginning of the dry seasons in the region (May to November) when the level of water is very low or the river dries up. The river characteristics / features should be taken into account, that is, that Chincha river is seasonal rivers. At the same time, the crop season cycle in the areas of direct influence should be taken into account, so that traffic jams caused by the large trucks and farming machinery is prevented.

2) It is recommended that the Project holder (DGIH) should define the limit of river area during detailed design stage, and identify the people who live within the river area illegally. Continually the DGIH should carry on the process of land acquisition based on the Land Acquisition Law, which are; Emission of Resolution for land acquisition by the State, Proposition of land cost and compensation for land owner, Agreement of the State and land owner, Payment, archaeological assessment certification.

3) DGIH has to promote the process to obtain the CIRA in the detail design stage. The process to be taken is i) Application form, ii) Copies of the location drawings and outline drawings, iii) voucher, iv) Archaeological Assessment Certificate.

4) The participation of the women in the workshops can be promoted through the existing women group such as Vaso de Leche.

Finally, the DGAA submitted the resolutions (Environmental Permissions) for Chincha basin. The Projects has been categorized as “Category I”, which means that the Projects is not required to carry out neither EIA-sd nor EIA-d.

## **4.9 Execution Plan**

The Project's Execution Plan will review the preliminary schedule, which includes the following components. For pre-investment stage: ① full execution of pre-feasibility and feasibility studies to obtain SNIP's approval in the pre-investment stage; for the investment stage: ② signing of loans (L/A), ③ consultant selection, ④ consulting services (detailed design and elaboration of technical specifications), ⑤ constructor selection and ⑥ work execution. For the post-investment stage: ⑦ Works' completion and delivery to water users associations and beginning of the operation and maintenance stage.

### **(1) Review by the Public Investment National System (SNIP)**

In Peru, the Public Investment National System (SNIP hereinafter) is under operation. This reviews the rationality and feasibility of public investment projects, and will be applied to this Project.

In SNIP, among previous studies to an investigation, it will be conducted in 3 stages: profile study (study on the project's summary), pre-feasibility and feasibility. SNIP was created under Regulation N° 27293 (published on June 28, 2000) in order to achieve efficient use of public resources for public investment. It establishes principles, procedures, methods and technical regulations to be fulfilled by central/regional governments in public investment scheme plans and executed by them.

SNIP, as described below, is all public works projects which are forced to perform a 3-stage pre-investment study: profile study, pre-feasibility and feasibility, and have them approved. However, following the Regulation amendment in April 2011, the execution of pre-feasibility study of the intermediate stage was considered unnecessary; but in return, a study based on primary data during the profile study is requested. The required precision degree throughout all stages of the study has hardly changed before and after this modification.

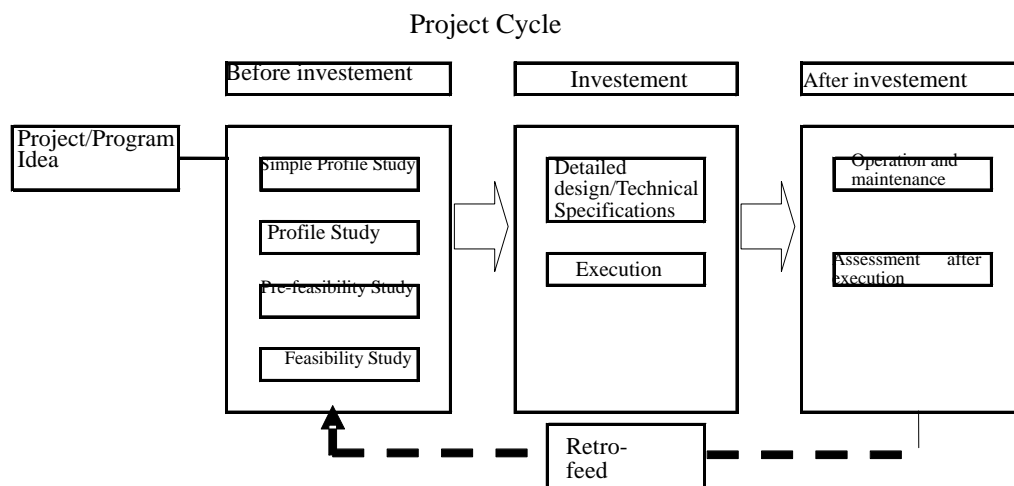

(Source: DGPM HP)

**Figure 4.9-1 SNIP Cycle Project**

In order to carry out this Project, which is a project composed by several programs, pre-investment studies at investments' programs level are required to be performed and also have them approved.

Although the procedure is quite different in each stage, in SNIP procedures, the project's training unit (UF) conducts studies of each stage, the Planning and Investment Office (OPI) assesses and approves the UF's presented studies and requests Public Sector Multi-Annual Programming General Direction (hereinafter referred DGPM) to approve feasibility studies and initiation of following studies. Finally DPGM evaluates, determines and approves the public investment's justification.

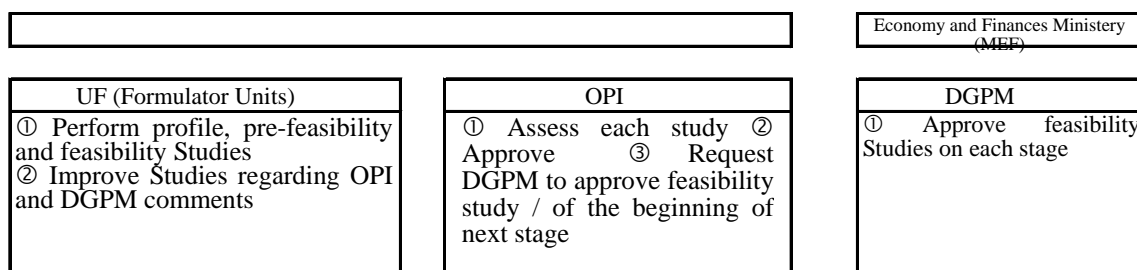

(See Regulation No.001-2009-EF/68.01.)

**Figure 4.9-2 Related Institutions to SNIP**

Due to the comments of examining authorities (OPI and DGPM) to FU, it will be necessary to prepare correspondent responses and improve the studies. Since these authorities officially



admit applications after obtaining definitive answers, there are many cases in which they take several months from the completion of the study report until the completion of the study.

(2) Yen loan contract

Once the feasibility studies reports are submitted and examined in SNIP, discussions on the loan in yen will begin. It is estimated to be a period of 6 months for procedures.

(3) Procedure of the project's execution

After the documents are assessed by SNIP and a loan agreement between Japan (JICA) and the Peruvian counterpart is signed, a consultant will be selected. The consulting service includes the development of detailed design and technical specifications, the contractors' selection and the work's supervision. Table 4.9-1 presents the Project's overall schedule.

1) Consultant selection: 3 months, builder selection: 3 months

2) Develop detailed design and technical specifications of the work's period

① River and re-forestation works along these works

Detailed design and technical specifications elaboration: 6 months

Working Period: 2 years

② Capacity Building

It will be executed on the same work period of river facilities.

Detailed design and technical specifications elaboration: 6 months

Working Period: 2 years

**Table 4.9-1 Implementation Plan**

ITEMS	2010			2011			2012			2013			2014			2015			2016				
	3	6	9	12	3	6	9	12	3	6	9	12	3	6	9	12	3	6	9	12	3	6	9
1 PROFILE STUDY / SNIP ASSESSMENT	STUDY			EVALUATION																			
2 FEASIBILITY STUDY / SNIP ASSESSMENT				STUDY			EVALUATION																
3 YEN CREDIT NEGOTIATION																							
4 CONSULTANT SELECTION																							
5 CONSULTANT SERVICE (DETAILED DESIGN, LAWFUL DOCUMENTS PREPARATION)							DESIGN / LAWFUL DOCUMENT						WORK SUPERVISION										
6 BUILDER SELECTION																							
7 WORK EXECUTION																							
1) STRUCTURES BUILDING																							
2) REFORESTATION																							
3) EARLY ALERT SYSTEM																							
4) DISASTER PREVENTIVE TRAINING																							
8 FINISH WORK / DELIVERY TO USERS BOARDS																							

#### **4.10 Institutions and Administration**

Peruvian institutions regarding the Project's execution and administration are the Agriculture Ministry, Economy and Finance Ministry and Irrigation Commission, with the following roles for each institution:

##### **Ministry of Agriculture (MINAG)**

- \* The Ministry of Agriculture (MINAG) is responsible for implementing programs and the Hydraulic Infrastructure General Direction (DGIH) is responsible for the technical administration of the programs. The Hydraulic Infrastructure General Direction (DGIH) is dedicated to the coordination, administration and supervision of investment programs.
- \* In investment stage, the PSI (Programa Subsectorial de Irrigaciones, Ministerio de Agricultura) is dedicated to calculate project costs, detail design and supervision of the works execution.
- \* The Planning and Investment Office (OPI) from the Agriculture Ministry is the one responsible for pre-feasibility and feasibility studies in the pre-investment stage of DGIH projects and requests approval of DGPI from the Economy and Finance Ministry (MEF).
- \* The General Administration Office of the Agriculture Ministry (OGA-MINAG) along with the Public Debt National Direction (DNEP) of the Economy and Finance Ministry is dedicated to financial management. It also manages the budget for procurement, commissioning works, contracting, etc. from the Agriculture Ministry.
- \* The Environmental Affairs General Direction (DGAA) is responsible for reviewing and approving the environmental impact assessment in the investment stage.

##### **Economy and Finance Ministry (MEF)**

- \* The DGPI approves feasibility studies. It also confirms and approves the conditions of loan contracts in yen. In the investment stage, it gives technical comments prior to the project execution.
- \* Financial management is in charge of DNEP from the Economy and Finance Ministry and OGA-MINAG.
- \* The Public Debt National Direction (DNEP) of the Economy and Finance Ministry administers expenses in the investment stage and post-investment operation.

##### **Irrigation Commission**

- \* Responsible for the operation and maintenance of facilities at the post-investment operation stage.

The relationship between the involved institutions in the Project's execution is shown in Figures 4.10-1 and 4.10-2.

In this Project, the investment stage (Project execution) corresponds to PSI from MINAG. The PSI is currently performing JBIC projects, etc. and in case of beginning a new project, it forms the correspondent Project Management Unit (UGP), who is responsible of choosing the consulting firm, hire construction services, works supervision, etc. The following figure describes the structure of the different entities involved in the Project's execution stage.

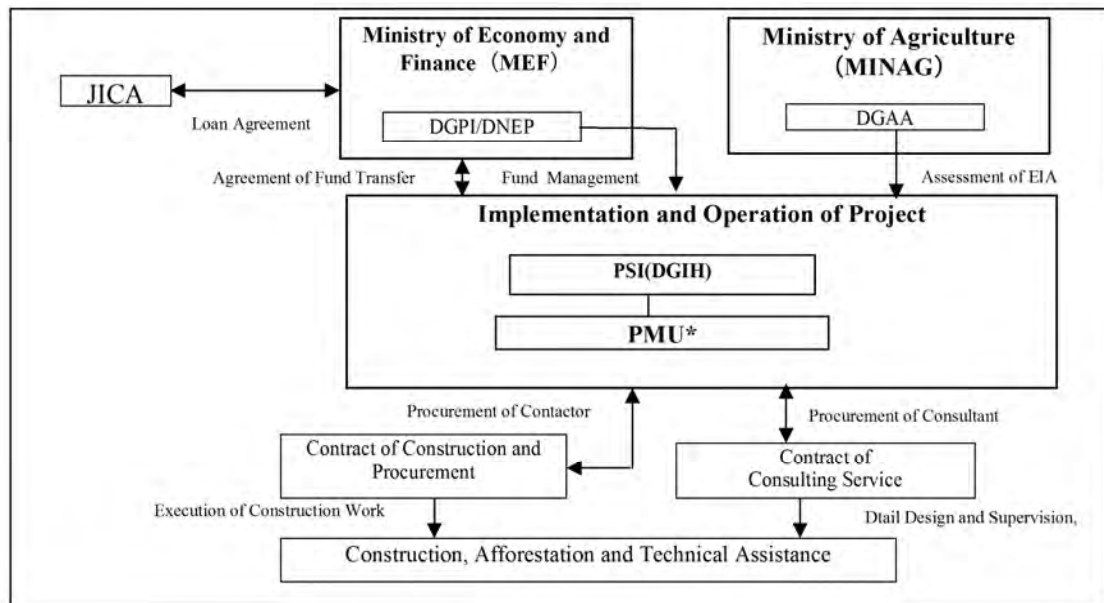

**Figure 4.10-1 Related Agencies in Implementation Stage of Project**

The main operations in the post-investment stage consist of operation and maintenance of the built works and the loan reimbursement. The O & M of the works will be assumed by the respective irrigation commission. Likewise, they should pay the construction costs in credits mode. Next, the relationship of different organizations involved in post-project implementation stage is detailed.

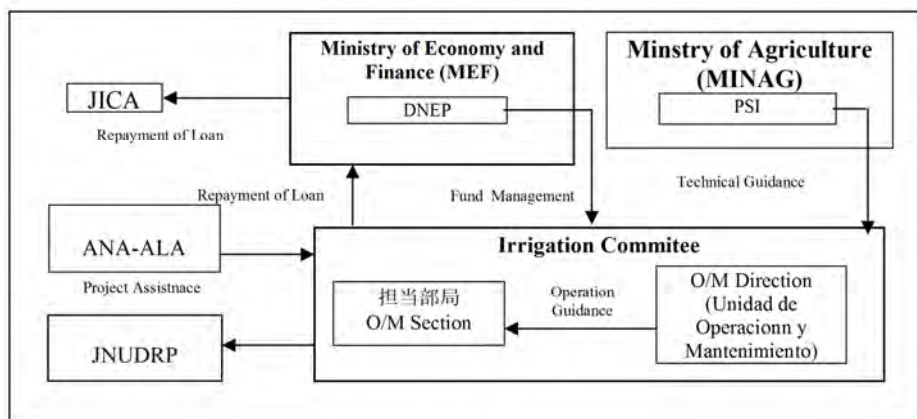

**Figure 4.10-2 Related Agencies in Operation Stage of Project**

## **(1) DGIH**

### 1) Role and Functions

The Hydraulic Infrastructure General Direction is in charge of proposing public policies, strategies and plans aimed to promoting water infrastructure development, according with the Water Resources National Policy and the Environmental National Policy.

Water Infrastructure development includes studies, works, operation, maintenance and construction risk management, fit-out, improve and expand dams, intakes, river beds, irrigation channels, drains, meters, outlets, groundwater wells and modernize plot irrigation.

### 2) Main functions

- a. Coordinate with the planning and budget office to develop water infrastructure and propose sectorial and management policies on infrastructure development. Monitor and assess the implementation of sectorial policies related to hydraulic infrastructure development
- b. Propose government, region and provinces intervention regulations, as part of sectorial policies
- c. Verify and prioritize hydraulic infrastructure needs
- d. Promote and develop public investment projects at the hydraulic infrastructure profile level
- e. Elaborate technical regulations to implement hydraulic infrastructure projects
- f. Promote technological development of hydraulic infrastructure
- g. Elaborate operation and maintenance technical standards for hydraulic infrastructure

## **(2) PSI**

### 1) Function

The Irrigation Sub-sectorial Program (PSI) is responsible of executing investment projects. A respective management unit is formed for each project.

### 2) Main functions

- a. Irrigation Sub-sectorial Program - PSI, under the Agriculture Ministry, is a body with administrative and financial autonomy. It assumes the responsibility of coordinating, managing and administering involved institutions in projects in order to meet goals and objectives proposed in investment projects
- b. Also, it coordinates the disbursements of foreign cooperation agencies financing, such as JICA.
- c. The Planning, Budget and Monitoring Office of PSI is responsible for hiring services, elaborating investment programs, as well as project execution plans. These Project preparation works are executed by hiring “in-house” consultants.

d. Likewise, it gathers contractors, makes a lease, executes works and implements supply projects, etc.

e. Contract management is leaded by the Planning, Budget and Monitoring Office

### 3) Budget

In Table 4.10-1 the PSI budget for 2011 is shown.

**Table 4.10-1 PSI Budget (2011)**

Programs / Projects / Activities	PIM (S/.)
JBIC Program (Loan Agreement EP-P31)	69.417.953
Program - PSI Sierra (Loan Agreement 7878-PE)	7.756.000
Direct management works	1.730.793
Southern Reconstruction Fund (FORSUR)	228.077
Crop Conversion Project (ARTRA)	132.866
Technified Irrigation Program (PRT)	1.851.330
Activity- 1.113819 small farmers...	783.000
PSI Management Program (Other expenses)	7.280.005
<b>TOTAL</b>	<b>89.180.024</b>

### 4) Organization

PSI is confirmed by 235 employees, from which 14 are assigned for JBIC Projects and 29 technicians and assistants are working under them.

**Table 4.10-2 PSI Payroll**

Central Level	Data from May 31, 2011		
	CAS	Servic. and Consult.	TOTAL
Main Office	61	43	104
Zonal Office LIMA	12	24	36
Zonal Office AREQUIPA	14	12	26
Zonal Office CHICLAYO	17	13	30
Zonal Office TRUJILLO	13	26	39
<b>TOTAL</b>	<b>117</b>	<b>118</b>	<b>235</b>

In Figure 4.10-3, PSI organization is detailed:

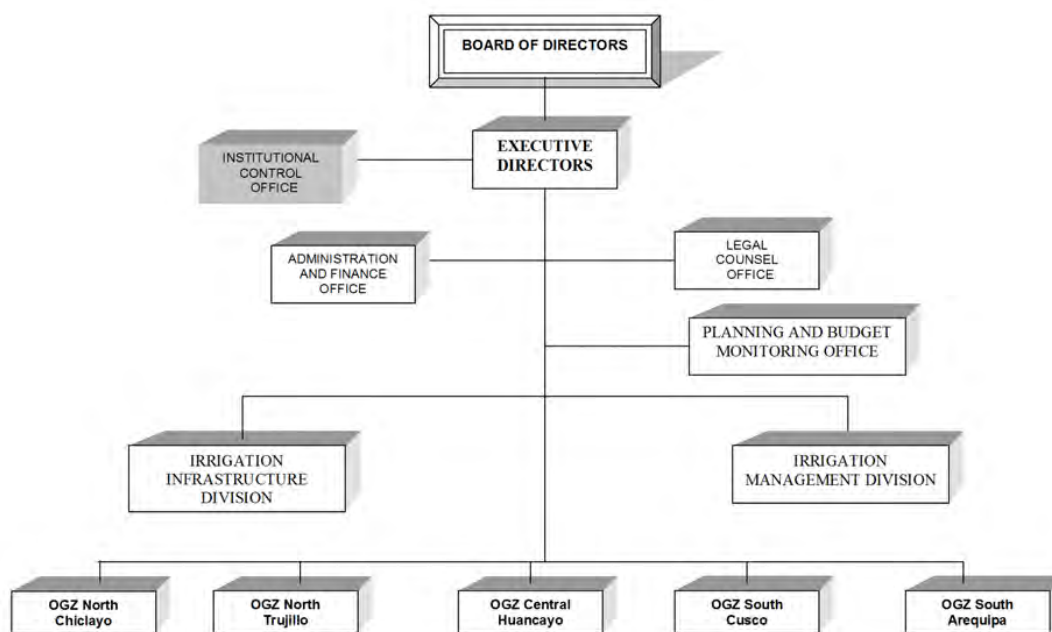

**Figure 4.10-3 Organization of PSI**

#### 4.11 Logical framework of the eventually selected option

In Table 4.11-1 the logical framework of the definite selected option is shown.

**Table 4.11-1 Logical framework of the definite selected option**

Narrative Summary	Verifying Indicators	Verifying Indicators Media	Preliminary Conditions
<b>Superior Goal</b>			
Promote socioeconomic local development and contribute in communities' social welfare.	Improve local productivity, generate more jobs, increase population's income and reduce poverty index	Published statistic data	Scio-economic and policy stability
<b>Objectives</b>			
Relief the high vulnerability of valleys and local continuity to floods	Types, quantity and distribution of flood control works, population and beneficiaries areas	Monitoring annual calendar works and financial plan, budget execution control	Ensure the necessary budget, active intervention from central and regional governments, municipalities, irrigation communities, local population, etc.
<b>Expected results</b>			

Reduction of areas and flooded areas, functional improvement of intakes, road destruction prevention, irrigation channels protection, bank erosion control and Poechos dike safety	Number of areas and flooded areas, water intake flow variation, road destruction frequency, bank erosion progress and watershed's downstream erosion.	Site visits, review of the flood control plan and flood control works reports and periodic monitoring of local inhabitants	Maintenance monitoring by regional governments, municipalities and local community, provide timely information to the superior organisms
<b>Activities</b>			
Component A: Structural Measures	Dikes rehabilitation, intake and bank protection works, road damages prevention, construction of 28 works, including dike's safety	Detailed design review, works reports, executed expenses	Ensure the works budget, detailed design/works execution/good quality works supervision
Component B: Non-Structural Measures			
B-1 Reforestation and vegetation recovery	Reforested area, coastal forest area	Works advance reports, periodic monitor by local community	Consultants support, NGO's, local community, gathering and cooperation of lower watershed community
Component C: Disaster prevention and capabilities development education	Number of seminars, trainings, workshops, etc	Progress reports, local governments and community monitoring	Predisposition of the parties to participate, consultants and NGO's assessments
Project's execution management			
Project's management	Detailed design, work start order, work operation and maintenance supervision	Design plans, work's execution plans, costs estimation, works specifications, works management reports and maintenance manuals	High level consultants and contractors selection, beneficiaries population participation in operation and maintenance

#### 4.12 Middle and long term Plan

Up to this point, only flood control measures have been proposed and these must be executed most urgently, due to the limitations on the available budget for this Project. However, there are other measures that must be performed in the long term framework. In this section we will be talking about the middle and long term flood control plan.

#### **4.12.1 Flood Control General Plan**

There are several ways to control floods in the entire watershed, for example building dams, reservoirs, dikes or a combination of these.

In case of building a dam proposal, assuming that this dam will reduce the flood peak with a 10 year return period reaching a return period flow of 50 return years, it will be necessary to build a dam with a very big capacity, calculating it in 48.6 million m<sup>3</sup> for Chíncha River. Usually upstream of an alluvial area, there is a rough topography in order to build a dam, a very high dam will be required to be built, which implies investing a large amount (more than thousand millions of soles).

Also, it would take between three to five years to identify the dam site, perform geological survey, material assessment and conceptual design. The impact on the local environment is huge. So, it is considered inappropriate to include the dam analysis option in this Study.

Likewise, the option of building a retarding basin would be hardly viable for the same reasons already given for the dam, because it would be necessary to build a great capacity reservoir and it is difficult to find a suitable location because most of the flat lands along the river's downstream are being used for agricultural purposes. So, its analysis has been removed from this Study.

Therefore, we will focus our study in the construction of dike because it is the most viable option.

##### (1) Plan of the river course

###### 1) Discharge capacity

An estimation was done on the discharge capacity of the current flow of this river based on longitudinal and cross sectional survey of the river, which results are shown in the section 3.1.10, Figure 3.1.10-3 and Figure 3.1.10-4.

###### 2) Inundation characteristics

The inundation analysis of Chíncha river was performed. In the section 3.1.10, Figure 3.1.10-5 and in Figure 3.1.10-6 the inundation condition for flood with probabilities of 50 years is shown.

The right tributary, Chico River, overflows on km 15 and km 4 sections, from the mouth. This floods vast extensions of left bank. Likewise, left tributary, Matagente, overflows on km 10 and km 4, from the mouth. This floods vast extensions of right bank.

###### 3) Design flood level and dike's standard section

The design flood level was determined in the flood water level with a return period of 50 years,



and the dike's standard section will be determined as already mentioned in section 4.3.1, 5), 1). In the section 4.2, Table 4.2-2 and Table 4.2-3 the theoretical design flood level and the required height of the dike's crown is shown.

#### 4) Dikes' Alignment

Considering the current conditions of existing dikes the alignment of the new dikes was defined. Basically, the broader possible river width was adopted to increase the discharge capacity and the retard effect. In Figure 4.12.1-1 the current channel and the setting alignment method of a section where the current channel has more width is explained schematically. In a normal section, the dike's crown has the same height to the flood water level with a return period of 50 years plus free board, while in the sections where the river has greater width, double dikes be constructed with inner consistent dike alignment and continuous with normal sections upstream and downstream. The crown height is equal to the flood water level with a return period of 50 years. The external dike's crown height is equal to flood water level with a return period of 50 years, so in case the river overflows the internal dike, the open gap between the two dikes will serve to store sediments and retarding water.

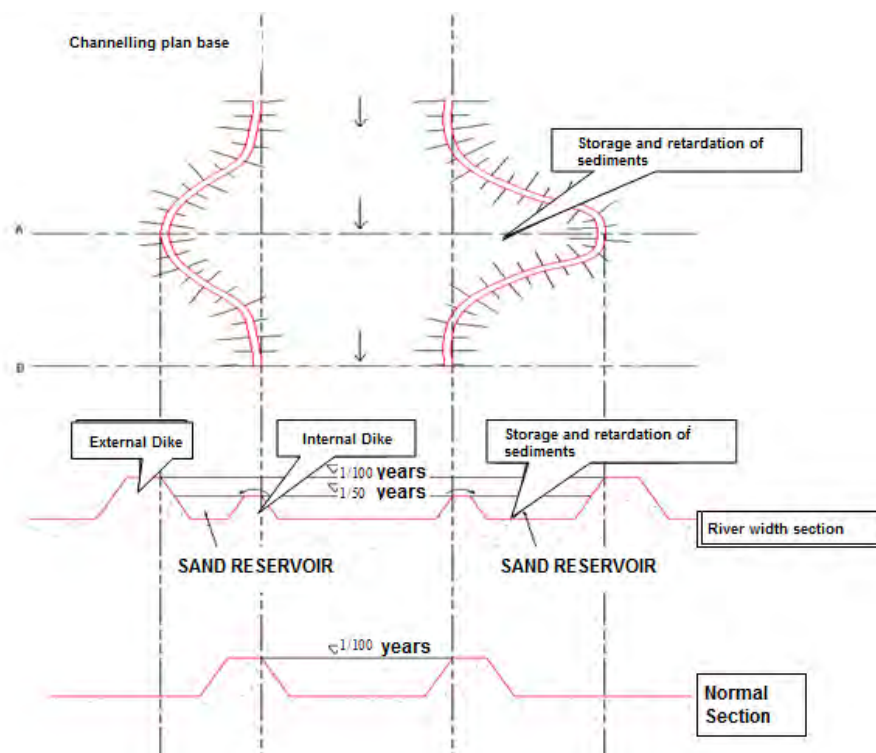

**Figure 4.12.1-1 Definition of dike alignment**

5) Plan and section of river

The plan and longitudinal section of river are as shown in the Figure 4.12.1-2, and -4.12.1-3 and Figure 4.12.1-4 respectively.

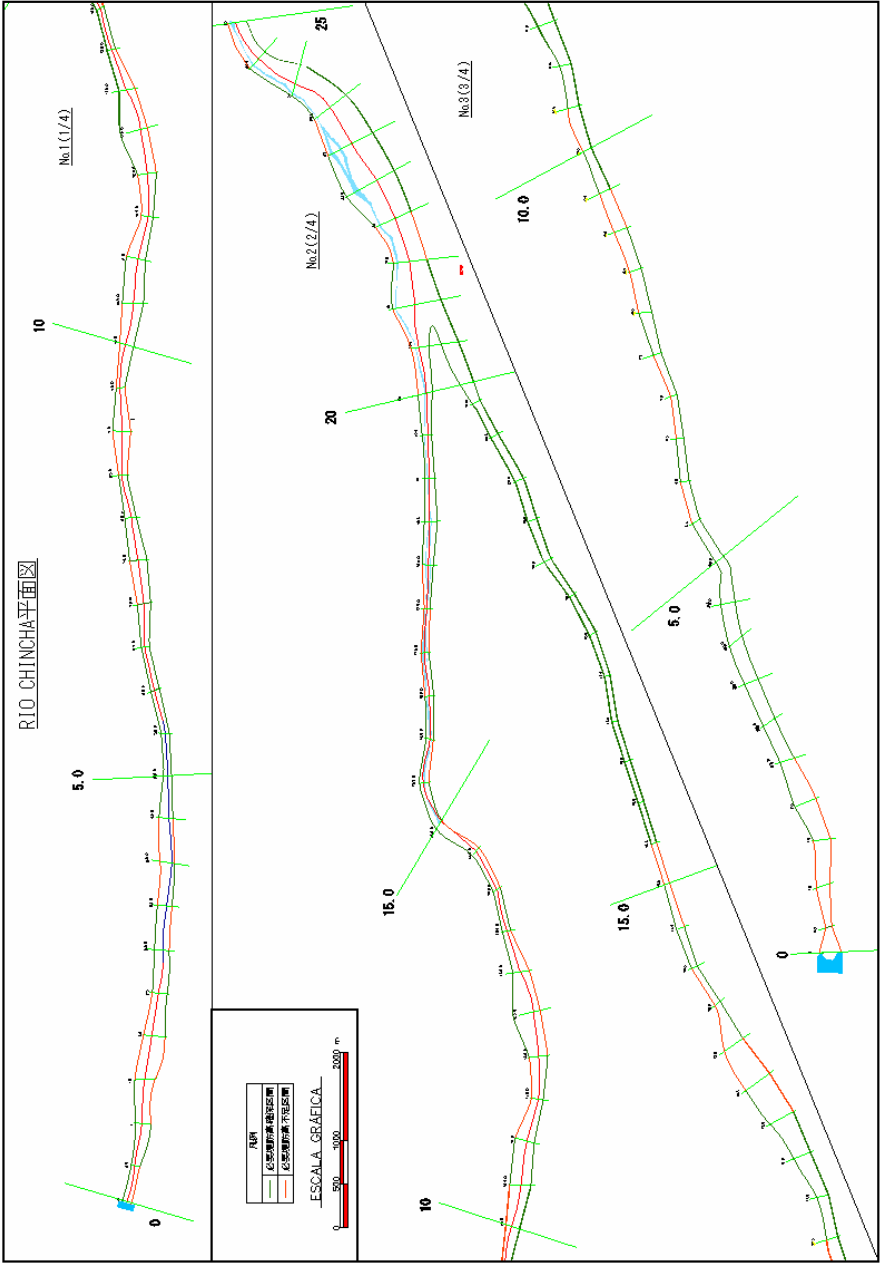
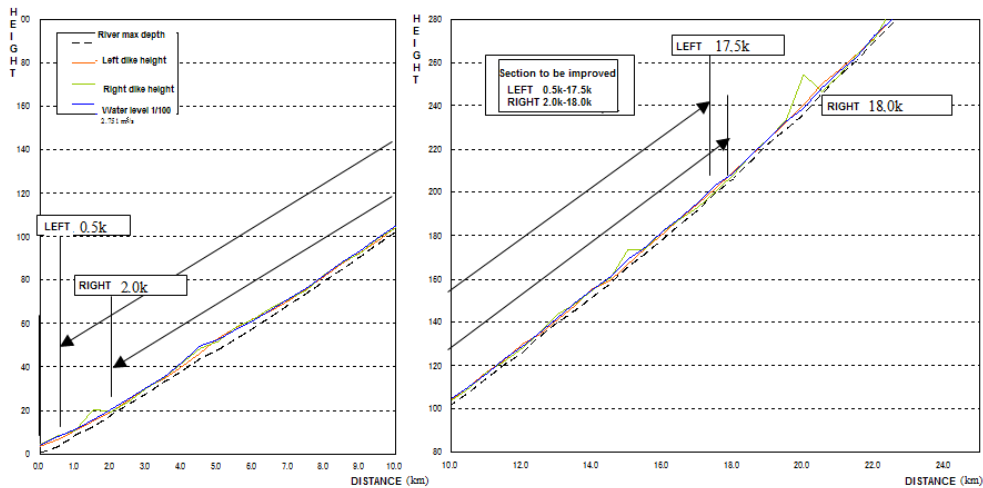
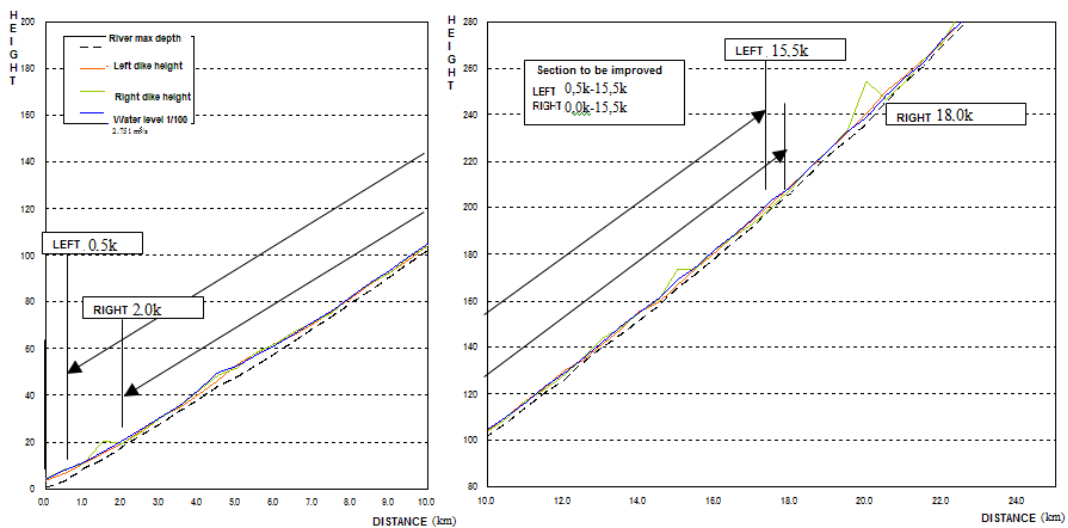

Figure 4.12.1-2 Plan of Chíncha River



**Figure 4.12.1-3 Chincha River Longitudinal Profile (Chico River)**



**Figure 4.12.1-4 Chincha River Longitudinal Profile (Matagente River)**

#### 6) Dike's construction plan

Next, basic policies for the dike's construction plan on the Chincha River are shown:

- Build dikes that allow flood flow safe passage with a return period of 50 years
- The dikes will be constructed in areas where overflowing water will enter the dike, according to the flood simulation
- The dikes will be placed in the sections above mentioned, where the design water level exceeds the existing dike's height or the ground level within the dike
- The dike's height is defined in the flood water level with a return period of 50 years plus the free board

Table 4.12.1-1 and Figure 4.12.1-5 and Figure 4.12.1-6 show the dike's construction plan on the Chincha River.

**Table 4.12.1-1 Dike's Construction Plan**

River	Sections to be improved		Dike missing height average (m)	Dike proposed size	Dike length (km)
	Left margin	Right margin			
Chincha	Left margin	0,5k-17,5k	0,56	Dikes' height = 1,5m Margin protection works height = 3,0m	7,0
	Right margin	2,0k-18,0k	0,53		5,5
	Total		-		12,5
	Left margin	0,5k-15,5k	0,58		7,5
	Right margin	0,0k-15,5k	0,55		13,0
	Total		0,56		25,5

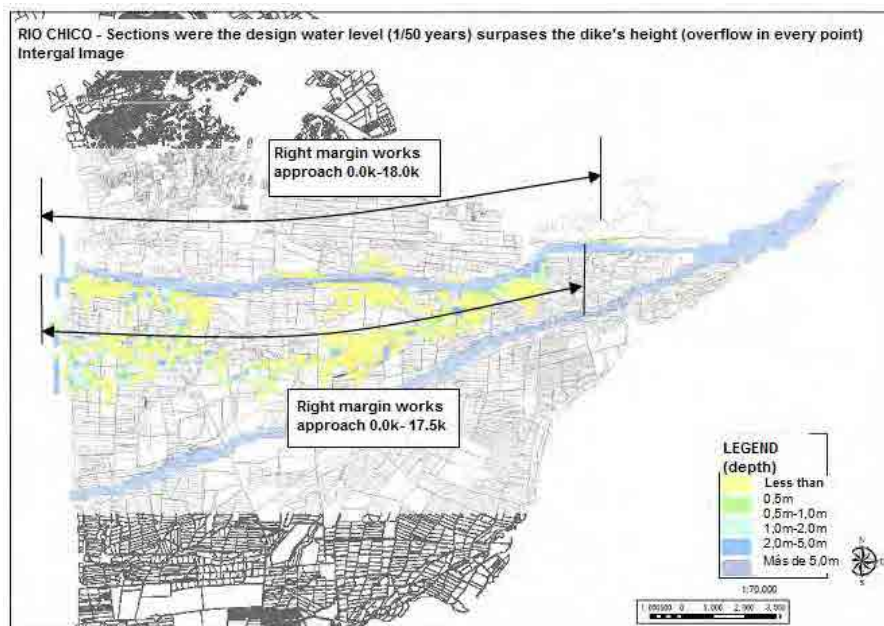

**Figure 4.12.1-5 Chinchá River (Chico River) dike's construction Works approach**

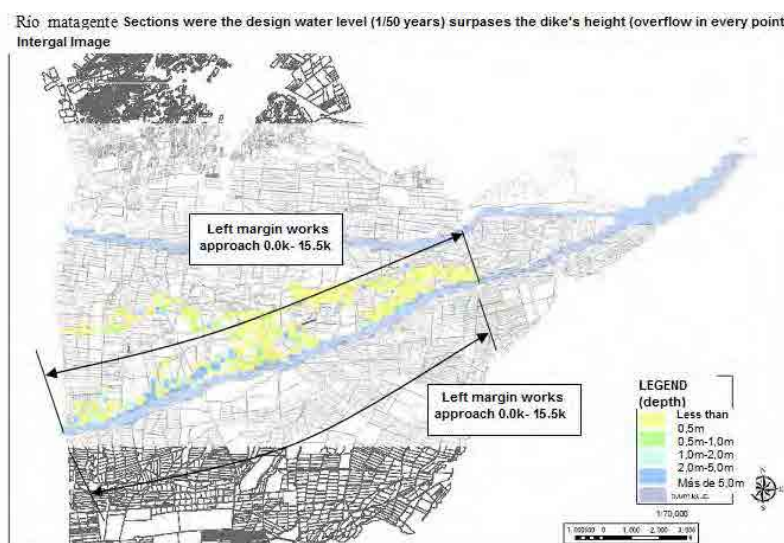

**Figure 4.12.1-6 Chinchá River (Matagente River) dike's construction Works approach**

## 7) Project Cost

In Tables 4.12.1-2 and 4.12.1-3 works' direct costs in private prices and the Project's cost are shown. Also, the cost of the project in social prices is presented in Table 4.12.1-4.

**Table 4.12.1-2 Works direct cost (at private prices)**

Di ke bui l di ng				Coastal defense			
B1	H1	B2	A	B1	H2	B2	A
3.0	1.0	8.5	5.8	1.0	1.0	2.4	10.8
3.0	2.0	14.0	17.0	1.0	2.0	2.9	13.4
3.0	3.0	19.5	33.8	1.0	3.0	3.4	16.5
3.0	4.0	25.0	56.0	1.0	4.0	3.9	20.1
3.0	5.0	30.5	83.8	1.0	5.0	4.4	24.3
3.0	1.5	11.3	10.7	1.0	6.0	4.9	28.9
				1.0	1.5	2.6	12.0
				1.0	10.0	6.9	52.4

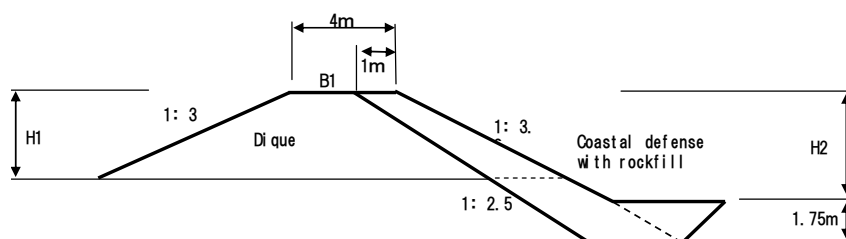

Wáter shed	Wórks	Amount	Unit	Unitary Price (in soles)	Wórk di rect cost/m (in soles)	Wórk di rect cost/km (in thousand soles)	Di ke l ength (k m)	Wórk di rect cost (in thousand soles)
Chincha	Diques	10.7	m <sup>3</sup>	10.0	107.0	107.0	25.5	2,728.5
	Protección de	16.5	m <sup>3</sup>	100.0	1650.0	1,650.0		42,075.0
Total						1,757.0		44,803.5

**Table 4.12.1-3 Projects' Cost (at private prices)**

流域名	DIRECT COST			INDIRECT COST								Hydraulic Infrastructure Total Cost 構造物・事業費 (12) = (8)+(9)+(10)+(11)	
	DIRECT COST	Temporary Works cost	WORKS COST	INDIRECT COST	OPERATIVE EXPENSES	UTILITY	INFRASTRUCTURE TOTAL COST	TAX	WORKS TOTAL COST	ENVIRONMENTAL IMPACT	TECHNICAL FILE		SUPERVISION
	直接工事費計	共通仮設費	工事費	諸経費	利益	構造物工事費	税金	建設費	環境影響	詳細設計	施工管理費		
	1	(2) = 0.1 x (1)	(3) = (1) + (2)	(4) = 0.15 x (3)	(5) = 0.1 x (3)	(6) = (3)+(4)+(5)	(7) = 0.18 x (6)	(8) = (6)+(7)	(9)=0.01 x (8)	(10) = 0.05 x (8)	(11) = 0.1 x (8)	0	
Chincha	44,803,500	4,480,350	49,283,850	7,392,578	4,928,385	61,604,813	11,088,866	72,693,679	726,937	3,634,684	7,269,368	84,324,667	

**Table 4.12.1-4 Projects' Cost (at social prices)**

流域名	DIRECT COST			INDIRECT COST								Hydraulic Infrastructure Total Cost 構造物・事業費 (12) = (8)+(9)+(10)+(11)	
	DIRECT COST	Temporary Works cost	WORKS COST	INDIRECT COST	OPERATIVE EXPENSES	UTILITY	INFRASTRUCTURE TOTAL COST	TAX	WORKS TOTAL COST	ENVIRONMENTAL IMPACT	TECHNICAL FILE		SUPERVISION
	直接工事費計	共通仮設費	工事費	諸経費	利益	構造物工事費	税金	建設費	環境影響	詳細設計	施工管理費		
	1	(2) = 0.1 x (1)	(3) = (1) + (2)	(4) = 0.15 x (3)	(5) = 0.1 x (3)	(6) = (3)+(4)+(5)	(7) = 0.18 x (6)	(8) = (6)+(7)	(9)=0.01 x (8)	(10) = 0.05 x (8)	(11) = 0.1 x (8)	0	
Chincha	36,022,014	3,602,201	39,624,215	5,943,632	3,962,422	49,530,269	8,915,448	58,445,718	584,457	2,922,286	5,844,572	67,797,033	

## (2) Operation and Maintenance Plan

The operation and maintenance cost was calculated identifying the trend of the sedimentation and erosion bed based on the one-dimensional analysis results of the bed variation, and a long-term operation and maintenance plan was created.

The current river course has some narrow sections where there are bridges, farming works (intakes, etc.) and there is a tendency of sediment gathering upstream of these sections. Therefore, in this project there is a suggestion to increase the discharge capacity of these narrow sections in order to avoid as possible upstream and in the bed (main part) sedimentation, together with gathering sediments as much as possible when floods over a return period of 50 years occur.

### 1) Bed variation analysis

Figure 4.12.1-7 and 4.12.1-8 show the results of the Bed variation analysis of the Chincha River for the next fifty years. From these figures a projection of the bed's sedimentation and erosion trend and its respective volume can be made.

### 2) Sections that need maintenance

In Table 4.12.1-5 possible sections that require a process of long-term maintenance in the Chincha River watershed is shown.

### 3) Operation and maintenance cost

Next the direct work cost at private prices for maintenance (bed excavation) required for each watershed in the next 50 years is shown.

#### Direct Work Cost

At private prices:  $479,000 \text{ m}^3 \times 10 = 4,790,000$  soles

**Table 4.12.1-5 Sections/Places to be Carried Out Maintenance Works**

River		Excavation extension		Maintenance method
Chincha River	(Chico)	Section 1	Section : 3,5km-4,5km Volume : 53.000m <sup>3</sup>	It is a section where the water overflows. It is necessary to perform a periodic excavation in these sections because its bed will increase gradually in time.
	(Matagente)	Section 1	Section : 10,5km-13,5km Volume : 229.000m <sup>3</sup>	
		Section 2	Section : 21,0km-23,5km Volume : 197.000m <sup>3</sup>	It is a section likely to have sediments accumulation due to the river's width. It is necessary to perform periodic excavation because its bed will increase gradually in time with possibilities of overflowing

\* Sediment volume that will gather in 50 year period

Tables 4.12.1-6 and 4.12.1-7 show a 50 year Project cost at private and social prices.

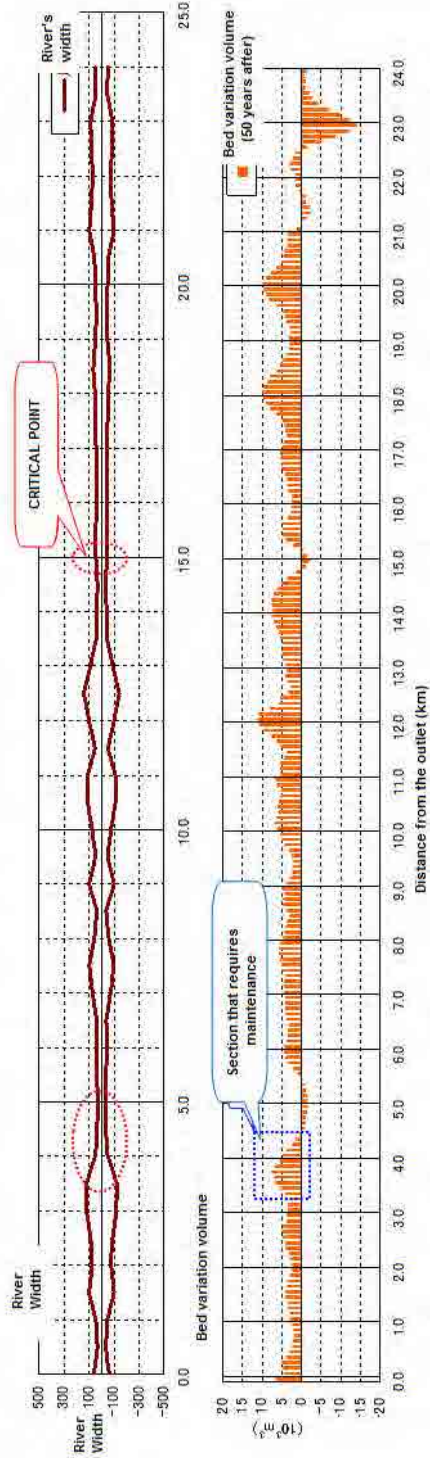

**Figure 4.15.1-7 Section that requires maintenance (Chincha River - Chico)**

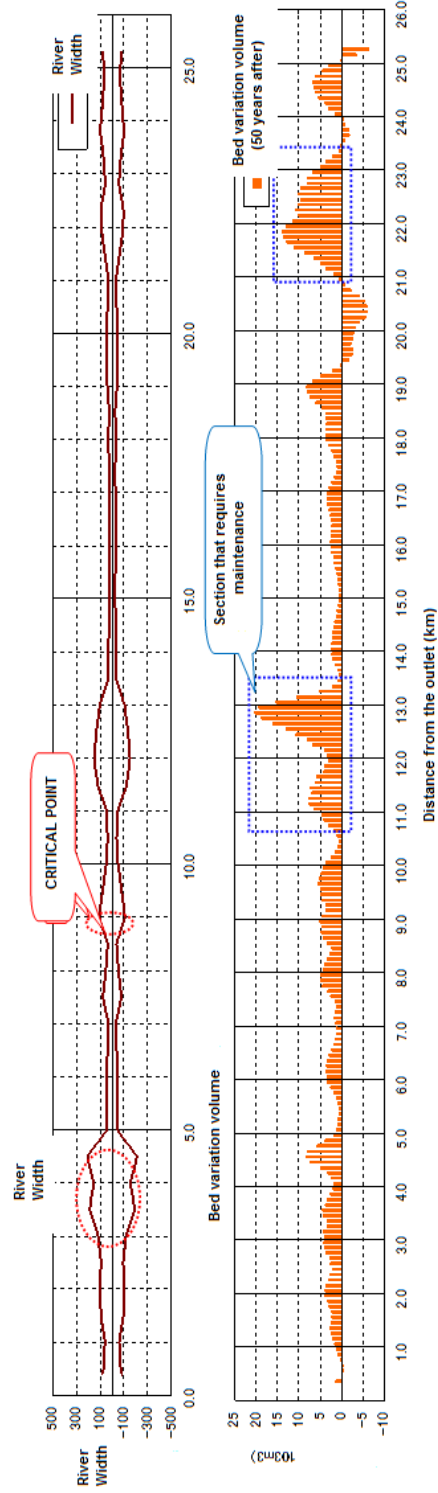

**Figure 4.12.1-8 Section that requires maintenance (Chincha River - Matagente)**



**Table 4.12.1-6 Excavation Works cost for a 50 year bed (at private prices)**

Name of Watershed 流域名	Direct Cost 直接工事費計 (1)	Temporal works cost 共通仮設費 (2) = 0.1 x (1)	Works Cost 工事費 (3) = (1) + (2)	Operative Expenses 諸経費 (4) = 0.15 x (3)	Utility 利益 (5) = 0.1 x (3)	Infrastructure total cost 構造物工事費 (6) = (3)+(4)+(5)	TAX 税金 (7) = 0.18 x (6)	Work's Total Cost 建設費 (8) = (6)+(7)	Environmental Impact 環境影響 (9)=0.01 x (8)	Technical File 詳細設計 (10) = 0.05 x (8)	Supervision 施工管理費 (11) = 0.1 x (8)	Total Cost 事業費 (12) = (8)+(9)+(10)+(11)
Chincha	4,790	479	5,269	790	527	6,586	1,186	7,772	78	389	777	9,015

**Table 4.12.1-7 Excavation Works cost for a 50 year bed (at social prices)**

Name of Watershed 流域名	Direct Cost 直接工事費計 (1)	Temporal works cost 共通仮設費 (2) = 0.1 x (1)	Works Cost 工事費 (3) = (1) + (2)	Operative Expenses 諸経費 (4) = 0.15 x (3)	Utility 利益 (5) = 0.1 x (3)	Infrastructure total cost 構造物工事費 (6) = (3)+(4)+(5)	TAX 税金 (7) = 0.18 x (6)	Work's Total Cost 建設費 (8) = (6)+(7)	Environmental Impact 環境影響 (9)=0.01 x (8)	Technical File 詳細設計 (10) = 0.05 x (8)	Supervision 施工管理費 (11) = 0.1 x (8)	Total Cost 事業費 (12) = (8)+(9)+(10)+(11)	Supervision 施工管理費 (12) = 0.1*(9)	Costo Total 事業費 (13) = (9)+(10)+(11)+(12)
Chincha	4,790	479	5,269	790	527	6,586	1,186	7,772	0.804	6,249	62	312	625	7,248

### (3) Social Assessment

#### 1) Private prices cost

##### a) Damage amount

Table 4.12.1-8 shows the damage amount calculated analyzing the overflow caused by floods in the Chincha River with return periods between 2 and 50 years.

**Table 4.12.1-8 Amount of damage for floods of different return periods (private prices)**

Damage Amount (1,000 soles). 被害額(千ソール)	
year	Chincha
2	14,576
5	36,902
10	51,612
25	72,416
50	96,886

b) Damage reduction annual average

Table 4.12.1-9 shows the damage reduction annual average of the watershed calculated with the data of Table 4.12.1-8.

c) Project's Cost and the operation and maintenance cost

Table 4.12.1-3 shows the projects' cost. Also, the annual operation and maintenance (O & M) cost for dikes and bank protection works can be observed in the table. This is calculated from the 0.5% of the construction cost plus the bed excavation annual average cost indicated in Table 4.12.1-6.

d) Social evaluation

In Table 4.12.1-9 the results of economic assessment are shown.

**Table 4.12.1-9 Damage Reduction Annual Average**

流域 Watershed	流量規模 Return Period	超過確率 Probability	被害額 (Total damages – thousand S/.)			区間平均被害 額 ④ Damages Average	区間確率 ⑤ Probability incremental value	年平均被害額 ④×⑤ Average value of damages flow	年平均被害額の 累計＝年平均被 害軽減期待額 Annual medial damages
			事業を実施し ない場合①	事業を実施し た場合②	軽減額 ③=①-②				
			Without Project ①	With Project ②	Mitigated damages ③=①-②				
CHINCHA	1	1.000	0	0	0			0	0
	2	0.500	14,576	0	14,576	7,288	0.500	3,644	3,644
	5	0.200	36,902	0	36,902	25,739	0.300	7,722	11,366
	10	0.100	51,612	0	51,612	44,257	0.100	4,426	15,791
	25	0.040	72,416	0	72,416	62,014	0.060	3,721	19,512
	50	0.020	96,886	0	96,886	84,651	0.020	1,693	21,205

**Table 4.12.1-10 Social evaluation results (private prices )**

流域名	年平均被害軽減額 Accumulated Average Annual Benefit	評価期間被害 軽減額(15年) Accumulated Average Annual Benefit (in 15 years)	事業費 Project's Cost	維持管理費 O&M Cost	C/B Cost/Benefit Relation	Net Present Value (NPV) NPV	Internal Rate of Return (IRR) IRR
Chincha	275,669,025	124,486,667	84,324,667	7,429,667	1.61	47,326,578	20%

2) Social prices cost

a) Damage amount

Table 4.15.1-11 shows the damage amount calculated analyzing the overflow caused by floods in the Majes-Camana River with return periods between 2 and 50 years in each watershed.

**Table 4.15.1-11 Amount of damage for floods of different return periods (at social prices)**

Damage Amount (1,000 soles). 被害額(千ソール)	
year	Chincha
2	16,283
5	42,375
10	70,525
25	95,769
50	125,742

b) Damage reduction annual average

Table 4.15.1-12 shows the damage reduction annual average of each watershed calculated with the data of Table 4.15.1-11.

c) Project's Cost and the operation and maintenance cost

Table 4.12.1-4 shows the projects' cost. Also, the annual operation and maintenance (O & M) cost for dikes and margin protection works can be observed in the table. This is calculated from the 0.5% of the construction cost, as well as the bed excavation annual average cost indicated in Table 4.15.1-7.

d) Social evaluation

In Table 4.15.1-13 the results of economic assessment are shown.

(4) Conclusions

The economic assessment result shows that the Project has positive economic impact in terms of cost on both private and social prices, but the required cost is extremely high (84.3 million soles), so that this Project is less viable to be adopted.

**Table 4.12.1-12 Damage Reduction Annual Average**

s/1000

流域 Watershed	流量規模 Return Period	超過確率 Probability	被害額 (Total damages - thousand S/.)			区間平均被害 額 ④ Damages Average	区間確率 ⑤ Probability incremental value	年平均被害額 ④×⑤ Average value of damages flow	年平均被害額の 累計=年平均被 害軽減期待額 Annual medial damages
			事業を実施し ない場合①	事業を実施し た場合②	軽減額 ③=①-②				
			Without Project ①	With Project ②	Mitigated damages ③=①-②				
CHINCHA	1	1.000	0	0	0		0	0	
	2	0.500	16,283	0	16,283	8,141	4,071	4,071	
	5	0.200	42,375	0	42,375	29,329	8,799	12,869	
	10	0.100	70,525	0	70,525	56,450	5,645	18,514	
	25	0.040	95,769	0	95,769	83,147	4,989	23,503	
	50	0.020	125,742	0	125,742	110,756	2,215	25,718	

**Table 4.12.1-13 Economic assessment results (social prices costs)**

流域名	年平均被害軽減額 Accumulated Average Annual Benefit	評価期間被害 軽減額(15年) Accumulated Average Annual Benefit (in 15 years)	事業費 Project's Cost	維持管理費 O&M Cost	C/B Cost/Benefit Relation	Net Present Value (NPV) NPV	Internal Rate of Return (IRR) IRR
Chincha	334,336,127	150,979,568	67,797,033	5,973,452	2.43	88,942,856	31%

## 4.12.2 Reforestation and Recovery of Vegetation Plan

### (1) Reforestation of the upper watershed

Long-term reforestation in all areas considered to be critical of the upper watershed is recommended. So, a detail analysis of this alternative will be explained next.

#### 1) Basic Policies

- Objectives: Improve the water source area's infiltration capacity, reduce surface soils water flow and at the same time, increase water flow in intermediate soils and ground-water level. Because of the above mentioned, water flow is interrupted in high flood season, this increases water resources in mountain areas, reduces and prevents floods increasing with it the amount and greater flow of ground-water level, reducing and preventing floods.
- Forestry area: means forestry in areas with planting possibilities around watersheds with water sources or in areas where forest area has decreased.
- Forestry method: local people plantations. Maintenance is done by promoters, supervision and advisory is led by NGOs.
- Maintenance after forestry: Maintenance is performed by the sow responsible in the

community. For this, a payment system (Payment for Environmental Services) will be created by downstream beneficiaries.

- Observations: After each thinning the area will have to be reforested, keeping and preserving it in a long-term sustainable way. An incentive for community people living upstream of the watershed shall be designed.

The forest is preserved after keeping and reforesting it after thinning, this also helps in the support and prevention of floods. For this, it is necessary that local people are aware, encourage people downstream, promote and spread the importance of forests in Peru during the project's execution.

## 2) Selection of forestry area

As mentioned in 1) forestry of the upper watershed will be done with the help of the communities' labor, during their spare time from their agricultural activities. However, the community mostly lives in the highlands performing their farming and cattle activities in harsh natural conditions. Therefore, it is difficult to tell if they have the availability to perform forestry. So, finding comprehension and consensus of the inhabitants will take a long time.

## 3) Time required for the reforestation project

Since it is a small population, the workforce availability is reduced. So, the work that can be carried out during the day is limited, and the work efficiency would be very low. The JICA Study Team estimated the time required to reforest the entire area throughout the population in the areas within the reforestation plan, plant quantity, work efficiency, etc. According to this estimate, it will take 14 years to reforest approximately 40,000 hectares of Chincha River Watershed.

## 4) Total reforestation volume in the upper watershed and project's period and cost

The surface to be reforested for the Chincha River Watershed is a vast area (approx 44,000 ha), in years (14 years) and in investment amount (119.0 million soles).

**Table 4.12.2-1 Upstream Watershed Forest General Plan**

Watershed	Forestry Area (ha) A	Required period for the project (years) B	Required budget (soles) C
Chincha	44.068,53	14	118.946.853

(Source: JICA Study Team)

## 5) Conclusions

The objective of this project is to execute the most urgent works and give such a long period

for reforestation which has an indirect effect with an impact that takes a long time to appear would not be consistent with the proposed objective for the Project. Considering that 14 years and invested 119,0 million soles are required, we can say that it is impractical to implement this alternative in this project and that it shall be timely executed within the framework of a long-term plan after finishing this project.

(2) Reforestation Model Area

Select a model area of the upper watershed and reforestate the area as pilot project (this is an existing reforestation project of the Chincha river). In this watershed, the irrigation commission has been having discussions with communities of the upper watershed to preserve water approximately for 10 past years, achieving to date the consensus for its implementation with some communities. PRONAMACHCS (currently, AGRORURAL) has followed this concertation process and lead a forestry study plan of the Mountain region of the Huancavelica region. However, sadly, this initiative was held only on study stage without reaching any agreement due to lack of resources.

1) Configuration (tree disposition)

Tree disposition is usually adopted in Peru as triangle disposition. So, in this Project we are proposing to adopt this disposition keeping between trees an interval of 3 meters.

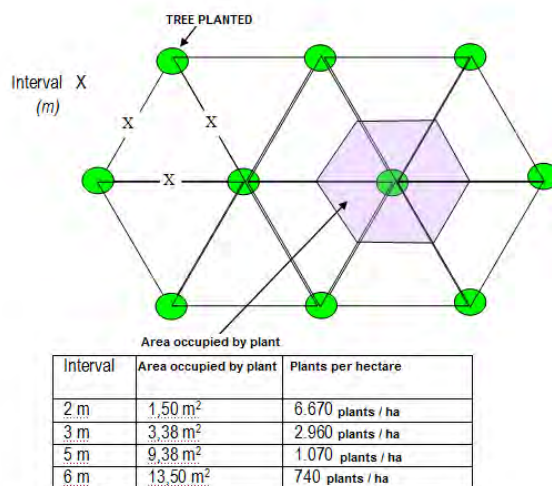

**Figure 4.12.2-1 Standard Reforestation map**

2) Species to be used

The mostly used specie in the Mountain region of Peru is the eucalyptus and then Pine. Especially on altitudes over 4.00mosl pine is very common. Also, native species such as Quañua, Molle, Aliso, etc. can be found. However, due to the producers economic reasons predominant species are eucalyptus and pine. Tara is also used in the agro forestry sector, in case of prioritized case of effective income.

In general, reforestry is planned and implemented with local community consensus. In such case, apart from explaining about forest public interest, property of species, etc, also species to be planted are discussed and agreed. In AGRORURAL project, species to be used are selected by listening local community's opinions, which mostly all of them chose pine and queñua in relatively low altitudes. So in this project we will select the same species.

### 3) Reforesting plan volume and vegetation recovery

Currently, there are 44.068,53 ha to be reforested in the upper watershed of Chíncha river. With aims of identifying the reforested area throughout the present project by reforestation volume within the established period, the following criteria shall be applied:

- That it is a aquifer recharge area
- That the soil is erodible
- That the altitude is less than 4.000mosl
- That several communities are near and capable to supply labor necessary for reforestation

In Figure 4.12.1-2 the location of the selected areas is shown applying these criteria. A and B groups were chosen as area subjected to this project. Groups C was not included due to the population's low density, which will translate as few labor supply for executing the necessary work

In Table 4.12.2-2 the volume of the reforestation plan and selected vegetation recovery is shown

**Table 4.12.2-2 Reforestation Plan and Selected Vegetation Recovery of the upper basin**

Group A

Area No.	Surface to reforest (ha)			Execute at:
	Pine	Queñua	Total	
47	650,04		650,04	Second year
48	311,91		311,91	Second year
49	211,90		211,90	Third year
50	276,40		276,40	Third year
51	79,94		79,94	Third year
52	166,27		166,27	Third year
53	55,96		55,96	Third year
56		0,05	0,05	Third year
61	67,58		67,58	Fourth year
102	548,38		548,38	Fourth year
103	161,45		161,45	Fourth year
Total	2.529,83	0,05	2.529,88	

Group B

Area No.	Surface to reforest (ha)			Execute at:
	Pine	Queñua	Total	
42		63,03	63,03	Second year
43		24,30	24,30	Second year
44		12,22	12,22	Second year
45	249,00		249,00	Third year
65		397,23	397,23	Second year
66	14,69		14,69	Third year
67	1,06		1,06	Third year
68	26,90		26,90	Third year
69	30,28		30,28	Third year
70	0,00		0,00	Third year
71	236,58		236,58	Third year
72		76,53	76,53	Fourth year
73		128,96	128,96	Fourth year
74	173,82		173,82	Fourth year
75	55,19		55,19	Fourth year
76	66,34		66,34	Fourth year
77	14,82		14,82	Fourth year
78	165,11		165,11	Fourth year
79	89,24		89,24	Fourth year
<b>Total</b>	<b>1.123,03</b>	<b>717,09</b>	<b>1.825,30</b>	

(Source: JICA Study Team)

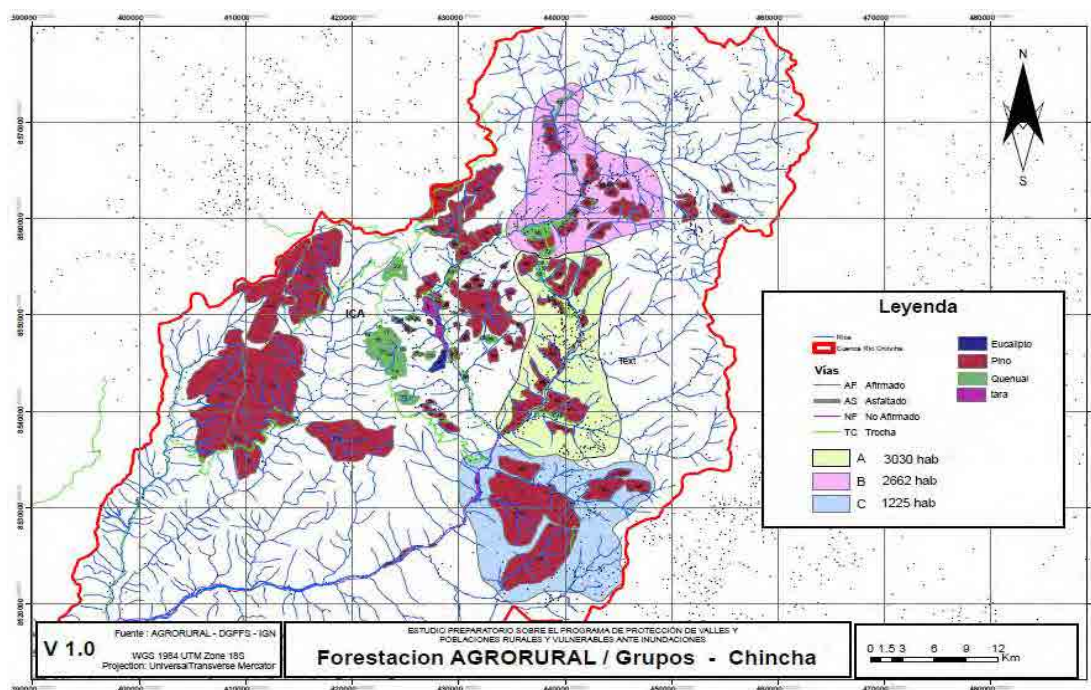

Figure 4.12.2-2 Reforesting Plan and Selected Vegetation Recovery of the Chincha River



#### 4) Execution costs

This execution costs were estimated following:

- Seedlings unitary costs (unitary price + transportation)
- Labor cost

Seedlings suppliers can be i) Agrorural or ii) Private Suppliers. For reforestry the upper watershed of Chincha River the seedlings will be obtained from AGRORURAL.

To estimate unitary cost of labor, we are proposing to apply unitary cost of common labor for forestry of banks, meanwhile for the upper watershed of Chincha River we are thinking of hiring local inhabitants disposing half of labor cost in order to beneficiate (additional income) to the local community.

##### (i) Seedlings unit cost

This cost was defined based on the information obtained through AGRORURAL interviews. Because seedlings costs and transportation cost varies depending on suppliers, the average was applied.

##### (ii) Labor cost

This was determined by 40 trees / person per day, according to the gathered info by AGRORURAL and irrigation commissions. In banks forestry, unit cost of labor would be 33.6 soles /men-day, in the upper basin was determined as 16.8 soles/men-day, which is half the first one.

In table 4.12.2-3 unit costs applied to estimate direct work costs by ha are shown.

**Table 4.12.2-3 Unit cost**

	Units	Eucalyptus	Pine	Queñua	Tara
Plants per hectare	Plant/ha	2.960	2.960	2.960	2.960
Cost of seedlings	Soles/ha	1.332	1.480	1.332	1.332
Labor Cost	Soles/ha	1.243	1.243	1.243	1.243
Total Cost of reforestation	Soles/ha	2.575	2.723	2.575	2.575

##### (iii) Reforestation execution cost

In table 4.12.2-4 direct cost of the works for the reforestry works on the upper watershed is shown.

**Table 4.12.2-4 Direct cost of forestry work**

Area No.	Species to be planted		
	Pine	Queñua	Total
<b>Group A</b>			
2 <sup>nd</sup> year	2.619.390	0	2.619.390
3 <sup>rd</sup> year	2.152.450	129	2.152.579
4 <sup>th</sup> year	2.116.887	0	2.116.887
Subtotal	6.888.727	129	6.888.856
<b>Group B</b>			
2 <sup>nd</sup> year	0	1.279.209	1.279.209
3 <sup>rd</sup> year	1.520.823	0	1.520.823
4 <sup>th</sup> year	1.537.188	529.137	2.066.325
Subtotal	3.058.011	1.808.345	4.866.356
<b>Total</b>	<b>9.946.738</b>	<b>1.808.474</b>	<b>11.755.212</b>

Within the cost of the project, the following will be estimated:

11.79 million soles (direct work cost) x 1.82 (indirect work cost, etc.) = 22.1 million soles

#### 5) Project's cost-benefit

For the estimation of benefits for the upper watershed, an example of the cash flow was taken for each hectare of Pine typical productive forest in the Mountain region of Peru, modifying density and plantation cost and adding up carbon benefit. So, a relation C/B by hectare unit of 5,20 was determined as well as the ENPV of US\$ 14.593 (see table 4.12.2-5).

#### 6) Working calendar

This includes for the 1<sup>st</sup> year: choosing an NGO (by the consultant) to offer support to the community, forestry detailed elaboration (by NGO), organize the community to perform reforestation works (by NGO), seedlings production, etc. Preparation stage

For the next three years (from the 2<sup>nd</sup> to the 4<sup>th</sup>) reforestation labors will be carried out. Seedling production require between 3 to 6 months. Aiming to ensure a high survival it is best to use big seedlings, dedicating its production to the dry season (7 months, between April and October) and completing the transplant in the rainy season (four months between November and March).

Years	Dry season						Rainy Season				
	May	June	July	August	Sept.	Oct.	Nov.	Dec.	January	February	March
First	Preparatives										
Second	Seedling production (7 months)						Transplant			Reserve	
Third	Ídem						Ídem			Reserve	
Fourth	Ídem						Ídem			Reserve	

**Figure 4.12.2-3 Reforestation and vegetal recovery calendar**

(Source: JICA Study Team)

#### 7) Conclusions

According to Table 4.12.2-5, this alternative will have a positive economic impact if benefits

of carbons absorption are taken into consideration. But it will have a negative impact if its impact is only to control floods and no damage is reduced nor reforesting 4.000 ha is done. The projects' cost is high, estimated in 22.1 million soles, that represent 51% of the total project's cost of this river, of 44.0 million soles. So, this alternative is concluded not to be included in this Project considering that the model area reforestation must be implemented as a project aside from the present Project.

**Table 4.12.2-5 Results from cost-benefit relation of the Pine reforesting project (In US\$/ha)**

Year	Investment Cost (A)	Forestry Labors (B)	Administrative expenses (C)	Incomes (D)	Cash flow (without taxes) $-(A)-(B)-(C)$ (D)	Taxes (E)	Cash flow (with taxes) (D)-(E)	Total costs (A)+(B)+(C)	Benefits as carbon sink (F)	Total benefits (D)-(E)+(F)
0	481,56	449,39	321,16	0,00	-1.252,11	0,00	-1.252,11	1.252,11	0,00	0,00
1	226,17	704,13	111,65	0,00	-1.041,95	0,00	-1.041,95	1.041,95	222,79	222,79
2	0,00	704,13	84,49	0,00	-788,62	0,00	-788,62	788,62	445,58	445,58
3	0,00	0,00	0,00	0,00	0,00	0,00	0,00	0,00	668,37	668,37
4	0,00	0,00	0,00	0,00	0,00	0,00	0,00	0,00	891,16	891,16
5	0,00	0,00	0,00	0,00	0,00	0,00	0,00	0,00	1.113,95	1.113,95
6	0,00	1.000,96	120,12	1.614,55	493,47	148,00	345,47	1.121,08	1.336,74	2.803,29
7	0,00	0,00	0,00	0,00	0,00	0,00	0,00	0,00	1.559,53	1.559,53
8	0,00	0,00	0,00	0,00	0,00	0,00	0,00	0,00	1.151,08	1.151,08
9	0,00	0,00	0,00	0,00	0,00	0,00	0,00	0,00	1.522,39	1.522,39
10	0,00	0,00	0,00	0,00	0,00	0,00	0,00	0,00	1.893,71	1.893,71
11	0,00	0,00	0,00	0,00	0,00	0,00	0,00	0,00	2.265,03	2.265,03
12	0,00	0,00	0,00	0,00	0,00	0,00	0,00	0,00	2.636,34	2.636,34
13	0,00	1.491,46	178,97	4.372,73	2.702,30	809,96	1.892,34	1.670,43	3.007,66	6.570,43
14	0,00	0,00	0,00	0,00	0,00	0,00	0,00	0,00	3.378,97	3.378,97
15	0,00	0,00	0,00	0,00	0,00	0,00	0,00	0,00	4.178,43	4.178,43
16	0,00	0,00	0,00	0,00	0,00	0,00	0,00	0,00	6.513,78	6.513,78
17	0,00	0,00	0,00	0,00	0,00	0,00	0,00	0,00	8.849,13	8.849,13
18	0,00	0,00	0,00	0,00	0,00	0,00	0,00	0,00	11.184,48	11.184,48
19	0,00	0,00	0,00	0,00	0,00	0,00	0,00	0,00	13.519,84	13.519,84
20	0,00	0,00	0,00	7.625,00	7.625,00	-2.288,00	5.337,00	0,00	15.855,19	21.192,19

Net cost current value = 3.477,84

Benefit net current value = 18.071,01

Relation C/B = 5,20

**ENPV = \$14.593**

### 4.12.3 Sediment control plan

For the long-term sediment control plan, it is recommended to execute the necessary works in the upper watershed.

The Sediment Control Plan in the upper watershed will mainly consist in construction of sediment control dikes and bank protection works. In Figure 4.12.3-1 the sediment control works disposition proposed to be executed throughout the watershed is shown. The cost of Chincha River works was estimated focusing on: a) covers the entire watershed, and b) covers only the priority areas, analyzing the disposition of works for each case. The results are shown in Table 4.12.3-1.

Due to the Chincha River extension, the construction cost for every alternative would be too high in case of carrying-out the bank protection works, erosion control dikes, etc. Apart from requiring a considerably long time. This implies that the project will take a long time to show positive results. So, it is decided that it is impractical to execute this alternative within this project and should be timely executed within the framework of a long-term plan, after finishing this project.

**Table 4.12.3-1 Upper watershed sediment control works execution estimated costs**

Watershed	Approach	Bank Protection		Strip		Sediment control dike		Total works direct cost	Project Cost (Millions S/.)
		Vol. (km)	Direct Cost (Million S/.)	Vol. (units)	Direct Cost (Million S/.)	Vol. (units)	Direct Cost (Million S/.)		
Camana-Majes	All Watershed	381	S/.407	38	S/.1	111	S/.116	S/.524	S/.986
	Prioritized Section	381	S/.407	38	S/.1	66	S/.66	S/.474	S/.892

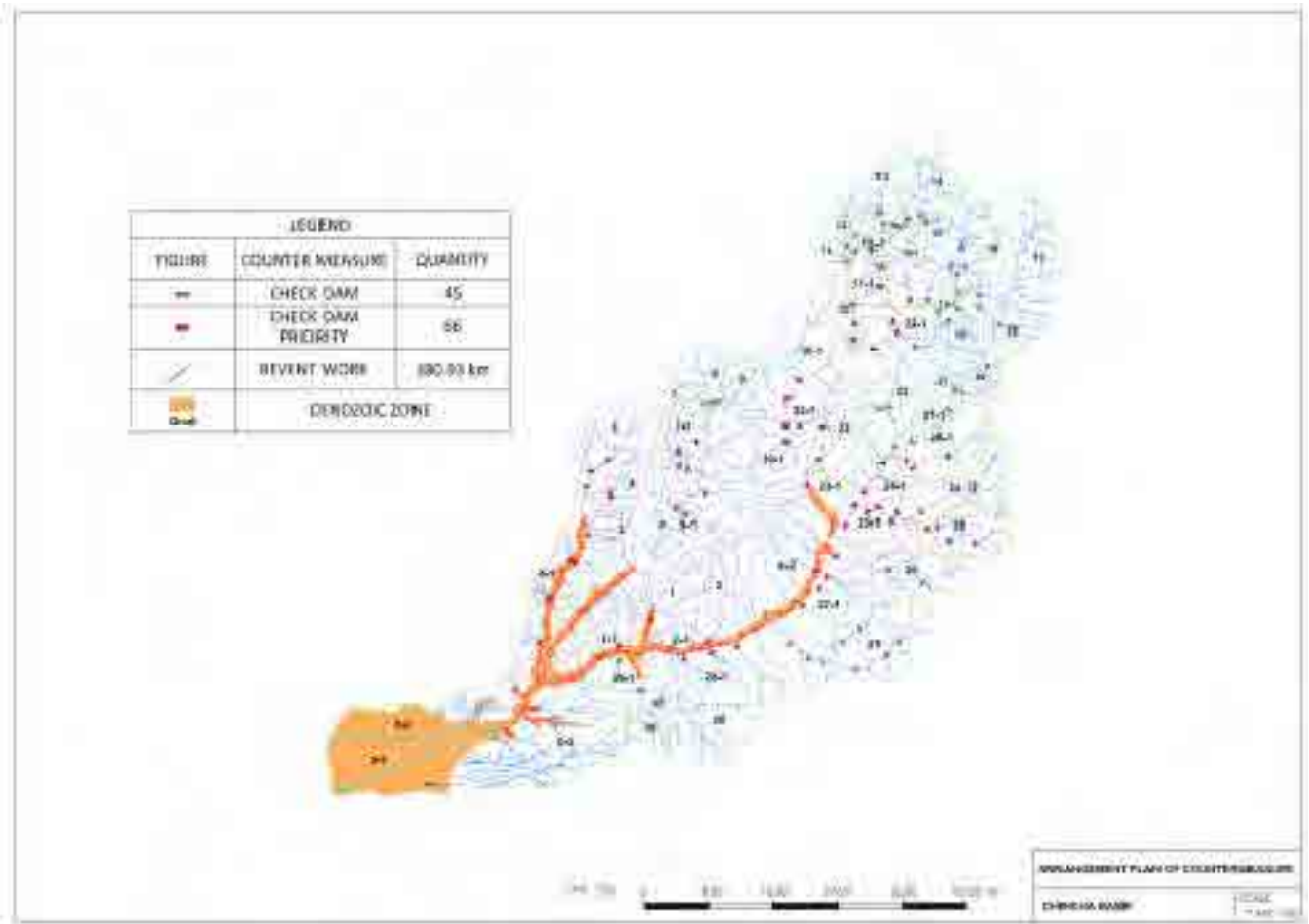

**Figure 4.12.3-1 Sediment control works location Chíncha River Watershed**

## **5. CONCLUSIONS**

The selected alternative for flood control in this Study is structurally safe. Also, the social assessment showed a sufficiently high economic value. Its environmental impact is reduced.

The implementation of this Project will contribute to relief the high vulnerability of valleys and local community to floods, and will also contribute with the local economic development. Therefore, we conclude to implement it as quickly as possible.





**Ministry of Agriculture  
Republic of Peru**

**THE PREPARATORY STUDY  
ON  
PROJECT OF THE PROTECTION OF  
FLOOD PLAIN AND VULNERABLE RURAL  
POPULATION AGAINST FLOOD IN THE  
REPUBLIC OF PERU**

**FINAL REPORT  
PRE-FEASIBILITY STUDY REPORT  
II-5 PROJECT REPORT (PISCO RIVER)**

**March 2013**

**JAPAN INTERNATIONAL COOPERATION AGENCY  
(JICA)**

**YACHIYO ENGINEERING CO., LTD.  
NIPPON KOEI CO., LTD.  
NIPPON KOEI LATIN AMERICA –  
CARIBBEAN Co., LTD.**



## Composition of Final Report

### I. Feasibility Study Report

I-1 Program Report

I-2 Project Report (Cañete River)

I-3 Project Report (Chincha River)

I-4 Project Report (Pisco River)

I-5 Project Report (Majes-Camana River )

I-6 Supporting Report

Annex – 1 Metrology /Hydrology /Run-off Analysis

Annex – 2 Inundation Analysis

Annex – 3 River Bed Fluctuation Analysis

Annex – 4 Flood Control Plan

Annex – 5 Forecasting and Warning System in Chira River

Annex – 6 Sediment Control

Annex – 7 Afforestation and Vegetation Recovery Plan

Annex – 8 Plan and Design of Facilities

Annex – 9 Construction Planning and Cost Estimate

Annex – 10 Socio-economy and Economic Evaluation

Annex – 11 Environmental and Social Considerations/ Gender

Annex – 12 Technical Assistance

Annex – 13 Stakeholders Meetings

Annex – 14 Implementation Program of Japanese Yen Loan Project

Annex – 15 Drawings

I-7 Data Book

### II. Pre- Feasibility Study Report

II-1 Program Report

II-2 Project Report (Chira River)

II-3 Project Report (Cañete River)

II-4 Project Report (Chincha River)

**II-5 Project Report (Pisco River) (This Report)**

II-6 Project Report (Yauca River)

II-7 Project Report (Majes-Camana River )







## Abbreviation

Abbreviation	Official Name or meaning
ANA	Water National Authority (Autoridad Nacional del Agua)
ALA	Water Local Authority (Autoridad Local del Agua)
C/B	Cost-Benefit relation (Cost-Benefit Ratio)
GDP	PBI (Producto Bruto Interno) (Gross Domestic Product)
GIS	Sistema de información geográfica (Geographic Information System)
DGAA	Dirección General de Asuntos Ambientales (Environmental Affairs General Direction)
DGFFS	Dirección General de Forestal y de Fauna Silvestre (Forestry and Fauna General Direction)
DGIH	Dirección General de Infraestructura Hidráulica (Hydraulic Infrastructure General Direction)
DGPM	Dirección General de Programación Multianual del Sector Público (Public Sector Multiannual Program General Direction)
DNEP	Dirección Nacional de Endeudamiento Público (Public Indebtedness National Direction)
DRA	Dirección Regional de Agricultura (Agriculture Regional Direction)
EIA	Estudio de impacto ambiental (Environmental Impact Assessment - EIA)
FAO	Organización de las Naciones Unidas para la Agricultura y la Alimentación (Food and Agriculture Organization of the United Nations)
F/S	Estudio de Factibilidad (Feasibility Study)
GORE	Gobiernos Regionales (Regional Governments)
HEC-HMS	Sistema de Modelado Hidrológico del Centro de Ingeniería Hidrológica (Hydrologic Model System from the Hydrology Engineer Center)
HEC-RAS	Sistema de Análisis de Ríos del Centro de Ingeniería Hidrológica (Hydrologic Engineering Centers River Analysis System)
IGN	Instituto Geográfico Nacional (National Geographic Institute)
IGV	Impuesto General a Ventas (TAX)
INDECI	Instituto Nacional de Defensa Civil (Civil defense National Institute)
INEI	Instituto Nacional de Estadística (Statistics National Institute)
INGEMMET	Instituto Nacional Geológico Minero Metalúrgico (Metallurgic Mining Geologic National Institute)
INRENA	Instituto Nacional de Recursos Naturales (Natural Resources National Institute)
IRR	Tasa Interna de Retorno (Internal Rate of Return - IRR)
JICA	Agencia de Cooperación Internacional del Japón (Japan International Cooperation Agency)
JNUDRP	Junta Nacional de Usuarios de los Distritos de Riego del Perú (Peruvian Irrigation District Users National Board)
L/A	Acuerdo de Préstamo (Loan Agreement)
MEF	Ministerio de Economía y Finanzas (Economy and Finance Ministry)
MINAG	Ministerio de Agricultura (Agriculture Ministry)
M/M	Minuta de Discusiones (Minutes of Meeting)

NPV	VAN (Valor Actual Neto) (NET PRESENT VALUE)
O&M	Operación y mantenimiento (Operation and maintenance)
OGA	Oficina General de Administración (Administration General Office)
ONERRN	Oficina Nacional de Evaluación de Recursos Naturales (Natural Resources Assessment National Office)
OPI	Oficina de Programación e Inversiones (Programming and Investment Office)
PE	Proyecto Especial Chira-Piura (Chira-Piura Special Project)
PES	PSA (Pago por Servicios ambientales) (Payment for Environmental Services)
PERFIL	Estudio del Perfil (Profile Study)
Pre F/S	Estudio de prefactibilidad (Pre-feasibility Study)
PERPEC	Programa de Encauzamiento de Ríos y protección de Estructura de Captación (River Channeling and Protection of Collection Structures Program)
PRONAMACHIS	Programa Nacional de Manejo de Cuencas Hidrográficas y Conservación de Suelos (Water Basins Management and Soil Conservation National Program)
PSI	Programa Sub Sectorial de irrigaciones (Sub-Sectorial Irrigation Program)
SCF	Factor de conversión estándar (Standard Conversion Factor)
SENAMHI	Servicio Nacional de Meteorología y Hidrología (Meteorology and Hydrology National Service)
SNIP	Sistema Nacional de Inversión Pública (Public Investment National System)
UF	Unidades Formuladoras (Formulator Units)
VALLE	Llanura aluvial, llanura de valle (Alluvial Plain, Valley Plain)
VAT	Impuesto al valor agregado (Value added tax)



**THE PREPARATORY STUDY**  
**ON**  
**PROJECT OF THE PROTECTION OF FLOOD PLAIN AND VULNERABLE RURAL**  
**POPULATION AGAINST FLOODS IN THE REPUBLIC OF PERU**  
**FINAL REPORT**  
**PRE-FEASIBILITY STUDY REPORT**  
**II-5 PROJECT REPORT**  
**(PISCO RIVER)**

**Table of Contents**

Location Map

Abbreviation

<b>1. EXECUTIVE SUMMARY .....</b>	<b>1-1</b>
1.1 Project Name.....	1-1
1.2 Project's Objective .....	1-1
1.3 Supply and Demand Balance .....	1-1
1.4 Structural Measures .....	1-2
1.5 Non-structural measures .....	1-4
1.6 Technical support .....	1-5
1.7 Costs.....	1-5
1.8 Social Assessment.....	1-6
1.9 Sustainability Analysis.....	1-8
1.10 Environmental Impact.....	1-9
1.11 Execution plan .....	1-10
1.12 Institutions and management .....	1-11
1.13 Logical Framework.....	1-12
1.14 Middle and Long Term Plans.....	1-13
<b>2. GENERAL ASPECTS .....</b>	<b>2-1</b>
2.1 Name of the Project .....	2-1

2.2	Formulator and Executor Units.....	2-1
2.3	Involved entities and Beneficiaries Participation.....	2-1
2.4	Framework .....	2-4
<b>3.</b>	<b>IDENTIFICATION.....</b>	<b>3-1</b>
3.1	Diagnosis of the current situation .....	3-1
3.2	Definition of Problem and Causes .....	3-46
3.3	Objective of the Project .....	3-50
<b>4.</b>	<b>FORMULATION AND EVALUATION .....</b>	<b>4-1</b>
4.1	Definition of the Assessment Horizon of the Project .....	4-1
4.2	Supply and Demand Analysis .....	4-1
4.3	Technical Planning.....	4-3
4.4	Costs.....	4-24
4.5	Social Assessment.....	4-25
4.6	Sensitivity Analysis.....	4-33
4.7	Sustainability Analysis.....	4-36
4.8	Environmental Impact.....	4-37
4.9	Execution Plan .....	4-50
4.10	Institutions and Administration .....	4-53
4.11	Logical framework of the eventually selected option .....	4-57
4.12	Middle and long term Plan.....	4-59
<b>5.</b>	<b>CONCLUSIONS .....</b>	<b>5-1</b>

## **1. EXECUTIVE SUMMARY**

### **1.1 Project Name**

“Protection program for valleys and rural communities vulnerable to floods  
Implementation of prevention measures to control overflows and floods of Pisco River,  
Ica department.”

### **1.2 Project’s Objective**

The ultimate impact that the project is design to achieve is to alleviate the vulnerability of  
valleys and the local community to flooding and boost local socioeconomic development.

### **1.3 Supply and Demand Balance**

It has been calculated the theoretical water level in case of flow design flood based on the  
cross sectional survey of the river with an interval of 500m, in the Chincha river  
watershed, assuming a design flood flow equal to the flood flow with a return period of  
50 years. Then, we determined the dike height as the sum of the design water level plus  
the dike’s free board.

This is the required height of the dike to control the damages caused by design floods and  
is the indicator of the demand of the local community.

The height of the existing dike or current ground height is the required height to control  
the current flood damages, and is the indicator of the current offer.

The difference between the dike design height (demand) and the height of the  
embankment or ground at present ground (supply) is the difference or gap between  
demand and supply.

Table 1.3-1 shows the average water levels floods, calculated with a return period of 50  
years, of the required height of the dike (demand) to control the flow by adding the  
design water level plus the free board of the dike; of dike height or current ground height  
(supply), and the difference between these two (difference between demand and supply)  
of the river. Then, in Table 4.2-2 the values at each point are shown. The current height  
of the dike or the current ground height is greater than the required height of the dike, at  
certain points. In these, the difference between supply and demand is considered null.

**Table 1.3-1 Demand and supply analysis**

Watershed	Dike Height / current land (supply)		Theoretical water level with a return period of 50 years	Dike Freeboard	Required dike's height (demand)	Diff. demand/supply	
	Left bank	Right bank				Left bank	Right bank
	①	②				③	④
Pisco	219.72	217.26	214.82	1.00	215.82	0.63	0.76

### 1.4 Structural Measures

Structural measures are a subject that must be analyzed in the flood control plan covering the entire watershed. The analysis results are presented in section 4.12 “medium and long term plan” This plan proposes the construction of dikes for flood control throughout the watershed. However, the case of Pisco River requires a large project investing at an extremely high cost, far beyond the budget for this Project, which makes this proposal impractical. Therefore, assuming that the dikes to control floods throughout the whole basin will be constructed progressively over a medium and long term period. Here is where this study focused on the most urgent works, priority for flood control.

#### (1) Design flood flow

The Methodological Guide for Protection Projects and/or Flood Control in Agricultural or Urban Areas (Guía Metodológica para Proyectos de Protección y/o Control de Inundaciones en Áreas Agrícolas o Urbanas, 3.1.1 Horizonte de Proyectos) prepared by the Public Sector Multi Annual Programming General Direction (DGPM) of the Ministry of Economy and Finance (MEF) recommends a comparative analysis of different return periods: 25, 50 and 100 years for the urban area and 10, 25 and 50 years for rural and agricultural land.

Considering that the present Project is aimed at protecting the rural and agricultural land, the design flood flow is to be determined in a return period of 10 years to 50 years in the mentioned Guide.

It was confirmed that the flood discharge with return period of 50 years in the basin is determined as design flood discharge and it is almost same as the past maximum observed discharge.

In Peru the flood protection works in the basins are developed almost nil, therefore it is not necessary to adopt the design discharge more than the past maximum discharge. However, the large disasters occurred in the past so that the design flood discharge with return period of 50 years, which is almost equal to the past maximum, is to be adopted considering to avoid the flood damage nearly equal to the damage occurred in the past .

The relation among flood discharge with different return period, damage caused by the floods and inundation areas is analyzed in the basin. The results are that the more the return periods of flood increase the more inundation area and damage amount increase in the basin, however the increase tendency of damage with project is more gentle compared with former two items, and the reduction of damage with project reaches to maximum in the case of the flood with return period of 50 years within the cases of flood with less return period of 50 years.

As described above, the adopted design flood discharge with return period of 50 years is almost same as the past maximum discharge and damage reduction amount in the adopted case becomes more than that of the flood discharges with less return period, and the result of social evaluation is also high.

## **(2) Selection of prioritized flood prevention works**

We applied the following five criteria for the selection of priority flood control works.

- Demand from the local community (based on historical flood damage)
- Lack of discharge capacity of river channel (including the sections affected by the scouring)
- Conditions of the adjacent area (conditions in urban areas, farmland, etc.).
- Conditions and area of inundation (type and extent of inundation according to inundation analysis)
- Social and environmental conditions (important local infrastructures)

Based on the river survey, field investigation, discharge capacity analysis of river channel, inundation analysis, and interviews to the local community (irrigation committee needs, local governments, historical flood damage, etc...) a comprehensive evaluation was made applying the five evaluation criteria listed above. After that we selected a total of six (6) critical points (with the highest score in the assessment) that require flood protection measures.

Concretely, since the river cross sectional survey was carried out every 500m interval and discharge capacity analysis and inundation analysis were performed based on the survey results, the integral assessment was also done for sections of 500 meters. This sections have been assessed in scales of 1 to 3 (0 point, 1 point and 2 points) and the sections of which score is more than 6 were selected as prioritized areas. The lowest limit (6 points) has been determined also taking into account the budget available for the Project in general

## **1.5 Non-structural measures**

### **1.5.1 Reforestation and vegetation recovery**

#### **(1) Basic Policies**

The reforestation plan and vegetation recovery that meets the objective of this project can be divided into: i) reforestation along river structures, and ii) reforestation in the upper watershed. The first has a direct effect on flood prevention expressing its impact in a short time, while the second one requires high cost and a long period for its implementation, as indicated later in the section 4.12 “Middle and long term Plan”, and also it is impractical to be implemented within the framework of this project. Therefore, this study focused on the first alternative.

#### **(2) Regarding reforestation along river structures**

This alternative proposes planting trees along the river structures, including dikes and bank protection works.

- Objective: Reduce the impact of flooding of the river when an unexpected flood or narrowing of the river by the presence of obstacles, using vegetation strips between the river and the elements to be protected.
- Methodology: Create vegetation stripes of a certain width between the river and river structures.
- Execution of works: Plant vegetation on a portion of the river structures (dikes, etc.).
- Maintenance after reforestation: Maintenance will be taken by irrigation committees under their own initiative.

The width, length and area of reforestation along river structures are 11-600m, 6.5 km and 125. 0 ha respectively.

### **1.5.2 Sediment control plan**

The sediment control plan must be analyzed within the general plan of the watershed. The results of the analysis are presented in section 4.12 “Medium and long term plan”. To sum up, the sediment control plan for the entire watershed requires a high investment cost, which goes far beyond the budget of this project, which makes it impractical to adopt.

The bed variation analysis has shown that the volume of sediment dragged in the Pisco river watershed is high, and therefore the bed variation (sediment volume) is also large. However, seeing the average height of the bed, there has only been a variation of approximately 0.2 m in 50 years, and the entry of sediments seem to have almost no impact on the downstream bed. So, we conclude that it is necessary to take special measures to control sediment.

There are different types of sediment control structures applicable in alluvial fans, such as retardation of reservoir sediments, compaction of the bed, bands, piers, and protection works combining some of them broken. These works are not only used to control sediments, but also river structures.

The priority work of flood control in Pisco River is the retarding basin construction (Pisco-6). This retarding basin is also used for gathering sediments, so it has two functions: flood and sediments control. This structure is characterized to be cheap and its high returns on investment, compared to other sediment control works in the entire watershed. Its return on investment is much higher, even when taking into account the cost of maintenance (removal of stones, etc.).

### **1.6 Technical support**

Based on the technical proposals of structural and nonstructural measures, it is also intends to incorporate in this project technical assistance to strengthen the measures.

The objective of the technical assistance is to “improve the capacity and technical level of the local community, to manage risk to reduce flood damage in selected valleys.”

Technical assistance will cover the Pisco river watershed.

Aiming to train characteristics of the watershed, courses for one will be prepared. The beneficiaries are the representatives of the committees and irrigation groups from each watershed, governments employees (provincial and district), local community representatives, local people etc.

Qualified as participants in the training, people with ability to replicate and disseminate lessons learned in the courses to other community members, through meetings of the organizations to which they belong.

In order to carry out the technical assistance goal, the three activities propose the following:

- Bank protection activity and knowledge enhancement on agriculture and natural environment
- Community disaster prevention planning for flood damages
- Watershed (slope) management against fluvial sedimentation

### **1.7 Costs**

In the Table 1.7-1 the costs of this Project in Pisco watershed is shown. The cost of the watersheds is around 71.6 million soles.

**Table 1.7-1 Project Cost**

Watershed	Structural Cost					Non-structural cost		Technical Assistance Cost	Total
	Construction Cost	Detail Design Cost	Construction Supervision Cost	Environmental Cost	Sub total	Afforestation Cost	Flood Alert System Cost		
Pisco	60,170	3,009	6,017	601	69,797	1,593	0	219	71,609

## 1.8 Social Assessment

### (1) Benefits

The benefits of flood control are the reduction of losses caused by floods which would be achieved by the implementation of the project and is determined by the difference between the loss amount without project and with project. Specifically, to determine the benefits, first the amount of losses by floods is calculated from different return periods (between 2 and 50 years), assuming that flood control works will last 50 years, and then the average annual reduction loss amount is determined from the reduction of losses from different return periods. In Tables 1.8-1 and 1.8-2 show the average annual amount of reduction loss that would be achieved by implementing this project, expressed in costs at private prices and costs at social prices.

**Table 1.8-1 Annual average damage reduction amount (at private prices)**

s/1000

Watershed	流量規模 Return Period	超過確率 Probability	被害額 (Total Damages - thousand S/.)			区間平均被害 額 ④ Damages Average	区間確率 ⑤ Probability Incremental value	年平均被害額 ④×⑤ Damages Flow Average Value	年平均被害額の 累計=年平均被 害軽減期待額 Annual Medial Damage
			事業を実施し ない場合①	事業を実施し た場合②	軽減額 ③=①-②				
			With Project ①	With Project ②	Mitigated damages ③=①-②				
PISCO	1	1.000	0	0	0		0	0	
	2	0.500	15,788	197	15,591	7,795	0.500	3,898	3,898
	5	0.200	22,310	270	22,040	18,815	0.300	5,645	9,542
	10	0.100	47,479	2,556	44,923	33,481	0.100	3,348	12,890
	25	0.040	56,749	6,019	50,730	47,826	0.060	2,870	15,760
	50	0.020	76,992	8,318	68,674	59,702	0.020	1,194	16,954



**Table 1.8-2 Annual average damage reduction amount (at social prices)**

s/1000

Watershed	流量規模 Return Period	超過確率 Probability	被害額 (Total Damages - thousand S/.)			区間平均被害 額 ④ Damages Average	区間確率 ⑤ Probability Incremental value	年平均被害額 ④×⑤ Damages Flow Average Value	年平均被害額の 累計=年平均被 害軽減期待額 Annual Medial Damage
			事業を実施し ない場合①	事業を実施し た場合②	軽減額 ③=①-②				
			With Project ①	With Project ②	Mitigated damages ③=①-②				
PISCO	1	1.000	0	0	0			0	0
	2	0.500	16,681	289	16,392	8,196	0.500	4,098	4,098
	5	0.200	22,436	402	22,034	19,213	0.300	5,764	9,862
	10	0.100	52,469	3,055	49,414	35,724	0.100	3,572	13,434
	25	0.040	61,739	7,985	53,754	51,584	0.060	3,095	16,529
	50	0.020	84,256	10,889	73,368	63,561	0.020	1,271	17,801

## (2) Social assessment results

The objective of the social assessment in this study is to evaluate the efficiency of investments in the structural measures using the method of cost-benefit relation (C/B) from the point of view of national economy. To do this, we determined the economic evaluation indicators (C/B relation, Net Present Value-NPV, and Internal return rate - IRR).

The benefits of the evaluation period were estimated, from the first 15 years since the start of the project. Because, from these 15 years, two are from the work execution period, the evaluation was conducted for the 13 years following the completion of works.

In Tables 1.8-3 and 1.8-4 the costs at private prices and at social prices resulting from this project assessment are shown. It is noted that the project will have enough economic effect.

**Table 1.8-3 Social Assessment (at private prices)**

流域名	年平均被害軽減額	評価期間被害 軽減額(15年)	事業費	維持管理費	C/B	Net Present Value (NPV)	Internal Rate of Return (IRR)
	Gathered Average Annual Benefit	Gathered Average Annual Benefit (in 15 years)	Project Cost	O&M Cost	Cost/Benefit Relation	Valor Actual Neto (VAN)	Tasa Interna de Retorno (TIR)
Pisco	220,402,316	99,529,317	71,608,946	3,911,056	1.55	35,225,349	19%

**Table 1.8-4 Social Assessment (at social prices)**

流域名	年平均被害軽減額 Gathered Average Annual Benefit	評価期間被害軽減額(15年) Gathered Average Annual Benefit (in 15 years)	事業費 Project Cost	維持管理費 O&M Cost	C/B Cost/Benefit Relation	Net Present Value (NPV) Valor Actual Neto (VAN)	Internal Rate of Return (IRR) Tasa Interna de Retorno (TIR)
Pisco	231,407,622	104,499,095	57,564,591	3,144,489	2.02	52,806,516	25%

Below are the positive effects of the Project that are difficult to quantify in economic values.

- ① Contribution to local economic development to alleviate the fear to economic activities suspension and damages
- ② Contribution to increase local employment opportunities thanks to the local construction project
- ③ Strengthening the awareness of local people regarding damages from floods and other disasters
- ④ Contribution to increase from stable agricultural production income, relieving flood damage
- ⑤ Rise in farmland prices

From the results of the economic evaluation presented above, it is considered that this project will substantially contribute to the development of the local economy.

### 1.9 Sustainability Analysis

This project will be co-managed by the central government (through the DGIH), irrigation committees and regional governments, and the project cost will be covered with the respective contributions of the three parties. Usually the central government (in this case, the DGIH) assumes 80%, the irrigation commissions 10% and regional governments 10%. However, the percentages of the contributions of these last two are decided through discussions between both parties. On the other hand, the operation and maintenance (O & M) of completed works is taken by the irrigation committees. Therefore, the sustainability of the project is depends on the profitability of the project and the ability of O & M of irrigation committees.

#### (1) Profitability

We have seen that Pisco river watershed is sufficiently profitable and sustainable. The amount of investment required is estimated at S/ 71.6 million soles (cost at private prices).

It is a cost-effective project with a C/B relation of 2.02, a relatively high IRR of approximately 25% and NPV of S/.52. 8 million soles.

## (2) Operation and maintenance costs

The annual cost of operation and maintenance required for the project, having as base year 2008 is estimated at 300,850 soles, which corresponds to 0.5% of the construction cost of the project in the Pisco river watershed. On the other hand, the operating expenses average in the last four years of irrigation committees is 1,617,127.

When considering that the annual cost of operation and maintenance represents 18.6% of the annual irrigation budget, the project would be sustainable enough because of the financial capacity of these committees to maintain and operate the constructed works.

**Table 1.9-1 Irrigation committee's budget**

Rivers	Annual Budget				(In Soles)
	2007	2008	2009	2010	4 year average
Pisco	1,648,019.62	1,669,237.35	1,725,290.00	1,425,961.39	1,617,127

## 1.10 Environmental Impact

### (1) Procedure of Environmental Impact Assessment

Projects are categorized in three scales, based on the significance level of the negative and positive impacts, and each sector has an independent competence on this categorization. The Project holder should submit the Environmental Impact Statement (DIA, in Spanish) for all Projects under Category I. The project holder should prepare an EIA-sd or an EIA-d if the Project is categorized under Category II or III, respectively, to be granted the Environmental Certification from the relevant Ministry Directorate.

First, the Project holder applies for the Project classification, by submitting the Preliminary Environmental Assessment (PEA). The relevant sector assesses and categorizes the Project. The Project's PEA that is categorized under Category I becomes an EID, and those Projects categorized under Category II or III should prepare an EIA-sd or EIA-d, as applicable.

The preliminary environmental assessment (EAP) for Pisco river was carried out between December 2010 and January 2011 and by a consulting firm registered in the Ministry of Agriculture (CIDES Ingenieros S.A.). EAP for Pisco was submitted to DGIH January 25, 2011 by JICA Study Team and from DGIH to DGAA July 19, 2011.

DGAA examined EAP and issued approval letter of Category I. Therefore, no further environmental impact assessment is required for Pisco.

## (2) Results of Environmental Impact Assessment

The procedures to review and evaluate the impact of the natural and social environment of the Project are the following. First, we reviewed the implementation schedule of the construction of river structures, and proceeded to develop the Leopold matrix.

The impact at environmental level (natural, biological and social environment) was evaluated and at Project level (construction and maintenance stage). The quantitative levels were determined by quantifying the environmental impact in terms of impact to nature, manifestation possibility, magnitude (intensity, reach, duration and reversibility).

The EAP showed that the environmental impact would be manifested by the implementation of this project in the construction and maintenance stages, mostly, it is not very noticeable, and if it were, it can be prevented or mitigated by appropriately implementing the management plan environmental impact.

On the other hand, the positive impact is very noticeable in the maintenance stage, which manifests at socioeconomic and environmental level, specifically, in greater security and reduced vulnerability, improved life quality and land use.

### 1.11 Execution plan

Table 1.11-1 presents the Project execution plan.

**Table 1.11-1 Execution plan**

ITEMS	2010			2011			2012			2013			2014			2015			2016				
	3	6	9	12	3	6	9	12	3	6	9	12	3	6	9	12	3	6	9	12	3	6	9
1 PROFILE STUDY / SNIP ASSESSMENT	STUDY			EVALUATION																			
2 FEASIBILITY STUDY / SNIP ASSESSMENT	STUDY			EVALUATION																			
3 YEN CREDIT NEGOTIATION																							
4 CONSULTANT SELECTION																							
5 CONSULTANT SERVICE (DETAILED DESIGN, LAWFUL DOCUMENTS PREPARATION)							DESIGN / LAWFUL DOCUMENT						WORK SUPERVISION										
6 BUILDER SELECTION																							
7 WORK EXECUTION																							
1) STRUCTURES BUILDING																							
2) REFORESTATION																							
3) EARLY ALERT SYSTEM																							
4) DISASTER PREVENTIVE TRAINING																							
8 FINISH WORK / DELIVERY TO USERS BOARDS																							

### 1.12 Institutions and management

The institutions and its administration in the investment stage and in the operation and maintenance stage after the investment shown in the figures 1.12-1 and 1.12-2.

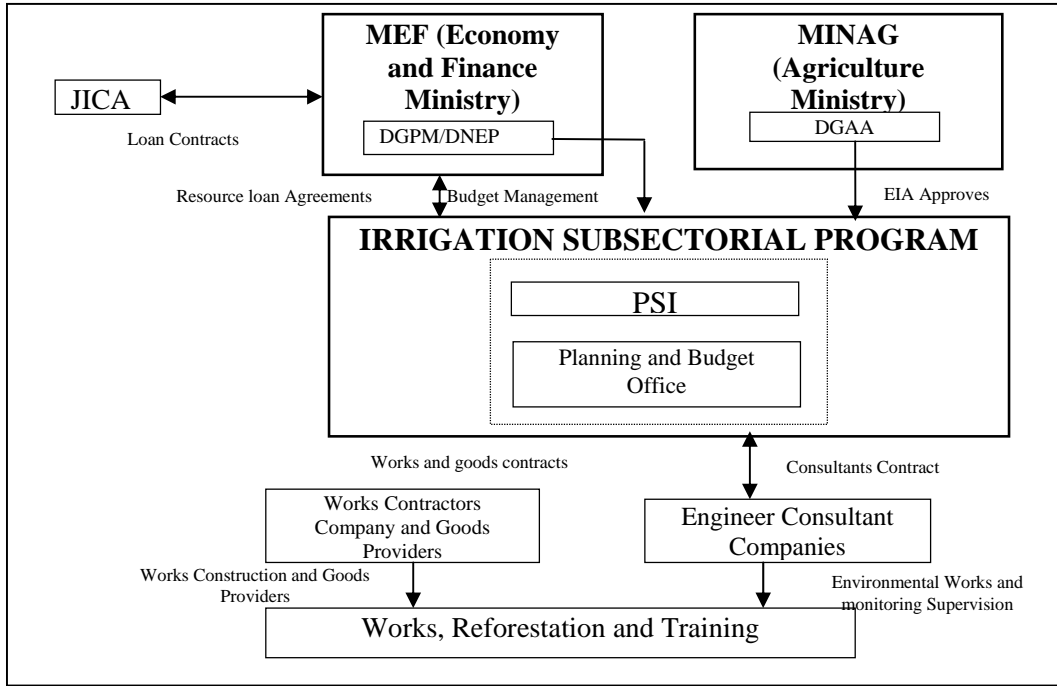

**Figure 1.12-1 Related Agencies in Implementation Stage of Project**

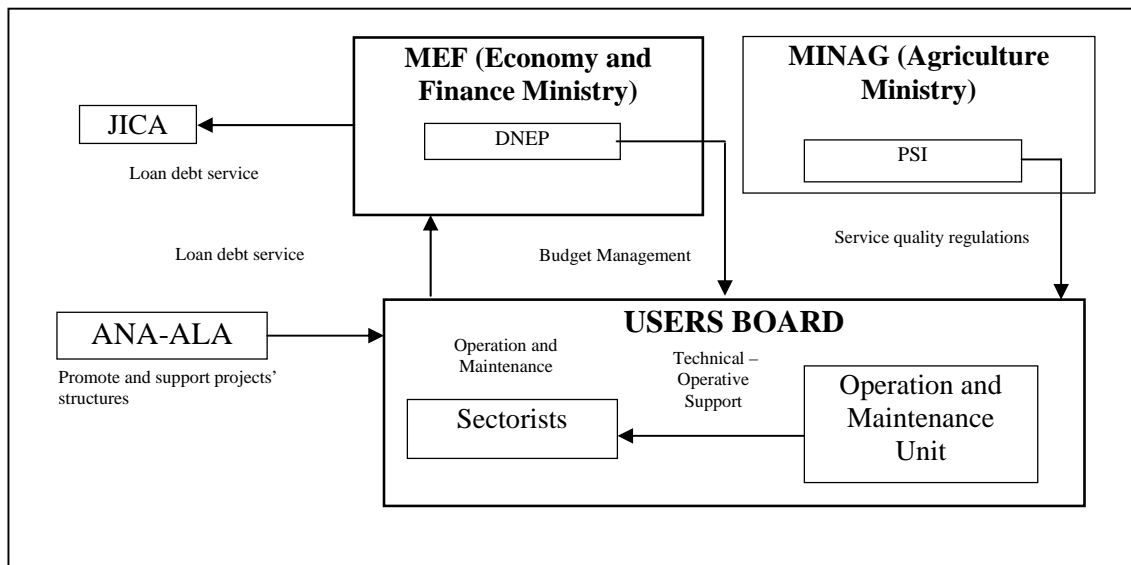

**Figure 1.12-2 Related Agencies in Operation Stage of Project**

**1.13 Logical Framework**

Table 1.13-1 presents the logical framework of the final selected alternative.

**Table 1.13-1 Logical framework of the final selected alternative**

Narrative Summary	Verifying Indicators	Verifying Indicators Media	Preliminary Conditions
<b>Superior Goal</b>			
Promote socioeconomic local development and contribute in communities' social welfare.	Improve local productivity, generate more jobs, increase population's income and reduce poverty index	Published statistic data	Scio-economic and policy stability
<b>Objectives</b>			
Relief the high vulnerability of valleys and local continuity to floods	Types, quantity and distribution of flood control works, population and beneficiaries areas	Monitoring annual calendar works and financial plan, budget execution control	Ensure the necessary budget, active intervention from central and regional governments, municipalities, irrigation communities, local population, etc.
<b>Expected results</b>			
Reduction of areas and flooded areas, functional improvement of intakes, road destruction prevention, irrigation channels protection, bank erosion control and Poechos dike safety	Number of areas and flooded areas, water intake flow variation, road destruction frequency, bank erosion progress and watershed's downstream erosion.	Site visits, review of the flood control plan and flood control works reports and periodic monitoring of local inhabitants	Maintenance monitoring by regional governments, municipalities and local community, provide timely information to the superior organisms
<b>Activities</b>			
Component A: Structural Measures	Dikes rehabilitation, intake and bank protection works, road damages prevention, construction of 28 works, including dike's safety	Detailed design review, works reports, executed expenses	Ensure the works budget, detailed design/works execution/good quality works supervision
Component B: Non-Structural Measures			
B-1 Reforestation and vegetation recovery	Reforested area, coastal forest area	Works advance reports, periodic monitor by local community	Consultants support, NGO's, local community, gathering and cooperation of lower watershed community
Component C: Disaster prevention and capabilities development education	Number of seminars, trainings, workshops, etc	Progress reports, local governments and community monitoring	Predisposition of the parties to participate, consultants and NGO's assessments
Project's execution management			

Project's management	Detailed design, work start order, work operation and maintenance supervision	Design plans, work's execution plans, costs estimation, works specifications, works management reports and maintenance manuals	High level consultants and contractors selection, beneficiaries population participation in operation and maintenance
----------------------	---	--	---

### 1.14 Middle and Long Term Plans

While it is true that due to the limited budget available for the Project, this study is focused mainly on the flood control measures analysis that must be implemented urgently. It is considered necessary to timely implement other necessary measures within a long term. In this section we will discuss the medium and long term plans.

#### (1) Flood Control General Plan

There are several ways to control floods in the entire watershed, for example, the building of dams, retarding basin, dikes or a combination of these. The options to build dams or retarding basin are not viable because in order to answer to a flood flow with a return period of 50 years, enormous works would be necessary to be built. So, the study was focused here on dikes' construction because it was the most viable option.

Flood water level was calculated in the watershed adopting a designed flood flow with a return period of 50 years. At this water level, freeboard was added in order to determine the required dikes height. After, sections of the rivers where the dikes or ground did not reach the required height were identified. These sections, altogether, add up to approx.34km. Also, from maintaining these works, annually a dragged of the rivers has to be done in the sections where, according to the bed fluctuation analysis the sediment gathering is elevating the bed's height. The volume of sediments that shall be eliminated annually was determined in approximately 12,000 m<sup>3</sup>.

In Tables 1.14-1 and 1.14-2 the flood control general plan project cost is shown as well as the social assessment results in terms of private and social costs.

**Table 1.14-1 Social Assessment of the general flood control plan (private prices )**

Basin	年平均被害軽減額 Annual Average Damage Reduction	評価期間被害 軽減額(15年) Damage Reduction in Evaluation Period(15years)	事業費 Project Cost	維持管理費 O&M Cost	B/C Cost Benefit Ration	NPV Net Present Value	IRR(%) Internal Return of Rate
Pisco	229,000,371	103,412,028	110,779,465	9,420,215	1.02	2,217,423	10%

**Table 1.14-2 Project Cost and Social Assessment of the general flood control plan  
(social prices costs)**

Basin	年平均被害軽減額 Annual Average Damage Reduction	評価期間被害 軽減額(15年) Damage Reduction in Evaluation Period(15years)	事業費 Project Cost	維持管理費 O&M Cost	B/C Cost Benefit Ration	NPV Net Present Value	IRR(%) Internal Return of Rate
Pisco	242,702,673	109,599,716	89,066,690	7,573,853	1.35	28,239,253	16%

In case of executing flood control works in the watershed, the works is economically viable, however the Projects' cost would elevate to 110.8 million soles, which is a huge amount for this project.

### (2) Reforestation Plan and Vegetation Recovery

The forestry option was analyzed, in a long term basis, to cover every area that requires being covered with vegetation in the upper watershed. The objective is improving this areas' infiltration capacity, reduce of surface water and increase semi-underground and underground water. So, the flood maximum flow will be decreased, also it could be possible to increase the water reserve in the mountain areas and prevent and soothe floods. The areas to be reforested will be the afforested areas or where the forest mass in the water infiltration areas has been lost.

In Table 1.14-3 the area to be afforested and the project's cost for the watershed is shown. These were calculated based on forestry plan of Chincha River. The total surface would be approximately 54,000hectares and in order to forest them the required time would be from 17 years and 145.6 million soles. To sum up, the Project has to cover an extensive area, with an investment of much time and at a high cost.

**Table 1.14-3 General Plan for forestry on upper stream watersheds**

Watershed	Forestry Area (ha)	Required Period for the project (years)	Required Budget (1,000soles)
Pisco	53,938	17	145,586

### (3) Sediment Control Plan

As long term sediment control plan, it is recommended to perform necessary works on the upper watershed. These works will mainly consist of dams and bank protection. In Table 1.14-4 the estimate work cost is shown. There are two costs, one for executing works in the entire watershed and another one for executing works only in prioritized areas.

All the chosen watersheds for this Project are big. So, if bank protection works and sediment control dams want to be built, not only the works' cost would elevate but also a very long period of investment would have to be done in the watershed. This means that its positive impact will be seen in a long time.



**Table 1.14-4 Projects Costs of Sediment Control**

Watersheds	Areas	Bank Protection		Bands		Dams		Works direct cost (total)	Project Cost (in millions de s/.)
		Qty. (km)	Works direct costs (million s/.)	Qty. (No.)	Works direct costs (million s/.)	Qty. (No.)	Works direct costs (million s/.)		
Pisco	Totally	269	S/.287	27	S/.1	178	S/.209	S/.497	S/.935
	Prioritized areas	269	S/.287	27	S/.1	106	S/.126	S/.414	S/.779



## **2. GENERAL ASPECTS**

### **2.1 Name of the Project**

“Protection program for valleys and rural communities vulnerable to floods Implementation of prevention measures to control overflows and floods of Pisco River, Ica department”

### **2.2 Formulator and Executor Units**

#### (1) Formulator Unit

Name: Hydraulic Infrastructure General Direction, Agriculture Ministry

Responsible: Orlando Chirinos Hernan Trujillo

General Director of the Water Infrastructure General Direction

Address: Av. Benavides N° 395 Miraflores, Lima 12 - Peru

Phone: (511) 4455457 / 6148154

Email: ochirinos@minag.gob.pe

#### (2) Executor Unit

Name: Sub-sectorial Irrigation Program, Agriculture Ministry

Manager: Jorge Zúñiga Morgan

Executive Director

Address: Jr. Emilio Fernandez N° 130 Santa Beatriz, Lima-Peru

Phone: (511) 4244488

Email: postmast@psi.gob.pe

### **2.3 Involved entities and Beneficiaries Participation**

Here are the institutions and entities involved in this project, as well as beneficiaries.

#### (1) Agriculture Ministry (MINAG)

MINAG, as manager of natural resources of watersheds promotes agricultural development in each of them and is responsible of maintaining the economical, social and environmental to benefit agricultural development.

To accomplish effectively and efficiently this objective, the MINAG has been working since 1999 in the River Channeling and Collection Structures Protection Program (PERPEC). The river disaster prevention programs that are been carried out by regional governments are funded with PERPEC resources.

1) Administration Office (OA)

- Manages and executes the program's budget
- Establishes the preparation of management guides and financial affairs

2) Hydraulic Infrastructure general Direction (DGIH)

- Performs the study, control and implementation of the investment program
- Develops general guidelines of the program together with OPI

3) Planning and Investment Office (OPI)

- Conducts the preliminary assessment of the investment program
- Assumes the program's management and the execution of the program's budget
- Plans the preparation of management guides and financial affairs

4) Irrigation Sub-Sectorial Program (PSI)

- Carries-out the investment program approved by OPI and DGPM

(2) Economy and Finance Ministry (MEF)

Public Sector's Multiannual Programming General Direction (DGPM)

Is in charge of approving public investment works according to procedures under the Public Investment National System (SNIP) to assess the relevance and feasibility of processing the disbursement request of the national budget and the loan from JICA.

(3) Japan's International Cooperation Agency (JICA)

It is a Japanese government institution with the objective of contributing in the socioeconomic development of developing countries through international cooperation. JICA has extended financial assistance to carry out pre-feasibility and feasibility studies of this Project.

(4) Regional Governments (GORE)

Regional governments assume the promotion of integrated and sustainable regional development following the national and regional plans and programs, trying to increase public and private investment, generating employment opportunities, protecting citizens rights and ensuring equal opportunities.

The regional governments' participation with their possible financial support is a very important factor to ensure the Project's sustainability.

The Special Project Chira-Piura, Regional Government of Piura implemented by the regional government of Piura also includes Chira River which is the area of this Study.

(5) Irrigation Commission

Currently there are 19 irrigation commissions in the Pisco River Watershed. These have

expressed a strong desire for the starting of works because these will help constructing dikes, protecting margins, repairing water intakes, etc. These commissions are currently suffering major damages due to rivers flooding. Next, a brief overview of the Pisco River Watershed is described (for more details, see Section 3.1.3). Currently, the operation and maintenance of dikes, margin protection works, irrigation intakes and channels linked to agricultural land and irrigation systems in the Watershed, are mainly made by irrigation commissions and their members, with the assistance of local governments.

Number of irrigation blocks:	11
Number of Irrigation Commissions:	19
Irrigated Area:	22,468ha
Beneficiaries:	3,774 producers

(6) Meteorology and Hydrology National Service (SENAMHI)

It is an agency from the Environment Ministry responsible for all activities related to meteorology, hydrology, environment and agricultural meteorology. Take part in global level monitoring, contributing to sustainable development, security and national welfare, and gathering information and data from meteorological stations and hydrological observation.

(7) Civil Defense National Institute (INDECI)

INDECI is the main agency and coordinator of the Civil Defense National System. It is responsible for organizing and coordinating the community, elaborating plans and developing disaster risk's management processes. Its objective is to prevent or alleviate human life loss due to natural and human disasters and prevent destruction of property and the environment.

(8) Water National Authority (ANA)

It is the highest technical regulating authority in charge of promoting, monitoring and controlling politics, plans, programs and regulations regarding sustainable use of water resources nationwide.

Its functions include sustainable management of these resources, as well as improving the technical and legal framework on monitoring and assessment of water supply operations in each region.

Along with maintaining and promoting a sustainable use of water resources, it is also responsible for conducting the necessary studies and developing main maintenance plans, national and international economic and technical cooperation programs.

## (9) Agriculture Regional Directorates (DRA's)

Agricultural regional addresses fulfill the following functions under the respective regional government:

- 1) Develop, approve, assess, implement, control and manage national agriculture policies, sectorial plans as well as regional plans and policies proposed by municipalities
- 2) Control agriculture activities and services fitting them to related policies and regulations, as well as on the regional potential
- 3) Participate in the sustainable management of water resources agreeing with the watershed's general framework, as well as the policies of the Water National Authority (ANA)
- 4) Promote the restructure of areas, market development, export and agricultural and agro-industrial products consumption
- 5) Promote the management of: irrigation, construction and irrigation repair programs, as well as the proper management and water resources and soil conservation

## **2.4 Framework**

### **2.4.1 Background**

#### (1) Study Background

The Republic of Peru (hereinafter "Peru") is a country with high risk of natural disasters such as earthquakes, Tsunamis, etc. Among these natural disasters there are also floods. In particular, El Niño takes place with an interval of several years and has caused major flood of rivers and landslides in different parts of the country. The most serious disaster in recent years due to El Niño occurred in the rainy season of 1982-1983 and 1997-1998. In particular, the period of 1997-1998, the floods, landslides, among others left loss of 3,500 million of dollars nationwide. The latest floods in late January 2010, nearby Machupicchu World Heritage Site, due to heavy rains interrupted railway and roads traffic, leaving almost 2,000 people isolated.

In this context, the central government has implemented El Niño phenomenon I and II contingency plans in 1997-1998, throughout the Agriculture and Livestock Ministry (MINAG) in order to rebuild water infrastructures devastated by this phenomenon. Next, the Hydraulic Infrastructure General Direction (DGIH) of the Agriculture Ministry (MINAG) began in 1999 the River Channeling and Collection Structures Protection Program (PERPEC) in order to protect villages, farmlands, agricultural infrastructure, etc located within flood risk areas. The program consisted of financial support for regional government to carry out works of margin protection. In the multiyear PERPEC plan between 2007-2009 it had been intended to execute a total of 206 margin protection works nationwide. These projects were designed to withstand floods with a return period of 50 years, but all the works have been small and punctual, without giving a full and integral solution to control floods. So, every time floods occur in different

places, damages are still happening.

MINAG developed a “Valley and Rural Populations Vulnerable to Floods Protection Project” for nine watersheds of the five regions. However, due to the limited availability of experiences, technical and financial resources to implement a pre-investment study for a flood control project of such magnitude, MINAG requested JICA’s help to implementation this study. In response to this request, JICA and MINAG held discussions under the premise of implementing it in the preparatory study scheme to formulate a loan draft from AOD of JICA, about the content and scope of the study, the implementation’s schedule, obligations and commitments of both parties, etc. expressing the conclusions in the Discussions Minutes (hereinafter “M/D”) that were signed on January 21 and April 16, 2010. This study was implemented on this M/D.

## (2) Progress of Study

The Profile Study Report for this Project at Program’s level for nine watersheds of five regions has been elaborated by DGIH and sent to the Planning and Investment Office (OPI) on December 23, 2009, and approved on the 30<sup>th</sup> of the same month. Afterwards, DGIH presented the report to the Public Sector Multiannual Programming General Direction (DGPM) of the Economy and Finance Ministry (MEF) on January 18, 2010. On March 19<sup>th</sup>, DGPM informed DGIH about the results of the review and the correspondent comments.

The JICA Study Team began the study in Peru on September 5<sup>th</sup>, 2010. At the beginning, nine watersheds were going to be included in the study. One, the Ica River was excluded of the Peruvian proposal leaving eight watersheds. The eight watersheds were divided into two groups: Group A with five watersheds and Group B with three watersheds. The study for the first group was assigned to JICA and the second to DGIH. Group A includes Chira, Cañete, Chincha, Pisco and Yauca Rivers’ Watersheds and Group B includes the Cumbaza, Majes and Camana Rivers’ Watersheds.

The JICA Study Team conducted the profile study of the five watersheds of Group A, with an accurate pre-feasibility level and handed DGIH the Program Report of group A and the reports of the five watershed projects by late June 2011. Also, the feasibility study has already started, omitting the pre-feasibility study.

For the watersheds of Group B which study corresponded to DGIH, this profile study took place between mid-February and early March 2011 (and not with a pre-feasibility level, as established in the Meetings Minutes), where Cumbaza River Watershed was excluded because it was evident that it would not have an economic effect. The report on the Majes and Camana rivers watersheds were delivered to OPI, and OPI official comments were received through DGIH on April 26<sup>th</sup>, indicating that the performed study for these two watersheds did not meet the accuracy level required and it was necessary to study them again. Also, it was indicated to

perform a single study for both rivers because they belong to a single watershed (Majes-Camana).

On the other hand, due to the austerity policy announced on March 31<sup>st</sup>, prior to the new government assumption by new president on July 28<sup>th</sup>, it has been noted that it is extremely difficult to obtain new budget, DGIH has requested JICA on May 6<sup>th</sup> to perform the prefeasibility and feasibility studies of the Majes-Camana Watershed.

JICA accepted this request and decided to perform the mentioned watershed study modifying for the second time the Meeting Minutes (refer to Meetings Minutes Second Amendment about the Initial Report, Lima, July 22<sup>nd</sup>, 2011)

So, the JICA Study Team began in August the prefeasibility study for the watershed above mentioned, which was completed in late November.

Remember that DGIH processed on July 21<sup>st</sup>, the SNIP registration of four of the five watersheds from JICA (except Yauca), based on projects reports at pre-feasibility level (according to the watersheds). DHIG decided to discard Yauca River due to its low impact in economy.

The Project Reports with pre-feasibility level for 4 watersheds (Chira, Cañete , Chinchá, Pisco) were submitted to OPI from DGIH, and OPI issued their comments on the reports on September 22, 2011. The revision of the reports is under discussion among OPI, DGIH and JICA Study Team.

#### **2.4.2 Laws, regulations, policies and guidelines related to the Program**

This program has been elaborated following the mentioned laws and regulations, policies and guidelines:

(1) Water Resources Law N° 29338

##### **Article 75 .- Protection of water**

The National Authority, in view of the Watershed Council, must ensure for the protection of water, including conservation and protection of their sources, ecosystems and natural assets related to it in the regulation framework and other laws applicable. For this purpose, coordination with relevant government institutions and different users must be done.

The National Authority, throughout the proper Watershed Council, executes supervision and control functions in order to prevent and fight the effects of pollution in the oceans, rivers and lakes. It can also coordinate for that purpose with public administration, regional governments and local governments sectors.



The State recognizes as environmentally vulnerable areas the headwater watersheds where the waters originate. The National Authority, with the opinion of the Environment Ministry, may declare protected areas the ones not granted by any right of use, disposition or water dumping.

**Article 119 .- Programs flood control and flood disasters**

The National Authority, together with respective Watershed Board, promotes integral programs for flood control, natural or manmade disasters and prevention of flood damages or other water impacts and its related assets. This promotes the coordination of structural, institutional and necessary operational measures.

Within the water planning, the development of infrastructure projects for multi-sectorial advantage is promoted. This is considered as flood control, flood protection and other preventive measures.

(2) Water Resources Law Regulation N° 29338

**Article 118 .- From the maintenance programs of the marginal strip**

The Water Administrative Authority, in coordination with the Agriculture Ministry , regional governments, local governments and water user organizations will promote the development of programs and projects of marginal strips forestry protection from water erosive action.

Article 259 ° .- Obligation to defend margins

All users have as duty to defend river margins against natural phenomenon effects, throughout all areas that can be influenced by an intake, whether it is located on owned land or third parties' land. For this matter, the correspondent projects will be submitted to be reviewed and approved by the Water National Authority.

(3) Water Regulation

Article 49. Preventive measures investments for crop protection are less than the recovery and rehabilitation cost measures. It is important to give higher priority to these protective measures which are more economic and beneficial for the country, and also contribute to public expenses savings.

Article 50. In case the cost of dikes and irrigation channels protection measures is in charge of family production units or it exceeds the payment capacity of users, the Government may pay part of this cost.

(4) Multi-Annual Sectorial Strategic Plan of the Agriculture Ministry for the period 2007-2011 (RM N° 0821-2008-AG)

Promotes the construction and repair of irrigation infrastructure works with the premise of

having enough water resources and their proper use.

(5) Organic Law of the Agriculture Ministry, N° 26821

In Article 3, it is stipulated that the agricultural sector is responsible for executing river works and agricultural water management. This means that river works and water management for agricultural purposes shall be paid by the sector.

(6) Guidelines for Peruvian Agricultural Policy - 2002, by the Policy Office of MINAG

Title 10 - Sectorial Policies

“Agriculture is a high risk productive activity due to its vulnerability to climate events, which can be anticipated and mitigated... The damage cost to infrastructure, crops and livestock can be an obstacle for the development of agriculture, and as consequence, in the deterioration of local, regional and national levels.”

(7) River Channeling and Collection Structures Protection Program, PERPEC

The MINAG's DGIH started in 1999 the River Channeling and Collection Structures Protection Program (PERPEC) in order to protect communities, agricultural lands and facilities and other elements of the region from floods damages, extending financial support to margin protection works carried out by regional governments.

### 3. IDENTIFICATION

#### 3.1 Diagnosis of the current situation

##### 3.1.1 Nature

##### (1) Location

Figure 3.1.1-1 shows the location map of the Pisco River.



Figure 3.1.1-1 Objective River for the Study

##### (2) Watershed overall description

Pisco River runs approximately 200 km from the capital Lima, and borders the Chincha River watershed to the north. The surface of the watershed is about 4,300 km<sup>2</sup> which is average among the five selected watersheds in this study. It is an elongated watershed, and altitudes over 4,000 m occupy 20% of the total. The river flows in the lower

watershed with an average gradient of 1/90 and its width varies between 200 and 600 meters.

The annual rainfall around 500 mm at altitudes greater than 4,000 m and 10 mm at altitudes less than 1,000 meters. Thus, the average flow rate is reduced.

Regarding the vegetation, the upper watershed is occupied in large part by grassland, and the lower and middle watersheds of deserts. In the lower watershed, also have farmlands on both river banks.

### 3.1.2 Socio-economic conditions of the Study Area

#### (1) Administrative Division and Surface

The Pisco River is located in the Pisco province, Ica Region.

Table 3.1.2-1 shows the main districts surrounding this river, with their corresponding surface.

**Table 3.1.2-1 Districts surrounding Pisco River with areas**

Region	Province	District	Area (km <sup>2</sup> )
Ica	Pisco	Pisco	24.92
		San Clemente	127.22
		Tupac Amaru	55.48
		San Andres	39.45
		Humay	1,112.96
		Independencia	273.34

#### (2) Population and number of households

The following Table 3.1.2-2 shows how population varied within the period 1993-2007. In 2007, from 119,975 inhabitants, 89% (106,394 inhabitants) lived in urban areas while 11% (13,581 inhabitants) lived in rural areas.

Population is increasing in all districts. However, the population tends to decrease, except in Humay and Independencia.

**Table 3.1.2-2 Variation of the urban and rural population**

District	Total Population 2007				Total Population 1993				Variation (%)			
	Urban	%	Rural	%	Urban	%	Rural	%	Urban	%	Rural	%
Pisco	54.677	99 %	320	1 %	54.997	51.639	99 %	380	1 %	52.019	0,4 %	-1,2 %
San Clemente	18.849	98 %	475	2 %	19.324	13.200	93 %	1.002	7 %	14.202	2,6 %	-5,2 %
Túpac Amaru Inca	14.529	99 %	147	1 %	14.676	9.314	98 %	228	2 %	9.542	3,2 %	-3,1 %
San Andrés	11.495	87 %	1.656	13 %	13.151	10.742	86 %	1.789	14 %	12.531	0,5 %	-0,6 %
Humay	3.099	57 %	2.338	43 %	5.437	2.016	46 %	2.331	54 %	4.347	3,1 %	0,0 %
Independencia	3.745	30 %	8.645	70 %	12.390	1.630	19 %	7.004	81 %	8.634	6,1 %	1,5 %
<b>Total</b>	<b>106.394</b>	<b>89 %</b>	<b>13.581</b>	<b>11 %</b>	<b>119.975</b>	<b>88.541</b>	<b>87 %</b>	<b>12.734</b>	<b>13 %</b>	<b>101.275</b>	<b>1,3 %</b>	<b>0,5 %</b>

Source: Prepared by JICA Study Team, Statistics National Institute- INEI, 2007 and 1993 Population and Housing Census.

Table 3.1.2-3 shows the number of households and members per home in 2007. Each house has between 3.8 and 4.4 people, according to the district. Each family has an average

between 3.7 and 4.1 people.

**Table 3.1.2-3 Number of households and families**

Variables	District					
	Pisco	San Clemente	Túpac Amaru Inca	San Andrés	Humay	Independencia
Population (inhabitants)	54,997	19,324	14,676	13,151	5,437	12,390
Number of households	12,483	4,837	3,609	3,087	1,409	3,062
Number of families	13,356	5,163	3,828	3,206	1,455	3,204
Members per household (person/home)	4.41	4.00	4.07	4.26	3.86	4.05
Members per family (person/family)	4.12	3.74	3.83	4.10	3.74	3.87

**Table 3.1.2-4 Number of households and families**

Variables	District					
	Pisco	San Clemente	Túpac Amaru Inca	San Andrés	Humay	Independencia
Population (inhabitants)	54,997	19,324	14,676	13,151	5,437	12,390
Number of households	12,483	4,837	3,609	3,087	1,409	3,062
Number of families	13,356	5,163	3,828	3,206	1,455	3,204
Members per household (person/home)	4.41	4.00	4.07	4.26	3.86	4.05
Members per family (person/family)	4.12	3.74	3.83	4.10	3.74	3.87

### (3) Occupation

Table 3.1.2-4, shows occupation lists of local inhabitants itemized by sector. In Humay and Independencia, there is a predominance of primary sector accounts for more than 70% of the occupation. In the remaining districts, the largest percentage is concentrated in the tertiary sector.

**Table 3.1.2-4 Occupation**

	District											
	Pisco		San Clemente		Túpac Amaru Inca		San Andrés		Humay		Independencia	
	People	%	People	%	People	%	People	%	People	%	People	%
EAP	19,837	100	7,027	100	5,057	100	4,406	100	2,011	100	4,451	100
Primary Sector	1,657	8.4	2,381	33.9	1,065	21.1	1,429	32.4	1,512	75.2	3,234	72.7
Secondary Sector	4,866	24.5	1,328	18.9	1,366	27.0	767	17.4	93	4.6	259	5.8
Tertiary Sector	13,313	67.1	3,318	47.2	2,626	51.9	2,207	50.1	406	20.2	958	21.5

\* Primary Sector: agriculture, livestock, forestry and fishing; secondary: mining, construction, manufacture; tertiary: services and others

### (4) Poverty index

Table 3.1.2-5 shows poverty rate. 18.7% of the population (22,406 inhabitants) belongs to the poor segment, and 0.4% (493 people) to the extreme poverty segment. Pisco is noted for its low poverty rate and extreme poverty from 15.8% and 0.3% respectively, compared to other districts.

**Table 3.1.2-5 Poverty index**

	District												Total	
	Pisco		San Clemente		Túpac Amaru Inca		San Andrés		Humay		Independencia			
	People	%	People	%	People	%	People	%	People	%	People	%		
Regional Population	54,997	100	19,324	100	14,676	100	13,151	100	5,437	100	12,390	100	119,975	100
In poverty	8,716	15.8	4,455	23.1	3,042	20.7	2,613	19.9	1,024	18.8	2,556	20.6	22,406	18.7
In extreme poverty	172	0.3	126	0.7	69	0.5	39	0.3	22	0.4	65	0.5	493	0.4

**(5) Type of housing**

The walls of the houses are built 45% of bricks or cement, and 19% of adobe and mud. The floor is made 87% of earth or cement.

The public drinking water service in Humay and Independence is low, with 25%. Except these two districts, the coverage of this service is 45% on average. Meanwhile, sewage service is 48% on average, but again and Independence Humay shows a low coverage of 11% and 13% respectively.

The electrification reaches 65% on average.

**Table 3.1.2-6 Type of housing**

Variable/Indicator	Districts													
	Pisco		San Clemente		Túpac Amaru Inca		San Andrés		Humay		Independencia			
	Hogares	%	Hogares	%	Hogares	%	Hogares	%	Hogares	%	Hogares	%		
<b>Name of housings</b>														
Common residents housing	12.483	83,7	4.837	84,1	3.609	90	3.087	88,2	1.409	79,9	3.062	87,8		
<b>Walls materials</b>														
Bricks or cement	7.600	60,9	1.339	27,7	1.198	33,2	2.088	67,6	65	4,6	401	13,1		
Adobe and mud	1.008	8,1	1.780	36,8	284	7,9	159	5,2	644	45,7	1.621	52,9		
Bamboo + mud or wood	623	5,0	80	1,7	99	2,7	113	3,7	76	5,4	298	9,7		
Others	3.252	26,1	1.638	33,9	2.028	56,2	727	23,6	624	44,3	742	24,2		
<b>Floor Materials</b>														
Soil	4.199	33,6	2.552	52,8	2.244	62,2	894	29	899	63,8	1.896	61,9		
Cement	5.752	46,1	2.109	43,6	1.179	32,7	1.749	56,7	438	31,1	997	32,6		
Ceramics, parquet, quality wood	2.320	18,6	136	2,8	131	3,6	361	11,7	40	2,8	147	4,8		
Others	212	1,7	40	0,8	55	1,5	83	2,7	32	2,3	22	0,7		
<b>Running water system</b>														
Public network within household	8.351	66,9	2.359	48,8	2.226	61,7	1.928	62,5	266	18,9	706	23,1		
Public network within building	726	5,8	302	6,2	255	7,1	352	11,4	355	25,2	67	2,2		
public use	645	5,2	109	2,3	163	4,5	30	1	3	0,2	139	4,5		
<b>Sewage</b>														
Public sewage within household	7.771	62,3	1.729	35,7	1.712	47,4	1.941	62,9	157	11,1	410	13,4		
Public sewage within building	526	4,2	113	2,3	79	2,2	201	6,5	178	12,6	26	0,8		
Septic Tank	977	7,8	1.532	31,7	587	16,3	302	9,8	250	17,7	1.623	53		
<b>Electricity</b>														
Public electric service	8.933	71,6	2.975	61,5	2.043	56,6	2.342	75,9	949	67,4	1.283	41,9		
<b>Member quantity</b>														
<b>Common residents housing</b>	<b>13.356</b>	<b>100</b>	<b>5.163</b>	<b>100</b>	<b>3.828</b>	<b>100</b>	<b>3.206</b>	<b>100</b>	<b>1.455</b>	<b>100</b>	<b>3.204</b>	<b>100</b>		
<b>Appliances</b>														
More than three	5.976	44,7	1.426	27,6	1.086	28,4	1.417	44,2	402	27,6	553	17,3		
<b>Communication Services</b>														
Phones and mobiles	11.385	85,2	3.401	65,9	2.795	73,0	2.579	80,4	630	43,3	1.719	53,7		

Source: Prepared by JICA Study Team, Statistics National Institute- INEI, 2007 Population and Housing Census.

**(6) GDP**

Peru's GDP in 2009 was S./392,565,000.000.

The growth rate in the same year was of + 0.9 % compared with the previous year with the poorest level within 11 years.

Itemized by regions, Ica registered a growth of 3.8 %, Piura 2.0 %, Lima 0.4 % and Arequipa 0.2 %. Particularly Ica and Piura regions registered Figures that were beyond the national average.

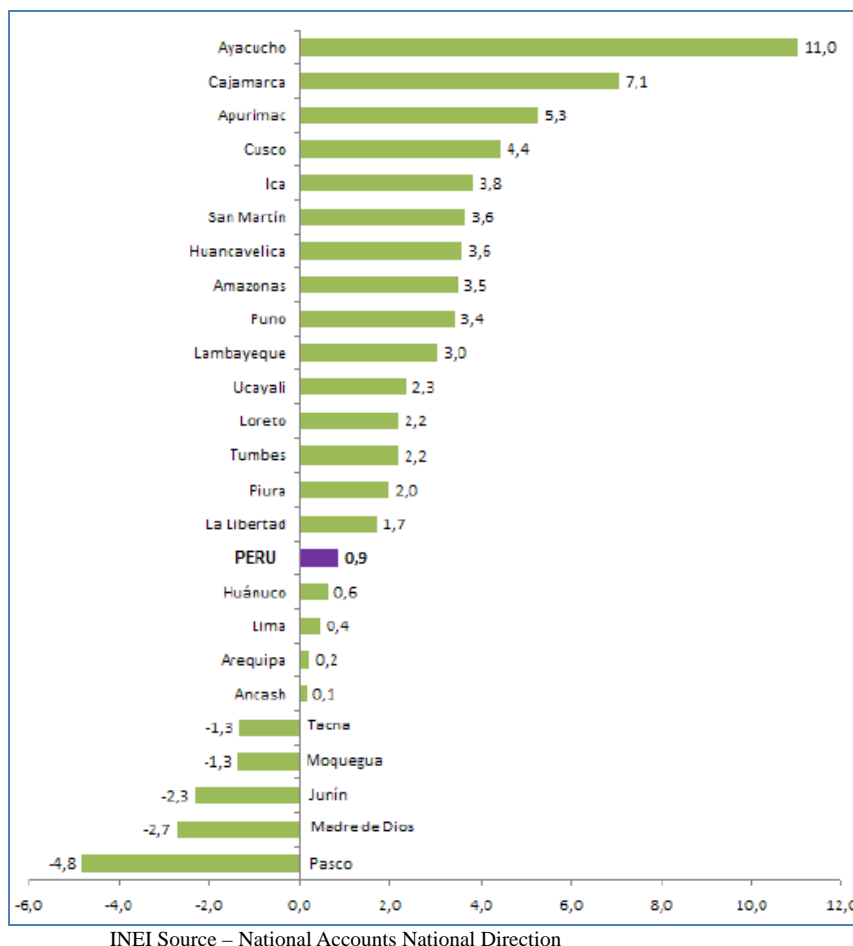

**Figure 3.1.2-1 Growth rate of GDP per region (2009/2008)**

The table below shows the contribution of each region to the GDP. Lima Region represents almost half of the total, that is to say 44.8%. Arequipa contributed with 5.3 %, Piura 4.6 % and Ica 2.9 %. Taxes and duties contributed with 7.2 % and 0.4 %, respectively.

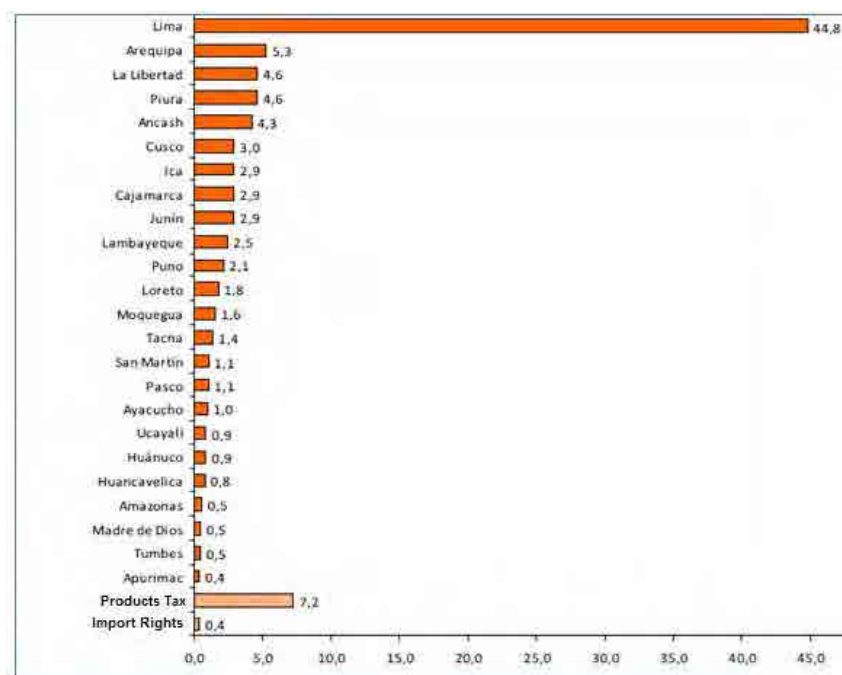

INEI Source – National Accounts National Direction

**Figure 3.1.2-2 Region contribution to GDP**

The GDP per capita in 2009 was of S/.13.475.

The Table below shows data per region: Lima S/.17,800, Arequipa S/.17,200, Ica S/.15,600 and Piura S/.10,200. The first three regions exceeded the national average, with exception of Piura.

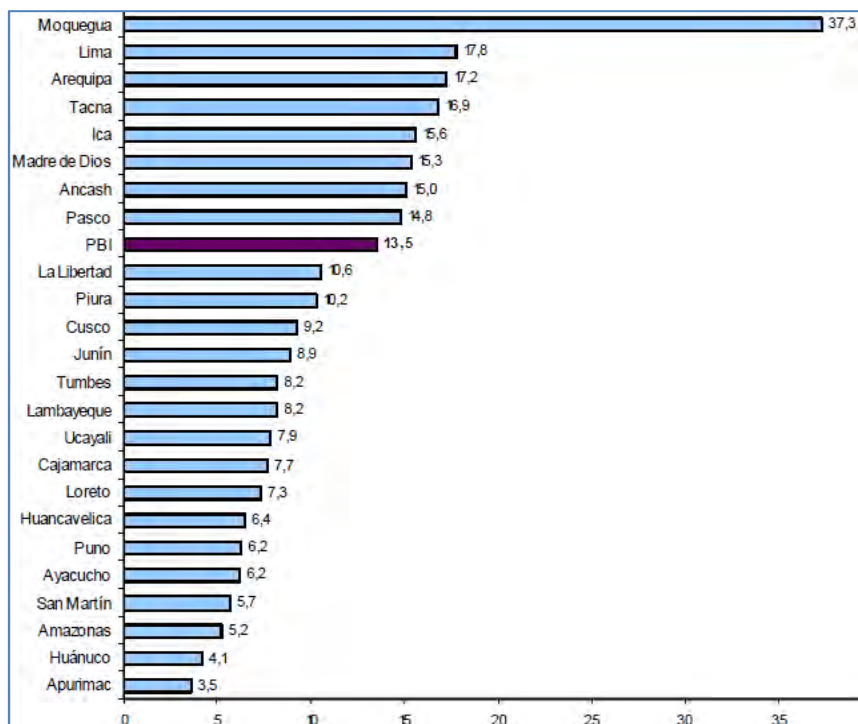

INEI Source – National Accounts National Direction

**Figure 3.1.2-3 GDP per capita (2009)**



Table 3.1.2-7 shows the variation along the years of the GDP per capita per region, during the last 9 years (2001-2009).

The GDP national average increased in 44% within nine years from 2001 until 2009. The Figures per region are: +83.9 % for Ica, +54.2 % for Arequipa, +48.3 % for Piura y +42.9 % for Lima.

Figures in Table 3.1.2-11 were established taking 1994 as base year.

**Table 3.1.2-7 Variation of the GDP per capita (2001-2009)**

(1994 Base year, S/.)

Departament	2001	2002	2003	2004	2005	2006	2007P/	2008P/	2009E/	Accumulated Growth 2001-2009 (%)
Cusco	2 194	2 086	2 195	2 565	2 768	3 071	3 340	3 554	3 685	67,9
Ica	4 055	4 259	4 343	4 663	5 214	5 582	6 025	7 265	7 457	83,9
La Libertad	3 162	3 316	3 483	3 410	3 697	4 216	4 586	4 874	4 895	54,8
Ucayali	3 063	3 149	3 203	3 411	3 584	3 754	3 846	4 007	4 039	31,9
Moquegua	10 405	11 967	12 670	13 455	13 882	13 794	13 606	14 201	13 865	33,3
Arequipa	5 387	5 766	5 895	6 143	6 488	6 807	7 786	8 379	8 308	54,2
Apurimac	1 216	1 278	1 334	1 400	1 494	1 619	1 653	1 691	1 770	45,5
Piura	2 733	2 780	2 847	3 049	3 192	3 472	3 780	4 007	4 052	48,3
San Martín	2 026	2 059	2 094	2 232	2 393	2 476	2 655	2 870	2 928	44,5
Ayacucho	1 788	1 870	1 942	1 900	2 045	2 207	2 448	2 640	2 896	61,9
Anazonas	1 835	1 910	1 996	2 081	2 212	2 349	2 510	2 684	2 761	50,5
Madre de Dios	4 441	4 708	4 550	4 846	5 171	5 215	5 617	5 878	5 564	25,3
Cajamarca	2 493	2 731	2 947	2 968	3 165	3 113	2 864	3 094	3 295	32,2
Ancash	4 037	4 703	4 772	4 876	4 999	5 089	5 408	5 852	5 827	44,3
Tumbes	2 744	2 802	2 873	3 018	3 385	3 212	3 427	3 594	3 611	31,6
Lima	6 451	6 579	6 700	6 925	7 284	7 817	8 520	9 314	9 220	42,9
Puno	2 105	2 236	2 234	2 270	2 365	2 460	2 617	2 731	2 800	33,0
Lambayeque	2 941	3 046	3 132	2 959	3 164	3 300	3 615	3 882	3 963	34,8
Junin	3 245	3 311	3 350	3 527	3 505	3 856	4 072	4 379	4 248	30,9
Loreto	2 827	2 917	2 936	2 995	3 079	3 192	3 287	3 402	3 429	21,3
Huanuco	1 678	1 694	1 833	1 866	1 890	1 915	1 942	2 050	2 044	21,8
Pasco	5 137	5 552	5 481	5 634	5 644	6 062	6 711	6 729	6 349	23,6
Tarma	6 004	6 124	6 382	6 643	6 782	6 941	7 256	7 458	7 253	20,8
Huancavelica	2 700	2 632	2 683	2 697	2 864	3 014	2 903	2 959	3 039	12,5
<b>GDP</b>	<b>4 601</b>	<b>4 765</b>	<b>4 890</b>	<b>5 067</b>	<b>5 345</b>	<b>5 689</b>	<b>6 121</b>	<b>6 643</b>	<b>6 625</b>	<b>44,0</b>

INEI Source – National Accounts National Direction

### 3.1.3 Agriculture

Next is a summarized report on the current situation of agriculture in the Watershed of the Majes-Camana River, including irrigation commissions, crops, planted area, performance, sales, etc.

#### (1) Irrigation Sectors

Table 3.1.3-1 and 3.1.3-2 shows basic data on the irrigation commissions of the Pisco River. In the watershed of the Pisco River there are 19 irrigation sectors, 6 irrigation commissions with 3,774 beneficiaries. The surface managed by these sectors amounts 22,468 hectares.

**Table 3.1.3-1 Basic data of the irrigation commissions**

Irrigation Sectors	Irrigation Commissions	Areas under irrigation		N° of Beneficiaries (People)	River
		ha	%		
Pisco	Casalla	2.276	10	513	Pisco
	El Pueblo Figueroa	756	3	138	
	Caucato	1.612	7	325	
	Chongos	453	2	74	
Independencia	Agua Santa - El Porvenir	469	2	63	
	Francia	931	4	126	
	Montalván	1.596	7	275	
	Manrique	1.555	7	288	
Chacarilla	Condor	1.970	9	315	
Dadelso					
Jose Olaya					
Mencia					
San Jacinto					
Urrutia					
Cabeza de Toro	Cabeza de Toro	6.123	27	633	
Murga	Murga - Casaconcha	1.383	6	273	
	La Floresta	303	1	51	
	Bernales	1.286	6	294	
	Miraflores	129	1	35	
	Chunchanga	460	2	75	
Humay	San Ignacio	333	1	56	
	Montesierpe	449	2	118	
	Pallasca Tambo Colorado	145	1	65	
	Huaya Letrayoc	238	1	57	
<b>Total</b>		<b>22.468</b>	<b>100</b>	<b>3.774</b>	

Source: Prepared by JICA Study Team, Users Board of Pisco, October 2011

## (2) Main crops

Table 3.1.3-2 shows the variation between 2004 and 2009 of the planted surface and the performance of main crops. In the Pisco River Watershed the planted area tends to be maintained or reduced due to crop surface reduction because of cotton. Instead of this, the area of alfalfa and corn (yellow) is increasing. The revenue was S/.132,512,157 in 2008-2009, which is the lousiest level reached in the last five years. This reduction is due mostly for the reduction of cotton crop and the low transaction price.

The main crops in this watershed are cotton, alfalfa and corn (yellow).

**Table 3.1.3-2 Sowing and sales of main crops**

	Variables	2004-2005	2005-2006	2006-2007	2007-2008	2008-2009
Cotton	Planted Area (ha)	16,598	15,586	13,300	13,536	7,771
	Unit performance (kg/Ha)	2,123	1,923	2,104	2,209	2,166
	Harvest (Kg)	35,237,554	29,971,878	27,983,200	29,901,024	16,831,986
	Unit price (S./kg)	2.13	2.18	2.81	2.76	1.95
	Sales (S./)	75,055,990	65,338,694	78,632,792	82,526,826	32,822,373
Alfalfa	Planted Area (ha)	2,817	2,941	2,966	3,739	4,133
	Unit performance (kg/Ha)	31,965	29,626	30,485	24,078	25,770
	Harvest (Kg)	90,045,405	87,130,066	90,418,510	90,027,642	106,507,410
	Unit price (S./kg)	0.10	0.10	0.10	0.10	0.10
	Sales (S./)	9,004,541	8,713,007	9,041,851	9,002,764	10,650,741
Corn (yellow)	Planted Area (ha)	1,065	1,410	2,377	2,447	4,167
	Unit performance (kg/Ha)	7,289	6,960	8,197	8,665	8,262
	Harvest (Kg)	7,762,785	9,813,600	19,484,269	21,203,255	34,427,754
	Unit price (S./kg)	0.60	0.63	0.77	0.85	0.73
	Sales (S./)	4,657,671	6,182,568	15,002,887	18,022,767	25,132,260
Corn	Planted Area (ha)	813	2,188	1,272	1,605	2,088
	Unit performance (kg/Ha)	13,279	10,511	11,579	11,672	9,672
	Harvest (Kg)	10,795,827	22,998,068	14,728,488	18,733,560	20,195,136
	Unit price (S./kg)	0.63	0.46	0.79	0.73	0.80
	Sales (S./)	6,801,371	10,579,111	11,635,506	13,675,499	16,156,109
Asparagus	Planted Area (ha)	648	663	720	1,028	980
	Unit performance (kg/Ha)	6,654	7,231	6,491	4,375	4,788
	Harvest (Kg)	4,311,792	4,794,153	4,673,520	4,497,500	4,692,240
	Unit price (S./kg)	3.13	3.02	3.65	2.65	2.79
	Sales (S./)	13,495,909	14,478,342	17,058,348	11,918,375	13,091,350
Tangelo	Planted Area (ha)	311	331	367	367	367
	Unit performance (kg/Ha)	26,463	24,033	26,432	27,109	26,608
	Harvest (Kg)	8,229,993	7,954,923	9,700,544	9,949,003	9,765,136
	Unit price (S./kg)	0.52	0.56	0.59	0.55	0.51
	Sales (S./)	4,279,596	4,454,757	5,723,321	5,471,952	4,980,219
Paprika	Planted Area (ha)	223	354	461	310	209
	Unit performance (kg/Ha)	5,058	5,068	5,490	5,864	5,849
	Harvest (Kg)	1,127,934	1,794,072	2,530,890	1,817,840	1,222,441
	Unit price (S./kg)	4.64	3.45	5.67	5.33	4.02
	Sales (S./)	5,233,614	6,189,548	14,350,146	9,689,087	4,914,213
Tomatoe	Planted Area (ha)	306	349	307	258	293
	Unit performance (kg/Ha)	71,395	54,399	57,824	65,525	60,604
	Harvest (Kg)	21,846,870	18,985,251	17,751,968	16,905,450	17,756,972
	Unit price (S./kg)	0.97	0.83	0.76	1.08	0.86
	Sales (S./)	21,191,464	15,757,758	13,491,496	18,257,886	15,270,996
Grapes	Planted Area (ha)	136	174	192	218	230
	Unit performance (kg/Ha)	8,640	11,429	10,332	17,345	19,504
	Harvest (Kg)	1,175,040	1,988,646	1,983,744	3,781,210	4,485,920
	Unit price (S./kg)	1.66	1.88	2.21	1.95	2.00
	Sales (S./)	1,950,566	3,738,654	4,384,074	7,373,360	8,971,840
Lima beans	Planted Area (ha)	103	253	136	97	163
	Unit performance (kg/Ha)	1,055	1,062	1,230	1,212	1,020
	Harvest (Kg)	108,665	268,686	167,280	117,564	166,260
	Unit price (S./kg)	3.34	2.80	2.95	3.65	3.14
	Sales (S./)	362,941	752,321	493,476	429,109	522,056
Others	Planted Area (ha)	615	907	989	518	1,644
Total	Planted Area (ha)	23,635	25,156	23,087	24,123	22,045
	Harvest (Kg)	180,641,865	185,699,343	189,422,413	196,934,048	216,051,255
	Sales (S./)	142,033,663	136,184,761	169,813,897	176,367,624	132,512,157

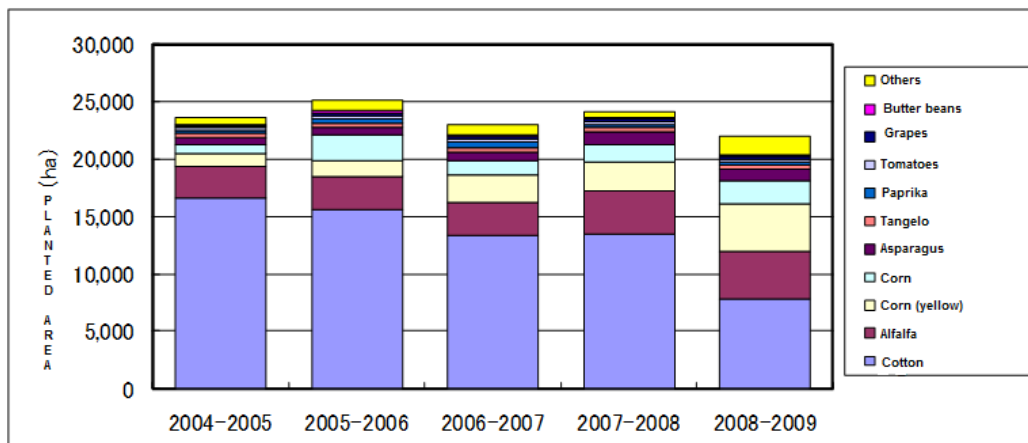

Figure 3.1.3-1 Planted Surface

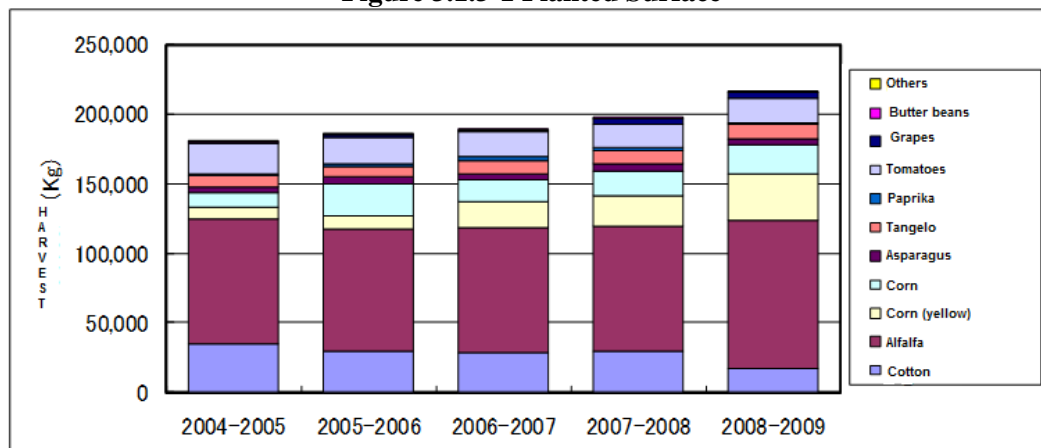

Figure 3.1.3-2 Harvest

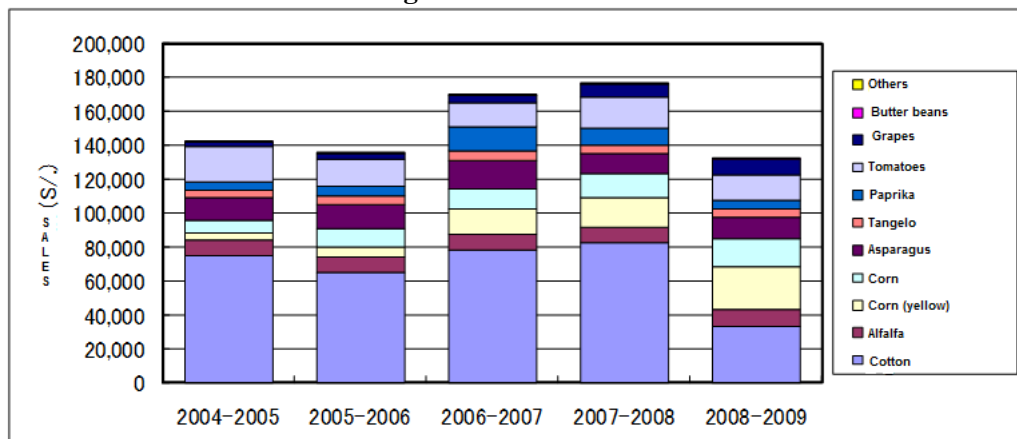

Figure 3.1.3-3 Sales

### 3.1.4 Infrastructure

#### (1) Road Infrastructures

Table 3.1.4-1 shows irrigation infrastructures of Pisco River. There are 41 intakes, 41 main channels and 167 secondary channels.

**Table 3.1.4-1 Irrigation infrastructure**

<b>Nº</b>	<b>STRUCTURE</b>		<b>QUANTITY</b>
1	INTAKE		41
2	CHANNEL	MAIN	41
		SECONDARY	167
3	WATERWORKS		11
4	SEWERS		73
5	SPILLWAY		6
6	DUMP		105
7	FALLS		163
8	CANOES		85
9	COVERED CONDUCT		2
10	BRIDGES	PEDESTRIAN	36
		VEHICLE	381
11	QUICK		10
12	TRAP		3
13	METER		39
14	TUNNELS		32

Source: JICA Study Team

### 3) PERPEC

Table 3.1.4-4 shows implemented projects by PERPEC between 2006 and 2009.

**Table 3.1.4-2 Projects implemented by PERPEC**

N°	Year	Work name	Location				Description	Total cost (\$/.)
			Departamt	Province	District	Town		
1	2006	Pisco River coastal defense - Condor area	Ica	Pisco	Independencia	Cóndor	Channel conformation	0.5 Km. 186,723.00
2	2007	Hydraulic infrastructure protection with coastal defense on right bank of Pisco River, Manrique area, Independece District, Pisco Province - Ica Region	Ica	Pisco	Independencia	Manrique	Dike with gavions and /or cushion	0.84 Km 501,939.72
3	2007	Channel and drains conduction capability restitution on right bank of Pisco River	Ica	Pisco	Independencia	Several	Channel box replacement	17.03 Km 145,810.00
4	2007	Main channel cleanliness Chunchanga- Murga-Pisco Area	Ica	Pisco	Humay	Chunchanga	Channel box replacement	2.824 Km 42,700.00
5	2007	Channel and drains conduction capability restitution on left bank of Pisco River	Ica	Pisco	Independencia	Varias	Channel box replacement Drains Rehabilitation	10.909 Km 6.307 Km 92,504.00
6	2007	Slide rehabilitation of Huaya, Tambo colorado and Miraflores derivation channels - Pisco	Ica	Pisco	Humay	Varias	Intake rockfilling	0.051 Km 52,003.00
7	2007	Main and secondary channels rehabilitation in the Huancano-Pampano High area of Pisco River	Ica	Pisco	Huancano	Varias	Channel sheathing	0.5435 Km 71,219.00
8	2007	Rehabilitation in Cabeza de Toro and Storage pools fixing for agricultural supply purposes in Cabeza de Toro - Pisco River	Ica	Pisco	Independencia	Cabeza de Toro	Replacement and fixing of pools	55 und. 106,819.00
9	2008	Coastal defense with short breakwaters with tumbling rocks right bank (several areas) Pisco river (Contingency)	Ica	Pisco	Independencia	Several Areas	Building of 23 breakwaters of 40 mts. Dike conformation	23 Und 1 Km 107,735.00
10	2008	Derivation channel protection in Chunchanga (Contingency)	Ica	Pisco	Pisco	Chunchanga	Desilting Dike with rockfilling	400 ml 200 ml 279,240.00
11	2008	Coastal defense with aims of San Ignacio intakes protection on the right bank and Bernales on the left bank of Pisco River, Bernales area, Humay district, Pisco province (Prevention)	Ica	Pisco	Humay	Bernales	Rockfilling dike Rock breakwaters Dike conformation	260 ml 19 und 520 ml 435,781

### 3.1.5 Real flood damages

#### (1) Damages on a nationwide scale

Table 3.1.5-1 shows the present situation of flood damages during the last five years (2003-2007) in the whole country. As observed, there are annually dozens to hundreds of thousands of flood affected inhabitants.

**Table 3.1.5-1 Situation of flood damages**

		Total	2003	2004	2005	2006	2007
Disasters	Cases	1,458	470	234	134	348	272
Víctims	persons	373,459	118,433	53,370	21,473	115,648	64,535
Housing loss victims	persons	50,767	29,433	8,041	2,448	6,328	4,517
Decesased individuals	persons	46	24	7	2	9	4
Partially destroyed houses	Houses	50,156	17,928	8,847	2,572	12,501	8,308
Totally destroyed	Houses	7,951	3,757	1,560	471	1,315	848

Source : SINADECI Statistical Compendium

Peru has been hit by big torrential rain disasters caused by the El Niño Phenomenon. Table 3.1.5-2 shows damages suffered during the years 1982-1983 and 1997-1998 with extremely serious effects. Victims were approximately 6,000,000 inhabitants with an economic loss of about US\$ 1.000.000.000 in 1982-1983. Likewise, victims number in 1997-1998 reached approximately 502,461 inhabitants with economic loss of US\$ 1,800,000,000. Damages in 1982-1983 were so serious that they caused a decrease of 12 % of the Gross National Product.

**Table 3.1.5-2 Damages**

Damages	1982-1983	1997-1998
Persons who lost their homes	1.267.720	—
Victims	6.000.000	502.461
Injured	—	1.040
Deceased	512	366
Missing persons	—	163
Partially destroyed houses	—	93.691
Totally destroyed houses	209.000	47.409
Partially destroyed schools	—	740
Totally destroyed schools	—	216
Hospitals and health centers partially destroyed	—	511
Hospitals and health centers totally destroyed	—	69
Damaged arable lands (ha)	635.448	131.000
Head of cattle loss	2.600.000	10.540
Bridges	—	344
Roads (km)	—	944
Economic loss (\$)	1.000.000.000	1.800.000.000

“—”: No data

#### (2) Disasters in the watersheds object of this study

Table 3.1.5-3 summarizes damages occurred in the Ica region.

**Table 3.1.5-3 Disasters in the Ica Region**

Years	1995	1996	1997	1998	1999	2000	2001	2002	2003	2004	2005	2006	2007	2008	2009	2010	Total	Media
LANDSLIP																	0	
FLOOD																	0	
COLLAPSE											2						2	
LANDSLIDE									2	1				1			4	
AVALANCHE	2		2		5	2				2	1	1	3	1		1	20	
TOTAL DESASTRES DE SEDIMENTOS	2	0	2	0	5	2	0	0	2	3	3	1	3	2	0	1	26	2
TOTAL FLOODING	4	4	0	13	14	1	2	0	0	1	1	0	4	6	1	0	51	3

### 3.1.6 Results on the visits to Study Sites

JICA Study Team made some technical visits to the selected watersheds and identified some challenges on flood control through visits and interviews to regional government authorities and irrigation associations on damages suffered in the past and the problems each watershed is currently facing.

#### (1) Interviews

(On critical points)

- The 1<sup>st</sup> critical point is 1.5 km downstream the bridge (km7). Flooded water floods the left bank's community. There is no dike under this point (1,5km from the bridge)
- The 2<sup>nd</sup> critical point is 11.5km away, where flood to the left bank is produced
- There is an intake on km 14.5. The work itself is not destroyed, but what is destroyed is the protection constructed on the right bank. There is a water channel connected to the urban area and an irrigation channel that covers all the left bank
- There are cement blocks criss-crossed on the left bank (km 12.5 and 13.5)
- The bed has elevated 3 meters approximately in the last 40 years (between 1970 and 2010)
- 40 years ago the dike existed but no floods existed. Nowadays, the dike exists and it produces floods
- There is purify plant and an intake on km 28
- The 3<sup>rd</sup> critical point is on km 20.5. Conduction tubes were dragged when the flood occurred on this area
- There are 5 reservoirs upstream, with a total capacity of 54 x 106m<sup>3</sup>.
- When El Niño occurred in Quitasol, 50km upstream, always produces floods

(Others: visited sites by the Study Team)

- Intake, km 27,5
  - Currently 7m<sup>3</sup>/s of water are taken (to supply 620 ha of agricultural lands)
  - A bank against overflowing was built on the right bank
  - Flood season: December through March
- Flood point, km 5,5
  - Bank protection works were executed using track type tractors, hydraulic shovels and trailers. The stones were brought from upstream the intake
  - With this section 500m<sup>3</sup>/s of water will flow (during El Niño a 700m<sup>3</sup>/s flow was reduced and we adopted the minimum value of such event)
  - The left bank's area is private property, but it was decided to adopt this width considering that is not necessary to buy the land
  - There are cement blocks criss-crossed up to the bed's height + 2meters
  - There is no other disaster prevention plan in this area
  - We are planning to build a new bridge 100meters downstream the existing bridge in km7 (Panamericana Highway)
  - The project's building cost of the dike + cement blocks installation



- (L=800mts on both banks) is estimated in S/. 960.000 (equivalent to 30 million Japanese yens)
- Km 13,5 (Floodable area)
    - A new dike on the exterior of the former dike is being built on the left bank. However, the work was stopped without being finished. The soil of the area was originally crop soil and then passed to be State land, 2 years was this area abandoned
    - The construction cost of the dike of 600 meters is \$850.000
  - Casaya Intake
    - The intake was not destroyed by floods, but the right bank protection did
  - Murga Bridge
    - Left bank protection was not destroyed during 1998 floods, but was destroyed during the February 1999 event. The penetration depth was approx 1meter
  - Montalbán Intake
    - The intake was destroyed due to 1998 floods. Previously, the upstream bed was elevated and the high waters entered into the right bank (where the intake is) destroying the floodgate
    - Water level reaches chest height
    - Right bank's channel was buried
    - The river's width at the intakes area is 90m approx, which is narrower than the upstream and downstream sections. The land of the left bank is private property
    - The value of agricultural lands is approx %5,000 per hectare (10.000 m<sup>2</sup>).
  - Francia Intake (between km 19,5 and km 20)
    - Because this area is not protected, both banks flooded
    - The bed has risen in the last years
    - Limit demarking of private properties has been investigated by MINAG in 1998. Originally, this work was done by INRENA and then passed to MINAG. It is probable that there is similar information in another watershed

## **(2) Description of the visit to the study sites**

Figure 3.1.6-1 shows pictures of main sites visited.

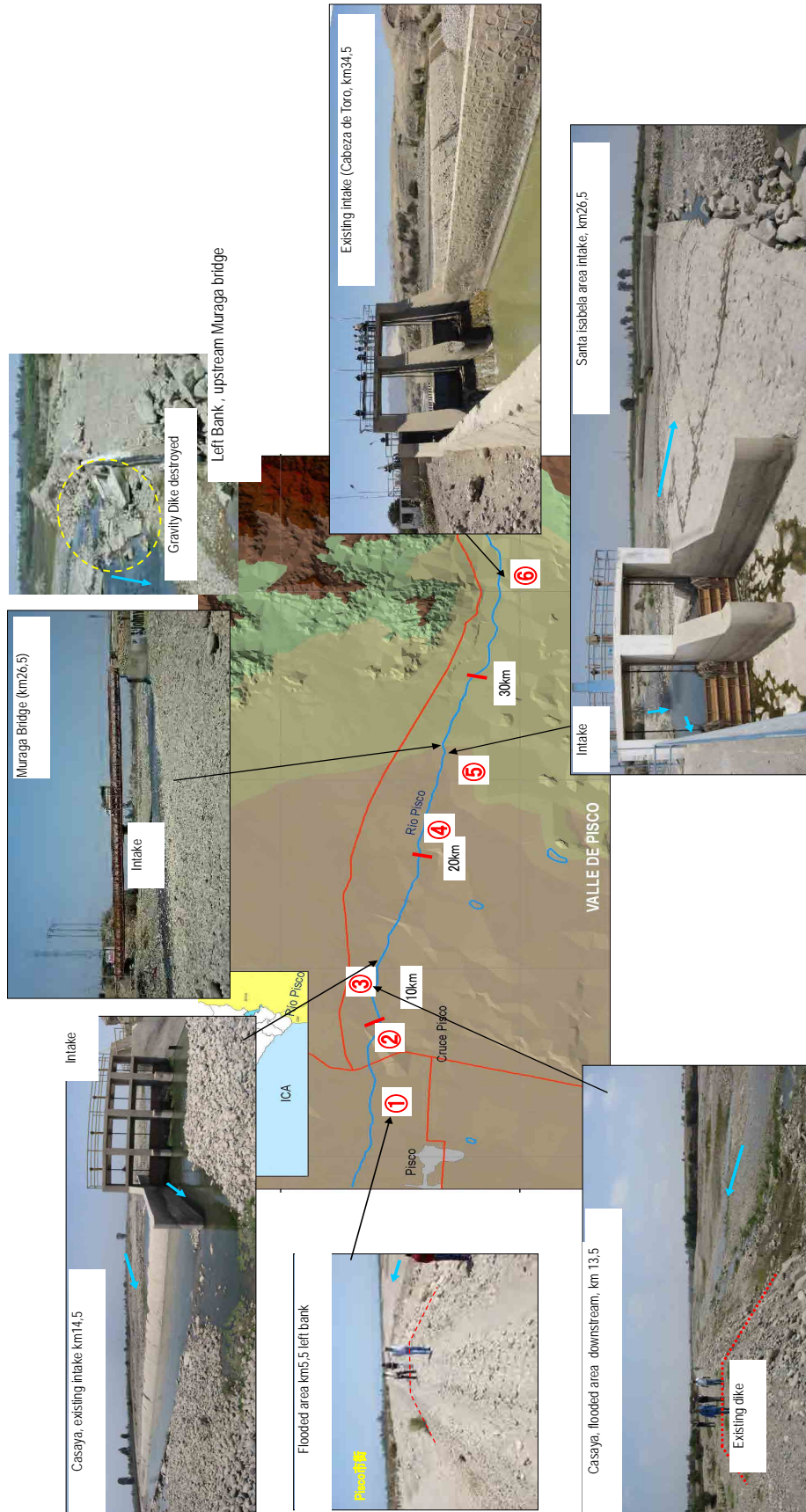

Figure 3.1.6-1 Visit to the Study Site (Pisco River)

**(3) Challenges and measures**

The following table shows challenges and possible solution measures for flood control considered at this moment, based on the results of technical visits.

1) Challenge 1: Flood area (km 5.5)

Current situation and challenges	<ul style="list-style-type: none"> <li>• A flood of 700 m<sup>3</sup>/s was registered during El Niño</li> <li>• Pisco Municipality was flooded by the overflow of the left bank in km 5.5</li> <li>• The bed has been rising up approx 3 meters in the past 40 years</li> <li>• The dike needs to be extended to the lower region, but there is no actual concrete plan</li> </ul>
Main elements to be conserved	<ul style="list-style-type: none"> <li>• Agricultural lands</li> <li>• Pisco urban area</li> </ul>
Basic measures	<ul style="list-style-type: none"> <li>• Construct a dike on the non-protected section</li> <li>• Bank protection works</li> </ul>

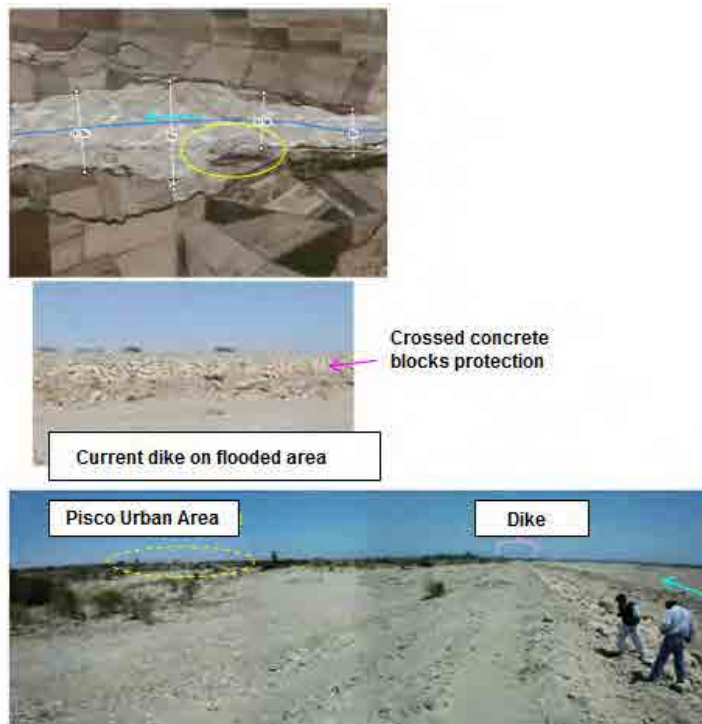

**Figure 3.1.6-2 Local conditions related with Challenge 1 (Pisco River)**

2) Challenge 2: Intake (km 26.5)

Current situation and challenges	<ul style="list-style-type: none"> <li>• During El Niño in 1998, the overflow waters gathered on the intake and destroyed it. Also, the channels were buried</li> <li>• Currently, the intake and the channel have been repaired</li> <li>• The river's width to the intake's height is 90meters and is narrower Downstream than upstream (between 250 and 500meters)</li> </ul>
Main elements to be conserved	<ul style="list-style-type: none"> <li>• Agricultural lands (main products are not known currently)</li> </ul>
Basic measures	<ul style="list-style-type: none"> <li>• Rehabilitate destroyed installations and reinforce the existing dike</li> <li>• Stable water flow throughout widening and rehabilitation of channels, buying the necessary lands</li> </ul>



Figure 3.1.6-3 Local conditions related with Challenge 2 (Pisco River)

3) Challenge 3: Flooding area (km 34.5)

Current situation and challenges	<ul style="list-style-type: none"> <li>• One time the water has overflow from the right bank, upstream the intake, and this event left several sediments amounts gathered</li> <li>• A dike upstream the intake was built alter the floods</li> </ul>
Main elements to be conserved	<ul style="list-style-type: none"> <li>• Agricultural lands (main product: corn)</li> </ul>
Basic measures	<ul style="list-style-type: none"> <li>• Rehabilitate the intake</li> <li>• Build retardation reservoirs upstream the intake</li> </ul>

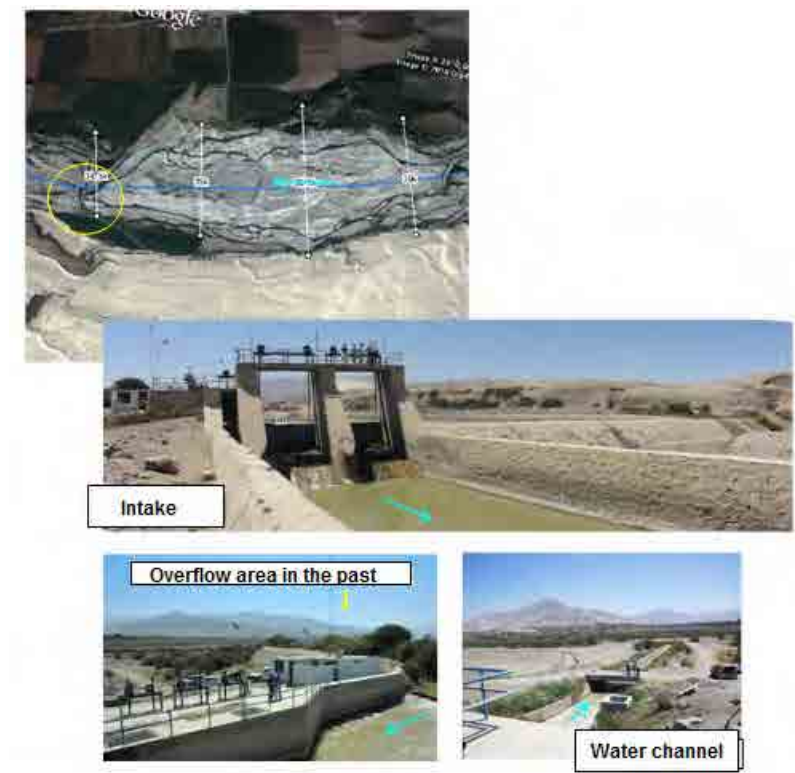

**Figure 3.1.6-4 Local conditions related with Challenge 3 (Pisco River)**

### 3.1.7 Current situation of vegetation and reforestation

#### (1) Current Vegetation

According to the Forest Map 1995 and its clarification, the basins of the rivers Cañete, Chincha, Pisco and Yauca extend from the coast to the Andean region, presenting different types of vegetation according to altitude. From the coast to 2,500 m (Cu, DC) is characterized by its low vegetation. Except for the river banks, mainly herbal areas, cactus areas or areas without vegetation extend. In areas somewhat higher, only bushes distribute sparsely. Between 2,500 and 3,500 meters mosl, bushes develop through rainfall occurring in these areas. Further, the vegetation disappears again due to low temperatures and extends mainly herbal areas. Even in the bushes, the tree maximum height is approximately 4 meters. However, on the riverbanks tall trees grow even in dry areas.

**Table 3.1.7-1 List of representative vegetable forming in the Pisco River watershed**

Symbol	Life Zone	Distribution of Altitude	Rainfall	Representative Vegetation
1)Cu	Coast Crop Lands	Coast	Almost none.	Coastal crops
2)Dc	Coast Desert	0~1,500 mosl	Almost none, there are mist zones.	Almost none, there are vegetation slopes
3)Ms	Dry Thicket	1,500~3,900 mosl	120~220mm	Cactus and grass
4)Msh	Subhumid Forest	North-center: 2,900~3,500 mosl Inter Andean 2,000~3,700 mosl	220~1,000mm	Perennial bushes, less than 4m high
5)Mh	Humid Forest	North: 2,500~3,400 mosl South 3,000~3,900 mosl	500~2,000mm	Perennial bushes, less than 4m high
6)Cp	Puna grass	Approx 3,800 mosl	No description	Gramineae
7)Pj	Scrubland	3,200~3,300 mosl Center-South up to 3,800 mosl	South zone with low rainfall: less than 125mm East springs: higher than 4,000mm	Gramineae
8)N	Ice-capped mountains		—	—

Source: Prepared by the JICA Team based on the Forest Map. 1995

#### (2) Area of vegetation

In the present study we determined the percentage of area occupied by each vegetation type compared to the total area of the basin, overlapping the results of INRENA from 1995 to GIS (see Tables 3.1.7-2 and Figures 3.7. 2-1). Then, we calculated the sum of the areas of each ecological life zone, distinguishing the coastal desert (Cu, Dc), dry scrub (Ms), shrubs (Msh, Mh), and grassland / Puna grass (Cp, Pj .) Table 3.1.7-3 shows the percentage of each ecologic off the whole area of each basin. It is observed that the desert occupies 30% of the total dry scrubland between 10 and 20% grassland / Puna grass between 30 and 50%. The shrubs occupy 10 to 20%. The shrubs are distributed in areas of extremely unfavorable conditions for the development of dense forest, which is why the surface of the brush is not extensive. Thus it follows that the natural conditions in the Pisco Basin. In particular, low rainfall, infertile soil and slope are limiting factors for growth of vegetation, especially tall tree species.

**Table 3.1.7-2 Plant formations on surface opposite to the surface of the basin  
(Pisco River Watershed)**

Watershed	Vegetation Cover								
	Cu	Dc	Ms	Msh	Mh	Cp	Pj	N	Total
(Surface: ha)									
Pisco River	217,88	1.354,39	469,99	381,55	140,01	672,59	1,035,68	0,00	4,272,09
(Percentage of the watershed: %)									
Pisco river	5,1	31,7	11,0	8,9	3,3	15,7	24,2	0,0	99,9

Source: Prepared by the JICA Team based on the INRENA Forest Map of 1995

**Table 3.1.7-3 Percentage of ecological life areas opposite to the surface of the watersheds  
(Pisco River Watershed)**

Watershed	Ecologic areas					Total
	Desert, etc. (Cu, Dc)	Dry bushes (Ms)	Bushes (Msh, Mh)	Grass (Cp, Pj)	Snow (N)	
(Percentage of the watershed: %)						
Pisco	36.8	11.0	12.2	40.0	0.0	100.0

Source: Prepared by the JICA Team based on the INRENA Forest Map of 1995

### (3) Forest area variation

Although a detailed study on the variation of the forest area in Peru has not been performed yet, the National Reforestation Plan Peru 2005-2024, Annex 2 of INRENA shows the areas deforested per department until 2005. These areas subject matter of this study are included in the regions of Arequipa, Ayacucho, Huancavelica, Ica, Lima and Piura, but they only belong to these regions partially. Table 3.1.7-4 shows the lost forest surface (total accumulated) of the corresponding areas. There is no data corresponding to Ica department

**Table 3.1.7-4 Area Deforested Until 2005**

Department	Area (ha)	Area deforested accumulated (ha) and the percentage of such area in the department area (%)	Post-Felling Situation	
			Non used Area (ha)	Used area(ha)
Ica	2.093.457	-	-	-

Source: National Reforestation Plan, INRENA, 2005

The variation of the distribution of vegetation was analyzed per watershed, comparing the from the FAO study performed in 2005 (prepared based on satellite figures from 2000) and the results of the 1995 INRENA study (prepared base on satellite figures from 1995). (See Table 3.1.7-5).

By analyzing the variation of the surface of each vegetation type, we can see that vegetation in dry areas has reduced (desert and cactus: Cu, DC, and Ms) and bushes increased (Msh, Mh).

**Table 3.1.7-5 Changes in the areas of distribution of vegetation from 1995 to 2000**

Watershed	Formaciones vegetales								
	Cu		Cu		Cu		Cu		Cu
(Surface of the vegetation cover: hectare)									
Pisco	-3.59	-3.44	-50.99	46.88	7.01	-9.52	13.65	—	4,272.09
Current Surface (b)	217.88	1,354.39	469.99	381.55	140.01	672.59	1,035.68	0.00	4,272.09
Percentage of current surface (a/b) %	-1.6	-0.3	-10.8	+12.3	+5.0	-1.4	+1.3	—	

Source: Prepared by the JICA Study Team based on the studies performed by the INRENA 1995 and FAO 2005

#### (4) Current situation of forestation

In low and middle basins, trees are planted mainly for three purposes: 1) reforestation along the river for disaster prevention, ii) to protect farmland from wind and sand, and iii) as perimeter fences for houses. In any case, the surface is extremely low. The species most commonly planted is eucalyptus, and follows Casuarinaceae. It is very uncommon the use native species. On the other hand, in the Andean highlands, reforestation for the production of firewood takes place, agricultural land protection (against the cold and the entry of livestock) and for the protection of aquifer recharge areas. The most planted species are eucalyptus and pine. Many reforestation projects in the Andean highlands have been executed in the framework of PRNAMACHIS (now AgroRural). This program involves the delivery of seedlings to the agro-rural community, which are planted and managed by farmers. There is also a reforestation program implemented by the regional government, but of reduced magnitude. In this case, the program states that the need for community consensus for the selection of areas to be reforested. But generally, most farmers want more land to cultivate, and delay in reaching consensus to undertake reforestation. Another limiting factor is the cold weather at altitudes of 3,800 meters or more. Overall, it has been almost been able to collect information on reforestation projects implemented to date, since the files were not available due to the process of institutional reform. The National Reforestation Plan (INRENA, 2005) shows the data of reforestation carried out between 1994 and 2003 according to departments (former administrative division). We extracted data from the former departments that are included in this study (Table 3.1.7-6). It is observed that the reforested area increased in 1994, and then decreased drastically.

**Table 3.1.7-6 Forestation carried out between 1994-2003**

(Units: ha)

Department	1994	1995	1996	1997	1998	1999	2000	2001	2002	2003	Total
Ica	2.213	20	159	159	89	29	61	15	4	1	2.750

Source: National Reforestation Plan, INRENA, 2005



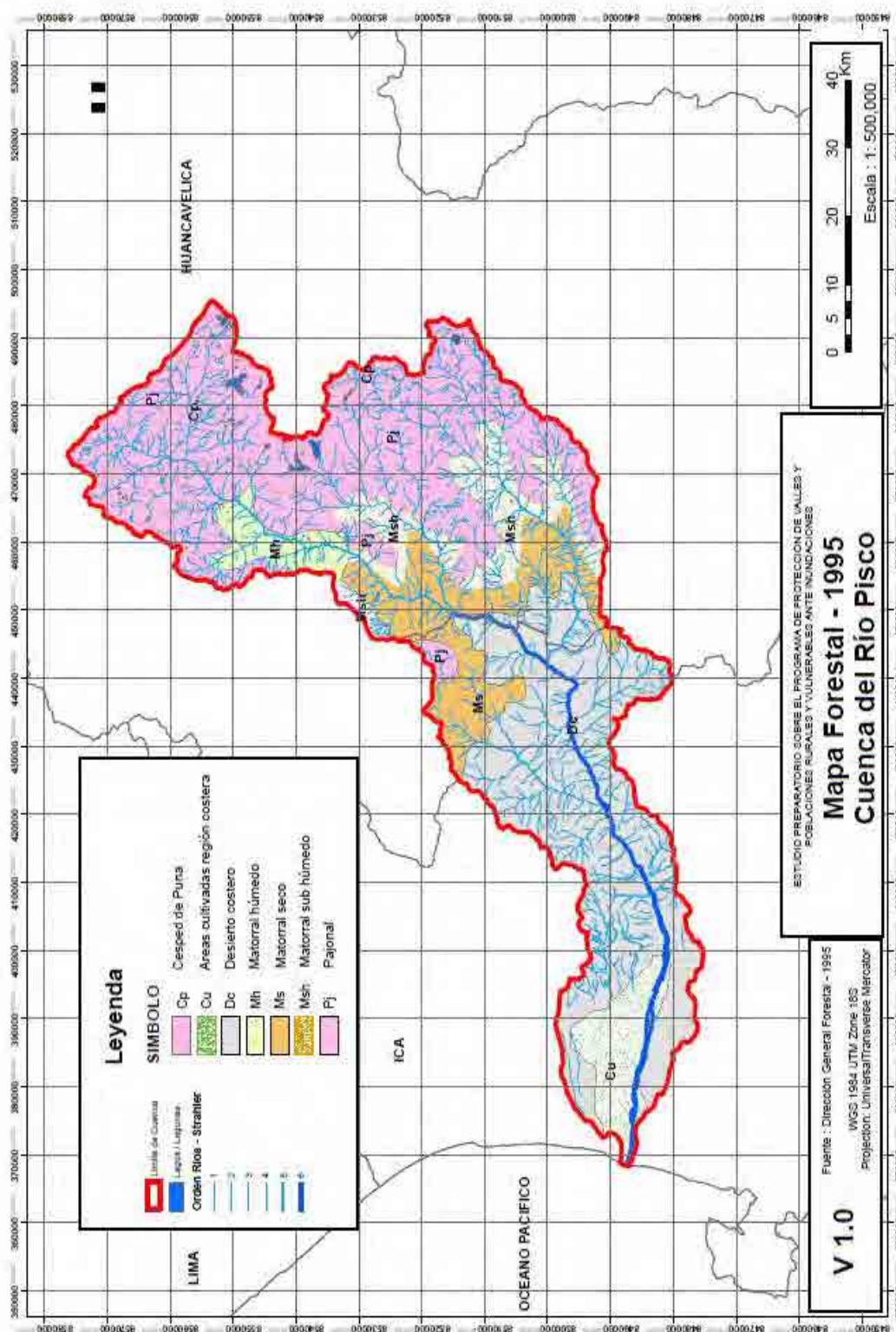

Table 3.1.7-1 Forestation map of Pisco river watershed

### 3.1.8 Current situation of the soil erosion

#### (1) Information gathering and basic data preparation

##### Information Gathering

During this study the data and information indicated in Table 3.1.8-1 was collected in other to know the current situation of the sediment production behind the Study Area.

**Table 3.1.8-1 List of collected information**

	Forms	Prepared by:
Topographic map (Scale 1/50.000)	Shp	INSTITUTO GEOGRAFICO NACIONAL
Topographic map (Scale 1/100.000)	Shp,dxf	INSTITUTO GEOGRAFICO NACIONAL
Topographic map (Scale 1/250.000)	SHP	Geologic data systems
Topographic map (Scale 1/100.000)	Shock Wave	INGEMMET
30 m grid data	Text	NASA
River data	SHP	ANA
Watershed data	SHP	ANA
Erosion potential risk map	SHP	ANA
Soils map	SHP	INRENA
Vegetal coverage map	SHP2000 PDF1995	DGFFS
Rainfall data	Text	Senami

##### Preparation of basic data

The following data was prepared using the collected material. Details appear in Annex 6.

- Hydrographic watershed map (zoning by third order valleys)
- Slope map
- Geological Map
- Erosion and slope map
- Erosion and valley order map
- Soil map
- Isohyets map

#### (2) Analysis of the causes of soil erosion

##### 1) Topographic characteristics

- i) Surface pursuant to altitudes

Table 3.1.8-2 and Figure 3.1.8-1 show the percentage of surface according to altitudes of Pisco River watershed.

**Table 3.1.8-2 Surface according to altitude**

Altitude (mosl)	Area ( Km <sup>2</sup> )
	Pisco
0 – 1000	694,58
1000 – 2000	476,7
2000 – 3000	684,78
3000 – 4000	760,47
4000 – 5000	1647,8
5000 – Más	6,19
TOTAL	4270,52
Maximum altitude	5110,00

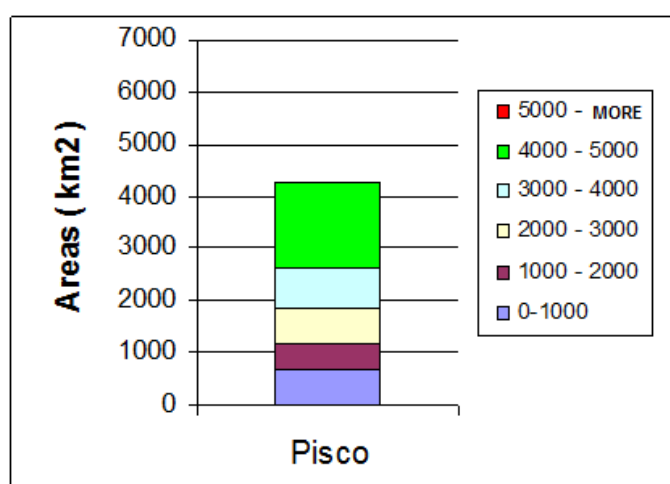

**Figure 3.1.8-1 Surface according to altitude**

ii) Zoning according to slopes

Table 3.1.8-3 and Figure 3.1.8-2 show the slopes in each watershed.

**Table 3.1.8-3 Slopes and surface**

Watershed slope ( % )	Pisco	
	Area (km <sup>2</sup> )	Percentage
0 - 2	869,75	5%
2 - 15	6210,54	36%
15 - 35	5452,97	32%
More than 35	4516,25	26%
TOTAL	17049,51	100%

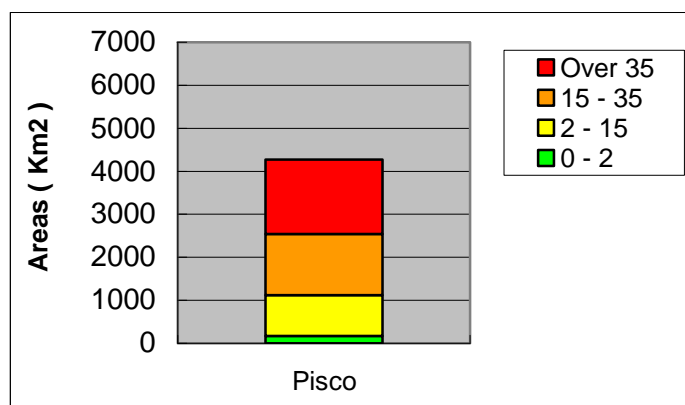

**Figure 3.1.8-2 Slopes and surface**

iii) River-bed slope

Table 3.1.8-4 and Figure 3.1.8-3 show the slope in every river and the length of streams including tributaries. Figure 3.1.8-4 shows the general relation of the movement of sediments and the river-bed slope. Supposedly, sections with more than 33.3 % of slope tend to produce higher amount of sediments, and hillsides with slopes between 3.33 % and 16.7 %, accumulate sediments easier.

**Table 3.1.8-4 River-bed Slope and total length of stream**

River-bed slope (%)	Pisco
0,00 - 1,00	12,15
1,00 - 3,33	165,05
3,33 - 16,67	1683,15
16,67 - 25,00	519,64
25,00 - 33,33	291,84
33,33 - More	511,76
<b>TOTAL</b>	<b>3183,59</b>

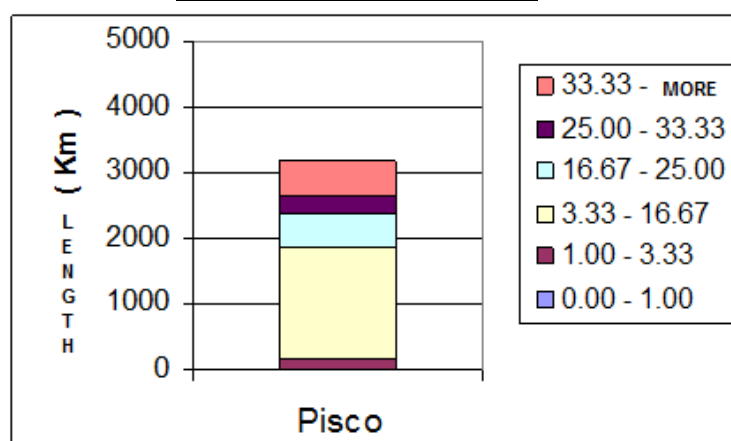

**Figure 3.1.8-3 River-bed Slope and total length of streams**

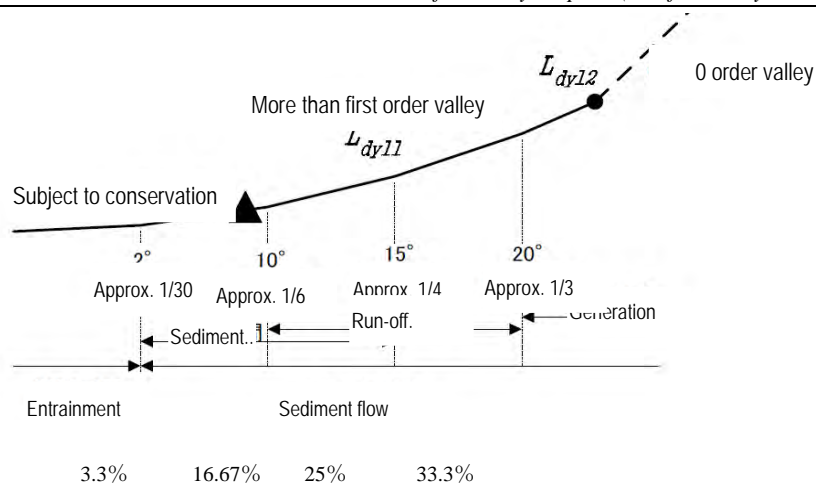

**Figure 3.1.8-4 River-bed slope and sediment movement pattern**

## 2) Rainfall

In the Pacific coast there is an arid area (Coast) of between 30 and 50 km wide and approx. 3,000 km long. This region belongs to the Chala climate area where the average annual temperature is around 20 ° C, and almost no rain throughout the year.

Altitudes between 2,500 and 3,000 m belongs to the Quechua climate, where annual rainfall is between 200 and 300 mm. Beyond this area, between altitudes of 3,500 and 4,500 meters lies a natural region called Suni, characterized by its sterility. Rainfall of 700 mm occurs annually in this region.

Figure 3.1.8-4 shows the isohyetal maps (annual rainfall) of the Pisco River basin.

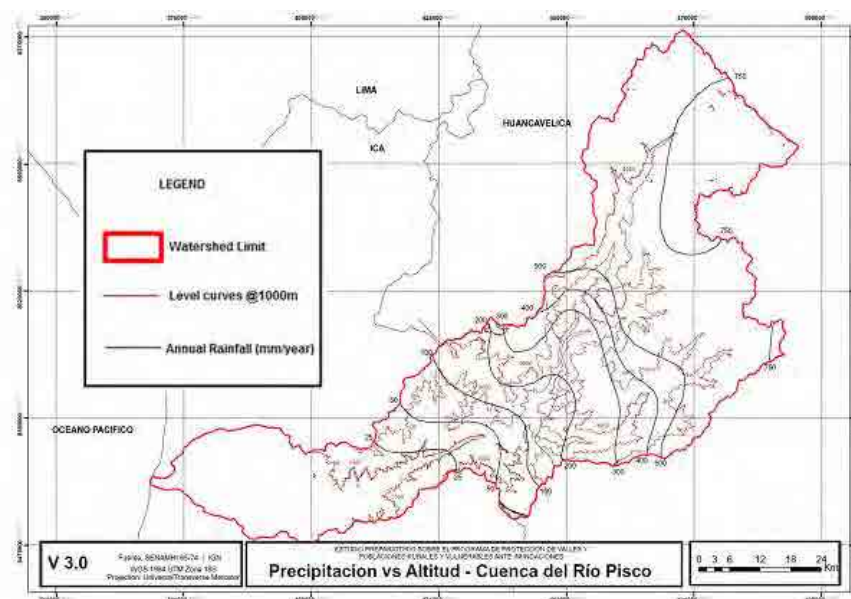

Source: Prepared by the JICA Study Team based on the SENAMHI data

**Figure 3.1.8-5 Isohyet Map of the Pisco river watershed**

Annual rainfall in the area subject to flooding analysis range from 0 to 25 mm. The average annual rainfall in the area of 4000 m in the northern part between 500 and 750 mm.

### 3) Erosion

The characteristics of erosion of the watershed in general are presented below. This is divided in three large natural regions: Coast (Area A), Mountain/Suni (Area B), and Puna (Area C). Figure 3.1.8-6 shows the corresponding weather and the rainfalls. It is observed that the area most sensitive to erosion is Mountain/Suni where the pronounced topography without vegetal coverage predominates.

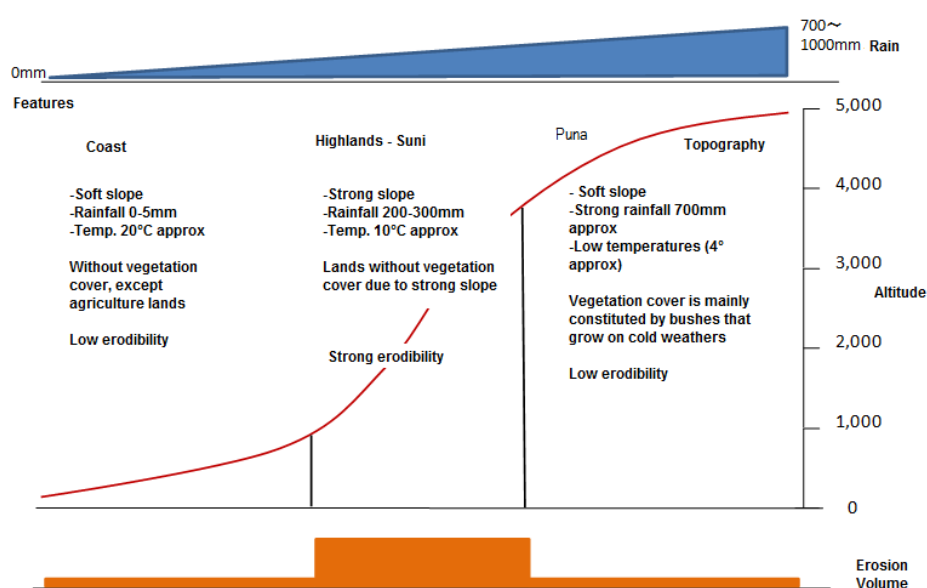

**Figure 3.1.8-6 Relation between the erosion volume and the different causes**

#### (3) Identification of the zones more vulnerable to erosion

The erosion map prepared by ANA considers the geology, hill sloping and rainfalls. Supposedly, the erosion depth depends on the hillside slope, and in such sense the erosion map and the slope map are consistent. Thus, it is deduced that the zones more vulnerable to erosion according to the erosion map are those where most frequently erosion happens within the corresponding watershed.

Between 1,000 and 4,000 m are numerous slopes over 35 degrees of tilt, particularly between 2,000 and 3,000 m, 79% of the slopes are of these inclinations, and we can say that areas very susceptible to erosion. Similar trend occur in the adjacent basin of the Pisco River.

**Table 3.1.8-5 Slopes according to altitudes of Pisco river**

Altitude	SLOPES				Total
	0-2	2 - 15	15 - 35	More than	
0 - 1000	132.09	371.35	118.98	60.92	683.34
Ratio	19%	54%	17%	9%	100%
1000 - 2000	1.79	25.01	107.69	373.82	508.31
Ratio	0%	5%	21%	74%	100%
2000 - 3000	2.08	23.33	101.38	479.29	606.08
Ratio	0%	4%	17%	79%	100%
3000 - 4000	3.58	67.75	230.25	415.34	716.92
Ratio	0%	9%	32%	58%	100%
4000 - 5000	33.74	459.43	856.43	398.45	1748.05
Ratio	2%	26%	49%	23%	100%
5000 - More	0.02	1.51	4.06	3.8	9.39
Ratio	0%	16%	43%	40%	100%
Total	173.30	948.38	1418.79	1731.62	4272.09
Ratio	4%	22%	33%	41%	100%

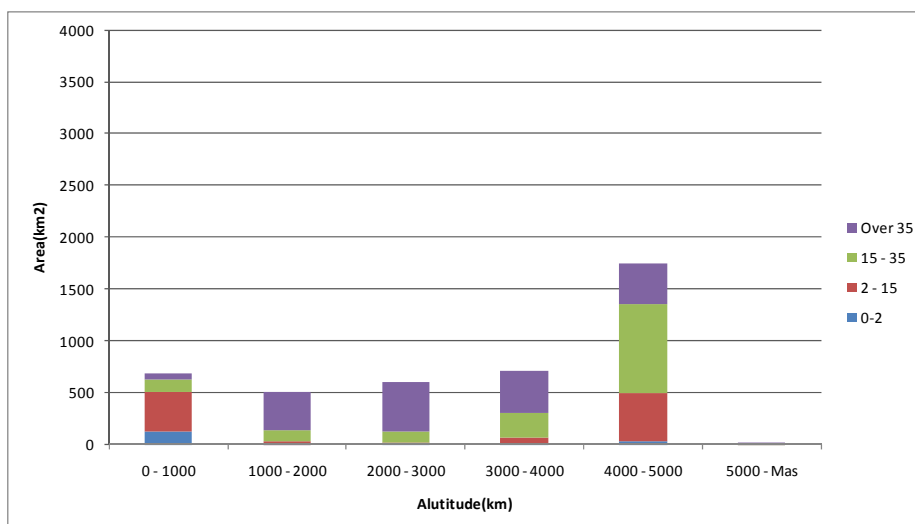

**Figure 3.1.8-7 Slopes according to altitudes Pisco River**

**(4) Production of sediments**

**1) Results of the field investigation**

Was conducted to study the upper basin of Pisco. Here are the results of the study.

- At mountain slopes the formation of clastic material released by the collapse or wind erosion.
- Production patterns differ depending on the geology of the rock base. If the rock is andesite or basalt basis, the mechanism consists mainly of large gravel falling and fracturing (see Figure 3.1.8-8 and Figure 3.1.8-9).

- Rooted vegetation is not observed (Figure 3.1.8-10) probably due to sediment transport in ordinary time. In the joints of the rock layer andesite, etc. where little sediment movement occurs, there has been the development of algae and cactus.
- In almost every the channel we observed the formation of the lower terraces. In these places, the sediment washed from the slopes does not directly enter the channel, but are deposited on the terrace. For this reason, most of the sediment entering the river, probably supplied by the eroded terraces deposits or sediments accumulated due to the alteration of the bed (see Figure 3.1.8-11).
- In the upper terraces and there was less sediment washed from the slopes fall directly into the river, although its amount is extremely small.



**Figure 3.1.8-8 Crumbled andesitic and basaltic land**

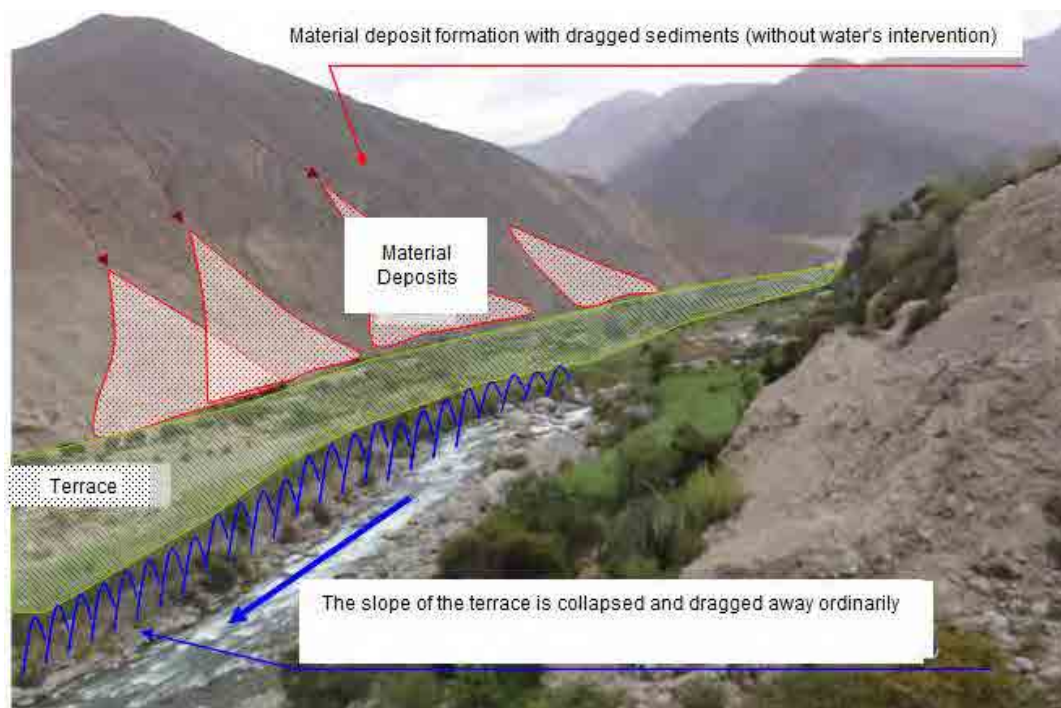

**Figure 3.1.8-9 Sediment production of sedimentary rocks**



**Figure 3.1.8-10 Cactus invasion**





**Figure 3.1.8-11 Sediment movement in the stream**

## **2) Movement of sediments (in the stream)**

In the ravines terraces develops (over 10 m high in the Pisco Basin). The base of these terraces is contacted directly with the channels and from these places the sediments are again washed and transported with a regular flow (including small and medium floods in the rainy season).

## **3) Production forecast and sediments entrainment**

It is expected that the amount of sediment production and entrainment will vary depending of the dimension of factors such as rainfall, volume of flow, etc.

Since a quantitative sequential survey has not been performed, nor a comparative study, here we show some qualitative observations for an ordinary year, a year with a rainfall similar to that of El Niño and one year with extraordinary overflow. The scope of this Study is focused on a rainfall with 50 year return period, as indicated in the Figure below, which is equivalent to the rainfall producing the sediment flow from the tributaries.

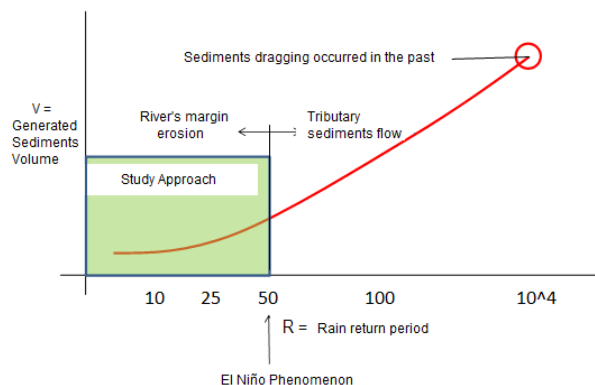

(i) An ordinary year

- Almost no sediments are produced from the hillsides
- Sediments are produced by the encounter of water current with the sediment deposit detached from the hillsides and deposited at the bottom of terraces
- It is considered that the entrainment is produced by this mechanism: the sediments accumulated in the sand banks within the bed are pushed and transported downstream by the bed change during low overflows (see Figure 3.1.8-12)

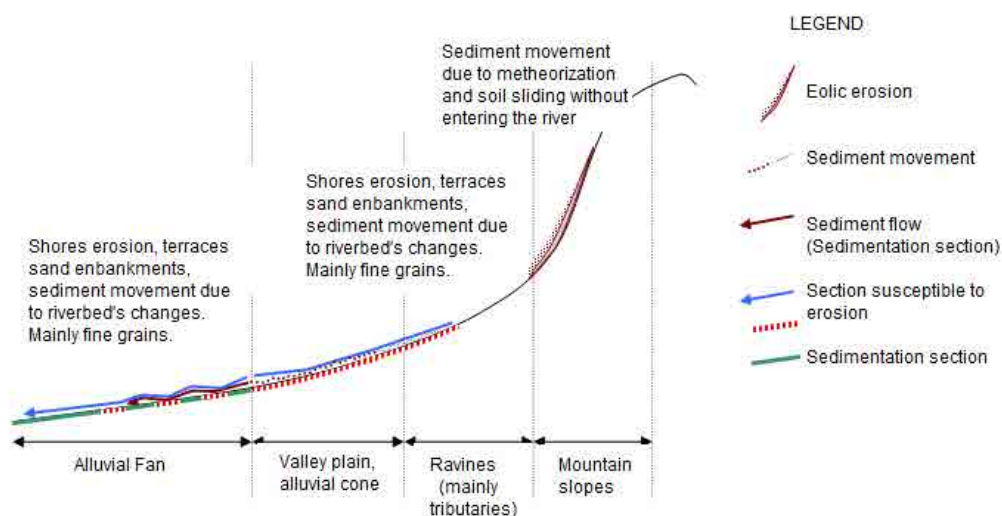

**Figure 3.1.8-12 Production and entrainment of sediments in an ordinary year**

(ii) When torrential rains with magnitude similar to that of the El Niño happen (50 years return period)

Pursuant to the interviews performed in the locality, every time El Niño phenomenon occurs the tributary sediment flow occurs. However, since the bed has enough capacity to regulate sediments, the influence on the lower watershed is reduced.

- The amount of sediments entrained varies depending on the amount of water running by the hillsides
- The sediment flow from the tributaries reaches to enter to the main river

- Since the bed has enough capacity to regulate the sediments, the influence in the watershed is reduced

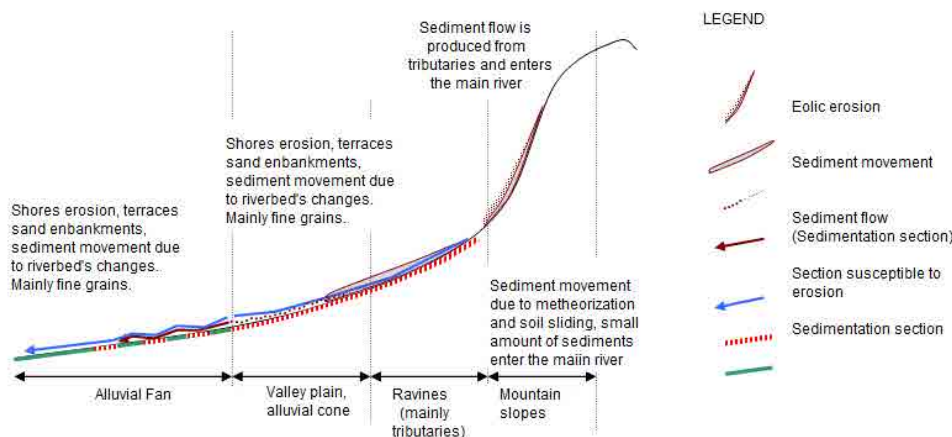

**Figure 3.1.8-20 Production and entrainment of sediments during the torrential rainfall of magnitude similar to that of El Niño (1:50 year return period)**

(iii) Large magnitude overflows (which may cause the formation of terraces similar to those existing now), with a 1:10.000 year return period

In the coast, daily rainfall with 100 years of probability are approximately 50 mm, so land slides entrained by water scarcely occur currently. However, precisely since there are few rains, when torrential rainfall occurs, there is a high potential of water sediment entrainment.

If we suppose that rainfall occurs with extremely low possibilities, for example, 1:10.000 years, we estimate that the following situation would happen (see Figure 3.1.8-14).

- Sediment entrainment from hillsides, by the amount congruent with water amount
- Exceeding sediment entrainment from the bank and bottom of hillsides by the amount congruent with the water amount, provoking landslides which may close streams or beds
- Destruction of the natural embankments of beds closed by the sediments, sediment flow by the destruction of sand banks
- Formation of terraces and increase of sediments in the beds of lower watershed due to the large amount of sediments
- Overflowing in section between alluvial cone and critical sections, which may change the bed.

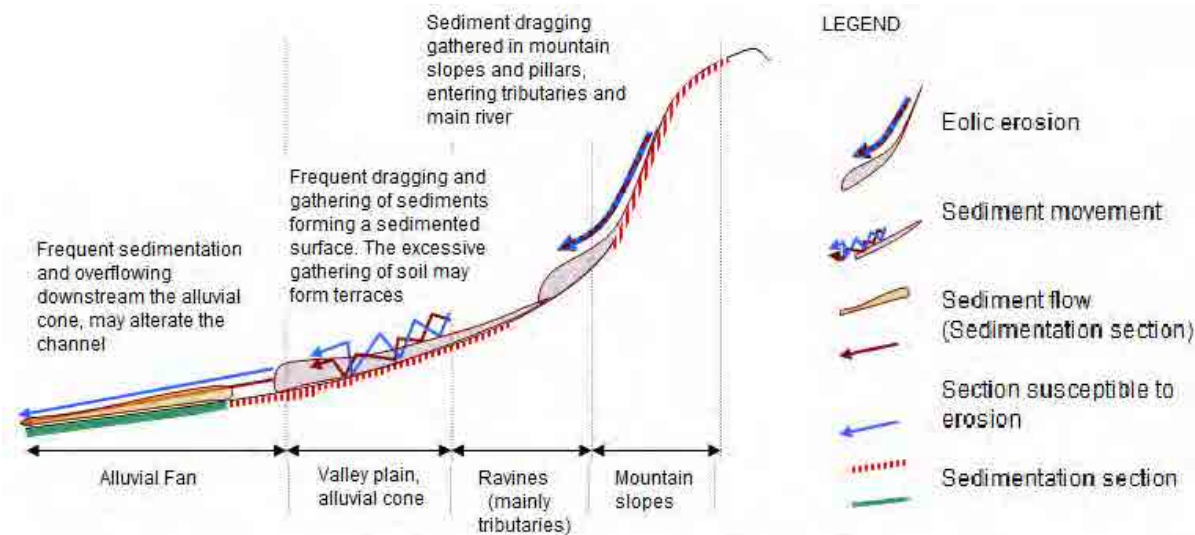

Figure 3.1.8-21 Production of sediments in large overflowing (geologic scale)

### 3.1.9 Run off analysis

#### (1) Rainfall data

##### 1) Current rainfall monitoring system

The current rainfall data collection system used for the discharge analysis was reviewed; besides, the necessary rainfall data was collected and processed for such analysis. Rainfall data was obtained from SENAMHI and ELECT.PERU.

Tables 3.1.9-1~2 and Figure 3.1.9-1 indicate the rainfall monitoring points and the data collected according to the period.

In Pisco river watershed monitoring is performed in 20 stations (including those currently non-operative), for a maximum period of 39 years from 1964 to 2002.

Table 3.1.9-1 List of rainfall monitoring stations (Pisco river watershed)

STATION	Station Code	Category	Political Location			Geographic Location			Information Period
			Department	Province	District	Latitude	Length	Latitude	
Agnococha	156 141	CO	Huancaavelica	Castrovirreyña	Pilpichaca	13° 08'	75° 09'	4650	1964 - 1989
Astobamba	155 495	PLU	Huancaavelica	Huancaavelica	Huancaavelica	12° 57'	75° 06'	4500	1964 - 1984
Bemales	157 105	CO	Ica	Pisco	Humay	13° 45'	75° 57'	250	1972 - 1981, 1984 - 1987, 1989 - 1991, 1993, 1994, 1999 - 2002
Castrovirreyña	156 145	CO	Huancaavelica	Castrovirreyña	Castrovirreyña	13° 17'	75° 19'	3956	1964 - 1980
Choclococha	156 130	PLU	Huancaavelica	Castrovirreyña	Santa Ana	13° 09'	75° 04'	4550	1964 - 1983, 1985 - 2001
Chuncho	155 269	PLU	Huancaavelica	Castrovirreyña	Chuncho	12° 45'	75° 22'	3800	1945 - 1968
Cocas	156 143	CO	Huancaavelica	Castrovirreyña	Cocas	13° 16'	75° 22'	3246	1964 - 1979
Cusicancha	156 121	PLU	Huancaavelica	Castrovirreyña	S.A. Cusicancha	13° 29'	75° 18'	3550	1964 - 1986, 1988 - 2002
Fonagro	130 791	MAP	Ica	Chincha	Chincha Baja	13° 28'	76° 08'	50	1986 - 1990, 1995 - 2002
San Genaro	156 129	PLU	Huancaavelica	Castrovirreyña	Santa Ana	13° 12'	75° 06'	4570	1964 - 1975
Huamani	157 107	CO	Ica	Ica	Los Molinos	13° 50'	75° 35'	800	1970 - 1984, 1987 - 1991, 1993, 1994, 1999
Huancano	157 103	CO	Ica	Pisco	Huancano	13° 36'	75° 37'	1006	1964, 1966 - 1976, 1978 - 1982, 1988, 1994, 1999 - 2002
Pariona	156 131	PLU	Huancaavelica	Castrovirreyña	Tambo	13° 32'	75° 04'	4240	1970 - 1982
Pisco	157 106	S	Ica	Pisco	Pisco	13° 45'	76° 13'	7	1948 - 1969
San Juan	156 114	PLU	Huancaavelica	Castrovirreyña	Castrovirreyña	13° 12'	75° 37'	2200	1966 - 2002
Tambo	156 122	PLU	Huancaavelica	Castrovirreyña	Tambo	13° 41'	75° 16'	3080	1964 - 2002
Ticrapo	156 117	PLU	Huancaavelica	Castrovirreyña	Ticrapo	13° 23'	75° 26'	2174	1964 - 1988
Tотора	156 119	PLU	Huancaavelica	Castrovirreyña	Castrovirreyña	13° 08'	75° 19'	3900	1964 - 1984, 1986 - 1988
Tunel Cero	156 142	CO	Huancaavelica	Castrovirreyña	Pilpichaca	13° 15'	75° 05'	4425	1964 - 2002
Pampa de Villacuri	157 108	CO	Ica	Pisco	Pisco	13° 57'	75° 48'	430	1971, 1972, 1975, 1984 - 1986, 1991



Figure 3.1.9-2 shows the isohyets map of the Rio Pisco.

The Pisco River basin shows that the annual rainfall varies considerably depending on the area, with a minimum of 50 mm and maximum 750 mm. Rainfall is low in the lower basin and increases as it approaches the upper basin, increasing altitudes. The annual rainfall in the low watershed, subject to the control of floods, is reduced ranging from 50 to 200 mm.

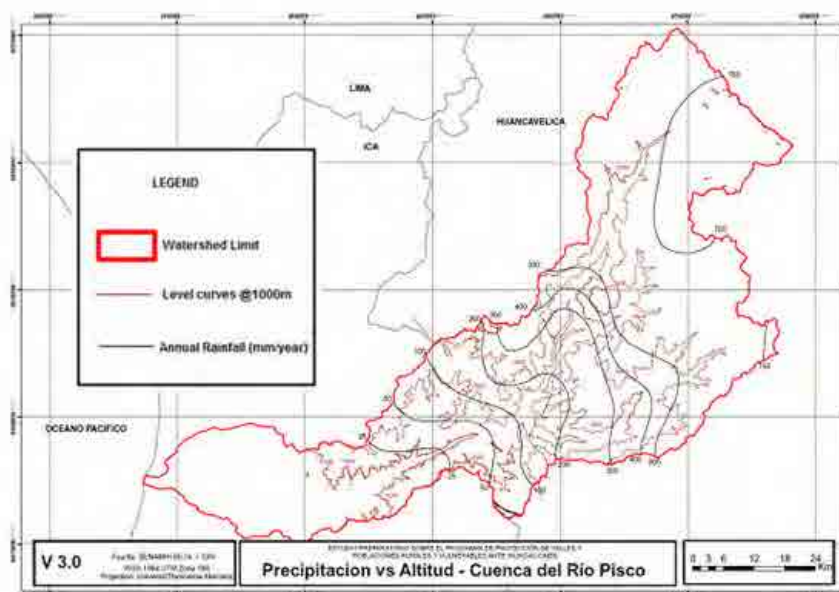

Figure 3.1.9-2 Isohyet Map (Pisco River watershed)

## (2) Rainfall analysis

### 1) Methodology

The statistic hydrologic calculation was made using the rainfall data collected from several stations, to determine the rainfall with 24 hour return period in every station.

Several models of distribution of return periods were tested and the most adequate one was adopted. Thus, the precipitation with 24 hours return period was determined with this model.

The statistic hydrologic models were.

- Normal or Gaussian distribution
- Log-normal distribution of 3 parameters
- Log-normal distribution of 2 parameters
- Distribution gamma 2 or 3 parameters
- Log Pearson Typo III distribution
- Gumbel distribution
- Generalized distribution of extreme value

## 2) Results of the rainfall analysis of return period– t

The rainfall of several stations are shown below and the reference point of each watershed, according to return periods.

The observed precipitation stations in the Pisco River are more than 10 mm with a maximum of 66 mm with a return period of 50 years.

Table 3.1.9-3 shows the monitoring points and the rainfall with 24 hour return period in the reference point. Figure 3.1.9-3 shows the map of isohyets of rainfall with 50 year return period.

**Table 3.1.9-3 Rainfall with 24 hour return period  
(Pisco river watershed)**

STATION NAME	RETURN PERIOD [YEARS]						
	PT_2	PT_5	PT_10	PT_25	PT_50	PT_100	PT_200
ACNOCOCHA	27,0	30,0	32,0	34,0	35,0	36,0	37,0
CHOCLOCOCHA	30,0	43,0	51,0	60,0	66,0	71,0	76,0
COCAS	22,0	30,0	34,0	38,0	40,0	42,0	43,0
CUSICANCHA	19,0	26,0	29,0	33,0	35,0	37,0	39,0
HACIENDA BERNALES	0,0	1,0	3,0	6,0	11,0	19,0	34,0
HUAMANI	2,0	7,0	13,0	25,0	39,0	61,0	93,0
PARIONA	33,0	40,0	43,0	46,0	48,0	49,0	50,0
SAN JUAN DE CASTROVTIREYNA	17,0	23,0	29,0	36,0	42,0	49,0	56,0
TAMBO	26,0	35,0	40,0	46,0	49,0	52,0	55,0
TICRAPO	20,0	31,0	37,0	45,0	50,0	55,0	60,0
TOTORA	24,0	29,0	32,0	36,0	38,0	40,0	42,0
TUNEL CERO	29,0	36,0	41,0	48,0	54,0	61,0	67,0

**Table 3.1.9-3 Rainfall with 24 hour for different return periods  
(Reference point: Letrayoc Station)**

Return period (years)	Maximum 24 hours precipitation (mm)
5	28,90
10	33,23
25	38,78
50	42,59
100	46,92

**Table 3.1.9-5 Different return periods of rainfall**

Years	Hours										Total precipitation (mm)
	1	2	3	4	5	6	7	8	9	10	
5	1	2	3	4	3	3	2	2	1	1	22,6
10	1	2	3	5	4	3	3	2	2	1	26,0
25	2	3	4	6	4	4	3	2	2	1	30,3
50	2	3	4	6	5	4	3	3	2	1	33,3
100	2	3	5	7	5	4	4	3	2	1	36,7

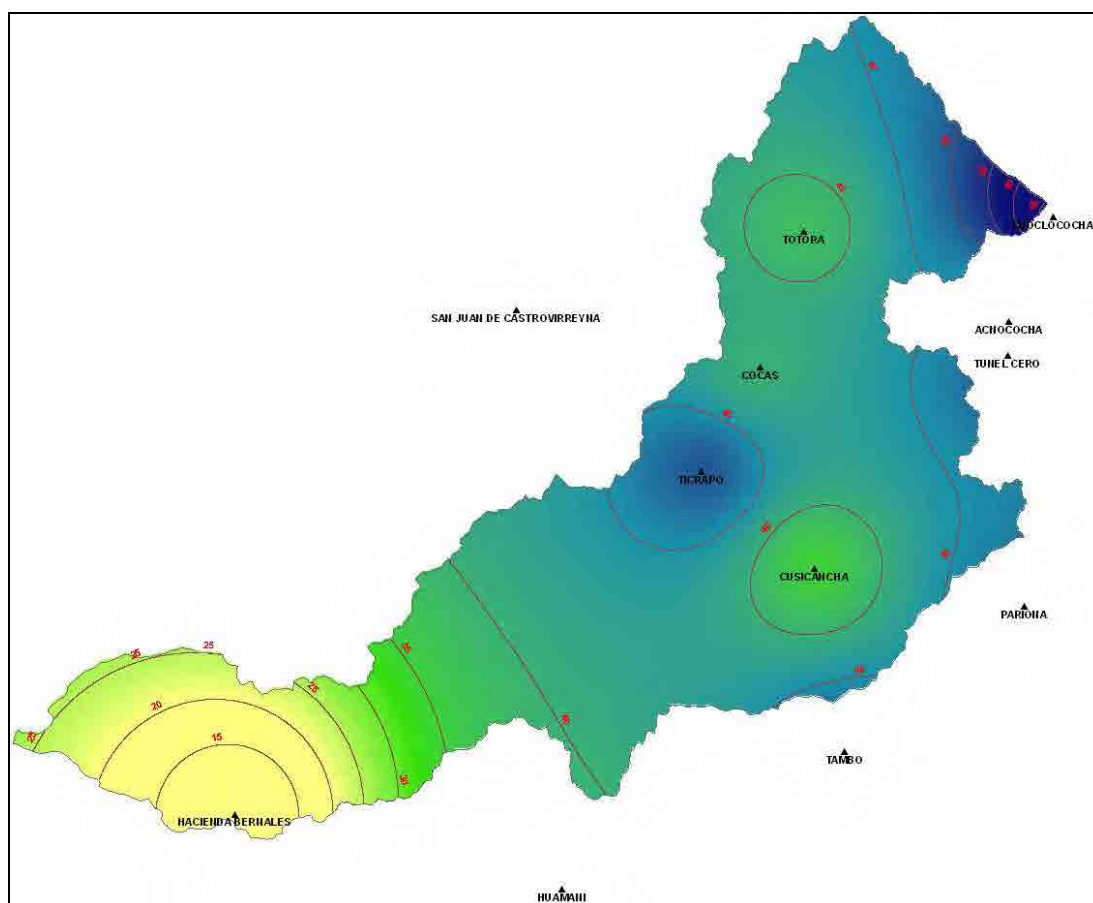

**Figure 3.1.9-4 Map of isohyets of a 50 years period rainfall (Pisco river watershed)**

### (3) Run off analysis

#### 1) Flow monitoring

The current flow data collection system used in the discharge analysis was reviewed, and the necessary flow monitoring data were collected and processed for such analysis. The flow data has been obtained from the DGIH, irrigation committees, National Water Authority (ANA in Spanish) and the special Chira – Piura project.



## 2) Run off analysis

Se realizó el cálculo estadístico hidrológico utilizando los datos de la descarga máxima anual recogidos y procesados en los puntos de referencia, para determinar el caudal con diferentes probabilidades. En la Tabla 3.1.9-6 se muestra el caudal probable con períodos de retorno entre 2 y 100 años.

**Table 3.1.9-5 Probable flow in control points**

River	Return Period					
	2 Years	5 Years	10 Years	25 Years	60 Years	100 Years
Pisco River Letrayoc	267	398	500	648	774	914

## 3) Analysis of flooding flow with t-years return periods

### (a) Methodology

The probable flooding flow was analysed using the HEC-HMS model, with which the hyetograph or return periods was prepared, and the peak flow was calculated. For the rainfall used in the analysis, the hyetograph of several periods prepared in the rainfall analysis was used. The hyetograph was determined taking as reference the peak flow estimated in the discharge analysis.

### (b) Analysis results

Table 3.1.9-7 shows the flow of floodings with return periods between 2 and 100 years of the Pisco river watershed.

Likewise, Figure 3.1.9-4 shows the hydrographical map of probable flood in the Pisco river watershed. Since the figures on Tables 3.1.9-6 and 3.1.9-7 are very similar, for the flood analysis the figures from Table 3.1.9-7 that match with the hydrograph were applied.

**Table 3.1.9-7 Flood flow according to the return periods**

**(Peak flow: Reference point)**

(m<sup>3</sup>/s)

River	Return Period					
	2 Years	5 Years	10 Years	25 Years	60 Years	100 Years
Pisco River Letrayoc	213	287	451	688	855	962

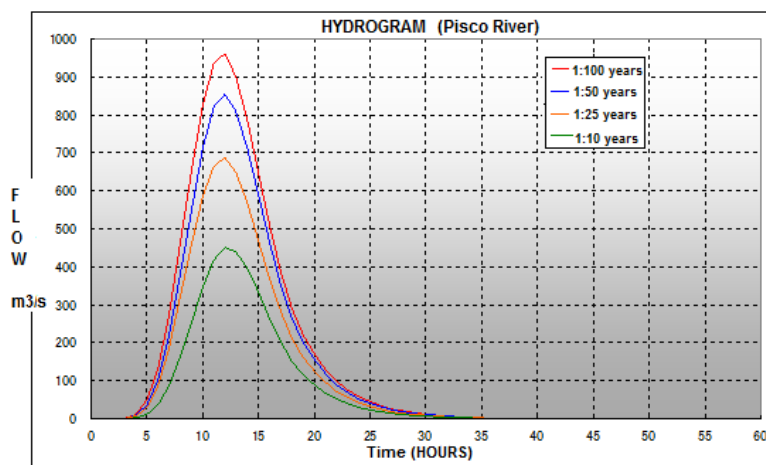

**Figure 3.1.9-4 Hydrogram of Pisco River**

### 3.1.10 Analysis of inundation

#### (1) River survey

Prior to the flood analysis, the transversal survey of Pisco river was performed as well as the longitudinal survey of dikes. Table 3.1.10-1 shows the results of the surveys in the river.

In order to obtain the topographic data for the analysis of the flooding zones, the results of the true measurement results indicated in Table 3.1.10-1 were used as a complement, using the satellite figures data.

**Table 3.1.10-1 Basic data of river raise**

Lifting	Unit	Quantity	Notes
1. Control spots lifting			
Pisco River	No.	5	
2. Dike's transversal lifting			Interval of 250 m, only one margin
Pisco River	km	45	
3. River's transversal lifting			Interval 500 m
Pisco River	km	54.6	91 lines 1x0.6 km
4. Landmarks			
Type A	No.	5	Each one of the control spots
Type B	No.	45	45km x one spot/ km
Subtotal		50	

#### (2) Inundation analysis methods

Since the DGIH carried out the flood analysis of the profile study at a program level using the HEC-RAS model, for this Study, we decided to used this method, and review and modify it, if necessary.

1) Analysis basis

Normally, for the flooding analysis the following three methods are used.

- ① Varied flow unidimensional model
- ② Tank model
- ③ Varied flow horizontal bidimensional model

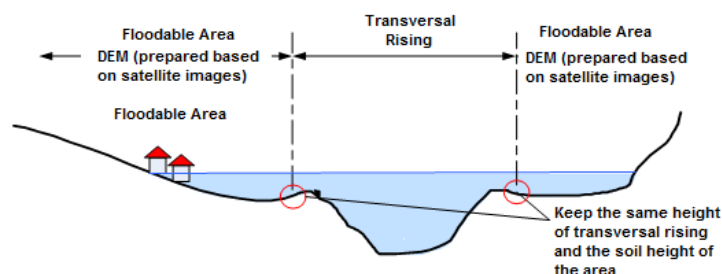
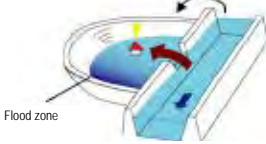
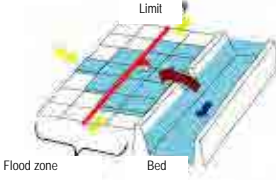

**Figure 3.1.10-1 Idea of unidimensional model**

The time and cost required by each method vary considerably, so only the most efficient method will be chosen, which guarantees the necessary accurateness degree for the preparation of the floodable zone maps.

Table 3.1.10-2 shows the characteristics of each analysis method. From the results of the simulation performed by DGIH, it is known that the rivers have a slope between 1/100 and 1/300, so initially the varied flow one-dimensional model was chosen assuming that the floods were serious. However, we considered the possibility that the overflowed water extends within the watershed in the lower watershed, so for this study the variable regimen horizontal bi-dimensional model was used to obtain more accurate results

**Table 3.1.10-2 Methodology of flooding analysis**

Analysis methods	Vary flow unidimensional model	Tank model	Varied flow bi-dimensional horizontal model
Basic concept of the flood zone definition	In this method, the flood zone is considered to be included in the river bed, and the flood zone is determined by calculating the water level of the bed in relation to the maximum flooding flow	This method manages the flood zone and bed separately, and considers the flooding zone as a closed body. This closed water body is called <i>pond</i> where the water level is uniform. The flood zone is determined in relation to the relationship between the overflowed water from the river and entered to the flood zone, and the topographic characteristics of such zone (water level– capacity– surface).	This method manages the flood zones and the bed separately, and the flood zone is determined by analyzing the bidimensional flow of the behaviour of water entered to the flood zone.
Approach	 <p style="text-align: center;">Flood zone, Bed</p>	 <p style="text-align: center;">Flood zone</p>	 <p style="text-align: center;">Flood zone Bed</p>
Characteristics	It is applicable to the floods where the overflowed water runs by the flood zone by gravity; that means, current type floods. This method must manage the analysis area as a protected area (without dikes).	Applicable to blocked type floods where the overflowed water does not extend due to the presence of mountains, hills, embankments, etc. The water level within this closed body is uniform, without flow slope or speed. In case there are several embankments within the same flood zone, it may be necessary to apply the pond model in series distinguishing the internal region.	Basically, it is applicable to any kind of flood. Beside the flood maximum area and the water level, this method allows reproducing the flow speed and its temporary variation. It is considered as an accurate method compared with other methods, and as such, it is frequently applied in the preparation of flood irrigation maps. However, due to its nature, the analysis precision is subject to the size of the analysis model grids.

## 2) Overflow analysis method

Figure 3.1.10-2 shows the conceptual scheme of the variable regimen horizontal bi-dimensional model.

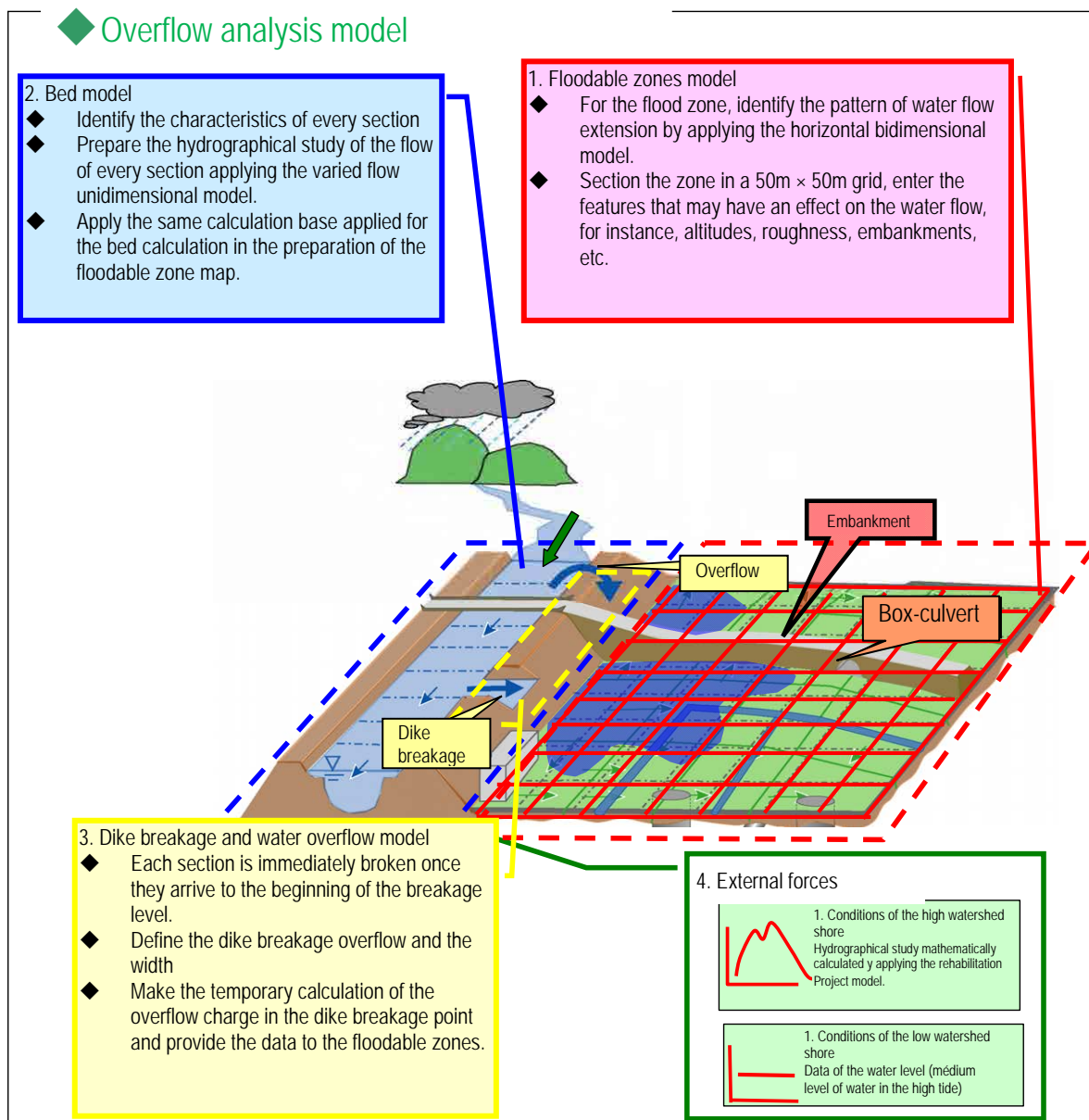

**Figure 3.1.10-2 Conceptual scheme of the overflow analysis model**

**(3) Discharge capacity analysis**

The current discharge capacity of the beds was estimated based on the results of the river survey and applying the HEC-RAS method, which results appear in Figure 3.1.10-3. This Figure also shows the flooding flows of different return periods, which allow evaluating in what points of the Pisco river watershed flood may happen and what magnitude of flood flow may they have.

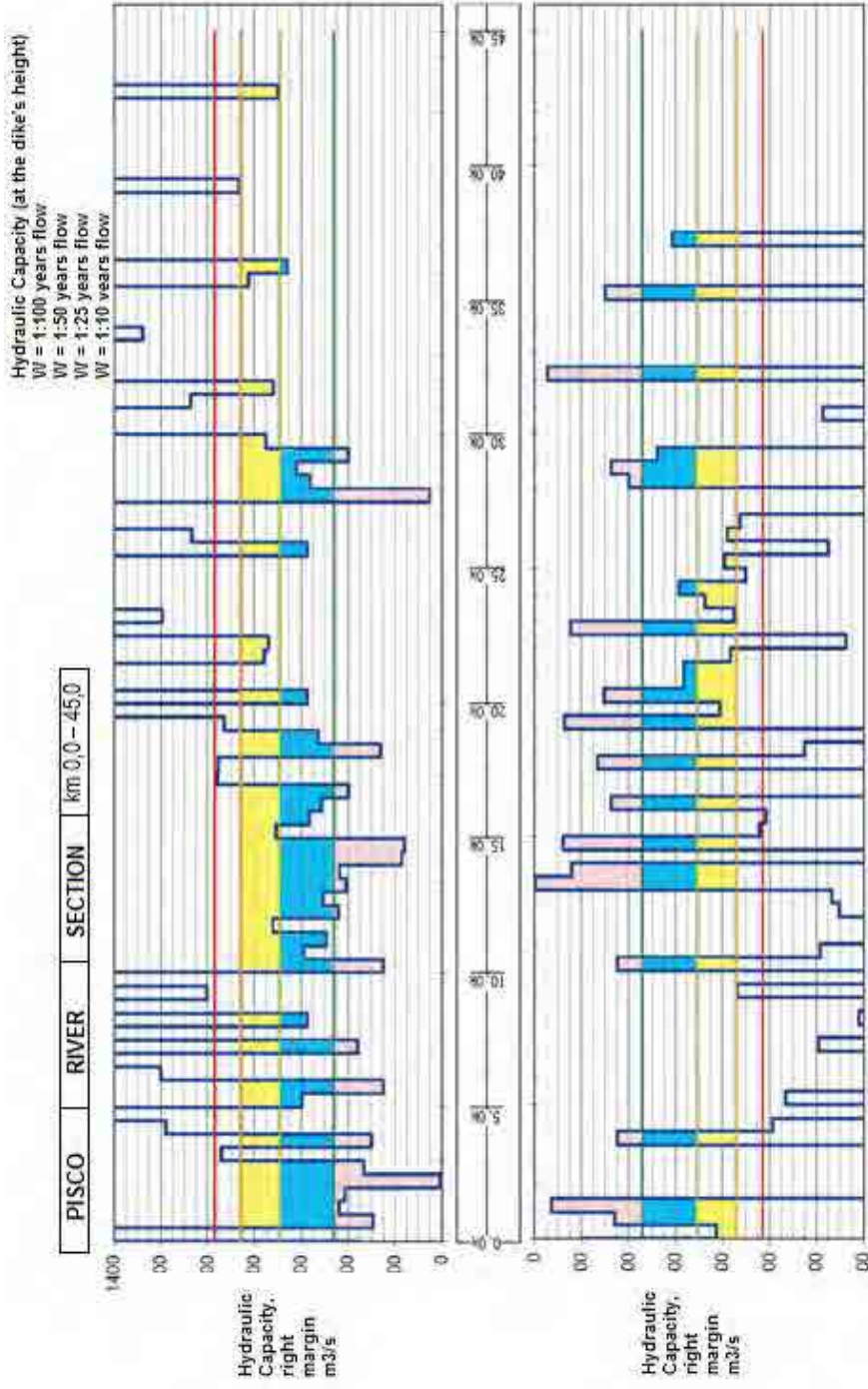
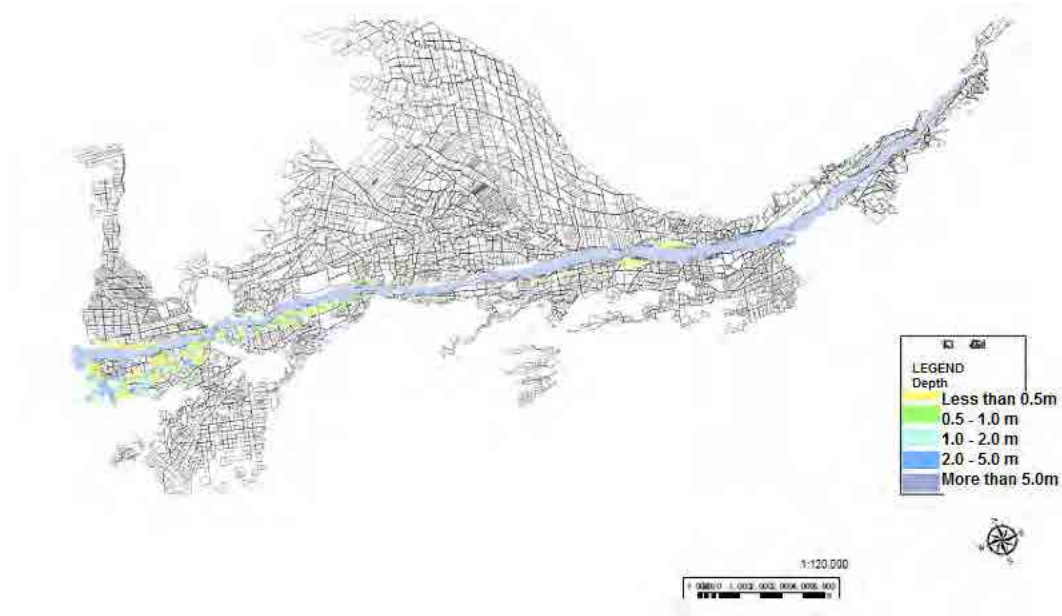

Figure 3.1.10-3 Current discharge capacity of Pisco River

**(4) Inundation area**

As a reference, Figures 3.1.10-4 show the results of the inundation area calculation in the Pisco river watershed compared to the flooding flow with a 50 year return period.



**Figure 3.1.10-4 Inundation area of Pisco River (50 year period floods)**

## 3.2 Definition of Problem and Causes

### 3.2.1 Problems of flood control measures in the Study Area

Based on the results of the Pisco River, the main problem on flood control was identified, as well as the structures to be protected, which results are summarized in Table 3.2.1-1.

**Table 3.2.1-1 Problems and conservation measures of flood control works**

Problems		Overflowing			Dike erosion	Banks erosion	Non-working intake	Non-working derivation works
		Without dikes	Sediment in bed	Lack of width				
Structures to be protected	Agricultural lands	○	○	○	○	○	○	○
	Irrigation channels					○	○	
	Urban area	○		○				○
	Roads					○		
	Bridges		○					

### 3.2.2 Problem causes

Next, the main problem and its direct and indirect causes for flood control in the Study Area are described:

(1) Main Problem

Valleys and local communities highly vulnerable to floods

(2) Direct and indirect causes

Table 3.2.2-2 shows the direct and indirect causes of the main problem



**Table 3.2.2-2 direct and indirect causes of the main problem**

Direct cause	1. Excessive flood flow	2. Overflowing	3. Insufficient maintenance of control works	4. Insufficient communitarian activities for flood control
Indirect causes	1.1 Frequent occurrence of extraordinary weather (El Niño, etc..)	2. Lack of flood control works	3.1 Lack of maintenance knowledge and skills	4.1 Lack of knowledge and flood prevention techniques
	1.2 Extraordinary rains in the middle and upper basins	2.2 Lack of resources for the construction of works	3.2 Lack of training in maintenance	4.2 Lack of training in flood prevention
	1.3 Vegetation cover almost zero in the middle and upper basins	2.3 Lack of plans for flood control in basins	3.3 Lack of dikes and banks repair	4.3 Lack of early warning system
	1.4 Excessive sediment dragging from the upper and middle river levee	2.4 Lack of dikes	3.4 Lack of repair works and referral making	4.4 Lack of monitoring and collection of hydrological data
	1.5 Reduction of hydraulic capacity of rivers by altering slopes, etc.	2.5 Lack of bed channel width	3.5 Use of illegal bed for agricultural purposes	
		2.6 Accumulation of sediments in beds	3.6 Lack of maintenance budget	
		2.7 Lack of width at the point of the bridge construction		
		2.8 Elevation of the bed at the point of the bridge construction		
		2.9 Erosion of dikes and banks		
		2.10 Lack of capacity for the design of the works		

### 3.2.3 Problem Effects

#### (1) Main Problem

Valleys and local communities highly vulnerable to floods

#### (2) Direct and indirect effects

Table 3.2.3-1 shows the direct and indirect effects of the main problem

**Table 3.2.3-1 Direct and indirect effects of the main problem**

Direct Effects	1. Agriculture Damages	2. Direct damages to the community	3. Social infrastructure damages	4. Other economical damages
Indirect Effects	1.1 Agriculture and livestock damage	2.1 Private property and housing loss	3.1 Roads destruction	4.1 Traffic interruption
	1.2 Agricultural lands loss	2.2 Industries and facilities loss	3.2 Bridges loss	4.2 Flood and evacuations prevention costs
	1.3 Irrigation channels destruction	2.3 Human life loss and accidents	3.3 Running water, electricity, gas and communication infrastructures' damages	4.3 Reconstruction costs and emergency measures
	1.4 Work destruction and derivation	2.4 Commercial loss		4.4 Work loss by local inhabitants
	1.5 Dikes and banks erosion			4.5 Communities income reduction
				4.6 Life quality degradation
				4.7 Loss of economical dynamism

(2) Final effect

The main problem final effect is the community socio-economic impediment development of the affected area.



### 3.3 Objective of the Project

The final impact that the Project wants to achieve is to alleviate the vulnerability of valleys and local community to flooding and promote local economic development.

#### 3.3.1 Solving measures for the main problem

(1) Main objective

Soothe the valleys and local community to flooding vulnerability.

(2) Direct and indirect measures

In table 3.3.1-1, direct and indirect solutions measures for the problem are shown.

**Table 3.3.1-1 Direct and indirect solution measures to the problem**

Direct measures	1. Analyze and relieve excessive flood flow	2. Prevent overflow	3. Full compliance with maintenance of flood control works	4. Encourage community flood prevention
Indirect measures	1.1 Analyze extraordinary weather (El Niño, etc..)	2.1 Construct flood control works	3.1 Strengthen maintenance knowledge and skills	4.1 Strengthen knowledge and skills to prevent flooding
	1.2 Analyze extraordinary rainfall in the upper and middle basins	2.2 Provide resources for the works construction	3.2 Reinforce training maintenance	4.2 Running flood prevention training
	1.3 Planting vegetation on the upper and middle basins	2.3 Develop plans for flood control basins	3.3 Maintain and repair dikes and banks	4.3 Creating early warning system
	1.4 Relieve Excessive sediment entrainment from the upper and middle river dikes	2.4 Build dikes	3.4 Repair intake and derivation works	4.4 Strengthen monitoring and water data collection
	1.5 Take steps to alleviate the reduction in hydraulic capacity of rivers by altering slopes, etc.	2.5 Extends the width of the channel	3.5 Control the illegal use of bed for agricultural purposes	
		2.6 Excavation of bed	3.6 Increase the maintenance budget	
		2.7 Extending the river at the bridge's construction		
		2.8 Dredging at the point of the bridge construction		
		2.9 Control dikes and banks erosion		
		2.10 Strengthen the capacity for works design		

#### 3.3.2 Expected impacts for the main's objective fulfillment

(1) Final Impact

The final impact that the Project wants to achieve is to alleviate the vulnerability of the valleys and the local community to floods and promoting local socio-economic development.

(2) Direct and indirect impacts

In table 3.3.2-1 direct and indirect impacts expected to fulfill the main objective to achieve the final impact are shown.

**Table 3.3.2-1 direct and indirect impacts**

Direct Impacts	1. Agricultural damage relief	2. Relief of direct harm to the community	3. Relief of social infrastructure damage	4. Relief of other economic damage
Indirect Impacts	1.1 Relief to crops and livestock damage	2.1 Housing and private properties loss prevention	3.1 Road destruction prevention	4.1 Traffic interruption prevention
	1.2 Relief for farmland loss	2.2 Prevention of Industries and facilities establishments	3.2 Prevention of bridges loss	4.2 Reducing costs of flood prevention and evacuation
	1.3 Prevention of the destruction of irrigation channels	2.3 Prevention of accidents and human life loss	3.3 Running water, electricity, gas and communication infrastructures' relief	4.3 Cost reduction of the reconstruction and emergency measures
	1.4 Prevention of destruction works of intake and derivation	2.4 Commercial loss relief		4.4 Increase of local community hiring
	1.5 Dikes and banks erosion relief			4.5 Community income increase
				4.6 Life quality improvement
			4.7 Economic activities development	

**3.3.3 Measures - objectives – impacts Diagram**

In Figure 3.3.3-1 the measures - objectives – impacts diagram is shown.

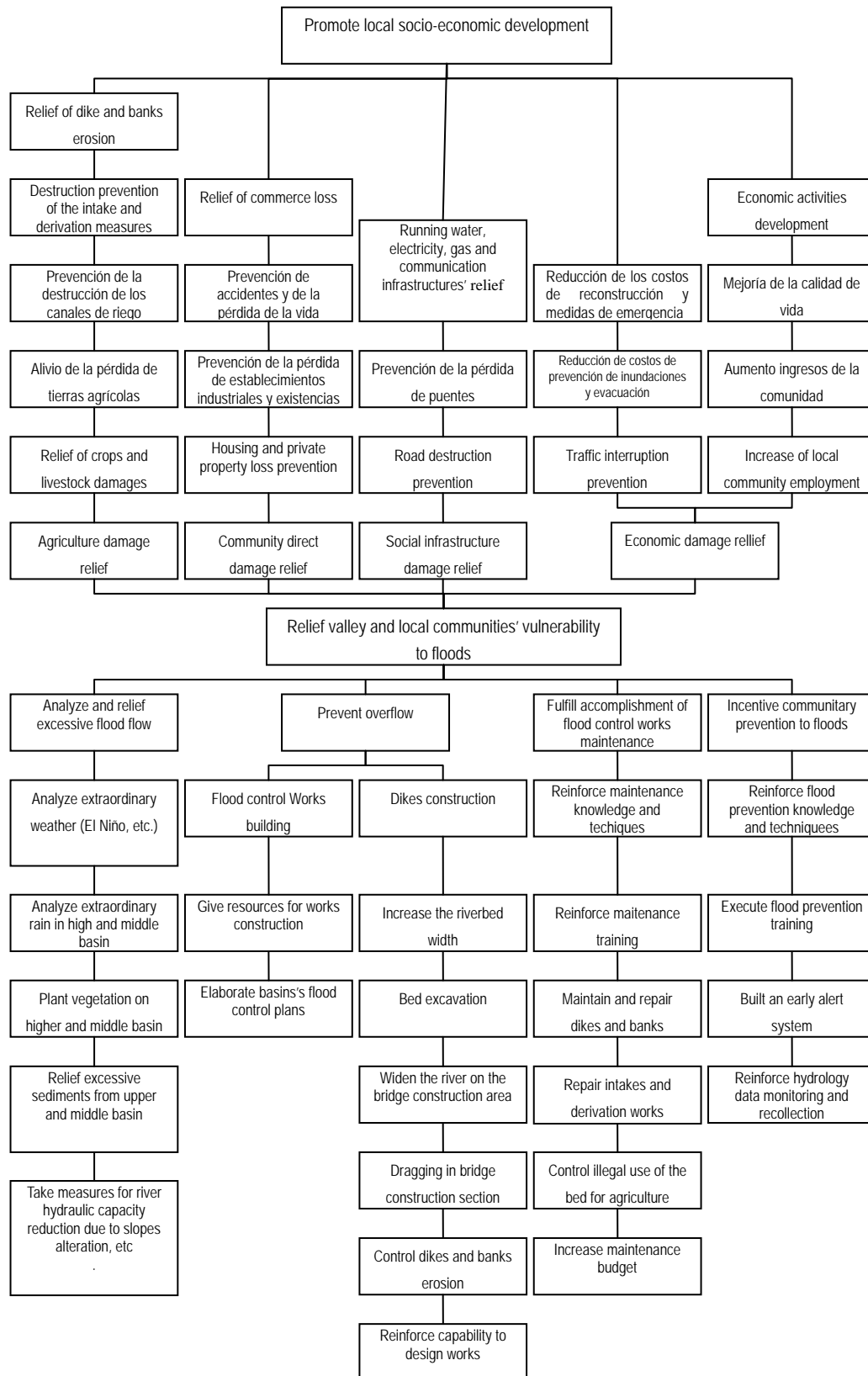

**Figure 3.3.3-1 Measures - objectives – impacts diagram**

## 4. FORMULATION AND EVALUATION

### 4.1 Definition of the Assessment Horizon of the Project

The Project's assessment horizon will be of 15 years, same as the one applied on the Program Profile Report. The Annex-10 of SNIP regulation stipulates that the assessment horizon should be basically 10 years; however the period can be changed in case that the project formulator (DGIH in this Project) admits the necessity of change. DGIH adopted 15 years in the Program Profile Report and OPI and DGPM approved it in March 19, 2010. In JICA's development study it should be generally 50 years, so the JICA Study Team inquired on the appropriate period to DGIH and OPI, they directed JICA Study Team to adopt 15 years. And the social evaluation in case of 50 years assessment horizon is described in Annex-14 Implementation Program of Japanese Yen Loan Project.

### 4.2 Supply and Demand Analysis

The theoretical water level was calculated considering flowing design flood discharge based on river cross sectional survey executed with a 500m interval, in each Watershed, considering a flood discharge with a return period of 50 years. Afterwards, the dike height was determined as the sum of the design water level plus the freeboard of dike.

This is the dike height required to prevent damages caused by design floods and represents the local community demand indicator.

The height of the existing dike or the height of the present ground is that required to prevent present flood damages, and represents the present supply indicator.

The difference between the design dike (demand) and the height of the present dike or ground represents the difference or gap between demand and supply.

Table 4.2-1 shows the averages of flood water level calculated with a return period of 50 years in "3.1.9 Run-off Analysis"; of the required dike height (demand) to control the discharge adding the design water level plus the freeboard dike; the dike height or that of the present ground (supply), and the difference between these last two (difference between demand-supply) of the river. Then, Table 4.2-2 shows the values of each point in Pisco river. The dike height or that of the present ground is greater than the required dike height, at certain points. In these, the difference between supply and demand was considered null.

**Table 4.2-1 Watershed Demand and Supply**

Watershed	Dike Height / current land (supply)		Theoretical water level with a return period of 50 years	Dike Freeboard	Required dike's height (demand)	Diff. demand/supply	
	Left bank	Right bank				Left bank	Right bank
	①	②				③	④
Pisco	219.72	217.26	214.82	1.00	215.82	0.63	0.76

**Table 4.2-2 Demand and Supply according to calculation (Pisco River)**

Distance (km)	Present Height of Embankment or Ground (supply)		Flood Water level of 1/50Year Probability	Freeboard of Embankment	Required Height of Embankment (demand)	Supply and Demand Gap	
	Left Bank	Right Bank				Left Bank	Right Bank
	①	②				⑥=⑤-①	⑦=⑤-②
0.0	2.47	2.71	3.30	1.00	4.30	1.83	1.59
0.5	3.80	5.11	4.12	1.00	5.12	1.31	0.00
1.0	5.28	5.20	5.76	1.00	6.76	1.48	1.56
1.5	7.89	8.34	8.65	1.00	9.65	1.76	1.31
2.0	13.15	11.82	12.16	1.00	13.16	0.00	1.34
2.5	16.51	14.57	15.80	1.00	16.80	0.29	2.23
3.0	25.64	19.07	19.62	1.00	20.62	0.00	1.55
3.5	24.20	23.61	23.54	1.00	24.54	0.34	0.93
4.0	27.00	26.93	27.51	1.00	28.51	1.51	1.58
4.5	31.55	31.66	31.43	1.00	32.43	0.88	0.77
5.0	37.35	37.31	36.54	1.00	37.54	0.19	0.23
5.5	40.53	40.09	40.35	1.00	41.35	0.82	1.26
6.0	44.98	43.66	44.45	1.00	45.45	0.47	1.79
6.5	49.78	48.97	48.52	1.00	49.52	0.00	0.55
7.0	56.31	56.69	52.72	1.00	53.72	0.00	0.00
7.5	56.28	55.40	55.91	1.00	56.91	0.63	1.51
8.0	60.66	60.23	59.52	1.00	60.52	0.00	0.28
8.5	64.92	64.20	64.49	1.00	65.49	0.56	1.29
9.0	69.49	69.05	68.58	1.00	69.58	0.09	0.53
9.5	73.22	73.24	73.13	1.00	74.13	0.91	0.88
10.0	78.17	87.08	76.49	1.00	77.49	0.00	0.00
10.5	79.60	79.39	80.30	1.00	81.30	1.70	1.91
11.0	85.06	84.53	84.78	1.00	85.78	0.72	1.25
11.5	91.61	89.30	89.65	1.00	90.65	0.00	1.35
12.0	96.04	94.38	94.58	1.00	95.58	0.00	1.20
12.5	99.09	98.36	98.76	1.00	99.76	0.67	1.39
13.0	103.98	103.27	103.65	1.00	104.65	0.68	1.38
13.5	107.23	108.24	108.74	1.00	109.74	2.51	1.50
14.0	112.45	113.10	113.75	1.00	114.75	2.29	1.64
14.5	118.77	116.28	117.30	1.00	118.30	0.00	2.02
15.0	125.85	122.38	122.20	1.00	123.20	0.00	0.82
15.5	126.60	126.39	126.52	1.00	127.52	0.92	1.13
16.0	131.82	131.42	131.71	1.00	132.71	0.89	1.29
16.5	136.08	136.32	136.65	1.00	137.65	1.57	1.34
17.0	143.80	141.45	142.09	1.00	143.09	0.00	1.64
17.5	147.98	147.40	147.30	1.00	148.30	0.31	0.89
18.0	151.54	152.41	152.32	1.00	153.32	1.77	0.91
18.5	157.07	155.95	156.77	1.00	157.77	0.70	1.82
19.0	166.46	161.42	161.94	1.00	162.94	0.00	1.52
19.5	166.46	168.01	167.92	1.00	168.92	2.46	0.91
20.0	173.43	174.70	173.49	1.00	174.49	1.06	0.00
20.5	178.93	179.30	179.59	1.00	180.59	1.66	1.29
21.0	184.96	187.88	185.15	1.00	186.15	1.19	0.00
21.5	190.89	190.81	190.91	1.00	191.91	1.02	1.10
22.0	196.74	196.23	196.34	1.00	197.34	0.60	1.11
22.5	201.23	202.48	202.07	1.00	203.07	1.84	0.59
23.0	208.45	208.82	208.47	1.00	209.47	1.01	0.65
23.5	212.59	214.69	212.69	1.00	213.69	1.10	0.00
24.0	218.64	219.69	218.85	1.00	219.85	1.21	0.16
24.5	224.51	225.32	224.45	1.00	225.45	0.94	0.13
25.0	229.61	231.33	229.69	1.00	230.69	1.07	0.00
25.5	236.02	235.32	235.64	1.00	236.64	0.62	1.32
26.0	241.27	241.61	241.33	1.00	242.33	1.06	0.72
26.5	247.52	256.44	247.48	1.00	248.48	0.96	0.00
27.0	254.12	263.85	251.69	1.00	252.69	0.00	0.00
27.5	257.70	255.68	257.05	1.00	258.05	0.35	2.37
28.0	261.99	262.22	262.55	1.00	263.55	1.56	1.33
28.5	267.82	268.20	268.44	1.00	269.44	1.62	1.24
29.0	274.48	274.33	274.80	1.00	275.80	1.32	1.47
29.5	281.84	280.46	280.56	1.00	281.56	0.00	1.10
30.0	291.17	316.87	290.00	1.00	291.00	0.00	0.00
30.5	292.63	320.90	292.30	1.00	293.30	0.67	0.00
31.0	300.50	298.22	298.01	1.00	299.01	0.00	0.79
31.5	306.03	304.11	304.24	1.00	305.24	0.00	1.13
32.0	308.19	311.58	309.37	1.00	310.37	2.18	0.00
32.5	318.33	322.80	317.35	1.00	318.35	0.02	0.00
33.0	325.11	329.73	323.46	1.00	324.46	0.00	0.00
33.5	331.02	330.64	330.17	1.00	331.17	0.15	0.53
34.0	348.32	337.51	335.88	1.00	336.88	0.00	0.00
34.5	343.73	344.76	341.81	1.00	342.81	0.00	0.00
35.0	351.25	354.05	352.39	1.00	353.39	2.14	0.00
35.5	359.29	357.35	357.63	1.00	358.63	0.00	1.28
36.0	402.55	363.51	363.73	1.00	364.73	0.00	0.22
36.5	371.86	373.96	370.13	1.00	371.13	0.00	0.00
37.0	375.78	379.66	376.03	1.00	377.03	1.25	0.00
37.5	425.76	386.95	382.44	1.00	383.44	0.00	0.00
38.0	432.47	393.78	389.60	1.00	390.60	0.00	0.00
38.5	439.56	400.77	395.90	1.00	396.90	0.00	0.00
39.0	449.06	402.74	402.74	1.00	403.74	0.00	1.00
39.5	457.67	413.14	408.67	1.00	409.67	0.00	0.00
40.0	449.76	421.44	416.83	1.00	417.83	0.00	0.00
40.5	441.31	430.28	422.24	1.00	423.24	0.00	0.00
41.0	437.72	434.93	429.32	1.00	430.32	0.00	0.00
41.5	447.00	441.37	437.31	1.00	438.31	0.00	0.00
42.0	453.31	451.72	443.63	1.00	444.63	0.00	0.00
42.5	455.27	450.09	450.24	1.00	451.24	0.00	1.15
43.0	464.45	464.02	456.92	1.00	457.92	0.00	0.00
43.5	472.01	489.37	464.80	1.00	465.80	0.00	0.00
44.0	483.96	480.24	470.90	1.00	471.90	0.00	0.00
44.5	484.27	485.63	478.17	1.00	479.17	0.00	0.00
45.0	495.46	494.34	485.30	1.00	486.30	0.00	0.00
Average	219.72	217.26	214.82	1.00	215.82	0.63	0.76



### 4.3 Technical Planning

#### 4.3.1 Structural Measures

As structural measures it was necessary to prepare a flood control plan for the whole Watershed. The later section 4.12 “Medium and Long Term Plan” and 4.12.1 “General Flood Control Plan” details results on the analysis. This plan proposes the construction of dikes for flood control in the entire Watershed. However, in the case of the Watershed of the Pisco River, a big project needs to be set up investing very high costs, far beyond those considered in the budget of the present Project, what makes it difficult to take this proposal. Therefore, supposing the flood control dikes in the whole Watershed are built progressively within a medium and long term plan, they would be focused on the study of more urgent and priority works for flood control.

#### (1) Design flood discharge

##### 1) Guideline for flood control in Peru

The Methodological Guide for Projects on Protection and/or Flood Control in Agricultural or Urban Areas prepared by the Public Sector Multiannual Programming General Direction (DGPM) of the Economy and Finance Ministry (MEF) recommends to carry out the comparative analysis of different return periods: 25 years, 50 years and 100 years for the urban area, and 10 years, 25 years and 50 years for rural area and agricultural lands.

Considering that the present Project is focused on the protection of rural and agricultural areas, the design flood discharge should be the discharge with return period of 10-year to 50-year.

##### 2) Maximum discharge in the past and design flood discharge

The yearly maximum discharge in each watershed is as shown in Figure-4.3.1-1. Based on the figure, the maximum discharge in the past can be extracted as shown in the Table- 4.3.1-1 together with the flood discharges with different return periods.

The maximum discharge in the past in the watershed occurred one times of which scale is same as the flood discharge with return period of 50-year. And it is true that the flood discharges of same scale as the flood discharge with return period of 50-year caused large damages in the past. The maximum flood in the past is same as or less than the flood discharge with return period of 50-year.

Since the flood control facilities in Peru not well developed, it is not necessary to construct the facilities for more than the maximum discharge in the past, however it is true that the past floods caused much disaster so that the facilities should be safe for the same scale of flood, therefore the design flood discharge in this Project is to be the discharge with return period of 50-year.

**Table - 4.3.1-1 Flood discharge with different return period(m<sup>3</sup>/sec)**

<b>Watershed</b>	<b>2-year</b>	<b>10-year</b>	<b>25-year</b>	<b>50-year</b>	<b>100-year</b>	<b>Max. in the Past</b>
Pisco	213	451	688	855	963	956

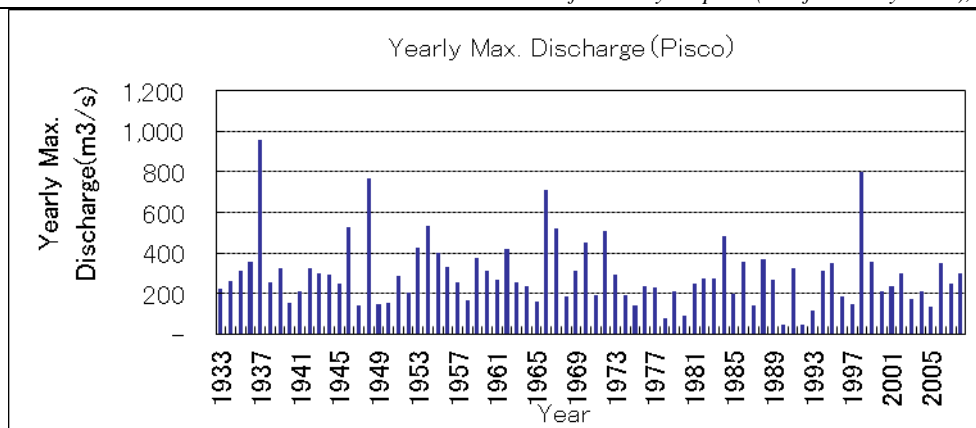

**Figure- 4.3.1-1 Yearly Max. Discharge (Pisco)**

3) Relation among probable flood, Damage and inundation area

The relation among probable flood, Damage and inundation area in the watershed are shown in the Figure-4.3.1-2.

Based on the figure the following facts can be expressed.

- ① The more increase probable flood discharge, the more increase inundation area (green line in the figure).
- ② The more increase probable flood discharge, the more increase damage (red line in the figure).
- ③ According to increase of probable flood discharge, the damage with project increase gently (blue line in the figure).
- ④ According to increase of probable flood discharge, damage reduction (difference between red line and blue line) increase steadily, and it reaches maximum at the probable flood of 50- year within the scope of study.

As shown in the above section, the design flood discharge with return period of 50-year is almost equal to the maximum flood in the past, and absolute damage reduction amount in the design discharge is largest among the probable flood discharge less than with return period of 50-year, and economic viability of the design flood is confirmed.

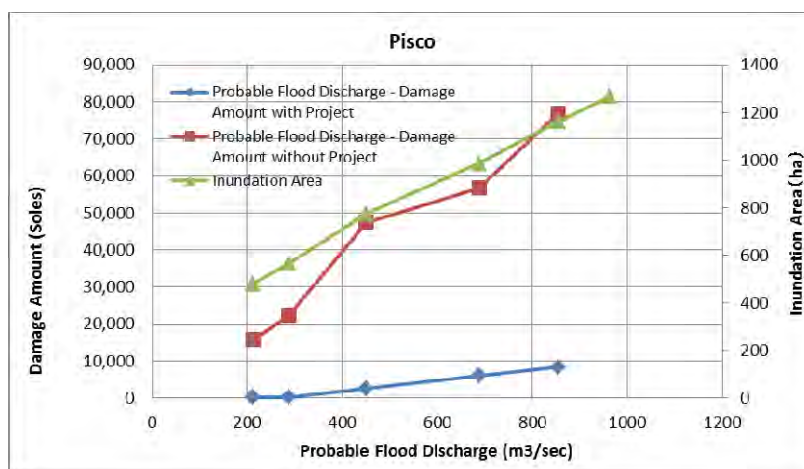

**Figure— 4.3.1-2 Probable Flood Discharge, Damage Amount and Inundation Area (Pisco river)**

## (2) Topographical survey

The topographical survey was carried out in selected places for the execution of structural measurements (Table 4.3.1-2). The preliminary design of control works was based on these topographical survey results.

**Table 4.3.1-1 Profile of Topographical Survey**

River	Location (No.)	Installations	Topo lift.	Transversal Lifting (S=1/200)		
			(ha)	Line No.	Middle length (m)	Total length (m)
Pisco	Pi-1	Dike	10.0	21	50.0	1,050
	Pi-2	Dike & excavation	30.0	16	200.0	3,200
	Pi-3	Dike	7.5	16	50.0	800
	Pi-4	Dike	5.0	11	50.0	550
	Pi-5	Reservoir	30.0	11	300.0	3,300
	Pi-6	Reservoir	100.0	21	500.0	10,500
Total			182.5	96		19,400

## (3) Selection of flood protection works with high priority

### 1) Basic Guidelines

For the selection of priority flood protection works, the following elements were considered:

- Demand from the local community (based on historical flood damage)
- Lack of discharge capacity of river channel (including the sections affected by the scouring)
- Conditions of the adjacent area (conditions in urban areas, farmland, etc.).
- Conditions and area of inundation (type and extent of inundation according to inundation analysis)
- Social and environmental conditions (important local infrastructures)

Based on the river survey, field investigation, discharge capacity analysis of river channel, inundation analysis, and interviews to the local community (irrigation committee needs, local governments, historical flood damage, etc...) a comprehensive evaluation was made applying the five evaluation criteria listed above. After that we selected a total of six (6) critical points (with the highest score in the assessment) that require flood protection measures.

Concretely, since the river cross sectional survey was carried out every 500m interval and discharge capacity analysis and inundation analysis were performed based on the survey results, the integral assessment was also done for sections of 500 meters. This sections have been assessed in scales of 1 to 3 (0 point, 1 point and 2 points) and the sections of which score is more than 6 were selected as prioritized areas. The lowest limit (6 points) has been determined also taking into account the budget available for the Project in general

Table 4.3.1-3 details evaluated aspects and assessment criteria.

**Table 4.3.1-3 Assessment Aspects and Criteria**

Assessment Aspects	Description	Assessment Criteria
Demand of local population	<ul style="list-style-type: none"> <li>• Flood damages in the past</li> <li>• Demand of local population and producers</li> </ul>	<ul style="list-style-type: none"> <li>• Flooding area with big floods in the past and with great demand from local community (2 points)</li> <li>• Demand of local population (1 point)</li> </ul>
Lack of discharge capacity (bank scouring)	<ul style="list-style-type: none"> <li>• Possibility of river overflow given the lack of discharge capacity</li> <li>• Possibility of dike and bank collapse due to scouring</li> </ul>	<ul style="list-style-type: none"> <li>• Extremely low discharge capacity (discharge capacity with return period of 10 years or less) (2 points)</li> <li>• Low discharge capacity (with return period of less than 25 years) (1 point)</li> </ul>
Conditions of surrounding areas	<ul style="list-style-type: none"> <li>• Large arable lands, etc.</li> <li>• Urban area, etc.</li> <li>• Assessment of lands and infrastructure close to the river.</li> </ul>	<ul style="list-style-type: none"> <li>• Area with large arable lands (2 points)</li> <li>• Area with arable lands mixed with towns, or big urban area (2 points)</li> <li>• Same configuration as the previous one, with shorter scale (1 point)</li> </ul>
Inundation conditions	<ul style="list-style-type: none"> <li>• Inundation magnitude</li> </ul>	<ul style="list-style-type: none"> <li>• Where overflow extends on vast surfaces (2 points)</li> <li>• Where overflow is limited to a determined area (1 point)</li> </ul>
Socio-environmental conditions (important structures)	<ul style="list-style-type: none"> <li>• Intake of the irrigation system, drinking water, etc.</li> <li>• Bridges and main roads (Carretera Panamericana, etc.)</li> </ul>	<ul style="list-style-type: none"> <li>• Where there are important infrastructures for the area (2 points)</li> </ul> <p>Where there are important infrastructures (but less than the first ones) for the area (regional roads, little intakes, etc.) (1 point)</p>

## 2) Selection results

Figure 4.3.1-3 details assessment results of each the river, as well as the selection results of flood protection priority works.

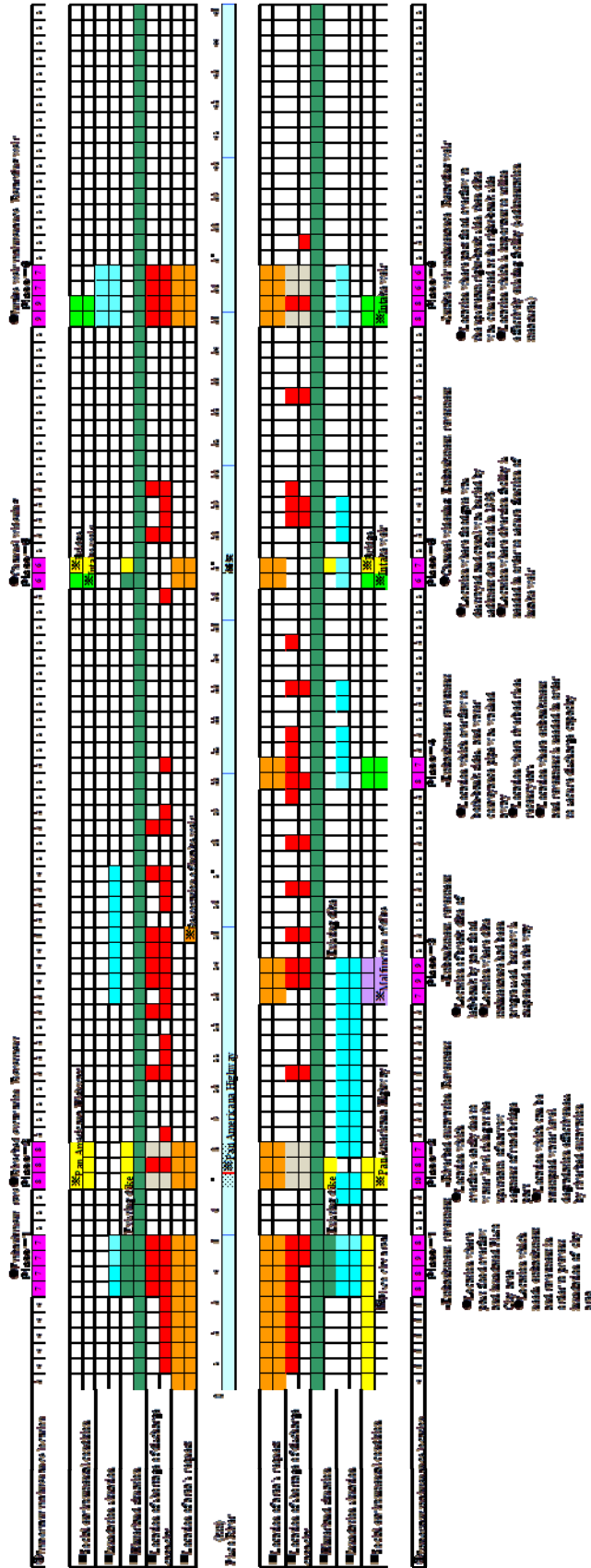

Figure 4.3.1-3 Selection results of prioritized flood protection works in Pisco river

### 3) Basis of Selection

At the section from the river mouth to 7km upstream, the water inundates farmland nearby due to lack of discharge capacity, but not extending beyond. However, when the inundation occurs in the lower reach (from the mouth to 7 km), the water inundates large areas of the left bank causing serious damage in urban areas of Pisco. Therefore at the downstream section from 7km, the embankment is executed in the section with highest risk of inundation and at the upstream area countermeasures in the sections with low discharge capacity such as bridges and intake.

At the Pan-American road the river width is narrowed, so that the widening the river width with building new bridge is considered, however taking account of the large traffic volume, necessity of access road to the bridge causing large cost, and that DGIH judged that the construction of new bridge is difficult for demarcation of administrative responsibility among Ministries, the construction of new bridge is not adopted in this Project.

**Table 4.3.1-4 Selected sections bases to execute works (Pisco River)**

No	Location	Basis of Selection
①	3.0km~5.0km (both banks))	<p>In this section once the inundation reaches urban area, the influence to the regional economy will be serious. And in case that the flood protection work is constructed in the upstream section, inundation occurs and enlarges in the right bank. And this section the river meanders so that slope and end of sloe are to be protected. Therefore the embankment at both banks is required. And also it should be taken note that the existing dikes were constructed from 5.0km ~5.5km at both banks.</p> <p>[Characteristics of the section]</p> <ul style="list-style-type: none"> <li>● Section that inundation occurred in the past flood to the city of Pisco.</li> <li>● Section where it is needed to build embankment with bank protection to prevent inundation of the city.</li> <li>● Section in which the inundation will be extended on the right bank in the case that the flood prevention work is performed in the upstream.</li> </ul> <p>[Elements to protect]</p> <ul style="list-style-type: none"> <li>○ Large agricultural land extending to both sides of the section in question</li> <li>○ The city of Pisco to the left of the section in question</li> </ul> <p>[Method of Protection]</p> <ul style="list-style-type: none"> <li>▼ Inundation occurs at the flood with return period of 5-year and the damage become heavily at the flood with return period of 50-year(nearly equal to 950m<sup>3</sup>/sec causing maximum damages) , so that the flood protection work is implemented for the latter flood flowing down safely.</li> <li>▼ Embankment with bank protection is to be constructed with consideration of upstream and downstream reach and land acquisition.</li> </ul>
②	6.5km~8.0km (riverbed excavation)	<p>The section in question is the narrow section of the river where it crosses the bridge, and sediment deposits and discharge capacity is insufficient. Damming up of water causes the elevation of the water level in the upper section. Since it is impossible to reconstruct the bridge it is required to dredge the bed around the bridge site to increase discharge capacity and lower the water level in the upper section.</p> <p>[Characteristics of the section]</p> <ul style="list-style-type: none"> <li>● Section narrow (where the road bridge) in which the discharge capacity is insufficient.</li> <li>● Section in which sediments have accumulated in the upper due to the damming up effect.</li> <li>● Section which may reduce the water level in the upper bed by river bed excavation.</li> </ul>

		<p>[Elements to protect]</p> <ul style="list-style-type: none"> <li>○ Farmland extending to the left bank of the section in question and on the upper section.</li> </ul> <p>[Method of Protection]</p> <ul style="list-style-type: none"> <li>▼ Insufficient discharge capacity promote the inundation of the upstream so that the facility which can discharge the flood with return period of 50-year(nearly equal to 950m<sup>3</sup>/sec causing maximum damages) is to be performed.</li> <li>▼ The discharge capacity is to be secured by riverbed excavation, and without rebuilding the Pan-American bridge.</li> </ul>
③	12.5km~14.0km (left bank)	<p>In this section the discharge capacity is lowest at the left bank, and is likely to inundate frequently even with a small scale of flooding. In the event of major floods, the damage can be severe, so it is urgent to build dikes with bank protection.</p> <p>On the other hand, given that a new dike between km14. 5-km 14. 0, taking the necessary precautions for the connection of the dikes.</p> <p>[Characteristics of the section]</p> <ul style="list-style-type: none"> <li>● Section in which the embankment was destroyed on the left bank by flooding.</li> <li>● Section in which the construction of the embankment was suspended on the way.</li> </ul> <p>[Elements to protect]</p> <ul style="list-style-type: none"> <li>○ Cropland to both sides of the section in question.</li> </ul> <p>[Method of Protection]</p> <ul style="list-style-type: none"> <li>▼ Inundation occurs at the flood with return period of 5-year and the damage become heavily at the flood with return period of 50-year, so that the flood protection work is implemented for the latter flood flowing down safely.</li> <li>▼ The embankment with bank protection is executed in the section in which the height of dike is not enough utilizing the existing dikes and condition of natural grand.</li> </ul>
④	19.5km~20.5km (left bank)	<p>In this section the discharge capacity is lowest at the left bank, and is likely to inundate frequently even with a small scale of flooding. In the event of major floods, the damage can be severe, so it is urgent to build dikes with bank protection.</p> <p>[Characteristics of the section]</p> <ul style="list-style-type: none"> <li>● No embankment section where inundate occurs on both banks and the water conveyance pipe leading to Pisco was lost.</li> <li>● Section in which the river bed is raising in recent years.</li> <li>● Section where embankment with bank protection is required to recover adequate discharge capacity.</li> </ul> <p>[Elements to protect]</p> <ul style="list-style-type: none"> <li>○ Cropland on the left bank of the section in question.</li> <li>○ Water conveyance pipe to Pisco (important facility).</li> </ul> <p>[Method of Protection]</p> <ul style="list-style-type: none"> <li>▼ Inundation occurs at the flood with return period of 5-year and the damage become heavily at the flood with return period of 50-year, so that the flood protection work is implemented for the latter flood flowing down safely. And the conservation of water conveyance pipe to Pisco.</li> <li>▼ The embankment with bank protection is executed in the section in which the height of dike is not enough utilizing the existing dikes and condition of natural grand.</li> </ul>

⑤	26.0km~27.0km (widening river width to the left bank)	<p>In this section it is important to keep the operational function of the existing intake. The gate was destroyed in the floods of the past, and the accumulation of sediment has left irrigation channels inoperative. Therefore, it is necessary to build a bypass work at km26. 75point (upstream of the intake) to allow water to flow towards the right bank at the time of low water and let more water flow to the left in the flood season.</p> <p>[Characteristics of the section]</p> <ul style="list-style-type: none"> <li>● Section where the gate was destroyed by the 1998 floods also being buried the irrigation channel.</li> <li>● Section which requires to build the bypass to protect the operation of the intake.</li> </ul> <p>[Elements to protect]</p> <ul style="list-style-type: none"> <li>○ Intake on the right bank of the section in question</li> </ul> <p>[Method of Protection]</p> <p>▼This intake is the most important in the river. The influence to the region is very big in case of lost function so that the protection work should be safe in the flood of 950m<sup>3</sup>/sec which caused serious damage in the past and nearly equal to the flood with return period of 50-years.</p> <p>▼There are no existing dikes in this section so that the river width can be widened considering the condition of upstream and downstream and land acquisition.</p>
⑥	34.5km~36.5km (total)	<p>The site of the weir built at the km34.5 is a narrow section, and has accumulated large amounts of sediment upstream. It is considered necessary to effectively use this weir, and take the upper reservoir of the weir as retarding basin when floods occur which exceed the magnitude of design. Intends to use the existing weir to retard the flood exceeding the design scale and at the same time, reduce sediment transport. Ideally, to achieve progressively a degree of safety on the order of 1/50 years from downstream. However, for the moment it is important to make effective use of existing structures where possible to control water flow exceeding the design scale (return period of 50 years).</p> <p>[Characteristics of the section]</p> <ul style="list-style-type: none"> <li>● Section where inundation occurred in the upstream right bank of the weir in the past floods.</li> <li>● Section where it is important to effectively use existing works (sediment control, etc.).</li> </ul> <p>[Elements to protect]</p> <ul style="list-style-type: none"> <li>○ The entire area downstream of the section in question.</li> </ul> <p>[Method of Protection]</p> <p>▼This section is located in the most upstream of the river and appropriate to control flood and sediment flow. The characteristics of Pisco river such that the inundation area increases gradually in accordance with the increase of flood discharge. However when the discharges over the discharge with return period of 50-years the damage increases greatly. Once the discharge more than the discharge with return period of 50-years, the more the damage increases. Therefore it is important to prepare for flood over the return period of 50 years. In that case the excess of design flood and sediment flow are to be reserved in this section.</p>

#### (4) Location of prioritized flood control works

In Figure 4.3.1-4 the location of prioritized flood control works is indicated in the watershed and in the



Table- 4.3.1-5 the summary of flood control works is indicated..

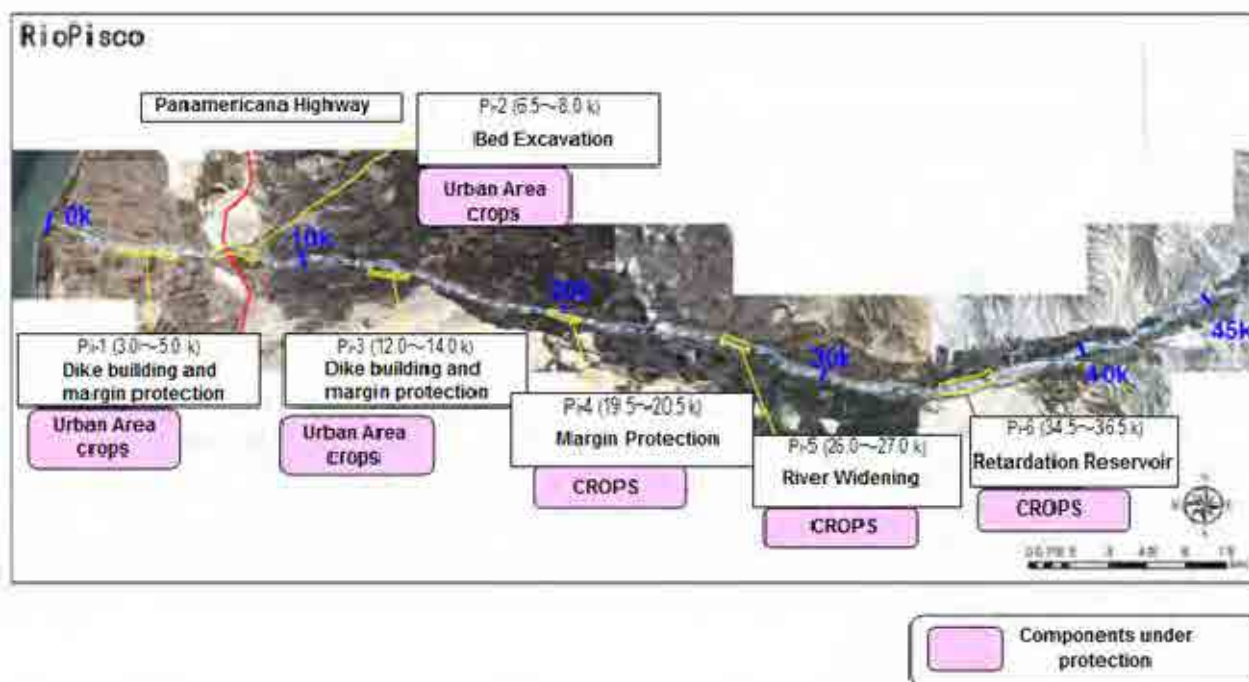

Figure 4.3.1-4 Prioritized flood control works in Pisco River

Table 4.3.1-5 Summary of Facilities

Basin	Location		Preservation Object	Counter Measure	Summary of Facility	Objective Section	
Pisco	1	5.5k	Inundation	Crop land	Dike (no dike section) Revetment	Top W; 4.0m H; 2.0m Slope; 1:3 L; 2,000m	3.0km~5.0km (left bank)
	2	7.0k	Narrow Section		Riverbed excavation	Ex. width; 100m Ex. depth; 1.0m L; 1,500m	6.5km~8.0km (total)
	3	13.5k	Inundation		Dike (no dike section) Revetment	Top W; 4.0m H; 2.0m Slope; 1:3 L; 1,500m	12.5km~14.0km (left bank)
	4	20.5k	Inundation	Crop land	Dike (no dike section) Revetment	Top W; 4.0m H; 2.0m Slope; 1:3 L; 2,000m	19.5km~20.5km (left bank)
	5	26.5k	Narrow Section		Widening river width	Ex. width; 100m Ex. depth; 1.0m L; 1,000m	26.0km~27.0km (total)
	6	34.5k	Intake		Retarding basin	Retarding basin; 1,800m × 700m	34.5km~36.5km (total)

### (5) Standard section of the dike

#### 1) Width of the crown

The width of the dike crown was defined in 4 meters, considering the dike stability when facing design overflows, width of the existing dike, and width of the access road or that of local communication.

#### 2) Dike structure

The dike structure has been designed empirically, taking into account historic disasters, soil condition, condition of surrounding areas, etc.

Dikes are made of soil in all the Watersheds. Although there is a difference in its structure varying from area to area, this can be summarized as follows, based on the information given by the administrators interviewed:

- ① The gradient of the slope is mainly 1:2 (vertical: horizontal relationship); the form may vary depending on rivers and areas.
- ② Dike materials are obtained from the river bed in the area. Generally these are made of sand/gravel ~sandy soil with gravel, of reduced plasticity. As to the resistance of the materials, we cannot expect cohesiveness.
- ③ The Watershed of the Cañete River is made of loamy soil with varied pebble, relatively compacted.
- ④ The lower stretch of the Sullana weir of the Chira River is made of sandy soil mixed with silt. Dikes have been designed with a “zonal-type” structure where material with low permeability is placed on the riverside of the dike and the river; material with high permeability is placed on landside of the dike. However, given the difficulty to obtain material with low permeability, it has been noticed that there is lack of rigorous control of grain size distribution in supervision of construction.
- ⑤ When studying the damaged sections, significant differences were not found in dike material or in the soil between broken and unbroken dike. Therefore, the main cause of destruction has been water overflow.
- ⑥ There are groins in the Chira and Cañete rivers, and many of them are destroyed. These are made of big rocks, with filler material of sand and soil in some cases, what may suggest that destruction must be caused by loss of filler material.
- ⑦ There are protection works of banks made of big rocks in the mouth of the Pisco River. This structure is extremely resistant according to the administrator. Material has been obtained from quarries, 10 km. away from the site.

Therefore, the dike should have the following structure.

- ① Dikes will be made of material available in the zone (river bed or banks). In this case, the material would be sand and gravel or sandy soil with gravel, of high permeability. The stability problems forecasted in this case are as follows.
  - i) Infiltrate destruction caused by piping due to washing away fine material
  - ii) Sliding destruction of slope due to infiltrate pressure

In order to secure the stability of dike the appropriate standard section should be determined by infiltration analysis and stability analysis for sliding based on unit weight, strength and permeability of embankment material.

- ② The gradient of the slope of the dike will be between  $30^\circ \sim 35^\circ$  (angle of internal friction) if the material to be used is sandy soil with low cohesiveness. The stable gradient of the slope of an embankment executed with material with low cohesiveness is determined as:  $\tan\theta = \tan\phi/n$  (where “ $\theta$ ” is gradient of the slope; “ $\phi$ ” is angle of internal friction and “ $n$ ” is 1.5 ,safety factor).

The stable slope required for an angle of internal friction of  $30^\circ$  is determined as: V:H=1:2.6 ( $\tan\theta=0.385$ ).

Taking into consideration this theoretical value, a gradient of the slope of 1:3.0 was considered, with more gentle inclination than the existing dikes, considering the results of the discharge analysis, the prolonged time of the design flood discharge (more than 24 hours), the fact that most of the dikes with slope of 1:2 have been destroyed, and the relative resistance in case of overflow due to unusual flooding.

The infiltration analysis and stability analysis of dike based on the soil investigation and

marital tests are not performed in this Study so that the slope is determined by simple stability analysis assuming the strength factors of dike material estimated by field survey of material and by adding some safety allowance.

And the slope of dike in Japan is generally 1:2.0 in minimum, however the average slope will be more than 1:3.0 because the dike has several steps in every interval of 2m~3m of height.

- ③ The dike slope by the riverside must be protected for it must support a fast water flow given the quite steep slope of the riverbed. This protection will be executed using big stones or big rocks easily to get in the area, given that it is difficult to get connected concrete blocks.

The size of the material was determined between 30cm and 1m of diameter, with a minimum protection thickness of 1m, although these values will be determined based on flow speed of each river.

### 3) Freeboard of the dike

The dike is made of soil material, and as such, it generally turns to be a weak structure when facing overflow. Therefore, it is necessary to prevent water overflow, to a lower water rise than the design discharge. So it is necessary to keep a determined freeboard when facing a possible increase in water level caused by the waves by the wind during water rise, tidal, hydraulic jump, etc. Likewise, it is necessary that the dikes have sufficient height to guarantee safety in surveillance activities and flood protection work , removal of logs and other carryback material, etc.

Table 4.3.1-6 shows guidelines applied in Japan regarding freeboard. Although in Peru there is a norm on freeboard, it has been decided to apply the norms applied in Japan, considering that rivers in both countries are alike.

**Table-4.3.1-6 Design discharge and freeboard**

Design discharge	Freeboard
Less than 200 m <sup>3</sup> /s	0.6m
More than 200 m <sup>3</sup> /s, less than 500 m <sup>3</sup> /s	0.8m
More than 500 m <sup>3</sup> /s, less than 2,000 m <sup>3</sup> /s	1.0 m
More than 2,000 m <sup>3</sup> /s, less than 5,000 m <sup>3</sup> /s	1.2 m
More than 5,000 m <sup>3</sup> /s, less than 10,000 m <sup>3</sup> /s	1.5 m
More than 10,000 m <sup>3</sup> /s	2.0 m

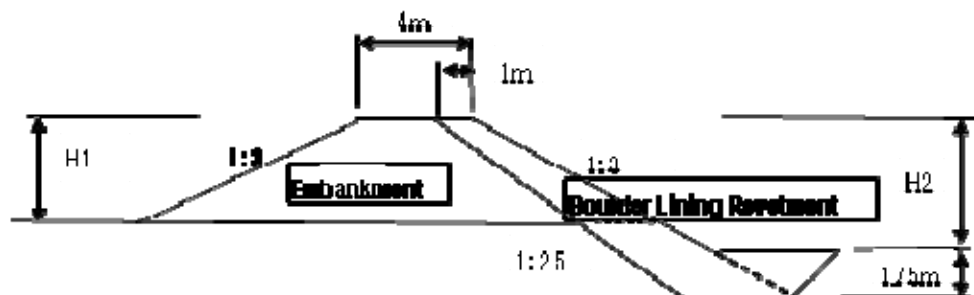

**Figure 4.3.1-5 Standard dike section**

## 4.3.2 Nonstructural measures

### 4.3.2.1 Reforestation and vegetation recovery

#### (1) Basic policies

The Reforestation and Vegetation Recovery Plan satisfying the goal of the present Project can be classified in: i) reforestation along fluvial works; and ii) reforestation in the high Watershed. The first one contributes directly to flood control and expresses its effect in short time. The second one demands a huge investment and an extended time, as detailed in the later section 4.12 “Medium and long term Plan”, 4.12.2 “Reforestation Plan and Vegetation Recovery”, what makes not feasible to implement it in the present Project. Therefore, the analysis is here focused only in option i).

#### (2) Reforestation plan along fluvial structures

This proposal consists in planting trees along fluvial structures such as protection works of banks, dikes, etc.

- i) Objective: Reduce impact of river overflow when water rise occurs or when river narrowing is produced by the presence of obstacles, by means of vegetation borders between the river and the elements to be protected.
- ii) Methodology: Create vegetation borders of a certain width between fluvial structures and the river.
- iii) Work execution: Plant vegetation at a side of the fluvial structures (dikes, etc.)
- iv) Maintenance post reforestation: The maintenance will be assumed by irrigator commissions by own initiative.

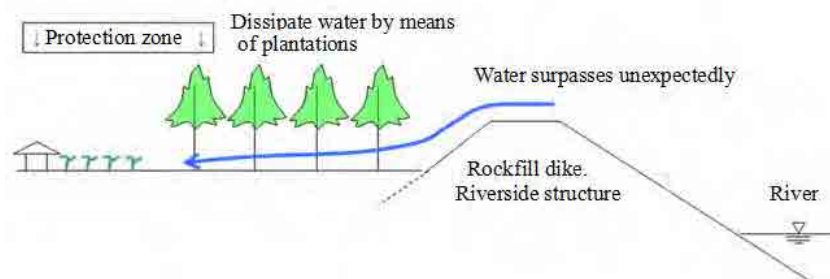
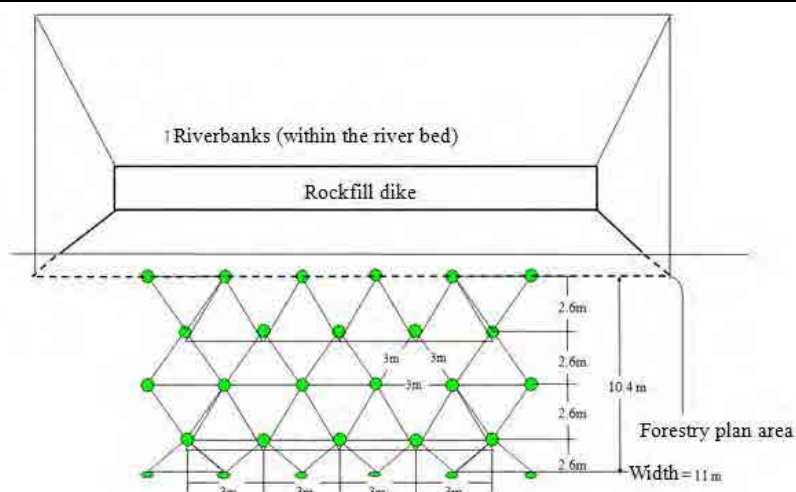

**Figure 4.3.2.1-1 Conceptual Diagram Afforestation in the Riverside structures (A Type)**  
(Source: JICA Study Team)

#### (3) Afforestation plan area measuring

##### 1) Structure (Afforestation location)

In Peru the most common location for afforestation is with equilateral triangles. This project also uses this model by planting trees with 3-meter intervals. If this method is used, it is expected that trees will act to stop and cushion even 1-meter diameter rocks, for what rows will be quadrupled, thus increasing their effectiveness. However, the main goal is to avoid overflow surpass the limit; in case floods strike directly with plants sowed, good results might be expected.



(Source: JICA Study Team)

**Figure 4.3.2.1-3 Location of the afforestation design plan in the riverside structure**

## 2) Species to be afforested

Species to be planted along the river were selected applying the following criteria and submitted to an overall assessment.

- 1 Species with adequate properties to grow and develop in the riverside (preferably native)
- 2 Possibility of growing in plant nurseries
- 3 Possibility of wood and fruit use
- 4 Demand of local population
- 5 Native species (preferably)

After making a land survey, a list of planted or indigenous species of each zone was firstly made. Then, a list of species whose plants would grow in seedbeds, according to interviews made to plant growers, was prepared.

Priority was given to the aptitude of local conditions and to plant production precedents, leaving as second priority its usefulness and demand or if they were native species or not. Table 4.3.2.1-1 shows the assessment criterion.

**Table 4.3.2.1-1 Assessment criterion for forest species selection**

		Assessment Criterion				
		1 Adaptation to the area	2 Seedling production experience	3 Use	4 Populators need	5 local species
Assessment points	A	In situ testing (natural or reforested growth)	Major production	Possible use as wood or for fruit production	Water demand by the Users Committee, among others	Local specie
	B	Growth has not been checked in situ, however it adapts in the zone	Sporadic production	Possible use as wood or for fruit production	There is NO water demand by the Users Committee	No local specie
	C	None of the above	Possible reproduction but not usual	No use as wood nor fruit	—	—
	D	Unknown	Not produced	Unknown	—	—

(Source: JICA Study Team)

Table-4.3.2.1-2 shows a list of selected species applying these assessment criterion. © marks

main species, ○ are those species that would be planted with a proportion of 30% to 50%. This proportion is considered to avoid irreversible damages such as plagues that can kill all the trees.

**Table 4.3.2.1-2 Selection of forest species**

Pisco Watershed: Eucalyptus (⊙), Huarango (○), Casuarina (○)

Pisco River Basin will be afforested with eucalyptus. Eucalyptus is a tree that has experience in afforestation in these areas, is a species that fits in the area and has high demand by water users committees. The Huarango (*Prosopis limensis*: is as its known in northern Peru, comes from another seed) is a native of the southern region of Peru. It is planted along the Panamericana Highway. The spice Casuarina has been planted in this area for protection from strong winds and sand, especially areas that are located on farms.

### 1) Volume of the Reforestation

At sites of bank protection works, dams and reservoirs of sand to be built along rivers, afforestation projects adopting the arrangement described in subsection paragraph (a). The forest will be 11 meters wide, and within the reservoir sand, trees will be planted except for the normal route of water.

Following Table 4.3.2.1-3 shows the Afforestation and Recovery of Vegetation Cover for Pisco river watershed.

**Table 4.3.2.1-3 Construction estimating for the afforestation and vegetation cover recovery plan (along the river)**

N°	Location (bank)	Length (m)	Width (m)	Area (ha)	Quantity (unit)	Distribution according to the specie (unit)			
						Eucaliptus	Huarango	Casuarina	(m)
Pi-1	left	2.000	11	2,2	6.512	3.256	1.954	1.302	6.512
Pi-2	General			0,0	0	—	—	—	—
Pi-3	left	1.500	11	1,7	5.032	2.516	1.510	1.006	5.032
Pi-4	left	1.000	11	1,1	3.256	1.628	977	651	3.256
Pi-5	General			0,0	0	—	—	—	—
Pi-6	General	2.000	600	120,0	355.200	177.600	106.560	71.040	355.200
Pisco watershed Total		6.500		125,0	370.000	185.000	111.001	73.999	370.000

(Source: JICA Study Team)

### 2) Areas subject to the Reforestation and Vegetation Recovery Plan

In areas subject to the Reforestation/Vegetation Recovery Plan along fluvial works, the structure arrangement is similar everywhere. See section 4.3.1.3(2).

### 3) Execution costs of the Reforestation and Vegetation Recovery Plan

Execution costs of works for the Reforestation and Vegetation Recovery Plan were estimated as follows:

- Planting unitary cost (planting unitary cost + transportation)
- Labor cost

Planting providers may include i) AGRORURAL or ii) private providers. For reforestation along rivers private providers will be requested.

#### i) Planting unitary cost

Planting unitary cost was defined as detailed in Table 4.3.2.1-4, based on information obtained through interviews to private providers. Given that planting prices and

transportation cost varies per provider, an average Figure was applied.

**Table 4.3.2.1-4 Unitary cost of plants**

Watershed	Species	Seedling unitary cost
Pisco	Eucalipto	1,4
	Huarango	1,8
	Casuarina	2,2

ii) Labor cost

Reforestation work performance ratio was determined in 40 trees/person-day according to the information gathered through interviews to AGRORURAL and to irrigator commissions. As to riverside reforestation, the labor unitary cost will be 33.6 Soles/man-day. In the high Watershed 16,8 Soles/man-day, corresponding to half of the first one.

iii) Reforestation execution cost

Work costs for the afforestation and vegetation cover recovery plan in the riverside structures are detailed in Table 4.3.2.1-5.

**Table 4.3.2.1-5 Afforestation work cost (afforestation in riverside structures)**

Watershed	Code	Cost		
		Plants	Labor	Total
Pisco	Pi-1	10.940	5.470	16.410
	Pi-2			
	Pi-3	8.454	4.227	12.681
	Pi-4	5.470	2.735	8.205
	Pi-5			
	Pi-6	596.736	298.368	895.104
Total Pisco watershed		621.600	310.800	932.400

## 6) Implementation process plan

Since bank forests are part of the river structures, their reforestation will depend on the same work execution plan. The ideal is to start planting immediately before or at the beginning of the rainy season, ending a month before this time to promote the survival of plants. But since almost no rain in the coastal area, in this case there is no difference between the rainy and dry season. Therefore, although it should be good to perform the transplant on the dates when river water raises, there would be no problem even if you perform this work when the water level is low, if for the schedule for implementation of river structures requires it. Water will be required only for three months after transplantation using a simple irrigation system based on gravity (with hose), until the river water level rises. This irrigation is performed using perforated horse which is a field technique actually carried out in Pochos dam area.

### 4.3.2.2 Sediment Control Plan

#### (1) Importance of the Sediment Control Plan

Below flood control issues in selected Watersheds are listed. Some of them relate to sediment control. In the present Project an overall flood control plan covering both the high and the low Watershed is prepared. The study for the preparation of the Sediment Control Plan comprised the whole Watershed.

- Water rise causes overflow and floods.
- Rivers have a steep slope of 1/30 to 1/300. The flow speed is high, as well as the sediment transport capacity.
- The accumulation of large quantities of dragged sediment and the consequent elevation of the river bed aggravate flood damages.

- There is a great quantity of sediment accumulated on the river bed forming a double sandbank. The water route and the spot of greater water impact are un-stable, causing route change and consequently, change of spot of greater water impact.
- Riverside is highly erodible, causing a decrease of adjacent farming lands, destruction of regional roads, etc., for what they should be duly protected.
- Big stones and rocks cause damages and destruction of water intakes.

**(2) Sediment Control Plan (structural measures)**

The sediment control plan for the present sediment movement pattern was analyzed. Table 4.3.2.2-1 details basic guidelines.

**Table 4.3.2.2-1 Basic guidelines of the Sediment Control Plan**

Conditions	Typical year	Precipitations with 50-year return period
Sediment dragging	Bank erosion and river bed change	Bank erosion and river bed change Sediment flow from ravines
Measures	Erosion control → Bank protection  Control of riverbed variation → compaction of ground, bands (compaction of ground in the alluvial cone, bands)	Erosion control → bank protection Riverbed variation control → compaction of ground, bands (compaction of ground in the alluvial cone, bands) Sediment flow → protection of slopes, sediment control dams

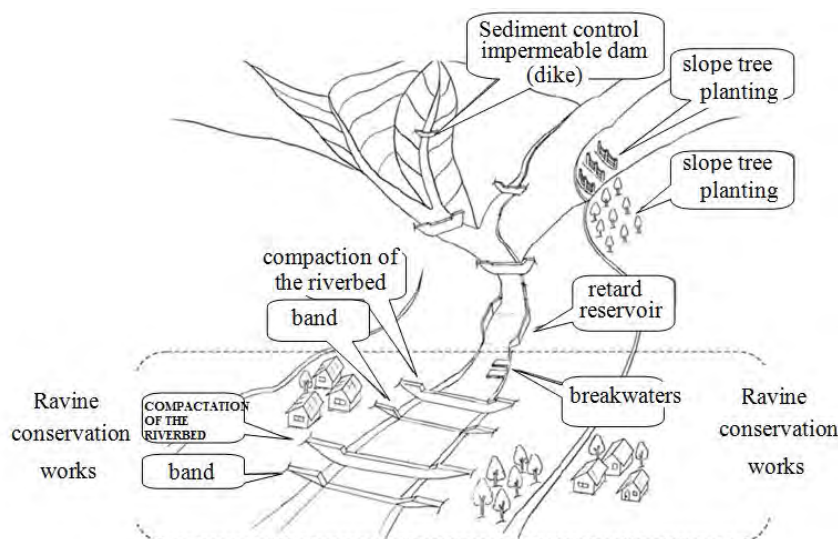

**Figure 4.3.2.2-1 Sediment control works**

1) Sediment control plan in the high Watershed

The next section 4.12 “Medium and long term Plan” 4.12.3 “Sediment Control Plan” details the sediment control plan covering the whole high Watershed. This plan will require an extremely long time with huge costs, what makes it quite not feasible. Therefore, it must be executed progressively within the medium and long term.

2) Sediment control plan in the alluvial fan

We observed that building sediment control dams covering the whole Watershed will demand huge



costs. Therefore, the same calculation was done but reducing its scope to just the lower Watershed of the river. In this process, analysis results on riverbed variation were taken into consideration, also included in the present study.

i) Riverbed fluctuation analysis results

- The results of riverbed fluctuation analysis are as shown below. The average riverbed rising shows the average of rising in the objective section in future 50 years. The average bed height has been increasing in the river, so basically it is concluded that this is the general trend. The total variation volume of the bed and sediment transport is augmenting in the Pisco river.

Total volume of dragged sediment (in thousands of m <sup>3</sup> )	8,658
Annual average of dragged sediment (in thousands of m <sup>3</sup> )	173
Total volume of riverbed variation (in thousands of m <sup>3</sup> )	2,571
Annual average of variation of riverbed height (m)	0.2

- The most susceptible to the accumulation of sediment is Pisco river. This tendency coincides to the field hearing results and actual riverbed conditions.
- According to the results of the analysis of variation of the river bed, Pisco river is more susceptible to the accumulation of sediments carried, so sediment control works must be done in the alluvial fan. However the sediment disaster will happen suddenly and locally so that the required river channel maintenance work will be examined for the river with monitoring of river bed sedimentation.

ii) Sediment control plan in the alluvial fan

To control sediments within the fan there are ravine conservation works, combined with sand reservoirs, riverbed consolidation, groin or a combination of these. These do not only work for sediment control, but as river structures.

Currently there is a plan to build a retarding basin at the point of 34.5 km from river mouth in the Pisco River watershed, which also serves as a sediment retarding basin.

This structure is more economical and yield better cost benefit compared with structures designed to cover the entire watershed. It is much more profitable even when the cost of maintenance includes removal of stones and rocks.

Whereas the main objective of this project is in mitigating flood damage, the most effective option would be to control sediment in the alluvial fan.

It is already being planned to build river structure which also serves to control sediment in Pisco river, and its implementation would be the most effective.

### 4.3.3 Technical Assistance

Based on the proposals on flood control measures, a component on technical assistance is proposed in order to strengthen risk management capabilities in the Program.

(1) **Component objective**

The component objective in the Program is the “Adequate capability of local population and professionals in risk management application to reduce flood damages in Watersheds”.

(2) **Target area**

The target area for the implementation of the present component is the Pisco watershed.

In the execution stage, the implementation has to be coordinated with local authorities in the watershed. However, each authority has to execute those activities related with the characteristics of the watershed to carry out an adequate implementation.

**(3) Target population**

Target populations will represent irrigator associations and other community groups, provincial, district and local community governments and local people in the watershed, considering the limited capacity to receive beneficiaries of this component.

Participants are those with skills to widespread technical assistance contents of local populations in the watershed.

Besides, the participation of women has to be considered because currently only few ones participate in technical assistance opportunities.

**(4) Activities**

In order to achieve the above purpose, the following 3 components of study and training is to be carried out.

**Component 1: Knowledge on River Bank Protection Actions in consideration of Agriculture and Natural Environment**

Course	a) River Bank Operation and Maintenance b) River Bank Plant Management c) Erosion Prevention and Mitigation Natural Resource Management
Objectives	a) In this project, local populations learn suitable technology to operate and give maintenance to constructions and works from prior projects. b) Local populations learn suitable technology on river bank plants and vegetation for flooding control purposes. c) Local populations learn suitable technology on erosion and natural resources for flooding control purposes.
Participants	a) Engineers and / or technicians from local Governments b-c) Engineers and / or technicians from local Governments and Water Users Associations, Community representatives
Times	a) 12 times in all (every six (6) hours) b) 12 times in all (every five (5) hours) c) 26 times in all (every three (3) hours)
Lecturers	a) Contractors of constructions and works, Engineers from MINAG and / or the Regional Government b-c) Engineers from MINAG and / or the Regional Government, College professors (From universities, institutes, NGOs, etc.)
Contents	a-1) Suitable operation and maintenance technology for constructions and works from prior projects a-2) Suitable operation and maintenance technology for constructions and works in this project b-1) River bank protection with the use of plants b-2) The importance of river bank vegetation in flooding control b-3) Types of river bank plants and their characteristics c-1) Evaluation of the erosion conditions c-2) Evaluation of natural resource conditions c-3) Erosion approach for flooding control c-4) Natural resource approach for flooding control c-5) Environmental consideration approach c-6) Use of water resources c-7) Alternatives for suitable farming crops

**Component 2: Preparation of Community Disaster Management Plan for Flood Control**

Course	a) Risk management Plan Formulation b) Detailed Risk management Plan Formulation
Objectives	a) Local populations gain knowledge and learn technology to prepare a flooding

	control plan b) Ditto
Participants	a-c) Engineers and / or technicians from local Governments and Water Users Associations, Community representatives
Times	a) 19 times in all (every four (4) hours) b) 34 times in all (every five (5) hours) c) 24 times in all (every five (5) hours)
Lecturers	a-c) Engineers from MINAG and / or the Regional Government, Community Development Expert, Facilitator (local participation )
Contents	a-1) Flooding control plan preparation manuals a-2) Current condition analyses for flooding control a-3) Community development alternatives by means of local participation a-4) Workshop for flooding control plan preparation b-1) Community activity planning in consideration of ecological zoning b-2) Risk management b-3) Resource management c-1) Preparation of community disaster management plan c-2) Joint activity with local governments, users' association, etc.

### Component 3: Basin Management for Anti – River Sedimentation Measures

Courses	a) Hillside Conservation Techniques b) Forest Seedling Production c) Forest Seedling Planting d) Forest Resource Management and Conservation
Objectives	a) Local populations learn suitable technology on hillside conservation for flooding control purposes b) Local populations learn suitable technology on forest seedling production c) Local populations learn suitable technology on forest seedling planting d) Local populations learn suitable technology on forest resource management and conservation
Participants	a-d) Engineers and / or technicians from local Governments and Water Users Associations, Community representatives and Local People
Times	a) 12 times in all (every five (5) hours) b-d) 40 times in all for three (3) “Courses on Basin Management for Anti - River Sedimentation Measures” (every five (5) hours)
Lecturers	a-d) Engineers from MINAG and / or the Regional Government, College professors (From universities, institutes, NGOs, etc.)
Contents	a-1) Soil characteristics and conservation on hillsides a-2) Hillside agroforestry system a-3) Animal herding system on hillsides a-4) Reforestation with traditional vegetation and plants a-5) Hillside conservation and alleviation alternatives b-1) A selection of plants that are suitable to the local characteristics b-2) Forest seedling production technology  b-3) Control carried out by the local population's involvement c-1) Candidate areas for forestation c-2) Forest plantation control technology c-3) Forest plantation soil technology c-4) Control carried out by the local population's involvement d-1) Forestation for flooding control purposes d-2) Forest plantation control technology d-3) Forest plantation output technology d-4) Control carried out by the local population's involvement

**(5) Direct cost and period**

The direct cost for the above activities is as shown in the Table 4.3.3-1. The total cost for the objective basin is estimated as 144,050 soles, and the brake down of the unit cost is as shown in the Annex-12, Appendix No.5. And the period required for study and training is assumed to be as same as the construction period of 2 years.

**Table 4.3.3-1 Contents of technical assistance and direct cost**

Item	Activities	Unit	Unit price(soles)	No.of basin	Amount(soles)
1.0	<b>Knowledge on river bank protection action in consideration of agriculture and natural environment</b>				
1.1	Workshop on operation and maintenance of facilites	event	9,300	1	9,300
1.2	Workshop on river bank plantation management	event	9,300	1	9,300
	Prevention and mitigation for erosion	event	9,300	1	9,300
	Natural resources management	event	9,300	1	9,300
2.0	<b>Preparation of community disaster management plan for flood control</b>				
2.1	Workshop on risk management plan	event	8,370	1	8,370
2.2	Details of 2.1	event			
	Community activity planning in consideration of ecological zoning	event	12,200	1	12,200
	Risk management	event	12,200	1	12,200
	Resource management	event	12,200	1	12,200
	Preparation of community disaster management plan	event	12,200	1	12,200
2.3	Preliminary flood forecasting and warning	event			
	Risk management and early warning system	event	9,300	1	9,300
	Joint activity with local government, users' association, etc.	event	5,580	1	5,580
3.0	<b>Hillside management for river sedimentation prevention</b>				
3.1	Field works for hillside conservation technique	event	7,500	1	7,500
	Forest seedling productions	event	7,900	1	7,900
	Forest planatation setting up	event	7,900	1	7,900
	Forest resource management and conservation		7,900	1	7,900
3.2	Difusion of posters and leaflet		3,600	1	3,600
	<b>Total</b>				<b>144,050</b>

**(6)Implementation Plan**

The Hydraulic Infrastructure General Direction (DGIH-MINAG) executes this component as the executing unity in cooperation with the Agriculture Regional Direction (DRA), the Board of Users and related Institutions. In order to execute the activities efficiently the following has to be considered:

- For the implementation of the present component, the DGIH-MINAG will coordinate actions with the Central Management Unit responsible for each Watershed, as well as with Regional Managements of Agriculture (DRA).
- For the Project administration and management, the DGIH-MINAG will coordinate actions with PSI-MINAG (Sub-sector Irrigation Program with extensive experience in similar projects).

- Considering there are some local governments that have initiated the preparation of a similar crisis management plan through the corresponding civil defense committee, under the advice of the National Institute of Civil Defense (INDECI) and local governments, the DGIH-MINAG must coordinate so that these plans be consistent with those existing in each Watershed.
- Training courses will be managed and administered by irrigator associations (particularly the unit of skills development and communications) with the support of local governments in each Watershed, to support timely development in each town.
- Experts in disaster management departments in each provincial government, ANA, AGRORURAL, INDECI, etc., as well as (international and local) consultants will be in charge of course instruction and facilitation.

## 4.4 Costs

### 4.4.1 Cost Estimate (at private prices)

#### (1) Project Costs Components

Project costs include the following:

- ① Work direct costs = total number of works by type × unit price
- ② Common provisional works = ① × 10%
- ③ Construction cost -1 = ① + ②
- ④ Miscellaneous = ③ × 15%
- ⑤ Benefits = ③ × 10%
- ⑥ Construction cost -2 = ③ + ④ + ⑤
- ⑦ Tax = ⑥ × 18% (IGV)
- ⑧ Construction cost = ⑥ + ⑦
- ⑨ Environmental measures cost = ⑧ × 1%
- ⑩ Detailed design cost = ⑧ × 5%
- ⑪ Works supervision cost = ⑧ × 10%
- ⑫ Project Cost = ⑧ + ⑨ + ⑩ + ⑪

#### (2) Work direct costs

On Table 4.4.1-1 a summary table of direct costs for structural measures is presented for the Pisco River basin.

#### (3) Project Costs

The project cost is estimated in 71.6 million of soles as shown in Table 4.4.1-2. It includes reforestation and vegetation recovery costs, construction of early warning system and technical assistance. The annual operation and maintenance cost of completed works is approximately 0.5% of the project's cost.

**Table 4.4.1-1 Summary Table of the work's direct cost (at private prices)**

Watershed 流域名	Critical Points クリティカル・ポイント		Measures 対策		SOLES (ソル)
					Direct Cost 直接工事費計 (1)
Rio Pisco ピスコ川	1	5.5K	Dike building + coastal defense	築堤・護岸工	5,240,000
	2	7.0K	Flow desilting	河床掘削	2,700,000
	3	13.5K	Dike building + coastal defense	築堤・護岸工	5,486,000
	4	20.5K	Dike building + coastal defense	築堤・護岸工	1,965,000
	5	26.5K	Fluvial flow widening	河道拡幅	9,530,800
	6	34.5K	Retention Reservoir	遊水地	12,163,000
<b>SUB TOTAL</b>					<b>37,084,800</b>

**Table 4.4.1-2 Construction cost (at private prices)**

Watershed 流域名	PRIVATE PRICES COSTS															
	STRUCTURAL MEASURES											NON STRUCTURAL MEASURES 非構造物対策		TECHNICAL ASSISTANCE 能力開発	TOTAL COST OF THE PROGRAM 全体事業費	
	Direct Cost (直接工事費)			INDIRECT COST (間接工事費)								HYDRAULIC INFRASTRUCTURE Total Cost	REFORESTATION Total Cost 植林・植生回復 事業費	EARLY ALERT SYSTEM Total Cost 洪水予警報 事業費		TRAINING Total Cost 防災教育 事業費
	Direct Cost	Temporary works cost	Works Cost	Operative Expenses	Utility	Total Cost of Infrastructure	TAX	Total work cost	Environmental Impact	Technical File	Supervision					
(1)	(2) = 0.1 x (1)	(3) = (1) + (2)	(4) = 0.15 x (3)	(5) = 0.1 x (3)	(6) = (3)+(4)+(5)	(7) = 0.18 x (6)	(8) = (6)+(7)	(9) = 0.01 x (8)	(10) = 0.05 x (8)	(11) = 0.1 x (8)						
PISCO	37,084,800	3,708,480	40,793,280	6,118,992	4,079,328	50,991,600	9,178,488	60,170,088	601,701	3,008,504	6,017,009	69,797,302	1,592,538	0	219,105	71,608,946

#### 4.4.2 Cost Estimate (at social prices)

##### (1) Work direct costs

In Table 4.4.2-1 a summary table of direct costs for structural measures is presented for the Pisco River basin. The works' direct cost at private prices was turned into social prices applying the conversion factor.

##### (2) Project Costs

The project cost is estimated in 57.6 million of soles as shown in Table 4.4.2-2. It includes reforestation and vegetation recovery costs, construction of early warning system and technical assistance, before converting from private prices.

**Table 4.4.2-1 Summary Table of the work's direct cost (at social prices)**

Watershed 流域名	Critical Points クリティカル・ポイント	Measures 対策	Private Prices 民間価格 (PP)	Correction Factor 係数 (fs)	SOLES (ソル)
					Social Prices 社会価格 (P <sub>S</sub> ) (PP) × (fs)
Rio Pisco ピスコ川	1	5.5K Dike building+coastal defense	5,240,000	0.804	4,212,960
	2	7.0K Flow desilting	2,700,000	0.804	2,170,800
	3	13.5K Dike building+coastal defense	5,486,000	0.804	4,410,744
	4	20.5K Dike building+coastal defense	1,965,000	0.804	1,579,860
	5	26.5K Fluvial flow widening	9,530,800	0.804	7,662,763
	6	34.5K Retention reservoir	12,163,000	0.804	9,779,052
SUB TOTAL			37,084,800		29,816,179

**Table 4.4.2-2 Construction cost at (social prices)**

Watershed 流域名	SOCIAL PRICES COSTS															
	STRUCTURAL MEASURES											NON STRUCTURAL MEASURES 非構造物対策		TECHNICAL ASSISTANCE 能力開発	TOTAL COST OF THE PROGRAM 全体事業費	
	DIRECT COST (直接工事費)			INDIRECT COST (間接工事費)								HYDRAULIC INFRASTRUCTURE Total Cost	REFORESTATION Total Cost 植林・植生回復 事業費	EARLY ALERT SYSTEM Total Cost 洪水予警報 事業費		TRAINING Total Cost 防災教育 事業費
	Direct Cost	Temporal works cost	Works Cost	Operative Expenses	Utility	Infrastructure total cost	TAX	Work's Total Cost	Environmental Impact	Technical File	Supervision					
(1)	(2) = 0.1 x (1)	(3) = (1) + (2)	(4) = 0.15 x (3)	(5) = 0.1 x (3)	(6) = (3)+(4)+(5)	(7) = 0.18 x (6)	(8) = (6)+(7)	(9) = 0.01 x (8)	(10) = 0.05 x (8)	(11) = 0.1 x (8)						
PISCO	29,816,179	2,981,618	32,797,797	4,919,670	3,279,790	40,897,246	7,378,504	48,375,751	483,768	2,418,530	4,837,675	56,117,031	1,257,801	0	189,750	57,564,581

## 4.5 Social Assessment

### 4.5.1 Private prices costs

#### (1) Benefits

Flood control benefits are flood loss reduction that would be achieved by the implementation of the Project and is determined by the difference between the amount of loss with and without Project. Specifically, in order to determine the benefits that will be achieved by the works' construction. First, the flood amount per flood loss of the different return periods

(between 2 to 50 years) is calculated; assuming that the flood control works have a useful life of 50 years. To finish, determine the annual average amount of the loss reduction from the loss amount of different return periods. The Methodological Guideline for Protection and/or Flood Control Projects in agricultural or urban areas, 4.1.2p-105) establishes similar procedures.

Following are the description of the procedures to determine concrete benefits

- Determine the flood loss amount in the flood area by analyzing the magnitude of overflow that occurs without the Project for each return period (between 2 and 50 years)
- After, determine the amount of flood loss in the flood area by analyzing the magnitude of overflow that occurs when flood control priority works are built (Cañete 1 to 6).
- Determine the difference between ① and ②. Add the benefits of other works different than dikes (intakes, roads and dams protection, etc.) in order to determine the total profits

“Benefits of the Project” are considered as the sum of direct loss amount caused by overflow and indirect loss caused by the destruction of structures in vulnerable sections (farmland loss, interruption of traffic, etc.)

### 1) Method of loss amount calculation

In this study, the amount of loss from direct and indirect damages to the variables listed in Table 4.5.1-1 was determined.

**Table 4.5.1-1 Flood loss amount calculation variables**

Loss	Variables	Description
(1) Direct	① Crops	<ul style="list-style-type: none"> <li>• Crops in flooding season The amount of crop loss by flooding is determined by multiplying the damage % regarding water depth and the number of days flooded</li> <li>• Agricultural land and infrastructure (channels, etc.)</li> <li>• Crop loss amount is determined by multiplying the damage % regarding water depth and the number of days flooded</li> </ul>
	② Hydraulic Works	<ul style="list-style-type: none"> <li>• Loss amount due to hydraulic structures destruction (intakes, channels, etc.).</li> </ul>
	③ Road Infrastructures	<ul style="list-style-type: none"> <li>• Flood damage related to road infrastructure is determined by the damage in transport sector</li> </ul>
	④ Housing	<ul style="list-style-type: none"> <li>• Residential and industrial buildings It is calculated applying the loss coefficient depending on the flood depth Housing: residential and industrial buildings; household goods: furniture, household appliances, clothing, vehicles, etc. Flood damages in housing, commercial buildings, assets and inventories (buildings and assets) is determined applying the loss coefficient according to the flood depth</li> </ul>
	⑤ Public Infrastructures	<ul style="list-style-type: none"> <li>• Determine the loss amount in roads, bridges, sewers, urban infrastructures, schools, churches and other public facilities</li> <li>• Determine the loss amount in public works by applying the</li> </ul>



		correspondent coefficient to the general assets loss amount
	⑥ Public Services	• Electricity, gas, water, rail, telephone, etc.
(2) Indirect	① Agriculture	• Estimate the loss caused by irrigation water interruption due to the damage of hydraulic structures • Determine the construction and repair costs of hydraulic structures such as direct year costs
	② Traffic Interruption	• Estimate the loss lead by traffic interruption due to damages on flooded roads • Determine road's repair and construction costs as damage direct cost

#### A. Direct loss

Direct loss is determined by multiplying the damage coefficient according to the flood depth as the asset value.

#### B. Indirect Loss

Indirect loss is determined taking into account the impact of intakes and damaged roads. Below, calculation procedures are described.

##### a. Dams damage

The loss amount due to dam damage is calculated by adding the direct loss (dam's rehabilitation and construction) and the indirect loss amount (harvest loss due to the interruption of irrigation water supply)

##### ① Calculating the infrastructure cost

Works Cost = construction cost per water unit taken × size (flow, work length)

Unit cost of the work: for intakes and channels, it is required to gather information on the water intake volume of the existing work and the works' execution cost (construction or repair). The unit cost is calculated by analyzing the correlation among them both.

It was estimated that the work will be completely destroyed by the flow with a return period of 10 years.

##### ② Crop loss

Annual earnings are determined according to the crops grown in the correspondent irrigation district.

Annual Profit = (crops selling - cost) × frequency of annual harvest

Crop Sale = planted area (ha) x yield (kg/ha) × transaction unit price

Cost = unit cost (s/ha) × planted area (ha)

##### b. Road infrastructure damage

Determine the loss due to traffic interruption.

Amount of loss = direct loss + indirect loss

Direct loss: road construction cost (construction, rehabilitation)

Indirect Loss: opportunity loss cost due to road damage (vehicle depreciation + staff expenses loss)

A 5 days period takes place of non-trafficability (usually in Peru it takes five days to complete the rehabilitation of a temporary road)

**2) Loss estimated amount according to disasters in different return periods**

In table 4.5.1-2 the amounts of loss with and without Project are shown. These are estimated for disasters of different return periods in the Pisco River.

**Table 4.5.1-2 Loss Estimated Value (at private prices)**

(s./ 1,000)

Case	t	Pisco
Without Project	2	15,788
	5	22,310
	10	47,479
	25	56,749
	50	76,992
	Total	219,318
With Project	2	197
	5	270
	10	2,556
	25	6,019
	50	8,318
	Total	17,360

**3) Loss amount (annual average) expected to be reduced by the Project**

The annual average loss amount that is expected to be reduced by the Project by the total annual average loss amount occurred as flow multiplying the amount of loss reduction occurred as flow for the corresponding flood probabilities.

Considering that floods happen probabilistically, the annual benefit is determined as the annual average amount of loss reduction. Next find the procedures of calculation.

**Table 4.5.1-3 Loss reduction annual average amount**

Probabilities	Loss Amount			Average path's loss	Paths' Probabilities	Loss reduction annual average amount
	Without Project	With Project	Loss Reduction			
1/1			$D_0 = 0$			
1/2	$L_1$	$L_2$	$D_1 = L_1 - L_2$	$(D_0 + D_1)/2$	$1 - (1/2) = 0,500$	$d_1 = (D_0 + D_1)/2 \times 0,67$
1/5	$L_3$	$L_4$	$D_2 = L_3 - L_4$	$(D_1 + D_2)/2$	$(1/2) - (1/5) = 0,300$	$d_2 = (D_1 + D_2)/2 \times 0,300$
1/10	$L_5$	$L_6$	$D_3 = L_5 - L_6$	$(D_2 + D_3)/2$	$(1/5) - (1/10) = 0,100$	$d_3 = (D_2 + D_3)/2 \times 0,100$
1/20	$L_7$	$L_8$	$D_4 = L_7 - L_8$	$(D_3 + D_4)/2$	$(1/10) - (1/20) = 0,050$	$d_4 = (D_3 + D_4)/2 \times 0,050$
1/30	$L_9$	$L_{10}$	$D_5 = L_9 - L_{10}$	$(D_4 + D_5)/2$	$(1/20) - (1/30) = 0,017$	$d_5 = (D_4 + D_5)/2 \times 0,017$
1/50	$L_{11}$	$L_{12}$	$D_6 = L_{11} - L_{12}$	$(D_5 + D_6)/2$	$(1/30) - (1/50) = 0,013$	$d_6 = (D_5 + D_6)/2 \times 0,013$
1/100	$L_{13}$	$L_{14}$	$D_7 = L_{13} - L_{14}$	$(D_6 + D_7)/2$	$(1/50) - (1/100) = 0,010$	$d_7 = (D_6 + D_7)/2 \times 0,010$
Foreseen average annual amount of loss reduction				$d_1 + d_2 + d_3 + d_4 + d_5 + d_6 + d_7$		

In Table 4.5.1-4 Results of loss amount calculus are presented (annual average), which are expected to be reduced when implementing the Project in Pisco River Basin.

**Table 4.5.1-4 Annual average damage reduction amount (at private prices)**

s/1000

流域 Watershed	流量規模 Return Period	超過確率 Probability	被害額 (Total damage - thousands of S/.)			区間平均被害額 ④ Damage Averagare	区間確率 ⑤ Probability incremental value	年平均被害額 ④×⑤ Average value of the damages flow	年平均被害額の 累計=年平均被害 軽減期待額 Annual Medial Damage
			事業を実施しない場合①	事業を実施した場合②	軽減額 ③=①-②				
			Without Project ①	With Project	Mitigated damages ③=①-②				
PISCO	1	1.000	0	0	0			0	0
	2	0.500	15,788	197	15,591	7,795	0.500	3,898	3,898
	5	0.200	22,310	270	22,040	18,815	0.300	5,645	9,542
	10	0.100	47,479	2,556	44,923	33,481	0.100	3,348	12,890
	25	0.040	56,749	6,019	50,730	47,826	0.060	2,870	15,760
	50	0.020	76,992	8,318	68,674	59,702	0.020	1,194	16,954

## (2) Social Assessment

### 1) Assessment's objective and indicators

The social assessment's objective in this Study is to evaluate investment's efficiency in structural measures using the analysis method of cost-benefit (C/B) from the national economy point of view. For this, economic assessment indicators were determined (relation C/B, Net Present Value - NPV and IRR). The internal return rate (IRR) is an indicator that denotes the efficiency of the project's investment. It is the discount rate to match the current

value of the project’s generated cost regarding the benefit’s current value. It is the discount rate necessary so the Net Present Value (NPV) equals zero and the relation C/B equals one. It also indicates the percentage of benefits generated by such investment. The internal return rate used in the economic assessment is called “economical internal return rate (EIRR)”. The market price is turned into the economical price (costs at social prices) eliminating the impact of market distortion.

The IRR, C/B relation and NPV are determined applying mathematical expressions shown in the Table below. When IRR is greater than the social discount rate, the relation C/B is greater than one and NPV is greater than zero, it is considered that the project is efficient from the national economic growth point of view.

**Table 4.5.1-5 Analysis assessment indicators of cost-benefit relation and its characteristics**

Indicators	Definition	Characteristics
Net Present Value (NPV)	$NPV = \sum_{i=1}^n \frac{B_i}{(1+r)^i} - \sum_{i=1}^n \frac{C_i}{(1+r)^i}$	<ul style="list-style-type: none"> <li>- Allows comparing net benefit magnitude performed by the project</li> <li>- It varies depending on the social discount rate</li> </ul>
Cost-Benefit Relation (C/B)	$B/C = \sum_{i=1}^n \frac{B_i}{(1+r)^i} / \sum_{i=1}^n \frac{C_i}{(1+r)^i}$	<ul style="list-style-type: none"> <li>- Allows comparing the investment efficiency by the magnitude of benefit per investment unit</li> <li>- Varies depending on the social discount rate</li> </ul>
Economical Internal Return Rate (EIRR)	$\sum_{i=1}^n \frac{B_i}{(1+r)^i} = \sum_{i=1}^n \frac{C_i}{(1+r)^i}$	<ul style="list-style-type: none"> <li>- Allows knowing the investment efficiency comparing it to the social discount rate</li> <li>- Does not vary depending on the social discount rate</li> </ul>
Where Bi: benefit per “i” year / Ci: cost per “i” year / r: social discount rate (11 %) / n: years of assessment		

## 2) Assumptions

Next, find the assumptions of every indicator used from the economical assessment

### i) Assessment Period

The assessment period is set between 2013 and 2027 (15 years after construction works started). This Project implementing schedule is the following:

- 2012: Detailed Design
- 2013-2014: Construction
- 2013-2027: Assessment Period

### ii) Standard Conversion Factor (SCF)

The standard conversion factor (SCF) is the relationship between socioeconomic prices established along the border and national private prices of all goods in a country’s economy. It is used to convert goods and services prices purchased in the local market at affordable

prices. In this Study the following SCF values were used:

Dams 0.804

Gabions 0.863

Intakes 0.863

TAX (Peruvians use IGV) is not taken into account in the conversion of market prices to socioeconomic prices.

iii) Other preliminary conditions

Price level: 2011

Social discount rate: 10%

Annual maintenance cost: 0.5% of construction cost

### 3) Cost-benefit relation analysis (C/B)

A comparison of the total cost and total benefit of flood control works converted to present values applying the social discount rate was performed. In this case, the total cost is the addition of construction, operation and maintenance costs. The total benefit is the loss amount that was reduced due to the works. For this, a base year was established for the conversion into the current value at the moment of the assessment, and the assessment period was set for the next 15 years from the beginning of the Project. The total cost was determined adding-up the construction, operation and maintenance costs of the works converted into present values; and the total benefit adding-up the annual average loss amount turned into current values.

In table 4.5.1-6 results of calculations C/B, NPV and IRR to private prices is shown.

**Table 4.5.1-6 Social Assessment (C/B, NPV, IRR) (at private prices)**

流域名	年平均被害軽減額 Accumulated Average Annual Benefit	評価期間被害 軽減額(15年) Accumulated Average Annual Benefit (in 15 years)	事業費 Project's Cost	維持管理費 O&M Cost	C/B Cost/Benefit Relation	Net Present Value (NPV) NPV	Internal Rate of Return (IRR) IRR
Pisco	220,402,316	99,529,317	71,608,946	3,911,056	1.55	35,225,349	19%

## 4.5.2 Costs at social prices

### (1) Benefits

1) Estimated loss amount according to different return periods

In table 4.5.2-1 the amounts of loss with and without Project are shown. These are estimated for disaster of different return periods in the Pisco River Watershed.

**Table 4.5.2-1 Estimated loss amount (at social prices)**

(s./1,000)

Case	t	Pisco
Without Project	2	16,681
	5	22,436
	10	52,469
	25	61,739
	50	84,256
	Total	237,581
With Project	2	289
	5	402
	10	3,055
	25	7,985
	50	10,889
	Total	22,620

**2) Loss amount (annual average) is expected to be reduced with the Project**

In table 4.5.2-2 results of loss amount calculation (annual average) that are expected to reduce to implement the Project in the Pisco River are shown.

**Table 4.5.2-2 Annual average damage reduction amount (at social prices)**

s/1000

流域 Watershed	流量規模 Return Period	超過確率 Probability	被害額 (Total damage - thousands of S/)			区間平均被害 額 ④ Damage Averagare	区間確率 ⑤ Probability incremental value	年平均被害額 ④×⑤ Average value of the damages flow	年平均被害額の 累計=年平均被 害軽減期待額 Annual Medial Damage
			事業を実施し ない場合①	事業を実施し た場合②	軽減額 ③=①-②				
			Without Project ①	With Project	Mitigated damages ③=①-②				
PISCO	1	1.000	0	0	0		0	0	
	2	0.500	16,681	289	16,392	8,196	4,098	4,098	
	5	0.200	22,436	402	22,034	19,213	0.300	5,764	9,862
	10	0.100	52,469	3,055	49,414	35,724	0.100	3,572	13,434
	25	0.040	61,739	7,985	53,754	51,584	0.060	3,095	16,529
	50	0.020	84,256	10,889	73,368	63,561	0.020	1,271	17,801

**(2) Social Assessment**

In table 4.5.2-3 results of the calculation C/B, NPV and IRR at social prices are shown.

**Table 4.5.2-3 Social Assessment (C/B, NPV, IRR) (at social prices)**

流域名	年平均被害軽減額 Accumulated Average Annual Benefit	評価期間被害軽減額(15年) Accumulated Average Annual Benefit (in 15 years)	事業費 Project's Cost	維持管理費 O&M Cost	C/B Cost/Benefit Relation	Net Present Value (NPV) NPV	Internal Rate of Return (IRR) IRR
Pisco	231,407,622	104,499,095	57,564,591	3,144,489	2.02	52,806,516	25%

### 4.5.3 Social assessment conclusions

The social assessment shows that the Project in Pisco River watershed has a high economic impact at both the private and social prices. Also, the following economical hardly-quantifiable positive impacts are shown:

- ① Contribution to local economic development when soothing the fear due to economic activities suspension and damage
- ② Contribution by increasing local employment opportunities for the construction of the project
- ③ Strengthening the local population's awareness for floods damage and other disasters
- ④ Income increase contributions due to an stable agricultural production because flood damages are soothed
- ⑤ Increase of agricultural land price

For the economic assessment results previously presented, it is considered that this Project will contribute substantially to the local economic development.

## 4.6 Sensitivity Analysis

### (1) Objective

A sensitivity analysis was made in order to clarify the uncertainty due to possible changes in the future of the socioeconomic conditions. For the cost-benefit analysis it is required to foresee the cost and benefit variation of the project, subject to assessment, to the future. However, it is not easy to perform an adequate projection of a public project, since this is characterized for the long period required from planning to the beginning of operations. Also because of the long useful life of works already in operation and the intervention of a number of uncertainties that affect the future cost and benefit of the project. So, analysis results are obtained frequently and these are discordant to reality when the preconditions or assumptions used do not agree with reality. Therefore, for the uncertainty compensation of the cost-benefit analysis it should be better to reserve a wide tolerance-bank, avoiding an absolute and unique

result. The sensitivity analysis is a response to this situation.

The objective of the sensitivity analysis is to provide the cost-benefit analysis results a determined bank that will allow a proper managing of the project's implementation, give numbers to the population and achieve greater accuracy and reliability of the project's assessment results.

## (2) Sensitivity Analysis

### 1) General description of the sensitivity analysis

There are three methods of the sensitivity analysis, as indicated in Table 4.6-1.

**Table 4.6-1 Sensitivity Analysis Methods**

Methods	Description	Products
Variables sensitivity analysis	It consists in changing only one predetermined variable (precondition or hypothesis), to assess how the analysis result is affected	Bank values from the analysis when a precondition or hypothesis varies
Better and worst alternatives	It consists in defining the cases in which the analysis results are improved or worsen when changing the main pre-established preconditions or hypothesis to assess the analysis result bank	Bank values from the analysis when the main precondition or hypothesis vary
Monte Carlo	It consists in knowing the probability distribution of the analysis results by simulating random numbers of Monte Carlo simulation of pre-established preconditions and hypothesis	Probable results distribution when all main precondition or hypothesis vary

### 2) Description of the sensitivity analysis

In this project the sensitivity analysis method of the variables usually used in public works investments was adopted. Next, the scenarios and economic indicators used in the sensitivity analysis are shown.

**Table 4.6-2 Cases subjected to the sensitivity analysis and economic indicators**

Indicators	Variation bank according to factors	Economic indicators to be evaluated
Construction cost	In case the construction cost increases in 5 % and 10 %	IRR, NPV, C/B
Benefit	In case of reducing the benefit in 5 % and 10 %	IRR, NPV, C/B
Social discount rate	In case of increase and reduction of the discount social rate in 5 % respectively	NPV, C/B

### 3) Results of the sensitivity analysis

In table 4.6-3 the results of the sensitivity analysis of each assessed case to private and social prices is shown.



**Table 4.6-3 Results of the sensitivity analysis of IRR, C/B and NPV**

	Watershed	Variables	Base Case	Case 1	Case 2	Case 3	Case 4	Case 5	Case 6
				Cost increase 5%	Cost increase 10%	Benefit reduction 5%	Benefit reduction 10%	Discount rate increase 5%	Discount rate increase 10%
Private prices	PISCO	IRR (%)	19%	18%	17%	18%	16%	19%	19%
		B/C	1.55	1.47	1.41	1.47	1.39	1.19	2.08
		NPV(s)	35,225,349	32,010,150	28,794,952	30,248,883	25,272,417	11,533,380	75,102,472
Social prices	PISCO	IRR (%)	25%	24%	23%	24%	23%	25%	25%
		B/C	2.02	1.93	1.84	1.92	1.82	1.56	2.72
		NPV(s)	52,806,516	50,221,887	47,637,258	47,581,561	42,356,606	26,882,586	95,916,361

### (3) Assessment of the sensitivity analysis

We performed a sensitivity analysis of the impact of the project in terms of socioeconomic change, to both private and social prices. According to this analysis, even when the costs, benefits and the discount rate suffer a certain degree of variation, their impact on IRR, B/C and NPV levels is reduced, and it remains being a Project with high economic impact.

## 4.7 Sustainability Analysis

This project will be co-managed by the central government (through the DGIH), irrigation committees and regional governments. Also, the project cost will be covered with the respective contributions of the three parties. Usually the central government (in this case, the DGIH) takes the 80%, irrigation commissions 10% and regional governments 10%. However, the percentages of the contributions of these last two are decided through discussions between both parties. On the other hand, the operation and maintenance (O & M) of the completed works is assumed by the irrigation committee. So, the sustainability of the project depends on the profitability of the Project and the ability of the irrigation committees for O & M.

Table 4.7-1 presents the data of the budget for irrigation committees Pisco River Watershed in recent years.

**Table 4.7-1 Project Budget of the irrigation commissions**

Rivers	Annual Budget				(In soles)
	2007	2008	2009	2010	4 year average
Pisco	1,648,019.62	1,669,237.35	1,725,290.00	1,425,961.39	1,617,127

### (1) Profitability

The project in Pisco river Watershed is sufficiently profitable and highly sustainable. The investment amount in this watershed is estimated in 71.6 million soles (at private prices). It is an economically efficient Project with a C/B relation of 2.02, a relatively high IRR of approximately 25%, and the NPV is 52.8 million soles in 15 years.

### (2) Cost of operation and maintenance

The annual cost of operation and maintenance required for the project, having as a base year 2008 is estimated at 300,850 soles, corresponding to 0.5% of the project in the Pisco River watershed. On the other hand, the average operating expenses in the last years from the irrigation commissions was 1,617,127soles.

When considering that the annual operation and maintenance cost represents 18.6% of the annual irrigation commissions' expenses, the project would be sustainable enough according to the financial capacity of these committees to maintain and operate the constructed works.

## 4.8 Environmental Impact

### 4.8.1 Procedure of Environmental Impact Assessment

Projects are categorized in three scales, based on the significance level of the negative and positive impacts, and each sector has an independent competence on this categorization. The following table shows the environmental management instruments that are required for each category. The Project holder should submit the Environmental Impact Statement (DIA, in Spanish) for all Projects under Category I. The project holder should prepare an EIA-sd or an EIA-d if the Project is categorized under Category II or III, respectively, to be granted the Environmental Certification from the relevant Ministry Directorate.

**Table 4.8.1-1 Project Categorization and Environmental Management Instruments**

	Description	Required Environmental Management Instrument
Category I	It includes those Projects that when carried out, they cause no significant negative environmental impacts whatsoever.	PEA that is considered a DIA after the assessment for this category
Category II	It includes those Projects that when carried out, they can cause moderate environmental impacts, and their negative effects can be removed or minimized through the adoption of easily applicable measures.	Semi-Detailed Environmental Impact Assessment (EIA-sd)
Category III	It includes those Projects than can cause significant quantitative or qualitative negative environmental impacts because of their characteristics, magnitude and/or location. Therefore, a deep analysis is required to revise those impacts and set out a relevant environmental management strategy.	Detailed Environmental Impact Assessment (EIA-d)

Source: Prepared by the JICA Study Team based on the SEIA Law (2001)

The next graph shows the Environmental Document's Classification, the Environmental Document's Assessment, and the Environmental Certification.

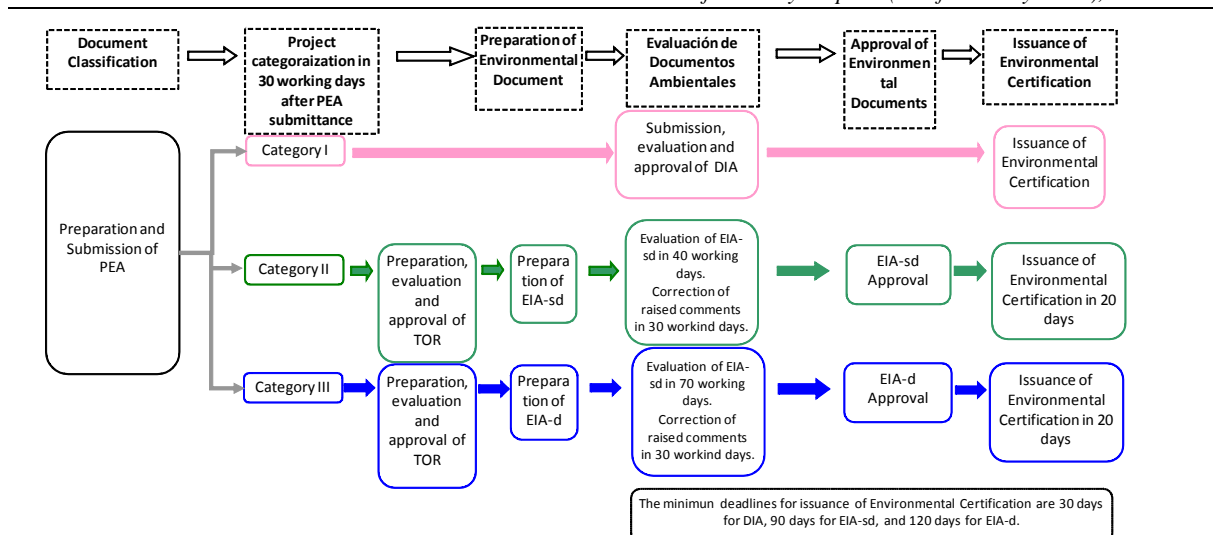

Source: Prepared by the JICA Study Team based on the SEIA Regulations (2009)

**Figure 4.8.1-1 Process to Obtain the Environmental Certification**

First, the Project holder applies for the Project classification, by submitting the Preliminary Environmental Assessment (PEA). The relevant sector assesses and categorizes the Project within the next 30 working days after the document's submission. The Project's PEA that is categorized under Category I becomes an EID, and those Projects categorized under Category II or III should prepare an EIA-sd or EIA-d, as applicable. There are cases in which the relevant sector prepares the Terms of Reference for these two studies, and submits them to the holder. There are other cases in which the holder prepares the Terms of Reference and these are approved by the relevant sector, based on the interview with DGAA. Number of working days required for EIA-sd revision and approval is 90, and number of working days required for EIS-d is 120; however, these maximum deadlines may be extended.

The progress of the environmental impact study is as shown below.

The JICA Study Team subcontracted a local Consultant (CIDE Ingenieros S.A.), and a Preliminary Environmental Assessment (PEA) was carried out, from December 2010 to January 2011 for Pisco river.

EAP for the Pisco river was submitted to DGIH from JICA on January 25, 2011. DGIH submitted the EAP to DGAA on July 19, 2011.

EAP for Pisco river was examined by DGAA, and DGAA issued their comments on EAP to DGIH. JICA Study Team revised EAP upon the comments and submitted it to DGAA on September 21, 2011. DGAA completed examination on the revised EAP and issued approval letter on Pisco river in which DGAA classified Pisco river into Category I. Therefore the additional environmental impact analysis for Pisco river is not required.

The positive and negative environmental impact associated with the implementation of this project was confirmed and evaluated, and the plan for prevention and mitigation measures are prepared by EAP results, field investigation and hearing by JICA Study Team.

The proposed works in this project include: the reparation of existing dikes, construction of new dikes, riverbed excavation, bank protection works, repair and improvement of the derivation and intakes works, and also river expansion. Table 4.8.1-2 describes “working sites” to be considered in the Environmental Impact section for Pisco river.

**Table 4.8.1-2 Works Description**

Basin	Location		Preservation Object	Counter Measure	Summary of Facility	Objective Section	
Pisco	1	5.5k	Inundation	Crop land	Dike (no dike section) Revetment	Top W; 4.0m H; 2.0m Slope; 1:3 L; 2,000m	3.0km~5.0km (left bank)
	2	7.0k	Narrow Section		Riverbed excavation	Ex. width; 100m Ex. depth; 1.0m L; 1,500m	6.5km~8.0km (total)
	3	13.5k	Inundation		Dike (no dike section) Revetment	Top W; 4.0m H; 2.0m Slope; 1:3 L; 1,500m	12.5km~14.0km (left bank)
	4	20.5k	Inundation	Crop land	Dike (no dike section) Revetment	Top W; 4.0m H; 2.0m Slope; 1:3 L; 2,000m	19.5km~20.5km (left bank)
	5	26.5k	Narrow Section		Widening river width	Ex. width; 100m Ex. depth; 1.0m L; 1,000m	26.0km~27.0km (total)
	6	34.5k	Intake		Retarding basin	Retarding basin; 1,800m × 700m	34.5km~36.5km (total)

Source: JICA Study Team

### 4.8.2 Methodology

In order to identify environmental impacts of the works to be executed in the different watersheds, we developed identification impact matrixes for watershed.

First, the operation and activities for each project based on typical activities of “hydraulic works” construction were determined. Afterwards, the concrete activities type was determined which will be executed for each work that will be developed in the watersheds. Then, to evaluate Socio-environmental impacts the Leopold matrix was used.

**Table 4.8.2-1 Evaluation Criterion - Leopold Matrix**

Index		Description	Valuation
"Na" nature		It defines whether change in each action on the means is positive or negative	Positive (+) : beneficial
			Negative (-): harmful
Probability of Occurrence "P.O."		It includes the probability of occurrence of the impact on the component	High (>50 %) = 1.0
			Medium (10 – 50 %) = 0.5
			Low (1 – 10 %) = 0.2
Magnitude	Intensity (In)	It indicates the magnitude of change in the environmental factor. It reflects the degree of disturbance	Negligible (2)
			Moderate intensity (5)
			Extreme Disturbance (10)
	Extension "Ex"	It indicates the affected surface by the project actions or the global scope on the environmental factor.	Area of indirect influence: 10
			Area of direct influence: 5
			Area used up by the works: 2
	Duration "Du"	It refers to the period of time when environmental changes prevail	> 10 years: 10
			5 – 10 years : 5
			1 – 5 years: 2
	Reversibility "Rev"	It refers to the system's capacity to return to a similar, or an equivalent to the initial balance.	Irreversible: 10
			Partial return: 5
			Reversible: 2

Source: Prepared based on PEAs of 6 Basins

**Table 4.8.2-2 Impact Significance Degrees**

SIA	Extent of Significance
≤ 15	Of little significance
15.1 - 28	Significant
≥ 28	Very significant

Source: Prepared based on PEAs of 6 Basins

### 4.8.3 Identification, Description and Social Environmental Assessment

#### (1) Identification of social environmental impacts

In the following matrix (construction/operation stages) in the watershed, elaborated based on the report analysis of the Preliminary Environmental Assessment.

**Table 4.8.3-1 Impact Identification Matrix (Construction and Operation Stage) – Pisco River**

Construction Stage			Work	1-6	1-6	1,3,4	1-6	5	1-5	1,3,4,6	1,3,4,6	1-6	1-5	1-6	1-6	Total Negative	Total Positive	
Environment	Component	Environmental Factors	Activity	Labor Recruitment	Site preparation work (Cleaning, land grading, Levelled)	Diversion of riverbed (Cofferdams)	Digging and movement of Land	Digging and refilling in riverside	Digging and refilling in riverbed	Civil Work (Concreting)	I&O of stone pits and material production plants	DME I&O	Camps work I&O	Carriage Staff	Transportation of machinery, equipment, materials and supplies			
Physique	Air	PM-10 (Particulate matter)		N	N	N	N	N	N	N	N	N	N	N	N	9	0	
		Gas emissions			N	N	N	N	N	N	N	N	N	N	N	N	10	0
	Noise	Noise			N	N	N	N	N	N	N	N	N	N	N	N	11	0
		Soil fertility			N								N				2	0
	Soil	Land Use			N							N	N				3	0
		Calidad del agua superficial					N		N	N		N		N			5	0
	Water	Cantidad de agua superficial									N						1	0
		Morfología fluvial					N		N	N							4	0
Physiography	Morfología terrestre			N			N					N				3	0	
	Terrestrial flora			N								N				2	0	
Biotic	Flora	Aquatic flora			N			N	N		N					4	0	
		Terrestrial fauna			N							N				2	0	
	Fauna	Aquatic fauna			N	N	N	N	N		N					5	0	
		Visual landscape			N							N	N				3	0
Socio-economic	Social	Quality of life		P									N	N	N	3	1	
		Vulnerability - Security															0	0
	Economic	PEA		P													0	1
		Current land use															0	0
<b>Total</b>				2	9	7	5	7	7	3	9	9	3	4	4	67	2	
<b>Percentage of positive and negative</b>																97 %	3 %	

Operation Stage			Works	Dike-Left Side Point 1	Riverbed without Siltling Point 2	Dike-Left Side Point 3	Dike-Right Side Point 4	extended Riverbed Punto 5	Well of Control Point 6	Total Negative	Total Positive
Environment	Component	Environmental Factors									
Physique	Air	PM-10 (Particulate matter)								0	0
		Gas emissions								0	0
	Noise	Noise								0	0
		Soil fertility								0	0
	Soil	Land Use								0	0
		Calidad del agua superficial								0	0
	Water	Cantidad de agua superficial		P	P	P	P			0	4
		Morfología fluvial		N	N	N	N			4	0
Physiography	Morfología terrestre								0	0	
	Terrestrial flora								0	0	
Biotic	Flora	Aquatic flora								0	0
		Terrestrial fauna								0	0
	Fauna	Aquatic fauna		N	N	N	N			4	0
		Visual landscape		P	P	P	P			0	4
Socio-economic	Social	Quality of life		P	P	P	P	P	P	0	6
		Vulnerability - Security		P	P	P	P	P	P	0	6
	Economic	PEA								0	0
		Current land use		P	P	P	P	P	P	0	6
<b>Total</b>				7	7	7	7	3	3	8	26
<b>Percentage of positive and negative</b>										24 %	76 %

N: Negative, P:Positive

Source: Prepared by the JICA Study Team

On the Pisco River basin, based on the impact identification results for the construction stage, a total number of 69 interactions have been found. 67 of these interactions (97 %) correspond to impacts that will be perceived as negative, and 2 (3 %) correspond to impacts that will be perceived as positive. In addition, 34 interactions have been found for the operation stage; 8 of these interactions (24 %) correspond to impacts that will be perceived as negative, and 26 (76 %) correspond to impacts that will be perceived as positive.

## (2) Environmental and Social Impact Assessments

Environmental and social impacts are assessed with the methodology that was explained in 4.8.2 Methodology. The following tables show the environmental and social assessment results for the basin, during the construction and operation stages.

**Table 4.8.3-2 Environmental Impact Assessment Matrix – Pisco River**

			The Pisco River Basin											
Medio	Componente	Acciones del proyecto	Construction Stage						Operation Stage					
			Civil Work (Concreting)	I&O of stone pits and material production plants	DME I&O	Camps work I&O	Carnage Staff	Transportation of machinery, equipment, materials and supplies	P11	P12	P13	P14	P15	P16
		Puntos de Obras: Factores Ambientales	Pi 1,3,4 y 6	Pi 1,3,4 y 6	Pi 1-6	Pi 1-5	Pi 1-6	Pi 1-6						
Physique	Air	PM-10 (Particulate matter)	0.0	-11.5	-18.0	0.0	-11.5	-11.5	0.0	0.0	0.0	0.0	0.0	0.0
		Gas emissions	-11.5	-11.5	-11.5	0.0	-11.5	-11.5	0.0	0.0	0.0	0.0	0.0	0.0
	Noise	Noise	-15.0	-12.0	-15.0	-15.0	-12.0	-12.0	0.0	0.0	0.0	0.0	0.0	0.0
		Soil fertility	0.0	0.0	-14.2	0.0	0.0	0.0	0.0	0.0	0.0	0.0	0.0	0.0
	Soil	Land Use	0.0	-15.0	-15.0	0.0	0.0	0.0	0.0	0.0	0.0	0.0	0.0	0.0
		Calidad del agua superficial	0.0	-15.0	0.0	-15.0	0.0	0.0	0.0	0.0	0.0	0.0	0.0	0.0
	Water	Cantidad de agua superficial	-9.0	0.0	0.0	0.0	0.0	0.0	26.0	31.0	26.0	26.0	0.0	0.0
		Morfología fluvial	0.0	-23.0	0.0	0.0	0.0	0.0	-25.5	-30.5	-25.5	-25.5	0.0	0.0
Physiography	Morfología terrestre	0.0	0.0	-28.0	0.0	0.0	0.0	0.0	0.0	0.0	0.0	0.0	0.0	
	Terrestrial flora	0.0	0.0	-22.5	0.0	0.0	0.0	0.0	0.0	0.0	0.0	0.0	0.0	
Biotic	Flora	Aquatic flora	0.0	-14.5	0.0	0.0	0.0	0.0	0.0	0.0	0.0	0.0	0.0	0.0
		Terrestrial fauna	0.0	0.0	-22.5	0.0	0.0	0.0	0.0	0.0	0.0	0.0	0.0	0.0
	Fauna	Aquatic fauna	0.0	-15.0	0.0	0.0	0.0	0.0	-25.5	-30.5	-25.5	-25.5	0.0	0.0
		Visual landscape	0.0	-12.0	-12.0	0.0	0.0	0.0	36.0	36.0	36.0	36.0	0.0	0.0
Socio-economic	Esthetic	Quality of life	0.0	0.0	0.0	-18.0	-18.0	-17.5	36.0	36.0	36.0	31.0	41.0	36.0
		Vulnerability - Security	0.0	0.0	0.0	0.0	0.0	0.0	36.0	36.0	36.0	31.0	41.0	36.0
	Economic	PEA	0.0	0.0	0.0	0.0	0.0	0.0	0.0	0.0	0.0	0.0	0.0	0.0
		Current land use	0.0	0.0	0.0	0.0	0.0	0.0	36.0	36.0	36.0	36.0	41.0	36.0

Grade of Positive Impacts		Grade of Negative Impacts	
0-15.0	Little significant	0-15.0	Little significant
15.1-28.0	Significant	15.1-28.0	Significant
28.1-	Very significant	28.1-	Very significant

Source: Prepared based on PEAs of 6 Basins

It must be pointed out that in the Pisco River basin only 12 out of a total of 67 negative impacts have been quantified as significant, and 2 have been quantified as very significant, during the construction stage. Meanwhile, out of a total of 8 negative impacts, only 6 have been quantified as significant, and 2 have been quantified as very significant, during the operation stage.

During the construction stage, the works site preparation component will significantly affect the land morphology. At the same time, the Riverbed Excavation and Filling component will affect the “Pi1”, “Pi2”, “Pi3”, and “Pi4” points. During the operation stage, river morphology and aquatic fauna will be significantly affected at the “Pi2” points, where the river basin will be unclogged.



During the construction stage, actions that will generate most significant negative impacts along the basin include: “Site Works Preparation and Clearance”, “Riverbed Excavation and Filling”, and “Surplus Material Deposits Operation (DME, in Spanish).” “Site works Preparation and Clearance” will bring about a significant modification to the land morphology, whereas “Riverbed Excavation and Filling” will bring about a significant modification to river morphology.

During the operation stage, hydraulic infrastructure works that will bring about most significant negative environmental impacts include “Riverbed excavation and embankment” that will cause a modification to the river morphology and subsequently, decreased river habitability conditions that will directly impact the aquatic fauna.

Most significant positive impacts are related to all works to be constructed along the river basins, and are directly related to improve the quality of the lives of the population around the area of influence, improve the “Current Use of land / soil”, improve the security conditions, and reduce vulnerability at social and environmental levels.

#### **4.8.4 Socio-Environmental Management Plans**

The objective of the Socio-Environmental Plans is to internalize both positive and negative significant and very significant environmental impacts that are related to the Project’s construction and operation stages, so that prevention and/or mitigation of significant and very significant negative impacts, preservation of environmental heritage, and Project sustainability are ensured.

During the construction stage, Project of Pisco river has set out the following measures: “Local Hiring Program”, “Works Sites Management and Control Program”, “Riverbed Diversion Program”, “Riverbank Excavation and Filling Management”, “Riverbed Excavations and Filling Management”, “Quarry Management”, “DME Management”, “Camp and Site Residence Standards”, and “Transportation Activity Management.” During the operation stages, Project for the basin has considered the development of activities with regard to “Riverbed and Aquatic Fauna Management”. These activities should develop riverbed conditioning downstream the intervention points, for erosion probabilities to be reduced, and habitability conditions to be provided for aquatic fauna species. The following are measures related to those negative impacts to be mitigated or those positive impacts to be potentiated. Overall measures have been established for the basin, based on the impacts.

**Table 4.8.4-1 Environmental Impact and Prevention/Mitigation Measures**

Item	Impact	Counter Measures	Period
Natural environment	Water quality of surface water	Management of river diversion and coffering	Construction period
		Management of bank excavation and banking	
		Management of riverbed excavation and back filling	
	River topography	Management of bank excavation and banking	
		Management of riverbed excavation and back filling	
		Management of quarry site	
	Other topography	Management of construction site	
		Management of large amount of excavated or dredged material	
Dust	Management of construction site		
	Management of large amount of excavated and dredged material		
Biological environment	Aquatic fauna	Management of riverbed excavation and back filling	O/M period
	Terrestrial fauna	Management of construction site	Construction period
		Management of large amount of excavated and dredged material	
	Terrestrial flora	Management of construction site	
Management of large amount of excavated and dredged material			
Social environment	Quality of life	Management of labor and construction office	Construction period
		Management of traffic of construction vehicle	
		Employment plan of local people	
	Population of economic activity	Employment plan of local people	

Source: JICA Study Team

#### 4.8.5 Monitoring and Control Plan

##### (1) Follow up and monitoring plan

The follow-up plan has to implement firmly the management of environmental plan. The monitoring plan is to be carried out to confirm that the construction activity fulfill the environmental standard such as Environmental Quality Standards (EQS) either or Maximum Permissible Limits (MPL). And the monitoring and control must be carried out under the responsibility of the project's owner or a third party under the supervision of the owner.

##### · Construction stage

During the construction period of the projects to be done in the watershed, the Monitoring and Control Plan will be directed to the verification of the fulfillment measures designed as part of the environmental monitoring plan and the verification of the fulfillment of laws and regulation of the Peruvian Legislation. The following aspects will also be monitored:

##### Water Quality and Biological Parameters:

Water quality and biodiversity parameters control shall be performed at downstream of these works must be monitored. In the following table the profile of this plan is shown.

**Table 4.8.5-1 Monitoring to Water Quality and Biological Parameters**

Item	Unit	Measured Value (Mean)	Measured Value (Max.)	Country's Standards
pH	pH			"National Standard for Water Quality" D.S. No. 002-2009 MINAM
TSS	mg/l			
BOD/COD	mg/l			
DO	mg/l			
Total Nitrogen	mg/l			
Heavy Metals	mg/l			
Temperature	°C			
Biological Diversity indices: Shannon; Pielou; richness and abundance				

[Measurement Points]

-50 meters upstream the intervention points

-50 meters downstream the intervention points

-100 meters downstream the intervention points

[Frequency]

Quarterly

[Person in charge of Implementation]

DGIH-MINAG, or a third party under the project holder's supervision

Source: JICA Study Team

### Air Quality:

During impact analysis, in the projects to be developed in the watershed no significant impacts will be seen in the activities related to hydraulic infrastructure works. However, the generation of dust and atmospheric contaminant emissions always affects the working area and the workers and inhabitants health. So, it is recommended to monitor air quality.

**Table 4.8.5-2 Monitoring to Air Quality**

Item	Unit	Measured Value (Mean)	Measured Value (Max.)	Peruvian Standards (D.S. No 074-2001-PCM)	Referred International Standards
SO <sup>2</sup>				"National Standard for Air Quality" D.S. No.074-2001-PCM	National Ambient Air Quality Standards (NAAQS) (Updated in 2008)
NO <sup>2</sup>					
CO					
O <sup>3</sup>					
PM-10					
PM-2.5					

[Measurement Points]

\*02 stations per monitoring point: Windward and downwind (upwind and against the wind direction)

-1 point at the working zones

-1 point at a quarry, away from the river (the largest and / or the closest point to a populated area)

-1 point at a D.M.E. (the largest and / or the closest point to a populated area)

[Frequency]

Quarterly

[Person in charge of the Implementation]

DGIH-MINAG, or a third party under the project holder's supervision

Source: JICA Study Team

### Noise Quality

Likewise, it is proposed to perform a noise monitoring at the potential receptors located near the noise emission spots towards the working sites, in the next table 4.8.5-3, the terms are described.

**Table 4.8.5-3 Monitoring to Noise Quality**

Item	Unit	Measured Value (Mean)	Measured Value (Max.)	Country's Standards	Referred International Standards
Noise level	LAeqT (dB(A))			National Environmental Quality Standards for noise (EQS) - S.N. N° 085-2003-PCM	-IEC 651/804 - International -IEC 61672- New Law: Replaces IECs 651/804 -ANSI S 1.4 - America

[Measurement Point]

Monitoring to acoustic contamination levels will be carried out at the potential receivers that are located around the noise emission points per work front.

01 point per potential receiver will be monitored.

[Frequency]

Every two months during construction phase  
 [Person in charge of the Implementation]  
 DGIH-MINAG, or a third party under the project holder's supervision  
 Source: JICA Study Team

· Operation Stages

Regarding works impact of all projects, it is mainly recommended to monitor biologic parameters and water quality as river topography and the habitat of aquatic life.

**Table 4.8.5-4 Monitoring to Water Quality (Operation Stage)**

Item	Unit	Measured Value (Mean)	Measured Value (Max.)	Country's Standards
pH	pH			"National Standard for Water Quality" D.S. No. 002-2009 MINAM
TSS	mg/l			
BOD/COD	mg/l			
DO	mg/l			
Total Nitrogen	mg/l			
Heavy Metals	mg/l			
Temperature	°C			
Biological Diversity indices: Shannon; Pielou; richness and abundance				

[Measurement Points]  
 -50 meters upstream the intervention points  
 -50 meters downstream the intervention points  
 -100 meters downstream the intervention points  
 [Frequency]  
 Quarterly in first two years of operation phase  
 [Person in charge of Implementation]  
 DGIH-MINAG, or a third party under the project holder's supervision  
 Source: JICA Study Team

(2) Closure or Abandon Plan

Closure or abandon plans have been made for each watershed. These will be executed at the end of construction activities and involves the removal of all temporary works and restoration of intervened and/or affected areas as a result of the works execution. The restoration includes the removal of contaminated soil, disposal of waste material, restoration of soil morphology and restoration with vegetation of intervened sites.

(3) Citizen Participation

Citizen participation plans have been made for each watershed, which must be executed before and during construction and when the works are completed. The recommended activities are:

- Before works: Organize workshops in the surrounding community's area near the project and let them know what benefits they will have. Informative materials in communities, which

will explain the profile, lapse, objectives, benefits, etc. of the Project

- During works execution: Give out information on the construction progress. Responding complaints generated from the local community during works execution. For this, a consensus wants to be previously achieved with the community in order to determine how claims will be met
- When works are completed: Organize workshops to inform about works completion. Works delivery to the local community inviting local authorities for the transfer of goods, which means the work finished.

#### 4.8.6 Cost for the environmental impact management

The direct costs of previously mentioned measures to mitigate environmental impacts in the Pisco River Watershed is as shown in the Table 4.8.6-1. In any case, it is necessary to determine in detail these measures' budget for each watershed in the detailed design stage.

**Table 4.8.6-1 Direct costs of measures to manage environmental impact**

Actions	Unit	Qty	Unitary price (S/.)	Subtotal (S/.)	Total (s/.)
Sign for vehicles entrance	Month	6	S/. 1.400,0	S/. 8.400,0	S/. 8.400,0
Industrial waste transportation	Month	6	S/. 4.200,0	S/. 25.200,0	S/. 25.200,0
Project sites landscape protection measures	Month	6	S/. 2.800,0	S/. 16.800,0	S/. 16.800,0
Operation and maintenance of construction equipment	Month	6	S/. 1.960,0	S/. 11.760,0	S/. 11.760,0
Measures for staff noise protection	Month	6	S/. 1.120,0	S/. 6.720,0	S/. 6.720,0
Functioning expenses to implement environmental impact mitigation measures	Month	6	S/. 4.480,0	S/. 26.880,0	S/. 26.880,0
Soil and air contaminant prevention capacity development	Month	6	S/. 2.520,0	S/. 15.120,0	S/. 15.120,0
Bed and aquatic fauna monitoring					S/. 11.239,2
Diversity indicators monitoring	times	3	S/. 672,0	S/. 2.016,0	
Water flow monitoring	times	3	S/. 588,0	S/. 1.764,0	
T°, pH, OD monitoring	times	3	S/. 571,2	S/. 1.713,6	
DBO monitoring	times	3	S/. 638,4	S/. 1.915,2	
Total solids dissolve monitoring (SDT)	times	3	S/. 638,4	S/. 1.915,2	
Total suspended solids monitoring (SST)	times	3	S/. 638,4	S/. 1.915,2	
Air and noise quality monitoring					S/. 37.500,0
Gas emissions monitoring	times	3	S/. 4.500,0	S/. 13.500,0	
Dust monitoring	times	3	S/. 5.000,0	S/. 15.000,0	
Noise monitoring	times	3	S/. 3.000,0	S/. 9.000,0	
Total					S/. 159.619,2

## **4.8.7 Conclusions and Recommendations**

### **(1) Conclusions**

According to the Preliminary Environmental Appraisals to Pisco basin, most impacts identified during the construction and operation stages were found out to be of little significance. Significant and very significant negative impacts can be controlled or mitigated, as long as suitable Environmental Management Plans are carried out. In addition, the Project will be implemented in the short term, as environmental conditions will be quickly restored. However, the execution of a follow – up and monitoring plan is important, and in the event that unexpected impacts are generated, immediate mitigation measures must be taken.

In addition, significant positive impacts are also present, especially during the operation stage. These positive impacts include: An enhanced security / safety and a decreased vulnerability at social and environmental levels; an improved quality of life among the population in the area of influence, and an improved “Current use of land / soil”.

### **(2) Recommendations**

1) We mainly recommend that the beginning of the construction activities coincides with the beginning of the dry seasons in the region (May to November) when the level of water is very low or the river dries up. The river characteristics / features should be taken into account, that the Pisco River is seasonal rivers. At the same time, the crop season cycle in the areas of direct influence should be taken into account, so that traffic jams caused by the large trucks and farming machinery is prevented.

2) It is recommended that the Project holder (DGIH) should define the limit of river area during detailed design stage, and identify the people who live within the river area illegally. Continually the DGIH should carry on the process of land acquisition based on the Land Acquisition Law, which are; Emission of Resolution for land acquisition by the State, Proposition of land cost and compensation for land owner, Agreement of the State and land owner, Payment, archaeological assessment certification.

3) DGIH has to promote the process to obtain the CIRA in the detail design stage. The process to be taken is i) Application form, ii) Copies of the location drawings and outline drawings, iii) voucher, iv) Archaeological Assessment Certificate.

4) The participation of the women in the workshops can be promoted through the existing women group such as Vaso de Leche.

Finally, the DGAA submitted the resolutions (Environmental Permissions) for Pisco basin. The project has been categorized as “Category I”, which means that the project is not required to carry out neither EIA-sd nor EIA-d.

## **4.9 Execution Plan**

The Project's Execution Plan will review the preliminary schedule, which includes the following components. For pre-investment stage: ① full execution of pre-feasibility and feasibility studies to obtain SNIP's approval in the pre-investment stage; for the investment stage: ② signing of loans (L/A), ③ consultant selection, ④ consulting services (detailed design and elaboration of technical specifications), ⑤ constructor selection and ⑥ work execution. For the post-investment stage: ⑦ Works' completion and delivery to water users associations and beginning of the operation and maintenance stage.

### **(1) Review by the Public Investment National System (SNIP)**

In Peru, the Public Investment National System (SNIP hereinafter) is under operation. This reviews the rationality and feasibility of public investment projects, and will be applied to this Project.

In SNIP, among previous studies to an investigation, it will be conducted in 3 stages: profile study (study on the project's summary), pre-feasibility and feasibility. SNIP was created under Regulation N° 27293 (published on June 28, 2000) in order to achieve efficient use of public resources for public investment. It establishes principles, procedures, methods and technical regulations to be fulfilled by central/regional governments in public investment scheme plans and executed by them.

SNIP, as described below, is all public works projects which are forced to perform a 3-stage pre-investment study: profile study, pre-feasibility and feasibility, and have them approved. However, following the Regulation amendment in April 2011, the execution of pre-feasibility study of the intermediate stage was considered unnecessary; but in return, a study based on primary data during the profile study is requested. The required precision degree throughout all stages of the study has hardly changed before and after this modification.



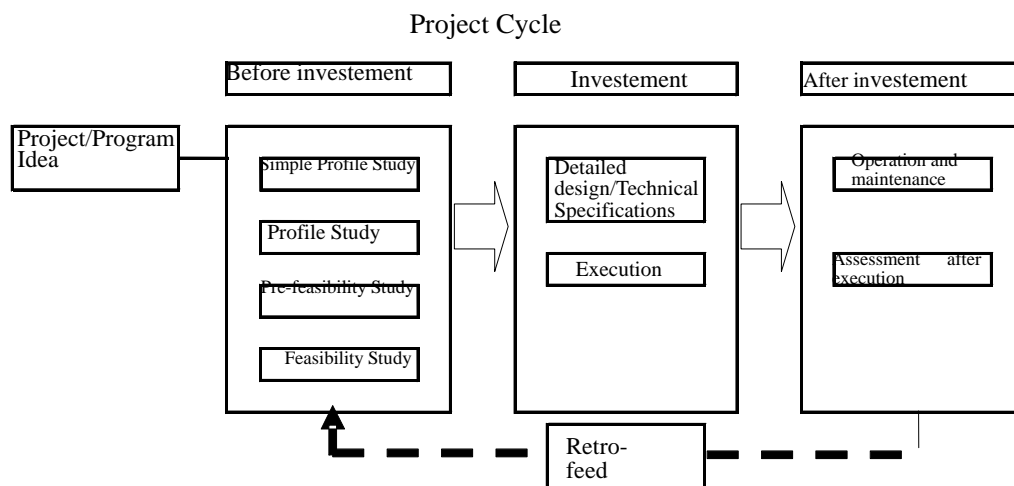

(Source: DGPM HP)

**Figure 4.9-1 SNIP Cycle Project**

In order to carry out this Project, which is a project composed by several programs, pre-investment studies at investments' programs level are required to be performed and also have them approved.

Although the procedure is quite different in each stage, in SNIP procedures, the project's training unit (UF) conducts studies of each stage, the Planning and Investment Office (OPI) assesses and approves the UF's presented studies and requests Public Sector Multi-Annual Programming General Direction (hereinafter referred DGPM) to approve feasibility studies and initiation of following studies. Finally DPGM evaluates, determines and approves the public investment's justification.

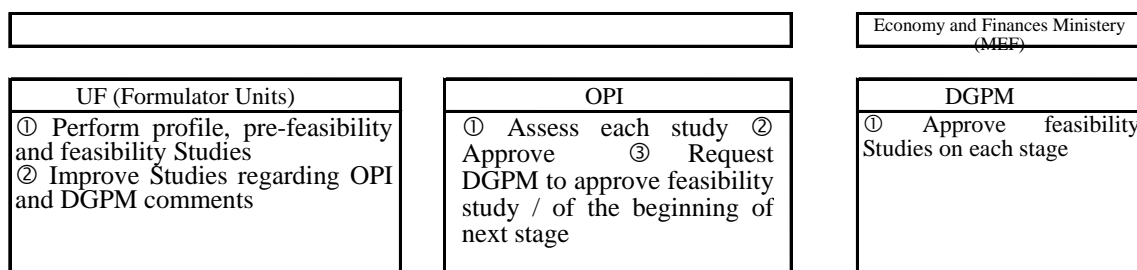

(See Regulation No.001-2009-EF/68.01.)

**Figure 4.9-2 Related Institutions to SNIP**

Due to the comments of examining authorities (OPI and DGPM) to FU, it will be necessary to prepare correspondent responses and improve the studies. Since these authorities officially

admit applications after obtaining definitive answers, there are many cases in which they take several months from the completion of the study report until the completion of the study.

(2) Yen loan contract

Once the feasibility studies reports are submitted and examined in SNIP, discussions on the loan in yen will begin. It is estimated to be a period of 6 months for procedures.

(3) Procedure of the project's execution

After the documents are assessed by SNIP and a loan agreement between Japan (JICA) and the Peruvian counterpart is signed, a consultant will be selected. The consulting service includes the development of detailed design and technical specifications, the contractors' selection and the work's supervision. Table 4.9-1 presents the Project's overall schedule.

1) Consultant selection: 3 months, builder selection: 3 months

2) Develop detailed design and technical specifications of the work's period

① River and re-forestation works along these works

Detailed design and technical specifications elaboration: 6 months

Working Period: 2 years

② Capacity Building

It will be executed on the same work period of river facilities.

Detailed design and technical specifications elaboration: 6 months

Working Period: 2 years

**Table 4.9-1 Implementation Plan**

ITEMS	2010			2011			2012			2013			2014			2015			2016				
	3	6	9	12	3	6	9	12	3	6	9	12	3	6	9	12	3	6	9	12	3	6	9
1 PROFILE STUDY / SNIP ASSESSMENT	STUDY			EVALUATION																			
2 FEASIBILITY STUDY / SNIP ASSESSMENT				STUDY			EVALUATION																
3 YEN CREDIT NEGOTIATION																							
4 CONSULTANT SELECTION																							
5 CONSULTANT SERVICE (DETAILED DESIGN, LAWFUL DOCUMENTS PREPARATION)							DESIGN / LAWFUL DOCUMENT						WORK SUPERVISION										
6 BUILDER SELECTION																							
7 WORK EXECUTION																							
1) STRUCTURES BUILDING																							
2) REFORESTATION																							
3) EARLY ALERT SYSTEM																							
4) DISASTER PREVENTIVE TRAINING																							
8 FINISH WORK / DELIVERY TO USERS BOARDS																							

#### **4.10 Institutions and Administration**

Peruvian institutions regarding the Project's execution and administration are the Agriculture Ministry, Economy and Finance Ministry and Irrigation Commission, with the following roles for each institution:

##### **Ministry of Agriculture (MINAG)**

- \* The Ministry of Agriculture (MINAG) is responsible for implementing programs and the Hydraulic Infrastructure General Direction (DGIH) is responsible for the technical administration of the programs. The Hydraulic Infrastructure General Direction (DGIH) is dedicated to the coordination, administration and supervision of investment programs.
- \* In investment stage, the PSI(Programa Subsectorial de Irrigaciones, Ministerio de Agricultura) is dedicated to calculate project costs, detail design and supervision of the works execution.
- \* The Planning and Investment Office (OPI) from the Agriculture Ministry is the one responsible for pre-feasibility and feasibility studies in the pre-investment stage of DGIH projects and requests approval of DGPI from the Economy and Finance Ministry (MEF).
- \* The General Administration Office of the Agriculture Ministry (OGA-MINAG) along with the Public Debt National Direction (DNEP) of the Economy and Finance Ministry is dedicated to financial management. It also manages the budget for procurement, commissioning works, contracting, etc. from the Agriculture Ministry.
- \* The Environmental Affairs General Direction (DGAA) is responsible for reviewing and approving the environmental impact assessment in the investment stage.

##### **Economy and Finance Ministry (MEF)**

- \* The DGPI approves feasibility studies. It also confirms and approves the conditions of loan contracts in yen. In the investment stage, it gives technical comments prior to the project execution.
- \* Financial management is in charge of DNEP from the Economy and Finance Ministry and OGA-MINAG.
- \* The Public Debt National Direction (DNEP) of the Economy and Finance Ministry administers expenses in the investment stage and post-investment operation.

##### **Irrigation Commission**

- \* Responsible for the operation and maintenance of facilities at the post-investment operation stage.

The relationship between the involved institutions in the Project's execution is shown in Figures 4.10-1 and 4.10-2.

In this Project, the investment stage (Project execution) corresponds to PSI from MINA. The PSI is currently performing JBIC projects, etc. and in case of beginning a new project, it forms the correspondent Project Management Unit (UGP), who is responsible of choosing the consulting firm, hire construction services, works supervision, etc. The following figure describes the structure of the different entities involved in the Project's execution stage.

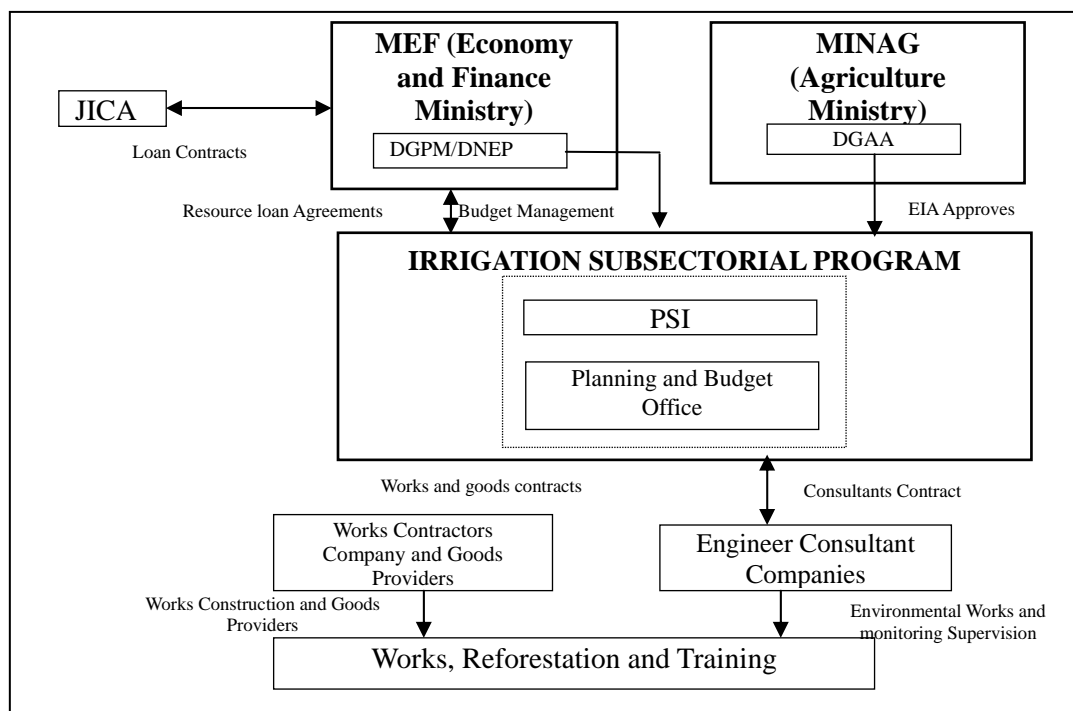

**Figure 4.10-1 Related institutions to the Project's execution (investment stage)**

The main operations in the post-investment stage consist of operation and maintenance of the built works and the loan reimbursement. The O & M of the works will be assumed by the respective irrigation commission. Likewise, they should pay the construction costs in credits mode. Next, the relationship of different organizations involved in post-project implementation stage is detailed.

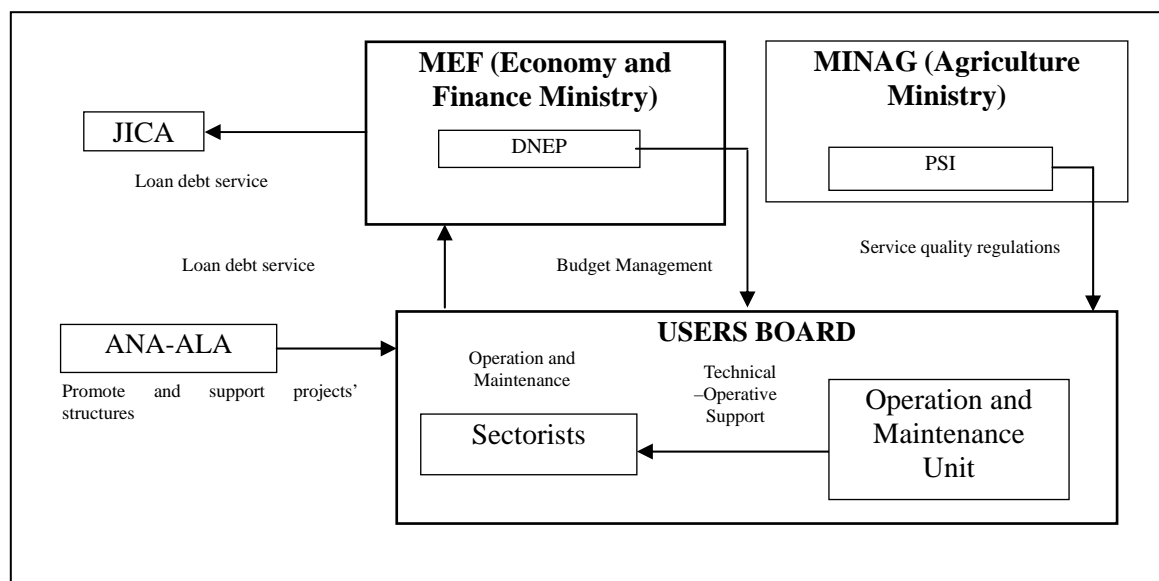

**Figure 4.10-2 Institutions related to the Project  
 (Post-investment operation and maintenance stage)**

**(1) DGIH**

1) Role and Functions

The Hydraulic Infrastructure General Direction is in charge of proposing public policies, strategies and plans aimed to promoting water infrastructure development, according with the Water Resources National Policy and the Environmental National Policy.

Water Infrastructure development includes studies, works, operation, maintenance and construction risk management, fit-out, improve and expand dams, intakes, river beds, irrigation channels, drains, meters, outlets, groundwater wells and modernize plot irrigation.

2) Main functions

- a. Coordinate with the planning and budget office to develop water infrastructure and propose sectorial and management policies on infrastructure development. Monitor and assess the implementation of sectorial policies related to hydraulic infrastructure development
- b. Propose government, region and provinces intervention regulations, as part of sectorial policies
- c. Verify and prioritize hydraulic infrastructure needs
- d. Promote and develop public investment projects at the hydraulic infrastructure profile level
- e. Elaborate technical regulations to implement hydraulic infrastructure projects
- f. Promote technological development of hydraulic infrastructure
- g. Elaborate operation and maintenance technical standards for hydraulic infrastructure

## (2) PSI

### 1) Function

The Irrigation Sub-sectorial Program (PSI) is responsible of executing investment projects. A respective management unit is formed for each project.

### 2) Main functions

a. Irrigation Sub-sectorial Program - PSI, under the Agriculture Ministry, is a body with administrative and financial autonomy. It assumes the responsibility of coordinating, managing and administering involved institutions in projects in order to meet goals and objectives proposed in investment projects

b. Also, it coordinates the disbursements of foreign cooperation agencies financing, such as JICA.

c. The Planning, Budget and Monitoring Office of PSI is responsible for hiring services, elaborating investment programs, as well as project execution plans. These Project preparation works are executed by hiring “in-house” consultants

d. Likewise, it gathers contractors, makes a lease, executes works and implements supply projects, etc.

e. Contract management is leaded by the Planning, Budget and Monitoring Office

### 3) Budget

In Table 4.10-1 the PSI budget for 2011 is shown.

Table 4.10-1 PSI Budget (2011)

Programs / Projects / Activities	PIM (S/.)
JBIC Program (Loan Agreement EP-P31)	69.417.953
Program - PSI Sierra (Loan Agreement 7878-PE)	7.756.000
Direct management works	1.730.793
Southern Reconstruction Fund (FORSUR)	228.077
Crop Conversion Project (ARTRA)	132.866
Technified Irrigation Program (PRT)	1.851.330
Activity- 1.113819 small farmers...	783.000
PSI Management Program (Other expenses)	7.280.005
<b>TOTAL</b>	<b>89.180.024</b>

### 4) Organization

PSI is conformed by 235employees, from which 14 are assigned for JBIC Projects and 29 technicians and assistants are working under them.

Table 4.10-2 PSI Payroll

Central Level	Data from May 31, 2011		
	CAS	Servic. and Consult.	TOTAL
Main Office	61	43	104
Zonal Office LIMA	12	24	36
Zonal Office AREQUIPA	14	12	26
Zonal Office CHICLAYO	17	13	30
Zonal Office TRUJILLO	13	26	39
<b>TOTAL</b>	<b>117</b>	<b>118</b>	<b>235</b>

In Figure 4.10-3, PSI flowtable is detailed:

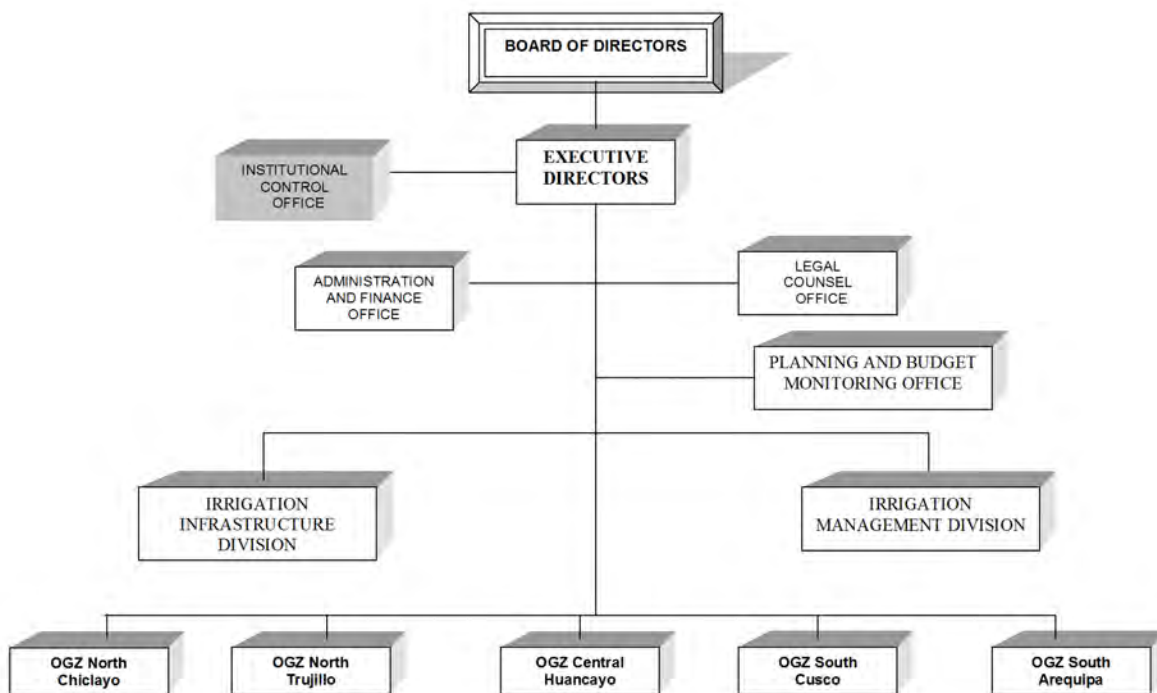

#### 4.11 Logical framework of the eventually selected option

In Table 4.11-1 the logical framework of the definite selected option is shown.

**Table 4.11-1 Logical framework of the definite selected option**

<b>Narrative Summary</b>	<b>Verifying Indicators</b>	<b>Verifying Indicators Media</b>	<b>Preliminary Conditions</b>
<b>Superior Goal</b>			
Promote socioeconomic local development and contribute in communities' social welfare.	Improve local productivity, generate more jobs, increase population's income and reduce poverty index	Published statistic data	Scio-economic and policy stability
<b>Objectives</b>			
Relief the high vulnerability of valleys and local continuity to floods	Types, quantity and distribution of flood control works, population and beneficiaries areas	Monitoring annual calendar works and financial plan, budget execution control	Ensure the necessary budget, active intervention from central and regional governments, municipalities, irrigation communities, local population, etc.
<b>Expected results</b>			
Reduction of areas and flooded areas, functional improvement of intakes, road destruction prevention, irrigation channels protection, bank erosion control and Poechos dike safety	Number of areas and flooded areas, water intake flow variation, road destruction frequency, bank erosion progress and watershed's downstream erosion.	Site visits, review of the flood control plan and flood control works reports and periodic monitoring of local inhabitants	Maintenance monitoring by regional governments, municipalities and local community, provide timely information to the superior organisms
<b>Activities</b>			
Component A: Structural Measures	Dikes rehabilitation, intake and bank protection works, road damages prevention, construction of 28 works, including dike's safety	Detailed design review, works reports, executed expenses	Ensure the works budget, detailed design/works execution/good quality works supervision
Component B: Non-Structural Measures			
B-1 Reforestation and vegetation recovery	Reforested area, coastal forest area	Works advance reports, periodic monitor by local community	Consultants support, NGO's, local community, gathering and cooperation of lower watershed community
Component C: Disaster prevention and capabilities development education	Number of seminars, trainings, workshops, etc	Progress reports, local governments and community monitoring	Predisposition of the parties to participate, consultants and NGO's assessments
Project's execution management			



Project's management	Detailed design, work start order, work operation and maintenance supervision	Design plans, work's execution plans, costs estimation, works specifications, works management reports and maintenance manuals	High level consultants and contractors selection, beneficiaries population participation in operation and maintenance
----------------------	---	--	---

## 4.12 Middle and long term Plan

Up to this point, only flood control measures have been proposed and these must be executed most urgently, due to the limitations on the available budget for this Project. However, there are other measures that must be performed in the long term framework. In this section we will be talking about the middle and long term flood control plan.

### 4.12.1 Flood Control General Plan

There are several ways to control floods in the entire watershed, for example building dams, reservoirs, dikes or a combination of these.

In case of building a dam, assuming that this will reduce the flood peak (maximum flow) with a 50 year return period reaching an equivalent flow of 10 return years. It will be necessary to build a dam with a 5.8 million m<sup>3</sup> capacity, which is quite an oversized number. Usually upstream of an alluvial area, there is a rough topography, and in order to build a dam with enough capacity, a very high dam need to be built, which implies investing a large amount (more than thousand millions of soles). Also, it would take between three to five years to identify the dam site, perform geological survey, material assessment and conceptual design. The impact on the local environment is huge. So, it is considered inappropriate to include the dam analysis option in this Study.

Likewise, the option of building a retarding basin would be not viable for the same reasons already given for the dam, because it would be necessary to build a great capacity of retarding basin and it is difficult to find a suitable location because most of the flat lands along the river's downstream are being used for agricultural purposes. So, its analysis has been removed from this Study.

Therefore, we will focus our study in the construction of dams because it is the most viable option.

(1) Plan of the river

1) Discharge capacity

An estimation was done on the discharge capacity of the current river's flow based on

longitudinal and transversal river survey, which results are shown in the section 3.1.10, Figure 3.1.10-3.

#### 2) Inundation characteristics

Inundation analysis of the Pisco River was performed. In the section 3.1.10, Figure 3.1.10-4 the inundation condition for flood with probabilities of 50 years is shown. In the Pisco River watershed there are several sections where discharge capacity is not enough, causing floods for example on the left bank around km 7 upwards and downwards.

#### 3) Design flood level and dike's standard section

The design flood level was determined in the flood water level with a return period of 50 years, and the dike's standard section will be determined as already mentioned in section 4.3.1, 5), 1). In 4.2, Table 4.2-2 the theoretical design flood level and the required height of the dike's crown is shown.

#### 4) Dikes' Alignment

Considering the current conditions of existing dikes the alignment of the new dikes was defined. Basically, the broader possible river width was adopted to increase the discharge capacity and the retard effect. In Figure 4.12.1-1 the current channel and the setting alignment method of a section where the current channel has more width is explained schematically. In a normal section, the dike's crown has the same height to the flood water level with a return period of 50 years plus free board, while in the sections where the river has greater width, double dikes be constructed with inner consistent dike alignment and continuous with normal sections upstream and downstream. The crown height is equal to the flood water level with a return period of 50 years. The external dike's crown height is equal to flood water level with a return period of 50 years, so in case the river overflows the internal dike, the open gap between the two dikes will serve to store sediments and slow water.

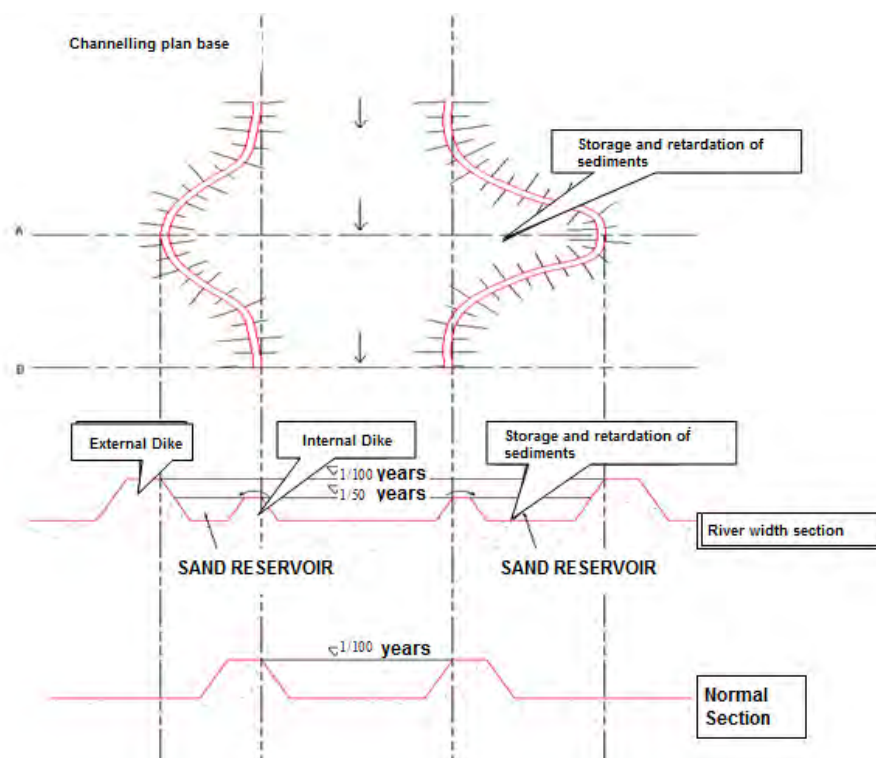

**Figure 4.12.1-1 Definition of dike alignment**

#### 5) Plan and River section

In Figures 4.12.1-2 and -4.12.1-3 the plan and longitudinal section of the Pisco River are shown.

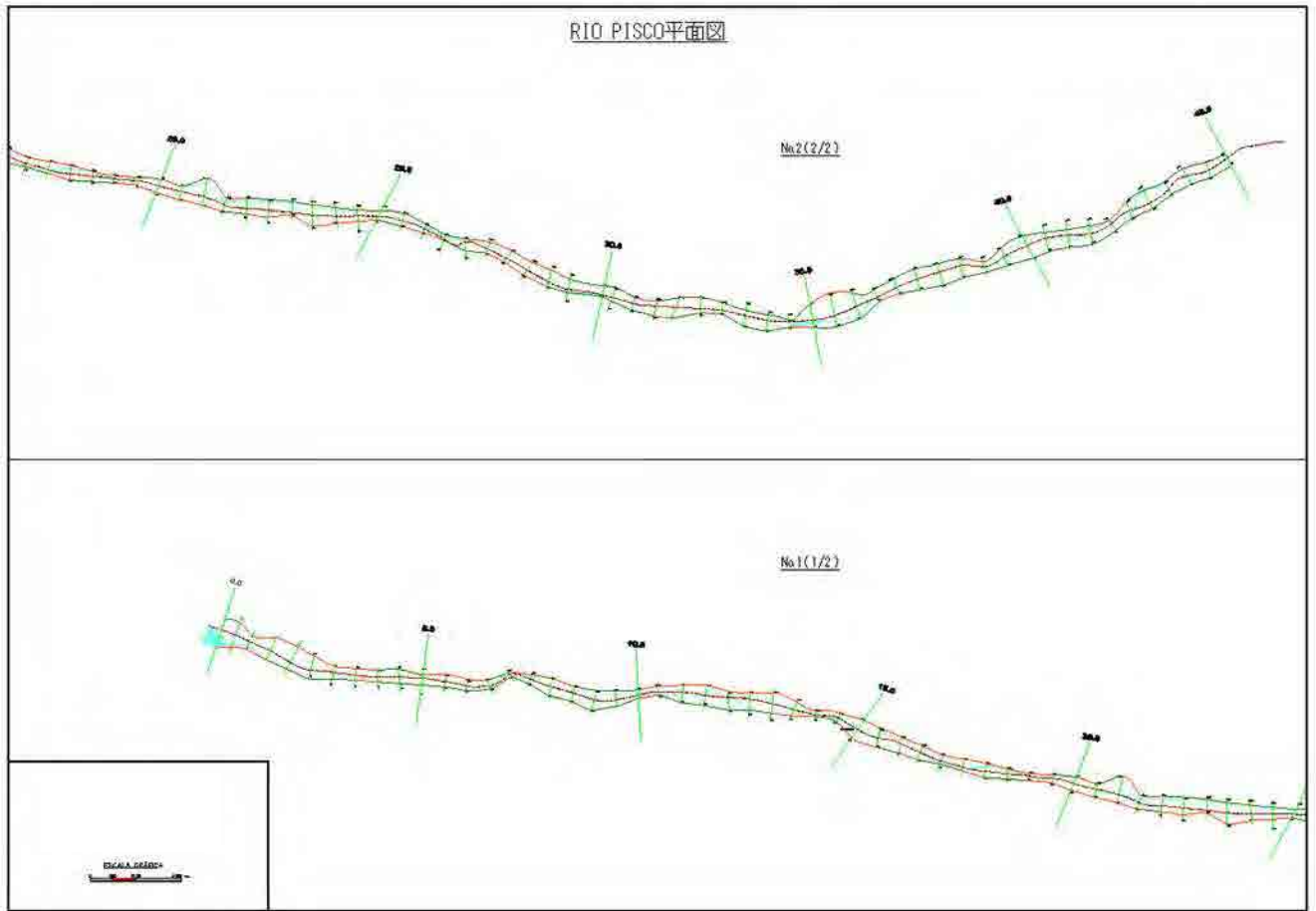

Figure 4.12.1-2 Plan of Pisco River

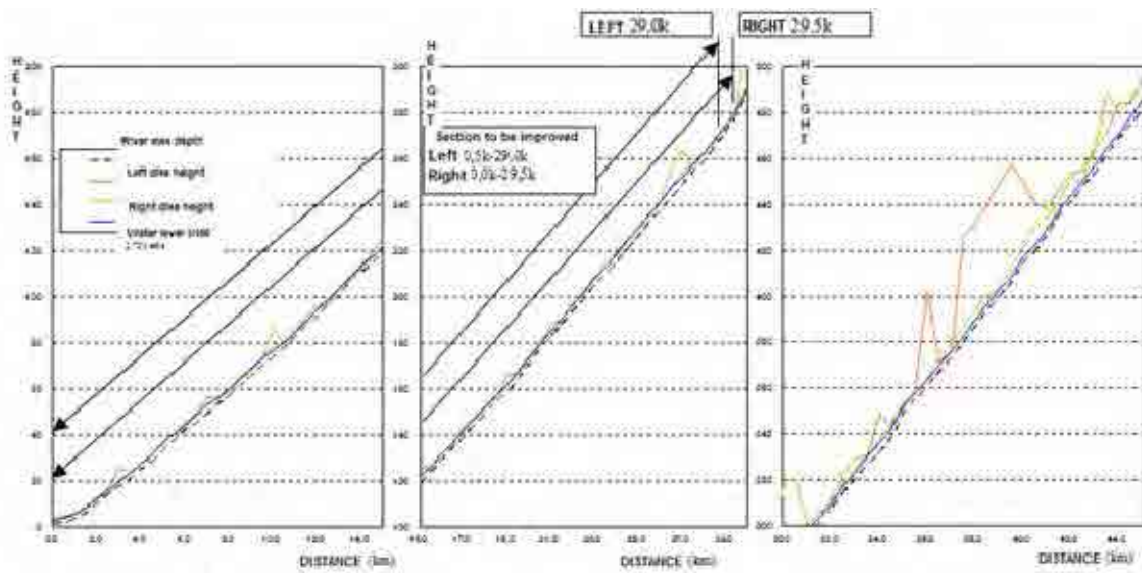

Figure 4.12.1-3 Pisco River Longitudinal Profile

### 6) Dike's construction plan

Next, basic policies for the dike's construction plan on the Pisco River are shown:

- Build dikes that allow flood flow safe passage with a return period of 50 years
- The dikes will be constructed in areas where overflowing water will enter the dike, according to the flood simulation
- The dikes will be placed in the sections above mentioned, where the design water level exceeds the existing dike's height or the ground level within the dike
- The dike's height is defined in the flood water level with a return period of 50 years plus the free board

Table 4.12.1-1 and Figure 4.12.1-4 show the dike's construction plan on the Pisco River

**Table 4.12.1-1 Dike's Construction Plan**

River	Sections to be improved		Dike missing height average (m)	Dike proposed size	Dike length (km)
Pisco	Left bank	0,0k-29,0k	0,55	Dike height = 1,5m Bank protection works height = 3,0m	14,0
	Right bank	0,0k-29,5k	0,53		19,5
	Total		0,53		33,5

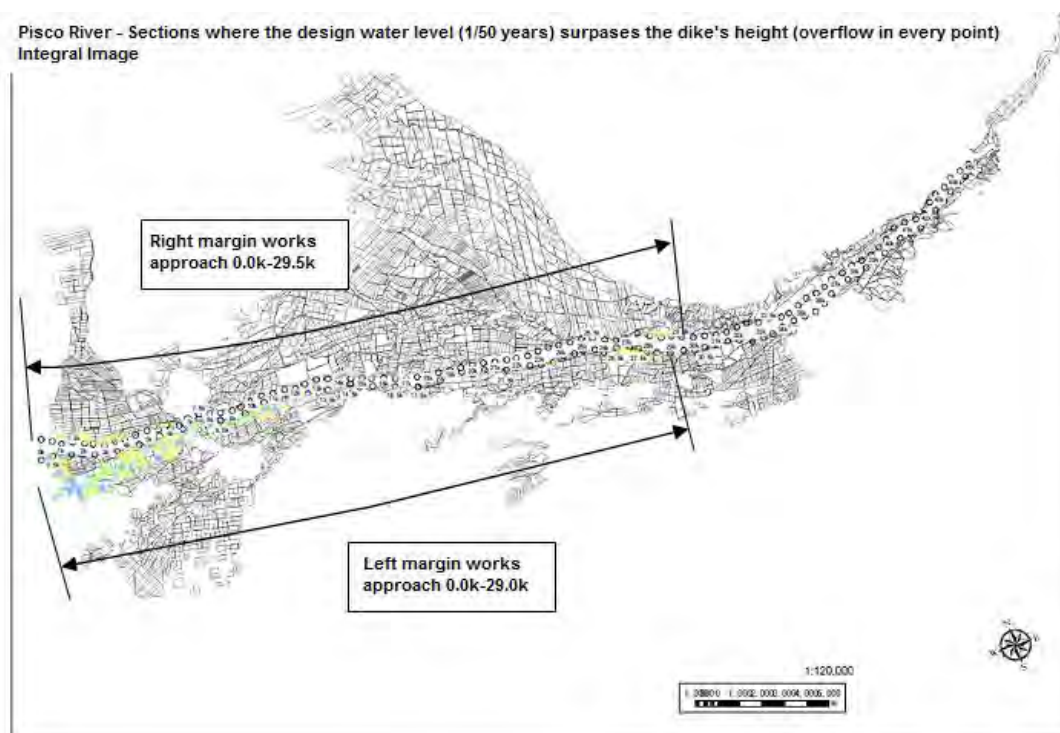

**Figure 4.12.1-4 Pisco River dike construction works approach**

## 7) Project Cost

In Tables 4.12.1-2 and 4.12.1-3 works' direct costs in private prices and the Project's cost are shown. Also, the cost of the project in social prices is presented in Table 4.12.1-4.

**Table 4.12.1-2 Works direct cost (at private prices)**

Di ke bui l di ng				Coastal defense			
B1	H1	B2	A	B1	H2	B2	A
3.0	1.0	8.5	5.8	1.0	1.0	2.4	10.8
3.0	2.0	14.0	17.0	1.0	2.0	2.9	13.4
3.0	3.0	19.5	33.8	1.0	3.0	3.4	16.5
3.0	4.0	25.0	56.0	1.0	4.0	3.9	20.1
3.0	5.0	30.5	83.8	1.0	5.0	4.4	24.3
3.0	1.5	11.3	10.7	1.0	6.0	4.9	28.9
				1.0	1.5	2.6	12.0
				1.0	10.0	6.9	52.4

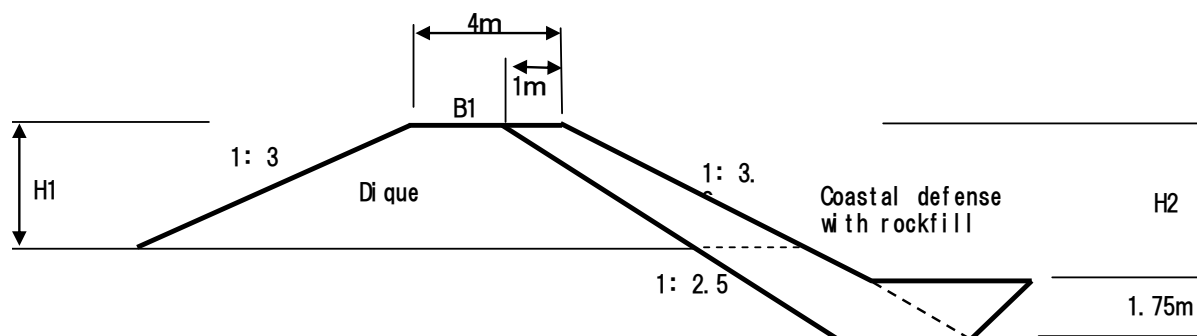

Watershed	Wrks	Amount	Unit	Unitary Price	Work direct cost/m	Work direct cost/km	Dike length ( km )	Work direct cost
				( in sol es )	( in sol es )	( in thousand sol es )		( in thousand sol es )
Pisco	Dikes	10.7	m <sup>3</sup>	10.0	107.0	107.0	33.5	3,584.50
	Margin Protection	16.5	m <sup>3</sup>	100.0	1650.0	1,650.0		55,275.0
Total						1,757.0		58,859.50

**Table 4.12.1-3 Projects' Cost (at private prices)**

WATERSHED	PRIVATE PRICES COSTS - TOTAL 民間価格 - 洪水防衛施設のみ											
	DIRECT COST			INDIRECT COST								Hydraulic Infrastructure Total Cost 構造物・事業費 (12) = (8)+(9)+(10)+(11)
	DIRECT COST Direct Cost	Temporary Works Cost	WORKS COST	INDIRECT COST OPERATIVE EXPENSES	UTILITY	INFRASTRUCTURE TOTAL COST	TAX	WORKS TOTAL COST	ENVIRONMENTAL IMPACT	TECHNICAL FILE	SUPERVISION	
流域名	-1	(2) = 0.1 x (1)	(3) = (1) + (2)	(4) = 0.15 x (3)	(5) = 0.1 x (3)	(6) = (3)+(4)+(5)	(7) = 0.18 x (6)	(8) = (6)+(7)	(9)=0.01 x (8)	(10) = 0.05 x (8)	(11) = 0.1 x (8)	0
PISCO	58,859,500	5,885,950	64,745,450	9,711,818	6,474,545	80,931,813	14,567,726	95,499,539	954,995	4,774,977	9,549,954	110,779,465

**Table 4.12.1-4 Projects' Cost (at social prices)**

WATERSHED	PRIVATE PRICES COSTS - TOTAL 民間価格 - 洪水防衛施設のみ											
	DIRECT COST			INDIRECT COST								Hydraulic Infrastructure Total Cost 構造物・事業費 (12) = (8)+(9)+(10)+(11)
	DIRECT COST Direct Cost	Temporary Works Cost	WORKS COST	INDIRECT COST OPERATIVE EXPENSES	UTILITY	INFRASTRUCTURE TOTAL COST	TAX	WORKS TOTAL COST	ENVIRONMENTAL IMPACT	TECHNICAL FILE	SUPERVISION	
流域名	-1	(2) = 0.1 x (1)	(3) = (1) + (2)	(4) = 0.15 x (3)	(5) = 0.1 x (3)	(6) = (3)+(4)+(5)	(7) = 0.18 x (6)	(8) = (6)+(7)	(9)=0.01 x (8)	(10) = 0.05 x (8)	(11) = 0.1 x (8)	0
PISCO	47,323,038	4,732,304	52,055,342	7,808,301	5,205,534	65,069,177	11,712,452	76,781,629	767,816	3,839,081	7,678,163	89,066,690

## 2) Operation and Maintenance Plan

The operation and maintenance cost was calculated identifying the trend of the sedimentation and erosion bed based on the one-dimensional analysis results of the bed variation, and a long-term operation and maintenance plan was created.

The current river course has some narrow sections where there are bridges, farming works (intakes, etc.) and there is a tendency of sediment gathering upstream of these sections. Therefore, in this project there is a suggestion to increase the discharge capacity of these narrow sections in order to avoid as possible upstream and in the bed (main part) sedimentation, together with gathering sediments as much as possible when floods over a return period of 50 years occur.

### 1) Bed variation analysis

Figure 4.12.1-5 shows the results of the Bed variation analysis of the Pisco River for the next fifty years. From this figure a projection of the bed's sedimentation and erosion trend and its respective volume can be made.

### 2) Sections that need maintenance

In table 4.12.1-5 possible sections that require a process of long-term maintenance in the Pisco River watershed is shown.

### 3) Operation and maintenance cost

Next the direct work cost at private prices for maintenance (bed excavation) required for each watershed in the next 50 years is shown.

#### Direct Work Cost

At private prices:  $569,000 \text{ m}^3 \times 10 = 5,690,000$  soles

Tables 4.12.1-6 and 4.12.1-7 show a 50 year Project cost at private and social prices.

**Table 4.12.1-5 Sections which bed must be excavated in a programmed way**

River	Excavation extension		Maintenance method
Pisco	1 Section	Section :18,0km-20,5km Volume : 314.000m <sup>3</sup>	It is necessary to perform periodic excavation to prevent possible overflow due to its gradual elevation
	2 Section	Section : 34,0km-35,0km Volume : 255.000m <sup>3</sup>	The existing intakes upstream section were the river widens is susceptible to gather sediments and periodic bed excavation is recommended to avoid the risk of the bed elevation downstream

\* Sediments volume that will gather in a 50 year  
period



**Figure 4.12.1-5 Section that requires maintenance (Pisco River)**

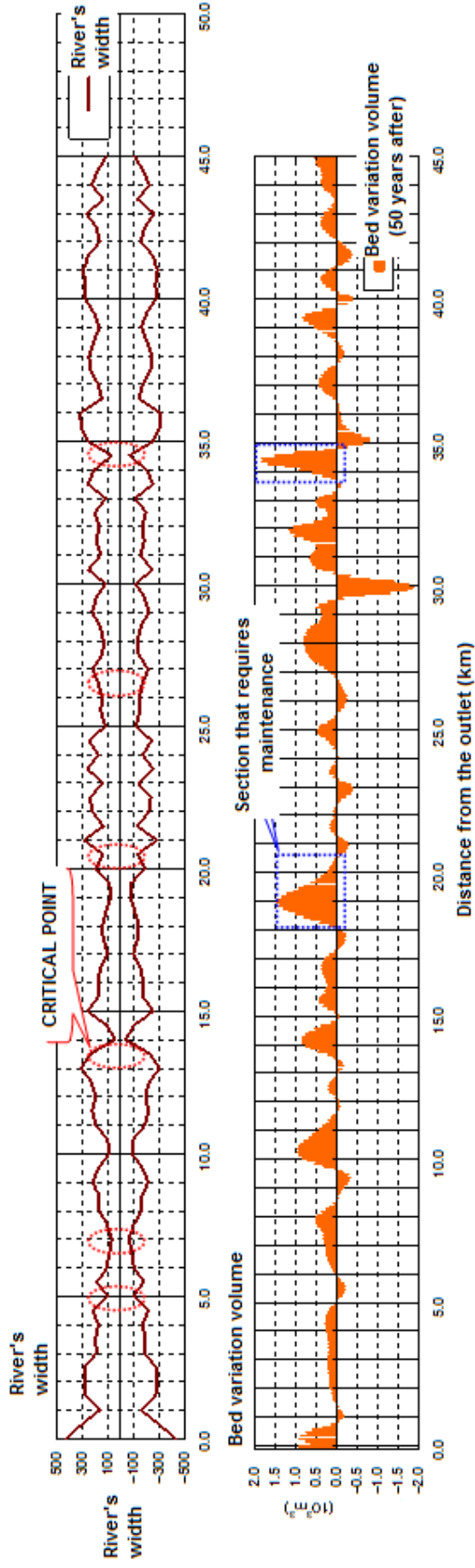

**Table 4.12.1-6 Excavation Works cost for a 50 year bed (at private prices)**

Name of Watershed 流域名	Pisco	Direct Cost 直接工事費計 (1)	5,690	Temporal works cost 共通仮設費 (2) = 0.1 x (1) (1)	569	Works Cost 工事費 (3) = (1) + (2)	6,259	Operative Expenses 諸経費 (4) = 0.15 x (3) (3)	939	Utility 利益 (5) = 0.1 x (3) (3)	626	Infrastructure total cost 構造物工事費 (6) = (3)+(4)+(5)	7,824	TAX 税金 (7) = 0.18 x (6)	1,408	Work's Total Cost 建設費 (8) = (6)+(7)	9,232	Environmental Impact 環境影響 (9)=0.01 x (8)	92	Technical File 詳細設計 (10) = 0.05 x (8) (8)	462	Supervision 施工管理費 (11) = 0.1 x (8) (8)	923	Total Cost 事業費 (12) = (8)+(9)+(10)+(11)	10,709
--------------------------	-------	------------------------------	-------	--	-----	--------------------------------------	-------	--	-----	---	-----	--	-------	-------------------------------	-------	---	-------	--	----	--	-----	---	-----	---	--------

**Table 4.12.1-7 Excavation Works cost for a 50 year bed (at social prices)**

Name of Watershed 流域名	Direct Cost 直接工事費計	Temporal works cost 共通仮設費	Works Cost 工事費	Operative Expenses 諸経費	Utility 利益	Infrastructure total cost 構造物工事費	TAX 税金	Work's Total Cost 建設費	Environmental Impact 環境影響	Technical File 詳細設計	Supervision 施工管理費	Total Cost 事業費	Supervisión 施工管理費	Costo Total 事業費
	Pisco	(1) 5,690	(2) = 0.1 x (1) 569	(3) = (1) + (2) 6,259	(4) = 0.15 x (3) 939	(5) = 0.1 x (3) 626	(6) = (3)+(4)+(5) 7,824	(7) = 0.18 x (6) 1,408	(8) = (6)+(7) 9,232	(9) = 0.01 x (8) 0.804	(10) = 0.05 x (8) 7,423	(11) = 0.1 x (8) 74	(8)+(9)+(10)+(11) 371	(12) = 0.1 * (9) 742

(3) Social Assessment

1) Private prices cost

a) Damage amount

Table 4.12.1-8 shows the damage amount calculated analyzing the overflow caused by floods in the Pisco River with return periods between 2 and 50 years.

**Table 4.12.1-8 Amount of damage for floods of different return periods**

	Damages in thousand S/. 被害額(千ソール)
確率年(t)	Pisco
2	15,788
5	22,310
10	47,479
25	56,749
50	76,992

b) Damage reduction annual average

Table 4.12.1-9 shows the damage reduction annual average of each watershed calculated with the data of Table 4.12.1-8.

c) Project's Cost and the operation and maintenance cost

Table 4.12.1-3 shows the projects' cost. Also, the annual operation and maintenance (O & M) cost for dikes and bank protection works can be observed in the table. This is calculated from the 0.5% of the construction cost plus the bed excavation annual average cost indicated in Table 4.12.1-6.

d) Economic evaluation

In Table 4.12.1-10 the results of economic assessment are shown.

**Table 4.12.1-9 Damage Reduction Annual Average**

流域 Basin	雨量規模 Return period	超過確率 Probability	被害額 (Total damage - miles de S/.)			区間平均被害額 ④ Average damage	区間確率 ⑤ Section probability	年平均被害額 ④×⑤ Annual average damage ⑥	Accumulation of ⑥ = Annual average damage reduction
			事業費再臨した 場合①	事業を再臨した 場合②	軽減額 ②-①-②				
			Without project ①	With project ②	Damage reduction ②-①-②				
PISCO	1	1.000	0	0	0		0	0	
	2	0.500	15,788	0	15,788	7,994	0.500	7,997	7,997
	5	0.200	22,310	0	22,310	11,045	0.300	7,119	9,668
	10	0.100	47,479	0	47,479	14,994	0.100	4,999	13,181
	25	0.040	56,749	0	56,749	22,114	0.050	2,127	15,279
	50	0.020	76,992	0	76,992	38,970	0.040	1,527	17,615

**Table 4.12.1-10 Economic assessment results (private prices costs)**

流域名	年平均被害軽減額 Accumulated Average Annual Benefit	評価期間被害軽減額(15年) Accumulated Average Annual Benefit (in 15 years)	事業費 Project's Cost	維持管理費 O&M Cost	C/B Cost/Benefit Relation	Net Present Value (NPV) NPV	Internal Rate of Return (IRR) IRR
Pisco	229,000,371	103,412,028	110,779,465	9,420,215	1.02	2,217,423	10%

2) Social prices cost

a) Damage amount

Table 4.12.1-11 shows the damage amount calculated analyzing the overflow caused by floods in the Pisco River with return periods between 2 and 50 years in each watershed.

**Table 4.12.1-11 Amount of damage for floods of different return periods**

Damages in thousand S/. 被害額(千ソールレス)	
Periodo de retorno (+)	Pisco
2	16,681
5	22,436
10	52,469
25	61,739
50	84,256

b) Damage reduction annual average

Table 4.12.1-12 shows the damage reduction annual average of each watershed calculated with the data of Table 4.12.1-11.

c) Project's Cost and the operation and maintenance cost

Table 4.12.1-4 shows the projects' cost. Also, the annual operation and maintenance (O & M) cost for dikes and bank protection works can be observed in the table. This is calculated from the 0.5% of the construction cost, as well as the bed excavation annual average cost indicated in Table 4.12.1-7.

d) Economic assessment

In Table 4.12.1-13 the results of economic assessment are shown.

**Table 4.12.1-12 Damage Reduction Annual Average**

s/1000

社会価格:流域全体									
流域 Watershed	流量規模 Return Period	超過確率 Probability	被害額 (Total damages - thousand S/.)			区間平均被害 額 ④ Damages Average	区間確率 ⑤ Probability incremental value	年平均被害額 ④×⑤ Average value of damages flow	年平均被害額の 累計=年平均被 害軽減期待額 Annual medial damages
			事業を実施し ない場合①	事業を実施し た場合②	軽減額 ③=①-②				
			Without Project ①	With Project ②	Mitigated damages ③=①-②				
PISCO	1	1.000	0	0	0			0	0
	2	0.500	16,681	0	16,681	8,341	0.500	4,170	4,170
	5	0.200	22,436	0	22,436	19,559	0.300	5,868	10,038
	10	0.100	52,469	0	52,469	37,452	0.100	3,745	13,783
	25	0.040	61,739	0	61,739	57,104	0.060	3,426	17,209
	50	0.020	84,256	0	84,256	72,998	0.020	1,460	18,669

**Table 4.12.1-10 Economic assessment results (social prices costs)**

流域名	年平均被害軽減額 Accumulated Average Annual Benefit	評価期間被害 軽減額(15年) Accumulated Average Annual Benefit (in 15 years)	事業費 Project's Cost	維持管理費 O&M Cost	C/B Cost/Benefit Relation	Net Present Value (NPV) NPV	Internal Rate of Return (IRR) IRR
Pisco	242,702,673	109,599,716	89,066,690	7,573,853	1.35	28,239,253	16%

(4) Conclusions

The economic assessment result shows that the Project has positive economic impact in terms of cost on both private and social prices, but the required cost is extremely high (110.8 million of soles), so, this Project is not viable to be adopted for this Project.

**4.12.2 Reforestation and Recovery of Vegetation Plan**

(1) Reforestation of the upper watershed

Long-term reforestation in all areas considered to be critical of the upper watershed is recommended. So, a detail analysis of this alternative will be explained next.

## 1) Basic Policies

Objectives: Improve the water source area's infiltration capacity, reduce surface soils water flow and at the same time, increase water flow in intermediate soils and ground-water level. Because of the above mentioned, water flow is interrupted in high flood season, this increases water resources in mountain areas, reduces and prevents floods increasing with it the amount and greater flow of ground-water level, reducing and preventing floods

Forestry area: means forestry in areas with planting possibilities around watersheds with water sources or in areas where forest area has decreased.

Forestry method: local people plantations. Maintenance is done by promoters, supervision and advisory is leaded by NGOs.

Maintenance after forestry: Maintenance is performed by the sow responsible in the community. For this, a payment system (Payment for Environmental Services) will be created by downstream beneficiaries

Observations: After each thinning the area will have to be reforested, keeping and preserving it in a long-term sustainable way. An incentive for community people living upstream of the watershed shall be designed.

The forest is preserved after keeping and reforesting it after thinning, this also helps in the support and prevention of floods. For this, it is necessary that local people are aware, encourage people downstream, promote and spread the importance of forests in Peru during the project's execution.

## 2) Selection of forestry area

In case of executing forestry upstream the watershed, as mentioned in "1) Basic Policies", the activities are executed by local people. In this case, the community will forest during their spare time from their agricultural activities. However, the community mostly lives in the highlands performing their farming and cattle activities in harsh natural conditions. Therefore, it is difficult to tell if they have the availability to perform forestry. So, finding comprehension and consensus of the inhabitants will take a long time.

## 3) Time required for the reforestation project

Since it is a small population, the workforce availability is reduced. So, the work that can be carried out during the day is limited, and the work efficiency would be very low. The JICA Study Team estimated the time required to reforest the entire area throughout the population in the areas within the reforestation plan, plant quantity, work efficiency, etc. According to this estimate, it will take 14 years to reforest approximately 40,000 hectares from the Chincha River Watershed. When estimating the required time for other watersheds, by simply applying this rate to the respective watershed area, we obtained that reforestation in Pisco River Watershed

will take 17 years.

4) Total reforestation volume in the upper watershed and project's period and cost

It has been estimated that the surface needed to be reforested in the Pisco River Watershed, as well as the execution cost, having as reference Chinchá River Watershed project reforestation data. According to this estimate, the area to be reforested is approximately a total of 54,000 hectares. The required period is 17 years, and the cost is calculated in 146 million nuevos soles. In other words, investing a great amount of time and money is required to reforest.

**Table 4.12.2-1 Upstream Watershed Forest General Plan**

Watershed	Forestry Area (ha)	Required period for the project (years)	Required budget (soles)
Pisco	53.933,75	17	145.574.401

(Source: JICA Study Team)

5) Conclusions

The objective of this project is to execute the most urgent works and give such a long period for reforestation which has an indirect effect with an impact that takes a long time to appear would not be consistent with the proposed objective for the Project. Considering that 17 years and invested 146 million soles are required, we can say that it is impractical to implement this alternative in this project and that it shall be timely executed within the framework of a long-term plan after finishing this project.

**4.12.3 Sediment control plan**

For the long-term sediment control plan, it is recommended to execute the necessary works in the upper watershed.

The Sediment Control Plan in the upper watershed will mainly consist in construction of sediment control dikes and bank protection works. In Figure 4.12.3-1 the sediment control works disposition proposed to be executed throughout the watershed is shown. The cost of Pisco River works was estimated focusing on: a) covers the entire watershed, and b) covers only the priority areas, analyzing the disposition of works for each case. The results are shown in Table 4.12.3-1.

Due to the Pisco River extension, the construction cost for every alternative would be too high in case of carrying-out the bank protection works, erosion control dikes, etc. Apart from requiring a considerably long time. This implies that the project will take a long time to show positive results. So, it is decided that it is impractical to execute this alternative within this

project and should be timely executed within the framework of a long-term plan, after finishing this project.

**Table 4.12.3-1 Upper watershed sediment control works execution estimated costs**

Watershed	Approach	Bank Protection		Strip		Sediment control dike		Total works direct cost	Project Cost (Millions S/.)
		Vol. (km)	Direct Cost (Million S/.)	Vol. (units)	Direct Cost (Million S/.)	Vol. (units)	Direct Cost (Million S/.)		
Pisco	All Watershed	269	S/.287	27	S/.1	178	S/.209	S/.497	S/.935
	Prioritized Section	269	S/.287	27	S/.1	106	S/.126	S/.414	S/.779



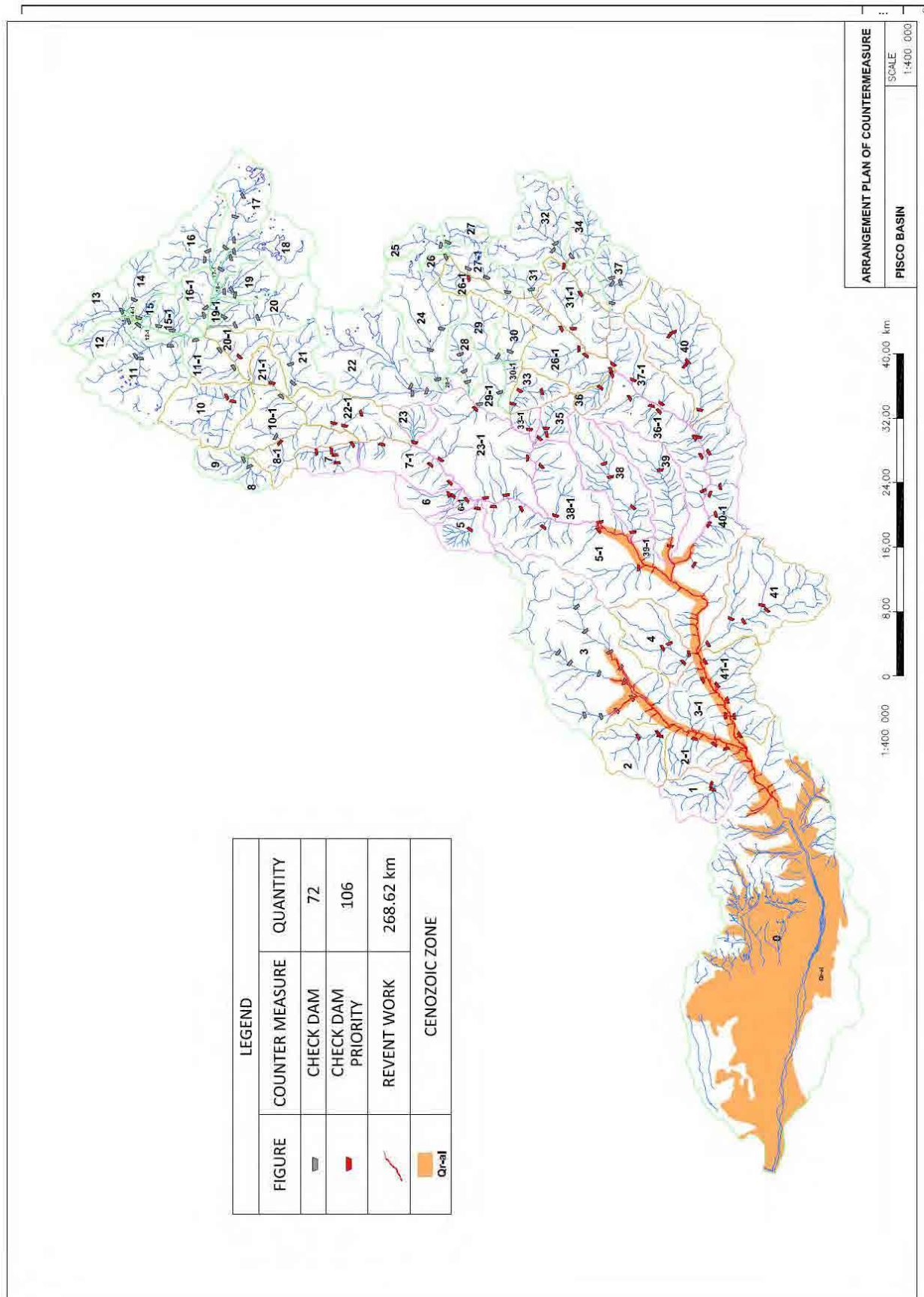

Figure 4.12.3-1 Sediment control works location Pisco River Watershed



## **5. CONCLUSIONS**

The selected alternative for flood control in this Study is structurally safe. Also, the social assessment showed a sufficiently high economic value. Its environmental impact is reduced. The implementation of this Project will contribute to relief the high vulnerability of valleys and local community to floods, and will also contribute to the local economic development. Therefore, we conclude to implement it as quickly as possible.



**Ministry of Agriculture  
Republic of Peru**

**THE PREPARATORY STUDY  
ON  
PROJECT OF THE PROTECTION OF  
FLOOD PLAIN AND VULNERABLE RURAL  
POPULATION AGAINST FLOOD IN THE  
REPUBLIC OF PERU**

**FINAL REPORT  
PRE-FEASIBILITY STUDY REPORT  
II-6 PROJECT REPORT (YAUCA RIVER)**

**March 2013**

**JAPAN INTERNATIONAL COOPERATION AGENCY  
(JICA)**

**YACHIYO ENGINEERING CO., LTD.  
NIPPON KOEI CO., LTD.  
NIPPON KOEI LATIN AMERICA –  
CARIBBEAN Co., LTD.**



## Composition of Final Report

### I. Feasibility Study Report

I-1 Program Report

I-2 Project Report (Cañete River)

I-3 Project Report (Chincha River)

I-4 Project Report (Pisco River)

I-5 Project Report (Majes-Camana River )

I-6 Supporting Report

Annex – 1 Metrology /Hydrology /Run-off Analysis

Annex – 2 Inundation Analysis

Annex – 3 River Bed Fluctuation Analysis

Annex – 4 Flood Control Plan

Annex – 5 Forecasting and Warning System in Chira River

Annex – 6 Sediment Control

Annex – 7 Afforestation and Vegetation Recovery Plan

Annex – 8 Plan and Design of Facilities

Annex – 9 Construction Planning and Cost Estimate

Annex – 10 Socio-economy and Economic Evaluation

Annex – 11 Environmental and Social Considerations/ Gender

Annex – 12 Technical Assistance

Annex – 13 Stakeholders Meetings

Annex – 14 Implementation Program of Japanese Yen Loan Project

Annex – 15 Drawings

I-7 Data Book

### II. Pre- Feasibility Study Report

II-1 Program Report

II-2 Project Report (Chira River)

II-3 Project Report (Cañete River)

II-4 Project Report (Chincha River)

II-5 Project Report (Pisco River)

**II-6 Project Report (Yauca River) (This Report)**

II-7 Project Report (Majes-Camana River )







Location Map

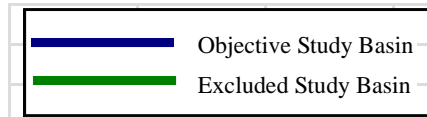



## Abbreviation

Abbreviation	Official Name or meaning
ANA	Water National Authority (Autoridad Nacional del Agua)
ALA	Water Local Authority (Autoridad Local del Agua)
C/B	Cost-Benefit relation (Cost-Benefit Ratio)
GDP	PBI (Producto Bruto Interno) (Gross Domestic Product)
GIS	Sistema de información geográfica (Geographic Information System)
DGAA	Dirección General de Asuntos Ambientales (Environmental Affairs General Direction)
DGFFS	Dirección General de Forestal y de Fauna Silvestre (Forestry and Fauna General Direction)
DGIH	Dirección General de Infraestructura Hidráulica (Hydraulic Infrastructure General Direction)
DGPM	Dirección General de Programación Multianual del Sector Público (Public Sector Multiannual Program General Direction)
DNEP	Dirección Nacional de Endeudamiento Público (Public Indebtedness National Direction)
DRA	Dirección Regional de Agricultura (Agriculture Regional Direction)
EIA	Estudio de impacto ambiental (Environmental Impact Assessment - EIA)
FAO	Organización de las Naciones Unidas para la Agricultura y la Alimentación (Food and Agriculture Organization of the United Nations)
F/S	Estudio de Factibilidad (Feasibility Study)
GORE	Gobiernos Regionales (Regional Governments)
HEC-HMS	Sistema de Modelado Hidrológico del Centro de Ingeniería Hidrológica (Hydrologic Model System from the Hydrology Engineer Center)
HEC-RAS	Sistema de Análisis de Ríos del Centro de Ingeniería Hidrológica (Hydrologic Engineering Centers River Analysis System)
IGN	Instituto Geográfico Nacional (National Geographic Institute)
IGV	Impuesto General a Ventas (TAX)
INDECI	Instituto Nacional de Defensa Civil (Civil defense National Institute)
INEI	Instituto Nacional de Estadística (Statistics National Institute)
INGEMMET	Instituto Nacional Geológico Minero Metalúrgico (Metallurgic Mining Geologic National Institute)
INRENA	Instituto Nacional de Recursos Naturales (Natural Resources National Institute)
IRR	Tasa Interna de Retorno (Internal Rate of Return - IRR)
JICA	Agencia de Cooperación Internacional del Japón (Japan International Cooperation Agency)
JNUDRP	Junta Nacional de Usuarios de los Distritos de Riego del Perú (Peruvian Irrigation District Users National Board)
L/A	Acuerdo de Préstamo (Loan Agreement)
MEF	Ministerio de Economía y Finanzas (Economy and Finance Ministry)
MINAG	Ministerio de Agricultura (Agriculture Ministry)
M/M	Minuta de Discusiones (Minutes of Meeting)

NPV	VAN (Valor Actual Neto) (NET PRESENT VALUE)
O&M	Operación y mantenimiento (Operation and maintenance)
OGA	Oficina General de Administración (Administration General Office)
ONERRN	Oficina Nacional de Evaluación de Recursos Naturales (Natural Resources Assessment National Office)
OPI	Oficina de Programación e Inversiones (Programming and Investment Office)
PE	Proyecto Especial Chira-Piura (Chira-Piura Special Project)
PES	PSA (Pago por Servicios ambientales) (Payment for Environmental Services)
PERFIL	Estudio del Perfil (Profile Study)
Pre F/S	Estudio de prefactibilidad (Pre-feasibility Study)
PERPEC	Programa de Encauzamiento de Ríos y protección de Estructura de Captación (River Channeling and Protection of Collection Structures Program)
PRONAMACHIS	Programa Nacional de Manejo de Cuencas Hidrográficas y Conservación de Suelos (Water Basins Management and Soil Conservation National Program)
PSI	Programa Sub Sectorial de irrigaciones (Sub-Sectorial Irrigation Program)
SCF	Factor de conversión estándar (Standard Conversion Factor)
SENAMHI	Servicio Nacional de Meteorología y Hidrología (Meteorology and Hydrology National Service)
SNIP	Sistema Nacional de Inversión Pública (Public Investment National System)
UF	Unidades Formuladoras (Formulator Units)
VALLE	Llanura aluvial, llanura de valle (Alluvial Plain, Valley Plain)
VAT	Impuesto al valor agregado (Value added tax)

**THE PREPARATORY STUDY**

**ON**

**PROJECT OF THE PROTECTION OF FLOOD PLAIN AND VULNERABLE RURAL  
POPULATION AGAINST FLOODS IN THE REPUBLIC OF PERU**

**FINAL REPORT  
PRE-FEASIBILITY STUDY REPORT  
II-6 PROJECT REPORT  
(YAUCA RIVER)**

**Table of Contents**

Location Map

Abbreviation

<b>1. EXECUTIVE SUMMARY .....</b>	<b>1-1</b>
1.1 Project Name.....	1-1
1.2 Project's Objective .....	1-1
1.3 Supply and Demand Balance .....	1-1
1.4 Structural Measures .....	1-2
1.5 Non-structural measures .....	1-4
1.6 Technical support .....	1-5
1.7 Costs.....	1-5
1.8 Social Assessment.....	1-6
1.9 Sustainability Analysis.....	1-8
1.10 Environmental Impact.....	1-9
1.11 Execution plan .....	1-10
1.12 Institutions and management .....	1-10
1.13 Logical Framework.....	1-12
1.14 Middle and Long Term Plans.....	1-13
<b>2. GENERAL ASPECTS .....</b>	<b>2-1</b>
2.1 Name of the Project .....	2-1

2.2	Formulator and Executor Units.....	2-1
2.3	Involved entities and Beneficiaries Participation.....	2-1
2.4	Framework .....	2-4
<b>3.</b>	<b>IDENTIFICATION.....</b>	<b>3-1</b>
3.1	Diagnosis of the current situation .....	3-1
3.2	Definition of Problem and Causes .....	3-44
3.3	Objective of the Project .....	3-48
<b>4.</b>	<b>FORMULATION AND EVALUATION .....</b>	<b>4-1</b>
4.1	Definition of the Assessment Horizon of the Project .....	4-1
4.2	Supply and Demand Analysis .....	4-1
4.3	Technical Planning.....	4-4
4.4	Costs.....	4-24
4.5	Social Assessment.....	4-26
4.6	Sensitivity Analysis.....	4-34
4.7	Sustainability Analysis.....	4-36
4.8	Environmental Impact.....	4-37
4.9	Execution Plan .....	4-49
4.10	Institutions and Administration .....	4-52
4.11	Logical framework of the eventually selected option .....	4-57
4.12	Middle and long term Plan.....	4-58
<b>5.</b>	<b>CONCLUSIONS .....</b>	<b>5-1</b>

## **1. EXECUTIVE SUMMARY**

### **1.1 Project Name**

“Protection program for valleys and rural communities vulnerable to floods Implementation of prevention measures to control overflows and floods of Yauca River, Arequipa Department.”

### **1.2 Project’s Objective**

The ultimate impact that the project is design to achieve is to alleviate the vulnerability of valleys and the local community to flooding and boost local socioeconomic development.

### **1.3 Supply and Demand Balance**

It has been calculated the theoretical water level in case of flow design flood based on the transversal lifting data of the river with an interval of 500m, in the Yauca river watershed, assuming a design flood flow equal to the flood flow with a return period of 50 years. Then, we determined the dike height as the sum of the design water level plus the dike’s free board.

This is the required height of the dike to control the damages caused by design floods and is the indicator of the demand of the local community.

The height of the existing dike or current terrain height is the required height to control the current flood damages, and is the indicator of the current offer.

The difference between the dike design height (demand) and the height of the dam or current field is the difference or gap between demand and supply.

Table 4.2-2 shows the average water levels floods, calculated with a return period of 50 years, of the required height of the dike (demand) to control the flow by adding the design water level plus the free board of the dike; from dike height or current ground (supply), and the difference between these two (difference between demand and supply) of the river. Then, in Table 1.3-1 the values at each point are shown. The current height of the dike or the current field is greater than the required height of the dike, at certain points. In these, the difference between supply and demand is considered null.

**Table 1.3-1 Demand and supply analysis**

Watershed	Dike Height / current land (supply)		Theoretical water level with a return period of 50 years	Dike Freeboard	Required dike's heigh (demand)	Diff. demand/supply	
	Left bank	Right bank				Left bank	Right bank
	①	②				③	④
Yauca	187.54	183.01	179.03	0.80	179.83	0.21	0.40

### 1.4 Structural Measures

Structural measures are a subject that must be analyzed in the flood control plan covering the entire watershed. The analysis results are presented in section 4.12 “medium and long term plan” This plan proposes the construction of dikes for flood control throughout the watershed. However, the case of Yauca River requires a large project investing at a extremely high cost, far beyond the budget for this Project, which makes this proposal it impractical. Therefore, assuming that the dikes to control floods throughout the whole basin will be constructed progressively over a medium and long term period. Here is where this study focused on the most urgent works, priority for flood control.

#### (1) Design flood flow

The Methodological Guide for Protection Projects and / or Flood Control in Agricultural or Urban Areas prepared by the Public sector multi annual programming general direction (DGPM) of the Ministry of Economy and Finance (MEF) recommends a comparative analysis of different return periods: 25, 50 and 100 years for the urban area and 10, 25 and 50 years for rural and agricultural land.

Considering that the present project is aimed at protecting the rural and agricultural land, the design flood flow was determined in the set value for floods with a return period of 50 years in the mentioned Guide.

The maximum discharge observed in the past in Yauca river is considerably less than the flood discharge with return period of 50 years, and the same class of floods occurred three times in the past.

In Peru the flood protection works in the basins are developed almost nil, therefore it is not necessary to adopt the design discharge more than the past maximum discharge. However, the large disasters occurred in the past so that the design flood discharge with return period of 50 years, which is larger than the past maximum, is to be adopted as design flood as in safe side.



The relation among flood discharge with different return period, damage caused by the floods and inundation areas is analyzed in the basin. The results are that the more the return periods of flood increase the more inundation area and damage amount increase in the basin, however the increase tendency of damage with project is more gentle compared with former two items, and the reduction of damage with project reaches to maximum in the case of the flood with return period of 50 years within the cases of flood with less return period of 50 years.

As described above, the adopted design flood discharge with return period of 50 years is bigger than the past maximum discharge and damage reduction amount in the adopted case becomes more than that of the flood discharges with less return period. However the Project in Yauca river is to be cancelled due to low economic viability studied in the section 4.5 Social Evaluation

## **(2) Selection of prioritized flood control works**

We applied the following five criteria for the selection of priority flood control works.

- Demand from the local community (based on historical flood damage)
- Lack of discharge capacity (including the sections affected by the excavation)
- Conditions of the adjacent area (conditions in urban areas, farmland, etc.).
- Flood conditions (extent of overflowed water according to the results of flood analysis)
- Social and environmental conditions (important local infrastructures)

Based on the river survey, field investigation, discharge capacity analysis of river channel, inundation analysis, and interviews to the local community (irrigation committee needs, local governments, historical flood damage, etc...) a comprehensive evaluation was made applying the five evaluation criteria listed above. After that we selected a total of six (6) critical points (with the highest score in the assessment) that require flood protection measures.

Concretely, since the river cross sectional survey was carried out every 500m interval and discharge capacity analysis and inundation analysis were performed based on the survey results, the integral assessment was also done for sections of 500 meters. This sections have been assessed in scales of 1 to 3 (0 point, 1 point and 2 points) and the sections of which score is more than 6 were selected as prioritized areas. The lowest limit (6 points) has been determined also taking into account the budget available for the Project in general

## **1.5 Non-structural measures**

### **1.5.1 Reforestation and vegetation recovery**

#### **(1) Basic Policies**

The reforestation plan and vegetation recovery that meets the objective of this project can be divided into: i) reforestation along river structures, and ii) reforestation in the upper watershed. The first has a direct effect on flood prevention expressing its impact in a short time, while the second one requires high cost and a long period for its implementation, as indicated later in the section 4.12 “Medium and long term Plan”, and also it is impractical to be implemented within the framework of this project. Therefore, this study focused on the first alternative.

#### **(2) Regarding reforestation along river structures**

This alternative proposes planting trees along the river structures, including dikes and bank protection works.

- Objective: Reduce the impact of flooding of the river when an unexpected flood or narrowing of the river by the presence of obstacles, using vegetation strips between the river and the elements to be protected.
- Methodology: Create vegetation stripes of a certain width between the river and river structures.
- Execution of works: Plant vegetation on a portion of the river structures (dikes, etc.).
- Maintenance after reforestation: Maintenance will be taken by irrigation committees under their own initiative.

The width, length and area of reforestation along river structures are 11m, 4.4km y 4.9ha respectively.

### **1.5.2 Sediment Control Plan**

The sediment control plan must be analyzed within the general plan of the watershed. The results of the analysis are presented in section 4.12 “Medium and long term plan”. To sum up, the sediment control plan for the entire watershed requires a high investment cost, which goes far beyond the budget of this project, which makes it impractical to adopt.

Regarding sediment control of the lower watershed, the bed variation analysis has shown that the volume of sediments that are entering and the bed variation volume are not so much so that the urgent sediment control actions are not required at present although the monitoring

the riverbed variation and the maintenance of river channel depending on the monitoring results will be required.

## 1.6 Technical support

Based on the technical proposals of structural and nonstructural measures, it is also intends to incorporate in this project technical assistance to strengthen the measures.

The objective of the technical assistance is to “improve the capacity and technical level of the local community, to manage risk to reduce flood damage in selected valleys.”

Technical assistance will cover the Yauca river watershed.

Aiming to train characteristics of the watershed, courses for one will be prepared. The beneficiaries are the representatives of the committees and irrigation groups from each watershed, governments employees (provincial and district), local community representatives, local people etc.

Qualified as participants in the training, people with ability to replicate and disseminate lessons learned in the courses to other community members, through meetings of the organizations to which they belong.

In order to carry out the technical assistance goal, the three activities propose the following:

- Bank protection activity and knowledge enhancement on agriculture and natural environment
- Community disaster prevention planning for flood damages
- Watershed (slope) management against fluvial sedimentation

## 1.7 Costs

In the Table 1.7-1 the costs of this Project in Yauca watershed is shown. The cost of the watersheds is around 20.9 million soles.

**Table 1.7-1 Project Cost**

Watershed	Structural Cost					Non-structural cost		Technical Assistance Cost	Total
	Construction Cost	Detail Design Cost	Construction Supervision Cost	Environmental Cost	Sub total	Afforestation Cost	Flood Alert System Cost		
Yauca	17,773	889	1,777	178	20,617	64	0	219	20,900

## 1.8 Social Assessment

### (1) Benefits

The benefits of flood control are the reduction of losses caused by floods which would be achieved by the implementation of the project and is determined by the difference between the loss amount without project and with project. Specifically, to determine the benefits, first the amount of losses by floods is calculated from different return periods (between 2 and 50 years), assuming that flood control works will last 50 years, and then the average annual reduction loss amount is determined from the reduction of losses from different return periods. In Tables 1.8-1 and 1.8-2 show the average annual amount of reduction loss that would be achieved by implementing this project, expressed in costs at private prices and costs at social prices.

**Table 1.8-1 Annual average damage reduction amount (at private prices)**

s/1000

Watershed	流量規模 Return Period	超過確率 Probability	被害額 (Total Damages - thousand S/.)			区間平均被害 額 ④ Damages Average	区間確率 ⑤ Probability Incremental value	年平均被害額 ④×⑤ Damages Flow Average Value	年平均被害額の 累計=年平均被 害軽減期待額 Annual Medial Damage
			事業を実施し ない場合①	事業を実施し た場合②	軽減額 ③=①-②				
			With Project ①	With Project ②	Mitigated damages ③=①-②				
YAUCA	1	1.000	0	0	0		0	0	
	2	0.500	0	0	0	0	0.500	0	
	5	0.200	0	0	0	0	0.300	0	
	10	0.100	1,695	7	1,688	844	0.100	84	84
	25	0.040	2,569	1,005	1,564	1,626	0.060	98	182
	50	0.020	11,497	2,028	9,469	5,517	0.020	110	292

**Table 1.8-2 Annual average damage reduction amount (at social prices)**

s/1000

Watershed	流量規模 Return Period	超過確率 Probability	被害額 (Total Damages - thousand S/.)			区間平均被害 額 ④ Damages Average	区間確率 ⑤ Probability Incremental value	年平均被害額 ④×⑤ Damages Flow Average Value	年平均被害額の 累計=年平均被 害軽減期待額 Annual Medial Damage
			事業を実施し ない場合①	事業を実施し た場合②	軽減額 ③=①-②				
			With Project ①	With Project ②	Mitigated damages ③=①-②				
YAUCA	1	1.000	0	0	0		0	0	
	2	0.500	0	0	0	0	0.500	0	
	5	0.200	0	0	0	0	0.300	0	
	10	0.100	2,150	9	2,141	1,071	0.100	107	107
	25	0.040	3,313	1,341	1,972	2,057	0.060	123	230
	50	0.020	12,092	2,653	9,439	5,706	0.020	114	345

## (2) Social assessment results

The objective of the social assessment in this study is to evaluate the efficiency of investments in the structural measures using the method of cost-benefit relation (C/B) from the point of view of national economy. To do this, we determined the economic evaluation indicators (C/B relation, Net Present Value-NPV, and Internal return rate - IRR).

The benefits of the evaluation period were estimated, from the first 15 years since the start of the project. Because, from these 15 years, two are from the work execution period, the evaluation was conducted for the 13 years following the completion of works.

In Tables 1.8-3 and 1.8-4 the costs at private prices and at social prices resulting from this project assessment are shown. It is noted that the project will have extremely low economic effect.

**Table 1.8-3 Social Assessment (private prices)**

流域名	年平均被害軽減額 Gathered Average Annual Benefit	評価期間被害軽減額(15年) Gathered Average Annual Benefit (in 15 years)	事業費 Project Cost	維持管理費 O&M Cost	C/B Cost/Benefit Relation	Net Present Value (NPV) Valor Actual Neto (VAN)	Internal Rate of Return (IRR) Tasa Interna de Retorno (TIR)
Yauca	3,799,425	1,715,745	20,899,762	1,155,236	0.09	(17,059,601)	-

**Table 1.8-4 Social Assessment (social prices)**

流域名	年平均被害軽減額 Gathered Average Annual Benefit	評価期間被害軽減額(15年) Gathered Average Annual Benefit (in 15 years)	事業費 Project Cost	維持管理費 O&M Cost	C/B Cost/Benefit Relation	Net Present Value (NPV) Valor Actual Neto (VAN)	Internal Rate of Return (IRR) Tasa Interna de Retorno (TIR)
Yauca	4,479,470	2,022,840	16,816,195	928,810	0.13	(13,083,633)	-

Social assessment showed that the Yauca river watershed project will not give a palpable economic impact in social prices costs terms. Below are the positive effects of the Project that are difficult to quantify in economic values.

- ① Contribution to local economic development to alleviate the fear to economic activities suspension and damages
- ② Contribution to increase local employment opportunities thanks to the local construction project
- ③ Strengthening the awareness of local people regarding damages from floods and other disasters
- ④ Contribution to increase from stable agricultural production income, relieving flood damage

⑤ Rise in farmland prices

From the results of the economic evaluation presented above, it is difficult to implement this Project, even if there is the positive effects of the Project that are difficult to quantify in economic values.

### 1.9 Sustainability Analysis

This project will be co-managed by the central government (through the DGIH), irrigation committees and regional governments, and the project cost will be covered with the respective contributions of the three parties. Usually the central government (in this case, the DGIH) assumes 80%, the irrigation commissions 10% and regional governments 10%. However, the percentages of the contributions of these last two are decided through discussions between both parties. On the other hand, the operation and maintenance (O & M) of completed works is taken by the irrigation committees. Therefore, the sustainability of the project is depends on the profitability of the project and the ability of O & M of irrigation committees.

In Table 1.9-1 data of the irrigation commission’s budget of the Yauca River in the last years is shown.

**Table 1.9-1 Irrigation commission Project’s Budget**

River	Annual Budget (In soles)			
	2006	2007	2008	3 year average
Yauca	114,482.12	111,102.69	130,575.40	118,720

#### (1) Profitability

We have seen that Yauca river watershed is not sufficiently profitable, so it is not viable. The amount of investment required is estimated at S/ 20.9 million soles (cost at private prices), the C/B relation is 0.13, IRR = null and NPV = S/. – 13.0 millions. These figures are showing the economic low efficiency of the project.

#### (2) Operation and maintenance costs

The annual cost of operation and maintenance required for the project, having as base year 2008 is estimated at 88,864 soles, which corresponds to 0.5% of the construction cost of the project in the Yauca river watershed. On the other hand, the operating expenses average in the last four years of irrigation committees is 118,720.

When considering that the annual cost of operation and maintenance represents 75.9% of the

annual irrigation budget, the project would not be sustainable because of the financial capacity of these committees to maintain and operate the constructed works.

As conclusion, the project is economically less effective; also, it is hardly that irrigation commissions may pay maintenance costs. So, this project is almost not viable.

## **1.10 Environmental Impact**

### **(1) Procedure of Environmental Impact Assessment**

Projects are categorized in three scales, based on the significance level of the negative and positive impacts, and each sector has an independent competence on this categorization. The Project holder should submit the Environmental Impact Statement (DIA, in Spanish) for all Projects under Category I. The project holder should prepare an EIA-sd or an EIA-d if the Project is categorized under Category II or III, respectively, to be granted the Environmental Certification from the relevant Ministry Directorate.

First, the Project holder applies for the Project classification, by submitting the Preliminary Environmental Assessment (PEA). The relevant sector assesses and categorizes the Project. The Project's PEA that is categorized under Category I becomes an EID, and those Projects categorized under Category II or III should prepare an EIA-sd or EIA-d, as applicable.

The preliminary environmental assessment (EAP) for Yauca river was carried out between December 2010 and January 2011 and by a consulting firm registered in the Ministry of Agriculture (CIDES Ingenieros S.A.). EAP for Yauca was submitted to DGIH January 25, 2011 by JICA Study Team and from DGIH to DGAA July 19, 2011.

DGAA examined EAP and issued approval letter of Category I. Therefore, no further environmental impact assessment is required for Yauca river.

### **(2) Results of Environmental Impact Assessment**

The procedures to review and evaluate the impact of the natural and social environment of the Project are the following. First, we reviewed the implementation schedule of the construction of river structures, and proceeded to develop the Leopold matrix.

The impact at environmental level (natural, biological and social environment) was evaluated and at Project level (construction and maintenance stage). The quantitative levels were determined by quantifying the environmental impact in terms of impact to nature, manifestation possibility, magnitude (intensity, reach, duration and reversibility).

The EAP showed that the environmental impact would be manifested by the implementation of this project in the construction and maintenance stages, mostly, it is not very noticeable, and if it were, it can be prevented or mitigated by appropriately implementing the

management plan environmental impact.

On the other hand, the positive impact is very noticeable in the maintenance stage, which manifests at socioeconomic and environmental level, specifically, in greater security and reduced vulnerability, improved life quality and land use.

### 1.11 Execution plan

Table 1.11-1 presents the Project execution plan.

**Table 1.11-1 Execution plan**

ITEMS	2010				2011				2012				2013				2014				2015				2016			
	3	6	9	12	3	6	9	12	3	6	9	12	3	6	9	12	3	6	9	12	3	6	9	12	3	6	9	12
1 PROFILE STUDY / SNIP ASSESSMENT	STUDY								EVALUATION																			
2 FEASIBILITY STUDY / SNIP ASSESSMENT					STUDY				EVALUATION																			
3 YEN CREDIT NEGOTIATION																												
4 CONSULTANT SELECTION																												
5 CONSULTANT SERVICE (DETAILED DESIGN, LAWFUL DOCUMENTS PREPARATION)									DESIGN / LAWFUL DOCUMENT								WORK SUPERVISION											
6 BUILDER SELECTION																												
7 WORK EXECUTION																												
1) STRUCTURES BUILDING																												
2) REFORESTATION																												
3) EARLY ALERT SYSTEM																												
4) DISASTER PREVENTIVE TRAINING																												
8 FINISH WORK / DELIVERY TO USERS BOARDS																												

### 1.12 Institutions and management

The institutions and its administration in the investment stage and in the operation and maintenance stage after the investment, shown in the figures 1.12-1 and 1.12-2.



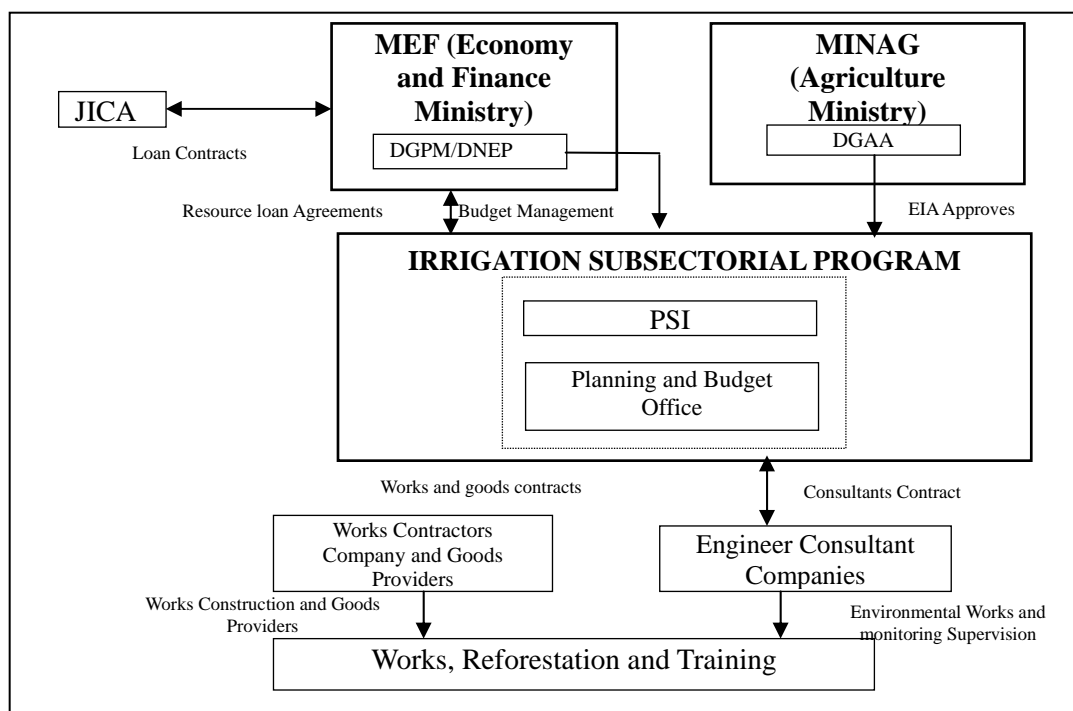

**Figure 1.12-1 Institutions related to the Project (investment stage)**

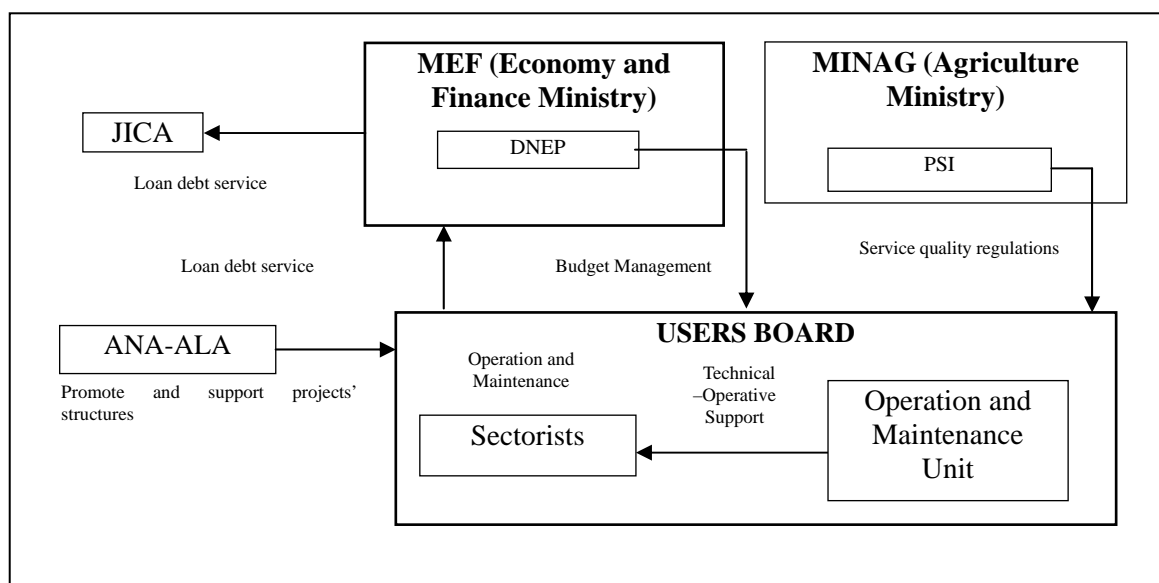

**Figure 1.12-2 Institutions related to the project (operation and maintenance stage)**

## 1.13 Logical Framework

Table 1.13-1 presents the logical framework of the final selected alternative.

**Table 1.13-1 Logical framework of the final selected alternative**

Narrative Summary	Verifying Indicators	Verifying Indicators Media	Preliminary Conditions
<b>Superior Goal</b>			
Promote socioeconomic local development and contribute in communities' social welfare.	Improve local productivity, generate more jobs, increase population's income and reduce poverty index	Published statistic data	Scio-economic and policy stability
<b>Objectives</b>			
Relief the high vulnerability of valleys and local continuity to floods	Types, quantity and distribution of flood control works, population and beneficiaries areas	Monitoring annual calendar works and financial plan, budget execution control	Ensure the necessary budget, active intervention from central and regional governments, municipalities, irrigation communities, local population, etc.
<b>Expected results</b>			
Reduction of areas and flooded areas, functional improvement of intakes, road destruction prevention, irrigation channels protection, bank erosion control and Poechos dike safety	Number of areas and flooded areas, water intake flow variation, road destruction frequency, bank erosion progress and watershed's downstream erosion.	Site visits, review of the flood control plan and flood control works reports and periodic monitoring of local inhabitants	Maintenance monitoring by regional governments, municipalities and local community, provide timely information to the superior organisms
<b>Activities</b>			
Component A: Structural Measures	Dikes rehabilitation, intake and bank protection works, road damages prevention, construction of 28 works, including dike's safety	Detailed design review, works reports, executed expenses	Ensure the works budget, detailed design/works execution/good quality works supervision
Component B: Non-Structural Measures			
B-1 Reforestation and vegetation recovery	Reforested area, coastal forest area	Works advance reports, periodic monitor by local community	Consultants support, NGO's, local community, gathering and cooperation of lower watershed community
Component C: Disaster prevention and capabilities development education	Number of seminars, trainings, workshops, etc	Progress reports, local governments and community monitoring	Predisposition of the parties to participate, consultants and NGO's assessments

Project's execution management			
Project's management	Detailed design, work start order, work operation and maintenance supervision	Design plans, work's execution plans, costs estimation, works specifications, works management reports and maintenance manuals	High level consultants and contractors selection, beneficiaries population participation in operation and maintenance

### 1.14 Middle and Long Term Plans

While it is true that due to the limited budget available for the Project, this study is focused mainly on the flood control measures analysis that must be implemented urgently. It is considered necessary to timely implement other necessary measures within a long term. In this section we will discuss the medium and long term plans.

#### (1) Flood Control General Plan

There are several ways to control floods in the entire watershed, for example, the building of dams, retarding basin, dikes or a combination of these. The options to build dams or retarding basin are not viable because in order to answer to a flood flow with a return period of 50 years, enormous works would be necessary to be built. So, the study was focused here on dikes' construction because it was the most viable option.

Flood water level was calculated in the watershed adopting a designed flood flow with a return period of 50 years. At this water level, freeboard was added in order to determine the required dikes height. After, sections of the rivers where the dikes or ground did not reach the required height were identified. These sections, altogether, add up to approx.3km. Also, from maintaining these works, annually a dragged of the rivers has to be done in the sections where, according to the bed fluctuation analysis the sediment gathering is elevating the bed's height. The volume of sediments that shall be eliminated annually was determined in approximately 1,200 m<sup>3</sup>.

In Tables 1.14-1 and 1.14-2 the flood control general plan project cost is shown as well as the social assessment results in terms of private and social costs.

**Table 1.14-1 Social Assessment (private prices )**

流域名	年平均被害軽減額 Annual Average Damage Reduction	評価期間被害 軽減額(15年) Damage Reduction in Evaluation Period(15years)	事業費 Project Cost	維持管理費 O&M Cost	B/C Cost Benefit Ration	NPV Net Present Value	IRR(%) Internal Return of Rate
Yauca	4,592,758	2,073,999	9,920,549	894,671	0.23	-7,014,101	-

**Table 1.14-2 Social Assessment (prices costs)**

流域名	年平均被害軽減額 Annual Average Damage Reduction	評価期間被害 軽減額(15年) Damage Reduction in Evaluation Period(15years)	事業費 Project Cost	維持管理費 O&M Cost	B/C Cost Benefit Ration	NPV Net Present Value	IRR(%) Internal Return of Rate
Yauca	5,531,228	2,497,793	7,976,121	719,315	0.34	-4,809,039	-

In case of executing flood control works in the watershed, the works is not economically viable at both private price and social price, and the Projects' cost would elevate to 9.9 million soles, which is a huge amount for this project, so that this project could not be implemented.

### (2) Reforestation Plan and Vegetation Recovery

The forestry option was analyzed, in a long term basis, to cover every area that requires being covered with vegetation in the upper watershed. The objective is improving this areas' infiltration capacity, reduce of surface water and increase semi-underground and underground water. So, the flood maximum flow will be decreased, also it could be possible to increase the water reserve in the mountain areas and prevent and soothe floods. The areas to be reforested will be the afforested areas or where the forest mass in the water infiltration areas has been lost.

In Table 1.14-3 the area to be afforested and the project's cost for the watershed is shown. These were calculated based on forestry plan of Chinchá River. The total surface would be approximately 68,000hectares and in order to forest them the required time would be from 22 years and 184.3 million soles. To sum up, the Project has to cover an extensive area, with an investment of much time and at a high cost.

**Table 1.14-3 General Plan for forestry on upper stream watersheds**

Watershed	Forestry Area (ha) A	Required Period for the project (years) B	Required Budget (soles) C
Yauca	68.296	22	184.340,033

### (3) Sediment Control Plan

As long term sediment control plan, it is recommended to perform necessary works on the upper watershed. These works will mainly consist of dams and bank protection. In Table 1.14-4 the estimate work cost is shown. There are two costs, one for executing works in the entire watershed and another one for executing works only in prioritized areas.

All the chosen watersheds for this Project are big. So, if bank protection works and sediment control dams want to be built, not only the works' cost would elevate but also a very long period of

investment would have to be done in the watershed. This means that its positive impact will be seen in a long time.

**Table 1.14-4 Projects Costs of Sediment Control**

Watersheds	Areas	Margin Protection		Bands		Dams		Works direct cost (total)	Project Cost (in millions de s/.)
		Qty. (km)	Works direct costs (million s/.)	Qty. (km)	Works direct costs (million s/.)	Qty. (km)	Works direct costs (million s/.)		
Yauca	Totally	565	S/.604	57	S/.2	97	S/.144	S/.750	S/.1,412
	Prioritized areas	565	S/.604	57	S/.2	37	S/.54	S/.660	S/.1,242



## **2. GENERAL ASPECTS**

### **2.1 Name of the Project**

“Protection program for valleys and rural communities vulnerable to floods  
Implementation of prevention measures to control overflows and floods of Yauca  
River, Arequipa Department”

### **2.2 Formulator and Executor Units**

#### **(1) Formulator Unit**

Name: Hydraulic Infrastructure General Direction, Agriculture Ministry  
Responsible: Orlando Chirinos Hernan Trujillo  
General Director of the Water Infrastructure General Direction  
Address: Av. Benavides N° 395 Miraflores, Lima 12 - Peru  
Phone: (511) 4455457 / 6148154  
Email: [ochirinos@minag.gob.pe](mailto:ochirinos@minag.gob.pe)

#### **(2) Executor Unit**

Name: Sub-sectorial Irrigation Program, Agriculture Ministry  
Manager: Jorge Zúñiga Morgan  
Executive Director  
Address: Jr. Emilio Fernandez N° 130 Santa Beatriz, Lima-Peru  
Phone: (511) 4244488  
Email: [postmast@psi.gob.pe](mailto:postmast@psi.gob.pe)

### **2.3 Involved entities and Beneficiaries Participation**

Here are the institutions and entities involved in this project, as well as beneficiaries.

#### **(1) Agriculture Ministry (MINAG)**

MINAG, as manager of natural resources of watersheds promotes agricultural development in each of them and is responsible of maintaining the economical, social and environmental to benefit agricultural development.

To accomplish effectively and efficiently this objective, the MINAG has been working since 1999 in the River Channeling and Collection Structures Protection Program (PERPEC). The river disaster prevention programs that are been carried out by regional governments are funded with PERPEC resources.

1) Administration Office (OA)

- Manages and executes the program's budget
- Establishes the preparation of management guides and financial affairs

2) Hydraulic Infrastructure general Direction (DGIH)

- Performs the study, control and implementation of the investment program
- Develops general guidelines of the program together with OPI

3) Planning and Investment Office (OPI)

- Conducts the preliminary assessment of the investment program
- Assumes the program's management and the execution of the program's budget
- Plans the preparation of management guides and financial affairs

4) Irrigation Sub-Sectorial Program (PSI)

- Carries-out the investment program approved by OPI and DGPM

(2) Economy and Finance Ministry (MEF)

Public Sector's Multiannual Programming General Direction (DGPM)

Is in charge of approving public investment works according to procedures under the Public Investment National System (SNIP) to assess the relevance and feasibility of processing the disbursement request of the national budget and the loan from JICA.

(3) Japan's International Cooperation Agency (JICA)

It is a Japanese government institution with the objective of contributing in the socioeconomic development of developing countries through international cooperation. JICA has extended financial assistance to carry out pre-feasibility and feasibility studies of this Project.

(4) Regional Governments (GORE)

Regional governments assume the promotion of integrated and sustainable regional development following the national and regional plans and programs, trying to increase public and private investment, generating employment opportunities, protecting citizens rights and ensuring equal opportunities.

The regional governments' participation with their possible financial support is a very important factor to ensure the Project's sustainability.

The Special Project Chira-Piura, Regional Government of Piura implemented by the regional government of Piura also includes Chira River which is the area of this Study.

(5) Irrigation Commission

Currently there are 3 irrigation commissions in the Yauca River Watershed. These have expressed a strong desire for the starting of works because these will help constructing dikes,



protecting margins, repairing water intakes, etc. These commissions are currently suffering major damages due to rivers flooding. Next, a brief overview of the Yauca River Watershed is described (for more details, see Section 3.1.3). Currently, the operation and maintenance of dikes, margin protection works, irrigation intakes and channels linked to agricultural land and irrigation systems in the Watershed, are mainly made by irrigation commissions and their members, with the assistance of local governments.

Number of irrigation blocks:	3
Number of Irrigation Commissions:	3
Irrigated Area:	1, 614 ha
Beneficiaries:	557 productores

(6) Meteorology and Hydrology National Service (SENAMHI)

It is an agency from the Environment Ministry responsible for all activities related to meteorology, hydrology, environment and agricultural meteorology. Take part in global level monitoring, contributing to sustainable development, security and national welfare, and gathering information and data from meteorological stations and hydrological observation.

(7) Civil Defense National Institute (INDECI)

INDECI is the main agency and coordinator of the Civil Defense National System. It is responsible for organizing and coordinating the community, elaborating plans and developing disaster risk's management processes. Its objective is to prevent or alleviate human life loss due to natural and human disasters and prevent destruction of property and the environment.

(8) Water National Authority (ANA)

It is the highest technical regulating authority in charge of promoting, monitoring and controlling politics, plans, programs and regulations regarding sustainable use of water resources nationwide.

Its functions include sustainable management of these resources, as well as improving the technical and legal framework on monitoring and assessment of water supply operations in each region.

Along with maintaining and promoting a sustainable use of water resources, it is also responsible for conducting the necessary studies and developing main maintenance plans,

national and international economic and technical cooperation programs.

(9) Agriculture Regional Directorates (DRA's)

Agricultural regional addresses fulfill the following functions under the respective regional government:

- 1) Develop, approve, assess, implement, control and manage national agriculture policies, sectorial plans as well as regional plans and policies proposed by municipalities
- 2) Control agriculture activities and services fitting them to related policies and regulations, as well as on the regional potential
- 3) Participate in the sustainable management of water resources agreeing with the watershed's general framework, as well as the policies of the Water National Authority (ANA)
- 4) Promote the restructure of areas, market development, export and agricultural and agro-industrial products consumption
- 5) Promote the management of: irrigation, construction and irrigation repair programs, as well as the proper management and water resources and soil conservation

## **2.4 Framework**

### **2.4.1 Background**

(1) Study Background

The Republic of Peru (hereinafter "Peru") is a country with high risk of natural disasters such as earthquakes, Tsunamis, etc. Among these natural disasters there are also floods. In particular, El Niño takes place with an interval of several years and has caused major flood of rivers and landslides in different parts of the country. The most serious disaster in recent years due to El Niño occurred in the rainy season of 1982-1983 and 1997-1998. In particular, the period of 1997-1998, the floods, landslides, among others left loss of 3,500 million of dollars nationwide. The latest floods in late January 2010, nearby Machupicchu World Heritage Site, due to heavy rains interrupted railway and roads traffic, leaving almost 2,000 people isolated.

In this context, the central government has implemented El Niño phenomenon I and II contingency plans in 1997-1998, throughout the Agriculture and Livestock Ministry (MINAG) in order to rebuild water infrastructures devastated by this phenomenon. Next, the Hydraulic Infrastructure General Direction (DGIH) of the Agriculture Ministry (MINAG) began in 1999 the River Channeling and Collection Structures Protection Program (PERPEC) in order to protect villages, farmlands, agricultural infrastructure, etc located within flood risk areas. The

program consisted of financial support for regional government to carry out works of margin protection. In the multiyear PERPEC plan between 2007-2009 it had been intended to execute a total of 206 margin protection works nationwide. These projects were designed to withstand floods with a return period of 50 years, but all the works have been small and punctual, without giving a full and integral solution to control floods. So, every time floods occur in different places, damages are still happening.

MINAG developed a “Valley and Rural Populations Vulnerable to Floods Protection Project” for nine watersheds of the five regions. However, due to the limited availability of experiences, technical and financial resources to implement a pre-investment study for a flood control project of such magnitude, MINAG requested JICA’s help to implementation this study. In response to this request, JICA and MINAG held discussions under the premise of implementing it in the preparatory study scheme to formulate a loan draft from AOD of JICA, about the content and scope of the study, the implementation’s schedule, obligations and commitments of both parties, etc. expressing the conclusions in the Discussions Minutes (hereinafter “M/D”) that were signed on January 21 and April 16, 2010. This study was implemented on this M/D.

## (2) Progress of Study

The Profile Study Report for this Project at Program’s level for nine watersheds of five regions has been elaborated by DGIH and sent to the Planning and Investment Office (OPI) on December 23, 2009, and approved on the 30<sup>th</sup> of the same month. Afterwards, DGIH presented the report to the Public Sector Multiannual Programming General Direction (DGPM) of the Economy and Finance Ministry (MEF) on January 18, 2010. On March 19<sup>th</sup>, DGPM informed DGIH about the results of the review and the correspondent comments.

The JICA Study Team began the study in Peru on September 5<sup>th</sup>, 2010. At the beginning, nine watersheds were going to be included in the study. One, the Ica River was excluded of the Peruvian proposal leaving eight watersheds. The eight watersheds were divided into two groups: Group A with five watersheds and Group B with three watersheds. The study for the first group was assigned to JICA and the second to DGIH. Group A includes Chira, Cañete, Chincha, Pisco and Yauca Rivers’ Watersheds and Group B includes the Cumbaza, Majes and Camana Rivers’ Watersheds.

The JICA Study Team conducted the profile study of the five watersheds of Group A, with an accurate pre-feasibility level and handed DGIH the Program Report of group A and the reports of the five watershed projects by late June 2011. Also, the feasibility study has already started, omitting the pre-feasibility study.

For the watersheds of Group B which study corresponded to DGIH, this profile study took place between mid-February and early March 2011 (and not with a pre-feasibility level, as established in the Meetings Minutes), where Cumbaza River Watershed was excluded because it was evident that it would not have an economic effect. The report on the Majes and Camana rivers watersheds were delivered to OPI, and OPI official comments were received through DGIH on April 26<sup>th</sup>, indicating that the performed study for these two watersheds did not meet the accuracy level required and it was necessary to study them again. Also, it was indicated to perform a single study for both rivers because they belong to a single watershed (Majes-Camana).

On the other hand, due to the austerity policy announced on March 31<sup>st</sup>, prior to the new government assumption by new president on July 28<sup>th</sup>, it has been noted that it is extremely difficult to obtain new budget, DGIH has requested JICA on May 6<sup>th</sup> to perform the prefeasibility and feasibility studies of the Majes-Camana Watershed.

JICA accepted this request and decided to perform the mentioned watershed study modifying for the second time the Meeting Minutes (refer to Meetings Minutes Second Amendment about the Initial Report, Lima, July 22<sup>nd</sup>, 2011)

So, the JICA Study Team began in August the prefeasibility study for the watershed above mentioned, which was completed in late November.

This report corresponds with the pre-feasibility study of the Yauca watershed project, of a five watershed Group A. The feasibility study of Majes - Camana watershed wants to be finished by mid-January 2012, and the feasibility study for all selected watersheds around the same dates.

Remember that DGIH processed on July 21<sup>st</sup>, the SNIP registration of four of the five watersheds from JICA (except Yauca), based on projects reports at pre-feasibility level (according to the watersheds). DHIG decided to discard Yauca River due to its low impact in economy.

#### **2.4.2 Laws, regulations, policies and guidelines related to the Program**

This program has been elaborated following the mentioned laws and regulations, policies and guidelines:

- (1) Water Resources Law N° 29338

Article 75 .- Protection of water

The National Authority, in view of the Watershed Council, must ensure for the

protection of water, including conservation and protection of their sources, ecosystems and natural assets related to it in the regulation framework and other laws applicable. For this purpose, coordination with relevant government institutions and different users must be done.

The National Authority, throughout the proper Watershed Council, executes supervision and control functions in order to prevent and fight the effects of pollution in the oceans, rivers and lakes. It can also coordinate for that purpose with public administration, regional governments and local governments sectors.

The State recognizes as environmentally vulnerable areas the headwater watersheds where the waters originate. The National Authority, with the opinion of the Environment Ministry, may declare protected areas the ones not granted by any right of use, disposition or water dumping.

#### Article 119 .- Programs flood control and flood disasters

The National Authority, together with respective Watershed Board, promotes integral programs for flood control, natural or manmade disasters and prevention of flood damages or other water impacts and its related assets. This promotes the coordination of structural, institutional and necessary operational measures.

Within the water planning, the development of infrastructure projects for multi-sectorial advantage is promoted. This is considered as flood control, flood protection and other preventive measures.

#### (2) Water Resources Law Regulation N° 29338

##### Article 118 .- From the maintenance programs of the marginal strip

The Water Administrative Authority, in coordination with the Agriculture Ministry , regional governments, local governments and water user organizations will promote the development of programs and projects of marginal strips forestry protection from water erosive action.

#### Article 259 ° .- Obligation to defend margins

All users have as duty to defend river margins against natural phenomenon effects, throughout all areas that can be influenced by an intake, whether it is located on owned land or third parties' land. For this matter, the correspondent projects will be submitted to be reviewed and approved by the Water National Authority.

#### (3) Water Regulation

Article 49. Preventive measures investments for crop protection are less than the recovery and rehabilitation cost measures. It is important to give higher priority to these protective measures

which are more economic and beneficial for the country, and also contribute to public expenses savings.

Article 50. In case the cost of dikes and irrigation channels protection measures is in charge of family production units or it exceeds the payment capacity of users, the Government may pay part of this cost.

(4) Multi-Annual Sectorial Strategic Plan of the Agriculture Ministry for the period 2007-2011 (RM N° 0821-2008-AG)

Promotes the construction and repair of irrigation infrastructure works with the premise of having enough water resources and their proper use.

(5) Organic Law of the Agriculture Ministry, N° 26821

In Article 3, it is stipulated that the agricultural sector is responsible for executing river works and agricultural water management. This means that river works and water management for agricultural purposes shall be paid by the sector.

(6) Guidelines for Peruvian Agricultural Policy - 2002, by the Policy Office of MINAG  
Title 10 - Sectorial Policies

“Agriculture is a high risk productive activity due to its vulnerability to climate events, which can be anticipated and mitigated... The damage cost to infrastructure, crops and livestock can be an obstacle for the development of agriculture, and as consequence, in the deterioration of local, regional and national levels.”

(7) River Channeling and Collection Structures Protection Program, PERPEC

The MINAG's DGIH started in 1999 the River Channeling and Collection Structures Protection Program (PERPEC) in order to protect communities, agricultural lands and facilities and other elements of the region from floods damages, extending financial support to margin protection works carried out by regional governments.

### 3. IDENTIFICATION

#### 3.1 Diagnosis of the current situation

##### 3.1.1 Nature

##### (1) Location

Figure 3.1.1-1 shows the location map of the Yauca River.



Figure 3.1.1-1 Objective River for the Study

##### (2) Watershed overall description

The Yauca River runs 460km to the south of the Capital of Lima and it is the river closer to the south within the five rivers chosen in this city. It belongs to the Arequipa Region. Its area covers 4.300 km<sup>2</sup>. It's characterized because its width increases as getting closer to the upper watershed. Altitudes above 4.000 most only represent a 10% of the total and 60% is constituted

by 2000 and 4000 mosl altitudes. In its lower watershed, is where the river has a slope approximately of 1/100 with a 200 meters width.

Annual rainfalls are approximately 500mm at altitudes between 2000 and 3000 mosl. But this data is not well confirmed because there is no complete monitoring of the details. The middle flow is the most reduced among the 5 rivers, due to which we are deducing that precipitations themselves are pretty low.

As to vegetation, upper watersheds are covered with grassland, bushes in the middle watershed and deserts in the middle and lower watersheds. Agriculture lands are only 1% of the watershed. The main product is olive, which production occupies almost the entire agricultural lands in this area .

### 3.1.2 Socio-economic conditions of the Study Area

#### (1) Administrative Division and Surface

The Yauca River is located in the provinces of Caraveli in the Arequipa Region.

Table 3.1.2-1 shows the main districts surrounding this river, with their corresponding surface.

**Table 3.1.2-1 Districts surrounding the Yauca River with areas**

Region	Province	District	Area (km <sup>2</sup> )
Arequipa	Caravelí	Yauca	556.30
		Jaquí	424.73

#### (2) Population and number of households

The following Table 3.1.2-2 shows how population varied within the period 1993-2007. From 1,708 inhabitants in 2007, 84% (2,844 inhabitants) lived in urban areas while 16% (549 inhabitants) lived in rural areas.

Yauca population has not varied. However, a reduction of rural population is observed. In Jaqui district, both populations, rural and urban, have decreased.

**Table 3.1.2-2 Variation of the urban and rural population**

District	Total Population 2007					Total Population 1993					Variation (%)	
	Urban	%	Rural	%	Total	Urban	%	Rural	%	Total	Urban	Rural
Yauca	1.442	84 %	266	16 %	1.708	1.370	81 %	321	19 %	1.691	0,4 %	-1,3 %
Jaqui	1.402	83 %	283	17 %	1.685	2.016	81 %	482	19 %	2.498	-2,6 %	-3,7 %
<b>Total</b>	<b>2.844</b>	<b>84 %</b>	<b>549</b>	<b>16 %</b>	<b>3.393</b>	<b>3.386</b>	<b>81 %</b>	<b>803</b>	<b>19 %</b>	<b>4.189</b>	<b>-1,2 %</b>	<b>-2,7 %</b>

Source: Prepared by JICA Study Team, Statistics National Institute- INEI, 2007 and 1993 Population and Housing Census.

Table 3.1.2-3 shows the number of households and members per home. The number of members per household has been 3.5 in average in Yauca and 3.7 in Jaqui. The number of members per family in Yauca is 3.4 and 3.5 in Jaqui.



**Table 3.1.2-3 Number of households and families**

Variables	Distrito	
	Yauca	Jaqui
Population (inhabitants)	1,708	1,685
Number of households	492	461
Number of families	499	483
Members per household (person/home)	3.47	3.66
Members per family (person/family)	3.42	3.49

**(3) Occupation**

Table 3.1.2-4, shows occupation lists of local inhabitants itemized by sector. In Yauca, primary sector is 39% of labor; meanwhile tertiary sector is 51%, being the second one predominant. In Jaqui, primary sector is 55% of labor and the tertiary sector is 35%, being the first one predominant

**Table 3.1.2-5 Occupation**

	Distrito			
	Yauca		Jaqui	
	人	%	人	%
EAP	688	100	604	100
Primary Sector	269	39.1	334	55.3
Secondary Sector	68	9.9	56	9.3
Tertiary Sector	351	51.0	214	35.4

\* Sector primario: agricultura, ganadería, forestal y pesca; secundario: minería, construcción, manufactura; terciario servicios y otros

**(4) Poverty index**

Table 3.1.2-5, shows the poverty index. 28.2% of the districts' population (956 inhabitants) belongs to the poor segment, and 4.4% (150 inhabitants) belong to extreme poverty.

**Table 3.1.2-7 Poverty index**

	District					
	Chincha Alta		Tambo de Mora			
	People	%	People	%	Total	%
Regional Population	1,708	100	1,685	100	3,393	100
In poverty	449	26.3	507	30.1	956	28.2
In extreme poverty	71	4.2	79	4.7	150	4.4

**(5) Type of housing**

The walls of the houses are made 55% of bricks or cement, and 24% of adobe and mud. The floor is made 95% of earth or cement.

The public drinking water service covers approximately 66% in Yauca and 68% in Jaqui, while the sewage service is 63% in Yauca and 22% in Jaqui (Jaqui is a little far behind in this topic). Electrification reaches 78% in average.

**Table 3.1.2-9 Type of housing**

Variable/Indicator	Districts			
	Yauca		Jaqui	
	Households	%	Households	%
<b>Name of housings</b>				
Common residents housing	492	59,3	461	79,2
<b>Walls materials</b>				
Bricks or cement	262	53,3	265	57,5
Adobe and mud	133	27	100	21,7
Bamboo + mud or wood	44	8,9	68	14,8
Others	53	10,8	28	6,1
<b>Floor Materials</b>				
Soil	136	27,6	160	34,7
Cement	315	64	290	62,9
Ceramics, parquet, quality wood	38	7,7	10	2,2
Others	3	0,6	1	0,2
<b>Running water system</b>				
Public network within household	325	66,1	313	67,9
Public network within building	27	5,5	49	10,6
public use	4	0,8		
<b>Sewage</b>				
Public sewage within household	308	62,6	99	21,5
Public sewage within building	19	3,9	27	5,9
Septic Tank	23	4,7	147	31,9
<b>Electricity</b>				
Public electric service	422	85,8	321	69,6
<b>Member quantity</b>				
<b>Common residents housing</b>	<b>499</b>	<b>100</b>	<b>483</b>	<b>100</b>
<b>Appliances</b>				
More than three	198	39,7	136	28,2
<b>Communication Services</b>				
Phones and mobiles	241	48,3	7	1,4

Source: Prepared by JICA Study Team, Statistics National Institute- INEI, 2007 Population and Housing Census.

## (6) GDP

Peru's GDP in 2009 was S./392,565,000,000.

The growth rate in the same year was of + 0.9 % compared with the previous year with the poorest level within 11 years.

Itemized by regions, Ica registered a growth of 3.8 %, Piura 2.0 %, Lima 0.4 % and Arequipa 0.2 %. Particularly Ica and Piura regions registered Figures that were beyond the national average.

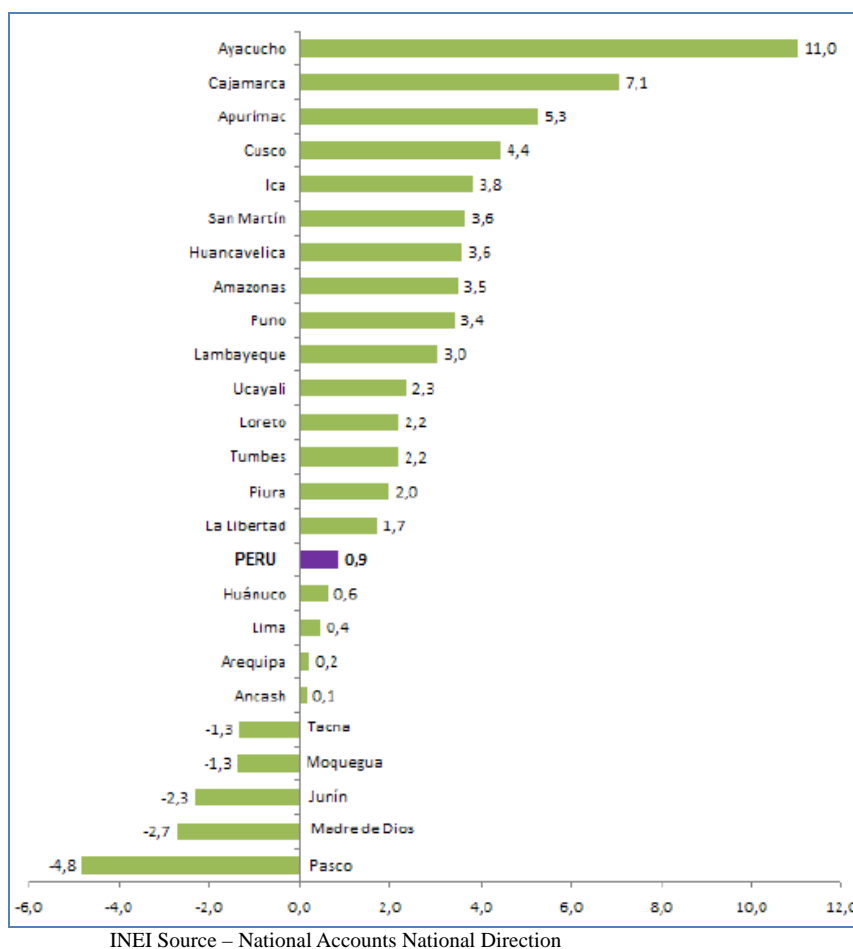

**Figure 3.1.2-1 Growth rate of GDP per region (2009/2008)**

The Figure 3.1.2-2 shows the contribution of each region to the GDP. Lima Region represents almost half of the total, that is to say 44.8%. Arequipa contributed with 5.3 %, Piura 4.6 % and Ica 2.9 %. Taxes and duties contributed with 7.2 % and 0.4 %, respectively.

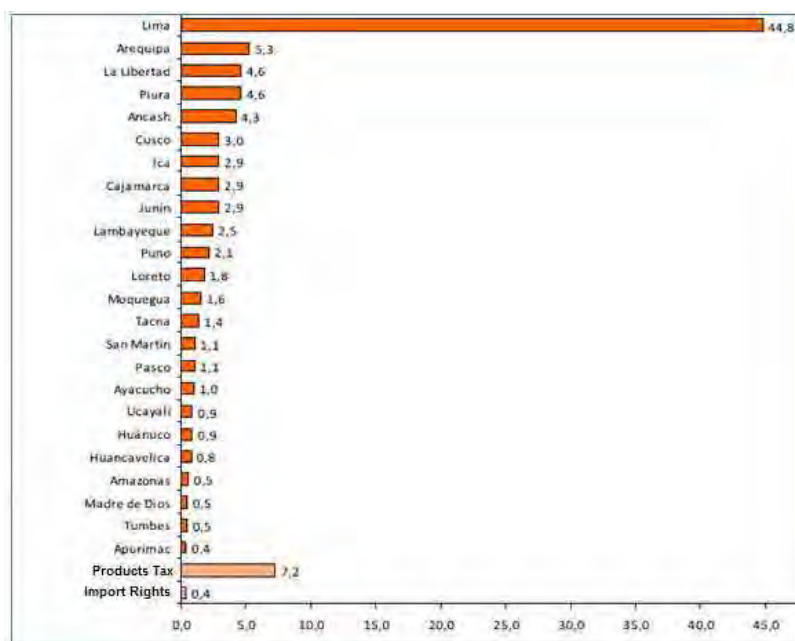

INEI Source – National Accounts National Direction

**Figure 3.1.2-2 Region contribution to GDP**

The GDP per capita in 2009 was of S/.13,475.

The Table below shows data per region: Lima S/.17,800, Arequipa S/.17,200, Ica S/.15,600 and Piura S/.10,200. The first three regions exceeded the national average, with exception of Piura.

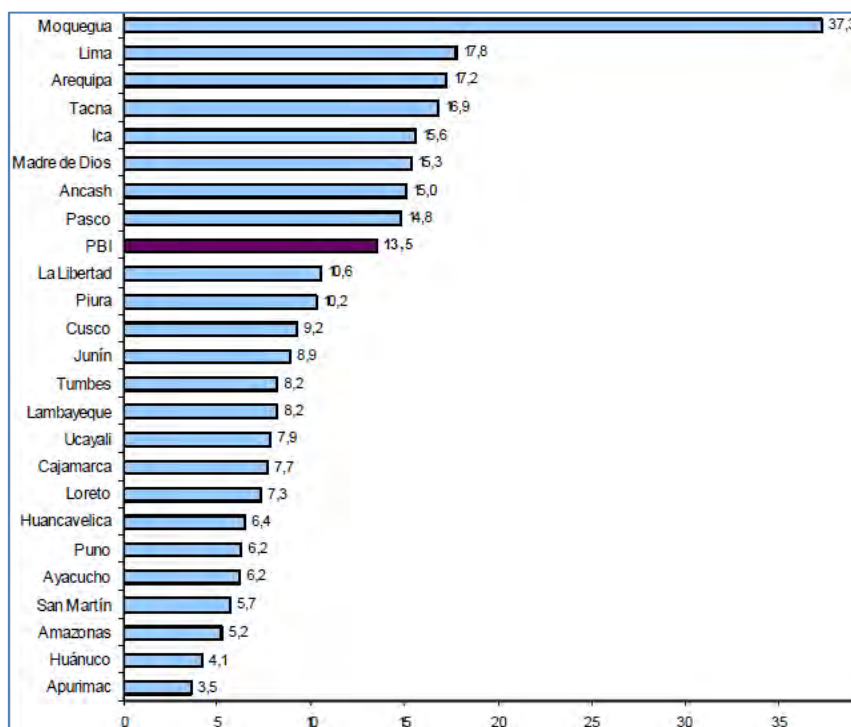

INEI Source – National Accounts National Direction

**Figure 3.1.2-3 GDP per capita (2009)**

Table 3.1.2-7 shows the variation along the years of the GDP per capita per region, during the last 9 years (2001-2009).

The GDP national average increased in 44% within nine years from 2001 until 2009. The Figures per region are: +83.9 % for Ica, +54.2 % for Arequipa, +48.3 % for Piura and 2.9 % for Lima.

Figures in Table 3.1.2-7 were established taking 1994 as base year.

**Table 3.1.2-7 Variation of the GDP per capita (2001-2009)**

(1994 Base year, S/.)

Departament	2001	2002	2003	2004	2005	2006	2007P/	2008P/	2009E/	Accumulated Growth 2001-2009 [%]
Cusco	2 194	2 086	2 195	2 565	2 768	3 071	3 340	3 554	3 685	67,9
Ica	4 055	4 259	4 343	4 663	5 214	5 582	6 025	7 265	7 457	83,9
La Libertad	3 162	3 316	3 483	3 410	3 697	4 216	4 586	4 874	4 895	54,8
Ucayali	3 063	3 149	3 203	3 411	3 584	3 754	3 846	4 007	4 039	31,9
Moquegua	10 405	11 967	12 670	13 455	13 882	13 794	13 606	14 201	13 865	33,3
Arequipa	5 387	5 766	5 895	6 143	6 488	6 807	7 786	8 379	8 308	54,2
Apurimac	1 216	1 278	1 334	1 400	1 494	1 619	1 653	1 691	1 770	45,5
Piura	2 733	2 780	2 847	3 040	3 192	3 472	3 780	4 007	4 052	48,3
San Martín	2 026	2 059	2 094	2 232	2 393	2 476	2 655	2 870	2 928	44,5
Ayacucho	1 788	1 870	1 942	1 900	2 045	2 207	2 448	2 640	2 896	61,9
Amazonas	1 835	1 910	1 996	2 081	2 212	2 349	2 510	2 684	2 761	50,5
Madre de Dios	4 441	4 708	4 550	4 846	5 171	5 215	5 617	5 878	5 564	25,3
Cajamarca	2 493	2 731	2 947	2 968	3 165	3 113	2 864	3 094	3 295	32,2
Ancash	4 037	4 703	4 772	4 876	4 999	5 089	5 408	5 852	5 827	44,3
Tumbes	2 744	2 802	2 873	3 018	3 385	3 212	3 427	3 594	3 611	31,6
Lima	6 451	6 579	6 700	6 925	7 284	7 817	8 520	9 314	9 220	42,9
Puno	2 105	2 236	2 234	2 270	2 365	2 460	2 617	2 731	2 800	33,0
Lambayeque	2 941	3 046	3 132	2 959	3 164	3 300	3 615	3 882	3 963	34,8
Junín	3 245	3 311	3 350	3 527	3 505	3 856	4 072	4 379	4 248	30,9
Loeeto	2 827	2 917	2 936	2 995	3 079	3 192	3 287	3 402	3 429	21,3
Huánuco	1 678	1 694	1 833	1 866	1 890	1 915	1 942	2 050	2 044	21,8
Pasco	5 137	5 552	5 481	5 634	5 644	6 062	6 711	6 729	6 349	23,6
Tarma	6 004	6 124	6 382	6 643	6 782	6 941	7 256	7 458	7 253	20,8
Huancavelca	2 700	2 632	2 683	2 697	2 864	3 014	2 903	2 959	3 039	12,5
<b>GDP</b>	<b>4 601</b>	<b>4 765</b>	<b>4 890</b>	<b>5 067</b>	<b>5 345</b>	<b>5 689</b>	<b>6 121</b>	<b>6 643</b>	<b>6 625</b>	<b>44,0</b>

INEI Source – National Accounts National Direction

### 3.1.3 Agriculture

Next is a summarized report on the current situation of agriculture in each Watershed, including irrigation commissions, crops, planted area, performance, sales, etc.

#### (1) Irrigation Sectors

Table 3.1.3-1 shows basic data on the irrigation commissions. In the Yauca River Watershed there are 3 irrigation sectors, 3 irrigation commissions with 557 beneficiaries. The surface managed by these sectors reach a total of 1,614 hectares.

**Table 3.1.3-1 Basic data of the irrigation commissions**

Irrigation Sectors	Irrigation Commissions	Areas under irrigation		N° of Beneficiaries (People)	River
		ha	%		
Yauca	Yauca	523	32	350	Yauca
Mochica	Mochica	456	28	57	
Jaqui	Jaqui	635	39	150	
<b>Total</b>		<b>1,614</b>	<b>100</b>	<b>557</b>	

Source: Prepared by JICA Study Team, Users Board of Yauca, October 2010

**(2) Main crops**

Table 3.1.3-2 shows the variation between 2004 and 2009 of the planted surface and the performance of main crops.

In the Yauca River Watershed, olive represents 70% of the planted area and between 80 to 90% of the profit, being the key product of this area.

The profits of 2007-2008 were a total of S/.24,808,192, duplicating compared to former years calculations, thanks to the increase of olives production.

**Table 3.1.3-3 Sowing and sales of main crops**

	Variables	2004-2005	2005-2006	2006-2007	2007-2008	2008-2009
Olive	Planted Area (ha)	1,002	1,002	1,002	1,162	SD
	Unit Performance (kg/Ha)	6,009	4,846	3,604	11,635	SD
	Harvest (Kg)	6,021,018	4,855,692	3,611,208	13,519,870	
	Unit Price (S/./kg)	1.41	1.75	1.90	1.70	1.90
	Sales (S/.)	8,489,635	8,497,461	6,861,295	22,983,779	
Alfalfa	Planted Area (ha)	328	347	309	290	257
	Unit Performance (kg/Ha)	31,160	28,096	33,074	32,480	28,674
	Harvest (Kg)	10,220,480	9,749,312	10,219,866	9,419,200	7,369,218
	Unit Price (S/./kg)	0.09	0.10	0.10	0.10	0.10
	Sales (S/.)	919,843	974,931	1,021,987	941,920	736,922
Cotton	Planted Area (ha)	56	53	85	77	85
	Unit Performance (kg/Ha)	2,035	1,990	2,693	3,297	2,760
	Harvest (Kg)	113,960	105,470	228,905	253,869	234,600
	Unit Price (S/./kg)	2.20	2.00	2.70	2.54	1.82
	Sales (S/.)	250,712	210,940	618,044	644,827	426,972
Corn (yellow)	Planted Area (ha)	20	163	110	33	13
	Unit Performance (kg/Ha)	6,633	7,752	6,719	7,202	8,005
	Harvest (Kg)	132,660	1,263,576	739,090	237,666	104,065
	Unit Price (S/./kg)	0.52	0.50	0.70	1.00	0.70
	Sales (S/.)	68,983	631,788	517,363	237,666	72,846
Sweet potatoe	Planted Area (ha)	10	16	22	23	11
	Unit Performance (kg/Ha)	7,583	7,792	7,710	7,611	10,127
	Harvest (Kg)	75,830	124,672	169,620	175,053	111,397
	Unit Price (S/./kg)	0.59	0.60	0.75	0.83	0.92
	Sales (S/.)	44,740	74,803	127,215	145,294	102,485
Others	Planted Area (ha)	27	147	46	29	95
Total	Planted Area (ha)	2,522	3,189	3,037	2,864	
	Harvest (Kg)	49,052,450	47,090,300	47,103,115	56,176,725	41,216,009
	Sales (S/.)	42,792,095	41,282,962	47,588,416	66,174,879	35,998,549

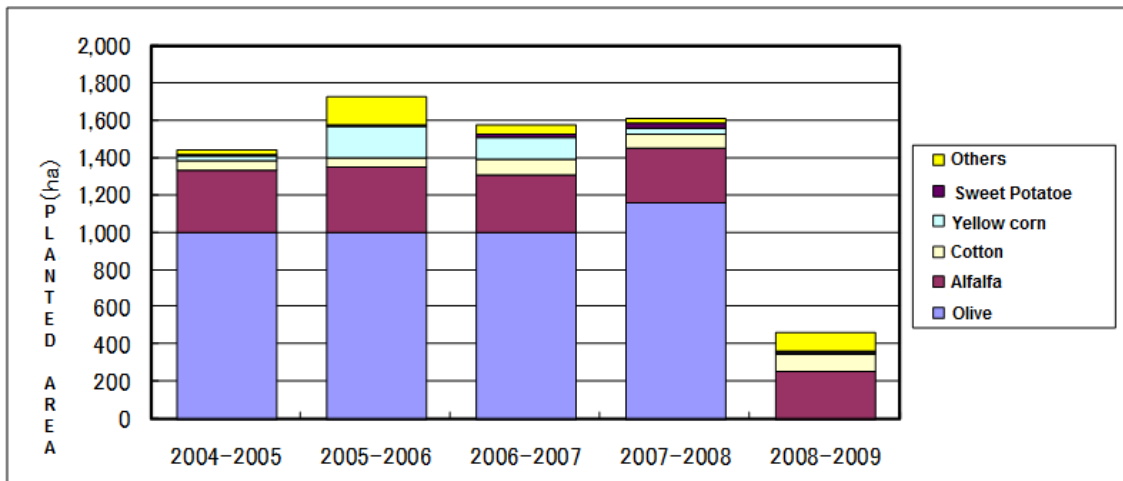

**Figure 3.1.3-1 Planted Surface**

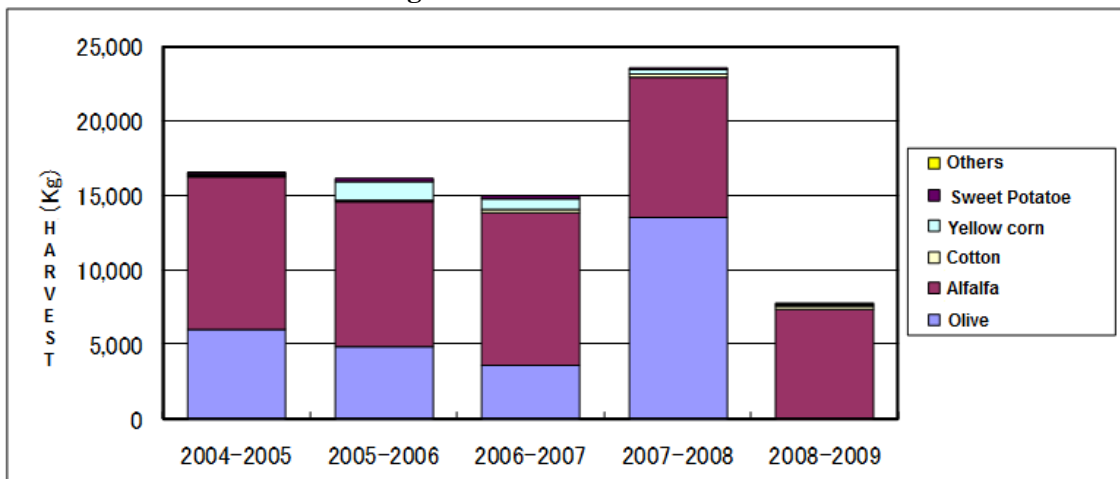

**Figure 3.1.3-2 Harvest**

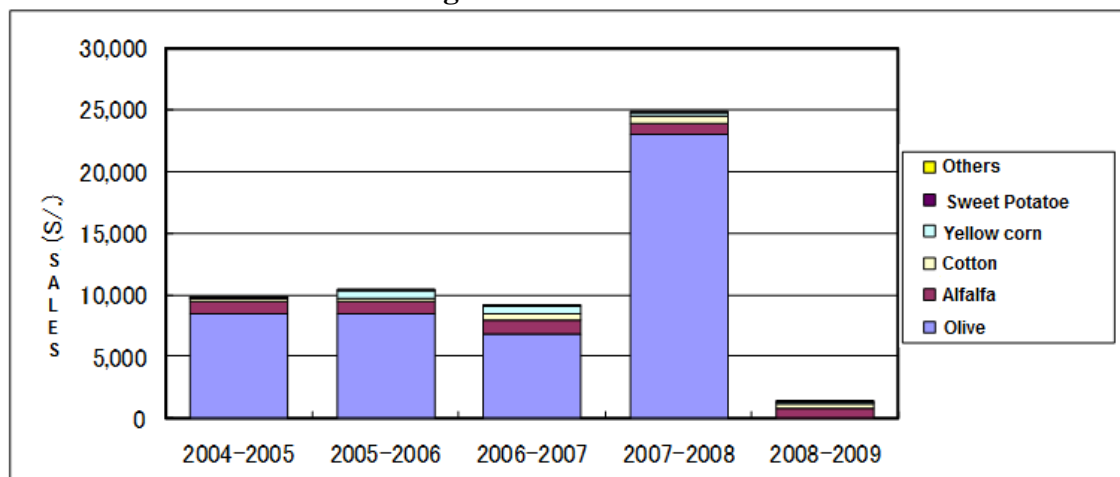

**Figure 3.1.3-3 Sales**

### 3.1.4 Infrastructure

#### (1) Irrigation Infrastructures

In Yauca River there are a total of 48 intakes, from which 2 are permanent. Derivation channels of first, second and third order add up to 191.96km, from which 24.14km (12.6%) are lagged.

**Table 3.1.4-1 Existing Irrigation Channels**

JUNTA USUARIO	COMISION DE REGANTES	BOCATOMA			CANAL DE DERIVACION			CANAL DE PRIMER ORDEN			CANAL SEGUNDO ORDEN			CANAL TERCER ORDEN			TOTAL DEL SISTEMA						
		TIPO (cantidad)	Nº	Nº	Revestido (km)	sin Revestido (km)	Longitud Total (km)	Revestido (km)	sin Revestido (km)	Longitud Total (km)	Revestido (km)	sin Revestido (km)	Longitud Total (km)	Revestido (km)	sin Revestido (km)	Longitud Total (km)	Revestido (km)	sin Revestido (km)	Longitud Total (km)				
Sub Distrito de Riego Acari	Chaviña	1	1	1	2.708	1.372	4.080	1	0.000	1.336	1.336				0.000	2	2.71	2.71	5.42				
	Acari Bajo	10	1	9	4.882	10.673	15.555	5	4.562	6.324	10.886	1	0.00	2.50	2.50	0.000	16	9.44	19.50	28.94			
	Acari Pueblo	1	0	1	2.540	0.000	2.540	1	4.000	0.000	4.000	7	2.48	14.49	16.96	2	0.000	0.842	0.842	24.34			
	Chocavente	2	2	2	0.250	1.850	2.100	2	4.500	6.000	10.500			0.00			0.000	4	4.75	7.85	12.60		
	Molino	3	1	2	3	6.360	1.125	7.485	2	3.300	3.200	6.500	1	0.00	0.60	0.60	0.000	6	9.66	4.92	14.58		
	Quarato Amato			8	8	1.800	15.847	17.647			0.000			0.00		0.000	8	1.80	15.85	17.65			
	Visija			2	2	3.000	2.350	5.350	2	0.000	1.500	1.500		0.00		0.000	4	3.00	3.85	6.85			
	Huanca	3	3	3	2.700	11.827	14.527			0.000				0.00		0.000	3	2.70	11.83	14.53			
	Lisahuacho	12	12	12	0.000	36.430	36.430			0.000				0.00		0.000	12	0.00	36.43	36.43			
	<b>SUBTOTAL</b>	<b>42</b>	<b>4</b>	<b>38</b>	<b>42</b>	<b>24.24</b>	<b>81.47</b>	<b>105.71</b>	<b>13</b>	<b>16.36</b>	<b>18.36</b>	<b>34.72</b>	<b>9</b>	<b>2.48</b>	<b>17.58</b>	<b>20.06</b>	<b>2</b>	<b>0.00</b>	<b>0.84</b>	<b>0.84</b>	<b>66</b>	<b>43.08</b>	<b>118.25</b>
Bella Unión	Lateral 1	1	1	1	17.75	2.053	19.803										1	17.75	2.05	19.80			
	Lateral 2	1	1	1			0	1	5.584	3.216	8.8	5	2.476	5.497	7.973		0	6	8.06	8.71	16.77		
	Lateral 3	1	1	1			0	1	2.35	6.35	8.7	4	1.25	4.79	6.04		0	5	3.60	11.14	14.74		
	<b>SUBTOTAL</b>	<b>4</b>	<b>4</b>	<b>0</b>	<b>1</b>	<b>17.75</b>	<b>2.05</b>	<b>19.80</b>	<b>3</b>	<b>16.76</b>	<b>9.57</b>	<b>26.33</b>	<b>13</b>	<b>5.18</b>	<b>16.99</b>	<b>22.10</b>	<b>0</b>	<b>0.00</b>	<b>0.00</b>	<b>0.00</b>	<b>17</b>	<b>39.69</b>	<b>28.61</b>
Sub Distrito de Riego Yauca	Yauca	9	2	7	9	5.75	15.55	21.30	9	1	7.96	8.96	3	0.65	3.91	4.56				21	7.40	27.42	34.82
	Mochica	1	0	1	1	2.50	11.00	13.50	0	0	0	0	0	0.00	0.00	0.00				1	2.50	11.00	13.50
	Paqui	13	0	13	13	14.24	27.72	41.96	5	0	4.35	4.35	0	0.00	0.00	0.00				18	14.24	32.07	46.31
	San Luis Palca	0	11	11	11	0.00	35.80	35.80	0	0	0	0	0	0.00	0.00	0.00				11	0.00	35.80	35.80
	Lampalla	12	0	12	12	0.00	48.82	48.82	0	0	0	0	0	0.00	0.00	0.00				12	0.00	48.82	48.82
	Cuesta Chacui	2	2	2	2	0.00	12.70	12.70	0	0	0	0	0	0.00	0.00	0.00				2	0.00	12.70	12.70
<b>SUBTOTAL</b>	<b>48</b>	<b>2</b>	<b>46</b>	<b>48</b>	<b>22.49</b>	<b>151.59</b>	<b>174.08</b>	<b>14</b>	<b>1</b>	<b>12.31</b>	<b>13.31</b>	<b>3</b>	<b>0.65</b>	<b>3.91</b>	<b>4.56</b>	<b>0</b>	<b>0</b>	<b>0</b>	<b>0</b>	<b>65</b>	<b>24.14</b>	<b>167.81</b>	<b>191.95</b>
<b>TOTAL</b>	<b>94</b>	<b>10</b>	<b>84</b>	<b>91</b>	<b>64.48</b>	<b>235.17</b>	<b>299.59</b>	<b>730</b>	<b>34.12</b>	<b>40.23</b>	<b>74.35</b>	<b>25</b>	<b>8.302</b>	<b>38.47</b>	<b>46.71</b>	<b>2</b>	<b>0</b>	<b>0.842</b>	<b>0.842</b>	<b>148</b>	<b>106.91</b>	<b>314.61</b>	<b>421.5</b>

#### (2) PERPEC

No PERPEC project has been implemented in Yauca River between 2006 and 2009.



### 3.1.5 Real flood damages

#### (1) Damages on a nationwide scale

Table 3.1.5-1 shows the present situation of flood damages during the last five years (2003-2007) in the whole country. As observed, there are annually dozens to hundreds of thousands of flood affected inhabitants.

**Table 3.1.5-1 Situation of flood damages**

		Total	2003	2004	2005	2006	2007
Disasters	Cases	1,458	470	234	134	348	272
Víctims	people	373,459	118,433	53,370	21,473	115,648	64,535
Housing loss victims	people	50,767	29,433	8,041	2,448	6,328	4,517
Decesased individuals	people	46	24	7	2	9	4
Partially destroyed houses	Houses	50,156	17,928	8,847	2,572	12,501	8,308
Totally destroyed houses	Houses	7,951	3,757	1,560	471	1,315	848

Source : SINADECI Statistical Compendium

Peru has been hit by big torrential rain disasters caused by the El Niño Phenomenon. Table 3.1.5-2 shows damages suffered during the years 1982-1983 and 1997-1998 with extremely serious effects. Victims were approximately 6.000.000 inhabitants with an economic loss of about US\$ 1.000.000.000 in 1982-1983. Likewise, victims number in 1997-1998 reached approximately 502.461 inhabitants with economic loss of US\$ 1.800.000.000. Damages in 1982-1983 were so serious that they caused a decrease of 12 % of the Gross National Product.

**Table 3.1.5-2 Damages**

Damages	1982-1983	1997-1998
Persons who lost their homes	1.267.720	—
Victims	6.000.000	502.461
Injured	—	1.040
Deceased	512	366
Missing persons	—	163
Partially destroyed houses	—	93.691
Totally destroyed houses	209.000	47.409
Partially destroyed schools	—	740
Totally destroyed schools	—	216
Hospitals and health centers partially destroyed	—	511
Hospitals and health centers totally destroyed	—	69
Damaged arable lands (ha)	635.448	131.000
Head of cattle loss	2.600.000	10.540
Bridges	—	344
Roads (km)	—	944
Economic loss (\$)	1.000.000.000	1.800.000.000

“—”: No data

**(2) Disasters in the watersheds object of this study**

Table 3.1.5-3 summarizes damages occurred in the Arequipa region, to which this study belongs to.

**Table 3.1.5-3 Disasters in Arequipa Region**

Years	1995	1996	1997	1998	1999	2000	2001	2002	2003	2004	2005	2006	2007	2008	2009	2010	Total	Media
LANDSLIP																1	1	
FLOOD											5						5	
COLLAPSE						1	1	1									1	4
LANDSLIDE		1		1	1	2	1	1	4	3	4	2			1		2	23
AVALANCHE	6	1	7	14	3	2	4				2	2	1		9	3	54	
TOTAL SEDIMENT DISASTERS	6	2	7	15	4	5	6	2	4	3	11	4	1	0	10	7	87	5
TOTAL FLOODING	3	1	42	6	44	2	15	3	1	2	2	3	0	1	3	3	131	8

**3.1.6 Results on the visits to Study Sites**

JICA Study Team made some technical visits to the selected watersheds and identified some challenges on flood control through visits and interviews to regional government authorities and irrigation associations on damages suffered in the past and the problems each watershed is currently facing.

**(1) Interviews**

Lowest watershed's bridge

- Main crop is olive
- 400 olives, approximately of 100 years were overthrown by the river's overflow a couple of years ago
- The river's bed elevated due to El Niño floods in 1998
- The maximum water level was reached during 1983 el Niño, which water raised up to the upper section of the bridge on Panamericana Highway

○ San Francisco

- Small olives trees are seen downstream this area, this was the affected area by lasts year's floods
- Olives may be harvested 8 years after the trees are planted. Trees with more than 20 to 30 years have more to harvest. There are trees of 100 to 500 years
- From one tree you can obtain a harvest of approx 200 to 250 kg/year. There are 100 trees per hectare. The cost of 1 kg is about 3.5 soles
- The lower watershed sector has an approx extension of 400 hectares

○ Mochica Intake

- 1700L/s are taken
- There are 580 hectares of olives in the middle watershed

- The harvest volume is 80kg/year per tree (max 200kg). In an abundant harvest year, a hectare may pay up to 10.000kg
- There is a Dam in Ayacucho, upstream, where water is discharged for a month between August and September
- The total capacity of this dam is  $23 \times 106 \text{ m}^3$
- This dam has been built 120 years ago, it has cracks and water leaks. This dam had been used in Yauca and another community until 2006, then another community was added, but it cannot supply more communities any longer
- MINAG determines the water discharge period from the dam
- It is hoped to give the maximum use to the water. It is better to control the water from the river's bed
- The fluvial terrace is used without authorization for agriculture production, which is an issue
- The bed continues to raise
- Bridge in the narrow section (last bridge on the Yauca River upper watershed)
  - From this point upwards is Jaqui sector
  - There are 490 hectares of olives and 14 intakes
  - Floods destroy intakes leaving them out of service
- Intakes
  - Flood water reaches olives
  - The channel upstream the intake is destroyed due to floods
  - Water volume has been decreasing in the past 15 years, so much that producers have been planting olives even near the river bed
  - Every Jaqui channels are made of masonry and are destroyed every time a flood occurs. All 14 channels have been destroyed with the same frequency (it does not happen that some of them are destroyed and some are left ok)
- Drinking water Intake
  - It was finished building last year
- Purification Plant
  - It was finished recently
  - Currently, chemical treatment is not being done
  - Water is used for human consumption in Jaqui, downstream

**(2) Description of the visit to the study sites**

Figure 3.1.6-1 shows pictures of main sites visited.



**Figure 3.1.6-1 Visit to the Study Site (Yauca River)**

**(3) Challenges and measures**

The following table shows challenges and possible solution measures for flood control considered at this moment, based on the results of technical visits.

1) Challenge 1: Floodplain area (km 7.0 downstream)

Current situation and challenges	<ul style="list-style-type: none"> <li>• Main product is olive</li> <li>• Urban area is relatively in a high elevation so direct risk of floods and overflowing is reduced. The elements to be protected are the trees and hydraulic installations</li> <li>• A dike is built empirically and partially, but banks are eroded and flood may affect the olives</li> </ul>
Main elements to be conserved	<ul style="list-style-type: none"> <li>• Agricultural lands (main product: olive)</li> </ul>
Basic measures	<ul style="list-style-type: none"> <li>• Repair existing dike</li> <li>• Execute bank protection Works (banks erosion control)</li> <li>• Build retarding reservoirs</li> </ul>



**Figure 3.1.6-2 Local conditions related with Challenge 1 (Yauca River)**

2) Challenge 2: Water intake point in the middle watershed (km 25.0)

Current situation and challenges	<ul style="list-style-type: none"> <li>• The fluvial terrace of the opposite bank began to be cultivated recently, so, overflows will be on the right bank</li> <li>• As main problem that has to be solved, the flood impact on the intake is mentioned, also the right bank's erosion were the highway passes is mentioned too</li> </ul>
Main elements to be conserved	<ul style="list-style-type: none"> <li>• Olives (from this area and from the lower watershed)</li> </ul>
Basic measures	<ul style="list-style-type: none"> <li>• Reinforce the intake</li> <li>• Execute bank protection works (right bank erosion control)</li> <li>• Built retarding reservoirs (buying lands from the opposite bank)</li> </ul>

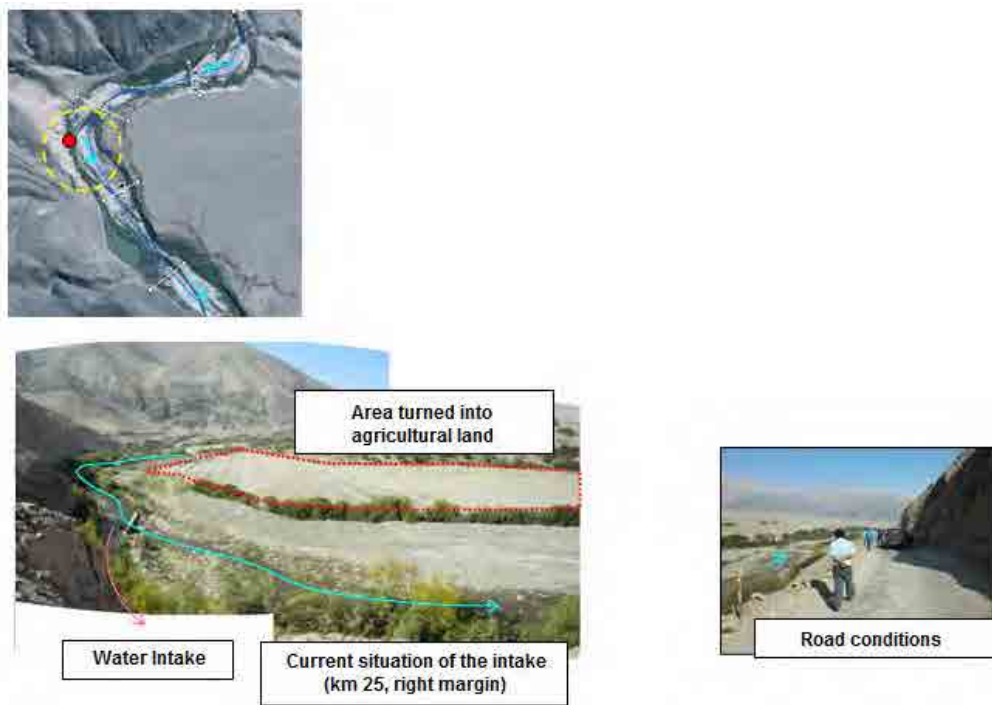

**Figure 3.1.6-3 Local conditions related with Challenge 2 (Yauca River)**

3) Challenge 3: Upper watershed intake point (km 27.0 upper watershed)

Current situation and challenges	<ul style="list-style-type: none"> <li>▪ There are several relatively simple intakes</li> <li>▪ Some of these intakes are destroyed and require to be repaired every time a flood takes place</li> </ul>
Main elements to be conserved	<ul style="list-style-type: none"> <li>▪ Olives (from this area and from the lower watershed)</li> </ul>
Basic measures	<ul style="list-style-type: none"> <li>▪ Built retarding reservoirs (to reduce floods peak stream)</li> <li>▪ Built an intake (to integrate the existing small works)</li> </ul>

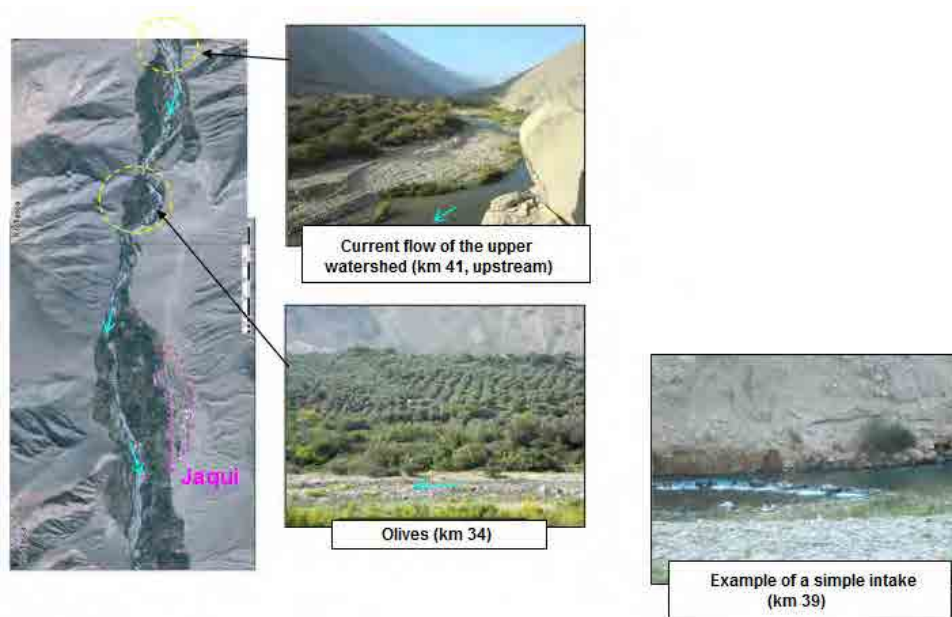

**Figure 3.1.6-4 Local conditions related with Challenge 3 (Yauca River)**

### 3.1.7 Current situation of vegetation and reforestation

#### (1) Current Vegetation

Pursuant to the 1995 Forest Map and its explanations, the Cañete, Chinchá, Pisco and Yauca watersheds extends from the coast to the Andean mountains; usually, they feature different vegetal coverage according to the altitude. From coast up to the 2,500m.a.s.l (Cu, Dc) have scarce vegetation. Some meters above in altitude, there are only scarce bushes disseminated in the area due to the rains. Although, in zones close to the rivers, high trees are mainly develop (4 meters approximately), even in arid zones.

**Table 3.1.7-1 List of representative vegetable forming in the Yauca watersheds**

Symbol	Life Zone	Distribution of Altitude	Rainfall	Representative Vegetation
1)Cu	Coast Crop Lands	Coast	Almost none.	Coastal crops
2)Dc	Coast Desert	0~1,500 m.a.s.l	Almost none, there are mist zones.	Almost none, there are vegetation slopes
3)Ms	Dry Thicket	1,500~3,900 m.a.s.l	120~220mm	Cactus and grass
4)Msh	Subhumid Forest	North-center: 2,900~3,500 m.a.s.l Inter Andean 2,000~3,700 m.a.s.l	220~1,000mm	Perennial bushes, less than 4m high
5)Mh	Humid Forest	North: 2,500~3,400 m.a.s.l South 3,000~3,900 m.a.s.l	500~2,000mm	Perennial bushes, less than 4m high
6)Cp	Puna grass	Approx 3,800 m.a.s.l	No description	Gramineae
7)Pj	Scrubland	3,200~3,300 m.a.s.l Center-South up to 3,800 m.a.s.l	South zone with low rainfall: less than 125mm East springs: higher than 4,000mm	Gramineae
8)N	Ice-capped mountains		—	—

Source: Prepared by the JICA Team based on the Forest Map. 1995

#### (2) Area and distribution of vegetation

The present study was determined by the surface percentage that each vegetation formation occupies on the total watershed's surface, overcoming the INRENA study results of 1995 to the GIS (see Tables 3.1.7-2 and Figures 3.7.2-1). Then, the addition of each ecologic life zone's surface, outstanding the coastal desert (Cu, Pj), dry grass (Ms), bushes (Msh, Mh) and puna grass (Cp, Pj). Table 3.1.7-3 shows the percentage of each ecologic area. It is observed that the desert occupies 20% of the total area, 10% of dried grass and puna grass 50%. Bushes occupy between 10 to 20%. They are distributed on areas with unfavorable conditions for the development of dense forests, due to which the surface of these bushes is not wide. So, natural conditions of the four watersheds, Cañete, Chinchá, Pisco and Yauca are set. In particular, the low precipitations, the almost non-fertile soil and accentuated slopes are the limiting factors for the vegetation growth, especially on high size species.

**Table 3.1.7-2 Vegetation formation surface of the watershed's surface  
(Yauca River)**

Watershed	Vegetation Cover								Total
	Cu	Dc	Ms	Msh	Mh	Cp	Pj	N	
(Surface: hectares)									
Yauca River	69,48	1.433,26	990,99	730,67	234,49	428,64	435,04	0,00	4,322,57
(Percentage: %)									
Yauca River	1,6	33,2	22,9	16,9	5,4	9,9	10,1	0,0	100,0

Source: Prepared by the JICA Team based on the INRENA 1995 Forest Map



**Table 3.1.7-3 Ecologic Life Areas Percentage (Yauca River)**

Watershed	Ecologic life areas					
	Desert, etc. (Cu, Dc)	Dry grass (Ms)	Grass (Msh, Mh)	Bushes (Cp, Pj)	Snowy (N)	Total
(Percentage: %)						
Yauca	34.8	22.9	22.3	20.0	0.0	100.0

Source: Prepared by the JICA Team based on the INRENA1995 Forest Map

### (3) Forest area variation

Although a detailed study on the variation of the forest area in Peru has not been performed yet, the National Reforestation Plan Peru 2005-2024, Annex 2 of INRENA shows the areas deforested per department until 2005. These areas subject matter of this study are included in the regions of Arequipa, Ayacucho, Huancavelica, Ica, Lima and Piura, but they only belong to these regions partially. Table 3.1.7-4 shows the Figures accumulated areas deforested in these regions. However, in relation to the Arequipa Region, data is not available.

**Table 3.1.7-4 Area Deforested Until 2005**

Department	Area (ha)	Area deforested accumulated (ha) and the percentage of such area in the department area (%)	Post-Felling Situation	
			Non used Area (ha)	Used area(ha)
Arequipa	6.286.456	-	-	-

Source: National Reforestation Plan, INRENA, 2005

The variation of the distribution of vegetation was analyzed per watershed, comparing data from the FAO study performed in 2005 (prepared based on satellite figures from 2000) and the results of the 1995 INRENA study (prepared base on satellite figures from 1995). (See Table 3.1.7-5).

Analyzing the variation of the surface of each vegetation formation, it is observed that the vegetation has reduced in the arid zones (desert and cactus: Cu, DC and Ms) and bushes (Cp, Pj) but have increased in the arid area (desert DC) and scrub area (Msh, Mh).

**Table 3.1.7-5 Changes in the areas of distribution of vegetation from 1995 to 2000**

Watershed	Vegetation Formation								
	Cu		Cu		Cu		Cu		Cu
(Surface of the vegetation cover: hectare)									
Yauca (a)	-20,22	33,63	-10,87	34,13	21,15	-42,62	-15,20	—	4.322,57
Current Surface (b)	69,48	1,433,26	990,99	730,67	234,49	428,64	435,04	0,00	4.322,57
Percentage of current surface (a/b) %	-29,1	+2,3	-1,1	+4,7	+9,0	-9,9	-3,5	-	

Source: Prepared by the JICA Study Team based on the studies performed by the INRENA 1995 and FAO 2005

### (4) Current situation of forestation

As indicated before, the climate conditions of Yauca River watershed do not improve high trees species development, so natural vegetation is not distributed; this only happens in the banks were the freatic water table is near the surface.

So, due to the difficult situation of finding a good spot to grow trees is why reforestation great

projects have not happened in this area. There is no reforest project known with commercial aims.

In the lower and medium watersheds, trees are planted mainly for three objectives: i) reforest along the river to prevent disasters; ii) for agricultural lands protection from wind and sand; and iii) as perimeter for housings. In any case, the surface is much reduced. The most planted specie is Eucalyptus and is followed by *Casuarinaceae*. The use of native species is not very common. On the other hand, in the Mountain region, reforestation is done for logging, crops protection (against cold and livestock entrance) and to protect the recharge water areas. There are mostly eucalyptus and pines. Many reforest projects in the Mountain region have been executed following PRONAMACHS (currently, AGRORURAL). Such program gives throughout AGRORURAL seedlings to the community, which are planted and monitored by producers. There is also a reforest program implemented by the regional government, but in a much reduced way. In this case, the program establishes the needs to achieve consensus from the community to choose the areas to be reforested. However, in general, mostly all farmers want to have greater crop lands and achieving consensus always takes more time. Another limiting factor is the cold weather on altitudes greater than 3.800m.a.s.l. In general, no information has been able to be collected on reforestation projects to date, because these files were not available.

The National Reforestation Plan (INRENA, 2005) registers forestation per department from 1994 to 2003, from which the history data corresponding to the environment of this study was searched (See Table 3.1.7-6). It is observed that the reforested area increased in 1994, drastically decreasing later. Arequipa, Ica and Lima are departments located in the coast zone with scarce rainfall, thus the forestation possibility is limited, besides the scarce forest demand.

**Table 3.1.7-6 History registry of forestation 1994-2003**

Department	1994	1995	1996	1997	1998	1999	2000	2001	2002	2003	Total
Arequipa	3.758	435	528	1.018	560	632	nr	37	282	158	7.408

Source: National Reforestation Plan, INRENA, 2005

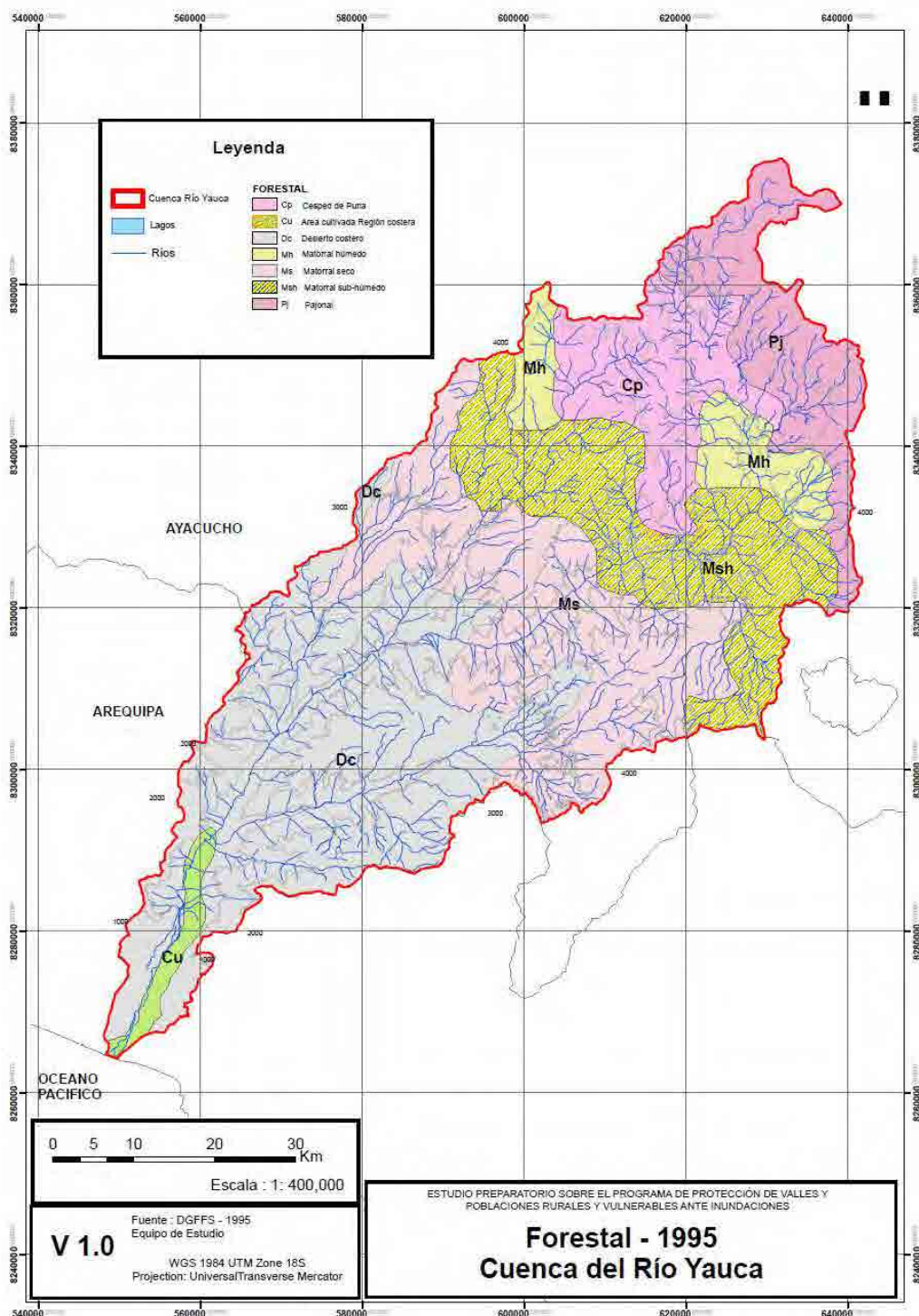

**Figure 3.1.7-1 Forestry map of Yauca River Watershed**

### 3.1.8 Current situation of the soil erosion

#### (1) Information gathering and basic data preparation

##### 1) Information Gathering

During this study the data and information indicated in Table 3.1.8-1 was collected in order to know the current situation of the sediment production behind the Study Area.

**Table 3.1.8-1 List of collected information**

	Forms	Prepared by:
Topographic map (Scale 1/50.000)	Shp	INSTITUTO GEOGRAFICO NACIONAL
Topographic map (Scale 1/100.000)	Shp,dxf	INSTITUTO GEOGRAFICO NACIONAL
Topographic map (Scale 1/250.000)	SHP	Geologic data systems
Topographic map (Scale 1/100.000)	Shock Wave	INGEMMET
30 m grid data	Text	NASA
River data	SHP	ANA
Watershed data	SHP	ANA
Erosion potential risk map	SHP	ANA
Soils map	SHP	INRENA
Vegetal coverage map	SHP2000 PDF1995	DGFFS
Rainfall data	Text	Senami

## 2) Preparation of basic data

The following data was prepared using the collected material. Details appear in Annex 6.

- Hydrographic watershed map (zoning by third order valleys)
- Slope map
- Geological Map
- Erosion and slope map
- Erosion and valley order map
- Soil map
- Isohyets map

## (2) Analysis of the causes of soil erosion

### 1) Topographic characteristics

- i) Surface pursuant to altitudes

Table 3.1.8-2 and Figure 3.1.8-1 show the percentage of surface according to altitudes

**Table 3.1.8-2 Surface according to altitude**

Altitude (m.a.s.l)	Area (k m <sup>2</sup> )
	Yauca
0 – 1000	332,79
1000 – 2000	575,82
2000 – 3000	1302,58
3000 – 4000	1504,8
4000 – 5000	602
5000 – More	0,55
TOTAL	4318,54
Maximum Altitude	5060,00

Source: Prepared by the JICA Study Team based on the 30 m grid data

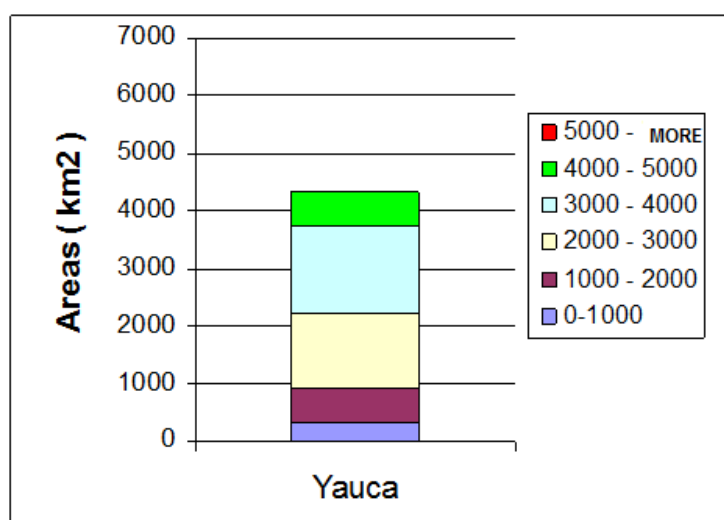

**Figure 3.1.8-1 Surface according to altitude**

ii) Zoning according to slopes

Table 3.1.8-3 and Figure 3.1.8-2 show the slopes in each watershed.

**Table 3.1.8-3 Slopes and surface**

Watershed slope ( % )	Yauca	
	Área (km <sup>2</sup> )	Percentage
0 - 2	79,01	2%
2 - 15	1190,19	28%
15 - 35	1591,21	37%
More than 35	1458,13	34%
TOTAL	4318,54	100%

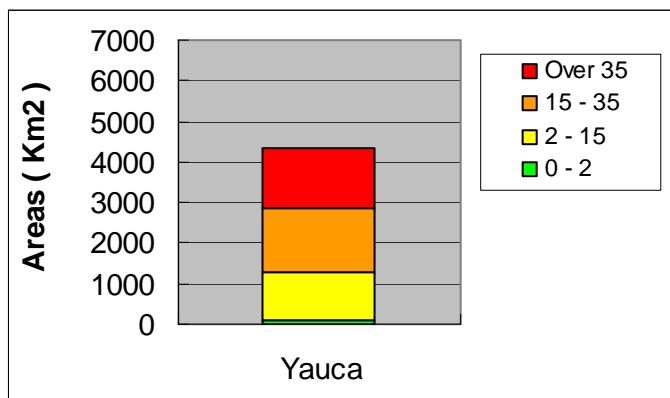

**Figure 3.1.8-2 Slopes and surface**

iii) River-bed slope

Table 3.1.8-4 and Figure 3.1.8-3 show the slope in every river and the length of streams including tributaries. Figure 3.1.8-4 shows the general relation of the movement of sediments and the river-bed slope. Supposedly, sections with more than 33,3 % of slope tend to produce higher amount of sediments, and hillsides with slopes between 3,33 % and 16,7 %, accumulate sediments easier.

**Table 3.1.8-4 River-bed Slope and total length of stream**

River-bed slope (%)	Yauca
0,00 - 1,00	39,13
1,00 - 3,33	312,82
3,33 - 16,67	1687,19
16,67 - 25,00	352,42
25,00 - 33,33	185,78
33,33 – More	226,92
<b>TOTAL</b>	<b>2804,26</b>

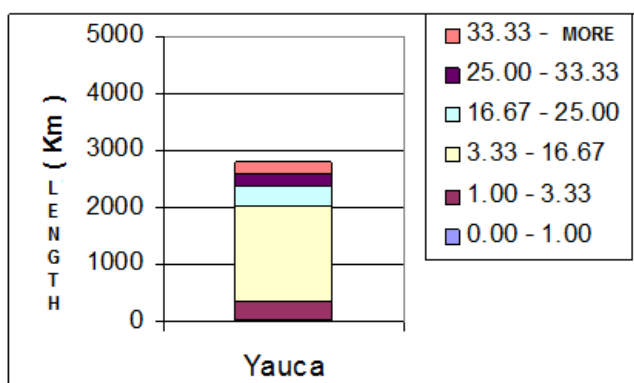

**Figure 3.1.8-3 River-bed Slope and total length of streams**

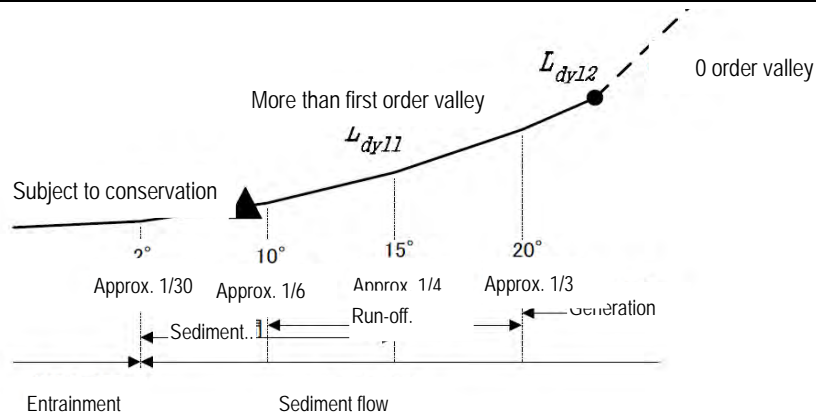

**Figure 3.1.8-4 River-bed slope and sediment movement pattern**

### 3) Rainfall

On the Pacific coast there is an arid area of 30 to 50km width and approx 3.000km long. This region belongs to a climate zone called Chala, where the middle annual temperature is about 20 °C and almost it does not rain along the year.

Altitudes between 2500 and 3000 m.a.s.l. belong to the Quechua zone, where annual precipitation exist between 200 and 300mm. On altitudes from 3500 and 4500m.a.s.l there is another region, called Suni, characterized by its sterility. Precipitations in this region occur annually with 700mm of rain.

Figure 3.1.8-5 shows the isohyets map (annual rainfall) of the watershed.

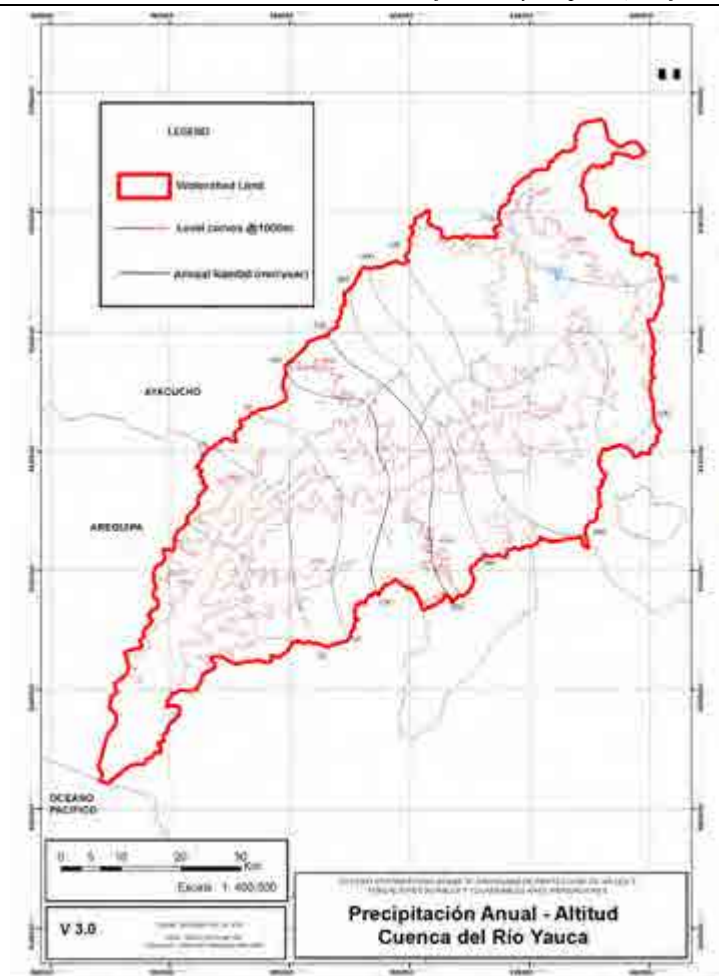

Source: Prepared by the JICA Study Team based on the SENAMHI data

**Figure 3.1.8-5 Isohyet Map of the Yauca river watershed**

Annual precipitations in the flood analysis area fluctuate between 0 and 25mm. The average annual precipitation in the northern area of 4000 m.a.s.l is between 500 and 750 m.a.s.l.

#### 4) Erosion

The characteristics of erosion of the watershed in general are presented below. This is divided in three large natural regions: Coast, Mountain/Suni and Puna. Figure 3.1.8-6 shows the corresponding weather and the rainfalls. It is observed that the area most sensitive to erosion is Mountain/Suni where the pronounced topography without vegetal coverage predominates.



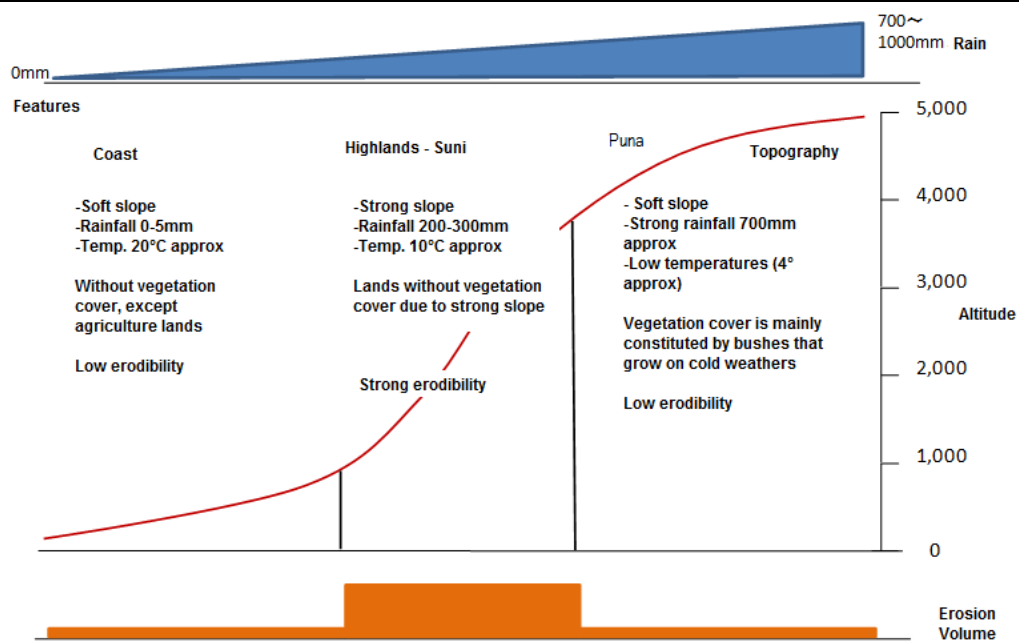

**Figure 3.1.8-6 Relation between the erosion volume and the different causes**

### (3) Identification of the zones more vulnerable to erosion

The erosion map prepared by ANA considers the geology, hill sloping and rainfalls. Supposedly, the erosion depth depends on the hillside slope, and in such sense the erosion map and the slope map are consistent. Thus, it is deduced that the zones more vulnerable to erosion according to the erosion map are those where most frequently erosion happens within the corresponding watershed. Next, the tendencies regarding the watershed are described.

Between 1000 and 3000 m.a.s.l are located on slopes with more than 35 degrees. It is observed that this watershed's topography is less accentuated than the Cañete, Chinchá and Pisco watersheds. In particular, between 1000 and 2000m.a.s.l, 76% of slopes are more than 35° and are deduced to be more susceptible to erosion.

**Table 3.1.8-5 Slopes according to altitudes of the Yauca river watershed**

Altitude	SLOPES				Total
	0-2	2 - 15	15 - 35	More than 35	
0 - 1000	21.13	106.81	86.07	118.78	332.79
Ratio	6%	32%	26%	36%	100%
1000 - 2000	1.48	40.14	94.66	439.54	575.82
Ratio	0%	7%	16%	76%	100%
2000 - 3000	14.72	350.89	399.92	538.08	1303.61
Ratio	1%	27%	31%	41%	100%
3000 - 4000	25.07	498.75	686.54	295.34	1505.7
Ratio	2%	33%	46%	20%	100%
4000 - 5000	17.56	194.38	324.82	67.24	604
Ratio	3%	32%	54%	11%	100%
5000 - More	0.15	0.22	0.1	0.18	0.65
Ratio	23%	34%	15%	28%	100%
<b>Total</b>	<b>80.11</b>	<b>1191.19</b>	<b>1592.11</b>	<b>1459.16</b>	<b>4322.57</b>
<b>Ratio</b>	<b>2%</b>	<b>28%</b>	<b>37%</b>	<b>34%</b>	<b>100%</b>

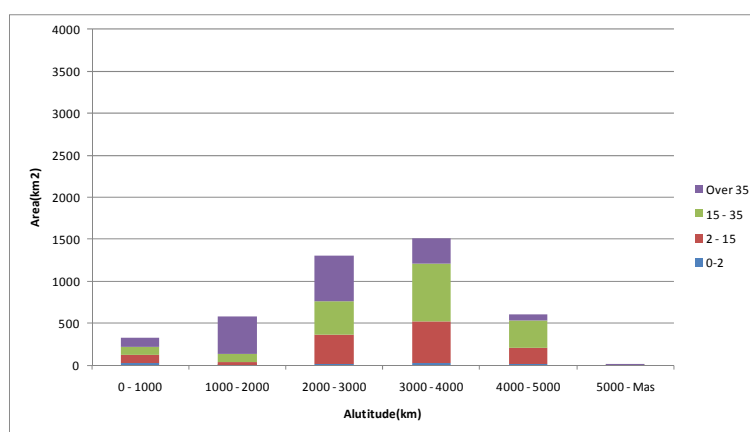

**Figure 3.1.8-7 Slopes according to altitudes of Yauca River**

#### (4) Production of sediments

##### 1) Results of the geological study

The study was performed on the upper watersheds of Pisco and Cañete Rivers. It is considered that the conditions for Yauca River are similar. The results are described below.

- On mountain slopes there are formations of clastic deposits leaved by collapses or wind erosion
- Production patterns are differentiated according to the foundation rock geology. If this foundation is andesitic or basaltic, the mechanisms consists mainly in great gravel falling (see Figure 3.1.8-8 and 3.1.8-9)
- There is no rooted vegetation (Figure 3.1.8-10) due to the sediment in ordinary time. On the joints of the andesitic rock layer where few sediment movements occur, algae and cactus have developed
- In almost every stream lower terrace formation was observed. In these places, sediments

dragged from slopes do not enter directly to the stream, but they stay as deposits on the terraces. Due to this, most of the sediments that enter the river probably are part of the deposits of the erosion terraces or accumulated sediments due to the bed's alteration (see Figure 3.1.8-11)

- On the upper watershed there are less terraces and the dragged sediments of slopes enter directly to the river, even though its amount is very little



**Figure 3.1.8-8 Andesitic and Basaltic lands collapse**



**Figure 3.1.8-9 Sediment production of the sedimentary rocks**



**Figure 3.1.8-10 Cactus Invasion**

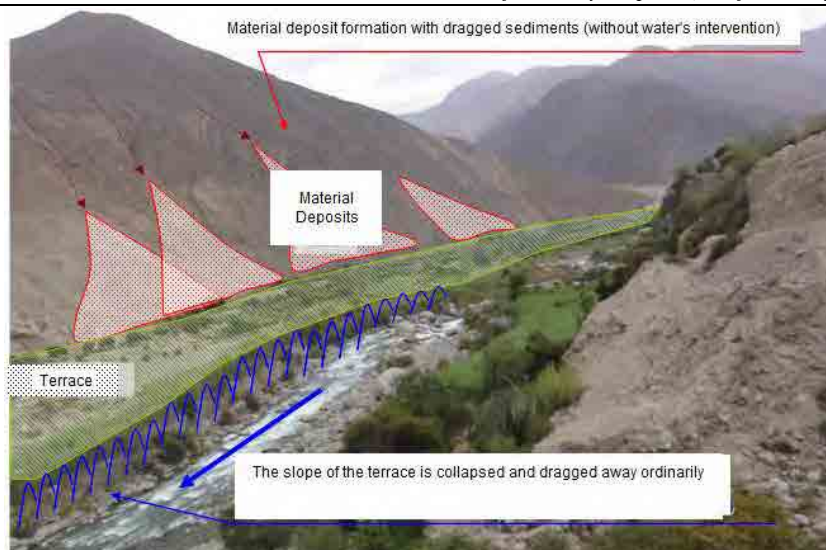

**Figure 3.1.8-11 Movement of the sediment in the stream**

## 2) Sediments movement (in the stream)

In ravines terraces are developed. The base of these terraces is directly contacted with channels and from these places the sediments will be dragged and transported with an ordinary stream (including small and medium overflows in rainy season).

## 3) Production forecast and sediments entrainment

It is expected that the amount of sediment production and entrainment will vary depending of the dimension of factors such as rainfall, volume of flow, etc.

Since a quantitative sequential survey has not been performed, nor a comparative study, here we show some qualitative observations for an ordinary year, a year with a rainfall similar to that of El Niño and one year with extraordinary overflow. The scope of this Study is focused on a rainfall with 50 year return period, as indicated in the Figure below, which is equivalent to the rainfall producing the sediment flow from the tributaries.

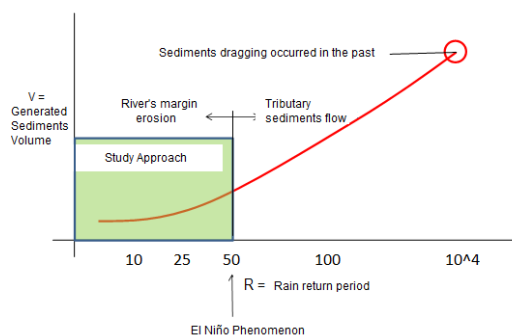

### (i) An ordinary year

- Almost no sediments are produced from the hillsides
- Sediments are produced by the encounter of water current with the sediment deposit

detached from the hillsides and deposited at the bottom of terraces

- It is considered that the entrainment is produced by this mechanism: the sediments accumulated in the sand banks within the bed are pushed and transported downstream by the bed change during low overflows (see Figure 3.1.8-12)

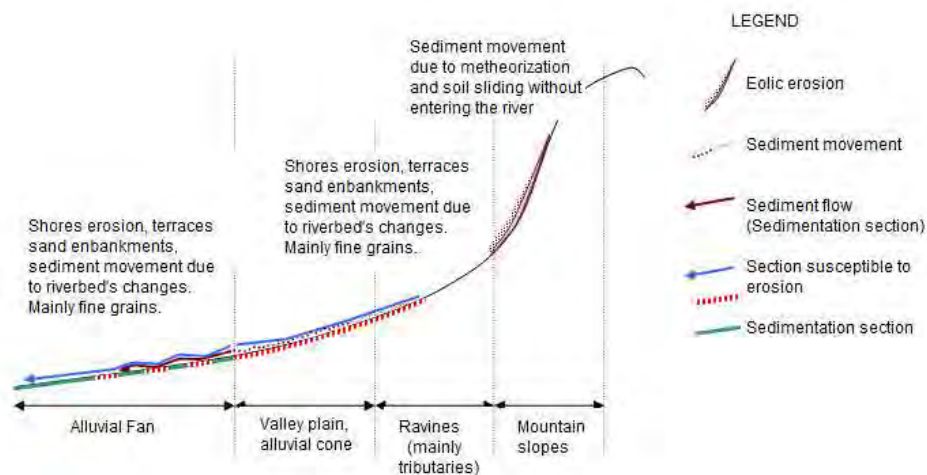
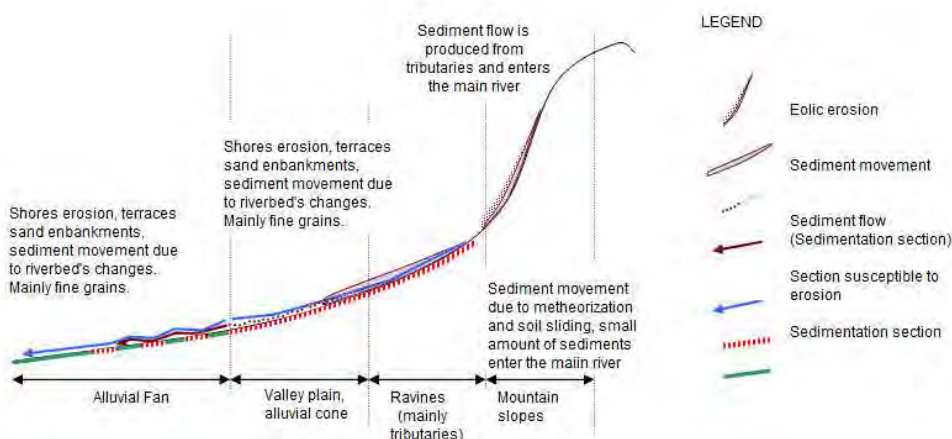

**Figure 3.1.8-12 Production and entrainment of sediments in an ordinary year**

- (ii) When torrential rains with magnitude similar to that of the El Niño happen (50 years return period)

Pursuant to the interviews performed in the locality, every time El Niño phenomenon occurs the tributary sediment flow occurs. However, since the bed has enough capacity to regulate sediments, the influence on the lower watershed is reduced.

- The amount of sediments entrained varies depending on the amount of water running by the hillsides
- The sediment flow from the tributaries reaches to enter to the main river
- Since the bed has enough capacity to regulate the sediments, the influence in the watershed is reduced



**Figure 3.1.8-13 Production and entrainment of sediments during the torrential rainfall of magnitude similar to that of El Niño (1:50 year return period)**

(iii) Large magnitude overflows (which may cause the formation of terraces similar to those existing now), with a 1:10.000 year return period

In the coast, daily rainfall with 100 years of probability are approximately 50 mm, so land slides entrained by water scarcely occur currently. However, precisely since there are few rains, when torrential rainfall occurs, there is a high potential of water sediment entrainment.

If we suppose that rainfall occurs with extremely low possibilities, for example, 1:10.000 years, we estimate that the following situation would happen (see Figure 3.1.8-14).

- Sediment entrainment from hillsides, by the amount congruent with water amount
- Exceeding sediment entrainment from the bank and bottom of hillsides by the amount congruent with the water amount, provoking landslides which may close streams or beds
- Destruction of the natural embankments of beds closed by the sediments, sediment flow by the destruction of sand banks
- Formation of terraces and increase of sediments in the beds of lower watershed due to the large amount of sediments
- Overflowing in section between alluvial cone and critical sections, which may change the bed.

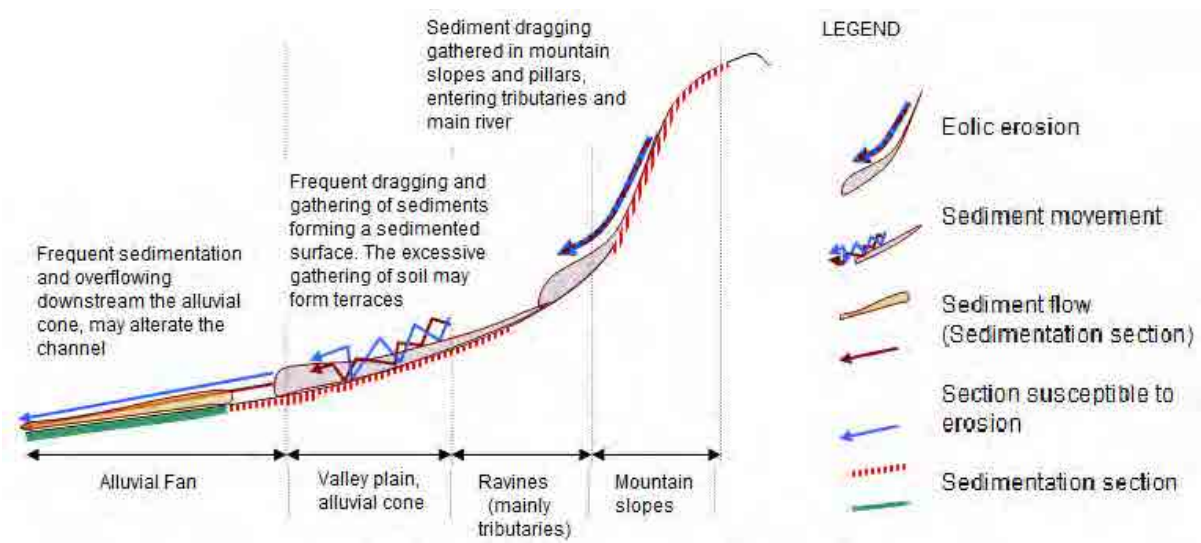

**Figure 3.1.8-21 Production of sediments in large overflowing (geologic scale)**

### 3.1.2 Run off analysis

#### (1) Rainfall data

##### 1) Current rainfall monitoring system

The current rainfall data collection system used for the discharge analysis was reviewed; besides, the necessary rainfall data was collected and processed for such analysis. Rainfall data was obtained from SENAMHI and ELECT.PERU.



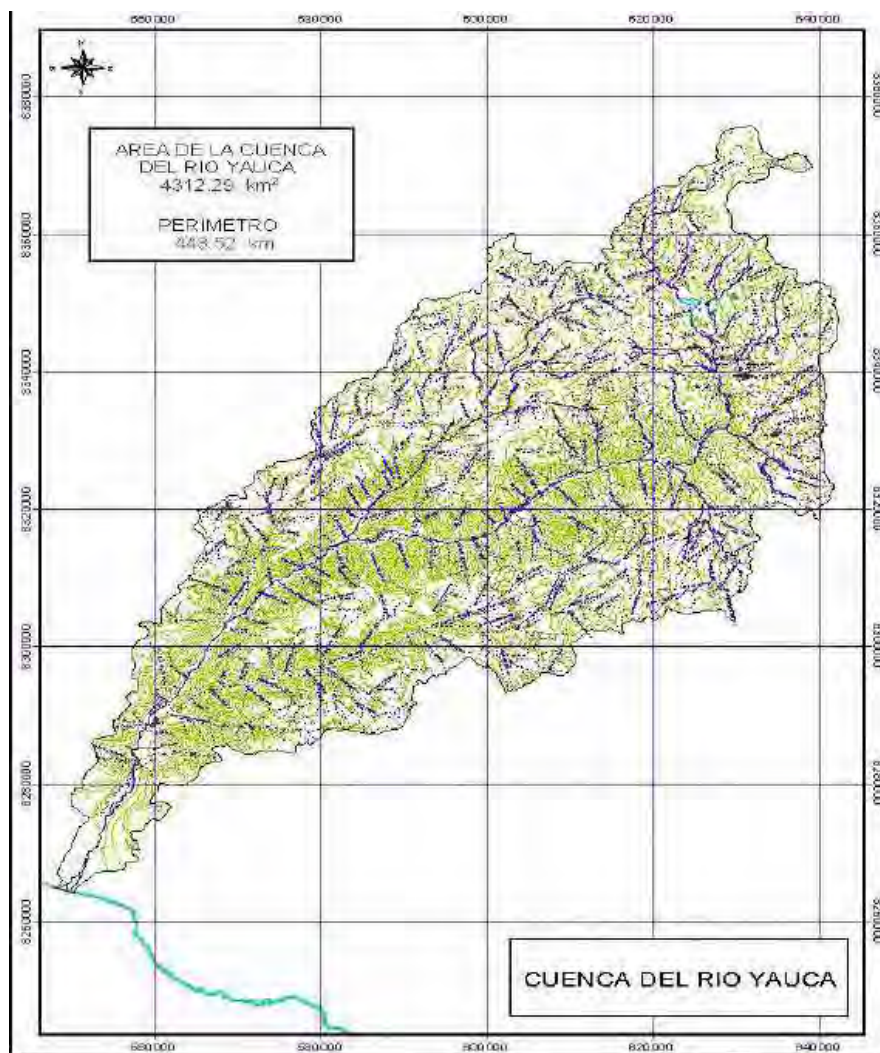

**Figure 3.1.9-1 Monitoring stations location map  
(Yauca River watershed)**

## 2) Isohyet map

Annual rain isohyets maps are described next (average of 10 years) elaborated by SENAMHI using data recovered in the period 1965-1974.

Figure 3.1.9-2 shows a map of the isohyet of Yauca River watershed.

In the Yauca River Watershed is observed that the considerable variation of the annual rainfall depending on the zones, with a minimum of 25mm and a maximum of 750 mm approximately. The rainfall is lower on the lower watershed and it increases as the altitudes gets near the upper watershed, increasing the altitudes.

The annual rainfall in the low watershed, subject to the control of floods, is reduced ranging from 25 to 50 mm.



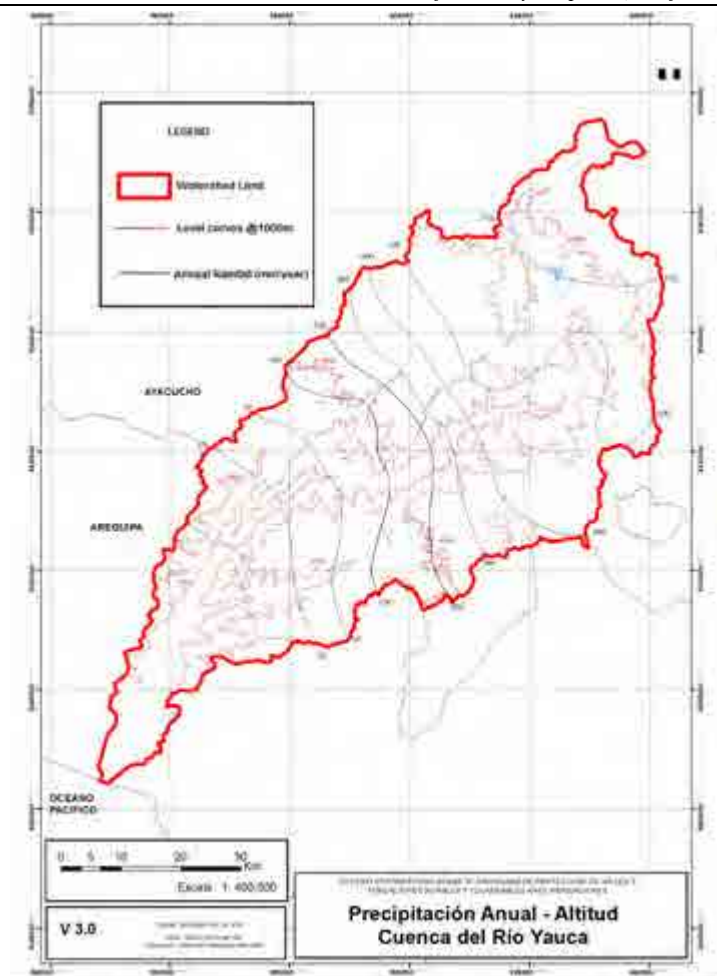

**Figure 3.1.9-2 Isohyet Map (Yauca River watershed)**

## (2) Rainfall analysis

### 1) Methodology

The statistic hydrologic calculation was made using the rainfall data collected from several stations, to determine the rainfall with 24 hour return period in every station.

Several models of distribution of return periods were tested and the most adequate one was adopted. Thus, the precipitation with 24 hours return period was determined with this model.

The statistic hydrologic models were:

- Normal o Gaussian distribution
- Log-Normal of 3 parameters distribution
- Log-Normal of 2-parameters distribution
- Gamma distribution of 2 or 3 parameters
- Log Pearson Type III distribution
- Gumbel distribution
- General distribution of extreme value

## 2) Results of the rainfall analysis of return period– t

The rainfall of several stations are shown below and the reference point of each watershed, according to return periods.

Rain observed in Yauca River stations has been greater than 40mm with a maximum of 84mm.

Table 3.1.9-3 shows the monitoring points and the rainfall with 24 hour return period in each station. Figure 3.1.9-3 shows the map of isohyets of rainfall with 50 year return period.

**Table 3.1.9-3 Rainfall with 24 hour return period  
(Yauca river watershed)**

Station Name	Return Period T [YEARS]						
	PT_2	PT_5	PT_10	PT_25	PT_50	PT_100	PT_200
CARHUANILLAS	26.0	42.0	54.0	70.0	84.0	98.0	114.0
CHAVIÑA	32.0	42.0	48.0	54.0	59.0	62.0	66.0
CORA CORA	28.0	36.0	41.0	46.0	49.0	52.0	54.0
SANCOS	34.0	48.0	57.0	67.0	74.0	80.0	86.0
TARCO	20.0	32.0	41.0	54.0	65.0	77.0	91.0

**Table 3.1.9-4 Rain of 24 hours for the different return periods  
(Reference Point: San Francisco Alto Station)**

Return Period (years)	Maximum Precipitation in 24 hours (mm)
5	28
10	33
25	39
50	45
100	50

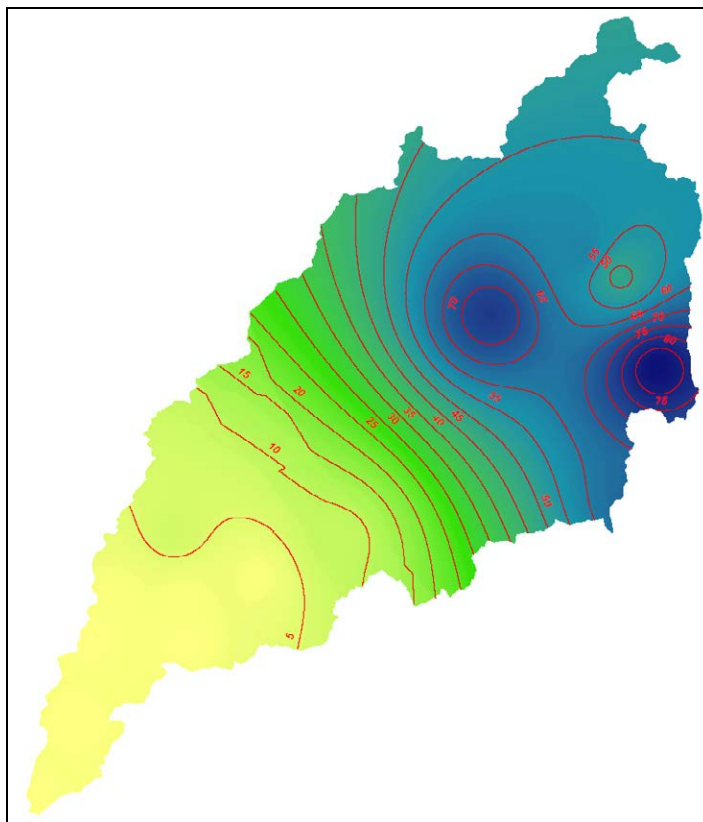

**Figure 3.1.9-3 Map of isohyets of a 50 years period rainfall (Yauca river watershed)**

**Table 3.1.9-5 Pluviograph of the different return periods**

Years	Hours										Total Precipitation (mm)
	1	2	3	4	5	6	7	8	9	10	
5	1	2	3	4	3	3	2	2	1	1	22
10	1	2	3	5	4	3	3	2	2	1	26.5
25	2	3	4	6	4	4	3	3	2	1	31.3
50	2	3	5	7	5	4	4	3	2	1	36.2
100	2	4	5	8	6	5	4	3	2	2	40.2

**(3) Run off analysis**

**1) Flow monitoring**

The current flow data collection system used in the discharge analysis was reviewed, and the necessary flow monitoring data were collected and processed for such analysis. The flow data have been obtained mainly from the DGIH, irrigation commissions, Water National Authority (ANA) and the Chira-Piura Special Project.

**2) Run off analysis**

The statistic hydrological calculation was made using the data of the maximum annual discharge

collected and processed in the reference points, to determine the flow with different probabilities.

Table 3.1.9-6 shows the probable flow with return periods between 2 and 100 years.

**Table 3.1.9-4 Probable flow in control points**

Rivers	Return periods					
	2 years	5 years	10 years	25 years	60 years	100 years
Yauca River San Francisco Alto	41	81	116	171	219	273

(m<sup>3</sup>/s)

### 3) Analysis of flooding flow with t-years return periods

#### (a) Methodology

The probable flooding flow was analysed using the HEC-HMS model, with which the hyetograph or return periods was prepared, and the peak flow was calculated.

For the rainfall used in the analysis, the hyetograph of several periods prepared in the rainfall analysis was used.

#### (b) Analysis results

Table 3.1.9-7 shows the flow of floodings with return periods between 2 and 100 years of the Yauca river watershed.

Likewise, Figure 3.1.9-4 shows the hydrographical map of probable flood in the Yauca river watershed. It can be noticed that the numbers in Tables 3.1.9-6 and 3.1.9-7 are similar. So, for the following flood analysis the figures of Table 3.1.9-7 were decided to be used because they match the hydrograph.

**Table 3.1.9-6 Flood flow according to the return periods  
(Peak flow: Reference point)**

Rivers	Return period					
	2 years	5 years	10 years	25 years	50 years	100 years
Yauca River San Francisco Alto	24	37	90	167	263	400

(m<sup>3</sup>/s)

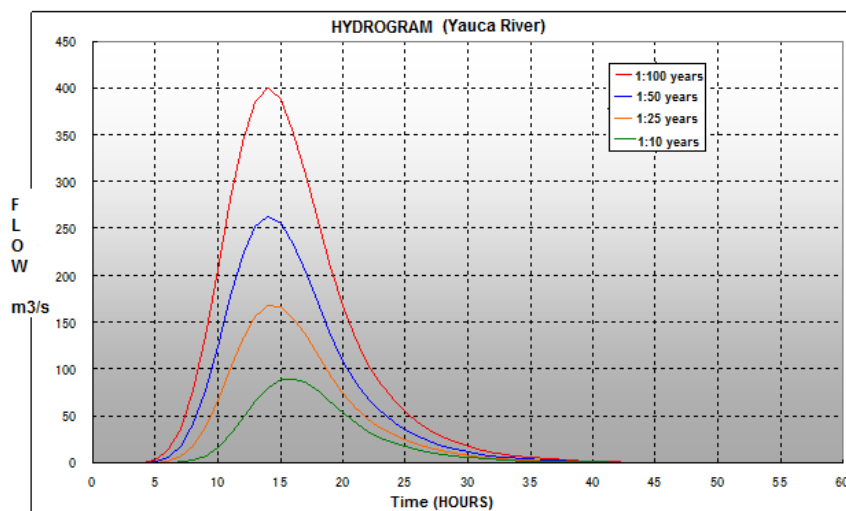

**Figure 3.1.9-4 Hydrogram of Yauca river**

### 3.1.10 Analysis of inundation

#### (1) River surveys

Prior to the flood analysis, the transversal survey of Yauca river was performed as well as the longitudinal survey of dikes. Table 3.1.10-1 shows the results of the surveys in the five rivers subject of this Study.

In order to obtain the topographic data for the analysis of the flooding zones, the results of the true measurement results indicated in Table 3.1.10-1 were used as a complement, using the satellite figures data.

**Table 3.1.10-1 Basic data of the river surveys**

Survey	Unit	Quantity	Notes
1. Control points survey			
Yauca river	No.	5	
2. Dikes transversal survey			250m Interval, only one bank
Yauca river	km	45	
3. River transversal survey			500m Interval
Yauca river	km	31.9	91 lines x 0.35km
4. Benchmarks			
Type A	No.	5	Every control point
Type B	No.	25	25km x one point/km

## (2) Inundation analysis methods

Since the DGIH carried out the flood analysis of the profile study at a program level using the HEC-RAS model, for this Study, we decided to use this method, and review and modify it, if necessary.

### 1) Analysis basis

Normally, for the flooding analysis the following three methods are used.

- ① Varied flow unidimensional model
- ② Tank model
- ③ Varied flow horizontal bidimensional model

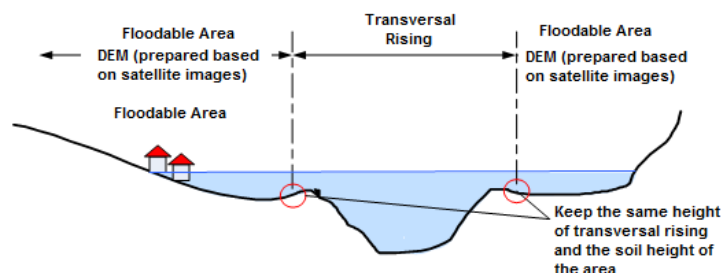
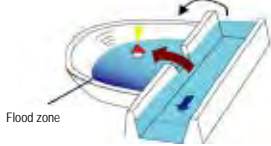
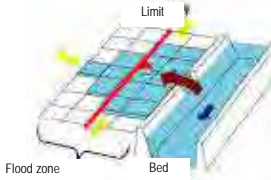

**Figure 3.1.10-1 Idea of unidimensional model**

The time and cost required by each method vary considerably, so only the most efficient method will be chosen, which guarantees the necessary accurateness degree for the preparation of the floodable zone maps.

Table 3.1.10-2 shows the characteristics of each analysis method. From the results of the simulation performed by DGIH, it is known that the rivers have a slope between 1/100 and 1/300, so initially the varied flow one-dimensional model was chosen assuming that the floods were serious. However, we considered the possibility that the overflowed water extends within the watershed in the lower watershed, so for this study the variable regimen horizontal bi-dimensional model was used to obtain more accurate results

**Table 3.1.10-2 Methodology of flooding analysis**

Analysis methods	Vary flow unidimensional model	Tank model	Varied flow bi-dimensional horizontal model
Basic concept of the flood zone definition	In this method, the flood zone is considered to be included in the river bed, and the flood zone is determined by calculating the water level of the bed in relation to the maximum flooding flow	This method manages the flood zone and bed separately, and considers the flooding zone as a closed body. This closed water body is called <i>pond</i> where the water level is uniform. The flood zone is determined in relation to the relationship between the overflowed water from the river and entered to the flood zone, and the topographic characteristics of such zone (water level– capacity– surface).	This method manages the flood zones and the bed separately, and the flood zone is determined by analyzing the bidimensional flow of the behaviour of water entered to the flood zone.
Approach			
Characteristics	It is applicable to the floods where the overflowed water runs by the flood zone by gravity; that means, current type floods. This method must manage the analysis area as a protected area (without dikes).	Applicable to blocked type floods where the overflowed water does not extend due to the presence of mountains, hills, embankments, etc. The water level within this closed body is uniform, without flow slope or speed. In case there are several embankments within the same flood zone, it may be necessary to apply the pond model in series distinguishing the internal region.	Basically, it is applicable to any kind of flood. Beside the flood maximum area and the water level, this method allows reproducing the flow speed and its temporary variation. It is considered as an accurate method compared with other methods, and as such, it is frequently applied in the preparation of flood irrigation maps. However, due to its nature, the analysis precision is subject to the size of the analysis model grids.

## 2) Overflow analysis method

Figure 3.1.10-2 shows the conceptual scheme of the variable regimen horizontal bi-dimensional model.

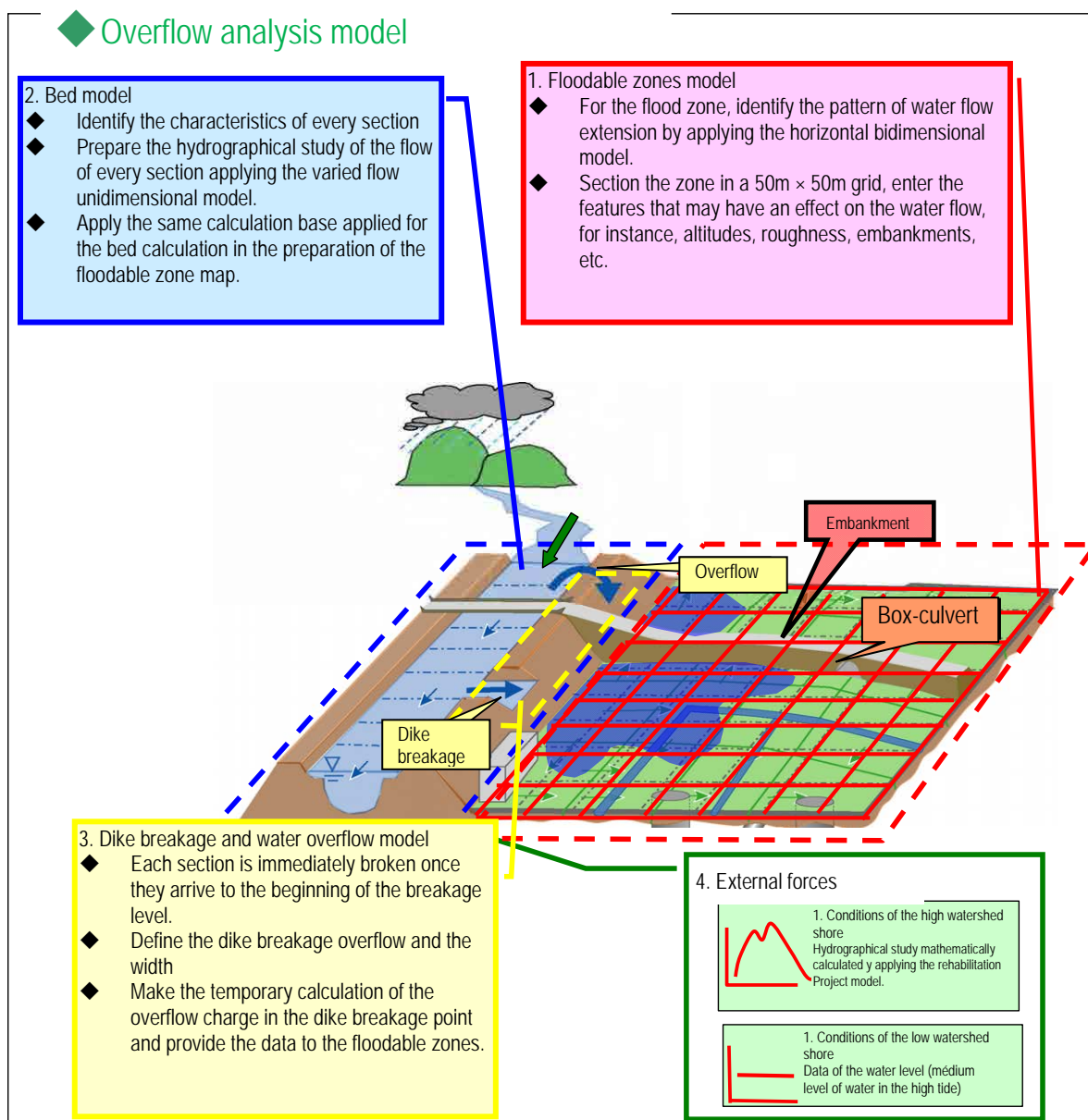
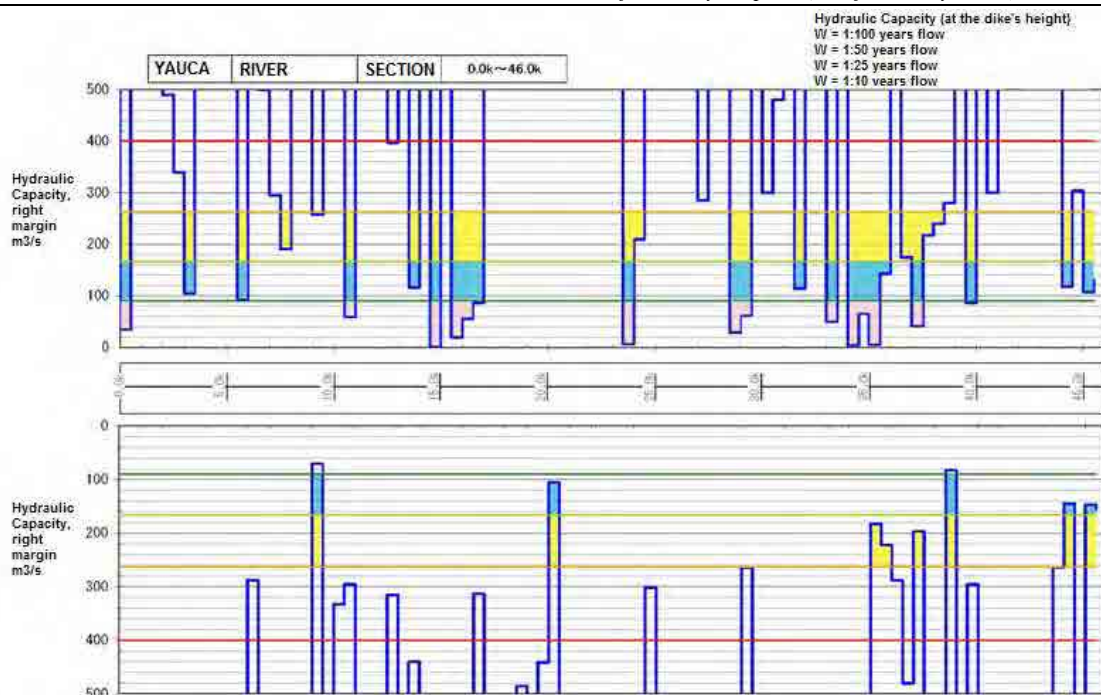

**Figure 3.1.10-2 Conceptual scheme of the overflow analysis model**

**(3) Discharge capacity analysis**

The current discharge capacity of the beds was estimated based on the results of the river survey and applying the HEC-RAS method, which results appear in Figure 3.1.10-3. This Figure also shows the flooding flows of different return periods, which allow evaluating in what points of the Yauca river watershed flood may happen and what magnitude of flood flow may they have.

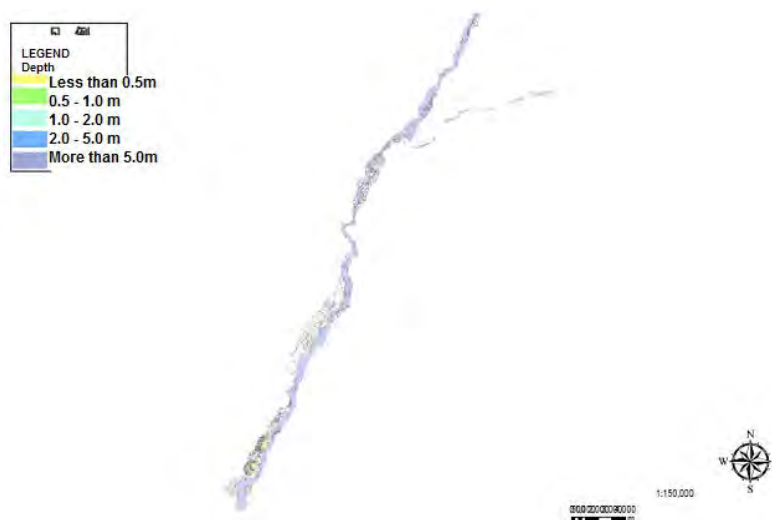



**Figure 3.1.10-3(1) Current discharge capacity of Yauca River**

**(4) Inundation area**

As a reference, Figures 3.1.10-4 show the results of the inundation area calculation in the Yauca river watershed compared to the flooding flow with a 50 year return period.



**Figure 3.1.10-4 Inundation area of Yauca river (50 year period floods)**

### 3.2 Definition of Problem and Causes

#### 3.2.1 Problems of flood control measures in the Study Area

Based on the results of the Yauca River, the main problem on flood control was identified, as well as the structures to be protected, which results are summarized in Table 3.2.1-1.

**Table 3.2.1-1 Problems and conservation measures of flood control works**

Problems		Overflowing			Dike erosion	Banks erosion	Non-working intake	Non-working derivation works
		Without dikes	Sediment in bed	Lack of width				
Structures to be protected	Agricultural lands	○	○	○	○	○	○	○
	Irrigation channels					○	○	
	Urban area	○		○				○
	Roads					○		
	Bridges		○					

#### 3.2.2 Problem causes

Next, the main problem and its direct and indirect causes for flood control in the Study Area are described:

##### (1) Main Problem

Valleys and local communities highly vulnerable to floods

##### (2) Direct and indirect causes

Table 3.2.2-2 shows the direct and indirect causes of the main problem

**Table 3.2.2-2 Direct and indirect causes of the main problem**

Direct cause	1. Excessive flood flow	2. Overflowing	3. Insufficient maintenance of control works	4. Insufficient communitarian activities for flood control
Indirect causes	1.1 Frequent occurrence of extraordinary weather (El Niño, etc..)	2. Lack of flood control works	3.1 Lack of maintenance knowledge and skills	4.1 Lack of knowledge and flood prevention techniques
	1.2 Extraordinary rains in the middle and upper basins	2.2 Lack of resources for the construction of works	3.2 Lack of training in maintenance	4.2 Lack of training in flood prevention
	1.3 Vegetation cover almost zero in the middle and upper basins	2.3 Lack of plans for flood control in basins	3.3 Lack of dikes and banks repair	4.3 Lack of early warning system
	1.4 Excessive sediment dragging from the upper and middle river levee	2.4 Lack of dikes	3.4 Lack of repair works and referral making	4.4 Lack of monitoring and collection of hydrological data
	1.5 Reduction of discharge capacity of rivers by altering slopes, etc.	2.5 Lack of bed channel width	3.5 Use of illegal bed for agricultural purposes	
		2.6 Accumulation of sediments in beds	3.6 Lack of maintenance budget	
		2.7 Lack of width at the point of the bridge construction		
		2.8 Elevation of the bed at the point of the bridge construction		
		2.9 Erosion of dikes and banks		
		2.10 Lack of capacity for the design of the works		

### 3.2.3 Problem Effects

#### (1) Main Problem

Valleys and local communities highly vulnerable to floods

#### (2) Direct and indirect effects

Table 3.2.3-1 shows the direct and indirect effects of the main problem

**Table 3.2.3-1 Direct and indirect effects of the main problem**

Direct Effects	1. Agriculture Damages	2. Direct damages to the community	3. Social infrastructure damages	4. Other economical damages
Indirect Effects	1.1 Agriculture and livestock damage	2.1 Private property and housing loss	3.1 Roads destruction	4.1 Traffic interruption
	1.2 Agricultural lands loss	2.2 Industries and facilities loss	3.2 Bridges loss	4.2 Flood and evacuations prevention costs
	1.3 Irrigation channels destruction	2.3 Human life loss and accidents	3.3 Running water, electricity, gas and communication infrastructures' damages	4.3 Reconstruction costs and emergency measures
	1.4 Work destruction and derivation	2.4 Commercial loss		4.4 Work loss by local inhabitants
	1.5 Dikes and banks erosion			4.5 Communities income reduction
				4.6 Life quality degradation
				4.7 Loss of economical dynamism

(3) Final effect

The main problem final effect is the community socio-economic impediment development of the affected area.

### 3.2.4 Causes and effects diagram

Figure 3.2.4-1 shows the causes and effects diagram done based on the above analysis results.

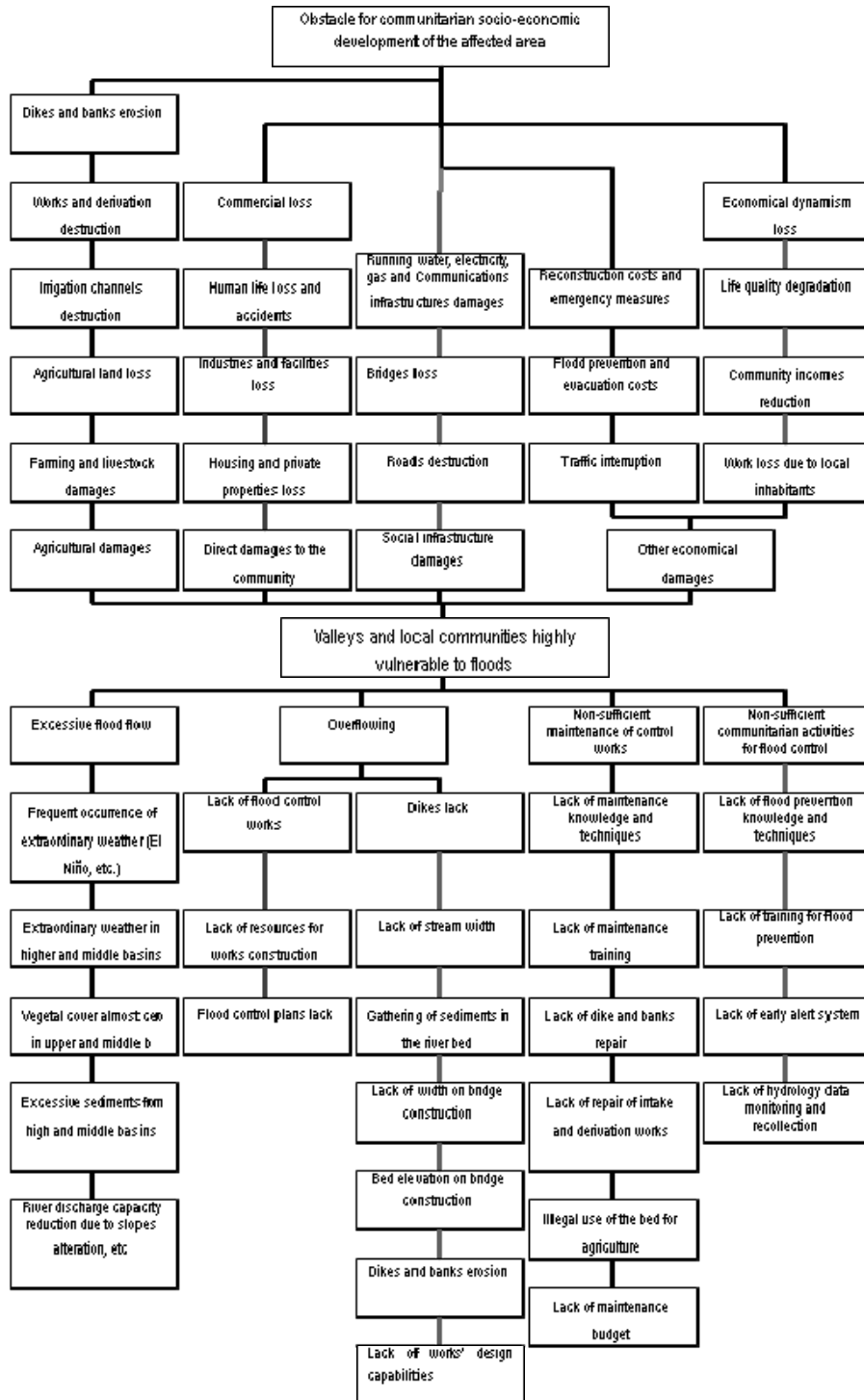

Figure 3.2.4-1 Causes and effects diagram

### 3.3 Objective of the Project

The final impact that the Project wants to achieve is to alleviate the vulnerability of valleys and local community to flooding and promote local economic development.

#### 3.3.1 Solving measures for the main problem

(1) Main objective

Soothe the valleys and local community to flooding vulnerability.

(2) Direct and indirect measures

In table 3.3.1-1, direct and indirect solutions measures for the problem are shown.

**Table 3.3.1-1 Direct and indirect solution measures to the problem**

Direct measures	1. Analyze and relieve excessive flood flow	2. Prevent overflow	3. Full compliance with maintenance of flood control works	4. Encourage community flood prevention
Indirect measures	1.1 Analyze extraordinary weather (El Niño, etc..)	2.1 Construct flood control works	3.1 Strengthen maintenance knowledge and skills	4.1 Strengthen knowledge and skills to prevent flooding
	1.2 Analyze extraordinary rainfall in the upper and middle basins	2.2 Provide resources for the works construction	3.2 Reinforce training maintenance	4.2 Running flood prevention training
	1.3 Planting vegetation on the upper and middle basins	2.3 Develop plans for flood control basins	3.3 Maintain and repair dikes and banks	4.3 Creating early warning system
	1.4 Relieve Excessive sediment entrainment from the upper and middle river dikes	2.4 Build dikes	3.4 Repair intake and derivation works	4.4 Strengthen monitoring and water data collection
	1.5 Take steps to alleviate the reduction in discharge capacity of rivers by altering slopes, etc.	2.5 Extends the width of the channel	3.5 Control the illegal use of bed for agricultural purposes	
		2.6 Excavation of bed	3.6 Increase the maintenance budget	
		2.7 Extending the river at the bridge's construction		
		2.8 Dredging at the point of the bridge construction		
		2.9 Control dikes and banks erosion		
		2.10 Strengthen the capacity for works design		

#### 3.3.2 Expected impacts for the main's objective fulfillment

(1) Final Impact

The final impact that the Project wants to achieve is to alleviate the vulnerability of the valleys and the local community to floods and promoting local socio-economic development.

(2) Direct and indirect impacts

In table 3.3.2-1 direct and indirect impacts expected to fulfill the main objective to achieve the final impact are shown.

**Table 3.3.2-1 Direct and indirect impacts**

Direct Impacts	1. Agricultural damage relief	2. Relief of direct harm to the community	3. Relief of social infrastructure damage	4. Relief of other economic damage
Indirect Impacts	1.1 Relief to crops and livestock damage	2.1 Housing and private properties loss prevention	3.1 Road destruction prevention	4.1 Traffic interruption prevention
	1.2 Relief for farmland loss	2.2 Prevention of Industries and facilities establishments	3.2 Prevention of bridges loss	4.2 Reducing costs of flood prevention and evacuation
	1.3 Prevention of the destruction of irrigation channels	2.3 Prevention of accidents and human life loss	3.3 Running water, electricity, gas and communication infrastructures' relief	4.3 Cost reduction of the reconstruction and emergency measures
	1.4 Prevention of destruction works of intake and derivation	2.4 Commercial loss relief		4.4 Increase of local community hiring
	1.5 Dikes and banks erosion relief			4.5 Community income increase
				4.6 Life quality improvement
				4.7 Economic activities development

**3.3.3 Measures - objectives – impacts Diagram**

In Figure 3.3.3-1 the measures - objectives – impacts diagram is shown.

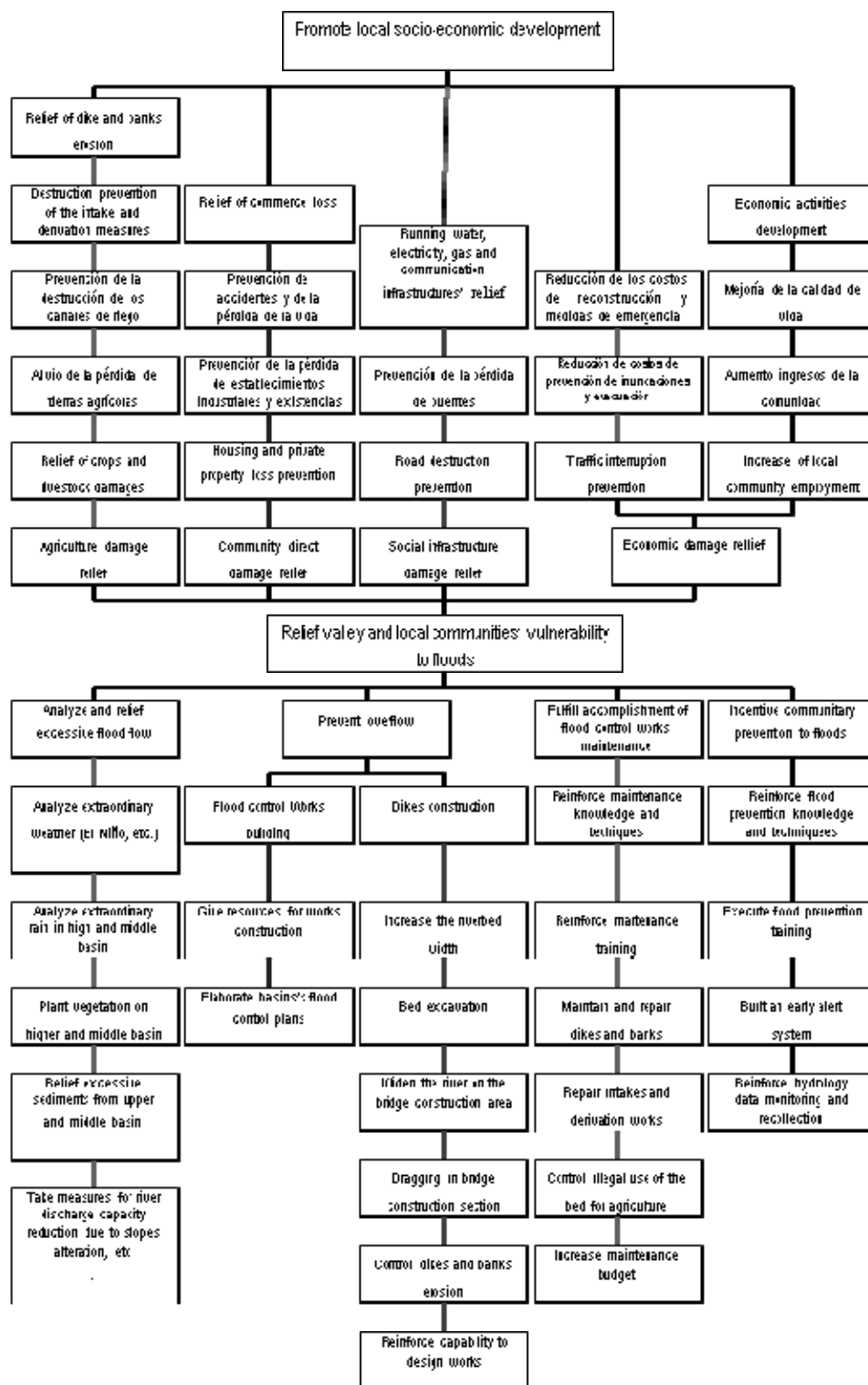

Figure 3.3.3-1 Measures - objectives – impacts diagram



## 4. FORMULATION AND EVALUATION

### 4.1 Definition of the Assessment Horizon of the Project

The Project's assessment horizon will be of 15 years, same as the one applied on the Program Profile Report. The Annex-10 of SNIP regulation stipulates that the assessment horizon should be basically 10 years; however the period can be changed in case that the project formulator (DGIH in this Project) admits the necessity of change. DGIH adopted 15 years in the Program Profile Report and OPI and DGPM approved it in March 19, 2010. In JICA's development study it should be generally 50 years, so the JICA Study Team inquired on the appropriate period to DGIH and OPI, they directed JICA Study Team to adopt 15 years. And the social evaluation in case of 50 years assessment horizon is described in Annex-14 Implementation Program of Japanese Yen Loan Project.

### 4.2 Supply and Demand Analysis

The theoretical water level was calculated considering flowing design flood discharge based on river cross sectional survey executed with a 500m interval, in each Watershed, considering a flood discharge with a return period of 50 years. Afterwards, the dike height was determined as the sum of the design water level plus the freeboard of dike.

This is the dike height required to prevent damages caused by design floods and represents the local community demand indicator.

The height of the existing dike or the height of the present ground is that required to prevent present flood damages, and represents the present supply indicator.

The difference between the design dike (demand) and the height of the present dike or ground represents the difference or gap between demand and supply.

Table 4.2-1 shows the averages of flood water level calculated with a return period of 50 years in "3.1.9 Run-off Analysis"; of the required dike height (demand) to control the discharge adding the design water level plus the freeboard dike; the dike height or that of the present ground (supply), and the difference between these last two (difference between demand-supply) of the river. Then, Table 4.2-2 shows the values of each point in Yauca river. The dike height or that of the present ground is greater than the required dike height, at certain points. In these, the difference between supply and demand was considered null.

**Table 4.2-1 Watershed Demand and Supply**

Watershed	Dike Height / current land (supply)		Theoretical water level with a return period of 50 years	Dike Freeboard	Required dike's height (demand)	Diff. demand/supply	
	Left bank	Right bank				Left bank	Right bank
	①	②				③	④
Yauca	187.54	183.01	179.03	0.80	179.83	0.21	0.40

**Table 4.2-2 Demand and Supply according to calculation (Yauca River)**

(m)

Distance (km)	Dike Height / current land (supply)		Theoretical water level with a return period of 50 years ③	Dike Freeboard ④	Required dike's height (demand) ⑤=③+④	Diff. demand/supply	
	Left bank ①	Right bank ②				Left bank ⑥=⑤-①	Right bank ⑦=⑤-②
0.0	4.97	2.94	2.11	0.80	2.91	0.00	0.00
0.5	3.27	1.76	2.37	0.80	3.17	0.00	1.41
1.0	10.87	3.64	3.10	0.80	3.90	0.00	0.26
1.5	4.97	4.97	4.10	0.80	4.90	0.00	0.00
2.0	5.80	7.83	4.90	0.80	5.70	0.00	0.00
2.5	7.47	7.31	6.96	0.80	7.76	0.30	0.45
3.0	14.25	8.72	8.61	0.80	9.41	0.00	0.69
3.5	37.20	10.24	10.62	0.80	11.42	0.00	1.17
4.0	27.20	14.89	13.45	0.80	14.25	0.00	0.00
4.5	41.61	16.73	15.01	0.80	15.81	0.00	0.00
5.0	48.40	18.05	17.08	0.80	17.88	0.00	0.00
5.5	49.60	21.82	20.69	0.80	21.49	0.00	0.00
6.0	66.64	22.59	22.57	0.80	23.37	0.00	0.78
6.5	26.15	27.58	26.44	0.80	27.24	1.10	0.00
7.0	31.56	30.44	29.54	0.80	30.34	0.00	0.00
7.5	35.06	33.45	33.74	0.80	34.54	0.00	1.09
8.0	55.64	36.76	36.54	0.80	37.34	0.00	0.58
8.5	92.42	42.03	40.95	0.80	41.75	0.00	0.00
9.0	47.78	51.89	43.97	0.80	44.77	0.00	0.00
9.5	46.33	47.03	47.70	0.80	48.50	2.16	1.47
10.0	63.63	57.95	50.05	0.80	50.85	0.00	0.00
10.5	54.18	54.90	54.33	0.80	55.13	0.95	0.23
11.0	58.49	57.64	58.23	0.80	59.03	0.55	1.39
11.5	67.51	65.23	62.01	0.80	62.81	0.00	0.00
12.0	78.41	69.53	64.45	0.80	65.25	0.00	0.00
12.5	80.32	87.31	68.29	0.80	69.09	0.00	0.00
13.0	71.34	71.52	71.17	0.80	71.97	0.63	0.45
13.5	83.84	83.32	75.46	0.80	76.26	0.00	0.00
14.0	79.35	78.03	78.67	0.80	79.47	0.12	1.45
14.5	94.44	83.42	83.15	0.80	83.95	0.00	0.53
15.0	103.94	85.08	86.11	0.80	86.91	0.00	1.83
15.5	91.45	93.23	90.89	0.80	91.69	0.24	0.00
16.0	103.13	94.80	95.66	0.80	96.46	0.00	1.66
16.5	101.27	99.13	99.45	0.80	100.25	0.00	1.12
17.0	105.25	104.77	105.16	0.80	105.96	0.71	1.19
17.5	117.49	114.65	109.53	0.80	110.33	0.00	0.00
18.0	115.48	124.95	112.85	0.80	113.65	0.00	0.00
18.5	120.59	118.49	117.47	0.80	118.27	0.00	0.00
19.0	122.18	122.34	121.71	0.80	122.51	0.32	0.17
19.5	128.61	130.38	127.62	0.80	128.42	0.00	0.00
20.0	132.85	134.29	132.42	0.80	133.22	0.37	0.00
20.5	136.79	141.05	137.34	0.80	138.14	1.34	0.00

Preparatory study on the protection program for  
valleys and rural communities vulnerable to floods in Peru  
*Profile Study Report (Pre-feasibility level), Yauca River*

21.0	146.87	158.06	141.99	0.80	142.79	0.00	0.00
21.5	152.18	167.34	147.07	0.80	147.87	0.00	0.00
22.0	166.56	166.11	151.74	0.80	152.54	0.00	0.00
22.5	167.23	176.01	157.30	0.80	158.10	0.00	0.00
23.0	200.98	174.62	162.00	0.80	162.80	0.00	0.00
23.5	179.36	168.30	167.46	0.80	168.26	0.00	0.00
24.0	192.88	172.51	172.67	0.80	173.47	0.00	0.96
24.5	177.96	190.53	177.87	0.80	178.67	0.71	0.00
25.0	207.59	202.14	183.38	0.80	184.18	0.00	0.00
25.5	207.43	215.11	188.96	0.80	189.76	0.00	0.00
26.0	238.50	207.55	193.98	0.80	194.78	0.00	0.00
26.5	208.54	208.50	201.43	0.80	202.23	0.00	0.00
27.0	217.45	208.19	208.06	0.80	208.86	0.00	0.68
27.5	222.97	215.11	213.55	0.80	214.35	0.00	0.00
28.0	231.57	220.68	219.73	0.80	220.53	0.00	0.00
28.5	237.11	230.00	226.05	0.80	226.85	0.00	0.00
29.0	233.54	236.00	233.35	0.80	234.15	0.61	0.00
29.5	243.36	239.69	239.11	0.80	239.91	0.00	0.22
30.0	247.66	246.30	246.24	0.80	247.04	0.00	0.74
30.5	254.22	253.31	252.58	0.80	253.38	0.00	0.07
31.0	262.98	262.55	258.54	0.80	259.34	0.00	0.00
31.5	268.93	264.18	264.74	0.80	265.54	0.00	1.37
32.0	271.56	271.80	270.59	0.80	271.39	0.00	0.00
32.5	294.15	281.23	277.73	0.80	278.53	0.00	0.00
33.0	289.54	285.00	283.63	0.80	284.43	0.00	0.00
33.5	314.58	292.43	291.29	0.80	292.09	0.00	0.00
34.0	301.91	300.00	298.40	0.80	299.20	0.00	0.00
34.5	309.96	303.26	304.17	0.80	304.97	0.00	1.71
35.0	309.63	308.91	309.80	0.80	310.60	0.97	1.69
35.5	316.12	315.88	316.26	0.80	317.06	0.94	1.18
36.0	321.67	322.81	321.73	0.80	322.53	0.86	0.00
36.5	327.48	342.42	326.88	0.80	327.68	0.20	0.00
37.0	333.64	332.74	333.85	0.80	334.65	1.01	1.90
37.5	340.40	339.28	339.41	0.80	340.21	0.00	0.93
38.0	350.09	345.56	345.70	0.80	346.50	0.00	0.93
38.5	351.81	352.28	352.26	0.80	353.06	1.25	0.78
39.0	386.18	358.72	357.64	0.80	358.44	0.00	0.00
39.5	364.24	363.43	364.22	0.80	365.02	0.78	1.59
40.0	371.86	370.50	369.82	0.80	370.62	0.00	0.12
40.5	376.35	375.80	375.71	0.80	376.51	0.16	0.71
41.0	384.23	399.63	381.90	0.80	382.70	0.00	0.00
41.5	395.43	406.83	388.05	0.80	388.85	0.00	0.00
42.0	406.80	394.91	393.12	0.80	393.92	0.00	0.00
42.5	410.39	408.45	399.38	0.80	400.18	0.00	0.00
43.0	405.33	418.83	404.79	0.80	405.59	0.26	0.00
43.5	410.55	423.82	410.54	0.80	411.34	0.78	0.00
44.0	417.99	417.91	418.22	0.80	419.02	1.04	1.11
44.5	438.95	424.57	424.52	0.80	425.32	0.00	0.75
45.0	431.48	431.34	431.86	0.80	432.66	1.18	1.32

45.5	438.56	438.49	438.89	0.80	439.69	1.12	1.20
46.0	447.75	446.76	446.80	0.80	447.60	0.00	0.84
Average	187.54	183.01	179.03	0.80	179.83	0.21	0.40

## 4.3 Technical Planning

### 4.3.1 Structural Measures

As structural measures it was necessary to prepare a flood control plan for the whole Watershed. The later section 4.12 “Medium and Long Term Plan” and 4.12.1 “General Flood Control Plan” details results on the analysis. This plan proposes the construction of dikes for flood control in the entire Watershed. However, in the case of the Watershed of the Yauca River, a big project needs to be set up investing very high costs, far beyond those considered in the budget of the present Project, what makes it difficult to take this proposal. Therefore, supposing the flood control dikes in the whole Watershed are built progressively within a medium and long term plan, they would be focused on the study of more urgent and priority works for flood control.

#### (1) Design flood discharge

##### 1) Guideline for flood control in Peru

The Methodological Guide for Projects on Protection and/or Flood Control in Agricultural or Urban Areas prepared by the Public Sector Multiannual Programming General Direction (DGPM) of the Economy and Finance Ministry (MEF) recommends to carry out the comparative analysis of different return periods: 25 years, 50 years and 100 years for the urban area, and 10 years, 25 years and 50 years for rural area and agricultural lands.

Considering that the present Project is focused on the protection of rural and agricultural areas, the design flood discharge should be the discharge with return period of 10year to 50-year.

##### 2) Maximum discharge in the past and design flood discharge

The yearly maximum discharge in the watershed is as shown in Figure-4.3.1-1. Based on the figure, the maximum discharge in the past can be extracted as shown in the Table- 4.3.1-1 together with the flood discharges with different return periods.

The maximum discharge observed in the past in Yauca river is considerably less than the flood discharge with return period of 50 years, and the same class of floods occurred three times in the past.

In Peru the flood protection works in the basins are developed almost nil, therefore it is not necessary to adopt the design discharge more than the past maximum discharge. However, the large disasters occurred in the past so that the design flood discharge with return period of 50 years, which is larger than the past maximum, is to be adopted as design flood as in safe side.

The relation among flood discharge with different return period, damage caused by the floods and inundation areas is analyzed in the basin. The results are that the more the return periods of flood increase the more inundation area and damage amount increase in the basin, however the increase tendency of damage with project is more gentle compared with former two items, and the reduction of damage with project reaches to maximum in the case of the

flood with return period of 50 years within the cases of flood with less return period of 50 years.

**Table - 4.3.1-1 Flood discharge with different return period(m<sup>3</sup>/sec)**

Watershed	2-year	10-year	25-year	50-year	100-year	Max.in Past
Yauca	24	90	167	263	400	211

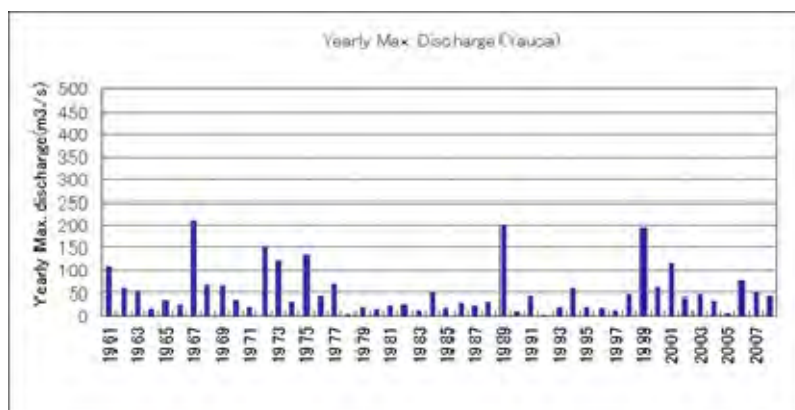

**Figure- 4.3.1-1 Yearly Max. Discharge (Yauca)**

3) Relation among probable flood, Damage and inundation area

The relation among probable flood, Damage and inundation area in the watershed are shown in the Figure-4.3.1-2.

Based on the figure the following facts can be expressed.

- ① The more increase probable flood discharge, the more increase inundation area (green line in the figure).
- ② The more increase probable flood discharge, the more increase damage (red line in the figure).
- ③ According to increase of probable flood discharge, the damage with project increase gently (blue line in the figure).
- ④ According to increase of probable flood discharge, damage reduction (difference between red line and blue line) increase steadily, and it reaches maximum at the probable flood of 50- year within the scope of study.

As described above, the adopted design flood discharge with return period of 50 years is bigger than the past maximum discharge and damage reduction amount in the adopted case becomes more than that of the flood discharges with less return period. However the Project in Yauca river is to be cancelled due to low economic viability studied in the section 4.5 Social Evaluation.

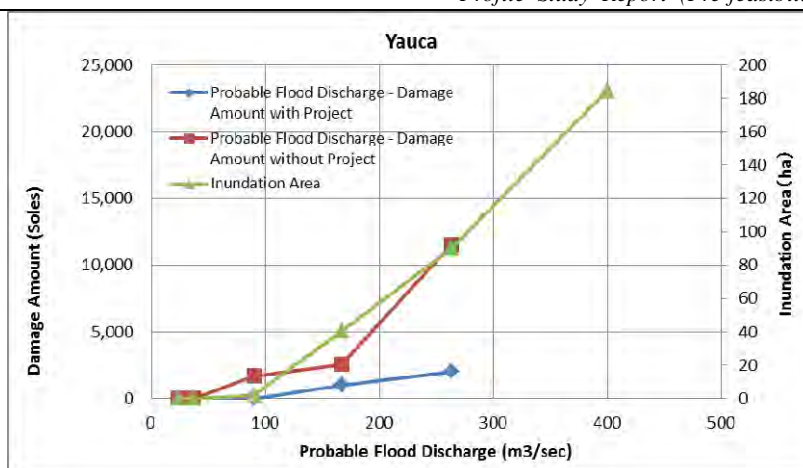

**Figure—4.3.1-2 Probable Flood Discharge, Damage Amount and Inundation Area (Yauca river)**

## (2) Topographical Uplift

The topographical survey was carried out in selected places for the execution of structural measurements (Table 4.3.1-1). The preliminary design of control works was based on these topographical survey results.

**Table 4.3.1-1 Summary of Topographical Survey**

River	Location (No.)	Installations	Topo lift.	Transversal Lifting (S=1/200)		
			(ha)	Line No.	Middle length (m)	Total length (m)
Yauca	Ya-1	Dike	5.0	11	50.0	550
	Ya-2	Dike & excavation	10.0	6	200.0	1,200
	Ya-3	Dike	12.5	26	50.0	1,300
	Ya-4	Reservoir	10.0	6	200.0	1,200
	Ya-5	Dike	2.5	6	50.0	300
	Ya-6	Dike	2.0	5	50.0	250
<b>Total</b>			<b>42.0</b>	<b>60</b>		<b>4,800</b>

## (3) Selection of control works against priority floods

### 1) Basic Guidelines

For the selection of priority flood protection works, the following elements were considered:

- Demand from the local community (based on historical flood damage)
- Lack of discharge capacity of river channel (including the sections affected by the scouring)
- Conditions of the adjacent area (conditions in urban areas, farmland, etc.).
- Conditions and area of inundation (type and extent of inundation according to inundation analysis)
- Social and environmental conditions (important local infrastructures)

Based on the river survey, field investigation, discharge capacity analysis of river channel, inundation analysis, and interviews to the local community (irrigation committee needs, local governments, historical flood damage, etc...) a comprehensive evaluation was made applying the five evaluation criteria listed above. After that we selected a total of six (6) critical points (with the highest score in the assessment) that require flood protection measures.

Concretely, since the river cross sectional survey was carried out every 500m interval and discharge capacity analysis and inundation analysis were performed based on the survey results, the integral assessment was also done for sections of 500 meters. This sections have been assessed in scales of 1 to 3 (0 point, 1 point and 2 points) and the sections of which score is more than 6 were selected as prioritized areas. The lowest limit (6 points) has been determined also taking into account the budget available for the Project in general

Table 4.3.1-3 details evaluated aspects and assessment criteria.

**Table 4.3.1-3 Assessment Aspects and Criteria**

Assessment Aspects	Description	Assessment Criteria
Demand of local population	<ul style="list-style-type: none"> <li>● Flood damages in the past</li> <li>● Demand of local population and producers</li> </ul>	<ul style="list-style-type: none"> <li>• Flooding area with big floods in the past and with great demand from local community (2 points)</li> <li>• Demand of local population (1 point)</li> </ul>
Lack of discharge capacity (bank scouring)	<ul style="list-style-type: none"> <li>● Possibility of river overflow given the lack of discharge capacity</li> <li>● Possibility of dike and bank collapse due to scouring</li> </ul>	<ul style="list-style-type: none"> <li>• Extremely low discharge capacity (discharge capacity with return period of 10 years or less) (2 points)</li> <li>• Low discharge capacity (with return period of less than 25 years) (1 point)</li> </ul>
Conditions of surrounding areas	<ul style="list-style-type: none"> <li>● Large arable lands, etc.</li> <li>● Urban area, etc.</li> <li>● Assessment of lands and infrastructure close to the river.</li> </ul>	<ul style="list-style-type: none"> <li>• Area with large arable lands (2 points)</li> <li>• Area with arable lands mixed with towns, or big urban area (2 points)</li> <li>• Same configuration as the previous one, with shorter scale (1 point)</li> </ul>
Inundation conditions	<ul style="list-style-type: none"> <li>● Inundation magnitude</li> </ul>	<ul style="list-style-type: none"> <li>• Where overflow extends on vast surfaces (2 points)</li> <li>• Where overflow is limited to a determined area (1 point)</li> </ul>
Socio-environmental conditions (important structures)	<ul style="list-style-type: none"> <li>● Intake of the irrigation system, drinking water, etc.</li> <li>● Bridges and main roads (Carretera Panamericana, etc.)</li> </ul>	<ul style="list-style-type: none"> <li>• Where there are important infrastructures for the area (2 points)</li> </ul> <p>Where there are important infrastructures (but less than the first ones) for the area (regional roads, little intakes, etc.) (1 point)</p>

## 2) Selection results

Figure 4.3.1-3 details assessment results of each the river, as well as the selection results of flood protection priority works.





Yauca river is characterized due to its overflowing tendency at km 7 downwards the intake, flooding right bank crops. Therefore the flood prevention works are to be inundation prevention work for farmland in the section downstream of 7km and conservation works for intake and regional road eroded by scouring with high priority.

**Table 4.3.1-8 Selected sections bases to execute works (Yauca River)**

No	Location	Basis of Selection
①		<p>The existing dikes in this section may be destroyed due to the erosion caused during floods; so, repair and bank protection works must be executed</p> <p>[Characteristics of the section]</p> <ul style="list-style-type: none"> <li>●The overflow water from the lower section swept away the olives</li> <li>●Section in which the existing dike has to be repaired</li> </ul> <p>[Elements to Protect]</p> <ul style="list-style-type: none"> <li>○Agricultural lands of the right bank</li> </ul> <p>[Method of Protection]</p> <p>In this section the conservation of olive field which is special product in this region is main target. The bank protection is to be executed utilizing the existing dike eroded by the past flood with same scale of the flood with return period of 50-years.</p>
②	3.5km ~ 7.5km (right bank)	<p>Inundation occurred at km 7 downstream from river mouth, spreading farm land of the right bank. Excavation of the riverbed has to be carried out to maintain the necessary discharge capacity at the road bridge</p> <p>[Characteristics of the section]</p> <ul style="list-style-type: none"> <li>●Narrow section (where the road bridge is) in which the discharge capacity is reduced</li> <li>●Section on which sediments have deposited due to damming up caused by the narrowness</li> <li>●Section in which the water level can be reduced due to the riverbed excavation</li> </ul> <p>[Elements to Protect]</p> <ul style="list-style-type: none"> <li>○ Agricultural lands of the right bank in the section (olive field of regional special product)</li> </ul> <p>[Method of Protection]</p> <p>The riverbed excavation is to be executed considering the balance of upstream and downstream flood protection works as well as aiming at lowering the water level in the upstream section.</p>
③		<p>Inundation occurred at km 7 downstream from river mouth, spreading farm land of the right bank. The existing dike in this section may be destroyed due to the erosion caused during floods; so, repair and bank protection works must be executed</p> <p>[Characteristics of the section]</p> <ul style="list-style-type: none"> <li>●Both sides of dikes are partially constructed. Sand and gravel material is embanked there empirically and annually</li> <li>●Floods swept away part of the olives</li> <li>●The existing dikes have to be repaired to prevent inundation on right bank</li> </ul> <p>[Elements to Protect]</p> <ul style="list-style-type: none"> <li>○ Agricultural lands of the right bank</li> </ul> <p>[Method of Protection]</p>

		In this section the conservation of olive field which is special product in this region is main target. The bank protection is to be executed utilizing the existing dike eroded by the past flood with same scale of the flood with return period of 50-years.
④	25.0km~25.7km (total)	In this section the intake is constructed, however it is not working properly due to the enlarged private property of the left bank to the river, and floods flow into the intake directly, sediment deposit and destruction of intake, therefore the appropriate river section is to be secured considering comprehensive flow condition in this section .  [Characteristics of the section] ●Section in which it is important to protect the intakes functioning ●Section in which it is important to maintain the river's section delimitating it from the left bank  [Elements to Protect] ○Intake  [Method of Protection] ▼The most important intake in this river. In case that the function of it is damaged, the influence to the region will be serious, therefore the protection work is to be implemented not to cause the damage in the past flood of 210m <sup>3</sup> /sec which is almost equal the flood with return period of 50-year. ▼It is difficult to take water due to sediment deposit, and the private property enlarges at the left bank to the river causing direct inflow to the intake in flooding, therefore the appropriate layout of river is to be planned considering comprehensive flow condition in this section .
⑤		This section formulates bending and quick flow at the right bank, which is causing bank erosion. If no adequate measure is taken, the eroded bank may disturb the regional road located on the upper section of the right bank resulting in stop of traffic. So, it is necessary to take erosion control actions, such as bank protection works for conservation of the road.  [Characteristics of the section] ●Right bank's progressive erosion (the main road is located on the upper section) ●Section in which bank erosion control together with regional road conservation should be performed  [Elements to Protect] ○Regional road of the right bank  [Method of Protection] ▼In case that the regional main road is destroyed , the influence to the region will be serious, therefore the protection work is to be implemented not to cause the damage in the past flood of 210m <sup>3</sup> /sec which is almost equal the flood with return period of 50-year. ▼If it is left as it is, the bank will be eroded resulting in destruction of road, therefore the erosion protection work such as groin is to be implemented.
⑥	40.9km~41.3km (left bank)	The intake located on the upper watershed of the Yauca River is an important facility to ensure drinking water for local population. However, erosion still affects the upstream left bank of the intake, also affecting regional road located on the upper part of the left bank. So, it is urgent to take action on the erosion control of this section.  [Characteristics of the section]

		<ul style="list-style-type: none"> <li>● Section in which the base of the road that runs upstream and downstream the intake is eroded.</li> <li>● Section in which bank erosion control works as well as regional road conservation should be performed.</li> </ul> <p>[Elements to Protect]</p> <ul style="list-style-type: none"> <li>○ Intake</li> <li>○ Regional road of the left bank</li> </ul> <p>[Method of Protection]</p> <ul style="list-style-type: none"> <li>▼ The intake is the most important facility in this river. In case that the function of the facility is lost, the influence to the region will be serious, therefore the protection work is to be implemented not to cause the damage in the past flood of 210m<sup>3</sup>/sec which is almost equal the flood with return period of 50-year.</li> <li>▼ If the erosion to the important intake for securing drinking water and regional main road will progress, there is possibility to hinder intake of drinking water and destruction of regional main road, therefore the erosion protection work is to be executed.</li> </ul>
--	--	--

#### (4) Location of priority works on flood control

In Figure 4.3.1-4 the location of prioritized flood control works is indicated in the watershed and in the Table- 4.3.1-5 the summary of flood control works is indicated..



Figure 4.3.1-4 Prioritized flood control works in Yauca River

**Table 4.3.1-5 Summary of Facilities**

Basin	Location		Preservation Object	Counter Measure	Summary of Facility	Objective Section
Yauca	1	4.5k下流	Inundation	Crop land (olive)	Rehabilitation of dike	3.5km~7.5km(total)
	2	4.1km	Narrow Section		Riverbed excavation	
	3	4.5~7.0k	Inundation		Rehabilitation of dike	
	4	25.0k	Intake	Crop land (olive)	Rehabilitation of intake	25.0km~25.7km(total)
	5	25.0k	Intake		Revetment	
	6	41km	Intake	Road	Revetment	40.9~41.3km(left bank)

### (5) Standard section of the dike

#### 1) Width of the crown

The width of the dike crown was defined in 4 meters, considering the dike stability when facing design overflows, width of the existing dike, and width of the access road or that of local communication.

#### 2) Dike structure

The dike structure has been designed empirically, taking into account historic disasters, soil condition, condition of surrounding areas, etc.

Dikes are made of soil in all the Watersheds. Although there is a difference in its structure varying from area to area, this can be summarized as follows, based on the information given by the administrators interviewed:

- ① The gradient of the slope is mainly 1:2 (vertical: horizontal relationship); the form may vary depending on rivers and areas.
- ② Dike materials are obtained from the river bed in the area. Generally these are made of sand/gravel ~sandy soil with gravel, of reduced plasticity. As to the resistance of the materials, we cannot expect cohesiveness.
- ③ The Watershed of the Cañete River is made of loamy soil with varied pebble, relatively compacted.
- ④ The lower stretch of the Sullana weir of the Chira River is made of sandy soil mixed with silt. Dikes have been designed with a “zonal-type” structure where material with low permeability is placed on the riverside of the dike and the river; material with high permeability is placed on landside of the dike. However, given the difficulty to obtain material with low permeability, it has been noticed that there is lack of rigorous control of grain size distribution in supervision of construction.
- ⑤ When studying the damaged sections, significant differences were not found in dike material or in the soil between broken and unbroken dike. Therefore, the main cause of destruction has been water overflow.
- ⑥ There are groins in the Chira and Cañete rivers, and many of them are destroyed. These are made of big rocks, with filler material of sand and soil in some cases, what may suggest that destruction must be caused by loss of filler material.
- ⑦ There are protection works of banks made of big rocks in the mouth of the Pisco River. This structure is extremely resistant according to the administrator. Material has been obtained

from quarries, 10 km. away from the site.

Therefore, the dike should have the following structure.

- ① Dikes will be made of material available in the zone (river bed or banks). In this case, the material would be sand and gravel or sandy soil with gravel, of high permeability. The stability problems forecasted in this case are as follows.
  - i) Infiltrate destruction caused by piping due to washing away fine material
  - ii) Sliding destruction of slope due to infiltrate pressure

In order to secure the stability of dike the appropriate standard section should be determined by infiltration analysis and stability analysis for sliding based on unit weight, strength and permeability of embankment material.

- ② The gradient of the slope of the dike will be between  $30^\circ \sim 35^\circ$  (angle of internal friction) if the material to be used is sandy soil with low cohesiveness. The stable gradient of the slope of an embankment executed with material with low cohesiveness is determined as:  $\tan\theta = \tan\phi/n$  (where “ $\theta$ ” is gradient of the slope; “ $\phi$ ” is angle of internal friction and “ $n$ ” is 1.5, safety factor).

The stable slope required for an angle of internal friction of  $30^\circ$  is determined as: V:H=1:2.6 ( $\tan\theta=0.385$ ).

Taking into consideration this theoretical value, a gradient of the slope of 1:3.0 was considered, with more gentle inclination than the existing dikes, considering the results of the discharge analysis, the prolonged time of the design flood discharge (more than 24 hours), the fact that most of the dikes with slope of 1:2 have been destroyed, and the relative resistance in case of overflow due to unusual flooding.

The infiltration analysis and stability analysis of dike based on the soil investigation and martial tests are not performed in this Study so that the slope is determined by simple stability analysis assuming the strength factors of dike material estimated by field survey of material and by adding some safety allowance.

And the slope of dike in Japan is generally 1:2.0 in minimum, however the average slope will be more than 1:3.0 because the dike has several steps in every interval of 2m~3m of height.

- ③ The dike slope by the riverside must be protected for it must support a fast water flow given the quite steep slope of the riverbed. This protection will be executed using big stones or big rocks easily to get in the area, given that it is difficult to get connected concrete blocks.

The size of the material was determined between 30cm and 1m of diameter, with a minimum protection thickness of 1m, although these values will be determined based on flow speed of each river.

### 3) Freeboard of the dike

The dike is made of soil material, and as such, it generally turns to be a weak structure when facing overflow. Therefore, it is necessary to prevent water overflow, to a lower water rise than the design discharge. So it is necessary to keep a determined freeboard when facing a possible increase in water level caused by the waves by the wind during water rise, tidal, hydraulic jump, etc. Likewise, it is necessary that the dikes have sufficient height to guarantee safety in surveillance activities and flood protection work, removal of logs and other carryback material, etc.

Table 4.3.1-6 shows guidelines applied in Japan regarding freeboard. Although in Peru there is a norm on freeboard, it has been decided to apply the norms applied in Japan, considering that rivers in both countries are alike.

<b>Design discharge</b>	<b>Freeboard</b>
Less than 200 m <sup>3</sup> /s	0.6m
More than 200 m <sup>3</sup> /s, less than 500 m <sup>3</sup> /s	0.8m
More than 500 m <sup>3</sup> /s, less than 2,000 m <sup>3</sup> /s	1.0 m
More than 2,000 m <sup>3</sup> /s, less than 5,000 m <sup>3</sup> /s	1.2 m
More than 5,000 m <sup>3</sup> /s, less than 10,000 m <sup>3</sup> /s	1.5 m
More than 10,000 m <sup>3</sup> /s	2.0 m

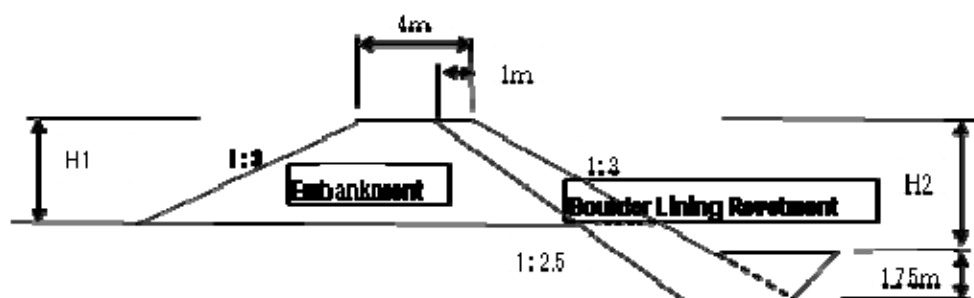

**Figure 4.3.1-5 Standard dike section**

## 4.3.2 Nonstructural measures

### 4.3.2.1 Reforestation and vegetation recovery

#### (1) Basic policies

The Reforestation and Vegetation Recovery Plan satisfying the goal of the present Project can be classified in: i) reforestation along fluvial works; and ii) reforestation in the high Watershed. The first one contributes directly to flood control and expresses its effect in short time. The second one demands a huge investment and an extended time, as detailed in the later section 4.12 “Medium and long term Plan”, 4.12.2 “Reforestation Plan and Vegetation Recovery”, what makes not feasible to implement it in the present Project. Therefore, the analysis is here focused only in option i).

#### (2) Reforestation plan along fluvial structures

This proposal consists in planting trees along fluvial structures such as protection works of banks, dikes, etc.

- a) Objective: Reduce impact of river overflow when water rise occurs or when river narrowing is produced by the presence of obstacles, by means of vegetation borders between the river and the elements to be protected.
- b) Methodology: Create vegetation borders of a certain width between fluvial structures and the river.
- c) Work execution: Plant vegetation at a side of the fluvial structures (dikes, etc.)
- d) Maintenance post reforestation: The maintenance will be assumed by irrigator commissions by own initiative.

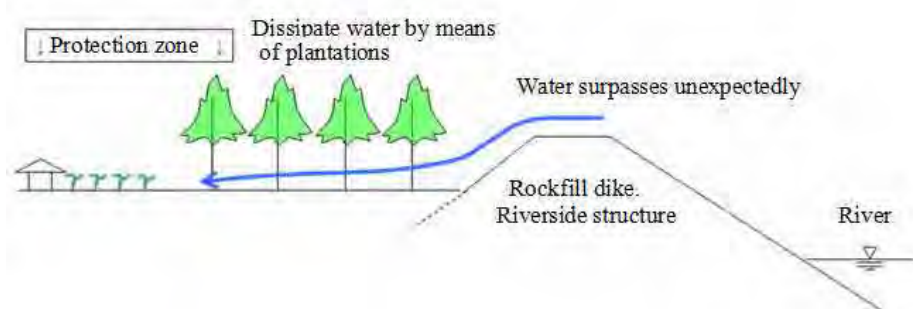
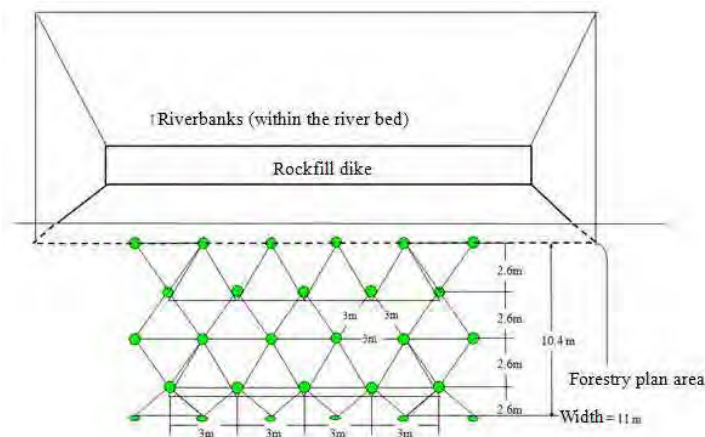

**Figure 4.3.2.1-1 Conceptual Diagram Forestry in the Riverside structures (A Type)**  
 (Source: JICA Study Team)

**(3) Reforestation Plan Measure**

1) Structure (forestry location)

In Peru the most common location for forestry is with equilateral triangles. This project also uses this model by planting trees with 3-meter intervals. If this method is used, it is expected that trees will act to stop and cushion even 1-meter diameter rocks, for what rows will be quadrupled, thus increasing their effectiveness. However, the main goal is to avoid overflow surpass the limit; in case floods strike directly with plants sowed, good results might be expected.



(Source: JICA Study Team)

**Figure 4.3.2.1-3 Location of the forestry design plan in the riverside structure**

2) Species to be forested

Species to be planted along the river were selected applying the following criteria and submitted to an overall assessment.

- ① Species with adequate properties to grow and develop in the riverside (preferably native)
- ② Possibility of growing in plant nurseries
- ③ Possibility of wood and fruit use
- ④ Demand of local population
- ⑤ Native species (preferably)

After making a land survey, a list of planted or indigenous species of each zone was firstly made. Then, a list of species whose plants would grow in seedbeds, according to interviews made to plant growers, was prepared.

Priority was given to the aptitude of local conditions and to plant production precedents, leaving

as second priority its usefulness and demand or if they were native species or not. Table 4.3.2.1-1 shows the assessment criterion.

**Table 4.3.2.1-1 Assessment criterion for forest species selection**

		Assessment Criterion				
		1	2	3	4	5
Assessment points	A	In situ testing (natural or reforested growth)	Major production	Possible use as wood or for fruit production	Water demand by the Users Committee, among others	Local specie
	B	Growth has not been checked in situ, however it adapts in the zone	Sporadic production	Possible use as wood or for fruit production	There is NO water demand by the Users Committee	No local specie
	C	None of the above	Possible reproduction but not usual	No use as wood nor fruit	—	—
	D	Unknown	Not produced	Unknown	—	—

(Source: JICA Study Team)

Table-4.3.2.1-2 shows a list of selected species applying this assessment criterion. © marks main species, ○ are those species that would be planted with a proportion of 30% to 50%. This proportion is considered to avoid irreversible damages such as plagues that can kill all the trees.

**Table 4.3.2.1-2 Selection of forest species**

Watershed	Forest species
Yauca	Eucalipto (©), Huarango (○), Casuarina (○)

In the Cañete Watershed the main forestry specie is Eucalyptus. This specie adapts very well in this area, it adapts to the zone and has high demand by the Water User's Committees. Huarango (*Prosopis limensis*: is how this plant is known in the northern region of Peru, comes from another seed) is a native specie from the southern region of Peru. It is planted along the Panamericana Highway. Casuarinas specie has been planted in this area to protect from wind and sand, moreover for the lands near farms.

### 3) Volume of the Reforestation Plan

The forestry plan has been selected as it is mentioned in the location and type of species plan, in the dikes and rockfill, sedimentation wells along the riverside. The width of the forest is 11 meters; and within sand reservoir, tree will be planted excepting on the normal water route.

Following Table 4.3.2.1-3 shows the construction estimating for the Forestry and Recovery of Vegetation Cover Plan for Yauca Watershed.

**Table 4.3.2.1-3 Construction estimating for the forestry and vegetation cover recovery plan (Along the river)**

N°	Location (bank)	Length (m)	Width (m)	Area (ha)	Quantity (unit)	Distribution according to the specie (units)			
						Eucalyptus	Huarango	Casuarina	(m)
Ya-1	General	1.000	11	1,1	3.256	1.628	977	651	3.256
Ya-2	General			0,0	0	—	—	—	—
Ya-3	General	2.500	11	2,8	8.288	4.144	2.486	1.658	8.288
Ya-4		0	11	0,0	0	—	—	—	—
Ya-5	Right	500	11	0,6	1.776	888	533	355	1.776
Ya-6	Right	400	11	0,4	1.184	592	355	237	1.184
Yauca Total		4.400		4,9	14.504	7.252	4.351	2.901	14.504



(Source: JICA Study Team)

#### 4) Areas subject to the Reforestation and Vegetation Recovery Plan

In areas subject to the Reforestation/Vegetation Recovery Plan along fluvial works, the structure arrangement is similar everywhere. See section 4.5.1.3(2).

#### 5) Execution costs of the Reforestation and Vegetation Recovery Plan

Execution costs of works for the Reforestation and Vegetation Recovery Plan were estimated as follows:

- Planting unitary cost (planting unitary cost + transportation)
- Labor cost

Planting providers may include i) AGRORURAL or ii) private providers. For reforestation along rivers private providers will be requested.

For labor unitary cost estimation, common labor unitary cost is proposed to be applied for riverside reforestation.

##### i) Planting unitary cost

Planting unitary cost was defined as detailed in Table 4.3.2.1-4, based on information obtained through interviews to private providers. Given that planting prices and transportation cost varies per provider, an average was applied.

**Table 4.3.2.1-4 Unitary cost of plants**

Watersheds	Species	Unitary cost (unitary price + transportation) (in Soles/plant)
Yauca	Eucalyptus	1,5
	Huarango	1,8
	Casuarina	2,3

##### ii) Labor cost

Reforestation work performance ratio was determined in 40 trees/person-day according to the information gathered through interviews to AGRORURAL and to irrigator commissions. As to riverside reforestation, the labor unitary cost will be 33.6 Soles/man-day. In the high Watershed 16,8 Soles/man-day, corresponding to half of the first one.

##### iii) Reforestation execution cost

Work costs for the forestry and vegetation cover recovery plan in the riverside structures are detailed in Table 4.3.2.1-5.

**Table 4.3.2.1-5 Forestry work cost**

Watershed	Code	Cost		
		Plants	Labor	Total
Yauca	Ya-1	5.698	2.735	8.433
	Ya-2			
	Ya-3	14.504	6.962	21.466
	Ya-4			
	Ya-5	3.108	1.492	4.600
	Ya-6	2.072	995	3.067
Total Yauca		25.382	12.183	37.565

(Source: JICA Study Team)

## 6) Implementation process plan

The Process Plan of forestry works in riverbanks is part of the coastal structure, thus the same will be considered for the Construction Plan of the Coastal Structure. Forestry works should

generally start at the beginning of the rainy season or just before, and must end approximately one month before the season finishes. However, there is scarce rain in the coastal area; therefore there is no effect of dry and rainy seasons. For the sake of forestry, it is most convenient is to take advantage of water rise, but according to the Construction Process Plan of the coastal structure there are no major forestry issues in seasons where water level is low, if the execution schedule of water structures require so. The gravity irrigation system can only be used to irrigate just planted plants during approximately the first 3 months until water level rises. This irrigation is performed using perforated horse which is a field technique actually carried out in Poechos dam area.

#### 4.3.2.2 Sediment Control Plan

##### (1) Importance of the Sediment Control Plan

Below flood control issues in selected Watersheds are listed. Some of them relate to sediment control. In the present Project an overall flood control plan covering both the high and the low Watershed is prepared. The study for the preparation of the Sediment Control Plan comprised the whole Watershed.

- Water rise causes overflow and floods.
- Rivers have a steep slope of 1/30 to 1/300. The flow speed is high, as well as the sediment transport capacity.
- The accumulation of large quantities of dragged sediment and the consequent elevation of the river bed aggravate flood damages.
- There is a great quantity of sediment accumulated on the river bed forming a double sandbank. The water route and the spot of greater water impact are unstable, causing route change and consequently, change of spot of greater water impact.
- Riverside is highly erodible, causing a decrease of adjacent farming lands, destruction of regional roads, etc., for what they should be duly protected.
- Big stones and rocks cause damages and destruction of water intakes.

##### (2) Sediment Control Plan (structural measures)

The sediment control plan suitable for the present sediment movement pattern was analyzed. Table 4.3.2.2-1 details basic guidelines.

**Table 4.3.2.2-1 Basic guidelines of the Sediment Control Plan**

Conditions	Typical year	Precipitations with 50-year return period
Sediment dragging	Bank erosion and river bed change	Bank erosion and river bed change Sediment flow from ravines
Measures	Erosion control → Bank protection  Control of riverbed variation → compaction of ground, bands (compaction of ground in the alluvial cone, bands)	Erosion control → bank protection Riverbed variation control → compaction of ground, bands (compaction of ground in the alluvial cone, bands) Sediment flow → protection of slopes, sediment control dams

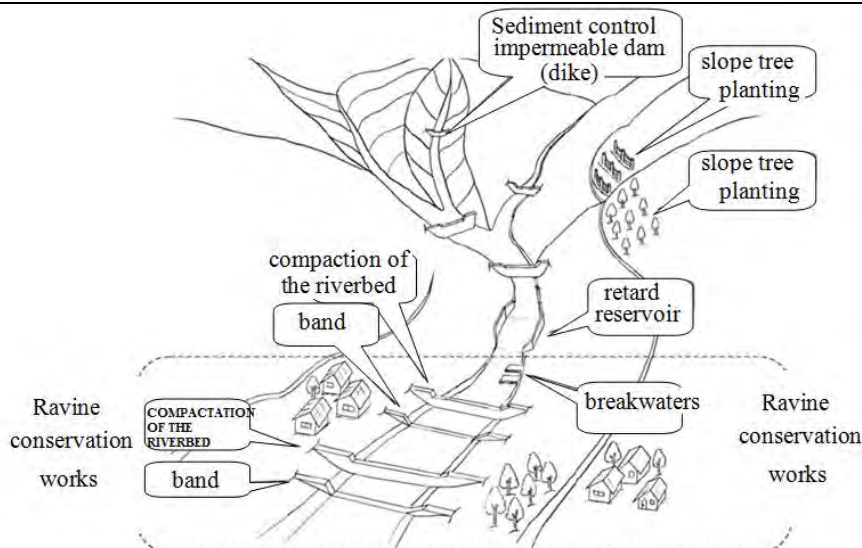

**Figure 4.3.2.2-1 Sediment control works**

1) Sediment control plan in the upper Watershed

The next section 4.12 “Medium and long term Plan” 4.12.3 “Sediment Control Plan” details the sediment control plan covering the whole Upper Watershed. This plan will require an extremely long time with huge costs, what makes it quite not feasible. Therefore, it must be executed progressively within the medium and long term.

2) Sediment control plan in the low Watershed

The riverbed fluctuation analysis is as shown below. The average bed height has been increasing in the river, so basically it is concluded that this is the general trend. The total variation volume of the bed and sediment transport is not so much in Yauca river,

Total volume of dragged sediment (in thousands of m <sup>3</sup> )	1,192
Annual average of dragged sediment (in thousands of m <sup>3</sup> )	23.8
Total volume of riverbed variation (in thousands of m <sup>3</sup> )	685
Annual average of variation of riverbed height (m)	0.1

While the variation of the bed (volume of sediment) is great too, looking at the average height of the bed, only 0.1 meters has changed in 50 years, and is therefore considered that the entry of sediments won't affect much the river downstream. Therefore, it is considered that the urgent sediment control actions are not required at present although the monitoring the riverbed variation and the maintenance of river channel depending on the monitoring results will be required.

**4.3.3 Technical Assistance**

Based on the proposals on flood control measures, a component on technical assistance is proposed in order to strengthen risk management capabilities in the Program.

**(1) Component objective**

The component objective in the Program is the “Adequate capability of local population and professionals in risk management application to reduce flood damages in Watersheds”.

**(2) Target area**

The target area for the implementation of the present component is the Yauca watershed.

In the execution stage, the implementation has to be coordinated with local authorities in the watershed. However, each authority has to execute those activities related with the characteristics of the watershed to carry out an adequate implementation.

**(3) Target population**

Target populations will represent irrigator associations and other community groups, provincial, district and local community governments and local people in the watershed, considering the limited capacity to receive beneficiaries of this component.

Participants are those with skills to widespread technical assistance contents of local populations in the watershed.

Besides, the participation of women has to be considered because currently only few ones participate in technical assistance opportunities.

**(4) Activities**

In order to achieve the above purpose, the following 3 components of study and training is to be carried out.

Component 1: Knowledge on River Bank Protection Actions in consideration of Agriculture and Natural Environment

Course	a) River Bank Operation and Maintenance b) River Bank Plant Management c) Erosion Prevention and Mitigation Natural Resource Management
Objectives	a) In this project, local populations learn suitable technology to operate and give maintenance to constructions and works from prior projects. b) Local populations learn suitable technology on river bank plants and vegetation for flooding control purposes. c) Local populations learn suitable technology on erosion and natural resources for flooding control purposes.
Participants	a) Engineers and / or technicians from local Governments b-c) Engineers and / or technicians from local Governments and Water Users Associations, Community representatives
Times	a) 12 times in all (every six (6) hours) b) 12 times in all (every five (5) hours) c) 26 times in all (every three (3) hours)
Lecturers	a) Contractors of constructions and works, Engineers from MINAG and / or the Regional Government b-c) Engineers from MINAG and / or the Regional Government, College professors (From universities, institutes, NGOs, etc.)
Contents	a-1) Suitable operation and maintenance technology for constructions and works from prior projects a-2) Suitable operation and maintenance technology for constructions and works in this project b-1) River bank protection with the use of plants b-2) The importance of river bank vegetation in flooding control b-3) Types of river bank plants and their characteristics c-1) Evaluation of the erosion conditions c-2) Evaluation of natural resource conditions c-3) Erosion approach for flooding control c-4) Natural resource approach for flooding control c-5) Environmental consideration approach c-6) Use of water resources c-7) Alternatives for suitable farming crops

**Component 2: Preparation of Community Disaster Management Plan for Flood Control**

Course	a) Risk management Plan Formulation b) Detailed Risk management Plan Formulation
Objectives	a) Local populations gain knowledge and learn technology to prepare a flooding control plan b) Ditto
Participants	a-c) Engineers and / or technicians from local Governments and Water Users Associations, Community representatives
Times	a) 19 times in all (every four (4) hours) b) 34 times in all (every five (5) hours) c) 24 times in all (every five (5) hours)
Lecturers	a-c) Engineers from MINAG and / or the Regional Government, Community Development Expert, Facilitator (local participation )
Contents	a-1) Flooding control plan preparation manuals a-2) Current condition analyses for flooding control a-3) Community development alternatives by means of local participation a-4) Workshop for flooding control plan preparation b-1) Community activity planning in consideration of ecological zoning b-2) Risk management b-3) Resource management c-1) Preparation of community disaster management plan c-2) Joint activity with local governments, users' association, etc.

**Component 3: Basin Management for Anti – River Sedimentation Measures**

Courses	a) Hillside Conservation Techniques b) Forest Seedling Production c) Forest Seedling Planting d) Forest Resource Management and Conservation
Objectives	a) Local populations learn suitable technology on hillside conservation for flooding control purposes b) Local populations learn suitable technology on forest seedling production c) Local populations learn suitable technology on forest seedling planting d) Local populations learn suitable technology on forest resource management and conservation
Participants	a-d) Engineers and / or technicians from local Governments and Water Users Associations, Community representatives and Local People
Times	a) 12 times in all (every five (5) hours) b-d) 40 times in all for three (3) “Courses on Basin Management for Anti - River Sedimentation Measures” (every five (5) hours)
Lecturers	a-d) Engineers from MINAG and / or the Regional Government, College professors (From universities, institutes, NGOs, etc.)
Contents	a-1) Soil characteristics and conservation on hillsides a-2) Hillside agroforestry system a-3) Animal herding system on hillsides a-4) Reforestation with traditional vegetation and plants a-5) Hillside conservation and alleviation alternatives b-1) A selection of plants that are suitable to the local characteristics b-2) Forest seedling production technology b-3) Control carried out by the local population's involvement c-1) Candidate areas for forestation c-2) Forest plantation control technology c-3) Forest plantation soil technology c-4) Control carried out by the local population's involvement d-1) Forestation for flooding control purposes d-2) Forest plantation control technology d-3) Forest plantation output technology d-4) Control carried out by the local population's involvement

**(5) Direct cost and period**

The direct cost for the above activities is as shown in the Table 4.3.3-1. The total cost for the objective basin is estimated as 144,050 soles, and the brake down of the unit cost is as shown in the Annex-12, Appendix No.5. And the period required for study and training is assumed to be as same as the construction period of 2 years.

**Table 4.3.3-1 Contents of technical assistance and direct cost**

Item	Activities	Unit	Unit price(soles)	No.of basin	Amount(soles)
1.0	<b>Knowledge on river bank protection action in consideration of agriculture and natural environment</b>				
1.1	Workshop on operation and maintenance of facilities	event	9,300	1	9,300
1.2	Workshop on river bank plantation management	event	9,300	1	9,300
	Prevention and mitigation for erosion	event	9,300	1	9,300
	Natural resources management	event	9,300	1	9,300
2.0	<b>Preparation of community disaster management plan for flood control</b>				
2.1	Workshop on risk management plan	event	8,370	1	8,370
2.2	Details of 2.1	event			
	Community activity planning in consideration of ecological zoning	event	12,200	1	12,200
	Risk management	event	12,200	1	12,200
	Resource management	event	12,200	1	12,200
	Preparation of community disaster management plan	event	12,200	1	12,200
2.3	Preliminary flood forecasting and warning	event			
	Risk management and early warning system	event	9,300	1	9,300
	Joint activity with local government, users' association, etc.	event	5,580	1	5,580
3.0	<b>Hillside management for river sedimentation prevention</b>				
3.1	Field works for hillside conservation technique	event	7,500	1	7,500
	Forest seedling productions	event	7,900	1	7,900
	Forest plantation setting up	event	7,900	1	7,900
	Forest resource management and conservation		7,900	1	7,900
3.2	Difusion of posters and leaflet		3,600	1	3,600
	<b>Total</b>				<b>144,050</b>

**(6) Implementation Plan**

The Hydraulic Infrastructure General Direction (DGIH-MINAG) executes this component as the executing unity in cooperation with the Agriculture Regional Direction (DRA), the Board of Users and related Institutions. In order to execute the activities efficiently the following has to be considered:

- For the implementation of the present component, the DGIH-MINAG will coordinate actions with the Central Management Unit responsible for each Watershed, as well as with Regional Managements of Agriculture (DRA).
- For the Project administration and management, the DGIH-MINAG will coordinate

actions with PSI-MINAG (Sub-sector Irrigation Program with extensive experience in similar projects).

- Considering there are some local governments that have initiated the preparation of a similar crisis management plan through the corresponding civil defense committee, under the advice of the National Institute of Civil Defense (INDECI) and local governments, the DGIH-MINAG must coordinate so that these plans be consistent with those existing in each Watershed.
- Training courses will be managed and administered by irrigator associations (particularly the unit of skills development and communications) with the support of local governments in each Watershed, to support timely development in each town.
- Experts in disaster management departments in each provincial government, ANA, AGRORURAL, INDECI, etc., as well as (international and local) consultants will be in charge of course instruction and facilitation.

## 4.4 Costs

### 4.4.1 Cost Estimate (at private prices)

#### (1) Project Costs Components

Project costs include the following:

- ① Work direct costs = total number of works by type × unit price
- ② Common provisional works = ① × 10%
- ③ Construction cost -1 = ① + ②
- ④ Miscellaneous = ③ × 15%
- ⑤ Benefits = ③ × 10%
- ⑥ Construction cost -2 = ③ + ④ + ⑤
- ⑦ Tax = ⑥ × 18% (IGV)
- ⑧ Construction cost = ⑥ + ⑦
- ⑨ Environmental measures cost = ⑧ × 1%
- ⑩ Detailed design cost = ⑧ × 5%
- ⑪ Works supervision cost = ⑧ × 10%
- ⑫ Project Cost = ⑧ + ⑨ + ⑩ + ⑪

#### (2) Work direct costs

On table 4.4.1-1 a summary table of direct costs for structural measures is presented for the Yauca River Watershed.

#### (3) Project Costs

The project cost is estimated in 20.9 million of soles as shown in Table 4.4.1-2. It includes reforestation and vegetation recovery costs, construction of early warning system and technical assistance. The annual operation and maintenance cost of completed works is approximately 0.5% of the project's cost.

**Table 4.4.1-1 Summary Table of the work's direct cost (at private prices)**

Structural Measures Direct Costs (Private Prices)  
構造物対策・直接工事費（民間価格）

Watershed 流域名	Critical Points クリティカル・ポイント	Measures		Direct Cost 直接工事費計 (1)	
			対策		
Rio Yauca	1	4.5K	Dike building + coastal defense	築堤・護岸工	321,000
	2	4.1K	Flow desilting	河床掘削	350,000
	3	4.5K~7.0K	Dike building + coastal defense	築堤・護岸工	6,995,000
	4	25.0K	Intake Rehabilitation	取水堰の修復（分流堰）	900,000
	5	25.0K	Coastal defense	護岸工	1,393,000
	6	41.1K	Coastal defense	護岸工	995,000
<b>SUB TOTAL</b>				<b>10,954,000</b>	



**Table 4.4.1-2 Construction cost (at private prices) (In soles)**

Watershed 流域名	PRIVATE PRICES COSTS															TOTAL COST OF THE PROGRAM 全体事業費
	COMPONENT A												COMPONENT B			
	STRUCTURAL MEASURES										NON STRUCTURAL MEASURES 非構造物対策		TECHNICAL ASSISTANCE 能力開発			
	Direct Cost (直接工事費)			INDIRECT COST (間接工事費)							HYDRAULIC INFRASTRUCTURE Total Cost	REFORESTATION Total Cost 植林・植生回復 事業費	EARLY ALERT SYSTEM Total Cost 洪水予警報 事業費	TRAINING Total Cost 防災教育 事業費		
Direct Cost	Temporary works cost	Works Cost	Operative Expenses	Utility	Total Cost of Infrastructure	TAX	Total work cost	Environmental Impact	Technical File	Supervision	HYDRAULIC INFRASTRUCTURE Total Cost	REFORESTATION Total Cost 植林・植生回復 事業費	EARLY ALERT SYSTEM Total Cost 洪水予警報 事業費	TRAINING Total Cost 防災教育 事業費	TOTAL COST OF THE PROGRAM 全体事業費	
(1)	(2) = 0.1 x (1)	(3) = (1) + (2)	(4) = 0.15 x (3)	(5) = 0.1 x (3)	(6) = (3)+(4)+(5)	(7) = 0.18 x (6)	(8) = (6)+(7)	(9) = 0.01 x (8)	(10) = 0.05 x (8)	(11) = 0.1 x (8)	(12) = (8)+(9)+(10)+(11)	(13)	(14)	(15)	(16) = (12)+(13)+(14)+(15)	
YAUCA	10,954,000	1,095,400	12,049,400	1,807,410	1,204,940	15,061,750	2,711,115	17,772,865	177,729	888,643	1,777,287	20,616,523	64,134	0	219,105	20,899,762

#### 4.4.2 Cost Estimate (at social prices)

##### (1) Work direct costs

In Table 4.4.2-1 a summary table of direct costs for structural measures is presented for the Yauca River watershed. The works' direct cost at private prices was turned into social prices applying the conversion factor.

##### (2) Project Costs

The project cost is estimated in 16,8 million of soles as shown in Table 4.4.2-2. It includes reforestation and vegetation recovery costs, construction of early warning system and technical assistance, before converting from private prices.

**Table 4.4.2-1 Summary Table of the work's direct cost (at social prices)**

Watershed 流域名	Critical Points クリティカル・ポイント	Measures 対策	SOLES (ソル)		
			Private prices 民間価格 (PP)	Correction Factor 係数 (fs)	Social Price 社会価格 (PS) = (fs) x (PP)
Rio Yauca	1	4.5K Dike building+coastal defense	321,000	0.804	258,084
	2	4.1K Flow desilting	350,000	0.804	281,400
	3	4.5K~7.0K Dike building+coastal defense	6,995,000	0.804	5,623,980
	4	25.0K Intake Rehabilitation	900,000	0.804	723,600
	5	25.0K Coastal defense	1,393,000	0.804	1,119,972
	6	41.1K Coastal defense	995,000	0.804	799,980
SUB TOTAL			10,954,000		8,807,016

**Table 4.4.2-2 Construction cost at (social prices)**

Watershed 流域名	SOCIAL PRICES COSTS															TOTAL COST OF THE PROGRAM 全体事業費
	COMPONENT A												COMPONENT B			
	STRUCTURAL MEASURES										NON STRUCTURAL MEASURES 非構造物対策		TECHNICAL ASSISTANCE 能力開発			
	DIRECT COST (直接工事費)			INDIRECT COST (間接工事費)							HYDRAULIC INFRASTRUCTURE Total Cost	REFORESTATION Total Cost 植林・植生回復 事業費	EARLY ALERT SYSTEM Total Cost 洪水予警報 事業費	TRAINING Total Cost 防災教育 事業費		
Direct Cost	Temporal works cost	Works Cost	Operative Expenses	Utility	Infrastructure total cost	TAX	Work's Total Cost	Environmental Impact	Technical File	Supervision	HYDRAULIC INFRASTRUCTURE Total Cost	REFORESTATION Total Cost 植林・植生回復 事業費	EARLY ALERT SYSTEM Total Cost 洪水予警報 事業費	TRAINING Total Cost 防災教育 事業費	TOTAL COST OF THE PROGRAM 全体事業費	
(1)	(2) = 0.1 x (1)	(3) = (1) + (2)	(4) = 0.15 x (3)	(5) = 0.1 x (3)	(6) = (3)+(4)+(5)	(7) = 0.18 x (6)	(8) = (6)+(7)	(9) = 0.01 x (8)	(10) = 0.05 x (8)	(11) = 0.1 x (8)	(12) = (8)+(9)+(10)+(11)	(13)	(14)	(15)	(16) = (12)+(13)+(14)+(15)	
YAUCA	8,807,016	880,702	9,687,718	1,453,158	968,772	12,109,647	2,179,736	14,289,383	142,894	714,469	1,428,938	16,575,685	50,751	0	189,759	16,816,195

## 4.5 Social Assessment

### 4.5.1 Private prices costs

#### (1) Benefits

Flood control benefits are flood loss reduction that would be achieved by the implementation of the Project and is determined by the difference between the amount of loss with and without Project. Specifically, in order to determine the benefits that will be achieved by the works' construction. First, the flood amount per flood loss of the different return periods (between 2 to 50 years) is calculated; assuming that the flood control works have a useful life of 50 years. To finish, determine the annual average amount of the loss reduction from the loss amount of different return periods. The Methodological Guideline for Protection and/or Flood Control Projects in agricultural or urban areas, 4.1.2p-105) establishes similar procedures.

Above find the description of the procedures to determine concrete benefits

- Determine the flood loss amount in the flood area by analyzing the magnitude of overflow that occurs without the Project for each return period (between 2 and 50 years)
- After, determine the amount of flood loss in the flood area by analyzing the magnitude of overflow that occurs when flood control priority works are built (Yauca 1 to 6).
- Determine the difference between ① and ②. Add the benefits of other works different than dikes (intakes, roads and dams protection, etc.) in order to determine the total profits

“Benefits of the Project” are considered as the sum of direct loss amount caused by overflow and indirect loss caused by the destruction of structures in vulnerable sections (farmland loss, interruption of traffic, etc.)

#### 1) Method of loss amount calculation

In this study, the amount of loss from direct and indirect damages to the variables listed in Table 4.5.1-1 was determined.

**Table 4.5.1-1 Flood loss amount calculation variables**

Loss	Variables	Description
(1) Direct	① Crops	<ul style="list-style-type: none"> <li>• Crops in flooding season The amount of crop loss by flooding is determined by multiplying the damage % regarding water depth and the number of days flooded</li> <li>• Agricultural land and infrastructure (channels, etc.)</li> <li>• Crop loss amount is determined by multiplying the damage % regarding water depth and the number of days flooded</li> </ul>
	② Hydraulic Works	<ul style="list-style-type: none"> <li>• Loss amount due to hydraulic structures destruction (intakes, channels, etc.).</li> </ul>
	③ Road Infrastructures	<ul style="list-style-type: none"> <li>• Flood damage related to road infrastructure is determined by the damage in transport sector</li> </ul>
	④ Housing	<ul style="list-style-type: none"> <li>• Residential and industrial buildings It is calculated applying the loss coefficient depending on the flood depth Housing: residential and industrial buildings; household goods: furniture, household appliances, clothing, vehicles, etc. Flood damages in housing, commercial buildings, assets and inventories (buildings and assets) is determined applying the loss coefficient according to the flood depth</li> </ul>
	⑤ Public Infrastructures	<ul style="list-style-type: none"> <li>• Determine the loss amount in roads, bridges, sewers, urban infrastructures, schools, churches and other public facilities</li> <li>• Determine the loss amount in public works by applying the correspondent coefficient to the general assets loss amount</li> </ul>
	⑥ Public Services	<ul style="list-style-type: none"> <li>• Electricity, gas, water, rail, telephone, etc.</li> </ul>
(2) Indirect	① Agriculture	<ul style="list-style-type: none"> <li>• Estimate the loss caused by irrigation water interruption due to the damage of hydraulic structures</li> <li>• Determine the construction and repair costs of hydraulic structures such as direct year costs</li> </ul>
	② Traffic Interruption	<ul style="list-style-type: none"> <li>• Estimate the loss lead by traffic interruption due to damages on flooded roads</li> <li>• Determine road's repair and construction costs as damage direct cost</li> </ul>

#### A. Direct loss

Direct loss is determined by multiplying the damage coefficient according to the flood depth as the asset value.

#### B. Indirect Loss

Indirect loss is determined taking into account the impact of intakes and damaged roads. Below, calculation procedures are described.

##### a. Dams damage

The loss amount due to dam damage is calculated by adding the direct loss (dam's rehabilitation and construction) and the indirect loss amount (harvest loss due to the interruption of irrigation water supply)

① Calculating the infrastructure cost

Works Cost = construction cost per water unit taken × size (flow, work length)

Unit cost of the work: for intakes and channels, it is required to gather information on the water intake volume of the existing work and the works' execution cost (construction or repair). The unit cost is calculated by analyzing the correlation among them both.

It was estimated that the work will be completely destroyed by the flow with a return period of 10 years.

② Crop loss

Annual earnings are determined according to the crops grown in the correspondent irrigation district.

Annual Profit = (crops selling - cost) × frequency of annual harvest

Crop Sale = planted area (ha) × yield (kg/ha) × transaction unit price

Cost = unit cost (s/ha) × planted area (ha)

b. Road infrastructure damage

Determine the loss due to traffic interruption.

Amount of loss = direct loss + indirect loss

Direct loss: road construction cost (construction, rehabilitation)

Indirect Loss: opportunity loss cost due to road damage (vehicle depreciation + staff expenses loss)

Then, a 5 days period takes place of non-trafficability (usually in Peru it takes five days to complete the rehabilitation of a temporary road)

2) Loss estimated amount according to disasters in different return periods

In table 4.5.1-2 the amounts of loss with and without Project are shown. These are estimated for disasters of different return periods in the Yauca River.

**Table 4.5.1-2 Loss Estimated Value (at private prices)**

(s./1,000)

Case	t	Yauca
Without Project	2	0
	5	0
	10	1,695
	25	2,569
	50	11,497
	Total	15,761
With Project	2	0
	5	0
	10	7
	25	1,005
	50	2,028
	Total	3,040

3) Loss amount (annual average) expected to be reduced by the Project

The annual average loss amount that is expected to be reduced by the Project by the total annual average loss amount occurred as flow multiplying the amount of loss reduction occurred as flow for the corresponding flood probabilities.

Considering that floods happen probabilistically, the annual benefit is determined as the annual average amount of loss reduction. Next find the procedures of calculation.

**Table 4.5.1-3 Loss reduction annual average amount**

Probabilities	Loss Amount			Average path's loss	Paths' Probabilities	Loss reduction annual average amount
	Without Project	With Project	Loss Reduction			
1/1			$D_0 = 0$			
1/2	$L_1$	$L_2$	$D_1 = L_1 - L_2$	$(D_0 + D_1)/2$	$1 - (1/2) = 0,500$	$d_1 = (D_0 + D_1)/2 \times 0,67$
1/5	$L_3$	$L_4$	$D_2 = L_3 - L_4$	$(D_1 + D_2)/2$	$(1/2) - (1/5) = 0,300$	$d_2 = (D_1 + D_2)/2 \times 0,300$
1/10	$L_5$	$L_6$	$D_3 = L_5 - L_6$	$(D_2 + D_3)/2$	$(1/5) - (1/10) = 0,100$	$d_3 = (D_2 + D_3)/2 \times 0,100$
1/20	$L_7$	$L_8$	$D_4 = L_7 - L_8$	$(D_3 + D_4)/2$	$(1/10) - (1/20) = 0,050$	$d_4 = (D_3 + D_4)/2 \times 0,050$
1/30	$L_9$	$L_{10}$	$D_5 = L_9 - L_{10}$	$(D_4 + D_5)/2$	$(1/20) - (1/30) = 0,017$	$d_5 = (D_4 + D_5)/2 \times 0,017$
1/50	$L_{11}$	$L_{12}$	$D_6 = L_{11} - L_{12}$	$(D_5 + D_6)/2$	$(1/30) - (1/50) = 0,013$	$d_6 = (D_5 + D_6)/2 \times 0,013$
1/100	$L_{13}$	$L_{14}$	$D_7 = L_{13} - L_{14}$	$(D_6 + D_7)/2$	$(1/50) - (1/100) = 0,010$	$d_7 = (D_6 + D_7)/2 \times 0,010$
Foreseen average annual amount of loss reduction				$d_1 + d_2 + d_3 + d_4 + d_5 + d_6 + d_7$		

In Table 4.5.1-4 Results of loss amount calculus are presented (annual average), which are expected to be reduced when implementing the Project in the Yauca River Watershed.

**Table 4.5.1-4 Annual average damage reduction amount (at private prices)**

s/1000

流域 Watershed	流量規模 Return Period	超過確率 Probability	被害額 (Total damage - thousands of S/.)			区間平均被害 額 ④ Damage Averagare	区間確率 ⑤ Probability incremental value	年平均被害額 ④×⑤ Average value of the damages flow	年平均被害額の 累計=年平均被 害軽減期待額 Annual Medial Damage
			事業を実施し ない場合①	事業を実施し た場合②	軽減額 ③=①-②				
			Without Project ①	With Project	Mitigated damages ③=①-②				
YAUCA	1	1.000	0	0	0		0	0	
	2	0.500	0	0	0	0	0.500	0	
	5	0.200	0	0	0	0	0.300	0	
	10	0.100	1,695	7	1,688	844	0.100	84	84
	25	0.040	2,569	1,005	1,564	1,626	0.060	98	182
	50	0.020	11,497	2,028	9,469	5,517	0.020	110	292

## (2) Social Assessment

### 1) Assessment's objective and indicators

The social assessment's objective in this Study is to evaluate investment's efficiency in structural measures using the analysis method of cost-benefit (C/B) from the national economy point of view. For this, economic assessment indicators were determined (relation C/B, Net Present Value - NPV and IRR). The internal return rate (IRR) is an indicator that denotes the efficiency of the project's investment. It is the discount rate to match the current value of the project's generated cost regarding the benefit's current value. It is the discount rate necessary so the Net Present Value (NPV) equals zero and the relation C/B equals one. It also indicates the percentage of benefits generated by such investment. The internal return rate used in the economic assessment is called "economical internal return rate (EIRR)". The market price is turned into the economical price (costs at social prices) eliminating the impact of market distortion.

The IRR, C/B relation and NPV are determined applying mathematical expressions shown in the Table below. When IRR is greater than the social discount rate, the relation C/B is greater than one and NPV is greater than zero, it is considered that the project is efficient from the national economic growth point of view.

**Table 4.5.1-5 Analysis assessment indicators of cost-benefit relation and its characteristics**

Indicators	Definition	Characteristics
Net Present Value (NPV)	$NPV = \sum_{i=1}^n \frac{B_i}{(1+r)^i} - \sum_{i=1}^n \frac{C_i}{(1+r)^i}$	<ul style="list-style-type: none"> <li>- Allows comparing net benefit magnitude performed by the project</li> <li>- It varies depending on the social discount rate</li> </ul>
Cost-Benefit Relation (C/B)	$B/C = \sum_{i=1}^n \frac{B_i}{(1+r)^i} / \sum_{i=1}^n \frac{C_i}{(1+r)^i}$	<ul style="list-style-type: none"> <li>- Allows comparing the investment efficiency by the magnitude of benefit per investment unit</li> <li>- Varies depending on the social discount rate</li> </ul>
Economical Internal Return Rate (EIRR)	$\sum_{i=1}^n \frac{B_i}{(1+r)^i} = \sum_{i=1}^n \frac{C_i}{(1+r)^i}$	<ul style="list-style-type: none"> <li>- Allows knowing the investment efficiency comparing it to the social discount rate</li> <li>- Does not vary depending on the social discount rate</li> </ul>
Where Bi: benefit per “i” year / Ci: cost per “i” year / r: social discount rate (11 %) / n: years of assessment		

## 2) Assumptions

Next, find the assumptions of every indicator used from the economical assessment

### i) Assessment Period

The assessment period is set between 2013 and 2027 (15 years after construction works started). This Project implementing schedule is the following:

- 2012: Detailed Design
- 2013-2014: Construction
- 2013-2027: Assessment Period

### ii) Standard Conversion Factor (SCF)

The standard conversion factor (SCF) is the relationship between socioeconomic prices established along the border and national private prices of all goods in a country’s economy. It is used to convert goods and services prices purchased in the local market at affordable prices. In this Study the following SCF values were used:

- Dams 0.804
- Gabions 0.863
- Intakes 0.863

TAX (Peruvians use IGV) is not taken into account in the conversion of market prices to socioeconomic prices.

### iii) Other preliminary conditions

- Price level: 2011
- Social discount rate: 10%
- Annual maintenance cost: 0.5% of construction cost

## 3) Cost-benefit relation analysis (C/B)

A comparison of the total cost and total benefit of flood control works converted to present

values applying the social discount rate was performed. In this case, the total cost is the addition of construction, operation and maintenance costs. The total benefit is the loss amount that was reduced due to the works. For this, a base year was established for the conversion into the current value at the moment of the assessment, and the assessment period was set for the next 15 years from the beginning of the Project. The total cost was determined adding-up the construction, operation and maintenance costs of the works converted into present values; and the total benefit adding-up the annual average loss amount turned into current values.

In table 4.5.1-6 results of calculations C/B, NPV and IRR to private prices is shown.

**Table 4.5.1-6 Social Assessment (C/B, NPV, IRR) (at private prices)**

流域名	年平均被害軽減額 Accumulated Average Annual Benefit	評価期間被害軽減額(15年) Accumulated Average Annual Benefit (in 15 years)	事業費 Project's Cost	維持管理費 O&M Cost	C/B Cost/Benefit Relation	Net Present Value (NPV) NPV	Internal Rate of Return (IRR) IRR
Yauca	3,799,425	1,715,745	20,899,762	1,155,236	0.09	(17,059,601)	-

## 4.5.2 Costs at social price

### (1) Benefits

#### 1) Estimated loss amount according to different return periods

In table 4.5.2-1 the amounts of loss with and without Project are shown. These are estimated for disaster of different return periods in the Yauca River Watershed.

**Table 4.5.2-1 Estimated loss amount (at social prices)**

(s./1,000)

Casoe	t	Cañete
Without Project	2	2,582
	5	10,558
	10	105,137
	25	144,972
	50	213,134
	Total	476,384
With Project	2	272
	5	1,024
	10	9,908
	25	14,260
	50	20,117
	Total	45,580

#### 2) Loss amount (annual average) is expected to be reduced with the Project

In table 4.5.2-2 results of loss amount calculation (annual average) that are expected to reduce to implement the Project in the Yauca River are shown.



**Table 4.5.2-2 Annual average damage reduction amount (at social prices)**

s/1000

流域 Watershed	流量規模 Return Period	超過確率 Probability	被害額 (Total damage - thousands of S/.)			区間平均被害 額 ④ Damage Averagare	区間確率 ⑤ Probability incremental value	年平均被害額 ④×⑤ Average value of the damages flow	年平均被害額の 累計＝年平均被害 軽減期待額 Annual Medial Damage
			事業を実施し ない場合①	事業を実施し た場合②	軽減額 ③=①-②				
			Without Project ①	With Project	Mitigated damages ③=①-②				
YAUCA	1	1.000	0	0	0		0	0	
	2	0.500	0	0	0	0	0	0	
	5	0.200	0	0	0	0	0	0	
	10	0.100	2,150	9	2,141	1,071	0.100	107	107
	25	0.040	3,313	1,341	1,972	2,057	0.060	123	230
	50	0.020	12,092	2,653	9,439	5,706	0.020	114	345

## (2) Social Assessment

In table 4.5.2-3 results of the calculation C/B, NPV and IRR at social prices are shown.

**Table 4.5.2-3 Social Assessment (C/B, NPV, IRR) (at social prices)**

流域名	年平均被害軽減額 Accumulated Average Annual Benefit	評価期間被害 軽減額(15年) Accumulated Average Annual Benefit (in 15 years)	事業費 Project's Cost	維持管理費 O&M Cost	C/B Cost/Benefit Relation	Net Present Value (NPV) NPV	Internal Rate of Return (IRR) IRR
Yauca	4,479,470	2,022,840	16,816,195	928,810	0.13	(13,083,633)	-

### 4.5.3 Social assessment conclusions

The social assessment shows that the Project in Yauca River watershed has extremely low economic impact on private and social prices. However, the following economical non-quantifiable positive impacts are shown:

- Contribution to local economic development when soothing the fear due to economic activities suspension and damage
- Contribution by increasing local employment opportunities for the construction of the project
- Strengthening the local population's awareness for floods damage and other disasters
- Income increase contributions due to an stable agricultural production because flood damages are soothed
- Increase of agricultural land price

From the results of the economic evaluation presented above, it is difficult to implement this

Project, even if there is the positive effects of the Project that are difficult to quantify in economic values.

## 4.6 Sensitivity Analysis

### (1) Objective

A sensitivity analysis was made in order to clarify the uncertainty due to possible changes in the future of the socioeconomic conditions. For the cost-benefit analysis it is required to foresee the cost and benefit variation of the project, subject to assessment, to the future. However, it is not easy to perform an adequate projection of a public project, since this is characterized for the long period required from planning to the beginning of operations. Also because of the long useful life of works already in operation and the intervention of a number of uncertainties that affect the future cost and benefit of the project. So, analysis results are obtained frequently and these are discordant to reality when the preconditions or assumptions used do not agree with reality. Therefore, for the uncertainty compensation of the cost-benefit analysis it should be better to reserve a wide tolerance-bank, avoiding an absolute and unique result. The sensitivity analysis is a response to this situation.

The objective of the sensitivity analysis is to provide the cost-benefit analysis results a determined bank that will allow a proper managing of the project's implementation, give numbers to the population and achieve greater accuracy and reliability of the project's assessment results.

### (2) Sensitivity Analysis

#### 1) General description of the sensitivity analysis

There are three methods of the sensitivity analysis, as indicated in Table 4.6-1.

**Table 4.6-1 Sensitivity Analysis Methods**

Methods	Description	Products
Variables sensitivity analysis	It consists in changing only one predetermined variable (precondition or hypothesis), to assess how the analysis result is affected	Bank values from the analysis when a precondition or hypothesis varies
Better and worst alternatives	It consists in defining the cases in which the analysis results are improved or worsen when changing the main pre-established preconditions or hypothesis to assess the analysis result bank	Bank values from the analysis when the main precondition or hypothesis vary
Monte Carlo	It consists in knowing the probability distribution of the analysis results by simulating random numbers of Monte Carlo simulation of pre-established preconditions and hypothesis	Probable results distribution when all main precondition or hypothesis vary

## 2) Description of the sensitivity analysis

In this project the sensitivity analysis method of the variables usually used in public works investments was adopted. Next, the scenarios and economic indicators used in the sensitivity analysis are shown.

**Table 4.6-2 Cases subjected to the sensitivity analysis and economic indicators**

Indicators	Variation bank according to factors	Economic indicators to be evaluated
Construction cost	In case the construction cost increases in 5 % and 10 %	IRR, NPV, C/B
Benefit	In case of reducing the benefit in 5 % and 10 %	IRR, NPV, C/B
Social discount rate	In case of increase and reduction of the discount social rate in 5 % respectively	NPV, C/B

## 3) Results of the sensitivity analysis

In table 4.6-3 the results of the sensitivity analysis of each assessed case to private and social prices is shown.

**Table 4.6-3 Results of the sensitivity analysis of IRR, C/B and NPV**

	Watershed	Variables	Base Case	Case 1	Case 2	Case 3	Case 4	Case 5	Case 6
				Cost increase 5%	Cost increase 10%	Benefit reduction 5%	Benefit reduction 10%	Discount rate increase 5%	Discount rate increase 10%
Private prices	YAUCA	IRR (%)	-	-	-	-	-	-	-
		B/C	0.09	0.09	0.08	0.09	0.08	0.07	0.12
		NPV(s)	(17,059,601)	(17,998,368)	(18,937,135)	(17,145,388)	(17,231,175)	(16,296,088)	(17,760,074)
Social prices	YAUCA	IRR (%)	-	-	-	-	-	-	-
		B/C	0.13	0.13	0.12	0.13	0.12	0.10	0.18
		NPV(s)	(13,083,633)	(13,838,957)	(14,594,281)	(13,184,775)	(13,285,917)	(12,649,776)	(13,357,212)

## (3) Assessment of the sensitivity analysis

The impact of socioeconomic conditions changes to the Project, has shown that the variation of economic effect indicators are small, however the indicators of base case itself show very low viability of this Project.

## 4.7 Sustainability Analysis

This project will be co-managed by the central government (through the DGIH), irrigation committees and regional governments. Also, the project cost will be covered with the respective contributions of the three parties. Usually the central government (in this case, the DGIH) takes the 80%, irrigation commissions 10% and regional governments 10%. However, the percentages of the contributions of these last two are decided through discussions between both parties. On the other hand, the operation and maintenance (O & M) of the completed works is assumed by the irrigation committee. So, the sustainability of the project depends on the profitability of the Project and the ability of the irrigation committees for O & M.

Table 4.7-1 presents the data of the budget for irrigation committees of Yauca River Watershed in recent years.

**Table 4.7-1 Project Budget of the irrigation commissions**

River	Annual Budget			
	2006	2007	2008	Average
Yauca	114,482.12	111,102.69	130,575.40	118,720

### (1) Profitability

The project in Yauca river Watershed is insufficiently profitable and sustainable. The investment amount in this watershed is estimated in 20.9 million soles at private prices. However, the C/B relation is 0.13, the NPV is estimated in – 13.0 million soles and the internal return rate is almost nil at social prices. These Figures show that the project's economic efficiency is very low.

### (2) Cost of operation and maintenance

The annual cost of operation and maintenance required for the project, having as a base year 2008 is estimated at 88,864 soles, corresponding to 0.5% of the project construction cost. On the other hand, the average operating expenses for the last 3 years of the irrigation commissions was 118,700 soles.

When considering that the annual operation and maintenance cost represents 75.9% of the annual irrigation commissions budget, the project would not be sustainable according to the financial capacity of these committees to maintain and operate the constructed works.

## 4.8 Environmental Impact

### 4.8.1 Procedure of Environmental Impact Assessment

Projects are categorized in three scales, based on the significance level of the negative and positive impacts, and each sector has an independent competence on this categorization. The following table shows the environmental management instruments that are required for each category. The Project holder should submit the Environmental Impact Statement (DIA, in Spanish) for all Projects under Category I. The project holder should prepare an EIA-sd or an EIA-d if the Project is categorized under Category II or III, respectively, to be granted the Environmental Certification from the relevant Ministry Directorate.

**Table 4.8.1-1 Project Categorization and Environmental Management Instruments**

	Description	Required Environmental Management Instrument
Category I	It includes those Projects that when carried out, they cause no significant negative environmental impacts whatsoever.	PEA that is considered a DIA after the assessment for this category
Category II	It includes those Projects that when carried out, they can cause moderate environmental impacts, and their negative effects can be removed or minimized through the adoption of easily applicable measures.	Semi-Detailed Environmental Impact Assessment (EIA-sd)
Category III	It includes those Projects than can cause significant quantitative or qualitative negative environmental impacts because of their characteristics, magnitude and/or location. Therefore, a deep analysis is required to revise those impacts and set out a relevant environmental management strategy.	Detailed Environmental Impact Assessment (EIA-d)

Source: Prepared by the JICA Study Team based on the SEIA Law (2001)

The next graph shows the Environmental Document's Classification, the Environmental

Document's Assessment, and the Environmental Certification.

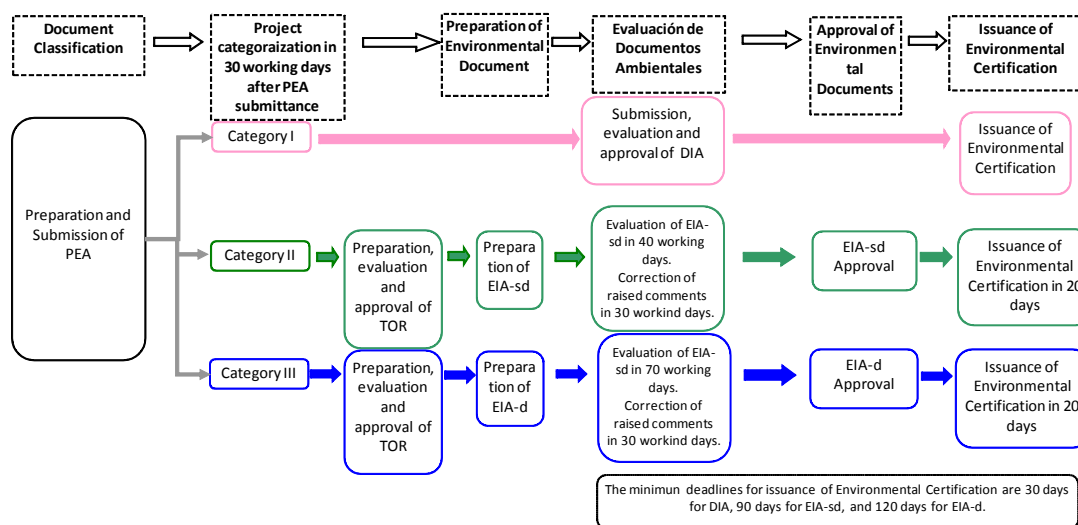

Source: Prepared by the JICA Study Team based on the SEIA Regulations (2009)

**Figure 4.8.1-1 Process to Obtain the Environmental Certification**

First, the Project holder applies for the Project classification, by submitting the Preliminary Environmental Assessment (PEA). The relevant sector assesses and categorizes the Project within the next 30 working days after the document's submission. The Project's PEA that is categorized under Category I becomes an EID, and those Projects categorized under Category II or III should prepare an EIA-sd or EIA-d, as applicable. There are cases in which the relevant sector prepares the Terms of Reference for these two studies, and submits them to the holder. There are other cases in which the holder prepares the Terms of Reference and these are approved by the relevant sector, based on the interview with DGAA. Number of working days required for EIA-sd revision and approval is 90, and number of working days required for EIS-d is 120; however, these maximum deadlines may be extended.

The progress of the environmental impact study is as shown below.

The JICA Study Team subcontracted a local Consultant (CIDE Ingenieros S.A.), and a Preliminary Environmental Assessment (PEA) was carried out, from December 2010 to January 2011 for Yauca river.

EAP for the Yauca river was submitted to DGIH from JICA on January 25, 2011. DGIH submitted the EAP to DGAA on July 19, 2011.

EAP for Yauca river was examined by DGAA, and DGAA issued their comments on EAP to DGIH. JICA Study Team revised EAP upon the comments and submitted it to DGAA on September 21, 2011. DGAA completed examination on the revised EAP and issued approval letter on Yauca river in which DGAA classified Yauca river into Category I. Therefore the additional environmental impact analysis for Yauca river is not required.

The positive and negative environmental impact associated with the implementation of this project was confirmed and evaluated, and the plan for prevention and mitigation measures are prepared by EAP results, field investigation and hearing by JICA Study Team.

The proposed works in this project include: the reparation of existing dikes, construction of new dikes, riverbed excavation, bank protection works, repair and improvement of the derivation and intakes works, and also river expansion. Table 4.8.1-2 describes “working sites” to be considered in the Environmental Impact section for Pisco river.

**Table 4.8.1-2 Works Description**

Basin	Location		Preservation Object	Counter Measure	Summary of Facility	Objective Section	
Yauca	1	4.5k下流	Inundation	Rehabilitation of dike	Top W; 4.0m H; 2.0m Slope; 1:3 L; 1,000m	3.5km~7.5km (total)	
	2	4.1km	Narrow Section	Riverbed excavation	Ex. width; 100m Ex. depth; 1.0m L; 500m		
	3	4.5~7.0k	Inundation	Rehabilitation of dike	Top W; 4.0m H; 2.0m Slope; 1:3 L; 2,500m		
	4	25.0k	Intake	Crop land (olive)	Rehabilitation of intake	Weir W; 100m H; 3.0m T; 2.0m	25.0km~25.7km (total)
	5	25.0k	Intake		Revetment	H; 2.0m Slope; 1:2 L; 500m	40.9~41.3km(left bank)
	6	41km	Intake	Road	Revetment	H; 2.0m Slope; 1:2 L; 400m	

Source: JICA Study Team

## 4.8.2 Methodology

In order to identify environmental impacts of the works to be executed in the different watersheds, we developed identification impact matrixes for watershed.

First, the operation and activities for each project based on typical activities of “hydraulic works” construction were determined. Afterwards, the concrete activities type was determined which will be executed for each work that will be developed in the watersheds. Then, to evaluate Socio-environmental impacts the Leopold matrix was used.

**Table 4.8.2-1 Evaluation Criterion - Leopold Matrix**

Index		Description	Valuation
“Na” nature		It defines whether change in each action on the means is positive or negative	Positive (+) : beneficial
			Negative (-): harmful
Probability of Occurrence “P.O.”		It includes the probability of occurrence of the impact on the component	High (>50 %) = 1.0
			Medium (10 – 50 %) = 0.5
			Low (1 – 10 %) = 0.2
Magnitude	Intensity (In)	It indicates the magnitude of change in the environmental factor. It reflects the degree of disturbance	Negligible (2)
			Moderate intensity (5)
			Extreme Disturbance (10)
	Extension “Ex”	It indicates the affected surface by the project actions or the global scope on the environmental factor.	Area of indirect influence: 10
			Area of direct influence: 5
			Area used up by the works: 2
	Duration “Du”	It refers to the period of time when environmental changes prevail	> 10 years: 10
			5 – 10 years : 5
1 – 5 years: 2			
Reversibility “Rev”	It refers to the system’s capacity to return to a similar, or an equivalent to the initial balance.	Irreversible: 10	
		Partial return: 5	
		Reversible: 2	

Source: Prepared based on PEAs of 6 Basins

**Table 4.8.2-2 Impact Significance Degrees**

SIA	Extent of Significance
≤ 15	Of little significance
15.1 - 28	Significant
≥ 28	Very significant

Source: Prepared based on PEAs of 6 Basins

### 4.8.3 Identification, Description and Social Environmental Assessment

#### (1) Identification of social environmental impacts

In the following matrix (construction/operation stages) in the watershed, elaborated based on the report analysis of the Preliminary Environmental Assessment.

**Table 4.8.3-1 Impact Identification Matrix (Construction and Operation Stage) – Yauca River**

Construction Stage			Work	1-6	1-6	1-6	1-6	4-6	1,2,3	1,3,4,5,6	1-6	1-6	1-6	1-6	1-6	Total Negative	Total Positive	
Environment	Component	Environmental Factors	Activity															
			Labor Recruitment	Site preparation work (Clearing, land grading, Levelled)	Diversion of riverbed (Cofferdams)	Digging and movement of Land	Digging and refilling in riverside	Digging and refilling in riverbed	Civil Work (Concreting)	I&O of stone pits and material production plants	DME I&O	Camps work I&O	Carriage Staff	Transportation of machinery, equipment, materials and supplies				
Physique	Air	PM-10 (Particulate matter)		N	N	N	N	N	N	N	N	N	N	N	N	9	0	
		Gas emissions		N	N	N	N	N	N	N	N	N	N	N	N	10	0	
	Noise	Noise		N	N	N	N	N	N	N	N	N	N	N	N	11	0	
		Soil fertility		N								N	N			3	0	
	Soil	Land Use		N								N	N			3	0	
		Calidad del agua superficial				N			N	N	N	N				5	0	
	Water	Cantidad de agua superficial									N			N		2	0	
		Morfología fluvial				N			N	N		N				4	0	
	Physiography	Morfología terrestre				N						N				3	0	
		Terrestrial flora				N						N				2	0	
Biotic	Flora	Aquatic flora									N				2	0		
		Terrestrial fauna			N							N			2	0		
	Fauna	Aquatic fauna				N			N	N		N			4	0		
Visual landscape											N	N			2	0		
Socio-economic	Social	Quality of life		P									N	N	N	3	1	
		Vulnerability - Security														0	0	
	Economic	PEA		P												0	1	
		Current land use														0	0	
<b>Total</b>				2	8	6	4	6	7	4	10	9	3	4	4	65	2	
<b>Percentage of positive and negative</b>																97 %	3 %	

Operation Stage			Works						Total Negative	Total Positive
Environment	Component	Environmental Factors	Repaired Dike Point 1	Riverbed without Siltling Point 2	Repaired Dike Point 3	Intake Point 4	Protection Point 5	Protection - Left Side Point 6		
			Physique	Air	PM-10 (Particulate matter)					
Gas emissions									0	0
Noise	Noise								0	0
	Soil fertility						P	P	0	2
Soil	Land Use								0	0
	Calidad del agua superficial					P	P	P	0	3
Water	Cantidad de agua superficial	P		P	P	P			0	4
	Morfología fluvial	N		N	N				3	0
Physiography	Morfología terrestre								0	0
	Terrestrial flora								0	0
Biotic	Flora	Aquatic flora						0	0	
		Terrestrial fauna							0	0
	Fauna	Aquatic fauna	N	N	N				3	0
Visual landscape		P	P	P		P	P	0	5	
Socio-economic	Social	Quality of life	P	P	P	P	P	P	0	6
		Vulnerability - Security	P	P	P	P	P	P	0	6
	Economic	PEA							0	0
		Current land use	P	P	P	P	P	P	0	6
<b>Total</b>			7	7	7	5	6	6	6	32
<b>Percentage of positive and negative</b>									16 %	84 %

N: Negative, P:Positive

Source: Prepared by the JICA Study Team

On the Yauca River basin, based on the impact identification results for the construction stage, a total number of 67 interactions have been found. 65 of these interactions (97 %)



correspond to impacts that will be perceived as negative, and 2 (3 %) correspond to impacts that will be perceived as positive. In addition, 38 interactions have been found for the operation stage; 6 of these interactions (16 %) correspond to impacts that will be perceived as negative, and 32 (84 %) correspond to impacts that will be perceived as positive.

(2) Environmental and Social Impact Assessments

Environmental and social impacts are assessed with the methodology that was explained in 4.8.2 Methodology. The following tables show the environmental and social assessment results for the basin, during the construction and operation stages.

**Table 4.8.3-2 Environmental Impact Assessment Matrix – Yauca River**

		The Yauca River Basin																									
Medio	Componente	Acciones del proyecto	Construction Stage											Operation Stage													
			Puntos de Obras:											Ya1	Ya2	Ya3	Ya4	Ya5	Ya6								
			Labor Recruitment	Site preparation work (Clearing, land grading, Levelled)	Diversion of riverbed (Cofferdams)	Digging and refilling in riverside	Digging and refilling in riverbed	Civil Work (Concreting)	I&O of stone pits and material production plants	DME I&O	Camps work I&O	Carriage Staff	Transportation of machinery, equipment, materials and supplies							Ya 1-6	Ya 1-6	Ya 1-6	Ya 1-6	Ya 1-6			
			Ya 1-6	Ya 1-6	Ya 1-6	Ya 4-6	Ya 1, 2 y 3	Ya 1, 3, 4, 5 y 6	Ya 1-6	Ya 1-6	Ya 1-6	Ya 1-6	Ya 1-6	Ya 1-6													
Physique	Air	PM-10 (Particulate matter)	0.0	-15.0	-11.5	-12.0	-12.0	0.0	-18.0	-18.0	0.0	-12.0	-12.0	0.0	0.0	0.0	0.0	0.0	0.0	0.0	0.0	0.0	0.0	0.0	0.0	0.0	
		Gas emissions	0.0	-11.5	-11.5	-11.5	-11.5	-11.5	-15.0	-11.5	0.0	-11.5	-11.5	0.0	-11.5	-11.5	0.0	0.0	0.0	0.0	0.0	0.0	0.0	0.0	0.0	0.0	0.0
	Noise	Noise	0.0	-12.0	-15.0	-15.0	-15.0	-15.0	-15.0	-15.0	-15.0	-15.0	-15.0	-15.0	0.0	0.0	0.0	0.0	0.0	0.0	0.0	0.0	0.0	0.0	0.0	0.0	0.0
		Soil	Soil fertility	0.0	-14.5	0.0	0.0	0.0	0.0	-14.2	-14.2	0.0	0.0	0.0	0.0	0.0	0.0	0.0	0.0	0.0	0.0	0.0	0.0	0.0	0.0	31.0	31.0
	Water	Land Use	0.0	-14.2	0.0	0.0	0.0	0.0	-15.0	-15.0	0.0	0.0	0.0	0.0	0.0	0.0	0.0	0.0	0.0	0.0	0.0	0.0	0.0	0.0	0.0	0.0	0.0
		Calidad del agua superficial	0.0	0.0	-17.5	-15.0	-23.0	-14.5	-15.0	0.0	0.0	0.0	0.0	0.0	0.0	0.0	0.0	0.0	0.0	0.0	0.0	0.0	0.0	28.0	31.0	31.0	
	Physiography	Canidad de agua superficial	0.0	0.0	0.0	0.0	0.0	-9.0	0.0	-15.0	0.0	0.0	0.0	0.0	0.0	0.0	0.0	0.0	0.0	0.0	0.0	0.0	0.0	0.0	0.0	0.0	
Morfología fluvial		0.0	0.0	-12.0	-26.0	-31.0	0.0	-23.0	0.0	0.0	0.0	0.0	0.0	-25.5	-30.5	-25.5	0.0	0.0	0.0	0.0	0.0	0.0	0.0	0.0	0.0		
Morfología terrestre		0.0	-33.0	0.0	0.0	0.0	0.0	0.0	-28.0	0.0	0.0	0.0	0.0	0.0	0.0	0.0	0.0	0.0	0.0	0.0	0.0	0.0	0.0	0.0	0.0		
Biotic	Flora	Terrestrial flora	0.0	-24.5	0.0	0.0	0.0	0.0	0.0	-22.5	0.0	0.0	0.0	0.0	0.0	0.0	0.0	0.0	0.0	0.0	0.0	0.0	0.0	0.0	0.0	0.0	
		Aquatic flora	0.0	0.0	0.0	0.0	-14.5	0.0	-14.5	0.0	0.0	0.0	0.0	0.0	0.0	0.0	0.0	0.0	0.0	0.0	0.0	0.0	0.0	0.0	0.0	0.0	
	Fauna	Terrestrial fauna	0.0	-24.2	0.0	0.0	0.0	0.0	0.0	-22.5	0.0	0.0	0.0	0.0	0.0	0.0	0.0	0.0	0.0	0.0	0.0	0.0	0.0	0.0	0.0	0.0	
		Aquatic fauna	0.0	0.0	-12.0	-11.5	-17.5	0.0	-14.5	0.0	0.0	0.0	0.0	0.0	-25.5	-30.5	-25.5	0.0	0.0	0.0	0.0	0.0	0.0	0.0	0.0	0.0	
Socio-economic	Esthetic	Visual landscape	0.0	0.0	0.0	0.0	0.0	0.0	-12.0	-12.0	0.0	0.0	0.0	0.0	0.0	0.0	0.0	0.0	0.0	0.0	0.0	0.0	0.0	0.0	0.0	0.0	
		Quality of life	0.0	0.0	0.0	0.0	0.0	0.0	0.0	0.0	0.0	-14.5	-17.5	0.0	0.0	0.0	0.0	0.0	0.0	0.0	0.0	0.0	0.0	0.0	0.0	0.0	
	Social	Vulnerability - Security	0.0	0.0	0.0	0.0	0.0	0.0	0.0	0.0	0.0	0.0	0.0	0.0	0.0	0.0	0.0	0.0	0.0	0.0	0.0	0.0	0.0	0.0	0.0	0.0	
		PEA	0.0	0.0	0.0	0.0	0.0	0.0	0.0	0.0	0.0	0.0	0.0	0.0	0.0	0.0	0.0	0.0	0.0	0.0	0.0	0.0	0.0	0.0	0.0	0.0	
Economic	Current land use	0.0	0.0	0.0	0.0	0.0	0.0	0.0	0.0	0.0	0.0	0.0	0.0	0.0	0.0	0.0	0.0	0.0	0.0	0.0	0.0	0.0	0.0	0.0	0.0		

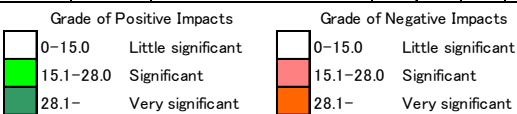

Source: Prepared based on PEAs of 6 Basins

It must be pointed out that in the Yauca River basin only 14 out of a total of 65 negative impacts have been quantified as significant, and 2 have been quantified as very significant, during the construction stage. Meanwhile, out of a total of 6 negative impacts, only 4 have been quantified as significant, and 2 have been quantified as very significant, during the operation stage.

During the construction stage, the works site preparation component and the DME installation and operation component will significantly affect the land morphology. At the same time, the Riverbed Excavation and Filling component will affect the “Ya1”, “Ya2”, and “Ya3” points. During the operation stage, river morphology and aquatic fauna will be

significantly affected at the “Ya2” points, where the river basin will be excavated.

During the construction stage, actions that will generate most significant negative impacts along the basin include: “Site Works Preparation and Clearance”, “Riverbed Excavation and Filling”, and “Surplus Material Deposits Operation (DME, in Spanish).” “Site works Preparation and Clearance” will bring about a significant modification to the land morphology, whereas “Riverbed Excavation and Filling” will bring about a significant modification to river morphology.

During the operation stage, hydraulic infrastructure works that will bring about most significant negative environmental impacts include “Riverbed excavation and embankment” that will cause a modification to the river morphology and subsequently, decreased river habitability conditions that will directly impact the aquatic fauna.

Most significant positive impacts are related to all works to be constructed along the river basins, and are directly related to improve the quality of the lives of the population around the area of influence, improve the “Current Use of land / soil”, improve the security conditions, and reduce vulnerability at social and environmental levels.

#### **4.8.4 Socio-Environmental Management Plans**

The objective of the Socio-Environmental Plans is to internalize both positive and negative significant and very significant environmental impacts that are related to the Project’s construction and operation stages, so that prevention and/or mitigation of significant and very significant negative impacts, preservation of environmental heritage, and Project sustainability are ensured.

During the construction stage, Project of Pisco river has set out the following measures: “Local Hiring Program”, “Works Sites Management and Control Program”, “Riverbed Diversion Program”, “Riverbank Excavation and Filling Management”, “Riverbed Excavations and Filling Management”, “Quarry Management”, “DME Management”, “Camp and Site Residence Standards”, and “Transportation Activity Management.” During the operation stages, Project for the basin has considered the development of activities with regard to “Riverbed and Aquatic Fauna Management”. These activities should develop riverbed conditioning downstream the intervention points, for erosion probabilities to be reduced, and habitability conditions to be provided for aquatic fauna species. The following are measures related to those negative impacts to be mitigated or those positive impacts to be potentiated. Overall measures have been established for the basin, based on the impacts.

**Table 4.9.4-1 Environmental Impact and Prevention/Mitigation Measures**

Item	Impact	Counter Measures	Period
Natural environment	Water quality of surface water	Management of river diversion and coffering	Construction period
		Management of bank excavation and banking	
		Management of riverbed excavation and back filling	
	River topography	Management of bank excavation and banking	
		Management of riverbed excavation and back filling	
		Management of quarry site	
	Other topography	Management of construction site	
		Management of large amount of excavated or dredged material	
Dust	Management of construction site		
	Management of large amount of excavated and dredged material		
Biological environment	Aquatic fauna	Management of riverbed excavation and back filling	O/M period
	Terrestrial fauna	Management of construction site	Construction period
		Management of large amount of excavated and dredged material	
	Terrestrial flora	Management of construction site	
		Management of large amount of excavated and dredged material	
Social environment	Quality of life	Management of labor and construction office	
		Management of traffic of construction vehicle	
		Employment plan of local people	
	Population of economic activity	Employment plan of local people	

Source: JICA Study Team

### 4.8.5 Monitoring and Control Plan

#### (1) Follow up and monitoring plan

The follow-up plan has to implement firmly the management of environmental plan. The monitoring plan is to be carried out to confirm that the construction activity fulfill the environmental standard such as Environmental Quality Standards (EQS) either or Maximum Permissible Limits (MPL). And the monitoring and control must be carried out under the responsibility of the project's owner or a third party under the supervision of the owner.

#### · Construction stage

During the construction period of the projects to be done in the watershed, the Monitoring and Control Plan will be directed to the verification of the fulfillment measures designed as part of the environmental monitoring plan and the verification of the fulfillment of laws and regulation of the Peruvian Legislation. The following aspects will also be monitored:

#### Water Quality and Biological Parameters:

Water quality and biodiversity parameters control shall be performed at downstream of these works must be monitored. In the following table the profile of this plan is shown.

**Table 4.8.5-1 Monitoring to Water Quality and Biological Parameters**

Item	Unit	Measured Value (Mean)	Measured Value (Max.)	Country's Standards
pH	pH			"National Standard for Water Quality" D.S. No. 002-2009 MINAM
TSS	mg/l			
BOD/COD	mg/l			
DO	mg/l			
Total Nitrogen	mg/l			
Heavy Metals	mg/l			
Temperature	°C			
Biological Diversity indices: Shannon; Pielou; richness and abundance				

[Measurement Points]

-50 meters upstream the intervention points

-50 meters downstream the intervention points

-100 meters downstream the intervention points

[Frequency]

Quarterly

[Person in charge of Implementation]

DGIH-MINAG, or a third party under the project holder's supervision

Source: JICA Study Team

Air Quality:

During impact analysis, in the projects to be developed in the watershed no significant impacts will be seen in the activities related to hydraulic infrastructure works. However, the generation of dust and atmospheric contaminant emissions always affects the working area and the workers and inhabitants health. So, it is recommended to monitor air quality.

**Table 4.8.5-2 Monitoring to Air Quality**

Item	Unit	Measured Value (Mean)	Measured Value (Max.)	Peruvian Standards (D.S. No 074-2001-PCM)	Referred International Standards
SO <sup>2</sup>				"National Standard for Air Quality" D.S. No.074-2001-PCM	National Ambient Air Quality Standards (NAAQS) (Updated in 2008)
NO <sup>2</sup>					
CO					
O <sup>3</sup>					
PM-10					
PM-2.5					

[Measurement Points]

\*02 stations per monitoring point: Windward and downwind (upwind and against the wind direction)

-1 point at the working zones

-1 point at a quarry, away from the river (the largest and / or the closest point to a populated area)

-1 point at a D.M.E. (the largest and / or the closest point to a populated area)

[Frequency]

Quarterly

[Person in charge of the Implementation]

DGIH-MINAG, or a third party under the project holder's supervision

Source: JICA Study Team

Noise Quality

Likewise, it is proposed to perform a noise monitoring at the potential receptors located near the noise emission spots towards the working sites, in the next table 4.8.5-3, the terms are described.

**Table 4.8.5-3 Monitoring to Noise Quality**

Item	Unit	Measured Value (Mean)	Measured Value (Max.)	Country's Standards	Referred International Standards
Noise level	LAeqT (dB(A))			National Environmental Quality Standards for noise (EQS) - S.N. N° 085-2003-PCM	-IEC 651/804 - International -IEC 61672- New Law: Replaces IECs 651/804 -ANSI S 1.4 – America

[Measurement Point]

Monitoring to acoustic contamination levels will be carried out at the potential receivers that are located around the noise emission points per work front.

01 point per potential receiver will be monitored.

[Frequency]

Every two months during construction phase

[Person in charge of the Implementation]

DGIH-MINAG, or a third party under the project holder's supervision

Source: JICA Study Team

· Operation Stages

Regarding works impact of all projects, it is mainly recommended to monitor biologic parameters and water quality as river topography and the habitat of aquatic life.

**Table 4.8.5-4 Monitoring to Water Quality (Operation Stage)**

Item	Unit	Measured Value (Mean)	Measured Value (Max.)	Country's Standards
pH	pH			"National Standard for Water Quality" D.S. No. 002-2009 MINAM
TSS	mg/l			
BOD/COD	mg/l			
DO	mg/l			
Total Nitrogen	mg/l			
Heavy Metals	mg/l			
Temperature	°C			
Biological Diversity indices: Shannon; Pielou; richness and abundance				

[Measurement Points]

-50 meters upstream the intervention points

-50 meters downstream the intervention points

-100 meters downstream the intervention points

[Frequency]

Quarterly in first two years of operation phase

[Person in charge of Implementation]

DGIH-MINAG, or a third party under the project holder's supervision

Source: JICA Study Team

(2) Closure or Abandon Plan

Closure or abandon plans have been made for each watershed. These will be executed at the end of construction activities and involves the removal of all temporary works and restoration of intervened and/or affected areas as a result of the works execution. The restoration includes the removal of contaminated soil, disposal of waste material, restoration of soil morphology and restoration with vegetation of intervened sites.

(3) Citizen Participation

Citizen participation plans have been made for each watershed, which must be executed before and during construction and when the works are completed. The recommended activities are:

- Before works: Organize workshops in the surrounding community's area near the project and let them know what benefits they will have. Informative materials in communities, which will explain the profile, lapse, objectives, benefits, etc. of the Project
- During works execution: Give out information on the construction progress. Responding complaints generated from the local community during works execution. For this, a consensus

wants to be previously achieved with the community in order to determine how claims will be met

- When works are completed: Organize workshops to inform about works completion. Works delivery to the local community inviting local authorities for the transfer of goods, which means the work finished.

#### 4.8.6 Cost for the environmental impact management

The direct costs of previously mentioned measures to mitigate environmental impacts in the Pisco River Watershed is as shown in the Table 4.8.6-1. In any case, it is necessary to determine in detail these measures' budget for each watershed in the detailed design stage.

**Table 4.8.6-1 Direct costs of measures to manage environmental impact**

Actions	Unit	Qty	Unitary price (S/.)	Subtotal (S/.)	Total (s/.)
Sign for vehicles entrance	Month	6	S/. 1.400,0	S/. 8.400,0	S/. 8.400,0
Industrial waste transportation	Month	6	S/. 4.200,0	S/. 25.200,0	S/. 25.200,0
Project sites landscape protection measures	Month	6	S/. 2.800,0	S/. 16.800,0	S/. 16.800,0
Operation and maintenance of construction equipment	Month	6	S/. 1.960,0	S/. 11.760,0	S/. 11.760,0
Measures for staff noise protection	Month	6	S/. 1.120,0	S/. 6.720,0	S/. 6.720,0
Functioning expenses to implement environmental impact mitigation measures	Month	6	S/. 4.480,0	S/. 26.880,0	S/. 26.880,0
Soil and air contaminant prevention capacity development	Month	6	S/. 2.520,0	S/. 15.120,0	S/. 15.120,0
Bed and aquatic fauna monitoring					S/. 11.239,2
Diversity indicators monitoring	times	3	S/. 672,0	S/. 2.016,0	
Water flow monitoring	times	3	S/. 588,0	S/. 1.764,0	
T°, pH, OD monitoring	times	3	S/. 571,2	S/. 1.713,6	
DBO monitoring	times	3	S/. 638,4	S/. 1.915,2	
Total solids dissolve monitoring (SDT)	times	3	S/. 638,4	S/. 1.915,2	
Total suspended solids monitoring (SST)	times	3	S/. 638,4	S/. 1.915,2	
Air and noise quality monitoring					S/. 37.500,0
Gas emissions monitoring	times	3	S/. 4.500,0	S/. 13.500,0	
Dust monitoring	times	3	S/. 5.000,0	S/. 15.000,0	
Noise monitoring	times	3	S/. 3.000,0	S/. 9.000,0	
Total					S/. 159.619,2

## **4.8.7 Conclusions and Recommendations**

### **(1) Conclusions**

According to the Preliminary Environmental Appraisals to Yauca basin, most impacts identified during the construction and operation stages were found out to be of little significance. Significant and very significant negative impacts can be controlled or mitigated, as long as suitable Environmental Management Plans are carried out. In addition, the Project will be implemented in the short term, as environmental conditions will be quickly restored. However, the execution of a follow – up and monitoring plan is important, and in the event that unexpected impacts are generated, immediate mitigation measures must be taken.

In addition, significant positive impacts are also present, especially during the operation stage. These positive impacts include: An enhanced security / safety and a decreased vulnerability at social and environmental levels; an improved quality of life among the population in the area of influence, and an improved “Current use of land / soil”.

### **(2) Recommendations**

1) We mainly recommend that the beginning of the construction activities coincides with the beginning of the dry seasons in the region (May to November) when the level of water is very low or the river dries up. The river characteristics / features should be taken into account, that the Yauca River is seasonal rivers. At the same time, the crop season cycle in the areas of direct influence should be taken into account, so that traffic jams caused by the large trucks and farming machinery is prevented.

2) It is recommended that the Project holder (DGIH) should define the limit of river area during detailed design stage, and identify the people who live within the river area illegally. Continually the DGIH should carry on the process of land acquisition based on the Land Acquisition Law, which are; Emission of Resolution for land acquisition by the State, Proposition of land cost and compensation for land owner, Agreement of the State and land owner, Payment, archaeological assessment certification.

3) DGIH has to promote the process to obtain the CIRA in the detail design stage. The process to be taken is i) Application form, ii) Copies of the location drawings and outline drawings, iii) voucher, iv) Archaeological Assessment Certificate.

4) The participation of the women in the workshops can be promoted through the existing women group such as Vaso de Leche.

Finally, the DGAA submitted the resolutions (Environmental Permissions) for Yauca basin. The project has been categorized as “Category I”, which means that the project is not required to carry out neither EIA-sd nor EIA-d.



## **4.9 Execution Plan**

The Project's Execution Plan will review the preliminary schedule, which includes the following components. For pre-investment stage: ① full execution of pre-feasibility and feasibility studies to obtain SNIP's approval in the pre-investment stage; for the investment stage: ② signing of loans (L/A), ③ consultant selection, ④ consulting services (detailed design and elaboration of technical specifications), ⑤ constructor selection and ⑥ work execution. For the post-investment stage: ⑦ Works' completion and delivery to water users associations and beginning of the operation and maintenance stage.

### **(1) Review by the Public Investment National System (SNIP)**

In Peru, the Public Investment National System (SNIP hereinafter) is under operation. This reviews the rationality and feasibility of public investment projects, and will be applied to this Project.

In SNIP, among previous studies to an investigation, it will be conducted in 3 stages: profile study (study on the project's summary), pre-feasibility and feasibility. SNIP was created under Regulation N° 27293 (published on June 28, 2000) in order to achieve efficient use of public resources for public investment. It establishes principles, procedures, methods and technical regulations to be fulfilled by central/regional governments in public investment scheme plans and executed by them.

SNIP, as described below, is all public works projects which are forced to perform a 3-stage pre-investment study: profile study, pre-feasibility and feasibility, and have them approved. However, following the Regulation amendment in April 2011, the execution of pre-feasibility study of the intermediate stage was considered unnecessary; but in return, a study based on primary data during the profile study is requested. The required precision degree throughout all stages of the study has hardly changed before and after this modification.

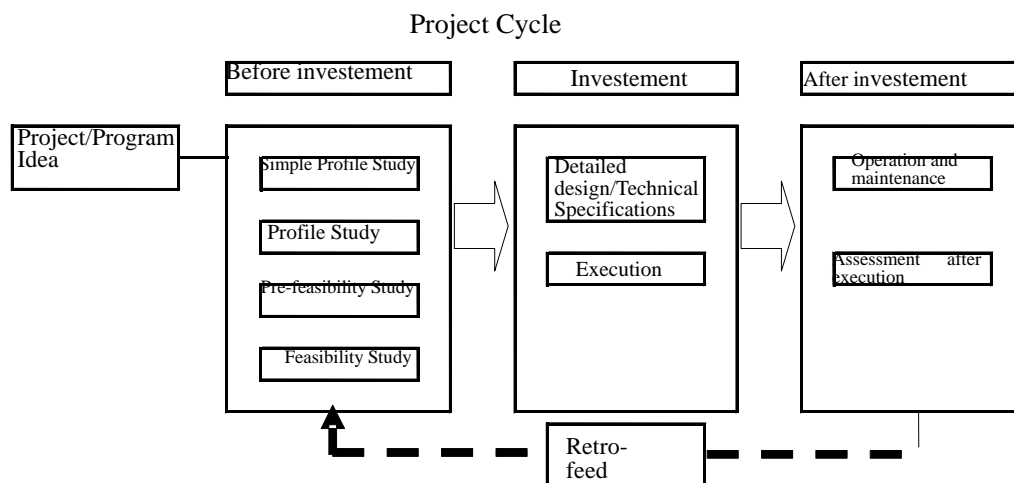

(Source: DGPM HP)

**Figure 4.9-1 SNIP Cycle Project**

In order to carry out this Project, which is a project composed by several programs, pre-investment studies at investments' programs level are required to be performed and also have them approved.

Although the procedure is quite different in each stage, in SNIP procedures, the project's training unit (UF) conducts studies of each stage, the Planning and Investment Office (OPI) assesses and approves the UF's presented studies and requests Public Sector Multi-Annual Programming General Direction (hereinafter referred DGPM) to approve feasibility studies and initiation of following studies. Finally DPGM evaluates, determines and approves the public investment's justification.

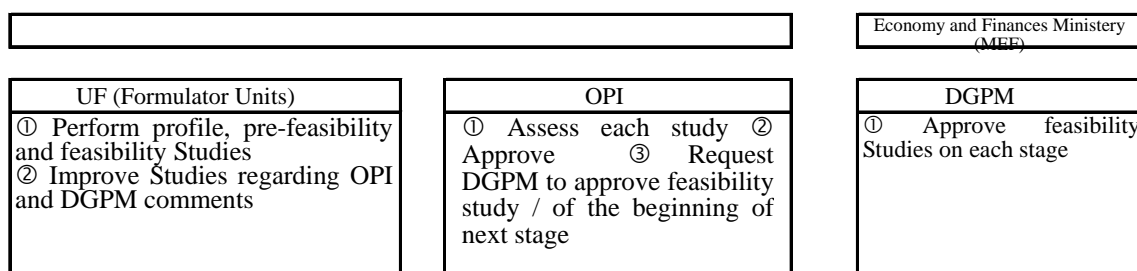

(See Regulation No.001-2009-EF/68.01.)

**Figure 4.9-2 Related Institutions to SNIP**

Due to the comments of examining authorities (OPI and DGPM) to FU, it will be necessary to prepare correspondent responses and improve the studies. Since these authorities officially

admit applications after obtaining definitive answers, there are many cases in which they take several months from the completion of the study report until the completion of the study.

(2) Yen loan contract

Once the feasibility studies reports are submitted and examined in SNIP, discussions on the loan in yen will begin. It is estimated to be a period of 6 months for procedures.

(3) Procedure of the project's execution

After the documents are assessed by SNIP and a loan agreement between Japan (JICA) and the Peruvian counterpart is signed, a consultant will be selected. The consulting service includes the development of detailed design and technical specifications, the contractors' selection and the work's supervision. Table 4.9-1 presents the Project's overall schedule.

1) Consultant selection: 3 months, builder selection: 3 months

2) Develop detailed design and technical specifications of the work's period

① River and re-forestation works along these works

Detailed design and technical specifications elaboration: 6 months

Working Period: 2 years

② Capacity Building

It will be executed on the same work period of river facilities.

Detailed design and technical specifications elaboration: 6 months

Working Period: 2 years

**Table 4.9-1 Implementation Plan**

ITEMS	2010			2011			2012			2013			2014			2015			2016				
	3	6	9	12	3	6	9	12	3	6	9	12	3	6	9	12	3	6	9	12	3	6	9
1 PROFILE STUDY / SNIP ASSESSMENT	STUDY						EVALUATION																
2 FEASIBILITY STUDY / SNIP ASSESSMENT				STUDY			EVALUATION																
3 YEN CREDIT NEGOTIATION																							
4 CONSULTANT SELECTION																							
5 CONSULTANT SERVICE (DETAILED DESIGN, LAWFUL DOCUMENTS PREPARATION)							DESIGN / LAWFUL DOCUMENT						WORK SUPERVISION										
6 BUILDER SELECTION																							
7 WORK EXECUTION																							
1) STRUCTURES BUILDING																							
2) REFORESTATION																							
3) EARLY ALERT SYSTEM																							
4) DISASTER PREVENTIVE TRAINING																							
8 FINISH WORK / DELIVERY TO USERS BOARDS																							

#### **4.10 Institutions and Administration**

Peruvian institutions regarding the Project's execution and administration are the Agriculture Ministry, Economy and Finance Ministry and Irrigation Commission, with the following roles for each institution:

##### **Ministry of Agriculture (MINAG)**

- \* The Ministry of Agriculture (MINAG) is responsible for implementing programs and the Hydraulic Infrastructure General Direction (DGIH) is responsible for the technical administration of the programs. The Hydraulic Infrastructure General Direction (DGIH) is dedicated to the coordination, administration and supervision of investment programs.
- \* In investment stage, the PSI (Programa Subsectorial de Irrigaciones, Ministerio de Agricultura) is dedicated to calculate project costs, detail design and supervision of the works execution.
- \* The Planning and Investment Office (OPI) from the Agriculture Ministry is the one responsible for pre-feasibility and feasibility studies in the pre-investment stage of DGIH projects and requests approval of DGPI from the Economy and Finance Ministry (MEF).
- \* The General Administration Office of the Agriculture Ministry (OGA-MINAG) along with the Public Debt National Direction (DNEP) of the Economy and Finance Ministry is dedicated to financial management. It also manages the budget for procurement, commissioning works, contracting, etc. from the Agriculture Ministry.
- \* The Environmental Affairs General Direction (DGAA) is responsible for reviewing and approving the environmental impact assessment in the investment stage.

##### **Economy and Finance Ministry (MEF)**

- \* The DGPI approves feasibility studies. It also confirms and approves the conditions of loan contracts in yen. In the investment stage, it gives technical comments prior to the project execution.
- \* Financial management is in charge of DNEP from the Economy and Finance Ministry and OGA-MINAG.
- \* The Public Debt National Direction (DNEP) of the Economy and Finance Ministry administers expenses in the investment stage and post-investment operation.

##### **Irrigation Commission**

- \* Responsible for the operation and maintenance of facilities at the post-investment operation stage.

The relationship between the involved institutions in the Project's execution is shown in Figures 4.10-1 and 4.10-2.

In this Project, the investment stage (Project execution) corresponds to PSI from MINA. The PSI is currently performing JBIC projects, etc. and in case of beginning a new project, it forms the correspondent Project Management Unit (UGP), who is responsible of choosing the consulting firm, hire construction services, works supervision, etc. The following figure describes the structure of the different entities involved in the Project's execution stage.

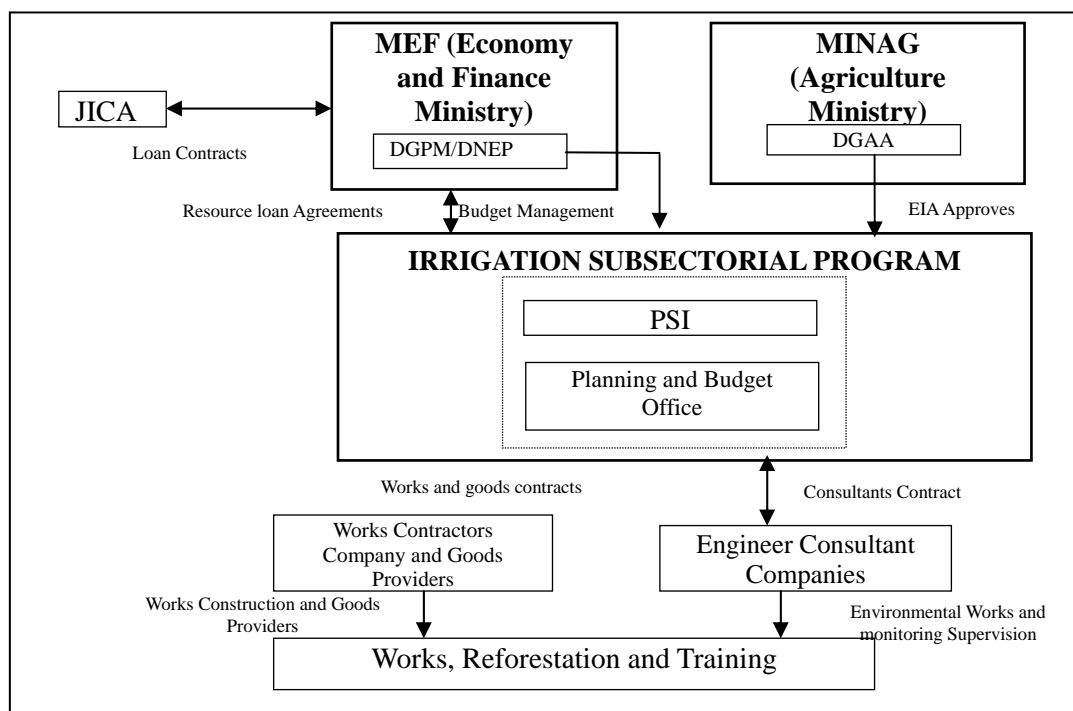

**Figure 4.10-1 Related institutions to the Project's execution (investment stage)**

The main operations in the post-investment stage consist of operation and maintenance of the built works and the loan reimbursement. The O & M of the works will be assumed by the respective irrigation commission. Likewise, they should pay the construction costs in credits mode. Next, the relationship of different organizations involved in post-project implementation stage is detailed.

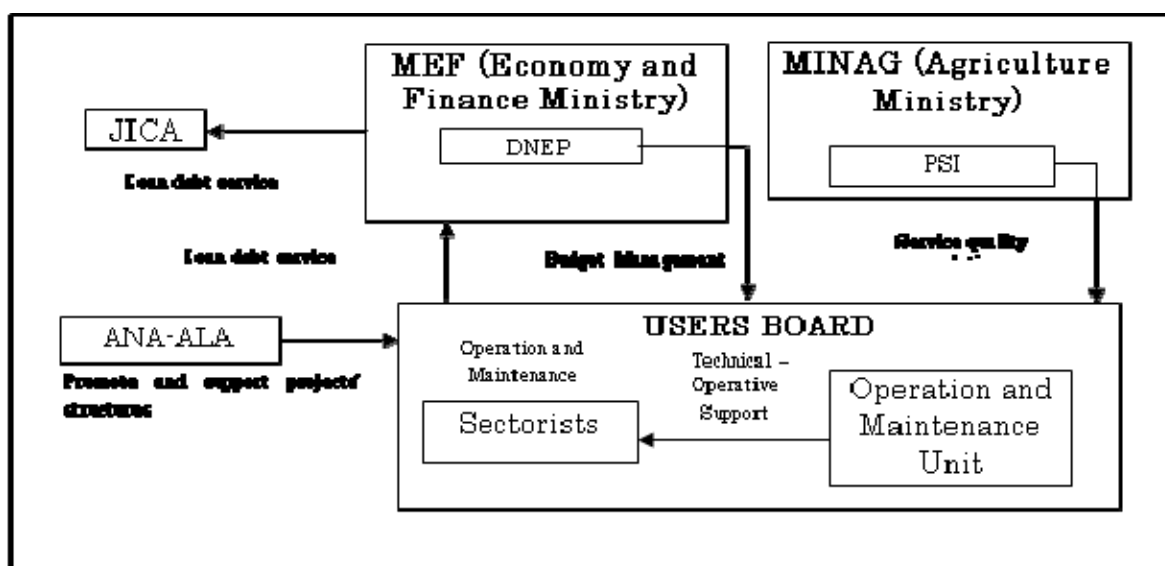

**Figure 4.10-2 institutions related to the Project  
 (Post-investment operation and maintenance stage)**

**(1) DGIH**

1) Role and Functions

The Hydraulic Infrastructure General Direction is in charge of proposing public policies, strategies and plans aimed to promoting water infrastructure development, according with the Water Resources National Policy and the Environmental National Policy.

Water Infrastructure development includes studies, works, operation, maintenance and construction risk management, fit-out, improve and expand dams, intakes, river beds, irrigation channels, drains, meters, outlets, groundwater wells and modernize plot irrigation.

2) Main functions

- a. Coordinate with the planning and budget office to develop water infrastructure and propose sectorial and management policies on infrastructure development. Monitor and assess the implementation of sectorial policies related to hydraulic infrastructure development
- b. Propose government, region and provinces intervention regulations, as part of sectorial policies
- c. Verify and prioritize hydraulic infrastructure needs
- d. Promote and develop public investment projects at the hydraulic infrastructure profile level
- e. Elaborate technical regulations to implement hydraulic infrastructure projects
- f. Promote technological development of hydraulic infrastructure
- g. Elaborate operation and maintenance technical standards for hydraulic infrastructure

## (2) PSI

### 1) Function

The Irrigation Sub-sectorial Program (PSI) is responsible of executing investment projects. A respective management unit is formed for each project.

### 2) Main functions

a. Irrigation Sub-sectorial Program - PSI, under the Agriculture Ministry, is a body with administrative and financial autonomy. It assumes the responsibility of coordinating, managing and administering involved institutions in projects in order to meet goals and objectives proposed in investment projects

b. Also, it coordinates the disbursements of foreign cooperation agencies financing, such as JICA.

c. The Planning, Budget and Monitoring Office of PSI is responsible for hiring services, elaborating investment programs, as well as project execution plans. These Project preparation works are executed by hiring “in-house” consultants

d. Likewise, it gathers contractors, makes a lease, executes works and implements supply projects, etc.

e. Contract management is leaded by the Planning, Budget and Monitoring Office

### 3) Budget

In Table 4.10-1 the PSI budget for 2011 is shown.

**Table 4.10-1 PSI Budget (2011)**

Programs / Projects / Activities	PIM (S/.)
JBIC Program (Loan Agreement EP-P31)	69.417.953
Program - PSI Sierra (Loan Agreement 7878-PE)	7.756.000
Direct management works	1.730.793
Southern Reconstruction Fund (FORSUR)	228.077
Crop Conversion Project (ARTRA)	132.866
Technified Irrigation Program (PRT)	1.851.330
Activity- 1.113819 small farmers...	783.000
PSI Management Program (Other expenses)	7.280.005
<b>TOTAL</b>	<b>89.180.024</b>

### 4) Organization

PSI is conformed by 235 employees, from which 14 are assigned for JBIC Projects and 29 technicians and assistants are working under them.

**Table 4.10-2 PSI Payroll**

Central Level	Data from May 31, 2011		
	CAS	Servic. and Consult.	TOTAL
Main Office	61	43	104
Zonal Office LIMA	12	24	36
Zonal Office AREQUIPA	14	12	26
Zonal Office CHICLAYO	17	13	30
Zonal Office TRUJILLO	13	26	39
<b>TOTAL</b>	<b>117</b>	<b>118</b>	<b>235</b>

In Figure 4.10-3, PSI flow table is detailed:

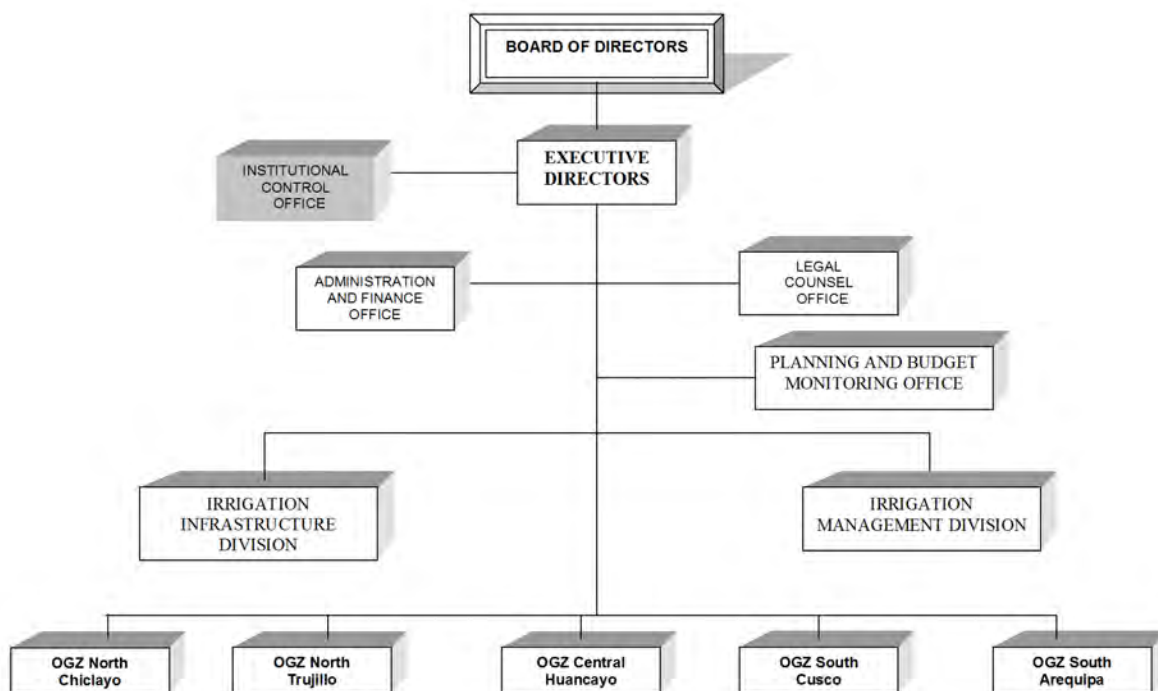



#### 4.11 Logical framework of the eventually selected option

In Table 4.11-1 the logical framework of the definite selected option is shown.

**Table 4.11-1 Logical framework of the definite selected option**

Narrative Summary	Verifying Indicators	Verifying Indicators Media	Preliminary Conditions
<b>Superior Goal</b>			
Promote socioeconomic local development and contribute in communities' social welfare.	Improve local productivity, generate more jobs, increase population's income and reduce poverty index	Published statistic data	Scio-economic and policy stability
<b>Objectives</b>			
Relief the high vulnerability of valleys and local continuity to floods	Types, quantity and distribution of flood control works, population and beneficiaries areas	Monitoring annual calendar works and financial plan, budget execution control	Ensure the necessary budget, active intervention from central and regional governments, municipalities, irrigation communities, local population, etc.
<b>Expected results</b>			
Reduction of areas and flooded areas, functional improvement of intakes, road destruction prevention, irrigation channels protection, bank erosion control and Poechos dike safety	Number of areas and flooded areas, water intake flow variation, road destruction frequency, bank erosion progress and watershed's downstream erosion.	Site visits, review of the flood control plan and flood control works reports and periodic monitoring of local inhabitants	Maintenance monitoring by regional governments, municipalities and local community, provide timely information to the superior organisms
<b>Activities</b>			
Component A: Structural Measures	Dikes rehabilitation, intake and bank protection works, road damages prevention, construction of 28 works, including dike's safety	Detailed design review, works reports, executed expenses	Ensure the works budget, detailed design/works execution/good quality works supervision
Component B: Non-Structural Measures			
B-1 Reforestation and vegetation recovery	Reforested area, coastal forest area	Works advance reports, periodic monitor by local community	Consultants support, NGO's, local community, gathering and cooperation of lower watershed community
Component C: Disaster prevention and capabilities development education	Number of seminars, trainings, workshops, etc	Progress reports, local governments and community monitoring	Predisposition of the parties to participate, consultants and NGO's assessments
Project's execution management			
Project's management	Detailed design, work start order, work operation and maintenance supervision	Design plans, work's execution plans, costs estimation, works specifications, works management reports and maintenance manuals	High level consultants and contractors selection, beneficiaries population participation in operation and maintenance

## **4.12 Middle and long term Plan**

Up to this point, only flood control measures have been proposed and these must be executed most urgently, due to the limitations on the available budget for this Project. However, there are other measures that must be performed in the long term framework. In this section we will be talking about the middle and long term flood control plan.

### **4.12.1 Flood Control General Plan**

There are several ways to control floods in the entire watershed, for example building dams, reservoirs, dikes or a combination of these.

In case of building a dam, assuming that this will reduce the flood peak (maximum flow) with a 50 year return period reaching an equivalent flow of 10 return years. It will be necessary to build a dam with a 3.7 million m<sup>3</sup> capacity, which is quite an oversized number. Usually upstream of an alluvial area, there is a rough topography, and in order to build a dam with enough capacity, a very high dam need to be built, which implies investing a large amount (more than thousand millions of soles). Also, it would take between three to five years to identify the dam site, perform geological survey, material assessment and conceptual design. The impact on the local environment is huge. So, it is considered inappropriate to include the dam analysis option in this Study.

Likewise, the option of building a retarding basin would be not viable for the same reasons already given for the dam, because it would be necessary to build a great capacity of retarding basin and it is difficult to find a suitable location because most of the flat lands along the river's downstream are being used for agricultural purposes. So, its analysis has been removed from this Study.

Therefore, we will focus our study in the construction of dams because it is the most viable option.

#### (1) Plan of the river

##### 1) Discharge capacity

An estimation was done on the discharge capacity of the current river's flow based on longitudinal and transversal river survey, which results are shown in the section 3.1.10, Figure 3.1.10-3.

## 2) Inundation characteristics

Inundation analysis of the Pisco River was performed. In the section 3.1.10, Figure 3.1.10-4 the inundation condition for flood with probabilities of 50 years is shown. In the Pisco River watershed there are several sections where discharge capacity is not enough, causing floods for example on the left bank around km 7 upwards and downwards.

## 3) Design flood level and dike's standard section

The design flood level was determined in the flood water level with a return period of 50 years, and the dike's standard section will be determined as already mentioned in section 4.3.1, 5), 1). In 4.2, Table 4.2-2 the theoretical design flood level and the required height of the dike's crown is shown.

## 4) Dikes' Alignment

Considering the current conditions of existing dikes the alignment of the new dikes was defined. Basically, the broader possible river width was adopted to increase the discharge capacity and the retard effect. In Figure 4.12.1-1 the current channel and the setting alignment method of a section where the current channel has more width is explained schematically. In a normal section, the dike's crown has the same height to the flood water level with a return period of 50 years plus free board, while in the sections where the river has greater width, double dikes be constructed with inner consistent dike alignment and continuous with normal sections upstream and downstream. The crown height is equal to the flood water level with a return period of 50 years. The external dike's crown height is equal to flood water level with a return period of 50 years, so in case the river overflows the internal dike, the open gap between the two dikes will serve to store sediments and slow water.

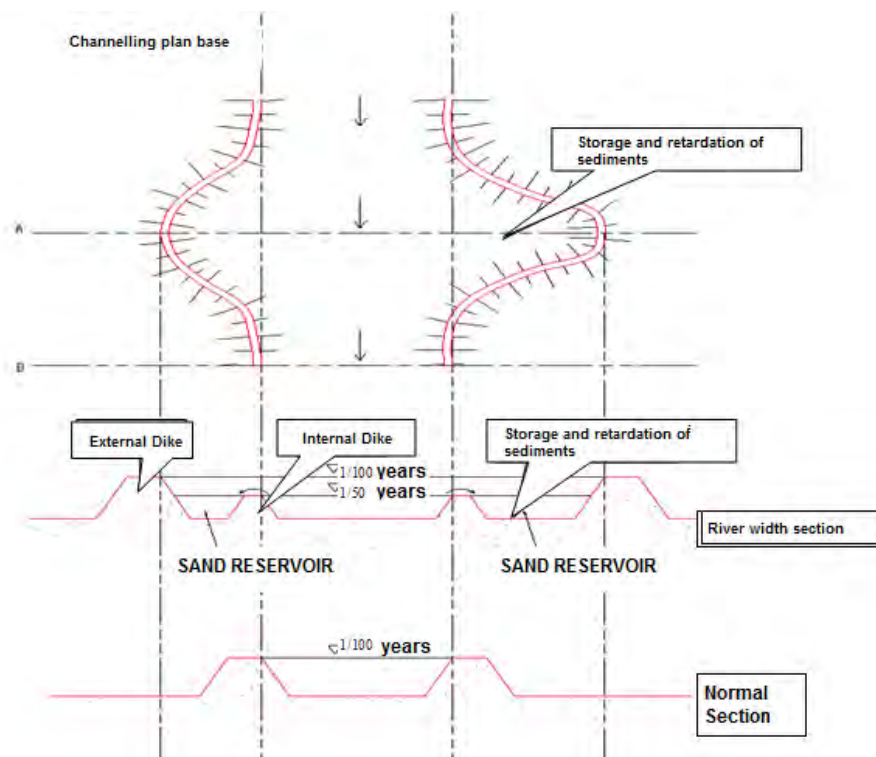

**Figure 4.12.1-1 Definition of dike alignment**

#### 5) Plan and River section

In Figures 4.12.1-2 and -4.12.1-3 the plan and longitudinal section of the Yauca River are shown.

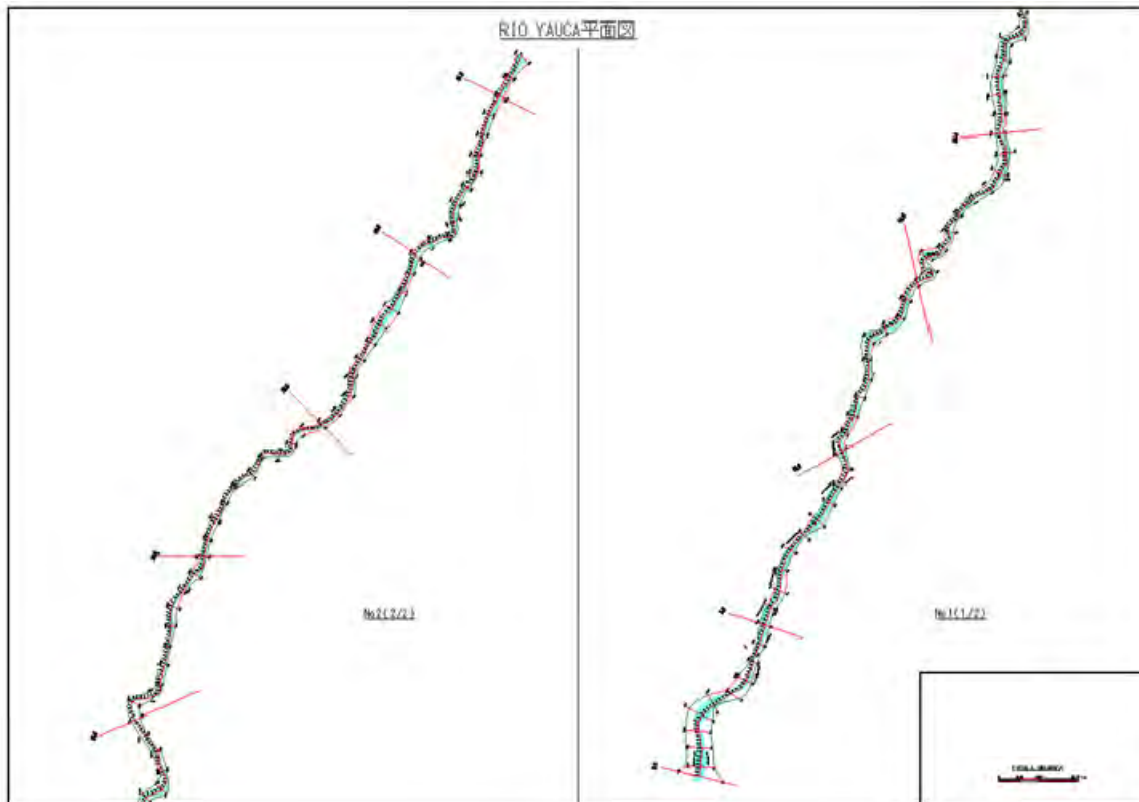

Figure 4.12.1-2 Plan of Yauca River

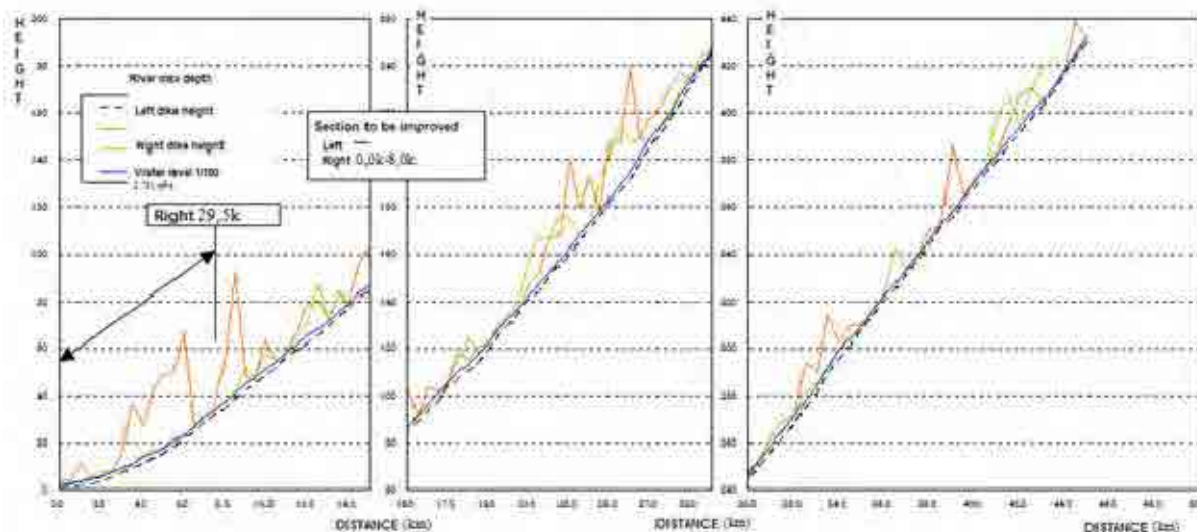

Figure 4.12.1-3 Yauca River Longitudinal Profile

#### 6) Dike's construction plan

Next, basic policies for the dike's construction plan on the Yauca River are shown:

- Build dikes that allow flood flow safe passage with a return period of 50 years
- The dikes will be constructed in areas where overflowing water will enter the dike, according to the flood simulation
- The dikes will be placed in the sections above mentioned, where the design water level exceeds the existing dike's height or the ground level within the dike
- The dike's height is defined in the flood water level with a return period of 50 years plus the free board

Table 4.12.1-1 and Figure 4.12.1-4 show the dike's construction plan on the Yauca River

**Table 4.12.1-1 Dike's Construction Plan**

River	Sections to be improved		Dike missing height average (m)	Dike proposed size	Dike length (km)
Yauca	Left margin	-	-	Dikes' height = 1,5m Margin protection works height = 3,0m	-
	Right margin	0,5k-8,0k	0,46		3,0
	Total		0,46		3,0

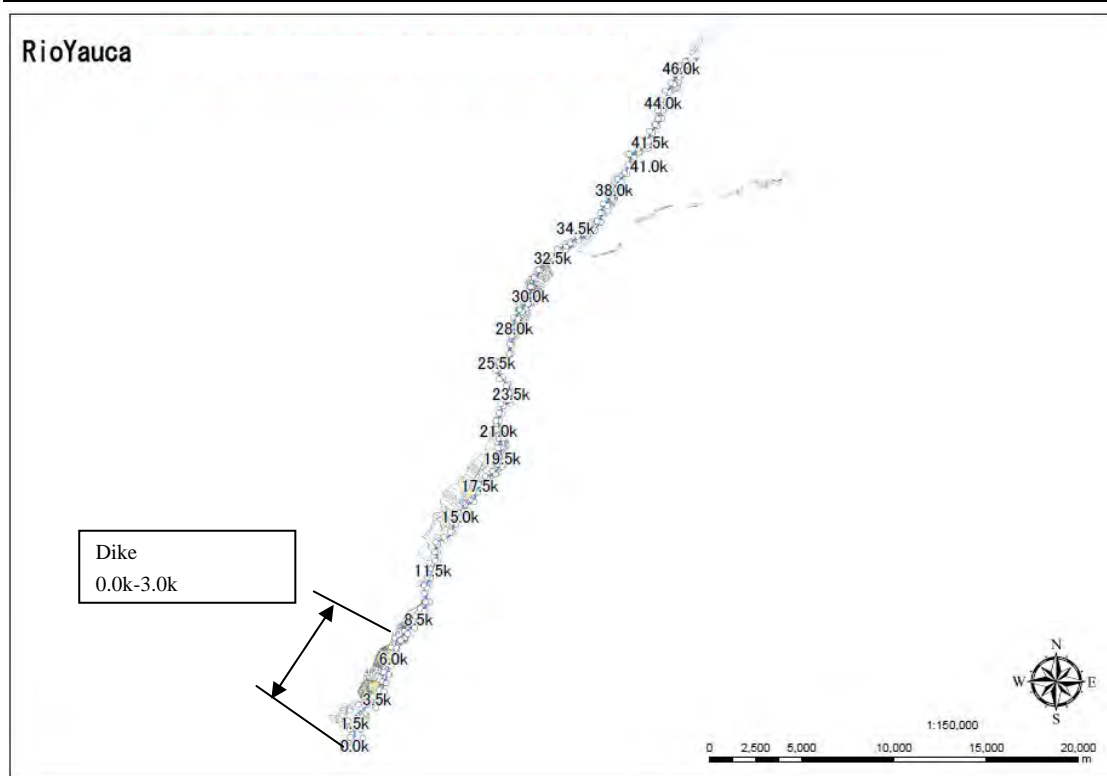

Figure 4.12.1-4 Yauca River dike construction works approach

7) Project Cost

In Tables 4.12.1-2 and 4.12.1-4 works' direct costs in private prices and the Project's cost are shown. Also, the cost of the project in social prices is presented in Table 4.12.1-5.

Table 4.12.1-2 Direct works' cost (at private prices)

Dike construction				Coastal defense			
B1	H 1	B2	A	B1	H 2	B2	A
3.0	1.0	8.5	5.8	1.0	1.0	2.4	10.8
3.0	2.0	14.0	17.0	1.0	2.0	2.9	13.4
3.0	3.0	19.5	33.8	1.0	3.0	3.4	16.5
3.0	4.0	25.0	56.0	1.0	4.0	3.9	20.1
3.0	5.0	30.5	83.8	1.0	5.0	4.4	24.3
3.0	1.5	11.3	10.7	1.0	6.0	4.9	28.9
				1.0	1.5	2.6	12.0
				1.0	10.0	6.9	52.4

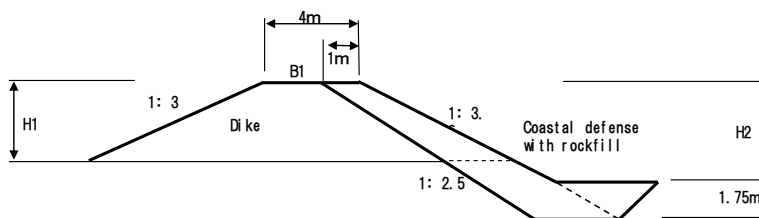

Váter shed	Wórks	Amount	Uni t	Uni tary Pri ce	Wórks di rect cost/m	Wórks di rect cost/km	Di ke length	Wórks di rect cost
Yauca	Dikes	10.7	m3	10.0	107.0	107.0	3.0	321.0
	Margin protection	16.5	m3	100.0	1,650.0	1,650.0		4,950.0
Total						1,820.0	1,820.0	55,510.0

Table 4.12.1-3 Projects' Cost (at private prices)

Watershed	Direct Cost	Temporary works cost	Works Cost	Operative Expenses	Utility	Total Cost of Infrastructure	TAX	Total work cost	Environmental Impact	Technical File	Supervision	Total Cost
流域名	直接工事費計	共通仮設費	工事費	諸経費	利益	構造物工事費	税金	建設費	環境影響	詳細設計	施工管理費	事業費
	(1)	(2) = 0.1 x (1)	(3) = (1) + (2)	(4) = 0.15 x (3)	(5) = 0.1 x (3)	(6) = (3)+(4)+(5)	(7) = 0.18 x (6)	(8) = (6)+(7)	(9) = 0.01 x (8)	(10) = 0.05 x (8)	(11) = 0.1 x (8)	(12) = (8)+(9)+(10)+(11)
YAUCA	5,271,000	527,100	5,798,100	869,715	579,810	7,247,625	1,304,573	8,552,198	85,522	427,610	855,220	9,920,549

**Table 4.12.1-4 Projects' Cost (at social prices)**

Watershed	Direct Cost	Temporary works cost	Works Cost	Operative Expenses	Utility	Total Cost of Infrastructure	TAX	Total work cost	Environmental Impact	Technical File	Supervision	Total Cost
流域名	直接工事費計	共通仮設費	工事費	諸経費	利益	構造物工事費	税金	建設費	環境影響	詳細設計	施工管理費	事業費
	(1)	(2) = 0.1 x (1)	(3) = (1) + (2)	(4) = 0.15 x (3)	(5) = 0.1 x (3)	(6) = (3)+(4)+(5)	(7) = 0.18 x (6)	(8) = (6)+(7)	(9) = 0.01 x (8)	(10) = 0.05 x (8)	(11) = 0.1 x (8)	(12) = (8)+(9)+(10)+(11)
YAUCA	4,237,884	423,788	4,661,672	699,251	466,167	5,827,091	1,048,876	6,875,967	68,760	343,798	687,597	7,976,121

## 2) Operation and Maintenance Plan

The operation and maintenance cost was calculated identifying the trend of the sedimentation and erosion bed based on the one-dimensional analysis results of the bed variation, and a long-term operation and maintenance plan was created.

The current river course has some narrow sections where there are bridges, farming works (intakes, etc.) and there is a tendency of sediment gathering upstream of these sections. Therefore, in this project there is a suggestion to increase the discharge capacity of these narrow sections in order to avoid as possible upstream and in the bed (main part) sedimentation, together with gathering sediments as much as possible when floods over a return period of 50 years occur.

### 1) Bed variation analysis

Figure 4.12.1-5 shows the results of the Bed variation analysis of the Pisco River for the next fifty years. From this figure a projection of the bed's sedimentation and erosion trend and its respective volume can be made.

### 2) Sections that need maintenance

In table 4.12.1-5 possible sections that require a process of long-term maintenance in the Pisco River watershed is shown.

### 3) Operation and maintenance cost

Next the direct work cost at private prices for maintenance (bed excavation) required for each watershed in the next 50 years is shown.



Direct Work Cost

At private prices:  $60,000 \text{ m}^3 \times 10 \text{ soles} = 600,000 \text{ soles}$

Tables 4.12.1-6 and 4.12.1-7 show a 50 year Project cost at private and social prices.

**Table 4.12.1-5 Sections which bed must be excavated in a programmed way**

River Name	Excavation Area		Method of Maintenance Works
Yauca River	Place 1	Target Section : 25.5km-26.5km Target Volume : $60,000\text{m}^3$	The section locates in the direct upstream of an existing intake weir. In order to keep the function of the weir, the periodical excavation maintenance should be carried out.

※Design sediment volume: Sediment volume deposited in 50 years

Preparatory study on the protection program for valleys and rural communities vulnerable to floods in Peru  
*Profile Study Report (Pre-feasibility level), Yauca River*

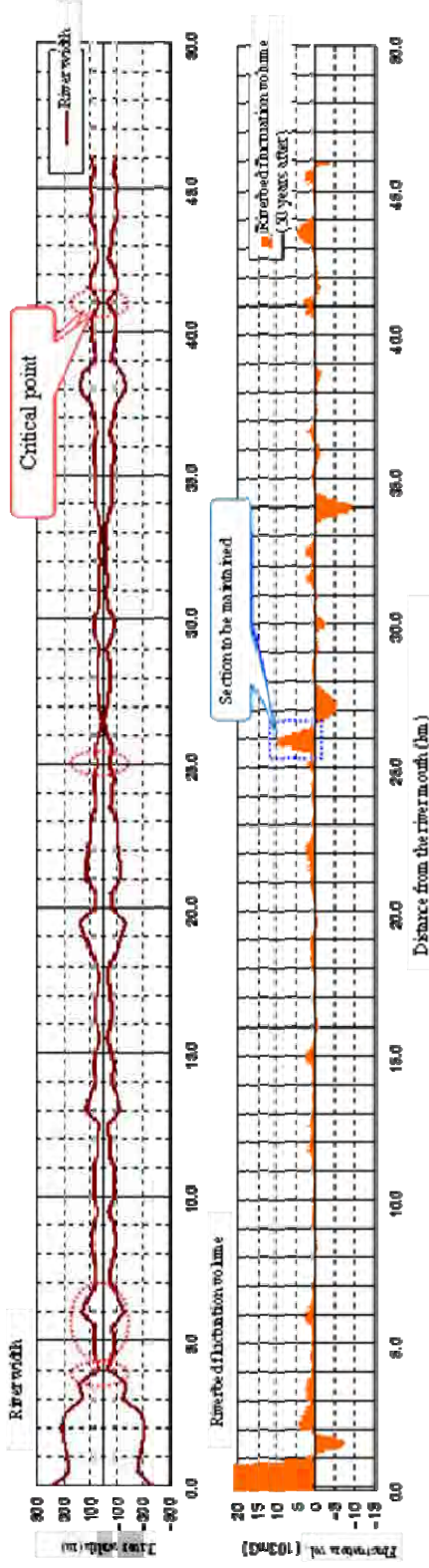

Figure 4.12.1-5 Section that requires maintenance (Cañete River)

Table 4.12.1-6 Excavation Works cost for a 50 year bed (at private prices)

Watershed	Direct Cost 直接工事費計 (1)	Temporary works cost 共通仮設費 (2) = 0.1 x (1)	Works Cost 工事費 (3) = (1) + (2)	Operative Expenses 諸経費 (4) = 0.15 x (3)	Utility 利益 (5) = 0.1 x (3)	Total Cost of Infrastructure 構築物工事費 (6) = (3)+(4)+(5)	TAX 税金 (7) = 0.18 x (6)	Total work cost 建設費 (8) = (6)+(7)	Environmental Impact 環境影響 (9) = 0.01 x (8)	Technical File 詳細設計 (10) = 0.005 x (8)	Supervision 施工管理費 (11) = 0.1 x (8)	Total Cost 事業費 (12) = (8)+(9)+(10)+(11)
YAUCA	600	60	660	99	66	825	149	974	10	49	97	1,129

Table 4.12.1-7 Excavation Works cost for a 50 year bed (at social prices)

Watershed	Direct Cost 直接工事費計 (1)	Temporary works cost 共通仮設費 (2) = 0.1 x (1)	Works Cost 工事費 (3) = (1) + (2)	Operative Expenses 諸経費 (4) = 0.15 x (3)	Utility 利益 (5) = 0.1 x (3)	Total Cost of Infrastructure 構築物工事費 (6) = (3)+(4)+(5)	TAX 税金 (7) = 0.18 x (6)	Total work cost 建設費 (8) = (6)+(7)	Correction Factor cf	Total work cost 建設費 (9) = cf*(8)	Environmental Impact 環境影響 (9) = 0.01 x (8)	Technical File 詳細設計 (10) = 0.005 x (8)	Supervision 施工管理費 (11) = 0.1 x (8)	Total Cost 事業費 (12) = (8)+(9)+(10)+(11)
YAUCA	600	60	660	99	66	825	149	974	0.804	783	8	39	78	89

(3) Social Assessment

1) Private prices cost

i) Damage amount

Table 4.12.1-8 shows the damage amount calculated analyzing the overflow caused by floods in the Cañete River with return periods between 2 and 50 years.

**Table 4.12.1-8 Amount of damage of different return periods (at private prices)**

Damage Amount (1,000 soles). 被害額(千ソール)	
year	Yauca
2	0
5	0
10	1,695
25	2,569
50	11,497

ii) Damage reduction annual average

Table 4.12.1-9 shows the damage reduction annual average of the watershed calculated with the data of Table 4.12.1-8.

iii) Project's Cost and the operation and maintenance cost

Table 4.12.1-3 shows the projects' cost. Also, the annual operation and maintenance (O & M) cost for dikes and bank protection works can be observed in the table. This is calculated from the 0.5% of the construction cost plus the bed excavation annual average cost indicated in Table 4.12.1-6.

iv) Economic evaluation

In Table 4.12.1-10 the results of economic assessment are shown.

**Table 4.12.1-9 Damage Reduction Annual Average**

s/1000

民間価格：流域全体 (Private Prices for ALL watersheds)									
流域 Watershed	流量規模 Return Period	超過確率 Probability	被害額 (Total damages - thousand S/.)			区間平均被害 額 ④ Damages Average	区間確率 ⑤ Probability incremental value	年平均被害額 ④×⑤ Average value of damages flow	年平均被害額の 累計＝年平均被 害軽減期待額 Annual medial damages
			事業を実施し ない場合①	事業を実施し た場合②	軽減額 ③=①-②				
			Without Project ①	With Project ②	Mitigated damages ③=①-②				
YAUCA	1	1.000	0	0	0			0	0
	2	0.500	0	0	0	0	0.500	0	0
	5	0.200	0	0	0	0	0.300	0	0
	10	0.100	1,695	0	1,695	847	0.100	85	85
	25	0.040	2,569	0	2,569	2,132	0.060	128	213
	50	0.020	11,497	0	11,497	7,033	0.020	141	353

**Table 4.12.1-10 Economic assessment results (private prices costs)**

流域名	年平均被害軽減額 Accumulated Average Annual Benefit	評価期間被害 軽減額(15年) Accumulated Average Annual Benefit (in 15 years)	事業費 Project's Cost	維持管理費 O&M Cost	C/B Cost/Benefit Relation	Net Present Value (NPV) NPV	Internal Rate of Return (IRR) IRR
Yauca	4,592,758	2,073,999	9,920,549	894,671	0.23	(7,014,101)	-

2) Social prices cost

i) Damage amount

Table 4.12.1-11 shows the damage amount calculated analyzing the overflow caused by floods in the Majes-Camana River with return periods between 2 and 50 years in each watershed.

**Table 4.12.1-11 Amount of damage of different return periods (at social prices)**

Damage Amount (1,000 soles). 被害額(千ソールレス)	
year	Yauca
2	0
5	0
10	2,150
25	3,313
50	12,092

ii) Damage reduction annual average

Table 4.12.1-12 shows the damage reduction annual average of each watershed calculated with the data of Table 4.12.1-11.

iii) Project's Cost and the operation and maintenance cost

Table 4.12.1-4 shows the projects' cost. Also, the annual operation and maintenance (O & M) cost for dikes and bank protection works can be observed in the table. This is calculated from the 0.5% of the construction cost, as well as the bed excavation annual average cost indicated in Table 4.12.1-7.

iv) Economic evaluation

In Table 4.12.1-13 the results of economic assessment are shown.

**Table 4.12.1-12 Damage Reduction Annual Average**

s/1000

社会価格:流域全体									
流域 Watershed	流量規模 Return Period	超過確率 Probability	被害額 (Total damages - thousand S./.)			区間平均被害 額 ④ Damages Average	区間確率 ⑤ Probability incremental value	年平均被害額 ④×⑤ Average value of damages flow	年平均被害額の 累計=年平均被 害軽減期待額 Annual medial damages
			事業を実施し ない場合①	事業を実施し た場合②	軽減額 ③=①-②				
			Without Project ①	With Project ②	Mitigated damages ③=①-②				
YAUCA	1	1.000	0	0	0		0	0	
	2	0.500	0	0	0	0.500	0	0	
	5	0.200	0	0	0	0.300	0	0	
	10	0.100	2,150	0	2,150	1,075	0.100	108	108
	25	0.040	3,313	0	3,313	2,732	0.060	164	271
	50	0.020	12,092	0	12,092	7,702	0.020	154	425

**Table 4.12.1-10 Economic assessment results (social prices costs)**

流域名	年平均被害軽減額 Accumulated Average Annual Benefit	評価期間被害 軽減額(15年) Accumulated Average Annual Benefit (in 15 years)	事業費 Project's Cost	維持管理費 O&M Cost	C/B Cost/Benefit Relation	Net Present Value (NPV) NPV	Internal Rate of Return (IRR) IRR
Yauca	5,531,228	2,497,793	7,976,121	719,315	0.34	(4,809,039)	-

(4) Conclusions

The economic assessment result shows that the Project has no positive economic impact in terms of cost on both private and social prices, and the required cost is extremely high (9.9 million of soles), so, this Project is less viable to be adopted.

#### **4.12.2 Reforestation and Recovery of Vegetation Plan**

##### (1) Reforestation of the upper watershed

Long-term reforestation in all areas considered to be critical of the upper watershed is recommended. So, a detail analysis of this alternative will be explained next.

##### 1) Basic Policies

Objectives: Improve the water source area's infiltration capacity, reduce surface soils water flow and at the same time, increase water flow in intermediate soils and ground-water level. Because of the above mentioned, water flow is interrupted in high flood season, this increases water resources in mountain areas, reduces and prevents floods increasing with it the amount and greater flow of ground-water level, reducing and preventing floods

Forestry area: means forestry in areas with planting possibilities around watersheds with water sources or in areas where forest area has decreased.

Forestry method: local people plantations. Maintenance is done by promoters, supervision and advisory is leaded by NGOs.

Maintenance after forestry: Maintenance is performed by the sow responsible in the community. For this, a payment system (Payment for Environmental Services) will be created by downstream beneficiaries

Observations: After each thinning the area will have to be reforested, keeping and preserving it in a long-term sustainable way. An incentive for community people living upstream of the watershed shall be designed.

The forest is preserved after keeping and reforesting it after thinning, this also helps in the support and prevention of floods. For this, it is necessary that local people are aware, encourage people downstream, promote and spread the importance of forests in Peru during the project's execution.

##### 2) Selection of forestry area

As mentioned in 1) Forestry on upper watershed is performed with the support of the community. In this case, the local inhabitants will participate in the upper watersheds during their spare time. However, take into account that the community mostly lives in the highlands where inhabitants live performing their farming and cattle activities in harsh natural conditions. Therefore, it is difficult to tell if they have the availability to perform forestry. So, finding comprehension and consensus of the inhabitants will take a long time.

##### 3) Time required for the reforestation project

Since it is a small population, the workforce availability is reduced. So, the work that can be carried out during the day is limited, and the work efficiency would be very low. The JICA Study Team estimated the time required to reforest the entire area throughout the population in

the areas within the reforestation plan, plant quantity, work efficiency, etc. According to this estimate, it will take 14 years to reforest approximately 40,000 hectares from the Chincha River Watershed. When estimating the required time for other watersheds, by simply applying this rate to the respective watershed area, we obtained that reforestation in Yauca River Watershed will take 22 years.

4) Total reforestation volume in the upper watershed and project's period and cost

It has been estimated that the surface needed to be reforested in the Yauca River Watershed, as well as the execution cost, having as reference Chincha River Watershed project reforestation data. According to this estimate, the area to be reforested is approximately a total of 68,000 hectares. The required period is 22 years, and the cost is calculated in 184.3 million soles. In other words, investing a great amount of time and money is required to reforest.

**Table 4.12.2-1 Upstream Watershed Forest General Plan**

Watershed	Forestry Area (ha) A	Required period for the project (years) B	Required budget (soles) C
Yauca	68,296	22	184,340,033

(Source: JICA Study Team)

5) Conclusions

The objective of this project is to execute the most urgent works and give such a long period for reforestation which has an indirect effect with an impact that takes a long time to appear would not be consistent with the proposed objective for the Project. Considering that 22 years and invested 184 million soles are required, we can say that it is impractical to implement this alternative in this project and that it shall be timely executed within the framework of a long-term plan after finishing this project.

**4.12.3 Sediment control plan**

For the long-term sediment control plan, it is recommended to execute the necessary works in the upper watershed.

The Sediment Control Plan in the upper watershed will mainly consist in construction of sediment control dikes and bank protection works. In Figure 4.12.3-1 the sediment control works disposition proposed to be executed throughout the watershed is shown. The cost of Yauca River works was estimated focusing on: a) covers the entire watershed, and b) covers only the priority areas, analyzing the disposition of works for each case. The results are shown in Table 4.12.3-1.

Due to the Yauca River extension, the construction cost for every alternative would be too high in case of carrying-out the bank protection works, erosion control dikes, etc., apart from

requiring a considerably long time. This implies that the project will take a long time to show positive results. So, it is decided that it is impractical to execute this alternative within this project and should be timely executed within the framework of a long-term plan, after finishing this project.

**Table 4.12.3-1 Upper watershed sediment control works execution estimated costs**

Watershed	Approach	Margin Protection		Strip		Sediment control dike		Total works direct cost	Project Cost (Millions S/.)
		Vol. (km)	Direct Cost (Million S/.)	Vol. (units)	Direct Cost (Million S/.)	Vol. (units)	Direct Cost (Million S/.)		
Yauca	All Watershed	565	S/.604	57	S/.2	97	S/.144	S/.750	S/.1.412
	Prioritized Section	565	S/.604	57	S/.2	37	S/.54	S/.660	S/.1.242

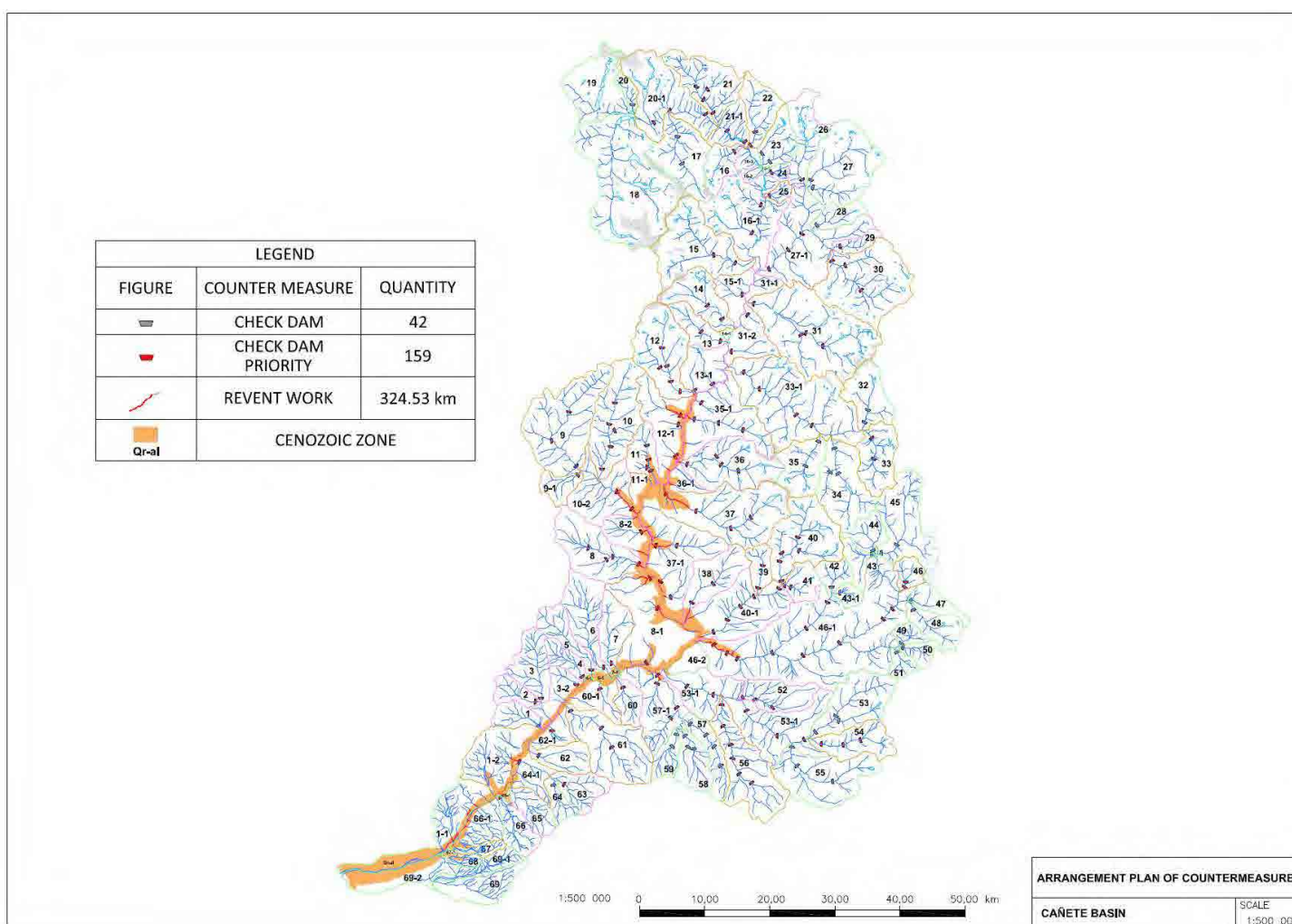

**4.12.3-1 Sediment control works location Cañete River Watershed**



## **5. CONCLUSIONS**

The selected alternative for flood control in this Study is structurally safe, and the environmental impact is small, however the social evaluation shows extremely low economic effect so that it is difficult to implement this Project.

