

**Ministry of Agriculture  
Republic of Peru**

**THE PREPARATORY STUDY  
ON  
PROJECT OF THE PROTECTION OF  
FLOOD PLAIN AND VULNERABLE RURAL  
POPULATION AGAINST FLOOD IN THE  
REPUBLIC OF PERU**

**FINAL REPORT  
MAINREPORT  
I-5 PROJECT REPORT  
(MAJES-CAMANA RIVER)**

**March 2013**

**JAPAN INTERNATIONAL COOPERATION AGENCY  
(JICA)**

**YACHIYO ENGINEERING CO., LTD.  
NIPPON KOEI CO., LTD.  
NIPPON KOEI LATIN AMERICA –  
CARIBBEAN Co., LTD.**

GE
CR (4)
13-090



## Composition of Final Report

### I. Feasibility Study Report

I-1 Program Report

I-2 Project Report (Cañete River)

I-3 Project Report (Chincha River)

I-4 Project Report (Pisco River)

**I-5 Project Report (Majes-Camana River) (This Report)**

I-6 Supporting Report

Annex – 1 Metrology /Hydrology /Run-off Analysis

Annex – 2 Inundation Analysis

Annex – 3 River Bed Fluctuation Analysis

Annex – 4 Flood Control Plan

Annex – 5 Forecasting and Warning System in Chira River

Annex – 6 Sediment Control

Annex – 7 Afforestation and Vegetation Recovery Plan

Annex – 8 Plan and Design of Facilities

Annex – 9 Construction Planning and Cost Estimate

Annex – 10 Socio-economy and Economic Evaluation

Annex – 11 Environmental and Social Considerations/ Gender

Annex – 12 Technical Assistance

Annex – 13 Stakeholders Meetings

Annex – 14 Implementation Program of Japanese Yen Loan Project

Annex – 15 Drawings

I-7 Data Book

### II. Pre- Feasibility Study Report

II-1 Program Report

II-2 Project Report (Chira River)

II-3 Project Report (Cañete River)

II-4 Project Report (Chincha River)

II-5 Project Report (Pisco River)

II-6 Project Report (Yauca River)

II-7 Project Report (Majes-Camana River River)





**Study Area Map**



## Abbreviation

Abbreviation	Official Name or meaning
ANA	Autoridad Nacional del Agua(Water National Authority )
ALA	Autoridad Local del Agua( Water Local Authority)
B/C	Cost-Benefit Ratio(Cost-Benefit relation)
GDP(PBI)	Producto Bruto Interno(PBI)( Gross Domestic Product)
GIS	Sistema de información geográfica (Geographic Information System)
DGAA	Dirección General de Asuntos Ambientales(Environmental Affairs General Direction)
DGFFS	Dirección General de Forestal y de Fauna Silvestre (Forestry and Fauna General Direction)
DGIH	Dirección General de Infraestructura Hidráulica (Hydraulic Infrastructure General Direction)
DGPI(previous DGPM)	Dirección General de Política de Inversiones (Investment Policy General Direction), (Dirección General de Programación Multianual del Sector Público )(Public Sector Multiannual Program General Direction)
DGETP(previous DNEP)	Dirección General de Endeudamiento y Tesoro Público (Public Indebtedness National Direction), Dirección Nacional de Endeudamiento Público
DRA	Dirección Regional de Agricultura (Agriculture Regional Direction)
EIA	Estudio de impacto ambiental (Environmental Impact Assessment - EIA)
FAO	Organización de las Naciones Unidas para la Agricultura y la Alimentación (Food and Agriculture Organization of the United Nations)
F/S	Estudio de Factibilidad (Feasibility Study)
GORE	Gobiernos Regionales (Regional Governments)
HEC-HMS	Sistema de Modelado Hidrológico del Centro de Ingeniería Hidrológica (Hydrologic Model System from the Hydrology Engineer Center)
HEC-RAS	Sistema de Análisis de Ríos del Centro de Ingeniería Hidrológica (Hydrologic Engineering Centers River Analysis System)
IGN	Instituto Geográfico Nacional (National Geographic Institute)
IGV	Impuesto General a Ventas (TAX)
INDECI	Instituto Nacional de Defensa Civil (Civil defense National Institute)
INEI	Instituto Nacional de Estadística (Statistics National Institute)
INGEMMET	Instituto Nacional Geológico Minero Metalúrgico (Metallurgic Mining Geologic National Institute)
INRENA	Instituto Nacional de Recursos Naturales (Natural Resources National Institute)
IRR	Tasa Interna de Retorno (Internal Rate of Return - IRR)
JICA	Agencia de Cooperación Internacional del Japón (Japan International Cooperation Agency)
JNUDRP	Junta Nacional de Usuarios de los Distritos de Riego del Perú (Peruvian Irrigation District Users National Board)
L/A	Acuerdo de Préstamo (Loan Agreement)
MEF	Ministerio de Economía y Finanzas (Economy and Finance Ministry)
MINAG	Ministerio de Agricultura (Agriculture Ministry)

M/M	Minuta de Discusiones (Minutes of Meeting)
NPV	VAN (Valor Actual Neto) (NET PRESENT VALUE)
O&M	Operación y mantenimiento (Operation and maintenance)
OGA	Oficina General de Administración (Administration General Office)
ONERRN	Oficina Nacional de Evaluación de Recursos Naturales (Natural Resources Assessment National Office)
OPI	Oficina de Programación e Inversiones (Programming and Investment Office)
PE	Proyecto Especial Chira-Piura (Chira-Piura Special Project)
PES	PSA (Pago por Servicios ambientales) (Payment for Environmental Services)
PERFIL	Estudio del Perfil (Profile Study)
Pre F/S	Estudio de prefactibilidad (Pre-feasibility Study)
PERPEC	Programa de Encauzamiento de Ríos y protección de Estructura de Captación (River Channeling and Protection of Collection Structures Program)
PRONAMACHIS	Programa Nacional de Manejo de Cuencas Hidrográficas y Conservación de Suelos (Water Basins Management and Soil Conservation National Program)
PSI	Programa Sub Sectorial de irrigaciones (Sub-Sectorial Irrigation Program)
SCF	Factor de conversión estándar (Standard Conversion Factor)
SENAMHI	Servicio Nacional de Meteorología y Hidrología (Meteorology and Hydrology National Service)
SNIP	Sistema Nacional de Inversión Pública (Public Investment National System)
UE	Unidad Ejectora(Execution Units)
UF	Unidades Formuladoras (Formulator Units)
VALLE	Llanura aluvial, llanura de valle (Alluvial Plain, Valley Plain)
VAT	Impuesto al valor agregado (Value added tax)



**THE PREPARATORY STUDY**  
**ON**  
**PROJECT OF THE PROTECTION OF FLOOD PLAIN AND VULNERABLE RURAL**  
**POPULATION AGAINST FLOODS IN THE REPUBLIC OF PERU**  
**FINAL REPORT**  
**I-5 MAIN REPORT**  
**PROJECT REPORT**  
**(MAJES-CAMANA RIVER)**

**Table of Contents**

**Location Map**

**Abbreviation**

1. EXECUTIVE SUMMARY .....	1-1
1.1 Project Name .....	1-1
1.2 Project's Objective .....	1-1
1.3 Supply and Demand Balance.....	1-1
1.4 Technical Proposal .....	1-2
1.4 .1 Structural Measures .....	1-2
1.4.2 Non-Structural Measures .....	1-3
1.4.3 Technical Support.....	1-4
1.5 Costs .....	1-5
1.6 Social Assessment .....	1-5
1.7 Sustainability Analysis .....	1-6
1.8 Environmental Impact .....	1-7
1.9 Institutions and Management.....	1-8
1.10 Execution Plan.....	1-9
1.11 Financial Planning .....	1-11
1.12 Conclusion and Recommendation .....	1-11
1.12.1 Conclusion .....	1-11
1.12.2 Recommendation .....	1-11
1.13 Logical Framework.....	1-12
1.14 Middle and Long Term Plans .....	1-14
2. GENERAL ASPECTS.....	2-1
2.1 Name of the Project .....	2-1
2.2 Formulator and Executor Units .....	2-1
2.3 Involved Entities and Beneficiaries Participation.....	2-1
2.4 Framework.....	2-4
2.4.1 Background.....	2-4
2.4.2 Laws, Regulations, Policies and Guidelines Related to the Program .....	2-7

3. IDENTIFICATION .....	3-1
3.1 Diagnosis of the Current Situation .....	3-1
3.1.1 Nature .....	3-1
3.1.2 Socio-Economic Conditions of the Study Area .....	3-2
3.1.3 Agriculture .....	3-10
3.1.4 Infrastructure.....	3-15
3.1.5 Real Flood Damages.....	3-18
3.1.6 Results on the Visits to Study Sites.....	3-19
3.1.7 Current situation of Vegetation and Reforestation.....	3-31
3.1.8 Current Situation of the Soil Erosion.....	3-35
3.1.9 Run-off Analysis .....	3-49
3.1.9.1 Rainfall .....	3-49
3.1.10 Analysis of Inundation .....	3-74
3.2 Definition of Problem and Causes.....	3-81
3.2.1 Problems of Flood Control Measures in the Study Area .....	3-81
3.2.2 Problem Causes .....	3-81
3.2.3 Problem Effects.....	3-82
3.2.4 Causes and Effects Diagram .....	3-82
3.3 Objective of the Project .....	3-84
3.3.1 Solving Measures for the Main Problem .....	3-84
3.3.2 Expected impacts for the main’s objective fulfillment .....	3-84
3.3.3 Measures - Objectives - Impacts Diagram.....	3-85
4. FORMULATION AND EVALUATION .....	4-1
4.1 Definition of the Assessment Horizon of the Project .....	4-1
4.2 Supply and Demand Analysis.....	4-1
4.3 Technical Planning .....	4-5
4.3.1 Structural Measures .....	4-5
4.3.2 Nonstructural Measures .....	4-22
4.4 Costs.....	4-35
4.4.1 Cost Estimate (at Private Prices) .....	4-35
4.4.2 Cost Estimate (at Social Price).....	4-54
4.5 Social Assessment .....	4-56
4.5.1 Private Prices Costs.....	4-56
4.5.2 Social Prices Costs .....	4-64
4.5.3 Social assessment conclusions .....	4-65
4.6 Sensitivity Analysis.....	4-66
4.7 Risk Analysis.....	4-67
4.8 Sustainability Analysis .....	4-69
4.9 Environmental Impact .....	4-71
4.9.1 Procedure of Environmental Impact Assessment .....	4-71

4.9.2 Methodology .....	4-73
4.9.4 Socio-Environmental Management Plans .....	4-77
4.9.5 Monitoring and Control Plan.....	4-79
4.9.6 Cost for the Environmental Impact Management.....	4-82
4.9.7 Conclusions and Recommendations.....	4-82
4.10 Institutions and Administration .....	4-83
4.11 Execution Plan.....	4-89
4.12 Financial Plan.....	4-92
4.13 Logical Framework of the Eventually Selected Option .....	4-94
4.14 Baseline for Impact Assessment.....	4-95
4.15 Middle and Long Term Plan.....	4-96
4.15.1 Flood Control General Plan.....	4-96
4.15.2 Reforestation and Recovery of Vegetation Plan .....	4-112
4.15.3 Sediment control plan.....	4-113
5. Conclusion and Recommendation.....	5-1
5.1 Conclusion.....	5-1
5.2 Recommendation.....	5-1
5.2.1 Recommendation on Implementation of This Project .....	5-1
5.2.2 Recommendation for Future Flood Control Plan in Peru .....	5-5



## 1. EXECUTIVE SUMMARY

### 1.1 Project Name

“Protection program for valleys and rural communities vulnerable to floods Implementation of prevention measures to control overflows and floods of Majes-Camana River, Arequipa department.”

### 1.2 Project’s Objective

The ultimate impact that the project is design to achieve is to alleviate the vulnerability of valleys and the local community to flooding and boost local socioeconomic development.

### 1.3 Supply and Demand Balance

It has been calculated the theoretical water level in case of flow design flood based on the transversal lifting data of the river with an interval of 500m, in the Pisco River watershed, assuming a design flood flow equal to the flood flow with a return period of 50 years. Then, we determined the dike height as the sum of the design water level plus the dike’s free board.

This is the required height of the dike to control the damages caused by design floods and is the indicator of the demand of the local community.

The height of the existing dike or current ground height is the required height to control the current flood damages, and is the indicator of the current offer.

The difference between the dike design height (demand) and the height of the embankment or current ground height is the difference or gap between demand and supply.

Table 1.3-1 shows the average water levels floods, calculated with a return period of 50 years, of the required height of the dike (demand) to control the flow by adding the design water level plus the free board of the dike; from dike height or current ground height (supply), and the difference between these two (difference between demand and supply) of the river. Then, in Table 4.2-2 the values at each point are shown. The current height of the dike or the current ground height is greater than the required height of the dike, at certain points. In these, the difference between supply and demand is considered null.

**Table 1.3-1 Demand and supply analysis**

Watersheds	Present Height of Embankment or Ground (supply)		Flood Water Level of 1/50 year Probability	Freeboard of Embankment	Required Height of Embankment (demand)	Supply and Demand Gap	
	Left Bank	Right Bank				Left Bank	Right Bank
	①	②				③	④
Majes-Camana	401.90	405.19	398.84	1.20	400.04	0.85	0.65

## **1.4 Technical Proposal**

### **1.4 .1 Structural Measures**

Structural measures are a subject that must be analyzed in the flood control plan covering the entire watershed. The analysis results are presented in section 1.14 “medium and long term plan” This plan proposes the construction of dikes for flood control throughout the watershed. However, the case of Majes-Camana River requires a large project investing at a extremely high cost, far beyond the budget for this Project, which makes this proposal it impractical. Therefore, assuming that the dikes to control floods throughout the whole basin will be constructed progressively over a medium and long term period. Here is where this study focused on the most urgent works, priority for flood control.

#### **(1) Design flood flow**

The Methodological Guide for Protection Projects and/or Flood Control in Agricultural or Urban Areas (Guia Metodologica para Proyectos de Proteccion y/o Control de Inundaciones en Áreas Agricolas o Urbanas, 3.1.1 Horizonte de Proyectos) prepared by the Public Sector Multi Annual Programming General Direction (DGPM) (present DGPI) of the Ministry of Economy and Finance (MEF) recommends a comparative analysis of different return periods: 25, 50 and 100 years for the urban area and 10, 25 and 50 years for rural and agricultural land.

Considering that the present Project is aimed at protecting the rural and agricultural land, the design flood flow is to be determined in a return period of 10 years to 50 years t in the mentioned Guide.

It was confirmed that the flood discharge with return period of 50 years in the basin is determined as design flood discharge and it is almost same as the past maximum observed discharge.

In Peru the flood protection works in the basins are developed almost nil, therefore it is not necessary to adopt the design discharge more than the past maximum discharge. However, the large disasters occurred in the past so that the design flood discharge with return period of 50 years, which is almost equal to the past maximum, is to be adopted considering to avoid the flood damage nearly equal to the damage occurred in the past .

The relation among flood discharge with different return period, damage caused by the floods and inundation areas is analyzed in the basin. The results are that the more the return periods of flood increase the more inundation area and damage amount increase in the basin, however the increase tendency of damage with project is more gentle compared with former two items, and the reduction of damage with project reaches to maximum in the case of the flood with return period of 50 years within the cases of flood with less return period of 50 years.

As described above, the adopted design flood discharge with return period of 50 years is almost same as the past maximum discharge and damage reduction amount in the adopted case becomes more than that of the flood discharges with less return period, and the result of social evaluation is also high.

## **(2) Selection of prioritized flood control works**

We applied the following five criteria for the selection of priority flood control works.

- Demand from the local community (based on historical flood damage)
- Lack of discharge capacity of river channel (including the sections affected by the scouring)
- Conditions of the adjacent area (conditions in urban areas, farmland, etc.).
- Conditions and area of inundation (type and extent of inundation according to inundation analysis)
- Social and environmental conditions (important local infrastructures)

Based on the river survey, field investigation, discharge capacity analysis of river channel, inundation analysis, and interviews to the local community (irrigation committee needs, local governments, historical flood damage, etc...) a comprehensive evaluation was made applying the five evaluation criteria listed above. After that we selected a total of seven (7) critical points (with the highest score in the assessment) that require flood protection measures.

Concretely, since the river cross sectional survey was carried out every 500m interval and discharge capacity analysis and inundation analysis were performed based on the survey results, the integral assessment was also done for sections of 500 meters. This sections have been assessed in scales of 1 to 3 (0 point, 1 point and 2 points) and the sections of which score is more than 6 were selected as prioritized areas. The lowest limit (6 points) has been determined also taking into account the budget available for the Project in general

### **1.4.2 Non-Structural Measures**

#### **(1) Reforestation and vegetation recovery**

##### 1) Basic policies

The reforestation plan and vegetation recovery that meets the objective of this project can be divided into: i) reforestation along river structures, and ii) reforestation in the upper watershed. The first has a direct effect on flood prevention expressing its impact in a short time, while the second one requires high cost and a long period for its implementation, as indicated later in the section “1.14 (2) Reforestation Plan and vegetation recovery”, and also it is impractical to be implemented within the framework of this project. Therefore, this study focused on the first alternative.

##### 2) Regarding reforestation along river structures

This alternative proposes planting trees along the river structures, including dikes and bank protection works.

- Objective: Reduce the impact of flooding of the river when an unexpected flood or narrowing of the river by the presence of obstacles, using vegetation strips between the river and the elements to be protected.

- Methodology: Create vegetation stripes of a certain width between the river and river structures.
- Execution of works: Plant vegetation on a portion of the river structures (dikes, etc.).
- Maintenance after reforestation: Maintenance will be taken by irrigation committees under their own initiative.

The width, length and area of reforestation along river structures are 11m, 29.0 km and 18.3 ha respectively.

## **(2) Sediment control plan**

The sediment control plan must be analyzed within the general plan of the watershed. The results of the analysis are presented in section 1.14 “Medium and long term plan (3)”. To sum up, the sediment control plan for the entire watershed requires a high investment cost, which goes far beyond the budget of this project, which makes it impractical to adopt.

The bed variation analysis has shown that the volume of sediment dragged in the Majes-Camana river watershed is high, and therefore the bed variation (sediment volume) is also large. However, seeing the average height of the bed, there has only been a variation of approximately 0.2 m in 50 years, and the entry of sediments seems to have almost no impact on the downstream bed. So, we conclude that it is necessary to take special measures to control sediment.

### **1.4.3 Technical Support**

Based on the technical proposals of structural and nonstructural measures, it is also intends to incorporate in this project technical assistance to strengthen the measures.

The objective of the technical assistance is to “improve the capacity and technical level of the local community, to manage risk to reduce flood damage in selected valleys.”

Technical assistance will cover the Majes-Camana river watershed.

Aiming to train characteristics of the watershed, courses for one will be prepared. The beneficiaries are the representatives of the committees and irrigation groups from each watershed, governments employees (provincial and district), local community representatives, local people etc.

Qualified as participants in the training, people with ability to replicate and disseminate lessons learned in the courses to other community members, through meetings of the organizations to which they belong.

In order to carry out the technical assistance goal, the three activities propose the following:

- Bank protection activity and knowledge enhancement on agriculture and natural environment
- Community disaster prevention planning for flood damages
- Watershed (slope) management against fluvial sedimentation



## 1.5 Costs

In the Table 1.5-1 the costs of this Project in Pisco watershed is shown. The cost of the watersheds is around 91.0 million soles.

**Table 1.5-1 Project Cost**

					(1000 soles)
Watershed	Constru ction Cost	Consultant Cost	Land Acquisition Cost	Management Cost of Implementation Agency	Total Cost
Majes-Camana	73,879	8,967	4,947	3,238	91,030

## 1.6 Social Assessment

The objective of the social assessment in this study is to evaluate the efficiency of investments in the structural measures from the point of view of national economy. To do this, we determined the economic evaluation indicators (B/C relation, Net Present Value-NPV, and Internal return rate - IRR).

The benefits of the evaluation period were estimated, from the first 15 years since the start of the project. Because, from these 15 years, two are from the work execution period, the evaluation was conducted for the 13 years following the completion of works.

Below the social assessment results for this Project based on the above economic evaluation indicators are shown.

**Table 1.6-1 Social Evaluation**

	流域 Basin	年平均被害軽減額 Average Annual Damage Reduction Amount	評価期間被害 軽減額(15年) Damage Reduction Amount in Evaluation	事業費 Project Cost	維持管理費 Operation & Maintenance Cost	B/C Benefit and Cost Ratio	Net Present Value (NPV) Valor Actual Neto (VAN)	Internal Rate of Return (IRR) Tasa Interna de Retorno (TIR)
Private Price	Majes-Camana	228,698,340	103,275,637	87,791,820	9,228,440	1.28	22,447,137	15%
Social Price	Majes-Camana	230,549,756	104,111,700	73,841,176	7,844,174	1.53	36,063,846	19%

Regarding social prices costs, the project may show a positive economic impact in Majes-Camana, the relation B/C will be over 1.0.

Next, the positive effects of the Project are shown, which are quite difficult to quantify in economic values:

- ① Contribution to local economic development to alleviate the fear to economic activities suspension and damages
- ② Contribution to increase local employment opportunities thanks to the local construction project

- ③ Strengthening the awareness of local people regarding damages from floods and other disasters
- ④ Contribution to increase from stable agricultural production income,relieving flood damage
- ⑤ Rise in farmland prices

From the results of the economic evaluation presented above, it is considered that this project will substantially contribute to the development of the local economy.

### **1.7 Sustainability Analysis**

This project will be co-managed by the central government (through the DGIH), irrigation committees and regional governments, and the project cost will be covered with the respective contributions of the three parties. On the other hand, the operation and maintenance (O & M) of completed works is taken by the irrigation committees. Therefore, the sustainability of the project is depends on the profitability of the project and the ability of O & M of irrigation committees.

The profitability of the project is high enough as described in the section 1.6 so that the sustainability of the project is guaranteed.

In the Table 1.7-1 the budget data from last year of the irrigation commissions is shown.

**Table 1.7-1 Irrigation Commission’s budget**

Rivers	Annual Budget			
	(Unit/ S)			
	2007	2008	2009	2010
Majes-Camana	-	1,867,880.10	1,959,302.60	1,864,113.30

On the other hand the annual O/M cost required after implementation of the Project is as shown in the Table-1.7-2, of which detail is described in the section 4.4.1. The percentage of O/M cost to the annual budget of irrigation committee in the basin and the annual flood damage reduction amount is also as shown in the same table.

The percentage of O/M cost to the annual budget of irrigation committee is 36.2% . And the percentage of O/M cost to the annual flood damage reduction amount is 4.0%, which is very low. Although the percentage of O/M cost to the annual budget is relatively high, the percentage of O/M cost to the yearly average damage reduction amount is very low. Since the benefit of agriculture increases due to the reduction of flood damage, it is possible enough that the irrigation committee will bear the O/M cost. The technical capacity of irrigation committee for O/M seems to be enough by the technical assistance of MINAG and regional government because the flood prevention facilities such as embankment, bank protection and weir are familiar structures to the committee

**Table 1.7-2 Percentage of O/M cost to annual budget and damage reduction amount**

Irrigation Committee	Annual Budget(1,000soles)	O/M Cost(1,000soles)	Percentage of O/M cost(%)	Average Yearly Damage Reduction(1,000soles)	Percentage of O/M cost(%)
	①	②	③=②/①	④	⑤=②/④
Majes-Camana	1,959	710	36.2	17,704	4.0

## 1.8 Environmental Impact

### (1) Procedure of environmental impact assessment

Projects are categorized in three scales, based on the significance level of the negative and positive impacts, and each sector has an independent competence on this categorization. The Project holder should submit the Environmental Impact Statement (DIA, in Spanish) for all Projects under Category I. The project holder should prepare an EIA-sd or an EIA-d if the Project is categorized under Category II or III, respectively, to be granted the Environmental Certification from the relevant Ministry Directorate.

First, the Project holder applies for the Project classification, by submitting the Preliminary Environmental Assessment (PEA). The relevant sector assesses and categorizes the Project. The Project's PEA that is categorized under Category I becomes an EID, and those Projects categorized under Category II or III should prepare an EIA-sd or EIA-d, as applicable.

The preliminary environmental assessment (EAP) for Majes-Camana river was carried out between September 2011 and November 2011 and by a consulting firm registered in the Ministry of Agriculture (CIDES Ingenieros S.A.). EAP for Majes-Camana was submitted to DGIH December 20, 2011 by JICA Study Team and from DGIH to DGAA January 4, 2012. The last watershed of Majes-Camana was also examined by DGAA and categorized as Category I as well as the previous 3 watersheds on August 16, 2012.

### (2) Results of environmental impact assessment

The procedures to review and evaluate the impact of the natural and social environment of the Project are the following. First, we reviewed the implementation schedule of the construction of river structures, and proceeded to develop the Leopold matrix.

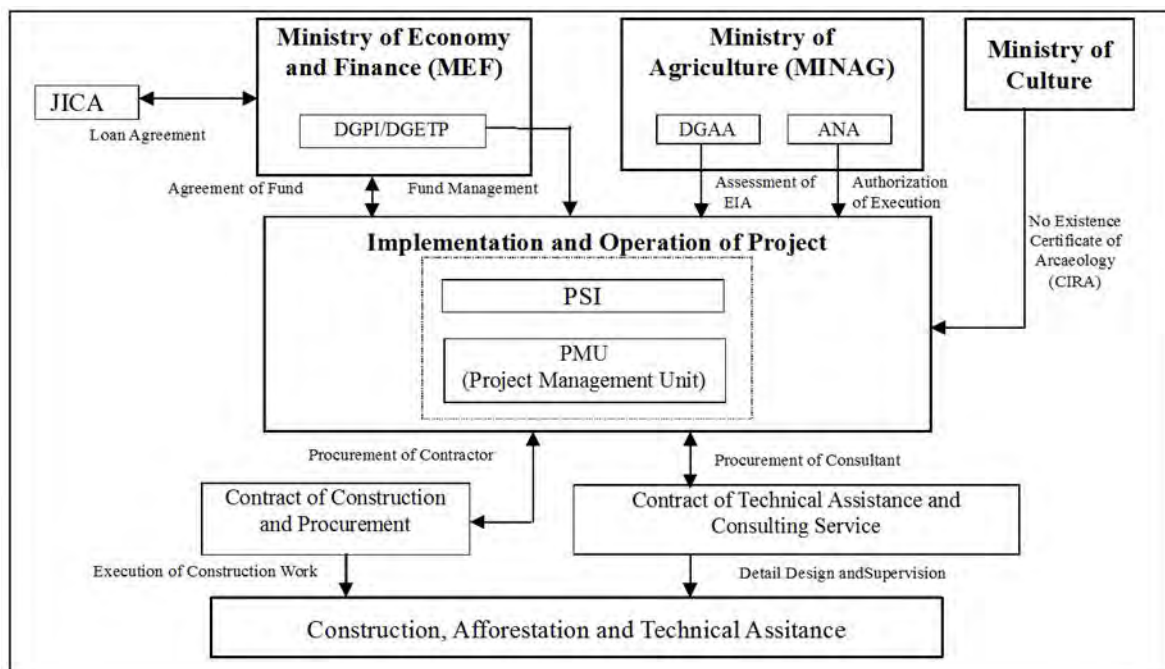
The impact at environmental level (natural, biological and social environment) was evaluated and at Project level (construction and maintenance stage). The quantitative levels were determined by quantifying the environmental impact in terms of impact to nature, manifestation possibility, magnitude (intensity, reach, duration and reversibility).

The EAP showed that the environmental impact would be manifested by the implementation of this project in the construction and maintenance stages, mostly, it is not very noticeable, and if it were, it can be prevented or mitigated by appropriately implementing the management plan environmental impact.

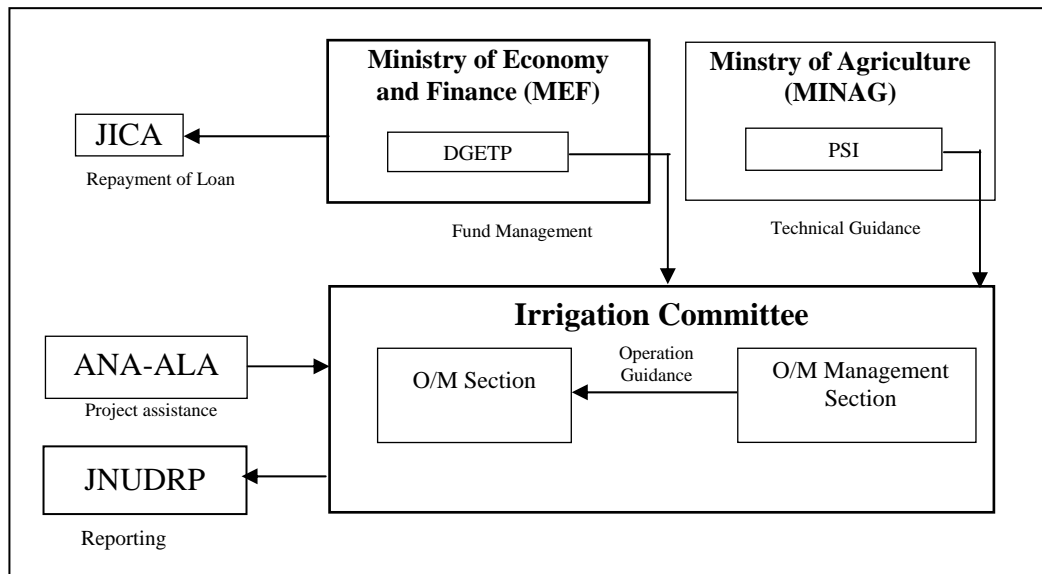
On the other hand, the positive impact is very noticeable in the maintenance stage, which manifests at socioeconomic and environmental level, specifically, in greater security and reduced vulnerability, improved life quality and land use.

### 1.9 Institutions and Management

The institutions and its administration in the investment stage and in the operation and maintenance stage after the investment are as shown in the Figures 1.9-1 and 1.9-2.

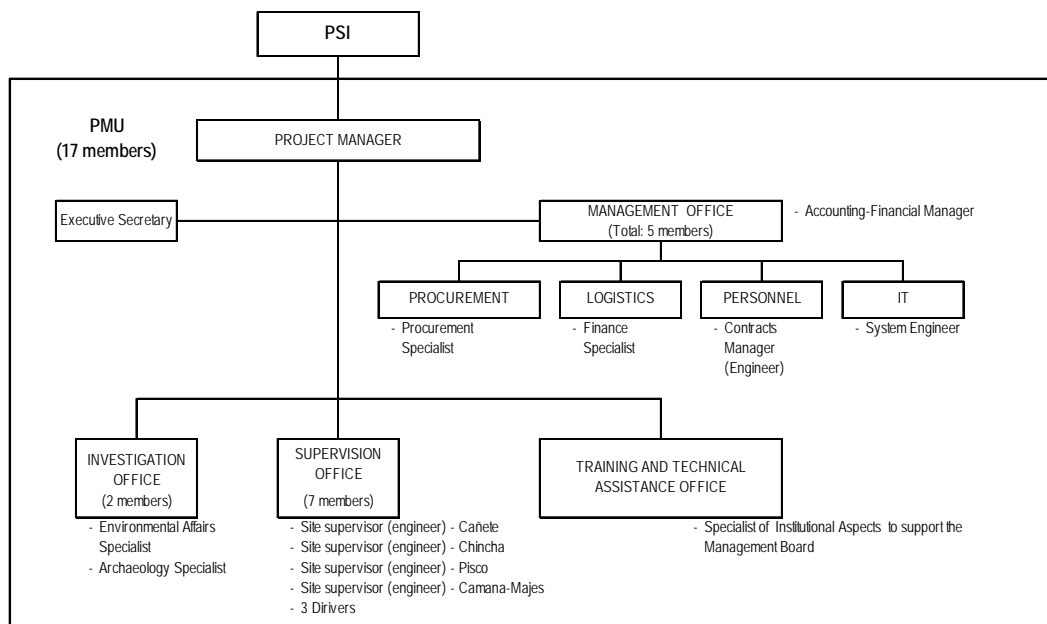


**Figure 1.9-1 Related agencies in implementation stage of project**



**Figure 1.9-2 Related agencies in operation stage of project**

The Project Management Unit (PMU) is to be organized under the Irrigation Infrastructure Direction of PSI, of which organization is as shown in the Figure-1.9-3 and 13 professionals are arranged. The operation cost of PMU is estimated as million soles



Note: ( ) shows number of personnel

**Figure-1.9-3 Organization of PMU**

### 1.10 Execution Plan

Table 1.10-1 presents the Project execution plan.

**Table 1.10-1 Execution plan**

Item	2010			2011			2012			2013			2014			2015			2016			2017			2018			Months
	3	6	9	12	3	6	9	12	3	6	9	12	3	6	9	12	3	6	9	12	3	6	9	12	3	6	9	
1 Profile Study/SNIP Appraisal	Study						Appraisal																		28			
2 Feasibility Study/SNIP Appraisal				Study			Appraisal																		27			
3 Loan Appraisal																									6			
4 Selection of Consultant																									10			
5 Project Management Unit																									45			
6 Consulting Services																									45			
1) Detailed Design																									6			
2) Tender Preparation, Assistance																									15			
3) Supervision																									24			
7 Selection of Contractor, Contract																									15			
8 Implementation																												
1) Structural Measures																									24			
2) Vegetation																									24			
3) Disaster Education/Capacity Building																									24			
4) Land Acquisition																									27			
9 Completion/Inauguration																									-			

1) Employment of consultants

The employment of consultant is to be made according the following itmes:

- ① The consultants should be active in international market and have enough qualification and experience.
- ② The consultants are to have efficiency, transparency and non-discrimination among eligible consultants
- ③ The selection procedure should be taken in accordance with the stipulation in the Loan Agreement and the guideline for the Employment of Consultants under Japanese ODA Loans prepared by JICA

2) Procurement of contractor

The procurement of contractors is to be made according to the following items:

- ① The procurement of contractors is to be made using due attention to consideration s of economy, efficiency, transparency and non-discrimination among eligible bidders.
- ② The procurement procedure should be taken in accordance with the stipulation in the Loan Agreement and the guideline for the Employment of Consultants under Japanese ODA Loans prepared by JICA
- ③ The International Competitive Bidding: ICB is to be applied.
- ④ The pre-qualification (PQ) of bidders is to be applied in order to confirm the technical and financial capability of bidders. The following items are to be considered in PQ: a) experience of and past performance on similar contracts, b) capabilities with respect to personnel, equipment and plant, c) financial position.

## 1.11 Financial Planning

This Project will be implemented by the central government, local government and irrigation committee. The cost sharing ratio among central government, local governments and irrigation committees is provisionally assumed to be 80%, 15% and 5% respectively. The final cost sharing ratio among stakeholders shall be determined through the discussions among them as soon as possible.

**Table 1.11-1 Financial planning in implementation of project**

(thousand soles)

	Item		Amount	Remarks
1	Project cost	①	239,474	
2	Yen loan	②	64,750	25millionUS\$x2.59
	Counter fund	③	174,724	①-②
3	Central government	④	139,779	③x80%
4	regional government	⑤	26,209	③x15%
	(1) Lima (canete)	⑥	3,355	⑤x12.8%(Ratio of Project Cost)
	(2) Ica (Chincha)	⑦	5,347	⑤x20.4%(Ratio of Project Cost)
	(Pisco)	⑧	7,548	⑤x28.8%(Ratio of Project Cost)
	Subtotal	⑨	12,895	⑦+⑧
	(3) Arequipa (Majes-Camana)	⑩	9,959	⑤x38.0%(Ratio of Project Cost)
5	Irrigation committee	⑪	8,736	③x5%
	(1) Canate	⑫	1,118	⑪x12.8%(Ratio of Project Cost)
	(2) Chincha	⑬	1,782	⑪x20.4%(Ratio of Project Cost)
	(3) Pisco	⑭	2,516	⑪x28.8%(Ratio of Project Cost)
	(4) Majes-Camana	⑮	3,320	⑪x38.0%(Ratio of Project Cost)

Note) 1 US \$ = 83,6 yen = 2,59 soles, 1 sol = 32,3 yen

## 1.12 Conclusion and Recommendation

### 1.12.1 Conclusion

The flood prevention facilities selected finally in this Project are safe in structural, and have high viability and give scarcely impact to the environment. It is concluded that the Project should be implemented as soon as possible so that the high vulnerability against flood in valleys (Valles) and rural communities could be reduced and the social economic development will be promoted in the Project area.

### 1.12.2 Recommendation

Based on the knowledge and experience obtained from this Study, the following recommendations are presented on the implementation of this Project and the future flood control measures in Peru. For further detail refer to the main text 5.2.2.

#### (1) Recommendation on implementation of this project

1) Problems to be solved at present

- \* Sharing ratio of Project cost among the central government(MINAG), the local governments and Irrigation committees in each basin

- \* Negotiation of land acquisition and compensation with local people
- \* Confirmation of implementation agency of the Project
- \* Acquisition of CIRA (Certificación de Inexistente de Restos Arqueológicos)
- \* Technical and economic assistance for the maintenance performed by irrigation committees by MINAG and local government

2) Structural measures

- \* Basic policy of flood control
- \* Problems for flood control planning in Majes-Camana river
- \* Problems in design and construction work
  - Construction work period is to be 9 months from April to December considering transition period to dry season from May to November
  - Stability of embankment
  - Requirement of stability analysis and infiltration analysis in the detail design stage
  - Method of compaction of embankment and supervision
  - Reduction of bank protection cost which occupies 80% of construction cost
  - Balance of embankment volume and excavation volume

3) Non-structural measures

- \* Necessity of reforestation such as i) Short term plan and ii) Long term plan
- \* Sediment control and riverbed fluctuation
  - Sediment control facility plan and soft counter measures
  - Riverbed fluctuation and necessity of monitoring

4) Disaster prevention education/capacity development

- \* Soft counter measures for reduction of flood damage
- \* Promotion of community disaster prevention

**(2) Recommendation for future flood control plan in Peru**

- 1) Preparation of comprehensive master plan for flood control
- 2) Establishment of implementation agency for integral flood control project
- 3) Execution of strict river management
- 4) Establishment of nationwide network of rainfall observation stations and discharge observation stations

**1.13 Logical Framework**

Table 1.13-1 presents the logical framework of the final selected alternative.



**Table 1.13-1 Logical framework of the final selected alternative**

<b>Narrative Summary</b>	<b>Verifying Indicators</b>	<b>Verifying Indicators Media</b>	<b>Preliminary Conditions</b>
<b>Superior Goal</b>			
Promote socioeconomic local development and contribute in communities' social welfare.	Improve local productivity, generate more jobs, increase population's income and reduce poverty index	Published statistic data	Socio-economic and policy stability
<b>Objectives</b>			
Relief the high vulnerability of valleys and local continuity to floods	Types, quantity and distribution of flood control works, population and beneficiaries areas	Monitoring annual calendar works and financial plan, budget execution control	Ensure the necessary budget, active intervention from central and regional governments, municipalities, irrigation communities, local population, etc.
<b>Expected results</b>			
Reduction of number and flooded areas, functional improvement of intakes, irrigation channels protection, bank erosion control	Number of areas and flooded areas, water intake flow variation, bank erosion progress	Site visits, review of the flood control plan and flood control works reports and periodic monitoring of local inhabitants	Maintenance monitoring by regional governments, municipalities and local community, provide timely information to the superior organisms
<b>Activities</b>			
Component A: Structural Measures	Dikes rehabilitation, intake and margin protection works construction of 23 works, including dike's safety	Detailed design review, works reports, executed expenses	Ensure the works budget, detailed design/works execution/good quality works supervision
Component B: Non-Structural Measures (Reforestation and vegetation recovery)	Reforested area, coastal forest area	Works advance reports, periodic monitor by local community	Consultants support, NGO's, local community, gathering and cooperation of lower watershed community
Component C: Disaster prevention and capabilities development education	Number of seminars, trainings, workshops, etc	Progress reports, local governments and community monitoring	Predisposition of the parties to participate, consultants and NGO's assessments
Project's execution management			
Project's management	Detailed design, work start order, work operation and maintenance supervision	Design plans, work's execution plans, costs estimation, works specifications, works management reports and maintenance manuals	High level consultants and contractors selection, beneficiaries population participation in operation and maintenance

## 1.14 Middle and Long Term Plans

While it is true that due to the limited budget available for the Project, this study is focused mainly on the flood control measures analysis that must be implemented urgently. It is considered necessary to timely implement other necessary measures within a long term. In this section we will discuss the medium and long term plans.

### (1) Flood control general plan

There are several ways to control floods in the entire watershed, for example, the building of dams, retarding basin, dikes or a combination of these. The options to build dams or retarding basin are not viable because in order to answer to a flood flow with a return period of 50 years, enormous works would be necessary to be built. So, the study was focused here on dikes' construction because it was the most viable option.

Flood water level was calculated in the watershed adopting a designed flood flow with a return period of 50 years. At this water level, freeboard was added in order to determine the required dikes height. After, sections of the rivers where the dikes or ground did not reach the required height were identified. These sections, altogether, add up to approx.136km. Also, from maintaining these works, annually a dragged of the rivers has to be done in the sections where, according to the bed fluctuation analysis the sediment gathering is elevating the bed's height. The volume of sediments that shall be eliminated annually was determined in approximately 11,000 m<sup>3</sup>.

In Tables 1.14-1 and 1.14-2 the flood control general plan project cost is shown as well as the social assessment results in terms of private and social costs.

**Table 1.14-1 Project cost and social assessment of the general flood control plan  
(private prices costs)**

流域名 Basin	年平均被害軽減額 Annual Average Damage Reduction	評価期間被害 軽減額(15年) Damage Reduction in Evaluation Period(15years)	事業費 Project Cost	維持管理費 O & M Cost	B/C Cost Benefit Ration	NPV Net Present Value
Majes-Camana	292,262,168	131,979,802	426,465,039	26,889,287	0.94	-252,892,589

**Table 1.14-2 Project cost and social assessment of the general flood control plan  
(social prices costs)**

流域名 Basin	年平均被害軽減額 Annual Average Damage Reduction	評価期間被害 軽減額(15年) Damage Reduction in Evaluation Period(15years)	事業費 Project Cost	維持管理費 O & M Cost	B/C Cost Benefit Ration	NPV Net Present Value	IRR(%) Internal Return of Rate
Majes-Camana	295,026,234	133,227,999	342,877,891	21,618,987	0.49	-176,161,163	-

In case of executing flood control works in the watershed, the works is not viable economically, and the Projects' cost would elevate to 426.5 million soles, which is a huge amount for this project.

## **(2) Reforestation plan and vegetation recovery**

The forestry option was analyzed, in a long term basis, to cover every area that requires being covered with vegetation in the upper watershed. The objective is improving this areas' infiltration capacity, reduce of surface water and increase semi-underground and underground water. So, the flood maximum flow will be decreased, also it could be possible to increase the water reserve in the mountain areas and prevent and soothe floods. The areas to be reforested will be the afforested areas or where the forest mass in the water infiltration areas has been lost.

In Table 1.14-3 the area to be afforested and the project's cost for the watershed is shown. These were calculated based on forestry plan of Chincha River (refer to Annex-7 Afforestation and Vegetation Recovery Plan, 3.2 Long Term Plan). The total surface would be approximately 307,000hectares and in order to forest them the required time would be from 98 years and 829.2 million soles. To sum up, the Project has to cover an extensive area, with an investment of much time and at a high cost.

**Table 1.14-3 General Plan for forestry on upper stream watersheds**

Watershed	Forestry Area (ha) A	Required Period for the project (years) B	Required Budget (1,000soles) C
Majes- Camana	307,210	98	829,201

## **(3) Sediment control plan**

As long term sediment control plan, it is recommended to perform necessary works on the upper watershed. These works will mainly consist of dams and bank protection. In Table 1.14-4 the estimate work cost is shown. There are two costs, one for executing works in the entire watershed and another one for executing works only in prioritized areas based on the slope of river channel (refer to Annex-6, Sediment Control , Table-1.5.1).

All the chosen watersheds for this Project are big. So, if bank protection works and sediment control dams want to be built, not only the works' cost would elevate but also a very long period of investment would have to be done in the watershed. This means that its positive impact will be seen in a long time.

**Table 1.14-4 Projects' general costs of the sediment control installations upstream the watershed**

Watersheds	Areas	Bank Protection		Bands		Dams		Works direct cost (total)	Project Cost (in millions de s/.)
		Qty. (km)	Works direct costs (million s/.)	Qty. (No.)	Works direct costs (million s/.)	Qty. (No.)	Works direct costs (million s/.)		
Majes-Camana	Totally	264	S/.282	26	S/.1	123	S/.165	S/.448	S/.843
	Prioritized areas	264	S/.282	26	S/.1	81	S/.105	S/.388	S/.730



## **2. GENERAL ASPECTS**

### **2.1 Name of the Project**

“Protection program for valleys and rural communities vulnerable to floods Implementation of prevention measures to control overflows and floods of Majes-Camana River, Arequipa department”

### **2.2 Formulator and Executor Units**

#### **(1) Formulator Unit (UF)**

Name: Hydraulic Infrastructure General Direction, Agriculture Ministry

Responsible: Gustavo Adolfo Canales Kriljenko

General Director of the Water Infrastructure General Direction

Address: Av. Guillermo Prescott No. 490, San Isidro – Perú

Phone: (511) 6148100, (511) 6148101

Email: [gcanales@minag.gob.pe](mailto:gcanales@minag.gob.pe)

#### **(2) Executor Unit (UE)**

Name: Sub-sectorial Irrigation Program, Agriculture Ministry

Manager: Jorge Zúñiga Morgan

Executive Director

Address: Jr. Emilio Fernandez N° 130 Santa Beatriz, Lima-Peru

Phone: (511) 4244488

Email: [postmast@psi.gob.pe](mailto:postmast@psi.gob.pe)

### **2.3 Involved Entities and Beneficiaries Participation**

Here are the institutions and entities involved in this project, as well as beneficiaries.

#### **(1) Agriculture Ministry (MINAG)**

MINAG, as manager of natural resources of watersheds promotes agricultural development in each of them and is responsible of maintaining the economical, social and environmental to benefit agricultural development.

To accomplish effectively and efficiently this objective, the MINAG has been working since 1999 in the River Channeling and Collection Structures Protection Program (PERPEC). The river disaster prevention programs that are been carried out by regional governments are funded with PERPEC resources.

##### 1) General Administration Office (OGA)

- Manages and executes the program’s budget
- Establishes the preparation of management guides and financial affairs

2) Hydraulic Infrastructure general Direction (DGIH)

- Performs the study, control and implementation of the investment program
- Develops general guidelines of the program together with OPI

3) Planning and Investment Office (OPI), present Planning and Budgetary Office (OPP)

- Conducts the preliminary assessment of the investment program
- Assumes the program's management and the execution of the program's budget
- Plans the preparation of management guides and financial affairs

4) Irrigation Sub-Sectorial Program (PSI)

- Carries-out the investment program approved by OPI and DGPM

**(2) Economy and Finance Ministry (MEF)**

Investment Policy General Direction (DGPI; previous DGPM) is in charge of approving public investment works according to procedures under the Public Investment National System (SNIP) to assess the relevance and feasibility of processing the disbursement request of the national budget and the loan from JICA.

**(3) Japan's International Cooperation Agency (JICA)**

It is a Japanese government institution with the objective of contributing in the socioeconomic development of developing countries through international cooperation. JICA has extended financial assistance to carry out profile and feasibility studies of this Project.

**(4) Regional Governments (GORE)**

Regional governments assume the promotion of integrated and sustainable regional development following the national and regional plans and programs, trying to increase public and private investment, generating employment opportunities, protecting citizens rights and ensuring equal opportunities.

The regional governments' participation with their possible financial support is a very important factor to ensure the Project's sustainability.

**(5) Irrigation Commission**

Currently there are 42 irrigation commissions in the Majes-Camana River Watershed. These have expressed a strong desire for the starting of works because these will help constructing dikes, protecting margins, repairing water intakes, etc. These commissions are currently suffering major damages due to rivers flooding. Next, a brief overview of the Majes-Camana River Watershed is described (for more details, see Section 3.1.3). Currently, the operation and maintenance of dikes, margin protection works, irrigation intakes and channels linked to agricultural land and irrigation systems in the Watershed, are mainly made by irrigation commissions and their members, with the assistance of local governments.

	Majes River Watershed	Camana River Watershed
Number of irrigation blocks:	17	17
Number of Irrigation	45	38
Commissions:		
Irrigated Area:	7,505 ha	6,796ha
Beneficiaries:	2.519 producers	3.388 producers

#### **(6) Meteorology and Hydrology National Service (SENAMHI)**

It is an agency from the Environment Ministry responsible for all activities related to meteorology, hydrology, environment and agricultural meteorology. Take part in global level monitoring, contributing to sustainable development, security and national welfare, and gathering information and data from meteorological stations and hydrological observation.

#### **(7) Civil Defense National Institute (INDECI)**

INDECI is the main agency and coordinator of SINAGERD (Sistema Nacional de Gestioh del Riesgo de Desastiv, established in May 2011. It is responsible for organizing and coordinating the community, elaborating plans and developing disaster risk's management processes. Its objective is to prevent or alleviate human life loss due to natural and human disasters and prevent destruction of property and the environment.

#### **(8) Water National Authority (ANA)**

It is the highest technical regulating authority in charge of promoting, monitoring and controlling politics, plans, programs and regulations regarding sustainable use of water resources nationwide.

Its functions include sustainable management of these resources, as well as improving the technical and legal framework on monitoring and assessment of water supply operations in each region.

Along with maintaining and promoting a sustainable use of water resources, it is also responsible for conducting the necessary studies and developing main maintenance plans, national and international economic and technical cooperation programs.

#### **(9) Agriculture Regional Directorates (DRA's)**

Agricultural regional addresses fulfill the following functions under the respective regional government:

- 1) Develop, approve, assess, implement, control and manage national agriculture policies, sectorial plans as well as regional plans and policies proposed by municipalities
- 2) Control agriculture activities and services fitting them to related policies and regulations, as well as on the regional potential

- 3) Participate in the sustainable management of water resources agreeing with the watershed's general framework, as well as the policies of the Water National Authority (ANA)
- 4) Promote the restructure of areas, market development, export and agricultural and agro-industrial products consumption
- 5) Promote the management of: irrigation, construction and irrigation repair programs, as well as the proper management and water resources and soil conservation

## **2.4 Framework**

### **2.4.1 Background**

#### **(1) Study Background**

The Republic of Peru (hereinafter "Peru") is a country with high risk of natural disasters such as earthquakes, Tsunamis, etc. Among these natural disasters there are also floods. In particular, El Niño takes place with an interval of several years and has caused major flood of rivers and landslides in different parts of the country. The most serious disaster in recent years due to El Niño occurred in the rainy season of 1982-1983 and 1997-1998. In particular, the period of 1997-1998, the floods, landslides, among others left loss of 3,500 million of dollars nationwide. The latest floods in late January 2010, nearby Machupicchu World Heritage Site, due to heavy rains interrupted railway and roads traffic, leaving almost 2,000 people isolated. In Majes-Camana river the flood with discharge of over 1,100m<sup>3</sup>/sec (equivalent to about 10years probability flood) occurred at the midnight in February 13, 2012 causing flood disaster in the project area. The total area of inundation was 1,085 ha, the total length of 780m of dike was destroyed, and the main irrigation canal of 800m and secondary canal of 1,550m were damaged. And in Pisco river the dike in various areas was damaged and the Miraflores road bridge in Humay area was washed away.

In this context, the central government has implemented El Niño phenomenon I and II contingency plans in 1997-1998, throughout the Agriculture and Livestock Ministry (MINAG) in order to rebuild water infrastructures devastated by this phenomenon. Next, the Hydraulic Infrastructure General Direction (DGIH) of the Agriculture Ministry (MINAG) began in 1999 the River Channeling and Collection Structures Protection Program (PERPEC) in order to protect villages, farmlands, agricultural infrastructure, etc located within flood risk areas. The program consisted of financial support for regional government to carry out works of margin protection. In the multiyear PERPEC plan between 2007-2009 it had been intended to execute a total of 206 margin protection works nationwide. These projects were designed to withstand floods with a return period of 50 years, but all the works have been small and punctual, without giving a full and integral solution to control floods. So, every time floods occur in different places, damages are still happening.

MINAG developed a "Valley and Rural Populations Vulnerable to Floods Protection Project" for nine watersheds of the five regions. However, due to the limited availability of experiences, technical and



financial resources to implement a pre-investment study for a flood control project of such magnitude, MINAG requested JICA's help to implementation this study. In response to this request, JICA and MINAG held discussions under the premise of implementing it in the preparatory study scheme to formulate a loan draft from AOD of JICA, about the content and scope of the study, the implementation's schedule, obligations and commitments of both parties, etc. expressing the conclusions in the Discussions Minutes (hereinafter "M/D") that were signed on January 21 and April 16, 2010. This study was implemented on this M/D.

## **(2) Progress of Study**

The Profile Study Report for this Project at Program's level for nine watersheds of five regions has been elaborated by DGIH and sent to the Planning and Investment Office (OPI) on December 23, 2009, and approved on the 30<sup>th</sup> of the same month. Afterwards, DGIH presented the report to the Public Sector Multiannual Programming General Direction (DGPM) (present DGPI) of the Economy and Finance Ministry (MEF) on January 18, 2010. On March 19<sup>th</sup>, DGPM informed DGIH about the results of the review and the correspondent comments.

The JICA Study Team began the study in Peru on September 5<sup>th</sup>, 2010. At the beginning, nine watersheds were going to be included in the study. One, the Ica River was excluded of the Peruvian proposal leaving eight watersheds. The eight watersheds were divided into two groups: Group A with five watersheds and Group B with three watersheds. The study for the first group was assigned to JICA and the second to DGIH. Group A includes Chira, Cañete, Chincha, Pisco and Yauca Rivers' Watersheds and Group B includes the Cumbaza, Majes and Camana Rivers' Watersheds.

The JICA Study Team conducted the Profile Study of the five watersheds of Group A, with an accurate of pre-feasibility level and handed DGIH the Program Report of group A and the reports of the five watershed projects by late June 2011. Also, the feasibility study has already started, omitting the pre-feasibility study.

For the watersheds of Group B which study corresponded to DGIH, this profile study took place between mid-February and early March 2011 (and not with a pre-feasibility level, as established in the Meetings Minutes), where Cumbaza River Watershed was excluded because it was evident that it would not have an economic effect. The report on the Majes and Camana rivers watersheds were delivered to OPI, and OPI official comments were received through DGIH on April 26<sup>th</sup>, indicating that the performed study for these two watersheds did not meet the accuracy level required and it was necessary to study them again. Also, it was indicated to perform a single study for both rivers because they belong to a single watershed (Majes-Camana).

On the other hand, due to the austerity policy announced on March 31<sup>st</sup>, prior to the new government assumption by new president on July 28<sup>th</sup>, it has been noted that it is extremely difficult to obtain new budget, DGIH has requested JICA on May 6<sup>th</sup> to perform the prefeasibility and feasibility studies of the Majes-Camana Watershed.

JICA accepted this request and decided to perform the mentioned watershed study modifying for the second time the Meeting Minutes (refer to Meetings Minutes Second Amendment about the Initial Report, Lima, July 22<sup>nd</sup>, 2011)

So, the JICA Study Team began in August the prefeasibility study for the watershed above mentioned, which was completed in late November.

Based on the Profile Study with the pre-feasibility level, the four rivers of Cañete, Chincha, Pisco and Majes-Camana excluding Chira and Yauca rivers are selected for the objective rivers for the feasibility study under the restriction of total budget for the Project and viability of social evaluation of each river (refer to Minutes of Meetings on Main Points of Interim Report, Lima , December 5, 2011

DGIH registered 4 rivers to SNIP on July 21, 2011 based on the Profile Study reports (for each basin) except Yauca. Yauca river was not registered due to its low viability of the social evaluation judged by DGIH. And DGIH registered Majes-Camana river to SNIP on January 9, 2012. DGIH submitted the Profile Study reports of 4 rivers (Chira, Cañete, Chincha, Pisco excluding Yauca) with pre-FS level accuracy to OPI, which issued their observations on the reports to DGIH on September 22, 2011, and on the report of Majes-Camana river on August 4, 2012.

DGIH revised these profile study reports in accordance with the OPI's observation and submitted them to OPI in May 2012 for 3 rivers of Cañete, Chincha, Pisco, and December 12, 2012 for Majes-Camana river.

OPI examined the revised reports of 3 rivers and transferred them to DGPI, MEF together with their comments in July 2012. DGPI, MEF examined the reports and approved the implementation of Feasibility Study for 3 rivers with their comments in October 2012

Since the examination process of OPI and DGPI based on SNIP regulation had delayed, JICA executed the feasibility study on the 4 watersheds which were selected based on the Profile Study and submitted the program report of 4 watersheds and the project reports of each watersheds were submitted to DGIH on March 9, 2012 in draft form.

DGIH has been revising the feasibility study reports in accordance with the comments of MEF, after completion of revision will obtain the approval on the reports from OPI and MEF. And DGIH will take same process for the Majes-Camana river for which the examination and approval process of OPI and MEF delay.

On the other hand, JICA headquarter commented the run-off study on Majes-Camana river in the feasibility study, and JICA Study Team has to begin the review of the study (June 29, 2012). JICA Study Team started the review study in July 2012 and completed the revised run-off study and related various studies in November 2012. The process of the above is as shown in the Table-2.4.1-1.

**Table-2.4.1-1 Process of study and submission of report**

Items	Date	Chira	Ica	Chincha	Pisco	Yauca	Cajete	Majes	Camana	Cumbaza	
Perfil Program		December 30, 2009 : prepared and submitted by DGIH, January 18, 2010 : approved by DGPI									
Start of JICA Study	2010/9/5	A group 5 rivers to be studied by JICA					B group 4 rivers to be studied by DGIH				
Amendment of M/M on ICR (No.1)	2010/11/12	-	excluded by DGIH	-	-	-	transferred to A group	-	-	-	
Responsible Organization	-	JICA	-	JICA			DGIH				
Perfil Program Report	2011/3中旬	-	-	-	-	-	-	Preparation and Submission			
DGIH excluded Cumbaza		-	-	-	-	-	-	-	-	excluded by DGIH	
OPI Observation	2011/4/26	-	-	-	-	-	-	Combination of both rivers and upgrade of study directed by OPI		-	
Amendment of M/M on ICR (No.2)	2011/6/22	-	-	-	-	-	-	DGIH requested study of this river to JICA		-	
Pre-F/S Level Study	2011/6/30	Submission to DGIH	-	Submission to DGIH				-	-	-	
SNIP Registration	2011/7/21	Registration to SNIP	-	Registration to SNIP		No registration to SNIP	Registration to SNIP	-	-	-	
OPI Observation	2011/9/22	OPI Observation	-	OPI Observation		-	OPI Observation	-	-	-	
Objectives for F/S Study	2011/12/5	excluded	-	Selected		-	Selected	Selected		-	
Pre-F/S Level Study on Majes-Camana	2011/12/15	-	-	-	-	-	-	Submission to DGIH		-	
Pre F/S Program Report of 6 rivers	2011/12/28	Submission to DGIH	-	Submission to DGIH			Submission to DGIH	Submission to DGIH	-	-	
FS Draft Report	2012/3/9	-	-	Submission to DGIH		-	Submission to DGIH	Submission to DGIH		-	
DGIH revised report to OPI	-	-	-	2012/5/15	2012/5/14	-	2012/5/21	2012/12/12	-	-	
OPI report to MEF	-	-	-	2012/7/26		-	2012/7/26	Unknown	-	-	
MEF approval for FS	-	-	-	2012/10/4	2012/10/16	2012/10/17	-	Unknown	-	-	
DGIH revision of FS report	-	-	-	Under preparation		-	Under preparation	Unknown	-	-	
OPI&MEF approval of revised FS report	-	-	-	Unknown	Unknown	-	Unknown	Unknown	-	-	
Revised Study of Majes-Camana	-	-	-	-	-	-	-	2012/8~2012/11		-	
Expalation of the above	-	-	-	-	-	-	-	Scheduled in 2013/2/27		-	
Submission of final FS report	-	-	-	scheduled in 2013/3		-	scheduled in 2013/3	scheduled in 2013/3		-	

## 2.4.2 Laws, Regulations, Policies and Guidelines Related to the Program

This program has been elaborated following the mentioned laws and regulations, policies and guidelines:

### (1) Water Resources Law N° 29338

#### 1) Article 75 .- Protection of water

The National Authority, in view of the Watershed Council, must ensure for the protection of water, including conservation and protection of their sources, ecosystems and natural assets related to it in the regulation framework and other laws applicable. For this purpose, coordination with relevant government institutions and different users must be done.

The National Authority, throughout the proper Watershed Council, executes supervision and control functions in order to prevent and fight the effects of pollution in the oceans, rivers and lakes. It can also coordinate for that purpose with public administration, regional governments and local governments sectors.

The State recognizes as environmentally vulnerable areas the headwater watersheds where the waters originate. The National Authority, with the opinion of the Environment Ministry, may declare protected areas the ones not granted by any right of use, disposition or water dumping.

2) Article 119 .- Programs flood control and flood disasters

The National Authority, together with respective Watershed Board, promotes integral programs for flood control, natural or manmade disasters and prevention of flood damages or other water impacts and its related assets. This promotes the coordination of structural, institutional and necessary operational measures.

Within the water planning, the development of infrastructure projects for multi-sectorial advantage is promoted. This is considered as flood control, flood protection and other preventive measures.

**(2) Water Resources Law Regulation N° 29338**

1) Article 118 .- From the maintenance programs of the marginal strip

The Water Administrative Authority, in coordination with the Agriculture Ministry , regional governments, local governments and water user organizations will promote the development of programs and projects of marginal strips forestry protection from water erosive action.

2) Article 259 °.- Obligation to defend margins

All users have as duty to defend river margins against natural phenomenon effects, throughout all areas that can be influenced by an intake, whether it is located on owned land or third parties' land. For this matter, the correspondent projects will be submitted to be reviewed and approved by the Water National Authority.

**(3) Water regulation**

1) Article 49. Preventive measures investments for crop protection are less than the recovery and rehabilitation cost measures. It is important to give higher priority to these protective measures which are more economic and beneficial for the country, and also contribute to public expenses savings.

2) Article 50. In case the cost of dikes and irrigation channels protection measures is in charge of family production units or it exceeds the payment capacity of users, the Government may pay part of this cost.

**(4) Multi-annual sectorial strategic plan of the Agriculture Ministry for the period 2007-2011 (RM N° 0821-2008-AG)**

Promotes the construction and repair of irrigation infrastructure works with the premise of having enough water resources and their proper use.

**(5) Organic law of the Agriculture Ministry, N° 26821**

In Article 3, it is stipulated that the agricultural sector is responsible for executing river works and agricultural water management. This means that river works and water management for agricultural purposes shall be paid by the sector.

**(6) Guidelines for Peruvian Agricultural Policy - 2002, by the Policy Office of MINAG**

Title 10 - Sectorial Policies

“Agriculture is a high risk productive activity due to its vulnerability to climate events, which can be anticipated and mitigated... The damage cost to infrastructure, crops and livestock can be an obstacle for the development of agriculture, and as consequence, in the deterioration of local, regional and national levels.”

**(7) River Channeling and Collection Structures Protection Program, PERPEC**

The MINAG’s DGIH started in 1999 the River Channeling and Collection Structures Protection Program (PERPEC) in order to protect communities, agricultural lands and facilities and other elements of the region from floods damages, extending financial support to margin protection works carried out by regional governments.



### 3. IDENTIFICATION

#### 3.1 Diagnosis of the Current Situation

##### 3.1.1 Nature

##### (1) Location

Figure 3.1.1-1 shows the location map of the Majes – Camana River, included in the Area of this study.



Figure 3.1.1-1 Location Map for the Study

## **(2) Watershed overall description**

The Majes – Camana River runs 700 m to the south of the Capital of Lima. It is the river running at the most southern point of all the rivers object of the present Study and belongs to the Arequipa Region. The watershed surface is of 17.000 km<sup>2</sup> approximately and 60% of it is located above 4.000 mosl. The area object of the Project is approximately 100km from the river mouth, which is below 2.000 mosl, representing 20% of the total surface of the watershed.

The limit between Majes and Camana is located approximately 40 km from the rivers' mouth. From this point downstream the river is called "Camana" and "Majes" from this limit upstream. The slope of the riverbed is approximately 1/200 in Camana and 1/100 in Majes. Its width varies between 100 and 200 meters in Camana and between 200 and 500 meters in Majes. The river is wider in the upper part because, while in the lower part (Camana) the water course has been stabilized with dikes built by the irrigation commission, in the upper watershed (Majes) there are no sufficient dikes constructed.

Annual rainfalls show a clear tendency to increase in upper areas. This trend is such that they are of approximately 50 mm below 1.000 mosl and more than 500 mm above 4.000 mosl. The flow is abundant and the superficial water (fluvial) does not run out even in dried seasons.

As to vegetation, upper areas of more than 4.000 mosl represent 60% of the total area and are covered by wetlands, while the lower areas below 2.000 mosl are desert. Flat lands along the river are being used, mostly for agriculture, particularly for irrigated rice crops.

### **3.1.2 Socio-Economic Conditions of the Study Area**

#### **(1) Administrative division and surface**

The Majes – Camana River is located in the provinces of Castilla and Camana in the Arequipa Region. Table 3.1.2-1 shows the main districts surrounding this river, with their corresponding surface.

**Table 3.1.2-1 Districts surrounding the Majes – Camana river with areas**

<b>Region</b>	<b>Province</b>	<b>District</b>	<b>Area (Km<sup>2</sup>)</b>
<b>Arequipa</b>	<b>Castilla</b>	Uraca	713.83
		Aplao	640.04
		Huancarqui	803.65
	<b>Camana</b>	Camana	11.67
		Nicolas de Pierola	391.84
		Mariscal Caceres	579.31
		Samuel Pastor	113.4
		Jose Maria Quimper	16.72

#### **(2) Population and number of households**

The following Table 3.1.2-2 shows how population varied within the period 1993-2007. In 2007, from 44,175 inhabitants, 91% (40,322 inhabitants) lived in urban areas while 9% (3,853 inhabitants) lived



in rural areas.

Population is increasing in all districts. However, while the urban area registers an annual medium increase of 2.8% to 3.4%, exceeding the national average, the rural area experiments a decrease of -1.3% to -6.6%.

**Table 3.1.2-2 Variation of the urban and rural population**

Province	District	2007 Total Population					1993 Total Population					Variation (%)	
		Urban	%	Rural	%	Total	Urban	%	Rural	%	Total	Urban	Rural
Castilla	Uraca	2,664	37%	4,518	63%	7,182	1,953	29%	4,698	71%	6,651	2.20%	-0.30%
	Aplao	4,847	45%	4,004	55%	8,851	2,928	35%	5,334	65%	8,262	3.70%	-2.00%
	Huancarqui	1,191	18%	254	82%	1,445	1,047	65%	555	35%	1,602	0.90%	-5.40%
<b>Total</b>		<b>8,702</b>	<b>49.80%</b>	<b>8,776</b>	<b>50.20%</b>	<b>17,478</b>	<b>5,928</b>	<b>36%</b>	<b>10,587</b>	<b>64%</b>	<b>16,515</b>	<b>2.80%</b>	<b>-1.30%</b>
Camana	Camana	14,642	1%	116	99%	14,758	13,284	94%	809	6%	14,093	0.70%	-13.00%
	Nicolas de Pierola	5,362	88%	703	12%	6,065	4,688	88%	613	12%	5,301	1.00%	1.00%
	Mariscal Caceres	4,705	86%	758	14%	5,463	2,562	67%	1,253	33%	3,815	4.40%	-3.50%
	Samuel Pastor	12,004	91%	1,138	9%	13,142	2,285	26%	6,501	74%	8,786	12.60%	-11.70%
	Jose Maria Quimper	3,609	76%	1,138	24%	4,747	2,426	74%	870	26%	3,296	2.90%	1.90%
<b>Total</b>		<b>40,322</b>	<b>91.30%</b>	<b>3,853</b>	<b>8.70%</b>	<b>44,175</b>	<b>25,245</b>	<b>72%</b>	<b>10,046</b>	<b>28%</b>	<b>35,291</b>	<b>3.40%</b>	<b>-6.60%</b>

Source: Prepared by JICA Study Team, Statistics National Institute- INEI, 2007 and 1993 Population and Housing Census.

Table 3.1.2-3 -4 shows the number of households and members per home in 2007. Apparently Huancarqui has fewer members per household (3.36 persons) while Jose Maria Quimper has a greater number with 4.4; remaining districts vary between 3.6 and 4.1 persons.

The number of members per family is around 4.1 persons, with exception of Nuevo Imperial, with a lower Figure of 3.77.

**Table 3.1.2-3 Number of households and families in Castilla**

Variables	District		
	Uraca	Aplao	Huancarqui
Population (inhabitants)	7,182	8,851	1,445
Number of households	1,760	2,333	430
Number of families	1,887	2,416	434
Members per household (persons/household)	4.08	3.79	3.36
Members per family (persons/family)	3.81	3.66	3.33

**Table 3.1.2-4 Number of households and families in Camana**

Variables	District				
	Camana	Nicolas de Pierola	Mariscal Cáceres	Samuel Pastor	Jose Maria Quimper
Population (inhabitants)	14,758	6,065	5,463	13,142	4,747
Number of households	3,845	1,680	1,394	3,426	1,078
Number of families	4,066	1,738	1,448	3,554	1,108
Members per household (persons/household)	3.84	3.61	3.92	3.84	4.4
Members per family (persons/family)	3.63	3.49	3.77	3.7	4.28

### (3) Occupation

Table 3.1.2-5, shows occupation lists of local inhabitants itemized by sector. It highlights the primary sector in Uraca, Aplao, Huancarqui, and Mariscal Cáceres in 54%~65%.

**Table 3.1.2-5 Occupation in Castilla**

EAP	Uraca		Aplao		Huancarqui	
	persons	%	Persons	%	Persons	%
Economically Active Pop. <sup>1/</sup>	3,343	100	3,618	100	649	100
a) Primary sector	2,174	65.03	1,966	54.34	413	63.64
b) Secondary sector	160	4.79	251	6.94	40	6.16
c) Tertiary sector	1,009	30.18	1,401	38.72	196	30.2

Source: National Institute of Statistics - INEI, 2007 Population and Housing Census.

1/ Primary sector: agriculture, livestock, forest and fishery; secondary: mining, construction, manufacturing; tertiary: services and others

**Table 3.1.2-6 Occupation in Camana**

PEA	District									
	Samuel Pastor		Camana		Jose Maria Quimper		Mariscal Cáceres		Nicolas de Pierola	
	persons	%	persons	%	persons	%	persons	%	persons	%
Economically Active Pop. 1/	5,237	100	6,292	100	1,463	100	1,888	100	2,348	100
a) Primary sector	1,749	33	1,469	23	548	37	1,181	63	1,125	48
b) Secondary sector	624	12	473	8	127	9	88	5	167	7
c) Tertiary sector	2,864	55	4,350	69	788	54	619	33	1,056	45

Source: National Institute of Statistics - INEI, 2007 Population and Housing.

1/ Primary sector: agriculture, livestock, forest and fishery; secondary: mining, construction, manufacturing; tertiary: services and others

### (4) Poverty index

Table 3.1.2-7, -8 shows the poverty index. 20.4~33.5% of the districts' population belongs to the poor segment, and 3.8% to 4.4% belong to extreme poverty. Particularly, the Huancarqui district stands out for its high poverty percentage with 33.1%, and 6.9% of extreme poverty.

**Table 3.1.2-7 Poverty index in Castilla**

Variable /Indicator	District (Castilla)							
	Aplao		Huancarqui		Uraca		Total	
	Persons	%	Persons	%	Persons	%	Persons	%
<b>Total Population (inhab.)</b>	8,851		1,445		7,182		17,478.00	100
Poor	2,153	24.3	480	33.1	1,731	24.1	4,364	25
Extreme Poverty	358	4.1	98	6.9	305	4.3	761	4.4

**Table 3.1.2-8 Poverty index in Camana**

Variable /Indicator	District (Canana)											
	Mariscal Caceres		Samuel pastor		Nicolas de Pierola		Jose Maria Quimper		Camana		Total	
	Persons	%	Persons	%	Persons	%	Persons	%	Persons	%	Persons	%
<b>Total Population (inhab)</b>	5,463		13,142		6,065.00		4,747.00		14,758.00		44,175.00	100
Poor	1,927	35.2	4,410.00	33.5	1,494.00	24.6	979	24.9	3,013.00	20.4	11,823	26.8
Extreme Poverty	391	7.4	629	4.9	221	3.8	140	3.7	303	2.1	1,684	3.8

### **(5) Type of housing**

Tables 3-1.2-9 and 3-1.2-10 show data on Castilla and Camana housing. The walls of the houses in Castilla are made 46% of bricks or cement, and 43% of adobe and mud. The floor is made 96% of earth or cement. The public drinking water service covers 50%, while the sewage service is scarcely 45.5% in Huancarqui. The average electrification rate is 86%.

In Camana, walls are made 65% bricks or cement, and 4% with adobe and mud. The floor is made of 98% earth or cement. The public drinking water service covers more than 50% while the sewage service is less than 50%, with exception of Camana. The average electrification rate is 84%.

**Table 3.1.2-9 Type of housing in Castilla**

Variable/Indicator	Districts					
	Urcu		Aplao		Huancarqui	
	Households	%	Households	%	Households	%
<b>Number of Households</b>						
Common houses with residents	1,760	86	2,333	75.3	430	63
<b>Wall material</b>						
Brick or cement	999	56.8	820	35.1	106	24.7
Adobe and mud	195	11.1	1,067	45.7	237	55.1
With walls of quincha and wood	521	29.6	332	14.2	78	18.1
Other	45	2.6	114	4.9	9	2.1
<b>Floor material</b>						
Earth	687	39	831	35.6	195	45.3
Cement	996	56.6	1,381	59.2	226	52.6
Tile, terrazzo tile, parquet or polished wood, wood, boards	71	4	106	4.5	7	1.6
Other	6	0.3	15	0.6	2	0.5
<b>Drinking water system</b>						
Public service in the house	1,216	69.1	1,483	63.6	255	59.3
Public service out of the house but within the building	86	4.9	228	9.8	20	4.7
Public sink	115	6.5	34	1.5		
<b>Sewage and latrine service</b>						
Public sewage service in the house	472	26.8	705	30.2	193	44.9
Public sewage service within the building	26	1.5	58	2.5	4	0.9
Cesspit/ latrine	753	42.8	875	37.5	153	35.6
<b>Houses with lighting system</b>						
Public network	1,505	85.5	1,790	76.7	340	79.1
<b>HOUSEHOLD</b>						
<b>Households in special houses with present occupants</b>	<b>1,887</b>	<b>100</b>	<b>2,416</b>	<b>100</b>	<b>434</b>	<b>100</b>
<b>Head of household</b>						
Man	1,477	78.3	1,839	76.1	335	77.2
Woman	410	21.7	577	23.9	99	22.8
<b>Home appliances</b>						
Has three or more home appliances or equipment	541	28.7	683	28.3	113	26
<b>Information and communication service</b>						
Has landline telephone or mobile	1,353	71.7	1,301	53.8	242	55.8

Source: Prepared by JICA Study Team, Statistics National Institute- INEI, 2007 Population and Housing Census.

**Table 3.1.2-10 Type of housing in Camana**

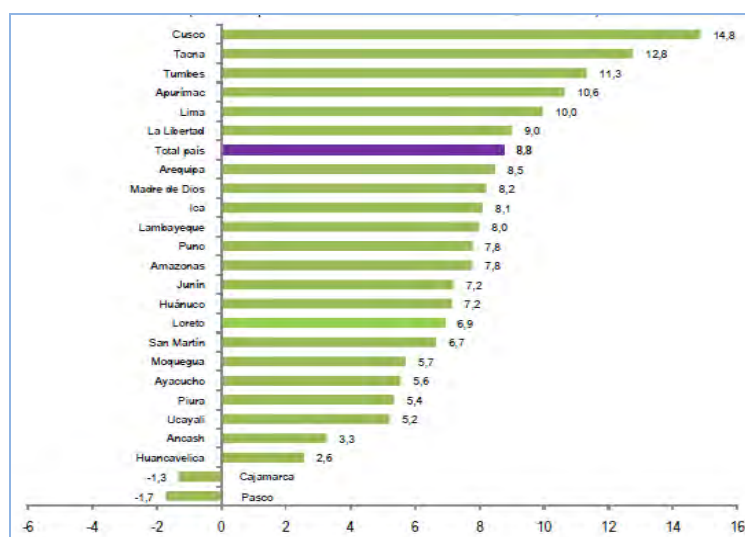
Variable/Indicador	Samuel Pastor		Camana		Jose Maria Quimper		Mariscal Caceres		Nicolas d
	Households	%	Households	%	Households	%	Households	%	Households
<b>Number of Households</b>									
Common houses with residents	3,426	69.7	3,845	90.7	1,078	74.7	1,394	70	1,680
<b>Wall material</b>									
Brick or cement	1,956	57.1	2,942	76.5	674	62.5	664	47.6	986
Adobe and mud	66	1.9	175	4.6	20	1.9	28	2	78
With walls of quincha and wood	716	20.9	427	11.1	226	21	172	12.3	419
Other	688	20.1	301	7.8	158	14.7	530	38	197
<b>Floor material</b>									
Earth	1,780	52	961	25	487	45.2	841	60.3	792
Cement	1,432	41.8	2,335	60.7	547	50.7	530	38	806
Tile, terrazzo tile, parquet or polished wood, wood, boards	154	4.5	514	13.4	38	3.5	16	1.1	70
Other	60	1.8	35	0.9	6	0.6	7	0.5	12
<b>Drinking water system</b>									
Public service in the house	1,987	58	3,028	78.8	732	67.9	774	55.5	957
Public service out of the house but within the building	231	6.7	236	6.1	108	10	160	11.5	323
Public sink	851	24.8	164	4.3	13	1.2	9	0.6	57
<b>Sewage and latrine service</b>									
Public sewage service in the house	1,466	42.8	2,816	73.2	181	16.8	243	17.4	778
Public sewage service within the building	104	3	246	6.4	24	2.2	5	0.4	208
Cesspit/latrine	1,144	33.4	360	9.4	526	48.8	763	54.7	463
<b>Houses with lighting system</b>									
Public network	2,734	79.8	3,556	92.5	935	86.7	1,017	73	1,284
<b>HOUSEHOLD</b>									
Households in special houses with present occupants	3,554	100	4,066	100	1,108	100	1,448	100	1,738
<b>Home appliances</b>									
Has three or more home appliances or equipment	997	28.1	1,902	46.8	360	32.5	304	21	524
<b>Information and communication service</b>									
Has landline telephone or mobile	2,297	64.6	3,586	88.2	790	71.3	654	45.2	1,073

Source: Prepared by JICA Study Team, Statistics National Institute–INEI, 2007 Population and Housing Census.

## (6) GDP

Peru's GDP in 2010 was US\$ 153.919.000.000. The growth rate in the same year was of + 8.8 % compared with the previous year.

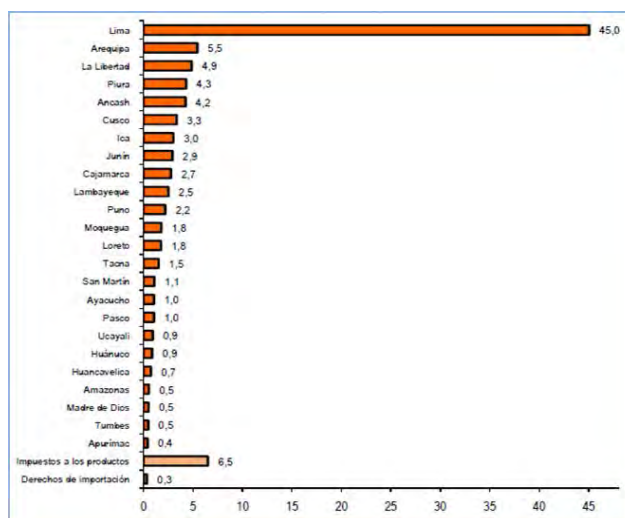
Itemized by regions, Ica registered a growth of 8.1 %, Piura 5.4 %, Lima 10.0 % and Arequipa 8.5 %. Particularly Lima regions registered Figures that were beyond the national average.



Fuente INEI – Dirección Nacional de Cuentas Nacionales-2010

**Figure 3.1.2-1 Growth rate of GDP per region (2010/2009)**

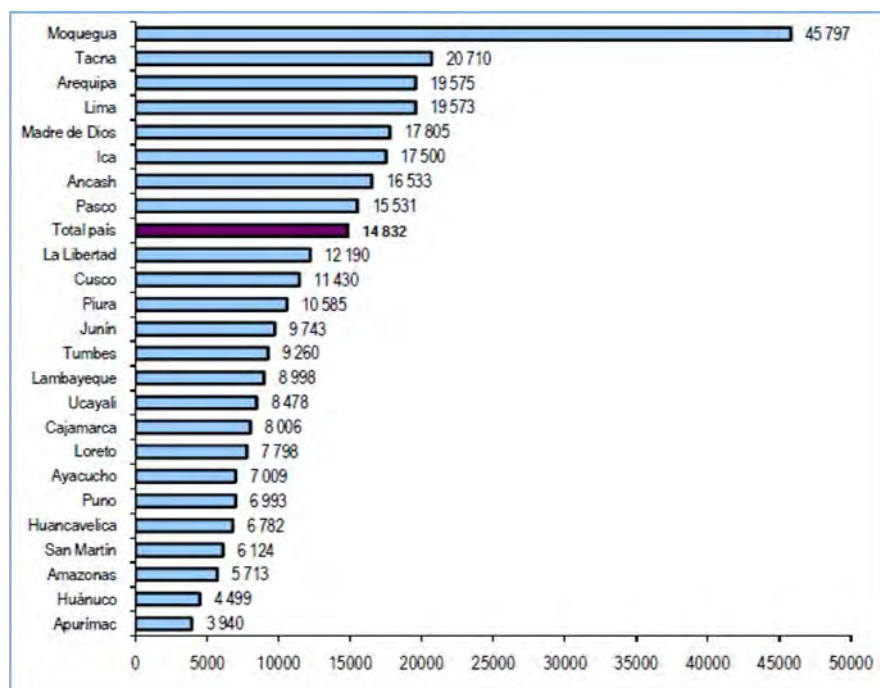
The table below shows the contribution of each region to the GDP. Lima Region represents almost half of the total, that is to say 45.0%. Arequipa contributed with 5.5 %, Piura 4.3 % and Ica 3.0 %. Taxes and duties contributed with 6.5 % and 0.3 %, respectively.



Fuente INEI – Dirección Nacional de Cuentas Nacionales-2010,

**Figure 3.1.2-2 Region contribution to GDP**

The GDP per capita in 2010 was of S/14,832 (5,727 US\$). The Table below shows data per region: Lima S/19,573(7,557 US\$), Arequipa S/19,575( 7,558US\$), Ica S/17,500( 6,757US\$) show the higher value than national average, but Piura S/10,585(4,087 US\$) is lower than the national average.



Fuente INEI – Dirección Nacional de Cuentas Nacionales-2010,

**Figure 3.1.2-3 GDP per capita (2010)**

Table 3.1.2-7 shows the variation along the years of the GDP per capita per region, during the last 10 years (2001-2010).

The GDP national average increased in 54.8% within 10 years from 2001 until 2010. The Figures per region are: +96.6 % for Ica, +65.5 % for Arequipa, +55.2 % for Piura y +54.8 % for Lima. Figures in Table 3.1.2-7 were established taking 1994 as base year.

**Table 3.1.2-7 Variation of the GDP per capita (2001-2009)**

(1994 Base year, S/.)

Departamento	2001	2002	2003	2004	2005	2006	2007P/	2008P/	2009P/	2010E/	Variación acumulada 2001-2010 (%)
<b>Total país</b>	<b>4 601</b>	<b>4 765</b>	<b>4 890</b>	<b>5 067</b>	<b>5 345</b>	<b>5 689</b>	<b>6 121</b>	<b>6 643</b>	<b>6 625</b>	<b>7 124</b>	<b>54,8</b>
Amazonas	1 835	1 910	1 996	2 081	2 212	2 349	2 510	2 684	2 761	2 959	61,3
Ancash	4 037	4 703	4 772	4 876	4 999	5 089	5 408	5 852	5 824	5 979	48,1
Apurímac	1 216	1 278	1 334	1 400	1 494	1 619	1 653	1 691	1 770	1 946	60,0
Arequipa	5 387	5 766	5 895	6 143	6 488	6 807	7 786	8 379	8 307	8 917	65,5
Ayacucho	1 788	1 870	1 942	1 900	2 045	2 207	2 448	2 640	2 896	3 020	68,9
Cajamarca	2 493	2 731	2 947	2 968	3 165	3 113	2 864	3 094	3 295	3 235	29,8
Cusco	2 194	2 086	2 195	2 565	2 768	3 071	3 340	3 554	3 685	4 202	91,5
Huancavelica	2 700	2 632	2 683	2 697	2 864	3 014	2 903	2 959	3 039	3 090	14,4
Huánuco	1 678	1 694	1 833	1 866	1 890	1 915	1 942	2 050	2 044	2 170	29,4
Ica	4 055	4 259	4 343	4 663	5 214	5 582	6 025	7 265	7 457	7 973	96,6
Junín	3 245	3 311	3 350	3 527	3 505	3 856	4 072	4 379	4 248	4 520	39,3
La Libertad	3 162	3 316	3 483	3 410	3 697	4 216	4 586	4 874	4 895	5 269	66,6
Lambayeque	2 941	3 046	3 132	2 959	3 164	3 300	3 615	3 882	3 963	4 240	44,2
Lima	6 451	6 579	6 700	6 925	7 284	7 817	8 520	9 314	9 219	9 990	54,8
Loreto	2 827	2 917	2 936	2 995	3 079	3 192	3 287	3 402	3 430	3 621	28,1
Madre de Dios	4 441	4 708	4 550	4 846	5 171	5 215	5 617	5 878	5 564	5 862	32,0
Moquegua	10 405	11 967	12 670	13 455	13 882	13 794	13 606	14 201	13 863	14 503	39,4
Pasco	5 137	5 552	5 481	5 634	5 644	6 062	6 711	6 729	6 349	6 187	20,4
Piura	2 733	2 780	2 847	3 049	3 192	3 472	3 780	4 007	4 059	4 241	55,2
Puno	2 105	2 236	2 234	2 270	2 365	2 460	2 617	2 731	2 800	2 992	42,1
San Martín	2 026	2 059	2 094	2 232	2 393	2 476	2 655	2 870	2 928	3 075	51,8
Tacna	6 004	6 124	6 382	6 643	6 782	6 941	7 256	7 458	7 256	8 067	34,4
Tumbes	2 744	2 802	2 873	3 018	3 385	3 212	3 427	3 594	3 611	3 957	44,2
Ucayali	3 063	3 149	3 203	3 411	3 584	3 754	3 846	4 007	4 040	4 190	36,8

Fuente INEI – Dirección Nacional de Cuentas Nacionales-2010

### 3.1.3 Agriculture

Next is a summarized report on the current situation of agriculture in the Watershed of the Majes – Camana River, including irrigation commissions, crops, planted area, performance, sales, etc.

#### (1) Irrigation sectors

Table 3.1.3-1 and 3.1.3-2 shows basic data on the irrigation commissions of the Majes River and the Camana River, respectively. In the first one there are 45 irrigation sectors, 17 irrigation commissions with 2,519 beneficiaries. The surface managed by these sectors reach a total of 7,505 hectares.

In the watershed of the Camana River there are 38 irrigation sectors, 17 irrigation commissions with 3,388 beneficiaries. The surface managed by these sectors amounts 6,796 hectares.



**Table 3.1.3-1 Basic data of the irrigation commissions in the Majes river**

Irrigation Commissions	Irrigation sectors	Irrigated areas		N° de Beneficiaries	River
		ha	%	(Person)	
Ongoro	Las Joyitas Las Palmas	8.08	0.11%	4	Majes
	Andamayo	94.35	1.26%	25	
	Luchea	35.26	0.47%	24	
	Ongoro	368.13	4.91%	65	
	Huatiapilla	367.26	4.89%	75	
	La Central	406.57	5.42%	66	
	El Castillo	623.05	8.30%	73	
	La Banda	4.15	0.06%	3	
Jaran	3.52	0.05%	6		
Ongoro Bajo	Huanco Iquiapaza	4.46	0.06%	11	
	Huatiapilla Baja	103.62	1.38%	23	
	Alto Huatiapa	44.47	0.59%	20	
	Bajo Huatiapa	19.11	0.25%	8	
	Quiscay	17.84	0.24%	1	
Beringa	San Isidro	10.53	0.14%	3	
	Beringa	109.07	1.45%	80	
Huancarqui	La Collpa	14.93	0.20%	14	
	Huancarqui	342.56	4.56%	211	
Cosos	Cosos	125.43	1.67%	92	
Aplao	Aplao	232.26	3.09%	145	
	Bajos Aplao	11.50	0.15%	5	
La Real	Caspani	20.54	0.27%	18	
	La Real	172.07	2.29%	125	
Monte los Apuros	Monte los Apuros	370.86	4.94%	160	
Querulpa	Alto Maran Trapiche	131.78	1.76%	53	
	La Revilla Valcarcel	151.01	2.01%	50	
Tomaca	Tomaca	296.32	3.95%	54	
	El Rescate	92.34	1.23%	41	
Uraca	Uraca	688.81	9.18%	239	
Cantas Pedregal	Alto Cantas	162.87	2.17%	74	
	Bajo Cantas	147.09	1.96%	47	
Sogiata	Sogiata	522.66	6.96%	154	
San Vicente	San Vicente	230.68	3.07%	100	
	Caceres	57.31	0.76%	12	
Pitis	Pitis	93.10	1.24%	53	
	Escalerillas	155.61	2.07%	74	
Sarcas Toran	Sarcas Toran	777.69	10.36%	195	
	Hinojosa Pacheco	1.00	0.01%	2	
	Medrano	12.29	0.16%	7	
	La Cueva	6.24	0.08%	6	
	Callan Jaraba	37.91	0.51%	10	
	Sahuani	58.47	0.78%	17	
	Paycan	24.44	0.33%	6	
Vertiente	2.29	0.03%	3		
El Granado	El Granado	345.45	4.60%	65	
<b>Total</b>		<b>7,504.98</b>	<b>100%</b>	<b>2,519</b>	

Source: Prepared by JICA Study Team, Users Board of Camana-Majes, September 2011

**Table 3.1.3-2 Basic data of irrigation commissions in the Camana river**

Irrigation Commission	Irrigation Sectors	Irrigated areas		N° de Beneficiaries	River
		ha	%	(Person)	
Socso-Sillan	Huambo	28.23	0.42%	8	Camana
	Puccor	13.30	0.20%	2	
	Pillistay	13.91	0.20%	6	
	Nueva Esperanza	27.31	0.40%	19	
	Socso	52.97	0.78%	15	
	Socso Medio	21.27	0.31%	12	
	Casias-Sillan	45.32	0.67%	20	
Sonay	Sonay	110.48	1.63%	34	
Pisques	Pisques	86.82	1.28%	39	
Characta	Soto	16.29	0.24%	4	
	Characta	174.35	2.57%	54	
Pampata	Naspas-Pampata	130.31	1.92%	21	
	Pampata-Baja	164.77	2.42%	27	
La Bombon	Tirita	15.67	0.23%	12	
	Montes Nuevos	49.41	0.73%	26	
	La Bombon	402.38	5.92%	265	
	Gordillo	8.14	0.12%	9	
	La Era	1.44	0.02%	4	
	La Rama Era I	45.53	0.67%	37	
	Toma Davila	58.20	0.86%	11	
El Alto	El Alto	314.57	4.63%	128	
Los Molinos	Los Molinos	435.97	6.41%	295	
El Medio	El Medio	477.98	7.03%	231	
	Los Castillos	44.36	0.65%	48	
	Flores	4.73	0.07%	5	
La Valdivia	El Desague	45.56	0.67%	55	
	La Lurin	17.35	0.26%	11	
	La Chingana	51.27	0.75%	33	
	La Valdivia	323.86	4.77%	196	
La Deheza	La Deheza	336.71	4.95%	228	
La Gamero	La Gamero	356.04	5.24%	257	
El Molino	El Molino	370.29	5.45%	302	
El Cuzco	El Cuzco	290.02	4.27%	261	
Montes Nuevos	Montes Nuevos	192.46	2.83%	123	
Huacapuy	Huacapuy	23.12	0.34%	21	
Pucchun	Mal Paso-Sta. Elizabeth	1070.90	15.76%	296	
	1er y 2do Canal Aereo	872.79	12.84%	202	
	Jahuay	102.11	1.50%	71	
<b>Total</b>		<b>6,796.19</b>	<b>100%</b>	<b>3,388</b>	

Source: Prepared by JICA Study Team, Users Board of Camana-Majes, September 2011

## (2) Main crops

Table 3.1.3-3 shows the variation between 2004 and 2009 of the planted surface and the performance

of main crops.

In the Majes – Camana River Watershed, in 2004 the planted area, performance and sales decreased, but later increased so that during the period 2008-2009 profits were of S/.188,596,716. Main crops in this watershed were represented by: rice, beans, onions, corn and pumpkins.

**Table 3.1.3-3 Sowing and sales of main crops**

	Variables	2004-2005	2005-2006	2006-2007	2007-2008	2008-2009
Paddy Rice	Sown surface (ha)	6,216	6,246	6,211	6,212	6,224
	Unit performance (kg/Ha)	12,041	13,227	12,841	13,370	13,823
	Harvest (Kg)	74,844,450	82,617,571	79,753,422	83,057,334	86,032,532
	Unit price (S/./kg)	0.92	0.65	0.80	1.10	0.70
	Sales (S/.)	68,868,814	53,701,421	63,802,738	91,354,778	60,222,772
Dried beans	Sown surface (ha)	4,458	4,433	3,947	4,045	3,886
	Unit performance (kg/Ha)	1,630	1,660	1,745	1,743	1,920
	Harvest (Kg)	7,264,349	7,359,607	6,888,684	7,051,876	7,460,849
	Unit price (S/./kg)	2.93	2.44	3.03	4.12	3.85
	Sales (S/.)	21,304,797	17,970,689	20,888,054	29,058,175	28,746,981
Onion	Sown surface (ha)	2,063	1,958	2,168	2,331	1,886
	Unit performance (kg/Ha)	40,552	32,073	41,231	46,034	35,840
	Harvest (Kg)	83,659,519	62,798,588	89,388,731	107,304,225	67,594,277
	Unit price (S/./kg)	0.58	0.38	0.71	0.43	1.37
	Sales (S/.)	48,800,305	24,067,447	63,582,270	46,002,256	92,290,918
Corn	Sown surface (ha)	50	30	34	618	558
	Unit performance (kg/Ha)	4,192	3,500	3,680	5,670	4,580
	Harvest (Kg)	209,600	105,000	125,120	3,503,916	2,555,501
	Unit price (S/./kg)	0.85	0.80	1.00	0.90	0.75
	Sales (S/.)	178,160	84,000	125,120	3,153,524	1,918,916
Pumpkin	Sown surface (ha)	193	223	217	129	159
	Unit performance (kg/Ha)	29,341	34,419	32,869	40,346	42,789
	Harvest (Kg)	5,662,900	7,675,350	7,132,607	5,204,624	6,803,456
	Unit price (S/./kg)	0.36	0.30	0.30	0.41	0.26
	Sales (S/.)	2,056,542	2,295,721	2,123,348	2,154,472	1,786,014
Chala Corn	Sown surface (ha)	55	35	38	29	44
	Unit performance (kg/Ha)	60,800	59,435	59,962	60,675	58,332
	Harvest (Kg)	3,344,000	2,080,242	2,278,540	1,759,566	2,566,613
	Unit price (S/./kg)	0.08	0.10	0.10	0.10	0.25
	Sales (S/.)	267,520	208,024	227,854	175,957	633,487
Sweet Corn	Sown surface (ha)	51	40	27	19	51
	Unit performance (kg/Ha)	16,980	17,694	18,053	18,201	18,223
	Harvest (Kg)	865,998	707,742	487,426	345,824	929,377
	Unit price (S/./kg)	0.30	0.40	0.61	0.32	0.58
	Sales (S/.)	259,799	283,097	296,066	111,028	536,123
Potato	Sown surface (ha)	39	38	22	22	65
	Unit performance (kg/Ha)	31,538	26,368	27,866	27,524	32,091
	Harvest (Kg)	1,230,000	1,002,000	613,045	605,531	2,085,916
	Unit price (S/./kg)	0.50	0.50	0.46	0.83	0.63
	Sales (S/.)	615,000	501,000	281,443	500,939	1,310,597
Tomato	Sown surface (ha)	5	45	36	11	48
	Unit performance (kg/Ha)	29,000	38,951	30,584	34,963	36,310
	Harvest (Kg)	145,000	1,752,790	1,101,025	384,597	1,742,875
	Unit price (S/./kg)	0.50	0.38	0.73	0.45	0.41
	Sales (S/.)	72,500	662,165	804,360	173,418	714,942
Watermelon	Sown surface (ha)	29	30	13	14	40
	Unit performance (kg/Ha)	9,862	17,265	12,920	13,087	13,718
	Harvest (Kg)	286,000	517,938	167,960	183,218	548,708
	Unit price (S/./kg)	0.30	0.40	0.40	0.47	0.80
	Sales (S/.)	85,800	207,175	67,184	86,112	438,966
Otros	Sown surface (ha)	95	153	204	190	116
Total	Sown surface (ha)	13,254	13,231	12,917	13,620	13,077
	Harvest (Kg)	177,511,816	166,616,828	187,936,560	209,400,711	178,320,104
	Sales (S/.)	142,509,238	99,980,740	152,198,437	172,770,659	188,599,716

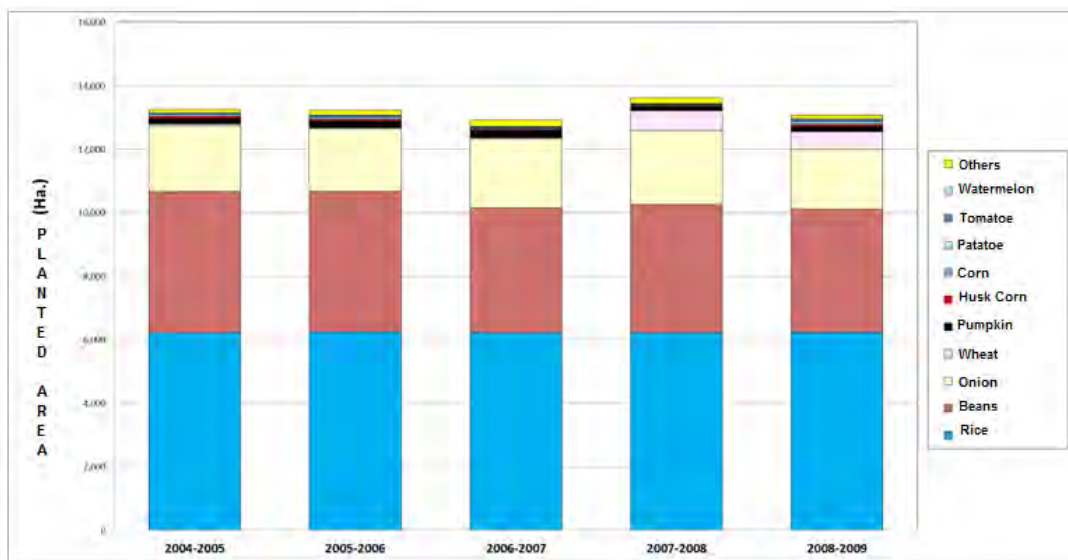


Figure 3.1.3-1 Planted Surface

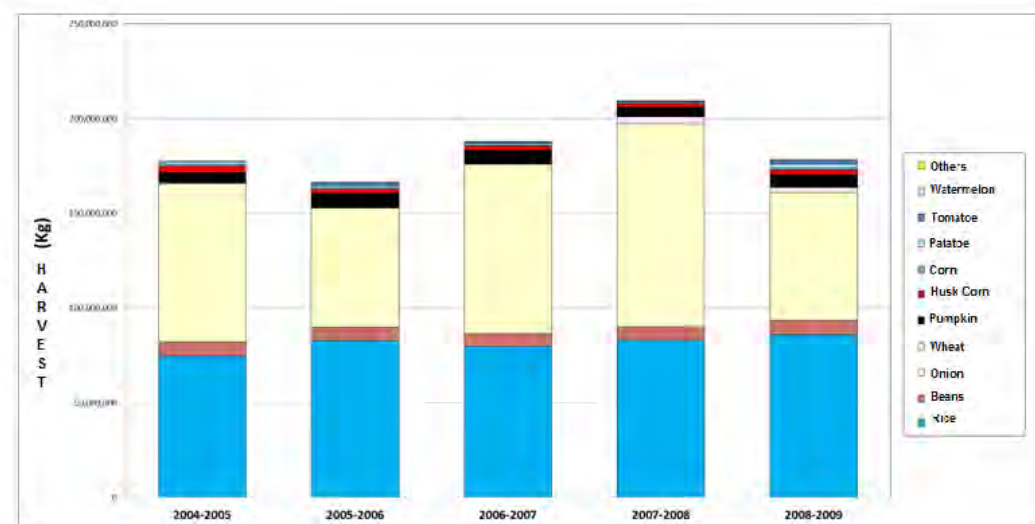


Figure 3.1.3-2 Harvest

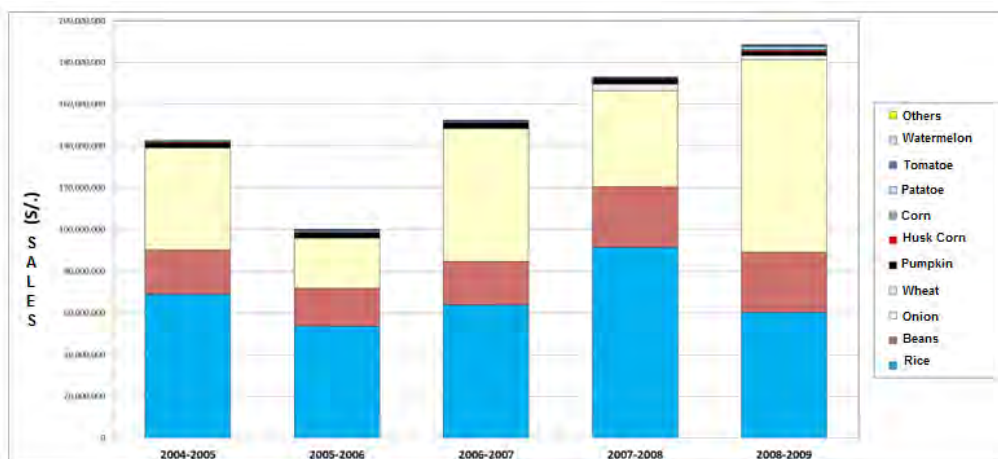


Figure 3.1.3-3 Sales

### 3.1.4 Infrastructure

#### (1) Road Infrastructures

Table 3.1.4-1 shows road infrastructures in the watershed of the Majes River. In total there are 981.291 km of roads, 282.904 km of them (28.8 %) are national roads, 208.163 km (21.2 %) regional roads, and 490.223 km (50.0 %) municipal roads.

Table 3.1.4-2 shows road infrastructures in the watershed of the Camana River. In total there are 574.039 km of roads, 143.608 km of them (25.0 %) area national roads, 365.940 km (63.8 %) regional roads, and 64.491 km (11.2 %) municipal roads.

**Table 3.1.4-1 Basic data of road infrastructure in the Majes river**

Roads	Total Length (Km)		Paving (Km)			
			Asphalted	Trail Road	Gravel Road	Path
National Road	282.904	28.83%	64.400	173.842		44.662
Regional roads	208.164	21.21%			2.727	205.437
Municipal roads	490.223	49.96%		10.321		479.902
Total	981.291	100.00%	64.400	184.163	2.727	685.339

**Table 3.1.4-2 Basic data of road infrastructure in the Camana river**

Roads	Total Length (Km)		Paving (Km)			
			Asphalted	Trail Road	Gravel Road	Path
National Road	143.608	25.02%	114.748	28.860		
Regional roads	365.940	63.75%	16.100	82.610		267.230
Municipal roads	64.491	11.23%	1.040	6.677		56.774
Total	574.039	100.00%	131.888	118.147		324.004

#### (2) Irrigation systems

Table 3.1.4-3 shows data on existing irrigation systems in watershed of the Majes - Camana River. There are 58 water inlets and 79 water direct inlets. Besides, there are 58 main channels, 128 primary ones, 54 secondary and 5 tertiary. Main channels have an accumulated length of 167.24 km. Lagged channels amount 3.498 km, while 334.019 km have no lagging.

#### (3) PERPEC

Table 3.1.4-4 shows implemented projects by PERPEC between 2006 and 2009

**Table 3.1.4-3 Present conditions of irrigation channels**

IRRIGATION COMMISSION	Number of Water Inlets	Number of Direct Water Inlets	N° of Intakes and sluiceways at CD level				Number of channels				Long. de C.D. (Kms.)	Total System Length	
			Housing inlets	N° of sluiceways	Lateral inlets	N° of sluiceways	C.D.	1er.	2do.	3er.		Lagged (Kms.)	Rustic (Kms.)
ONGORO	5	5	63	35	25	25	5	25	6	0	30.064	0.363	69.600
ONGORO BAJO	3	6	49	0	4	0	3	4	1	0	9.841	0.600	11.586
BERINGA	2	0	29	0	2	0	2	2	0	0	5.530	0.000	7.880
COSOS	1	2	37	0	4	0	1	4	3	0	3.976	0.000	9.140
APLAO	2	0	47	2	6	2	1	6	1	0	5.933	0.000	9.660
HUANCARQUI	3	0	36	0	10	0	2	10	3	0	7.401	0.000	20.483
TOMACA	3	0	47	0	1	0	3	10	12	2	7.653	0.000	29.180
LA REAL	2	0	71	0	9	0	2	9	3	1	6.664	0.000	7.604
MONTE LOS PUROS	0	4	0	0	0	0	0	0	0	0	0.000	0.000	0.000
QUERULPA	1	8	66	2	7	1	1	7	5	1	4.941	0.000	16.766
URACA	8	23	48	0	1	0	0	0	0	0	0.000	0.000	0.000
SOGIATA	1	0	42	0	8	0	1	8	2	0	7.650	0.000	16.920
SAN VICENTE	0	9	0	0	0	0	0	0	0	0	0.000	0.000	0.000
CANTAS PEDREGAL	1	0	26	0	7	3	1	7	2	0	3.925	0.000	9.655
PITIS	2	0	21	0	0	0	2	0	0	0	3.100	0.000	3.100
SARCAS - TORAN	2	0	33	4	6	1	2	6	4	0	4.770	2.085	15.512
EL GRAMADO	2	0	97	0	5	0	2	5	1	0	6.252	0.000	11.385
TOTAL	58	79	1,043	57	126	34	58	126	54	5	167.240	3.498	334.019

**Table 3.1.4-4 Projects implemented by PERPEC**

N°	YEAR	Work	Location				Description	Total Cost (\$/.)
			Department	Province	District	Town		
1	2006	Construction of a Rockfill Dike - Huantay Sector	Arequipa	Camana	Ocona	Huantay	Conformacion de Dique	150,000.00
2	2006	Construction of breakwaters and rockfill dikes in the Majes Valley	Arequipa	Castilla	Aplao y Uruca	El Granado	Rockfill Dike	607,186.00
3	2006	Construction of Coastal Defense - Oulica Valley Sector	Arequipa	Camana	Oulica	El Platanal	Conformacion de Dique	81,305.00
4	2006	Majes River Coastal Defense - Montes Sector	Arequipa	Castilla	Aplao	El Monte	Conformacion de Dique	96,000.00
5	2006	Construction of Coastal Defense - Ocona Valley, Jayhuiche Sector	Arequipa	Camana	Mariano Nicolas Valcarcel	Jayhuiche	Rockfill Dike	149,992.00
6	2006	Construction of rockfill dike - Zurita Sector	Arequipa	Camana	Ocona	Zurita	Conformacion de Dique	151,484.00
7	2006	Construction of Coastal Defense - Ocona Valley, Santa Rita Sector	Arequipa	Camana	Ocona	Santa Rita	Conformacion de Dique	149,487.00
8	2007	Construction of coastal defense - Querulpa Tomaca Sectors	Arequipa	Castilla	Aplao, Huancarqui	Querulpa Tomaca	Breakwater with Rock	380,233.00
9	2007	Construction of dike with breakwaters - El Platanal Sector, Oulica District, Province of Camana - Arequipa	Arequipa	Camana	Oulica	El Platanal	Breakwater with Rock	259,174.00
10	2008	Construction of Provisional Coastal Defense Construction in the Majes River - Los Puros Sector, Aplao District, Province of Castilla - Arequipa (Contingency)	Arequipa	Castilla	Aplao	Los Puros	Construction of Dike and Breakwaters	117,215.00
11	2008	Construction of Provisional Coastal Defense in the Ocona River - Santa Rita Sector, Ocona District, Province of Camana - Arequipa (Contingency)	Arequipa	Camana	Ocona	Santa Rita	Construction of Dike and Breakwaters	97,066.00
12	2008	Construction of Provisional Coastal Defense in the Majes River - San Vicente and Sacramento Sectors, Uruca District, Province of Castilla - Arequipa (Contingency)	Arequipa	Castilla	Uruca	San Vicente y Sacramento	Construction of Dike and Breakwaters	124,952.00
13	2008	Construction of rockfill dike - Sonay Sector (Prevention)	Arequipa	Camana	Nicolas de Pirola	Sonay	Descolmatacion y conformacion de dique	230,058.00
14	2008	Construction of coastal defense - Anchalo Huacan Sector - Ocona Valley (Prevention)	Arequipa	Camana	Ocona	Huacan	Rockfill Dike	123,352.00
15	2008	Construction of Rockfill Dike - Huantay Sector - Ocona Valley (Prevention)	Arequipa	Camana	Ocona	Huantay	Rockfill Dike	117,348.00

### 3.1.5 Real Flood Damages

#### (1) Damages on a nationwide scale

Table 3.1.5-1 shows the present situation of flood damages during the last five years (2003-2007) in the whole country. As observed, there are annually dozens to hundreds of thousands of flood affected inhabitants.

**Table 3.1.5-1 Situation of flood damages**

		Total	2003	2004	2005	2006	2007
Disasters	Cases	1,458	470	234	134	348	272
Víctims	persons	373,459	118,433	53,370	21,473	115,648	64,535
Housing loss victims	persons	50,767	29,433	8,041	2,448	6,328	4,517
Decesased individuals	persons	46	24	7	2	9	4
Partially destroyed houses	Houses	50,156	17,928	8,847	2,572	12,501	8,308
Totally destroyed	Houses	7,951	3,757	1,560	471	1,315	848

Source : SINADECI Statistical Compendium

Peru has been hit by big torrential rain disasters caused by the El Niño Phenomenon. Table 3.1.5-2 shows damages suffered during the years 1982-1983 and 1997-1998 with extremely serious effects. Victims were approximately 6,000,000 inhabitants with an economic loss of about US\$ 1,000,000,000 in 1982-1983. Likewise, victims number in 1997-1998 reached approximately 502,461 inhabitants with economic loss of US\$ 1,800,000,000. Damages in 1982-1983 were so serious that they caused a decrease of 12 % of the Gross National Product.

**Table 3.1.5-2 Damages**

Damages	1982-1983	1997-1998
Persons who lost their homes	1.267.720	—
Victims	6.000.000	502.461
Injured	—	1.040
Deceased	512	366
Missing persons	—	163
Partially destroyed houses	—	93.691
Totally destroyed houses	209.000	47.409
Partially destroyed schools	—	740
Totally destroyed schools	—	216
Hospitals and health centers partially destroyed	—	511
Hospitals and health centers totally destroyed	—	69
Damaged arable lands (ha)	635.448	131.000
Head of cattle loss	2.600.000	10.540
Bridges	—	344
Roads (km)	—	944
Economic loss (\$)	1.000.000.000	1.800.000.000

“—”: No data



## (2) Disasters in the watersheds object of this study

Table 3.1.5-3 summarizes damages occurred in the Arequipa region.

**Table 3.1.5-3 Disasters in the Arequipa region**

Years	1995	1996	1997	1998	1999	2000	2001	2002	2003	2004	2005	2006	2007	2008	2009	2010	Total	Media
LANDSLIP																1	1	
FLOOD											5						5	
COLLAPSE						1	1	1									1	4
LANDSLIDE		1		1	1	2	1	1	4	3	4	2			1	2	23	
AVALANCHE	6	1	7	14	3	2	4				2	2	1		9	3	54	
TOTAL SEDIMENT DISASTER	6	2	7	15	4	5	6	2	4	3	11	4	1	0	10	7	87	5
TOTAL FLOOD	3	1	42	6	44	2	15	3	1	2	2	3	0	1	3	3	131	8

### 3.1.6 Results on the Visits to Study Sites

JICA Study Team made some technical visits to the selected watersheds and identified some challenges on flood control through visits and interviews to regional government authorities and irrigation associations on damages suffered in the past and the problems each watershed is currently facing.

#### (1) Interviews

##### 1) Camana river

(General conditions of the watershed)

- The jurisdiction area of Camana covers from the river mouth to 39 km upstream
- The dike was constructed thirty years ago by the irrigation commission, but there are various eroded parts
- 99% of rice crops are commercialized in Lima's market
- Flow is measured once a day. The maximum historical flow was from 1.200 to 1.500 m<sup>3</sup>/s. Floods last almost a week
- There are some colonial ruins in the upper area at the left riverbank between km 2 and 6

(On critical points)

##### ○ Obstruction of the river mouth

- The formation of the gravel bank in the river mouth caused by beach waves obstructs water flow in the river mouth (obstruction in the river mouth). The construction of a longitudinal dike along the sea side has been considered in order to control this situation. The gravel bank disappeared with floods and reappeared between June and December
- The path km 2.5 – km 4.5 burst its banks the same year El Niño Phenomenon hit, 1998. The right bank also did burst in the past

##### ➤ Riverbed elevation

##### ○ Path with lower dike (left bank between km 6 and km 7.5).

- The dike at the left bank is particularly low between km 6 – 7.5 (LA BOMBOM)
- There are arable lands between the dike at the left bank and the river downstream in the

Camana Bridge that can eventually be removed for being illegal. As to the arable lands outside the dike, the negotiation might be complicated

- The riverbed has elevated more than a meter
- Erosion in the riverbank around the channel (left bank between km 12– 13)
  - There is an arm water inlet for Camana's drinking water by km 13
  - There is a channel that goes from the water inlet along the river. The river's left bank is seriously eroded at km12, endangering the adjacent channel
- Scour of bridge piers (by km 26)
  - There is a local community at the right bank of the river, by km 26 (SONAI) with 40 households. There is a suspension bridge constructed a year ago with semi-eroded piers because of floods, presenting collapse risks with following floods
- Other parts presenting problems
  - The left bank dike at km 3 is eroded and has been provisionally repaired
  - There is an unprotected part at km 14.2
  - There is a path whose left bank is being eroded at km 19 (CHARACTA)
  - The left bank dike at km 26.5 is eroded
  - A left bank dike at km 28 needs to be constructed
  - Arable lands at km 29 of the left bank are eroded (CULATA DE SIYAN)
  - The left bank at km 30 is being eroded and needs protection (FUNDO CASIAS)
  - A dike at km 33.5 needs to be constructed given that annually the water inlet and the irrigation channels get flooded
  - A 1km dike needs to be constructed at the right bank of km 34
  - A 2km dike needs to be constructed at km 37.5 downstream in order to protect the water inlet and adjacent arable lands (80 ha) of the left bank (HUAMBOY)
  - A 1km dike needs to be constructed at km 39 downstream in order to protect the water inlet and adjacent arable lands (80 ha) of the right bank (HUAMBOY)

## 2) Majes river

(Critical points)

- Areas overflowing (right bank at km 104)
  - A 500m dike needs to be constructed at the right bank
  - Elements to be protected: arable lands (ONGORO BAJO)
  - Landslide occurred on 1977 left arable lands buried at river banks. Accumulated sediment in the river course was dragged downstream by river level rise
- Fluvial erosion (right river bank, km 101)
  - Arable lands were eroded by 1997 floods
  - The elements to be conserved are arable lands (HUATIAPILLA BAJA)
  - The current dike (600 m) at the right river bank needs to be extended between 500 and 800 m
- Fluvial erosion (right river bank, km 88.5)

- River banks have been eroded by the floods in February 2011 dragging also part of a house (which is still being occupied)
- The elements to be conserved are arable lands and houses (BERINGA)
- The existing dike (1 km) as well as protection works at the right river bank need to be prolonged 600 m
- Dike erosion (right river bank, km 84.5)
  - The dike at the right river bank is being progressively eroded year by year, and if measures are not taken, this could affect the adjacent bridge (Huancarqui Bridge)
  - The dike has been repaired in an improvised way, but it needs a pertinent measure as river bank protection, etc.
  - The elements to be conserved are arable lands and the bridge (APLAO)
  - The town of Aplao, the biggest city hall in Majes, has 18 thousand inhabitants, and Huancarqui at the other side of the river, crossing the bridge, has 5 thousand inhabitants
- Unprotected stretch (right river bank, between km 70,5 and km 71)
  - Currently an 800m dike is being constructed financed by the regional government. However, other 1.3 km are considered to be built in order to protect approximately 30 houses located in lower lands of the lower watershed
  - Last August 2010, the area was flooded after eight years
  - The elements to be conserved are arable lands and private houses (EL DEQUE)
  - There is an irrigation channel upstream, conducting water to arable lands (700 ha) downstream. The water inlet is being eventually repaired, to be finished in 15 days
  - Big rocks for river bank protection are extracted and transported from a quarry in Aplao
- Overflowed stretch (both river banks, between km 60 and km 62)
  - It is necessary to construct 2km dikes at the left river bank and 1.5 dikes at the right river bank
  - Elements to be conserved are arable lands (Pitis at the left river bank and San Vicente at the right river bank)
- Overflowed stretch (left river bank, between km 58 and km 58.5k)
  - A dike needs to be constructed at the left river bank
  - The elements to be conserved are arable lands (ESCALERILLAS)
- Fluvial erosion (left river bank between km 55 and km 56.5k)
  - Agriculture lands are being progressively eroded year by year by floods
  - Elements to be conserved are arable lands (SARCAS)
  - Part of the area has been flooded in 1998 by 1,500 m<sup>3</sup>/s floods, forcing three small communities to move from lower lands to upper ones
  - The river overflowed in February 2011 by floods of 800 m<sup>3</sup>/s
- Other parts presenting problems
  - A dike is looked to be built at the left river bank, between km 81.5 and km 82 (HUANCARUQUI)
  - A dike is looked to be built at the right river bank, between km 81.5 and km 82 (CASPANI)

- Parts between km 75–km 75.5k and km 71–km 71.5 are unprotected at the left river bank (TOMACA)
- The stretch km 73.5 – km 74 is unprotected at the right river bank (QUERULPA)
- A dike is looked to be built at the left river bank, between km 49 and km 51.5 (PAMPA BLANCA)

## **(2) Description of the visit to the study sites**

Figure 3.1.6-1 and Figure 3.1.6-2 shows pictures of main sites visited, which figures are colored to represent the topography schematic.

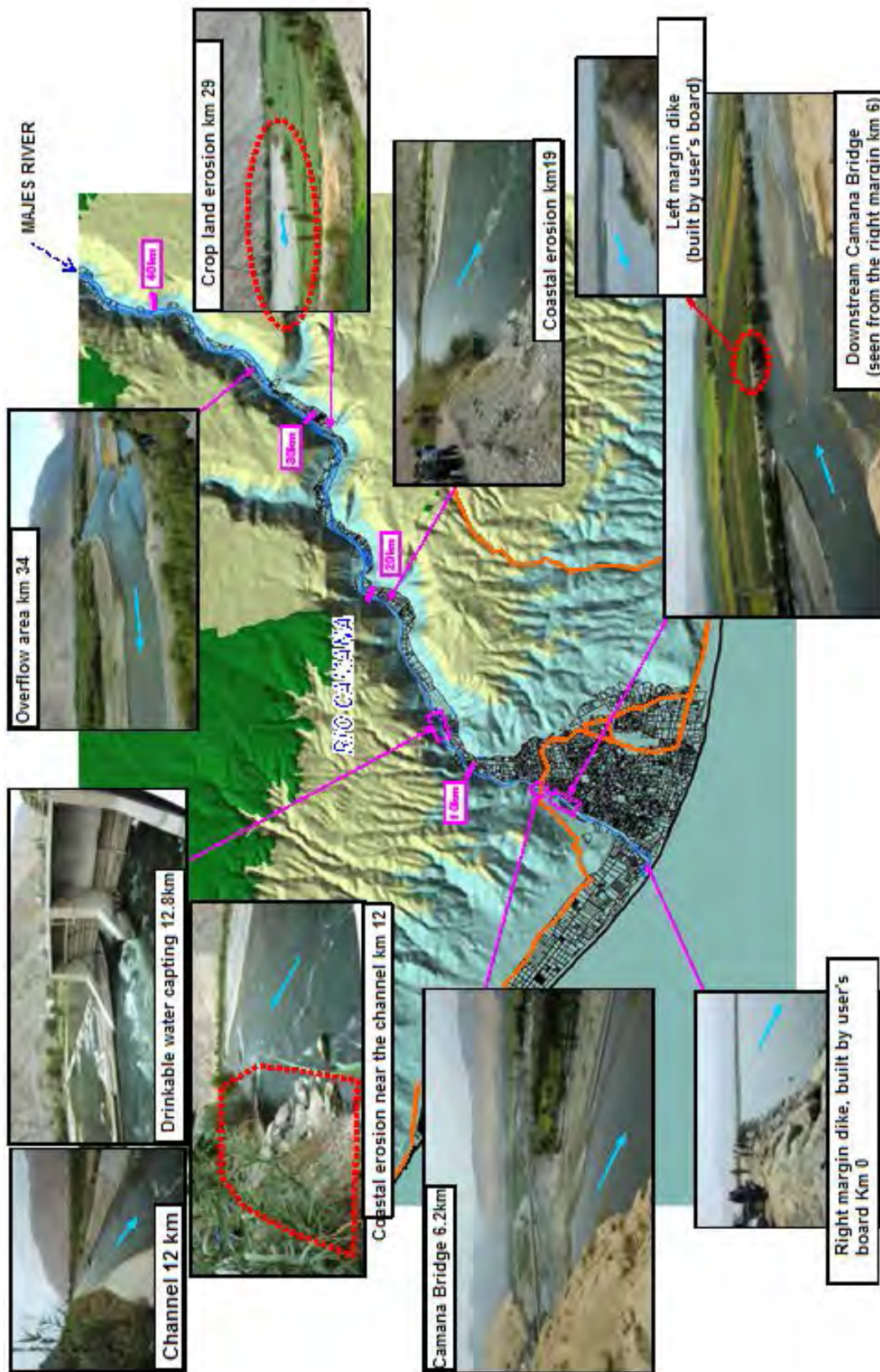


Figure -3.1.6-1 Visit to the study site (Camana river)

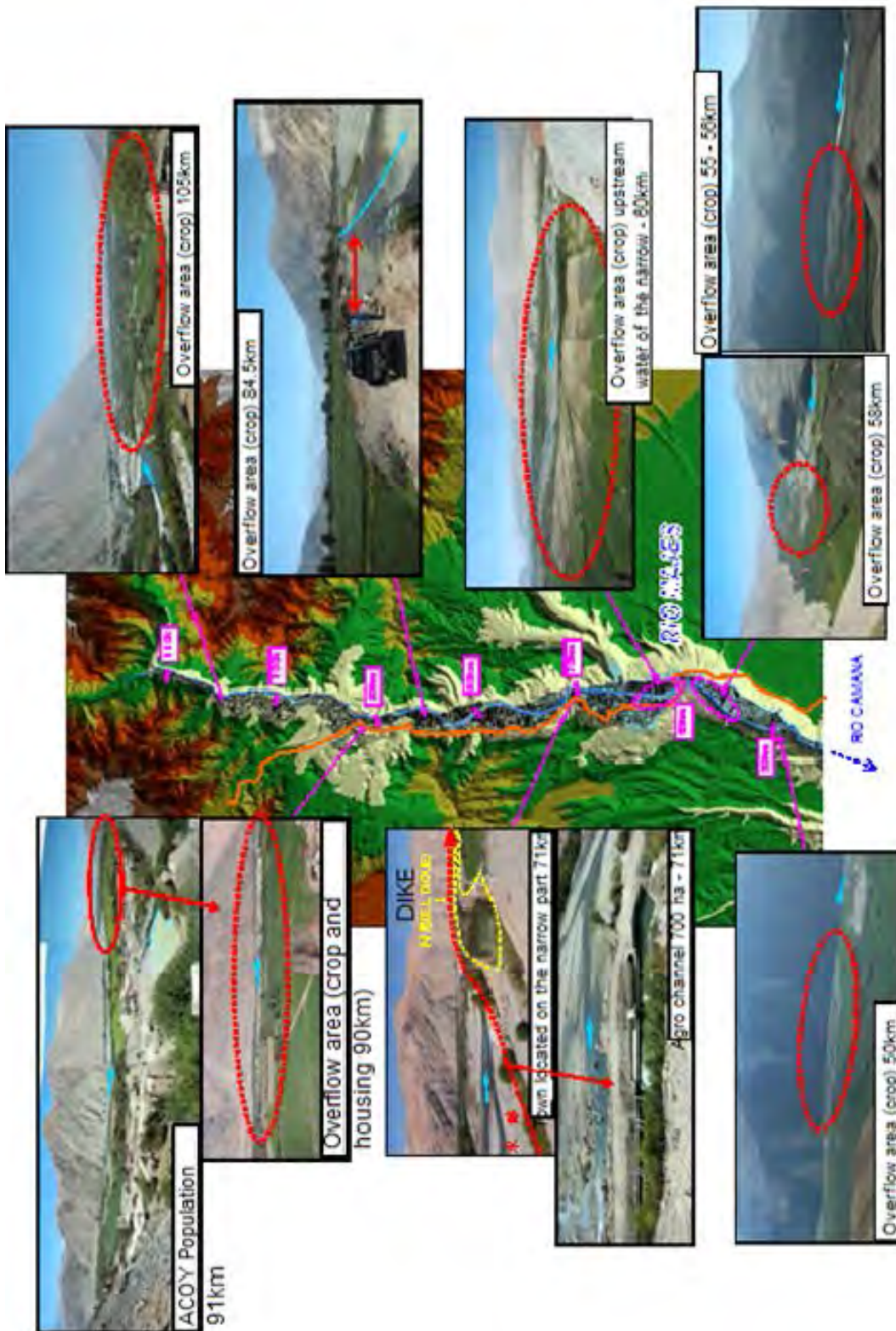


Figure 3.1.6-2 Visit to the study site (Majes river)

### (3) Challenges and measures

The following table shows challenges and possible solution measures for flood control considered at this moment, based on the results of technical visits.

1) Challenge 1: Deterioration of the existing dike caused by fluvial erosion (km 0 - 5 of the Camana River)

Current situation and challenges	<ul style="list-style-type: none"> <li>• The existing dike which control corresponds to the Irrigation Commission of Camana has been constructed about 30 years ago with their own resources. There are several eroded parts</li> <li>• The dike is low upstream and downstream of Camana Bridge at km 6, putting at flood risk arable lands and urban area</li> </ul>
Main elements to be conserved	<ul style="list-style-type: none"> <li>• Urban area of Camana</li> <li>• Arable lands (main crop: rice)</li> </ul>
Basic measures	<ul style="list-style-type: none"> <li>• Construction of dikes and riverbank protection</li> </ul>



**Figure 3.1.6-3 Local conditions related with Challenge 1 (Camana river)**

2) Challenge 2: Fluvial erosion impact on the drinking water inlet (Camana river, km 12)

Current situation and challenges	<ul style="list-style-type: none"> <li>• There is an inlet for the drinking water service to Camana at km 13, as well as a channel along the river</li> <li>• Currently the left bank at km 12 is eroded and if not taking correct measures, this could affect the adjacent channel</li> </ul>
Main elements to be conserved	<ul style="list-style-type: none"> <li>• Channel for drinking water</li> </ul>
Basic measures	<ul style="list-style-type: none"> <li>• Reinforcement of the existing dike and riverbank protection</li> </ul>

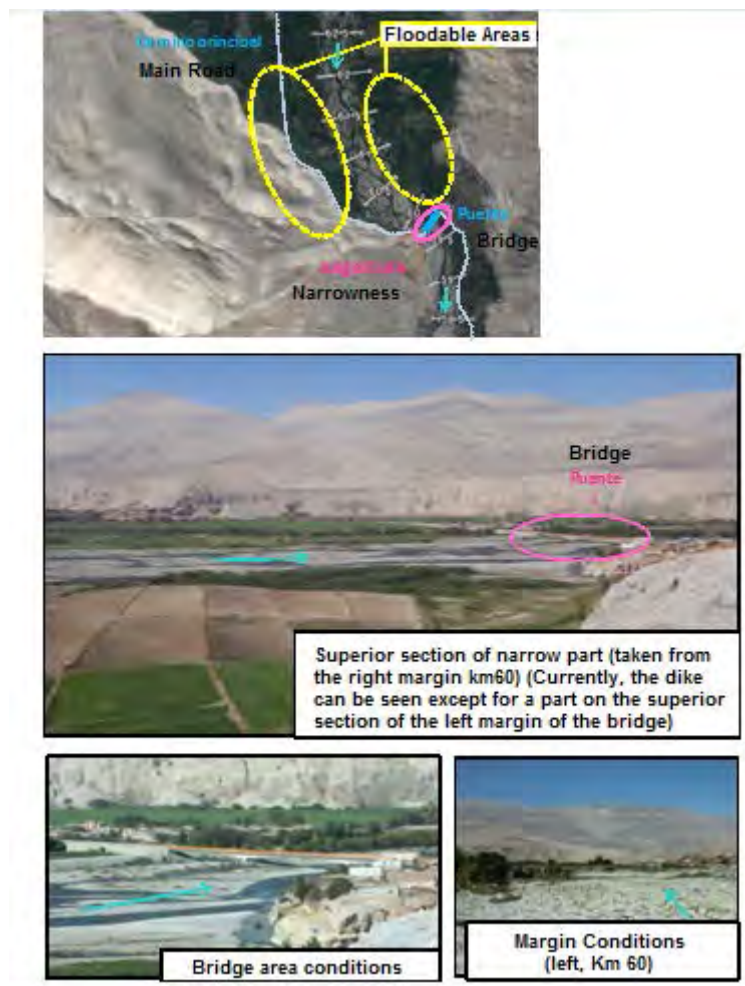


**Figure 3.1.6-4 Local conditions related with Challenge 2 (Camana river)**



3) Challenge 3: Overflow of the narrow upper stretch (Majes river, km 60-km 62)

Current situation and challenges	<ul style="list-style-type: none"> <li>• The hydraulic capacity is reduced given the narrowing of the river, causing flood damages on arable lands of the upper areas</li> <li>• There is a new bridge at the narrow area of the river. Parts are unprotected at both banks presenting high overflow risks</li> </ul>
Main elements to be conserved	<ul style="list-style-type: none"> <li>• Arable lands (main crop: rice)</li> </ul>
Basic measures	<ul style="list-style-type: none"> <li>• Construction of dikes and river bank protection (construction of retarding basin is difficult due to good agricultural land spreads in the upstream)</li> </ul>



**Figure 3.1.6-5 Local conditions related with Challenge 3 (Majes river)**

4) Challenge 4: Overflowing towards rural zone (Majes river km 70.5–km 71)

Current situation and challenges	<ul style="list-style-type: none"> <li>• There is a community, Deque, along the riverside, in the narrow section, 30 houses in the low lands</li> <li>• Even though it is true that the higher section of this community is protected by a dike, there is a section downstream which is unprotected, with higher risk of overflowing</li> <li>• There is a water intake to supply irrigation water to 700ha of crop land, which is also exposed to flood risk</li> </ul>
Main elements to be conserved	<ul style="list-style-type: none"> <li>• Houses, water intake for irrigation</li> <li>• Croplands (main crop: rice)</li> </ul>
Basic measures	<ul style="list-style-type: none"> <li>• Construction of dikes and protection of banks (the extension of dike to the downstream non-dike section using existing small dike at river side of housing settlement is better compared with removal of 30 households in the cost and implementation of the project.)</li> </ul>



**Figure 3.1.6-6 Local conditions related to Challenge 4 (Majes river)**

5) Challenge 5: Impact of fluvial erosion to the bridge (Majes river km 84,5)

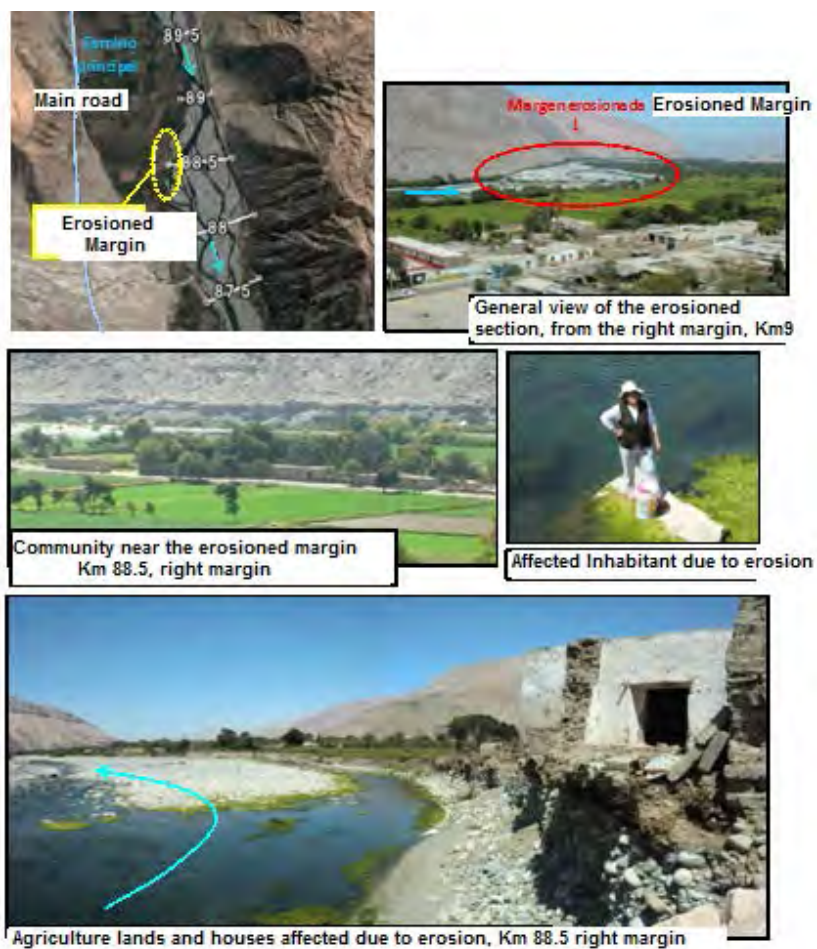
Current situation and challenges	<ul style="list-style-type: none"> <li>• The dike of the right bank is progressively eroded year by year, and if no measure is taken, it could affect the next bridge downstream (Huancariqui bridge)</li> <li>• This bridge is an important path which connects Aplao, the larger town of Majes (with a population of 18 thousand inhabitants), and Huancariqui (with a population of 5 thousand inhabitants)</li> </ul>
Main elements to be conserved	<ul style="list-style-type: none"> <li>• Bridge (Huancariqui)</li> <li>• Croplands (main crop: rice)</li> </ul>
Basic measures	<ul style="list-style-type: none"> <li>• Construction of dikes and protection to the banks</li> </ul>



**Figure 3.1.6-7 Local conditions related to Challenge 5 (Majes river)**

6) Challenge 6: Damages from fluvial erosion to the community (Majes river km 88-km 88.5)

Current situation and challenges	<ul style="list-style-type: none"> <li>• The river banks are progressively eroded per year due to the risings and floods of February 2011, which dragged a house</li> <li>• Currently, the banks are unprotected and if the appropriate measures are not taken, it may worsen the damages, so taking measures is urgently needed</li> </ul>
Main elements to be conserved	<ul style="list-style-type: none"> <li>• Houses</li> <li>• Croplands (main crop: rice)</li> </ul>
Basic measures	<ul style="list-style-type: none"> <li>• Construction of dikes and protection to the banks</li> </ul>



**Figure 3.1.6-8 Local conditions related to Challenge 6 (Majes river)**

### 3.1.7 Current situation of Vegetation and Reforestation

#### (1) Current vegetation

The most recent study<sup>1</sup> about the classification of vegetation is that carried out by FAO on 2005, with the collaboration of National Institute of Natural Resources of the Ministry of Agriculture (INRENA<sup>2</sup> in Spanish).

In this study the 1995 Forest Map was used as database and its Explanatory Guide<sup>3</sup> prepared by INRENA and the Forest General Direction. Likewise, during the 70's the National Planning Institute and the National Bureau of Natural Resources Evaluation (ONERN in Spanish) prepared the Budget, Evaluation and Use of Natural Resources of the Coast which describes the classification of the vegetation and the coast flora.

Pursuant to the 1995 Forest Map and its explanations, the distribution of the watersheds extend from the coast to the Andean mountains; usually, they feature different vegetal coverage according to the altitude (see Table 3.1.7-1.). In this watershed, the zones from coast up to the 2,500 m.a.s.l (Cu, Dc) have scarce vegetation, and they are featured by arid lands mainly covered by grass and cactus; some meters above in altitude, there are only scarce bushes disseminated in the area. In zones from 2,500 m.a.s.l up to 3,500 m.a.s.l, small bushy forests are formed thanks to the optimal rainfall, while in higher altitude areas the low temperature hardens the vegetal growth, so grassy species mainly grow on it. Although the bushes forming thicket generally reach up to 4 m high, in zones close to the rivers, high trees are mainly develop.

**Table 3.1.7-1 List of representative vegetable forming in the watersheds extending from the coast to the Andean mountains**

Symbol	Life Zone	Distribution of Altitude	Rainfall	Representative Vegetation
1)Cu	Coast Crop Lands	Coast	Almost none.	Coastal crops
2)Dc	Coast Desert	0~1,500 m.a.s.l	Almost none, there are mist zones.	Almost none, there are vegetation slopes
3)Ms	Dry Thicket	1,500~3,900 m.a.s.l	120~220mm	Cactus and grass
4)Msh	Subhumid Forest	North-center: 2,900~3,500 m.a.s.l Inter Andean 2,000~3,700 m.a.s.l	220~1,000mm	Perennial bushes, less than 4m high
5)Mh	Humid Forest	North: 2,500~3,400 m.a.s.l South 3,000~3,900 m.a.s.l	500~2,000mm	Perennial bushes, less than 4m high
6)Cp	Puna grass	Approx 3,800 m.a.s.l	No description	Gramineae
7)Pj	Scrubland	3,200~3,300 m.a.s.l Center-South up to 3,800 m.a.s.l	South zone with low rainfall: less than 125mm East springs: higher than 4,000mm	Gramineae
8)N	Ice-capped mountains		—	—

Source: Prepared by the JICA Team base don the Forest Map. 1995

According to vegetation formation map of 1995, the vegetation distribution in Majes-Camana watershed is similar to the above. The difference of this watershed with the above is: i) absence of Cu

<sup>1</sup> Use of Landsat-TM (Data from 1999 y 2000).

<sup>2</sup> Subsequently, INRENA was dissolved and its functions were assumed by the Wild Forest and Fauna General Direction.

<sup>3</sup> Use of Landsat-MSS (Data from 1998).

(arid and semiarid zones), ii) existence of hills “Lo” and iii) existence of Bf (wetlands).

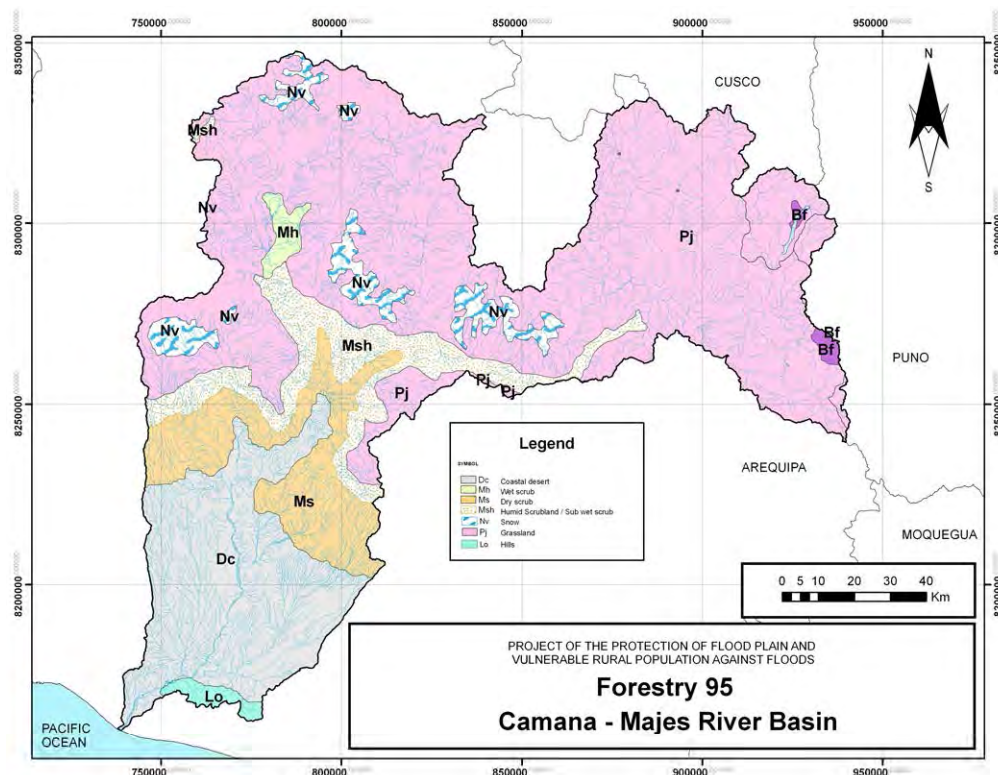
The following explanations are only for this watershed. In Figure 3.1.7-4 a vegetation formation map is show of the Majes-Camana River.

1) Lo: Hills

It goes from 0 to 1000m.a.s.l, from coastal desert of Peru to Chile. In winter (May to September) the hazel from the sea allows the development of plants communities. It is characterized for *Tillandsia spp*, tara (*Caesalpinea spinosa*), amancaes fower (*Ismene amancae*), cactus (*Haageocereus spp.*), clover (*Oxalis spp.*), wild potatoe (*Solanum spp*) among others. On the other hand, the coastal desert area is 11% of Peruvian territory, 2,000 km along the coast, also the area has 14,000km2. The coastal hills area couldn't be found in this study.

2) Bf: Wetlands

From 3,900 to 4,800 m.a.s.l , its topography is basically flat lands, with mils slopes and slight depressions. They are in areas where there are springs and have permanent water the whole year. It's characterized for species such as champa (*Distichia muscoides*), sillu - sillu (*Alchemilla pinnata*), libro-libro (*Alchemilla diplophylla*), chillihua (*Festuca dolichophylla*), crespillos (*Calamagrostis curvula*), tajlla (*Lilecopsis andina*), sora (*Calamagrostis eminens*), ojho pilli (*Hipochoeris stenocephala*) among others. These plants are short and the fauna, American camelids (llama, alpaca, vicuña and guanaco) feed from them.



(Source: INRENA, Prepared by the JICA Team based on the Forest Map. 1995)

**Figure 3.1.7-1 Distribution of the vegetation (Majes-Camana river watershed)**

## (2) Area and distribution of vegetation

Rio Camana-Majes watershed compared the results of 1995 INRENA study to those of SIG, and the area percentage of the watershed of each classification of vegetation was obtained. (See Table 3.1.7-2).

**Table 3.1.7-2 Area of each classification of vegetation (Majes-Camana river watershed)**

Distribution	Classification of vegetation								Total
	Lo	Dc	Ms	Msh	Mh	Bf	Nv	Pj	
Area of distribution of vegetation (km <sup>2</sup> )	104,54	3108,12	1570,08	1334,76	155,20	66,16	641,44	10069,21	17.049,51
Watershed area percentage (%)	0,6	18,2	9,2	7,8	0,9	0,4	3,8	59,1	100,0

Source: Prepared by the JICA Team based on the INRENA 1995 Forest Map

If the classification is added to this result, Table 3.1.7-3 is obtained. The characteristic of the vegetation classification of the Majes-Camana River watershed consists of low percentages of thicket areas (less than 9%); on the other hand, there are high percentages of scrublands (less than 60%). The altitude of high watershed of Rio Majes consists of more than 4,000m.a.s.l, which cover most of the scrublands.

**Table 3.1.7-3 Area and percentages of each classification of vegetation gathered (Majes-Camana river watershed)**

EE	Desserts and others (Lo,Dc)	Dry thicket (Ms)	Scrublands (Msh, Mh)	High elevation hills (Cp/Pj)	Ice-capped mountain (N)	Total
Vegetation area (km <sup>2</sup> )	3.212,66	1.570,08	1.489,96	10.135,37	641,44	17.049,51
Watershed area percentage (%)	18,8	9,2	8,7	59,4	3,8	99,9

## (3) Forest area variation

Although a detailed study on the variation of the forest area in Peru has not been performed yet, the National Reforestation Plan Peru 2005-2024, Annex 2 of INRENA shows the areas deforested per department until 2005. These areas subject matter of this study are included in the regions of Arequipa, Ayacucho, Huancavelica, Ica, Lima and Piura, but they only belong to these regions partially. Table 3.1.7-4 shows the Figures accumulated areas deforested in these regions. However, in relation to the Arequipa Region, data are not available.

**Table 3.1.7-4 Area deforested until 2005**

Department	Area (ha)	Area deforested accumulated (ha) and the percentage of such area in the department area (%)	Post-Felling Situation	
			Non used Area (ha)	Used area(ha)
Arequipa	6.286.456	-	-	-

Source: National Reforestation Plan, INRENA, 2005

The variation of the distribution of vegetation was analyzed per watershed, comparing the SIG to the data from the FAO study performed in 2005 (prepared based on satellite figures from 2000) and the results of the 1995 INRENA study (prepared base on satellite figures from 1995). (See Table 3.1.7-5).

From 1995 to 2000, the semi-humid and humid thicket diminished on 30km<sup>2</sup> (2.3%) and 5km<sup>2</sup> (3.2%) respectively, scrublands (Pj), ice-capped mountains (Nv) have significantly diminished on 364km<sup>2</sup> (3.6%) and 60km<sup>2</sup> (9.4%) respectively, moors (Bf) are increasing approximately on 12km<sup>2</sup> (18.2%). The area with higher increase is the coast dessert (Dc) approximately on 40km<sup>2</sup> (13%).

**Table 3.1.7-5 Changes in the areas of distribution of vegetation from 1995 to 2000 (Majes-Camana river watershed)**

Area	Classification of vegetation							
	Lo	Dc	Ms	Msh	Mh	Bf	Pj	Nv
1995 (km2) (a)	104,54	3.108,12	1.570,08	1.334,76	155,20	66,16	10.069,21	641,44
2000 (km2) (b)	131,55	3.512,24	1.586,48	1.304,54	150,25	78,18	9.705,02	581,25
Changes (b-a) (km2) (c)	27,01	404,12	16,40	-30,22	-4,95	12,02	-364,19	-60,19
Change percentage (%) (c/a)	25,8	13,0	1,0	-2,3	-3,2	18,2	-3,6	-9,4

Source: Prepared by the JICA Study Team based on the studies performed by the INRENA 1995 and FAO 2005

#### (4) Current situation of forestation

The National Reforestation Plan (INRENA, 2005) registers forestation per department from 1994 to 2003, from which the history data corresponding to the environment of this study was searched (See Table 3.1.7-6). It is observed that the reforested area increased in 1994, drastically decreasing later. Arequipa, Ica and Lima are departments located in the coast zone with scarce rainfall, thus the forestation possibility is limited, besides the scarce forest demand.

**Table 3.1.7-6 History registry of forestation 1994-2003 (formerly Department)**

Department	(Units: ha)										
	1994	1995	1996	1997	1998	1999	2000	2001	2002	2003	Total
Arequipa	3.758	435	528	1.018	560	632	nr	37	282	158	7.408

Source: National Reforestation Plan, INRENA, 2005

According to the information obtained by the interviews by Agrorural, the experiences of forestation appear in Table 3.1.7-7. Forestation has been performed in 4 places, all of them very small areas, and mainly experimental forestation. On the other hand, ONG Nature Conservancy currently performs vegetation recovery activities in the hills of Peruvian coast.

**Table 3.1.7-7 Forestation experiences (Department of Arequipa)**

Year	Place of plantation	Executing unit	Planted Species	Area (ha)	Observations
1992	Arequipa	Univ. Nac. San Agustín	Native species	2	Forest Diagnosis and possibilities
2004	Usuña, Bellavista District of Polobaya, Prov. Arequipa	AGRORURAL	eucalyptus, pine, cypress	3	
2005	Arequipa	University Thesis	Pepper tree	0,5	

Source: Prepared by the JICA Study Team based on the interview to AGORURAL



### 3.1.8 Current Situation of the Soil Erosion

#### (1) Information gathering and basic data preparation

##### 1) Information Gathering

During this study the data and information indicated in Table 3.1.8-1 was collected in order to know the current situation of the sediment production behind the Study Area.

**Table 3.1.8-1 List of collected information**

	Forms	Prepared by:
Topographic map (Scale 1/50.000)	Shp	INSTITUTO GEOGRAFICO NACIONAL
Topographic map (Scale 1/100.000)	Shp,dxf	INSTITUTO GEOGRAFICO NACIONAL
Topographic map (Scale 1/250.000)	SHP	Geologic data systems
Topographic map (Scale 1/100.000)	Shock Wave	INGEMMET
30 m grid data	Text	NASA
River data	SHP	ANA
Watershed data	SHP	ANA
Erosion potential risk map	SHP	ANA
Soils map	SHP	INRENA
Vegetal coverage map	SHP2000 PDF1995	DGFFS
Rainfall data	Text	Senami

##### 2) Preparation of basic data

The following data was prepared using the collected material. Details appear in Annex 6.

- Hydrographic watershed map (zoning by third order valleys)
- Slope map
- Geological Map
- Erosion and slope map
- Erosion and valley order map
- Soil map
- Isohyets map

#### (2) Analysis of the causes of soil erosion

##### 1) Topographic characteristics

###### i) Surface pursuant to altitudes

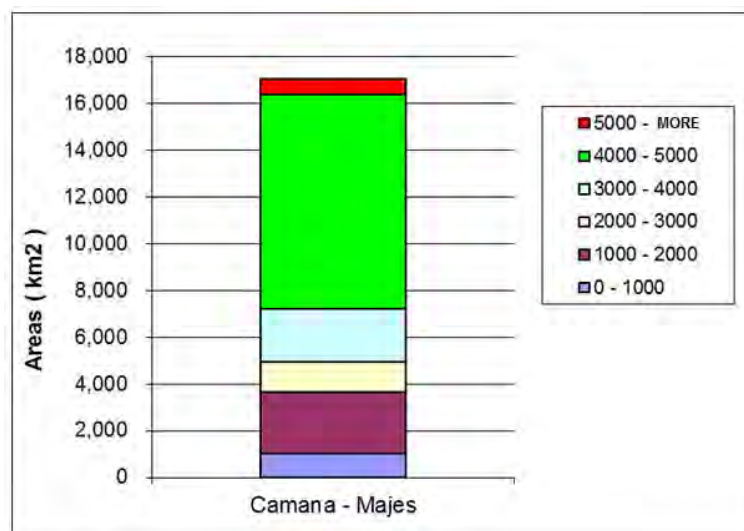
Table 3.1.8-2 and Figure 3.1.8-1 show the percentage of surface according to altitudes of Majes-Camana River watersheds. The Cañete River and Majes-Camana river watersheds are characterized for a percentage of watersheds located at more than 4,000 m.a.s.l. The hills at this height are little pronounced and several ice-capped mountains and reservoirs are distributed in the zone. This part of the Majes-Camana River watershed is large and has plentiful and large

hydrological resources compared to other watersheds. The altitudes between 4,000 and 5,000 m.a.s.l represent 53% of total surface.

**Table 3.1.8-2 Surface according to altitude**

Altitude (msnm)	Area (k m <sup>2</sup> )
	Majes-Camana
0 – 1000	1040,56
1000 – 2000	2618,77
2000 – 3000	1277,54
3000 – 4000	2305,64
4000 – 5000	9171,56
5000 – More	635,44
TOTAL	17049,51
Maximum Altitude	5821

Source: Prepared by the JICA Study Team based on the 30 m grid data



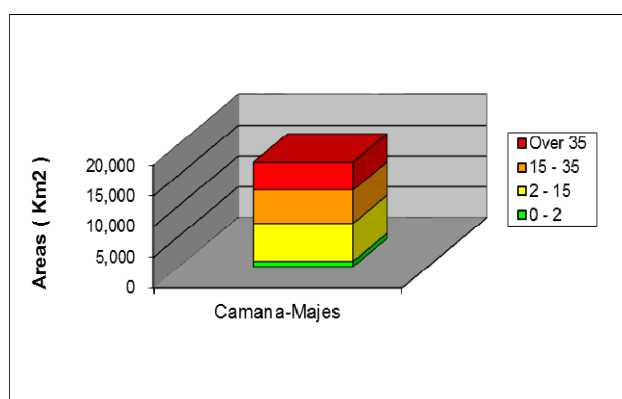
**Figure 3.1.8-1 Surface according to altitude**

ii) Zoning according to slopes

Table 3.1.8-3 and Figure 3.1.8-2 show the slopes in Majes-Camana River watershed.

**Table 3.1.8-3 Slopes and surface**

Watershed slope ( % )	Majes-Camana	
	Area (km <sup>2</sup> )	Percentage
0 - 2	869,75	5%
2 - 15	6210,54	36%
15 - 35	5452,97	32%
More than 35	4516,25	26%
TOTAL	17049,51	100%



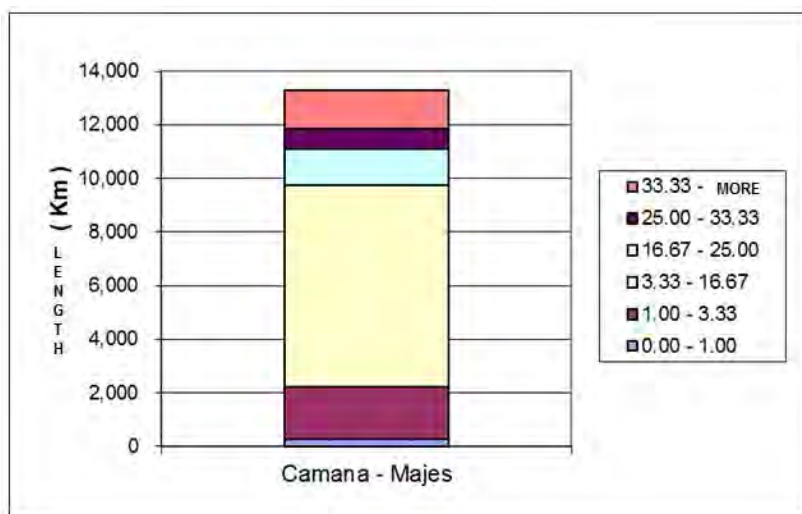
**Figure 3.1.8-2 Slopes and surface**

iii) River-bed slope

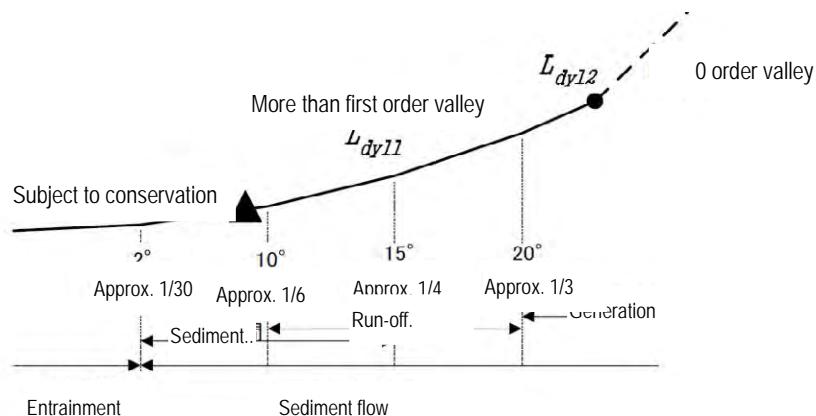
Table 3.1.8-4 and Figure 3.1.8-3 show the slope in every river and the length of streams including tributaries. Figure 3.1.8-4 shows the general relation of the movement of sediments and the river-bed slope. Supposedly, sections with more than 33.3 % of slope tend to produce higher amount of sediments, and hillsides with slopes between 3.33 % and 16.7 %, accumulate sediments easier.

**Table 3.1.8-4 River-bed Slope and total length of stream**

River-bed slope (%)	Majes-Camana
0,00 - 1,00	263,45
1,00 - 3,33	1953,19
3,33 - 16,67	7511,73
16,67 - 25,00	1383,17
25,00 - 33,33	761,15
33,33 – More	1425,65
<b>TOTAL</b>	<b>13298,34</b>



**Figure 3.1.8-3 River-bed Slope and total length of streams**



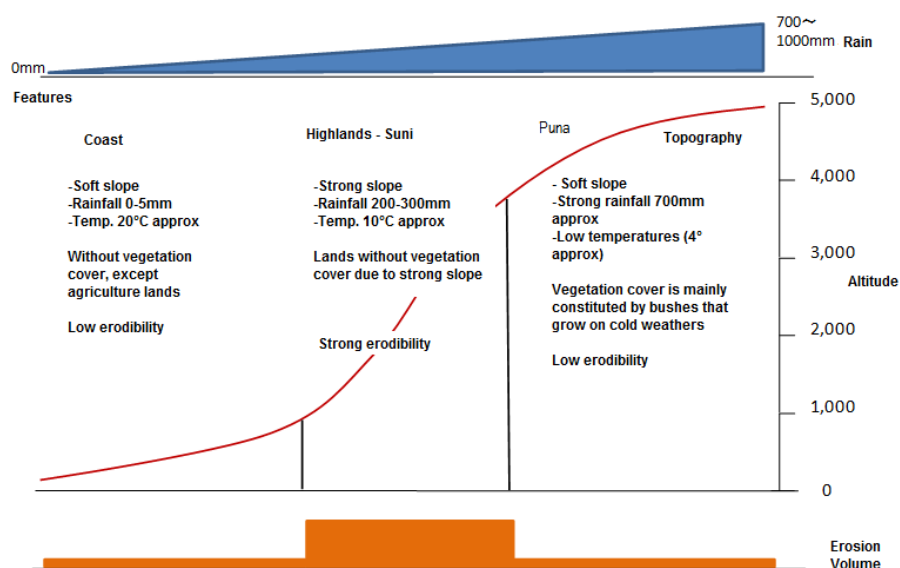
**Figure 3.1.8-4 River-bed slope and sediment movement pattern**

## 2) Rainfall

Isohyets' maps of each watershed were prepared, based on the isohyets maps prepared by SENAMHI using the rainfall data collected during 1965-1974. Figure 3.1.8-5 shows the isohyets map (annual rainfall) of Majes-Camana River watershed.

Annual rainfall in the area subject to flood analysis ranges from 0 to 50 mm. The annual mean rainfall in the zone of 4000 – 5000 m.a.s.l of the southeast ranges from 500 to 750 mm.





**Figure 3.1.8-6 Relation between the erosion volume and the different causes**

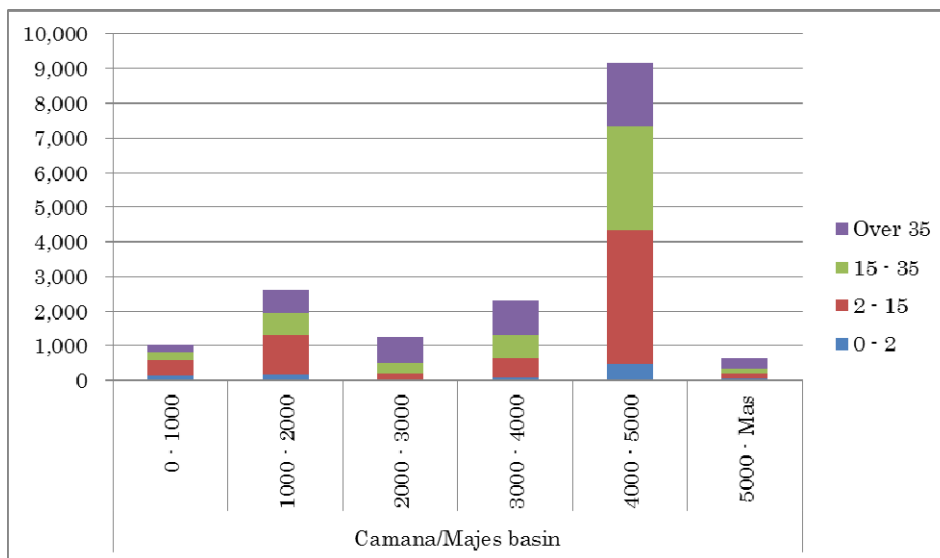
### (3) Identification of the zones more vulnerable to erosion

The erosion map prepared by ANA considers the geology, hill sloping and rainfalls. Supposedly, the erosion depth depends on the hillside slope, and in such sense the erosion map and the slope map are consistent. Thus, it is deduced that the zones more vulnerable to erosion according to the erosion map are those where most frequently erosion happens within the corresponding watershed.

The Majes-Camana watershed is characterized because its topography is very varied between 1,000 and 4,000 m.a.s.l. Colca Canyon considered one of the deepest valleys of the world is in this zone.

**Table 3.1.8-5 Slopes according to altitudes of the Majes-Camana river watershed**

Watershed	Slope	Altitudes (m)												total
		0 - 1000		1000 - 2000		2000 - 3000		3000 - 4000		4000 - 5000		5000 - More		
Majes-Camana	0 - 2	140,95	15%	158,22	17%	14,72	2%	78,54	8%	480,22	51%	61,23	7%	140,95
	2 - 15	446,73	7%	1164,54	18%	350,89	5%	560,22	9%	3850,12	59%	128,91	2%	446,73
	15 - 35	222,03	4%	622,51	12%	399,92	8%	673,63	13%	3014,22	59%	154,69	3%	222,03
	More than 35	230,75	5%	677,32	15%	537,05	12%	993,25	22%	1823,81	40%	290,08	6%	230,75



**Figure 3.1.8-7 Slopes according to altitudes of Majes-Camana river**

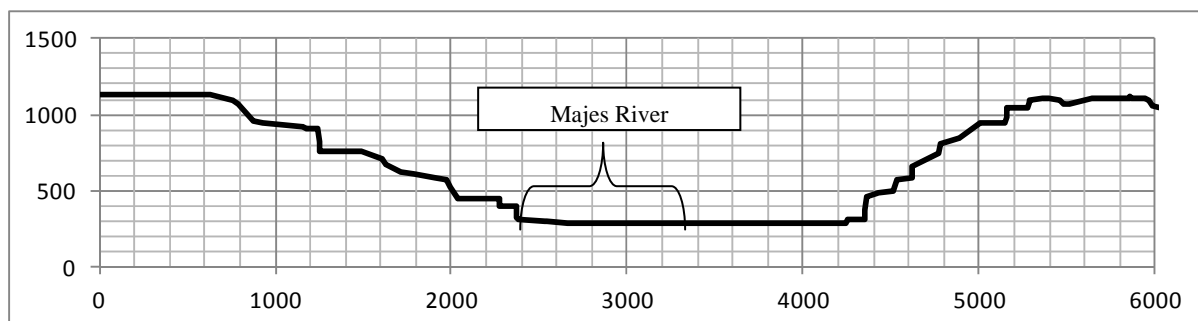
#### **(4) Production of sediments**

##### 1) Results of the geological study

The study results are described below.

- A canyon of approximately 800 m from the soil has been formed, the river flows in the middle. The valley width is 4.2km; the river width is 400m (see Figure 3.1.8-10). It has the characteristics of a terrain setting similar that of Yauca Watershed; however, the depth and the width of Camana-Majes Watershed is larger
- In the mountain surface there is no vegetation, the formation of clastic material deposits is observed, which are detached due to collapse or eolic erosion (See Figure 3.1.8-16)
- The Mesozoic sedimentary rock is the main one in the production patterns, mainly due to the mechanism of fall of large amounts of gravel and eolic fracture and erosion. As shown in the picture, there is no vegetation deeply rooted by the sediment entrainment in common time (see Figure 3.1.8-10 and Figure 3.1.8-16)
- In the case of the section subject of this study, the valley base width is broad (111km from the river mouth, in the intersection of Andamayo), the formation of low lands were observed in the beds. IN these places, the sediments dragged from the hillsides do not enter directly to the stream, but are deposited on the terrace. Thus, the most of sediments entering the river are probably produced by the eroded terraces deposits or accumulated sediments due to the alteration of bed (see Figure 3.1.8-16)
- In the higher watershed, fewer terraces were observed and dragged sediments to the hillsides directly enter to the river, although in a reduced amount (see Figure 3.1.8-16)
- According to the interviews, the situation of the sediment generation of the study section sub-watersheds is showed below. On the other hand, it was said that there was sediment entrainment from upstream silting to the flow, however, this fact was not observed

- In the canyon, terraces have been developed; terrace bottoms are in contact with the flow channel in several points. It may be considered that the ordinary water current (including small and medium floods during rainy season) brings sediments



**Figure 3.1.8-8 Cross-section of Majes watershed (50km approx. from the mouth)**

**Table 3.1.8-6 Generation of the water alluvium upstream Majes river**

No	River name	Distance	Situation
1	Cosos Figure 3.1.8-11 Figure 3.1.8-12	88km approx.	In rainy season, once per month, alluvium are generated which, due to the sediment entrainment, obstruct rural (=local) highways. The situation may be restored in a day. Sometimes it affects the water pipelines.
2	Ongoro Figure 3.1.8-13	103km approx.	In 1998, an alluvium was generated, 2 persons died due to the sediment entrainment. It took one month to recover the damages in the irrigation channels. 30 minutes before, approximately 8 families listened from the mountain a sound anticipating the alluvium, which helped them to evacuate. These 8 families currently live in the same place of the disaster. The main river of the Majes river is very large and the bed has not been silted. An NGO supported the restoration of the irrigation channels.
3	San Francisco Figure 3.1.8-14	106km approx.	In 1998, an alluvium was generated, producing damages in the irrigation channels. It took one month to temporary restore it and 4 years for restoration. The amount of the alluvium with sand sediment has been 10m. high approximately.
4	Jorón Figure 3.1.8-15	106km approx.	The alluvium was generated and the sediments were entrained to the main river. The sand sediment alluvium was 10m high. It is thought it entrained 100.000 to 1.000.000 m <sup>3</sup> of sediments.



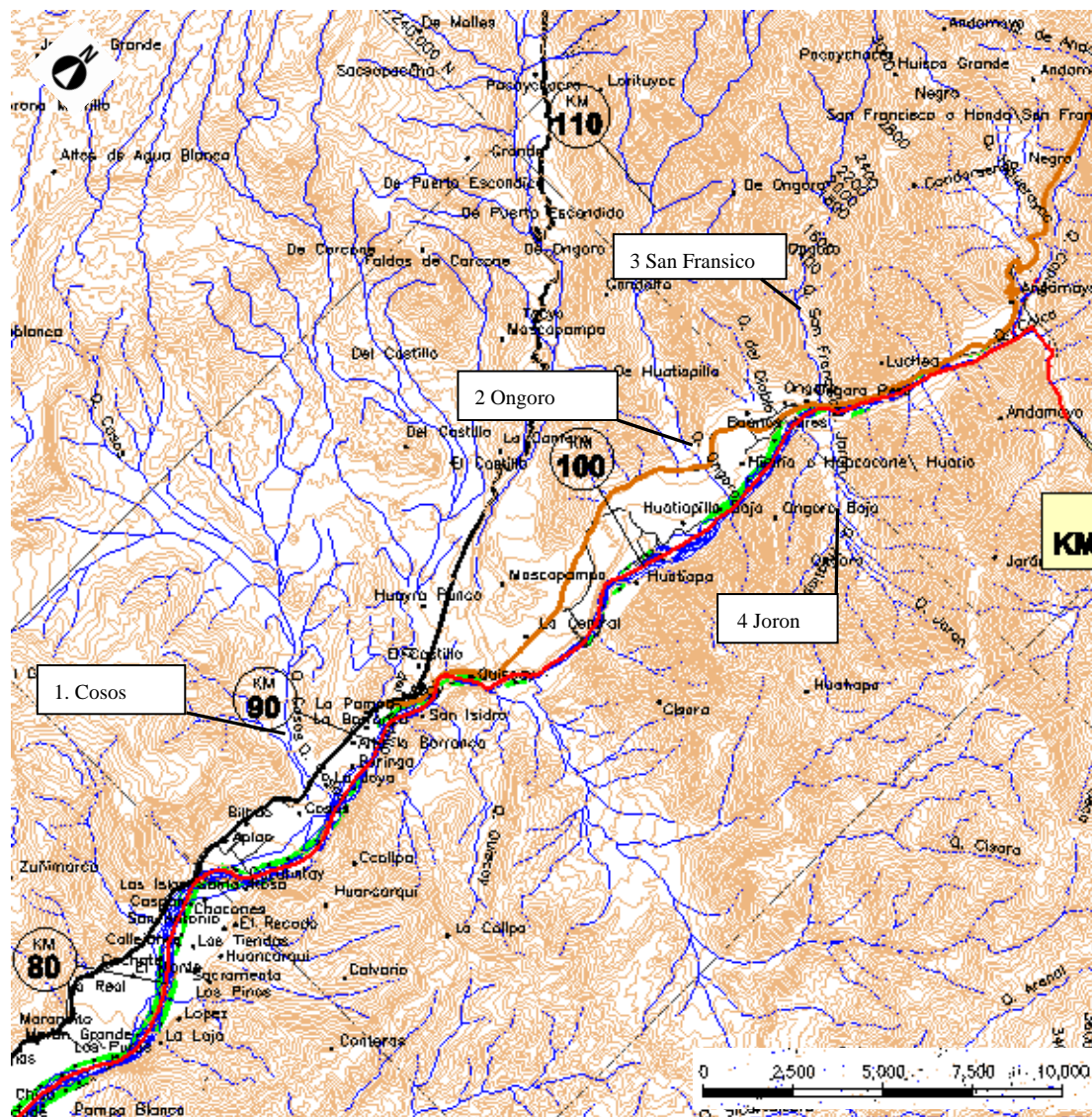


Figure 3.1.8-9 Location of the alluvium generation



Figure 3.1.8-10 Situation around Km 60 (formation of the valley approximately 5km width)



Figure 3.1.8-11 Situation of the sediment silting in Cosos river (Approx. 900m width)



**Figure 3.1.8-12 Rural (=local) highway crossing the Cosos river (in rainy season the sediments cover the rural highway, however, it is restored in a day)**



**Figure 3.1.8-13 Situation of Ongoro (in 1998, 2 persons died due to the alluvium)**



**Figure 3.1.8-14 Situation of the sediment deposition in the San Francisco river (obstruction of irrigation channels due to the disaster. The walls of the highway are the soil and sand sediments at that time)**



**Figure 3.1.8-15 Situation of Jorón river (alluvium sediments arrived up to the main river in 1998)**



**Figure 3.1.8-16 Situation around the Km110 mouth (It may be deduced that there is low affluence of sediments from hillsides to the river channel)**



**Figure 3.1.8-17 Intersection of the Camana river and Andamayo river (Andamayo river is an overflow channel)**

2) Relation of the damages by sediment and rainfall

In 1998, several damages were produced due to sediments in the Camana-Majes watershed. Due to that, a rainfall study was made on 1998. The rainfall data is obtained by the hydrographic analysis of Annex 1 of the Support Report. The pluviometric stations closest to the where the sediments were identified were verified (Table 3.1.8-7), thus obtaining the information of years with probability of higher rainfall and the larger amount of rain days on 1998, as shown in Table 3.1.8-8. In Chuquibamba 15 year rainfall precipitation data have been observed, in Pampacolca, 25 years, in Aplao and Huambo only 2 years.

In general, during the powerful El Niño Phenomenon of 1982-1983 and 1998, has occurred almost every 50 years<sup>4</sup>, it considered 50 year rainfall; therefore, it was determined that the sediment damages were due to these rainfall.

**Table 3.1.8-7 List of pluviometric station to check rainfall**

Station	Coordinates		
	Latitude	Length	Altitude (m.a.s.l)
Aplao	16° 04'10	72° 29'26	625
Chuquibamba	15° 50'17	72° 38'55	2839
Huambo	15° 44'1	72° 06'1	3500
Pampacolca	15° 42'51	72° 34'3	2895

**Table 3.1.8-8 Probability of rainfall in every Pluviometric Station and the larger amount of rainfall per day in 1998**

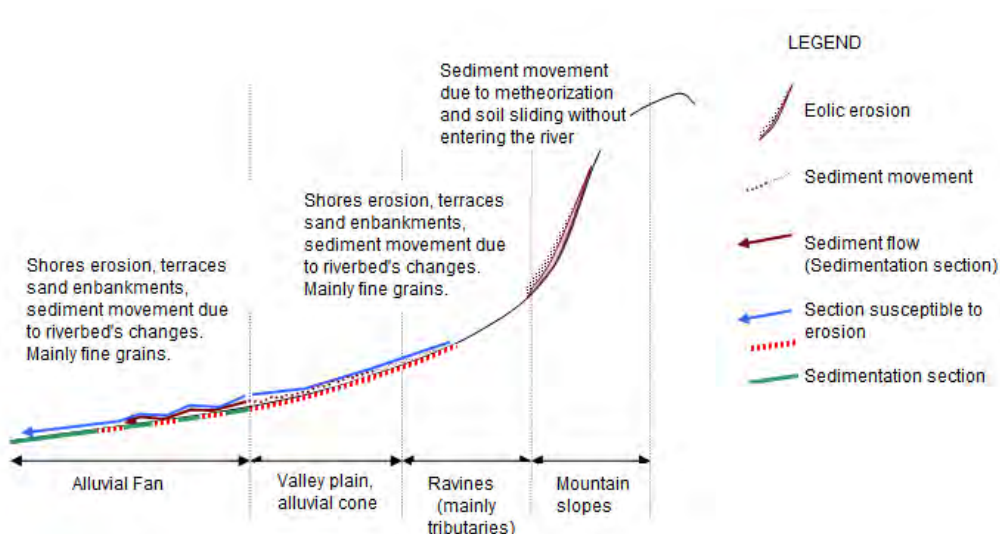
Station	Rainfall for T (years)							Rainfall in 1998
	2	5	10	25	50	100	200	
Aplao	1,71	5,03	7,26	9,51	10,71	11,56	12,14	1,20
Chuquibamba	21,65	36,96	47,09	59,89	69,39	78,82	88,21	82,00
Huambo	22,87	30,14	34,96	41,05	45,57	50,05	54,52	25,30
Pampacolca	21,13	29,11	34,40	41,08	46,04	50,95	55,86	42,40

---

<sup>4</sup> (Source) Lorenzo Huertas DILUVIOS ANDINOS A TRAVÉS DE LAS FUENTES DOCUMENTALES - COLECCIÓN CLÁSICOS PERUANOS 05/2003



bed change during low overflows (see Figure 3.1.8-19)

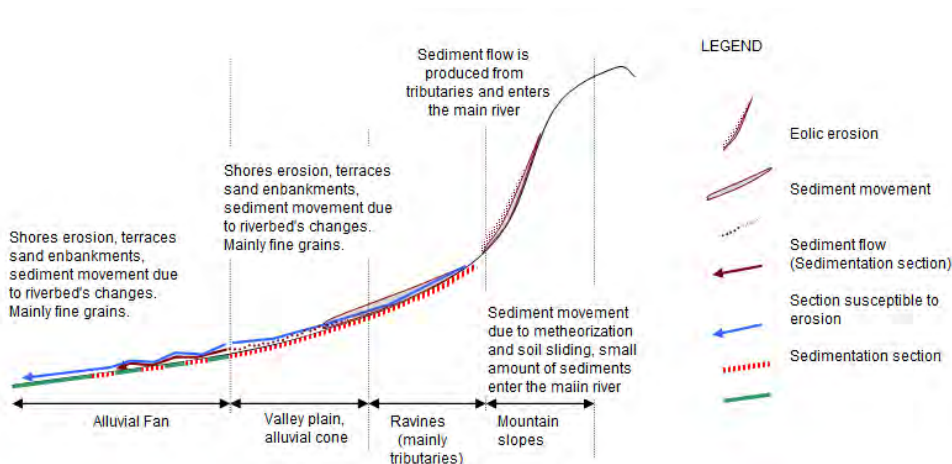


**Figure 3.1.8-19 Production and entrainment of sediments in an ordinary year**

ii) When torrential rains with magnitude similar to that of the El Niño happen (50 years return period)

Pursuant to the interviews performed in the locality, every time El Niño phenomenon occurs the tributary sediment flow occurs. However, since the bed has enough capacity to regulate sediments, the influence on the lower watershed is reduced.

- The amount of sediments entrained varies depending on the amount of water running by the hillsides
- The sediment flow from the tributaries reaches to enter to the main river
- Since the bed has enough capacity to regulate the sediments, the influence in the watershed is reduced



**Figure 3.1.8-20 Production and entrainment of sediments during the torrential rainfall of magnitude similar to that of El Niño (1:50 year return period)**

iii) Large magnitude overflows (which may cause the formation of terraces similar to those existing now), with once for a few thousands years return period

In the coast, daily rainfall with 100 years of probability are approximately 50 mm, so land slides entrained by water scarcely occur currently. However, precisely since there are few rains, when torrential rainfall occurs, there is a high potential of water sediment entrainment.

If we suppose that rainfall occurs with extremely low possibilities, for example, 1:10.000 years, we estimate that the following situation would happen (see Figure 3.1.8-21).

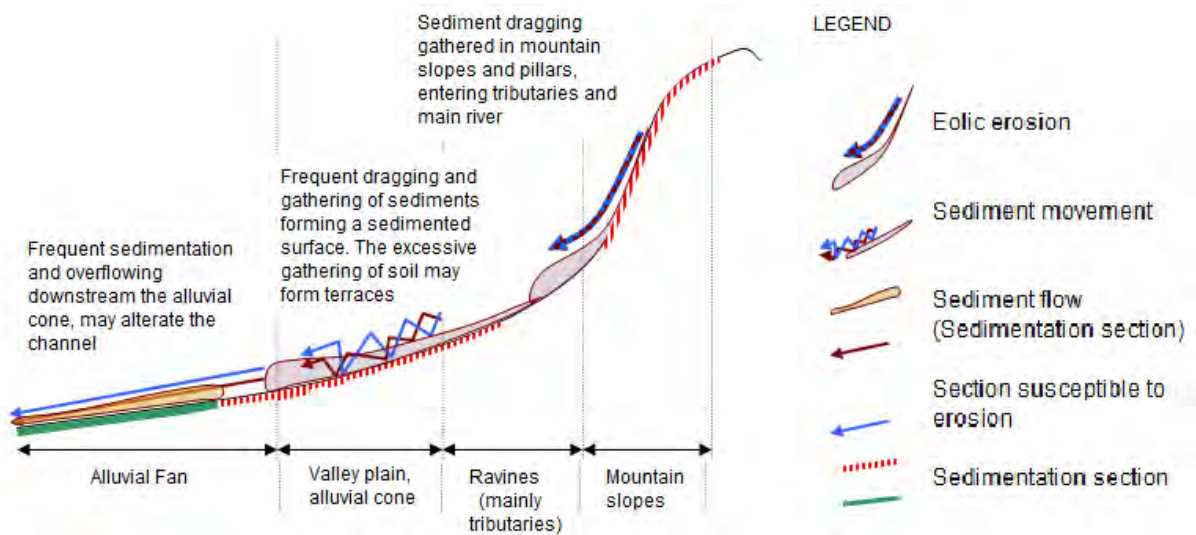
Sediment entrainment from hillsides, by the amount congruent with water amount

Exceeding sediment entrainment from the bank and bottom of hillsides by the amount congruent with the water amount, provoking landslides which may close streams or beds

Destruction of the natural embankments of beds closed by the sediments, sediment flow by the destruction of sand banks

Formation of terraces and increase of sediments in the beds of lower watershed due to the large amount of sediments

- Overflowing in section between alluvial cone and critical sections, which may change the bed.



**Figure 3.1.8-21 Production of sediments in large overflowing (geologic scale)**

### **3.1.9 Run-off Analysis**

The run-off study in the study area is described as follows. For further detail of Meteorology/Hydrology and Run-off study, refer to the Annex-1 Meteorology/Hydrology and Run-off Study.

#### **3.1.9.1 Rainfall**

The rainfall data is collected and processed in order to obtain the observation conditions of rainfall data in the study area, which are to be used in the run-off study. The rainfall data is collected mainly from SENAMHI which is the observation agency of the most of the stations. The observation method is not automatic but manual at regular time of a day for all of the stations in the study area so that there is no hourly data but only daily data (24 hour -rainfall data). In the other hand, from the year 2011 Chivay station, located in the middle basin, began an automatic telemetric monitoring. The Study Team collected information from periods of precipitation in February 2011 and February 2012 (rainy season).

##### **(1) Conditions of rainfall observation**

The rainfall observation stations and their observation period in Majes-Camana basin are as shown in the Table-3.1.9.1-1 ~ Table-3.1.9.1-2 and the Figure-3.1.9.1-1.

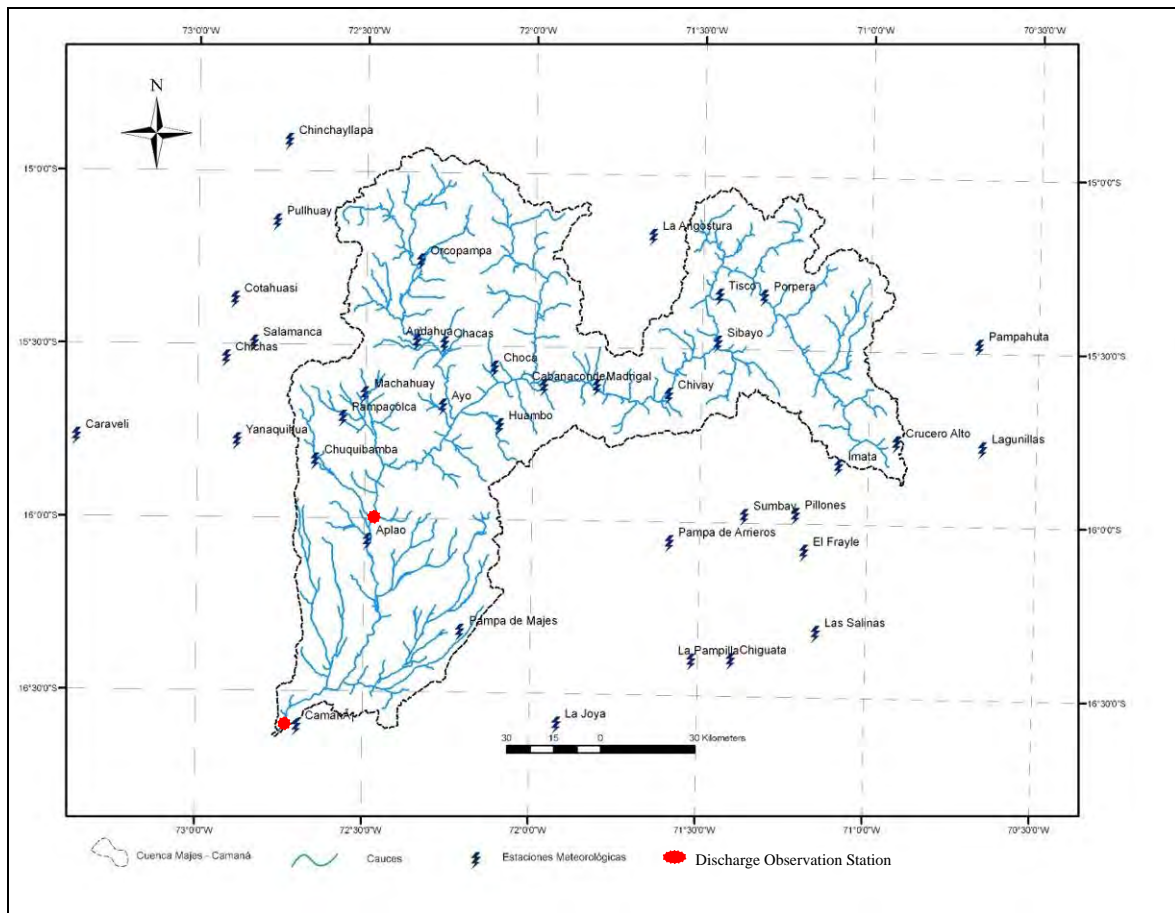
In Majes-Camana basin, the rainfall has been observed in 48 stations, and the longest observation began from 1964. However some of station have no good quality of data such as lack of long period of observation, so that the 38 stations with good quality of data were selected suitable for run-off study as shown in the Table-3.1.9.1-2.

**Table-3.1.9.1-1 Rainfall observation station (Majes-Camana river)**

Weather station	Coordinates		
	Latitude	Longitude	Altitude (masl)
Andahua	15° 29'37	72° 20'57	3528
Aplao	16° 04'10	72° 29'26	645
Ayo	15° 40'45	72° 16'13	1956
Cabanaconde	15° 37'7	71° 58'7	3379
Camaná	16° 36'24	72° 41'49	15
Caravelí	15° 46'17	73° 21'42	1779
Chachas	15° 29'56	72° 16'2	3130
Chichas	15° 32'41	72° 54'59.7	2120
Chiguata	16° 24'1	71° 24'1	2943
Chinchayllapa	14° 55'1	72° 44'1	4497
Chivay	15° 38'17	71° 35'49	3661
Choco	15° 34'1	72° 07'1	3192
Chuquibamba	15° 50'17	72° 38'55	2832
Cotahuasi	15° 22'29	72° 53'28	5088
Crucero Alto	15° 46'1	70° 55'1	4470
El Frayle	16° 05'5	71° 11'14	4267
Huambo	15° 44'1	72° 06'1	3500
Imata	15° 50'12	71° 05'16	4445
La Angostura	15° 10'47	71° 38'58	4256
La Joya	16°35'33	71°55'9	1292
La Pampilla	16° 24'12.2	71° 31'6	2400
Lagunillas	15° 46'46	70° 39'38	4250
Las Salinas	16° 19'5	71° 08'54	4322
Machahuay	15° 38'43	72° 30'8	3150
Madrigal	15° 36'59.7	71° 48'42	3262
Orcopampa	15° 15'39	72° 20'20	3801
Pampa de Arrieros	16° 03'48	71° 35'21	3715
Pampa de Majes	16° 19'40	72° 12'39	1434
Pampacolca	15° 42'51	72° 34'3	2950
Pampahuta	15° 29'1	70° 40'33.3	4320
Pillones	15° 58'44	71° 12'49	4455
Porpera	15° 21'1	71° 19'1	4152
Pullhuay	15° 09'1	72° 46'1	3113
Salamanca	15° 30'1	72° 50'1	3303
Sibayo	15° 29'8	71° 27'11	3827
Sumbay	15° 59'1	71° 22'1	4294
Tisco	15° 21'1	71° 27'1	4175
Yanaquihua	15° 46'59.8	72° 52'57	2815







**Figure-3.1.9.1-1 Location of rainfall and discharge observation station  
(Majes-Camana river)**

**(2) Monthly rainfall**

Among 48 rainfall observation stations in Majes-Camana basin and adjacent basin the rainfall data of 38 stations is used for analysis, excluding 10 stations due to short observation period less than 20 years, lack of recent 10 years data, far location from the objective basin.

The monthly rainfall data in TISCO with good quality of data is shown in the Table-3.1.9.1-3 as an example.

**Table-3.1.9.1-3 Monthly rainfall in TISCO**

TOTAL MONTHLY PRECIPITATION (mm)													
BASIN Camana - Majes	GAGE TISCO	DEPARTMENT AREQUIPA	LONGITUDE 71° 27'1	LATITUDE 15° 21'1									
Year	Month												Total
	Jan	Feb	Mar	Apr	May	Jun	Jul	Aug	Sep	Oct	Nov	Dec	
1963											41.1	131.8	
1964	86.1	72.9	114.4	42.9	22.0	0.0	0.0	6.1	4.4	17.9	59.7	57.6	484.0
1965	75.0	161.1	85.9	42.5	0.3	0.0	9.2	0.0	24.0	22.0	10.4	151.7	582.1
1966	110.3	184.9	64.6	10.6	45.1	0.0	0.0	4.5	0.0	43.3	79.7	55.0	598.0
1967	103.8	161.0	220.2	64.5	13.1	0.6	8.2	9.4	41.8	23.6	12.7	90.5	749.4
1968	266.0	119.6	179.4	31.6	4.0	5.1	5.5	5.8	20.0	52.9	84.6	31.7	806.3
1969	150.1	113.0	52.5	0.0	0.0	0.0	0.0	0.0	0.0	4.0	60.8	97.7	478.0
1970	139.6	150.5	138.5	22.4	9.5	0.0	1.0	1.1	35.6	5.1	4.7	146.8	654.9
1971	140.0	183.5	101.2	30.1	2.6	0.9	0.0	0.0	0.0	5.0	2.2	132.7	598.2
1972	362.1	188.7	235.5	32.7	0.1	0.0	2.3	0.1	55.1	32.9	32.1	90.1	1031.7
1973	297.8	190.2	159.2	81.1	15.9	0.0	8.2	10.2	31.1	7.6	60.6	53.9	915.7
1974	290.2	172.9	44.7	80.7	1.5	14.5	0.0	111.1	9.3	4.3	7.5	50.2	786.8
1975	146.6	246.7	122.4	30.2	20.8	3.2	0.0	1.0	8.0	48.3	1.4	131.4	760.1
1976	153.0	107.7	166.8	41.6	9.3	7.5	4.6	2.3	58.9	0.5	0.6	71.9	624.7
1977	67.0	239.2	118.8	7.1	4.1	0.0	2.3	0.0	11.7	16.3	110.2	49.8	626.6
1978	317.6	24.1	78.7	68.9	0.0	4.0	0.0	1.0	2.3	26.9	78.6	60.0	662.2
1979	127.4	88.0	123.3	16.5	0.0	0.0	2.5	2.5	0.0	59.2	71.2	93.7	584.4
1980	72.5	43.1	183.6	2.2	0.0	0.0	13.5	25.9	28.1	94.1	2.1	30.2	495.3
1981	205.2	52.0	73.0	2.0	0.0	0.0	0.0	46.8	9.0	24.8	52.3	110.6	
1982	161.0	45.9	122.8	34.9	0.0	0.5	0.0	0.0	80.9	105.5	150.5	70.0	772.0
1983	46.7	93.7	81.0	47.9	12.0	0.5	0.5	0.0	35.2	18.0	2.5	32.4	370.5
1984	178.4	256.0	284.8	11.1	10.5	3.0	0.0	28.4	0.0	46.3	135.5	125.6	1079.6
1985	32.9	263.0	134.4	49.7	10.0	14.8	0.0	0.0	15.4	0.0	70.0	142.4	732.6
1986	105.9	162.7	178.9	98.4	12.5	0.0	2.8	52.2	18.1	11.0	11.0	149.6	803.1
1987	212.5	42.9	26.2	23.6	3.4	2.1	27.0	4.5	2.0	23.3	24.6	29.0	421.1
1988	216.9	72.5	97.0	63.5	8.5	0.0	0.0	4.0	6.8	0.0	4.0	30.2	503.4
1989	123.9	93.0	159.5	50.7	0.0	0.0	0.0	3.0	0.0	0.0	12.0	4.0	446.1
1990	118.4	27.6	58.5	25.6	12.5	39.5	0.0	13.0	5.0	52.5	0.0		
1991	150.6	72.7	162.3	10.7	3.5	30.7	3.0	1.6	3.5	29.2	48.6	0.0	516.4
1992	51.6	73.8	32.9	4.8	0.0	2.7	2.8	40.0	1.0	25.2	24.7	85.6	345.1
1993	230.9	82.4	133.9	49.9	6.2	1.3	0.3	25.1	15.5	34.2	63.7	106.1	749.5
1994	241.6	218.1	74.3	45.6	10.1	2.8	1.5	1.7	0.0	1.0	25.2	72.7	694.6
1995	121.5	135.0	215.7	27.8	3.7	0.1	0.0	2.8	8.6	13.1	22.3	122.0	672.7
1996	187.3	156.8	83.0	61.6	12.0	0.0	0.3	14.1	11.7	10.6	41.3	146.6	725.4
1997	175.0	201.8	86.5	31.7	18.1	0.0	0.0	33.1	64.8	14.0	60.1	102.2	787.3
1998	271.1	114.9	96.6	15.9	0.5	3.0	0.0	0.8	0.5	9.6	48.5	75.9	637.4
1999	199.2	273.9	198.2	30.5	6.0	0.1	1.2	0.6	23.5	75.3	10.7	90.3	909.5
2000	194.3	242.5	157.2	21.5	28.7	7.8	0.4	11.4	1.6	70.9	22.1	97.9	856.4
2001	240.3	239.0	144.2	108.9	31.3	5.4	16.5	12.0	8.4	18.7	8.6	35.9	869.0
2002	123.6	241.6	186.8	134.9	17.4	8.0	31.8	0.6	19.1	44.7	82.2	113.3	1004.1
2003	83.5		193.1	29.2	11.8	1.5	3.6	4.1	13.2	14.8		114.6	
2004	208.7	176.4	138.0	39.4	2.4	0.5	20.3	14.9	15.4	3.2	7.0	72.7	698.8
2005	124.4	207.0	127.5	56.9	0.5	0.0	0.1	0.7	23.2	11.6	18.8	103.4	674.1
2006	202.0	200.4	195.5	62.4	6.1	4.1	0.0	7.7	25.6	29.3	61.6	78.8	873.4
2007	187.0	179.7	180.4	38.4	9.1	0.1	9.7	0.8	16.1	13.7	22.9	96.2	753.8
2008	257.8	123.5	70.0	5.5	3.2	2.7	0.1	0.6	1.7	17.1	5.0	95.6	582.7
2009	104.6	203.6	133.3	65.6	2.8	0.0	11.1	2.4	23.9	9.9	47.9	64.6	669.7
2010	179.1	164.6	73.0	69.3	6.4	2.1	2.2	1.0	6.2	21.2	13.4	142.9	681.4
2011		233.8	96.9	104.8									
Pp Maxima	362.1	273.9	284.8	134.9	45.1	39.5	31.8	111.1	80.9	105.5	150.5	151.7	1079.6
Pp Media	166.8	153.2	128.4	43.7	8.5	3.6	4.1	10.8	16.7	25.8	38.7	85.9	687.9
Pp Minima	32.9	24.1	26.2	0.0	0.0	0.0	0.0	0.0	0.0	0.0	0.0	0.0	345.1

**(3) Yearly maximum of 24-hour rainfall**

The yearly maximum of 24-hour rainfall (daily rainfall) of each observation station in Majes-Camana basin is as shown in the Table-3.1.9.1-4.

**Table-3.1.9.1-4 Yearly maximum of 24-hour rainfall (daily rainfall)  
in Majes-Camana basin(1/2) (mm)**

Year	Andahuay	Aplao	Ayo	Cabanaconde	Camana	Caraveli	Chachas	Chichas	Chiguata	Chinchaylla pa	Chivay	Choco	Chuquibamb	Cotahuasi	Cruceiro Alto	El Frayle	Huambo
1963													200				
1964		7.2						13.0					10.5	11.8	21.5		28.8
1965		2.2					10.0	18.2	7.5	20.0	14.2	8.0	0.9	16.3	38.1		23.3
1966		2.2			6.0	0.0	15.8	23.0	9.3	7.0	24.0	8.4	13.3	17.2	31.5		17.7
1967		7.3			2.5	14.0	16.7	3.8	17.1	18.9		8.2	29.5	18.8	34.7		28.4
1968		0.6			2.5	29.0	22.0	19.7	16.3	30.0		9.8	23.3	30.1	38.5		22.5
1969		1.5			13.0	7.0	27.0	30.2	9.0	19.3		11.1	37.4	18.2	26.8		17.8
1970	18.0	7.5	11.5	24.8	0.4	19.6	30.5	25.6	8.2	25.2		14.3	35.3	14.2	21.9		23.7
1971	22.0	4.7	13.5	31.1	5.2	4.5	34.5	22.0	16.0	50.0	21.5	31.5	28.5	17.1	18.5	24.1	25.1
1972	30.1	2.8	12.0	26.9	5.4	19.3	23.6	10.0	39.0	28.9	21.5	18.2	32.5	59.4	27.2	19.7	40.3
1973	21.9	6.3	9.1	25.0	16.4	7.3	21.7	15.0	19.5	20.0	24.0	16.6	32.8	30.0	32.8	21.7	20.7
1974	23.4	1.4	7.1	22.0	0.0	4.3	18.5	8.3	30.9	21.5	30.0	15.5	18.4	16.0	27.9	25.4	31.2
1975	71.0	1.2	9.0	29.2	8.0	4.0	33.3	23.6	23.3	18.8	49.0	24.0	20.5	26.4	28.5	21.8	26.4
1976	27.5	5.4	13.4	33.4	10.3	30.0	36.7	10.1	42.9	20.0	24.5	20.2	36.6	22.5	15.0	15.8	22.7
1977	19.2	1.8	7.3	28.9	2.1	5.7	27.0	14.0	34.6	23.0	38.0	15.0	30.7	20.8	28.4	32.4	14.0
1978	19.8	0.3	10.5	26.0	1.3	0.5	22.4	7.0	12.8	16.7	17.0	33.3	19.2	19.2	14.9	31.5	28.7
1979	16.4	0.0	8.6	16.9	0.5	10.1	17.4	5.8	24.8	25.8	20.6	15.0	12.2	20.1	31.0	16.5	21.1
1980	18.7	0.3	10.0	17.1	0.0	5.3	21.6	9.8	12.4	15.5	28.3	7.7	15.8	26.7	24.7	21.7	16.7
1981	20.6	2.3	11.4	26.5	0.3	23.0	24.5	15.0	28.9	20.0	20.6	18.6	25.8	40.7	21.5	30.4	23.2
1982	20.1	0.0	4.1	31.0	6.5	2.5	13.9	6.8	9.2	17.0	29.8	19.0		13.2	38.9	27.7	16.4
1983	5.4	0.0	0.1	21.1	4.0	2.8	7.3	6.0	3.8	14.3	9.0	10.0			20.0	32.5	17.4
1984	28.6	13.0	18.9	33.5		22.7	29.0	13.8	21.0	34.1	36.2	22.1		24.3	28.3	17.8	33.9
1985	17.9	0.0	12.2	29.1		2.0	19.0	22.9	20.3	20.7	25.5	15.0		18.9	22.9	21.2	24.6
1986	22.4	6.0	12.8	71.5		11.3	21.3	23.5	37.9	18.8	27.5	18.0		30.0	19.2	18.4	34.4
1987	30.7	0.8	10.3	92.8		2.2	36.0	21.0	39.4	18.7	17.4	10.0	27.2	17.3	14.4	12.6	42.8
1988	30.7	0.4	9.9	40.0		8.4	22.8	22.2	22.7	18.4	31.3		7.2	26.9	18.8	20.0	30.4
1989	32.8	0.5	5.3	24.5		12.5	19.0	27.5	32.2	19.1	13.0	11.7	33.0	19.2	18.6	17.0	
1990	20.6	1.6	4.5	23.0		6.5	35.6	12.9	18.9	18.5	34.7	13.3	23.0	18.0	58.5	36.0	
1991	33.2	0.9	3.4	6.9		0.0	20.0	12.0	13.5	20.0	36.8	16.7	3.2		19.5	23.5	15.8
1992	12.4	2.8	1.8	17.0			10.5	2.3	5.2	14.8	8.0	10.4			13.9	18.2	6.3
1993	17.8	0.3	1.7	20.0		2.0	16.1	12.5	21.8	14.3	16.4	6.5	8.0		22.6	24.7	16.8
1994	31.4	1.2	8.6	23.2	0.0	11.0	23.0	26.1	33.3	21.6	16.0	16.7	36.8	0.0	32.1	39.0	16.9
1995	21.6	2.1	14.8	32.8	0.0	15.2	18.6	22.2	48.8	30.6	30.1	24.0	29.6	14.7	31.8	32.5	17.9
1996	22.4	1.3	15.6	22.2	0.9	1.9	21.1	19.5	10.2	25.0	39.7	11.8	10.0	29.8	27.6	21.4	16.9
1997	28.9	3.7	18.3	51.0	2.2	33.0	35.4	14.2	44.0	29.4	30.3	21.3	19.6	26.7	27.4	21.6	32.9
1998	33.5	1.2	16.9	38.3	3.6	18.5	25.9	29.6	12.6	34.9	23.4	24.5	82.0	26.2	23.6	20.9	25.3
1999	26.6	1.4	14.5	32.9	2.3	7.1	35.3	23.0	25.0	24.0	29.2	19.2	26.0	33.0	32.7	25.7	26.6
2000	24.9	1.0	8.6	24.6	2.9	15.6	15.8	19.8	36.2	45.1	24.4	18.4	28.0	26.6	21.9	15.9	18.7
2001	30.6	2.0	15.4	48.6	1.4	11.5	19.0	17.4	20.9	31.5	29.8	19.8	70.4	22.8	25.9	13.4	17.0
2002	27.3	4.8	16.6	30.6	4.4	13.7	22.5	22.6	24.3	28.8	28.1	20.9	47.7	27.5	30.6	17.8	27.9
2003	17.5	0.0	8.7	19.3	0.4	0.0	17.8	8.7	9.2	31.6	14.7	13.7	14.5	18.0	15.7	11.7	25.5
2004	23.0	9.0	35.6	22.9	0.5	1.5	21.4	18.9	18.7	25.8	24.8	24.6	16.6	25.7	28.2	28.4	30.4
2005	21.1	1.7	12.1	24.4	0.8	16.5	12.8	10.7	13.0	39.1	27.8	13.6	14.6	11.0	35.3	20.1	18.3
2006	25.0	0.9	9.4	25.3	0.6	4.2	19.6	18.3	14.4	30.9	26.5	17.7	18.2	13.5	23.4	28.3	31.8
2007	21.6	2.7	14.0	27.4	3.0	2.6	28.6	10.6	23.4	30.2	24.7	40.0	10.9	29.4	32.5	21.2	21.0
2008	23.3	6.4	23.5	24.0	9.8	5.0	18.0	25.7	20.7	30.8	35.7	23.8	15.4	17.4	15.4	28.2	29.2
2009	19.7	0.0	10.2	16.8	3.2	9.1	17.1	23.0	9.9	28.6	30.6	20.6	15.7	11.8	32.7	43.6	16.8
2010	27.2	0.9	7.8	23.9	4.5	1.3	18.7	9.3	9.7	25.6	26.9	11.9	17.0	17.7	33.8	23.3	
2011	21.2	2.0	13.3	26.6		7.2	31.2	15.1	19.2		27.7	19.8	17.0	21.7	27.9		

**Table-3.1.9.1-5 Yearly Maximum of 24-hour rainfall (daily rainfall)  
in Majes-Camana basin (2/2) (mm)**

Year	Imata	La Angostura	La Joya	La Pampilla	Lagunillas	Las Salinas	Machaguay	Madrigal	Orcopampa	Pampa de Arneros	Pampa de Majes	Pampacolca	Pampahuta	Pillones	Porpera	Pullhuay	Salamanca	Sibayo	Sumbay	Tisco	Yanaquihua	
1963						21.5				15.3		12.7										20.5
1964						18.0	8.0	18.7		20.0		17.7		60.7		30.2	15.0					28.2
1965						19.9		18.4		11.8	8.2			19.0	32.7	12.2	10.5			12.5	33.5	17.6
1966			0.0			19.2	20.3	20.1		34.0	29.9		23.1	26.7	28.5	22.6				22.3	45.6	14.1
1967			1.0			17.2	23.5	28.1		15.0	21.2		39.7	36.7	21.6	18.5				30.7	30.9	23.8
1968			3.0			20.0	18.1	20.7		17.8	43.8		33.3	21.5	45.8	26.3	21.5			67.5	50.0	17.5
1969	21.5	34.6	5.1		34.2	11.0	22.9	18.9	83.1	18.3	1.9	22.1	33.3	23.2	40.5	26.3	24.6	35.9		15.8	38.0	42.6
1970	32.2	40.5	0.7		24.8	23.1	18.6	22.5	17.0	20.9	7.1	18.7	33.6	31.4	38.5	54.3	26.9	26.0	39.5	24.9	10.1	
1971	33.4	38.0	1.7	21.3	24.3	13.6	40.2	33.3	27.3	41.8	1.0	27.5	35.4	22.3	36.0	40.0	30.7	51.3	38.7	44.7	55.0	
1972	35.2	27.7	0.6	22.1	41.3	13.2	24.1	16.2	57.0	18.0	21.5	23.5	31.4	15.6	21.2	41.1	24.2	29.8	22.5	25.7	20.9	
1973	34.7	43.7	4.0	16.0	43.6	12.4	13.5	31.6	36.7	17.2	1.8	19.5	39.1	9.4	27.5	29.2	17.5	40.0	44.0	37.4	17.2	
1974	23.7	58.5	3.0	46.7	38.4	10.4	23.2	24.9	23.2	19.6	1.2	18.8	28.2	18.3	21.0	44.1	32.4	48.1	27.2	37.7	15.9	
1975	24.1	44.0	4.9	24.0	23.7	15.0	23.1	24.9	23.7	30.7	2.2	26.2	17.6	13.5	36.3	22.3	31.4	23.8	38.5	18.7		
1976	24.2	52.2	0.0	6.8	25.8	16.9	9.6	20.1	21.9	27.3	1.8	31.6	27.0	28.3	21.5	25.5	20.2	30.5	18.3	38.5	34.5	
1977	35.1	36.2	0.0	8.0	27.7	12.3	9.2	25.1	26.5	20.0	0.0	27.4	34.0	38.5	22.4	21.8	15.3	31.3	36.8	33.2	9.3	
1978	30.8	22.2	0.0	10.9	32.5	13.9	17.0	15.8	25.7	9.5	0.0	27.6	31.8	19.4	17.5	22.3	17.7	40.8	22.0	49.0	15.1	
1979	21.2	38.7	3.0	8.7	26.2	24.8	23.0	19.5	18.9	29.8	0.8	15.7	36.5	17.4	21.2	19.5	10.8	23.8	15.8	46.5	13.5	
1980	36.3	37.9	0.0	5.4	36.4	18.6	14.0	33.8	18.8	28.4	0.3	17.6	45.3	28.1	19.2	33.1	34.2	31.2	24.5	52.0	21.6	
1981	20.7	31.0	0.0	3.9	25.6	17.1	9.2	18.8	19.1	20.9	0.0	18.5	22.9	16.1	15.0	15.5	14.8	35.8	18.9	37.0	12.1	
1982	15.4	38.2	0.0	1.5	33.0	10.0		10.0	15.3		0.1	15.0	30.4	23.8	16.0	13.8	12.9	21.5		30.0	38.0	
1983	29.3	89.9	3.0	14.7	32.0	13.4	24.0	24.6	32.2	50.6	0.9	26.6	43.6	28.0	14.7	33.9	49.0	40.1	25.7	33.0	41.0	
1984	34.9	53.2	6.3	15.3	28.3	14.5	18.4	31.7	18.4	30.9	0.8	32.6	20.1	21.5	33.7	14						

#### (4) Isohyetal map of yearly average rainfall

The isohyetal map of yearly average rainfall in Majes-Camana basin is as shown in the Figure-3.1.9.1-2.

There is big difference in the yearly rainfall data by areas in Majes-Camana basin, for instance yearly rainfall is approximately 50mm in the minimum, on the other hand 750mm in the maximum, and the amount is small in the downstream area near the Pacific Oceans and becomes large toward the upstream with higher elevation. In the objective section for flood protection, the yearly rainfall is not so much from 50~200mm.

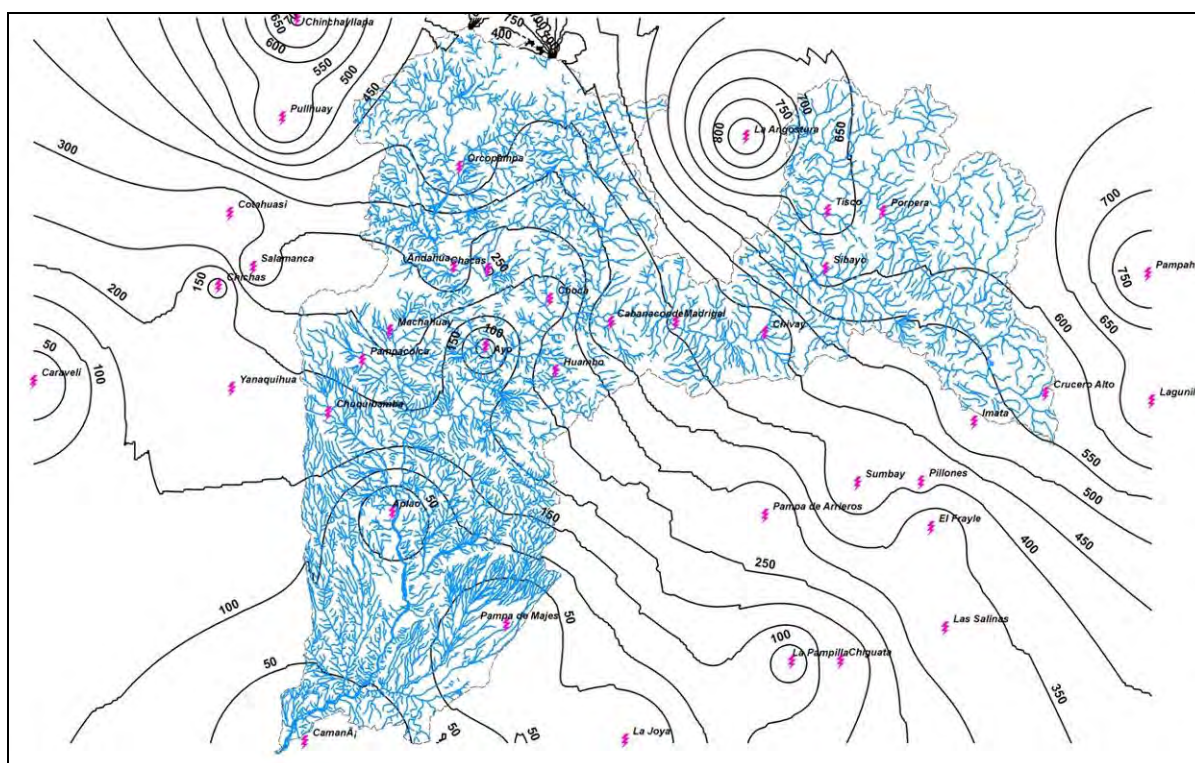


Figure-3.1.9.1-2 Isohyetal map of yearly rainfall(Majes-Camana basin )

#### 3.1.9.2 Discharge

The discharge observation method is generally not automatic but manual at regular time of a day, once a day at 7 a.m. or twice a day at 7a.m. and 7p.m. for all of the stations in the study area so that there is no hourly data but only daily data (24 hour -discharge data). Being a fixed monitoring times, is not likely to have registered maximum instantaneous flows as flood peak flows.

The water level is observed by staff gauge, and the discharge is estimated applying the water level to the relation curve between the water level and discharge which is prepared beforehand by actual measurement of flow area and velocity.

However, from 2006 at the discharge gauging station at Huatiapa (Majes-Camana river) the water

level measurements made by SENAMHI 4 times a day (7:00, 10:00, 14:00 and 18:00) using a staff gauge are compared to the water levels recorded by an automatic float type water level gauging system (starting in 2006). In times of flood the water level measurements are made every hour.

On the other hand, although the Huatiapa gauging station at the valley of Majes-Camana is recording water levels using an automatic float type gauging system, the data is only partially being ordered digitally through a computer, the in charge operator is making a manual record. The data of maximum annual discharge published by SENAMHI before year 2006, represents the maximum of daily mean discharges obtained from the mean discharge measured 2 or 4 times a day. Therefore it is necessary to establish measurement system to obtain real-time water level and discharge values and organize those observed data during inundation time by means of installation of an automatic telemetry system in each gauge in each watershed.

The river originates at high land connected with Andes Mountains and flow down through alluvial fan to the coast. The discharge observation stations are generally located at the middle stream or downstream of the alluvial fan (refer to the location map of rainfall observation stations). Since there is hardly rainfall in the coastal area, the discharge will not enter from residual area of downstream basin so that the discharge observation shows the total discharge from the whole basin. Therefore it is desirable to select the reference point for run-off analysis at such observation station.

### **(1) Discharge observation station**

The discharge observation station in Majes-Camana river is as shown in the Table-3.1.9.2-1.

**Table-3.1.9.2-1 Discharge observation station(Majes-Camana river)**

<b>Observation Station</b>	<b>Latitude</b>	<b>Longitude</b>	<b>Elevation (m.a.s.l.)</b>
Huatiapa	15°59'41.0" S	72°28'13.0" W	700
Puente Carretera Camaná	16°36'00.0" S	72°44'00.0"W	122

### **(2) Yearly maximum daily discharge**

The yearly maximum daily discharge of each year is as shown in the Table-3.1.9.2-2.

**Table-3.1.9.2-2    Yearly maximum daily discharge (Majes-Camana river) (m<sup>3</sup>/s)**

Huatiapa		Puente Carretera Camaná	
Year	Max.Discharge	Year	Max.Discharge
1945	620.00	1961	301.10
1946	619.00	1962	399.87
1947	580.79	1963	340.16
1948	506.50	1971	340.72
1949	1012.80	1972	800.42
1950	458.33	1973	750.19
1951	687.32	1974	950.00
1952	592.50	1975	890.00
1953	980.00	1977	1200.00
1954	980.00	1978	2000.00
1955	2400.00	1979	150.70
1956	445.30	1980	89.00
1957	316.00	1981	530.00
1958	985.50	1982	300.00
1959	1400.00	1983	40.00
1960	600.00	1984	1300.00
1965	171.94	1986	600.00
1966	237.00		
1967	420.00		
1968	442.55		
1969	308.60		
1970	362.00		
1971	356.00		
1972	633.00		
1973	1040.00		
1974	902.00		
1975	748.00		
1976	514.00		
1977	592.00		
1978	1600.00		
1979	410.00		
1980	415.00		
1981	1000.00		
1982	345.00		
1983	23.20		
1984	1025.00		
1986	750.00		
2006	590.87		
2007	366.33		
2008	418.50		
2009	400.22		

### 3.1.9.3 Probable flood discharge based on observation data

The reference point for run-off analysis was selected among the observation stations in each basin, and where the flood discharge with return period from 2years to 100 years are calculated based on the observation data of yearly maximum daily discharge by statistical processing.

The results of calculation are as shown in the Table-3.1.9.3-1.

The following probable distribution models are used for hydrological statistic calculation, and the most adaptable value among models is adopted for each basin, for further details refer to the Appendix attached at end of this report.

- Distribution Normal or Gaussiana
- Log - Normal 3 parameters

- Log - Normal 2 parameters
- Gamma 2 or 3 parameters
- Log - Pearson III)
- Gumbel Distribution
- Generalized Extreme Values

**Table-3.1.9.3-1 Probable discharge at reference point**

(m<sup>3</sup>/s)

River/Reference Point	Return Period of 2years	Return Period of 5years	Return Period of 10years	Return Period of 25 years	Return Period of 50 years	Return Period of 100 years
Majes-Camana/ Huatiapa	560	901	1,169	1,565	1,906	2,292

#### **3.1.9.4 Run-off analysis based on rainfall data (HEC-HMS method)**

There is only daily discharge data in the objective study area, and the probable discharges calculated in the previous section 3.1.9.3 show the peak discharge. In order to perform the inundation analysis described later clause, the hourly distribution of flood discharge (flood hydrograph) is required. Therefore the run-off study based on rainfall data is performed in this section.

The run-off analysis method is to be HEC-HMS (Hydrologic Engineering Center- Hydrologic Modeling System) which is developed by US Army Corps of Engineer. This system is the run-off analysis program for general purpose which is widely used in the North America and other areas in the world, and one of the most popular programs in Peru.

##### **(1) Summary of HEC-HMS**

HEC-HMS is designed to simulate the precipitation-runoff processes of dendritic watershed system. The basin model can be composed of sub-basin, reach, junction, diversion, reservoir etc. To simulate infiltration loss options for event modeling include SCS curve number, Initial Constant, Exponential, Green Ampt etc.

Several methods are included for transforming excess precipitation into surface runoff such as unit hydrograph methods including Clark, Snyder, SCS technique. Several methods including Muskingum, kinematic wave can be applied for flood routing in channel. And several methods can be applied for representing base flow contribution to sub-basin outflow.

Six different historical and synthetic precipitation methods are included. Four different methods for analyzing historical precipitation are included. The gage weights method uses an limited number of recording and no-recording gages and Thiessen technique is one possibility for determining the weights.



The frequency storm method uses statistical data to produce balanced storms with a specific exceeding probability. The SCS hypothetical storm method implements the primary distribution for design analysis using Natural Resources Conservation Service Criteria (NRCS). Most parameters for methods included in sub-basin and reach elements can be estimated automatically using optimization trials. Six different objective functions are available to estimate goodness-of-fit between the computed results and observed discharge.

The procedure of applying HEC-HMS in this analysis is as shown below. According to this procedure the summary of run-off analysis on Majes-Camana basin is described below. As to detail of run-off study for each basin refer to Annex-1 Meteorology/Hydrology and Run-off Study, Appendix.

- (1) Preparation of Basin Model
- (2) Rainfall Analysis
  - 1) Calculation of Probable 24-hour Rainfall in Each Station
  - 2) Calculation of 24-hour Rainfall in Each Sub-basin
  - 3) Selection of Type of 24-hour Rainfall Curve
- (3) Calculation of Infiltration Loss by SSC Method
  - 1) Selection of Initial Curve Number in Each Sub-basin
  - 2) Selection of Final Curve Number in Each Sub-basin
  - 3) Verification of Model
- (4) Calculation of Probable Flood Discharges and their Flood Hydrograph

## **(2) Preparation of basin model**

### 1) Division of basin

Majes-Camana basin is divided into 4 sub-basins each of which has similar hydraulic characteristics, such as topography, distribution pattern of river channel, forestation conditions, surface soil conditions etc. The division of the basin is as shown in the Figure -3.1.9.4-1.

### 2) Preparation of basin model

The sub-basin, reach and junction are represented schematically in HEC-HMS. In accordance with these, the whole basin model of Majes-Camana basin is expressed as shown in the Figure-3.1.9.4-2



Figure-3.1.9.4-1 Division of Majes-Camana basin

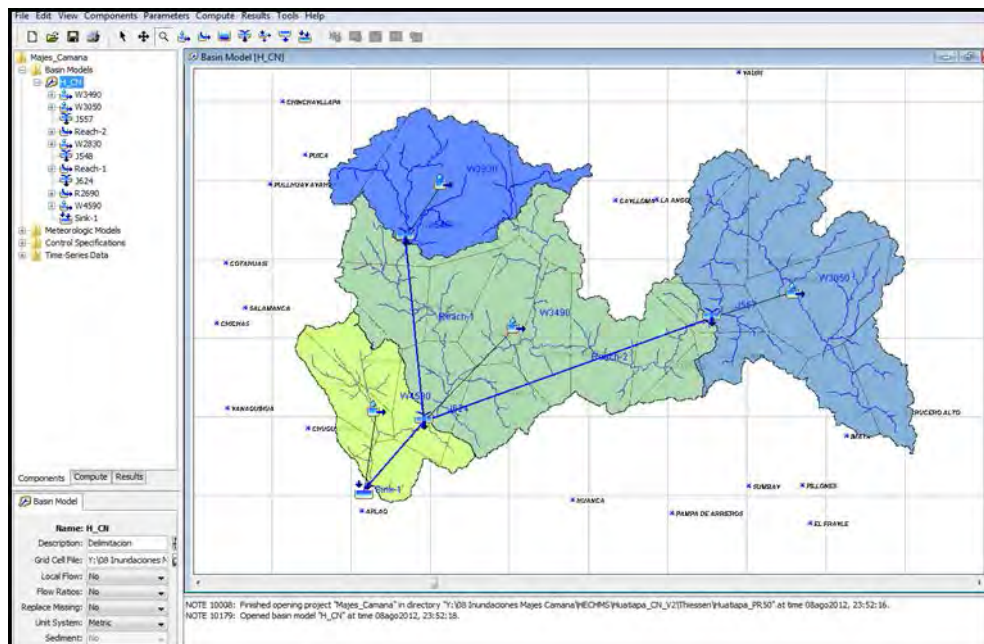


Figure-3.1.9.4-2 HEC-HMS model of Majes-Camana basin

### (3) Rainfall analysis

Information was collected on hourly rainfall of Chivay station located in the middle basin for the period February 2011 to February 2012. Using this information, a Depth-Duration Analysis was performed for 3 different periods of flood. Of the 3 cases of floods, the longest storm duration was measured in the period of February 2012 ( $Q_p = 1.400 \text{ m}^3/\text{sec.}$ ) and the duration was 17 hours. Thus in

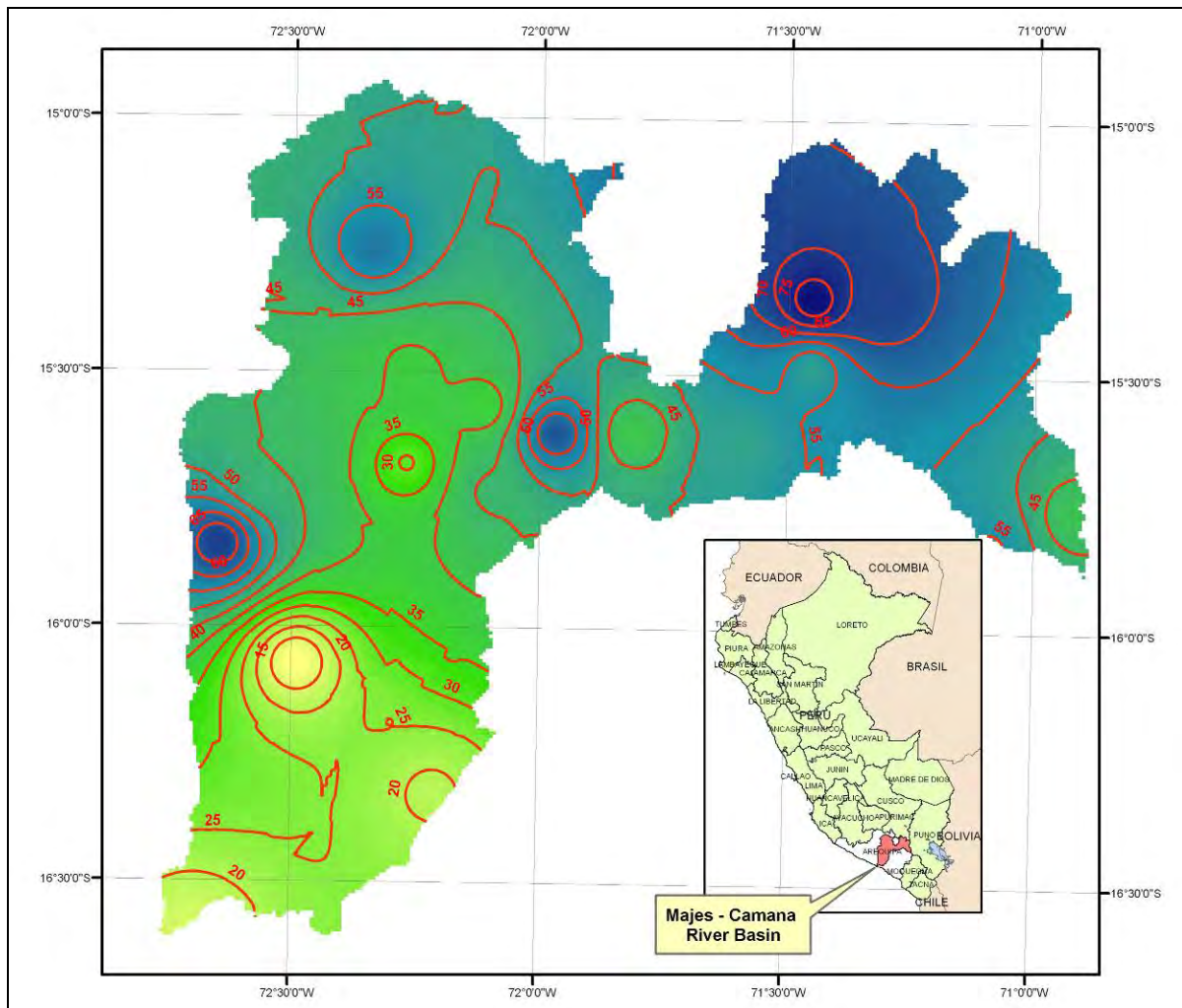
the discharge analysis the used storm duration was 24 hours. Furthermore, according to interviews with representatives of SENAMHI and Peruvian universities, on the Peruvian coast storm duration range is from 6 to 12 hours and for calculations for discharge analysis the usually used storm duration is 24 hours.

1) Probable 24-hour Daily Rainfall

The probable 24-hour rainfall in each observation station is calculated by statistical processing of yearly maximum rainfall of 24-hour as shown in the Table-3.1.9.4-1. Based on the table the isohyetal map of 24h-hour rainfall with return period of 50-year is as shown in the Figure-3.1.9.4-3.

**Table-3.1.9.4-1 Probable 24-hour Rainfall in Each Station (Majes-Camana Basin)**

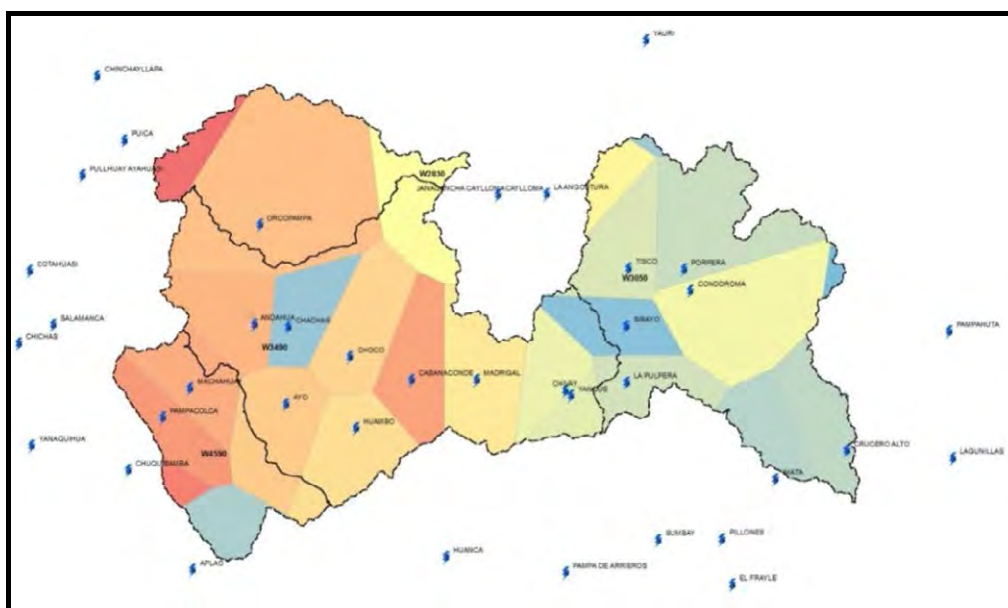
Station	Coordinates			Precipitation for T (years)						
	Latitude	Longitude	Altitude (masl)	2	5	10	25	50	100	200
Andahua	15° 29'37	72° 20'57	3538	24.30	31.33	34.83	38.29	40.33	42.02	43.43
Aplao	16° 04'10	72° 29'26	625	1.71	5.03	7.26	9.51	10.71	11.56	12.14
Ayo	15° 40'45	72° 16'13	1950	10.28	16.43	20.51	25.66	29.48	33.27	37.05
Cabanaconde	15° 37'7	71° 58'7	3369	26.58	37.88	45.89	56.58	64.95	73.67	82.79
Camaná	16° 36'24	72° 41'49	29	3.18	7.16	9.79	13.11	15.58	18.03	20.46
Caravelí	15° 46'17	73° 21'42	1757	7.67	16.07	22.60	31.46	38.30	45.21	52.15
Chachas	15° 29'56	72° 16'2	3130	22.21	28.60	32.08	35.83	38.24	40.37	42.30
Chichas	15° 32'41	72° 54'59.7	2120	16.28	23.47	27.01	30.37	32.23	33.67	34.80
Chiguata	16° 24'1	71° 24'1	2945	18.88	29.98	37.33	46.40	52.94	59.27	65.42
Chinchayllapa	14° 55'1	72° 44'1	4514	23.12	31.21	36.57	43.34	48.37	53.35	58.32
Chivay	15° 38'17	71° 35'49	3663	24.50	32.74	38.20	45.09	50.21	55.29	60.35
Choco	15° 34'1	72° 07'1	3160	16.10	22.92	27.45	33.16	37.39	41.60	45.79
Chuquibamba	15° 50'17	72° 38'55	2839	21.65	36.96	47.09	59.89	69.39	78.82	88.21
Cotahuasi	15° 22'29	72° 53'28	5086	21.20	29.97	35.78	43.12	48.56	53.96	59.35
Crucero Alto	15° 46'1	70° 55'1	4486	25.33	31.66	35.20	39.10	41.67	44.02	46.17
El Frayle	16° 05'5	71° 11'14	4110	22.33	29.95	35.43	42.89	48.83	55.12	61.82
Huambo	15° 44'1	72° 06'1	3500	22.87	30.14	34.96	41.05	45.57	50.05	54.52
Imata	15° 50'12	71° 05'16	4451	28.35	37.09	42.87	50.18	55.60	60.98	66.34
La Angostura	15° 10'47	71° 38'58	4260	35.90	45.89	53.22	63.31	71.46	80.18	89.57
La Joya	16°35'33	71°55'9	1279	1.22	4.74	7.89	11.93	14.65	16.98	18.92
La Pampilla	16° 24'12.2	71° 31'.6	2388	12.65	21.64	27.66	35.01	40.23	45.20	49.94
Lagunillas	15° 46'46	70° 39'38	4385	28.55	34.30	37.75	41.81	44.67	47.40	50.05
Las Salinas	16° 19'5	71° 08'54	3369	18.05	25.72	30.80	37.22	41.98	46.70	51.41
Machahuay	15° 38'43	72° 30'8	3000	21.06	29.80	34.71	40.03	43.45	46.46	49.14
Madrigal	15° 36'59.7	71° 48'42	3238	23.63	30.07	33.66	37.59	40.17	42.50	44.63
Orcopampa	15° 15'39	72° 20'20	3805	21.51	29.58	36.83	48.66	59.81	73.37	89.92
Pampa de Arrieros	16° 03'48	71° 35'21	3720	18.86	32.08	40.82	51.88	60.07	68.21	76.32
Pampa de Majes	16° 19'40	72° 12'39	1442	2.07	6.68	10.56	15.55	18.98	22.04	24.69
Pampacolca	15° 42'51	72° 34'3	2895	21.13	29.11	34.40	41.08	46.04	50.95	55.86
Pampahuta	15° 29'1	70° 40'33.3	4317	34.18	39.66	42.87	46.58	49.14	51.57	53.89
Pillones	15° 58'44	71° 12'49	4428	24.00	32.95	38.88	46.36	51.92	57.43	62.92
Porpera	15° 21'1	71° 19'1	4142	27.40	40.61	49.37	60.42	68.63	76.77	84.88
Pullhuay	15° 09'1	72° 46'1	3098	24.47	32.43	37.63	44.15	48.97	53.77	58.60
Salamanca	15° 30'1	72° 50'1	3153	19.86	26.64	31.13	36.81	41.02	45.20	49.36
Sibayo	15° 29'8	71° 27'11	3839	31.25	38.61	42.98	48.06	51.59	54.93	58.13
Sumbay	15° 59'1	71° 22'1	4300	25.43	35.57	43.10	53.56	62.08	71.26	81.17
Tisco	15° 21'1	71° 27'1	4198	33.41	42.74	51.24	65.12	78.15	93.95	113.15
Yanaquihua	15° 46'59.8	72° 52'57	2834	20.70	35.78	45.76	58.38	67.74	77.03	86.29



**Figure-3.1.9.4-3 Isohyetal Map of 24-hour rainfall with return period of 50-year  
(Majes-Camana basin)**

2) 24-hour rainfall in sub-basin

Based on the 24-hour maximum rainfall and using the method of Thiessen polygons rainfalls were calculated for each sub-basin. Figure- 3.1.9.4-4 shows the Thiessen polygons and distribution of rainfall stations.



**Figure- 3.1.9.4-4 Thiessen polygons and distribution of rainfall stations**

It is usually required to determine for each sub-basin the probabilistic rainfall using the maximum values of precipitation for each year calculated from the average precipitation. However, since the rainfall information is incomplete, it is difficult to calculate average rainfall, this is the reason why there was no choice but to use probabilistic rainfall average of each sub-basin calculated from probabilistic rainfall information from each of the rainfall stations. The results of this calculation are presented in the Table -3.1.9.4-2. Same methodology is used for other basins.

**Table -3.1.9.4-2 Probabilistic rainfall for each sub-basin (Majes-Camaná)**

Sub-Basin	Average Areal Rainfall (mm.)				
	T5	T10	T25	T50	T100
W2830	29.60	36.80	48.68	59.96	73.45
W3050	38.20	46.10	55.14	62.47	70.23
W3490	29.25	34.14	40.63	45.15	50.03
W4590	23.05	27.70	33.23	36.98	40.77

### 3) Selection of type of 24-hour rainfall curve

There is not hourly rainfall observation data but 24-hour rainfall observation data (daily rainfall data) so that the hourly data cannot but being estimated by 24-hour rainfall data.

SCS (Soil Conservation Service) hypothetical storm which is generally used in HEC-HMS is used for 24-hour rainfall curve.

This method is developed through the analysis of rainfall data in USA, which is expressed 4 types of rainfall curve with non-dimension as shown in the Table-3.1.9.4-3 and the Figure-3.1.9.4-5. The distribution of rainfall is as shown in the Figure-3.1.9.4-6 assuming time interval. And the applied area of 4 types in USA is as shown in the Figure-3.1.9.4-7, according to which the type II is

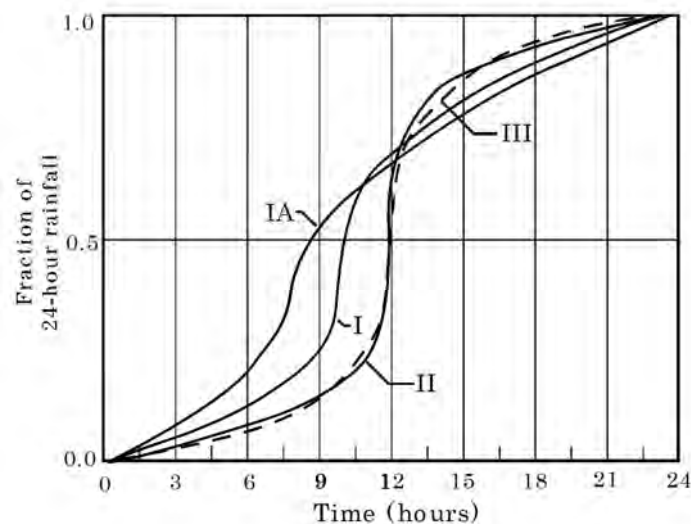
recommended to be applied to major part of USA. In addition to this it is said that 24-hour rainfall can be applicable for most of basins.

Since there is no hourly rainfall data in the study area, it is difficult to judge the type of rainfall, however the type is determined actually based on a few study examples in Peru.

As to Majes-Camana watershed the type IA (modified type I) was applied based on the hourly rain fall pattern obtained from Chivay station

**Table-3.1.9.4-3 Accumulated Curve of 24-hour Rainfall in SCS Hypothetical Storm**

Time (hr)	t/24	24 hr precipitation temporal distribution			
		Type I	Type IA	Type II	Type III
0.00	0.000	0.000	0.000	0.000	0.000
2.00	0.083	0.035	0.050	0.022	0.020
4.00	0.167	0.076	0.116	0.048	0.043
6.00	0.250	0.125	0.206	0.080	0.072
7.00	0.292	0.156	0.268	0.098	0.089
8.00	0.333	0.194	0.425	0.120	0.115
8.50	0.354	0.219	0.480	0.133	0.130
9.00	0.375	0.254	0.520	0.147	0.148
9.50	0.396	0.303	0.550	0.163	0.167
9.75	0.406	0.362	0.564	0.172	0.178
10.00	0.417	0.515	0.577	0.181	0.189
10.50	0.438	0.583	0.601	0.204	0.216
11.00	0.458	0.624	0.624	0.235	0.250
11.50	0.479	0.654	0.645	0.283	0.298
11.75	0.490	0.669	0.655	0.357	0.339
12.00	0.500	0.682	0.664	0.663	0.500
12.50	0.521	0.706	0.683	0.735	0.702
13.00	0.542	0.727	0.701	0.772	0.751
13.50	0.563	0.748	0.719	0.799	0.785
14.00	0.583	0.767	0.736	0.820	0.811
16.00	0.667	0.830	0.800	0.880	0.886
20.00	0.833	0.926	0.906	0.952	0.957
24.00	1.000	1.000	1.000	1.000	1.000



Source :Urban water hydrology for small watersheds(TR-55) Appendix B

**Figure-3.1.9.4-5 Distribution of 24hour rainfall in each type**

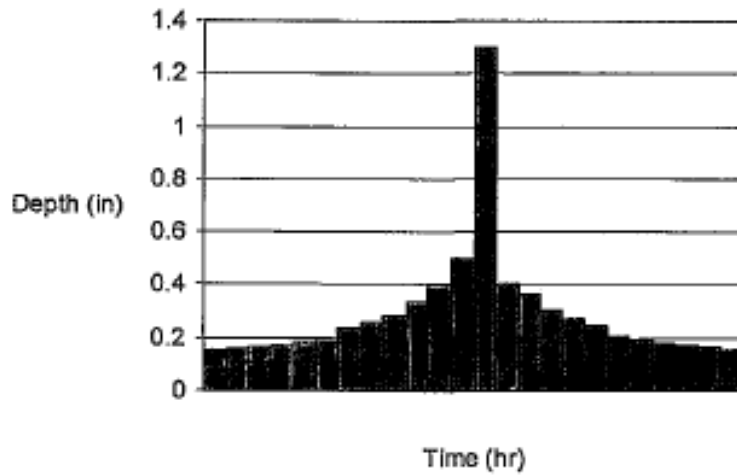
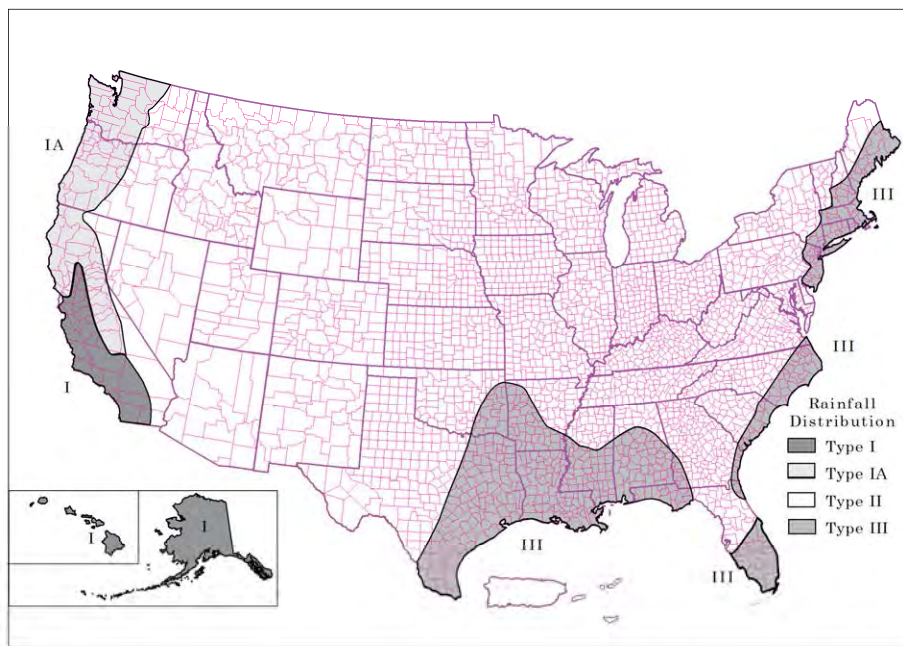


Figure-3.1.9.4-6 Division of 24-hour rainfall



Source :Urban water hydrology for small watersheds(TR-55) Appendix B

**Figure-3.1.9.4-7 Type of 24-hour rainfall and applied area**

**(4) Excess rainfall by SSC method**

1) Basic formula

SSC Curve Number (CN) Loss Model is to estimate the excess rainfall based on the function of accumulated rainfall, soil conditions, land use, initial rainfall loss etc. in the following formula.

$$P_e = \frac{(P - I_a)^2}{P - I_a + S}$$

where;  $P_e$  :Excess rainfall at time  $t$  ;  $P$  : Accumulated rainfall at time  $t$  ;  $I_a$  :Initial loss ;  $S$  : Possible storage volume

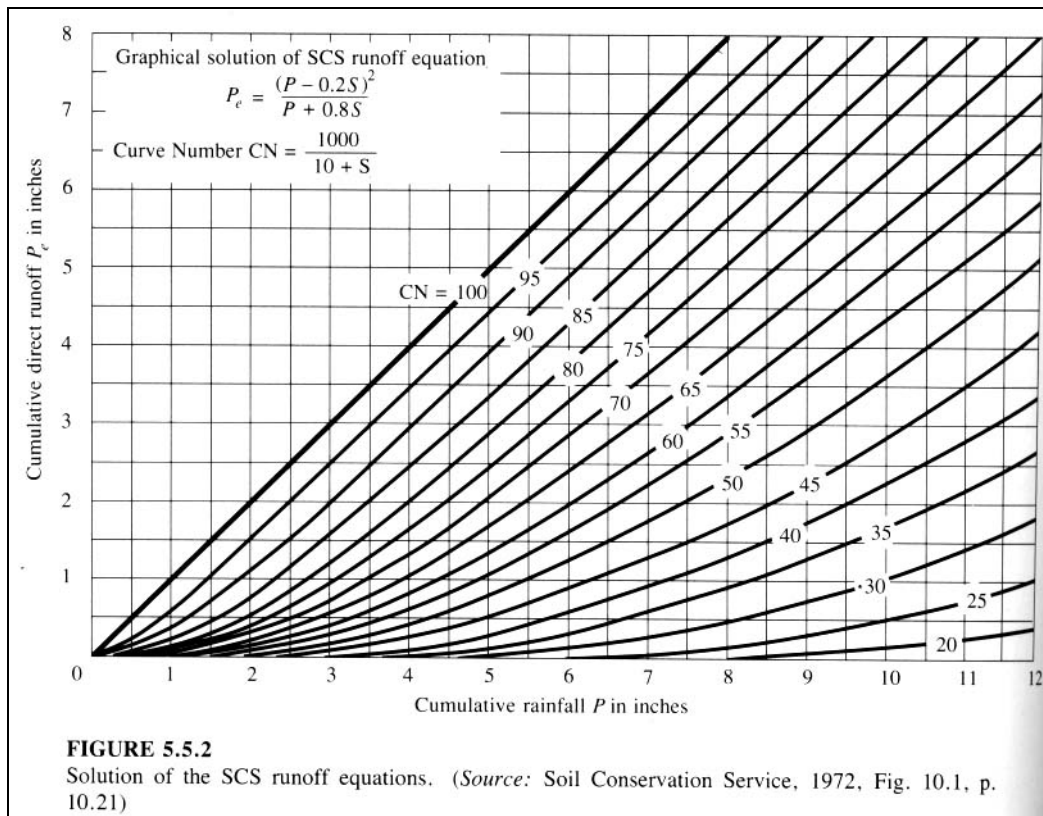
Assuming  $I_a = 0.2 S$

$$P_e = \frac{(P_e - 0.2S)^2}{P + 0.8S}$$

Relation  $S$  and  $CN$  representing basin characteristics is as shown below.

$$S = \frac{1000}{CN} - 10$$

Assuming  $CN$ , the relation  $P_e$  and  $P$  is calculated as shown the Figure-3.1.9.4-8.



**Figure-3.1.9.4-8 Relation among CN, P and  $P_e$**

## 2) Selection of CN in sub-basin

Referring to the Table-3.1.9.4-5 and based on the land use and soil conditions, CN of each sub-division is determined. The initial value of CN in Majes-Camana basin is determined as shown in the Figure-3.1.9.4-9.



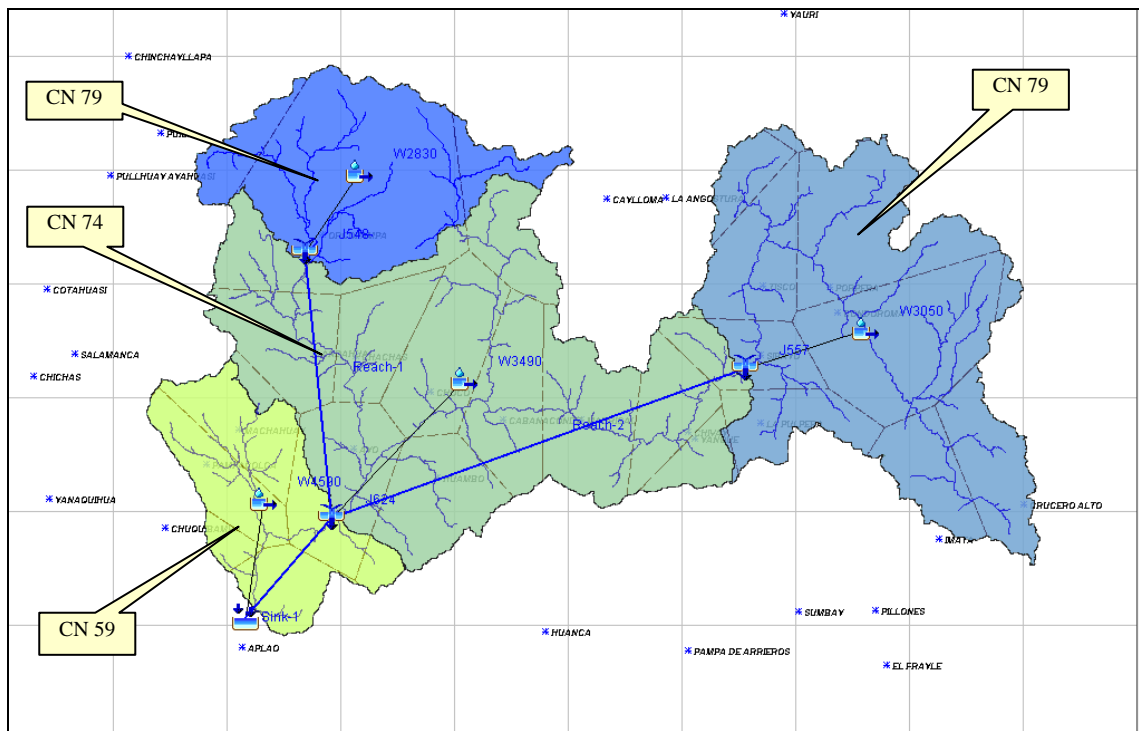


Figure-3.1.9.4-9 Selected CN value in Majes-Camana basin

Table-3.1.9.4-4 Selected CN value

Sub Basin	Condition	CN
Upper Basin – Colca(W3050)	Barren area with scarce vegetation.	79
Middle Basin – Colca(W3490)	Pastures, shrub, small trees.	74
Upper Basin – Andahua(W2830)	Barren area with scarce vegetation.	79
Lower Basin – Majes(W4590)	Desert, hyper arid area	59

**Table-3.1.9.4-5(1) CN value depending on land use and soil conditions (1/3)**

Land Use Description		Hydrologic Soil Group			
		A	B	C	D
Cultivated land <sup>1</sup> : without conservation treatment		72	81	88	91
with conservation treatment		62	71	78	81
Pasture or range land: poor condition		68	79	86	89
good condition		39	61	74	80
Meadow: good condition		30	58	71	78
Wood or forest land: thin stand, poor cover, no mulch		45	66	77	83
good cover <sup>2</sup>		25	55	70	77
Open Spaces, lawns, parks, golf courses, cemeteries, etc.					
good condition: grass cover on 75% or more of the area		39	61	74	80
fair condition: grass cover on 50% to 75% of the area		49	69	79	84
Commercial and business areas (85% impervious)		89	92	94	95
Industrial districts (72% impervious)		81	88	91	93
Residential <sup>3</sup> :					
Average lot size	Average % impervious <sup>4</sup>				
1/8 acre or less	65	77	85	90	92
1/4 acre	38	61	75	83	87
1/3 acre	30	57	72	81	86
1/2 acre	25	54	70	80	85
1 acre	20	51	68	79	84
Paved parking lots, roofs, driveways, etc. <sup>5</sup>		98	98	98	98
Streets and roads:					
paved with curbs and storm sewers <sup>5</sup>		98	98	98	98
gravel		76	85	89	91
dirt		72	82	87	89

<sup>1</sup>For a more detailed description of agricultural land use curve numbers, refer to Soil Conservation Service, 1972, Chap. 9

<sup>2</sup>Good cover is protected from grazing and litter and brush cover soil.

<sup>3</sup>Curve numbers are computed assuming the runoff from the house and driveway is directed towards the street with a minimum of roof water directed to lawns where additional infiltration could occur.

<sup>4</sup>The remaining pervious areas (lawn) are considered to be in good pasture condition for these curve numbers.

<sup>5</sup>In some warmer climates of the country a curve number of 95 may be used.

**Table3.1.9.4-5(2) CN Value depending on land use and soil conditions (2/3)**

TABLE 5.5.1 SCS Runoff Curve Numbers (Continued)					
c. Other agricultural areas					
Cover description		Curve numbers for hydrologic soil group			
Cover type	Hydrologic condition	A	B	C	D
Pasture, grassland, or range—continuous forage for grazing*	Poor	68	79	86	89
	Fair	49	69	79	84
	Good	39	61	74	80
Meadow—continuous grass, protected from grazing and generally mowed for hay	—	30	58	71	78
Brush—brush-weed-grass mixture with brush the major element†	Poor	48	67	77	83
	Fair	35	56	70	77
	Good	30	48	65	73
Woods-grass combination (orchard or tree farm)‡	Poor	57	73	82	86
	Fair	43	65	76	82
	Good	32	58	72	79
Woods§	Poor	45	66	77	83
	Fair	36	60	73	79
	Good	30	55	70	77
Farmsteads—buildings, lanes, driveways, and surrounding lots	—	59	74	82	86
<p>* Poor: &lt; 50% ground cover or heavily grazed with no mulch.            Fair: 50 to 75% ground cover and not heavily grazed.            Good: &gt; 75% ground cover and lightly or only occasionally grazed.            † Poor: &lt; 50% ground cover.            Fair: 50 to 75% ground cover.            Good: &gt; 75% ground cover.            ‡ CNs shown were computed for areas with 50% woods and 50% grass (pasture) cover. Other combinations of conditions may be computed from the CNs for woods and pasture.            § Poor: Forest litter, small trees, and brush are destroyed by heavy grazing or regular burning.            Fair: Woods are grazed but not burned, and some forest litter covers the soil.            Good: Woods are protected from grazing, and litter and brush adequately cover the soil.            Source: Ref. 105.</p>					
d. Arid and semiarid range areas					
Cover description		Curve numbers for hydrologic soil group			
Cover type	Hydrologic condition*	A†	B	C	D
Herbaceous—mixture of grass, weeds, and low-growing brush, with brush the minor element	Poor		80	87	93
	Fair		71	81	89
	Good		62	74	85
Oak-aspen—mountain brush mixture of oak brush, aspen, mountain mahogany, bitter brush, maple, and other brush	Poor		66	74	79
	Fair		48	57	63
	Good		30	41	48
Piñon-juniper—piñon, juniper, or both: grass understory	Poor		75	85	89
	Fair		58	73	80
	Good		41	61	71
Sagebrush with grass understory	Poor		67	80	85
	Fair		51	63	70
	Good		35	47	55

**Table-3.1,9.4-5(3) CN Value depending on land use and soil conditions (3/3)**

TABLE 5.5.1 SCS Runoff Curve Numbers (Continued)					
d. Arid and semiarid range areas					
Cover description		Curve numbers for hydrologic soil group			
Cover type	Hydrologic condition*	A†	B	C	D
Desert shrub—major plants include saltbush, greasewood, creosotebush, blackbrush, bursage, palo verde, mesquite, and cactus	Poor	63	77	85	88
	Fair	55	72	81	86
	Good	49	68	79	84

\* Poor: <30% ground cover (litter, grass, and brush overstory).  
Fair: 30 to 70% ground cover.  
Good: >70% ground cover.  
† Curve numbers for group A have been developed only for desert shrub.  
Source: Ref. 105.

Source: Maidment (1993).

Note: Hydrological Soil Group

**Group A**soils have low runoff potential and high infiltration rates even when thoroughly wetted. They consist chiefly of deep, well to excessively drained sand or gravel and have a high rate of water transmission (greater than 0.30 in/hr).

**Group B**soils have moderate infiltration rates when thoroughly wetted and consist chiefly of moderately deep to deep, moderately well to well drained soils with moderately fine to moderately coarse textures. These soils have a moderate rate of water transmission (0.15-0.30 in/hr).

**Group C**soils have low infiltration rates when thoroughly wetted and consist chiefly of soils with a layer that impedes downward movement of water and soils with moderately fine to fine texture. These soils have a low rate of water transmission (0.05-0.15 in/hr).

**Group D**soils have high runoff potential. They have very low infiltration rates when thoroughly wetted and consist chiefly of clay soils with a high swelling potential, soils with a permanent high water table, soils with a claypan or clay layer at or near the surface, and shallow soils over nearly impervious material. These soils have a very low rate of water transmission (0-0.05 in/hr).

### (5) Probable flood discharge and hydrograph

The probable flood discharge and hydrograph are calculated by HEC-HM. The beginning of rainfall and flood hydrograph is assumed to be same hour. The kinematic wave method is applied for the flood routing of river channel.

The calculation results are as shown in the Table-3.1.9.4-6 ~ Table-3.1.9.4-8, and the Figure-3.1.9.4-10,

and which are to be used for discharge capacity analysis of river channel, inundation analysis and flood protection planning.

**Table-3.1.9.4-6 Probable flood discharge**

(m<sup>3</sup>/s)

River/Reference Point	Return Period of 2-year	Return Period of 5-year	Return Period of 10-year	Return Period of 25-year	Return Period of 50-year	Return Period of 100-year
Majes-Camana/Huatiapa	360	638	1,007	1,566	2,084	2,703

**Table-3.1.9.4-7 Probable specific flood discharge**

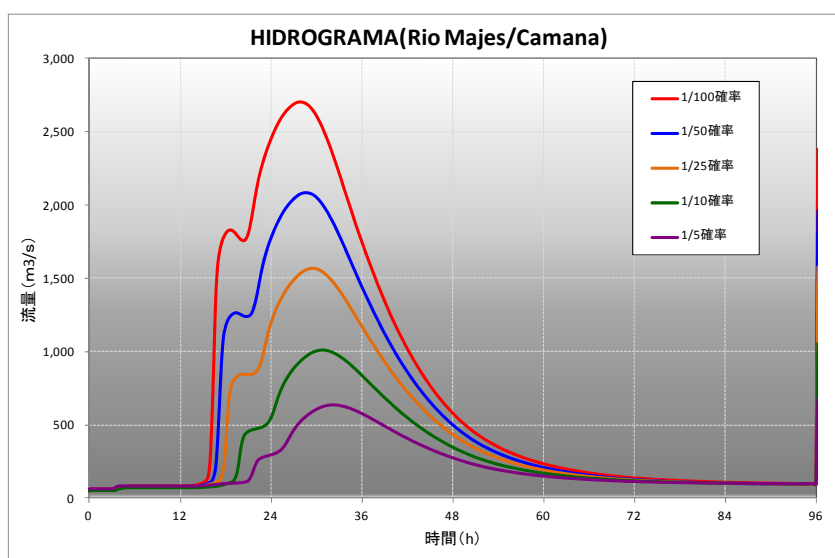
(m<sup>3</sup>/s/km<sup>2</sup>)

River/Reference Point	Return Period of 2-year	Return Period of 5-year	Return Period of 10-year	Return Period of 25-year	Return Period of 50-year	Return Period of 100-year	Basin Area Km2
Majes-Camana/Huatiapa	0.024	0.050	0.078	0.122	0.162	0.210	12,854

**Table 3.1.9.4-8 Past maximum discharge and flood discharge of 50-year probability**

(m<sup>3</sup>/s)

Basin/Base point	Historical Maximum Discharge	Measurement Period	Calculated Peak Discharge (t=1/50)
Majes-Camáná Huatiapa	2,400	41	2,084

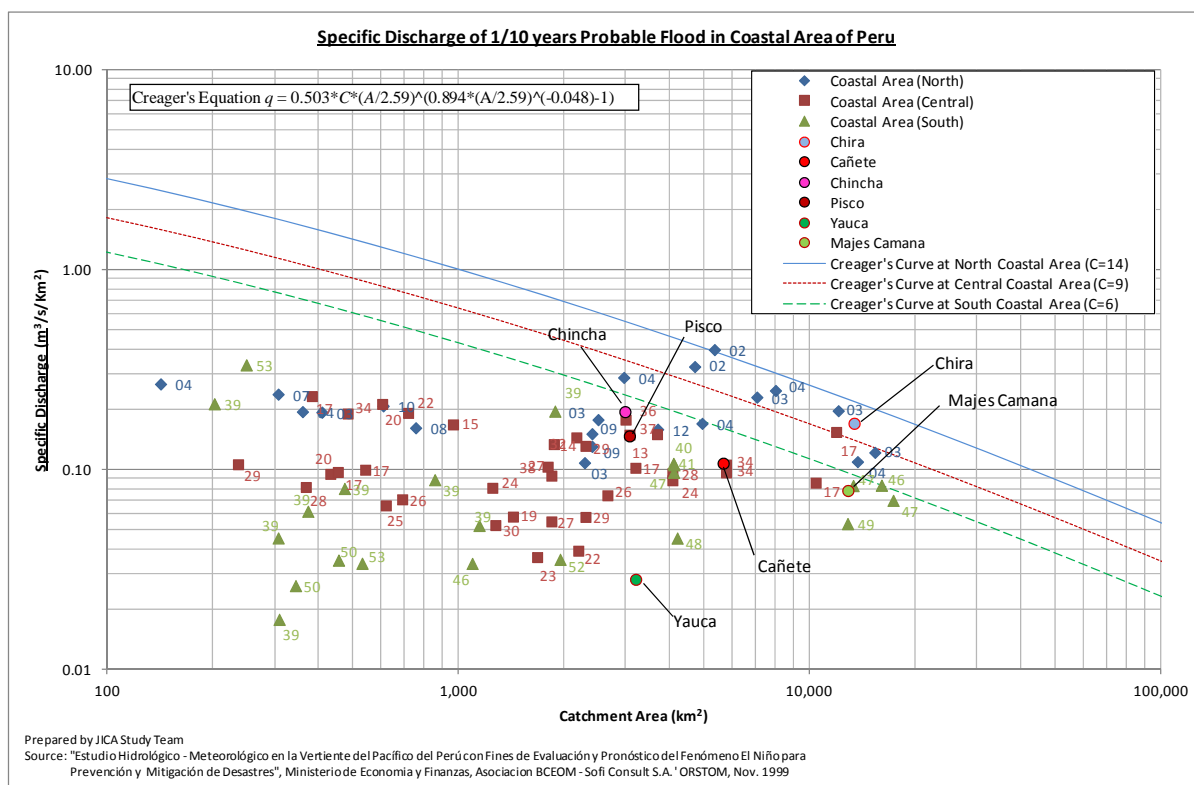


**Figure-3.1.9.4-10 Flood hydrograph in Majes-Camana basin**

### 3.1.9.5 Consideration on results of analysis

In Figure-3.1.9.5-1 to 3.1.9.5-4 is plotted the specific probabilistic return flow and the results of discharges analyzes conducted for each river in coastal area of Peru. (Source: "Estudio Hidrológico - Meteorológico en la Vertiente del Pacífico del Perú con Fines de Evaluación y Pronóstico del Fenómeno El Niño para Prevención y Mitigación de Desastres", Ministerio de Economía y Finanzas, Asociación BCEOM - Sofi Consult S.A. ORSTOM, Nov. 1999.)

Comparing the Creager envelopes curves and the calculated specific flows for each of the basins we can conclude that calculated probabilistic discharges are within the acceptable range.



**Figure 3.1.9.5-1 Probabilistic specific discharges and calculated peak discharges (t=1/10)**

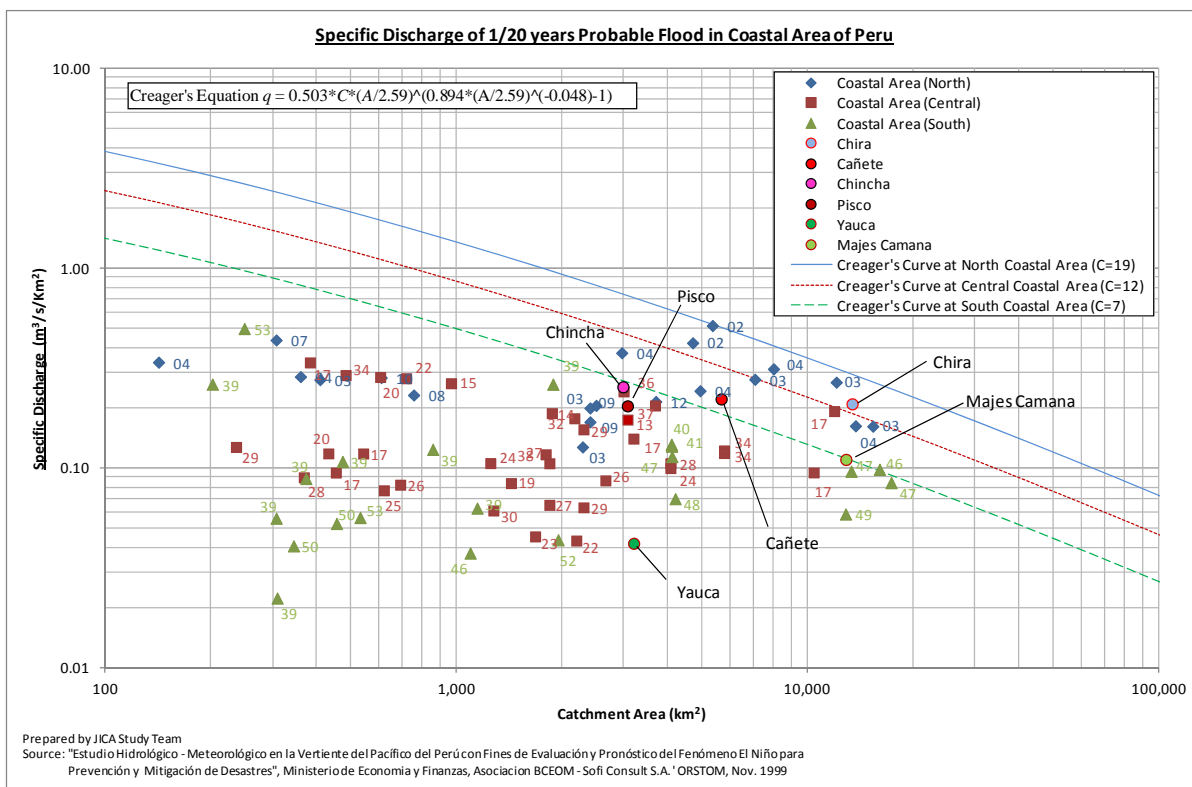


Figure 3.1.9.5-2 Probabilistic specific discharges and calculated peak discharges (t=1/20)

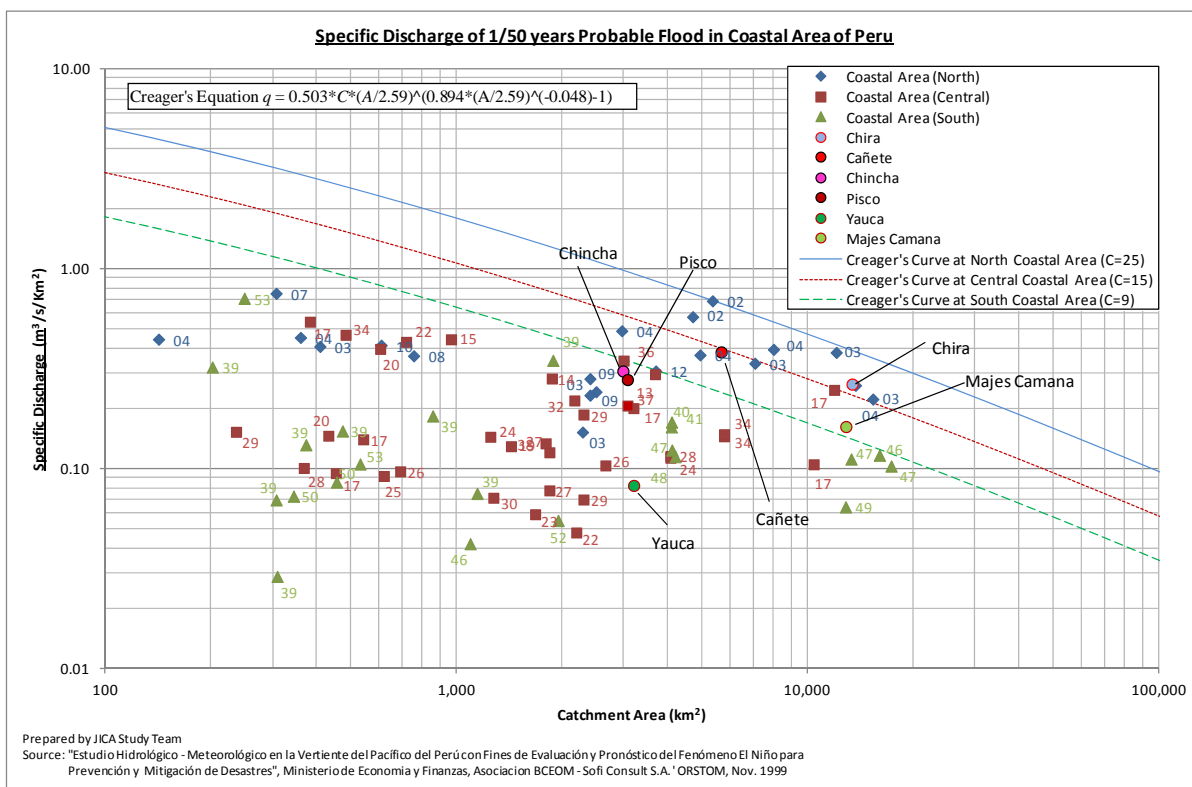
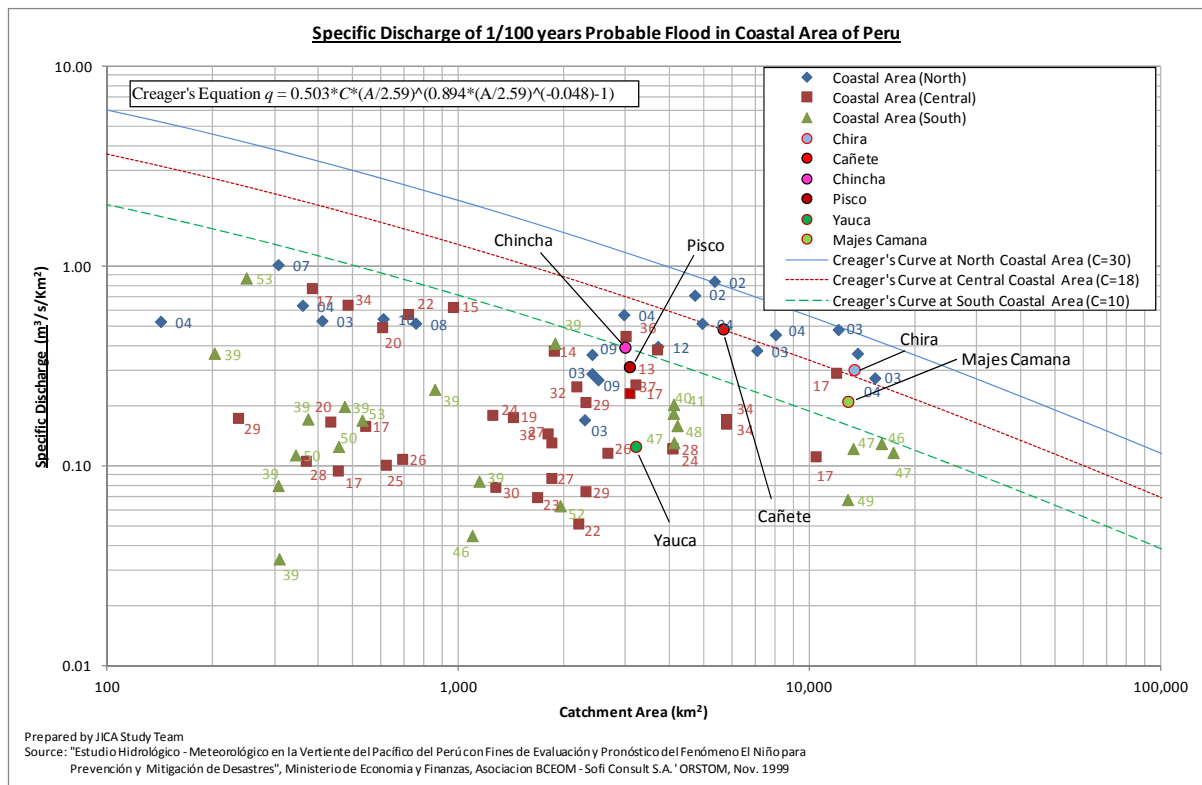


Figure 3.1.9.5-3 Probabilistic specific discharges and calculated peak discharges (t=1/50)



**Figure 3.1.9.5-4 Probabilistic specific discharges and calculated peak discharges (t=1/100)**

### 3.1.10 Analysis of Inundation

#### (1) River surveys

Prior to the flood analysis, the transversal survey of Majes-Camana river was performed as well as the longitudinal survey of dikes. Table 3.1.10-1 shows the results of the surveys in the five rivers subject of this Study.

In order to obtain the topographic data for the analysis of the flooding zones, the results of the true measurement results indicated in Table 3.1.10-1 were used as a complement, using the satellite figures data.



**Table 3.1.10-1 Basic data of the river surveys**

Survey	Unit	Quantity	Notes
1. Control points survey			
Majes-Camana river	No.	13	
2. Dikes transversal survey			250m Interval, only one shore
Majes-Camana river	km	143	
3. River transversal survey			500m Interval
Majes-Camana river	km	86	
4. Benchmarks			
Type A	No.	13	Every control point
Type B	No.	130	130km x one point/km

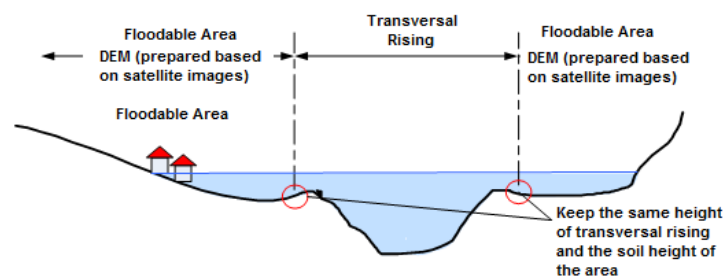
## (2) Inundation analysis methods

Since the DGIH carried out the flood analysis of the profile study at a program level using the HEC-RAS model, for this Study, we decided to use this method, and review and modify it, if necessary.

### 1) Analysis basis

Normally, for the flooding analysis the following three methods are used.

- ① Varied flow unidimensional model
- ② Tank model
- ③ Varied flow horizontal bidimensional model




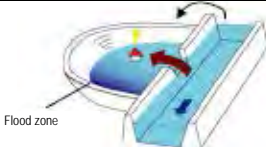
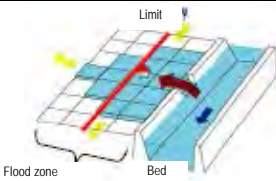
**Figure 3.1.10-1 Idea of unidimensional model**

The time and cost required by each method vary considerably, so only the most efficient method will be chosen, which guarantees the necessary accurateness degree for the preparation of the floodable zone maps.

Table 3.1.10-2 shows the characteristics of each analysis method. From the results of the simulation performed by DGIH, it is known that the rivers have a slope between 1/100 and 1/300, so initially the varied flow one-dimensional model was chosen assuming that the floods were serious. However,

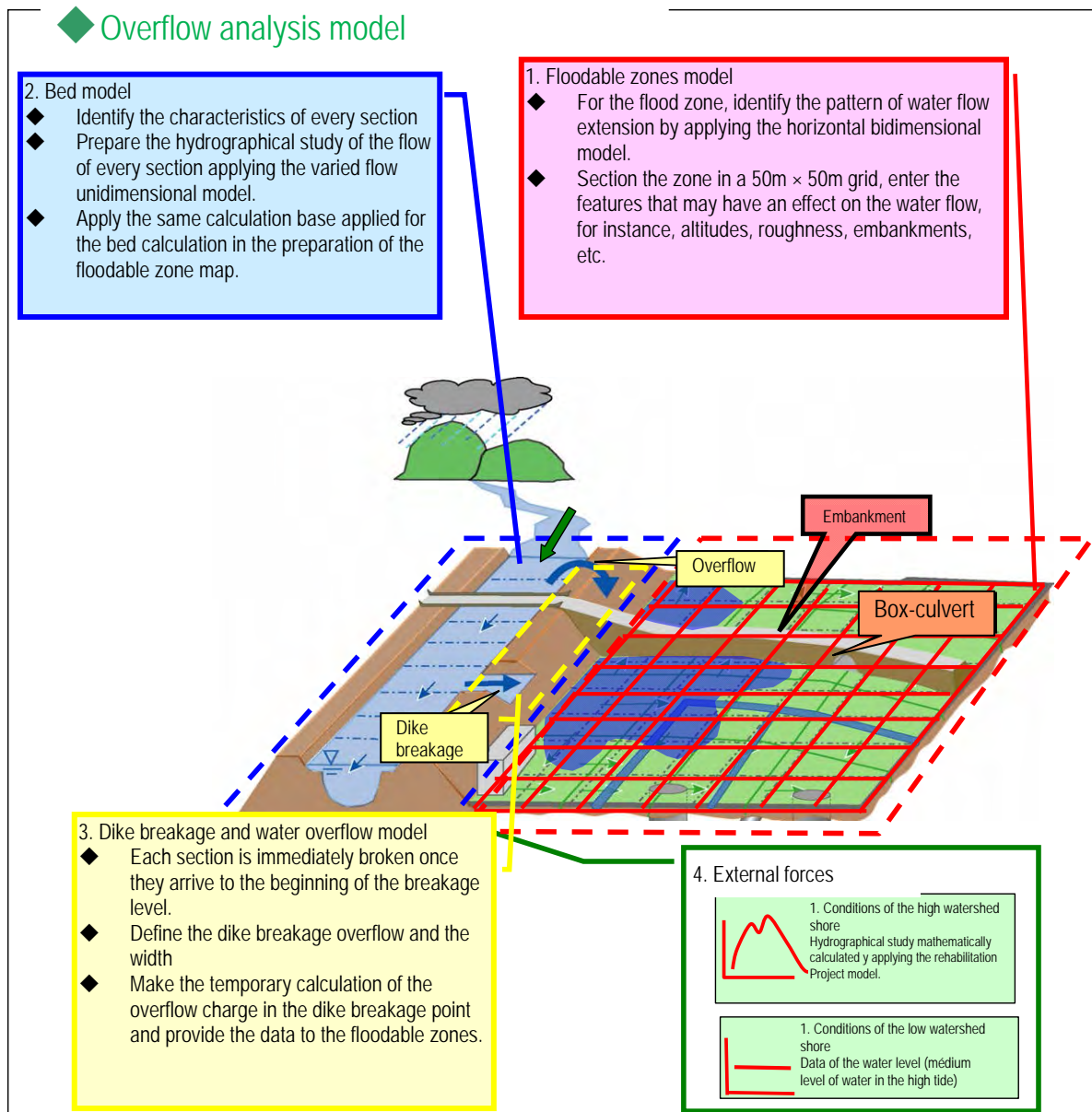
we considered the possibility that the overflowed water extends within the watershed in the lower watershed, so for this study the variable regimen horizontal bi-dimensional model was used to obtain more accurate results

**Table 3.1.10-2 Methodology of inundation analysis**

Analysis methods	Vary flow unidimensional model	Tank model	Varied flow bi-dimensional horizontal model
Basic concept of the flood zone definition	In this method, the flood zone is considered to be included in the river bed, and the flood zone is determined by calculating the water level of the bed in relation to the maximum flooding flow	This method manages the flood zone and bed separately, and considers the flooding zone as a closed body. This closed water body is called <i>pond</i> where the water level is uniform. The flood zone is determined in relation to the relationship between the overflowed water from the river and entered to the flood zone, and the topographic characteristics of such zone (water level– capacity– surface).	This method manages the flood zones and the bed separately, and the flood zone is determined by analyzing the bidimensional flow of the behaviour of water entered to the flood zone.
Approach			
Characteristics	It is applicable to the floods where the overflowed water runs by the flood zone by gravity; that means, current type floods. This method must manage the analysis area as a protected area (without dikes).	Applicable to blocked type floods where the overflowed water does not extend due to the presence of mountains, hills, embankments, etc. The water level within this closed body is uniform, without flow slope or speed. In case there are several embankments within the same flood zone, it may be necessary to apply the pond model in series distinguishing the internal region.	Basically, it is applicable to any kind of flood. Beside the flood maximum area and the water level, this method allows reproducing the flow speed and its temporary variation. It is considered as an accurate method compared with other methods, and as such, it is frequently applied in the preparation of flood irrigation maps. However, due to its nature, the analysis precision is subject to the size of the analysis model grids.

## 2) Overflow analysis method

Figure 3.1.10-2 shows the conceptual scheme of the variable regimen horizontal bi-dimensional model.



**Figure 3.1.10-2 Conceptual scheme of the overflow analysis model**

**(3) Discharge flow analysis**

The current discharge capacity of the beds was estimated based on the results of the river survey and applying the HEC-RAS method, which results appear in Figure 3.1.10-3 and 3.1.10-4. These Figures also show the flooding flows of different return periods, which allow evaluating in what points of the Majes-Camana river watershed flood may happen and what magnitude of flood flow may they have.

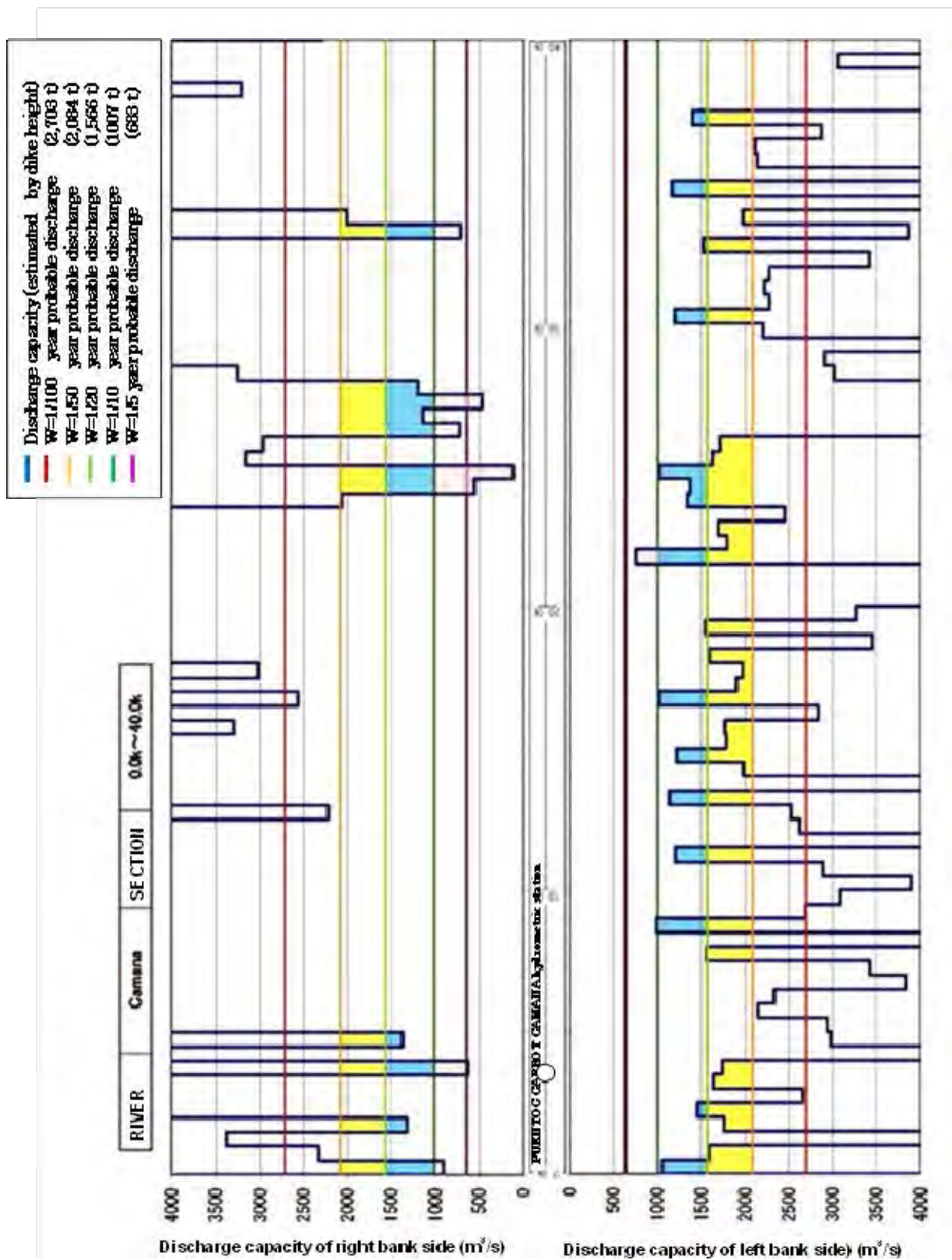


Figure 3.1.10-3 Current discharge capacity of Camana river

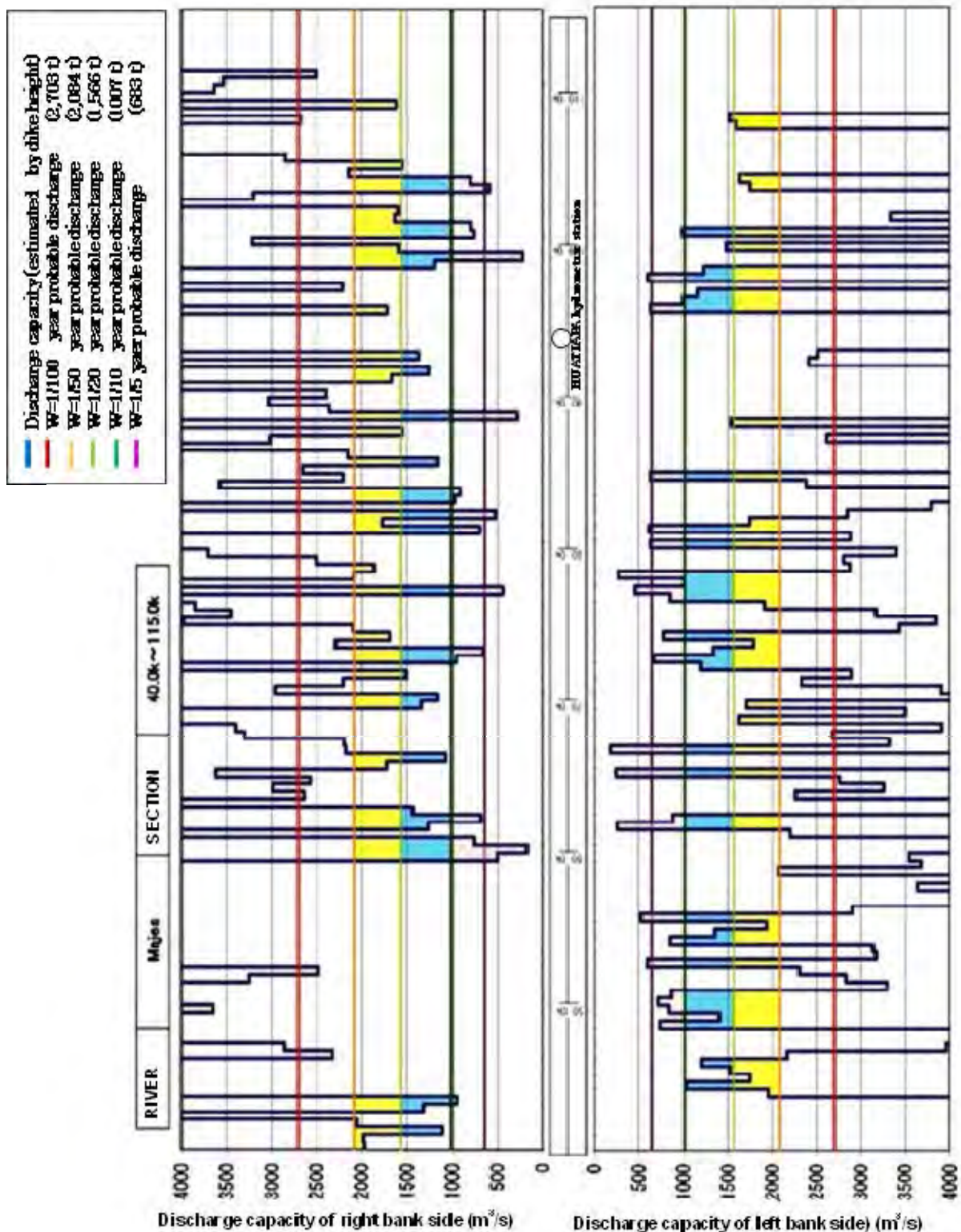


Figure 3.1.10-4 Current discharge capacity of Majes river

#### (4) Inundation area

As a reference, Figures 3.1.10-5 and Figure 3.1.10-6 show the results of the inundation area calculation in the Majes-Camana river watershed in the flooding flow with a 50 year return period.



Figure 3.1.10-5 Inundation area of Majes-Camana river - (50 year period floods)

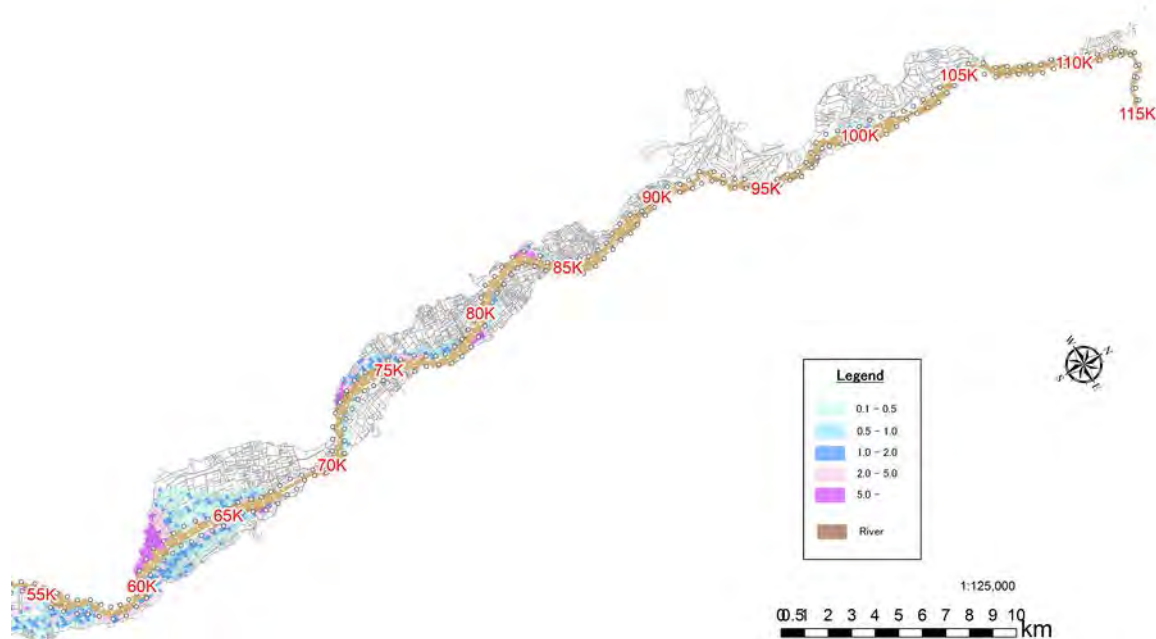


Figure 3.1.10-6 Inundation area of Majes-Camana river - (50 year period floods)

### 3.2 Definition of Problem and Causes

#### 3.2.1 Problems of Flood Control Measures in the Study Area

Based on the results of the Majes-Camana River, the main problem on flood control was identified, as well as the structures to be protected, which results are summarized in Table 3.2.1-1.

**Table 3.2.1-1 Problems and conservation measures of flood control works**

Problems		Overflowing			Dike erosion	Margins erosion	Non-working intake	Non-working derivation works
		Without dikes	Sediment in bed	Lack of width				
Structures to be protected	Agricultural lands	○	○	○	○	○	○	○
	Irrigation channels					○	○	
	Urban area	○		○				○
	Roads					○		
	Bridges		○					

#### 3.2.2 Problem Causes

Next, the main problem and its direct and indirect causes for flood control in the Study Area are described:

##### (1) Main problem

Valleys and local communities highly vulnerable to floods

##### (2) Direct and indirect causes

Table 3.2.1-2 shows the direct and indirect causes of the main problem

**Table 3.2.1-2 direct and indirect causes of the main problem**

Direct cause	1. Excessive flood flow	2. Overflowing	3. Insufficient maintenance of control works	4. Insufficient communitarian activities for flood control
Indirect causes	1.1 Frequent occurrence of extraordinary weather (El Niño, etc..)	2. Lack of flood control works	3.1 Lack of maintenance knowledge and skills	4.1 Lack of knowledge and flood prevention techniques
	1.2 Extraordinary rains in the middle and upper basins	2.2 Lack of resources for the construction of works	3.2 Lack of training in maintenance	4.2 Lack of training in flood prevention
	1.3 Vegetation cover almost zero in the middle and upper basins	2.3 Lack of plans for flood control in basins	3.3 Lack of dikes and margins repair	4.3 Lack of early warning system
	1.4 Excessive sediment dragging from the upper and middle river levee	2.4 Lack of dikes	3.4 Lack of repair works and referral making	4.4 Lack of monitoring and collection of hydrological data
	1.5 Reduction of hydraulic capacity of	2.5 Lack of bed channel width	3.5 Use of illegal bed for agricultural	

rivers by altering slopes, etc.		purposes	
	2.6 Accumulation of sediments in beds	3.6 Lack of maintenance budget	
	2.7 Lack of width at the point of the bridge construction		
	2.8 Elevation of the bed at the point of the bridge construction		
	2.9 Erosion of dikes and margins		
	2.10 Lack of capacity for the design of the works		

### 3.2.3 Problem Effects

#### (1) Main problem

Valleys and local communities highly vulnerable to floods

#### (2) Direct and indirect effects

Table 3.2.3-1 shows the direct and indirect effects of the main problem

**Table 3.2.3-1 Direct and indirect effects of the main problem**

Direct Effects	1. Agriculture Damages	2. Direct damages to the community	3. Social infrastructure damages	4. Other economical damages
Indirect Effects	1.1 Agriculture and livestock damage	2.1 Private property and housing loss	3.1 Roads destruction	4.1 Traffic interruption
	1.2 Agricultural lands loss	2.2 Industries and facilities loss	3.2 Bridges loss	4.2 Flood and evacuations prevention costs
	1.3 Irrigation channels destruction	2.3 Human life loss and accidents	3.3 Running water, electricity, gas and communication infrastructures' damages	4.3 Reconstruction costs and emergency measures
	1.4 Work destruction and derivation	2.4 Commercial loss		4.4 Work loss by local inhabitants
	1.5 Dikes and margins erosion			4.5 Communities income reduction
				4.6 Life quality degradation
				4.7 Loss of economical dynamism

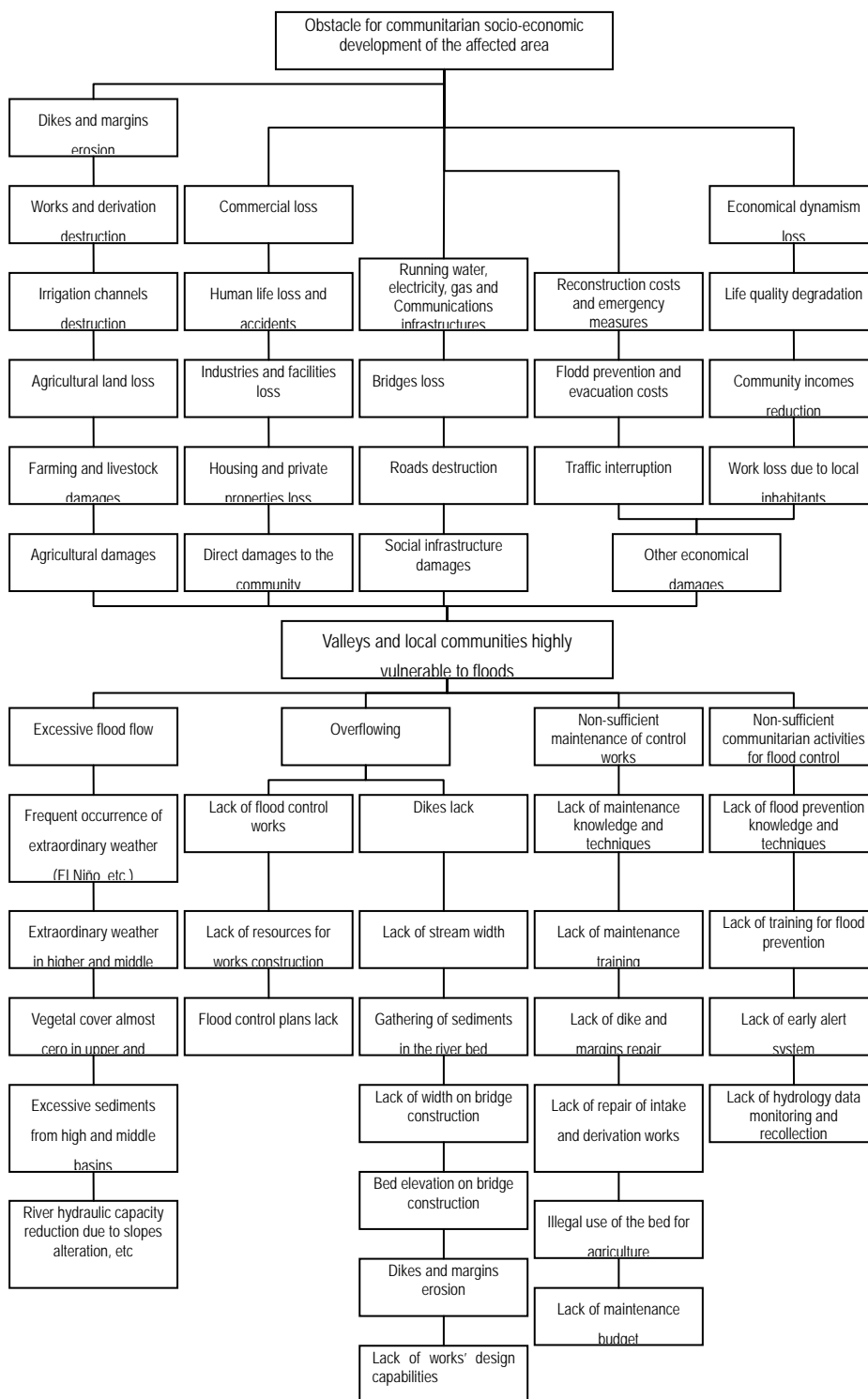
#### (3) Final effect

The main problem final effect is the community socio-economic impediment development of the affected area.

### 3.2.4 Causes and Effects Diagram

Figure 3.2.4-1 shows the causes and effects diagram done based on the above analysis results.





**Figure 3.2.4-1 Causes and effects diagram**

### 3.3 Objective of the Project

The final impact that the Project wants to achieve is to alleviate the vulnerability of valleys and local community to flooding and promote local economic development.

#### 3.3.1 Solving Measures for the Main Problem

##### (1) Main objective

Soothe the valleys and local community to flooding vulnerability.

##### (2) Direct and indirect measures

In table 3.3.1-1, direct and indirect solutions measures for the problem are shown.

**Table 3.3.1-1 Direct and indirect solution measures to the problem**

Direct measures	1. Analyze and relieve excessive flood flow	2. Prevent overflow	3. Full compliance with maintenance of flood control works	4. Encourage community flood prevention
Indirect measures	1.1 Analyze extraordinary weather (El Niño, etc..)	2.1 Construct flood control works	3.1 Strengthen maintenance knowledge and skills	4.1 Strengthen knowledge and skills to prevent flooding
	1.2 Analyze extraordinary rainfall in the upper and middle basins	2.2 Provide resources for the works construction	3.2 Reinforce training maintenance	4.2 Running flood prevention training
	1.3 Planting vegetation on the upper and middle basins	2.3 Develop plans for flood control basins	3.3 Maintain and repair dikes and margins	4.3 Creating early warning system
	1.4 Relieve Excessive sediment entrainment from the upper and middle river dikes	2.4 Build dikes	3.4 Repair intake and derivation works	4.4 Strengthen monitoring and water data collection
	1.5 Take steps to alleviate the reduction in hydraulic capacity of rivers by altering slopes, etc.	2.5 Extends the width of the channel	3.5 Control the illegal use of bed for agricultural purposes	
		2.6 Excavation of bed	3.6 Increase the maintenance budget	
		2.7 Extending the river at the bridge's construction		
		2.8 Dredging at the point of the bridge construction		
		2.9 Control dikes and margins erosion		
		2.10 Strengthen the capacity for works design		

#### 3.3.2 Expected impacts for the main's objective fulfillment

##### (1) Final impact

The final impact that the Project wants to achieve is to alleviate the vulnerability of the valleys and the local community to floods and promoting local socio-economic development.

**(2) Direct and indirect impacts**

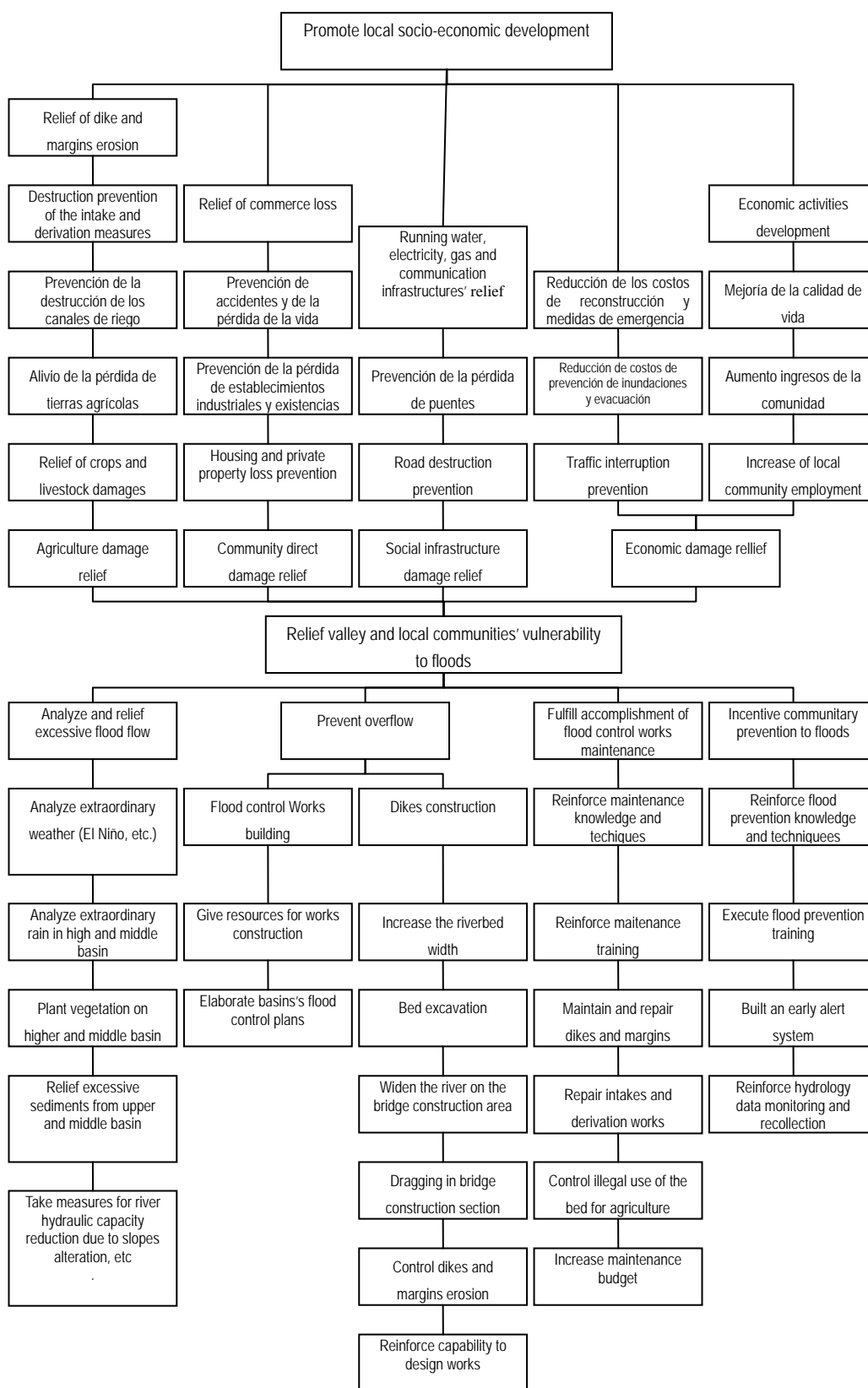
In table 3.3.2-1 direct and indirect impacts expected to fulfill the main objective to achieve the final impact are shown.

**Table 3.3.2-1 direct and indirect impacts**

Direct Impacts	1. Agricultural damage relief	2. Relief of direct harm to the community	3. Relief of social infrastructure damage	4. Relief of other economic damage
Indirect Impacts	1.1 Relief to crops and livestock damage	2.1 Housing and private properties loss prevention	3.1 Road destruction prevention	4.1 Traffic interruption prevention
	1.2 Relief for farmland loss	2.2 Prevention of Industries and facilities establishments	3.2 Prevention of bridges loss	4.2 Reducing costs of flood prevention and evacuation
	1.3 Prevention of the destruction of irrigation channels	2.3 Prevention of accidents and human life loss	3.3 Running water, electricity, gas and communication infrastructures' relief	4.3 Cost reduction of the reconstruction and emergency measures
	1.4 Prevention of destruction works of intake and derivation	2.4 Commercial loss relief		4.4 Increase of local community hiring
	1.5 Dikes and margins erosion relief			4.5 Community income increase
				4.6 Life quality improvement
				4.7 Economic activities development

**3.3.3 Measures - Objectives - Impacts Diagram**

In Figure 3.3.3-1 the measures - objectives – impacts diagram is shown.



**Figure 3.3.3-1 Measures - objectives – impacts diagram**

## 4. FORMULATION AND EVALUATION

### 4.1 Definition of the Assessment Horizon of the Project

The Project's assessment horizon will be of 15 years, same as the one applied on the Program Profile Report. The Annex-10 of SNIP regulation stipulates that the assessment horizon should be basically 10 years; however the period can be changed in case that the project formulator (DGIH in this Project) admits the necessity of change. DGIH adopted 15 years in the Program Profile Report and OPI and DGPM approved it in March 19, 2010. In JICA's development study it should be generally 50 years, so the JICA Study Team inquired on the appropriate period to DGIH and OPI, they directed JICA Study Team to adopt 15 years. And the social evaluation in case of 50 years assessment horizon is described in Annex-14 Implementation Program of Japanese Yen Loan Project.

### 4.2 Supply and Demand Analysis

The theoretical water level was calculated considering flowing design flood discharge based on river cross sectional survey executed with a 500m interval, in each Watershed, considering a flood discharge with a return period of 50 years. Afterwards, the dike height was determined as the sum of the design water level plus the freeboard of dike. This is the dike height required to prevent damages caused by design floods and represents the local community demand indicator. The height of the existing dike or the height of the present ground is that required to prevent present flood damages, and represents the present supply indicator. The difference between the design dike (demand) and the height of the present dike or ground represents the difference or gap between demand and supply.

Table 4.2-1 shows the averages of flood water level calculated with a return period of 50 years in "3.1.9 Run-off Analysis"; of the required dike height (demand) to control the discharge adding the design water level plus the freeboard dike; the dike height or that of the present ground (supply), and the difference between these last two (difference between demand-supply) of the river. Then, Table 4.2-2 shows values of each point in Majes-Camana river. The dike height or that of the present ground is greater than the required dike height, at certain points. In these, the difference between supply and demand was considered null.

**Table 4.2-1 Watershed demand and supply**

Watersheds	Present Height of Embankment or Ground (supply)		Flood Water Level of 1/50 year Probability	Freeboard of Embankment	Required Height of Embankment (demand)	Supply and Demand Gap	
	Left Bank	Right Bank				Left Bank	Right Bank
	①	②				③	④
Majes-Camana	401.90	405.19	398.84	1.20	400.04	0.85	0.65

**Table 4.2-2 Demand and supply according to the calculation**

Watershed	Current Dike (Ground) Height (Supply)		Water Level with Return Period of 50 Years	Dike Freeboard	Required Dike's Height (Demand)	Difference of Demand/Supply	
	Left bank	Right bank				Left bank	Right bank
	①	②				③	④
0.0	5.26	4.99	3.90	1.20	5.10	0.00	0.11
0.5	6.25	6.05	7.36	1.20	8.56	2.31	2.51
1.0	8.01	8.70	8.46	1.20	9.66	1.65	0.97
1.5	11.64	11.22	10.92	1.20	12.12	0.48	0.90
2.0	13.01	12.62	13.33	1.20	14.53	1.51	1.91
2.5	15.09	22.64	15.70	1.20	16.90	1.81	0.00
3.0	18.47	23.25	17.98	1.20	19.18	0.71	0.00
3.5	20.47	23.68	20.97	1.20	22.17	1.70	0.00
4.0	22.57	21.29	22.83	1.20	24.03	1.46	2.74
4.5	25.45	26.89	24.71	1.20	25.91	0.45	0.00
5.0	28.79	27.41	28.10	1.20	29.30	0.51	1.89
5.5	31.35	38.06	30.82	1.20	32.02	0.67	0.00
6.0	32.90	51.69	32.84	1.20	34.04	1.14	0.00
6.5	35.90	46.14	35.64	1.20	36.84	0.94	0.00
7.0	37.81	43.39	37.32	1.20	38.52	0.71	0.00
7.5	41.14	45.63	40.25	1.20	41.45	0.31	0.00
8.0	43.87	49.52	44.43	1.20	45.63	1.76	0.00
8.5	47.06	50.55	46.19	1.20	47.39	0.33	0.00
9.0	48.70	58.23	49.45	1.20	50.65	1.95	0.00
9.5	52.00	57.35	51.48	1.20	52.68	0.68	0.00
10.0	55.01	60.22	54.46	1.20	55.66	0.65	0.00
10.5	58.19	60.00	56.69	1.20	57.89	0.00	0.00
11.0	60.14	60.96	59.58	1.20	60.78	0.64	0.00
11.5	62.71	71.89	63.85	1.20	65.05	2.34	0.00
12.0	67.26	71.79	65.72	1.20	66.92	0.00	0.00
12.5	69.14	71.54	68.94	1.20	70.14	1.00	0.00
13.0	71.82	71.53	71.42	1.20	72.62	0.80	1.09
13.5	73.31	89.35	74.67	1.20	75.87	2.56	0.00
14.0	77.69	84.03	76.15	1.20	77.35	0.00	0.00
14.5	78.61	94.88	78.74	1.20	79.94	1.33	0.00
15.0	82.06	90.00	83.01	1.20	84.21	2.15	0.00
15.5	83.91	94.56	84.19	1.20	85.39	1.48	0.00
16.0	87.18	88.81	87.54	1.20	88.74	1.56	0.00
16.5	90.33	99.09	90.08	1.20	91.28	0.95	0.00
17.0	91.77	93.73	93.18	1.20	94.38	2.61	0.65
17.5	95.34	101.83	95.42	1.20	96.62	1.28	0.00
18.0	98.31	99.56	98.40	1.20	99.60	1.29	0.04
18.5	100.52	107.63	101.12	1.20	102.32	1.80	0.00
19.0	104.47	112.23	103.61	1.20	104.81	0.34	0.00
19.5	106.02	116.45	106.79	1.20	107.99	1.97	0.00
20.0	109.64	118.45	108.53	1.20	109.73	0.09	0.00
20.5	111.77	120.01	110.73	1.20	111.93	0.16	0.00
21.0	116.33	116.11	113.94	1.20	115.14	0.00	0.00
21.5	121.18	123.21	117.43	1.20	118.63	0.00	0.00
22.0	119.60	126.53	120.22	1.20	121.42	1.82	0.00
22.5	123.59	130.43	123.94	1.20	125.14	1.55	0.00
23.0	125.50	150.14	125.87	1.20	127.07	1.57	0.00
23.5	128.40	131.49	128.24	1.20	129.44	1.04	0.00
24.0	130.06	130.94	130.96	1.20	132.16	2.10	1.22
24.5	133.45	132.02	134.35	1.20	135.55	2.10	3.53
25.0	137.05	134.85	138.55	1.20	139.75	2.70	4.90
25.5	139.43	141.44	140.14	1.20	141.34	1.91	0.00
26.0	140.95	142.25	141.33	1.20	142.53	1.58	0.28
26.5	146.60	142.12	143.66	1.20	144.86	0.00	2.74
27.0	167.92	146.57	147.40	1.20	148.60	0.00	2.03
27.5	165.14	147.71	150.00	1.20	151.20	0.00	3.49
28.0	157.32	152.67	154.28	1.20	155.48	0.00	2.81
28.5	155.64	155.76	155.28	1.20	156.48	0.84	0.72
29.0	158.95	162.66	158.22	1.20	159.42	0.47	0.00
29.5	162.56	182.70	160.75	1.20	161.95	0.00	0.00
30.0	164.97	172.07	164.82	1.20	166.02	1.05	0.00
30.5	167.68	173.08	168.58	1.20	169.78	2.10	0.00
31.0	170.61	182.03	170.41	1.20	171.61	1.00	0.00
31.5	173.60	180.56	173.36	1.20	174.56	0.96	0.00
32.0	177.87	185.81	177.55	1.20	178.75	0.88	0.00
32.5	181.11	182.27	179.70	1.20	180.90	0.00	0.00
33.0	180.74	183.57	181.32	1.20	182.52	1.78	0.00

*Preparatory study about the protection program for  
valleys and rural communities vulnerable to floods in Peru  
Final Report I-5 Main Report Project Report (Majes-Camana River)*

33.5	185.23	183.68	184.45	1.20	185.65	0.42	1.97
34.0	187.81	187.85	187.90	1.20	189.10	1.29	1.25
34.5	204.28	197.86	192.14	1.20	193.34	0.00	0.00
35.0	193.16	199.85	193.89	1.20	195.09	1.93	0.00
35.5	204.46	213.40	198.08	1.20	199.28	0.00	0.00
36.0	199.68	203.21	199.54	1.20	200.74	1.07	0.00
36.5	202.82	220.00	202.69	1.20	203.89	1.07	0.00
37.0	205.50	213.29	205.26	1.20	206.46	0.96	0.00
37.5	208.96	224.00	209.42	1.20	210.62	1.66	0.00
38.0	222.38	225.00	213.72	1.20	214.92	0.00	0.00
38.5	232.41	216.82	216.10	1.20	217.30	0.00	0.48
39.0	225.78	224.00	220.28	1.20	221.48	0.00	0.00
39.5	222.90	224.90	222.34	1.20	223.54	0.64	0.00
40.0	231.24	254.46	226.83	1.20	228.03	0.00	0.00
40.5	238.75	229.19	229.23	1.20	230.43	0.00	1.24
41.0	243.35	232.04	232.06	1.20	233.26	0.00	1.22
41.5	244.83	235.47	236.10	1.20	237.30	0.00	1.83
42.0	250.73	239.16	239.32	1.20	240.52	0.00	1.36
42.5	255.17	244.44	243.07	1.20	244.27	0.00	0.00
43.0	259.78	246.46	247.00	1.20	248.20	0.00	1.74
43.5	260.99	249.74	250.83	1.20	252.03	0.00	2.29
44.0	254.07	255.56	254.16	1.20	255.36	1.29	0.00
44.5	256.54	355.37	257.51	1.20	258.71	2.17	0.00
45.0	260.61	413.49	260.91	1.20	262.11	1.50	0.00
45.5	263.51	369.98	263.91	1.20	265.11	1.60	0.00
46.0	266.25	315.14	266.80	1.20	268.00	1.75	0.00
46.5	269.88	270.01	269.78	1.20	270.98	1.10	0.97
47.0	275.60	274.95	274.42	1.20	275.62	0.02	0.67
47.5	289.11	286.44	276.94	1.20	278.14	0.00	0.00
48.0	286.18	312.30	280.43	1.20	281.63	0.00	0.00
48.5	283.73	291.87	284.76	1.20	285.96	2.23	0.00
49.0	287.36	292.03	287.88	1.20	289.08	1.72	0.00
49.5	290.36	292.12	291.28	1.20	292.48	2.12	0.36
50.0	295.18	298.86	296.23	1.20	297.43	2.25	0.00
50.5	299.70	307.87	300.72	1.20	301.92	2.22	0.00
51.0	305.12	310.49	304.39	1.20	305.59	0.48	0.00
51.5	308.74	309.00	308.18	1.20	309.38	0.65	0.38
52.0	312.36	312.50	312.15	1.20	313.35	0.99	0.85
52.5	313.91	347.19	315.86	1.20	317.06	3.15	0.00
53.0	319.46	324.98	318.65	1.20	319.85	0.39	0.00
53.5	322.86	324.29	322.08	1.20	323.28	0.42	0.00
54.0	325.34	339.40	326.54	1.20	327.74	2.39	0.00
54.5	329.86	346.99	330.95	1.20	332.15	2.29	0.00
55.0	332.90	372.91	332.94	1.20	334.14	1.25	0.00
55.5	336.67	369.23	337.59	1.20	338.79	2.13	0.00
56.0	344.01	388.32	343.26	1.20	344.46	0.44	0.00
56.5	348.44	371.67	346.90	1.20	348.10	0.00	0.00
57.0	353.00	356.86	351.48	1.20	352.68	0.00	0.00
57.5	357.06	360.00	356.13	1.20	357.33	0.27	0.00
58.0	362.04	369.90	359.80	1.20	361.00	0.00	0.00
58.5	365.00	366.31	365.03	1.20	366.23	1.23	0.00
59.0	370.06	390.29	368.96	1.20	370.16	0.10	0.00
59.5	374.33	371.96	373.42	1.20	374.62	0.29	2.66
60.0	378.14	374.96	376.81	1.20	378.01	0.00	3.05
60.5	382.86	381.01	381.87	1.20	383.07	0.20	2.06
61.0	385.73	387.67	385.66	1.20	386.86	1.12	0.00
61.5	389.13	390.16	390.67	1.20	391.87	2.74	1.70
62.0	395.20	395.05	395.88	1.20	397.08	1.88	2.03
62.5	402.87	400.16	400.51	1.20	401.71	0.00	1.55
63.0	406.88	405.88	404.91	1.20	406.11	0.00	0.23
63.5	411.27	411.54	411.11	1.20	412.31	1.04	0.77
64.0	416.36	416.12	415.18	1.20	416.38	0.01	0.25
64.5	420.47	420.33	419.88	1.20	421.08	0.61	0.75
65.0	422.49	425.54	424.55	1.20	425.75	3.26	0.20
65.5	429.42	428.00	428.17	1.20	429.37	0.00	1.37
66.0	437.95	432.88	433.46	1.20	434.66	0.00	1.78

*Preparatory study about the protection program for  
valleys and rural communities vulnerable to floods in Peru  
Final Report I-5 Main Report Project Report (Majes-Camana River)*

66.5	437.32	439.27	439.20	1.20	440.40	3.09	1.13
67.0	445.23	444.37	444.21	1.20	445.41	0.18	1.04
67.5	449.17	449.58	448.70	1.20	449.90	0.73	0.32
68.0	454.82	454.48	453.38	1.20	454.58	0.00	0.10
68.5	457.23	459.54	457.69	1.20	458.89	1.65	0.00
69.0	461.75	463.52	460.78	1.20	461.98	0.23	0.00
69.5	466.00	465.64	466.30	1.20	467.50	1.50	1.86
70.0	475.66	469.12	470.11	1.20	471.31	0.00	2.19
70.5	476.00	475.57	475.09	1.20	476.29	0.29	0.72
71.0	480.07	480.00	479.89	1.20	481.09	1.02	1.09
71.5	484.80	484.00	484.33	1.20	485.53	0.73	1.53
72.0	487.93	494.51	488.54	1.20	489.74	1.81	0.00
72.5	492.57	492.89	493.79	1.20	494.99	2.42	2.10
73.0	497.47	496.99	497.86	1.20	499.06	1.59	2.07
73.5	504.05	504.44	504.25	1.20	505.45	1.40	1.01
74.0	508.89	509.79	510.08	1.20	511.28	2.39	1.49
74.5	515.17	514.14	514.06	1.20	515.26	0.10	1.13
75.0	520.15	520.23	518.96	1.20	520.16	0.01	0.00
75.5	524.58	524.75	523.80	1.20	525.00	0.42	0.25
76.0	528.22	529.44	528.34	1.20	529.54	1.32	0.11
76.5	531.64	534.26	532.64	1.20	533.84	2.19	0.00
77.0	535.15	535.13	537.00	1.20	538.20	3.05	3.08
77.5	540.28	542.37	541.00	1.20	542.20	1.92	0.00
78.0	545.08	546.72	546.70	1.20	547.90	2.82	1.17
78.5	552.44	551.73	551.88	1.20	553.08	0.64	1.35
79.0	557.05	556.80	556.40	1.20	557.60	0.55	0.80
79.5	562.51	562.79	561.19	1.20	562.39	0.00	0.00
80.0	563.91	567.45	565.12	1.20	566.32	2.41	0.00
80.5	571.02	572.31	570.42	1.20	571.62	0.60	0.00
81.0	574.60	574.68	575.65	1.20	576.85	2.25	2.17
81.5	581.23	581.25	581.45	1.20	582.65	1.42	1.40
82.0	587.36	585.34	586.84	1.20	588.04	0.68	2.70
82.5	593.38	607.08	592.17	1.20	593.37	0.00	0.00
83.0	598.15	595.22	596.05	1.20	597.25	0.00	2.04
83.5	603.56	601.15	602.14	1.20	603.34	0.00	2.19
84.0	606.51	607.41	606.24	1.20	607.44	0.93	0.02
84.5	609.11	610.58	610.44	1.20	611.64	2.53	1.06
85.0	622.61	615.37	615.02	1.20	616.22	0.00	0.85
85.5	628.43	620.06	620.54	1.20	621.74	0.00	1.68
86.0	645.54	627.56	627.48	1.20	628.68	0.00	1.12
86.5	632.65	633.82	631.08	1.20	632.28	0.00	0.00
87.0	635.86	636.22	635.24	1.20	636.44	0.58	0.22
87.5	641.45	639.17	639.51	1.20	640.71	0.00	1.54
88.0	644.21	650.70	644.60	1.20	645.80	1.59	0.00
88.5	657.62	650.10	651.66	1.20	652.86	0.00	2.76
89.0	667.85	656.55	656.30	1.20	657.50	0.00	0.95
89.5	668.63	660.78	660.10	1.20	661.30	0.00	0.52
90.0	673.44	664.19	663.93	1.20	665.13	0.00	0.93
90.5	697.69	670.28	668.25	1.20	669.45	0.00	0.00
91.0	686.00	671.51	671.77	1.20	672.97	0.00	1.46
91.5	685.08	675.39	676.49	1.20	677.69	0.00	2.30
92.0	682.72	695.65	682.30	1.20	683.50	0.78	0.00
92.5	687.29	685.90	686.81	1.20	688.01	0.72	2.11
93.0	696.78	693.52	690.93	1.20	692.13	0.00	0.00
93.5	697.53	698.07	695.72	1.20	696.92	0.00	0.00
94.0	704.83	723.65	700.72	1.20	701.92	0.00	0.00
94.5	717.41	715.23	704.54	1.20	705.74	0.00	0.00
95.0	714.48	711.75	707.31	1.20	708.51	0.00	0.00
95.5	709.48	710.99	711.35	1.20	712.55	3.07	1.56
96.0	713.23	720.86	714.48	1.20	715.68	2.45	0.00



96.5	718.39	724.80	719.36	1.20	720.56	2.17	0.00
97.0	724.98	723.32	723.22	1.20	724.42	0.00	1.10
97.5	726.65	730.79	728.21	1.20	729.41	2.76	0.00
98.0	731.07	735.05	732.10	1.20	733.30	2.23	0.00
98.5	744.51	735.62	736.49	1.20	737.69	0.00	2.07
99.0	748.48	740.07	741.84	1.20	743.04	0.00	2.97
99.5	746.53	746.62	746.94	1.20	748.14	1.61	1.51
100.0	765.13	752.28	751.711	1.20	752.91	0.00	0.63
100.5	757.25	757.09	757.802	1.20	759.00	1.75	1.91
101.0	773.81	762.97	763.638	1.20	764.84	0.00	1.87
101.5	772	770.41	770.885	1.20	772.09	0.09	1.68
102.0	787.47	774.78	775.278	1.20	776.48	0.00	1.70
102.5	789.63	788.67	779.852	1.20	781.05	0.00	0.00
103.0	797.97	785.87	784.921	1.20	786.12	0.00	0.25
103.5	790	788.37	790.258	1.20	791.46	1.46	3.09
104.0	794	792.84	794.298	1.20	795.50	1.50	2.66
104.5	807.88	799.11	799.061	1.20	800.26	0.00	1.15
105.0	813.04	803.88	804.371	1.20	805.57	0.00	1.69
105.5	817.72	811.8	811.057	1.20	812.26	0.00	0.46
106.0	821.32	822.8	818.998	1.20	820.20	0.00	0.00
106.5	836	838.53	824.376	1.20	825.58	0.00	0.00
107.0	838.79	865.15	828.999	1.20	830.20	0.00	0.00
107.5	833.74	837.9	834.195	1.20	835.40	1.66	0.00
108.0	839.44	840.38	839.921	1.20	841.12	1.68	0.74
108.5	856.86	850.08	845.625	1.20	846.83	0.00	0.00
109.0	864.52	849.96	850.457	1.20	851.66	0.00	1.70
109.5	872.07	859.31	856.981	1.20	858.18	0.00	0.00
110.0	866.43	865.82	863.958	1.20	865.16	0.00	0.00
110.5	881.45	872.36	870.889	1.20	872.09	0.00	0.00
111.0	881.73	878.24	877.611	1.20	878.81	0.00	0.57
111.5	949.26	892.01	886.739	1.20	887.94	0.00	0.00
112.0	912.4	904.94	893.295	1.20	894.50	0.00	0.00
112.5	904.46	911.05	894.19	1.20	895.39	0.00	0.00
113.0	907.55	912.94	901.15	1.20	902.35	0.00	0.00
113.5	916.04	920.44	903.621	1.20	904.82	0.00	0.00
114.0	923.28	921.43	910.753	1.20	911.95	0.00	0.00
114.5	929.36	925.09	915.679	1.20	916.88	0.00	0.00
115.0	929.96	929.64	917.282	1.20	918.48	0.00	0.00
115.5	933.64	931.67	921.557	1.20	922.76	0.00	0.00
平均	401.90	405.19	398.84	1.20	400.04	0.85	0.65

### 4.3 Technical Planning

#### 4.3.1 Structural Measures

As structural measures it is necessary to prepare a flood control plan for the whole Watershed. The later section 4.15 “Medium and Long Term Plan” and 4.15.1 “General Flood Control Plan” details results on the analysis. This plan proposes the construction of dikes for flood control in the entire Watershed. However, in the case of each watershed, a big project needs to be set up investing very high costs, far beyond those considered in the budget of the present Project, which makes it difficult to take this proposal. Therefore, supposing the flood control dikes in the whole watershed are to be built progressively within a medium and long term plan, hereinafter they would be focused on the study of more urgent and priority works for flood prevention.

### (1) Design flood discharge

#### 1) Guideline for flood control in Peru

The Methodological Guide for Projects on Protection and/or Flood Control in Agricultural or Urban Areas prepared by the Public Sector Multiannual Programming General Direction (DGPM) (present DGPI) of the Economy and Finance Ministry (MEF) recommends to carry out the comparative analysis of different return periods: 25 years, 50 years and 100 years for the urban area, and 10 years, 25 years and 50 years for rural area and agricultural lands.

Considering that the present Project is focused on the protection of rural and agricultural areas, the design flood discharge should be the discharge with return period of 10-year to 50-year.

#### 2) Maximum discharge in the past and design flood discharge

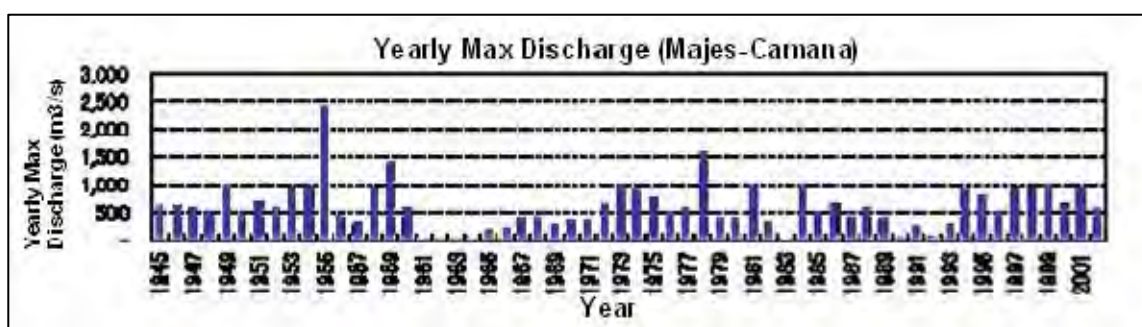
The yearly maximum discharge in the watershed is as shown in Figure-4.3.1. Based on the figure, the maximum discharge in the past can be extracted as shown in the Table- 4.3.1-1 together with the flood discharges with different return periods.

The maximum discharge in the past in Majes-Camana watershed is less than the flood discharge with return period of 50-year. However it seems that the flood discharge with return period of 50-year caused large damages.

Since the flood control facilities in Peru not well developed, it is true that the past floods caused much disaster so that the facilities should be safe for the same scale of flood with return period of 50 years, therefore the design flood discharge in this Project is to be the discharge with return period of 50-year.

**Table - 4.3.1-1 Flood discharge with different return period(m<sup>3</sup>/sec)**

Watershed	2-year	10-year	25-year	50-year	100-year	Max. in the Past
Majes-Camana	306	1,007	1,416	2,084	2,703	2,400



**Figure- 4.3.1-1 Yearly max. discharge (Majes-Camana)**

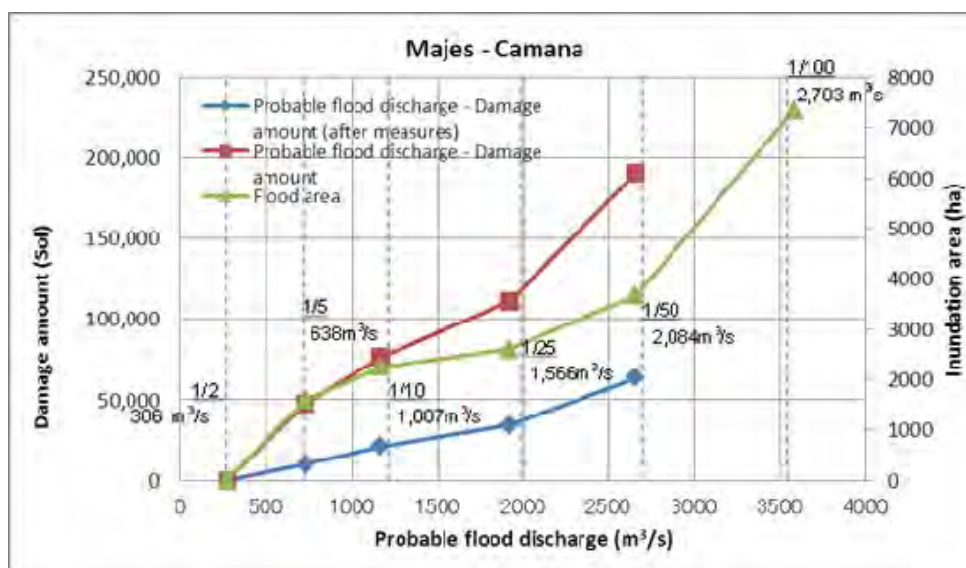
#### 3) Relation among probable flood, damage and inundation area

The relation among probable flood, Damage and inundation area in each watershed are shown in the Figure-4.3.1-2.

Based on the figures the following facts can be expressed.

- ① The more increase probable flood discharge, the more increase inundation area (green line in the figure).
- ② The more increase probable flood discharge, the more increase damage (red line in the figure).
- ③ According to increase of probable flood discharge, the damage with project increase gently (blue line in the figure).
- ④ According to increase of probable flood discharge, damage reduction (difference between red line and blue line) increase steadily, and it reaches maximum at the probable flood of 50- year within the scope of study.

As shown in the above section, the design flood discharge with return period of 50-year is more than the maximum flood in the past, and absolute damage reduction amount in the design discharge is largest among the probable flood discharge less than with return period of 50-year, and economic viability of the design flood is confirmed. Although the design discharge is the flood with return period of 50-year, the inundation area of the flood with return period of 100-year is described in the figures.



**Figure—4.3.1-2 Probable flood discharge, damage amount and inundation area  
(Majes-Camana river)**

## (2) Topographical survey

The topographical survey was carried out in selected places for the execution of structural measurements (Table 4.3.1-2). The preliminary design of control works was based on these topographical survey results.

**Table 4.3.1-2 Quantities of topographical survey**

River	Topographical Uplift	Transverse Uplift
Majes - Camana	$S = 1/2.500$	$S = 1/100$ , 100 m interval
	Ha	km
	193	21,3

### (3) Selection of flood protection works with high priority

#### 1) Basic guidelines

For the selection of priority flood protection works, the following elements were considered:

- Demand from the local community (based on historical flood damage)
- Lack of discharge capacity of river channel (including the sections affected by the scouring)
- Conditions of the adjacent area (conditions in urban areas, farmland, etc.).
- Conditions and area of inundation (type and extent of inundation according to inundation analysis)
- Social and environmental conditions (important local infrastructures)

Based on the river survey, field investigation, discharge capacity analysis of river channel, inundation analysis, and interviews to the local community (irrigation committee needs, local governments, historical flood damage, etc.) a comprehensive evaluation was made applying the five evaluation criteria listed above. After that we selected a total of seven (7) critical points (with the highest score in the assessment) that require flood protection measures.

Concretely, since the river cross sectional survey was carried out every 500m interval and discharge capacity analysis and inundation analysis were performed based on the survey results, the integral assessment was also done for sections of 500 meters. This sections have been assessed in scales of 1 to 3 (0 point, 1 point and 2 points) and the sections of which score is more than 6 were selected as prioritized areas. The lowest limit (6 points) has been determined also taking into account the budget available for the Project in general Table 4.3.1-3 details evaluated aspects and assessment criteria.

**Table 4.3.1-3 Assessment aspects and criteria**

Assessment Aspects	Description	Assessment Criteria
Demand of local population	<ul style="list-style-type: none"> <li>● Flood damages in the past</li> <li>● Demand of local population and producers</li> </ul>	<ul style="list-style-type: none"> <li>• Flooding area with big floods in the past and with great demand from local community (2 points)</li> <li>• Demand of local population (1 point)</li> </ul>
Lack of discharge capacity (bank scouring)	<ul style="list-style-type: none"> <li>● Possibility of river overflow given the lack of discharge capacity</li> <li>● Possibility of dike and bank collapse due to scouring</li> </ul>	<ul style="list-style-type: none"> <li>• Extremely low discharge capacity (discharge capacity with return period of 10 years or less) (2 points)</li> <li>• Low discharge capacity (with return period of less than 25 years) (1 point)</li> </ul>
Conditions of surrounding areas	<ul style="list-style-type: none"> <li>● Large arable lands, etc.</li> <li>● Urban area, etc.</li> <li>● Assessment of lands and</li> </ul>	<ul style="list-style-type: none"> <li>• Area with large arable lands (2 points)</li> <li>• Area with arable lands mixed with towns, or big urban area (2 points)</li> </ul>

	infrastructure close to the river.	<ul style="list-style-type: none"> <li>• Same configuration as the previous one, with shorter scale (1 point)</li> </ul>
Inundation conditions	<ul style="list-style-type: none"> <li>• Inundation magnitude</li> </ul>	<ul style="list-style-type: none"> <li>• Where overflow extends on vast surfaces (2 points)</li> <li>• Where overflow is limited to a determined area (1 point)</li> </ul>
Socio-environmental conditions (important structures)	<ul style="list-style-type: none"> <li>• Intake of the irrigation system, drinking water, etc.</li> <li>• Bridges and main roads (Carretera Panamericana, etc.)</li> </ul>	<ul style="list-style-type: none"> <li>• Where there are important infrastructures for the area (2 points)</li> </ul> <p>Where there are important infrastructures (but less than the first ones) for the area (regional roads, little intakes, etc.) (1 point)</p>

## 2) Selection results

Figure 4.3.1-3 details assessment results of the river, as well as the selection results of flood protection priority works.



### 3) Basis of selection

The existing dike in Camana river presents an advanced degree of obsolescence, and numerous eroded sections can be observed.

Currently, overflow occurs mainly in the upstream reach (Majes river), reducing the impact in this area. However, once this problem is solved in the upstream reach, impact would increase in this area, extending inundation area.

Likewise, at 13km there are a water supply intake to the urban area of Camana and a water channel along the river. Given that currently the left bank in the 12 km of the river is eroded and feared that the effect might strike the adjacent channel.

On the other hand, there are many sections without dike in Majes river so that damage by inundation and lost of farmland occur in every year.

Therefore in Camana river the rehabilitation and raising of existing dike is the most important in the left bank area which has large potential of damage, and in Majes river the embankment in the area without dike and with frequent flood damage is to be executed with priority.

The flood protection works in Majes river will affect the Camana river, therefore the order of the works should be carefully considered.

**Table 4.3.1-4 Selected sections bases to execute works (Majes-Camana river)**

No	Location	Basis of Selection
①	0.0km-4.5km (left bank)	<p>In this section the existing dike is deteriorated and eroded sections are observed scattering here and there. At present inundation in this area is reduced due to inundation in upstream area (Majes river), however when the flood protection work in the upstream will progress, which will affect this area increasing inundation area.</p> <p>[Characteristics of the section]</p> <ul style="list-style-type: none"> <li>● Section where it is important to solve the obsolescence issue in the existing dike and increase its height.</li> <li>● Section where inundation in the left bank can affect the urban area of Camana as well as its adjoining vast arable lands.</li> <li>● Section where inundation risk increases associated with the development of flood protection work in the upstream reach.</li> </ul> <p>[Elements to be protected]</p> <ul style="list-style-type: none"> <li>○ Large arable lands extending in the left bank</li> <li>○ Urban area of Camana city</li> </ul> <p>[Method of Protection]</p> <p>▼It is characteristics of Camana river that once the flood discharge over the discharge with scale of 50-years, damage increases become serious so that the protection works are to be safe for the discharge with return period of 50-years.</p> <p>▼Embankment with bank protection is to be executed in the section of insufficient dike height, utilizing the existing dikes.</p>
②	7.5km-9.5km (left bank)	<p>In this section the existing dike is deteriorated and eroded sections are observed scattering here and there. At present inundation in this area is reduced due to inundation in upstream area (Majes river), however when the flood protection work in the upstream will progress, which will affect this area increasing inundation area.</p> <p>[Characteristics of the section]</p> <ul style="list-style-type: none"> <li>● Section where it is important to solve the obsolescence issue in the existing dike and increase its height.</li> </ul>

		<ul style="list-style-type: none"> <li>● Section where inundation in the left bank can affect the urban area of Camana as well as its adjoining vast arable lands.</li> <li>● Section where inundation risk increases associated with the development of flood protection work in the upstream reach.</li> </ul> <p>[Elements to be protected]</p> <ul style="list-style-type: none"> <li>○ Large arable lands extending in the left bank</li> <li>○ Urban area of Camana city</li> </ul> <p>[Method of Protection]</p> <ul style="list-style-type: none"> <li>▼ It is characteristics of Camana river that once the flood discharge over the discharge with scale of 50-years, damage increases become serious so that the protection works are to be safe for the discharge with return period of 50-years.</li> <li>▼ Embankment with bank protection is to be executed in the section of insufficient dike height, utilizing the existing dikes.</li> </ul>
③	11.0km-17.0km (left bank)	<p>In this section the existing dike is deteriorated and eroded sections are observed scattering here and there. The intake for drinking water of Camana urban area is constructed at 13km and conveyance channel along river. The left bank at 12km is eroded and feared that the effect might strike the adjacent channel.</p> <p>[Characteristics of the section]</p> <ul style="list-style-type: none"> <li>● Section where it is important to solve the obsolescence issue in the existing dike and increase its height.</li> <li>● Section where inundation causes serious damage to the conveyance channel of drinking water.</li> </ul> <p>[Elements to be protected]</p> <ul style="list-style-type: none"> <li>○ Channel (of drinking water service) in the left bank</li> </ul> <p>[Method of Protection]</p> <ul style="list-style-type: none"> <li>▼ At present inundation in this area is reduced due to inundation in upstream area (Majes river), however when the flood protection work in the upstream will progress, which will affect this area increasing damage in this area. The conveyance channel along the river will be also affected. In case that the channel is destroyed, the damage will be serious, therefore it will be safe in the flood with return period of 50-year.</li> <li>▼ Embankment with bank protection is to be executed to secure the discharge capacity in the section of insufficient dike height, utilizing the existing dikes.</li> </ul>
④	48.0km-50.5km (left bank)	<p>This is a section with most insufficient discharge capacity in the river that inundates easily with small flooding and causes big damages in accordance with increase of the flood discharge.</p> <p>[Characteristics of the section]</p> <ul style="list-style-type: none"> <li>● Section where it is important to build a dike to keep necessary discharge capacity and to protect the secondary wide farmland in Majes area .</li> </ul> <p>[Elements to be protected]</p> <ul style="list-style-type: none"> <li>○ Arable lands extending in the left bank (maximum area of inundation n)</li> </ul> <p>[Method of Protection]</p> <ul style="list-style-type: none"> <li>▼ Inundation occurs at the flood with return period of 5-year and the damage become heavily at the flood with return period of 50-year, so that the flood</li> </ul>

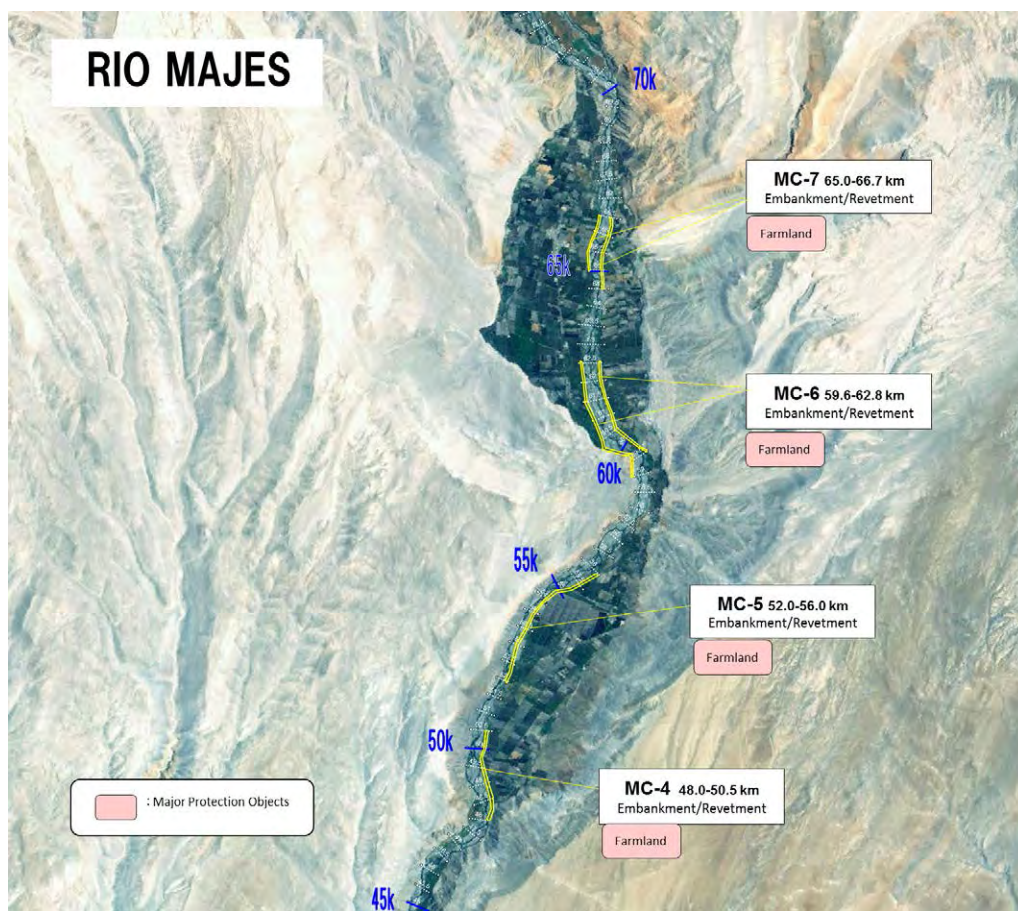


		<p>protection work is implemented for the latter flood flowing down safely. ▼The combination of protection work of ④and ⑤ can increase the effect of facilities.</p>
⑤	52.0km-56.0km (left bank)	<p>This is a section with most insufficient discharge capacity in the river that inundates easily with small flooding and causes big damages in accordance with increase of the flood discharge. The whole area was inundated in flooding in 1998 and damaged heavily.</p> <p>[Characteristics of the section] ●Section where it is important to build a dike to keep necessary discharge capacity and to protect the secondary wide farmland in Majes area .</p> <p>[Elements to be protected] ○ Arable lands extending in the left bank (secondary wide farmland in Majes area with the maximum area of inundation)</p> <p>[Method of Protection] ▼Inundation occurs at the flood with return period of 5-year and the damage become heavily at the flood with return period of 50-year, so that the flood protection work is implemented for the latter flood flowing down safely. ▼The combination of protection work of ④and ⑤ can increase the effect of facilities.</p>
⑥	59.0km-62.5km (right bank)  59.5km-62.5km (left bank)	<p>It is a narrow section where discharge capacity is insufficient, causing frequent flood damages in arable lands in the upstream section. There is a road bridge in the narrowness, and no dike in the adjacent area.</p> <p>[Characteristics of the section] ● Section where it is important to build a dike to keep necessary discharge capacity and to protect the maximum farmland in Majes area.</p> <p>[Elements to be protected] ○ Arable lands in both banks of the selected stretch (largest arable lands in Majes)</p> <p>[Method of Protection] ▼Inundation occurs at the flood with return period of 5-year and the damage become heavily at the flood with return period of 50-year, so that the flood protection work is implemented for the latter flood flowing down safely. ▼The combination of protection work of ⑥ and ⑦ can increase the effect of facilities.</p>
⑦	65.0km-66.5km (right bank)  64.5km-66.5km (left bank)	<p>This is a section with most insufficient discharge capacity in the river that inundates easily with small flooding and causes big damages in accordance with increase of the flood discharge.</p> <p>[Characteristics of the section] ● Section where it is important to build a dike to keep necessary discharge capacity and to protect the maximum farmland in Majes area.</p> <p>[Elements to be protected] ○ Arable lands in both banks of the selected stretch (largest arable lands in Majes)</p> <p>[Method of Protection] ▼Inundation occurs at the flood with return period of 5-year and the damage become heavily at the flood with return period of 50-year, so that the flood</p>

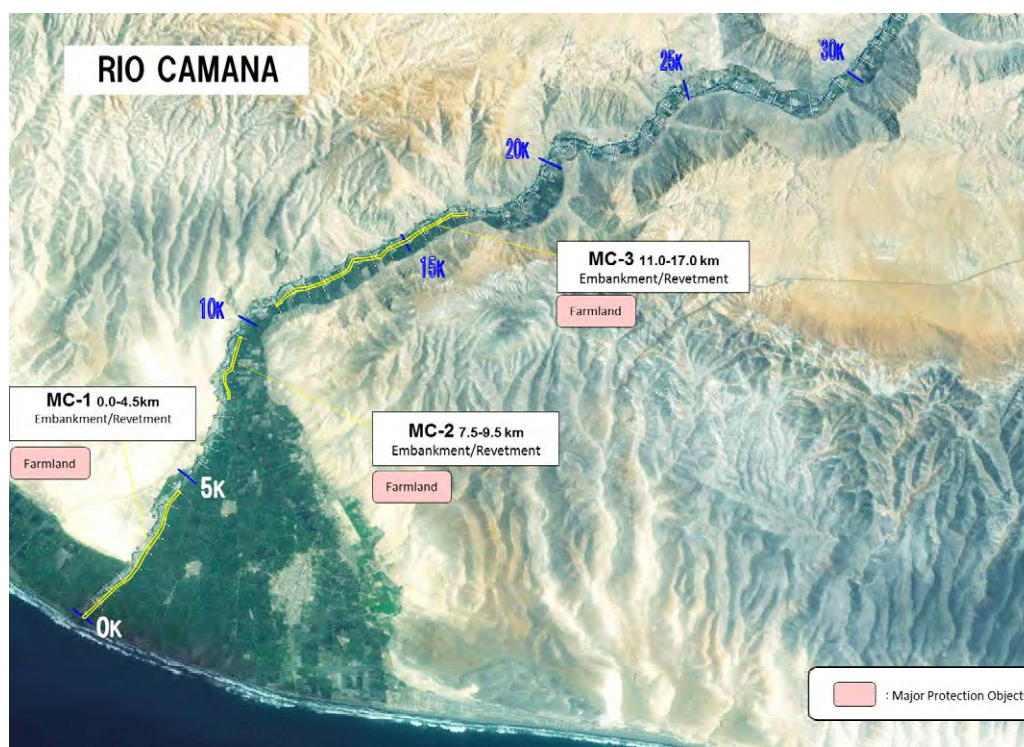
		<p>protection work is implemented for the latter flood flowing down safely.                  ▼The combination of protection work of ⑥ and ⑦ can increase the effect of facilities.</p>
--	--	--

**(4) Location of prioritized flood control works**

In Figure 4.3.1-4 ~ Figure 4.3.1-5 the location of prioritized flood control works is indicated in each watershed and in the Table- 4.3.1-5 the summary of flood control works is indicated..



**Figure 4.3.1-4 Prioritized flood control works in Majes river**



**Figure 4.3.1-5 Prioritized flood control works in Camana river**

**Table 4.3.1-5 Summary of facilities**

River	Location		Critical Point	Main Protection Objects	Measure	Feature of Work	
	MC	km				Length	Volume
Rio Camana	MC-1	0.0-4.5km	Innuded Point	Agricultural Lands	Dike with Bank Protection	Length 4,500 m	155,700 m <sup>3</sup>
						Large Boulder Riplap	44,300 m <sup>3</sup>
						Length 2,000 m	
Rio Camana	MC-2	7.5-9.5 km	Innuded Point	Agricultural Lands	Dike with Bank Protection	Dike with Bank Protection Length 2,000 m	43,100 m <sup>3</sup>
						Large Boulder Riplap	18,300 m <sup>3</sup>
						Length 6,000 m	
Rio Camana	MC-3	11.0-17.0 km	Innuded Point	Agricultural Lands	Dike with bank Protection	Dike with Bank Protection Length 6,000 m	169,000 m <sup>3</sup>
						Large Boulder Riplap	59,000 m <sup>3</sup>
						Length 2,500 m	
Rio Majes	MC-4	48.0-50.5 km	Innuded Point	Agricultural Lands	Dike with Bank Protection	Dike with Bank Protection Length 2,500 m	75,200 m <sup>3</sup>
						Large Boulder Riplap	17,700 m <sup>3</sup>
						Length 4,300 m	
	MC-5	52.0-56.0 km	Innuded Point	Agricultural Lands	Dike with bank Protection	Dike with Bank Protection Length 4,300 m	179,000 m <sup>3</sup>
						Large Boulder Riplap	39,400 m <sup>3</sup>
Rio Majes	MC-6	59.6-62.8 km	Innuded Point, Local Erosion	Agricultural lands	Dike with Bank Protection	Dike with Bank Protection Length 6,200 m	235,000 m <sup>3</sup>
						Large Boulder Riplap	51,400 m <sup>3</sup>
						Length 2,900 m	
Rio Majes	MC-7	65.0-66.7 km	Innuded Point	Agricultural Lands	Dike with Bank Protection	Dike with Bank Protection Length 2,900 m	32,300 m <sup>3</sup>
						Large Boulder Riplap	27,500 m <sup>3</sup>

### (5) Standard section of the dike

#### 1) Width of the crown

The width of the dike crown was defined in 4 meters, considering the dike stability when facing design overflows, width of the existing dike, and width of the access road or that of local communication.

#### 2) Dike structure

The dike structure has been designed empirically, taking into account historic disasters, soil condition, condition of surrounding areas, etc.

Dikes are made of soil in all the Watersheds. Although there is a difference in its structure varying from area to area, this can be summarized as follows, based on the information given by the administrators interviewed:

- ① The gradient of the slope is mainly 1:2 (vertical: horizontal relationship); the form may vary depending on rivers and areas.
- ② Dike materials are obtained from the river bed in the area. Generally these are made of sand/gravel ~sandy soil with gravel, of reduced plasticity. As to the resistance of the materials, we cannot expect cohesiveness.
- ③ The Watershed of the Cañete River is made of loamy soil with varied pebble, relatively compacted.
- ④ The lower stretch of the Sullana weir of the Chira River is made of sandy soil mixed with silt. Dikes have been designed with a “zonal-type” structure where material with low permeability is placed on the riverside of the dike and the river; material with high permeability is placed on landside of the dike. However, given the difficulty to obtain material with low permeability, it has been noticed that there is lack of rigorous control of grain size distribution in supervision of construction.
- ⑤ When studying the damaged sections, significant differences were not found in dike material or in the soil between broken and unbroken dike. Therefore, the main cause of destruction has been water overflow.
- ⑥ There are groins in the Chira and Cañete rivers, and many of them are destroyed. These are made of big rocks, with filler material of sand and soil in some cases, what may suggest that destruction must be caused by loss of filler material.
- ⑦ There are protection works of banks made of big rocks in the mouth of the Pisco River. This structure is extremely resistant according to the administrator. Material has been obtained from quarries, 10 km. away from the site.

Therefore, the dike should have the following structure.

- ① Dikes will be made of material available in the zone (river bed or banks). In this case, the material would be sand and gravel or sandy soil with gravel, of high permeability. The stability problems forecasted in this case are as follows.
  - i) Infiltrate destruction caused by piping due to washing away fine material
  - ii) Sliding destruction of slope due to infiltrate pressure

In order to secure the stability of dike the appropriate standard section should be determined by infiltration analysis and stability analysis for sliding based on unit weight, strength and permeability of embankment material.

- ② The angle of internal friction will be between  $30^\circ \sim 35^\circ$  if the material to be used is sandy soil with low cohesiveness. The stable gradient of the slope of an embankment executed with material with low cohesiveness is determined as:  $\tan\theta = \tan\phi/n$  (where “ $\theta$ ” is gradient of the

slope; “ $\phi$ ” is angle of internal friction and “ $n$ ” is 1.5 ,safety factor).

The stable slope required for an angle of internal friction of  $30^\circ$  is determined as: V:H=1:2.6 ( $\tan\theta=0.385$ ).

Taking into consideration this theoretical value, a gradient of the slope of 1:3.0 was considered, with more gentle inclination than the existing dikes, considering the results of the discharge analysis, the prolonged time of the design flood discharge (more than 24 hours), the fact that most of the dikes with slope of 1:2 have been destroyed, and the relative resistance in case of overflow due to unusual flooding.

The infiltration analysis and stability analysis of dike based on the soil investigation and martial tests are not performed in this Study so that the slope is determined by simple stability analysis assuming the strength factors of dike material estimated by field survey of material and by adding some safety allowance.

And the slope of dike in Japan is generally 1:2.0 in minimum, however the average slope will be more than 1:3.0 because the dike has several steps in every interval of 2m~3m of height.

- ③ The dike slope by the riverside must be protected for it must support a fast water flow given the quite steep slope of the riverbed. This protection will be executed using big stones or big rocks easily to get in the area, given that it is difficult to get connected concrete blocks .

The size of the material was determined between 30cm and 1m of diameter, with a minimum protection thickness of 1m, although these values will be determined based on flow speed of each river.

- ④ The penetration depth to bank protection is to be i) difference height between the deepest riverbed in the past and present riverbed or ii) empirical depth (0.5m~1.5m in Japan), the former is u certain without chronological riverbed fluctuation data, therefore according to the latter the depth is to be 1.75m referring to the river channel improvement section in Ica river

- ⑤ Heightening Method of Dike

The heightening length of existing dike is 15.0km among the total length of dike construction of 24.8 km in Majes-Camana.

The heightening method of dike is basically an overall enlargement type due to the following reasons and the alignment of dike accords with the one of exiting dike.

- i) The heightening method of widening dike in riverside decreases river width so that the discharge capacity is reduced resulting in raising height of dike more than the other methods.
- ii) The heightening method of widening dike in land side requires more land acquisition. It is desirable that the land acquisition is to be reduced as much as possible because the land is mainly important agricultural land of expensive.
- iii) Although the workmanship of dike construction such as the compaction condition and material characteristics are unknown, the existing dike is to be utilized because the dike has been functioned in the past flooding, and the heightening method of

overall enlargement type is to be applied, in which the existing dike is covered by the new dike with high strength, and can secure the safety and be economical with less land acquisition.

On the other hand, in the section with the narrow river width and river channel near to the dike, the heightening method of widening dike in land side is applied, in this case the riverside slope is protected with revetment.

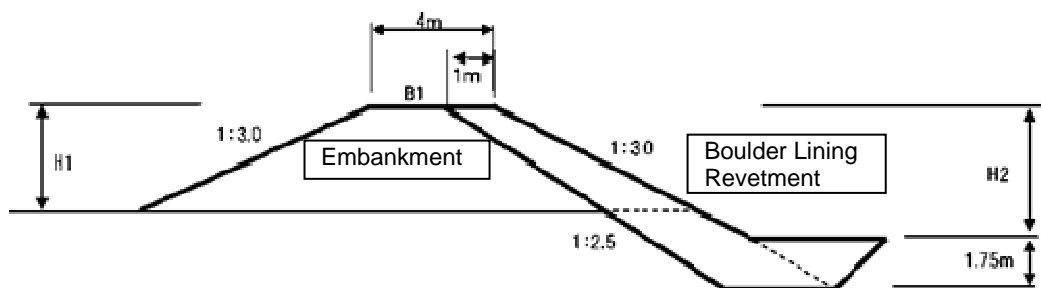
### 3) Freeboard of the dike

The dike is made of soil material, and as such, it generally turns to be a weak structure when facing overflow. Therefore, it is necessary to prevent water overflow, to a lower water rise than the design discharge. So it is necessary to keep a determined freeboard when facing a possible increase in water level caused by the waves by the wind during water rise, tidal, hydraulic jump, etc. Likewise, it is necessary that the dikes have sufficient height to guarantee safety in surveillance activities and flood protection work, removal of logs and other carryback material, etc.

Table 4.3.1-9 shows guidelines applied in Japan regarding freeboard. Although in Peru there is a norm on freeboard, it has been decided to apply the norms applied in Japan, considering that rivers in both countries are alike.

**Table-4.3.1-6 Design discharge and freeboard**

Design discharge	Freeboard
Less than 200 m <sup>3</sup> /s	0.6m
More than 200 m <sup>3</sup> /s, less than 500 m <sup>3</sup> /s	0.8m
More than 500 m <sup>3</sup> /s, less than 2,000 m <sup>3</sup> /s	1.0 m
More than 2,000 m <sup>3</sup> /s, less than 5,000 m <sup>3</sup> /s	1.2 m
More than 5,000 m <sup>3</sup> /s, less than 10,000 m <sup>3</sup> /s	1.5 m
More than 10,000 m <sup>3</sup> /s	2.0 m



**Figure 4.3.1-6 Standard dike section**

#### 4) Importance in Construction Work

The importance in dike construction is sufficient compaction of dike material. The cost estimate standard in Peru the compaction is to be made by tractor; however for the sufficient compaction it is desirable to use compaction equipment such as vibration roller etc.

And in order to supervise the compaction of material, the density test and grain size analysis are important, of which are specified in the technical specification of the tender document.

#### **(6) Effect of flood prevention facilities**

The discharge capacity of each river is enlarged up to the flood discharge with return period of 50-year by construction of the flood prevention facilities as shown in the Figure-4.3.1-7~Figure-4.3.1-8, and the inundation area is reduced remarkably.

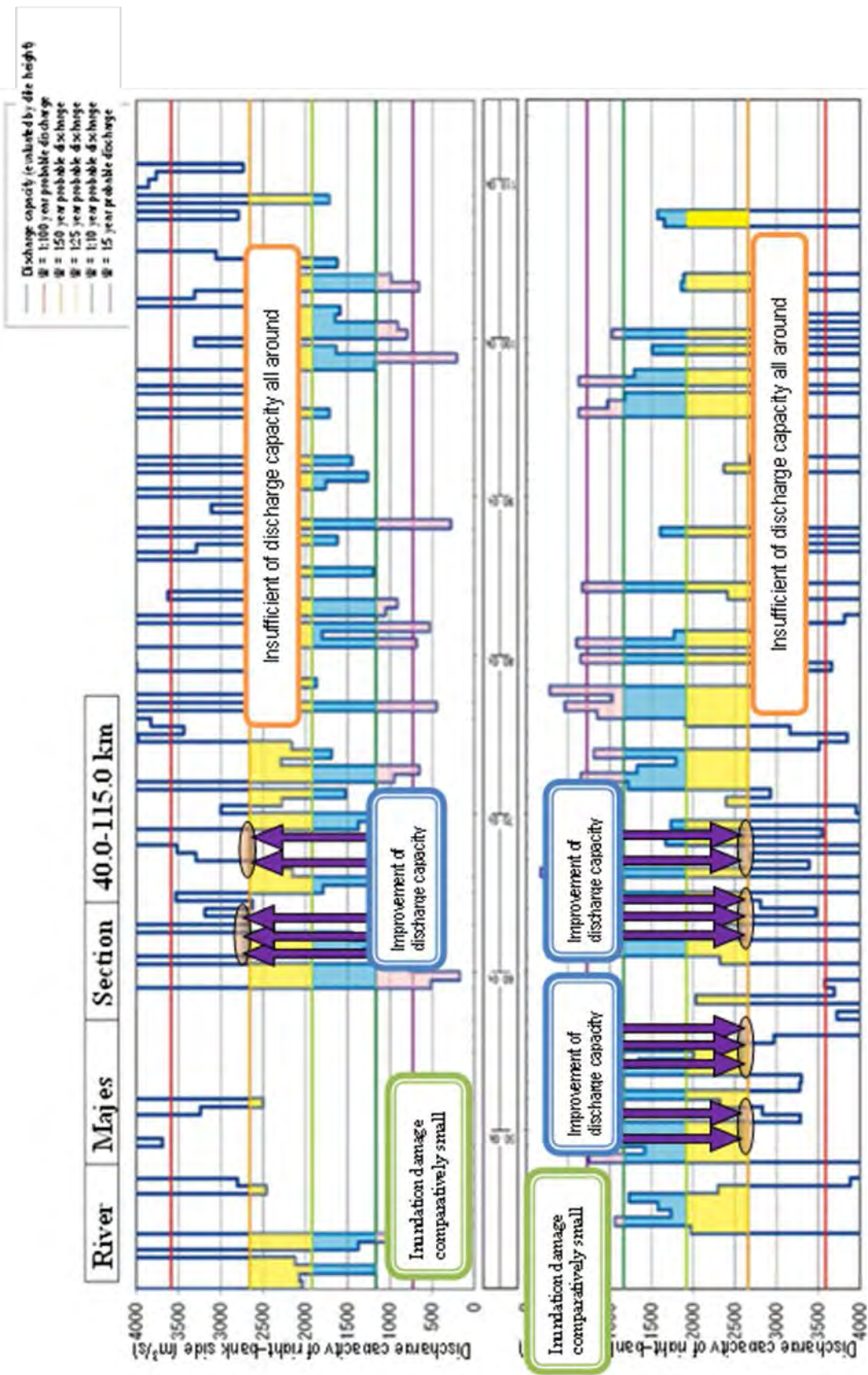


Figure-4.3.1-7 Effect of flood prevention facilities (Rio Majes)



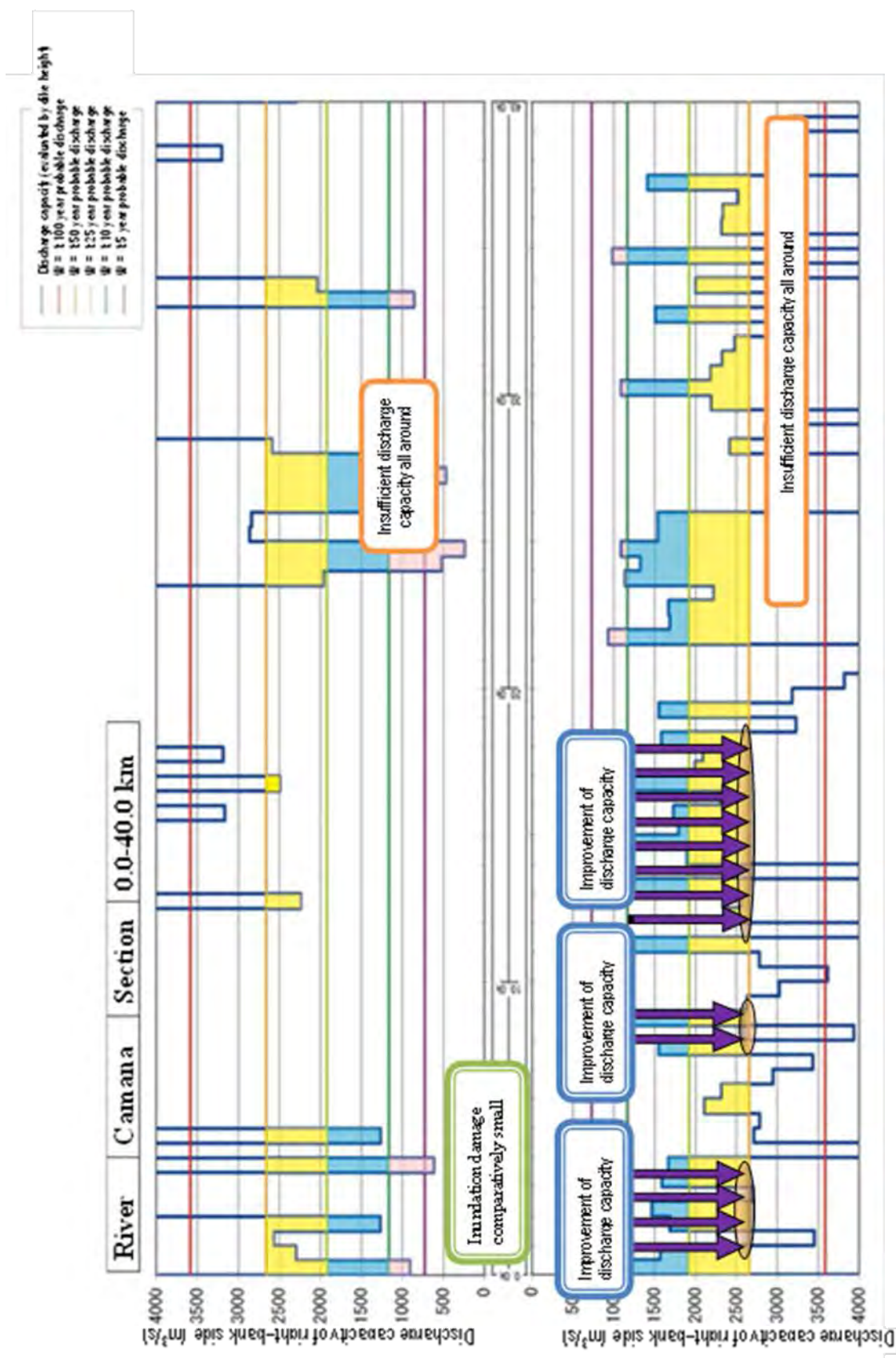


Figure-4.3.1-8 Effect of flood prevention facilities (Rio Camana)

## **4.3.2 Nonstructural Measures**

### **4.3.2.1 Reforestation and Vegetation Recovery**

#### **(1) Basic policies**

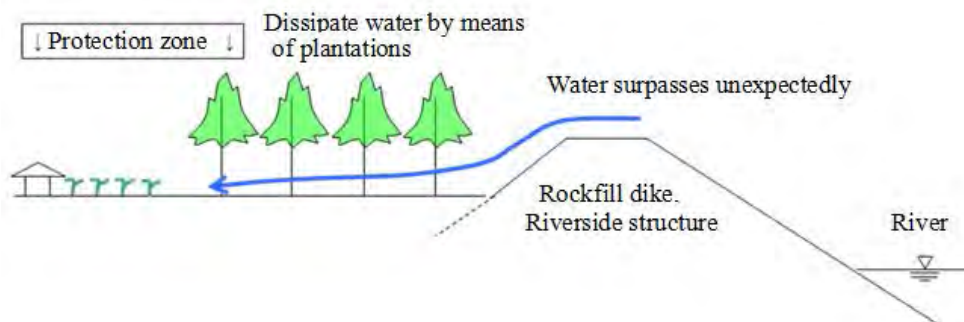
The Reforestation and Vegetation Recovery Plan satisfying the goal of the present Project can be classified in: i) reforestation along river structures; and ii) reforestation in the high Watershed. The first one contributes directly to flood control and expresses its effect in short time. The second one demands a huge investment and an extended time, as detailed in the later section 4.15 “Medium and long term Plan”, 4.15.2 “Reforestation Plan and Vegetation Recovery”, what makes not feasible to implement it in the present Project. Therefore, the analysis is here focused only in option i).

#### **(2) Reforestation plan along fluvial structures**

This proposal consists in planting trees along fluvial structures such as protection works of banks, dikes, etc.

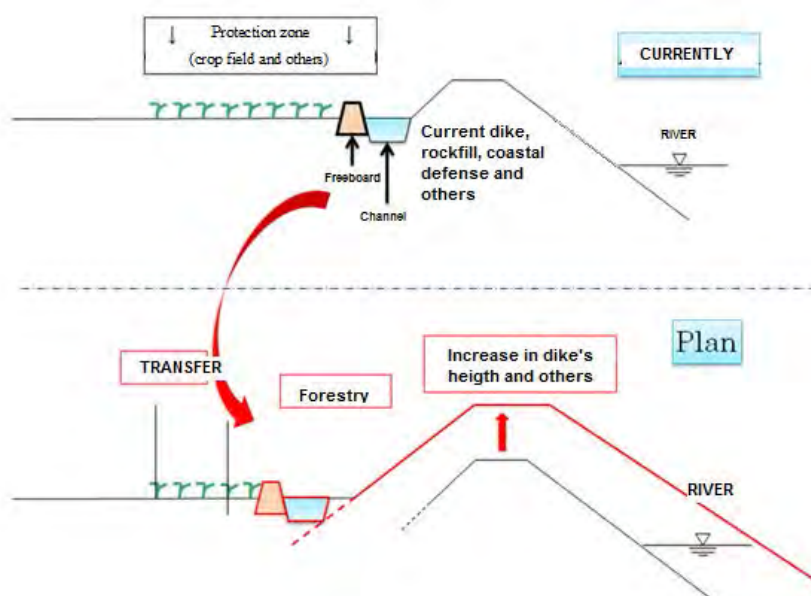
- a) Objective: Reduce impact of river overflow when water rise occurs or when river narrowing is produced by the presence of obstacles, by means of vegetation borders between the river and the elements to be protected.
- b) Methodology: Create vegetation borders of a certain width between fluvial structures and the river.
- c) Work execution: Plant vegetation at a side of the fluvial structures (dikes, etc.)
- d) Maintenance post reforestation: The maintenance will be assumed by irrigator commissions by own initiative.

Policies for the afforestation plan to be applied in constructions on the riverbanks are detailed below. Figures 4.3.2.1-1 and 4.3.2.1-2 show afforestation plan conceptual diagrams. There are two types of afforestation. In case A-type forestation cannot be applied in the Watershed of the Camana-Majes River, B-Type afforestation will do it. In the Watersheds, with exception of the before mentioned, A-Type afforestation will be used.



(Source: JICA Study Team)

**Figure 4.3.2.1-1 Conceptual diagram afforestation in the riverside structures (A Type)**



(Source: JICA Study Team)

**Figure 4.3.2.1-2 Conceptual diagram afforestation of riverside structures (B Type)**

In the Watershed of the Camana River, channels along the existing dikes have been built, and most of rice fields are covered with water. According to the interview to the Board of Users, land owners would not agree with A-Type afforestation (11-meter width afforestation) for it would reduce the arable area. Therefore afforestation is seen as a difficult issue. That is why in case the land cannot be acquired, B-Type afforestation is proposed as well as afforestation of channels for its conservation.

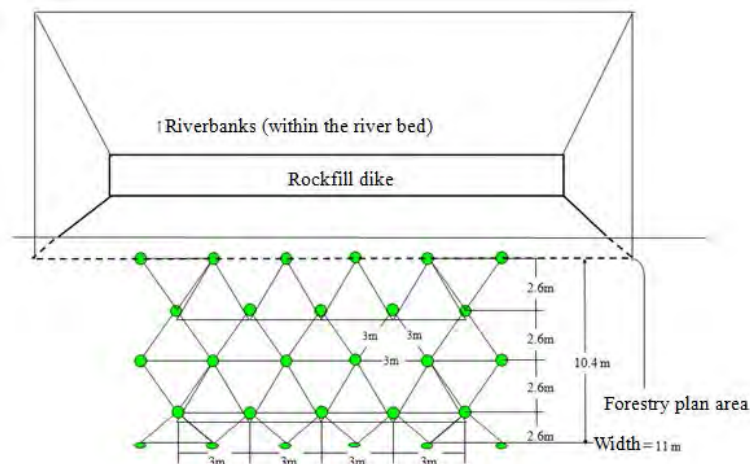
### **(3) Reforestation and vegetation recovery plan along river structures**

This plan consists of conforming vegetation borders along river structures, serving as buffer zone in case for some reason water overflows the dike, etc. during water rise.

1) **Structure (afforestation location)**

i) **A Type**

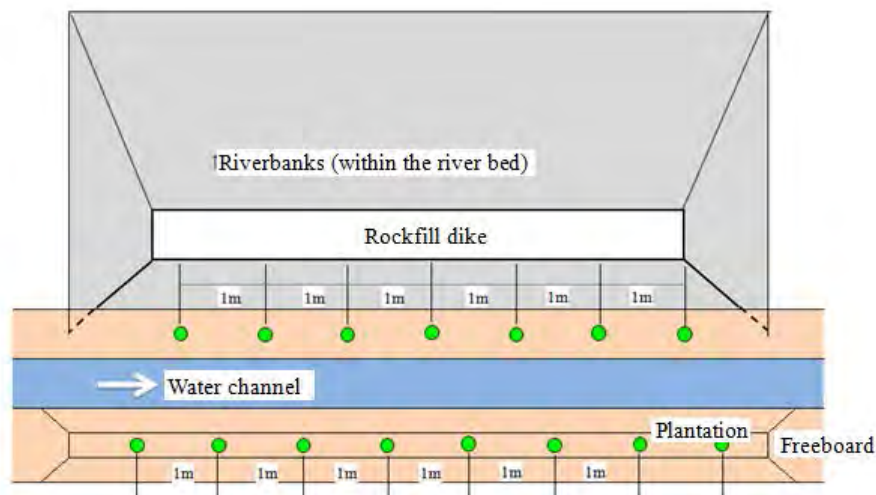
In Peru the most common pattern for afforestation is with equilateral triangles. This project also uses this model by planting trees with 3-meter intervals (Figure 4.3.2.1-3). If this method is used, the interval of trees vertical to the dike will be 2.6m and in the case of zigzag arrangement, the width will be 1.3m of which interval can stop the boulder with diameter of 1m or dissipate the energy of the boulder. And 4 lines of trees can increase the effect. Thus the width of plantation zone will be 11 m adding the allowance to 10.4 m.



(Source: JICA Study Team)

**Figure 4.3.2.1-3 Conceptual diagram afforestation in the riverside structures (A Type)**

ii) **B Type:** in the current situation, afforestation is applied with a 1meter interval parallel to the channel. In this plan this afforestation will be applied. Figure 4.3.2.1-4 shows the location of the afforestation design plan.



(Source: JICA Survey)

**Figure 4.3.2.1-4 Conceptual diagram afforestation in the riverside structures (B type)**

2) Species to be afforested

Species to be planted along the river were selected applying the following criteria and submitted to an overall assessment.

- ① Species with adequate properties to grow and develop in the riverside (preferably native)
- ② Possibility of growing in plant nurseries
- ③ Possibility of wood and fruit use
- ④ Demand of local population
- ⑤ Native species (preferably)

After making a land survey, a list of planted or indigenous species of each zone was firstly made. Then, a list of species whose plants would grow in seedbeds, according to interviews made to plant growers, was prepared. Priority was given to the aptitude of local conditions and to plant production precedents, leaving as second priority its usefulness and demand or if they were native species or not. Table 4.3.2.1-1 shows the assessment criterion.

**Table 4.3.2.1-1 Assessment criterion for forest species selection**

		Assessment Criterion				
		1	2	3	4	5
Assessment points	A	In situ testing (natural or reforested growth)	Major production	Possible use as wood or for fruit production	Water demand by the Users Committee, among others	Local specie
	B	Growth has not been checked in situ, however it adapts in the zone	Sporadic production	Possible use as wood or for fruit production	There is NO water demand by the Users Committee	No local specie
	C	None of the above	Possible reproduction but not usual	No use as wood nor fruit	—	—
	D	Unknown	Not produced	Unknown	—	—

(Source: JICA Study Team)

Table-4.3.2.1-2 shows a list of selected species applying these assessment criterions. ⊙ marks main species, ○ are those species that would be planted with a proportion of 30% to 50%. This proportion is considered to avoid irreversible damages such as plagues that can kill all the trees.

**Table 4.3.2.1-2 Selection of forest species**

Watershed	Forest species
Majes- Camana Watershed	Willow (⊙), Casuarina (○)

In the Watershed of the Majes-Camana River the main afforestation specie is the Willow. This specie adapts very well in highly humid environments and there is experience in afforestation activities in the zone. This specie is generally afforested by the Users Board. However, the Willow and the Callacas are found between the seashore up to 1.5km, and still its growth is not optimal.

This is due to the tide impact, for what it is proposed to replace the Willow with the Casuarina, given that the later one adapts better in salty zones. In the area there is abundance of Callacas, but they do not grow in plant nurseries. In the Watershed of the Majes- Camana River most of the fields are rice crop fields, therefore water level is high and the soil is clay soil. For this reason, the Eucalyptus is not apt for afforestation in this zone, since it may wither.

### 3) Volume of the Reforestation and Vegetation Recovery Plan

The afforestation plan has been selected as it is mentioned in the location and type of species plan, in the dikes and bank protection along the riverside. The width of the A-type afforestation is of 11 meters; in the case of the sedimentation well, afforestation occurs in places where river water does not pass through. In the case of B-type afforestation, it has been calculated to afforest two lines along the dike, with 1-meter interval.

Following Table 4.3.2.1-3 shows the construction estimating for the Afforestation and Recovery of Vegetation Cover Plan for Watersheds.

**Table 4.3.2.1-3 Amount of afforestation/vegetation recovery plan (riparian afforestation)**

N°	Location (bank)	Length (m)	Width (m)	Area (ha)	Quantity (unit)	Distribution according to the specie (unit)		
						Willow	Casuarina	Total
<b>B Type</b>								
Camana-1	Left	1.500	—	—	3.000	1.500	1.500	3.000
Camana-1	Left	3.000	—	—	6.000	6.000	—	6.000
Camana-2	Left	2.000	—	—	4.000	4.000	—	4.000
Camana-3	Left	6.000	—	—	12.000	12.000	—	12.000
<b>A Type</b>								
Majes-4	Left	2.500	11	2,8	8.288	8.288	—	8.288
Majes-5		4.000	11	4,4	13.024	13.024	—	13.024
Majes-6	Right	3.500	11	3,9	11.544	11.544	—	11.544
Majes-6		3.000	11	3,3	9.768	9.768	—	9.768
Majes-7	Right	1.500	11	1,7	5.032	5.032	—	5.032
Majes-7	Left	2.000	11	2,2	6.512	6.512	—	6.512
Camana-Majes River Total				18,3	79.168	79.168	1.500	79.168

(Source: JICA Study Team)

### 4) Areas subject to the Reforestation and Vegetation Recovery Plan

In areas subject to the Reforestation/Vegetation Recovery Plan along river structures, the structure arrangement is similar everywhere. See section 4.5.1.3(2).

### 5) Execution costs of the Reforestation and Vegetation Recovery Plan

Execution costs of works for the Reforestation and Vegetation Recovery Plan were estimated as follows:

- Planting unitary cost (planting unitary cost + transportation)
- Labor cost

Planting providers may include i) AGRORURAL or ii) private providers. For reforestation along rivers private providers will be requested.

For labor unitary cost estimation, common labor unitary cost is proposed to be applied for riverside reforestation.

i) Planting unitary cost

Planting unitary cost was defined as detailed in Table 4.3.2.1-4, based on information obtained through interviews to private providers. Given that planting prices and transportation cost varies per provider, an average Figure was applied.

**Table 4.3.2.1-4 Unitary cost of plants**

Watersheds	Species	Unitary cost (unitary price + transportation) (in Soles/plant)
Majes- Camana River	Sauce	2.5
	Casuarinaceae	2.8

ii) Labor cost

Reforestation work performance ratio was determined in 40 trees/person-day according to the information gathered through interviews to AGRORURAL and to irrigator commissions. As to riverside reforestation, the labor unitary cost will be 33.6 Soles/man-day. In the high Watershed 16.8 Soles/man-day, corresponding to half of the first one.

iii) Reforestation execution cost

Work costs for the afforestation and vegetation cover recovery plan in the riverside structures are detailed in Table 4.3.2.1-5. The total cost of works is 504,745 Soles.

To carry out the afforestation plan a construction company is required for the execution of riverside structures. Like work construction cost, 88% of direct costs is allocated to indirect costs.

**Table 4.3.2.1-5 Afforestation work cost (afforestation in riverside structures)**

N°	Work location	Afforestation work cost (Soles)					
		Direct work cost				Indirect Cost	TOTAL
		Planting cost	Sowing cost	Direct cost	Total		
29	MC-1	7.950	2.520	126	10.596	9.346	19,942
30	MC-1	15.000	5.040	252	20.292	17.898	38,190
31	MC-2	10.000	3.360	168	13.528	11.932	25,460
32	MC-3	30.000	10.080	504	40.584	35.795	76,379
33	MC-4	20.720	6.962	348	28.030	24.722	52,752
34	MC-5	32.560	10.940	547	44.047	38.849	82,896
35	MC-6	28.860	9.697	485	39.042	34.435	73,477
36	MC-6	24.420	8.205	410	33.035	29.137	62,172
37	MC-7	12.580	4.227	211	17.018	15.010	32,028
38	MC-7	16.280	5.470	274	22.024	19.425	41,449
Camana-Majes Watershed		198,370	66.501	3.325	268.196	236.549	504.745

(Source: JICA Study Team)

#### 6) Implementation process plan

The Process Plan of afforestation works in riverbanks is part of the river structure, thus the same will be considered for the Construction Plan of the River Structure. Afforestation works should generally start at the beginning of the rainy season or just before, and must end approximately one month before the season finishes. However, there is scarce rain in the coastal area; therefore there is no effect of dry and rainy seasons. For the sake of afforestation, it is most convenient is to take advantage of water rise, but according to the Construction Schedule of the river structure there are no major afforestation issues in seasons where water level is low. The simple gravity irrigation system can be used to irrigate just planted plants during approximately the first 3 months until water level rises. This irrigation is performed using perforated hose which is a field technique actually carried out in Poechos dam area

#### **4.3.2.2 Sediment Control Plan**

##### **(1) Importance of the sediment control plan**

Below flood control issues in selected Watersheds are listed. Some of them relate to sediment control. In the present Project an overall flood control plan covering both the high and the low Watershed is prepared. The study for the preparation of the Sediment Control Plan comprised the whole Watershed.

- Flood water overflows bank and inundates.
- Rivers have a steep slope of 1/30 to 1/300. The flow speed is high, as well as the sediment transport capacity.
- The accumulation of large quantities of sediment and the consequent elevation of the river bed aggravate flood damages.
- There is a great quantity of sediment accumulated on the river bed forming plural sandbar. The flow route and the flow collision point are unstable, causing route change and consequently, change of flow collision point.
- Riverside is highly erodible, causing a decrease of adjacent farming lands, destruction of regional roads, etc., for what they should be duly protected.
- Big stones and rocks cause damages and destruction of water intakes.

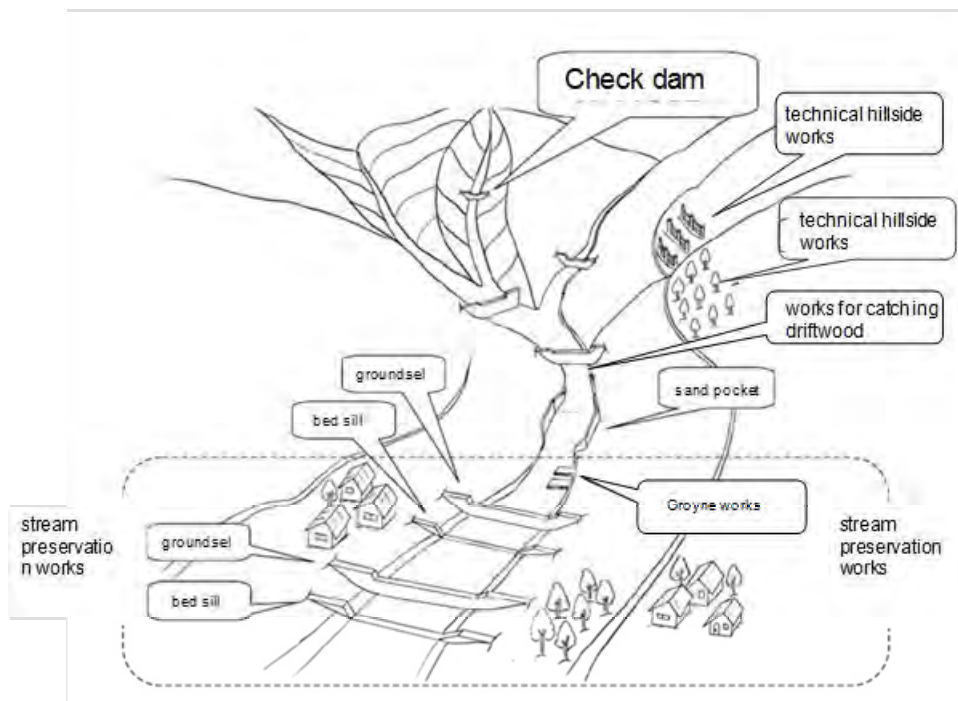
##### **(2) Sediment control plan (structural measures)**

The sediment control plan suitable for the present sediment movement pattern was analyzed. Table 4.3.2.2-1 details basic guidelines.



**Table 4.3.2.2-1 Basic guidelines of the sediment control plan**

Conditions	Typical year	Precipitations with 50-year return period
Sediment transport impact	Bank erosion and river bed change	Bank erosion and river bed change Sediment flow from ravines
Measures	Erosion control → Bank protection  Control of riverbed variation → compaction of ground, bands (compaction of ground in the alluvial cone, bands)	Erosion control → bank protection Riverbed variation control → compaction of ground, bands (compaction of ground in the alluvial cone, bands) Sediment flow → protection of slopes, sediment control dams



**Figure 4.3.2.2-1 Sediment control works**

1) Sediment control plan in the high watershed

The later section 4.15 “Medium and long term Plan” 4.15.3 “Sediment Control Plan” details the sediment control plan covering the whole high Watershed. This plan will require an extremely long time with huge costs, what makes it quite not feasible. Therefore, it must be executed progressively within the medium and long term.

2) Sediment control plan in the low watershed

We observed that building sediment control dams covering the whole Watershed will demand huge costs. Therefore, the same calculation was done but reducing its scope to just the lower Watershed of the river. In this process, analysis results on riverbed variation were taken into consideration, also included in the present study.

### 3) Riverbed fluctuation analysis results

The analysis results of river bed fluctuation is as shown below. The average riverbed raising shows the average of raise in the objective section in future 50 years. The average bed height has been increasing, so basically it is concluded that this is the general trend. The total variation volume of the bed and sediment transport is augmenting in the Majes-Camana river.

Total volume of dragged sediment (in thousands of m <sup>3</sup> )	20,956
Annual average of dragged sediment (in thousands of m <sup>3</sup> )	419
Total volume of riverbed variation (in thousands of m <sup>3</sup> )	5,316
Annual average of variation of riverbed height (m)	0.2

- Majes-Camana is the most susceptible to the accumulation of sediment. This tendency coincides to the field hearing results and actual riverbed conditions.
- One of the reasons why the Majes-Camana river discharges a relatively large amount of sediment is in the vast watershed area compared with other rivers, and the great magnitude of floods, what makes this river to transport large amounts of sediment downstream. While the variation of the bed (volume of sediment) is great too, looking at the average height of the bed, only 0.2 meters has changed in 50 years, and is therefore considered that the entry of sediments won't affect much the river downstream. Therefore, it is considered that it is not necessary to take a special sediment control measure. However the sediment disaster will happen suddenly and locally so that the required river channel maintenance work will be examined with monitoring of river bed sedimentation.

#### **4.3.3 Technical Assistance**

Based on the proposals on flood control measures, a component on technical assistance is proposed in order to strengthen risk management capabilities in the Program.

##### **(1) Component objective**

The component objective in the Program is the “Adequate capability of local population and professionals in risk management application to reduce flood damages in Watersheds”.

##### **(2) Target area**

The target area for the implementation of the present component is the Majes-Camana watershed. In the execution stage, the implementation has to be coordinated with local authorities in the watershed. However, each authority has to execute those activities related with the characteristics of the watershed to carry out an adequate implementation.

##### **(3) Target population**

Target populations will represent irrigator associations and other community groups,

provincial, district and local community governments and local people in the watershed, considering the limited capacity to receive beneficiaries of this component. Participants are those with skills to widespread technical assistance contents of local populations in the watershed. Besides, the participation of women has to be considered because currently only few ones participate in technical assistance opportunities.

#### **(4) Activities**

In order to achieve the above purpose, the following 3 components of study and training is to be carried out.

#### Component 1: Knowledge on River Bank Protection Actions in consideration of Agriculture and Natural Environment

Course	a) River Bank Operation and Maintenance b) River Bank Plant Management c) Erosion Prevention and Mitigation Natural Resource Management
Objectives	a) In this project, local populations learn suitable technology to operate and give maintenance to constructions and works from prior projects. b) Local populations learn suitable technology on river bank plants and vegetation for flooding control purposes. c) Local populations learn suitable technology on erosion and natural resources for flooding control purposes.
Participants	a) Engineers and / or technicians from local Governments b-c) Engineers and / or technicians from local Governments and Water Users Associations, Community representatives
Times	a) 12 times in all (every six (6) hours) b) 12 times in all (every five (5) hours) c) 26 times in all (every three (3) hours)
Lecturers	a) Contractors of constructions and works, Engineers from MINAG and / or the Regional Government b-c) Engineers from MINAG and / or the Regional Government, College professors (From universities, institutes, NGOs, etc.)
Contents	a-1) Suitable operation and maintenance technology for constructions and works from prior projects a-2) Suitable operation and maintenance technology for constructions and works in this project b-1) River bank protection with the use of plants b-2) The importance of river bank vegetation in flooding control b-3) Types of river bank plants and their characteristics c-1) Evaluation of the erosion conditions c-2) Evaluation of natural resource conditions c-3) Erosion approach for flooding control c-4) Natural resource approach for flooding control c-5) Environmental consideration approach c-6) Use of water resources c-7) Alternatives for suitable farming crops

#### Component 2: Preparation of Community Disaster Management Plan for Flood Control

Course	a) Risk management Plan Formulation b) Detailed Risk management Plan Formulation
--------	---

Objectives	a) Local populations gain knowledge and learn technology to prepare a flooding control plan b) Ditto
Participants	a-c) Engineers and / or technicians from local Governments and Water Users Associations, Community representatives
Times	a) 19 times in all (every four (4) hours) b) 34 times in all (every five (5) hours) c) 24 times in all (every five (5) hours)
Lecturers	a-c) Engineers from MINAG and / or the Regional Government, Community Development Expert, Facilitator (local participation )
Contents	a-1) Flooding control plan preparation manuals a-2) Current condition analyses for flooding control a-3) Community development alternatives by means of local participation a-4) Workshop for flooding control plan preparation b-1) Community activity planning in consideration of ecological zoning b-2) Risk management b-3) Resource management c-1) Preparation of community disaster management plan c-2) Joint activity with local governments, users' association, etc.

### Component 3: Basin Management for Anti – River Sedimentation Measures

Courses	a) Hillside Conservation Techniques b) Forest Seedling Production c) Forest Seedling Planting d) Forest Resource Management and Conservation
Objectives	a) Local populations learn suitable technology on hillside conservation for flooding control purposes b) Local populations learn suitable technology on forest seedling production c) Local populations learn suitable technology on forest seedling planting d) Local populations learn suitable technology on forest resource management and conservation
Participants	a-d) Engineers and / or technicians from local Governments and Water Users Associations, Community representatives and Local People
Times	a) 12 times in all (every five (5) hours) b-d) 40 times in all for three (3) “Courses on Basin Management for Anti - River Sedimentation Measures” (every five (5) hours)
Lecturers	a-d) Engineers from MINAG and / or the Regional Government, College professors (From universities, institutes, NGOs, etc.)
Contents	a-1) Soil characteristics and conservation on hillsides a-2) Hillside agroforestry system a-3) Animal herding system on hillsides a-4) Reforestation with traditional vegetation and plants a-5) Hillside conservation and alleviation alternatives b-1) A selection of plants that are suitable to the local characteristics b-2) Forest seedling production technology b-3) Control carried out by the local population's involvement c-1) Candidate areas for forestation c-2) Forest plantation control technology c-3) Forest plantation soil technology c-4) Control carried out by the local population's involvement d-1) Forestation for flooding control purposes d-2) Forest plantation control technology

	d-3) Forest plantation output technology
	d-4) Control carried out by the local population's involvement

### (5) Direct cost and period

The direct cost for the above activities is as shown in the Table 4.3.3-1. The total cost for the objective basin is estimated as 144,050 soles, and the brake down of the unit cost is as shown in the Annex-12, Appendix No.5. And the period required for study and training is assumed to be as same as the construction period of 2 years.

**Table 4.3.3-1 Contents of technical assistance and direct cost**

Item	Activities	Unit	Unit price(soles)	No.of basin	Amount(soles)
1.0	<b>Knowledge on river bank protection action in consideration of agriculture and natural environment</b>				
1.1	Workshop on operation and maintenance of facilities	event	9,300	1	9,300
1.2	Workshop on river bank plantation management	event	9,300	1	9,300
	Prevention and mitigation for erosion	event	9,300	1	9,300
	Natural resources management	event	9,300	1	9,300
2.0	<b>Preparation of community disaster management plan for flood control</b>				
2.1	Workshop on risk management plan	event	8,370	1	8,370
2.2	Details of 2.1	event			
	Community activity planning in consideration of ecological zoning	event	12,200	1	12,200
	Risk management	event	12,200	1	12,200
	Resource management	event	12,200	1	12,200
	Preparation of community disaster management plan	event	12,200	1	12,200
2.3	Preliminary flood forecasting and warning	event			
	Risk management and early warning system	event	9,300	1	9,300
	Joint activity with local government, users' association, etc.	event	5,580	1	5,580
3.0	<b>Hillside management for river sedimentation prevention</b>				
3.1	Field works for hillside conservation technique	event	7,500	1	7,500
	Forest seedling productions	event	7,900	1	7,900
	Forest plantation setting up	event	7,900	1	7,900
	Forest resource management and conservation		7,900	1	7,900
3.2	Difusion of posters and leaflet		3,600	1	3,600
	<b>Total</b>				<b>144,050</b>

### (6) Implementation plan

The Hydraulic Infrastructure General Direction (DGIH-MINAG) executes this component as the executing unity in cooperation with the Agriculture Regional Direction (DRA), the Board of Users and related Institutions. In order to execute the activities efficiently the following has to be considered:

- For the implementation of the present component, the DGIH-MINAG will coordinate actions with the Central Management Unit responsible for each Watershed, as well as with Regional Managements of Agriculture (DRA).
- For the Project administration and management, the DGIH-MINAG will coordinate actions with PSI-MINAG (Sub-sector Irrigation Program with extensive experience in similar projects).
- Considering there are some local governments that have initiated the preparation of a similar crisis management plan through the corresponding civil defense committee, under the advice of the National Institute of Civil Defense (INDECI) and local governments, the DGIH-MINAG must coordinate so that these plans be consistent with those existing in each Watershed.
- Training courses will be managed and administered by irrigator associations (particularly the unit of skills development and communications) with the support of local governments in each Watershed, to support timely development in each town.
- Experts in disaster management departments in each provincial government, ANA, AGRORURAL, INDECI, etc. as well as (international and local) consultants will be in charge of course instruction and facilitation.

## 4.4 Costs

### 4.4.1 Cost Estimate (at Private Prices)

#### (1) Project costs components

Project cost is composed of the following components:

##### 1) Infrastructure cost

###### i) Construction work cost

① Work direct costs (including plantation cost, environmental work cost, disaster prevention education/capacity development cost, infrastructure rehabilitation cost)

② Overhead cost = ① x 15%

③ Profit = ① x 10%

④ Work cost = ① + ② + ③

⑤ Tax = ④ x 18% (IGV)

⑥ Construction cost = ④ + ⑤

ii) Consultant cost (for structure, plantation, environmental work and disaster prevention education/capacity development)

⑦ Detailed design cost

⑧ Construction supervision cost

⑨ Consultant cost = ⑦ + ⑧

iii) Infrastructure cost = ⑥ + ⑨

##### 2) Land acquisition cost

##### 3) Management cost of implementation agency

4) Total project cost = 1) + 2) + 3)

#### (2) Direct cost

The direct costs were calculated by multiplying the unit prices with the work quantities. And the unit price is estimated for each work item based on the labor cost, material cost and equipment cost,

##### 1) Labor cost

The labor costs in Majes-Camana river are as shown in the Table-4.4.1-1.

##### 2) Material cost

The major material costs in Majes-Camana river are as shown in the Table-4.4.1-2.

##### 3) Equipment cost

The rental costs of equipment in Majes-Camana river are as shown in the Table-4.4.1-3 .

4) Work quantities

The work quantity of each work item in each flood prevention facility is as shown in the Table-4.4.1-4. For further detail of work quantities refer to Annex-8 Plan and Design of Facility.

5) Unit price of work

Based on the above costs the unit price of each work is estimated, of which results in in Cañete river are as shown in the Table--4.4.1-5. For further detail refer to Annex-9 Construction Planning and Cost Estimate. Based on the work quantities and the unit price of work, the direct cost of construction work is calculated as shown in the Table-4.4.1-6

**(3) Infrastructure cost**

The infrastructure cost is as shown in the Table4.4.1-12, in which the breakdown of the detail design cost and construction supervision cost are as shown in the Table-4.4.1-7 and Table-4.4.1-8 respectively. The consultant cost was estimated based on the Terms of Reference attached to Annex-14 Implementation Program of Japanese Yen Loan Project as Appendix-1

**(4) Land acquisition and infrastructure rehabilitation**

The land acquisition coat and infrastructure rehabilitation cost are as shown in the Table-4.4.1-9 and the Table-4.4.1-10 respectively. For further detail refer to Annex-9 Construction Planning and Cost Estimate, 4. Compensation.

**(5) Management cost of implementation agency**

The management cost of implementation agency is as shown in the Table-4.4.1-11.

**(6) Total project cost**

The total project cost is calculated as shown in the Table-4.4.1-12.

**(7) Operation and maintenance cost**

The operation and maintenance cost after completion of the Project is estimated as shown in the Table-4.4.1-14 (refer to Annex-9 Constructoion Planning and Cost Estimation).



**Table-4.4.1-1 Unit labor cost (1)**

(SOLES)

Items	Skilled Labor	Common Labor	Aassitant Labor	ChiefLabor **
Basic Wages (RB)	45.50	39.50	35.30	52.33
Bonus of Construction Dept. (BUC)	14.56	11.85	10.59	16.74
Social Benefit by Law Skilled Labor → 18.03% Common Labor → 17.83% AssitantLabor → .83%	53.70	46.54	41.59	61.76
Life Insurance ESSALUD - VIDA (S/. 5.00/month)	0.17	0.17	0.17	0.19
Work ware (2sets) -(2x90 / 303)	0.60	0.60	0.60	0.69
Transpotation Wages	7.20	7.20	7.20	8.28
<b>Daily Wages (8 hours)</b>	<b>121.73</b>	<b>105.86</b>	<b>95.45</b>	<b>139.99</b>
<b>Hourly Wages</b>	<b>15.22</b>	<b>13.23</b>	<b>11.93</b>	<b>17.50</b>

\*\* ) 15% increase of hourly wages of skilled labor

source: REVISTA DE LA CAMARA PERUANA DE LA CONSTRUCCION

**Table-4.4.1-1 Unit labor cost (2)**

	Description	Unit	Unit Price (soles)
1	Rock Driller Assistant	h	15.22
2	Surveyor	h	17.50
3	Chief Labor	h	17.50
4	Skilled Labor	h	15.22
5	Common Labor	h	13.23
6	AssitantLabor	h	11.93
7	Blasting specialist	h	17.50
8	Rock Driller	h	17.50

**Table-4.4.1-2 Unit price of main material**

	Material	Unit	Unit Price (soles)
1	Nail for wood C/C 3"	KG	3.69
2	Nail for calamina 1 1/2"	KG	6.15
3	Dynamite 65%	KG	7.29
4	Plus bit	No.	36.91

5	Drill hammer 7/8" X 3in	No.	295.32
6	Drill hammer 7/8" X 5in	No.	319.93
7	Plaster (28kg/sack)	sack	6.56
8	Train of powder	M	0.33
9	Primer	M	0.62
10	Installation of construction notice board	set	820.32
11	Wood 2" x 3" x 2.4M	No.	6.56
12	Control panel 4MM	sheet	30.16
13	Wooden pile	No.	1.64
14	Enamel paint	gallon	30.35
15	Galvanized roof sheet 1.83 x 0.90 x 0.3 mm	sheet	9.02
16	Anfo explosive	sack	57.75
17	Scale	No.	41.02
18	Fuel DIESEL N° 02	gallon	12.3
19	GEOTEXTILE	M2	5.2

**Table-4.4.1-3 Unit cost of main heavy equipment**

	Equipment	Unit	Unit Price(soles)
1	Compressor 335-375 PCM, 93 HP	h	98.44
2	Braker21 KG	h	20.51
3	Semi-trailer 6x4, 260-300 HP	L.S	10504.1
4	Staff&Pole	h	1.64
5	Water supply car 4 x 2(ASF) 178-210HP 2,000G	h	106.64
6	Theodlite	h	6.56
7	Tractors/O HP / D155X5	h	270.71
8	Back-hoe 158 HP / PC220	h	127.15
9	Dump truck 6X4 / 318 - 395 HP / 10 - 12 M3	h	110.74
10	Total station	h	13.14
11	Bulldozer 160-195 HP 3.5 YD3	h	159.66

**Table-4.4.1-4 Work quantities**

	Work	Unit	Quantities
			MAJES - CAMANA
<b>1.0</b>	<b>Temporary work</b>		
1.1	Field office	M2	1,150
1.2	Construction notice board	L.S.	7
1.3	Temporary road	KM	30
1.4	Equipment transportation	L.S.	
<b>2.0</b>	<b>Preparatory work 準備工事</b>		
2.1	Coordinates and leveling survey	M	26,600
2.2	Supervision of survey	M	26,600
2.3	Equipment transportation	L.S.	7
2.4	Removal of existing concrete	M3	0
2.5	Riverbed excavation	M3	
2.6	Soil disposal	M3	0
<b>3.0</b>	<b>Earth work</b>		
3.1	Riverbed excavation	M3	104,821
3.2	-ditto-	M3	695,325
3.3	Banking and compaction	M3	1,103,196
3.4	Ripper excavation	M3	303,050
3.5	Finishing slope of dike	M3	136,936
3.6	Soil disposal	M2	
3.7	Riverbed excavation(for structure)	M3	
<b>4.0</b>	<b>Bank protection</b>		
4.1	Quarry of rock with blasting	M3	400,293
4.2	Accumulation of boulders	M3	400,293
4.3	Transportation of boulders	M3	400,293
4.4	Rivetment	M3	142,701
4.5	Installation of boulders	M3	257,592
4.6	Supply and installation of GEOTEXTILE sheet	M2	275,443
<b>5.0</b>	<b>Concrete work</b>		
5.1	Form work	M2	0
5.2	Concrete placing (FC=210 KG/CM2)	M3	0
<b>6.0</b>	<b>Gabion work</b>		
6.1	Accumulation of crushed stone (6~8インチ)	M3	0
6.2	Transportation of crushed stone	M3	0
6.3	Installation of mattress basket(5.0x1.0x1.0)m	No.	0
6.4	Putting crushed stone into basket(5.0x1.0x1.0)m	M3	0
6.5	Covering basket(5.0x1.0x1.0)m	No.	0

**Table-4.4.1-5 Estimate of work unit cost (example of Majes-Camana River: Mc-1)**

Work Rate	Temprary field office				Unit cost per : M2	85.73
Code	Discription	Unit	Party	Quantities	Unit price	Sub total
<b>Labor cost</b>						
470101	Chief Labor	h	0.10	0.04	17.50	0.70
470102	Skilled Labor	h	1.00	0.40	15.22	6.09
470103	Common Labor	h	1.00	0.40	13.23	5.29
470104	Assistant Labor	h	3.00	1.20	11.93	14.32
						<b>26.40</b>
<b>Material cost</b>						
020105	Nail for woodC/C 3"	KG		0.30	3.69	1.11
020112	Nail for calamina 1 1/2"	KG		0.22	6.15	1.35
430101	Wood 2" x 3" x 2.4M	No.		4.00	6.56	26.24
430201	Control panel 4MM	sheet		0.75	30.16	22.62
560101	Galvanized roof sheet 1.83 x 0.90 x 0.3 mm	sheet		0.80	9.02	7.22
						<b>58.54</b>
<b>Equipment cost</b>						
370101	Hand tool	%		3.00	26.40	0.79
						<b>0.79</b>
Work Rate	Construction notice board				Unit cost per unit	922.20
Code	Discription	Unit	Party	Quantities	Unit price	Sub total
<b>Labor cost</b>						
470103	Common Labor	h	1.00	2.67	13.23	35.28
470104	Assistant Labor	h	2.00	5.33	11.93	63.63
						<b>98.91</b>
<b>Material cost</b>						
399095	Transportation & installation of notice board	unit		1.00	820.32	820.32
						<b>820.32</b>
<b>Equipment cost</b>						
370101	Hand tool	%		3.00	98.91	2.97
						<b>2.97</b>
Work Rate	Temporary road				Unit cost per KM	4,215.51
Code	Discription	Unit	Party	Quantities	Unit price	Sub total
<b>Labor cost</b>						
470101	Chief Labor	h	0.20	1.78	17.50	31.11
470103	Common Labor	h	1.00	8.89	13.23	117.60
470104	Assistant Labor	h	1.00	8.89	11.93	106.04

					254.75	
<b>Material cost</b>						
910101	Fuel DIESEL N° 02	gallon		106.49	12.30	1,309.83
						1,309.83
<b>Equipment cost</b>						
370101	Hand tool	%		3.00	254.75	7.64
490101	Water supply car 4 x 2(ASF) 178-210HP 2,000G	h	0.25	2.22	106.64	236.98
499401	Tractor S/O HP / D155X5	h	1.00	8.89	270.71	2,406.31
						2,650.93

---

<b>Work</b>	Coordinates & Levelling survey			
<b>Rate</b>	500 (m/day)	Unit cost per M	1.15	

---

Code	Discription	Unit	Party	Quantities	Unit price	Sub total
<b>Labor cost</b>						
470032	Surveyor	h	1.00	0.02	17.50	0.28
470104	Assistant Labor	h	3.00	0.05	11.93	0.57
						0.85
<b>Material cost</b>						
300201	Plaster (28kg/sack)	sack		0.01	6.56	0.03
540242	Enamel paint	gallon		0.00	30.35	0.03
						0.06
<b>Equipment cost</b>						
370101	Hand tool	%		3.00	0.85	0.03
499701	Total station	h	1.00	0.02	13.14	0.21
						0.24

---

<b>Work</b>	Supervision of survey			
<b>Rate</b>	300 (m/day)	Unit cost per M	1.79	

---

Code	Discription	Unit	Party	Quantities	Unit price	Sub total
<b>Labor cost</b>						
470032	Surveyor	h	1.00	0.03	17.50	0.47
470104	Assistant Labor	h	2.00	0.05	11.93	0.64
						1.11
<b>Material cost</b>						
300201	Plaster (28kg/sack)	sack		0.00	6.56	0.02
439901	Wooden peg	No.		0.20	1.64	0.33
900101	Scale	No.		0.00	41.02	0.08
						0.43
<b>Equipment cost</b>						
370101	Hand tool	%		3.00	1.11	0.03
375401	Staff& pole	h	1.00	0.03	1.64	0.04
491901	Theodlite	h	1.00	0.03	6.56	0.18
						0.25

---

<b>Work</b>	Transportation of heavy			
-------------	-------------------------	--	--	--

*Preparatory study about the protection program for  
valleys and rural communities vulnerable to floods in Peru  
Final Report I-5 Main Report Project Report (Majes-Camana River)*

---

	equipment		
<b>Rate</b>	1 (set/day)	Unit cost per set	10,504.11

---

Code	Discription	Unit	Party	Quantities	Unit price	Sub total
	<b>Equipment cost</b>					
320201	Semi-trailer 6x4, 260-300 HP	set	1.00	1.00	10,504.11	10,504.11
						<b>10,504.11</b>

---



---

<b>Work</b>	Riverbed excavation		
<b>Rate</b>	800 (m3/day)	Unit cost per M3	4.18

---

Code	Discription	Unit	Party	Quantities	Unit price	Sub total
	<b>Labor cost</b>					
470101	Chief Labor	h	0.20	0.00	17.50	0.04
470103	Common Labor	h	1.00	0.01	13.23	0.13
						<b>0.17</b>
	<b>Material cost</b>					
910101	Fuel DIESEL N° 02	gallon		0.11	12.30	1.29
						<b>1.29</b>
	<b>Equipment cost</b>					
370101	Hand tool	%		3.00	0.17	0.01
499401	Tractor S/O HP / D155X5	h	1.00	0.01	270.71	2.71
						<b>2.72</b>

---



---

<b>Work</b>	Transportation of back-fill soil		
<b>Rate</b>	1,100 (m3/day)	Unit cost per M3	6.05

---

Code	Discription	Unit	Party	Quantities	Unit price	Sub total
	<b>Labor cost</b>					
470101	Chief Labor	h	0.20	0.00	17.50	0.03
470103	Common Labor	h	1.00	0.01	13.23	0.10
						<b>0.13</b>
	<b>Material cost</b>					
910101	Fuel DIESEL N° 02	gallon		0.14	12.30	1.77
						<b>1.77</b>
	<b>Equipment cost</b>					
370101	Hand tool	%		3.00	0.13	0.00
499501	Hand tool	h	1.00	0.01	127.15	0.93
499601	Dump truck 6X4 / 318 - 395 HP / 10 - 12 M3	h	4.00	0.03	110.74	3.22
						<b>4.15</b>

---



---

<b>Work</b>	Banking & compaction		
<b>Rate</b>	900 (m3/day)	Unit cost per M3	3.71

---

Code	Discription	Unit	Party	Quantities	Unit price	Sub total
------	-------------	------	-------	------------	------------	-----------

<b>Labor cost</b>						
470101	Chief Labor	h	0.20	0.00	17.50	0.03
470103	Common Labor	h	1.00	0.01	13.23	0.12
						<b>0.15</b>
<b>Material cost</b>						
910101	Fuel DIESEL N° 02	gallon		0.09	12.30	1.15
						<b>1.15</b>
<b>Equipment cost</b>						
370101	Hand tool	%		3.00	0.15	0.00
499401	Tractor S/O HP / D155X5	h	1.00	0.01	270.71	2.41
						<b>2.41</b>

<b>Work</b>	Ripper excavation					
<b>Rate</b>	300 (m3/day)			Unit cost per M3	4.76	

Code	Discription	Unit	Party	Quantities	Unit price	Sub total
<b>Labor cost</b>						
470101	Chief Labor	h	0.20	0.01	17.50	0.09
470103	Common Labor	h	1.00	0.03	13.23	0.35
						<b>0.44</b>
<b>Material cost</b>						
910101	Fuel DIESEL N° 02	gallon		0.07	12.30	0.92
						<b>0.92</b>
<b>Equipment cost</b>						
370101	Hand tool	%		3.00	0.44	0.01
499501	Back-hoe 158 HP / PC220	h	1.00	0.03	127.15	3.39
						<b>3.40</b>

<b>Work</b>	Finishing slope of dike					
<b>Rate</b>	1,100 (m2/day)			Unit cost per M2	1.55	

Code	Discription	Unit	Party	Quantities	Unit price	Sub total
<b>Labor cost</b>						
470101	Chief Labor	h	0.20	0.00	17.50	0.03
470103	Common Labor	h	1.00	0.01	13.23	0.10
						<b>0.13</b>
<b>Material cost</b>						
910101	Fuel DIESEL N° 02	gallon		0.04	12.30	0.49
						<b>0.49</b>
<b>Equipment cost</b>						
370101	Hand tool	%		3.00	0.13	0.00
499501	Back-hoe 158 HP / PC220	h	1.00	0.01	127.15	0.93
						<b>0.93</b>

<b>Work</b>	Quarry of rock by blasting					
<b>Rate</b>	90 (m3/day)			Unit cost per M3	27.49	

*Preparatory study about the protection program for  
valleys and rural communities vulnerable to floods in Peru  
Final Report I-5 Main Report Project Report (Majes-Camana River)*

Code	Discription	Unit	Party	Quantities	Unit price	Sub total
<b>Labor cost</b>						
010101	Skilled Labor	h	2.00	0.18	15.22	2.71
470101	Chief Labor	h	0.20	0.02	17.50	0.31
470103	Common Labor	h	1.00	0.09	13.23	1.18
470104	Assistant Labor	h	1.00	0.09	11.93	1.06
470105	Blasting Specialist	h	1.00	0.09	17.50	1.56
980101	Rock Driller	h	2.00	0.18	17.50	3.11
						<b>9.93</b>
<b>Material cost</b>						
070101	Dynamite · 65%	KG		0.12	7.29	0.85
080101	Plus bit	No.		0.01	36.91	0.18
090101	Dril hammer7/8" X 3in	No.		0.00	295.32	0.35
100101	Drill hammer7/8" X 5in	No.		0.00	319.93	0.38
308601	Train of powder	M		0.89	0.33	0.29
308602	Primer	M		0.31	0.62	0.19
790101	Anfo explosive	sack		0.00	57.75	0.11
910101	Fuel DIESEL N° 02	gallon		0.20	12.30	2.51
						<b>4.86</b>
<b>Equipment cost</b>						
110101	Compressor 335-375 PCM, 93 HP	h	1.00	0.09	98.44	8.75
120101	Braker21 KG	h	2.00	0.18	20.51	3.65
370101	Hand tool	%		3.00	9.93	0.30
						<b>12.70</b>

<b>Work</b>	Accumulation of boulders					
<b>Rate</b>	100 (m3/day)			Unit cost per M3	15.65	

Code	Discription	Unit	Party	Quantities	Unit price	Sub total
<b>Labor cost</b>						
470101	Chief Labor	h	0.20	0.02	17.50	0.28
470103	Common Labor	h	1.00	0.08	13.23	1.06
						<b>1.34</b>
<b>Material cost</b>						
910101	Fuel DIESEL N° 02	gallon		0.33	12.30	4.10
						<b>4.10</b>
<b>Equipment cost</b>						
370101	Hand tool	%		3.00	1.34	0.04
499501	Back-hoe158 HP / PC220	h	1.00	0.08	127.15	10.17
						<b>10.21</b>

<b>Work</b>	Transportation of boulders					
<b>Rate</b>	220 (m3/day)			Unit cost per M3	48.17	

Code	Discription	Unit	Party	Quantities	Unit price	Sub total
<b>Labor cost</b>						
470101	Chief Labor	h	0.20	0.01	17.50	0.13
470103	Common Labor	h	1.00	0.04	13.23	0.48



*Preparatory study about the protection program for  
valleys and rural communities vulnerable to floods in Peru  
Final Report I-5 Main Report Project Report (Majes-Camana River)*

470104	Assistant Labor	h	1.00	0.04	11.93	0.43
						<b>1.04</b>
	<b>Material cost</b>					
910101	Fuel DIESEL N° 02	gallon		1.82	12.30	22.34
						<b>22.34</b>
	<b>Equipment cost</b>					
370101	Hand tool	%		3.00	1.04	0.03
499501	Back-hoe158 HP / PC220	h	1.00	0.04	127.15	4.63
499601	Dump truck6X4 / 318 - 395 HP / 10 - 12 M3	h	5.00	0.18	110.74	20.13
						<b>24.79</b>

<b>Work</b>	Revetment					
<b>Rate</b>	150 (m3/day)			Unit cost per M3	14.92	

Code	Discription	Unit	Party	Quantities	Unit price	Sub total
	<b>Labor cost</b>					
470101	Chief Labor	h	0.20	0.01	17.50	0.19
470103	Common Labor	h	1.00	0.05	13.23	0.71
470104	Assistant Labor	h	6.00	0.32	11.93	3.82
						<b>4.72</b>
	<b>Material cost</b>					
910101	Fuel DIESEL N° 02	gallon		0.27	12.30	3.28
						<b>3.28</b>
	<b>Equipment cost</b>					
370101	Hand tool	%		3.00	4.72	0.14
499501	Back-hoe158 HP / PC220	h	1.00	0.05	127.15	6.78
						<b>6.92</b>

<b>Work</b>	Installation of boulders					
<b>Rate</b>	200 (m3/day)			Unit cost per M3	9.43	

Code	Discription	Unit	Party	Quantities	Unit price	Sub total
	<b>Labor cost</b>					
470101	Chief Labor	h	0.50	0.02	17.50	0.35
470103	Common Labor	h	1.00	0.04	13.23	0.53
470104		h	2.00	0.08	11.93	0.95
						<b>1.83</b>
	<b>Material cost</b>					
910101	Fuel DIESEL N° 02	gallon		0.20	12.30	2.46
						<b>2.46</b>
	<b>Equipment cost</b>					
370101	Hand tool	%		3.00	1.83	0.05
499501	Back-hoe158 HP / PC220	h	1.00	0.04	127.15	5.09
						<b>5.14</b>

<b>Work</b>	Supply & installation of GEOTEXTILE					
<b>Rate</b>	600 (m2/day)			Unit cost per M2	6.00	

Code	Discription	Unit	Party	Quantities	Unit price	Sub total
<b>Labor cost</b>						
470101	Chief Labor	h	0.10	0.00	17.50	0.02
470103	Common Labor	h	1.00	0.01	13.23	0.18
470104		h	2.00	0.03	11.93	0.32
						<b>0.52</b>
<b>Material cost</b>						
940201	GEOTEXTILE	M2		1.05	5.20	5.46
						<b>5.46</b>
<b>Equipment cost</b>						
370101	Hand tool	%		3.00	0.52	0.02
						<b>0.02</b>

---

**Table-4.4.1-6 Direct cost(private price and social price)**

Basin		Name of Facility		Direct Cost 直接工事費計											
				River Structure		Plantation		Environmental Work		Disaster Prevention Education/Capacity Development		Rehabilitation of Existing Facility			
		Private Price 民間価格 (PP)	Social Price 社会価格 (PS)	Private Price 民間価格 (PP)	Social Price 社会価格 (PS)	Private Price 民間価格 (PP)	Social Price 社会価格 (PS)	Private Price 民間価格 (PP)	Social Price 社会価格 (PS)	Private Price 民間価格 (PP)	Social Price 社会価格 (PS)	Private Price 民間価格 (PP)	Social Price 社会価格 (PS)		
Majes-Camana		MC-1	8,130,313	6,759,640	30,888	24,836						97,271	80,443		
		MC-2	2,776,927	2,309,566	13,528	10,869									
		MC-3	10,548,430	8,763,887	40,584	32,606									
		MC-4	2,861,288	2,382,930	28,030	22,520							94,860	78,449	
		MC-5	7,211,419	5,998,561	44,047	35,388							115,699	95,683	
		MC-6	9,075,444	7,552,681	72,077	57,908							94,860	78,449	
		MC-7	6,862,786	5,716,072	39,042	31,367							762,163	630,309	
<b>SUB TOTAL</b>		<b>47,486,607</b>	<b>39,483,537</b>	<b>268,196</b>	<b>215,492</b>	<b>1,043,414</b>	<b>884,249</b>	<b>144,050</b>	<b>124,788</b>	<b>1,164,852</b>	<b>963,332</b>				

**Table 4.4.1-7 Consultant cost for detail design stage(for 4 basins)**

	Item	Unit	Qty	Foreign Portion		Local Portion		Combined	
				(Yen)		(soles)		Total	
				Rate	Amount ('000)	Rate	Amount ('000)	Amount ('000)	
A	Remuneration								
	1	Professional (A)	M/M	44	2,500,000	110,000	0	0	110,000
	2	Professional (B)	M/M	70	0	0	10,000	700	19,670
	3	Supporting Staffs	M/M	312	0	0	4,000	1,248	35,069
		Subtotal of A				110,000		1,948	164,739
B	Direct Cost								
	1	International Airfare		17	1,057,200	17,972	0	0	17,972
	2	Domestic Airfare (Duty Trip)		16		0	1,096	18	493
	3	Domestic Travel				0	0	0	0
	4	Accommodation Allowance (Pro A)	Month	44		0	5,480	241	6,775
		(Pro.B)	Month	70		0	2,740	192	5,390
	5	Per Diem for Duty Trip	Day	48		0	137	7	185
	6	Vehicle Rental	Month	0		0	5,480	0	0
	7	Office Rental	M/M	3		0	274	1	23
	8	International Communications	M/M	16		0	2,740	44	1,232
	9	Domestic Communications	M/M	16		0	1,370	22	616
	10	Office Supply	M/M	16		0	548	9	246
	11	Office Furniture and Equipment	L.M	1		0	54,800	55	1,540
	12	Report Preparation					0		
	1)	Detailed Design	Volume	12		0	55	1	18
	2)	Bid Documents	Volume	16		0	55	1	25
	3)	Monthly and Quaterly Progress R	Volume	28		0	55	2	43
	4)	Completion Report	Volume	5		0	55	0	8
	5)	Other Notes and Documents	Volume	10		0	55	1	15
	13	Sub-Contracting Work					0	0	0
		Topographic Survey	Site	4		0	137,000	548	15,399
		Geotechnical Investigation	Site	4		0	82,200	329	9,239
		Environmental Monitoring	Site	4		0	68,500	274	7,699
	14	Technical & PCM	time	4		0	8,220	33	924
		Subtotal of B				17,972		1,775	67,843
		A+B				127,972		3,723	232,582
		A+B(soles)							8,276,940
		C: VAT(18%)(soles)							1,489,849
		Total A+B+C(soles)							9,766,778

**Table 4.4.1-8 Consultant cost for construction supervision stage (for 4 basins)**

Item	Unit	Qty	Foreign Portion		Local Portion		Combined Total	
			(Yen)		(soles)		(yen)	
			Rate	Amount ('000)	Rate	Amount ('000)	Amount ('000)	
<b>A Remuneration</b>								
1	Professional (A)	M/M	82	2,500,000	205,000	0	0	205,000
2	Professional (B)	M/M	135	0	0	10,000	1,350	37,935
3	Supporting Staffs	M/M	336	0	0	4,000	1,344	37,766
	Subtotal of A				205,000		2,694	280,701
<b>B Direct Cost</b>								
1	International Airfare		8	1,057,200	8,458	0	0	8,458
2	Domestic Airfare (Duty Trip)		29		0	1,096	32	893
3	Domestic Travel		0		0	0	0	0
4	Accommodation Allowance (Pro A)	Month	82		0	5,480	449	12,627
	(Pro.B)	Month	135		0	2,740	370	10,394
5	Per Diem for Duty Trip	Day	87		0	137	12	335
6	Vehicle Rental	Month	159		0	5,480	871	24,484
7	Office Rental	M/M	138		0	274	38	1,063
8	International Communications	M/M	29		0	2,740	79	2,233
9	Domestic Communications	M/M	29		0	1,370	40	1,116
10	Office Supply	M/M	29		0	548	16	447
11	Office Furniture and Equipment	L.M	0		0	54,800	0	0
12	Report Preparation					0		
1)	Detailed Design	Volume	0		0	55	0	0
2)	Bid Documents	Volume	0		0	55	0	0
3)	Monthly and Quaterly Progress R	Volume	29		0	55	2	45
4)	Completion Report	Volume	0		0	55	0	0
5)	Other Notes and Documents	Volume	0		0	55	0	0
13	Sub-Contracting Work		0			0	0	0
	Topographic Survey	Site	0		0	137,000	0	0
	Geotechnical Investigation	Site	0		0	82,200	0	0
	Environmental Monitoring	Site	0		0	68,500	0	0
14	Technical & PCM	time	6		0	8,220	49	1,386
	Subtotal of B				8,458		1,958	63,480
	A+B				213,458		4,652	344,181
	A+B (soles)							12,248,434
	C: VAT(18%)(soles)							2,204,718
	Total A+B+C(soles)							14,453,162

**Table 4.4.1-9 Land acquisition cost (soles)**

Basin	Rural Area A	Rural Area B	Total
Majes-Camaná	917,730	4,010,426	4,928,156

**Table 4.4.1-10 Rehabilitation cost of existing facility (direct cost)**

Soles

Basin	Hydraulic Infrastructure			Road			Total
	Intake	Outlet	Channel	National	Departmental	Others	
Majes-Camaná	194,542	917,033	53,277	0	0	0	1,164,852

**Table-4.4.1-11 Administration cost of implementation agency (for 4 basins)**

	Item	Rate (US\$)	Rate (soles)	Period (month)	Total(soles)
<b>A</b>	<b>Program Management Unit (PMU)</b>				
1	Project Manager	6,000	16,320	36	587,520
2	Contact specialist	5,000	13,600	36	489,600
3	Secretary	1,200	3,264	36	117,504
4	Construction supervisor (Cañete river)	3,500	9,520	30	285,600
5	Construction supervisor (Chincha river)	3,500	9,520	30	285,600
6	Construction supervisor (Majes-Camana river)	3,500	9,520	30	285,600
7	Construction supervisor (Majes-Camana river)	3,500	9,520	30	285,600
8	IT Engineer	2,750	7,480	36	269,280
9	Procurement specialist	3,300	8,976	36	323,136
10	Financial manager	3,300	8,976	36	323,136
11	Organization specialist (Adviser for irrigation committee)	3,300	8,976	36	323,136
12	Environmental assessment specialist	3,300	8,976	30	269,280
13	Archaeological specialist	3,300	8,976	30	269,280
14	Accountant	4,200	11,424	36	411,264
15	Driver ①	1,200	3,264	36	117,504
16	Driver ②	1,200	3,264	36	117,504
17	Driver ③	1,200	3,264	36	117,504
Subtotal					<b>4,878,048</b>
<b>B</b>	<b>Audit Cost</b>				
1	2012 year	25,000	68,000		68,000
2	2013 year	40,000	108,800		108,800
3	2014 year	40,000	108,800		108,800
4	2015 year	50,000	136,000		136,000
Subtotal					<b>421,600</b>
<b>C</b>	<b>Capacity Building</b>				
<b>C1</b>	<b>For JICA Project</b>				
1	Project manager	30	81.60	100	8,160
2	Contact specialist	30	81.60	100	8,160
3	Lawyer	30	81.60	100	8,160
4	Construction supervisor (Cañete river)	30	81.60	100	8,160

5	Construction supervisor (Chincha river)	30	81.60	100	8,160
6	Construction supervisor (Majes-Camana river)	30	81.60	100	8,160
7	Construction supervisor (Majes-Camana river)	30	81.60	100	8,160
8	Miscellaneous procurement specialist	30	81.60	100	8,160
9	Accountant ①	30	81.60	100	8,160
10	Accountant ②	30	81.60	100	8,160
	Subtotal				<b>81,600</b>
<b>C2 Capacity Building</b>					
1	Project manager (management and finance)	10,000	27,200		27,200
2	Contract specialist(management and finance))	10,000	27,200		27,200
3	Lawyer	8,000	21,760		21,760
4	Construction supervisor (Cañete river)	8,000	21,760		21,760
5	Construction supervisor (Chincha river)	8,000	21,760		21,760
6	Construction supervisor (Majes-Camana river)	8,000	21,760		21,760
7	Construction supervisor (Majes-Camana river)	8,000	21,760		21,760
8	IT engineer ①	8,000	21,760		21,760
9	IT engineer ②	8,000	21,760		21,760
10	Miscellaneous procurement specialist (contrac)	8,000	21,760		21,760
11	Accountant ① (accounting and finance)	8,000	21,760		21,760
12	Accountant ② (accounting and finance)	8,000	21,760		21,760
	Subtotal				<b>272,000</b>
<b>D Procurement of Equipment</b>					
1	Office funituturs	50,000	136,000	1	136,000
2	PC & copy maschine	35,000	95,200	1	95,200
3	Vhicle ① (4WD)	32,000	87,040	1	87,040
4	Vhicle ② (4WD)	32,000	87,040	1	87,040
5	Vhicle ③ (4WD)	32,000	87,040	1	87,040
6	Fuel & car maintenance	2,880	7,834	36	282,010
7	Office suply	1,000	2,720	36	97,920
	Subtotal				<b>872,250</b>
<b>E Monitoring of Project</b>					

*Preparatory study about the protection program for  
valleys and rural communities vulnerable to floods in Peru  
Final Report I-5 Main Report Project Report (Majes-Camana River)*

1	Administrator (project monitoring)	4,050	11,016	36	396,576
2	Engineer (project monitoring)	3,300	8,976	36	323,136
3	Consultant (organizing irrigation committee information & capacity building))	100,000	272,000	1	272,000
4	Consultant (preparation of completion report)	80,000	217,600	1	217,600
5	Air ticket	2,000	5,440	36	195,840
6	Per diem	6,000	16,320	36	587,520
	<b>1,992,672</b>				<b>1,992,672</b>
<b>Total</b>					<b>8,518,170</b>



Table-4.4.1-12 Total project cost (private price)

Name of Basin	Direct Cost					Indirect Cost					Consultant Cost			Infrastructure Cost Total Cost	Land Aquisition Cost	Cost Total for Basin	
	COMPONENT A				Direct Cost	Overhead	Profit	Work Cost	Tax(IGV)	Total Construction Cost	Detatil Design Cost	Construction Supervision Cost	Total Construction Cost				
	Sutstructure Cost		Aforestation/ Reforestation	Environmental Cost													COMPONENT B
	Flood Prevention Facility	Rehabilitation cost of Existing Structure			Disaster Prevention Education/ Capacity Development												
(1)-1	(1)-2	(2)	(3)	(4)	(5)=(1)+(2)+(3)+(4)	(6) = 0.15 x (5)	(7) = 0.1 x (5)	(8) = (5)+(6)+(7)	(9) = 0.18 x (8)	(10) = (8)+(9)	(11)	(12)	(13)=(11)+(12)	(14)=(10)+(13)	(15)	(17)=(14)+(15)+(16)	
MAJES-CAMANA	47,466,607	1,164,852	268,196	1,043,414	144,050	50,087,119	7,513,068	5,008,712	62,608,899	11,269,602	73,878,501	3,615,898	5,350,910	8,966,808	82,845,309	4,946,510	87,791,820

Table-4.4.1-13 Total project cost (social price)

Name of Basin	Total Construction Cost (Private Price)	Factor of Correction	Total Construction Cost (Social Price)	Consultant Cost			Infrastructure Cost Total Cost	Land Acquisition Cost	Cost Total for Basin
				Detail Design Cost	Construction Supervision Cost	Total Construction Cost			
(10) = (8)+(9)	(11)	(12)	(13)=(11)+(12)	(14) = (10)+(13)	(15)	(17) = (14)+(15)+(16)			
MAJES-CAMANA	73,878,501	0.832	61,465,314	3,240,727	4,830,303	8,071,030	69,536,344	4,304,833	73,841,176

Table-4.4.1-14 Annual operation and maintenance cost

Basin	Cost(soles) (Private Price)	Ratio to Construction Cost (%)	Cost (soles) (Social Price)	Ratio to Construction Cost (%)
Majes-Camana	709,880	0.9	603,398	0.9



#### 4.4.2 Cost Estimate (at Social Price)

The direct cost at social price is as shown in the previous Table-4.4.1-6. The consultant cost, land acquisition cost and administration cost of the implementation agency are converted from the private price to the social price. The total project cost at social price is calculated as shown in the Table - 4.4.1-13.

The social price is calculated by multiplying the private price (labor cost, material cost and equipment cost) with the standard conversion factor (SCF). SCF is the ratio of the private price in domestic and the social price calculated at the border with respect to all goods of the country's economy,

In this study, economic evaluation is calculated based on the Guidelines which are available in Peru (Guideline of the National Public Investment System (Directorial Resolution No. 003-2011-EF/68.01, Annex SNIP 10-V3.1)). Ministry of Economy and Finance is indicated SCF as shown in Table -4.4.2-1.

**Table-4.4.2-1 Standard conversion factor (SCF)**

<b>Correction Factors for Social Rates (Methodology MEF)</b>	
<b>DESCRIPCION</b>	<b>VALOR</b>
<b>·National Property Expenditures</b>	0.85
<b>·Imported Goods Expenditures</b>	0.92
<b>·Indirect Imported Goods Expenditures*</b>	
Tasa Ad. Valorem	0.12
General Sales Tax Rate	0.18
<b>·Currency correction factor</b>	1.08
<b>·Fuel costs</b>	0.66
<b>·Indirect costs (administrative and financial)</b>	0.85
Legal entity	0.85
Natural Person	0.91
<b>·Expenditures on skilled labor</b>	0.91
<b>·Expenditures on non skilled labor</b>	0.68
Lima Metropolitana urbano	0,86
Urban Coast Region	0,68
Rural Coast Region	0,57
Urban Sierra Region	0,60
Urban Sierra Region	0,41
Urban Forest Region	0,63
Rural Forest Region	0,49
<b>·Indirect taxes Manpower **</b>	
Fourth Category Rate for Non-Personal Services (10%)	0.91

As an example, the process of conversion from private price to social price for the direct cost of river structures is as shown in the Table-4.4.2-2. For other costs the process is shown in the Annex-10 Socio-economy and Economic Evaluation, Attachment-3.



## **4.5 Social Assessment**

### **4.5.1 Private Prices Costs**

#### **(1) Benefits**

Flood control benefits are flood loss reduction that would be achieved by the implementation of the Project and is determined by the difference between the amount of loss with and without Project. Specifically, in order to determine the benefits that will be achieved by the works' construction. First, the flood amount per flood loss of the different return periods (between 2 to 50 years) is calculated; assuming that the flood control works have a useful life of 50 years. To finish, determine the annual average amount of the loss reduction from the loss amount of different return periods. [The Methodological Guideline for Protection and/or Flood Control Projects in agricultural or urban areas, 4.1.2p-105] establishes similar procedures. Above find the description of the procedures to determine concrete benefits.

- ① Determine the flood loss amount in the flood area by analyzing the magnitude of overflow that occurs without the Project for each return period (between 2 and 50 years).
- ② After, determine the amount of flood loss in the flood area by analyzing the magnitude of overflow that occurs when flood control priority works are built.
- ③ Determine the difference between ① and ②. Add the benefits of other works different than dikes (intakes, roads protection, etc.) in order to determine the total profits.

“Benefits of the Project” are considered as the sum of direct loss amount caused by overflow and indirect loss caused by the destruction of structures in vulnerable sections (farmland loss, interruption of traffic, etc.)

#### 1) Method of loss amount calculation

In this study, the amount of loss from direct and indirect damages to the variables listed in Table 4.5.1-1 was determined.

**Table 4.5.1-1 Flood loss amount calculation variables**

Loss	Variables	Description
(1) Direct	① Crops	<ul style="list-style-type: none"> <li>• Crops in flooding season The amount of crop loss by flooding is determined by multiplying the damage % regarding water depth and the number of days flooded</li> <li>• Agricultural land and infrastructure (channels, etc.)</li> <li>• Crop loss amount is determined by multiplying the damage % regarding water depth and the number of days flooded</li> </ul>
	② Hydraulic Works	<ul style="list-style-type: none"> <li>• Loss amount due to hydraulic structures destruction (intakes, channels, etc.).</li> </ul>
	③ Road Infrastructures	<ul style="list-style-type: none"> <li>• Flood damage related to road infrastructure is determined by the damage in transport sector</li> </ul>
	④ Housing	<ul style="list-style-type: none"> <li>• Residential and industrial buildings It is calculated applying the loss coefficient depending on the flood depth Housing: residential and industrial buildings; household goods: furniture, household appliances, clothing, vehicles, etc. Flood damages in housing, commercial buildings, assets and inventories (buildings and assets) is determined applying the loss coefficient according to the flood depth</li> </ul>
	⑤ Public Infrastructures	<ul style="list-style-type: none"> <li>• Determine the loss amount in roads, bridges, sewers, urban infrastructures, schools, churches and other public facilities</li> <li>• Determine the loss amount in public works by applying the correspondent coefficient to the general assets loss amount</li> </ul>
	⑥ Public Services	<ul style="list-style-type: none"> <li>• Electricity, gas, water, rail, telephone, etc.</li> </ul>
(2) Indirect	① Agriculture	<ul style="list-style-type: none"> <li>• Estimate the loss caused by irrigation water interruption due to the damage of hydraulic structures</li> <li>• Determine the construction and repair costs of hydraulic structures such as direct year costs</li> </ul>
	② Traffic Interruption	<ul style="list-style-type: none"> <li>• Estimate the loss lead by traffic interruption due to damages on flooded roads</li> <li>• Determine road's repair and construction costs as damage direct cost</li> </ul>

i) Direct loss

Direct loss is determined by multiplying the damage coefficient according to the inundation depth as the asset value.

ii) Indirect Loss

Indirect loss is determined taking into account the impact of intakes and damaged roads. Below, calculation procedures are described.

● Intake damage

The loss amount due to intake damage is calculated by adding the direct loss (intake's rehabilitation and construction) and the indirect loss amount (harvest loss due to the interruption of irrigation water supply)

① Calculating the infrastructure cost

Works Cost = construction cost per water unit taken × size (flow, work length)

Unit cost of the work: for intakes and channels, it is required to gather information on the water intake volume of the existing work and the works' execution cost (construction or repair). The unit cost is calculated by analyzing the correlation among them both.

It was estimated that the work will be completely destroyed by the flow with a return period of 10 years.

② Crop loss

Annual earnings are determined according to the crops grown in the correspondent irrigation district.

Annual Profit = (crops selling - cost) × frequency of annual harvest

Crop Sale = planted area (ha) × yield (kg/ha) × transaction unit price

Cost = unit cost (s/ha) × planted area (ha)

● Road infrastructure damage

Determine the loss due to traffic interruption

Amount of loss = direct loss + indirect loss

Direct loss: road construction cost (construction, rehabilitation)

Indirect Loss: opportunity loss cost due to road damage (vehicle depreciation + staff expenses loss)

Then, a 5 days period takes place of non-traffic ability (usually in Peru it takes five days to complete the rehabilitation of a temporary road)

2) Loss estimated amount according to different return periods

The loss amount according to the different return periods is calculated as shown in the Table 4.5.1-2. For further detail refer to I-7 Data Book.

**Table 4.5.1-2 Estimated loss by flooding at private price (Majes-Camana river)**

(1,000 soles)

Description	Majes river		Camana river	
	Without Project	With Project	Without Project	With Project
Agricultural Product	102,748	27,026	24,265.10	8,868
Hydraulic Structure	24,562	6,042	6,291.29	3,028
Road	18,611	5,303	2,059.50	272
Housing	4,809	105	5,974.00	0
Public Facility	1,045	21	1,318.50	0
Public Service	119	69	186.75	0
<b>TOTAL</b>	<b>151,895</b>	<b>38,566</b>	<b>40,095.15</b>	<b>12,168</b>

In the Table 4.5.1-3, the estimated amounts of loss by flooding of different return periods with or without Project is shown.

**Table 4.5.1-3 Loss estimated value (at private prices)**

(10<sup>3</sup> Soles)

Case	t	Private Price
		Majes-Camana
Without Project	2	311
	5	48,616
	10	78,391
	25	111,072
	50	191,990
	Total	430,380
With Project	2	0
	5	8,349
	10	18,278
	25	31,256
	50	50,734
	Total	108,617

The estimated loss by flood without project in return period of 50- year will be 208.8 million soles in Majes-Camana.

3) Loss amount (annual average) expected to be reduced by the Project

The average annual damage reduction amount is calculated by multiplying the annual damage reduction corresponding to probable flood with occurrence probability and by accumulating the annual damage reduction of each probable flood. The calculation method is as shown in the Table 4.5.1-4.

**Table 4.5.1-4 Calculation method of annual average of loss reduction amount**

Probabilities	Loss Amount			Average path's loss	Paths' Probabilities	Loss reduction annual average amount
	Without Project	With Project	Loss Reduction			
1/1			$D_0 = 0$			
1/2	$L_1$	$L_2$	$D_1 = L_1 - L_2$	$(D_0 + D_1)/2$	$1 - (1/2) = 0,500$	$d_1 = (D_0 + D_1)/2 \times 0,67$
1/5	$L_3$	$L_4$	$D_2 = L_3 - L_4$	$(D_1 + D_2)/2$	$(1/2) - (1/5) = 0,300$	$d_2 = (D_1 + D_2)/2 \times 0,300$
1/10	$L_5$	$L_6$	$D_3 = L_5 - L_6$	$(D_2 + D_3)/2$	$(1/5) - (1/10) = 0,100$	$d_3 = (D_2 + D_3)/2 \times 0,100$
1/20	$L_7$	$L_8$	$D_4 = L_7 - L_8$	$(D_3 + D_4)/2$	$(1/10) - (1/20) = 0,050$	$d_4 = (D_3 + D_4)/2 \times 0,050$
1/30	$L_9$	$L_{10}$	$D_5 = L_9 - L_{10}$	$(D_4 + D_5)/2$	$(1/20) - (1/30) = 0,017$	$d_5 = (D_4 + D_5)/2 \times 0,017$
1/50	$L_{11}$	$L_{12}$	$D_6 = L_{11} - L_{12}$	$(D_5 + D_6)/2$	$(1/30) - (1/50) = 0,013$	$d_6 = (D_5 + D_6)/2 \times 0,013$
1/100	$L_{13}$	$L_{14}$	$D_7 = L_{13} - L_{14}$	$(D_6 + D_7)/2$	$(1/50) - (1/100) = 0,010$	$d_7 = (D_6 + D_7)/2 \times 0,010$
Foreseen average annual amount of loss reduction				$d_1 + d_2 + d_3 + d_4 + d_5 + d_6 + d_7$		



4) Results of the loss amount calculation (annual average)

In Table 4.5.1-5 the results of the loss amount calculation are shown (annual average), which are expected to be reduced by implementing each river's Project.

**Table 4.5.1-5 Annual average of loss reduction amount (private prices)**

(10<sup>6</sup> Soles)

Basin	Return Period	Probability	Total Damage (10 <sup>6</sup> Soles)			Average Damage ④	Section Probability ⑤	Annual Average Damage ⑥=④×⑤	Accumulation of Annual Average Damage
			Without Project ①	With Project ②	Damage Reduction ③=①-②				
MAJES- CAMANA	1	1.000	0	0	0		0	0	
	2	0.500	311	0	311	155	0.500	78	
	5	0.200	48,618	8,349	40,269	20,289	0.300	6,087	
	10	0.100	78,391	18,278	60,113	50,191	0.100	5,019	
	25	0.040	111,072	31,256	79,816	69,965	0.060	4,198	
	50	0.020	191,990	50,734	141,256	110,536	0.020	2,211	17,592

**(2) Social assessment**

1) Assessment's objective and indicators

The social assessment's objective in this Study is to evaluate investment's efficiency in structural measures using the analysis method of cost-benefit (C/B) from the national economy point of view. For this, economic assessment indicators were determined (relation C/B, Net Present Value - NPV and IRR). The internal return rate (IRR) is an indicator that denotes the efficiency of the project's investment. It is the discount rate to match the current value of the project's generated cost regarding the benefit's current value. It is the discount rate necessary so the Net Present Value (NPV) equals zero and the relation C/B equals one. It also indicates the percentage of benefits generated by such investment. The internal return rate used in the economic assessment is called "economical internal return rate (EIRR)". The market price is turned into the economical price (costs at social prices) eliminating the impact of market distortion.

The IRR, C/B relation and NPV are determined applying mathematical expressions shown in the Table below. When IRR is greater than the social discount rate, the relation C/B is greater than one and NPV is greater than zero, it is considered that the project is efficient from the national economic growth point of view.

**Table 4.5.1-6 Evaluation indicator of economic benefit and its characteristics**

Indicators	Definition	Characteristics
Net Present Value (NPV)	$NPV = \sum_{i=1}^n \frac{B_i}{(1+r)^i} - \sum_{i=1}^n \frac{C_i}{(1+r)^i}$	- Allows comparing net benefit magnitude performed by the project - It varies depending on the social discount rate
Cost-Benefit Relation (C/B)	$B/C = \sum_{i=1}^n \frac{B_i}{(1+r)^i} / \sum_{i=1}^n \frac{C_i}{(1+r)^i}$	- Allows comparing the investment efficiency by the magnitude of benefit per investment unit - Varies depending on the social discount rate
Economical Internal Return Rate (EIRR)	$\sum_{i=1}^n \frac{B_i}{(1+r)^i} = \sum_{i=1}^n \frac{C_i}{(1+r)^i}$	- Allows knowing the investment efficiency comparing it to the social discount rate - Does not vary depending on the social discount rate

Where Bi: benefit per "i" year / Ci: cost per "i" year / r: social discount rate (11 %) / n: years of assessment

## 2) Assumptions

Next, find the assumptions of every indicator used from the economical assessment

### i) Assessment period

The assessment period is set between 2013 and 2027 (15 years after construction works started). This Project implementing schedule is the following:

2012: Detailed Design

2013-2014: Construction

2013-2027: Assessment Period

The assessment period is 15 years which is same period as the adopted period in the Perfil program report of this Project. The SNIP regulation stipulates that the assessment period is to be 10 years basically, however the period can be changed if the project formulation agency (DGIH in this Project) admits that it is necessary. DGIH adopted 15 years in the Perfil program report and which was approved by OPI and DGPI (March 19, 2010). In JICA's development project the evaluation period of 50 years is generally adopted, so that JICA Study Team inquired DGIH and OPI on this matter, they directed to adopt 15 years. In case of 50 years, the evaluation will be made in the Annex-14, Implementation Program of Japan Yen Loans Project.

### ii) Standard conversion factor (SCF)

The standard conversion factor (SCF) is the relationship between socioeconomic prices established along the border and national private prices of all goods in a country's economy. It is used to convert goods and services prices purchased in the local market at affordable prices. SCF is stipulated by MEF as shown in the previous Table 4.4.2-1.

### iii) Other preliminary conditions

Price level: 2011

Social discount rate: 10% (according to SNIP regulation)

Annual maintenance cost: estimated in the Table 4.4.1-14

## 3) Cost-benefit relation analysis

A comparison of the total cost and total benefit of flood control works converted to present values applying the social discount rate was performed. In this case, the total cost is the addition of construction, operation and maintenance costs. The total benefit is the loss amount that was reduced due to the works. For this, a base year was established for the conversion into the current value at the moment of the assessment, and the assessment period was set for the next 15 years from the beginning of the Project. The total cost was determined adding-up the construction, operation and maintenance costs of the works converted into present values; and the total benefit adding-up the annual average loss amount turned into current values.

In Table 4.5.1-7 results of calculations C/B, NPV and IRR to private prices is shown.

**Table 4.5.1-7 Social assessment (C/B, NPV, IRR) (at private prices)**

流域 Basin	年平均被害軽減額 Average Annual Damage Reduction Amount	評価期間被害 軽減額(15年) Damage Reduction Amount in Evaluation Period(15years)	事業費 Project Cost	維持管理費 Operation & Maintenance Cost	B/C Benefit and Cost Ratio	Net Present Value (NPV) Valor Actual Neto (VAN)	Internal Rate of Return (IRR) Tasa Interna de Retorno (TIR)
Majes-Camana	228,698,340	103,275,637	87,791,820	9,228,440	1.28	22,447,137	15%

The social evaluation at private price level is calculated as shown in the Table 4.5.1-8 for Majes-Camana river.

Table-4.5.1-8 Social evaluation at private prices(Majes-Camana river)

Period	Year	Cost										Salvage Value	Cost/Benefit (C/B)	Net Present Value (NPV)	Internal Rate of Return (IRR)		
		Expected Annual Average Reduction Benefit Value (PV) (1)	Construction Cost (C) (2)	Operation & Maintenance Cost (C) (3)	Plantation Cost (C) (4)	Environmental Cost (C) (5)	Disaster Prevention Education/Community Building Cost (C) (6)	Land Acquisition Cost (C) (7)	Implementation Agency Administration Cost (C) (8)	Total Cost (C) (9)	Total Present Value (PV) (10)						
Investment Construction Period	0		3812,988														
	1	173,249.7	2,182,566	27,117.37	158,922	1,151.12	18,272	1,725.25	2,741.47	2,452.29	341,588.8	3019,986	0	-31,159.8	-31.16%	18.7%	
	2	173,249.7	2,182,566	27,117.37	158,922	1,151.12	18,272	1,725.25	2,741.47	2,452.29	341,588.8	3019,986	0	-31,159.8	-31.16%	18.7%	
	3	173,249.7	2,182,566	27,117.37	158,922	1,151.12	18,272	1,725.25	2,741.47	2,452.29	341,588.8	3019,986	0	-31,159.8	-31.16%	18.7%	
	4	173,249.7	2,182,566	27,117.37	158,922	1,151.12	18,272	1,725.25	2,741.47	2,452.29	341,588.8	3019,986	0	-31,159.8	-31.16%	18.7%	
	5	173,249.7	2,182,566	27,117.37	158,922	1,151.12	18,272	1,725.25	2,741.47	2,452.29	341,588.8	3019,986	0	-31,159.8	-31.16%	18.7%	
	6	173,249.7	2,182,566	27,117.37	158,922	1,151.12	18,272	1,725.25	2,741.47	2,452.29	341,588.8	3019,986	0	-31,159.8	-31.16%	18.7%	
	7	173,249.7	2,182,566	27,117.37	158,922	1,151.12	18,272	1,725.25	2,741.47	2,452.29	341,588.8	3019,986	0	-31,159.8	-31.16%	18.7%	
	8	173,249.7	2,182,566	27,117.37	158,922	1,151.12	18,272	1,725.25	2,741.47	2,452.29	341,588.8	3019,986	0	-31,159.8	-31.16%	18.7%	
	9	173,249.7	2,182,566	27,117.37	158,922	1,151.12	18,272	1,725.25	2,741.47	2,452.29	341,588.8	3019,986	0	-31,159.8	-31.16%	18.7%	
	10	173,249.7	2,182,566	27,117.37	158,922	1,151.12	18,272	1,725.25	2,741.47	2,452.29	341,588.8	3019,986	0	-31,159.8	-31.16%	18.7%	
	11	173,249.7	2,182,566	27,117.37	158,922	1,151.12	18,272	1,725.25	2,741.47	2,452.29	341,588.8	3019,986	0	-31,159.8	-31.16%	18.7%	
	12	173,249.7	2,182,566	27,117.37	158,922	1,151.12	18,272	1,725.25	2,741.47	2,452.29	341,588.8	3019,986	0	-31,159.8	-31.16%	18.7%	
	13	173,249.7	2,182,566	27,117.37	158,922	1,151.12	18,272	1,725.25	2,741.47	2,452.29	341,588.8	3019,986	0	-31,159.8	-31.16%	18.7%	
	14	173,249.7	2,182,566	27,117.37	158,922	1,151.12	18,272	1,725.25	2,741.47	2,452.29	341,588.8	3019,986	0	-31,159.8	-31.16%	18.7%	
15	173,249.7	2,182,566	27,117.37	158,922	1,151.12	18,272	1,725.25	2,741.47	2,452.29	341,588.8	3019,986	0	-31,159.8	-31.16%	18.7%		
Total			21,825,304	271,173.7	2,182,566	158,922	1,151.12	18,272	2,741.47	2,452.29	341,588.8	3,019,986	0	-31,159.8	-31.16%	18.7%	

Table-4.5.1-9 Social evaluation at social prices(Majes-Camana river)

Period	Year	Cost										Salvage Value	Cost/Benefit (C/B)	Net Present Value (NPV)	Internal Rate of Return (IRR)		
		Expected Annual Average Reduction Benefit Value (PV) (1)	Construction Cost (C) (2)	Operation & Maintenance Cost (C) (3)	Plantation Cost (C) (4)	Environmental Cost (C) (5)	Disaster Prevention Education/Community Building Cost (C) (6)	Land Acquisition Cost (C) (7)	Implementation Agency Administration Cost (C) (8)	Total Cost (C) (9)	Total Present Value (PV) (10)						
Investment Construction Period	0		3,402,721														
	1	173,249.7	2,182,566	27,117.37	158,922	1,151.12	18,272	1,725.25	2,741.47	2,452.29	341,588.8	3,019,986	0	-31,159.8	-31.16%	18.7%	
	2	173,249.7	2,182,566	27,117.37	158,922	1,151.12	18,272	1,725.25	2,741.47	2,452.29	341,588.8	3,019,986	0	-31,159.8	-31.16%	18.7%	
	3	173,249.7	2,182,566	27,117.37	158,922	1,151.12	18,272	1,725.25	2,741.47	2,452.29	341,588.8	3,019,986	0	-31,159.8	-31.16%	18.7%	
	4	173,249.7	2,182,566	27,117.37	158,922	1,151.12	18,272	1,725.25	2,741.47	2,452.29	341,588.8	3,019,986	0	-31,159.8	-31.16%	18.7%	
	5	173,249.7	2,182,566	27,117.37	158,922	1,151.12	18,272	1,725.25	2,741.47	2,452.29	341,588.8	3,019,986	0	-31,159.8	-31.16%	18.7%	
	6	173,249.7	2,182,566	27,117.37	158,922	1,151.12	18,272	1,725.25	2,741.47	2,452.29	341,588.8	3,019,986	0	-31,159.8	-31.16%	18.7%	
	7	173,249.7	2,182,566	27,117.37	158,922	1,151.12	18,272	1,725.25	2,741.47	2,452.29	341,588.8	3,019,986	0	-31,159.8	-31.16%	18.7%	
	8	173,249.7	2,182,566	27,117.37	158,922	1,151.12	18,272	1,725.25	2,741.47	2,452.29	341,588.8	3,019,986	0	-31,159.8	-31.16%	18.7%	
	9	173,249.7	2,182,566	27,117.37	158,922	1,151.12	18,272	1,725.25	2,741.47	2,452.29	341,588.8	3,019,986	0	-31,159.8	-31.16%	18.7%	
	10	173,249.7	2,182,566	27,117.37	158,922	1,151.12	18,272	1,725.25	2,741.47	2,452.29	341,588.8	3,019,986	0	-31,159.8	-31.16%	18.7%	
	11	173,249.7	2,182,566	27,117.37	158,922	1,151.12	18,272	1,725.25	2,741.47	2,452.29	341,588.8	3,019,986	0	-31,159.8	-31.16%	18.7%	
	12	173,249.7	2,182,566	27,117.37	158,922	1,151.12	18,272	1,725.25	2,741.47	2,452.29	341,588.8	3,019,986	0	-31,159.8	-31.16%	18.7%	
	13	173,249.7	2,182,566	27,117.37	158,922	1,151.12	18,272	1,725.25	2,741.47	2,452.29	341,588.8	3,019,986	0	-31,159.8	-31.16%	18.7%	
	14	173,249.7	2,182,566	27,117.37	158,922	1,151.12	18,272	1,725.25	2,741.47	2,452.29	341,588.8	3,019,986	0	-31,159.8	-31.16%	18.7%	
15	173,249.7	2,182,566	27,117.37	158,922	1,151.12	18,272	1,725.25	2,741.47	2,452.29	341,588.8	3,019,986	0	-31,159.8	-31.16%	18.7%		
Total			21,825,304	271,173.7	2,182,566	158,922	1,151.12	18,272	2,741.47	2,452.29	341,588.8	3,019,986	0	-31,159.8	-31.16%	18.7%	

## 4.5.2 Social Prices Costs

### (1) Benefits

1) Estimated loss amount according to different return periods

The loss amount according to the different return periods is calculated as shown in the Table 4.5.2-1.

For further detail refer to I-7 Data Book.

**Table 4.5.2-1 Estimated loss by flooding at social price (Majes-Camana river)**

1,000 soles

Description	Majes River		Camana River	
	Without Project	With Project	Without Project	With Project
Agricultural Product	116,366	30,779	32,027	11,719
Hydraulic Structure	20,313	4,997	5,203	2,504
Road	14,703	4,190	1,627	215
Housing	4,075	89	5,063	0
Public Facility	885	18	1,117	0
Public Service	94	54	148	0
<b>TOTAL</b>	156,437	40,127	45,185	14,437

In the Table 4.5.2-2, the estimated amounts of loss by flooding of different return periods with or without Project are shown.

**Table 4.5.2-2 Loss estimated value (at social prices)**

(10<sup>3</sup> Soles)

Case	t	Social Price
		Majes-Camana
Without Project	2	317
	5	48,503
	10	78,738
	25	113,789
	50	201,622
	Total	442,970
With Project	2	0
	5	8,540
	10	17,867
	25	31,916
	50	54,564
	Total	112,888

2) Loss amount (annual average) is expected to be reduced with the Project

In Table 4.5.2-3 results of loss amount calculation (annual average) that are expected to reduce to implement the Project are shown.

**Table 4.5.2-3 Annual average of loss reduction amount (Social prices)**

Basin	Return Period	Probability	Total Damage (10 <sup>6</sup> Soles)			Average Damage ④	Section Probability ⑤	Annual Average Damage ⑥=④×⑤	Accumulation of Annual Average Damage
			Without Project ①	With Project ②	Damage Reduction ③=①-②				
			(10 <sup>6</sup> Soles)						
MAJES- CAMANA	1	1.000	0	0	0		0	0	
	2	0.500	317	0	317	159	0.500	80	
	5	0.200	48,503	8,540	39,963	20,140	0.300	6,042	
	10	0.100	78,738	17,867	60,871	50,417	0.100	5,042	
	25	0.040	113,789	31,916	81,873	71,372	0.060	4,282	
	50	0.020	201,622	54,564	147,058	114,465	0.020	2,289	

## (2) Social assessment

In Table 4.5.2-4 results of the calculation C/B, NPV and IRR at social prices are shown.

**Table 4.5.2-4 Social assessment (C/B, NPV, IRR) (at social prices)**

流域 Basin	年平均被害軽減額 Average Annual Damage Reduction Amount	評価期間被害 軽減額(15年) Damage Reduction Amount in Evaluation Period(15years)	事業費 Project Cost	維持管理費 Operation & Maintenance Cost	B/C Benefit and Cost Ratio	Net Present Value (NPV) Valor Actual Neto (VAN)	Internal Rate of Return (IRR) Tasa Interna de Retorno (TIR)
Majes-Camana	230,549,756	104,111,700	73,841,176	7,844,174	1.53	36,063,846	19%

The social evaluation at social price level is calculated as shown in the Table 4.5.1-9 for Majes-Camana river.

### 4.5.3 Social assessment conclusions

The social evaluation of this Project is shown as follows:

#### (1) The economic viability of the project in Majes-Camana basin

It is confirmed. Also, the following hardly quantifiable positive economical Projects effects are shown:

- Contribution to local economic development when soothing the fear due to economic activities suspension and damage
- Contribution by increasing local employment opportunities for the construction of the project
- Strengthening the local population's awareness for floods damage and other disasters
- Income increase contributions due to an stable agricultural production because flood damages are soothed
- Increase of agricultural land price

For the economic assessment results previously presented, it is considered that this Project will contribute substantially to the local economic development.

## **4.6 Sensitivity Analysis**

### **(1) Objective**

A sensitivity analysis was made in order to clarify the uncertainty due to possible changes in the future of the socioeconomic conditions. For the cost-benefit analysis it is required to foresee the cost and benefit variation of the project, subject to assessment, to the future. However, it is not easy to perform an adequate projection of a public project, since this is characterized for the long period required from planning to the beginning of operations. Also because of the long useful life of works already in operation and the intervention of a number of uncertainties that affect the future cost and benefit of the project. So, analysis results are obtained frequently and these are discordant to reality when the preconditions or assumptions used do not agree with reality. Therefore, for the uncertainty compensation of the cost-benefit analysis it should be better to reserve a wide tolerance-margin, avoiding an absolute and unique result. The sensitivity analysis is a response to this situation.

The objective of the sensitivity analysis is to provide the cost-benefit analysis results a determined margin that will allow a proper managing of the project's implementation, give numbers to the population and achieve greater accuracy and reliability of the project's assessment results.

### **(2) Sensitivity Analysis**

#### 1) General description of the sensitivity analysis

There are three methods of the sensitivity analysis, as indicated in Table 4.6-1.

**Table 4.6-1 Sensitivity analysis methods**

Methods	Description	Products
Variables sensitivity analysis	It consists in changing only one predetermined variable (precondition or hypothesis), to assess how the analysis result is affected	Margin values from the analysis when a precondition or hypothesis varies
Better and worst alternatives	It consists in defining the cases in which the analysis results are improved or worsen when changing the main pre-established preconditions or hypothesis to assess the analysis result margin	Margin values from the analysis when the main precondition or hypothesis vary
Monte Carlo	It consists in knowing the probability distribution of the analysis results by simulating random numbers of Monte Carlo simulation of pre-established preconditions and hypothesis	Probable results distribution when all main precondition or hypothesis vary

## 2) Description of the sensitivity analysis

In this project the sensitivity analysis method of the variables usually used in public works investments was adopted. Next, the scenarios and economic indicators used in the sensitivity analysis are shown.

**Table 4.6-2 Cases subjected to the sensitivity analysis and economic indicators**

Indicators	Variation margin according to factors	Economic indicators to be evaluated
Construction cost	In case the construction cost increases in 5 % and 10 %	IRR, NPV, C/B
Benefit	In case of reducing the benefit in 5 % and 10 %	IRR, NPV, C/B
Social discount rate	In case of increase and reduction of the discount social rate in 5 % respectively	NPV, C/B

## 3) Results of the sensitivity analysis

In Table 4.6-3 the results of the sensitivity analysis of each assessed case to private and social prices are shown.

**Table 4.6-3 Results of the sensitivity analysis of IRR, C/B and NPV**

	Basin	Item	Basic Case	Case 1	Case 2	Case 3	Case 4	Case 5	Case 6
				Cost increase 5%	Cost increase 10%	Benefit decrease 5%	Benefit decrease 10%	Disc. rate increase 5%	Disc. rate decrease 5%
PRIVATE PRICE	MAJES - CAMANA	IRR (%)	15%	14%	13%	14%	13%	15%	15%
		B/C	1.28	1.22	1.17	1.21	0.99	1.70	
		NPV(s)	22,447,137	18,614,081	14,781,025	17,283,356	12,119,574	-767,319	61,966,685
SOCIAL PRICE	MAJES - CAMANA	IRR (%)	19%	18%	17%	18%	16%	19%	19%
		B/C	1.53	1.46	1.40	1.45	1.38	1.19	2.04
		NPV(s)	36,063,846	32,838,567	29,613,288	30,858,261	25,652,676	11,693,501	77,083,721

### (3) Assessment of the sensitivity analysis

The impact on the economic evaluation due to the socio-economic change in the Project is as follows: As to Majes-Camana river, the effectiveness becomes less than the boundary of the viability when the discount rate increases by 5%, however the effectiveness at social price is still high in any case.

### 4.7 Risk Analysis

The risk analysis is performed for flood prevention facilities of Chinchá basin.

#### (1) Definition of risk

The increase % of cost and decrease % of benefit which make NPV value equal to zero, are calculated, then the magnitude of risk is defined as shown below.

High risk : When the cost increases from 0% to less than 15% or the benefit decrease from 0% to less than 15%, NPV becomes zero.

Middle risk: When the cost increases more than 15% to less than 30% or the benefit decrease more than 15% to less than 30%, NPV becomes zero.



Low risk: When the cost increases more than 30% or the benefit decrease more than 30%, NPV becomes zero.

**(2) Magnitude risk in each basin**

The increase % of cost and decrease % of benefit which make NPV equal to zero, are calculated as shown in the Table 4.7-1. According to the Table, the risk is very low in Majes-Camana basin

**Table 4.7-1 Increase % of cost and decrease % of benefit for NPV=0%**

Basin	(Amount:1,000 soles)							
	Construction Cost				Benefit			
	Base Case	Increase	Rate (%)	Risk	Base Case	Decrease	Rate (%)	Risk
Majes-Camana	73,879	122,825	66%	low	104,112	68,048	35%	low

## **4.8 Sustainability Analysis**

This project will be implemented by the central government (through the DGIH), irrigation committees and regional governments. Also, the project cost will be covered with the respective contributions of the three parties. Although the sharing percentage will be determined through discussions among stake holders, the percentage is assumed provisionally 80% for the central government (in this case MINAG), 15% for regional government and 5% for irrigation committee. On the other hand, the operation and maintenance (O & M) of the completed works is assumed by the irrigation committee. So, the sustainability of the project depends on the profitability of the Project and the ability of the irrigation committees for O & M.

### **(1) Profitability**

The profitability of projects in Majes-Camana basin is high enough as shown in 4.5 social evaluation so that there is no questionable point in the sustainability of the Project.

### **(2) Irrigation committee**

The irrigation committee is non-profitable organization established by local people based on the law (Resolución Ministerial N° 0837-87-AG) issued on October 14, 1987.

Peru irrigation committee is composed of 114 committees which are divided into 1582 sectors. It is registered to the National Committee (Junta Nacional, composed of 7 members

elected by all irrigation committees) and acts as an representative of agricultural sector in all Peru, and recognized in the various sectors such as public and private agricultural departments.

Each irrigation committee is composed of plural irrigation sectors. The irrigation sector means the unit irrigation area which has same characteristics of irrigation area with same topography, and same intake, secondary and thirdly irrigation canals etc.

The decisions of committee is made by the Assignment Board (Cesión de Consejo Directivo) held twice per month, which is composed of 7 members such as president, vice president, secretary, 2-directors, accountant and assistant accountant etc.

The main task of the committee is as follows:

- To promote the agreement of will among members and to integrate members' will as the opinion of the committee
- Effective and fair distribution of water resources
- Administration and operation and maintenance of hydraulic facilities
- Education and capacity building for water resources
- Promotion of agricultural development and increase of life quality by increase of income

### (3) Capacity of operation and maintenance

The recent annual budget of the irrigation committee of Majes-Camana basin is as shown in the Table 4.8-1.

**Table 4.8-1 Irrigation Committee's budget**

River	Annual Budget (Unit/ S)			
	2007	2008	2009	2010
Majes-Camana	-	1,867,880.10	1,959,302.60	1,864,113.30

Note: Since the Irrigation Commission of Majes-Camana has no budget data for Majes River in 2008, we have supposed it in Rio Camana 2008 (1.122.078,40) + Majes River budget of 2009 (745.810,70)

The annual revenue of irrigation committee is composed of ① irrigation water cost (/m3), ② rental cost of heavy equipment to private company etc. and there is no governmental subsidy. And the annual expenditure is composed of ① operation cost of intake facilities (operator cost of intake weir etc.) ② operation and maintenance cost for such as irrigation canal and intake etc., ③ investigation cost for upgrading of irrigation facilities, ④ operation cost for irrigation committee office.

On the other hand the required operation and maintenance cost is as shown in the Table 4.8-2 according to the section 4.4.1. The ratio of O/M cost to the annual budget in 2009 and to the annual average of the damage reduction amount are also as shown in the same table.

The ratio of O/M cost to the annual budget in 2009 is 36.2 % in Majes-Camana river. On the other hand the ratio of O/M cost to the annual average of the damage reduction amount is 4.0 %, which seems to be very low.

The ratio of O/M cost to the annual budget seems to be rather high, however the ratio of O/M cost to the annual average flood damage amount is very low so that after the flood damage is reduced and profit of farmer increase, it is quite possible that the irrigation committee bears the O/M cost.

And the committee has heavy equipment such as bull-dozer, excavator, trailer, dump truck etc. and performed maintenance works for dike, revetment, intake, irrigation channel etc. therefore the committee could carry out the O/M of the facilities constructed in the Project under the technical assistance of MINAG and the regional government.

**Table 4.8-2 Ratio of O/M cost to Annual budget and damage reduction amount**

Irrigation Committee	Annual Budget(1,000soles)	O/M Cost(1,000soles)	Percentage of O/M cost(%)	Average Yearly Damage Reduction(1,000soles)	Percentage of O/M cost(%)
	①	②	③=②/①	④	⑤=②/④
Majes-Camana	1,959	710	36.2	17,592	4.0

### (4) Agreement with irrigation committee

The following items are to be discussed and made agreement between the central government (MINAG) and the irrigation committee as soon as possible.

- Sharing ratio of Project cost
- Delivery of flood prevention facilities
- O/M of facilities
- Delivery of plantation along river structure and O/M

## 4.9 Environmental Impact

### 4.9.1 Procedure of Environmental Impact Assessment

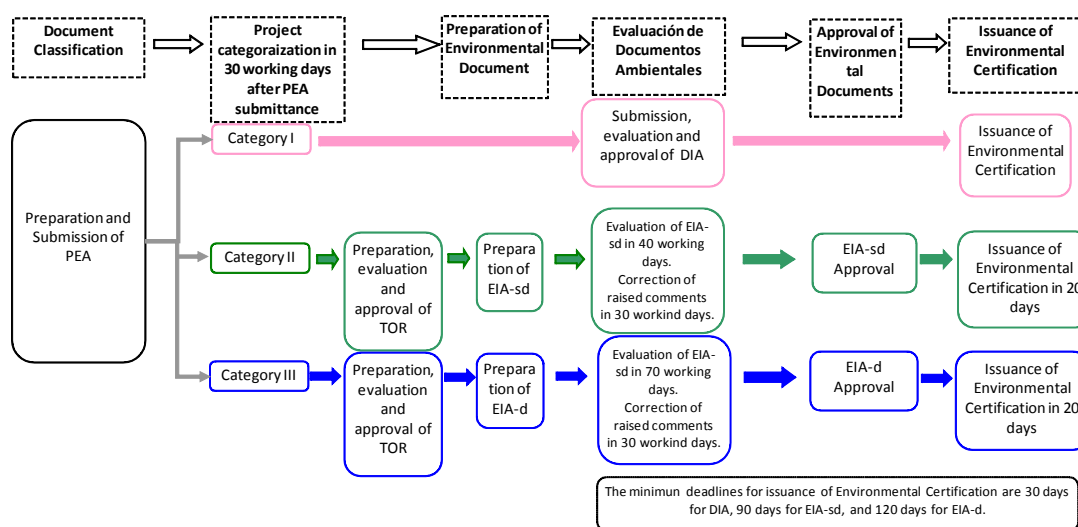
Projects are categorized in three scales, based on the significance level of the negative and positive impacts, and each sector has an independent competence on this categorization. The following table shows the environmental management instruments that are required for each category. The Project holder should submit the Environmental Impact Statement (DIA, in Spanish) for all Projects under Category I. The project holder should prepare an EIA-sd or an EIA-d if the Project is categorized under Category II or III, respectively, to be granted the Environmental Certification from the relevant Ministry Directorate.

**Table 4.9.1-1 Project Categorization and Environmental Management Instruments**

	Description	Required Environmental Management Instrument
Category I	It includes those Projects that when carried out, they cause no significant negative environmental impacts whatsoever.	PEA that is considered a DIA after the assessment for this category
Category II	It includes those Projects that when carried out, they can cause moderate environmental impacts, and their negative effects can be removed or minimized through the adoption of easily applicable measures.	Semi-Detailed Environmental Impact Assessment (EIA-sd)
Category III	It includes those Projects than can cause significant quantitative or qualitative negative environmental impacts because of their characteristics, magnitude and/or location. Therefore, a deep analysis is required to revise those impacts and set out a relevant environmental management strategy.	Detailed Environmental Impact Assessment (EIA-d)

Source: Prepared by the JICA Study Team based on the SEIA Law (2001)

The next graph shows the Environmental Document's Classification, the Environmental Document's Assessment, and the Environmental Certification.



Source: Prepared by the JICA Study Team based on the SEIA Regulations (2009)

**Figure 4.9.1-1 Process to obtain the environmental certification**

First, the Project holder applies for the Project classification, by submitting the Preliminary Environmental Assessment (PEA). The relevant sector assesses and categorizes the Project within the next 30 working days after the document’s submission. The Project’s PEA that is categorized under Category I becomes an EID, and those Projects categorized under Category II or III should prepare an EIA-sd or EIA-d, as applicable. There are cases in which the relevant sector prepares the Terms of Reference for these two studies, and submits them to the holder. There are other cases in which the holder prepares the Terms of Reference and these are approved by the relevant sector, based on the interview with DGAA. Number of working days required for EIA-sd revision and approval is 90, and number of working days required for EIS-d is 120; however, these maximum deadlines may be extended.

The progress of the environmental impact study is as shown below. The JICA Study Team subcontracted a local Consultant (CIDE Ingenieros S.A.), and a Preliminary Environmental Assessment (PEA) was carried out from September to October 2011 for Majes-Camana river.

EAP for Majes- Camana was submitted to DGIH from JICA on December 20, 2012. DGIH submitted it on January 4, 2012, and DGAA issued the approval of EAP of Majes-Camana river and categorized the project as Category I in August 16, 2012 so that the additional environmental impact analysis is not required for the Majes-Camana river for Feasibility Study.

The positive and negative environmental impact associated with the implementation of this project was confirmed and evaluated, and the plan for prevention and mitigation measures are prepared by EAP results, field investigation and hearing by JICA Study Team.

The proposed works in this project include: the reparation of existing dikes, construction of new dikes, riverbed excavation, bank protection works and so on. Table 4.9.1-2 describes “Work Description” to be considered in the Environmental Impact section.

**Table 4.9.1-2 Works description**

River	Location		Critical Point	Main Protection Objects	Measure	Feature of Work	
Rio Camana	MC-1	0.0-4.5km	Innuded Point	Agricultural Lands	Dike with Bank Protection	Length Dike with Bank Protection Large Boulder Riplap	4,500 m 155,700 m3 44,300 m3
	MC-2	7.5-9.5 km	Innuded Point	Agricultural Lands	Dike with Bank Protection	Length Dike with Bank Protection Large Boulder Riplap	2,000 m 43,100 m3 18,300 m3
	MC-3	11.0-17.0 km	Innuded Point	Agricultural Lands	Dike with bank Protection	Length Dike with Bank Protection Large Boulder Riplap	6,000 m 169,000 m3 59,000 m3
Rio Majes	MC-4	48.0-50.5 km	Innuded Point	Agricultural Lands	Dike with Bank Protection	Length Dike with Bank Protection Large Boulder Riplap	2,500 m 75,200 m3 17,700 m3
	MC-5	52.0-56.0 km	Innuded Point	Agricultural Lands	Dike with bank Protection	Length Dike with Bank Protection Large Boulder Riplap	4,300 m 179,000 m3 39,400 m3
	MC-6	59.6-62.8 km	Innuded Point, Local Erosion	Agricultural lands	Dike with Bank Protection	Length Dike with Bank Protection Large Boulder Riplap	6,200 m 235,000 m3 51,400 m3
	MC-7	65.0-66.7 km	Innuded Point	Agricultural Lands	Dike with Bank Protection	Length Dike with Bank Protection Large Boulder Riplap	2,900 m 32,300 m3 27,500 m3

Source: JICA Study Team

## 4.9.2 Methodology

In order to identify environmental impacts of the works to be executed in the different watersheds, we developed identification impact matrixes for watershed.

First, the operation and activities for each project based on typical activities of “hydraulic works” construction were determined. Afterwards, the concrete activities type was determined which will be executed for each work that will be developed in the watersheds. Then, to evaluate Socio-environmental impacts the Leopold matrix was used.

**Table 4.9.2-1 Evaluation criterion - leopold matrix**

Index		Description	Valuation
“Na” nature		It defines whether change in each action on the means is positive or negative	Positive (+) : beneficial
			Negative (-): harmful
Probability of Occurrence “P.O.”		It includes the probability of occurrence of the impact on the component	High (>50 %) = 1.0
			Medium (10 – 50 %) = 0.5
			Low (1 – 10 %) = 0.2
Magnitude	Intensity (In)	It indicates the magnitude of change in the environmental factor. It reflects the degree of disturbance	Negligible (2)
			Moderate intensity (5)
			Extreme Disturbance (10)
	Extension “Ex”	It indicates the affected surface by the project actions or the global scope on the environmental factor.	Area of indirect influence: 10
			Area of direct influence: 5
			Area used up by the works: 2
	Duration “Du”	It refers to the period of time when environmental changes prevail	> 10 years: 10
			5 – 10 years : 5
1 – 5 years: 2			
Reversibility “Rev”	It refers to the system’s capacity to return to a similar, or an equivalent to the initial balance.	Irreversible: 10	
		Partial return: 5	
		Reversible: 2	

Source: Prepared based on PEAs of 6 Basins

**Table 4.9.2-2 Impact significance degrees**

SIA	Extent of Significance
$\leq 15$	Of little significance
15.1 - 28	Significant
$\geq 28$	Very significant

Source: Prepared based on PEAs of 6 Basins

### **4.9.3 Identification, Description and Social Environmental Assessment**

#### **(1) Identification of social environmental impacts**

In the following matrix (construction/operation stages) in the Watersheds, elaborated based on the report analysis of the Preliminary Environmental Assessment.

**Table 4.9.3-1 Impact identification matrix (construction and operation stage)  
– Majes-Camana river**

Construction Stage			Work	1-7	1-7	1-7	1-7	1-7	1-7	1-7	1-7	Total Negative	Total Positive	
Environment	Component	Environmental Factors	Activity	Labor Recruitment	Site preparation work (Clearing, land grading, Levelled)	Digging and movement of Land	Civil Work (Concreting)	I&O of stone pits and material production plants	DME I&O	Camps work I&O	Carriage Staff			Transportation of machinery, equipment, materials and supplies
Physique	Air	PM-10 (Particulate matter)		N	N			N	N		N	N	6	0
		Gas emissions			N	N	N	N	N		N	N	7	0
	Noise	Noise			N	N	N	N	N	N	N	N	8	0
		Soil fertility			N				N				2	0
	Soil	Land Use			N			N	N				3	0
		Calidad del agua superficial						N	N		N		3	0
	Water	Cantidad de agua superficial											0	0
		Morfología fluvial						N					1	0
		Morfología terrestre			N	N				N			3	0
		Physiography												
Biotic	Flora	Terrestrial flora			N				N				2	0
		Aquatic flora						N					1	0
	Fauna	Terrestrial fauna			N				N				2	0
		Aquatic fauna				N			N				2	0
Socio-economic	Esthetic	Visual landscape						N	N				2	0
		Quality of life		P						N	N	N	3	1
	Social	Vulnerability - Security											0	0
		PEA		P									0	1
Economic	Current land use											0	0	
<b>Total</b>				2	8	5	3	9	9	3	4	4	45	2
Percentage of positive and negative													96 %	4 %

N: Negative, P:Positive

Source: Prepared by the JICA Study Team

Operation Stage			Works	Dike Point 1	Dike Point 2	Dike Point 3	Dike Point 4	Dike Point 5	Dike Point 6	Dike Point 7	Total Negative	Total Positive	
Environment	Component	Environmental Factors											
Physique	Air	PM-10 (Particulate matter)									0	0	
		Gas emissions										0	0
	Noise	Noise										0	0
		Soil fertility										0	0
	Soil	Land Use										0	0
		Calidad del agua superficial										0	0
	Water	Cantidad de agua superficial		P	P	P	P	P	P	P	P	0	7
		Morfología fluvial		N	N	N	N	N	N	N	N	7	0
	Physiography	Morfología terrestre		N	N	N	N	N	N	N	N	7	0
		Terrestrial flora										0	0
Biotic	Flora	Aquatic flora									0	0	
		Terrestrial fauna									0	0	
	Fauna	Aquatic fauna		N	N	N	N	N	N	N	N	7	0
		Terrestrial fauna										0	0
Socio-economic	Esthetic	Visual landscape		P	P	P	P	P	P	P	0	7	
		Quality of life		P	P	P	P	P	P	P	P	0	7
	Social	Vulnerability - Security		P	P	P	P	P	P	P	P	0	7
		PEA										0	0
Economic	Current land use		P	P	P	P	P	P	P	0	7		
<b>Total</b>				8	8	8	8	8	8	8	21	35	
Percentage of positive and negative											38 %	63 %	

N: Negative, P:Positive

Source: Prepared by the JICA Study Team



On the Majes-Camana River basin, based on the impact identification results for the construction stage, a total number of 47 interactions have been found. 45 of these interactions (97 %) correspond to impacts that will be perceived as negative, and 2 (3 %) correspond to impacts that will be perceived as positive. In addition, 56 interactions have been found for the operation stage; 21 of these interactions (37.5%) correspond to impacts that will be perceived as negative, and 35 (62.5 %) correspond to impacts that will be perceived as positive.

## (2) Environmental and social impact assessments

Environmental and social impacts are assessed with the methodology that was explained in 4.9.2 Methodology. The following tables show the environmental and social assessment results for each basin, during the construction and operation stages.

**Table 4.9.3-2 Environmental impact assessment matrix – Majes-Camana river**

			The Majes-Camaná River Basin										
Medio	Componente	Acciones del proyecto	Construction Stage										Operation Stage
			Labor Recruitment	Site preparation work (Cleaning, land grading, Levelled)	Digging and refilling in riverside	Civil Work (Concreting)	I&O of stone pits and material production plants	DME I&O	Camps work I&O	Carriage Staff	Transportation of machinery, equipment, materials and supplies	MC1-MC7	
			Factores Ambientales	MC1-MC7	MC1-MC7	MC1-MC7	MC1-MC7	MC1-MC7	MC1-MC7	MC1-MC7	MC1-MC7		MC1-MC7
Physique	Air	PM-10 (Particulate matter)	0.0	-12.0	-12.0	0.0	-18.0	-18.0	0.0	-12.0	-12.0	0.0	
		Gas emissions	0.0	-11.5	-11.5	-11.5	-11.5	-11.5	0.0	-11.5	-11.5	0.0	
	Noise	Noise	0.0	-15.0	-12.0	-12.0	-15.0	-15.0	-15.0	-11.5	-15.0	0.0	
		Soil	Soil fertility	0.0	-11.5	0.0	0.0	-14.2	-14.2	0.0	0.0	0.0	
	Water	Land Use	0.0	-14.2	0.0	0.0	-15.0	-15.0	0.0	0.0	0.0	0.0	
		Calidad del agua superficial	0.0	0.0	-12.0	0.0	-15.0	0.0	0.0	0.0	0.0	0.0	
	Physiography	Cantidad de agua superficial	0.0	0.0	0.0	-9.0	0.0	0.0	-15.0	0.0	0.0	26.0	
Morfología fluvial		0.0	0.0	0.0	0.0	-23.0	0.0	0.0	0.0	0.0	-25.5		
Biotic	Flora	Morfología terrestre	0.0	-33.0	-15.0	0.0	0.0	-28.0	0.0	0.0	0.0	-25.5	
		Terrestrial flora	0.0	-28.0	0.0	0.0	0.0	-22.5	0.0	0.0	0.0	0.0	
	Fauna	Aquatic flora	0.0		-14.5	0.0	-14.5	0.0	0.0	0.0	0.0	0.0	
		Terrestrial fauna	0.0	-24.2	0.0	0.0	0.0	-22.5	0.0	0.0	0.0	0.0	
Socio-economic	Social	Aquatic fauna	0.0	0.0	-14.5	0.0	-15.0	0.0	0.0	0.0	0.0	-25.5	
		Visual landscape	0.0	0.0	0.0	0.0	-12.0	-12.0	0.0	0.0	0.0	36.0	
	Economic	Quality of life	17.0	0.0	0.0	0.0	0.0	0.0	-17.5	-17.5	-17.5	36.0	
		Vulnerability - Security	0.0	0.0	0.0	0.0	0.0	0.0	0.0	0.0	0.0	36.0	
Esthetic	PEA	17.0	0.0	0.0	0.0	0.0	0.0	0.0	0.0	0.0	0.0		
	Current land use	0.0	0.0	0.0	0.0	0.0	0.0	0.0	0.0	0.0	36.0		



Source: Prepared based on PEAs of 6 Basins

It must be pointed out that in the Majes-Camaná River basin 11 out of a total of 14 negative impacts have been quantified as significant, and 1 has been quantified as very significant, during the

construction stage. Meanwhile, 3 significant negative impacts have been quantified as during the operation stage.

During the construction stage, the works site preparation component will significantly affect the land morphology. During the operation stage, river morphology and aquatic fauna will be significantly affected all the point, where the dikes will be built.

The Environmental Management Plan will be detailed in 3 Environmental Management Plans for Probable Impacts.

During the construction stage, actions that will generate most significant negative impacts include: “Site Works Preparation and Clearance”, “Riverbed Excavation and Embankment”, and “Surplus Material Deposits Operation (DME, in Spanish).” “Site works Preparation and Clearance” will bring about a significant modification to the land morphology, whereas “Riverbed Excavation and Filling” will bring about a significant modification to river morphology.

During the operation stage, hydraulic infrastructure works that will bring about most significant negative environmental impacts include “Riverbed excavation and embankment” that will cause a modification to the river morphology and subsequently, decreased river habitability conditions that will directly impact the aquatic fauna.

Most significant positive impacts are related to all works to be constructed along the river basins, and are directly related to improve the quality of the lives of the population around the area of influence, improve the “Current Use of land / soil”, improve the security conditions, and reduce vulnerability at social and environmental levels.

#### **4.9.4 Socio-Environmental Management Plans**

The objective of the Socio-Environmental Plans is to internalize both positive and negative significant and very significant environmental impacts that are related to the Project’s construction and operation stages, so that prevention and/or mitigation of significant and very significant negative impacts, preservation of environmental heritage, and Project sustainability are ensured.

During the construction stage, Projects of all the basin have set out the following measures: “Local Hiring Program”, “Works Sites Management and Control Program”, “Riverbed Diversion Program”, “Riverbank Excavation and Filling Management”, “Riverbed Excavations and Filling Management”, “Quarry Management”, “DME Management”, “Camp and Site Residence Standards”, and “Transportation Activity Management.” During the operation stages, Projects for the basin have considered the development of activities with regard to “Riverbed and Aquatic Fauna Management”. These activities should develop riverbed conditioning downstream the intervention points, for erosion probabilities to be reduced, and habitability conditions to be provided for aquatic fauna species. The following are measures related to those negative impacts to be mitigated or those positive impacts to be potentiated. Overall measures have been established for the basin, based on the impacts, as identified in the basin.

**Table 4.9.4-1 Environmental impact and prevention/mitigation measures**

<b>Item</b>	<b>Impact</b>	<b>Counter Measures</b>	<b>Period</b>
Natural environment	Water quality of surface water	Management of river diversion and coffering	Construction period
		Management of bank excavation and banking	
		Management of riverbed excavation and back filling	
	River topography	Management of bank excavation and banking	
		Management of riverbed excavation and back filling	
		Management of quarry site	
	Other topography	Management of construction site	
		Management of large amount of excavated or dredged material	
	Dust	Management of construction site	
Management of large amount of excavated and dredged material			
Biological environment	Aquatic fauna	Management of riverbed excavation and back filling	O/M period
	Terrestrial fauna	Management of construction site	Construction period
		Management of large amount of excavated and dredged material	
	Terrestrial flora	Management of construction site	
		Management of large amount of excavated and dredged material	
	Social environment	Quality of life	
Management of traffic of construction vehicle			
Employment plan of local people			
Population of economic activity		Employment plan of local people	

Source: JICA Study Team

## 4.9.5 Monitoring and Control Plan

### (1) Follow up and monitoring plan

The follow-up plan has to implement firmly the management of environmental plan. The monitoring plan is to be carried out to confirm that the construction activity fulfill the environmental standard such as Environmental Quality Standards (EQS) either or Maximum Permissible Limits (MPL). And the monitoring and control must be carried out under the responsibility of the project's owner or a third party under the supervision of the owner.

#### Construction stage

During the construction period of the projects to be done in the 4 watersheds, the Monitoring and Control Plan will be directed to the verification of the fulfillment measures designed as part of the environmental monitoring plan and the verification of the fulfillment of laws and regulation of the Peruvian Legislation. The following aspects will also be monitored:

#### Water Quality and Biological Parameters:

Water quality and biodiversity parameters control shall be performed at downstream of these works must be monitored. In the following table the profile of this plan is shown.

**Table 4.9.5-1 Monitoring to water quality and biological parameters**

Item	Unit	Measured Value (Mean)	Measured Value (Max.)	Country's Standards
pH	pH			"National Standard for Water Quality" D.S. No. 002-2009 MINAM
TSS	mg/l			
BOD/COD	mg/l			
DO	mg/l			
Total Nitrogen	mg/l			
Heavy Metals	mg/l			
Temperature	°C			
Biological Diversity indices: Shannon; Pielou; richness and abundance				

[Measurement Points]

-50 meters upstream the intervention points

-50 meters downstream the intervention points

-100 meters downstream the intervention points

[Frequency]

Quarterly

[Person in charge of Implementation]

DGIH-MINAG, or a third party under the project holder's supervision

Source: JICA Study Team

#### Air quality:

During impact analysis, in the projects to be developed in the 4 watersheds no significant impacts will be seen in the activities related to hydraulic infrastructure works. However, the generation of dust and atmospheric contaminant emissions always affects the working area and the workers and inhabitants health. So, it is recommended to monitor air quality.

**Table 4.9.5-2 Monitoring to air quality**

Item	Unit	Measured Value (Mean)	Measured Value (Max.)	Peruvian Standards (D.S. No 074-2001-PCM)	Referred International Standards
SO <sup>2</sup>				"National Standard for Air Quality" D.S. No.074-2001-PCM	National Ambient Air Quality Standards (NAAQS) (Updated in 2008)
NO <sup>2</sup>					
CO					
O <sup>3</sup>					
PM-10					
PM-2.5					

[Measurement Points]

\*02 stations per monitoring point: Windward and downwind (upwind and against the wind direction)

-1 point at the working zones

-1 point at a quarry, away from the river (the largest and / or the closest point to a populated area)

-1 point at a D.M.E. (the largest and / or the closest point to a populated area)

[Frequency]

Quarterly

[Person in charge of the Implementation]

DGIH-MINAG, or a third party under the project holder's supervision

Source: JICA Study Team

### Noise quality

Likewise, it is proposed to perform a noise monitoring at the potential receptors located near the noise emission spots towards the working sites, in the next table 4.9.4-3, the terms are described.

**Table 9.5-3 Monitoring to noise quality**

Item	Unit	Measured Value (Mean)	Measured Value (Max.)	Country's Standards	Referred International Standards
Noise level	LAeqT (dB(A))			National Environmental Quality Standards for noise (EQS) - S.N. N° 085-2003-PCM	-IEC 651/804 - International -IEC 61672- New Law: Replaces IECs 651/804 -ANSI S 1.4 - America

[Measurement Point]

Monitoring to acoustic contamination levels will be carried out at the potential receivers that are located around the noise emission points per work front.

01 point per potential receiver will be monitored.

[Frequency]

Every two months during construction phase

[Person in charge of the Implementation]

DGIH-MINAG, or a third party under the project holder's supervision

Source: JICA Study Team

### **Operation stages**

Regarding works impact of all projects, it is mainly recommended to monitor biologic parameters and water quality as river topography and the habitat of aquatic life.

**Table 4.9.5-4 Monitoring to water quality (operation stage)**

Item	Unit	Measured Value (Mean)	Measured Value (Max.)	Country's Standards
pH	pH			"National Standard for Water Quality" D.S. No. 002-2009 MINAM
TSS	mg/l			
BOD/COD	mg/l			
DO	mg/l			
Total Nitrogen	mg/l			
Heavy Metals	mg/l			
Temperature	°C			
Biological Diversity indices: Shannon; Pielou; richness and abundance				

[Measurement Points]

-50 meters upstream the intervention points  
-50 meters downstream the intervention points  
-100 meters downstream the intervention points

[Frequency]

Quarterly in first two years of operation phase

[Person in charge of Implementation]

DGIH-MINAG, or a third party under the project holder's supervision

Source: JICA Study Team

## **(2) Closure or abandon plan**

Closure or abandon plans have been made for each watershed. These will be executed at the end of construction activities and involves the removal of all temporary works and restoration of intervened and/or affected areas as a result of the works execution. The restoration includes the removal of contaminated soil, disposal of waste material, restoration of soil morphology and restoration with vegetation of intervened sites.

## **(3) Citizen participation**

Citizen participation plans have been made for each watershed, which must be executed before and during construction and when the works are completed. The recommended activities are:

- Before works: Organize workshops in the surrounding community's area near the project and let them know what benefits they will have. Informative materials in communities, which will explain the profile, lapse, objectives, benefits, etc. of the Project
- During works execution: Give out information on the construction progress. Responding complaints generated from the local community during works execution. For this, a consensus wants to be previously achieved with the community in order to determine how claims will be met
- When works are completed: Organize workshops to inform about works completion. Works delivery to the local community inviting local authorities for the transfer of goods, which means the work finished.

#### 4.9.6 Cost for the Environmental Impact Management

The cost for the environmental management in this Project is as shown in the Table 4.9.6-1. In the table, (1) shows the cost for the environmental management of each facility, based on which the cost required in each basin (2) is calculated. And the cost for the counter measures 1) – 7) is calculated based on the accumulated construction period of each facility which is described in the Annex-9 Construction Plan/Cost Estimate, Table 2.1-1.

**Table 4.9.6-1 Cost of environmental management plan**

(1) Cost per one work site					(2) Cost per Basin
Item	Unit	Quantity	Unit Price (S/.)	Parcial Price (S/.)	Majes-Camaná Basin (7 sites)
<b>Work duration</b>	<b>Month</b>				<b>38</b>
1) Transportation Activities Program	Month	-	S/. 1,400.0	-	S/. 53,200.0
2) Industrial wastes Management Program	Month	-	S/. 4,200.0	-	S/. 159,600.0
3) Landscape management within the project site	Month	-	S/. 2,800.0	-	S/. 106,400.0
4) Worksite Management Program	Month	-	S/. 1,960.0	-	S/. 74,480.0
5) Noise control program	Month	-	S/. 1,120.0	-	S/. 42,560.0
6) Environmental Management Activities	Month	-	S/. 4,480.0	-	S/. 170,240.0
7) Training for control of foil and water contamination	Month	-	S/. 2,520.0	-	S/. 95,760.0
8) Monitoring to Water Quality, Flow, and Biological Indices				S/. 11,239.20	S/. 78,674.4
Índices de diversidad	Monitoring	3	S/. 672.0	S/. 2,016.00	
Caudal	Monitoring	3	S/. 588.0	S/. 1,764.00	
Tº, pH, OD	Monitoring	3	S/. 571.2	S/. 1,713.60	
DBO	Monitoring	3	S/. 638.4	S/. 1,915.20	
Sólidos disueltos totales	Monitoring	3	S/. 638.4	S/. 1,915.20	
Sólidos suspendidos totales	Monitoring	3	S/. 638.4	S/. 1,915.20	
9) Monitoring to Ari quality and noise				S/. 37,500.0	S/. 262,500.0
Monitoring of air emission	Monitoring	3	S/. 4,500.0	S/. 13,500.0	
Monitoring of PM	Monitoring	3	S/. 5,000.0	S/. 15,000.0	
Monitoring of noise	Monitoring	3	S/. 3,000.0	S/. 9,000.0	
<b>Total</b>					<b>S/. 1,043,414.4</b>

#### 4.9.7 Conclusions and Recommendations

##### (1) Conclusions

According to the Preliminary Environmental Appraisals to the basin, most impacts identified during the construction and operation stages were found out to be of little significance. Significant and very significant negative impacts can be controlled or mitigated, as long as suitable Environmental Management Plans are carried out. In addition, the Project will be implemented in the short term, as environmental conditions will be quickly restored. However, the execution of a follow – up and monitoring plan is important, and in the event that unexpected impacts are generated, immediate mitigation measures must be taken.

In addition, significant positive impacts are also present, especially during the operation stage. These positive impacts include: An enhanced security / safety and a decreased vulnerability at social and environmental levels; an improved quality of life among the population in the area of influence, and an improved “Current use of land / soil”.

## **(2) Recommendations**

1) We mainly recommend that the beginning of the construction activities coincides with the beginning of the dry seasons in the region (May to November) when the level of water is very low or the river dries up. Each river characteristics / features should be taken into account, that is, that the Majes-Camana Rivers are year - round rivers. At the same time, the crop season cycle in the areas of direct influence should be taken into account, so that traffic jams caused by the large trucks and farming machinery is prevented.

2) It is recommended that the Project holder (DGIH) should define the limit of river area during detailed design stage, and identify the people who live within the river area illegally. Continually the DGIH should carry on the process of land acquisition based on the Land Acquisition Law, which are; Emission of Resolution for land acquisition by the State, Proposition of land cost and compensation for land owner, Agreement of the State and land owner, Payment, archaeological assessment certification.

3) DGIH has to promote the process to obtain the CIRA in the detail design stage. The process to be taken is i) Application form, ii) Copies of the location drawings and outline drawings, iii) voucher, iv) Archaeological Assessment Certificate.

4) The participation of the women in the workshops can be promoted through the existing women group such as Vaso de Leche.

DGAA issued the approval of EAP for Majes-Camana river and categorized the project as Category I in August 16, 2012. Therefore the additional environmental impact analysis for the river is not required.

### **4.10 Institutions and Administration**

Peruvian institutions regarding the Project’s execution and administration are the Agriculture Ministry, Economy and Finance Ministry and Irrigation Commission, with the following roles for each institution. The following description was prepared by the local consultant and governmental offices and is used in the office of DGIH.

#### **(1) Ministry of Agriculture (MINAG)**

\*The Ministry of Agriculture (MINAG) is responsible for implementing programs and the Hydraulic Infrastructure General Direction (DGIH) is responsible for the technical



administration of the programs. The Hydraulic Infrastructure General Direction (DGIH) is dedicated to the coordination, administration and supervision of investment programs.

- \* In investment stage, the PSI (Programa Subsectorial de Irrigaciones, Ministerio de Agricultura) is dedicated to calculate project costs, detail design and supervision of the works execution.
- \* The Planning and Investment Office (OPI) from the Agriculture Ministry is the one responsible for pre-feasibility and feasibility studies in the pre-investment stage of DGIH projects and requests approval of DGPI (previous DGPM) from the Economy and Finance Ministry (MEF).
- \* The General Administration Office of the Agriculture Ministry (OGA-MINAG) along with the Public Debt National Direction (DGETP, previous DNEP) of the Economy and Finance Ministry is dedicated to financial management. It also manages the budget for procurement, commissioning works, contracting, etc. from the Agriculture Ministry.
- \* The Environmental Affairs General Direction (DGAA) is responsible for reviewing and approving the environmental impact assessment in the investment stage.

## **(2) Economy and Finance Ministry (MEF)**

- \* The DGPI approves feasibility studies. It also confirms and approves the conditions of loan contracts in yen. In the investment stage, it gives technical comments prior to the project execution.
- \* Financial management is in charge of (DGETP, previous DNEP) from the Economy and Finance Ministry and OGA-MINAG.
- \* The Public Debt National Direction (DGETP, previous DNEP) of the Economy and Finance Ministry administers expenses in the investment stage and post-investment operation.

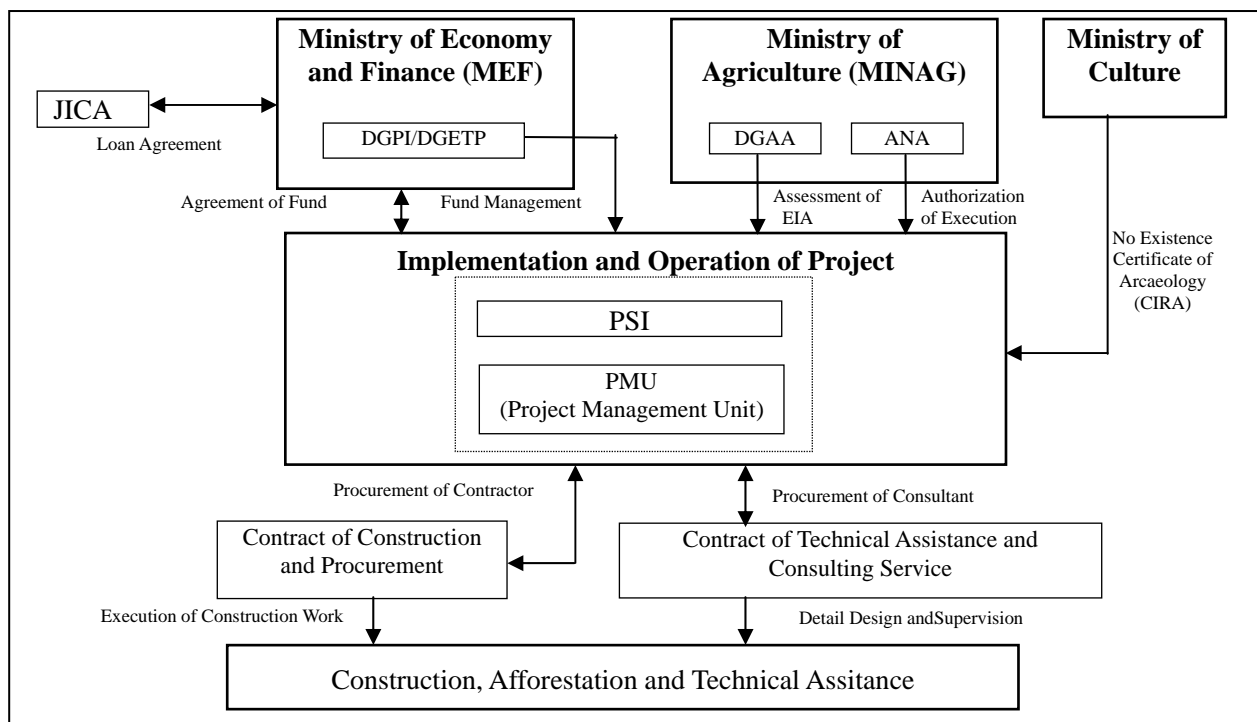
## **(3) Irrigation Commission**

- \* Responsible for the operation and maintenance of facilities at the post-investment operation stage.

The relationship between the involved institutions in the Project's execution is shown in Figures 4.10-1 and 4.10-2.

In this Project, PSI from MINAG is scheduled to be the execution agency in the investment stage (Project execution). The PSI is currently performing JICA projects, etc. and in case of beginning a new project, it forms the correspondent Project Management Unit (PMU), and PSI is responsible of employment of international consultant with deep experience on Japanese Yen Loan project and carried out the detail design, procurement of contractor, and supervision of construction work etc. The following figure describes the structure of the different entities involved in the Project's execution stage. PMU is organized directly under PSI and the organization is as shown in the Figure-4.10-4.

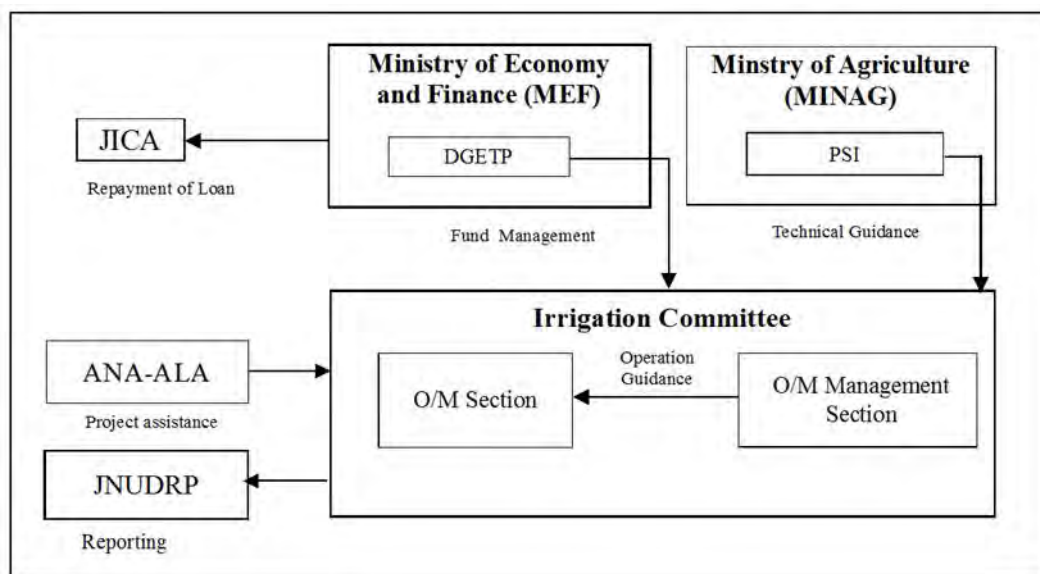
The Agreement of Fund Transfer and Fund Management in the Figure-4.10-1 means MEF transfers the fund to PSI and controls the expenditure.



**Figure 4.10-1 Related agencies in implementation stage of project**

The main operations in the post-investment stage consist of operation and maintenance of the built works and the loan reimbursement. The O & M of the works will be assumed by the respective irrigation commission.

Next, the relationship of different organizations involved in post-project implementation stage is detailed.



**Figure 4.10-2 Related agencies in operation stage of project**

## **(1) DGIH**

### 1) Role and functions

The Hydraulic Infrastructure General Direction is in charge of proposing public policies, strategies and plans aimed to promoting water infrastructure development, according with the Water Resources National Policy and the Environmental National Policy.

Water Infrastructure development includes studies, works, operation, maintenance and construction risk management, fit-out, improve and expand dams, intakes, river beds, irrigation channels, drains, meters, outlets, groundwater wells and modernize plot irrigation.

### 2) Main functions

- a) Coordinate with the planning and budget office to develop water infrastructure and propose sectorial and management policies on infrastructure development. Monitor and assess the implementation of sectorial policies related to hydraulic infrastructure development
- b) Propose government, region and provinces intervention regulations, as part of sectorial policies
- c) Verify and prioritize hydraulic infrastructure needs
- d) Promote and develop public investment projects at the hydraulic infrastructure profile level
- e) Elaborate technical regulations to implement hydraulic infrastructure projects
- f) Promote technological development of hydraulic infrastructure
- g) Elaborate operation and maintenance technical standards for hydraulic infrastructure

## **(2) PSI**

### 1) Function

The Irrigation Sub-sectorial Program (PSI) is responsible of executing investment projects. A respective management unit is formed for each project.

### 2) Main functions

- a) Irrigation Sub-sectorial Program - PSI, under the Agriculture Ministry, is a body with administrative and financial autonomy. It assumes the responsibility of coordinating, managing and administering involved institutions in projects in order to meet goals and objectives proposed in investment projects
- b) Also, it coordinates the disbursements of foreign cooperation agencies financing, such as JICA.
- c) The Planning, Budget and Monitoring Office of PSI is responsible for hiring services, elaborating investment programs, as well as project execution plans. These Project preparation works are executed by hiring “in-house” consultants.
- d) Likewise, it gathers contractors, makes a lease, executes works and implements supply projects, etc.
- e) Contract management is leaded by the Planning, Budget and Monitoring Office

### 3) Budget

In Table 4.10-1 the PSI budget for 2011 is shown.

**Table 4.10-1 PSI Budget (2011)**

Programs / Projects / Activities	PIM (S/.)
JBIC Program (Loan Agreement EP-P31)	69,417.953
Program - PSI Sierra (Loan Agreement 7878-PE)	7,756.000
Direct management works	1,730.793
Southern Reconstruction Fund (FORSUR)	228.077
Crop Conversion Project (ARTRA)	132.866
Technified Irrigation Program (PRT)	1,851.330
Activity- 1.113819 small farmers...	783.000
PSI Management Program (Other expenses)	7,280.005
<b>TOTAL</b>	<b>89,180,024</b>

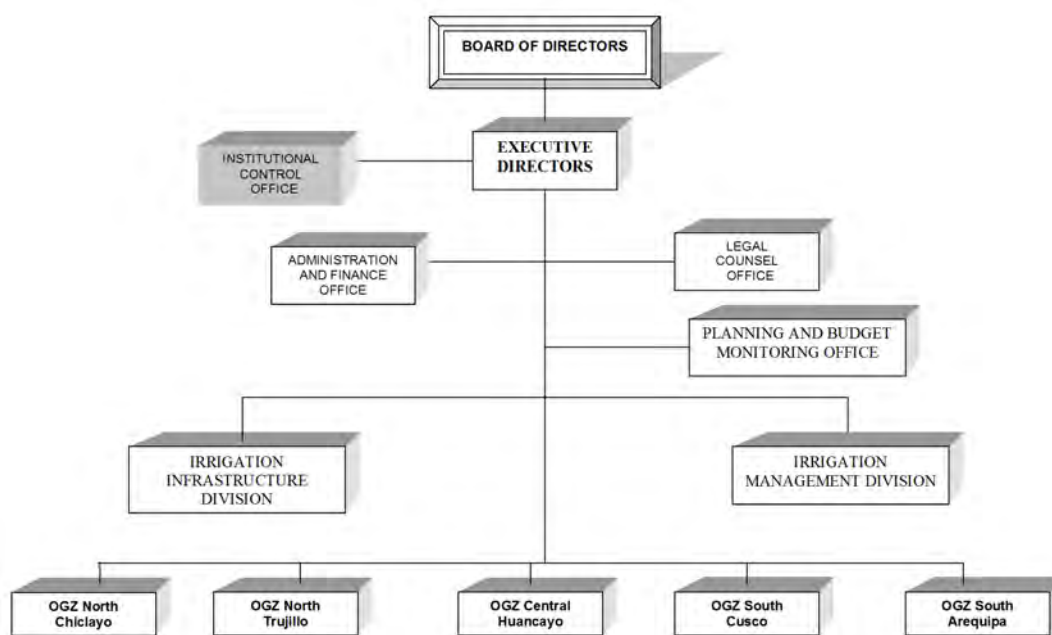
### 4) Organization

PSI is confirmed by 235 employees, from which 14 are assigned for JBIC Projects and 29 technicians and assistants are working under them.

**Table 4.10-2 PSI payroll**

Central Level	Data from May 31, 2011		
	CAS	Servic. and Consult.	TOTAL
Main Office	61	43	104
Zonal Office LIMA	12	24	36
Zonal Office AREQUIPA	14	12	26
Zonal Office CHICLAYO	17	13	30
Zonal Office TRUJILLO	13	26	39
<b>TOTAL</b>	<b>117</b>	<b>118</b>	<b>235</b>

In Figure 4.10-3, PSI organization is detailed:

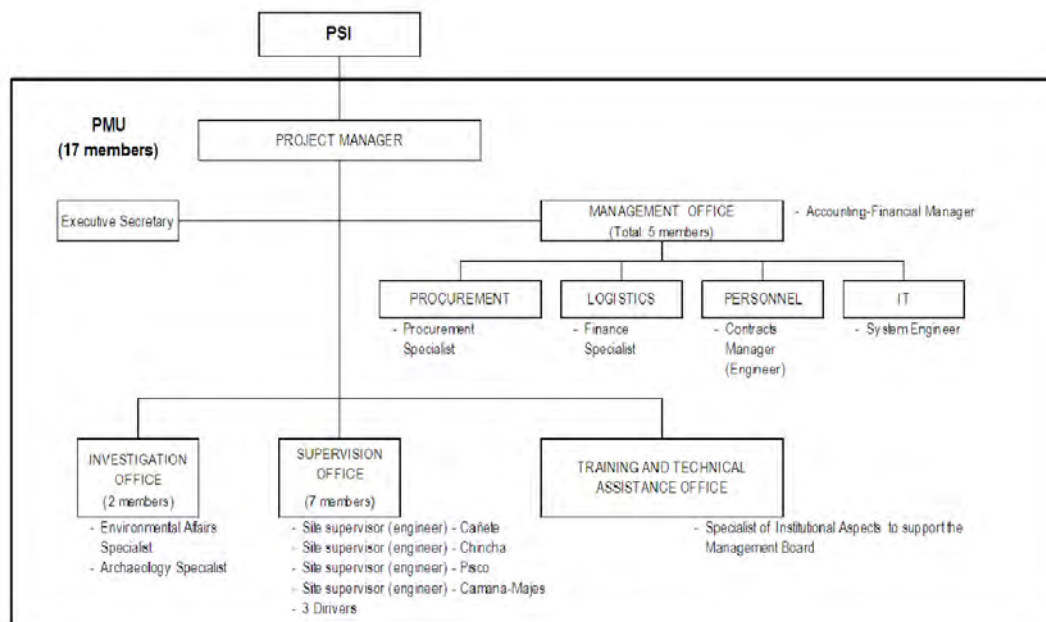


**Figure 4.10-3 Organization of PSI**

**(3) Organization of PMU (Project Management Unit)**

1) Organization

PMU is installed directly connected the Irrigation Infrastructure Division of PSI. The organization of PMU is as shown in the Figure 4.10-4.



Note: ( ) shows number of personnel

**Figure 4.10-4 Organization of PMU**

## 2) Main staff

PMU is composed of the following main staff.

- Project manager
- Contract specialist
- Construction supervisor
- IT specialist
- Procurement specialist
- Financial specialist
- Organization specialist (Adviser to the irrigation committee)
- Environmental assessment specialist
- Archeological specialist
- Accountant

## 3) Cost

The cost for operation of PMU is budgeted at        million soles as described in the clause 4.4.1, Table 4.4.1-11.

The Project will be promoted safely, by installing PMU in the implementation agency (PSI) and receiving the assistance of the consultant procured separately.

### **4.11 Execution Plan**

The Project's Execution Plan will be examined in the preliminary schedule, which includes the following components. For pre-investment stage: ① full execution of profile and feasibility studies to obtain SNIP's approval in the pre-investment stage; for the investment stage: ② signing of loans (L/A), ③ consultant selection, ④ consulting services (detailed design and elaboration of technical specifications), ⑤ constructor selection and ⑥ work execution. For the post-investment stage: ⑦ Works' completion and delivery to water users associations and beginning of the operation and maintenance stage.

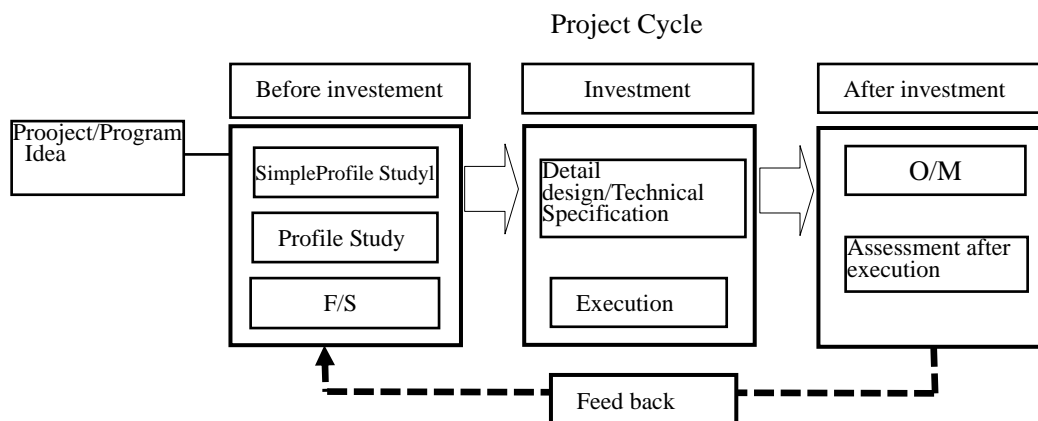
#### **(1) Review by the Public Investment National System (SNIP)**

In Peru, the Public Investment National System (SNIP hereinafter) is under operation. This reviews the rationality and feasibility of public investment projects, and will be applied to this Project.

In SNIP, among previous studies to an investigation, it will be conducted in 3 stages: profile study (study on the project's summary), pre-feasibility and feasibility. SNIP was created under Regulation N° 27293 (published on June 28, 2000) in order to achieve efficient use of public resources for public investment. It establishes principles, procedures, methods and technical regulations to be fulfilled by central/regional governments in public investment scheme plans and executed by them.

SNIP, as described below, is all public works projects which are forced to perform a 3-stage pre-investment study: profile study, pre-feasibility and feasibility, and have them approved. However, following the Regulation amendment in April 2011, the execution of pre-feasibility study of the

intermediate stage was considered unnecessary; but in return, a study based on primary data during the profile study is requested. The required precision degree throughout all stages of the study has hardly changed before and after this modification.

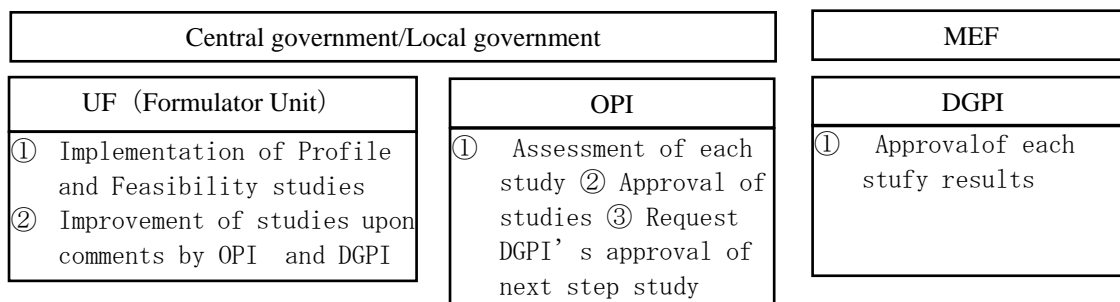


(Source : DGPI)

**Figure 4.11-1 SNIP Project Cycle**

In order to carry out this Project, which is a project composed by several programs, pre-investment studies at investments' programs level are required to be performed and also have them approved.

Although the procedure is a little bit different in each stage, in SNIP procedures, the project's formulation unit (UF) conducts studies of each stage, the Planning and Investment Office (OPI) assesses and approves the UF's presented studies and requests Direction General of Investment Policy (hereinafter referred to DGPI) to approve feasibility studies and initiation of following studies. Finally DGPI evaluates, determines and approves the public investment's justification.



(Directiva No. 001-2009-EF/68.01)

**Figure 4.11-2 Related Institutions to SNIP**

Due to the comments of examining authorities (OPI and DGPI) to UF, it will be necessary to prepare correspondent responses and improve the studies. Since these authorities officially admit applications after obtaining definitive answers, there are many cases in which they take several months from the completion of the study report until the completion of the study.

It is important to obtain well recognition of the contents and effectiveness of the project, for which UF is required to present the effect of project from the view point of study, design, construction plan as

well as public investment and operation in continuity of the project. The study of natural conditions, planning of facilities, cost estimate, financial analysis etc. and also the table of contents of the study report should follow the regulation of SNIP.

DGIH registered Majes-Camana river to SNIP on January 9, 2012 based on the Project Report. OPI examined project report of Majes-Camana river and issued its comment on August 4, 2012.

DGIH revised the report of Majes-Camana and submitted to OPI December 12, 2012, of which the examination is still under process in OPI and DGPI.

## **(2) Yen loan contract**

Once the feasibility report of this Project is submitted, then the OPI and DGPI examine the contents of report, and finally the declaration of viability of the Project is to be issued by DGPI. When the declaration of viability is almost confirmed, the appraisal mission of JICA is dispatched and the negotiation of loan agreement is commenced and Loan Agreement (LA) is concluded. The period of negotiation period is assumed about 6 months.

## **(3) Procedure of the project's execution**

After the documents are assessed by SNIP and a loan agreement between Japan (JICA) and the Peruvian counterpart is signed, a consultant will be selected. The consulting service includes the detailed design and technical specifications, the contractors' selection and the work's supervision. Next find the required time for each process. Table 4.11-1 presents the Project's overall schedule (As to the details of construction time schedule, refer to Annex-9 Construction Planning and Cost Estimate).

- 1) Consultant selection: 10 months
- 2) Detailed design and technical specifications of the work: 6 months
- 3) Contractor selection: 15 months
- 4) Construction supervision by Consultant on river structures and plantation along river structures: 24 months
- 5) The afforestation along river structures is carried out in parallel with the construction.
- 6) Disaster prevention education/Capacity development is carried out from time to time in parallel with construction work.



**Table 4.11-1 Implementation plan**

Item	2010			2011			2012			2013			2014			2015			2016			2017			2018			Months			
	3	6	9	3	6	9	3	6	9	3	6	9	3	6	9	3	6	9	3	6	9	3	6	9	3	6	9				
1 Profile Study/SNIP Appraisal	Study									Appraisal																		28			
2 Feasibility Study/SNIP Appraisal				Study						Appraisal																					27
3 Loan Appraisal																															6
4 Selection of Consultant																															10
5 Project Management Unit																															45
6 Consulting Services																															45
1) Detailed Design																															6
2) Tender Preparation, Assistance																															15
3) Supervision																															24
7 Selection of Contractor, Contract																															15
8 Implementation																															
1) Structural Measures																															24
2) Vegetation																															24
3) Disaster Education/Capacity Building																															24
4) Land Acquisition																															27
9 Completion/Inauguration																															-

#### (4) Procurement

##### 1) Employment of consultants

The employment of consultant is to be made according to the following items:

- ① The consultants should be active in international market and have enough qualification and experience.
- ② The consultants are to have efficiency, transparency and non-discrimination among eligible consultants
- ③ The selection procedure should be taken in accordance with the stipulation in the Loan Agreement and the guideline for the Employment of Consultants under Japanese ODA Loans prepared by JICA

##### 2) Procurement of contractor

The procurement of contractors is to be made according to the following items:

- ① The procurement of contractors is to be made using due attention to considerations of economy, efficiency, transparency and non-discrimination among eligible bidders.
- ② The procurement procedure should be taken in accordance with the stipulation in the Loan Agreement and the guideline for the Employment of Consultants under Japanese ODA Loans prepared by JICA
- ③ The International Competitive Bidding: ICB is to be applied.
- ④ The pre-qualification (PQ) of bidders is to be applied in order to confirm the technical and financial capability of bidders. The following items are to be considered in PQ: a) experience of and past performance on similar contracts, b) capabilities with respect to personnel, equipment and plant, c) financial position.

#### 4.12 Financial Plan

##### (1) Sharing ratio of project cost

This project will be implemented by the central government (through the DGIH), irrigation

committees and regional governments. Also, the project cost will be covered with the respective contributions of the three parties.

As to the sharing ratio among the central government, regional government and irrigation committee, DGIH reported that in some dam project the ratio among the central government, regional government, local government and irrigation committee is 50%, 30%, 10% and 10% respectively and JICA Peru office reported that in some irrigation project, the irrigation committee bore 20%. However there are no such examples as the flood protection project of this Project

Considering the direct benefit received by the irrigation committee is not so much as in the irrigation project, the sharing percentage will be determined through discussions among stake holders, the ratio is assumed provisionally 80% for the central government (in this case MINAG), 15% for regional government and 5% for irrigation committee. And the final ratio will be determined through negotiation among 3 parties.

## (2) Financial plan

The total project cost is 239,474 thousand soles and Japan yen loan amount is 64,750 thousand soles (25,000 thousand US\$) so that the counter fund to be borne by Peru side is 174,724 thousand soles (=239,474 – 64,750).

The counter fund is divided into stakeholders as shown in the Table 4.12-1. The contribution of regional government and irrigation committee is distributed in proportion of project cost of each basin.

**Table 4.12-1 Financial plan at implementation of project**

(thousand soles)

	Item		Amount	Remarks
1	Project cost	①	239,474	
2	Yen loan	②	64,750	25millionUS\$x2.59
	Counter fund	③	174,724	① – ②
3	Central government	④	139,779	③x80%
4	regional government	⑤	26,209	③x15%
	(1) Lima (canete)	⑥	3,355	⑤x12.8%(Ratio of Project Cost)
	(2) Ica (Chincha)	⑦	5,347	⑤x20.4%(Ratio of Project Cost)
	(Pisco)	⑧	7,548	⑤x28.8%(Ratio of Project Cost)
	Subtotal	⑨	12,895	⑦ + ⑧
	(3) Arequipa (Majes-Camana)	⑩	9,959	⑤x38.0%(Ratio of Project Cost)
5	Irrigation committee	⑪	8,736	③x5%
	(1) Canate	⑫	1,118	⑪x12.8%(Ratio of Project Cost)
	(2) Chincha	⑬	1,782	⑪x20.4%(Ratio of Project Cost)
	(3) Pisco	⑭	2,516	⑪x28.8%(Ratio of Project Cost)
	(4) Majes-Camana	⑮	3,320	⑪x38.0%(Ratio of Project Cost)

Note) 1 US \$ = 83.6 yen = 2.59 soles, 1 sol = 32.3 yen

## (3) Repayment of loan

The yen loan shall be repaid according to the conditions stipulated in the Loan Agreement which is estimated as shown in the Table 4.12-2. The repayment will be made by the stakeholders according to

the sharing ratio including the interest of loan.

**Table 4.12-2 Estimated conditions of Japan Yen Loan**

Interest	1.70%
Commitment Charge	0.10%
Maturity Period	25 years
Grace Period	7 years

#### 4.13 Logical Framework of the Eventually Selected Option

In Table 4.13-1 the logical framework of the definite selected option is shown.

**Table 4.13-1 Logical framework of the definite selected option**

Narrative Summary	Verifying Indicators	Verifying Indicators Media	Preliminary Conditions
<b>Superior Goal</b>			
Promote socioeconomic local development and contribute in communities' social welfare.	Improve local productivity, generate more jobs, increase population's income and reduce poverty index	Published statistic data	Socio-economic and policy stability
<b>Objectives</b>			
Relief the high vulnerability of valleys and local continuity to floods	Types, quantity and distribution of flood control works, population and beneficiaries areas	Monitoring annual calendar works and financial plan, budget execution control	Ensure the necessary budget, active intervention from central and regional governments, municipalities, irrigation communities, local population, etc.
<b>Expected results</b>			
Reduction of number and flooded areas, functional improvement of intakes, irrigation channels protection, bank erosion control	Number of areas and flooded areas, water intake flow variation, bank erosion progress	Site visits, review of the flood control plan and flood control works reports and periodic monitoring of local inhabitants	Maintenance monitoring by regional governments, municipalities and local community, provide timely information to the superior organisms
<b>Activities</b>			
Component A: Structural Measures	Dikes rehabilitation, intake and bank protection works construction of 23 works, including dike's safety	Detailed design review, works reports, executed expenses	Ensure the works budget, detailed design/works execution/good quality works supervision
Component B: Non-Structural Measures (Reforestation and vegetation recovery)	Reforested area, coastal forest area	Works advance reports, periodic monitor by local community	Consultants support, NGO's, local community, gathering and cooperation of lower watershed community
Component C: Disaster prevention and capabilities development education	Number of seminars, trainings, workshops, etc.	Progress reports, local governments and community monitoring	Predisposition of the parties to participate, consultants and NGO's assessments

Project's execution management			
Project's management	Detailed design, work start order, work operation and maintenance supervision	Design plans, work's execution plans, costs estimation, works specifications, works management reports and maintenance manuals	High level consultants and contractors selection, beneficiaries population participation in operation and maintenance

#### 4.14 Baseline for Impact Assessment

The indicators of impact assessment are as shown below.

- Scale of flood discharge
- Inundation area
- Damage caused by flood
- Environment impact
- Operation and maintenance cost

##### 1) Scale of flood discharge

As to the flood which causes the damage, the flood discharge is to be estimated using the rainfall and discharge observation data. Since the probable flood discharges were estimated in each basin in this Study, the occurrence probability of actual flood could be estimated and the impact given by the flood could be assessed.

##### 2) Inundation area

The inundation caused by the actual flood is to be plotted on the topographical map or satellite figure so that the inundation area around flood prevention facilities can be identified. Since the inundation area corresponding to the probable flood was estimated in the this Study, this area can be compared with the actual inundation area and the impact given by the actual inundation can be assessed.

##### 3) Flood damage

The actual flood damage is to be estimated for crops, loss of farm land, irrigation facilities, intake, traffic interruption, and other indirect damage. The actual damage can be compared with the damage caused by the probable flood. The impact caused by the actual damage can be assessed.

##### 4) Environment impact

In the operation and maintenance stage, the environment impact is to be assessed regularly using the same method in this Study. The results are to be compared with the original results, then the environmental impact of the project can be assessed.

5) Operation and maintenance cost

The operation and maintenance cost of the Project was estimated in this Study. The actual O/M cost incurred to the irrigation committee is monitored in every year. The actual cost is to be compared with the estimated and the impact on O/M cost can be assessed.

#### **4.15 Middle and Long Term Plan**

Up to this point, only flood control measures have been proposed and these must be executed most urgently, due to the limitations on the available budget for this Project. However, there are other measures that must be performed in the long term framework. In this section we will be talking about the middle and long term flood control plan.

##### **4.15.1 Flood Control General Plan**

There are several ways to control floods in the entire watershed, for example building dams, reservoirs, dikes or a combination of these.

In case of building a dam proposal, assuming that this dam will reduce the flood peak with a 10 year return period reaching a return period flow of 50 return years, it will be necessary to build a dam with a very big capacity, calculating it in 46.5 million m<sup>3</sup> for Majes-Camana River. Usually upstream of an alluvial area, there is a rough topography in order to build a dam, a very high dam will be required to be built, which implies investing a large amount (more than thousand millions of soles).

Also, it would take between three to five years to identify the dam site, perform geological survey, material assessment and conceptual design. The impact on the local environment is huge. So, it is considered inappropriate to include the dam analysis option in this Study.

Likewise, the option of building a retarding basin would be hardly viable for the same reasons already given for the dam, because it would be necessary to build a great capacity reservoir and it is difficult to find a suitable location because most of the flat lands along the river's downstream are being used for agricultural purposes. So, its analysis has been removed from this Study. Therefore, we will focus our study in the construction of dike because it is the most viable option.

##### **(1) Plan of the river course**

###### **1) Discharge capacity**

An estimation was done on the discharge capacity of the current flow of this river based on longitudinal and cross sectional survey of the river, which results are shown in the section 3.1.10, Figure 3.1.10-3 and Figure 3.1.10-4.

###### **2) Inundation characteristics**

The inundation analysis of Majes-Camana river was performed. In the section 3.1.10, Figure 3.1.10-5 and in Figure 3.1.10-6 the inundation condition for flood with probabilities of 50 years is shown.

It overflows at the vicinity of 5km from the river mouth, and the flood flow spreads greatly in the left-bank side. In middle stream and upstream areas, It overflows in lowland plain, and flood flow stagnates by the surrounded hills and mountains.

### 3) Design flood level and dike's standard section

The design flood level was determined in the flood water level with a return period of 50 years applying the standard section of dike already mentioned in section 4.3.1, 5), 3) to the present river channel, and the dike's standard section will be determined as already mentioned in section 4.3.1, 5), 1). In the section 4.2, Table 4.2-2 and Table 4.2-3 the theoretical design flood level and the required height of the dike's crown is shown.

### 4) Dikes' alignment

Considering the current conditions of existing dikes the alignment of the new dikes was defined. Basically, the broader possible river width was adopted to increase the discharge capacity and the retard effect. In Figure 4.15.1-1 the current channel and the setting alignment method of a section where the current channel has more width is explained schematically. In a normal section, the dike's crown has the same height to the flood water level with a return period of 50 years plus free board, while in the sections where the river has greater width, double dikes be constructed with inner consistent dike alignment and continuous with normal sections upstream and downstream. The crown height is equal to the flood water level with a return period of 50 years. The external dike's crown height is equal to flood water level with a return period of 50 years, so in case the river overflows the internal dike, the open gap between the two dikes will serve to store sediments and retarding water.

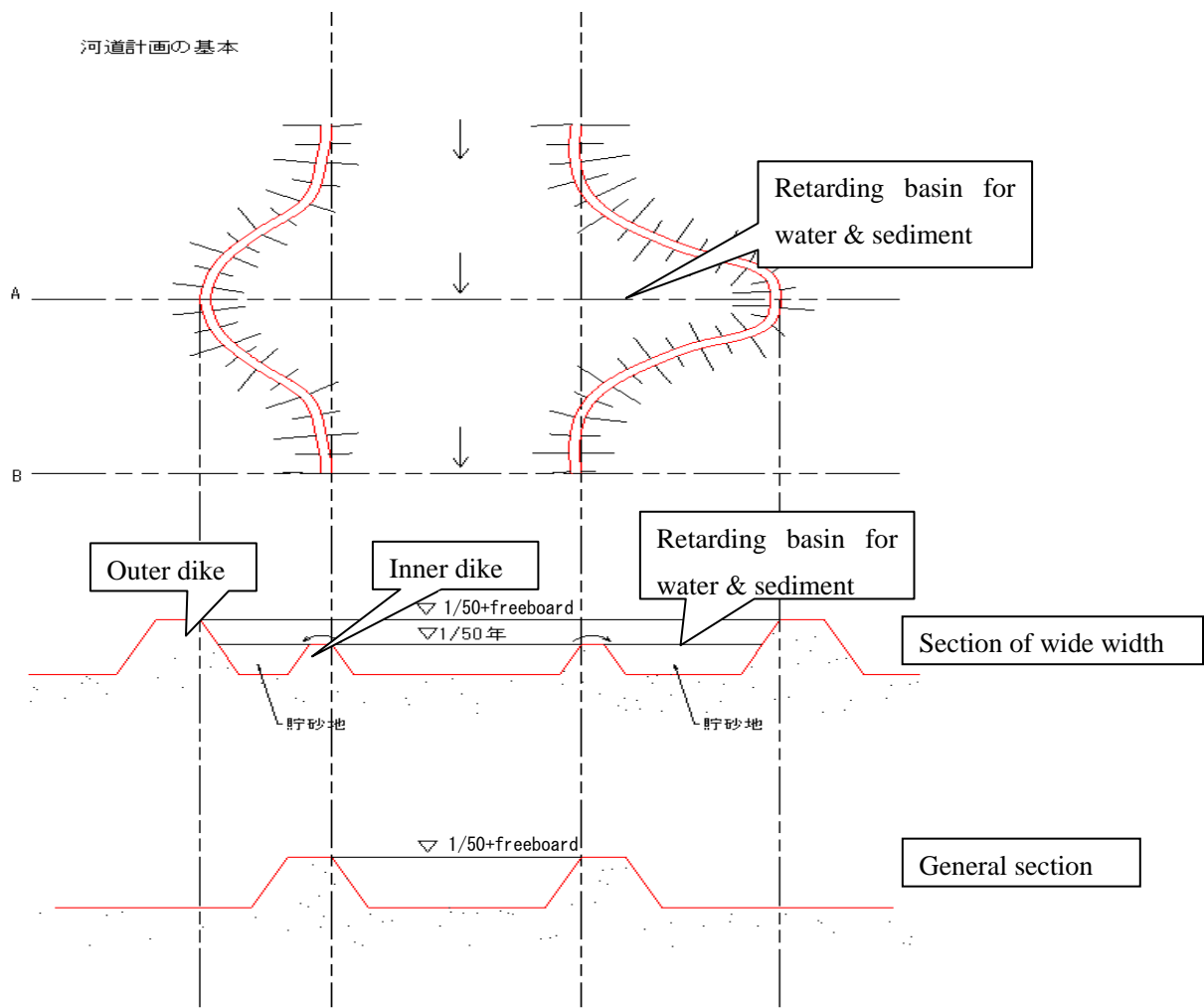
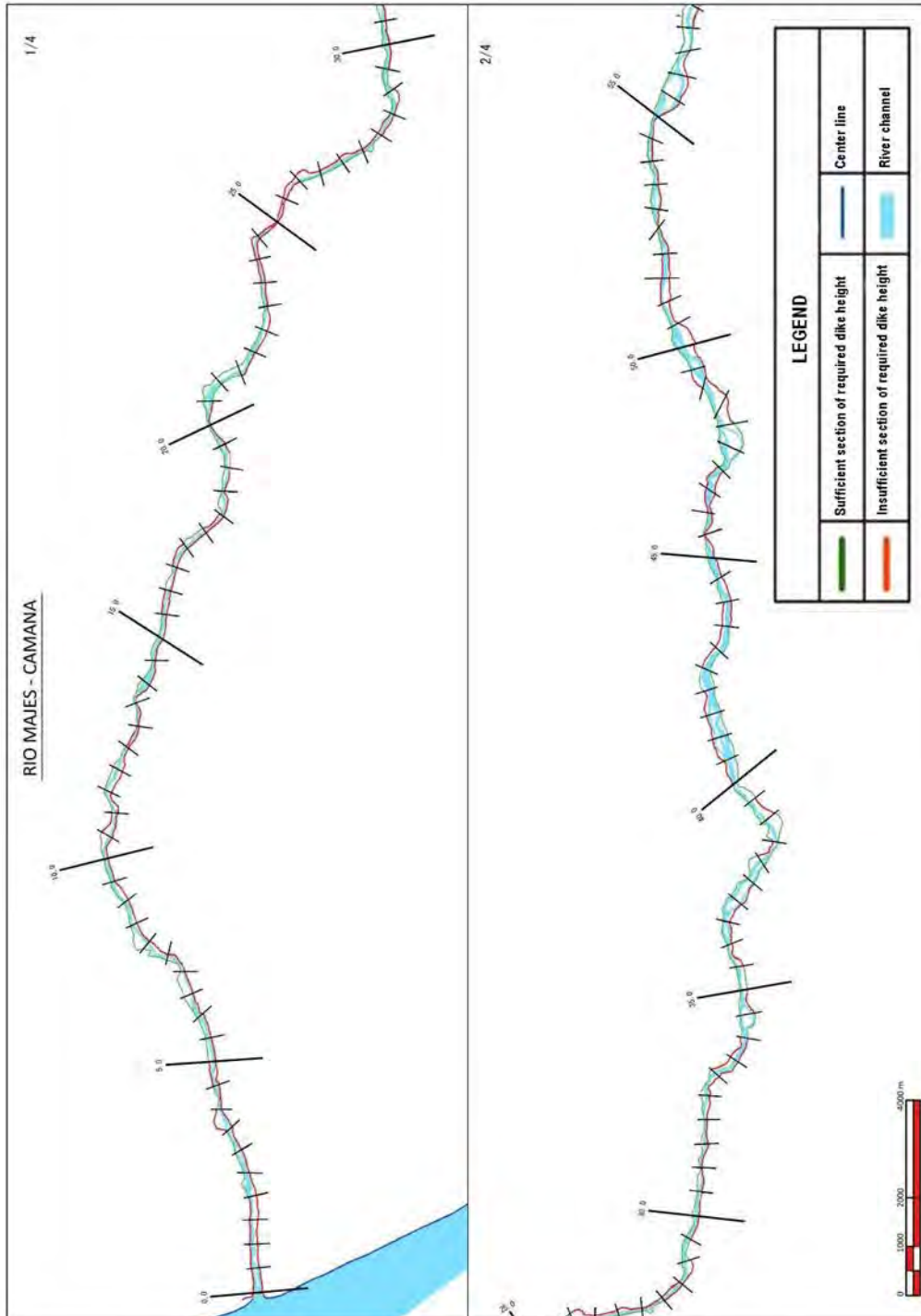


Figure 4.15.1-1 Definition of dike alignment

5) Plan and section of river

The plan and longitudinal section of river are as shown in the Figure 4.15.1-2, Figure 4.15.1-3 and Figure -4.15.1-4, Figure -4.15.1-5 respectively.



**Figure 4.15.1-2 Plan of Majes-Camana river (0-55K)**



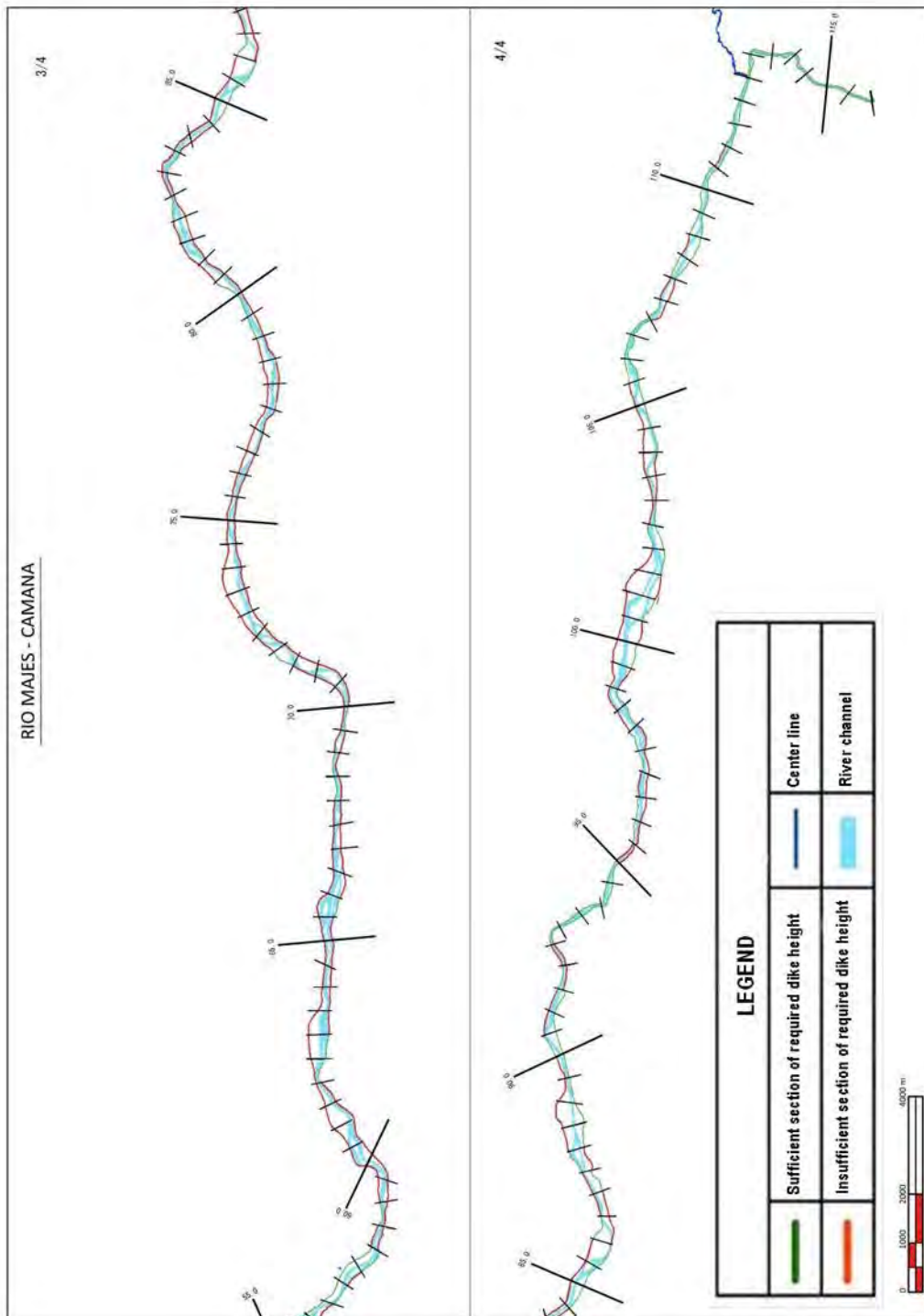


Figure 4.15.1-3 Plan of Majes-Camana river (55-115K)

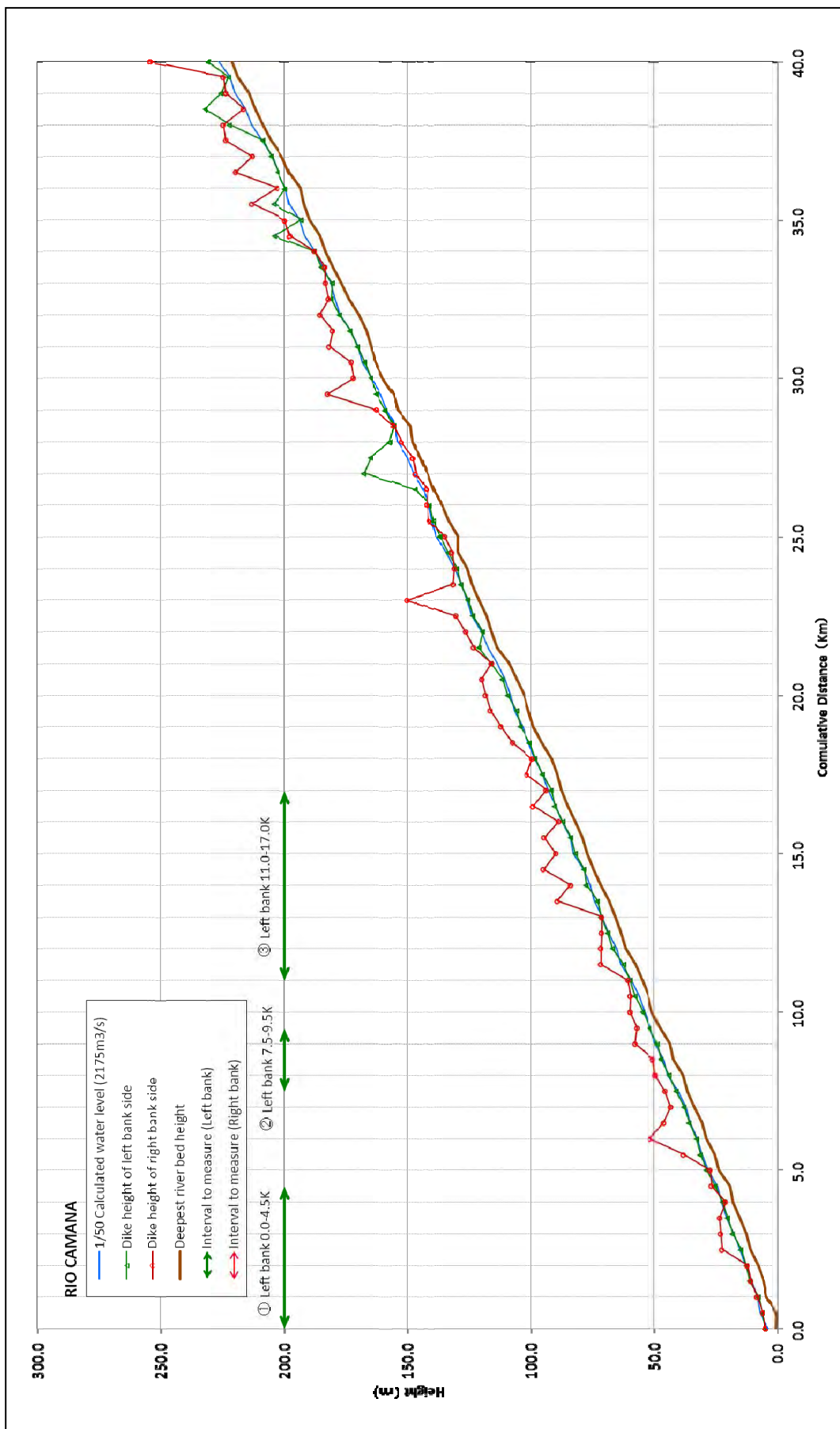


Figure 4.15.1-4 Majes-Camana river longitudinal profile (Camana)

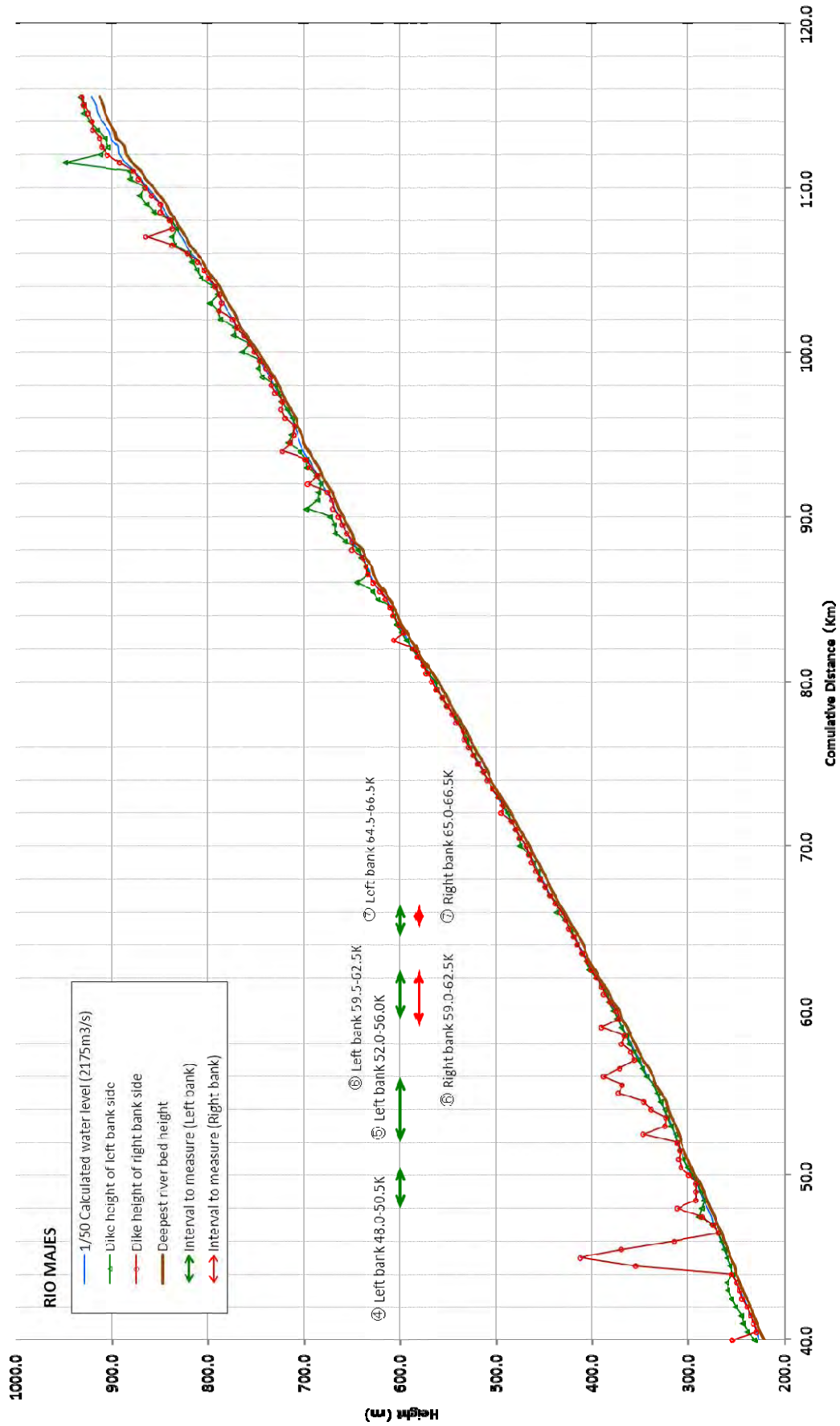


Figure 4.15.1-5 Majes-Camana river longitudinal profile (Majes)

6) Dike's construction plan

Next, basic policies for the dike's construction plan on the Majes-Camana River are shown:

- Build dikes that allow flood flow safe passage with a return period of 50 years
- The dikes will be constructed in areas where overflowing water will enter the dike, according to the flood simulation
- The dikes will be placed in the sections above mentioned, where the design water level exceeds the existing dike's height or the ground level within the dike
- The dike's height is defined in the flood water level with a return period of 50 years plus the free board

Table 4.15.1-1 and Figure 4.15.1-6 show the dike's construction plan on the Majes-Camana River.

**Table 4.15.1-1 Dike's construction plan**

River Name	Improvement Section		Shortage for Design Height (m)	Dike Plan	Dike Length (km)
Majes-Camana River	Left bank side	0.0k-108.0k	1.36	Dike h=2.0m Revetment h=3.0m	72.5
	Right bank side	0.0k-111.0k	1.46		52.0
	Total		1.40		124.5

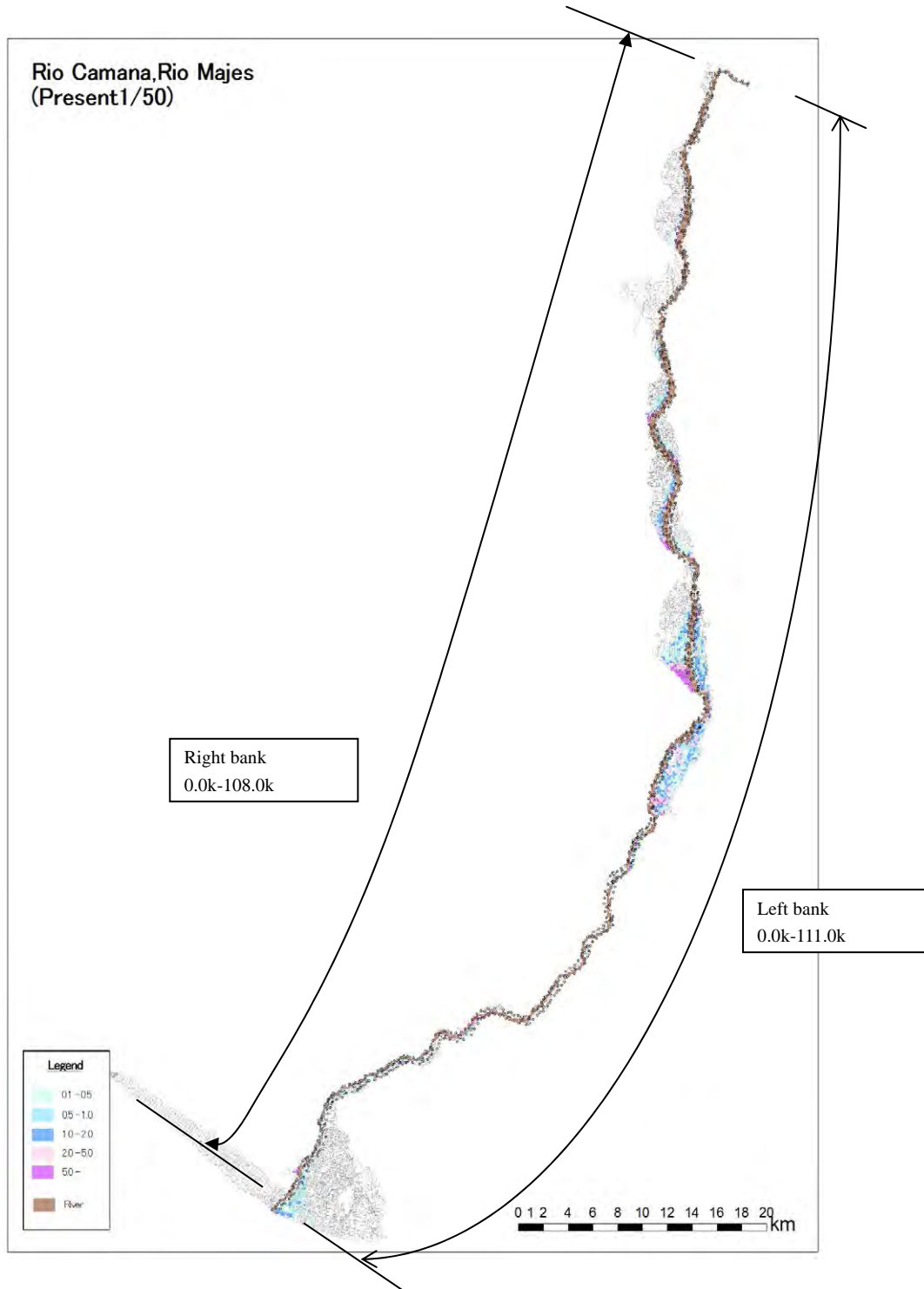


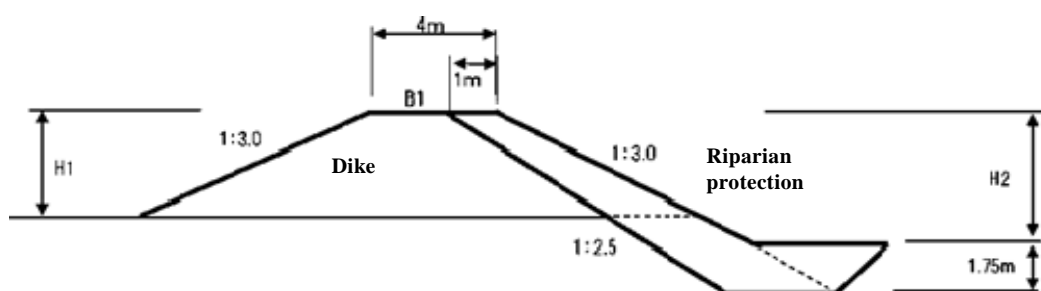
Figure 4.15.1-6 Layout of dike in Majes-Camana river

## 7) Project Cost

In Tables 4.15.1-2 and 4.15.1-3 works' direct costs in private prices and the Project's cost are shown. Also, the cost of the project in social prices is presented in Table 4.15.1-4.

**Table 4.15.1-2 Works direct cost (at private prices)**

Construction of dike				Riparian protection			
B1	H1	B2	A	B1	H2	B2	A
3.0	1.0	8.5	5.8	1.0	1.0	2.4	10.8
3.0	1.5	11.3	10.7	1.0	1.5	2.6	12.0
3.0	2.0	14.0	17.0	1.0	2.0	2.9	13.4
3.0	3.0	19.5	33.8	1.0	3.0	3.4	16.5
3.0	4.0	25.0	56.0	1.0	4.0	3.9	20.1
3.0	5.0	30.5	83.8	1.0	5.0	4.4	24.3
3.0	1.5	11.3	10.7	1.0	6.0	4.9	28.9



Basin		Quantity	Unit	Unit Price (Sol)	Direct Construction Cost /m (Sol)	Direct Construction Cost /km (10 <sup>3</sup> Soles)	Total Dike Length (km)	Direct Construction Cost (10 <sup>3</sup> Soles)
Majes - Camana	Embankment/ Revetmen	170	m <sup>3</sup>	100	1700	1700	1245	21,165.0
		165	m <sup>3</sup>	100.0	1,650.0	1,650.0		205,425.0

**Table 4.15.1-3 Projects' Cost (at private prices)**

Basin Name	Direct Cost		Indirect Cost							Infrastructure Cost, Total Cost (12)=(8)+(9)+(10)+(11)		
	Direct Cost (1)	Temporary Construction Cost (2)	Total Direct Cost (3)=(1)+(2)	Overhead (4)=0.15x(3)	Profit (5)=0.1x(3)	Work Cost (6)=(3)+(4)+(5)	Tax (IGY) (7)=0.18x(6)	Total Construction Cost (8)=(6)+(7)	Environmental Cost (9)=0.01x(8)		Detail Design Cost (10)=0.05x(8)	Construction Supervision Cost (11)=0.1x(8)
MAJES-CAMANA	226,590,000	22,659,000	249,249,000	37,387,350	24,924,900	311,561,250	56,081,025	367,642,275	3,676,423	18,382,114	36,764,228	426,465,039

**Table 4.15.1-4 Projects' Cost (at social prices)**

Basin Name	Direct Cost		Indirect Cost							Infrastructure Cost, Total Cost (12)=(8)+(9)+(10)+(11)		
	Direct Cost (1)	Temporary Construction Cost (2)	Total Direct Cost (3)=(1)+(2)	Overhead (4)=0.15x(3)	Profit (5)=0.1x(3)	Work Cost (6)=(3)+(4)+(5)	Tax (IGY) (7)=0.18x(6)	Total Construction Cost (8)=(6)+(7)	Environmental Cost (9)=0.01x(8)		Detail Design Cost (10)=0.05x(8)	Construction Supervision Cost (11)=0.1x(8)
MAJES-CAMANA	182,178,360	18,217,836	200,396,196	30,059,429	20,039,620	250,495,245	45,089,144	295,584,389	2,955,844	14,779,219	29,558,439	342,877,891

## (2) Operation and maintenance plan

The operation and maintenance cost was calculated identifying the trend of the sedimentation and erosion bed based on the one-dimensional analysis results of the bed variation, and a long-term operation and maintenance plan was created.

The current river course has some narrow sections where there are bridges, farming works (intakes, etc.) and there is a tendency of sediment gathering upstream of these sections. Therefore, in this project there is a suggestion to increase the hydraulic capacity of these narrow sections in order to avoid as possible upstream and in the bed (main part) sedimentation, together with gathering sediments as much as possible when floods over a return period of 50 years occur.

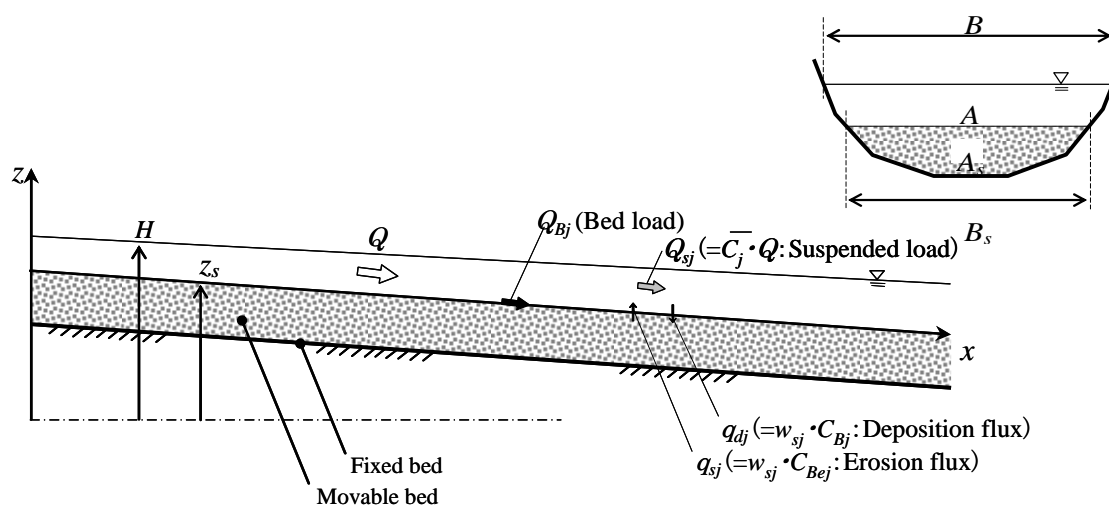
### 1) Riverbed fluctuation analysis

The summary of the riverbed fluctuation analysis model is as shown in the Table 4.15.1-5 and the analysis conditions are as shown in the Table 4.15.1-6.

The Figure 4.14.1-6 shows the results of the riverbed fluctuation analysis of the river for the next fifty years. From this figure a projection of the riverbed's sedimentation and scouring trend and its respective volume can be made.

**Table 4.15.1-5 Summary of riverbed fluctuation analysis model**

Items	Content
Water Flow	One-dimensional Non-uniform Flow Model
Sediment Transportation	One-dimensional Mixed Grain Size Riverbed Fluctuation Model
Bed Load	Ashida & Michiue' s Bed load formula
Suspended Load	Ashida & Michiue' s Suspended Load formula considering non-equilibrium of suspended sediment
Calculation Method	MacCormack Method



**Figure 4.15.1-5 Pattern diagram of riverbed fluctuation analysis model**



**Table 4.15.1-6 Analysis condition of river**

	Majes-Camana
Calculation river length	115km
Period	For future 50 years
Space interval ( $\Delta x$ )	250m
Time interval ( $\Delta t$ )	2.0sec
Input discharge	50 years discharge prepared based on observation data (max. annual discharge), in case of insufficient year number prepared by repeating the limited year data.
Sediment Supply	419,000m <sup>3</sup> /year
Tributary inflow	Disregarded since there are only small tributaries
Grain size	Based on the grain size distribution in the riverbed material, 8~ 9 grain size are assumed (d=0.075mm ~500mm) .
Water level at downstream end	Assumed normal water depth at the downstream end
Roughness coefficient	n=0.05 (all section)
Void ration	0.4 (representative value of sand and gravel)

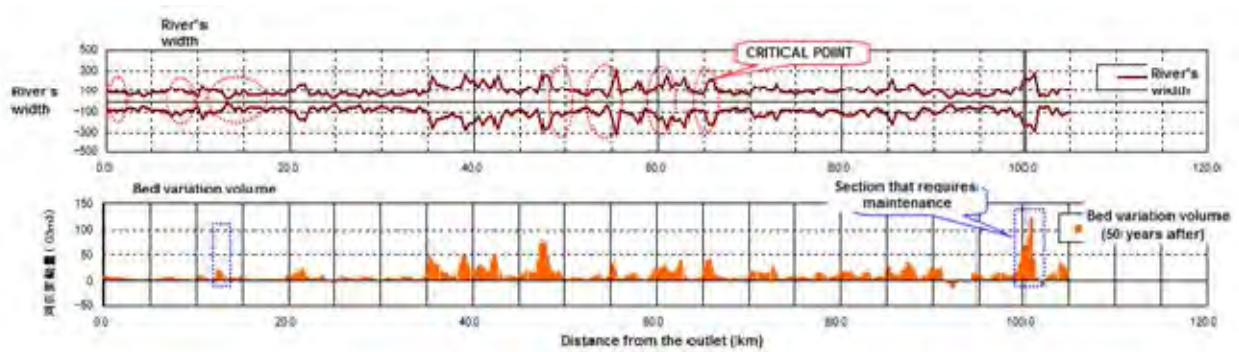
2) Sections that need maintenance

In Table 4.15.1-7 possible sections that require a process of long-term maintenance in the Majes-Camana River watershed is shown.

**Table 4.12.1-7 Sections/places to be carried out maintenance works**

River Name	Excavation Area		Method of Maintenance Works
Majes-Camana River	Place1	Target Section: 12.0km-13.0km Target Volume: 70,000m <sup>3</sup>	It is comparatively narrow section. The possibility that a remarkable riverbed aggradation will occur also in small amount of sediment is surmised to be high. Periodical excavation maintenance every year is desirable in consideration of the influence on intake facilities.
	Place2	Target Section: 100.0km-101.0km Target Volume: 460,000m <sup>3</sup>	It is a wide channel section. It has high possibility that a lot of sediment accumulates easily. By carrying out excavation maintenance in the section, it is expectable that the effectiveness of the riverbed aggradation in the middle stream can be also controlled. The place is considered to be carried out the planned excavation maintenance from the viewpoint on flood control.

※Design sediment volume: Sediment volume deposited in 50 years



**Figure 4.15.1-6 Section that requires maintenance (Majes-Camana river)**

### 3) Operation and maintenance cost

Next the direct work cost at private prices for maintenance (bed excavation) required for the watershed in the next 50 years is shown.

Direct Work Cost

At private prices:  $530,000 \text{ m}^3 \times 10 = 5,300,000$  soles

Tables 4.15.1-8 and 4.15.1-9 show a 50 year Project cost at private and social prices.

**Table 4.15.1-8 Excavation works cost for a 50 year bed (at private prices)**

(million soles)

Basin 流域名	Direct cost 直接工事費計 (1)	Common Temporary Work Cost 共通仮設費 (2) = 0.1*(1)	Construction cost 工事費 (3) = (1) + (2)	Overhead Cost 諸経費 (4) = 0.15*(3)	Profit 利益 (5) = 0.1*(3)	Structure Construction Cost 構造物工事費 (6) = (3)+(4)+(5)	Tax (IGV) 税金 (7) = 0.18*(6)	Construction Cost 建設費 (8) = (6)+(7)	Environment Cost 環境影響 (9) = 0.01*(8)	Detail Design Cost 詳細設計 (10) = 0.05*(8)	Construction Supervision Cost 施工管理費 (11) = 0.1*(8)	Total Project Cost 事業費 (12) = (8)+(9)+(10)+(11)
MAJES-CAMANA	5,300	530	5,830	875	583	7,288	1,312	8,599	86	430	860	9,975

**Table 4.15.1-9 Excavation works cost for a 50 year bed (at social prices)**

(million soles)

Basin 流域名	Direct Cost 直接工事費計 (1)	Common Temporary Work Cost 共通仮設費 (2) = 0.1*(1)	Construction Cost 工事費 (3) = (1) + (2)	Overhead Cost 諸経費 (4) = 0.15*(3)	Profit 利益 (5) = 0.1*(3)	Structure Construction Cost 構造物工事費 (6) = (3)+(4)+(5)	Tax(IGV) 税金 (7) = 0.18*(6)	Construction Cost 建設費 (8) = (6)+(7)	Conversion Factor 修正係数 $f_c$	Construction Cost 建設費 (9) = $f_c*(8)$	Environment Cost 環境影響 (10) = 0.01*(9)	Detail Design Cost 詳細設計 (11) = 0.05*(9)	Construction Supervision Cost 施工管理費 (12) = 0.1*(9)	Total Project Cost 事業費 (13) = (9)+(10)+(11)+(12)
MAJES-CAMANA	5,300	530	5,830	875	583	7,288	1,312	8,599	0.804	6,914	69	346	691	8,020

### (3) Social assessment

#### 1) Private prices cost

##### a) Damage amount

Table 4.15.1-10 shows the damage amount calculated analyzing the overflow caused by floods in the Majes-Camana River with return periods between 2 and 50 years.

**Table 4.15.1-10 Amount of damage for floods of different return periods (private prices)**

(10<sup>3</sup> Soles)

Year	Damage Amount
	Majes-Camana
2	311
5	48,616
10	78,391
25	111,072
50	191,990
Total	430,380

b) Damage reduction annual average

Table 4.15.1-11 shows the damage reduction annual average of the watershed calculated with the data of Table 4.12.1-10.

c) Project's Cost and the operation and maintenance cost

Table 4.15.1-3 shows the projects' cost. Also, the annual operation and maintenance (O & M) cost for dikes and bank protection works can be observed in the table. This is calculated from the 0.5% of the construction cost plus the bed excavation annual average cost indicated in Table 4.15.1-6.

d) Economic evaluation

In Table 4.15.1-12 the results of economic assessment are shown.

**Table 4.15.1-11 Damage reduction annual average**

(10<sup>3</sup> Soles)

Basin	Return Period	Probability	Total Damage			Average Damage ④	Section Probability ⑤	Annual Average Damage ⑥=④×⑤	Accumulation of Annual Average Damage
			Without Project ①	With Project ②	Damage Reduction ③=①-②				
MAJES- CAMANA	1	1.000	0	0	0			0	0
	2	0.500	311	0	311	155	0.500	78	78
	5	0.200	48,616	0	48,616	24,464	0.300	7,339	7,417
	10	0.100	78,391	0	78,391	63,604	0.100	6,360	13,767
	25	0.040	111,072	0	111,072	94,732	0.060	5,684	19,451
	50	0.020	191,990	0	191,990	151,531	0.020	3,031	22,482

**Table 4.15.1-12 Economic assessment results (private prices costs)**

流域名	年平均被害軽減額	評価期間被害軽減額(15年)	事業費	維持管理費	B/C	NPV	IRR(%)
Basin	Annual Average Damage Reduction	Damage Reduction in Evaluation Period(15years)	Project Cost	O&M Cost	Cost Benefit Ration	Net Present Value	Internal Return of Rate
Majes-Camana	292,262,168	131,979,802	426,465,039	26,889,287	0.34	-252,832,589	-

2) Social prices cost

a) Damage amount

Table 4.15.1-13 shows the damage amount calculated analyzing the overflow caused by floods in the Majes-Camana River with return periods between 2 and 50 years in each watershed.

**Table 4.15.1-13 Amount of damage for floods of different return periods (at social prices)**

(10<sup>3</sup> Soles)

Year	Damage Amount
	Majes-Camana
2	317
5	48,503
10	78,738
25	113,789
50	201,622
Total	442,970

b) Damage reduction annual average

Table 4.15.1-14 shows the damage reduction annual average of each watershed calculated with the data of Table 4.15.1-13.

c) Project's cost and the operation and maintenance cost

Table 4.15.1-4 shows the projects' cost. Also, the annual operation and maintenance (O & M) cost for dikes and margin protection works can be observed in the table. This is calculated from the 0.5% of the construction cost, as well as the bed excavation annual average cost indicated in Table 4.15.1-7.

d) Economic evaluation

In Table 4.15.1-15 the results of economic assessment are shown.

(4) Conclusions

The economic assessment result shows that the Project has negative economic impact in terms of social evaluation on both private and social prices, in addition to that the required cost is extremely high (426.5 million soles), so that this Project is difficult to be adopted.

**Table 4.15.1-14 Damage reduction annual average**

(10<sup>6</sup> Soles)

Basin	Return Period	Probability	Total Damage			Average Damage ④	Section Probability ⑤	Annual Average Damage ⑥=④×⑤	Accumulation of Annual Average Damage
			Without Project ①	With Project ②	Damage Reduction ③=①-②				
MAJES- CAMANA	1	1.000	0	0	0		0	0	
	2	0.500	317	0	317	159	0.500	80	
	5	0.200	48,503	0	48,503	24,410	0.300	7,323	
	10	0.100	78,738	0	78,738	63,621	0.100	6,362	
	25	0.040	113,789	0	113,789	96,264	0.060	5,776	
	50	0.020	201,622	0	201,622	157,706	0.020	3,154	

**Table 4.15.1-15 Economic assessment results (social prices costs)**

流域名 Basin	年平均被害軽減額 Annual Average Damage Reduction	評価期間被害 軽減額(15年) Damage Reduction in Evaluation Period(15years)	事業費 Project Cost	維持管理費 O&M Cost	B/C Cost Benefit Ration	NPV Net Present Value	IRR(%) Internal Return of Rate
Majes-Camana	295,026,234	133,227,999	342,877,891	21,618,987	0.43	-176,161,163	-

#### 4.15.2 Reforestation and Recovery of Vegetation Plan

Long-term reforestation in all areas considered to be critical of the upper watershed is recommended. So, a detail analysis of this alternative will be explained next.

##### 1) Basic Policies

Objectives: Improve the water source area's infiltration capacity, reduce surface soils, water flow and at the same time, increase water flow in intermediate soils and ground-water level. Because of the above mentioned, water flow is interrupted in high flood season, this increases water resources in mountain areas, reduces and prevents floods increasing with it the amount and greater flow of ground-water level, reducing and preventing floods.

- Forestry area: means forestry in areas with planting possibilities around watersheds with water sources or in areas where forest area has decreased.
- Forestry method: local people plantations. Maintenance is done by promoters, supervision and advisory is led by NGOs.
- Maintenance after forestry: Maintenance is performed by the sow responsible in the community. For this, a payment system (Payment for Environmental Services) will be created by downstream beneficiaries.
- Observations: After each thinning the area will have to be reforested, keeping and preserving it in a long-term sustainable way. An incentive for community people living upstream of the watershed shall be designed.

The forest is preserved after keeping and reforesting it after thinning, this also helps in the support and prevention of floods. For this, it is necessary that local people are aware, encourage people downstream, promote and spread the importance of forests in Peru during the project's execution.

2) Selection of forestry area

As mentioned in 1) forestry of the upper watershed will be done with the help of the communities' labor, during their spare time from their agricultural activities. However, the community mostly lives in the highlands performing their farming and cattle activities in harsh natural conditions. Therefore, it is difficult to tell if they have the availability to perform forestry. So, finding comprehension and consensus of the inhabitants will take a long time.

3) Time required for the reforestation project

Since it is a small population, the workforce availability is reduced. So, the work that can be carried out during the day is limited, and the work efficiency would be very low. The JICA Study Team estimated the time required to reforest the entire area throughout the population in the areas within the reforestation plan, plant quantity, work efficiency, etc. According to this estimate, it will take 98 years to reforest approximately 307,000 hectares of Majes-Camana River Watershed.

4) Total reforestation volume in the upper watershed and project's period and cost

The surface to be reforested for the Majes-Camana River Watershed is a vast area (approx. 307,000 ha), in years (98 years) and in investment amount (829.2million soles).

**Table 4.15.2-1 Upstream Watershed Forest General Plan**

Watershed	Forestry Area (ha) A	Required period for the project (years) B	Required budget (soles) C
Majes- Camaná	307,210	98	829,200,856

(Source: JICA Study Team)

5) Conclusions

The objective of this project is to execute the most urgent works and give such a long period for reforestation which has an indirect effect with an impact that takes a long time to appear would not be consistent with the proposed objective for the Project. Considering that 98 years and invested 829.2 million soles are required, we can say that it is impractical to implement this alternative in this project and that it shall be timely executed within the framework of a long-term plan after finishing this project.

**4.15.3 Sediment control plan**

For the long-term sediment control plan, it is recommended to execute the necessary works in the upper watershed.

The Sediment Control Plan in the upper watershed will mainly consist in construction of sediment control dikes and bank protection works. In the Figure 4.15.3-1 the sediment control works layout proposed to be executed throughout the watershed is shown. The cost of Majes-Camana River works was estimated focusing on: a) covers the entire watershed, and b) covers only the priority areas,

analyzing the disposition of works for each case (refer to Annex-6 Sediment Control Plan, 2.3). The results are shown in the Table 4.15.3-1.

Due to the Majes-Camana River extension, the construction cost for every alternative would be too high in case of carrying-out the bank protection works, erosion control dikes etc. apart from requiring a considerably long time. This implies that the project will take a long time to show positive results. So, it is decided that it is impractical to execute this alternative within this project and should be timely executed within the framework of a long-term plan, after finishing this project.

**Figure 4.15.3-1 Upper watershed sediment control works execution estimated costs**

Watershed	Approach	Bank Protection		Riverbed Girdle		Sediment Control dam		Total works direct cost	Project Cost (Millions S/.)
		Vol. (km)	Direct Cost (Million S/.)	Vol. (units)	Direct Cost (Million S/.)	Vol. (units)	Direct Cost (Million S/.)		
Majes-Camana	All Watershed	264	S/.282	26	S/.1	123	S/.165	S/.448	S/.843
	Prioritized Section	264	S/.282	26	S/.1	81	S/.105	S/.388	S/.730

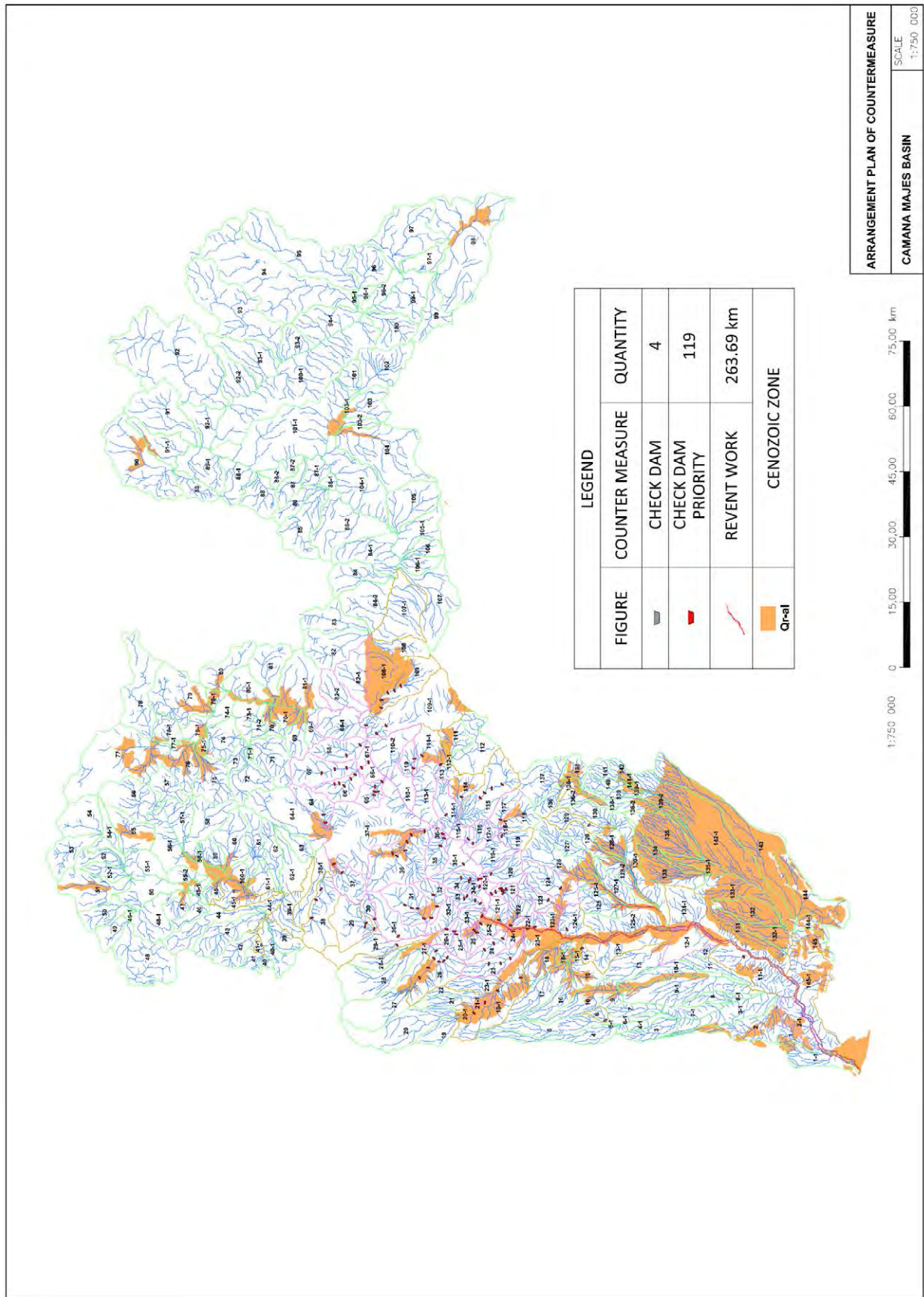


Image 4.15.3-1 Sediment control works location (Majes-Camana river watershed)



## **5. Conclusion and Recommendation**

### **5.1 Conclusion**

The flood prevention facilities selected finally in this Project are safe in structural, and have high viability and give scarcely impact to the environment. It is concluded that the Project should be implemented as soon as possible so that the high vulnerability against flood in valleys (Valles) and rural communities could be reduced and the social economic development will be promoted in the Project area.

### **5.2 Recommendation**

Based on the knowledge and experience obtained from this Study, the following recommendations are presented on the implementation of this Project and the future flood control measures in Peru.

#### **5.2.1 Recommendation on Implementation of This Project**

##### **(1) Problems to be solved at present**

1) The project cost will be covered by the central government (through the DGIH), regional governments and irrigation committees.

The sharing ratio among stakeholders is assumed provisionally 80% for the central government (in this case MINAG), 15% for regional government and 5% for irrigation committee. Since the total cost of this Project was determined in the Feasibility Study, the final ratio will be determined through negotiation among 3 parties as soon as possible.

2) The area to be occupied by the flood prevention facilities and the plantation along river was determined in this study. It is recommended that the Project holder (DGIH) should define the limit of river area with private land and continually should carry on the process of land acquisition based on the Land Acquisition Law, which are; Emission of Resolution for land acquisition by the State, Proposition of land cost and compensation for land owner, Agreement of the State and land owner, Payment etc.

3) Confirmation of implementation agency of the Project

The implementation agency is assumed to be PSI, MINAG, however DGPI, MEF and OPI, MINAG do not always agree that, so that the final implementation agency will be determined as soon as possible.

4) As to the environment impact assessment of this Project, DGAA, MINAG evaluated the Initial Environment Assessment (EAP) of the Project and classified this Project in to Category I so that the additional environment assessment is not required, however it is necessary to proceed the process of preservation of archeological heritage.

5) Acquisition of CIRA (Certificación de Inexistente de Restos Arqueológicos)

DGIH has to promote the process to obtain the CIRA in the detail design stage. The process to be taken is i) Application form, ii) Copies of the location drawings and outline drawings, iii) voucher, iv) Archaeological Assessment Certificate.

6) The operation and maintenance after implementation of the Project will be carried out by the irrigation committee. They are not familiar the flood prevention facilities which are different type of structure from the agricultural facilities such as irrigation channel, intake and so on, so that that the technical and economic assistance by MINAG and local government

**(2) Structural measures**

1) Basic policy of flood control

In the basic policy of flood control, the flood prevention measures should be prepared gradually from the downstream to the upstream of river. However the facilities with high priority such as wide inundation area and giving serious impact on the socio-economy of the region were selected and planned to be implemented in this Project.

Once the preparation in the upstream area is completed, of which influence occurs in the opposite bank or downstream area. And the asset will be accumulated by preparation of flood prevention measures which means the increase of damage potential, if the flood over design flood will occur the damage might be enlarged more than before due to increase of damage potential. Therefore it could not be said that the damage will be not always decreased, which should be noticed to people and the land use regulation should be prepared.

2) Problems for flood control planning in the river

The existing dike in Camana river presents an advanced degree of obsolescence, and numerous eroded sections can be observed. Currently, overflow occurs mainly in the upstream reach (Majes river), reducing the impact in this area. However, once this problem is solved in the upstream reach, impact would increase in this area, extending inundation area.

Likewise, at 13km there are a water supply intake to the urban area of Camana and a water channel along the river. Given that currently the left bank in the 12 km of the river is eroded and feared that the effect might strike the adjacent channel.

On the other hand, there are many sections without dike in Majes river so that damage by inundation and loss of farmland occur in every year.

Therefore in Camana river the rehabilitation and raising of existing dike is the most important in the left bank area which has large potential of damage, and in Majes river the embankment in the area without dike and with frequent flood damage is to be executed with priority.

The flood protection works in Majes river will affect the Camana river, therefore the order of the works should be carefully considered.

The sections with high priority are selected as described above, even when the facility in each section is complete it cannot be said that the preparation of whole Majes-Camana river is completed.

In future the sections where discharge capacity is not enough and need the strengthening dike will be continuously prepared for flood control.

And implementation of flood prevention facilities affects on the downstream Camana river so that the preparation order of facilities in Majes river should be well considered not to affect on the downstream Camana river

### 3) Problems in design and construction work

#### i) Construction work period

The dry season in the study area is from May to November when the level of water is very low or the river dries up, however the possible construction period is desirable to be from April to December considering the transition period from season to season.

Each river characteristics / features should be taken into account, that is, that the Majes-Camana Rivers is year - round river. At the same time, the crop season cycle in the areas of direct influence should be taken into account, so that traffic jams caused by the large trucks and farming machinery is prevented.

#### ii) Safety of dike

Dikes will be made of material available in the zone (river bed or banks). In this case, the material would be sand and gravel or sandy soil with gravel, of high permeability. The stability problems forecasted in this case are as follows.

- Infiltrate destruction caused by piping due to washing away fine material
- Sliding destruction of slope due to infiltrate pressure

In order to secure the stability of dike the appropriate standard section should be determined by infiltration analysis and stability analysis for sliding based on unit weight, strength and permeability of embankment material.

The importance in dike construction is sufficient compaction of dike material. The cost estimate standard in Peru the compaction is to be made by tractor; however for the sufficient compaction it is desirable to use compaction equipment such as vibration roller etc.

And in order to supervise the compaction of material, the density test and grain size analysis are important, of which are specified in the technical specification of the tender document (refer to Annex-9 Construction Planning/Cost Estimate, 3.3 Cost Estimate of Direct Cost, Item 2.2 Survey and Quality Control of Integrated List).

#### iii) Reduction of bank protection cost

The cost of construction work for the revetment occupies over 80% of the direct cost of the project in the embankment section. Moreover, the conveyance cost for the rocks from quarry site occupies 45% of the revetment works. In the places where existing revetment works and groin works still remain, such as in the Majes-Camana River, it should be considered that reusing of materials leads to reduction of construction costs.

#### iv) Balance of banking and excavation volume

As for balance of earth volume for embankment and excavation, there are shortages earth materials for embankment with 695,000 m<sup>3</sup> in the Majes-Camana River. Since the land along the river is used for farmland, the earth materials for embankment shall be taken from riverbed material. In case of excavation in riverbed for making flow capacity increase, there is a possibility that dike height will be lower a little. On the other hand, there is a possibility for promoting riverbed scouring due to steep slope of river. In the detail design phase, the selection of adequate places for borrow pits shall be important.

### **(3) Non-structural measures**

#### 1) Afforestation

The afforestation and vegetation recovery plan is divided into i) short term plan and ii) long term plan (upstream area in the river), of which the short term plan is adopted in this Project. In future flood control plan it is necessary that the long term plan will be executed, however the long term plan requires enormous project period and project cost. Therefore it is recommended that the long term plan will be realized by the effort of securing budget step by step.

#### 2) Sediment control and riverbed fluctuation

##### i) Sediment control plan

Cost for sediment control plan in the mountainous area is expensive (829.2million soles ), in addition project need long term periods. There are no objects to be conserved in the mountainous area, so cost-benefit performance is low. Main purpose in this project is mitigation of the flood disaster. With the view to this purpose, it is judged that sediment control works in the alluvial fans is most effective.

Despite being distinct from the project purpose, in Peru sediment disasters have occurred frequently. So Non-structural measures to mitigate the sediment disasters would be suggested as shown below. These Non-structural measures are more economical than structural measures and have function to prevent the human life and minimum property from the sediment disaster.

- Regulation of agricultural areas and residential areas
- Setting the alert rainfall for each region and establishment early warning Systems.
- Collect sample of sediment disaster and raise awareness of disaster prevention through education and patrimony of disaster prevention

##### ii) Riverbed fluctuation

The results of field investigation and riverbed fluctuation analysis show no urgent necessity of sediment control measures in all rivers. However from the long term point of view the decrease of riverbed elevation is forecasted and the riverbed elevation increases by the unstable sediment run-off in Majes-Camana river upstream of which no sediment control facilities exist so that the flood control function is reduced.

From now on the monitoring system for topography of river channel and local scouring should be established in all rivers depending on the riverbed fluctuation characteristics, and the

accumulation of such basic data is required.

#### **(4) Disaster prevention education/capacity development**

##### 1) Soft counter measures for reduction of flood damage

The design flood discharge in this Study is a flood with return period of 50 years which is calculated based on the past rainfall observation data. However the flood over design flood may occur due to El Niño or extraordinary meteorological phenomena. Since the forecasting of such floods is difficult it is impossible to prepare for such floods by hard counter measures. Since there is still risk for such floods, the establishment of soft countermeasures such as flood defense work, evacuation, preparation of hazard map and the notification and education to people is required.

##### 2) Promotion of community disaster prevention

It is important to promote the community disaster prevention, which reinforces the effect of this Project and induces the local people participation to the Project. The long time approach and activities are required until that the self and mutual assistance is motivated and the people start voluntarily concrete activities as a first step of activation of voluntary disaster prevention organization

It is necessary that the irrigation committee builds the community disaster prevention system as a core based on the disaster prevention education in this Project in order to increase the effect of the Project

### **5.2.2 Recommendation for Future Flood Control Plan in Peru**

#### **(1) Preparation of comprehensive master plan for flood control**

There are almost no flood prevention facilities in the Study area although the dikes are built in some places. The flood prevention facilities constructed in this Project are also partly, however they cover the important points and give the high economic effect as seen in the social evaluation results so that it can be said very significant project.

However, as to the future flood control in Peru, the integral master plan for major basins should be established and implemented step by step for objectives of not only agricultural facilities but also urban areas, roads, bridges etc.

#### **(2) Establishment of implementation agency for integral flood control project**

The counterpart ministry of this Project is MINAG which is responsible for the agricultural sector so that they cannot easily implement the disaster prevention project belong to the other sector.

In order to realize the above (1) it is necessary that the role of the existing agency will be change to be able to implement the flood control plan with integral purpose or establishment of new agency. By such agency the integral flood prevention measures and operation and maintenance of river such as dike, bank protection, groin, erosion of river bank, sedimentation in riverbed, intake weir etc. should

be carried out completely.

### **(3) Execution of strict river management**

The boundary of river area and private land is not clear, the river area is used sometimes as agricultural land, and the garbage is dumped in the river area illegally, which means the administration of river area is not well performed.

Therefore the preparation of river law system and strict application of it is quite required.

### **(4) Establishment of nationwide network of rainfall and discharge observation stations**

The estimation of flood discharge and flood pattern is indispensable as basic data for establishment of flood control plan. In order to estimate the above data with appropriate accuracy, the rainfall observation stations with enough density in the basin and the discharge observation stations at important points along the river are necessary as well as hourly observation data. And in order to estimate the flood discharge and flood pattern, the hourly data is indispensable.

However the data to be used in the Study area is very limited, for example, in the Yauca basin with area of 4,312km<sup>2</sup> there are 7 rainfall stations, of which only one station (Cora Cora2) is under operation. The observation data is all daily base for rainfall and discharge and is not hourly base

To promote the flood control in Peru, the establishment of network of rainfall and observation stations is indispensable. To do so, it is necessary that the master plan of observation network covering all Peru is to be established and the base stations are selected and the observation is carried out. The followings are to be examined to make the master plan and to select the basic stations.

- \* Review of observation data of existing stations
- \* Select observation stations to be used and digitalize of available data
- \* Plan of observation network and classification of planned and existing stations depending on importance
- \* Renewal of observation equipment in the existing stations depending on importance
- \* Installation new basic stations
- \* Plan of transmission system of data
- \* Plan of recording and keeping system of observation data
- \* Plan of operation and maintenance system
- \* Trial observation at the stations above

In implementation of above project, the all Peru is divided into several areas depending on the importance, then the project will be implemented step by step, and the implementation might be done by the assistance of foreign country. The administration of observation data is performed by SENAMHI at present, the observation data will be opened regularly to the public and can be used widely by the utilizer.